



Report No.: EA1908054F 01001

1 of 39

**ELECTROMAGNETIC EMISSIONS COMPLIANCE REPORT
INTENTIONAL RADIATOR CERTIFICATION TO
FCC PART 15 SUBPART C REQUIREMENT**

OF

Embedded wireless charger

**Model No.: WCP BA 01, WCP BL 01, WCP BC 01, WCP BP 01, WCP SL
01, WCP PBC 01, WCP MTL 01, WCP HBP 01,
WCP XX 01(XX means A-Z, denote as the surface treatment of the
outer casing)**

Trademark: 

FCC ID: YZHWCPXX01

Report No.: EA1908054F 01001

Issue Date: August 20, 2019

Prepared for

**Raffel Systems, LLC
N112 W14600 Mequon Road, Germantown, WI 53022, USA**

Prepared by

Dong Guan Anci Electronic Technology Co., Ltd.

**1-2 Floor, Building A, No.11, Headquarters 2 Road, Songshan, Lake
Hi-tech Industrial Development Zone, Dongguan City, evelopment
Zone, Dongguan City, Guangdong Pr., China.**

**This report shall not be reproduced, except in full, without the written approval of
Dong Guan Anci Electronic Technology Co., Ltd.**



VERIFICATION OF COMPLIANCE

Applicant:	Raffel Systems, LLC N112 W14600 Mequon Road, Germantown, WI 53022, USA
Manufacturer:	Raffel Systems, LLC N112 W14600 Mequon Road, Germantown, WI 53022, USA
Factory:	FORTRESS ELECTRONICS (XIAMEN) CO.,LTD East of the fifth floor, 181 banqiao road, jimei district, Xiamen, Fujian, China
Product Description:	Embedded wireless charger
Trade Mark:	
Model Number:	WCP BA 01, WCP BL 01, WCP BC 01, WCP BP 01, WCP SL 01, WCP PBC 01, WCP MTL 01, WCP HBP 01, WCP XX 01(XX means A-Z, denote as the surface treatment of the outer casing) (Note: The samples are the same except difference color of appearance and model number, Here WCP BA 01 was selected for full test.)

We hereby certify that:

The above equipment was tested by Dong Guan Anci Electronic Technology Co., Ltd. The test data, data evaluation, test procedures, and equipment configurations shown in this report were made in accordance with the procedures given in ANSI C63.10-2013 and the energy emitted by the sample EUT tested as described in this report is in compliance with conducted and radiated emission limits of FCC Rules Part 15.209.

Date of Test : August 08, 2019 to August 20, 2019

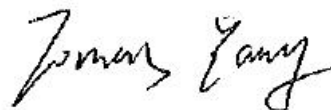

Prepared by : Tomas Yang/Supervisor



Reviewer & Authorized Signer : Alan He/Manager



Modified Information

Version	Summary	Revision Date	Report No.
Ver.1.0	Original Report	/	EA1908054F 01001



Table of Contents

1 GENERAL INFORMATION.....	5
1.1 PRODUCT DESCRIPTION.....	5
1.2 RELATED SUBMITTAL(S) / GRANT(S).....	6
1.3 TEST METHODOLOGY.....	6
1.4 SPECIAL ACCESSORIES.....	6
1.5 EQUIPMENT MODIFICATIONS.....	6
1.6 TEST FACILITY.....	6
2 SYSTEM TEST CONFIGURATION.....	7
2.1 EUT CONFIGURATION.....	7
2.2 EUT EXERCISE.....	7
2.3 TEST PROCEDURE.....	7
2.4 CONFIGURATION OF TESTED SYSTEM.....	8
3 SUMMARY OF TEST RESULTS.....	8
4 CONDUCTED EMISSIONS TEST.....	9
4.1 MEASUREMENT PROCEDURE.....	9
4.2 TEST SET-UP (BLOCK DIAGRAM OF CONFIGURATION).....	9
4.3 MEASUREMENT EQUIPMENT USED.....	9
4.4 CONDUCTED EMISSION LIMIT.....	9
4.5 MEASUREMENT RESULT.....	10
4.6 CONDUCTED MEASUREMENT PHOTO.....	19
5 RADIATED EMISSION TEST.....	20
5.1 MEASUREMENT PROCEDURE.....	20
5.2 TEST SET-UP (BLOCK DIAGRAM OF CONFIGURATION).....	20
5.3 MEASUREMENT EQUIPMENT USED.....	21
5.4 RADIATED EMISSION LIMIT.....	21
5.5 MEASUREMENT RESULT.....	23
5.6 RADIATED MEASUREMENT PHOTOS.....	32
6 20DB BANDWIDTH.....	33
6.1 20DB BANDWIDTH LIMIT.....	33
6.2 TEST INSTRUMENTS.....	33
6.3 TEST PROCEDURE.....	33
6.4 TEST SETUP.....	33
6.5 TEST RESULT.....	33
7 ANTENNA APPLICATION.....	35
7.1 ANTENNA REQUIREMENT.....	35
7.2 RESULT.....	35

1 General Information

1.1 Product Description

Characteristics	Description
Product Name	Embedded wireless charger
Model number	WCP BA 01
Operation Mode	Wireless Charging
Input Rating	AC 100-120V 50/60Hz 1.5A
Power Supply	AC120V/60Hz and AC 240V/50Hz for adapter
Operating Frequency	110-205KHz
Wireless Charging Power	10W Max(Backward compatible with 5W)
Modulation Technique	ASK
Antenna Type	Induction coil



1.2 Related Submittal(s) / Grant(s)

This submittal(s) (test report) is intended for FCC ID: YZHWCPXX01 filing to comply with the FCC Part 15, Subpart C Rules.

1.3 Test Methodology

Both conducted and radiated testing was performed according to the procedures in ANSI C63.10 (2013). Radiated testing was performed at an antenna to EUT distance 3 meters.

1.4 Special Accessories

Not available for this EUT intended for grant.

1.5 Equipment Modifications

Not available for this EUT intended for grant.

1.6 Test Facility

Site Description
EMC Lab. : Accredited by CNAS, 2017.06.26
The certificate is valid until 2022.10.28
The Laboratory has been assessed and proved to be in compliance with
CNAS-CL01:2006 (identical to ISO/IEC 17025:2005)
The Certificate Registration Number is L0468.

Accredited by A2LA, 2018.03.15
The Certificate Number is 4422.01.

Name of Firm : Dong Guan Anci Electronic Technology Co., Ltd.
Site Location : 1-2 Floor, Building A, No.11, Headquarters 2 Road, Songshan, Lake
Hi-tech Industrial Development Zone, Dongguan City, development Zone,
Dongguan City, Guangdong Pr., China.



2 System Test Configuration

2.1 EUT Configuration

The EUT configuration for testing is installed on RF field strength measurement to meet the Commissions requirement and operating in a manner which intends to maximize its emission characteristics in a continuous normal application.

2.2 EUT Exercise

The Transmitter was operated in the normal operating mode. The TX frequency was fixed which was for the purpose of the measurements.

2.3 Test Procedure

2.3.1 Conducted Emissions

The EUT is a placed on as turn table which is 0.8 m above ground plane. According to the requirements in Section 13.1.4.1 of ANSI C63.10-2013 Conducted emissions from the EUT measured in the frequency range between 0.15 MHz and 30 MHz using CISPR Quasi-Peak and average detector mode.

2.3.2 Radiated Emissions

The EUT is a placed on as turn table which is 0.8 m above ground plane. The turn table shall rotate 360 degrees to determine the position of maximum emission level. EUT is set 3m away from the receiving antenna which varied from 1m to 4m to find out the highest emission. And also, each emission was to be maximized by changing the polarization of receiving antenna both horizontal and vertical. In order to find out the max. emission, the fixed in a particular direction according to the requirements in Section 13.1.4.1 of ANSI C63.10-2013.

2.4 Configuration of Tested System

Fig. 2-1 Configuration of Tested System

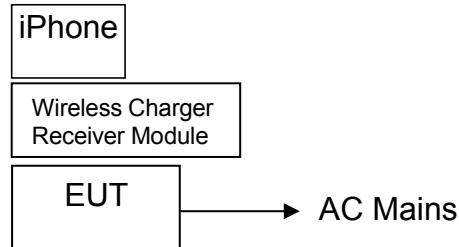

Table 2-1 Equipment Used in Tested System

Item	Equipment	Trade Mark	Model No.	FCC ID	Note
1.	Embedded wireless charger	Raffel Systems	WCP BA 01	YZHWCPXX01	EUT
2.	Adapter	N/A	Model:FS0900-2000 Input: AC 100-240V, 50/60Hz Output: DC 9V, 2000mA	N/A	Support EUT
3.	iPhone	Apple	A1524	N/A	Support Equipment
4.	SAMSUNG S9	SAMSUNG	Samsung Galaxy S9	N/A	Support Equipment
5.	Wireless Charger Receiver Module	Universal	N/A	N/A	Support Equipment

Note:

- (1) Unless otherwise denoted as EUT in 『Remark』 column, device(s) used in tested system is a support equipment.

3 Summary of Test Results

FCC Rules	Description Of Test	Result
§15.207	AC Power Conducted Emission	Compliant
§15.209	Radiated Emission	Compliant
§2.1049	20dB Bandwidth	Compliant
§15.203	Antenna Requirement	Compliant

4 Conducted Emissions Test

4.1 Measurement Procedure

1. The EUT was placed on a table which is 0.8m above ground plane.
2. Maximum procedure was performed on the six highest emissions to ensure EUT compliance.
3. Repeat above procedures until all frequency measured was complete.

4.2 Test SET-UP (Block Diagram of Configuration)

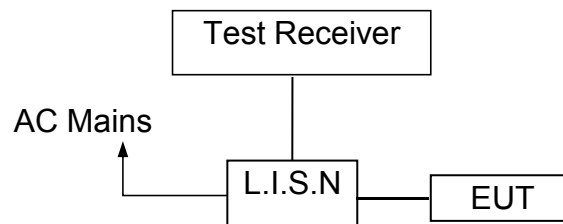

4.3 Measurement Equipment Used

EQUIPMENT TYPE	MFR	MODEL NUMBER	SERIAL NUMBER	Calibrated until
L.I.S.N	SCHWARZBECK	NSLK 8127	8127-669	2020-05-19
10 db attenuator	JFW	50FP-010-H4	4360846-427-1	2020-05-19
RF Cable	N/A	N/A	2#	2020-05-19
EMI Test Receiver	ROHDE&SCHWARZ	ESCI	101358	2020-05-19

4.4 Conducted Emission Limit

Conducted Emission

Frequency(MHz)	Quasi-peak	Average
0.15-0.5	66-56	56-46
0.5-5.0	56	46
5.0-30.0	60	50

Note: 1. The lower limit shall apply at the transition frequencies

2. The limit decreases in line with the logarithm of the frequency in the range of 0.15 to 0.50MHz.



4.5 Measurement Result

Operation Mode:	TX	Test Date :	August 08, 2019
Frequency Range:	0.15MHz~30MHz	Temperature :	28°C
Test Result:	PASS	Humidity :	65 %
Test By:	Best		

Pass

We pretested modes (Wireless Charging(10W),Wireless Charging(5W)) for EUT. The test data see follow the table.



Report No.: EA1908054F 01001

11 of 39

Test mode: Wireless Charging 5W use iphone

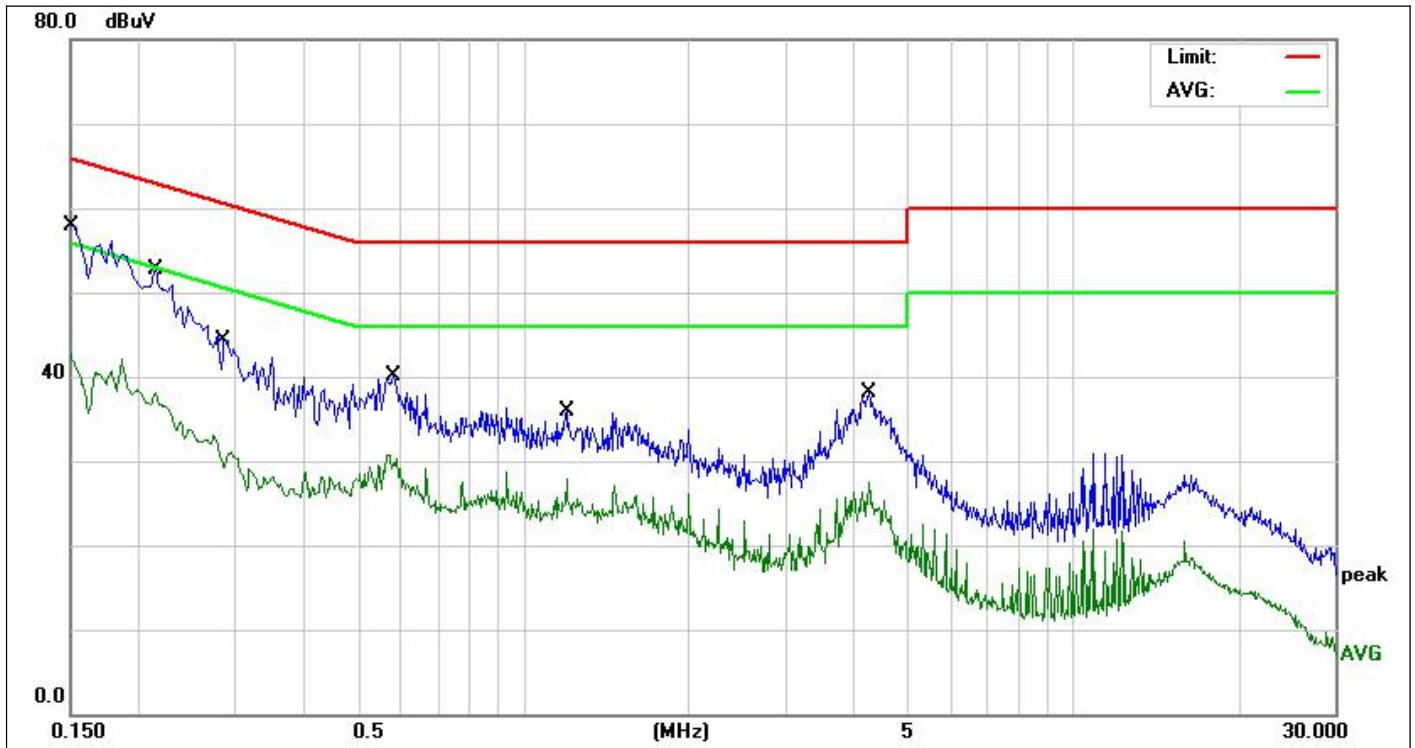

Site:	843	Phase:	N	Temperature(C):	26(C)
Limit:	FCC Part 15 C Conduction(QP)	Test Time:	2019/8/8 8:48:19	Humidity(%):	60%
EUT:	Wireless Charger	Power Rating:	AC 240V/50Hz	Test Engineer:	Jack
M/N.:	WCP BA 01				
Mode:	Wireless Charging 5W				
Note:					

No.	Frequency (MHz)	Reading Level(dBuV)	Factor (dB)	Measurement(dBuV)	Limit (dBuV)	Over (dB)	Detector	Comment
1 *	0.1500	44.95	9.67	54.62	65.99	-11.37	QP	
2	0.1500	28.02	9.67	37.69	55.99	-18.30	AVG	
3	0.2140	37.34	9.71	47.05	63.04	-15.99	QP	
4	0.2140	25.67	9.71	35.38	53.04	-17.66	AVG	
5	0.2878	30.21	9.70	39.91	60.59	-20.68	QP	
6	0.2878	20.18	9.70	29.88	50.59	-20.71	AVG	
7	0.5820	26.94	9.68	36.62	56.00	-19.38	QP	
8	0.5820	19.44	9.68	29.12	46.00	-16.88	AVG	
9	1.1980	22.69	9.72	32.41	56.00	-23.59	QP	
10	1.1980	17.89	9.72	27.61	46.00	-18.39	AVG	
11	4.2660	24.22	9.85	34.07	56.00	-21.93	QP	
12	4.2660	15.75	9.85	25.60	46.00	-20.40	AVG	

*:Maximum data x:Over limit !:over margin

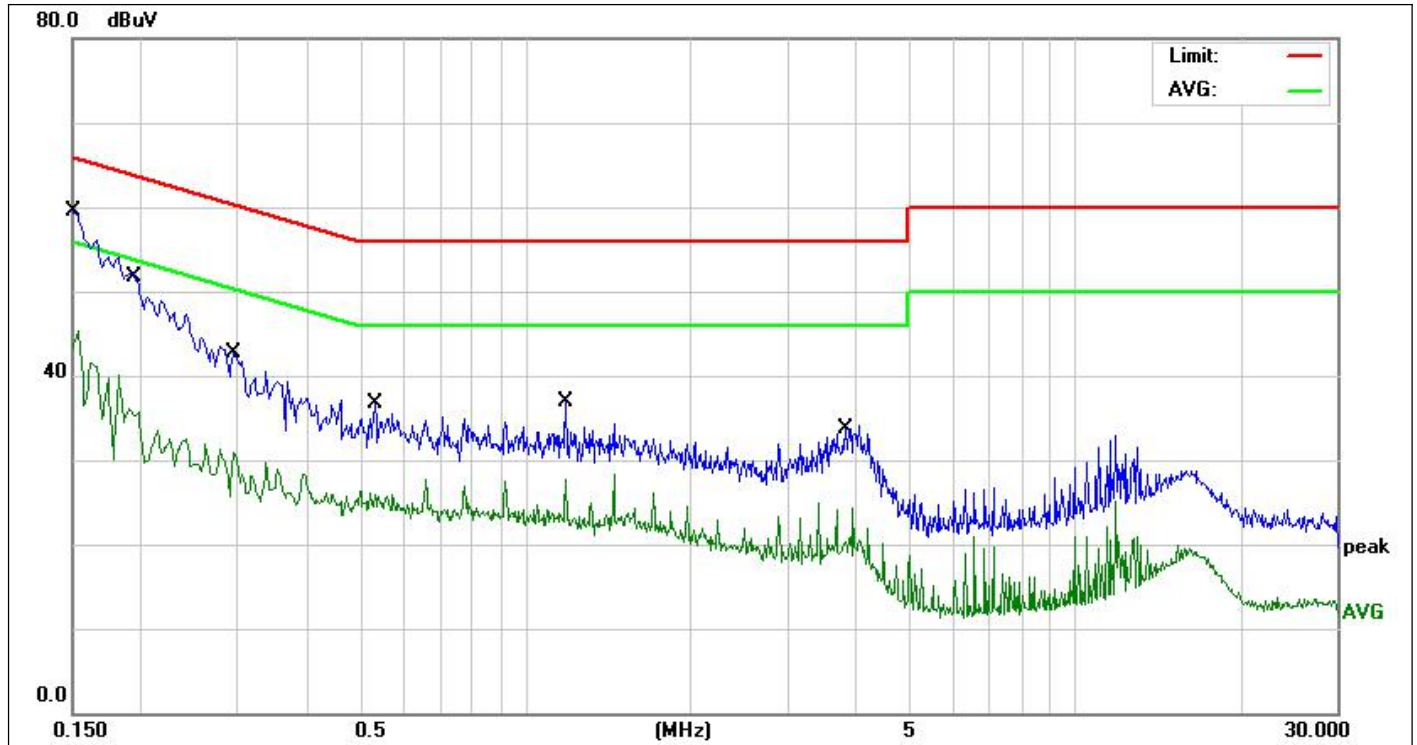

Site:	843	Phase:	L1	Temperature(C):	26(C)
Limit:	FCC Part 15 C Conduction(QP)	Humidity(%):	60%	Test Time:	2019/8/8 8:50:36
EUT:	Wireless Charger	Power Rating:	AC 120V/60Hz	Test Engineer:	Jack
M/N.:	WCP BA 01				
Mode:	Wireless Charging 5W				
Note:					

No.	Frequency (MHz)	Reading Level(dBuV)	Factor (dB)	Measurement(dBuV)	Limit (dBuV)	Over (dB)	Detector	Comment
1 *	0.1500	46.95	9.67	56.62	65.99	-9.37	QP	
2	0.1500	30.12	9.67	39.79	55.99	-16.20	AVG	
3	0.1955	37.94	9.71	47.65	63.80	-16.15	QP	
4	0.1955	23.00	9.71	32.71	53.80	-21.09	AVG	
5	0.2980	28.01	9.70	37.71	60.30	-22.59	QP	
6	0.2980	18.50	9.70	28.20	50.30	-22.10	AVG	
7	0.5340	21.19	9.67	30.86	56.00	-25.14	QP	
8	0.5340	15.59	9.67	25.26	46.00	-20.74	AVG	
9	1.1860	22.12	9.72	31.84	56.00	-24.16	QP	
10	1.1860	18.02	9.72	27.74	46.00	-18.26	AVG	
11	3.8380	18.17	9.84	28.01	56.00	-27.99	QP	
12	3.8380	8.95	9.84	18.79	46.00	-27.21	AVG	

*:Maximum data x:Over limit !:over margin

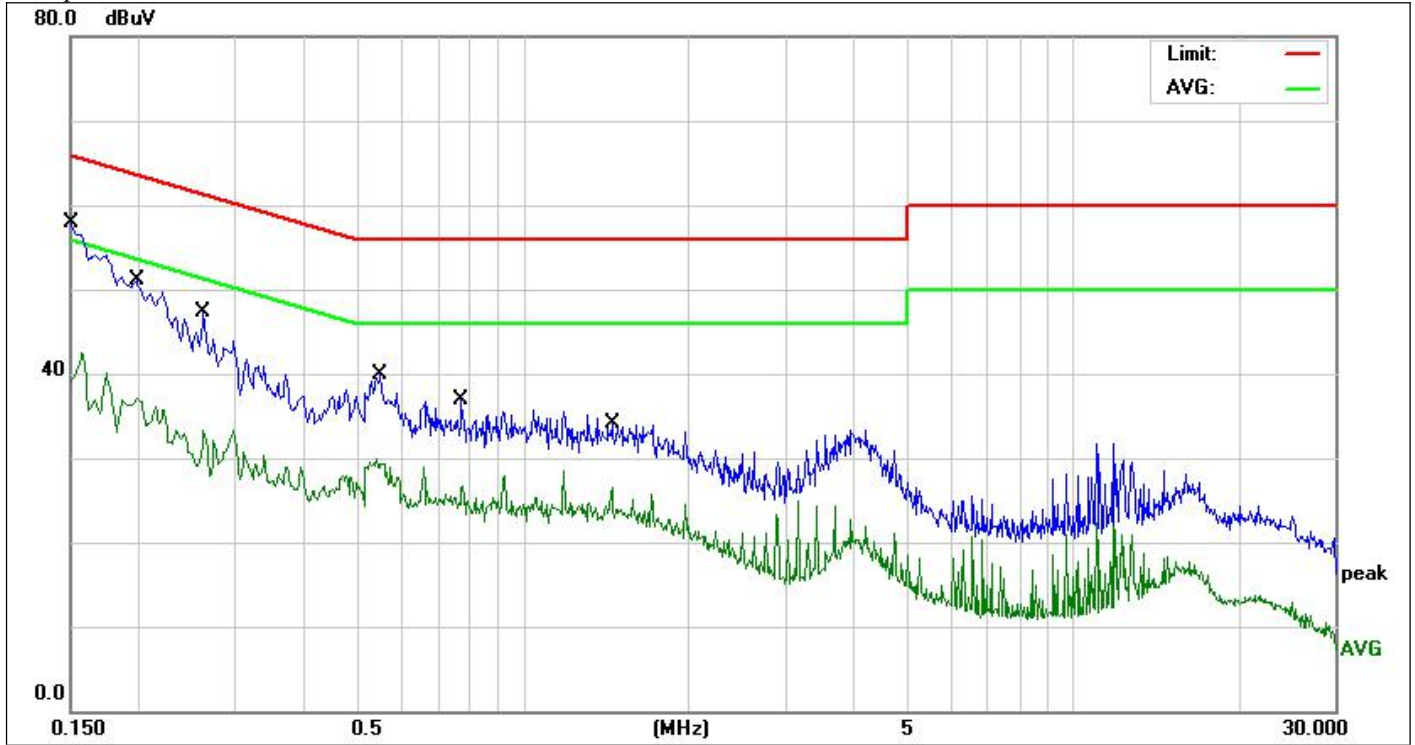

Site:	843	Phase:	N	Temperature(C):	26(C)
Limit:	FCC Part 15 C Conduction(QP)	Test Time:	2019/8/8 8:52:40	Humidity(%):	60%
EUT:	Wireless Charger	Power Rating:	AC 120V/60Hz	Test Engineer:	Jack
M/N.:	WCP BA 01				
Mode:	Wireless Charging 5W				
Note:					

No.	Frequency (MHz)	Reading Level(dBuV)	Factor (dB)	Measurement(dBuV)	Limit (dBuV)	Over (dB)	Detector	Comment
1 *	0.1500	46.67	9.67	56.34	65.99	-9.65	QP	
2	0.1500	30.17	9.67	39.84	55.99	-16.15	AVG	
3	0.1986	36.74	9.71	46.45	63.66	-17.21	QP	
4	0.1986	22.52	9.71	32.23	53.66	-21.43	AVG	
5	0.2620	30.66	9.70	40.36	61.36	-21.00	QP	
6	0.2620	20.05	9.70	29.75	51.36	-21.61	AVG	
7	0.5500	26.15	9.67	35.82	56.00	-20.18	QP	
8	0.5500	19.01	9.67	28.68	46.00	-17.32	AVG	
9	0.7740	21.38	9.70	31.08	56.00	-24.92	QP	
10	0.7740	16.40	9.70	26.10	46.00	-19.90	AVG	
11	1.4500	22.25	9.74	31.99	56.00	-24.01	QP	
12	1.4500	17.65	9.74	27.39	46.00	-18.61	AVG	

*:Maximum data x:Over limit !:over margin

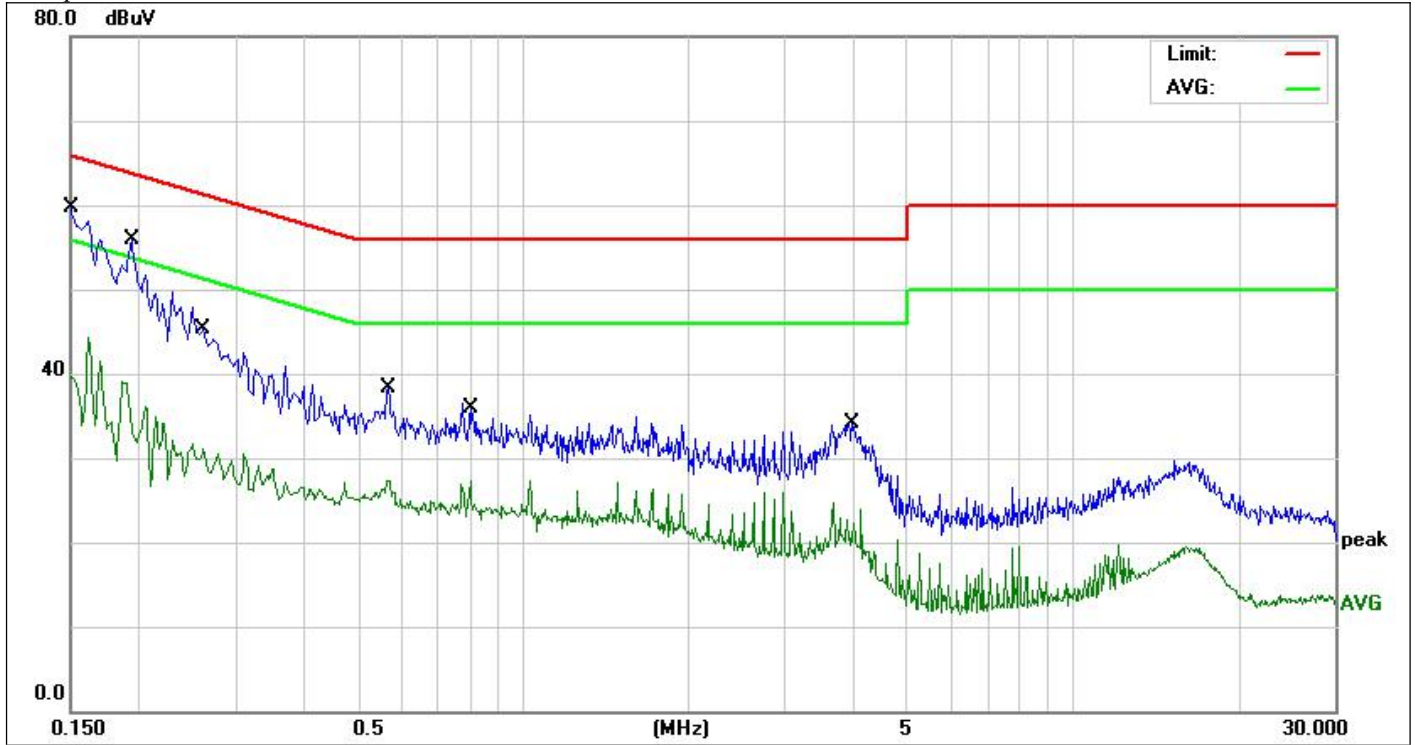

Site:	843	Phase:	L1	Temperature(C):	26(C)
Limit:	FCC Part 15 C Conduction(QP)	Test Time:	2019/8/8 9:02:10	Humidity(%):	60%
EUT:	Wireless Charger	Power Rating:	AC 120V/60Hz	Test Engineer:	Jack
M/N.:	WCP BA 01	Note:			
Mode:	Wireless Charging 5W				

No.	Frequency (MHz)	Reading Level(dBuV)	Factor (dB)	Measurement(dBuV)	Limit (dBuV)	Over (dB)	Detector	Comment
1 *	0.1500	47.57	9.67	57.24	65.99	-8.75	QP	
2	0.1500	30.99	9.67	40.66	55.99	-15.33	AVG	
3	0.1940	39.20	9.71	48.91	63.86	-14.95	QP	
4	0.1940	24.33	9.71	34.04	53.86	-19.82	AVG	
5	0.2620	30.61	9.70	40.31	61.36	-21.05	QP	
6	0.2620	19.20	9.70	28.90	51.36	-22.46	AVG	
7	0.5700	23.30	9.68	32.98	56.00	-23.02	QP	
8	0.5700	18.18	9.68	27.86	46.00	-18.14	AVG	
9	0.8020	22.05	9.70	31.75	56.00	-24.25	QP	
10	0.8020	17.64	9.70	27.34	46.00	-18.66	AVG	
11	3.9660	18.29	9.84	28.13	56.00	-27.87	QP	
12	3.9660	9.01	9.84	18.85	46.00	-27.15	AVG	

*:Maximum data x:Over limit !:over margin



Report No.: EA1908054F 01001

15 of 39

Test mode: **Wireless Charging 10W use Samsung S9**

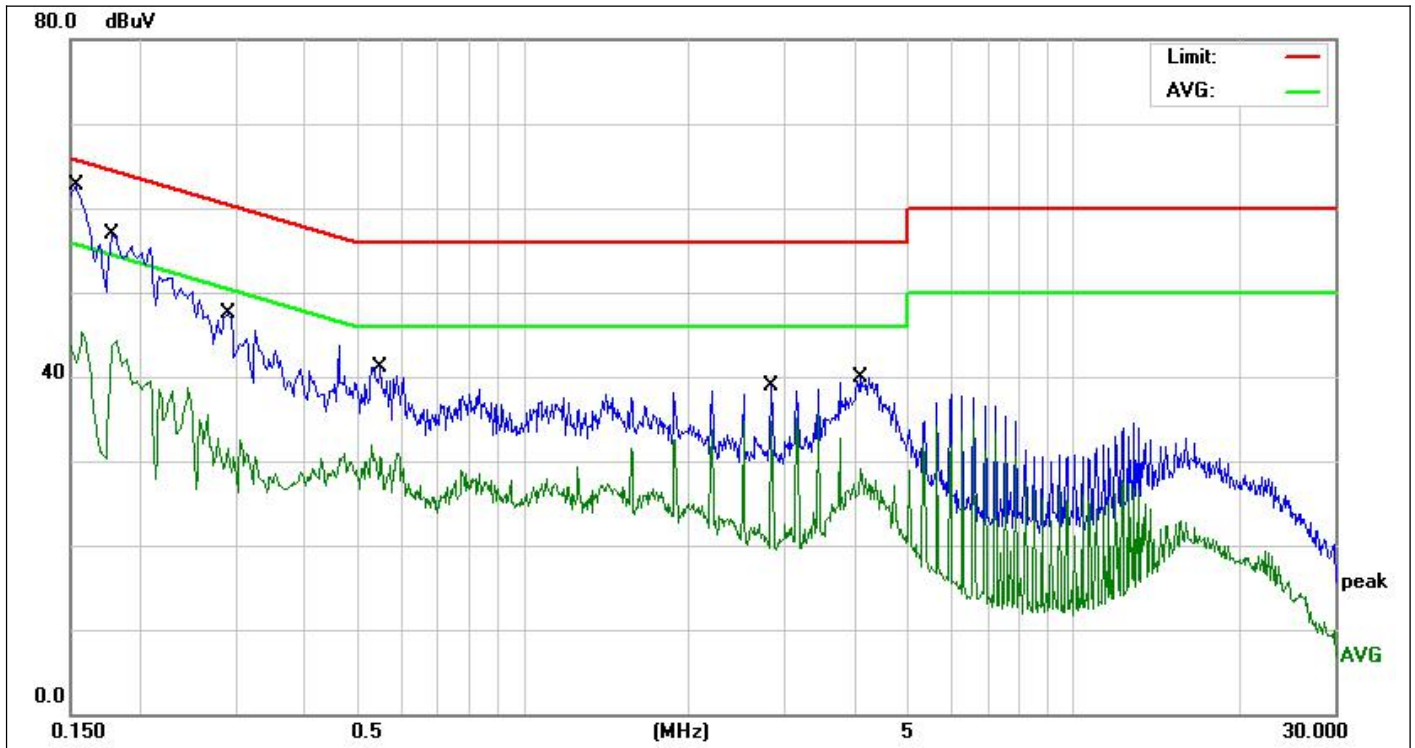

Site:	843	Phase:	N	Temperature(C):	26(C)
Limit:	FCC Part 15 C Conduction(QP)	Test Time:	2019/8/8 9:11:47	Humidity(%):	60%
EUT:	Wireless Charger	Power Rating:	AC 240V/50Hz	Test Engineer:	Jack
M/N.:	WCP BA 01				
Mode:	Wireless Charging 10W				
Note:					

No.	Frequency (MHz)	Reading Level(dBuV)	Factor (dB)	Measurement(dBuV)	Limit (dBuV)	Over (dB)	Detector	Comment
1 *	0.1539	47.95	9.67	57.62	65.78	-8.16	QP	
2	0.1539	32.80	9.67	42.47	55.78	-13.31	AVG	
3	0.1780	44.07	9.69	53.76	64.57	-10.81	QP	
4	0.1780	30.73	9.69	40.42	54.57	-14.15	AVG	
5	0.2900	30.33	9.70	40.03	60.52	-20.49	QP	
6	0.2900	19.19	9.70	28.89	50.52	-21.63	AVG	
7	0.5500	27.61	9.67	37.28	56.00	-18.72	QP	
8	0.5500	19.66	9.67	29.33	46.00	-16.67	AVG	
9	2.8300	16.18	9.83	26.01	56.00	-29.99	QP	
10	2.8300	9.07	9.83	18.90	46.00	-27.10	AVG	
11	4.1100	24.48	9.85	34.33	56.00	-21.67	QP	
12	4.1100	15.54	9.85	25.39	46.00	-20.61	AVG	

*:Maximum data x:Over limit !:over margin

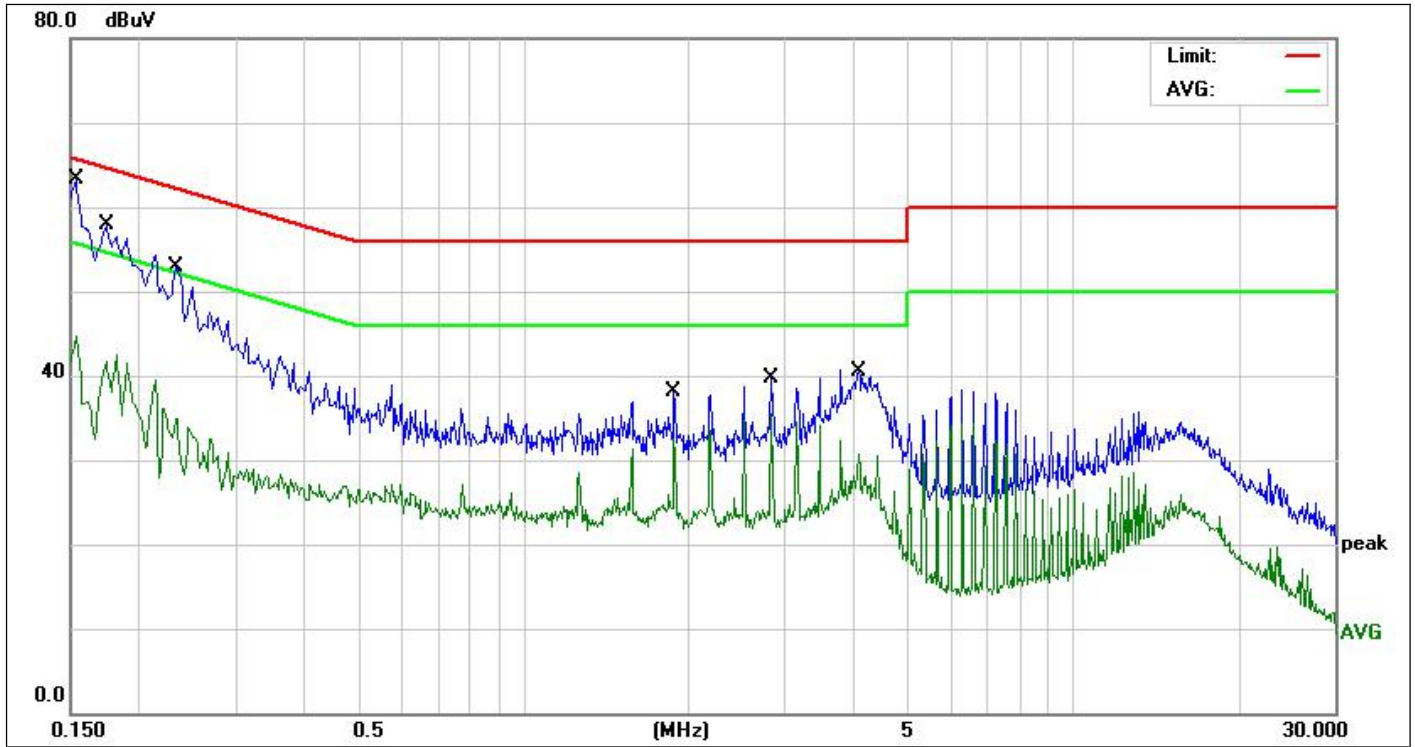

Site:	843	Phase:	L1	Temperature(C):	26(C)
Limit:	FCC Part 15 C Conduction(QP)	Test Time:	2019/8/8 9:13:55	Humidity(%):	60%
EUT:	Wireless Charger	Power Rating:	AC 240V/50Hz	Test Engineer:	Jack
M/N.:	WCP BA 01	Note:			
Mode:	Wireless Charging 10W				

No.	Frequency (MHz)	Reading Level(dBuV)	Factor (dB)	Measurement(dBuV)	Limit (dBuV)	Over (dB)	Detector	Comment
1 *	0.1539	47.56	9.67	57.23	65.78	-8.55	QP	
2	0.1539	31.03	9.67	40.70	55.78	-15.08	AVG	
3	0.1740	44.04	9.69	53.73	64.76	-11.03	QP	
4	0.1740	27.76	9.69	37.45	54.76	-17.31	AVG	
5	0.2340	37.16	9.71	46.87	62.30	-15.43	QP	
6	0.2340	22.24	9.71	31.95	52.30	-20.35	AVG	
7	1.8860	24.20	9.78	33.98	56.00	-22.02	QP	
8	1.8860	21.03	9.78	30.81	46.00	-15.19	AVG	
9	2.8380	24.56	9.83	34.39	56.00	-21.61	QP	
10	2.8380	20.96	9.83	30.79	46.00	-15.21	AVG	
11	4.0860	24.57	9.85	34.42	56.00	-21.58	QP	
12	4.0860	15.77	9.85	25.62	46.00	-20.38	AVG	

*:Maximum data x:Over limit !:over margin

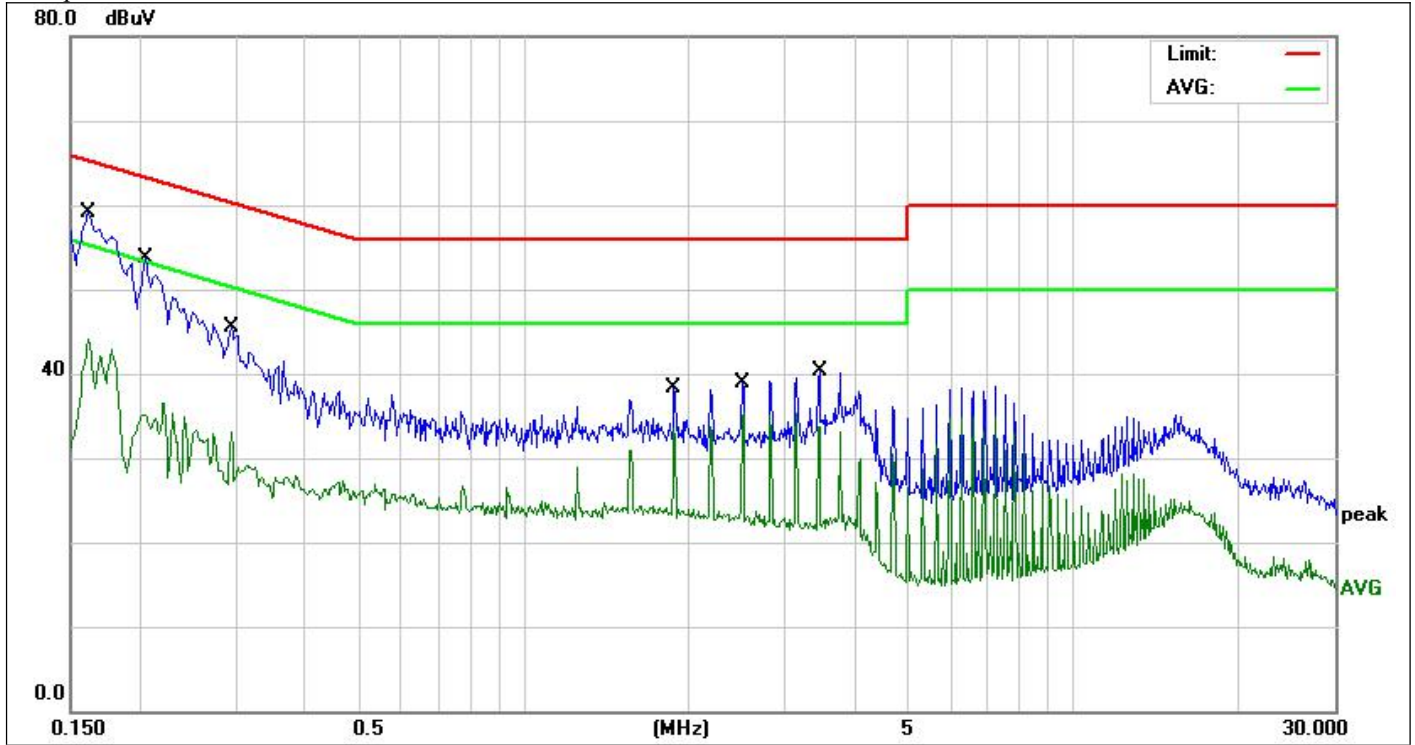

Site:	843	Phase:L1	Temperature(C):26(C)
Limit:	FCC Part 15 C Conduction(QP)		Humidity(%):60%
EUT:	Wireless Charger	Test Time:	2019/8/8 9:16:27
M/N.:	WCP BA 01	Power Rating:	AC 120V/60Hz
Mode:	Wireless Charging 10W	Test Engineer:	Jack
Note:			

No.	Frequency (MHz)	Reading Level(dBuV)	Factor (dB)	Measurement(dBuV)	Limit (dBuV)	Over (dB)	Detector	Comment
1 *	0.1620	44.86	9.68	54.54	65.36	-10.82	QP	
2	0.1620	28.75	9.68	38.43	55.36	-16.93	AVG	
3	0.2060	37.88	9.71	47.59	63.36	-15.77	QP	
4	0.2060	23.94	9.71	33.65	53.36	-19.71	AVG	
5	0.2940	29.68	9.70	39.38	60.41	-21.03	QP	
6	0.2940	19.05	9.70	28.75	50.41	-21.66	AVG	
7	1.8780	25.18	9.78	34.96	56.00	-21.04	QP	
8	1.8780	22.51	9.78	32.29	46.00	-13.71	AVG	
9	2.5059	22.00	9.82	31.82	56.00	-24.18	QP	
10	2.5059	17.37	9.82	27.19	46.00	-18.81	AVG	
11	3.4620	18.75	9.84	28.59	56.00	-27.41	QP	
12	3.4620	11.43	9.84	21.27	46.00	-24.73	AVG	

*:Maximum data x:Over limit !:over margin

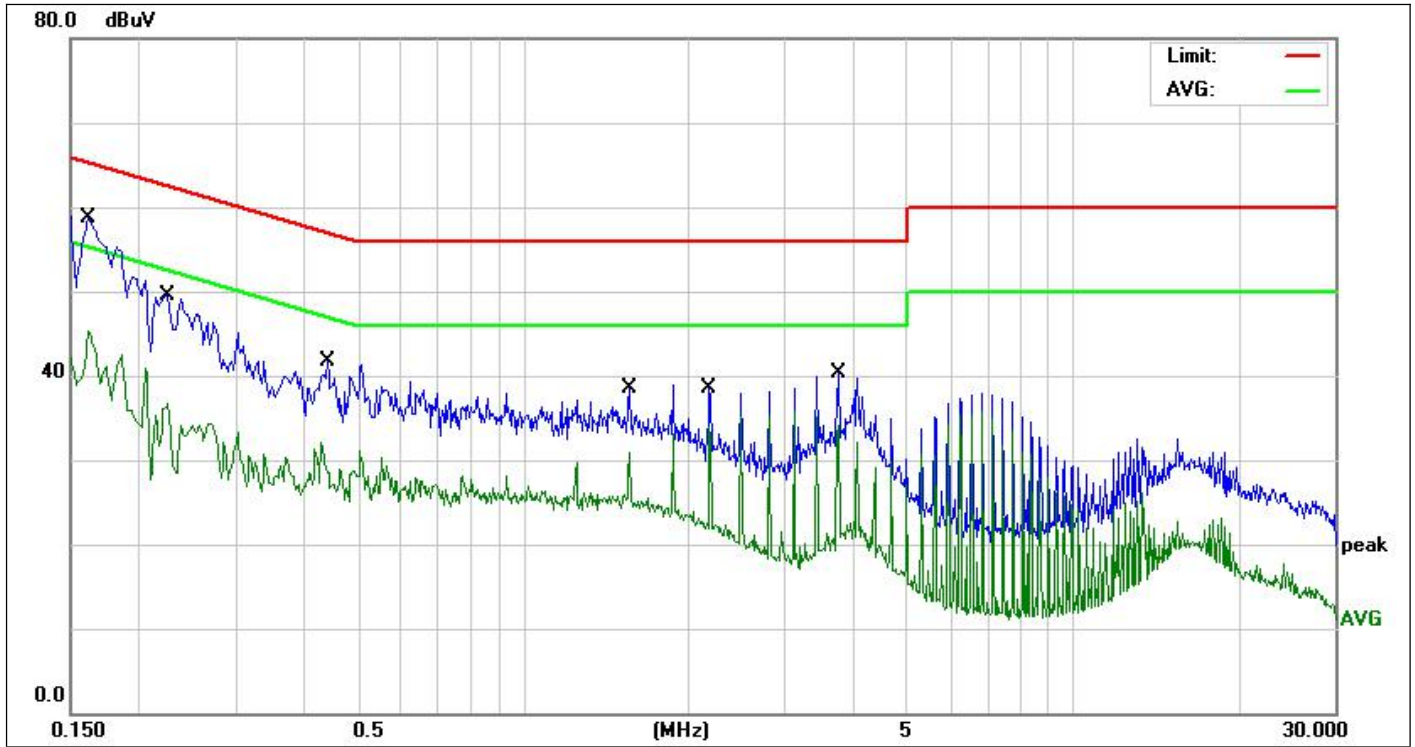

Site:	843	Phase:	N	Temperature(C):	26(C)
Limit:	FCC Part 15 C Conduction(QP)	Test Time:	2019/8/8 9:18:36	Humidity(%):	60%
EUT:	Wireless Charger	Power Rating:	AC 120V/60Hz	Test Engineer:	Jack
M/N.:	WCP BA 01	Test Engineer:	Jack		
Mode:	Wireless Charging 10W				
Note:					

No.	Frequency (MHz)	Reading Level(dBuV)	Factor (dB)	Measurement(dBuV)	Limit (dBuV)	Over (dB)	Detector	Comment
1 *	0.1620	44.77	9.68	54.45	65.36	-10.91	QP	
2	0.1620	28.21	9.68	37.89	55.36	-17.47	AVG	
3	0.2260	35.85	9.71	45.56	62.59	-17.03	QP	
4	0.2260	23.39	9.71	33.10	52.59	-19.49	AVG	
5	0.4420	25.71	9.68	35.39	57.02	-21.63	QP	
6	0.4420	18.15	9.68	27.83	47.02	-19.19	AVG	
7	1.5620	20.80	9.76	30.56	56.00	-25.44	QP	
8	1.5620	15.22	9.76	24.98	46.00	-21.02	AVG	
9	2.1860	18.04	9.80	27.84	56.00	-28.16	QP	
10	2.1860	12.35	9.80	22.15	46.00	-23.85	AVG	
11	3.7420	18.92	9.84	28.76	56.00	-27.24	QP	
12	3.7420	10.16	9.84	20.00	46.00	-26.00	AVG	

*:Maximum data x:Over limit !:over margin

4.6 Conducted Measurement Photo



5 Radiated Emission Test

5.1 Measurement Procedure

1. The EUT was placed on a turn table which is 0.8m above ground plane.
2. Maximum procedure was performed on the six highest emissions to ensure EUT compliance.
3. And also, each emission was to be maximized by changing the polarization of receiving antenna both horizontal and vertical.
4. Repeat above procedures until all frequency measured were complete.

5.2 Test SET-UP (Block Diagram of Configuration)

(A) Radiated Emission Test Set-Up, Frequency Below 30MHz

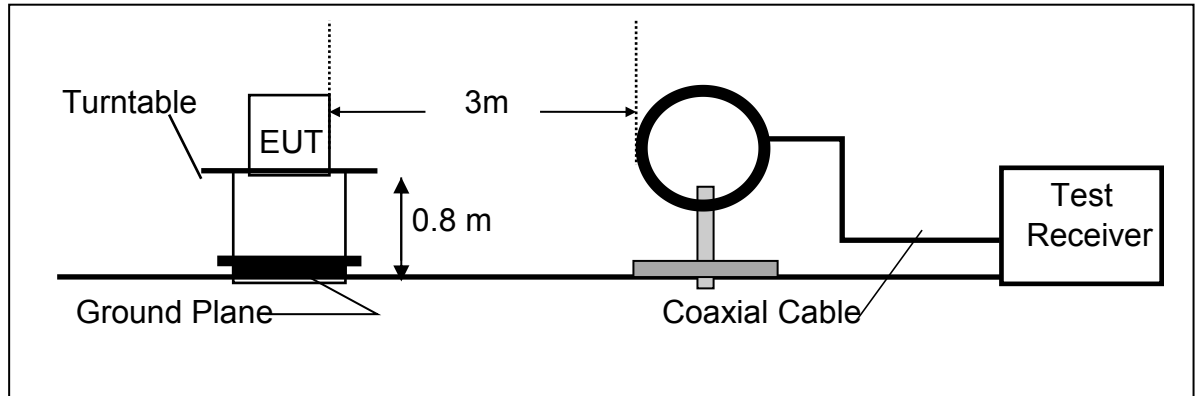

(B) Radiated Emission Test Set-Up, Frequency Below 1000MHz

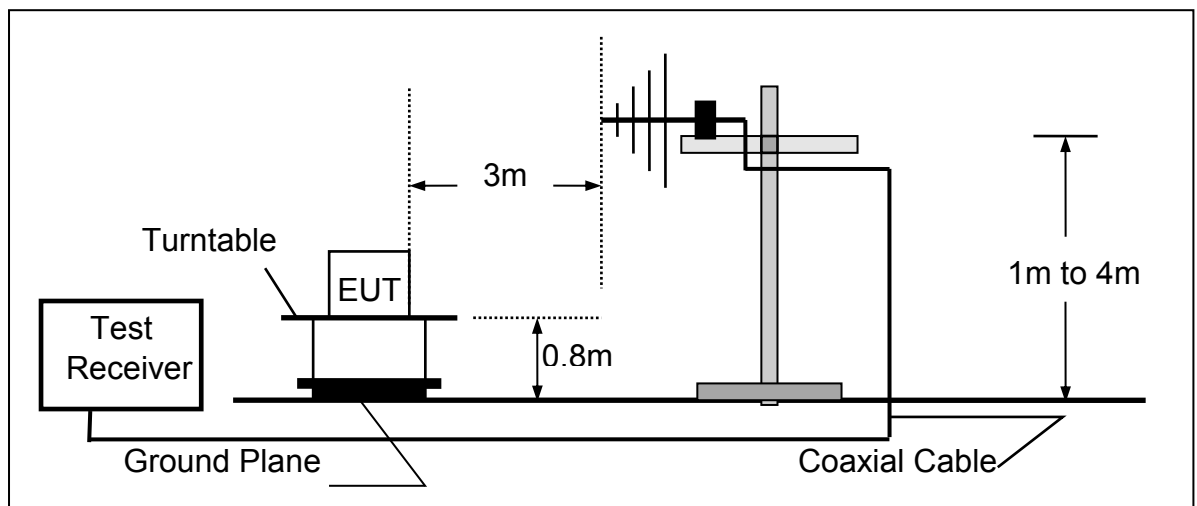

5.3 Measurement Equipment Used

Item	Equipment	Manufacturer	Model No.	Serial No.	Calibrated until
1.	EMI Test Receiver	Rohde & Schwarz	ESPI	100502	2019-11-29
2.	Pre-Amplifier	HP	8447D	2727A06172	2020-05-19
3.	Bilog Antenna	Schwarzbeck	VULB9163	VULB9163-588	2020-05-19
4.	Loop Antenna	Schwarzbeck	FMZB 1516	1516-141	2020-01-04
5.	RF Cable	Gigalink Microwave	ZT40-2.92J-2.92 J-2m	N/A	2020-03-12
6.	RF Cable	Gigalink Microwave	ZT40-2.92J-2.92 J-0.3m	N/A	2020-03-12
7.	RF Cable	N/A	N/A	6#	2020-05-19
8.	3m Semi-anechoic Chamber	chengyu	9m*6m*6m	N/A	2020-05-19
9.	Test Software	Farad	EZ-EMC Ver:ANCI-3A1	N/A	N/A

5.4 Radiated Emission Limit

The emissions from an intentional radiator shall not exceed the field strength levels specified in the following table 15.209(a):

FCC Part 15.209				
Frequency (MHz)	Field Strength Limitation		Field Strength Limitation Frequency tion at 3m Measurement Dist	
	(uV/m)	Dist	(uV/m)	(dBuV/m)
0.009 – 0.490	2400 / F(KHz)	300m	10000 * 2400/F(KHz)	20log 2400/F(KHz) + 80
0.490 – 1.705	24000 / F(KHz)	30m	100 * 24000/F(KHz)	20log 24000/F(KHz) + 40
1.705 – 30.00	30	30m	100* 30	20log 30 + 40
30.0 – 88.0	100	3m	100	20log 100
88.0 – 216.0	150	3m	150	20log 150
216.0 – 960.0	200	3m	200	20log 200
Above 960.0	500	3m	500	20log 500



15.205 Restricted bands of operation

MHz	MHz	MHz	GHz
0.090 - 0.110	16.42 - 16.423	399.9 - 410	4.5 - 5.15
¹ 0.495 - 0.505	16.69475 - 16.69525	608 - 614	5.35 - 5.46
2.1735 - 2.1905	16.80425 - 16.80475	960 - 1240	7.25 - 7.75
4.125 - 4.128	25.5 - 25.67	1300 - 1427	8.025 - 8.5
4.17725 - 4.17775	37.5 - 38.25	1435 - 1626.5	9.0 - 9.2
4.20725 - 4.20775	73 - 74.6	1645.5 - 1646.5	9.3 - 9.5
6.215 - 6.218	74.8 - 75.2	1660 - 1710	10.6 - 12.7
6.26775 - 6.26825	108 - 121.94	1718.8 - 1722.2	13.25 - 13.4
6.31175 - 6.31225	123 - 138	2200 - 2300	14.47 - 14.5
8.291 - 8.294	149.9 - 150.05	2310 - 2390	15.35 - 16.2
8.362 - 8.366	156.52475 - 156.52525	2483.5 - 2500	17.7 - 21.4
8.37625 - 8.38675	156.7 - 156.9	2690 - 2900	22.01 - 23.12
8.41425 - 8.41475	162.0125 - 167.17	3260 - 3267	23.6 - 24.0
12.29 - 12.293	167.72 - 173.2	3332 - 3339	31.2 - 31.8
12.51975 - 12.52025	240 - 285	3345.8 - 3358	36.43 - 36.5
12.57675 - 12.57725	322 - 335.4	3600 - 4400	(²)

- Remark:
1. Emission level in dBuV/m=20 log (uV/m)
 2. Measurement was performed at an antenna to the closed point of EUT distance of meters.
 3. Only spurious frequency is permitted to locate within the Restricted Bands specified in provision of ξ 15.205, and the emissions located in restricted bands also comply with 15.209 limit.



5.5 Measurement Result

We pretested modes (Wireless Charging(10W),Wireless Charging(5W)) for EUT. The worst mode (Wireless Charging(10W))test data see follow the table.

Operation Mode:	Low frequency	Test Date :	August 12, 2019
Frequency Range:	9KHz~30MHz	Temperature :	20°C
Test Result:	PASS	Humidity :	55 %
Measured Distance:	3m	Test By:	Best

Freq. (MHz)	Ant.Pol. H/V	Emission Level (dBuV/m)	Limit 3m (dBuV/m)	Over (dB)	Note
0.140(F)	H	74.12	104.68	-30.56	PK
0.2810	H	64.37	98.63	-34.26	PK
0.4196	H	65.42	95.15	-29.73	PK
0.5613	H	61.89	72.62	-10.73	PK
0.7025	H	61.77	70.67	-8.9	PK
0.140(F)	V	74.32	104.68	-30.36	PK
0.2810	V	63.54	98.63	-35.09	PK
0.4196	V	63.72	95.15	-31.43	PK
0.5613	V	65.88	72.62	-6.74	PK
0.7025	V	62.15	70.67	-8.52	PK

- Note:**
- (1) All Readings are Peak Value.
 - (2) Emission Level= Reading Level+Probe Factor +Cable Loss.
 - (3) The average measurement was not performed when the peak measured data under the limit of average detection.
 - (4) EUT lying on the table position is the worst case result in the report.

We pretested modes (Wireless Charging(10W),Wireless Charging(5W)) for EUT. The test data see follow the table.



Report No.: EA1908054F 01001

24 of 39

Test mode: **Wireless Charging 5W use iphone**

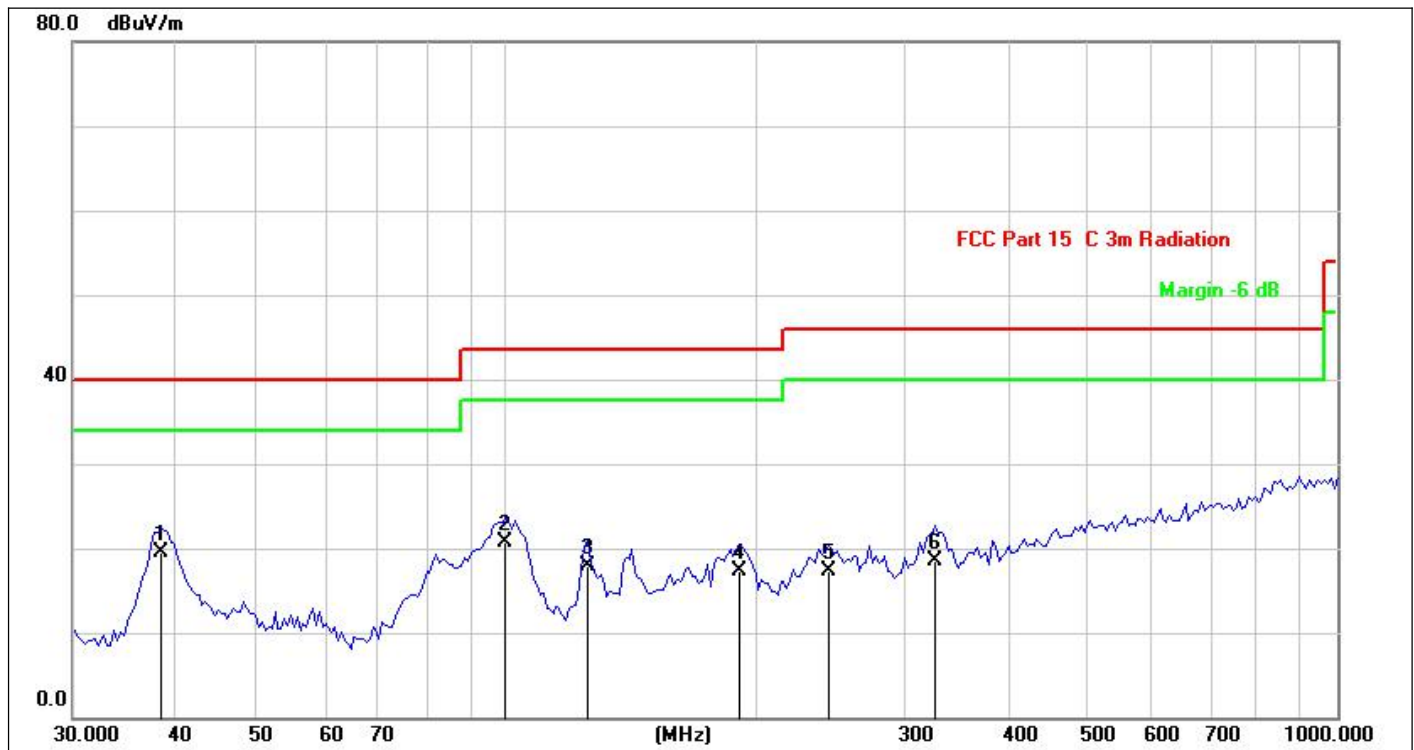

Site:	LAB	Antenna::	Horizontal	Temperature(C):	23.4(C)
Limit:	FCC Part 15 Class B 3m Radiation(QP)	Test Time:	2019-08-20 15:02:28	Humidity(%):	56.7%
EUT:	Embedded wireless charger	Power Rating:	AC 120V/60Hz	Test Engineer:	sunshine
M/N.:	WCP BA01				
Mode:	Wireless Charging 5W				
Note:					

No.	Frequency (MHz)	Reading (dBuV)	Factor (dB/m)	Level (dBuV/m)	Limit (dBuV/m)	Margin (dB)	Det.	Height (cm)	Azimuth (deg)	Remark
1 *	38.3462	35.95	-16.49	19.46	40.00	-20.54	QP			
2	99.7028	36.73	-16.01	20.72	43.50	-22.78	QP			
3	125.2260	35.43	-17.59	17.84	43.50	-25.66	QP			
4	190.7390	34.81	-17.43	17.38	43.50	-26.12	QP			
5	243.8043	32.09	-14.73	17.36	46.00	-28.64	QP			
6	328.4627	30.55	-12.06	18.49	46.00	-27.51	QP			

*:Maximum data x:Over limit !:over margin



Site:	LAB	Antenna::Vertical	Temperature(C):23.4(C)
Limit:	FCC Part 15 Class B 3m Radiation(QP)		Humidity(%):56.7%
EUT:	Embedded wireless charger	Test Time:	2019-08-20 15:04:00
M/N.:	WCP BA01	Power Rating:	AC 120V/60Hz
Mode:	Wireless Charging 5W	Test Engineer:	sunshine
Note:			

No.	Frequency (MHz)	Reading (dBuV)	Factor (dB/m)	Level (dBuV/m)	Limit (dBuV/m)	Margin (dB)	Det.	Height (cm)	Azimuth (deg)	Remark
1 *	38.3462	51.52	-16.49	35.03	40.00	-4.97	QP			
2	48.1626	39.56	-16.14	23.42	40.00	-16.58	QP			
3	75.3142	44.70	-20.46	24.24	40.00	-15.76	QP			
4	94.5941	40.03	-17.14	22.89	43.50	-20.61	QP			
5	124.1330	46.03	-17.47	28.56	43.50	-14.94	QP			
6	192.4186	45.58	-17.34	28.24	43.50	-15.26	QP			

*:Maximum data x:Over limit !:over margin



Site:	LAB	Antenna::	Vertical	Temperature(C):	23.4(C)
Limit:	FCC Part 15 Class B 3m Radiation(QP)	Test Time:	2019-08-20 15:05:44	Humidity(%):	56.7%
EUT:	Embedded wireless charger	Power Rating:	AC 240V/50Hz	Test Engineer:	sunshine
M/N.:	WCP BA01				
Mode:	Wireless Charging 5W				
Note:					

No.	Frequency (MHz)	Reading (dBuV)	Factor (dB/m)	Level (dBuV/m)	Limit (dBuV/m)	Margin (dB)	Det.	Height (cm)	Azimuth (deg)	Remark
1 *	38.3462	50.68	-16.49	34.19	40.00	-5.81	QP			
2	49.4460	48.25	-16.16	32.09	40.00	-7.91	QP			
3	75.3142	47.01	-20.46	26.55	40.00	-13.45	QP			
4	94.5941	41.33	-17.14	24.19	43.50	-19.31	QP			
5	125.2260	45.85	-17.54	28.31	43.50	-15.19	QP			
6	194.1128	44.97	-17.27	27.70	43.50	-15.80	QP			

*:Maximum data x:Over limit !:over margin



Site:	LAB	Antenna::Horizontal	Temperature(C):23.4(C)
Limit:	FCC Part 15 Class B 3m Radiation(QP)	Test Time:	Humidity(%):56.7%
EUT:	Embedded wireless charger	Power Rating:	2019-08-20 15:07:59
M/N.:	WCP BA01	Test Engineer:	AC 240V/50Hz
Mode:	Wireless Charging 5W		sunshine
Note:			

No.	Frequency (MHz)	Reading (dBuV)	Factor (dB/m)	Level (dBuV/m)	Limit (dBuV/m)	Margin (dB)	Det.	Height (cm)	Azimuth (deg)	Remark
1 *	38.6839	41.34	-16.42	24.92	40.00	-15.08	QP			
2	49.4460	32.42	-16.16	16.26	40.00	-23.74	QP			
3	96.2672	40.82	-16.79	24.03	43.50	-19.47	QP			
4	140.3421	36.75	-18.57	18.18	43.50	-25.32	QP			
5	241.6763	32.02	-14.85	17.17	46.00	-28.83	QP			
6	416.1791	32.59	-9.54	23.05	46.00	-22.95	QP			

*:Maximum data x:Over limit !:over margin



Report No.: EA1908054F 01001

28 of 39

Test mode: **Wireless Charging 10W use Samsung S9**



Site:	LAB	Antenna::	Vertical	Temperature(C):	23.4(C)
Limit:	FCC Part 15 Class B 3m Radiation(QP)	Test Time:	2019-08-20 14:55:04	Humidity(%):	56.7%
EUT:	Embedded wireless charger	Power Rating:	AC 120V/60Hz	Test Engineer:	sunshine
M/N.:	WCP BA01				
Mode:	Wireless Charging 10W				
Note:					

No.	Frequency (MHz)	Reading (dBuV)	Factor (dB/m)	Level (dBuV/m)	Limit (dBuV/m)	Margin (dB)	Det.	Height (cm)	Azimuth (deg)	Remark
1 *	38.3462	50.76	-16.49	34.27	40.00	-5.73	QP			
2	54.9309	42.27	-16.35	25.92	40.00	-14.08	QP			
3	112.7218	44.61	-16.75	27.86	43.50	-15.64	QP			
4	149.2238	54.53	-19.04	35.49	43.50	-8.01	QP			
5	167.2366	52.84	-18.39	34.45	43.50	-9.05	QP			
6	252.5049	44.19	-14.34	29.85	46.00	-16.15	QP			

*:Maximum data x:Over limit !:over margin



Site:	LAB	Antenna::Horizontal	Temperature(C):23.4(C)
Limit:	FCC Part 15 Class B 3m Radiation(QP)		Humidity(%):56.7%
EUT:	Embedded wireless charger	Test Time:	2019-08-20 15:00:51
M/N.:	WCP BA01	Power Rating:	AC 120V/60Hz
Mode:	Wireless Charging 10W	Test Engineer:	sunshine
Note:			

No.	Frequency (MHz)	Reading (dBuV)	Factor (dB/m)	Level (dBuV/m)	Limit (dBuV/m)	Margin (dB)	Det.	Height (cm)	Azimuth (deg)	Remark
1	39.0245	37.47	-16.32	21.15	40.00	-18.85	QP			
2	98.8324	38.70	-16.21	22.49	43.50	-21.01	QP			
3	125.2259	37.77	-17.59	20.18	43.50	-23.32	QP			
4	167.2366	39.98	-18.45	21.53	43.50	-21.97	QP			
5	325.5957	34.36	-12.16	22.20	46.00	-23.80	QP			
6 *	423.5403	38.17	-9.24	28.93	46.00	-17.07	QP			

*:Maximum data x:Over limit !:over margin

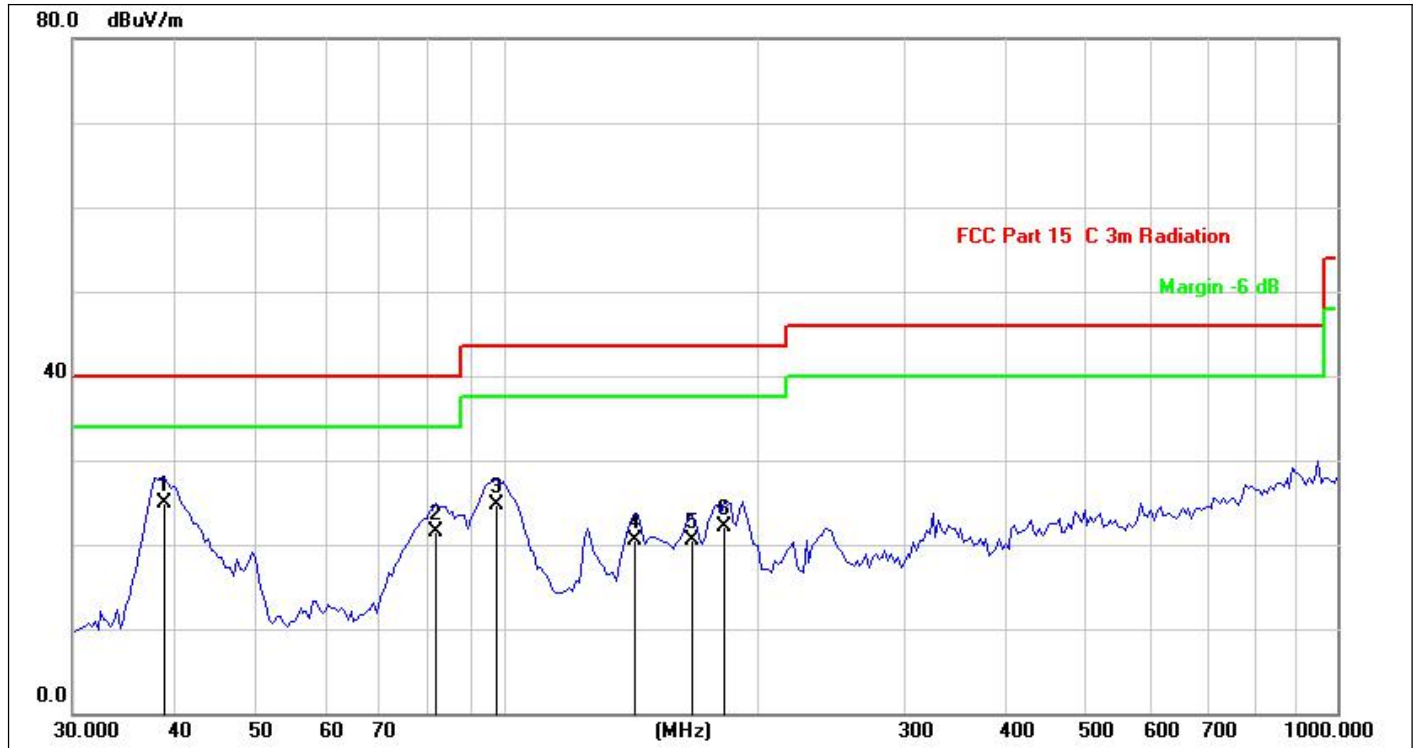

Site:	LAB	Antenna::Horizontal	Temperature(C):23.4(C)
Limit:	FCC Part 15 Class B 3m Radiation(QP)		Humidity(%):56.7%
EUT:	Embedded wireless charger	Test Time:	2019-08-20 15:09:41
M/N.:	WCP BA01	Power Rating:	AC 240V/50Hz
Mode:	Wireless Charging 10W	Test Engineer:	sunshine
Note:			

No.	Frequency (MHz)	Reading (dBuV)	Factor (dB/m)	Level (dBuV/m)	Limit (dBuV/m)	Margin (dB)	Det.	Height (cm)	Azimuth (deg)	Remark
1 *	38.6839	41.33	-16.42	24.91	40.00	-15.09	QP			
2	82.2146	41.68	-20.09	21.59	40.00	-18.41	QP			
3	97.1148	41.27	-16.59	24.68	43.50	-18.82	QP			
4	142.8243	39.27	-18.72	20.55	43.50	-22.95	QP			
5	167.2368	39.05	-18.45	20.60	43.50	-22.90	QP			
6	182.5592	39.96	-17.78	22.18	43.50	-21.32	QP			

*:Maximum data x:Over limit !:over margin

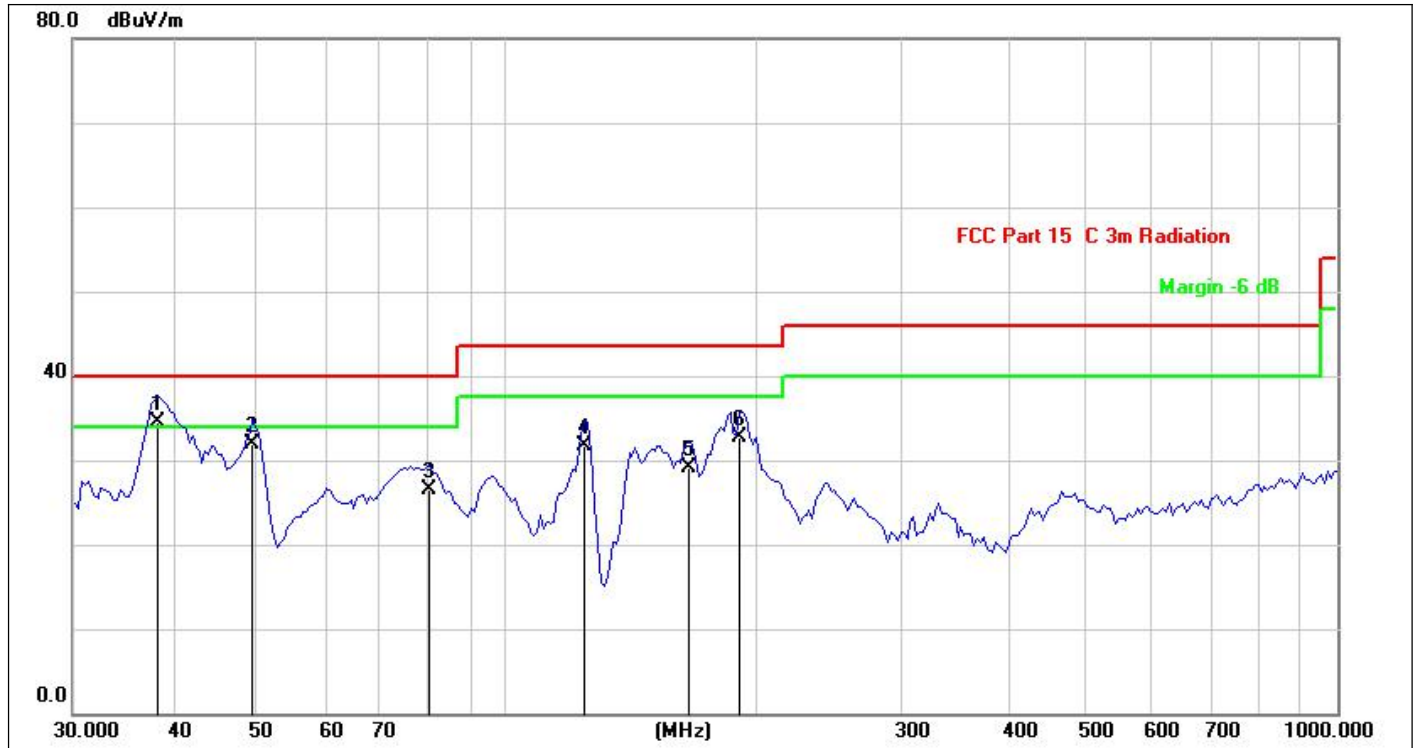

Site:	LAB	Antenna::Vertical	Temperature(C):23.4(C)
Limit:	FCC Part 15 Class B 3m Radiation(QP)	Test Time:	Humidity(%):56.7%
EUT:	Embedded wireless charger	Power Rating:	AC 240V/50Hz
M/N.:	WCP BA01	Test Engineer:	sunshine
Mode:	Wireless Charging 10W		
Note:			

No.	Frequency (MHz)	Reading (dBuV)	Factor (dB/m)	Level (dBuV/m)	Limit (dBuV/m)	Margin (dB)	Det.	Height (cm)	Azimuth (deg)	Remark
1 *	38.0114	51.03	-16.58	34.45	40.00	-5.55	QP			
2	49.4459	48.03	-16.16	31.87	40.00	-8.13	QP			
3	80.7857	46.88	-20.44	26.44	40.00	-13.56	QP			
4	124.1329	49.21	-17.47	31.74	43.50	-11.76	QP			
5	165.7768	47.64	-18.45	29.19	43.50	-14.31	QP			
6	190.7390	50.16	-17.42	32.74	43.50	-10.76	QP			

*:Maximum data x:Over limit !:over margin

5.6 Radiated Measurement Photos

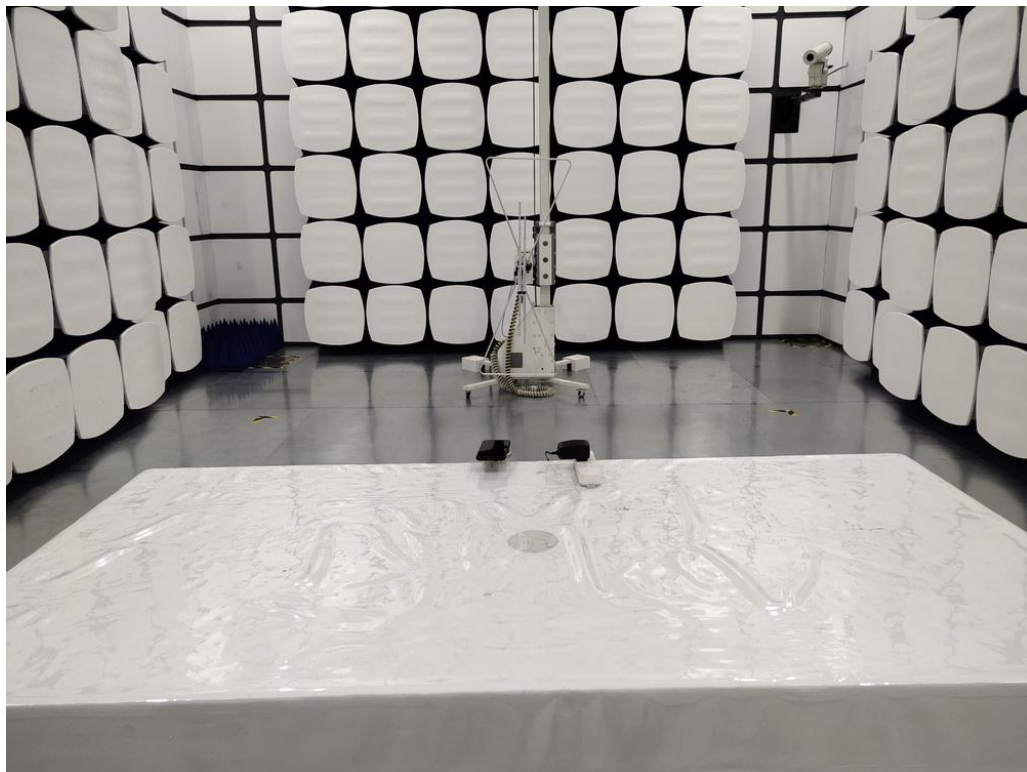
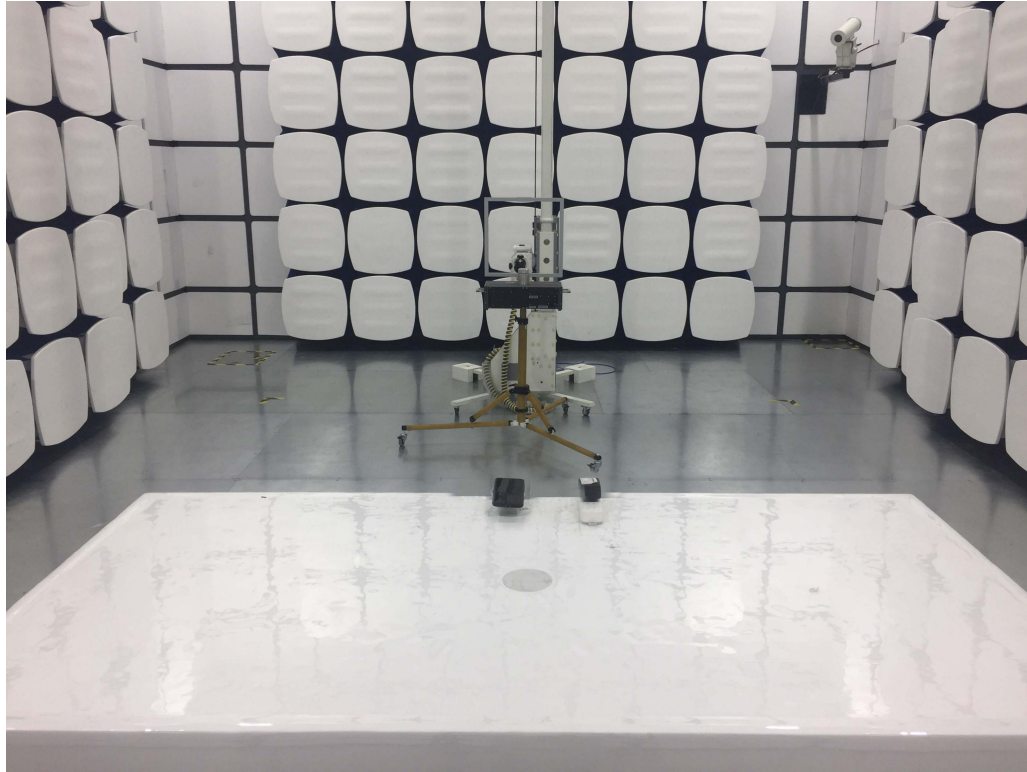

6 20db Bandwidth

6.1 20dB Bandwidth Limit

None: for reporting purposed only.

6.2 Test Instruments

Refer a test equipment and calibration data table in this test report.

6.3 Test Procedure

The bandwidth of the fundamental frequency was measured by spectrum analyzer with 300Hz RBW and 1KHz VBW. The 20dB bandwidth is defined as the total spectrum the power of which is higher than peak power minus 20dB.

6.4 Test Setup

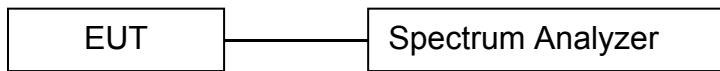

6.5 Test Result

Frequency (KHz)	20dB Bandwidth (Hz)	Results
140	864	PASS



20 dB Bandwidth Test plot

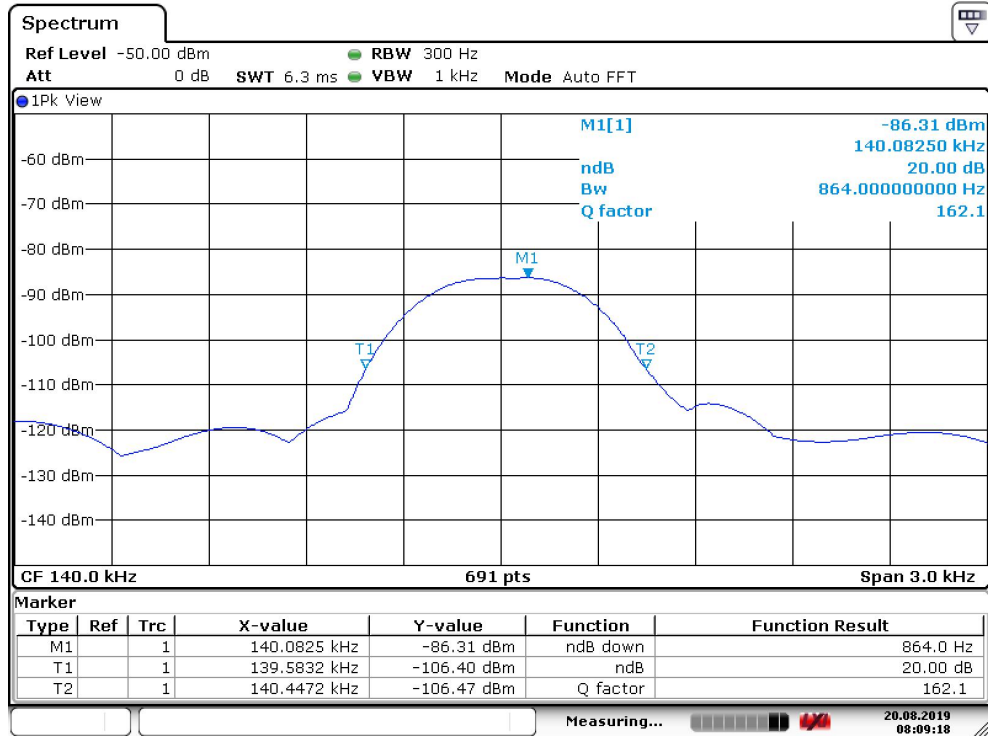

Date: 20.AUG.2019 08:09:18

7 Antenna Application

7.1 Antenna requirement

For intentional device, according to FCC 47 CFR Section 15.203, an intentional radiator shall be designed to ensure that no antenna other than that furnished by the responsible party shall be used with the device.

7.2 Result

The EUT's antenna, permanent attached antenna, used an Induction coil and integrated on PCB, The antenna's gain meets the requirement.



APPENDIX (Photos of EUT)

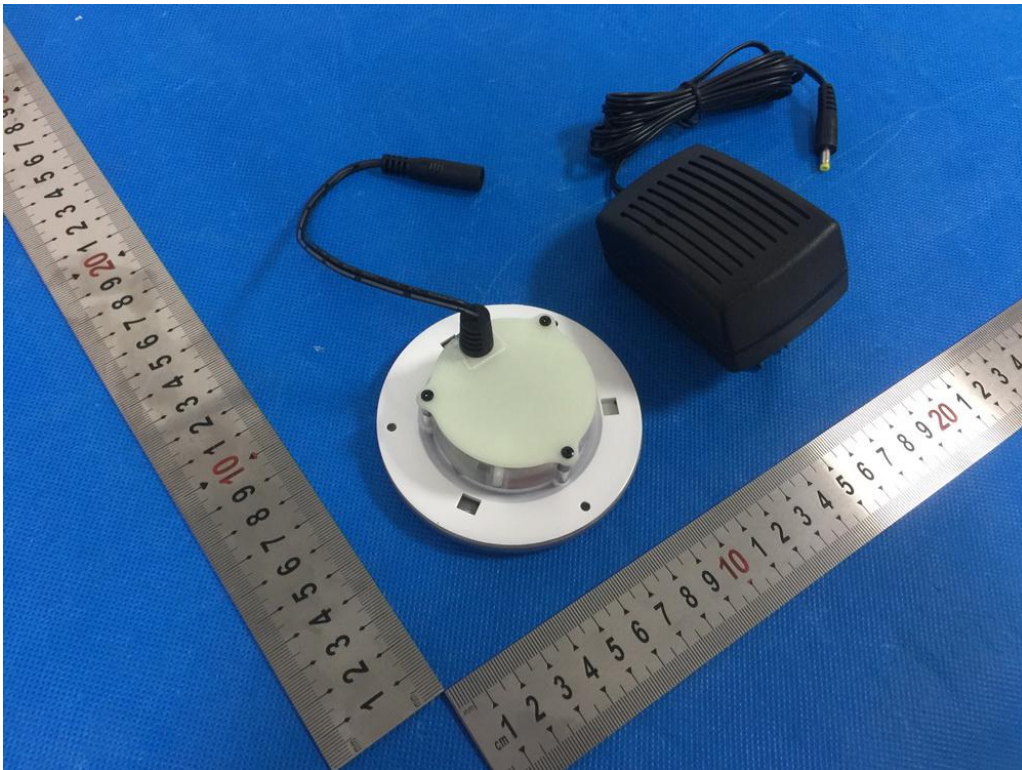
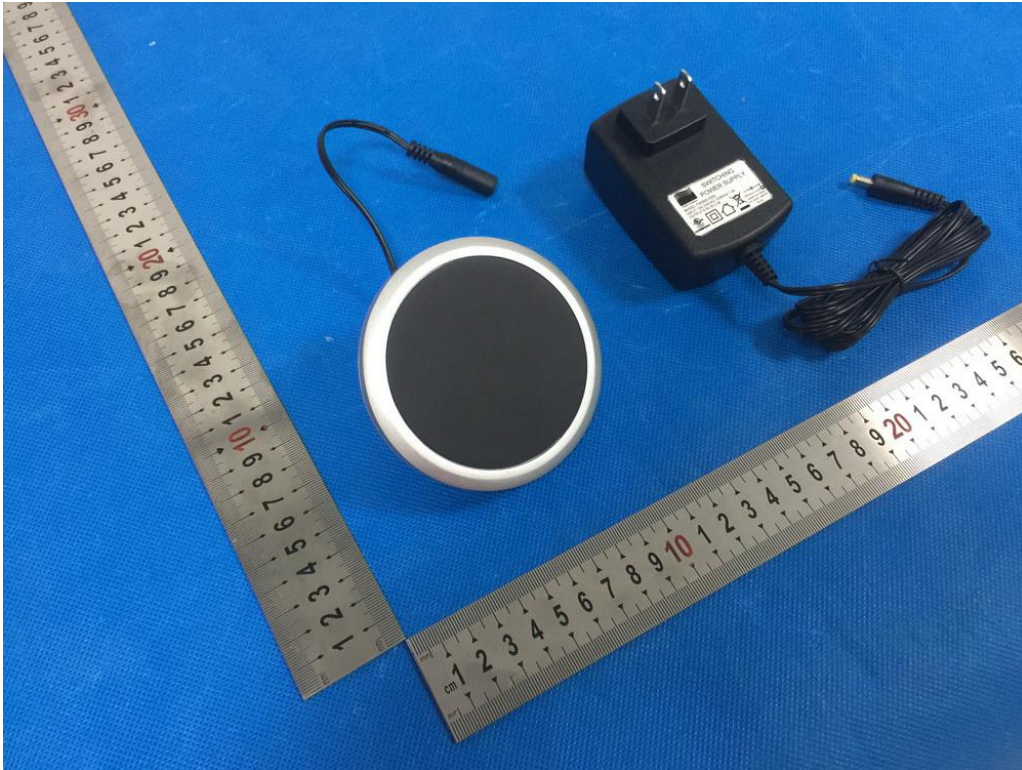

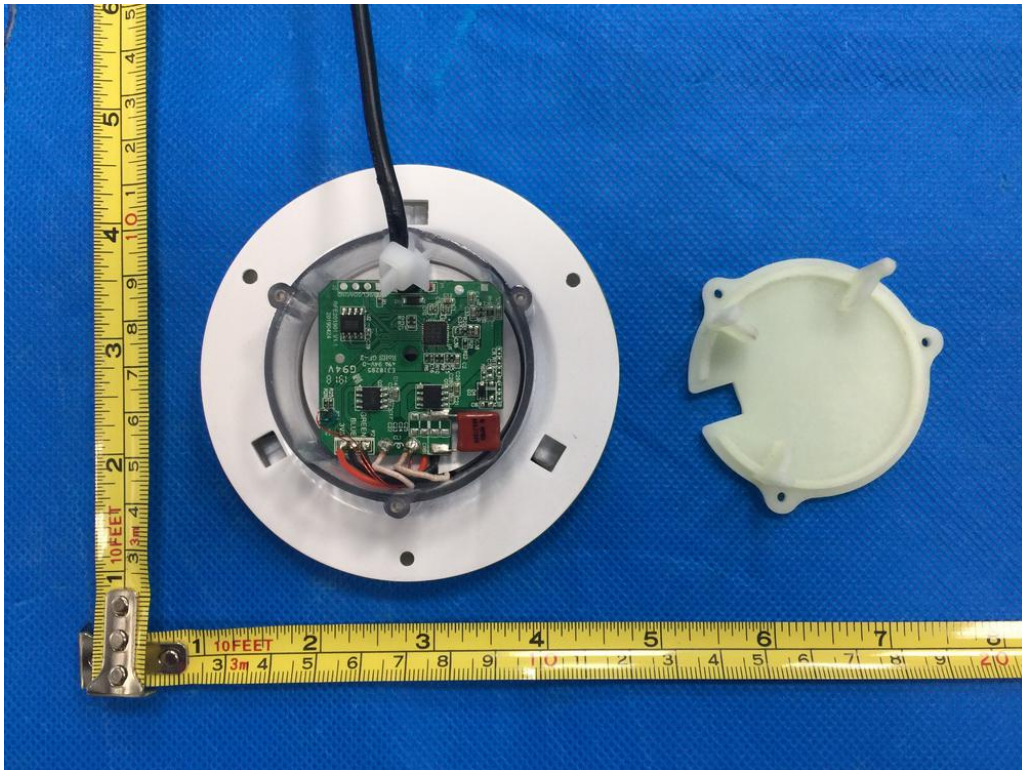

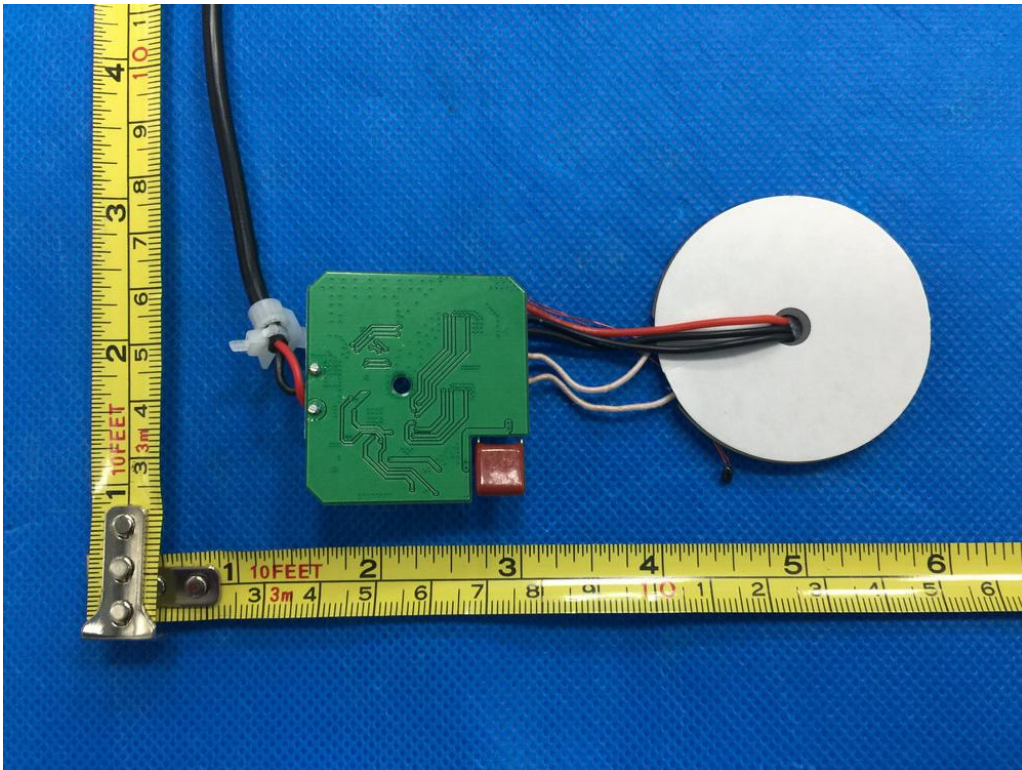
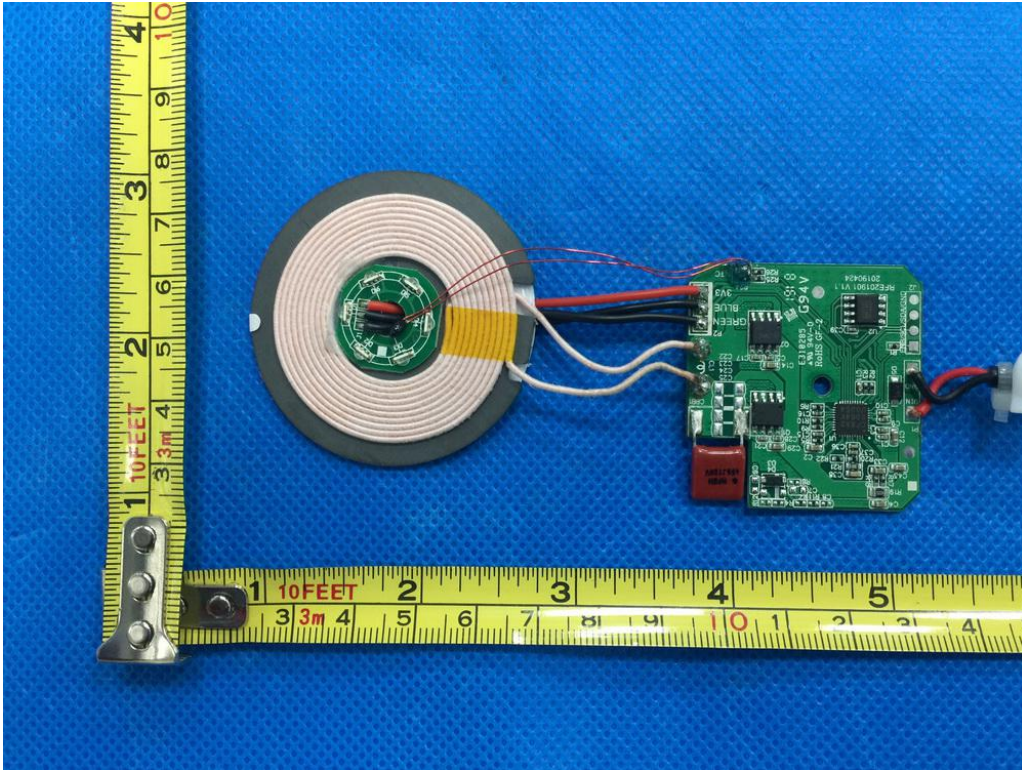

-----The end of report-----