

# **KOGAN SMARTERHOME™ 2.0KW PORTABLE AIR CONDITIONER**

**7,000 BTU**

KAWFPAC07JA

Safety & Warnings	<b>3</b>
Components	<b>5</b>
Overview	<b>6</b>
Installation	<b>9</b>
Before Use	<b>11</b>
Operation	<b>11</b>
Connect to SmarterHome™ App	<b>14</b>
Google Home Control	<b>17</b>
Amazon Alexa Control	<b>20</b>
Cleaning & Care	<b>23</b>
Maintenance	<b>26</b>
Troubleshooting	<b>32</b>
Specifications	<b>35</b>
Schematic Diagram	<b>36</b>
Electric Wiring Diagram	<b>37</b>
Notes	<b>38</b>

# SAFETY & WARNINGS

Ensure to read all instructions and warnings in this user guide prior to assembly and first use. Retain this user guide for future reference.



This air conditioner uses flammable R290 refrigerant.

## **WARNING:**

- Maintenance and repair requiring the assistance of other skilled personnel shall be carried out under the supervision of professionals in the use of flammable refrigerants.
  - Any person who is involved with working on or breaking into a refrigerant circuit should hold a current valid certificate from an industry-accredited assessment authority which authorises their competence to handle refrigerants safely in accordance with an industry recognised assessment specification.
- 
- The air conditioner can be used by children aged 8 years and above and by persons with reduced physical, sensory, or mental capabilities if they have been given supervision or instruction concerning the use of the air conditioner in a safe way and understand the hazards involved.
  - Do not allow children to play with the air conditioner.
  - Constant adult supervision is required of cleaning and maintenance is performed by children.
  - This air conditioner is suitable for indoor use. Do not use this air conditioner outdoors.
  - The operating environment of this air conditioner is between 7–35°C.
  - Follow local grid interconnection rules while installing the air conditioning and ensure that it is properly grounded. If there are questions on electrical installation, ask a professional electrician to install the air conditioner.
  - The air conditioner shall be installed in accordance with national wiring regulations.
  - Ensure there is at least a 50cm clearance between the air conditioner and walls or other obstructions.

- Do not use this air conditioner near gasoline, flammable gas, stoves, or other heat sources.
- Do not use the air conditioner in humid environments (for example, bathroom, or laundry).
- Do not insert any objects into the air inlet and air outlet.
- Keep the air inlet and outlet free from obstructions.
- Keep any required ventilation openings clear of obstructions.
- Do not touch the water or any parts of the air conditioner that are covered by water while it is on or plugged in.
- Do not place cups or other objects on the air conditioner body to prevent water or other liquids from spilling onto the air conditioner.
- Do not use any means to accelerate the defrosting process or clean the air conditioner other than those recommended in this user guide.
- Ensure the area in which the air conditioner is installed, operated, and stored has a floor area larger than 7m<sup>2</sup>.
- Do not store this air conditioner in an area with continuously operating ignition sources (for example, open flames, an operating gas appliance, or an operating electric heater).
- Do not pierce or burn the air conditioner.
- Be aware that refrigerants may not contain an odour.
- Servicing shall be performed only as recommended in this user guide.
- Ensure the power cord is always visible to avoid a tripping hazard.
- When drainage pipes are installed, ensure that the drainage pipes are properly connected and are not distorted or bent.
- If adjusting the slats of the air outlet, handle them gently with your hands to avoid damage.
- Do not disassemble or modify the air conditioner yourself.
- If the air conditioner is damaged, stop use immediately and contact **help.Kogan.com** for assistance.
- If the power cord is damaged, stop use immediately and contact **help.Kogan.com** for assistance.
- Do not use extension pipes or use different pipes than those provided as this may result in a malfunction.
- Do not directly pull on the power cord to turn off the air conditioner.
- Do not use insecticide sprays or other flammable substances near the air conditioner.
- Do not wipe or wash the air conditioner with chemical solvents (for example, gasoline and alcohol).

# COMPONENTS

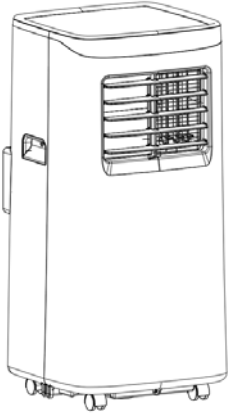

**A** Air conditioner (x1)

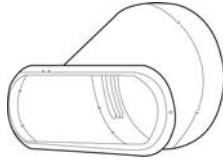

**B** Window seal connector (x1)

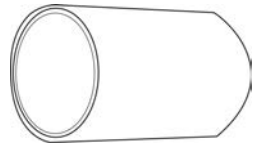

**C** Exhaust pipe (x1)



**D** Duct interface (x1)



**E** Window sealing plate (x1)



**F** 1m drainage pipe (x1)



**G** Remote control (x1)



**H** AAA battery (x2)



**I** User guide (x1)

# OVERVIEW

## Front view

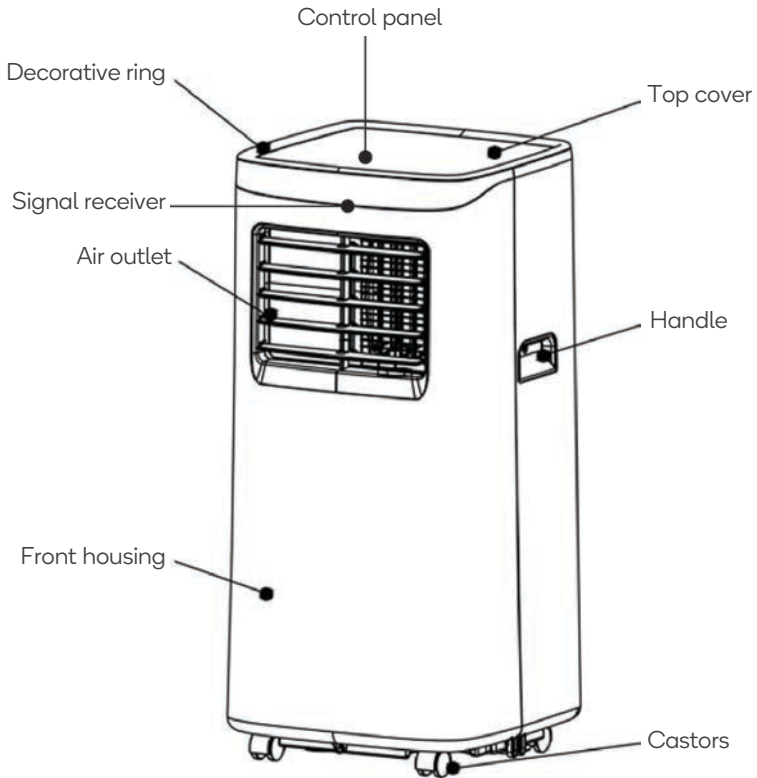

## Side view

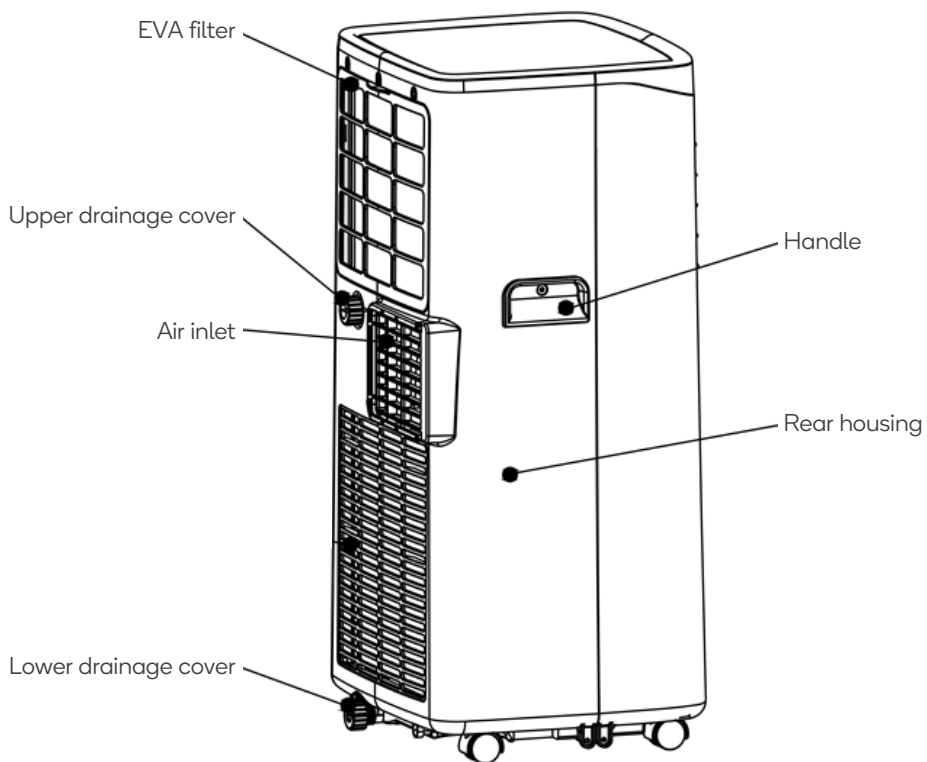

## Control panel

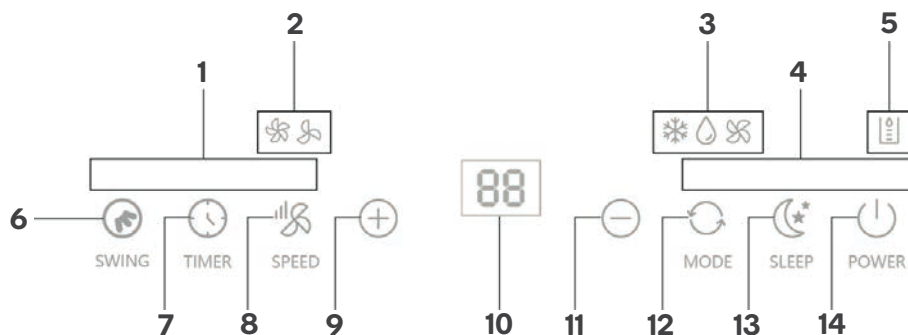

- |   |                      |    |                  |    |                   |
|---|----------------------|----|------------------|----|-------------------|
| 1 | Indicator lights     | 6  | Swing button     | 11 | Decrease button   |
| 2 | Fan speed indicators | 7  | Timer button     | 12 | Mode button       |
| 3 | Mode indicators      | 8  | Fan speed button | 13 | Sleep mode button |
| 4 | Indicator lights     | 9  | Increase button  | 14 | Power button      |
| 5 | Full indicator       | 10 | Display          |    |                   |

## Remote control

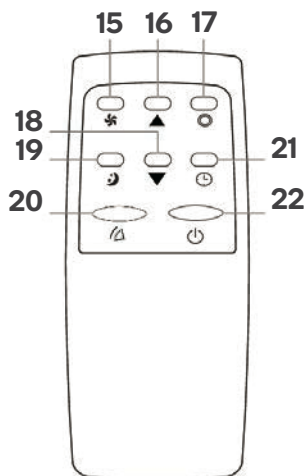

- |    |                  |    |                   |
|----|------------------|----|-------------------|
| 15 | Fan speed button | 19 | Sleep mode button |
| 16 | Increase button  | 20 | Swing button      |
| 17 | Mode button      | 21 | Timer button      |
| 18 | Decrease button  | 22 | Power button      |



# INSTALLATION

## Notes:

- Ensure the air conditioner is kept upright.
- Do not install the air conditioner in humid areas.

## Installing the exhaust pipe assembly

1. Remove the packaging from the duct interface, exhaust pipe, and window seal connector.
2. Straighten one end of the folded exhaust pipe and screw the duct interface clockwise into the exhaust pipe.
3. Secure the window seal connector onto the other end of the exhaust pipe, completing the exhaust pipe assembly.
4. Insert the duct interface end of the exhaust pipe assembly into the air inlet on the rear panel, pushing it to the left.

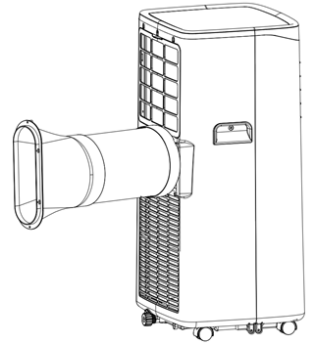

## Notes:

- The exhaust pipe joints must be snapped into place.
- The pipe cannot be distorted nor has substantial turning (greater than 45°). Keep the ventilation of the exhaust pipe unblocked.

## Installing the window sealing plate

The window sealing plate is designed to fit most standard 'vertical' and 'horizontal' window applications. However, it may be necessary for you to improvise/modify some aspects of the installation procedures for certain types of windows as noted in the diagram below.

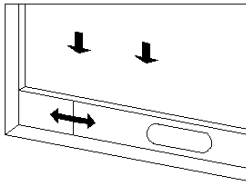

Horizontal window  
Min: 650mm  
Max: 1220mm

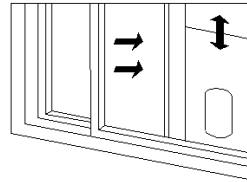

Vertical window  
Min: 650mm  
Max: 1220mm

1. Open the window that is closest to where you would like to locate the air conditioner.
2. Mount the window sealing plate assembly to the window by pulling the sealing plate to ensure it fits snugly onto the ends of the window frame. The sealing plate can be mounted both horizontally or vertically.
3. Close the window so the window sealing plate touches the window.

### Placing the air conditioner

1. Place the air conditioner on a dry, flat surface. Ensure there is at least a 50cm clearance away from any walls or obstructions.

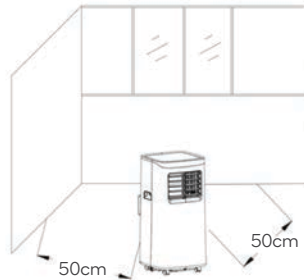

2. Elongate the exhaust pipe assembly and snap the window seal connector into the hole of the window sealing plate.

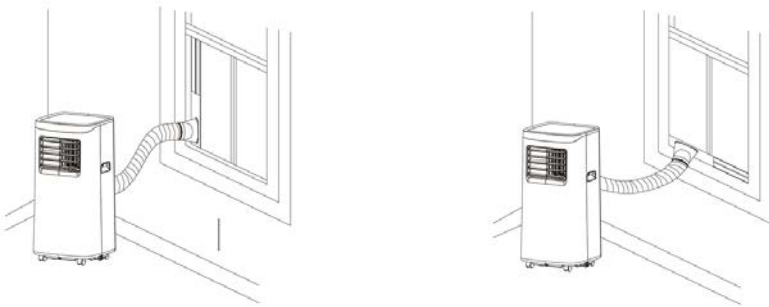

#### Notes:

- The pipe cannot be distorted nor be turned greater than 45°. Keep the ventilation of the exhaust pipe unblocked.
- The length of the exhaust pipe shall be 280–1500mm and this length is based on the specifications of the air conditioner.
- Do not use extension tubes or replace it with other tubes as this may cause a malfunction.
- The exhaust pipe must be not blocked otherwise it may cause overheating.

# BEFORE USE

**WARNING:** Before use, keep the air conditioner upright for at least two hours to allow the refrigerant to settle.

## Remote control battery

The remote control of air conditioner requires batteries to operate.

1. Remove the back cover of the remote control.
2. Noting the polarity markings (+, -), insert x2 AAA batteries into the remote control.
3. Resecure the back cover.

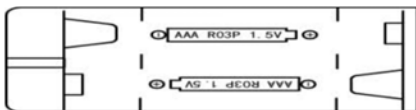

# OPERATION

## Powering on/off

1. Ensure that the power cord is intact, then plug it into the power outlet. Turn on the outlet. On first use, the air conditioner will emit a beeping sound. It will then enter standby.
2. Press the power button on the remote control or control panel to turn on the air conditioner. An indicator light will illuminate above the power button on the control panel.
3. Press the power button again on the remote control or control panel to turn off the air conditioner.

## Selecting the mode

This air conditioner features three modes:

- Cooling – Used primarily in hotter conditions to lower the temperature of an area.
- Dehumidifying – Used to decrease the humidity of an area.
- Fan – Used to bring greater ventilation to an area.

To switch between the modes, press the mode button on the remote control or control panel. The modes will cycle through and the relevant indicator lights below the mode indicators will illuminate.



Cooling mode indicator



Dehumidifying mode indicator



Fan mode indicator

### Adjusting the temperature

In cooling mode, press the increase and decrease buttons to adjust to the desired temperature (16–31°C). This will be reflected on the display.

**Note:**

The temperature cannot be adjusted in the dehumidifying or fan modes.

### Adjusting the fan speed

This air conditioner features a low and high fan speed setting. To adjust the fan speed, press the fan speed button on the remote control or control panel. The relevant indicator lights below the fan speed indicators will then illuminate.



Low fan speed indicator



High fan speed indicator

**Notes:**

- The fan speed cannot be adjusted in dehumidifying mode. In this mode, the air conditioner will always run on a low fan speed.
- If the temperature is too cold, the air conditioner may not run at the set speed.

### Swing button

Press the swing button on the remote control or control panel to activate the fan to oscillate left and right. The indicator light above the swing indicator will be illuminated.

Press the swing button again to turn the oscillation off.

## Timer

If the air conditioner is on standby, the timer can be set to turn on the air conditioner after a user-specified period.

If the air conditioner is currently operating, the timer can be set to turn off the air conditioner after a user-specified period.

To set the timer:

1. Press the timer button on the remote control or control panel.
2. When the timer button on the control panel starts flashing, press the increase and decrease buttons to adjust the desired time for the timer (1–24 hours). Each press will adjust the time by one hour.
3. Wait for 5 seconds and the display will stop flashing, confirming the timer has been set.

## Sleep mode

As our bodies get colder at night when sleeping, the sleep mode will gradually increase the temperature over the night, keeping you warm.

- When the air conditioner is in cooling mode, press the sleep mode button on the remote control or control panel to activate sleep mode.

## Frost protection

In cooling mode, if the temperature of the exhaust pipe is below 0°C for more than three minutes, the air conditioner will automatically enter frost protection. Once the temperature of the exhaust pipe rises to an optimal temperature, the air conditioner will automatically continue operating.

### Notes:

To minimise the risk of this occurring, ensure the air conditioner is operating in an environment with an ambient temperature between 7–35°C.

## Overflow protection

Water will be condensed within the air conditioner over extended use. When enough water is condensed needing it to be emptied, the air conditioner will emit an alarm and the full indicator will start flashing.

Refer to the drainage details in the 'Cleaning & Care' section of this user guide for more information.

## Compressor protection

To increase the service life of the compressor, it has a three-minute delay booting protection function after the compressor is turned off.

# CONNECT TO SMARTERHOME™ APP

## Install App

Download the 'Kogan SmarterHome' app from the Play Store (Android) or App Store (iOS).



Play Store (Android)



App Store (iOS)



## To register:

1. If you already have a SmarterHome account, select 'Log In'. To register a new account, select 'Sign Up'.
2. The system will automatically recognise your country. If needed, you can manually select your country from the drop-down box. Enter your email address and tap 'Get Verification Code' to continue.
3. A 6-digit code will be sent to the submitted email address. Enter this code before the one-minute timer expires.
4. Continue to the next page and complete your SmarterHome profile.

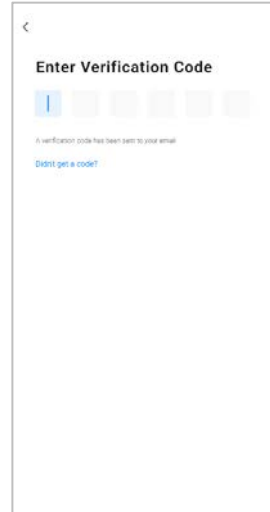

## Set device in pairing mode

When the device is first turned on, it may automatically enter pairing mode (power button on the control panel is flashing rapidly).

If not automatically in pairing mode when powered on, you can manually set the device in pairing mode by pressing and holding the fan speed button for five seconds until power button on the control panel is flashing rapidly.

If the power button is flashing slowly, press and hold the fan speed button for five seconds again, and the power button will be flashing rapidly.

## Add device through network

1. Once registered, tap **“Add Device”** on the app’s home page, or the **“+”** in the upper right corner, to add a new device through the network.
2. Select the product type from the list of options in the app (Heating & Cooling > Air Conditioners).
3. Enter your Wi-Fi details. It is important that your SmarterHome™ device and the app are connected to the same Wi-Fi network during setup.

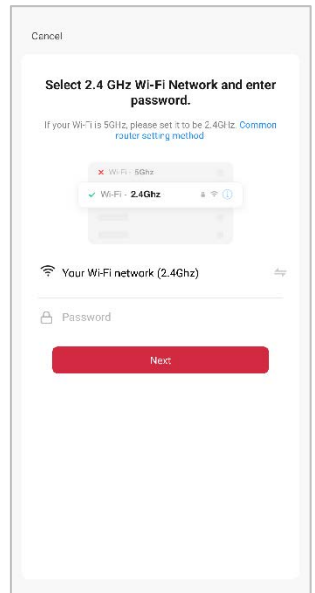
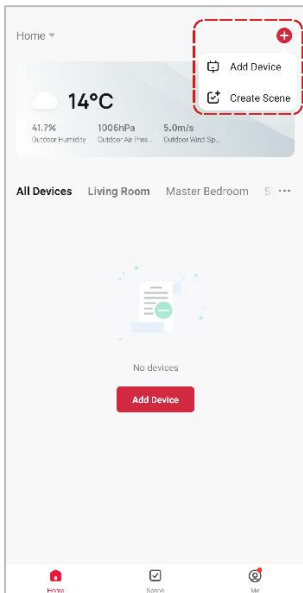

### Notes:

- The device and the app have to use the same Wi-Fi network.
- The device is only compatible with 2.4Ghz networks.

4. Ensure that the device is in pairing mode, with the power button on the control panel flashing rapidly, and tap “Confirm light is rapidly flashing”.
5. The device will commence the pairing process and connect to the app. Ensure your Wi-Fi router, mobile phone, and the SmarterHome™ device are kept close until connection is complete.
6. After successfully being added, you will have the option to rename the device and assign it to a location. It will now be listed on the app’s home page. Tap the device listing to enter its control page.

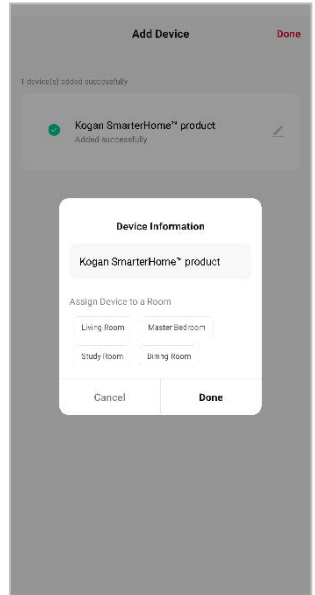
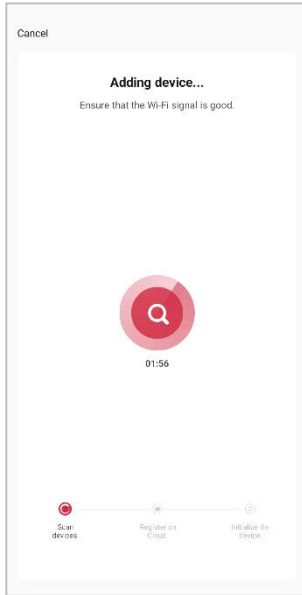
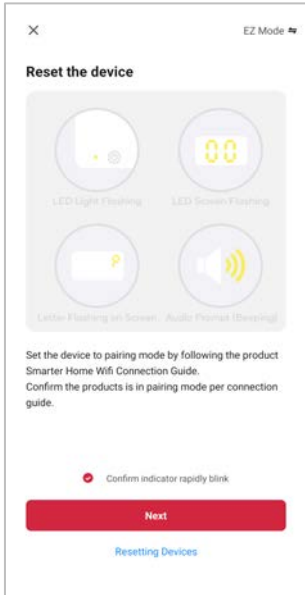

**Note:**  
Once connected, you can select Create Scene from the “+” in the upper right corner (or from the Scene tab) to group connected SmarterHome™ products and automate their functions.



# GOOGLE HOME CONTROL

## Note:

You will need to have set up a Google Home account prior to linking your Kogan SmarterHome™ device.

## Adding 'SmarterHome' to the Google Home app

1. From the home page of the Google Home app, select the '+' icon (top left corner, see arrow in the below screenshot) to access the 'Add and manage' page.
2. Select 'Set up device', then select the 'Works with Google' option.

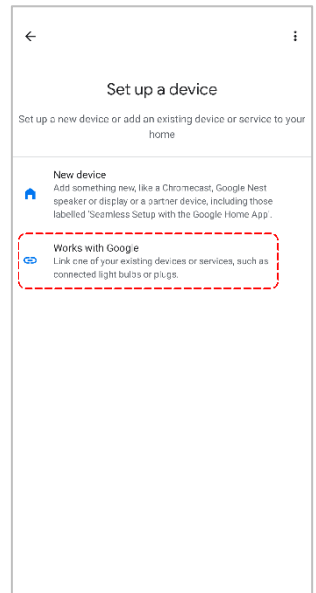
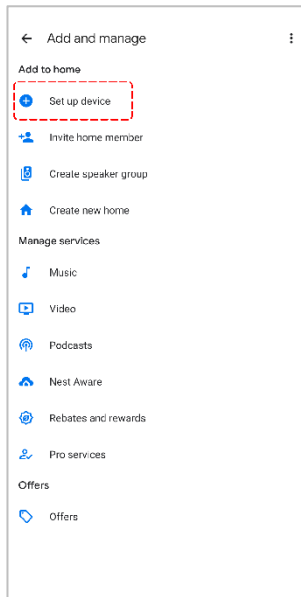
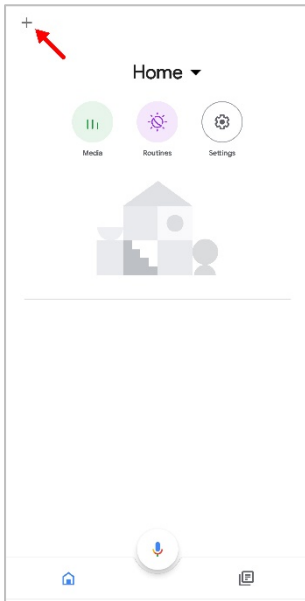

3. Select the search bar and type 'Smarter Home' to locate the Kogan SmarterHome™ service.
4. From here, you will be prompted to sign into your SmarterHome™ account using either your email or mobile phone number, depending on which method you used to register your account.
5. Select 'Kogan SmarterHome™' from the app options.

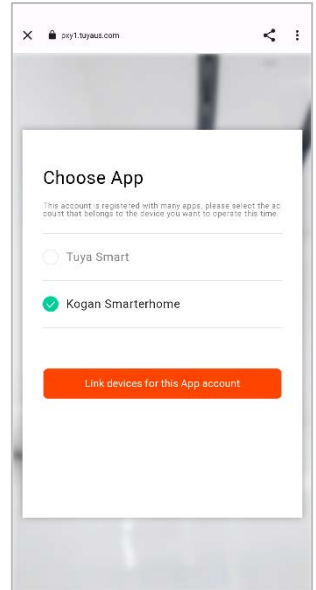
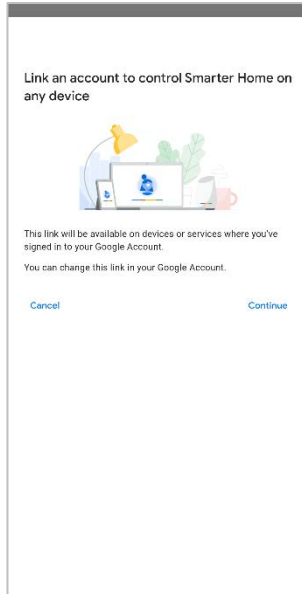
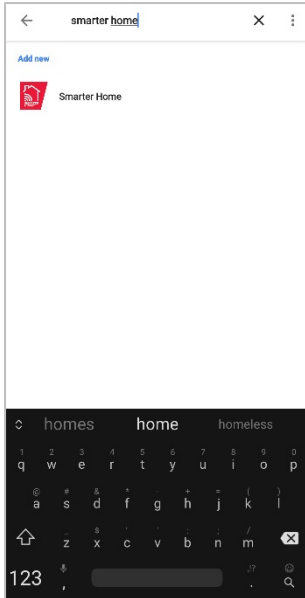

6. Tap 'Authorise' to grant Google permission to access the SmarterHome™ app and your devices.
7. Once connected, the app will display any compatible devices linked to your SmarterHome™ account. From here you can assign them to rooms and set up any routines. Tap on any of the devices to view a list of available commands.

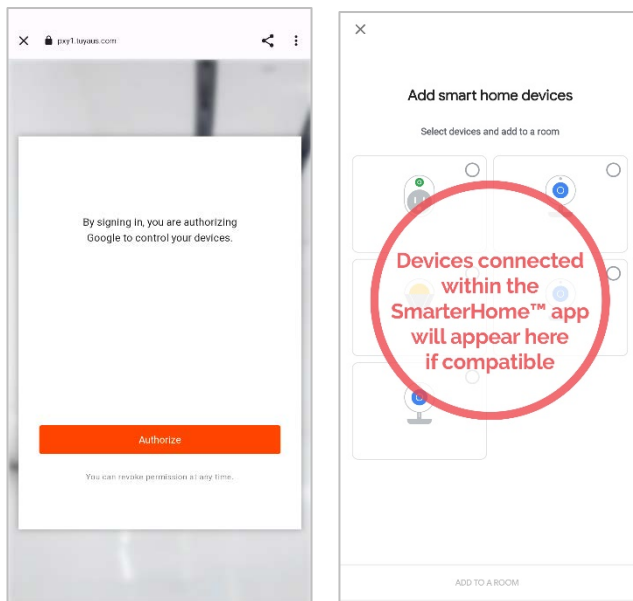

**Note:**

Please note that Google Home can only control the base/core functions of any compatible SmarterHome™ devices. To make full use of this product's smart functionality, please use the Kogan SmarterHome™ app.

# AMAZON ALEXA CONTROL

## Note:

You will need to have set up an Alexa account prior to linking your Kogan SmarterHome™ device.

## Adding 'SmarterHome' to the Alexa app

1. From the home page of the Alexa app, select the  icon in the bottom-right and select 'Skills & Games' from the sidebar.
2. Select the search bar and type 'Smarter Home' to locate the Kogan SmarterHome™ skill.

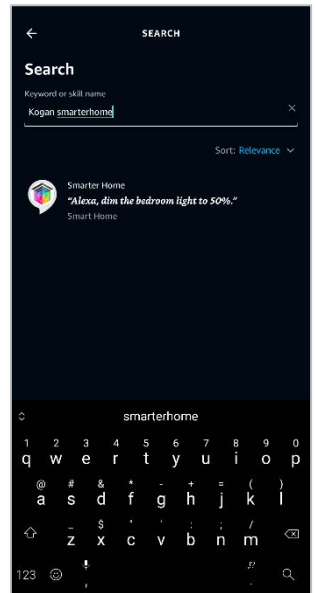
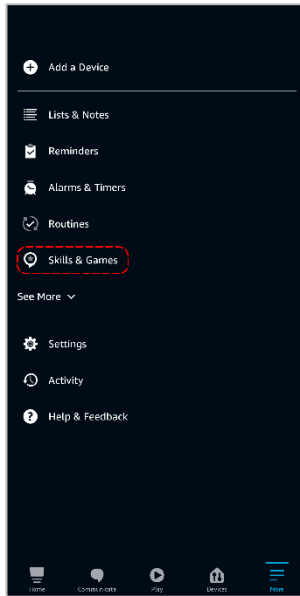
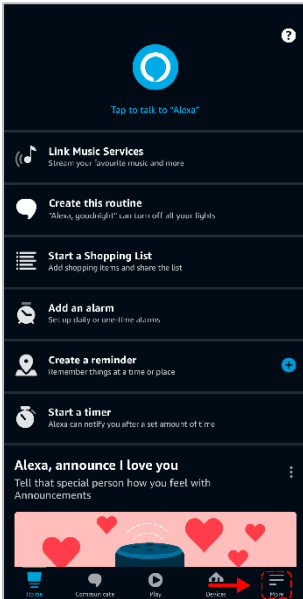

3. Tap 'Enable to Use' to add the Kogan SmarterHome™ skill to Alexa.
4. From here, you will be prompted to sign into your SmarterHome™ account using either your email or mobile phone number, depending on which method you used to register your account.
5. Select 'Kogan SmarterHome™' from the app options.

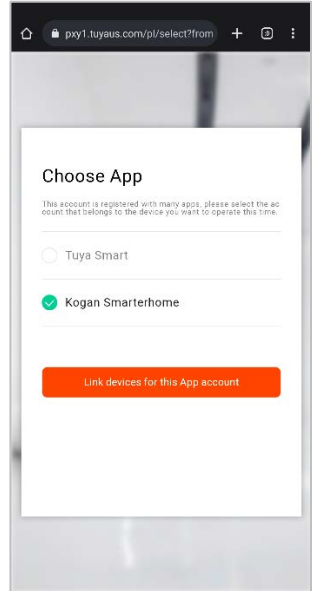
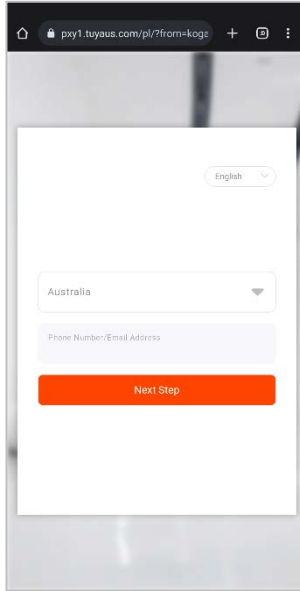
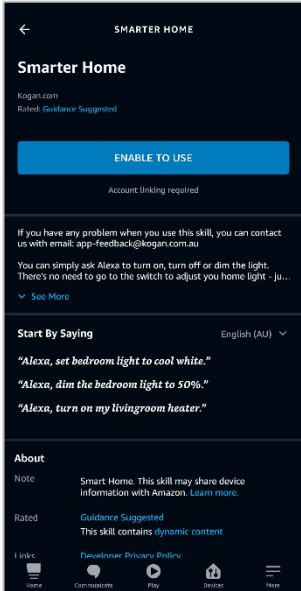

6. Tap 'Authorise' to grant Alexa permission to access the SmarterHome™ app and your devices.
7. Once connected, the app will perform a search and display the devices linked to your SmarterHome™ account. When your devices have successfully connected to the Alexa app, you will be able to control your Kogan SmarterHome™ devices via Alexa's voice commands.

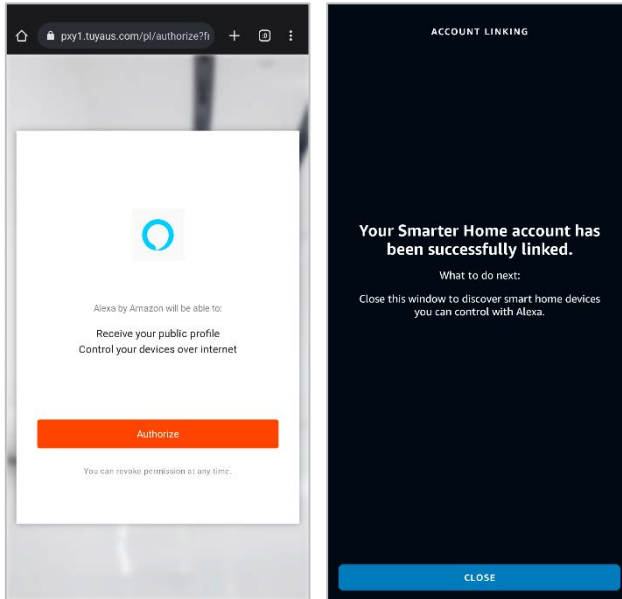

**Note:**

Please note that Alexa can only control the base/core functions of any compatible SmarterHome™ devices. To make full use of this product's smart functionality, please use the Kogan SmarterHome™ app.

# CLEANING & CARE

## Drainage

When the water inside the air conditioner needs to be emptied, there are two ways to drain it:

- Manual drainage
- Continuous drainage

### Manual drainage

1. Press the power button to turn off the air conditioner, then unplug the power cord.
2. Move the air conditioner carefully to prevent water from spilling at the bottom. Place a container next to the lower drainage cover.
3. Unscrew the lower drainage cover and unplug the water plug from the water outlet. Allow the water to flow into the container. Tilt the air conditioner backward slightly to ensure all water is drained.
4. Once drained, plug in the water plug and screw the lower drainage cover back on. Resume use.

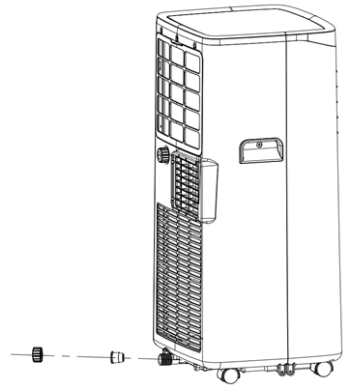

### Notes:

- Keep the lower drainage cover and water plug nearby.
- If the container is unable to hold all the water, quickly plug the water plug onto the water outlet before the container is full. This will prevent water from flowing onto the floor.

### Continuous drainage

This drainage method is suitable if the air conditioner is operating in the dehumidifying mode.

1. Unscrew the upper drainage cover and unplug the water plug.
2. Connect one end of the drainage pipe into the water outlet.
3. Connect the other end of the drainage pipe into a container. The water will then drain out whilst the air conditioner is operating.

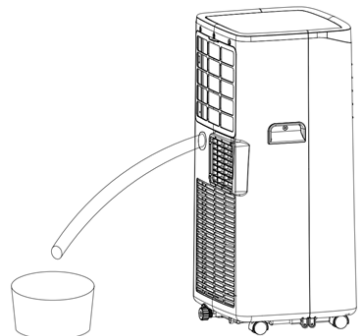

## Cleaning

Before cleaning and maintenance, ensure the air conditioner is turned off and unplugged.

## Exterior

Wipe with exterior with a wet soft cloth. If the exterior has stubborn stains, wipe with a mild detergent.

### Note:

Do not use chemicals (for example, benzene, alcohol, gasoline) as the exterior and air conditioner may become damaged.

## EVA filter

1. Using a screwdriver (not supplied), remove one screw fixing the EVA filter and back shell.
2. Remove the EVA filter.
3. Rinse the EVA filter in warm water (around 40°C) with a neutral detergent.
4. Dry the EVA filter in the shade.

## Storage

1. Unscrew the drainage cover, unplug the water plug, and tilt the air conditioner backward to ensure no water is stored inside.
2. Connect the drainage pipe. Turn on the air conditioner and run it on a low fan speed until the drainage pipe becomes dry to keep the inside of the body in dry and prevent it from mildewing.
3. Turn off the air conditioner and unplug the power cord.
4. Secure the water plug and drainage cover back on the air conditioner.
5. Disconnect the exhaust pipe and store it in a cool, dry place.

### Note:

Ensure the exhaust pipe is not stored bent.

6. Cover the air conditioner with a plastic bag. Place the air conditioner in a cool, dry place with an area larger than 7m<sup>2</sup>. Keep it out of the reach of children and ensure it does not gather dust.
7. Remove the batteries of the remote control and keep them safe.



# MAINTENANCE

## Regarding appliances containing R290

### Checks to the area

Prior to beginning work on systems containing flammable refrigerants, safety checks are necessary to ensure that the risk of ignition is minimised. For repairs to the refrigerating system, the following precautions shall be completed prior to conducting work on the system.

### Work procedure

Work shall be undertaken under a controlled procedure to minimise the risk of a flammable gas or vapour being present while the work is being performed.

### General work area

- All maintenance staff and others working in the local area shall be instructed on the nature of the work being carried out.
- Work in confined spaces shall be avoided.
- The area around the workspace shall be sectioned off. Ensure that the conditions within the area have been made safe by controlling any flammable materials.

### Checking for the presence of refrigerant

- The area shall be checked with an appropriate refrigerant detector prior to, and during work to ensure the technician is aware of potentially toxic or flammable atmospheres.
- Ensure that the leak detection equipment being used is suitable for use with all applicable refrigerants, i.e. non-sparking, adequately sealed, or intrinsically safe.

### Presence of a fire extinguisher

If any hot work is to be conducted on the refrigerating equipment or any associated parts, appropriate fire extinguishing equipment shall be available to hand. Have a dry powder or CO<sub>2</sub> fire extinguisher adjacent to the charging area.

### No ignition sources

- No person carrying out work in relation to a refrigerating system that involves exposing any pipe work shall use any sources of ignition in such a manner that may lead to the risk of fire or explosion.
- All possible ignition sources, including cigarette smoking, should be kept sufficiently far away from the site of installation, repair, removal, and disposal, during which refrigerant can possibly be released to the surrounding space.

- Prior to work taking place, the area around the equipment is to be surveyed to make sure that there are no flammable hazards or ignition risks.
- ‘No Smoking’ signs shall be displayed.

### **Ventilated area**

Ensure that the area is in the open or that it is adequately ventilated before breaking into the system or conducting any hot work. A degree of ventilation shall continue during the period that the work is carried out. The ventilation should safely disperse any released refrigerant and preferably expel it externally into the atmosphere.

### **Checks to the refrigerating equipment**

Where electrical components are being changed, they shall be fit for the purpose and to the correct specification. At all times, the manufacturer’s maintenance and service guidelines shall be followed. If in doubt, consult a professional for assistance.

The following checks shall be applied to installations using flammable refrigerants:

- The actual refrigerant charge is in accordance with the room size within which the refrigerant-containing parts are installed.
- The ventilation machinery and outlets are operating adequately and are not obstructed.
- If an indirect refrigerating circuit is being used, the secondary circuit shall be checked for the presence of refrigerant.
- Marking on the equipment continues to be visible and legible. Markings and signs that are illegible shall be corrected.
- Refrigerating pipes/components are installed in a position where they are unlikely to be exposed to any substance which may corrode refrigerant-containing components, unless the components are constructed of materials that are inherently resistant to being corroded or are suitably protected against being so corroded.

### **Checks to electrical devices**

Repair and maintenance of electrical components shall include initial safety checks and component inspection procedures. If a fault exists that could compromise safety, then no electrical supply shall be connected to the circuit until it is satisfactorily dealt with.

If the fault cannot be corrected immediately but is necessary to continue operation, an adequate temporary solution shall be used. This shall be reported to the owner of the equipment so all parties are advised.

Initial safety checks shall include:

- That the capacitor is discharged: this shall be done safely to avoid the possibility of sparking.
- That no live electrical components and wiring are exposed while charging, recovering, or purging the system.
- That there is continuity of earth bonding.

## Repairs to sealed components

During repairs to sealed components, all electrical supplies shall be disconnected from the equipment being worked upon before any removal of sealed covers, etc. If it is necessary to have an electrical supply to equipment during servicing, then a permanently operating form of leak detection shall be located at the most critical point to warn of a potentially hazardous situation.

Particular attention shall be paid to the following to ensure that by working on electrical components:

- The casing is not altered in such a way that the level of protection is affected. This shall include damage to cables, an excessive number of connections, terminals not made to original specification, damage to seals, incorrect fitting of glands, etc.
- The apparatus is mounted securely.
- The seals or sealing materials have not degraded to the point that they no longer serve the purpose of preventing the ingress of flammable atmospheres. Contact **help.Kogan.com** if requiring replacements.

### Notes:

The use of silicon sealant may inhibit the effectiveness of some types of leak detection equipment. Intrinsically safe components do not have to be isolated prior to working on them.

## Repair to intrinsically safe components

- Do not apply any permanent inductive or capacitive loads to the circuit without ensuring that this will not exceed the permissible voltage and currently permitted for the equipment in use.
- Intrinsically safe components are the only types that can be worked on while living in the presence of a flammable atmosphere.
- The test apparatus shall be at the correct rating.
- Replace components only with parts specified by the manufacturer. Other parts may result in the ignition of refrigerant in the atmosphere from a leak.

## Cabling

Check that cabling will not be subject to wear, corrosion, excessive pressure, vibration, sharp edges, or any other adverse environmental effects. The check shall also consider the effects of aging or continual vibration from sources such as compressors or fans.

## Detection of flammable refrigerants

Under no circumstances shall potential sources of ignition be used in the searching for or detection of refrigerant leaks. A halide torch (or any other detector using a naked flame) shall not be used.

## **Leak detection methods**

The following leak detection methods/guidelines are deemed acceptable for systems containing flammable refrigerants:

- Electronic leak detectors shall be used to detect flammable refrigerants, but the sensitivity may not be adequate or may need re-calibration. (Detection equipment shall be calibrated in a refrigerant-free area.) Ensure that the detector is not a potential source of ignition and is suitable for the refrigerant used.
- Leak detection equipment shall be set at a percentage of the LFL of the refrigerant and shall be calibrated to the refrigerant employed. The appropriate percentage of gas (25 % maximum) must be confirmed.
- Leak detection fluids are suitable for use with most refrigerants but the use of detergents containing chlorine shall be avoided as the chlorine may react with the refrigerant and corrode the copper pipework.
- If a leak is suspected, all naked flames shall be removed/extinguished.
- If a leakage of refrigerant is found which requires brazing, refrigerant shall be recovered from the system or isolated (using shut-off valves) in a part of the system remote from the leak. Oxygen-free nitrogen (OFN) shall then be purged through the system both before and during the brazing process.

## **Removal and evacuation**

When breaking into the refrigerant circuit to make repairs – or for any other purpose – conventional procedures shall be used. For flammable refrigerants, best practices must be followed due to the flammability. The following procedure shall be adhered to:

- Remove refrigerant
- Purge the circuit with inert gas
- Evacuate
- Purge with inert gas
- Open the circuit by cutting or brazing

The refrigerant charge shall be recovered into the correct recovery cylinders. For appliances containing flammable refrigerants, the system shall be purged with oxygen-free nitrogen to render the appliance safe for flammable refrigerants. This process may need to be repeated several times. Compressed air or oxygen shall not be used for purging refrigerant systems.

For appliances containing flammable refrigerants, refrigerants purging shall be achieved by breaking the vacuum in the system with oxygen-free nitrogen and continuing to fill until the working pressure is achieved, then venting to the atmosphere and finally pulling down to a vacuum. This process shall be repeated until no refrigerant is within the system. When the final oxygen-free nitrogen charge is used, the system shall be vented down to atmospheric pressure to enable work to take place. This operation is vital if brazing operations on the pipework are to take place.

- Ensure that the outlet for the vacuum pump is not close to any potential ignition sources and that ventilation is available.

## Charging procedures

In addition to conventional charging procedures, the following requirements shall be followed:

- Ensure that contamination of different refrigerants does not occur when using charging equipment.
- Hoses or lines shall be as short as possible to minimise the amount of refrigerant contained in them.
- Cylinders shall be kept upright.
- Ensure that the refrigerating system is earthed before charging the system with refrigerant.
- Label the system when charging is complete (if not already).
- Extreme care shall be taken not to overfill the refrigerating system.
- Before recharging the system, it shall be pressure-tested with the appropriate purging gas.
- The system shall be leak-tested on completion of charging and before commissioning. A follow-up leak test shall be carried out before leaving the site.

## Decommissioning

- Before carrying out this procedure, the technician must be completely familiar with the equipment and all its detail. It is recommended good practice that all refrigerants are recovered safely.
- Before the task is carried out, an oil and refrigerant sample shall be taken for case analysis and is required before reusing recovered refrigerant. Electrical power must be available before the task is commenced.
- Become familiar with the equipment and its operation.
- Isolate the system electrically.
- Before attempting the procedure, ensure that:
  - Mechanical handling equipment is available if required for handling refrigerant cylinders.
  - All personal protective equipment is available and being used correctly.
  - The recovery process is always supervised by a qualified person.
  - Recovery equipment and cylinders conform to the appropriate standards.
- Pump down the refrigerant system if possible. If a vacuum is not possible, make a manifold so that refrigerant can be removed from various parts of the system.
- Ensure the cylinder is situated on the scales before recovery takes place.
- Start the recovery machine and operate following the manufacturer's instructions and guidelines.
- Do not overfill the cylinders (no more than 80% volume liquid charge).
- Do not exceed the maximum working pressure of the cylinder, even temporarily.

- When the cylinders have been filled correctly and the process completed, make sure that the cylinders and the equipment are removed from the site promptly and all isolation valves on the equipment are closed off.
- Recovered refrigerant shall not be charged into another refrigerating system unless it has been cleaned and checked.

### **Labelling**

- Equipment shall be labelled stating that it has been de-commissioned and emptied of refrigerant.
- The label shall be dated and signed.
- For appliances containing flammable refrigerants, ensure that there are labels on the equipment stating the equipment contains flammable refrigerant.

### **Recovery**

- When removing refrigerant from a system either for servicing or decommissioning, it is recommended good practice that all refrigerants are removed safely.
- When transferring refrigerant into cylinders, ensure that only appropriate refrigerant recovery cylinders are employed.
- Ensure that the correct number of cylinders for holding the total system charge is available.
- All cylinders to be used are designated for the recovered refrigerant and labelled for that refrigerant (i.e. special cylinders for the recovery of refrigerant).
- Cylinders shall be complete with a pressure-relief valve. Associated shut-off valves shall be in good working order.
- Empty recovery cylinders are evacuated and if possible, cooled before recovery occurs.
- The recovery equipment shall be in good working order with a set of instructions concerning the equipment that is at hand and shall be suitable for the recovery of all appropriate refrigerants including when applicable, flammable refrigerants. Also, a set of calibrated weighing scales shall be available and in good working order.
- Hoses shall be complete with leak-free disconnect couplings and in good condition. Before using the recovery equipment, check that it is in satisfactory working order, has been properly maintained, and that any associated electrical components are sealed to prevent ignition in the event of a refrigerant release. Consult a qualified professional if in doubt.
- The recovered refrigerant shall be returned to the refrigerant supplier in the correct recovery cylinder, following local regulations regarding waste disposal.
- Do not mix refrigerants in recovery units, especially not in cylinders.
- If compressors or compressor oils are to be removed, ensure that they have been evacuated to an acceptable level to make certain that flammable refrigerant does not remain within the lubricant. The evacuation process shall be carried out before returning the compressor to the suppliers. Only electric heating to the compressor body shall be employed to accelerate this process. When the oil is drained from a system, it shall be carried out safely.

# TROUBLESHOOTING

Problem	Possible causes	Solution
The air conditioner is not working.	The air conditioner is unplugged.	Plug the power cord into an outlet and turn it on.
	The power plug is loose.	Ensure the power plug is fully inserted into the outlet.
	The display shows 'FL' and the full indicator is illuminated.	Drain the water from the air conditioner.
	The ambient temperature is too low or too high.	Ensure the ambient temperature is between 7–35°C.
	If in cooling mode, the ambient temperature is colder than the set temperature.	Adjust the set temperature to be above the ambient temperature.
The cooling effect is weak.	If in dehumidification mode, the ambient temperature is too low.	Place the air conditioner in an area with an ambient temperature above 17°C.
	There is direct sunlight.	Ensure the air conditioner is in direct sunlight.
	Doors or windows are open, or there are many people in the area.	<ul style="list-style-type: none"> <li>• Close all doors and windows.</li> <li>• Additional fans or cooling appliances may need to be used.</li> <li>• Ensure the area is between 10–15m<sup>2</sup>.</li> </ul>
	If in cooling mode, there are other heat sources nearby.	
	The area is too large.	
	The filters are dirty.	Clean or replace the filters.
	The ventilation openings are blocked.	Ensure there are no obstructions and there is at least a 50cm clearance between the air conditioner and any other objects.

The air conditioner is unable to cool the area.	The ambient temperature is warmer than the set temperature.	Adjust the set temperature to be below the ambient temperature.
	The compressor is not starting.	Wait for three minutes, then restart the air conditioner.
	The refrigerant is leaking or has run out.	Stop use and contact a professional to refill the air conditioner with refrigerant.
	The area is too large.	Move the air conditioner to an area between 10–15m <sup>2</sup> .
The display is malfunctioning, or the indicators have turned off.	The control panel has poor contact with the display panel.	Contact a professional to reconnect the wire between the main control board and display board.
	The display panel is damaged.	Replace the display board.
The air conditioner is making loud noises.	The air conditioner is not placed on a flat surface.	Place the air conditioner on a stable, flat surface.
	The filters are dirty.	Clean the filters.
Water is leaking from the air conditioner.	The air conditioner is not upright.	Stand the air conditioner upright.
	The water outlet is blocked.	Unblock the water outlet.
The compressor is not working.	The overheat protection has activated.	Wait for three minutes until the temperature has lowered, then restart the air conditioner.



The remote control is not working.	The distance between the air conditioner and the remote control is too far.	<ul style="list-style-type: none"> <li>• When using the remote control, ensure it is within proximity of the air conditioner.</li> <li>• Point the remote control towards the signal receiver.</li> </ul>
	The remote control is not facing the direction of the signal receiver when used.	
	The batteries are dead.	Replace the batteries.
There is a strange smell emitting from the air conditioner.	The air conditioner has not been used for an extended period and has absorbed smells from the surroundings.	Operate the air conditioner for 2–5 minutes and the smell should disappear.
The displays show 'E1'.	The room temperature sensor has failed.	<ul style="list-style-type: none"> <li>• Contact a professional to check the room temperature sensor and related circuitry.</li> <li>• Re-plug the sensor terminal or replace the main board (PCB) if necessary.</li> </ul>
The display shows 'E2'.	The pipe temperature sensor has failed.	<ul style="list-style-type: none"> <li>• Contact a professional to check the pipe temperature sensor and related circuitry.</li> <li>• Re-plug the sensor terminal or replace the PCB if necessary.</li> </ul>
The display shows 'E3'.	There is a failure between the main board and the display board.	Contact a professional to re-plug the connection terminal of the display board to the PCB, or replace the PCB.

**Note:**

If problems not listed in the table occur or recommended solutions do not work, contact [help.Kogan.com](http://help.Kogan.com) for assistance.

# SPECIFICATIONS

Cooling capacity	7,000BTU/hr
Power	2.06kW
Rated current	3.5A
Standby power consumption	0.7W
Power supply supported	220–240V, 50Hz
Power input	792W
Dehumidification capacity	0.7L/hr
Refrigerant	R290, 0.13kg
Air flow volume	300m <sup>3</sup> /hr
Coverage area	10–15m <sup>2</sup>
Cooling temperature range	16–31°C
Noise level	59dB(A)

## Fuse parameters

Type	5ET, SMT
Voltage	250V
Current	3.15A

## Other

Dimensions	329 x 319 x 674mm
Net weight	19.5kg

# SCHEMATIC DIAGRAM

The specific technical parameters of the machine shall be subject to the nameplate on the product.

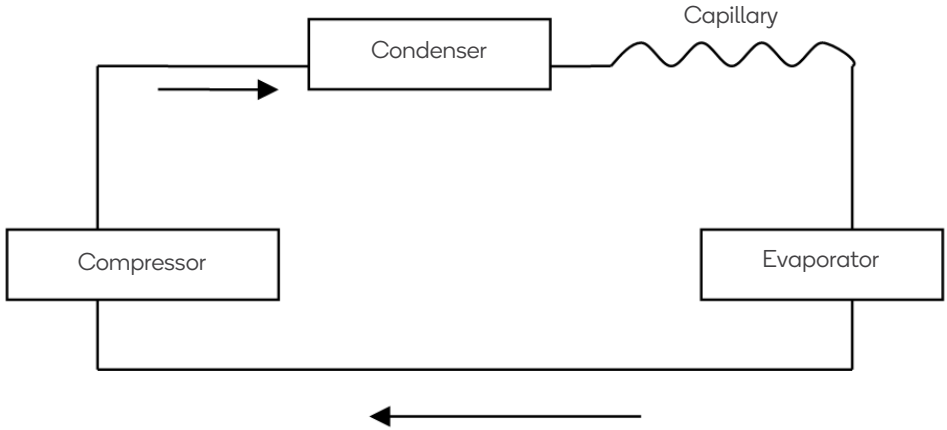

# ELECTRIC WIRING DIAGRAM

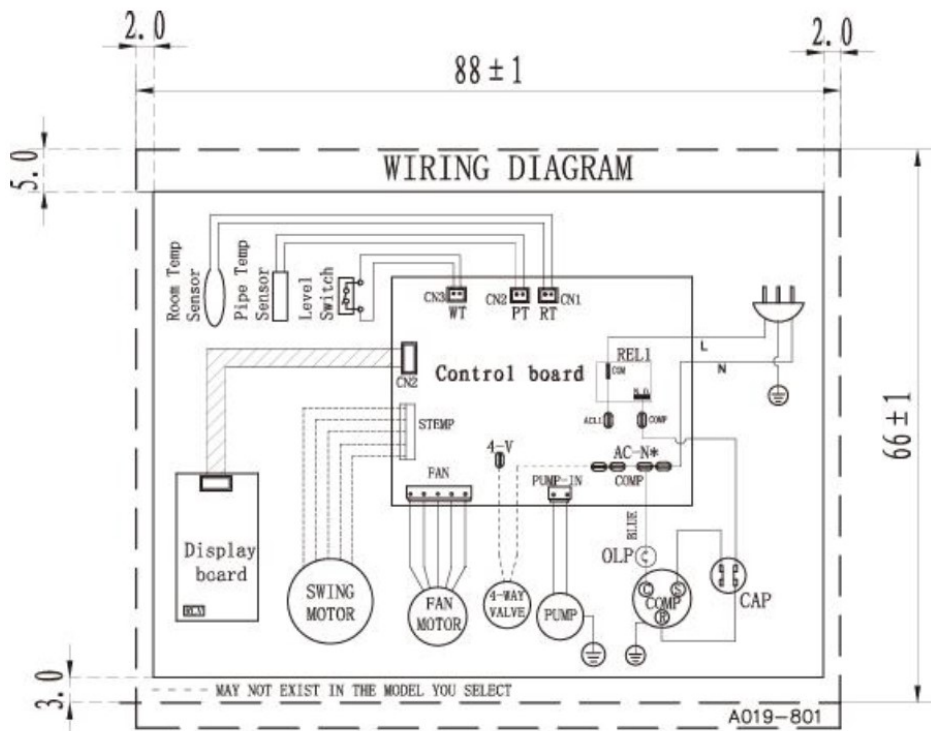

This marking indicates that this appliance should not be disposed of with other household wastes. To prevent possible harm to the environment or human health from uncontrolled waste disposal, recycle it responsibly to promote the sustainable reuse of material resources.







### **Need more information?**

We hope that this user guide has given you the assistance needed for a simple set-up.

For the most up-to-date guide for your product, as well as any additional assistance you may require, head online to **[help.kogan.com](https://help.kogan.com)**

**kogan.com**