

# BLU MKII

## Manual

### V.1.0



Chord Electronics Ltd.

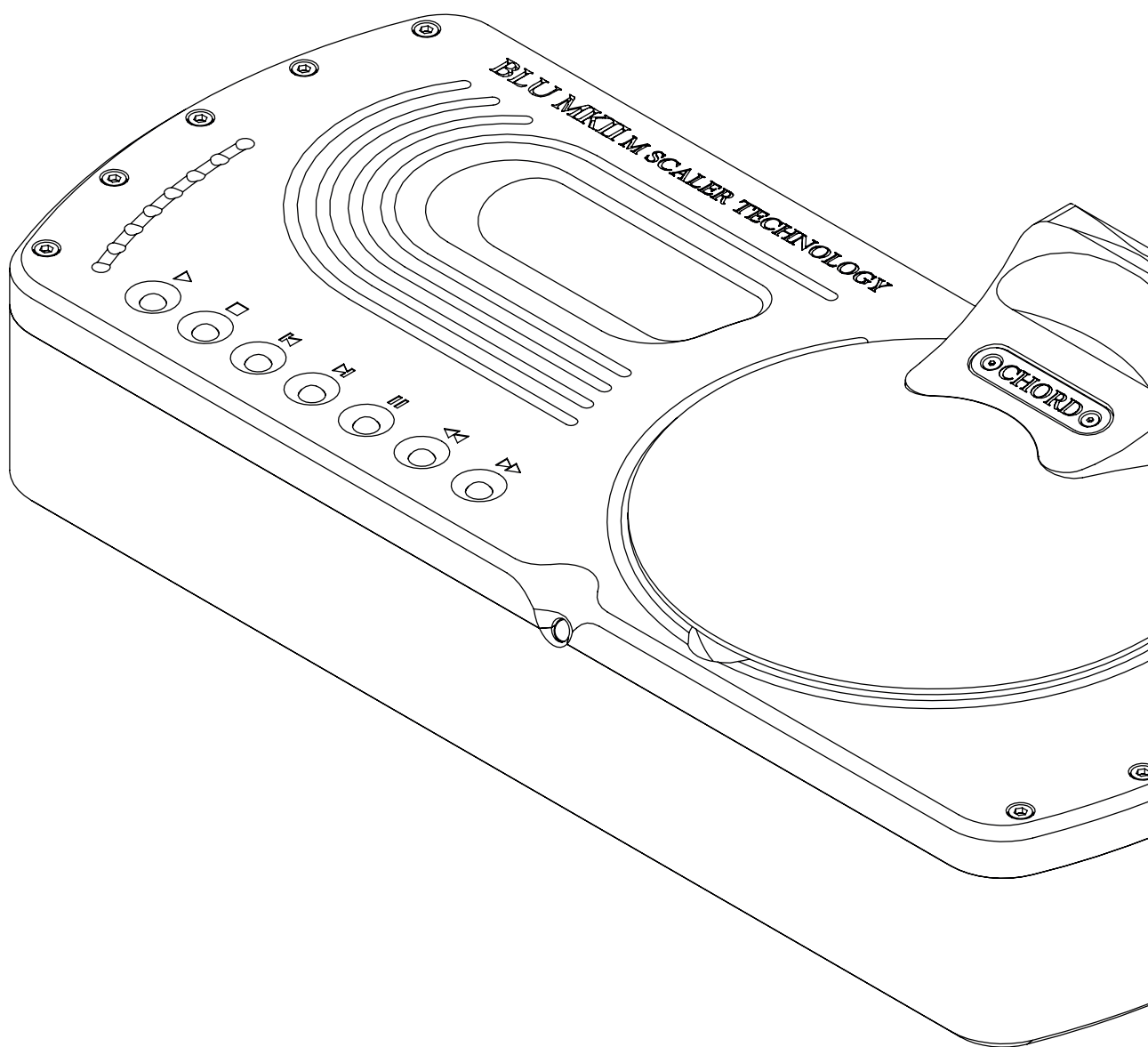

## Contents

## 0.0

<b>1.0 Safety instructions</b>	<b>03</b>	<b>2.0 Warranty</b>	<b>08</b>
1.1 Introduction	04	2.1 Warranty period & registering your purchase	09
1.2 Protection against liquids & heat	05	2.2 Making a claim & warranty exclusions	10
1.3 Dismantling & Radio frequency interference	06		
1.4 Connecting your equipment	07		
<b>3.0 Getting to know BLU MKII</b>	<b>11</b>	<b>4.0 Setting up BLU MKII</b>	<b>16</b>
3.1 Getting to know BLU MKII	12	4.1 Placement	17
3.3 The top panel	13	4.2 Connecting an input to BLU MKII & drivers	18
3.4 The rear panel	14	4.3 Connecting BLU MKII to DAVE	19
3.5 The remote control	15	4.4 Connecting BLU MKII to another DAC	20
		4.5 Sample Rate	21
		4.6 Output sample rate settings	22
<b>5.0 How to navigate the menu</b>	<b>23</b>	<b>6.0 Special features</b>	<b>26</b>
5.1 Display and basic navigation	24	6.1 Galvanic isolation	27
5.2 Video mode and Dither	25		

# 0.0

# Contents

## Safety instructions

1.0

- 1.1 Introduction
- 1.2 Protection against liquids & heat
- 1.3 Dismantling & Radio Frequency interference
- 1.4 Connecting your equipment

# 1.0 *Safety instructions*

## Introduction

### 1.1



BLU MKII is a highly advanced, multi-award-winning CD transport and digital audio upscaling device. BLU MKII uses the world's most advanced audio filtering technology to achieve an unprecedented 1,015,808 taps and can have a transformational effect on your existing digital music collection and library.

Before operation, we strongly advise you read this user manual thoroughly.

We also recommend that you store this user manual, along with your original receipt of purchase, in a safe place should you require assistance in the future.



 *Made in* **BRITAIN**

## Protection against liquids & heat

### 1.2



BLU MKII is not protected against liquids of any kind. Never place containers of liquid on BLU MKII. Never allow BLU MKII to come into contact with moisture or liquids; doing so could result in electrocution or damage to the BLU MKII's internal circuitry.

Be aware that liquids, including water that has dried, can leave minerals that can affect the PCB and other components, which could eventually lead to oxidation and short-circuiting.

If the BLU MKII comes into contact with moisture or liquids, immediately disconnect from the mains power supply, and connected equipment and contact Chord Electronics for further advice.



The BLU MKII has internal thermal protection which will shut down the unit in the event of excessive temperatures being reached. Never operate the BLU MKII near sources of heat or naked flames as this will decrease the lifespan of the internal components. It is advised that you do not operate the BLU MKII in an area of direct sunlight or on top of significant heat-producing devices.

Please be aware that it is entirely normal for the BLU MKII to become warm during use, particularly within a stacked configuration. If you are concerned about the temperatures, please switch the device off or consider a different placement.

## Dismantling & radio frequency interference

### 1.3



There are no user-serviceable components within the BLU MKII.

Dangerous voltages/currents exist within the BLU MKII, posing a severe risk of electrocution and/or fire.



Never attempt to open, dismantle or apply internal third-party devices to it or insert anything other than the listed interconnects within this user manual.

If the BLU MKII develops a fault or the casework becomes damaged, immediately disconnect from the mains power supply and connected equipment, and contact Chord Electronics for further advice.

With a thick, solid aluminium chassis, the BLU MKII's casework largely protects the sensitive internal circuitry from radio frequency interference. However, for optimal performance, it is recommended that the following points are observed:



**1. Consider placing the BLU MKII away from wireless routers.**



**2. Separate the BLU MKII from amplifiers using toroidal transformers.**



**3. Operate mobile phones at a distance to avoid interference.**



Although the BLU MKII is largely shielded, it can generate radio frequency interference that may have an effect on radio and television reception. If this occurs, please reconsider your placement.

## Connecting your equipment 1.4

Before connecting the BLU MKII to any equipment, consult the manufacturer's user guide to confirm compatibility.

When connecting the BLU MKII to any equipment please make sure that all devices are off, including the BLU MKII.

Once your devices are connected, switch all equipment on starting with the source and ending with the amplification. You can learn about the inputs and outputs on page 14.

You must always initially operate any connected equipment on its lowest gain setting and lowest volume setting before gently increasing to a comfortable listening level. This is to prevent any possible damage to connected equipment.

If the power supply is prematurely disconnected BLU MKII may still remain active for up to 15 seconds, however, this may cause damage to connected equipment.



Never disconnect the power cable during operation. Only disconnect when BLU MKII is off. If the power cable is disconnected during operation there is a risk of damage to connected equipment.



## Warranty

### 2.0

- 2.1 Warranty period & registering your purchase
- 2.2 Making a claim & warranty exclusions

# 2.0 *Warranty*



## Warranty period & registering your purchase

### 2.1

At point of sale, Chord Electronics Ltd. provides the BLU MKII with a comprehensive five-year warranty\* which covers defects in materials and workmanship through fair wear and tear. The warranty will be void if any other PSU other than that supplied is used.

\*The warranty is transferable with proof of purchase, however is not available on ex-demonstration products.



Please use the form below to record the details of your purchase in the event that these are required at a later date, we further advise that all purchases are registered with Chord Electronics at: [chordelectronics.co.uk/register-product/](https://chordelectronics.co.uk/register-product/)



RETAILER:	
PURCHASE PRICE:	
UNIT COLOUR:	
DATE OF PURCHASE:	
TRANSACTION ID:	

## Making a claim & warranty exclusions

### 2.2

In the unlikely event of a warranty claim, you must provide Chord Electronics with the details of the claim, including your original proof of purchase and serial number in order to validate the nature of the repair.

Upon receipt, Chord Electronics will make an assessment within 30 days and provide a reasonable solution.

All warranty repairs must be carried out by Chord Electronics or an approved service centre to guarantee the quality and safety of the repair.

**WARRANTY EXCLUSIONS:** The warranty does not cover connected equipment, personal injury or development natural patina of the metalwork and will be null and void if the following is applied: wilful neglect; modification or tampering of the product; improper use of the product; acts of God; damage caused by a connected device; mechanical shock; fire or application of excessive heat or repair/modification by a non-authorized third-party vendor.

**Getting to know  
BLU MKII**

**3.0**

- 3.1 Getting to know BLU MKII
- 3.2 The top panel
- 3.3 The rear panel
- 3.4 The remote control

# 3.0 *Getting to know BLU MKII*

## Getting to know BLU MKII

### 3.1

The BLU MKII is a highly advanced standalone upscaler as well as a CD transport, capable of redefining sound quality from digital audio.

The following pages will allow you to familiarise yourself with BLU MKII's inputs, outputs, capabilities and method of operation.



## The top panel

### 3.2

The top panel of BLU MKII is the main display that you will interact with on a day-to-day basis. First, it features a screen that displays all the current function of the CD transport. An in-depth explanation of its messaging can be found on page 24.

The CD function buttons on the top of the device are used to only control playback of the CD transport function of BLU MKII. These cannot be used to control playback of digital audio via the USB.

On the far right you will find the CD tray. This is covered by a convex CD lid. To access the CD tray gently lever the knuckle at the back of the device, confidently pushing down and away from you. Never open the CD tray when playback is initiated.

The IR receiver is located at the front of the device. Please do not cover this. If it is the remote control may not function.

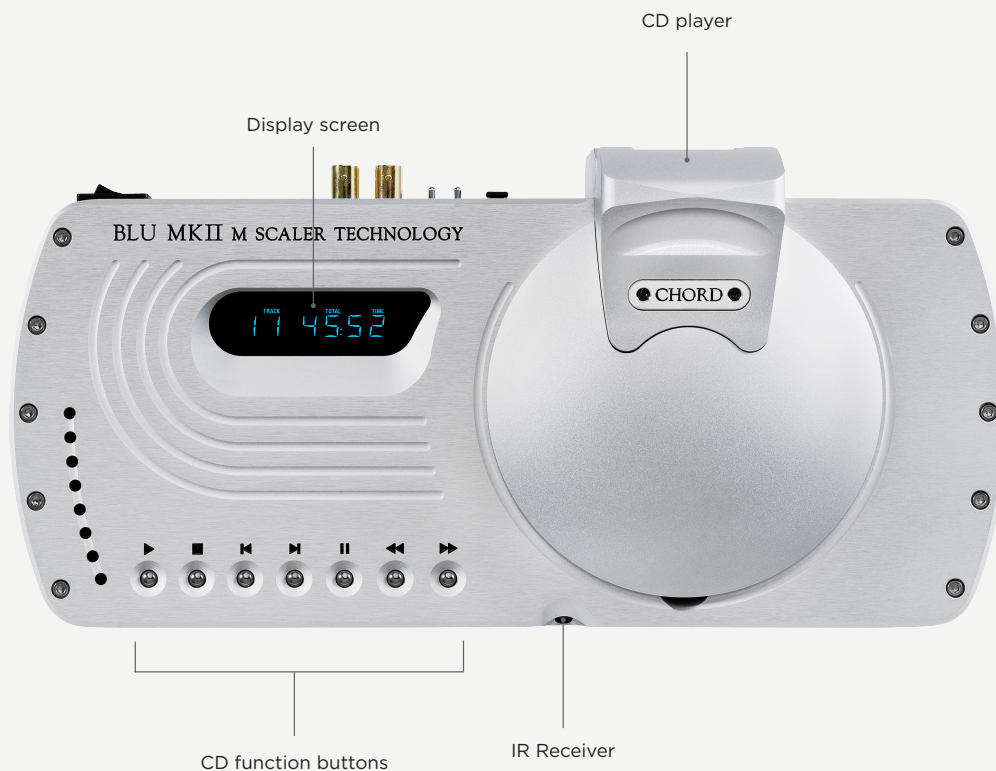
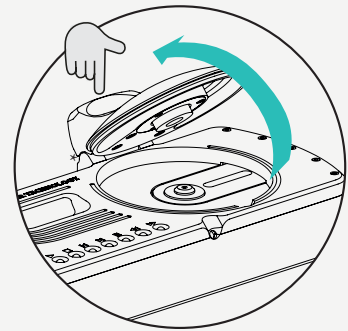

## The rear panel

### 3.3

The rear panel houses the device's wide-ranging connectivity inputs and outputs. The BLU MKII also features a dual-data output, which should be used for optimum performance with selected Chord Electronics' DACs.

When installing any cable, you must make sure that they securely click into place, especially optical.



**DRIVERS:** If you intend to use BLU MKII to upscale digital audio via USB the device is driverless with Mac OS X and Linux operating systems. Use with Windows operating systems does, however, require a driver.

These can be found on the product page at: [chordelectronics.co.uk/product/blu-mk-2/](http://chordelectronics.co.uk/product/blu-mk-2/)

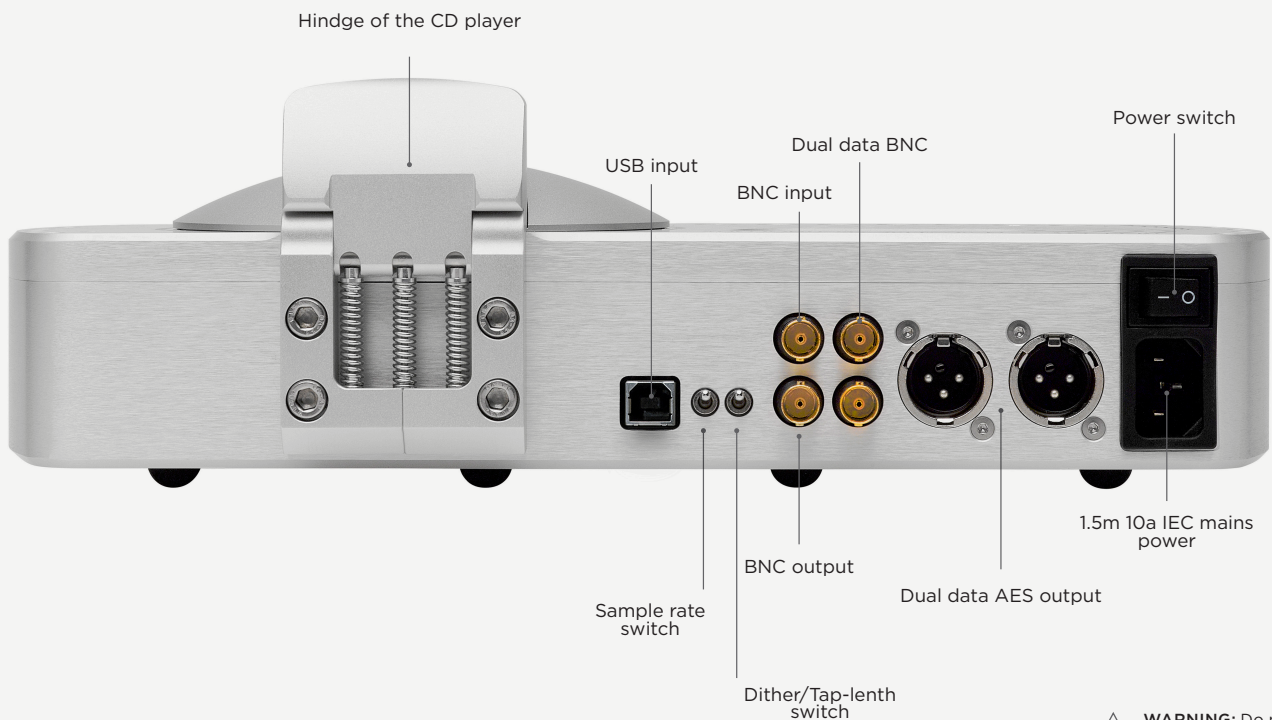

**WARNING:** Do not use any other power supply other than that supplied. Doing so will invalidate your warranty.

## The remote control

### 3.4

A comprehensive remote control is supplied with BLU MKII. It can control BLU MKII as well as other devices within the range. You will notice that the top section of the remote control is dedicated to the operation of BLU MKII and DAVE, our flagship digital to analogue converter. The buttons below the playback controls are reserved to control the Choral series preamplifier, Prima.

The supplied remote control connects to BLU MKII using infra-red. If the infra-red receiver on the front of BLU MKII is covered the remote control will not function. Please avoid placing objects in front of either device.

**NOTE:** The volume buttons shown on the BLU MKII remote will only control the volume on the Choral series preamplifier, Prima. They will not control the volume of DAVE. To see how to change the inputs of DAVE using this remote control please refer to the DAVE user manual.

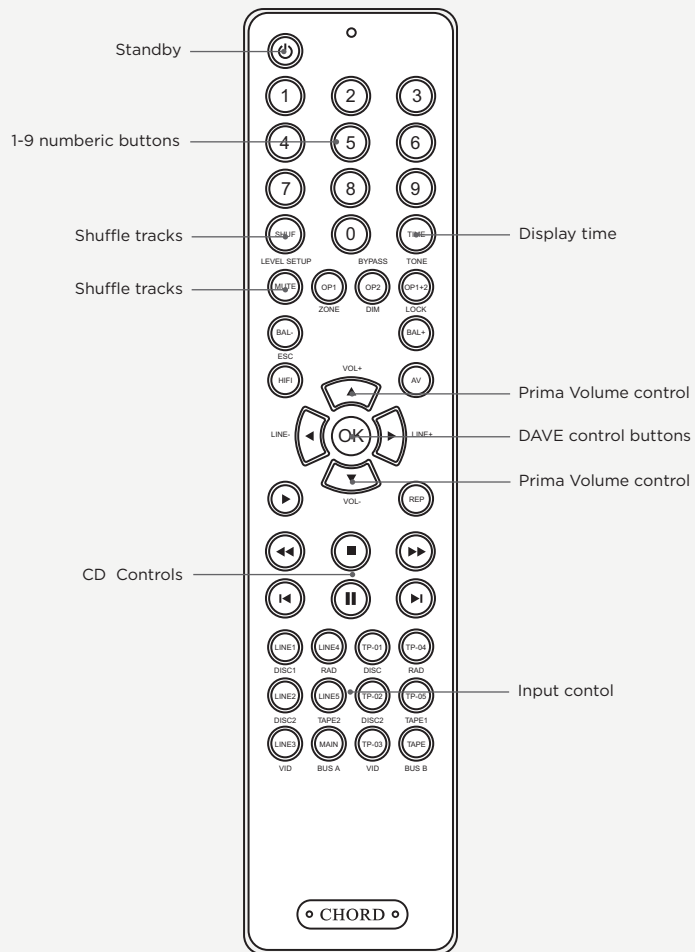

**NOTE:** Please only insert AAA batteries into the IR remote control and observe the correct orientation as indicated within the remote control. Failure to do so could result in non-operation or battery leakage.

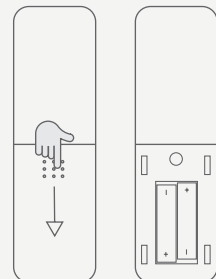

## Setting up BLU MKII

### 4.0

- 4.1 Placement
- 4.2 Connecting an input to BLU MKII
- 4.3 Connecting BLU MKII to DAVE
- 4.4 Connecting BLU MKII to another DAC
- 4.5 Sample rate
- 4.6 Output sample rate settings

# 4.0

## *Setting up BLU MKII*



4.1	Placement	4.4	Connecting BLU MKII to another DAC
4.2	Connecting an input to BLU MKII	4.5	Sample rate
4.3	Connecting BLU MKII to DAVE	4.6	Output sample rate settings

## Placement

### 4.1

Whilst the BLU MKII operates normally within a stack of Chord Electronics Emsable stands along with units such as the DAVE and Etude, it is recommended that you allow the device to breathe. Allocating 10cm of space around it to convection-cool during operation is advised. If possible, do not place the unit(s) inside a cabinet.



As the infra-red remote control requires a direct line of sight to the viewing portal, please avoid placing objects in front of either device.



## Connecting an input to BLU MKII & drivers 4.2

BLU MKII is not just an upscaling CD transport, it can also upscale digital audio via USB or BNC.

In order for this to occur you must now connect the digital output of your source to a digital input of BLU MKII. The two available inputs are highlighted below.

It is not possible to select between inputs. If you wish to use two sources you must make sure that they are both not operating at the same time. Alternatively, do not connect them at the same time.

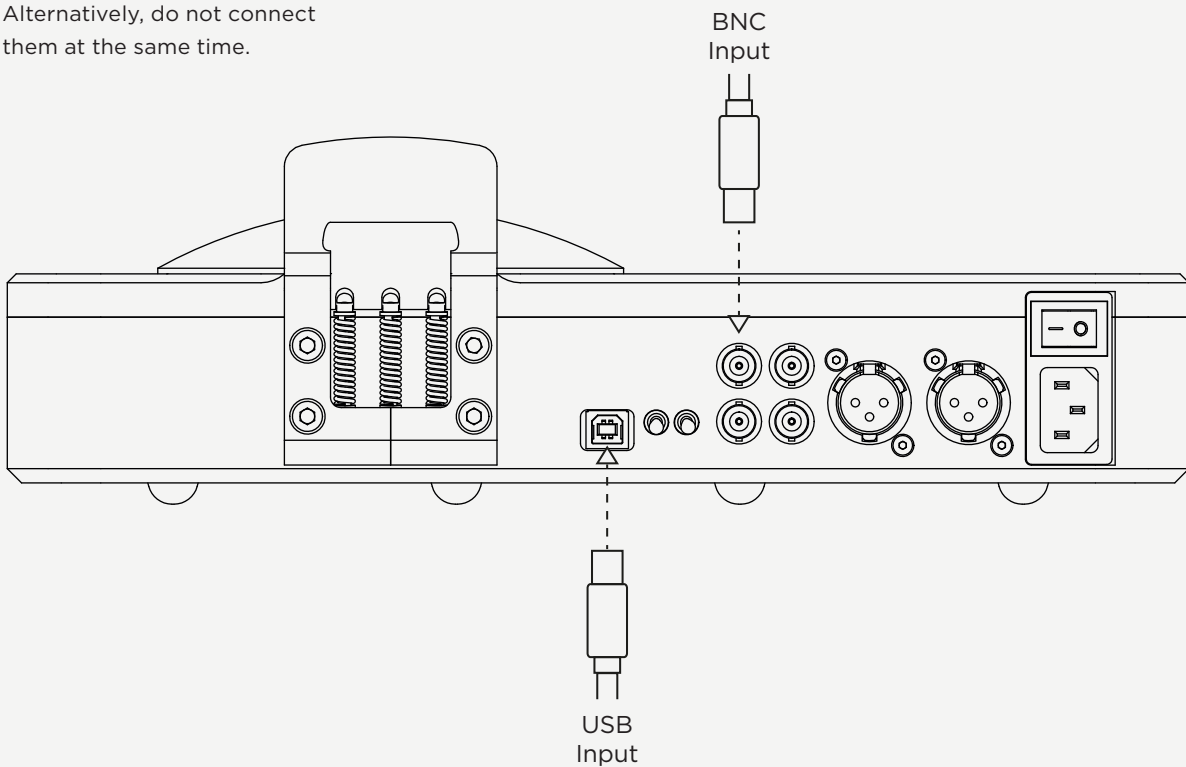

## Connecting BLU MK II to DAVE

### 4.3

Using the supplied BNC cables, it is simple to connect the BLU MKII to the DAVE:

- 1) Turn the BLU MKII and DAVE off, along with any connected equipment
- 2) Locate the Dual BNC outputs on the rear of BLU MKII and plug both BNC cables into the sockets.
- 3) Locate a single pair of the BNC inputs on DAVE, either the right pair (1 and 2) or the left pair (3 and 4), and plug the BNC cables in. You must pay careful

attention to make sure that you are connecting them in the same order. For example; top to top and bottom to bottom

- 4) Turn both BLU MKII and DAVE on, but not any other connected equipment.
- 4) If you have connected your dual data BNC's to BNC 1 or 2 on DAVE, use the buttons on DAVE to navigate forward within the menu and select BNC 1. Pause here for a few seconds until D BNC1 is displayed.

or

If you have connected your dual data BNC's to BNC 3 or 4 on DAVE, use the buttons on DAVE to navigate forward within the menu and select BNC 3. Pause here for a few seconds until D BNC3 is displayed.

5) You can now turn on any additional connected equipment and commence playback.

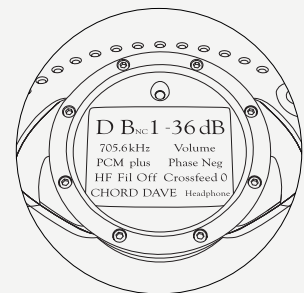
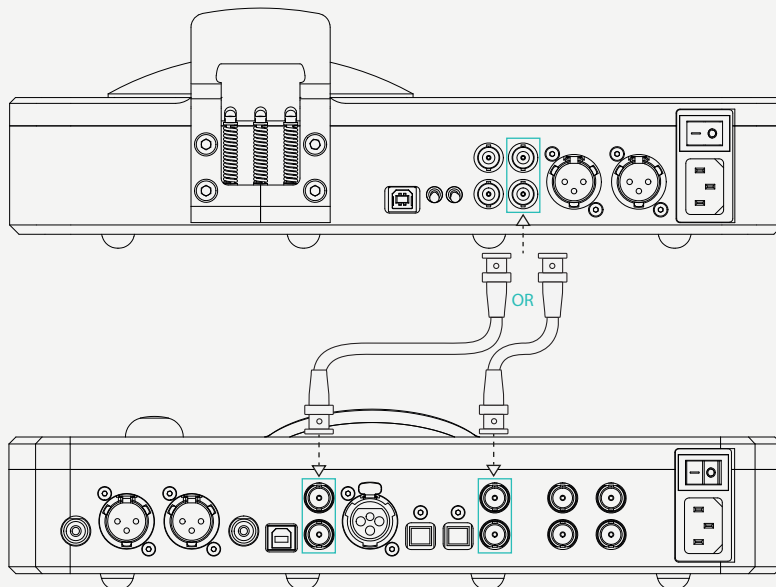

\*DAVE will only display Dual BNC when BLU MK II is transmitting a 768kHz or 705.6kHz signal. Therefore BLU MK II must be set to maximum upsampling which is denoted by the white button colour.

## Connecting BLU MK II to another DAC

### 4.4

Although the BLU MK II is optimised for use with Chord Electronics' DACs to take advantage of the full 768kHz upscaling, BLU MKII can be connected to any third-party DAC to increase performance. However, it should be noted that only a maximum of 384kHz upsampling can be achieved.

To make a connection to a third-party DAC you must only use the highlighted BNC output. Dual-data BNC's or the BNC input cannot be used. To do this follow these simple instructions;

1) Turn the BLU MKII and your third-party device off, along with any connected equipment

2) Locate the Dual BNC output on the rear of BLU MKII, highlighted below, and connect a BNC cable into the socket

3) Locate the BNC input on your third-party device and connect the other end of the cable to it

4) Turn on both BLU MKII and your third-party device and select the appropriate input

5) Turn on any additional equipment and commence playback

**NOTE:** It is possible to use the digital AES outputs on BLU to connect it to another DAC. However, on their own, each AES output can only offer a maximum sample rate of 96kHz. Because of this BNC is recommended over an AES (XLR) connection.

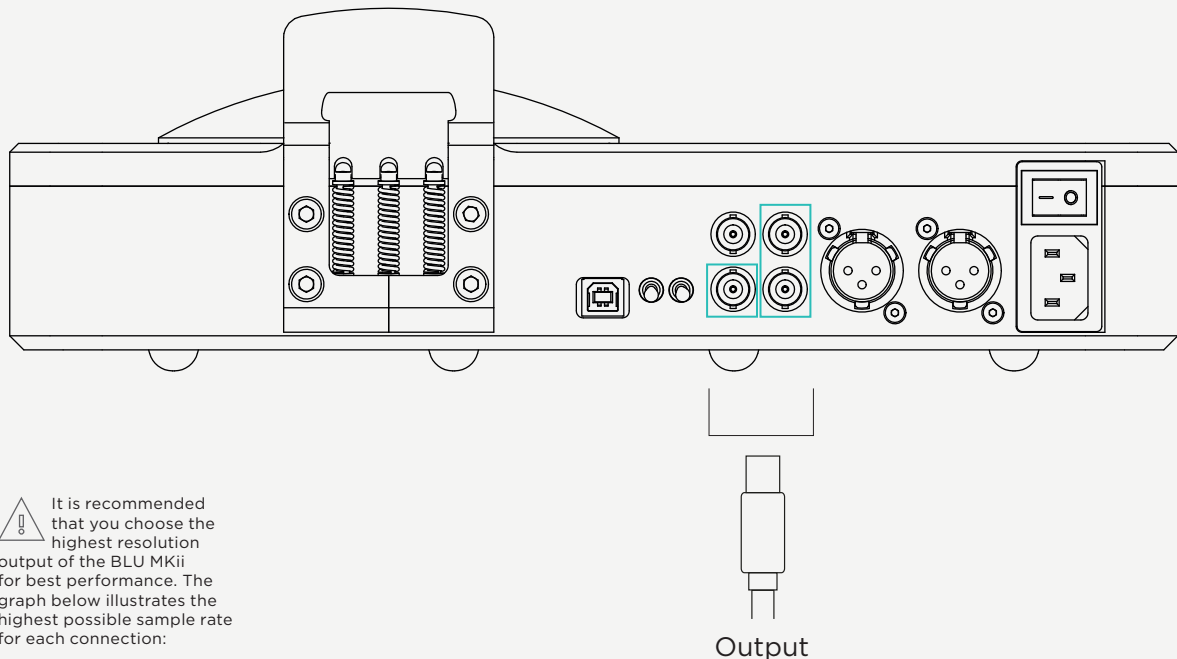

## Sample rate

## 4.5

BLU MKII allows you to select the best sample rate for your system.

To select a sample rate first locate the switch next to the USB input. Then you must move its position according to the sample rate that you wish to engage, as shown below.

For most uses, including that with DAVE, we recommend the maximum possible level of upsampling. This is denoted by the switch being in a downwards position.



**POSITION - UP:**  
Upsampling none  
eg. original signal 44.1kHz



**POSITION - MID:**  
Upsampling medium  
eg. signal now 176k.4kHz



**POSITION DOWN:**  
Upsampling maximum  
eg. signal now 705.6kHz

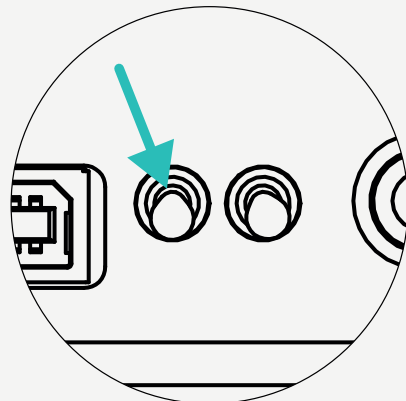

## Output sample rate settings 4.6

ASK MITCH FOR GRAPH OF UPSAMPLING ON BLU - IT IS DIFFERENT TO M SCALER

Please use the graph shown on the right hand page to determine your optimum sample rate settings.

The maximum achieved upsampling will depend entirely on your source input sample rate.

Key

- Improvement
- No improvement
- Not supported

SAMPLE FREQUENCY	OP SR POSITIONS	DUAL BNC/USB INPUT	SINGLE BNC	OPTICAL	DUAL BNC/USB INPUT	SINGLE BNC	OPTICAL
44.1 - 48 kHz		44.1 kHz	44.1 kHz	44.1 kHz	48 kHz	48 kHz	48 kHz
	POSITION - UP	176.4 kHz	88.2 kHz	88.2 kHz	192 kHz	96 kHz	96 kHz
	POSITION - MID	352.8 kHz	176.4 kHz	176.4 kHz	384 kHz	192 kHz	192 kHz
	POSITION - DOWN	705.6 kHz	352.8 kHz	176.4 kHz	768 kHz	384 kHz	192 kHz
88.2 - 96 kHz		88.2 kHz	88.2 kHz	88.2 kHz	96 kHz	96 kHz	96 kHz
	POSITION - UP	176.4 kHz	88.2 kHz	88.2 kHz	192 kHz	96 kHz	96 kHz
	POSITION - MID	352.8 kHz	176.4 kHz	176.4 kHz	384 kHz	192 kHz	192 kHz
	POSITION - DOWN	705.6 kHz	352.8 kHz	176.4 kHz	768 kHz	384 kHz	192 kHz
176.4 - 192 kHz		176.4 kHz	176.4 kHz	176.4 kHz	192 kHz	192 kHz	192 kHz
	POSITION - UP	176.4 kHz	176.4 kHz		192 kHz	192 kHz	192 kHz
	POSITION - MID	352.8 kHz	176.4 kHz		384 kHz	192 kHz	192 kHz
	POSITION - DOWN	705.6 kHz	352.8 kHz		768 kHz	384 kHz	192 kHz
352.8 - 384 kHz		352.8 kHz	352.8 kHz	352.8 kHz	384 kHz	384 kHz	384 kHz
	POSITION - UP	352.8 kHz	352.8 kHz	N/A	384 kHz	384 kHz	N/A
	POSITION - MID	352.8 kHz	352.8 kHz	N/A	384 kHz	384 kHz	N/A
	POSITION - DOWN	705.6 kHz	352.8 kHz	N/A	768 kHz	384 kHz	N/A
705.6 - 768 kHz		705.6 kHz	705.6 kHz	705.6 kHz	768 kHz	768 kHz	768 kHz
	POSITION - UP	705.6 kHz	N/A	N/A	768 kHz	N/A	N/A
	POSITION - MID	705.6 kHz	N/A	N/A	768 kHz	N/A	N/A
	POSITION - DOWN	705.6 kHz	N/A	N/A	768 kHz	N/A	N/A

How to navigate the menu

5.0

5.1 Display and basic navigation

5.2 Video mode

# 5.0

## *How to navigate the menu*

## Display and basic navigation 5.1

If you do not wish to use the included remote control to control the functions of BLU MKII, many of the basic functions can be accessed from the top panel including; play, pause, stop and fast forward. These functions can only control the CD transport functionality and not playback via the USB or BNC inputs.

Additionally, if you wish to reference the current play state of the CD transport or to confirm that dual data mode is active for any of the dual BNC connections, BLU MKII has a screen that can display this information. Please reference the below chart to learn about BLU MKII's display.

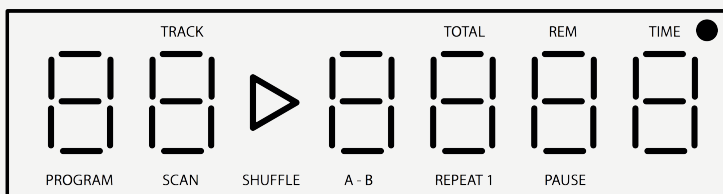

- ① Track no.
- ② Play status
- ③ Minutes
- ④ Seconds
- ⑤ Dual data indicator



## Video mode and dither

## 5.2

The BLU MKII is a highly flexible standalone upscaler that is not only designed to be used with music, but with video, too. You can playback video via a computer/laptop/server or a Blu-ray player to get the best audio quality from video soundtracks.

When you are playing back video, via USB or BNC, you may notice that there is now a delay between the action on screen and the resulting audio. This is due to the fact that BLU MKII has enormous processing capabilities, which can introduce an undesired latency.

To solve this, BLU MKII comes equipped with a 'Video mode';

**Video filter off:** This will resolve the full 1-million tap upsampling performance for all music and audio playback. It is not recommended for video playback.

**Video filter on:** The tap-length is moderately reduced\* to allow for a latency reduction. This mode is recommended for video but not music playback.

*\*Video mode reduces the tap count to 666,666, taps for low latency (104mS) playback. Not advisable for general audio playback.*

It should be noted that it is not possible to engage video mode during CD playback and therefore the same switch will perform a different action. In this respect you can choose to add dither, a form of noise added to audio to increase the accuracy of digital audio, or not add dither. Please reference the graph below to learn the switch options.

The switch to modify both video mode and dither is located next to the BNC sockets:

### During USB or Coax use:

 **POSITION - UP:**  
Video mode off  
1million taps

 **POSITION DOWN:**  
Video mode on  
666,666 taps

### During CD playback:

 **POSITION - UP:**  
Dither off  
1million taps

 **POSITION DOWN:**  
16-bit dither on  
1million taps

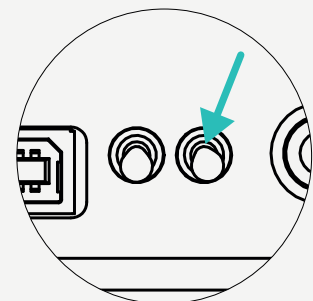

## Special features

### 6.0

#### 6.1 Galvanic isolation

# 6.0

## *Special features*

## Galvanic isolation

### 6.1

BLU MKII features a Class 2 Type-B USB input with galvanic isolation.

Galvanic isolation allows for greater sonic performance because the power rails of the input are totally isolated from the data lines.

No special attention or cables are required to allow the BLU MK II to function in this mode. However, the usual USB +5V rail will need to be present.

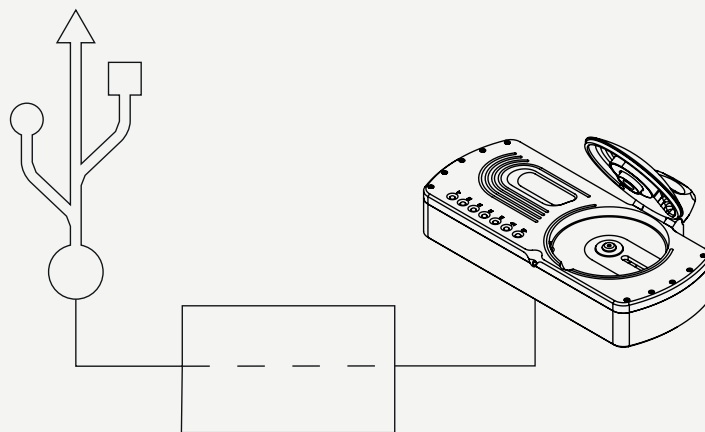



Chord Electronics Ltd.

