



VCCI TEST REPORT

According to

VCCI: 2015-04 Class B

Applicant : ASUSTEK COMPUTER INC.
Address : 4F, No. 150, LI-TE Rd., PEITOU, TAIPEI
112, TAIWAN
Equipment : Motherboard
Model No. : Z170 PRO GAMING
Brand name : ASUS

I HEREBY CERTIFY THAT :

The sample was received on Jun. 18, 2015 and the testing was carried out on Jun. 20, 2015 at CerpPASS Technology Corp. The test result refers exclusively to the test presented test model / sample. Without written approval of CerpPASS Technology Corp., the test report shall not be reproduced except in full.

Approved by:

Miro Chueh
EMC/RF B.U. Manager



VCCI TEST REPORT

Issued by:

CerpPASS Technology (Suzhou) Co.,Ltd

No.66,Tangzhuang Road, Suzhou Industrial Park, Jiangsu 215006, China

Tel:86-512-6917-5888

Fax:86-512-6917-5666

The test record, data evaluation & Equipment. Under Test configurations represented herein are true and accurate accounts of the measurements of the samples EMC characteristics under the conditions specified in this report.

Laboratory Accreditation:

CerpPASS Technology Corporation Test Laboratory

NVLAP LAB Code:	200954-0
TAF LAB Code:	1439

CerpPASS Technology(SuZhou) Co., Ltd.

NVLAP LAB Code:	200814-0
CNAS LAB Code:	L5515



Contents

1. Summary of Test Procedure and Test Results	5
1.1. Applicable Standards	5
2. Test Configuration of Equipment under Test	6
2.1. Feature of Equipment under Test.....	6
2.2. Test Manner	7
2.3. Description of Support Unit	8
2.4. Connection Diagram of Test System.....	9
2.5. General Information of Test.....	10
2.6. Measurement Uncertainty	11
3. Test of Conducted Emission	12
3.1. Test Limit	12
3.2. Test Procedures	13
3.3. Typical Test Setup	13
3.4. Measurement Equipment.....	14
3.5. Test Result and Data.....	15
3.6. Test Photographs of Power Port	23
3.7. Test Photographs of Telecommunication Port.....	24
4. Test of Radiated Emission	25
4.1. Test Limit	25
4.2. Test Procedures	26
4.3. Typical Test Setup	26
4.4. Measurement Equipment.....	27
4.5. Test Result and Data (30MHz ~ 1GHz).....	28
4.6. Test Result and Data (1GHz ~ 6GHz).....	30
4.7. Test Photographs (30MHz~1GHz)	32
4.8. Test Photographs (1GHz~6GHz)	33
5. Photographs of EUT	34



History of this test report

ORIGINAL.

Additional attachment as following record:

Report No	Version	Date	Description
SEJV1506085	Rev 01	Jul 16,2015	Initial Issue



1. Summary of Test Procedure and Test Results

1.1. Applicable Standards

The measurements shown in this test report were made in accordance with the procedures given in **Implementation Regulation for the VOLUNTARY CONTROL of RADIO INTERFERENCE by DATA PROCESSING EQUIPMENT and ELECTRONIC OFFICE MACHINES.**

The energy emitted by this equipment was *passed* both Radiated and Conducted Emissions **Class B** limits.

Test Item	Normative References	Test Result	Remarks
Conducted Emission (Mains Ports)	VCCI-Technical Requirement (V-3/2015.04) , CISPR22 : 2008	PASS	Meets Class B Limit Minimum passing margin(AV) is -15.18 dB at 24.0500 MHz
Conducted Emission (Telecommunication Ports)	VCCI-Technical Requirement (V-3/2015.04) , CISPR22 : 2008	PASS	Meets Class B Limit Minimum passing margin(AV) is -6.53 dB at 0.9740 MHz
Radiated Emission	VCCI-Technical Requirement (V-3/2015.04) , CISPR22 : 2008	PASS	Meets Class B Limit Minimum passing margin(QP) is -6.10 dB at 140.5800 MHz



2. Test Configuration of Equipment under Test

2.1. Feature of Equipment under Test

Motherboard	Model No.:	Z170 PRO GAMING
Switching Power Supply	Model No.:	FSP350-60HHN(85)
	Input	AC 200V~240V~3A 50Hz
	Output:	DC(+3.3V/21A; +5V/20A; +12V1/15A; +12V2/15A; -12V/0.5A; +5Vsb/2.5A)

Key component List			
Item	Manufactory	Model	Specification
CPU	Intel	QJE9	3.40GHz
RAM	---	DDR4	16GB
HDD	Seagate	ST380815AS	80GB

CPU	Intel CPU Support Type	LGA 1151	
Chipset	PCH Vendor	Intel	
	PCH Type	Z170	
Memory	Memory Type	DDR4	
	Memory size	Min: 1024MB Max: 16GB	
Network:	10M/bps,100M/bps,1000M/bps		
D-Sub Max. resolution	1920*1200@60Hz		
DVI Max. resolution	1920*1200@60Hz		
I/O Ports:	1	PS-2 port:	1
	2	USB1.1&2.0 port	2
	3	USB3.0 port	4
	4	DVI port	1
	5	D-sub port	1
	6	HDMI port	1
	7	RJ-45 port(10M/bps,100M/bps,1000M/bps)	1
	8	Audio port	5
	9	DP port	1
	10	USB3.1 port	1



2.2. Test Manner

- a. During testing, the interface cables and equipment positions were varied according to VCCI-Technical Requirement.
- b. The complete test system included the Notebook PC, PS/2 Keyboard, Mouse, LCD Monitor, iPod, HDD, Earphone and EUT for EMI test.
- c. During the test, setup up the EUT and all system, turn on the power of all Equipments.
- d. An executive program, "BurnIn Test professional V6", run the EMC test software "H", "H" font size No. is 11, CPU+RAM+2D+3D 100%..
- e. An executive program, "WINTHRAX.EXE" was executed to read and write data from IPOD, HDD.
- f. During the disturbances at telecommunication port test, the condition of LAN utilization in excess of 10%.
- g. Make the EUT at the test mode and it is normal operation, and then test.
- h. The test mode as follow:

The pre-test modes

- Mode 1: Full System with VGA (1920*1200@60Hz) and HDMI (1920*1200@60Hz) with Status 1
- Mode 2: Full System with VGA (1920*1200@60Hz) and HDMI (1920*1200@60Hz) with Status 2
- Mode 3: Full System with VGA (1920*1200@60Hz) and HDMI (1920*1200@60Hz) with Status 3
- Mode 4: Full System with VGA (1920*1200@60Hz) and HDMI (1920*1200@60Hz) with Status 4
- Mode 5: Full System with VGA (1920*1200@60Hz) and HDMI (1920*1200@60Hz) with Status 5
- Mode 6: Full System with DVI (1920*1200@60Hz) and HDMI (1920*1200@60Hz) with Status 1
- Mode 7: Full System with VGA (1920*1200@60Hz) and DVI (1920*1200@60Hz) with Status 1
- Mode 8: Full System with VGA (1920*1200@60Hz) and Display (1920*1200@60Hz) Status 1
- Mode 9: Full System with DVI (1920*1200@60Hz) and Display (1920*1200@60Hz) Status 1
- Mode 10: Full System with HDMI (1920*1200@60Hz) and Display (1920*1200@60Hz) with Status 1
- Mode 11: Full System with HDMI (1920*1200@60Hz) and Display (1920*1200@60Hz) with Status 1
- Mode 12: Full System with VGA (1280*1024@75Hz) and HDMI (1280*1024@75Hz) with Status 1
- Mode 13: Full System with VGA (640*480@60Hz) and HDMI (640*480@60Hz) with Status 1

The final test mode

- Mode 1: Full System with VGA (1920*1200@60Hz) and HDMI (1920*1200@60Hz) with Status 1
- Note1:
- Status1: USB 2.0 Port Connect to mouse and Ipod, USB3.0 port connect to HDD
 - Status2: USB 2.0 Port Connect to mouse and keyboard, USB3.0 port connect to HDD
 - Status3: USB 2.0 Port Connect to mouse , USB3.0 port connect to keyboard
 - Status4: USB 2.0 Port Connect to keyboard , USB3.0 port connect to mouse
 - Status5: USB 3.0 Port Connect to mouse and keyboard, USB2.0 port connect to Ipod

- i. The maximum operating frequency is above 108MHz, the test frequency range is from 30MHz to 6GHz.



2.3. Description of Support Unit

No.	Device	Manufacturer	Model No.	Description
1	Notebook PC	SONY	PCG-71811P	Non-Shielded, 1.5m R33021
2	PS/2 Keyboard	DELL	SK-8115	T3A002
3	Mouse	DELL	G0K02XYK	N/A
4	LCD Monitor	DELL	3008WFPT	Non-Shielded, 1.8m R3A002
5	LCD Monitor	Lenovo	L2364wA	Non-Shielded, 1.8m R33B65
6	iPod	APPLE	A1373	N/A
7	iPod	APPLE	A1373	N/A
8	iPod	APPLE	3409A	N/A
9	HDD	WD	WDBPCK5000ABK-01	N/A
10	HDD	WD	WDBPCK5000ABK-01	N/A
11	HDD	WD	WDBPCK5000ABK-01	N/A
12	HDD	WD	WDBPCK5000ABK-02	N/A
13	HDD	WD	WD4711.A	N/A
14	HDD	WD	WD4711.A	N/A
15	HDD	WD	WD4711.A	N/A
16	Earphone	SALAR	V18	N/A
17	Earphone	SALAR	V18	N/A
18	Earphone	SALAR	V18	N/A



2.4. Connection Diagram of Test System

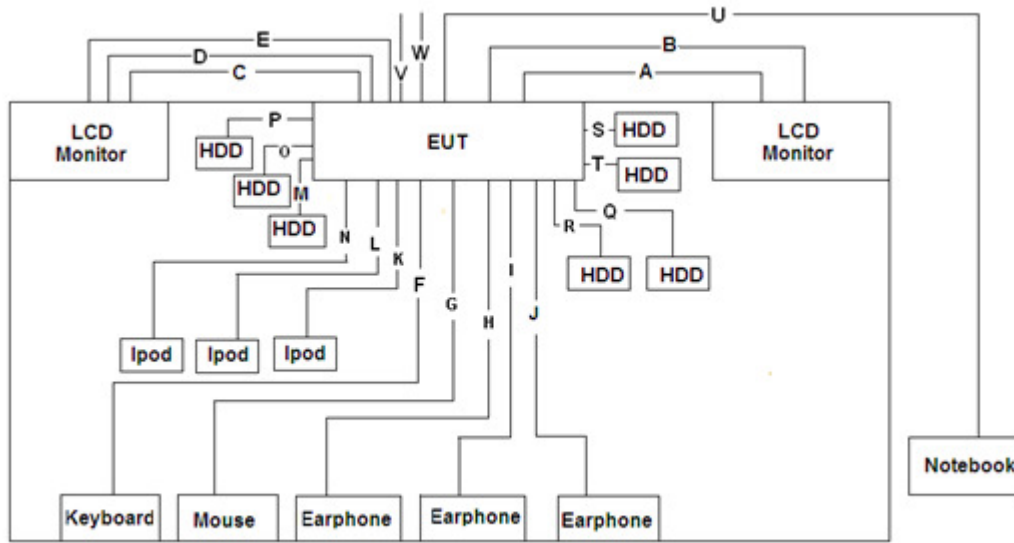

Item	Cable	Quantity	Description
A	VGA Cable	1	Shielded, 1.8m,with two ferrites core bonded
B	DVI Cable	1	Shielded, 1.8m,with two ferrites core bonded
C	HDMI Cable	1	Non-Shielded, 1.5m
D	Display Cable	1	Non-Shielded, 1.5m
E	Audio Cable	1	Shielded, 1.8m
F	PS/2 Cable	1	Shielded, 1.8m,with a ferrite core bonded
G	USB Cable	1	Shielded, 1.2m
H	Audio Cable	1	Shielded, 1.8m
I	Audio Cable	1	Shielded, 1.8m
J	Audio Cable	1	Shielded, 1.8m
K	USB Cable	1	Shielded, 1.0m
L	USB Cable	1	Shielded, 1.0m
N	USB Cable	1	Shielded, 1.0m
M	USB Cable	1	Shielded,0.6m
O	USB Cable	1	Shielded,0.6m
P	USB Cable	1	Shielded,0.6m
Q	USB Cable	1	Shielded,0.6m
R	USB Cable	1	Shielded,0.6m
S	USB Cable	1	Shielded,0.6m
T	USB Cable	1	Shielded, 0.6m
U	LAN Cable	1	Non-Shielded, >3.0m
V	USB 3.1Cable	1	Shielded, 1.2m
W	Optical fiber Cable	1	Shielded, 1.5m



2.5. General Information of Test

<input type="checkbox"/>	Test Site	<p>CerpPASS Technology Corporation Test Laboratory Address: No.10, Ln. 2, Lianfu St., Luzhu Dist., Taoyuan City 33848, Taiwan (R.O.C.) Tel:+886-3-3226-888 Fax:+886-3-3226-881 Address: No.68-1, Shihbachongsi, Shihding Township, New Taipei City 223, Taiwan, R.O.C. Tel: +886-2-2663-8582</p>
	FCC	TW1079, TW1061,390316, 228391, 641184
	IC	4934B-1, 4934E-1, 4934E-2
	VCCI	T-2205 for Telecommunication Test C-4463 for Conducted emission test R-3428, R-4128 for Radiated emission test G-812, G-813 for radiated disturbance above 1GHz
<input checked="" type="checkbox"/>	Test Site	<p>CerpPASS Technology (Suzhou) Co.,Ltd Address: No.66,Tangzhuang Road, Suzhou Industrial Park, Jiangsu 215006, China Tel: +86-512-6917-5888 Fax: +86-512-6917-5666</p>
	FCC	331395
	IC	7290A-1, 7290A-2
	VCCI	T-1945 for Telecommunication Test C-2919 for Conducted emission test R-2670 for Radiated emission test G-227 for radiated disturbance above 1GHz
Frequency Range Investigated:		Conducted: from 150kHz to 30 MHz Radiation: from 30 MHz to 6000MHz
Test Distance :		The test distance of radiated emission below 1GHz from antenna to EUT is 10 M. The test distance of radiated emission above 1GHz from antenna to EUT is 3 M.



2.6. Measurement Uncertainty

Where relevant, the following measurement uncertainty levels have been estimated for tests performed on the EUT as specified in CISPR 16-4-2:

Test results and Measurement uncertainty without any relationship in the test report.

Measurement	Frequency	Uncertainty
Conducted emissions(LINE)	9KHz-30MHz	+/- 0.6888 dB
Conducted emissions(NEUTRAL)	9KHz-30MHz	+/- 0.7002 dB

Measurement	Polarity	Frequency	Uncertainty
Radiated emissions (below 1GHz)	H	30MHz ~ 200MHz	+/- 4.0677dB
		200MHz ~1000MHz	+/- 3.9131dB
	V	30MHz ~ 200MHz	+/- 4.0678dB
		200MHz ~1000MHz	+/- 3.9142dB
Radiated emissions (above 1GHz)	H	1000MHz ~18000MHz	+/- 3.8904 dB
		18000MHz ~40000MHz	+/-3.9356dB
	V	1000MHz ~18000MHz	+/- 3.8896dB
		18000MHz ~40000MHz	+/- 3.8766dB

This uncertainty represents an expanded uncertainty expressed at approximately the 95% confidence level using a coverage factor of k=2.

Consistent with industry standard (e.g. CISPR 22: 2008, clause 11, Measurement Uncertainty) determining compliance with the limits shall be base on the results of the compliance measurement. Consequently the measure emissions being less than the maximum allowed emission result in this be a compliant test or passing test.



3. Test of Conducted Emission

3.1. Test Limit

Conducted Emissions were measured from 150 kHz to 30 MHz with a bandwidth of 9 kHz on the 100V AC power and return leads of the EUT according to the methods defined in Implementation Regulation for the Voluntary Control of Radio Interference by Data Processing Equipment and Electronic Office Machines, Section 4.1. The EUT was placed on a nonmetallic stand in a shielded room 0.8 meters above the ground plane as shown in section 4.2. The interface cables and equipment positioning were varied within limits of reasonable applications to determine the position producing maximum conducted emissions.

Table 1 Conducted Emission Limits (dB μ V):

Frequency range (MHz)	Class A Equipment		Class B Equipment	
	Quasi Peak	Average	Quasi Peak	Average
0.15 to 0.50	79	66	66 to 56	56 to 46
0.50 to 5	73	60	56	46
5. to 30.	73	60	60	50

Note 1: The lower limits shall apply at the transition frequencies.
 Note 2: The limit decreases linearly with the logarithm of the frequency in the range 0.15 MHz to 0.5MHz.

Table 2 - Limits of conducted common mode (asymmetric mode) disturbance at telecommunication ports in the frequency range 0.15 MHz to 30 MHz(dB(μ V)).

Frequency range (MHz)	Class A Equipment				Class B Equipment			
	Voltage		Current		Voltage		Current	
	Quasi Peak	Avg.	Quasi Peak	Avg.	Quasi Peak	Avg.	Quasi Peak	Avg.
0.15 to 0.5	97~ 87	84~74	53~43	40~30	84~74	74~64	40~30	30~20
0.5 to 5	87	74	43	30	30	20	30	20
5 to 30	87	74	43	30	30	20	30	20

Note 1: The limits decrease linearly with the logarithm of the frequency in the range 0.15 to 0.5 MHz.
 Note 2 : The current and voltage disturbance limits are derived for use with an impedance stabilization network (ISN) which presents a common mode (asymmetric mode) impedance of 150 Ω to the telecommunication under test (conversion factor is $20 \log_{10} 150/1 = 44\text{dB}$).

3.2. Test Procedures

- a. The EUT was placed on a desk 0.8 meters height from the metal ground plane and 0.4 meter from the conducting wall of the shielding room and it was kept at least 0.8 meters from any other grounded conducting surface.
- b. Connect EUT to the power mains through a line impedance stabilization network (LISN).
- c. All the support units are connecting to the other LISN.
- d. The LISN provides 50 ohm coupling impedance for the measuring instrument.
- e. The CISPR states that a 50 ohm, 50 micro-Henry LISN should be used.
- f. Both sides of AC line were checked for maximum conducted interference.
- g. The frequency range from 150 kHz to 30 MHz was searched
- h. Set the test-receiver system to Peak Detect Function and Specified Bandwidth with Maximum Hold Mode.

3.3. Typical Test Setup

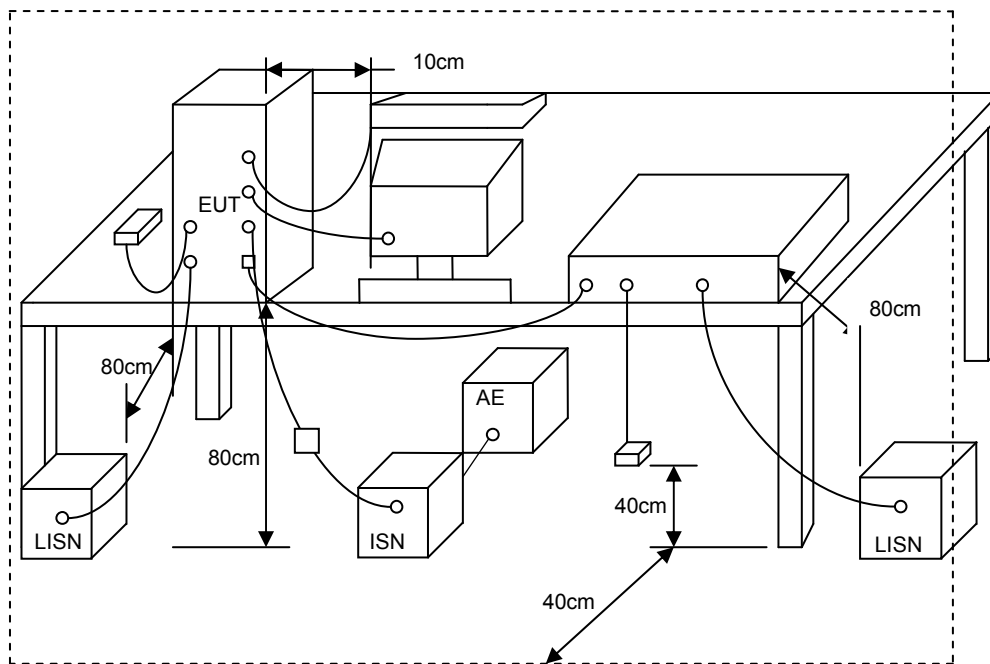



3.4. Measurement Equipment

Instrument/Ancillary	Manufacturer	Model No.	Serial No.	Calibration Date	Valid Date.
Test Receiver	R&S	ESCI	100565	2015.03.29	2016.03.28
AMN	R&S	ESH2-Z5	100182	2014.09.04	2015.09.03
Two-Line V-Network	R&S	ENV216	100325	/	/
ISN	FCC	FCC-TLISN-T2-02	20379	2015.03.29	2016.03.28
ISN	FCC	FCC-TLISN-T4-02	20380	2015.03.29	2016.03.28
ISN	FCC	FCC-TLISN-T8-02	20381	2015.03.29	2016.03.28
ISN	TESEQ	ISN ST08	30175	2015.03.29	2016.03.28
Current Probe	R&S	EZ-17	100303	2015.03.29	2016.03.28
Passive Voltage Probe	R&S	ESH2-Z3	100026	2015.03.29	2016.03.28
Pulse Limiter	R&S	ESH3-Z2	100529	2015.03.29	2016.03.28
Temperature/ Humidity Meter	Zhicheng	ZC1-11	CEP-TH-004	2015.04.02	2016.04.01
EZ-EMC	Fala	Ver CT3A1	N/A	N/A	N/A



3.5. Test Result and Data

3.5.1 Conducted Emission for Power Port Test Data

Test Mode :	Mode 1: Full System with VGA (1920*1200@60Hz) and HDMI (1920*1200@60Hz) with Status 1		
AC Power :	AC 100V/50Hz	Phase :	LINE
Temperature :	24°C	Humidity :	48%
Pressure(mbar) :	1002	Date :	2015/06/20

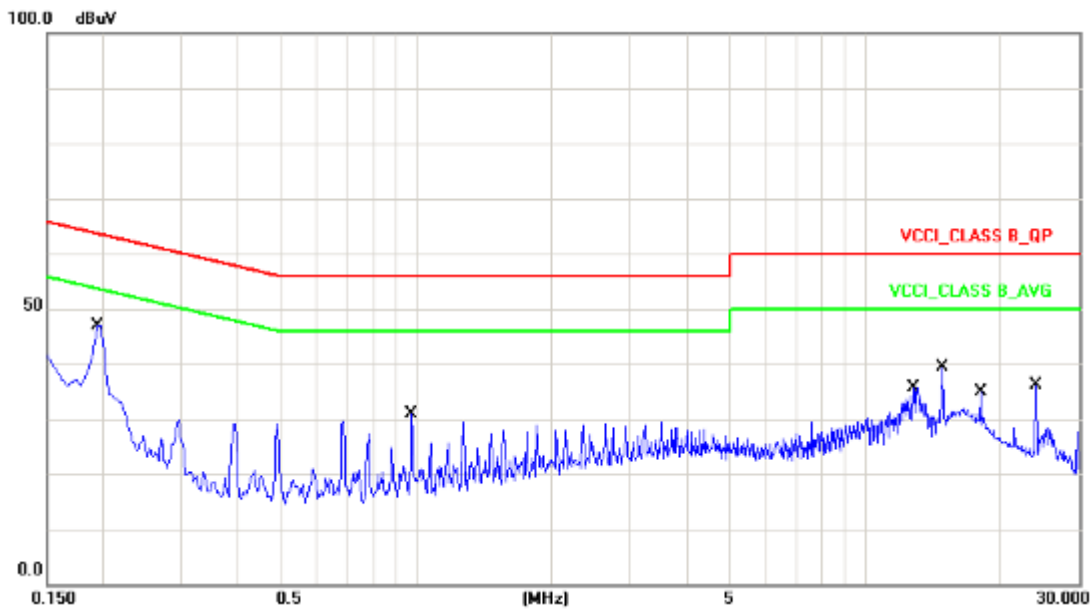

No.	Frequency (MHz)	Factor (dB)	Reading (dBuV)	Level (dBuV)	Limit (dBuV)	Margin (dB)	Detector
1	0.1940	10.12	35.22	45.34	63.86	-18.52	QP
2	0.1940	10.12	27.41	37.53	53.86	-16.33	AVG
3	0.9780	10.16	18.66	28.82	56.00	-27.18	QP
4	0.9780	10.16	18.41	28.57	46.00	-17.43	AVG
5	12.7980	10.40	21.27	31.67	60.00	-28.33	QP
6	12.7980	10.40	16.52	26.92	50.00	-23.08	AVG
7	14.8500	10.52	26.28	36.80	60.00	-23.20	QP
8	14.8500	10.52	22.22	32.74	50.00	-17.26	AVG
9	18.0500	10.41	22.62	33.03	60.00	-26.97	QP
10	18.0500	10.41	21.74	32.15	50.00	-17.85	AVG
11	24.0500	10.41	24.69	35.10	60.00	-24.90	QP
12	24.0500	10.41	24.40	34.81	50.00	-15.19	AVG

Note: Measurement Level = Reading Level + Correct Factor



Test Mode :	Mode 1: Full System with VGA (1920*1200@60Hz) and HDMI (1920*1200@60Hz) with Status 1		
AC Power :	AC 100V/50Hz	Phase :	NEUTRAL
Temperature :	24°C	Humidity :	48%
Pressure(mbar) :	1002	Date :	2015/06/20

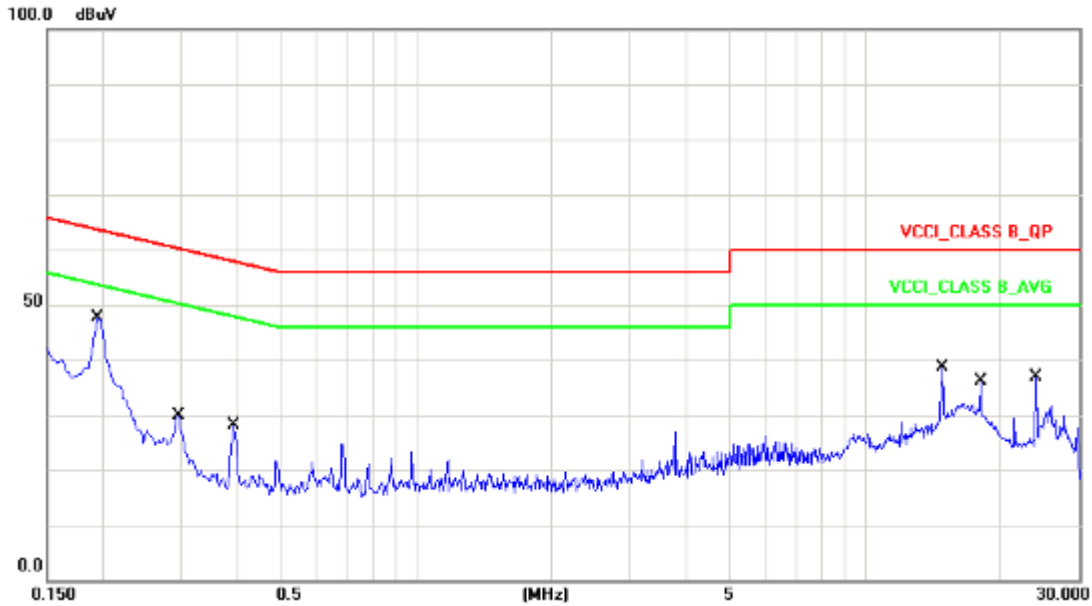

No.	Frequency (MHz)	Factor (dB)	Reading (dBuV)	Level (dBuV)	Limit (dBuV)	Margin (dB)	Detector
1	0.1940	10.13	34.96	45.09	63.86	-18.77	QP
2	0.1940	10.13	27.83	37.96	53.86	-15.90	AVG
3	0.2940	10.14	15.31	25.45	60.41	-34.96	QP
4	0.2940	10.14	6.55	16.69	50.41	-33.72	AVG
5	0.3899	10.15	15.83	25.98	58.06	-32.08	QP
6	0.3899	10.15	15.43	25.58	48.06	-22.48	AVG
7	14.8500	10.52	25.94	36.46	60.00	-23.54	QP
8	14.8500	10.52	21.91	32.43	50.00	-17.57	AVG
9	18.0500	10.47	22.68	33.15	60.00	-26.85	QP
10	18.0500	10.47	21.60	32.07	50.00	-17.93	AVG
11	24.0500	10.36	24.79	35.15	60.00	-24.85	QP
12	24.0500	10.36	24.46	34.82	50.00	-15.18	AVG

Note: Measurement Level = Reading Level + Correct Factor

Test engineer: Seben



3.5.2 Conducted Emission for Telecommunication Port Test Data

Test Mode :	Mode 1: Full System with VGA (1920*1200@60Hz) and HDMI (1920*1200@60Hz) with Status 1		
AC Power :	AC 100V/50Hz	Phase :	10M(No-Shielded)
Temperature :	24°C	Humidity :	48%
Pressure(mbar) :	1002	Date :	2015/06/20



No.	Frequency (MHz)	Factor (dB)	Reading (dBuV)	Level (dBuV)	Limit (dBuV)	Margin (dB)	Detector
1	0.5860	19.58	36.88	56.46	74.00	-17.54	QP
2	0.5860	19.58	27.76	47.34	64.00	-16.66	AVG
3	0.9940	19.30	43.84	63.14	74.00	-10.86	QP
4	0.9940	19.30	36.60	55.90	64.00	-8.10	AVG
5	2.3300	19.25	31.73	50.98	74.00	-23.02	QP
6	2.3300	19.25	25.14	44.39	64.00	-19.61	AVG
7	3.3980	19.43	33.73	53.16	74.00	-20.84	QP
8	3.3980	19.43	24.53	43.96	64.00	-20.04	AVG
9	9.8380	19.64	24.09	43.73	74.00	-30.27	QP
10	9.8380	19.64	17.21	36.85	64.00	-27.15	AVG
11	25.2620	19.81	38.38	58.19	74.00	-15.81	QP
12	25.2620	19.81	35.96	55.77	64.00	-8.23	AVG

Note: Measurement Level = Reading Level + Correct Factor



Test Mode :	Mode 1: Full System with VGA (1920*1200@60Hz) and HDMI (1920*1200@60Hz) with Status 1		
AC Power :	AC 100V/50Hz	Phase :	100M(No-Shielded)
Temperature :	24°C	Humidity :	48%
Pressure(mbar) :	1002	Date :	2015/06/20



No.	Frequency (MHz)	Factor (dB)	Reading (dBuV)	Level (dBuV)	Limit (dBuV)	Margin (dB)	Detector
1	0.4620	19.60	35.54	55.14	75.09	-19.95	QP
2	0.4620	19.60	26.76	46.36	65.09	-18.73	AVG
3	0.6020	19.58	35.90	55.48	74.00	-18.52	QP
4	0.6020	19.58	28.85	48.43	64.00	-15.57	AVG
5	0.9740	19.32	44.79	64.11	74.00	-9.89	QP
6	0.9740	19.32	38.15	57.47	64.00	-6.53	AVG
7	2.2820	19.25	32.08	51.33	74.00	-22.67	QP
8	2.2820	19.25	22.64	41.89	64.00	-22.11	AVG
9	3.5460	19.45	34.90	54.35	74.00	-19.65	QP
10	3.5460	19.45	24.69	44.14	64.00	-19.86	AVG
11	25.2660	19.81	37.17	56.98	74.00	-17.02	QP
12	25.2660	19.81	33.42	53.23	64.00	-10.77	AVG

Note: Measurement Level = Reading Level + Correct Factor



Test Mode :	Mode 1: Full System with VGA (1920*1200@60Hz) and HDMI (1920*1200@60Hz) with Status 1		
AC Power :	AC 100V/50Hz	Phase :	1000M (No-Shielded)
Temperature :	24°C	Humidity :	48%
Pressure(mbar) :	1002	Date :	2015/06/20



No.	Frequency (MHz)	Factor (dB)	Reading (dBuV)	Level (dBuV)	Limit (dBuV)	Margin (dB)	Detector
1	0.4660	19.60	36.21	55.81	74.97	-19.16	QP
2	0.4660	19.60	27.19	46.79	64.97	-18.18	AVG
3	0.5820	19.58	36.47	56.05	74.00	-17.95	QP
4	0.5820	19.58	27.25	46.83	64.00	-17.17	AVG
5	0.9980	19.30	43.13	62.43	74.00	-11.57	QP
6	0.9980	19.30	36.14	55.44	64.00	-8.56	AVG
7	1.3619	19.26	30.57	49.83	74.00	-24.17	QP
8	1.3619	19.26	22.32	41.58	64.00	-22.42	AVG
9	2.2980	19.25	34.41	53.66	74.00	-20.34	QP
10	2.2980	19.25	28.10	47.35	64.00	-16.65	AVG
11	26.2860	19.80	36.11	55.91	74.00	-18.09	QP
12	26.2860	19.80	32.12	51.92	64.00	-12.08	AVG

Note: Measurement Level = Reading Level + Correct Factor



Test Mode :	Mode 1: Full System with VGA (1920*1200@60Hz) and HDMI (1920*1200@60Hz) with Status 1		
AC Power :	AC 100V/50Hz	Phase :	10M (Shielded)
Temperature :	24°C	Humidity :	48%
Pressure(mbar) :	1002	Date :	2015/06/20

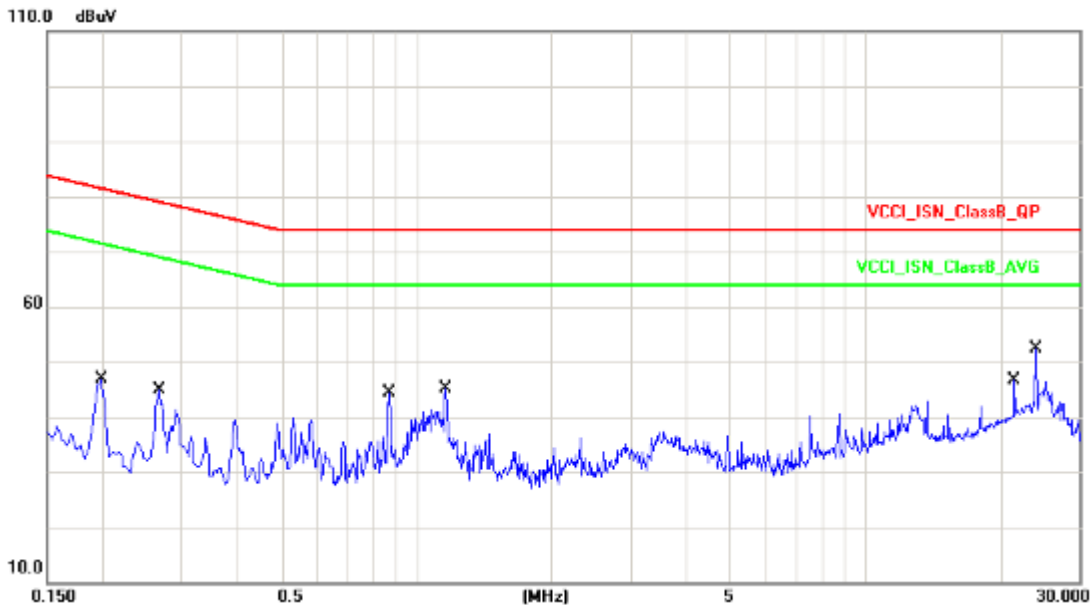

No.	Frequency (MHz)	Factor (dB)	Reading (dBuV)	Level (dBuV)	Limit (dBuV)	Margin (dB)	Detector
1	0.1980	19.61	25.13	44.74	82.63	-37.89	QP
2	0.1980	19.61	24.92	44.53	72.63	-28.10	AVG
3	0.2660	19.61	23.04	42.65	80.68	-38.03	QP
4	0.2660	19.61	22.96	42.57	70.68	-28.11	AVG
5	0.8700	19.41	23.05	42.46	74.00	-31.54	QP
6	0.8700	19.41	13.55	32.96	64.00	-31.04	AVG
7	1.1620	19.28	22.66	41.94	74.00	-32.06	QP
8	1.1620	19.28	20.35	39.63	64.00	-24.37	AVG
9	21.5060	19.65	24.87	44.52	74.00	-29.48	QP
10	21.5060	19.65	23.48	43.13	64.00	-20.87	AVG
11	24.0540	19.77	31.19	50.96	74.00	-23.04	QP
12	24.0540	19.77	30.75	50.52	64.00	-13.48	AVG

Note: Measurement Level = Reading Level + Correct Factor



Test Mode :	Mode 1: Full System with VGA (1920*1200@60Hz) and HDMI (1920*1200@60Hz) with Status 1		
AC Power :	AC 100V/50Hz	Phase :	100M(Shielded)
Temperature :	24°C	Humidity :	48%
Pressure(mbar) :	1002	Date :	2015/06/20

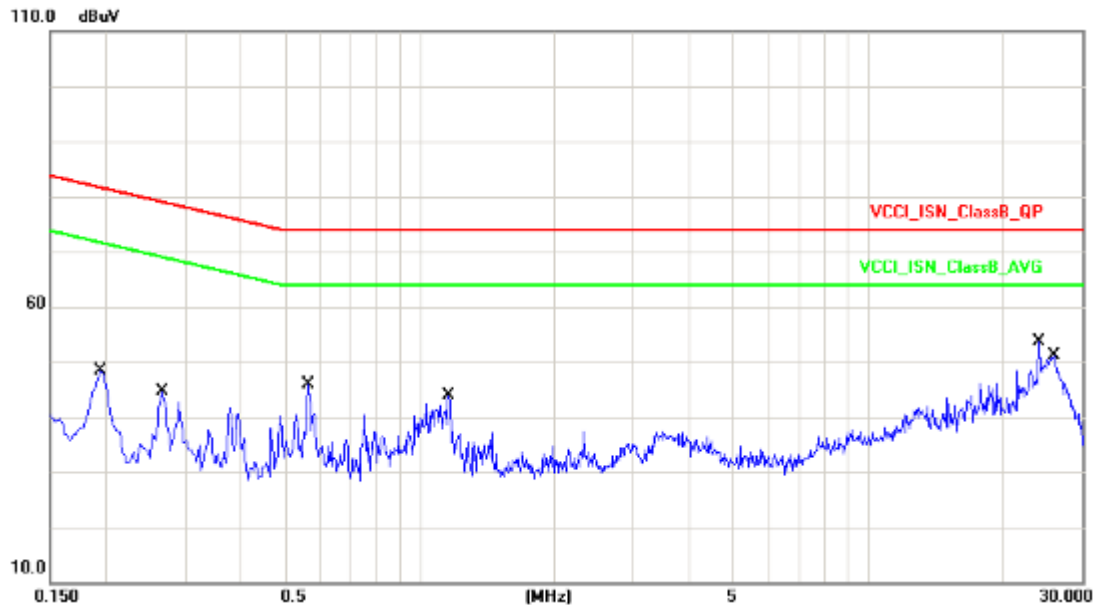

No.	Frequency (MHz)	Factor (dB)	Reading (dBuV)	Level (dBuV)	Limit (dBuV)	Margin (dB)	Detector
1	0.1940	19.61	25.44	45.05	82.74	-37.69	QP
2	0.1940	19.61	25.12	44.73	72.74	-28.01	AVG
3	0.2660	19.61	23.17	42.78	80.68	-37.90	QP
4	0.2660	19.61	22.91	42.52	70.68	-28.16	AVG
5	0.5660	19.59	24.38	43.97	74.00	-30.03	QP
6	0.5660	19.59	12.45	32.04	64.00	-31.96	AVG
7	1.1620	19.28	23.02	42.30	74.00	-31.70	QP
8	1.1620	19.28	20.50	39.78	64.00	-24.22	AVG
9	24.0660	19.77	30.89	50.66	74.00	-23.34	QP
10	24.0660	19.77	29.57	49.34	64.00	-14.66	AVG
11	26.0459	19.80	24.34	44.14	74.00	-29.86	QP
12	26.0459	19.80	16.45	36.25	64.00	-27.75	AVG

Note: Measurement Level = Reading Level + Correct Factor



Test Mode :	Mode 1: Full System with VGA (1920*1200@60Hz) and HDMI (1920*1200@60Hz) with Status 1		
AC Power :	AC 100V/50Hz	Phase :	1000M(Shielded)
Temperature :	24°C	Humidity :	48%
Pressure(mbar) :	1002	Date :	2015/06/20

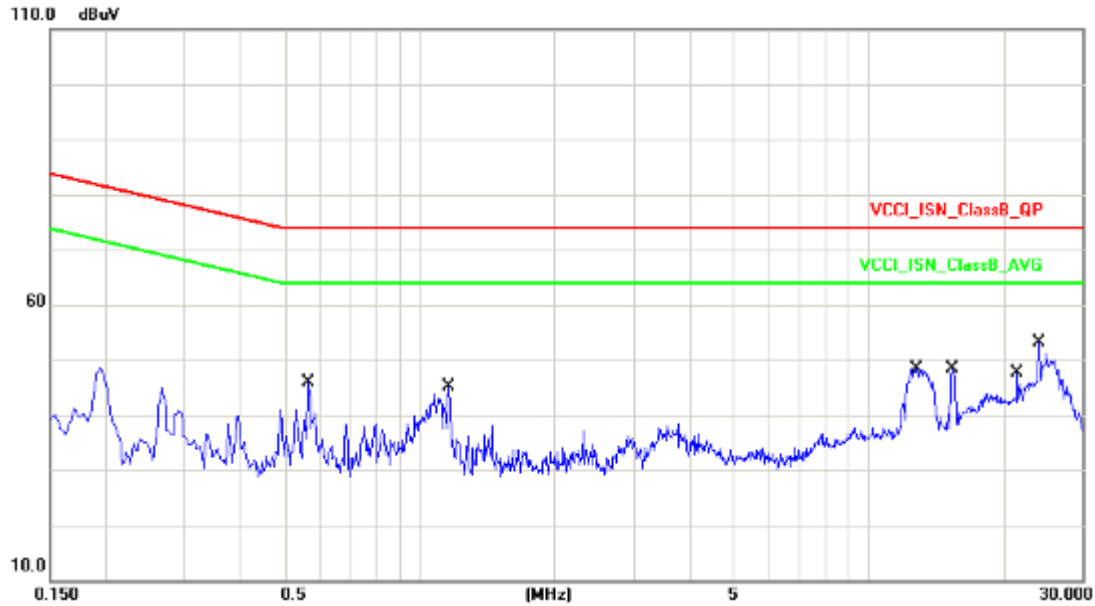

No.	Frequency (MHz)	Factor (dB)	Reading (dBuV)	Level (dBuV)	Limit (dBuV)	Margin (dB)	Detector
1	0.5660	19.59	24.33	43.92	74.00	-30.08	QP
2	0.5660	19.59	13.03	32.62	64.00	-31.38	AVG
3	1.1620	19.28	23.16	42.44	74.00	-31.56	QP
4	1.1620	19.28	20.96	40.24	64.00	-23.76	AVG
5	12.8220	19.42	15.80	35.22	74.00	-38.78	QP
6	12.8220	19.42	10.63	30.05	64.00	-33.95	AVG
7	15.4100	19.27	13.50	32.77	74.00	-41.23	QP
8	15.4100	19.27	8.05	27.32	64.00	-36.68	AVG
9	21.5060	19.65	26.18	45.83	74.00	-28.17	QP
10	21.5060	19.65	24.84	44.49	64.00	-19.51	AVG
11	24.0500	19.77	30.68	50.45	74.00	-23.55	QP
12	24.0500	19.77	29.64	49.41	64.00	-14.59	AVG

Note: Measurement Level = Reading Level + Correct Factor

Test engineer: Seben



3.6. Test Photographs of Power Port

Front View



Rear View

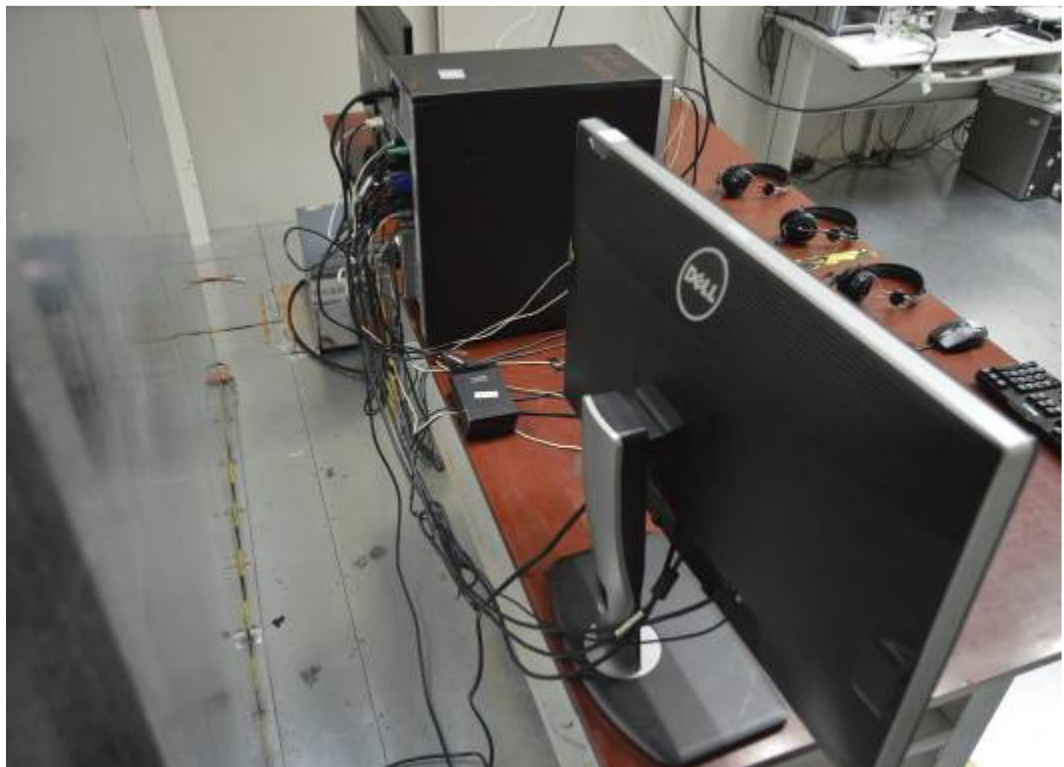



3.7. Test Photographs of Telecommunication Port

Front View



Rear View

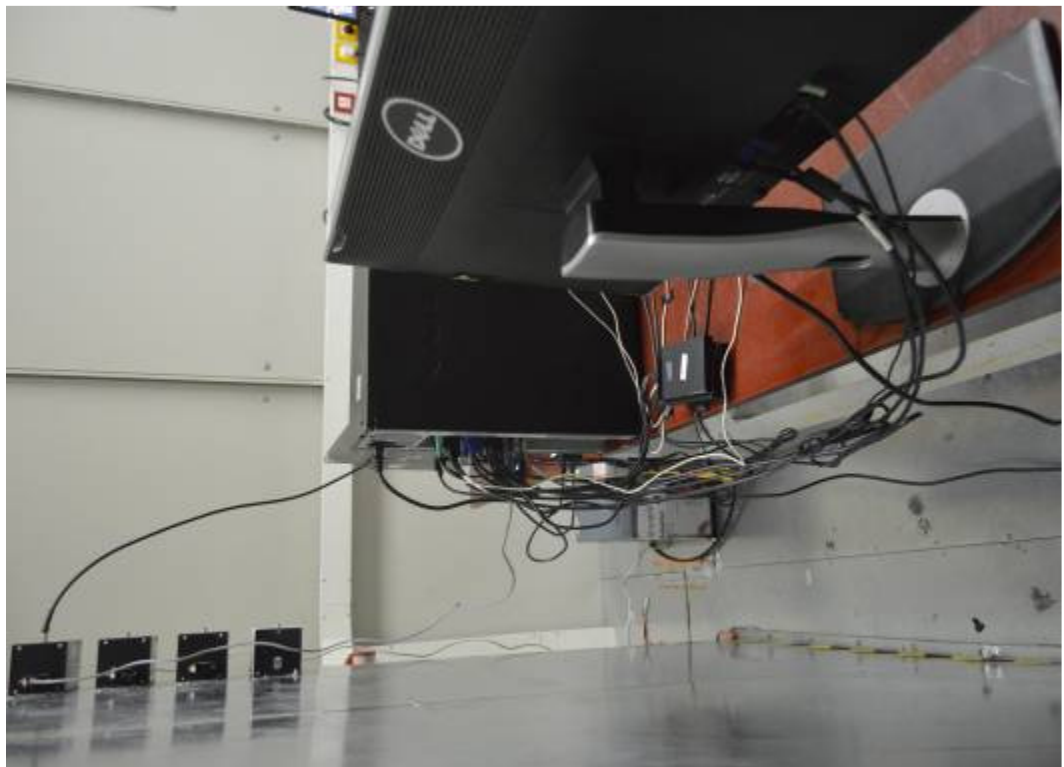



4. Test of Radiated Emission

4.1. Test Limit

Radiated emissions from 30 MHz to 6000 MHz were measured with a bandwidth of 120 kHz according to the methods defines in implementation Regulation for the Voluntary Control of Radio Interference by Data Processing Equipment and Electronic Office Machines. The EUT was placed on a nonmetallic stand in the open-field site, 0.8 meter above the ground plane, as shown in section 5.2. The interface cables and equipment positions were varied within limits of reasonable applications to determine the positions producing maximum radiated emissions.

Table 1 – Limits for radiated disturbance at a measuring distance of 10 m (dB(μV/m))

Frequency range(MHz)	Class A Equipment		Class B Equipment	
	Quasi-peak		Quasi-peak	
30 to 230	40		30	
230 to 1000	47		37	
NOTE 1 The lower limit shall apply at the transition frequency.				
NOTE 2 Additional provisions may be required for cases where interference occurs.				

The EUT shall meet the limits of below Table when measured in accordance with the method described in European Standard EN 55022 Clause 10 and the conditional testing procedure described below.

Table 2 – Limits for radiated disturbance at a measuring distance of 3 m (dB (μV/m))

Frequency range (GHz)	Class A Equipment		Class B Equipment	
	Avg.	Peak	Avg.	Peak
1 to 3	56	76	50	70
3 to 6	60	80	54	74
NOTE The lower limit applies at the transition frequency.				

• Conditional testing procedure:

The highest internal source of an EUT is defined as the highest frequency generated or used within the EUT or on which the EUT operates or tunes.

If the highest frequency of the internal sources of the EUT is less than 108 MHz, the measurement shall only be made up to 1 GHz.

If the highest frequency of the internal sources of the EUT is between 108 MHz and 500 MHz, the measurement shall only be made up to 2 GHz.

If the highest frequency of the internal sources of the EUT is between 500 MHz and 1 GHz, the measurement shall only be made up to 5 GHz.

If the highest frequency of the internal sources of the EUT is above 1 GHz, the measurement shall be made up to 5 times the highest frequency or 6 GHz, whichever is less.



4.2. Test Procedures

- a. The EUT was placed on a rotatable table top 0.8 meter above ground.
- b. The EUT was set 3/10 meters from the interference receiving antenna which was mounted on the top of a variable height antenna tower.
- c. The table was rotated 360 degrees to determine the position of the highest radiation.
- d. The antenna is a half wave dipole and its height is varied between one meter and four meters above ground to find the maximum value of the field strength both horizontal polarization and vertical polarization of the antenna are set to make the measurement.
- e. For each suspected emission the EUT was arranged to its worst case and then tune the antenna tower (from 1 M to 4 M) and turn table (from 0 degree to 360 degrees) to find the maximum reading.
- f. Set the test-receiver system to Peak Detect Function and specified bandwidth with Maximum Hold Mode.
- g. If the emission level of the EUT in peak mode was 3 dB lower than the limit specified, then testing will be stopped and peak values of EUT will be reported, otherwise, the emissions which do not have 3 dB margin will be repeated one by one using the quasi-peak method and reported.

4.3. Typical Test Setup

Below 1GHz Test Setup

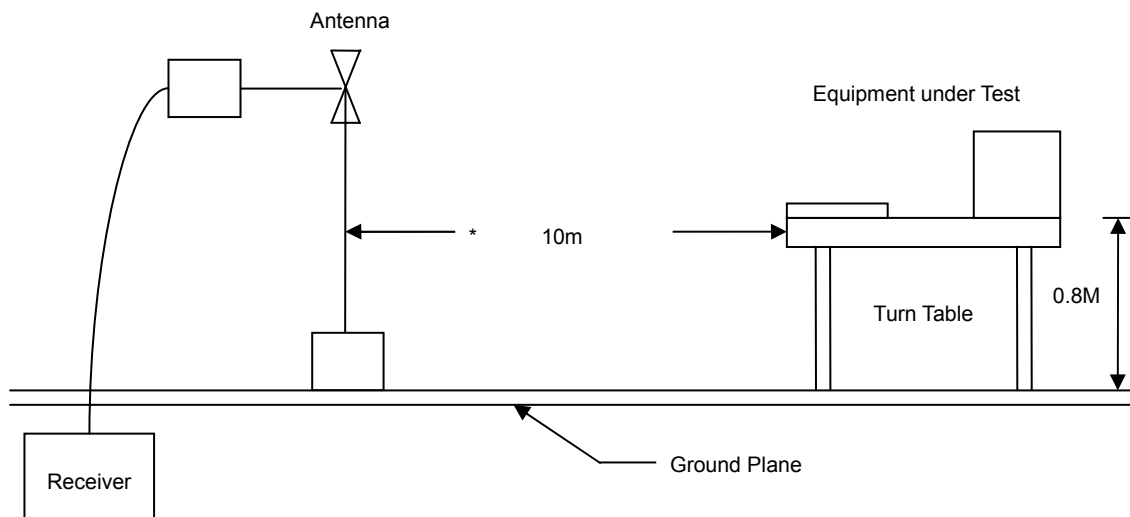

Above 1GHz Test Setup

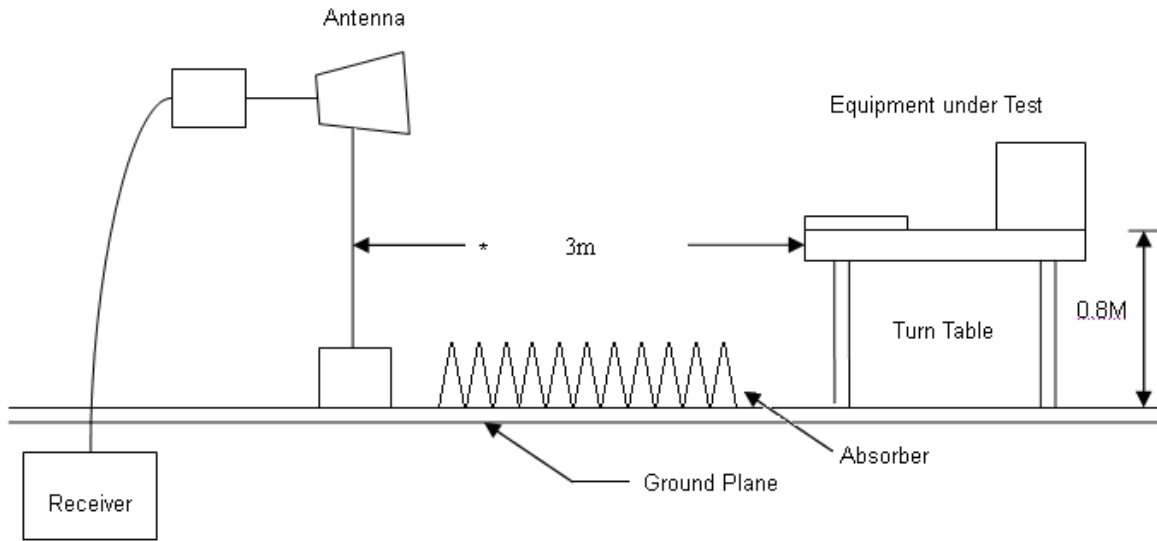

4.4. Measurement Equipment

Instrument/Ancillary	Manufacturer	Model No.	Serial No.	Calibration Date	Valid Date.
EMI Test Receiver	R&S	ESC17	100968	2014.06.11	2015.06.10
Preamplifier	Agilent	87405B	My39500554	2015.03.29	2016.03.28
Preamplifier	Agilent	8449B	3008A02342	2015.03.29	2016.03.28
Bilog Antenna	Sunol Science	JB1	A072414-3	2014.08.05	2015.08.04
Broad-Band Horn Antenna	Schwarzbeck	BBHA9120D	9120D-618	2015.04.20	2016.04.19
Spectrum Analyzer	R&S	FSP40	100324	2015.03.29	2016.03.28
Temperature/ Humidity Meter	Zhicheng	ZC1-11	CEP-TH-001	2015.04.02	2016.04.01
EZ-EMC	Fala	Ver CT3A1	N/A	N/A	N/A



4.5. Test Result and Data (30MHz ~ 1GHz)

Test Mode :	Mode 1: Full System with VGA (1920*1200@60Hz) and HDMI (1920*1200@60Hz) with Status 1		
AC Power :	AC 100V/50Hz	Ant. Polarization:	Horizontal
Temp :	24°C	Humidity :	42%
Pressure(mbar) :	1002	Date :	2015/06/19

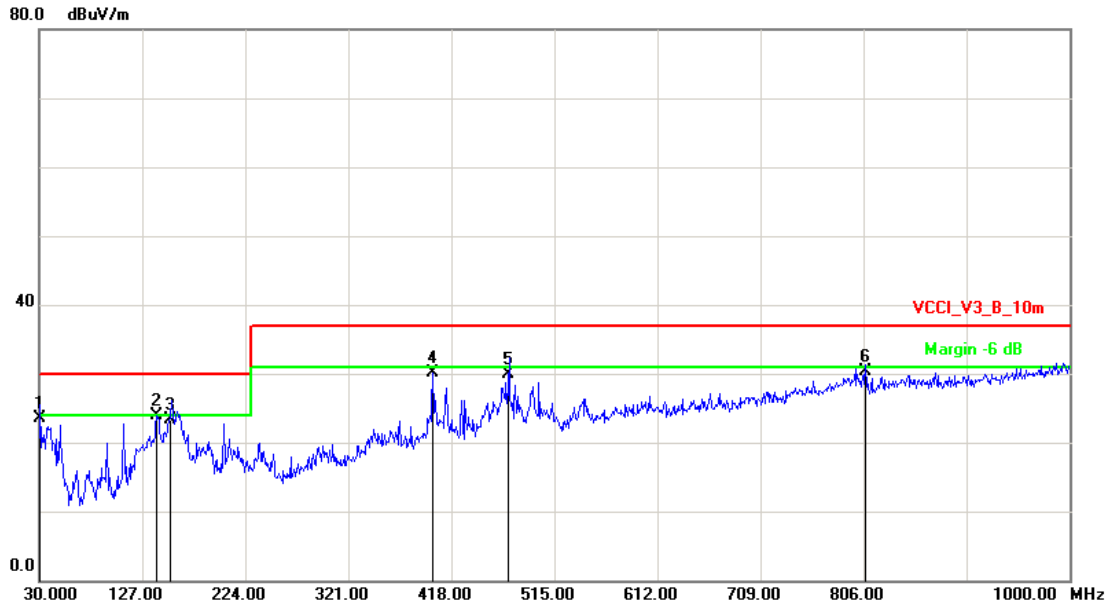

No.	Frequency (MHz)	Factor (dB/m)	Reading (dBuV)	Level (dBuV/m)	Limit (dBuV/m)	Margin (dB)	Det.	Height (cm)	Azimuth (deg)
1	30.9699	-1.20	24.69	23.49	30.00	-6.51	QP	400	97
2	140.5800	-10.43	34.33	23.90	30.00	-6.10	QP	400	341
3	154.1599	-10.66	33.92	23.26	30.00	-6.74	QP	400	352
4	400.5400	-4.77	34.89	30.12	37.00	-6.88	QP	100	234
5	472.3199	-3.21	33.12	29.91	37.00	-7.09	QP	100	0
6	807.9400	3.48	26.76	30.24	37.00	-6.76	QP	100	0

Note: Measurement Level = Reading Level + Correct Factor



Test Mode :	Mode 1: Full System with VGA (1920*1200@60Hz) and HDMI (1920*1200@60Hz) with Status 1		
AC Power :	AC 100V/50Hz	Ant. Polarization:	Vertical
Temp :	24°C	Humidity :	42%
Pressure(mbar) :	1002	Date :	2015/06/19

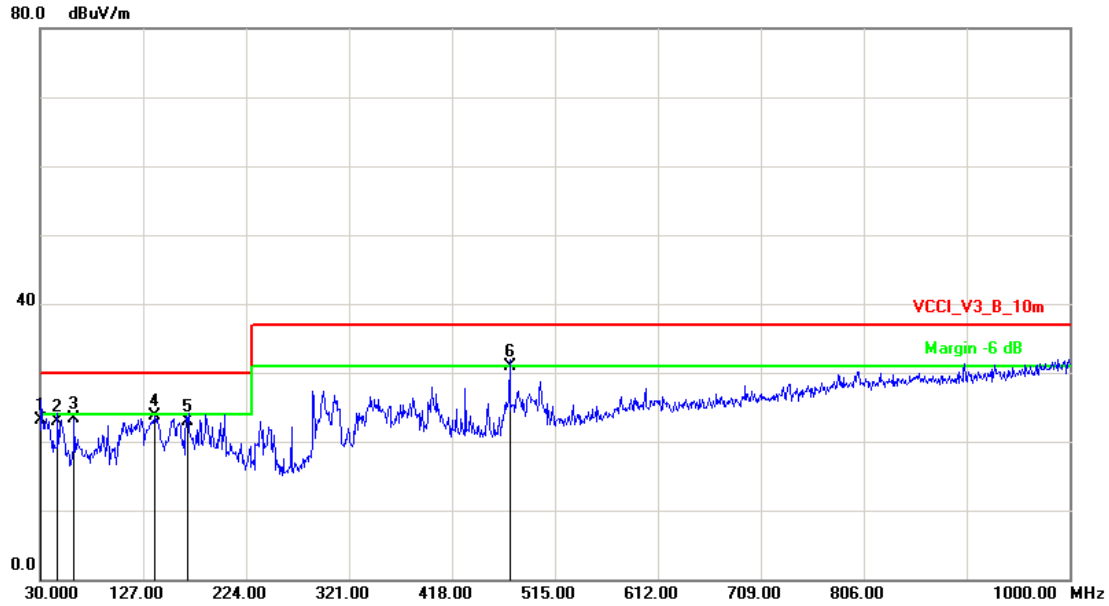

No.	Frequency (MHz)	Factor (dB/m)	Reading (dBuV)	Level (dBuV/m)	Limit (dBuV/m)	Margin (dB)	Det.	Height (cm)	Azimuth (deg)
1	30.9700	-1.20	24.22	23.02	30.00	-6.98	QP	400	118
2	46.4900	-8.49	31.43	22.94	30.00	-7.06	QP	400	129
3	62.0100	-14.60	37.85	23.25	30.00	-6.75	QP	100	113
4	137.6700	-10.52	34.14	23.62	30.00	-6.38	QP	100	251
5	169.6799	-11.64	34.58	22.94	30.00	-7.06	QP	100	333
6	472.3200	-3.21	34.02	30.81	37.00	-6.19	QP	100	298

Note: Measurement Level = Reading Level + Correct Factor



4.6. Test Result and Data (1GHz ~ 6GHz)

Test Mode :	Mode 1: Full System with VGA (1920*1200@60Hz) and HDMI (1920*1200@60Hz) with Status 1		
AC Power :	AC 100V/50Hz	Ant. Polarization:	Horizontal
Temp :	24°C	Humidity :	42%
Pressure(mbar) :	1002	Date :	2015/06/19

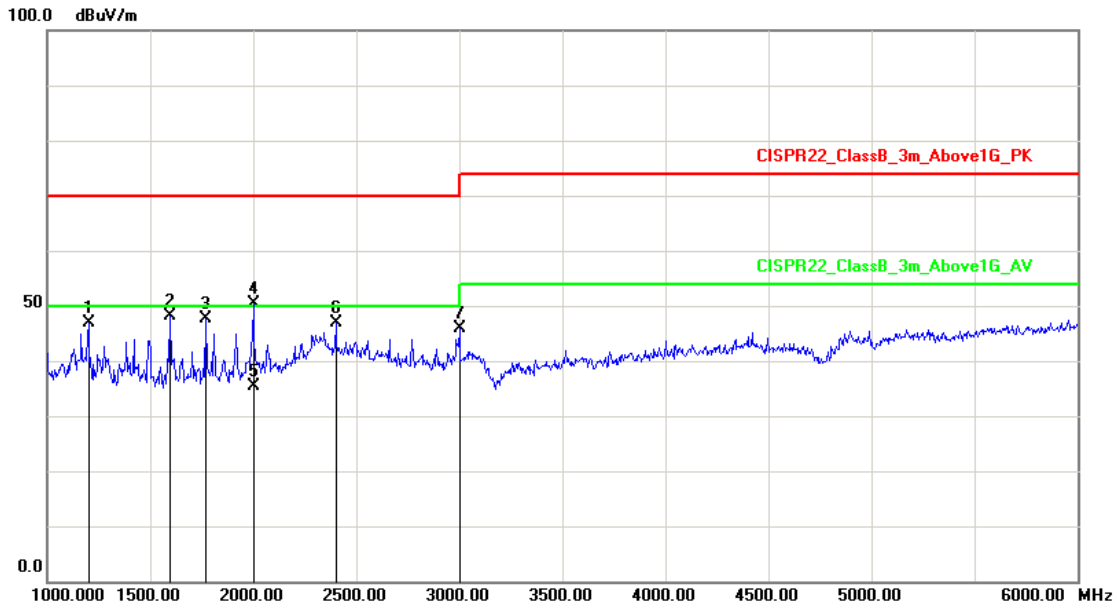

No.	Frequency (MHz)	Factor (dB/m)	Reading (dBuV)	Level (dBuV/m)	Limit (dBuV/m)	Margin (dB)	Det.	Height (cm)	Azimuth (deg)
1	1200.000	-14.52	61.39	46.87	70.00	-23.13	peak	100	46
2	1595.000	-12.02	60.25	48.23	70.00	-21.77	peak	100	166
3	1770.000	-10.87	58.46	47.59	70.00	-22.41	peak	100	226
4	2000.000	-9.01	59.31	50.30	70.00	-19.70	peak	100	149
5	2000.000	-9.01	44.27	35.26	50.00	-14.74	AVG	100	149
6	2400.000	-3.26	50.23	46.97	70.00	-23.03	peak	100	209
7	3000.000	-2.61	48.59	45.98	70.00	-24.02	peak	100	222

Note: Measurement Level = Reading Level + Correct Factor



Test Mode :	Mode 1: Full System with VGA (1920*1200@60Hz) and HDMI (1920*1200@60Hz) with Status 1		
AC Power :	AC 100V/50Hz	Ant. Polarization:	Vertical
Temp :	24°C	Humidity :	42%
Pressure(mbar) :	1002	Date :	2015/06/19

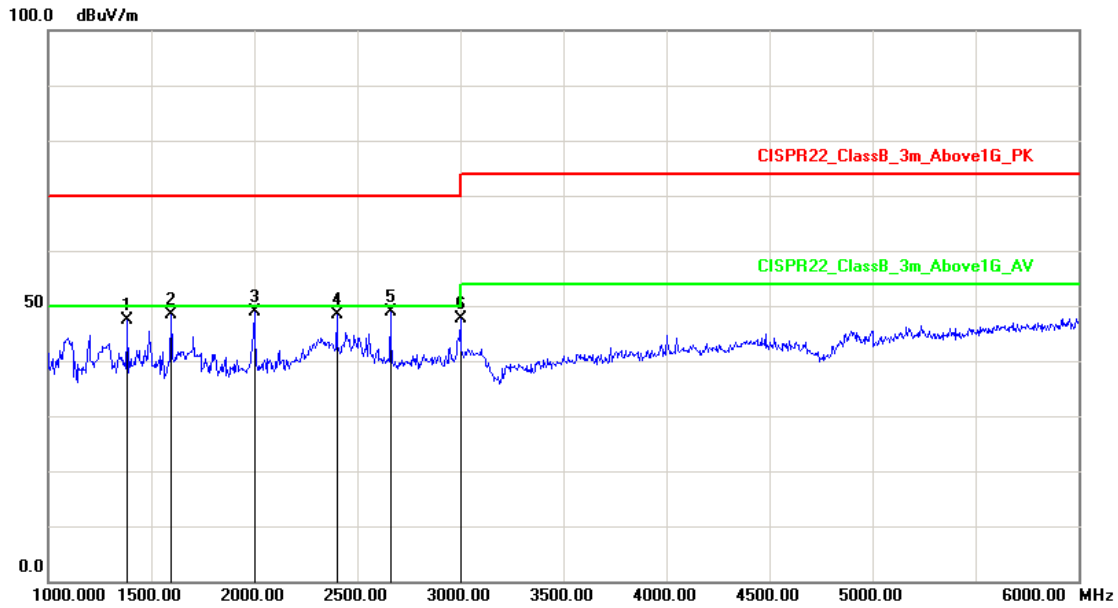

No.	Frequency (MHz)	Factor (dB/m)	Reading (dBuV)	Level (dBuV/m)	Limit (dBuV/m)	Margin (dB)	Det.	Height (cm)	Azimuth (deg)
1	1385.000	-12.76	60.04	47.28	70.00	-22.72	peak	100	198
2	1595.000	-12.02	60.51	48.49	70.00	-21.51	peak	100	123
3	2000.000	-9.01	57.92	48.91	70.00	-21.09	peak	100	0
4	2400.000	-3.26	51.60	48.34	70.00	-21.66	peak	100	35
5	2660.000	-4.68	53.58	48.90	70.00	-21.10	peak	100	142
6	3000.000	-2.61	50.21	47.60	70.00	-22.40	peak	100	0

Note: Measurement Level = Reading Level + Correct Factor

Test engineer: Seben



4.7. Test Photographs (30MHz~1GHz)

Front View

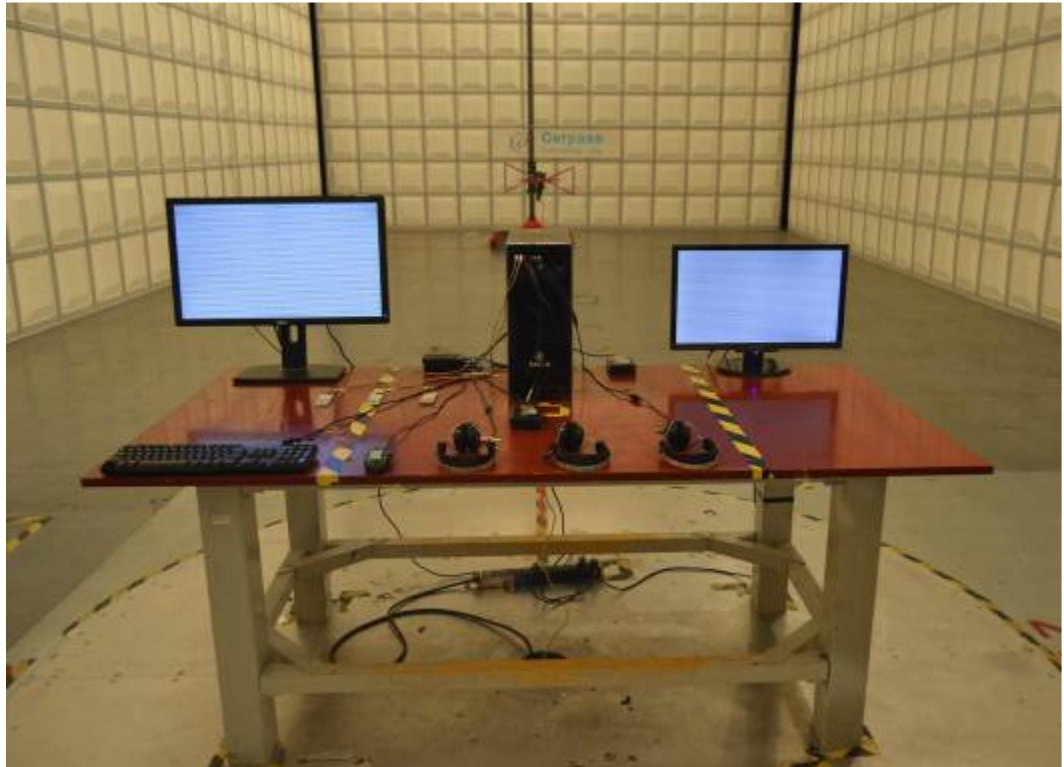

Rear View

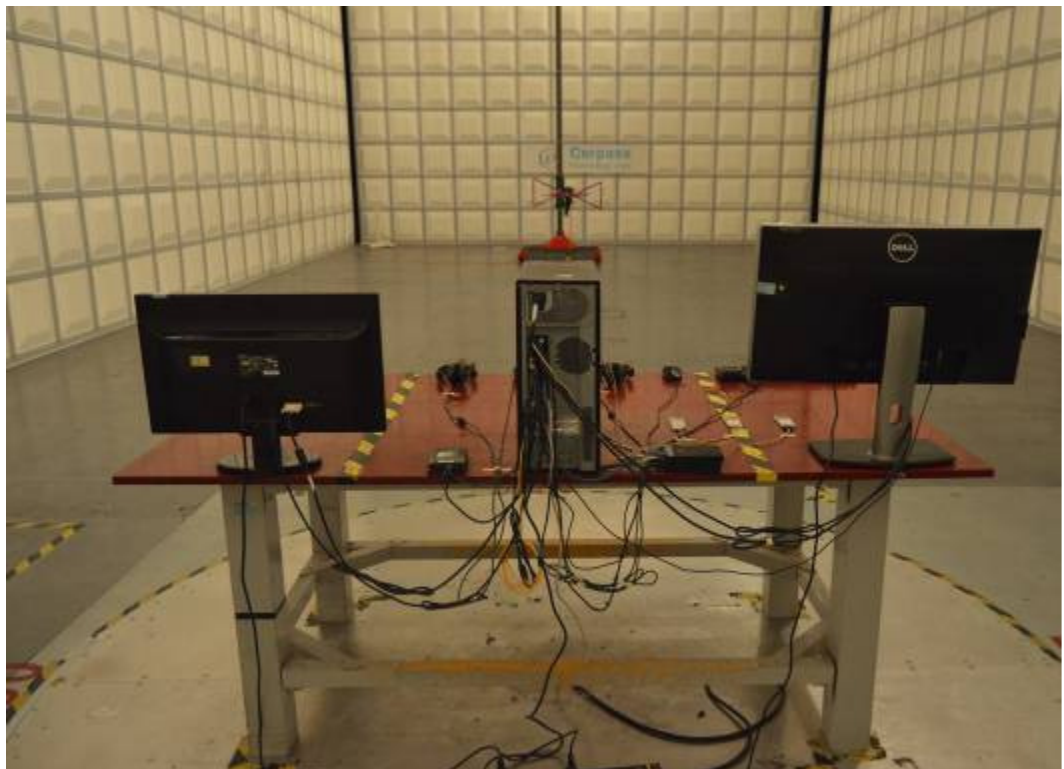



4.8. Test Photographs (1GHz~6GHz)

Front View



Rear View

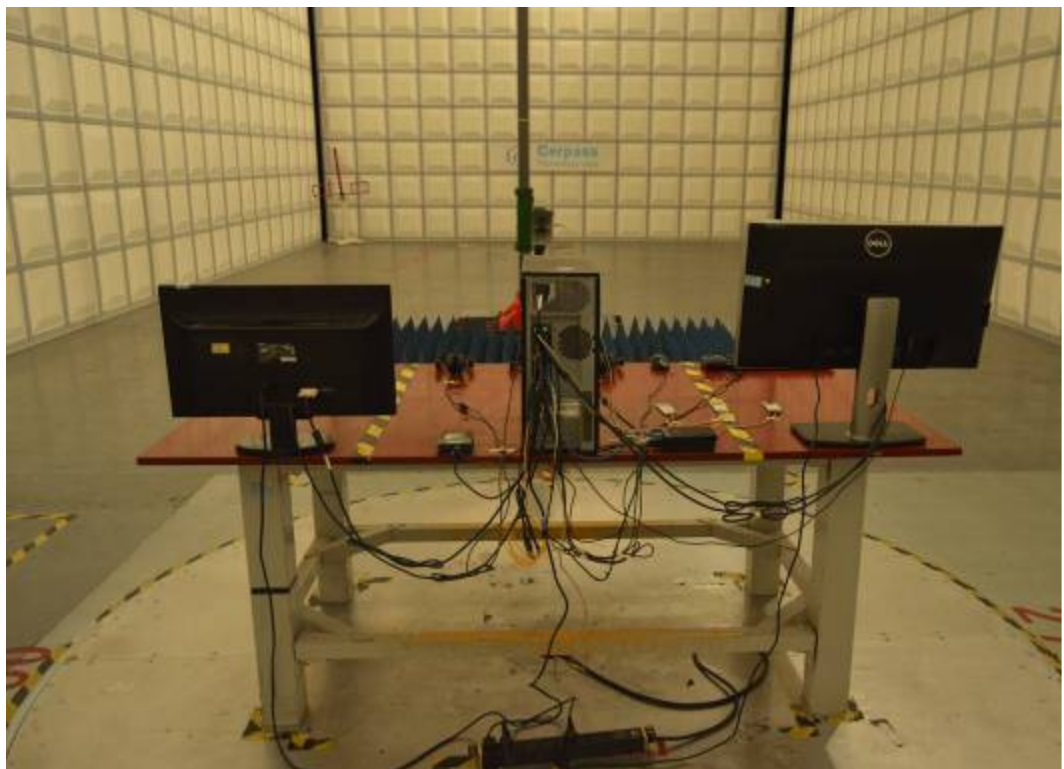



5. Photographs of EUT

1) EUT Photo



2) EUT Photo

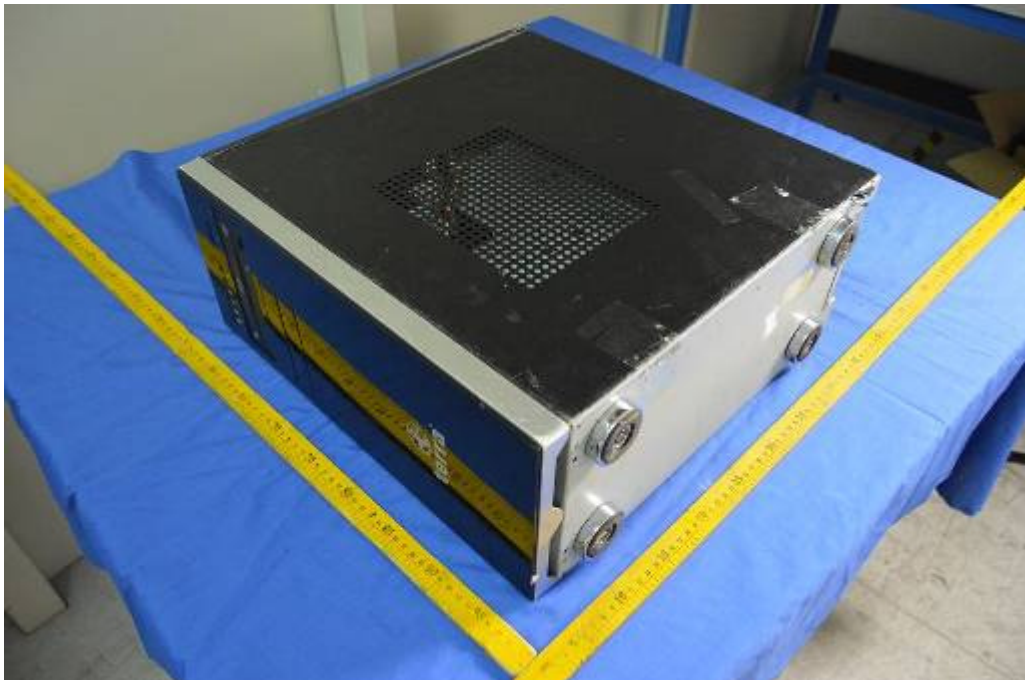



3) EUT Photo

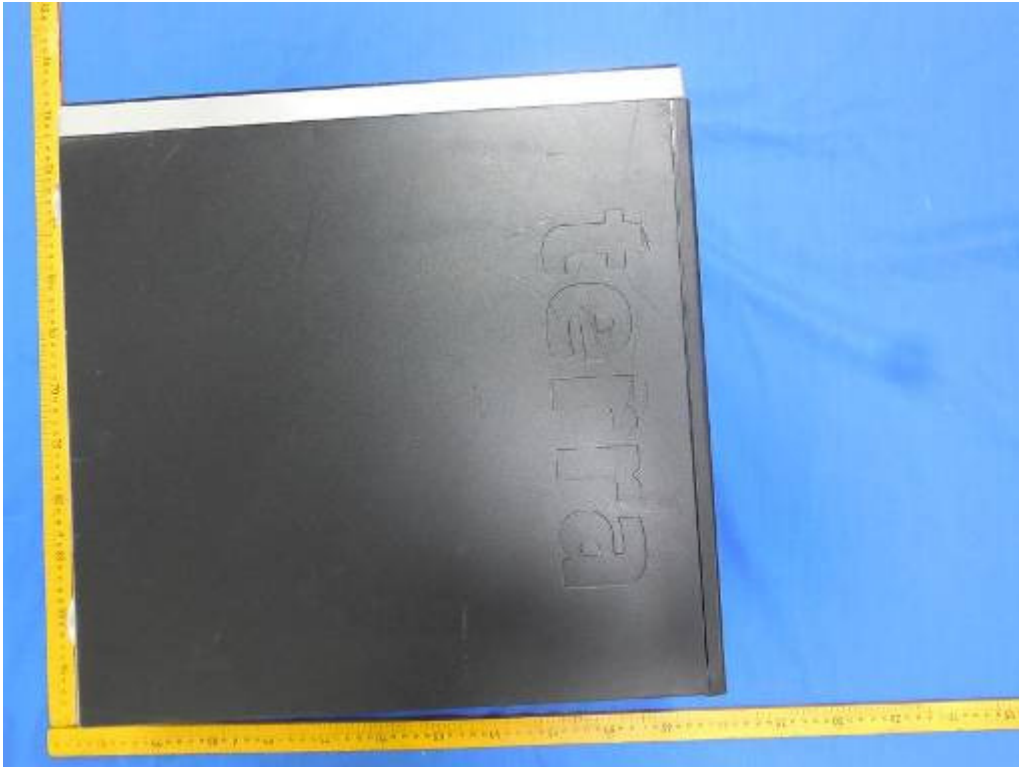

4) EUT Photo





5) EUT Photo



6) EUT Photo





7) EUT Photo



8) EUT Photo





9) EUT Photo



10) EUT Photo





11) EUT Photo



12) EUT Photo





15) EUT Photo



16) EUT Photo

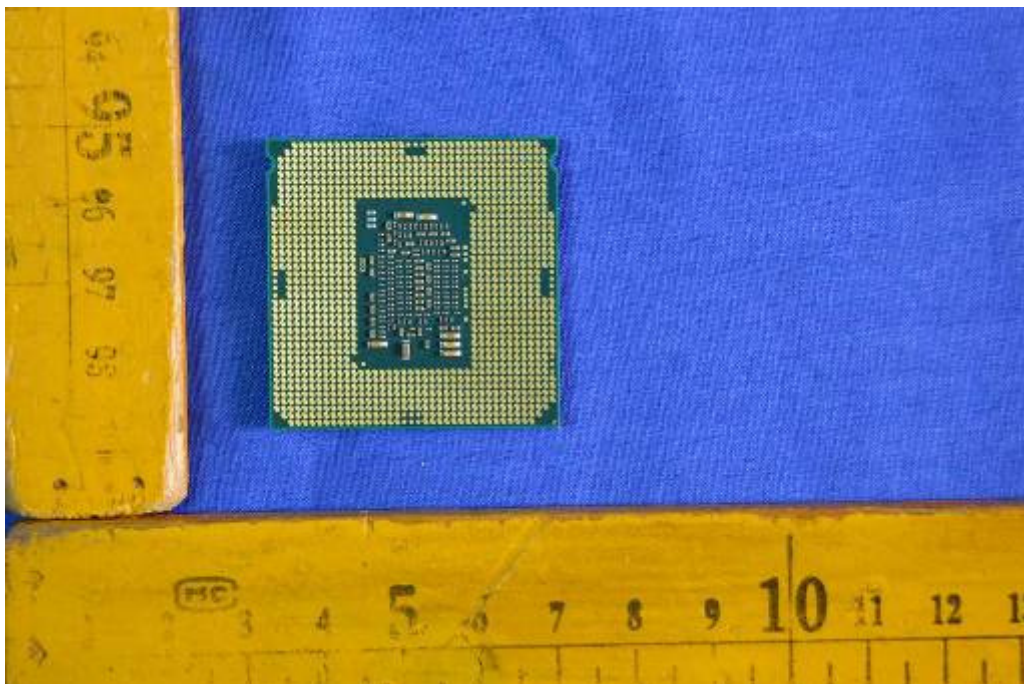



17) EUT Photo



18) EUT Photo

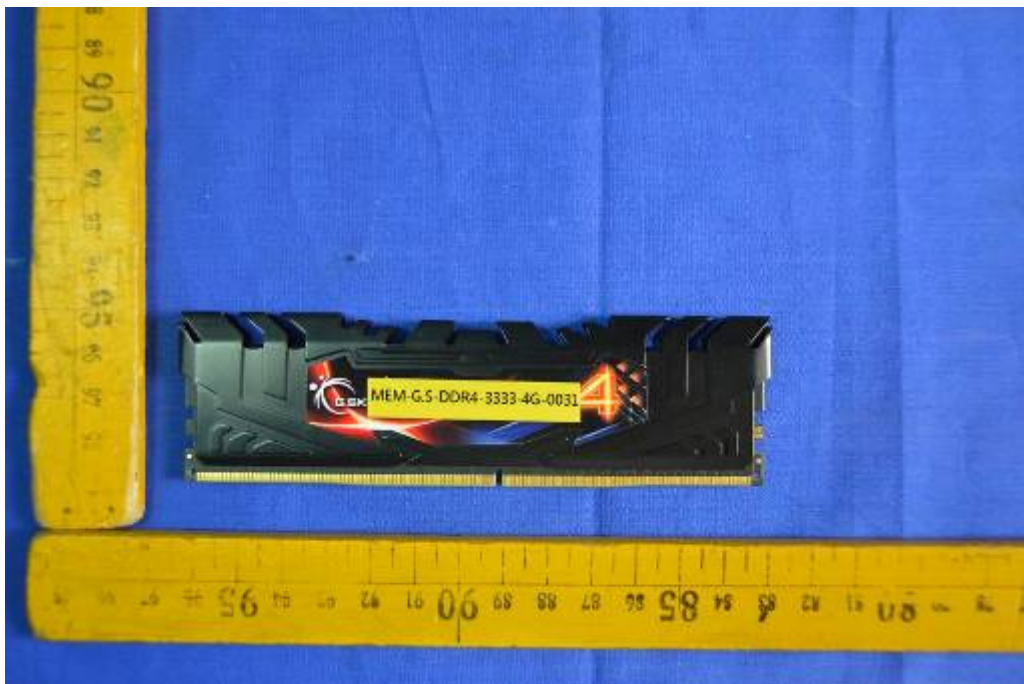



19) EUT Photo

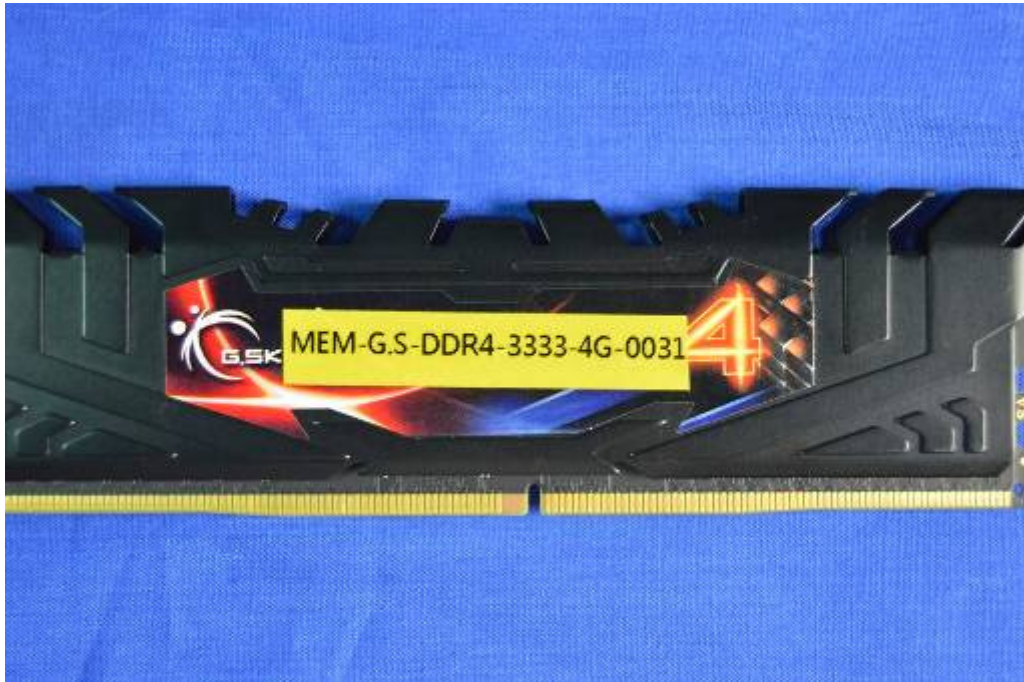

20) EUT Photo





21) EUT Photo



22) EUT Photo

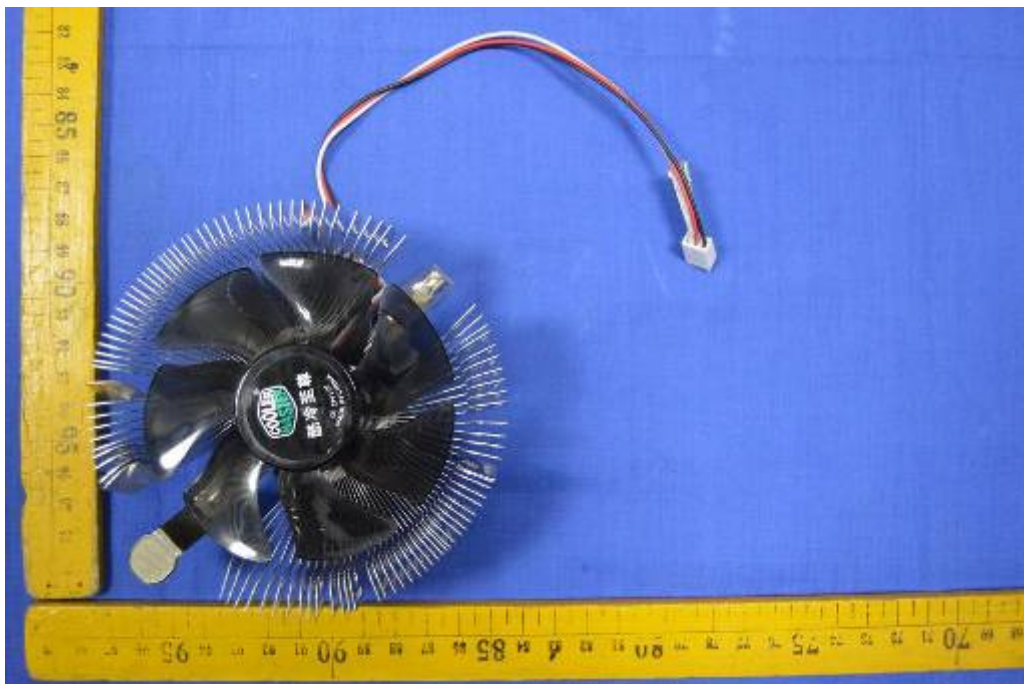



23) EUT Photo

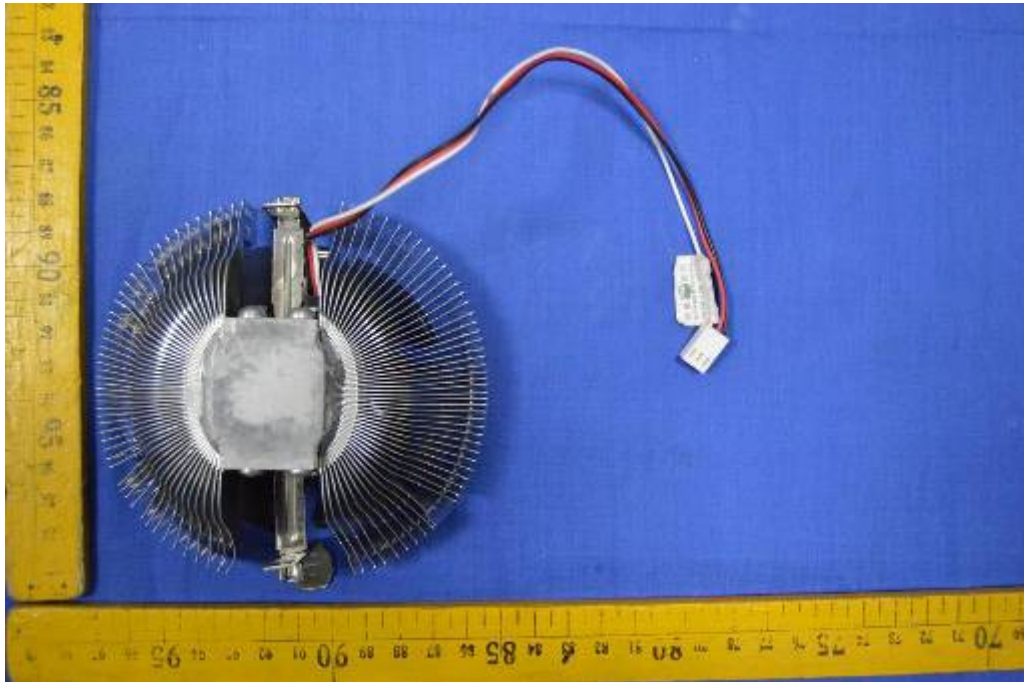

24) EUT Photo





25) EUT Photo



26) EUT Photo

