

DJI RS 3 Quick Start Guide

Introduction

DJI RS 3 is a professional single-handed 3-axis gimbal specifically designed for DSLR and mirrorless cameras. Users can calibrate the gimbal and set parameters on the screen and use the onboard buttons to control the gimbal and switch profiles and working modes.

When used with the provided camera control cables, DJI RS 3 can also control the camera focus, shutter, and recording. The grip has a built-in battery. After connecting to the Ronin app, it is easy to control gimbal movement and parameter settings with intelligent functions.

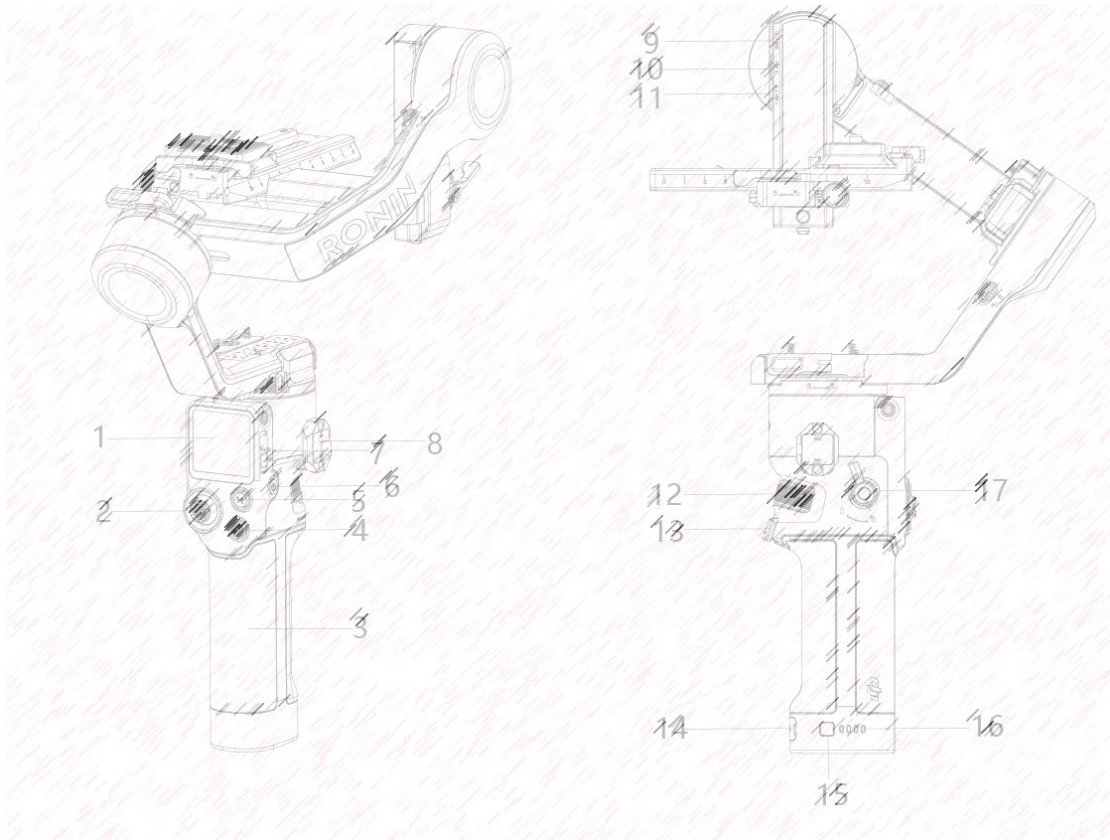

1. Touchscreen
2. Joystick
3. Grip (Built-in battery with 1/4"-20 screw hole)
4. Camera Control Button
5. M Button
6. Power Button
7. Gimbal Mode Switch
8. Ronin Series Accessories (RSA)/NATO Ports

9. RSS Camera Control Port
10. Focus Motor Port
11. Image Transmission/Focus Motor Port
12. Front Dial
13. Trigger
14. Charging Port
15. Battery Level Button
16. Battery Level Indicators
17. Grip Lever/Safety Button

Getting Started

- A. Downloading the DJI Ronin App



Ronin App

- B. Charging the gimbal via the USB-C port on the grip.
- C. Attaching the Tripod.

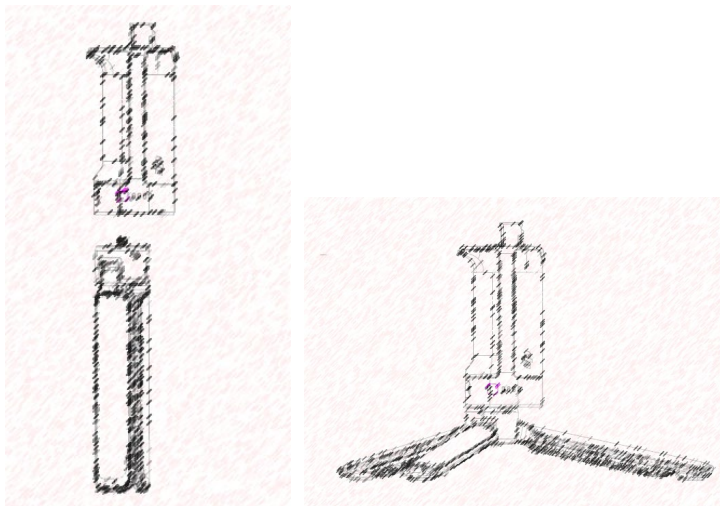

- D. Attaching the Grip

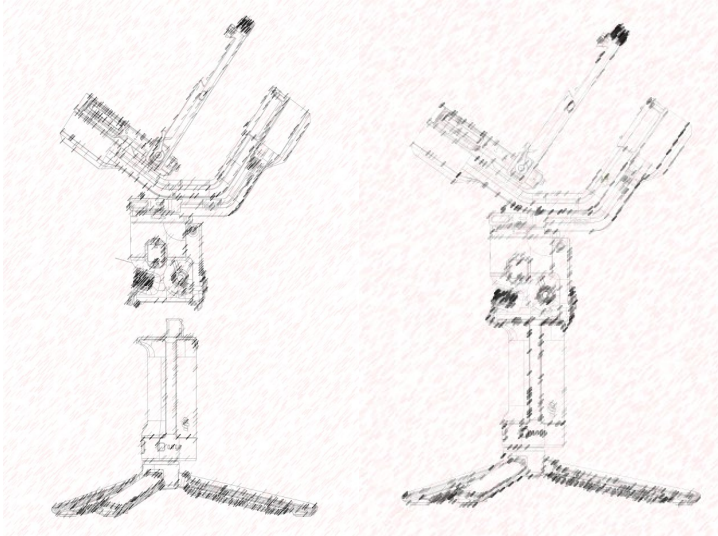

E. Power On

Press and hold on the power button to power on the gimbal.

Mounting the camera

Mount the camera onto the gimbal.

1. Attach the Upper Quick-Release Plate.

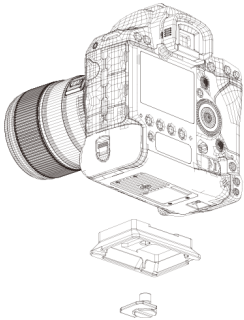

2. Attach the Lower Quick-Release Plate and lens support.

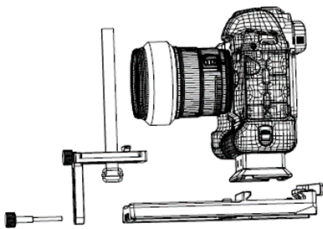

3. Attach the camera to the gimbal.

Balancing

1. Balancing the vertical tilt

- a. Unlock the tilt axis, and loosen the mounting plate knob.
 - b. Rotate the tilt axis so that the camera lens is pointing upward. Check to make sure the camera is not top or bottom-heavy. If top-heavy, move the camera backward. If bottom-heavy, move the camera forward.
 - c. Tighten the knob. The vertical tilt is balanced until the camera is steady while pointing upward.
2. Balancing depth for the tilt axis
- a. Rotate the tilt axis so that the camera lens is pointing forward. Toggle the lever to the unlocked position.
 - b. Check to make sure the camera is not front or back-heavy. If front-heavy, move the camera backward by turning the knob. If back-heavy, move the camera forward.
 - c. Toggle the lever to the locked position. The Tilt axis is balanced if the camera is steady while tilting up or down for 45 degrees.
 - d. Lock the tilt axis.
3. Balancing the roll axis
- a. Unlock the roll axis. Toggle the lever on the roll arm to the unlocked position.
 - b. Check the direction in which the roll motor swings. If the camera rotates to the left, move the camera to the right. If the camera rotates to the right, move the camera to the left.
 - c. Toggle the lever on the roll arm to the locked position. The roll axis is balanced if the camera is steady.
 - d. Lock the roll axis.
4. Balancing the pan axis
- a. Unlock the pan axis. Toggle the lever on the pan arm to the unlocked position.
 - b. Hold the grip, tilt the camera forward, and adjust the pan arm to parallel to you. Check the movement of the pan axis. If the camera lens rotates to the left, push the pan axis to the right. If the camera lens rotates to the right, push the pan axis to the left.
 - c. Toggle the lever on the pan arm to the locked position. The pan axis is balanced if the camera is steady when rotating the pan while lifting the grip.

Operation

Touch Screen

After installation, activation, and balancing, RS 3 must be auto-tuned before it can be used.

Home: tap gimbal calibration to start auto tune, and check the balance status, select follow mode and follow speed by tapping the icons.

Slide to the right to select shooting modes, slide to the left to set system settings, and slide up to enter joystick and front wheel settings page, slide down to view the image transmission.

Button Feature

Power Button: press and hold the power button to turn on or off. Tap or press twice on the power button to enter or exit sleep mode.

Battery Level Button: press once to check battery level.

Trigger: press once to start ActiveTrack. press and hold the trigger to enter Lock mode. Press twice to recenter the gimbal. Press three times to turn the gimbal 180° so that the camera faces you.

M Button: tap to select a user profile. Press and hold to enter Sport mode. Press and hold while press twice on the trigger to stay in Sport mode. Press twice to enter portrait mode. Press three times to enter Roll 360. Press and hold the M button which holding on the trigger to begin auto tune.

Camera Control Button: after connecting the camera control port and camera, press halfway for autofocus, as you would the shutter button on a camera. Press to start or stop recording. Press and hold to take a photo.

Joystick: push the joystick up or down to control the movement of the tilt axis, and push it left or right to control the movement of the pan axis. Go to the Joystick page of the Ronin app to adjust the parameters for the pan, tilt, and roll axes.

Front Wheel: turn the wheel to control focus.

Gimbal Mode Switch: Toggle the switch to switch the gimbal mode from PTF, PF, and FPV.

Ronin App

Use the Ronin app for more features, such as gimbal and camera settings, force mobile.

Firmware Update

Download the DJI Pro Assistant for Ronin software from DJI website, and then follow the steps below to update the firmware if there is new firmware available.

1. Connect the RS 3 and the computer via USB-C cable.
2. Launch the DJI Pro Assistant for Ronin, select update and wait for the process.
3. Reboot the RS 3.

Specifications

Model	P11C
Battery	Model: BHX711-3000-7.2 Type: 18650 2S Capacity: 3000mAh Energy: 21.6Wh Voltage: 12 V-17.6 V
Operating Current	Static Current: 0.2 A
USB Input	5V/2A,9V/2A,12V/1.5A
Bluetooth Operating Frequency	2.4000 GHz -2.4835 GHz
Bluetooth Transmitter Power	<8 dBm (EIRP)
Operating Temperature	-20°C to 45°C

Compliance Information

FCC Compliance Notice

Supplier's Declaration of Conformity

Product name: DJI RS 3

Model Number: P11C

Responsible Party: DJI Technology, Inc.

Responsible Party Address: 201 S. Victory Blvd., Burbank, CA 91502

Website: www.dji.com

We, DJI Technology, Inc., being the responsible party, declares that the above mentioned model was tested to demonstrate complying with all applicable FCC rules and regulations.

This device complies with Part 15 of the FCC Rules. Operation is subject to the following two conditions: (1) This device may not cause harmful interference, and (2) This device must accept any interference received, including interference that may cause undesired operation.

Any changes or modifications not expressly approved by the party responsible for compliance could void the user's authority to operate the equipment.

This equipment has been tested and found to comply with the limits for a Class B digital device, pursuant to part 15 of the FCC Rules. These limits are designed to provide reasonable protection against harmful interference in a residential installation. This equipment generates, uses and can radiate radio frequency energy and, if not installed and used in accordance with the instructions, may cause harmful interference to radio communications. However, there is no guarantee that interference will not occur in a particular installation. If this equipment does cause harmful interference to radio or television reception, which can be determined by turning the equipment off and on, the user is encouraged to try to correct the interference by one or more of the following measures:

- Reorient or relocate the receiving antenna.
- Increase the separation between the equipment and receiver.
- Connect the equipment into an outlet on a circuit different from that to which the receiver is connected.
- Consult the dealer or an experienced radio/TV technician for help.

ISED Compliance Notice

This device contains licence-exempt transmitter(s)/receiver(s) that comply with Innovation, Science and Economic Development Canada's licence-exempt RSS(s). Operation is subject to the following two conditions: (1) This device may not cause interference. (2) This device must accept any interference, including interference that may cause undesired operation of the device.

L'émetteur/récepteur exempt de licence contenu dans le présent appareil est conforme aux CNR d'Innovation, Sciences et Développement économique Canada applicables aux appareils radio exempts de licence. L'exploitation est autorisée aux deux conditions suivantes : (1) L'appareil ne doit pas produire de brouillage; (2) L'appareil doit accepter tout brouillage radioélectrique subi, même si le brouillage est susceptible d'en compromettre le

fonctionnement.

This equipment complies with ISED radiation exposure limits set forth for an uncontrolled environment. End user must follow the specific operating instructions for satisfying RF exposure compliance. This transmitter must not be co-located or operating in conjunction with any other antenna or transmitter. The portable device is designed to meet the requirements for exposure to radio waves established by the ISED.

部件名称	有害物质					
	铅 (Pb)	汞 (Hg)	镉 (Cd)	六价铬 (Cr ⁺⁶)	多溴联苯 (PBB)	多溴二苯醚 (PBDE)
线路板	×	○	○	○	○	○
外壳	×	○	○	○	○	○
显示屏	×	○	○	○	○	○
内部线材	×	○	○	○	○	○
其他配件	×	○	○	○	○	○

本表格依据SJ/T 11364 的规定编制。
○：表示该有害物质在该部件所有均质材料中的含量均在GB/T 26572 规定的限量要求以下。
×：表示该有害物质至少在该部件的某一均质材料中的含量超出GB/T 26572 规定的限量要求。
(产品符合欧盟ROHS指令环保要求)



KCC Compliance Notice

“해당무선설비는 운용 중 전파혼신 가능성이 있으므로 인명안전과 관련된 서비스는 할 수 없습니다.”

“해당 무선설비는 운용 중 전파혼신 가능성이 있음”

NCC Compliance Notice

取得審驗證明之低功率射頻器材，非經核准，公司、商號或使用者均不得擅自變更頻率、加大功率或變更原設計之特性及功能。低功率射頻器材之使用不得影響飛航安全及干擾合法通信；經發現有干擾現象時，應立即停用，並改善至無干擾時方得繼續使用。前述合法通信，指依電信管理法規定作業之無線電通信。低功率射頻器材須忍受合法通信或工業、科學及醫療用電波輻射性電機設備之干擾。



EU Compliance Statement: SZ DJI Osmo Technology Co., Ltd. hereby declares that this device (DJI RS 3) is in compliance with the essential requirements and other relevant provisions of the Directive 2014/53/EU.

A copy of the EU Declaration of Conformity is available online at www.dji.com/euro-compliance

EU contact address: DJI GmbH, Industriestrasse 12, 97618, Niederlauer, Germany

GB Compliance Statement: SZ DJI Osmo Technology Co., Ltd. hereby declares that this device(DJI RS 3) is in compliance with the essential requirements and other relevant provisions of Radio Equipment Regulations 2017.

A copy of the GB Declaration of Conformity is available online at www.dji.com/euro-compliance

Declaración de cumplimiento UE: SZ DJI Osmo Technology Co., Ltd. por la presente declara que este dispositivo(DJI RS 3) cumple los requisitos básicos y el resto de provisiones relevantes de la Directiva 2014/53/EU.

Hay disponible online una copia de la Declaración de conformidad UE en www.dji.com/euro-compliance

Dirección de contacto de la UE: DJI GmbH, Industriestrasse 12, 97618, Niederlauer, Germany

EU-verklaring van overeenstemming: SZ DJI Osmo Technology Co., Ltd. verklaart hierbij dat dit apparaat(DJI RS 3) voldoet aan de essentiële vereisten en andere relevante bepalingen van Richtlijn 2014/53/EU.

De EU-verklaring van overeenstemming is online beschikbaar op www.dji.com/euro-compliance

Contactadres EU: DJI GmbH, Industriestrasse 12, 97618, Niederlauer, Germany

Declaração de conformidade da UE: A SZ DJI Osmo Technology Co., Ltd. declara, através deste documento, que este dispositivo(DJI RS 3) está em conformidade com os requisitos essenciais e outras disposições relevantes da Diretiva 2014/53/EU.

Existe uma cópia da Declaração de conformidade da UE disponível online em www.dji.com/euro-compliance

Endereço de contacto na UE: DJI GmbH, Industriestrasse 12, 97618, Niederlauer, Germany

Dichiarazione di conformità UE: SZ DJI Osmo Technology Co., Ltd. dichiara che il presente dispositivo(DJI RS 3) è conforme ai requisiti essenziali e alle altre disposizioni rilevanti della direttiva 2014/53/EU.

Una copia della dichiarazione di conformità UE è disponibile online all'indirizzo Web www.dji.com/euro-compliance

Indirizzo di contatto UE: DJI GmbH, Industriestrasse 12, 97618, Niederlauer, Germany

Déclaration de conformité UE : Par la présente, SZ DJI Osmo Technology Co., Ltd. déclare que cet appareil(DJI RS 3) est conforme aux principales exigences et autres clauses pertinentes de la directive européenne 2014/53/EU.

Une copie de la déclaration de conformité UE est disponible sur le site www.dji.com/euro-compliance

Adresse de contact pour l'UE : DJI GmbH, Industriestrasse 12, 97618, Niederlauer, Germany

EU-Compliance: Hiermit erklärt SZ DJI Osmo Technology Co., Ltd., dass dieses Gerät(DJI RS 3) den wesentlichen Anforderungen und anderen einschlägigen Bestimmungen der EU-Richtlinie 2014/53/EU entspricht.

Eine Kopie der EU-Konformitätserklärung finden Sie online auf www.dji.com/euro-compliance

Kontaktadresse innerhalb der EU: DJI GmbH, Industriestrasse 12, 97618, Niederlauer, Germany

Декларация за съответствие на ЕС: SZ DJI Osmo Technology Co., Ltd. декларира, че това устройство(DJI RS 3) отговаря на основните изисквания и другите приложими разпоредби на Директива 2014/53/ЕС.

Копие от Декларацията за съответствие на ЕС ще намерите онлайн на адрес www.dji.com/euro-compliance

Адрес за контакт за ЕС: DJI GmbH, Industriestrasse 12, 97618, Niederlauer, Германия

Prohlášení o shodě pro EU: Společnost SZ DJI Osmo Technology Co., Ltd. tímto prohlašuje, že tohle zařízení(DJI RS 3) vyhovuje základním požadavkům a dalším příslušným ustanovením směrnice 2014/53/EU.

Kopie prohlášení o shodě pro EU je k dispozici on-line na webu www.dji.com/euro-compliance

Kontaktní adresa v EU: DJI GmbH, Industriestrasse 12, 97618, Niederlauer, Německo

EU-overensstemmelseserklæring: SZ DJI Osmo Technology Co., Ltd. erklærer hermed, at denne enhed(DJI RS 3) er i overensstemmelse med de væsentlige krav og andre relevante bestemmelser i direktiv 2014/53/EU.

Der er en kopi af EU-overensstemmelseserklæringen tilgængelig online på www.dji.com/euro-compliance

EU-kontaktadresse: DJI GmbH, Industriestrasse 12, 97618, Niederlauer, Tyskland

Δήλωση Συμμόρφωσης EE: Η SZ DJI Osmo Technology Co., Ltd. δια του παρόντος δηλώνει ότι η συσκευή(DJI RS 3) αυτή συμμορφώνεται με τις βασικές απαιτήσεις και άλλες σχετικές διατάξεις της Οδηγίας 2014/53/ΕΕ.

Αντίγραφο της Δήλωσης Συμμόρφωσης EE διατίθεται ηλεκτρονικά στη διεύθυνση www.dji.com/euro-compliance

Διεύθυνση επικοινωνίας στην EE: DJI GmbH, Industriestrasse 12, 97618, Niederlauer, Γερμανία

ELi vastavuskinnitus Käesolevaga teatab SZ DJI Osmo Technology Co., Ltd., et see seade(DJI RS 3) on kooskõlas direktiivi 2014/53/EL oluliste nõuete ja muude asjakohaste sätetega.

ELi vastavusdeklaratsiooni koopia on kättesaadav veebis aadressil www.dji.com/euro-compliance

Kontaktaadress ELis: DJI GmbH, Industriestrasse 12, 97618, Niederlauer, Saksamaa

Pranešimas dėl atitikties ES reikalavimams Bendrovė „SZ DJI Osmo Technology Co., Ltd.“ tvirtina, kad šis prietaisas(DJI RS 3) atitinka pagrindinius 2014/53/ES direktyvos reikalavimus ir kitas susijusias nuostatas.

ES atitikties deklaracijos kopiją galite rasti adresu www.dji.com/euro-compliance

ES kontaktinis adresas: „DJI GmbH“, Industriestrasse 12, 97618, Niederlauer, Germany (Vokietija)

ES atbilstības paziņojums: SZ DJI Osmo Technology Co., Ltd ar šo apliecina, ka šī ierīce(DJI RS 3) atbilst direktīvas 2014/53/ES pamatprasībām un pārējiem būtiskiem nosacījumiem.

ES atbilstības deklarācijas kopija pieejama tiešsaistē vietnē www.dji.com/euro-compliance

ES kontaktadrese: DJI GmbH, Industriestrasse 12, 97618, Niederlauer, Vācija

EU:n vaatimustenmukaisuusvakuutus: SZ DJI Osmo Technology Co., Ltd. ilmoittaa täten, että tämä laite(DJI RS 3) on direktiivin 2014/53/EU olennaisten vaatimusten ja sen muiden asiaankuuluvien ehtojen mukainen.

Kopio EU:n vaatimustenmukaisuusvakuutuksesta on saatavana verkossa osoitteessa www.dji.com/euro-compliance

Yhteystiedot EU:ssa: DJI GmbH, Industriestrasse 12, 97618, Niederlauer, Germany

RÁITEAS Comhlíonta an AE: Dearbhaíonn SZ DJI Osmo Technology Co., Ltd. leis seo go bhfuil an gléas seo(DJI RS 3) de réir na gceanglas riachtanach agus na bhforálacha ábhartha eile sa Treoir 2014/53/AE.

Tá coip de Dhearbhú Comhréireachta an AE ar fáil ar líne ag www.dji.com/euro-compliance
Seoladh teagmhála san AE: DJI GmbH, Industriestrasse 12, 97618, Niederlauer, Germany

Dikjarazzjoni ta' Konformità tal-UE: SZ DJI Osmo Technology Co., Ltd. hawnhekk tiddikjara li dan l-apparat(DJI RS 3) huwa konformi mar-rekwiżiti essenzjali u ma' dispożizzjonijiet relevanti oħra tad-Direttiva 2014/53/UE.

Kopja tad-Dikjarazzjoni ta' Konformità tal-UE hija disponibbli onlajn fis-sit www.dji.com/euro-compliance

Indirizz ta' kuntatt tal-UE: DJI GmbH, Industriestrasse 12, 97618, Niederlauer, il-^lermanja

Declarația UE de conformitate: Prin prezenta, SZ DJI Osmo Technology Co., Ltd. declară faptul că acest dispozitiv(DJI RS 3) este conform cu cerințele esențiale și celelalte prevederi relevante ale Directivei 2014/53/UE.

Un exemplar al Declarației UE de conformitate este disponibil online, la adresa www.dji.com/euro-compliance

Adresa de contact pentru UE: DJI GmbH, Industriestrasse 12, 97618, Niederlauer, Germania

Izjava EU o skladnosti: Družba SZ DJI Osmo Technology Co., Ltd. izjavlja, da ta naprava(DJI RS 3) ustreza osnovnim zahtevam in drugim ustreznim določbam Direktive 2014/53/EU.

Kopija izjave EU o skladnosti je na voljo na spletu na www.dji.com/euro-compliance

Kontaktni naslov EU: DJI GmbH, Industriestrasse 12, 97618, Niederlauer, Nemčija

EU Izjava o skladnosti: Tvrtka SZ DJI Osmo Technology Co. Ltd. izjavljuje da je ovaj uređaj(DJI RS 3) izrađen u skladu s osnovnim zahtjevima i ostalim relevantnim odredbama Direktive 2014/53/EU.

Kopija EU Izjave o skladnosti dostupna je na mrežnoj stranici www.dji.com/euro-compliance

Adresa EU kontakta: DJI GmbH, Industriestrasse 12 97618, Niederlauer, Njemačka

Vyhlasenie o zhode EÚ: SZ DJI Osmo Technology Co., Ltd. týmto vyhlasuje, že toto zariadenie(DJI RS 3) je v zhode so základnými požiadavkami a ďalšími relevantnými ustanoveniami smernice 2014/53/EÚ.

Kópia tohto Vyhlasenia o zhode EÚ je k dispozícii online na www.dji.com/euro-compliance

Kontaktná adresa v EÚ: DJI GmbH, Industriestrasse 12, 97618, Niederlauer, Nemecko

Deklaracja zgodności UE: Firma SZ DJI Osmo Technology Co., Ltd. niniejszym oświadcza, że przedmiotowe urządzenie(DJI RS 3) jest zgodne z zasadniczymi wymogami i innymi stosownymi postanowieniami dyrektywy 2014/53/UE.

Kopię deklaracji zgodności UE można znaleźć w Internecie na stronie www.dji.com/euro-compliance

Adres do kontaktu w UE: DJI GmbH, Industriestrasse 12, 97618, Niederlauer, Niemcy

EU megfeleléségi nyilatkozat: A DJI Osmo Technology Co., Ltd. ezúton megerősíti, hogy ez az eszköz(DJI RS 3) megfelel a 2014/53/EU Irányelv alapvető követelményeinek és más vonatkozó rendelkezéseinek.

Az EU megfeleléségi nyilatkozat másolata elérhető a www.dji.com/euro-compliance oldalon

EU kapcsolati cím: DJI GmbH, Industriestrasse 12, 97618, Niederlauer, Németország

EU-försäkran om efterlevnad: SZ DJI Osmo Technology Co., Ltd. härmed förklarar att denna enhet(DJI RS 3) uppfyller de väsentliga kraven och andra relevanta bestämmelser i direktivet 2014/53/EU.

En kopia av EU-försäkran om efterlevnad finns att tillgå online på adressen www.dji.com/euro-compliance

Kontaktadress EU: DJI GmbH, Industriestrasse 12, 97618, Niederlauer, Tyskland

Yfirlýsing um fylgni við reglur ESB: SZ DJI Osmo Technology Co., Ltd. lýsir hér með yfir að þetta tæki(DJI RS 3) hlíti mikilvægum kröfum og öðrum viðeigandi ákvæðum tilskipunar 2014/53/ESB.

Nálgast má eintak af ESB-samræmisyfirlýsingunni á netinu á www.dji.com/euro-compliance

Heimilisfang ESB-tengiliðar: DJI GmbH, Industriestrasse 12, 97618, Niederlauer, Germany

AB Uygunluk Beyanı: SZ DJI Osmo Technology Co., Ltd. bu belge ile bu cihazın (DJI RS 3) temel gerekliliklere ve 2014/53/EU sayılı Direktifin diğer ilgili hükümlerine uygun olduğunu beyan eder.

AB Uygunluk Beyanının bir kopyasına www.dji.com/euro-compliance adresinden çevrim içi olarak ulaşılabilir

AB için iletişim adresi: DJI GmbH, Industriestrasse 12, 97618, Niederlauer, Almanya

Environmentally friendly disposal



Old electrical appliances must not be disposed of together with the residual waste, but have to be disposed of separately. The disposal at the communal collecting point via private persons is for free. The owner of old appliances is responsible to bring the appliances to these collecting points or to similar collection points. With this little personal effort, you contribute to recycle valuable raw materials and the treatment of toxic substances.

Umweltfreundliche Entsorgung

Dies ist das Symbol für die getrennte Sammlung von Elektro- und Elektronikgeräten. Elektroaltgeräte dürfen nicht zusammen mit dem Restmüll entsorgt werden (einschließlich Batterien, Akkus und Lampen), sondern müssen separat entsorgt werden. Die Entsorgung an der kommunalen Sammelstelle durch Privatpersonen oder an den von Händlern oder Herstellern eingerichteten Sammelstellen ist kostenlos. Der Besitzer von Altgeräten ist dafür verantwortlich, die persönlichen oder vertraulichen Daten auf den zu entsorgenden Altgeräten zu löschen und die Geräte zu diesen oder ähnlichen Sammelstellen zu bringen. Die Händler sind verpflichtet, Elektroaltgeräte für dich kostenlos zurückzunehmen. Durch diesen geringen Aufwand kannst du zur Wiederverwertung von wertvollen Rohmaterialien beitragen und dafür sorgen, dass umweltschädliche und giftige Substanzen ordnungsgemäß unschädlich gemacht werden.

Tratamiento de residuos responsable con el medio ambiente

Los aparatos eléctricos viejos no pueden desecharse junto con los residuos orgánicos, sino que deben ser desechados por separado. Existen puntos limpios donde los ciudadanos pueden dejar estos aparatos gratis. El propietario de los aparatos viejos es responsable de llevarlos a estos puntos limpios o similares puntos de recogida. Con este pequeño esfuerzo estás contribuyendo a reciclar valiosas materias primas y al tratamiento de residuos tóxicos.

Mise au rebut écologique

Les appareils électriques usagés ne doivent pas être éliminés avec les déchets résiduels. Ils doivent être éliminés séparément. La mise au rebut au point de collecte municipale par l'intermédiaire de particuliers est gratuite. Il incombe au propriétaire des appareils usagés de les apporter à ces points de collecte ou à des points de collecte similaires. Avec ce petit effort personnel, vous contribuez au recyclage de matières premières précieuses et au traitement des substances toxiques.

Smaltimento ecologico

I vecchi dispositivi elettrici non devono essere smaltiti insieme ai rifiuti residui, ma devono essere smaltiti separatamente. Lo smaltimento da parte di soggetti privati presso i punti di raccolta pubblici è gratis. È responsabilità del proprietario dei vecchi dispositivi portarli presso tali punti di raccolta o punti di raccolta analoghi. Grazie a questo piccolo impegno personale contribuirete al riciclo di materie prime preziose e al corretto trattamento di sostanze tossiche.

Milieuvriendelijk afvoeren

Oude elektrische apparaten mogen niet worden weggegooid samen met het restafval, maar moeten afzonderlijk worden afgevoerd. Afvoeren via het gemeentelijke inzamelpunt is gratis voor particulieren. De eigenaar van oude toestellen is verantwoordelijk voor het inleveren van de apparaten op deze of vergelijkbare inzamelpunten. Met deze kleine persoonlijke inspanning lever je een bijdrage aan de recycling van waardevolle grondstoffen en de verwerking van giftige stoffen.

Eliminação ecológica

Os aparelhos elétricos antigos não podem ser eliminados juntamente com os materiais residuais. Têm de ser eliminados separadamente. A eliminação no ponto de recolha público através de entidades particulares é gratuita. É da responsabilidade do proprietário de aparelhos antigos levá-los a estes pontos de recolha ou a pontos de recolha semelhantes. Com este pequeno esforço pessoal, contribui para a reciclagem de matérias-primas úteis e para o tratamento de substâncias tóxicas.

Изхвърляне с оглед опазване на околната среда

Старите електрически уреди не трябва да се изхвърлят заедно с битовите отпадъци, а отделно. Изхвърлянето в общинския пункт за събиране на отпадъци от частни лица е безплатно. Собственикът на старите уреди е отговорен за пренасянето на уредите до тези или до подобни събирателни пунктове. С това малко собствено усилие допринасяте за рециклирането на ценни суровини и за обработката на токсични вещества.

Ekologicky šetrná likvidace

Stará elektrická zařízení nesmějí být likvidována spolu se zbytkovým odpadem, ale musí být likvidována samostatně. Likvidace na komunálních sběrných místech prostřednictvím soukromých osob je bezplatná. Vlastník starých zařízení odpovídá za to, že je donese do těchto sběrných míst nebo na obdobná sběrná místa. Tímto můžete přispět k recyklaci hodnotných surovin a zpracování toxických látek.

Miljøvenlig bortskaffelse

Gamle elektriske apparater må ikke bortskaffes sammen med restaffald, men skal bortskaffes separat. Bortskaffelse på et fælles indsamlingssted er gratis for privatpersoner. Ejere af gamle apparater er ansvarlige for at bringe apparater hen til disse indsamlingssteder eller til lignende indsamlingssteder. Med denne lille personlige indsats bidrager du til genanvendelse af værdifulde råvarer og behandlingen af giftige stoffer.

Απόρριψη φιλική προς το περιβάλλον

Οι παλιές ηλεκτρικές συσκευές δεν πρέπει να απορρίπτονται μαζί με τα υπολειμματικά απόβλητα, αλλά ξεχωριστά. Η απόρριψη στο δημοτικό σημείο συλλογής μέσω ιδιωτών γίνεται χωρίς χρέωση. Ο κάτοχος παλιών συσκευών είναι υπεύθυνος για τη μεταφορά των συσκευών σε αυτά ή παρόμοια σημεία συλλογής. Μέσω της ατομικής σας προσπάθειας, συμβάλλετε στην ανακύκλωση πολύτιμων πρώτων υλών και την επεξεργασία των τοξικών ουσιών.

Keskkonnasäästlik kasutuselt kõrvaldamine

Vanu elektriseadmeid ei tohi ära visata koos olmejäätmetega, vaid tuleb koguda ja kasutuselt kõrvaldada eraldi. Kohaliku omavalitsuse elektroonikaromude kogumispunktis on äraandmine eraisikutele tasuta. Vanade seadmete sellistesse või sarnastesse kogumispunktidesse toimetamise eest vastutavad seadmete omanikud. Selle väikese isikliku panusega aitate kaasa väärtusliku toorme ringlussevõtule ja mürgiste ainete töötlemisele.

Utilizavimas nekenkiant aplinkai

Senų elektrinių prietaisų negalima išmesti kartu su buitinėmis atliekomis; juos būtina utilizuoti atskirai. Tokių prietaisų utilizavimas per komunalinius atliekų surinkimo punktus yra nemokamas. Elektrinių prietaisų savininkai utilizuojamus prietaisus privalo priduoti į atitinkamus arba analogiškus atliekų surinkimo punktus. Tokiu būdu, įdėdami nedaug pastangų, prisidėsite prie vertingų medžiagų perdėbimo ir aplinkos apsaugojimo nuo toksinių medžiagų.

Videi draudzīga atkritumu likvidēšana

Vecas elektriskās ierīces nedrīkst likvidēt kopā ar pārējiem atkritumiem, bet tās jālikvidē atsevišķi. Privātpersonām atkritumu likvidēšana komunālajā savākšanas punktā ir bez maksas. Veco ierīču īpašnieks ir atbildīgs par ierīču nogādāšanu šajos savākšanas punktos vai līdzīgos savākšanas punktos. Ar šīm nelielām personiskajām pūlēm jūs veicināt vērtīgu izejmateriālu pārstrādi un toksisko vielu apstrādi.

Hävittäminen ympäristöystävällisesti

Vanhoja sähkölaitteita ei saa hävittää kaatopaikkajätteen mukana, vaan ne on hävitettävä erikseen. Kunnalliseen keräyspisteeseen vieminen on yksityishenkilölle ilmaista. Vanhojen laitteiden omistaja vastaa laitteiden toimittamisesta kyseisiin keräyspisteisiin tai vastaaviin. Tällä vähäisellä henkilökohtaisella vaivalla edistät omalta osaltasi arvokkaiden raaka-aineiden kierrätystä ja myrkyllisten aineiden käsittelyä.

Diúscairt neamhdhíobháilach don chomhshaol

Níor cheart seanghléasanna leictreacha a dhiúscairt leis an dramhaíl iarmharach, ach caithfear iad a chur de láimh astu féin. Tá an diúscairt ag an ionad bailiúcháin pobail ag daoine príobháideacha saor in aisce. Tá freagracht ar úinéir seanghléasanna na gléasanna a thabhairt chuig na hionaid bhailiúcháin sin nó chuig ionaid bhailiúcháin den chineál céanna. Le hiarracht bheag phearsanta mar sin, cuidíonn tú le hamhábhair luachmhara a athchúrsáil agus le

substaintí tocsaineacha a chóireáil

Rimi li jirrispetta l-ambjent

L-apparat elettriku qadim ma għandux jintrema flimkien ma' skart residwu, iżda għandu jintrema b'mod separat. Ir-rimi fil-post tal-ġbir komunalni minn persuni privati huwa b'xejn. Is-sit ta' apparat qadim huwa responsabbli biex iġib l-apparat f'dawn il-postijiet tal-ġbir jew f'postijiet tal-ġbir simili. B'dan l-isforz personali żgħir, inti tikkontribwixxi għar-riċiklaġġ ta' materja prima prezzjuża u għat-trattament ta' sustanzi tossiċi.

Eliminarea ecologică

Aparatele electrice vechi nu trebuie aruncate odată cu deșeurile reziduale, ci trebuie eliminate separat. Eliminarea în cadrul punctului de colectare local de către persoane fizice este gratuită. Proprietarii de aparate vechi sunt responsabili pentru transportul acestora la respectivele puncte de colectare sau la alte puncte de colectare similare. Prin acest efort personal ne semnificativ, puteți contribui la reciclarea materiilor prime valoroase și la tratarea substanțelor toxice.

Okolju prijazno odlaganje

Starih električnih aparatov ne smete odvreči skupaj z ostanki odpadkov, temveč ločeno. Odlaganje na komunalnem zbirnem mestu je za fizične osebe brezplačno. Lastnik starih naprav je odgovoren, da jih pripelje do teh ali podobnih zbirnih mest. S tako malo osebne truda prispevate k recikliranju dragocenih surovin in obdelavi strupenih snovi.

Ekološko odlaganje

Stari električni uređaji ne smiju se odlagati zajedno s kućnim otpadom, već ih treba odlagati odvojeno. Odlaganje na komunalnom sabirnom mjestu od strane privatnih osoba je besplatno. Vlasnik starih uređaja dužan je donijeti uređaje do tih sabirnih mjesta ili sličnih sabirnih mjesta. Ovim malim osobnim naporom doprinosite recikliranju vrijednih sirovina i pravilnoj obradi otrovnih tvari.

Ekologická likvidácia

Staré elektrospotrebiče sa nesmú likvidovať spolu so zvyškovým odpadom, ale musia sa zlikvidovať samostatne. Likvidácia v komunálnom zbernom mieste prostredníctvom súkromných osôb je bezplatná. Majiteľ starých spotrebičov je zodpovedný za prinesenie spotrebičov na tieto zberné miesta alebo na podobné zberné miesta. Týmto malým osobným úsilím prispievate k recyklovaniu cenných surovín a spracovaniu toxických látok

Utylizacja przyjazna dla środowiska

Nie można usuwać starych urządzeń elektrycznych wraz z pozostałymi odpadami. Wymagają one oddzielnej utylizacji. Utylizacja przez osoby prywatne w punkcie zbiórki odpadów komunalnych jest darmowa. Właściciel starych urządzeń jest odpowiedzialny za dostarczenie ich do takich lub podobnych punktów zbiórki. Zadając sobie tak niewielki trud, przyczyniasz się do recyklingu cennych surowców i odpowiedniego postępowania z substancjami toksycznymi.

Környezetbarát hulladékkezelés

A régi elektromos készülékeket nem szabad a nem szelektíven gyűjtött hulladékkal együtt kidobni, hanem a hulladékkezelésüket elkülönítve kell végezni. A közösségi gyűjtőpontokon a magánszemélyek ingyenesen leadhatják ezeket. A régi készülékek tulajdonosai felelnek azért, hogy e készülékeket ezekre a gyűjtőpontokra, vagy más gyűjtőpontokra elhozzák. Ezzel a kis személyes erőfeszítéssel Ön is hozzájárul az értékes nyersanyagok újrahasznosításához és a mérgező anyagok kezeléséhez.

Miljövämlig hantering av avfall

Gamla elektriska apparater får inte kasseras tillsammans med restavfallet utan måste kasseras separat. Kassering på den lokala insamlingsplatsen för privatpersoner är gratis. Ägaren av gamla apparater ansvarar för att ta apparaterna till dessa insamlingsplatser eller till liknande insamlingsplatser. Med denna lilla personliga insats bidrar du till återvinning av värdefulla råvaror och hantering av giftiga ämnen.

Umhverfisvæn förgun

Ekki má farga gömlum raftækjum með úrgangisleifum, heldur þarf að farga þeim sérstaklega. Förgun á almennum söfnunarstöðum er ókeypis fyrir einstaklinga. Eigandi gamalla tækja ber ábyrgð á að koma með tækin á þessa söfnunarstaði eða á svipaða söfnunarstaði. Með þessu litla persónulega átaki stuðlar þú að endurvinnslu verðmætra hráefna og meðferð eitrufna.

Çevre dostu bertaraf

Eski elektrikli cihazlar, diğer atıklarla birlikte bertaraf edilmemeli, ayrıca atılmalıdır. Özel kişiler aracılığıyla genel toplama noktasına bertaraf işlemi ücretsiz olarak yapılmaktadır. Eski cihazların sahibi, cihazları bu toplama noktalarına veya benzer toplama noktalarına getirmekten sorumludur. Bu az miktardaki kişisel çabayla, değerli ham maddelerin geri dönüştürülmesine ve toksik maddelerin işleme alınmasına katkıda bulunmuş olursunuz.

Thailand Warning message

เครื่องโทรคมนาคมและอุปกรณ์นี้ มีความสอดคล้องตามข้อกำหนดของ กทช.

Mexico Warning message

“La operación de este equipo está sujeta a las siguientes dos condiciones: (1) es posible que este equipo o dispositivo no cause interferencia perjudicial y (2) este equipo o dispositivo debe aceptar cualquier interferencia, incluyendo la que pueda causar su operación no deseada.”

Brazil Warning message

Informações sobre Regulamentação.

Este equipamento está certificado e homologado pela ANATEL.

Para maiores informações, consulte o site da ANATEL: www.anatel.gov.br.

Este equipamento não tem direito à proteção contra interferência prejudicial e não pode causar

interferência em sistemas devidamente autorizados.

