

MyHOME[®] Lighting Control and Energy Monitoring Kit – MHKIT3

Technical Guide

Home automation solutions
for a residential home



Contents

Kit inclusions	3
Installation configuration and placement	4
Kit wiring connection	5
Datasheets	6
User Guide	16
Warranty	17

The MyHOME Lighting Control and Energy Monitoring Kit provides a solution to control lighting circuits, switching and dimming, and the ability to monitor energy consumption. It includes a 3.5" colour touchscreen for centralised management of all functions and easy monitoring of energy consumption. This kit comes factory pre-programmed.





Kit Catalogue Number: MHKIT3

MHKIT3 Contents:

- 1 x power supply, 600mA output (Cat. No. E49)
- 3 x trailing Edge single channel 400VA dimmer (Cat. No. F418). To drive 3 separate dimmer circuits (Zone 1-2-3). Suitable for incandescent, CFL and LED fixtures†
- 1 x double channel 6A relay per channel (Cat. No. F411/2). To drive 2 separate lights in the ON/OFF function (Zone 4-5)
- 5 x 1 gang switches (Cat. No. 67552). Controls all 5 lighting channels
- 3 x current meter (Cat. No. F520). To monitor 3 phase power consumption of the house
- 1 x scenario unit (Cat. No. F420) controls 16 different scenarios from the 3.5" touchscreen
- 1 x 3.5" touchscreen (Cat. No. 573958). Controls and monitors every single load of automation system, plus the scenario and energy consumption
- 1 x 24 din module enclosure box (Cat. No. HL24S). Allows installation of all DIN devices in a single point for easy access

Functionality of the KIT:

- Control the dimming of your lights with a dedicated dimmer switch or the 3.5" touchscreen
- Switch your lights on/off using a dedicated switch or the 3.5" touchscreen
- Use the 3.5" touchscreen as a central controller to drive the Automation system (light-dimmer – 3 phase energy monitoring)
- Use a mobile device, such as a smart phone or tablet, to remotely monitor and control the lighting, automation scenarios and your energy consumption*

*Mobile device, App and WiFi access point not included in this kit.

†Recommend using HPM or Legrand dimmable LED fixtures.

Mobile device activation

For further details on mobile setup please contact the Legrand Customer Service team on 1300 369 777.

Warranty

Legrand 4 year extended warranty. See page 15 for details.

Installation configuration and placement plan

Example



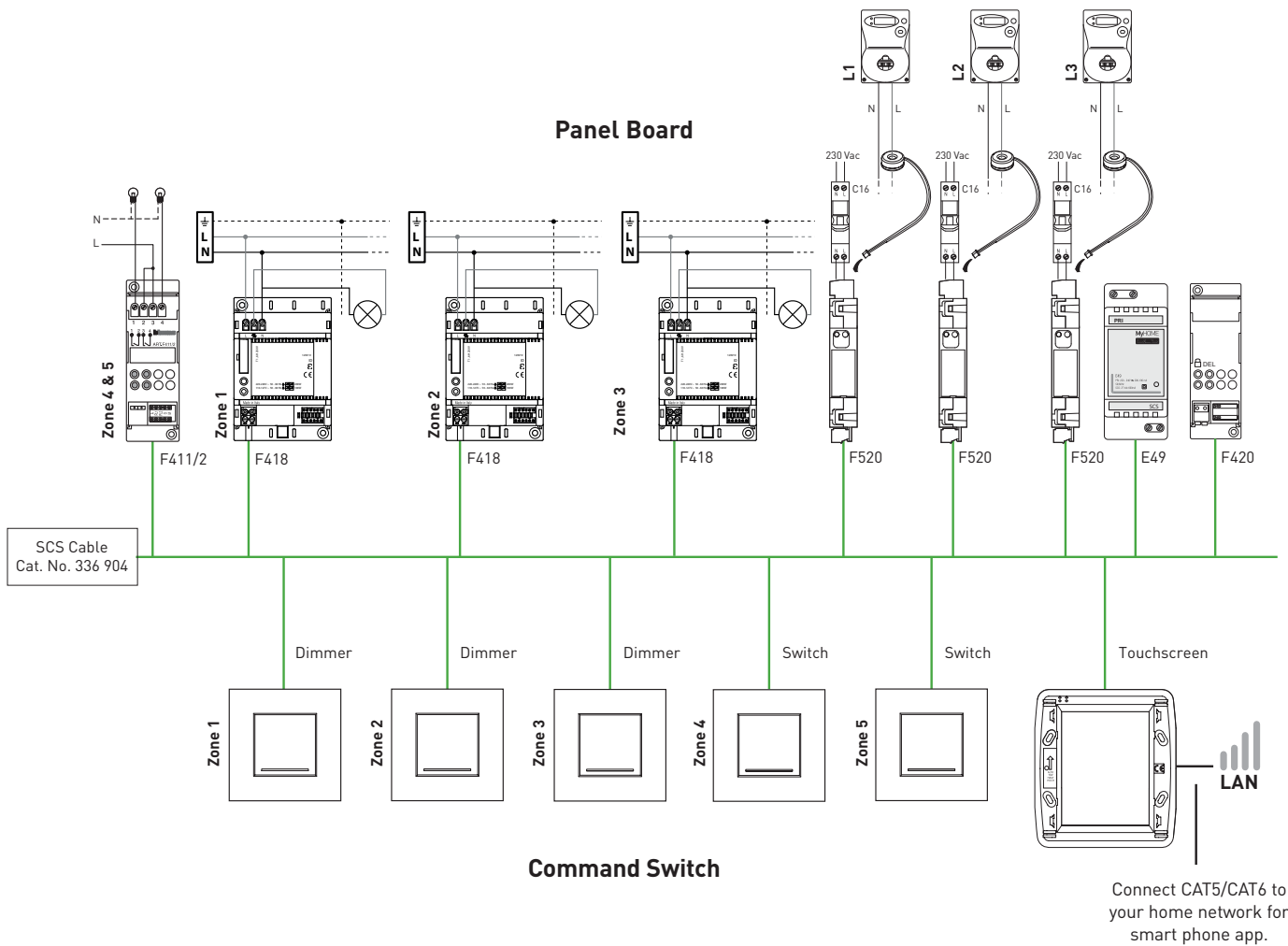

The dimension of the enclosure box (CAT No. HL24S) are:

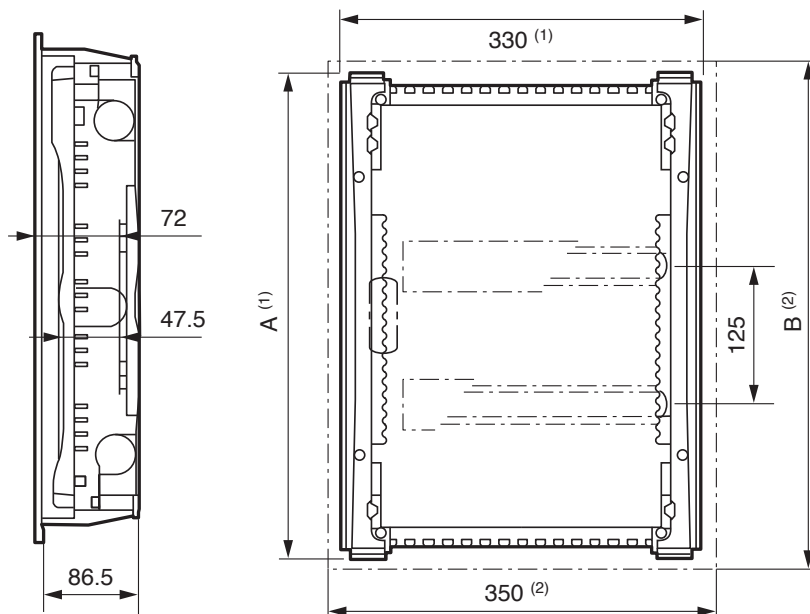



2 relay actuator in DIN module



Description

Actuator for installation in DIN rail distribution boards or switchboards. This device incorporates two independent relays for the activation of 2 loads, and includes local control push-buttons for each individual load, which are only active if the actuator has been configured. The device can be installed in a MyHOME system and configured physically or virtually. In this case when the PL1 and PL2 positions are configured using the same configurator the device interlocks the relays, to which it is possible to connect motors of rolling shutters, curtains, etc. When installed as a component of the Lighting Management system, specific configuration procedures are used (Plug&go, Project&Download).

Technical features

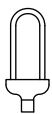
Power supply from BUS: 27 Vdc
 Operating power supply with SCS BUS: 18 - 27 Vdc
 Absorption: 28 mA
 Number of outputs: 2 x 6 A
 Power/Absorption of driven loads:

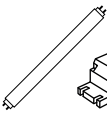
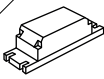
	Incandescent lamps Halogen lamp		LED lamp Compact fluorescent lamp	
				
230 Vac	1380 W	6 A	250 W	Max. 4 lamps

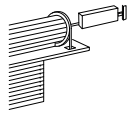
Linear fluorescent lamp Electronic transformer		Ferromagnetic transformers		Motor reducers for rolling shutters	
					
230 W	1 A	2 A cosφ 0.5	460 VA	460 W	2 A

Dissipated power with max load: 1.7 W⁽¹⁾
 Operating temperature: (-5) - (+45) °C
 Number of outputs: 2 x 6 A

NOTE: (1) The dissipated power indicated is that corresponding to the device with all the relays loaded at the maximum load. With lower loads also the dissipated power is lower and may be calculated by means of the following formula: $P(\text{mW}) = 140 + 400 * N + 10 * (I_{c1} + I_{c2})$
 P: dissipated power in mW, N: no. of loaded relays, IN: load current corresponding to the N relay.

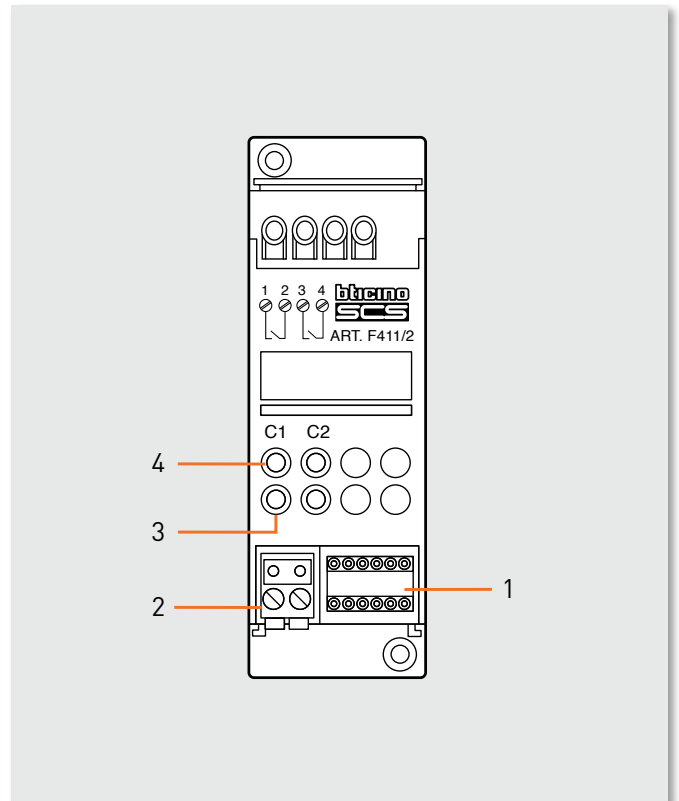

Legend

1. Configurator socket (attention, it must only be used in MyHOME systems with physical configuration)
2. BUS
3. LED
4. Push-button

Dimensional data

Size: 2 DIN modules

MyHOME Configuration

When installed in a MyHOME system, the device may be configured in two ways:

- PHYSICAL CONFIGURATION, by connecting the physical configurators to their sockets.
- VIRTUAL CONFIGURATION, by connecting the system to the PC using the Kit or the Web server. The Virtual configurator software must be installed on the PC.

Physical configuration

The actuator performs all the basic operating modes that can be configured directly on the control. Moreover further operating modes with the configurator in position M of the same actuator are listed in the table below.

Possible function	Configurator in M
Timed stop for motors. The device deactivates after the time set has elapsed ^[1] . This mode is only operative if LP1=LP2 (same configurators), i.e. with the two relays interlocked	none - 9 ^[1]
Master actuator with OFF control delayed on the corresponding Slave actuator. With the OFF control the Master actuator deactivates; the Slave actuator deactivates after the time set with the configurators has elapsed ^[2] . This model is only operative if PL1≠PL2.	none - 4 ^[2]
Actuator as Slave. Receives a control sent by a Master actuator with the same address.	SLA
Push-button (ON monostable) ignores Room and General controls.	PUL

Configurator	Time (minutes)
No configurator	1
1	2
2	5
3	10
4	infinite or until the next control
5	20 sec
6	10 sec
7	5 sec
8	15 sec
9	30 sec

2) The value of the configurator listed in the table defines the final time, after which the actuator disables its own slave.

Configurator	Time (minutes)
No configurator	0
1	1
2	2
3	3
4	4

Virtual configuration

Using the Virtual configurator software it is possible to perform all the functions listed below:

- light actuator
- rolling shutter actuator

Lighting Management configuration

When installed in a Lighting Management system, the device can be configured in the following ways:

- Plug&Go (see the dedicated technical guide)
- Project&Download,

Using the Virtual configurator software it is possible to perform all the functions listed below:

- Light actuator

Wiring diagrams

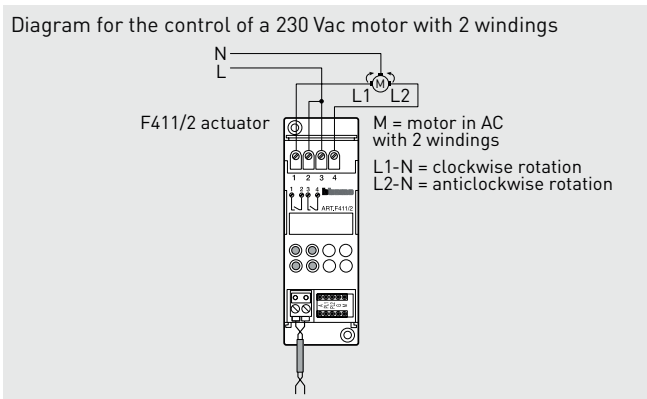
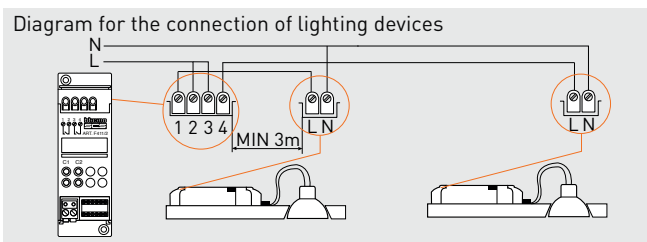

Bus meter with 3 inputs for toroids

Description

The SCS device measures currents and voltages of separate lines (up to 3), connecting maximum three toroids to the appropriate inputs (one toroid, item 3523 supplied as standard).

The meter processes and saves the following variables:

- instantaneous power in W;
- total energy accumulated in Wh.

The device has an internal memory that allows saving the following information:

- cumulative energy on an hourly basis for the last 12 months;
- cumulative energy on a daily basis for the last 2 years;
- cumulative energy on a monthly basis for the last 12 years.

In order to allow the device to archive consumption information, the system must be fitted with a device capable of supplying current date and time information (e.g. Touchscreen). If this information is not available, the meter will be unable to archive the data, and will continue calculating the values of the instantaneous variables (power). The space requirement for the device is equal to 1 DIN module. The device is provided with socket for 5 configurators: A1, A2, A3-Ta, A3-Tb, A3-Tc.

Technical features

Operating power supply with SCS BUS:	18 - 27 Vdc
Absorption:	35 mA max
Rated current:	16 A
Maximum current:	90 A
Operating temperature:	5 - 40 °C

Dimensional data

Size: 1 DIN module

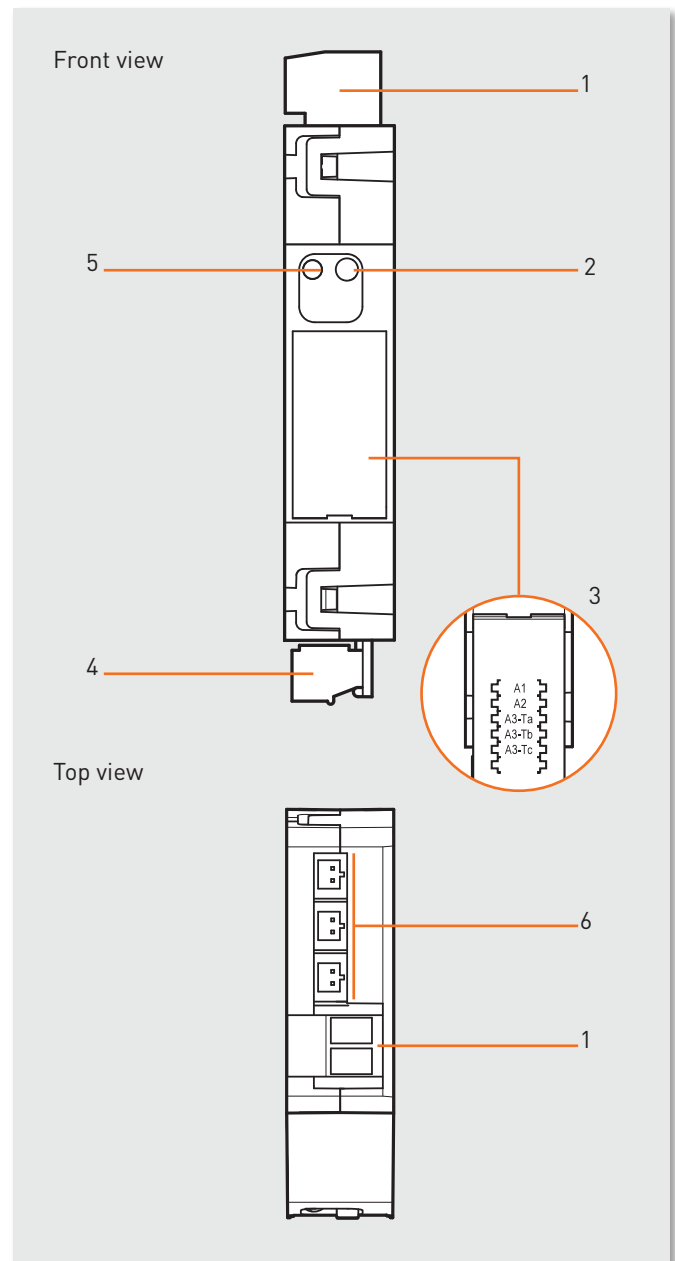

Legend

1. 230 Vac connection
2. Push-button for the deletion of cumulative energy data
3. Configurator sockets closing door
4. SCS/BUS connection
5. User interface LED, SEE TABLE
6. Ta, Tb, Tc connectors for toroids, item 3523

Configuration

The device can be configured by connecting the physical configurators to the correct sockets (Physical configuration).

The device is provided with socket for five configurators:

- A1 for the hundreds
- A2 for the tens
- A3 Ta for the units
- A3 Tb for the units
- A3 Tc for the units

The combination of the configurators defines:

- A1/A2/A3-Ta address of meter A
- A1/A2/A3-Tb address of meter B
- A1/A2/A3-Tc address of meter C

The maximum number of addresses is 255.

WARNING: The A3-Ta configurator cannot be zero, differently from configurators A3-Tb and A3-Tc, which can have a zero value (if the corresponding input is not managed). The meter must be installed as close as possible to the power supply, to ensure a high BUS voltage, and enable correct management of memory savings in case of voltage cut. If the supply voltage is insufficient (below 21 Vdc), the meter will cause the green LED to flash to signal the installation error. The device will work regularly, but will not guarantee correct saving and recovery of data in case of BUS failure.

- Procedure for the deletion of the cumulative energy data:
- 1 Press the key; after 20 seconds the orange LED flashes quickly; release the key.
 - 2 All the cumulative energy data are reset.

LED notifications based on the status of the power meter

Device status	LED
Normal operation	GREEN
BUS problems (BUS voltage insufficient, or voltage drop detected)	GREEN flashing 500 ms/500 ms
Installation error (230 Vac not detected)	RED flashing 100 ms/900 ms
Configuration error	ORANGE flashing irregularly on GREEN
No configuration	ORANGE flashing 128 ms/128 ms on GREEN

Wiring diagrams

Connection of the meter to the bus, the line, and the toroid

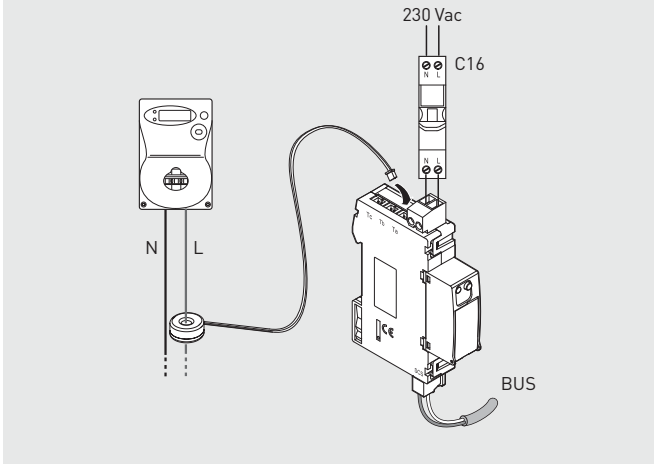

Scenario module

Description

This device allows you to manage scenarios for Automation, Sound system and Temperature Control systems which have been created, modified and activated using different devices of the Automation system. Up to 16 scenarios may be saved in the scenario module, with up to 100 controls each. The scenarios can also give door entry and Video door entry controls for one-family systems to switch on the staircase lights and open the door lock. If installed in large systems with interface item F422 in logical expansion, the module can save automation controls for the system where it is installed. On the front cover of the item there are two keys and two LED. The first push-button (padlock) locks or unlocks the programming procedure avoiding involuntary operations such as cancelling the scenarios and the corresponding LED indicates the status: **green** programming possible, **red** programming blocked, **orange** temporary block. The second push-button (DEL) cancels all the scenarios, the LED underneath indicates that the cancellation has taken place or that the device is performing the learning procedure.

Technical features

Power supply from SCS BUS:	27 Vdc
Operating power supply with SCS BUS:	18 - 27 Vdc
Absorption:	20 mA
Operating temperature:	0 - 40 °C
Size:	2 DIN modules

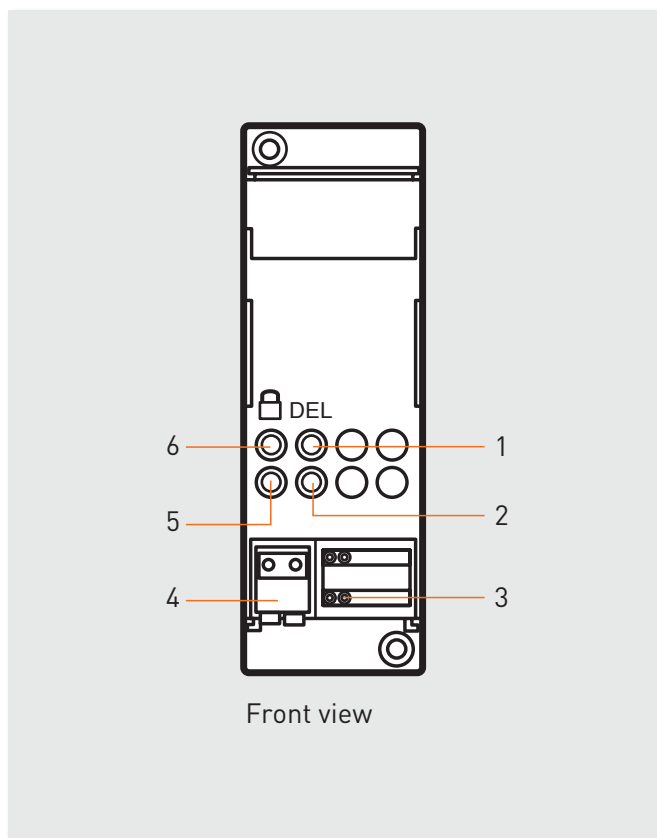

Legend

1. Scenario cancellation push-button
2. Scenarios/learning reset LED
3. Configurator socket
4. BUS
5. Programming status LED
6. Lock/unlock programming push-button

Configuration

The combination of the scenario module with a control device is ensured by assigning to both items the same address. This is identified by the configurators with a numeric value for position A = 0-9 and position PL = 1-9. When using a Touchscreen, the address of the scenario module must be specified during programming, using the Tidisplay software. Several scenario modules may be installed in one system, allocating a different address to each module.

Scenario programmer

In order to program, change or cancel a scenario, it is necessary to enable the programming mode of the Module item F420 so that the status LED is green (press the lock/unlock key on the Scenario Module for at least 0.5 seconds); continue with the following operations:

- 1) press one of the four control keys the scenario should be associated to for 3 seconds. The corresponding LED starts flashing;
- 2) set the scenario using the corresponding controls for the various Automation, Temperature control, Sound system, etc. functions;
- 3) Confirm the scenario by quickly pressing the corresponding key on the control to exit programming mode;
- 4) to change or create new scenarios to be linked to the other keys, repeat the procedures starting from point 1.

To call a set scenario just press its push-button on the control quickly. If the module does not receive any input for 30 minutes from the start of the learning procedure, programming will automatically be interrupted. To cancel a scenario completely, keep the corresponding push-button pressed for about ten seconds. To erase the entire memory keep the DEL push-button on the Scenario module pressed for 10 seconds, the yellow "reset scenarios" LED flashes quickly. Once the operations have been performed lock the programming by pressing the lock/unlock push-button for at least 0.5 seconds, so that the corresponding LED becomes red.

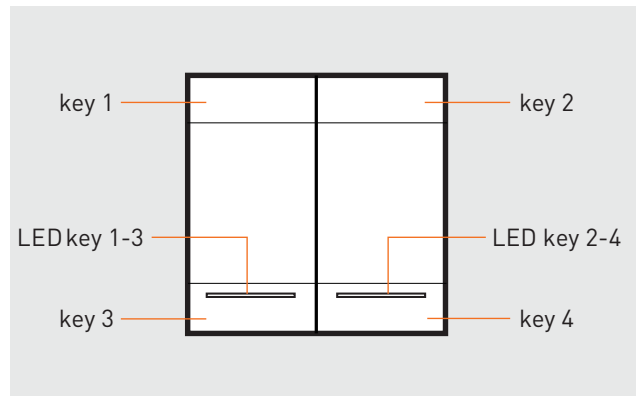

NOTES:

Inside the system itself one Scenario module can be programmed at a time as the other devices are temporarily locked; during this phase the "programming status" LED becomes orange signalling the temporary Lock. During the learning procedure and when there are timed controls or group controls, the Scenario module does not save events for 20 seconds. You must thus wait before continuing with creating the scenario. During the scenario learning procedure only the changes of status are saved. The scenario module should be configured with a different A and PL address from that of an actuator. Use A=0 and PL=1 to 9, which cannot be used by actuators. If the configuration is wrong the Programming status LED flashes ORANGE. In case of "virtual" configuration the LED flashes RED.

Basic control for 2 independent loads

Description

Two-module, push mounted and lowered special control with 4 push-buttons and 4 LEDs. The device can control one single actuator for single or double loads, or two actuators for single or double loads, independent from each other.

The device may be installed in a MY HOME system and can be configured both physically and virtually, or as a component of the Lighting Management system, using specific configuration procedures (Plug&go, Push&Learn, Project&Download).

Technical features

Power supply from SCS BUS:	27 Vdc
Operating power supply with SCS BUS:	18 – 27 Vdc
Absorption with maximum LED intensity:	6 mA for H4652/2 and 067552
	8.5 mA for L4652/2 and AM5832/2

Dimensional data

Size: 2 push mounted modules

Dimensional data

When installed in a MY HOME system, the device may be configured in two ways:

- PHYSICAL CONFIGURATION, by connecting the physical configurators to their sockets.
- VIRTUAL CONFIGURATION, by connecting the system to the PC using the 3503N Kit or the web server. The Virtual configurator software must be installed on the PC

Lighting Management configuration

When installed in a Lighting Management system, the device can be configured in the following ways:

- Plug&Go (see the dedicated technical guide)
- Push&Learn
- Project&Download,

Using the Virtual Configurator software it is possible to perform all the functions listed below:

- double light control
- double CEN control
- double CEN PLUS control
- double AUX control

For more information on the functions see the glossary before the Technical sheets chapter.

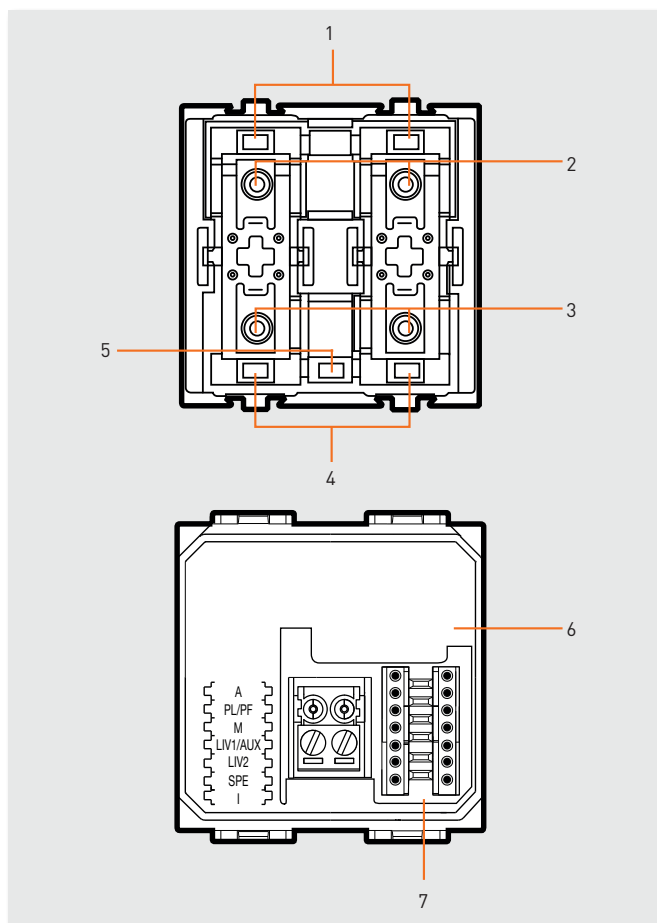

Legend

1. LED
2. Upper push-button
3. Lower push-button
4. LED
5. Push-button for LED adjustment/exclusion
6. Configurator socket (attention, it must only be used in MyHOME systems with physical configuration)
7. BUS

LED adjustment

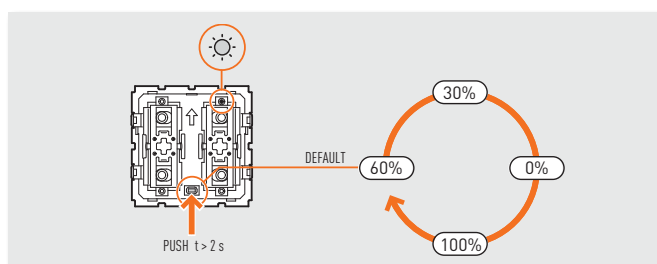

Configuration

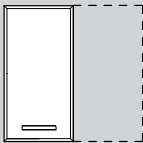
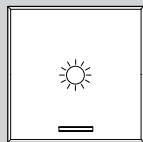
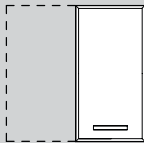
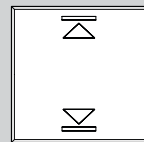
Possible function	Combination of key covers used/Configurator in M1 and M2	
	1 Function	2 Functions
	 	 
ON control	ON	-
OFF control	OFF	-
Timed ON control ²⁾	1 - 8	-
Dimmer - ON control (upper key)		
OFF (lower key) + adjustment ¹⁾	-	0/1
Cyclical ON-OFF control + adjustment ¹⁾	no configurator	-
UP/DOWN rolling shutter to end of stroke	-	
Monostable rolling shutter UP/DOWN	-	M
Bistable rolling shutter up-down movement. Blades adjustment if the pressure time is less than 1.5 s. Up-down to the end of travel if the control is pressed for more than 1.5 s.	-	6
Push-button (ON monostable)	PUL	-
Activation of scenarios managed by the programmer MH200N ³⁾	-	CEN
	Time (minutes)	
	-	6
Push-button (ON monostable)	PUL	-
Activation of scenarios managed by the programmer MH200N ³⁾	-	CEN
	Configurator	Time (minutes)



Virtual configuration

Using the Virtual Configurator software it is possible to perform all the functions listed below:

- double scenario control
- double CEN control
- double scenario PLUS control
- double CEN PLUS control

SCS Dimmer

Technical features

	Halogen lamps		LED dimmer lamps		Compact CFL dimmer lamps	
						
220 – 240 Vac	200 W	0,9 A	200 W	0,9 A	200 W	0,9 A
110 – 127 Vac	100 W	0,9 A	100 W	0,9 A	100 W	0,9 A

- Product tested using main brands of lamp
- NO connection mixed loads
- NO installation of several dimmers side by side
- NO installation of a dimmer side by side with a power supply

Wiring diagrams

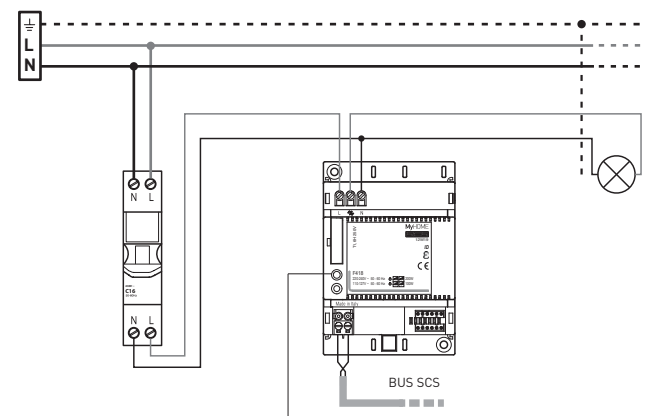

- Green LED = load voltage OFF
- Red LED = load ON
- Flashing LED = load fault

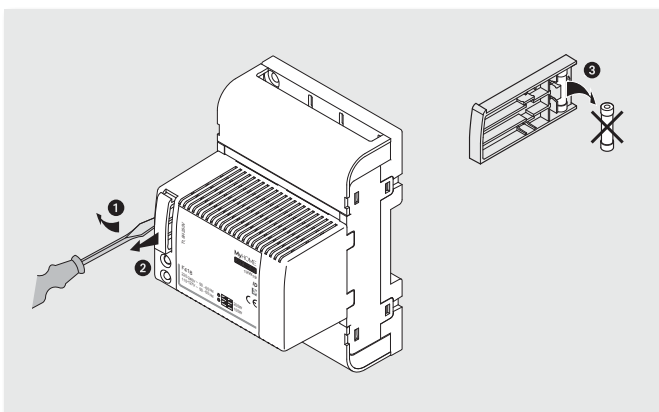
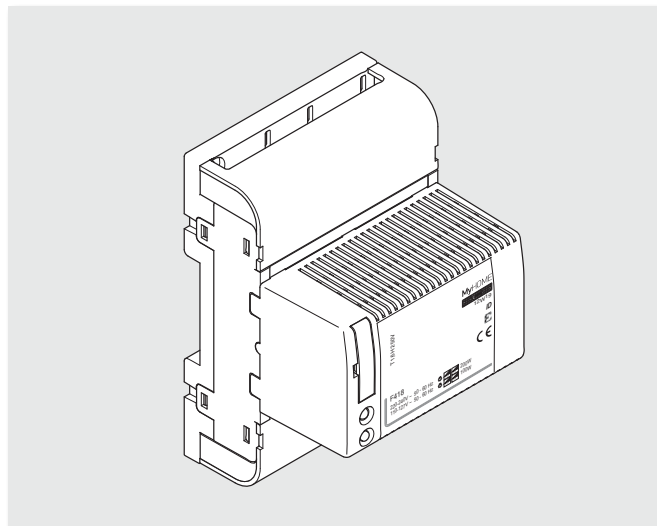

ATTENTION: when replacing faulty fuses always disconnect the supply voltage (open the main switch).

Power supply

Warning

During the operation of electric devices powered by the electric power line, some parts may be subjected to dangerous voltage levels. The installation and assembly of the device must be performed in accordance with the following installation rules:

- the power supply must only be installed and assembled by qualified personnel;
- the power supply must only be installed inside switchboards suitable for DIN devices;
- the device is only suitable for indoor installation;
- the device must be kept away from water drips and sprays.
- an omnipolar switch with minimum 3mm distance between contacts must be installed near the power supply;
- the above described switch is to be used as the device for disconnecting the power supply from the power line;
- ensure that during the assembly of the devices the power supply is not connected to the power line;
- before powering the system, check the cable connections, and ensure that the line voltage is compatible with the power supply;
- the installation must be completed in accordance with current installation rules. Improper use of any items may compromise their safety.

Technical features

PRI (AC power supply input)

- | | |
|-----------------------------------|---------------|
| ■ Rated voltages: | 220 – 240 V |
| ■ Rated currents: | 200 – 190 mA |
| ■ Nominal working voltages: | 187 – 265 V |
| ■ Nominal working frequencies: | 50 – 60 Hz |
| ■ Power consumption at full load: | 21.5 W max |
| ■ Power consumption: | 5.3 W max |
| ■ Performance at full load: | 80% typ. |
| ■ Stand-by consumption: | less than 1 W |
| ■ Operating temperature: | 5 – 40 °C |
| ■ Integrated fuse (PRI side): | F1 T2A 250 V |

SCS

- | | |
|------------------|-----------------|
| ■ Rated voltage: | 27 V +/- 100 mV |
| ■ Rated current: | 0 – 0,6 A |
| ■ Rated power: | 16,2 W |

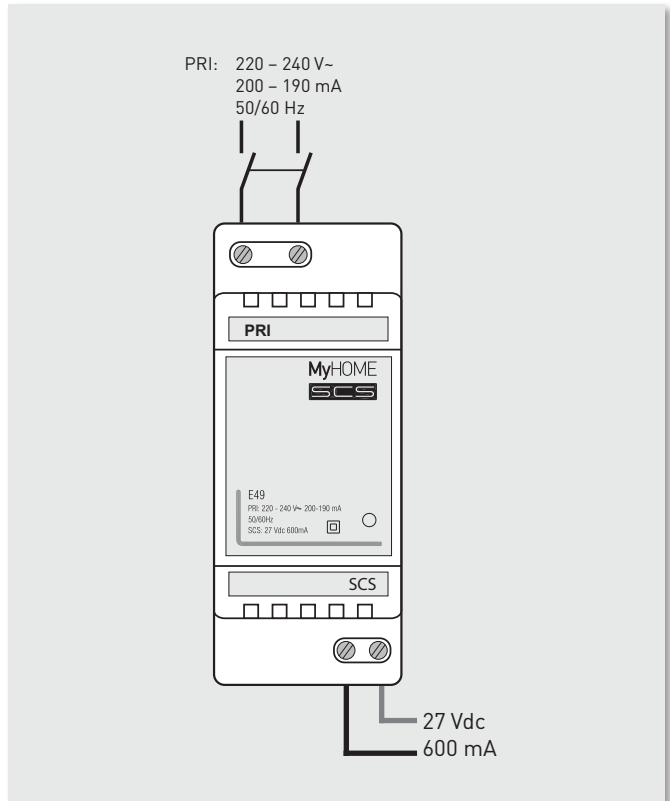

Legend

- Green LED - power supply on
- Red LED - output current overload

Scenarios

Lets you activate scenarios that have been previously stored in one or more "scenario units" and "scenario modules" of your MyHOME system.

Touch the scenario icon .

The display will show the page where you can find the scenarios you can activate.

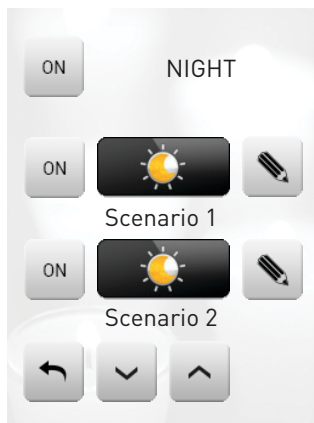

Touch the icon  to activate the scenario.

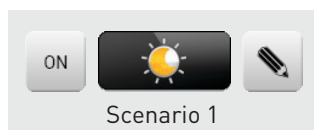

This command lets you activate a scenario of the Scenario Module.

Furthermore, when you touch the icon , new icons will appear which will allow you to cancel or programme a new scenario according to the functioning mode of the Scenario Module.



If the icon  is not displayed, the scenarios module is blocked.

Creating a new scenario



1. Touch the icon to start a new scenario programming procedure.
2. Prepare your scenario by adjusting the light level of the dimmer and the lights (on or off).
3. Return to the touch screen and touch the scenarios
4. Touch the icon to end programming.
5. Touch the icon to return to the menu of the scenarios programmed by you.

Removing a scenario



1. Touch the icon to remove a scenario programmed by you.

4 year extended warranty

Legrand understands the importance of having dependable products that work efficiently and effectively thus they offer a 4 year extended warranty on the MyHOME Lighting Control and Energy Monitoring kit. When you buy this kit you can be certain that the product lives up to the high standards of Legrand and that if in the unlikely event there is a problem with your kit, it will be repaired by a fully qualified and experienced Legrand technician.

HPM Legrand will honour all statutory guarantees that you as a consumer are entitled to rely upon under the Australian Consumer Law against a manufacturer including a guarantee that any products HPM Legrand has manufactured or imported/ the products which are described in this Instruction Manual (Products) are of acceptable quality.

To make a claim under any statutory guarantee or other warranty you should first contact the supplier, contractor or retailer from whom you purchased the Products.

1. HPM Legrand (“we” or “us”) has given each Purchaser who is a Consumer (“you”) a warranty against defects in its Products.
2. As a Consumer you are entitled to the benefit of the Warranty and should read and understand its terms. In addition for the purposes of the Australian and New Zealand Consumer Laws, we note the following:

(a) Our contact details for the purpose of any claims made under the Warranty are below:

AUSTRALIA ONLY

Legrand Australia Pty Ltd
Nexus Industry Park
Bldg 4, 43-47 Lyn Pde
PRESTONS NSW 2170
1300 369 777
sales.orders@hpmlegrand.com.au

NEW ZEALAND ONLY

HPM Legrand New Zealand Ltd
106-124 Target Rd
GLENFIELD AUCKLAND 0627
0800 476 009
nz.sales@hpmlegrand.co.nz

(b) Any claim under the Warranty must sent in writing to the following address:

AUSTRALIA ONLY

Warranty Claims Officer – Consumer Products
Legrand Australia Pty Ltd
Nexus Industry Park
Bldg 4, 43-47 Lyn Pde
PRESTONS NSW 2170

NEW ZEALAND ONLY

Warranty Claims Officer – Consumer Products
HPM Legrand New Zealand Ltd
106-124 Target Rd
GLENFIELD AUCKLAND 0627

(c) If we accept your claim under the Warranty we will reimburse all your reasonable expenses in making and pursuing the claim, including the cost of reimbursement of any defective Products returned in the ordinary course to us at the address above by post or other agreed means. Any such claim must be made within 14 days of your receiving notice of our acceptance of your claim and include any necessary supporting documentation or invoices.

3. As a Consumer you have rights under the Australian and New Zealand Consumer Laws and may have rights under other applicable laws which cannot be excluded, restricted or modified. Those rights are in addition to any rights you have under the Warranty.
4. Our goods (which we refer to in the Warranty as the Products) come with guarantees that cannot be excluded under the Australian and New Zealand Consumer Laws. You are entitled to a replacement or a refund for a major failure and for compensation for any other reasonably foreseeable loss or damage. You are also entitled to have the goods repaired if the goods fail to be acceptable quality and the failure does not amount to a major failure.

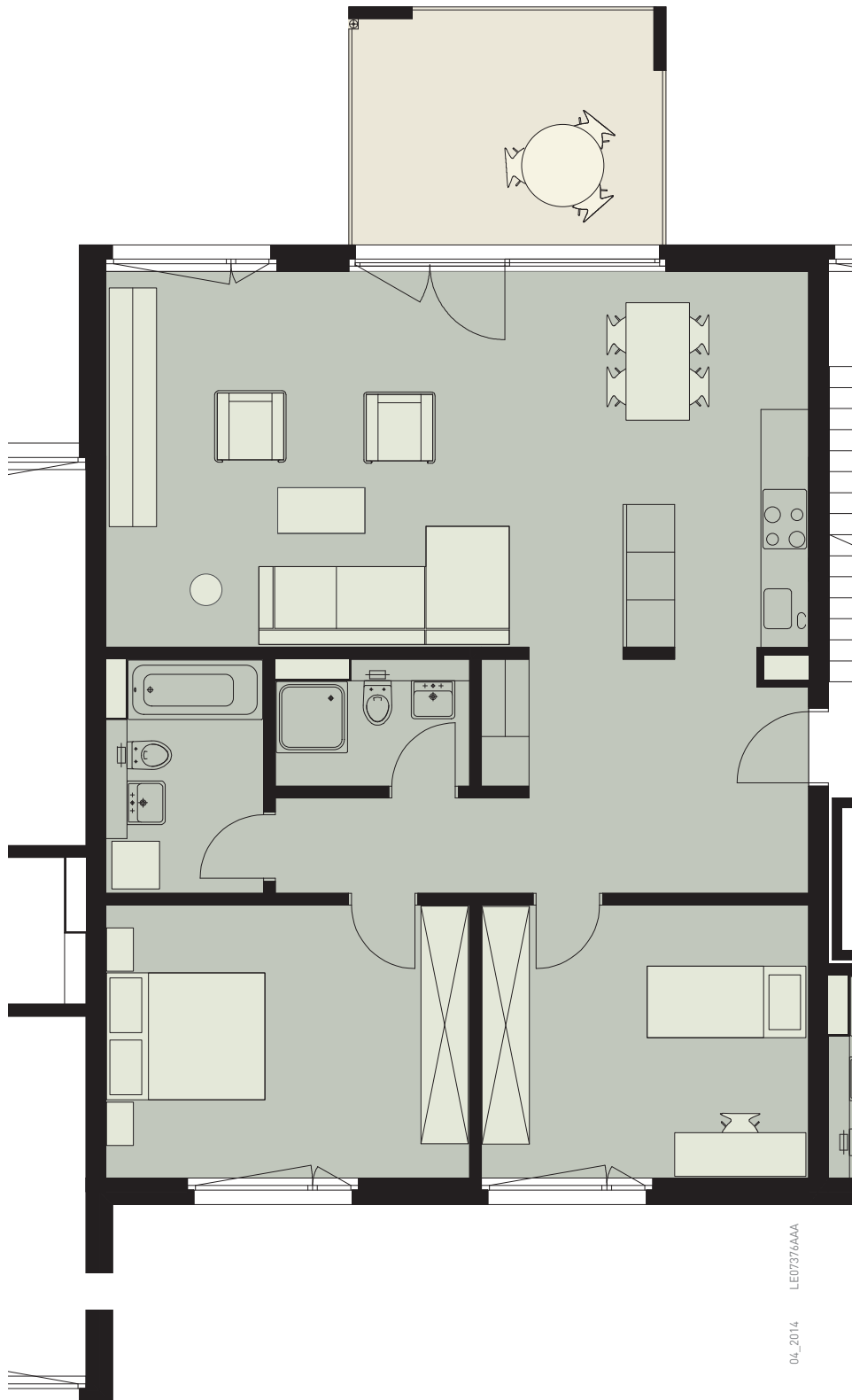

HPM Legrand Australia
Building 4, Nexus Industry Park
Lyn Parade, Prestons NSW 2170
Tel: 1300 369 777
www.legrand.com.au

HPM Legrand New Zealand
106-124 Target Road, Glenfield
Auckland 0627 New Zealand
Tel: 0800 476 009
www.legrand.co.nz