



BOSCH

Service Manual

Gas Condensing Combi Boilers Singular

Singular 4000 | Singular 5200



⚠ WARNING:

If the information in these instructions are not followed exactly, a fire or explosion may result causing property damage, personal injury or death.

⚠ WARNING:

Do not store or use gasoline or other flammable vapors and liquids in the vicinity of this or any other appliance.

WHAT TO DO IF YOU SMELL GAS

- Do not try to light any appliance.
- Do not touch any electrical switch; do not use any phone in your building.
- Immediately call your gas supplier from a neighbor's phone. Follow the gas supplier's instructions.
- If you cannot reach your gas supplier, call the fire department.

⚠ WARNING:

Improper installation, adjustment, alteration, service or maintenance can cause property damage, personal injury (exposure to hazardous materials)* or loss of life. Refer to the user's information manual provided with this boiler. Installation and service must be performed by a qualified installer, service agency or the gas supplier who must read and follow the supplied instructions before installing, servicing, or removing this boiler. This boiler contains materials that have been identified as carcinogenic, or possibly carcinogenic, to humans.

This boiler must be installed in accordance with local, state, and federal codes. In the absence of such requirements, then to the latest edition of the National Fuel Gas Code, ANSI Z223.1./NFPA 54. In Canada, installation must be in accordance with the requirements of CAN/CSA B149.1, Natural Gas and Propane Installation Code.

BTC 439002301A / 12.2021



Certified to NSF/ANSI 372

Table of Contents

1	Key to Symbols and Safety Instructions	4	9	Components Replacement Instructions	54
1.1	Key to Symbols	4	9.1	Preparation Step	54
1.2	Safety	4	9.2	Control Board	55
2	Key Components	6	9.3	Sensor, Heating/Return	55
3	Technical Data	8	9.4	Sensor, DHW	55
4	Dimensions	9	9.5	Exhaust Temperature Sensor_T4 (Blue)	55
5	Setting the DIP Switches	10	9.6	Gas Orifice	56
6	Wiring Diagram	11	9.7	Air Pressure Switch	56
7	Key Components Description	12	9.8	Gas Valve	57
7.1	Pump	12	9.9	High Limit Cutout HEX T2 (302°F)	57
7.2	Turn Down Ratio (TDR) Solenoid valve	12	9.10	High Limit Cutout Supply T3 (203°F)	57
7.3	Orifice	13	9.11	Ignition Transformer	57
7.4	Fan	13	9.12	Electrode Assembly	58
7.6	High Limit Cutout HEX T2 (302°F)	14	9.13	Flame Rod	58
7.7	High Limit Cutout Supply T3 (203°F)	14	9.14	Touch pad	59
7.8	Primary Heat Exchanger	14	9.15	Condensation Trap	59
7.9	Secondary Heat Exchanger	15	9.16	Turbo Fan	60
7.10	Sensor	15	9.17	Solenoid Valve	61
7.11	Electrode	16	9.18	Heat Exchanger	62
7.12	Flame Rod	16			
7.13	Ignition Transformer & Wire	16	10	Flushing the Heat Exchanger	65
7.14	Burner	17			
7.15	Gas Valve	17			
7.16	Touch Pad	17			
7.17	Control Board	18			
7.18	Condensate Trap Assembly	18			
7.19	Air Pressure Switch	18			
8	Troubleshooting	19			
8.1	A2 Error (Abnormal Operation: Fan)	19			
8.2	A3 Error (Abnormal Operation: Pump)	21			
8.3	A4 Error (Overheating of Heat Exchanger)	23			
8.4	A5 Error (Low Water Pressure)	25			
8.5	A6 Error (Ignition Error)	27			
8.6	A7 Error (Abnormal Operation: Gas Valve Relay)	29			
8.7	A8 Error (Abnormal Operation: Gas Valve)	29			
8.8	A9 Error (Exhaust Temperature Sensor Error)	31			
8.9	AA Error (Overheating)	33			
8.10	AB Error (Abnormal Operation: Heat Exchanger Temperature Sensor)	34			
8.11	AC Error (Abnormal Operation: DHW Sensor)	36			
8.12	AD Error (Clog of Condensate Trap)	38			
8.13	AE Error (Blockage of Flue Pipe)	40			
8.14	EO Error (Abnormal Operation: Outdoor Temperature Sensor)	42			
8.15	E1 Error (Abnormal Operation: Exhaust Temperature Sensor)	44			
8.16	E2 Error (Exhaust Temperature Overheating)	46			
8.17	E3 Error (Abnormal Operation: Return Sensor)	48			
8.18	E4 Error (Abnormal Operation: Pressure Sensor)	50			
8.19	E7 Error (Abnormal Operation: Gas Valve Relay)	52			
8.20	EB Error (Hot Water Overheating)	52			

1 Key to Symbols and Safety Instructions

1.1 Key to Symbols

Warnings



Warnings in this document are identified by a warning triangle printed against a grey background. Keywords at the start of a warning indicate the type and seriousness of the ensuing risk if measures to prevent the risk are not taken.

The following keywords are defined and can be used in this document:

- ▶ **DANGER** indicates a hazardous situation which, if not avoided, will result in death or serious injury.
- ▶ **WARNING** indicates a hazardous situation which, if not avoided, could result in death or serious injury.
- ▶ **CAUTION** indicates a hazardous situation which, if not avoided, could result in minor to moderate injury.
- ▶ **NOTICE** is used to address practices not related to personal injury.

Important information



This symbol indicates important information where there is no risk to people or property.

1.2 Safety

Please read before proceeding



WARNING: FIRE, EXPLOSION

- ▶ Vapors from flammable liquids can explode and/or catch fire causing death or severe burns.
- ▶ Keep flammable products far away from the boiler and store them in approved containers. Keep the containers tightly closed and out of the reach of children.
- ▶ The boiler has a main burner flame that can come on at any time and will ignite flammable vapors.
- ▶ Vapors cannot be seen and are heavier than air. They can travel long distances along the ground and can be carried from other rooms to the boiler's main burner flame by air current.



WARNING: SCALD HAZARD

- ▶ Water temperature over 125°F can cause severe burns or death from scalding.
- ▶ If it is necessary to set the water temperature above 125°F (52°C), consider installing a thermostatically-controlled mixing valve. Contact a licensed plumber or your local plumbing authority for more information.
- ▶ Children, the disabled and the elderly are at highest risk of being scalded.
- ▶ Test water before bathing or showering.

Temperature	Time to Produce Serious Burn
120 °F (48 °C)	More than 5 minutes
125 °F (51 °C)	1.5 to 2 minutes
130 °F (54 °C)	Approx. 30 seconds
135 °F (57 °C)	Approx. 10 seconds
140 °F (60 °C)	Less than 5 seconds
145 °F (62 °C)	Less than 3 seconds
150 °F (65 °C)	Approx. 1.5 seconds
155 °F (68 °C)	Approx. 1 second

Table 1



WARNING: RISK OF PERSONAL INJURY OR DEATH FROM EXPLOSION!

- ▶ Work on gas components may only be carried out by a trained and certified installer or service company.
- ▶ Appliance installation, the connection of gas and vent piping, initial commissioning, electrical connections, and service and maintenance must only be carried out by a trained and certified installer or service company.

WARNING: FIRE, EXPLOSION

- ▶ Do not store combustibles, such as papers or laundry, near the boiler or venting system.
- ▶ Do not store or use gasoline or other flammable liquids near this boiler.
- ▶ Do not store or use compressed gases, such as hair sprays or spray paints, near the boiler or venting system, including the vent termination.

WARNING: HAZARDOUS VOLTAGE

- ▶ Do not remove the front cover unless the power to the boiler is turned off or disconnected.
- ▶ Do not touch the internal components of the boiler or the power cord with wet hands.

WARNING: FIRE, CARBON MONOXIDE

- ▶ Do not operate the boiler with the front cover opened.
- ▶ Do not operate the boiler without proper venting.
- ▶ Do not place anything in or around the vent terminals that could obstruct the air flow in or out of the boiler.

WARNING: FIRE, EXPLOSION

- ▶ Have your installer or plumber show you the location of the gas shut off valve and demonstrate how to close the valve. If the boiler is damaged as a result of overheating, fire, flood, or any other reason, close the manual shut off valve and do not operate the boiler again until it has been inspected by a qualified technician.

WARNING: FIRE, EXPLOSION

- ▶ Should overheating occur or if the gas supply fails to shut off, turn off the manual gas shut off valve.

WARNING: PERSONAL INJURY, PROPERTY DAMAGE

- ▶ Do not allow children to operate or have access to the boiler.

WARNING: IMPROPER OR DANGEROUS OPERATION

- ▶ Immediately call a qualified service technician to inspect the appliance and replace any part of the control system and/or any gas control which has been immersed in water.

WARNING:

- ▶ This product can expose you to chemicals including Lead and Lead components, which are known to the State of California to cause cancer and birth defects or other reproductive harm. For more information go to www.P65Warnings.ca.gov.

WARNING: FIRE, CARBON MONOXIDE

- ▶ After replacement of a gas related component, where a gasket or seal has been disturbed or replaced, check for gas tightness using a gas detector / analyzer.
- ▶ On re-assembly check all affected seals for cracks hardness and deterioration. If damaged or in any doubt the seal must be replaced.

CAUTION: INTENDED USE

- ▶ Do not use the boiler for anything other than its intended purpose, as described in this manual.

CAUTION: IMPROPER OR DANGEROUS OPERATION

- ▶ Do not use unapproved replacement or accessory parts.
- ▶ When servicing the controls, label all wires prior to disconnecting them to prevent wiring errors.
- ▶ Do not attempt to repair or replace any part of the boiler, unless it is specifically recommended in this manual. For all other service, contact an authorized technician or licensed professional. Improper adjustments, alterations, service, or maintenance may lead to property damage, personal injury, or death and will void your warranty.

NOTICE: BOILER DAMAGE

- ▶ Do not turn on the boiler unless the water and gas supplies are fully opened. Failure to do so may damage the boiler.

2 Key Components

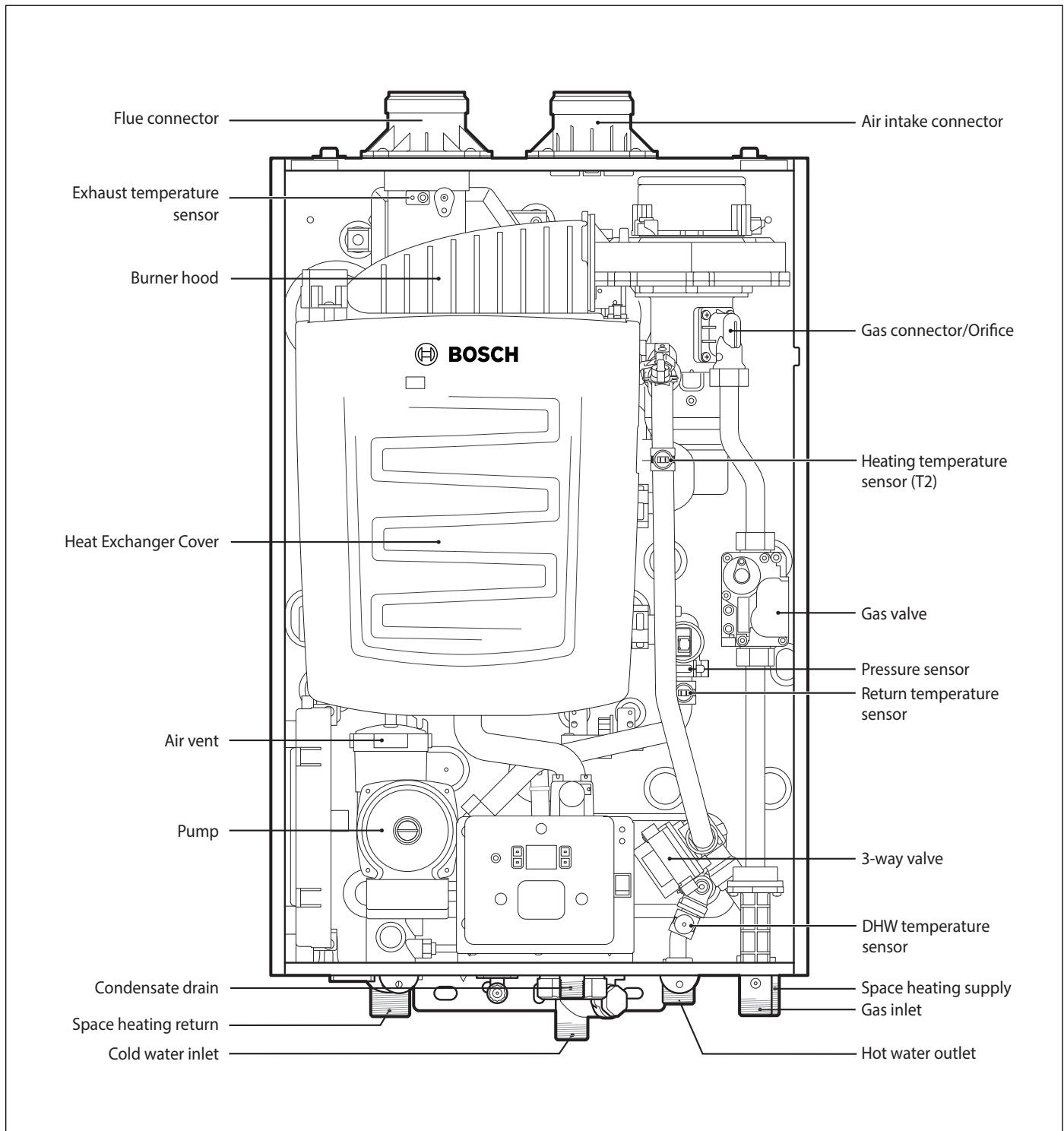

Figure 1

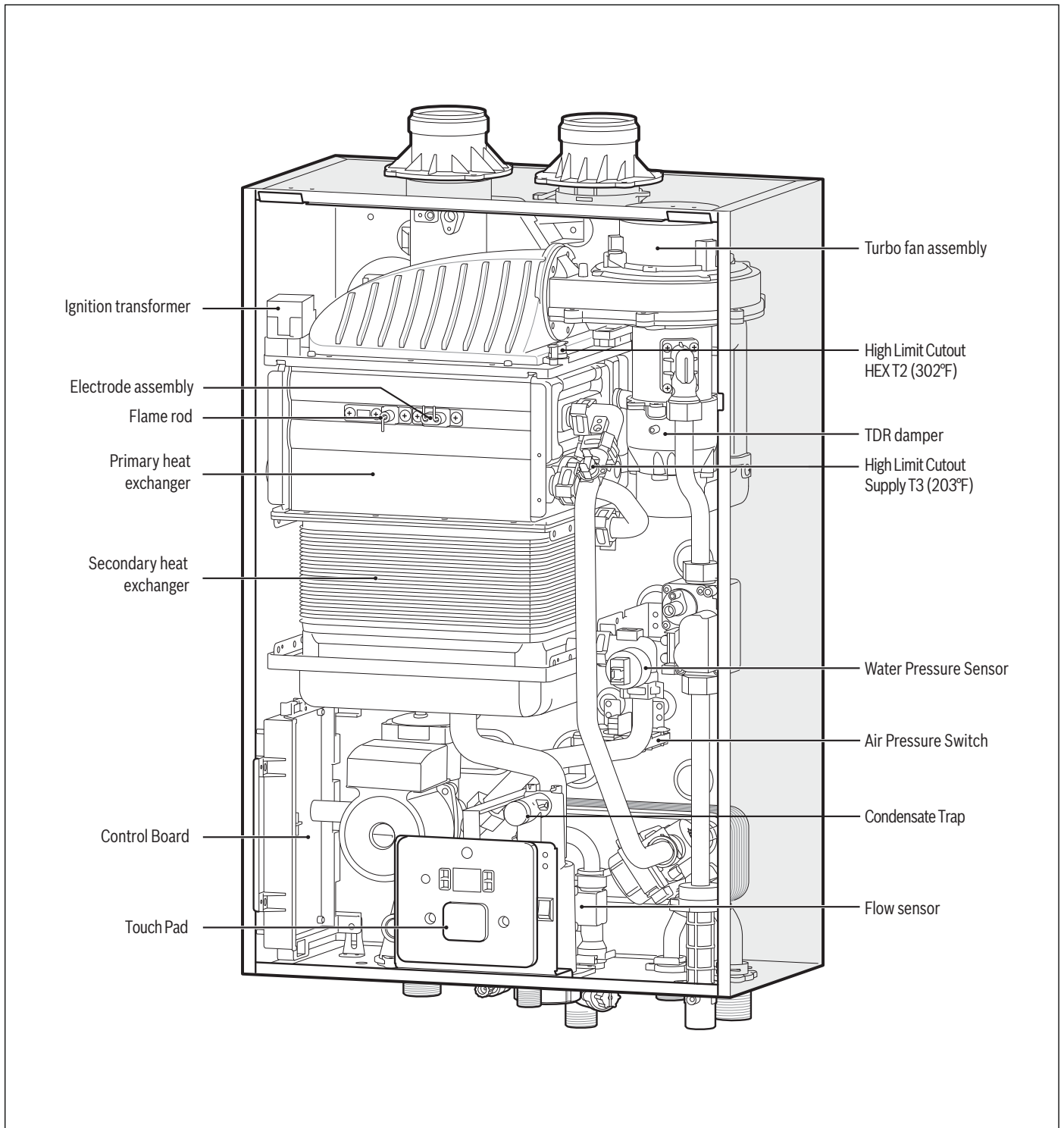

Figure 2

3 Technical Data

		Singular 4000	Singular 5200
Heat Capacity (Input)	Space Heating	19,900–80,000 BTU/H	19,900–140,000 BTU/H
	Domestic Hot Water	19,900–155,000 BTU/H	19,900–199,000 BTU/H
Flow Rate (DHW)	45°F (25°C) Temp Rise	6.0GPM (23LPM)	7.7GPM (29LPM)
	67°F (37°C) Temp Rise	4.0GPM (15LPM)	5.2GPM (20LPM)
AFUE	Natural Gas (propane)	95.0% (95.0%)	95.0% (95.0%)
Dimensions (W x D x H)		18.1" x 27.6" x 11.6" (460 mm x 700 mm x 295 mm)	
Installation Type		Indoor wall-hung	
Venting Type		Forced draft direct vent	
Ignition		Electronic ignition	
Water Pressure(Hydronic/DHW)		12~30psi /15~150 psi	
Supply Pressure	Natural Gas	3.5" – 10.5" WC	
	Propane	8" – 13" WC	
Temperature Range	Space Heating	82°F – 180°F(27°C – 82°C)	
	DHW	86°F – 140°F(31°C – 60°C)	
Minimum Flow Rate (DHW)		0.5GPM(2.0LPM)	
Power Supply	Main Supply	120V AC, 60 Hz / uses less than 5 AMP	
Connection Sizes	Space heating Supply/Return	1" NPT	
	Cold water Inlet	3/4" NPT	
	Hot Water Outlet	3/4" NPT	
	Gas Inlet	3/4" NPT	
Materials	Primary Heat Exchanger	Stainless steel	
	Secondary Heat Exchanger	Stainless steel	
Venting	Exhaust/Intake	"2"" or 3"" PVC, CPVC, Polypropylene 2"" or 3"" Special gas vent type BH (Class II, A/B/C)"	
	Length	2"	60ft(18.3m)
		3"	150ft(45.7m)
Vent Clearances		0" to combustibles	
Safety Devices		Flame rod, APS, Over heat preventer, Low water cut off switch, Exhaust temperature high limit sensor, Power surge fuse	

Table 2

4 Dimensions

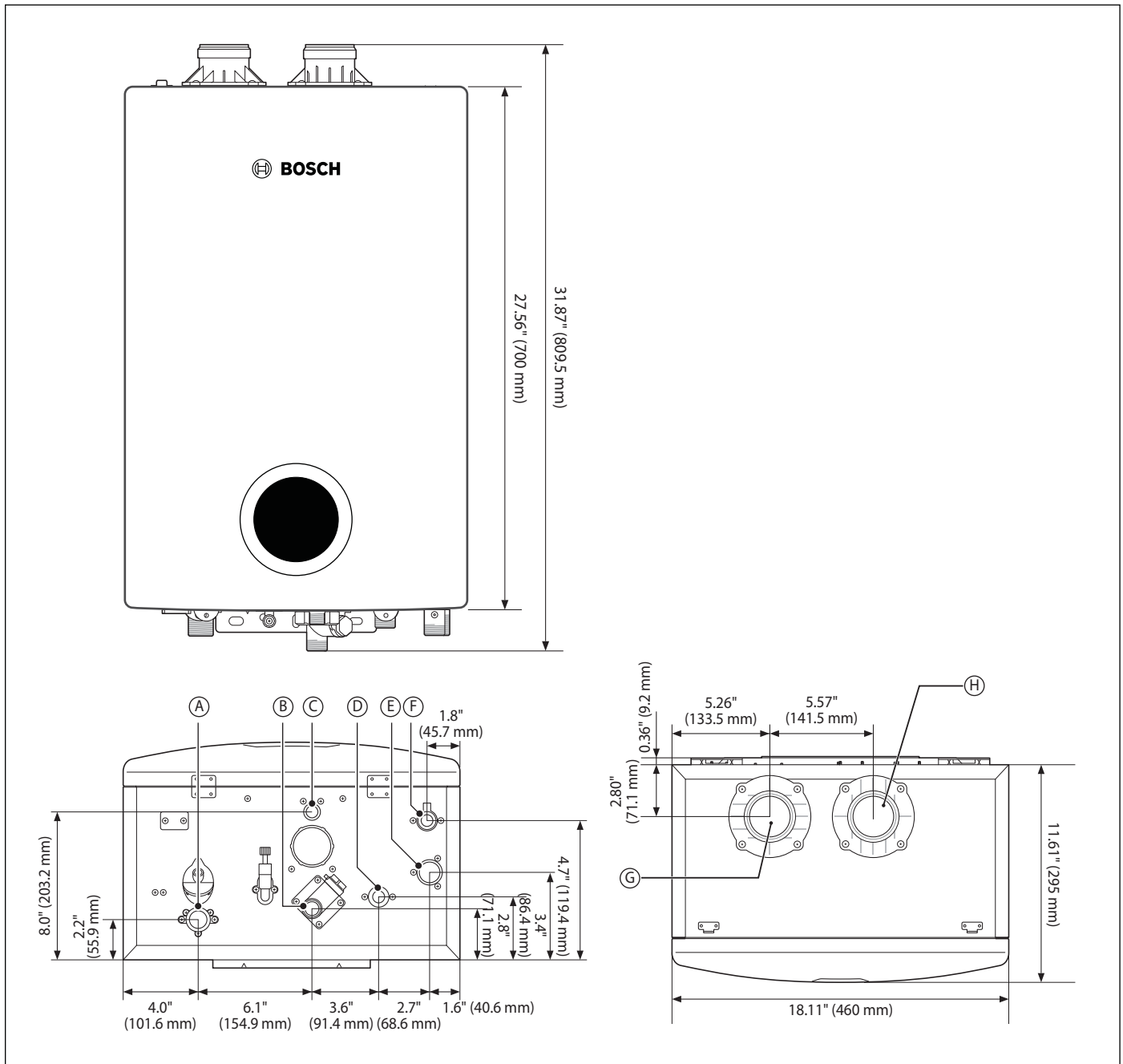

Figure 3

Position	Description	Diameter
A	Space heating Return	1" NPT
B	Cold water inlet	3/4" NPT
C	Condensate Outlet	1/2" NPT
D	Hot water Outlet	3/4" NPT
E	Space heating Supply	1" NPT
F	Gas Inlet	3/4" NPT
G	Exhaust Vent	2"
H	Air inlet	2"

Table 3

5 Setting the DIP Switches

The boiler has a DIP switch on the main circuit board (PCB)

Set the DIP switch appropriately, depending on the installation environment.

Switch	Function				
	Temperature limit switch for exhaust gas	ON: No temperature limit for exhaust gas OFF: Temperature limit for exhaust gas			
	EEP ROM data change switch	ON: Enable EEP ROM data change OFF: Disable EEP ROM data change			
	Long flue Length 1	DIP S/W #3	DIP S/W #4	FLUE LENGTH	
				2" PVC	3" PVC
	Long flue Length 2	OFF	OFF	Up to 15'	Up to 150'
		OFF	ON	Up to 30'	N/A
		ON	OFF	Up to 45'	
	N/A	N/A			
	Minimum heat capacity operation	ON : Minimum operation OFF : Normal operation			
	Maximum heat capacity operation	ON : Maximum operation OFF : Normal Operation			
	N/A	N/A			

Table 4 Dip Switches

6 Wiring Diagram

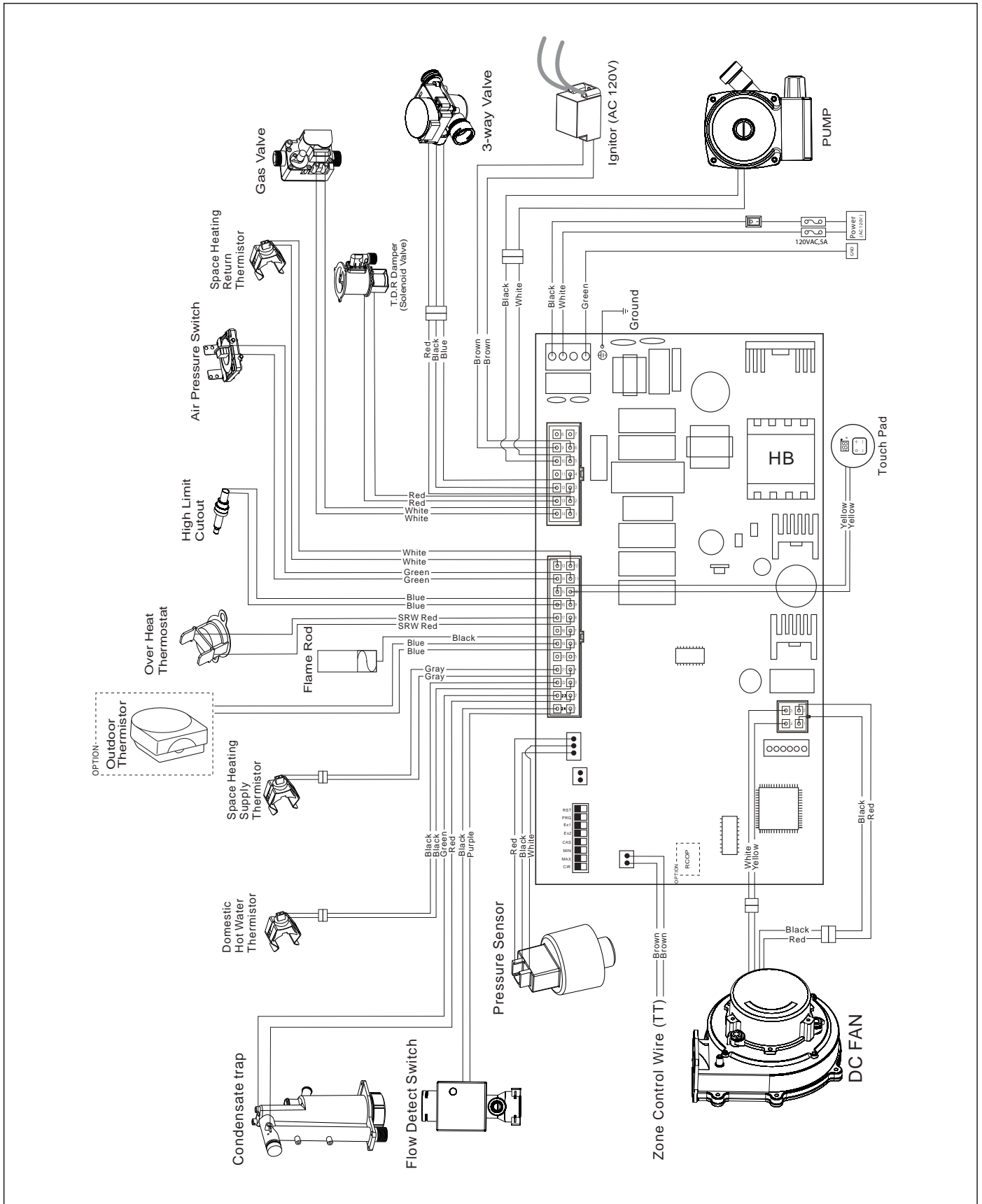

Figure 4

7 Key Components Description

7.1 Pump

Part No.	7738007283	
Function	<ul style="list-style-type: none"> ▶ Carries out combustion by circulating the water in the pipe. ▶ Circulates the water when the water temperature is 59°F (15°C) or below to prevent the boiler from freezing and bursting. 	
Failure Event	Unable to detect or measure water pressure change when the pump operates.	
Effects	<ul style="list-style-type: none"> ▶ The device may freeze. ▶ The boiler does not operate. 	
Error Code	—	
Diagnostic	<ul style="list-style-type: none"> ▶ Visual inspection : Check the circulation pump connection wire ▶ Voltage check : Check range of voltage shown below 	
Color/Number of Wires	BLACK - WHITE <ul style="list-style-type: none"> ▶ ON: AC 120 V ± ▶ OFF: 0 V 	

Table 5

7.2 Turn Down Ratio (TDR) Solenoid valve

Part No.	7738007264	
Function	<ul style="list-style-type: none"> ▶ To control the amount of mixed gas supplied with TDR of 10:1 ▶ It uses solenoid valve to control the amount of mixed gas 	
Failure Event	<ul style="list-style-type: none"> ▶ Solenoid valve not closing ▶ Solenoid valve not opening 	
Effects	<ul style="list-style-type: none"> ▶ Frequent On/Off due to excessive heat. ▶ Fail to reach the set temperature due to lack of heat 	
Error Code	—	
Diagnostic	<ul style="list-style-type: none"> ▶ Visual inspection : Check the Solenoid valve connection wire ▶ Voltage check : Check range of voltage shown below 	
Color/Number of Wires	RED - RED <ul style="list-style-type: none"> ▶ DC : 120 V ± 	

Table 6

7.3 Orifice

Part No.	7738007257 (NG) 7738007258 (LP)	
Function	Control the gas pressure and provide the proper quantity of the gas.	
Failure Event	<ul style="list-style-type: none"> ▶ Making combustion noise. ▶ Imperfect and lifting flame occurs. 	
Effects	<ul style="list-style-type: none"> ▶ Making a noise. ▶ Excess carbon monoxide emissions. 	
Error Code	N/A	
Diagnostic	Visual inspection: Check the gas type.	
Color/Number of Wires	N/A	

Table 7

7.4 Fan

Part No.	7738007262	
Function	<ul style="list-style-type: none"> ▶ Providing combustion air and gas. ▶ To make the ideal combustion, exhaust the flue gas before and after the combustion. 	
Failure Event	<ul style="list-style-type: none"> ▶ Fan speed failure: in case that the fan RPM is less than or equal to 600 RPM. ▶ The fan assembly screw loosens, or the fan is damaged. ▶ Connection of the wire connector in fault. 	
Effects	<ul style="list-style-type: none"> ▶ Unstable combustion condition. ▶ Unit vibrating and making a noise. ▶ The water heater is not operated. 	
Error Code	A2	
Diagnostic	<ul style="list-style-type: none"> ▶ Visual inspection: Connection or breakage of wires. ▶ Voltage check: Check range of voltage shown below. 	
Color/Number of Wires	<ul style="list-style-type: none"> ▶ Black-Red: DC 5 – 45 V ▶ Black-Yellow: DC 12 V ▶ Black-White: 600 – 8100 RPM 	

Table 8

7.6 High Limit Cutout HEX T2 (302°F)

Part No.	7738007253	
Function	Due to the excessively high temperature of the Heat Exchanger (HEX), it will trip and stop combusting.	
Failure Event	Unable to detect the excessively high temperature if the cutout fails.	
Effects	Unable to stop combusting if the heat exchanger temperature exceeds 302°F (150°C)	
Error Code	A4	
Diagnostic	<ul style="list-style-type: none"> ▶ Visual inspection: Connection or breakage of wires. ▶ Voltage check: Check range of voltage shown below. 	
Color/Number of Wires	Red-Red: DC 5 V	

Table 9

7.7 High Limit Cutout Supply T3 (203°F)

Part No.	7738007275	
Function	Due to the excessively high supply water temperature, it will trip and stop combusting.	
Failure Event	Unable to detect the excessively high supply water temperature if the cutout fails.	
Effects	Unable to stop combusting if the water temperature from the heat exchanger exceeds 203°F (95°C)	
Error Code	A4	
Diagnostic	<ul style="list-style-type: none"> ▶ Visual inspection: Connection or breakage of wires. ▶ Voltage check: Check range of voltage shown below. 	
Color/Number of Wires	Red-Red: DC 5 V	

Table 10

7.8 Primary Heat Exchanger

Part No.	7738007256*	
Function	<ul style="list-style-type: none"> ▶ Main part for heat transfer from the burner ▶ It has multiple paths of water tubes on the heat exchanger surface as well as inside the combustion chamber. 	
Failure Event	<ul style="list-style-type: none"> ▶ Water and/or exhaust gas leakage through a crack ▶ Improper heat transfer can cause the water in the heat exchanger to boil due to possible scale formation 	
Effects	<ul style="list-style-type: none"> ▶ Leakage of exhaust gas ▶ Excessive heating of water that produces boiling noises. 	
Error Code	AA, A4	
Diagnostic	<ul style="list-style-type: none"> ▶ Visual inspection : Check if there is a crack on the surface of heat exchanger. ▶ Sound inspection : Check if boiling occurs inside the unit 	
Color/Number of Wires	N/A	

Table 11

* part number is for fully assembled heat exchanger unit.

7.9 Secondary Heat Exchanger

Part No.	7738007256*	
Function	<ul style="list-style-type: none"> ▶ Main part for heat transfer from the burner ▶ It has multiple paths of water tubes on the heat exchanger surface as well as inside the combustion chamber. 	
Failure Event	<ul style="list-style-type: none"> ▶ Water and/or exhaust gas leakage through a crack ▶ Improper heat transfer can cause the water in the heat exchanger to boil due to possible scale formation 	
Effects	<ul style="list-style-type: none"> ▶ Leakage of exhaust gas ▶ Excessive heating of water that produces boiling noises. 	
Error Code	AA, A4	
Diagnostic	<ul style="list-style-type: none"> ▶ Visual inspection : Check if there is a crack on the surface of heat exchanger. ▶ Sound inspection : Check if boiling occurs inside the unit 	
Color/Number of Wires	N/A	

Table 12

* part number is for fully assembled heat exchanger unit.

7.10 Sensor



Part No.	7738007297 (Sensor, Supply/Return)	 <p>Sensor, Heating/Return</p>  <p>Sensor, DHW</p>  <p>Exhaust Temperature Sensor (Blue)</p>
	7738007295 (Sensor, DHW)	
	7738007268 (Exhaust Temperature Sensor)	
Function	Measure the temperature of the hot water, cold water, exhaust gas in the boiler.	
Failure Event	Unable to properly measure the temperature in the boiler.	
Effects	<ul style="list-style-type: none"> ▶ Unable to shut combustion off when the water temperature from the heat exchanger exceeds 203°F (95°C). ▶ Unable to reach the hot water temperature set by user. ▶ Unable to shut down the water heater when the flue gas temperature from the exhaust duct exceeds 203°F (95°C). 	
Error Code	AA, AB, AC, E1, E2, E3, EB	
Diagnostic	<ul style="list-style-type: none"> ▶ Visual inspection: Connection or breakage of wires. ▶ Voltage check: Check range of voltage shown below. ▶ Resistance check of the sensor. 	
Color/Number of Wires	▶ Blue-Blue: DC 0 – 5 V	

Table 13

7.11 Electrode

Part No.	7738007260	
Function	To ignite the gas, discharge the spark to the main burner repeatedly until igniting the gas.	
Failure Event	Unable to ignite during the ignition process.	
Effects	<ul style="list-style-type: none"> ▶ The unit cannot ignite during the ignition process and “A6” error code will be shown on the display panel. ▶ No effects on the unit, however, the durability of the spark plug are down. 	
Error Code	A6	
Diagnostic	Visual inspection: Connection or breakage of wires.	
Color/Number of Wires	N/A	
Ignitor Gap Distance	4.0 – 4.8 mm (0.16” – 0.19”)	

Table 14

7.12 Flame Rod

Part No.	7738007259	
Function	Detect the normal flame during the combustion.	
Failure Event	<ul style="list-style-type: none"> ▶ Fail to detect a flame in spite of the combustion process. ▶ Improper gap 	
Effects	The boiler is not operated.	
Error Code	A6, A8	
Diagnostic	<ul style="list-style-type: none"> ▶ Visual inspection: Connection or breakage of wires, check the flame rod gap. ▶ Check range of voltage shown below. 	
Color/Number of Wires	White-Ground : AC 24 V	

Table 15

7.13 Ignition Transformer & Wire

Part No.	7738007252	
Function	To ignite the gas, discharge the high voltage spark to the main burner.	
Failure Event	Unable to ignite during the ignition process.	
Effects	The unit cannot ignite during the ignition process and “A6” error code will be shown on the display panel.	
Error Code	A6	
Diagnostic	<ul style="list-style-type: none"> ▶ Visual inspection: Connection or breakage of wires. ▶ Check range of voltage shown below. 	
Color/Number of Wires	Brown-Brown: AC 120 V	
Input Voltage	120 V, 60 Hz	
Output Voltage	18 kV	

Table 16

7.14 Burner

Part No.	7738007256*	
Function	Combustion with a mixture of gas and air.	
Failure Event	<ul style="list-style-type: none"> ▶ Unable to initialize/sustain combustion. ▶ Foreign substance or soot deposit on the burner surface. ▶ Gas leakage from the burners. 	
Effects	<ul style="list-style-type: none"> ▶ Unexpected combustion. ▶ Unstable flame condition and flame lifting. ▶ Ignition failure. ▶ Excess carbon monoxide emissions. 	
Error Code	A6	
Diagnostic	Visual inspection: Excess foreign substance on the burner surface and unstable flame condition during combustion.	
Color/Number of Wires	N/A	

Table 17

* included in heat exchanger assembly

7.15 Gas Valve

Part No.	7738007270	
Function	<ul style="list-style-type: none"> ▶ Provide the gas for combustion. ▶ For some reason, it shuts off the gas valve automatically and prevents an unsafe condition due to combustion . 	
Failure Event	<ul style="list-style-type: none"> ▶ Gas leak from the valve. ▶ Unable to open/close. 	
Effects	<ul style="list-style-type: none"> ▶ Gas leak from the unit. ▶ The unit does not operate. 	
Error Code	A6, A8	
Diagnostic	<ul style="list-style-type: none"> ▶ Visual inspection: Disconnection or breakage of wires. ▶ Check range of voltage shown below. 	
Color/Number of Wires	White-White: DC 120 V	

Table 18

7.16 Touch Pad

Part No.	7738007238	
Function	Turn the boiler on or off, adjust the water temperature, and change the modes.	
Failure Event	Malfunction of Touch Pad	
Effects	No operation of unit.	
Error Code	EE	
Diagnostic	<ul style="list-style-type: none"> ▶ Visual inspection: Connection or breakage of wires. ▶ Voltage check: Check range of voltage shown below. 	
Color/Number of Wires	Yellow-Yellow: DC 24 V	

Table 19

7.17 Control Board

Part No.	7738007249 (Singular 5200)	
	7738007248 (Singular 4000)	
Function	To control each component and performance of unit.	
Failure Event	<ul style="list-style-type: none"> ▶ Malfunction of control board. ▶ Unit does not operate. 	
Effects	<ul style="list-style-type: none"> ▶ A component does not operate within the unit. ▶ In case of the control board failure, the water heater does not operate. 	
Error Code	—	
Diagnostic	Visual inspection: Connection or breakage of water or burn marks on the control board.	
Color/Number of Wires	N/A	

Table 20

7.18 Condensate Trap Assembly

Part No.	7738007273	
Function	Drain condensation, which is created while combusting.	
Failure Event	<ul style="list-style-type: none"> ▶ Fail to drain condensation caused by clogged trap. ▶ Condensation leakage into the unit. 	
Effects	<ul style="list-style-type: none"> ▶ Stop combustion. ▶ Condensation leakage. 	
Error Code	AD	
Diagnostic	<ul style="list-style-type: none"> ▶ Visual inspection: Connection or breakage of wires, check for physical damage to the trap body. ▶ Voltage Check: Check range of voltage shown below. 	
Color/Number of Wires	Green-Red: AC 24 V	

Table 21

7.19 Air Pressure Switch

Part No.	7738007247 (Singular 5200)	
	7738007246 (Singular 4000)	
Function	Prevents operation of the unit due to unsafe condition. Back pressure or blockage has occurred in the exhaust vent.	
Failure Event	No operation of the unit.	
Effects	<ul style="list-style-type: none"> ▶ Stop combustion. ▶ No operation of the unit. 	
Error Code	AE	
Diagnostic	<ul style="list-style-type: none"> ▶ Visual inspection: Connection or breakage of wires. ▶ Voltage check: Check range of voltage shown below. 	
Color/Number of Wires	Green-Green: DC 5 V	

Table 22

8 Troubleshooting

8.1 A2 Error (Abnormal Operation: Fan)

Error	Description
Turbo fan RPM error	Error occurs when the RPM is not measured due to no turbo fan operation or a defect of the hall sensor
Checkpoint	<ul style="list-style-type: none"> ▶ Check the connection of the wire ▶ Check the fan wire for disconnection ▶ Check the PCB output voltage <ul style="list-style-type: none"> — Red-Black: 0 – 45 V — Yellow-Black: 0 – 13 V

Table 23

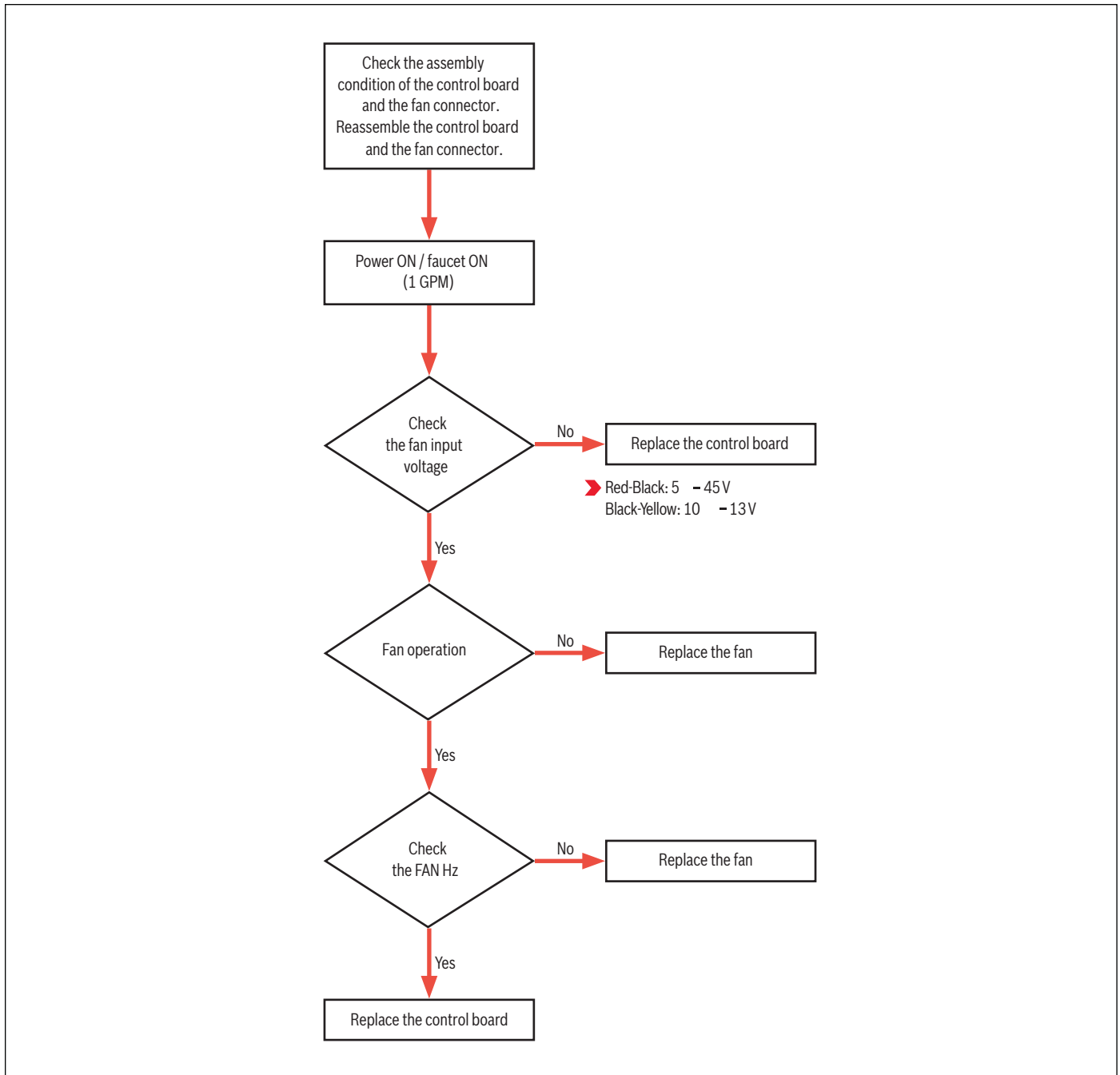

Figure 5

A2 Error - Wire Check

1. Check the connection of the Fan Connector Wire (Red-Black).
2. Check the connection of the Hall IC Connector Wire (Yellow-White).

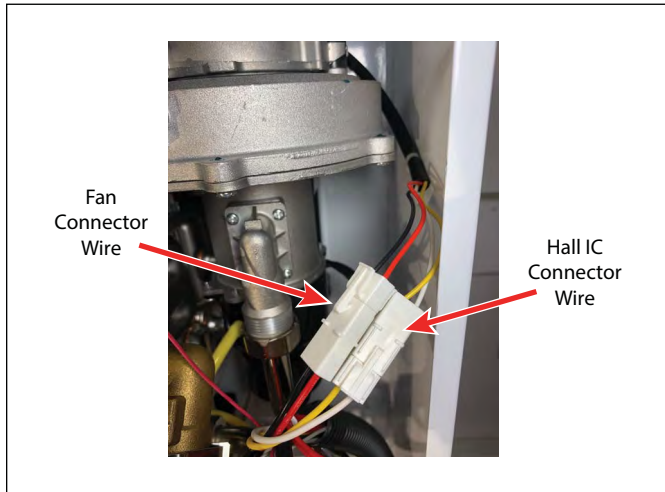

Figure 6

3. Check the connection of the control board Connector Wire (Red-Black).

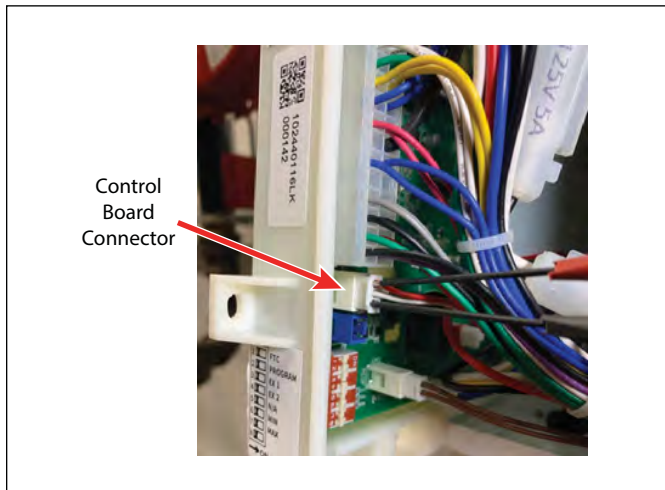

Figure 7

A2 Error - Control board Input Voltage Check

1. Measure the control board input voltage (measure while using the hot water)
 - ▶ Multi tester range: "DC V"

Measurement Method	Measured value
Measure the applied voltage	Red - Black: DC 5 - 45 V Yellow - Black: DC 10 - 13 V
Measure FAN Hz	White - Yellow: 0 - 270 Hz

Table 24



Figure 8 Applied Voltage Measurement Method

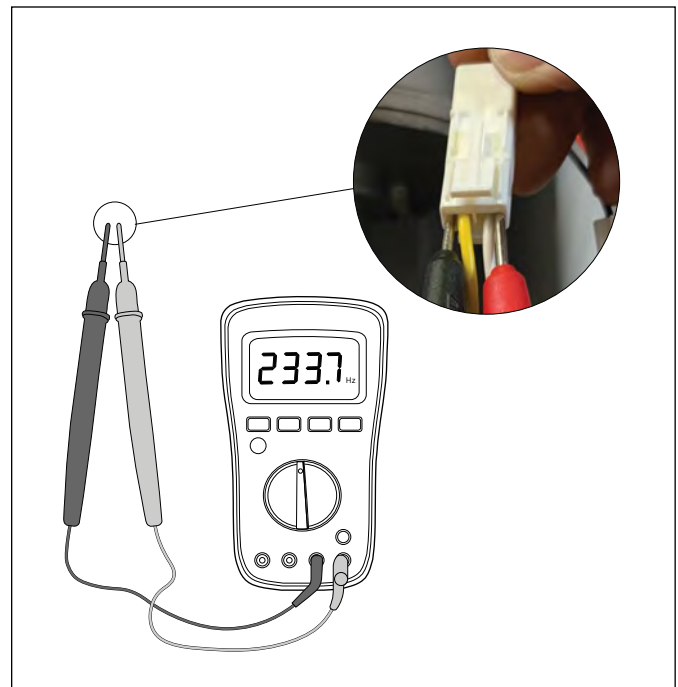

Figure 9 FAN Hz Measurement Method

2. If the voltage is measured normally but the fan does not operate, replace the fan.
3. If the fan operates but Hz cannot be measured, replace the fan.
4. If the voltage cannot be measured, replace the control board.

8.2 A3 Error (Abnormal Operation: Pump)

Error	Description
Abnormal Pump Operation	<ul style="list-style-type: none"> ▶ Determine whether the pump is in operation when the boiler operation signal is activated ▶ Before operating the pump, check the change in the pressure sensor before and after to see whether there are any problems in the operation of the pump.
Checkpoint	<ul style="list-style-type: none"> ▶ Check the assembly of the pump connector ▶ Check the operation voltage of the pump <ul style="list-style-type: none"> — Color: White – Black ▶ Check for any clogging of heating water pipes

Table 25

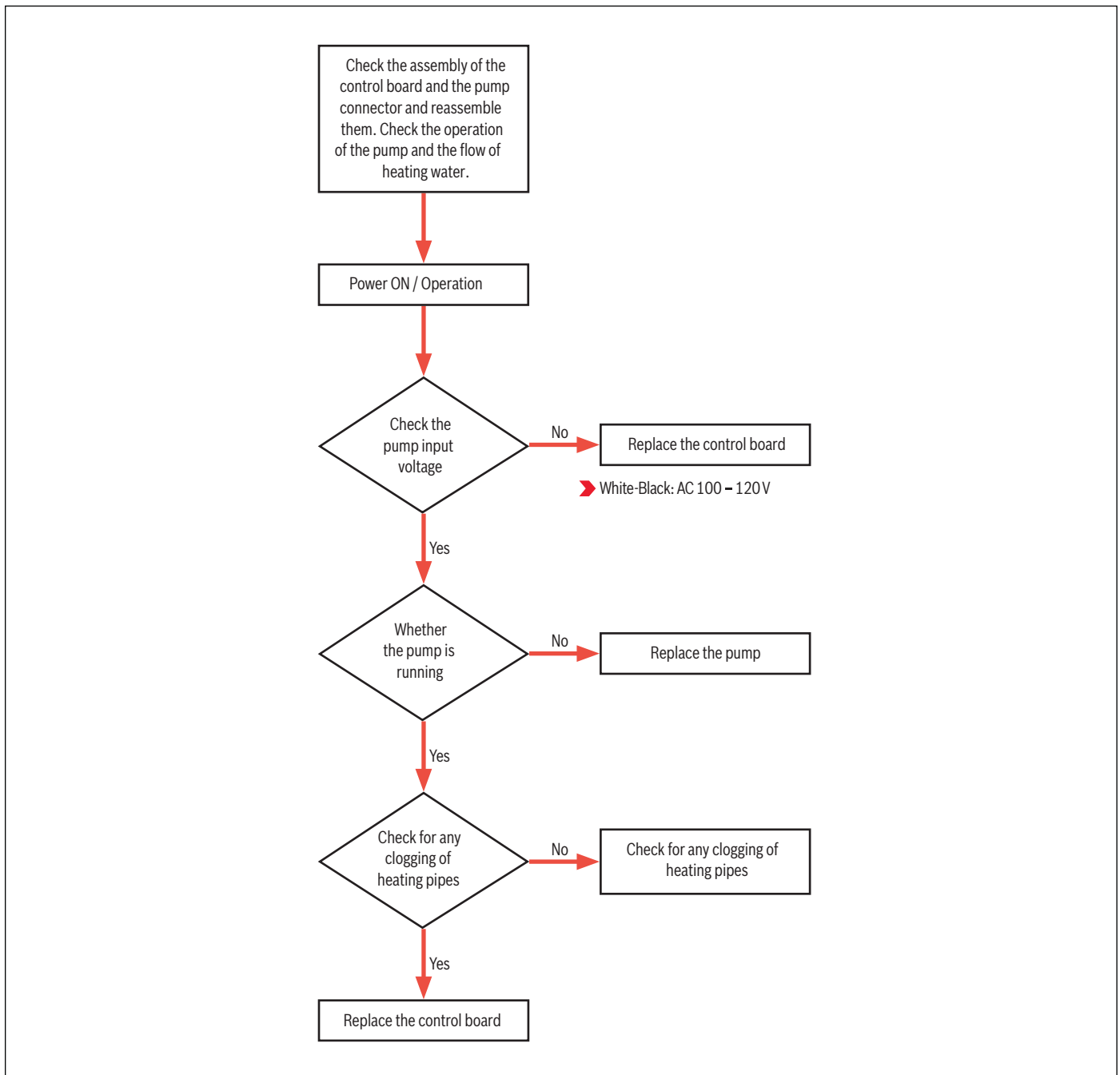

Figure 10

A3 Error - Wire Check

1. Check the pump connector.

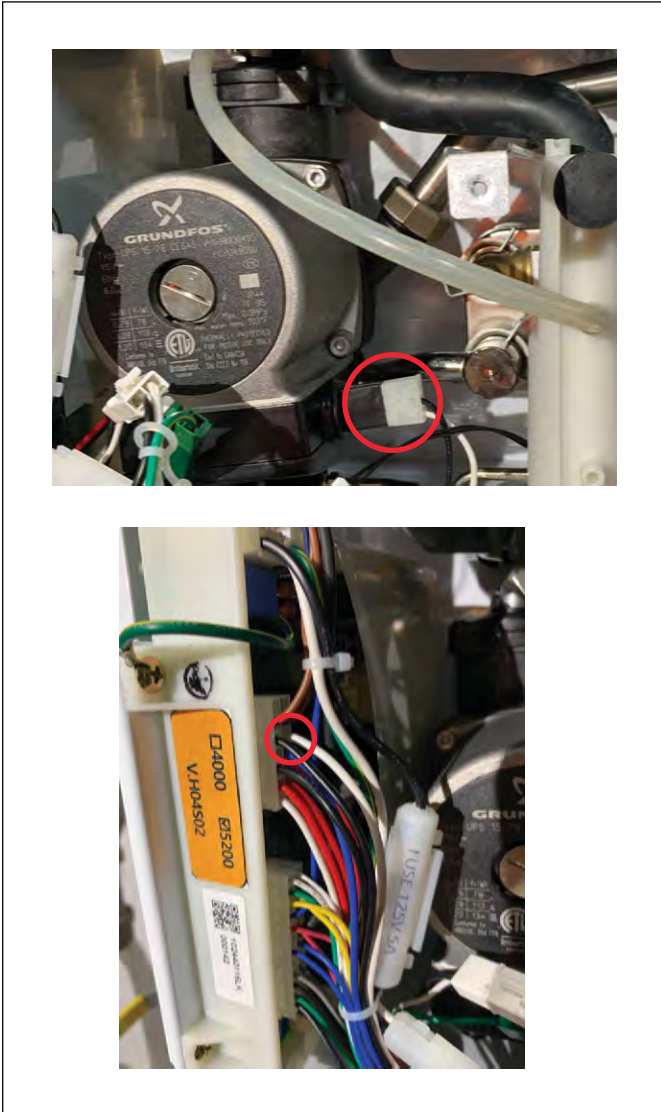

Figure 11

A3 Error - Control Board Operation Voltage Check

1. Check the output voltage when the pump operation signal is activated
 - Normal: Normal if the voltage is higher than the input voltage



Figure 12

8.3 A4 Error (Overheating of Heat Exchanger)

Error	Description
High Limit Cutout Error	<ul style="list-style-type: none"> ▶ T2: Stop the combustion when the surface temperature of the exhaust gas hood becomes higher than 302 °F due to backfire. ▶ T3: Stop the combustion when the surface temperature of the heat exchanger supply pipe becomes higher than 203 °F due to abnormal overheating. <p>(Operation principle: Bi-metal method, series connection)</p>
Checkpoint	<ul style="list-style-type: none"> ▶ Check the connection of the overheat prevention device and wire connector. <ul style="list-style-type: none"> — Color: Red-Red ▶ Check the connection of the high limit cutouts to the control board ▶ Check the conduction condition of the high limit cutouts ▶ Check if the High Limit Cutout HEX T2 (302°F) and High Limit Cutout Supply T3 (203°F) are normal <ol style="list-style-type: none"> 1) Check the temperature sensor resistance table 2) Check the scale on the detection part of the sensor

Table 26

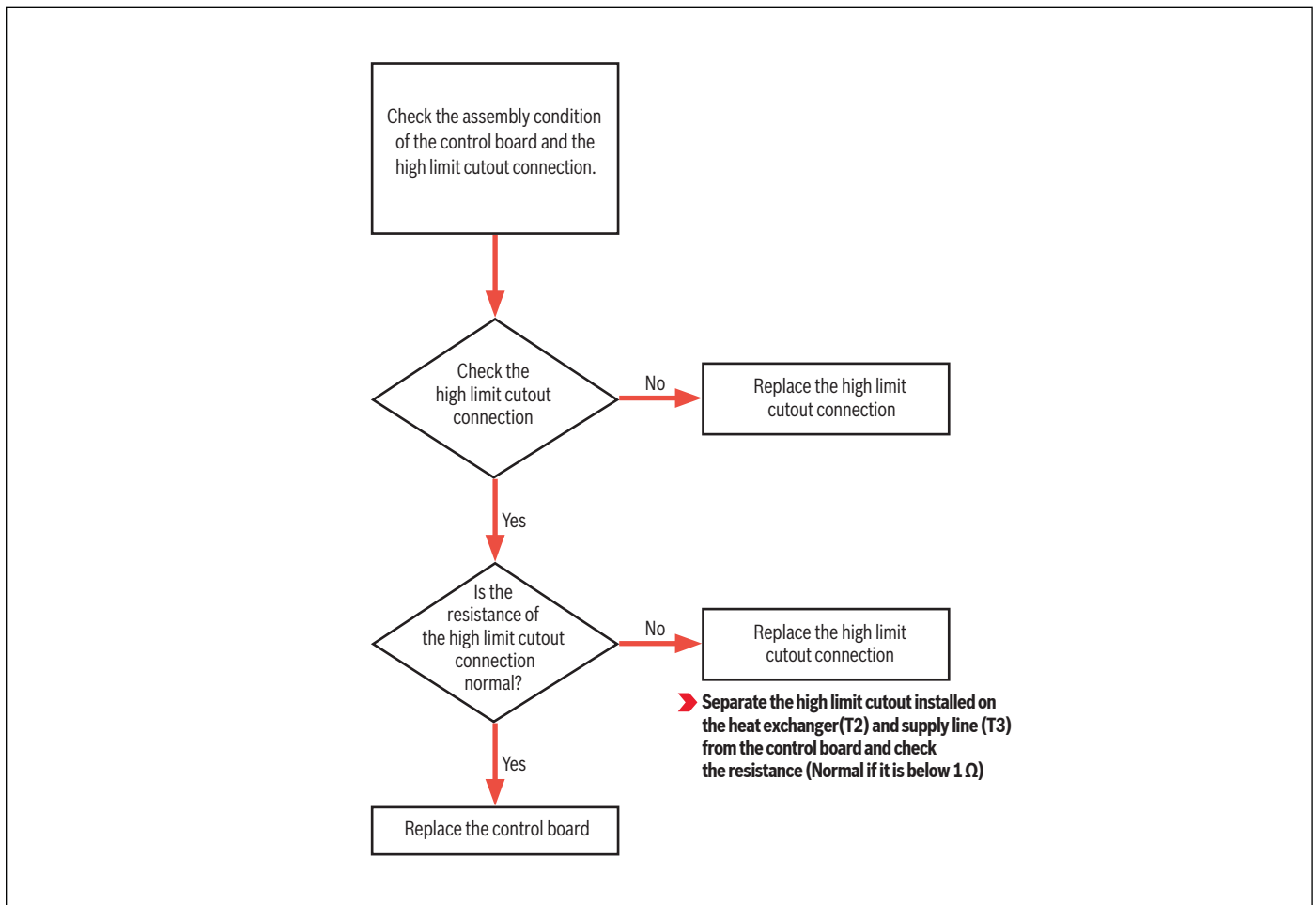

Figure 13

A4 Error - Wire Check

1. Check the connection status of the wire.



Figure 14

A4 Error - High Limit Cutouts Check

1. Measure the resistance of the cutouts.
 - ▶ Normal: 1 Ω or less
 - ▶ Abnormal: O.L
2. If the resistance cannot be measured normally, replace the high limit cutout.

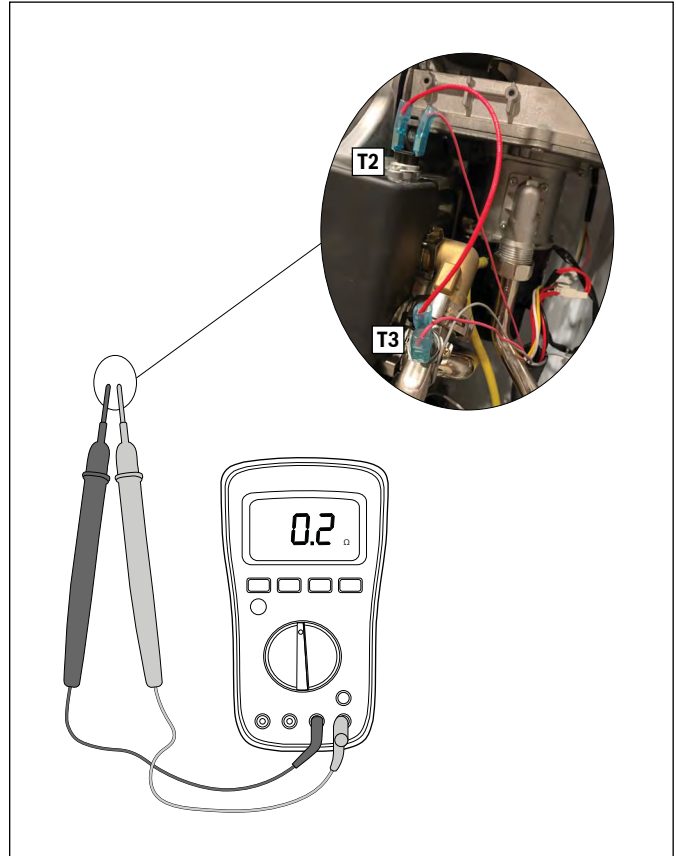

Figure 15

8.4 A5 Error (Low Water Pressure)

Error	Description
Low water pressure error	Internal pipe pressure decrease error — Internal pressure in pipes \leq 4.3PSI error occurs
Checkpoint	<ul style="list-style-type: none"> ▶ Check the input voltage of the pressure sensor <ul style="list-style-type: none"> — Color: Red – Black (DC 5 V) ▶ Check the output voltage of the pressure sensor <ul style="list-style-type: none"> — Color: White – Black ▶ Check the internal pressure in pipes

Table 27

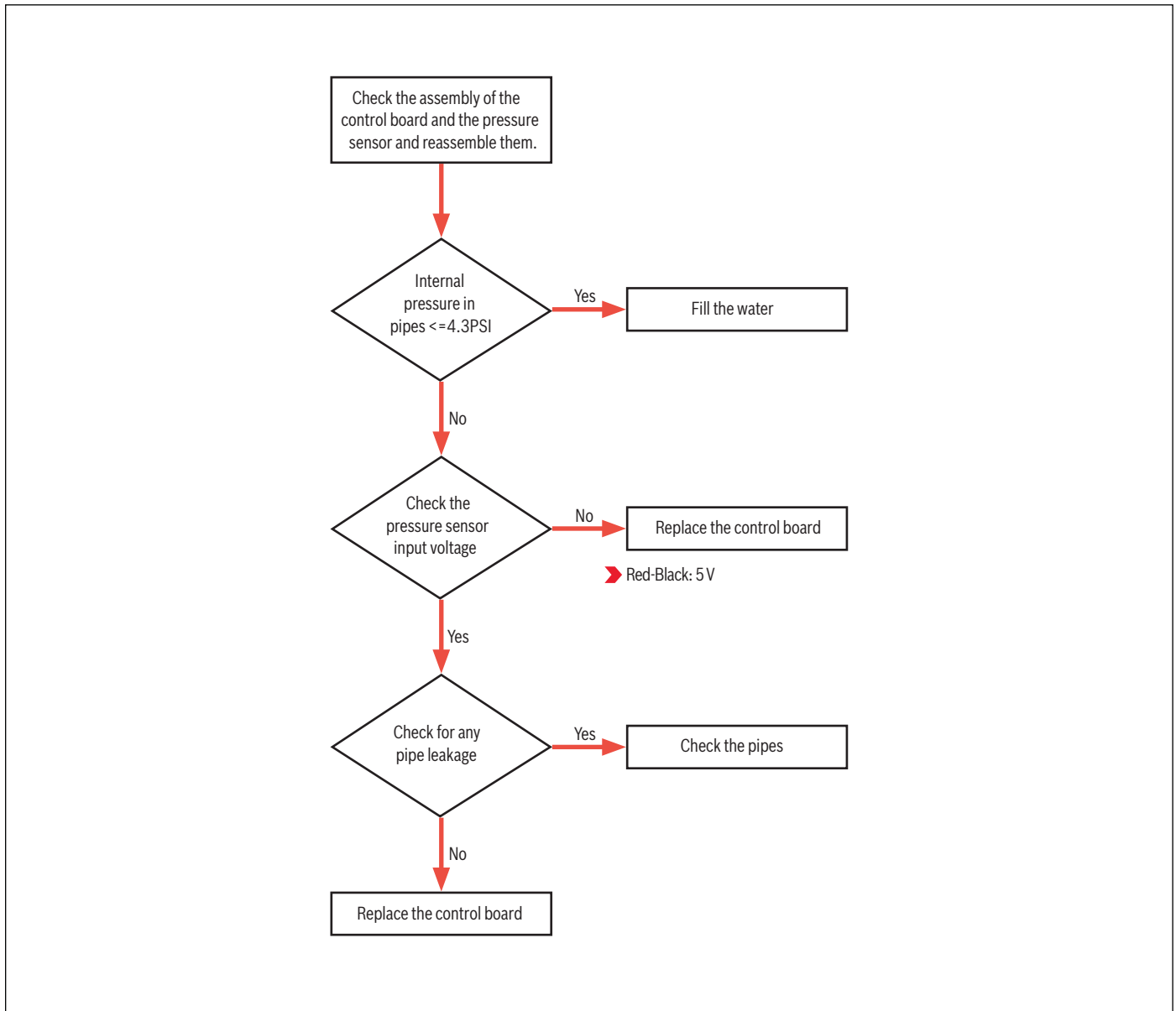
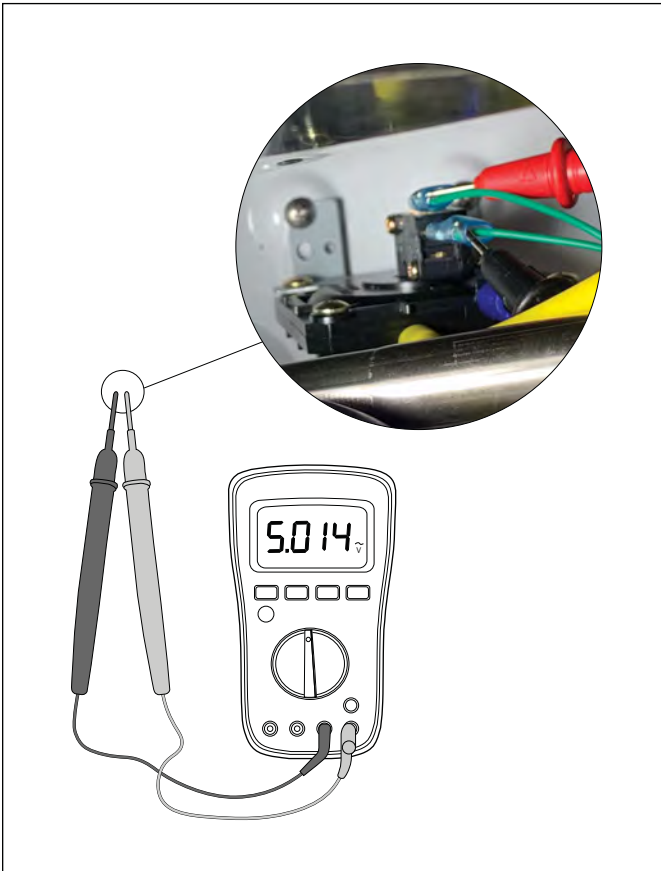

Figure 16

A5 Error - Input Voltage of the Pressure Sensor Check

1. Check the pressure sensor for abnormalities in the input voltage
 - Normal: DC 5 V

*Figure 17***A5 Error - Pipe Pressure Check**

1. Check for water leaks from the pipes and check the pressure of the expansion tank

8.5 A6 Error (Ignition Error)

Error	Description
Ignition Failure	When it is judged that flame is not recognized in normal combustion condition, ignition is attempted 6 times repeatedly. If the flame is not recognized, ignition is not attempted again and an error is issued
Checkpoint	<ul style="list-style-type: none"> ▶ Check if the main gas valve is closed. ▶ Check the operation condition of the gas valve (attempting to ignite) <ul style="list-style-type: none"> — Wire color: White-White (DC 105 – 135 V) ▶ Check the assembly and operation condition of the automatic igniter <ol style="list-style-type: none"> 1. Check the discharge state 2. Check the input voltage part of the automatic igniter Wire color: Brown-Brown (AC 105 – 135 V)

Table 28

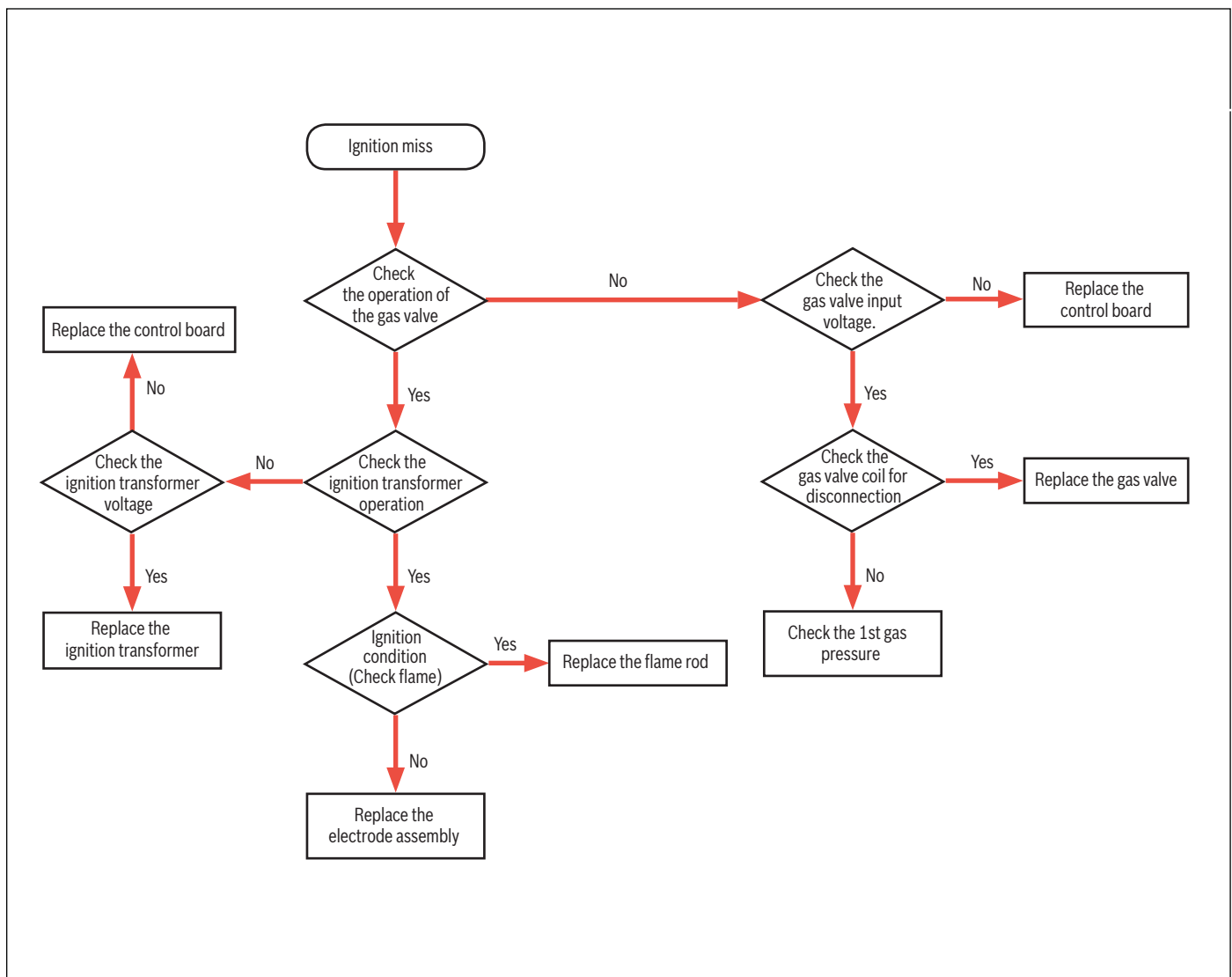

Figure 18

A6 Error - Main Gas Valve Check

1. Check if the main gas valve is closed.

A6 Error - Gas Valve Check

1. Check the coil for abnormalities.
 - (Normal: 1 – 1.5 kΩ)
 - If the coil is disconnected and has short-circuited, replace the gas valve.
2. Check the applied voltage of the gas valve. (DC 105 – 135 V)
 - If the voltage is correct, replace the gas valve, and if the voltage is not supplied normally, replace the control board.

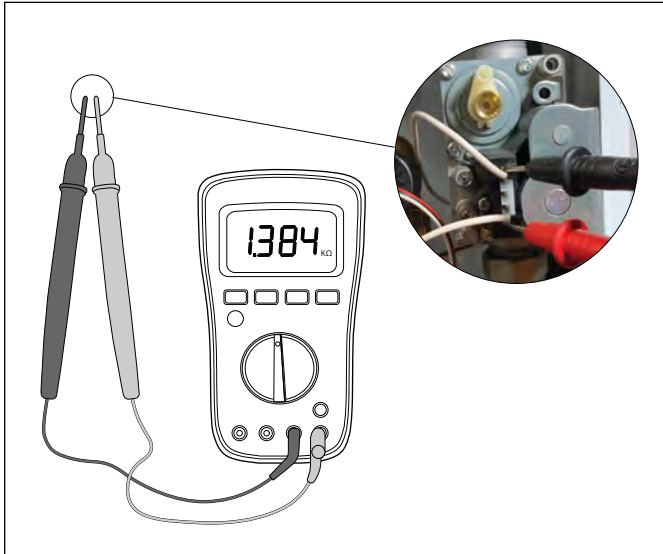

Figure 19

A6 Error - Igniter Check

1. Check the gap of the igniter.
 - Gap: 4 – 5 mm
2. Check the gap between the igniter and the burner.
 - Gap: 8 – 10 mm

A6 Error - Ignition Transformer Check

1. First, remove phillips screw on the ignition transformer and remove transformer for easier measurement of voltage.



Figure 20

2. Check the input voltage of the igniter
 - Wire color: Brown-Brown (AC 105 – 135 V)



Figure 21

A6 Error - Flame Rod Check

1. Check if the flame rod is loose or separated.
2. Check for any foreign material on the flame rod (remove any foreign material).

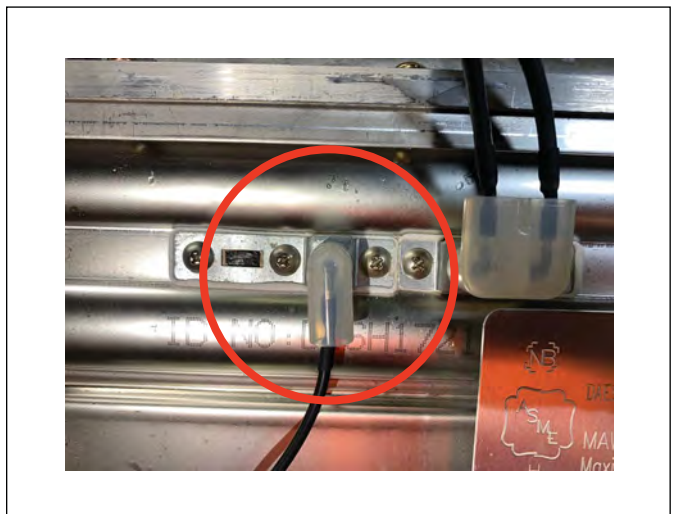

Figure 22

8.6 A7 Error (Abnormal Operation: Gas Valve Relay)

Error	Description
Gas valve relay error	It occurs when the gas valve relay which is mounted on PCB is stuck closed.
Checkpoint	Replace the control board

Figure 23

8.7 A8 Error (Abnormal Operation: Gas Valve)

Error	Description
Flame after combustion	This error occurs if flame is detected after burner had shut off.
Checkpoint	<ul style="list-style-type: none"> ▶ Check the operation condition of the gas valve ▶ Whether the flame rod is damaged or not ▶ Whether the flame rod comes into contact with the metal burner or not

Table 29

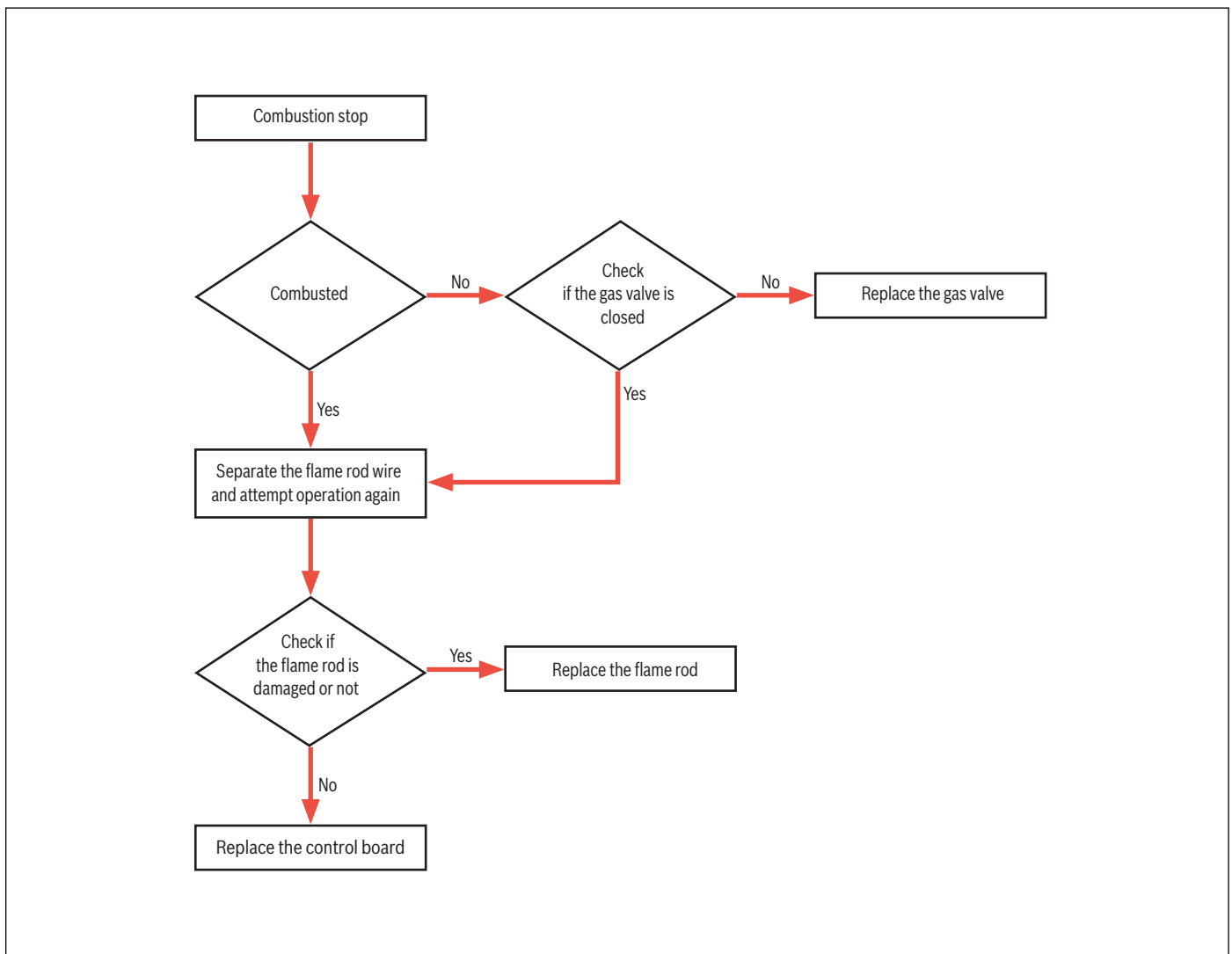

Figure 24

A8 Error - Voltage Check

1. Check the input voltage of the gas valve while burner is turned off.
 - ▶ Multi tester range: DC
 - If the voltage is measured: Gas valve relay error (DC 105 – 135 V)
 - If the voltage is not measured: Normal
2. If the voltage is measured, replace the control board.

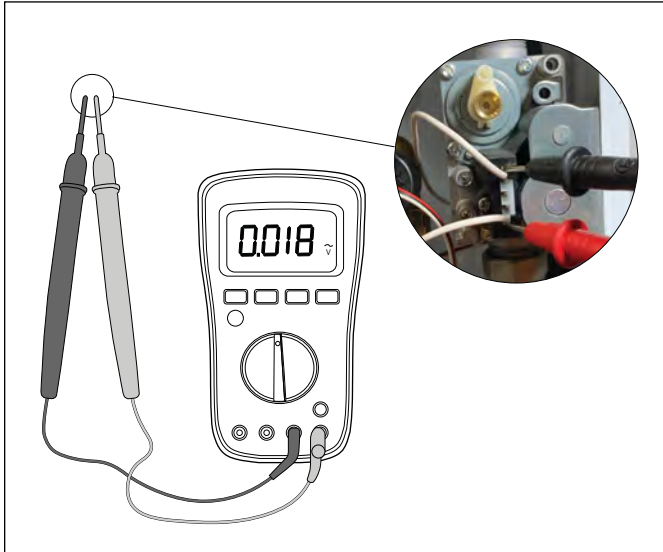

Figure 25

A8 Error - Gas Valve Check

1. If flame is present when there is not a call for demand, replace the gas valve.

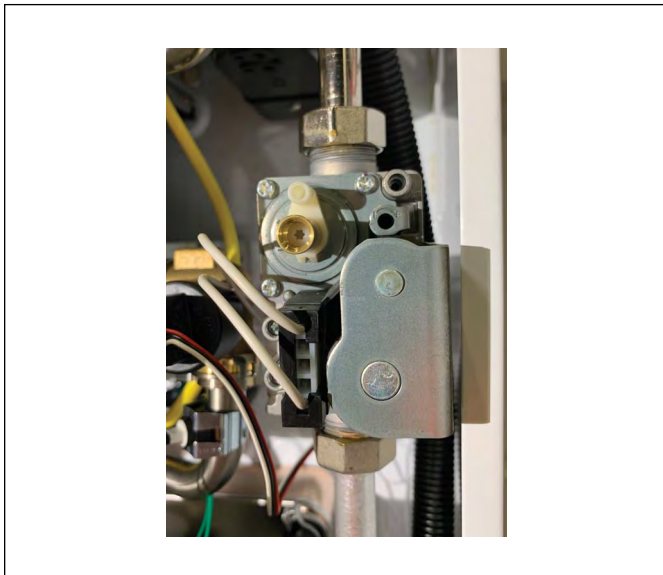

Figure 26

A8 Error - Flame Rod Check

1. Remove flame rod and check condition.
2. Reassemble the flame rod, turn on the power supply and measure the current.
 - ▶ Combustion condition
 - Multi tester range: μA (Normal : above 2 μA)
 - Connect the multi tester between the flame rod wire and the flame rod in series and measure)



Figure 27

8.8 A9 Error (Exhaust Temperature Sensor Error)

Error	Description
Exhaust temperature sensor error	<ul style="list-style-type: none"> ▶ Freeze prevention error due to a temperature decrease of the heating water <ul style="list-style-type: none"> – Heating water temperature $\leq 43\text{ }^{\circ}\text{F}$: Combustion in progress – Heating water temperature $\geq 104\text{ }^{\circ}\text{F}$: Combustion stopped
Checkpoint	<ul style="list-style-type: none"> ▶ Check if the heating water temperature is $\leq 43\text{ }^{\circ}\text{F}$ ▶ Check if the heating water sensor connection is OPEN ▶ Check the resistance of the heating water sensor

Table 30

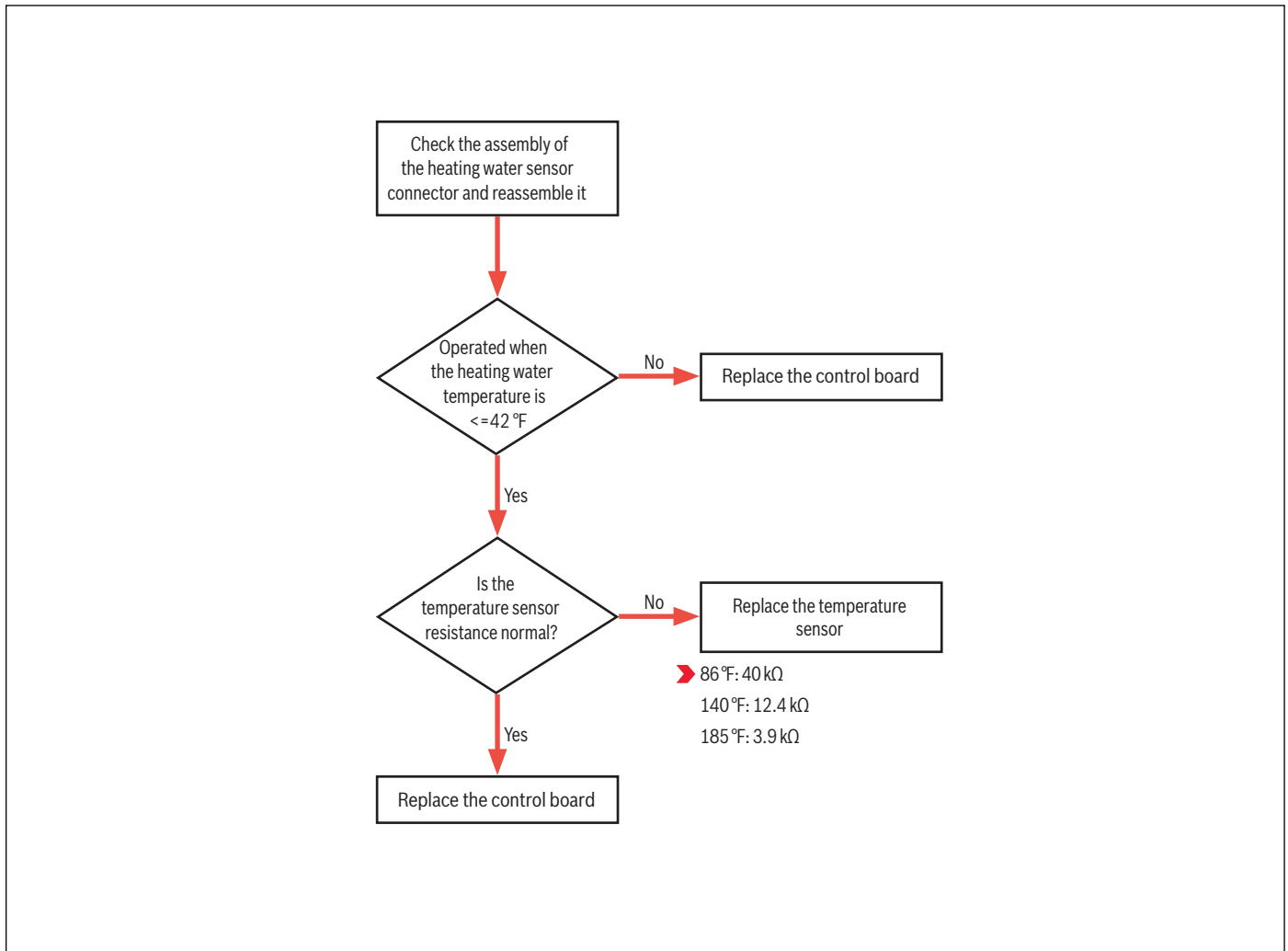

Figure 28

A9 Error - Wire Check

1. Check if the heating water sensor connector is disconnected

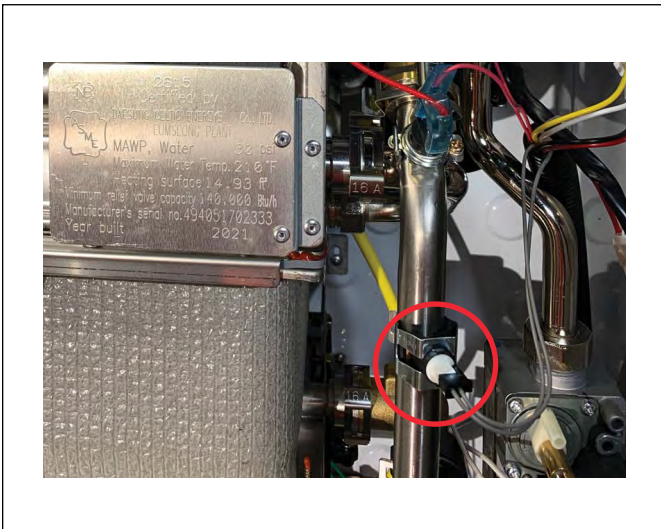

Figure 29

A9 Error - Exhaust Temperature Sensor Check

1. Check if the heating water sensor is defective
 - Defective: OL
 - Normal: 86 °F: 40 kΩ
140 °F: 12.4 kΩ
185 °F: 3.9 kΩ

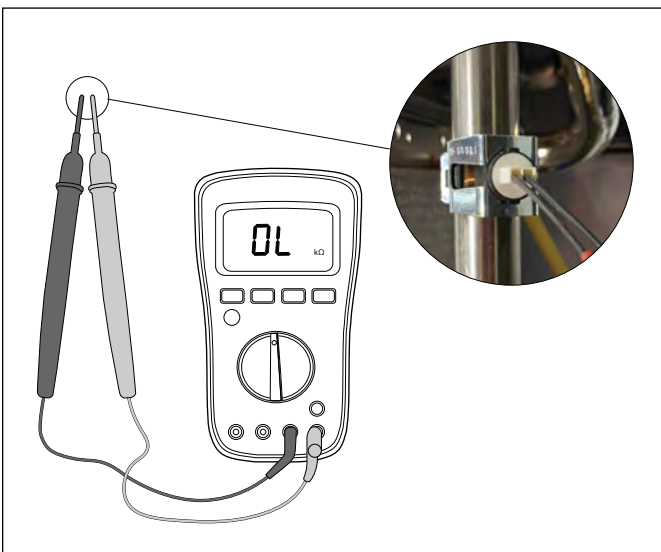

Figure 30

8.9 AA Error (Overheating)

Error	Description
Overheating of temperature sensor (Boiling superheat) over 208 °F	An error is displayed when abnormal overheating caused by heating water sensor
Checkpoint	<ul style="list-style-type: none"> ▶ Check the resistance of Heating water sensor (NTC method) (Measurement should be carried out after separating the sensor)

Table 31

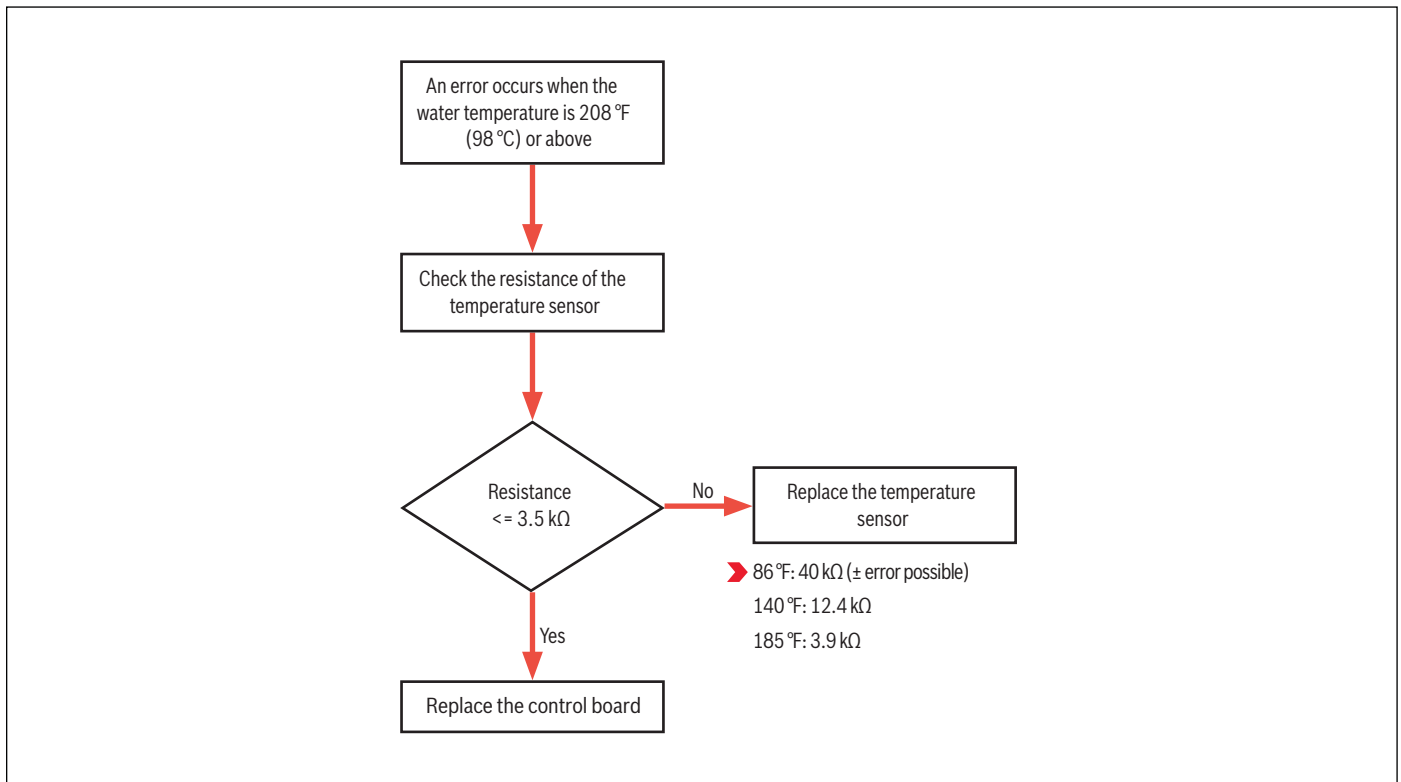

Figure 31

AA Error - T2 Temperature Resistance Check

1. Check if the resistance matches the temperature on the following temperature resistance values:

- 86 °F: 7.05 kΩ
- 140 °F: 2.5 kΩ
- 201 °F: 952 Ω

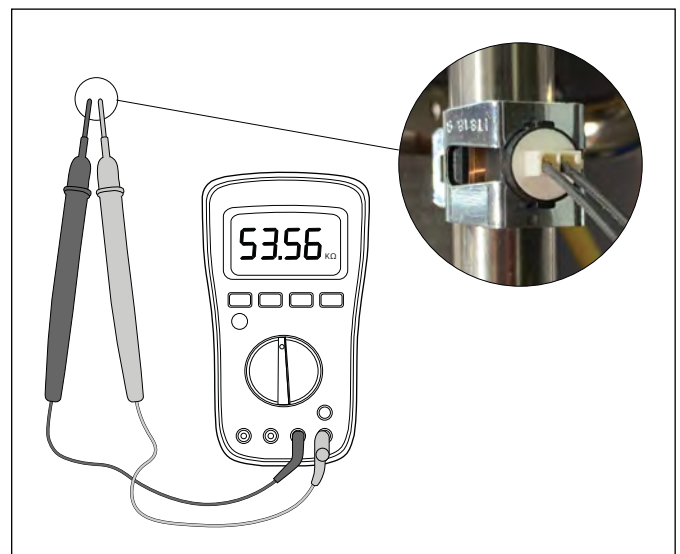

Figure 32

8.10 AB Error (Abnormal Operation: Heat Exchanger Temperature Sensor)

Error	Description
Hex Thermistor_T2 error	Error is displayed when the Heating water sensor has short-circuited or is disconnected
Checkpoint	<ul style="list-style-type: none"> ▶ Check if the Hex Thermistor connector is connected normally. <ol style="list-style-type: none"> 1. Control board wire 2. Heating water sensor wire ▶ Measure and check the resistance of the heating water sensor (NTC method). <ul style="list-style-type: none"> — Separate the sensor and measure it at room temperature. ▶ Check the heating water sensor for disconnection ▶ Check the heating water sensor for short-circuit

Figure 33

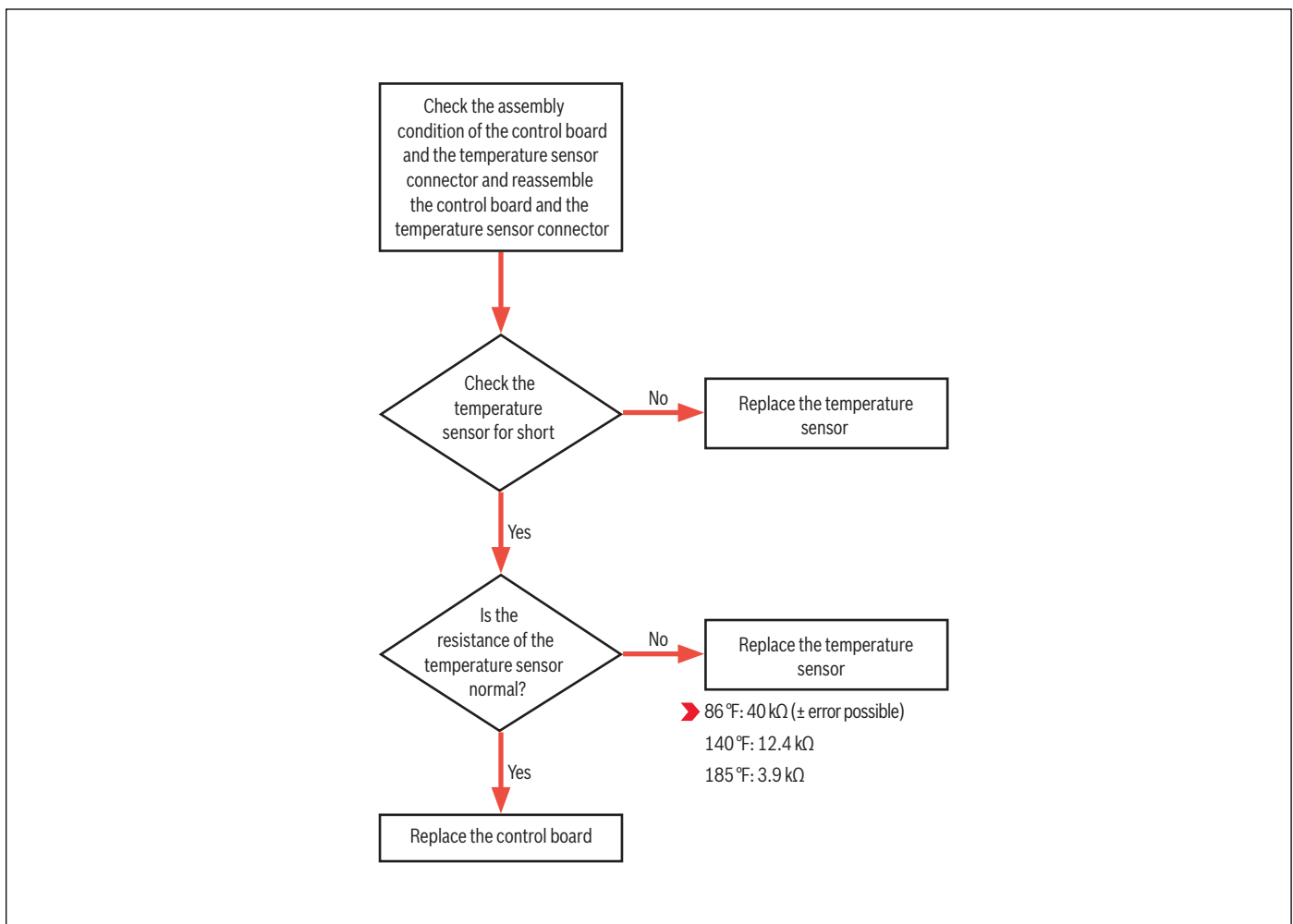

Figure 34

AB Error - Wire Check

1. Check the connection of the wire.



Figure 35 Control Board

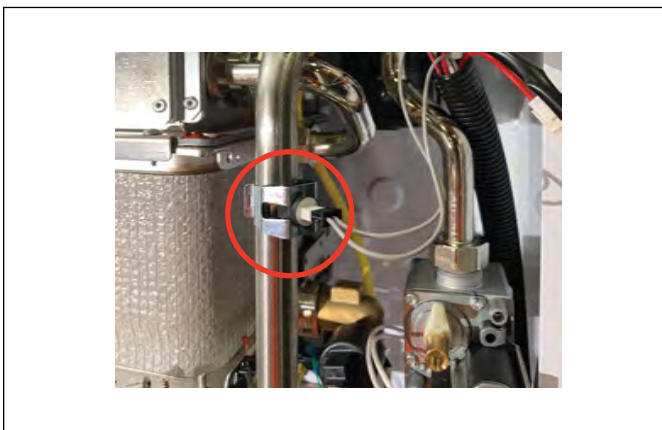

Figure 36 Heating Water Sensor

AB Error - Heating Water Sensor Check

1. If the resistance is not normal, replace the Heating water sensor.
 - Disconnection: OL
 - Normal: 86 °F: 40 kΩ
140 °F: 12.4 kΩ
185 °F: 3.9 kΩ

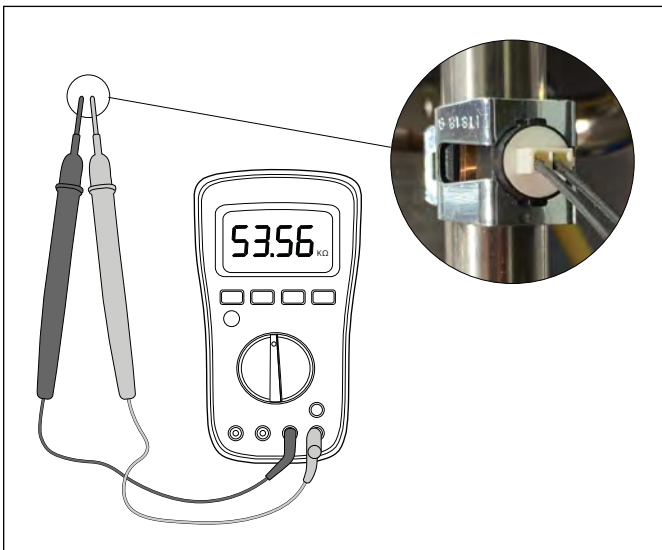

Figure 37

AB Error - Disconnection Check

1. Check if the heat exchanger overhear sensor is disconnected.
 - Disconnection: OL
 - Normal: 86 °F: 40 kΩ
140 °F: 12.4 kΩ
185 °F: 3.9 kΩ

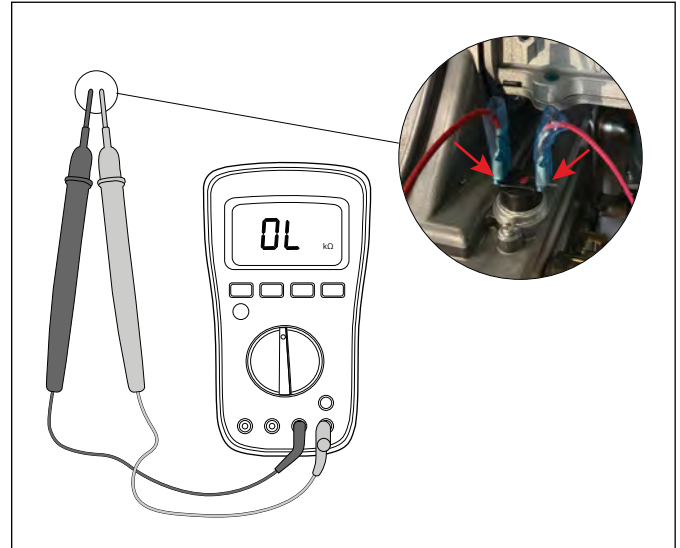

Figure 38

AB Error - Short Circuit Check

1. Check if the Heating water sensor has short-circuited.
 - Short circuit: 0 Ω
 - Normal: 86 °F: 40 kΩ
140 °F: 12.4 kΩ
185 °F: 3.9 kΩ

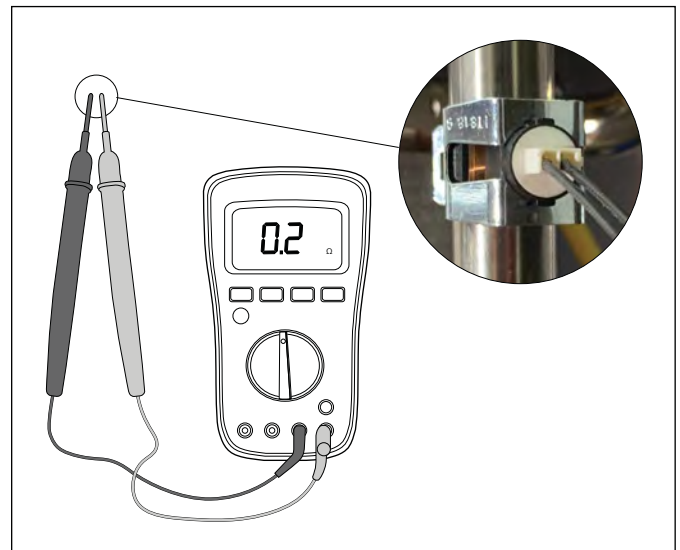

Figure 39

AB Error - Control Board Check

1. If the wire connection and the resistance of the heat exchanger overhear sensor are normal, replace the control board.

8.11 AC Error (Abnormal Operation: DHW Sensor)

Error	Description
DHW Sensor T3 error	Error is displayed when the DHW sensor has short-circuited or is disconnected
Checkpoint	<ul style="list-style-type: none"> ▶ Check if the DHW Thermistor connector is connected normally. <ol style="list-style-type: none"> 1. Control board wire 2. Heating water sensor wire ▶ Measure and check the resistance of the Hot Water DHW Sensor (NTC method). <ul style="list-style-type: none"> — Separate the sensor and measure it at room temperature. ▶ Check the DHW sensor for disconnection ▶ Check the DHW sensor for short-circuit

Figure 40

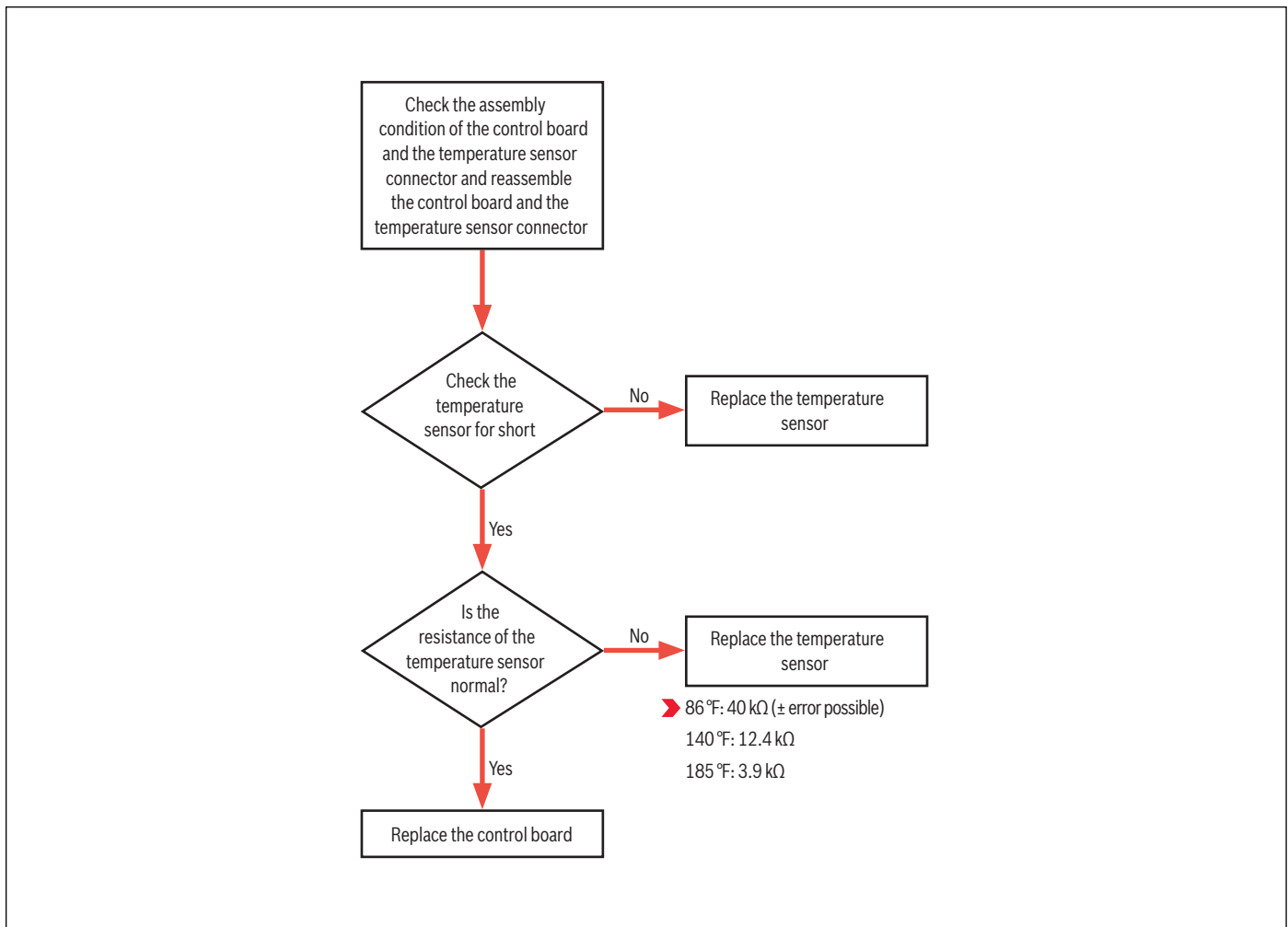

Figure 41

AC Error - Wire Check

1. Check the connection of the wire.

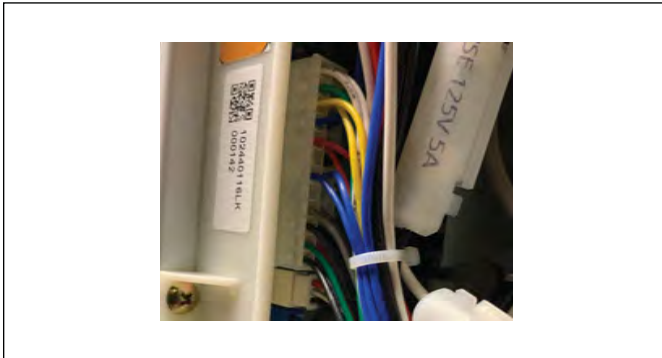

Figure 42 Control Board

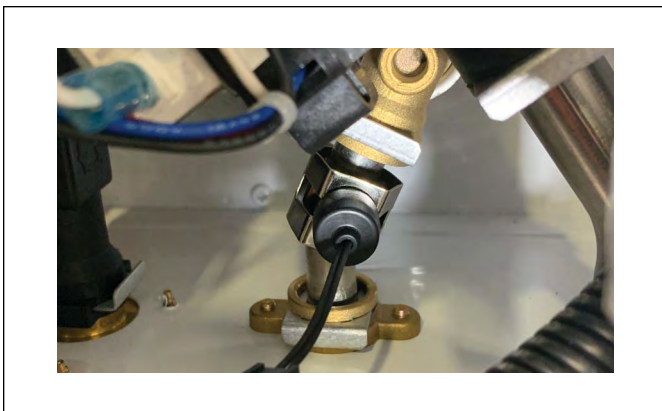

Figure 43 DHW Sensor

AC Error - DHW Sensor Check

1. Measure the resistance of the DHW sensor. If the resistance is not normal, replace the DHW sensor.
 - Disconnection: OL
 - Normal: 86 °F: 40 kΩ
140 °F: 12.4 kΩ
185 °F: 3.9 kΩ



Figure 44

AC Error - Disconnection Check

1. Check if the sensor is disconnected.
 - Disconnection: OL
 - Normal: 86 °F: 40 kΩ
140 °F: 12.4 kΩ
185 °F: 3.9 kΩ

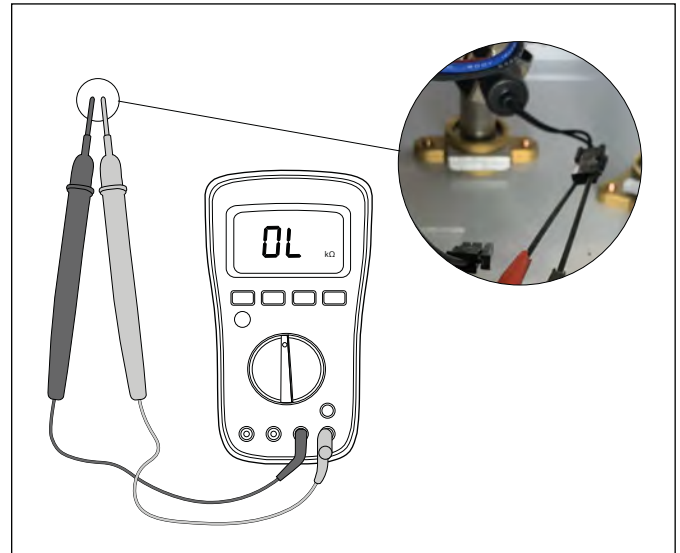

Figure 45

AC Error - Short Circuit Check

1. Check if the DHW sensor has short-circuited.
 - Short circuit: 0 Ω
 - Normal: 86 °F: 40 kΩ
140 °F: 12.4 kΩ
185 °F: 3.9 kΩ

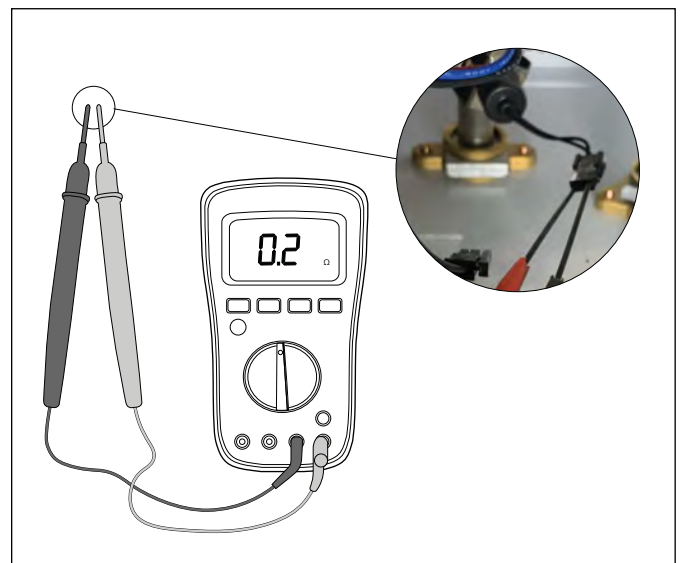

Figure 46

AC Error - Control Board Check

1. If the wire connection and the resistance of the DHW Thermistor are normal, replace the control board.

8.12 AD Error (Clog of Condensate Trap)

Error	Description
Clogging of the condensation trap	Error displayed when the condensation trap is clogged by foreign material.
Checkpoint	<ul style="list-style-type: none"> ▶ Check the connection (short circuit) of the wire connector. ▶ Check if foreign material exists inside the condensation trap. ▶ Check if the condensation water is frozen in the condensation hose.

Table 32

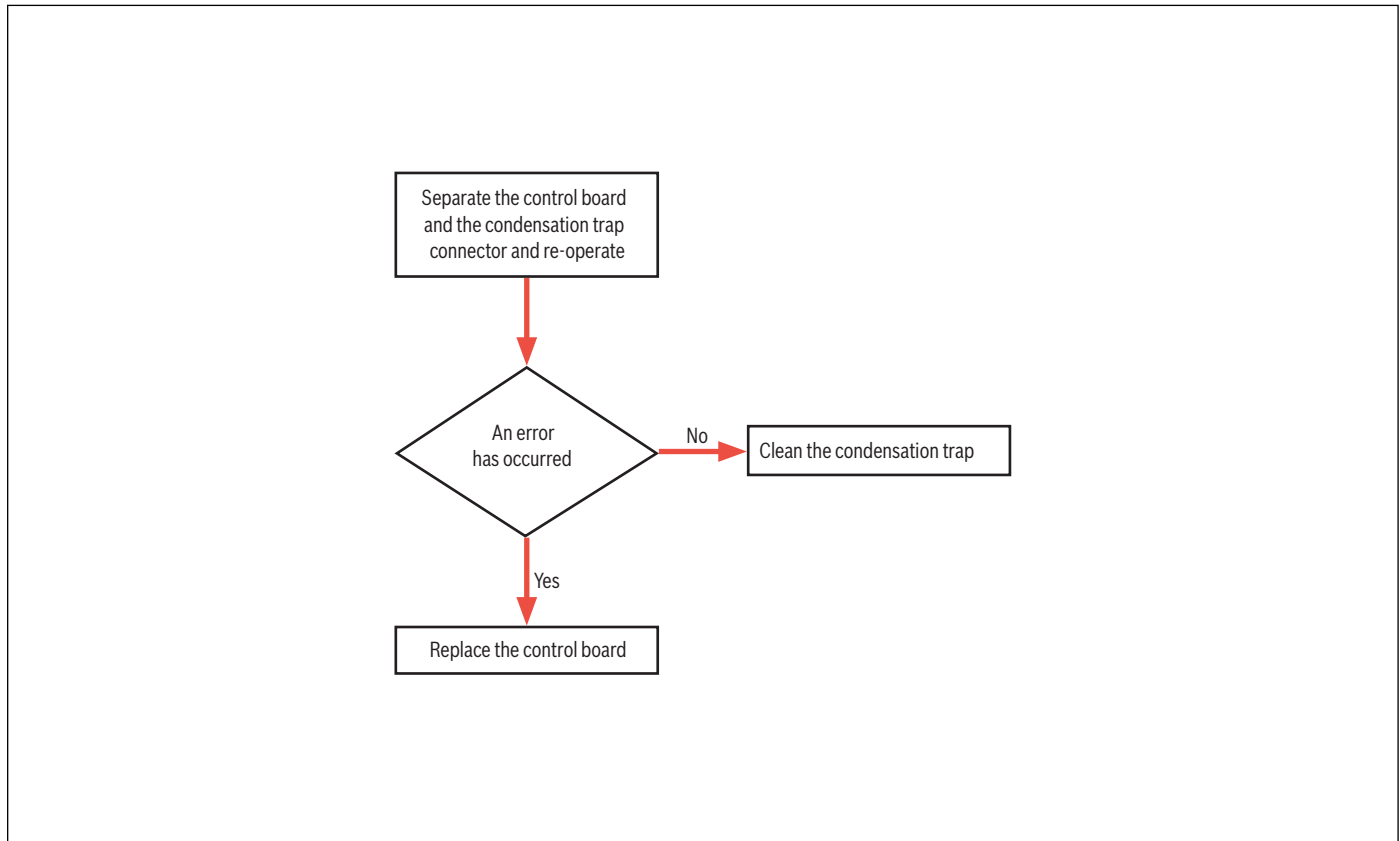

Figure 47

AD Error - Wire Check

1. Check the connection of the condensation trap and the wire.
2. Check wire condition for any damage or short circuit.



Figure 48 Control Board

AD Error - Control Board Check

1. The condensation trap is not clogged and the condensation water is discharged normally, replace the control board.

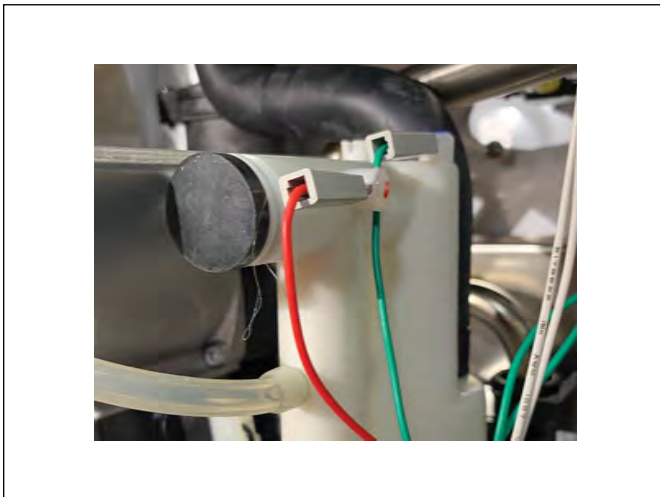

Figure 49 Condensation Trap Wire

AD Error - Foreign Material Check

1. Check if the condensation trap is clogged.
2. Separate the condensation trap and wash it with running water.
 - After washing the condensation trap, fill the condensation trap with water up to 2/3.

AD Error - Freezing Burst Check

1. Check if the condensation water is frozen in the condensation hose.
2. Melt the frozen condensation water with a tool if frozen.

8.13 AE Error (Blockage of Flue Pipe)

Error	Description
Blockage of air inlet	Error displayed when air is not supplied smoothly due to foreign material in the air inlet or external factors of when the air pressure switch is defective
Blockage of flue pipe	Error displayed when exhaust gas is not discharged normally due to foreign material in the flue pipe or external factors of when the air pressure switch is defective
Checkpoint	<ul style="list-style-type: none"> ▶ Check the connection of the wire connector part. <ol style="list-style-type: none"> 1. Control board and wire 2. Wind pressure S/W and wire ▶ Check the air pressure switch for abnormality. ▶ Check if there is foreign material in the flue pipe.

Table 33

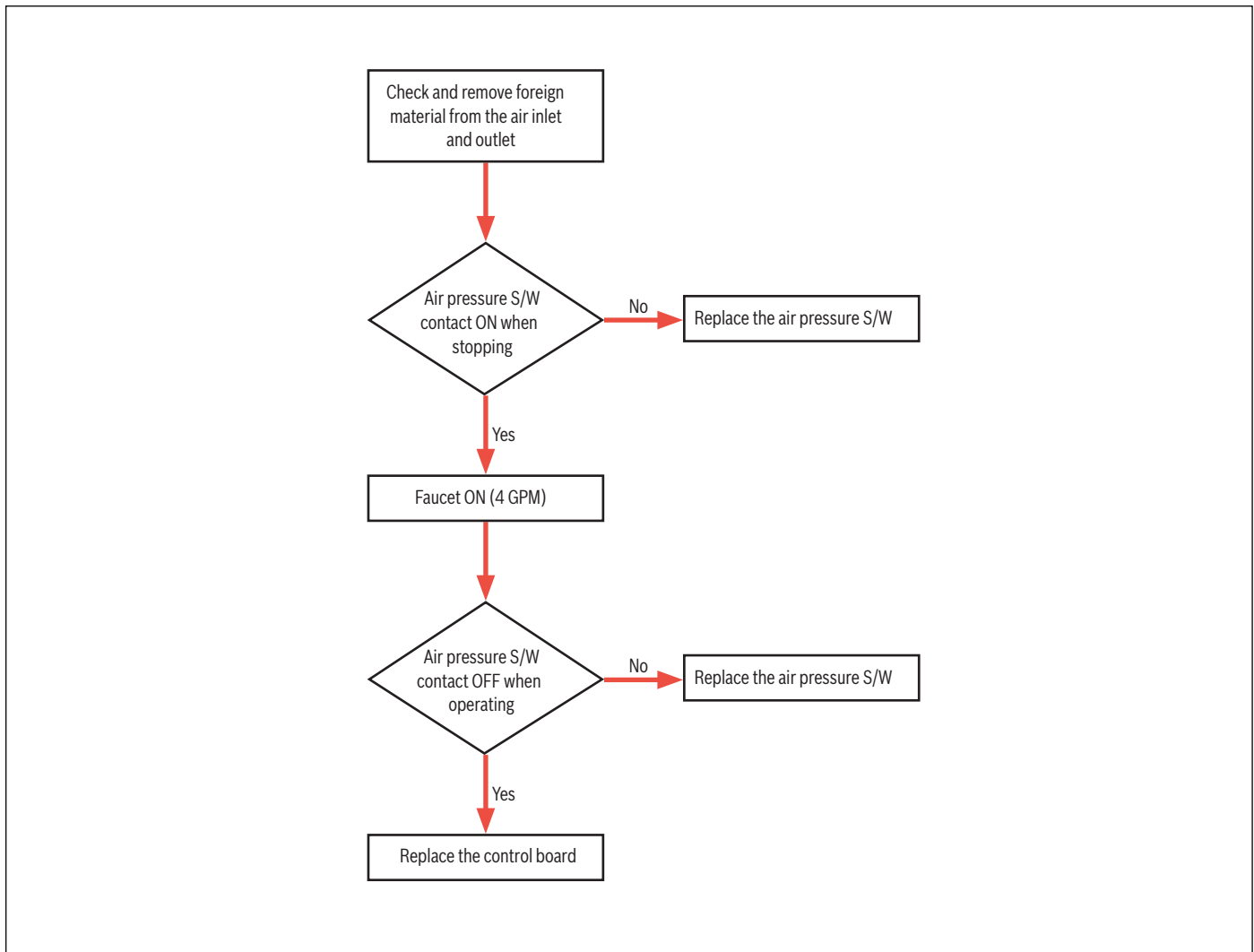

Figure 50

AE Error - Wire Check

1. Check the connection of the air pressure switch and the wire.

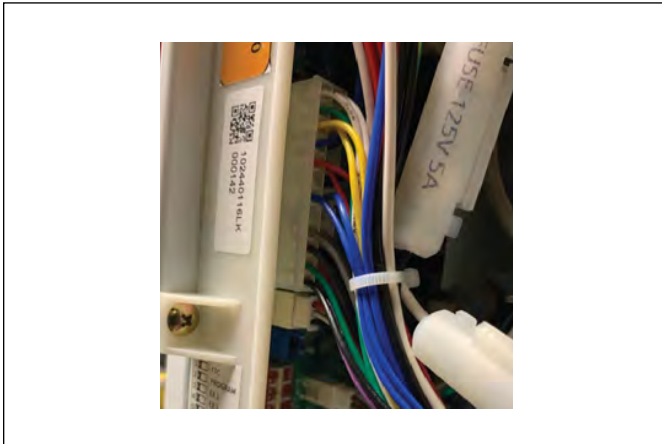

Figure 51 Control Board

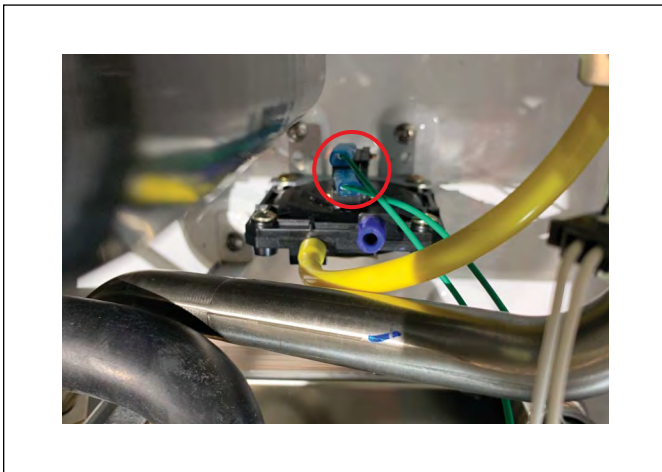

Figure 52 Air Pressure Switch Wire

AE Error - Air Pressure Switch Check

1. Check the air pressure switch for abnormalities under combustion stop condition.
 - Normal: under 1Ω
 - Abnormal: O.L

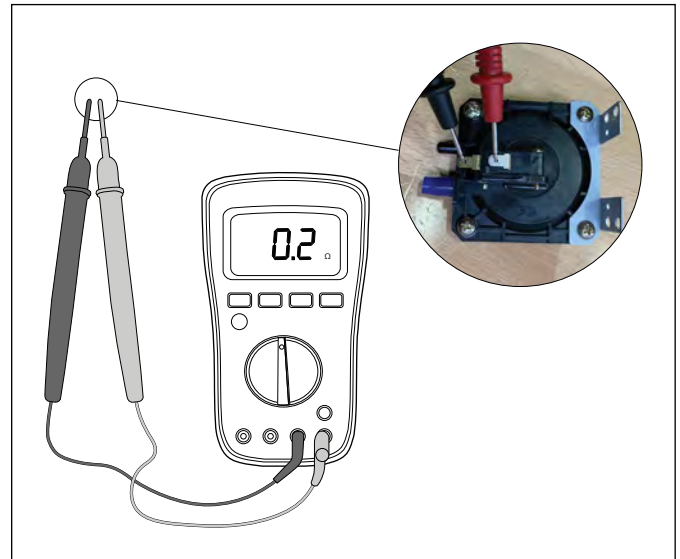

Figure 53

2. Operate the water heater using hot water over 4GPM and check the air pressure switch for abnormalities when the fan spins at the maximum speed.
 - Normal: O.L
 - Abnormal: under 1Ω
3. Replace the air pressure switch if the resistance is abnormal.

AE Error - Foreign Material Check

1. Check for any restrictions or blockage in the venting system.
 - Remove foreign material if present.

AE Error - Control Board Check

1. Replace the control board if the connection of air pressure switch and the resistance are normal and no foreign material is present in the air inlet and outlet.

8.14 EO Error (Abnormal Operation: Outdoor Temperature Sensor)

Error	Description
Outdoor Temperature Sensor Error	Error is displayed when the ambient sensor has short-circuited or is disconnected
Checkpoint	<ul style="list-style-type: none"> ▶ Check if the outdoor temperature sensor wire is connected correctly. <ol style="list-style-type: none"> 1. Control board wire 2. Outdoor temperature sensor wire ▶ Measure and check the resistance of the outdoor temperature sensor wire (NTC method). ▶ Check the outdoor temperature sensor for disconnection ▶ Check the outdoor temperature sensor for short-circuit

Table 34

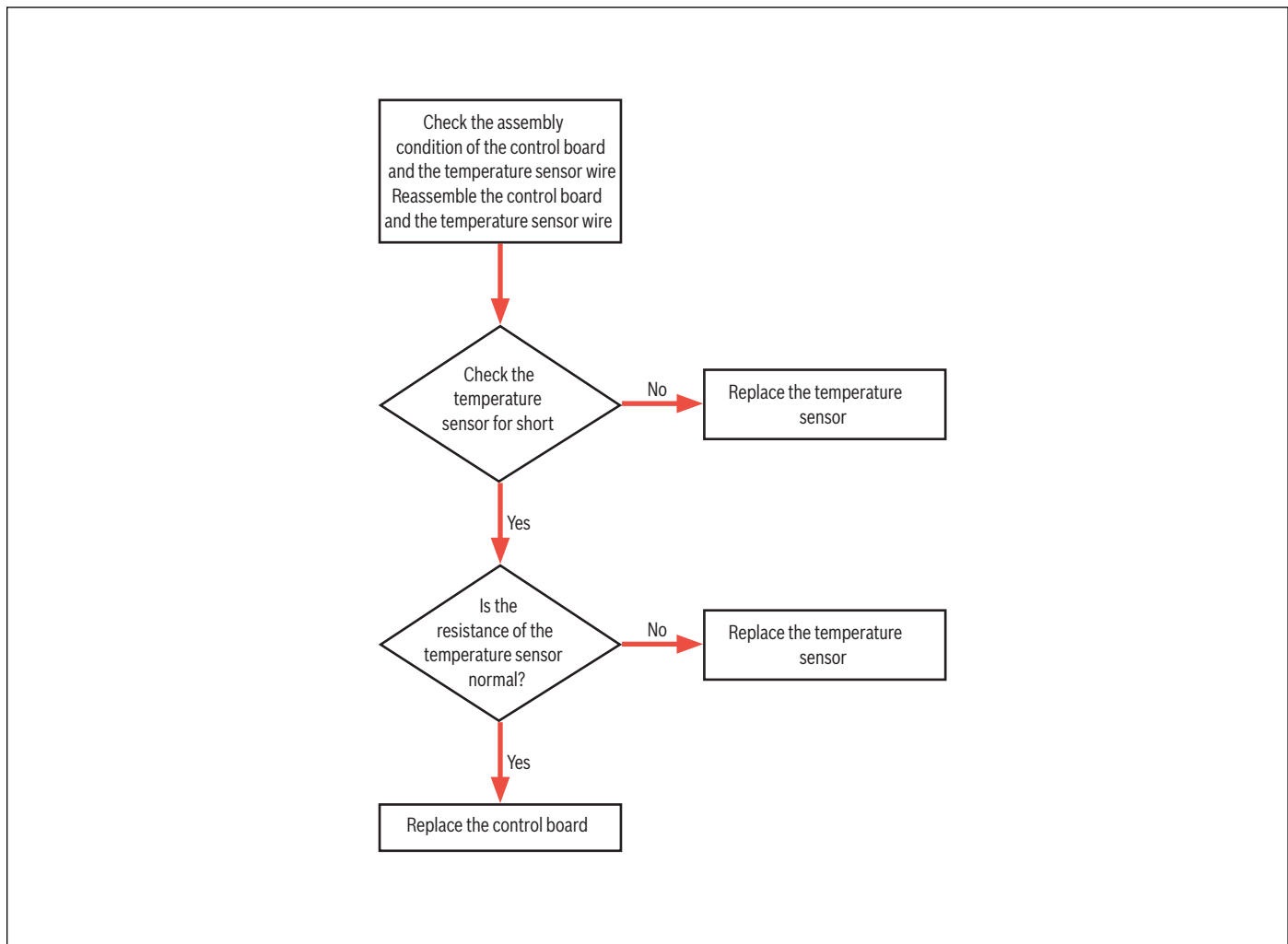

Figure 54

EO Error - Wire Check

1. Check the connection of the wire.

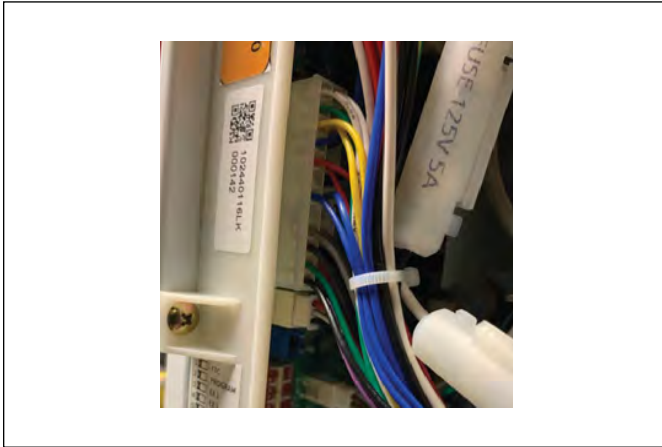

Figure 55 Control Board

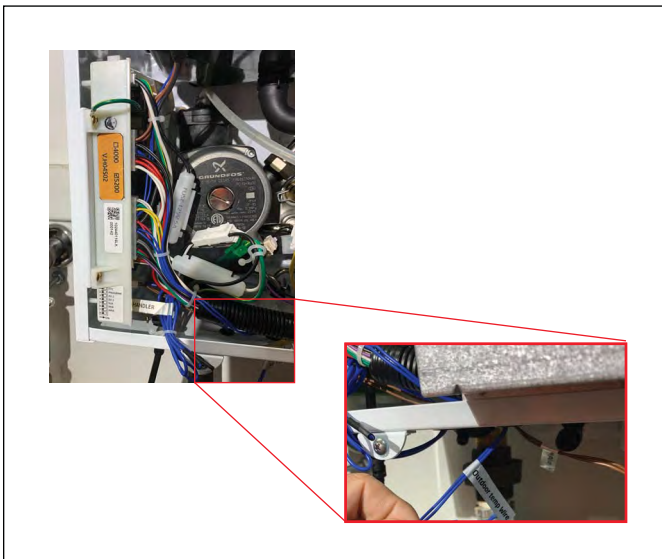

Figure 56 Outdoor Air Sensor

EO Error - Disconnection Check

1. Check if the outdoor air sensor is disconnected.

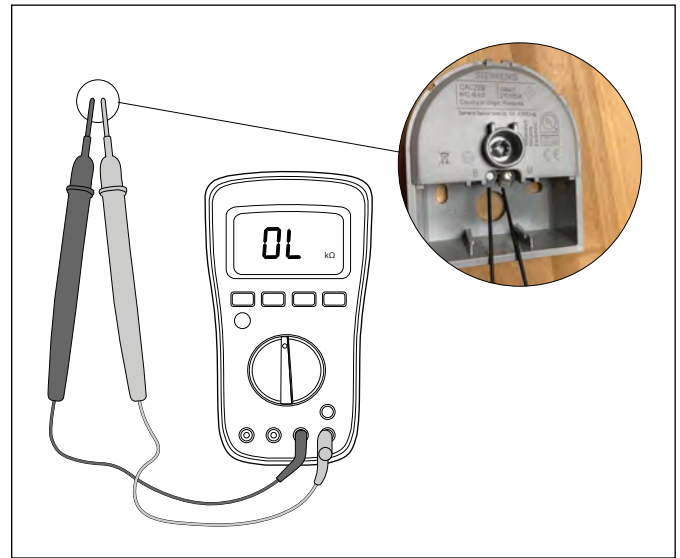

Figure 57

EO Error - Short Circuit Check

1. Check if the outdoor air sensor has short-circuited.

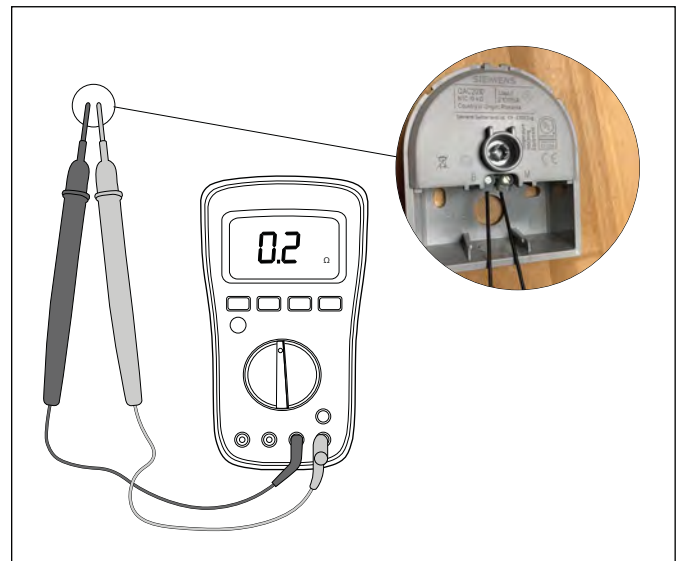

Figure 58

EO Error - Control Board Check

1. If the wire connection and the resistance of the Hex Thermistor are normal, replace the control board.

8.15 E1 Error (Abnormal Operation: Exhaust Temperature Sensor)

Error	Description
Hot Water Thermistor_T3 Error	Error is displayed when the Exhaust Thermistor has short-circuited or is disconnected
Checkpoint	<ul style="list-style-type: none"> ▶ Check if the Exhaust Thermistor connector is connected normally. <ol style="list-style-type: none"> 1. Control board wire 2. Exhaust Thermistor wire ▶ Measure the check the resistance of the Exhaust Thermistor (NTC method). <ul style="list-style-type: none"> — Separate the sensor and measure it at room temperature. ▶ Check the Exhaust Thermistor for disconnection ▶ Check the Exhaust Thermistor for short-circuit

Table 35

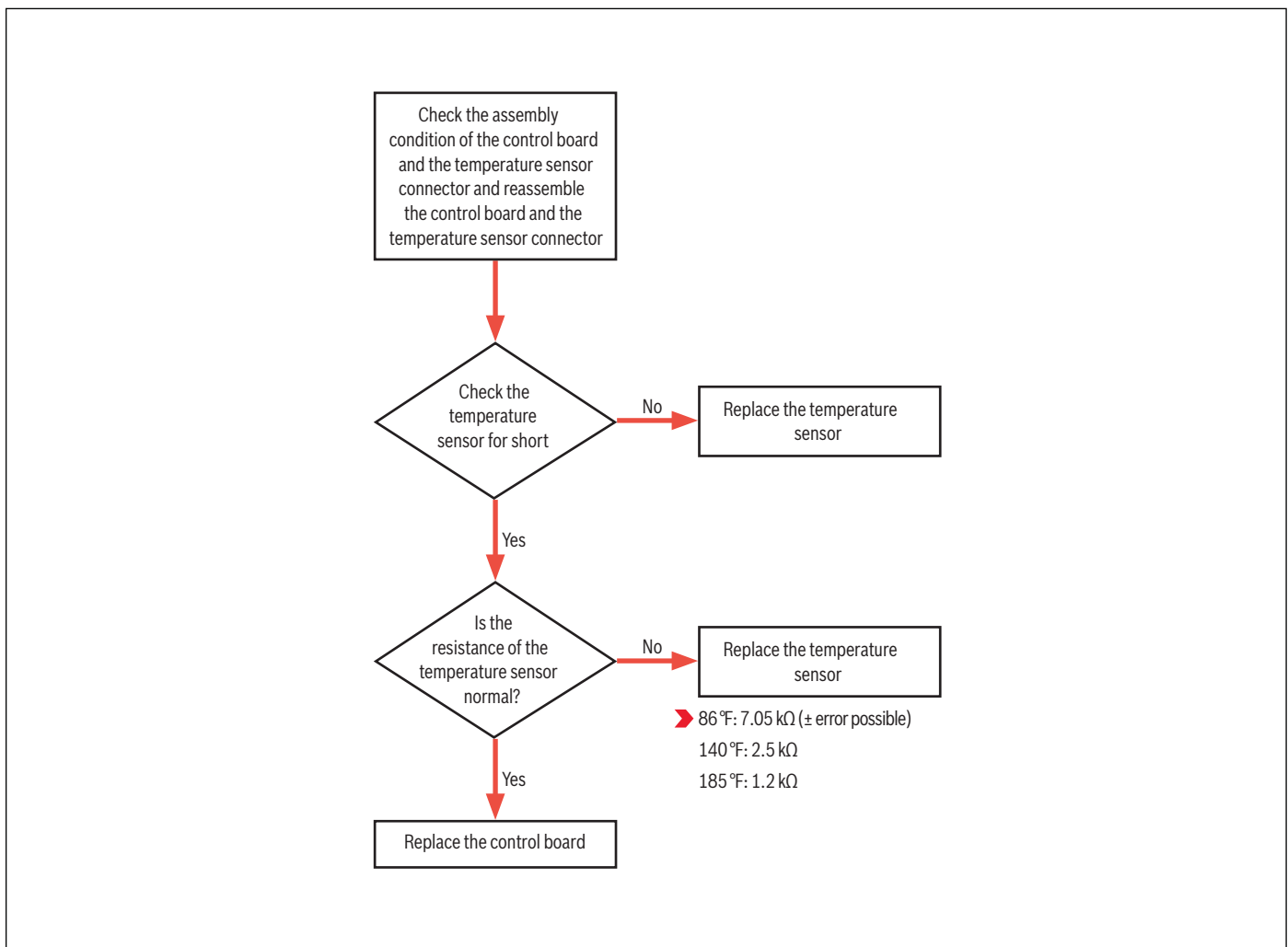

Figure 59

E1 Error - Wire Check

1. Check the connection of the wire.



Figure 60 Control Board



Figure 61 Exhaust Temp. Sensor

E1 Error - Exhaust Temperature Sensor Check

1. Measure the resistance of the Exhaust Temp. Sensor.
 - If the resistance is not normal, replace the Exhaust Temp. Sensor.



Figure 62

E1 Error - Disconnection Check

1. Check if the Exhaust Temp. Sensor is disconnected.
 - Disconnection: OL
 - Normal: 86 °F: 7.05 kΩ
140 °F: 2.5 kΩ
201 °F: 952 Ω

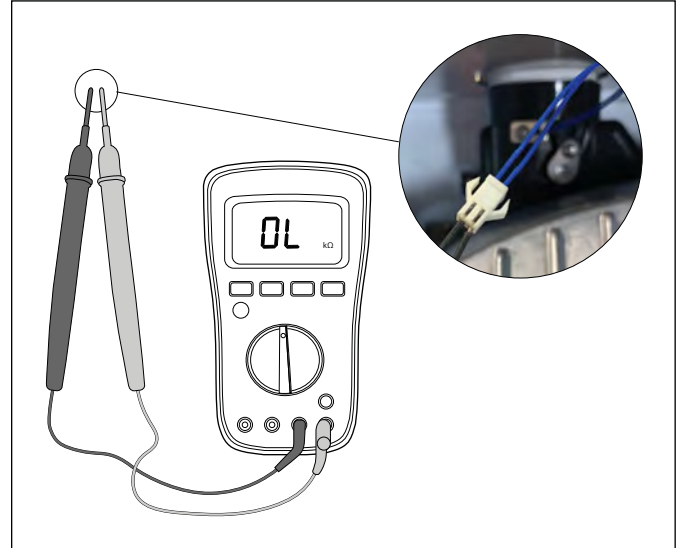

Figure 63

E1 Error - Short Circuit Check

1. Check if the Exhaust Temp. Sensor has short-circuited.
 - Short circuit: 0 Ω
 - Normal: 86 °F: 7.05 kΩ
140 °F: 2.5 kΩ
201 °F: 952 Ω



Figure 64

E1 Error - Control Board Check

1. If the wire connection and the resistance of the Exhaust Temp. Sensor are normal, replace the Control Board.

8.16 E2 Error (Exhaust Temperature Overheating)

Error	Description
Exhaust Temperature Sensor Error	The system stops combustion and issues an error when the temperature on the exhaust temperature sensor is rising abnormally (over 208 °F)
Checkpoint	<ul style="list-style-type: none"> ▶ Exhaust temperature sensor error (Wire color: Blue-Blue) ▶ Control board control error

Table 36

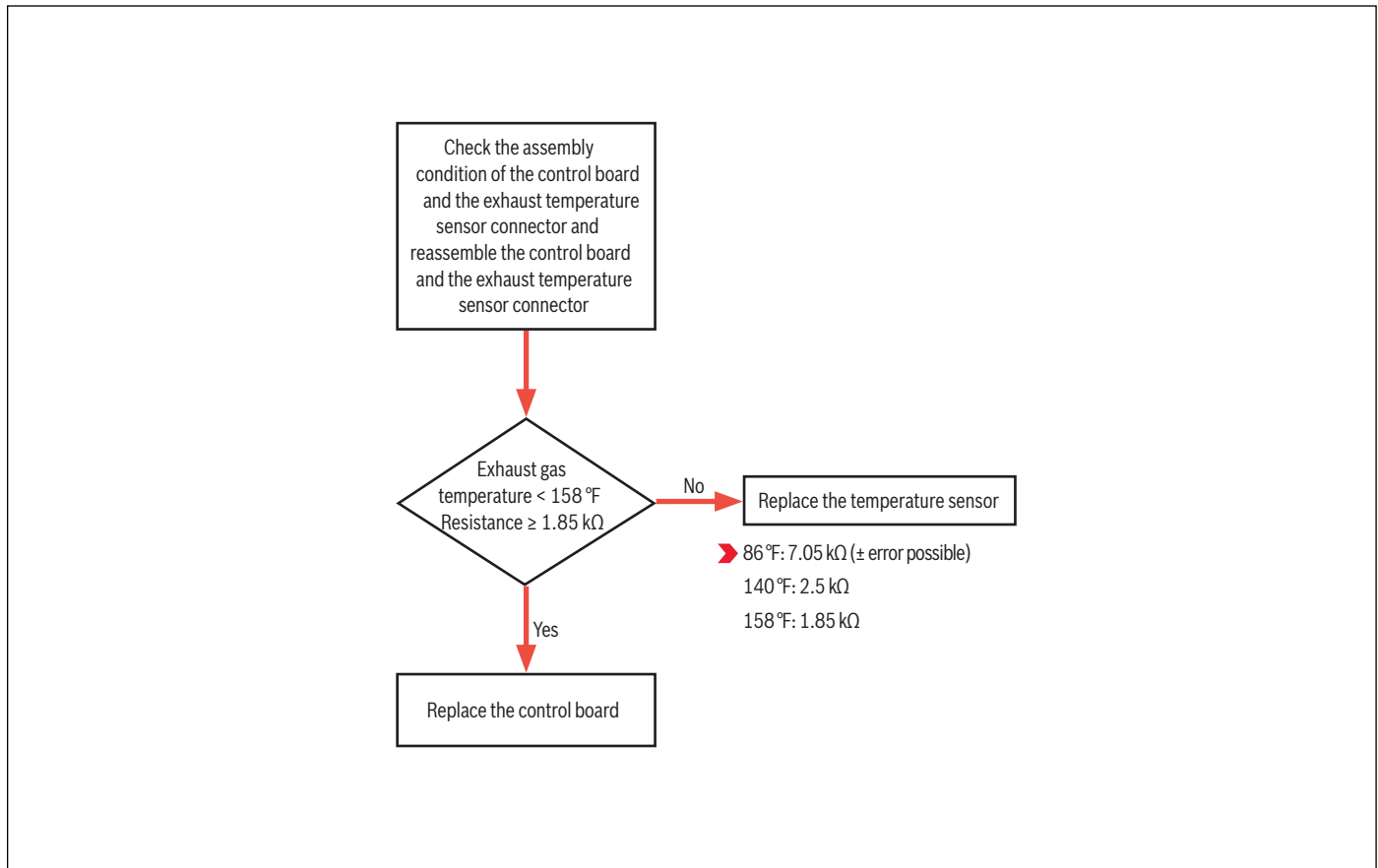

Figure 65

E2 Error - Wire Check

1. Check the connection of the wire.



Figure 66 Control Board



Figure 67 Exhaust Temp. Sensor

E2 Error - Exhaust Temperature Sensor Check

1. Measure the resistance of the Exhaust Temp. Sensor.
 - If the resistance is not normal, replace the Exhaust Temp. Sensor.

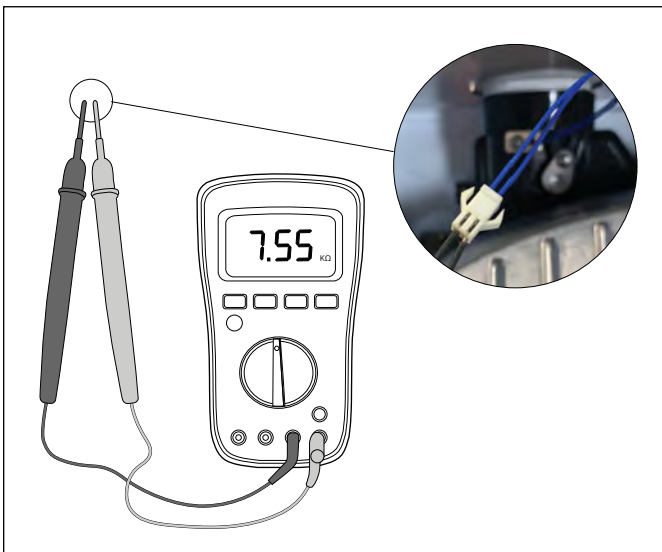

Figure 68

E2 Error - Disconnection Check

1. Check if the Exhaust Temp. Sensor is disconnected.
 - Disconnection: OL
 - Normal: 86 °F: 7.05 kΩ
140 °F: 2.5 kΩ
201 °F: 952 Ω

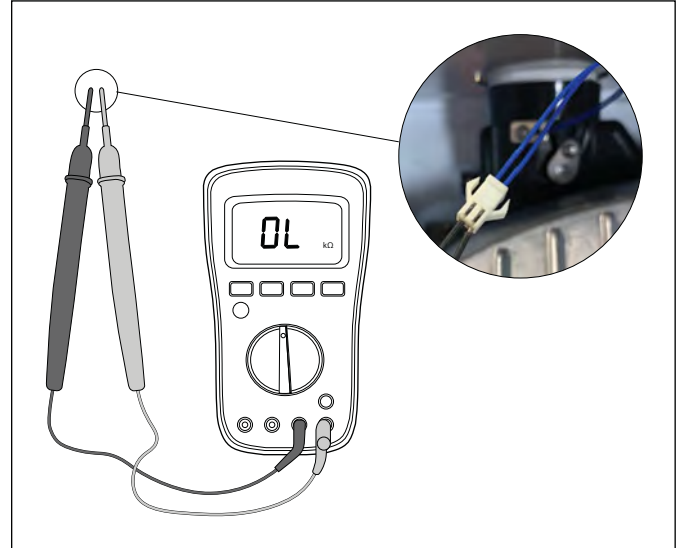

Figure 69

E2 Error - Short Circuit Check

1. Check if the Exhaust Temp. Sensor has short-circuited.
 - Short circuit: 0 Ω
 - Normal: 86 °F: 7.05 kΩ
140 °F: 2.5 kΩ
201 °F: 952 Ω

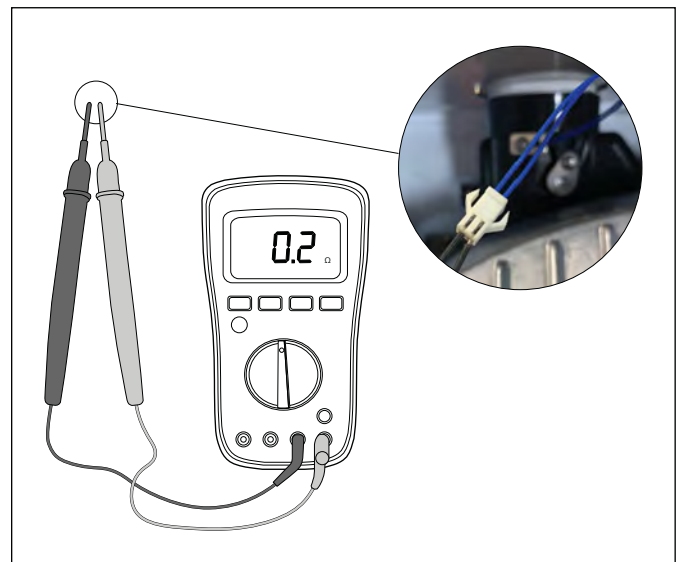

Figure 70

E2 Error - Control Board Check

1. If the wire connection and the resistance of the Exhaust Temp. Sensor are normal, replace the control board.

8.17 E3 Error (Abnormal Operation: Return Sensor)

Error	Description
Return Sensor Error	Error is displayed when the Return sensor has short-circuited or is disconnected
Checkpoint	<ul style="list-style-type: none"> ▶ Check if the Hot Water Thermistor connector is connected normally. <ol style="list-style-type: none"> 1. Control board wire 2. Return sensor wire ▶ Measure the check the resistance of the Return sensor (NTC method). <ul style="list-style-type: none"> — Separate the sensor and measure it at room temperature. ▶ Check the Return sensor for disconnection ▶ Check the Return sensor for short-circuit

Table 37

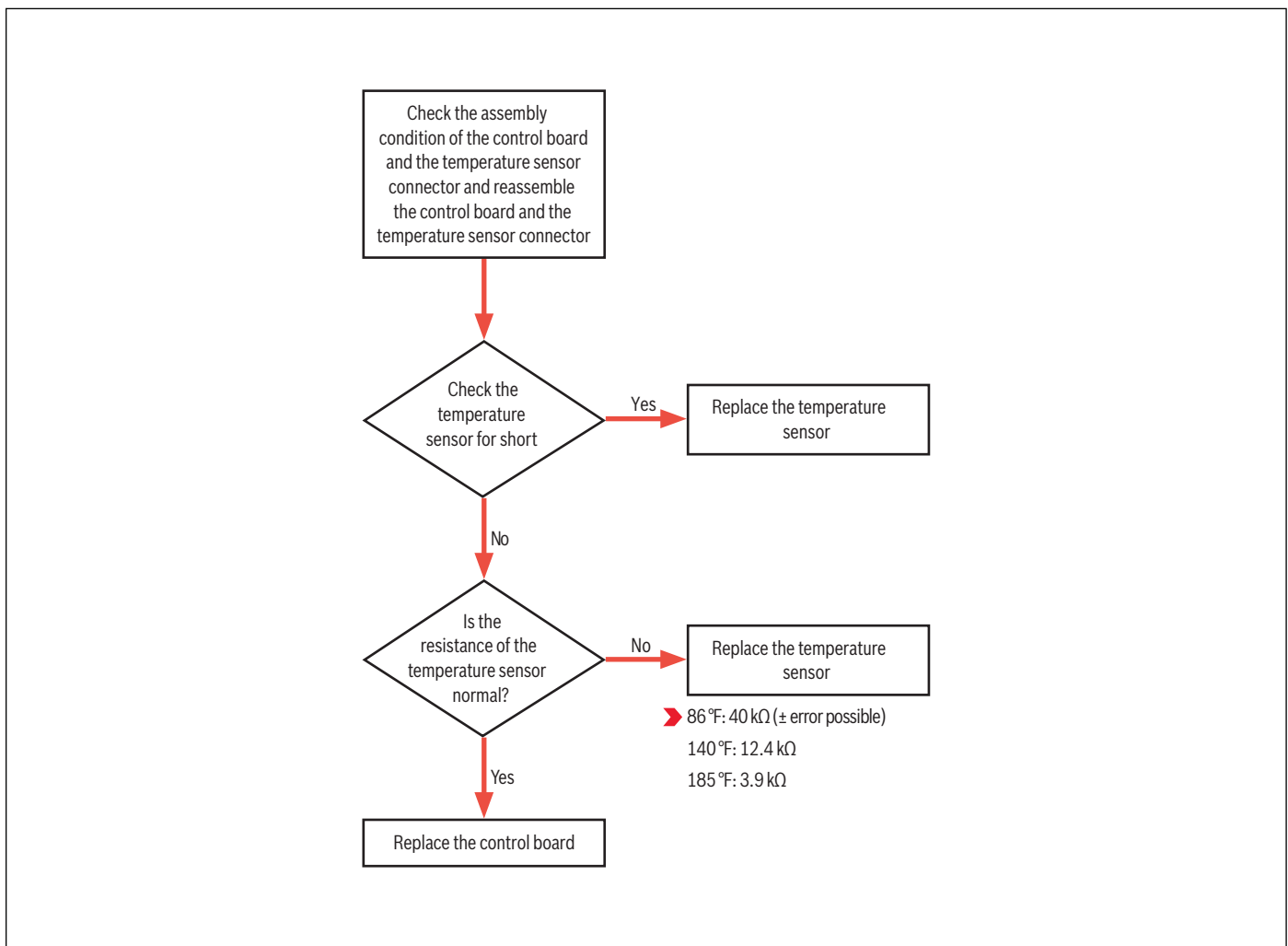

Figure 71

E3 Error - Wire Check

1. Check the connection of the wire.



Figure 72 Control Board

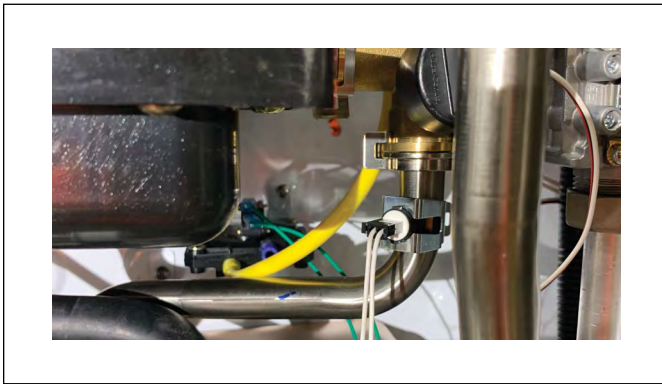

Figure 73 Return Sensor

E3 Error - Return Sensor Check

1. Measure the resistance of the Return sensor. If the resistance is not normal, replace the Return sensor.
 - Disconnection: OL
 - Normal: 86 °F: 40 kΩ
140 °F: 12.4 kΩ
185 °F: 3.9 kΩ

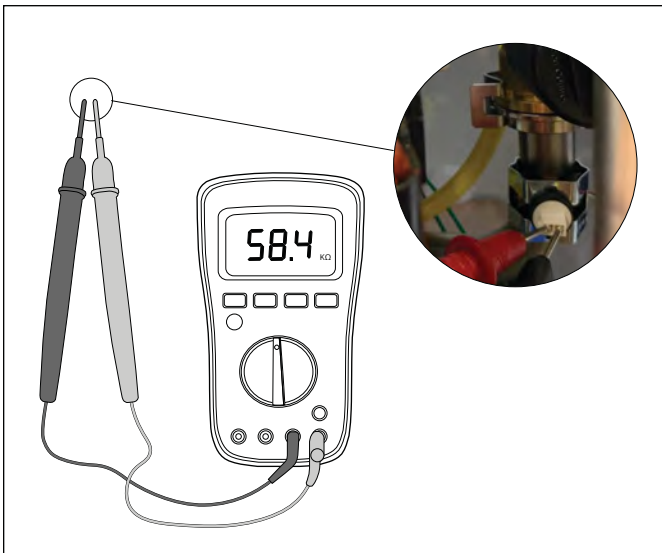

Figure 74

E3 Error - Disconnection Check

1. Check if the Hot Water Thermistor is disconnected.
 - Disconnection: OL
 - Normal: 86 °F: 40 kΩ
140 °F: 12.4 kΩ
185 °F: 3.9 kΩ

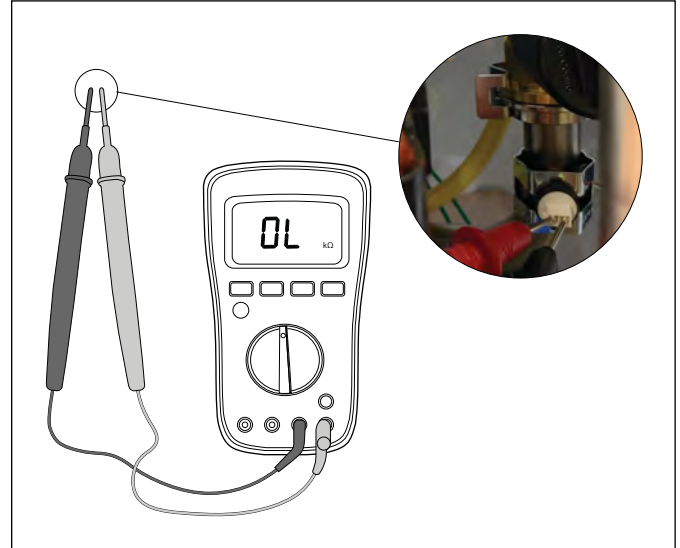

Figure 75

E3 Error - Short Circuit Check

1. Check if the Return sensor has short-circuited.
 - Short circuit: 0 Ω
 - Normal: 86 °F: 40 kΩ
140 °F: 12.4 kΩ
185 °F: 3.9 kΩ



Figure 76

E3 Error - Control Board Check

1. If the wire connection and the resistance of the Hot Water Thermistor are normal, replace the control board.

8.18 E4 Error (Abnormal Operation: Pressure Sensor)

Error	Description
Pressure Sensor Error	Error is displayed when the pressure sensor has short-circuited or is disconnected
Checkpoint	<ul style="list-style-type: none"> ▶ Check if the Hot Water Thermistor connector is connected normally. <ol style="list-style-type: none"> 1. PCB wire 2. Pressure sensor wire ▶ Measure the check the resistance of the pressure sensor (NTC method). <ul style="list-style-type: none"> — Separate the sensor and measure it at room temperature. ▶ Check the Pressure sensor for disconnection ▶ Check the Pressure sensor for short-circuit

Table 38

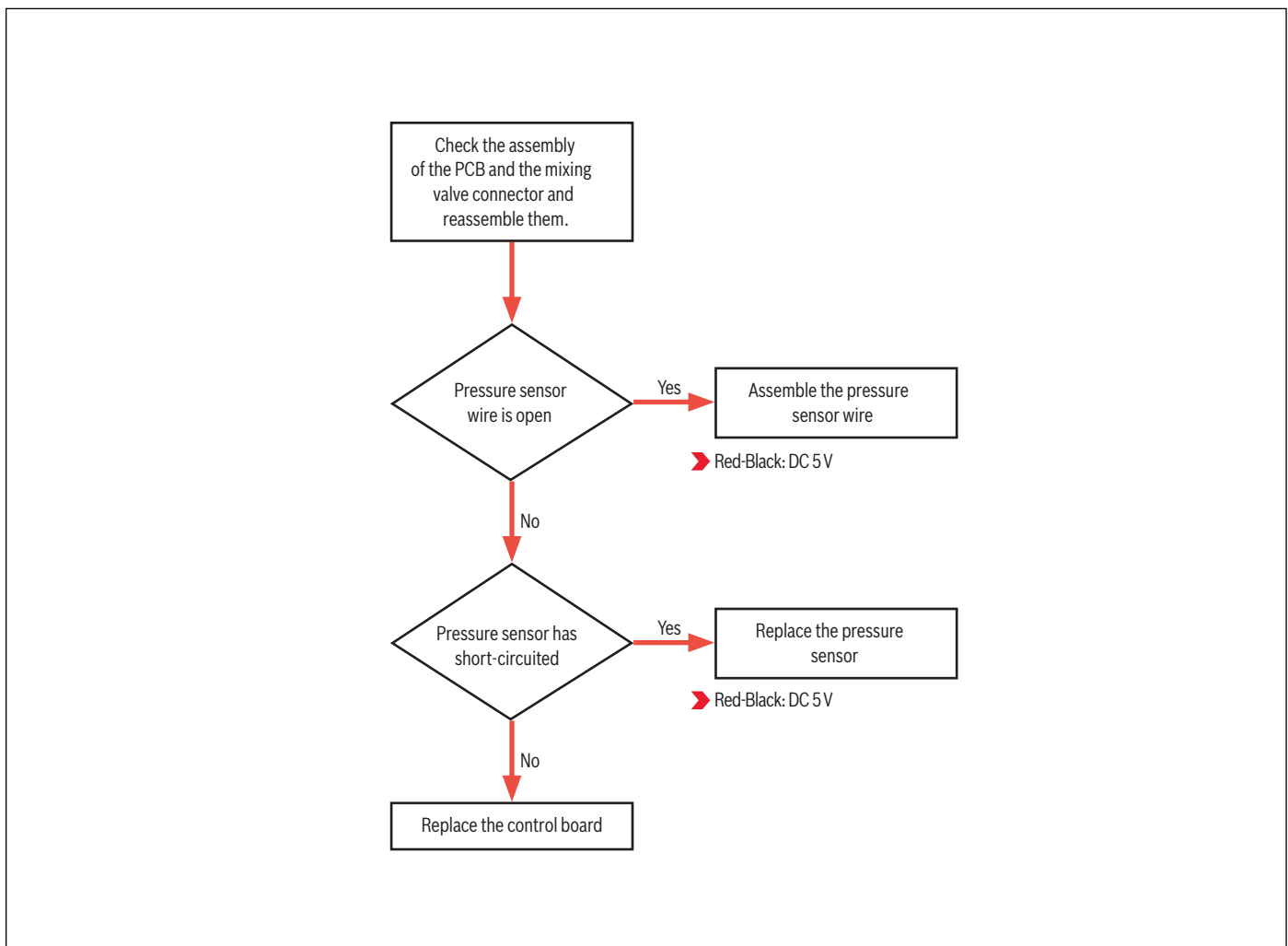

Figure 77

E4 Error - Wire Check

1. Check the connection of the wire.

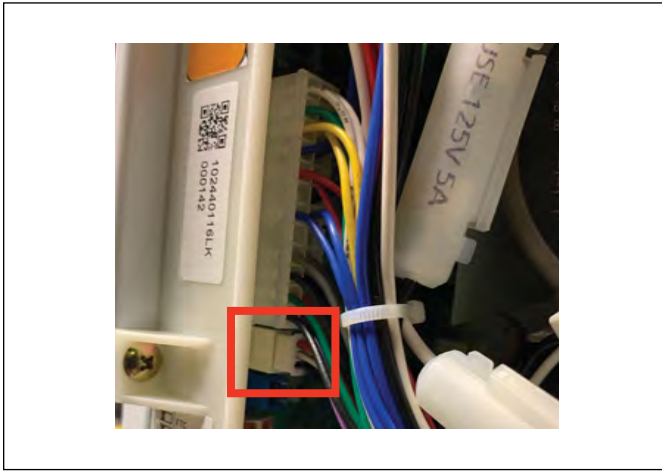

Figure 78 Control Board



Figure 79 Pressure Sensor

E4 Error - Pressure Sensor Check

1. Measure the resistance of the Pressure sensor.
2. Check the pressure sensor input voltage at the control board.
 - Normal: DC 5 V
 - Abnormal: 0 V
3. Replace the control board if the voltage output from the control board is abnormal.



Figure 80

8.19 E7 Error (Abnormal Operation: Gas Valve Relay)

Error	Description
Gas valve relay error	It occurs when the gas valve relay which is mounted on control board is stuck closed.
Checkpoint	► Replace the control board

Table 39

8.20 EB Error (Hot Water Overheating)

Error	Description
Overheating of temperature sensor (Boiling superheat) over 176 °F	An error is displayed when abnormal overheating caused by Hot water sensor
Checkpoint	► Check the resistance of Temperature sensor (NTC method) — Measurement should be carried out after separating the sensor.

Table 40

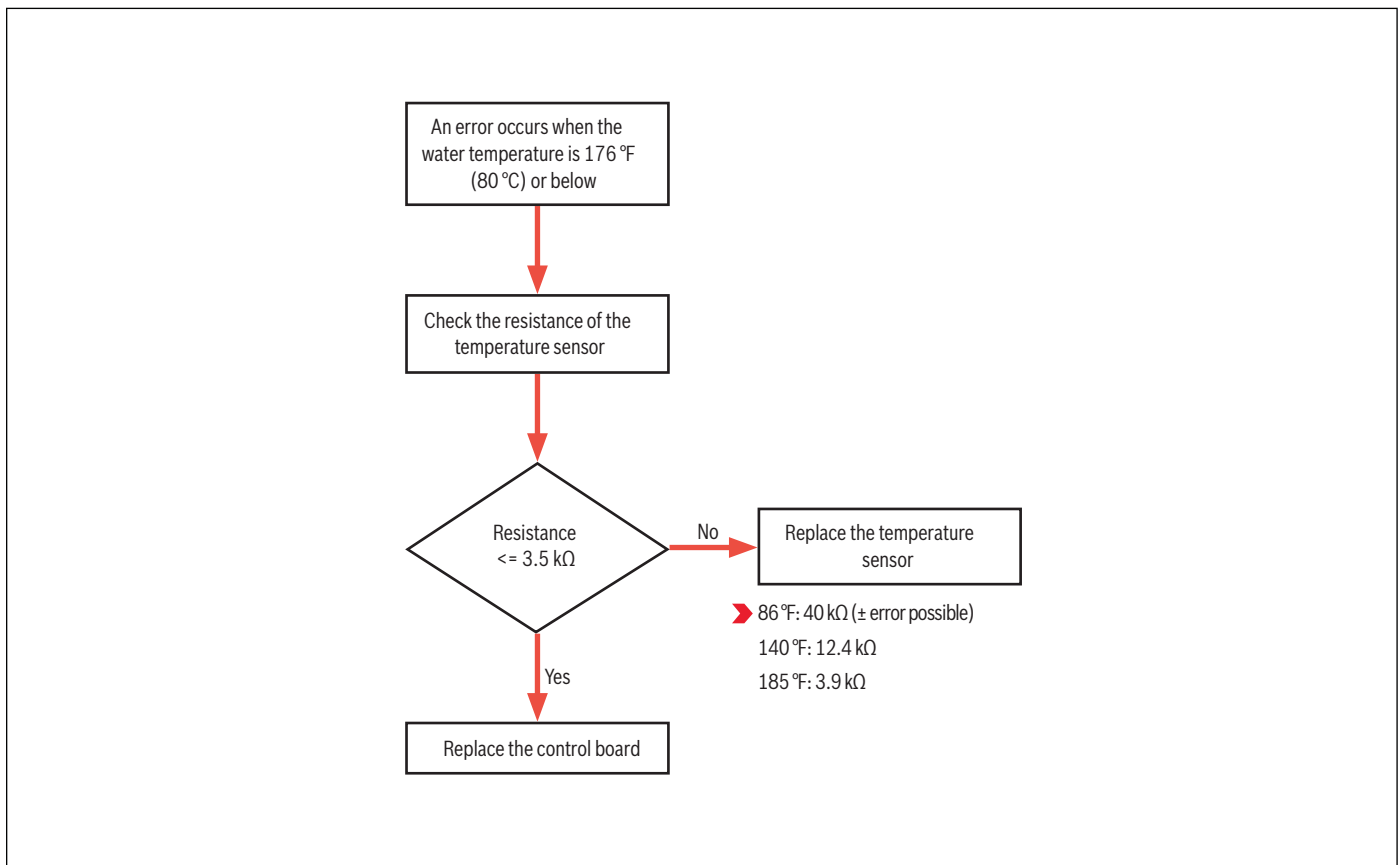

Figure 81

EB Error - Temperature Resistance Check

1. Check if the resistance matches the temperature on the following temperature resistance table.
 - 86 °F: 40 k Ω
 - 140 °F: 12.4 k Ω
 - 185 °F: 3.9 k Ω



Figure 82

9 Components Replacement Instructions

9.1 Preparation Step

1. Shut off the gas supply valve.

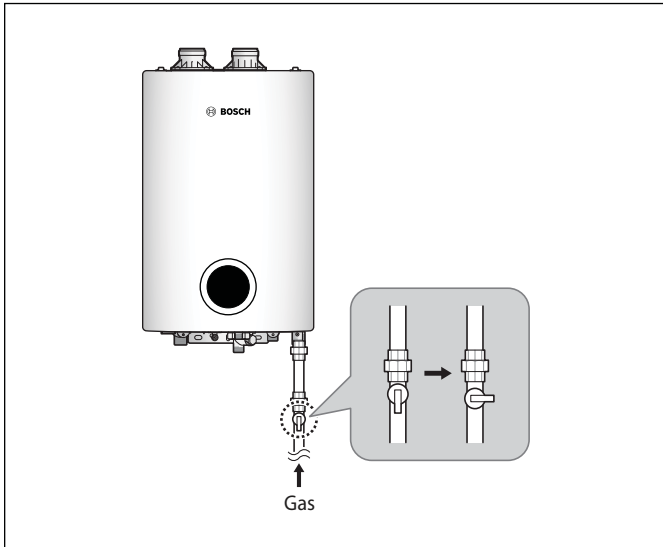

Figure 83

2. Pull out the power supply line.

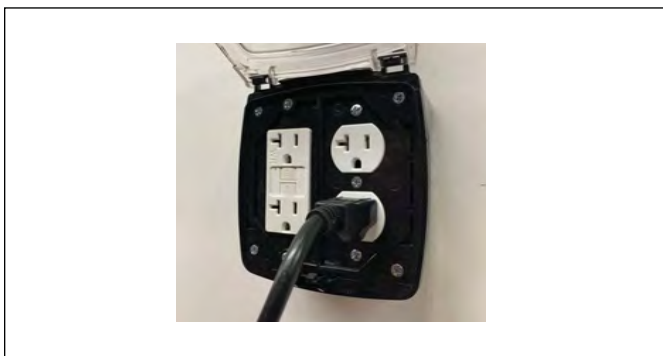

Figure 84

3. Shut off the water valves for both the heating and DHW lines.

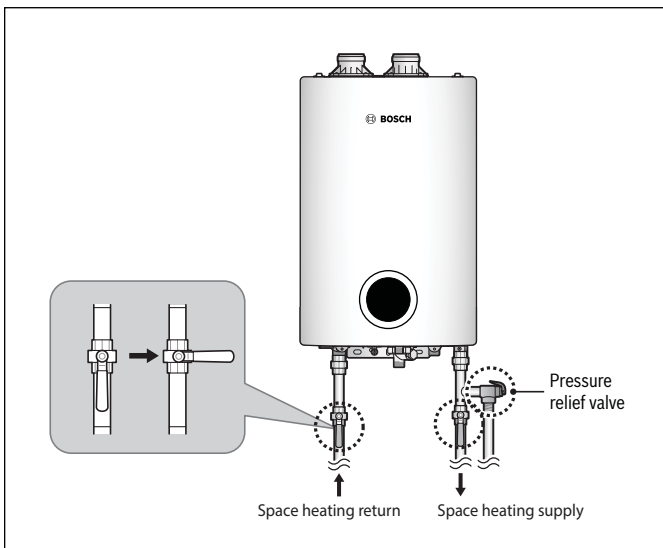

Figure 85

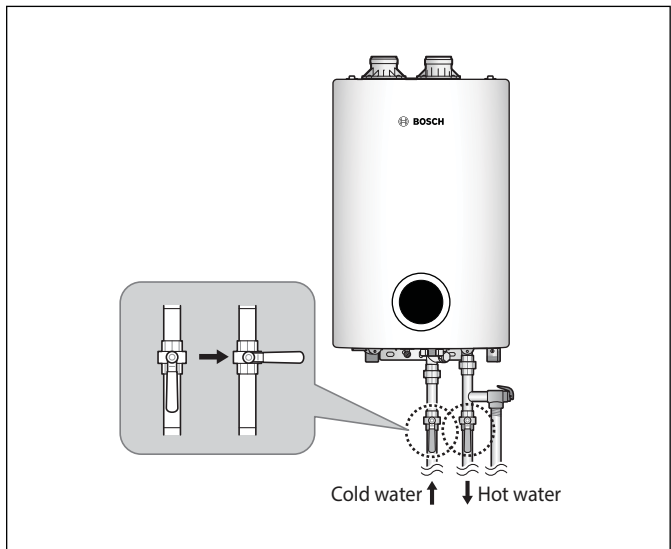

Figure 86

4. Loosen the 2 screws and open the case.



Figure 87

9.2 Control Board

1. Refer to 9.1 Preparation Step.
2. Loosen the connection terminals in the control board.
3. Loosen the 3 control board fixing screws (circled in blue) assembled to the chassis (Fig. 88).

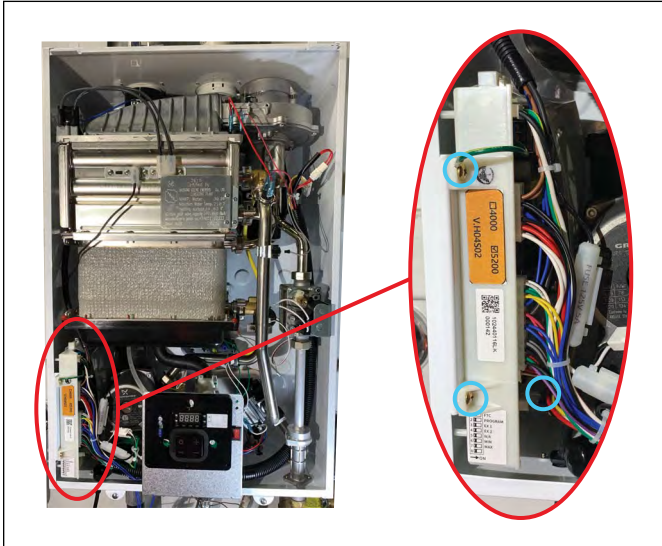

Figure 88

4. Replace with a new control board and tighten the connection terminals.
5. Tighten the 3 control board fixing screws. (Tighten the ground wire with the control board top screw together.)

9.3 Sensor, Heating/Return

1. Refer to 9.1 Preparation Step.
2. Disconnect the temperature sensor terminal.
3. Replace with a new temperature sensor.

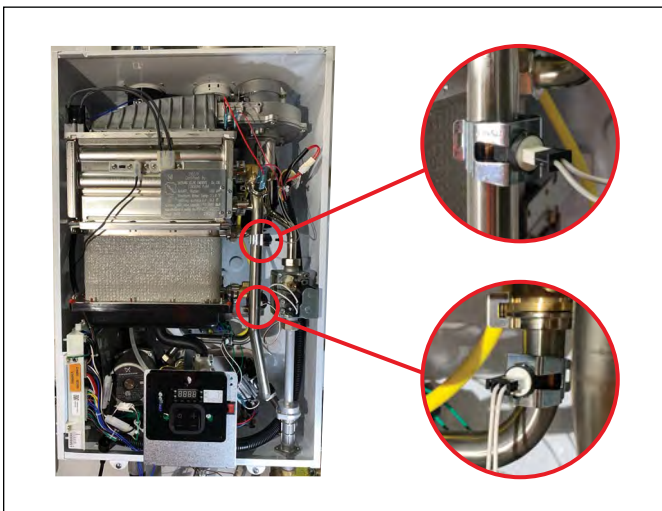

Figure 89

9.4 Sensor, DHW

1. Refer to 9.1 Preparation Step.
2. Disconnect the temperature sensor terminal.
3. Replace with a new temperature sensor.

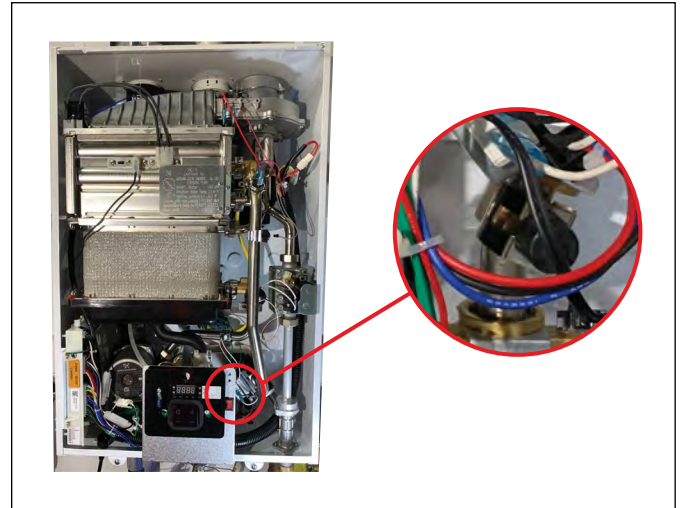

Figure 90

9.5 Exhaust Temperature Sensor_T4 (Blue)

1. Refer to 9.1 Preparation Step.
2. Disconnect the temperature sensor terminal (Item 1).
3. Loosen the screw and remove the temperature sensor (Item 2).

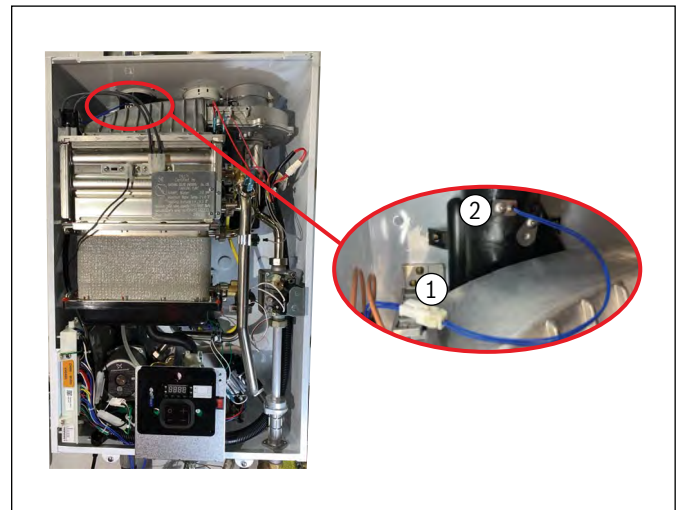

Figure 91

4. Replace with a new temperature sensor and tighten the screw.

9.6 Gas Orifice

1. Refer to 9.1 Preparation Step.
2. Loosen the bottom part of the gas outlet pipe slightly using a wrench.

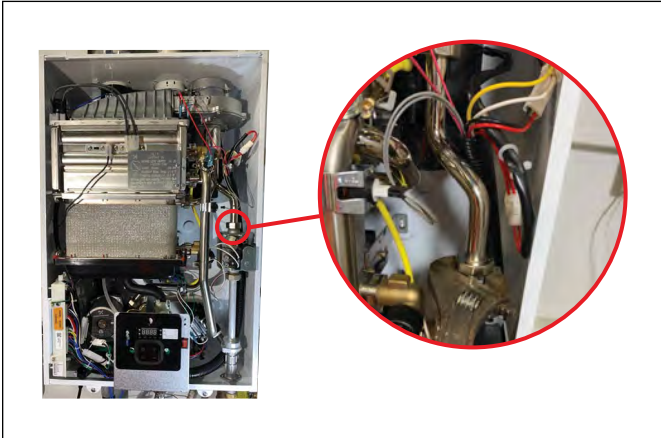

Figure 92

3. Loosen the 4 fixing screws.

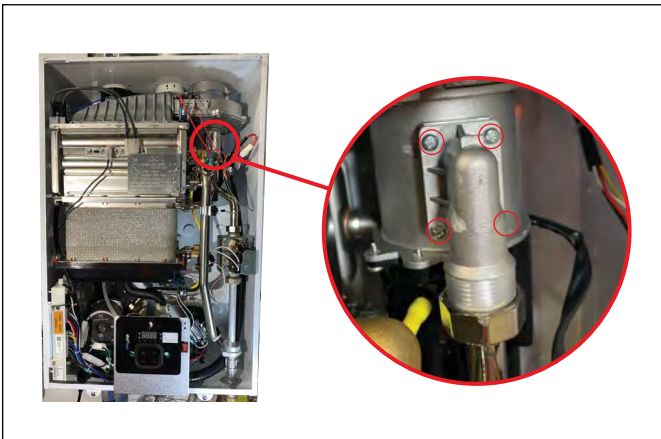

Figure 93

4. Loosen the middle orifice fixing screw (Item 1) and replace with a new orifice. Secure orifice fixing screw (Item 1).

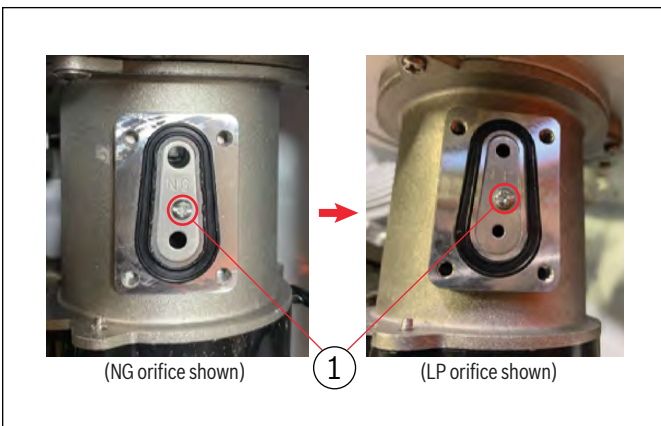

Figure 94

5. After replacing with the new orifice, refer to section 11.1 Combustion Analysis in the installation instructions.

9.7 Air Pressure Switch

1. Refer to 9.1 Preparation Step.
2. Separate the silicon hose from the air mixer.
3. Loosen the air pressure switch fixing screws (2 each, Item 3) and disconnect the green wire.

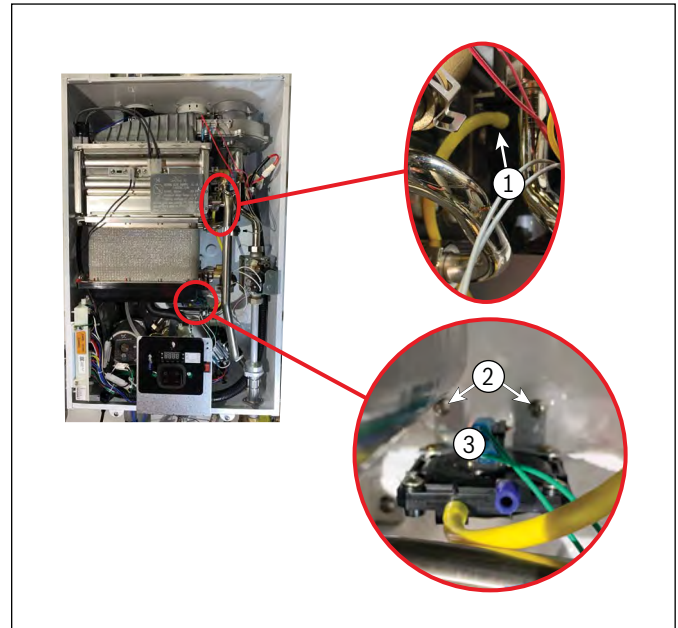

Figure 95

4. Replace with a new air pressure switch and connect the green wire.
5. Tighten the fixing screw and attach the silicon hose to the air mixer.

9.8 Gas Valve

1. Refer to 9.1 Preparation Step.
2. Disconnect the wire from the gas valve (Item 1).
3. Loosen the nut connecting the gas valve and the gas inlet & outlet using a wrench (Item 2).

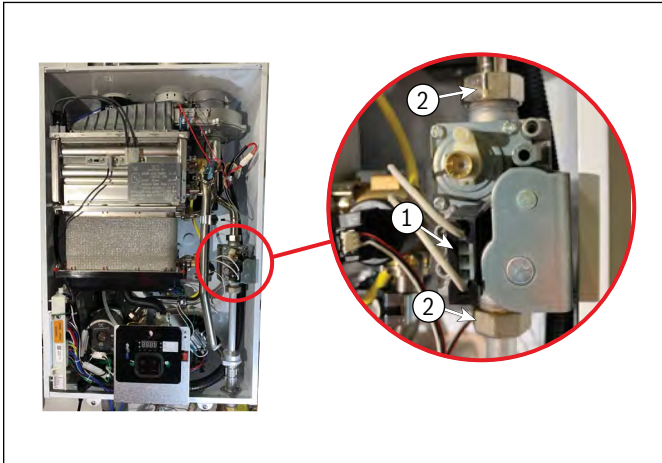

Figure 96

4. Replace with a new gas valve, and when assembling the gas inlet & outlet nut, insert the packing.
5. Connect the wire (Item 1).

9.9 High Limit Cutout HEX T2 (302°F)

1. Refer to 9.1 Preparation Step.
2. Disconnect the wire from the high limit cutout (Item 1).
3. Loosen the 2 high limit cutout fixing screws (Item 2).

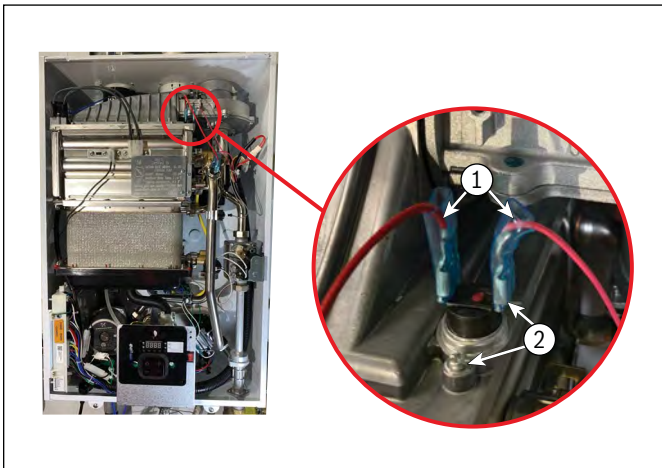

Figure 97

4. Replace with a new high limit cutout and tighten the 2 fixing screws.
5. Connect the wires to the high limit cutout. (Connect 13+21 pin wire to one terminal and the high limit cutout wire to the other terminal). Make sure to connect the wires completely.

9.10 High Limit Cutout Supply T3 (203°F)

1. Refer to 9.1 Preparation Step.
2. Disconnect the wire from the high limit cutout (Item 2).
3. Loosen the 1 high limit cutout fixing screw. (Item 3).

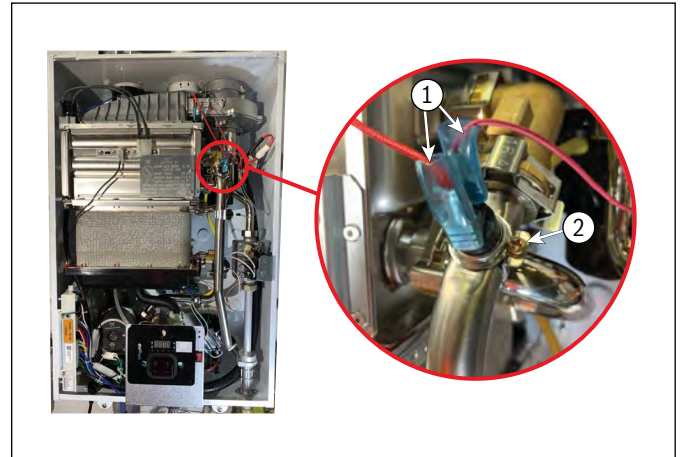

Figure 98

4. Remove the high limit cutout bracket, replace the high limit cutout with a new one, and tighten the fixing screw.
5. Connect the wires to the high limit cutout. (Connect 13+21 pin wire to one terminal and the high limit cutout wire to the other terminal). Make sure to connect the wires completely.

9.11 Ignition Transformer

1. Refer to 9.1 Preparation Step.
2. Disconnect the wires from the electrode (Item 1).
3. Separate the wires from the ignition transformer connection terminal (Item 2).
4. Loosen the 1 ignition transformer fixing screw (Item 3).

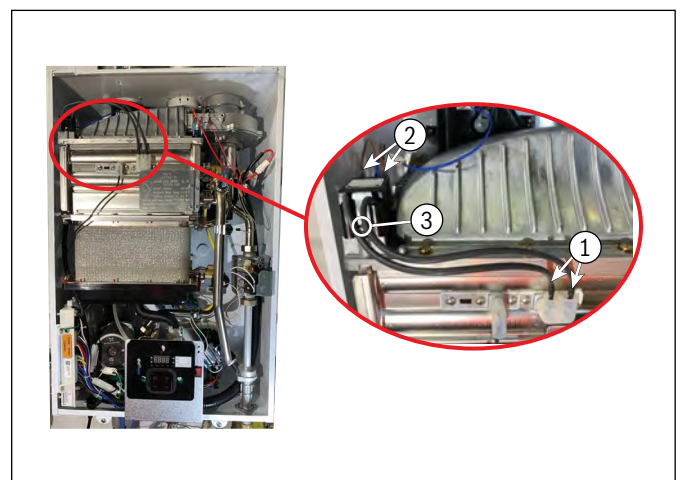

Figure 99

5. Replace with a new ignition transformer and tighten the 1 fixing screw.
6. Connect the wire to the ignition transformer and electrode. Make sure to connect the wires to the terminal completely.

9.12 Electrode Assembly

1. Refer to 9.1 Preparation Step.
2. Separate the electrode assembly connection terminal (Item 1).
3. Separate the electrode assembly cap (Item 2).
4. Loosen the 2 fixing screws (Item 3).

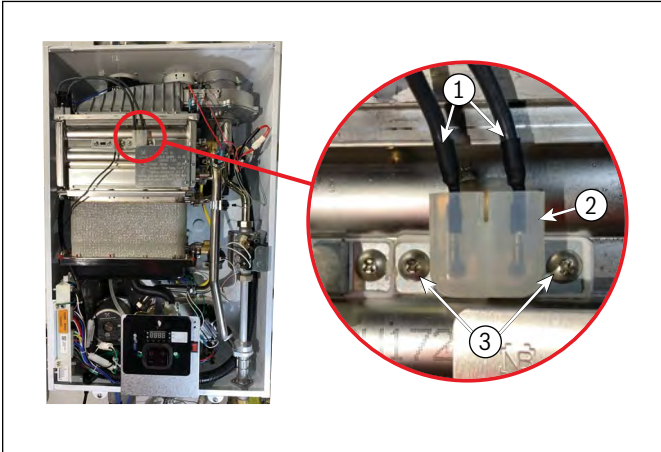

Figure 100

5. Replace with a new electrode.
6. When replacing the electrode assembly, use the new gasket and bracket that are provided with the new part. Assemble in the order of gasket (1), electrode assembly (2) and bracket (3) as shown in the figure below.

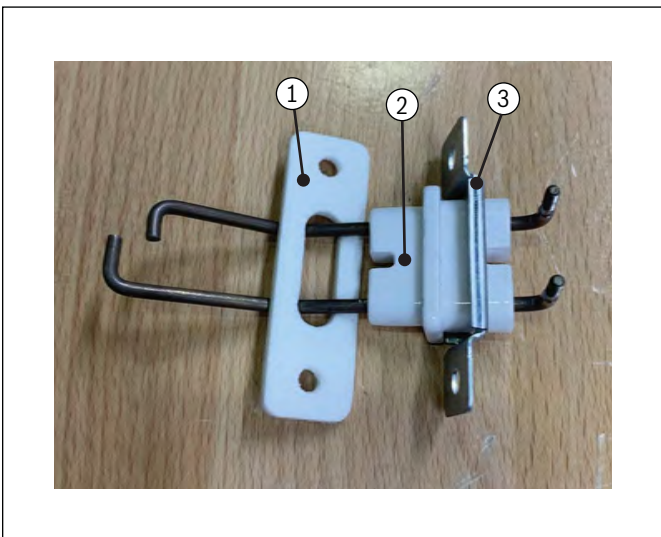

Figure 101

9.13 Flame Rod

1. Refer to 9.1 Preparation Step.
2. Separate the flame rod connection terminal. (Item 1).
3. Separate the flame rod cap. (Item 2).
4. Loosen the 3 fixing screws. (Item 3).

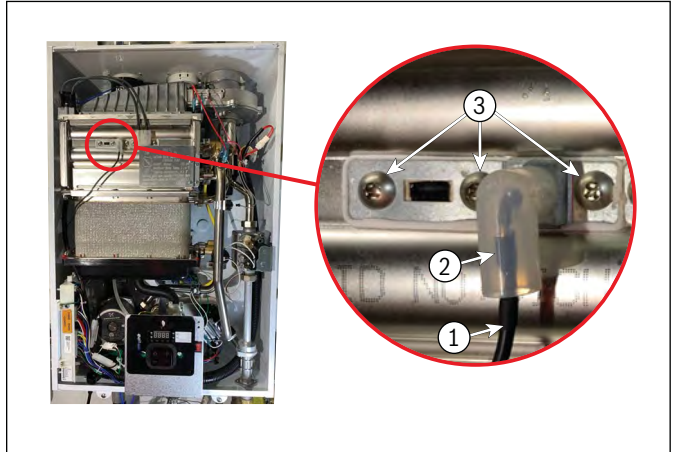

Figure 102

5. Replace with a new flame rod.
6. When replacing the flame rod, use the new gasket and bracket that are provided with the new part.
7. Assemble in the order of gasket (1), flame rod (2), and bracket (3) as shown in the figure below. Remove the brown tape part (4) from the gasket and attach it to the bracket. (Do not attach it to the sensible heat exchanger.)

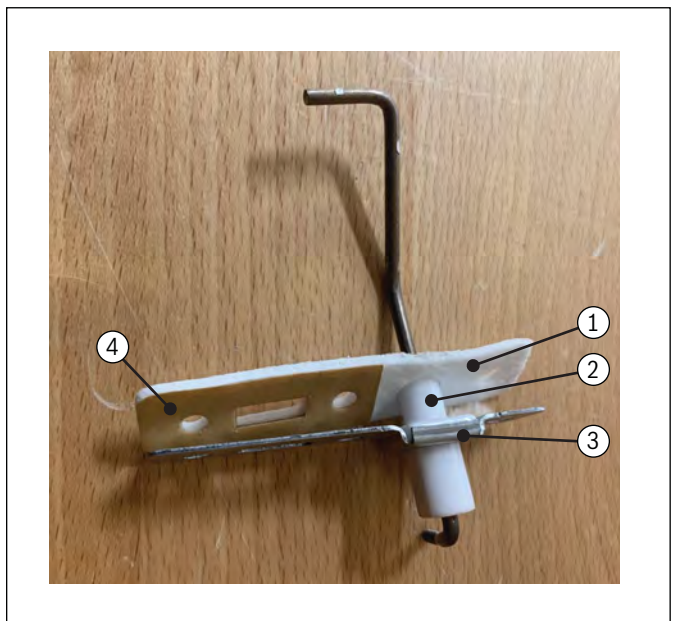

Figure 103

9.14 Touch pad

1. Refer to 9.1 Preparation Step.
2. Separate the touch pad from the touch pad bracket by pushing it up (Item 1).

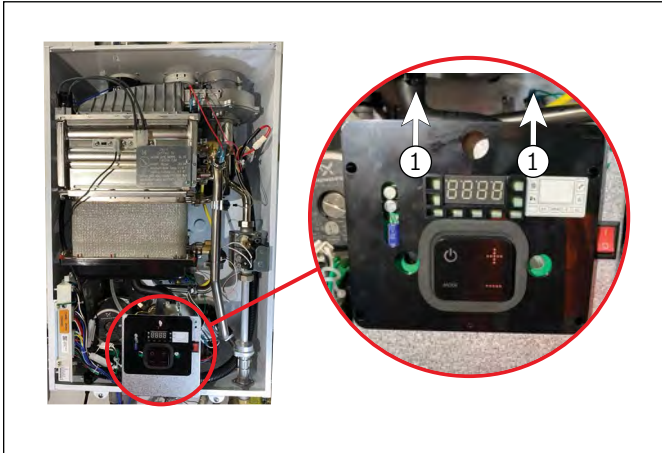

Figure 104



Figure 105

3. Disconnect the touch pad connection terminal (Item 2). Connect the new touch pad to the connection terminal. Insert touch pad into the 4 grooves (Item 3) marked on the figure below and push down.

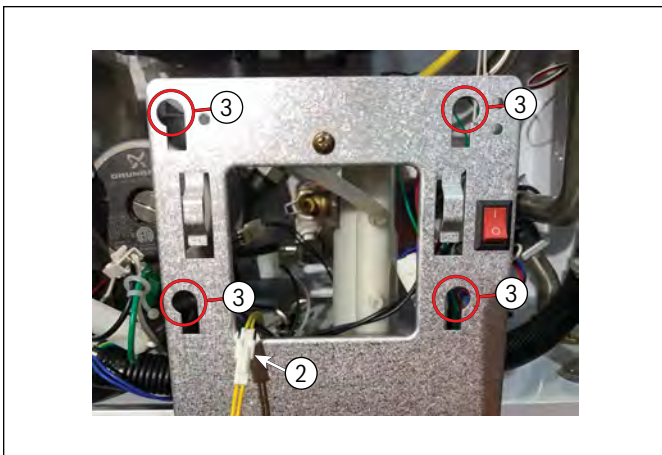

Figure 106

9.15 Condensation Trap

1. Refer to 9.1 Preparation Step.
2. Drain the water using the drain valve and water filter (Item 2).

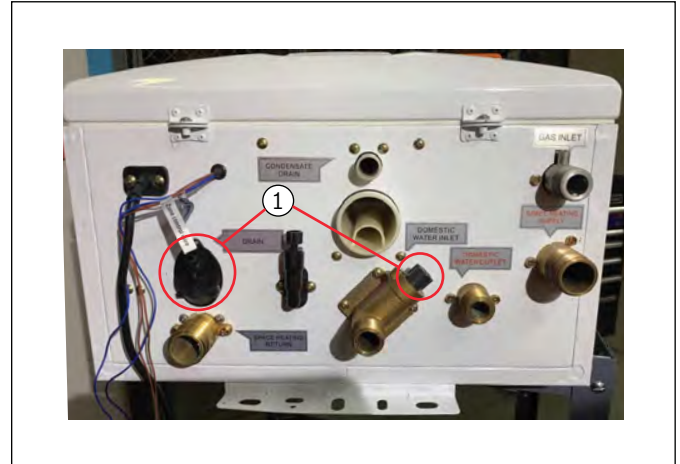

Figure 107

3. Disconnect the wire from the condensation trap (Item 2).
4. Separate the condensation trap hose by lowering the clip (Item 3).

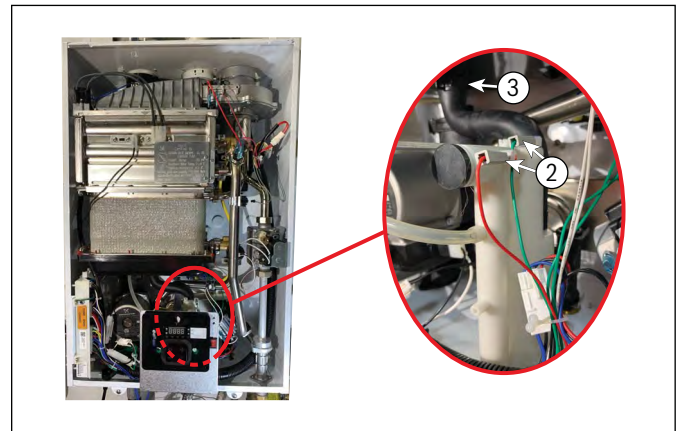

Figure 108

5. Loosen the condensation trap cap (Item 4). (Counterclockwise)
6. Loosen the 4 fixing screws at the bottom of the chassis (Item 5).

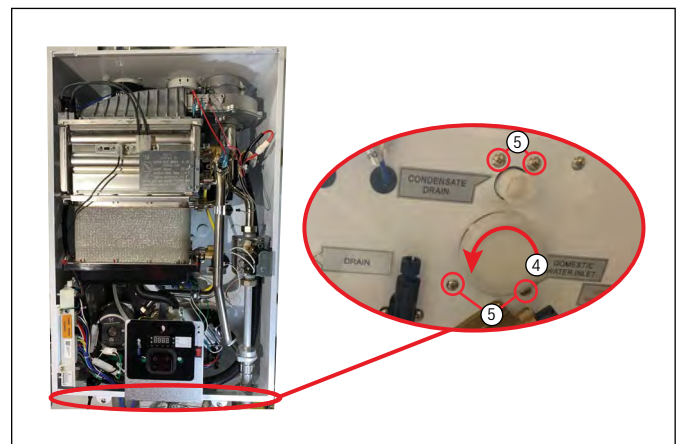

Figure 109

7. Replace with a new condensation trap.

9.16 Turbo Fan

1. Refer to 9.1 Preparation Step.
2. Separate the fan connection terminal (Item 1), solenoid valve terminal (Item 2), overheat sensor wire (Item 3), and heat exchanger temperature sensor (Item 4).

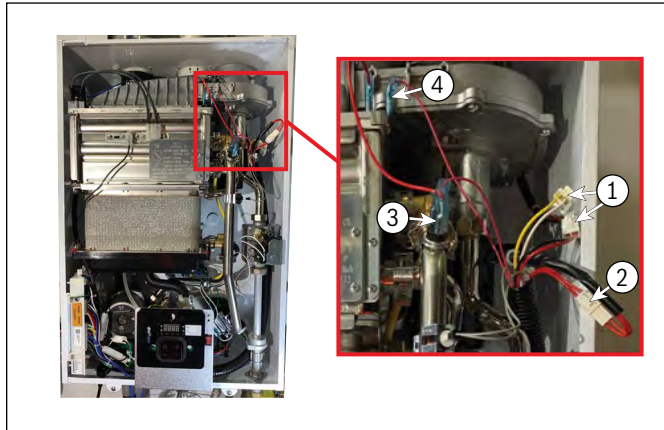

Figure 110

3. Separate the gas pipe (Item 1) using a wrench.

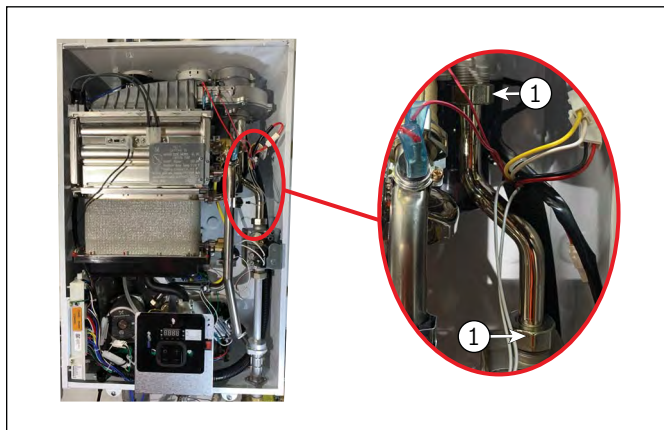

Figure 111

4. Loosen the 3 fan fixing screws (Item 1). Use the screwdriver for 2 screws/use a wrench for the screw in the back.

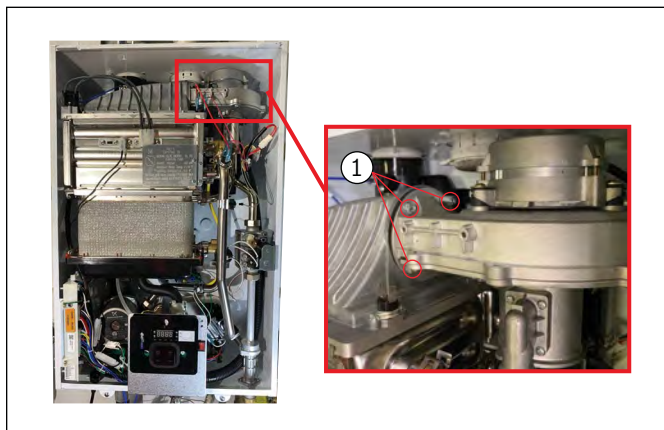

Figure 112

5. Remove fan and silencer from boiler by pulling out silencer end first.



Figure 113

6. Separate the silencer part from the fan by removing two fixing screws (Item 2) first.

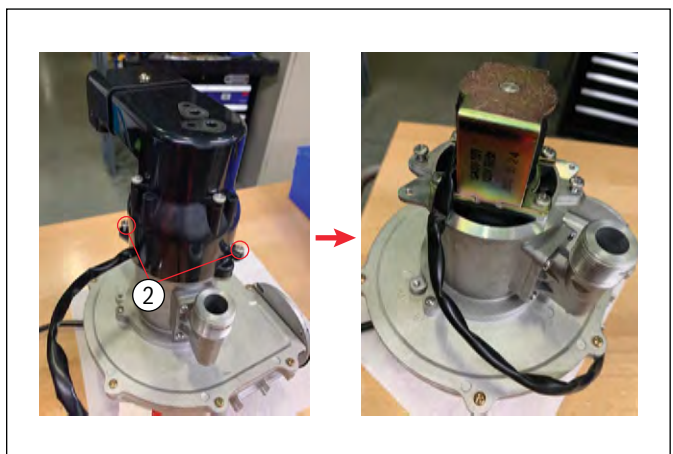

Figure 114

7. Replace with a new fan. When assembling a new unit for replacement, assemble it in reverse order of separating it. Check for the packing between the nut and the pipe when assembling the gas pipe.
8. Check the spring washer when assembling the fan fixing screw.

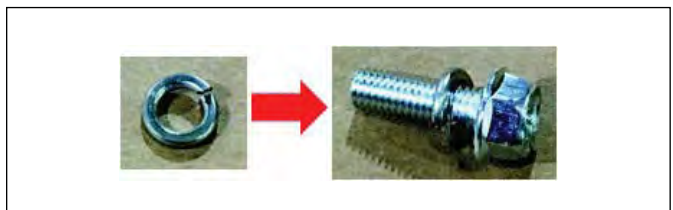

Figure 115

9.17 Solenoid Valve

1. Refer to 9.1 Preparation Step.
2. Remove the fan and then separate the silencer from the fan according to Section 9.16.
3. Separate the solenoid valve unit (Item 2) by removing the 2 fixing screws (Item 1),

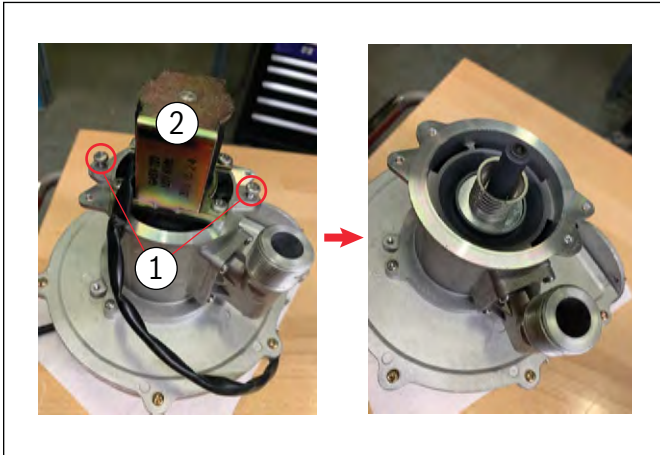

Figure 116

4. Replace with a new solenoid valve unit.
5. After replacing it, tighten the air mixer and the silencer fixing screws.

i When replacing the solenoid valve unit, pay attention to the the wire position. When connecting the air mixer/silencer, assemble it along the solenoid wire groove as shown below.

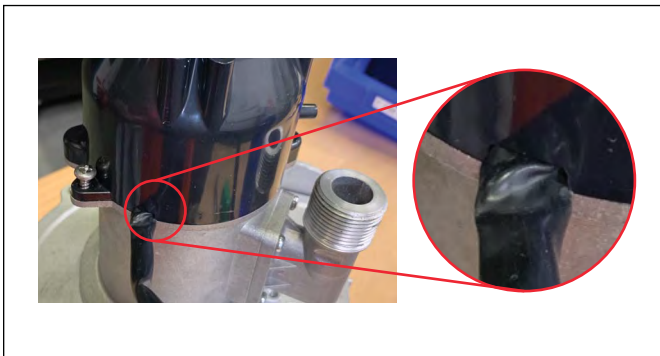

Figure 117

9.18 Heat Exchanger



WARNING: FIRE, EXPLOSION, PERSONAL INJURY

- ▶ Prior to performing any work on the boiler, ensure the gas supply is turned off and power unplugged .

1. Refer to 9.1 Preparation Step.
2. Drain the water using the drain valve and water filter (Item 1).

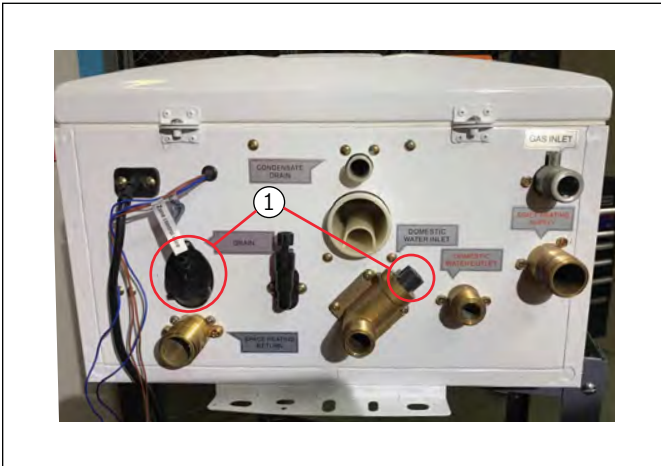

Figure 118

3. The Heat Exchanger and Turbo Fan will come out as one complete unit. However, if there is not space to remove all together, separate the fan from the heat exchanger according to Section 9.16.
4. Loosen fixing screw on bottom right hand side of heat exchanger cover and Remove heat exchanger cover and disconnect flame rod and electrode assembly wires (Fig.120, Item 2).

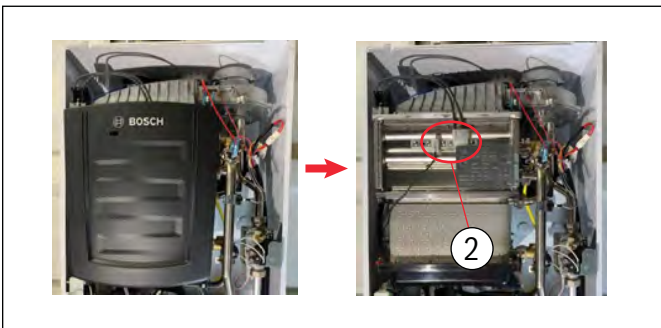

Figure 119

5. See Figure 121. Separate the fan connection terminal (Item 1), solenoid valve terminal (Item 2), overhear prevention device wire (Item 3), and heat exchanger temperature sensor (Item 4).

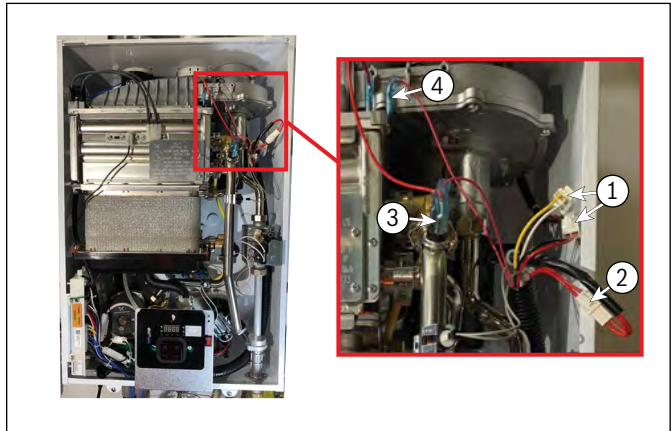

Figure 120

6. Separate the gas pipe (Item 1) using a wrench.

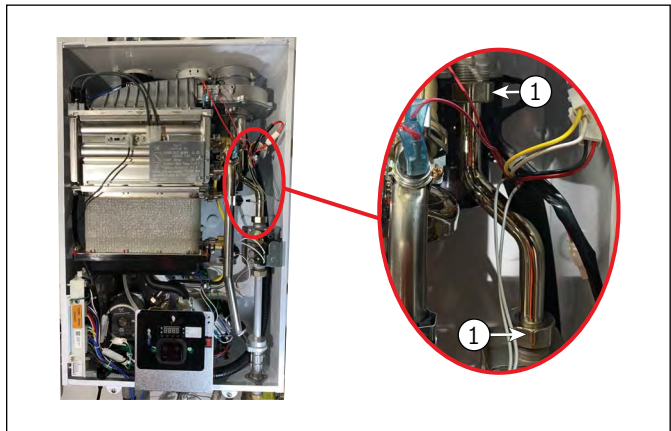

Figure 121

7. Loosen 2 screws and remove ignition transformer (Fig.123, Item 1) and save for reinstallation.
8. Unclip exhaust sensor connector (Fig.123, Item 2).

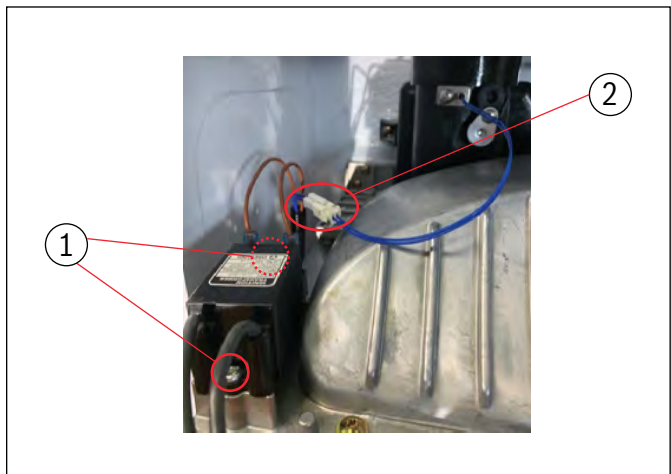

Figure 122

9. Remove four flue connector fixing screws and separate from top of boiler.

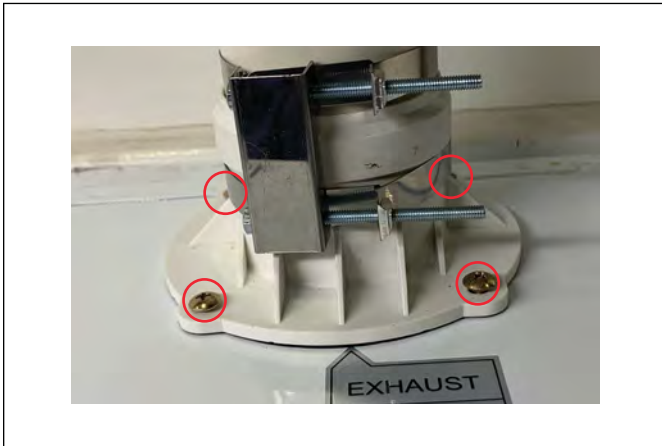

Figure 123

i Venting may need to be moved to make room for the flue connector to be removed.

10. Remove 2 screws on exhaust duct. This only applies to older models. New design does not have these screws.



Figure 124

11. Remove heat exchanger piping clips (x2) and separate piping from heat exchanger.

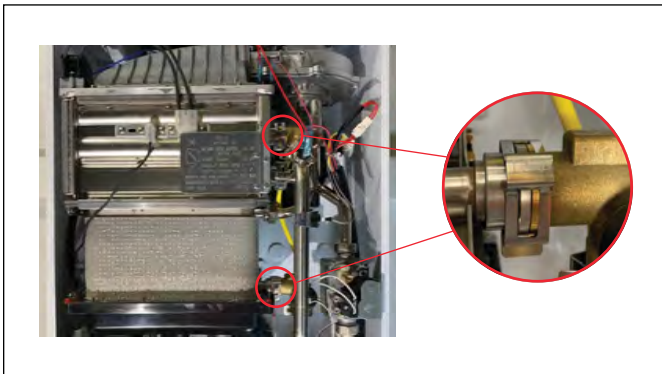

Figure 125

i Ensure gaskets remain in place with brass connector/piping to the heat exchanger. They will be necessary for reinstallation.

12. Remove connecting clip and separate condensate hose from bottom of heat exchanger.



Figure 126

13. Remove two screws (Item 2) on the right hand side and two screws (Item 2) on the left hand side of the burner hood (Item 1).

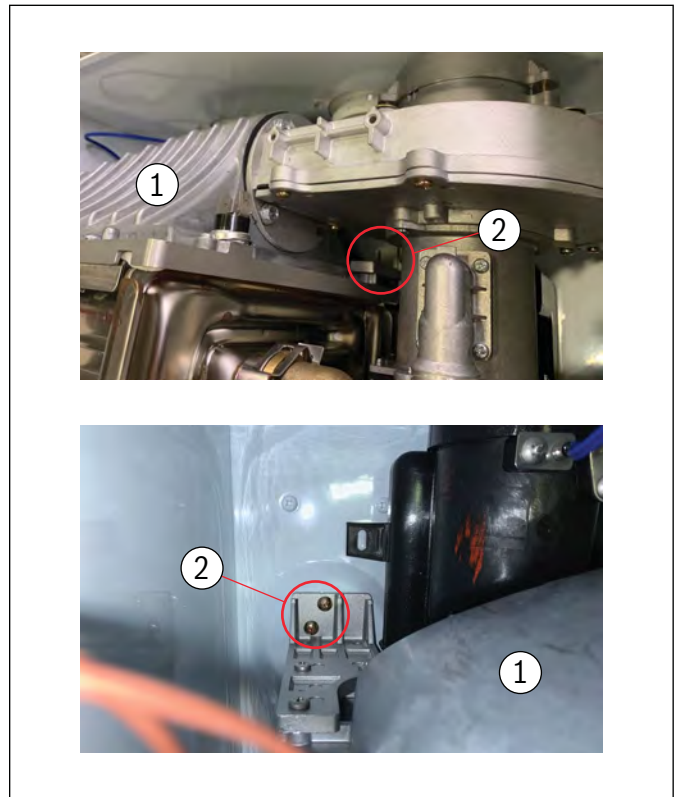

Figure 127

14. Remove phillips screws on upper and lower heat exchanger bracket located on right and left side of the heat exchanger (Fig.129).

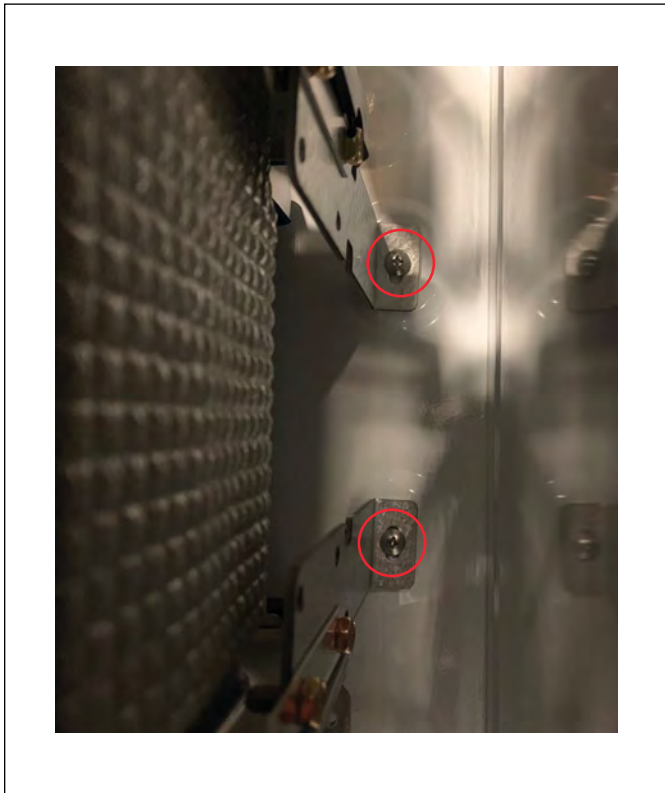

Figure 128

15. Remove heat exchanger/fan from boiler.
16. Install replacement heat exchanger in reverse order.

10 Flushing the Heat Exchanger

NOTICE: BOILER DAMAGE

- ▶ Flushing the Heat Exchanger annually is a required maintenance. In hard water conditions, it needs to take a place more often.

Flushing the Heat Exchanger is a somewhat complicated procedure. Read the following instruction carefully before attempting this procedure.

Before Flushing the Heat Exchanger, gather the following items.

- ▶ A bucket that is 5 gallons or larger (The capacity of this water heater is 0.5 gallons)
- ▶ Cleaning solution diluted with water (indicating it is safe for use with stainless steel)
- ▶ 3 hoses
- ▶ A water circulation pump

1. Disconnect electrical power to the boiler.
2. Close the shutoff valves on both the space heating return and space heating supply lines (V3 and V4).
3. Connect one of hoses to the circulation pump outlet and the space heating return line at the (V1) valve.
4. Connect one hose to the circulation pump inlet and place the free end in the bucket.
5. Connect the other hose to the space heating supply line at the (V2) valve and place the free end in the bucket.
6. Pour approximately 4 gallons of virgin, food grade, white vinegar into the bucket.
7. Open both valve(V1 and V2) on space heating return and space heating supply lines.
8. Operate the pump and allow the solution to circulate through the water heater for at least 45 minutes.
9. Rinse the cleaning solution from the boiler:
 - a. Remove the free end of the drain hose from the bucket.
 - b. Connect the hose to cold water.
 - c. Allow water to flow through the boiler for at least 10 minutes.
 - d. Close the valve(V1) and open shutoff valve(V4).
10. Disconnect all hose.
11. Restore electrical power to the boiler.

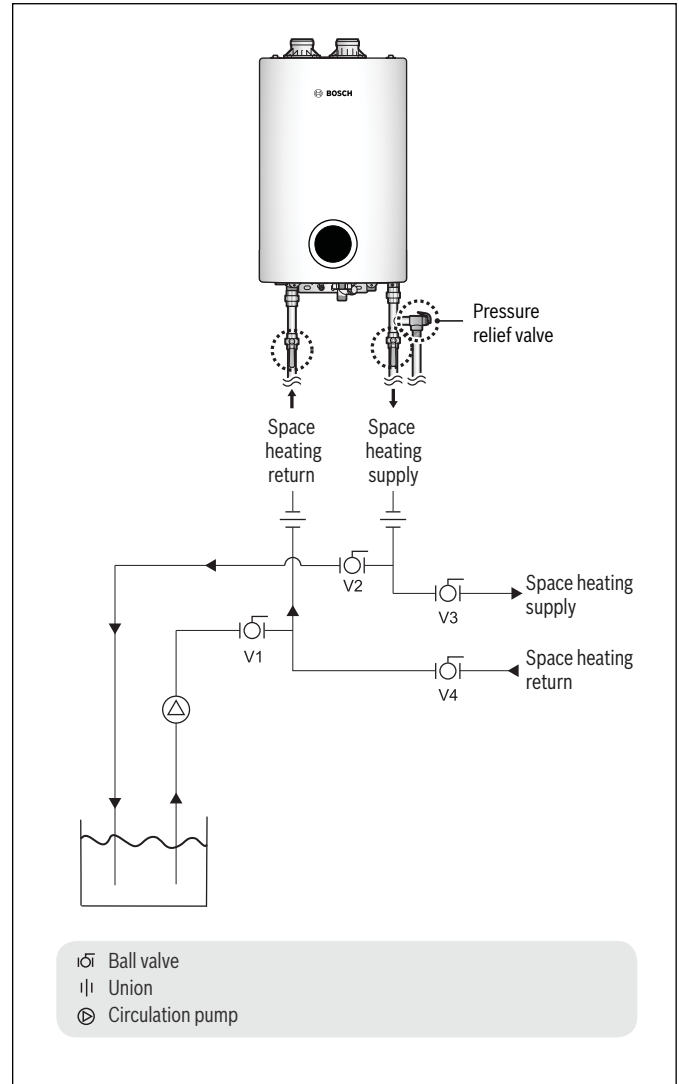

Figure 129

NOTES:

NOTES:

**United States and Canada
Bosch Thermotechnology Corp.
65 Grove St.
Watertown, MA 02472**

**Tel: 866-642-3198
Fax: 603-965-7581
www.bosch-thermotechnology.us**

BTC 439002301 A / 12.2021

**Bosch Thermotechnology Corp. reserves the right
to make changes without notice due to continuing
engineering and technological advances.**