

# **Intel® Manycore Platform Software Stack (Intel® MPSS)**

## **User's Guide**

---

*September 2015*

Copyright © 2013-2015 Intel Corporation

All Rights Reserved

US

Revision: 3.6

World Wide Web: <http://www.intel.com>

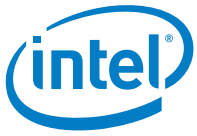

## ***Disclaimer and Legal Information***

---

You may not use or facilitate the use of this document in connection with any infringement or other legal analysis concerning Intel products described herein. You agree to grant Intel a non-exclusive, royalty-free license to any patent claim thereafter drafted which includes subject matter disclosed herein.

No license (express or implied, by estoppel or otherwise) to any intellectual property rights is granted by this document.

All information provided here is subject to change without notice. Contact your Intel representative to obtain the latest Intel product specifications and roadmaps.

The products described may contain design defects or errors known as errata which may cause the product to deviate from published specifications. Current characterized errata are available on request.

Copies of documents which have an order number and are referenced in this document may be obtained by calling 1-800-548-4725 or by visiting: <http://www.intel.com/design/literature.htm>

Intel, the Intel logo, Intel Xeon Phi, and Xeon are trademarks of Intel Corporation in the U.S. and/or other countries.

\*Other names and brands may be claimed as the property of others.

Copyright © 2015, Intel Corporation. All rights reserved.



## Revision History

---

Revision Number	Description	Revision Date
Version 3.6	Release of the 3.6 Intel® MPSS User's Guide	September 2015
Version 3.6	Initial draft of the 3.6 Intel® MPSS User's Guide	August 2015

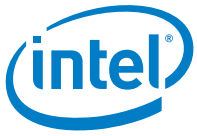

# Table of Contents

<b>1</b>	<b>About This Manual .....</b>	<b>10</b>
1.1	Overview of this Document .....	10
1.2	Intel® MPSS Release History.....	11
1.2.1	Technology Previews in this Release.....	11
1.3	Notational Conventions.....	11
1.3.1	Symbols within Normal Text.....	11
1.3.2	Code conventions .....	12
1.4	Terminology .....	14
<b>2</b>	<b>Intel® MPSS at a Glance.....</b>	<b>16</b>
2.1	Intel® Xeon Phi™ Hardware and System Architecture .....	16
2.2	Programming Models and the Intel® MPSS Architecture .....	18
2.2.1	Programming Models.....	18
2.2.2	Intel® MPSS Software Architecture and Components .....	20
2.2.3	Intel® Xeon Phi™ Coprocessor Networking .....	23
2.3	Supported Intel® Productivity Tools.....	26
2.4	Related Documentation.....	27
2.4.1	SCIF documentation.....	27
2.4.2	COI Documentation.....	27
2.4.3	MYO Documentation.....	28
2.4.4	Micperf Documentation.....	28
2.4.5	Intel® Xeon Phi™ Coprocessor Collateral.....	28
<b>3</b>	<b>Intel® Xeon Phi™ Coprocessor Installation Process .....</b>	<b>30</b>
3.1	Hardware and Software Prerequisites .....	30
3.1.1	Host System HW.....	30
3.1.2	BIOS Configuration .....	30
3.1.3	Supported Host Operating Systems.....	31
3.1.4	Host Operating System Configuration .....	31
3.1.5	Root Access .....	31
3.1.6	SSH Access to the Intel® Xeon Phi™ Coprocessor .....	32
3.1.7	Init Scripts.....	32
3.1.8	Network Manager .....	33
3.2	Intel® Xeon Phi™ Coprocessor Card Physical Installation.....	34
3.2.1	Workstation Considerations.....	35
3.2.2	Cluster Considerations.....	37
3.2.3	Validate Intel® Xeon Phi™ Coprocessor physical installation .....	38
3.3	Base Intel® MPSS Installation .....	39
3.3.1	Get the Intel® MPSS Distribution.....	39
3.3.2	Uninstall Previous Intel® MPSS Installation Prior to Upgrade.....	39
3.3.3	Rebuild Intel® MPSS Host Drivers .....	40
3.3.4	Update Intel® Xeon Phi™ Coprocessor Flash & SMC Firmware.....	41
3.3.5	Initialize Intel® MPSS default configuration settings.....	44
3.3.6	Start Intel® MPSS .....	45
3.3.7	Validate Base Intel® MPSS Installation .....	45
3.4	Basic Workstation Installation is Complete .....	49
3.5	Network Configuration.....	50
3.5.1	MAC Address Assignment.....	50
3.5.2	IP Address Considerations for External Bridging.....	50



3.5.3	Configuring a Basic External Bridge.....	51
3.5.4	Defining and Implementing Exported/Mounted File Systems.....	52
3.5.5	Configuring the Host Firewall.....	53
3.5.6	How to Install Lustre* on the Intel® Xeon Phi™ Coprocessor Card.....	53
3.6	Installing OFED with Intel® MPSS Support (optional) .....	54
3.6.1	Supported OFED distros.....	56
3.6.2	Tips for OFED distributions.....	57
3.6.3	Install OFED+ .....	58
3.6.4	Install OFED 1.5.4.1.....	59
3.6.5	Install OFED-3.5-2-MIC .....	60
3.6.6	Install OFED-3.12-1 .....	60
3.6.7	Install OFED 3.18 .....	61
3.6.8	Install Mellanox* OFED 2.x .....	61
3.6.9	Starting OFED .....	62
3.6.10	Stopping/restarting OFED .....	62
3.6.11	Validate OFED Installation.....	63
<b>4</b>	<b>Configuring and Booting the Intel® Xeon Phi™ Coprocessor Operating System</b> .....	<b>69</b>
4.1	Assisted Configuration and Control.....	70
4.1.1	Configuration Files .....	70
4.1.2	Initializing, Updating and Resetting the Configuration Files .....	75
4.1.3	micctrl Directory Path Modifiers .....	75
4.1.4	Boot Configuration .....	79
4.1.5	Assisted Boot Process.....	80
4.2	Manual Configuration and Control .....	82
4.2.1	Directly Editing (and persisting) Card /etc Files .....	83
4.2.2	NFS Mounting the Root and Other File Systems .....	84
4.2.3	Driver sysfs Settings .....	85
4.2.4	Card-side Kernel Commandline Parameters.....	85
4.2.5	Controlling the card .....	85
<b>5</b>	<b>Networking Configuration.....</b>	<b>88</b>
5.1	Assisted Configuration .....	88
5.1.1	Host SSH Keys .....	88
5.1.2	Name Resolution Configuration.....	89
5.1.3	Host Name Assignment .....	89
5.1.4	MAC Address Assignment.....	89
5.1.5	Network Topologies.....	90
5.2	Manual Configuration .....	96
5.2.1	Host Name.....	96
5.2.2	MAC Addresses.....	97
5.2.3	Network Topologies.....	97
5.3	IPoIB Networking Configuration .....	101
5.3.1	Managing the IPoIB Interface .....	102
5.3.2	IP Addressing .....	102
5.3.3	Datagram vs. Connected Modes.....	102
<b>6</b>	<b>User Credentialing and Authentication .....</b>	<b>103</b>
6.1	Assisted Configuration of User Credentials .....	103
6.1.1	Local Configuration .....	103
6.1.2	Enabling LDAP Service.....	104
6.1.3	Enabling NIS Service.....	105



6.2	Manual Configuration of User Credentials .....	105
6.2.1	Configuration File Based Credentialing .....	106
6.2.2	How to Enable SSH Host Based Authentication .....	108
<b>7</b>	<b>Adding Software to the Intel® Xeon Phi™ Coprocessor File System .....</b>	<b>110</b>
7.1	Adding Individual Files to a Host Resident File System Image .....	110
7.1.1	Assisted Configuration .....	110
7.1.2	Manual Configuration .....	111
7.1.3	Installing RPMs .....	112
7.2	Adding Software to a Coprocessor File System .....	113
7.2.1	Installing RPMs .....	113
7.2.2	Preserving the Modified File System .....	116
<b>8</b>	<b>Compilation for the Intel® Xeon Phi™ Coprocessor .....</b>	<b>118</b>
8.1	Cross Compiling Software with the Intel® MPSS SDK .....	118
8.1.1	SDK overview .....	118
8.1.2	Cross Compilation of GNU Build System Based Packages .....	118
8.1.3	Example case: zsh .....	119
8.1.4	Cross compiling with icc .....	124
8.2	Native Compilation .....	124
8.2.1	Create and attach to a repo .....	125
8.2.2	Install the development tool chain .....	125
8.2.3	Configure the build directory .....	125
8.2.4	Make and install the package .....	126
<b>9</b>	<b>Intel® MPSS Component Configuration and Tuning .....</b>	<b>128</b>
9.1	Intel® Xeon Phi™ Coprocessor Operating System Configuration and Tuning .....	128
9.1.1	Clock Source for the Intel® Xeon Phi™ Coprocessor .....	128
9.1.2	Process Oversubscription .....	128
9.1.3	Verbose Logging .....	129
9.1.4	Cgroup memory control .....	129
9.1.5	Power Management control .....	130
9.1.6	VFS Optimizations .....	130
9.2	Host Driver Configuration .....	130
9.2.1	Lost Node Watchdog .....	130
9.2.2	Watchdog Auto-Reboot .....	131
9.2.3	Crash Dump Capture .....	131
9.3	SCIF Configuration .....	131
9.3.1	Peer to Peer (P2P) Support .....	131
9.3.2	Peer to Peer Proxy Control .....	132
9.3.3	Ulimit Checks for Max Locked Memory in SCIF .....	132
9.3.4	Registration Caching .....	132
9.3.5	Registration Caching Limit .....	133
9.3.6	Huge Page Support .....	133
9.4	COI Configuration .....	133
9.4.1	COI Offload User Options .....	133
9.5	Virtual Console Configuration and Access .....	135
9.6	Intel® Xeon Phi™ Coprocessor Virtio Block Device Configuration and Use .....	136
9.6.1	Using a Virtio Block Device as an ext2 File System .....	136
9.6.2	Use the Virtblk Device as a Swap Device File System .....	137
<b>A</b>	<b>Intel® MPSS Configuration Parameters .....</b>	<b>138</b>
A.1	Meta Configuration .....	138



A.1.1	Configuration Version .....	138
A.1.2	Including Other Configuration Files .....	138
A.2	Boot Control.....	139
A.2.1	What to Boot.....	139
A.2.2	When to Boot .....	139
A.3	Kernel Configuration.....	140
A.3.1	ExtraCommandLine .....	140
A.3.2	Console Device.....	140
A.3.3	Power Management.....	140
A.3.4	ShutdownTimeout.....	141
A.3.5	CrashDump .....	141
A.3.6	Cgroup .....	142
A.3.7	VerboseLogging .....	142
A.4	File System Configuration Parameters .....	142
A.4.1	RootDevice .....	142
A.4.2	File Locations .....	143
A.4.3	Intel® MPSS RPM Location.....	145
A.5	Network Configuration.....	146
A.5.1	Host Name Assignment .....	146
A.5.2	MAC Address Assignment.....	146
A.5.3	Static Pair (Default) Topology.....	147
A.5.4	Internal Bridge Topology .....	148
A.5.5	External Bridge Topology .....	149
A.6	Deprecated Configuration Parameters.....	151
A.6.1	User Access .....	151
A.6.2	Service Startup .....	151
<b>B</b>	<b>The micctrl Utility .....</b>	<b>153</b>
B.1	micctrl Command Line Format .....	153
B.2	Global Options.....	154
B.2.1	--destdir, -d .....	154
B.2.2	--configdir, -c.....	154
B.3	Suboptions.....	154
B.3.1	Global Suboptions .....	154
B.3.2	Common SubOptions.....	155
B.4	micctrl Command Descriptions.....	159
B.4.1	Card State Control .....	159
B.4.2	Configuration Initialization and Propagation .....	161
B.4.3	Setting the Root Device .....	163
B.4.4	Configuring the Intel® Xeon Phi™ Coprocessor File System .....	167
B.4.5	Networking Configuration .....	170
B.4.6	User Credentialing .....	177
B.4.7	Configuring the Intel® Xeon Phi™ Coprocessor Linux* Kernel .....	182
B.4.8	Deprecated micctrl Commands .....	184
<b>C</b>	<b>Intel® MPSS Host Driver Sysfs Entries .....</b>	<b>186</b>
C.1	The Global Mic.ko Driver SYSFS Entries .....	186
C.1.1	Revision Information .....	186
C.1.2	Other Global Entries.....	186
C.2	The Intel® Xeon Phi™ Mic.ko Driver SYSFS Entries .....	186
C.2.1	Hardware Information .....	186
C.2.2	State Entries .....	187

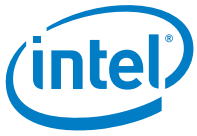

	C.2.3	IStatistics.....	188
	C.2.4	Debug Entries .....	188
	C.2.5	Flash Entries .....	189
	C.2.6	Power Management Entries .....	189
	C.2.7	Other Entries.....	189
<b>D</b>		<b>micrasd.....</b>	<b>191</b>
<b>E</b>		<b>micnativeloadex .....</b>	<b>192</b>
<b>F</b>		<b>Optional Intel® MPSS Components.....</b>	<b>193</b>
	F.1	Intel® MPSS GANGLIA Support (optional).....	193
		F.1.1 Requirements.....	193
		F.1.2 Steps to Install GANGLIA on the Host.....	194
		F.1.3 Installing Intel® MPSS GANGLIA RPMs in the Card .....	195
		F.1.4 Starting Intel® MPSS with GANGLIA Support .....	196
		F.1.5 Stopping Intel® MPSS with GANGLIA Support .....	196
	F.2	Intel® Xeon Phi™ Coprocessor Performance Workloads (optional) .....	196
		F.2.1 Installation Requirements .....	196
		F.2.2 Distributed Files.....	197
		F.2.3 RPM Installation.....	197
		F.2.4 Python Installation .....	198
		F.2.5 Alternative to Python Installation .....	199
	F.3	Intel® MPSS Reliability Monitor Support (optional) .....	199
		F.3.1 Requirements.....	199
		F.3.2 Steps to Install Intel® MPSS with Reliability Monitor Support .....	199
		F.3.3 Starting Intel® MPSS with Reliability Monitor Support .....	199
		F.3.4 Stopping Intel® MPSS with Reliability Monitor Support.....	200
		F.3.5 Reliability Monitor Configuration File and Log .....	200
<b>G</b>		<b>Rebuilding Intel® MPSS Components .....</b>	<b>201</b>
	G.1	Recompiling the Intel® MPSS GANGLIA Modules.....	201
	G.2	Recompiling the Intel® MPSS MIC Management Modules .....	202
	G.3	How to Extract and Use the COI Open Source Distribution .....	203
		G.3.1 Building COI Libraries and Binaries .....	203
		G.3.2 Installing Host Library .....	203
		G.3.3 Installing Card-side Binaries and Libraries.....	203
		G.3.4 COI Tutorial Build and Execution Instructions .....	204
	G.4	How to Extract and Use the MYO Open Source Distribution .....	204
<b>H</b>		<b>General Services Tutorial.....</b>	<b>205</b>
	H.1	Service Startup by Priorities (RHEL* 6.x).....	205
	H.2	Service Startup by Dependencies (SUSE* Linux* Enterprise Server 11 SP3) .....	206
	H.3	Intel® Xeon Phi™ Coprocessor Method for Service Start Priority .....	207
<b>I</b>		<b>Troubleshooting and Debugging .....</b>	<b>208</b>
	I.1	Log Files .....	208
		I.1.1 Dmesg Output.....	208
		I.1.2 Syslog Output .....	208
	I.2	Coprocessor Post Codes.....	209
	I.3	Kernel Crash Dump Support.....	212
	I.4	GNU Debugger (GDB) for the Intel® Xeon Phi™ Coprocessor .....	213
		I.4.1 Running natively on the Intel® Xeon Phi™ Coprocessors .....	213
		I.4.2 Running remote GDB on the Intel® Xeon Phi™ Coprocessors .....	213





I.4.3	GDB remote support for data race detection.....	213
I.4.4	Debugging heterogeneous/offload applications .....	213
I.4.5	Enabling MIC GDB Debugging for Offload Processes .....	214

## List of Figures

Figure 1: Typical Intel® Xeon Phi™ Based Workstation Configuration.....	16
Figure 2: Intel® Xeon Phi™ Based Compute Node within a Cluster .....	17
Figure 3: Intel® Xeon Phi™ Architecture Ring and Cores .....	18
Figure 4: Spectrum of Programming Models .....	19
Figure 5: Intel® MPSS Architecture .....	20
Figure 6: Static Pair Configuration .....	24
Figure 7: Internal bridge network .....	25
Figure 8: External bridge network.....	26
Figure 9: Uniform distribution of Intel® Xeon Phi™ coprocessors.....	35
Figure 10: Two Intel® Xeon Phi™ coprocessors Installed in the Same IO Hub .....	36
Figure 11: Intel(R) Xeon Phi(TM) and InfiniBand* HCA sharing an I/O hub .....	37
Figure 12: Symmetric Distribution of Coprocessors and HCAs.....	38
Figure 13: One-to-One IB Device (HCA, Port) Mapping between Host and Coprocessor.....	101

## List of Tables

Table 1: Intel® Productivity Tools Supported by Intel® MPSS 3.6 .....	26
Table 2: Supported Host Operating Systems .....	31
Table 3: System V format commands.....	33
Table 4: File System Characteristics.....	52
Table 5: OFED Distribution vs. Supported Features .....	56



# 1 About This Manual

---

This manual is intended to provide you with an understanding of the Intel® Manycore Platform Software Stack (Intel® MPSS), what it is, how to configure it, and how to use its components.

This chapter begins with an overview of the remainder of the document, presents notation used in this document, lists further documentation available for selected Intel® MPSS components, and concludes with a table of terminology.

It is recommended that the reader review at least Chapters 1-3 prior to a first installation of the software stack.

## 1.1 Overview of this Document

**Chapter 2:** Provides a high level overview of Intel® Xeon Phi™ architecture and then gives an overview of Intel® MPSS architecture.

**Chapter 3:** Is a thorough, step-by-step guide to installing Intel® MPSS, including basic configuration steps and considerations for both workstation and cluster environments.

**Chapter 4:** Is an in-depth discussion of the concepts and processes for configuring an Intel® Xeon Phi™ coprocessor installation.

**Chapter 5:** Describes how to configure user credentials on the Intel® Xeon Phi™ coprocessor.

**Chapter 6:** Describes supported network configurations, when each might be used, and how to configure each. It also discusses how to configure NFS mounts, as well as DHCP configuration.

**Chapter 7:** Presents methods for adding software to the Intel® Xeon Phi™ coprocessor file system.

**Chapter 8:** Explains how to cross-compile software for execution on Intel® Xeon Phi™ coprocessor, as well as how to compile and build on the Intel® Xeon Phi™ coprocessor itself (native build).

**Chapter 9:** Presents configuration options for Intel® MPSS components, including the Intel® Xeon Phi™ coprocessor Linux\* kernel, the host driver, the SCIF communication API, the COI offload interface, the virtual console, and the Virtio block device.

**Appendix A:** Describes each of the Intel® MPSS-specific configuration parameters.

**Appendix B:** Describes each Intel® MPSS *micctrl* command.

**Appendix C:** Presents sysfs entries exposed by the Intel® MPSS host driver.

**Appendix D:** Provides some details on the *micrasd* daemon.

**Appendix E:** Describes the *micnativeloadex* utility.

**Appendix F:** Provides detailed instructions on installing several optional *Ganglia*, *Micperf* and *Reliability Monitor* components.



## About This Manual

**Appendix G:** Provides instructions for rebuilding selected Intel® MPSS components.

**Appendix H:** Is a tutorial describing how services are started on supported Linux\* host Operating Systems and the Intel® Xeon Phi™ coprocessor.

**Appendix I:** Presents some tools and techniques that can be used in troubleshooting and debugging Intel® Xeon Phi™ coprocessor issues.

## 1.2 Intel® MPSS Release History

This version of the Intel® MPSS User's Guide covers the release 3.6.

Beginning with the Intel® MPSS 3.2 release, the significant new features in each release are described in a document entitled *Prominent features of the Intel® Manycore Platform Software Stack (Intel® MPSS) version M.N*, where M.N is the software stack release number. These documents can be found by searching on <https://software.intel.com/en-us/mic-developer>.

### 1.2.1 Technology Previews in this Release

#### 1.2.1.1 CCL-Direct for Kernel Mode Clients

This release includes a technology preview of CCL-Direct for kernel mode clients. This includes an experimental version of kernel mode InfiniBand\* verbs and RDMA\_CM and an experimental version of IPoIB. This experimental version of CCL-Direct kernel mode support was tested with a Lustre\* client. Refer to the document (`/usr/share/doc/ofed-driver-*/lustre-phi.txt`) for information on how to build and install a Lustre\* client on the Intel® Xeon Phi™ coprocessor. This preview only supports the Mellanox\* mlx4 driver and associated hardware, and currently only supports the OFED-1.5.4.1 and OFED-3.5-2-MIC versions of OFED software. See [Section 5.3](#) for information on IPoIB networking configuration.

#### 1.2.1.2 File IO Performance Improvements

This Intel® MPSS technology preview is intended to improve the performance of system calls that read and write to files on *tmpfs* and *ramfs* mount points. In addition to a set of kernel configuration parameters that enable these optimizations (ON by default in the release), kernel command line options provide additional control to enable or disable the read and write optimizations.

See [Section 9.1.6](#) for configuration instructions.

## 1.3 Notational Conventions

This document uses the following notational conventions.

### 1.3.1 Symbols within Normal Text

This guide *italicizes* commands and their arguments when they appear in prose sections of the document. For example: *micctrl* now executes *ifup micN* for each of the coprocessors.

This guide also *italicizes* the software stack configuration parameter names when they appear in prose sections. For example: When the *RootDevice* parameter `<type>` is *NFS* or *SplitNFS...*



Files and directories in prose sections are *italicized*. For example: */etc/mpss/default.conf*.

micN denotes any coprocessor name of the form mic0, mic1, etc. where N=0, 1, 2, etc, typically used in file names. For example, the file name *micN.conf* denotes any of the file names *mic0.conf*, *mic1.conf*, etc.

**Emboldened** text indicates the exact characters you type as input. It is also used to highlight the elements of a graphical user interface such as buttons and menu names. For example: Select the **ENTER** button, Select **Copy** from the **Edit** menu.

### 1.3.2 Code conventions

There are code snippets throughout this document.

COURIER text denotes code and commands entered by the user.

Italic COURIER text denotes terminal output by the computer.

"[host]\$" at the beginning of a line denotes a command entered on the host with user or root privileges.

"[host]#" at the beginning of a line denotes a command entered on the host with root privileges.

"[micN]\$" at the beginning of a line denotes a command entered on a coprocessor with user or root privileges.

"[micN]#" at the beginning of a line denotes a command entered on a coprocessor with root privileges.

For example the following shows the *micctrl --config* command executed as a non-root user, and the truncated output generated by *micctrl*:

```
[host]$ micctrl --config
mic0:
=====
    Config Version: 1.1

    Linux Kernel: /usr/share/mpss/boot/bzImage-knightscorner:
```

#### 1.3.2.1 Directory Symbols

For convenience, we define several symbols that denote commonly referenced directories.

*\$MPSS36* is the top directory into which the *mpss-3.6-linux.tar* file has been expanded.

*\$MPSS36\_K10M* is the directory into which the *mpss-3.6-k10m.tar* file has been expanded. Normally this will be *\$MPSS36/k10m*.

*\$MPSS36\_SRC* is the directory into which the *mpss-src-3.6.tar* file has been expanded. Normally this will be *\$MPSS36/src*.

*\$DESTDIR* is a symbol that indicates the directory path variable that *micctrl* prepends to all *micctrl* accesses of *micctrl* created files. Refer to [Appendix B.2.1](#) for details.



## About This Manual

`$CONFIGDIR` is a symbol that indicates the directory path variable at which `micctrl` creates MPSS-specific configuration files. Refer to [Appendix B.2.1](#) for details.

`$VARDIR` is a symbol that indicates the directory path variable at which `micctrl --initdefaults` and `--resetconfig` commands create the *common* and *micN* overlay hierarchies, and at which the `micctrl --rootdev` command places a ramfs file system image or NFS file system hierarchy. Refer to [Appendix B.3.2.1](#) for details.

`$SRCDIR` is a symbol that indicates the directory path at which the `micctrl --initdefaults`, `--resetdefaults`, `--resetconfig`, and `--cleanconfig` commands look for the coprocessor's Linux\* kernel image and default file system image. Refer to [Appendix B.3.2.2](#) for details.

`$NETDIR` is a symbol that indicates the directory path at which the `micctrl --initdefaults`, `--resetdefaults`, `--resetconfig`, and `--cleanconfig` commands create and/or edit control files. Refer to [Appendix B.3.2.3](#) for details.

### 1.3.2.2 Command Syntax

Following are conventions used in `micctrl` command syntax and Intel® MPSS configuration parameter syntax:

`<...>` indicates a variable value to be supplied.

`[...]` indicates an optional component.

`(x|y|...|z)` is used in `micctrl` command syntax and the software stack configuration parameter syntax to indicate a choice of values.

The syntax of the Overlay configuration parameter is:

```
Overlay (Filelist|Simple|File) <source> <target> (on|off)
Overlay RPM <source> (on|off)
```

It indicates that there are two basic forms. The first takes a *Filelist* or *Simple* or *File* type, followed by `<source>` and `<target>` values to be provided, followed by a choice of *on* or *off*. The second form takes the *RPM* type, followed by only a `<source>` value to be provided, followed by a choice of *on* or *off*.

The syntax of the `micctrl --userupdate` command:

```
micctrl --userupdate=(none|overlay|merge|nochange) \
[(-a |--pass=) (none|shadow)] [--nocreate]
```

It indicates that the `userupdate` method must be set to one of *none*, *overlay*, *merge*, or *nochange*. An optional argument can be invoked using either `-a` or `--pass` and must specify one of *none* or *shadow* (For Example: `-a none` or `--pass=none`). Finally, there is an optional `-nocreate` command.

The `--nocreate` option is *italicized*, indicating that it is a *common suboption*. These are suboptions of multiple commands, which, for brevity, are defined once in [Appendix B.3.2](#).



## 1.4 Terminology

ABI	Application binary interface
CCL	Coprocessor Communication Link
COI	Coprocessor Offload Infrastructure
Coprocessor	An Intel® Xeon Phi™ coprocessor
DHCP	Dynamic Host Configuration Protocol
Ganglia	A distributed monitoring system
GDB	Gnu debugger
HCA	Host Channel Adapter
IPoIB	Internet Protocol over InfiniBand*
K10M	Architecture of the Intel® Xeon Phi™ coprocessor x100 Product Family
LDAP	Lightweight Directory Access Protocol
Lustre	A parallel, distributed file system
MAC	Media Access Control
MIC	Many Integrated Cores, an informal name for the KNC architecture
MPI	Message Passing Interface
MPSS	Intel® Manycore Platform Software stack
MYO	Mine, Yours, Ours shared memory infrastructure
NIS	Network Information System
OFED	Open Fabric Enterprise Distribution
PCIe	PCI Express



PCIe2	PCI Express 2.0
QPI	Intel® QuickPath Interconnect, a point-to-point processor interconnect
RHEL	Red Hat* Enterprise Linux*
RPM	RPM package manager
SCIF	Symmetric Communication Interface
SLES	SUSE* Linux* Enterprise Server
SMP	Symmetric Multi-Processor
SSD	Solid state drive
SSH	Secure Shell
Sysfs	A virtual file system
VEth	Virtual Ethernet

## 2 Intel® MPSS at a Glance

This chapter provides an overview of Intel® MPSS. It begins with a very high level description of Intel® Xeon Phi™ hardware and system architecture. The chapter also discusses the programming models that the software stack is designed to support, how the various stack components support those programming models, and provides a description of the supported network configurations. It concludes with a subsection describing other available documentation.

### 2.1 Intel® Xeon Phi™ Hardware and System Architecture

The Intel® Xeon Phi™ coprocessor is a PCIe add-in card that has been designed to be installed into an Intel® Xeon™-based platform. A typical platform configuration consists of one or two Intel® Xeon™ processors and one or two Intel® Xeon Phi™ coprocessors. A typical configuration is shown in [Figure 1](#).

**Figure 1: Typical Intel® Xeon Phi™ Based Workstation Configuration**

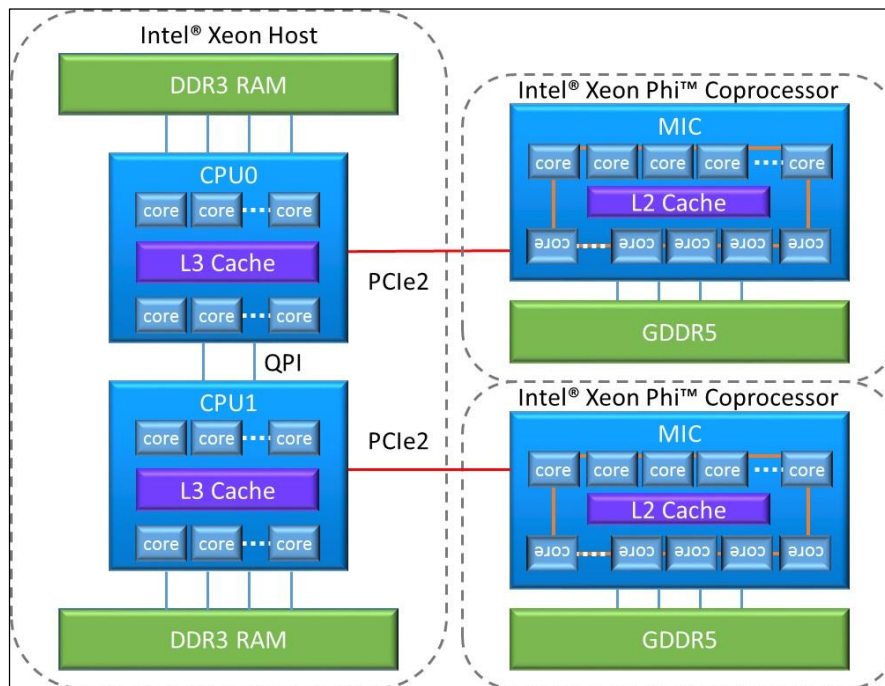

When one or more PCIe based InfiniBand\* host channel adapters, such as Intel® True Scale HCAs are installed in the platform, Intel® Xeon Phi™ coprocessors can communicate at high speed with Intel® Xeon™ processors and coprocessors in other platforms in a cluster configuration. [Figure 2](#) shows a typical Intel® Xeon Phi™ coprocessor based compute node within a cluster. Within a single system, the coprocessors can communicate with each other through the PCIe peer-to-peer interconnect without any intervention from the host. Other configurations are discussed in [Section 3.2](#).



Figure 2: Intel® Xeon Phi™ Based Compute Node within a Cluster

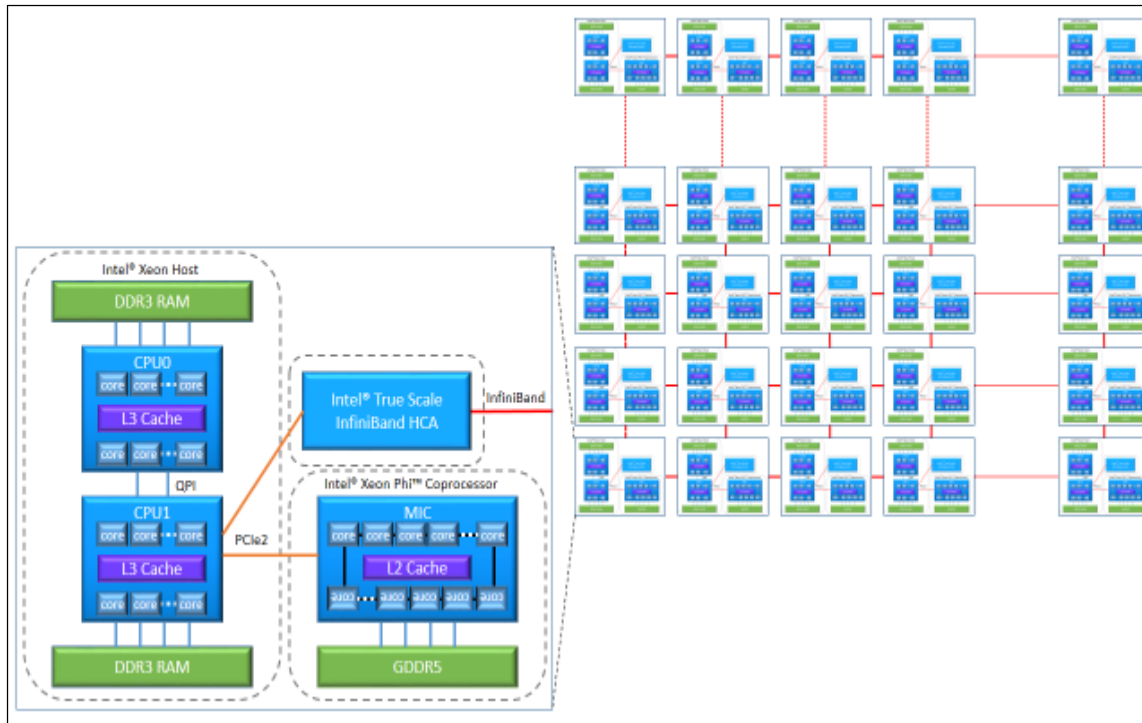

The Intel® Xeon Phi™ coprocessor is composed of more than 50 processor cores, caches, memory controllers, PCIe client logic, and a very high bandwidth, bidirectional ring interconnect (Figure 3). Each of the cores comes complete with a private L2 cache that is kept fully coherent by a global-distributed tag directory. The Intel® Xeon Phi™ coprocessor K1OM architecture cores support an X86 instruction set with additional vector instructions that are unique to its architecture, and the Intel® Xeon Phi™ coprocessor K1OM ABI differs from the Intel® Xeon™ ABI. For these reasons, Intel® Xeon™ binaries cannot be run on the coprocessor, and vice versa.

The memory controllers and the PCIe client logic provide a direct interface to the GDDR5 memory on the coprocessor and the PCIe bus, respectively. All these components are connected together by the ring interconnect.

Intel® Xeon Phi™ coprocessor cards do not have permanent file system storage, such as an SSD. Instead the file system is maintained in RAM and/or is remotely (for instance: NFS) mounted.

Each Intel® Xeon Phi™ coprocessor runs a standard Linux\* kernel (2.6.38 as of this writing) with some minor accommodations for the MIC hardware architecture. Because it runs its own OS, the coprocessor is not hardware cache coherent with the host Intel® Xeon™ processors or other PCIe devices.

Figure 3: Intel® Xeon Phi™ Architecture Ring and Cores

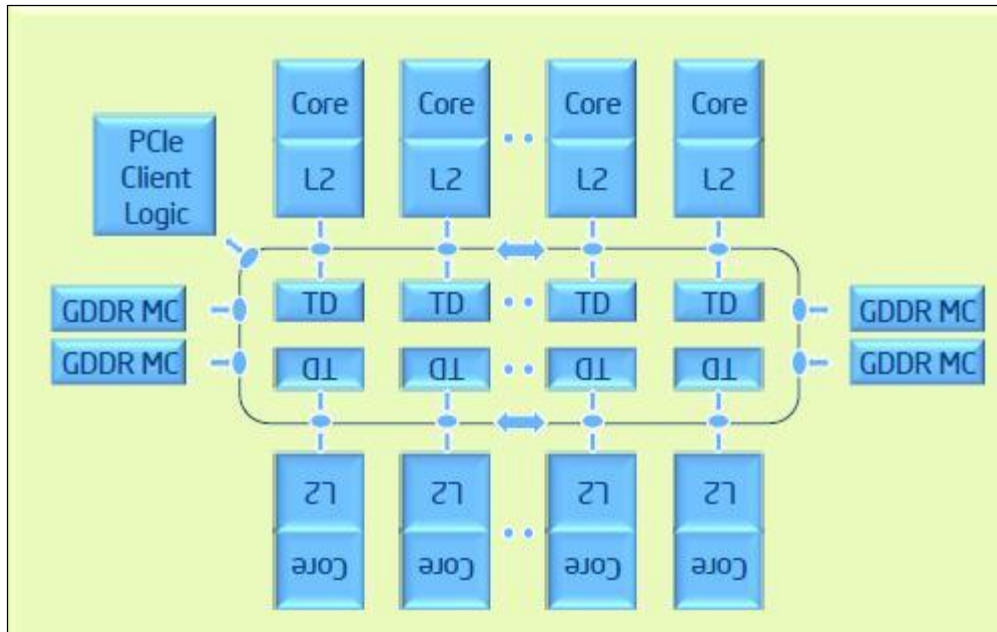

For more information on Intel® Xeon Phi™ coprocessor architecture, visit the [Intel® Xeon Phi™ Product Family](#) page.

## 2.2 Programming Models and the Intel® MPSS Architecture

To understand the software stack architecture, it helps to understand the range of programming models supported by Intel® MPSS and the Intel® Xeon Phi™ coprocessor.

### 2.2.1 Programming Models

The Offload, Symmetric and Native (MIC-hosted) programming models offer a diverse range of usage models and an overview of these options are depicted in [Figure 4](#).

Figure 4: Spectrum of Programming Models

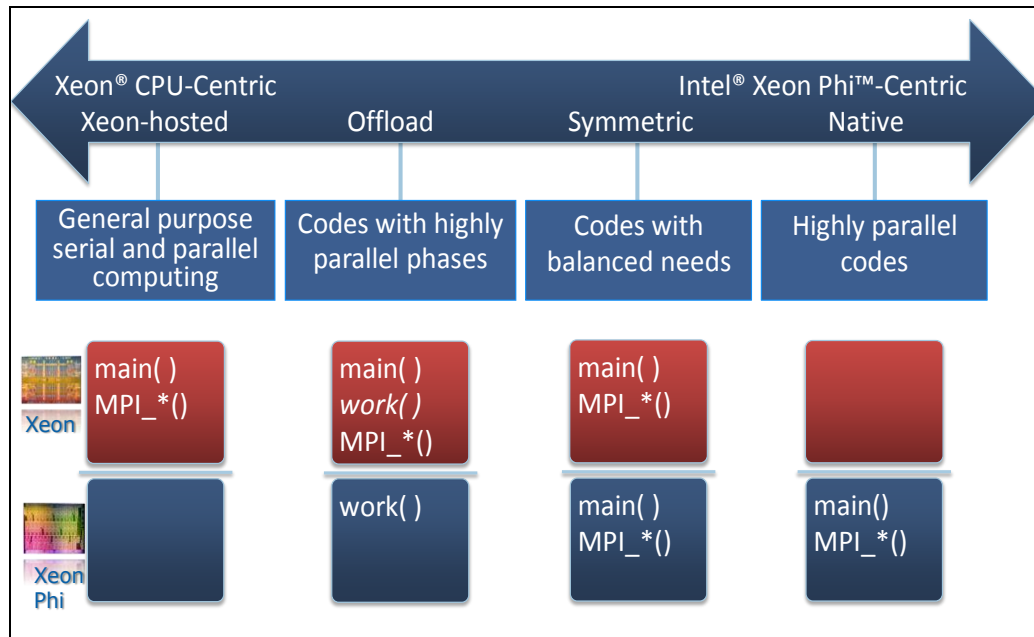

### 2.2.1.1 Offload Programming Model

In the *Offload* model, one or more processes of an application are launched on one or more Intel® Xeon™ host processors. These processes, represented in the figure by *main()*, can offload computation, represented by *work()*, to one or more attached Intel® Xeon Phi™ coprocessors, to take advantage of the many-core architecture with its wide vector units and high memory bandwidth. In the case where the application is composed of more than one process, the processes often communicate using some form of message passing, such as Message Passing Interface (MPI) thus we also show *MPI\_\*()*, on the host. This offload process is programmed via the use of offload pragmas supported by the Intel® C/C++ and FORTRAN compilers. When an application is created with one of these compilers, offloaded execution will fall back to the host in the event that a coprocessor is not available. This is why an instance of *work()* is shown on the host as well as on the Intel® Xeon Phi™ coprocessor.

### 2.2.1.2 Symmetric Programming Model

The *Symmetric* programming model is convenient for an existing HPC application that is composed of multiple processes, each of which could run on the host or coprocessor, and use some standard communication mechanism such as MPI. In this model, computation is not offloaded, but rather remains within each of the processes comprising the application. In such cases, where the application is MPI based, the *OFED distributions* enable high bandwidth/low latency communication using installed Intel® True Scale or Mellanox\* InfiniBand\* Host Communication Adapters.

### 2.2.1.3 Native Programming Model

The *Native* (MIC-hosted) programming model is just a variant of the Symmetric model in which the one or more processes of an application are launched only on MIC coprocessors.

From the software stack architecture perspective, these programming models typically depend on SCIF and the VEth (Virtual Ethernet) driver to launch processes on an Intel® Xeon Phi™ coprocessor.

## 2.2.2 Intel® MPSS Software Architecture and Components

Figure 5 provides a high level representation of Intel® MPSS and its relation to other important software components. The host software stack is shown to the left and the Intel® Xeon Phi™ coprocessor software stack to the right. While the stacks are mostly symmetric, host and coprocessor components (including applications) are not binary compatible.

Figure 5: Intel® MPSS Architecture

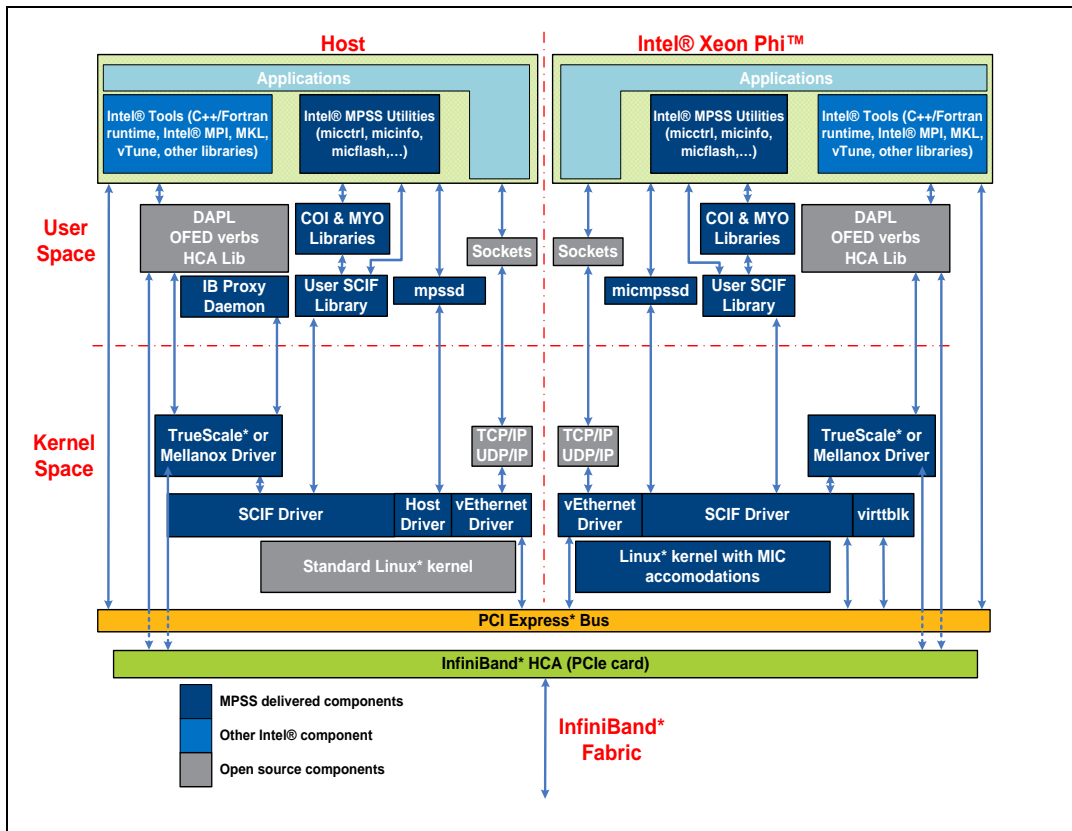

### 2.2.2.1 Intel® Xeon Phi™ Coprocessor Operating System

Underlying all computation on Intel® Xeon Phi™ coprocessors is the Intel® Xeon Phi™ Linux\* kernel. This is a standard Linux\* kernel (2.6.38 as of this writing) with some minor accommodations for the MIC architecture, such as for saving the state of the extended MIC register set on a context switch. The Linux\* kernel and initial file system image for the Intel® Xeon Phi™ coprocessors are installed into the host file system as part of Intel® MPSS installation. After installation the Intel® Xeon Phi™ coprocessor Linux\* installation will need to be configured according to the expected workload/application. Configuration will be covered in detail starting in Chapter 4.

The Linux\* environment on the coprocessor utilizes *BusyBox\** to provide a number of Linux\* utilities. These utilities may have limited functionality when compared to similar tools provided



with the host Linux\* distribution. For more information regarding *BusyBox\**, see the link <http://www.busybox.net/>.

### 2.2.2.2 Intel® MPSS Middleware Libraries

The compiler runtimes depend on the Coprocessor Offload Infrastructure (COI) library to offload executables and data for execution on an Intel® Xeon Phi™ coprocessor, and uses Mine Your Ours (MYO) shared memory infrastructure to provide a virtual shared memory model that simplifies data sharing between processes on the host and coprocessor(s). Similarly, some functions in the Intel® Math Kernel Library (MKL) automatically offload work to coprocessors using the COI library.

COI, MYO, and other Intel® MPSS components rely on the Symmetric Communication Interface (SCIF) user mode API for PCIe communication services between the host processor, Intel® Xeon Phi™ coprocessor, and installed InfiniBand\* host channel adapters. SCIF delivers very high bandwidth data transfers and sub- $\mu$ sec write latency to memory shared across PCIe, while abstracting the details of communication over PCIe.

The COI, MYO, and SCIF libraries are also available for use by other applications. [Section 2.4](#) lists additional documentation on these libraries.

### 2.2.2.3 Intel® MPSS Modules and Daemons

The host driver (*mic.ko*) is the component of Intel® MPSS that initializes, boots, and manages the Intel® Xeon Phi™ coprocessor. To boot a coprocessor, *mic.ko* injects the Linux\* kernel image and a kernel command line into the coprocessor's memory and signals it to begin execution. *SCIF* functionality is largely implemented in kernel mode *SCIF* drivers on the host and the coprocessor.

Virtual Ethernet (VEth) drivers on the host and coprocessor implement a virtual Ethernet transport between them. This supports a standard TCP/UDP/IP stack and standard tools, such as *ssh*, *scp*, etc., across PCIe. A virtual console driver is built into *mic.ko*. Finally, *mic.ko* directs power management of the installed coprocessors.

The *virtio* block device (*virtblk*) uses the Linux\* *virtio* data transfer mechanism to implement a block device on the Intel® Xeon Phi™ coprocessor. The device stores data on a specified storage location on the host and can therefore be persistent across rebooting of the coprocessor.

The Intel® *True Scale* and *Mellanox\** drivers enable direct data transfers between Intel® Xeon Phi™ coprocessor memory and an installed Intel® True Scale or Mellanox\* InfiniBand\* HCA. Intel® MPSS also includes an optional InfiniBand\* over SCIF (*ibscif*) driver which emulates an InfiniBand\* HCA to the higher levels of the OFED stack. This driver uses SCIF to provide high BW, low latency communication between multiple Intel® Xeon Phi™ coprocessors in an Intel® Xeon™ host platform, for example between MPI ranks on separate coprocessors.

An *mpssd* daemon runs on the host, and directs the initialization and booting of the Intel® Xeon Phi™ coprocessors based on a set of configuration files. The *mpssd* daemon is started and stopped with the Linux\* *mpss* service, and instructs the cards to boot or shutdown. In the event that the coprocessor's OS crashes, *mpssd* will reboot the coprocessor or bring it to a *ready* (to be booted) state. A *micmpssd* daemon on the coprocessor communicates with *mpssd* to perform operations, such as dynamically modifying user credentials, on behalf of *micctrl*.



*micrasd* is an application that runs on the Host to handle and log hardware errors reported by Intel® Xeon Phi™ coprocessors. It is normally controlled through the *micras* service. Refer to [Appendix D](#) for additional information.

#### 2.2.2.4 Tools and Utilities

Intel® MPSS includes several system management tools and utilities:

*micctrl* is a utility with which the user can control (boot, shutdown, reset) each of the installed Intel® Xeon Phi™ coprocessors. *micctrl* also offers numerous options to simplify the process of configuring each coprocessor. Configuration tasks can include controlling user access to coprocessors, adding coprocessors to a TCP/IP network, and installing software into the software stack-supplied default coprocessor file system (the default *initramfs*). A substantial portion of this document is devoted to creating an optimized configuration, which can be accomplished by use of *micctrl* and by directly editing configuration files. *micctrl* is discussed at length throughout this document. *micctrl* commands are described in detail in [Appendix B](#). The same information is available online from *micctrl* help:

```
[host]$ micctrl -h
```

*micinfo* and *mpssinfo* display information about the Intel® Xeon Phi™ coprocessors installed in the system as well as information about the host operating system and Intel® MPSS host driver. *mpssinfo* is a POSIX compliant version of *micinfo*. For detailed information, refer to the *micinfo* or *mpssinfo* man page.

```
[host]$ man micinfo
[host]$ man mpssinfo
```

*micflash* and *mpssflash* are used to update a coprocessor's flash image, save a coprocessor's flash image to a file on the host, and to display the current flash version that is loaded on a coprocessor. *mpssflash* is a POSIX-compliant version of *micflash*. For detailed information about *micflash* or *mpssflash*, refer to the *micflash* or *mpssflash* man page:

```
[host]$ man micflash
[host]$ man mpssflash
```

The *micsmc* tool is used to monitor Intel® Xeon Phi™ coprocessor statistics such as core utilization, temperature, memory usage, power usage statistics, and error logs. *micsmc* can function in two modes: GUI mode and command-line (CLI) mode. GUI mode provides real-time monitoring of all detected coprocessors installed in the system. The CLI mode produces a snap-shot view of the status, which allows CLI mode to be used in cluster scripting applications. For detailed information about *micsmc*, refer to the *micsmc* man page:

```
[host]$ man micsmc
```

The *miccheck* utility executes a suite of diagnostic tests that verify the configuration and current status of the Intel® Xeon Phi™ coprocessor software stack. For detailed information about *miccheck*, refer to the *miccheck* man page:

```
[host]$ man miccheck
```

The *micnativeloadex* utility copies an Intel® Xeon Phi™ coprocessor native binary to a specified coprocessor and executes it. Refer to [Appendix E](#) for additional information.



### 2.2.2.5 Optional Packages

The software stack distribution includes several packages that are optionally installed. Additional information and installation instructions can be found in [Appendix E](#):

*Reliability Monitor*, is an optional service that runs on the head node of a cluster, and monitors the health of MIC based compute nodes in the cluster.

The coprocessor *Performance Workloads* package can be used to evaluate the performance of an Intel® Xeon Phi™ coprocessor based installation.

An optional *Ganglia support* package to enable Ganglia based monitoring of Intel® Xeon Phi™ coprocessors, is also included. (*Ganglia* is an open source cluster monitoring system).

### 2.2.2.6 gcc Toolchain

The Intel® MPSS distribution includes both a *cross-compile gcc toolchain* and a *native gcc toolchain*. The cross compile gcc toolchain is used from the host to build components for execution on Intel® Xeon Phi™ coprocessors. Similarly, the native gcc toolchain executes on a coprocessor to build components for execution on a coprocessor. The native gcc toolchain is not installed into the default coprocessor file system image, but is available in a separate tarball that contains hundreds of binary RPMs that can be used to customize the default file system image. Among them are system daemons including *cron*, *rpcbind*, and *xinetd*; performance and debugging tools including *gperf*, *lsof*, *perf*, and *strace*; utilities including *bzip2*, *curl*, *rsync*, and *tar*; scripting languages including *awk*, *perl*, and *python*; and development tools including *autotools*, *bison*, *cmake*, *flex*, *git*, *make*, *patch*, and *subversion*, and the GCC toolchain mentioned above.

## 2.2.3 Intel® Xeon Phi™ Coprocessor Networking

There are three basic network configuration options that enable Intel® Xeon Phi™ coprocessors to operate in a wide range of networking environments. These are briefly described below. Network configuration is described in depth in [Chapter 5](#).

### 2.2.3.1 Static Pair Configuration

The static pair configuration creates a separate private network between the host and each Intel® Xeon Phi™ coprocessor. It assigns an IP address to each of the network endpoints. Various options for selecting the IP addresses (as seen by the host) and the host's IP address (as seen by the coprocessor) are available.

[Figure 6](#) depicts a host, on the left, with two Intel® Xeon Phi™ coprocessors. A private network was configured between the host and each coprocessor. Notice that mic0 and mic1 are on separate subnets.

Figure 6: Static Pair Configuration



This network configuration is established by default when `micctrl --initdefaults` is called for the first time. This configuration is sufficient for Intel® C++ and FORTRAN compiler pragma-based offload computation on a standalone (non-clustered) host platform and other program models where a coprocessor only needs a network connection to the host.

Additional information about this network configuration is in [Chapter 5](#).

### 2.2.3.2 Bridged Network Configurations

A network bridge is a way to connect two Ethernet segments or collision domains in a protocol independent way. It is a Link Layer device which forwards traffic between networks based on MAC addresses and is therefore also referred to as a Layer 2 device.

Two types of bridged networks are directly supported by Intel® MPSS.

#### 2.2.3.2.1 Internal Bridge Configuration

Some distributed applications running on Intel® Xeon Phi™ coprocessors on a single node need to communicate between coprocessors, and perhaps with the host. An internal bridge allows for the connection of one or more coprocessors within a single host system as a subnetwork. In this configuration, each coprocessor can communicate with the host and with other coprocessors in the platform. [Figure 7](#) shows an example of an internal bridge configuration.



Figure 7: Internal bridge network

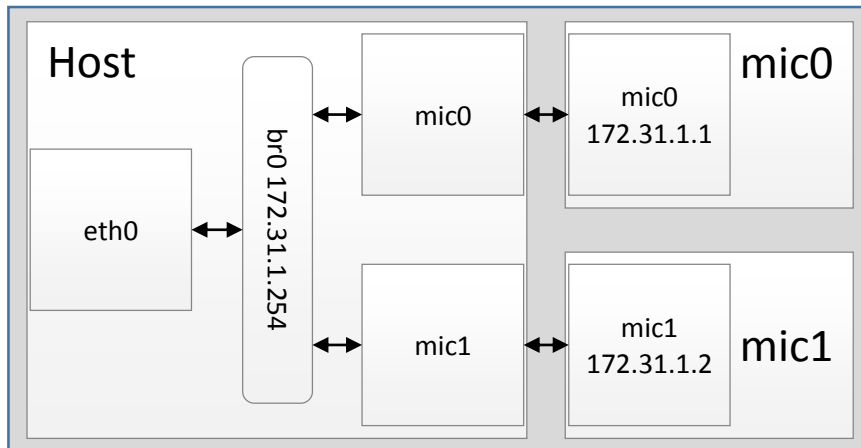

Such a network configuration could, for example, be used to support communication between the ranks of an MPI application that is distributed across the Intel® Xeon Phi™ coprocessors and host. (However, use of the IBSCIF virtual InfiniBand\* HCA driver will likely provide better performance.)

The additional considerations and steps to configure this network topology are described in [Chapter 5](#).

### 2.2.3.2.2 External Bridge Configuration

The external bridge configuration bridges Intel® Xeon Phi™ coprocessors to an external network. This is the typical configuration required when the coprocessors are deployed in a cluster to support remote communication among them and/or Xeon™ processors across different compute nodes.

[Figure 8](#) depicts a cluster in which the Intel® Xeon Phi™ coprocessors on each host node are bridged to the external network. The IP addresses in such a configuration can be assigned statically by the system administrator or by a DHCP server on the network, but must generally be on the same subnet.

InfiniBand\* based networking is not shown in this figure. InfiniBand\* based networking will usually provide significantly higher bandwidth than the IP networking supported by the Intel® MPSS Virtual Ethernet driver. Many clusters use Ethernet\* networking for low bandwidth communication such as command and control and use InfiniBand\* networking for high bandwidth communication as application data transfer.

Figure 8: External bridge network

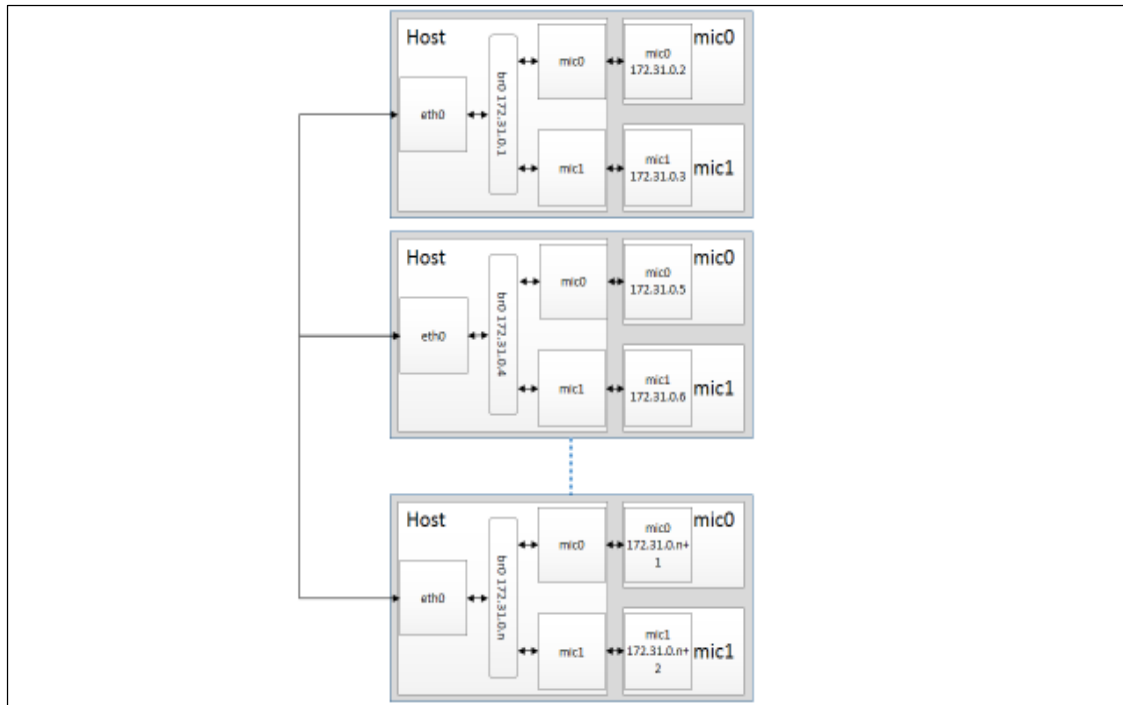

To prepare for configuring this network topology, you should ensure that you have provided a large enough IP address space to accommodate the nodes of the externally bridged networks.

These topics and steps to configure this network topology are described in [Chapter 5](#).

## 2.3 Supported Intel® Productivity Tools

The following table lists compatible versions of Intel® productivity tools that are supported with Intel® MPSS release 3.6.

Table 1: Intel® Productivity Tools Supported by Intel® MPSS 3.6

Name of Tool	Supported Version
Intel® Composer XE	2015
Intel® C++ Compiler	15.0
Intel® Integrated Performance Primitives for Linux*	8.2
Intel® Math Kernel Library for Linux*	11.2
Intel® Threading Building Blocks for Linux*	4.3
Intel® VTune™ Amplifier XE	2015



Name of Tool	Supported Version
Intel® SEP	3.11

**Note:** The intel-composerxe-compat-k10m RPM temporarily provides backward compatibility to ICC compiler versions prior to 14.0.0 via the soft links to /opt/mpss/3.6/sysroot. It is not a separate set of binaries for the x86\_64-k10m-linux architecture used in Intel® MPSS 2.1.6720.

## 2.4 Related Documentation

The [Intel® Xeon Phi™ Coprocessor Developer Zone website](#) has a wealth of information on all aspects of Intel® Xeon Phi™ coprocessor programming.

The following documentation specific to Intel® MPSS and Intel® Xeon Phi™ coprocessors is listed below.

### 2.4.1 SCIF documentation

The following SCIF documentation is installed during base Intel® MPSS installation

<code>\$MPSS36/docs/SCIF_UserGuide.pdf</code>	-SCIF User Guide
<code>/usr/share/man/man3/scif*</code>	-Man pages for SCIF API user mode
<code>/usr/share/man/man9/scif*</code>	-Man pages for SCIF API kernel mode

#### 2.4.1.1 SCIF Tutorials Location

<code>/usr/share/doc/scif/tutorials</code>	-SCIF tutorial source files
<code>/usr/share/doc/scif/tutorials/README.txt</code>	-Instructions for building and running the SCIF tutorials
<code>\$MPSS36/mpss-sciftutorials-doc-*.rpm</code>	-SCIF tutorial source package
<code>\$MPSS36/mpss-sciftutorials-3.*.rpm</code>	-SCIF tutorial binaries package
<code>\$MPSS36/mpss-sciftutorials-3.*.rpm</code>	-Debuggable SCIF tutorial binaries package

### 2.4.2 COI Documentation

The following COI documentation is installed during base Intel® MPSS installation

<code>/usr/share/doc/intel-coi-3.6-1/</code>	-release_notes.txt
<code>/usr/share/doc/intel-coi-3.6-1/</code>	-MIC_COI_API_Reference_Manual_1_0.pdf
<code>/usr/share/doc/intel-coi-3.6-1/</code>	-coi_getting_started.pdf
<code>/usr/include/intel-coi/</code>	-header files containing full API descriptions
<code>/usr/share/doc/intel-coi-3.6-1/tutorials/</code>	-Full tutorials source and Makefiles
<code>/usr/share/man/man3/COI*</code>	-man pages



### 2.4.3 MYO Documentation

The following MYO documentation is installed during base Intel® MPSS installation

<code>/usr/share/doc/myo</code>	-MYO tutorials and other documents
<code>/usr/include/</code>	-header files containing full API descriptions
<code>/usr/share/man/man3/myo*</code>	-man pages

### 2.4.4 Micperf Documentation

Intel® Xeon Phi™ coprocessor Performance Workload (Micperf) documentation is found at `/usr/share/doc/micperf-3.6` when micperf is installed (see [Appendix F.2](#)).

### 2.4.5 Intel® Xeon Phi™ Coprocessor Collateral

The following documents provide additional information on various aspects of Intel® Xeon Phi™ hardware and software.

Intel® Xeon Phi™ coprocessor Specification Update:

<https://www-ssl.intel.com/content/www/us/en/processors/xeon/xeon-phi-coprocessor-specification-update.html>

Intel® Xeon Phi™ coprocessor Safety and Compliance Guide:

<https://www-ssl.intel.com/content/www/us/en/processors/xeon/xeon-phi-coprocessor-safety-compliance-guide.html>

Intel® Xeon Phi™ coprocessor Datasheet:

<https://www-ssl.intel.com/content/www/us/en/processors/xeon/xeon-phi-coprocessor-datasheet.html>

Intel® Xeon Phi™ coprocessor Software Users Guide:

<https://www-ssl.intel.com/content/www/us/en/processors/xeon/xeon-phi-coprocessor-software-users-guide.html>

Intel® Xeon Phi™ coprocessor System Software Developers Guide:

<https://www-ssl.intel.com/content/www/us/en/processors/xeon/xeon-phi-coprocessor-system-software-developers-guide.html>

Intel® Xeon Phi™ coprocessor Developers Quick Start Guide:

<http://software.intel.com/en-us/articles/intel-xeon-phi-coprocessor-developers-quick-start-guide>

Intel® Xeon Phi™ coprocessor Instruction Set Architecture Reference Manual:

<http://software.intel.com/sites/default/files/forum/278102/327364001en.pdf>

Information on platforms that support the Intel® Xeon Phi™ coprocessor.



**Intel® MPSS at a Glance**

<http://software.intel.com/en-us/articles/which-systems-support-the-intel-xeon-phi-coprocessor>

Intel® MPSS Performance Guide

<https://software.intel.com/sites/default/files/managed/72/db/mpss-performance-guide.pdf>



## 3 Intel® Xeon Phi™ Coprocessor Installation Process

---

This chapter describes the steps for installing and configuring Intel® Xeon Phi™ coprocessor hardware and software. Most of these steps through [Section 3.3](#) are common to both workstation and cluster configurations. [Section 3.5](#) and later are primarily of interest to cluster administrators and those with advanced workstation programming configuration requirements.

**Caution:** It is strongly recommended that you read through this chapter before actually proceeding with installation to ensure that all required components and facilities are available. It is also strongly recommended that these installation steps be performed in the order in which they are presented.

### 3.1 Hardware and Software Prerequisites

#### 3.1.1 Host System HW

A system that supports the Intel® Xeon Phi™ coprocessor is required to run Intel® MPSS. You can find information on such platforms at the Intel® Developer Zone for Intel® Xeon Phi™ coprocessors: <https://software.intel.com/en-us/mic-developer>. Search for an article entitled *Which systems support the Intel® Xeon Phi™ coprocessor?*

#### 3.1.2 BIOS Configuration

Several BIOS settings are important to the proper functioning of the software stack.

##### 3.1.2.1 Enable Large Base Address Registers (BAR) Support in the Host Platform BIOS

BIOS and OS support for large (8GB+) Memory Mapped I/O Base Address Registers (MMIO BAR's) above the 4GB address limit must be enabled.

In some instances, motherboard BIOS implementations have this feature set to disabled and it must be enabled manually.

Contact your platform and/or BIOS vendor to determine whether changing this setting applies for the platform being used.

##### 3.1.2.2 Enable Intel® Turbo Boost on the Host Platform

For best performance, it is recommended that Intel® Turbo Boost is enabled. Enabling this setting in the BIOS is vendor specific. Contact your platform vendor for instructions.



### 3.1.3 Supported Host Operating Systems

Intel® MPSS 3.6 has been validated against specific versions of Red Hat\* Enterprise Linux\* (RHEL\*) and SUSE\* Linux\* Enterprise Server (SLES\*) as the host operating system. [Table 2](#) lists the supported versions of these operating systems.

To obtain the version of the kernel running on the host, execute:

```
[host]$ uname -r
```

**Table 2: Supported Host Operating Systems**

Supported Host OS Versions	Kernel Version
Red Hat* Enterprise Linux* 64-bit 6.5	2.6.32-431
Red Hat* Enterprise Linux* 64-bit 6.6	2.6.32-504
Red Hat* Enterprise Linux* 64-bit 6.7	2.6.32-573
Red Hat* Enterprise Linux* 64-bit 7.0	3.10.0-123
Red Hat* Enterprise Linux* 64-bit 7.1	3.10.0-229
SUSE* Linux* Enterprise Server 11 SP3 64-bit	3.0.76-0.11-default
SUSE* Linux* Enterprise Server 11 SP4 64-bit	3.0.101-63-default
SUSE* Linux* Enterprise Server 12 64-bit	3.12.28-4-default

[Section 3.3.3](#) and [Section 3.3.4](#) discuss rebuilding the Intel® MPSS host drivers and Intel® MPSS OFED drivers in the event that the host kernel has been patched/updated.

### 3.1.4 Host Operating System Configuration

1. The SUSE\* Linux\* Enterprise Server release kernel must be configured to allow non-SUSE\* driver modules to be loaded. Edit the file `/etc/modprobe.d/unsupported-modules` and set the value of `"allow_unsupported_modules"` to 1.
2. If SELinux\* is installed, it must be disabled before installing Intel® MPSS software to prevent SELinux\* from overriding standard Linux\* permissions settings.

### 3.1.5 Root Access

Many tasks described in this document require root access privileges. Verify that you have such privileges to the machines which you will configure.

The use of `sudo` to acquire root privileges should be done carefully because there may be subtle and undesirable side effects to its use. `Sudo` might not retain the non-root environment of the caller. This could, for example, result in use of a different `PATH` environment variable than was expected, resulting in execution of the wrong code.

When `su` is used to become root, the non-root environment is mostly retained. `HOME`, `SHELL`, `USER`, and `LOGNAME` are reset unless the `-m` switch is given. See the `su` man page for details.



### 3.1.6 SSH Access to the Intel® Xeon Phi™ Coprocessor

*Secure Shell* (SSH) is a connectivity tool for secure remote command-line login, command execution, and other services between two networked computers. SSH is an important capability for enabling users to move and launch native applications and data to Intel® Xeon Phi™ coprocessors and move results back. Developers can use SSH to access coprocessor to perform native compilation and other software development tasks.

Most Intel® Xeon Phi™ coprocessor configuration tasks can be done indirectly from the host, as will be discussed later. However, some administrators may prefer to use SSH to log on to a coprocessor to perform such configuration tasks directly or verify that a coprocessor's configuration is correct.

SSH access is generally not needed by users who will develop and/or execute offload applications using the Intel® C++ and FORTRAN offload pragmas.

The Intel® Xeon Phi™ coprocessor Linux\* OS supports network access using SSH keys or password authentication; this requires that valid credentials exist on the coprocessor. Depending on parameterization, the `micctrl --initdefaults` command, when performed following base software stack installation ([Section 3.3.3.3](#)), creates a user account on each coprocessor's file system, for selected users and root in the host `/etc/passwd` file. In addition, for each such user, if SSH key files are found in the user's ".ssh" directory, those keys may also be propagated to the Intel® Xeon Phi™ coprocessor's file system. This allows ssh access to the coprocessor without the need to enter a password.

Each user, including root, that will need SSH access should execute the `ssh-keygen` command:

```
[host]$ ssh-keygen
```

to generate a set of ssh keys.

**Note:** It is recommended to use default key names and not to provide key passphrases.

See [Chapter 6](#) for information on customizing the user credentialing behavior.

### 3.1.7 Init Scripts

Red Hat\* Enterprise Linux\* 6 and SUSE\* Linux\* Enterprise Server 11 use the System V init system, while Red Hat\* Enterprise Linux\* 7 and SUSE\* 12 uses the systemd init system. The System V init system uses the `service` command, which has the form:

```
service SCRIPT COMMAND [OPTIONS]
```

where the `SCRIPT` parameter specifies a System V init script, and the supported values of `COMMAND` depend on the invoked script. Systemd uses the `systemctl` command, which has the form:

```
systemctl [OPTIONS...] COMMAND [NAME...]
```

where `[NAME...]` is zero or more parameters to the `COMMAND`.

The `systemctl` command is also used on RHEL\* 7 and SUSE\* 12 instead of the `chkconfig` command. Init commands in this document are in System V format. On host systems with RHEL\* 7 or SUSE\* 12, those commands should be converted to system format as follows:



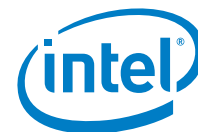

Table 3: System V format commands

RHEL* 6/SUSE 11 Command	RHEL* 7/SUSE* 12 Command
service mpss unload	systemctl stop mpss modprobe -r mic
service SCRIPT COMMAND	systemctl COMMAND SCRIPT
chkconfig NAME on	systemctl enable NAME
chkconfig NAME off	systemctl disable NAME

For example, the command:

```
[host]# service nfs restart
```

should be converted to:

```
[host]# systemctl restart nfs
```

on RHEL\* 7/SUSE\* 12. Similarly

```
[host]# chkconfig mpss on
```

becomes:

```
[host]# systemctl enable mpss
```

In the remainder of this document, `service` and `systemctl` are prepended with a superscript that links back to this section:

```
[host]# 1service mpss start
```

### 3.1.8 Network Manager

Some configuration of the *network* manager is required. Configuration is host operating system dependent.

#### 3.1.8.1 RHEL\* 6, RHEL\* 7 and SLES\* 11

Users have encountered issues in configuring the virtual network interfaces for Intel® Xeon Phi™ coprocessors when *NetworkManager* is being used on RHEL\* 6, RHEL\* 7 and SLES\* 11 platforms. It is strongly recommended to use the older and more server-oriented *network* daemon instead with these operating systems.

To determine if *NetworkManager* is active, execute:

<sup>1</sup> When running Intel® MPSS on RHEL\* 7.0, please replace:

```
service mpss unload
```

with

```
systemctl stop mpss
```

```
modprobe -r mic
```

For all other service commands, replace:

```
service <daemon> <action>
```

with

```
systemctl <action> <daemon>
```



```
[host]# service NetworkManager status
```

To switch to *network daemon*, perform the following on the host:

```
[host]# chkconfig NetworkManager off  
[host]# chkconfig network on  
[host]# service NetworkManager stop  
[host]# service network start
```

### 3.1.8.2 SLES\* 12

The *wicked network configuration framework* should be enabled by default on SLES\* 12. To verify whether it is running execute:

```
[host]$ systemctl status network.service
```

If the output shows another service force *wicked* by executing:

```
[host]# systemctl stop network.service  
[host]# systemctl enable --force wicked.service
```

For proper functioning of Intel® Xeon Phi™ coprocessors networking with *wicked*, the *nanny* daemon should also be enabled. The recommended procedure is to create and/or edit the file */etc/wicked/local.xml* to include a line that enables the *nanny* daemon, for example:

```
<config>  
  <use-nanny>true</use-nanny>  
</config>
```

More information is available at: [https://www.suse.com/documentation/sles-12/book\\_sle\\_admin/data/sec\\_basicnet\\_manconf.html](https://www.suse.com/documentation/sles-12/book_sle_admin/data/sec_basicnet_manconf.html)

After any change in network configuration, the *wicked* daemon should be restarted for configuration changes to take effect:

```
[host]# systemctl restart wicked
```

It is also recommended to flush the DNS cache by issuing:

```
# systemctl restart nscd
```

## 3.2 Intel® Xeon Phi™ Coprocessor Card Physical Installation

**Note:** You can skip this chapter if your host has just a single CPU socket because all PCIe slots are equivalent.

When installing Intel® Xeon Phi™ coprocessor cards into a host platform, some consideration should be given to the slot or slots where the cards are installed. The options depend on if a coprocessor card is to communicate with another PCIe device, such as another coprocessor or an InfiniBand\* HCA. We refer to such communication between PCIe devices as peer-to-peer (P2P).

An important factor is that when PCIe devices are plugged into I/O hubs of different CPU sockets, communication between those devices will be across the Quick Path interconnect. The

bandwidth of this communication will typically be lower than communication bandwidth when the two devices are plugged into the same I/O hub. Therefore, if you expect P2P data transfers between two PCIe devices, it is recommended to setup nodes with the above considerations in mind. Contact your host platform OEM or refer to motherboard documentation for information on bus/processor locality.

### 3.2.1 Workstation Considerations

Workstations typically do not have InfiniBand\* HCAs. In this case, P2P communication between Intel® Xeon Phi™ coprocessors will determine how cards are installed, and this is somewhat determined by the programming model. Programming models were discussed briefly in [Section 2.2](#). If there is just a single coprocessor, it makes little difference into which slot it is installed.

#### 3.2.1.1 Offload Programming Model

Most workstation applications use the offload programming model support provided by the Intel® C/C++ and FORTRAN compilers, and MKL libraries to offload work to one or more Intel® Xeon Phi™ coprocessors. In this framework, the coprocessors communicate only with the host processor, not with each other; P2P bandwidth is thus not important. Therefore it is recommended that cards are installed as uniformly as possible among the I/O hubs. [Figure 9](#) is an example of such an installation. Care should be taken to ensure that the host side of the offload program is running on the same NUMA node as the coprocessor to which it is offloading work. Refer to the [Intel® MPSS Performance Guide](#) for additional information.

**Figure 9: Uniform distribution of Intel® Xeon Phi™ coprocessors**

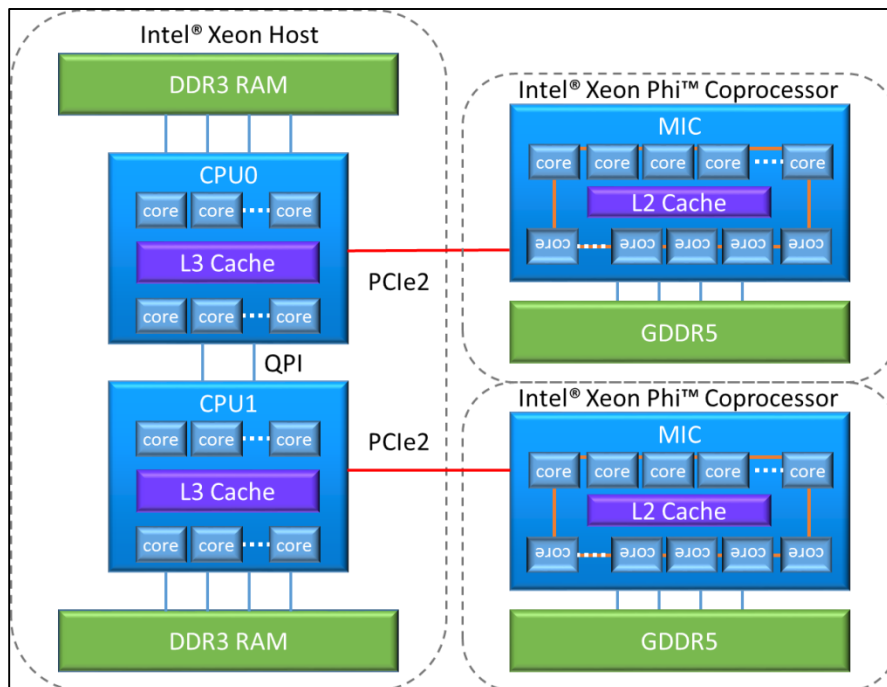

### 3.2.1.2 Symmetric and Native Programming Models

When an application is distributed across the Intel® Xeon Phi™ coprocessors it is likely that communication bandwidth between them is important. This might be the case, for example, when MPI ranks are instantiated on multiple coprocessors in a workstation. In this case, the best performance might be achieved by installing pairs of Intel® Xeon Phi™ coprocessors into each I/O hub as shown in [Figure 10](#).

**Figure 10: Two Intel® Xeon Phi™ coprocessors Installed in the Same IO Hub**

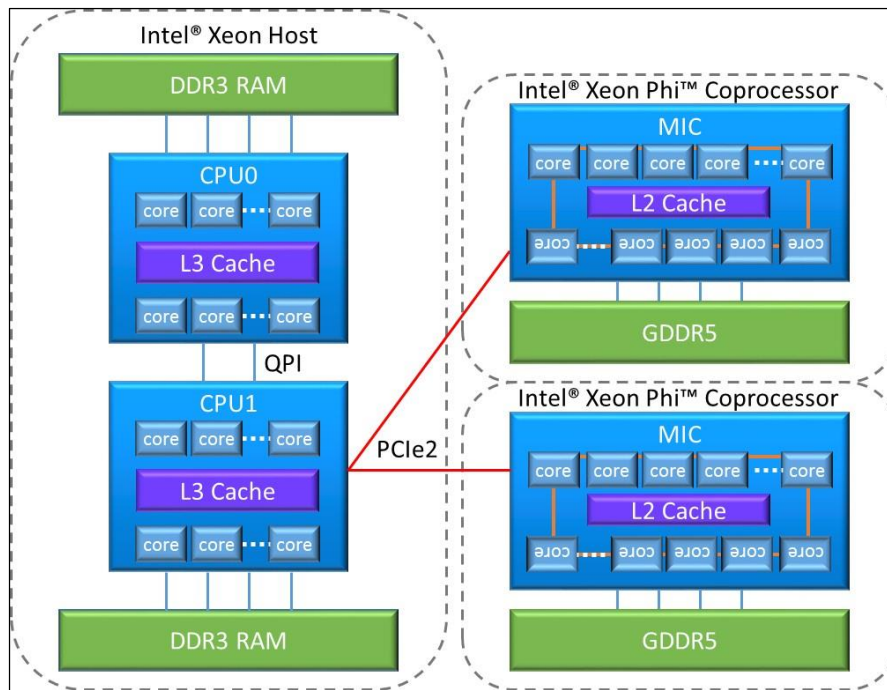

Experimentation to find the best configuration is recommended.

### 3.2.2 Cluster Considerations

When both an Intel® Xeon Phi™ coprocessor and an InfiniBand\* HCA are installed in the same platform, it is important to maximize communication bandwidth between the two devices. This suggests that, where there is one of each, they should be installed into the same I/O hub, as the example in [Figure 11](#) shows.

**Figure 11: Intel(R) Xeon Phi(TM) and InfiniBand\* HCA sharing an I/O hub**

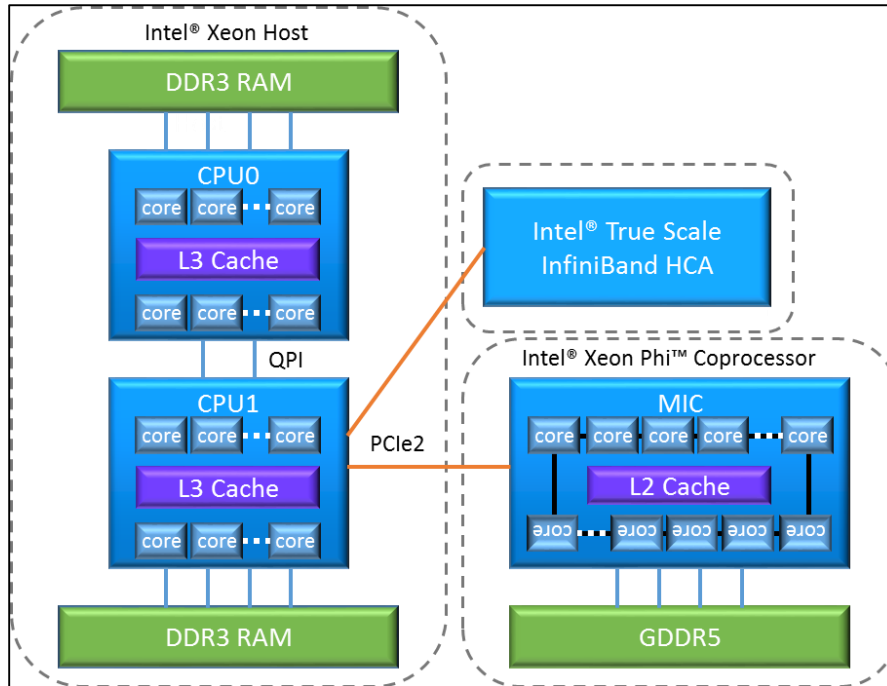

By extension, when there are equal numbers of Intel® Xeon Phi™ coprocessors and InfiniBand\* HCAs, we suggest installing the coprocessor and HCA pair into an I/O hub, as the example in [Figure 12](#) shows.

Figure 12: Symmetric Distribution of Coprocessors and HCAs

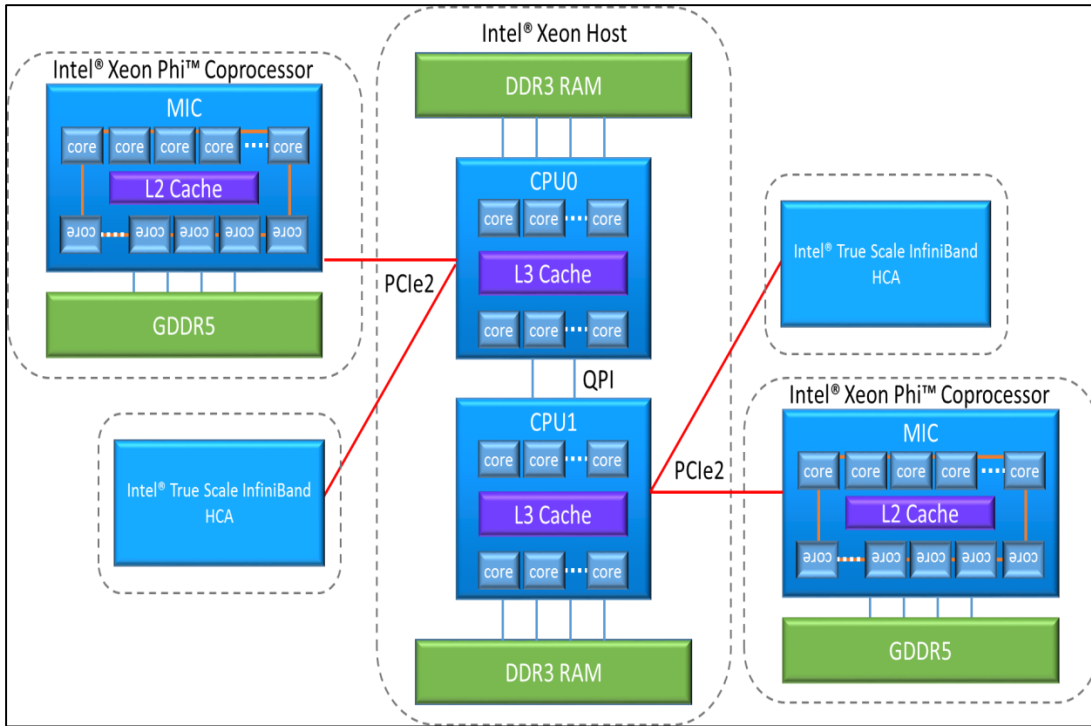

For other ratios of Intel® Xeon Phi™ coprocessors and IB HCAs, consideration should be given to how the devices are expected to inter-communicate, remembering the relative communication BWs between the various PCIe slots in a platform.

### 3.2.3 Validate Intel® Xeon Phi™ Coprocessor physical installation

Before installing and using Intel® MPSS, it is advisable to check if the host OS is able to enumerate and assign MMIO resources to the Intel® Xeon Phi™ coprocessors. The `lspci` command, commonly found on Linux\* installations, can be used to achieve this. The following shows typical output indicating the presence of a single coprocessor:

```
[host]$ lspci | grep -i Co-processor
08:00.0 Co-processor: Intel Corporation Device 225c (rev 20)
```

To verify that the BIOS/OS is able to assign all the required resources to the Intel® Xeon Phi™ coprocessor, execute the following, noting that the earlier command reported that the coprocessor is on bus:slot number 08:00.

```
[host]# lspci -s 08:00.0 -vv
08:00.0 Co-processor: Intel Corporation Device 225c (rev 20)
Subsystem: Intel Corporation Device 2500
Physical Slot: 4
Control: I/O+ Mem+ BusMaster+ SpecCycle- MemWINV- VGASnoop-
ParErr+ Stepping- SERR+ FastB2B- DisINTx+
Status: Cap+ 66MHz- UDF- FastB2B- ParErr- DEVSEL=fast
>TAbort- <TAbort- <MAbort- >SERR- <PERR- INTx-
Latency: 0, Cache Line Size: 64 bytes
Interrupt: pin A routed to IRQ 56
```



```
Region 0: Memory at 3c7e00000000 (64-bit, prefetchable)
[size=2000000000]
Region 4: Memory at ec000000 (64-bit, non-prefetchable)
[size=128K]
: <output truncated>
```

The output shows that both BAR0 (region 0) and BAR1 (region 4) have valid assigned values.

If the expected number of cards is not reported, it may help to reseal the cards before continuing. If the cards are detected, but no resources have been assigned, check the system BIOS for support of large BARs (see [Section 3.1.4](#))

## 3.3 Base Intel® MPSS Installation

You are now ready to install the “Base Intel® MPSS”. Base software stack includes all components that are needed to configure the Intel® MPSS environment, boot the installed Intel® Xeon Phi™ coprocessors, and execute applications that use the offload or native execution models. Optional stack components must be installed if application processes running on the coprocessors are to communicate with supported InfiniBand\* HCAs. This is covered later in [Section 3.6](#).

### 3.3.1 Get the Intel® MPSS Distribution

The Intel® MPSS distributions can be obtained from the [Intel® Developer Zone website \(Intel® DZ\)](#). For the software stack 3.3 and newer, there is a single distribution for all supported operating systems. Releases prior to 3.3 had a separate tar file for each supported host OS.

Untar the Intel® MPSS package:

```
[host]$ tar xvf mpss-3.6-linux.tar
[host]$ cd mpss-3.6
```

As described in the Notational Conventions [Section 1.3.2.1](#), we refer to the directory into which files are placed as *\$MPSS36*.

### 3.3.2 Uninstall Previous Intel® MPSS Installation Prior to Upgrade

Yum and zypper both support software upgrades and downgrades. However, it is necessary that Intel® MPSS upgrades and downgrades be carried out by first completely uninstalling existing Intel® MPSS components, followed by a clean installation of the replacement software.

1. To check for a previously installed version of Intel® MPSS package:

```
[host]$ rpm -qa | grep -e intel-mic -e mpss
```

Skip to [Section 3.3.3.3](#) if there is no previous installation.

Unload the software stack driver:

```
[host]# lservice mpss unload
```

Uninstall the software stack



- a. To uninstall 3.x-based builds:

```
[host]$ cd $MPSS3X  
[host]# ./uninstall.sh
```

- b. To uninstall the pre-3.x builds:
  - i. Red Hat\* Enterprise Linux\*

```
[host]# yum remove intel-mic\*
```

- ii. SUSE\* Linux\* Enterprise Server

```
[host]# zypper remove intel-mic\*
```

### 3.3.3 Rebuild Intel® MPSS Host Drivers

Both Red Hat\* and SUSE\* release minor kernel version updates. If an update of the kernel occurs, this may create version incompatibilities with the Intel® MPSS\* host and InfiniBand\* drivers, preventing these drivers from loading.

To determine if your host kernel has been updated, you can execute:

```
[host]$ uname -r
```

from the host console and compare the returned value to the default versions listed in [Table 2](#). If your host kernel is not updated, then proceed to [Section 3.3.3.3](#). Otherwise it may be required to rebuild Intel® MPSS drivers as follows for proper execution:

**Note:** If using InfiniBand\* as an interconnect, you may also need to recompile the OFED drivers; this is covered in [Section 3.3.4](#).

#### 3.3.3.1 Red Hat\* Enterprise Edition (RHEL\*)

1. Ensure the prerequisites are installed:

```
[host]# yum install kernel-headers kernel-devel
```

2. Regenerate the Intel® MPSS driver module package:

```
[host]$ cd $MPSS36/src/  
[host]$ rpmbuild --rebuild mpss-modules*.src.rpm
```

3. The resulting mpss-modules binary rpms are located by default at *\$HOME/rpmbuild/RPMS/x86\_64*. Copy the mpss-modules RPMs to the *modules* directory:

```
[host]$ cp $HOME/rpmbuild/RPMS/x86_64/mpss-modules*\`uname \  
-r`.rpm ../modules
```

4. Proceed to [Section 3.3.3.3](#).

#### 3.3.3.2 SUSE\* Linux\* Enterprise Server (SLES\*)

1. Ensure the prerequisites are installed:





```
[host]# zypper install kernel-default-devel rpm-build
```

2. Regenerate the Intel® MPSS driver module package:

```
[host]$ cd $MPSS36/src/  
[host]# rpmbuild --rebuild mpss-modules*.src.rpm
```

3. The resulting mpss-modules binary rpms are located by default at `/usr/src/packages/RPMS/x86_64` or `$HOME/rpmbuild/RPMS/x86_64` (depending on the OS version). Copy the mpss-modules RPMs to the `modules` directory:

```
[host]$ cp /usr/src/packages/RPMS/x86_64/mpss-modules*`uname` \ -r`*.rpm` ./modules
```

4. Proceed to [Section 3.3.3.3](#).

### 3.3.3.3 Install Base Intel® MPSS

1. The modules directory contains packages for all supported host OS kernels, including packages that were rebuilt in [Section 3.3.3](#). Copy the modules corresponding to your host kernel to `$MPSS36`:

```
[host]$ cd $MPSS36  
[host]$ cp ./modules/*`uname` -r`*.rpm` .
```

Install the software stack:

- a. Red Hat\* Enterprise Linux\*

```
[host]# yum install *.rpm
```

**Note:** Intel® MPSS packages are not GPG signed. If local package GPG check (`localpkg_gpgcheck`) is enabled in `yum.conf`, or if RHEL\* 6.0 `gpgcheck` is enabled, the `--nogpgcheck` option must be used:

```
[host]# yum install --nogpgcheck *.rpm
```

- b. SUSE\* Linux\* Enterprise Server

```
[host]# zypper install *.rpm
```

2. Load the mic.ko driver:

```
[host]# modprobe mic
```

### 3.3.4 Update Intel® Xeon Phi™ Coprocessor Flash & SMC Firmware

**Caution:** After the base software stack is installed, it is strongly recommended to update the Intel® Xeon Phi™ coprocessor flash and SMC firmware to the version distributed with the software stack installation. The `$MPSS36/docs/readme.txt` file lists the versions of the Flash and SMC firmware in the distribution.

Running Intel® MPSS with incorrect Flash or SMC firmware versions is not supported and may lead to erratic behavior.

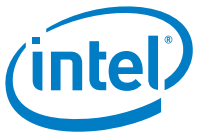

**Note:** These steps will not work if the flash files (ending in .rom.smc) are moved to a location other than the default install path.

**Note:** To verify what version of the flash is installed execute:

```
[host]#micflash -getversion
```

**Note:** The current flash version must be  $\geq 375$ . If not, contact your Intel® support representative.

1. Check the status of each coprocessor:

```
[host]$ micctrl -s
```

**Note:** In SLES\* it might be necessary to provide absolute path to execute the above command without root permissions. The default path to *micctrl* is */usr/sbin/micctrl*.

If the status for all of the coprocessors shows 'ready', go to step 2; otherwise, set the coprocessor(s) to a 'ready' state:

```
[host]# micctrl -rw
```

2. Determine the stepping and board SKU of each coprocessor to be updated. The *micinfo* utility can be used if this information is not already known. For example:

```
[host]# micinfo -group Board
Board
Vendor ID           : 0x8086
Device ID           : 0x225d
Subsystem ID        : 0x2500
Coprocessor Stepping ID : 1
PCIe Width          : x16
PCIe Speed          : 5 GT/s
PCIe Max payload size : 256 bytes
PCIe Max read req size : 512 bytes
Coprocessor Model    : 0x01
Coprocessor Model Ext : 0x00
Coprocessor Type     : 0x00
Coprocessor Family   : 0x0b
Coprocessor Family Ext : 0x00
Coprocessor Stepping : B0
Board SKU            : ES2-A1330
ECC Mode             : NotAvailable
SMC HW Revision      : NotAvailable
```

**Note:** Some data is not available while the coprocessor is not booted.

3. Update the flash image.
  - a. If the coprocessor to be updated is any C0 stepping SKU, or a 5110P B1 SKU with a TA of G65758-253 or higher (for 5110P B1 SKUs, the TA is on a sticker affixed to the coprocessor) then execute:

```
[host]# micflash -update -device all
```

This will update all installed coprocessors. To update coprocessor micN, execute:



```
[host]# micflash -update -device N
```

**For example:**

```
[host]# micflash -update -device 0
No image path specified - Searching: /usr/share/mpss/flash
mic0: Flash image: /usr/share/mpss/flash/EXT_HP2_B1_0390-02.rom.smc
mic0: Flash update started
mic0: Flash update done
mic0: SMC update started
mic0: SMC update done
mic0: Transitioning to ready state
```

Please restart host for flash changes to take effect

**b. Otherwise, execute:**

```
[host]# micflash -update -device all -smcbootloader
```

This will update all installed coprocessors. To update coprocessor micN, execute:

```
[host]# micflash -update -device N -smcbootloader
```

**For Example:**

```
[host]# micflash -update -device 0 -smcbootloader
No image path specified - Searching: /usr/share/mpss/flash
mic0: Flash image: /usr/share/mpss/flash/EXT_HP2_B0_0390-02.rom.smc
mic0: SMC boot-loader image:
/usr/share/mpss/flash/EXT_HP2_SMC_Bootloader_1_8_4326.css_ab
mic0: SMC boot-loader update started
mic0: SMC boot-loader update done
mic0: Transitioning to ready state
mic0: Flash update started
mic0: Flash update done
mic0: SMC update started
mic0: SMC update done
mic0: Transitioning to ready state
```

Please restart host for flash changes to take effect

4. Reboot the host system for all flash and SMC changes to take effect. Be sure to wait for the flash update to complete before rebooting.
5. You will validate the flash update in [Section 3.3.7](#).

*mpssflash* is a POSIX-compliant version of *micflash*. For detailed information about *micflash* or *mpssflash*, refer to the *micflash* or *mpssflash* man page:

```
[host]$ man micflash
[host]$ man mpssflash
```

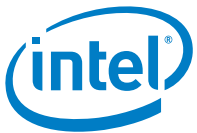

### 3.3.5 Initialize Intel® MPSS default configuration settings.

Intel® MPSS configuration is based on parameters in several configuration files. The parameters in `/etc/mpss/default.conf` are treated as common to all coprocessors in the system. In addition, there is a configuration file `/etc/mpss/micN.conf` for each coprocessor in the system, where N is an integer number (0, 1, 2, 3, etc.) that identifies a coprocessor. Each parameter in a coprocessor specific file takes precedence in configuring the corresponding coprocessor, overriding `default.conf` if the same parameter is in that file.

The `micctrl --initdefaults` command creates these files if they do not already exist, and populates them with default parameter values. In addition, if a previous configuration file exists, but some parameter is not configured, this command will add a default configuration value.

The `micctrl --initdefaults` command should be performed after the initial Intel® MPSS installation and after each subsequent installation of a new software stack release:

```
[host]# micctrl --initdefaults
```

The `micctrl --initdefaults` command *will not* change existing configuration settings, with the following exception: The Intel® MPSS configuration file format is versioned, with the version indicated by a `Version` parameter in the configuration file. If a configuration already exists, then `micctrl --initdefaults` will update the configuration format if necessary. The semantics of the updated configuration should be invariant.

Some users switch between different versions of the software stack. When this is the case, and because `micctrl --initdefaults` does not know how to downgrade a configuration from a newer to an older format, it is recommended to make a copy of the configuration files before calling `micctrl --initdefaults`.

The default configuration produced by the `micctrl --initdefaults` command is sufficient for many users who will be using the offload programming model on a workstation. You can view a summary of the current configuration parameters with:

```
[host]$ micctrl --config
```

The following is typical of the default configuration:

```
mic0:
=====
Config Version: 1.1

Linux Kernel:   /usr/share/mpss/boot/bzImage-knightscorner
BootOnStart:   Enabled
Shutdowntimeout: 300 seconds

ExtraCommandLine: highres=off
PowerManagment: cpufreq_on;corec6_off;pc3_on;pc6_off

Root Device:   Dynamic Ram Filesystem /var/mpss/mic0.image.gz from:
Base:         CPIO /usr/share/mpss/boot/initramfs-
              knightscorner.cpio.gz
CommonDir:    Directory /var/mpss/common
Micdir:       Directory /var/mpss/mic0

Network:      Static Pair
```



```
Hostname: snhondo-desktop7-mic0.dd.domain.com
MIC IP: 172.31.1.1
Host IP: 172.31.1.254
Net Bits: 24
NetMask: 255.255.255.0
MtuSize: 64512
MIC MAC: 4c:79:ba:15:00:1e
Host MAC: 4c:79:ba:15:00:1f
```

```
Cgroup:
Memory: Disabled
```

```
Console: hvc0
VerboseLogging: Disabled
CrashDump: /var/crash/mic 16GB
```

The *micctrl* tool can be used to modify the configuration, and it is also possible to modify the configuration by directly editing the Intel® MPSS configuration files. [Section 3.6.11.2](#) contains an overview of the configuration process, while later sections discuss a variety of configuration tasks.

### 3.3.6 Start Intel® MPSS

With Intel® MPSS installed and the flash and SMC versions up-to-date, it is time to boot the Intel® Xeon Phi™ coprocessors you have installed. To boot the coprocessors, execute the following:

```
[host]# lservice mpss start
```

Starting the mpss service launches the mpssd daemon, and also boots the installed Intel® Xeon Phi™ coprocessors if the BootOnStart config option is set to *enabled* (default).

The following command configures the mpss service to start when the host OS boots:

```
[host]# lchkconfig mpss on
```

This command disables the mpss service from starting when the host OS boots:

```
[host]# lchkconfig mpss off
```

See the `chkconfig` man page for details.

**Note:** On RHEL\* 7 and SLES\* 12, starting the mpss service (`systemctl start mpss`) on a system with a large number of coprocessors can take longer than the default value of five minutes of the *TimeoutSec* parameter in the `/etc/systemd/system/mpss.service` file. In this case it is necessary to increase *TimeoutSec* from its default value to some larger value.

### 3.3.7 Validate Base Intel® MPSS Installation

Having booted all the coprocessors in the system, Intel® MPSS provides utilities that can be used to perform basic tests to validate that the installation was performed correctly.

[Appendix I](#) provides troubleshooting advice in the event that problems are encountered during installation.

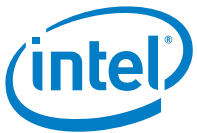

### 3.3.7.1 Log into a Coprocessor Using SSH

At this point you should be able to ssh into a coprocessor. For example, to ssh into mic0:

```
[host]$ ssh mic0
[mic0]$
```

If the following message appears:

```

@@@@@@@@@@@@@@@@@@@@@@@@@@@@@@@@@@@@@@@@@@@@@@@@@@@@@@@@@@@@@@@@@@@@@@@@@@@@@@@@
@      WARNING: REMOTE HOST IDENTIFICATION HAS CHANGED!      @
@@@@@@@@@@@@@@@@@@@@@@@@@@@@@@@@@@@@@@@@@@@@@@@@@@@@@@@@@@@@@@@@@@@@@@@@@@@@@@@@
IT IS POSSIBLE THAT SOMEONE IS DOING SOMETHING NASTY!
```

remove the mic0 RSA from the user's *known\_hosts* file, typically found in the *\$HOME/.ssh/* folder, and then try again.

**Note:** When running an ssh command in the background, it is preferable to use the *-f* option instead of appending "&" to the command:

```
[host]$ ssh -f hostname "sleep 20; echo complete"
```

### 3.3.7.2 Validate Using Intel® MPSS Tools

*miccheck* is a utility which performs sanity checks on a host system in which Intel® Xeon Phi™ coprocessors are installed, by running a suite of diagnostic tests. The following example shows miccheck output after a successful software stack installation:

```
[host]$ miccheck
MicCheck 3.6-r1
Copyright 2013 Intel Corporation All Rights Reserved

Executing default tests for host
  Test 0: Check number of devices the OS sees in the system ... pass
  Test 1: Check mic driver is loaded ... pass
  Test 2: Check number of devices driver sees in the system ... pass
  Test 3: Check mpssd daemon is running ... pass
Executing default tests for device: 0
  Test 4 (mic0): Check device is in online state and its postcode is
FF ... pass
  Test 5 (mic0): Check ras daemon is available in device ... pass
  Test 6 (mic0): Check running flash version is correct ... pass
  Test 7 (mic0): Check running SMC firmware version is correct ...
pass

Status: OK
```

Additionally, the *micinfo* tool provides information about the host and Intel® Xeon Phi™ coprocessor hardware and software. The following is example output from *micinfo* when executed on a platform with a single coprocessor installed. Certain device information is only available when executing *micinfo* with root privileges:



```
[host]# micinfo
MicInfo Utility Log
Created Tue Jan 27 20:49:53 2015
```

## System Info

```
HOST OS           : Linux
OS Version        : 2.6.32-431.17.1.el6.x86_64
Driver Version    : 3.6
MPSS Version      : 3.6
Host Physical Memory : 24541 MB
```

```
Device No: 0, Device Name: mic0
```

## Version

```
Flash Version      : 2.1.03.0386
SMC Firmware Version : 1.15.4830
SMC Boot Loader Version : 1.8.4326
Coprocessor OS Version : 2.6.38.8+mpss3.6
Device Serial Number : ADKC31101193
```

## Board

```
Vendor ID          : 0x8086
Device ID          : 0x2250
Subsystem ID       : 0x5804
Coprocessor Stepping ID : 2
PCIe Width         : x16
PCIe Speed         : 5 GT/s
PCIe Max payload size : 256 bytes
PCIe Max read req size : 4096 bytes
Coprocessor Model  : 0x01
Coprocessor Model Ext : 0x00
Coprocessor Type   : 0x00
Coprocessor Family : 0x0b
Coprocessor Family Ext : 0x00
Coprocessor Stepping : C0
Board SKU          : C0QS-5110P
ECC Mode           : Enabled
SMC HW Revision    : Product 225W Passive CS
```

## Cores

```
Total No of Active Cores : 60
Voltage                   : 972000 uV
Frequency                 : 1052631 kHz
```

## Thermal

```
Fan Speed Control       : N/A
Fan RPM                  : N/A
Fan PWM                  : N/A
Die Temp                 : 40 C
```

## GDDR

```
GDDR Vendor             : Elpida
GDDR Version            : 0x1
GDDR Density            : 2048 Mb
```



```
GDDR Size           : 7936 MB
GDDR Technology     : GDDR5
GDDR Speed         : 5.000000 GT/s
GDDR Frequency     : 2500000 kHz
GDDR Voltage       : 1501000 uV
```

See the miccheck and micinfo man pages for additional information.

### 3.3.7.3 Run “Hello World”

Now that the Intel® Xeon Phi™ coprocessors are up and running, run a simple program several different ways.

#### 3.3.7.3.1 “Hello World” Native Execution Using gcc

Shown below is a very simple example. The point of this exercise is to demonstrate the simplicity with which code can be compiled and run on the Intel® Xeon Phi™ coprocessor. As seen below, this is standard C code. In this example, the gcc cross compiler that is included in the Intel® MPSS cross-compilation SDK is used. The gcc cross compiler is installed at /opt/mpss/3.6/sysroots/x86\_64-mpss-sdk-linux/usr/bin/k10m-mpss-linux/k10m-mpss-linux-gcc. Cross compiling using the SDK is described in detail in [Section 8.1](#).

```
[host]$ cat hello_world.c
#include <stdio.h>
#include <stdlib.h>
void
main()
{
    printf("Hello World \n");
}
[host]$ /opt/mpss/3.6/sysroots/x86_64-mpss-sdk-linux/usr/bin/k10m-
mpss-linux/k10m-mpss-linux-gcc hello_world.c -o hello_world
```

Next, copy the code to the file system on the coprocessor using scp:

```
[host]$ scp hello_world mic0:
hello_world          100%  10KB  10.2KB/s   00:00
```

Invoke the application on the coprocessor:

```
[host]$ ssh mic0 /home/<USER>/hello_world
Hello World
```

#### 3.3.7.3.2 “Hello World” Native Execution Using the Intel® C Compiler

This is a repeat of the previous example, but this time using Intel® C Compiler for compilation. Note that you will need to install the Intel® Compiler suite to build this example (and the follow-on example highlighting offload directives.) See [Intel® C and C++ Compilers](#) for details on licensing and installation.

Notice that the Intel® C compiler (icc) is used with an additional flag (-mmic) to indicate that the target architecture in this case is the Intel® Xeon Phi™ coprocessor.

```
[host]$ cat hello_world.c
#include <stdio.h>
```





```
#include <stdlib.h>
void
main()
{
    printf("Hello World \n");
}
[host]$ icc -mmic hello_world.c -o hello_world
```

Next, copy the code to the file system on the coprocessor using scp

```
[host]$ scp hello_world mic0:
hello_world          100%  10KB  10.2KB/s  00:00
```

Invoke the application on the coprocessor.

```
[host]$ ssh mic0 /home/<USER>/hello_world
Hello World
```

### 3.3.7.3.3 “Hello World” via Compiler Based Offload Directives

This example demonstrates the use of offload directives to run code on the coprocessor.

```
[host]$ cat hello_offload.c
#include <stdio.h>
#include <stdlib.h>
void
main()
{
    #pragma offload target (mic:0)
    {
        printf("hello_world from offloaded code running on the
coprocessor \n");
    }
}
```

To build it, use the Intel® C compiler, as before with -offload flag.

```
[host]$ icc -offload hello_offload.c -o hello_offload
```

Finally, to run it, simply invoke the host side binary.

```
[host]$ ./hello_offload
hello_world from offloaded code running on the coprocessor
```

## 3.4 Basic Workstation Installation is Complete

At this point the host and Intel® Xeon Phi™ coprocessors are configured in the static pair networking configuration. In this configuration, a separate private network was created between the host and each coprocessor. As demonstrated in the previous “Hello World” examples, this configuration supports both the Offload and Native programming models as described in [Section 2.2.1](#).

For users who will be developing and/or executing only Intel® C++/FORTRAN offload directive based programming, basic installation is now complete. You may, however, want to consult [Chapter 6](#) to learn more about user credentials.



Users who will be performing Native program execution on a standalone platform might also wish to learn more about NFS mounting some or all of the coprocessor file system: see section [3.5.4](#) for a discussion on the tradeoffs of local vs. remote file system mounts. Building and adding software to the coprocessor file system may also be of interest: see [Chapters 7](#) and [8](#).

## 3.5 Network Configuration

This section touches briefly on criteria for choosing a network configuration type. It is primarily of interest to cluster administrators and those with advanced workstation programming models.

Although Intel® MPSS supports an Internal Bridge configuration, in which the host and all Intel® Xeon Phi™ coprocessors in the host are on a single network, the External Bridge configuration is more relevant for a cluster environment. This configuration was briefly introduced in [Section 2.2.3.2.2](#).

There are several important considerations.

### 3.5.1 MAC Address Assignment

Because Intel® Xeon Phi™ coprocessor networking is based on a Virtual Ethernet driver, MAC addresses of network endpoints must be generated locally. There are several options available including automatic generation by Intel® MPSS drivers based on device serial number, and direct assignment of an externally specified address. Automatic MAC address generation is sufficient for most configurations, but more information on MAC address assignment can be found in [Section 5.1](#)

### 3.5.2 IP Address Considerations for External Bridging

In an external bridge configuration, IP addresses of all endpoints on the network, including the bridge itself, and all Intel® Xeon Phi™ coprocessor endpoints, must be on the same subnet. Generally speaking, IP addresses can be assigned statically by editing appropriate configuration files, or appropriate configuration of a DHCP server made available on the local network. In either case, in a cluster environment it is usually desirable for the IP address of each endpoint to remain static over time so that there is easy correlation of IP address to node.

Local cluster site administrators will want to adopt an IP address assignment pattern that is amenable for their datacenter and local network configurations. To illustrate one example scheme, the following highlights a scenario with two Xeon Phi™ coprocessors installed per host. In this case, a simple IP ordering scheme is used to organize the host bridge interfaces and endpoints within the same subnet such that the IP address of the coprocessors can be the IP address of the host/bridge +1 and +2 respectively.

```
172.31.0.1    node0-eth0
172.31.0.2    node0-mic0
172.31.0.3    node0-mic1
172.31.0.4    node1-eth0
172.31.0.5    node1-mic0
172.31.0.6    node1-mic1
172.31.0.7    node2-eth0
:
:
```



A DHCP server can be configured to assign persistent static IP addresses to clients. This can be done by directly editing DHCP server configuration files. Some cluster manager utilities (For Instance: *Warewulf*) can also perform such DHCP assignments. Configuring the DHCP server either indirectly through the cluster manager or by directly editing DHCP server configuration files is beyond the scope of this document.

### 3.5.3 Configuring a Basic External Bridge

This section describes one approach to configuring the coprocessors and host as an external bridge, enabling coprocessors to communicate with other nodes in a cluster. The goal of this section is to configure the network such that InfiniBand\* installation can be validated. There are various options for configuring an external bridge which are described in more detail in [Chapter 5](#).

**Note:** You must manually add a gateway to the br0 config file.

Before you can change the network configuration, you must stop the mpss service:

```
[host]# lservice mpss stop
```

Assuming the IP address distribution shown above, an external bridge, br0, on node0 can be configured as:

```
[host]# micctrl --addbridge=br0 --type=external --ip=172.31.0.1
[host]# micctrl --network=static --bridge=br0 --ip=172.31.0.2
```

and on node1 as:

```
[host]# micctrl --addbridge=br0 --type=external --ip=172.31.0.4
[host]# micctrl --network=static --bridge=br0 --ip=172.31.0.5
```

*micctrl* does not slave the physical Ethernet endpoint, for example eth0, to the bridge. This must be done by the administrator by editing the Ethernet configuration file(s). For example, on RHEL\*, the *eth0* Ethernet configuration file, */etc/sysconfig/network-scripts/ifcfg-eth0*, should typically have the following contents:

```
DEVICE=eth0
NM_CONTROLLED=no
ONBOOT=yes
BRIDGE=br0
MTU=1500
```

On SLES\* host platforms, the physical port name must be added to the *BRIDGE\_PORTS* entry in the */etc/sysconfig/networks/ifcfg-br0* configuration file, for example:

```
BRIDGE_PORTS='eth0 mic0 mic1'
```

At this point the network service must be restarted:

```
[host]# lservice network restart
```

Now start the coprocessors:

```
[host]# lservice mpss start
```



Communication with Intel® Xeon Phi™ coprocessors from other nodes on the network should now be possible.

### 3.5.4 Defining and Implementing Exported/Mounted File Systems

As mentioned earlier, the Intel® Xeon Phi™ coprocessor root file system can be supported in coprocessor memory, remotely mounted via NFS, or a combination of the two. For example, sections of the file system that are common across multiple coprocessors might be mounted from a common export on a remote node such as a cluster's head node; in this case an external bridge is required. On the other hand, some files might be coprocessor specific; these files can be exported from the local host. It may also make sense to locate certain files in coprocessor memory in order to minimize access latency.

The Intel® Xeon Phi™ coprocessor operating system includes a virtio block device (*virtblk*), which uses the Linux\* virtio data transfer mechanism to implement a block device. *virtblk* can store data on the host processor in a regular file, Logical Volume Manager volume, or a designated physical device. *virtblk* is expected to exhibit lower latency than NFS mounted exports from the host.

One advantage of both NFS and *virtblk* file systems is persistence. That is, changes to *virtblk* or NFS mounted files can persist after Intel® Xeon Phi™ coprocessors are shutdown, whereas changes to files in coprocessor memory are lost unless steps are taken to capture those changes.

Another advantage of NFS and *virtblk* file systems is capacity. Not only is the ram file system limited by available Intel® Xeon Phi™ coprocessor memory, but allocating coprocessor memory to the file system makes that memory unavailable to application processes executing on the coprocessor.

Only NFS supports sharing of files among multiple devices. Sharing the same file to hold the *virtblk* file system of more than one coprocessor is not supported by Intel® MPSS.

The following table summarizes the characteristics of the available file systems classes.

**Table 4: File System Characteristics**

	<b>Latency</b>	<b>Persistence</b>	<b>Sharing</b>	<b>Capacity</b>	<b>Other</b>
RAM FS	Smallest	No	No	Small	Reduces memory available to app
VIRTBLK	Medium	Yes	No (not supported)	Large	
NFS	Largest	Yes	Yes (but not cache coherent)	Large	

NFS mounting is discussed throughout [Chapter 4](#). Configuring the virtio block device is discussed in [Section 9.6](#).



## 3.5.5 Configuring the Host Firewall

Client services running on the Intel® Xeon Phi™ coprocessor need access to services on a host. If a host firewall is enabled, it may need to be configured to allow access to these services.

### 3.5.5.1 NFS Client Access

NFS can be used to mount host exports on an Intel® Xeon Phi™ coprocessor. NFS generally requires five services to be running:

```
portmapper
nfsd
mountd
lockd
statd
```

Of these, at least portmapper, nfsd and mountd must be accessible to the coprocessor's NFS client through the firewall to enable basic NFS operation. Access to the lockd and statd ports is needed if file locking is required.

The ports for the portmapper and nfsd are statically assigned as follows:

```
tcp/udp port 111      - RPC 4.0 portmapper
tcp/udp port 2049     - nfs server
```

The ports for the other services are normally dynamically assigned. For firewall considerations, it may be desirable to statically assign ports to these services.

Consult documentation for your host operating system for instructions on static port assignment, and for instructions on allowing access to the NFS services ports through the firewall.

### 3.5.5.2 Other Port Access Considerations

As described in [Section 7.2.1.3](#), *zypper* can be used on the coprocessor to install rpms in a repository on the host. That section suggests using the python SimpleHTTPServer. The port which the server uses (8000 by default) must be accessible through the firewall.

Similarly, the ports used by the Ganglia daemon on the host (see [Section F.1.2](#)) may need to be exposed through the firewall.

Consult documentation for your host operating system for instructions on allowing access to these ports.

## 3.5.6 How to Install Lustre\* on the Intel® Xeon Phi™ Coprocessor Card

The following two RPMs should be installed on Intel® Xeon Phi™ coprocessor card:

```
[host]# rpm -ivh lustre-client-modules-<version>.k10m.rpm \
lustre-client-<version>.k10m.rpm
```

Now it's ready to configure and use.



### 3.5.6.1 How to Configure Lustre\* on the Intel® Xeon Phi™ Coprocessor Card

You should execute the following commands on the Intel® Xeon Phi™ coprocessor card for Lustre\* client over Virtual Ethernet configuration:

```
echo 'options lnet networks="tcp0(mic0)"' > /etc/modprobe.d/lustre.conf
modprobe lustre
```

This step assumes that IPoIB is correctly configured on the card. Please refer to appropriate topic of the Intel® MPSS manuals for instructions on how to do this.

In this example, the card's IPoIB interface is *ib0*.

```
echo 'options lnet networks="o2ib0(ib0),tcp0(mic0) "' > \
/etc/modprobe.d/lustre.conf modprobe lustre
```

If you would like to make this configuration persistent across all card reboots you can do the following on the host:

```
mkdir -p /var/mpss/mic0/etc/modprobe.d \

echo 'options lnet networks="o2ib0(ib0),tcp0(mic0) "' > \
/var/mpss/mic0/etc/modprobe.d/lustre.conf
```

After mpss service restart this configuration will be deployed to the Intel® Xeon Phi™ coprocessor cards.

### 3.5.6.2 How to Use Lustre\* on the Intel® Xeon Phi™ Coprocessor Card

After proper configuration you can just mount Lustre FS share from your network. You can execute the following commands on Intel® Xeon Phi™ coprocessor card:

```
mkdir -p /mnt/lustre \

/sbin/mount.lustre <MGS IP>@tcp0:/<lustreFS name> /mnt/lustre
```

or

```
/sbin/mount.lustre <MGS IP>@o2ib0:/<lustreFS name> /mnt/lustre
```

If you like to make this mount point persistent across all card reboots you can do the following:

```
mkdir -p /var/mpss/mic0/mnt/lustre
```

and then you can add this mount point to */etc/fstab* for automatic mount.

## 3.6 Installing OFED with Intel® MPSS Support (optional)

Intel® Xeon Phi™ coprocessors can communicate with external compute nodes over high-bandwidth InfiniBand\* when a supported Intel® True Scale or Mellanox\* InfiniBand\* host adapter is installed in the platform.



## **Intel® Xeon Phi™ Coprocessor Installation Process**

The section describes how to install the OFED components that support these capabilities.

The following installation processes assume that the mpss-3.6-linux.tar file was downloaded and untarred as a step during Intel® MPSS installation. Specifically: the rpm files in \$MPSS36/ofed are needed during OFED installation.

### **Option 1:**

The Offload computing model is characterized by MPI communication only between the host processors in a cluster. In this model, Intel® Xeon Phi™ coprocessors are accessed exclusively through the offload capabilities of products like the Intel® C, C++, and Fortran Compilers, and the Intel® Math Kernel Library (MKL). This mode of operation does not require CCL, and therefore the OFED version in a Red Hat\* or SUSE\* distribution can be used.

### **Option 2:**

If MPI ranks are to be executed on Intel® Xeon Phi™ coprocessors, and if it is required that these ranks communicate directly with an InfiniBand\* adapter, then the following installation should be performed. The ibscif virtual adapter will provide the best host-to-coprocessor and coprocessor-to-coprocessor transfer performance on systems without an InfiniBand\* adapter.



### 3.6.1 Supported OFED distros

Table 5: OFED Distribution vs. Supported Features

OFED Distribution (installation section)	Mlx4 (kernel mode)	Mlx5 (kernel mode)	PSM-Direct	ccl-proxy
OFED+ (cf. 3.6.3)	No (no)	No (no)	Yes	No
OFED 1.5.4.1 (cf. 3.6.4)	Yes (yes)	No (no)	No	Yes
OFED 3.5-2 MIC (cf. 3.6.5)	Yes (yes)	Yes (yes)	Yes	Yes
OFED-3.12-1 (cf. 3.6.6)	Yes (yes)	Yes (no)	Yes	Yes
OFED 3.18 (cf. 3.6.7)	Yes (yes)	Yes (no)	Yes	Yes
Mellanox* OFED 2.x (cf. 3.6.8)	Yes (yes)	Yes (no)	No	Yes

Several different OFED distributions are supported. Select one which matches hardware and software requirements, and install it using instructions from the accompanying section.

Each OFED distribution supports a subset of the Intel® MPSS supported OS distros; most support SLES\* 11 SP3 and RHEL\* 6.2/3/4/5/6. Newer distros may not be officially supported by any released OFED (at the time of this writing: RHEL\* 6.7, SLES\* 11 SP4). Check the respective *release notes* for the exact supported distros.

To run MPI applications using Intel MPI over tmi<sup>2</sup> fabric, the *tmi.conf* file should be copied to the Intel® Xeon Phi™ coprocessor using following procedure:

- a) Create a directory *"etc"* in *"/var/mpss/common/"* directory.
- b) Copy the *tmi.conf* file from *<impi\_install\_dir>/etc64/* directory to */var/mpss/common/etc* directory.
- c) Start/restart the *mpss* service.

<sup>2</sup> Intel MPI natively supports PSM using Tag Matching Interface (TMI)



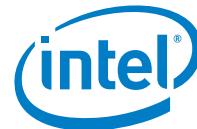

## 3.6.2 Tips for OFED distributions

When installing a new OFED distribution, it is recommended to first uninstall the currently installed distribution. Consult the current distribution's documentation for instructions.

Both Red Hat\* and SUSE\* release minor kernel version updates. If an update of the kernel occurs, this will create versioning incompatibilities with the OFED kernel modules, preventing these drivers from loading. To determine if your host kernel has been updated execute:

```
[host]$ uname -r
```

from the host console and compare the returned value to the default versions listed in Table 2. If your host kernel has not been updated, then proceed to install one of the OFED distributions. Otherwise it may be required to rebuild the Intel® MPSS OFED drivers as described in the next subsections for proper execution.

**Caution:** OFED installation may overlay some of the RDMA/InfiniBand\* components in your distribution. As a result the Linux\* kernel will not load kernel mode software that was built against the Red Hat\* or SUSE\* RDMA/InfiniBand\* software in your distribution. This may require that you rebuild such software against the installed OFED, or obtain a version of the software that was so built. For example, an implementation of the Lustre\* file system that was built against a Red Hat\* or SUSE\* distribution will not be loaded by the Linux\* kernel, and must be rebuilt against the installed OFED. Note that user mode applications will not need to be rebuilt due to this installation.

### 3.6.2.1 Red Hat\* Enterprise Linux\* systems

- 1) Install the kernel building prerequisites:

```
[host]# yum install kernel-headers kernel-devel
```

- 2) Rebuild the RPMs from the source RPMs:

```
[host]$ cd $MPSS36/src/
[host]$ rpmbuild --rebuild ofed-driver-*.src.rpm
```

- 3) The resulting mpss-modules binary rpms are located at *\$HOME/rpmbuild/RPMS/x86\_64*. Copy the ofed-driver RPMs to the *\$MPSS36/ofed/modules* directory:

```
[host]$ cp $HOME/rpmbuild/RPMS/x86_64/ofed-driver*\
`uname -r`.rpm ../ofed/modules
```

### 3.6.2.2 SUSE\* Linux\* Enterprise Server (SLES\*) 11 systems

- 1) Install the kernel building prerequisites:

```
[host]# zypper install kernel-default-devel
```

- 2) Rebuild the RPMs from the source RPMs:

```
[host]$ cd $MPSS36/src/
[host]$ rpmbuild --rebuild ofed-driver-*.src.rpm
```

- 4) The resulting mpss-modules binary rpms are located at */usr/src/packages/RPMS/x86\_64*. Copy the ofed-driver RPMs to the *\$MPSS36/ofed/modules* directory:

```
[host]$ cp /usr/src/packages/RPMS/x86_64/ofed-driver*\
```



```
`uname -r`*.rpm ../ofed/modules
```

### 3.6.3 Install OFED+

OFED+ is the Intel® True Scale Fabric Host Channel Adapter Drivers and Software stack.

OFED+ supports all Intel® MPSS-supported versions of RHEL\* 6 (except 6.7) SLES\* 11 SP3. If using RHEL\* 7 or SLES\* 12, go to Section [3.6.6](#) or [3.6.7](#).

**Caution:** Installing OFED+ support will replace the OFED components in your standard distribution. This section describes the steps to install Intel® True Scale Fabric Host Channel Adapter Drivers and Software stack (OFED+), an enhanced implementation of OFED that supports Intel® True Scale Fabric Host Channel Adapters (HCA), and enables communication between an Intel® Xeon Phi™ coprocessor and an Intel® True Scale Fabric HCA. This installation may overlay some of the RDMA/InfiniBand\* components in your Red Hat\* or SUSE\* distribution. As a result, the Linux\* kernel will not load kernel mode software that was built against the Red Hat\* or SUSE\* RDMA/InfiniBand\* software in your distribution. This may require that you rebuild such software against the installed OFED, or obtain a version of the software that was so built. For example, an implementation of the Lustre\* file system that was built against a Red Hat\* or SUSE\* distribution will not be loaded by the Linux\* kernel, and must be rebuilt against the installed OFED.

**Note:** This section describes the steps to install Intel® True Scale Fabric Host Channel Adapter Drivers and Software stack (OFED+), an enhanced implementation of OFED that supports PSM-Direct. PSM-Direct enables direct communication between an Intel® Xeon Phi™ coprocessor and an Intel® True Scale Fabric HCA, by default—no extra install steps are required.

User mode applications will not need to be rebuilt due to this installation.

The following installation should be performed on any compute node in which an Intel® True Scale Fabric HCA is installed.

After a successful installation, an `ibv_devices` command issued on the host will show both `qib0` and `scif_0`, while an `ibv_devices` command issued on the Intel® Xeon Phi™ coprocessor will show only `scif_0`.

**Note:** When running MPI in Symmetric mode with more than 16 processes per node, `PSM_RANKS_PER_CONTEXT=<value>` needs to be specified (the value can be 2, 3 or 4; the default value is 1) so that the available 16 contexts can be shared by the ranks.

Intel® True Scale Fabric Host Channel Adapter Drivers and Software (OFED+), including the PSM library, is available as a free download from <http://downloadcenter.intel.com>. It contains OFED software bug fixes and enhanced performance.

- 1) Go to <http://downloadcenter.intel.com>
- 2) Under **Search Downloads**, type **True Scale** and hit **Enter**.
- 3) Narrow the results by selecting the appropriate operating system.
- 4) Select the version of Intel® True Scale Fabric Host Channel Adapter Host Drivers and Software that supports your operating system. Details of the operating system can be found by clicking on a version and then clicking the *Release Notes* (pdf) link.
- 5) Download the appropriate *IB-Basic* file as well as the related publications file.



## Intel® Xeon Phi™ Coprocessor Installation Process

6) The Software Installation Guide (IFS\_FabricSW\_InstallationGuide\*.pdf) is contained in the Publications\_HCA\_SW\*.zip download. *Chapter 4, Install OFED+ Host Software* in the *Software Installation Guide* provides detailed installation instructions.

7) After rebooting the system as recommended by the previous install step, stop the openibd service and ensure that openibd does not start automatically after every reboot:

```
[host]# service openibd stop
[host]# chkconfig --level=123456 openibd off
```

8) If using OFED+ 7.2 version, ensure kernel-ib-devel, kernel-ib, and dapl packages are not installed.

```
[host]# rpm -e kernel-ib-devel kernel-ib
[host]# rpm -e {dapl,dapl-{devel,devel-static,utils}}
```

If using OFED+ version 7.3 or higher, ensure compat-rdma-devel, compat-rdma and dapl packages are not installed.

```
[host]# rpm -e compat-rdma-devel compat-rdma
[host]# rpm -e {dapl,dapl-{devel,devel-static,utils}}
```

9) If using yum to install Intel® MPSS, it is also necessary to remove infinipath-libs and infinipath-devel prior to installing the software stack:

```
[host]# rpm -e --nodeps --allmatches infinipath-libs \
infinipath-devel
```

10) Install Intel® MPSS OFED modules.

```
[host]$ cd $MPSS36
[host]$ cp ofed/modules/*`uname -r`.rpm ofed
```

- Red Hat\* Enterprise Linux\*

```
[host]# yum install ofed/*.rpm
```

- SUSE\* Linux\* Enterprise Server

```
[host]# zypper install ofed/*.rpm
```

11) Install required PSM (Performance Scaled Messaging ) libraries and drivers as follows:

- Red Hat\* Enterprise Linux\*

```
[host]# yum install psm/*.rpm
```

- SUSE\* Linux\* Enterprise Server

```
[host]# zypper install psm/*.rpm
```

### 3.6.4 Install OFED 1.5.4.1

1) Download the distribution tarball from:

<https://www.openfabrics.org/downloads/OFED/ofed-1.5.4/OFED-1.5.4.1.tgz>

2) Untar OFED 1.5.4.1 and access the untarred folder.



```
[host]$ tar xf OFED-1.5.4.1.tgz
[host]$ cd OFED-1.5.4.1
```

- 3) Install the OFED stack as instructed in OFED README.txt, with a few exceptions regarding installed packages.

```
[host]$ less README.txt
[host]# perl install.pl
```

During installation, select:

- Option 2 (Install OFED Software)
- Option 4 (Customize)
- ...exclude kernel-ib\* and dapl\* packages...
- "Install 32-bit packages? [y/N]", answer N
- "Enable ROMIO support [Y/n]", answer Y
- "Enable shared library support [Y/n]", answer Y
- "Enable Checkpoint-Restart support [Y/n]", answer N

- 4) Install Intel® MPSS OFED modules.

```
[host]$ cd $MPSS36
[host]$ cp ofed/modules/*`uname -r`.rpm ofed
[host]# rpm -Uvh ofed/*.rpm
```

### 3.6.5 Install OFED-3.5-2-MIC

- 2) Download the distribution tarball from:

<http://www.openfabrics.org/downloads/ofed-mic/ofed-3.5-2-mic/>

- 3) Untar OFED-3.5\* and access the untarred folder.

```
[host]$ tar xf OFED-3.5*.tgz
[host]$ cd OFED-3.5*
```

- 4) Install the OFED stack as instructed in OFED README.txt.

```
[host]$ less README.txt
[host]# perl install.pl
```

### 3.6.6 Install OFED-3.12-1

- 1) Download the distribution tarball from:

<http://downloads.openfabrics.org/OFED/ofed-3.12-1/>

- 2) Untar OFED-3.12\* and access the untarred folder.



```
[host]$ tar xf OFED-3.12*.tgz
[host]$ cd OFED-3.12*
```

- 3) Install the OFED stack as instructed in OFED README.txt.

```
[host]$ less README.txt
[host]# perl install.pl --with-xeon-phi
```

### 3.6.7 Install OFED 3.18

- 1) Download the distribution tarball from:

<https://www.openfabrics.org/downloads/OFED/ofed-3.18/>

- 2) Untar OFED-3.18\* and access the untarred folder.

```
[host]$ tar xf OFED-3.18*.tgz
[host]$ cd OFED-3.18*
```

- 3) Install the OFED stack as instructed in OFED README.txt.

```
[host]$ less README.txt
[host]# perl install.pl --with-xeon-phi
```

### 3.6.8 Install Mellanox\* OFED 2.x

- 1) Download Mellanox\* OFED from:

[http://www.mellanox.com/page/products\\_dyn?product\\_family=26](http://www.mellanox.com/page/products_dyn?product_family=26)

- 2) Untar, read the documentation, follow the normal installation procedure.

- 3) Install Intel® MPSS OFED ibpd rpm:

```
[host]# rpm -U ofed/ofed-ibpd*.rpm
```

- 4) From the src/ folder of the Intel® MPSS installation, compile dapl, libibscif, and ofed-driver source RPMs:

```
[host]$ cd $MPSS36/src
[host]$ rpmbuild --rebuild --define "MOFED 1" \
  dapl*.src.rpm libibscif*.src.rpm \
  ofed-driver*.src.rpm
```

- 5) Install the resultant RPMs:

- Red Hat\* Enterprise Linux\*

```
[host]# rpm -U ~/rpmbuild/RPMS/x86_64/dapl*.rpm
[host]# rpm -U ~/rpmbuild/RPMS/x86_64/libibscif*.rpm
[host]# rpm -U ~/rpmbuild/RPMS/x86_64/ofed-driver*.rpm
```

- SUSE\* Linux\* Enterprise Server:

```
[host]# rpm -U /usr/src/packages/RPMS/x86_64/dapl*.rpm
[host]# rpm -U /usr/src/packages/RPMS/x86_64/libibscif*.rpm
```



```
[host]# rpm -U /usr/src/packages/RPMS/x86_64/ofed-driver*rpm
```

### 3.6.9 Starting OFED

- 1) Ensure that the mpss service is started by using the Linux\* service command:

```
[host]# lservice mpss status
```

If the service is not running, refer to [Section 3.3.6](#) for instructions on starting the service.

- 2) If using Intel® True Scale Fabric HCAs, or using Mellanox\* InfiniBand\* adapters and/or the ibscif virtual adapter, start the IB and HCA services by doing the following:

```
[host]# lservice openibd start
```

- 3) If needed, start an opensmd service to configure the fabric:

```
[host]# lservice opensmd start
```

If using Intel® True Scale Fabric HCAs and Intel® True Scale Fabric Switches, it is recommended to use the Intel® Fabric Manager, rather than the opensm. Visit <http://www.intel.com/infiniband> for information on Intel's [fabric management and software tools](#), downloads and support contacts.

- 4) If using CCL-Direct and IPoIB with Mellanox\* InfiniBand\* adapters, you can enable the IPoIB module to be loaded as part of the ofed-mic service (see [Section 5.3](#)) and configure the IP Address and Netmask by editing the /etc/mpss/ipoib.conf file which contains instructions for how to make these changes. See the example ipoib.conf script in [Section 5.3](#).

IPoIB is a technology preview. It currently is supported by OFED-1.5.4.1 and OFED-3.5-2-MIC on the Mellanox\* mlx4 driver and hardware. See [Section 1.2.1.1](#).

- 5) If using Intel® True Scale Fabric HCAs, or using Mellanox\* InfiniBand\* adapters and/or the ibscif virtual adapter, then start the Intel® Xeon Phi™ coprocessor specific OFED service on the host using:

```
[host]# lservice ofed-mic start
```

- 6) The use of ccl-proxy service is applicable only if using Mellanox\* InfiniBand\* adapters. To start the ccl-proxy service (see configuration in: /etc/mpxyd.conf):

```
[host]# lservice mpxyd start
```

The use of PSM-Direct which is applicable only if using Intel® True Scale Fabric HCAs, is enabled by default and does not require to start any services.

### 3.6.10 Stopping/restarting OFED

To stop all OFED support on all variants, stop the following services in order:

```
[host]# lservice mpxyd stop
[host]# lservice opensmd stop
[host]# lservice ofed-mic stop
[host]# lservice openibd stop
```



To restart all OFED components: follow instructions for stopping then starting.

### 3.6.11 Validate OFED Installation

Several commands are available to validate OFED installation on the host and on Intel® Xeon Phi™ coprocessors.

#### 3.6.11.1 Validate OFED Installation on the host

1. `openibd status` reports whether or not the driver is loaded.
2. `ibv_devices` and `ibv_devinfo` will report whether the device and ports are up or down. On Mellanox\* OFED installations `ibv_devinfo` will not show the scif device, but `ibv_devices` should list it.
3. `ofed_info` reports the OFED version that is installed including installed packages.

The following are examples of the output generated by these commands when OFED is successfully installed. (The output from `ofed_info` has been truncated.):

```
[host]# service openibd status
HCA driver loaded
```

```
Configured IPoIB devices:
ib0
```

```
Currently active IPoIB devices:
```

```
The following OFED modules are loaded:
```

```
rdma_ucm
ib_sdp
rdma_cm
ib_addr
ib_ipoib
mlx4_core
mlx4_ib
mlx4_en
ib_mthca
ib_uverbs
ib_umad
ib_sa
ib_cm
ib_mad
ib_core
iw_cxgb3
iw_cxgb4
iw_nes
ib_qib
```

```
[host]$ ibv_devices
device                node GUID
-----
scif0                 4c79bafffe18168b
```



qib0 0011750000791882

```
[host]# ibv_devinfo
hca_id: scif0
  transport:          iWARP (1)
  fw_ver:             0.0.1
  node_guid:          4c79:baff:fe18:168b
  sys_image_guid:     4c79:baff:fe18:168b
  vendor_id:          0x8086
  vendor_part_id:     0
  hw_ver:             0x1
  phys_port_cnt:      1
    port: 1
      state:           PORT_ACTIVE (4)
      max_mtu:         4096 (5)
      active_mtu:      4096 (5)
      sm_lid:          1
      port_lid:        1000
      port_lmc:        0x00
      link_layer:      InfiniBand
```

```
hca_id: qib0
  transport:          InfiniBand (0)
  fw_ver:             0.0.0
  node_guid:          0011:7500:0079:1882
  sys_image_guid:     0011:7500:0079:1882
  vendor_id:          0x1175
  vendor_part_id:     29474
  hw_ver:             0x2
  board_id:           InfiniPath_QLE7342
  phys_port_cnt:      1
    port: 1
      state:           PORT_ACTIVE (4)
      max_mtu:         4096 (5)
      active_mtu:      2048 (4)
      sm_lid:          14
      port_lid:        16
      port_lmc:        0x00
      link_layer:      InfiniBand
```

```
[host]$ ofed_info | grep OFED
```

```
OFED-3.5-2:
```

```
[host]$ ofed_info
```

```
OFED-3.5-2:
```

```
compat-rdma:
```

```
git://git.openfabrics.org/compat-rdma/compat-rdma.git ofed_3_5
commit a5bbb7655356750939d8864091b1316cfd7dcc10
```

```
dapl:
```

```
http://www.openfabrics.org/downloads/dapl/dapl-2.0.39.tar.gz
```

```
ib-bonding:
```





## Intel® Xeon Phi™ Coprocessor Installation Process

```
http://www.openfabrics.org/downloads/ib-bonding/ib-bonding-0.9.0-43.src.rpm
```

ibacm:

```
http://www.openfabrics.org/downloads/rdmacm/ibacm-1.0.8.tar.gz
```

ibsim:

```
http://www.openfabrics.org/downloads/ibsim/ibsim-0.5-0.1.g327c3d8.tar.gz
```

ibutils:

```
http://www.openfabrics.org/downloads/ibutils/ibutils-1.5.7-0.1.g05a9d1a.tar.gz
```

:

### 3.6.11.2 Validate OFED Installation on Intel® Xeon Phi™ Coprocessor

The same `ibv_devinfo` command can be used to validate OFED installation on a coprocessor after starting the `ofed-mic` service. The following shows typical output when using an Intel® True Scale Fabric InfiniBand\* HCA:

```
[host]# ssh mic0
[mic0]# ibv_devinfo
hca_id: scif0
transport:                SCIF (2)
fw_ver:                   0.0.1
node_guid:                4c79:baff:fe18:16a0
sys_image_guid:          4c79:baff:fe18:16a0
vendor_id:                0x8086
vendor_part_id:          0
hw_ver:                   0x1
phys_port_cnt:           1
    port:                  1
        state:             PORT_ACTIVE (4)
        max_mtu:           4096 (5)
        active_mtu:       4096 (5)
        sm_lid:            1
        port_lid:         1001
        port_lmc:         0x00
        link_layer:       SCIF
```

The following is typical output when using a Mellanox\* InfiniBand\* HCA:

```
[root@node02-mic0 ~]# ibv_devinfo
hca_id: mlx4_0
transport:                InfiniBand (0)
fw_ver:                   2.30.8000
node_guid:                0002:c903:003d:5890
sys_image_guid:          0002:c903:003d:5893
vendor_id:                0x02c9
vendor_part_id:          4099
hw_ver:                   0x0
```



```
phys_port_cnt: 1
  port: 1
    state: PORT_ACTIVE (4)
    max_mtu: 4096 (5)
    active_mtu: 4096 (5)
    sm_lid: 6
    port_lid: 8
    port_lmc: 0x00
    link_layer: InfiniBand

hca_id: scif0
  transport: SCIF (2)
  fw_ver: 0.0.1
  node_guid: 4c79:baff:fe16:23ac
  sys_image_guid: 4c79:baff:fe16:23ac
  vendor_id: 0x8086
  vendor_part_id: 0
  hw_ver: 0x1
  phys_port_cnt: 1
    port: 1
      state: PORT_ACTIVE (4)
      max_mtu: 4096 (5)
      active_mtu: 4096 (5)
      sm_lid: 1
      port_lid: 1001
      port_lmc: 0x00
      link_layer: SCIF
```

### 3.6.11.3 Run the Intel MPI Benchmark

You can further validate the installation by running the *IMB-IMP1* Intel MPI Benchmark. Here we assume that External Bridging is configured on two compute nodes, each having one or more Intel® Xeon Phi™ coprocessors installed.

Refer to the [Intel® MPI Library](#) page for details on licensing and installing the Intel® MPI Library on the hosts and coprocessors. *IMB-IMP1* is included in the Intel® MPI distribution.

The following syntax can be used on a multinode configuration in which either Intel® True Scale or Mellanox\* InfiniBand\* HCAs are installed. The *mpiexec.hydra* process manager will attempt to use the Intel® True Scale supported tmi (tag matching) fabric, but will failover to the Mellanox\*-supported dapl fabric if the tmi fabric fails.

Define the `I_MPI_ROOT` environment variable, and establish other environment settings for the Intel MPI Library:

```
[host]$ source <mpi_installdir>/intel64/bin/mpivars.sh
```

Configure MPI to detect Intel® Xeon Phi™ coprocessors:

```
[host]$ export I_MPI_MIC=1
```

Use tmi if available, or fallback to dapl:

```
[host]$ export I_MPI_FABRICS_LIST=tmi,dapl
```



## Intel® Xeon Phi™ Coprocessor Installation Process

Establish connections dynamically:

```
[host]$ export I_MPI_DYNAMIC_CONNECTION=1
```

Execute the alltoall component of the MPI test. In this example, the test program is run on two Intel® Xeon nodes (node01 and node02) and two Intel® Xeon Phi™ coprocessor nodes (node01-mic0 and node02-mic0). In this example, tmi is not available so fabric selection fails over to dapl.

```
[host]$ mpiexec.hydra -o -ppn 1 \  
-n 2 -hosts node01,node02 $I_MPI_ROOT/intel64/bin/IMB-MPI1 alltoall  
: \  
-n 2 -hosts node01-mic0,node02-mic0 $I_MPI_ROOT/mic/bin/IMB-MPI1  
alltoall  
/opt/intel/impi/5.0.0.028/intel64/etc/tmi.conf: No such file or  
directory  
/opt/intel/impi/5.0.0.028/intel64/etc/tmi.conf: No such file or  
directory  
benchmarks to run alltoall  
#-----  
# Intel (R) MPI Benchmarks 4.0, MPI-1 part  
#-----  
# Date : Tue Dec 9 17:53:01 2014  
# Machine : x86_64  
# System : Linux  
# Release : 2.6.32-431.el6.x86_64  
# Version : #1 SMP Fri Nov 22 03:15:09 UTC 2013  
# MPI Version : 3.0  
# MPI Thread Environment:  
  
# New default behavior from Version 3.2 on:  
  
# the number of iterations per message size is cut down  
# dynamically when a certain run time (per message size sample)  
# is expected to be exceeded. Time limit is defined by variable  
# "SECS_PER_SAMPLE" (=> IMB_settings.h)  
# or through the flag => -time  
  
# Calling sequence was:  
  
# /opt/intel/impi/5.0.0.028/intel64/bin/IMB-MPI1 alltoall  
  
# Minimum message length in bytes: 0  
# Maximum message length in bytes: 4194304  
#  
# MPI_Datatype : MPI_BYTE  
# MPI_Datatype for reductions : MPI_FLOAT  
# MPI_Op : MPI_SUM  
#  
#  
  
# List of Benchmarks to run:  
  
# Alltoall
```



```
#-----  
# Benchmarking Alltoall  
# #processes = 2  
# ( 2 additional processes waiting in MPI_Barrier)  
#-----  
#bytes #repetitions  t_min[usec]  t_max[usec]  t_avg[usec]  
      0           1000 <remainder of output truncated>
```



# 4 Configuring and Booting the Intel® Xeon Phi™ Coprorocessor Operating System

---

Like any Linux\* based system, booting Linux\* on an Intel® Xeon Phi™ coprocessor requires a Linux\* kernel and a file system image. (This document does not cover coprocessor's firmware because it is not configurable.) Because the coprocessor does not have a permanent file storage system, these components cannot be installed directly onto a coprocessor. Instead, they are installed into the host's file system as part of Intel® MPSS installation. Unlike standard boot loaders, the kernel command line is constructed based on a set of configuration files on the host and provided to the coprocessor kernel at boot time. While any of these components can be changed as needed, the most common usage scenarios will involve changing the file system image (initramfs) and/or the kernel command line.

The initial file system and kernel command line can be configured by modifying various Intel® MPSS specific files and certain host configuration files. These files can be edited directly or modified using the *micctrl* utility. Configuration of other software stack components, such as the host driver, is described in later sections of this document.

[Section 3.3.4](#) briefly discussed some basic configuration tasks. In this section we present coprocessor configuration in more detail: which files typically need modification, different approaches and tools to aid configuration, and what goes on "under the hood" as a result of setting configuration parameters.

Configuration tasks range from specifying the location in the host's file system of the Intel® Xeon Phi™ coprocessor Linux\* kernel, to managing user accounts on the coprocessor and configuring network characteristics. Configuration also includes installing packages into the file system. That topic is covered in [Chapter 7](#).

The *micctrl* utility is a multi-purpose tool that provides two classes of functionality:

- Card state control – Boot, shutdown and reset of attached Intel® Xeon Phi™ coprocessors
- Configuration – Some *micctrl* configuration commands modify parameters in Intel® MPSS-specific configuration files. Other *micctrl* commands process those software stack configuration files to generate standard Linux\* configuration files that replace corresponding files in the default file system. Still other *micctrl* commands modify standard configuration files on the host. The configuration files can also be edited directly.

We refer to the use of *micctrl* as *assisted configuration and control*, or just *assisted configuration*, and discuss it in [Section 4.1](#)

Alternatively, an Intel® Xeon Phi™ coprocessor can also be controlled through the coprocessor's sysfs nodes. Configuration can be performed by directly editing or otherwise modifying the initial file system image while it is stored on the host or on a coprocessor, and by directly composing a coprocessor Linux\* kernel command line. Similarly, host configuration files can be edited to complete networking and similar configuration requirements. We call this *manual configuration and control*, or just *manual control*, and discuss it in [Section 4.2](#).

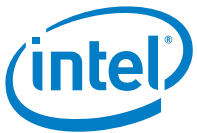

## 4.1 Assisted Configuration and Control

In its most basic form, the assisted configuration process has the following steps:

1. Call `micctrl --initdefaults` after each Intel® MPSS installation to create and/or upgrade a set of configuration files specific for the software stack.
2. Call additional `micctrl` commands to tailor the configuration as necessary.
3. Boot Intel® Xeon Phi™ coprocessors.

For simple configuration tasks, a basic understanding of the usage of `micctrl` configuration commands may be sufficient; the `micctrl` commands are described in detail in [Appendix B](#). For more complex configurations, a deeper understanding of the overall assisted configuration process can be very helpful.

### 4.1.1 Configuration Files

There are several different groups of files that contribute to the final configuration. The following subsections describe these groups, how and when they are created, and how they are identified.

#### 4.1.1.1 Intel® MPSS Specific Configuration Files

`micctrl --initdefaults` creates several Intel® MPSS specific configuration files, if they do not already exist, and populates them with default parameter values. There are two primary configuration files of interest here:

1. The parameters in `default.conf` are treated as common to all coprocessors in the system.
2. There is a `micN.conf` file for each coprocessor in the system. Each parameter in this file takes precedence in configuring the corresponding coprocessor, overriding `default.conf` if the same parameter is in that file. You can think of these as “meta-configuration” files in that they guide the completion of the configuration process.

By default, these files are created in `/etc/mpss`.

Each of these files contains a list of configuration parameters and their arguments. Each parameter must be on a single line. Comments begin with the '#' character and terminate at the first Newline/Carriage return. There are several configuration parameter categories:

- 1) Parameters that control the Intel® Xeon Phi™ boot process.
- 2) Parameters that select the Intel® Xeon Phi™ coprocessor Linux\* kernel to be booted.
- 3) Parameters that configure the Intel® Xeon Phi™ coprocessor file system.
- 4) Parameters that configure the Intel® Xeon Phi™ coprocessor boot command line.
- 5) Parameters that configure the Virtual Ethernet connection to each coprocessor.
- 6) Parameters that control some aspects of user accounts.

For example, here is a portion of the contents of `default.conf` when initially created:



## Configuring and Booting the Intel® Xeon Phi™ Coprorocessor Operating System

```
# Boot MIC card when MPSS stack is started
BootOnStart Enabled

# Root device for MIC card
RootDevice ramfs /var/mpss/mic0.image.gz

# Control card power state setting
# cpufreq: P state
# corec6: Core C6 state
# pc3: Package C3 state
# pc6: Package C6 state
PowerManagement "cpufreq_on;corec6_off;pc3_on;pc6_off"

Cgroup memory=disabled
```

In this fragment, `BootOnStart` configures the boot process, `RootDevice` defines where the coprocessor file system lives on the host before it is provided to the coprocessor kernel, and `PowerManagement` and `Cgroup` configure the boot command line.

Intel® MPSS-specific configuration file parameters are described in detail in [Appendix A](#).

### 4.1.1.2 Host Files

Several networking related host configuration files are optionally created and/or modified by `micctrl` commands. These include `/etc/hosts`, as well as `/etc/sysconfig/network-scripts/ifcfg-micN` on a RHEL\* host and `/etc/sysconfig/network/ifcfg-micN` on a SLES\* host.

Lines that `micctrl` adds to `/etc/hosts` are appended by the comment “`#Generated-by-micctrl`”.

See [Chapter 5](#) for details.

### 4.1.1.3 Overlay Sets

`micctrl` does not directly modify the installed Intel® MPSS file system image. Instead, one or more file hierarchies overlay corresponding files in the file system image during the boot process. That is, each file in a hierarchy will replace the corresponding file in the *base* file system image if that file already exists, or will be added to the file system image if the corresponding file does not already exist.

We refer to these hierarchies, collectively, as *overlay sets* or just *overlays*. There are several types of overlay sets.

The configuration files described previously include parameters that point to the various overlay sets described below. Because there can be multiple sets of the software stack configuration files, there can be multiple unique overlay sets.

#### 4.1.1.3.1 Base File System

The overlay process begins with the *Base* file system. The *Base* configuration file parameter:

```
Base <type> <location>
```

specifies the file system to be used. `<type>` can be *CPIO* to indicate a compressed CPIO archive at `<location>`, or *DIR* to indicate an expanded file system hierarchy rooted at `<location>`. By default, this parameter is in `/etc/mpss/micN.conf` and set to:



```
Base CPIO /usr/share/mpss/boot/initramfs-knightscorner.cpio.gz
```

See [Appendix A.4.2](#) for details.

The Base parameter can be modified using the `micctrl --base` command:

```
micctrl --base=<default|cpio|dir> [--new=<location>] [mic card list]
```

or by directly editing Intel® MPSS configuration files. See [Appendix B.4.4.1](#) for details.

#### 4.1.1.3.2 Common Overlay Set

The common overlay set, by default rooted at `/var/mpss/common`, can be populated with files that will overlay the file system of all coprocessors. For example, if administrator creates the file `/var/mpss/common/etc/foo`, it will overlay `/etc/foo` in the file system of each coprocessor.

The `CommonDir` parameter:

```
CommonDir <common_dir>
```

is typically found in the `default.conf` configuration file, and specifies the common overlay set, where `<common_dir>` is the root of the overlay hierarchy. By default, this parameter is set to:

```
CommonDir /var/mpss/common
```

No files are created in this directory by default. See [Appendix A.4.2](#) for details.

Overlay parameters can be created or modified using the `micctrl --common_dir` command:

```
micctrl --common_dir=<common_dir> [mic card list]
```

or by directly editing MPSS configuration files. See [Appendix B.4.4.3](#) for details.

#### 4.1.1.3.3 Per-coprocessor Overlay Set

`micctrl --initdefaults` creates and populates an overlay set of files for each installed coprocessor. However, if a file already exists, it is not changed. By default, these overlays are rooted at `/var/mpss/micN`. The per-processor overlay set includes the following files:

```
/etc  
/etc/fstab  
/etc/group  
/etc/hostname  
/etc/hosts  
/etc/localtime  
/etc/nswitch.conf  
/etc/passwd  
/etc/resolv.conf  
/etc/shadow  
  
/etc/init.d/  
  
/etc/network/  
/etc/network/interfaces  
  
/etc/pam.d/
```





**Configuring and Booting  
the Intel® Xeon Phi™  
Coprocessor Operating System**

```
/etc/pam.d/common-account
/etc/pam.d/common-auth
/etc/pam.d/common-session

/etc/ssh/
/etc/ssh/ssh_host_dsa_key
/etc/ssh/ssh_host_dsa_key.pub
/etc/ssh/ssh_host_rsa_key
/etc/ssh/ssh_host_rsa_key.pub
/etc/ssh/ssh_host_key
/etc/ssh/ssh_host_key.pub
/etc/ssh/ssh_host_ecdsa_key
/etc/ssh/ssh_host_ecdsa_key.pub

/etc/rc1.d/
/etc/rc5.d

/home
/home/micuser
/home/micuser/.profile
/home/micuser/.ssh
/home/micuser/.ssh/id_dsa
/home/micuser/.ssh/id_dsa.pub
/home/micuser/.ssh/id_rsa
/home/micuser/.ssh/id_rsa.pub
/home/micuser/.ssh/authorized_keys

/root
/root/.profile
/root/.ssh
/root/.ssh/id_dsa
/root/.ssh/id_dsa.pub
/root/.ssh/id_rsa
/root/.ssh/id_rsa.pub

/root/.ssh/authorized_keys
```

(The .ssh key files are created depending on which key files the user or root has created.)

Thus, for each of the above files, there is a corresponding file rooted at `/var/mpss/micN`. For example, `micctrl --initdefaults` creates and initializes the file `/var/mpss/mic0/etc/fstab`, which, at boot time, will replace `/etc/fstab` in the file system of coprocessor mic0.

The `MicDir` parameter in each `micN.conf` configuration file:

```
MicDir <micdir>
```

specifies the coprocessor specific overlay set for the corresponding coprocessor, where `<micdir>` is the root of the overlay hierarchy. By default, this parameter is set to:

```
MicDir /var/mpss/micN
```

for coprocessor micN. See [Appendix A.4.2](#) for details.

`Micdir` parameters can be created or modified using the `micctrl --micdir` command:



```
micctrl --micdir=<micdir> [mic card list]
```

or by directly editing Intel® MPSS configuration files. See [Appendix B.4.4.3](#) for details.

#### 4.1.1.3.4 User Defined Overlay Sets

Arbitrary sets of files can be defined by the user to overlay corresponding files in the file systems of one or more coprocessor. The Intel® MPSS configuration file `Overlay` parameter describes a single such overlay set:

```
Overlay (Simple|File|RPM) <source> <target>  
(on|off)
```

The `<Simple,File,RPM>` type parameter determines how the contents of the `<source>` and `<target>` are interpreted. No `Overlay` parameters are created by default. See [Appendix A.4.2](#) for details.

Overlay parameters can be created or modified using the `micctrl --overlay` command or by directly editing Intel® MPSS configuration files:

```
micctrl --overlay=<type> --source=<dir>  
[--target=<target>] --state=(on|off|delete)  
[mic card list]
```

A `default.conf` or `micN.conf` configuration file can have multiple `Overlay` parameters. See [Appendix A.4.2](#) for details.

The `RPM` overlay type is a special case that identifies `rpm` based packages that are to be installed into one or more coprocessor file systems at boot time. See [Section 7.2.1.1](#) and [Appendix B.4.4.5](#) for details. The `mpss-3.6-k10m.tar` file is comprised of over 1800 `rpm` files *that were built for installation into the Intel® Xeon Phi™ coprocessor file system.*

**Note:** It is strongly recommended that you **NOT** do the following:

```
[host]# micctrl --overlay=RPM --source=$MPSS36_K10M --state=on
```

*The coprocessor will attempt to install all 1800+ rpms from the mpss-3.6-k10m.tar file. In general, care should be taken to install only rpms that are actually needed.*

#### 4.1.1.4 Constructing the File System

`micctrl` constructs the coprocessor file system hierarchy for each coprocessor from the overlay sets described above. The process has the following steps:

- 1) If the `Base` file system is in the form of a compressed CPIO archive, it is first decompressed and extracted to a temporary location, before files are overlaid.
- 2) The `Base` file system is then overlaid by the `CommonDir` overlay set.
- 3) The resulting hierarchy is overlaid by any hierarchies indicated by `Overlay` parameters in `default.conf`.
- 4) The result is then overlaid by the coprocessor-specific `MicDir` hierarchy for that coprocessor, as specified by the `MicDir` parameter in the corresponding `micN.conf` file.

**Configuring and Booting  
the Intel® Xeon Phi™  
Coprocessor Operating System**

- 5) The resulting hierarchy is then overlaid by file hierarchies specified by *Overlay* parameters in the corresponding *micN.conf* file.
- 6) The resulting hierarchy is re-archived and compressed if the file system will be resident in coprocessor memory, as specified by the *RootDevice RamFS* or *RootDevice SplitRamFS* parameter. It is left as an expanded file hierarchy on the host if it is to be NFS mounted.

## 4.1.2 Initializing, Updating and Resetting the Configuration Files

As discussed previously, *micctrl --initdefaults* is used to create and initialize a set of configuration files. The same *micctrl --initdefaults* command should also be called after installing a revision of Intel® MPSS so that *micctrl* can perform any upgrades to a configuration file set in the event that some software stack configuration file parameters were deprecated. In that case *micctrl* will replace the deprecated parameter with equivalent replacement parameterization. To aid this process, each *micN.conf* configuration file includes a version parameter:

```
Version <major number> <minor number>
```

This parameter should not be manually edited.

*micctrl --initdefaults* can also be parameterized to perform some additional user authentication, network, and coprocessor configuration operations. Refer to [Appendix B.4.2.1](#) for details.

As mentioned earlier, create a copy of the existing configuration before calling *micctrl --initdefaults*, if you might want to use that configuration again, for example with an earlier Intel® MPSS release.

Many *micctrl* operations directly modify files in the per-coprocessor overlay file sets ([Section 4.1.1.3.2](#)). However network configuration can be a multistep process and directly editing the various network configuration files is not feasible. Instead, network configuration settings are accumulated in *micN.conf* configuration files, and the accumulated settings are propagated to the per-processor files set and host configuration files.

Several *micctrl* commands are intended to help the user recover when a configuration is problematic for some reason. *micctrl --resetdefaults* attempts to restore configuration parameters and the associated Intel® Xeon Phi™ coprocessor file systems back to the default state. It shuts down the current network, removes several files in the */etc* directories in the per-coprocessor overlay sets, removes the old configuration files *default.conf* and *micN.conf*, and effectively calls *micctrl --initdefaults*. *micctrl --resetdefaults* does not remove files that the user has added to the various overlay sets. See [Appendix B.4.2.2](#) for details.

Finally, if *micctrl --resetdefaults* fails to resolve configuration problems, *micctrl --cleanconfig* can be called to completely remove all software stack created files and overlay sets, include files that the user has created in an Intel® MPSS per-device or common overlay set. See [Appendix B.4.2.3](#) for details.

## 4.1.3 micctrl Directory Path Modifiers

*micctrl* supports several directory path modifiers that override the default directory locations that it accesses. These modifiers enable building and maintaining multiple Intel® MPSS configurations.



In the remainder of this document, we almost always assume the default values of these modifiers. That is, we typically describe the *default.conf* and *micN.conf* configuration files as being in the */etc/mpss* directory. It should be understood that the correct location of these files is *\$DESTDIR/\$CONFIGDIR/default.conf* (see below).

Similarly, we typically assume that per-coprocessor overlay hierarchy is rooted at the default */var/mpss/micN*, which is the default value of the *MicDir* configuration parameter.

#### 4.1.3.1 \$DESTDIR

We use the symbol *\$DESTDIR* to indicate a directory path that *micctrl* prepends to all accesses of files which it creates. By default *\$DESTDIR* is *"/*". The default can be overridden by defining the *MPSS\_DESTDIR* environment variable to some value, for instance:

```
[host]$ export MPSS_DESTDIR=<destdir>
```

The *\$DESTDIR* default and *MPSS\_DESTDIR* environment variable can be overridden with the *--destdir=<destdir> micctrl* global option.

*\$DESTDIR* is applied dynamically. That is, *micctrl* prepends the current value of *\$DESTDIR* to each file path at the time of file access. This means that the same *\$DESTDIR* value must be used consistently to access a particular set of files.

For example, given the following command sequence:

```
[host]# export MPSS_DESTDIR=/destdir1  
[host]# micctrl --initdefaults
```

*micctrl* will create a new configuration, if one does not exist, rooted at */destdir1*. However, for the command sequence:

```
[host]# export MPSS_DESTDIR=/destdir1  
[host]# micctrl --destdir=/destdir2 --initdefaults
```

*micctrl* will create a new configuration, if one does not exist, rooted at */destdir2* because the *--destdir* global option overrides the value of *\$DESTDIR* that was set by *MPSS\_DESTDIR* environment variable.

When the current value of *\$DESTDIR* is not the default *"/*", *micctrl* will not make any changes to the host's network configuration. In particular, it will not create network configuration files (For Instance: */etc/sysconfig/network-scripts/ifcfg-micN*), nor will it bring a network interface up or down.

#### 4.1.3.2 \$CONFIGDIR

We use the symbol *\$CONFIGDIR* to indicate the directory path at which *micctrl* creates and/or accesses the *default.conf* and *micN.conf* configuration files, and the *conf.d* configuration directory. By default *\$CONFIGDIR* is */etc/mpss*.

The default can be overridden by defining the *MPSS\_CONFIGDIR* parameter:

```
MPSS_CONFIGDIR <confdir>
```

in the */etc/sysconfig/mpss.conf* file. For example:

```
MPSS_CONFIGDIR /home/mic/configdir
```



### Configuring and Booting the Intel® Xeon Phi™ Coprocessor Operating System

**Note:** `/etc/sysconfig/mpss.conf` is not created by default, and must be created by the user.

The `$CONFIGDIR` default and `MPSS_CONFIGDIR` parameter can be overridden by defining the `MPSS_CONFIGDIR` environment variable to some value, for example:

```
[host]# export MPSS_CONFIGDIR=<confdir>
```

The `$CONFIGDIR` default, `MPSS_CONFIGDIR` parameter, and `MPSS_CONFIGDIR` environment variable can be overridden by the `--configdir=<confdir>` or `-c <confdir>` `micctrl` global option.

`$CONFIGDIR` is applied dynamically. That is, `micctrl` prepends the current `$DESTDIR/$CONFIGDIR` value to each access of a `default.conf` or `micN.conf` configuration file, or `conf.d` directory. Consequently the same `$DESTDIR/$CONFIGDIR` value must be used consistently to access a particular set of files.

#### 4.1.3.3 \$VARDIR

We use the symbol `$VARDIR` to indicate the directory path variable at which the `micctrl --initdefaults` and `--resetconfig` commands create the `common` and `micN` overlay hierarchies, and at which the `micctrl --rootdev` command places a ramfs file system image or NFS file system hierarchy. By default `$VARDIR` is `/var/mpss`. The default can be overridden by defining the `MPSS_VARDIR` environment variable to some value, for example:

```
[host]# export MPSS_VARDIR=<vardir>
```

The `$VARDIR` default and `MPSS_VARDIR` environment variable can be overridden by the `--vardir=<vardir>` suboption to the `micctrl --initdefaults`, `--resetconfig`, and `--rootdev` commands.

`$VARDIR` is applied persistently. That is, when `micctrl --initdefaults` or `--resetconfig` adds or modifies a `CommonDir` or `MicDir` parameter to an Intel® MPSS configuration file, the parameter values has the `$VARDIR` path prepended.

For example, assuming a configuration does not currently exist, then the command sequence:

```
[host]# export MPSS_VARDIR=/vardir1  
[host]# micctrl --initdefaults
```

will add the following parameter to `$DESTDIR/$CONFIGDIR/default.conf`:

```
CommonDir /vardir1/common
```

and the following parameters to `$DESTDIR/$CONFIGDIR/mic0.conf`:

```
Micdir /vardir1/mic0  
RootDevice Ramfs /vardir1/mic0.image.gz
```

The above paths are not prepended by the value of `$DESTDIR`, which is applied dynamically.

In the above example, `micctrl` will also populate a per-coprocessor overlay set at `$DESTDIR/vardir1/micN` rather than at the default `$DESTDIR/var/mpss/micN`.

#### 4.1.3.4 \$SRCDIR

We use the symbol `$SRCDIR` to indicate the directory path at which the `micctrl --initdefaults`, `--resetdefaults`, `--resetconfig`, and `--cleanconfig` commands look for the coprocessor's Linux\* kernel image and default file system image. By default `$SRCDIR` is `/usr/share/mpss/boot`. The



default can be overridden by defining the `MPSS_SRCDIR` environment variable to some value, for example:

```
export MPSS_SRCDIR=<srcdir>
```

The `$SRCDIR` default and `MPSS_SRCDIR` environment variable can be overridden by the `---srcdir` suboption to the `micctrl --initdefaults`, `--resetdefaults`, `--resetconfig`, and `--cleanconfig` commands.

`$SRCDIR` is applied persistently. For example, assuming that the `Base` and `OSImage` parameters are not currently defined in the `$DESTDIR/$CONFIGDIR/micN.conf` configuration file, then the command:

```
[host]# micctrl --initdefaults
```

or

```
[host]# micctrl --initdefaults --srcdir=srcdir1
```

adds the following parameters to `$DESTDIR/$CONFIGDIR/micN.conf`:

```
Base CPIO srcdir1/initramfs-knightscorner.cpio.gz
OSImage srcdir1/bzImage-knightscorner srcdir1/System.map-
knightscorner
```

to the `$DESTDIR/$CONFIGDIR/micN.conf` configuration file of each specified coprocessor. The above path is not prepended by `$DESTDIR`, which is applied dynamically.

#### 4.1.3.5 \$NETDIR

We use the symbol `$NETDIR` to indicate the directory path at which the `micctrl --initdefaults`, `--resetdefaults`, `--resetconfig`, `--cleanconfig`, `--mac`, `--network`, `--addbridge`, `--modbridge` and `--delbridge` commands create and/or edit network control files. By default `$NETDIR` is `/etc/sysconfig/network-scripts` on RHEL\* host platforms and `/etc/sysconfig/network` on SLES\* host platforms. The default can be overridden by defining the `MPSS_NETDIR` environment variable to some value, for example:

```
export MPSS_NETDIR=<netdir>
```

The `$NETDIR` default and `MPSS_NETDIR` environment variable can be overridden by the `--netdir` suboption to the `micctrl --initdefaults`, `--resetdefaults`, `--resetconfig`, and `--cleanconfig` commands.

For example, the command:

```
[host]# micctrl --network=static --mcu=1500 mic0
```

or

```
[host]# micctrl --network=static --netdir=<netdir>\
--mcu=1500 mic0
```

creates a `ifcfg-mic0` network control file in `<netdir>`, where `<netdir>` is the current value of `$NETDIR`.



## 4.1.4 Boot Configuration

To boot an Intel® Xeon Phi™ coprocessor, the mpss daemon needs to:

- Determine the kernel to be booted.
- Identify and/or build the file system image.
- Build the kernel command line.

Parameters in the `default.conf` and `micN.conf` Intel® MPSS configuration files are evaluated for this purpose. The `default.conf` and `micN.conf` configuration files to be consulted are determined by the `configdir` specification hierarchy described earlier in [Section 4.1.3.2](#).

The following sections describe the parameters that are evaluated for this purpose.

### 4.1.4.1 Specifying the Linux\* kernel

The `OSImage` parameter:

```
OSImage <linux_kernel_image> <system_address_map_file>
```

specifies the Intel® Xeon Phi™ coprocessor Linux\* OS kernel image and associated system address map file.

By default, this parameter is set to:

```
OSImage /usr/share/mpss/boot/bzImage-knightscorner  
/usr/share/mpss/boot/System.map-knightscorner
```

in the `/etc/mpss/micN.conf` configuration file of each specified coprocessor.

The `micctrl --osimage` command:

```
micctrl --osimage=<osimage> [mic card list]
```

can be used to modify the `--osimage` parameter, or the parameter can be edited directly.

### 4.1.4.2 Specifying and Building the File System Image

The `RootDevice` parameter specifies both where the root file system resides, as well as how and when it is constructed:

```
RootDevice <type> <location> [<usr_location>]
```

By default, this parameter is set to:

```
RootDevice Ramfs /var/mpss/micN.image.gz
```

in the `/etc/mpss/micN.conf` configuration file of each specified coprocessor.

When `<type>` is `Ramfs`, a compressed cpio ram disk image is first constructed from overlay sets, as described in [Section 4.1.1.4](#), and placed at `<location>` when a boot request is given. This image is pushed to coprocessor memory, where it is expanded into coprocessor memory.



When `<type>` is `StaticRamfs`, there must already be a compressed `cpio` ram disk image at `<location>`. The specified image will be used without rebuilding when the coprocessor is booted.

If `<type>` is `NFS`, the booting coprocessor will mount its root file system from the NFS export specified by `<location>`. The `<location>` must be a fully qualified NFS mount location with the format "server:location". At boot time, there must already be a root file system hierarchy at `<location>`.

If `<type>` is `SplitNFS`, the booting coprocessor will mount its root file system, `/`, from the NFS export specified by `<location>` and its `/usr` file system from the NFS export specified by `<usr_location>`. Both `<location>` and `<usr_location>` must be a fully qualified NFS mount locations with the format "server:location". At boot time, there must already be a root file system hierarchy (minus `/usr`) at `<location>`, and a `/usr` hierarchy at `<usr_location>`.

The `micctrl --rootdev` command:

```
micctrl --rootdev=<type> --target=<location> --server=<name>  
[--usr=<usr_location> [-c] [-d] [mic card list]
```

can be used to modify the `RootDevice` parameter in one or more `micN.conf` configuration files, or the parameter can be directly edited in a configuration file.

Refer to [Appendix B.4.3](#) for details.

### 4.1.4.3 Building the kernel commandline

The `mpssd` daemon constructs a kernel command line based on several parameters in the Intel® MPSS configuration files. Most of these are described in [Appendix A.3](#). For each such parameter, there is a corresponding `micctrl` command that can be used to modify the parameter, or these parameters can be modified directly.

## 4.1.5 Assisted Boot Process

This section describes the key steps that are performed during the Intel® MPSS boot process on the Intel® Xeon Phi™ coprocessor.

### 4.1.5.1 Instruct the Driver to Boot the Intel® Xeon Phi™ Coprocessor

On many Linux\* based systems the `grub` boot loader loads and executes a Linux\* kernel image selected from the `grub` configuration file. The `grub` configuration file lists available kernels as well as parameters to be passed through the kernel command line. The `mpssd` host daemon and Intel® MPSS configuration files play a similar role in directing the Intel® Xeon Phi™ coprocessor boot process

The `mpssd` daemon first constructs a (partial) kernel command line for each coprocessor being booted, based on parameters in the Intel® MPSS configuration files. These parameters are described throughout this document, and in [Appendices A.3](#) and [A.4.1](#). The resulting command line is written to the `/sys/class/mic/micN/cmdline` sysfs node, where the `mic.ko` driver will retrieve it.

Next, `mpssd` requests that the `mic.ko` driver start an Intel® Xeon Phi™ coprocessor by writing a boot string to the `/sys/class/mic/micN/state` sysfs node. The format of this string depends





### **Configuring and Booting the Intel® Xeon Phi™ Coprocessor Operating System**

on whether the coprocessor file system is to be a RAM file system or is to be NFS mounted. For the RAM file system, the format is:

```
boot:linux:<linux_kernel_image>:<ram_disk_file>
```

and for NFS, it is:

```
boot:linux:<linux_kernel_image>
```

The `linux:<linux_kernel_image>` part of the boot argument specifies the location of the Linux\* image which is used to boot the coprocessor. `mpssd` obtains this value from the `OSimage` parameter.

The `<ram_disk_file>` part specifies the file system image. `mpssd` obtains this file name from the `RootDevice` parameter.

When the `mic.ko` host driver receives the boot request, it first verifies that the card is in the *ready* state, indicating that it has finished its HW initialization sequence and is ready to receive a kernel and file system image to continue the boot process.

If the card is not ready to boot, the driver will report an error when the `sysfs state` entry is read and will not attempt to boot the card. Otherwise, the coprocessor state is set to *booting*.

Next the `mic.ko` host driver copies the specified Linux\* image and file system image to the coprocessor memory and writes the constructed command line via the standard Linux\* kernel boot protocol structure.

The driver's last step is to write to a coprocessor register, effectively instructing it to jump to the provided `bzImage` to finish the kernel boot process.

## **4.1.5.2 Coprocessor Linux\* Kernel Initial Phases**

The Intel® Xeon Phi™ coprocessor Linux\* kernel goes through virtually the same startup process as on any Intel® based machine. It initializes the bootstrap processor, starts kernel services, including various built-in modules, and brings up all the application processors (APs) to full SMP state. The final step in the boot process involves mounting the root file system so that `/init` can be executed.

The initial ram disk image contains the loadable modules required for the real root file system. Some of the arguments passed in the kernel command line are host memory addresses required by those modules. The `init` program parses the kernel command line for needed information and creates a `/etc/modprobe.d/modprobe.conf` file needed by the card's `init` process.

In the next step, the `root` command line parameter determines whether `init` mounts the file system image that `mic.ko` previously copied to coprocessor memory, or NFS mounts a remote file system.

### **4.1.5.2.1 Root is a Ram Disk Image**

If the root is set to be a ram file system, the `init` program creates a `tmpfs` (Linux\* ram disk file system type) in Intel® Xeon Phi™ coprocessor memory. It then copies all the files from the initial ram disk image into the new `tmpfs` mount.

If any RPM files exist in the `/RPMS-to-install` directory, they will be installed. After installation, this directory is removed to free disk space.



The ram disk image is activated as the root device by calling the Linux\* *switch\_root* utility. This command instructs the Linux\* kernel to remount the root device on the *tmpfs* mount directory, release all file system memory references to the old initial ram disk and start executing the new */sbin/init* function. */sbin/init* then performs the normal Linux\* user level initialization.

#### **4.1.5.2 Root is an NFS Export**

If an NFS mounted root file system is indicated, the *init* program initializes the *mic0* virtual network interface to the IP address supplied on the kernel command line and mount the NFS export from the host.

As in the ram disk image, the NFS mount is activated as the root device by calling the Linux\* *switch\_root* utility. This special utility instructs the Linux\* kernel to remount the root device on the NFS mount directory, release all file system memory references to the old initial ram disk and start executing the new */sbin/init* function.

*/sbin/init* performs the normal Linux\* user level initialization. All the information required must have already been in the NFS export.

#### **4.1.5.3 Notify the Host that the Intel® Xeon Phi™ Coprocessor System is Ready**

The last step is to notify the host that the coprocessor is ready for access. It does this by writing to its */sys/class/micnotify/notify/host\_notified* entry. This causes an interrupt into the host driver which, in turn, updates the card's state to *online*.

#### **4.1.5.4 Coprocessor Shutdown**

The *mpssd* daemon writes *reset* or *shutdown* respectively to the */sys/class/mic/micN/state* sysfs node request a reset or orderly shutdown of a coprocessor. The *mic.ko* driver, in turn, implements the request operation.

## **4.2 Manual Configuration and Control**

This section describes, at a high level, the considerations and steps in configuring and booting an Intel® Xeon Phi™ coprocessor without use of the *micctrl* tool or *mpssd* daemon.

In general, this requires:

- Editing configuration files in the default file system image as needed. Typical areas that require attention are networking and user access, the same as for assisted configuration.
- Adding additional software to the coprocessor file system.
- Constructing a coprocessor boot command line.
- Initiating the coprocessor boot and shutdown processes by directly interacting with the *mic.ko* driver.

The default installation automatically loads the *mic.ko* kernel module and starts the *mpss/ofed-mic* services. If this behavior is not desired, switch off the services and remove */etc/sysconfig/modules/mic.modules*:



**Configuring and Booting  
the Intel® Xeon Phi™  
Coprocessor Operating System**

```
[host]# lchkconfig --del ofed-mic  
[host]# lchkconfig --del mpss  
[host]# rm /etc/sysconfig/modules/mic.modules
```

## 4.2.1 Directly Editing (and persisting) Card /etc Files

As described in [Section 4.1](#), assisted configuration of the coprocessor file system is based on overlaying the default file system with a collection of overlay file sets. In that case, the default file system image that is installed as part of Intel® MPSS installation is not modified by the assisted configuration process.

While a similar overlay process could be employed as part of manual configuration, we will assume that the user directly edits the installed default file system.

The default file system image is a compressed CPIO archive, and is installed at `/usr/share/mpss/boot/initramfs-knightscorner.cpio.gz`. To edit files, extract them from the archive:

```
[host]$ gunzip -c /usr/share/mpss/boot/initramfs-knightscorner.cpio.gz | cpio -ivd
```

If the file system is to be NFS mounted, it is, left in this format. Otherwise, it should be re-archived and compressed for uploading to coprocessor memory:

```
[host]$ find . | cpio -o -H newc | gzip > <ramfs_location>
```

### 4.2.1.1 /init

The default file system's `/init` script was briefly mentioned in [Section 4.1.5.2](#), and is typical of Linux\* `/init` scripts. `/init` parses the command line parameters passed to it by the kernel, and performs the following major steps:

- Creates and configures `/etc/modules` and `/etc/modprobe.d/modprobe.conf`.
- Depending on command line parameters, mounts the file system image that the `mic.ko` pushed to coprocessor memory as `tmpfs`, or NFS mounts a remote export specified in the command line.
- Optionally `rpm` installs packages that it finds in a special `/RPMS_to_install` directory in the file system image.
- Finally, `/init` switches the root file system to the newly mounted file system image.

If `/init` is edited, for example, to support additional command line options, those changes will need to be propagated to any new version of `/init` in subsequent versions of Intel® MPSS.

### 4.2.1.2 Network Configuration and User Authentication

Network configuration and user authentication are the most significant configuration tasks, particularly for cluster administration. These topics are treated in detail in [Chapters 5](#) and [6](#) respectively.



### 4.2.1.3 Adding software to coprocessor file system

One way to add software is to add files to the file system image, but generally users will want to install rpm based packages. A simple way to do this is to create a /RPMs-to-install directory in the file system image, and place packages to be installed in that directory. The /init script, described above, will rpm install any .rpm packages that it finds in the directory as the last step before performing switch\_root.

See [Chapter 7](#) for more information on this topic.

## 4.2.2 NFS Mounting the Root and Other File Systems

/init will NFS mount a remote export if the command line includes the `root=nfs` command. This command has the syntax:

```
root=nfs:<server>:<export>
```

where <server> is the IP address of the exporting node and <export> is the exported directory. For example, the command:

```
root=nfs:172.31.1.254:/var/mpss/mic0.export
```

will cause the directory at `/var/mpss/mic0.export` on node 172.31.1.254 (the default static pair host IP address) to be NFS mounted as root.

The file system to be NFS mounted as root, as well as any other file systems to be NFS mounted, must be described in the `/etc/exports` file of the exporting host. For example, assume the coprocessor virtual endpoint IP address is 172.31.1.1. To export the host directory `/var/mpss/mic0.export`, add a descriptor to the host's `/etc/exports` such as:

```
/var/mpss/mic0.export 172.31.1.1 (rw,async,no_root_squash)
```

Next call `exportfs` to update NFS export tables:

```
[host]# exportfs -a
```

NFS mounting file systems other than root is done as on any standard Linux\* systems. The file system to be exported is described in `/etc/exports` as shown above, and the mount point is described in the coprocessor's `/etc/fstab` file. The NFS mounted root file system mount point does not need to be explicitly added to the coprocessor's `/etc/fstab` because `/init` mounts it.

For example, assume the host IP address is 172.31.1.254. To mount another host directory `/var/mpss/usr.export` as `/usr` on the coprocessor, add a descriptor to the coprocessor's `/etc/fstab`, for example:

```
172.31.1.254:/var/mpss/usr.export /usr nfs defaults 1 1
```

The mount point, in this case `/usr`, must exist in the coprocessor file system.

After the coprocessor is rebooted, the remote file system(s) will be mounted onto the coprocessor's files system.

The standard `mount` command can also be called interactively while the user is logged onto a coprocessor to mount an exported file system.



## 4.2.3 Driver sysfs Settings

The mic.ko driver exports information about installed Intel® Xeon Phi™ coprocessors via `/sys/class/mic`. As described in Section 4.1.5 and below, `/sys/class/mic/micN/cmdline` and `/sys/class/mic/micN/state` entries are also used in booting and controlling coprocessors.

Appendix C describes these sysfs entries.

## 4.2.4 Card-side Kernel Commandline Parameters

As mentioned in Section 4.1.5, a partial command line is written to the mic.ko driver sysfs node `/sys/class/mic/micN/cmdline` at boot time. The driver will augment that command line with additional commands. For example, in assisted configuration, the mpssd writes a command line similar to:

```
quiet root=ramfs console=hvc0 cgroup_disable=memory highres=off  
micpm=cpufreq_on;corec6_off;pc3_on;pc6_off
```

and a typical augmented command line is:

```
card=0 vnet=dma scif_id=1 scif_addr=0x835c6cd540  
vnet_addr=0x831a428118 vcons_hdr_addr=0x831a727540  
virtio_addr=0x835c35a9c0 mem=8192M ramoops_size=16384  
ramoops_addr=0x8669284000 p2p=1 p2p_proxy=1 etc_comp=1499  
reg_cache=1 ulimit=0 huge_page=1 crashkernel=1M@80M quiet root=ramfs  
console=hvc0 cgroup_disable=memory highres=off  
micpm=cpufreq_on;corec6_off;pc3_on;pc6_off
```

The augmented command line can be read at `/sys/class/mic/micN/kernel_cmdline`.

The mic.ko driver expanded the original kernel command line. The entries `card`, `vnet`, `scif_id`, `scif_addr`, `vnet_addr`, `cons_hdr_addr`, `virtio_addr`, `mem`, `ramoops_size`, `ramoops_addr`, and `crashkernel` are automatically generated by the driver. These options are non-configurable.

Chapter 9 describes a range of configuration options, many of which are conveyed to the coprocessor as kernel command line parameters.

## 4.2.5 Controlling the card

This section describes how to boot a coprocessor manually, not using `micctrl`. The mic.ko driver must be loaded:

```
[host]# modprobe mic
```

It is not necessary to start the mpss service (mpssd daemon).

Controlling a coprocessor is then done through the `/sys/class/mic/micN/state` sysfs node. When the state node:

```
[host]$ cat /sys/class/mic/micN/state
```

is read, one of the following state values is reported:

- **ready** card is ready for a boot command
- **booting** card is currently booting



- **no response** card is not responding
- **boot failed** card failed to boot
- **online** card is currently booted
- **shutdown** card is currently shutting down
- **lost** booted card is not responding
- **resetting** card is processing soft reset
- **reset failed** card cannot be reset – non recoverable

In order to boot or reboot the coprocessor, it must first be in the *ready* state. If it is in the *online* state from a previous boot, it can be shut down by writing *shutdown* to the state node:

```
[host]# echo shutdown > /sys/class/mic/micN/state
[host]$ cat /sys/class/mic/micN/state
shutdown
```

It can be reset by writing *reset* to the state node:

```
[host]# echo reset > /sys/class/mic/micN/state
[host]$ cat /sys/class/mic/micN/state
resetting
```

Shutting down the coprocessor rather than resetting it is generally recommended particularly if there might be I/O data that must be flushed to some external device.

Both shutdown and reset may take several seconds, so the user must continue to check the state until the coprocessor is reported to be ready:

```
[host]$ cat /sys/class/mic/micN/state
ready
```

Submit the command line:

```
[host]# echo "quiet root=ramfs console=hvc0 cgroup_disable=memory
highres=off micpm=cpufreq_on;corec6_off;pc3_on;pc6_off " >
/sys/class/mic/micN/cmdline
```

Now boot the coprocessor. For example:

```
[host]# echo "boot:linux:/usr/share/mpss/boot/bzImage-
knightscorner:/var/mpss/mic0.image.gz" > /sys/class/mic/mic0/state
[host]$ cat /sys/class/mic/mic0/state
booting
```

Wait until it is out of the booting state and in the online state:

```
[host]$ cat /sys/class/mic/micN/state
Online
```

The coprocessor is now ready for use. For example you can ssh to it:

```
[host]$ ssh mic0
[micN]$ dmesg | tail -n 5
[  9.529093] blcr: Supports kernel interface version 0.10.3.
```



**Configuring and Booting  
the Intel® Xeon Phi™  
Coprocessor Operating System**

```
[ 9.529103] blcr: Supports context file format versions 8  
though 9.  
[ 9.529111] blcr: http://ftg.lbl.gov/checkpoint  
[ 9.600401] MPSSBOOT Boot acknowledged  
[ 17.830104] mic0: no IPv6 routers present
```

## 5 Networking Configuration

---

The Intel® Xeon Phi™ coprocessor does not have a hardware Ethernet capability. Instead *Virtual Ethernet* drivers on the host and coprocessors emulate Ethernet devices to enable the standard TCP/UDP IP stack on the coprocessor. This chapter describes configuring these endpoints and the construction of networks of Intel® Xeon Phi™ coprocessors. Finally, configuration of IP networking over InfiniBand\* is discussed.

Assisted and manual networking configurations are addressed separately.

### 5.1 Assisted Configuration

The Intel® MPSS *micctrl* utility supports static pair, internal bridge and external bridge topologies. These were described in [Section 2.2.3](#). Using a combination of the *Bridge* and *Network* configuration parameters allows a diverse and robust network setup.

Each Linux\* system in a network uses a host name to identify itself. The *Hostname* Intel® MPSS configuration parameter is used to configure the host name of Intel® Xeon Phi™ coprocessor.

Each network interface is identified by its *MAC* address. Each virtual network endpoint on the host and on a coprocessor requires its own unique address. These addresses are configured using the *MacAddrs* parameter.

For the purpose of network configuration, several files are added or modified, based on the host OS type (Red Hat\* or SUSE\*). These may include:

```
/etc/hosts  
/etc/network/interfaces           # SUSE*  
/etc/sysconfig/network-scripts/ifcfg-*; # RHEL*: various depending on network topology
```

On the card file systems the files added are:

```
/etc/network/interfaces  
/etc/hostname  
/etc/ssh/ssh_host_key  
/etc/ssh/ssh_host_key.pub  
/etc/ssh/ssh_host_rsa_key  
/etc/ssh/ssh_host_rsa_key.pub  
/etc/ssh/ssh_host_dsa_key  
/etc/ssh/ssh_host_dsa_key.pub  
/etc/ssh/ssh_host_ecdsa_key      # if present  
/etc/ssh/ssh_host_ecdsa_key.pub  # if present  
/etc/resolv.conf  
/etc/nsswitch.conf  
/etc/hosts
```

All network configuration parameters take effect upon executing `service mpss start`.

#### 5.1.1 Host SSH Keys

The secure shell utilities recognize a Linux\* system on the network by its “host key files”. These files are found in the `/etc/ssh` directory. The host key values, like the MAC addresses,





## Networking Configuration

are considered to be highly persistent, and the *micctrl* command will retain their values if they exist.

In some clusters, detecting and protecting against “man in the middle” and other such attacks might not be required. In this case, the system administrator may use the *micctrl --hostkeys* command to set the host SSH keys to be the same cluster wide.

### 5.1.2 Name Resolution Configuration

*micctrl --initdefaults* configures name resolution on the coprocessors by creating an */etc/nsswitch.conf* file and copying the */etc/resolv.conf* file from the host to the Intel® Xeon Phi™ coprocessor file systems.

### 5.1.3 Host Name Assignment

Each Intel® Xeon Phi™ coprocessor needs its own host name. The Intel® MPSS *Hostname* parameter in each *micN.conf* configuration file defines the host name of the corresponding coprocessor. Parameter syntax is:

```
Hostname <name>
```

The default value set by the *micctrl --initdefaults* command is:

```
Hostname <short_host_name>-micN.<domain>
```

where *<short\_host\_name>* is the name returned by:

```
[host]$ hostname --short
```

*<domain>* is the host’s domain name. For example, if the host’s hostname is *abc.xyz.com*, then the coprocessor hostname will be *abc-micN.xyz.com*. The host name string may be changed by editing the *micN.conf* configuration file.

### 5.1.4 MAC Address Assignment

Because the Intel® Xeon Phi™ coprocessor does not have a hardware network interface, its network endpoint does not have a pre-assigned MAC address. Therefore a MAC address must be generated and assigned to each virtual network device; several options are available to facilitate this operation.

At driver load time, the host and coprocessor drivers generate MAC addresses for their respective endpoints, setting the first three octets to 4C:97:BA. This occurs regardless of whether configuration is assisted or manual.

Normally, these MAC addresses are based on the coprocessor serial number and are consistent across Intel® MPSS service restart. Some early coprocessors lacked serial numbers; for those coprocessors, the host and coprocessor drivers generate random MAC addresses.

It is recommended to use the default serial number based MAC addresses, but these can be overridden if necessary.

MAC assignment is controlled by the *MacAddrs* configuration parameter in the *micN.conf* configuration file:

```
MacAddrs Serial|Random|<host MAC>:<card MAC>
```



The initial parameter created by `micctrl --initdefaults` is:

```
MacAddrs Serial
```

This specifies serial number based MAC address generation. In addition to random MAC address generation, explicit host and card can be assigned. See [Appendix A.5.2](#) for details.

The `micctrl --mac` command:

```
micctrl --mac=serial|random|<MAC address>
```

can be used to modify the `MacAddrs` parameter in one or more `micN.conf` configuration files, or the parameter can be directly edited in a configuration file. See [Appendix B.4.5.1](#) for details.

## 5.1.5 Network Topologies

This section describes configuration of each of the basic network topologies.

**Note:** The `mpss` service must be stopped before using `micctrl` to configure the network topology:

```
[host]# service mpss stop
```

### 5.1.5.1 Static Pair Configuration

In the static pair topology, an Intel® Xeon Phi™ coprocessor is assigned to a separate subnet known only to the host. Only static IP address assignment is supported. The *Network* configuration parameter format for static pair networking is described in detail in [Appendix A.5.3](#).

#### 5.1.5.1.1 Static Pair Configuration Using Micctrl

Although a static pair network topology can be partially configured by editing the *Network* configuration parameter directly, other steps are required. Therefore the recommended method of changing the network configuration is to use the `micctrl --network` command. Specifically, the `micctrl --network` command will edit configuration files as needed to remove the current network configuration before implementing the new configuration. `micctrl --network` also creates and/or modifies host and coprocessor network configuration files, and brings network endpoints on the host down and up as needed.

Configuring a static pair network using the `micctrl --network` command is described in detail in [Appendix B.4.5.3](#).

#### 5.1.5.1.2 Micctrl Based Static Pair Configuration Implementation

This section describes in some detail the edits and other operations that `micctrl` performs when the `micctrl --network` command is used to configure a static pair network topology. The information in this section is not required in order to use these `micctrl` commands. The reader can skip this section unless a deeper understanding of the configuration process is needed.

For explanatory purposes we will assume the following command is executed on a host system with two Intel® Xeon Phi™ coprocessors installed:

```
[host]# micctrl --network=static --ip=172.31
```



## Networking Configuration

In this case, *micctrl* will set the third quad of each IP address to N+1 for each coprocessor with a name specified to micN. The fourth quad of the host endpoint IP address will be 254, and the coprocessor endpoint IP address will be 1. MTU will default to 64512, and *modhost* and *modcard* will both default to yes.

*micctrl* first parses the Network configuration parameter in each of the */etc/mpss/micN.conf* files to determine the existing network configuration.

*micctrl* next shuts down the current virtual network connections using the *ifdown micN* command for each of the coprocessors, deletes existing */etc/sysconfig/network-scripts/ifcfg-micN* files, removes the micN entries from */etc/hosts*, and then creates a new */etc/sysconfig/network-scripts/ifcfg-mic0* file for each coprocessor. The *ifcfg-mic0* will now have contents similar to:

```
DEVICE="mic0"  
TYPE=Ethernet  
ONBOOT=yes  
NM_CONTROLLED="no"  
BOOTPROTO=static  
IPADDR=172.31.1.254  
NETMASK=255.255.255.0  
MTU=64512
```

In general, an identical */etc/sysconfig/network-scripts/ifcfg-micN* file is created for each *micN* with *DEVICE=micN* and *IPADDR=172.31.1+N.254*

*micctrl* now executes *ifup micN* for each of the coprocessors. At this time, the *ifconfig* command relevant output should be similar to:

```
mic0    Link encap:Ethernet  
inet addr:172.31.1.254  Bcast:172.31.1.255  Mask:255.255.255.0  
mic1    Link encap:Ethernet  
inet addr:172.31.2.254  Bcast:172.31.2.255  Mask:255.255.255.0
```

showing that the two host endpoints have the IP address specified by the *micctrl --network* command.

*micctrl* then creates/updates the network configuration files for the Intel® Xeon Phi™ coprocessor file system. It will first create/update the network interface configuration file */var/mpss/mic0/etc/network/interfaces* with the contents:

```
# /etc/network/interfaces -- configuration file for ifup(8),  
ifdown(8)  
  
# The loopback interface  
auto lo  
iface lo inet loopback  
  
# MIC virtual interface  
auto mic0  
iface mic0 inet static  
    address 172.31.1.1  
    gateway 172.31.1.254  
    netmask 255.255.255.0  
    mtu 64512
```



The `/var/mpss/mic1/etc/network/interfaces` file is similar.

Next, `micctrl --network` replaces the `Network` configuration parameter in each coprocessor's configuration file with a new parameter. For example the `/etc/mpss/mic0.conf` file will now have the `Network` configuration parameter:

```
Network class=StaticPair micip=172.31.1.1 hostip=172.31.1.254
modhost=yes modcard=yes netbits=24 mtu=64512
```

`micctrl` now updates the `/etc/hosts` file to include descriptors of the remote endpoints:

```
172.31.1.1 blutune-mic0.music.local mic0 #Generated-by-micctrl
172.31.1.2 blutune-mic1.music.local mic1 #Generated-by-micctrl
```

and then creates/updates the `/var/mpss/micN/etc/hosts` files to have content similar to the following (`/var/mpss/mic0/etc/hosts` shown):

```
127.0.0.1 localhost.localdomain localhost
::1 localhost.localdomain localhost
172.31.1.254 host blutune.music.local
172.31.1.1 mic0 blutune-mic0.music.local mic0
172.31.2.1 blutune-mic1.music.local mic1
```

The next boot of the Intel® Xeon Phi™ coprocessors, by either `service mpss start` or `micctrl -b` will use the new network configuration.

### 5.1.5.2 Internal Bridge Configuration

Linux\* provides a mechanism for bridging network devices to a common network. The term *internal bridge*, in the context of Intel® Xeon Phi™ coprocessor configuration, refers to a network of multiple coprocessor virtual network endpoints that are connected through a host bridge endpoint. Only static IP address assignment is supported.

This network topology depends on a `Bridge` in the `default.conf` configuration file and a `Network` parameter `micN.conf` configuration file of each coprocessor to be included in the bridge. The `Bridge` and `Network` parameters for the internal bridge configuration are described in detail in [Appendix A.5.4](#).

#### 5.1.5.2.1 Internal Bridge Configuration File Parameters

Although an internal bridge network can be partially configured by editing the `Bridge` and `Network` configuration parameters directly, other steps are required. Therefore the recommended method of changing the network configuration is to use the `micctrl --network` command. Specifically, the `micctrl --network` command will edit configuration files as needed to remove the current network configuration before implementing the new configuration. `micctrl --network` also creates and/or modifies host and coprocessor network configuration files, and brings network endpoints on the host up and down as needed.

Configuring an internal bridge network using the `micctrl --network` command is described in detail in [Appendix B.4.5.4](#).

#### 5.1.5.2.2 micctrl Based Internal Bridge Configuration Implementation

This section describes in some detail the edits and other operations that `micctrl` performs when the `micctrl --network` and `--addbridge` commands are used to configure an internal bridge network topology. The information in this section is not required in order to use these



## Networking Configuration

*micctrl* commands. The reader can skip this section unless a deeper understanding of the configuration process is needed.

For explanatory purposes we will assume the following commands are executed on a host system with two Intel® Xeon Phi™ coprocessors installed:

```
[host]# micctrl --addbridge=br0 --type=internal --ip=172.31.1.254
[host]# micctrl --network=static --bridge=br0 --ip=172.31.1.1
```

The *micctrl --addbridge* command performs a series of steps starting with removal of the current network configuration. *micctrl* first parses the *Network* configuration parameter in each of the */etc/mpss/micN.conf* files and the *Bridge* parameter in the */etc/mpss/default.conf* file to determine the existing network configuration.

*micctrl* then adds/modifies the *Bridge* parameter in the */etc/mpss/default.conf* file to contain:

```
Bridge br0 Internal 172.31.1.254 24 64512
```

The value 24 in this parameter is the default netbits value, defining a netmask of FFFFFFF0. The value 64512 is the default MTU value.

Then, the host configuration file, */etc/sysconfig/network-scripts/ifcfg-br0*, is created or modified to describe the bridge with contents similar to:

```
DEVICE=br0
TYPE=Bridge
ONBOOT=yes
DELAY=0
NM_CONTROLLED="no"
BOOTPROTO=static
IPADDR=172.31.1.254
NETMASK=255.255.255.0
```

The *micctrl* utility then executes the *ifup br0* command to bring up the bridge interface.

The *micctrl --network* command slaves the host ends of the virtual networks to the designated bridge *br0*, and replaces the network configuration files for the Intel® Xeon Phi™ coprocessors with a configuration for the new IP addresses. *micctrl* again parses the *Network* configuration parameter in each of the */etc/mpss/micN.conf* files to determine the existing network configuration.

*micctrl* next shuts down the current virtual network connections using the *ifdown micN* command for each of the coprocessors, deletes existing */etc/sysconfig/network-scripts/ifcfg-micN* files, removes the *micN* entries from */etc/hosts*, and then creates a new */etc/sysconfig/network-scripts/ifcfg-micN* file for each coprocessor. The *ifcfg-mic0* will now have contents similar to:

```
DEVICE=mic0
ONBOOT=yes
NM_CONTROLLED="no"
BRIDGE=br0
MTU=64512
```

where *BRIDGE=br0* causes the new endpoint to be added to the bridge. In general, an identical */etc/sysconfig/network-scripts/ifcfg-micN* file is created for each *micN* with *DEVICE=micN*.



When this is complete *micctrl* executes *ifup micN*, for each coprocessor. At the end of this process, the *brctl show* command can be used to check the status of the bridge. Its output should be similar to:

```
bridge name bridge id      STP enabled interfaces
br0        8000.66a8476a8f15 no          mic0
                                          mic1
```

The *ifconfig* command relevant output should be:

```
br0        Link encap:Ethernet
           inet addr: 172.31.1.254 Bcast: 172.31.1.255
           Mask:255.255.255.0
mic0       Link encap:Ethernet
mic1       Link encap:Ethernet
```

These commands show that the mic0 and mic1 virtual network interfaces are slaved to bridge br0. Bridge br0 has been assigned the IP address specified by the *micctrl --addbridge* command, and the slaves do not have their host IP addresses.

*micctrl* then creates the network configuration files for the Intel® Xeon Phi™ coprocessor file system. It will first create/update the network interface configuration file */var/mpss/mic0/etc/network/interfaces* with the contents:

```
# /etc/network/interfaces -- configuration file for ifup(8),
ifdown(8)

# The loopback interface
auto lo
iface lo inet loopback

# MIC virtual interface
auto mic0
iface mic0 inet static
    address 172.31.1.1
    gateway 172.31.1.254
    netmask 255.255.255.0
```

The */var/mpss/mic1/etc/network/interfaces* file is similar.

The existing Network configuration parameter in each coprocessor's configuration file is then replaced with a new parameter. For example the */etc/mpss/mic0.conf* file now has the Network configuration line:

```
Network class=StaticBridge bridge=br0 micip=172.31.1.1 modhost=yes
modcard=yes
```

The */etc/mpss/mic1.conf* file will have the same line with the exception that the IP address is 172.31.1.2.

*micctrl* now updates the */etc/hosts* file to include descriptors of the remote endpoints:

```
172.31.1.1 blutune-mic0.music.local mic0 #Generated-by-micctrl
172.31.1.2 blutune-mic1.music.local mic1 #Generated-by-micctrl
```

and then creates/updates the */var/mpss/micN/etc/hosts* files to have content similar to the following (*/var/mpss/mic0/etc/hosts* shown):



## Networking Configuration

```
127.0.0.1      localhost.localdomain localhost
::1           localhost.localdomain localhost
172.31.1.254  host blutune.music.local
172.31.1.1    mic0 blutune-mic1.music.local mic0
172.31.1.2    mic1 blutune-mic1.music.local mic1
```

In general, each coprocessor's `/etc/hosts` file includes the IP addresses and host names of all coprocessors on the internal bridge network.

The next boot of the Intel® Xeon Phi™ coprocessors, by either `service mpss start` or `micctrl -b` will use the new network configuration.

### 5.1.5.3 External Bridge Configuration

The Linux\* bridging mechanism can also bridge the Intel® Xeon Phi™ coprocessor virtual connections to a physical Ethernet device. In this topology, the virtual network interfaces become configurable to the wider subnet. Both static IP address assignment and DHCP based IP address assignment/reservation are supported.

This network topology depends on a *Bridge* in the *default.conf* configuration file and a *Network* parameter *micN.conf* configuration file of each coprocessor to be included in the bridge. The *Bridge* and *Network* parameters for the external bridge configuration are described in detail in [Appendix A.5.5](#).

#### 5.1.5.3.1 External Bridge Configuration Using Micctrl

Although an external bridge network can be partially configured by editing the *Bridge* and *Network* configuration parameters directly, other steps are required. Therefore the recommended method of changing the network configuration is to use the `micctrl --network` command. Specifically, the `micctrl --network` command will edit configuration files as needed to remove the current network configuration before implementing the new configuration. `micctrl --network` also creates and/or modifies host and coprocessor network configuration files, and brings network endpoints on the host up and down as needed.

Configuring an external bridge network using the `micctrl --network` command is described in detail in [Appendix B.4.5.5](#).

#### 5.1.5.3.2 micctrl Based External Bridge Configuration Implementation

This section describes in some detail the edits and other operations that `micctrl` performs when the `micctrl --network` and `--addbridge` commands are used to configure an external bridge network topology. The information in this section is not required in order to use these `micctrl` commands. The reader can skip this section unless a deeper understanding of the configuration process is needed.

When IP address assignment is static, `micctrl` performs the same steps as for the Internal Bridge configuration, except that the default MTU size is 1500 bytes.

For dhcp based IP address assignment, the steps are similar except that the bridge descriptor file, for example `/etc/sysconfig/network-scripts/ifcfg-br0`, will specify dhcp address assignment. For example:

```
DEVICE=br0
TYPE=Bridge
ONBOOT=yes
```



```
DELAY=0
NM_CONTROLLED="no"
BOOTPROTO=dhcp
NETMASK=255.255.255.0
MTU=1500
```

`BOOTPROTO` is set to `dhcp` rather than `static`, and there is no `IPADDR` parameter. Similarly, each coprocessor endpoint must be described in that coprocessor's `/var/mpss/micN/etc/network/interfaces` file with contents similar to:

```
# /etc/network/interfaces -- configuration file for ifup(8),
ifdown(8)

# The loopback interface
auto lo
iface lo inet loopback

# MIC virtual interface
auto mic0
iface mic0 inet dhcp
    pre-up /bin/ip link set $IFACE mtu 1500
    hostname bjhondo-desktop7-mic0.dd.domain.com
```

This configures the `mic0` coprocessor endpoint for DHCP IP address assignment and configures the endpoint mtu to 1500 bytes for compatibility with other devices.

Because IP addresses are assigned by the dhcp server, the host and coprocessor `/etc/hosts` files are not modified.

## 5.2 Manual Configuration

Manual network configuration is mostly just a process of editing standard configuration files on the host and on the coprocessor file systems. Generally speaking, this includes the host and coprocessor configuration files listed in [Section 4.1.1.2](#). To edit or add files to the default file system image, refer to [Section 4.2.1](#).

**Note:** Network configuration on the coprocessor is Debian\* based. In particular, a single `/etc/network/interfaces` file describes all endpoints. Because each coprocessor has only a single network endpoint, this file is generally quite simple.

The default files system image, as installed, already includes several of these files, specifically:

```
/etc/network/interfaces
/etc/hostname
/etc/nsswitch.conf
/etc/hosts
```

Each of these must be modified to complete network configuration.

### 5.2.1 Host Name

The `/etc/hostname` file in the coprocessor's file system image should contain the coprocessor host name.





## 5.2.2 MAC Addresses

For manual configuration, nothing needs to be done in the case that serial number based MAC address generation is acceptable. To assign an explicit MAC address to a coprocessor, add

```
hwaddress ether XX:XX:XX:XX:XX:XX
```

in the section describing the *micN* endpoint of the */etc/network/interfaces* file in the coprocessor file system image.

Standard Linux\* utilities such as *ifconfig* can be used to change the MAC address of host endpoints. For example:

```
[host]# ifconfig mic0 hw ether 4A:79:BA:15:00:21
```

will set the *mic0* host endpoint MAC address to 4A:79:BA:15:00:21.

Such a direct assignment is not persistent. When the host driver is restarted, the MAC address will revert to the default value.

## 5.2.3 Network Topologies

This section describes in some detail the edits and other operations to manually configure each of the basic network topologies. Because IP address assignment is an intrinsic part of the network configuration, it is described in the following sections.

We assume a platform with two Intel® Xeon Phi™ coprocessors installed, and that virtual network endpoints are given *micN* names, for instance *mic0* for coprocessor 0. We also assume that the coprocessors have been reset and are in the *ready* state, and that previous network endpoints and bridges have been shut down, for example, by using the *ifdown* command.

### 5.2.3.1 Static Pair

To define the host endpoint of each static pair, create and/or edit the */etc/sysconfig/network-scripts/ifcfg-micN* file for each coprocessor to be paired, and assign the chosen device name, IP address, netmask, and MTU value. The *ifcfg-mic0* file should then have content similar to the following example:

```
DEVICE="mic0"  
TYPE=Ethernet  
ONBOOT=yes  
NM_CONTROLLED="no"  
BOOTPROTO=static  
IPADDR=172.31.1.254  
NETMASK=255.255.255.0  
MTU=64512
```

In general, an identical */etc/sysconfig/network-scripts/ifcfg-micN* file is created for each *micN* with *DEVICE=micN* and *IPADDR=172.31.1+N.254*.

Each coprocessor endpoint must be described in that coprocessor's */network/interfaces* file with contents similar to:



```
# /etc/network/interfaces -- configuration file for ifup(8),
ifdown(8)

# The loopback interface
auto lo
iface lo inet loopback

# MIC virtual interface
auto mic0
iface mic0 inet static
    address 172.31.1.1
    gateway 172.31.1.254
    netmask 255.255.255.0
    mtu 64512
```

The host and coprocessor IP addresses must be from the same subnet.

A descriptor of each coprocessor endpoint should be added to the host's `/etc/hosts` file to associate IP addresses with the coprocessor hostnames. For example:

```
172.31.1.1 blutune-mic0.music.local mic0
172.31.1.2 blutune-mic1.music.local mic1
```

Similarly, a descriptor of the corresponding host endpoint should be added to each coprocessor's `/etc/hosts` file to associate the host's endpoint IP address with the host's hostnames. For example, `mic0`'s `/etc/hosts` might contain:

```
127.0.0.1 localhost.localdomain localhost
::1 localhost.localdomain localhost
172.31.1.254 host blutune.music.local
172.31.1.1 mic0 blutune-mic0.music.local mic0
172.31.2.1 blutune-mic1.music.local mic1
```

For this example, `/etc/hosts` includes descriptors of both the host endpoint and the local endpoint.

Each of these endpoints can now be brought up by calling the `ifup micN` command for each bridged coprocessor. At this point the `ifconfig` command relevant output should be similar to:

```
mic0    Link encap:Ethernet
inet addr:172.31.1.254  Bcast:172.31.1.255  Mask:255.255.255.0
mic1    Link encap:Ethernet
inet addr:172.31.2.254  Bcast:172.31.2.255  Mask:255.255.255.0
```

The next boot of the Intel® Xeon Phi™ coprocessors will use the new network configuration.

### 5.2.3.2 Internal Bridge

To define the host bridge endpoint, create and/or edit a standard interface configuration file with the chosen bridge name, for example `/etc/sysconfig/network-scripts/ifcfg-br0`, assigning the chosen device name, IP address, netmask, and mtu value. For example, `ifcfg-br0` should have content similar to:

```
DEVICE=br0
TYPE=Bridge
ONBOOT=yes
```



## Networking Configuration

```
DELAY=0
NM_CONTROLLED="no"
BOOTPROTO=static
IPADDR=172.31.1.254
NETMASK=255.255.255.0
```

A standard host interface file, */etc/sysconfig/network-scripts/ifcfg-micN*, must be created for each coprocessor that is to be slaved to the bridge. File contents should be similar to:

```
DEVICE=mic0
ONBOOT=yes
NM_CONTROLLED="no"
BRIDGE=br0
MTU=64512
```

**Note:** Bridged host endpoints do not have IP addresses.

Each coprocessor endpoint must be described in that coprocessor's */var/mpss/micN/etc-/network/interfaces* file with contents similar to:

```
# /etc/network/interfaces -- configuration file for ifup(8),
ifdown(8)

# The loopback interface
auto lo
iface lo inet loopback

# MIC virtual interface
auto mic0
iface mic0 inet static
    address 172.31.1.1
    gateway 172.31.1.254
    netmask 255.255.255.0
```

The bridge and coprocessor IP addresses must be from the same subnet.

The host's */etc/hosts* file must contain a descriptor of coprocessor endpoint to associate IP addresses with the coprocessor hostnames. For example:

```
172.31.1.1 blutune-mic0.music.local mic0
172.31.1.2 blutune-mic1.music.local mic1
```

Similarly, a descriptor of the corresponding host bridge endpoint should be added to each coprocessor's */etc/hosts* file to associate the host's endpoint IP address with the host's hostnames. For example, *mic0's /etc/hosts* might contain:

```
127.0.0.1 localhost.localdomain localhost
::1 localhost.localdomain localhost
172.31.1.254 host blutune.music.local
172.31.1.1 mic0 blutune-mic1.music.local mic0
172.31.1.2 mic1 blutune-mic1.music.local mic1
```

In this example */etc/hosts* includes descriptors of the local endpoint, the host endpoint, and the other coprocessors.



The bridge interface can now be brought up using the `ifup br0` command, and each host endpoint can now be brought up by calling the `ifup micN` command for each bridged coprocessor. At this point the `brctl show` command can be used to check the status of the bridge. Its output should be similar to:

```
bridge name bridge id      STP enabled interfaces
br0          8000.66a8476a8f15 no      mic0
                                         mic1
```

The `ifconfig` command relevant output should be similar to:

```
br0          Link encap:Ethernet
             inet addr: 172.31.1.254  Bcast: 172.31.1.255
             Mask:255.255.255.0
mic0         Link encap:Ethernet
mic1         Link encap:Ethernet
```

These commands show that the `mic0` and `mic1` virtual network interfaces are slaved to bridge `br0`.

The next boot of the Intel® Xeon Phi™ coprocessors, by either `service mpss start` or `micctrl -b` will use the new network configuration.

### 5.2.3.3 External Bridge

The External Bridge configuration requires that the physical Ethernet endpoint is slaved to the bridge.

When IP address assignment is static, configuration is the same as for the Internal Bridge configuration, except that the default mtu size is 1500 bytes.

If DHCP based IP address assignment is dynamic, the steps are similar except that the bridge descriptor file, for example, `/etc/sysconfig/network-scripts/ifcfg-br0`, will be similar to:

```
DEVICE=br0
TYPE=Bridge
ONBOOT=yes
DELAY=0
NM_CONTROLLED="no"
BOOTPROTO=dhcp
NETMASK=255.255.255.0
MTU=1500
```

with `BOOTPROTO` now set to `dhcp` rather than `static`, and no `IPADDR` parameter.

In both the static and dynamic IP address assignment cases, it is the system administrator's responsibility to add the gateway to the host network bridge configuration. For example add `GATEWAY=10.23.185.1` to `/etc/sysconfig/network-scripts/ifcfg-br0`.

Similarly, each coprocessor endpoint must be described in that coprocessor's `/var/mpss/micN/etc/network/interfaces` file with contents similar to:

```
# /etc/network/interfaces -- configuration file for ifup(8),
ifdown(8)

# The loopback interface
```

## Networking Configuration

```

auto lo
iface lo inet loopback

# MIC virtual interface
auto mic0
iface mic0 inet dhcp
    pre-up /bin/ip link set $IFACE mtu 1500
    hostname whsniddo-desktop8-mic0.dd.domain.com

```

This configures the mic0 coprocessor endpoint for DHCP IP address assignment and configures the endpoint MTU to 1500 bytes for compatibility with other devices.

## 5.3 IPoIB Networking Configuration

The OFED IPoIB driver is an implementation of the IP over InfiniBand\* protocol as specified by RFC 4391 and 4392, issued by the IETF IPoIB working group. It is a native implementation in the sense of setting the interface type to ARPHRD\_INFINIBAND and the hardware address length to 20 versus implementations that are masqueraded to the kernel as Ethernet interfaces.

The code base is a direct port from OFED 1.5.4.1, without change. The module runs on top of Intel® Xeon Phi™ CCL-Direct Kernel IB Verbs. As a result, most of the functional and performance characteristics are bound by CCL-Direct restrictions. The driver is released to enable InfiniBand\*-based Lustre\* solutions that require IPoIB interface regardless of LNET configurations.

**Figure 13: One-to-One IB Device (HCA, Port) Mapping between Host and Coprocessor**

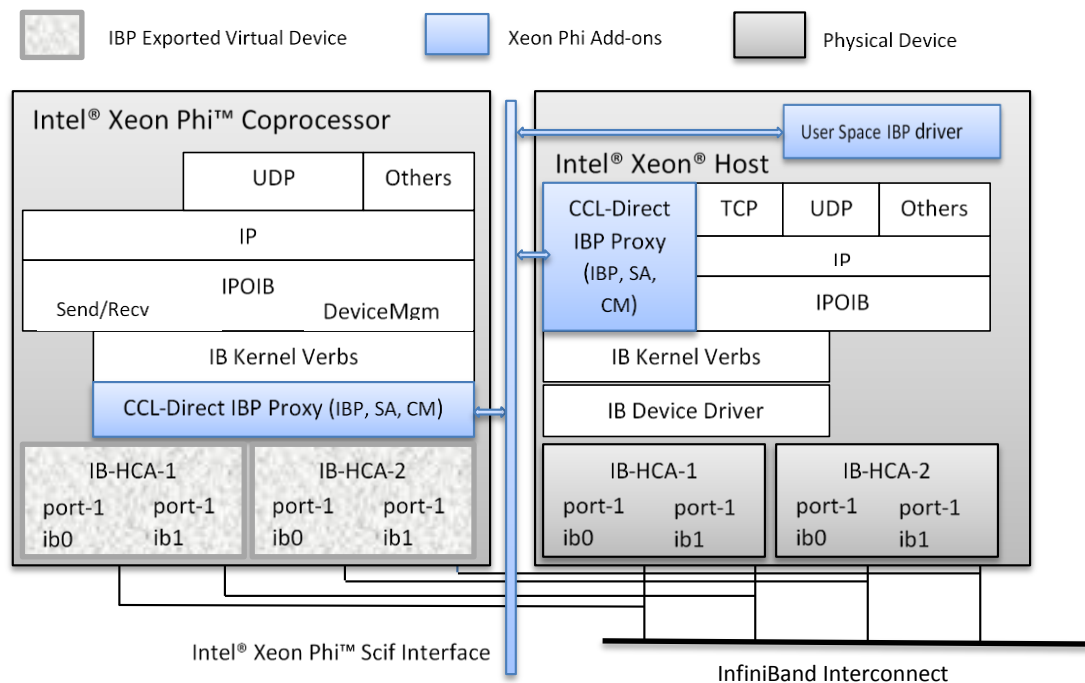



### 5.3.1 Managing the IPoIB Interface

The Intel® Xeon Phi™ coprocessor IPoIB currently manages the virtual IB devices via CCL-Direct IBP proxy drivers. Its existing configuration parameters are inherited from OFED settings without change.

To enable the IPoIB interface on the Intel® Xeon Phi™ coprocessor from the host, edit `/etc/mpss/ipoib.conf` to bring up the `ib0` interface on a coprocessor with the default hostname (`mic0`):

```
ipoib_enabled=yes
mic0_ib0=192.168.100.100
```

### 5.3.2 IP Addressing

Unlike the Intel® Xeon Phi™ coprocessor Ethernet virtual driver, IPoIB does not require bridging or routing to be configured. In the default case, there is an automatically created one-to-one mapping of the (HCA, Port) pairs between the host and coprocessor. [Figure 13](#) shows an example configuration with two 2-port HCAs on the host. All 8 ports (host and coprocessor combined) can be individually configured by `net-if` commands. On the Intel® Xeon Phi™ node, the setting is configured by `ifconfig` command, by adding a configuration file in `/etc/sysconfig/network`, or by editing `/etc/mpss/ipoib.conf`. The host side follows the host OS conventions.

### 5.3.3 Datagram vs. Connected Modes

The driver supports two modes of operation: datagram and connected. The mode is set and read through the interface's `/sys/class/net/<intf name>/mode` file. Datagram is the default mode.

In datagram mode, the CCL-Direct IB UD transport is used, and the IPoIB MTU is equal to the IB L2 MTU minus the IPoIB encapsulation header (4 bytes). For example, in a typical IB fabric with a 2K MTU, the IPoIB MTU will be  $2048 - 4 = 2044$  bytes.

In connected mode, the IB RC transport is used. Connected mode takes advantage of the connected nature of the IB transport that allows an MTU up to the maximal IP packet size of 64K. This reduces the number of IP packets needed for handling large UDP datagrams and TCP segments, and increases the performance for large messages.

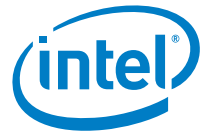

## 6 User Credentialing and Authentication

---

The Intel® Xeon Phi™ coprocessor's Linux\* operating system supports SSH access using SSH keys and/or password authentication, requiring that valid credentials are available to the coprocessor OS. In addition, some offload options require that specific user credentials are configured on the coprocessor; see the discussion on COI \_Authorized user ownership in [Section 9.4.1.1.2](#) for details.

The coprocessor OS obtains user credentials from standard configuration files such as `/etc/passwd` and `/etc/shadow` in the coprocessor filesystem, or from an LDAP or NIS server. The OS looks for a user's ssh keys in the `.ssh` directory in the user's home directory.

`micctrl` can be used to populate `/etc/passwd`, `/etc/shadow` and ssh key files in the coprocessor's file system, or those files can be edited directly. In addition, `micctrl` can be used to configure the coprocessor OS to access an LDAP or NIS server for user credentials, or that configuration can be performed by directly editing LDAP or NIS configuration files.

### 6.1 Assisted Configuration of User Credentials

Assisted configuration of user credentialing is entirely through `micctrl` operations. There are no parameters in the Intel® MPSS `default.conf` and `micN.conf` files that apply.

#### 6.1.1 Local Configuration

Several `micctrl` commands support configuring user credentials. The `micctrl --initdefaults` command creates and initializes `/var/mpss/micN/etc/passwd` and `/var/mpss/micN/etc/shadow` in the per-coprocessor `/var/mpss/micN` overlay set of each specified coprocessor if those files did not previously exist. The `--users` and `--pass` parameters control which user accounts populate those files and whether passwords are copied to the coprocessor. In the event that those files already exist, `micctrl --initdefaults` will not change these files unless the `--users` and/or `--pass` parameters require that these files be deleted and recreated with a different set of data. `micctrl` always creates these files if they did not previously exist, and the `--users` and `--pass` parameters control how these files are populated.

`micctrl --initdefaults` also populates `/var/mpss/micN/etc/group` with the group attributes of each user in `/var/mpss/micN/etc/passwd`.

When `micctrl --initdefaults` (re)creates `/var/mpss/micN/etc/passwd`, for each `<user>` in `/var/mpss/micN/etc/passwd`, it also copies the files `/home/<user>/.ssh/*` to `/var/mpss/micN/home/<user>/.ssh`. Similarly it will copy files from `/root/.ssh/*` to `/var/mpss/micN/root/.ssh`. The users `sshd`, `nobody`, `nfsnobody` and `micuser` do not have ssh keys.

The `--nocreate` parameter to `micctrl --initdefaults` suppresses population of `/var/mpss/micN/home/<user>` directories. This can save ram file system memory when LDAP home directory auto mount is enabled or the `/home` directories are NFS mounted.

Other `micctrl --initdefaults` parameters are unrelated to user credentialing. Refer to [Appendix B.4.2.1](#) for additional details on `micctrl --initdefaults`.



`micctrl --initdefaults` is designed to establish an initial user credential configuration. Other `micctrl` commands are intended to support adding, modifying, and/or removing user credentials as needed. The default user credentialing behavior on the coprocessor can be customized with the `micctrl --userupdate` command. This command duplicates the semantics of `micctrl --initdefaults` with respect to user credentials and ssh keys. Refer to [Appendix B.4.6.1](#) for additional details.

The `micctrl --useradd` command can be used to add a specified users attributes to `/var/mpss/micN/etc/passwd` and `/var/mpss/micN/etc/shadow`. This command would typically be called after a new user is added on the host. In the case that a specified coprocessor is in the online (running) state, the corresponding changes are made dynamically on the coprocessor. Refer to [Appendix B.4.6.2](#) for additional details.

The `micctrl --userdel` command removes user credentials, and optionally the user's home directory, from the current configuration. Specifically, the user is removed from `/var/mpss/micN/etc/passwd` and `/var/mpss/micN/etc/shadow` of the specified coprocessors, and `/var/mpss/micN/home/<user>` is optionally deleted. In the case that a specified coprocessor is in the online state, the corresponding changes are made dynamically on the coprocessor. Refer to [Appendix B.4.6.3](#) for additional details.

The `micctrl --passwd` command allows a non-privileged user to change his/her password on both host and in the current configuration. Root can use this command to change the password of any user. In the case that a specified coprocessor is in the online state, the corresponding changes are made dynamically on the coprocessor. Refer to [Appendix B.4.6.4](#) for additional details.

The `micctrl --groupadd` and `--groupdel` commands enable adding and/or removing a specified group from the configuration. In the case that a specified coprocessor is in the online state, the corresponding changes are made dynamically on the coprocessor. Refer to [Appendix B.4.6.5](#) and [Appendix B.4.6.6](#) for additional details.

The `micctrl --hostkeys` command can be used to populate the `/var/mpss/micN/etc/ssh` directory with some previously created keys. For example, the keys in `/var/mpss/micN/etc/ssh` might be copied, using the standard `cp` command, to some temporary directory before calling `micctrl --cleanconfig` and `micctrl --initdefaults`. Then `micctrl --hostkeys` can be called to restore those keys, overwriting the new host keys which `micctrl --initdefaults` generated. By doing this the corresponding micN coprocessor will continue to be recognized as a *known host*. Refer to [Appendix B.4.6.7](#) for additional details.

The `micctrl --sshkeys` command copies the `*.pub` public ssh keys of a user, `<user>`, to `/var/mpss/micN/home/<user>/.ssh`. This command might be called in the event that a user's ssh keys are created or changed after the initial configuration is established. Refer to [Appendix B.4.6.8](#) for additional details.

## 6.1.2 Enabling LDAP Service

The coprocessor can use the LDAP service for user authentication.

The network must be configured to enable access to the LDAP server, which typically will not be on the local host. Thus, to be able to access the LDAP server from the coprocessor, the external bridge configuration should be used. See [Section 5.1.5.3](#) for details.

An LDAP client is not preinstalled in the coprocessor default file system and therefore must be added. The `micctrl --rpmkdir` command:

```
[host]# micctrl --rpmkdir=$MPSS36_K10M
```





## User Credentialing and Authentication

creates a configuration parameter that tells the `micctrl --ldap` command where to find the rpms that it will need to install the LDAP service, so that it can configure the needed RPM overlay parameters.

The `micctrl --ldap` command:

```
[host]# micctrl --ldap=(<server>|default) --base=<domain> [mic card list]
```

is then used to configure the coprocessor OS to use LDAP for user authentication. The `<server>` value specifies the LDAP authentication server to be used, and the `base` argument specifies the domain to be used. For example:

```
[host]# micctrl --ldap=192.168.122.129 --base="example.com"
```

In the case of `--ldap=disable`, LDAP authentication is disabled.

### 6.1.3 Enabling NIS Service

The coprocessor can use the NIS service for user authentication.

Since the NIS server will not be running on the local host, the network must be configured to enable access to a remote NIS server. To be able to access the NIS server from the coprocessor, the external bridge configuration should be used. See [Section 5.1.5.3](#) for details.

The NIS client is not preinstalled in the coprocessor default file system and, therefore must be installed. The `micctrl --rpmdir` command

```
micctrl --rpmdir=$MPSS36_K10M
```

creates a configuration parameter that the needed rpms can be found in the `$MPSS36_K10M` directory.

The `micctrl --nis` command:

```
micctrl --nis=(<server>|default) --domain=<domain> [mic card list]
```

is then used to configure the coprocessor OS to use NIS for user authentication. The `<server>` value specifies the NIS authentication server to be used, and the `domain` argument specifies the domain to be used. For example:

```
[host]# micctrl --nis=192.168.122.129 --domain="example.com"
```

In the case of `--nis=disable`, NIS authentication is disabled.

## 6.2 Manual Configuration of User Credentials

`Micctrl` provides credentialing support that is sufficient for many situations. However, particularly in a cluster environment, configuring services such as LDAP may require cluster-specific configuration. This section briefly discusses basic file based credentialing and then provides step by step instructions for enabling LDAP, NIS and SSH based authentication. These latter instructions are intended as a starting reference; it is expected that the system administrator may wish to refine or customize these configurations.



## 6.2.1 Configuration File Based Credentialing

[Section 4.2.1](#) discussed how to directly edit configuration files that will be in a coprocessor's file system. The same general guidelines apply to creating and editing a coprocessor's `/etc/passwd`, `/etc/shadow`, `~/.profile`, and files in `~/.ssh` for each user, including root, that is to have access to the coprocessor.

As described in [Section 4.2](#), one must reboot a coprocessor in order for changes to user credentialing to take effect. Alternatively, credentialing can be changed dynamically via ssh.

### 6.2.1.1 Enabling LDAP Service for Credentialing

LDAP service on a coprocessor can be configured manually.

The network must be configured to enable access to the LDAP server, which typically will not be on the host. In that case the network should be configured as an external bridge so the LDAP server can be reached from the coprocessor. See [Section 5.2.3.3](#) for details.

The following steps document enabling LDAP service. This particular configuration does not allow changing the user's password from the coprocessor.

- 1) Install `nss-ldap` and `pam-ldap` RPM files into the coprocessor file system. These rpms are included in the `mpss-3.6-k10m.tar` file. There are several ways to install these. See [Chapter 7](#) to learn about other approaches to adding software. In this example, required rpms are copied from `$MPSS36_K10M` to a booted coprocessor `micN`:

```
[host]$ scp $MPSS36_K10M/nss-ldap-265-r0.k10m.rpm micN:/tmp
[host]$ scp $MPSS36_K10M/pam-ldap-186-r0.k10m.rpm micN:/tmp
```

and rpm installed:

```
[micN]# rpm -ivh /tmp/nss-ldap-265-r0.k10m.rpm
[micN]# rpm -ivh /tmp/pam-ldap-186-r0.k10m.rpm
```

- 2) Configure `nss-ldap`. Edit `/etc/nsswitch.conf` to add LDAP to the services you want to have enabled, and add the coprocessor host information to `/etc/hosts`.

```
[micN]# cp /etc/nsswitch.ldap /etc/nsswitch.conf
[micN]# sed -ie"/^hosts:/s/dns ldap/files/" /etc/nsswitch.conf
[micN]# SelfIp=`/sbin/ifconfig mic0 | grep "inet addr" | \
  cut -d":" -f2 | cut -d" " -f1`
[micN]# echo ${SelfIp} `hostname` `hostname -s` >> /etc/hosts
```

- 3) Configure LDAP. Add the LDAP server and base domain name to `/etc/ldap.conf`

```
[micN]# cp /etc/openldap/ldap.conf /etc
[micN]# echo "URI ldap://<LDAP server IP address>/" \
  >>/etc/ldap.conf
[micN]# echo "BASE dc=example,dc=com" >> /etc/ldap.conf
```

- 4) Configure `PAM` to allow the LDAP module for SSH and others.

```
[micN]# sed -ie"s/^$/auth sufficient pam_ldap.so/" \
  /etc/pam.d/common-auth
[micN]# sed -ie"/session/s/required/optional/" /etc/pam.d/sshd
```



## 6.2.1.2 Enabling NIS/YP Service for Credentialing

The NIS service on a coprocessor can be configured manually.

The network must be configured to enable the coprocessor to access the NIS server, which typically will not be on the host. In that case the network should be configured as an external bridge. See [Section 5.2.3.3](#) for details.

The following steps document enabling NIS service. This particular configuration does not allow changing the user's password from the coprocessor.

- 1) Install `rpcbind`, `ypbind-mt`, `yp-tools`, and `glibc-extra-nss` RPM files on the coprocessor. These rpms are included in the `mpss-3.6-k10m.tar` file. There are several ways to install these. See [Chapter 7](#) to learn about other approaches to adding software. In this example, required rpms are copied from `$MPSS36_K10M` to a booted coprocessor `micN`:

```
[host]$ scp $MPSS36_K10M/rpcbind-0.*.k10m.rpm micN:/tmp
[host]$ scp $MPSS36_K10M/yp-tools-*.k10m.rpm micN:/tmp
[host]$ scp $MPSS36_K10M/ypbind-mt-*.k10m.rpm micN:/tmp
[host]$ scp $MPSS36_K10M/glibc-extra-nss-*.k10m.rpm micN:/tmp
```

and rpm installed:

```
[micN]# rpm -ivh /tmp/rpcbind-0.*.k10m.rpm
[micN]# rpm -ivh /tmp/yp-tools-*.k10m.rpm
[micN]# rpm -ivh /tmp/ypbind-mt-*.k10m.rpm
[micN]# rpm -ivh /tmp/glibc-extra-nss-2.*.k10m.rpm
```

- 2) Start the `rpcbind` daemon.

```
[micN]# /etc/init.d/rpcbind start
```

- 3) Add the `NIS/YP` server to `/etc/yp.conf` and start the `ypbind` daemon.

```
[micN]# echo "domain <domain name> server <server IPAddress>" \
  >>/etc/yp.conf
[micN]# domainname <domain name>
[micN]# /etc/init.d/ypbind start
```

- 4) Configure `nss`.

```
[micN]# cat <<EOF >>/etc/nsswitch.conf
passwd: nis files
shadow: nis files
group: nis files
EOF
```

Configure `sshd`.

```
[micN]# echo "UsePAM yes" >>/etc/ssh/sshd_config
```

- 5) Configure `PAM`.

```
[micN]# sed -ie"s/pam_unix.so/pam_unix.so nis/" \
  /etc/pam.d/common-auth
[micN]# sed -ie"s/pam_unix.so/pam_unix.so nis/" \
```



```
/etc/pam.d/common-account  
[micN]# sed -ie"/session/s/required/optional/" /etc/pam.d/sshd
```

- 6) Restart *sshd* (the above changes will take effect).

```
[micN]# /etc/init.d/sshd restart
```

### 6.2.1.3 Enabling NFS Auto Mount with NIS/YP Service

*autofs* can be installed on a coprocessor and configured to dynamically mount the NIS server. The following steps modify steps 1) and 6) in the previous [Section 6.2.1.2](#):

- 1) Copy and install additional rpms:

```
[host]$ scp $MPSS36_K10M/nfs-utils-client-*.k10m.rpm mic0:/tmp  
[host]$ scp $MPSS36_K10M/autofs-5.*.k10m.rpm mic0:/tmp
```

and rpm install them:

```
[micN]# rpm -ivh /tmp/nfs-utils-client-*.k10m.rpm  
[micN]# rpm -ivh /tmp/autofs-5.*.k10m.rpm
```

- 6) After configuring *PAM*, and before restarting *sshd*, configure *autofs* and re-start the *autofs/automount* daemon:

```
[micN]# echo "/home /etc/auto.misc " >>/etc/auto.master  
[micN]# /etc/init.d/autofs stop  
[micN]# sleep 2  
[micN]# /etc/init.d/autofs start
```

## 6.2.2 How to Enable SSH Host Based Authentication

- 1) Configure *sshd* to enable host based authentication.

```
[host]# cat <<EOF >>/etc/ssh/sshd_config  
HostbasedAuthentication yes  
IgnoreRhosts no  
EOF
```

- 2) Register SSH client to a user.

```
[host]# cat <<EOF >><home directory>/.shosts  
<micN>  
<server IP address>  
EOF  
[host]# chmod 600 <home directory>/.shosts  
[host]# chown <owner:group> <home directory>/.shosts
```

- 3) Create an entry for SSH client in user's *known\_hosts*.

```
[host]# ssh -X <user>:<HostBasedAuthClient>  
Are you sure you want to continue connecting (yes/no)? yes  
<user>@<server IP address>'s password:  
^D  
exit
```



### ***User Credentialing and Authentication***

- 4) Restart SSH daemon.

```
[mic]# /etc/init.d/sshd restart
```

- 5) Remove SSH key to ensure that user based authentication is not used.

```
[host]$ cd <home directory>/.ssh  
[host]$ rm -f authorized_keys id_rsa*
```



# 7 Adding Software to the Intel® Xeon Phi™ Coprocessor File System

Typical installations are not static, and often require the system administrator to add additional files or directories to the Intel® Xeon Phi™ root file system. This chapter describes a range of techniques and considerations for performing such additions.

The *mpss-3.6-k10m.tar* file, which can be obtained from the [Intel® Developer Zone website \(Intel® DZ\)](#), is composed of over 1900 rpm packages built for installation into the Intel® Xeon Phi™ coprocessor file system. This chapter will describe options for installing these rpms. For those cases where some component or application is not included in *mpss-3.6-k10m.tar*, refer to [Chapter 8](#) to learn how to build software packages for the Intel® Xeon Phi™ coprocessor.

Most software can be added to a file system while it is resident on the host or another node from which it is NFS exported, or while it is resident on an Intel® Xeon Phi™ coprocessor. In all of these cases, the software to be added might be in the form of an rpm, a tarred installation package, or another form.

## 7.1 Adding Individual Files to a Host Resident File System Image

### 7.1.1 Assisted Configuration

The process of creating the file system image is driven by the *Base*, *CommonDir*, *MicDir*, and *Overlay* configuration parameters. These were previously described in [Section 4.1.1.3](#). The overlay process can be used to add individual files as well as directory hierarchies to the coprocessor file system. Software added to directories indicated by these parameters is persistent from one boot to the next.

For example, assume that you have cross-compiled an autotools-based software package. (Cross compiling is discussed in [Section 8.1](#).) The last step in that process is to *make install* the resulting components. One option is to *make install* into the *CommonDir* overlay directory. The *CommonDir* parameter syntax is:

```
CommonDir <source>
```

Assuming that the *CommonDir* parameter has the value */var/mpss/common*, for example:

```
CommonDir /var/mpss/common
```

then the command:

```
[host]# make install DESTDIR=/var/mpss/common
```

installs the component into that overlay. On booting an Intel® Xeon Phi™ coprocessor, the software will be available on all coprocessors because the *CommonDir* overlay is common to all coprocessors.



## Adding Software to the Intel® Xeon Phi™ Coprocessor File System

The *Overlay* parameter:

```
Overlay (Filelist|Simple|File) <source> <target> (on|off)
Overlay RPM <source> (on|off)
```

can be used to add software to the coprocessor file system. The *Overlay* parameter(s) can be unique to each coprocessor.

As an example of using the *Overlay Simple* option, you could perform the sequence:

```
[host]$ mkdir <component>
[host]# make install DESTDIR=<component>
```

to install software into a directory that is specific to that component, and then use the *Simple* overlay type to add the component to the coprocessor file system:

```
[host]# micctrl --overlay=simple --source=<component>/* \
--target=/ --state=on
```

In this way, a collection of components can be built, each in its own directory, which can be selectively added to the coprocessor file system:

```
[host]# micctrl --overlay=simple --source=<component1>/* \
--target=/ --state=on
[host]# micctrl --overlay=simple --source=<component2>/* \
--target=/ --state=on
:
:
[host]# micctrl --overlay=simple --source=<componentN>/* \
--target=/ --state=on
```

**Note:** The *Filelist* overlay type might be deprecated in a future Intel® MPSS release. Use the *Simple* and *File* overlay types instead.

### 7.1.2 Manual Configuration

When doing manual configuration, you can directly install individual files or tarred groups of files directly into a coprocessor file system hierarchy. Assuming the file system is maintained as a compressed CPIO archive (the form in which it is installed), you must first expand it. Here we expand the installed file system image to <some directory>:

```
[host]$ mkdir <some directory>; cd <some directory>
[host]# gunzip -c /usr/share/mpss/boot/\
initramfs-knightscorner.cpio.gz | cpio -ivd
```

After adding software, and if the file system is to be pushed to coprocessor memory, then it must first be re-archived and compressed:

```
[host]$ cd <some directory>
[host]# find . | cpio -o -H newc | gzip > <some_ramfs.cpio.gz>
```

Boot the Intel® Xeon Phi™ coprocessor(s) specifying this new file system image as described in [Section 4.2.5](#). If the coprocessor file system is to be NFS mounted, then there is no need to perform the re-archive step.



### 7.1.3 Installing RPMs

Many of the RPMs in the `mpss-3.6-k10m.tar` file can be installed into the Intel® Xeon Phi™ coprocessor file system while it is resident on the host. Some rpm installations require execution of a binary, such as a program to validate the installation. Since rpms in the `mpss-3.6-k10m.tar` file are built for execution on the coprocessor, no such binary can execute on an Intel® Xeon™ host processor. Generally, library rpms can be installed on the host, while application rpms are more likely to require installation on an Intel® Xeon Phi™ coprocessor.

As discussed in more detail in [Chapter 8](#), the rpm database in the default file system is built with rpm v5, and rpm v5 should thus be used to add software to that file system. The MPSS SDK includes an rpm v5 implementation that can be used for that purpose. Sourcing the file `/opt/mpss/3.6/environment-setup-k10m-mpss-linux` prepends your PATH with `/opt/mpss/3.6/sysroots/x86_64-mpsssdk-linux/usr/bin` so that the rpm command resolves to the rpm v5 executable in the Intel® MPSS SDK. It's recommended to use `su` to become root when doing this.

```
[host]$ su
[host]# source /opt/mpss/3.6/environment-setup-k10m-mpss-linux
```

**Note:** The resulting PATH will cause other binaries, such as python, to be found in `/opt/mpss/3.6/sysroots/x86_64-mpsssdk-linux/usr/bin`. It is therefore recommended that `/opt/mpss/3.6/environment-setup-k10m-mpss-linux` is only sourced into the environment in which cross compilation is being performed.

Verify that you will execute the rpm from the Intel® MPSS sdk:

```
[host]# which rpm \
/opt/mpss/3.6/sysroots/x86_64-mpsssdk-linux/usr/bin/rpm
```

#### 7.1.3.1 Assisted Configuration

Rpms can be installed into a Base file system, for example into the default file system image that is installed at `/usr/share/mpss/boot/initramfs-knightscorner.cpio.gz`. The default file system includes the database of rpms that are already installed.

Use the `micctrl --base` command to extract the default filesystem compressed CPIO image to some directory:

```
[host]# micctrl --base=DIR --new=<some directory>
```

**Note:** `micctrl` only extracts files to `<some directory>` if that directory does not already exist. If `<some directory>` already exists, `micctrl` will only change the Base configuration parameter.

You can now install k10m rpms into the file system at `<some directory>`. For example:

```
[host]# rpm --root=<some directory> --dbpath=/var/lib/rpm \
-i $MPSS36_K10M/<some.rpm>
```

The `--dbpath` option tells rpm to use the database at `/var/lib/rpm` relative to `--root`. Thus it will use the rpm data base in the coprocessor file system.

You can leave the file system in `<some directory>`. It will be used when constructing either an NFS mounted file system or ram file system according to the `RootDevice` parameter. For example:





## Adding Software to the Intel® Xeon Phi™ Coprocessor File System

```
[host]# micctrl --rootdev=NFS -c
```

builds the NFS exported file system using the Base at *<some directory>*. Alternatively, if *RootDevice* is set to *RamFS*:

```
[host]# micctrl --rootdev=RAMFS
```

then the CPIO image will be built at boot time from the file system at *<some directory>*.

### 7.1.3.2 Manual Configuration

If doing Manual Configuration, expand a CPIO compressed image such as the default file system `/usr/share/mpss/boot/initramfs-knightscorner.cpio.gz`:

```
[host]$ mkdir <some directory>; cd <some directory>
[host]# gunzip -c <some ramfs> | cpio -ivd
```

Install k10m rpms as needed:

```
[host]# rpm --root=<some directory> --dbpath=/var/lib/rpm \
-i $MPSS36_K10M/<some.rpm>
```

If not NFS exporting the file system, re-archive the image:

```
[host]$ cd <some directory>
[host]# find . | cpio -o -H newc | gzip > <some other ramfs>
```

Boot as described in [Section 4.2.5](#).

## 7.2 Adding Software to a Coprocessor File System

Installing software to a coprocessor file system while mounted on the coprocessor is much like adding software to any Linux\* file system. Individual files can be directly copied to the target directory on the coprocessor using *scp*. Tar files can be copied to the coprocessor using *scp* and untarred into the appropriate directory.

The rest of this chapter discusses different ways to install rpms and how to preserve the modified file system

### 7.2.1 Installing RPMs

To install rpms into a coprocessor mounted file system, you can use one of the following procedures.

**Note:** These instructions assume that `mpss-3.6-k10m.tar` has been untarred to some `$MPSS36_K10M` directory. The `mpss-3.6-k10m.tar` is available at the website (Intel® DZ): <http://software.intel.com/en-us/articles/intel-manycore-platform-software-stack-mpss>.

#### 7.2.1.1 Using the Overlay RPM Configuration Parameter or Micctrl --overlay Utility

The *Overlay RPM* configuration parameter has the form:

```
Overlay RPM <source> (on|off)
```



If `<source>` is an rpm file, then it is copied to a special `/RPMs-to-install` directory in the file system image that is pushed to one or more coprocessors, depending on whether the parameter is added to `micN.conf` or the `default.conf` configuration file. If `<source>` is a directory, then all the rpm files in that directory are copied to `/RPMs-to-install`. Multiple `Overlay` parameters are allowed. These parameters can be edited directly or the `micctrl --overlay` command can be used to add, modify or remove such parameters; see [Appendix A.4.2](#) and [Appendix B.4.4.4](#) for additional details.

The rpms in `/RPMs-to-install` are installed during the early phase of booting a coprocessor. Some rpms cannot be successfully installed during early boot phase, due to dependencies that cannot be satisfied during that phase. If rpms are not installed successfully, log files (refer to [Appendix I.1](#)) may provide helpful information.

### 7.2.1.2 Manually Install RPMs on a Coprocessor Using SCP

An alternative is to copy rpms to a coprocessor and rpm install them.

SCP the RPMs to the card:

```
[host]$ scp <rpm_packages> micN:<some directory>
```

SSH to the card as root:

```
[host]# ssh micN
```

Install the RPMs using the rpm utility:

```
[micN]# cd <some directory>
[micN]# rpm -ihv <rpm_packages>
```

For example, to install man, copy the man rpm to a coprocessor:

```
[host]$ scp $MPSS36_K10M/man-1.6f-r2.k10m.rpm micN:/tmp
man-1.6f-r2.k10m.rpm          100% 130KB 129.7KB/s  00:00
```

On micN, attempt to install the rpm. Here we assume that `/tmp` only holds rpm files that we have copied for this example:

```
[micN]# cd /tmp
[micN]# rpm -ihv *.rpm
error: Failed dependencies:
    less is needed by man-1.6f-r2.k10m
    groff is needed by man-1.6f-r2.k10m
```

By iteratively copying rpms and attempting to install them, less, groff, perl and libperl5 rpms are copied to the coprocessor, where installation can now complete successfully:

```
[micN]# rpm -ihv *.rpm
Preparing... ##### [100%]
 1:libperl5  ##### [ 20%]
 2:man      ##### [ 40%]
 3:less    ##### [ 60%]
update-alternatives: Linking //usr/bin/less to less.less
 4:perl    ##### [ 80%]
 5:groff   ##### [100%]
```



### 7.2.1.3 Installing RPMs Using an HTTP Repo with Zypper

One obvious disadvantage of the previous method is that, where there are dependencies, the user must install rpms in the correct order. This can be solved by creating a repo on the host that *zypper* can access from a coprocessor. *Zypper* is preinstalled in the Intel® Xeon Phi™ coprocessor default file system.

The steps in this section are for creating a repository of rpms and using the *Python SimpleHTTPServer* for serving them; we assume that these tools have been previously installed on the host. Though other repository creation tools and HTTP servers are available, we only provide instructions for using *createrepo* and *Python SimpleHTTPServer*. The host firewall or iptables may need to be configured to allow *zypper* to access the repository on the host.

Change to the folder where the Intel® MPSS k10m rpms were extracted:

```
[host]$ cd $MPSS36_K10M
```

Use the *createrepo* tool to create a new repo:

```
[host]$ createrepo .
```

Start an http server as follows:

```
[host]# python -m SimpleHTTPServer ${PORT_NUMBER}
```

From another terminal, add the repo on a coprocessor:

```
[host]$ ssh root@micN -R ${SOME_PORT}:host:${PORT_NUMBER}
[micN]# zypper addrepo http://host:${PORT_NUMBER} mpss
```

If no port is specified, *python -m SimpleHTTPServer* defaults to port 8000. In that case, the following is sufficient:

```
[host]$ ssh root@micN
[micN]# zypper addrepo http://host:8000 mpss
```

Now install rpms as needed:

```
[micN]# zypper install <rpm file>...
```

For example, to install *man*:

```
[micN]# zypper install man
File 'repomd.xml' from repository 'mpss' is unsigned, continue?
[yes/no] (no): yes
Building repository 'mpss' cache [done]
Loading repository data...
Reading installed packages...
Resolving package dependencies...
```

```
The following NEW packages are going to be installed:
  groff less libperl5 man perl
```

```
5 new packages to install.
Overall download size: 2.8 MiB. After the operation, additional 8.4
MiB will be used.
```



```
Continue? [y/n/?] (y): y
Retrieving package libperl5-5.14.2-r7.klom (1/5), 709.0 KiB (1.5 MiB
unpacked)
Retrieving: libperl5-5.14.2-r7.klom.rpm [done]
Retrieving package less-444-r2.klom (2/5), 78.0 KiB (163.0 KiB
unpacked)
Retrieving: less-444-r2.klom.rpm [done]
Retrieving package perl-5.14.2-r7.klom (3/5), 16.0 KiB (36.0 KiB
unpacked)
Retrieving: perl-5.14.2-r7.klom.rpm [done]
Retrieving package groff-1.20.1-r1.klom (4/5), 1.9 MiB (6.4 MiB
unpacked)
Retrieving: groff-1.20.1-r1.klom.rpm [done]
Retrieving package man-1.6f-r2.klom (5/5), 130.0 KiB (266.0 KiB
unpacked)
Retrieving: man-1.6f-r2.klom.rpm [done]
Installing: libperl5-5.14.2-r7 [done]
Installing: less-444-r2 [done]
Additional rpm output:
update-alternatives: Linking //usr/bin/less to less.less
Installing: perl-5.14.2-r7 [done]
Installing: groff-1.20.1-r1 [done]
Installing: man-1.6f-r2 [done]
```

We see that zypper takes care of all the dependencies when those dependencies can be satisfied by the rpms in the repo.

The directory containing such a repository can also be NFS mounted. Zypper can then access it as in a local directory.

## 7.2.2 Preserving the Modified File System

An important consideration in adding software to a file system in coprocessor memory is persistence. Assuming the file system is exported from a permanent storage device, modifications to an NFS mounted file system are persistent. Conversely, when the file system is in coprocessor memory (*RAMFS*), any modifications to the file system are lost when the coprocessor is shut down unless steps are taken to capture the file system image to permanent storage.

The following command, executed from the host, captures the current file system of a specified coprocessor to host file `/usr/share/mpss/boot/custom.cpio.gz`:

```
[host]# ssh root@micN 'cd / ; find . /dev -xdev ! -path
"/etc/modprobe.d*" ! -path "/var/volatile/run*" | cpio -o -H newc |
gzip -9' > /usr/share/mpss/boot/custom.cpio.gz
```

**Note:** `/dev` is specified as a path because the `-xdev` option would otherwise prevent capturing that path.

To use the captured file system image, change the *RootDevice* parameter to *StaticRamFS*, and target the captured file. For example:

```
[host]# micctrl --rootdev=StaticRamFS \
--target=/usr/share/mpss/boot/custom.cpio.gz
```



## ***Adding Software to the Intel® Xeon Phi™ Coprocessor File System***

and restart the coprocessor:

```
[host]# micctrl -Rw
```

If doing manual configuration, the captured image is specified in the boot string. For example:

```
[host]# micctrl -rw
[host]# echo \
"boot:linux:/usr/share/mpss/boot/bzImage-knightscorner:/usr/share/mp
ss/boot/custom.cpio.gz" > /sys/class/mic/micN/state
```

See Section [4.2.5](#) for details on manual configuration control of the coprocessor.



## 8 Compilation for the Intel® Xeon Phi™ Coprocessor

---

This chapter takes you through using some of the techniques and tools that you will need to know in order to compile software for native execution on Intel® Xeon Phi™ coprocessors. We begin by describing how to cross compile software using the Intel® MPSS SDK. We then discuss native compilation on the Intel® Xeon Phi™ coprocessor.

This document does not cover Intel® Composer XE support of offload programming. There are numerous other documents and books that cover this topic. For more information, see [Programming and Compiling for Intel® Many Integrated Core Architecture](#).

### 8.1 Cross Compiling Software with the Intel® MPSS SDK

Intel® MPSS includes an SDK that supports cross compilation of software for execution on an Intel® Xeon Phi™ coprocessor. In this section we will discuss the components of the SDK, and general recommendations for cross compiling software components to be added to the coprocessor file system. We will illustrate this process by building the zsh shell for execution on the Intel® Xeon Phi™ coprocessor.

#### 8.1.1 SDK overview

The cross-compilation SDK is installed at `/opt/mpss/3.6/sysroots/x86-64-mpssdk-linux`. It includes a gcc cross compiler as well as standard utilities such as `ar`, `as`, `ld`, `nm`, `objcopy`, `objdump`, `ranlib`, `rpm` (v5) and `strip`. Generally speaking, the SDK only includes tools that must be aware of the format of Intel® Xeon Phi™ coprocessor binary executables. For example, `make` has no dependence on binary executable formats, and thus does not need to be in the SDK; the version of `make` that is installed on the build machine can be used.

The `/opt/mpss/3.6/sysroots/k10m-mpss-linux` subtree contains header files and libraries that are built for the Intel® Xeon Phi™ coprocessor, and that are expected to be needed during the build process. Additional dependencies can be added as illustrated later in an example.

The rpm databases in both `sysroots`:

- `/opt/mpss/3.6/sysroots/k10m-mpss-linux/var/lib/rpm`
- `/opt/mpss/3.6/sysroot/x86-64-mpssdk-linux/var/lib/rpm`

and the default `initramfs` are in rpm v5 format. This format differs from the format generated by rpm v4. Therefore rpm v5 (rpm5) must be used to install packages into `/opt/mpss/3.6/sysroots/k10m-mpss-linux` and into the coprocessor file system. The `/opt/mpss/3.6/environment-setup-k10m-mpss-linux` script sets `PATH` so that rpm v5, as well as the other sdk utilities mentioned above, will be found.

#### 8.1.2 Cross Compilation of GNU Build System Based Packages

The GNU Build System, also known as the Autotools, is the part of the GNU toolchain that is used for making source code packages portable to a wide range of Unix\*-like systems. A vast number of source code packages are based on the GNU Build System. In fact, virtually every



rpm package in *mpss-3.6-k10m.tar* was built from an open source GNU Build System source code package.

On many platforms, native compilation - building a GNU Build System package for execution on the same platform - only requires unpacking the package, and changing to the newly created directory to run the *configure* script. *configure* probes the system for various features to create the *Makefile* needed to build the package on the local system. *make* is then executed to create libraries, executables and other files that comprise the package, followed by *make install* to copy the resulting files to their proper location on the system. In the case of native compilation, the *configure* script can determine the compiler and other build tools to use by probing the system.

When cross compiling a GNU Build System package, however, *configure* must be told explicitly about the build platform: where compilation is performed, and the host platform: where the executable will be run. This is done via the configure options:

- The system on which the package is built.

```
--build=build
```

- The system where built programs and libraries will run.

```
--host=host
```

- When building compiler tools, the system for which the tools will create output:

```
--target=target
```

Specifying the *--host* option tells *configure* that this is a cross compilation build. *configure*, in turn, searches for the cross-compiling suite for the named host platform. In the case of cross-compiling for the Intel® Xeon Phi™ coprocessor on an x86\_64 Linux\* platform, the following configure options are required:

```
--build=x86_64-linux  
--host=k10m-mpss-linux  
--target=k10m-mpss-linux
```

Cross-compilation tools commonly have their target architecture as a prefix of their name, thus *configure* will search for *k10m-mpss-linux-gcc*, etc.

The */opt/mpss/3.6/environment-setup-k10m-mpss-linux* script, mentioned earlier, sets up for GNU Build System based builds, defining environment variables as needed by *configure* and *make*, and by *rpm* installation into the SDK. In particular, it defines the configure options described above and prepends to PATH such that *configure* will find the cross tools.

**Note:** The resulting PATH will cause certain binaries, such as python, to be found in */opt/mpss/3.6/sysroots/x86\_64-mpssdk-linux/usr/bin*. It is therefore recommended that only cross-compilation be performed in an environment in which */opt/mpss/3.6/environment-setup-k10m-mpss-linux* has been sourced. This will avoid executing a binary in */opt/mpss/3.6/sysroots/x86\_64-mpssdk-linux/usr/bin* when it was intended to execute the version installed on the host, for example in */usr/bin*.

### 8.1.3 Example case: zsh

*mpss-3.6-k10m.tar* includes prebuilt rpm packages for many components. These packages can be directly installed into the coprocessor file system as described in [Chapter 7](#). It does not,



however, include a package for the *zsh* shell. To illustrate the cross-compilation process, we will step through building *zsh*, and installing it into the coprocessor file system.

**Note:** We assume that the rpms in `mpss-3.6-k10m.tar` were extracted to `$MPSS36_K10M`.

### 8.1.3.1 Download and untar the *zsh* source distribution from the internet

```
[host]$ tar xvf zsh-5.0.5.tar.bz2
[host]$ cd zsh-5.0.5
[host]$ export ZSH=`pwd`
```

### 8.1.3.2 Setup the environment, and try to generate a Makefile

Source the *environment-setup-k10m-mpss-linux* script and invoke *gnu-configize*:

```
[host]# source /opt/mpss/3.6/environment-setup-k10m-mpss-linux
[host]# gnu-configize
```

*gnu-configize* is an Autotools generated binary whose purpose is to update *config.sub*, which, for most software packages, is sufficient to teach it to understand `--host=k10m-mpss-linux`. If *gnu-configize* doesn't work, the most likely reason is that the software package wasn't generated by autotools—perhaps the *configure* script was hand-written; in this case you'll probably have to read the code to determine how to properly cross compile it. Cross compiling software that doesn't use autotools is beyond the scope of this document.

Now invoke the *zsh configure* script. In this example, *configure* fails due to an unresolved dependency on *ncurses* and *ncurses-devel*. The output from *configure* is abbreviated:

```
[host]# ./configure $CONFIGURE_FLAGS --prefix=/usr \
--libdir=/usr/lib64
configure: WARNING: unrecognized options: --with-libtool-sysroot
configure: loading site script /opt/mpss/3.6/site-config-k10m-mpss-
linux
:
checking for library containing tigetflag... no
checking for library containing tgetent... no
configure: error: in '/home/mic/Downloads/zsh-5.0.5':
configure: error: "No terminal handling library was found on your
system.
This is probably a library called 'curses' or 'ncurses'. You may
need to install a package called 'curses-devel' or 'ncurses-devel'
on your
system."
See 'config.log' for more details
```

### 8.1.3.3 Resolve dependency issues

The next step is to satisfy dependencies; this is an iterative process. Prebuilt packages for both *ncurses* and *ncurses-dev* are included in *mpss-3.6-k10m.tar*.

Install *ncurses* and *ncurses-dev*:

```
[host]# rpm --root $OECORE_TARGET_SYSROOT --dbpath /var/lib/rpm \
-i $MPSS36_K10M/ncurses-5.9-r8.1.k10m.rpm \
-i $MPSS36_K10M/ncurses-dev-5.9-r8.1.k10m.rpm
```





```
error: Failed dependencies:
libform5 is needed by ncurses-dev-5.9-r8.1.klom
libtic5 is needed by ncurses-dev-5.9-r8.1.klom
libpanel5 is needed by ncurses-dev-5.9-r8.1.klom
libmenu5 is needed by ncurses-dev-5.9-r8.1.klom
/usr/lib64/libform.so.5 is needed by ncurses-dev-5.9-r8.1.klom
/usr/lib64/libmenu.so.5 is needed by ncurses-dev-5.9-r8.1.klom
/usr/lib64/libpanel.so.5 is needed by ncurses-dev-5.9-r8.1.klom
/usr/lib64/libtic.so.5 is needed by ncurses-dev-5.9-r8.1.klom
```

We now see that *libform5*, *libtic5*, *libpanel5*, and *libmenu5* are also needed. Adding them to the command reveals that *libncurses* is also needed:

```
[host]# rpm --root $OECORE_TARGET_SYSROOT --dbpath /var/lib/rpm \
-i $MPSS36_K10M/ncurses-5.9-r8.1.klom.rpm \
$MPSS36_K10M/ncurses-dev-5.9-r8.1.klom.rpm \
$MPSS36_K10M/libform5-5.9-r8.1.klom.rpm \
$MPSS36_K10M/libtic5-5.9-r8.1.klom.rpm \ $MPSS36_K10M/libpanel5-5.9-
r8.1.klom.rpm \
$MPSS36_K10M/libmenu5-5.9-r8.1.klom.rpm
error: Failed dependencies:
libncurses5 >= 5.9 is needed by libform5-5.9-r8.1.klom
libncurses.so.5() (64bit) is needed by libform5-5.9-r8.1.klom
libncurses5 >= 5.9 is needed by libpanel5-5.9-r8.1.klom
libncurses.so.5() (64bit) is needed by libpanel5-5.9-r8.1.klom
libncurses5 >= 5.9 is needed by libmenu5-5.9-r8.1.klom
libncurses.so.5() (64bit) is needed by libmenu5-5.9-r8.1.klom
```

When *libncurses* is added to the command, it reveals that *pkgconfig* is needed:

```
[host]# rpm --root $OECORE_TARGET_SYSROOT --dbpath /var/lib/rpm -i \
$MPSS36_K10M/ncurses-5.9-r8.1.klom.rpm \

$MPSS36_K10M/ncurses-dev-5.9-r8.1.klom.rpm \

$MPSS36_K10M/libform5-5.9-r8.1.klom.rpm \

$MPSS36_K10M/libtic5-5.9-r8.1.klom.rpm \

$MPSS36_K10M/libpanel5-5.9-r8.1.klom.rpm \

$MPSS36_K10M/libmenu5-5.9-r8.1.klom.rpm \

$MPSS36_K10M/libncurses5-5.9-r8.1.klom.rpm

error: Failed dependencies:

    pkgconfig is needed by ncurses-dev-5.9-r8.1.klom
```

When *pkgconfig* is added to the command, we see that *libpopt0* is also needed:

```
[host]# rpm --root $OECORE_TARGET_SYSROOT --dbpath /var/lib/rpm -I \
$MPSS36_K10M/ncurses-5.9-r8.1.klom.rpm \

$MPSS36_K10M/ncurses-dev-5.9-r8.1.klom.rpm \

$MPSS36_K10M/libform5-5.9-r8.1.klom.rpm \
```



```
$MPSS36_K10M/libtic5-5.9-r8.1.k10m.rpm \  
$MPSS36_K10M/libpanel5-5.9-r8.1.k10m.rpm \  
$MPSS36_K10M/libmenu5-5.9-r8.1.k10m.rpm \  
$MPSS36_K10M/libncurses5-5.9-r8.1.k10m.rpm \  
$MPSS36_K10M/pkgconfig-0.25-r3.k10m.rpm  
error: Failed dependencies:  
  
    libpopt0 >= 1.16 is needed by pkgconfig-0.25-r3.k10m  
  
    libpopt.so.0() (64bit) is needed by pkgconfig-0.25-r3.k10m  
  
    libpopt.so.0(LIBPOPT_0) (64bit) is needed by pkgconfig-0.25-  
r3.k10m
```

So we add libpopt0 to the command, and rpm installation completes:

```
[host]# rpm --root $OECORE_TARGET_SYSROOT --dbpath /var/lib/rpm -i \  
$MPSS36_K10M/ncurses-5.9-r8.1.k10m.rpm \  
$MPSS36_K10M/ncurses-dev-5.9-r8.1.k10m.rpm \  
$MPSS36_K10M/libform5-5.9-r8.1.k10m.rpm \  
$MPSS36_K10M/libtic5-5.9-r8.1.k10m.rpm \  
$MPSS36_K10M/libpanel5-5.9-r8.1.k10m.rpm \  
$MPSS36_K10M/libmenu5-5.9-r8.1.k10m.rpm \  
$MPSS36_K10M/libncurses5-5.9-r8.1.k10m.rpm \  
$MPSS36_K10M/pkgconfig-0.25-r3.k10m.rpm \  
$MPSS36_K10M/libpopt0-1.16-r0.k10m.rpm
```

Now, try to configure the build again (abridged output shown):

```
[host]$ cd $ZSH  
[host]$ ./configure $CONFIGURE_FLAGS --prefix=/usr \  
--libdir=/usr/lib64  
configure: WARNING: unrecognized options: --with-libtool-sysroot  
configure: loading site script /opt/mpss/3.6/site-config-k10m-mpss-linux  
configuring for zsh 5.0.5  
:  
:  
zsh configuration  
-----  
zsh version : 5.0.5  
host operating system : k10m-mpss-linux-gnu  
source code location : .  
compiler : k10m-mpss-linux-gcc  
preprocessor flags : -m64 --sysroot=/opt/mpss/3.6/sysroots/k10m-mpss-  
linux
```



```
executable compiler flags : -m64 --sysroot=/opt/mpss/3.6/sysroots/k10m-mpss-linux
executable linker flags : --sysroot=/opt/mpss/3.6/sysroots/k10m-mpss-linux -rdynamic
library flags : -ldl -ltinfo -lrt -lm -lc
installation basename : zsh
binary install path : /usr/bin
man page install path : ${prefix}/share/man
info install path : ${prefix}/share/info
functions install path : ${prefix}/share/zsh/5.0.5/functions
See config.modules for installed modules and functions.
```

Configuration was successful, and a *Makefile* has been generated.

### 8.1.3.4 Build the binaries with the generated Makefile

You can now build *zsh*:

```
[host]$ make
make[1]: Entering directory `/home/mic/Downloads/zsh-5.0.5/Src'
:
:
make[1]: Nothing to be done for `all'.
make[1]: Leaving directory `/home/mic/Downloads/zsh-5.0.5/Doc'
```

### 8.1.3.5 Install the Component

You are now ready to install *zsh*. Where and how you install it depends to some extent on whether you are doing assisted configuration or manual configuration (see [Chapter 4](#)), and other considerations. If doing assisted configuration, one approach is to install the files into the *CommonDir* overlay directory, that is, the directory identified by the *CommonDir* configuration parameter. On booting a coprocessor, the *CommonDir* directory overlays the *Base* file system of each coprocessor (see [Section 4.1.1](#)). Here we assume the default location for *CommonDir*:

```
[host]# make install DESTDIR=/var/mpss/common
```

If doing manual configuration, you might install directly into a file system image. To do this, you must first expand the compressed cpio archive. Here we expand some ramfs image to `$HOME/initramfs`:

```
[host]$ mkdir $HOME/initramfs; cd $HOME/initramfs
[host]# gunzip -c <current_ramfs_location> | cpio -ivd
```

where `<current_ramfs_location>` is the path to some compressed CPIO file system archive.

Then install *zsh* into the file system image:

```
[host]# make install DESTDIR=$HOME/initramfs
```

Finally re-archive the file system image:

```
[host]# find . | cpio -o -H newc | gzip > <new_ramfs_location>
```

where `<new_ramfs_location>` is the name of the file system archive to be created.



Of course, you can also install into an empty directory and then tar the resulting hierarchy for later use.

### 8.1.4 Cross compiling with `icc`

For many tools and components, such as `zsh`, execution performance is not critical, and cross compiling with `gcc` is recommended. However, when building performance critical applications, cross compiling with `icc` is likely to result in better performance. Generally speaking, if an application can be compiled for `x86_64` using `icc`, then it can be cross compiled for the Intel® Xeon Phi™ coprocessor using `icc`. Since such performance sensitive applications are almost always ported to `x86_64` and `icc`, it follows that most such applications can be cross compiled for execution on the coprocessor.

The process for cross compiling with `icc` is as described above except that some variables need to be modified when calling `configure`:

- `CC` needs to be set to `icc`
- `CFLAGS` needs to be extended by `-mmic`
- `CXXFLAGS` needs to be extended by `-mmic`

A complete example might look like:

```
[host]$ ./configure $CONFIGURE_FLAGS --prefix=/usr \  
--libdir=/usr/lib64 LDFLAGS='' LD=klom-mpss-linux-ld \  
CPPFLAGS='' CC=icc CFLAGS='-mmic' -I/opt/include CXX=icpc \  
CXXFLAGS='-mmic'
```

There is no special cross compiling version of `icc` that generates code for the Intel® Xeon Phi™ coprocessor. Instead, the `-mmic` option to `icc` instructs it to cross compile for the coprocessor. Therefore `icc` is not included in the Intel® MPSS SDK, but rather must be installed on the host as part of Intel® Composer XE installation. The `klom-mpss-linux-ld` cross linker is still needed.

## 8.2 Native Compilation

Native compilation on the Intel® Xeon Phi™ coprocessor can often be easier than cross compilation. As we did for cross compilation, we focus here on building software packages created using the autotools.

As mentioned previously, the coprocessor does not have a hard disk based file system, so all tools, source code and temporary files need to fit into its memory. Large projects might require you to use alternatives, such as an NFS mounted file system.

Because there is no native version of the Intel® ICC compiler, native compilation uses `gcc` and is thus generally limited to components that are not particularly performance sensitive; performance oriented applications should be cross compiled using the Intel® ICC compiler.

In order to perform native compilation, `gcc`, the GNU binutils, and other common development tools must be installed into the coprocessor's file system. These components are not already installed in the `initramfs` to save space. This is performed by installing a single rpm, `task-mpss-toolchain`.



You can then perform the same autotools build process previously described, installing additional dependent rpms as needed. When you have successfully built the component, you will have to decide what you will do with the build results. For example, `make installing` the result into a local ramfs file system is not persistent unless the resulting file system image is captured for subsequent reuse. Alternatively, `make installing` the result into an NFS mounted file system captures the component for subsequent invocations.

To illustrate native compilation, we'll build and install emacs. We'll assume that you have already booted the coprocessor on which you will perform the build.

## 8.2.1 Create and attach to a repo

The first step is to create a repository of the rpms in the `mpss-3.6-k10m.tar` and start an http server to serve the repo data:

```
[host]$ tar -xf mpss-3.6-k10m.tar
[host]$ cd $MPSS36_K10M
[host]$ createrepo .
[host]$ python -m SimpleHTTPServer
```

Next, ssh to the selected coprocessor and add the repo:

```
[host]$ ssh root@micN
[micN]# zypper ar http://host:8000 mpss
```

## 8.2.2 Install the development tool chain

The default coprocessor file system does not include software development tools, so these must now be installed:

```
[micN]# zypper install task-mpss-toolchain
```

Installing the `task-mpss-toolchain-3.6-0.1.rc4.all.rpm` causes the following components to be installed as dependencies:

*cpp-symlinks, flex, byacc, cmake, makedepend, gperf, g++-symlinks, gcov-symlinks, gnu-config, pkgconfig, patch, automake, m4, bison, gccmakedep, gcc-symlinks, autoconf, libtool, elfutils, binutils-symlinks, and make*

Because building `task-mpss-toolchain-3.6-0.1.rc4.all.rpm` takes considerable time and adds significantly to the size of the file system, consider capturing the file system at this point for later reuse in building other components. See [Sections 7.1](#) and [7.2](#) for help.

## 8.2.3 Configure the build directory

Next, from the host, copy the software package that is to be built to the coprocessor file system. We will build `emacs` to illustrate this process:

```
[host]$ scp emacs-24.3.tar.gz mic0:/tmp
```

Now, on the coprocessor, try to configure the build directory:

```
[host]$ ssh micN
[micN]$ cd /tmp
```



```
[micN]$ tar xvf emacs-24.3.tar.gz
[micN]$ cd emacs-24.3
[micN]$ gnu-configize
[micN]$ ./configure --prefix=/usr --libdir=/usr/lib64
checking for a BSD-compatible install... build-aux/install-sh -c
checking whether build environment is sane... yes
:
configure: error: The required function `tputs' was not found in any
library.
The following libraries were tried (in order):
  libtinfo, libncurses, libterminfo, libtermcap, libcurses
Please try installing whichever of these libraries is most
appropriate
for your system, together with its header files.
For example, a libncurses-dev(el) or similar package.
```

Just as in cross-compiling **zsh**, we need to install *ncurses*. Assuming that the repo is still attached, this can be done easily with **zypper** (as root):

```
[micN]# zypper install ncurses-dev
```

We can now successfully configure the build directory:

```
[micN]$ ./configure --prefix=/usr --libdir=/usr/lib64
```

**Note:** In the case that **configure** has failed, it is sometimes helpful to execute:

```
[micN]$ make distclean
```

before executing **configure** again.

## 8.2.4 Make and install the package

Make the software package:

```
[mic]$ make
```

You can now just install the package into the current file system:

```
[mic]# make install
```

Alternatively, you can capture the results for later installation into some other file system image. For example, the following installs the package to some specified subdirectory, then creates a tarfile, *emacs.tar*, of that subdirectory:

```
[mic]# make install DESTDIR=`pwd`/tarhere
[mic]# tar -cf emacs.tar -C tarhere .
```

Copy the tar file to the host to save it:

```
[host]$ scp mic0:/tmp/emacs.tar .
```

The tar file can later be expanded onto an NFS mounted file system on the host, for example:

```
[host]# tar -xf emacs.tar -C /var/mpss/mic0.export
```

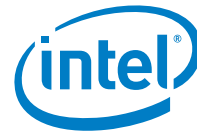

**Compilation for the Intel® Xeon Phi™ Coprocessor**

or copied to a coprocessor and expanded, for example:

```
[host]$ scp emacs.tar micN:/tmp
[host]$ ssh micN
[mic]$ cd /tmp
[mic]# tar -xf emacs.tar -C /
```



## 9 Intel® MPSS Component Configuration and Tuning

---

### 9.1 Intel® Xeon Phi™ Coprocessor Operating System Configuration and Tuning

#### 9.1.1 Clock Source for the Intel® Xeon Phi™ Coprocessor

By default, the Time Stamp Counter (TSC) is the clock source on the Intel® Xeon Phi™ coprocessor. The power management software for the coprocessor will keep the TSC clock source calibrated even when deep sleep states are enabled. Calibration of the TSC avoids clock drift.

Each coprocessor core also has an Elapsed Time Counter (MICETC). However, when MICETC is the clock source, the *gettimeofday()* access time is on the order of 100x slower than when TSC is the clock source.

The available clock sources can be queried from sysfs on a coprocessor:

```
[micN]$ cat /sys/devices/system/clocksource/clocksource0/\
available_clocksource
tsc micetc
```

and the current clock source can be queried from sysfs, for example:

```
[micN]$ cat /sys/devices/system/clocksource/clocksource0/\
current_clocksource
tsc
```

The clock source can be changed by writing to sysfs, for example:

```
[micN]# echo micetc > /sys/devices/system/clocksource/clocksource0/\
current_clocksource
```

#### 9.1.2 Process Oversubscription

Only configure concurrent processing when there is a real need for this feature. Otherwise, any workload running with the concurrent active processes on the device will likely result in performance degradation.

To run more concurrent processes, set the limit of file descriptors to 10 for each offload process. Depending on the memory usage of each process, a large number of concurrent offload processes may exhaust memory on the device.

To run 200 concurrent processes, users will need to modify the following parameters. Changes to the configuration will not persist when modifying the files directly on the card; a reboot will





reset these settings. To permanently change the configuration, refer to the documentation on *micctrl* and file overlays.

- 1) On the host, log into the card as superuser.

```
[host]# ssh micN
```

- 2) Locate and terminate the Intel® COI active process.

```
[micN]# ps axf | grep coi
5147 ? S1 0:00 /usr/bin/coi_daemon --coiuser=micuser
[micN]# killall coi_daemon
```

- 3) Set the concurrent process to 200.

```
[micN]# ulimit -n 200
[micN]# /usr/bin/coi_daemon --coiuser=micuser \
--max-connections=200 &
[micN]# exit
```

For the complete list of *coi\_daemon* parameters, refer to the *coi\_daemon* help option:

```
[micN]$ /usr/bin/coi_daemon -h
```

### 9.1.3 Verbose Logging

Verbose output of coprocessor kernel boot messages can be disabled or enabled.

Assisted Configuration of verbose logging is controlled by the *VerboseLogging* configuration parameter in */etc/mpss/default.conf* or */etc/mpss/micN.conf* configuration files:

```
VerboseLogging <Disabled|Enabled>
```

The default is:

```
VerboseLogging Disabled
```

For Manual Configuration, the *quiet* kernel command line parameter disables verbose logging.

### 9.1.4 Cgroup memory control

The cgroups memory controller can be disabled or enabled. The cgroups memory controller, when enabled, can limit the amount of memory available to an application or group of applications.

Assisted Configuration of cgroups is controlled by the *Cgroup* parameter in */etc/mpss/default.conf* or */etc/mpss/micN.conf* configuration files:

```
Cgroup [memory=(disabled|enabled)]
```

The default is:

```
Cgroup memory=disabled
```

For Manual Configuration, the *cgroup\_disable=memory* kernel command line parameter disables cgroups memory control. The absence of this parameter enables control.



## 9.1.5 Power Management control

Power management control can be disabled or enabled.

Assisted Configuration of power management is accomplished by the presence of the *PowerManagement* parameter in */etc/mpss/default.conf* or */etc/mpss/micN.conf* configuration files:

```
PowerManagement cpufreq_(on|off);corec6_(on|off):  
pc3_(on|off):pc6_(on|off)
```

The default varies by Intel® Xeon Phi™ coprocessor stepping.

For Manual Configuration, the

```
micpm=cpufreq_(on|off);corec6_(on|off);pc3_(on|off);pc6_(on|off)
```

kernel command line parameter controls power management.

**Note:** Default power management settings are recommended unless directed by an Intel® representative to change them.

## 9.1.6 VFS Optimizations

As described in [Section 1.2.1.2](#), a VFS technology preview is intended to improve the performance of system calls for reading and writing files on tmpfs and ramfs mount points. The following kernel command line options provide additional control to enable or disable the read and write optimizations:

- `vfs_read_optimization` - on/off. If not specified, it is off by default. When on, it enables read side optimizations for files in the above file systems.
- `vfs_write_optimization` - on/off. If not specified, it is off by default. When on, it enables write side optimizations for files in the above file systems.

As an example, to enable read optimizations, add `vfs_read_optimization` to the `ExtraCommandLine` as follows:

1. Edit */etc/mpss/default.conf*
2. Append "`vfs_read_optimization=on`" to the `ExtraCommandLine` parameter.
3. Restart the mpss service

For more information on the `ExtraCommandLine` parameter, see [Section A.3.1](#)

## 9.2 Host Driver Configuration

### 9.2.1 Lost Node Watchdog

The host driver includes a watchdog intended to detect and report to the host when another coprocessor (node) in the SCIF network is not responding.



## Intel® MPSS Component Configuration and Tuning

- The watchdog is controlled by the “watchdog” parameter in the host’s */etc/modprobe.d/mic.conf* module parameter control file.
- If the host driver is loaded it must be reloaded. Follow the procedure:

```
[host]# lservice mpss unload  
[host]# lservice mpss start
```

The watchdog is enabled by default.

### 9.2.2 Watchdog Auto-Reboot

On detecting a *lost* node, the host driver will either reset the node back to the *ready* state, or reboot the node to the *online* state.

- Watchdog auto-reboot is controlled by the *watchdog\_auto\_reboot* parameter in the host’s */etc/modprobe.d/mic.conf* module parameter control file.
- To change this parameter, the Intel® MPSS host driver must be reloaded if it is currently running. Follow the procedure:

```
[host]# lservice mpss unload  
[host]# lservice mpss start
```

Watchdog auto-reboot reboots the node to the online state by default.

### 9.2.3 Crash Dump Capture

The host driver can capture a coprocessor OS kernel crash dump to a file on the host.

- Crash dump capture is controlled by the *crash\_dump* parameter in the host’s */etc/modprobe.d/mic.conf* module parameter control file.
- To change this parameter, the Intel® MPSS host driver must be reloaded if it is currently running. Follow the procedure:

```
[host]# lservice mpss unload  
[host]# lservice mpss start
```

Crash dump capture is enabled by default.

## 9.3 SCIF Configuration

### 9.3.1 Peer to Peer (P2P) Support

SCIF supports the direct transfer of data from one Intel® Xeon Phi™ coprocessor directly into the physical memory of another coprocessor on the same host. This capability is referred to as Peer to Peer or P2P.

- P2P is controlled by the *p2p* parameter in the host’s */etc/modprobe.d/mic.conf* module parameter control file.



- To change this parameter, the Intel® MPSS host driver must be reloaded if it is currently running. Follow this procedure:

```
[host]# service mpss unload  
[host]# service mpss start
```

P2P support is enabled by default.

### 9.3.2 Peer to Peer Proxy Control

Under certain circumstances, SCIF implements peer-to-peer DMA reads (reading data from some remote peer coprocessor to the local coprocessor) into a peer-to-peer DMA write from the remote coprocessor to the local coprocessor. This is done to improve performance.

- P2P proxy is controlled by the `p2p_proxy` parameter in the host's `/etc/modprobe.d/mic.conf` module parameter control file.
- To change this parameter, the Intel® MPSS host driver must be reloaded if it is currently running. Follow this procedure:

```
[host]# service mpss unload  
[host]# service mpss start
```

P2P proxy is enabled by default.

### 9.3.3 Ulimit Checks for Max Locked Memory in SCIF

SCIF can enforce ulimit checks of the memory that `scif_register()` locks. Pages locked using `scif_register()` are counted towards the ulimit.

- P2P proxy is controlled by the `ulimit` parameter in the host's `/etc/modprobe.d/mic.conf` module parameter control file.
- To change this parameter, the Intel® MPSS host driver must be reloaded if it is currently running. Follow this procedure:

```
[host]# service mpss unload  
[host]# service mpss start
```

Ulimit checking is disabled by default.

**Note:** In kernel versions later than 3.1.0, the kernel has two different limits for locked pages: one limit for pages locked using standard system calls and another limit for pages locked by kernel modules on behalf of user processes.

### 9.3.4 Registration Caching

**Note:** The mechanism for specifying the pinned pages limit may change in a future release.

Registration caching is a SCIF feature intended to improve the performance of `scif_vreadfrom()/scif_vwriteto()`. When registration caching is enabled, SCIF caches virtual to physical address translations of the virtual addresses passed to `scif_vreadfrom()/scif_vwriteto()`, thus eliminating the overhead of pinning pages when the same virtual range is specified in future calls.



## Intel® MPSS Component Configuration and Tuning

- Registration caching is controlled by the “reg\_cache” parameter in the host’s */etc/modprobe.d/mic.conf* module parameter control file.
- To change this parameter, the Intel® MPSS host driver must be reloaded if it is currently running. Follow the procedure:

```
[host]# lservice mpss unload  
[host]# lservice mpss start
```

Registration caching is enabled by default.

### 9.3.5 Registration Caching Limit

There is a per-node tunable limit on the maximum number of pinned pages per SCIF endpoint. This limit can only be modified by the root user.

- Set the maximum number of pinned pages by writing to the coprocessor’s */proc/scif/reg\_cache\_limit* node:

```
[host]# echo <limit> > /proc/scif/reg_cache_limit
```

where <limit> is the decimal number of 4K pages.

- To disable caching at runtime, set the <limit> to 0 on each node.

### 9.3.6 Huge Page Support

SCIF has support for Huge Pages. Huge Pages should not to be confused with Transparent Huge Pages (THP); SCIF support of THP is always enabled.

- Huge Page support is controlled by the “huge\_page” parameter in the host’s */etc/modprobe.d/mic.conf* module parameter control file.
- If the host driver is loaded it must be reloaded. Follow this procedure:

```
[host]# lservice mpss unload  
[host]# lservice mpss start
```

Huge Page support is enabled by default.

## 9.4 COI Configuration

### 9.4.1 COI Offload User Options

The *coi\_daemon* on an Intel® Xeon Phi™ processor spawns processes on behalf of client processes on the host processor.

#### 9.4.1.1 Ownership Modes

The *coi\_daemon* has several options for assigning ownership of these COI processes.



### 9.4.1.1.1 micuser Ownership

When operating in *micuser* mode, each COI process spawned by the *coi\_daemon* is owned by user *micuser*.

### 9.4.1.1.2 \_Authorized User Ownership

When operating in *\_Authorized* mode, each COI process spawned by the *coi\_daemon* is owned by same user as the corresponding host client process. Authentication of user credentials occurs using an *.mpsscookie* file located in the user's home directory. The cookie is created and managed by the host's *mpss* daemon.

### 9.4.1.1.3 \_Dynamic User Ownership

When operating in *\_Dynamic* mode, each COI process spawned by the *coi\_daemon* is owned by a new, unique user created by the *coi\_daemon*. Files and directories created by such a process cannot be accessed by other COI processes. This effectively isolates all COI Processes from each other for better security.

**Note:** the *\_Dynamic* mode will be removed in future release.

## 9.4.1.2 Configuring the Ownership Mode

The Ownership mode is configured by the presence of the parameter:

```
coiparams='--coiuser=<mode>'
```

in one of the following files in the Intel® Xeon Phi™ coprocessor file system:

```
/etc/init.d/coi
```

```
/etc/coi.conf
```

```
/etc/sysconfig/coi.conf
```

and where *<mode>* is one of *micuser*, *\_Authorized*, or *\_Dynamic*.

*micuser* ownership mode is configured, by default, in the coprocessor's */etc/init.d/coi* file:

```
coiparams='--coiuser=micuser' #default parameters at boot
```

When */etc/coi.conf* contains the *coiparams* parameter, it takes precedence over */etc/init.d/coi*. When */etc/sysconfig/coi.conf* contains the *coiparams* parameter, it takes precedence over */etc/coi.conf* and */etc/init.d/coi*.

A change to the ownership mode only occurs when the *coi* daemon is restarted:

```
[micN]# /etc/init.d/coi restart
```

**Note:** Changes to files that reside in coprocessor memory are not retained when the coprocessor is shut down or restarted. Refer to [Chapter 7](#) for information on preserving changes to the coprocessor file system.

Alternatively, the *--coiuser* option can be passed to the *coi\_daemon* when it is started:

```
[micN]# coi_daemon --coiuser=<mode>
```



### 9.4.1.3 Example

The following configures for the `_Authenticated` user mode, overriding whatever is configured in `/etc/init.d/coi` and `/etc/coi.conf`:

```
[micN]# echo coiparams='--coiuser=_Authorized' > \
  /etc/sysconfig/coi.conf
[micN]# /etc/init.d/coi restart
```

For detailed information about the `--coiuser` and other `coi_daemon` parameters, run the `coi_daemon` on the card with the `--help` option:

```
[micN]$ coi_daemon --help
```

## 9.5 Virtual Console Configuration and Access

On a SLES\* host, `minicom` prompts for a username and password when logging into the coprocessor. Use `micctrl --passwd<=user>` to set the password for a user before using the virtual console on `minicom`.

The virtual console devices are `/dev/ttyMICN` for the each Intel® Xeon Phi™ coprocessor `micN`.

To configure `minicom` for virtual console access, perform the following instructions for each coprocessor:

1. Start `minicom`:

```
[host]# minicom -s
```

2. Select "Serial Port Setup"

- a. Choose option: **A - Serial Device**
- b. Edit Serial Device to `/dev/ttyMIC0`
- c. Hit **<Enter>** twice.

3. Select "Modem and dialing"

- a. Choose option: **A - Init string**
- b. Erase the entire line
- c. Hit **<Enter>** twice

4. Select "Save setup as.."

Enter the preferred name, for example: `mic0<enter>`

5. Select "Exit from Minicom"

Each coprocessor should have its own configuration name.

To open the virtual console for a coprocessor:



```
[host]# minicom <configname>
```

where <configname> is the name entered in step 4.

To exit minicom, enter: <CTRL+a> <x> <Enter>

## 9.6 Intel® Xeon Phi™ Coprocessor Virtio Block Device Configuration and Use.

The virtio block device (virtblk) uses the Linux\* virtio data transfer mechanism to implement a block device on the Intel® Xeon Phi™ coprocessor. The virtblk device stores data on the host processor, and therefore can be persistent like a hard or solid-state disk mounted on the coprocessor.

The virtio block device can be one of the following:

- A regular file, for instance: */srv/my\_k10m\_filesys*, or
- A Logical Volume Manager (LVM) volume, or
- A physical device such as */dev/sda4*

The block device to be used is communicated to the *mic.ko* driver by writing its path to the */sys/class/mic/micN/virtblk\_file* sysfs node after coprocessor micN has been booted. The virtblk driver supports only one virtio block device file on the host at any time. Once a virtio block device file is specified by writing to */sys/class/mic/micN/virtblk\_file*, it cannot be changed until the coprocessor is rebooted. To use multiple virtio block devices, create multiple partitions in a virtio block device file. Those partitions are referenced as */dev/vda1*, */dev/vda2*.

If a virtio block device file is not assigned, then unloading the Intel® MPSS host driver will trigger the message "*request comes in while coprocessor side driver is not loaded yet. Ignore*" in *dmesg* and */var/log/messages*.

If the coprocessor side driver, *mic\_virtblk*, is loaded without assigning a virtio block device file, the error message "*Have set virtblk file?*" will be displayed in *dmesg* and */var/log/messages*.

### 9.6.1 Using a Virtio Block Device as an ext2 File System

1) Host side:

Identify the file or block device on which the *virtblk* file system will reside.

```
[host]# echo <path_to_dev> > /sys/class/mic/micN/virtblk_file
```

2) Coprocessor side:

a) Load the *virtblk* driver.

```
[micN]# modprobe mic_virtblk
```

b) Create ext2 file system on *virtblk* and mount it on */mnt/vda*.

```
[micN]# mkdir -p /mnt/vda
[micN]# mkfs.ext2 /dev/vda
[micN]# mount -t ext2 /dev/vda /mnt/vda
```





You can now access `/mnt/vda` as a file structured device.

## 9.6.2 Use the Virtblk Device as a Swap Device File System

1) Host side:

```
[host]# echo <path_to_dev> > /sys/class/mic/micN/virtblk_file
```

2) Coprocessor side:

a) Load the *virtblk* driver:

```
[micN]# modprobe mic_virtblk
```

b) Assign a swap device and confirm:

```
[micN]# swapon /dev/vda  
[micN]# cat /proc/swaps
```

c) You can now use `/dev/vda` as a swap device.



# A Intel® MPSS Configuration Parameters

---

This Appendix describes the parameters in Intel® MPSS configuration files. The Parameter Syntax in the following sections sometimes extends to more than one line. However, each parameter in an actual software stack configuration file must be free of NewLines.

The first line of each parameter description is either:

**Parameter Syntax (default.conf):**

or:

**Parameter Syntax (micN.conf):**

indicating whether the parameter is created by default in a *default.conf* or *micN.conf* configuration file.

The line following *Initial Value:* in the descriptions below is the parameter value initially set by *micctrl --initdefaults*. Not all parameters have an initial value set by *micctrl --initdefaults*.

Intel® configuration file text lines beginning with the # character are treated as comments.

## A.1 Meta Configuration

### A.1.1 Configuration Version

**Parameter Syntax (micN.conf):**

```
Version <major number> <minor number>
```

**Initial Value:**

```
Version 1 1
```

(At this writing.)

**Description:**

The *Version* parameter sets the coprocessor configuration file version. As new releases are produced, the version is used by the *micctrl --initdefaults* command to identify where to update configuration files. This parameter should **NOT** be manually edited.

### A.1.2 Including Other Configuration Files

**Parameter Syntax (micN.conf):**

```
Include <config_file_name>
```

**Initial Value:**

```
Include default.conf  
Include "conf.d/*.conf"
```

**Description:**

Each configuration file can include other configuration files. The *Include* parameter lists configuration file(s) to be included. The configuration file(s) to be included must be in */etc/mpss*. The configuration parser processes each parameter sequentially. When the *Include* parameter is encountered, the included configuration file(s) are immediately processed. If a parameter is set multiple times, the last instance of the parameter setting will be applied.

Each *Include* parameter should identify a single file to be included.

By default, the */etc/mpss/default.conf* file is included at the beginning of each *micN.conf* coprocessor specific file. This allows parameters in the coprocessor specific file to override any parameter set in *default.conf*.

The second entry in the *micN.conf* files is typically (and by default) the line:

```
Include "conf.d/*.conf"
```

This is a special rule, specifying that any configuration file that is placed in the */etc/mpss/conf.d* directory will be included.

## A.2 Boot Control

### A.2.1 What to Boot

**Parameter Syntax (micN.conf):**

```
OSImage <linux_kernel_image> <system_address_map_file>
```

**Initial Value:**

```
OSImage /usr/share/mpss/boot/bzImage-knightscorner  
/usr/share/mpss/boot/System.map-knightscorner
```

**Description:**

The *OSImage* parameter specifies the Intel® Xeon Phi™ coprocessor Linux\* OS boot image and its associated system address map file.

*OSImage* may be changed using the *micctrl --osimage* command or by editing this parameter directly.

### A.2.2 When to Boot

**Parameter Syntax (micN.conf):**

```
BootOnStart (Enabled|Disabled)
```

**Initial Value:**

```
BootOnStart Enabled
```



**Description:**

The *BootOnStart* parameter controls whether the Intel® Xeon Phi™ coprocessor is booted when the mpss service starts. If set to *Enabled*, the *mpssd* daemon will attempt to boot the Intel® Xeon Phi™ coprocessor when `service mpss start` is called.

*BootOnStart* may be changed using the `micctrl --autoboot` command or by editing this parameter directly.

## A.3 Kernel Configuration

These parameters influence or control the execution of the Intel® Xeon Phi™ coprocessor Linux\* kernel through values passed to the kernel in the startup command line.

### A.3.1 ExtraCommandLine

**Parameter Syntax (default.conf):**

```
ExtraCommandLine "<commands>"
```

**Initial Value:**

```
ExtraCommandLine "highres=off"
```

**Description:**

The *ExtraCommandLine* parameter specifies additional kernel command line parameters to be passed to the Intel® Xeon Phi™ coprocessor kernel on boot.

*ExtraCommandLine* may be changed by editing the parameter directly.

### A.3.2 Console Device

**Parameter Syntax (default.conf):**

```
Console "<console device>"
```

**Initial Value:**

```
Console "hvc0"
```

**Description:**

Intel® MPSS software supports a PCIe bus virtual console driver. Its device node (*hvc0*) is the default value assigned to the *Console* parameter, and should not be changed.

### A.3.3 Power Management

**Parameter Syntax (micN.conf):**

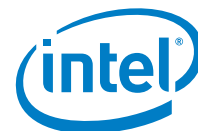

## Intel® MPSS Configuration Parameters

```
PowerManagement  
"cpufreq_(on|off);corec6_(on|off);pc3_(on|off);pc6_(on|off)"
```

### Initial Value:

```
PowerManagement "cpufreq_on;corec6_off;pc3_on;pc6_on"
```

### Description:

The *PowerManagement* parameter is a string of four attributes passed directly to the kernel command line for the card's power management driver. The *mpssd* daemon and *micctrl* utility do not validate any of the parameters in this string or its format.

*PowerManagement* may be changed using the *micctrl --pm* command or by editing this parameter directly.

Intel® Xeon Phi™ coprocessor power states are described in the [Intel® Xeon Phi™ Coprocessor Datasheet](#)

**Note:** It is recommended to use the default power management settings unless directed by an Intel representative to change them.

## A.3.4 ShutdownTimeout

### Parameter Syntax (default.conf):

```
ShutdownTimeout <value>
```

### Initial Value:

```
ShutdownTimeout 300
```

### Description:

Setting *value* to a positive integer specifies the maximum number of seconds to wait for the coprocessor to shut down. If shut down time exceeds the value, the coprocessor is reset.

Setting *value* to any negative value indicates to wait indefinitely for the card to shut down.

Setting *value* to zero indicates to reset the coprocessor without waiting for it to shut down.

*ShutdownTimeout* can be changed by editing the parameter directly.

## A.3.5 CrashDump

### Parameter Syntax (default.conf):

```
CrashDump <dirname> <limit>
```

### Initial Value:

```
CrashDump /var/crash/mic 16
```

### Description:



The *CrashDump* parameter specifies the host directory, *<dirname>*, in which to place coprocessor crash dump files, and the maximum size, *<limit>*, in gigabytes of such files.

*CrashDump* can be changed by editing the parameter directly.

### A.3.6 Cgroup

**Parameter Syntax (*micN.conf*):**

```
Cgroup [memory=(disabled|enabled)]
```

**Initial Value:**

```
Cgroup memory=disabled
```

**Description:**

The *Cgroup* parameter configures cgroups categories. cgroups configuration is currently limited to controlling the status of the memory cgroup.

The memory cgroup is disabled by default. Enabling cgroup memory support may reduce performance.

*Cgroup* may be changed using the *micctrl --cgroup* command or by editing the parameter directly.

### A.3.7 VerboseLogging

**Parameter Syntax (*micN.conf*):**

```
VerboseLogging (Enabled|Disabled)
```

**Initial Value:**

```
VerboseLogging Disabled
```

**Description:**

The *VerboseLogging* parameter specifies whether the *quiet* kernel command line parameter is passed to the Intel® Xeon Phi™ coprocessor on boot. The *quiet* kernel parameter suppresses most kernel messages during kernel boot. *VerboseLogging* is disabled by default. Enabling *VerboseLogging* will increase boot times.

*VerboseLogging* may be changed by editing the parameter directly.

**Note:** This parameter may be deprecated in future releases.

## A.4 File System Configuration Parameters

### A.4.1 RootDevice

**Parameter Syntax (*micN.conf*):**

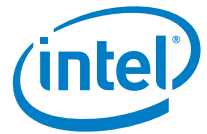

## Intel® MPSS Configuration Parameters

```
RootDevice (Ramfs|StaticRamfs) <ramfs_location>  
RootDevice NFS <share>  
RootDevice SplitNFS <share> <usr_share>
```

### Initial Value:

```
RootDevice Ramfs /var/mpss/mic0.image.gz
```

### Description:

The *RootDevice* parameter defines the type of root device to mount. Supported types are *RamFS*, *StaticRamFS*, *NFS*, and *SplitNFS*.

The *RamFS* type builds a compressed cpio ram disk image when a request to boot is received. *<ramfs\_location>* is the directory path and file name of the resulting ram disk image. The image is used as the contents to be loaded into the root *tmpfs* file system.

The *StaticRamFS* type causes the compressed cpio image *<ramfs\_location>* to be used as the contents of the root file system for the booting coprocessor. The *StaticRamFS* boot will fail if the image file is not already present at *<ramfs\_location>*.

The static ramfs image may have been previously created by booting with *RootDevice* set to *RamFS*. Optionally, when *RootDevice* is *StaticRamFS*, the *micctrl --updateramfs* command causes a compressed cpio image to be built and placed at the *<ramfs\_location>* of the *StaticRamFS* parameter. System administrators may also supply their own initial ram disk image.

The *NFS* type instructs the booting coprocessor to mount the NFS share specified by the *<share>* argument as the root file system. *<share>* must be a fully qualified NFS mount location with the format "server:location", for example *10.10.10.12:/export/mic0*.

The *SplitNFS* type is the same as *NFS* except it also provides a separate NFS share at *<usr\_share>* to mount as the */usr* directory on the card.

*RootDevice* may be changed using the *micctrl --rootdev* command or by editing the parameter directly.

## A.4.2 File Locations

The *mpssd* daemon and *micctrl* command require the location of the files to be placed in the final root disk image to be used on the card. The files are located using the four configuration parameters *Base*, *CommonDir*, *Overlay*, and *MicDir*. Of the four, the *Overlay* parameter is the only one allowed to be specified multiple times.

These parameters collectively specify all the files from which a root file system cpio image is to be built.

### A.4.2.1 Base

#### Parameter Syntax (micN.conf):

```
Base (CPIO|DIR) <target>
```

#### Initial Value:

```
Base CPIO /usr/share/mpss/boot/initramfs-knightscorner.cpio.gz
```

**Description:**

The *Base* parameter specifies the file system hierarchy over which other hierarchies are overlaid to produce the initial file system of an Intel® Xeon Phi™ coprocessor. When the *Base* type is *CPIO*, *<target>* is interpreted as the file name of a CPIO file system archive. When the *Base* type is *DIR*, *<target>* is interpreted as the root of an expanded (non-archived) file system.

*Base* may be changed using the *micctrl --base* command or by editing the parameter directly.

### A.4.2.2 CommonDir

**Parameter Syntax (default.conf):**

```
CommonDir <source> <target>
```

**Initial Value:**

```
CommonDir /var/mpss/common
```

**Description:**

The *CommonDir* parameter defines a directory at *<source>* whose contents overlay the *Base* file system at */*. Thus if *CommonDir* is */var/mpss/common* and there is a file */var/mpss/common/foo/bar*, then that file will be found as */foo/bar* in the resulting file system.

Intel® MPSS installation does not create or populate the *CommonDir* directory. It is typically created by the *micctrl --initdefaults* command. Files that are added to this directory are maintained between updates to the Intel® MPSS installation.

*<target>* is a deprecated argument, which will be ignored. If present when *micctrl --resetdefaults* is executed, the *<target>* argument will be removed.

*CommonDir* may be changed using the *micctrl --commondir* command or by editing the parameter directly.

### A.4.2.3 MicDir

**Parameter Syntax (micN.conf):**

```
MicDir <location>
```

**Initial Value:**

```
MicDir /var/mpss/micN
```

**Description:**

The *MicDir* parameter defines a directory at *<location>* whose contents overlay the *CommonDir* file system at */* to create file system unique each coprocessor. Intel® MPSS installation does not create or populate. It is typically created by the *micctrl --initdefaults* command. Files that are added to this directory are maintained between updates to the Intel® MPSS installation.

*MicDir* may be changed using the *micctrl --micdir* command or editing the parameter directly.



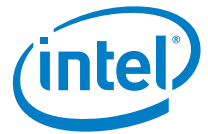

**Note:** In some previous Intel® MPSS versions, MicDir took a <descriptor file> parameter:

```
MicDir <location> <descriptor file>
```

The <descriptor file> parameter identified a file that described where files in the directory subtree at <location> were to be placed in the Intel® Xeon Phi™ coprocessor's file system, and the permissions of those files. The <descriptor file> parameter to MicDir has been deprecated. New configuration files generated with the `micctrl --initdefaults` command do not include it. If the `micctrl --resetdefaults` command is executed, the <descriptor file> argument will be removed wherever it is found.

#### A.4.2.4 Overlay

##### Parameter Syntax (*micN.conf*):

```
Overlay (Filelist|Simple|File) <source> <target> (on|off)
Overlay RPM <source> (on|off)
```

##### Initial Value:

<None>

##### Description:

The *Overlay* parameter specifies a file or set of files that are to be added to the initial file system, overlaying the *Base*, *CommonDir*, and *MicDir* specified directory hierarchies. There can be multiple *Overlay* parameters. If the *Overlay* state value is *off*, the parameter is ignored. The *Overlay* parameter is obeyed if the state value is *on*.

*Overlay File* overlays the file <source> onto the initial file system image at <target>. Directory and file ownership and permissions are preserved.

*Overlay Simple* overlays the file system hierarchy at <source> onto the initial file system image at <target>. Directory and file ownership and permissions are preserved.

*Overlay RPM* copies the <source> file to a special */RPMs-to-install* directory in the initial file system. During the coprocessor boot process, the *init* program will attempt to install any RPMs which it finds in that directory. Other types of files are ignored.

*Overlay Filelist* overlays files in the directory <source> onto the initial file system image based on specifications in the <target> file. Use of *Overlay Filelist* is deprecated.

*Overlay* may be changed using the `micctrl --overlay` command or editing the parameter directly.

**Note:** Do not overlay \$MPSS36\_K10M. That is, do not define a parameter similar to:

```
Overlay RPM $MPSS36_K10M on
```

Doing so will cause `micctrl` to attempt to upload and install all the *rpms* in the \$MPSS36\_K10M, and will likely result in the coprocessor running out of memory or hanging.

#### A.4.3 Intel® MPSS RPM Location

##### Parameter Syntax (*micN.conf*):



```
K1omRpms <location>
```

**Initial Value:**

```
<None>
```

**Description:**

The implementation of some *micctrl* commands, specifically those which configure for use of *LDAP* and *NIS* services, needs to know where to find the set of RPM files that it needs to complete installation of *LDAP* and *NIS* in the coprocessor file system. The *K1omRpms* parameter should point to such a *<location>*. This parameter is not defined by default. In general, it can be set to the directory which we refer to symbolically as *\$MPSS36\_K10M*.

*K1omRpms* may be changed using the *micctrl --rpmdir* command or by editing the parameter directly.

## A.5 Network Configuration

### A.5.1 Host Name Assignment

**Parameter Syntax (micN.conf):**

```
Hostname <name>
```

**Initial Value:**

```
<host name>-micN.<domain>
```

or

```
<host name>-micN
```

where *<host name>* is the "short" hostname of the host platform, as returned by calling *hostname -s*, *micN* is the coprocessor name, and *<domain>* is the host's domain name as return by *hostname -d*.

**Description:**

The *Hostname* parameter specifies the host name value to be inserted in the *hostname.conf* file of coprocessor *micN*.

*HostName* may be changed by editing the parameter directly.

### A.5.2 MAC Address Assignment

**Parameter Syntax (micN.conf):**

```
MacAddrs (Serial|Random|<host MAC>:<card MAC>)
```

**Initial Value:**

```
MacAddrs Serial
```

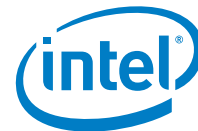

**Description:**

MAC addresses must be generated for the virtual network interfaces of the host and Intel® Xeon Phi™ coprocessors. However, as a prerequisite, both ends of the virtual network need to have MAC addresses assigned.

By default, MAC addresses are generated based on the serial number of the Intel® Xeon Phi™ coprocessor. Some older coprocessors do not have a usable serial number; in that case the MAC address is generated randomly.

The least significant bit is set in MAC addresses generated for host endpoints, and clear in MAC addresses generated for coprocessor endpoints. In addition, the top three octets of generated MAC addresses have the IEEE assigned value 4C:79:BA to enable identifying Intel® Xeon Phi™ coprocessor interfaces.

The system administrator may override the default *Serial* behavior with the *MacAddrs* configuration parameter. For *MacAddrs Random*, random addresses are generated.

For *MacAddrs <host MAC>:<card MAC>*, the specified MAC addresses are statically assigned to the host and coprocessor network endpoints of micN.

*MacAddrs* may be changed using the *micctrl --mac* command or by editing the parameter directly.

### A.5.3 Static Pair (Default) Topology

**Parameter Syntax (micN.conf):**

```
Network class=StaticPair micip=<cardIP> hostip=<hostIP>  
mtu=<mtu size> netbits=<netbits> modhost=(yes|no)  
modcard=(yes|no|<path_to_file>)
```

**Initial Value:**

```
Network class=StaticPair micip=172.31.<N+1>.1  
hostip=172.31.<N+1>.254 mtu=64512 netbits=24 modhost=yes modcard=yes  
  
for coprocessor micN.
```

**Description:**

In the static pair network topology, every Intel® Xeon Phi™ coprocessor is assigned to a separate subnet known only to the host.

<cardIP> and <hostIP> are the IP addresses of the coprocessor and host endpoints. They must each be a fully qualified IP address, and the first three quads of the address must match.

The *mtu* parameter specifies the packet size to use over the virtual network connection.

The *netbits* argument specifies the number of high order bits that are set in the Netmask. The <hostIP> and <cardIP> must be identical over the high order <netbits> bits. The default value is 24, defining a netmask of 255.255.255.0. For a static pair configuration it should never be necessary to change this parameter. It is up to the system administrator to correctly route the virtual Ethernet nodes to the external network or each other.

If *modhost* is set to *yes*, the coprocessor's 'IPaddress hostname' pair is appended to the contents of the host's */etc/host* file with the comment '#Generated-by-micctrl'. If *modhost* is



set to *no* the entry matching the coprocessor's IP address with the comment '#Generated-by-micctrl' will be removed from the host's */etc/hosts* file.

If *modcard* is set to *yes*, an */etc/hosts* file is created in the coprocessors file system, containing the 'IPAddress hostname' pair of both the host (bridge) and of the coprocessor. If *modcard* is set to *no*, the */etc/hosts* will not be created. User may also provide a path to a file which content will be copied to *<vardir>/etc/hosts*.

**Note:** The *modhost* and *modcard* options, if present, override the deprecated *hosts* parameter. The *hosts=(yes|no)* option may still be used; setting is equivalent to setting *modhost* and *modcard* with the specified *(yes|no|<path\_to\_file>)* value.

Although the static pair network configuration can be changed by editing *micN.conf* and *default.conf* configuration files, the recommended method of changing the network configuration is to use the *micctrl --network* command. Specifically, the *micctrl --network* command will edit configuration files as needed to remove the current network configuration before implementing the new configuration.

Linux\* networking supports routing a static pair to the external network and or to another static pair. It is the responsibility of the system administrator to configure such routing.

## A.5.4 Internal Bridge Topology

### Parameter Syntax:

```
Bridge <name> Internal <bridgeIP> <netbits> <mtu>
Network class=StaticBridge bridge=<name> micip=<cardIP>
modhost=(yes|no) modcard=(yes|no|<path_to_file>)
```

### Initial Value:

<None>

### Description:

Linux\* provides a mechanism for bridging network devices to a common network. The term "internal bridge", in the context of Intel® Xeon Phi™ coprocessor, refers to a configuration in which the host and one or more coprocessors on that host are connected through a bridge.

The internal bridge configuration is specified by a pair of parameters: a *Bridge* parameter in the *default.conf* file to specify the bridge information, and a *Network* parameter, in the *micN.conf* file of each coprocessor to be bridged, which specifies the bridge to which the coprocessor is connected and other information.

The same bridge name, *<name>*, must be given to both the *Bridge* and *Network* parameters.

*<bridgeIP>* and *<cardIP>* are the IP addresses of the bridge and coprocessor endpoints respectively. The *<netbits>* argument to *Bridge* specifies the number of high order bits that are set in the Netmask. The *<bridgeIP>* and *<cardIP>* must be identical over the high order *<netbits>* bits. For example, if *<netbits>* is 24, then the Netmask is 255.255.255.0, and IP addresses must be identical over the first three quads.

The *<mtu>* argument to *Bridge* specifies the packet size to use over the virtual network connection. The value of 64k has been shown to provide the highest network performance.

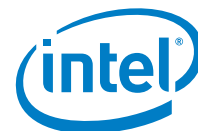

## Intel® MPSS Configuration Parameters

If *modhost* is set to *yes*, the coprocessor's 'IPaddress hostname' pair is appended to the host's */etc/host* file with the comment '#Generated-by-micctrl'. If *modhost* is set to *no* the entry matching the coprocessor's IP address with the comment '#Generated-by-micctrl' will be removed from the host's */etc/hosts* file.

If *modcard* is set to *yes*, an */etc/hosts* file is created in the coprocessors file system, containing the 'IPaddress hostname' pair of both the host (bridge) and of the coprocessor. If *modcard* is set to *no*, the */etc/hosts* will not be created. User may also provide a path to a file which content will be copied to *<vardir>/etc/hosts*.

**Note:** The *modhost* and *modcard* options, if present, override the deprecated *hosts* parameter. The *hosts=(yes|no)* option may still be used; setting is equivalent to setting *modhost* and *modcard* with the specified (*yes|no|<path\_to\_file>*) value.

The resulting configuration files will use the Bridge parameters for *<mtu>* and *<netbits>* values for the coprocessor endpoints.

The recommended method of changing the *Bridge* and *Network* parameters is to use the *micctrl --bridge* and *--network* commands (see the *micctrl* section of this document), rather than by directly editing. The *--bridge* and *--network* commands evaluate the current network configuration and can remove it before creating the new one. In either case, all the network control files will be created when the operation is done.

### A.5.5 External Bridge Topology

#### Parameter Syntax:

```
Bridge <name> External <bridgeIP> <netbits> <mtu>
Network class=StaticBridge bridge=<name> micip=<cardIP>
[mtu=<mtu size>] [netbits=<netbits>] modhost=(yes|no)
modcard=(yes|no|<path_to_file>)

Bridge <name> External dhcp
Network class=Bridge bridge=<name>
```

#### Initial Value:

<None>

#### Description:

The Linux\* bridging mechanism can bridge the Intel® Xeon Phi™ coprocessor virtual connections to a physical Ethernet device. In this topology, the virtual network interfaces become configurable to the wider subnet.

The external bridge configuration is specified by a pair of parameters: a *Bridge* parameter in the *default.conf* file to specify the bridge information, and a *Network* parameter, in the *micN.conf* file of each coprocessor to be bridged, which specifies the bridge to which the coprocessor is connected.

The same bridge name, *<name>*, must be used in both the *Bridge* and *Network* parameters.

IP addresses of the bridge and coprocessor endpoints can be statically assigned or configured for DHCP dynamic assignment.



The bridge IP address is assigned statically by specifying the `<bridgeIP>` argument to `Bridge`. The `<mtu>` argument to `Bridge` specifies the packet size to use over the virtual network connection. The default value is 1500 bytes to match default physical network settings. If attaching to a pre-existing external bridge configuration, the specified mtu value must match the setting in the system configuration file. For example, if, on a RHEL\* based host, the `/etc/sysconfig/network-scripts/ifcfg-br0` file contains the line "MTU=9000", then the MTU field must be set to 9000 to match. The `<netbits>` argument to `Bridge` specifies the number of high order bits that are set in the Netmask. It must be a value between 8 and 24. By default it is set to 24 by default and will rarely need to be changed.

Coprocessor IP address assignment is static when the `Network class=StaticBridge`; the coprocessor IP address is specified by `<cardIP>`. The `<bridgeIP>` and `<cardIP>` must be identical over the high order `<netbits>` bits. The resulting configuration will use the bridge's `<mtu>` and `<netbits>` values to ensure they match.

If `modhost` is set to `yes`, the coprocessor's 'IPAddress hostname' pair is appended to the host's `/etc/host` file with the comment '#Generated-by-micctrl'. If `modhost` is set to `no` the entry matching the coprocessor's IP address with the comment '#Generated-by-micctrl' will be removed from the host's `/etc/hosts` file.

If `modcard` is set to `yes`, an `/etc/hosts` file is created in the coprocessors file system, containing the 'IPAddress hostname' pair of both the host (bridge) and of the coprocessor. If `modcard` is set to `no`, the `/etc/hosts` will not be created. User may also provide a path to a file which content will be copied to `<vardir>/etc/hosts`.

**Note:** The `modhost` and `modcard` options, if present, override the deprecated `hosts` parameter. The `hosts=(yes|no)` option may still be used; setting is equivalent to setting `modhost` and `modcard` with the specified (`yes|no|<path_to_file>`) value.

The bridge IP address is configured for dynamic assignment by including value `dhcp` instead of a static IP address in the `Bridge` parameter. The DHCP server will also assign the mtu and Netmask values.

Coprocessor IP address assignment is dynamic by DHCP when `Network class=Bridge`.

The `modhost` and `modcard` parameters are not required because it is assumed the IP address for each coprocessor will be retrievable from a name server on the network.

If the corresponding bridge networking configuration file (ex: `ifcfg-br0`) does not exist then this parameter will cause it to be generated.

The Intel® configuration will not generate or modify the physical interface file to attach the physical network to the bridge. The system administrator must perform this step. For example, on a RHEL\* host, a file `/etc/sysconfig/network-scripts/ifcfg-eth0` to link the `eth0` interface to bridge `br0` might have the following contents:

```
DEVICE=eth0
NM_CONTROLLED=no
TYPE=Ethernet
ONBOOT=yes
BRIDGE=br0
```

On SLES\* host platforms, the physical port name must be added to the `BRIDGE_PORTS` entry in the `/etc/sysconfig/networks/ifcfg-br0` configuration file, for example:

```
BRIDGE_PORTS='eth0 mic0 mic1'
```

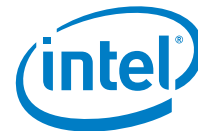

The recommended method of changing the *Bridge* and *Network* parameters is to use the *micctrl --bridge* and *--network* commands (see the *micctrl* section of this document), rather than by directly editing. The *--bridge* and *--network* commands evaluate the current network configuration and can remove it before creating the new one. In either case, all the network control files will be created when the operation is done.

## A.6 Deprecated Configuration Parameters

### A.6.1 User Access

#### Parameter Syntax (*micN.conf*):

```
UserAuthentication None
UserAuthentication Local <low uid> <high uid>
```

#### Description:

The *UserAuthentication* parameter has been removed. Refer to the sections on *micctrl* specification of users for the cards for configuration user access.

### A.6.2 Service Startup

**Note:** This parameter is still functional but there are no longer default services using it. It may be fully deprecated and removed in the future.

#### Parameter Syntax (*micN.conf*):

```
Service <name> <start> <stop> <state>
```

#### Description:

During boot, the embedded Linux\* OS on the Intel® Xeon Phi™ coprocessor executes the script files in the */etc/rc5.d* directory. These entries are links to the actual script files in the */etc/init.d* directory. The links are named with the standard Linux\* custom starting with an 'S' for start or 'K' for stop followed by the position parameter and then the file name from the *init.d* directory. The position parameter is a number from 01 to 99 establishing the order in which the scripts are executed.

The Intel® MPSS installs several pieces of software with various service scripts. The system administration may not want all of them to start at boot. To support this functionality, the configuration files specify the creation of the files in */etc/rc5.d* based on the *Service* configuration parameter. Each file in */etc/init.d* will require a *Service* entry in an Intel® Xeon Phi™ coprocessor configuration file.

The *name* argument is the name of the actual script found in the */etc/init.d* directory.

The *start* argument defines the order the service start relevant to other scripts. It will be a value from 1 to 99. As an example the network interface must be initialized before the secure shell daemon can be started. The *network* script is assigned a start value of 21 and *sshd* is assigned 80.

The *stop* argument is the opposite of the start parameter and is generally set to 100 minus the *start* value. This will assure that on shutdown the secure shell daemon at 5 will shut down before the network is unconfigured at 79.



The *state* argument determines whether the links specifies an 'S' for start or 'K' for stop. It follows the *chkconfig* utility convention of *on* for start and *off* for stop.



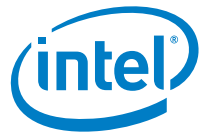

## B The micctrl Utility

---

The *micctrl* utility is a multi-purpose tool for the system administrator. It provides these categories of functionality.

- Card state control – boot, shutdown and reset control while the *mpssd* daemon is running.
- Configuration file initialization and propagation of values.
- Helper functions for modifying configuration parameters.
- Helper functions for modifying the root file system directory or associated download image.

### B.1 micctrl Command Line Format

The *micctrl* command line format is:

```
micctrl GlobalOptions Command SubOptions Coprocessors
```

*GlobalOptions* is a space separated list of 0 or more of the global options documented in [Appendix B.2](#). *GlobalOptions* list elements can appear in any order.

*Command* is one of the commands documented in [Appendix B.4](#) through [Appendix B.4.8](#).

*SubOptions* is a space separated list of 0 or more suboptions. A suboption can be one of the *Global SubOptions* described in [Appendix B.3.1](#), or one of the *Common SubOptions* documented in [Appendix B.3.2](#) or a command-specific suboption described in the documentation of the specified command. *SubOptions* list elements can appear in any order.

*Coprocessors* is a space separated list of 0 or more coprocessor identifiers of the form micN. *Coprocessors* list elements can appear in any order. If the *Coprocessors* list is empty, and the *mic.ko* driver is loaded, the command is applied to all discovered coprocessors. If the *mic.ko* driver is not loaded, then the *Coprocessors* list must be non-empty.

For brevity, the command-specific syntax of each command in [Appendix B.4](#) through [Appendix B.4.8](#) does not include *GlobalOptions*, *Coprocessors* or *Global SubOptions*. For example, the syntax of the *micctrl* wait command is shown as:

```
micctrl (-w|--wait)
```

rather than the full syntax:

```
micctrl [(-d |--destdir=<destdir>] [(-c |--configdir=<confdir>)\
(-w|--wait) [(-h|--help)] [(-v|--vv|--v -v|--vvv|--v -v -v)] \
Coprocessors
```

**Note:** Some aspects of network configuration are operating system dependent. By default, *micctrl* performs network configuration operations according to the operating system of the local host. The *distrib* suboption can be used to force *micctrl* to perform network configuration for a specified operating system. It is typically used with other options such as *--destdir* and *--netdir* when creating a configuration to be pushed to another system.



## B.2 Global Options

Global options are common to all *micctrl* commands.

### B.2.1 **--destdir, -d**

**Option Syntax:**

```
[(-d |--destdir=)<destdir>]
```

**Description:**

The *--destdir* global option, if specified, overrides the current value of the implicit *\$DESTDIR* variable.

We use the symbol *\$DESTDIR* to indicate the directory path that *micctrl* prepends to all *micctrl* accesses of *micctrl* created files.

*\$DESTDIR* is described in [Section 4.1.3.1](#).

### B.2.2 **--configdir, -c**

**Option Syntax:**

```
[(-c |--configdir=)<confdir>]
```

**Description:**

The *--configdir* global option, if specified, overrides the current value of the implicit *\$CONFIGDIR* variable.

We use the symbol *\$CONFIGDIR* to indicate the directory path at which *micctrl* creates Intel® MPSS-specific configuration files, specifically *default.conf* and *micN.conf*.

*\$CONFIGDIR* is described in [Section 4.1.3.2](#).

## B.3 Suboptions

Some suboptions are unique to each *micctrl* command; these are described with each of the commands. Other suboptions are common to some or all commands.

### B.3.1 **Global Suboptions**

Global suboptions are common to all commands. For brevity, command syntax does not show these global suboptions. For example, the syntax of the *micctrl --status* command is shown as

```
micctrl (-s|--status)
```

rather than:

```
micctrl (-s|--status) [(-h|--help)] \  
[(-v|-vv|-v -v|-vvv|-v -v -v)]
```

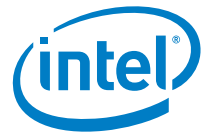

### B.3.1.1 Help

**Suboption Syntax:**

```
[(-h |--help)]
```

**Description:**

The *--help* suboption cause *micctrl* to ignore all other options and output help for the specified Command. For example to get help on the *micctrl --initdefaults*, use the *-h* option:

```
micctrl --initdefaults -h
```

### B.3.1.2 Verbose Output

**Suboption Syntax:**

```
[(-v|-vv|-v -v|-vvv|-v -v -v)]
```

**Description:**

By default *micctrl* only outputs errors and warnings.

The *-v* suboption causes *micctrl* to output additional informational messages. The *-vv* or *-v -v* suboptions add notification of changes to all files **micctrl** is creating, deleting or changing. The *-vvv* or *-v -v -v* suboptions add notification of calls to the host's networking utilities, for instance: *ifup*.

## B.3.2 Common SubOptions

Some suboptions are common to several commands. For brevity, we define these suboptions once here. When an individual command supports a particular common suboption, the command syntax shows that suboption in *italicized text* , but does not include a description of the suboption.

For example, the syntax of the *micctrl --rootdev* command is given as:

```
micctrl --rootdev=(RamFS|StaticRamFS) [--vardir=<vardir>] \  
[(-t |--target=<location>)] [(-d|--delete)]
```

The description of the *micctrl --rootdev* command does not include a description of the *--vardir* suboption, which is common to several commands and is described in this section.

### B.3.2.1 --vardir

**Suboption Syntax:**

```
[--vardir=<vardir>]
```

**Description:**

The *--vardir* suboption, if specified, overrides the current value of the implicit *\$VARDIR* variable.



We use the symbol `$VARDIR` to indicate the directory path at which the `micctrl --initdefaults`, `--resetdefaults`, `--resetconfig`, and `--cleanconfig` commands create the `common` and `micN` overlay hierarchies, and at which the `micctrl --rootdev` command places a ramfs file system image or NFS file system hierarchy. By default `$VARDIR` is `/var/mpss`.

`$VARDIR` is described in [Section 4.1.3.3](#).

### B.3.2.2 `--srcdir`

**Suboption Syntax:**

```
[--srcdir=<srcdir>]
```

**Description:**

The `--srcdir` suboption, if specified, overrides the current value of the implicit `$SRCDIR` variable.

We use the symbol `$SRCDIR` to indicate the directory path at which the `micctrl --initdefaults`, `--resetdefaults`, `--resetconfig`, and `--cleanconfig` commands look for the coprocessor's Linux\* kernel image and default file system image.

`$SRCDIR` is described in [Section 4.1.3.4](#).

### B.3.2.3 `--netdir, -n`

**Suboption Syntax:**

```
[(-n |--netdir=)<netdir>]
```

**Description:**

The `--netdir` suboption, if specified, overrides the current value of the implicit `$NETDIR` variable.

We use the symbol `$NETDIR` to indicate the directory path at which the `micctrl --initdefaults`, `--resetdefaults`, `--resetconfig`, and `--cleanconfig` commands create and/or edit network control files.

`$NETDIR` is described in [Section 4.1.3.5](#).

### B.3.2.4 `--distrib, -d`

**Suboption Syntax:**

```
[(-d |--distrib=) (redhat|suse) ]
```

**Description:**

Some aspects of network configuration are operating system dependent. By default, `micctrl` performs network configuration operations according to the operating system of the local host. The `--distrib` suboption can be used to force `micctrl` to perform network configuration for a specified operating system. It is typically used with other options such as `--destdir` and `--netdir` when creating a configuration to be pushed to another system.

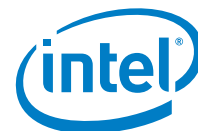

### B.3.2.5 --gw, -g

**Suboption Syntax:**

```
[ (-g | --gw=) <gateway> ]
```

**Description:**

The `--gw` suboption sets the gateway of a coprocessor network interface. If not specified, the gateway of the local host is assigned to the network. The `--gw` option is typically used with other options such as `--destdir` and `--netdir` when creating a configuration to be pushed to another system.

### B.3.2.6 --users, -u

**Suboption Syntax:**

```
[ (-u | --users=) (none|overlay|merge|nochange) ]
```

**Description:**

The `--users` suboption controls creation and/or modification of the `/etc/passwd` and `/etc/shadow` files of each specified coprocessor. The `MicDir` parameter specifies the directory in which these files are created and/or modified.

For `--users=none`, the `/etc/passwd` and `/etc/shadow` files are deleted and recreated to include only the minimal set of users required by Linux\*, which are the root, ssh, nobody, nfsnobody and micuser.

For `--users=overlay`, the `/etc/passwd` and `/etc/shadow` files are deleted and recreated to include the users from the 'none' option and any regular users found in the `/etc/passwd` file of the host.

For `--users=nochange`, behavior is as for `--users=overlay` if no configuration exists for the specified coprocessor. Otherwise the `/etc/passwd` and `/etc/shadow` files are unchanged.

For `--users=merge`, any users in the host's `/etc/passwd` file but not in the coprocessor's `/etc/passwd` file are added to the coprocessor's `/etc/passwd` and `/etc/shadow` files.

If the `--users` suboption is not given, behavior is as for `--users=nochange`.

### B.3.2.7 --pass, -a

**Suboption Syntax:**

```
[ (-a | --pass=) (none|shadow) ]
```

**Description:**

The `--pass` suboption selects the policy for copying passwords from the host's `/etc/shadow` file to the specified coprocessor's `/etc/shadow` file. For `--users=none` and `--users=overlay`, the policy is applied to all users in the newly created `/etc/shadow` file. For `--users=merge`, the policy is only applied to users that are added to the `/etc/shadow` file.

For `--pass=shadow`, the host's `/etc/shadow` file is parsed and values of the affected users are written to the coprocessor's `/etc/shadow` file. It should be noted that `--pass=shadow` is



disabled on SLES\* host systems; SLES\* uses Blow Fish encryption, which is not supported on the coprocessor.

For `--pass=none`, the passwords in the coprocessor's `/etc/shadow` file are set to the '\*' character.

If the `--pass` suboption is not given, behavior is as for `--pass=shadow` on a RHEL\* based host, and as for `--pass=none` on a SLES\* based host.

### B.3.2.8 `--modhost, -c`

**Suboption Syntax:**

```
[ (-c | --modhost=) (yes|no) ]
```

**Description:**

For `--modhost=yes`, the coprocessor's 'IPaddress hostname' pair is appended to the contents of the host's `/etc/host` file with the comment '#Generated-by-micctrl'.

For `--modhost=no`, the host's `/etc/hosts` file is unchanged.

**Note:** The `--modhost` suboption behaves as for `--modcard=no` if the configuration files already exist. In this case, use the `micctrl --modbridge` or `--network` command to change the host's `/etc/hosts`.

### B.3.2.9 `--modcard, -e`

**Suboption Syntax:**

```
[ (-e | --modcard=) (yes|no|<path_to_file>) ]
```

**Description:**

For `--modcard=yes`, an `/etc/hosts` file is created and populated in directory defined by the `MicDir` parameter of each specified coprocessor.

For `--modcard=no`, `/etc/hosts` files are not created.

For `--modcard=<path_to_file>` the content of a specified file will be copied to `<vardir>/etc/hosts`

If the `--modcard` option is not given, behavior is as for `--modcard=yes`.

The `--modcard` suboption behaves as for `--modcard=no` if the configuration files already exist. In this case, use the `micctrl --modbridge` or `--network` command to change the host's `/etc/hosts`.

### B.3.2.10 `--nocreate`

**Suboption Syntax:**

```
[ --nocreate ]
```

**Description:**

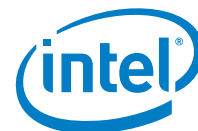

## The micctrl Utility

By default, a home directory is created in the coprocessor file system for each user in a coprocessor's */etc/passwd* and */etc/shadow* files. The *--nocreate* suboption disables the creation of such home directories. Doing so can reduce ram file system memory usage when LDAP home directory auto mount is enabled or the */home* directory is NFS mounted.

### B.3.2.11 --pm, -p

#### Suboption Syntax:

```
[(-p |--pm=) (default|defaultb)]
```

#### Description:

The *--pm* suboption modifies the *PowerManagement* parameter of each specified coprocessor.

For *--pm=default*, the *PowerManagement* parameter of each specified coprocessor is reset to default setting for the coprocessor's stepping. If the stepping cannot be determined, the power management parameters are set to the default for the Intel® Xeon Phi™ coprocessor C stepping.

For *--pm=defaultb*, the *PowerManagement* parameter of each specified coprocessor is reset to the default setting for the Intel® Xeon Phi™ coprocessor B stepping.

If the *--pm* suboption is not given, behavior is as for *--pm=default*.

## B.4 micctrl Command Descriptions

This section describes each of the *micctrl* commands.

The *\$DESTDIR*, *\$CONFIGDIR*, *\$VARDIR*, *\$SRCDIR* and *\$NETDIR* directory path modifiers can alter the default directory paths of files which *micctrl* accesses. For brevity, the following description assumes default values for these intrinsic variables. See [Section 4.1.3](#) for details.

### B.4.1 Card State Control

Several commands are available for controlling the state of Intel® Xeon Phi™ coprocessors.

#### B.4.1.1 Booting Intel® Xeon Phi™ Coprocessors

##### Command Syntax:

```
micctrl (-b|--boot) [(-w|--wait) [(-t |--timeout=)<timeout>]]
```

##### Description:

The *micctrl --boot* command requests that the specified Intel® Xeon Phi™ coprocessors be booted. *micctrl* uses configuration parameters to prepare and boot coprocessors. The process depends on the root device type specified by the *RootDevice* parameter. Refer to [Appendices A.4.1](#) and [B.4.3](#) for details on root device types. Refer to [Section 4.1.5](#) for a detailed description of the boot process.

By default, control returns before booting is complete. If the *--wait* suboption is specified, control returns after booting is complete, or after a timeout period, which ever is first.



If the `--timeout` suboption is specified, the timeout period is `<timeout>` seconds. If not specified, timeout period defaults to 300 seconds.

### B.4.1.2 Shutting Down Intel® Xeon Phi™ Coprocessors

#### Command Syntax:

```
micctrl (-S|--shutdown) [(-w|--wait) \  
  [(-t |--timeout=)<timeout>]]
```

#### Description:

The `micctrl --shutdown` command requests that the specified Intel® Xeon Phi™ coprocessors be shut down.

This command brings down the specified coprocessors in a safe way, and is equivalent to executing the Linux\* `shutdown` command on each of the specified coprocessors.

By default, control returns before shutting down is complete. If the `--wait` suboption is specified, control returns after shutting down is complete, or after a timeout period, which ever is first.

If the `--timeout` suboption is specified, the timeout period is `<timeout>` seconds. If not specified, timeout period defaults to 300 seconds.

### B.4.1.3 Rebooting Intel® Xeon Phi™ Coprocessors

#### Command Syntax:

```
micctrl (-R|--reboot) [(-w|--wait) \  
  [(-t |--timeout=)<timeout>]]
```

#### Description:

The `micctrl --reboot` command requests that the specified Intel® Xeon Phi™ coprocessors be rebooted. This command effectively performs the `micctrl --shutdown` followed by the `micctrl --boot` command.

By default, control returns before rebooting is complete. If the `--wait` suboption is specified, control returns after rebooting is complete, or after a timeout period, which ever is first.

If the `--timeout` suboption is specified, the timeout period is `<timeout>` seconds. If not specified, timeout period defaults to 300 seconds.

### B.4.1.4 Resetting Intel® Xeon Phi™ Coprocessors

#### Command Syntax:

```
micctrl (-r|--reset) [(-f|--force)] [(-i|--ignore)] \  
  [(-w|--wait) [(-t |--timeout=)<timeout>]]
```

#### Description:

The `micctrl --reset` command requests that the specified Intel® Xeon Phi™ coprocessors be reset. The coprocessors can be in any state.





## The *micctrl* Utility

The *--force* suboption forces the coprocessors to go through the reset process. Normally the driver will not reset a coprocessor that is already in the reset or 'ready' state and *micctrl* will return an error.

The *--ignore* suboption prevents *micctrl* from returning an error if a coprocessor is in the reset or *ready* state.

By default, control returns before resetting is complete. If the *--wait* suboption is specified, control returns after resetting is complete, or after a timeout period, whichever is first.

If the *--timeout* suboption is specified, the timeout period is <timeout> seconds. If not specified, timeout period defaults to 300 seconds.

**Note:** Performing a reset may result in the loss of file data that has not been flushed to a remote file system. It is therefore recommended to perform a shutdown when this would not be desired.

### B.4.1.5 Waiting for Intel® Xeon Phi™ Coprocessor State Change

#### Command Syntax:

```
micctrl (-w|--wait) [(-t |--timeout=)<timeout>]
```

#### Description:

The *micctrl --wait* command returns after the previous state change command is complete or after a timeout period, whichever is first.

If the *--timeout* suboption is specified, the timeout period is <timeout> seconds. If not specified, the timeout period defaults to 300 seconds.

### B.4.1.6 Intel® Xeon Phi™ Coprocessor Status

#### Command Syntax:

```
micctrl (-s|--status)
```

#### Description:

The *micctrl --status* command displays the status of the specified Intel® Xeon Phi™ coprocessors. If the status is "online" or "booting" it also displays the name of the associated boot image.

## B.4.2 Configuration Initialization and Propagation

This section discusses the *micctrl* command options for initializing, propagating, resetting, and cleaning configuration parameters.

### B.4.2.1 Initializing the Configuration Files

#### Command Syntax:

```
micctrl --initdefaults [--vardir=<vardir>] [--srcdir=<srcdir>]  
[(-d |--netdir=)<netdir>] \  
[(-u |--users=) (none|overlay|merge|nochange)] \  
[(-a |--pass=) (none|shadow)] [--nocreate] \  
[(-f |--force)]
```



```
[(-c |--modhost=) (yes|no)] [(-e |--modcard=) (yes|no|<path_to_file>)]
```

**Description:**

The Intel® MPSS distribution does not include the software stack configuration files (For Instance: *default.conf*, *micN.conf*) and overlay hierarchies (For Instance: */var/mpss/micN*). The *micctrl --initdefaults* command creates those files with default values, and can ensure that they are complete.

*--initdefaults* first creates the */etc/mpss/default.conf* configuration file with default parameters, if such a file does not already exist.

Then, for each specified coprocessor, *micctrl --initdefaults* creates the */etc/mpss/micN.conf* configuration file with default parameters, if such a file does not already exist.

If such a *default.conf* or *micN.conf* file already exists, it is parsed for missing parameters, and default parameter values are added as needed. In addition, *--initdefaults* checks for deprecated parameters and replaces them with updated parameters. For example: the deprecated *FileSystem* parameter is updated to *RootDevice RamFS*. *micctrl --initdefaults* will not otherwise change an existing configuration if *--users*, *--pass*, *--nocreate*, *--modhost*, and *-modcard* suboptions are not specified.

*--initdefaults* then creates the common directory */var/mpss/common* and creates and populates the per-coprocessor overlay hierarchy */var/mpss/micN* for each specified coprocessor if these directories do not already exist.

If a */var/mpss/micN* overlay hierarchy exists, it is parsed for missing files, and any missing files are added with values determined by the current configuration and *micctrl --initdefaults* suboptions.

For each user indicated by the *--users* suboption, and subject to the *--nocreate* suboption, *--initdefaults* copies ssh key files from the user's host file system *\$HOME/.ssh* to */var/mpss/micN/\$HOME/.ssh*. Next *--initdefaults* adds the user's .pub keys (For Instance: from *id\_rsa.pub*) to the */var/mpss/micN/\$HOME/authorized\_keys* file.

## B.4.2.2 Resetting Configuration Parameters

**Command Syntax:**

```
micctrl --resetdefaults [--vardir=<vardir>] [--srcdir=<srcdir>]
[(-d |--netdir=) <netdir>]
[(-u |--users=) (none|overlay|merge|nochange)] \
[(-a |--pass=) (none|shadow)] [--nocreate] \
[(-c |--modhost=) (yes|no)] [(-e |--modcard=) (yes|no|<path_to_file>)]
```

**Description:**

The *micctrl --resetdefaults* command attempts to restore configuration parameters and the associated Xeon Phi file systems to the default state. It shuts down the current network, removes a several files in the */etc* directory of each specified coprocessor, removes the old configuration files and then calls the *--initdefaults* command. This process is intended to leave files created by the user untouched.

## B.4.2.3 Cleaning Configuration Parameters

**Command Syntax:**

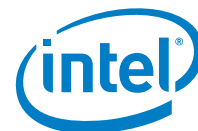

## The *micctrl* Utility

```
micctrl --cleanconfig [--vardir=<vardir>] [--srcdir=<srcdir>]  
[(-d | --netdir=) <netdir>]
```

The *micctrl --cleanconfig* command is intended to completely remove all Intel® MPSS configuration artifacts.

### B.4.2.3.1 Valid configuration file found

If a valid configuration is found, a series of steps are performed:

1. Shutdown the network and remove *micctrl* created network configuration files typically in */etc/sysconfig/network-scripts* on RHEL\* hosts and */etc/sysconfig/networks* on SLES\* hosts.
2. Remove all the files in the directory defined by the *MicDir* configuration parameter. Warning: this will also remove all the files in that directory not created by *micctrl*.
3. Remove the *ramfs* file or the NFS export directory associated with the NFS type in the *RootDevice* configuration parameter.
4. Remove the configuration file in */etc/mpss* directory (or the directory defined by *\$CONFIGDIR*).
5. If there are no more configuration files in the */etc/mpss* directory, then remove the contents of the directory defined by the *CommonDir* parameter and remove the *default.conf* file from the */etc/mpss* directory.

### B.4.2.3.2 No valid configuration files

If no valid configuration file is found for a coprocessor, the following method of cleanup is performed:

1. Remove the entire contents of */var/mpss/micN* for each specified coprocessor.
2. Delete file */var/mpss/micN.image.gz*, for each specified coprocessor.
3. Delete file */var/mpss/micN.export*, for each specified coprocessor.
4. Delete the */etc/mpss/micN.conf* file for each specified coprocessor.
5. Delete the contents of the directory specified by the *CommonDir* parameter in the */etc/mpss/default.conf* file.
6. Delete the */etc/mpss/default.conf* file.

## B.4.3 Setting the Root Device

The *micctrl --rootdev* command changes the configured *RootDevice* parameter which controls whether the Intel® Xeon Phi™ coprocessor file root system will be mounted from a ram disk, or an NFS export.



### B.4.3.1 RAM Root File System

**Command Syntax:**

```
micctrl --rootdev=(RamFS|StaticRamFS) [--vardir=<vardir>] \  
[(-t |--target=<location>)] [(-d|--delete)]
```

**Description:**

When the *RootDev* parameter type is either *RamsFS* or *StaticRamFS*, *micctrl* pushes a compressed CPIO archive to coprocessor memory at boot time, where it is uncompressed to become the coprocessor's RAM file system.

For *--rootdev=RamFS*, *micctrl* sets the *RootDevice* parameter in the *micN.conf* of each specified coprocessor to:

```
RootDevice RamFS <location>
```

if *--target* is specified, or, otherwise, to

```
RootDevice RamFS /var/mpss/micN.image.gz
```

At boot time, *micctrl* builds a ram disk image from the files specified by the *Base*, *CommonDir*, *Micdir*, and *Overlay* configuration parameters. The resulting archive is saved as *<ramfs\_location>*.

For *--rootdev=StaticRamFS*, *micctrl* sets the *RootDevice* parameter in the *micN.conf* of each specified coprocessor to:

```
RootDevice StaticRamFS <location>
```

if *--target* is specified, or, otherwise, to

```
RootDevice StaticRamFS /var/mpss/micN.image.gz
```

At boot time, there must be a previously created compressed CPIO archive at *<ramfslocation>* which will be used as the ram disk with which to boot the specified coprocessor(s).

If the current *RootDevice* parameter type is *NFS* or *SplitNFS* when *micctrl --RamFS* or *micctrl --StaticRamFS* is called with the *--delete* suboption, then the root and/or user file system hierarchies specified by the *RootDevice* configuration parameter are deleted.

### B.4.3.2 NFS Root File System

**Command Syntax:**

```
micctrl --rootdev=NFS [--vardir=<vardir>] \  
[(-t |--target=)[<host>:]<location>] [(-c|--create)] \  
[(-d|--delete)] \  
micctrl --rootdev=SplitNFS [--vardir=<vardir>] \  
[(-t |--target=)[<host>:]<location>] \  
[(-u |--usr=)[<host>:]<usr_location>] [(-c|--create)] \  
[(-d|--delete)]
```

**Description:**

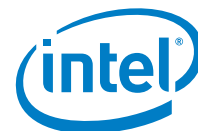

## The micctrl Utility

When the *RootDevice* parameter type is either *NFS* or *SplitNFS*, the file system of the specified coprocessors are remotely mounted from an NFS server(s).

For *--rootdev=NFS*, *micctrl* sets the *RootDevice* parameter in the *micN.conf* of each specified coprocessor to:

```
RootDevice NFS <share>
```

where *<share>* is set to:

```
<host>:<location>
```

if *--target=<host>:<location>*, or to:

```
<hostip>:<location>
```

if *--target=<location>*, or to:

```
<hostIP>:/var/mpss/micN.export
```

if *--target* is not specified, and where *<hostIP>* is the IP address of the local host.

For *--rootdev=SplitNFS*, *micctrl* sets the *RootDevice* parameter in the *micN.conf* of each specified coprocessor to:

```
RootDevice SplitNFS <share> <usr_share>
```

where *<share>* is set is as for *--rootdev=NFS*, and where *<usr\_share>* is set to:

```
<host>:<usr_location>
```

if *--usr=<host>:<location>*, or to:

```
<hostip>:<usr_location>
```

if *--usr=<location>*, or to:

```
<hostIP>:/var/mpss/usr.export
```

if *--usr* is not specified, and where *<hostIP>* is the IP address of the local host.

It is the user's responsibility to configure the specified or default location or locations for NFS export, typically in the specified host's */etc/exports* file. Generally each export specification should include *rw* and *no\_root\_squash* options.

If the *--create* suboption is specified, *micctrl* builds a root file system hierarchy from the files specified by the *Base*, *CommonDir*, *Micdir*, and *Overlay* configuration parameters and roots it at *<share>*. For *--rootdev=SplitNFS*, a file system hierarchy is also created and is rooted at *<usr\_share>* it is a duplicate of *<share>/usr*. These hierarchies are only created if *<host>* is the local host. *micctrl* will not create these hierarchies on a remote host.

If the *--delete* suboption is specified, *micctrl* deletes the current root and user file system hierarchies.

**Note:** A *--server* suboption was previously used to enable specification of the *<server>* IP addressed. It has been deprecated and is only supported for backward compatibility.



### B.4.3.3 Rootdev Configuration

**Command Syntax:**

```
micctrl --rootdev
```

**Description:**

When no type is specified, *micctrl --rootdev* outputs the current *RootDevice* configuration.

### B.4.3.4 Adding an NFS Mount

**Command Syntax:**

```
micctrl --addnfs=[<host>:]<location> (-d |--dir=)<mount dir> \  
[--options=<option>[,<option>] +]
```

**Description:**

The *micctrl --addnfs* command adds an NFS mount entry, *<host>:<location>*, to the */etc/fstab* file of each specified coprocessor. The optional *<host>*, if specified, must be a valid host name or host IP address. If *<host>* is not specified, it defaults to the local host.

The export will be mounted on the *<mount dir>* directory of each specified coprocessor. *micctrl* ensures that the mount directory is created on the coprocessor file system image.

The *--options* suboption specifies a list of NFS mount options. It must be a comma separated list in the standard form of the */etc/fstab* *fs\_mntops* field. Check NFS documentation for more information. The string supplied is placed into the options field in the coprocessors */etc/fstab* file that *micctrl* creates for the added mount.

As with other NFS exports, it is the users responsibility to configure the specified *<location>* for NFS export.

**Additional configuration for SUSE\* based host systems:** If NFS file system mounts have been added and the *chckconfig* utility has been used to indicate starting the Intel® MPSS at host boot time, edit the */etc/init.d/mpss* file and change the "# Required-Start:" line to read

```
"# Required-Start: nfsserver".
```

to ensure that NFS is started before the mpss service.

**Note:** A *--server* suboption was previously used to enable specification of the *<server>* IP addressed. It has been deprecated and is only supported for backward compatibility.

### B.4.3.5 Removing an NFS Mount

**Command Syntax:**

```
micctrl --remnfs=<mount dir>
```

**Description:**

The '*micctrl --remnfs*' command searches the */etc/fstab* files of the specified coprocessors for the entry corresponding to mount *<mount dir>*, and removes the mount point from the files.



### B.4.3.6 Updating the Compressed CPIO Image

**Command Syntax:**

```
micctrl --updateramfs
```

**Description:**

When the *RootDevice* parameter of a specified coprocessor is *RamFS* or *StaticRamFS*, the *micctrl --updateramfs* command updates the coprocessor's current ram disk image with a new image built from the files specified by the *Base*, *CommonDir*, *Micdir* and *Overlay* configuration parameters. The new image will be used the next time the card boots. The image file is saved at the location specified by the *RootDevice* parameter's *<ramfs\_location>* value.

### B.4.3.7 Updating NFS Root Exports

**Command Syntax:**

```
micctrl --updatenfs  
micctrl --updateusr
```

**Description:**

When the *RootDevice* parameter of a specified coprocessor is *NFS* or *SplitNFS*, the *micctrl --updatenfs* command updates or builds a root file system hierarchy from the files specified by the *Base*, *CommonDir*, *Micdir* and *Overlay* configuration parameters and roots it at the location specified by the *RootDevice* parameters *<share>* value.

When the *RootDevice* parameter of a specified coprocessor is *SplitNFS*, the *micctrl --updateusr* command updates or builds a */usr* file system hierarchy from the files specified by the *Base*, *CommonDir*, *Micdir*, and *Overlay* configuration parameters and roots it at the location specified by the *RootDevice* parameters *<usr\_share>* value.

## B.4.4 Configuring the Intel® Xeon Phi™ Coprocessor File System

### B.4.4.1 Base File System Location

**Command Syntax:**

```
micctrl --base  
micctrl --base=default  
micctrl --base=(cpio|dir) --new=<location>
```

**Description:**

The *micctrl --base* command modifies the *Base* parameter in the */etc/mpss/micN.conf* configuration files of the specified coprocessors.

For *--base=cpio*, *micctrl* sets the *Base* parameter to:

```
Base CPIO <location>
```

where *<location>* must be a compressed CPIO archive.

For *--base=dir*, *micctrl* sets the *Base* parameter to:



Base DIR <location>

where <location> is a ram file system hierarchy. If <location> does not exist, and the current *Base* type is currently *CPIO*, then the corresponding CPIO image is expanded and files are extracted to <location>. If <location> does not exist, and the current *Base* type is *DIR*, then the corresponding directory is copied to <location>.

For `--base=default`, *micctrl* resets the *Base* parameter to the default:

```
Base CPIO /usr/share/mpss/boot/initramfs-knightscorner.cpio.gz
```

For `--base` (For Example: a value is not specified), *micctrl* outputs the current *Base*, *CommonDir* and *MicDir* parameter values.

## B.4.4.2 Common Files Location

### Command Syntax:

```
micctrl --commondir  
micctrl --commondir=<commondir>
```

### Description:

The *micctrl --commondir* command modifies the *CommonDir* configuration parameter for each specified coprocessor.

For `--commondir=<commondir>`, *micctrl* adds or modifies the *CommonDir* parameter in the `/etc/mpss/micN.conf` configuration file of each specified coprocessors. As a result, it overrides the *CommonDir* parameter in `/etc/mpss/default.conf`. The resulting parameter has the form:

```
CommonDir <commondir>
```

If the <commondir> directory does not exist, then it is created and the contents of the previous *CommonDir* directory are copied to the new location.

After the files have been copied, the configurations for all known coprocessors in the host are checked for references to the old *CommonDir* <commondir> directory. If no references exist, the files in that directory are deleted.

For `--commondir` (For Example: <commondir> is not specified), *micctrl* outputs the current *Base*, *CommonDir* and *MicDir* parameter values.

**Note:** Previously, this command included a suboption to set a corresponding filelist associated with the files. The use of this file has been removed.

## B.4.4.3 Coprocessor Specific Files Location

### Command Syntax:

```
micctrl --micdir  
micctrl --micdir=<micdir>
```

### Description:

The *micctrl --micdir* command modifies the *MicDir* parameter in the `/etc/mpss/micN.conf` configuration file of each specified coprocessor.





## The micctrl Utility

For `--micdir=<micdir>`, `micctrl` modifies the `MicDir` parameter in the `micN.conf` configuration files of the specified coprocessors to:

```
MicDir <micdir>
```

If the `<micdir>` directory does not exist, it is created and the contents of the previous `MicDir` directory are copied to the new location. Finally, the previous `MicDir` directory is deleted.

For `--micdir` (For Example: `<micdir>` is not specified), `micctrl` outputs the current `Base`, `CommonDir` and `MicDir` parameter values.

**Note:** Previously, this command included a suboption to set a corresponding filelist associated with the files. The use of this file has been removed.

### B.4.4.4 Additional File System Overlays

#### Command Syntax:

```
micctrl --overlay
micctrl --overlay=(simple|file) (-s |--source=<source> \
(-t |--target=<target> (-d |--state=) (on|off|delete)
micctrl --overlay=rpm (-s |--source=<source> \
(-d |--state=) (on|off|delete)
```

#### Description:

The `micctrl --overlay` command creates, modifies or deletes an `Overlay` parameter in the `/etc/mpss/micN.conf` configuration file of each specified coprocessor. The `Overlay` parameter describes a file or directory of files that are added to the coprocessors file system. There may be multiple `Overlay` parameters.

**Note:** Do not add overlays to the `/tmp` directory on the card, as it is cleared each time the card boots.

For `--overlay=file` and `--state=on`, `micctrl` appends a parameter:

```
Overlay File <source> <target> on
```

to each `/etc/mpss/micN.conf` file. For `--overlay=file` and `--state=off`, `micctrl` appends a parameter:

```
Overlay File <source> <target> off
```

to each `/etc/mpss/micN.conf` file. For `--overlay=file` and `--state=delete`, `micctrl` searches `/etc/mpss/micN.conf` for the parameter:

```
Overlay File <source> <target> (on|off)
```

and removes it if found.

For `--overlay=simple` and `--state=on`, `micctrl` appends a parameter:

```
Overlay Simple <source> <target> on
```

to each `/etc/mpss/micN.conf` file. For `--overlay=simple` and `--state=off`, `micctrl` appends a parameter:



```
Overlay Simple <source> <target> off
```

to each /etc/mpss/micN.conf file. For `--overlay=file` and `--state=delete`, *micctrl* searches /etc/mpss/micN.conf for the parameter:

```
Overlay Simple <source> <target> (on|off)
```

and removes it if found.

For `--overlay=rpm` and `--state=on`, *micctrl* appends a parameter:

```
Overlay RPM <source> on
```

to each /etc/mpss/micN.conf file. For `--overlay=rpm` and `--state=off`, *micctrl* appends a parameter:

```
Overlay RPM <source> off
```

to each /etc/mpss/micN.conf file. For `--overlay=rpm` and `--state=delete`, *micctrl* searches /etc/mpss/micN.conf for the parameter:

```
Overlay RPM <source> (on|off)
```

and removes it if found.

For `--overlay` (no overlay type specified), *micctrl* outputs the currently defined overlays.

You can also add Overlay parameters to a user created configuration file by directly editing the file. The *Include* configuration parameter can be used to include such a file. *micctrl* does not modify such user created configuration files. To override an *Overlay* parameter in such a configuration file without editing the file, you can call *micctrl --overlay* to add an *Overlay* parameter to *micN.conf* that changes the state of a specified overlay to *off* or *on* as needed.

**Note:** The filelist overlay type has been deprecated and is only supported for backward compatibility; only files owned by root are supported. Use the simple and file overlay types instead.

**Note:** The state=off suboption has been deprecated and is only supported for backward compatibility.

#### B.4.4.5 Location of Additional RPMs for the Intel® Xeon Phi™ Coprocessor File System

**Command Syntax:**

```
micctrl --rpmdir=<location>
```

**Description:**

The *micctrl --rpmdir* command sets the *K10mRpms* configuration parameter in the micN.conf configuration file of the specified coprocessors to the specified <location>. See [Appendix A.4.3](#) for information on the *K10mRpms* parameter.

#### B.4.5 Networking Configuration

Several *micctrl* commands aid in configuring Intel® Xeon Phi™ coprocessor networking.

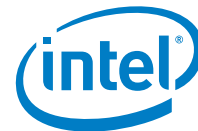

## The micctrl Utility

**Note:** On SUSE\* hosts, run `service networking restart` upon completion of all network change commands.

### B.4.5.1 MAC Address Assignment

#### Command Syntax:

```
micctrl --mac=(serial|random|<MAC address>) \  
[(-d |--netdir=)<netdir>] [(-w |--distrib=)(redhat|suse)]
```

#### Description:

The `micctrl --mac` command modifies the `MacAddrs` configuration parameter in the `micN.conf` configuration file of each specified coprocessor. The `MacAddrs` parameter defines the method for setting the MAC addresses of both the host and coprocessor endpoints.

For `--mac=serial`, `micctrl` sets `MacAddrs` to:

```
MacAddrs Serial
```

For `--mac=random`, `micctrl` sets `MacAddrs` to:

```
MacAddrs Random
```

For `--mac=<MAC address>`, and where `<MAC address>` is any valid MAC address in the format `XX:XX:XX:XX:XX:XX`, and `X` is an ASCII hex digit (0..F), `micctrl` sets the `MacAddrs` parameter of the first specified coprocessor to:

```
MacAddrs XX:XX:XX:XX:XX:(XX+1) XX:XX:XX:XX:XX:XX
```

the `MacAddrs` parameter of the second specified coprocessor to:

```
MacAddrs XX:XX:XX:XX:XX:(XX+3) XX:XX:XX:XX:XX:(XX+2)
```

the `MacAddrs` parameter of the `N`th specified coprocessor to:

```
MacAddrs XX:XX:XX:XX:XX:(XX+2*(N-1)+1) XX:XX:XX:XX:XX:(XX+2*(N-1))
```

For example, if the least significant octet of `<MAC address>` is '08', then `micctrl` sets the `MacAddrs` parameter of the first specified coprocessor to:

```
MacAddrs XX:XX:XX:XX:XX:09 XX:XX:XX:XX:XX:08
```

the `MacAddrs` parameter of the second specified coprocessor to:

```
MacAddrs XX:XX:XX:XX:XX:0B XX:XX:XX:XX:XX:0A
```

the `MacAddrs` parameter of the `N`th specified coprocessor to:

```
MacAddrs XX:XX:XX:XX:XX:(08+2*(N-1)+1) XX:XX:XX:XX:XX:(08+2*(N-1))
```

### B.4.5.2 Resetting the Network to a Default Configuration

#### Command Syntax:

```
micctrl --network=default
```

**Description:**

The `micctrl --network=default` command restores the network configuration for the specified coprocessors to the default (Static Pair).

**B.4.5.3 Static Pair****Command Syntax:**

```
micctrl --network=static [(-d |--netdir=)<netdir>] \  
[(-w |--distrib=) (redhat|suse)] [(-i |--ip=)<ip>] \  
[(-n |--netbits=)<netbits>] [(-m |--mtu=)<mtu>] \  
[(-c |--modhost=) (yes|no)] [(-e |--modcard=) (yes|no|<path_to_file>)]
```

**Description:**

The static pair network topology is configured using the `micctrl --network` command. This topology is described in [Section 2.2.3.1](#).

The `micctrl --network` command modifies the *Network* parameter of each specified coprocessor. This command also creates and/or modifies host and coprocessor network configuration files, and brings network endpoints on the host down and up as needed. That process is described in detail in [Section 5.1.5.1.2](#)

When the `--bridge` suboption is not specified, the `micctrl --network=static` command configures the static pair network topology between the host and each specified coprocessor.

There are several alternatives for setting IP addresses. If the `--ip` suboption is not given, then IP addresses are as assigned by `micctrl --initdefaults`. Refer to [Appendix A.5.3](#) for details.

If the `--ip` suboption is given and `<ip>` is two quads (XX.XX), then `micctrl` uses those as the high order quads of IP addresses which it constructs. The third quad of each such address is `N + 1` for each coprocessor with a name specified to micN. The fourth quad of each coprocessor endpoint address is 1, and the fourth quad of each host endpoint address is 254. For example, on a two coprocessor system, the suboption `--ip=172.31` will result in addresses 172.31.1.1 and 172.31.1.254 for mic0's coprocessor and host endpoints, and 172.31.2.1 and 172.31.2.254 for mic1's coprocessor and host endpoints.

Fully qualified IP addresses can be assigned. In this case `<ip>` must have the format `cardIP,hostIP:cardIP,hostIP:... and so on`. Each `cardIP,hostIP` pair specifies the IP address for one static pair network, where the first pair is the IP address of the network between the host and the first specified coprocessor. For example, if there are two cards in the system, the suboption `--ip=172.31.10.1, 172.31.10.2: 172.3.11.1,172.31.11.2` results in the first specified coprocessor and host endpoints having addresses 172.31.10.1 and 172.31.10.2 and the second specified coprocessor and host endpoints having addresses 172.31.11.1 and 172.31.11.2.

The `--mtu` suboption sets the virtual network packet size to `<mtu>` bytes. The default mtu size of mtu is 64KB. Testing has shown that the default value yields the best performance for this network type.

The `--netbits` suboption defines a netmask. If fully qualified IP addresses are assigned, the addresses must be identical over the high order `<netbits>` bits. The default value is 24, defining a netmask of 255.255.255.0. There is rarely any need to change this parameter.

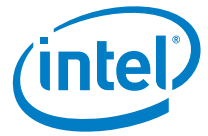

## B.4.5.4 Internal Bridging

### Command Syntax:

```
micctrl --addbridge=<brname> --type=internal
  (-i |--ip=)<bridge_ip> [(-d |--netdir=)<netdir>] \
  [(-w |--distrib=)(redhat|suse)] \
  [(-n |--netbits=)<netbits>] \
  [(-m |--mtu=)<mtu>]
micctrl --network=static --bridge=<name> --ip=<mic_ip> \
  [(-c |--modhost=)(yes|no)] [(-e |--
  modcard=)(yes|no|<path_to_file>)]
```

### Description:

The internal bridge network topology is configured using the *micctrl --addbridge* and *--network* commands. This topology is described in [Section 2.2.3.2.1](#). The bridge interface is created first, and is then connected to the virtual network interfaces of each specified coprocessor.

### --addbridge suboptions:

The *micctrl --addbridge* and *--network* commands modify the *Bridge* parameter common to all specified coprocessors, and the *Network* parameter of each specified coprocessor. These commands also create and/or modify host and coprocessor network configuration files, and bring network endpoints on the host down and up as needed. That process is described in detail in [Section 5.1.5.2.2](#).

The *micctrl --addbridge* command creates the bridge interface. The bridge name, *<brname>*, of the bridge must be specified. The *--type=internal* suboption causes *micctrl* to create the correct network configuration files for an internal bridge.

The bridge IP address, *<bridge\_ip>*, must be a fully qualified dot notated address.

The *--mtu* suboption sets the virtual network packet size to *<mtu>* bytes. The default mtu size of mtu is 64KB. Testing has shown that the default value yields the best performance for this network type.

The *--netbits* suboption defines a netmask. The bridge IP address and all coprocessor endpoint IP addresses must be identical over the high order *<netbits>* bits. The default value is 24, defining a netmask of 255.255.255.0. There is rarely any need to change this parameter.

*micctrl --addbridge* creates the bridge configuration file, for example *\$NETDIR/ifcfg-br0*, if it does not already exist. If the bridge configuration file already exists, then *<bridge\_ip>*, *<netbits>*, and *<mtu>* must match the corresponding values of the specified bridge.

### --network suboptions:

The *micctrl --network* command adds coprocessor virtual network interfaces to the bridge. The *--bridge=<name>* argument is required, and the *<name>* must be the same as the *<brname>*, the name specified to *--addbridge*.

The bridge's mtu and netbits values are used in configuring coprocessor virtual network interfaces.



## B.4.5.5 External Bridging

The external bridge network topology is configured using the *micctrl --addbridge* and *--network* commands. This topology is described in [Section 2.2.3.2.2](#). The bridge interface is created first, and is then connected to the virtual network interfaces of each specified coprocessor.

The *micctrl --addbridge* and *--network* commands modify the *Bridge* parameter common to all specified coprocessors, and the *Network* parameter of each specified coprocessor. These commands also creates and/or modifies host and coprocessor network configuration files, and brings network endpoints on the host down and up as needed. That process is described in detail in [Section 5.1.5.3.2](#).

Because external bridging gives coprocessors access to the external network, DHCP based IP address assignment is supported for this topology.

### B.4.5.5.1 External Bridging, Static IP Address Assignment

#### Command Syntax:

```
micctrl --addbridge=<brname> --type=external \  
  (-i |--ip=<bridge_ip> [(-d |--netdir=<netdir>] \  
  [(-w |--distrib=) (redhat|suse)] \  
  [(-n |--netbits=<netbits>] \  
  [(-m |--mtu=<mtu>] \  
micctrl --network=static --bridge=<name> --ip=<mic_ip> \  
  [(-c |--modhost=) (yes|no)] [(-e |--modcard=) (yes|no|<path_to_file>)]
```

#### Description:

##### --addbridge suboptions:

For the static IP address assignment case, *micctrl --addbridge* and *micctrl --network* commands are the same as for internal bridging with the exception that the bridge type is *external*.

The *--type=external* suboption causes *micctrl* to create the correct network configuration files for an external bridge.

The bridge IP address, *<bridge\_ip>*, must be a fully qualified dot notated address.

The *--mtu* suboption sets the virtual network packet size to *<mtu>* bytes. The default mtu size of mtu is 1500B for compatibility with typical external networks.

The *--netbits* suboption defines a netmask. The bridge IP address and all coprocessor endpoint IP addresses must be identical over the high order *<netbits>* bits. The default value is 24, defining a netmask of 255.255.255.0. There is rarely any need to change this parameter.

*micctrl --addbridge* creates the bridge configuration file, for example *\$NETDIR/ifcfg-br0*, if it does not already exist. If the bridge configuration file already exists, then *<bridge\_ip>*, *<netbits>*, and *<mtu>* must match the corresponding values of the specified bridge.

##### --network suboptions:

The *micctrl --network* command adds coprocessor virtual network interfaces to the bridge. The *--bridge=<name>* argument is required, and the *<name>* must be the same as the *<brname>*, the name specified to *--addbridge*. The *--ip* argument to *--network* is also

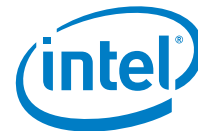

## The micctrl Utility

required, and *<mic\_ip>* must be a fully qualified dot notated IP address in which the first 3 quads match those of the bridge IP address, *<bridge\_ip>*. If more than one coprocessor is specified, each will be assigned the specified *<mic\_ip>* with the coprocessor's number added to the fourth quad. For example, for `--ip=172.31.10.12`, `mic0` will be assigned the address 172.31.10.12 and `mic1` will be assigned the address 172.31.10.13.

The bridge's `mtu` and `netbits` values are used in configuring coprocessor virtual network interfaces.

It is the user's responsibility to slave the physical Ethernet endpoint to the bridge. For example, on RHEL\*, the line `"BRIDGE=br0"` is added to the `eth0` Ethernet configuration file, `/etc/sysconfig/network-scripts/ifcfg-eth0` to connect endpoint `eth0` to bridge `br0`:

```
DEVICE=eth0
NM_CONTROLLED=no
TYPE=Ethernet
ONBOOT=yes
BRIDGE=br0
```

On SLES\* host platforms, the physical port name must be added to the `BRIDGE_PORTS` entry in the `/etc/sysconfig/networks/ifcfg-br0` configuration file, for example:

```
BRIDGE_PORTS='eth0 mic0 mic1'
```



### B.4.5.5.2 External Bridging, DHCP Address Assignment

#### Command Syntax:

```
micctrl --addbridge=<brname> --type=external --ip=dhcp \  
[(-d |--netdir=)<netdir>] [(-w |--distrib=) (redhat|suse)] \  
micctrl --network=dhcp --bridge=<name> \  
[(-c |--modhost=) (yes|no)] [(-e |--modcard=) (yes|no|<path_to_file>)]
```

#### Description:

##### --addbridge suboptions:

DHCP address assignment is configured by setting both the *micctrl --addbridge* command's *--ip* value and the *--network* type to *dhcp*. During coprocessor boot, the Intel® Xeon Phi™ coprocessor Linux\* OS will attempt to retrieve an IP address from a DHCP server. The DHCP server will also configure netbits and mtu values.

*micctrl --addbridge* creates the bridge configuration file, for example *\$NETDIR/ifcfg-br0*, if it does not already exist.

It is the user's responsibility to slave the physical Ethernet endpoint to the bridge. For example, on RHEL\*, the line "BRIDGE=br0" is added to the *eth0* Ethernet configuration file, */etc/sysconfig/network-scripts/ifcfg-eth0* to connect endpoint *eth0* to bridge *br0*:

```
DEVICE=eth0  
NM_CONTROLLED=no  
TYPE=Ethernet  
ONBOOT=yes  
BRIDGE=br0
```

On SLES\* host platforms, the physical port name must be added to the *BRIDGE\_PORTS* entry in the */etc/sysconfig/networks/ifcfg-br0* configuration file, for example:

```
BRIDGE_PORTS='eth0 mic0 mic1'
```

The *modhost* and *modcard* parameters are not needed for configuring host and coprocessor */etc/hosts* files in the case that a name server is available from which coprocessor and host IP addresses can be retrieved.

### B.4.5.6 Changing Network Parameters

#### Command Syntax:

```
micctrl --network [(-d |--netdir=)<netdir>] \  
[(-w |--distrib=) (redhat|suse)] [(-i |--ip=)<ip>] \  
[(-n |--netbits=)<netbits>] [(-m |--mtu=)<mtu>] \  
[(-c |--modhost=) (yes|no)] [(-e |--modcard=) (yes|no|<path_to_file>)]
```

#### Description:

The *micctrl --network* command (with no network type specified) may be used to change the parameters for a set of interfaces.



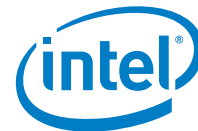

## B.4.5.7 Modifying a Bridge

### Command Syntax:

```
micctrl --modbridge=<brname> [(-d |--netdir=<netdir>] \  
[(-w |--distrib=(redhat|suse)] [(-i |--ip=<ip>] \  
[(-n |--netbits=<bits>] [(-m |--mtu=<mtu>]
```

### Description:

The *micctrl --modbridge* command modifies the IP address, netbits and/or MTU values of the specified network bridge. In addition any changed netbits or MTU values are propagated to any of the attached virtual network configuration files.

The *--ip* suboption sets the bridge's IP address. *<bridge\_ip>* must be a fully qualified dot notated address.

The *--mtu* suboption sets the virtual network packet size to *<mtu>* bytes. The default mtu size of mtu is 64KB. Testing has shown that the default value yields the best performance for this network type.

The *--netbits* suboption defines a netmask. The bridge IP address and all coprocessor endpoint IP addresses must be identical over the high order *<netbits>* bits. The default value is 24, defining a netmask of 255.255.255.0. There is rarely any need to change this parameter.

## B.4.5.8 Deleting a Bridge

### Command Syntax:

```
micctrl --delbridge=<brname> [(-d |--netdir=<netdir>] \  
[(-w |--distrib=(redhat|suse)]
```

### Description:

The *micctrl --delbridge* command removes a specified bridge from the Intel® Xeon Phi™ coprocessor configuration. If the specified bridge is marked as internal, the corresponding host network configuration file will be deleted.

All coprocessors must have been detached from the bridge before the bridge can be deleted. The *micctrl --network=default* command can be used for this purpose.

## B.4.6 User Credentialing

### B.4.6.1 Update User Credentials

#### Command Syntax:

```
micctrl --userupdate=(none|overlay|merge|nochange) \  
[(-a |--pass=(none|shadow)] [--ncreate]
```

#### Description:

The *micctrl --userupdate* command enables updating certain user credential information.



For `--userupdate=none`, the `/etc/passwd` and `/etc/shadow` files are recreated with the minimal set of users required by Linux\*, which are the root, ssh, nobody, nfsnobody and micuser.

For `--userupdate=overlay`, the `/etc/passwd` and `/etc/shadow` files are recreated with the users from the `--userupdate=none` suboption and any regular users found in the `/etc/passwd` file of the host.

For `--userupdate=nochange`, behavior is as for `--userupdate=overlay` if no configuration exists for the specified coprocessor. Otherwise the `/etc/passwd` and `/etc/shadow` files are unchanged.

For `--userupdate=merge`, any users in the host's `/etc/passwd` file but not in the specified coprocessor's `/etc/passwd` file are added to the coprocessor's `/etc/passwd` and `/etc/shadow` files.

## B.4.6.2 Adding Users to the Intel® Xeon Phi™ Coprocessor File System

### Command Syntax:

```
micctrl --useradd=<user> [(-u |--uid=<uid>) \
  [(-g |--gid=<gid>) [(-d |--home=<dir>) \
  [(-c |--comment=<string>) [--shell=<shell>) \
  [(-k |--sshkeys=<keydir>) [--nocreate] [--non-unique]
```

### Description:

The `micctrl --useradd` command adds the user named `<user>` to the `/etc/passwd` and `/etc/shadow` files in the directory identified by the `MicDir` parameter of each specified coprocessor.

The `--uid` suboption specifies the user ID of user `<user>`. By default, the user ID of user `<user>` on the host is used.

The `--gid` suboption specifies the group ID of user `<user>`. By default, the group ID of user `<user>` on the host is used.

The `--home` suboption specifies the home directory in the coprocessor file system of user `<user>`. By default, the home directory is `/home/<user>`.

The `--comment` suboption specifies a comment string to be added to the comment field of the `/etc/passwd` entry for user `<user>`. The default comment string is `<user>`.

The `--shell` suboption replaces the default shell used to login. If it is not specified and user exists on the host system shell will be copied from the host. Otherwise it will set The default to `/bin/bash` shell.

The `--sshkeys` suboption specifies the host directory in which the user's secure shell key files are to be found. The default is `/home/<user>/.ssh`. The `*.pub` public ssh keys are copied to the `.ssh` directory in the user's home directory of the coprocessor file system.

The `--non-unique` suboption will allow the user to be added to the coprocessor's `/etc/passwd` and `/etc/shadow` files with the specified `uid` even if a user with that `uid` already exists.

A default `.profile` file is created in the user's home directory of the coprocessor file system home directory.

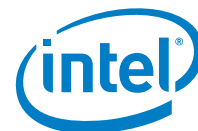

## The micctrl Utility

The user is also added to the */etc/passwd* and */etc/shadow* files of each specified coprocessor that is in the *online* state. In addition, a home directory is created if the *--nocreate* suboption is not specified, and the user's ssh keys are pushed to the user's home directory.

### B.4.6.3 Removing Users from the Intel® Xeon Phi™ Coprocessor File System

#### Command Syntax:

```
micctrl --userdel=<user> [(-r |--remove)]
```

#### Description:

The *micctrl --userdel* command removes the user named *<user>* from the */etc/passwd* and */etc/shadow* files in the directory identified by the *MicDir* parameter of each specified coprocessor.

By default, *--userdel* does not remove the user's home directory on the coprocessor; this is intended to prevent the inadvertent removal of a user's remote mounted home directory. Home directory removal can be forced by including the *--remove* suboption.

### B.4.6.4 Changing the Password for Users on the Intel® Xeon Phi™ Coprocessor File System

#### Command Syntax:

```
micctrl --passwd
```

```
micctrl --passwd=<user> [(-s |--stdin)]
```

#### Description:

Phi file systems */etc/ssh* directory. The *micctrl --passwd* command changes a user's password in the */etc/shadow* file in the directory identified by the *MicDir* parameter of each specified coprocessor.

A non-superuser calls *micctrl --passwd* with no name, and is prompted for the current password and then for the new password.

The superuser specifies a user's name, *<user>*, when calling *micctrl --passwd*. If the *--stdin* suboption is not specified then *micctrl* will be prompted to provide a new password for a user and to confirm it.

The *-p --pass* option was deprecated, superuser may use the *--stdin* suboption to pass a new password in the standard input:

```
micctrl --passwd=username --stdin <<< password
```

or using pipe from a different program:

```
echo "newPassword" | micctrl --passwd=username --stdin
```

**echo** should be a shell built-in. If it resolves to */bin/echo* the password may be visible to other users.



The `--stdin` option is considered as less secure and should be used only in justified cases. It is also advised to pass the password using pipe from different program.

The user account on each specified coprocessor that is in the online state will be updated with the password.

#### B.4.6.5 Adding Groups to the Intel® Xeon Phi™ Coprocessor File System

**Command Syntax:**

```
micctrl --groupadd=<name> (-g | --gid=<gid>)
```

**Description:**

The `micctrl --groupadd` command adds the specified group name and ID to the `/etc/group` file in the directory identified by the `MicDir` parameter of each specified coprocessor.

The group will also be added to the `/etc/group` file of each specified coprocessor that is in the *online* state.

#### B.4.6.6 Removing Groups from the Intel® Xeon Phi™ Coprocessor File System

**Command Syntax:**

```
micctrl --groupdel=<name>
```

The `micctrl --groupdel` command removes the specified group name, along with its ID, from the `/etc/group` file in the directory identified by the `MicDir` parameter of each specified coprocessor.

The group will also be deleted from the `/etc/group` file of each specified coprocessor that is in the *online* state.

#### B.4.6.7 Specifying the Host Secure Shell Keys

**Command Syntax:**

```
micctrl --hostkeys=<keydir>
```

**Description:**

The `micctrl --hostkeys` command copies files from the `<keydir>` directory to the `$(MICDIR)/etc/ssh` file of each specified coprocessor.

`micctrl --initdefaults` generates a set of ssh key files in the `/etc/ssh` directory of each specified coprocessor, in the directory identified by the `MicDir` parameter. The keys in this directory identify aniIntel® Xeon Phi™ coprocessor as a “known host” during ssh operations if there is a match to the user’s `known_hosts` file (typically in `$(HOME)/.ssh`).

If a configuration is completely regenerated, such as by calling `micctrl --cleanconfig` followed by `micctrl --initdefaults`, the user’s `known_hosts` will have to be revised to match the new set(s) of host keys. To avoid the need to do this, the existing sets of host keys can be saved before regenerating the configuration to some `<keydir>` directory, and then restored afterward using the `micctrl --hostkeys` command.



#### B.4.6.8 Updating a User's SSH Keys on the Intel® Xeon Phi™ Coprocessor File System

**Command Syntax:**

```
micctrl --sshkeys [(-d |--dir=)<dir>]  
micctrl --sshkeys=<user> [(-d |--dir=)<dir>]
```

**Description:**

The *micctrl --sshkeys* command copies a set of \*.pub public ssh keys to the \$HOME/.ssh directory of some user in the file system of each specified coprocessor.

A non-root user does not specify a <user> to *micctrl --sshkeys*. Any \*.pub public Keys are copied to that user's \$HOME/.ssh directory. Key files are copied from <dir> if specified, otherwise from the user's \$HOME/.ssh directory on the host. Only files owned by the user are copied.

A root-user specifies a <user> to *micctrl --sshkeys*. Any \*.pub Keys are copied to that user's \$HOME/.ssh directory. Key files are copied from <dir> if specified, otherwise from the user's \$HOME/.ssh directory on the host. Only files owned by the specified user are copied.

*micctrl --sshkeys* will also use add any \*.pub files to the 'authorized\_keys' file if not already present.

#### B.4.6.9 Configuring LDAP on the Intel® Xeon Phi™ Coprocessor File System

**Command Syntax:**

```
micctrl --ldap=(<server>|disable) (-b |--base=)<domain>
```

**Description:**

The *micctrl --ldap* command configures the coprocessor to use LDAP for user authentication.

For *--ldap=<server>*, *micctrl* configures LDAP to use the <server> as the authentication server and configures <domain> as the domain.

For *--ldap=disable*, *micctrl* disables LDAP service on each specified coprocessor.

When this command is called, the *K10mRpm*s configuration parameter must be set as needed.

#### B.4.6.10 Configuring NIS on the Intel® Xeon Phi™ Coprocessor File System

**Command Syntax:**

```
micctrl --nis=(<server>|disable) (-d |--domain=)<domain>
```

**Description:**

The *micctrl --nis* command configures the coprocessor to use NIS for user authentication.

For *--nis=<server>*, *micctrl* configures NIS to use the <server> as the NIS/YP server and configures <domain> as the domain.



For `--nis=disable`, `micctrl` disables NIS service on each specified coprocessor.

When this command is called, the `K10mRpm`s configuration parameter must be set as needed.

## B.4.7 Configuring the Intel® Xeon Phi™ Coprocessor Linux\* Kernel

### B.4.7.1 Coprocessor Linux\* Image Location

#### Command Syntax:

```
micctrl --osimage  
micctrl --osimage=<osimage> (-s |--sysmap=)<sysmapfile>
```

#### Description:

The `micctrl --osimage` command sets the `OSImage` parameter in the `micN.conf` configuration file of each specified coprocessor to `<osimage> <sysmapfile>`. The `<osimage>` argument is the Linux\* operating system image to be booted, and `<sysmapfile>` identifies the matching system map file which holds values used by the `mpssd` daemon.

For `--osimage` (For Example: no `<osimage>` value is specified), `micctrl` outputs the current `OSImage` parameter value for each specified coprocessor.

### B.4.7.2 Boot On Intel® MPSS Service Start

#### Command Syntax:

```
micctrl --autoboot  
micctrl --autoboot=(yes|no)
```

#### Description:

The `micctrl --autoboot` command sets the `BootOnStart` configuration parameter to the specified value.

For `--autoboot` (For Example: no `--autoboot` value is specified), `micctrl` outputs the current `BootOnStart` value for each specified coprocessor.

### B.4.7.3 Power Management Configuration

#### Command Syntax:

```
micctrl --pm  
micctrl --pm=(set|default|defaultb|off) [(-c |--corec6=) (on|off)] \  
[(-t |--pc3=) (on|off)] [(-s |--pc6=) (on|off)] \  
[(-f |--cpufreq=) (on|off)]
```

#### Description:

The `micctrl --pm` command sets the `PowerManagement` configuration parameter for each specified coprocessor.

For `--pm=set`, the power management parameters are set as specified by the optional arguments `--corec6`, `--pc3`, `--pc6`, and `--cpufreq`. Each optional parameter can be individually enabled or disabled by setting the `on` or `off` values.

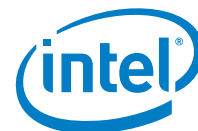

## The micctrl Utility

For `--pm=default`, the power management configuration is set to the default for each card for which the card's stepping can be determined. If the stepping of a coprocessor cannot be determined, its power management configuration is set to the default for C stepping Intel® Xeon Phi™ coprocessors.

For `--pm=defaultb`, the power management configuration for each specified coprocessor is set to the default for B stepping Intel® Xeon Phi™ coprocessors.

For `--pm=off`, all parameters other than `cpufreq` are set to the off state.

For `--pm` (For Example: no `--pm` value is specified), `micctrl` outputs the current *Power-Management* value for each specified coprocessor.

*It is recommended to use the default power management settings unless directed by an Intel® representative to change them.*

### B.4.7.4 Cgroups Configuration

#### Command Syntax:

```
micctrl --cgroup [(-m |--memory=) (enable|disable)]
```

#### Description:

The `micctrl --cgroup` command modifies the *Cgroup* parameter for each specified coprocessor to value of the `--memory` suboption.

If the `--memory` suboption is not specified, `micctrl` outputs the current value of the *Cgroup* parameter of each specified coprocessor.

### B.4.7.5 Syslog Configuration

#### Command Syntax:

```
micctrl --syslog
micctrl --syslog=buffer [(-l |--loglevel=) <loglevel>]
micctrl --syslog=file [(-f |--logfile=) <location>] \
[(-l |--loglevel=) <loglevel>]
micctrl --syslog=remote (-s |--host=) <targethost[:port]> \
[(-l |--loglevel=) <loglevel>]
```

#### Description:

The `micctrl --syslog` command creates and/or modifies the `/etc/syslog-startup.conf` file in the filesystem of each specified coprocessor.

For `--syslog=buffer`, syslog is only available from the `kmsg` buffer.

For `--syslog=file`, the syslog daemon logs to the optional `<location>` or to the `/var/log/messages` log file.

For `--syslog=remote`, the syslog daemon is instructed to log to the remote node specified by the optional `host` argument. The `port` value defaults to 514. If the `--host` suboption is not specified then the remote host defaults to `host:514`.

For `--syslog` (no `--syslog` type is specified), the current syslog configuration is output.



Changes to the logfile location take effect immediately on each specified coprocessor that is in the *online* state.

**NOTE:** *micctrl --syslog* only configures syslog on the coprocessor. Remote host may need additional configuration. Please refer to the documentation of your host logger daemon to determine how to enable collecting logs from remote hosts.

## B.4.8 Deprecated micctrl Commands

### B.4.8.1 --service Command

#### Command Syntax:

```
micctrl --service
micctrl --service=<name> --state=(on|off) [--start=<num>] \
 [--stop=<num>] [mic card list]
```

#### Description:

The Intel® Xeon Phi™ coprocessor Linux\* OS, like any Linux\* OS, executes a series of scripts on boot, which are located in */etc/init.d*. To determine which of the installed scripts are executed on any boot, links to these scripts are created in runlevel directory. The card's OS runs at level 5, defining the runlevel directory to be */etc/rc5.d*.

On most Linux\* systems, the service scripts to be executed are enabled or disabled using the *chkconfig* command. On the MPSS stack this is performed by the *micctrl --service* command.

The *--state* suboption must be set to *on* or *off* and determines whether the script will execute on boot. Services already included in the configuration may have their state changed without specifying new *start* or *stop* values.

The *start* and *stop* parameters must be between 1 and 100, and determine the order in which the services are executed. If *stop* is not specified, then it will be set to *100 - start*.

Add on software containing a service script will include the *Service* parameter associated with it. Modifying the default value included in its own configuration file will cause an overriding entry to be set in the *micN.conf* file.

*micctrl --service* may be called with no arguments and will display a list of current service settings. Currently, no services are configured by default.

### B.4.8.2 --configuser Command

#### Command Syntax:

```
micctrl --configuser=none [-ids] [mic card list]
micctrl --configuser=local [--low=<low uid>] [--high=<high uid>] \
 [-ids] [mic card list]
```

#### Description:

This command has been removed. Refer to the section on the *micctrl --userupdate* command for its functional replacement.



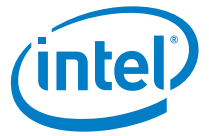

### B.4.8.3 --resetconfig Command

**Command Syntax:**

```
micctrl --resetconfig [--users=(none|overlay|merge|nochange) \  
[--pass=<none|shadow>] [--nocreate] [--modhost=(yes|no)] \  
[--modcard=(yes|no|<path_to_file>)] [mic card list]
```

**Description:**

Changes to the configuration files are propagated with the *micctrl --resetconfig* command. The *--resetconfig* command first removes the files in *MicDir* created by the configuration process, with the exception of the highly persistent ssh host key files. It then regenerates those files according to the parameters in the */etc/mpss/micN.conf* and */etc/mpss/default.conf* files. This process will not add default parameters, but only causes the changed parameters to be propagated.

The *--resetconfig* command added several new options with the 3.2 release. Consult the previous documentation for the *--initdefaults* command.



## C Intel® MPSS Host Driver Sysfs Entries

---

The mic.ko driver supplies configuration and control information to host software through the Linux\* Sysfs file system. The driver presents two sets of information:

- Driver global information is presented in the `/sys/class/mic/ctrl` directory.
- Information unique to an Intel® Xeon Phi™ coprocessor instance is presented in the `/sys/class/mic/micN` directories.

### C.1 The Global Mic.ko Driver SYSFS Entries

#### C.1.1 Revision Information

Sysfs Entries:

`/sys/class/mic/ctrl/version`

This entry is read-only. The `version` sysfs entry displays a string containing the ID of the build producing the current installed software.

#### C.1.2 Other Global Entries

Sysfs Entries:

`/sys/class/mic/ctrl/peer2peer`

`/sys/class/mic/ctrl/vnet`

These entries are read-only.

The peer 2 peer reports the state, *enable* or *disable*, of Symmetric Communication Interface (SCIF) based communication between Intel® Xeon Phi™ coprocessors, referred to as peer-to-peer (p2p) communication.

On reading, the `vnet` entry returns the number of active links to the virtual Ethernet.

### C.2 The Intel® Xeon Phi™ Mic.ko Driver SYSFS Entries

#### C.2.1 Hardware Information

Sysfs Entries:

`/sys/class/mic/micN/family`

`/sys/class/mic/micN/sku`

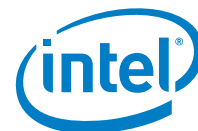

## Intel® MPSS Host Driver Sysfs Entries

`/sys/class/mic/micN/stepping`

`/sys/class/mic/micN/active_cores`

`/sys/class/mic/micN/memsize`

These sysfs entries are all read-only.

The *family* node reports the Intel® Xeon Phi™ coprocessor family. At this time the family should always report the string *x100*.

The *sku* node returns a string defining the device type, for example: *C0-3120/3120A*.

The *stepping* node returns the processor stepping, for example: B0, B1, or C0.

The *active\_cores* node reports (base 16) the number of working cores on the card.

The *memsize* node returns the size of memory (in hexadecimal) on the Intel® Xeon Phi™ coprocessor.

### C.2.2 State Entries

Sysfs Entries:

`/sys/class/mic/micN/state`

`/sys/class/mic/micN/mode`

`/sys/class/mic/micN/image`

`/sys/class/mic/micN/cmdline`

`/sys/class/mic/micN/kernel_cmdline`

The *state* and *cmdline* nodes are read/write. The others are read-only.

On reading, the *state* node reports one of the following values:

- **ready** card is ready for a boot command
- **booting** card is currently booting
- **no response** card is not responding
- **boot failed** card failed to boot
- **online** card is currently booted
- **shutdown** card is currently shutting down
- **lost** booted card is not responding
- **resetting** card is processing soft reset
- **reset failed** card cannot be reset – non recoverable

Additionally, if the state is *booting*, *online* or *shutdown*, the state is modified by the information from the *mode* and *image* sysfs nodes. The *mode* will be either *linux* or *elf*. The *image* file will report the name of the file used to boot into the associated mode.



Writing to the *state* node requests the driver to initiate a change in state. The allowable requests are to boot, reset or shutdown the Intel® Xeon Phi™ coprocessor.

To boot a card, the string to write has the format "boot:linux:<image name>". The *mpssd* daemon uses its *OSimage* parameter to fill in the image name. For example the default Linux\* image for the Intel® Xeon Phi™ coprocessor will create the string "boot:linux:/usr/share/mpss/boot/bzImage-2.6.38.8". After a successful boot the *state* will be *online*, *mode* will be *linux*, and *image* will be */usr/share/mpss/boot/bzImage-2.6.38.8*.

The *cmdline* parameter is set by user software, normally the *mpssd* daemon or *micctrl* utility, to pass kernel command line parameters to the Intel® Xeon Phi™ coprocessor Linux\* boot process. Current parameters include root file system, console device information, power management options and verbose parameters. When the *state* sysfs node requests the card to boot, the driver adds other kernel command line information to the string and records the complete string that was passed to the booting embedded Linux\* OS in the *kernel\_cmdline* sysfs node.

### C.2.3 IStatistics

Sysfs Entries:

```
/sys/class/mic/micN/boot_count  
  
/sys/class/mic/micN/crash_count
```

These entries are read-only. The *boot\_count* sysfs node returns the number of times that the Intel® Xeon Phi™ coprocessor has booted to the online state. The *crash\_count* sysfs node records the number of times that the card has crashed.

### C.2.4 Debug Entries

Sysfs Entries:

```
/sys/class/mic/micN/platform  
  
/sys/class/mic/micN/post_code  
  
/sys/class/mic/micN/scif_status  
  
/sys/class/mic/micN/log_buf_addr  
  
/sys/class/mic/micN/log_buf_len  
  
/sys/class/mic/micN/virtblk_file
```

The *platform*, *post\_code* and *scif\_status* entries are read-only; the *log\_buf\_addr*, *log\_buf\_len*, and *virtblk\_file* entries are read and write.

The *platform* sysfs node should always return a zero value.

The *post\_code* sysfs node returns the contents of the hardware register containing the state of the boot loader code. Reading it always returns two ASCII characters. Possible values of note are the strings "12", "FF" and any starting with the character '3'. A string of "12" indicates the Intel® Xeon Phi™ coprocessor is in the ready state and waiting for a command to start executing. A string of "FF" indicates the coprocessor is executing code. A string starting with the character '3' indicates the coprocessor is in the process of training memory. Any other

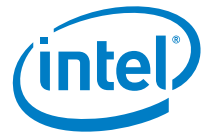

## Intel® MPSS Host Driver Sysfs Entries

value should be transitory. Any other value remaining for any length of time indicates an error and should be reported to Intel.

The *log\_buf\_addr* and *log\_buf\_len* parameters inform the host driver of the memory address in the Intel® Xeon Phi™ coprocessor memory at which to read its Linux\* kernel log buffer. The correct values to set are found by looking for the strings "log\_buf\_addr" and "log\_buf\_len" in the Linux\* system map file associated with the file in the *OSImage* parameter, and are typically set by the *mpssd* daemon.

The *virtblk\_file* sysfs node indicates the file assigned to the virtio block interface.

### C.2.5 Flash Entries

Sysfs Entries:

```
/sys/class/mic/micN/flashversion
```

```
/sys/class/mic/micN/flash_update
```

```
/sys/class/mic/micN/fail_safe_offset
```

These nodes are all read-only. The *flashversion* sysfs node returns the current version of the flash image installed on the card by the *micflash* utility. The other two are used by the *micflash* command. Root privileges are required to read *flash\_update* and *fail\_safe\_offset* entries.

### C.2.6 Power Management Entries

Sysfs Entries:

```
/sys/class/mic/micN/pc3_enabled
```

```
/sys/class/mic/micN/pc6_enabled
```

The *pc3\_enabled* node reports the current setting of the *pc3* power management setting. If *pc3* power management is causing errors, writing a "0" to this setting will disable *pc3* power management.

The *pc6\_enabled* node reports the current setting of the *pc6* power management setting. If *pc6* power management is causing errors, writing a "0" to this setting will disable *pc6* power management.

### C.2.7 Other Entries

Sysfs Entries:

```
/sys/class/mic/micN/extended_family
```

```
/sys/class/mic/micN/extended_model
```

```
/sys/class/mic/micN/fuse_config_rev
```

```
/sys/class/mic/micN/meminfo
```

```
/sys/class/mic/micN/memoryfrequency
```



*/sys/class/mic/micN/memoryvoltage*

*/sys/class/mic/micN/model*

*/sys/class/mic/micN/stepping*

*/sys/class/mic/micN/stepping\_data*

These sysfs nodes are all read-only and return the contents of a particular hardware register. They are used by the *micinfo* command.

## D *micrasd*

---

*micrasd* is a Linux\* host side daemon that monitors for and logs Intel® Xeon Phi™ coprocessor hardware errors (MCEs). Normally, *micrasd* is run as a service:

```
[host]# service micras start
[host]# service micras stop
```

To start *micrasd* with secure communications to Reliability Monitor, use:

For RHEL\* 6.x and SLES\* 11.x:

```
[host]# service micras start-with-security
```

For RHEL\* 7.x and SLES\* 12.x you have to set

```
START_WITH_SECURITY=true on /etc/mpss/micrasrelmond.conf
```

and then start micras normally.

The *micras* service has a dependency on the mpss service. The *micras* service must be started after the mpss service, and stopped prior to stopping the mpss service. To automatically start the *micras* service in boot time, use the command:

```
[host]# chkconfig micras on
```

To disable automatically starting the *micras* service, use the command:

```
[host]# chkconfig micras off
```

Intel® Xeon Phi™ coprocessor hardware errors are logged into Linux\* syslog under */var/log/messages* with the *micras* tag.

*micrasd* log messages are logged into */var/log/micras.log*. These messages can be useful in tracing *micras* functional flow for diagnostic purposes.

If *micrasd* is executed with no arguments, it runs at the console prompt, connects to devices, and waits for errors. For more information about *micrasd* refer to:

```
[host]# micrasd -help
```



## E *micnativeloadex*

---

The *micnativeloadex* utility will copy an Intel® Xeon Phi™ coprocessor native binary to a specified coprocessor and execute it. The utility automatically checks library dependencies for the application. If they are found in the default search path (set using the `SINK_LD_LIBRARY_PATH` environment variable), the libraries are copied to the card prior to execution. This simplifies running Intel® Xeon Phi™ coprocessor native applications.

In addition, the utility can also redirect output from an application running remotely on the Intel® Xeon Phi™ coprocessor back to the local console. This feature is enabled by default but can be disabled with a command line option.

**Note:** If the application has any library dependencies, then the `SINK_LD_LIBRARY_PATH` environment variable must be set to include those directories. This environment variable works just like `LD_LIBRARY_PATH` for normal Linux\* applications. To help determine the required libraries, execute *micnativeloadex* with the `-l` command line option:

```
[host]$ micnativeloadex -l Appname
```

This will display the list of dependencies and which ones have been found. Any dependencies not found will likely need to be included in the `SINK_LD_LIBRARY_PATH`.

Refer to *micnativeloadex* help for more information:

```
[host]$ micnativeloadex -help
```

The `SINK_LD_LIBRARY_PATH` must include the directory path for `libcoi_host.so` library

For example:

```
[host]$ export LD_LIBRARY_PATH=/usr/lib64:$LD_LIBRARY_PATH
```

**Note:** When linking in libraries installed in `/lib64`, do not add `/lib64` to the `LD_LIBRARY_PATH` environment variable. This path is already implicit in the dynamic linker/loader's search path, and modifying the path variable will result in breaking the order in which library paths are searched for offload compilation.





# F **Optional Intel® MPSS Components**

---

This chapter provides detailed instructions on installing several optional MPSS components.

## F.1 **Intel® MPSS GANGLIA Support (optional)**

This section describes how to install Ganglia components on the host and Intel® Xeon Phi™ coprocessor for host platforms running RHEL\* 6, RHEL\* 7 or SLES\* 11. Due to 3<sup>rd</sup> party incompatibilities Ganglia is not supported on SLES\* 12.

### F.1.1 **Requirements**

The following software components must be installed on the host.

#### 1) Red Hat\* Enterprise

- apr
- apr-devel
- expat
- expat-devel
- gcc-c++
- libconfuse
- libconfuse-devel
- libtool
- rpm-build
- rrdtool
- rrdtool-devel

#### 2) SUSE\* Linux\* Enterprise Server (SLES\*)

- gcc-c++
- libapr1
- libapr1-devel
- libconfuse0
- libconfuse-devel
- libexpat0
- libexpat-devel



- libtool
- rpmbuild
- rrdtool
- rrdtool-devel

## F.1.2 Steps to Install GANGLIA on the Host

**Note:** Only GANGLIA 3.1.7 is currently supported.

**Note:** For additional information on the installation of GANGLIA, consult the documentation at <http://ganglia.sourceforge.net>

**Note:** The default path for the GANGLIA web page is /usr/share/ganglia. If the ganglia-web RPM was installed, the files conf.php, get\_context.php and host\_view.php will be overwritten.

Steps:

1. Create working directories. For example:

```
[host]# mkdir -p /var/lib/ganglia/rrds
[host]# mkdir -p /var/www/html
```

2. Download GANGLIA 3.1.7 from <http://ganglia.info/?p=269>.

3. Untar GANGLIA 3.1.7 package and access the untar folder:

```
[host]$ tar xf ganglia-3.1.7.tar.gz
[host]$ cd ganglia-3.1.7
```

4. Execute the configure tool:

```
[host]$ ./configure --with-gmetad \
--with-libpcre=no --sysconfdir=/etc/ganglia
```

5. Build GANGLIA content and install binaries:

```
[host]$ make
[host]# make install
```

6. Generate default configuration for gmond:

```
[host]# gmond --default_config > /etc/ganglia/gmond.conf
```

7. Edit (as root) the host's */etc/ganglia/gmond.conf* and confirm that a *udp\_recv\_channel* is defined and that it assigns a port value. For example:

```
udp_recv_channel {
    : /*other parameters */
    port = <port>
    : /*other parameters */
}
```

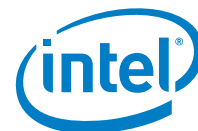

## Optional Intel® MPSS Components

If a `udp_recv_channel` is not defined, or if the port is not assigned, then define it. The standard ganglia port is 8649:

```
udp_recv_channel {
    : /*other parameters */
    port = 8649
    : /*other parameters */
}
```

8. Edit (as root) the host's `/etc/ganglia/gmetad.conf` to configure the cluster name in the "data\_source" line. For example:

```
data_source "mic_cluster" localhost
```

9. Change the owner of the RRDS folder:

```
[host]# chown -R nobody /var/lib/ganglia/rrds
```

10. Copy GANGLIA web content to local web path.:

```
[host]# cp -r web <web_path>/ganglia
```

11. Start the `gmond` and `gmetad` daemons:

```
[host]# gmond
[host]# gmetad
```

12. Install web front end for Intel® MPSS GANGLIA.

- Red Hat\* Enterprise Linux\*

```
[host]# yum install $MPSS36/ganglia/mpss-ganglia*.rpm
```

- SUSE\* Linux\* Enterprise Server

```
[host]# zypper install $MPSS36/ganglia/mpss-ganglia*.rpm
```

13. Copy the web content under `/usr/share/mpss/ganglia` to the GANGLIA web path:

```
[host]$ cp -r /usr/share/mpss/ganglia/* <web_path>/ganglia/
```

### F.1.3 Installing Intel® MPSS GANGLIA RPMs in the Card

The following rpms must be installed: `ganglia-3.1.7-r0.k10m.rpm`, `libapr-1-0-1.4.6-r0.k10m.rpm`, `libconfuse0-2.7-r1.k10m.rpm`, and `mpss-ganglia-mpss-r0.k10m.rpm`

You can use any of the methods described earlier in this chapter to install Intel® MPSS Ganglia rpms into the coprocessor file system. In the example below we will use `micctrl` to add an *Overlay RPM* parameter for each rpm:

```
[host]# micctrl --overlay=rpm \
--source=$MPSS36_K10M/libconfuse0-2.7-r1.k10m.rpm --state=on
[host]# micctrl --overlay=rpm \
--source=$MPSS36_K10M/libapr-1-0-1.4.6-r0.k10m.rpm --state=on
[host]# micctrl --overlay=rpm \
--source=$MPSS36_K10M/ganglia-3.1.7-r0.k10m.rpm --state=on
```



```
[host]# micctrl --overlay=rpm \  
--source=$MPSS36_K10M/mpss-ganglia-mpss-r0.k10m.rpm --state=on
```

Restart the mpss service:

```
[host]# !!service mpss restart
```

## F.1.4 Starting Intel® MPSS with GANGLIA Support

- 1) Configure the `/etc/ganglia/gmond.conf` files on the both the host and the coprocessors as needed.

**Note:** The collection of several CPU metrics is disabled by default in the coprocessor's `/etc/ganglia/gmond.conf`. Enabling their collection will cause a performance penalty. To enable these metrics, search for the comment:

```
/*CPU metrics are disabled by default, uncommenting this block will have a  
performance penalty*/  
and uncomment the following collection groups.
```

- 2) The Intel® Xeon Phi™ coprocessor specific GANGLIA stack is started by executing:

```
[host]# ssh mic0 gmond
```

## F.1.5 Stopping Intel® MPSS with GANGLIA Support

Stop the `gmond` for all installed coprocessors in the system, for Instance:

```
[host]# ssh mic0 killall gmond  
[host]# ssh mic1 killall gmond
```

## F.2 Intel® Xeon Phi™ Coprocessor Performance Workloads (optional)

The Intel® Xeon Phi™ coprocessor Performance Workloads component of Intel® MPSS (micperf) can be used to evaluate the performance of coprocessor based installation. Micperf incorporates a variety of benchmarks into a simple user experience with a single interface for execution and a unified means of data inspection. The user interface to micperf consists of five executables: one for execution of benchmarks (micprun), and four that interpret the output of the first. These executables are documented with standard UNIX\* style command line interfaces. The results can be displayed as professional quality plots, human readable text or comma separated value output that can be easily imported into a variety of other applications. Results of different runs can be easily combined and compared. Documentation is installed at `/usr/share/doc/micperf-3.6`.

The remainder of this chapter describes micperf installation.

### F.2.1 Installation Requirements

- 1) Intel® Composer XE Requirements

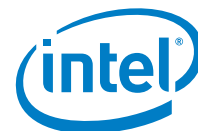

## Optional Intel® MPSS Components

There are two options to installing the Intel® Composer XE requirements. The first option is to install the full Intel® Composer XE package and source the `compilervars.sh` or `compilervars.csh` script at run time.

If the full composer installation is not available, then two packages can be used instead. The required shared object libraries can be installed via the Intel® Composer XE redistributable package, freely distributed on the web at:

<http://software.intel.com/en-us/articles/redistributable-libraries-for-the-intel-c-and-fortran-composer-xe-2013-sp1-for-linux>

This package has an `install.sh` script for installation. After installation, there are `compilervars.sh` and `compilervars.csh` scripts which serve a similar purpose to those scripts in the full Intel® Composer XE distribution and must be sourced at run time.

Besides the shared object libraries, the MKL Linpack benchmark is also a requirement. This is also freely distributed on the web at:

<http://software.intel.com/en-us/articles/intel-math-kernel-library-linpack-download>

This download is a tarball that can be unpacked anywhere, but the environment variable `MKLROOT` must point to the top level directory of the untarred package. For instance, if the user extracted the tarball into their home directory they should set `MKLROOT` as follows (in bash or Bourne shell):

```
[host]$ export MKLROOT=<home_directory_path>/linpack_<version_num>
```

If `MKLROOT` is set in the user's shell environment at run time, then `micprun` will be able to locate the linpack binaries. The version of linpack linked above may be newer than 11.1.2, and `MKLROOT` variable should reflect this.

### 2) MATPLOTLIB Requirements

The `micplot` and `micprun` applications use the MATPLOTLIB Python module to plot performance statistics. The `micprun` application only creates plots when verbosity is set to two or higher, and it only requires MATPLOTLIB for this use case. MATPLOTLIB must be installed in order to create plots. Download it from:

[matplotlib.sourceforge.net](http://matplotlib.sourceforge.net)

## F.2.2 Distributed Files

This package is distributed as two RPM files:

```
$MPSS36/perf/micperf-3.*.rpm  
$MPSS36/perf/micperf-data-3.*.rpm
```

The first of these packages contains everything except the reference performance measurements, which are distributed in the second package.

## F.2.3 RPM Installation

To install the RPM files, `cd` to `$MPSS36/perf`, then:

- Red Hat\* Enterprise Linux\*



```
[host]# yum install *.rpm
```

- SUSE\* Linux\* Enterprise Server

```
[host]# zypper install *.rpm
```

This installs files to the following directories:

- Source code: `/usr/src/micperf`
- Documentation and licenses: `/usr/share/doc/micperf-3.6`
- Benchmark binaries: `/usr/libexec/micperf`
- Reference data: `/usr/share/micperf/micp`
- Links to executables: `/usr/bin`

## F.2.4 Python Installation

Once the RPM packages have been installed, an additional step must be executed to access the micp Python package: either install it to your global Python site packages, or set up your environment to use the micp package from the installed location.

To install into the Python site packages:

```
[host]$ cd /usr/src/micperf/micp
[host]# python setup.py install
```

This method provides access to the micp package and executable scripts to all non-root users who use the same Python version as the root user (sudoer). If Python is in the default location and uses a standard configuration, *setup.py* installs the micp package to the directories:

```
/usr/bin
/usr/lib/pythonPYVERSION/site-packages/micp
```

An intermediate product of running "setup.py install" is the creation of the directory:

```
/usr/src/micperf/micp-<version>/build
```

None of the products of running *setup.py* discussed above will be removed by uninstalling the micperf RPMs. The installation with *setup.py* uses Python's distutils module, and this module does not support uninstall. If installing on a Linux\* system where Python is configured in a standard way, it should be possible to uninstall with the following commands:

```
[host]# sitepackages=`sudo python -c \
"from distutils.sysconfig import get_python_lib; \
print(get_python_lib())"`
[host]# rm -rf /usr/src/micperf/micp/build \
/usr/bin/micpcsv \
/usr/bin/micpinfo \
/usr/bin/micpplot \
/usr/bin/micpprint \
/usr/bin/micprun \
${sitepackages}/micp \
```



```

${sitepackages}/micp-[version number]*

```

## F.2.5 Alternative to Python Installation

Another way to access the micp package after installing the RPMs is to alter the shell run time environment of a user. To set up your bash or Bourne shell environment:

```

[host]$ export PYTHONPATH=/usr/src/micperfm/micp:${PYTHONPATH}

```

To set up your csh run time environment:

```

[host]$ setenv PYTHONPATH /usr/src/micperfm/micp:${PYTHONPATH}

```

## F.3 Intel® MPSS Reliability Monitor Support (optional)

The Intel® MPSS Reliability Monitor is designed to monitor the overall health of compute nodes in a cluster. It typically runs on a cluster's head, or management, node. The Reliability Monitor works closely with the RAS agent running on each compute node. Uncorrectable errors or crash symptoms are reported to the Reliability Monitor.

### F.3.1 Requirements

Intel® MPSS and the *micrasd* daemon must be installed on each node to be monitored. *micrasd* is installed as part of normal software stack installation. Refer to [Section 3.3](#).

### F.3.2 Steps to Install Intel® MPSS with Reliability Monitor Support

Only install Reliability Monitor on the head node, or management node.

The default path for the Reliability Monitor node configuration file is `/etc/mpss`.

Steps:

Install Intel® MPSS Reliability Monitor:

- Red Hat\* Enterprise Linux\*

```

[host]$ cd $MPSS36/relmon
[host]# yum install mpss-sysmgmt-relmon-3.*.rpm

```

- SUSE\* Linux\* Enterprise Server

```

[host]$ cd $MPSS36/relmon
[host]# zypper install mpss-sysmgmt-relmon-3.*.rpm

```

### F.3.3 Starting Intel® MPSS with Reliability Monitor Support

- 1) On each compute node, make sure mpss service and micras service are up and running. If mpss service and micras service are not running, use:

```

[micN]# lservice mpss start
[micN]# lservice micras start

```



2) On head node, start Reliability Monitor service by using:

```
[host]# service relmon start
```

### F.3.4 Stopping Intel® MPSS with Reliability Monitor Support

On head node, stop Reliability Monitor service by using:

```
[host]# service relmon stop
```

### F.3.5 Reliability Monitor Configuration File and Log

The node configuration file *mic\_node.cfg* for Reliability Monitor is located at */etc/mpss*. The file is in comma-separated values (CSV) format so it is supported by almost all spreadsheets and database management systems.

Errors will be logged into Linux\* syslog */var/log/messages*. You can check the error log by using:

```
[host]# cat /var/log/messages | grep relmon
```

Reliability Monitor is installed in */usr/bin*. After *relmon* service is running, you can issue commands to monitor node status and error information by using:

```
[host]$ relmond --cmd shownode  
[host]$ relmond --cmd showerr
```

For more information about Reliability Monitor, refer to:

```
[host]$ relmond --help
```



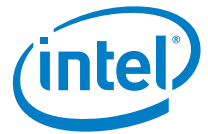

# G Rebuilding Intel® MPSS Components

---

This appendix describes the steps to rebuild selected Intel® MPSS GPL libraries and components. Rebuilding the host and OFED drivers was covered in [Sections 3.3.3](#) and [3.3.4](#) respectively.

For any of these components, perform the following steps:

- 1) Install Intel® MPSS (see [Section 3.3](#)).
- 2) Download and untar the mpss-src-3.6.tar file:
  - a. Go to the Intel® Developer Zone website (Intel® DZ): <http://software.intel.com/en-us/articles/intel-manycore-platform-software-stack-mpss>.

Download the mpss-src-3.6.tar file from the "SOURCE" link associated with your MPSS release.

- b. Extract the source archive:

```
[host]$ tar xvf mpss-src-3.6.tar
```

By definition, source rpms are extracted to the \$MPSS36\_SRC directory.

## G.1 Recompiling the Intel® MPSS GANGLIA Modules

Support enabled for RHEL\* 6 and 7, and SLES\* 11. Ganglia is not supported in SLES\* 12.

- 3) Obtain and install Ganglia prerequisites (see [F.1.1](#)).
- 4) Obtain and install ganglia-devel-3.1.7 and apr-devel-1.3.9-3 on the host
- 5) Extract mpss-ganglia-mpss.tar.bz2.

```
[host]$ cd $MPSS36_SRC
[host]$ tar xvf mpss-ganglia-mpss.tar.bz2
[host]$ cd mpss-ganglia-mpss
```

- 6) Define the environment variable CROSS\_COMPILE.

```
[host]$ export CROSS_COMPILE=/opt/mpss/3.6/sysroots/ \
x86_64-mpsssdk-linux/usr/bin/k1om-mpss-linux/k1om-mpss-linux
```

For RHEL\* 7.1:

An additional variable is required.

```
[host]# export C_INCLUDE_PATH=/usr/include/apr-1
```

- 7) Regenerate the GANGLIA modules.



```
[host]$ make
```

## G.2 Recompiling the Intel® MPSS MIC Management Modules

1. Install Intel® MPSS™.
2. Ensure that the following packages are installed.
  - mpss-modules-headers-3.6
  - glibc2.12.2pkg-libmicmgmt0-3.6
  - libscif0-3.6
  - libscif-dev-3.6
  - glibc2.12pkg-libmicmgmt-dev-3.6
  - asciidoc
3. Download and untar the mpss-src-3.6.tar to \$MPSS36\_SRC
  - [host]# tar xvf mpss-src-3.6.tar
4. Extract mpss-micmgmt-3.6.tar.bz2 and mpss-metadata-3.6.tar.bz2.
  - [host]\$ cd \$MPSS36\_SRC
  - [host]# tar xvf mpss-micmgmt-3.6.tar.bz2
  - [host]# tar xvf mpss-metadata-3.6.tar.bz2
5. Regenerate the Intel MPSS MIC management modules.
  - [host]\$ cd \$MPSS36\_SRC/mpss-micmgmt-3.6
  - [host]# cp ../mpss-metadata-3.6/mpss-metadata.mk miclib/
  - [host]# cp ../mpss-metadata-3.6/mpss-metadata.c miclib/
  - [host]# cp ../mpss-metadata-3.6/mpss-metadata.mk apps/mpssinfo
  - [host]# cp ../mpss-metadata-3.6/mpss-metadata.c apps/mpssinfo
  - [host]# cp ../mpss-metadata-3.6/mpss-metadata.mk apps/mpssflash
  - [host]# cp ../mpss-metadata-3.6/mpss-metadata.c apps/mpssflash
  - [host]# cp ../mpss-metadata-3.6/mpss-metadata.mk apps/micsmc
  - [host]# cp ../mpss-metadata-3.6/mpss-metadata.c apps/micsmc

Set the DESTDIR environment variable to the desired make install target path, for example /usr/local.

- [host]# export DESTDIR=/usr/local
6. Build the micmgmt modules:
    - [host]# make lib
    - [host]# make install\_lib
    - [host]# make
    - [host]# make install

A build directory will be created at \$DESTDIR, and everything will be installed there.

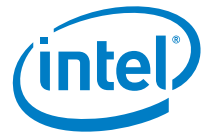

## G.3 How to Extract and Use the COI Open Source Distribution

COI source is delivered in the file `mpss-coi-3.6.tar.bz2`. In the tar file, the files are packaged with paths relative to the original source directory structure.

### G.3.1 Building COI Libraries and Binaries

- 1) Ensure that the asciidoc utility is installed.
- 2) Extract `mpss-metadata.tar.bz2` and `mpss-coi-3.6.tar.bz2`:

```
[host]$ cd $MPSS36_SRC
[host]$ tar xvf mpss-metadata-3.6.tar.bz2
[host]$ tar xvf mpss-coi-3.6.tar.bz2
[host]$ cd mpss-coi-3.6
```

- 3) Rebuild COI, either the debug or release version as needed:

```
[host]$ make [debug|release] -I ../mpss-metadata-3.6/
```

### G.3.2 Installing Host Library

To install the host-side COI library, first make sure that the Intel® MPSS driver is running, then do the following:

```
[host]# cp build/host-linux-[debug|release]/libcoi_host.so
/usr/lib64/
[host]# cd /usr/lib64/
[host]# ln -s libcoi_host.so libcoi_host.so.0
```

### G.3.3 Installing Card-side Binaries and Libraries

To install the COI library, first kill the `coi_daemon` so that the new one can be installed:

```
[host]# ssh micN
[micN]# killall -9 coi_daemon
[micN]# exit
```

Install the new components and start the COI daemon:

```
[host]# cd $MPSS36_SRC/mpss-coi-3.6
[host]# scp build/device-linux-[debug|release]/coi_daemon \
micN:/usr/bin/coi_daemon
[host]# scp \
build/device-linux-[debug|release]/libcoi_device.so \
micN:/usr/lib64/libcoi_device.so
[host]# ssh micN
[host]# cd /usr/lib64/
[micN]# ln -s libcoi_device.so libcoi_device.so.0
[micN]# coi_daemon --coiuser=micuser&
[micN]# exit
```



Once installed, and now that the new `coi_daemon` is running, the new COI binaries and libraries will be in use in the current running driver.

Building the COI stack also builds the COI tools. If you wish to install the newly built tools `coitrace` and `micnativeloadex`, do the following:

```
[host]# cp build/host-linux-[debug|release]/coitrace /usr/bin/
[host]# cp build/host-linux-[debug|release] \
  /libcoitracelib.so /usr/lib64/
[host]# cp build/host-linux-[debug|release] /micnativeloadex \
  /usr/bin/
[host]# cd /usr/lib64/
[host]# ln -s libcoitracelib.so libcoitracelib.so.0
```

### G.3.4 COI Tutorial Build and Execution Instructions

To build and run the COI tutorials, follow the instructions below:

- 1) Ensure all the Intel® Xeon Phi™ coprocessors are booted to the online state:

```
[host]$ micctrl -s
mic0: online (mode: linux image:
  /usr/share/mpss/boot/bzImage-knightscorner)
```

- 2) Extract `mpss-coi-3.6.tar.bz2`:

```
[host]$ cd $MPSS36_SRC
[host]$ tar xvf mpss-coi-3.6.tar.bz2
```

- 3) Build a COI tutorial, `<coi_tutorial>`:

```
[host]$ cd mpss-coi-3.6/src/tutorial/<coi_tutorial>
[host]$ make
```

- 4) Execute the debug or release version of the tutorial

```
[host]$ cd [debug|release]
[host]$ ./<coi_tutorial>_source_host
```

## G.4 How to Extract and Use the MYO Open Source Distribution

MYO source is delivered in the file `mpss-myo-3.6.tar.bz2`. In the tar file, the files are a tree relative to the `mpss-myo-3.6` directory.

Extract the MYO archive to the desired directory with the following steps.

```
[host]$ cd $MPSS36_SRC
[host]$ tar -xf mpss-myo-3.6.tar.bz2
[host]$ cd mpss-myo-3.6
```

The `mpss-myo-3.6/src/README` text file explains the purpose, content, and use of the MYO Open Source Distribution. It includes information about compiler selection, building and installing the MYO libraries, MYO system requirements, and the MYO tutorials.

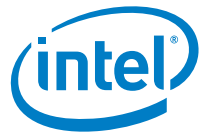

# H General Services Tutorial

---

This chapter briefly describes how services are started on supported Linux\* host Operating Systems and the Intel® Xeon Phi™ coprocessor. This is intended for customers who are adding custom services that may interact with the services supplied with Intel® MPSS. In all cases the described priority only applies to initial boot and run level changes. The priority or dependencies are not checked when services are manually started and stopped.

## H.1 Service Startup by Priorities (RHEL\* 6.x)

Red Hat\* traditionally uses this method of startup and shutdown. A line is added to the top of the service script that defines the run levels and priority of when a service starts at boot time.

Here is an example snippet from the top of a service file:

```
— #!/bin/bash
— # chkconfig: 2345 10 90
— # ...
```

This tells the startup daemon in Linux\* to shut down the service early (priority 10) and start the service late (priority 90) when entering Linux\* run levels 2, 3, 4, and 5. If a service A depends on another service B the shutdown and startup priorities should reflect the relative priorities sooner and later respectively:

```
— #!/bin/bash
— # Service B
— # chkconfig: 2345 10 90
```

and:

```
— #!/bin/bash
— # Service A
— # chkconfig: 2345 9 91
```

The priority increases in time for both shut down and startup of a service. Now service A will start after service B and service B will shut down after service A.

When you have multiple dependencies make sure the new service's shutdown time is the minimum of the dependencies minus 1 and the start priority is max of dependencies + 1.



There is a tool for managing services runlevels and priorities called chkconfig. For more details please see:

[https://access.redhat.com/site/documentation/en-US/Red\\_Hat\\_Enterprise\\_Linux/6/html/Deployment\\_Guide/s2-services-chkconfig.html](https://access.redhat.com/site/documentation/en-US/Red_Hat_Enterprise_Linux/6/html/Deployment_Guide/s2-services-chkconfig.html)

## H.2 Service Startup by Dependencies (SUSE\* Linux\* Enterprise Server 11 SP3)

In addition to the chkconfig comment line from the Red Hat\* distribution priority method, SUSE\* Linux\* Enterprise Server 11 adds a new concept to the startup order, dependencies. The chkconfig method is present for backward compatibility.

Here is a snippet we can refer to:

```
— #!/bin/bash
— # chkconfig: 35 75 54
# Description: Novell Identity Manager User Application
#
### BEGIN INIT INFO
# Provides: userapp
# Required-Start: $ndsd $network $time
# Required-Stop:
# Default-Start: 3 5
# Default-Stop: 0 1 2 6
# Short-Description: Novell IDM UserApp
# Description: Novell Identity Manager User Application
### END INIT INFO
```

Some short definitions:

- |                          |   |
|--------------------------|---|
| <b>Provides</b>          | - The name used to identify this service in the init daemon                 |
| <b>Required-Start</b>    | - Space delimited Provides names of services to start before this service   |
| <b>Required-Stop</b>     | - Space delimited Provides names of services to stop before this service    |
| <b>Default-Start</b>     | - Space delimited list of run levels to start when transitioning run levels |
| <b>Default-Stop</b>      | - Space delimited list of run levels to stop when transitioning run levels  |
| <b>Short-Description</b> | - Short display name of service   |
| <b>Description</b>       | - Full display name of service  |

To make sure the service start order is correct, pick the list of service dependencies and list them on the *Required-Start* line. Make sure to fill in the start and stop run levels as appropriate. Optionally list the services to stop after the service represented by this script.

**Note:** All names used for service reference must be the Provides name and not the file name of the script!



For more details on this method see:

<http://www.novell.com/support/kb/doc.php?id=7002295>

### **H.3 Intel® Xeon Phi™ Coprocessor Method for Service Start Priority**

The Intel® Xeon Phi™ coprocessor's init daemon using the SUSE\* Linux\* Enterprise Server 11 dependency system is described in the previous section.

# I Troubleshooting and Debugging

---

This appendix is a collection of tips and techniques that can be helpful in troubleshooting an Intel® Xeon Phi™ coprocessor installation and/or coprocessor debugging execution.

## I.1 Log Files

The Intel® Xeon Phi™ coprocessor supports BusyBox\* implementations of dmesg and syslogd.

### I.1.1 Dmesg Output

Viewing dmesg output can sometimes help in troubleshooting when a coprocessor fails to boot.

First, verify that debugfs is mounted:

```
[host]$ mount | grep debugfs
none on /sys/kernel/debug type debugfs (rw)
```

Mount debugfs, if not already mounted:

```
[host]# mount -t debugfs none /sys/kernel/debug
```

Coprocessor dmesg output can be viewed during coprocessor boot (or later) at `/sys/kernel/debug/mic_debug/micN/log_buf`. For example:

```
[host]$ cat /sys/kernel/debug/mic_debug/micN/log_buf
```

### I.1.2 Syslog Output

By default, each coprocessor's syslog messages are logged to the coprocessor's `/var/log/messages` file. The log target and other logging details, such as the log (severity) level, can be changed using the `micctrl --syslog` command:

```
micctrl --syslog=(buffer|file|remote) \
  [--host=<targethost[:port]>] [--logfile=<location>] \
  [--loglevel=<loglevel> [mic card list]
```

Of particular note is that syslog messages can be forwarded to the host or another node (when the coprocessor is bridged to the external network). For this purpose, the `targethost` syslog or rsyslog daemon must be configured for UDP reception on the specified port. On RHEL\* 6, uncomment the following line in `/etc/rsyslog.conf`:

```
# Provides UDP syslog reception
#$ModLoad imudp
#$UDPServerRun 514
```

For example:

```
# Provides UDP syslog reception
$ModLoad imudp
$UDPServerRun 514
```





## Troubleshooting and Debugging

The syslog or rsyslog daemon then typically must be restarted in order to pick up this new configuration. On RHEL\* 6, the rsyslog daemon is restarted as follows:

```
[host]# /etc/rc.d/init.d/rsyslog restart
```

If a host firewall is enabled, it may need to be configured to allow forwarding of syslog messages to the specified host. By default, the syslog or rsyslog daemon listens on UDP port 514. Consult your firewall documentation for configuration help.

Now use the `micctrl --syslog=remote` command to , for example:

```
[host]# micctrl --syslog=remote
```

In this case the `<targethost[:port]>` defaults to `host:514`. See [Appendix B.4.7.5](#) for more details on the `micctrl --syslog` command.

If not using `micctrl` (configuring manually), edit the `/etc/syslog-startup.conf` file in the default ramfs image. Consult BusyBox\* documentation on the parameters in this configuration file.

## I.2 Coprocessor Post Codes

Like any other Intel® IA-32, Intel® 64 or IA-64 platform, the Intel® Xeon Phi™ coprocessor produces POST codes at power on and boot to identify the stage that the card is at during the boot process. These POST codes can be viewed using the Linux\* command "dmesg" after a system power on. The POST codes can also be viewed during a boot cycle of the coprocessor by "tailing" `/var/log/messages`:

```
[host]# tail -f /var/log/messages | grep "Post Code"
```

The current POST code of a coprocessor can be obtained from its sysfs node:

```
[host]$ cat /sys/class/mic/micN/post_code
```

The POST codes are defined as follow:

"01"	LIDT
"02"	SBOX initialization
"03"	Set GDDR top
"04"	Begin memory test
"05"	Program E820 table
"06"	Initialize DBOX
"09"	Enable caching
"0b"	Pass initialization parameters to APs
"0c"	Cache C code
"0d"	Program MP Table
"0E"	Copy AP boot code to GDDR



- "0F" Wake up APs
- "10" Wait for APs to boot
- "11" Signal host to download Coprocessor OS
- "12" Wait for Coprocessor OS download - this is also known as the "ready" state. The coprocessor will be in this state after powering on, running "*micctrl -r*" or "*iservice mpss stop*". It means that the coprocessor is ready to receive the coprocessor OS either by a "*iservice mpss start*", "*iservice mpss restart*" or "*micctrl -b*" depending on how the coprocessor got into this state. It is not an error condition for the coprocessor to be in this state. See the sections above to learn how to start Intel® MPSS when the card is showing POST code 12
- "13" Signal received from host to boot Coprocessor OS
- "15" Report platform information
- "17" Page table setup
- "30" Begin memory training
- "31" Begin GDDR training to query memory modules
- "32" Find GDDR training parameters in flash
- "33" Begin GDDR MMIO training
- "34" Begin GDDR RCOMP training
- "35" Begin GDDR DCC disable training
- "36" Begin GDDR HCK training
- "37" Begin GDDR ucode training
- "38" Begin GDDR vendor specific training
- "39" Begin GDDR address training
- "3A" Begin GDDR memory module identification
- "3b" Begin GDDR WCK training
- "3C" Begin GDDR read training with CDR enabled
- "3d" Begin GDDR read training with CDR disabled
- "3E" Begin GDDR write training
- "3F" Finalize GDDR training
- "40" Begin Coprocessor OS authentication
- "50"- "5F" Coprocessor OS loading and setup

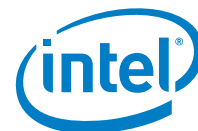

## **Troubleshooting and Debugging**

"6P" int 13 General Protection  
"75" int 10 Invalid TSS  
"87" int 16 x87 FPU Floating Point Error  
"AC" int 17 Alignment Check  
"bP" int 3 Breakpoint  
"br"int 5 BOUND Range Exceeded  
"CC" int 18 Machine Check  
"co" int 9 Coprocessor Segment Overrun  
"db" int 1 Debug  
"dE" int 0 Divide Error  
"dF" int 8 Double Fault  
"EE" Memory test failed  
"F0" GDDR parameters not found in flash  
"F1" GBOX PLL lock failure  
"F2" GDDR failed memory training  
"F3" GDDR memory module query failed  
"F4" Memory preservation failure  
"F5" int 12 Stack Fault  
"FF" Bootstrap finished execution  
"FP" int 19 SIMD Floating Point  
"Ld" Locking down hardware access  
"nA" Coprocessor OS image failed authentication  
"nd" int 7 Device Not Available  
"no" int 2 Non-maskable Interrupt  
"nP" int 11 Segment Not Present  
"oF" int 4 Overflow  
"PF" int 14 Page fault  
"r5"int 15 reserved  
"ud" int 6 Invalid opcode

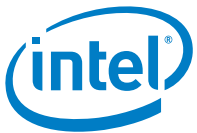

## I.3 Kernel Crash Dump Support

- 1) The host driver configuration option to enable/disable coprocessor kernel crash dumps is located in `/etc/modprobe.d/mic.conf`.

```
# crash_dump enables Coprocessor OS Kernel Crash Dump Captures
# 1 to enable or 0 to disable
:
options mic reg_cache=1 huge_page=1 watchdog=1
watchdog_auto_reboot=1 crash_dump=1 p2p=1 p2p_proxy=1 ulimit=0
```

Crash dump support is enabled by default. Edit the `options` line to disable support.

- 2) The `mpssd` daemon configuration options to tune crash dump storage location and storage limit (gigabytes) are typically in the `/etc/mpss/default.conf` Intel® MPSS configuration file.

```
# Storage location and size for MIC kernel crash dumps
CrashDump /var/crash/mic/ 16
```

Edit the `CrashDump` parameter to change the crash dump storage location and limit.

- 3) If a coprocessor OS crash occurs, a gzipped kernel crash dump core file will be available at the storage location configured in step 2.
- 4) Install the crash utility on the host to analyze the crash dump (RHEL\* example shown):

```
[host]# yum install crash
```

- 5) An example showing how a crash dump can be analyzed is shown below:

```
[host]$ cd /var/crash/mic/mic0/
[host]# gunzip vmcore-xxxx.gz
[host]# cp /opt/mpss/3.6/sysroots/k1om-mpss-linux/boot/vmlinux-2.6.38.8+mpss3.6 .
[host]# /opt/mpss/3.6/sysroots/k1om-mpss-linux/boot/x86_64-k1om-linux-elfedit --output-mach x86-64 vmlinux-2.6.38.8+mpss3.6
[host]# crash vmlinux-2.6.38.8+mpss3.6 vmcore-2012-9-24-15\:50\:29
```

Useful commands include `foreach`, `bt`, `ps`, `log`, etc.

Refer to [http://people.redhat.com/anderson/crash\\_whitepaper/#HELP](http://people.redhat.com/anderson/crash_whitepaper/#HELP)

- 6) If a custom user space utility other than the `mpssd` daemon is being used, then a crash dump can be obtained as follows:
  - a) Poll the `sysfs` entry `/sys/devices/virtual/mic/ctrl/subsystem/mic0/state` for coprocessor state changes.
  - b) Upon detection of the "lost" state, read from `/proc/mic_vmcore/` and write the contents to a crash dump file.
  - c) Gzip the content of the file.
  - d) Now reset the card and reboot it if required.

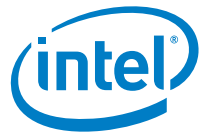

## I.4 GNU Debugger (GDB) for the Intel® Xeon Phi™ Coprocessor

GDB can be used to debug applications on an Intel® Xeon Phi™ coprocessor. GDB supports both native execution on a coprocessor as well as remote execution from a host processor. The *Debugging with GDB* manual is installed as the file `$MPSS36/docs/GDB.pdf`; it provides detailed instructions on the use of GDB. This section presents some additional information on using GDB on Intel® Xeon Phi™ coprocessors.

### I.4.1 Running natively on the Intel® Xeon Phi™ Coprocessors

To execute GDB natively, the rpm file `$MPSS36_K10M/gdb-7.*+mpss3.6.k10m.rpm` must be installed into the Intel® Xeon Phi™ coprocessor file system. Refer to [Chapter 7](#) for help on installing rpms into the coprocessor file system.

### I.4.2 Running remote GDB on the Intel® Xeon Phi™ Coprocessors

The remote Intel® Xeon Phi™ coprocessor enabled GDB client is located on the host at:

```
/opt/mpss/3.6/sysroots/x86_64-mpss-sdk-linux/usr/bin/k10m-mpss-  
linux/k10m-mpss-linux-gdb
```

The GDB Server is pre-installed in the coprocessor file system by default at:

```
/usr/bin/gdbserver
```

For complete GDB remote debugging instructions, refer to the chapter "Debugging Remote Programs" in the GDB manual.

### I.4.3 GDB remote support for data race detection

GDB supports data race detection based on Intel® PDBX data race detector for Intel® Many Integrated Core (MIC) architecture. See the "Debugging data races" chapter in the GDB manual.

Ensure that the environment is set up correctly and that GDB finds the correct version of the Intel® compiler's run-time support libraries. See the PROBLEMS-INTEL file in the GDB source package for additional help on troubleshooting.

### I.4.4 Debugging heterogeneous/offload applications

Heterogeneous application debugging is supported in Eclipse\*. This requires the installation of an Eclipse\* plugin. Install `mpss-eclipse-cdt-mpm-*.x86_64.rpm`.

Installation steps for the Eclipse\* plugin:

- 1) From the Eclipse\* menu use "Help" -> "Install new Software".
- 2) Click on "Add...".
- 3) Click on "Local...".



- 4) Use the "/usr/share/eclipse/mic\_plugin" path and click "OK".
- 5) Click "OK" again in the popup window.
- 6) Unselect the following two checkboxes: "Group items by category" and "Contact all update sites during install...".
- 7) Select the plugin using the corresponding checkbox, then click "Next".
- 8) Click "Next".
- 9) Accept the license agreement and click "Finish".
- 10) In the "Security Warning" popup, click "OK".
- 11) Restart the Eclipse\* IDE.

### **I.4.5 Enabling MIC GDB Debugging for Offload Processes**

An environment variable must be set in order to allow the debugger to enable module name mapping with the generated files needed to attach to the card side offload processes. To do this, execute the following step:

```
[host]$ export AMPLXE_COI_DEBUG_SUPPORT=TRUE
```