



Key Features

- 15" Intel skylake Fanless Stainless Panel PC
- IP66 full sealed with Anti-corrosion enclosure
- 15" LCD with full flat Resistive touch
- IP67 M12 metal connectors
- Special inspection of 100% waterproof guarantee
- CE, FCC, VCCI Class B certified
- Support Intel Vpro technology by CPU
- Optional Mini-PCIe WLAN with external antenna
- Customized PCAP touch with IP69K true tested
- Customized IP67 solution
- Screen touch lock function



Main System

CPU	FCBGA1356 6th generation Intel® Core i7/i5/i3 processor (15W max.)
Chipset	SoC
VGA	Intel® integrated HD Graphics 520 by CPU
Memory	Two 2133 MHz DDR4 SODIMM socket support dual Channel, non-ECC, up to 32GB

LCD Panel

Size	15" 4:3
Resolution	1024 x 768 (XGA)
Color numbers	16.7M colors (RGB 6bit + HIFRC)
Viewing angle	160 (H) / 160 (V)
Contrast	600:1
Brightness	300 nits

Touch Panel

Type	Full Flat Resistive touch, 5-wire
Light transmission	80±5%
Hardness	4H
Life time	490,000 hours

Storage & Expansion

HDD	2.5" SATA HDD drive bay x 1
Expansion slot	Mini PCIe x 2

Ordering Information

WTP-9E66-15 (i5)	15" FANLESS	Core i5-6200U / DDR4 4G RAM / 500G HDD / Full flat R-Touch
WTP-9E66-15 (i7)	15" FANLESS	Core i7-6500U / DDR4 4G RAM / 500G HDD / Full flat R-Touch

I/O & Power & Control Keys

USB	1 x M12 8pin for USB 1/2 1 x M12 8pin for USB 3/4
COM	1 x M12 8pin for COM 1/RS-232 1 x M12 8pin for COM 2/RS-232
LAN	1 x M12 8pin for LAN 1
Power input	1 x M12 5pin DC power connector, DC7V~32V
Power adaptor	AC 90 ~ 264V / 47 ~ 63 Hz / DC output 12V IP67(LV6)
Power consumption	53.3W (MAX. Loading without adapter)
Control keys	Rear bottom: Power on/off

Mechanical & Environmental

Housing	Stainless steel (SUS304), chassis type
IP rating	IP66 whole set (include the I/O connectors & control keys)
Cooling	Fanless
Dimension	395 x 309.5 x 58 mm (W x H x D, not include I/O connectors)
Weight (net)	8.4 Kg (net)
Temperature	12V DC Input 0~40°C (IEC60068-2-56, air flow cooling) 12V DC Input 0~50°C (Change HDD to SSD) Storage -20°C~60°C
Humidity	Operating & storage - 10%~90%, non-condensing
Regulatory	FCC, CE (EMC), VCCI Class B

Outline Drawing

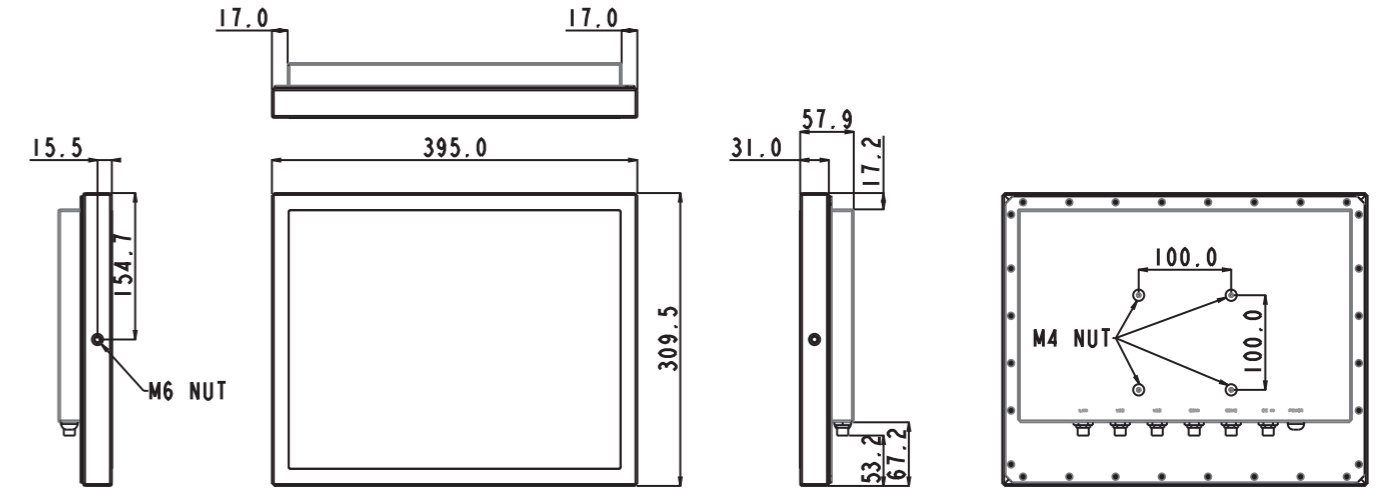

Options

Wireless or Wireless + BT kit (2 dipole ant)
M12 to 1x COM cable (cable length is 2 meters)
M12 to 1x USB cable (1 USB Port) (cable length is 2 meters)
M12 to 2x USB cable (2 USB Port) (cable length is 2 meters)
M12 to 1x LAN cable (cable length is 2 meters)
SSD
Wall mount / table mount bracket
Wireless or Wireless and BT kit (easy clean and Robust Antenna)

Customization

1000 nits high brightness LCD
Full flat PCT touch screen IP69K
Sunlight readable optical bonding
LCD Auto dimming
LCD Super dimming (Low brightness)
USB 3.0
IP67
5W/2W speaker
Second HD
2 External LAN (USB x2, LAN x2, COM x1)
Intel Core i7-6500U
Barcode reader
COM+power 5V or 12V
SUS316 enclosure
LCD 450 nits
TPM

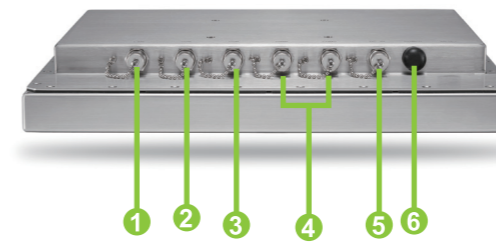

- 1 Giga LAN
- 2 USB 1/2
- 3 USB 3/4
- 4 COM x 2
- 5 DC-in
- 6 Power on/off

