

Intelli-Balance™ 100 Energy Recovery Ventilator

Specification Submittal Data / Panasonic ERV

Description

Ceiling or wall mount Cold Climate Energy Recovery Ventilator (ERV) provides a tempered air supply, humidity control, and a balanced amount of exhaust to help maintain balanced, positive or negative pressure throughout the home. Panasonic ERV is engineered for use in any North America climate zone. Only one unit is needed for a ≤ 3,000 sq. ft., up to 7 bedroom home to meet the ASHRAE 62.2 ventilation requirement. Built-in ASHRAE 62.2 Timing function helps ensure code compliance.

Motor/Blower:

- Two (2) enclosed DC brushless motors rated for continuous run.
- ERV Supply and Exhaust ventilation rates shall be manually adjustable for 50-60-70-80-90-100 CFM.
- Power rating shall be 120 volts and 60 Hz.
- Motor equipped with thermal cut-off fuse control.
- Removable, permanently lubricated, plug-in motor.

Housing:

- 22 gauge galvanized steel body.
- Four 4" or 6" intake and exhaust ducts.
- Built in dampers on exhaust and Outdoor Air ducts for defrost and recirculation cycling.
- Filters on supply and exhaust air extend the life of the ERV core.
- (4) Pressure ports allow for easy airflow verification.
- Pre-drilled mounting bracket can accommodate 16", 19", or 24" on center.

Maintenance:

- MERV 8 filter included; MERV 8 (FV-FL0810VE1) and optional MERV 13 (FV-FL1310VE1) replacements available.
- Unobtrusive alarm notifies owner for filter check and maintenance.

Warranty:

- DC Motors: 6 years from original purchase date
- All Parts: 3 Years from original purchase date.

Architectural Specifications:

ERV shall be ceiling or wall mount type with built-in speed selectors for both Supply and Exhaust air. Select from 50/60/70/80/100 CFM. ERV shall have 96 Net CFM on the exhaust ports and 98 Net CFM on the supply ports as tested in accordance with HVI 915 and 916 standards at 0.1 static pressure in inches water gauge. ERV shall have 95 Net CFM on the exhaust ports and Net 96 CFM on the supply ports at 0.4" w.g. static pressure. Power consumption shall be no greater than 64 watts at 0.1" w.g. and 84 watts at 0.4" w.g. static pressure. Apparent Sensible Effectiveness for heating shall be no less than 88% at 53 CFM net air flow under 32°F (0°C) as tested in accordance with CSA-C439. Total Recovery Effectiveness for cooling shall be no less than 65% at 48 CFM net air flow under 95°F (35°C). The supply port damper shall close when outdoor temperatures are < -22°F (-30°C) to prevent freezing of the core. The (2) motors shall be totally enclosed DC brushless motors rated for continuous run. DC motor speed shall automatically increase when the fan senses static pressure to maintain selected CFM. ERV shall incorporate an ASHRAE 62.2 Timing function for code compliance. Power rating shall be 120v/60Hz. Duct diameters shall be no less than 4". ERV can be used to comply with ASHRAE 62.2, Ontario, ENERGY STAR® and Novoclimat requirements; LEED, IAP, California Title-24, and WA Ventilation Code.

ERV Core Technology:

- Indoor and outdoor air passes through Panasonic's capillary core technology. This process tempers supply air while transferring moisture and energy.
- Built in Frost Prevention Mode prevents the core from freezing. Frost Prevention Mode is free of interaction and operates without intervention.

FV-10VEC1 Cold Climate ERV

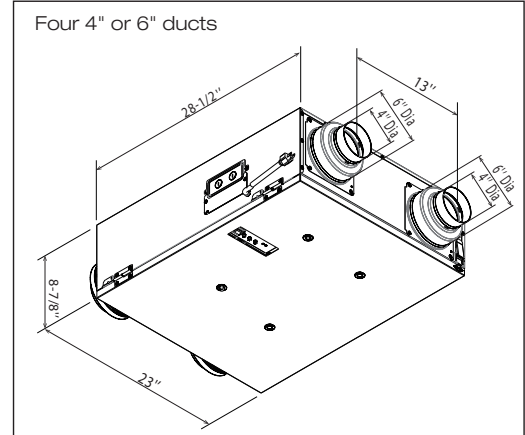

FV-10VEC1

Optional Exterior Wall Cap (see next page)

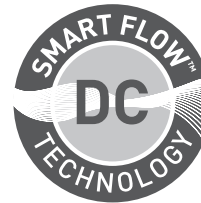

DC Motor Technology

When the ERV senses static pressure, its speed is automatically increased to ensure that the desired CFM is not compromised, which allows the ERV to perform as rated.

For complete Installation Instructions visit us.panasonic.com/ventfans

Model	Quantity	Comments	Project:
			Location:
			Architect:
			Engineer:
			Contractor:
			Submitted by:
			Date:

Panasonic Eco Solutions North America
Eco Products Division
Two Riverfront Plaza
Newark, NJ 07102

us.panasonic.com/ventfans



*This product meets strict energy efficiency guidelines set by Natural Resources Canada and is ENERGY STAR® certified for the Canadian market only.

Panasonic

Intelli-BalanceTM 100 Energy Recovery Ventilator

FV-10VEC1 Cold Climate ERV

Specification Submittal Data / Panasonic ERV (Continued)

Specifications: Intelli-Balance 100 FV-10VEC1		
Static Pressure in inches w. g.	0.1	0.4
Net Exhaust Air Volume (CFM)	96	95
Net Supply Air Volume (CFM)	98	96
Power Consumption (watts)	64.0	84.0
Power Rating (V/Hz)	120/60	
ENERGY STAR [®] Certified	Yes	

Energy Performance: Intelli-Balance 100 FV-10VEC1							
Supply Temperature		Net Air Flow		Power Consumed (Watts)	Sensible Recovery Efficiency	Apparent Sensible Effectiveness	Net Moisture Transfer
°C	°F	L/S	CFM				
Heating							
0	32	25	53	24	81	88	0.8
0	32	31	67	34	77	86	0.76
0	32	40	86	54	75	83	0.72
-25	-13	27	57	66	65	85	0.7
-25	-13	32	68	84	64	80	0.7
Cooling				Total Recovery Efficiency			
35	95	23	48	16	65		

Performance Curve 4" or 6" duct

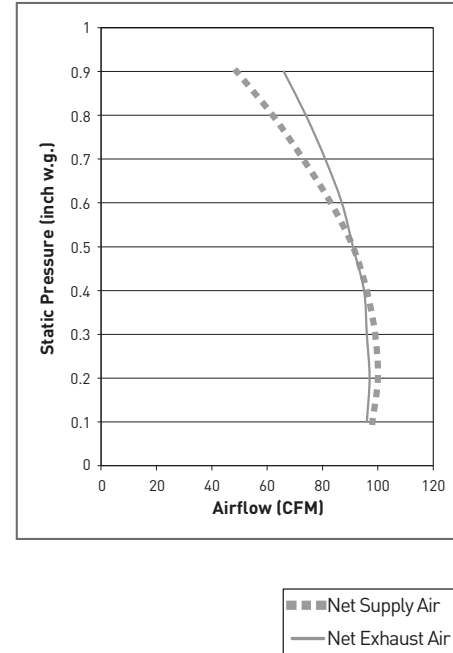

Optional Accessory

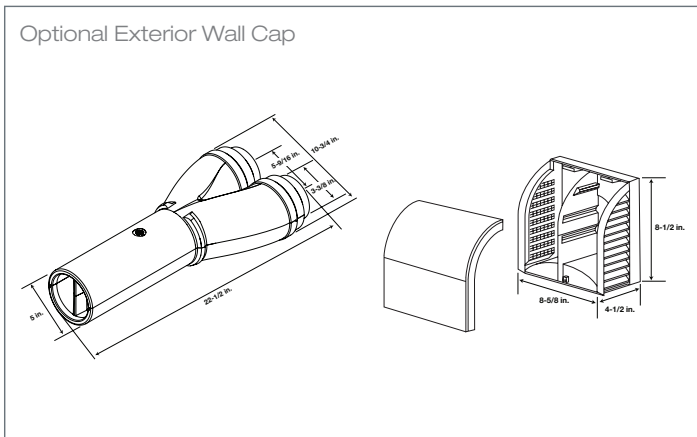

Exterior Wall Cap

FV-WC04VE1 polypropylene wall cap with styrofoam adaptor allows both exhaust (from the right) and supply (from the left) airflow through a 5.5"-5.75" hole in the building envelope. The dividers inside the bottom portion of the Y shape chamber and the new wall cap help prevent cross contamination.

NOTE: FV-WC04VE1 is NOT recommended for use at CFM settings higher than 50 CFM.

Panasonic Eco Solutions North America
Eco Products Division
Two Riverfront Plaza
Newark, NJ 07102
us.panasonic.com/ventfans



*This product meets strict energy efficiency guidelines set by Natural Resources Canada and is ENERGY STAR[®] certified for the Canadian market only.

Panasonic