

## HMI Software



<b>4/2</b>	<b>Introduction</b>	<b>4/88</b>	<b>SCADA system SIMATIC WinCC</b>
<b>4/5</b>	<b>HMI Software in the TIA Portal</b>	4/89	SIMATIC WinCC
4/6	SIMATIC WinCC (TIA Portal) Engineering	<u>4/107</u>	<u>SIMATIC WinCC options</u>
<u>4/12</u>	<u>SIMATIC WinCC (TIA Portal) Runtime</u>	4/108	SIMATIC BATCH for WinCC
4/14	WinCC Runtime Advanced	4/110	SIMATIC Information Server
4/19	WinCC Runtime Professional	4/111	SIMATIC Logon
4/25	WinCC Runtime Communication	4/112	SIMATIC Maintenance Station
<u>4/31</u>	<u>SIMATIC WinCC (TIA Portal) options</u>	4/115	SIMATIC Process Historian
4/32	WinCC Recipes	4/116	WinCC/Calendar Scheduler
4/34	WinCC Logging	4/117	WinCC/Central Archive Server (CAS)
4/36	WinCC Audit	4/118	WinCC/ChangeControl & WinCC/Audit
4/37	SIMATIC Logon	4/120	WinCC/Connectivity Pack & WinCC Connectivity Station
4/38	WinCC Sm@rtServer	4/122	WinCC/DataMonitor
4/42	WinCC Server / WinCC Client	4/124	WinCC/DowntimeMonitor
4/44	WinCC WebNavigator	4/126	WinCC/Event Notifier
4/47	WinCC DataMonitor	4/127	WinCC/IndustrialDataBridge
4/50	WinCC ControlDevelopment	4/129	WinCC/IndustrialX
<b>4/51</b>	<b>Software for energy management</b>	4/130	WinCC/Open Development Kit (ODK)
4/52	SIMATIC B.Data	4/131	WinCC/ProAgent
4/56	SIMATIC powerrate	4/132	WinCC/Redundancy
<b>4/59</b>	<b>SIMATIC WinCC flexible HMI system</b>	4/133	WinCC/Server
4/60	SIMATIC WinCC flexible ES	4/134	WinCC/TeleControl
4/64	SIMATIC WinCC flexible RT	4/138	WinCC/User Archives
<u>4/71</u>	<u>SIMATIC WinCC flexible options</u>	4/139	WinCC/Web Navigator
4/72	WinCC flexible /ChangeControl	<b>4/144</b>	<b>WinCC add-ons and partner management</b>
4/73	WinCC flexible /Archives	<b>4/146</b>	<b>SCADA System</b>
4/74	WinCC flexible /Recipes	<b>SIMATIC WinCC Open Architecture</b>	
4/75	WinCC flexible /Audit	4/155	SIMATIC WinCC Open Architecture Add-ons
4/76	SIMATIC Logon for WinCC flexible	<b>4/161</b>	<b>SIMATIC ProAgent process diagnostics software</b>
4/78	WinCC flexible /Sm@rtAccess		
4/82	WinCC flexible /Sm@rtService		
4/85	WinCC flexible /OPC server		
4/87	WinCC flexible /ProAgent		

# HMI Software

## Introduction

### HMI software

#### Overview

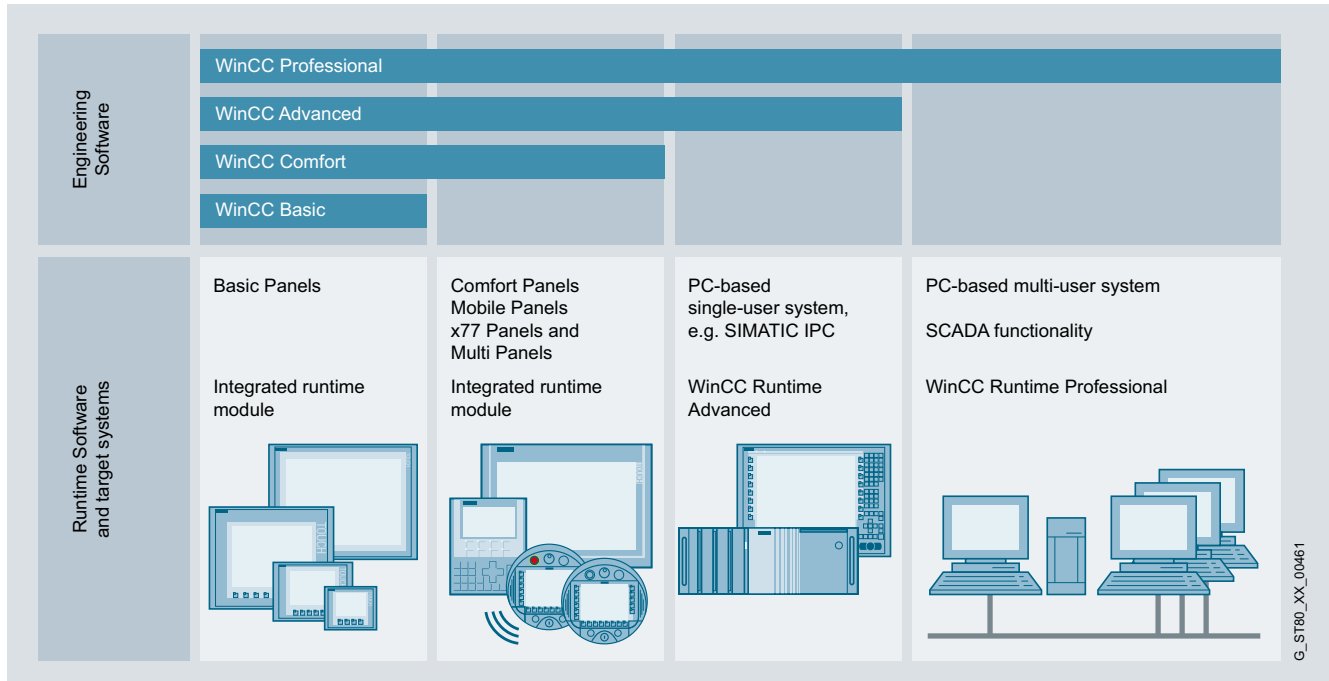

With the product families SIMATIC WinCC (TIA Portal), SIMATIC WinCC flexible, SIMATIC WinCC and SIMATIC WinCC Open Architecture, SIMATIC HMI offers visualization and configuration software for the entire HMI spectrum:

- SIMATIC WinCC (TIA Portal)  
Creation of applications in the machine-level area and of process visualization or SCADA systems
- SIMATIC WinCC flexible  
Creation of applications in the machine-level area:
- SIMATIC WinCC  
Creation of process visualization or SCADA systems
- SIMATIC WinCC Open Architecture  
Creation of applications with a high demand for customer-specific adaptations, large and/or complex applications, as well as projects that demand special system requirements and functions.

#### **SIMATIC WinCC (TIA Portal)**

WinCC (TIA Portal) is based on the new central engineering framework Totally Integrated Automation Portal (TIA Portal), which provides users with an integrated, efficient and intuitive solution to all automation tasks. SIMATIC WinCC (TIA Portal) covers applications in the machine-level area and applications in the process visualization or SCADA environment. WinCC (TIA Portal) offers the uniform and scalable configuration tools WinCC Basic, Comfort, Advanced and Professional for configuring the current SIMATIC HMI devices:

- SIMATIC Basic Panels
- SIMATIC Comfort Panels
- SIMATIC Mobile Panels
- SIMATIC Panels 77/177/277 series
- SIMATIC Multi Panels of the 177/277/377 series
- PC-based systems
  - SIMATIC WinCC Runtime Advanced
  - SIMATIC WinCC Runtime Professional

In addition, WinCC (TIA Portal) offers:

- Intuitive user interface with maximum degree of operator friendliness
- Clear configuration of devices and network topologies
- Shared data management and uniform symbols via controller and HMI
- Optimum interaction with the controller and HMI in a working environment
- Powerful editors for efficient engineering
- Integrated mass data operations for efficient configuration
- System diagnostics as an integral component
- Comprehensive library concept

### Overview (continued)

#### **SIMATIC WinCC flexible**

Covers applications in the machine-level area. WinCC flexible offers the integrated and scalable configuration tools WinCC flexible Micro, Compact, Standard and Advanced for configuring SIMATIC HMI devices:

- SIMATIC Basic Panels
- SIMATIC Mobile Panels
- SIMATIC Micro Panels
- SIMATIC Panels of the 70/170/270 series as well as C7-635 and C7-636
- SIMATIC Multi Panels of the 170/270/370 series
- PC-based systems
  - SIMATIC WinCC flexible Runtime
- Runs under Windows XP Professional / Windows 7 Professional, Ultimate, Enterprise
- Expanded integration into STEP 7 and SIMOTION
- Optionally expandable with functions for version administration and logging changes (WinCC flexible /ChangeControl)
- Modular PC-based HMI solution for single-user systems directly at the machine level
- Basic package for visualization, reporting and logging; can be expanded by implementing option packages
- Flexible expansion possible with VB scripts and customized ActiveX controls created with OPP (Open Platform Program)

#### **SIMATIC WinCC**

The process visualization or SCADA system for visualizing and operating processes, production flows, machines and plants in all sectors – from the simple single-user station through to distributed multi-user systems with redundant servers and cross-location solutions with web clients. WinCC is the information hub for company-wide, vertical integration (process visualization and platform for IT & business integration).

- For universal use thanks to solutions for all sectors, e.g. conforming to FDA 21 CFR Part 11, and multiple languages for worldwide use
- All HMI functions on-board with industry-standard functions for signaling and acknowledging events, archiving of messages and measured values, logging of all process and configuration data, user administration and visualization (WinCC basic software).
- Company-wide, flexible client/server structures with operator stations on the Web, distributed servers and data integrity thanks to redundancy
- Easy to integrate over standard interfaces such as OPC (OLE for Process Control), WinCC OLE-DB, VBA (Visual Basic for Applications), VB script, C-API (ODK)
- Integration platform in the company thanks to the Historian functionality integrated into WinCC based on the Microsoft SQL Server, standard and programming interfaces and tools and clients for evaluation
- Modular expansion with options and add-ons as well as individual functional expansions with VB Script, Visual Basic for Applications, C-API (ODK) and integration of ActiveX elements.
- Object-orientation supports efficient engineering and flexible plant expansion
- For large, distributed systems with up to 2048 servers
- Scalable – from a small single-user system up to a networked, redundant high-end system
- WinCC OA can be used on any platform and is available for Windows, Linux and Solaris
- Hot-standby redundancy and disaster recovery system assure maximum fail-safety and availability
- WinCC OA offers a platform for customer-specific solutions
- Extensive driver and interfacing options: S7, SINAUT, OPC, OPC UA, Modbus, IEC 60870-5-101/104, DNP3, BACnet, and many others.
- Flexible logging of data either in file-based value archive or in a relational database (ORACLE)
- Modular expansion is possible using options and add-ons as well as individual functional expansions by means of own script language CONTROL, API(C++) and integration of ActiveX elements

**Overview** (continued)**SIMATIC WinCC Open Architecture**

The SCADA system SIMATIC WinCC Open Architecture addresses applications with high demand for customer-specific adaptations, large and/or complex applications, as well as projects that demand special system requirements and functions.

SIMATIC WinCC Open Architecture demonstrates its high performance in networked and redundant high-end control systems in particular. From the field level to the control station, from the machine to the company headquarters – integrated, high-performance communication is ensured. In every situation, a high level of availability, reliable information, fast interaction and user friendliness are guaranteed. Applications can also be changed without interrupting the process. Profitability, efficiency and safety are therefore always in equilibrium.

With its disaster recovery system and SIL3 certification, SIMATIC WinCC Open Architecture demonstrates its reliability in a wide range of critical applications.

SIMATIC WinCC Open Architecture is open for independent in-house developments, which means that ideas can be turned into new applications quickly and easily.

- Object-orientation supports efficient engineering and flexible plant expansion
- For large, distributed systems with up to 2048 servers
- Scalable – from a small single-user system up to a networked, redundant high-end system
- WinCC OA can be used on any platform and is available for Windows, Linux and Solaris
- Hot-standby redundancy and disaster recovery system assure maximum fail-safety and availability
- WinCC OA offers a platform for customer-specific solutions
- Extensive driver and interfacing options: S7, SINAUT, OPC, OPC UA, Modbus, IEC 60870-5-101/104, DNP3, BACnet, and many others.
- Flexible logging of data either in file-based value archive or in a relational database (ORACLE)
- Modular expansion is possible using options and add-ons as well as individual functional expansions by means of own script language CONTROL, API(C++) and integration of ActiveX elements

### Overview

#### ***SIMATIC WinCC (TIA Portal) engineering software***

- Family of configuration systems with WinCC Basic, Comfort, Advanced and Professional for SIMATIC operator panels, as well as for the PC-based visualization systems WinCC Runtime Advanced and WinCC Runtime Professional

#### ***SIMATIC WinCC Runtime Advanced visualization software***

- PC-based HMI solution for single-user systems directly at the machine
- Basic package for visualization, reporting and logging, user administration, can be expanded flexibly with VB scripts
- Basic package expandable by means of option packages
- Integration of customer-specific ActiveX Controls created with WinCC ControlDevelopment
- Can be integrated into automation solutions based on TCP/IP networks
- Expanded service concepts with remote operation, diagnostics and administration over the Intranet and Internet in combination with e-mail communication

#### ***SIMATIC WinCC Runtime Professional visualization software***

- PC-based operator control and monitoring system for visualization and operator control of processes, production flows, machines and plants in all sectors – from the simple single-user station through to distributed multi-user systems and cross-location solutions with web clients. WinCC Runtime Professional is the information hub for corporation-wide vertical integration.
- Industry-standard functions for signaling and acknowledging events, archiving of messages and measured values, logging of all process and configuration data, user administration, can be expanded flexibly with VB and C scripts
- Basic package expandable by means of option packages
- Also included are APIs for the Runtime to utilize the open programming interfaces
- Integration of customer-specific ActiveX Controls created with WinCC ControlDevelopment

# HMI Software

## HMI Software in the TIA Portal

### SIMATIC WinCC (TIA Portal) Engineering

#### Overview

- Integrated family of engineering tools for configuring SIMATIC HMI operator panels, as well as for the PC-based visualization systems WinCC Runtime Advanced and WinCC Runtime Professional.
- WinCC (TIA Portal) is based on the new central engineering framework Totally Integrated Automation Portal (TIA Portal), which offers the user a uniform, efficient and intuitive solution to all automation tasks.
- WinCC (TIA Portal) also offers uniform engineering from the Basic Panel through to the SCADA application.
- Together with the STEP 7 (TIA Portal) products, WinCC (TIA Portal) forms the optimum solution for integrated, efficient engineering.

Current version:

- SIMATIC WinCC Basic V12 SP1
- SIMATIC WinCC Comfort V12 SP1
- SIMATIC WinCC Advanced V12 SP1
- SIMATIC WinCC Professional V12 SP1

#### Benefits

- The integrated configuration software reduces training, maintenance and service overhead and protects the customer's investments.
- Minimized engineering overhead and reduction of lifecycle costs thanks to Totally Integrated Automation (TIA)
- Minimized configuration overhead due to reuse of scalable and dynamizable objects
- Intelligent tools for efficient and simple configuration:
  - Wizard for defining the basic structure of the HMI project
  - Table-based editors simplify the generation and processing of similar types of object, e.g. for tags, texts, or alarms.
  - Complex configuration tasks such as the definition of paths of motion or the creation of the fundamental operator prompting are simplified by means of graphical configuration.
- Comprehensive support of multi-language configurations for worldwide use
  - Selectable views for entering configuration data in several languages
  - System and user-specific text lexicons
  - Export/import of language-dependent texts
- Investment protection due to
  - Import of the configuration from WinCC flexible 2008 SP2 and 2008 SP3
  - Transfer of the configuration from WinCC V7.0 SP3

#### Application

SIMATIC WinCC in the editions Basic, Comfort, Advanced and Professional are innovative engineering tools for configuring SIMATIC HMI operator panels, as well as for the PC-based visualization systems WinCC Runtime Advanced and WinCC Runtime Professional.

Depending on the selected product, various target systems can be configured:

##### WinCC Basic

- Basic Panels

##### WinCC Comfort

- As WinCC Basic, plus:
- Comfort Panels
- Mobile Panels: Mobile Panel 177, Mobile Panel 277
- Panels of the 70 series: OP 73, OP 77A, OP 77B
- Panels of the 170 series: TP 177A, TP 177B, OP 177B
- Panels of the 270 series: TP 277, OP 277
- Multi Panels: MP 177, MP 277, MP 377

##### WinCC Advanced

- As WinCC Comfort, plus:
- SIMATIC PCs with WinCC Runtime Advanced:
  - SIMATIC Panel PC: IPC277D, Panel PC 477B, IPC477C, IPC477D, Panel PC 577B, IPC577C, Panel PC 677B, IPC677C
  - SIMATIC Box PC: IPC227D, Box PC 427B, IPC427C, IPC427D, Box PC 627B, IPC627C, Box PC 827B, IPC827C
  - SIMATIC Rack PC: Rack PC 547B, IPC547C, IPC547D, Rack PC 647B, IPC647C, Rack PC 847B, IPC847C
  - SIMATIC modular Embedded Controller: EC31
- Standard PC with WinCC Runtime Advanced
- SINUMERIK PC: PCU 50.3, PCU 50.5

##### WinCC Professional

- As WinCC Advanced, plus:
- SIMATIC PCs with WinCC Runtime Professional:
  - SIMATIC Panel PC: IPC477C, IPC477D, Panel PC 577B, IPC577C, Panel PC 677B, IPC677C,
  - SIMATIC Box PC: IPC427C, IPC427D, Box PC 627B, IPC627C, IPC827C
  - SIMATIC Rack PC: Rack PC 547B, IPC547C, IPC547D, Rack PC 647B, IPC647C, Rack PC 847B, IPC847C
- Standard PC with WinCC Runtime Professional

### Design

The functionalities of the engineering tools of the SIMATIC WinCC family are based on each other. The available editors are largely determined by the respective configurable target systems and their function. A more comprehensive engineering tool such as WinCC Advanced can always be used to configure lower-level target devices as well (e.g. Basic Panels)

A Powerpack can be used to upgrade from a smaller edition to a larger one. This does not apply to WinCC Basic.

The functionality of WinCC engineering tools already contains the configuration support of the available Runtime options for SIMATIC Panels, WinCC Runtime Advanced or WinCC Runtime Professional, irrespective of the purchased RT licenses. A separate license is required for the target system when using the configured Runtime options.

### Function

#### Integration into automation systems

Integration into the SIMATIC Totally Integrated Automation Portal (TIA Portal)

- Shared data management and uniform symbols via the controller and HMI
- Optimum interaction between the controller and HMI in a working environment
- System diagnostics as an integral component
- Shared use of communication settings and process point definitions
- Simple dragging and dropping of tags from STEP 7 to an HMI device, e.g. onto a screen
- Excellent support for the new SIMATIC S7-1500 controller
  - With symbolic addressing
  - Access to the new memory-optimized data blocks
  - New alarm and diagnostics concept

#### Configuration interface

- Intuitive user interfaces with maximum degree of user friendliness
- Comprehensive and fast access to editors and project data
- Adaptive user interface of engineering tools depending on configured target system
- User-definable user interface settings, e.g. layout, toolbars
- Integrated mass data operations for efficient configuration

#### Project handling

- Device-independent configuration data can be used on a variety of target systems without the need for conversion. The interface adapts itself to the functional possibilities of the target device.
- Cross-device utilization of common configuration data (e.g. alarm classes, text library) in multi-device projects
- Wizard-assisted definition of basic structure of HMI projects (e.g. display layout, operator prompting)

#### Screen editor with comprehensive options for efficient and fast screen configuration

- Generation of interconnected screen objects via Drag&Drop, e.g. tags for the creation of input/output fields with process interfacing or buttons with screen selection function
- Definition of screen templates and functions (comparable with the Slide Master in MS PowerPoint)
- User-friendly editor for the creation of faceplates with defined external interface from screen objects
- Graphics-based configuration of motion paths
- Layer technology with up to 32 layers
- Tools for the Align, Rotate and Mirror functions

#### Import/export

- of tags, links, text lists, and alarms

#### Tabular editors

- Quick and easy generation and modification of configuration objects of the same type, e.g. tags, texts or messages, in tabular editors
- Intelligent default settings depending on previously configured data, e.g. automatic incrementing of addresses when generating consecutive tags
- Simple access to the properties of an object without superfluous user intervention
- Simultaneous modification of common object properties

#### Object-based data management with user-friendly search and edit options

- Configuration of alarms and logs directly on the HMI tag, no switching between different editors
- Cross-reference list with direct access to all objects, e.g. for editing or selection
- Search for objects in entire project
- Text search and replace functions

#### Project documentation

- Selective project documentation, the following contents can be printed:
  - An entire project
  - One or more project-associated devices
  - Contents of an editor
  - Libraries



# HMI Software

## HMI Software in the TIA Portal

### SIMATIC WinCC (TIA Portal) Engineering

#### Function (continued)

##### Libraries for predefined/user-defined configuration objects

- Storage of all configuration objects in the library, e.g. blocks and even entire screens or tags
- Faceplates can be constructed from simple screen objects on a customer-specific or project-specific basis. Changes to these faceplates can be made centrally (block definition).
- A large number of scalable and dynamizable screen objects is included in the scope of delivery
- Size-scalable graphics for industrial applications are included in the scope of delivery
- Preview function for library objects

##### Language support

- Multilingual project creation (max. 32 languages) in editors thanks to selectable views
- Central management of language-specific texts and graphics in libraries
- Edit, export and import of texts for translation
- Language-specific graphics

##### Visual Basic and C-Script Support

- IntelliSense function for fast programming of access to runtime objects
- Simple creation of control sequences in script code
- Visual Basic Script debugging in simulator and WinCC Runtime Advanced and WinCC Runtime Professional

##### Test and commissioning support

- Simulation of HMI projects on engineering PC
- Marking of incomplete or incorrect configuration directly in the respective editor
- Jump to error cause based on alarm messages in the Compiler

##### Migration of existing HMI projects

- Data transfer in projects from WinCC flexible
- Data transfer in projects from WinCC

#### System prerequisites

	WinCC engineering software
<b>Processor type (min.)</b>	Core i5; 2.4 GHz or comparable
<b>RAM (min.)</b>	3 GB (32-bit operating system) 8 GB (64-bit operating system)
<b>Free hard disk space</b>	2 GB on system drive "C:."
<b>Operating systems</b>	32-bit operating systems <ul style="list-style-type: none"> <li>• Windows XP Home SP3 (only WinCC Basic)</li> <li>• Windows XP Professional SP3</li> <li>• Windows 7 Home Premium SP1 (only WinCC Basic)</li> <li>• Windows 7 Professional SP1</li> <li>• Windows 7 Enterprise SP1</li> <li>• Windows 7 Ultimate SP1</li> <li>• Windows Server 2003 R2 Standard Edition SP2 (only WinCC Advanced and Professional)</li> <li>• Windows Server 2008 Standard Edition SP2 (only WinCC Advanced and Professional)</li> </ul> 64-bit operating systems <ul style="list-style-type: none"> <li>• Windows 7 Home Premium SP1 (only WinCC Basic)</li> <li>• Windows 7 Professional SP1</li> <li>• Windows 7 Enterprise SP1</li> <li>• Windows 7 Ultimate SP1</li> <li>• Windows Server 2008 R2 Standard Edition SP2 (only WinCC Advanced and Professional)</li> </ul>
<b>Screen resolution</b>	at least 1280 x 1024
<b>Optical drive</b>	DVD-ROM

#### Note:

Opening several instances of WinCC on your engineering PC at the same time may result in more demanding hardware requirements.

In addition to WinCC, Windows also requires space on the hard disk; e.g. free disk space should be available for the swap file.

The following formula has proven itself in the past: Size of swap file = 3 x size of RAM.

For further information, refer to your Windows documentation



Ordering data	Order No.	Order No.	
<p><b>WinCC Basic V12 SP1</b></p> <p>Engineering software for the configuration and simulation of Basic Panels; electronic documentation in English, French, German, Italian, Spanish, simplified Chinese, traditional Chinese</p> <ul style="list-style-type: none"> <li>Software and documentation on DVD, floating license, license key on USB stick</li> <li>New type of delivery: Online software delivery <sup>1)</sup>, floating license, software and license key download, e-mail address required for the delivery</li> </ul>	<p><b>6AV2100-0AA02-0AA5</b></p> <p><b>6AV2100-0AA02-0AH5</b></p>	<p><b>WinCC Professional 4096 PowerTags V12 SP1</b></p> <p>Engineering software for the configuration and simulation of SIMATIC Panels; WinCC Runtime Professional (with max. 4096 PowerTags), WinCC Runtime Advanced electronic documentation in English, French, German, Italian, Spanish, simplified Chinese, traditional Chinese</p> <ul style="list-style-type: none"> <li>Software and documentation on DVD, floating license, license key on USB stick</li> <li>New type of delivery: Online software delivery <sup>1)</sup>, floating license, software and license key download, e-mail address required for the delivery</li> </ul>	<p><b>6AV2103-0HA02-0AA5</b></p> <p><b>6AV2103-0HA02-0AH5</b></p>
<p><b>WinCC Comfort V12 SP1</b></p> <p>Engineering software for the configuration and simulation of SIMATIC Panels; electronic documentation in English, French, German, Italian, Spanish, simplified Chinese, traditional Chinese</p> <ul style="list-style-type: none"> <li>Software and documentation on DVD, floating license, license key on USB stick</li> <li>New type of delivery: Online software delivery <sup>1)</sup>, floating license, software and license key download, e-mail address required for the delivery</li> </ul>	<p><b>6AV2101-0AA02-0AA5</b></p> <p><b>6AV2101-0AA02-0AH5</b></p>	<p><b>WinCC Professional max. PowerTags V12 SP1</b></p> <p>Engineering software for the configuration and simulation of SIMATIC Panels; WinCC Runtime Professional (unlimited PowerTags), WinCC Runtime Advanced electronic documentation in English, French, German, Italian, Spanish, simplified Chinese, traditional Chinese</p> <ul style="list-style-type: none"> <li>Software and documentation on DVD, floating license, license key on USB stick</li> <li>New type of delivery: Online software delivery (OSD) <sup>1)</sup>, floating license, software and license key download, e-mail address required for the delivery</li> </ul>	<p><b>6AV2103-0XA02-0AA5</b></p> <p><b>6AV2103-0XA02-0AH5</b></p>
<p><b>WinCC Advanced V12 SP1</b></p> <p>Engineering software for the configuration and simulation of SIMATIC Panels; WinCC Runtime Advanced, electronic documentation in English, French, German, Italian, Spanish, simplified Chinese, traditional Chinese</p> <ul style="list-style-type: none"> <li>Software and documentation on DVD, floating license, license key on USB stick</li> <li>New type of delivery: Online software delivery <sup>1)</sup>, floating license, software and license key download, e-mail address required for the delivery</li> </ul>	<p><b>6AV2102-0AA02-0AA5</b></p> <p><b>6AV2102-0AA02-0AH5</b></p>	<p><b>Trial licenses</b></p> <p>on DVD, 21 day trial</p> <ul style="list-style-type: none"> <li>WinCC Basic V12 SP1</li> <li>WinCC Comfort/Advanced V12 SP1</li> <li>WinCC Professional V12 SP1</li> </ul>	<p><b>6AV2100-0AA02-0AA7</b></p> <p><b>6AV2102-0AA02-0AA7</b></p> <p><b>6AV2103-0AA02-0AA7</b></p>
<p><b>WinCC Professional 512 PowerTags V12 SP1</b></p> <p>Engineering software for the configuration and simulation of SIMATIC Panels; WinCC Runtime Professional (with max. 512 PowerTags), WinCC Runtime Advanced electronic documentation in English, French, German, Italian, Spanish, simplified Chinese, traditional Chinese</p> <ul style="list-style-type: none"> <li>Software and documentation on DVD, floating license, license key on USB stick</li> <li>New type of delivery: Online software delivery <sup>1)</sup>, floating license, license key download, e-mail address required for the delivery</li> </ul>	<p><b>6AV2103-0DA02-0AA5</b></p> <p><b>6AV2103-0DA02-0AH5</b></p>		

<sup>1)</sup> Current information and availability regarding the new delivery package can be found at: <http://www.siemens.com/tia-online-software-delivery>

# HMI Software

## HMI Software in the TIA Portal

### SIMATIC WinCC (TIA Portal) Engineering

#### Ordering data

#### Order No.

#### Order No.

##### Powerpacks

##### SIMATIC WinCC Engineering System Powerpacks (without version change)

Floating license, license key only on USB stick

- WinCC Basic to WinCC Comfort V12 <sup>2)</sup>
- WinCC Comfort to WinCC Advanced V12
- WinCC Advanced to WinCC Professional 512 PowerTags V12
- WinCC Professional Powerpack 512 PowerTags to 4096 PowerTags V12
- WinCC Professional Powerpack 4096 PowerTags to max. PowerTags V12

**6AV2101-2AA02-0AC5**

**6AV2102-2AA02-0BD5**

**6AV2103-2AD02-0AC5**

**6AV2103-2DH02-0BD5**

**6AV2103-2HX02-0BD5**

##### Online software delivery (OSD) <sup>1)</sup>

Floating license, license key download only  
e-mail address required for the delivery

- WinCC Basic to WinCC Comfort V12 <sup>2)</sup>
- WinCC Comfort to WinCC Advanced V12
- WinCC Advanced to WinCC Professional 512 PowerTags V12
- WinCC Professional Powerpack 512 PowerTags to 4096 PowerTags V12
- WinCC Professional Powerpack 4096 PowerTags to max. PowerTags

**6AV2101-2AA02-0BJ5**

**6AV2102-2AA02-0BJ5**

**6AV2103-2AD02-0BJ5**

**6AV2103-2DH02-0BJ5**

**6AV2103-2HX02-0BJ5**

##### Software Update Service

For a period of 12 months and for a fixed price, the customer is automatically provided with all upgrades and service packs for each installed WinCC engineering system or option.

The contract is automatically extended by a further year unless canceled at least 12 weeks prior to expiration.

##### Software Update Service (Standard Edition)

The delivery is implemented according to the number of ordered SUS products (e.g. 10 upgrade packages with 10 DVDs, 10 USB flash drives, etc.)

- WinCC Comfort
- WinCC Advanced
- WinCC Professional 512 PowerTags
- WinCC Professional 4096 PowerTags
- WinCC Professional max. PowerTags

**6AV6612-0AA00-0AL0**

**6AV6613-0AA00-0AL0**

**6AV2103-0DA00-0AL0**

**6AV2103-0HA00-0AL0**

**6AV2103-0XA00-0AL0**

##### Software Update Service (Compact Edition)

The delivery items are combined. For several contracts, only 1 package with 1 data medium set, 1 USB flash drive with the corresponding number of licenses and the corresponding number of CoLs will be supplied.

Delivery items to be combined must be ordered as one item.

- WinCC Comfort
- WinCC Advanced
- WinCC Professional 512 PowerTags
- WinCC Professional 4096 PowerTags
- WinCC Professional max. PowerTags

**6AV6612-0AA00-0AM0**

**6AV6613-0AA00-0AM0**

**6AV2103-0DA00-0AM0**

**6AV2103-0HA00-0AM0**

**6AV2103-0XA00-0AM0**

##### Online software delivery (OSD) <sup>1)</sup>

##### Software Update Service (Download)

All deliveries to be downloaded. E-mail address required for the delivery

- WinCC Comfort
- WinCC Advanced
- WinCC Professional 512 PowerTags
- WinCC Professional 4096 PowerTags
- WinCC Professional max. PowerTags

**6AV6612-0AA00-0AY0**

**6AV6613-0AA00-0AY0**

**6AV2103-0DA00-0AY0**

**6AV2103-0HA00-0AY0**

**6AV2103-0XA00-0AY0**

<sup>1)</sup> Current information and availability regarding the new delivery package can be found at:

<http://www.siemens.com/tia-online-software-delivery>

<sup>2)</sup> Valid only for order numbers 6AV2100-0AA02-0AA5 and 6AV2100-0AA02-0AH5

Ordering data	Order No.	Ordering data	Order No.
<b>Upgrades</b> <b>WinCC V11 -&gt; WinCC V12 SP1</b> Software and documentation on DVD, upgrade license, license key on USB stick <ul style="list-style-type: none"> <li>• SIMATIC WinCC Basic V12 SP1 Upgrade V11 -&gt; V12 SP1</li> <li>• SIMATIC WinCC Comfort V12 SP1 Upgrade V11 -&gt; V12 SP1</li> <li>• SIMATIC WinCC Advanced V12 SP1 Upgrade V11 -&gt; V12 SP1</li> <li>• SIMATIC WinCC Professional 512 PowerTags V12 SP1 Upgrade V11 -&gt; V12 SP1</li> <li>• SIMATIC WinCC Professional 4096 PowerTags V12 SP1 Upgrade V11 -&gt; V12 SP1</li> <li>• SIMATIC WinCC Professional max. PowerTags V12 SP1 Upgrade V11 -&gt; V12 SP1</li> </ul>	<b>6AV2100-3AA02-0AE5</b> <b>6AV2101-3AA02-0AE5</b> <b>6AV2102-3AA02-0AE5</b> <b>6AV2103-3DA02-0AE5</b> <b>6AV2103-3HA02-0AE5</b> <b>6AV2103-3XA02-0AE5</b>	<b>Upgrades</b> <b>WinCC flexible 2008 -&gt; WinCC V12 SP1</b> Software and documentation on DVD, upgrade license, license key on USB stick <ul style="list-style-type: none"> <li>• WinCC flexible 2008 Compact to WinCC Comfort V12 SP1</li> <li>• WinCC flexible 2008 Standard to WinCC Comfort V12 SP1</li> <li>• WinCC flexible 2008 Advanced to WinCC Advanced V12 SP1</li> </ul>	<b>6AV2101-4AB02-0AE5</b> <b>6AV2101-4BB02-0AE5</b> <b>6AV2102-4AA02-0AE5</b>
<b>Online software delivery (OSD) <sup>1)</sup></b> Floating license, software and license key download e-mail address required for the delivery <ul style="list-style-type: none"> <li>• SIMATIC WinCC Basic V12 SP1 Upgrade V11 -&gt; V12 SP1</li> <li>• SIMATIC WinCC Comfort V12 SP1 Upgrade V11 -&gt; V12 SP1</li> <li>• SIMATIC WinCC Advanced V12 SP1 Upgrade V11 -&gt; V12 SP1</li> </ul>	<b>6AV2100-3AA02-0AK5</b> <b>6AV2101-3AA02-0AK5</b> <b>6AV2102-3AA02-0AK5</b>	<b>Online software delivery (OSD) <sup>1)</sup></b> Upgrade license, software and license key download, e-mail address required for the delivery <ul style="list-style-type: none"> <li>• WinCC flexible 2008 Compact to WinCC Comfort V12 SP1</li> <li>• WinCC flexible 2008 Standard to WinCC Comfort V12 SP1</li> <li>• WinCC flexible 2008 Advanced to WinCC Advanced V12 SP1</li> </ul>	<b>6AV2101-4AB02-0AK5</b> <b>6AV2101-4BB02-0AK5</b> <b>6AV2102-4AA02-0AK5</b>
		<b>WinCC V7 RC -&gt; WinCC V12 SP1</b> Software and documentation on DVD, upgrade license, license key on USB stick <ul style="list-style-type: none"> <li>• Upgrade SIMATIC WinCC V7.0 RC 128 -&gt; WinCC Professional 512 PowerTags V12 SP1 and WinCC RT Professional 128 PowerTags</li> <li>• Upgrade SIMATIC WinCC V7.0 RC 512 -&gt; WinCC Professional 512 PowerTags V12 SP1 and WinCC RT Professional 512 PowerTags</li> <li>• Upgrade SIMATIC WinCC V7.0 RC 2048 -&gt; WinCC Professional 4096 PowerTags V12 SP1 and WinCC RT Professional 2048 PowerTags</li> <li>• Upgrade SIMATIC WinCC V7.0 RC 8192 -&gt; WinCC Professional max. PowerTags V12 SP1 and WinCC RT Professional 8192 PowerTags</li> <li>• Upgrade SIMATIC WinCC V7.0 RC 65536 -&gt; WinCC Professional max. PowerTags V12 SP1 and WinCC RT Professional 65536 PowerTags</li> </ul>	<b>6AV2103-4BD02-0AE5</b> <b>6AV2103-4DD02-0AE5</b> <b>6AV2103-4FH02-0AE5</b> <b>6AV2103-4KX02-0AE5</b> <b>6AV2103-4MX02-0AE5</b>

<sup>1)</sup> Current information and availability regarding the new delivery package can be found at: <http://www.siemens.com/tia-online-software-delivery>

### More information

Further information can be found in the Internet at:  
<http://www.siemens.com/tia-portal>

# HMI Software

## SIMATIC WinCC (TIA Portal) Runtime

### SIMATIC WinCC (TIA Portal) Runtime

#### Overview

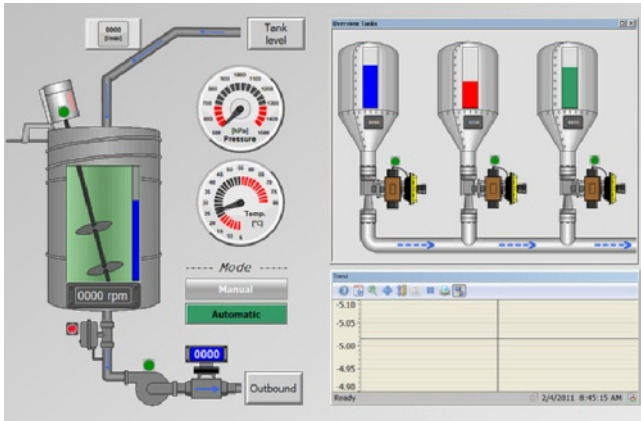

#### **SIMATIC WinCC Runtime Advanced visualization software**

- PC-based HMI solution for single-user systems directly at the machine
- Basic package for visualization, reporting and logging, user administration, can be expanded flexibly with VB scripts
- Basic package expandable by means of option packages
- Can be integrated into automation solutions based on TCP/IP networks
- Expanded service concepts with remote operation, diagnostics and administration over the intranet and Internet in combination with email communication

#### **SIMATIC WinCC Runtime Professional visualization software**

- PC-based operator control and monitoring system for visualization and operator control of processes, production flows, machines and plants in all sectors – from the simple single-user station through to distributed multi-user systems and cross-location solutions with web clients. WinCC Runtime Professional is the information hub for corporation-wide vertical integration.
- Industry-standard functions for signaling and acknowledging events, archiving of messages and measured values, logging of all process and configuration data, user administration, can be expanded flexibly with VB and C scripts
- Basic package expandable by means of option packages
- Also included are APIs for the Runtime to utilize the open programming interfaces

### Overview

PC-based HMI solution for single-user systems directly at the machine. SIMATIC WinCC Runtime Advanced is configured with the SIMATIC WinCC Advanced or SIMATIC WinCC Professional configuration software.

### Benefits

- Functions for all visualization tasks:
  - Operator functions
  - Graphics and trend displays
  - Alarm logging
  - Report system
  - Archiving (option)
  - Recipe management (option)
  - Audit Trail (option)
- Flexible runtime functionality due to Visual Basic scripts
- Innovative service concepts with remote operation, diagnostics and administration via intranet and Internet as well as e-mail communication to increase availability (option)
- Support for simple distributed automation solutions based on TCP/IP networks at the machine level (option)
- Part of the Totally Integrated Automation Portal
  - Direct access to the tag and message configuration of the SIMATIC controller
  - Excellent support of the new SIMATIC S7-1500 controller
    - With symbolic addressing
    - Access to the new memory-optimized data blocks
    - New alarm and diagnostics concept
  - Integrated diagnostic functions for increasing productivity

### Application

SIMATIC WinCC Runtime Advanced is the high-performance visualization software for simple, machine-oriented visualization tasks. It can be used as a single-user solution for all automation applications in production automation, process automation and building services automation.

SIMATIC WinCC Runtime Advanced can be used in combination with the following HMI devices:

- SIMATIC Panel PC: IPC277D, Panel PC 477B, HMI IPC477C, IPC477D, Panel PC 577B, HMI IPC577C, Panel PC 677B, HMI IPC677C
- SIMATIC Box PC: IPC227D, Box PC 427B, IPC427C, IPC427D, Box PC 627B, IPC627C, Box PC 827B, IPC827C
- SIMATIC Rack PC: Rack PC 547B, IPC547C, IPC547D, Rack PC 647B, IPC647C, Rack PC 847B, IPC847C
- SIMATIC modular Embedded Controller: EC31
- SINUMERIK PC: PCU 50.3, PCU 50.5
- Standard PCs with resolutions (W x H in pixels) of:
  - 4:3 format: 640 x 480, 800 x 600, 1024 x 768, 1280 x 1024, 1600 x 1200
  - Widescreen format: 800 x 480, 1280 x 800, 1366 x 768, 1440 x 900, 1680 x 1050, 1920 x 1080, 1920 x 1200, 1980 x 1080

# HMI Software

## SIMATIC WinCC (TIA Portal) Runtime

### WinCC Runtime Advanced

#### Design

SIMATIC WinCC Runtime Advanced is available as a software package with 128, 512, 2 048 or 4 096 PowerTags.

The term PowerTags is used to identify process variables and area pointers that have a process link to the controller.

Variables without process link, constant limit values of variables, and messages (up to 4 000 bit-triggered messages) are also available for additional system performance.

The range of functions of WinCC Runtime Advanced includes the centralized HMI components for visualizing and reporting, and it can be expanded to suit requirements and costs by using optional packages.

SIMATIC WinCC Runtime Advanced is configured with the SIMATIC WinCC Advanced or SIMATIC WinCC Professional configuration software.

#### Function

##### Visualization via Windows-compliant user interface

Made up of parameterizable screen objects and faceplates created on a project-specific basis:

- Numeric and alphanumeric input/output fields
- Static text and graphic display plus vector graphics
- Dynamizable graphics from HMI symbol library
- Bar graph, trend curve graph with scroll and zoom function as well as read line
- Signal-specific text and graphic lists
- Buttons and switches for operator-process communication
- Editing fields for process values (signals)
- Analog display, slider as example for further screen objects
- Project-specific faceplates created from basic objects of the system
- Graphic displays for various standard graphic formats, e.g. bitmaps, .jpg, .wmf

#### **Alarms and messages**

- Discrete alarms and analog alarms as well as event-driven Alarm-S/Alarm-D message procedure with SIMATIC S7
- The new alarm and diagnostics concept of the S7-1500 controller is also supported
- Freely-definable alarm classes for definition of acknowledgment response and display of alarm events

##### Logging of alarms and process values <sup>1)</sup>

- Logging in files (e.g. CSV or TXT file) and Microsoft SQL databases
- Online evaluation of process value and alarm logs
- Evaluation of process value and alarm logs using standard Microsoft tools such as Excel

##### Recipes <sup>1)</sup>

- Generation of data records for machine data or production data
- Display or entry of data records via a configurable screen object or via process screens distributed within the project
- Transmission of data records from or to the controller
- Import/export of data records from/to CSV files for further processing with other tools (e.g. MS Excel)

<sup>1)</sup> Option for SIMATIC WinCC Runtime Advanced, runtime licenses must be purchased separately. For further information, refer to "WinCC options".

##### Documentation of process data, alarm events, and recipes

- Time or event-driven report output
- User-definable layout

##### Flexible expansion of integrated system function using Visual Basic script

##### Language support for multilingual projects

- Up to 32 online languages
- Language-dependent texts and graphics
- Language selection during runtime

### Function (continued)

#### User-oriented access protection according to requirements of regulated sectors

- Authentication with user ID and password
- User group-specific rights
- Central system-wide user administration based on SIMATIC Logon<sup>1)</sup>
- Monitoring of changes by operators in runtime operation<sup>1)</sup>
- Recording of operator actions in an Audit Trail<sup>1)</sup>

#### Onboard controller connection to many different controllers

- Communication via native drivers and standard OPC channel
- Simultaneous connection using several protocols: OPC Client and SIMATIC HMI HTTP protocol are additive, i.e. they can be used in conjunction with other controller connections

#### Open communication between HMI systems and with higher-level systems

- OPC server
  - Use of the visualization system as a data server (OPC Server) for higher-level automation components, e.g. control systems or systems in the office area
  - OPC-DA-Server: tags, e.g. process values
- Communication between HMI systems is established on the basis of Ethernet networks, or via the Intranet/Internet
  - Read and write access to tags. The WinCC Runtime Advanced or SIMATIC Panels provide other SIMATIC HMI systems or office applications with data (variables)
- Sending of e-mails on demand or event-driven
  - e.g. to maintenance personnel via SMTP server (Simple Mail Transfer Protocol)
  - The optional use of e-mail/SMS gateways enables access to standard networks (external service provider required)
- System diagnostics via device-specific HTML pages; the following functions are available:
  - Starting and stopping the HMI runtime for maintenance
  - Remote access to recipe data records, passwords and information specific to the HMI system
  - Access to the HMI system files via a file explorer
  - Download of configuration data via the Intranet/Internet
  - Supplement with own HTML pages

#### WinCC Sm@rtServer for the remote control via the Intranet and Internet<sup>1)</sup>

- Display and control of process screens on remote PC or Panel
- A SIMATIC HMI system can be used to control or monitor another system remotely; entry level for client/server configurations for distributed operator stations or for solutions with head end or control room

#### WinCC ControlDevelopment for extending the functionality by adding own Controls<sup>1)</sup>

- Development of proprietary VB.net or C# Controls for integration in SIMATIC WinCC Runtime Advanced

<sup>1)</sup> Option for SIMATIC WinCC Runtime Advanced, runtime licenses must be purchased separately. For further information, refer to "WinCC options".

### System prerequisites

	<b>SIMATIC WinCC Runtime Advanced</b>
<b>Processor type (min.)<sup>1)</sup></b>	All processors of the SIMATIC IPC, Pentium III or processor running at 500 MHz or comparable
<b>RAM (min.)<sup>2)</sup></b>	512 MB
<b>Free hard disk space<sup>3)</sup></b>	2 GB on system drive "C:"
<b>Operating systems</b>	32-bit operating systems <ul style="list-style-type: none"> <li>• Microsoft Windows XP Professional SP3</li> <li>• Windows Embedded Standard 2009 (for IPC / IPC2x7D, HMI IPC4x7C only)</li> <li>• Microsoft Windows Server 2003 R2 StdE SP2</li> <li>• Microsoft Windows Server 2008 StdE SP2</li> <li>• Microsoft Windows 7 Professional SP1</li> <li>• Microsoft Windows 7 Enterprise SP1</li> <li>• Microsoft Windows 7 Ultimate SP1</li> <li>• Microsoft Windows Embedded Standard 7 SP1 (for IPC / IPC2x7D, HMI IPC4x7C only)</li> </ul> 64-bit operating systems <ul style="list-style-type: none"> <li>• Microsoft Windows 7 Professional SP1</li> <li>• Microsoft Windows 7 Enterprise SP1</li> <li>• Microsoft Windows 7 Ultimate SP1</li> <li>• Microsoft Windows Server 2003 R2 StdE SP2</li> <li>• Microsoft Windows Server 2008 R2 Standard Edition SP1</li> </ul>
<b>Optical drive</b>	DVD-ROM

<sup>1)</sup> In combination with options, more powerful systems may be required

<sup>2)</sup> The required RAM is determined primarily by the size of the graphics used.

<sup>3)</sup> Without taking archives into account.

In addition to WinCC, Windows also requires space on the hard disk; e.g. free disk space should be available for the swap file.

The following formula has proven itself in the past: Size of swap file = 3 x size of RAM.

For further information, refer to your Windows documentation.



# HMI Software

## SIMATIC WinCC (TIA Portal) Runtime

### WinCC Runtime Advanced

#### Technical specifications

The following tables of system limitations provide assistance in estimating whether a specific project is still within the system limitations for WinCC Runtime Advanced.

The stated maximum values are not additive.

We cannot guarantee proper functioning of configurations that make full use of all system limits on the HMI devices.

In addition to the limitations specified, allowances must be made for restrictions in configuration memory resources.

	SIMATIC WinCC Runtime Advanced
<b>Tags</b>	
Number of tags in the project	6 144
Number of PowerTags	128 –4 096
Number of elements per array	1 600
Number of local tags	2 048
<b>Alarms</b>	
Number of alarm classes	32
Number of discrete alarms	4 000
Number of analog alarms	500
Length of an alarm in characters	80
Number of process values per alarm	8
Size of the alarm buffer	1 024
Number of queued alarm events	500
<b>Screens</b>	
Number of screens	500
Number of fields per screen	400
Number of tags per screen	400
Number of complex objects per screen <sup>1)</sup>	40
<b>Recipes</b>	
Number of recipes	999
Number of elements per recipe <sup>2)</sup>	2 000
User data length in KB per data record	256
Number of data records per recipe	5 000

	SIMATIC WinCC Runtime Advanced
<b>Logs</b>	
Number of logs	100
Number of entries per log (including all log segments) <sup>3)</sup>	500 000
Number of log segments	400
Cyclical trigger for tag logging	1 s
Number of tags that can be logged per log	6 144
<b>Trends</b>	
Number of trends	800
<b>Text lists and graphics lists</b>	
Number of graphic lists	500
Number of text lists	500
Number of entries per text or graphic list	3 500
Number of graphic objects	2 000
Number of text elements	30 000
<b>Scripts</b>	
Number of scripts	200
<b>Communication</b>	
Number of connections	8
Number of connections based on "SIMATIC HMI HTTP"	16
Maximum number of connected Sm@rtClients (including a service client)	4 <sup>4)</sup>
<b>Help system</b>	
Number of characters in a help text	320
<b>Languages</b>	
Number of runtime languages	32
<b>Scheduler</b>	
Time-triggered tasks <sup>5)</sup>	48
<b>User administration</b>	
Number of user groups	50
Number of user rights	32
Number of users	100

- 1) Complex objects are: Bars, sliders, symbol library, clock, and all objects from the Controls area.
- 2) When using arrays, each array element represents a recipe element
- 3) For the "segmented circular log" logging method, the number of entries for all sequence logs is valid. The product derived from the number of circular logs times the number of data records in this log may not be exceeded.
- 4) Up to three Sm@rtClients can interconnect with the Sm@rtServer on Panel PC 477.
- 5) Event-triggered tasks are not relevant for the system limits.

Ordering data	Order No.	Order No.
<p><b>Basic Packages</b></p> <p><b>SIMATIC WinCC Runtime Advanced V12 SP1</b></p> <p>Software and documentation on DVD, including options software <sup>1)</sup></p> <p>Single license, license key on USB stick</p> <ul style="list-style-type: none"> <li>• 128 PowerTags</li> <li>• 512 PowerTags</li> <li>• 2048 PowerTags</li> <li>• 4096 PowerTags</li> </ul>	<p><b>6AV2104-0BA02-0AA0</b></p> <p><b>6AV2104-0DA02-0AA0</b></p> <p><b>6AV2104-0FA02-0AA0</b></p> <p><b>6AV2104-0HA02-0AA0</b></p>	<p><b>Online software delivery (OSD) <sup>2)</sup></b></p> <p>Single license, software and license key download. E-mail address required for the delivery.</p> <ul style="list-style-type: none"> <li>• WinCC Runtime Advanced 128 PowerTags to WinCC Runtime Professional 128 PowerTags</li> <li>• WinCC Runtime Advanced 512 PowerTags to WinCC Runtime Professional 512 PowerTags</li> <li>• WinCC Runtime Advanced 2048 PowerTags to WinCC Runtime Professional 2048 PowerTags</li> <li>• WinCC Runtime Advanced 4096 PowerTags to WinCC Runtime Professional 4096 PowerTags</li> </ul> <p><b>6AV2105-2BB02-0AJ0</b></p> <p><b>6AV2105-2DD02-0AJ0</b></p> <p><b>6AV2105-2FF02-0AJ0</b></p> <p><b>6AV2105-2HH02-0AJ0</b></p>
<p><b>Online software delivery (OSD) <sup>2)</sup></b></p> <p>Single license, software and license key download. E-mail address required for the delivery.</p> <ul style="list-style-type: none"> <li>• 128 PowerTags</li> <li>• 512 PowerTags</li> <li>• 2048 PowerTags</li> <li>• 4096 PowerTags</li> </ul>	<p><b>6AV2104-0BA02-0AH0</b></p> <p><b>6AV2104-0DA02-0AH0</b></p> <p><b>6AV2104-0FA02-0AH0</b></p> <p><b>6AV2104-0HA02-0AH0</b></p>	
<p><b>Powerpacks</b></p> <p><b>SIMATIC WinCC Runtime Advanced V12 (without version change)</b></p> <p>Single license, license key only on USB stick for PowerTags from</p> <ul style="list-style-type: none"> <li>• 128 PowerTags to 512 PowerTags</li> <li>• 512 PowerTags to 2048 PowerTags</li> <li>• 2048 PowerTags to 4096 PowerTags</li> </ul>	<p><b>6AV2104-2BD02-0BD0</b></p> <p><b>6AV2104-2DF02-0BD0</b></p> <p><b>6AV2104-2FH02-0BD0</b></p>	<p><b>SIMATIC WinCC Runtime Advanced to SIMATIC WinCC Runtime Professional ASIA V12 SP1</b></p> <ul style="list-style-type: none"> <li>• SIMATIC WinCC Runtime Professional Powerpack Runtime Advanced 128 PowerTags -&gt; Runtime Professional 128 PowerTags ASIA V12 SP1</li> <li>• SIMATIC WinCC Runtime Professional Powerpack Runtime Advanced 512 PowerTags -&gt; Runtime Professional 512 PowerTags ASIA V12 SP1</li> <li>• SIMATIC WinCC Runtime Professional Powerpack Runtime Advanced 2048 PowerTags -&gt; Runtime Professional 2048 PowerTags ASIA V12 SP1</li> <li>• SIMATIC WinCC Runtime Professional Powerpack Runtime Advanced 4096 PowerTags -&gt; Runtime Professional 4096 PowerTags ASIA V12 SP1</li> </ul> <p><b>6AV2105-2BB12-0AC0</b></p> <p><b>6AV2105-2DD12-0AC0</b></p> <p><b>6AV2105-2FF12-0AC0</b></p> <p><b>6AV2105-2HH12-0AC0</b></p>
<p><b>Online software delivery (OSD) <sup>2)</sup></b></p> <p>Single license, software and license key download. E-mail address required for the delivery.</p> <ul style="list-style-type: none"> <li>• 128 PowerTags to 512 PowerTags</li> <li>• 512 PowerTags to 2048 PowerTags</li> <li>• 2048 PowerTags to 4096 PowerTags</li> </ul>	<p><b>6AV2104-2BD02-0BJ0</b></p> <p><b>6AV2104-2DF02-0BJ0</b></p> <p><b>6AV2104-2FH02-0BJ0</b></p>	
<p><b>SIMATIC WinCC Runtime Advanced V12 to SIMATIC WinCC Runtime Professional V12 SP1</b></p> <p>Single license, software and documentation on DVD, license key on USB stick for PowerTags from</p> <ul style="list-style-type: none"> <li>• WinCC Runtime Advanced 128 PowerTags to WinCC Runtime Professional 128 PowerTags</li> <li>• WinCC Runtime Advanced 512 PowerTags to WinCC Runtime Professional 512 PowerTags</li> <li>• WinCC Runtime Advanced 2048 PowerTags to WinCC Runtime Professional 2048 PowerTags</li> <li>• WinCC Runtime Advanced 4096 PowerTags to WinCC Runtime Professional 4096 PowerTags</li> </ul>	<p><b>6AV2105-2BB02-0AC0</b></p> <p><b>6AV2105-2DD02-0AC0</b></p> <p><b>6AV2105-2FF02-0AC0</b></p> <p><b>6AV2105-2HH02-0AC0</b></p>	<p><b>Upgrades</b></p> <p><b>WinCC V11 to WinCC V12 SP1</b></p> <p><b>SIMATIC WinCC Runtime Advanced V11 to SIMATIC WinCC Runtime Advanced V12 SP1</b></p> <p>Software and documentation on DVD, including options software</p> <p>Single license, license keys on USB stick for</p> <ul style="list-style-type: none"> <li>• SIMATIC WinCC Runtime Advanced 128 PowerTags V12 SP1 Upgrade V11 -&gt; V12 SP1</li> <li>• SIMATIC WinCC Runtime Advanced 512 PowerTags V12 SP1 Upgrade V11 -&gt; V12 SP1</li> <li>• SIMATIC WinCC Runtime Advanced 2048 PowerTags V12 SP1 Upgrade V11 -&gt; V12 SP1</li> <li>• SIMATIC WinCC Runtime Advanced 4096 PowerTags V12 SP1 Upgrade V11 -&gt; V12 SP1</li> </ul> <p><b>6AV2104-3BB02-0AE0</b></p> <p><b>6AV2104-3DD02-0AE0</b></p> <p><b>6AV2104-3FF02-0AE0</b></p> <p><b>6AV2104-3HH02-0AE0</b></p>

<sup>1)</sup> Runtime licenses for WinCC flexible Runtime Advanced options must be purchased separately for each target system

<sup>2)</sup> Current information and availability regarding the new delivery package can be found at: <http://www.siemens.com/tia-online-software-delivery>

# HMI Software

## SIMATIC WinCC (TIA Portal) Runtime

### WinCC Runtime Advanced

Ordering data	Order No.	Order No.
<p><b>Online software delivery (OSD)</b> <sup>2)</sup></p> <p>Single license, software and license key download. E-mail address required for the delivery.</p> <ul style="list-style-type: none"> <li>• SIMATIC WinCC Runtime Advanced 128 PowerTags V12 SP1 Upgrade V11 -&gt; V12 SP1</li> <li>• SIMATIC WinCC Runtime Advanced 512 PowerTags V12 SP1 Upgrade V11 -&gt; V12 SP1</li> <li>• SIMATIC WinCC Runtime Advanced 2048 PowerTags V12 SP1 Upgrade V11 -&gt; V12 SP1</li> <li>• SIMATIC WinCC Runtime Advanced 4096 PowerTags V12 SP1 Upgrade V11 -&gt; V12 SP1</li> </ul>	<p><b>6AV2104-3BB02-0AK0</b></p> <p><b>6AV2104-3DD02-0AK0</b></p> <p><b>6AV2104-3FF02-0AK0</b></p> <p><b>6AV2104-3HH02-0AK0</b></p>	<p><b>SIMATIC WinCC flexible Panel Options to SIMATIC WinCC V11 / V12 Panel Options</b></p> <ul style="list-style-type: none"> <li>• WinCC flexible /Audit for SIMATIC Panels to SIMATIC WinCC Audit for SIMATIC Panels</li> <li>• WinCC flexible /Sm@rtAccess for SIMATIC Panel to SIMATIC WinCC Sm@rtServer for SIMATIC Panels</li> <li>• WinCC flexible /Sm@rtService for SIMATIC Panels to SIMATIC WinCC Sm@rtServer for SIMATIC Panels</li> </ul> <p><b>6AV2107-4XP00-0BF0</b></p>
<p><b>Upgrades WinCC flexible 2008 to WinCC V12 SP1</b></p> <p><b>SIMATIC WinCC flexible 2008 to SIMATIC WinCC Runtime Advanced V12 SP1</b></p> <p>Software and documentation on DVD, including options software single license, license keys on USB stick for</p> <ul style="list-style-type: none"> <li>• WinCC flexible 2008 Runtime 128 PowerTags to WinCC Runtime Advanced 128 PowerTags <sup>1)</sup></li> <li>• WinCC flexible 2008 Runtime 512 PowerTags to WinCC Runtime Advanced 512 PowerTags <sup>1)</sup></li> <li>• WinCC flexible 2008 Runtime 2048 PowerTags to WinCC Runtime Advanced 2048 PowerTags <sup>1)</sup></li> <li>• WinCC flexible 2008 Runtime 4096 PowerTags to WinCC Runtime Advanced 4096 PowerTags <sup>1)</sup></li> </ul>	<p><b>6AV2104-4BB02-0AE0</b></p> <p><b>6AV2104-4DD02-0AE0</b></p> <p><b>6AV2104-4FF02-0AE0</b></p> <p><b>6AV2104-4HH02-0AE0</b></p>	<p><b>SIMATIC WinCC flexible Panel Options to SIMATIC WinCC V11 / V12 Panel Options</b></p> <ul style="list-style-type: none"> <li>• WinCC flexible /Audit for SIMATIC Panels to SIMATIC WinCC Audit for SIMATIC Panels</li> <li>• WinCC flexible /Sm@rtAccess for SIMATIC Panel to SIMATIC WinCC Sm@rtServer for SIMATIC Panels</li> <li>• WinCC flexible /Sm@rtService for SIMATIC Panels to SIMATIC WinCC Sm@rtServer for SIMATIC Panels</li> </ul> <p><b>6AV2107-4XP00-0BK0</b></p>
<p><b>Online software delivery (OSD)</b> <sup>2)</sup></p> <p>Single license, software and license key download. E-mail address required for the delivery.</p> <ul style="list-style-type: none"> <li>• WinCC flexible 2008 Runtime 128 PowerTags to WinCC Runtime Advanced 128 PowerTags <sup>1)</sup></li> <li>• WinCC flexible 2008 Runtime 512 PowerTags to WinCC Runtime Advanced 512 PowerTags <sup>1)</sup></li> <li>• WinCC flexible 2008 Runtime 2048 PowerTags to WinCC Runtime Advanced 2048 PowerTags <sup>1)</sup></li> <li>• WinCC flexible 2008 Runtime 4096 PowerTags to WinCC Runtime Advanced 4096 PowerTags <sup>1)</sup></li> </ul>	<p><b>6AV2104-4BB02-0AK0</b></p> <p><b>6AV2104-4DD02-0AK0</b></p> <p><b>6AV2104-4FF02-0AK0</b></p> <p><b>6AV2104-4HH02-0AK0</b></p>	<p><b>Online software delivery (OSD)</b> <sup>2)</sup></p> <p>Single license, license key download only. E-mail address required for the delivery.</p>

<sup>1)</sup> Each including 1 upgrade license to the WinCC Runtime Advanced options

<sup>2)</sup> Current information and availability regarding the new delivery package can be found at: <http://www.siemens.com/tia-online-software-delivery>

#### More information

Further information can be found in the Internet at:  
<http://www.siemens.com/tia-portal>

### Overview

PC-based operator control and monitoring system for visualization and operator control of processes, production flows, machines and plants in all sectors – from the simple single-user station through to distributed multi-user systems and cross-location solutions with web clients.

SIMATIC WinCC Runtime Professional is the information hub for corporation-wide vertical integration. SIMATIC WinCC Runtime Professional is configured with the SIMATIC WinCC Professional configuration software.

### Benefits

- Functions for all visualization tasks:
  - Operator functions
  - Graphics and trend displays
  - Alarm logging
  - Report system
  - Archiving (option)
  - Recipe management (option)
- Universally scalable
  - Expandable from single station to client-server configurations
  - Process visualization via the web with the WinCC WebNavigator
- Open standards for easy integration
  - Efficient real-time database MS SQL Server
  - Open for application modules with ActiveX controls
  - Visual Basic for Applications for individual expansions
  - OPC for cross-vendor communication
- Part of the Totally Integrated Automation Portal
  - Direct access to the tag and message configuration of the SIMATIC controller
  - Excellent support of the new SIMATIC S7-1500 controller With symbolic addressing
  - Access to the new memory-optimized data blocks
  - New alarm and diagnostics concept
  - Integrated diagnostic functions for increasing productivity

### Application

SIMATIC WinCC Runtime Professional is designed for visualization and operation of processes, manufacturing cycles, machines and plants. With its powerful process interface, especially to the SIMATIC family, and the secure data logging, WinCC Runtime Professional enables solutions for the process control.

The sector-neutral basic system enables universal usage in all automation applications.

SIMATIC WinCC Runtime Professional can be used in combination with the following HMI devices:

SIMATIC PCs:

- SIMATIC Panel PC: HMI IPC477C, IPC477D, Panel PC 577B, HMI IPC577C, Panel PC 677B, HMI IPC677C
- SIMATIC Box PC: IPC427C, IPC427D, Box PC 627B, IPC627C, IPC827C
- SIMATIC Rack PC: Rack PC 547B, IPC547C, IPC547D, Rack PC 647B, IPC647C, Rack PC 847B, IPC847C
- Standard PC

### Design

SIMATIC WinCC Runtime Professional is available as a software package with 128, 512, 2 048, 4 096, 8 192, 65 536 PowerTags.

PowerTags are data points that are connected to controllers or other data sources via a WinCC Runtime Professional channel. Up to 32 alarms can be obtained from one data point. Moreover, internal tags without coupling are available for additional system performance.

WinCC Runtime Professional also contains 500 archive tags. Additional archive licenses can be obtained for greater quantity structures.

#### **Licenses for a multi-user configuration**

The system software with the required number of PowerTags and additionally the SIMATIC WinCC Server for Runtime Professional option must be installed on the server. For the clients in the basic configuration, a SIMATIC WinCC Client for Runtime Professional license is sufficient.

### Function

#### Visualization via Windows-compliant user interface

Made up of parameterizable screen objects and faceplates created on a project-specific basis:

- Numeric and alphanumeric input/output fields
- Static text and graphic display plus vector graphics
- Dynamizable graphics from HMI symbol library
- Bar graph, trend curve graph with scroll and zoom function as well as read line
- Signal-specific text and graphic lists
- Buttons and switches for operator-process communication
- Editing fields for process values (signals)
- Analog display, slider as example for further screen objects
- Project-specific faceplates created from basic objects of the system
- Graphic displays for various standard graphic formats, e.g. bitmaps, .jpg, .wmf

#### Alarms and messages

- Discrete alarms and analog alarms, as well as event-driven Alarm-S/Alarm-D message procedure with SIMATIC S7
- The new alarm and diagnostics concept of the S7-1500 controller is also supported
- Freely-definable alarm classes for definition of acknowledgment response and display of alarm events

#### Logging of alarms and process values <sup>1)</sup>

- Signaling system for detecting and archiving events with display and control options according to DIN 19235
- Process logging for the acquisition, compression and storage of measured values
- Online evaluation of process value and alarm logs

<sup>1)</sup> Option for SIMATIC WinCC Runtime Professional; runtime licenses must be purchased separately. For further information, refer to "WinCC options".

# HMI Software

## SIMATIC WinCC (TIA Portal) Runtime

### WinCC Runtime Professional

#### Function (continued)

##### Recipes <sup>1)</sup>

- Generation of data records for machine data or production data
- Display or entry of data records via a configurable screen object or via process screens distributed within the project
- Transmission of data records from or to the controller
- Import/export of data records for further processing with other tools (e.g. MS Excel)

##### Documentation of process data, alarm events, and recipes

- Time or event-driven report output
- User-definable layout

##### Flexible expansion by means of Visual Basic Script and ANSI-C

- Programming interfaces for individual access to data and functions of WinCC Runtime Professional and for the integration in user programs with VBA, VB Script, C-API, C-Script (ANSI-C)

##### Language support for multilingual projects

- Language-dependent texts and graphics
- Language selection during runtime

##### Onboard controller connection to many different controllers

- Communication via native drivers and standard OPC channel
- For communication with subordinate controls (SIMATIC protocols, PROFIBUS DP, PROFIBUS FMS, DDE and OPC server included in the scope of delivery)

##### Open communication between HMI systems and with higher-level systems

- OPC-Server
  - Use of the visualization system as a data server (OPC-Server) for higher-level automation components such as control systems or systems in the office sector
  - OPC-DA-Server: tags, e.g. process values
  - OPC-HDA-Server: logged process values
  - OPC-A&E-Server: Alarms
  - OPC-XML-DA-Server: tags, e.g. process values
  - OPC-UA-DA-Server: tags, e.g. process values
- OLE DB Server
  - Standardized and user-friendly access to WinCC log data (MS SQL Server 2005).
  - Access is via the OLE-DB Provider supplies all WinCC log data available along with the accompanying process values, as well as alarm and user texts.
  - The WinCC OLE-DB provider also supports analysis functions such as minimum, maximum, alarm hit list, etc.
- WinCC WebNavigator for Runtime Professional <sup>1)</sup>
  - Option for SIMATIC WinCC Runtime Professional for operating and monitoring plants over the Internet, company Intranet or LAN.
  - Configuration from a web server with the SIMATIC WinCC Runtime Professional software as a single-user, client or server version and a web client that enables operator control and monitoring of a current WinCC Runtime Professional project via an Internet browser with ActiveX support. The WinCC basic system does not have to be installed on the client computer.
- WinCC DataMonitor for Runtime Professional <sup>1)</sup>
  - The WinCC DataMonitor is used for displaying and evaluating current process states and historical data on office PCs using standard tools such as Microsoft Internet Explorer or Microsoft Excel.
  - The DataMonitor Client is supported by a web server with current and historic process data and alarms. All staff ranging from machine operators to corporate managers can use the DataMonitor to obtain information.

<sup>1)</sup> Option for SIMATIC WinCC Runtime Professional; runtime licenses must be purchased separately. For further information, refer to "WinCC options".

### Function (continued)

WinCC ControlDevelopment  
for extending the functionality by adding own Controls <sup>1)</sup>

- Development of proprietary VB.net or C# Controls for integration in WinCC Runtime Professional

<sup>1)</sup> Option for SIMATIC WinCC Runtime Professional; runtime licenses must be purchased separately. For further information, refer to "WinCC options".

System prerequisites	SIMATIC WinCC Runtime Professional
Processor type (min.) <sup>1)</sup>	<ul style="list-style-type: none"> <li>• Windows XP: 2.5 GHz P4 or comparable, Pentium M, 1.6 GHz or comparable</li> <li>• Windows 7 (32-bit): 3.5 GHz P4 or comparable, dual core</li> <li>• Windows Server 2003: 3 GHz P4 or comparable</li> <li>• Windows Server 2008: 3 GHz P4 or comparable, dual/multi core</li> </ul>
RAM (min.) <sup>2)</sup>	2 GB
Free hard disk space <sup>3)</sup>	2 GB on system drive "C:"
Operating systems	32-bit operating systems <ul style="list-style-type: none"> <li>• Microsoft Windows XP Professional SP3</li> <li>• Windows Embedded Standard 2009 (for IPC / IPC2x7D, HMI IPC4x7C only)</li> <li>• Microsoft Windows Server 2003 R2 StdE SP2</li> <li>• Microsoft Windows Server 2008 StdE SP2</li> <li>• Microsoft Windows 7 Professional SP1</li> <li>• Microsoft Windows 7 Enterprise SP1</li> <li>• Microsoft Windows 7 Ultimate SP1</li> <li>• Microsoft Windows Embedded Standard 7 SP1 (for IPC / IPC2x7D, HMI IPC4x7C only)</li> </ul> 64-bit operating systems <ul style="list-style-type: none"> <li>• Microsoft Windows 7 Professional SP1</li> <li>• Microsoft Windows 7 Enterprise SP1</li> <li>• Microsoft Windows 7 Ultimate SP1</li> <li>• Microsoft Windows Server 2003 R2 StdE SP2</li> <li>• Microsoft Windows Server 2008 R2 Standard Edition SP1</li> </ul>
Graphics card	32 MB RAM, 24 bit color depth
Network	Ethernet 10 Mbit/s or higher
Optical drive	DVD-ROM

<sup>1)</sup> In combination with options, more powerful systems may be required

<sup>2)</sup> The required RAM is determined primarily by the size of the graphics used.

<sup>3)</sup> Without taking archives into account.

### Note:

In addition to WinCC, Windows also requires space on the hard disk; e.g. free disk space should be available for the swap file.

The following formula has proven itself in the past:  
Size of swap file = 3 x size of RAM.

For further information, refer to your Windows documentation.

### Integration

#### Integration in company-wide solutions (IT and business integration)

WinCC Runtime Professional is strictly based on Microsoft technology, which provides for the greatest possible compatibility and integration ability. ActiveX and .net Controls support technology and sector-specific expansions.

Cross-manufacturer communication is also a simply exercise. The reason: WinCC Runtime Professional can be used as an OPC client and server, and in addition to access to current process values, it also supports standards such as OPC HDA (Historical Data Access), OPC Alarm & Events, OPC UA Data Access and OPC XML Data Access. Just as important: Visual Basic Scripting (VBS) as an easy-to-learn, open Runtime language. If desired, professional application developers can also use ANSI-C.

WinCC Runtime Professional integrates a powerful and scalable Historian function based on the Microsoft SQL Server in the basic system.

Thus the user is given all possibilities: from high-performance archiving of current process data, to long-term archiving with high data compression, through to a central information turntable in form of a company-wide Process Historian.

Open interfaces form the basis for an effective IT and business integration.

# HMI Software

## SIMATIC WinCC (TIA Portal) Runtime

### WinCC Runtime Professional

#### Technical specifications

The following tables of system limits provide assistance in estimating whether a specific project is still within the system limitations for WinCC Runtime Professional. The stated maximum values are not additive.

We cannot guarantee proper functioning of configurations that make full use of all system limits on the HMI devices. In addition to the limitations specified, allowances must be made for restrictions in configuration memory resources.

	SIMATIC WinCC Runtime Professional
<b>Alarms</b>	
Configurable alarms per server/single user	20 000
PowerTags per alarm line	10
User text blocks per alarm line	10
Alarm classes (incl. system alarm classes)	18
Alarm types	16
Alarm priorities	17 (0...16)
<b>Alarms in Runtime</b>	
Alarms per alarm log	Unlimited <sup>1)</sup>
Alarms per short-term log list	1 000
Alarms per long-term log list	1 000 <sup>2)</sup>
Alarms per alarm display	5 000 <sup>3)</sup>
<b>Screens</b>	
Objects per screen <sup>4)</sup>	3 000 <sup>5)</sup>
Levels per screen	32
Screens per project	1 000 <sup>5)</sup>
Instances of fixed faceplates in a process screen	31 instances of the same picture type
Screen size in pixels	10 000 x 10 000
Nesting levels of screen objects	20
<b>Recipes</b>	
Number of recipes	1 000 <sup>5)</sup>
Number of recipe elements	500 <sup>6)</sup>
Number of recipe data records	3 000 <sup>6)</sup>
Number of views	Unlimited <sup>5)</sup>

	SIMATIC WinCC Runtime Professional
<b>Logs</b>	
Trend views per screen	25
Trends per trend view	80
Tables per screen	25
Columns per table	12
Values per table	30 000
Logs per single-user station/server	100
Log tags per single-user station/server <sup>7)</sup>	8 000
<b>Trends</b>	
Trend views per image	25
Trends per trend view	80
<b>User administration</b>	
Number of user groups	128
Number of user rights	999
Number of users	128
<b>Configurations – Quantity structure in a multi-user system</b>	
WinCC clients in a system	32 <sup>8) 9)</sup>
Web clients in a system	50 <sup>10)</sup>

<sup>1)</sup> Limited by system resources.

<sup>2)</sup> On single-user station or server or on client per server if "LongTimeArchiveConsistency" is set to "No". On single-user station, server, or client if "LongTimeArchiveConsistency" is set to "Yes".

<sup>3)</sup> On single-user station or server or on client per server.

<sup>4)</sup> The number and complexity of the objects affect the performance.

<sup>5)</sup> Limited by system resources.

<sup>6)</sup> The sum of the number of recipe elements and number of data records must not exceed a value of 320,000.

<sup>7)</sup> Dependent on the Logging Powerpack used for the log tags. 500 log tags are contained in the basis version.

<sup>8)</sup> If the server is also used as an operating unit, the number of clients for this server is reduced to four.

<sup>9)</sup> Mixed configuration: 32 Clients + 3 Web Clients

<sup>10)</sup> Mixed configuration: 50 Web Clients + 1 WinCC Client



Ordering data	Order No.	Order No.
<p><b>Basic software</b></p> <p><b>SIMATIC WinCC Runtime Professional V12 SP1</b></p> <p>For PC systems; incl. software options <sup>1)</sup>; language/script versions: DE, EN, FR, IT, ES Single License, on DVD incl. licensing, on USB stick, for:</p> <ul style="list-style-type: none"> <li>• 128 PowerTags</li> <li>• 512 PowerTags</li> <li>• 2048 PowerTags</li> <li>• 4096 PowerTags</li> <li>• 8192 PowerTags</li> <li>• 65535 PowerTags</li> </ul> <p>Incl. 500 archive tags each</p>	<p><b>6AV2105-0BA02-0AA0</b></p> <p><b>6AV2105-0DA02-0AA0</b></p> <p><b>6AV2105-0FA02-0AA0</b></p> <p><b>6AV2105-0HA02-0AA0</b></p> <p><b>6AV2105-0KA02-0AA0</b></p> <p><b>6AV2105-0MA02-0AA0</b></p>	<p><b>Powerpacks</b></p> <p><b>SIMATIC WinCC Runtime Professional V12 and SIMATIC WinCC Runtime Professional ASIA V12</b></p> <p>Single license, license key only on USB sticks for PowerTags from</p> <ul style="list-style-type: none"> <li>• 128 to 512 PowerTags</li> <li>• 512 to 2048 PowerTags</li> <li>• 2048 to 4096 PowerTags</li> <li>• 4096 to 8192 PowerTags</li> <li>• 8192 to 65536 PowerTags</li> </ul> <p><b>6AV2105-2BD02-0BD0</b></p> <p><b>6AV2105-2DF02-0BD0</b></p> <p><b>6AV2105-2FH02-0BD0</b></p> <p><b>6AV2105-2HK02-0BD0</b></p> <p><b>6AV2105-2KM02-0BD0</b></p>
<p><b>Online software delivery (OSD) <sup>3)</sup></b></p> <p>Single license, software and license key download. E-mail address required for the delivery.</p> <ul style="list-style-type: none"> <li>• 128 PowerTags</li> <li>• 512 PowerTags</li> <li>• 2048 PowerTags</li> <li>• 4096 PowerTags</li> <li>• 8192 PowerTags</li> <li>• 65535 PowerTags</li> </ul> <p>Incl. 500 archive tags each</p>	<p><b>6AV2105-0BA02-0AH0</b></p> <p><b>6AV2105-0DA02-0AH0</b></p> <p><b>6AV2105-0FA02-0AH0</b></p> <p><b>6AV2105-0HA02-0AH0</b></p> <p><b>6AV2105-0KA02-0AH0</b></p> <p><b>6AV2105-0MA02-0AH0</b></p>	<p><b>Online software delivery (OSD) <sup>3)</sup></b></p> <p>Single license, license key download only. E-mail address required for the delivery.</p> <ul style="list-style-type: none"> <li>• 128 to 512 PowerTags</li> <li>• 512 to 2048 PowerTags</li> <li>• 2048 to 4096 PowerTags</li> <li>• 4096 to 8192 PowerTags</li> <li>• 8192 to 65536 PowerTags</li> </ul> <p><b>6AV2105-2BD02-0BJ0</b></p> <p><b>6AV2105-2DF02-0BJ0</b></p> <p><b>6AV2105-2FH02-0BJ0</b></p> <p><b>6AV2105-2HK02-0BJ0</b></p> <p><b>6AV2105-2KM02-0BJ0</b></p>
<p><b>SIMATIC WinCC Runtime Professional ASIA V12 SP1</b></p> <p>For PC systems; incl. software options <sup>1)</sup>; language/script versions: EN, CHS, CHT, KOR, JPN Single License, on DVD incl. licensing, for:</p> <ul style="list-style-type: none"> <li>• 128 PowerTags</li> <li>• 512 PowerTags</li> <li>• 2048 PowerTags</li> <li>• 4096 PowerTags</li> <li>• 8192 PowerTags</li> <li>• 65535 PowerTags</li> </ul> <p>Incl. 500 archive tags each</p>	<p><b>6AV2105-0BA12-0AA0</b></p> <p><b>6AV2105-0DA12-0AA0</b></p> <p><b>6AV2105-0FA12-0AA0</b></p> <p><b>6AV2105-0HA12-0AA0</b></p> <p><b>6AV2105-0KA12-0AA0</b></p> <p><b>6AV2105-0MA12-0AA0</b></p>	<p><b>Upgrades WinCC V11 to WinCC V12 SP1</b></p> <p><b>SIMATIC WinCC Runtime Professional V11 to SIMATIC WinCC Runtime Professional V12 SP1 and SIMATIC WinCC Runtime Professional ASIA V11 to SIMATIC WinCC Runtime Professional ASIA V12 SP1</b></p> <p>Single license, on DVD incl. licensing on USB stick</p> <ul style="list-style-type: none"> <li>• SIMATIC WinCC Runtime Professional 128 PowerTags V12 SP1 Upgrade V11 -&gt; V12 SP1</li> <li>• SIMATIC WinCC Runtime Professional 512 PowerTags V12 SP1 Upgrade V11 -&gt; V12 SP1</li> <li>• SIMATIC WinCC Runtime Professional 2048 PowerTags V12 SP1 Upgrade V11 -&gt; V12 SP1</li> <li>• SIMATIC WinCC Runtime Professional 4096 PowerTags V12 SP1 Upgrade V11 -&gt; V12 SP1</li> <li>• SIMATIC WinCC Runtime Professional 8192 PowerTags V12 SP1 Upgrade V11 -&gt; V12 SP1</li> <li>• SIMATIC WinCC Runtime Professional 65536 PowerTags V12 SP1 Upgrade V11 -&gt; V12 SP1</li> </ul> <p><b>6AV2105-3BB02-0AE0</b></p> <p><b>6AV2105-3DD02-0AE0</b></p> <p><b>6AV2105-3FF02-0AE0</b></p> <p><b>6AV2105-3HH02-0AE0</b></p> <p><b>6AV2105-3KK02-0AE0</b></p> <p><b>6AV2105-3MM02-0AE0</b></p>
<p><b>SIMATIC WinCC Client for Runtime Professional</b></p> <ul style="list-style-type: none"> <li>• WinCC Client for Runtime Professional</li> <li>• WinCC Client for Runtime Professional (form of delivery OSD <sup>3)</sup>)</li> <li>• WinCC Client for Runtime Professional ASIA</li> </ul>	<p><b>6AV2107-0DB02-0AA0</b></p> <p><b>6AV2107-0DB02-0AH0</b></p> <p><b>6AV2107-0DB12-0AA0</b></p>	

<sup>1)</sup> Runtime licenses for WinCC Runtime Professional options must be purchased separately for each target system.

<sup>2)</sup> Each including 1 upgrade license to the WinCC Runtime Professional options.

<sup>3)</sup> Current information and availability regarding the new delivery package can be found at: <http://www.siemens.com/tia-online-software-delivery>

# HMI Software

## SIMATIC WinCC (TIA Portal) Runtime

### WinCC Runtime Professional

Ordering data	Order No.	Ordering data	Order No.
<b>Upgrades WinCC V11 to WinCC V12 SP1 (continued)</b> <b>Online software delivery (OSD) <sup>2)</sup></b> Single license, software and license key download. E-mail address required for the delivery. <ul style="list-style-type: none"> <li>SIMATIC WinCC Runtime Professional 128 PowerTags V12 SP1 Upgrade V11 -&gt; V12 SP1</li> <li>SIMATIC WinCC Runtime Professional 512 PowerTags V12 SP1 Upgrade V11 -&gt; V12 SP1</li> <li>SIMATIC WinCC Runtime Professional 2048 PowerTags V12 SP1 Upgrade V11 -&gt; V12 SP1</li> <li>SIMATIC WinCC Runtime Professional 4096 PowerTags V12 SP1 Upgrade V11 -&gt; V12 SP1</li> <li>SIMATIC WinCC Runtime Professional 8192 PowerTags V12 SP1 Upgrade V11 -&gt; V12 SP1</li> <li>SIMATIC WinCC Runtime Professional 65536 PowerTags V12 SP1 Upgrade V11 -&gt; V12 SP1</li> </ul>	<b>6AV2105-3BB02-0AK0</b>  <b>6AV2105-3DD02-0AK0</b>  <b>6AV2105-3FF02-0AK0</b>  <b>6AV2105-3HH02-0AK0</b>  <b>6AV2105-3KK02-0AK0</b>  <b>6AV2105-3MM02-0AK0</b>	<b>Upgrades WinCC V7 to WinCC V12 SP1 (continued)</b> <b>SIMATIC WinCC V7.0 to SIMATIC WinCC Runtime Professional V12 SP1 and SIMATIC WinCC V7.0 ASIA to SIMATIC WinCC Runtime Professional ASIA V12 SP1</b> <ul style="list-style-type: none"> <li>WinCC V7.0 Runtime 2048 PowerTags to WinCC Runtime Professional 2048 PowerTags V12 SP1 <sup>1)</sup></li> <li>WinCC V7.0 Runtime 8192 PowerTags to WinCC Runtime Professional 8192 PowerTags V12 SP1 <sup>1)</sup></li> <li>WinCC V7.0 Runtime 65536 PowerTags to WinCC Runtime Professional 65536 PowerTags V12 SP1 <sup>1)</sup></li> <li>WinCC V7.0 RC/RT128 / RC/RT Client to WinCC Client for Runtime Professional V12 SP1</li> </ul>	<b>6AV2105-4KK02-0AE0</b>  <b>6AV2105-4MM02-0AE0</b>  <b>6AV2107-4DB02-0AE0</b>  <b>6AV2105-4BB02-0AE0</b>
<b>Upgrades WinCC V7 to WinCC V12 SP1</b> <b>SIMATIC WinCC V7.0 to SIMATIC WinCC Runtime Professional V12 SP1 and SIMATIC WinCC V7.0 ASIA to SIMATIC WinCC Runtime Professional ASIA V12 SP1</b> Single license, on DVD incl. licensing on USB stick <ul style="list-style-type: none"> <li>WinCC V7.0 Runtime 128 PowerTags to WinCC Runtime Professional 128 PowerTags V12 SP1 <sup>1)</sup></li> <li>WinCC V7.0 Runtime 512 PowerTags to WinCC Runtime Professional 512 PowerTags V12 SP1 <sup>1)</sup></li> </ul>	<b>6AV2105-4BB02-0AE0</b>  <b>6AV2105-4DD02-0AE0</b>  <b>6AV2105-4FF02-0AE0</b>	<b>Online software delivery (OSD) <sup>2)</sup></b> Single license, software and license key download. E-mail address required for the delivery. <ul style="list-style-type: none"> <li>WinCC V7.0 Runtime 128 PowerTags to WinCC Runtime Professional 128 PowerTags V12 SP1 <sup>1)</sup></li> <li>WinCC V7.0 Runtime 512 PowerTags to WinCC Runtime Professional 512 PowerTags V12 SP1 <sup>1)</sup></li> <li>WinCC V7.0 Runtime 2048 PowerTags to WinCC Runtime Professional 2048 PowerTags V12 SP1 <sup>1)</sup></li> <li>WinCC V7.0 Runtime 8192 PowerTags to WinCC Runtime Professional 8192 PowerTags V12 SP1 <sup>1)</sup></li> <li>WinCC V7.0 Runtime 65536 PowerTags to WinCC Runtime Professional 65536 PowerTags V12 SP1 <sup>1)</sup></li> <li>WinCC V7.0 RC/RT128 / RC/RT Client to WinCC Client for Runtime Professional V12 SP1</li> </ul>	<b>6AV2105-4BB02-0AK0</b>  <b>6AV2105-4DD02-0AK0</b>  <b>6AV2105-4FF02-0AK0</b>  <b>6AV2105-4KK02-0AK0</b>  <b>6AV2105-4MM02-0AK0</b>  <b>6AV2107-4DB02-0AK0</b>

<sup>1)</sup> Each including 1 upgrade license to the WinCC Runtime Professional options.

<sup>2)</sup> Current information and availability regarding the new delivery package can be found at: <http://www.siemens.com/tia-online-software-delivery>

#### More information

Further information can be found in the Internet at:  
<http://www.siemens.com/tia-portal>

### Overview

#### Communication – SIMATIC WinCC Runtime Advanced

WinCC Advanced is an open visualization system and offers the option of connecting the most diverse control systems.

#### Number of connectable controllers

WinCC Advanced permits the parallel coupling of up to 8 controllers.

Connection to third-party controllers

The following "Coupling overview" table lists third-party protocols and controllers which are directly supported by WinCC Advanced. Generally it is also possible to connect third-party controllers via OPC (OLE for Process Control).

Current notes and information about OPC servers from many different suppliers can be found at:

<http://www.opcfoundation.org/>

WinCC Advanced supports the standards:

- OPC Data Access 2.05a
- OPC UA Data Access 1.01
- OPC XML Data Access 1.00 (client via DCOM/XML gateway)

Protocol	Description	PC interface
<b>SIMATIC HMI</b>		
<b>Ethernet TCP/IP (HTTP communication)</b>	HTTP communication for data exchange between SIMATIC HMI (client + server) <sup>1)</sup>	CP 1612 A2
<b>SIMATIC S7</b>		
<b>Ethernet TCP/IP (S7 communication)</b>	Channel for communication via Ethernet TCP/IP with max. 8 x SIMATIC S7 controllers S7-1200, S7-1500 S7-300, S7-400, S7-200 with CP 243-1	CP 1612 A2 CP 1613 A2 CP 1623
<b>MPI, PROFIBUS (S7 communication)</b>	Channel for communication via MPI, PROFIBUS with max. 8 x SIMATIC S7 controllers S7-1200 with CM 1243-5 (DP master), S7-1500 S7-300, S7-400 S7-200 (only passive S7-200)	CP 5611 A2 CP 5621 CP 5512 CP 5711 CP 5613 A2 CP 5623
<b>PPI (PPI protocol)</b>	Channel for communication via PPI with 1 x SIMATIC S7-200 (network operation, e.g. parallel PG possible)	CP 5611 A2 CP 5621 CP 5512 CP 5711 CP 5613 A2 CP 5623
<b>Software interface (S7 communication)</b>	Channel for communication via software interface with WinAC	
<b>SINUMERIK <sup>2)</sup></b>		
<b>Ethernet TCP/IP (S7 communication)</b>	Channel for communication via Ethernet TCP/IP with SINUMERIK 840D sl	CP 1612 A2 CP 1613 A2 CP 1623
<b>MPI (S7 communication)</b>	Channel for communication via MPI with SINUMERIK 840D sl	CP 5611 A2 CP 5621 CP 5512 CP 5711 CP 5613 A2 CP 5623

Protocol	Description	PC interface
<b>Third-party controllers (from WinCC V11.0) <sup>3)</sup></b>		
<b>Allen Bradley Ethernet IP</b>	Channel for communication with max. 4 x Allen Bradley controllers via Ethernet TCP/IP with Allen Bradley Ethernet IP protocol The controllers ControlLogix / CompactLogix, SLC500 / MicroLogix and PLC5 are supported	CP 1612 A2
<b>Allen Bradley DF1</b>	Channel for communication with Allen Bradley controllers via DF1 protocol The controllers SLC500 / MicroLogix and PLC5 are supported <sup>3)</sup>	COM1/COM2
<b>Mitsubishi MC TCP/IP</b>	Channel for communication with max. 4 x Mitsubishi controllers via Ethernet TCP/IP with Mitsubishi MC TCP/IP protocol The FX3, Q, and iQ/QnUD controller series are supported	CP 1612 A2
<b>Mitsubishi FX</b>	Channel for communication with Mitsubishi controllers via FX protocol The FX1N, FX2N controllers are supported	COM1/COM2
<b>Modbus TCP/IP</b>	Channel for communication with max. 4 x Modicon controllers via Ethernet TCP/IP using the Modbus TCP/IP protocol The Quantum, Momentum, Premium, TSX Micro, Compact and M340 controllers are supported	CP 1612 A2
<b>Modbus RTU</b>	Channel for communication with Modicon controllers via the Modbus RTU protocol The Quantum, Momentum, and Compact controllers are supported	COM1/COM2
<b>Omron Link / Multi Link</b>	Channel for communication with Omron controllers via the Link/Multi protocol The CP1x, CJ1x, CJ2H, CS1x, and CP2MC controllers are supported	COM1/COM2
<b>Cross-manufacturer</b>		
<b>OPC client <sup>1) 4)</sup> for OPC DA, OPC UA DA, XML DA</b>	Channel for OPC communication, WinCC can acquire data from OPC server applications	CP 1612 A2
<b>OPC server for OPC DA</b>	Server applications for OPC communication; WinCC provides process data to OPC clients	CP 1612 A2

<sup>1)</sup> HTTP and OPC communication can be used in combination with the other couplings; regarding SIMATIC Panels that support HTTP or OPC communication, see the overview under "System interfaces (WinCC V11)".

<sup>2)</sup> "SINUMERIK Operate WinCC RT Advanced" license required; for further information, see NC 60 Catalog.

<sup>3)</sup> For detailed information regarding supported controllers, see "System interfaces (WinCC V11)".

<sup>4)</sup> Application note:  
The parallel use of the OPC client channel allows, for example, the connection to an SNMP OPC Server for visualization of the data present there. The SNMP OPC Server enables monitoring of any network components (e.g. switch) that support the SNMP protocol. Further information can be found under SIMATIC NET communications systems/SNMP OPC Server.

# HMI Software

## SIMATIC WinCC (TIA Portal) Runtime

### WinCC Runtime Communication

#### Overview (continued)

#### Communication – SIMATIC WinCC Runtime Professional

WinCC Professional is an open process visualization system and offers the option of connecting the most diverse control systems.

#### Released communication software

Only communication software with the listed (or higher) product versions should be used. Corresponding SIMATIC NET upgrades are available for the upgrading of older versions.

#### Number of connectable controllers

With CP 1613, a maximum of 64 S7 controllers can be connected via Industrial Ethernet; with CP 5611 a maximum of 8 and with CP 5613 a maximum of 44 S7 controllers can be connected via PROFIBUS. With approx. 10 or more controllers, the use of Industrial Ethernet is recommended.

#### Client-server communication

Communication between the clients and the server is implemented using the TCP/IP protocol. The construction of a separate PC-LAN is recommended. For small projects with correspondingly small message frame advent, a SIMATIC NET Industrial Ethernet can be used for both process communication (WinCC/server ↔ PLC) and for PC-PC communication (WinCC/client ↔ WinCC/server)

#### Connection to third-party controllers

The following "Coupling overview" table lists third-party protocols and controllers which are directly supported by WinCC Professional. Generally it is also possible to connect third-party controllers via OPC (OLE for Process Control).

Current notes and information about OPC servers from many different suppliers can be found at:

<http://www.opcfoundation.org/>

WinCC Professional supports the standards:

- OPC Data Access 2.05a
- OPC Data Access 3.00
- OPC UA Data Access 1.01
- OPC XML Data Access 1.00
- OPC HDA 1.20
- OPC A&E 1.10

Protocol	Description	PC interface
<b>SIMATIC S7</b>		
<b>SIMATIC S7</b>	Protocol Suite with channel units for communication with SIMATIC S7 via <ul style="list-style-type: none"> <li>• Ethernet TCP/IP (S7 communication) to S7-1200, S7-1500, S7-300, S7-400</li> <li>• MPI, PROFIBUS (S7 communication) to S7-1200 with CM 1243-5 (DP master), S7-1500, S7-300, S7-400</li> <li>• Software interface (S7 communication) to Win AC</li> </ul>	CP 1612 A2 CP 1613 A2 CP 5611 A2 CP 5621 CP 5512 CP 5711 CP 5613 A2 CP 5623
<b>Third-party controllers (from WinCC V11.0)</b>		
<b>Allen Bradley Ethernet IP</b>	Channel for communication with Allen Bradley controllers via Ethernet TCP/IP with Ethernet IP protocol The controllers ControlLogix / CompactLogix, SLC500 / MicroLogix, and PLC5 are supported	CP 1612 A2
<b>Mitsubishi MC TCP/IP</b>	Channel for communication with Mitsubishi controllers via Ethernet TCP/IP with Mitsubishi MC TCP/IP protocol The FX3, Q, and iQ/QnUD controller series are supported	CP 1612 A2
<b>Modbus TCP/IP</b>	Channel for communication with Modicon controllers via Ethernet TCP/IP using the Modbus TCP/IP protocol The Quantum, Momentum, Premium, TSX Micro, Compact and M340 controllers are supported	CP 1612 A2
<b>Cross-manufacturer</b>		
<b>OPC client <sup>1)</sup> for OPC DA, OPC XML DA</b>	Channel for OPC communication, WinCC can acquire data from OPC server applications	CP 1612 A2
<b>OPC server for OPC DA, OPC UA DA, OPC XML DA, OPC A&amp;E, OPC HDA</b>	Server applications for OPC communication; WinCC provides process data to OPC clients	CP 1612 A2

<sup>1)</sup> Application note:

The parallel use of the OPC client channel allows, for example, the connection to an SNMP OPC Server for visualization of the data present there.

The SNMP OPC Server enables monitoring of any network components (e.g. switch) that support the SNMP protocol.

Further information can be found under SIMATIC NET communications systems/SNMP OPC Server.

**Overview** (continued)

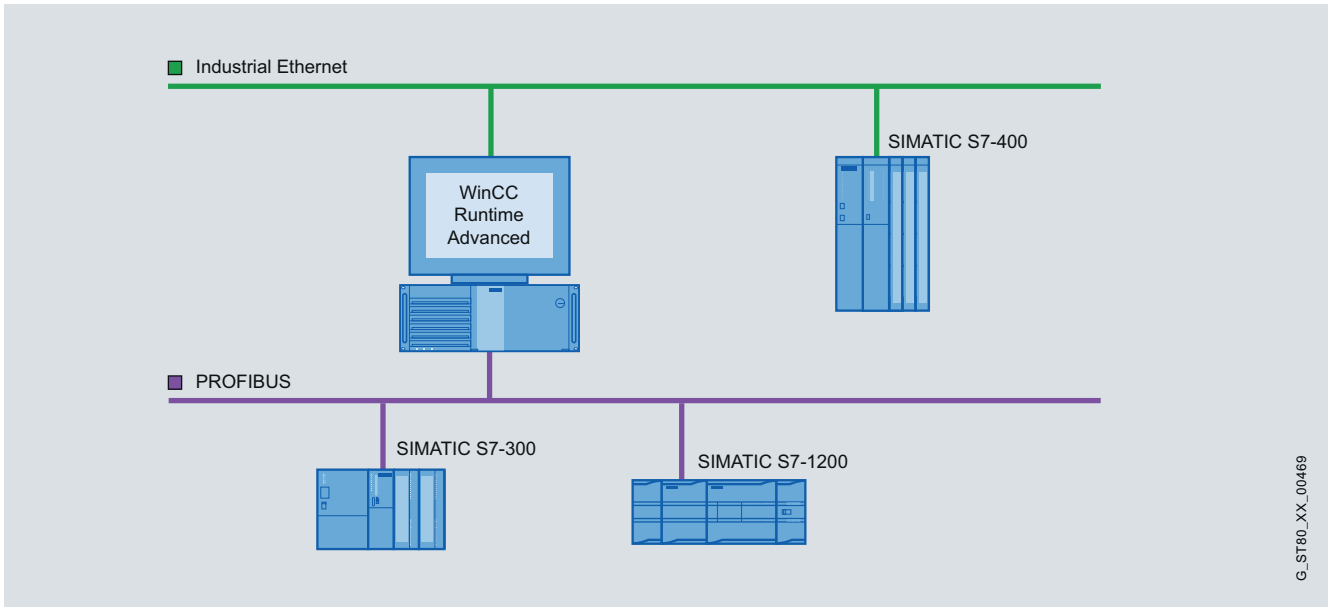

G\_ST80\_XX\_00469

WinCC Runtime Advanced single-user system

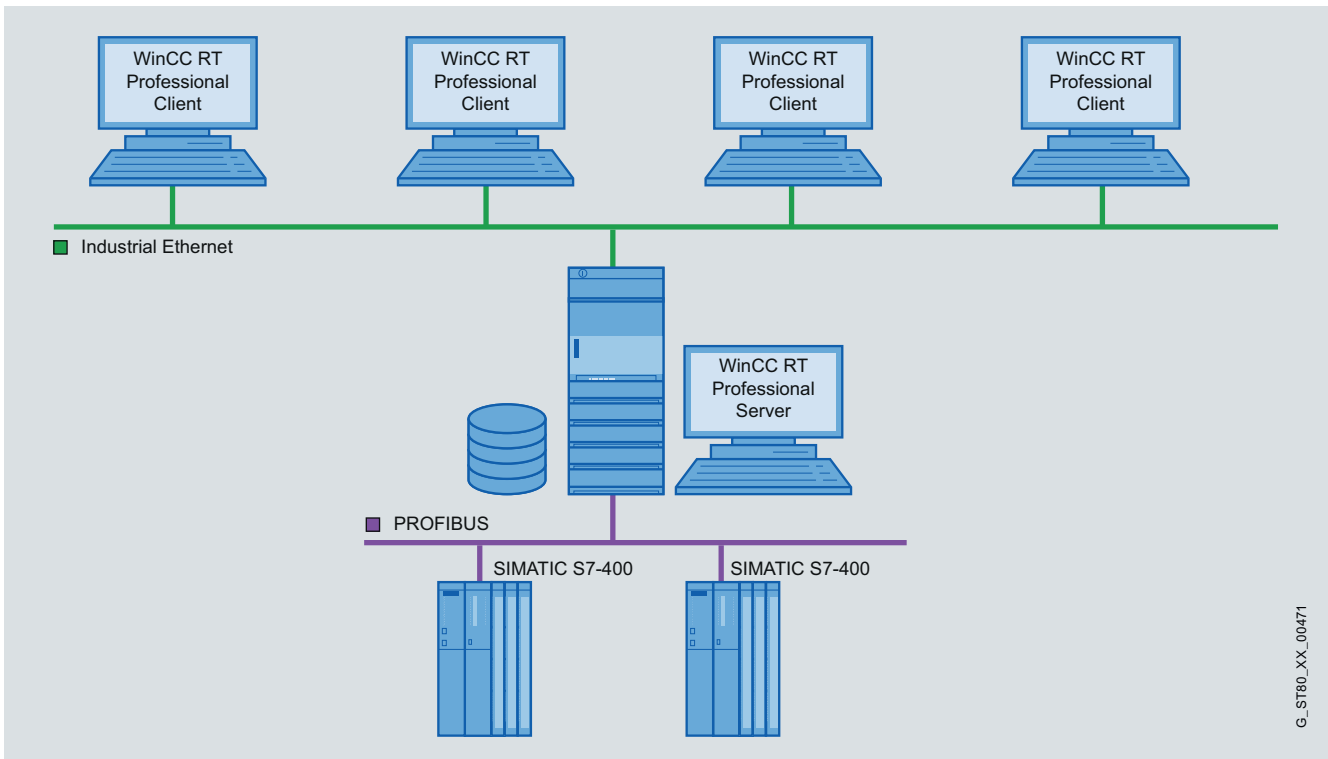

G\_ST80\_XX\_00471

WinCC Runtime Professional multi-user system with operable Server

# HMI Software SIMATIC WinCC (TIA Portal) Runtime

## WinCC Runtime Communication

### Overview (continued)

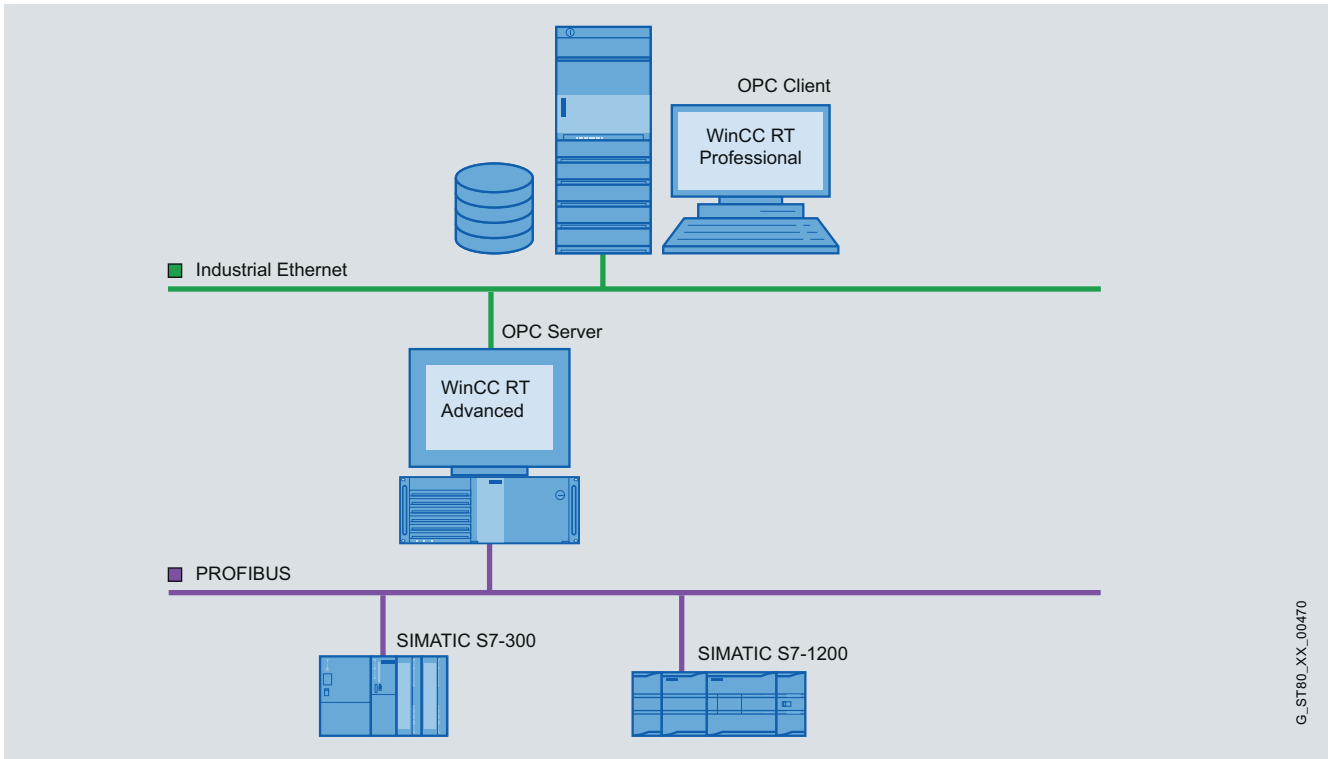

G\_ST80\_XX\_00470

4

OPC coupling

Ordering data	Order No.	Order No.
<p><b>Communication via Industrial Ethernet TCP/IP</b></p> <p><b>CP 1612 A2</b></p> <p>PCI card (32-bit) for connection of a programming device or PC to Industrial Ethernet (10/100/1000 Mbit/s) with RJ45 connection via SOFTNET S7 and SOFTNET PG.</p> <p>Software requirement: WinCC Runtime Advanced: No further installation is required (SOFTNET-S7)</p> <p>WinCC Runtime Professional: SOFTNET-S7 Lean (maximum of 8 connections) or SOFTNET-S7 (maximum of 64 connections) must be installed (SOFTNET-S7 Lean is included in the scope of delivery of WinCC Runtime Professional)</p>	<b>6GK1161-2AA01</b>	<p><b>Version 8.0 SP1</b></p> <p>For (32-bit) Windows 7 Ultimate, Professional; for CP 1612; CP 1612 A2 German/English (included in scope of supply: Edition 2008 SP2 (V7.1) )</p> <p><b>Edition 2008 SP2 (V7.1)</b></p> <p>For (32-bit) Windows XP Professional, Windows 2003 Server, VISTA Ultimate/Business; for CP 1612; CP 1612 A2 German/English</p> <ul style="list-style-type: none"> <li>• Single license for 1 installation</li> <li>• Upgrade package for SIMATIC NET from Edition 2006</li> <li>• Upgrade package for SIMATIC NET V6.0, V6.1, V6.2 and Edition 2005</li> </ul> <p><b>6GK1704-1LW80-3AA0</b> <b>6GK1704-1LW00-3AE0</b> <b>6GK1704-1LW00-3AE1</b></p>
<p><b>SOFTNET-S7 Version 8.0 SP1 / Edition 2008 SP2 (V7.1)</b></p> <p>Software for S7 and S5-compatible communication, incl. OPC server, PG/OP communication and NCM PC; up to 64 connections, single license for 1 installation, runtime software, software and electronic manual on CD-ROM, license key on USB flash drive, Class A</p> <p><b>Version 8.0 SP1</b></p> <p>For (32-bit) Windows 7 Ultimate, Professional; for CP 1612; CP 1612 A2 German/English (included in the scope of delivery: Edition 2008 SP2 (V7.1) )</p> <p><b>Edition 2008 SP2 (V7.1)</b></p> <p>For (32-bit) Windows XP Professional, Windows 2003 Server, VISTA Ultimate/Business; for CP 1612; CP 1612 A2 German/English</p> <ul style="list-style-type: none"> <li>• Single license for 1 installation</li> <li>• Upgrade package for SIMATIC NET from Edition 2006</li> <li>• Upgrade package for SIMATIC NET V6.0, V6.1, V6.2 and Edition 2005</li> </ul> <p><b>6GK1704-1CW80-3AA0</b> <b>6GK1704-1CW00-3AE0</b> <b>6GK1704-1CW00-3AE1</b></p>	<b>6GK1161-3AA01</b>	<p><b>CP 1613-A2</b></p> <p>PCI card (32 bit) for connecting a PG/PC to Industrial Ethernet (communications software must be ordered separately)</p> <p><b>S7-1613 Version 8.0 SP1 / Edition 2008 SP2 (V7.1)</b></p> <p>Software for S7 and S5-compatible communication, incl. PG/OP communication, OPC server and NCM PC; up to 120 connections, single license for 1 installation, runtime software, software and electronic manual on CD-ROM, license key on USB flash drive, Class A</p> <p><b>Version 8.0 SP1</b></p> <p>For (32-bit) Windows 7 Ultimate, Professional; for CP 1613; CP 1613 A2, CP 1623 German/English (included in the scope of delivery: Edition 2008 SP2 (V7.1) )</p> <p><b>Edition 2008 SP2 (V7.1)</b></p> <p>For (32-bit) Windows XP Professional, Windows 2003 Server, VISTA Ultimate/Business; for CP 1613; CP 1613 A2, CP 1623 German/English</p> <ul style="list-style-type: none"> <li>• Single license for 1 installation</li> <li>• Upgrade package for SIMATIC NET from Edition 2006</li> <li>• Upgrade package for SIMATIC NET V6.0, V6.1, V6.2 and Edition 2005</li> </ul> <p><b>6GK1716-1CB80-3AA0</b> <b>6GK1716-1CB00-3AE0</b> <b>6GK1716-1CB00-3AE1</b></p>
<p><b>SOFTNET-S7 Lean Version 8.0 SP1 / Edition 2008 SP2 (V7.1)</b></p> <p>(included in the scope of delivery of WinCC V11)</p> <p>Software for S7-compatible and S5-compatible communication incl. OPC server, PG/OP communication and NCM PC; up to 8 connections; single license for one installation of runtime software, software and electronic manual on CD-ROM; license key on USB stick; Class A</p>		<p><b>CP 1623</b></p> <p>PCI Express X1 card (32-bit) for connection of PG/PC to Industrial Ethernet (communications software to be ordered separately)</p> <p><b>6GK1162-3AA00</b></p>



# HMI Software

## SIMATIC WinCC (TIA Portal) Runtime

### WinCC Runtime Communication

#### Ordering data

#### Order No.

#### Order No.

#### Communication via PROFIBUS

##### PC adapter USB

6ES7972-0CB20-0XA0

Can be used under Windows XP

##### CP 5611 A2

6GK1561-1AA01

PCI Card (32-bit) for connecting a PG/PC to PROFIBUS  
(Communication software included in the WinCC basic package)

##### CP 5621

6GK1562-1AA00

PCI Express X1 card (32-bit) for connection of PG/PC to PROFIBUS  
(communications software included in WinCC basic package)

##### CP 5621 MPI

6GK1562-1AM00

Comprising CP 5621 (32-bit) and MPI cable, 5 m

##### CP 5512

6GK1551-2AA00

PCMCIA card (CARDBUS 32-bit) for the connection of a PG/notebook to PROFIBUS or MPI  
(communications software included in WinCC basic package)

##### CP 5711

6GK1571-1AM00

USB adapter for connecting a PG/PC to PROFIBUS or MPI  
(communications software included in the WinCC basic package)

##### CP 5613 A2

PCI card (32-bit) for connecting a PC to PROFIBUS  
(communications software must be ordered separately).

6GK1561-3AA01

##### CP 5623

PCI Express X1 card (32-bit) for connection of PG/PC to Industrial Ethernet (communications software to be ordered separately)

6GK1562-3AA00

##### S7-5613 Version 8.0 SP1 / Edition 2008 SP2 (V7.1)

Software for S7 Communication incl. PG/OP protocol, FDL, OPC server; runtime software, software and electronic manual on CD-ROM, license key on USB flash drive, Class A

##### Version 8.0 SP1

For (32-bit) Windows 7 Ultimate, Professional; for CP 5613 A2, CP 5623 German/English

For (32-bit) Windows XP Professional, Windows 2003 Server, VISTA Ultimate/Business; for CP 5613 A2, CP 5623 German/English

- Single license for 1 installation
- Upgrade package for SIMATIC NET from Edition 2006
- Upgrade package for SIMATIC NET V6.0, V6.1, V6.2 and Edition 2005

6GK1713-5CB80-3AA0

6GK1713-5CB00-3AE0

6GK1713-5CB00-3AE1

### Overview

#### **Options for SIMATIC Panels, SIMATIC WinCC Runtime Advanced and SIMATIC WinCC Runtime Professional**

##### SIMATIC WinCC Recipes for SIMATIC WinCC Runtime Advanced and SIMATIC WinCC Runtime Professional

- Generation and management of data records for machine or production data
- Display or entry of data records via a configurable screen object or via process screens distributed within the project
- Transmission of data records from or to the controller
- Import/export of data records for further processing with other tools (e.g. MS Excel)

##### SIMATIC WinCC Logging for SIMATIC WinCC Runtime Advanced and SIMATIC WinCC Runtime Professional

- Logging of alarms and process values
- Online evaluation of process value logs and alarm logs
- Evaluation of process value and alarm logs using standard MS tools such as Excel

##### SIMATIC WinCC Audit for SIMATIC Panels and SIMATIC WinCC Runtime Advanced

- Recording of operator actions in an Audit Trail
- Electronic signature for important operator actions relevant to production
- Audit supports users in meeting special quality requirements, e.g.
  - Production plant requiring validation according to 21 CFR Part 11 (Food Drug Administration law)
  - In respect of traceability according to EU 175/2002 (EU directive)

##### SIMATIC Logon for SIMATIC Panels and SIMATIC WinCC Runtime Advanced and SIMATIC WinCC Runtime Professional

- Creates user administration on a central computer to which one or more WinCC stations can be connected over Ethernet.
- With each logging-on/off of a user on one of the connected stations, SIMATIC Logon checks whether a user password has been created and that the required privileges exist.
- SIMATIC Logon supports the user in combination with the Audit option in meeting requirements in accordance with FDA 21 CFR Part 11 and EU178.

##### SIMATIC WinCC Sm@rtServer for SIMATIC Panels and SIMATIC WinCC Runtime Advanced

- Flexible solution for remote access to HMI systems
- Remote maintenance of machines and plants via the Internet/ Intranet
- Reduced downtimes for machines and plants due to direct remote access
- Flexible solution for remote access to machines and plants

##### SIMATIC WinCC Server and SIMATIC WinCC Client for SIMATIC WinCC Runtime Professional

For setting up a high-performance client-server system

- A number of coordinated HMI stations can be operated in a single group with networked automation systems
- Client/server solution:
  - One server can supply up to 32 connected clients with process and archive data, alarms, screens and reports
  - Depending on the size of the plant, up to 12 servers and 32 clients can be employed.

##### SIMATIC WinCC WebNavigator for SIMATIC WinCC Runtime Professional

- Operator control and monitoring of plants via the Internet or the in-house intranet or LAN
- Web Client permits the operator control and monitoring of a current WinCC Runtime Professional project via an Internet browser with ActiveX support.

##### SIMATIC WinCC DataMonitor for SIMATIC WinCC Runtime Professional

- Display and analysis of current process states and historical data on office PCs with standard tools.
- Information can be compiled online individually during runtime via the Internet/Intranet.

##### SIMATIC WinCC ControlDevelopment for SIMATIC WinCC Runtime Advanced and SIMATIC WinCC Runtime Professional

- Expansion of the basic functionality with proprietary controls.
- Development of proprietary VB.net or C# Controls for integration in WinCC Runtime Advanced and WinCC Runtime Professional

# HMI Software

## SIMATIC WinCC (TIA Portal) options

### WinCC Recipes

#### Overview

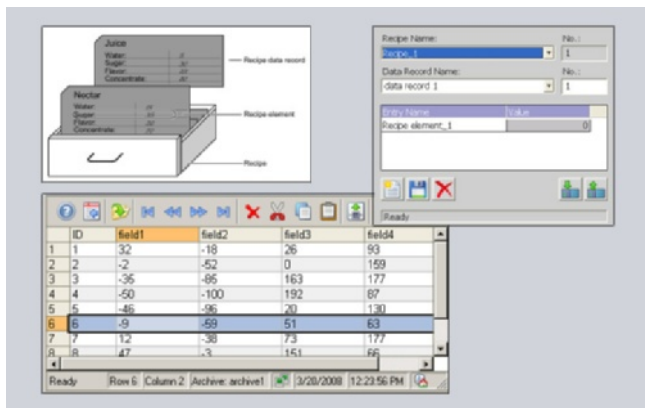

- Option for SIMATIC WinCC Runtime Advanced and WinCC Runtime Professional for managing data records in recipes that contain related machine or production data
- The data in a data set can be transferred, for example, from the control unit to the PLC to switch production to a different product variant
- Licensing:
  - SIMATIC Panels / Multi Panels / Comfort Panels: No license is required.
  - WinCC Runtime Advanced: One license is required per operator station
  - WinCC Runtime Professional: A license is only required on the server (or single-user system).

#### Benefits

- Generation and management of machine parameters and production data on the basis of data records, and exchange with the automation device, e.g. with the machine.
- Clear tabular representation of the data elements with the aid of a configurable screen object, or depiction in technological relationships across several process screens.
- Simple operator guidance through standard functions.
- Export/import of data records for further processing with other tools (e.g. MS Excel)

#### Function

- Input of data records (e.g. operating parameters of a machine, production data for a plastics machine) on the HMI device as well as their storage and transfer to the control
- Display or entry of data records via a configurable screen object or via several process screens distributed within the project
- The data record elements are coupled with the process via a direct tag connection
- Transmission of data records from or to the controller
- Powerful interfaces enable a synchronized data exchange with the controller
- Storage of data records on local data carriers or on remote data servers via networks
- Logging of data records, e.g. as batch report/shift report
- User-friendly and flexible management of data records by powerful standard functions

The recipes and the associated data records are created using a separate, user-friendly WinCC Engineering editor and data is pre-assigned to them. A configurable table object is used for displaying the data at runtime. Furthermore, the individual data record elements can also be displayed directly based on standard input/output fields across several process screens. In this way, the data in technological views can be presented clearly to the operator.

Import and export functions support the importing and exporting of data via external applications (e.g. MS Excel).

### Technical specifications

	WinCC Recipes for Runtime Advanced
	The values specified are maximum values
Number of recipes	999
Number of elements per recipe <sup>1)</sup>	2 000
User data length in KB per data record	256
Number of data records per recipe	5 000

<sup>1)</sup> When using arrays, each array element represents a recipe element

	WinCC Recipes for Runtime Professional
	The values specified are maximum values
Number of recipes	Unlimited <sup>2)</sup>
Number of elements per recipe <sup>2)</sup>	500 <sup>3)</sup>
User data length in KB per data record	3 000 <sup>3)</sup>
Number of data records per recipe	5 000 <sup>2)</sup>

<sup>2)</sup> Limited by system resources.

<sup>3)</sup> The sum of the number of recipe elements and number of data records must not exceed a value of 320,000.

### Ordering data

### Order No.

<b>SIMATIC WinCC Recipes for Runtime Advanced</b> <sup>1)</sup>	<b>6AV2107-0JA00-0BB0</b>
Single license, license key only on USB stick	
<b>SIMATIC WinCC Recipes + Logging for Runtime Advanced</b> <sup>1)</sup>	<b>6AV2107-0HA00-0BB0</b>
Single license, license key only on USB stick	
<b>SIMATIC WinCC Recipes for Runtime Professional</b> <sup>1)</sup>	<b>6AV2107-0JB00-0BB0</b>
Single license, license key only on USB stick	
<b>Online software delivery (OSD)</b> <sup>2)</sup>	
<b>WinCC Recipes for Runtime Advanced</b> <sup>1)</sup>	<b>6AV2107-0JA00-0BH0</b>
Single license, license key download only; E-mail address required for the delivery	
<b>WinCC Recipes for Runtime Professional</b> <sup>1)</sup>	<b>6AV2107-0JB00-0BH0</b>
Single license, license key download only; E-mail address required for the delivery	

<sup>1)</sup> One license is required for each operator console. A license is not required for the engineering system for configuring the runtime option.

<sup>2)</sup> Current information and availability regarding the new delivery package can be found at: <http://www.siemens.com/tia-online-software-delivery>

# HMI Software

## SIMATIC WinCC (TIA Portal) options

### WinCC Logging

#### Overview

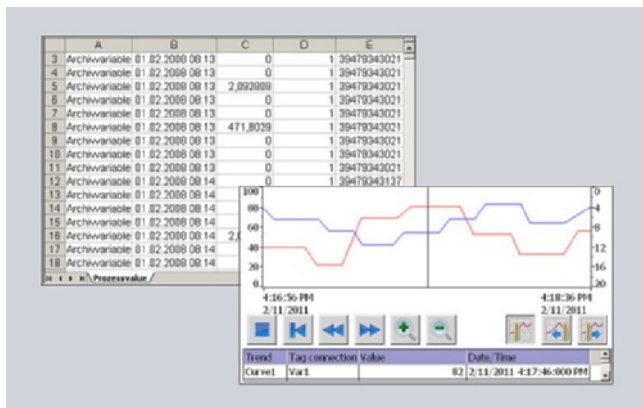

- Option for SIMATIC WinCC Runtime Advanced and WinCC Runtime Professional for logging process values and alarms
- Logging of process values and alarms supports the acquisition and processing of process data from an industrial plant or machine. Evaluation of the logged process data provides information about the operating states of the plant or machine
- Licensing:
  - SIMATIC Panels / Multi Panels / Comfort Panels: No license is required.
  - WinCC Runtime Advanced: One license is required per operator station
  - WinCC Runtime Professional: 500 Logging Tags are already included in the basic package. The number of Logging Tags can be increased by means of additional licenses

#### Benefits

- Alarm and process value logs enable predictive diagnostics, which avoids downtimes
- Early detection of danger and fault conditions
- Increase of the product quality and the productivity thanks to regular analysis of the alarm and process value logs

#### Application

- Transfer of the logs for evaluation and long-term archiving
- Detection of recurring error states
- Optimization of maintenance cycles
- Ensuring the quality standard
- Quality assurance and checking the utilization of production sequences
- Documentation of process sequences

#### Function

- Time-controlled as well as manual or process-controlled swapping out of process data and alarms for long-term archiving
- During runtime, swapped out data are read in and selectively analyzed using WinCC Runtime Professional
  - Presentation and evaluation of archived process data based on a configurable trend display. Reading of the values is facilitated by a read line.
  - Presentation and evaluation of archived alarms based on a configurable alarm view.
  - User-friendly navigation in the logs
- External evaluation of the logs using MS standard tools
- Various log types are supported: sequence and circular logs
- Logging of process values and alarms on external, Windows-supported storage media
  - SIMATIC Panels and WinCC Runtime Advanced: CSV files, RDB files, Microsoft SQL Server via ODBC
  - WinCC Runtime Professional: Microsoft SQL Server 2005
- Powerful standard functions permit user-friendly and flexible utilization of the logs

### Technical specifications

	<b>WinCC Logging for Runtime Advanced</b>
	The values specified are maximum values
Number of logs	100
Archivable data	Process values, alarms
Cyclical trigger for archiving process values (variables)	1 s
Max. number of entries per log (incl. sequence log)	500 000 <sup>1)</sup>
Log types	Circular logs, sequence logs (max. 400 per log)
Data storage format	CSV ( <b>C</b> omma <b>S</b> eparated <b>V</b> ariable), <b>R</b> DB ( <b>R</b> untime <b>D</b> ata <b>B</b> ase), Microsoft SQL database (database not included in scope of delivery)

<sup>1)</sup> Dependent on memory medium used

	<b>WinCC Logging for Runtime Professional</b>
	The values specified are maximum values
Number of logs per single-user station/server	100
Archivable data	Process values, alarms
Measured values per second, max.	Server/single-user station: 5 000 per sec.
Log tags per single-user station/server	80 000 <sup>2)</sup>
Log types	Circular log with and without long-term logging
Data storage format	Microsoft SQL 2005 database

<sup>2)</sup> Dependent on the Logging Powerpack used for the log tags. 500 log tags are contained in the basis version.

### Ordering data

### Order No.

<b>SIMATIC WinCC Logging for Runtime Advanced</b> <sup>1)</sup>	<b>6AV2107-0GA00-0BB0</b>
Single license, license key only on USB stick	
<b>SIMATIC WinCC Recipes + Logging for Runtime Advanced</b> <sup>1)</sup>	<b>6AV2107-0HA00-0BB0</b>
Single license per option, license key only on USB stick	
<b>SIMATIC WinCC Logging for Runtime Professional 1500 Logging Tags</b>	<b>6AV2107-0GB00-0BB0</b>
Single license, license key only on USB stick	
<b>SIMATIC WinCC Logging for Runtime Professional 5000 Logging Tags</b>	<b>6AV2107-0GD00-0BB0</b>
Single license, license key only on USB stick	
<b>WinCC Logging for Runtime Professional Powerpack 1500 -&gt; 5000 Logging Tags</b>	<b>6AV2107-2GD00-0BD0</b>
Single license, license key only on USB stick	
<b>WinCC Logging Upgrade for SIMATIC WinCC Archives V7.0 (10 licenses)</b>	<b>6AV2107-4GX00-0BF0</b>
Single license per option, license key only on USB stick	
<b>Online software delivery (OSD)</b> <sup>2)</sup>	
<b>WinCC Logging for Runtime Advanced</b> <sup>1)</sup>	<b>6AV2107-0GA00-0BH0</b>
Single license, license key download only e-mail address required for the delivery	
<b>WinCC Logging for Runtime Professional - 1500 Logging Tags</b>	<b>6AV2107-0GB00-0BH0</b>
Single license, license key download only e-mail address required for the delivery	
<b>WinCC Logging for Runtime Professional - 5000 Logging Tags</b>	<b>6AV2107-0GD00-0BH0</b>
Single license, license key download only e-mail address required for the delivery	
<b>WinCC Logging for Runtime Professional Powerpack 1500 -&gt; 5000 Logging Tags</b>	<b>6AV2107-2GD00-0BJ0</b>
Single license, license key download only e-mail address required for the delivery	

<sup>1)</sup> One license is required for each operator console. A license is not required for the engineering system for configuring the runtime option.

<sup>2)</sup> Current information and availability regarding the new delivery package can be found at: <http://www.siemens.com/tia-online-software-delivery>

# HMI Software

## SIMATIC WinCC (TIA Portal) options

### WinCC Audit

#### Overview

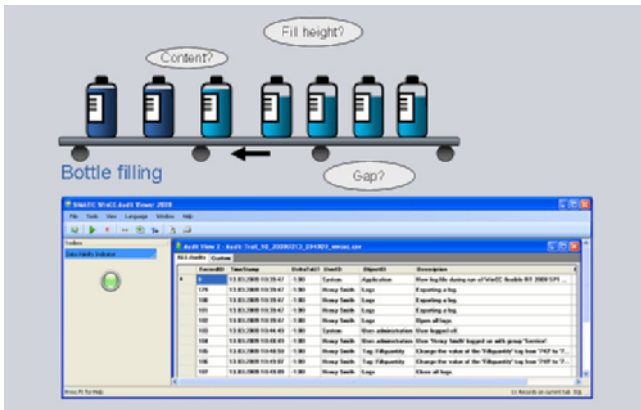

- Option for SIMATIC WinCC Runtime Advanced as well as SIMATIC Panels for recording operations in an audit trail, and electronic signature
- The audit trail is furnished with a security mechanism that displays subsequent manipulations.
- A user-friendly configuration function, which is included as standard in WinCC, is used to define the following:
  - Which user actions should be recorded in the audit trail during runtime
  - Which important operator actions during execution time require electronic signature/comments
- Available for the following SIMATIC HMI systems:
  - Comfort Panels
  - Mobile Panels
  - TP/OP 277
  - MP 277
  - MP 377
  - WinCC Runtime Advanced
- Licensing:
  - A license is required for every operator control unit (panel or PC).

#### Benefits

- Audit supports the user in meeting special quality requirements, e.g.
  - Production plant requiring validation according to 21 CFR Part 11 FDA <sup>1)</sup>
  - In respect of traceability according to EU 175/2002 <sup>2)</sup>
- The entries in the audit trail are uniquely assigned to users. This means that responsibilities are clearly identifiable.
- The audit trail, stored as a CSV file <sup>3)</sup>, can be checked via a security mechanism to find out if subsequent changes have been made.
- For particularly important user actions, e.g., starting production or loading new recipes, electronic signatures and comments can be configured and then called up and logged during runtime.

<sup>1)</sup> The FDA (Food and Drug Administration) is the American public health body

<sup>2)</sup> 21 CFR Part 11- law on plant validation

<sup>3)</sup> CSV Comma Separated Values

#### Technical specifications

WinCC Audit	
Storage location for Audit Trail when used on the Panel	Plug-in Flash memory card or via Ethernet in the higher-level PC
Storage location for Audit Trail when using WinCC Runtime Advanced	Local hard disk or via Ethernet in the higher-level PC
Execution platform	
SIMATIC Panels	Mobile Panel 277, TP/OP 277
SIMATIC Multi Panels	MP 277, MP 377
SIMATIC Comfort Panels	all
PC systems	SIMATIC WinCC Runtime Advanced

#### Ordering data

#### Order No.

##### SIMATIC WinCC Audit for SIMATIC Panels

**6AV2107-0RP00-0BB0**

Single license,  
license key only on USB stick

##### SIMATIC WinCC Audit for Runtime Advanced

**6AV2107-0RA00-0BB0**

Single license,  
license key only on USB stick

##### Online software delivery (OSD) <sup>1)</sup>

##### WinCC Audit for SIMATIC Panels

**6AV2107-0RP00-0BH0**

Single license,  
license key download only  
E-mail address required for the delivery

##### WinCC Audit for Runtime Advanced

**6AV2107-0RA00-0BH0**

Single license,  
license key download only  
E-mail address required for the delivery

<sup>1)</sup> Current information and availability regarding the new delivery package can be found at: <http://www.siemens.com/tia-online-software-delivery>



### Overview

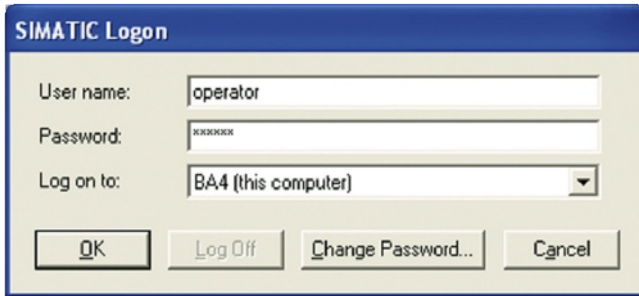

- Option for connecting SIMATIC Panels and PCs with SIMATIC WinCC Runtime Advanced as well as WinCC Runtime Professional to a central user administration.
- Creates user administration on a central computer to which one or more panels or WinCC stations can be connected over Ethernet.
- With each logging-on/off of a user on one of the connected stations, SIMATIC Logon checks whether a user password has been created and that the required privileges exist.

#### **SIMATIC Logon for Panels and WinCC Runtime Advanced**

- All users of the SIMATIC Panels or WinCC Runtime Advanced stations can be managed plant-wide from a central location
- Supports the user in combination with the Audit option in meeting requirements in accordance with FDA 21 CFR Part 11 and EU 178.
- Licensing:  
SIMATIC Logon (basic license) and SIMATIC Logon Remote Access (3-pack license) for the connection of 3 panels or WinCC Runtime Advanced stations to a central user administration. Additional stations can be connected by using further SIMATIC Logon Remote Access licenses (3-pack/10-pack).

#### **SIMATIC Logon for WinCC Runtime Professional**

- All users of WinCC Runtime Professional can be managed plant-wide from a central location.
- The central user management with SL utilizes Windows mechanisms and must be installed on all participating WinCC Runtime Professional stations.
- Licensing:  
SIMATIC Logon (basic license) is included in the basic package of WinCC Runtime Professional

### Benefits

- Centralized configuration of all access authorizations of a distributed system avoids unnecessary travel times. Time-consuming multiple configurations for each individual local station become unnecessary. Accordingly, users can be easily configured from a central location.
- All access data apply throughout the plant on every connected station. Additional access data on local subsystems is no longer necessary.

### Design

#### **SIMATIC Logon for Panels and WinCC Runtime Advanced**

SIMATIC Logon and SIMATIC Logon Remote Access are installed on a central station.

The following Runtime stations are connected to the central station via the Ethernet network:

- PCs with WinCC Runtime Advanced
- SIMATIC Panels from the 177 series or higher (with Ethernet interface)
- SIMATIC Mobile Panels from the 177 series or higher (with Ethernet interface)
- SIMATIC Multi Panels
- SIMATIC Comfort Panels

#### **SIMATIC Logon for WinCC Runtime Professional**

The SIMATIC Logon can be used for the central user management of several WinCC Runtime Professional stations. Operation in a Windows Workgroup or even in a domain is possible.

### Function

Users receive a unique user ID, user name and password.

This information is encrypted and stored at a central point (for SIMATIC Logon in the Windows user management). Functions such as changing the password, automatic log-off after a predefined time and lockout after several incorrect entries of a password ensure maximum security of operation.

In addition, SIMATIC Logon allows setting up new users online, plant-wide and across applications, or blocking of existing users. SIMATIC Logon also supports electronic signature.

### Ordering data

### Order No.

<b>SIMATIC Logon V1.5</b> Basic license <sup>1)</sup> For panels or WinCC Runtime Advanced stations, the corresponding number of additional SIMATIC Logon Remote Access licenses is required. No SIMATIC Logon Remote Access licenses are required for WinCC Runtime Professional	<b>6ES7658-7BX51-0YA0</b>
<b>SIMATIC Logon Upgrade to V1.5</b>	<b>6ES7658-7BX51-0YE0</b>
<b>SIMATIC Logon Remote Access (3 clients)</b> Remote Access for 3 clients; Single License for 3 SIMATIC Logon Remote Access clients; the number of licensed clients is determined from the sum of the installed SIMATIC Logon Remote Access licenses.	<b>6ES7658-7BA00-2YB0</b>
<b>SIMATIC Logon Remote Access (10 clients)</b> Remote Access for 10 clients; Single License for 10 SIMATIC Logon Remote Access clients; the number of licensed clients is determined from the sum of the installed SIMATIC Logon Remote Access licenses.	<b>6ES7658-7BB00-2YB0</b>

<sup>1)</sup> SIMATIC Logon V1.5 included in scope of supply of WinCC Runtime Professional.

# HMI Software

## SIMATIC WinCC (TIA Portal) options

### WinCC Sm@rtServer

#### Overview

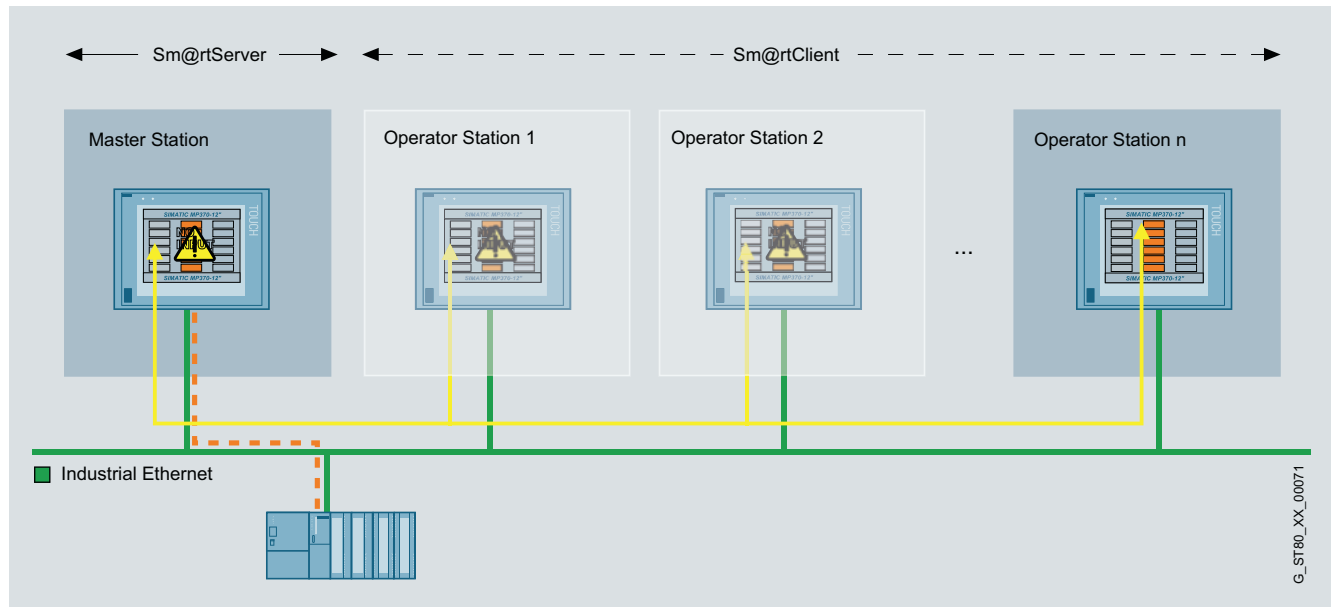

4

- Option for SIMATIC WinCC Runtime Advanced plus SIMATIC Panels for communication between various SIMATIC HMI systems.
- Available for the following SIMATIC HMI systems:
  - Comfort Panels
  - Mobile Panel 177 PN, Mobile Panel 277
  - TP 177B PN/DP, OP 177B PN/DP
  - TP 277, OP 277
  - MP 177, MP 277, MP 377
  - WinCC Runtime Advanced
- A SIMATIC HMI system can be used to control or monitor another system remotely; entry level for client/server configurations for distributed operator stations or for solutions with head end or control room
- Local operation, visualization and data processing are as possible as plant-wide access to information. Integrated information flows ensure an overview of the status of all processes.

- Licensing:  
The "SIMATIC WinCC Sm@rtServer for Panel" or "SIMATIC WinCC Sm@rtServer for WinCC Runtime Advanced" license must be installed on the server HMI device. A license is not required for the engineering system for configuring the runtime option.

#### Note:

When accessing the operator stations via the Sm@rtServer option, suitable protective measures (including IT security such as network segmentation) should be taken in order to ensure safe operation of the system.

You will find more information on the topic of Industrial Security on the Internet at:

<http://www.siemens.com/industrialsecurity>

#### Benefits

- Flexible solution for remote access to HMI systems
- Quick elimination of malfunctions or downtimes – thus increasing the productivity – through global access to machines/plants by the service and maintenance personnel.
- Avoidance of on-site service calls.

### Application

- Operator control and monitoring of machines covering large areas with several operator stations by one operator.
- Operator control and monitoring of machine-level HMI systems from one central station (e.g. head-end station of a production line or from a control room)
- Remote maintenance and servicing of machines/plants over the Internet/Intranet

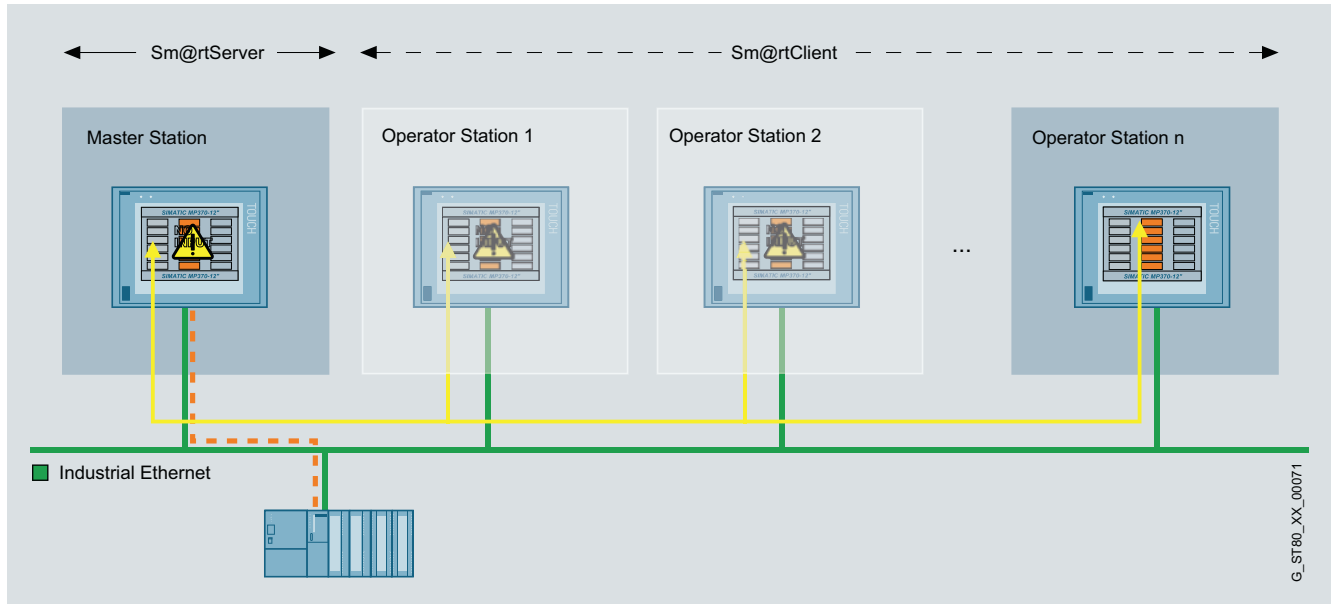

Application of the Sm@rtClient concept: Coordinated operation of several operator stations

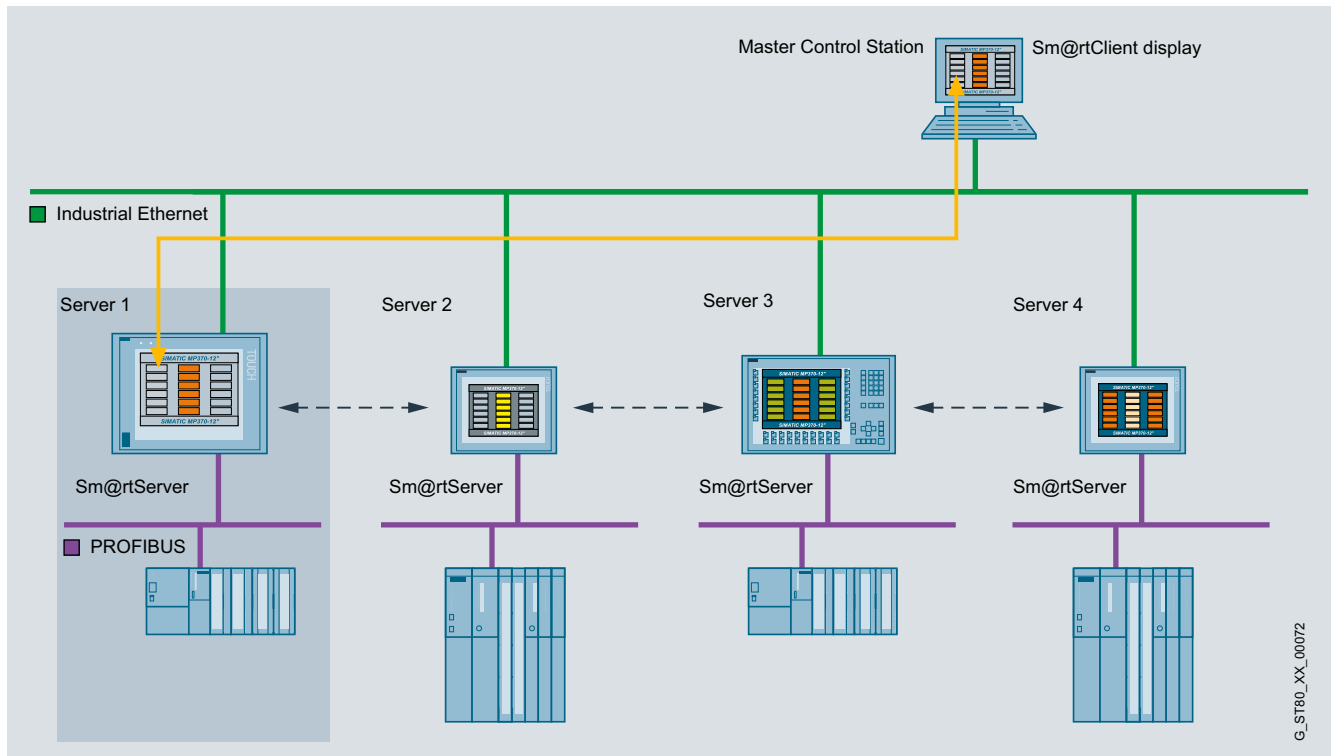

Use of the Sm@rtClient display: Operator control and monitoring of machine-level HMI systems from one central station

# HMI Software

## SIMATIC WinCC (TIA Portal) options

### WinCC Sm@rtServer

#### Application (continued)

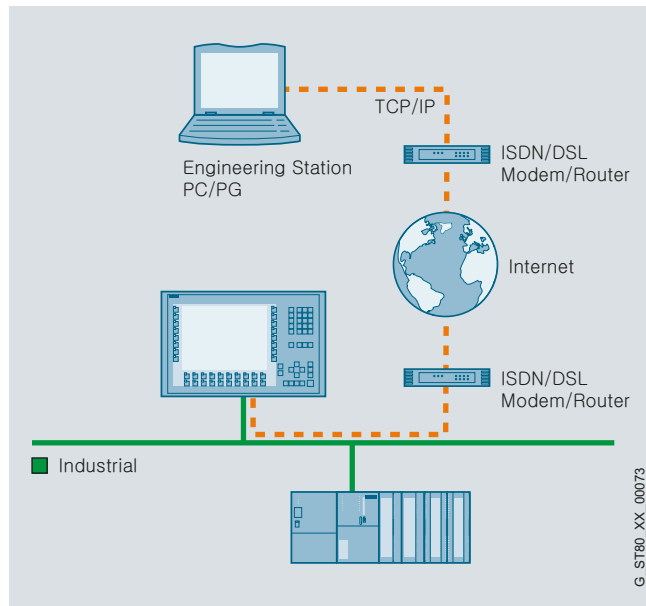

Remote operator control and monitoring of SIMATIC HMI systems using Industrial Ethernet and/or via the Intranet/Internet

4

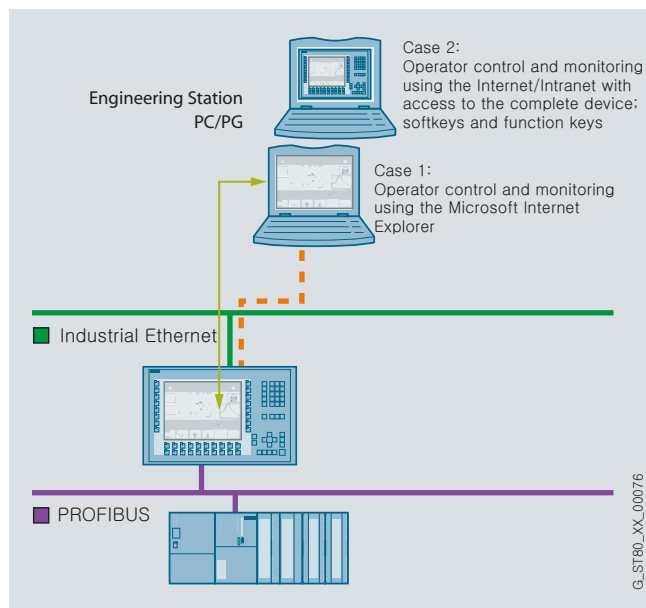

Remote operator control and monitoring of SIMATIC HMI systems using Industrial Ethernet and/or via the Intranet/Internet

#### Function

##### Coordinated operation of several operator stations:

- The HMI application and communication with the controller takes place via the master station. "Sm@rtClients" can be activated from here in the case of machines/plants with larger dimensions which require a larger number of HMI devices. The Sm@rtClients are then provided with access to the master station and thus to the process. Access procedures guarantee that only one operator system can actively access the process at any given time.
- Embedded in process screens, a configurable screen object (Sm@rtClient display) represents the screen of the relevant HMI system (Sm@rtServer)
- Powerful standard functions permit user-friendly and flexible operation of the display

##### Remote control of an operating station:

- The HMI application and communication with the controller takes place via the HMI system. Using the Sm@rtServer, the HMI systems in the machines/systems can be serviced remotely. An access process ensures that only one operator (either locally at the machine or remotely via Internet Explorer) can actively access the process at one time.
- Microsoft Internet Explorer V6.0 SP1 or higher is sufficient for accessing an HMI system.

# HMI Software

## SIMATIC WinCC (TIA Portal) options

WinCC Sm@rtServer

Technical specifications		Ordering data	Order No.
<b>WinCC Sm@rtServer</b>		<b>WinCC Sm@rtServer for SIMATIC Panels</b> <sup>1)</sup>	<b>6AV2107-0CP00-0BB0</b>
The values specified are maximum values		Single license, license key only on USB stick	
<b>Execution platform</b>		<b>WinCC Sm@rtServer for Runtime Advanced</b> <sup>1)</sup>	<b>6AV2107-0CA00-0BB0</b>
SIMATIC Comfort Panels	all	Single license, license key only on USB stick	
SIMATIC Panels	Mobile Panel 177 PN, Mobile Panel 277, TP/OP 177B PN/DP, TP/OP 277	<b>Online software delivery (OSD)</b> <sup>2)</sup>	
SIMATIC Multi Panels	MP 177, MP 277, MP 377	<b>WinCC Sm@rtServer for SIMATIC Panels</b> <sup>1)</sup>	<b>6AV2107-0CP00-0BH0</b>
PC systems	SIMATIC WinCC Runtime Advanced	Single license, license key download only E-mail address required for the delivery	
<b>Number of Sm@rtClients that can simultaneously connect to a Sm@rtServer</b>		<b>WinCC Sm@rtServer for Runtime Advanced</b> <sup>1)</sup>	<b>6AV2107-0CA00-0BH0</b>
Comfort Panel as Sm@rtServer	2 clients for 4" devices 3 clients for 7", 9", 12" and 15" devices 2 clients for 19" devices 1 client for 22" devices	Single license, license key download only E-mail address required for the delivery	
Mobile Panel 177 PN, TP/OP 177B PN/DP, MP 177 as Sm@rtServer	2 clients		
Mobile Panel 277, TP/OP 277, MP 277 as Sm@rtServer	3 clients for 6" devices 2 clients for 8" and 10" devices		
MP 377 as Sm@rtServer	3 clients for 12" devices 2 clients for 15" devices 1 client for 19" devices		
WinCC Runtime Advanced as Sm@rtServer	5 clients		

<sup>1)</sup> The license must be installed on the Sm@rtServer HMI device. A license is not required for the engineering system for configuring the runtime option.

<sup>2)</sup> Current information and availability regarding the new delivery package can be found at: <http://www.siemens.com/tia-online-software-delivery>

# HMI Software

## SIMATIC WinCC (TIA Portal) options

### WinCC Server / WinCC Client

#### Overview

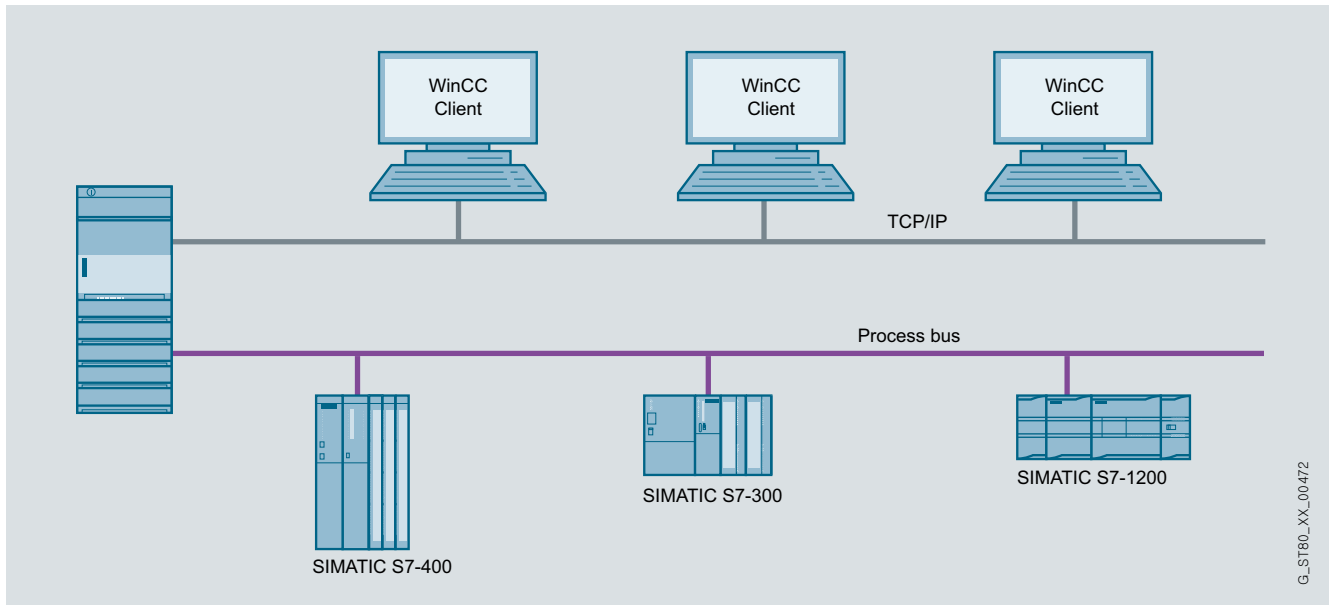

4

- Option for SIMATIC WinCC Runtime Professional, which permits the configuration of a powerful client/server system
- One of the following operating systems must be available to install the option on the server: Windows Server 2003, Windows Server 2003 R2, Windows Server 2008 or Windows XP Professional. When using Windows XP Professional, max. 3 clients can be connected.
- A number of coordinated HMI stations can be operated in a single group with networked automation systems
- Client/server solution: One server can supply up to 32 connected clients with process and archive data, alarms, screens and reports
  - Requirement: Network connection (TCP/IP) between the server PC and the connected clients
- Licensing:
  - A WinCC Runtime Professional license on the server with the appropriate number of PowerTags and the "WinCC Server for RT Professional" license.
  - The "WinCC Client for RT Professional" license on the clients.

# HMI Software

## SIMATIC WinCC (TIA Portal) options

### WinCC Server / WinCC Client

#### Benefits

- Integrated scalability from the single-user system to the client/server solution
- Considerably expanded quantity structure, relieves the load on the individual servers, and thus better performance through the distribution of the overall application or of the tasks among several servers

#### Application

In a complex plant, WinCC Runtime Professional can be configured as a distributed system depending on the requirements:

- Functional distribution (e.g. alarm server, log server, etc.), or
- Distribution corresponding to the physical plant structure (e.g. body-in-white, paint shop, etc.).

#### Function

All process data of a WinCC project is stored in different Runtime databases, e.g. alarms, trend values, etc. These Runtime databases are located on a central computer, the WinCC Server, instead on each HMI device. The operator stations, i.e. the WinCC Clients, then access the WinCC Server.

WinCC Clients and WinCC Server are independent systems. You can also connect WinCC Clients subsequently. Alternatively, you can activate and deactivate a project from a WinCC Client.

#### Ordering data

#### Order No.

##### **SIMATIC WinCC server for Runtime Professional**

Single license, license key only on USB stick

**6AV2107-0EB00-0BB0**

##### **SIMATIC WinCC Client for Runtime Professional V12**

Single license, license key on USB stick, software and documentation on DVD

**6AV2107-0DB02-0AA0**

##### **SIMATIC WinCC Client for Runtime Professional ASIA V12**

Single license, license key on USB stick, software and documentation on DVD

**6AV2107-0DB12-0AA0**

##### **Online software delivery (OSD) <sup>1)</sup>**

##### **SIMATIC WinCC server for Runtime Professional**

Single license, license key download only, e-mail address required for the delivery

**6AV2107-0EB00-0BH0**

##### **SIMATIC WinCC Client for Runtime Professional V12**

Single license, software and license key download. E-mail address required for the delivery

**6AV2107-4DB02-0AK0**

A license is not required for the engineering system for configuring the runtime option.

<sup>1)</sup> Current information and availability regarding the new delivery package can be found at: <http://www.siemens.com/tia-online-software-delivery>



# HMI Software

## SIMATIC WinCC (TIA Portal) options

### WinCC WebNavigator

#### Overview

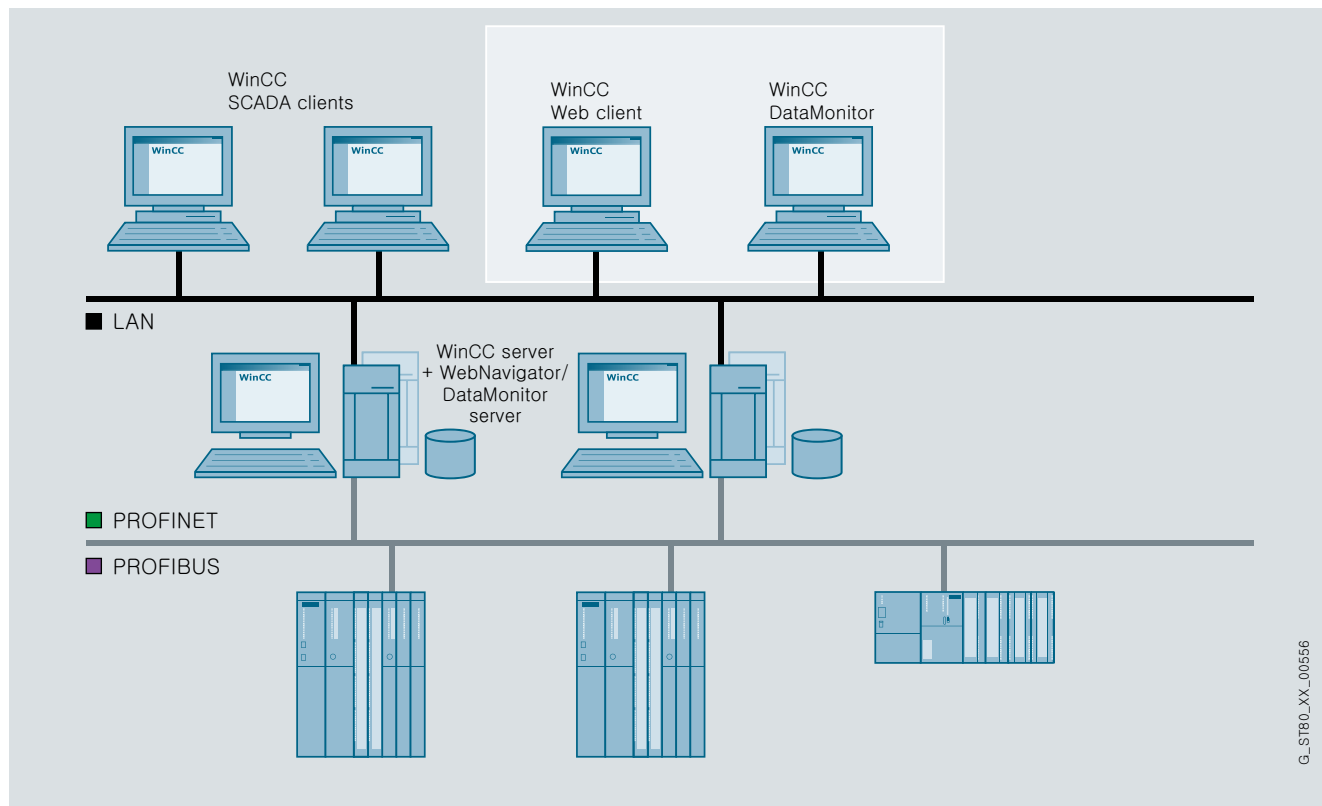

G\_STB0\_XX\_00556

- Option for SIMATIC WinCC Runtime Professional for operating and monitoring plants over the Internet, company Intranet or LAN.
- Configuration from:
  - A web server with SIMATIC WinCC Runtime Professional as single-user or server version and a web client that permits operator control and monitoring of a current WinCC Runtime Professional project using the Internet Explorer.
- Licensing:
  - A license is required for using the Web server.
  - Server-based licenses are available for access to the web server by 3, 10, 25 or 50 clients.
  - Client-based licenses are available for guaranteed access to the web server (Diagnostics Client)

#### Note:

When accessing the operator stations via the WinCC WebNavigator option, suitable protective measures (including IT security such as network segmentation) should be taken in order to ensure safe operation of the system.

You will find more information on the topic of Industrial Security on the Internet at:

<http://www.siemens.com/industrialsecurity>

### Benefits

- Operator control and monitoring across long distances and on different platforms (PC, local panel, mobile PDA)
- Large configurations with up to 50 operator stations
- Fast update rates due to event-driven communication
- Optimally tailored clients for operating and monitoring, analysis, service and diagnostics
- Acceptance of configuration data for the web, generally without changes
- Minimum maintenance costs due to central software administration
- High security standards and availability
  - Support for commonly used security mechanisms (routers, firewalls, proxy servers)
  - WinCC access authorizations and user administration
- Support of Microsoft Internet Explorer, including "tabbed browsing". A new license is not required for separate tabs.
- With the WinCC Web Viewer (WinCC Viewer RT), the process screens can be displayed on the web client independently of the Internet Explorer. Settings for the client are made on the client itself. The WinCC Web Viewer can also be used in conjunction with the MS Terminal Service.
- The SIMATIC WinCC WebNavigator can also be operated in "view only" mode and is thus used as tool for monitoring and navigating using Internet Explorer or WinCC Web Viewer (WinCC Viewer RT).
- Web server logins and logouts are recorded in the alarm and audit log.
- There is a gadget available for the Windows 7 operating system in which selected WinCC process screens can be displayed. No additional WebNavigator license is required for the gadget. The WebNavigator server can be selected directly via the gadget.
- Security is increased by adjustable automatic logout. If an automatic logout is to take place, an absolute or inactive time period can be set.

### Highlights:

- Multiple Web servers can be accessed from a single Web client
- User-friendly services and tools for distributing customized objects (controls, files) to web clients can be supplied for use as an integration platform. These components can then also be integrated into cross-web/server navigation.
- Both Internet Explorer and the supplied, browser-independent WinCC Web Viewer (WinCC Viewer RT) can be used as a front end
- Access to WebNavigator Server of the WinCC V7.x series.

### Application

In addition to the typical use of the WebNavigator in WANs (Wide Area Networks), the WebNavigator can also be used to implement especially low-cost applications. This especially includes applications that have a pronounced distributed structure (water/wastewater, oil and gas), or in which access to process information is only sporadic (building management).

The WebNavigator also permits vertical integration, i.e. a networked IT landscape with integrated data flow between the planning and operating level of a company. Only a standard browser is required for direct access to current process information.

In addition to the standard WebNavigator licensing, there is the "Diagnostics Client" with identical functionality but different licensing. It is especially suitable for the following applications:

- Remote diagnostics/operation of several unmanned WinCC Runtime Professional stations
- Central control rooms that monitor several web servers via one user interface
- Maintenance personnel who require guaranteed access to the server at any time, regardless of the number of users already logged on to the server. On the server side, only one WebNavigator Diagnostics Server license or, alternatively, one Standard WebNavigator license is required.

### Design

#### Licenses for the WebNavigator

The WebNavigator Client software can be installed as many times as required without the need for a license.

- Server-based licensing
  - A license is required for using the WebNavigator Server.
  - Licenses are available for simultaneous access to the Web server by 3, 10, 25 or 50 clients.
- Diagnostics client licensing
  - For cost-optimized access by one or a small number of WebNavigator clients to numerous Web servers (e.g. for diagnostic purposes). This client license provides guaranteed access to Web servers at any time. In respect of function there is no difference compared with regular WebNavigator clients and the two can be mixed.

WebNavigator Clients are capable of accessing several different Web Servers.

#### Thin client solutions

The WebNavigator can also run under Windows Server 2003 or Windows Server 2008 terminal services. A Windows Server 2003 or Windows Server 2008 (or higher) operating system is required. This makes it possible to connect SIMATIC Thin Clients as visualization stations to WinCC Runtime Professional, for example.

For this purpose, the Windows terminal services must be installed on the PC on which the Web Client is installed. A Windows Server 2003 or Windows Server 2008 (or higher) operating system is required. Up to 25 thin clients can be connected to one terminal server.

Applications:

- Mobile devices
- Handhelds
- Rugged on-site visualizations

# HMI Software

## SIMATIC WinCC (TIA Portal) options

### WinCC WebNavigator

#### Design (continued)

##### Hybrid configuration

##### System requirements: WinCC WebNavigator – Server V12

- Windows 7 SP1 (32- and 64-bit) Business, Enterprise and Ultimate (max. 3 Clients)
- Windows XP Professional Service Pack 3 (max. 3 clients)
- Windows Server 2003 SP2
- Windows Server 2008 SP2 32-bit
- Windows Server 2008 R2 SP1 64-bit
- Internet Explorer V7.0, V8.0, V9.0
- Microsoft SQL Server 2008 R2 SP1 32-bit (included in the WinCC product delivery)
- WinCC Basic System V12

##### System requirements: WinCC WebNavigator – Client V12

- Internet Explorer 7, IE 8, IE9

##### System requirements: WinCC WebNavigator – Server V11

- Windows 7 (32-bit) Business, Enterprise and Ultimate (max. 3 clients)
- Windows XP Professional Service Pack 2 (max. 3 clients)
- Windows Server 2003 SP2 and Windows Server R2 SP2
- Windows Server 2008
- Internet Explorer 7 as well as Internet Explorer 8
- Microsoft SQL Server 2005 SP2 (scope of supply of WinCC)
- WinCC Runtime Professional V11

##### System requirements: WinCC WebNavigator – Client V11

- Internet Explorer 7 as well as Internet Explorer 8

#### Function

WinCC Professional makes setting up and configuring a WebNavigator server very easy. WinCC process screens to be visualized via the Internet are created as usual in WinCC Professional and the web access is activated via a process screen option. To display WinCC process screens on the web client, the Microsoft Internet Explorer or browser is used independent of the supplied WinCC Web Viewer (WinCC Viewer RT).

The operator on the Web Client is integrated in the central WinCC user administration and can operate and monitor the system according to the configured access rights. The WebNavigator supports all standard security mechanisms that can be used for applications on the Internet, e.g. routers, firewalls and proxy servers.

#### Ordering data

#### Order No.

##### SIMATIC WinCC WebNavigator for Runtime Professional

Single license, license key only on USB stick

- 3 clients, runtime software
- 10 clients
- 25 clients
- 50 clients
- 100 clients
- 150 clients

6AV2107-0KD00-0BB0  
6AV2107-0KF00-0BB0  
6AV2107-0KH00-0BB0  
6AV2107-0KK00-0BB0  
6AV2107-0KM00-0BB0  
6AV2107-0KP00-0BB0

##### SIMATIC WinCC WebNavigator for Runtime Professional Powerpacks

Single license, license key only on USB stick

- From 3 to 10 clients
- From 10 to 25 clients
- From 25 to 50 clients
- From 50 to 100 clients
- From 100 to 150 clients

6AV2107-2KF00-0BD0  
6AV2107-2KH00-0BD0  
6AV2107-2KK00-0BD0  
6AV2107-2KM00-0BD0  
6AV2107-2KP00-0BD0

##### SIMATIC WinCC WebNavigator Diagnostics Server/Client

Single license, license key only on USB stick

- WinCC WebDiagnostics Server for Runtime Professional, Runtime software
- WinCC WebDiagnostics Client for Runtime Professional, Runtime software

6AV2107-0KR00-0BB0

6AV2107-0KT00-0BB0

#### New type of delivery

##### Online software delivery (OSD) <sup>1)</sup>

##### WinCC WebNavigator for Runtime Professional

Single license, license key download only, e-mail address required for the delivery

- 3 clients
- 10 clients
- 25 clients
- 50 clients
- 100 clients
- 150 clients

6AV2107-0KD00-0BH0  
6AV2107-0KF00-0BH0  
6AV2107-0KH00-0BH0  
6AV2107-0KK00-0BH0  
6AV2107-0KM00-0BH0  
6AV2107-0KP00-0BH0

##### WinCC WebNavigator for Runtime Professional Powerpacks

Single license, license key download only, e-mail address required for the delivery

- 3 to 10 clients
- 10 to 25 clients
- 25 to 50 clients
- 50 to 100 clients
- 100 to 150 clients

6AV2107-2KF00-0BJ0  
6AV2107-2KH00-0BJ0  
6AV2107-2KK00-0BJ0  
6AV2107-2KM00-0BJ0  
6AV2107-2KP00-0BJ0

##### WinCC WebNavigator Diagnostics Server/Client

Single license, license key download only, e-mail address required for the delivery

- WinCC Web Diagnostics Server for Runtime Professional
- WinCC Web Diagnostics Client for Runtime Professional

6AV2107-0KR00-0BH0

6AV2107-0KT00-0BH0

A license is not required for the engineering system for configuring the runtime option.

<sup>1)</sup> Current information and availability regarding the new delivery package can be found at: <http://www.siemens.com/tia-online-software-delivery>

### Overview

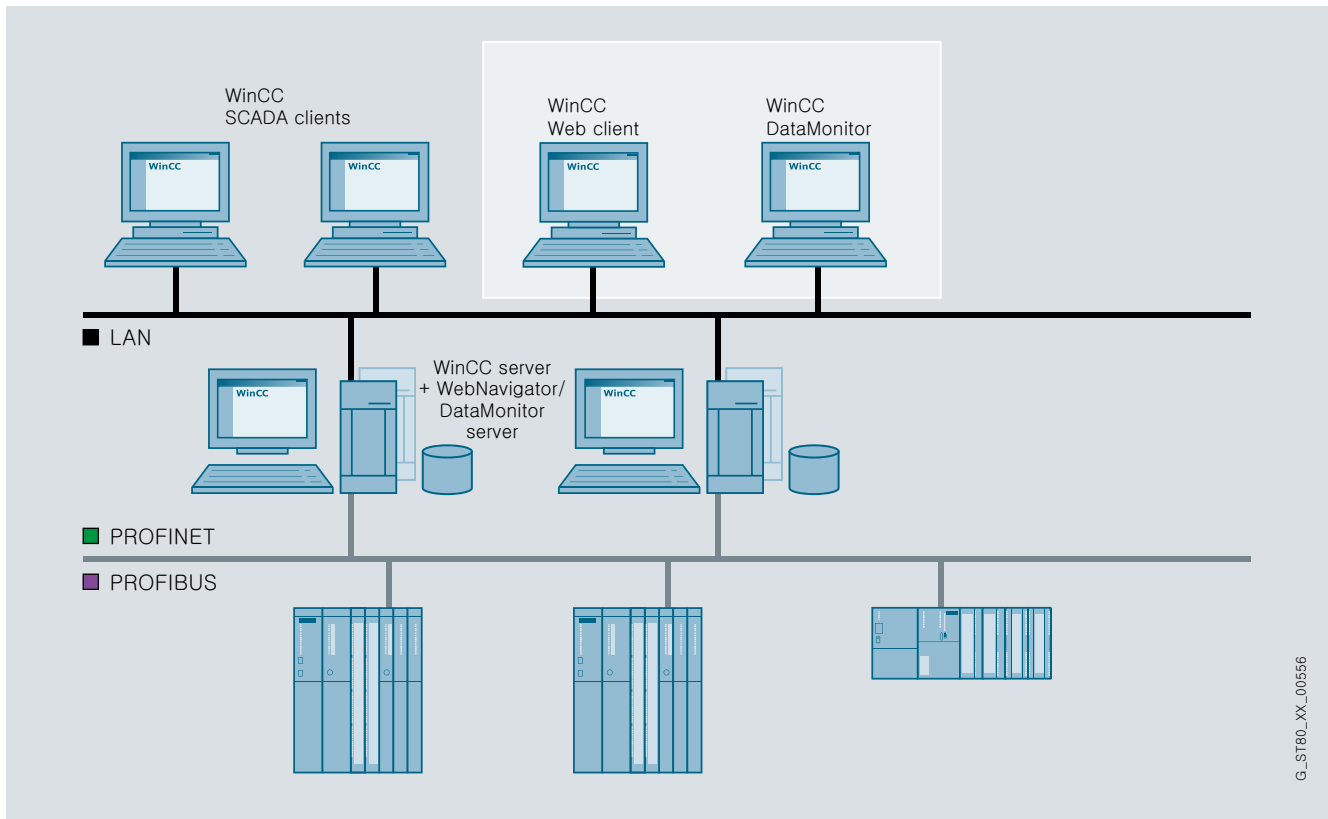

G\_ST80\_XX\_00556

4

- The WinCC DataMonitor is used for displaying and evaluating current process states and historical data on office PCs using standard tools such as Microsoft Internet Explorer or Microsoft Excel. In doing so, the DataMonitor client is supplied by a Web server with current and historic process data and alarms. All staff ranging from machine operators to corporate managers can use the DataMonitor to obtain information.
- DataMonitor is a suite of Internet-capable tools:
  - **Process Builder**  
Tool exclusively for monitoring and navigating via WinCC Runtime Professional screens using Internet Explorer (view only) or the WinCC Web Viewer (WinCCViewerRT)
  - **Excel Workbooks**  
Logging tool that integrates WinCC Runtime Professional Archive and online values into Microsoft Excel and supports online analysis
  - **Published Reports**  
Event or time-driven implementation of Excel or PDF reports for the output of process data and analysis results
  - **Webcenter**  
Individual configuration of Internet pages and summary of information within a portal with reference to WinCC Runtime Professional applications
  - **Trends and Alarms**  
(tables and graphs) are preconfigured Webcenter pages
- DataMonitor does not require manual client installation because it loads the required components from the web server.
- There is no installation required on the client for the Webcenter and Trends and Alarms functions.
- Licensing:
  - Licenses for access by 1, 3, 10, 25, or 50 DataMonitor clients are available.
  - Any combination of DataMonitor and WebNavigator licenses can be used in an application.

**Note:**

When accessing the operator stations via the WinCC DataMonitor option, suitable protective measures (including IT security such as network segmentation) should be taken in order to ensure safe operation of the system.

You will find more information on the topic of Industrial Security on the Internet at:

<http://www.siemens.com/industrialsecurity>

# HMI Software

## SIMATIC WinCC (TIA Portal) options

### WinCC DataMonitor

#### Benefits

- Information can be compiled online individually during runtime via the Internet/Intranet.
- Efficiently monitor and analyze production lines.
  - Display and evaluation of current process states and historical data on remote office PCs with standard tools such as Microsoft Internet Explorer or Excel.
  - Easy access to production data via the Intranet or Internet
  - Quick ascertainment of the production situation
- Easily collect and distribute information.
  - Automated report creation
  - No additional configuration effort through direct use of screens from the WinCC project
  - No training required for standard products
  - Easy exchange of configuration data
- Substantiate decisions with reports.
  - Evaluation via ready-made templates for special analyses of the business processes (e.g. reports, statistics)
  - Display bottlenecks transparently
  - Individual views for user and situation
  - Relative and absolute timeframe for information generation
- View production status anywhere and anytime.
  - Individual views of information in production
  - View the process and system operation
  - Historical data can be compiled online individually

#### Highlights:

- With the Webcenter function, WinCC Runtime Professional archive tags can be accessed without changing the configuration system.
- Dedicated Internet pages can be created for displaying data with the Webcenter. For this purpose, the following tools, which can be integrated in the Internet sites, are available.
  - Bar chart, pie chart, trend curve display
  - Process value table and statistics functions for the process values
  - Alarms, hit list for alarms
  - Message text display for individual message texts, message display, selection list of created reports,
  - Links to internal and external pages
  - Display of graphics in jpg format
  - Representation of the WinCC Runtime Professional process screens
- The analyses can be made with relative or absolute time specification. This enables comparisons of identical time periods on different days.
- Reports generated with Excel or with WinCC Professional can be made available on the DataMonitor server or e-mailed automatically to the relevant group of people based on time intervals or triggered by events.
- Connections to WinCC Runtime Professional and to swapped out archives can be established
- Support of Microsoft Internet Explorer version, including "tabbed browsing".

#### Function

- All tools are fully Internet-compatible and, therefore, support access via any type of connection (LAN, GSM, radio, modem, Internet, etc.).
- All popular security mechanisms such as login/password, firewalls, encryption, etc. are supported.
- Users can combine the available tools at will. Licensing only takes into account simultaneous access to one Web server.
- For display purposes, screens from the WinCC project can be used or special overview displays configured. Animations, scripts, navigation and access rights remain valid.
- The WinCC DataMonitor supports a display function only.
- Company-wide Excel reports, which contain historical and current process values, can be stored centrally for general access (reports, statistics). However, local queries to meet individual requirements can be compiled and executed online. Plot and tabular representation are supported for archive data already swapped out.
- Data can be automatically entered into created report templates and distributed by e-mail.
- Pre-made elements make the assembly of individual web pages easier for evaluating information.
- Individual information compilation on one or more Internet pages with the option of branching to other detail pages.
- Pre-made Internet pages for trend and alarm display enable an ad-hoc entry to Internet data evaluation.
- An higher-level navigation feature provides a common framework for the various tools.
- Enhanced user management for the web center in order to assign individual Internet pages and created reports to specific user groups.
- A search function facilitates the management of connections to the WinCC server.
- Swapped out archives can be connected and evaluated in the DataMonitor WebCenter.
- Excel reports created offline can be loaded onto the DataMonitor server and are thus made available to selected user groups or for automatic distribution.

Ordering data	Order No.	Order No.
<b>SIMATIC WinCC DataMonitor for Runtime Professional</b> Single license, license key only on USB stick <ul style="list-style-type: none"> <li>• 1 client</li> <li>• 3 clients</li> <li>• 10 clients</li> <li>• 25 clients</li> <li>• 50 clients</li> </ul>	<b>6AV2107-0LB00-0BB0</b> <b>6AV2107-0LD00-0BB0</b> <b>6AV2107-0LF00-0BB0</b> <b>6AV2107-0LH00-0BB0</b> <b>6AV2107-0LK00-0BB0</b>	<b>Online Software Delivery (OSD) <sup>1)</sup></b> <b>SIMATIC WinCC DataMonitor for Runtime Professional</b> Single license, license key download only, e-mail address required for the delivery <ul style="list-style-type: none"> <li>• 1 client</li> <li>• 3 clients</li> <li>• 10 clients</li> <li>• 25 clients</li> <li>• 50 clients</li> </ul>
<b>SIMATIC WinCC DataMonitor for Runtime Professional Powerpacks</b> Single license, license key only on USB stick <ul style="list-style-type: none"> <li>• From 1 to 3 Clients</li> <li>• From 3 to 10 Clients</li> <li>• From 10 to 25 Clients</li> <li>• From 25 to 50 Clients</li> </ul>	<b>6AV2107-2LD00-0BD0</b> <b>6AV2107-2LF00-0BD0</b> <b>6AV2107-2LH00-0BD0</b> <b>6AV2107-2LK00-0BD0</b>	<b>SIMATIC WinCC DataMonitor for Runtime Professional Powerpacks</b> Single license, license key download only, e-mail address required for the delivery <ul style="list-style-type: none"> <li>• From 1 to 3 clients</li> <li>• From 3 to 10 clients</li> <li>• From 10 to 25 clients</li> <li>• From 25 to 50 clients</li> </ul>
		<b>6AV2107-0LB00-0BH0</b> <b>6AV2107-0LD00-0BH0</b> <b>6AV2107-0LF00-0BH0</b> <b>6AV2107-0LH00-0BH0</b> <b>6AV2107-0LK00-0BH0</b>  <b>6AV2107-2LD00-0BJ0</b> <b>6AV2107-2LF00-0BJ0</b> <b>6AV2107-2LH00-0BJ0</b> <b>6AV2107-2LK00-0BJ0</b>

A license is not required for the engineering system for configuring the runtime option.

<sup>1)</sup> Current information and availability regarding the new delivery package can be found at: <http://www.siemens.com/tia-online-software-delivery>

# HMI Software

## SIMATIC WinCC (TIA Portal) options

### WinCC ControlDevelopment

#### Overview

You use the ControlDevelopment option to create your own .net controls for controlling and monitoring processes. You can use the controls in screens for WinCC Runtime Advanced and WinCC Runtime Professional. You create the controls based on the standard controls from Visual Studio 2005/2008 Professional .net.

Application examples:

- Special trend views
- Own recipe managements
- Complex display objects

#### Benefits

The ControlDevelopment option enables user-specific software solutions based on a proven building block principle:

- Lower development overhead by using standards (Visual Studio 2005/2008 Professional .net)
- Very short "Time-to-Market" resulting in a competitive advantage
- Utilization of tried components and proven industrial functionality

The development of proprietary controls for WinCC Runtime Advanced and WinCC Runtime Professional does not require expensive, special hardware.

#### Ordering data

#### Order No.

##### WinCC ControlDevelopment V12

- Runtime license, single license, software and documentation on CD
- Runtime software, single license, software download (e-mail address required for the delivery) <sup>1)</sup>

**6AV2107-0TA02-0DA8**

**6AV2107-0TA02-0DG8**

<sup>1)</sup> Current information and availability regarding the new delivery package can be found at:  
<http://www.siemens.com/tia-online-software-delivery>

#### More information

Further information can be found in the Internet at:  
<http://www.siemens.com/tia-portal>



#### Overview

SIMATIC offers numerous reasons for corporate energy management in industrial plants.

However, there is one in particular:

It makes an important contribution towards improving plant productivity. This results in enhanced competitiveness. Energy management with SIMATIC makes energy flows transparent in production plants. This supports the analysis and derivation of energy saving potential.

The result:

Permanently increased efficiency, higher productivity and an improved cost situation.

# HMI Software

## Software for energy management

### SIMATIC B.Data

#### Overview

#### **SIMATIC B.Data V5.3 SP2 Energy Management System**

SIMATIC B.Data is a modular, cross-sector energy management system for industrial firms.

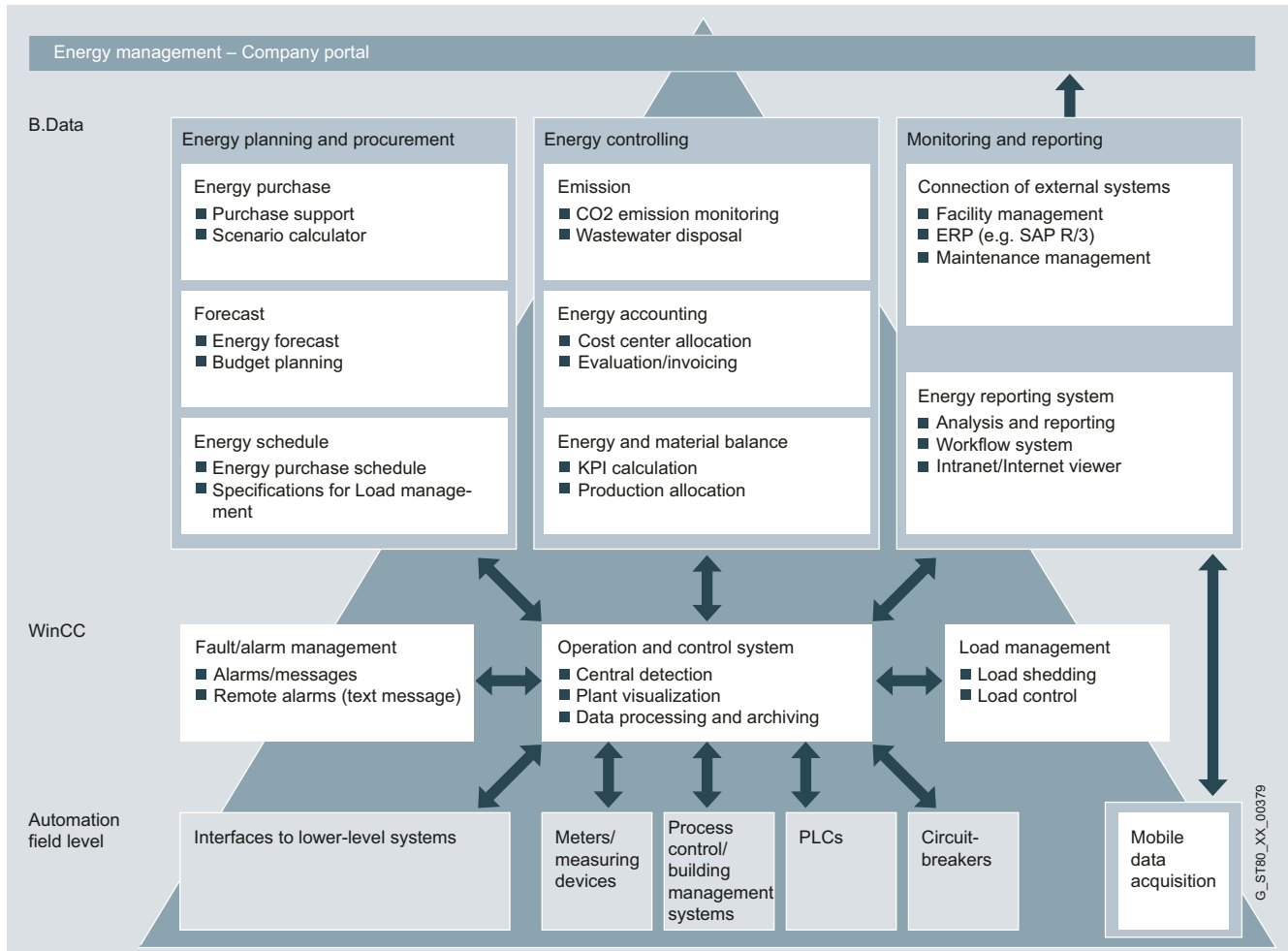

#### Benefits

The option SIMATIC B.Data forms the basis of a cost-effective energy management system for reducing energy costs and increasing energy efficiency, and it confers the following immediate benefits:

- It creates company-wide transparency, thanks to continuous energy balancing and materials balancing for the power generation systems and loads
- It allows energy costs to be allocated according to the costs-by-cause principle and permits transfer to the billing system (e.g. SAP R/3 CO)
- It generates characteristic values for well-informed suggestions for increasing the efficiency of power generation systems and loads
- It provides planning reliability thanks to production-related load and demand forecasts
- It supports purchasing with cost-optimized energy procurement
- It fulfills the legal obligations for monitoring and reporting on greenhouse gas emissions (CO2 emissions)
- It relieves personnel of extra work through automatically updating internal and external energy reports
- It supports customers in the continuous improvement of energy efficiency (e.g. ISO 50001) by integrated project management for energy efficiency measures

### Design

#### **SIMATIC B.Data V5.3 SP2 Basic System**

The B.Data Basic System is available in variants for 100, 500, 1 000 and 30 000 tags and comprises the following components:

- A B.Data acquisition component (WinCC, OPC, etc.)
- A B.Data Client
- B.Data Mobile
- ERP interface
- Reporting, Trender, Visu, document management, Matrix, KPI, Profile

#### **SIMATIC B.Data Software Update Service (SUS)**

For each B.Data Basic System there is a corresponding SUS (Software Update Service), which is dependent on the number of tags. The SUS is valid for 1 year. The contract is automatically extended by 1 more year unless canceled 3 months prior to expiration.

#### **SIMATIC B.Data V5 Expansions**

The scope of B.Data can be extended by purchasing add-on packages:

- B.Data Web Server
- B.Data Client
- B.Data Energy Forecasting and Planning
- B.Data Acquisition Component

### Function

#### **Acquisition and pre-processing of energy and operating data from WinCC**

- In addition to an interface to WinCC, SIMATIC B.Data also offers the latest interface standards such as OPC, ODBC, ASCII, or XML
- Preprocessing of energy data in a real-time calculation core that can be freely modeled including a formula editor for defining and configuring new calculation functions (heat calculations for boilers, quality for cogeneration plants, etc.)
- B.Data Mobile for mobile recording of energy data including route planning for meter reading operations
- Management and analysis of energy data
- Automatic plausibility check and generation of simulated values
- Long-term archive with versioning, compression and consolidation functions
- Measured value editor for entering and processing energy and operating values
- Trender for presenting up-to-date (online) and historical load curves (trends), also for setpoint/actual value analyses
- Energy management dashboards for creating cross-company transparency through visualization of parameters and display of Sankey diagrams.

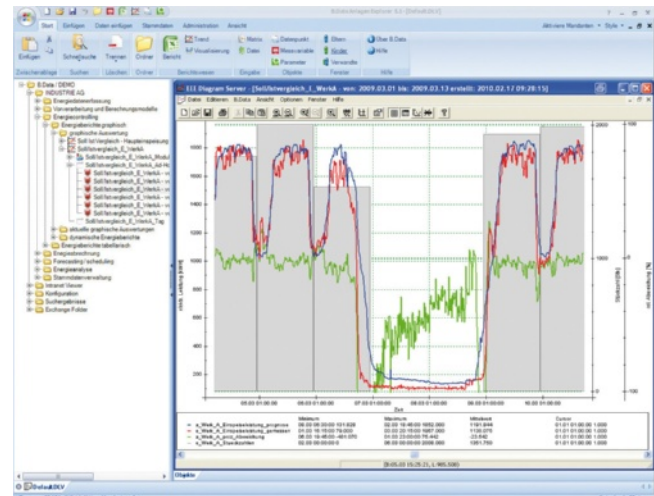

# HMI Software

## Software for energy management

### SIMATIC B.Data

**Function** (continued)

**Energy and material balance**

Freely parameterizable balancing of the energy flows of various media such as electricity, heat, gas, steam, and emissions (CO2) in the B.Data Plant Explorer

- Calculation of characteristic values (KPIs, efficiency coefficients, etc.) with direct reference to production (batches, quantities, etc.).

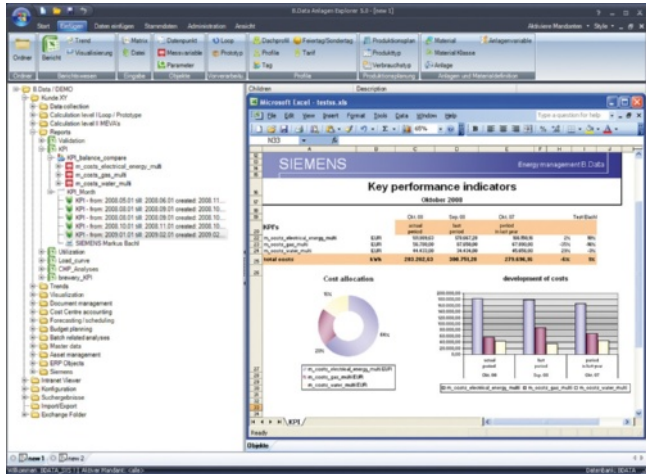

**Energy planning**

- Generation of requirement forecasts based on production-dependent factors (production planning) and basic load profiles (typical days)
- Generation of energy schedules for registering with the energy suppliers. Energy reporting
- Freely parameterizable report generator for creating balances, protocols, shift logs, bills
- Fully automated reporting with task management, e-mail dispatch and document management
- B.Data Intranet/Internet viewer (web client) for company-wide viewing of reports and results
- Information about discrepancies from specified parameters through KPI warning system

4

**Energy accounting (costs and revenue accounting)**

Calculation and allocation/assignment of energy costs to plants and/or customers/cost units in accordance with the costs-by-cause principle. The bottom up (measurement) and top down (allocation) procedures are supported here

- Flexible modeling of the hierarchic accounting structures in the Plant Explorer
- Tariff allocation of quantities, flexible price assessment with tariff and price time series
- Transfer of costs/revenues to the ERP system (e.g. SAP R/3 CO)

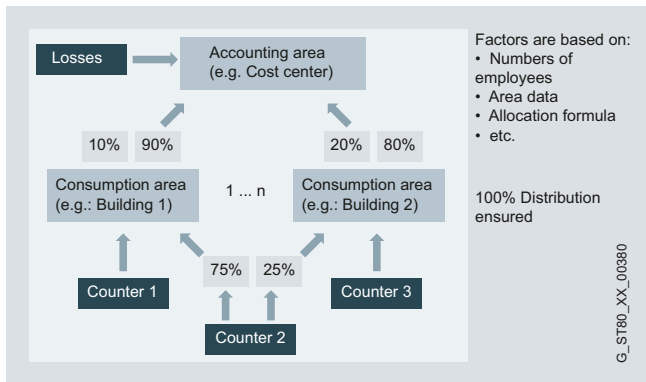

Technical specifications	Ordering data	Order No.
<p><b>SIMATIC B.Data V5.3 SP2</b><sup>2)</sup></p> <p><b>Operating system</b></p> <ul style="list-style-type: none"> <li>Windows Server 2003 SP2 32 bit Eng./Ger.</li> <li>Windows Server 2008 Std. Edition 32 bit Eng./Ger.</li> <li>Windows Server 2008 R2 Eng./Ger.</li> <li>Windows XP Professional SP3 32 bit Eng./Ger.</li> <li>Windows 7 Professional/Ultimate 32 bit/64 bit Eng./Ger.</li> <li>Minimum of 2 GB RAM</li> </ul> <p><b>Interface</b></p> <p>In addition to an interface to WinCC, B.Data also offers the latest interface standards, such as OPC, ODBC, ASCII and XML.</p> <p><b>WinCC versions</b><sup>1)</sup></p> <ul style="list-style-type: none"> <li>SIMATIC WinCC V7.0 SP3, V7.2</li> <li>SIMATIC WinCC RT Professional V11 SP2, V12</li> </ul> <p><b>PCS 7 versions</b><sup>3)</sup></p> <ul style="list-style-type: none"> <li>SIMATIC PCS 7 V8.0 SP1</li> </ul>	<p><b>SIMATIC B.Data V5.3 SP2 Basic System</b></p> <p>In the basic system of B.Data, the following components are already included:</p> <p>One B.Data acquisition component (WinCC, OPC, etc.), 1 B.Data client, B.Data Data Mobile, ERP interface, Reporting, Trender, Visu, document management, Matrix, KPI, Profile</p> <ul style="list-style-type: none"> <li>Basic system, 100 tags<sup>1)</sup></li> <li>SUS for 100 tags<sup>2)</sup></li> <li>Basic system, 500 tags<sup>1)</sup></li> <li>SUS for 500 tags<sup>2)</sup></li> <li>Basic system, 1 000 tags<sup>1)</sup></li> <li>SUS for 1 000 tags<sup>2)</sup></li> <li>Basic system, 30 000 tags<sup>1)</sup></li> <li>SUS for 30 000 tags<sup>2)</sup></li> </ul>	<p><b>6AV6372-1DF05-3AX0</b></p> <p><b>6AV6372-1DF00-0AL1</b></p> <p><b>6AV6372-1DF05-3BX0</b></p> <p><b>6AV6372-1DF00-0BL1</b></p> <p><b>6AV6372-1DF05-3CX0</b></p> <p><b>6AV6372-1DF00-0CL1</b></p> <p><b>6AV6372-1DF05-3DX0</b></p> <p><b>6AV6372-1DF00-0DL1</b></p>
	<p><b>SIMATIC B.Data V5 Powerpack</b></p> <ul style="list-style-type: none"> <li>Basic system, Powerpack<sup>1)</sup></li> <li>Tag upgrade by 1 level</li> <li>SUS and support contract for Powerpack<sup>2)</sup></li> </ul>	<p><b>6AV6372-1DF05-3XX0</b></p> <p><b>6AV6372-1DF00-0XL1</b></p>
<p><b>SIMATIC B.Data V5.3 Trial License</b></p> <p>Basic System, 90 days<sup>5)</sup></p>	<p><b>SIMATIC B.Data V5.3 Trial License</b></p>	<p><b>6AV6372-1DF15-3AX0</b></p>
<p><b>SIMATIC B.Data V5 Expansions</b><sup>3)</sup></p> <p>The functional scope of B.Data can be expanded with the following packages.</p>	<p><b>SIMATIC B.Data V5 Expansions</b><sup>3)</sup></p>	
<p><b>SIMATIC B.Data Web Server</b></p> <ul style="list-style-type: none"> <li>incl. 3 web clients</li> <li>incl. 20 web clients</li> </ul>	<p><b>SIMATIC B.Data Web Server</b></p>	<p><b>6AV6372-1DF25-2AX0</b></p> <p><b>6AV6372-1DF25-2BX0</b></p>
<p><b>SIMATIC B.Data Client</b></p>	<p><b>SIMATIC B.Data Client</b></p>	<p><b>6AV6372-1DF35-2AX0</b></p>
<p><b>SIMATIC B.Data Prognosis &amp; Planning</b></p>	<p><b>SIMATIC B.Data Prognosis &amp; Planning</b></p>	<p><b>6AV6372-1DF45-2AX0</b></p>
<p><b>SIMATIC B.Data Acquisition Component</b></p>	<p><b>SIMATIC B.Data Acquisition Component</b></p>	<p><b>6AV6372-1DF55-2AX0</b></p>
<p><b>SIMATIC B.Data upgrades</b></p> <ul style="list-style-type: none"> <li>SIMATIC B.Data 100 tags, upgrade V5.2 -&gt; V5.3 SP2<sup>4)</sup></li> <li>SIMATIC B.Data 500 tags, upgrade V5.2 -&gt; V5.3 SP2<sup>4)</sup></li> <li>SIMATIC B.Data 1 000 tags, upgrade V5.2 -&gt; V5.3 SP2<sup>4)</sup></li> <li>SIMATIC B.Data 30 000 tags, upgrade V5.2 -&gt; V5.3 SP2<sup>4)</sup></li> </ul>	<p><b>SIMATIC B.Data upgrades</b></p>	<p><b>6AV6372-1DF05-3AX4</b></p> <p><b>6AV6372-1DF05-3BX4</b></p> <p><b>6AV6372-1DF05-3CX4</b></p> <p><b>6AV6372-1DF05-3DX4</b></p>

<sup>1)</sup> If an acquisition computer is installed on a WinCC system, these requirements must also be complied with.

<sup>2)</sup> The SIMATIC B.Data V5.3 Basic System is delivered with an Oracle Database Standard Edition Embedded. For larger quantity frameworks (as of 250 million stored measured values), you need Oracle Database Enterprise Edition with Partitioning Option, which must be ordered separately from Oracle.

<sup>3)</sup> The SIMATIC B.Data system for connection to the PCS 7 must always be installed on a separate PC.

### More information

Further information can be found on the Internet at:  
[www.siemens.com/simatic-bdata](http://www.siemens.com/simatic-bdata)

<sup>1)</sup> The SIMATIC B.Data V5.3 Basic System is delivered with an Oracle Database Standard Edition Embedded. For larger quantity frameworks (as of approx. 250 million stored measured values), you need Oracle Database Enterprise Edition with Partitioning Option, which must be ordered separately from Oracle.

<sup>2)</sup> The SUS contract runs for 1 year. The contract is automatically extended by a further year unless canceled 3 months prior to expiration.

<sup>3)</sup> B.Data expansions can also be used with B.Data V5.2 (SP1).

<sup>4)</sup> The upgrades are delivered without Oracle Database Standard Edition Embedded.

<sup>5)</sup> The trial DVD can also be used to upgrade V5.3 SP1 -> V5.3 SP2.

# HMI Software

## Software for energy management

### SIMATIC powerrate

#### Overview

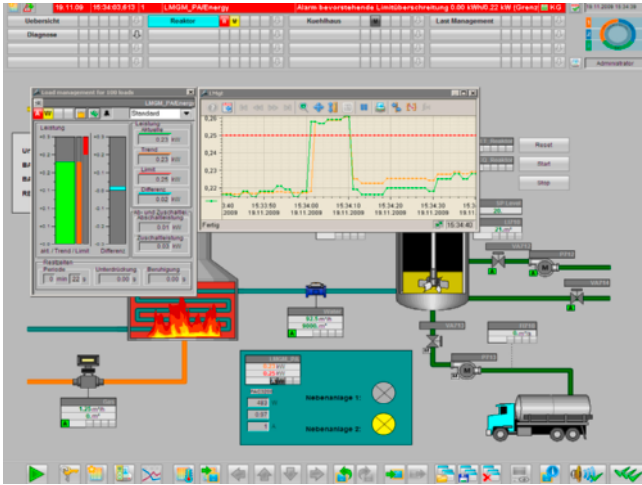

SIMATIC powerrate, as an option for WinCC / PCS 7, ensures transparency in energy consumption from the infeed to the load.

SIMATIC powerrate is used in all sectors in which WinCC or PCS 7 are deployed and energy efficiency considerations play a major role.

Total integration into WinCC or PCS 7 means that there is no need for a special system environment. Predefined modules and symbols give you the assurance of building on tested product components, with interfaces that support customized expansion.

SIMATIC powerrate therefore provides a solution that you can use to obtain an overview of the energy consumption of a plant easily and cost-effectively through integration in an existing SIMATIC SCADA system.

#### Benefits

- Identification of energy-intensive equipment and processes to develop measures for improving energy efficiency.
- Comparison of consumption profiles for more efficient processes.
- Optimization of the company according to energy parameters, based on an evaluation of consumption and costs.
- Compliance with the contractually agreed power limits, thus preventing higher power supply costs or penalty payments.
- Integration of the 7KM PAC3200/4200 measuring devices for a clear overview of selected measured values and alarms.
- Integration of switches with an overview of the switch status and the switching possibilities.
- Accurate assignment and comparison of the consumption data of specific work processes or batches

#### Design

SIMATIC powerrate comprises the following components:

- Blocks for acquiring and conditioning energy data
- Faceplates for displaying and editing energy data
- Blocks for implementing load management (calculating the trend, monitoring the limit, releasing/inhibiting loads), batch-related consumption recording and for integrating measuring instruments and switches
- Additional blocks – for example, for time synchronization, data backup, data exchange with archives
- Faceplates for displaying results and entering values (e.g. for configuration, or manually measured values)
- Excel-based reports for allocating energy data to cost centers, for batch-related evaluation and for determining and displaying the load duration curve
- Exporting data to Excel

### Function

#### Acquiring and conditioning energy data

Using ready-to-use function blocks, energy data can be acquired by any PROFIBUS-capable devices. The data can be input to the function blocks in the form of counter pulses, count values or power values. Count values can also be entered manually.

From this data, the function block calculates the power averages and the work values for a predefined period. This calculated data is subsequently saved in the WinCC archive. In addition, a final value forecast is extrapolated for the power values for each period.

A sample function (heat calculation) that can be adapted to the needs of the customer at any time by means of open interfaces has been implemented for the purpose of visualizing customized calculations.

Data from manually read counters can be entered directly into the system and used for further analysis. Absolute numerical values (entry of an absolute value instead of the difference from the previous value) can also be recorded and used in further processing.

The up-to-date, acquired energy data is displayed as power averages/work values for each time interval (total value for the previous interval, current value of the current interval, extrapolated value for the end of the current interval). A load trend display enables analysis of archived energy data as well as its representation in tables.

The archived data can be exported to Excel directly from WinCC using the export functions. The exported energy data can also be included in further customized processing. WinCC tools can be used to access the data from the WinCC archive.

For this purpose, selected energy data is read from archives (Tag Logging archive, user archives) from the WinCC Runtime database; using Microsoft Excel the following reports can then be generated:

- **Cost center report**  
Here the consumption can be allocated to different cost centers and the costs can be calculated on the basis of predefined tariffs. The results can be output by means of 2 reports in the form of tables or diagrams.
- **Load duration curve**  
An analysis is carried out on the basis of the archived power averages to establish how often a certain power average has occurred in a given period. It can be quickly detected from this characteristic curve whether temporary power peaks exist which can represent a possible starting point for cost savings by means of load management.
- **Batch report**  
This is used to allocate consumption to batches, whereby the data can be presented in chronological order or in order of batch name.

The generation of exports or reports can be activated manually or automatically time-controlled (daily, weekly or monthly). Data access and report generation can also take place via a separate "office" PC; which enables the WinCC installation and the "office" applications to be distributed across different PCs.

Contractually agreed power limits (in the case of electricity, normally the 15-minute average power value) must be observed, otherwise significantly higher supply prices or even penalty payments may become due to the energy supply company. The load management feature of SIMATIC powerrate carries out cyclic trend calculations in order to issue warnings/alarms if violation of the limit is likely and to switch off loads in accordance with the given configuration should this be required. If a limit is exceeded despite this, the latest load management data is archived to enable future evaluation or analysis.

To prevent unnecessary switching operations, numerous parameters are available for adapting the load management to the current process conditions - and all this can be done easily and conveniently via the faceplate.

For loads that are distributed over different PLCs, SIMATIC powerrate contains appropriate PLC-to-PLC communication blocks which can be used to integrate these loads into the load management system. Load management is scalable, according to the maximum number of loads to be integrated or monitored, for up to 10, 25, 50, 75 or 100 loads. Load management can be performed for different media (e.g. electricity, gas) simultaneously.

A batch comprises all the units of a product that have been produced in one production cycle, i.e. under identical conditions. Batch-related consumption recording allows accurate recording of energy consumption for each batch. Batch-related consumption recording is possible for five types of energy each with up to 10 loads. Appropriate reports can be generated for analysis of the data (see also the batch report).

If the 7KM PAC3200/PAC4200 measuring devices are integrated, selected measured values can be displayed and alarms (current, voltage, pulse frequency too high) can be generated from the digital status information and displayed.

Switch integration via digital inputs/outputs (DI/DO) supports display of the switch status (On, Off, tripped, unplugged).

With the appropriate authorization, switching is also possible via the faceplate. Switching takes place in a 2-step operation (switch command is issued, followed by a prompt for repeated confirmation; the switch command is not forwarded to the switch until confirmation has been received).

Support for the WinCC Web Navigator option also makes the powerrate functionality possible via the web.

To avoid data loss in the event of a communication fault, the data is stored temporarily in a circulating buffer on the S7.



# HMI Software

## Software for energy management

### SIMATIC powerrate

#### Technical specifications

SIMATIC powerrate V4.0 SP1	
<b>Hardware requirements</b>	
SIMATIC powerrate can be used in the PCS 7 or WinCC SCADA environments. For installation, the respective hardware requirements of the following products apply:	<ul style="list-style-type: none"> <li>• PCS 7</li> <li>• STEP 7 and WinCC SCADA</li> </ul>
Released CPUs - SIMATIC powerrate is released in the PCS 7 environment for	<ul style="list-style-type: none"> <li>• S7-400 CPUs supported by PCS 7</li> <li>• WinAC RTX 2010</li> </ul>
Released CPUs - SIMATIC powerrate is released in the WinCC SCADA environment for	<ul style="list-style-type: none"> <li>• S7-400</li> <li>• S7-300</li> <li>- SIMATIC S7 CPU 319-3 PN/DP V2.5 and higher</li> <li>- SIMATIC S7 CPU 317-2 PN/DP V2.6 and higher</li> <li>- SIMATIC S7 CPU 315-2 PN/DP V3.1 and higher</li> <li>• SIMATIC ET 200S IM151-8 PN/DP CPU V3.2 and higher</li> <li>• WinAC RTX 2010</li> </ul>
<b>Software requirements</b>	
You can use SIMATIC powerrate in the PCS 7 or WinCC SCADA environments. For installation, the respective software requirements of the following products apply:	<ul style="list-style-type: none"> <li>• PCS 7</li> <li>• STEP 7 and WinCC SCADA</li> </ul>
The library is released for the following PCS 7 versions	<ul style="list-style-type: none"> <li>• SIMATIC PCS 7 V8.0 with Update 1 (Europe &amp; ASIA)</li> <li>• SIMATIC PCS 7 V7.1 SP3</li> </ul>
The library is released for the following WinCC version with the corresponding versions of STEP 7	<ul style="list-style-type: none"> <li>• SIMATIC WinCC V7. 0 SP3, SP3 with Update 1 (Europe &amp; ASIA)</li> </ul>
For use with WinCC V7.0 SP3, the following installations are required	<ul style="list-style-type: none"> <li>• WinCC minimum installation               <ul style="list-style-type: none"> <li>- Basic Process Control</li> <li>- User archives for load management and batch-oriented energy acquisition</li> </ul> </li> <li>• WinCC add-on "AS-OS Engineering" For the use of SIMATIC powerrate V4.0, WinCC must execute in integrated mode with STEP 7.</li> <li>• SIMATIC NET</li> <li>• STEP 7</li> </ul>
powerrate Reports has been released for the following versions	<ul style="list-style-type: none"> <li>• Microsoft Excel 2003</li> <li>• Microsoft Excel 2007</li> <li>• Microsoft Excel 2010</li> </ul>

#### Ordering data

#### Order No.

<b>SIMATIC powerrate V4.0 SP1 ES + OS Runtime</b> <sup>1)</sup> Also included are <ul style="list-style-type: none"> <li>• License for user/archive</li> <li>• PAC3200 function block library for WinCC</li> <li>• Block library PAC3200, 3WL/3VL for PCS 7</li> </ul>	<b>6AV6372-1DE04-0AX0</b>
<b>SIMATIC powerrate V4.0 SP1 upgrade</b> Upgrade V3.0 SP1 to V 4.0 SP1, ES + OS-RT <sup>1)</sup>	<b>6AV6372-1DE04-0AX4</b>
<b>SIMATIC powerrate V4.0 SP1 update</b> Update V4.0 to V 4.0 SP1	<b>6AV6372-1DE04-0AX3</b>
<b>SIMATIC powerrate V4.0 SP1 trial license</b> Limited 30-day ES + OS Runtime license	<b>6AV6372-1DE04-0AX7</b>

<sup>1)</sup> For operation on a WinCC/PCS 7 OS single-user workstation or server and any number of automation systems. When using additional WinCC/PCS 7 OS single-user stations/servers, one license is required per WinCC/PCS 7 OS single-user station/server.

#### More information

Further information can be found on the Internet at:  
<http://www.siemens.com/simatic-powerrate>

Important information on the use of SIMATIC powerrate is available on the Internet at:  
<http://support.automation.siemens.com/WW/view/en/48204134/133200>

### Overview

#### ***SIMATIC WinCC flexible ES engineering software***

- Family of configuration systems with WinCC flexible Micro/Compact/Standard/Advanced for SIMATIC operator panels, the HMI part of SIMATIC C7 as well as for the PC-based visualization software WinCC flexible Runtime
- Runs under Windows XP Professional / Windows 7 Professional, Ultimate, Enterprise
- Can be expanded by the option "WinCC flexible /ChangeControl" for version management and change logging

#### ***SIMATIC WinCC flexible Runtime visualization software***

- Modular PC-based HMI solution for single-user systems directly at the machine (further development of ProTool/Pro RT)
- Runs under Windows XP Professional / Windows 7 Professional, Ultimate, Enterprise
- Basic package for visualization, reporting and logging; can be expanded by implementing option packages
- Flexible expansion possible with VB scripts and customized ActiveX controls created with OPP (Open Platform Program)
- Can be integrated into automation solutions based on TCP/IP networks
- Expanded service concepts with remote operation, diagnostics and administration over the intranet and Internet in combination with email communication

# HMI Software

## SIMATIC WinCC flexible HMI system

### SIMATIC WinCC flexible ES

#### Overview

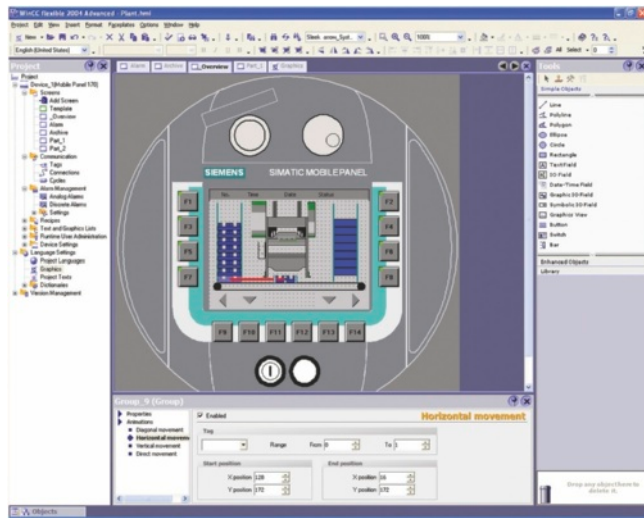

- Uniform family of engineering tools for configuration SIMATIC HMI Operator Panels, the operator control part of SIMATIC C7 units, SIMOTION/SINUMERIK Panel PCs as well as the PC-based visualization software WinCC flexible Runtime.
- Runs under Windows XP Professional / Windows 7 Professional, Ultimate, Enterprise
- Current version:
  - SIMATIC WinCC flexible 2008 SP3 Micro
  - SIMATIC WinCC flexible 2008 SP3 Compact
  - SIMATIC WinCC flexible 2008 SP3 Standard
  - SIMATIC WinCC flexible 2008 SP3 Advanced

#### Benefits

- The integrated configuration software reduces training, maintenance and service overhead and protects the customer's investments
- Minimized configuration overhead due to reuse of scalable and dynamizable objects
- Tools for efficient and simple configuration:
  - Wizard for defining the basic structure of the HMI project
  - Table-based editors simplify the generation and processing of similar types of object, e.g. for tags, texts, or alarms.
  - Complex configuration tasks such as the definition of paths of motion or the creation of the fundamental operator prompting are simplified by means of graphical configuration.
- Comprehensive support of multi-language configurations for worldwide use
  - Selectable views for entering configuration data in several languages
  - System and user-specific text lexicons
  - Export/import of language-dependent texts

#### Application

SIMATIC WinCC flexible Micro/Compact/Standard/Advanced are engineering tools for configuring SIMATIC HMI devices, the operating component of SIMATIC C7 devices, the SIMOTION/SINUMERIK Panel PCs as well as the PC-based visualization system WinCC flexible Runtime.

Depending on the selected product, various target systems can be configured:

##### WinCC flexible Micro

- Micro Panels: OP 73micro, TP 170micro, TP 177micro

##### WinCC flexible Compact

In addition to the target systems that are configured using WinCC flexible Micro:

- Basic Panels: KTP400 Basic, KTP600 Basic, KTP1000 Basic, TP1500 Basic
- Mobile Panels: Mobile Panel 170, Mobile Panel 177
- 70 series Panels: OP 73, OP 77A, OP 77B
- 170 series Panels: TP 170A, TP 177A, TP 170B, TP 177B, OP 170B, OP 177B
- 170 series Multi Panels: MP 177
- C7 devices: C7-635 (Touch/Key)

##### WinCC flexible Standard

In addition to the target systems that are configured using WinCC flexible Compact:

- Mobile Panels: Mobile Panel 277
- 270 series Panels: TP 270, TP 277, OP 270, OP 277
- 270 series Multi Panels: MP 270B, MP 277
- 370 series Multi Panels: MP 370, MP 377
- C7 devices: C7-636 (Touch/Key)

##### WinCC flexible Advanced

In addition to the target systems that are configured using WinCC flexible Standard:

- Standard PC
- SIMATIC Panel PC: Panel PC IL 70, Panel PC IL 77, Panel PC 477/477B, Panel PC 577/577B, Panel PC 670, Panel PC 677/677B, Panel PC 870, Panel PC 877
- SIMOTION Panel PC: P012K, P012T, P015K, P015T, PCR, PCR-Touch
- SINUMERIK Panel PC: HT8, OP08T, OP010, OP012, TP012, OP015, TP015, OP015A

For configuring panels released after the start of delivery of WinCC flexible 2008, an HSP (Hardware Support Package) is required that can be downloaded free of charge via the following link:

<http://www.siemens.com/wincc-flexible-hsp>

### Design

The engineering tools of the SIMATIC WinCC flexible range are based on one another. The available editors largely depend on the respectively configured target systems and their functions. A more comprehensive engineering tool such as WinCC flexible Standard also offers the facilities of the smaller engineering tools, e.g. WinCC flexible Compact or Micro.

Upgrading of a smaller engineering tool to a larger one is possible using a Powerpack. An exception is WinCC flexible Micro.

The scope of functions of the WinCC flexible engineering tools already includes project support for the Runtime options available for SIMATIC Panels or WinCC flexible Runtime, independent of the RT licenses purchased. Separate licensing is required for the target system in order to use the configured Runtime options.

### Function

#### Integration into automation systems

- Integration into SIMATIC STEP 7 V5.x and Simotion
  - Management of HMI projects within the SIMATIC Manager
  - Shared use of communication settings and process point definitions, i.e., symbols and messages
  - Display of the HMI configuring objects in the SIMATIC Manager
  - Transfer of configuring data via MPI/PROFIBUS/Ethernet using routing

#### Configuration interface

- Comprehensive and fast access to editors and project data via Workbench applications
- Adaptive user interface of engineering tools depending on configured target system
- User-definable user interface settings, e.g., layout, toolbars, object defaults

#### Project handling

- Device-independent configuration data can be used on a variety of target systems without the need for conversion; the interface adapts to the functional possibilities of the device currently configured.
- Cross-device utilization of common configuration data (e.g., text library) in multi-device projects
- Wizard-assisted definition of basic structure of HMI projects (e.g., display layout, operator prompting)

#### Screen editor with extensive options for efficient and fast screen configuration

- Generation of interconnected screen objects via Drag&Drop, e.g., tags for the creation of input/output fields with process interfacing or buttons with screen selection function
- Template for the definition of global screen objects and functions (comparable with the Slide Master in MS PowerPoint)
- User-friendly editor for the creation of image blocks with defined external interface from screen objects
- Graphics-based configuration of motion paths
- Layer technology with up to 32 layers
- Tools for the Align, Rotate and Mirror functions

#### Import/export

- of texts for translation
- of tags, links, text lists, and messages
- Generation of variable lists for importing from controller programming tools

#### Object-based data management with user-friendly search and edit options

- Cross-reference list with direct access to all objects, e.g. for editing or selection
- Search for objects in entire project
- Central reassignment of variables
- Text search and replace functions

#### Libraries for predefined/user-defined configuration objects

- Large number of scalable and dynamizable screen objects included in scope of delivery
- Size-scalable WMF-format graphics for industrial applications included in scope of delivery
- Preview function for library objects
- Storage of all engineering objects in library, e.g., blocks and even entire displays or variables; picture blocks can be created on a customer- or project-specific basis by combining simple screen objects. Changes to these picture blocks can be made centrally (block definition).

#### Language support

- Multilingual project creation (max. 32 languages) in editors thanks to selectable views
- Automatic translation on basis of system- and user-specific dictionaries in central text library
- Central management of language-specific texts and graphics in libraries
- Edit, export and import of texts for translation
- Language-specific graphics

#### Visual Basic Script support

- IntelliSense function for fast programming of access to runtime objects
- Simple creation of control sequences in script code;
- Script debugging in Simulator and WinCC flexible Runtime

#### Test and startup support

- Simulation of HMI projects on engineering PC
- Jump to error cause based on alarm messages in the Compiler
- Advanced ProSave service tool for all operating systems supported by WinCC flexible

#### ChangeControl (option)

- Version management of project versions with rollback
- Logging of configuration changes, e.g., for regulated industries

#### Note:

For further information, refer to "WinCC flexible options".

#### Default runtime data in engineering tools

- Users and passwords
- Recipe data records

# HMI Software

## SIMATIC WinCC flexible HMI system

### SIMATIC WinCC flexible ES

#### Technical specifications

System requirements (minimum requirements)	WinCC flexible Engineering Software
<b>Operating system</b>	Windows XP Professional SP3 (32 bit), Windows 7 Professional, Ultimate, Enterprise (32 and 64 bit)
	Additionally for SIMATIC WinCC flexible Micro: Windows XP Home SP3
<b>Processor</b>	Pentium 4 (or comparable) processor running at 1.6 GHz or faster
<b>Resolution</b>	1024 x 768 or higher
<b>Main memory (RAM)</b>	≥ 1 GB, ≥ 512 MB for WinCC flexible Micro
<b>Hard disk (free memory space) <sup>1)</sup></b>	≥ 2 GB <sup>2)</sup> ≥ 1.2 GB for WinCC flexible Micro <sup>3)</sup>
<b>DVD drive</b>	for software installation

- <sup>1)</sup> In addition to the space needed by WinCC flexible, Windows also requires space on the hard disk; e.g. for the swap file. The following formula has proven itself in the past: The size of the swap file = 3 x the size of available RAM. For further information, refer to your Windows documentation
- <sup>2)</sup> When installing one language. An additional 200 MB are required for each further language. In the case of different partitions for system and configuration: System partition approx. 700 MB, project partition approx. 1.3 GB.
- <sup>3)</sup> When installing one language. An additional 80 MB are required for each further language. In the case of different partitions for system and configuration: System partition approx. 600 MB, project partition approx. 600 MB.

#### Ordering data

#### Order No.

<b>WinCC flexible 2008 Micro incl. SP3</b> Single license, without license key software and documentation on DVD, without license key, contains: <ul style="list-style-type: none"> <li>• Engineering software for configuration of Micro Panels</li> <li>• Electronic documentation (.pdf)</li> </ul>	<b>6AV6610-0AA01-3CA8</b>
<b>WinCC flexible 2008 Compact incl. SP3</b> Floating license, license key on USB stick, software and documentation on DVD, contains: <ul style="list-style-type: none"> <li>• Engineering software for configuring Micro Panels, Basic Panels and 70/170 series Panels incl. C7-635</li> <li>• Software for WinCC flexible /ChangeControl engineering option <sup>1)</sup></li> <li>• Simulation software for Micro Panels, Basic Panels, and 70/170 series Panels incl. C7-635</li> <li>• Native drivers</li> <li>• Electronic documentation (.pdf)</li> </ul>	<b>6AV6611-0AA51-3CA5</b>
<b>WinCC flexible 2008 Standard incl. SP3</b> Floating license, license key on USB stick, software and documentation on DVD, contains: <ul style="list-style-type: none"> <li>• Engineering software for configuring Micro Panels, Basic Panels and 70/170/270/370 series Panels incl. C7-635/636</li> <li>• Software for WinCC flexible /ChangeControl engineering option <sup>1)</sup></li> <li>• Simulation software for Micro Panels, Basic Panels, and 70/170/270/370 series Panels incl. C7-635/636</li> <li>• Native drivers</li> <li>• Electronic documentation (.pdf)</li> </ul>	<b>6AV6612-0AA51-3CA5</b>

#### Order No.

<b>WinCC flexible 2008 Advanced incl. SP3</b> Floating license, license key on USB stick, software and documentation on DVD, contains: <ul style="list-style-type: none"> <li>• Engineering software for configuring WinCC flexible Runtime on basic PCs/Panel PCs as well as Micro Panels, Basic Panels and 70/170/270/370 series Panels incl. C7-635/636</li> <li>• Software for WinCC flexible /ChangeControl engineering option <sup>1)</sup></li> <li>• Simulation software for WinCC flexible Runtime as well as Micro Panels, Basic Panels, and 70/170/270/370 series Panels incl. C7-635/636</li> <li>• Native drivers</li> <li>• Electronic documentation (.pdf)</li> </ul>	<b>6AV6613-0AA51-3CA5</b>
<b>WinCC flexible /ChangeControl for WinCC flexible 2008 Compact/Standard/Advanced <sup>1) 2)</sup></b> Floating license, option, license key only	<b>6AV6613-6AA01-3AB5</b>
<b>Powerpacks</b> <b>SIMATIC WinCC flexible Powerpacks</b> Single license, license key only <ul style="list-style-type: none"> <li>• WinCC flexible 2008 Standard to 2008 Advanced</li> <li>• WinCC flexible 2008 Compact to 2008 Advanced</li> <li>• WinCC flexible 2008 Compact to 2008 Standard</li> </ul>	<b>6AV6613-2CD01-3AD5</b> <b>6AV6613-2BD01-3AD5</b> <b>6AV6612-2BC01-3AD5</b>
<b>Updates</b> <b>WinCC flexible 2008 Micro Update 2008, 2008 SP1, 2008 SP2 -&gt; 2008 SP3</b>	<b>6AV6610-0AA51-3CU8</b>
<b>WinCC flexible 2008 Compact/Standard/Advanced Update 2008, 2008 SP1, 2008 SP2 -&gt; 2008 SP3</b>	<b>6AV6613-0AA51-3CU8</b>

<sup>1)</sup> A separate license for WinCC flexible /ChangeControl must be purchased for each engineering station

<sup>2)</sup> The ChangeControl option has not been released for integrated operation with STEP 7

# HMI Software

## SIMATIC WinCC flexible HMI system

SIMATIC WinCC flexible ES

Ordering data	Order No.	Order No.
<b>Upgrades</b> <b>SIMATIC WinCC flexible 2004/2005/2007 to SIMATIC WinCC flexible 2008 incl. SP3</b> <ul style="list-style-type: none"> <li>• Upgrade to WinCC flexible 2008 Micro <sup>2)</sup></li> <li>• Upgrade to WinCC flexible 2008 Compact, incl. ChangeControl option <sup>1)</sup></li> <li>• Upgrade to WinCC flexible 2008 Standard, incl. ChangeControl option <sup>1)</sup></li> <li>• Upgrade to WinCC flexible 2008 Advanced, incl. ChangeControl option <sup>1)</sup></li> </ul>	<b>6AV6610-0AA01-3CE8</b>  <b>6AV6611-0AA51-3CE5</b>  <b>6AV6612-0AA51-3CE5</b>  <b>6AV6613-0AA51-3CE5</b>	<b>WinCC flexible 2008 ASIA Advanced incl. SP3</b> Floating license, license key on USB stick, software and documentation on DVD, contains: <ul style="list-style-type: none"> <li>• Engineering software for configuring WinCC flexible Runtime as well as Micro Panels, Basic Panels and 70/170/270/370 series Panels incl. C7-635/636</li> <li>• Software for WinCC flexible /ChangeControl engineering option <sup>1)</sup></li> <li>• Simulation software for WinCC flexible Runtime as well as Micro Panels, Basic Panels, and 70/170/270/370 series Panels incl. C7-635/636</li> <li>• Native drivers</li> <li>• Electronic documentation (.pdf)</li> </ul>
<b>SIMATIC WinCC flexible ASIA 2004/2005/2007 to SIMATIC WinCC flexible ASIA 2008 incl. SP3</b> <ul style="list-style-type: none"> <li>• Upgrade to WinCC flexible 2008 ASIA Standard, incl. ChangeControl option <sup>1)</sup></li> <li>• Upgrade to WinCC flexible 2008 ASIA Advanced, incl. ChangeControl option <sup>1)</sup></li> </ul>	<b>6AV6612-0AA11-3CE5</b>  <b>6AV6613-0AA11-3CE5</b>	<b>Documentation (must be ordered separately)</b>  <b>User Manual WinCC flexible Communication</b> <ul style="list-style-type: none"> <li>• German <b>6AV6691-1CA01-3AA0</b></li> <li>• English <b>6AV6691-1CA01-3AB0</b></li> <li>• French <b>6AV6691-1CA01-3AC0</b></li> <li>• Italian <b>6AV6691-1CA01-3AD0</b></li> <li>• Spanish <b>6AV6691-1CA01-3AE0</b></li> </ul>
<b>Versions for China/Taiwan/Korea/Japan</b> <b>WinCC flexible 2008 ASIA Standard incl. SP3</b> Floating license, license key on USB stick, software and documentation on DVD, contains: <ul style="list-style-type: none"> <li>• Engineering software for configuring Micro Panels, Basic Panels and 70/170/270/370 series Panels incl. C7-635/636</li> <li>• Simulation software for Micro Panels, Basic Panels and 70/170/270/370 series Panels incl. C7-635/636</li> <li>• Native drivers</li> <li>• Electronic documentation (.pdf)</li> </ul>	<b>6AV6612-0AA11-3CA5</b>	<b>WinCC flexible Micro User Manual</b> <ul style="list-style-type: none"> <li>• German <b>6AV6691-1AA01-3AA0</b></li> <li>• English <b>6AV6691-1AA01-3AB0</b></li> <li>• French <b>6AV6691-1AA01-3AC0</b></li> <li>• Italian <b>6AV6691-1AA01-3AD0</b></li> <li>• Spanish <b>6AV6691-1AA01-3AE0</b></li> </ul>
		<b>User Manual WinCC flexible Compact/Standard/Advanced</b> <ul style="list-style-type: none"> <li>• German <b>6AV6691-1AB01-3AA0</b></li> <li>• English <b>6AV6691-1AB01-3AB0</b></li> <li>• French <b>6AV6691-1AB01-3AC0</b></li> <li>• Italian <b>6AV6691-1AB01-3AD0</b></li> <li>• Spanish <b>6AV6691-1AB01-3AE0</b></li> </ul>

<sup>1)</sup> A separate license for WinCC flexible /ChangeControl must be purchased for each engineering station

<sup>2)</sup> Original delivery note or Certificate of License (CoL) from previous WinCC flexible Micro is required

### More information

Additional information is available in the Internet under: <http://www.siemens.com/wincc-flexible>

### Note

Do you require a specific modification or extension to the products described here? You will find information about the Open Platform Program for the creation of user-specific functions and controls for WinCC flexible under "Customized Products".



# HMI Software

## SIMATIC WinCC flexible HMI system

### SIMATIC WinCC flexible RT

#### Overview

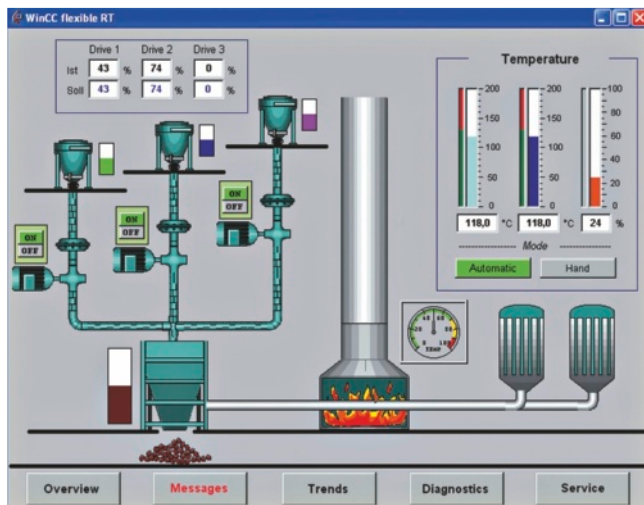

PC-based visualization software for single-user systems directly at the machine.

- Runs under Windows XP Professional and Windows 7 Professional, Ultimate, Enterprise
- Current version: SIMATIC WinCC flexible 2008 SP3 Runtime

SIMATIC WinCC flexible Runtime is configured with the SIMATIC WinCC flexible Advanced configuration software.

#### Benefits

- Optimum price/performance ratio thanks to individually scalable system functionality
- Functions for all visualization tasks: Operator functions, graphical and trend displays, signaling system, log system, archiving (option), recipe management (option), Audit Trail (option), process fault diagnostics (option)
- Flexible runtime functionality thanks to Visual Basic scripts
- Innovative service concepts with remote operation, diagnostics and administration via intranet and Internet as well as e-mail communication to increase availability (option)
- Support for simple distributed automation solutions based on TCP/IP networks at the machine level (option)

#### Application

SIMATIC WinCC flexible Runtime is the high-performance visualization software for simple visualization tasks at machine level. It can be used as a single-user solution for all automation applications in factory automation, process automation and building services automation.

SIMATIC WinCC flexible Runtime can be used in combination with the following operator panels:

- SIMATIC Panel PCs
  - PC IL 70/77
  - Microbox 420
  - Panel PC 477
  - Panel PC 577
  - Panel PC 670/677
  - Panel PC 870/877
- SIMOTION Panel PCs
  - P012, P015
  - PCR, PCR-Touch
- SINUMERIK Panel PCs
  - HT8; OP08T
  - OP010, OP012, OP015
  - TP012, TP015, OP015A
- Standard PCs with resolutions (W x H in pixels) of:
  - 4:3 format: 640 x 480, 800 x 600, 1024 x 768, 1280 x 1024, 1600 x 1200
  - Widescreen format: 800 x 480, 1280 x 800, 1366 x 768, 1440 x 900, 1680 x 1050, 1920 x 1080, 1920 x 1200, 1980 x 1080

#### Design

SIMATIC WinCC flexible Runtime is available as a software package with 128, 512, 2048 or 4096 PowerTags. The term PowerTags is used exclusively to identify process variables and range pointers that have a process link to the controller. Variables without process link, constant limit values of variables, and messages (up to 4000 bit-triggered messages) are also available for additional system performance.

The range of functions of WinCC flexible Runtime includes the centralized HMI components for visualizing and reporting, and it can be expanded to suit requirements and costs by using optional packages.

SIMATIC WinCC flexible Runtime is configured with the SIMATIC WinCC flexible Advanced configuration software.



### Function

#### Visualization via Windows-compliant operator interface

made up of parameterizable screen objects and image blocks created on a project-specific basis:

- Numeric and alphanumeric input/output fields
- Static text and graphic display plus vector graphics
- Dynamizable graphics from HMI symbol library
- Bar graph, trend curve graph with scroll and zoom function as well as read line
- Signal-specific text and graphic lists
- Buttons and switches for operator-process communication
- Editing fields for process values (signals)
- Analog display, slider as example for further screen objects
- Project-specific image blocks created from system basic objects
- Graphic displays for various standard graphic formats, e.g., bitmaps, .jpg, .wmf

#### Alarms and messages

- Discrete alarms and analog alarms as well as event-driven Alarm-S/Alarm-D message procedure with SIMATIC S7 and SIMOTION
- Freely-definable message classes for definition of acknowledgment response and display of message events

#### Logging of alarms and process values <sup>1)</sup>

- Archiving in files (e.g. CSV or TXT file) and Microsoft SQL databases
- Online evaluation of process value archives and alarm logs
- Evaluation of process value archives and alarm logs using standard Microsoft tools such as Excel

#### Recipes <sup>1)</sup>

- Generation of data records for machine or production data
- Display or entry of data records via a configurable screen object or via process images when distributed within the project
- Transmission of data records from or to the PLC
- Import/export for data records from/to CSV files

#### Documentation of process data, alarm events and recipes

- Time- or event-driven report output
- User-definable layout

#### Flexible expansion of system function

- thanks to Visual Basic Script

#### Language support for multilingual projects

- Up to 16 online languages (incl. Asian and Cyrillic)
- Language-dependent texts and graphics
- Language selection during runtime

#### User-oriented access protection according to requirements of regulated sectors

- Authentication with user ID and password
- User-group-specific rights
- Central system-wide user administration based on SIMATIC Logon <sup>1)</sup>
- Monitoring of changes by operators in runtime operation <sup>1)</sup>
- Recording of operator actions in an Audit Trail <sup>1)</sup>

#### PLC link for a wide variety of PLCs on-board

- Simultaneous connection using several protocols: OPC Client or SIMATIC HMI HTTP protocol are additive, i.e. can be used in conjunction with other PLC links
- Communication via native drivers and standard OPC channel

#### Open communication between HMI systems and with higher-level systems <sup>1)</sup>

- OPC server
- Sm@rtAccess for communication between HMI systems based on Ethernet networks, or via the intranet/Internet:
- Read and write access to variables; WinCC flexible Runtime or SIMATIC Panels make data (variables) available to other SIMATIC HMI systems or Office applications.
- A SIMATIC HMI system can be used to control or monitor another system remotely; entry level for client/server configurations for distributed operator stations or for solutions with headend or control room.

#### Sm@rtService for remote control, diagnostics and administration via intranet and Internet <sup>1)</sup>

- Display and control of process images on remote PC or Panel
- Sending of e-mails on demand or event-driven
- System diagnostics visualized via device-specific HTML pages

<sup>1)</sup> Option for SIMATIC WinCC flexible Runtime; runtime licenses must be purchased separately. For further information, refer to "WinCC flexible options".

System requirements	WinCC flexible Runtime
<b>Operating system</b>	Windows XP Professional SP3 (32 bit) Windows XP Embedded <sup>1)</sup> Windows 7 Professional / Ultimate / Enterprise (32 bit and 64 bit)
<b>Processor</b> <sup>4)</sup>	
• Minimum	Windows XP: 300 MHz Windows 7: 1 GHz
• Recommended	Windows XP: ≥ Pentium III, 500 MHz Windows 7: ≥ 1 GHz
<b>Graphics</b>	
• Minimum	SVGA
• Resolution	640 x 480 to 1600 x 1200 or 800 x 480 to 1980 x 1080
<b>RAM</b> <sup>2)</sup>	
• Minimum	Windows XP: 128 MB Windows 7: 1 GB
• Recommended	Windows XP: ≥ 512 MB Windows 7: ≥ 1 GB
<b>Hard disk (free memory space)</b> <sup>3)</sup>	≥ 250 MB

<sup>1)</sup> Only for enabled platforms (e.g. Panel PC 477). You can get information from your Siemens contact.

<sup>2)</sup> RAM requirements are determined primarily by the size of the graphics used.

<sup>3)</sup> Without taking archives into account. In addition to the space needed by WinCC flexible, Windows also requires space on the hard disk; e.g., for the swap file. The following formula has proven itself in the past: The size of the swap file = 3 x the size of the RAM. For further information, refer to your Windows documentation

<sup>4)</sup> More powerful systems (Pentium 4 and higher) may be required in order to use options

# HMI Software

## SIMATIC WinCC flexible HMI system

### SIMATIC WinCC flexible RT

#### Integration

SIMATIC WinCC flexible Runtime supports linking to:

Protocol	PC interfaces
<b>SIMATIC S5 via AS511 (TTY)</b>	
S5-90U	COM1/COM2 <sup>13)</sup>
S5-90U	
S5-100U (CPU 100, 102, 103)	
S5-115U (CPU 941, 942, 943, 944, 945)	
S5-135U (CPU 928A, 928B)	
S5-155U (CPU 946/947, 948)	
<b>SIMATIC S5 via PROFIBUS DP <sup>1)</sup></b>	
S5-95U/L2-DP master	CP 5512 <sup>2)</sup> CP 5611 A2 <sup>2)</sup>
S5-115U (CPU 941, 942, 943, 944, 945)	
S5-135U (CPU 928A, 928B)	
S5-155U (CPU 946/947, 948)	
<b>SIMATIC S7 via PPI</b>	
S7-200	CP 5512 <sup>2)</sup> CP 5611 A2 <sup>2)</sup> CP 5621 <sup>1)</sup> CP 5613 A2 CP 5614 A2 PC/PPI adapter <sup>3)</sup>
<b>SIMATIC S7 via MPI</b>	
S7-200 (except CPU 212) <sup>4)</sup>	CP 5512 <sup>2)</sup> CP 5611 A2 <sup>2)</sup> CP 5621 <sup>1)</sup> CP 5711 <sup>2)</sup>
S7-300	CP 5613 A2
S7-400	CP 5614 A2
WinAC Basis (V3.0 and higher)	PC adapter USB <sup>6)</sup>
WinAC RTX	Teleservice V6.1
<b>SIMATIC S7 via PROFIBUS DP <sup>5)</sup></b>	
S7-215 <sup>4)</sup>	CP 5512 <sup>2)</sup> CP 5611 A2 <sup>2)</sup> CP 5621 <sup>1)</sup> CP 5711 <sup>2)</sup>
S7-300 CPUs with integr. PROFIBUS interface	CP 5613 A2 CP 5614 A2
S7-300 with CP 342-5	
S7-400 CPUs with integr. PROFIBUS interface	
S7-400 with CP 443-5 or IM 467	
WinAC Basis (V3.0 and higher)	
WinAC RTX	
<b>SIMATIC S7 via Ethernet (TCP/IP)</b>	
S7-200 with CP 243-1	CP 1612 <sup>7)</sup> CP 1613 A2
S7-300 CPUs with integral Ethernet interface	
S7-300 with CP 343-1	
S7-400 CPUs with integral Ethernet interface	
S7-400 with CP 443-1	
WinAC Basis (V3.0 and higher)	
WinAC RTX	
<b>SIMATIC S7 via integrated interface</b>	
WinAC Basis (V2.0 and higher)	Internal system interface
WinAC RTX	

Protocol	PC interfaces
<b>SIMATIC 505 NITP</b>	
SIMATIC 500/505 RS 232/RS 422	COM1/COM2
<b>SIMATIC 505 via PROFIBUS DP</b>	
SIMATIC 545/555 with CP 5434	CP 5512 <sup>2)</sup> CP 5611 A2 <sup>2)</sup>
<b>SIMOTION <sup>8)</sup></b>	
<b>SINUMERIK <sup>9)</sup></b>	
<b>Third-party controllers</b>	
Allen Bradley (DF1/DH485)	COM1/COM2
Allen Bradley (Ethernet)	CP 1612 <sup>7)</sup>
GE Fanuc (SNP/SNPX)	COM1/COM2
LG GLOFA GM	COM1/COM2
Mitsubishi (FX/MP4)	COM1/COM2
Modicon (Modbus)	COM1/COM2
Modicon (Modbus TCP/IP)	CP 1612 <sup>7)</sup>
OMRON (Link/Multilink)	COM1/COM2
<b>OPC <sup>10)</sup> <sup>12)</sup></b>	
Data Access V2.05a (client + server)	CP 1612 <sup>7)</sup>
Data Access XML V1.00 (client)	
<b>HTTP communication for data exchange between SIMATIC HMI (client + server) <sup>11)</sup> <sup>12)</sup></b>	CP 1612 <sup>7)</sup>

- <sup>1)</sup> WinCC flexible Runtime is passive (DP slave); the function block required for the link is included in the scope of delivery of WinCC flexible
- <sup>2)</sup> For Microbox 427 and Panel PC 477/577/677 via internal MPI/DP interface
- <sup>3)</sup> Only point-to-point to S7-200; no configuration download, operating systems: Windows 2000/XP; Order number: 6ES7 901-3CB30-0AX0
- <sup>4)</sup> Constraint with regard to baud rate for S7-200; see [Catalog ST 70](#)
- <sup>5)</sup> WinCC flexible RT is active; communication with S7 functions
- <sup>6)</sup> Only point-to-point to S7-300/-400; No configuration download, operating systems: Windows 2000/XP; order number: 6ES7 972-0CB20-0XA0 (USB)
- <sup>7)</sup> For Microbox 427 and Panel PC 477/577/677/877 via internal Ethernet interface
- <sup>8)</sup> For further information, see [Catalog PM 10](#)
- <sup>9)</sup> "SINUMERIK HMI copy license OA" option required; for further information, see [Catalog NC 60](#)
- <sup>10)</sup> OPC Client is included in scope of delivery, the "WinCC flexible /OPC Server for WinCC flexible Runtime" license is required for the OPC Server option
- <sup>11)</sup> "WinCC flexible /Sm@rtAccess for WinCC flexible Runtime" license required
- <sup>12)</sup> OPC and HTTP communication are additive, i.e. can be used in conjunction with the PLC links listed above
- <sup>13)</sup> Via PC cable with integrated level converter RS 232/TTY; Order number: 6ES5 734-1BD20

For information about SIMATIC Panels that support OPC/http communication, see the overview under "System interfaces".

**Integration** (continued)

**Application note**

In parallel with each and every PLC link, WinCC flexible Runtime supports the use of the OPC Client channel; this enables, for example, connection to an SNMP OPC Server for the purpose of visualizing the data stored there.

The SNMP OPC Server provides a means of monitoring network components of any type (e.g. switches) which support the SNMP protocol. For further information, see Catalog IK PI.

**Note:**

For further information, see "HMI devices/System interfaces"

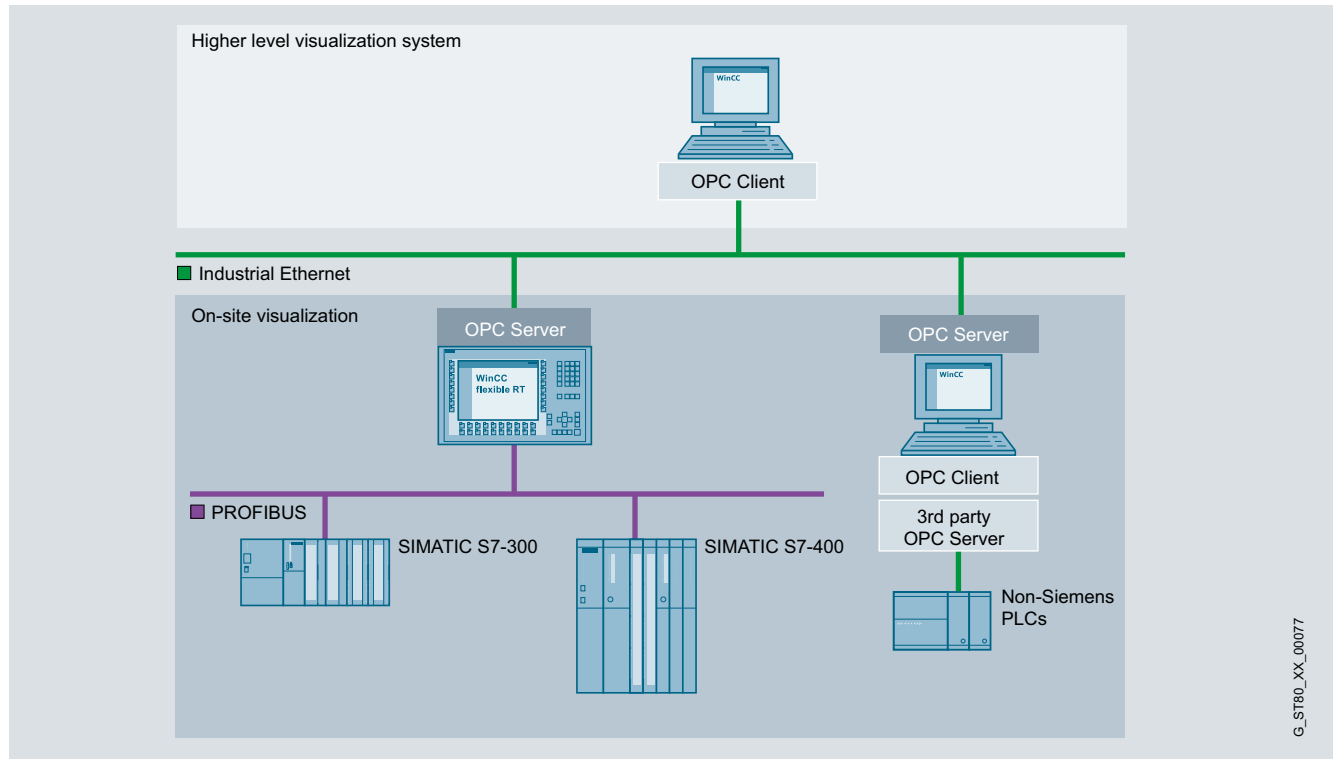

SIMATIC WinCC flexible Runtime application example

# HMI Software

## SIMATIC WinCC flexible HMI system

### SIMATIC WinCC flexible RT

#### Technical specifications

Type	SIMATIC WinCC flexible Runtime
	The specifications are maximum values
<b>Displays</b>	500
• Fields per screen	400
• Variables per screen	400
• Static text	30,000
• Graphics objects	2,000
• Complex objects per display (e.g. bars)	40
• Trends	800
• Graphics lists <sup>1)</sup>	500
• Text lists <sup>1)</sup>	500
• Number of entries in symbol tables	3,500
<b>Variables</b>	4,096 <sup>3)</sup>
<b>Messages bit-triggered / analog</b>	4,000 / 500
• Message text (number of characters)	80
• Number of process values per message	8
• Size of message buffer	1,024
• Pending message events	500
<b>Archives <sup>4)</sup></b>	100
• Archivable data	Process data, messages
• Max. number of entries per archive (incl. all archive segments)	500,000
• Archive types	Short-term archive, sequence archive (max. 400 per archive)
• Data storage format	CSV ( <b>C</b> omma <b>S</b> eparated <b>V</b> ariable), RDB ( <b>R</b> untime <b>D</b> ata <b>B</b> ase), interface to MS SQL database
<b>Recipes <sup>4)</sup></b>	1,000
• Elements per recipe	2,000 <sup>3)</sup>
• Data records per recipe	5,000 <sup>2)</sup>

Type	SIMATIC WinCC flexible Runtime
<b>Password protection</b>	
• User rights	32
• Number of user groups	50
<b>Visual Basic scripts</b>	200
<b>Online languages, max.</b>	16
<b>Communication</b>	
SIMATIC S7 MPI interface/ PROFIBUS DP interface	Depending on the scope of the configuration (communication) from the point of view of WinCC flexible Runtime, as many as 8 connections are possible
• Number of connectable stations, max.	
SIMATIC S7 PPI interface	
• Number of connectable stations, max.	1 from viewpoint of WinCC flexible Runtime
SIMATIC S5 PROFIBUS DP interface	
• Number of connectable stations, max.	1 from viewpoint of WinCC flexible Runtime
Multi-protocol operation	Yes, OPC Client or SIMATIC HMI HTTP protocol are additive, i.e. can be used in conjunction with other PLC links

<sup>1)</sup> Together only 500 text and graphics lists

<sup>2)</sup> Dependent on memory medium used

<sup>3)</sup> Dependent on number of licensed PowerTags

<sup>4)</sup> Option for SIMATIC WinCC flexible Runtime.  
For further information, refer to "WinCC flexible options".



# HMI Software

## SIMATIC WinCC flexible HMI system

### SIMATIC WinCC flexible RT

#### Ordering data

##### Communication via Industrial Ethernet

###### CP 1613-A2

PCI card (32-bit) for connecting a PG/PC to Industrial Ethernet (communications software must be ordered separately)

**6GK1161-3AA01**

###### SIMATIC NET IE S7-1613 V8.0 SP1

Software for S7 and open communication, incl. PG/OP communication, OPC server and NCM PC; up to 120 connections, Runtime software, software and electronic manual on CD-ROM, license key on USB flash drive, Class A, for 32-bit Windows 7 Professional/Ultimate for up to 4 CP 1613/CP 1613 A2 / CP 1623; English/German

- Single license for 1 installation
- Software Update Service for one year, with automatic extension; requirement: Current software version
- Upgrade S7-1613 from V6.4 to S7-1613 V8.0 SP1
- Upgrade S7-1613 from V6.0, V6.1, V6.2 or V6.3 to S7-1613 V8.0 SP1

**6GK1716-1CB80-3AA0**  
**6GK1716-1CB00-3AL0**

**6GK1716-1CB00-3AE0**

**6GK1716-1CB00-3AE1**

##### Communication via PROFIBUS

###### CP 5613-A2

PCI card (32-bit) for connecting a PC to PROFIBUS (communications software must be ordered separately)

**6GK1561-3AA01**

###### CP 5614-A2

PCI card (32-bit) for connecting a PC to PROFIBUS (communications software must be ordered separately)

**6GK1561-4AA01**

##### SIMATIC NET PB S7-5613 V8.0 SP1

Software for S7 communication, incl. PG and FDL protocol, OPC server and NCM PC; Runtime software, software and electronic manual on USB flash drive, license key on diskette, Class A, for 32-bit Windows 7 Professional/Ultimate for up to 4 CP 5613 A2, CP5614 A2, CP 5603 / CP 5623 / CP 5624;

- Single license for 1 installation
- Software Update Service for one year, with automatic extension; requirement: Current software version
- Upgrade S7-5613 from V6.4 to S7-5613 V8.0 SP1
- Upgrade S7-5613 from V6.0, V6.1, V6.2 or V6.3 to S7-5613 V8.0 SP1

**6GK1713-5CB80-3AA0**  
**6GK1713-5CB00-3AL0**

**6GK1713-5CB00-3AE0**

**6GK1713-5CB00-3AE1**

###### CP 5512

PCMCIA card (32-bit CARDBUS) for connecting a PG/Notebook to PROFIBUS or MPI (communications software included in WinCC flexible).

**6GK1551-2AA00**

###### CP 5611-A2

PCI card (32-bit) for connecting a PG/PC to PROFIBUS (communications software included in WinCC flexible basic package)

**6GK1561-1AA01**

###### CP 5611 MPI

Comprising CP 5611 A2 (32-bit) and MPI cable, 5 m

**6GK1561-1AM01**

###### CP 5621

PCI Express X1 card (32-bit) for connection of PG/PC to PROFIBUS or MPI (communications software included in WinCC flexible basic package)

**6GK1562-1AA00**

###### CP 5711

USB adapter (USB V2.0) for connecting a PG or Notebook to PROFIBUS or MPI (2 m USB cable and 5 m MPI cable included)

**6GK1571-1AM00**

###### PC/PPI adapter

RS 232, 9-pin; male with RS 232/PPI converter, max. 19.2 kbps

**6ES7901-3CB30-0XA0**

###### PC adapter USB

For use with Windows 2000/XP

**6ES7972-0CB20-0XA0**

#### More information

Additional information is available in the Internet under:  
<http://www.siemens.com/wincc-flexible>

#### Note

Do you need a specific modification or option for the products described here? You will find information about the Open Platform Program for the creation of user-specific functions and controls for WinCC flexible under "Customized Products".

### Overview

#### Option for SIMATIC WinCC flexible Engineering

##### SIMATIC WinCC flexible /ChangeControl

WinCC flexible/ChangeControl enables consistent backup of configuration data. The history of changes can be verified down to the last detail for applications requiring interruption-free proof for the complete life cycle of a product.

- Delivered customer projects, approved reference states or development stages are managed in a database.
- Changes to project data can be integrated without problem into the version management using new versions.
- A rollback is possible at any time.

##### SIMATIC WinCC flexible /Archives

Archiving of alarms and process values

- Archiving in files (e.g. CSV file) and Microsoft SQL databases
- Online evaluation of process value archives and alarm logs
- Evaluation of process value archives and alarm logs using standard MS tools such as Excel

##### SIMATIC WinCC flexible /Recipes

Generation and management of data records for machine or production data

- Display or entry of data records via a configurable screen object or via process images when distributed within the project
- Transmission of data records from or to the controller
- Import/export of data sets as CSV files

##### SIMATIC WinCC flexible /Audit

Recording of operator actions in an Audit Trail

- Electronic signature for important operator actions relevant to production
- The ChangeControl option supports users in respect of tracking modifications to projects.
- Audit supports users in meeting special quality requirements, e.g.
  - Production plant requiring validation according to 21 CFR Part 11 (Food Drug Administration law)
  - In respect of traceability according to EU 175/2002 (EU directive)

##### SIMATIC Logon for WinCC flexible

Option for connecting PCs with SIMATIC WinCC flexible Runtime and SIMATIC Panels to central user administration.

- Creates user administration on a central computer to which one or more WinCC flexible stations can be connected over Ethernet.
- With each logging-on/off of a user on one of the connected stations, SIMATIC Logon checks whether a user password has been created and that the required privileges exist.
- SIMATIC Logon for WinCC flexible supports the user in combination with the /Audit and /ChangeControl options in meeting requirements in accordance with FDA 21 CFR Part 11 and EU178.

##### SIMATIC WinCC flexible /Sm@rtAccess

- Flexible solution for access to HMI systems and process data from any location
- Communication between different SIMATIC HMI systems

##### SIMATIC WinCC flexible /Sm@rtService

- Remote maintenance and servicing of machines and plant via Internet/intranet
- Reduced downtimes for machines and plant with direct remote access
- Flexible solution for remote access to machines and plant

##### SIMATIC WinCC flexible /OPC Server

- Incorporation of automation components from different vendors into a single automation concept
- Communication for data exchange between HMI systems and/or higher-level control system
- Communication with applications from different vendors, e.g. MES, ERP or applications in the office sector

##### SIMATIC WinCC flexible /ProAgent

- Precise and rapid process fault diagnostics in plant and machines for SIMATIC S7 and SIMATIC HMI
- Standardized diagnostics concept for various SIMATIC components
- No further configuration overhead for diagnostics functionality
- Frees up PLC capacity with regard to memory and program execution time



# HMI Software

## SIMATIC WinCC flexible options

### WinCC flexible /ChangeControl

#### Overview

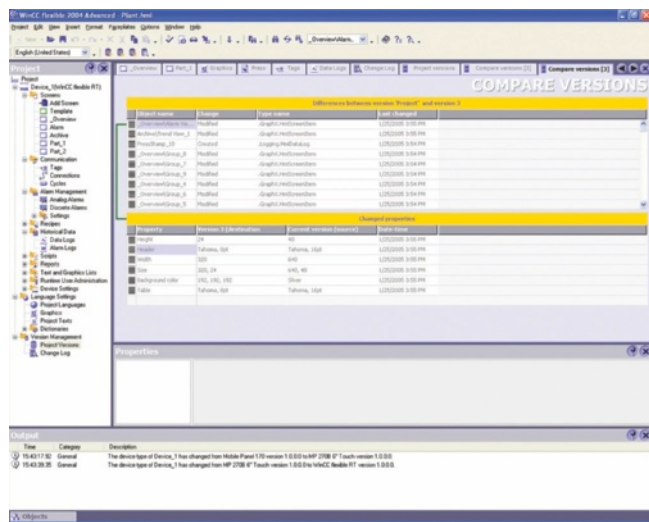

- Options for the versioning of configuration data and for tracing configuration changes (e.g. as verification in regulated sectors)
- For the engineering tool SIMATIC WinCC flexible Compact/Standard/Advanced
- One license is required for each configuration computer

#### Benefits

- Consistent backup of configuration data
  - Delivered versions, approved reference states or development stages are managed in a database.
  - Changes to project data can be integrated without problem into the version management using new versions. A rollback is possible at any time.
- Tracing of configuration changes
  - The history of changes can be verified down to the last detail for applications requiring interruption-free proof for the complete life cycle of a product.

#### Application

- In machine/special machine construction for project management, e.g. delivered customer versions and their modifications
- For saving of intermediate states during complex new developments or expansions, with rollback facility
- During work for specific orders as basis for calculating costs for modifications
- In regulated sectors as proof of state of plants or machines and any modifications made to them

#### Function

- Integral GUI for management of project versions (version tree with main line and secondary lines for modified project versions)
- Modification log can be activated/deactivated and shows who carried out modifications, and when/which. Modification reasons can be entered as comments

#### Ordering data

**WinCC flexible /ChangeControl for WinCC flexible 2008 Compact/Standard/Advanced <sup>1)</sup>**

Floating License, option, license key only

<sup>1)</sup> The ChangeControl option has not been released for integrated operation with STEP 7.

#### Order No.

**6AV6613-6AA01-3AB5**

#### More information

##### Note

Do you need a specific modification or option for the products described here? Then look up "Customized products", where you will find information about the Open Platform Program for the creation of user-specific functions and controls for WinCC flexible.

### Overview

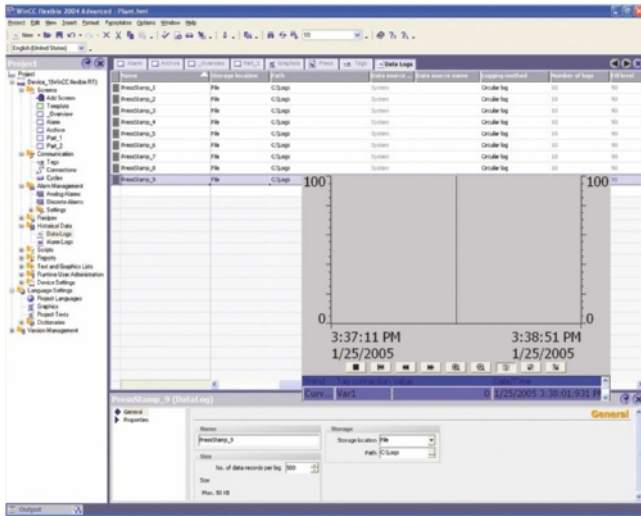

- Option for SIMATIC WinCC flexible Runtime for archiving process values and messages
- Archiving of process values and messages supports the acquisition and processing of process data from an industrial plant or machine. Evaluation of the archived process data provides information about the operating states of the plant or machine
- One license is required per operator station (no license is required for SIMATIC Panels/Multi Panels)

### Benefits

- Message and process value archives permit foresighted diagnostics which prevents downtimes
- Early detection of danger or fault states
- Increase in product quality and productivity thanks to regular evaluation of process value and message archives

### Application

- Further use of archives for evaluation and long-term archiving
- Record of repeated fault states
- Optimization of maintenance cycles
- Ensured quality standards
- Control of quality as well as production capacity utilization
- Documentation of process sequence

### Function

- Time-controlled as well as manual or process-controlled swapping out of process data and messages for long-term archiving
- During runtime, swapped out data are read in and selectively analyzed using WinCC flexible Runtime
  - Presentation and evaluation of archived process data based on a configurable trend display. Reading of the values is facilitated by a read line.
  - Presentation and evaluation of archived alarms based on a configurable alarm view.
  - User-friendly navigation in the archives
- External evaluation of the archives using MS standard tools
- Various archive types are supported: sequence and short-term archives
- Archiving of process values and messages on external, Windows-supported storage media
  - CSV files
  - RDB files
  - Microsoft SQL server via ODBC
- Power standard functions permit user-friendly and flexible utilization of the archives

### Technical specifications

Type	WinCC flexible /Archives
	The specifications are maximum values
<b>Execution platform</b>	SIMATIC WinCC flexible Runtime
<b>Archives</b>	100
• Archivable data	Process values, messages
• Cyclical trigger for archiving process values (variables)	1 s
• Max. number of entries per archive (incl. sequence archive)	500,000 <sup>1)</sup>
• Archive types	<ul style="list-style-type: none"> <li>• Circulating archive</li> <li>• Sequence archive (max. 400 per archive)</li> </ul>
• Data storage format	CSV (Comma Separated Variable), RDB (Runtime Data Base) and interface to Microsoft SQL database (database not included in scope of delivery)

<sup>1)</sup> Dependent on memory medium used

### Ordering data

Ordering data	Order No.
<b>WinCC flexible /Archives for WinCC flexible 2008 Runtime</b> <sup>1)</sup> Single License, license key only	<b>6AV6618-7ED01-3AB0</b>
<b>WinCC flexible /Archives+ Recipes for WinCC flexible 2008 Runtime</b> <sup>1)</sup> Single License for each option, license key only	<b>6AV6618-7GD01-3AB0</b>

<sup>1)</sup> One license is required for each operator station. A license is not required for the engineering system for configuring the runtime option.

### More information

#### Note

Do you need a specific modification or option for the products described here? Then look up "Customized products", where you will find information about the Open Platform Program for the creation of user-specific functions and controls for WinCC flexible.

# HMI Software

## SIMATIC WinCC flexible options

### WinCC flexible /Recipes

#### Overview

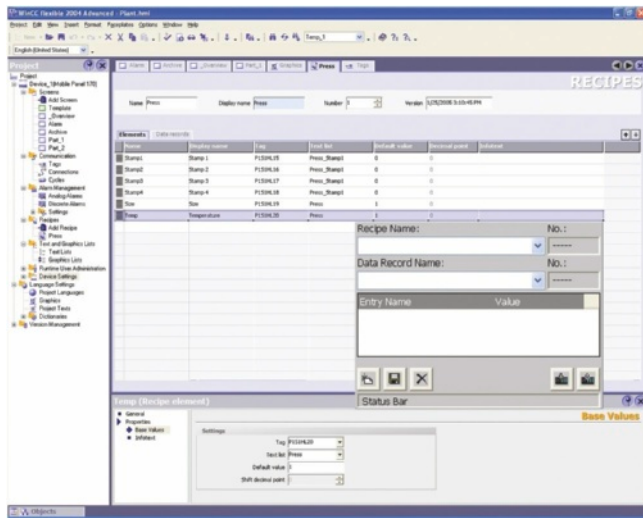

- Option for SIMATIC WinCC flexible Runtime for managing data records in recipes that contain related machine or production data
- The data in a data set can be transferred, for example, from the control unit to the PLC to switch production to a different product variant
- One license is required per operator station (no license is required for SIMATIC Panels/Multi Panels)

#### Benefits

- Generation and management of machine parameters and production data on the basis of data sets, and exchange with the automation equipment, e.g. with the machine
- Clear tabular representation of data elements with support of a configurable graphic object, or representation in technical relationships for several process graphics
- Simple operator prompting using standard functions
- Export/import of data sets for further processing with other tools (e.g. MS Excel)

#### Application

- Assignment of plant/machine parameters in the production industry
- Batch-oriented production, e.g. in the food or plastics industry

#### Function

- Input of data sets (e.g. operating parameters for a machine, production data for a plastics processing machine) in WinCC flexible Runtime, their storage, and passing on to the PLC
- Display and input of data sets using a configurable graphics object, or distributed among several process displays within the project
- Data set elements are coupled to the process using direct linking of the variables
- Transmission of data records from or to the PLC
- Powerful interfaces permit synchronized exchange of data with the PLC
- Saving of data sets on local media or on remote data servers via networks
- Import/export of data sets as CSV files
- Logging of data sets, e.g. as batch report/shift report
- Convenient and flexible management of data sets using powerful standard functions

WinCC flexible recipes and the associated data sets are conveniently created using a separate editor in the WinCC flexible Advanced engineering tool, and assigned default data.

A configurable table object is used to display the data during runtime. Furthermore, the individual data set elements can also be directly output for several process displays on the basis of standard input/output boxes. The data can therefore be clearly presented for the operator in technological layers.

#### Technical specifications

Type	WinCC flexible /Recipes
	The specifications are maximum values
<b>Execution platform</b>	SIMATIC WinCC flexible Runtime
<b>Recipes</b>	1000
• Entries per recipe	2000 <sup>1)</sup>
• Data records per recipe	5000 <sup>2)</sup>
• User data length in bytes per data record	8000 KB <sup>2)</sup>

<sup>1)</sup> Dependent on number of licensed PowerTags

<sup>2)</sup> Dependent on memory medium used

#### Ordering data

#### Order No.

##### WinCC flexible /Recipes for WinCC flexible 2008 Runtime <sup>1)</sup>

Single License, license key only

**6AV6618-7FD01-3AB0**

##### WinCC flexible /Archives+Recipes for WinCC flexible 2008 Runtime <sup>1)</sup>

Single License for each option, license key only

**6AV6618-7GD01-3AB0**

<sup>1)</sup> One license is required for each operator station.

A license is not required for the engineering system for configuring the Runtime option.

#### More information

##### Note

Do you need a specific modification or option for the products described here? Then look up "Customized products", where you will find information about the Open Platform Program for the creation of user-specific functions and controls for WinCC flexible.

### Overview

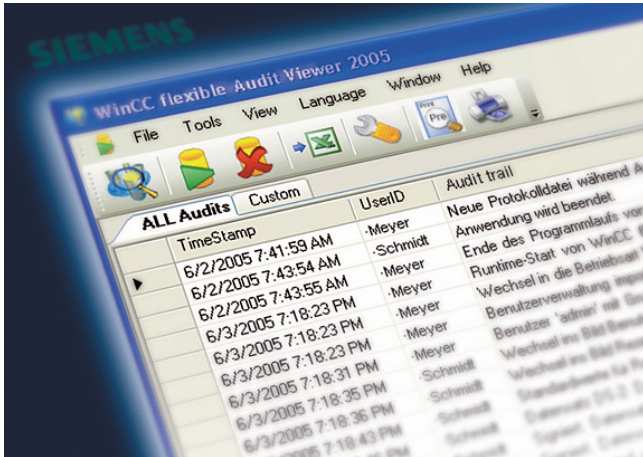

- Option for SIMATIC WinCC flexible Runtime as well as SIMATIC Panels for recording operations in an audit trail, and electronic signature
- The audit trail features a safety mechanism that indicates subsequent manipulation.
- An easy-to-use configuration option included as standard in WinCC flexible enables you to set:
  - The operator actions to be recorded in the audit trail during runtime
  - The important operator actions requiring electronic signature/comments during runtime
- The audit option combined with the WinCC flexible ES ChangeControl option supports the user with plant validation
- Available for the following SIMATIC HMI systems: TP/OP 270, TP/OP 277, MP 270B, MP 277, MP 370, MP 377, WinCC flexible Runtime
- A license is required for every operator control unit (panel or PC)

### Benefits

- Audit supports the user in meeting special quality requirements, e.g.,
  - production plant requiring validation according to 21 CFR Part 11 FDA <sup>2)</sup>
  - in respect of traceability according to EU 175/2002 <sup>3)</sup>
- Entries in the audit trail are allocated to individual users. This ensures that responsibilities can be clearly identified.
- The audit trail, stored as a CSV file <sup>1)</sup>, can be checked via a security mechanism to find out if subsequent changes have been made.
- For particularly important user actions, e.g., starting production or loading new recipes, electronic signatures and comments can be configured and then called up and logged during runtime.

<sup>1)</sup> CSV Comma Separated Values

<sup>2)</sup> The FDA (Food and Drug Administration) is the American public health authority

<sup>3)</sup> 21 CFR Part 11- law on plant validation

### Technical specifications

WinCC flexible /Audit	
Archive for Audit Trail use on the Panel	<ul style="list-style-type: none"> <li>• Plug-in flash memory card on the panel</li> <li>• In the higher-level PC (memory medium) connected to the panel via Ethernet</li> </ul>
Archive for Audit Trail use of WinCC flexible Runtime	On the PC (storage medium)
<b>Execution platform</b>	
SIMATIC Panels	Mobile Panel 277, TP/OP 270, TP/OP 277
SIMATIC Multi Panels	MP 270B, MP 277, MP 370, MP 377
PCs	SIMATIC WinCC flexible Runtime

### Ordering data

**WinCC flexible /Audit for SIMATIC Panels**  
Single license, license key only

### Order No.

**6AV6618-7HB01-3AB0**

**WinCC flexible /Audit for WinCC flexible Runtime 2008**  
Single license, license key only

**6AV6618-7HD01-3AB0**

### More information

#### Note

Do you need a specific modification or option for the products described here? Then look up "Customized products", where you will find information about the Open Platform Program for the creation of user-specific functions and controls for WinCC flexible.

# HMI Software

## SIMATIC WinCC flexible options

### SIMATIC Logon for WinCC flexible

#### Overview

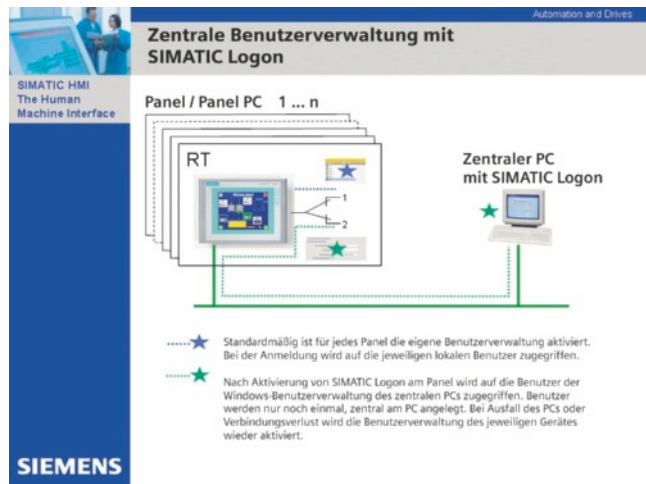

- Option for connecting PCs with SIMATIC WinCC flexible Runtime and SIMATIC Panels to central user administration.
- Creates user administration on a central computer to which one or more WinCC flexible stations can be connected over Ethernet.
- With each logging-on/off of a user on one of the connected stations, SIMATIC Logon checks whether a user password has been created and that the required privileges exist.
- SIMATIC Logon for WinCC flexible supports the user in combination with the /Audit and /ChangeControl options in meeting requirements in accordance with FDA 21 CFR Part 11 and EU178.
- Licensing:  
SIMATIC Logon (basic license) and SIMATIC Logon Remote Access (3-pack license) for connection of 3 WinCC flexible stations to a central user administration. Additional stations can be connected by using further SIMATIC Logon Remote Access licenses (3-pack/10-pack).

#### Benefits

- Centralized configuration of all access authorizations of a distributed system avoids unnecessary travel times. Time-consuming multiple configurations for each individual local station become unnecessary. Accordingly, users can be easily configured from a central location.
- All access data apply throughout the plant on every connected station. Additional access data on local subsystems is no longer necessary.

#### Design

SIMATIC Logon and SIMATIC Logon Remote Access are installed on a central station.

The following WinCC flexible stations are connected to the central station via Ethernet network:

- PCs with WinCC flexible Runtime
- SIMATIC Panels from the 177 series or higher (panels with Ethernet interface)

#### Licensing

The following licenses are required:

- SIMATIC Logon basic license
- SIMATIC Logon Remote Access license (3-pack license 10-pack license); more than one SIMATIC Logon Remote Access license can be installed.

The number of connectable stations depends on the SIMATIC Logon Remote Access licenses used. This number is the total of the connections provided by the individual licenses. As an example: Two installed licenses for 10 enable the connection of 20 stations to the central station.

#### Function

##### Configuration

In the first step, the following data must be saved in the user administration of WinCC flexible on every WinCC flexible station in the plant:

- Required user groups with associated user privileges
- IP address, port number, Windows domain of the central station on which the central user administration is stored.

All user groups are configured with the same names in the central user administration. All users are created here, and have automatic access to the connected WinCC flexible stations in accordance with the relevant user group.

If the connection fails between the central station with SIMATIC Logon and a WinCC flexible station, the operation is handled through an "emergency user" which must first be preconfigured locally.

Intervals for password aging and regulations for the structure of a password are defined according to the configuration on the central station and then also apply to all decentrally connected WinCC flexible stations or the respective users.

#### Technical specifications

	SIMATIC Logon for WinCC flexible
<b>Execution platform</b>	
SIMATIC Panels	Mobile Panel 177 PN; Mobile Panel 277, TP/OP 177B PN/DP, TP/OP 277
SIMATIC Multi Panels	MP 177, MP 277, MP 377
PCs	WinCC flexible Runtime



# HMI Software

## SIMATIC WinCC flexible options

### SIMATIC Logon for WinCC flexible

Ordering data	Order No.
<b>SIMATIC Logon V1.5</b> Basic license; for panels or WinCC flexible Runtime stations, the corresponding number of additional SIMATIC Logon Remote Access licenses is required.	<b>6ES7658-7BX51-0YA0</b>
<b>SIMATIC Logon Upgrade to V1.5</b>	<b>6ES7658-7BX51-0YE0</b>
<b>SIMATIC Logon Remote Access for WinCC flexible (3 clients)</b> Remote access for 3 WinCC flexible 2008 clients; single license for 3 remote access clients; type of delivery: CD, license key disk, Certificate of License, Terms and Conditions The number of licensed clients is determined based on the amount of installed SIMATIC logon remote access licenses.	<b>6ES7658-7BA00-2YB0</b>
<b>SIMATIC Logon Remote Access for WinCC flexible (10 clients)</b> Remote access for 10 WinCC flexible 2008 clients; single license for 10 remote access clients; type of delivery: CD, license key disk, Certificate of License, Terms and Conditions The number of licensed clients is determined based on the amount of installed SIMATIC logon remote access licenses.	<b>6ES7658-7BB00-2YB0</b>

#### More information

##### Note

Do you need a specific modification or addition to the products described here? Then take a look under "Customer-specific products". There, we provide information on the Open Platform Program for creating your own functions or Controls for WinCC flexible.

# HMI Software

## SIMATIC WinCC flexible options

### WinCC flexible /Sm@rtAccess

#### Overview

- Option for SIMATIC WinCC flexible Runtime plus SIMATIC Panels for communication between various SIMATIC HMI systems.
- Available for the following SIMATIC HMI systems:
  - Mobile Panel 177 PN, Mobile Panel 277
  - TP 177B PN/DP, OP 177B PN/DP
  - TP 270, TP 277, OP 270, OP 277
  - MP 177, MP 270B, MP 277, MP 370, MP 377
  - WinCC flexible Runtime
- Communication between HMI systems is established on the basis of Ethernet networks, or via the intranet/Internet:
  - Read and write access to variables; WinCC flexible Runtime or SIMATIC Panels make data (variables) available to other SIMATIC HMI systems or Office applications.
  - A SIMATIC HMI system can be used to control or monitor another system remotely; entry level for client/server configurations for distributed operator stations or for solutions with headend or control room.
- Local operation, visualization and data processing is as possible as plant-wide access to information or central archiving of process data. Integrated information flows ensure an overview of the status of all processes.
- Licensing:
  - The license "WinCC flexible /Sm@rtAccess for Panel" or "WinCC flexible/Sm@rtAccess for WinCC flexible Runtime" must be installed on both the server and client HMI device. Server applications are the options Sm@rtServer, HTTP-Server and SOAP-Server. Client applications are the screen object Sm@rtClient display, and the utilization of the communication driver SIMATIC HTTP protocol.
  - No license is required on the client system for access to a Sm@rtServer using the application Sm@rtClient.EXE or the Microsoft Internet Explorer. A license is also not required for the engineering system for configuring the runtime option.

#### Note:

If the operator stations are accessed using the Sm@rtAccess option, suitable protective measures (including IT security such as network segmentation) should be taken in order to ensure safe operation of the system.

You will find more information on the topic of Industrial Security on the Internet at:

<http://www.siemens.com/industrialsecurity>

#### Benefits

- Flexible solution for location-independent access to HMI systems and process data
- Reduction in load on fieldbuses: WinCC flexible Runtime as well as SIMATIC Panels permit a control system, for example, to access the process data. The sensitive field level is not loaded by the control level as far as the communications requirements are concerned. The requirements are processed by WinCC flexible Runtime and the SIMATIC Panels.
- Simple, fast configuration of communications relationships using the WinCC flexible engineering software

#### Application

- Use of machine-level HMI systems as data servers for higher-level automation components such as control systems or office systems. Process values from different machines, for example, are displayed on a process screen.
- Operator control and monitoring of machines covering large areas with several operator stations by one operator
- Operator control and monitoring of machine-level HMI systems from one central station (e.g. head-end station of a production line or from a control room)



### Application (continued)

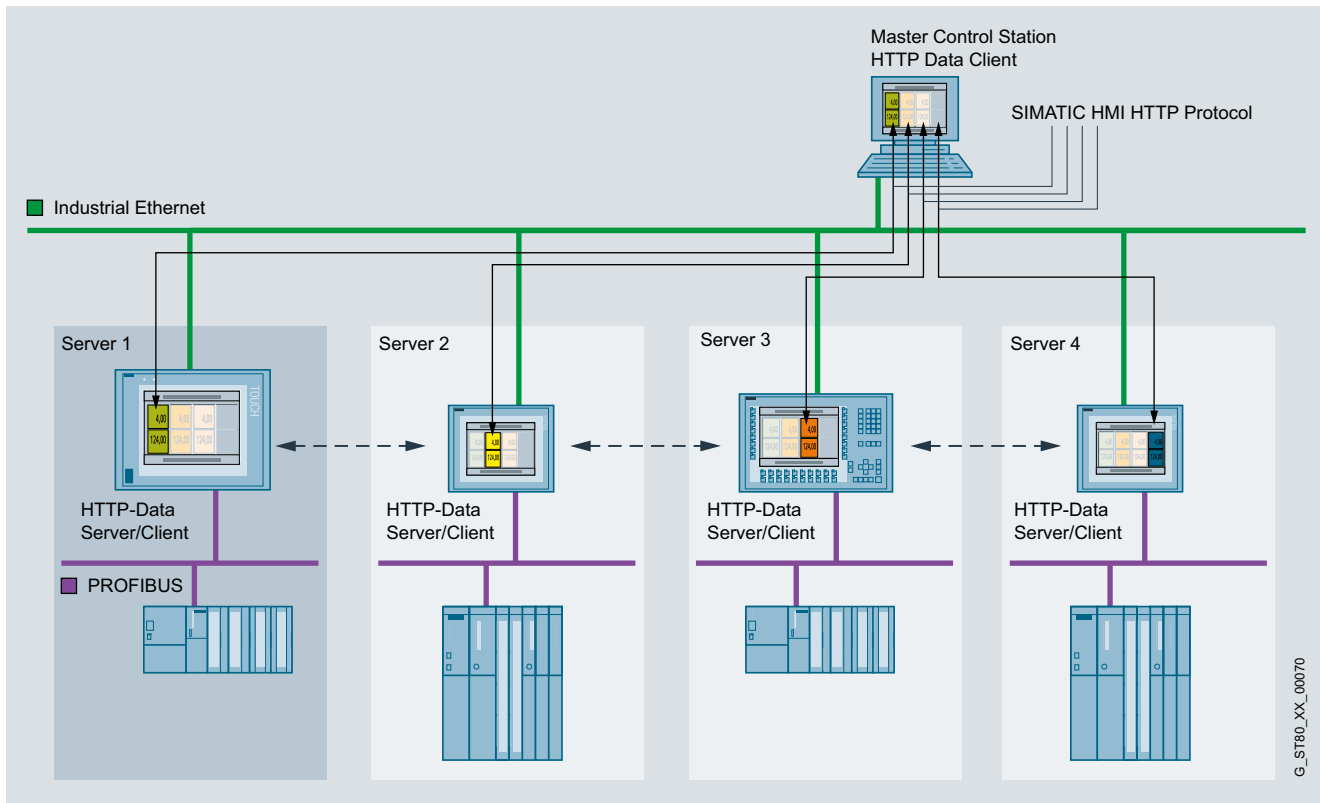

4

Communication between HMI systems via Industrial Ethernet: Use of machine-level HMI systems as data servers for higher-level automation components

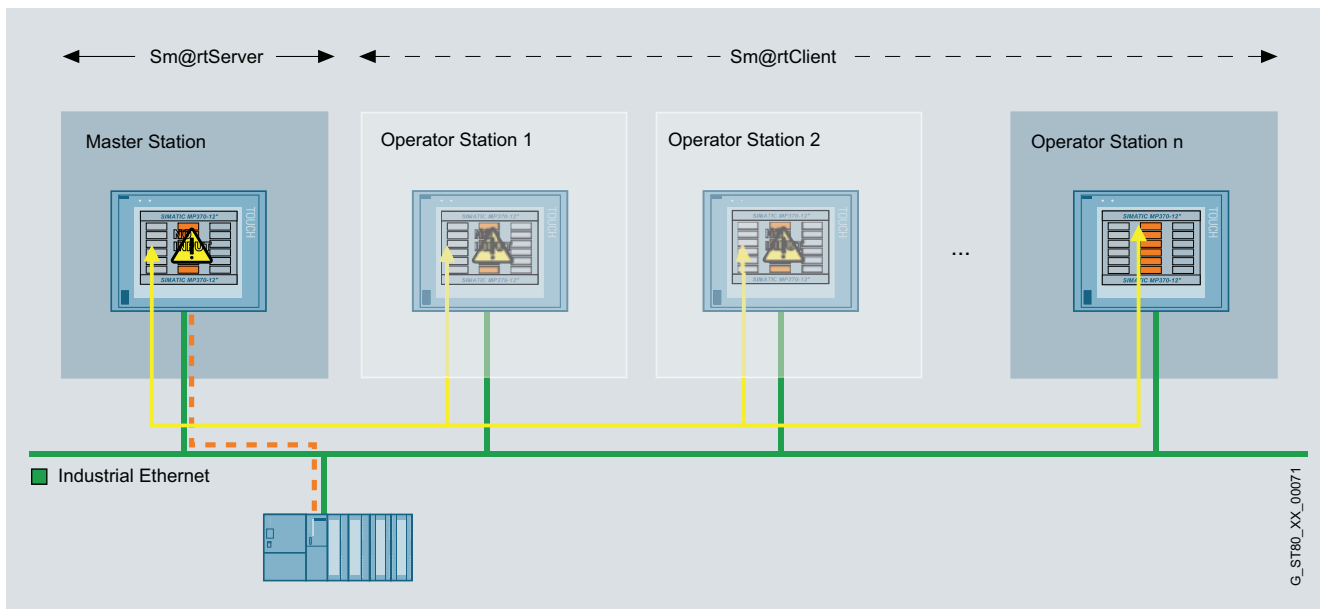

Application of the Sm@rtClient concept: Coordinated operation of several operator stations

# HMI Software

## SIMATIC WinCC flexible options

### WinCC flexible /Sm@rtAccess

#### Application (continued)

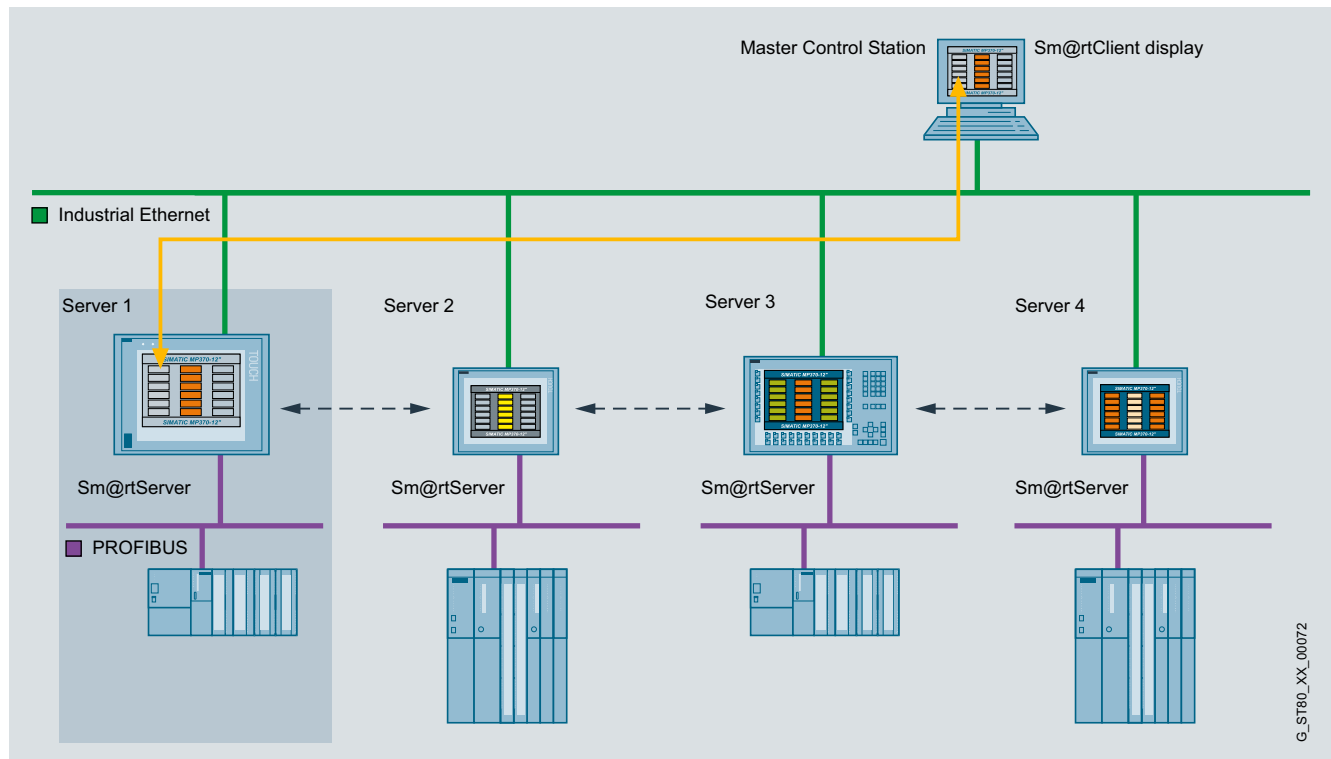

Use of the Sm@rtClient display: Operator control and monitoring of machine-level HMI systems from one central station

#### Function

Communication between **different SIMATIC HMI systems** or between **the units of a machine or plant** is carried out via Industrial Ethernet or intranet/Internet on the basis of Sm@rtAccess

Possible communication relationships:

- Reading and writing the variables of a SIMATIC HMI system on the basis of an HTTP protocol
  - Reading and writing the variables of different HMI systems
  - Simple configuring of variables in the HMI client configuration using browsers in the WinCC flexible engineering tool
  - Reading and writing the variables of an HMI system using standard applications such as MS Excel. Communication is made possible by embedding a script in the application, on the basis of the SOAP protocol (Simple Object Access Protocol) superimposed by HTTP
- Remote control of an operator station; the HMI application and communication with the PLC are via the master station. In the case of spatially distributed machines/plants (which require a larger number of operator panels), so-called Sm@rtClients can be activated from here which are then assigned access to the master station and thus to the process. Access procedures guarantee that only one operator system can actively access the process at a time.
  - A configurable graphic object (Sm@rtClient display) embedded in process displays represents the screen of the associated HMI system (Sm@rtServers)
  - Powerful standard functions permit convenient and flexible operation of the display

Password protection can be optionally activated for access to variables or for remote operation of an HMI system.

G\_ST80\_XX\_00072

Technical specifications	
<b>Type</b>	<b>WinCC flexible /Sm@rtAccess</b> The specifications are maximum values
<b>Execution platform</b>	
• SIMATIC Panels	Mobile Panel 177 PN, Mobile Panel 277, TP/OP 177B PN/DP, TP/OP 270, TP/OP 277
• SIMATIC Multi Panels	MP 177, MP 270B, MP 277, MP 370, MP 377
• PCs	WinCC flexible Runtime
<b>Sm@rtAccess SIMATIC HMI HTTP protocol</b>	
Number of connections for one client	
• Mobile Panel 177 PN, TP/OP 177 B PN/DP, MP 177 as HTTP server	4
• Mobile Panel 277, TP/OP 270, TP/OP 277, MP 270B, MP 277, MP 370, MP 377 as HTTP server	8
• for WinCC flexible Runtime	16
<b>Sm@rtAccess Sm@rtClient concept</b>	
Number of Sm@rtClients that can connect to a Sm@rtServer at the same time <sup>1) 2)</sup>	
• Mobile Panel 177 PN, TP/OP 177B PN/DP, MP 177 as Sm@rtServer	2 clients
• Mobile Panel 277, TP/OP 270, TP/OP 277, MP 270B, MP 277 as Sm@rtServer	3 clients for 6" devices 2 clients for 8" and 10" devices
• MP 370, MP 377 as Sm@rtServer	3 clients for 12" devices 2 clients for 15" devices 1 client for 19" devices
• for WinCC flexible Runtime as Sm@rtServer	5 clients
Number of Sm@rtClient displays per screen	
• for Panels/Multi Panels	1
• for WinCC flexible Runtime	2

<sup>1)</sup> Including 1 Service Client

<sup>2)</sup> The Sm@rtServer and the WinCC flexible /Pro Agent option cannot be used simultaneously on OP/TP/MP 270/370. Parallel operation of the runtime options ProAgent, Sm@rtAccess and Sm@rtService is possible in the context of the MP 277 8" and 10" devices, Mobile Panel 277 as well as the MP 377. Limitation: a maximum of 2 clients can be connected simultaneously to a Sm@rtServer.

Ordering data	Order No.
<b>WinCC flexible /Sm@rtAccess for SIMATIC Panel</b> <sup>1)</sup> Single license, license key only	<b>6AV6618-7AB01-3AB0</b>
<b>WinCC flexible /Sm@rtAccess for WinCC flexible 2008 Runtime</b> <sup>1)</sup> Single license, license key only	<b>6AV6618-7AD01-3AB0</b>

<sup>1)</sup> The license must be installed on the server and on the client HMI device. Server applications are the options Sm@rtServer, HTTP-Server and SOAP-Server. Client applications are the screen object Sm@rtClient display, and the utilization of the communication driver HTTP protocol. A license is not required for the engineering system for configuring the runtime option.

### More information

#### Note

Do you need a specific modification or option for the products described here? Then look up "Customized products", where you will find information about the Open Platform Program for the creation of user-specific functions and controls for WinCC flexible.

# HMI Software

## SIMATIC WinCC flexible options

### WinCC flexible /Sm@rtService

#### Overview

- Option for SIMATIC WinCC flexible Runtime and SIMATIC Panels for remote maintenance and servicing of machines/plant via the Internet/intranet
- Available for the following SIMATIC HMI systems:
  - Mobile Panel 177 PN, Mobile Panel 277
  - TP 177B PN/DP, OP 177B PN/DP
  - TP 270, TP 277, OP 270, OP 277
  - MP 177, MP 270B, MP 277, MP 370, MP 377
  - WinCC flexible Runtime
- Licensing
 

The "WinCC flexible /Sm@rtService for Panel" license or "WinCC flexible /Sm@rtService for WinCC flexible Runtime" license must be installed on the operator panels that use one of the following options/functions: Sm@rtServer, HTML pages (mini-Web server), e-mail.

The remote service PC and engineering system do not require a license for configuration the runtime option.

#### Note

If the operator stations are accessed using the Sm@rtService option, suitable protective measures (including IT security such as network segmentation) should be taken in order to ensure safe operation of the system.

You will find more information on the topic of Industrial Security on the Internet at:  
<http://www.siemens.com/industrialsecurity>

#### Benefits

- Fast elimination of faults or downtimes and thus increased productivity by means of global access to machines/systems by the service and maintenance personnel
- Avoids the need for site visits

#### Application

- Remote maintenance and servicing of machines and plants via Internet/Intranet
- Calling of system information, control of target systems, and updating of data sets via Internet/Intranet
- Automatic sending of emails to experts for fast elimination of faults

#### Function

##### **Remote operator control and monitoring of SIMATIC HMI systems using Industrial Ethernet and/or via the Intranet/Internet**

Microsoft Internet Explorer V6.0 SP1 or higher is sufficient for accessing an HMI system.

##### Remote control of an operating station

the HMI application and communication with the controller takes place via the HMI system. Using Sm@rtService, the HMI systems in the machines/systems can be serviced remotely. An access process ensures that only one operator (either locally at the machine or remotely via Internet Explorer) can actively access the process at one time.

**Integrated Web Server** to process standard HTML pages  
 The following functions can be accessed from the homepage:

- Starting and stopping the HMI runtime for maintenance
- Remote access to recipe data sets, passwords and information specific to the HMI system
- Access the HMI system files via a file explorer
- Download configuration data via the Intranet/Internet
- Supplement with own HTML pages

**Sending e-mails** to maintenance personnel via SMTP server (Simple Mail Transfer Protocol)

- Events that trigger an e-mail:
  - Reporting of a message class
  - Configurable standard functions: Changing the value of a variable, pressing a function key, scripts, etc.
- Possible e-mail content
  - Subject
  - Message text with process variables
  - Date/Time
- The optional use of e-mail/SMS gateways enables access to standard networks (external service provider required)

Standard functions make maintenance and service functionality easier. WinCC flexible allows you to quickly and easily configure maintenance and service functions.

Password protection can be activated as an option for accessing the HMI system. Different passwords may be configured for different functions.

**Function** (continued)

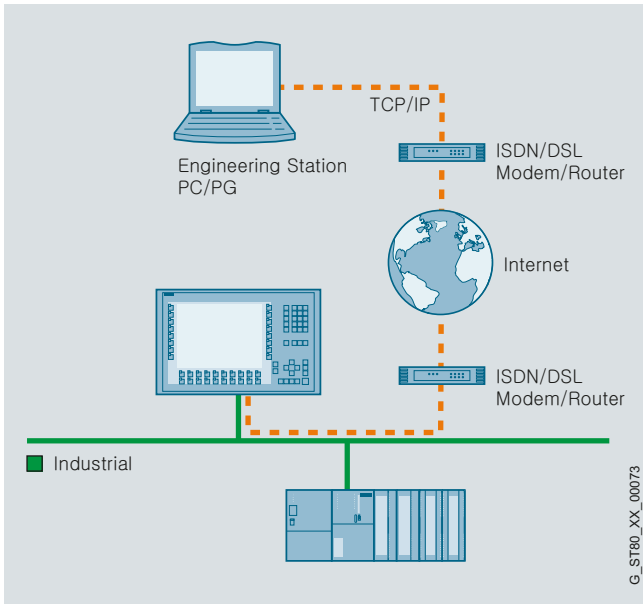

Remote operator control and monitoring of SIMATIC HMI systems using Industrial Ethernet and/or via the Intranet/Internet

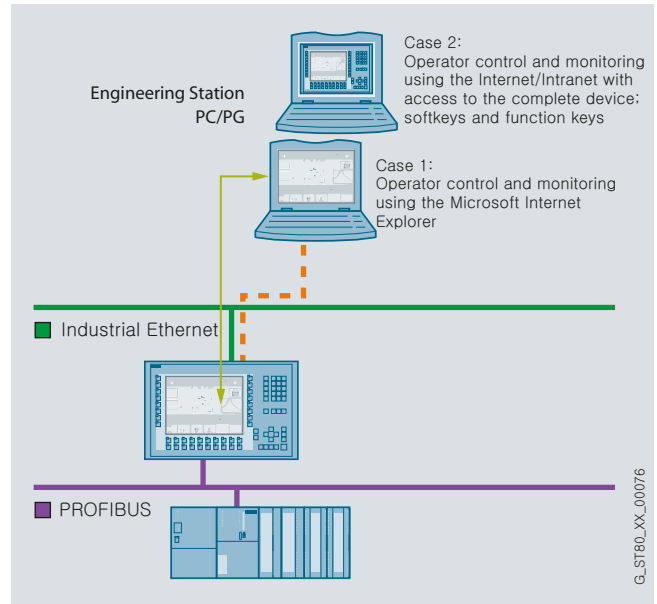

Remote operator control and monitoring of SIMATIC HMI systems using Industrial Ethernet and/or via the Intranet/Internet

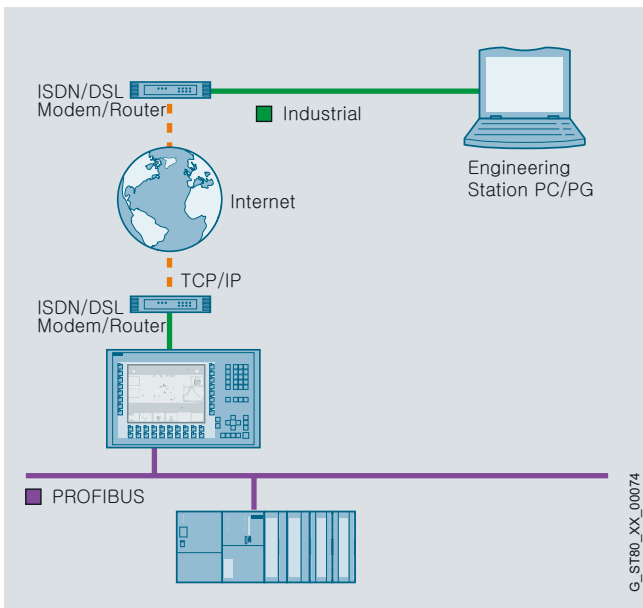

Remote operator control and monitoring of SIMATIC HMI systems using Industrial Ethernet and/or via the Intranet/Internet

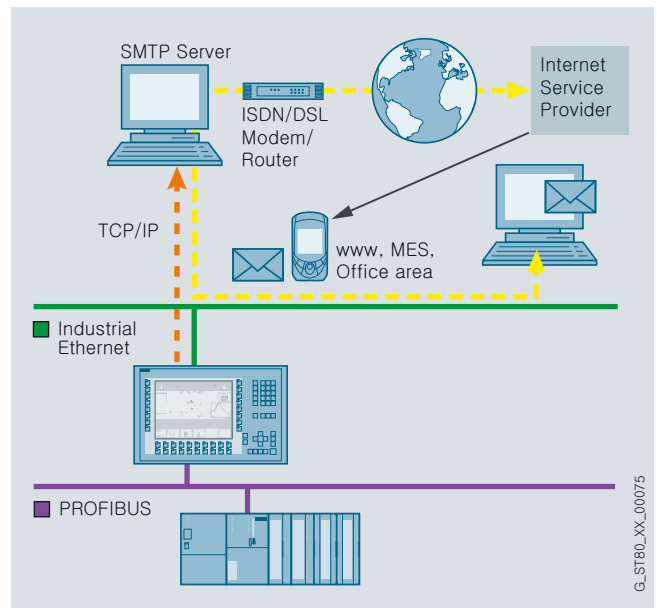

Sending e-mails to maintenance personnel via SMTP server (Simple Mail Transfer Protocol)

# HMI Software

## SIMATIC WinCC flexible options

### WinCC flexible /Sm@rtService

#### Technical specifications

Type	WinCC flexible /Sm@rtService
<b>Execution platform</b>	
• SIMATIC Panels	Mobile Panel 177 PN, Mobile Panel 277, TP 177B PN/DP, OP 177B PN/DP, TP/OP 270, TP/OP 277
• SIMATIC Multi Panels	MP 177, MP 270B, MP 277, MP 370, MP 377
• PCs	SIMATIC WinCC flexible Runtime
<b>Sm@rtService</b> <sup>1)</sup>	
Remote access via	Internet Explorer V6.0 SP1 and higher
HTML pages	
• for Panels/Multi Panels	HTML V1.1 (no support for ActiveX, Java, ASP)
• for WinCC flexible Runtime	HTML V1.1
Sending emails	<ul style="list-style-type: none"> <li>• via SMTP server</li> <li>• Subject, message texts with 250 characters of text per email; date/time of message, message No.</li> </ul>

<sup>1)</sup> The Sm@rtServer and the WinCC flexible /ProAgent option cannot be used simultaneously on OP/TP/MP 270/370. Parallel operation of the runtime options ProAgent, Sm@rtAccess and Sm@rtService is possible in the context of the MP 277 8" and 10" devices, Mobile Panel 277 as well as the MP 377. Limitation: a maximum of 2 clients can be connected with a Sm@rtServer.

#### Ordering data

#### Order No.

<b>WinCC flexible /Sm@rtService for SIMATIC Panels</b> <sup>1)</sup>	<b>6AV6618-7BB01-3AB0</b>
Single license, license key only	
<b>WinCC flexible /Sm@rtService for WinCC flexible Runtime 2008</b> <sup>1)</sup>	<b>6AV6618-7BD01-3AB0</b>
Single license, license key only	

<sup>1)</sup> The "WinCC flexible /Sm@rtService for Panel" license or "WinCC flexible /Sm@rtService for WinCC flexible Runtime" license must be installed on the operator panels that use one of the following options: Sm@rtServer, HTML pages, e-mail. The remote service PC and engineering system do not require a license for configuration of the Runtime option.

#### More information

##### Note

Do you need a specific modification or option for the products described here? Then look up "Customized products", where you will find information about the Open Platform Program for the creation of user-specific functions and controls for WinCC flexible.

### Overview

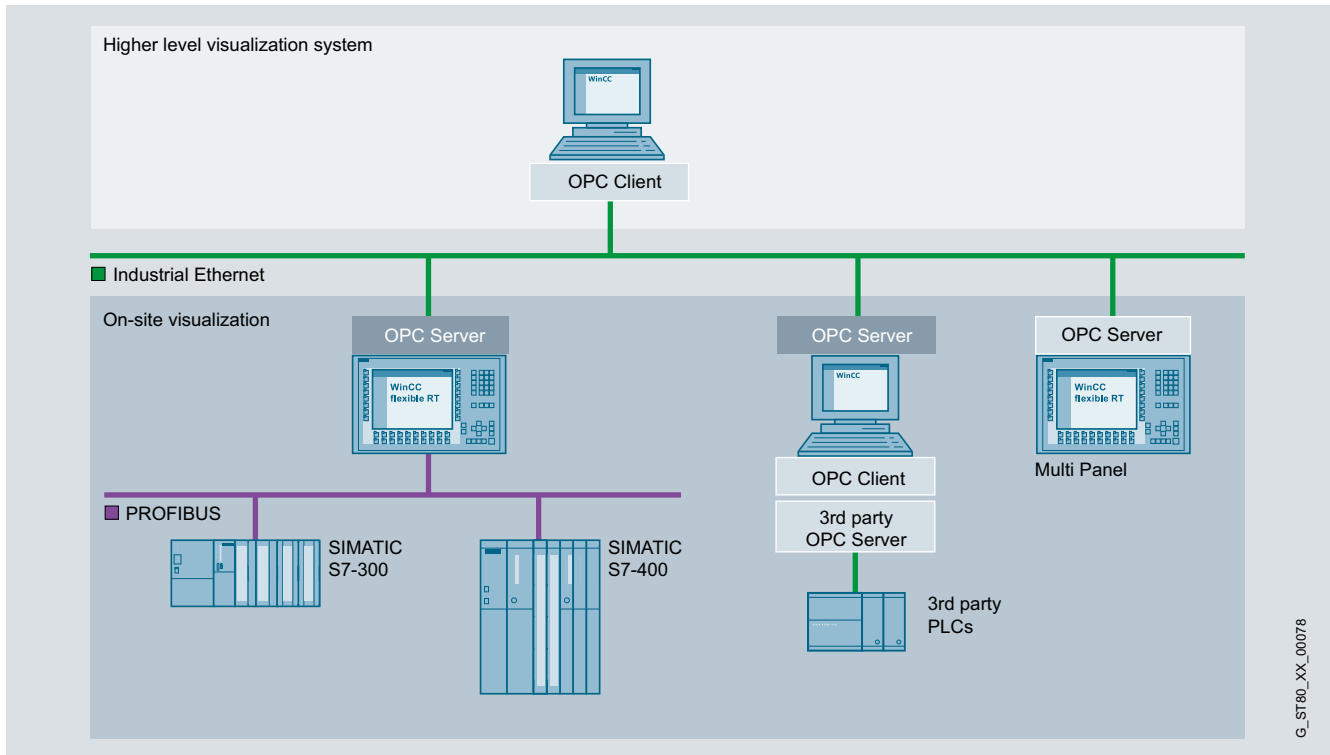

- Option for SIMATIC WinCC flexible Runtime as well as Multi Panels for communication with applications from different vendors (e.g. MES, ERP, or applications in the office sector)
- Available for the following SIMATIC HMI systems:
  - Mobile Panel 277, MP 270B, MP 277, MP 370, MP 377 (use of OPC on XML basis)
  - WinCC flexible Runtime (use of OPC based on DCOM)
- One license is required for each operator station.

### Benefits

- Incorporation of automation components from different vendors into an automation concept
- Saving of development costs through communication between automation systems based on a homogeneous, uniform protocol
- Reduction in load on fieldbuses: WinCC flexible Runtime as well as SIMATIC Panels permit a control system, for example, to access the process data. The sensitive field level is not loaded by the control level as far as the communications requirements are concerned. The requirements are processed by WinCC flexible Runtime and the SIMATIC Panels.

### Application

OPC (OLE for Process Control) is a standardized, open, uniform and multi-vendor software interface. OPC is based on the Windows technology of COM (Component Object Model), DCOM (Distributed COM) or on XML.

Windows-based systems such as SIMATIC Panel PC or SIMATIC Multi Panels are used for tasks at the machine and process levels, and can communicate with all OPC-compatible applications via Ethernet using TCP/IP and OPC. WinCC flexible Runtime or the SIMATIC Multi Panel (OPC server) provide data for one or more OPC clients. As a result, local visualization and data processing are possible to the same extent as plant-wide calling of information or archiving of process data. Uniform flows of information guarantee an overview of the status of all processes.

Communication with OPC-compatible applications from different vendors (e.g. MES, ERP, or applications in the office sector) is possible.

#### OPC Foundation

<http://www.opcfoundation.org>



# HMI Software

## SIMATIC WinCC flexible options

### WinCC flexible /OPC server

#### Function

- Use of a visualization system as a data server (OPC server) for higher-level automation components such as control systems or office systems
  - OPC-XML server for multi panels
  - OPC server (DCOM) for WinCC flexible Runtime
- The WinCC flexible engineering system can conveniently select a desired OPC item from the variables function of the OPC server using an OPC browser (component of the OPC server). To do this, the OPC server must be started and must be accessible for the engineering system.

#### Technical specifications

Type	WinCC flexible /OPC Server
	The specifications are maximum values
<b>Execution platform</b>	
<ul style="list-style-type: none"> <li>• SIMATIC Panels</li> <li>• SIMATIC Multi Panels</li> <li>• PCs</li> </ul>	Mobile Panel 277 MP 270B, MP 277, MP 370, MP 377 SIMATIC WinCC flexible Runtime
<b>OPC server</b>	
<ul style="list-style-type: none"> <li>• XML server for Multi Panels</li> <li>• DCOM server for WinCC flexible Runtime</li> <li>• Number of connections that an OPC server can accommodate</li> </ul>	Supports the OPC XML Data Access specification V1.0 <sup>1)</sup> Supports the OPC Data Access specification V1.0a and V2.0 8

<sup>1)</sup> Data access via XML has a functional scope that is similar to OPC Data Access. A software adapter is required that must be installed on the OPC client PC to enable DCOM-based OPC clients to access the OPC XML server without any modification. The software adapter is supplied with WinCC flexible Engineering and Runtime.

#### Ordering data

#### Order No.

<b>WinCC flexible /OPC Server for SIMATIC Multi Panels</b> <sup>1)</sup> Single license, license key only	<b>6AV6618-7CC01-3AB0</b>
<b>WinCC flexible /OPC server for WinCC flexible Runtime 2008</b> <sup>1)</sup> Single license, license key only	<b>6AV6618-7CD01-3AB0</b>

<sup>1)</sup> One license is required for each operator station.  
A license is not required for the engineering system for configuring the Runtime option.

#### More information

##### Note

Do you need a specific modification or option for the products described here? Then look up "Customized products", where you will find information about the Open Platform Program for the creation of user-specific functions and controls for WinCC flexible.

### Overview

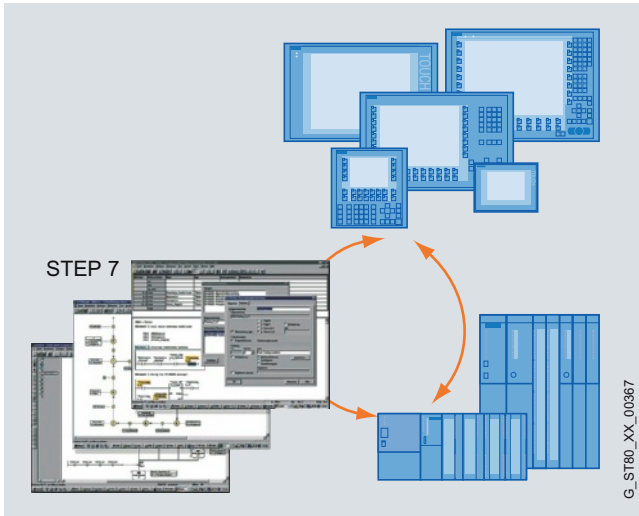

- Targeted and rapid process diagnostics in plants and machines for SIMATIC S7 and SIMATIC HMI
- Standardized diagnostics concept for various SIMATIC components
- No further configuration overhead for diagnostics functionality
- Frees up PLC capacity with regard to memory and program execution time

#### Note

For further information, refer to "SIMATIC ProAgent Process Diagnostics Software".

### Ordering data

### Order No.

#### WinCC flexible /ProAgent

Software option package for process diagnostics based on Functional enhancement for SIMATIC WinCC flexible; electronic documentation in English, French, German, Italian, and Spanish

#### • WinCC flexible /ProAgent for SIMATIC Panels <sup>1)</sup>

Runtime license (Single License) executable on Mobile Panel 277, TP/OP/MP 270/277 and MP 370/377

**6AV6618-7DB01-3AB0**

#### • WinCC flexible/ProAgent for WinCC flexible Runtime 2008 <sup>1)</sup>

Runtime license (single license)

**6AV6618-7DD01-3AB0**

<sup>1)</sup> One license is required for each operator station. A license is not required for the engineering system for configuring the Runtime option.

### More information

#### Note

Do you need a specific modification or option for the products described here? Then look up "Customized products", where you will find information about the Open Platform Program for the creation of user-specific functions and controls for WinCC flexible.

# HMI Software

## SCADA system SIMATIC WinCC

### SIMATIC WinCC

#### Overview

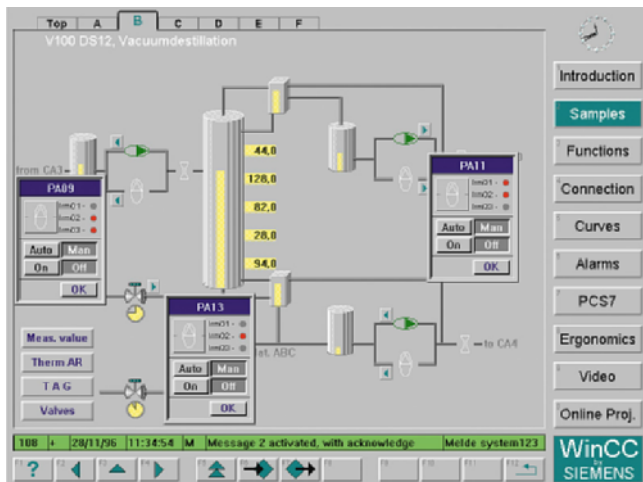

- PC-based operator control and monitoring system for visualizing and operating processes, production flows, machines and plants in all sectors – from the simple single-user station through to distributed multi-user systems with redundant servers and cross-location solutions with Web clients. WinCC is the information hub for corporation-wide vertical integration.
- The basic system configuration (WinCC basic software) includes industry-standard functions for signaling and acknowledging events, archiving of messages and measured values, logging of all process and configuration data, user administration and visualization.
- The WinCC basic software forms the core of a wide range of different applications. Based on the open programming interfaces, a wide range of WinCC options (from Siemens Industry Automation) and WinCC add-ons have been developed (by Siemens-internal and external partners).
- WinCC can be operated with every PC that meets the given HW requirements. The SIMATIC Box / Panel PC and SIMATIC Rack PC product range in particular is available for the industrial use of WinCC systems. SIMATIC PCs impress with their powerful PC technology, are designed for round-the-clock operation, and can be operated in both office areas and harsh industrial environments.
- SIMATIC WinCC can be ordered in combination with a SIMATIC IPC (Box/Rack/Panel PC) as SIMATIC HMI Package at a price advantage
- Together with the SIMATIC IPC427C and IPC477C there are turnkey solutions available as WinCC standard client or single station (see also Packages and IPC427C/IPC477C)

Current versions:

#### **SIMATIC WinCC V7.2**

Executable with:

- Windows 7 SP1 (32 / 64 bit) Professional, Enterprise, Ultimate
- Windows XP Professional SP3
- Windows Server 2003 SP2, Standard
- Windows Server 2008 SP2 (32 bit) Standard
- Windows Server 2008 R2 SP1 (64 bit) Standard
- contains the Microsoft SQL Server 2008 R2 SP1 (32 bit)

#### **SIMATIC WinCC V7.0 SP3**

Executable with:

- Windows 7 SP1 (32 / 64 bit) Professional, Enterprise, Ultimate
- Windows XP Professional SP3
- Windows Server 2003 SP2 and Windows Server 2003 R2 SP2 Standard
- Windows Server 2008 SP2 (32 bit) Standard
- Windows Server 2008 R2 SP1 (64 bit) Standard includes the Microsoft SQL Server 2005 SP4
- Use in virtual environments – for additional information, see <http://support.automation.siemens.com/WW/view/en/49370459>

#### **SIMATIC WinCC V6.2 SP3**

Executable with:

- Windows XP Professional SP3
- Windows 2000 Professional SP4
- Windows Server 2003 SP2 and Windows Server 2003 R2 SP2 include Microsoft SQL Server 2005 SP2

### Benefits

- All-purpose
  - Solutions for all sectors
  - Multilingual for worldwide usage
  - Can be integrated into all automation solutions
- All HMI functions on board
  - User administration
  - Operator control and monitoring
  - Reporting, acknowledging, and archiving of events
  - Acquisition, compression and archiving of measured values (incl. long-term backup)
  - Logging and documenting of process and configuration data
- Can be configured simply and efficiently
  - Configuration wizards let the user focus on the essentials
  - In the picture by means of cross-reference lists and screen property displays
  - Configuration of multilingual applications
  - Configuring tool for configuring bulk data
- Universally scalable
  - Expandable from single station to client-server configurations
  - Increased availability by means of redundant servers
  - Process visualization via the web with the WinCC WebNavigator
- Open standards for simple integration
  - Powerful real-time database Microsoft SQL Server 2008 R2 SP1 (32 bit)
  - Open for application modules with ActiveX controls
  - Visual Basic for Applications for individual expansions
  - OPC for cross-vendor communication
- Process visualization with Plant Intelligence
  - Integrated high-performance Historian on the basis of the Microsoft SQL Server 2008 R2 SP1 (32 bit)
  - Integrated evaluation functions for the online analysis (statistical process control)
  - Production optimization with the help of diverse options
- Expandable using options and add-ons
  - Options for scalable configurations
  - Options for increasing the availability
  - Options for IT & business integration
  - Options for SCADA expansions
  - Options for validation in accordance with FDA 21 CFR Part 11
  - Options for the use of telecontrol protocols
- Part of Totally Integrated Automation
  - Direct access to the tag and message configuration of the SIMATIC control system
  - Integrated diagnostic functions for increasing productivity
  - Options for the use of telecontrol protocols

### New in V7.2

- Expansion into Graphic Designer
  - Know-how protection by means of password protection for PDL images and image blocks
- Unicode support
  - WinCC SETUP in 5 languages / up to 9 installed languages
  - Individual language selection for engineering and runtime, regardless of the language settings in the operating system
- Simplified configuration of the Tag Management by means of the innovative WinCC Configuration Studio
  - Configuration options similar to those in Excel
  - Simplified tags / structure tag management
- New communication channels
  - Communication channel to new CPU (S7-1200 / S7-1500) (absolute address only, no CPU alarming support)
  - Introduction of the OPC UA server (DA, HDA)
- Expansion into archive system
  - New archive recording (day, week, year)
  - New archiving methods (difference)

and more ...

# HMI Software

## SCADA system SIMATIC WinCC

### SIMATIC WinCC

#### Application

SIMATIC WinCC is designed for visualization and operation of processes, manufacturing cycles, machines and plants. With its powerful process interface, especially to the SIMATIC family, and the secure data archiving, WinCC enables highly available solutions for the process control.

The sector-neutral basic system enables universal usage in all automation applications. Sector-specific solutions can, for example, be implemented using WinCC options (e.g. FDA options for the pharmaceutical industry) and sector-specific add-ons (e.g. for the water industry).

#### Design

SIMATIC WinCC is available as a complete package and as a runtime package with 128, 512, 2048, 8192, 65536, 102400, 153600, 262144 PowerTags<sup>1)</sup>.

PowerTags are data points that are connected to controllers or other data sources over a WinCC channel. Up to 32 alarms can be obtained from one data point. Moreover, internal tags without coupling are available for additional system performance. In addition WinCC also contains 512 archive tags. Individual archive licenses can be obtained for greater quantity structures.

#### Licenses for a multi-user configuration

The system software with the required number of PowerTags and additionally the option WinCC/Server must be installed on the WinCC server.

In the basic configuration, an RT128 or RT client license is sufficient for the WinCC clients. In order to configure on clients, an RC128 or RC client license is required. Remote configuration is possible if WinCC clients without their own project (UniClient) on the server project are configured.

<sup>1)</sup> V6: 128, 256, 1024, 8192, 65536 PowerTags

#### Function

The powerful configuration functions of SIMATIC WinCC contribute to a reduced engineering and training overhead and lead to a more flexible use of personnel and greater operational reliability. Whoever is familiar with Microsoft Windows can also operate the WinCC Explorer, the central switching point of WinCC.

In combination with other SIMATIC components, the system is also equipped with auxiliary functions such as process diagnostics and maintenance. All SIMATIC engineering tools work together in the configuration of the functions.

SIMATIC WinCC offers a complete basic functionality for process visualization and operation. To this end WinCC has a number of editors and interfaces that can be used to individually configure this functionality according to the respective application. Expansions of a WinCC station for control tasks are also possible with minimal engineering effort.

WinCC editors	Task or configurable runtime functionality
WinCC Explorer	Central project management for the quick access to all project data and central settings
WinCC Graphics Designer	Graphics system for user-defined visualization and operation via pixel-graphic objects
WinCC Alarm Logging	Signaling system for detecting and archiving events with display and control options according to DIN 19235; freely selectable message classes, message display and logging
WinCC Tag Logging	Process archiving for the acquisition, compression and storage of measured values, e.g., presentation in trend and table format as well as further processing
WinCC Report Designer	Reporting and logging system for time and event-controlled documentation of messages, operator inputs and current process data in the form of user reports or project documentation in an arbitrary layout
WinCC User Administrator	Tool for user-friendly administration of users and authorizations
WinCC Global Script	Processing functions with limitless functionality by means of the use of VBScript and ANSI-C

### Function (continued)

#### Interfaces

	Task or configurable runtime functionality
Communication channels	For communication with subordinate controls (SIMATIC protocols, PROFIBUS DP, PROFIBUS FMS, DDE and OPC server included in the scope of delivery)
Standard interfaces	For the open integration of other Windows applications via WinCC, WinCC-OLE-DB, ActiveX, OLE, DDE, OPC, etc.)
Programming ports	For the individual access to data and functions of WinCC and for the integration in user programs with VBA, VB Script, C-API (ODK), C-Script (ANSI-C)

### Integration

#### Integration in company-wide solutions (IT and business integration)

WinCC is strictly based on Microsoft technology, which provides the greatest possible compatibility and integration ability. ActiveX and .net<sup>1)</sup> controls support technology-specific and industry-specific expansions. Cross-manufacturer communication is also a simple exercise. The reason: WinCC can be used as an OPC client and server, and in addition to access to current process values, it also supports standards such as OPC HDA (Historical Data Access), OPC Alarm & Events, and OPC XML Data Access.

Just as important: Visual Basic for Applications (VBA) for user-specific expansions of the WinCC Graphics Designer and Visual Basic Scripting (VBS) as an easy-to-learn, open runtime language. If desired, professional application developers can also use ANSI-C. And access to the API programming interfaces is really simple with the Open Development Kit ODK.

WinCC integrates a powerful and scalable historian function based on Microsoft SQL Server 2005 into the basic system. As a result, users have every possibility: from high-performance archiving of current process data, to long-term archiving with high data compression, through to a central information hub in the form of a company-wide process historian. With the help of the Central Archive Server option, this can be set up within the framework of a WinCC solution. Versatile clients and tools for evaluation, the open interfaces, and special options (Connectivity Pack, Connectivity Station, IndustrialDataBridge) provide the basis for effective IT and business integration.

If external networks are accessed, suitable protective measures (incl. IT security measures, such as network segmentation) should be taken in order to ensure safe operation of the system.

You can find more information on the topic of Industrial Security on the Internet at:

<http://www.siemens.com/industrialsecurity>

<sup>1)</sup> Only supported in WinCC V7.0 or higher

#### Integration in automation solutions

WinCC is an open process visualization system and provides the option to connect the most diverse control systems.

#### Approved communication software

Only communication software with the listed product versions (or higher) should be used. Corresponding SIMATIC NET upgrades are available for upgrading older versions.

#### Number of connectable controls

For the number of controls connectable via Industrial Ethernet CP 1613, the following applies to a message frame length of 512 bytes:

Type of connection	Number of nodes
SIMATIC S5 Ethernet Layer 4 + TCP/IP	Up to 60
SIMATIC S7 Protocol Suite	Up to 64
SIMATIC 505 Ethernet Layer 4 + TCP/IP	Up to 60

Via PROFIBUS, a maximum of 8 controls can be connected with CP 5611, and a maximum of 44 controls with CP 5613. With approx. 10 or more controls, the usage of Industrial Ethernet is recommended.

#### Mixed operation with different controls

With their multi-protocol stack, the CP 1613 and CP 5613 communication processors allow parallel operation of two protocols, such as for the mixed operation of different controls, via a bus cable. WinCC supports the operation of two similar interface boards only in connection with the channels SIMATIC S5 Ethernet Layer 4 (2 x CP 1613), SIMATIC S7 Protocol Suite (2 x CP 1613, 2 x CP 5613) as well as PROFIBUS DP (4 x CP 5613; each CP 5613 max. 122 slaves). In addition to communication over industrial Ethernet CP 1613 or PROFIBUS CP 5613, one CP 5611 can be used in each case for communication with SIMATIC S7 via MPI.

#### Client-server communication

Communication between the clients and the server is via TCP/IP protocol. Setting up a separate PC LAN is recommended. For small projects with a correspondingly low incidence of message frames, SIMATIC NET Industrial Ethernet communication can be used for both process communication (WinCC/Server ↔ PLC) and PC-PC communication (WinCC/client ↔ WinCC/server).

#### Channel DLL PROFIBUS DP

In accordance with the PROFIBUS standard, DP/slaves are always permanently assigned to a DP master; i.e. a second WinCC station (DP/master) cannot access the same controls (DP/slave). This means that redundant operation of two WinCC stations is not possible using the PROFIBUS DP connection.

# HMI Software

## SCADA system SIMATIC WinCC

### SIMATIC WinCC

#### Integration (continued)

##### Connection to controls from other manufacturers:

OPC (OLE for Process Control) is recommended for the connection of controls from other manufacturers.

Current notes and information about OPC servers from various suppliers can be found at: <http://www.opcfoundation.org>

WinCC supports the standards:

- OPC Data Access 2.05a
- OPC Data Access 3.00
- OPC XML Data Access 1.00 (Connectivity Pack / Connectivity Station)
- OPC HDA 1.20 (Connectivity Pack / Connectivity Station)
- OPC A&E 1.10 (Connectivity Pack / Connectivity Station)
- OPC UA Client Data Access
- OPC UA Server Data Access, HDA (Connectivity Pack / Connectivity Station)

#### Connection overview

Protocol	Description
<b>SIMATIC S7</b>	
SIMATIC S7 Protocol Suite	Channel DLL for S7 functions via MPI, PROFIBUS or Ethernet Layer 4 + TCP/IP
<b>SIMATIC S5</b>	
SIMATIC S5 Ethernet Layer 4	Channel DLL for S5 Layer 4 communication + TCP/IP
SIMATIC S5 Programmer Port AS511	Channel DLL and driver for serial communication with S5 using AS511 protocol to programmers port
SIMATIC S5 Serial 3964R	Channel DLL and driver for serial communication with S5 using RK512 protocol
SIMATIC S5 PROFIBUS-FDL	Channel DLL for S5-FDL
<b>SIMATIC 505</b>	
SIMATIC 505 Serial	Channel DLL and driver for serial communication with 505 using NITP/TBP protocol to SIMATIC 535/545/555/565/575
SIMATIC 505 Ethernet Layer 4	Channel DLL for 505 Layer 4 communication
SIMATIC 505 TCP/IP	Channel DLL for 505 TCP/IP communication
<b>SIMATIC S7-1200, S7-1500 (WinCC 7.2 or higher)</b>	
SIMATIC S7-1200, S7-1500 Channel <sup>1)</sup>	Channel DLL for S7-1200 and S7-1500 communication
<b>Controllers from other manufacturers (from WinCC V7.0 SP3)</b>	
Allen Bradley Ethernet IP	Channel DLL and drivers for communication with Allen Bradley controllers via Ethernet TCP/IP using Ethernet IP protocol
Modbus TCP/IP	Channel DLL and drivers for communication with Modicon controllers via Ethernet TCP/IP using Modbus TCP/IP protocol
Mitsubishi MC TCP/IP	Channel DLL and drivers for communication with Mitsubishi controllers via Ethernet TCP/IP using Mitsubishi MC TCP/IP protocol
<b>Cross-manufacturer</b>	
OPC client <sup>1) 2)</sup> for DA, XML DA	Channel DLL for OPC communication, WinCC can acquire data from OPC server applications.
OPC server for DA, XML DA, A&E, HDA	Server applications for OPC communication; WinCC provides process data to OPC clients
OPC UA server for DA, HDA	Server applications for OPC UA communication
PROFIBUS FMS	Channel DLL for PROFIBUS FMS
PROFIBUS DP	Channel DLL for PROFIBUS DP
SIMOTION	Channel DLL for SIMOTION

<sup>1)</sup> WinCC version V7.2 or higher supports communication with S7-1200 / S7-1500 CPU.  
Restrictions: No symbolic address, type safe structure support (absolute address only) No CPU alarming support

<sup>2)</sup> Application note:  
Parallel usage of the OPC client channel allows, for example, connection to an SNMP-OPC server for visualization of the data contained there. The SNMP OPC server enables monitoring of any network components (such as switches) that support the SNMP protocol. You can find more information under SIMATIC NET Communications Systems/SNMP OPC Server.

<sup>3)</sup> WinCC V7.0 SP3 and later supports OPC UA (United Architecture) Client for DA.



### Integration (continued)

#### Communications components for PG/PC for SIMATIC (for WinCC V7.2)

Industrial Ethernet	SIMATIC S5 Ethernet Layer 4	SIMATIC S5 TCP/IP	SIMATIC S7 Protocol Suite	SIMATIC 505 Ethernet Layer 4	SIMATIC 505 TCP/IP <sup>1)</sup>	Order No.
<b>WinCC – channel DLL</b>						
<b>SIMATIC S5 Ethernet Layer 4</b> Channel DLL for S5 Layer 4 communication + TCP/IP	•	•				Included in the basic package
<b>SIMATIC S7 Protocol Suite</b> Channel DLL for S7 functions			•			Included in the basic package
<b>SIMATIC 505 Ethernet Layer 4</b> Channel DLL for 505 Layer 4 communication				•		Included in the basic package
<b>SIMATIC 505 TCP/IP<sup>1)</sup></b> Channel DLL for 505 TCP/IP communication					•	Included in the basic package

#### Communication components for extension of the OS/OP

<b>CP 1612</b> PCI card for connecting a PG/PC to Industrial Ethernet (SOFTNET-S7 or SOFTNET-S7 Lean communication software must be ordered separately)		•	•		•	<b>6GK1161-2AA00</b>
<b>SOFTNET-S7</b> Communication software for S7 functions (max. 64 connections) • Version 8.1 <sup>2)3)</sup> for Windows 7 (32/64-bit) and Server 2008 R2 (64-bit)		•	•			<b>6GK1704-1CW81-3AA0</b>
• Edition 2008 SP2 (V7.1) <sup>2)</sup> for Windows XP/2003 Server/(32-bit) 2008 Server						<b>6GK1704-1CW71-3AA0</b>
<b>SOFTNET-S7 Lean</b> Communication software for S7 functions (max. 8 connections) • Version 8.2 SP1 <sup>2)4)</sup> for Windows 7 (32/64-bit) and Server 2008 R2 (64-bit)		•	•			<b>6GK1704-1LW08-2AA0</b>
• Edition 2008 SP2 (V7.1) <sup>2)4)</sup> for Windows XP/2003 Server / (32-bit) 2008 Server						<b>6GK1704-1LW71-3AA0</b>
<b>CP 1613</b> PCI card for connecting a PG/PC to Industrial Ethernet (S7-1613 communication software must be ordered separately)	•	•	•	•	•	<b>6GK1161-3AA00</b>
<b>CP 1613 A2</b> PCI card (32-bit) for connecting a PG/PC to Industrial Ethernet (S7-1613 communication software required)	•	•	•	•	•	<b>6GK1161-3AA01</b>
<b>CP 1623</b> PCI Express X1 card (32-bit) for connecting a PG/PC to Industrial Ethernet (S7-1613 communication software required)	•	•	•	•	•	<b>6GK1162-3AA00</b>
<b>S7-1613</b> Communication software for S7 functions and S5/505 Layer 4 communication with TCP/IP • Version 8.2 SP1 <sup>2)3)</sup> for Windows 7 (32/64-bit) and Server 2008 R2 (64-bit)	•	•	•	•		<b>6GK1716-1CB08-2AA0</b>
• Edition 2008 SP2 (V7.1) <sup>2)</sup> for Windows XP/2003 Server / (32-bit) 2008 Server						<b>6GK1 716-1CB71-3AA0</b>

- System interface possible

<sup>1)</sup> Via any interface board with NDIS 3.0 interface; no separate communication software required

<sup>2)</sup> See ordering data for SIMATIC NET upgrade packages

<sup>3)</sup> SIMATIC NET Version 8.2 SP1

<sup>4)</sup> SOFTNET-S7 Lean included in scope of supply of WinCC V7.2

# HMI Software

## SCADA system SIMATIC WinCC

### SIMATIC WinCC

#### Integration (continued)

#### Communication components for PG/PC for SIMATIC (for WinCC V7.0)

PROFIBUS	SIMATIC S5 PROFIBUS FDL	SIMATIC S7 Protocol Suite	PROFIBUS DP	PROFIBUS FMS	Order No.
<b>WinCC – channel DLL</b>					
<b>SIMATIC S5 PROFIBUS FDL</b> Channel DLL for S5-FDL	•				Included in the basic package
<b>SIMATIC S7 Protocol Suite</b> Channel DLL for S7 functions		•			Included in the basic package
<b>PROFIBUS DP</b> Channel DLL for PROFIBUS DP			•		Included in the basic package
<b>PROFIBUS FMS</b> Channel DLL for PROFIBUS FMS				•	Included in the basic package

#### Communication components for extension of the OS/OP

<b>CP 5611 A2</b> PCI card (32-bit) for connecting a PG/PC to PROFIBUS or MPI (communication software included in WinCC basic package)		•			<b>6GK1561-1AA01</b>
<b>CP 5612</b> <sup>2)</sup> PCI card (32-bit) for connecting a PG/PC to PROFIBUS (communication software included in WinCC basic package)		•			<b>6GK1561-2AA00</b>
<b>CP 5621</b> PCI Express X1 card (32-bit) for connecting a PG/PC to PROFIBUS or MPI (communication software included in WinCC basic package)		•			<b>6GK1562-1AA00</b>
<b>CP 5622</b> <sup>2)</sup> PCI Express X1 card (32-bit) for connecting a PG/PC to PROFIBUS (communication software included in WinCC basic package)		•			<b>6GK1562-2AA00</b>
<b>CP 5711</b> <sup>2)</sup> USB adapter for connecting a PG/PC to PROFIBUS or MPI (communication software included in the WinCC basic package)		•			<b>6GK1571-1AA00</b>
<b>CP 5512</b> PCMCIA card (Cardbus 32-bit) for connecting a PG/PC to PROFIBUS or MPI (communication software included in WinCC basic package)		•			<b>6GK1551-2AA00</b>

• System interface possible

<sup>1)</sup> See ordering data for SIMATIC NET upgrade package

<sup>2)</sup> SIMATIC NET Version 8.2 SP1

### Integration (continued)

#### Communication components for PG/PC for SIMATIC (for WinCC V7.0)

PROFIBUS	SIMATIC S5 PROFIBUS FDL	SIMATIC S7 Protocol Suite	PROFIBUS DP	PROFIBUS FMS	Order No.
<b>Communication components for extension of the OS/OP (continued)</b>					
<b>CP 5613 A2</b> PCI card (32-bit) for connecting a PC to PROFIBUS (S7-5613, DP-5613 or FMS-5613 communication software required)	•	•	•	•	6GK1561-3AA01
<b>CP 5614 A2</b> PCI card (32-bit) for connecting a PC to PROFIBUS (communication software must be ordered separately)	•	•	•	•	6GK1561-4AA01
<b>CP 5623</b> PCI Express X1 card (32-bit) for connecting a PG/PC to PROFIBUS or MPI (S7-5613 communication software or DP-5613 or FMS-5613 required)	•	•	•	•	6GK1562-3AA00
<b>S7-5613</b> communication software for S7 functions + FDL	•	•			
• Version 8.1 <sup>1) 2)</sup> for Windows 7 (32/64-bit) and Server 2008 R2 (64-bit)					6GK1713-5CB81-3AA0
• Edition 2008 SP2 (V7.1) <sup>1) 2)</sup> for Windows XP/2003 Server / (32-bit) 2008 Server					6GK1713-5CB71-3AA0
<b>DP-5613</b> Communication software for DP master + FDL	•		•		
• Version 8.1 <sup>1) 2)</sup> for Windows 7 (32/64-bit) and Server 2008 R2 (64-bit)					6GK1713-5DB81-3AA0
• Edition 2008 SP2 (V7.1) <sup>1) 2)</sup> for Windows XP/2003 Server / (32-bit) 2008 Server					6GK1713-5DB71-3AA0
<b>FMS-5613</b> Communication software for PROFIBUS-FMS + FDL	•			•	
• Edition 2008 SP2 (V7.1) <sup>1) 2)</sup> for Windows XP/2003 Server / (32-bit) 2008 Server					6GK1713-5FB71-3AA0

• System interface possible

<sup>1)</sup> See ordering data for SIMATIC NET upgrade package

<sup>2)</sup> SIMATIC NET Version 8.2 SP1

# HMI Software SCADA system SIMATIC WinCC

## SIMATIC WinCC

### Integration (continued)

#### Communication examples

4

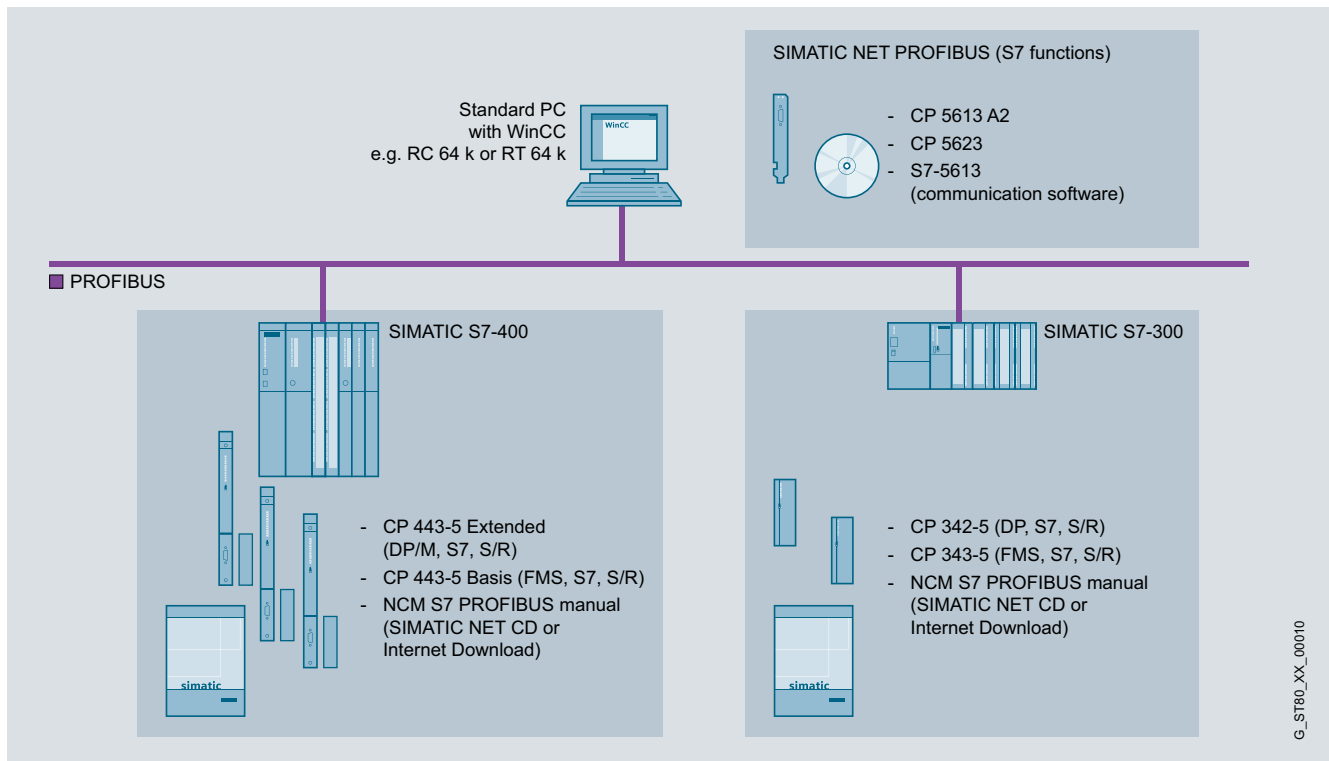

WinCC single-user system: PROFIBUS with S7 communication

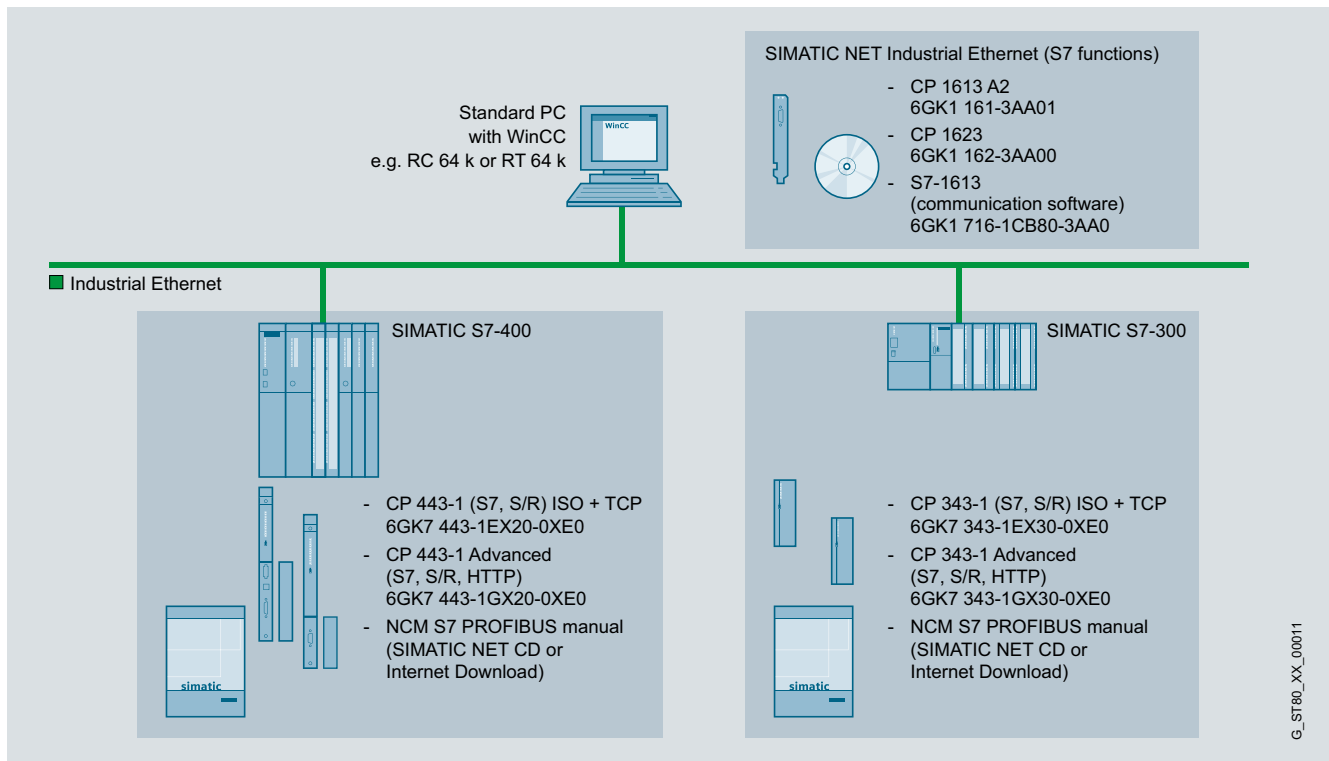

WinCC single-user system: Industrial Ethernet with S7 communication

**Integration** (continued)

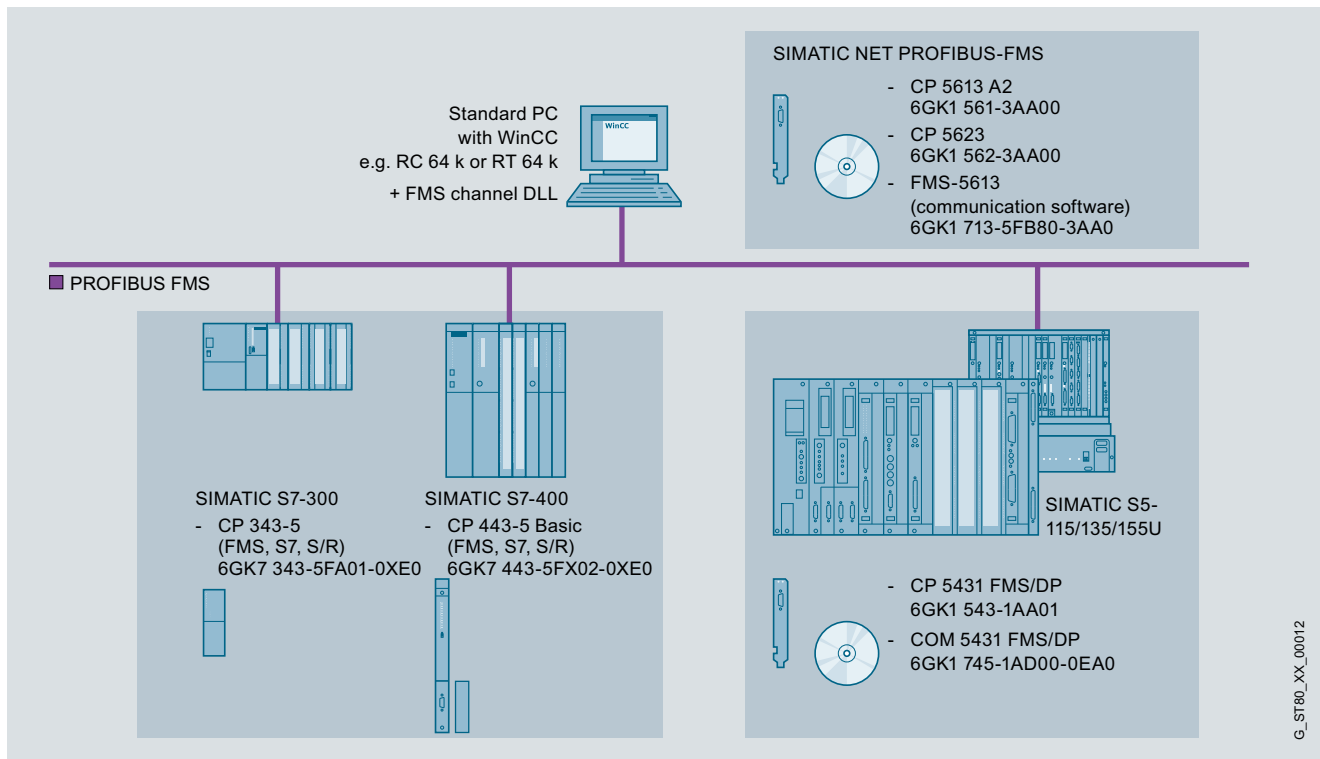

WinCC single-user system: PROFIBUS FMS

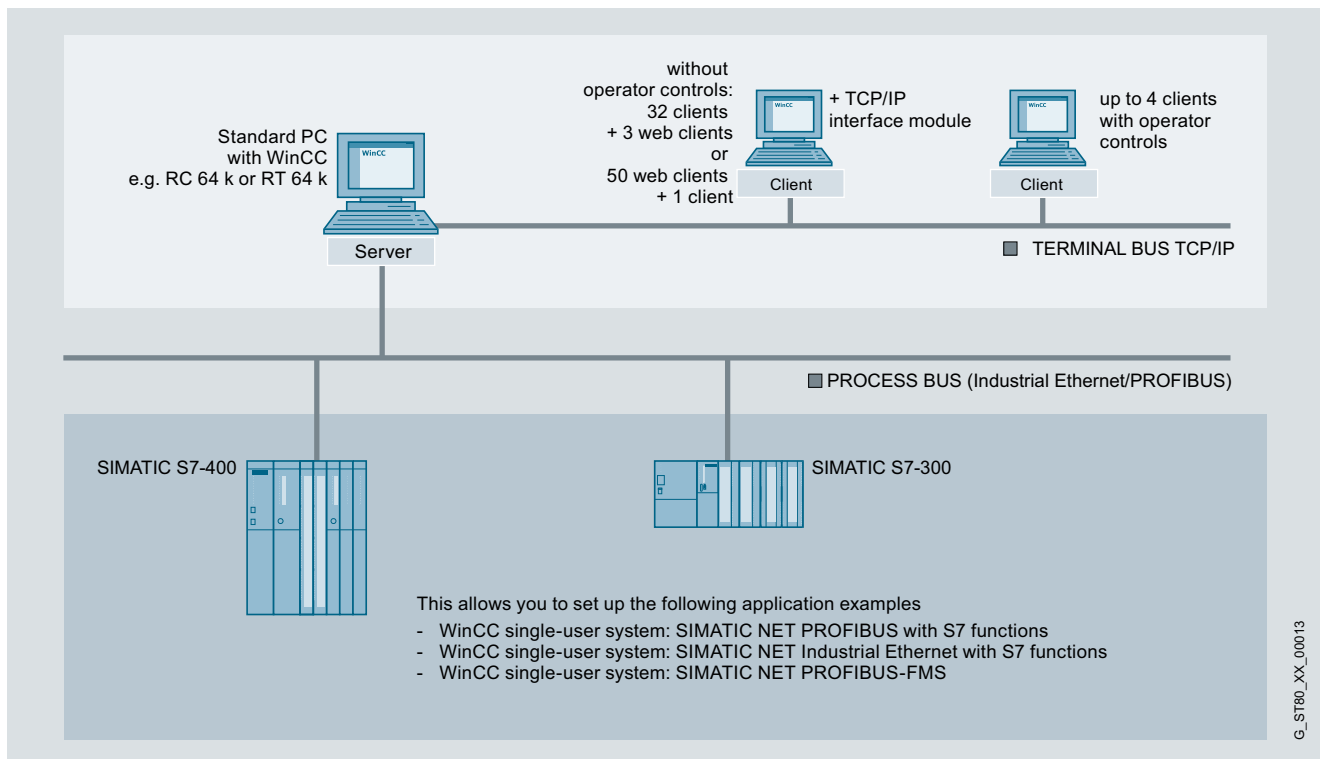

WinCC multi-user system with operable server

# HMI Software SCADA system SIMATIC WinCC

## SIMATIC WinCC

### Integration (continued)

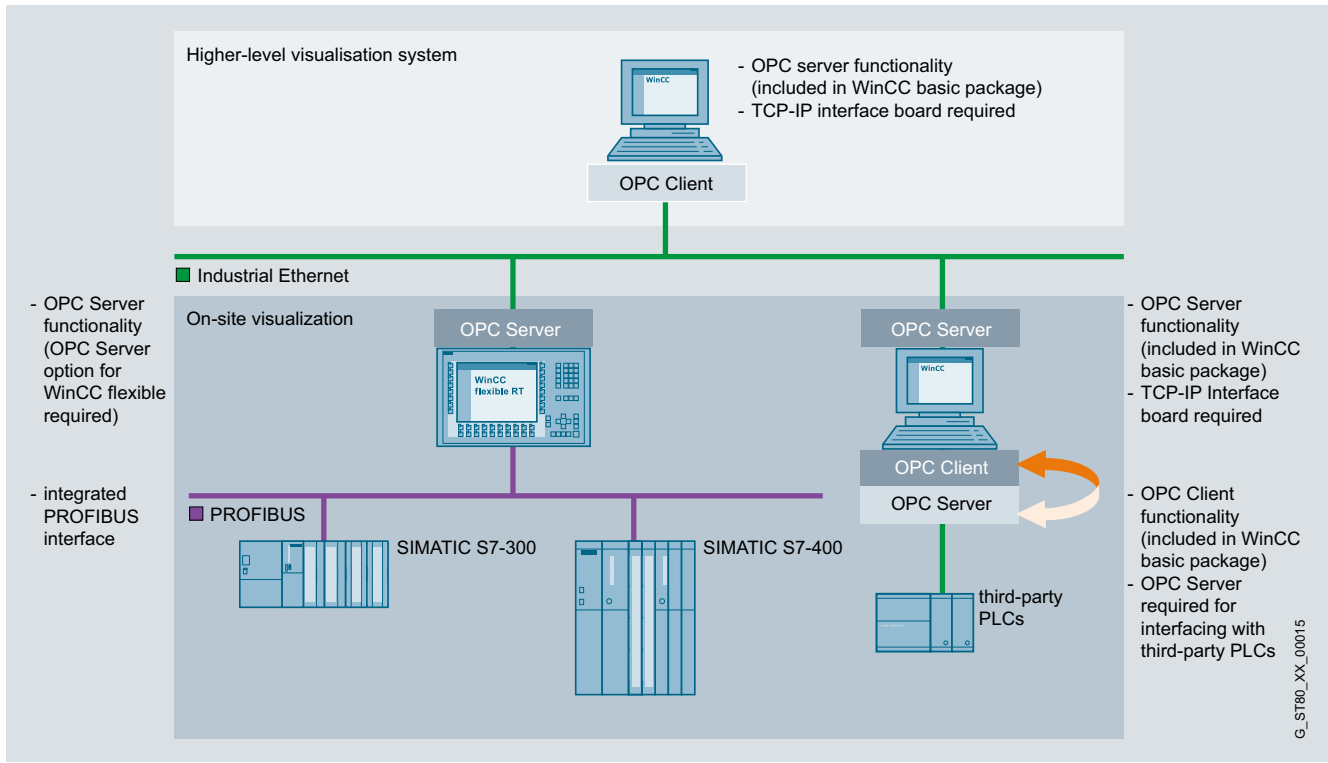

G\_ST80\_XX\_00015

OPC link

### Technical specifications

Type	SIMATIC WinCC V7.2 and V7.0 SP3	SIMATIC WinCC V6.2 SP3
<b>Operating system</b>	<ul style="list-style-type: none"> <li>Windows 7 (32 bit / 64 bit) Ultimate, Professional and Enterprise</li> <li>Windows XP Professional SP3</li> <li>Windows 2003 Server SP2 and Windows 2003 Server R2 SP2</li> <li>Windows Server 2008 SP2 (32 bit) Standard</li> <li>Windows Server 2008 R2 SP1 (64 bit) Standard</li> </ul>	<ul style="list-style-type: none"> <li>Windows XP Professional SP3,</li> <li>Windows 2000 Professional SP4,</li> <li>Windows Server 2003 SP2,</li> <li>Windows Server 2003 R2 SP2</li> </ul>
<b>PC hardware requirements</b>		
<b>Processor type</b> <sup>1)</sup>		
• Minimum	Single-user station/server: Pentium 4, 2.5 GHz <sup>2)</sup>	Single-user station/server: Pentium III, 1 GHz
	Central Archive Server (V7.0 SP3): Pentium 4, 2.5 GHz	Central Archive Server: Pentium 4, 2 GHz
	Client: Pentium 3, 1 GHz <sup>2)</sup>	Client: Pentium III, 600 MHz
	WebClient/DataMonitor Client: Pentium III, 600 MHz <sup>2)</sup>	
• Recommended	Single-user station/server: Pentium 4 or Dual Core, 3 GHz <sup>2)</sup>	Single-user station/server: Pentium 4, 2 GHz
	Central Archive Server (V7.0 SP3): Pentium 4 or Dual Core, 3 GHz	Central Archive Server: Pentium 4, 2.5 GHz
	Client: Pentium 4, 2 GHz <sup>2)</sup>	Client: Pentium III, 1 GHz
	WebClient/DataMonitor Client: Pentium III, 1 GHz	WebClient/DataMonitor Client: Pentium III, 1 GHz
<b>RAM</b>		
• Minimum	Single-user station/server: 4 GB <sup>2)</sup>	Single-user station: 512 MB, server: 1 GB
	Central Archive Server: 4 GB	Central Archive Server: 1 GB
	Client: 1 GB <sup>2)</sup>	Client: 512 MB
	WebClient/DataMonitor Client: 512 MB <sup>2)</sup>	WebClient/DataMonitor Client: 256 MB
• Recommended	Single-user station/server: 8 GB <sup>2)</sup>	Single-user station: ≥ 1 GB, server: >1 GB
	Central Archive Server: ≥ 4 GB	Central Archive Server: ≥ 2 GB
	Client: 2 GB <sup>2)</sup>	Client: 512 MB
	WebClient/DataMonitor Client: 1 GB <sup>2)</sup>	WebClient/DataMonitor Client: 512 MB
<b>Graphics card</b>		
• Minimum	16 MB, 800 x 600 <sup>2)</sup>	16 MB, 800 x 600
• Recommended	32 MB, 1280 x 1024 <sup>2)</sup>	32 MB, 1280 x 1024
<b>Hard disk</b>		
• Minimum	Single-user station/server: 80 GB	Single-user station/server: 20 GB
	Client: 20 GB	Client: 5 GB
	Central Archive Server: 40 GB	Central Archive Server: 40 GB
	WebClient/DataMonitor Client: 5 GB	WebClient/DataMonitor Client: 5 GB
• Recommended	Single-user station/server: 160 GB	Single-user station/server: 80 GB
	Client: 40 GB	Client: 20 GB
	Central Archive Server: 2 x 80 GB	Central Archive Server: 2 x 80 GB
	WebClient/DataMonitor Client: 10 GB	WebClient/DataMonitor Client: 10 GB
• Hard disk (available memory for installation)		
- Minimum	Server: >1.5 GB	Server: 1.5 GB
	Client: 1.5 GB	Client: 1 GB
- Recommended	Server: >10 GB	Server: >10 GB
	Client: >1.5 GB	Client: >1.5 GB
<b>CD-ROM/DVD-ROM/disk drive/ USB port</b>	for software installation	for software installation

<sup>1)</sup> An AMD system with comparable performance can also be used

<sup>2)</sup> Hardware requirements when using Microsoft XP Professional



# HMI Software

## SCADA system SIMATIC WinCC

### SIMATIC WinCC

#### Technical specifications (continued)

Type	SIMATIC WinCC
<b>Functionality/ quantity structure</b>	
Number of messages	150,000
• Message text (number of characters)	10 x 256
• Message archive	> 500,000 messages <sup>1)</sup>
• Process values per message	10
• Constant load of messages, max.	Central Archive Server: 100/sec Server/single-user station: 10/s
• Message burst, max.	Server/single-user station: 2,000/10 s every 5 min
Archives	
• Archive data points	Max. 120,000 per server <sup>2)</sup>
• Archive types	Short-term archive with and without long-term archiving
• Data storage format	Microsoft SQL Server 2005
• Measured values per second, max.	Server/single-user station: 5,000/s
User archive	
• Archives and views	500 each
• Product consisting of data record and column per user archive	320,000
• Fields per user archive	500
Graphics system	
• Number of screens	System-limited <sup>1)</sup>
• Number of objects per screen	System-limited <sup>1)</sup>
• Number of controllable fields per screen	System-limited <sup>1)</sup>

Type	SIMATIC WinCC
PowerTags	256 K <sup>3)</sup>
Trends	
• Trend views per image	25
• Trends per trend view	80
User administration	
• User groups	128
• Number of users	128
• Authorization groups	999
Configuration languages	5 European (Eng., Fr., Ger., It., Sp.), 4 Asian (simpl.+trad. Chi/Kor/Jpn) <sup>4)</sup>
Protocols	
• Message sequence reports (simultaneously)	1 per server/single-user station
• Message archive reports (simultaneously)	3
• User reports	System-limited <sup>1)</sup>
• Report lines per group	66
• Variables per report	300 <sup>5)</sup>
Multi-user system	
• Server	18
• Clients for server with operator station	4
• Clients for server without operator station	32 clients + 3 WebClients or 50 WebClients + 1 client

<sup>1)</sup> Dependent on the available storage space

<sup>2)</sup> Dependent on the number of licensed archive variables

<sup>3)</sup> Dependent on number of licensed PowerTags

<sup>4)</sup> Asian versions for Version 7 SP1 or higher

<sup>5)</sup> The number of variables per report is dependent on process communication performance

Ordering data	Order No.	Order No.
<b>SIMATIC WinCC system software V7.2</b> <b>Runtime packages on DVD</b> Language/script versions: De, En, Fr, It, Es; with license for <ul style="list-style-type: none"> <li>WinCC RT Client</li> <li>128 PowerTags (RT 128)</li> <li>512 PowerTags (RT 512)</li> <li>2048 PowerTags (RT 2048)</li> <li>8192 PowerTags (RT 8192)</li> <li>65536 PowerTags (RT 65536)</li> <li>102400 PowerTags (RT 102400)</li> <li>153600 PowerTags (RT 153600)</li> <li>262144 PowerTags (RT 262144)</li> </ul> Including 512 archive tags each	<b>6AV6381-2CA07-2AX0</b> <b>6AV6381-2BC07-2AX0</b> <b>6AV6381-2BD07-2AX0</b> <b>6AV6381-2BE07-2AX0</b> <b>6AV6381-2BH07-2AX0</b> <b>6AV6381-2BF07-2AX0</b> <b>6AV6381-2BJ07-2AX0</b> <b>6AV6381-2BK07-2AX0</b> <b>6AV6381-2BL07-2AX0</b>	<b>SIMATIC WinCC V7.2 Powerpacks</b> For upgrading from: <b>Runtime packages</b> <ul style="list-style-type: none"> <li>128 to 512 PowerTags</li> <li>512 to 2048 PowerTags</li> <li>2048 to 8192 PowerTags</li> <li>8192 to 65536 PowerTags</li> <li>65536 to 102400 PowerTags</li> <li>102400 to 153600 PowerTags</li> <li>153600 to 262144 PowerTags</li> </ul> <b>Complete packages</b> <ul style="list-style-type: none"> <li>128 to 512 PowerTags</li> <li>512 to 2048 PowerTags</li> <li>2048 to 8192 PowerTags</li> <li>8192 to 65536 PowerTags</li> <li>65536 to 102400 PowerTags</li> <li>102400 to 153600 PowerTags</li> <li>153600 to 262144 PowerTags</li> </ul>
<b>Complete packages on DVD</b> Language versions: De, En, Fr, It, Es; with license for <ul style="list-style-type: none"> <li>WinCC RC Client</li> <li>128 PowerTags (RC 128)</li> <li>512 PowerTags (RC 512)</li> <li>2048 PowerTags (RC 2048)</li> <li>8192 PowerTags (RC 8192)</li> <li>65536 PowerTags (RC 65536)</li> <li>102400 PowerTags (RC 102400)</li> <li>153600 PowerTags (RC 153600)</li> <li>262144 PowerTags (RC 262144)</li> </ul>	<b>6AV6381-2CB07-2AX0</b> <b>6AV6381-2BM07-2AX0</b> <b>6AV6381-2BN07-2AX0</b> <b>6AV6381-2BP07-2AX0</b> <b>6AV6381-2BS07-2AX0</b> <b>6AV6381-2BQ07-2AX0</b> <b>6AV6381-2BT07-2AX0</b> <b>6AV6381-2BU07-2AX0</b> <b>6AV6381-2BV07-2AX0</b>	<b>SIMATIC WinCC V7.2 archives</b> <ul style="list-style-type: none"> <li>1500 archives</li> <li>5000 archives</li> <li>10000 archives</li> <li>30000 archives</li> <li>80000 archives</li> </ul>
<b>SIMATIC WinCC system software V7.2 ASIA</b> <b>Runtime packages on DVD</b> Language/script versions: En, Chs, Cht, Kor, Jpn; with license for <ul style="list-style-type: none"> <li>WinCC RT Client</li> <li>128 PowerTags (RT 128)</li> <li>512 PowerTags (RT 512)</li> <li>2048 PowerTags (RT 2048)</li> <li>8192 PowerTags (RT 8192)</li> <li>65536 PowerTags (RT 65536)</li> <li>102400 PowerTags (RT 102400)</li> <li>153600 PowerTags (RT 153600)</li> <li>262144 PowerTags (RT 262144)</li> </ul> Including 512 archive tags each	<b>6AV6381-2CA07-2AV0</b> <b>6AV6381-2BC07-2AV0</b> <b>6AV6381-2BD07-2AV0</b> <b>6AV6381-2BE07-2AV0</b> <b>6AV6381-2BH07-2AV0</b> <b>6AV6381-2BF07-2AV0</b> <b>6AV6381-2BJ07-2AV0</b> <b>6AV6381-2BK07-2AV0</b> <b>6AV6381-2BL07-2AV0</b>	<b>SIMATIC WinCC V7.2 archive powerpacks</b> For upgrading archiving from <ul style="list-style-type: none"> <li>1500 to 5000 archive tags</li> <li>5000 to 10000 archive tags</li> <li>10000 to 30000 archive tags</li> <li>30000 to 80000 archive tags</li> </ul>
<b>Complete packages on DVD</b> Language versions: EN, CHS, CHT, KOR, JPN; with license for <ul style="list-style-type: none"> <li>WinCC RC Client</li> <li>128 PowerTags (RC 128)</li> <li>512 PowerTags (RC 512)</li> <li>2048 PowerTags (RC 2048)</li> <li>8192 PowerTags (RC 8192)</li> <li>65536 PowerTags (RC 65536)</li> <li>102400 PowerTags (RC 102400)</li> <li>153600 PowerTags (RC 153600)</li> <li>262144 PowerTags (RC 262144)</li> </ul>	<b>6AV6381-2CB07-2AV0</b> <b>6AV6381-2BM07-2AV0</b> <b>6AV6381-2BN07-2AV0</b> <b>6AV6381-2BP07-2AV0</b> <b>6AV6381-2BS07-2AV0</b> <b>6AV6381-2BQ07-2AV0</b> <b>6AV6381-2BT07-2AV0</b> <b>6AV6381-2BU07-2AV0</b> <b>6AV6381-2BV07-2AV0</b>	<b>SIMATIC WinCC Upgrade/ Software Update Service</b> <b>SIMATIC WinCC V7.2 upgrade <sup>1)</sup></b> For upgrading the RT version <ul style="list-style-type: none"> <li>from V6.2 to V7.2</li> <li>from V7.0 to V7.2</li> <li>from V6.2 ASIA to V7.2 ASIA</li> <li>from V7.0 ASIA to V7.2 ASIA</li> </ul> For upgrading the Client RT version <ul style="list-style-type: none"> <li>from V6.2 to V7.2</li> <li>from V7.0 to V7.2</li> <li>from V6.2 ASIA to V7.2 ASIA</li> <li>from V7.0 ASIA to V7.2 ASIA</li> </ul> For upgrading the RC version <ul style="list-style-type: none"> <li>from V6.2 to V7.2</li> <li>from V7.0 to V7.2</li> <li>from V6.2 ASIA to V7.2 ASIA</li> <li>from V7.0 ASIA to V7.2 ASIA</li> </ul>
<b>Clients</b> <ul style="list-style-type: none"> <li>RT Client ASIA</li> <li>RT Client</li> <li>RC Client ASIA</li> <li>RC Client</li> </ul>	<b>6AV6381-2CA07-2AV0</b> <b>6AV6381-2CA07-2AX0</b> <b>6AV6381-2CB07-2AV0</b> <b>6AV6381-2CB07-2AX0</b>	<b>SIMATIC WinCC Software Update Service (SUS) <sup>2) 3)</sup></b> <b>SIMATIC WinCC V7 Update</b> Software Update Service for WinCC basic software and options: <ul style="list-style-type: none"> <li>1 license</li> <li>3 licenses</li> <li>10 licenses</li> </ul>

<sup>1)</sup> According to licensing provisions, 1 upgrade package must be ordered for each WinCC station

<sup>2)</sup> The Software Update Service is valid for 1 year. The contract is automatically extended by 1 more year unless canceled 3 months prior to expiration. According to licensing provisions, 1 Software Update Service must be ordered for each WinCC station.

<sup>3)</sup> Requires the current software version

# HMI Software

## SCADA system SIMATIC WinCC

### SIMATIC WinCC

#### Ordering data

#### Order No.

#### Order No.

##### SIMATIC WinCC system software V6.2 SP3

##### Runtime packages on CD-ROM

Language/script versions:  
DE/EN/FR/IT/ES; with license for

- 128 PowerTags (RT 128)
- 256 PowerTags (RT 256)
- 1024 PowerTags (RT 1024)
- 8192 PowerTags (RT 8192)
- 65536 PowerTags (RT 65536)
- 102400 PowerTags (RT 102400)
- 153600 PowerTags (RT 153600)
- 262144 PowerTags (RT 262144)

Including 512 archive tags each

**6AV6381-1BC06-2AX0**  
**6AV6381-1BD06-2AX0**  
**6AV6381-1BE06-2AX0**  
**6AV6381-1BH06-2AX0**  
**6AV6381-1BF06-2AX0**  
**6AV6381-1BJ06-2AX0**  
**6AV6381-1BK06-2AX0**  
**6AV6381-1BL06-2AX0**

##### Complete packages on CD-ROM

Language versions:  
DE/EN/FR/IT/ES; with license for

- 128 PowerTags (RC 128)
- 256 PowerTags (RC 256)
- 1024 PowerTags (RC 1024)
- 8192 PowerTags (RC 8192)
- 65536 PowerTags (RC 65536)
- 102400 PowerTags (RC 102400)
- 153600 PowerTags (RC 153600)
- 262144 PowerTags (RC 262144)

Including 512 archive tags each

**6AV6381-1BM06-2AX0**  
**6AV6381-1BN06-2AX0**  
**6AV6381-1BP06-2AX0**  
**6AV6381-1BS06-2AX0**  
**6AV6381-1BQ06-2AX0**  
**6AV6381-1BT06-2AX0**  
**6AV6381-1BU06-2AX0**  
**6AV6381-1BV06-2AX0**

##### SIMATIC WinCC system software V6.2 SP3 ASIA

##### Runtime packages on CD-ROM

Language versions: English/simplified and traditional Chinese/Korean/Taiwanese/Japanese; with license for

- 128 PowerTags (RT 128)
- 256 PowerTags (RT 256)
- 1024 PowerTags (RT 1024)
- 8192 PowerTags (RT 8192)
- 65536 PowerTags (RT 65536)

Including 512 archive tags each

**6AV6381-1BC06-2AV0**  
**6AV6381-1BD06-2AV0**  
**6AV6381-1BE06-2AV0**  
**6AV6381-1BH06-2AV0**  
**6AV6381-1BF06-2AV0**

##### Complete packages on CD-ROM

Language versions: English/simplified and traditional Chinese/Korean/Taiwanese, Japanese; with license for

- 128 PowerTags (RC 128)
- 256 PowerTags (RC 256)
- 1024 PowerTags (RC 1024)
- 8192 PowerTags (RC 8192)
- 65536 PowerTags (RC 65536)

Including 512 archive tags each

**6AV6381-1BM06-2AV0**  
**6AV6381-1BN06-2AV0**  
**6AV6381-1BP06-2AV0**  
**6AV6381-1BS06-2AV0**  
**6AV6381-1BQ06-2AV0**

##### SIMATIC WinCC V6.2 Powerpacks

For upgrading from:

##### Runtime packages

- 128 to 256 PowerTags
- 128 to 1024 PowerTags
- 128 to 8192 PowerTags
- 128 to 65536 PowerTags
- 256 to 1024 PowerTags
- 256 to 8192 PowerTags
- 256 to 65536 PowerTags
- 1024 to 8192 PowerTags
- 1024 to 65536 PowerTags
- 8192 to 65536 PowerTags

**6AV6371-1BD06-2AX0**  
**6AV6371-1BE06-2AX0**  
**6AV6371-1BK06-2AX0**  
**6AV6371-1BF06-2AX0**  
**6AV6371-1BG06-2AX0**  
**6AV6371-1BL06-2AX0**  
**6AV6371-1BH06-2AX0**  
**6AV6371-1BM06-2AX0**  
**6AV6371-1BJ06-2AX0**  
**6AV6371-1BN06-2AX0**

##### Complete packages

- 128 to 256 PowerTags
- 128 to 1024 PowerTags
- 128 to 8192 PowerTags
- 128 to 65536 PowerTags
- 256 to 1024 PowerTags
- 256 to 8192 PowerTags
- 256 to 65536 PowerTags
- 1024 to 8192 PowerTags
- 1024 to 65536 PowerTags
- 8192 to 65536 PowerTags

**6AV6371-1BD16-2AX0**  
**6AV6371-1BE16-2AX0**  
**6AV6371-1BK16-2AX0**  
**6AV6371-1BF16-2AX0**  
**6AV6371-1BG16-2AX0**  
**6AV6371-1BL16-2AX0**  
**6AV6371-1BH16-2AX0**  
**6AV6371-1BM16-2AX0**  
**6AV6371-1BJ16-2AX0**  
**6AV6371-1BN16-2AX0**

##### SIMATIC WinCC V6.2 Archive

- 1500 archives
- 5000 archives
- 10000 archives
- 30000 archives
- 80000 archives
- 120000 archives

**6AV6371-1DQ16-2AX0**  
**6AV6371-1DQ16-2BX0**  
**6AV6371-1DQ16-2CX0**  
**6AV6371-1DQ16-2EX0**  
**6AV6371-1DQ16-2GX0**  
**6AV6371-1DQ16-2JX0**

##### SIMATIC WinCC V6.2 Archive Powerpacks

For upgrading archiving from

- 1500 to 5000 archive tags
- 5000 to 10000 archive tags
- 10000 to 30000 archive tags
- 30000 to 80000 archive tags
- 80000 to 120000 archive tags

**6AV6371-1DQ16-2AB0**  
**6AV6371-1DQ16-2BC0**  
**6AV6371-1DQ16-2CE0**  
**6AV6371-1DQ16-2EG0**  
**6AV6371-1DQ16-2GJ0**

##### SIMATIC WinCC V6.2 upgrade <sup>1)</sup>

For upgrading the RT version

- from V5.x to V6.2 SP3
- from V6.x to V6.2 SP3
- from V5.x ASIA to V6.2 SP3 ASIA
- from V6.x ASIA to V6.2 SP3 ASIA

**6AV6381-1AA06-2AX4**  
**6AV6381-1AA06-2AX3**  
**6AV6381-1AA06-2AV4**  
**6AV6381-1AA06-2AV3**

For upgrading the RC version

- from V5.x to V6.2 SP3
- from V6.x to V6.2 SP3
- from V5.x ASIA to V6.2 SP3 ASIA
- from V6.x ASIA to V6.2 SP3 ASIA

**6AV6381-1AB06-2AX4**  
**6AV6381-1AB06-2AX3**  
**6AV6381-1AB06-2AV4**  
**6AV6381-1AB06-2AV3**

<sup>1)</sup> According to licensing provisions, 1 upgrade package must be ordered for each WinCC station.

Ordering data	Order No.	Order No.	
<b>SIMATIC WinCC V7.2 communication</b> <b>Communication via Industrial Ethernet</b> <b>CP 1612 A2</b> PCI card (32-bit) for connection of a programming device or PC to Industrial Ethernet (10/100/1000 Mbps) with RJ45 connection via SOFTNET S7 and SOFTNET PG	<b>6GK1161-2AA01</b>		
<b>SOFTNET-IE S7 Version 8.2 SP1<sup>1)</sup></b> Software for S7-compatible and S5-compatible communication incl. OPC server, PG/OP communication and NCM PC; up to 64 connections; single license for one installation of Runtime software, software and electronic manual on CD-ROM; license key on USB stick; Class A for CP 1612-A2 English/German <ul style="list-style-type: none"> <li>• Single license for 1 installation</li> <li>• Upgrade package for SIMATIC NET Edition 2006 or higher</li> <li>• Upgrade package for SIMATIC NET V6.0, V6.1, V6.2 and Edition 2005</li> </ul>	<b>6GK1704-1CW08-2AA0</b> <b>6GK1704-1CW00-3AE0</b> <b>6GK1704-1CW00-3AE1</b>	<b>HARDNET-IE S7 V8.2 SP1<sup>1)</sup></b> Software for S7-compatible and S5-compatible communication incl. OPC server, PG/OP communication and NCM PC, single license for one installation of Runtime software, software and electronic manual on CD-ROM, license key on USB stick, Class A for CP 1613-A2, CP 1623, CP 1628; English/German <ul style="list-style-type: none"> <li>• Single license for 1 installation</li> <li>• Upgrade package for SIMATIC NET Edition 2006 or higher</li> <li>• Upgrade package for SIMATIC NET V6.0, V6.1, V6.2 and Edition 2005</li> </ul>	<b>6GK1716-1CB08-2AA0</b> <b>6GK1716-1CB00-3AE0</b> <b>6GK1716-1CB00-3AE1</b>
<b>SOFTNET-IE S7 Lean Version 8.2 SP1 (license included in scope of delivery of WinCC V7.2)</b> Software for S7-compatible and S5-compatible communication incl. OPC server, PG/OP communication and NCM PC; up to 8 connections; single license for one installation of Runtime software, software and electronic manual on CD-ROM; license key on USB stick; Class A for CP 1612-A2 English/German <ul style="list-style-type: none"> <li>• Single license for 1 installation</li> <li>• Upgrade package for SIMATIC NET Edition 2006 or higher</li> <li>• Upgrade package for SIMATIC NET V6.0, V6.1, V6.2 and Edition 2005</li> </ul>	<b>6GK1704-1LW81-3AA0</b> <b>6GK1704-1LW00-3AE0</b> <b>6GK1704-1LW00-3AE1</b>	<b>Communication via PROFIBUS</b> <b>CP 5611 A2</b> PCI card (32-bit) for connecting a PG/PC to PROFIBUS (communications software included in the WinCC basic package)	<b>6GK1561-1AA01</b>
<b>CP 1613 A2</b> PCI card (32-bit) for connecting a PG/PC to Industrial Ethernet (communications software must be ordered separately)	<b>6GK1161-3AA01</b>	<b>CP 5612<sup>2)</sup></b> PCI card (32-bit) for connecting a PG/PC to PROFIBUS (communications software included in the WinCC basic package)	<b>6GK1561-2AA00</b>
<b>CP 1623</b> PCI Express X1 card (32-bit) for connection of PG/PC to Industrial Ethernet (communications software must be ordered separately)	<b>6GK1162-3AA00</b>	<b>CP 5621</b> PCI Express X1 card (32-bit) for connection of PG/PC to PROFIBUS (communications software included in WinCC basic package)	<b>6GK1562-1AA00</b>
<b>CP 1628</b> PCI Express X1 card (32-bit) for connection of PG/PC to Industrial Ethernet (communications software must be ordered separately)	<b>6GK1162-8AA00</b>	<b>CP 5622<sup>2)</sup></b> PCI Express X1 card (32-bit) for connecting a PG/PC to PROFIBUS (communications software included in WinCC basic package)	<b>6GK1562-2AA00</b>
		<b>CP 5711</b> USB adapter for connecting a PG/PC to PROFIBUS or MPI (communications software included in WinCC basic package)	<b>6GK1571-1AA00</b>
		<b>CP 5512</b> PCMCIA card (CARDBUS 32-bit) for the connection of a PG/notebook to PROFIBUS or MPI (communications software included in WinCC basic package)	<b>6GK1551-2AA00</b>
		<b>CP 5613 A2</b> PCI card (32-bit) for connecting a PC to PROFIBUS (communications software must be ordered separately)	<b>6GK1561-3AA01</b>

<sup>1)</sup> According to licensing provisions, 1 upgrade package must be ordered for each WinCC station

<sup>2)</sup> The Software Update Service is valid for 1 year. The contract is automatically extended by 1 more year unless canceled 3 months prior to expiration. According to licensing provisions, 1 Software Update Service must be ordered for each WinCC station.

# HMI Software

## SCADA system SIMATIC WinCC

### SIMATIC WinCC

Ordering data	Order No.	Order No.	
<b>Communication via PROFIBUS</b> (continued)  <b>CP 5614 A2</b> PCI card (32-bit) for connecting a PC to PROFIBUS (communications software must be ordered separately)	<b>6GK1561-4AA01</b>	<b>SIMATIC WinCC V6.2 communication</b> <b>Communication via Industrial Ethernet</b>  <b>CP 1612 A2</b> PCI card (32-bit) for connecting a PG/PC to Industrial Ethernet (SOFTNET-S7 must be ordered separately)	<b>6GK1161-2AA01</b>
<b>CP 5623</b> PCI Express X1 card (32-bit) for connection of PG/PC to Industrial Ethernet (communications software must be ordered separately)	<b>6GK1562-3AA00</b>	<b>SOFTNET-S7 V7.1 SP6 (Edition 2008+SP6)</b> <sup>1)</sup> Software for S7-compatible and S5-compatible communication incl. OPC server, PG/OP communication and NCM PC; up to 64 connections; single license for one installation of Runtime software, software and electronic manual on CD-ROM, license key on USB stick, Class A, for CP 1612-A2, English/German	<b>6GK1704-1CW71-3AA0</b> <b>6GK1704-1CW00-3AE1</b>
<b>HARDNET-PB S7 V8.2 SP1</b> <sup>1)</sup> Software for S7 communication incl. PG/OP communication, FDL, OPC server, Runtime software, software and electronic manual on CD-ROM, license key on USB stick, Class A for CP 5613-A2, CP 5614-A2, CP 5623 English/German <ul style="list-style-type: none"> <li>• Single license for 1 installation</li> <li>• Upgrade package for SIMATIC NET Edition 2006 or higher</li> <li>• Upgrade package for SIMATIC NET V6.0, V6.1, V6.2 and Edition 2005</li> </ul>	<b>6GK1713-5CB08-2AA0</b> <b>6GK1713-5CB00-3AE0</b> <b>6GK1713-5CB00-3AE1</b>	<b>SOFTNET-S7 Lean V7.1 SP6 (Edition 2008+SP6)</b> <sup>1)</sup> <b>(license included in scope of delivery of WinCC V6.2)</b> Software for S7-compatible and S5-compatible communication incl. OPC server, PG/OP communication and NCM PC; up to 8 connections; single license for one installation of Runtime software, software and electronic manual on CD-ROM, license key on USB stick, Class A, for CP 1612-A2, English/German <ul style="list-style-type: none"> <li>• Single license for 1 installation</li> <li>• Upgrade package for SIMATIC NET V6.0, V6.1, V6.2 and Edition 2005<sup>1)</sup></li> </ul>	<b>6GK1704-1LW71-3AA0</b> <b>6GK1704-1LW00-3AE1</b>
<b>HARDNET-PB DP V8.2 SP1</b> <sup>1)</sup> Software for DP protocol incl. PG/OP communication, FDL, DP OPC server, Runtime software, software and electronic manual on CD-ROM, license key on USB stick, Class A, for CP 5613-A2, CP 5614-A2, CP 5623; English/German <ul style="list-style-type: none"> <li>• Single license for 1 installation</li> <li>• Upgrade package for SIMATIC NET Edition 2006 or higher</li> <li>• Upgrade package for SIMATIC NET V6.0, V6.1, V6.2 and Edition 2005</li> </ul>	<b>6GK1713-5DB08-2AA0</b> <b>6GK1713-5DB00-3AE0</b> <b>6GK1713-5DB00-3AE1</b>	<b>CP 1613 A2</b> PCI card (32-bit) for connecting a PG/PC to Industrial Ethernet (communications software must be ordered separately)	<b>6GK1161-3AA01</b>
<b>FMS-5613 V7.1 SP6 (Edition 2008+SP6)</b> <sup>1)</sup> Software for FMS protocol incl. PG/OP communication, FDL, OPC server, Runtime software, software and electronic manual on CD-ROM, license key on USB stick, Class A; for CP 5613-A2, CP 5614-A2, CP 5623; English/German <ul style="list-style-type: none"> <li>• Single license for 1 installation</li> <li>• Upgrade package for SIMATIC NET Edition 2006 or higher</li> <li>• Upgrade package for SIMATIC NET V6.0, V6.1, V6.2 and Edition 2005</li> </ul>	<b>6GK1713-5FB71-3AA0</b> <b>6GK1713-5FB00-3AE0</b> <b>6GK1713-5FB00-3AE1</b>	<b>S7-1613 V7.1 SP6 (Edition 2008+SP6)</b> <sup>1)</sup> Software for S7-compatible and S5-compatible communication incl. PG/OP communication, OPC server and NCM PC; single license for one installation of Runtime software, software and electronic manual on CD-ROM, license key on USB stick, Class A for CP 1613-A2; English/German <ul style="list-style-type: none"> <li>• Single license for 1 installation</li> <li>• Upgrade package for SIMATIC NET V6.0, V6.1, V6.2 and Edition 2005<sup>1)</sup></li> </ul>	<b>6GK1716-1CB71-3AA0</b> <b>6GK1716-1CB00-3AE1</b>

<sup>1)</sup> According to licensing provisions, 1 upgrade package must be ordered for each WinCC station



Ordering data	Order No.	Order No.
<b>Communication via Industrial Ethernet</b> <b>T7-1613 V7.1 SP6 (Edition 2008+SP6)</b> <sup>1)</sup> Software for TF protocol, S5-compatible communication incl. OPC, PG/OP communication (S5/505 layer 4 communication with TCP/IP) single license for one installation of Runtime software, software and electronic manual on CD-ROM, license key on USB stick; Class A for CP 1613-A2 English/German <ul style="list-style-type: none"> <li>• Single license</li> <li>• Upgrade package for SIMATIC NET Edition 2007</li> <li>• Upgrade package for SIMATIC NET V6.0, V6.1, V6.2, and Edition 2005<sup>1)</sup></li> </ul>	<b>6GK1716-1TB71-3AA0</b> <b>6GK1716-1CB00-3AE1</b>	<b>S7-5613 V7.1 SP6 (Edition 2008 SP6)</b> Software for S7 communication incl. PG/OP communication, FDL, OPC server; for Windows XP Professional/2003 Server/2000 Professional/Server for CP 5613/CP 5614; English/German <ul style="list-style-type: none"> <li>• Single license for 1 installation</li> <li>• Upgrade package for SIMATIC NET Edition 2007</li> <li>• Upgrade package for SIMATIC NET V6.0, V6.1, V6.2, and Edition 2005<sup>1)</sup></li> </ul> <b>6GK1713-5CB71-3AA0</b> <b>6GK1713-5CB00-3AE1</b>
<b>Communication via PROFIBUS</b> <b>CP 5611 A2</b> PCI card (32-bit) for connecting a PG/PC to PROFIBUS (communications software included in the WinCC basic package)	<b>6GK1561-1AA01</b>	<b>DP-5613 V7.1 SP6 (Edition 2008 + SP6)</b> Software for DP protocol incl. PG/OP communication, FDL, OPC server, Runtime software, software and electronic manual on CD-ROM, license key on USB flash drive, Class A, for 32-bit: Windows XP Professional, Windows 2003 Server, Windows VISTA Ultimate/Business; for CP 5613 A2; English/German <ul style="list-style-type: none"> <li>• Single license for 1 installation</li> <li>• Upgrade package for SIMATIC NET Edition 2007</li> <li>• Upgrade package for SIMATIC NET V6.0, V6.1, V6.2, and Edition 2005<sup>1)</sup></li> </ul> <b>6GK1713-5DB71-3AA0</b> <b>6GK1713-5DB00-3AE1</b>
<b>CP 5621</b> PCI Express X1 card (32-bit) for connection of PG/PC to PROFIBUS (communications software included in WinCC basic package)	<b>6GK1562-1AA00</b>	
<b>CP 5611 MPI</b> Comprising CP 5611 A2 and MPI cable, 5 m	<b>6GK1561-1AM01</b>	
<b>CP 5621 MPI</b> Comprising CP 5621 (32-bit) and MPI cable, 5 m	<b>6GK1562-1AM00</b>	
<b>CP 5512</b> PCMCIA card (CARDBUS 32-bit) for the connection of a PG/notebook to PROFIBUS or MPI (communications software included in WinCC basic package)	<b>6GK1551-2AA00</b>	
<b>CP 5613 A2</b> PCI card (32-bit) for connecting a PC to PROFIBUS (communications software must be ordered separately)	<b>6GK1561-3AA01</b>	
<b>CP 5614-A2</b> PCI Card (32-Bit) for connecting a PC to PROFIBUS (communications software must be ordered separately)	<b>6GK1561-4AA01</b>	
<sup>1)</sup> The SIMATIC NET PC software delivered with SIMATIC WinCC V7.2 must always be used. The scope of supply for WinCC V7.2 includes the SIMATIC NET PC software V8.2 SP1 / supported operating systems: 32/64-bit Windows 7 Professional, Ultimate, 64-bit Windows Server 2008 R2 and SIMATIC NET PC Software V7.1 SP6 (Edition 2008+SP6) / supported operating systems: 32-bit Windows XP Professional, Windows Vista Professional, Ultimate, Windows Server 2003, Windows Server 2008 Standard. Only the license is to be used from the scope of supply of the above-listed SIMATIC NET PC software products. The licenses supplied with SIMATIC NET V8.2 SP1 are valid for all older versions up to and including Edition 2006.		
		<b>Hardware for process control functions</b> <b>DCF-77 receiver</b> for time synchronization <ul style="list-style-type: none"> <li>• DCF77 (Europe)</li> </ul> <b>2XV9450-1AR14</b>
		<b>Note</b> For further information on control technology options see Catalog ST PCS7.

# HMI Software

## SCADA system SIMATIC WinCC

### SIMATIC WinCC

#### More information

##### **WinCC language versions**

SIMATIC WinCC is also offered in simplified Chinese, traditional Chinese, Korean and Japanese especially for Asian markets. These WinCC versions are intended for machine manufacturers, plant constructors and exporters who supply the regions of China, Taiwan, Korea and Japan.

WinCC ASIA includes all familiar WinCC functions and offers in addition the configuration user interface in the respective national language and English. The online help is available in simplified Chinese, traditional Chinese, Korean, Japanese and English. A Chinese, Korean, Japanese or multilingual Windows operating system is required for operation.

WinCC ASIA is delivered on a separate DVD which contains all of the above mentioned language versions. The corresponding documentation can be obtained from the national subsidiaries in China, Korea, Taiwan and Japan.

The runtime licenses are language-neutral. The English handling program (Automation License Manager – ALM) is executable under the Chinese, Korean and Japanese Windows versions. In order to use the Asian languages in WinCC, an Asia hardware dongle is required.

Additional information is available on the Internet at:  
<http://www.siemens.com/wincc>

Separate configurators are available for PC hardware:

- SIMATIC IPC547C, SIMATIC Rack PC 547B
- SIMATIC IPC647C, SIMATIC Rack PC 647B
- SIMATIC IPC847C, SIMATIC Rack PC 847B
- SIMATIC IPC427C
- SIMATIC IPC627C, SIMATIC Box PC 627B
- SIMATIC Box PC 827B
- SIMATIC HMI IPC577C, SIMATIC Panel PC 577B
- SIMATIC HMI IPC677C, SIMATIC Panel PC 677B



### Overview

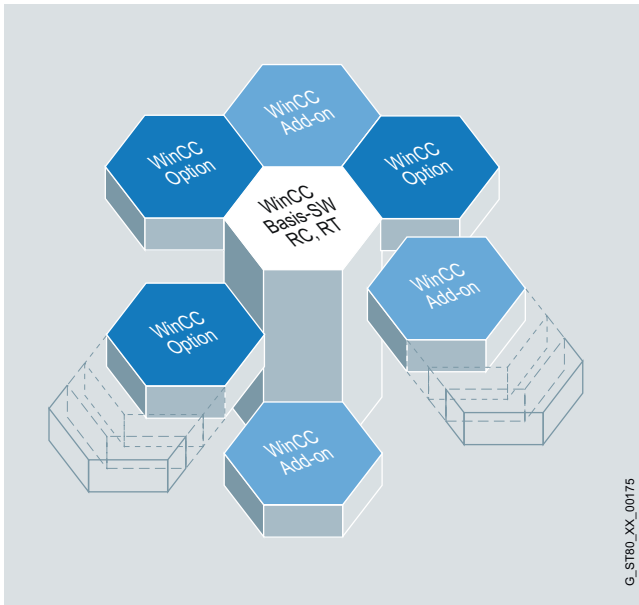

The universal WinCC basic software is the basis for modular expansions. These functional expansions can be obtained in the form of WinCC options and as WinCC Premium add-ons.

WinCC options are created by WinCC Development and are Siemens Industry Automation products. You can obtain support from our Advisory Services and via the central hotline.

#### Options for scalable plant configurations

- WinCC/Server  
For configuring a powerful client/server system
- WinCC/Web Navigator  
For controlling and monitoring plants via the Internet, in-house intranet or LAN
- WinCC/TeleControl  
For connecting to outlying stations (remote terminal units = RTUs) via telecontrol protocols in a WinCC SCADA system.
- SIMATIC ProcessHistorian  
Central scalable long-term archive for the whole plant

#### Options for increasing the availability

- WinCC/Redundancy  
For increasing system availability through redundancy
- SIMATIC Maintenance Station  
For system-integrated diagnostics and plant asset management
- WinCC/ProAgent  
For reliable process diagnostics

#### Options for IT and Business Integration – Plant Intelligence

- SIMATIC InformationServer  
Web-based, integrated reporting from production to management, based on archived data
- WinCC/DataMonitor  
For displaying and evaluating current process states and historical data on office PCs with standard tools
- WinCC/DowntimeMonitor  
For detecting and analyzing downtimes for machines and plants
- WinCC/Connectivity Pack  
Access to WinCC archives via OPC HDA, OPC A&E, OPC XML Server and WinCC OLE-DB /OLE-DB
- WinCC/Connectivity Station  
Gateway to WinCC server data over OPC HDA, OPC A&E, OPC XML server and WinCC OLE-DB /OLE-DB from independent computers
- WinCC/IndustrialDataBridge  
Configurable connection to databases and IT systems

#### Options for SCADA expansions

- WinCC/User Archives  
For managing data records in user archives
- WinCC/Calendar Scheduler  
Calendar-based planning of events
- WinCC/Event Notifier  
For sending of notifications depending on specific events in the WinCC message system

#### Options for sector-specific expansions

- WinCC/ChangeControl
  - Change and version management
  - Generation of audit trails for engineering
- WinCC/Audit
  - Change management
  - Generation of audit trails for engineering and runtime
- SIMATIC Logon
  - Central management of WinCC users, plant-wide (to CFR 21 Part 11)

#### Options for individual system expansions

- WinCC/IndustrialX <sup>1)</sup>  
For creating customized WinCC ActiveX objects in a VB development environment
- WinCC/ODK (Open Development Kit)  
For the use of open programming interfaces

<sup>1)</sup> For WinCC V7.2, the option WinCC/IndustrialX is part of the option WinCC/ODK.

#### More information

##### WinCC options

<http://www.siemens.com/wincc/options>

# HMI Software

## SIMATIC WinCC options

### SIMATIC BATCH for WinCC

#### Overview

- WinCC in connection with the SIMATIC BATCH product range offers a solution for the implementation of batch processes in accordance with ISA S88.
- SIMATIC BATCH for WinCC is of particular interest where different PLCs such as S7-400/300, S5 or non-Siemens PLCs are to be used in a BATCH system.
- SIMATIC BATCH for WinCC is offered as a bundle that includes the SIMATIC BATCH components as well as the WinCC components.
- SIMATIC BATCH for WinCC contains the software for SIMATIC BATCH including options, as well as for SIMATIC WinCC including options. These products are released for any combinations.
  - SIMATIC BATCH for WinCC includes the licenses SIMATIC BATCH Server (10 units <sup>1)</sup>), SIMATIC BATCH CC, and SIMATIC BATCH Recipe.
  - All other SIMATIC BATCH and SIMATIC WinCC products require the purchase of the relevant license or licenses.

<sup>1)</sup> Units are the number of subsystems that can be operated with this license.

#### Current versions:

- SIMATIC BATCH for WinCC V7.1 SP1 (only runs on Windows XP und Windows 2003 Server operating systems)
  - WinCC V7.0 SP3
  - SIMATIC BATCH V7.1 SP1

#### Configuration

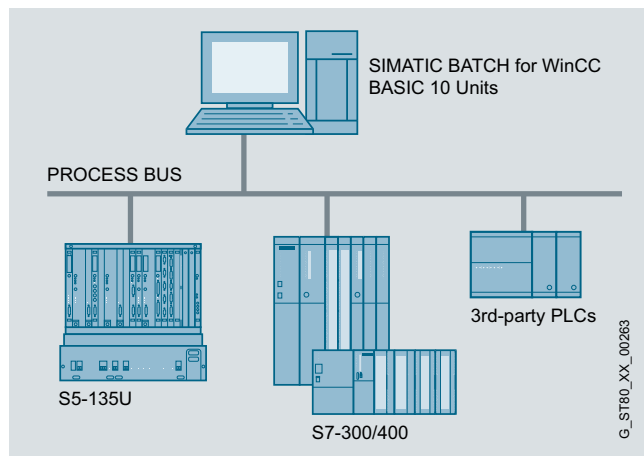

SIMATIC BATCH for WinCC

#### Benefits

- SIMATIC BATCH for WinCC supports the user in the implementation of batch processes in accordance with ISA S88
- Modular architecture with flexible scalability and optimal adaptation to plant size and individual requirements, especially with regard to the use of PLCs such as SIMATIC S7-400/300, SIMATIC S5 and non-Siemens devices
- High availability via redundant system configurations provides protection against loss of batch data
- Cross-subsystem recipes with significant simplification of recipe management
- Hierarchical recipes in accordance with ISA S88.01 for the creation of recipes oriented toward process engineering
- Saving, archiving and comprehensive reporting of batch data
- Formula support
- Validation in accordance with 21 CFR Part 11 is significantly simplified by functions such as Audit Trail (change log), versioning of recipes, recipe operations and formulas, electronic signature and access protection.

#### Application

SIMATIC BATCH for WinCC has been designed for:

- Batch processes in the WinCC environment in accordance with ISA S88
- Users of S7-300, S7-400, S5 or non-Siemens controllers
- Users of STEP5/STEP7

#### Design

SIMATIC BATCH for WinCC ships with the following 3 software components and licenses:

- SIMATIC BATCH Server for 10 units
- SIMATIC BATCH Recipe system (Floating License)
- SIMATIC BATCH CC (Floating License)

The following SIMATIC BATCH options can be used to expand or configure a plant or the relevant licenses can be purchased:

- SIMATIC BATCH Recipe system (Floating License)
- SIMATIC BATCH Planning (Floating License)
- SIMATIC BATCH CC (Floating License)
- SIMATIC BATCH Library
- SIMATIC BATCH Hierarchical Recipe
- SIMATIC BATCH Formula
- SIMATIC BATCH Powerpacks (20, 40, 100, unlimited)

#### Design (continued)

The following basic products and SIMATIC WinCC options can be used to expand or configure a plant or the relevant licenses can be purchased.

- SIMATIC WinCC RT/RC (incl. Powerpacks)
- SIMATIC WinCC/Server
- SIMATIC WinCC/Redundancy
- SIMATIC WinCC/Archives (incl. Powerpacks)
- SIMATIC Logon

All previously listed software components including options of SIMATIC BATCH and SIMATIC WinCC are supplied with the product SIMATIC BATCH for WinCC. In addition, supplementary components for configuring the interfaces between WinCC and SIMATIC BATCH are included in the basic package.

The use and compatibility of WinCC and SIMATIC BATCH is only guaranteed for the software versions that come with SIMATIC BATCH for WinCC.

#### Function

The functions of SIMATIC BATCH for WinCC are based on the SIMATIC BATCH range of products. SIMATIC BATCH for WinCC includes the following licenses or functions:

- SIMATIC BATCH Server for 10 units
- SIMATIC BATCH CC (BATCH Control Center)
- SIMATIC BATCH Recipe System (recipe editor)

It can be used to run a SIMATIC BATCH project with 10 subsystems on a single-user station or a client/server combination (Batch Client and Batch Server).

The capacity of the Server Basic Packages with 10 units can be expanded to 20, 40, 100 or unlimited units using SIMATIC BATCH Powerpacks.

SIMATIC BATCH CC offers powerful functions for the following tasks:

- Reading in and updating the plant data of the basic automation
- Defining user privileges for all functions, for clients or subsystems
- Definition of material names and codes
- Managing master recipes and starting the recipe editor
- Management of libraries with recipe elements (library operations)
- Editing of formula categories and management of associated formulas (parameter sets)
- Creation of batches with master recipes
- Starting of batch processing and controlling of batches
- Monitoring and diagnostics of batch processing
- Recording and archiving of recipes and batch data

Use of the "SIMATIC BATCH Hierarchical Recipe" license permits the creation of hierarchical recipes in accordance with ISA-88

The hierarchical recipe structure is mapped on the plant module as follows:

- Recipe procedure for controlling the process or the production in a plant
- Partial recipe procedure for controlling a process step in a plant unit
- Recipe operation/function to implement the process engineering task/function in a technical facility

SIMATIC BATCH **Separation, Procedures and Formulas** offers powerful functions for the following tasks:

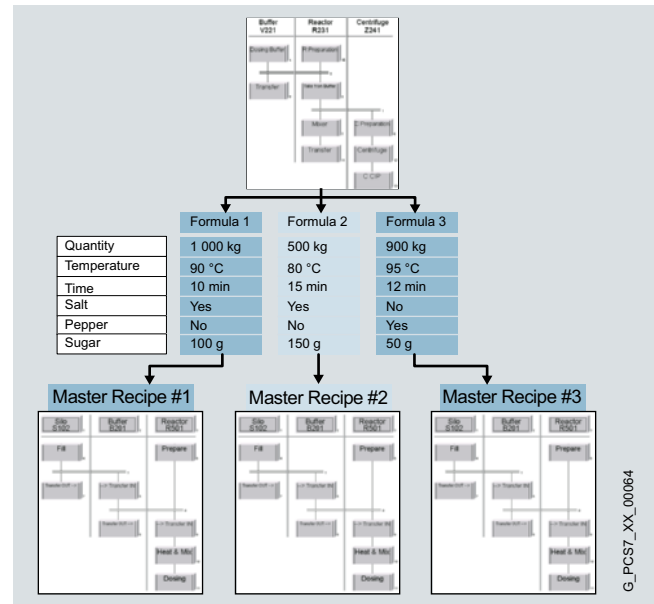

The flexibility achieved by recipes which are independent of plant units can be increased even further if the procedure and parameter sets (formulas) are separated from one another.

Various master recipes can be created by linking several formulas using a recipe procedure. This enables central modification of procedures. The formula structure is determined by the formula category defined by the user.

#### Compatibility

In respect of compatibility, please note that only the SIMATIC WinCC and SIMATIC BATCH versions included in the product package are compatible with each other. Only predecessor products of the product bundle SIMATIC BATCH for WinCC are upward compatible, not single components of the product range SIMATIC WinCC and SIMATIC BATCH.

#### Integration

A detailed description of how to integrate SIMATIC Batch in WinCC appears in the interface description "SIMATIC BATCH Configuration Guide".

#### Ordering data

#### Order No.

#### SIMATIC BATCH for WinCC

Software bundle for the creation of recipes and control of batch processes in accordance with ISA S88 based on SIMATIC BATCH.

- SIMATIC BATCH Server 10 units
- SIMATIC BATCH Recipe system (Floating License)
- SIMATIC BATCH CC (Floating License)

**6ES7657-1SA17-0YA0**

# HMI Software SIMATIC WinCC options

## SIMATIC Information Server

### Overview

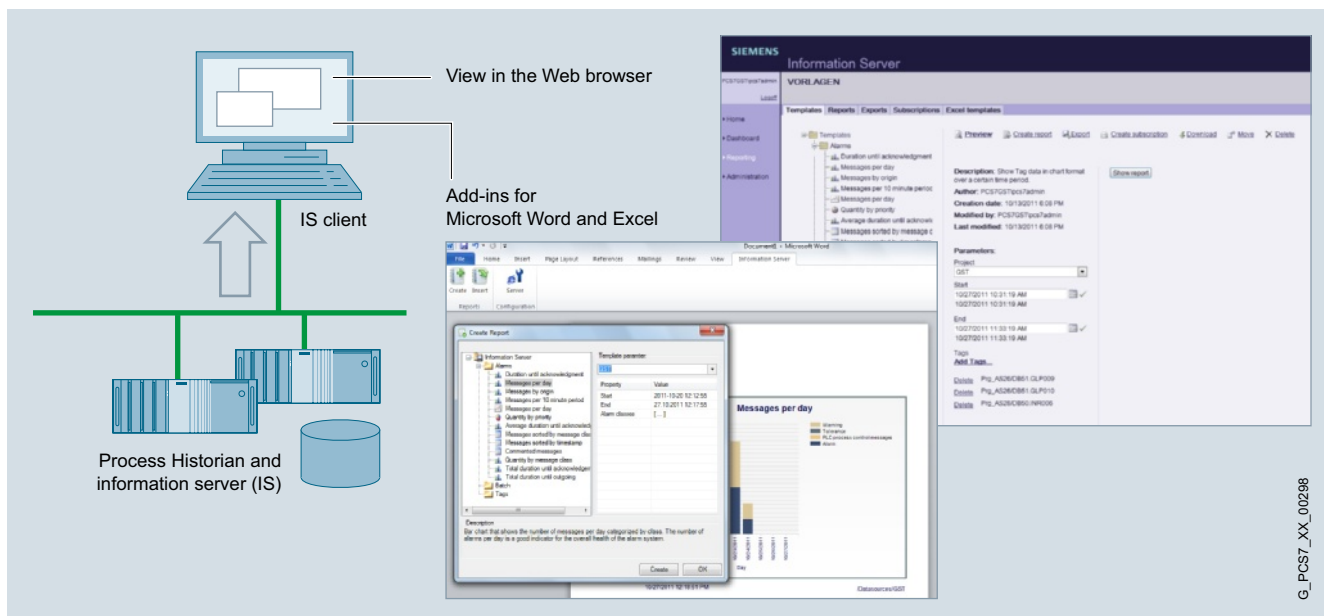

G\_PCS7\_XX\_00288

4

The Information Server is the reporting system for WinCC and the Process Historian. Based on Microsoft Reporting Services, the historical data (tags and alarms) are made available via a web client.

The Information Server Client does not need a client installation. Using a pure web client, it offers functionality for administration, configuration, and visualization of reports. Add-ins for Microsoft Office applications such as Word and Excel offer additional ways to access the WinCC and Process Historian database.

Reports can be created automatically cyclically and sent by email. The Information Server can be used on a WinCC station, on a Process Historian, or independently.

The basic package contains licenses for three clients and one data source. The available licenses are additive and refer to simultaneous access to the client computer. Pre-created report, such as for trends and alarms, are contained in the standard package.

### Benefits

- Central, web-based report system as interface for all corporate areas up to the management level.
- Simple handling through use of standard tools such as Microsoft Word and Excel
- Provision of freely configurable reports via the web
- Automatic sending of reports via email
- Import of data from any number of WinCC applications
- Transparent access to WinCC tag and alarm logs as well as SIMATIC Process Historian data

### Highlights:

- Frequently used report templates for process values, messages, and batches
- Open reporting system for creating any number of new report templates
- Storage of configured (parameterized) report templates for faster access
- Report export in common document formats
- Support of subscriptions for cyclic report generation including email service
- Creation and storage of role-based dashboards
- Role management for Windows users; supports workgroups and Active Directory; user rights can be assigned for specific projects
- Generation of reports and inserting as graphics in Microsoft Office Word documents
- Creation of Microsoft Excel reports for historical process values and messages as well as storage of the Excel report templates on the Information
- Server Support for subscriptions to Excel report templates

### Ordering data

### Order No.

#### SIMATIC Information Server 2013 "Basic Package"

- Information server
- Information Server - Client access (3)
- Information Server - Datasource access (1)

6AV6361-2AA01-3AA0

#### SIMATIC Information Server

- 1 Client access
- 3 Client access
- 5 Client access
- 10 Client access
- 1 Datasource access
- 3 Datasource access

6AV6361-2BD01-3BB0  
6AV6361-2BE01-3BB0  
6AV6361-2BF01-3BB0  
6AV6361-2BG01-3BB0  
6AV6361-2CD01-3BB0  
6AV6361-2CE01-3BB0

### Overview

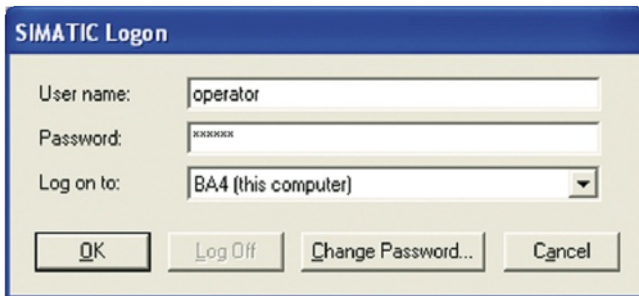

- **SIMATIC Logon (SL)** for WinCC is a software option package supporting the central administration of all WinCC users on a plant-wide basis. The central user management with SL uses the Windows mechanisms and is to be installed on all participating WinCC stations. The user management actions such as logging in and out are automatically supplied in the audit trail of WinCC/Audit and WinCC/ChangeControl by SL.
- The WinCC/Audit or WinCC/ChangeControl and SIMATIC Logon options support users in respect of plant validation and meet the requirements of FDA CFR 21 Part 11. A declaration of conformity (White Paper) offers proof of this.

### Benefits

- Central, system-wide user management
- Conforms with the requirements of the Food and Drug Administration (FDA) for the pharmaceuticals and food processing industry

### Design

The SIMATIC Logon Service can be used for the central user management of a number of WinCC stations. Operation in a Windows Workgroup or even in a domain is possible.

### Function

#### **SIMATIC Logon**

Users receive a unique user ID, user name and password. This information is stored encrypted at a central point (for SIMATIC Logon in the Windows user management). Functions such as changing the password, automatic logoff after a predefined time and lockout after several incorrect entries of a password ensure maximum security of operation.

In the case of the SIMATIC Logon, user administration is integrated into the security system and user administration of MS Windows.

To meet in particular the Food and Drug Administration (FDA) requirements for the pharmaceuticals and food processing industry, all user and administrator actions, such as log in, log out, password changes, incorrect password inputs, and creating and deleting users, are recorded with timestamp in a secure database or are available in the audit trail of WinCC/Change Control or WinCC/Audit.

In addition, SIMATIC Logon allows setting up new users online, plant-wide and across applications, or blocking existing users. SIMATIC Logon also supports electronic signature.

### Ordering data

### Order No.

#### **SIMATIC Logon V1.4 SP1**

Central user management for WinCC V6.2 and WinCC V7.0 Runtime license for an operator station <sup>1)</sup>

**6ES7658-7BX41-2YA0**

#### **SIMATIC Logon V1.5 upgrade**

Single License, 7 languages (De, En, Fr, Es, Jap, Chin)

**6ES7658-7BX51-0YA0**

<sup>1)</sup> SIMATIC Logon included in scope of supply of WinCC

### More information

Information on FDA can be found in a White Paper: Declaration of conformity of SIMATIC WinCC for FDA21 CFR Part 11.

[http://www.siemens.com/automation/hmi/html\\_76/products/software/wincc/fda01.htm](http://www.siemens.com/automation/hmi/html_76/products/software/wincc/fda01.htm)

# HMI Software

## SIMATIC WinCC options

### SIMATIC Maintenance Station

#### Overview

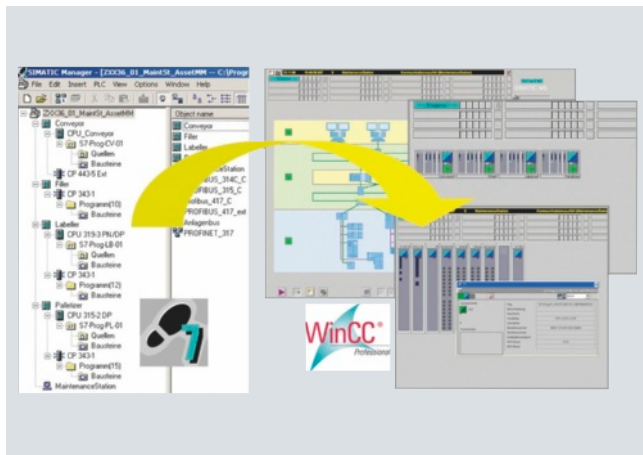

#### System-integrated plant asset management system

- Automatic generation of a maintenance view in WinCC from the STEP 7 hardware configuration
- Plant-wide visualization of all automation components from the management level to the field level in ready linked, hierarchically arranged WinCC displays
- Mapping of central and distributed SIMATIC S7 components, PROFIBUS and PROFINET networks as well as associated bus nodes
- Ethernet network components and industrial PCs can be integrated through SIMATIC NET SNMP OPC Server
- Display of device status with group status generation in overview and detail displays
- The device statuses "Maintenance required" and "Maintenance request" are supported for status-based maintenance
- Provision of uniform faceplates showing detailed information for all components displayed
- Display of the device identification data (electronic rating plate)
- Integrated display of the status of the request

#### Benefits

- Reducing down times:
  - Problems in the plant are detected sooner due to the uniform presentation and clear overview of all information that is important for maintenance.
- Avoiding downtimes:
  - Support of condition-based maintenance.
- Reduced maintenance costs:
  - Optimization of the flow of information between production and maintenance by submitting maintenance requests and presenting the status of requests.
- Transparency and traceability:
  - All procedures are based on messages and can therefore be archived and traced.
  - A comprehensive database is generated that can be analyzed with WinCC functions or external tools.

- Scalability:
  - Support of WinCC single-user stations and client/server configurations.
  - The SIMATIC Maintenance Station can be added to an existing WinCC project.
- Consistency:
  - The maintenance view is generated from the control project and is consistent with it.
- Flexibility in selection of devices:
  - Use of the PROFIBUS and PROFINET standards for device interfacing.
  - An additional proxy concept allows devices to be displayed that are not included in the STEP 7 hardware configuration or that do not support the standard diagnostics of PROFIBUS/PROFINET.

#### Application

The SIMATIC Maintenance Station is a tool for the diagnosis and maintenance of machines and plants. This is an option package for STEP 7 V5.4 and WinCC V6.2 or V7.0 that generates a WinCC maintenance view for a STEP 7 project/multiproject.

#### Design

The SIMATIC Maintenance Station is available in various different packages:

- Basic package:
  - Contains all the tools needed to configure a Maintenance Station and a license for the display of 100 devices.
- Powerpacks:
  - For larger quantities, powerpacks are available with licenses for 100, 500 or 1000 devices. These can be added to the existing licenses and can be combined as required.

In this context, devices can be:

- AS systems
- Distributed devices (PROFIBUS / PROFINET)
- PCs
- Network components
- Asset proxies

#### Requirements for configuring a SIMATIC Maintenance Station

- STEP 7 license (V5.4 upwards)
- WinCC RC license (V7.0 upwards)
- The SIMATIC NET licenses required for the plant configuration

#### Requirements for operation of a SIMATIC Maintenance Station

- The WinCC licenses (V7.0 upwards) complying with the plant configuration



#### Function

- Hierarchic visualization of plant components in WinCC
- Generation of a WinCC picture tree for hierarchic display of the plant components.
- Automatic creation and linking of displays, equipment symbols, status indicators, faceplates and the required variables.
- Presentation of the detailed data in faceplates with selectable views.
- Easy navigation in the plant using the WinCC Picture Tree Manager.
- Generated pictures can be enhanced using the WinCC Graphic Designer.
- Switchover between a WinCC SCADA project and the picture tree of the SIMATIC Maintenance Station can be configured using standard WinCC functions.

Display of the current status of the plant and its components

- Clearly understandable status displays through the use of uniform symbols.
- Display of no-fault status, fault, maintenance requirement and maintenance request.
- Display of status of request for submitted repair requests.
- Display of order status.
- Display of the alarm status of the components.

Display of the identification data of the plant components

- Display of the identification data available for a device in the faceplate for the device.
- Automatic loading of the data available in the configuration into the maintenance station.
- Reading of the "Identification & Maintenance functions (I&M<sup>1)</sup>)" in accordance with the PROFIBUS International specification.
- Export<sup>2)</sup> of I&M data for all devices in the form of an XML file.

Displaying alarms

- Loading of system error messages from STEP 7. STEP 7 provides the messages in 5 languages<sup>3)</sup>, translation into additional languages is possible in STEP 7.
- Display of the most recent message in a message line.
- Presentation of the active/archived messages of the selected device in the faceplate.

Calling the STEP 7 hardware configuration

- The STEP 7 hardware configuration can be opened for a selected device using a button in the faceplate. STEP 7 and the project must be installed on the maintenance station for this purpose.

<sup>1)</sup> The Maintenance Station 2007 supports reading of I&M data for PROFIBUS devices with C1 channel access.

<sup>2)</sup> The I&M data loaded from the configuration are exported.

<sup>3)</sup> For Siemens components that are included in the STEP 7 hardware catalog. In the case of components that are integrated in STEP 7 using GSD files, the GSD files must support the relevant languages.

#### Technical specifications

##### Hardware requirements

System	Clock frequency	Main memory	Free hard disk space
Engineering station	2.8 GHz	1 GB	15 GB
Maintenance Station Stand-alone / WinCC-Station "Single-user Workstation"	2.8 GHz	1 GB	15 GB
Maintenance Station Server / WinCC Server	2.8 GHz	1 GB	15 GB
Maintenance Station Client / WinCC Client	2.8 GHz	512 MB	3 GB

##### Software requirements

System	Operating system
Engineering station "ES"	Windows XP Professional SP3 Windows Server 2003 (R2) SP2 Windows Server 2008 R2 SP1 MS Windows 7 SP1. Supported versions: Ultimate and Professional
Maintenance Station Stand-alone / WinCC-Station "Single-user Workstation"	Windows XP Professional SP3 Windows Server 2003 (R2) SP2 Windows Server 2008 R2 SP1 MS Windows 7 SP1. Supported versions: Ultimate and Professional
ES with Maintenance Station Stand-alone	Windows XP Professional SP3 Windows Server 2003 (R2) SP2 Windows Server 2008 R2 SP1 Windows 7 SP1. Supported versions: Ultimate and Professional
Maintenance Station Server / WinCC Server	Windows Server 2003 (R2) SP2 Windows Server 2008 SP2 Windows Server 2008 R2 SP1
Maintenance Station Client / WinCC Client	Windows XP Professional SP3 Windows Server 2003 (R2) SP2 Windows Server 2008 SP2 Windows Server 2008 R2 SP1 Windows 7 SP1. Supported versions: Ultimate and Professional



# HMI Software

## SIMATIC WinCC options

### SIMATIC Maintenance Station

#### Technical specifications (continued)

##### Requirements for the integration of devices

Type	Integration	Comment
<b>SIMATIC S7 controllers / I/O</b>		
• S7-300 <sup>1)</sup>	Yes	
• S7-400	Yes	
• WinAC	Yes	
<b>Distributed devices</b>		
• ET 200	Yes	PROFIBUS DP and PROFINET IO according to STEP 7 hardware catalog
• PROFIBUS standard slaves	Yes	Integration using a GSD file
• PROFINET standard devices	Yes	Integration using a GSD file
<b>Network components</b>		
Ethernet network components	Yes	SIMATIC NET SNMP OPC Server and MIB also required
PROFINET network components	Yes	
PROFIBUS diagnostic repeater	Yes	
<b>Personal Computer</b>		
PC/Industrial PC	Yes	SIMATIC NET SNMP OPC Server also required
<b>Drives</b>		
Drives with PROFIBUS connection	Yes	For integrating devices designed to the PROFIDRIVE profile, Drive ES SIMATIC (V5.4 SP1 or higher) is required
Drives with PROFINET connection	Yes	For integrating devices designed to the PROFIDRIVE profile, Drive ES SIMATIC (V5.4 SP1 or higher) is required
<b>Accessory devices</b>		
Devices not configured in STEP 7 Hardware Config	Yes	Integrated via function block (asset proxy)

<sup>1)</sup> With S7-300, PROFIBUS/PROFINET systems are supported if they are connected to the internal CPU interfaces

#### Ordering data

#### Order No.

##### SIMATIC Maintenance Station 2009

Can be used with STEP 7 V5.4 or higher and WinCC V7

- Basic package with engineering software (Floating License) and Runtime License for 100 devices
- Powerpack 100 Runtime License for 100 additional devices
- Powerpack 500 Runtime License for 500 additional devices
- Powerpack 1000 Runtime License for 1000 additional devices
- Basic demo package 2009
- Upgrade from SIMATIC Maintenance Station 2007 to SIMATIC Maintenance Station 2009

**6ES7840-0WD01-0YA0**

**6ES7840-0WD11-0YD0**

**6ES7840-0WD21-0YD0**

**6ES7840-0WD31-0YD0**

**6ES7840-0WD01-0YA7**

**6ES7840-0WD01-0YE0**

### Overview

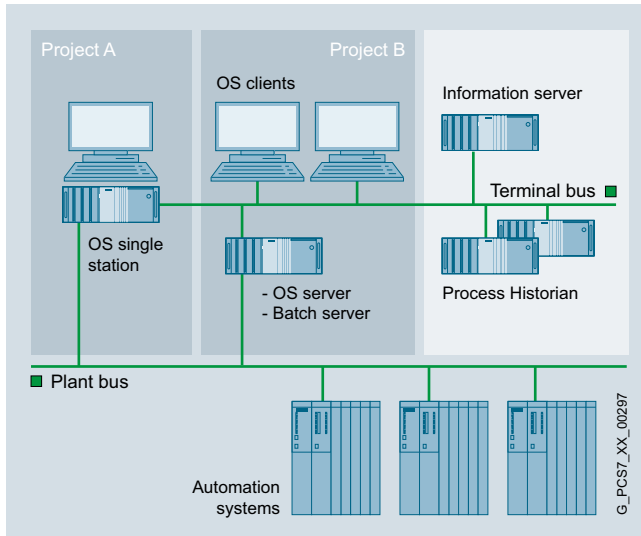

The Process Historian is a high-performance long-term archiving server solution that stores WinCC process values and messages in a central database. The system offers full scalability for performance and scope: It records and saves data from one or several WinCC and PCS 7 projects. The number of connected single stations, servers, or redundant server pairs is unrestricted. SIMATIC Process Historian is designed for use throughout your plant, below the corporate management level (ERP, MES).

Process Historian is the basis for the Information Server reporting system, which accesses the central Process Historian database and ensures clear, user-friendly data visualization on WinCC stations and office PCs.

The central Process Historian database provides access to real-time data throughout the plant. This data is the key to sustainable plant optimization.

Because this is a completely integratable archive system, the engineering can also be performed without additional effort. SIMATIC Process Historian uses the integrated relational database Microsoft® SQL Server.

No complex reconfiguration is needed because the archive system is integrated in WinCC. Time or event-driven archiving of selected process values or messages in the WinCC long-term archive is possible.

### Benefits

- Fully integrated long-term archive solution for large volumes of data
- Central, plant-wide long-term archive as company-wide information hub
- Process data and messages can be archived from any number of lower-level WinCC systems
- Plant expansions without interrupting the production process
- High availability in redundant mode
- High degree of security due to integrated backup system
- Database for analyses with the goal of optimizing the plant and thus the productivity

### Function

- Real-time data storage of the WinCC archive data (process values and messages) from any number of WinCC stations
- Visualization of the archive data on WinCC clients or WinCC single stations either directly or using the SIMATIC Information Server. Process Historian configuration tool for fast, simple engineering
- The redundant Process Historian is based on Microsoft SQL Server Mirroring (third system for monitoring the availability of redundancy).
- The database and segmenting are set up in the initial configuration.
- For archiving to the PH, the PH Ready component is installed on the WinCC server
- The PH automatically detects all connected WinCC server projects (via the PH Ready component)
- The "Process Historian Management" dashboard for diagnostics, displaying data sources, changing the database segmentation

### Ordering data

### Order No.

<b>SIMATIC Process Historian Server 2013 Single License</b>	<b>6AV6361-1AA01-3AA0</b>
---	---------------------------

<b>SIMATIC Process Historian Server 2013 Single License (Redundancy Complete)</b>	<b>6AV6361-1BA01-3AA0</b>
<ul style="list-style-type: none"> <li>• 2x Process Historian Server</li> <li>• 2x Process Historian Server - Redundancy</li> </ul>	

<b>SIMATIC Process Historian 2013 Single License Redundancy</b>	<b>6AV6361-1CA01-3AA0</b>
---	---------------------------

### Upgrades

<b>Upgrade from CAS (Central Archive Server) V7.0 SP3 to Process Historian 2013</b>	<b>6AV6361-1AA01-3AE0</b>
---	---------------------------

# HMI Software

## SIMATIC WinCC options

### WinCC/Calendar Scheduler

#### Overview

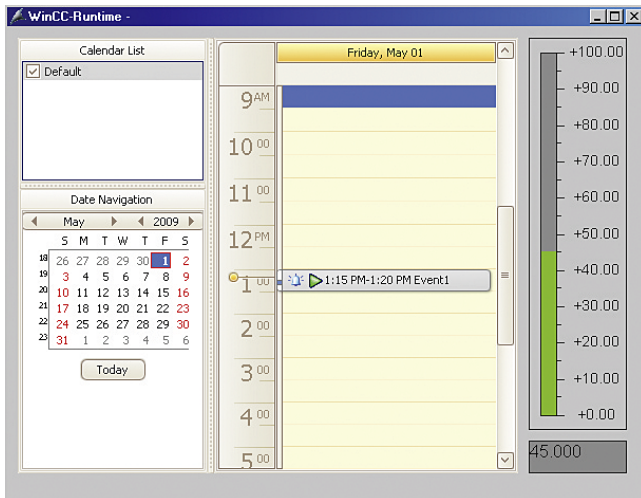

- Option for SIMATIC WinCC for managing events in a calendar.
- Setting WinCC variables or starting global scripts at defined times.
- A license is only necessary on the server (or single user system).

#### Benefits

- Simple operation, configuration and planning of events thanks to handling in the style of Microsoft Office Calendar
- Simple configuration of the actions by parameterization (execution of WinCC scripts or writing of WinCC tags at certain times)
- Configuration of recurring events taking account of configurable public holidays, vacation periods, and maintenance periods
- Secure operation of the plant taking account of different authentication levels
- Clear representation of events at runtime by means of Calendar Runtime Control
- Flexible use in all typical WinCC plant configurations, client/server, redundant systems, WebNavigator

#### Function

With the WinCC Calendar Scheduler, events and their associated actions can be configured in a user-friendly and clear way in an editor in WinCC Explorer.

The events are represented in a calendar. The period represented can be freely selected. Recurring events can be defined as serial events with any desired exceptions.

The events are displayed in a .Net control. The Calendar Scheduler is easy and intuitive to operate and supports drag & drop during configuration and runtime.

#### Ordering data

##### WinCC/Calendar Scheduler

- for WinCC V7.2
- for WinCC V7.0 SP3

#### Order No.

**6AV6372-1DC07-2AX0**  
**6AV6372-1DC07-0AX0**

#### Overview

Central data management, reliable, high-performance archiving and central backup mechanisms form the basis of a Process Historian solution: Integration in the SCADA world, data interfaces for access to archived data and analysis functions are the component parts.

The option CAS was designed for this purpose and is used to export the archived data of all servers in the system to a computer and manage it. Integration of CAS in the WinCC world means that the data remains available for the WinCC clients as well as for the WinCC standard interfaces.

WinCC/CAS contains all licenses for the central archive server including 1500 archive tags. The number of archive tags can be increased to 120000 using Powerpacks or further WinCC archives.

#### Benefits

- Central data management of all archived alarms and process values
- Integrated back-up system for the archive data
- Transparent access to the data from all WinCC clients and over the open interfaces
- Integrated Web viewer for analyzing data

#### Function

Both the process value archive and alarm log are created on the separate WinCC servers and transferred to CAS when individual database segments have been closed.

With "Store&Forward", when the network is interrupted between the WinCC server and CAS, data will be reliably transferred as soon as the network is operating again.

Data access is transparent for display and analysis and is still possible through the standard WinCC clients. For the clients, it is of no consequence whether the data are on the WinCC server or already on CAS. Data saved in CAS can also be viewed using the Web viewer included in the package.

The data of the distributed WinCC system can also be accessed through the familiar interfaces (OPC DA, OPC A&E, OPC HDA and Ole-DB) with the help of the Connectivity Pack or the Connectivity Station. In this manner, the data saved in CAS can be efficiently transferred to higher-level systems or used for the purposes of analysis.

#### Ordering data

#### Order No.

##### WinCC/CAS V7.0 SP3 basic packages

- WinCC/CAS V7.0 SP3
- WinCC/CAS V7.0 SP3 ASIA

**6AV6371-1DQ17-0XX0**

**6AV6371-1DQ17-0XV0**

##### WinCC/CAS upgrade

- V6.2 to V7.0 SP3
- V6.2 ASIA to V7.0 SP3 ASIA

**6AV6371-1DQ17-0XX3**

**6AV6371-1DQ17-0XV3**

##### WinCC/CAS V6.2 SP3 basic packages

- WinCC/CAS V6.2 SP3
- WinCC/CAS V6.2 SP3 ASIA

**6AV6371-1DQ16-2XX0**

**6AV6371-1DQ16-2XV0**

#### Note:

Standard Archive Powerpacks (see WinCC ordering data) can also be used for WinCC/Central Archive Server (CAS)

WinCC V7.2 is not supported. The successor product is the option Process Historian for V7.2.

# HMI Software

## SIMATIC WinCC options

### WinCC/ChangeControl & WinCC/Audit

#### Overview

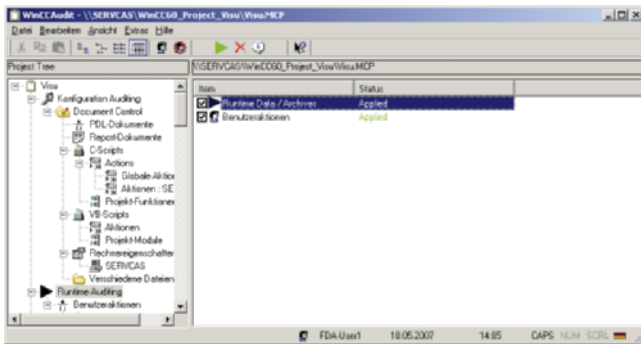

- WinCC/ChangeControl** is used to **trace engineering changes** in a tamper-proof long-term audit trail database, called the audit trail for short. All changes are automatically entered in the engineering system in the audit trail. This enables all the changes to be traced that have been made, to deduce the causes and minimize downtimes on the system. To begin tracing at a defined project status, a project version definition is provided that contains all data and files of a WinCC project version. The project version definition naturally provides the ability to reactivate earlier project versions. Document management is also provided, which manages and archives intermediate status for system graphics, reports or user files and stores change information of the user. An audit viewer with helpful filter functions can be used for quickly and simply evaluating the audit trail, exporting it to an Excel sheet or printing it out.
- WinCC/Audit** Includes the full functionality of **WinCC/ChangeControl** and is also used for **tracing all operations**. All operations are automatically recorded in the audit trail at RT.
- Licensing** : To configure which change information from the project should be recorded in the audit trail, the WinCC/ChangeControl RC or WinCC/Audit RC package is required. "RC" stands for Runtime and Configuration. It is required on the station that is to be configured and also includes an RT license. For recording an audit trail, one WinCC/Audit RT license is required per WinCC station (Client/Server).
- The WinCC/Audit or WinCC/ChangeControl and SIMATIC Logon options support users in respect of plant validation and meet the requirements of FDA CFR 21 Part 11. A declaration of conformity (White Paper) offers proof of this.

#### Benefits

- Quick and easy traceability configuration
- Gap-free and automated recording of engineering changes and operator actions in an audit trail
- Reduction in plant downtimes thanks to fast analysis of the gap-free recorded audit trail information
- Logging of defined WinCC project status with all database information and files of the application
- Gap-free documentation of the project version definition procedures with version number, user and comments
- Complete tracing support by WinCC single and multi-station systems, single and multi-project solutions, Client/Server architecture
- Extensive reduction in engineering outlay in order to meet the requirements of FDA 21 CFR Part 11 & EU 178/2002
- Compliance with the requirements of the Food and Drug Administration (FDA) for the pharmaceutical and food industries.

#### Design

WinCC/ChangeControl and WinCC/Audit consist of five components:

- The audit editor for configuration the audit trail content
- The project version definition for logging WinCC projects
- Document management for automatic archiving and versioning of WinCC plant mimics, scripts, reports, and project-specific documents, and the recording of the associated change information
- The audit viewer for visualizing, exporting and printing WinCC and WinCC flexible audit trails. The viewer is available as an executable program under Windows, as well as OCX with WinCC Runtime.
- The audit trail, which tracks all changes in respect of both engineering and plant operation in a separate SQL database. The audit trail can be set up as a central audit trail for a number of projects or even just for a single project.

WinCC/ChangeControl and WinCC/Audit support both single-user and multi-user systems, client/server architectures and even the WinCC redundancy system. No redundant audit trail is created however.

#### Function

##### **WinCC/ChangeControl**

WinCC/ChangeControl is a functional subset of WinCC/Audit. WinCC/ChangeControl is for tracing engineering changes in the engineering phase or in online operation. All change data is recorded in an audit trail.

There are two types of engineering changes:

- those that change the WinCC database or are executed through the WinCC Explorer, such as e.g. changes to tag management or creating a user group,

and those

- limited to changing files, the so-called document administration.

The document management manages system images, scripts and log layouts and customer-specific documents and stores respective intermediate versions as backups. All of these documents or files are subject to a change process, i.e. documents can be booked out for processing, booked in for finalization and intermediate versions can be retrieved from backup storage with a rollback function.

The project version definition as a component of WinCC/ChangeControl archives WinCC projects and creates reproducible project status or defined start-time points for starting tracing. An audit trail is also provided with information on who has created which project version or which version has been reproduced or deleted.

Configuring the audit trail, the project version definition and the document management is simple, quick and comfortable.

The audit trail data is visualized from WinCC, as well as from WinCC flexible via the audit viewer, an executable program under Windows. The data can also be evaluated with the audit viewer OCX in Runtime by WinCC however. Users select the desired view of the audit trail information via filters or selection criteria and can export the data to an Excel file or print it on a printer. Audit trail information is tamper-proof and can thus not be modified or deleted. An export function can be used to swap out the audit trail to an XML file or to archive it.

##### **WinCC/Audit**

WinCC/Audit has all of the functionality of WinCC/ChangeControl and is also used for tracing user operations in RT operation. Tracing can be used for determining who, when and what conditions the machine has undergone. In addition to recording operator activities, the audit trail also records the starting and modifying of recipes or user logs. At specific objects or events, such as function buttons or sliders, the user can also record activities of an individual nature such as e.g., pressing a function button, moving sliders and other actions with a so-called audit entry function in the audit trail.

A WinCC/ChangeControl RC license or a WinCC/Audit RC license is required for configuring the audit trail. One RT license is required for each station (client/server) to be monitored. One RC license always includes one RT license.

#### Ordering data

#### Order No.

##### **WinCC/ChangeControl**

For the configuration of the audit trail incl. RT

- WinCC V7.0 SP3
- V6.2, for WinCC V6.2 and WinCC V6.2 SP2/SP3

**6AV6371-1DV27-0AX0**  
**6AV6371-1DV26-2AX0**

##### **WinCC/Audit RC**

For the configuration of the audit trail incl. RT

- WinCC V7.0 SP3
- V6.2, for WinCC V6.2 and WinCC V6.2 SP2/SP3

**6AV6371-1DV17-0AX0**  
**6AV6371-1DV16-2AX0**

##### **WinCC/Audit RT**

Creation of audit trails in RT

- WinCC V7.0 SP3
- V6.2, for WinCC V6.2 and WinCC V6.2 SP2/SP3

**6AV6371-1DV07-0AX0**  
**6AV6371-1DV06-2AX0**

##### **Upgrades**

V6.x to V7.0

- for WinCC/Audit RT
- for WinCC/Audit RC or WinCC/ChangeControl

**6AV6371-1DV07-0BX4**  
**6AV6371-1DV17-0BX4**

V6.x to V6.2

- for WinCC/Audit RC and WinCC/Audit RT

**6AV6371-1DV06-2AX3**

#### More information

Information about FDA can be found in a White Paper: Declaration of conformity of SIMATIC WinCC to FDA21 CFR Part 11.

[http://www.siemens.com/automation/hmi/html\\_76/products/software/wincc/fda01.htm](http://www.siemens.com/automation/hmi/html_76/products/software/wincc/fda01.htm)

# HMI Software

## SIMATIC WinCC options

### WinCC/Connectivity Pack & WinCC/Connectivity Station

#### Overview

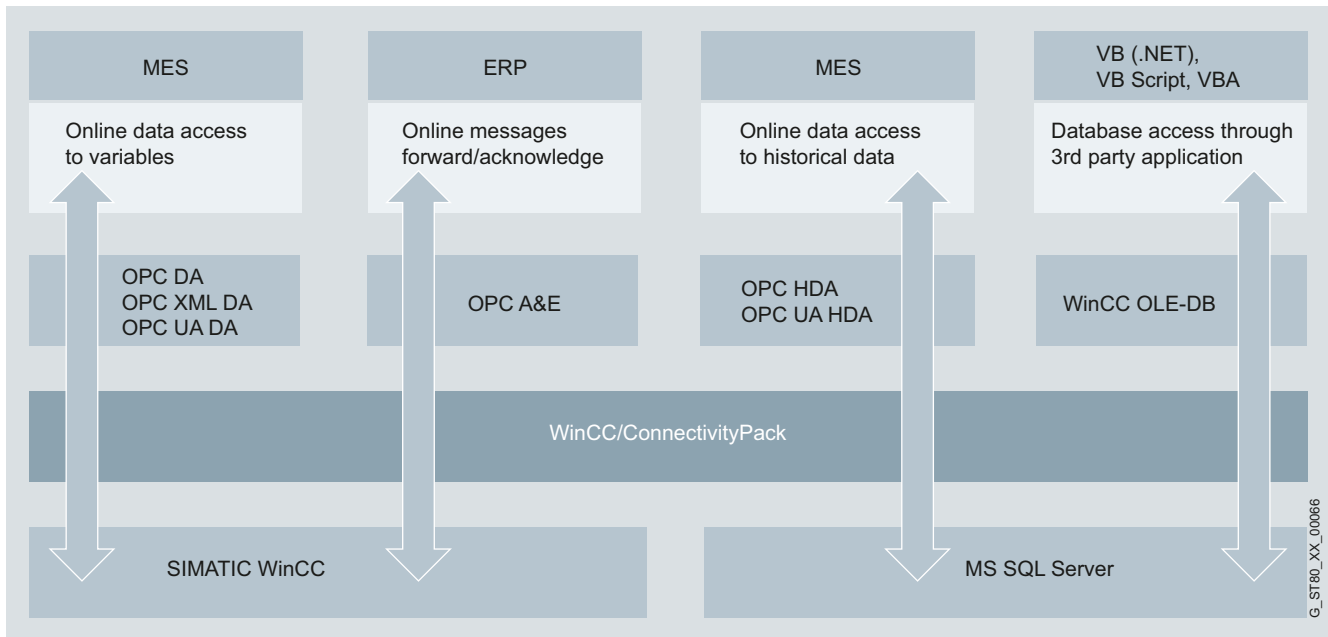

4

Cross-vendor communication in the automation sector has always been of primary importance for WinCC. This is even more true for the release of preprocessed production data for higher-level information systems (e.g., MES = Management Execution System, ERP = Enterprise Resource Planning or Office packages = MS Excel, MS Access etc.). WinCC features integrated OPC Data Access and OPC XML DA servers for access to all online values in the system and makes open interfaces available for access to historical WinCC data.

- The Connectivity Pack includes OPC XML DA 1.00, OPC HDA 1.20 (Historical Data Access), OPC A&E 1.10 (Alarm & Events) and a WinCC OLE-DB interface which even allows remote computers without WinCC to access WinCC archive and alarm data.
- The function of the OPC servers (XML DA, HDA and A&E) is assured by the WinCC/Connectivity Pack. In order to access data in the database via WinCC OLE-DB/OLE-DB, you will also need a license for the WinCC/Connectivity Pack.

- A Connectivity Pack license is required for every WinCC system to be accessed.
- If the Connectivity Station is used, an additional Connectivity Pack license does not have to be installed on the WinCC systems that are accessed. The Connectivity Station functions autonomously and does not require a WinCC installation on the computer.
- For versions below V7.0  
Access to WinCC archive and alarm data from a computer without installed WinCC basic system license or WinCC option via the interfaces of the Connectivity Pack or Connectivity Station requires a WinCC/Client Access license on the client side (see also "WinCC/Client Access License").
- Connectivity Station Option for WinCC V6.2 and higher

#### Benefits

- Access to variables, historical WinCC data, alarm data and user archives from any computer
- Options for analyzing and evaluating process data with specialist tools or user-defined applications (e.g., via VisualBasic)



#### Function

As an OPC HDA server, WinCC makes historical data from the WinCC archive system available to other applications. An OPC HDA client (e.g. a reporting tool) can define the time interval for the required data by entering a start and end time. OPC HDA servers also support the generation of a variety of aggregate functions on the server itself (e.g. standard deviation, variance, mean values, integral values, etc.), thereby helping to relieve the load on the network, as only preprocessed data are transmitted.

OPC A&E servers are used to forward WinCC messages (along with all associated process values) to any client at production or enterprise control level. Filter mechanisms and subscriptions ensure that only selected modified data are transmitted. Acknowledgement is of course also supported.

The WinCC OPC XML DA server makes cross-platform communication between Windows and non-Windows systems possible, even via the Internet. This enables read and write WinCC online values (external and internal WinCC variables) to be exchanged with non-Siemens systems.

WinCC OLE-DB makes standardized and user-friendly access to WinCC archive data possible (MS SQL Server 2005). In exactly the same way as access via the OPC HDA and OPC A&E interfaces, access via the WinCC OLE DB provider makes all WinCC archive data available along with the associated process values and message/user texts. The WinCC OLE-DB provider also supports analysis functions such as minimum, maximum, message hit list, etc.

The WinCC Connectivity Station was designed as a stand-alone gateway to WinCC server data. It supports access to WinCC server data over the OPC channels described as well as those for process values (not alarms) over OLE DB. Access to WinCC data is transparent, i.e. independent of which server of a redundant pair is active or whether data have already been transferred to the central archive server.

#### Connectivity Station

If no visualization is required at a station, any Windows computer with access to WinCC via OPC and OLE-DB can be configured via the Connectivity Station. This permits access to WinCC stations with server packages from a central computer without WinCC installation. The WinCC stations can be accessed via the following interfaces:

- OPC interfaces of the Connectivity Station
- OLE DB interface of the Connectivity Pack

The two access variants are autonomous access options with different ranges of functions.

#### OPC interfaces of the Connectivity Station

The Connectivity Station provides interfaces via which you can access the following using an OPC-Client.

- OPC-DA-Server: tags, e.g. process values
- OPC-HDA-Server: archived process values
- OPC-A&E-Server: alarms

#### Licensing

You require the "WinCC Connectivity Station" license in order to utilize the OPC interfaces of the Connectivity Station on a computer without WinCC installed.

If you only use the OPC interfaces of a WinCC installation, you only need the "Connectivity Pack" license.

The following table shows the combinations:

	New: WinCC-independent installation with Connectivity Station	Standard installation: OPC with WinCC
OPC DA	"WinCC Connectivity Station" license	No license required
OPC HDA	"WinCC Connectivity Station" license	"WinCC Connectivity Pack" license
OPC A&E	"WinCC Connectivity Station" license	"WinCC Connectivity Pack" license
OPC UA DA		"WinCC OPC UA HDA Connectivity Pack" license

The Connectivity Station is planned over NCM PC Manager or SIMATIC Manager. In Version 7, the Connectivity Station does not run as service.

Ordering data	Order No.
<b>WinCC/Connectivity Pack &amp; WinCC/Connectivity Station</b>	
<b>V7.2; for WinCC V7.2</b>	
<b>Basic packages</b>	
• WinCC/Connectivity Pack V7.2 <sup>1)</sup>	<b>6AV6371-1DR07-2AX0</b>
• WinCC/Connectivity Station V7.2 <sup>1)</sup>	<b>6AV6371-1DR17-2AX0</b>
<b>V7.0; for WinCC V7.0, WinCC V7.0 SP1/SP2/SP3 and WinCC V7.0 SP1/SP2/SP3 ASIA</b>	
<b>Basic packages</b>	
• WinCC/Connectivity Pack V7.0 <sup>1)</sup>	<b>6AV6371-1DR07-0AX0</b>
• WinCC/Connectivity Station V7.0 <sup>1)</sup>	<b>6AV6371-1DR17-0AX0</b>
<b>V6.2 SP3; for WinCC V6.2 SP3 and WinCC V6.2 SP3 ASIA</b>	
<b>Basic packages</b>	
• WinCC/Connectivity Pack V6.2 SP3	<b>6AV6371-1DR06-2AX0</b>
• WinCC/Connectivity Station V6.2 SP3	<b>6AV6371-1DR16-2AX0</b>
• WinCC/Connectivity Pack V6.2 SP3 ASIA	<b>6AV6371-1DR06-2AV0</b>
• WinCC/Connectivity Station V6.2 SP3 ASIA	<b>6AV6371-1DR16-2AV0</b>
<b>Upgrade<sup>1)</sup></b>	
• WinCC/Connectivity Pack V6.x -> V6.2 SP3	<b>6AV6371-1DR06-2AX3</b>

<sup>1)</sup> Upgrades from V6.x to V7.x are included in the WinCC V7.x upgrades

# HMI Software

## SIMATIC WinCC options

### WinCC/DataMonitor

#### Overview

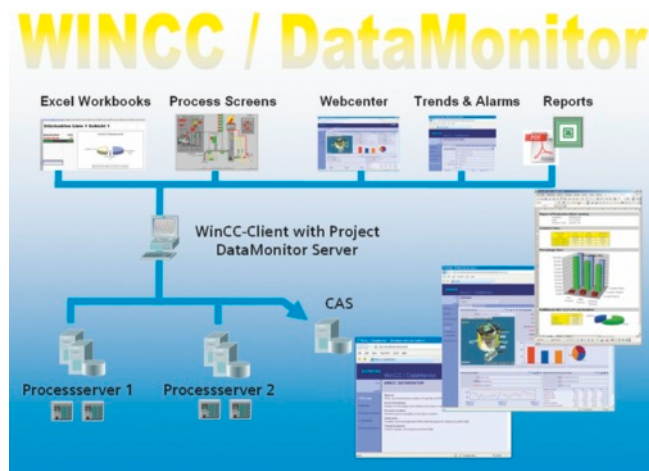

- The WinCC/DataMonitor is a component of WinCC Plant Intelligence and is used for displaying and evaluating current process statuses and historical data on office PCs with standard tools such as Microsoft Internet Explorer or Microsoft Excel. The DataMonitor client is provided with current and historic process data and alarms by a DataMonitor server. All staff ranging from machine operators to corporate managers can use the DataMonitor to obtain information.
- DataMonitor is a suite of Internet-capable tools:
  - Process Builder - Tool for simple visualization and navigation with WinCC screens using WinCC Web Viewer (WinC Viewer RT) in "view only" mode
  - Excel Workbooks - Protocol tool that integrates WinCC archives and online values into MS Excel and supports online analysis
  - Published Reports - Event- or time-driven execution of Excel or PDF reports for the output of process data and analysis results
  - Web center - Individual configuration of Internet pages and summary of information within a portal in terms of WinCC applications
  - Trends and alarms are preconfigured Web Center pages
- DataMonitor does not require manual client installation because it loads the required components from the DataMonitor server
- There is no installation required on the client for the Webcenter, Trends and Alarms functions.
- Licenses for simultaneous access by 1, 3, 10, 25 or 50 DataMonitor clients. Any combination of DataMonitor and Web Navigator licenses can be used for an application.
- Preconfigured Web Center pages permit ad hoc entry

#### Benefits

- Information can be compiled online individually during runtime via the Internet/intranet.
- Efficiently monitor and analyze production lines.
  - Display and evaluation of current process states and historical data on remote office PCs with standard tools such as Microsoft Internet Explorer or Excel.
  - Easy access to production data via the intranet or Internet
  - Quick ascertainment of the production situation
  - Use of standard products
- Easily collect and distribute information.
  - Automated report creation
  - No additional configuration effort through direct use of images from the WinCC project
  - No training required for standard products
  - Easy exchange of configuration data
- Substantiate decisions with reports.
  - Evaluation via ready-made templates for special analyses of the business processes (e.g. reports, statistics)
  - Make bottlenecks transparent
  - Individual views for user and situation
  - Relative and absolute timeframe for information generation
- View production status anywhere and anytime.
  - Individual views of information in production
  - View the process and system operation
  - Historical data can be compiled online individually

#### Highlights

- Access to the lower-level servers when installing the DataMonitor server on a WinCC Client with separate project (RT128 license)
- Tag logging archive tags can be accessed by means of the web center function without changing the WinCC configuration system.
- Installation of the DataMonitor web center function on a WinCC file server
- Dedicated Internet pages can be created for displaying data with the Webcenter. For this purpose, the following tools which can be integrated in the Internet sites are available.
  - Bar diagram, pie chart, trend curve display
  - Process value table and statistics functions for the process values
  - Alarms, hit list for alarms
  - Message text display for individual message texts, message display, selection list of created reports
  - Links to internal and external pages
  - Display of graphics in converted jpg format
  - Display of the WinCC process images
- The analyses can be made with relative or absolute time specification. This enables comparisons of identical time periods on different days.
- Reports generated with Excel or the WinCC Report Designer can be made available on the DataMonitor server or e-mailed automatically to the relevant group of people based on time intervals or triggered by events.
- Connections can be established to WinCC Runtime, the central archive server, and the swapped-out archives

### Benefits (continued)

#### New in V7.2

- DataMonitor
  - In V7.2 or higher, the upgrade license is contained in the corresponding WinCC version
  - Supports Internet Explorer V 7.0, V8.0 and V9.0, including tabbed browsing.
  - Excel reports can be generated with Microsoft Excel version 2003 / 2007 / 2010

### Function

- All tools are fully Internet-compatible and, therefore, support access via any type of connection (LAN, GSM, radio, modem, Internet, etc.).
- All popular security mechanisms such as login/password, firewalls, encryption, etc. are supported.
- Users can combine the available tools at will. Licensing only takes into account simultaneous access to one Web server.
- For display purposes, screens from the WinCC project can be used or special overview displays configured. Animations, scripts, navigation and access rights remain valid.
- The WinCC/DataMonitor has purely a display function.
- Company-wide Excel reports, which contain historical and current process values, can be stored centrally for general access (reports, statistics). However, local queries to meet individual requirements can be compiled and executed online. Plot and tabular representation are supported for archive data already swapped out.
- Data can be automatically entered into created report templates and distributed by e-mail or saved on the server.
- The screens are displayed in the WinCC Web Viewer or in the Internet Explorer in the view only mode of the Web Navigator.
- Enhanced user management for the web center in order to assign individual Internet pages and created reports to specific user groups.
- Integrating WinCC process screens on Internet pages without installation download
- A search function facilitates the management of connections to the WinCC Server.
- Swapped out archives can be connected and evaluated in the DataMonitor Web center. Expansion of the display area in the Web center (Menu Hide function)
- Excel reports created offline can be loaded onto the DataMonitor server and are thus made available to selected user groups or for automatic distribution.
- Pre-made elements make the assembly of individual web pages easier for evaluating information.
- Individual information compilation on one or more Internet pages with the option of branching to other detail pages.
- Pre-made Internet pages for trend and alarm display enable an ad-hoc entry to Internet data evaluation.
- An higher-level navigation feature provides a common framework for the various tools.

### Ordering data

### Order No.

#### WinCC/DataMonitor V7.2 for WinCC V7.2 and WinCC V7.2 ASIA

- 1 client license
- 3 client licenses
- 10 client licenses
- 25 client licenses
- 50 client licenses

6AV6371-1DN07-2LX0  
6AV6371-1DN07-2AX0  
6AV6371-1DN07-2BX0  
6AV6371-1DN07-2CX0  
6AV6371-1DN07-2DX0

#### WinCC/DataMonitor Powerpacks V7.0

- From 1 to 3 clients
- From 3 to 10 clients
- From 10 to 25 clients
- From 25 to 50 clients

6AV6371-1DN07-2LA0  
6AV6371-1DN07-2AB0  
6AV6371-1DN07-2BC0  
6AV6371-1DN07-2CD0

#### WinCC/DataMonitor V7.0 for WinCC V7.0, WinCC V7.0 SP3 and WinCC V7.0 SP3 ASIA

- 1 client license
- 3 client licenses
- 10 client licenses
- 25 client licenses
- 50 client licenses

6AV6371-1DN07-0LX0  
6AV6371-1DN07-0AX0  
6AV6371-1DN07-0BX0  
6AV6371-1DN07-0CX0  
6AV6371-1DN07-0DX0

#### WinCC/DataMonitor Powerpacks V7.0

- From 1 to 3 clients
- From 3 to 10 clients
- From 10 to 25 clients
- From 25 to 50 clients

6AV6371-1DN07-0LA0  
6AV6371-1DN07-0AB0  
6AV6371-1DN07-0BC0  
6AV6371-1DN07-0CD0

#### WinCC/DataMonitor, Upgrade

- from V6.0 to V7.0
- from V6.2 to V7.0
- from V6.x to V6.2 SP3
- from V6.x ASIA to V6.2 SP3 ASIA

6AV6371-1DN07-0XX4  
6AV6371-1DN07-0XX3  
6AV6371-1DN06-2XX3  
6AV6371-1DN06-2XV3

#### WinCC/DataMonitor V6.2 SP3 for WinCC V6.2 SP3

- 1 client license
- 3 client licenses
- 10 client licenses
- 25 client licenses
- 50 client licenses

6AV6371-1DN06-2LX0  
6AV6371-1DN06-2AX0  
6AV6371-1DN06-2BX0  
6AV6371-1DN06-2CX0  
6AV6371-1DN06-2DX0

#### WinCC/DataMonitor V6.2 SP3 ASIA for WinCC V6.2 SP3 ASIA

- 1 client license
- 3 client licenses
- 10 client licenses
- 25 client licenses
- 50 client licenses

6AV6371-1DN06-2LV0  
6AV6371-1DN06-2AV0  
6AV6371-1DN06-2BV0  
6AV6371-1DN06-2CV0  
6AV6371-1DN06-2DV0

#### WinCC/DataMonitor, Powerpacks V6.2

- From 1 to 3 clients
- From 3 to 10 clients
- From 10 to 25 clients
- From 25 to 50 clients

6AV6371-1DN06-2LA0  
6AV6371-1DN06-2AB0  
6AV6371-1DN06-2BC0  
6AV6371-1DN06-2CD0

# HMI Software

## SIMATIC WinCC options

### WinCC/DowntimeMonitor

#### Overview

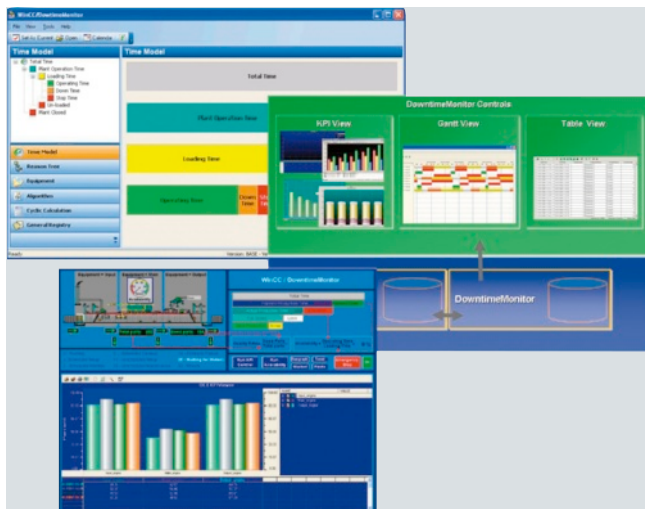

The entry point to SIMATIC Plant Intelligence can be through options for the SIMATIC WinCC process visualization system. The WinCC/DowntimeMonitor is a component of WinCC Plant Intelligence and is used for monitoring the efficiency and performance of individual machine modules, subsystems and production lines. The combined elements to be monitored are designated as equipment. Using the WinCC/DowntimeMonitor, the machine data management software, standstill time can be recorded and analyzed centrally in production. For individual devices, machines or entire production lines, the specific parameters can be determined this way. Integration into WinCC ensures complete transparency of all machine and plant data as a basis for optimizing the plant's productivity.

The process values are read directly from WinCC and are connected with the respective analysis function.

- The SIMATIC WinCC DowntimeMonitor can be installed on a WinCC single station, WinCC Server or WinCC Client with project (RT128 license), and consists of an Engineering Client as well as a Runtime User interface.
- All engineering operations are performed using a graphic Engineering Client. The Engineering Client is called up from the WinCC Explorer.
- SIMATIC WinCC DowntimeMonitor provides ActiveX control elements. These are used for displaying the determined parameters and the progress of the various status over a certain time period. These controls are integrated in WinCC process images for presenting results.
- The recorded data is stored in an online database set and can be moved to an offline database set.
- The basic package consists of the Engineering and Runtime software and 5 licensed equipment units. Other licenses are available for up to 25, up to 50, 100 and up to 200 equipment units.

#### Benefits

- Recording failure times, localizing causes and reasons for failure times, and monitoring of equipment efficiency.
- Weak-point analysis in production processes and recording of undesirable process activities.
- Basis for decision making based on performance indicators.
- Identification of the events that lead to cost-intensive failures.
- Entry point for an extended downtime analysis with upgrade options in the MES software SIMATIC IT.
- Identification of speed and quality losses.
- Complete transparency for all machines as basis for optimizing the plant's productivity. Faults and bottlenecks are prevented to increase availability.
- Derivation of specific parameters (KPI - Key Performance Indicators).
- Integration of respective display instruments (controls) in WinCC process images.
- Can be utilized for individual machines or even complete production plants.
- Distribution of evaluations to various people over the web.

#### Function

- Creation of a time model by defining various time categories as a basis for the KPI calculation for elements (equipment) to be evaluated.
- Creation of equipment, as central components for the evaluation by dividing the system into individual groups.
- Creation of a Reason Tree for detailed display of reasons for downtimes.
- Allocation of the system status in the controller to the time categories and Reason Trees defined in the DowntimeMonitor.
- Storing the system status for calculating and presenting Key Performance Indicators.
- The following pre-defined Key Performance Indicators are available: Availability, change-over, cycle time, failure time loss, duration, effective performance, maintenance, Mean Time Between Assist (MTBA), Mean Time Between Failures (MTBF), Mean Time To Assists (MTTA), Mean Time To Repair (MTTR), failure time frequency, Overall Equipment Effectiveness (OEE), performance rate, production duration, quality rate, speed loss, Total Efficient Equipment Performance (TEEP), utilization.
- Integration of three new controls Gantt View, KPI View, and Table View in WinCC for the display of results for one or more equipment units.
- The WinCC DowntimeMonitor Gantt View presents the equipment status development within a certain time period.
- The WinCC DowntimeMonitor KPI View shows the distribution of failure times and the Key Performance Indicators in a trend, bar, segmented bar charts or Pareto chart using historical data.
- The WinCC DowntimeMonitor Table View shows raw data for failure times and analyzes it in the selected time period. The user can utilize these control elements to enter, change, distribute or combine and comment on failure times manually.
- The controls can be displayed on intranet or Internet using the option WinCC/Web Navigator.

Ordering data	Order No.	Order No.
<b>WinCC/DowntimeMonitor V7.0 SP3 for WinCC V7.0 SP3 and WinCC V7.0 SP3 ASIA</b> <ul style="list-style-type: none"> <li>• 5 equipment units</li> <li>• 25 equipment units</li> <li>• 50 equipment units</li> <li>• 100 equipment units</li> <li>• 200 equipment units</li> </ul>	<b>6AV6372-1DB07-0BX0</b> <b>6AV6372-1DB07-0DX0</b> <b>6AV6372-1DB07-0FX0</b> <b>6AV6372-1DB07-0HX0</b> <b>6AV6372-1DB07-0KX0</b>	<b>WinCC/DowntimeMonitor V1.0 SP1 for WinCC V6.2 SP2 and WinCC V6.2 SP2 ASIA</b> <ul style="list-style-type: none"> <li>• 5 equipment units</li> <li>• 25 equipment units</li> <li>• 50 equipment units</li> <li>• 100 equipment units</li> <li>• 200 equipment units</li> </ul>
<b>WinCC/DowntimeMonitor Powerpacks V7.0</b> <ul style="list-style-type: none"> <li>• From 5 to 25 equipment units</li> <li>• From 25 to 50 equipment units</li> <li>• From 50 to 100 equipment units</li> <li>• From 100 to 200 equipment units</li> </ul>	<b>6AV6372-1DB07-0BD0</b> <b>6AV6372-1DB07-0DF0</b> <b>6AV6372-1DB07-0FH0</b> <b>6AV6372-1DB06-2HK0</b>	<b>WinCC/DowntimeMonitor Powerpacks V1.0</b> <ul style="list-style-type: none"> <li>• From 5 to 25 equipment units</li> <li>• From 25 to 50 equipment units</li> <li>• From 50 to 100 equipment units</li> <li>• From 100 to 200 equipment units</li> </ul>
<b>WinCC/DowntimeMonitor upgrade</b> <ul style="list-style-type: none"> <li>• V1.x to V7.0 SP3</li> </ul>	<b>6AV6372-1DB07-0XX4</b>	<b>6AV6372-1DB06-2BX0</b> <b>6AV6372-1DB06-2DX0</b> <b>6AV6372-1DB06-2FX0</b> <b>6AV6372-1DB06-2HX0</b> <b>6AV6372-1DB06-2KX0</b>  <b>6AV6372-1DB06-2BD0</b> <b>6AV6372-1DB06-2DF0</b> <b>6AV6372-1DB06-2FH0</b> <b>6AV6372-1DB06-2HX0</b>

**Note**

WinCC V7.2 is not supported.



# HMI Software

## SIMATIC WinCC options

### WinCC/Event Notifier

#### Overview

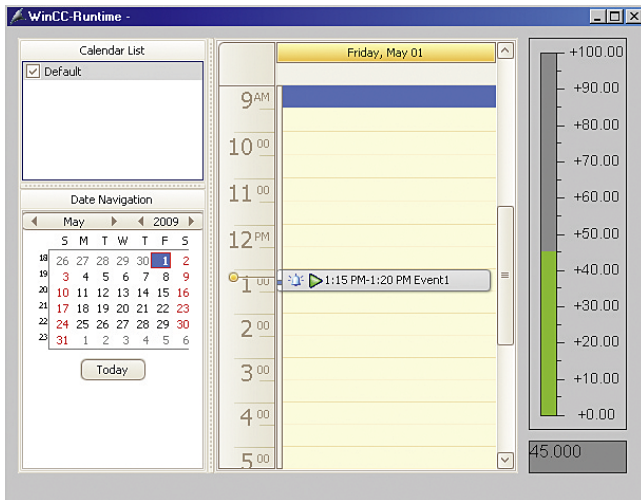

- Option for SIMATIC WinCC for notifying selected persons by e-mail in specified time slots
- Notification depends on events occurring in the WinCC Alarm System.
- Escalation levels, i.e. Group 2 is only notified when nobody "on site" or from Group 1 has reacted within a specified time.
- Final notification of all persons previously notified in connection with the specific event about the reaction that has taken place

A license is only necessary on the server (or single user system).

#### Benefits

- Simple operation, configuration and planning of notifications thanks to handling like the Microsoft Office Calendar
- Easy configuration of the notifications including support of the WinCC Runtime languages by connecting to the WinCC alarm system
- Configuration of recurring events taking account of configurable public holidays, vacation periods, and maintenance periods
- Secure operation of the plant taking account of different authentication levels
- Clear display and intuitive operation at runtime by means of Calendar Control
- Flexible use in all typical WinCC plant configurations, single station, client/server, redundant systems, WebNavigator

#### Function

The WinCC Event Notifier enables the following to be configured in a clear and user-friendly manner via the Calendar Options Editor in the WinCC Explorer:

- The e-mail service for sending and receiving messages
- The messages by selecting configured messages in the WinCC Alarm System as well the setup and contents of the message by selecting the message blocks
- Contacts by selecting predefined persons from the WinCC user administration.

In a calendar it is then possible to select the persons to be notified within in the opened time slot from the existing contacts. If several persons or groups of persons are set up for the same time slot, escalation levels can be implemented by assigning different escalation times (= dead time before notification). The period represented by the calendar can be freely selected. Recurring events can be defined as serial events with any desired exceptions.

The calendar can also be integrated as .Net Control in WinCC screens; the appearance of the calendar controls at runtime is configurable. Via the calendar control, you can create time slots during runtime with contacts who should be notified upon occurrence of the configured events in the WinCC Alarm System. In addition, the calendar control allows the creation of new contacts by means of selection from the WinCC user management.

The Event Notifier is easy and intuitive to operate and supports drag & drop during configuration and runtime.

#### Ordering data

##### WinCC/Event Notifier

- for WinCC V7.2
- for WinCC V7.0 SP3

#### Order No.

**6AV6372-1DD07-2AX0**  
**6AV6372-1DD07-0AX0**

#### Overview

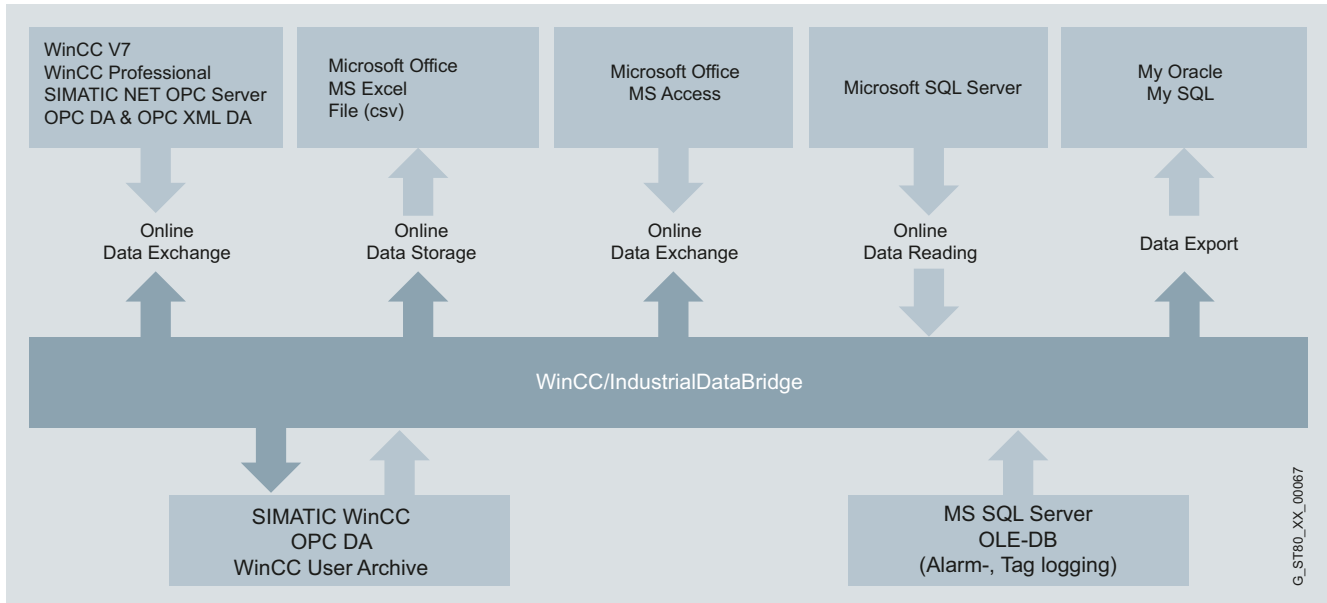

- The WinCC/IndustrialDataBridge option uses standard interfaces in order to connect the automation world with the world of IT and ensure two-way information flow. Typical examples of such interfaces are OPC in the field of automation and SQL database interfaces in the world of IT.
- With the SIMATIC WinCC/IndustrialDataBridge, simple configuration/parameterization of communication connections between various data sources and data destinations can be created. The IndustrialDataBridge can be integrated into WinCC and can also be used in stand-alone mode (not in conjunction with WinCC).
- For example, SIMATIC WinCC with its OPC DA server interface is the data source and an external database is the data destination.
  - Highly flexible, thanks to support for various database formats and standard interfaces
  - Fast and secure thanks to configuration instead of programming
- In addition to access to WinCC variables, access to messages, process values and user archive data (in the WinCC database) is also supported.
- WinCC/IndustrialDataBridge can be used as stand-alone application with its standard interfaces.
- Option from WinCC V6
- For versions below V7.0  
On a computer without a license for the WinCC basic system or a WinCC option, which is to be accessed in read/write mode by the option WinCC/IndustrialDataBridge, a WinCC Client Access License is required (see also "WinCC/Client Access License").

#### Benefits

- Connecting the automation level with the IT world
- Integration of systems from different manufacturers via a host of standard interfaces (including OPC, OLE-DB, Office formats)
- Simple configuration with standard software without programming and thus at low cost
- High-performance data transfer between several systems simultaneously

#### Design

The software comprises a configuration environment and a runtime environment. The different data interfaces are integrated via software modules. In each case, one module is required as the data source and one module as the data destination. The different modules can be combined in any way.

The connections between data source and data destination are created in the configuration environment.

In the runtime environment, the IndustrialDataBridge establishes the connection autonomously and transfers the data of the linked variables.



# HMI Software

## SIMATIC WinCC options

### WinCC/IndustrialDataBridge

#### Function

- IndustrialDataBridge establishes a link between the source and destination interfaces and transfers data on the basis of a change in value, once a configurable period of time has elapsed or when a specific event occurs.
- IndustrialDataBridge exchanges data between automation systems from different vendors, e.g., via OPC. The connection of OPC servers via IndustrialDataBridge enables communication between a variety of devices, data sources and data destinations. The OPC international interface standard is the key to open systems both now and in the future. Thanks to IndustrialDataBridge, OPC data exchange can already be supported.
- WinCC supports access to variables, tag logging, alarm logging and user archive data.
- Storage of process data in Office formats such as Excel or Access. Databases can also be integrated for the archiving of larger aggregates.
- One of the features of IndustrialDataBridge is a Send/Receive interface supporting data transfer to SIMATIC S5/S7 stations or other Send/Receive-compatible devices.
- IndustrialDataBridge enables SCADA and control systems from different vendors to be linked via the OPC interface. Communication via RFC1006 or Send/Receive is also supported.
- SQL databases are available as data destinations for production data acquisition. Data can be transferred from the data source on an event-driven basis with the OPC module or sent directly from the PLC with the Send/Receive module.
- Cyclic data archiving can be implemented via the OPC Data Access, WinAC ODK or Send/Receive data sources and the SQL database data destinations. On the database side, various transmission mechanisms are supported.
- Individual control during runtime for each IndustrialDataBridge connection (start, stop, connect, and disconnect).
- Integration of IndustrialDataBridge runtime control in WinCC screens if IDB is installed on a WinCC station.
- Independent CSV files are created if a configurable number of entries is reached or the value of a WinCC tag changes.
- Block transfer for databases through support for the operators "<" and ">" in the Select instruction.
- Available providers (data sources) can be connected to any consumers (data destinations) (see table, below)

#### New functions in Version 7.2:

- Faster configuration due to new configuration interface
- OPC XML DA Provider / Consumer (data exchange via the Internet using HTTP and SOAP)
- Support for Asian languages (Simplified Chinese, Japanese)
- Unicode support
- Getting Started for data exchange between User Archive and Microsoft Access
- For installation in combination with the WebNavigator Server, the IndustrialDataBridge can be controlled via the Internet

#### Interfaces:

The table below shows the possible data sources and destinations

Provider (data sources)	Consumer (data destinations)
<ul style="list-style-type: none"> <li>• MS Access 2003, 2007, 2010</li> <li>• MS SQL server 2005, 2008, 2008 R2</li> <li>• MySQL ODBC 3, 5, 5.1, 5.5</li> <li>• Oracle 8i, 10g, 11g</li> <li>• OPC Data Access 3.0, OPC XML 1.0</li> <li>• Send / Receive</li> <li>• WinCC OLE DB V7.2</li> <li>• WinCC User Archive V7.2</li> </ul>	<ul style="list-style-type: none"> <li>• CSV, TXT</li> <li>• MS Access 2003, 2007, 2010</li> <li>• MS SQL server</li> <li>• MySQL ODBC 3, 5, 5.1, 5.5</li> <li>• Oracle 8i, 19g, 11g</li> <li>• MS Excel</li> <li>• OPC Data Access Server (internal)</li> <li>• OPC Data Access 3.0, OPC XML 1.0</li> <li>• Send / Receive</li> <li>• WinCC User Archive V7.2</li> </ul>

#### Ordering data

#### Order No.

<b>WinCC/IndustrialDataBridge V7.2, option for WinCC V7.2</b> For data exchange with databases and OPC servers; language versions: German, English, Chinese simplified, Japanese <ul style="list-style-type: none"> <li>• with 128 tags</li> <li>• with 512 tags</li> <li>• with 2048 tags</li> <li>• with 10000 tags</li> </ul>	<b>6AV6371-1DX07-2AX0</b> <b>6AV6371-1DX07-2BX0</b> <b>6AV6371-1DX07-2CX0</b> <b>6AV6371-1DX07-2DX0</b>
<b>WinCC/IndustrialDataBridge V7.0 SP1, option for WinCC V7.0 SP3</b> For data exchange with databases and OPC servers; language versions: German/English <ul style="list-style-type: none"> <li>• with 128 tags</li> <li>• with 512 tags</li> <li>• with 2048 tags</li> <li>• with 10000 tags</li> </ul>	<b>6AV6371-1DX07-0AX0</b> <b>6AV6371-1DX07-0BX0</b> <b>6AV6371-1DX07-0CX0</b> <b>6AV6371-1DX07-0DX0</b>
<b>WinCC/IndustrialDataBridge Powerpack V7.2</b> <ul style="list-style-type: none"> <li>• from 128 to 512 tags</li> <li>• from 512 to 2048 tags</li> <li>• from 2048 to 10000 tags</li> </ul>	<b>6AV6371-1DX07-2AB0</b> <b>6AV6371-1DX07-2BC0</b> <b>6AV6371-1DX07-2CD0</b>
<b>WinCC/IndustrialDataBridge Powerpack V7.0</b> <ul style="list-style-type: none"> <li>• from 128 to 512 tags</li> <li>• from 512 to 2048 tags</li> <li>• from 2048 to 10000 tags</li> </ul>	<b>6AV6371-1DX07-0AB0</b> <b>6AV6371-1DX07-0BC0</b> <b>6AV6371-1DX07-0CD0</b>
<b>WinCC/IndustrialDataBridge upgrade</b> <ul style="list-style-type: none"> <li>• from V7.0 to V7.2</li> <li>• from V6.x to V7.2</li> <li>• from V6.x to V7.0 SP3</li> </ul>	<b>6AV6371-1DX07-2XX3</b> <b>6AV6371-1DX07-2XX4</b> <b>6AV6371-1DX07-0XX4</b>
<b>WinCC/IndustrialDataBridge V6.1, option for WinCC V6. 2</b> For data exchange with databases and OPC servers; language versions: English/German <ul style="list-style-type: none"> <li>• with 128 tags</li> <li>• with 512 tags</li> <li>• with 2048 tags</li> <li>• with 10000 tags</li> </ul>	<b>6AV6371-1DX06-1AX0</b> <b>6AV6371-1DX06-1BX0</b> <b>6AV6371-1DX06-1CX0</b> <b>6AV6371-1DX06-1DX0</b>
<b>WinCC/IndustrialDataBridge Powerpack V6.1</b> <ul style="list-style-type: none"> <li>• from 128 to 512 tags</li> <li>• from 128 to 2048 tags</li> <li>• from 128 to 10000 tags</li> <li>• from 512 to 2048 tags</li> <li>• from 512 to 10000 tags</li> <li>• from 2048 to 10000 tags</li> </ul>	<b>6AV6371-1DX06-1AB0</b> <b>6AV6371-1DX06-1AC0</b> <b>6AV6371-1DX06-1AD0</b> <b>6AV6371-1DX06-1BC0</b> <b>6AV6371-1DX06-1BD0</b> <b>6AV6371-1DX06-1CD0</b>

### Overview

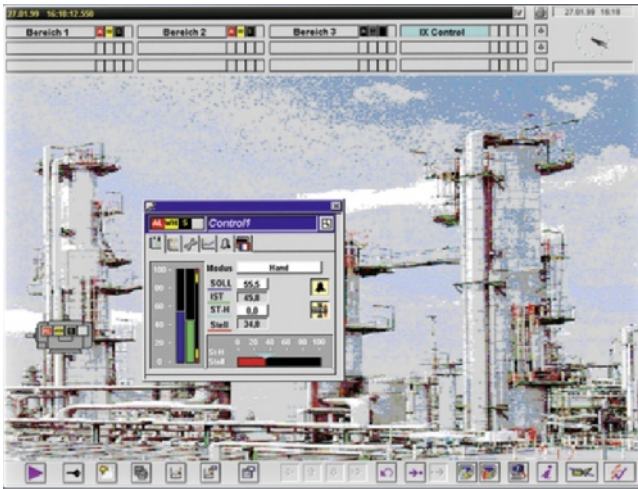

- WinCC/IndustrialX makes it easier to develop a solution for a visualization task by allowing customized objects to be standardized
- A license must be installed on each development computer (current version of Visual Basic must be installed on the development computer)

### Benefits

- Easy creation using configuration wizards
- Quick entry due to the use of standards: ActiveX technology, creating with the aid of Visual Basic
- Central creating and changing of object displays of the same type (typing) saves time and money
- Configuring of intelligent, sector-specific objects (graphic illustration and logical processing) with know-how protection
- Can be used in versatile ways: in WinCC screens and other Windows applications (e.g. Internet Explorer, Excel)

### Innovations of V7.0

Support of Visual Studio 2005 (.NET)

### Application

IndustrialX controls create standardized presentations and allow flexible customization to the requirements of a wide range of applications, e.g. applications in the chemical, glass or paper manufacturing industries.

### Function

- Configuring intelligent, industry-specific objects (graphic illustration and logical processing) with know-how protection
- Automatic object supply with WinCC data structures (templates)
- Creation of Web Navigator-compatible, customer-specific ActiveX components with active process data supply
- Integration into WinCC via structure names

### Ordering data

**WinCC/IndustrialX**  
• V7.0; for WinCC V7.0 and V6.x

### Order No.

**6AV6371-1EL17-0AX0**

### Note

For WinCC V7.2, the WinCC/IndustrialX option is part of the WinCC/ODK option.

# HMI Software

## SIMATIC WinCC options

### WinCC/Open Development Kit (ODK)

#### Overview

##### **WinCC/ODK (Open Development Kit)**

- WinCC option for utilization of the exposed programming interfaces that can be used to access data and functions of the WinCC configuration and WinCC runtime system
- The interfaces are designed as "C-Application Programming Interface" (C-API)
- Scope of delivery:
  - CD-ROM with examples
  - Voucher for a one-day intensive workshop

#### Benefits

- Individual system expansions via an open standard programming language
- Access to data and functions of the WinCC configuration and runtime system
- Development of your own applications and add-ons for the WinCC basic system

##### **New in V7.0**

- Support for Visual Studio 2005 (.NET)

##### **New in V7.2**

- UNICODE support
- Support for Visual Studio 2008, 2012

#### Function

The API functions are configuration and runtime functions, and include:

- MSRTCreateMsg: Creates a message
- DMGetValue: Gets the value of a variable
- PDLRTSetProp: Sets the object properties in a display

They can be used in the following places:

- within WinCC, for example in global scripts or as part of C actions in the Graphics Designer,
- in Windows applications in the programming language C (the current version of Microsoft Visual C++ is necessary as a development environment for WinCC).

#### Ordering data

##### **WinCC/ODK**

- V7.2; for WinCC V7.x
- V7.0; for WinCC V7.0 and V6.x

#### Order No.

**6AV6371-1CC07-2AX0**  
**6AV6371-1CC07-0AX0**

### Overview

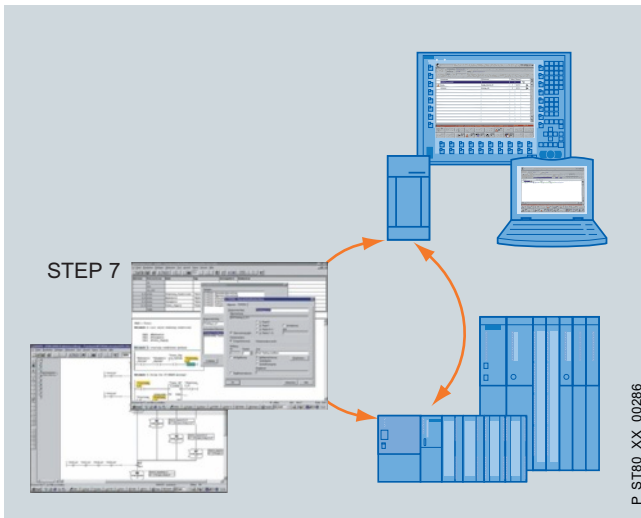

- Precise and rapid process fault diagnostics in plants and machines for SIMATIC S7 and SIMATIC HMI
- Standardized diagnostics concept for various SIMATIC components
- No further configuration for diagnostics functionality
- Reduces PLC memory and processor usage

#### Note

For further details, see "SIMATIC ProAgent process diagnostics software"

### Ordering data

### Order No.

#### SIMATIC WinCC/ProAgent

- V7.2; for WinCC V7.2
- V7.0 SP3; for WinCC V7.0 SP3

**6AV6371-1DG07-2AX0**  
**6AV6371-1DG07-0AX0**

#### SIMATIC WinCC/ProAgent Upgrade

- to SIMATIC WinCC/ProAgent V7.2
- to SIMATIC WinCC/ProAgent V7.0 SP3

**6AV6371-1DG07-2AX3**  
**6AV6371-1DG07-0AX4**

# HMI Software

## SIMATIC WinCC options

### WinCC/Redundancy

#### Overview

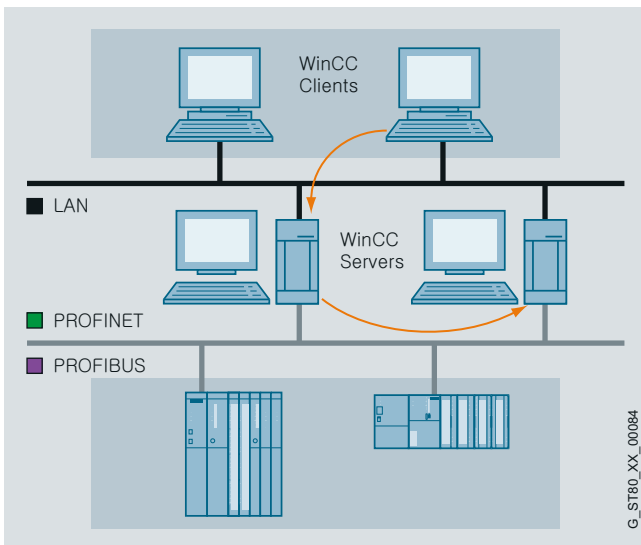
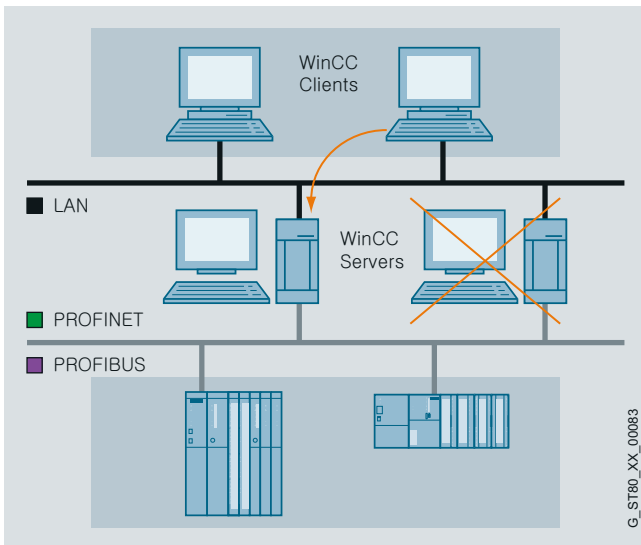
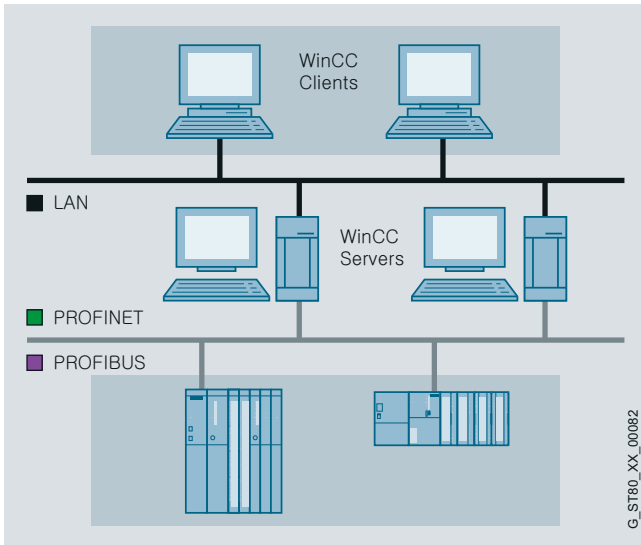

- Option for SIMATIC WinCC, supporting the parallel operation of two interfaced WinCC single-user systems or process data servers for mutual monitoring
- If one of the two server PCs or one of the two WinCC stations fails, the second one will take over control of the entire system. Once the failed server or station is restored to operation, the content of all the message and process value archives are copied to it.
- One WinCC/Redundancy package is required for each redundant pair of servers.

#### Benefits

- Increased system availability with continuous data integrity
- Automatic changeover of client in the event of failure of a server or failure of the communication to a server
- Continuous operator control and visualization thanks to automatic client changeover to the intact server
- Automatic updating of all archives in the background after rectification of the fault

#### Function

Normally, two WinCC stations or process data servers run in parallel. Each station has its own process connection and its own data archives. WinCC/Redundancy ensures automatic matching of system and user archive data.

If one of the two server computers or WinCC stations fails, the second will take over the archiving of messages and process data, thereby ensuring seamless data integrity. In client/server mode, the clients are automatically switched from the failed server to the redundant partner. This ensures continuous plant visualization and operation on every operator station.

When the failed partner resumes operation, all process values, messages and data archived during the fail period are automatically matched with the partner. This process runs in the background and does not affect plant continuity. Once this is complete, two equivalent servers/stations will be available again.

Communication with the SIMATIC S7 can also be configured with redundancy (an H Series SIMATIC S7 is required) by plugging in two communication modules and configuring two communication paths (S7-REDCONNECT software package). The use of failsafe H Series SIMATIC S7 can, if required, further increase availability at control level.

#### Ordering data

#### Order No.

##### SIMATIC WinCC/Redundancy

- Option for SIMATIC WinCC V7.2, Runtime software, single license for 2 installations
- Option for SIMATIC WinCC V7.0, Runtime software, single license for 2 installations
- Option for SIMATIC WinCC V6.2, Single license for 2 installations

**6AV6371-1CF07-2AX0**

**6AV6371-1CF07-0AX0**

**6AV6371-1CF06-2AX0**

### Overview

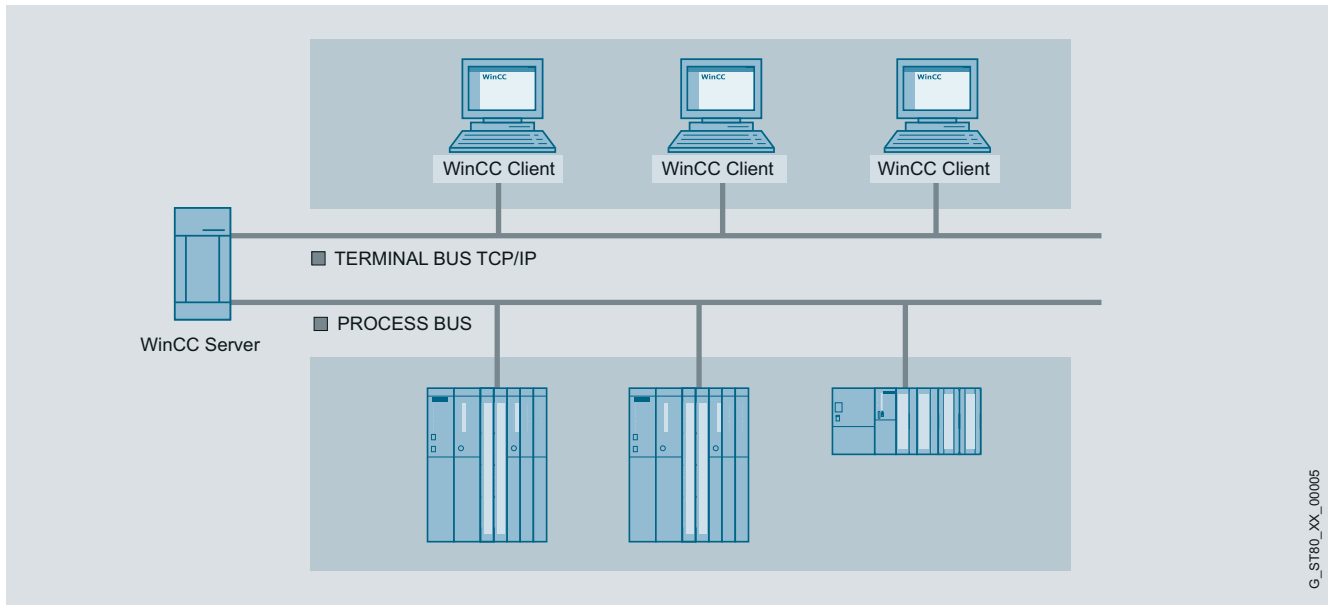

- Option for SIMATIC WinCC, which permits the configuration of a powerful client/server system
- One of the following operating systems must be available to install the option on the server: Windows Server 2003 (for V6) or Windows Server 2003 R2 (for V6.2 / V7.0 / V7.2) or Windows Server 2008 (for V7.0 with SP2 and higher or V7.2). When using Windows XP Professional and Windows 7 SP1, no more than 3 clients can be connected.
- A number of coordinated HMI stations can be operated in a single group with networked automation systems
- Client/server solution:
  - One server can supply up to 32 connected clients with process and archive data, messages, images and reports
  - Depending on the size of the plant, up to 12 servers (or up to 18 in version 7.2 or higher) can be used.
  - 32 clients (max. 12 or 18 redundant WinCC servers) possible per system
- Requirement: Network connection (TCP/IP) between the server PC and the connected clients. <sup>1)</sup>
- One license is required for each server.

<sup>1)</sup> One of the following operating systems is installed on one WinCC server: Windows Server 2003, Windows Server 2003 R2 or Windows Server 2008. Max. 3 clients with Windows XP Professional and Windows 7 SP1.

### Benefits

- Plant-wide scalability from the single-user system to the client/server solution
- Significantly higher quantity framework, relieving the individual servers and better performance due to distributing the complete application or tasks over several servers
- Low-cost configuration on the client is possible (the minimum RC license is sufficient)

### Application

In a complex plant, WinCC can also be configured as a distributed system according to requirements:

- Functional distribution (e.g. message servers, archive servers, etc.) or
- Distribution according to the physical plant structure (e.g. body-in-white, paintshop, etc.)

### Function

Each client can access more than one server at a time. Clients can also be used for configuration on the server.

A configuration of WinCC clients as a central Web server - as a distributed system if required - with an overview of all server projects in the system is also possible.

For WinCC clients, only the smallest runtime license RT128 is required. In order to also configure on WinCC clients, the smallest complete license RC128 is required. Remote configuration is possible if WinCC clients without their own project (Uniclents) on the server project are configured. This makes it possible to configure inexpensive operator and configuration stations in a network.

### Ordering data

### Order No.

#### SIMATIC WinCC/Server

- Option for SIMATIC WinCC V7.2, Runtime software, single license
- Option for SIMATIC WinCC V7.0, Runtime software, single license
- Option for SIMATIC WinCC V6.2, Single license

**6AV6371-1CA07-2AX0**

**6AV6371-1CA07-0AX0**

**6AV6371-1CA06-2AX0**



# HMI Software

## SIMATIC WinCC options

### WinCC/TeleControl

#### Overview

WinCC/TeleControl for WinCC V7.0 SP2 supports connection to outlying stations (Remote Terminal Units = RTUs) via telecontrol protocols.

#### Benefits

WinCC/TeleControl for WinCC V7.0 SP2 cannot only integrate newly configured RTUs, it can also integrate units which already exist in outlying areas by means of DNP3 or IEC 870-5-101/104 drivers.

For communication with the outstations, WinCC/TeleControl for WinCC V7.0 SP2 uses the SINAUT ST7 and DNP3 protocols (both via serial and TCP/IP communication connections) as well as IEC 870-5-101 (serial) and IEC 870-5-104 (Ethernet TCP/IP).

The serial RTU link is possible via the following components, which can be connected directly via WinCC (single station or server):

- SINAUT TIM communication modules (SINAUT ST7 telecontrol protocol)
- TCP/IP serial converter (telecontrol protocols DNP3, Modbus (not released for WinCC TC), IEC 870-5-101)

Equipment from MOXA or Lantronix, for example, can be used as TCP/IP serial converters.

By means of Ethernet TCP/IP, the RTUs can be connected directly or via TCP/IP WAN routers to the SIMATIC WinCC system bus (SINAUT ST7, DNP3, IEC 870-5-104 telecontrol protocols). When using the SINAUT ST7 telecontrol protocol, the SINAUT TIM communication module can be used in addition to the TCP/IP WAN router or as an alternative.

#### Application

Telecontrol communication over the wide area network is largely determined by the communication infrastructure which already exists. Various transmission media such as dedicated line, analog or digital telephone networks, wireless networks (GSM or private), DSL or GPRS can also be combined with each other.

##### **SINAUT ST7 telecontrol protocol**

Detailed information for implementing telecontrol applications with the SINAUT ST 7 telecontrol protocol via the Industry Mall.

##### **IEC 870-5-101/-104 telecontrol protocols**

Detailed information for implementing telecontrol applications with the IEC 870-5-101/-104 telecontrol protocols via the Industry Mall.

##### **DNP3 telecontrol protocol**

WinCC/TeleControl for WinCC V7.0 SP2 also supports the DNP3 telecontrol protocol. Widely distributed outstations (RTUs) can be controlled and monitored with the DNP3 telecontrol protocol via serial or Ethernet TCP/IP communication links by means of the telecontrol center in SIMATIC WinCC. The control center integrated with SIMATIC WinCC TeleControl into the SCADA system is the master during telecontrol communication. The slaves are represented by the outstations. SIMATIC S7-300/S7-300F and S7-400/S7-400F/S7-400H/S7-400FH controllers as well as third-party RTUs can be used as outstations.

Further hardware and software components round off the range of products:

- TIM communication modules
- TCP/IP converters – serial and MD modem modules
- GSM/GPRS components
- TCP/IP routers and switches
- SCALANCE S612 and S613 security modules
- Dedicated-line accessories
- Connecting cables and cables
- Engineering package for configuration of DNP3 data objects, stations, networks and connections as well as for diagnostics

In order to implement telecontrol networks, basic topologies including point-to-point, multi-point, star and ring can be configured using classic or TCP/IP-based media. These can be combined flexibly independent from existing infrastructure.

Classic WAN media:

- Dedicated line via modem, e.g. SINAUT MD2
- Private wireless networks
- Analog telephone network
- Digital ISDN network
- Mobile radio network GSM

TCP/IP-based WAN media:

- Ethernet networks, e.g. SCALANCE X with fiber-optic cables
- Industrial Wireless LAN with SCALANCE W
- Public networks and the Internet using DSL and/or GPRS

#### Function

##### Special characteristics of DNP3 communication

- Change-driven data transmission
  - Change-driven transmission of process data between RTU and control center
  - Signaling of RTU, control center or connection failure
  - Automatic data updating for all communication partners involved following troubleshooting and following the startup of the RTU or control center
- Chronological processing of process data
  - Time tagging of all data frames at the place of origin allows process data to be archived by the process control system in the correct chronological order
  - The time of the DNP3 stations in the WAN can be synchronized via SIMATIC WinCC (including summertime/wintertime switchover)
- Local data storage
  - The TIM communication module can temporarily store (for several hours or even days) message frames should the connection or the communication partner fail
  - Intermediate storage of message frames of lower priority in the case of priority-controlled data transmission (with dial-up networks or quantity-dependent data transmission costs)

##### Operating modes

The DNP3 telecontrol protocol supports the following operating modes:

- Polling
- Polling with time slot procedure
- Multi-master polling with time slot procedure
- Spontaneous mode in dial-up networks
- Spontaneous mode in the TCP/IP-based WAN



### Integration

Integration of WinCC/TeleControl for WinCC V7.0 SP2 into the WinCC SCADA system offers particular advantages for the water and waste water sectors, as well as oil and gas sectors, especially in the case of the following types of plant:

- Freshwater treatment and distribution
- Wastewater treatment plants
- Oil and gas pipelines and water pipes
- Oil and gas drilling fields and the associated treatment plants

In these types of plant, remote outstations such as pumping stations, valve stations or automated stations for wellheads must be integrated.

Through the support of communication protocols for RTUs such as SINAUT ST7, WinCC/TeleControl for WinCC V7.0 SP2 supports the following advanced communication concepts:

- Reduction in the transferred data volume by means of event-controlled communication mechanisms for alarm and measured value information.
- Time-synchronization of RTUs and correct time stamping of all data in the RTU.
- Tolerance of lower bandwidth, high latency or lack of reliability of communication lines
- Prevention of data loss due to communications failure through data backup in the RTU
- Support of communication media with serial interface (dedicated lines, dial-up connections over analog telephone lines and ISDN lines), various radio devices (standard, spread spectrum modulation), microwave and GSM
- Support for TCP/IP-based WANs (Wide Area Networks) such as DSL, GPRS or Ethernet radio networks
- Support for redundant communication connections
- Expanded communication diagnostics functions for RTU communication links
- Remote programming of RTUs
- Support for different communication topologies – point-to-point, multidrop (multistation mode) and hierarchic network structures
- High quality server redundancy scheme without data loss in the case of server failure

Through the support of communication protocols for RTUs such as IEC 60870-5 and DNP3, SIMATIC TeleControl for WinCC V7.0 SP2 supports the following advanced communication concepts:

- Reduction in the transferred data volume by means of event-controlled communication mechanisms for alarm and measured value information.
- Time synchronization of RTUs and correct time stamping of all data in the RTU.
- Tolerance of lower bandwidth, high latency or lack of reliability of communication lines
- Prevention of data loss due to communications failure through data backup in the RTU (not all non-Siemens RTUs support this)
- Support of communication media with serial interface (dedicated lines, dial-up connections over analog telephone lines and ISDN lines), various radio devices (standard, spread spectrum modulation), microwave and GSM
- Support for TCP/IP-based WANs (Wide Area Networks) such as DSL, GPRS or Ethernet radio networks
- Support for redundant communication connections
- Expanded communication diagnostics functions for RTU communication links
- Remote programming of RTUs
- Support for different communication topologies – Point-to-point, multidrop (multistation mode) and hierarchic network structures
- High quality server redundancy scheme without data loss in the case of server failure

#### Outstations/remote terminal units

WinCC/TeleControl for WinCC V7.0 SP2 supports the following preferred outstations for local distributed automation:

- Controller integrated into ET 200S (IEC 870-5-101/104 telecontrol protocols); for cost-sensitive applications, up to approx. 30 I/O signals or approx. 200 data points
- S7-300/S7-300F controller (SINAUT ST7, DNP3, IEC 870-5-101/104 telecontrol protocols); for extremely flexible configuration, up to 100 I/O signals or approx. 2000 data points
- S7-400/S7-400F controller (SINAUT ST7, DNP3, IEC 870-5-101/104 telecontrol protocols); up to 500 I/O signals or approx. 5000 data points
- S7-400/S7-400F redundant controller (IEC 870-5-101/104 and DNP3 telecontrol protocols); up to 500 I/O signals or approx. 5000 data points
- Third-party station with the IEC 870-5-101/104 and DNP3 telecontrol protocols (depending on type of station)

# HMI Software

## SIMATIC WinCC options

### WinCC/TeleControl

#### Integration (continued)

The following table provides an overview of the current options for connecting to these outstations:

Spectrum of outstations and integration versions							
Telecontrol protocol	SINAUT ST 7		DNP3		IEC 870-5-01	IEC 870-5-04	
Type of communication	Serial	Ethernet TCP/IP	Serial	Ethernet TCP/IP	Serial	Ethernet TCP/IP	
Interface	TIM 4R-IE	TCP/IP WAN router or/and TIM 4R-IE	TCP/IP serial converter	TCP/IP WAN router	TCP/IP serial converter	TCP/IP WAN router	
RTU/interface	ET 200S with integr. CPU (corresponding to S7-314)	-	-	-	IM 151-7 CPU or IM 151-8 PN/DP CPU as well as 1 SI module + SIPLUS RIC library	IM 151-8 PN/DP CPU + SIPLUS RIC library	
	S7-300/S7-300F	TIM 3V-IE	TIM 3V-IE	TIM 3V-IE DNP3	TIM 3V-IE DNP3	CP 341 + SIPLUS RIC library	CP 343 + IEC on S7 or integr. PN interface + SIPLUS RIC library
	S7-400/S7-400F	TIM 4R-IE	TIM 4R-IE	TIM 4R-IE DNP3	TIM 4R-IE DNP3	CP 441 + SIPLUS RIC library	CP 443 + SIPLUS RIC library or integr. PN interface + SIPLUS RIC library
	S7-400H/S7-400FH	-	-	TIM 4R-IE DNP3	TIM 4R-IE DNP3	ET 200M + 2 x CP 341 + SIPLUS RIC library	CP 443 + SIPLUS RIC library
	Third-party station	-	-	Depends on type of station		Depends on type of station	
Dial-up lines	•	-	•	-	-	-	
Dedicated line and radio networks	•	•	•	•	•	•	
Master/slave	•	•	•	•	•	•	
Peer-to-peer	•	•	-	-	•	•	
Mesh networks	•	•	•	•	•	•	
Time tagging in RTU	•	•	•	•	•	•	
RTU time synchronization	•	•	•	•	•	•	
Data buffering in RTU	•	•	•	•	• <sup>1)</sup>	• <sup>1)</sup>	
Routing with SIMATIC PDM	•	•	-	-	-	•	
International standard	-	-	•	•	•	•	

<sup>1)</sup> Data buffering is limited to two SIMATIC S7 data blocks. Depending on the SIMATIC CPU, this corresponds to approx. 800 to 3200 buffered frames.

Ordering data	Order No.	Order No.	
<p><b>SIMATIC TeleControl 7.0 SP2 for WinCC Basic Engineering</b></p> <p>Software package with SIMATIC TeleControl for WinCC 7.0 SP2 Engineering Software, 2 languages (English, German), executable with Windows XP Professional/Server 2003, Floating License for one user; electronic documentation on CD/DVD, 2 languages (English, German) Type of delivery: License key memory stick, Certificate of License incl. terms and conditions, SIMATIC WinCC Data Medium Package V7.0 + SP2 and CD "WinCC TeleControl Option V7.0 + SP2"</p>	<b>6DL5000-7AA07-0XA5</b>	<p><b>SIMATIC TeleControl 7.0 SP2 for Server Runtime (unlimited stations)</b></p> <p>Software package with SIMATIC TeleControl for WinCC 7.0 SP2 Runtime Software, 2 languages (English, German), executable with Windows Server 2003, Single License for one user; electronic documentation on CD/DVD, 2 languages (English, German) Type of delivery: License key memory stick, Certificate of License incl. Terms and Conditions, SIMATIC WinCC Data Medium Package V7.0 + SP2 and CD "WinCC TeleControl Option V7.0 + SP2"</p>	<b>6DL5002-7AF07-0XA0</b>
<p><b>SIMATIC TeleControl 7.0 SP2 for Server Runtime (6 stations)</b></p> <p>Software package with SIMATIC TeleControl for WinCC 7.0 SP2 Runtime Software, 2 languages (English, German), executable with Windows Server 2003, Single License for one user; electronic documentation on CD/DVD, 2 languages (English, German) Type of delivery: License key memory stick, Certificate of License incl. terms and conditions, SIMATIC WinCC Data Medium Package V7.0 + SP2 and CD "WinCC TeleControl Option V7.0 + SP2"</p>	<b>6DL5002-7AA07-0XA0</b>	<p><b>Driver software for telecontrol protocols TeleControl SINAUT Driver</b></p> <p>Runtime license for one WinCC Single Station or one WinCC server, Single License for 1 installation Requirement: Software SIMATIC TeleControl 7.0 SP2 for WinCC Server Runtime (6, 12, 256 stations) Type of delivery: License key memory stick, Certificate of License incl. terms and conditions</p>	<b>6DL5101-8AX00-0XB0</b>
<p><b>SIMATIC TeleControl 7.0 SP2 for Server Runtime (12 stations)</b></p> <p>Software package with SIMATIC TeleControl for WinCC 7.0 SP2 Runtime software, 2 languages (English, German), executable with Windows Server 2003, single license for one user; electronic documentation on CD/DVD, 2 languages (English, German) Type of delivery: License key memory stick, Certificate of License incl. terms and conditions, SIMATIC WinCC Data Medium Package V7.0 + SP2 and CD "WinCC TeleControl Option V7.0 + SP2"</p>	<b>6DL5002-7AB07-0XA0</b>	<p><b>TeleControl DNP3 Driver</b></p> <p>Runtime license for one WinCC Single Station or one WinCC server, single license for 1 installation Requirement: Software SIMATIC TeleControl 7.0 SP2 for WinCC Server Runtime (6, 12, 256 stations) Type of delivery: License key memory stick, Certificate of License incl. terms and conditions</p>	<b>6DL5101-8EX00-0XB0</b>
<p><b>SIMATIC TeleControl 7.0 SP2 for Server Runtime (256 stations)</b></p> <p>Software package with SIMATIC TeleControl for WinCC 7.0 SP2 Runtime software, 2 languages (English, German), executable with Windows Server 2003, single license for one user; electronic documentation on CD/DVD, 2 languages (English, German) Type of delivery: License key memory stick, Certificate of License incl. terms and conditions, SIMATIC WinCC Data Medium Package V7.0 + SP2 and CD "WinCC TeleControl Option V7.0 + SP2"</p>	<b>6DL5002-7AE07-0XA0</b>	<p><b>TeleControl IEC 870-5-101/-104 Driver</b></p> <p>Runtime license for one WinCC Single Station or one WinCC server, single license for 1 installation Requirement: Software SIMATIC TeleControl 7.0 SP2 for WinCC Server Runtime (6, 12, 256 stations) Type of delivery: License key memory stick, Certificate of License incl. terms and conditions</p>	<b>6DL5101-8CX00-0XB0</b>

### More information

For an overview of the complete performance spectrum on the Internet, visit:

Service & Support:

[http://www.siemens.com/automation/csi\\_en\\_WW/service](http://www.siemens.com/automation/csi_en_WW/service)  
(international)

Technical Support (hotline) for Automation & Drives:

[http://www.siemens.com/automation/csi\\_en\\_WW/support\\_request](http://www.siemens.com/automation/csi_en_WW/support_request)  
(international)

# HMI Software

## SIMATIC WinCC options

### WinCC/User Archives

#### Overview

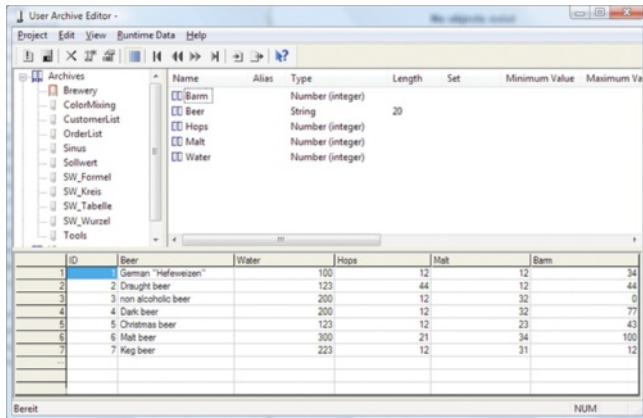

- Option for SIMATIC WinCC for managing data sets in user archives that contain related data.
- WinCC and its automation partners (e.g. a SIMATIC S7 controller) write these data sets and exchange them if required.
- A license is only required for the server (or single-user system).

The WinCC/User Archives option can also be used in the context of the WinCC/Web Navigator (see also WinCC/Web Navigator option).

#### Benefits

- Storing and managing of any user data in data sets
- Flexible display using ActiveX controls
- Simple linking of data set fields to the process via direct tag linking
- Import/export functions for further processing with other tools (e.g. MS Excel)

#### Function

- Input of parameter sets (e.g. operating parameters of a machine) in WinCC, storage of the sets in the user archive, and forwarding to the automation level
- Continuous acquisition of production parameters by the automation system and forwarding of the parameters to WinCC at the end of the shift
- Acquisition of batch data
- Specification of production parameters
- Management of warehousing data

WinCC user archives are created and assigned data in a user-friendly way using a dedicated editor. Special ActiveX controls are used for displaying data from the user archives at runtime.

Data sets and fields from user archives are linked to the process via direct tag linking.

Import and export functions support read-in/out of data via external applications (e.g. MS Excel). Freely selectable filter criteria allow clear representation of data sets.

WinCC provides functions for free organization of the data storage in the user archives that affect archives, data sets and fields. Archives can thus be generated, opened, closed, or reset, and data sets or field contents can be read, written or overwritten.

Sequence archives can accommodate batch data, shift production data, or also product quality data, and meet legal obligations for verification thanks to gap-free recording.

#### Ordering data

#### Order No.

##### SIMATIC WinCC/User Archives

- Option for SIMATIC WinCC V7.2, Runtime software, single license
- Option for SIMATIC WinCC V7.0, Runtime software, single license
- Option for SIMATIC WinCC V6.2, Single license

**6AV6371-1CB07-2AX0**

**6AV6371-1CB07-0AX0**

**6AV6371-1CB06-2AX0**

### Overview

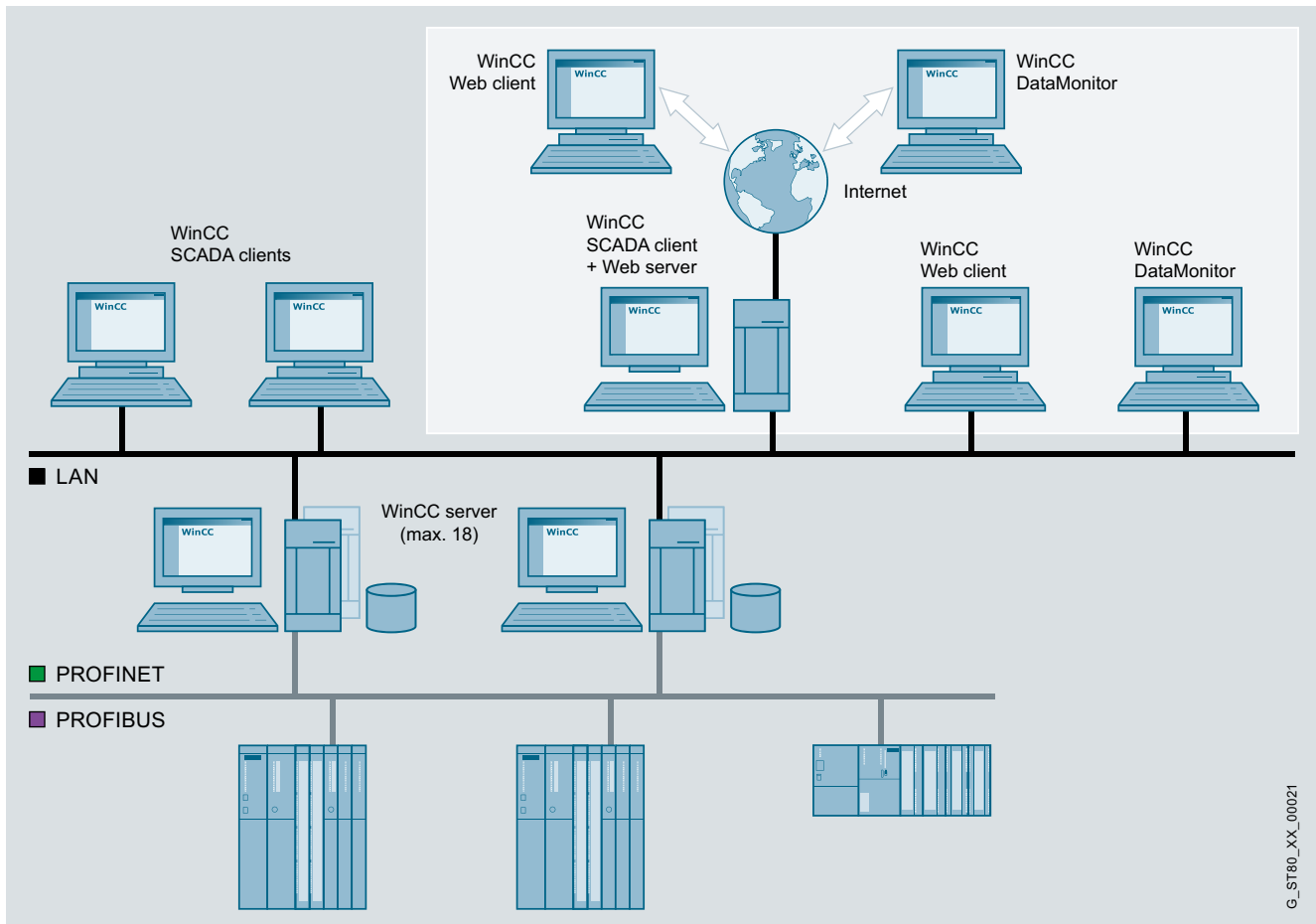

G\_ST80\_XX\_00021

- Option for SIMATIC WinCC for operator control and monitoring of plants via the Internet, in-house intranet or LAN
- Configuration from:
  - a Web server with the SIMATIC WinCC software as a single-user, client or server version and a Web client that enables operator control and monitoring of a current WinCC project via an Internet browser with ActiveX support. The WinCC basic system does not have to be installed on the client computer. It is also possible to use the Web client without Microsoft Internet Explorer.
- Licensing:
  - A license is required in order to use the Web server.
  - Licenses are available for access to the Web server by 1, 3, 5, 10, 25, 50, 100 or 150 clients.
  - Low-priced WebNavigator diagnostics licenses are available for the remote diagnostics via multiple, distributed Web servers.

# HMI Software

## SIMATIC WinCC options

### WinCC/Web Navigator

#### Overview (continued)

##### Highlights:

- Installation of the Web server - in distributed systems - also on a WinCC Client;
  - Access to as many as 18 subordinate WinCC stations (servers) possible
  - Web clients offer common views of data on various WinCC Servers
  - If you are using WinCC/Redundancy, the Web clients will also transfer via the subordinate WinCC servers (requires WebNavigator server to be installed on the WinCC Client (RT128) )
  - Separating the Web functionality from the WinCC data servers makes the overall system safer and more scalable in respect of load. Integrated user management with WinCC: The configured WinCC operator authorizations are taken into account on the Web client.
- Access to WebNavigator server from the WebNavigator TIA Portal series of products.
- Access to user archives.
- VB scripts are supported in the same way as the new objects and RT functions in WinCC V7.x.
- User-friendly services and tools for distributing customized objects (controls, files) to Web clients can be supplied for use as an integration platform. These components can then also be integrated into cross-Web/Server navigation.
- Distribution of load across a number of Web servers in order to run several hundred Web clients in a single system; Web clients are distributed across Web servers automatically.
- Version 7.2 supports Microsoft Internet Explorer Version 8.0 and 9.0, including tabbed browsing. A new license is not required for separate tabs.
- With the WinCC Web Viewer, the process screens can be displayed on the Web client independently of the Internet Explorer. Settings for the client are made on the client itself.
- The WinCC Web Viewer can also be used in conjunction with the Microsoft Terminal Service.
- From version 7 on, the WebNavigator can also be operated in "view only" mode and is thus used as tool for operating and navigating only via WinCC screens by means of the Internet Explorer.
- The cursor for View only mode can be selected according to individual requirements.
- Web server logins and logouts are recorded in the alarm and audit archive.
- There is a gadget available for the Windows 7 operating system in which selected WinCC process screens can be displayed. The gadget does not require any additional WebNavigator license. The WebNavigator server can be selected direct using the gadget.
- Security is increased by adjustable automatic logout. If an automatic logout is to take place, an absolute or inactive time period can be set.
- Runtime in the Web client can be terminated by means of scripting.

#### Benefits

- Operator control and monitoring across long distances and on different platforms (PC, local panel, mobile PDA)
- Large configurations with up to 150 operator stations
- Fast updating rates thanks to event-driven communication
- Optimally tailored clients for operating and monitoring, analysis, service and diagnostics
- Acceptance of configuration data for the Web, generally without changes
- Minimum maintenance costs thanks to centralized software administration
- High security standards and availability
  - Increased security due to separation of WinCC server and Web server (Web server in secure environment)
  - Support for commonly used security mechanisms (routers, firewalls, proxy servers)
  - Access authorization and user administration

#### New in V7.2

- New license stages for 1, 5, 100, 150 clients and associated powerpacks 1/3, 3/5, 50/100, 100/150
- Unicode support
- PDL password protection with WebNavigator PDLPad
- Login / logout / register:
- Log user in/out on the WebNavigator client
- Manual logout in the Internet Explorer by means of ODK C-Script (PWRTLogout function)
- Configurable logout/login in the WinCC RT Viewer

#### Application

In addition to the typical use of the Web Navigator in WANs (**Wide Area Network**), the Web Navigator is also suitable for solving especially low-cost applications. This especially includes applications that have a pronounced distributed structure (water/wastewater, oil & gas), or in which access to process information is only sporadic (building management).

The Web Navigator also permits vertical integration, i.e. a networked IT landscape with integrated data flow between the planning and operating levels within a company. Only a standard browser is required for direct access to current process information.

The Web Server can have its own dedicated direct process connection. An alternative is coupling via OPC or the use of a remote Web Server to a WinCC Client. This simultaneously increases security and reduces the communication load of the plant.

In addition to the Standard Web Navigator licensing there is the so-called Diagnostics Client, with identical functions in principle, but which is especially suitable for the following applications:

- Remote diagnostics/operation of several unmanned WinCC stations.
- Central control rooms which monitor multiple Web Servers on one user interface.
- Power Users that always require guaranteed access to the server regardless of the number of users already logged on to the server.

### Design

#### **Licenses for the Web Navigator**

The Web Navigator Client software can be installed as many times as required without the need for a license.

- Server-based licensing;  
a license is required in order to use the Web Navigator Server. Licenses are available for simultaneous access to the Web server by 1, 3, 5, 10, 25, 50, 100 or 150 clients.
- Diagnostics client licensing;  
for optimum-cost access by one or a small number of Web Navigator Clients to numerous Web servers (e.g., for the purpose of diagnostics). This client license provides guaranteed access to Web servers at any time. In respect of function there is no difference compared with regular Web Navigator Clients and the two can be mixed.

Web Navigator Clients can:

- Access a number of different web servers or
- Access data on a number of higher-level WinCC stations simultaneously via a remote Web server

On the server side, only one Web Navigator Diagnostics Server license or, alternatively, one Standard Web Navigator license is required.

Alternatively, a number of Web Navigator Servers with the same WinCC project can be combined to create a "server farm". This means that it is possible for several hundred Web clients to have access to the same database. The service ensures that the clients accessing are distributed evenly across all servers. If a server fails the Web client is automatically forwarded to the next available server.

In order to use this functionality you will need to install a Web Load Balancing license on the Web servers involved. Each Load Balance package contains 2 licenses.

An inexpensive expansion option for Web Load Balancing is available for redundant WinCC stations on which the Web Navigator is also installed. For this purpose, you need to install a Web Load Balancing Step Up license on the web servers involved. Each Step Up package contains 2 licenses.

#### **Thin Client solutions**

The Web Navigator can also run under Windows Server 2003 or Windows Server 2008 terminal services. A Windows Server 2003 or Windows Server 2008 (or higher) operating system is required. This makes it possible to connect SIMATIC Thin Clients as visualization stations to WinCC, for example.

For this purpose, the Windows terminal services must be installed on the PC on which the Web client is installed. A Windows Server 2003 or Windows Server 2008 (or higher) operating system is required. Up to 25 ThinClients can be connected to one terminal server.

Applications:

- Mobile devices
- Handhelds
- Rugged on-site visualizations

#### **Hybrid configuration**

Web Navigator and DataMonitor clients can be mixed in a single system.

### Function

The Web Configurator (Wizard) makes setting up and configuring a Web Navigator Server very easy. WinCC process screens to be visualized via the Internet are created as usual using WinCC Graphics Designer. Under normal circumstances the project can be worked on locally without modification. The Web Publishing Wizard optimizes the screens for transmission and display on the Internet. A standard browser is all that is required to display WinCC process screens on the Web Client. The MS Internet Explorer is used depending on the Web Navigator version used (tip: start the Internet Explorer in full-screen mode with the start parameter "-k").

The operator on the Web Client is integrated in the central WinCC user administration and can operate and monitor the system according to the configured access rights. The Web Navigator supports all standard security mechanisms that can be used for applications on the Internet, e.g. routers, firewalls and proxy servers.



# HMI Software

## SIMATIC WinCC options

### WinCC/Web Navigator

Ordering data	Order No.	Order No.	
<b>WinCC/Web Navigator</b> <b>V7.2; for WinCC V7.2</b> <ul style="list-style-type: none"> <li>• 1 client license</li> <li>• 3 client licenses</li> <li>• 5 client licenses</li> <li>• 10 client licenses</li> <li>• 25 client licenses</li> <li>• 50 client licenses</li> <li>• 100 client licenses</li> <li>• 150 client licenses</li> </ul>	6AV6371-1DH07-2LX0 6AV6371-1DH07-2AX0 6AV6371-1DH07-2MX0 6AV6371-1DH07-2BX0 6AV6371-1DH07-2CX0 6AV6371-1DH07-2DX0 6AV6371-1DH07-2GX0 6AV6371-1DH07-2HX0	<b>V7.0; for WinCC V7.0, WinCC V7.0 SP1/SP2/SP3 and WinCC V7.0 SP1/SP2/SP3 ASIA</b> <ul style="list-style-type: none"> <li>• Base Pack (3 client licenses)</li> <li>• 10 client licenses</li> <li>• 25 client licenses</li> <li>• 50 client licenses</li> </ul>	6AV6371-1DH07-0AX0 6AV6371-1DH07-0BX0 6AV6371-1DH07-0CX0 6AV6371-1DH07-0DX0
<b>WinCC/Web Navigator Powerpacks V7.2</b> <ul style="list-style-type: none"> <li>• From 1 to 3 clients</li> <li>• From 3 to 5 clients</li> <li>• From 5 to 10 clients</li> <li>• From 10 to 25 clients</li> <li>• From 25 to 50 clients</li> <li>• From 50 to 100 clients</li> <li>• From 100 to 150 clients</li> </ul>	6AV6371-1DH07-2LA0 6AV6371-1DH07-2AM0 6AV6371-1DH07-2MB0 6AV6371-1DH07-2BC0 6AV6371-1DH07-2CD0 6AV9681-1DH07-2DG0 6AV9681-1DH07-2GH0	<b>WinCC/Web Navigator Powerpacks V7.0</b> <ul style="list-style-type: none"> <li>• From 3 to 10 clients</li> <li>• From 10 to 25 clients</li> <li>• From 25 to 50 clients</li> </ul>	6AV6371-1DH07-0AB0 6AV6371-1DH07-0BC0 6AV6371-1DH07-0CD0
<b>WinCC/Web Navigator Diagnostics Client</b> <ul style="list-style-type: none"> <li>• for WinCC V7.2</li> </ul>	6AV6371-1DH07-2EX0	<b>WinCC/Web Navigator Diagnostics Client</b> <ul style="list-style-type: none"> <li>• for WinCC V7.0</li> </ul>	6AV6371-1DH07-0EX0
<b>WinCC/Web Navigator Diagnostics Server</b> <ul style="list-style-type: none"> <li>• for WinCC V7.2</li> </ul>	6AV6371-1DH07-2FX0	<b>WinCC/Web Navigator Diagnostics Server</b> <ul style="list-style-type: none"> <li>• for WinCC V7.0</li> </ul>	6AV6371-1DH07-0FX0
<b>WinCC/Web Navigator upgrade</b> <b>V6.0 to V7.0; V6.2 to V7.0; V6.2 to V7.2</b> <ul style="list-style-type: none"> <li>• For 3, 10, 25, 50 clients</li> <li>• Diagnostics server and diagnostics client</li> <li>• Load Balancing</li> </ul>	Included in corresponding WinCC upgrade	<b>WinCC/Web Navigator upgrade</b> <b>V6.0 to V7.0</b> <ul style="list-style-type: none"> <li>• For 3 clients</li> <li>• For 10 clients</li> <li>• For 25 clients</li> <li>• For 50 clients</li> </ul>	6AV6371-1DH07-0AX4 6AV6371-1DH07-0BX4 6AV6371-1DH07-0CX4 6AV6371-1DH07-0DX4
<b>WinCC/Web Load Balancing V7.2</b> <ul style="list-style-type: none"> <li>• Load Balancing</li> <li>• Load Balancing Step Up</li> </ul>	6AV6371-1DH07-2JX0 6AV6371-1DH07-2FJ0	<b>V6.2 to V7.0</b> <ul style="list-style-type: none"> <li>• For 3 clients</li> <li>• For 10 clients</li> <li>• For 25 clients</li> <li>• For 50 clients</li> </ul>	6AV6371-1DH07-0AX3 6AV6371-1DH07-0BX3 6AV6371-1DH07-0CX3 6AV6371-1DH07-0DX3
		<b>V6.x to V7.0</b> <ul style="list-style-type: none"> <li>• For Web Navigator Diagnostics Client</li> <li>• For Web Navigator Diagnostics Server</li> </ul>	6AV6371-1DH07-0EX4 6AV6371-1DH07-0FX4
		<b>WinCC/Web Load Balancing V7.0</b> <ul style="list-style-type: none"> <li>• Load Balancing</li> <li>• Load Balancing Step Up</li> </ul>	6AV6371-1DH07-0JX0 6AV6371-1DH07-0FJ0

Ordering data	Order No.
<b>WinCC/Web Navigator</b>	
<b>V6.2 SP3; for WinCC V6.2 SP3</b>	
<ul style="list-style-type: none"> <li>• Base Pack (3 client licenses)</li> <li>• 10 client licenses</li> <li>• 25 client licenses</li> <li>• 50 client licenses</li> </ul>	<b>6AV6371-1DH06-2AX0</b> <b>6AV6371-1DH06-2BX0</b> <b>6AV6371-1DH06-2CX0</b> <b>6AV6371-1DH06-2DX0</b>
<b>V6.2 SP3 ASIA; for WinCC V6.2 SP3 ASIA</b>	
<ul style="list-style-type: none"> <li>• Base Pack (3 client licenses)</li> <li>• 10 client licenses</li> <li>• 25 client licenses</li> <li>• 50 client licenses</li> </ul>	<b>6AV6371-1DH06-2AV0</b> <b>6AV6371-1DH06-2BV0</b> <b>6AV6371-1DH06-2CV0</b> <b>6AV6371-1DH06-2DV0</b>
<b>WinCC/Web Navigator Powerpacks</b>	
<ul style="list-style-type: none"> <li>• V6.2 (for ASIA variants as well)</li> <li>• From 3 to 10 clients</li> <li>• From 10 to 25 clients</li> <li>• From 25 to 50 clients</li> </ul>	<b>6AV6371-1DH06-2AB0</b> <b>6AV6371-1DH06-2BC0</b> <b>6AV6371-1DH06-2CD0</b>
<b>WinCC/Web Navigator Diagnostics Client</b>	
<ul style="list-style-type: none"> <li>• for WinCC V6.2 SP3</li> <li>• for WinCC V6.2 SP3 ASIA</li> </ul>	<b>6AV6371-1DH06-2EX0</b> <b>6AV6371-1DH06-2EV0</b>
<b>WinCC/Web Navigator Diagnostics Server</b>	
<ul style="list-style-type: none"> <li>• for WinCC V6.2 SP3</li> <li>• for WinCC V6.2 SP3 ASIA</li> </ul>	<b>6AV6371-1DH06-2FX0</b> <b>6AV6371-1DH06-2FV0</b>
<b>WinCC/Web Navigator upgrade</b>	
<b>V1.x to V6.2 SP3</b>	
<ul style="list-style-type: none"> <li>• For 3 clients</li> <li>• For 10 clients</li> <li>• For 25 clients</li> <li>• For 50 clients</li> </ul>	<b>6AV6371-1DH06-2AX4</b> <b>6AV6371-1DH06-2BX4</b> <b>6AV6371-1DH06-2CX4</b> <b>6AV6371-1DH06-2DX4</b>
<b>V6.x to V6.2 SP3</b>	
<ul style="list-style-type: none"> <li>• For 3, 10, 25, 50 clients <sup>1)</sup></li> <li>• For Web Navigator Diagnostics Client</li> <li>• For Web Navigator Diagnostics Server</li> </ul>	<b>6AV6371-1DH06-2XX3</b> <b>6AV6371-1DH06-2EX3</b>  <b>6AV6371-1DH06-2FX3</b>
<b>V6.x ASIA to V6.2 SP3 ASIA</b>	
<ul style="list-style-type: none"> <li>• For 3, 10, 25, 50 clients <sup>1)</sup></li> </ul>	<b>6AV6371-1DH06-2XV3</b>
<b>WinCC/Web Load Balancing V6.2 SP3</b>	
<ul style="list-style-type: none"> <li>• Web Load Balancing (2 licenses)</li> <li>• Web Load Balancing Step Up (2 licenses)</li> </ul>	<b>6AV6371-1DH06-2JX0</b> <b>6AV6371-1DH06-2FJ0</b>

<sup>1)</sup> Including upgrade for diagnostics client, diagnostics server, Web Load Balancing and Web Load Balancing Step Up.

### More information

#### System requirements – Web server

For WinCC/Web Navigator V7.2

- Windows 7 SP1 (32- and 64-bit) Business, Enterprise and Ultimate (max. 3 clients)
- Windows XP Professional Service Pack 3 (max. 3 clients)
- Windows Server 2003 SP2
- Windows Server 2008 SP2 32-bit
- Windows Server 2008 R2 SP1 64-bit
- Internet Explorer V7.0, V8.0 and V9.0
- Microsoft SQL Server 2008 R2 SP1, 32-bit (included in the WinCC product delivery)

For WinCC/Web Navigator V7.0

- Windows 7 (32-bit) Business, Enterprise and Ultimate (max. 3 clients)
- Windows XP Professional Service Pack 3 (max. 3 clients)
- Windows Server 2003 SP2 and Windows Server 2003 R2 SP2
- Windows Server 2008 SP2
- Internet Explorer V6.0 SP1 or SP2 as well as Internet Explorer V7.0.
- Microsoft SQL Server 2005 SP2 (scope of supply of WinCC)
- WinCC Basic System V7.0 SP2

For WinCC/Web Navigator V6.2 SP3

- Windows 2000 Professional Service Pack 4 (max. 3 clients)
- Windows XP Professional or Service Pack 3 (max. 3 clients)
- Windows Server 2003 SP2 or Windows Server 2003 R2 SP2
- Internet Explorer 6.0 SP1, SP2 or 7.0 (without multitabbing)
- Microsoft SQL Server 2005 SP1 (scope of supply of WinCC)
- WinCC basic system V6.2 SP3

#### System requirements – Web client

For WinCC/Web Navigator V7.0

- Internet Explorer V6.0 SP1 or SP2 as well as Internet Explorer V7.0

For WinCC/Web Navigator V6.2 SP3

- Internet Explorer 6.0 SP1, SP2 or 7.0 (without multitabbing)

WinCC Web Navigator V6.2 SP3 ASIA

(requires SIMATIC WinCC V6.2 SP3 ASIA)

The functions included in this version differ from the standard version of WinCC/Web Navigator V6.2 SP3 as follows:

- This version does not allow an Asian Web Navigator client to access a non-Asian server and vice versa.

# HMI Software

## WinCC add-ons und partner management

### WinCC add-ons and partner management

#### Overview

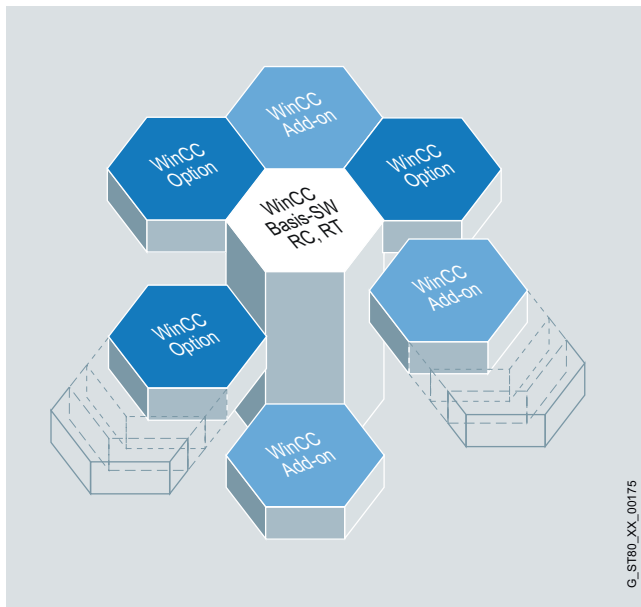

#### 4 WinCC Premium Add-ons – Solutions for all sectors and technologies

The basic system is designed to be independent of any specific technology or industrial sector, to be modular and flexibly expandable and to permit not only simple single-user applications in machine construction, but also complex multi-user solutions or even distributed systems with several servers and clients in plant engineering. WinCC Premium Add-ons are supplementary products that have been created by competent partners working in the specific sectors and technologies and represent interesting expansions for WinCC.

**WinCC Premium Add-ons** are not IA (Siemens Industry Automation) products, but the products of partners who are committed to complying with certain quality features and boundary conditions. The Premium Add-ons are checked, for example, in the Siemens Test Center for their compatibility with the basic WinCC system and supported in the first instance by the central Hotline. As they are important application- and sector-specific add-on products for SIMATIC WinCC, they are marketed jointly by Siemens and the respective add-on suppliers. The WinCC Premium Add-on products can be found on the Internet (see Further Information) and in the "Online WinCC Premium Add-on Catalog".

#### Premium Add-ons for Connectivity:

- **PM OPEN IMPORT system software** for importing WinCC flexible archives into the WinCC system.
- **PM OPEN EXPORT system software** for exporting WinCC data to local storage media or storage media released in the network.
- **PM OPEN TCP/IP system software** permits bidirectional exchange of WinCC data (tags, messages) with one or more computers that communicate using the TCP/IP protocol.
- **Historian CONNECT ALARM system software** permits importing of messages and alarms from WinCC and WinCC flexible into the SIMATIC IT Historian.
- **TOP Server/TOP Server UCON** expands OPC-based the connection capability for WinCC & WinCC flexible Advanced (PC based runtime)

#### Premium Add-on for process management:

- **PM CONTROL system software** is a recipe system for user-friendly generation and modification of recipes.
- **PM QUALITY system software** is an archive system for the administration of job and batch-related production and process data.

#### Premium Add-on for sector products:

- **Library SENTRON PAC3200 for SIMATIC WinCC** permits seamless integration of the SENTRON PAC3200 multi-functional measuring instrument in WinCC.
- **Sm@rtlib function library** provides function blocks for S7-300/400 as well as faceplates and icons for WinCC and WinCC flexible from the areas of process industry, HVAC, pharmaceuticals and energy.
- **ACRON for WinCC/PCS 7** is used for long-term archiving and logging of process data for small to medium-sized plants, specifically in the water supply and treatment industry.

#### Premium Add-on for configuration tools:

- **DCC TranslationEditor** for translating multilingual projects with in-built security, convenience and globalization features.

#### Premium Add-on for diagnostics and maintenance:

- **Management System Alarm Control Center** for transmitting fault messages via various communication paths, such as GSM, LAN, e-mail.
- **PM MAINT system software** is a tool for the maintenance of production plants.
- **PM ANALYZE system software** for analysis of fault and operating messages, as well as process values.

**Overview** (continued)**Competent partners**

With SIMATIC WinCC, you not only get excellent products to suit your requirements, but we will also support you with selecting a partner for your automation solution. In our global network of Siemens Automation Solution Providers you will always find competent partners in your neighborhood. In addition, we implement and support the Siemens-internal WinCC Competence Centers and the WinCC Professionals external system integrators on the basis of WinCC customer- and industry-specific and economic solutions.

**WinCC Competence Centers****Mannheim**

Emphasis on process management

- Sector-independent solutions and products in the fields: Production, environmental protection, maintenance and diagnostics
- Connectivity tools, system integration, connection to SAP R/3
- Support of FDA validation and WinCC ODK
- Support for advanced users with application of ODK and VBA
- Customer-specific software development for panels, PCs/IPC, and servers
- Consulting on web technologies, web servers/thin clients, DataMonitor
- Customer-specific workshops, e.g. VBS, VBA, and all WinCC options, e.g. Process Historian
- Information Server and other WinCC topics according to customer requirements

**Stuttgart**

Emphasis on production technology

- Solutions for maintenance management
- Web-based solutions with WinCC

**Nuremberg**

Solutions in the Oil & Gas, Metal & Mining, Pulp & Paper sectors

- Network and security
- Microsoft Certified
- Migration from COROS to WinCC
- Customized expansions also for WinCC flexible
- Web solutions
- Customer-specific workshops, e.g. training courses for VBS, VBA, web technologies à Web Server/Thin Client, DataMonitor à Webcenter Reports, Excell Workbook, and all WinCC topics as required by the customer (the latter with lead time)

Further information can be found in the Internet at:

<http://www.siemens.com/wincc/competencecenter>

**More information****WinCC Competence Center**

<http://www.siemens.com/winCC/competencecenter>

**Siemens Solution Partner Automation**

<http://www.siemens.com/automation/solutionpartner>

**WinCC Premium Add-on**

<http://www.siemens.com/winCC/addons>

# HMI Software

## SCADA System SIMATIC WinCC Open Architecture

### SIMATIC WinCC Open Architecture

#### Overview



SIMATIC WinCC Open Architecture is a SCADA system for visualizing and operating processes, production flows, machines and plants in all industrial sectors.

SIMATIC WinCC OA relies throughout on object-oriented structures. Due to this consistent and well-considered use of object-oriented structures, from process pictures to the database, the engineering costs improve for SIMATIC WinCC OA customers.

Distributed systems enable the connection of up to 2048 autonomous SIMATIC WinCC Open Architecture systems via one network. Each subsystem can be configured either as single-user or multi-user system, each of which may be redundant or non-redundant.

- Current version: **SIMATIC WinCC Open Architecture V3.11**  
Runs on:
  - Windows 8 Enterprise (64-bit)
  - Windows 7 Ultimate/Enterprise/Professional SP1 (32/64-bit)
  - Windows XP SP2/SP3 (32-bit)
  - Windows Server 2008 R2 (64-bit)
  - Red Hat Linux 5 (32/64-bit)
  - OpenSuse 12.1 (32/64-bit)
  - Sun Solaris 10 SPARC (32-bit)
  - Sun Solaris 10 x86 (64-bit)
  - VMWare ESXi Version 4.0.0 & 5.0.0

#### Note

Native 64-bit support on 64-bit systems.

#### Benefits

- Efficient engineering and flexible plant expansion
  - Object orientation
  - Unlimited number of data points
  - Mass engineering
  - Multilingual with UTF-8 support

- Object-oriented data model
  - Mapping of setpoint values and measured values for a physical plant object onto a structured data point
  - Data point comprises a tree structure with data point elements
  - The individual process values are mapped onto the data point elements
  - Any number of data points can be instanced from one defined data point structure (data point type), e.g. 20 pumps of the same type.
  - Data point types can be embedded in other data point types, which enables more complex plant objects to be generated (e.g. one pump station comprises 2 pumps).
  - Graphical plant symbols can be linked with a data point type, in which case they only need to be drawn once, but can be used for all instances of the linked type.
  - Savings in engineering outlay.
- Freely scalable
  - From a small single-user system up to a networked, redundant high-end system
  - Distributed systems of up to 2048 servers
- Platform-independent
  - Available for Windows, Linux and Solaris
- Native 64-bit support
  - More system memory is usable, due to native 64-bit support
  - This means that larger data quantity structures per server can be processed
- Maximum fail-safety and availability
  - Hot standby redundancy
  - Disaster recovery system
  - SIL3 certification according to IEC 61508
- Platform for customized solutions
  - Quick and easy implementation of new processes
  - Swift adaptation of the control and visualization of the plant to current market requirements
  - Company-internal programming and in-house developments enable independence and protection of intellectual property
  - Structure of standardized solutions permits continuous use
  - Support of brand-labeling
  - Individual brand names for OEM developments
- Openness thanks to comprehensive driver and interface options:
  - Modbus serial, Modbus Plus / RS485, RK512, TLS, Teleperm M, SSI driver, IEC 60870-5-101, -104, DNP3, SINAUT, PROFIBUS DP, PROFIBUS S7 + MPI, S7 TCP/IP, Modbus TCP/IP, Ethernet/IP, OPC DA Client & Server, OPC A&E Client & Server, OPC UA Client & Server (DA, AC), SNMP, BACnet, API, Kerberos
- Seamless traceability of system states by means of high-performance archiving:
  - Data archiving in value archives (internal database format)
  - Data archiving in an Oracle database
- Expandable by means of add-ons and solution frameworks:
  - Add-on for quick and easy engineering (Etool, AdvS7, etc.)
  - Add-on for increasing the availability (DRS, etc.)
  - Add-on for clarity in distributed systems (GIS Viewer, etc.)
  - Add-on for efficient maintenance management (AMS, Scheduler, etc.)
  - Add-on for mobile operability (Web Client, Ultralight Client, etc.)
  - Add-on for efficient building automation technology (BacNet, etc.)
  - Add-on for the integration of video management



# HMI Software

## SCADA System SIMATIC WinCC Open Architecture

### SIMATIC WinCC Open Architecture

#### Application

The SCADA system SIMATIC WinCC Open Architecture addresses applications with high demand for customer-specific adaptations, large and/or complex applications, as well as projects that demand special system requirements and functions.

SIMATIC WinCC Open Architecture demonstrates its high performance in networked and redundant high-end control systems in particular. Integrated, high-performance communication is guaranteed from the field level to the control station, from the machine to the company headquarters. In every situation, high availability, reliable information, fast interaction, and user friendliness are guaranteed. Applications can also be changed without interrupting the process. Profitability, efficiency and safety are therefore always in equilibrium. SIMATIC WinCC Open Architecture displays its reliability in a wide range of business-critical applications.

With SIMATIC WinCC Open Architecture, ideas can be quickly and easily converted into new applications. SIMATIC WinCC Open Architecture is open for independent in-house developments and also enables own product branding.

Thanks to its special system properties, SIMATIC WinCC Open Architecture meets the highest demands especially in the case of traffic solutions, building management systems and supply systems (power, water, oil and gas, etc.).

#### Design

SIMATIC WinCC Open Architecture is available as a single-user runtime license, multi-user runtime license, Web Client license, and parameterization and development license. With SIMATIC WinCC Open Architecture the required license is determined, among other things, according to the number of inputs and outputs (I/O).

An "I/O" refers to a data point element (DPE) whose content is exchanged either by means of drivers (e.g. S7 driver communicates with a PLC), with other software systems. Internal data point elements, i.e. DPEs without communication to the outside, are not counted for licensing. The licenses are available either with an unlimited number of I/Os or with limitations of 500 to 250 000 I/Os.

The multi-user runtime license allows working simultaneously from different PCs, with the licensing taking place via the server. The active clients are then counted. The web client and the ultra-light client enable the visualization and operation of process pictures over an exclusively HTTP connection between the server and the respective web client. The parameterization and development licenses extend a runtime license with the option of configuration and parameterization. They each require a server license.

#### Function

SIMATIC WinCC Open Architecture is a very modular SCADA system. The required functionalities are realized by specific, functional entities created for various tasks. In SIMATIC WinCC Open Architecture these units are called "Managers" – they are also independent processes in software terms.

WinCC OA Manager	Task
<b>Event Manager (EV)</b>	The Event Manager (EV) is the processing center in WinCC OA. This unit provides a constantly updated image of all PowerTags in the memory. Each other functional unit (Manager) that wants to access the data receives it from the process image of the Event Manager and does not have to communicate directly with a controller. Conversely, a command from an operator station is initially set only as a value change in the process image of the Event Manager. The associated driver then forwards it to the corresponding target device (e.g. PLC) automatically. The Event Manager is a kind of central data distributor, in effect the communication center for WinCC OA. Furthermore, this Manager also carries out the alarm handling and can execute various arithmetic functions autonomously.
<b>Driver Manager (D)</b>	The lowest level in a WinCC OA System is represented by the process connections, referred to in WinCC OA as drivers (D). These are special programs that handle the communication with the control and field level. Since numerous different forms of communication are possible with the PLCs or telecontrol nodes, there are different drivers that can be selected. In very simple terms, the driver is a unit for converting a particular protocol into the internal communication form of WinCC OA. The driver reads the current states, measurement or counter values from the field and in the opposite direction it forwards commands and set-points to the lower-level controllers (= the term "control" should be used here and below to represent all possible devices of the basic automation (PLC, DDC, telecontrol system, etc.)).
<b>Data Manager (DB)</b>	The Data Manager (DB) represents the link to database. On one hand, it involves the parameterization data of an application that is to be stored in such a database. On the other hand, it involves the historical recording of changes in values or alarms. If a user wishes to query historical data at a later date, then the Data Manager completes this request and not the database itself.

# HMI Software

## SCADA System SIMATIC WinCC Open Architecture

### SIMATIC WinCC Open Architecture

**Function** (continued)

WinCC OA Manager	Task
<b>Control Manager (CTRL)</b>	<p>WinCC OA has numerous options for implementing your own algorithms and processing. The two most important are the internal language control (CTRL) and the general application programming interface (API).</p> <p>Control is an extremely powerful scripting language. The processing is interpretative, so that no compilation is required. The syntax is almost identical with ANSI-C, with some modifications for simplification. This is a fully developed, procedural high-level language with multi-threading (= quasi-parallel processing of individual programs; the system itself carries out the processing check). The language offers a comprehensive function library for tasks of the control and visualization technology. Control can be used as a stand-alone process (Control Manager), for animation and user interface design or for standardized, data object-oriented processing functions.</p> <p>The API (WinCC OA API) represents the most powerful form of functional expansion. It is configured as a C++ class library and allows the software developer to implement individual functions as an independent, additional manager (forecast system, simulation, tools, proprietary databases, etc. ).</p>
<b>User Interface Manager (UI)</b>	<p>The interface to the user is created by the User Interface Manager (UI). This comprises a graphics editor (GED), a database editor (PARA) or the general user interface of the application (Vision module). The User Interface serves to display values, issue commands or track alarms in the alarm list. Trends and reports are also usually part of the UI. From a programming viewpoint, the user interaction in WinCC OA is completely isolated from the background processing – this is merely a view of the data of the current process image or the history.</p>

For special tasks such as redundancy, management for distributed systems, web server, reporting, simulation, COM etc., further managers are available.

The powerful configuration functions contribute to a reduction of engineering and training overheads and lead to increased flexibility and operational reliability.

Special functions	Task
<b>Access to external databases</b>	<p>The database interfaces offer the possibility of access to external databases.</p> <p>Under Windows, the link is established via the ADO Standard. ADO (ActiveX Data Objects) is an interface developed by Microsoft for vendor-independent access to data sources of all types, primarily databases. The data source for ADO is an OLE DB Provider, although ODBC-compatible databases can also be addressed via an internal wrapper.</p> <p>In Linux, the Qt library is used as an interface to relational databases. Access in this case is either direct via the native DB-API or via ODBC.</p>
<b>Application Programming Interface (API)</b>	<p>The API offers a series of functions that enable WinCC OA to be extended with special managers. A manager means a program that communicates with the system by via a protocol defined by WinCC OA.</p>
<b>COM (Component Object Model)</b>	<p>This is a specification for the development of modular software components that can be used by each COM-compatible application.</p> <p>COM components can easily be integrated into such applications and can even be removed from an application during runtime. COM components can be programmed in a host of different languages, even though C++ is usually used for this purpose. The specifications OLE, ActiveX and DirectX are based on the COM technology.</p>
<b>Control expansion</b>	<p>Expansion that allows C++ functions to be added to the programming language.</p>
<b>Panel topology/ summation signal</b>	<p>Generation of panel hierarchies/topologies in existing or new projects and automatic creation of summation signals of the alarm data points that are located in the panels of the topology.</p>
<b>Redundancy (see figure below)</b>	<p>The failure safety in a redundant system is implemented by means of hot standby.</p> <p>Hot standby is a hardware-independent solution for high availability. This is a safety concept that consists of two interconnected server systems. Both servers are constantly in operation and are subject to the same functional loading (but only one server is ever active; the second compares the data with the primary unit at runtime). On the failure of one unit, an "on-the-fly changeover" takes place and the previously passive server assumes the leading role. This guarantees access to data or functions at all times.</p>

4

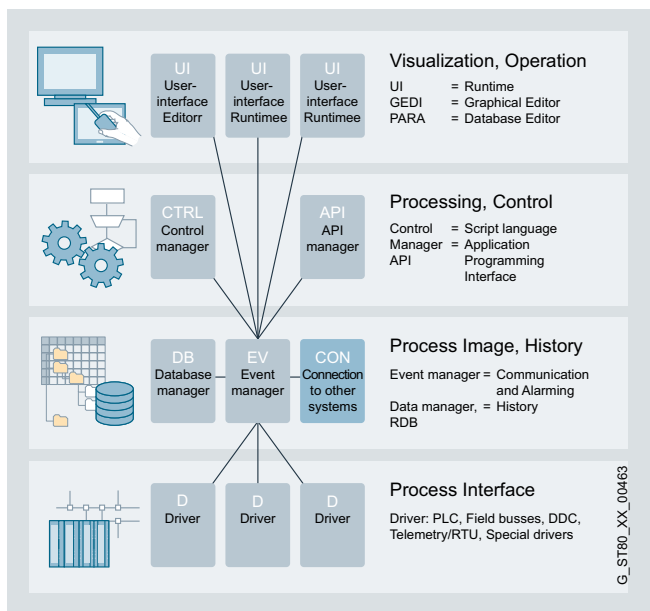

A WinCC OA System consists of function-specific units, the managers



**Function** (continued)

Special functions	Task
<b>SMS</b>	Allows the sending and receiving of text messages with WinCC OA.
<b>Encryption of panels and CTRL scripts/libraries</b>	Allows your panels or scripts to be encrypted, thereby protecting your knowledge and work.
<b>Script Wizard</b>	Easy-to-use tool that simplifies the creation of animated, graphical plant symbols, which saves time during engineering.
<b>Simple Symbols</b>	Basic package of plant symbols that have been created using the script wizard. These can be adapted quickly and easily to the specific requirements of the customer.
<b>Easy Faceplates</b>	Simple parameter assignment of predefined pop-up windows that display details of the associated plant symbol. Without any additional drawing overlay, several standard functions per object can be activated for the detail view (alarm display, trend display, measured value table, setpoint value table, address table, notes).

Special functions	Task
<b>Drag and Draw</b>	Several representative graphical objects can be defined and configured for each plant object in the data model (data point type). These are pre-configured and need only be moved to the panel via drag-and-drop when the plant pictures are drawn. This saves valuable time during engineering.
<b>Distributed systems (see the diagram below)</b>	Permits the coupling of two or more autonomous WinCC OA systems via a network. Each subsystem of a distributed system can be configured either as a single-user or multi-user system, each of which may be redundant or non-redundant. A sub-system in this context means a server on which an Event Manager is running, whereby in case of redundancy both redundantly operating servers are considered as one system.

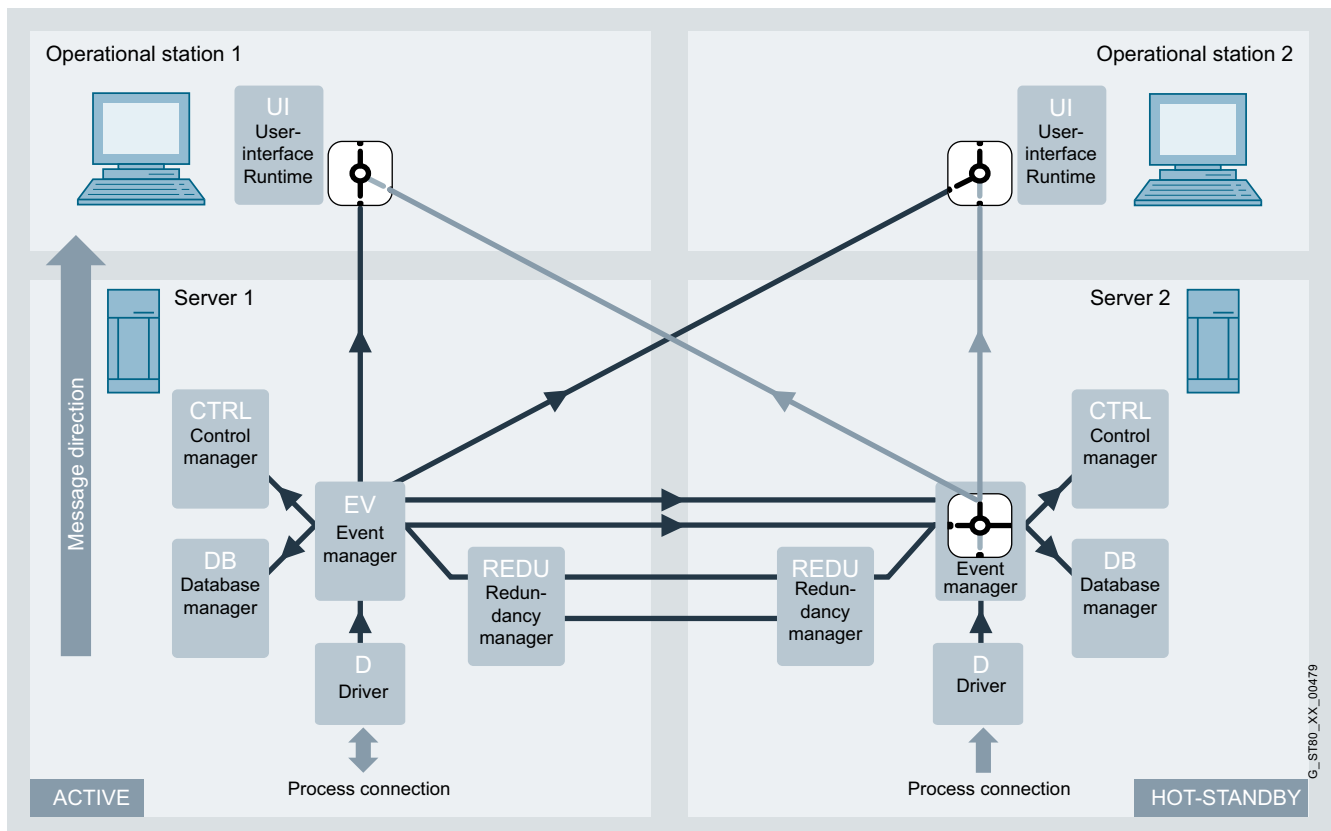

The diagram shows a detailed representation of the two computers Server 1 and Server 2. Server 1 is in the management mode (active) and Server 2 is in hot standby mode (passive). In the case of redundant operation, the UIs of both operator stations are connected to both Event Managers, however only the data of the active system is displayed on both UIs.

The Event Manager of the passive system is restricted exclusively to communication with the Event Manager of the active system for comparison of the process data (it sends no data to the connected UIs or it discards messages from the drivers – this can be seen in the figure with the switches on the UIs or on the passive Event Manager).

# HMI Software

## SCADA System SIMATIC WinCC Open Architecture

### SIMATIC WinCC Open Architecture

#### Integration

##### Integration in automation solutions

SIMATIC WinCC Open Architecture is an open SCADA system with comprehensive drivers and flexible options for connection to other external systems.

Depending on the communications protocol and the bus physics used, specific drivers are used in each case:

- Serial protocols: RK512, 3964R, etc.
- Ethernet: Industrial Ethernet (S7), Modbus TCP (OpenModbus), Ethernet IP (AB), etc.

##### Coupling overview

Protocol	Description
<b>SIMATIC S7</b>	via TCP/IP and MPI
<b>OPC Client (Data Access)</b>	<ul style="list-style-type: none"> <li>• Compatibility with the specifications DA 1.0 and 2.05a</li> <li>• Connection to inproc, local or remote server</li> <li>• Connection with up to 20 servers at the same time</li> <li>• Monitoring of the connection to the server and automatic reconnection if the connection is interrupted.</li> <li>• Address browsing if supported by the server.</li> <li>• Benefits of the CALL-R functionality for CALL-R servers (simplified parameter assignment)</li> </ul>
<b>OPC Server (Data Access)</b>	<ul style="list-style-type: none"> <li>• Corresponds to Data Access 2.05a specification (reading/writing of online values).</li> <li>• Is to be started as a manager just like other drivers.</li> <li>• The provided DPEs (server -&gt; client) can be easily and quickly defined via data point groups.</li> <li>• DPEs can be declared as readable (read-only access is permitted; Group OPCRead) or as writable items (Group OPCWrite).</li> <li>• Clients can browse the WinCC OA OPC Server hierarchically.</li> </ul>
<b>OPC Alarms &amp; Events</b>	OPC Alarms & Events (abbreviated to OPC A&E) is, in addition to Data Access, a further standard for performing central alarm management on a cross-vendor basis. OPC A&E is used to ensure the link to other control systems and the display of alarms/events in a hierarchical system.
<b>OPC UA (Unified Architecture)</b>	<ul style="list-style-type: none"> <li>• The OPC UA client supports the OPC UA standards Data Access and Alarms &amp; Conditions.</li> <li>• The OPC UA Server supports the OPC UA standards Data Access and Alarms &amp; Conditions.</li> </ul>
<b>Modbus TCP</b>	Modbus/TCP is based on the serial Modbus protocol, which was adapted for TCP/IP. The Modbus/TCP driver can be used simultaneously for Modbus/TCP or UNICOS.
<b>Serial: RK512/3964R</b>	Is used for interfacing a PLC via the 3964R/RK512 protocol
<b>Cerberus</b>	Cerberus is a fire, intrusion and gas alarm system. The Cerberus driver guarantees communication to and from the central fire alarm systems and building security facilities in the event a fire, gas or intruder alarm.

- Telecontrol systems: SINAUT, SSI (Ethernet), IEC 60870-5-101, IEC 60870-5-104, etc.
- Vendor-independent interfaces: OPC UA, etc.

In SIMATIC WinCC Open Architecture, several drivers can be operated in parallel. These can be of the same type or also of different types. It is possible in a SIMATIC WinCC Open Architecture system, for example, to establish connections via the S7 protocol to a SIMATIC controller, via IEC 60870-5-104 to a telecontrol system, and via OPC DA to any OPC server at the same time.

Protocol	Description
<b>SSI</b>	Is used for the interfacing of SAT remote control systems. The data is exchanged via the LAN (Ethernet, IEEE 802.3); the frame formats used are the SSI formats defined by SAT. The SK 1703 telecontrol components with a suitable communication card (KE/ET) are supported.
<b>IEC 60870-5-101, -104</b>	IEC drivers are standardized telecontrol drivers that can process proprietary frames. IEC stands for International Electrotechnical Commission, the international standardization committee for electrical engineering. <ul style="list-style-type: none"> <li>• IEC 60870-5-104 for data exchange via TCP/IP</li> <li>• IEC 60870-5-101 for serial connection</li> </ul>
<b>DNP3</b>	The DNP3 ( <b>D</b> istributed <b>N</b> etwork <b>P</b> rotocol <b>3</b> ) driver is an open, rugged and modern protocol which exhibits characteristics and strengths similar to the IEC driver. The transfer of any number of frames with different data types takes place between the WinCC OA System (Master) and the remote stations (Slave).
<b>SINAUT</b>	SINAUT ( <b>S</b> iemens <b>N</b> etwork <b>A</b> UTomation) is a communication protocol for automated monitoring and control of remote process stations on the basis of SIMATIC S7. Communication takes place via TCP/IP.
<b>SNMP Manager &amp; Agent</b>	SNMP ( <b>S</b> imple <b>N</b> etwork <b>M</b> anagement <b>P</b> rotocol) is a protocol for monitoring network elements (servers, workstations, routers, switches, hubs, etc.) and their functions. <ul style="list-style-type: none"> <li>• SNMP Manager supports SNMP V1, V2, and V3</li> <li>• SNMP Agent supports SNMP V1 and V2</li> </ul>
<b>BACnet over IP – driver</b>	BACnet ( <b>B</b> uilding <b>A</b> utomation and <b>C</b> ontrol <b>N</b> etworks) is a standardized protocol for building automation and has been set by the ASHRAE (American Society of Heating, Refrigerating and Air-conditioning Engineers) as a guideline to provide a uniform and cross-company standard for data communication within and between building automation systems. <p>The BACnet Standard 2004 is supported in accordance with the PIC list (see product documentation)</p>
<b>Dynamic Logic – driver</b>	The Dynamic Logic driver communicates with different Dynamic Logic devices via the "FSK outstation protocol".
<b>Applicom General Interface</b>	Applicom is, among other things, a manufacturer of I/O cards and software tools, with a wide range of applications in automation engineering. The Applicom products are compatible with many common fieldbus systems and communications components.

Further drivers on request or via C++ API

### Technical specifications

Type	SIMATIC WinCC Open Architecture V3.11
<b>Operating system</b>	<ul style="list-style-type: none"> <li>Windows 8 Enterprise (64-bit)</li> <li>Windows 7 Ultimate/Enterprise/Professional SP1 (32/64-bit)</li> <li>Windows XP SP2/SP3 (32-bit)</li> <li>Windows Server 2008 R2 (64-bit)</li> <li>Red Hat Linux 5 (32/64-bit)</li> <li>OpenSuse 12.1 (32/64-bit)</li> <li>Sun Solaris 10 SPARC (32-bit)</li> <li>Sun Solaris 10 x86 (64-bit)</li> <li>VMWare ESXi Version 4.0.0 &amp; 5.0.0</li> </ul> Note: Native 64-bit support on 64-bit systems
<b>PC hardware requirements</b> <sup>1)</sup>	
<b>Processor type</b>	Intel Pentium or equivalent
Minimum	Intel Pentium IV 1.6 GHz (or better) <sup>2)3)</sup>
Recommended	<ul style="list-style-type: none"> <li>Client: Intel Pentium IV/Core2/i3, 2 GHz<sup>2)3)</sup></li> <li>Server: Intel Core i3 CPU Dual, 3 GHz<sup>2)</sup></li> <li>Server large system<sup>4)</sup>: Intel(R) Core(TM) i5/i7 CPU Dual / Quad, 3 GHz<sup>2)3)</sup></li> </ul>
<b>RAM</b>	
Minimum	2 GB <sup>2)</sup>
Recommended	<ul style="list-style-type: none"> <li>Client: 2 GB<sup>2)3)</sup></li> <li>Server: 8 GB<sup>2)3)</sup></li> <li>Server large system: 16 GB<sup>2)</sup></li> </ul>
<b>Hard disk (available memory for installation)</b>	
Minimum	HD with 800 MB available <sup>2)</sup>
Recommended	Server large system with local logging: SCSI LVD Controller, WIDE SCSI / LVD HDD or comparable storage system with at least 500 MB of available space <sup>2)</sup>
<b>Screen and graphics card (TrueColor)</b>	
Minimum	1024 x 768 <sup>2)</sup>
Recommended	1280 x 1024 <sup>2)</sup>
<b>Mouse and keyboard</b>	Mouse, keyboard
<b>DVD drive</b>	for software installation
<b>Local power user rights</b>	<ul style="list-style-type: none"> <li>for installation</li> <li>for operation</li> </ul>

<sup>1)</sup> For actual use in plants, the hardware requirements are largely dependent on the project size and the dynamic response of the process variables. Whenever possible, use rugged, high-quality hardware with corresponding functionalities such as redundant power supply units or RAID hard disks. WinCC OA supports dual and multi-processor mode and benefits significantly from the fact that each WinCC OA Manager can be assigned to one processor core as a system process. At the same time, however, it is important that the individual cores offer the highest possible performance (high clocking), since load-critical core processes such as the event manager run on exactly one core (for this reason, multi-core machines with low-clocked cores are unsuitable for WinCC OA). As for RAM, CPU and HDD, the usual rule applies: more is better

<sup>2)</sup> System requirements generally only refer to WinCC OA Version 3.11 under the supported versions of the Windows and Linux operating systems

<sup>3)</sup> A precondition for the minimum requirement is that the operating system used does not have any greater requirements itself

<sup>4)</sup> With a large system it is essential that the system permits not only the highest data point numbers but also a high dynamic response

WinCC OA is ideally suited for use in very large distributed systems. The optimum design of such systems demands corresponding system knowledge of WinCC OA. Due to the event-oriented processing, individual design parameters can be increased or reduced as necessary in actual applications.

Type	SIMATIC WinCC Open Architecture
<b>Functionality/quantity structure</b>	
Number of messages	150,000 <sup>2)</sup>
Message text (number of characters)	System-limited <sup>1)</sup>
Message archive	System-limited <sup>1)</sup>
Process values per message	1 process value + up to 32 alarm associated values per message
Constant load of messages, max.	500/s <sup>2)</sup>
Message burst, max.	15,000/10 s every 5 min <sup>2)</sup>
<b>Archives</b>	
Archive data points	Max. 250,000 per server <sup>2)</sup>
Archive types	< 20 parallel logs, different retention period for each log
Data storage format	Oracle or file system
Measured values per second, max.	Server/single-user station: 7,000/s <sup>2)3)</sup>
<b>User archive</b>	
Archives	System-limited <sup>1)</sup>
Type	SIMATIC WinCC Open Architecture
Table size	System-limited by ORACLE database
<b>Graphics system</b>	
Number of screens	System-limited <sup>1)</sup>
Number of objects per screen	System-limited <sup>1)</sup>
Number of controllable fields per screen	System-limited <sup>1)</sup>
PowerTags	< 750,000 per server <sup>2)</sup>
<b>User administration</b>	
User accounts	< 4096
Configuration languages	2 (De, En)
Runtime languages	40 (of which 8 Asian)
<b>Multi-user system</b>	
Server	< 2048 <sup>2)4)</sup>
Number of clients	< 244 per server <sup>2)5)</sup>

<sup>1)</sup> Dependent on the available storage space

<sup>2)</sup> Dependent on the system configuration and the system load (due to the event-oriented architecture, the system load is essentially determined by the change rates of the values to be processed)

<sup>3)</sup> By means of high-performance hardware configuration (one archiving cluster and approx. 120 distributed systems that archive parallel values in the cluster): 200,000 archived value changes per second

<sup>4)</sup> Physical limit: <2048, in practice systems have already been implemented with up to 550 distributed systems

<sup>5)</sup> Physical limit: < 244 clients per server, recommended: max. 100 clients per server

# HMI Software

## SCADA System SIMATIC WinCC Open Architecture

### SIMATIC WinCC Open Architecture

Ordering data	Order No.	Order No.
<b>SIMATIC WinCC Open Architecture system software V3.11</b> <b>WinCC OA core components</b> <b>WinCC OA Server</b> Language/script versions: De, En; with license for:		<b>WinCC OA Server unlimited V3.11</b> License for server and one single-user station (expandable to several operator stations by means of clients) with unlimited number of I/O, alerting, extended trend, historical recording, including S7 driver, OPC client, OPC server, and OPC UA client.
<b>WinCC OA single-user station 500 I/O V3.11</b> License for single-user station with up to 500 I/Os of any type (bit, integer), alerting, extended trend, historical recording, not expandable to more than one operator station, not expandable by means of add-ons, including S7 driver, OPC client, OPC server, and OPC UA client.	<b>6AV6351-1HA31-1AA0</b>	<b>WinCC OA Dongle V3.11</b> Hardware dongle on the USB port for operation with a hardware-independent license attached to the dongle, which can also extend the hardware-linked license of the operator station or server on a temporary basis.
<b>WinCC OA Server I/O V3.11</b> License for server (without operator station licenses), alerting, extended trend, historical recording, including S7 driver, OPC client, OPC server, and OPC UA client.		<b>WinCC OA on data medium</b> WinCC OA Software DVD – current version on disk
<ul style="list-style-type: none"> <li>• <b>WinCC OA Server 1,000 I/O V3.11</b> with a max. of 1,000 I/Os of any type</li> <li>• <b>WinCC OA Server 3,000 I/O V3.11</b> with a maximum of 3,000 I/Os of any type</li> <li>• <b>WinCC OA Server 5,000 I/O V3.11</b> with a max. of 5,000 I/Os of any type</li> <li>• <b>WinCC OA Server 10,000 I/O V3.11</b> with a max. of 10,000 I/Os of any type</li> <li>• <b>WinCC OA Server 15,000 I/O V3.11</b> with a max. of 15,000 I/Os of any type</li> <li>• <b>WinCC OA Server 25,000 I/O V3.11</b> with a max. of 25,000 I/Os of any type</li> <li>• <b>WinCC OA Server 50,000 I/O V3.11</b> with a max. of 50,000 I/Os of any type</li> <li>• <b>WinCC OA Server 75,000 I/O V3.11</b> with a max. of 75,000 I/Os of any type</li> <li>• <b>WinCC OA Server 100,000 I/O V3.11</b> with a max. of 100,000 I/Os of any type</li> <li>• <b>WinCC OA Server 150,000 I/O V3.11</b> with a max. of 150,000 I/Os of any type</li> <li>• <b>WinCC OA Server 200,000 I/O V3.11</b> with a maximum of 200,000 I/Os of any type</li> <li>• <b>WinCC OA Server 250,000 I/O V3.11</b> with a maximum of 250,000 I/Os of any type</li> </ul>	<b>6AV6351-1HB31-1AA0</b>  <b>6AV6351-1HC31-1AA0</b>  <b>6AV6351-1HD31-1AA0</b>  <b>6AV6351-1HE31-1AA0</b>  <b>6AV6351-1HF31-1AA0</b>  <b>6AV6351-1HG31-1AA0</b>  <b>6AV6351-1HH31-1AA0</b>  <b>6AV6351-1HJ31-1AA0</b>  <b>6AV6351-1HK31-1AA0</b>  <b>6AV6351-1HL31-1AA0</b>  <b>6AV6351-1HM31-1AA0</b>  <b>6AV6351-1HN31-1AA0</b>	<b>WinCC OA Client floating</b> Language/script versions: De, En; with license for:
		<b>WinCC OA Client V3.11</b> Additional operator station license with all server operator station functionalities. The client license can be installed on more than one PC – only the number of simultaneously active clients is counted.
		<b>WinCC OA Web User Interface</b> Language versions: De, En; with license for:
		<b>WinCC OA Web Client V3.11</b> Web client license for WinCC OA Server. Only the number of simultaneously active web clients is counted.

# HMI Software

## SCADA System SIMATIC WinCC Open Architecture

### SIMATIC WinCC Open Architecture

Ordering data	Order No.	Order No.	
<b>WinCC OA Ultralight Client</b> <b>WinCC OA Ultralight PC Client</b> Licenses for one or several ultralight clients running on a laptop or PC. Only the number of simultaneously active ultralight clients is counted. Please note restrictions of the ultralight client according to the online help. <ul style="list-style-type: none"> <li>• <b>WinCC OA 1 Ultralight PC Client</b> License for one ultralight client</li> <li>• <b>WinCC OA 3 Ultralight PC Clients</b> License for 3 ultralight clients</li> <li>• <b>WinCC OA 10 Ultralight PC Clients</b> License for 10 ultralight clients</li> </ul>	<b>6AV6351-1JA31-1AA0</b>  <b>6AV6351-1JB31-1AA0</b>  <b>6AV6351-1JC31-1AA0</b>	<b>WinCC OA API interface gen. V3.11</b> Application programming interface for the integration of customer-specific managers or drivers. One license is required for each development workstation. We strongly recommend the participation in a Certified WinCC OA Developer Workshop when ordering this product for the first time.	<b>6AV6351-1EK31-1AA0</b>
<b>WinCC OA Ultralight Mobile Client</b> Licenses for one or several ultralight clients running on a smartphone or tablet PC. Only the number of simultaneously active ultralight clients is counted. Please note restrictions of the ultralight client according to the online help. <ul style="list-style-type: none"> <li>• <b>WinCC OA 1 Ultralight Mobile Client</b> License for one ultralight client</li> <li>• <b>WinCC OA 3 Ultralight Mobile Clients</b> License for 3 ultralight clients</li> <li>• <b>WinCC OA 10 Ultralight Mobile Clients</b> License for 10 ultralight clients</li> </ul>	<b>6AV6351-1JG31-1AA0</b>  <b>6AV6351-1JG31-1AA0</b>  <b>6AV6351-1JH31-1AA0</b>  <b>6AV6351-1JJ31-1AA0</b>	<b>WinCC OA Custom Driver V3.11</b> Extends a WinCC OA server license with the option of communication with a customer-specific driver. One license is required for each customer-specific driver.	<b>6AV6351-1EL31-1AA0</b>
<b>WinCC OA parameter assignment and development license</b> <b>WinCC OA Para for single-user station V3.11</b> Parameterization and development license for single-user station, graphic editor with symbol catalog and ActiveX Controls, user-friendly script development language, alerting, extended trend, historical recording. Requires a corresponding single-user station license.	<b>6AV6351-1EA31-1AA0</b>	<b>WinCC OA Custom Manager V3.11</b> Extends a WinCC OA server license with the option of communicating with a customer-specific manager. One license is required for each customer-specific manager.	<b>6AV6351-1EM31-1AA0</b>
<b>WinCC OA Para V3.11</b> Parameterization and development license for server, graphic editor with symbol catalog and ActiveX Controls, user-friendly script development language, alerting, extended trend, historical recording. Requires corresponding server license.	<b>6AV6351-1EP31-1AA0</b>	<b>WinCC OA redundancy</b> <b>WinCC OA Redundancy V3.11</b> Extends a WinCC OA Server with the option of bumpless switchover to a hot standby partner.	<b>6AV6351-1FP31-1AA0</b>
<b>WinCC OA ETool V3.11</b> License for the use of the integrated WinCC OA ETool engineering environment, including the object library S7-BaseLib. Intellectual property right owner: Siemens AG.	<b>6AV6351-1EJ31-1AA0</b>	<b>WinCC OA distributed systems V3.11</b> Extends a WinCC OA Server to include the Multiserver option.	<b>6AV6351-1GP31-1AA0</b>
		<b>WinCC OA Disaster Recovery System</b> <b>WinCC OA Disaster Recovery Center V3.11</b> Allows the configuration of a remote backup control center. A disaster recovery center comprises two distributed systems. Each system can be redundant or non-redundant. Requires Oracle databases and RDB. Refer to the online help for example configurations. Each server in the Disaster Recovery System requires one WinCC OA Disaster Recovery Center option.	<b>6AV6352-1AA31-1AA0</b>

# HMI Software

## SCADA System SIMATIC WinCC Open Architecture

### SIMATIC WinCC Open Architecture

#### Ordering data

#### SIMATIC WinCC Open Architecture V3.11 communication

##### WinCC OA TLS driver

Driver in accordance with TLS regulations in connection with Siemens Commbox (see separate data sheet).

6AV6352-1BA31-1AA0

##### WinCC OA Teleperm M

Driver for Teleperm M Bus C275 (requires an Acotex Comm Box)

6AV6352-1BB31-1AA0

##### WinCC OA S7 TCP/IP driver

TCP/IP for Siemens Industrial Ethernet

6AV6352-1BC31-1AA0

##### WinCC OA Modbus TCP/IP driver

TCP/IP for Schneider Modbus

6AV6352-1BD31-1AA0

##### WinCC OA Modbus serial

Serial driver for Schneider Modbus

6AV6352-1BE31-1AA0

##### WinCC OA SSI driver

Driver for SAT telecontrol components

6AV6352-1BF31-1AA0

##### WinCC OA SNMP

Driver SNMP – network monitoring (V2&V3)

6AV6352-1BG31-1AA0

##### WinCC OA IEC 104

Driver IEC 60870-5-104

6AV6352-1BH31-1AA0

##### WinCC OA IEC 101

Driver IEC 60870-5-101

6AV6352-1BJ31-1AA0

##### WinCC OA DNP3 10 devices

Driver DNP3 for connecting up to 10 DNP3 devices

6AV6352-1BK31-1AA0

##### WinCC OA DNP3 25 devices

Driver DNP3 for connecting up to 25 DNP3 devices

6AV6352-1BL31-1AA0

##### WinCC OA DNP3 50 devices

Driver DNP3 for connecting up to 50 DNP3 devices

6AV6352-1BM31-1AA0

##### WinCC OA DNP3 250 devices

Driver DNP3 for connecting up to 250 DNP3 devices

6AV6352-1BN31-1AA0

##### WinCC OA DNP3 unlimited

Driver DNP3 – unlimited license

6AV6352-1BP31-1AA0

##### WinCC OA SINAUT 10 devices

SINAUT driver for connecting up to 10 controllers

6AV6352-1BQ31-1AA0

#### Order No.

##### WinCC OA SINAUT 25 devices

SINAUT driver for connecting up to 25 controllers

6AV6352-1BR31-1AA0

##### WinCC OA SINAUT 50 devices

SINAUT driver for connecting up to 50 controllers

6AV6352-1BS31-1AA0

##### WinCC OA SINAUT 250 devices

SINAUT driver for connecting up to 250 controllers

6AV6352-1BT31-1AA0

##### WinCC OA SINAUT unlimited

SINAUT driver – unlimited license

6AV6352-1BU31-1AA0

##### WinCC OA RK512

Driver for connection via 3964R / RK512 protocol

6AV6352-1CA31-1AA0

##### WinCC OA PROFIBUS DP

Driver PROFIBUS DP, an Applicom card is required

6AV6352-1CB31-1AA0

##### WinCC OA PROFIBUS S7

Driver PROFIBUS S7 + MPI, an Applicom card is required

6AV6352-1CC31-1AA0

##### WinCC OA Omron FINS TCP-IP

Driver Omron FINSTCP-IP, an Applicom card is required

6AV6352-1CE31-1AA0

##### WinCC OA GE Fanuc SRTP

Driver GE Fanuc SRTP, an Applicom card is required

6AV6352-1CF31-1AA0

##### WinCC OA Allen Bradley Ethernet/IP

Driver Allen Bradley Ethernet/IP, an Applicom card is required.

6AV6352-1CG31-1AA0

##### WinCC OA Cerberus

Driver for connection with the Siemens DMS7000 / Cerberus fire alarm system. Communication is implemented via the C-Bus (Cer-Ban) using the serial interface RS 232 (MK 7022).

6AV6352-1CH31-1AA0

##### WinCC OA OPC UA Server

Driver for OPC UA DA and OPC UA AC Server

6AV6352-1CJ31-1AA0

#### More information

Further information can be found in the Internet at:  
<http://www.siemens.com/wincc-open-architecture>



# HMI Software

## SCADA System SIMATIC WinCC Open Architecture

### SIMATIC WinCC Open Architecture Add-ons

#### Overview

SIMATIC WinCC Open Architecture is a SCADA system for visualizing and operating processes, production flows, machines and plants in all industrial sectors.

SIMATIC WinCC OA is built consistently on object-oriented structures. The rigorous and well-considered use of object-oriented structures, from process images to the database, help to improve engineering costs for SIMATIC WinCC OA customers.

Distributed systems enable the connection of up to 2048 autonomous SIMATIC WinCC Open Architecture systems via one network. Each subsystem can be configured either as single-user or multi-user system, each of which may be redundant or non-redundant.

- Current version: **SIMATIC WinCC Open Architecture V3.11**  
Runs on:
  - Windows 8 Enterprise (64-bit)
  - Windows 7 Ultimate/Enterprise/Professional SP1 (32/64-bit)
  - Windows XP SP2/SP3 (32-bit)
  - Windows Server 2008 R2 (64-bit)
  - Red Hat Linux 5 (32/64-bit)
  - OpenSuse 12.1 (32/64-bit)
  - Sun Solaris 10 SPARC (32-bit)
  - Sun Solaris 10 x86 (64-bit)
  - VMWare ESXi Version 4.0.0 & 5.0.0

#### Note:

Native 64-bit support on 64-bit systems.

#### Function

##### SIMATIC WinCC Open Architecture add-ons

The universal WinCC Open Architecture basic software is the basis for modular expansions. These functional expansions are available in the form of WinCC Open Architecture add-ons.

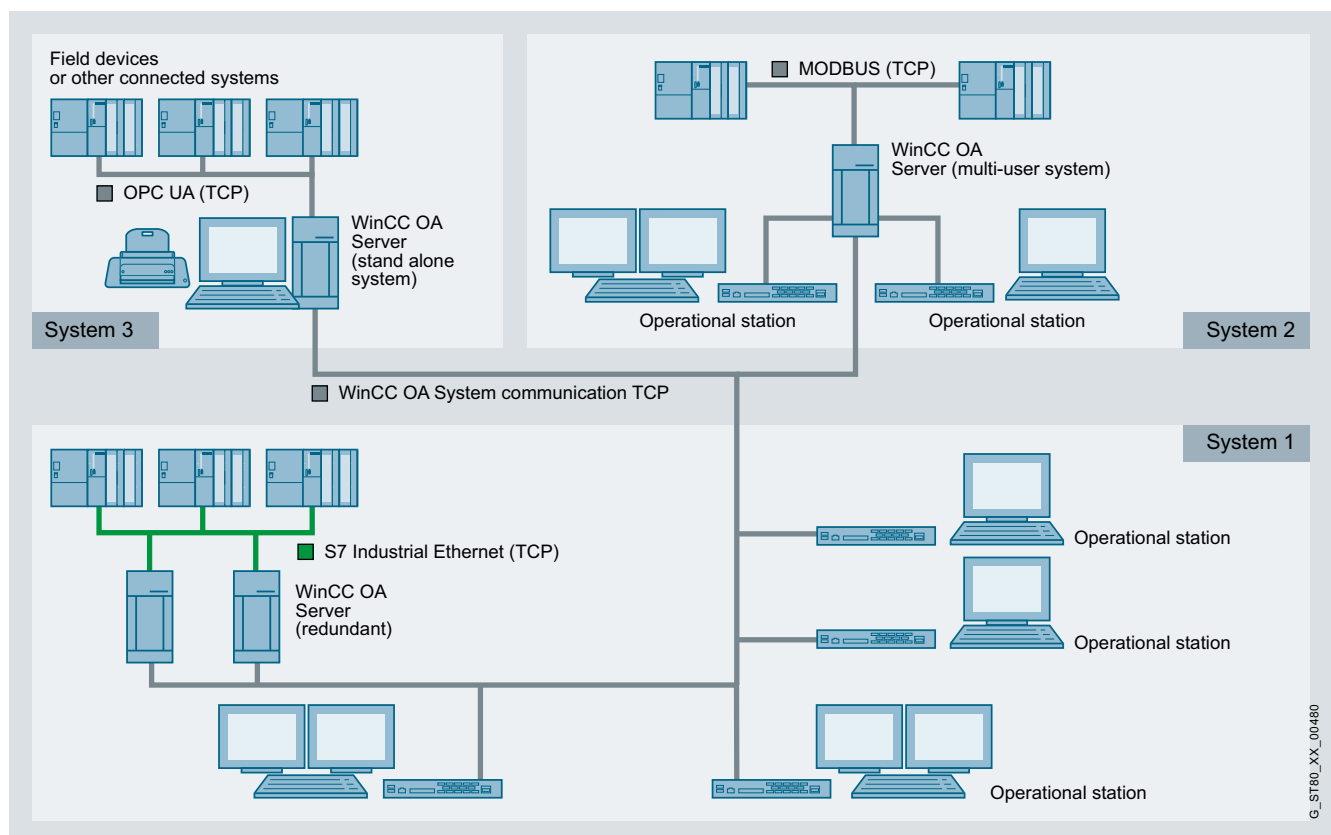

Distributed systems with WinCC OA



# HMI Software

## SCADA System SIMATIC WinCC Open Architecture

### SIMATIC WinCC Open Architecture Add-ons

#### Function (continued)

Add-ons	Task
<b>ETool</b>	The engineering tool ETool offers significant benefits in engineering in the case of combined WinCC OA and SIMATIC STEP7/PCS7 projects. It provides a user-friendly engineering environment that permits easy, integrated and fast configuration on the basis of the WinCC OA mass parameterization.
<b>BACnet</b>	BACnet provides an integrated BACnet-compliant online/offline engineering solution for building automation technology, including object library. Designed for heating, ventilation and air-conditioning, lighting control and safety systems.
<b>S7 AdvancedLib object library</b>	The S7 AdvancedLib (AdvS7) is an industry-independent object library that permits the use and visualization of objects from the process control system (e.g.: drives, valves, regulators, motors, etc.) in a project with WinCC OA and S7. In addition to the WinCC OA and AdvS7 license, the use of S7 AdvancedLib requires the use of the relevant library on the SIMATIC side.
<b>Maintenance package</b>	Includes the following functions: Operating hours counter, operating cycle counter and maintenance log.
<b>Scheduler</b>	Permits the creation, parameterization and management of time programs that allow the time and event-driven triggering of specific actions.
<b>Recipes</b>	WinCC OA recipes allow setpoints or commands for certain data point elements to be sent simultaneously. Based on "recipe types", which define the quantity of the assigned data point elements, recipes are created that send their values to the data point elements upon activation.
<b>GIS Viewer</b>	With the help of this viewer, standardized cards of a geo-information system (GIS) can be fully integrated in WinCC OA. Furthermore, it is possible to display all WinCC OA objects in the cards.
<b>Excel report</b>	Powerful report generator directly in Microsoft Excel. Templates can be created easily and directly in Excel. If a report has to be created over a defined period of time, the system accesses the template and automatically completes it with data from the WinCC OA process database. Reports can also be created, printed and saved on a time-controlled basis, without any need for user access. The Excel Report fully supports compression structures (AC - archive compression) of WinCC OA.
<b>Communication Center</b>	Stands for modern alarm management/remote alerting and communication using the latest standards and various media. The Communication Center creates synergies by using the various interfaces for remote alerting via the control system. Text message and email media are covered with the Communication Center.

Add-ons	Task
<b>Video (see figure below)</b>	Enables the integration of a video management system in WinCC OA. Through the combination of SCADA and video monitoring in one system, the costs for separate video interfaces and the additional expense of maintenance and operation can be saved, and the period of training for operating personnel can also be reduced.
<b>HTTP server</b>	For displaying WinCC OA data via Intranet and Web.
<b>Authentication via Kerberos</b>	A WinCC OA system can be exposed to a variety of attacks. An unauthorized WinCC OA System could set up a connection to the distribution manager or hackers could try to manipulate WinCC OA messages. Secure authentication has been developed to prevent such attacks. The authentication based on Kerberos enables each WinCC OA component to verify the identity of another component. WinCC OA servers can verify the identity of the clients and clients can verify the identity of the servers. In addition, Kerberos ensures that messages are not modified during their transmission (capture-replay attacks are prevented). Furthermore, it is also possible to send messages in encrypted form.
<b>AMS (Advanced Maintenance Suite)</b>	For the effective planning, administration, implementation and monitoring of maintenance work and faults. The processes are evaluated by means of statistics and reports are communicated.
<b>Web client</b>	From a technical standpoint, the WinCC OA Web Client is a plug-in that is downloaded via the web browser (which is used on the client computer) and a WinCC OA UI Manager is then displayed embedded in the HTML page. No WinCC OA installation on the client computer is required, except for the required web client plug-ins.
<b>Ultralight client</b>	A "thin client" that supports access to the plant via a mobile device (such as a cell phone or tablet) in addition to a PC workstation. Access is possible via a standard Web browser using native Web technologies (Javascript, SVG) without the need for any additional installations. It provides a user interface even at those locations with Internet connections offering very low bandwidth, as only the most essential data is transferred.
<b>Disaster Recovery System (see figure below)</b>	This system expands the simple redundancy to include a second redundant system, to which the system can switch over in the event of a fault (e.g. fire or explosion in the building of the primary system). By means of this additional local redundancy, the highest level of system stability is obtained.

# HMI Software SCADA System SIMATIC WinCC Open Architecture

## SIMATIC WinCC Open Architecture Add-ons

### Function (continued)

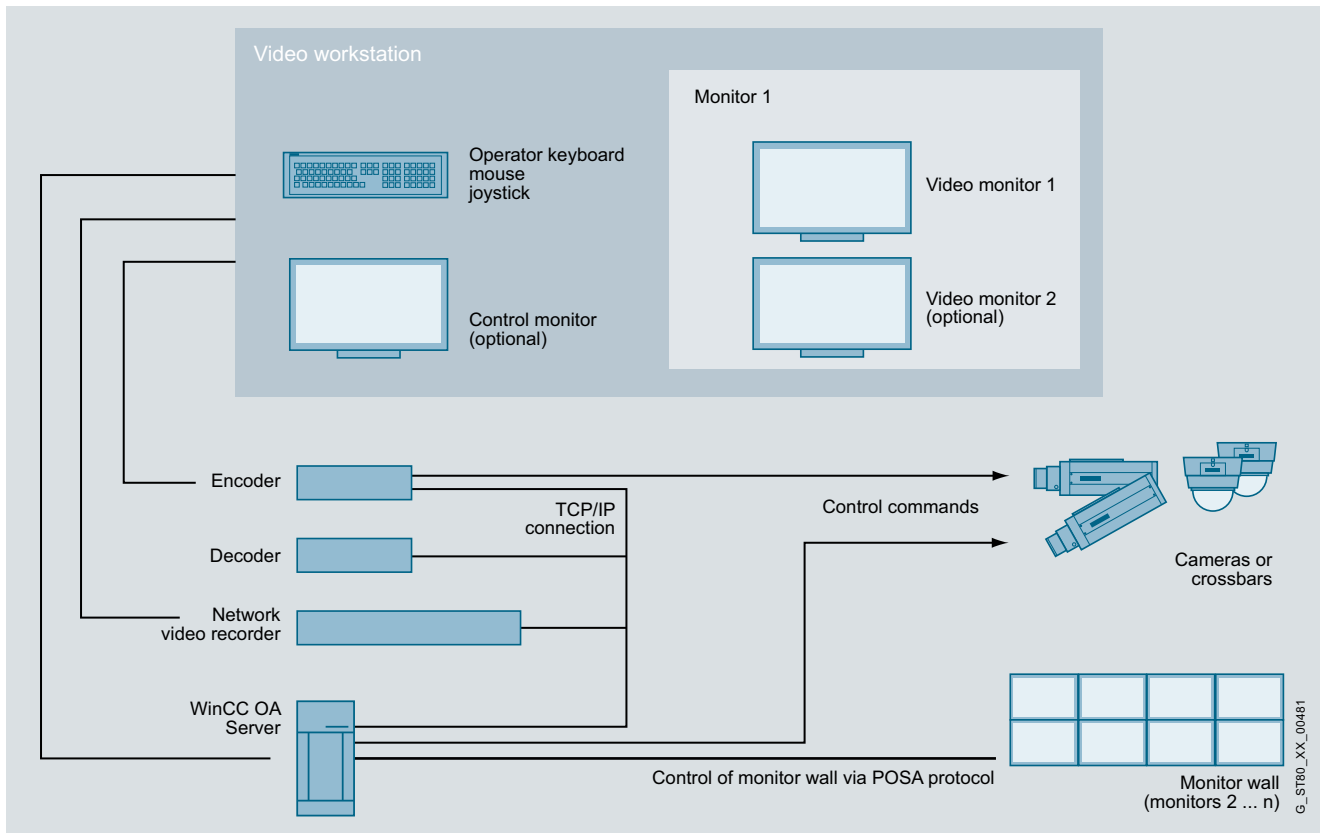

4

Network topology Video

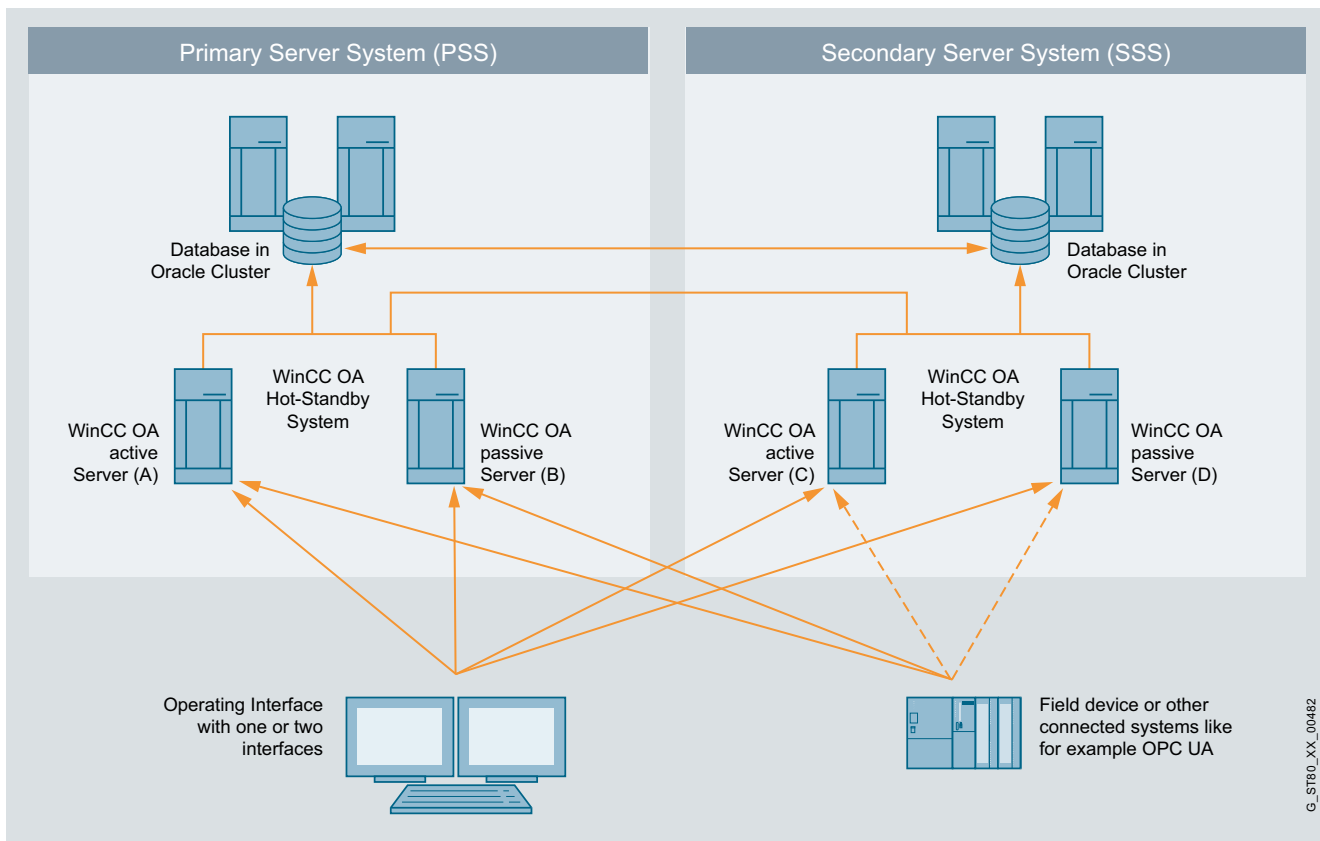

Disaster Recovery System architecture with WinCC OA

# HMI Software

## SCADA System SIMATIC WinCC Open Architecture

### SIMATIC WinCC Open Architecture Add-ons

Ordering data	Order No.	Order No.
<b>SIMATIC WinCC Open Architecture add-ons</b> <b>WinCC OA BACnet driver + diagnostics</b> Extends a WinCC OA Server to include a license for using the WinCC OA BACnet online engineering environment consisting of WinCC OA BACnet driver, WinCC OA BACnet object library including faceplates, and WinCC OA BACnet browser (max. 5,000 objects per server).	6AV6352-1DA31-1AA0	<b>Solution Frameworks</b> <b>WinCC OA PMS</b> Application framework for the implementation of production management systems. The framework offers functions for recording and evaluating production and batch-related quality data. This item is not available as a product but only in combination with consulting and additional testing overhead.
<b>WinCC OA BACnet Engineering</b> Extends a WinCC OA Server to include a license for using the WinCC OA BACnet engineering environment consisting of WinCC OA BACnet browser, WinCC OA EDE-Tool + EDE file interface (requires the WinCC OA engineering license) (max. 5,000 objects per server).	6AV6352-1DB31-1AA0	<b>WinCC OA topology package</b> The topology package is an application framework enabling the topological coloring of network views. A qualitative statement is made regarding which parts of a network are directly connected to which infeed units in a connection established by switching elements. Only available in combination with consulting and additional testing overhead.
<b>WinCC OA GIS</b> GIS viewer for displaying ESRI Shapes Files. One license is required for each UI. Can be used in WinCC OA Client and Web Client. Maps are not included. Dynamization performed using Ctrl scripting.	6AV6352-1DC31-1AA0	<b>WinCC OA ACAS</b> WinCC OA Advanced Command Authority Suite framework for managing and visualizing authority settings. The license includes the management panel and panel expansions for alarm, horn and acknowledgement functions. This item is not available as a product but only in combination with consulting and additional testing overhead.
<b>WinCC OA S7 AdvancedLib</b> Runtime license for using the object library WinCC OA S7 AdvancedLib, coordinated with the SIMATIC object library also supplied, which is free of charge until revoked. License required for each server.	6AV6352-1DD31-1AA0	<b>Excel report</b> <b>WinCC OA Report 1 UI</b> Expands a WinCC OA Server by 1 active Excel report process; Microsoft Excel is not included.
<b>WinCC OA Maintenance</b> Maintenance management for recording operating hours, switching cycles, alarm handling and notepad function. License required for each server.	6AV6352-1DE31-1AA0	<b>WinCC OA Report 2 UI</b> Expands a WinCC OA Server by 2 parallel active Excel report processes; Microsoft Excel is not included.
<b>WinCC OA Scheduler</b> Daily, weekly and monthly program, as well as individual non-periodic events with consideration of public holidays, assignment of priority and override function. License required for each server.	6AV6352-1DF31-1AA0	<b>WinCC OA Report 5 UI</b> Expands a WinCC OA Server by 5 parallel active Excel report processes; Microsoft Excel is not included.
<b>WinCC OA Recipe</b> Creation of any recipe types and recipes, acceptance of current process values as recipe, activation/download to data points, import and export (Microsoft Excel). License required for each server.	6AV6352-1DG31-1AA0	<b>WinCC OA Report 10 UI</b> Expands a WinCC OA Server by 10 parallel active Excel report processes; Microsoft Excel is not included.
<b>WinCC OA RDB</b> RDB Oracle connection for WinCC OA Server S-UL. Oracle licenses are not included. License required for each server.	6AV6352-1DH31-1AA0	

# HMI Software

## SCADA System SIMATIC WinCC Open Architecture

### SIMATIC WinCC Open Architecture Add-ons

Ordering data	Order No.	Order No.
<b>Communication Center</b>		
<b>WinCC OA CommCenter 1</b> Basic package for 25 alarms. Output as text message or e-mail is possible. Price per WinCC OA Server.	6AV6352-1GA31-1AA0	<b>WinCC OA video driver RS 485TVI</b> Driver for controlling TVI pan-tilt cameras. One license is required for each WinCC OA Server.
<b>WinCC OA CommCenter 2</b> Basic package for 250 alarms. Output as text message or e-mail is possible. Price per WinCC OA Server.	6AV6352-1GB31-1AA0	<b>WinCC OA video driver SNK RS485 Funkwerk</b> Driver for controlling Funkwerk pan-tilt cameras. One license is required for each WinCC OA Server.
<b>WinCC OA CommCenter 3</b> Basic package for 2,500 alarms. Output as text message or e-mail is possible. Price per WinCC OA Server.	6AV6352-1GC31-1AA0	<b>WinCC OA video driver SNK RS485 Globe</b> Driver for controlling Globe pan-tilt cameras. One license is required for each WinCC OA Server.
<b>WinCC OA CommCenter 4</b> Basic package for unlimited alarms. Output as text message or e-mail is possible. Price per WinCC OA Server.	6AV6352-1GD31-1AA0	<b>WinCC OA video driver SNK development</b> Driver development for controlling pan-tilt cameras
<b>Video management</b>		
<b>WinCC OA Video Light</b> Including 4 streams. Possible video operator station configuration: 1 x quad image or 2 dual images or 4 single images. Not expandable with further streams, redundancy not possible.	6AV6352-1HA31-1AA0	<b>WinCC OA video driver for cameras with RCP+ and H264</b> Drivers for controlling cameras with RCP+ and H264. One license is required for each WinCC OA Server.
<b>WinCC OA Video Basic</b> Including 7 streams. Possible video operator station configuration: Display in quad, dual or single images. Expandable by additional streams, redundancy is possible. One license is required for each WinCC OA Server.	6AV6352-1HB31-1AA0	<b>WinCC OA video driver dev.</b> Driver development for controlling decoder/encoder/host protocols
<b>WinCC OA Video Extension 5 Streams</b> Extends WinCC OA Video Basic by 5 streams	6AV6352-1HC31-1AA0	<b>WinCC OA video driver Bosch IntKey</b> Driver for controlling Bosch IntKey console controller. One license is required per server
<b>WinCC OA Video Extension 7 Streams</b> Extends WinCC OA Video Basic by 7 streams	6AV6352-1HD31-1AA0	<b>WinCC OA Video driver development for console controllers</b> Driver development for controlling console controllers
<b>WinCC OA Video Extension 32 Streams</b> Extends WinCC OA Video Basic by 32 streams	6AV6352-1HE31-1AA0	<b>WinCC OA video driver Bosch VRM (NVR)</b> Drivers for controlling Bosch video recording equipment / NVR. One license is required per server
<b>WinCC OA Video Extension 128 Streams</b> Extends WinCC OA Video Basic by 128 streams	6AV6352-1HF31-1AA0	<b>WinCC OA video driver development for recording equipment / NVR</b> Driver development for video recorder equipment / NVR
<b>WinCC OA Video Extension 256 Streams</b> Extends WinCC OA Video Basic by 256 streams	6AV6352-1HG31-1AA0	<b>HTTP server</b> <b>WinCC OA HTTP Server</b> Forwarding of alarms, events and WinCC OA information to the Internet in HTML format including 1 HTTP connection.
<b>WinCC OA Video Extension 512 Streams</b> Extends WinCC OA Video Basic by 512 streams	6AV6352-1HH31-1AA0	<b>WinCC OA HTTP Server Extension5</b> Extends the WinCC OA HTTP server by 5 HTTP connections.
<b>WinCC OA video driver SNK RS485 eneo</b> Driver for controlling eneo pan-tilt cameras. One license is required for each WinCC OA Server.	6AV6352-1HJ31-1AA0	<b>WinCC OA HTTP Server Extension10</b> Extends the WinCC OA HTTP server by 10 HTTP connections.
		<b>WinCC OA HTTP Server Extension25</b> Extends the WinCC OA HTTP server by 25 HTTP connections.

# HMI Software

## SCADA System SIMATIC WinCC Open Architecture

### SIMATIC WinCC Open Architecture Add-ons

Ordering data	Order No.	Order No.	
<b>Kerberos</b> <b>WinCC OA Secure</b> Extends a WinCC OA Server to include protection by Kerberos. Each WinCC OA Server requires a separate WinCC OA Secure license.	<b>6AV6352-1LA31-1AA0</b>	<b>AMS Upgrade Large</b> The license contains an upgrade of the AMS Large 5,000 A/E license with 1,000 A/E = 1,000 checklists assigned to alarm/event DP.	<b>6AV6352-1MF31-1AA0</b>
<b>AMS (Advanced Maintenance Suite)</b> <b>AMS Starter Package 20A/E</b> This fully functional trial license valid for 90 days includes the AMS application as well as up to 20 A/E = 20 checklists assigned to alarm/event DP. <sup>1)2)3)</sup>	<b>6AV6352-1MA31-1AA0</b>	<b>AMS UL A/E</b> The license includes the AMS application as well as an unlimited number of alarm/event DP checklist assignments. <sup>1)2)3)</sup>	<b>6AV6352-1MG31-1AA0</b>
<b>AMS Entry 20 A/E</b> The license includes the AMS application as well as up to 20 A/E = 20 checklists assigned to alarm/event DP. <sup>1)2)3)</sup>	<b>6AV6352-1MB31-1AA0</b>	<b>AMS Client 2 UI</b> Operating station license for simultaneous use of no more than 2 parallel client sessions. The client license can be installed on more than one PC – only the number of simultaneously active clients is counted.	<b>6AV6352-1MH31-1AA0</b>
<b>AMS Small 100 A/E</b> The license includes the AMS application as well as up to 100 A/E = 100 checklists assigned to alarm/event DP. <sup>1)2)3)</sup>	<b>6AV6352-1MC31-1AA0</b>	<b>AMS Client 5 UI</b> Operating station license for simultaneous use of no more than 5 parallel client sessions. The client license can be installed on more than one PC – only the number of simultaneously active clients is counted.	<b>6AV6352-1MJ31-1AA0</b>
<b>AMS Medium 1,000 A/E</b> The license includes the AMS application as well as up to 1,000 A/E = 1,000 checklists assigned to alarm/event DP. <sup>1)2)3)</sup>	<b>6AV6352-1MD31-1AA0</b>	<b>AMS Client 10 UI</b> Operating station license for simultaneous use of no more than 10 parallel client sessions. The client license can be installed on more than one PC – only the number of simultaneously active clients is counted.	<b>6AV6352-1MK31-1AA0</b>
<b>AMS Large 5,000 A/E</b> The license includes the AMS application as well as up to 5,000 A/E = 5,000 checklists assigned to alarm/event DP. <sup>1)2)3)</sup>	<b>6AV6352-1ME31-1AA0</b>		

- 1) The basic price also includes the AMS Reports packages.
- 2) AMS importer as well as 1 day of consulting for initial design by ETM Consultants (excluding travel expenses) and 5 hours of telephone support within 3 months after delivery.
- 3) AMS Reports and AMS Importer, and 1 day of consulting for initial conceptualization by ETM consultants (not incl. travel costs). This license does not include any support and cannot be expanded or extended.

#### More information

Additional information is available on the Internet at:  
<http://www.siemens.com/wincc-open-architecture>

### Overview

- Process error diagnostics software for quick and precise diagnosis of faults/errors in plants and machines for SIMATIC S7 and SIMATIC HMI
- Standardized diagnostics concept for various SIMATIC components: optimum interaction of STEP 7 engineering tools and SIMATIC HMI
- Standardized user interface

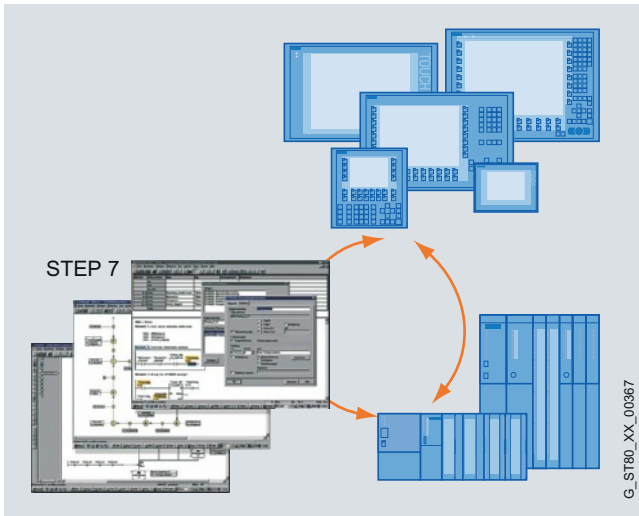

Process error diagnostics with ProAgent for WinCC flexible /ProAgent and with the STEP 7 engineering tools

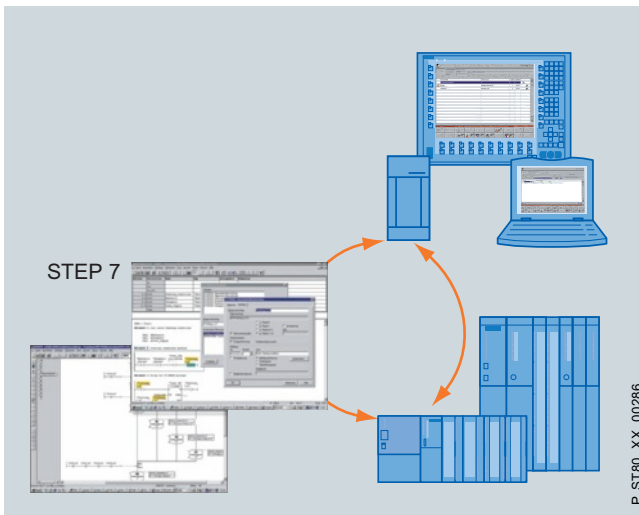

Process error diagnostics with WinCC/ProAgent and the STEP 7 engineering tools

### Benefits

- Integral component of Totally Integrated Automation (TIA): increases productivity, minimizes the engineering outlay, reduces the lifecycle costs
- ProAgent:
  - Provides optimum support for plant and machine personnel in respect of troubleshooting and fault rectification
  - Increases plant availability
  - Reduces downtimes
- No further configuration overhead for diagnostics functionality
- Frees up PLC capacity with regard to memory and program execution time
- No special operator know-how is required thanks to clearly comprehensible indication of the cause of error

### Application

Increased productivity is being achieved more and more by cutting costs.

In this context, the focus is increasingly on maintenance. The emphasis here is on rectifying faults as quickly and efficiently as possible.

Ideally, the operating personnel should also perform part of the maintenance tasks. The operating personnel are on-site, they are familiar with the procedures and can intervene quickly. This saves time and reduces costs. It is precisely here that ProAgent can assist operating personnel in identifying faults quickly, in particular in the automotive and machine tool industries.

In the event of a process fault, process fault diagnostics with SIMATIC ProAgent will provide information about the location and cause of that fault and support personnel with troubleshooting.

The ProAgent solution has been optimized specifically for use with SIMATIC S7-300/S7-400 and SIMATIC WinAC.

It can be used in combination with the S7-PDIAG, S7-GRAPH and S7-HiGraph<sup>1)</sup> STEP 7 engineering tools. The ProAgent option package features standard displays that are updated with process-specific data during runtime.

<sup>1)</sup> Process diagnostics with S7-HiGraph in combination with TP/OP/MP 270/277, MP 370/377, and C7636 and PC RT systems.



# HMI Software

## SIMATIC ProAgent process diagnostics software

### SIMATIC ProAgent

#### Function

- Context-sensitive diagnostics initiation due to process error message
- Output of operands with symbols and comment
- Switching is possible between LAD, STL and signal list
- Supporting fault rectification with direct process access when using the motion display
- Output of the faulty operands directly in the message including address, symbol and comment <sup>1)</sup>
- Consistency test in RT:  
Inconsistent diagnostic units are marked with icons. This permits quick locating of faults regarding configured data in the commissioning phase.
- Direct, unit-related entry point in the diagnostic display from user displays by using ProAgent functions
- Unit or message-related entry to STEP 7 (LAD/STL/FD editor, S7-GRAPH, HW CONFIG (upon system error messages)), supported fully automatically <sup>2)</sup>
- Unit or message-related entry to STEP 7), supported fully automatically <sup>3)</sup>
- Graphic display of step sequences (overview display) <sup>4)</sup>

<sup>1)</sup> In combination with TP/OP/MP 270/277, MP 370/377, C7 636, WinCC/ProAgent as of V6.0, and WinCC flexible /ProAgent

<sup>2)</sup> WinCC/ProAgent as of V5.5 and as of WinCC flexible 2007 /ProAgent on PC RT

<sup>3)</sup> Only WinCC/ProAgent as of V5.5

<sup>4)</sup> As of WinCC flexible 2007 /ProAgent, WinCC/ProAgent as of V5.6 in combination with S7-GRAPH as of V5.1 (OCX is delivered as of S7-GRAPH 5.1)

#### Standardized user interface with standard displays

- Message display
- Unit overview
- Diagnostics detail display
- Motion display
- Sequencer operating display

The displayed image contents are related to the previously selected units or messages. This means that the proper context-sensitive diagnostics display can be called up based on a message or a selected technological unit.

#### Message display

All of the existing process messages are shown in the message display. Context-sensitive branching to other diagnostic displays is also possible with a selected message. The operating personnel can also take the message directly from the erroneous operands and react immediately without having to perform any other operations on the HMI device. WinCC flexible permits this function on the Windows CE-based devices TP/OP/MP 270/277, MP 370/377, and on PC Runtime systems.

The function is available as of version 6.0 for WinCC/ProAgent.

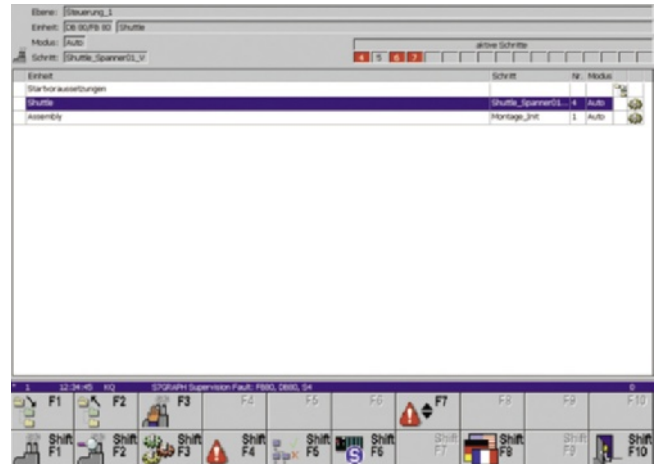

#### Unit overview

The units overview displays all technological units and the respective sub-units (system/machine components) in table form. In this display, the user is able to recognize, for example, which operating mode or which status the respective unit is in. The operating mode can be changed by the user if required.

Faulty units are marked with attributes.

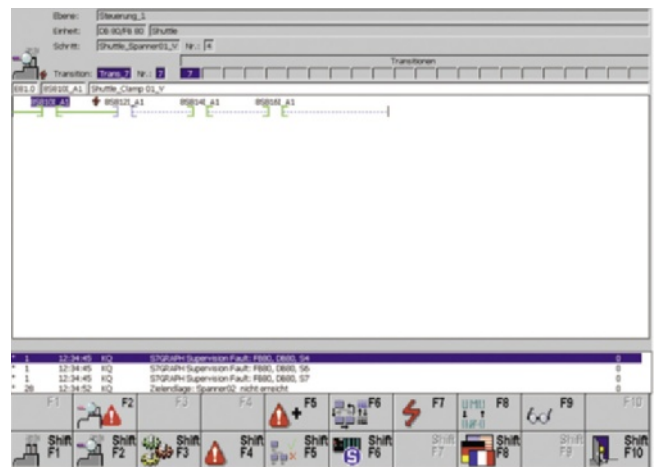



**Function (continued)**

**Diagnostics detail display**

The diagnostic detail display shows the faulty operands at the time of origination of a process error. As an option, current status information can also be displayed. The diagnostics results are either displayed in a ladder diagram (LAD), statement list (STL), or in a clearly arranged signal list overview. The output of the operands depends on the display format with symbols and comments from the S7 symbol table. Only the operands that cause the fault are displayed and marked with a highlighted attribute. Switching to a display that calls up the current status of all operands in the controller is also possible.

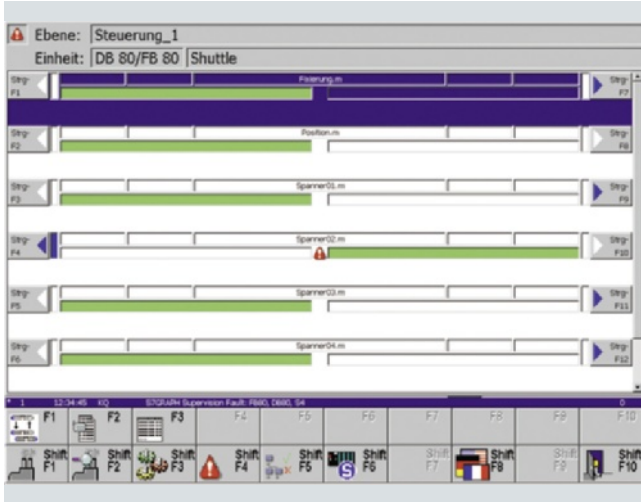

**Motion display**

The motion display is used for supported fault rectification. Every motion line contains a comment line that describes the motion (e.g. x-axis), two actions for implementing the motion, response concerning the actuation of a motion and information on the respectively achieved end positions (max. 16).

The motion itself is controlled with softkeys on the side of SIMATIC Panels and Multi Panels. For time-critical motions, the actuation can be done directly through inputs of the controller (depending on the capabilities of the target hardware: 24 V direct keys, DP direct keys via PROFIBUS).

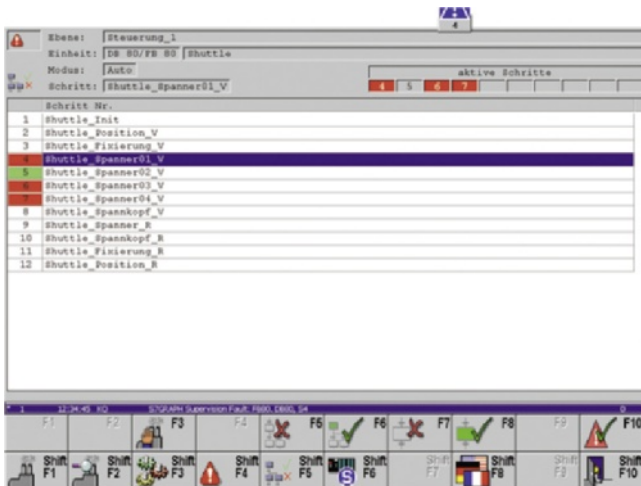

**Sequencer operating display**

The sequencer operating display supports sequencer control. This makes functions such as initializing and acknowledging sequencers, activating/deactivating individual steps and operating mode settings possible analog to the status/control in S7-GRAPH.

The steps are output to a list with step number/name. Attributes for identifying an active/faulty step give the operating personnel an overview of the current status of the step sequence.

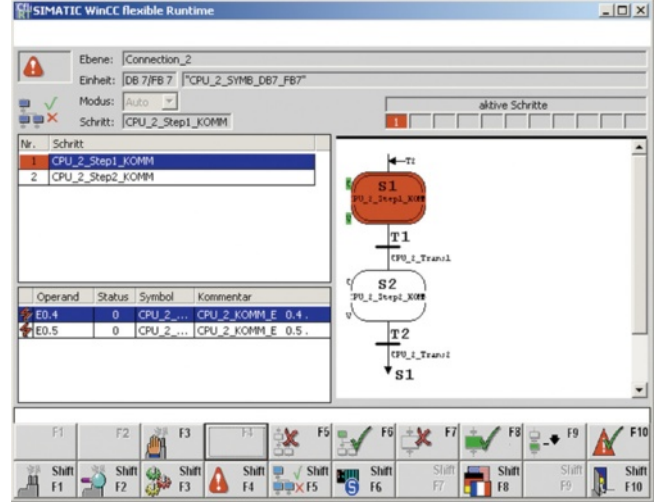

**Sequencer diagnostic display**

WinCC flexible/ProAgent and WinCC/ProAgent<sup>1)</sup> also offer capabilities for graphic monitoring and sequencer diagnostics. This gives the user the ability to monitor active/faulty steps as well as the fault cause, e.g. faulty transition conditions, simultaneously on the HMI device.

<sup>1)</sup> WinCC/ProAgent as of V5.6 in combination with S7-GRAPH as of V5.1 (OCX is delivered as of S7-GRAPH 5.1)

# HMI Software

## SIMATIC ProAgent process diagnostics software

### SIMATIC ProAgent

#### Technical specifications

	WinCC/ProAgent	WinCC flexible /ProAgent
<b>Interfaces</b>		
<ul style="list-style-type: none"> <li>• Can be used in conjunction with programmable controllers:</li> <li>• Types of connection</li> </ul>	SIMATIC S7: S7-300/S7-400; WinAC SIMATIC S7 Protocol Suite: MPI, PROFIBUS DP, Industrial Ethernet, TCP/IP	SIMATIC S7: S7-300/S7-400; WinAC SIMATIC S7 Protocol Suite: MPI, PROFIBUS DP, PROFINET IO, Industrial Ethernet, TCP/IP
<b>Display units</b>		
Standard images for:		Standard displays for easy embedding in user displays, example project for MP 377
Number of languages for online language selection	3 (de/en/fr)	5 (de/en/fr/it/es)
<b>Functionality</b>		
Modification of HMI diagnostics data management in RT	WinCC/ProAgent V6.0 and higher	No
Unit overview	Yes	Yes
Message display	Yes	Yes
Sequencer operating display	Yes	Yes
Diagnostics detail display	Yes	Yes
<ul style="list-style-type: none"> <li>• Display STL/LAD/signal list</li> <li>• Display of operands with symbol and comment</li> </ul>	Yes/Yes/Yes Yes	Yes/Yes/Yes Yes
Criteria analysis	When fault occurs/current status/can be archived	When fault occurs/current status
<b>Motion display</b>		
<ul style="list-style-type: none"> <li>• Number of viewable movements</li> <li>• Directions of motion</li> <li>• Number of viewable end positions per movement</li> </ul>	6 2 16	6 2 16
<b>Documentation</b>		
In electronic format	de/en/fr; included in scope of delivery	de/en/fr/it/es; included in scope of delivery
<b>Requirements</b>		
HMI software	WinCC V7.0 SP3 (ProAgent V7.0 SP3)	WinCC flexible 2008
Operating system: Configuration	WinCC/ProAgent V7.0 + SP2: Windows Professional SP3, Windows 7 (32 bit) Ultimate, Business, and Enterprise	WinCC flexible /ProAgent 2008 + SP2: Windows XP SP3, Windows 7 Professional, Ultimate, Enterprise
Operating system Runtime	WinCC/ProAgent V7.0 + SP2: Windows XP Professional SP3, Windows 7 (32 bit) Ultimate, Business and Enterprise, Windows 2003 Server SP2, Windows 2008 Server SP2	WinCC flexible /ProAgent for SIMATIC Panels: WinCC flexible /ProAgent for WinCC flexible Runtime: Windows XP SP3, Windows 7 Professional, Ultimate, Enterprise
<b>STEP 7</b>		
<ul style="list-style-type: none"> <li>• S7-GRAPH</li> <li>• S7-PDIAG</li> <li>• S7-HiGraph</li> </ul>	V5.4 SP4 and higher V5.3 SP6 and higher V5.3 SP3 and higher No	V5.3 and higher V5.2 + SP3 and higher V5.1 and higher V5.3 and higher
Type of delivery (one license is required for each target hardware)	CD-ROM / Runtime license	Runtime license

# HMI Software

## SIMATIC ProAgent process diagnostics software

SIMATIC ProAgent

Ordering data	Order No.	Ordering data	Order No.
<p><b>SIMATIC WinCC/ProAgent</b></p> <p>Software option package for process error diagnostics based on S7 GRAPH V5 and higher and S7 PDIAG V5 and higher; functional enhancement for SIMATIC WinCC; electronic documentation in English, French and German; functions and standard screens for use on a PC (resolution 1024 x 768 pixel) and Panel PC 577/677/877 15" (resolution 1024 x 768 pixel) in English, French and German, Runtime license (single license) WinCC version:</p> <ul style="list-style-type: none"> <li>• V7.0 SP3; for WinCC V7.0 SP3 <sup>1)</sup></li> </ul> <p>Upgrade</p> <ul style="list-style-type: none"> <li>• to V7.0 SP3 <sup>1)</sup></li> </ul>	<p><b>6AV6371-1DG07-0AX0</b></p> <p><b>6AV6371-1DG07-0AX4</b></p>	<p><b>Documentation (must be ordered separately)</b></p> <p><b>SIMATIC HMI Manual Collection</b></p> <p>Electronic documentation on CD-ROM</p> <p>5 languages (English, German, French, Italian and Spanish); contains: all currently available user manuals, device manuals and communication manuals for SIMATIC HMI</p>	<p><b>6AV6691-1SA01-0AX0</b></p>
<p><b>SIMATIC WinCC flexible /ProAgent</b></p> <p>Software option package for process error diagnostics based on S7 PDIAG V5.1 and higher, S7 GRAPH V5.2 + SP3 and higher; S7 HiGRAPH V5.3 and higher. Functional enhancement for SIMATIC WinCC flexible; electronic documentation in English, French, German, Italian and Spanish</p> <ul style="list-style-type: none"> <li>• <b>WinCC flexible /ProAgent for SIMATIC Panels</b> Runtime license (Single License) executable on TP/OP/MP 270/277, Mobile Panel 277 and MP 370/377</li> <li>• <b>WinCC flexible /ProAgent for WinCC flexible Runtime</b> Runtime license (single license)</li> </ul>	<p><b>6AV6618-7DB01-3AB0</b></p> <p><b>6AV6618-7DD01-3AB0</b></p>		

<sup>1)</sup> Not multi-station-capable

Notes

4