



ThinkSystem ST650 V2 Maintenance Manual



Machine Types: 7Z74 and 7Z75

Note

Before using this information and the product it supports, be sure to read and understand the safety information and the safety instructions, which are available at:

http://thinksystem.lenovofiles.com/help/topic/safety_documentation/pdf_files.html

In addition, ensure that you are familiar with the terms and conditions of the Lenovo warranty for your server, which can be found at:

<http://datacentersupport.lenovo.com/warrantylookup>

Second Edition (July 2021)

© Copyright Lenovo 2021.

LIMITED AND RESTRICTED RIGHTS NOTICE: If data or software is delivered pursuant to a General Services Administration (GSA) contract, use, reproduction, or disclosure is subject to restrictions set forth in Contract No. GS-35F-05925.

Contents

Safety v

Safety inspection checklist vi

Chapter 1. Introduction 1

Server form factor 1

Specifications 1

 Particulate contamination 8

Firmware updates 9

Tech Tips 13

Security advisories 13

Power on the server 13

Power off the server 13

Chapter 2. Server components 15

Front view 16

 Front panel 21

Rear view 24

 Rear view LEDs 26

 External LCD diagnostics handset 27

System board components 33

 System board LEDs 35

 System board switches 36

Server locks 38

Backplates and backplanes 39

 2.5-inch drive backplanes 39

 3.5-inch drive backplanes 40

 3.5-inch drive backplate 41

Power distribution board connectors 41

Parts list 42

 Power cords 46

Chapter 3. Internal cable routing 47

Backplane and backplate cable routing 48

Front panel cable routing 48

Front USB cable routing 49

GPU cable routing 50

Internal CFF RAID adapter cable routing 50

M.2 boot adapter cable routing 51

Optical drive cable routing 52

PCIe slot 8 cable routing 52

Power distribution board cable routing 53

Tape drive cable routing 54

Chapter 4. Hardware replacement procedures 57

Installation guidelines 57

 Safety inspection checklist 58

 System reliability guidelines 59

 Working inside the server with the power on 59

 Handling static-sensitive devices 60

2.5-inch hot-swap drive backplane replacement 60

 Remove a 2.5-inch hot-swap drive backplane 60

 Install a 2.5-inch hot-swap drive backplane 62

2.5-inch drive replacement from 3.5-inch drive bay 63

 Remove a 2.5-inch drive from a 3.5-inch drive bay 64

 Install a 2.5-inch drive into a 3.5-inch drive bay 65

3.5-inch hot-swap drive backplane replacement 66

 Remove a 3.5-inch hot-swap drive backplane 67

 Install a 3.5-inch hot-swap drive backplane 68

3.5-inch simple-swap drive backplate replacement 69

 Remove a 3.5-inch simple-swap drive backplate 69

 Install a 3.5-inch simple-swap drive backplate 71

Air baffle replacement 72

 Remove the air baffle 72

 Install the air baffle 74

CMOS battery (CR2032) replacement 76

 Remove the CMOS battery (CR2032) 76

 Install the CMOS battery (CR2032) 78

Drive replacement 79

 Remove a simple-swap drive 80

 Install a simple-swap drive 81

 Remove a hot-swap drive 83

 Install a hot-swap drive 84

EIA brackets replacement 86

 Remove the EIA brackets 86

 Install the EIA brackets 88

Expansion drive cage replacement 90

 Remove the expansion drive cage 90

 Install the expansion drive cage 91

Fan and fan cage replacement 93

 Remove a hot-swap fan 93

 Install a hot-swap fan 94

 Remove the fan cage assembly 95

 Install the fan cage assembly 97

Flash power module replacement 98

 Remove a flash power module 98

 Install a flash power module 100

Foot stands replacement	102	Install the 5.25-inch drive bay adapter assembly	156
Remove the foot stands	102	PCIe adapter holder replacement	159
Install the foot stands	104	Remove a PCIe adapter holder	160
Front bezel replacement	105	Install a PCIe adapter holder	161
Remove the front bezel	105	PCIe adapter replacement	162
Install the front bezel	106	Remove a PCIe adapter	162
Front door replacement	107	Install a PCIe adapter	164
Remove the front door	107	Power distribution board replacement	166
Install the front door	109	Remove the power distribution board	166
Front panel board assembly replacement	110	Install the power distribution board	168
Remove the front panel board assembly	110	Power supply unit replacement	170
Install the front panel board assembly	111	Remove a hot-swap power supply	170
Full-length GPU adapter replacement	113	Install the hot-swap power supply	173
Remove a full-length GPU adapter	113	Processor and heat sink replacement	177
Install a full-length GPU adapter	114	Remove a processor and heat sink	177
GPU filler replacement	116	Separate the processor from carrier and heat sink	181
Remove a GPU filler	116	Install a processor and heat sink	183
Install a GPU filler	118	Server cover replacement	188
Heat sink Torx T30 nut replacement	119	Remove the server cover	188
Remove a heat sink Torx T30 nut	119	Install the server cover	190
Install a heat sink Torx T30 nut	121	System board replacement (trained technician only)	192
Internal CFF adapter replacement	122	Remove the system board	192
Remove the internal CFF adapter	122	Install the system board	196
Install the internal CFF adapter	124	Update the machine type and serial number	198
Intrusion switch replacement	127	Enable TPM/TCM	200
Remove the intrusion switch	127	Enable UEFI Secure Boot	202
Install the intrusion switch	128	T4 filler replacement	203
M.2 boot adapter replacement	130	Remove a T4 filler	203
Remove the M.2 boot adapter	130	Install a T4 filler	204
Install the M.2 boot adapter	131	Complete the parts replacement	206
M.2 drive replacement	133		
Remove an M.2 drive	133	Chapter 5. Problem determination	207
Adjust the retainer on the M.2 boot adapter	134	Event logs	207
Install an M.2 drive	135	Light path diagnostics	209
Memory module replacement	137	General problem determination procedures	209
Remove a memory module	137	Resolving suspected power problems	209
Install a memory module	139	Resolving suspected Ethernet controller problems	210
NVLink bridge replacement	141	Troubleshooting by symptom	211
Remove an NVLink bridge	141	Drive problems	211
Install an NVLink bridge	142	Fan problems	213
Optical drive cage replacement	144	Intermittent problems	213
Remove the optical drive cage	144	Keyboard, mouse, or USB-device problems	214
Install the optical drive cage	145	Memory problems	215
Optical drive or tape drive replacement	147	Monitor and video problems	219
Remove an optical drive or a tape drive	147		
Install an optical drive or a tape drive	150		
Remove the 5.25-inch drive bay adapter assembly	153		

Network problems	221	Before you call	231
Observable problems.	221	Collecting service data	232
Optional-device problems	223	Contacting Support	233
Power on and power off problems.	224	Appendix C. Notices.235
Processor problems	225	Trademarks	236
Serial-device problems	226	Important notes.	236
Software problems.	226	Telecommunication regulatory statement.	236
Appendix A. Hardware		Electronic emission notices	237
disassembling for recycle229	Taiwan BSMI RoHS declaration.	237
Disassemble the server for chassis recycle	229	Taiwan import and export contact information	237
Appendix B. Getting help and		Index239
technical assistance231		

Safety

Before installing this product, read the Safety Information.

قبل تركيب هذا المنتج، يجب قراءة الملاحظات الأمنية

Antes de instalar este produto, leia as Informações de Segurança.

在安装本产品之前，请仔细阅读 Safety Information（安全信息）。

安裝本產品之前，請先閱讀「安全資訊」。

Prije instalacije ovog produkta obavezno pročitajte Sigurnosne Upute.

Před instalací tohoto produktu si přečtěte příručku bezpečnostních instrukcí.

Læs sikkerhedsforskrifterne, før du installerer dette produkt.

Lees voordat u dit product installeert eerst de veiligheidsvoorschriften.

Ennen kuin asennat tämän tuotteen, lue turvaohjeet kohdasta Safety Information.

Avant d'installer ce produit, lisez les consignes de sécurité.

Vor der Installation dieses Produkts die Sicherheitshinweise lesen.

Πριν εγκαταστήσετε το προϊόν αυτό, διαβάστε τις πληροφορίες ασφαλείας (safety information).

לפני שתתקינו מוצר זה, קראו את הוראות הבטיחות.

A termék telepítése előtt olvassa el a Biztonsági előírásokat!

Prima di installare questo prodotto, leggere le Informazioni sulla Sicurezza.

製品の設置の前に、安全情報をお読みください。

본 제품을 설치하기 전에 안전 정보를 읽으십시오.

Пред да се инсталира овој продукт, прочитајте информацијата за безбедност.

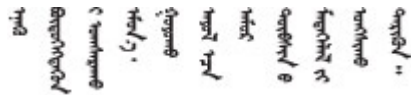

Les sikkerhetsinformasjonen (Safety Information) før du installerer dette produktet.

Przed zainstalowaniem tego produktu, należy zapoznać się z książką "Informacje dotyczące bezpieczeństwa" (Safety Information).

Antes de instalar este produto, leia as Informações sobre Segurança.

Перед установкой продукта прочтите инструкции по технике безопасности.

Pred inštaláciou tohto zariadenia si pečítajte Bezpečnostné predpisy.

Pred namestitvijo tega proizvoda preberite Varnostne informacije.

Antes de instalar este producto, lea la información de seguridad.

Läs säkerhetsinformationen innan du installerar den här produkten.

ཐོན་ཇུས་འདི་བདེ་སྤྱོད་མ་བྱས་གོང་། སྐྱོར་གྱི་ཡིད་གཟབ་
བྱ་འདྲ་མིན་ཡིད་པའི་འོད་ཟེར་བལྟ་དགོས།

Bu ürünü kurmadan önce güvenlik bilgilerini okuyun.

مەزكۇر مەھسۇلاتنى ئورنىتىشتىن بۇرۇن بىخەتەرلىك ئۇچۇرلىرىنى ئوقۇپ چىقىڭ.

Youq mwngz yungh canjbinj neix gaxgonq, itdingh aeu doeg aen
canjbinj soengq cungj vahgangj ancien siusik.

Safety inspection checklist

Use the information in this section to identify potentially unsafe conditions with your server. As each machine was designed and built, required safety items were installed to protect users and service technicians from injury.

CAUTION:

This equipment must be installed or serviced by trained personnel, as defined by the NEC, IEC 62368-1 & IEC 60950-1, the standard for Safety of Electronic Equipment within the Field of Audio/Video, Information Technology and Communication Technology. Lenovo assumes you are qualified in the servicing of equipment and trained in recognizing hazards energy levels in products.

Important: Electrical grounding of the server is required for operator safety and correct system function. Proper grounding of the electrical outlet can be verified by a certified electrician.

Notes:

1. The product is not suitable for use at visual display workplaces according to §2 of the Workplace Regulations.
2. The set-up of the server is made in the server room only.

Use the following checklist to verify that there are no potentially unsafe conditions:

1. Make sure that the power is off and the power cord is disconnected.
2. Check the power cord.
 - Make sure that the third-wire ground connector is in good condition. Use a meter to measure third-wire ground continuity for 0.1 ohm or less between the external ground pin and the frame ground.
 - Make sure that the power cord is the correct type.

To view the power cords that are available for the server:

- a. Go to:

<http://dcsc.lenovo.com/#/>

- b. In the Customize a Model pane:
 - 1) Click **Select Options/Parts for a Model**.
 - 2) Enter the machine type and model for your server.
- c. Click the Power tab to see all line cords.
 - Make sure that the insulation is not frayed or worn.
3. Check for any obvious non-Lenovo alterations. Use good judgment as to the safety of any non-Lenovo alterations.
4. Check inside the server for any obvious unsafe conditions, such as metal filings, contamination, water or other liquid, or signs of fire or smoke damage.
5. Check for worn, frayed, or pinched cables.
6. Make sure that the power-supply cover fasteners (screws or rivets) have not been removed or tampered with.

Chapter 1. Introduction

The ThinkSystem ST650 V2 server is a 4U tower server designed for performance and expansion for various IT workloads. With the modular design, the server is flexible to be customized for maximum storage capacity or high storage density with selectable input/output options and tiered system management.

Performance, ease of use, reliability, and expansion capabilities were key considerations in the design of the server. These design features make it possible for you to customize the system hardware to meet your needs today and provide flexible expansion capabilities for the future.

The server comes with a limited warranty. For details about the warranty, see: <https://support.lenovo.com/us/en/solutions/ht503310>

For details about your specific warranty, see: <http://datacentersupport.lenovo.com/warrantylookup>

Server form factor

The ThinkSystem ST650 V2 server is designed to support both tower and rack form factors.

You can change the server from tower form factor to rack form factor by installing the tower to rack conversion kit. For instructions on how to install the tower to rack conversion kit, refer to “Install the tower to rack conversion kit” in the *ThinkSystem ST650 V2 Setup Guide*.

Specifications

The following information is a summary of the features and specifications of the server. Depending on the model, some features might not be available, or some specifications might not apply.

Table 1. Specifications

Specification	Description
Dimension	4U server <ul style="list-style-type: none">• Height:<ul style="list-style-type: none">– Without foot stand: 448 mm (17.64 inches)– With foot stand: 461.4 mm (18.17 inches)• Width:<ul style="list-style-type: none">– Without foot stand: 174.2 mm (6.86 inches)– With foot stand: 247.4 mm (9.74 inches)• Depth:<ul style="list-style-type: none">– Without front door: 710.8 mm (27.98 inches)– With front door: 733.8 mm (28.89 inches)
Weight (depending on the configuration)	<ul style="list-style-type: none">• 2.5-inch drive configuration:<ul style="list-style-type: none">– Maximum: 39.28 kg (86.60 lb)• 3.5-inch drive configuration:<ul style="list-style-type: none">– Maximum: 46.23 kg (101.92 lb)

Table 1. Specifications (continued)

Specification	Description
<p>Processor</p>	<p>Supports multi-core Intel Xeon processors, with integrated memory controller and Intel Mesh UPI (Ultra Path Interconnect) topology.</p> <ul style="list-style-type: none"> • Supports up to two 250W processors • Designed for the LGA 4189 socket • Scalable up to 52 cores (with two processors installed) • Supports up to 4 UPI links at 11.2 GT/s <p>Notes:</p> <ul style="list-style-type: none"> • Only two-socket type CPUs are supported in two CPU configurations. • UPI function is only available when two or more processors are installed. <p>For a list of supported processors, see: https://static.lenovo.com/us/en/serverproven/index.shtml</p>
<p>Memory</p>	<ul style="list-style-type: none"> • Minimum: 16 GB • Maximum: <ul style="list-style-type: none"> – 2048 GB using registered DIMMs (RDIMMs) – 3072 GB using registered DIMMs (RDIMMs) and Persistent Memory Modules (PMEM) • Slots: thirty-two DIMM slots • Supports: <ul style="list-style-type: none"> – 16 GB, 32 GB, 64 GB TruDDR4 3200 MHz RDIMM – 128 GB Persistent Memory Modules (PMEM) <p>For a list of supported memory modules, see: https://static.lenovo.com/us/en/serverproven/index.shtml</p>
<p>Drive bays (varies by model)</p>	<p>Drive bays and drives supported by your server vary by model.</p> <ul style="list-style-type: none"> • Storage drive bays: <ul style="list-style-type: none"> – Server models with 3.5-inch simple-swap drive bays <ul style="list-style-type: none"> – Supports up to twelve SATA drives – Server models with 3.5-inch hot-swap drive bays <ul style="list-style-type: none"> – Supports up to sixteen SAS/SATA drives – Supports up to eight SAS/SATA drives and eight NVMe drives – Server models with 2.5-inch hot-swap drive bays <ul style="list-style-type: none"> – Supports up to thirty-two SAS/SATA drives – Supports up to sixteen SAS/SATA drives and sixteen NVMe drives • Optical drive bays <ul style="list-style-type: none"> – Two optical drive bays <ul style="list-style-type: none"> – Supports up to one tape drive (RDX or LTO) and one optical disk drive <p>Notes:</p> <ul style="list-style-type: none"> • The server supports the installation of 2.5-inch SSDs in a 3.5 inch disk bay through the use of a conversion kit. See “Install a 2.5-inch drive into a 3.5-inch drive bay” on page 65 for details. • When GPUs are installed, only two backplanes or backplates are supported and no optical drive or tape drive can be installed.

Table 1. Specifications (continued)

Specification	Description
M.2 drive	<p>Supports up to two M.2 drives:</p> <ul style="list-style-type: none"> • 42 mm (2242) • 60 mm (2260) • 80 mm (2280) • 110 mm (22110)
Expansion slots	<p>Nine PCIe expansion slots are available:</p> <ul style="list-style-type: none"> • Slot 1: PCIe4 x16, 75W, Full-height, half-length • Slot 2: PCIe4 x8 (open end), 75W, Full-height, half-length • Slot 3: PCIe4 x16, 75W, Full-height, half-length • Slot 4: PCIe4 x8 (open end), 75W, Full-height, half-length • Slot 5: PCIe4 x16, 75W, Full-height, half-length • Slot 6: PCIe4 x8 (open end), 75W, Full-height, half-length • Slot 7: PCIe4 x16, 75W, Full-height, half-length • Slot 8: PCIe3 x8 (open end), 75W, Full-height, half-length (requires additional cable connection, see “PCIe slot 8 cable routing” on page 52) • Slot 9: PCIe4 x8 (open end), 75W, Full-height, half-length <p>Notes: When Slot 8 is used:</p> <ul style="list-style-type: none"> • Up to 6 NVMe drives can be supported in 3.5-inch configurations with two NVMe/AnyBay backplanes. • Up to 14 NVMe drives can be supported in 2.5-inch configurations with two NVMe/AnyBay backplanes. • 3.5-inch configurations with two NVMe/AnyBay backplanes and no NVMe Retimer Adapter or one NVMe Retimer Adapter is not supported. • 2.5-inch configurations with two NVMe/AnyBay backplanes and two NVMe Retimer Adapters or three NVMe Retimer Adapters are not supported.
Onboard NVMe connectors	<p>Four onboard NVMe connectors are available:</p> <ul style="list-style-type: none"> • PCIe 1: Gen3 • PCIe 2: Gen3 • PCIe 3: Gen4 • PCIe 4: Gen4 when connected to backplane, Gen3 when connected to PCIe slot 8 enable connector.
Input/Output (I/O) features	<ul style="list-style-type: none"> • Front panel <ul style="list-style-type: none"> – One USB 2.0 connector with Lenovo XClarity Controller management – One USB 3.2 Gen 1 connector • Rear panel <ul style="list-style-type: none"> – One External LCD diagnostics handset connector – Four USB 3.2 Gen 1 connectors – Two 10Gb Ethernet connectors – One VGA connector – One serial-port-module slot – One XClarity Controller network connector (RJ-45 Ethernet connector)
Network	<ul style="list-style-type: none"> • Two 10Gb ethernet connectors • One XClarity Controller network connector (RJ-45 Ethernet connector) <p>Notes:</p> <ul style="list-style-type: none"> • Use CAT6A UTP cables rated at 625 MHz bandwidth for the 10Gb on-board LAN. • Wake-on-LAN (WoL) is not supported on 10Gb ethernet connector under Windows OS.

Table 1. Specifications (continued)

Specification	Description
Storage controller	<ul style="list-style-type: none"> • Twelve onboard SATA ports (only the first 8 drives can be configured using Intel VROC SATA RAID) • Eight onboard NVMe ports (Intel VROC NVMe RAID) • NVMe Retimer Adapter (Intel VROC NVMe RAID) • The following SAS/SATA RAID/HBA options are available for this server: <ul style="list-style-type: none"> – ThinkSystem 430-8i SAS/SATA 12Gb HBA (No RAID) – ThinkSystem 430-8e SAS/SATA 12Gb HBA (No RAID) – ThinkSystem 430-16i SAS/SATA 12Gb HBA (No RAID) – ThinkSystem 430-16e SAS/SATA 12Gb HBA (No RAID) – ThinkSystem 440-16i SAS/SATA PCIe Gen4 12Gb Internal HBA (No RAID) – ThinkSystem RAID 530-8i PCIe 12Gb Adapter (RAID 0, 1, 10, 5, 50) – ThinkSystem RAID 930-8i 2GB Flash PCIe 12Gb Adapter (RAID 0, 1, 10, 5, 50, 6, 60) – ThinkSystem RAID 930-8e 4GB Flash PCIe 12Gb Adapter (RAID 0, 1, 10, 5, 50, 6, 60) – ThinkSystem RAID 940-8i 4GB Flash PCIe Gen4 12Gb Adapter (RAID 0, 1, 10, 5, 50, 6, 60) – ThinkSystem RAID 940-8i 8GB Flash PCIe Gen4 12Gb Adapter (RAID 0, 1, 10, 5, 50, 6, 60) – ThinkSystem RAID 530-16i PCIe 12Gb Adapter (RAID 0, 1, 10) – ThinkSystem RAID 930-16i 4GB Flash PCIe 12Gb Adapter (RAID 0, 1, 10, 5, 50, 6, 60) – ThinkSystem RAID 940-16i 8GB Flash PCIe Gen4 12Gb Adapter (RAID 0, 1, 10, 5, 50, 6, 60) – ThinkSystem RAID 940-16i 8GB Flash PCIe Gen4 12Gb Internal Adapter (RAID 0, 1, 10, 5, 50, 6, 60) – ThinkSystem RAID 940-32i 8GB Flash PCIe Gen4 12Gb Adapter (RAID 0, 1, 10, 5, 50, 6, 60) <p>Notes:</p> <ul style="list-style-type: none"> • ThinkSystem RAID 940-32i 8GB Flash PCIe Gen4 12Gb Adapter can only be installed in slot 9 in one CPU configurations, and installed in slot 9, 5, 6, 7, or 8 in two CPU configurations. • Onboard SATA 8-11 connector can only support ACHI mode when ThinkSystem M.2 NVMe 2-Bay RAID Enablement Kit or ThinkSystem M.2 SATA 2-Bay RAID Enablement Kit is installed. • Drives connected to SATA 6-7 (from onboard SATA 4-7 connector) cannot be used for bootable Windows system disk when in RAID mode. <p>For a list of supported adapters, see: https://static.lenovo.com/us/en/serverproven/index.shtml</p>
Fans	<p>Supports up to four hot-swap fans:</p> <ul style="list-style-type: none"> • 9238 single-rotor hot-swap fans • 9256 dual-rotor hot-swap fans <p>Note: Single-rotor hot-swap fans cannot be mixed with dual-rotor hot-swap fans.</p>

Table 1. Specifications (continued)

Specification	Description
<p>Power supply</p>	<p>Supports up to two power supplies with N+N redundancy:</p> <ul style="list-style-type: none"> • ThinkSystem 2400W (230V) v2 Platinum hot-swap power supply • ThinkSystem 1800W (230V) v2 Platinum hot-swap power supply • ThinkSystem 1100W (230V/115V) v2 Platinum hot-swap power supply • ThinkSystem 750W (230V) v2 Titanium hot-swap power supply • ThinkSystem 750W(230/115V) v2 Platinum hot-swap power supply <p>Notes:</p> <ul style="list-style-type: none"> • 100V+ is only allowed on the following: <ul style="list-style-type: none"> – 750W Platinum – 1100W Platinum • 200V+ is only allowed on the following: <ul style="list-style-type: none"> – 750W Platinum – 750W Titanium – 1100W Platinum – 1800W Platinum – 2400W Platinum <p>CAUTION:</p> <ul style="list-style-type: none"> • 240 V dc input (input range: 180-300 V dc) is ONLY supported in Chinese Mainland. • Power supplies with 240 V dc are not hot-swappable. To remove the power cord, ensure you have turned off the server or disconnected the dc power sources at the breaker panel. • In order for the ThinkSystem products to operate error free in both a DC or AC electrical environment, a TN-S earthing system which complies to 60364-1 IEC 2005 standard has to be present or installed.
<p>Minimal configuration for debugging</p>	<ul style="list-style-type: none"> • One processor in processor socket 1 • One DRAM DIMM in DIMM slot 14 • One power supply in PSU slot 1 • One drive with RAID adapter and backplane or backplate (if OS is needed for debugging) • Three single rotor fans in fan slot 1, 2, and 4. • One fan filler in fan slot 3.

Table 1. Specifications (continued)

Specification	Description
<p>Environment</p>	<p>The ThinkSystem ST650 V2 server complies with ASHRAE Class A2 specifications. Depending on the hardware configuration, some models comply with ASHRAE Class A3 and Class A4 specifications. System performance may be impacted when operating temperature is outside ASHRAE A2 specification.</p> <ul style="list-style-type: none"> • Air temperature: <ul style="list-style-type: none"> – Operating <ul style="list-style-type: none"> – ASHRAE Class A2: 10°C to 35°C (50°F to 95°F); the maximum ambient temperature decreases by 1°C for every 300 m (984 ft) increase in altitude above 900 m (2,953 ft). – ASHRAE Class A3: 5°C to 40°C (41°F to 104°F); the maximum ambient temperature decreases by 1°C for every 175 m (574 ft) increase in altitude above 900 m (2,953 ft). – ASHRAE Class A4: 5°C to 45°C (41°F to 113°F); the maximum ambient temperature decreases by 1°C for every 125 m (410 ft) increase in altitude above 900 m (2,953 ft). – Server off: -10°C to 60°C (14°F to 140°F) – Shipment/storage: -40°C to 60°C (-40°F to 140°F) • Maximum altitude: 3,050 m (10,000 ft) • Relative Humidity (non-condensing): <ul style="list-style-type: none"> – Operating <ul style="list-style-type: none"> – ASHRAE Class A2: 8% to 80%; maximum dew point: 21°C (70°F) – ASHRAE Class A3: 8% to 85%; maximum dew point: 24°C (75°F) – ASHRAE Class A4: 8% to 90%; maximum dew point: 24°C (75°F) – Shipment/storage: 8% to 90% • Particulate contamination <p>Attention: Airborne particulates and reactive gases acting alone or in combination with other environmental factors such as humidity or temperature might pose a risk to the server. For information about the limits for particulates and gases, see “Particulate contamination” on page 8.</p>
<p>Acoustical noise emissions</p>	<p>The server has the following acoustic noise emissions declaration:</p> <ul style="list-style-type: none"> • Sound power level ($L_{WA,d}$) <ul style="list-style-type: none"> – Idling: <ul style="list-style-type: none"> – Min: 5.0 Bel – Typical: 5.6 Bel – GPU: 7.2 Bel – Operating: <ul style="list-style-type: none"> – Min: 5.6 Bel – Typical: 5.6 Bel – GPU: 8.5 Bel • Sound pressure level (L_{pAm}): <ul style="list-style-type: none"> – Idling: <ul style="list-style-type: none"> – Min: 37 dBA – Typical: 41 dBA – GPU: 57 dBA – Operating: <ul style="list-style-type: none"> – Min: 41 dBA – Typical: 41 dBA – GPU: 69 dBA

Table 1. Specifications (continued)

Specification	Description
	<p>Notes:</p> <ul style="list-style-type: none"> • The fans will temporarily run at higher speeds on system boot due to processor power calibration. • These sound levels were measured in controlled acoustical environments according to procedures specified by ISO7779 and are reported in accordance with ISO 9296. • The declared acoustic sound levels are based on the specified configurations, which may change slightly depending on configuration/conditions. <ul style="list-style-type: none"> – Min configuration: one 105W processor, four 16 GB DIMMs, two 480 GB SSD drives, two onboard 10GB LAN ports, one 750W power supply unit. – Typical configuration: two 125W processors, sixteen 32 GB DIMMs, eight SAS hard disk drives, one 530-8i RAID Adapter, two onboard 10GB LAN ports, two 750W power supply units. – GPU configuration: two 165W processors, thirty-two 64 GB DIMMs, eight SAS hard disk drives, one 930-8i RAID adapter, two onboard 10GB LAN ports, eight Nvidia Tesla T4 GPU adapters, two 1800W power supply units. • The declared acoustic noise levels may increase greatly, if high-power components are installed such as high-power NICs, high-power processors and GPUs. • Government regulations (such as those prescribed by OSHA or European Community Directives) may govern noise level exposure in the workplace and may apply to you and your server installation. The actual sound pressure levels in your installation depend upon a variety of factors, including the number of racks in the installation; the size, materials, and configuration of the room; the noise levels from other equipment; the room ambient temperature, and employee's location in relation to the equipment. Further, compliance with such government regulations depends on a variety of additional factors, including the duration of employees' exposure and whether employees wear hearing protection. Lenovo recommends that you consult with qualified experts in this field to determine whether you are in compliance with the applicable regulations.
<p>Ambient temperature management</p>	<p>Adjust ambient temperature when specific components are installed:</p> <p>Note: Ensure that you observe the fan installation rules and sequence in “Technical rules for system fans” in the <i>ThinkSystem ST650 V2 Setup Guide</i>.</p> <ul style="list-style-type: none"> • Keep ambient temperature to 30°C or lower when one or more of the following components are installed. <ul style="list-style-type: none"> – Processors with 205 to 250 watts – GPU adapter • Keep ambient temperature to 35°C or lower when one or more of the following components are installed. <ul style="list-style-type: none"> – Processors with 165 to 195 watts – Thirty-two registered DIMMs (RDIMMs) with 64 GB or less – Persistent Memory Modules (PMEM) – Retimer – ThinkSystem Mellanox ConnectX series adapter – Fibre Channel adapter – NVMe drive – RAID/HBA adapter – External NIC adapter

Table 1. Specifications (continued)

Specification	Description
	<ul style="list-style-type: none"> • Keep ambient temperature to 40°C or lower when one or more of the following components are installed. <ul style="list-style-type: none"> – Processors with 135 to 150 watts • Keep ambient temperature to 45°C or lower when one or more of the following components are installed. <ul style="list-style-type: none"> – Processors with 120 watts or less – Thirty-two registered DIMMs (RDIMMs) with 32 GB or less – Two backplanes/backplates
Operating systems	<p>Supported and certified operating systems:</p> <ul style="list-style-type: none"> • Microsoft Windows Server • VMware ESXi • Red Hat Enterprise Linux • SUSE Linux Enterprise Server <p>References:</p> <ul style="list-style-type: none"> • Complete list of available operating systems: https://lenovopress.com/osig. • OS deployment instructions: See “Deploy the operating system” in <i>Setup Guide</i>.

Particulate contamination

Attention: Airborne particulates (including metal flakes or particles) and reactive gases acting alone or in combination with other environmental factors such as humidity or temperature might pose a risk to the device that is described in this document.

Risks that are posed by the presence of excessive particulate levels or concentrations of harmful gases include damage that might cause the device to malfunction or cease functioning altogether. This specification sets forth limits for particulates and gases that are intended to avoid such damage. The limits must not be viewed or used as definitive limits, because numerous other factors, such as temperature or moisture content of the air, can influence the impact of particulates or environmental corrosives and gaseous contaminant transfer. In the absence of specific limits that are set forth in this document, you must implement practices that maintain particulate and gas levels that are consistent with the protection of human health and safety. If Lenovo determines that the levels of particulates or gases in your environment have caused damage to the device, Lenovo may condition provision of repair or replacement of devices or parts on implementation of appropriate remedial measures to mitigate such environmental contamination. Implementation of such remedial measures is a customer responsibility.

Table 2. Limits for particulates and gases

Contaminant	Limits
Gaseous	Severity level G1 as per ANSI/ISA 71.04-1985 ¹ , which states that the reactivity rate of copper coupons shall be less than 300 Angstroms per month ($\text{\AA}/\text{month}$, $\approx 0.0039 \mu\text{g}/\text{cm}^2\text{-hour}$ weight gain). ² In addition, the reactivity rate of silver coupons shall be less than $200\text{\AA}/\text{month}$ ($\approx 0.0035 \mu\text{g}/\text{cm}^2\text{-hour}$ weight gain). ³ The reactive monitoring of gaseous corrosivity must be conducted approximately 5 cm (2 in.) in front of the rack on the air inlet side at one-quarter and three-quarter frame height off the floor or where the air velocity is much higher.
Particulate	Data centers must meet the cleanliness level of ISO 14644-1 class 8. For data centers without airside economizer, the ISO 14644-1 class 8 cleanliness might be met by choosing one of the following filtration methods: <ul style="list-style-type: none"> • The room air might be continuously filtered with MERV 8 filters. • Air entering a data center might be filtered with MERV 11 or preferably MERV 13 filters. For data centers with airside economizers, the choice of filters to achieve ISO class 8 cleanliness depends on the specific conditions present at that data center. <p>The deliquescent relative humidity of the particulate contamination should be more than 60% RH.⁴</p> Data centers must be free of zinc whiskers. ⁵
<p>¹ ANSI/ISA-71.04-1985. <i>Environmental conditions for process measurement and control systems: Airborne contaminants</i>. Instrument Society of America, Research Triangle Park, North Carolina, U.S.A.</p> <p>² The derivation of the equivalence between the rate of copper corrosion growth in the thickness of the corrosion product in $\text{\AA}/\text{month}$ and the rate of weight gain assumes that Cu_2S and Cu_2O grow in equal proportions.</p> <p>³ The derivation of the equivalence between the rate of silver corrosion growth in the thickness of the corrosion product in $\text{\AA}/\text{month}$ and the rate of weight gain assumes that Ag_2S is the only corrosion product.</p> <p>⁴ The deliquescent relative humidity of particulate contamination is the relative humidity at which the dust absorbs enough water to become wet and promote ionic conduction.</p> <p>⁵ Surface debris is randomly collected from 10 areas of the data center on a 1.5 cm diameter disk of sticky electrically conductive tape on a metal stub. If examination of the sticky tape in a scanning electron microscope reveals no zinc whiskers, the data center is considered free of zinc whiskers.</p>	

Firmware updates

Several options are available to update the firmware for the server.

You can use the tools listed here to update the most current firmware for your server and the devices that are installed in the server.

Note: Lenovo typically releases firmware in bundles called UpdateXpress System Packs (UXSPs). To ensure that all of the firmware updates are compatible, you should update all firmware at the same time. If you are updating firmware for both the Lenovo XClarity Controller and UEFI, update the firmware for Lenovo XClarity Controller first.

Best practices related to updating firmware is available at the following location:

<http://lenovopress.com/LP0656>

Important terminology

- **In-band update.** The installation or update is performed using a tool or application within an operating system that is executing on the server's core CPU.

- **Out-of-band update.** The installation or update is performed by the Lenovo XClarity Controller collecting the update and then directing the update to the target subsystem or device. Out-of-band updates have no dependency on an operating system executing on the core CPU. However, most out-of-band operations do require the server to be in the S0 (Working) power state.
- **On-Target update.** The installation or update is initiated from an Operating System executing on the server's operating system.
- **Off-Target update.** The installation or update is initiated from a computing device interacting directly with the server's Lenovo XClarity Controller.
- **UpdateXpress System Packs (UXSPs).** UXSPs are bundled updates designed and tested to provide the interdependent level of functionality, performance, and compatibility. UXSPs are server machine-type specific and are built (with firmware and device driver updates) to support specific Windows Server, Red Hat Enterprise Linux (RHEL) and SUSE Linux Enterprise Server (SLES) operating system distributions. Machine-type-specific firmware-only UXSPs are also available.

See the following table to determine the best Lenovo tool to use for installing and setting up the firmware:

Note: The server UEFI settings for option ROM must be set to **Auto** or **UEFI** to update firmware using Lenovo XClarity Administrator or Lenovo XClarity Essentials. For more information, see the following Tech Tip:

<https://datacentersupport.lenovo.com/us/en/solutions/ht506118>

Tool	In-band update	Out-of-band update	On-target update	Off-target update	Graphical user interface	Command-line interface	Supports UXSPs
Lenovo XClarity Provisioning Manager V3 Limited to core system firmware only	√ ²			√	√		√
Lenovo XClarity Controller Supports core system firmware and most advanced I/O option firmware updates		√		√	√	√	
Lenovo XClarity Essentials OneCLI Supports all core system firmware, I/O firmware, and installed operating system driver updates	√	√	√	√		√	√
Lenovo XClarity Essentials UpdateXpress Supports all core system firmware, I/O firmware, and installed operating system driver updates	√	√	√	√	√		√
Lenovo XClarity Essentials Bootable Media Creator Supports core system firmware and I/O firmware updates. You can update the Microsoft® Windows® operating system, but device drivers are not included on the bootable image	√			√	√	√	√
Lenovo XClarity Administrator Supports core system firmware and I/O firmware updates	√ ¹	√ ²		√	√		

Tool		In-band update	Out-of-band update	On-target update	Off-target update	Graphical user interface	Command-line interface	Supports UXSPs
Lenovo XClarity Integrator offerings	Lenovo XClarity Integrator for VMware vCenter Supports all core system firmware, I/O firmware, and installed operating system driver updates		√		√	√		
	Lenovo XClarity Integrator for Microsoft Windows Admin Center Supports all core system firmware, I/O firmware, and installed operating system driver updates	√	√	√	√	√		
	Lenovo XClarity Integrator for Microsoft System Center Configuration Manager Supports all core system firmware, I/O firmware, and installed operating system driver updates	√		√		√		√
Notes:								
1. For I/O firmware updates.								
2. For BMC and UEFI firmware updates.								

The latest firmware can be found at the following site:

<http://datacentersupport.lenovo.com/us/en/products/servers/thinksystem/st650v2/7Z74/downloads>

- **Lenovo XClarity Provisioning Manager V3**

From Lenovo XClarity Provisioning Manager V3, you can update the Lenovo XClarity Controller firmware, the UEFI firmware, and the Lenovo XClarity Provisioning Manager V3 software.

Note: By default, the Lenovo XClarity Provisioning Manager V3 Graphical User Interface is displayed when you press F1. If you have changed that default to be the text-based system setup, you can bring up the Graphical User Interface from the text-based system setup interface.

Additional information about using Lenovo XClarity Provisioning Manager V3 to update firmware is available at:

https://sysmgt.lenovofiles.com/help/topic/LXPMv3/platform_update.html

- **Lenovo XClarity Controller**

If you need to install a specific update, you can use the Lenovo XClarity Controller interface for a specific server.

Notes:

- To perform an in-band update through Windows or Linux, the operating system driver must be installed and the Ethernet-over-USB (sometimes called LAN over USB) interface must be enabled.

Additional information about configuring Ethernet over USB is available at:

http://sysmgt.lenovofiles.com/help/topic/com.lenovo.systems.management.xcc.doc/NN1ia_c_configuringUSB.html

- If you update firmware through the Lenovo XClarity Controller, make sure that you have downloaded and installed the latest device drivers for the operating system that is running on the server.

Specific details about updating firmware using Lenovo XClarity Controller are available at:

http://sysmgt.lenovofiles.com/help/topic/com.lenovo.systems.management.xcc.doc/NN1ia_c_manageserverfirmware.html

- **Lenovo XClarity Essentials OneCLI**

Lenovo XClarity Essentials OneCLI is a collection of command line applications that can be used to manage Lenovo servers. Its update application can be used to update firmware and device drivers for your servers. The update can be performed within the host operating system of the server (in-band) or remotely through the BMC of the server (out-of-band).

Specific details about updating firmware using Lenovo XClarity Essentials OneCLI is available at:

http://sysmgt.lenovofiles.com/help/topic/toolstr_cli_lenovo/onecli_c_update.html

- **Lenovo XClarity Essentials UpdateXpress**

Lenovo XClarity Essentials UpdateXpress provides most of OneCLI update functions through a graphical user interface (GUI). It can be used to acquire and deploy UpdateXpress System Pack (UXSP) update packages and individual updates. UpdateXpress System Packs contain firmware and device driver updates for Microsoft Windows and for Linux.

You can obtain Lenovo XClarity Essentials UpdateXpress from the following location:

<https://datacentersupport.lenovo.com/solutions/Invo-xpress>

- **Lenovo XClarity Essentials Bootable Media Creator**

You can use Lenovo XClarity Essentials Bootable Media Creator to create bootable media that is suitable for firmware updates, VPD updates, inventory and FFDC collection, advanced system configuration, FoD Keys management, secure erase, RAID configuration, and diagnostics on supported servers.

You can obtain Lenovo XClarity Essentials BoMC from the following location:

<https://datacentersupport.lenovo.com/solutions/Invo-bomc>

- **Lenovo XClarity Administrator**

If you are managing multiple servers using the Lenovo XClarity Administrator, you can update firmware for all managed servers through that interface. Firmware management is simplified by assigning firmware-compliance policies to managed endpoints. When you create and assign a compliance policy to managed endpoints, Lenovo XClarity Administrator monitors changes to the inventory for those endpoints and flags any endpoints that are out of compliance.

Specific details about updating firmware using Lenovo XClarity Administrator are available at:

http://sysmgt.lenovofiles.com/help/topic/com.lenovo.lxca.doc/update_fw.html

- **Lenovo XClarity Integrator offerings**

Lenovo XClarity Integrator offerings can integrate management features of Lenovo XClarity Administrator and your server with software used in a certain deployment infrastructure, such as VMware vCenter, Microsoft Admin Center, or Microsoft System Center.

Specific details about updating firmware using Lenovo XClarity Integrator offerings are available at:

https://sysmgt.lenovofiles.com/help/topic/lxci/lxci_product_page.html

Tech Tips

Lenovo continually updates the support website with the latest tips and techniques that you can use to solve issues that your server might encounter. These Tech Tips (also called retain tips or service bulletins) provide procedures to work around issues or solve problems related to the operation of your server.

To find the Tech Tips available for your server:

1. Go to <http://datacentersupport.lenovo.com> and navigate to the support page for your server.
2. Click **Knowledge Base & Guides** from the navigation pane.

Follow the on-screen instructions to choose the category for the problem that you are having.

Security advisories

Lenovo is committed to developing products and services that adhere to the highest security standards in order to protect our customers and their data. When potential vulnerabilities are reported, it is the responsibility of the Lenovo Product Security Incident Response Team (PSIRT) to investigate and provide information to our customers so they may put mitigation plans in place as we work toward providing solutions.

The list of current advisories is available at the following location:

https://datacentersupport.lenovo.com/product_security/home

Power on the server

After the server performs a short self-test (power status LED flashes quickly) when connected to input power, it enters a standby state (power status LED flashes once per second).

The server can be turned on (power LED on) in any of the following ways:

- You can press the power button.
- The server can restart automatically after a power interruption.
- The server can respond to remote power-on requests sent to the Lenovo XClarity Controller.

For information about powering off the server, see “Power off the server” on page 13.

Power off the server

The server remains in a standby state when it is connected to a power source, allowing the Lenovo XClarity Controller to respond to remote power-on requests. To remove all power from the server (power-on LED off), you must disconnect all power cables.

To place the server in a standby state (power-on LED flashes once per second):

Note: The Lenovo XClarity Controller can place the server in a standby state as an automatic response to a critical system failure.

- Start an orderly shutdown using the operating system (if supported by your operating system).
- Press the power-on button to start an orderly shutdown (if supported by your operating system).
- Press and hold the power button for more than 4 seconds to force a shutdown.

When in a standby state, the server can respond to remote power-on requests sent to the Lenovo XClarity Controller. For information about powering on the server, see “Power on the server” on page 13.

Chapter 2. Server components

This section provides information that helps locate the server components.

Identifying your server

When you contact Lenovo for help, the machine type and serial number information helps support technicians to identify your server and provide faster service.

The machine type and serial number are on the ID label on the front of the server.

The following illustration shows the location of the ID label.

Note: The illustrations in this document might differ slightly from your server.

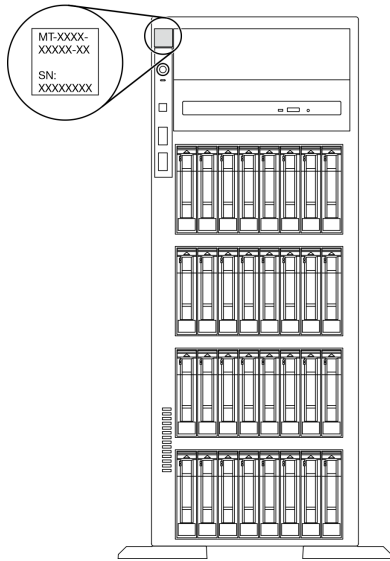

Figure 1. Location of the ID label

XClarity Controller network access label

The XClarity Controller network access label is attached on the front bezel. After you get the server, peel the XClarity Controller network access label away and store it in a safe place for future use.

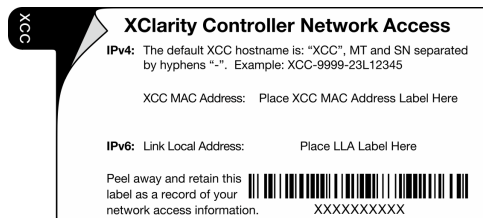

Figure 2. XClarity Controller network access label

Quick response code

The system service label on the inside of the server cover provides a QR code for mobile access to service information. You can scan the QR code with a mobile device for quick access to additional information including parts installation, replacement, and error codes.

The following illustration shows the QR code.

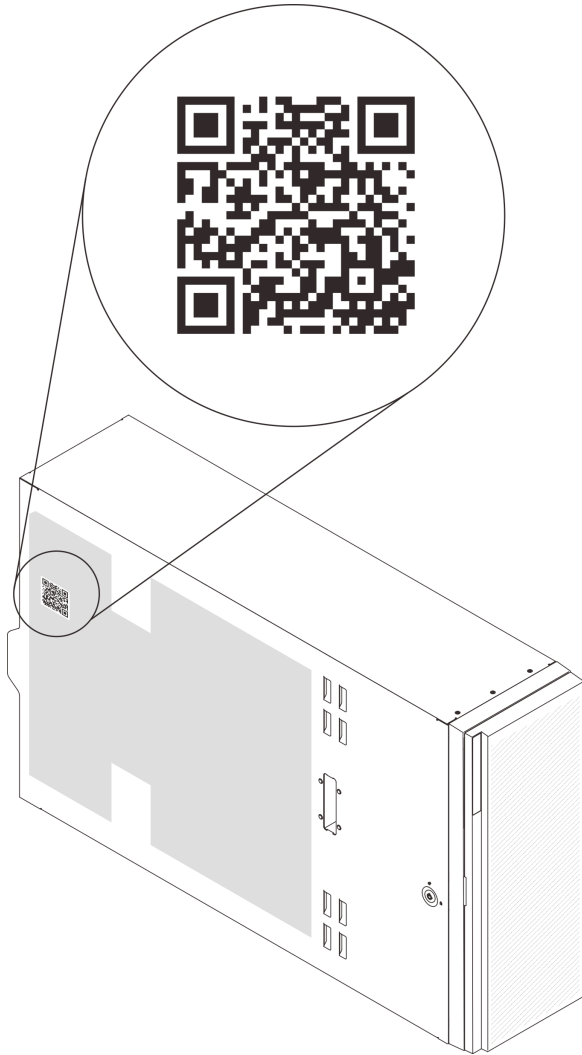

Figure 3. Location of QR code

Front view

The front view of the server varies by model.

The illustrations in this topic show the server front views based on the supported drive bays.

Note: Your server might look different from the illustrations in this topic.

Server models with twelve 3.5-inch simple-swap drive bays

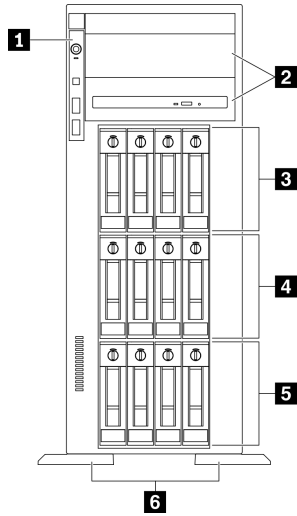

Figure 4. Front view of server models with twelve 3.5-inch simple-swap drive bays

Table 3. Components on server models with twelve 3.5-inch simple-swap drive bays

1 Front panel	4 3.5-inch simple-swap drive bays 4-7
2 Optical-drive bays 1-2	5 3.5-inch simple-swap drive bays 0-3
3 3.5-inch simple-swap drive bays 8-11	6 Foot stands

1 Front panel

For information about the controls, connectors, and status LEDs on the front panel, see “Front panel” on page 21.

2 Optical-drive bays 1-2

Depending on the model, your server might come with an optical drive installed in the lower 5.25-inch optical-drive bay. The upper 5.25-inch optical-drive bay is for a secondary optical drive or a tape drive. Some models have a secondary optical drive or a tape drive installed.

3 4 5 3.5-inch simple-swap drive bays

The drive bays are used to install 3.5-inch simple-swap drives. When you install drives, follow the order of the drive bay numbers. The EMI integrity and cooling of the server are protected by having all drive bays occupied. The vacant drive bays must be occupied by drive bay fillers or drive fillers.

6 Foot stands

For tower form factor models, the foot stands help the server stand steadily.

Server models with twelve 3.5-inch hot-swap drive bays

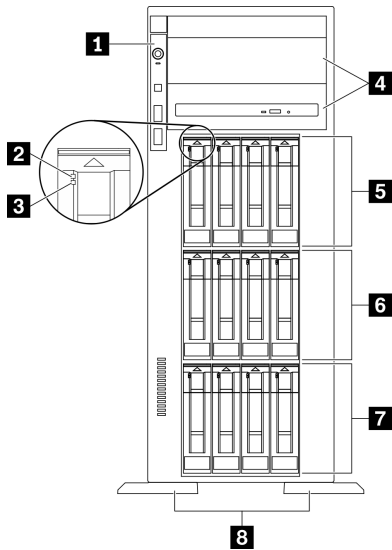

Figure 5. Front view of server models with twelve 3.5-inch hot-swap drive bays

Table 4. Components on server models with twelve 3.5-inch hot-swap drive bays

1 Front panel	5 3.5-inch hot-swap drive bays 8-11
2 Drive activity LED (green)	6 3.5-inch hot-swap drive bays 4-7
3 Drive status LED (yellow)	7 3.5-inch hot-swap drive bays 0-3
4 Optical-drive bays 1-2	8 Foot stands

1 Front panel

For information about the controls, connectors, and status LEDs on the front panel, see “Front panel” on page 21.

2 Drive activity LED (green)

Each hot-swap drive comes with an activity LED. When this LED is flashing, it indicates that the drive is in use.

3 Drive status LED (yellow)

These LEDs are on SAS or SATA hard disk drives and solid-state drives, and indicate the following status:

Lit: The drive has failed.

Flashing slowly (once per second): The drive is being rebuilt.

Flashing rapidly (three times per second): The drive is being identified.

4 Optical-drive bays 1-2

Depending on the model, your server might come with an optical drive installed in the lower 5.25-inch optical-drive bay. The upper 5.25-inch optical-drive bay is for a secondary optical drive or a tape drive. Some models have a secondary optical drive or a tape drive installed.

5 6 7 3.5-inch hot-swap drive bays

The drive bays are used to install 3.5-inch hot-swap drives. When you install drives, follow the order of the drive bay numbers. The EMI integrity and cooling of the server are protected by having all drive bays occupied. The vacant drive bays must be occupied by drive bay fillers or drive fillers.

Note: For 3.5-inch drive bay models that support NVMe drives, you can install up to eight NVMe drives in bays 0-3 and 4-7.

8 Foot stands

For tower form factor models, the foot stands help the server stand steadily.

Server models with sixteen 3.5-inch hot-swap drive bays

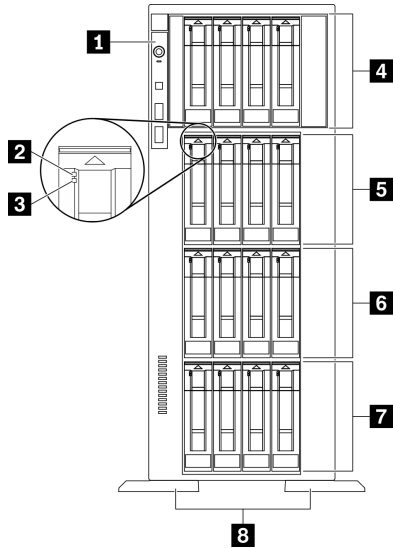

Figure 6. Front view of server models with sixteen 3.5-inch hot-swap drive bays

Table 5. Components on server models with sixteen 3.5-inch hot-swap drive bays

1 Front panel	5 3.5-inch hot-swap drive bays 8-11
2 Drive activity LED (green)	6 3.5-inch hot-swap drive bays 4-7
3 Drive status LED (yellow)	7 3.5-inch hot-swap drive bays 0-3
4 3.5-inch hot-swap drive bays 12-15	8 Foot stands

1 Front panel

For information about the controls, connectors, and status LEDs on the front panel, see “Front panel” on page 21.

2 Drive activity LED (green)

Each hot-swap drive comes with an activity LED. When this LED is flashing, it indicates that the drive is in use.

3 Drive status LED (yellow)

These LEDs are on SAS or SATA hard disk drives and solid-state drives, and indicate the following status:

Lit: The drive has failed.

Flashing slowly (once per second): The drive is being rebuilt.

Flashing rapidly (three times per second): The drive is being identified.

4 5 6 7 3.5-inch hot-swap drive bays

The drive bays are used to install 3.5-inch hot-swap drives. When you install drives, follow the order of the drive bay numbers. The EMI integrity and cooling of the server are protected by having all drive bays occupied. The vacant drive bays must be occupied by drive bay fillers or drive fillers.

Note: For 3.5-inch drive bay models that support NVMe drives, you can install up to eight NVMe drives in bays 0-3 and 4-7.

8 Foot stands

For tower form factor models, the foot stands help the server stand steadily.

Server models with thirty-two 2.5-inch drive bays

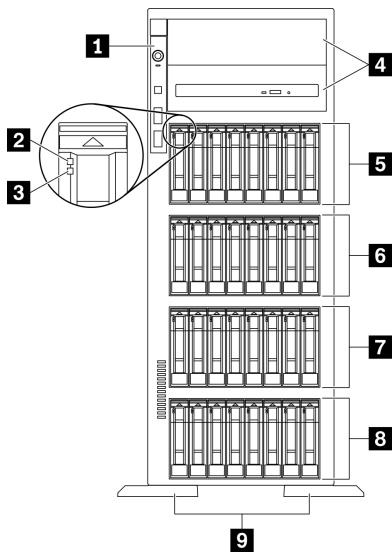

Figure 7. Front view of server models with thirty-two 2.5-inch drive bays

Table 6. Components on server models with thirty-two 2.5-inch drive bays

1 Front panel	6 2.5-inch hot-swap drive bays 16-23
2 Drive activity LED (green)	7 2.5-inch hot-swap drive bays 8-15
3 Drive status LED (yellow)	8 2.5-inch hot-swap drive bays 0-7
4 Optical-drive bays 1-2	9 Foot stands
5 2.5-inch hot-swap drive bays 24-31	

1 Front panel

For information about the controls, connectors, and status LEDs on the front panel, see “Front panel” on page 21.

2 Drive activity LED (green)

Each hot-swap drive comes with an activity LED. When this LED is flashing, it indicates that the drive is in use.

3 Drive status LED (yellow)

These LEDs are on SAS or SATA hard disk drives and solid-state drives, and indicate the following status:

Lit: The drive has failed.

Flashing slowly (once per second): The drive is being rebuilt.

Flashing rapidly (three times per second): The drive is being identified.

4 Optical-drive bays 1-2

Depending on the model, your server might come with an optical drive installed in the lower 5.25-inch optical-drive bay. The upper 5.25-inch optical-drive bay is for a secondary optical drive or a tape drive. Some models have a secondary optical drive or a tape drive installed.

5 6 7 8 2.5-inch hot-swap drive bays

The drive bays are used to install 2.5-inch hot-swap drives. When you install drives, follow the order of the drive bay numbers. The EMI integrity and cooling of the server are protected by having all drive bays occupied. The vacant drive bays must be occupied by drive bay fillers or drive fillers.

Note: For 2.5-inch drive bay models that support NVMe drives, you can install up to sixteen NVMe drives in bays 0-7 and 8-15.

9 Foot stands

For tower form factor models, the foot stands help the server stand steadily.

Front panel

The front panel of the server provides controls, connectors, and LEDs.

The following illustration shows the control, connectors, and LEDs on the front panel of the server.

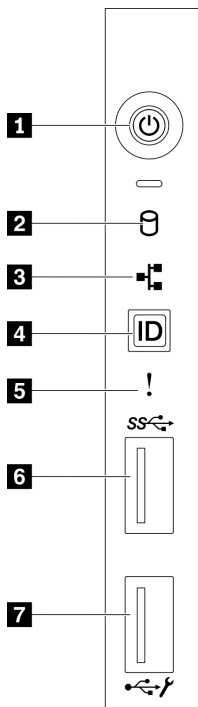

Figure 8. Front panel

Table 7. Components on the front panel

1 Power button with power status LED (green)	5 System error LED (yellow)
2 Simple-swap drive activity LED (green)	6 USB 3.2 Gen 1 connector
3 Network activity LED (green)	7 USB 2.0 connector with Lenovo XClarity Controller management
4 System ID button with system ID LED (blue)	

1 Power button with power status LED (green)

Press this button to turn the server on and off manually. The states of the power LED are as follows:

Off: No power supply is properly installed, or the LED itself has failed.

Flashing rapidly (four times per second): The server is turned off and is not ready to be turned on. The power-control button is disabled. This will last approximately 5 to 10 seconds.

Flashing slowly (once per second): The server is turned off and is ready to be turned on. You can press the power-control button to turn on the server.

Lit: The server is turned on.

2 Simple-swap drive activity LED (green)

The simple-swap drive activity LED is only for server models with simple-swap storage drives.

Status	Color	Description
Solid on	Green	The simple-swap drive is active.
Off	None	The simple-swap drive is not active.

3 Network activity LED (green)

The network activity LED on the front panel helps you identify the network connectivity and activity.

Status	Color	Description
On	Green	The server is connected to a network.
Blinking	Green	The network is connected and active.
Off	None	The server is disconnected from the network.

4 System ID button with system ID LED (blue)

Use this system ID button and the blue system ID LED to visually locate the server. A system ID LED is also located on the rear of the server. Each time you press the system ID button, the state of both the system ID LEDs changes. The LEDs can be changed to on, blinking, or off. You can also use the Lenovo XClarity Controller or a remote management program to change the state of the system ID LEDs to assist in visually locating the server among other servers.

If the XClarity Controller USB connector is set to have both the USB 2.0 function and XClarity Controller management function, you can press the system ID button for three seconds to switch between the two functions.

5 System error LED (yellow)

The system error LED provides basic diagnostic functions for your server.

Status	Color	Description	Action
On	Yellow	An error has been detected on the server. Causes might include one or more of the following errors: <ul style="list-style-type: none">• The temperature of the server reached the non-critical temperature threshold.• The voltage of the server reached the non-critical voltage threshold.• A fan has been detected to be running at low speed.• A fan has been removed.• The power supply has a critical error.• The power supply is not connected to the power.	Check the event log to determine the exact cause of the error.
Off	None	The server is off or the server is on and is working correctly.	None.

6 USB 3.2 Gen 1 connector

Used to attach a device that requires a USB 2.0 or 3.2 Gen 1 connection, such as a keyboard, a mouse, or a USB flash drive.

7 USB 2.0 connector with Lenovo XClarity Controller management

Depending on the setting, this connector supports USB 2.0 function, XClarity Controller management function, or both.

- If the connector is set for USB 2.0 function, you can attach a device that requires a USB 2.0 connection, such as a keyboard, a mouse, or a USB storage device.
- If the connector is set for XClarity Controller management function, you can attach a mobile device installed with the application to run XClarity Controller event logs.
- If the connector is set to have both functions, you can press the system ID button for three seconds to switch between the two functions.

Rear view

The rear of the server provides access to several connectors and components.

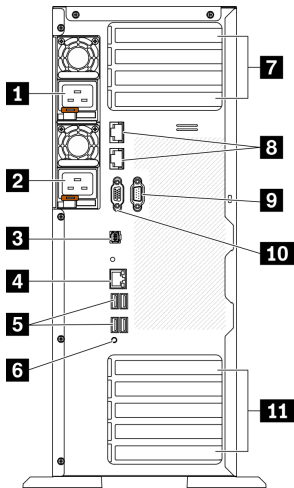

Figure 9. Rear view

Table 8. Rear view

1 Hot-swap power supply 1	7 PCIe slots 1-4 (top to bottom)
2 Hot-swap power supply 2 (optional)	8 10Gb ethernet connectors (2)
3 External LCD diagnostics handset connector	9 Serial-port-module slot
4 XClarity Controller network connector	10 VGA connector
5 Four USB 3.2 Gen 1 connectors (4)	11 PCIe slots 5-9 (top to bottom)
6 NMI button	

1 2 Hot-swap power supplies

Install power supply units to these bays, connect them to power cords. Make sure the power cords are connected properly.

You can purchase a power supply option from Lenovo and install the power supply to provide power redundancy without turning off the server.

On each power supply, there are three status LEDs near the power cord connector. For information about the status LEDs, see “Rear view LEDs” on page 26.

3 External LCD diagnostics handset connector

Connect the external LCD diagnostics handset here. See “External LCD diagnostics handset” on page 27 for more details.

4 XClarity Controller network connector

Used to attach an Ethernet cable to manage the system using XClarity Controller.

5 USB 3.2 Gen 1 connectors

Used to attach a device that requires a USB 2.0 or 3.2 Gen 1 connection, such as a keyboard, a mouse, or a USB flash drive.

6 NMI button

Press this button to force a nonmaskable interrupt to the processor. You might have to use a pen or the end of a straightened paper clip to press the button. You can also use it to force a blue-screen memory dump. Use this button only when you are directed to do so by Lenovo Support.

7 PCIe slots 1-4 (top to bottom)

Install PCIe adapters into these slots.

- Slot 1: PCIe4 x16, 75W, Full-height, half-length
- Slot 2: PCIe4 x8 (open end), 75W, Full-height, half-length
- Slot 3: PCIe4 x16, 75W, Full-height, half-length
- Slot 4: PCIe4 x8 (open end), 75W, Full-height, half-length

8 10Gb Ethernet connector

Used to attach a 10Gb Ethernet cable. Each 10Gb Ethernet connector has two status LEDs to help you identify the Ethernet connectivity and activity. For more information, see “Rear view LEDs” on page 26.

Notes:

- Use CAT6A UTP cables rated at 625 MHz bandwidth for the 10Gb on-board LAN.
- Wake-on-LAN (WoL) is not supported on 10Gb ethernet connector under Windows OS.

9 Serial-port-module slot

Connect a 9-pin serial device to this connector. The serial port is shared with the XCC. The XCC can take control of the shared serial port to redirect serial traffic, using Serial over LAN (SOL).

10 VGA connector

Used to attach a VGA-compatible video device, such as a VGA monitor.

11 PCIe slots 5-9 (top to bottom)

Install PCIe adapters into these slots.

- Slot 5: PCIe4 x16, 75W, Full-height, half-length
- Slot 6: PCIe4 x8 (open end), 75W, Full-height, half-length
- Slot 7: PCIe4 x16, 75W, Full-height, half-length
- Slot 8: PCIe3 x8 (open end), 75W, Full-height, half-length (requires additional cable connection, see “PCIe slot 8 cable routing” on page 52)

- Slot 9: PCIe4 x8 (open end), 75W, Full-height, half-length

Rear view LEDs

The illustration in this section shows the LEDs on the rear the server.

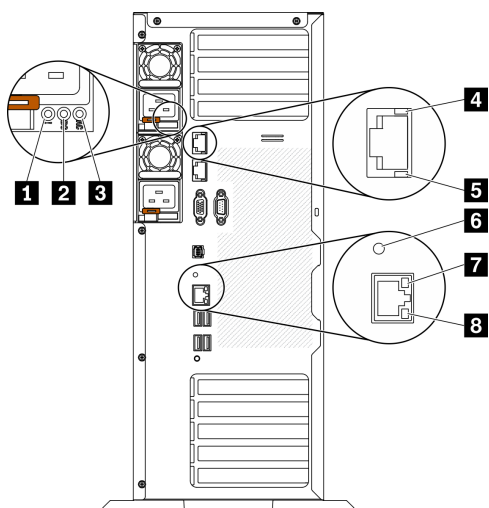

Figure 10. Rear view LEDs of the server

Table 9. LEDs on the rear of the server

1 Power supply error LED (yellow)	5 10Gb ethernet activity LED (green)
2 DC power LED (green)	6 System ID LED (blue)
3 AC power LED (green)	7 Ethernet link LED (green)
4 10Gb ethernet link LED (green)	8 Ethernet activity LED (green)

1 Power supply error LED (yellow)

When the power-supply error LED is lit, it indicates that the power supply has failed.

2 DC power LED (green)

Each hot-swap power supply comes with a dc power LED and an ac power LED. When the dc power LED is lit, it indicates that the power supply is supplying adequate dc power to the system. During normal operation, both the ac and dc power LEDs are lit.

3 AC power LED (green)

Each hot-swap power supply comes with an ac power LED and a dc power LED. When the ac power LED is lit, it indicates that sufficient power is being supplied to the power supply through the power cord. During normal operation, both the ac and dc power LEDs are lit.

4 10Gb ethernet link LED (green) **5** 10Gb ethernet activity LED (green)

Each 10Gb ethernet connector has two status LEDs.

Ethernet status LED	Color	Status	Description
4 Ethernet link LED	Green	On	Network link is established.
	None	Off	Network link is disconnected.
5 Ethernet activity LED	Green	Blinking	Network link is connected and active.
	None	Off	The server is disconnected from a LAN.

6 System ID LED (blue)

Use this blue system ID LED to visually locate the server. A system ID LED is also located on the front of the server. Each time you press the system ID button on the front panel, the state of both the system ID LEDs changes. The LEDs can be changed to on, blinking, or off. You can also use the Lenovo XClarity Controller or a remote management program to change the state of the system ID LEDs to assist in visually locating the server among other servers.

If the XClarity Controller USB connector is set to have both the USB 2.0 function and XClarity Controller management function, you can press the system ID button for three seconds to switch between the two functions.

7 Ethernet link LED (green) 8 Ethernet activity LED (green)

Each network connector has two status LEDs.

Ethernet status LED	Color	Status	Description
7 Ethernet link LED	Green	On	Network link is established.
	None	Off	Network link is disconnected.
8 Ethernet activity LED	Green	Blinking	Network link is connected and active.
	None	Off	The server is disconnected from a LAN.

External LCD diagnostics handset

The external LCD diagnostics handset is an external device that is connected to the server with a cable, and it allows quick access to system information such as errors, system status, firmware, network, and health information.

Location of the external LCD diagnostics handset

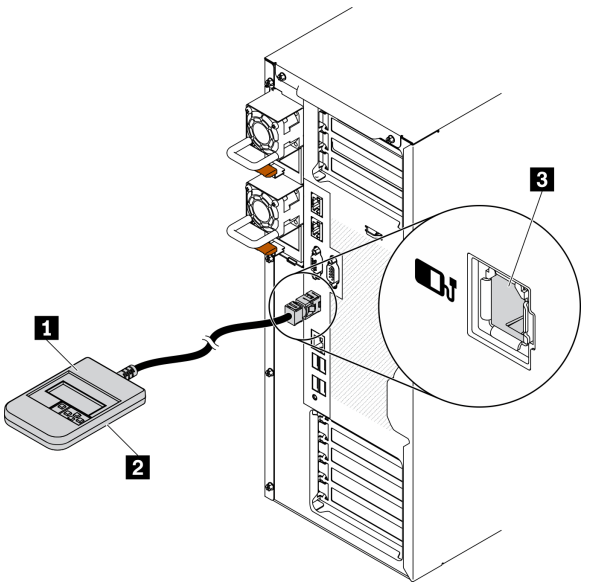
Location	Callouts
<p>The external LCD diagnostics handset is connected to the server with an external cable.</p> 	<p>1 External LCD diagnostics handset</p> <p>2 Magnetic bottom With this component, the diagnostic handset can be attached to the top or side of the rack or chassis with hands spared for service tasks.</p> <p>3 External diagnostics connector This connector is located on the rear of the server, and is used to connect an external LCD diagnostics handset.</p>

Note: When unplugging the external handset, see the following instructions:

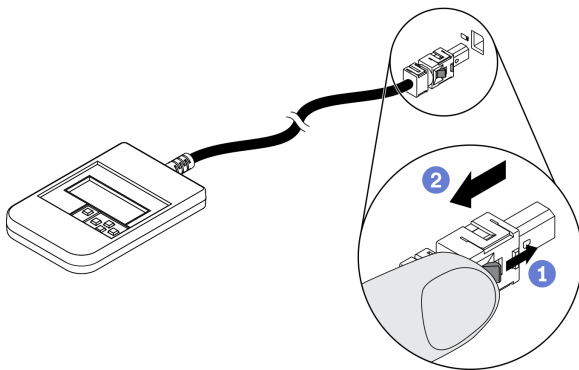

- 1** Press the plastic clip on the plug forward.
- 2** Hold the clip and remove the cable from the connector.

Display panel overview

The diagnostics device consists of an LCD display and 5 navigation buttons.

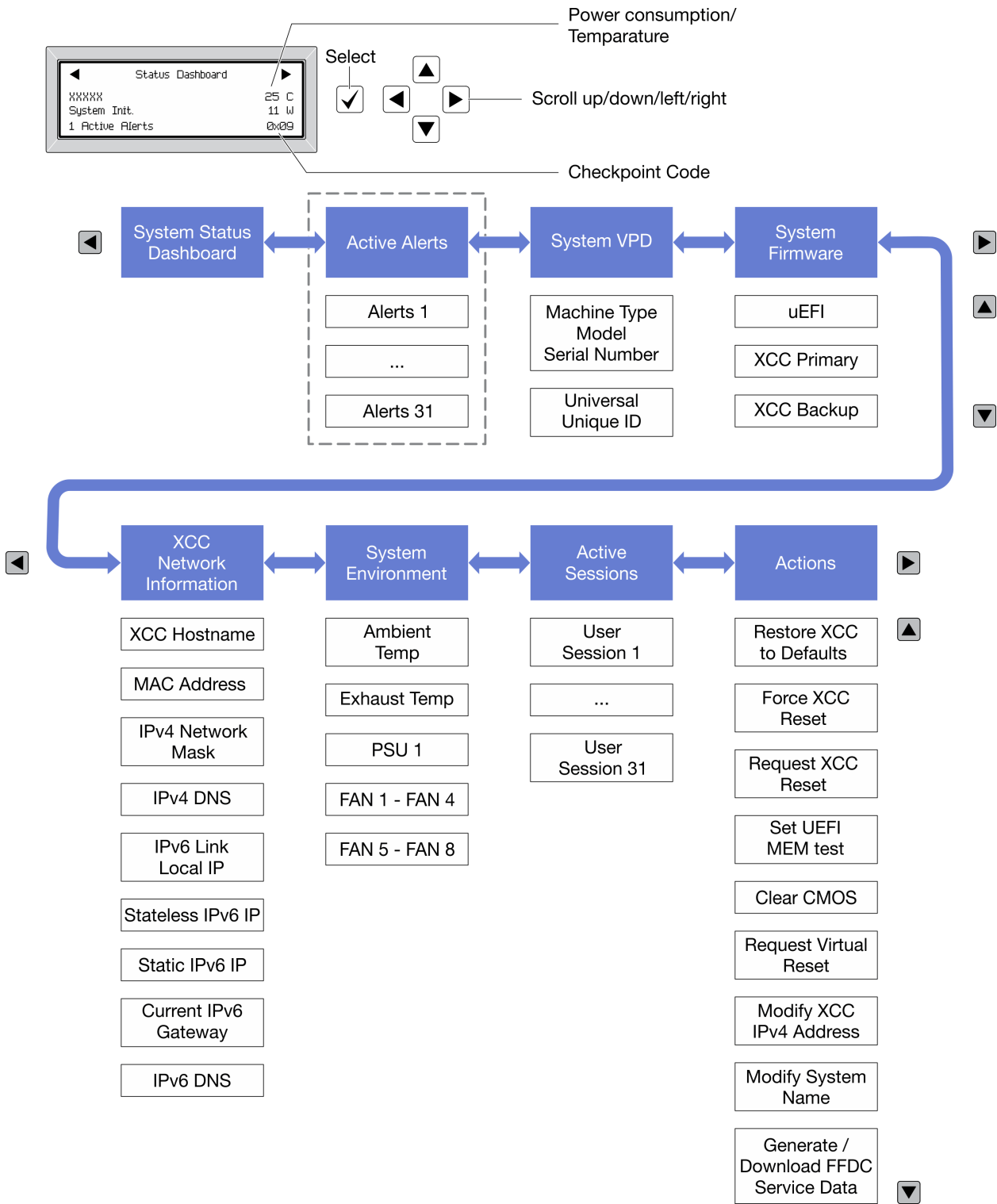

Full menu list

Following is the list of available options. Switch between an option and the subordinate information entries with the select button, and switch among options or information entries with the scroll buttons.

Depending on the model, the options and entries on the LCD display might be different.

Home Menu (System Status Dashboard)

Home Menu	Example
<ul style="list-style-type: none"> 1 System name 2 System status 3 Active alert quantity 4 Temperature 5 Power consumption 6 Checkpoint code 	

Active Alerts

Sub Menu	Example
Home screen: Active error quantity Note: The “Active Alerts” menu displays only the quantity of active errors. If no errors occur, the “Active Alerts” menu will not be available during navigation.	<pre>1 Active Alerts</pre>
Details screen: <ul style="list-style-type: none"> • Error message ID (Type: Error/Warning/Information) • Occurrence time • Possible sources of the error 	<pre>Active Alerts: 1 Press ▼ to view alert details FQXSPPU009N(Error) 04/07/2020 02:37:39 PM CPU 1 Status: Configuration Error</pre>

System VPD Information

Sub Menu	Example
<ul style="list-style-type: none"> • Machine type and serial number • Universal Unique ID (UUID) 	<pre>Machine Type: xxxx Serial Num: xxxxxx Universal Unique ID: xxxxxxxxxxxxxxxxxxxxxxxxxxxxxxxx</pre>

System Firmware

Sub Menu	Example
UEFI <ul style="list-style-type: none"> Firmware level (status) Build ID Version number Release date 	UEFI (Inactive) Build: D0E101P Version: 1.00 Date: 2019-12-26
XCC Primary <ul style="list-style-type: none"> Firmware level (status) Build ID Version number Release date 	XCC Primary (Active) Build: DVI399T Version: 4.07 Date: 2020-04-07
XCC Backup <ul style="list-style-type: none"> Firmware level (status) Build ID Version number Release date 	XCC Backup (Active) Build: D8BT05I Version: 1.00 Date: 2019-12-30

XCC Network Information

Sub Menu	Example
<ul style="list-style-type: none"> XCC hostname MAC address IPv4 Network Mask IPv4 DNS IPv6 Link Local IP Stateless IPv6 IP Static IPv6 IP Current IPv6 Gateway IPv6 DNS <p>Note: Only the MAC address that is currently in use is displayed (extension or shared).</p>	XCC Network Information XCC Hostname: XCC-xxxx-SN MAC Address: xx:xx:xx:xx:xx:xx IPv4 IP: xx.xx.xx.xx IPv4 Network Mask :x.x.x.x IPv4 Default Gateway : x.x.x.x

System Environmental Information

Sub Menu	Example
<ul style="list-style-type: none">• Ambient temperature• Exhaust temperature• PSU status• Spinning speed of fans by RPM	Ambient Temp: 24 C Exhaust Temp: 30 C PSU1: Vin= 213 w Inlet= 26 C FAN1 Front: 21000 RPM FAN2 Front: 21000 RPM FAN3 Front: 21000 RPM FAN4 Front: 21000 RPM

Active Sessions

Sub Menu	Example
Quantity of active sessions	Active User Sessions: 1

Actions

Sub Menu	Example
Several quick actions are available: <ul style="list-style-type: none">• Restore XCC to Defaults• Force XCC Reset• Request XCC Reset• Set UEFI Memory Test• Clear CMOS• Request Virtual Reseat• Modify XCC Static IPv4 Address/Net mask/Gateway• Modify System Name• Generate/Download FFDC Service Data	Request XCC Reset? This will request the BMC to reboot itself. Hold <input checked="" type="checkbox"/> for 3 seconds

System board components

The illustration in this section shows the component locations on the system board.

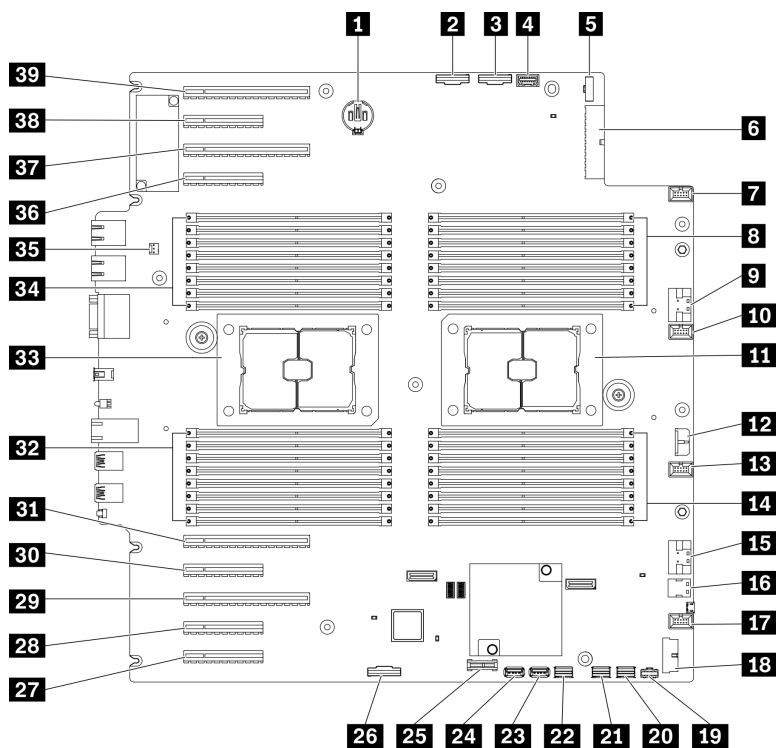

Figure 11. System board components

Table 10. Components on the system board

1 CMOS battery connector	21 SATA 0-3 connector
2 PCIe 2 connector	22 SATA 8-11 connector
3 PCIe 1 connector	23 Internal USB connector 3
4 Operator-information-panel connector	24 Internal USB connector 4
5 Power distribution board signal connector	25 TPM ¹ /TCM ² connector (for Chinese Mainland only)
6 Power distribution board power connector	26 PCIe slot 8 enable connector ³
7 Fan 4 connector	27 PCIe slot 9 (processor 1)
8 DIMM 17-24 slots (processor 2)	28 PCIe slot 8 (processor 2) ³
9 PCIe 3 connector	29 PCIe slot 7 (processor 2)
10 Fan 3 connector	30 PCIe slot 6 (processor 2)
11 Processor 2 socket	31 PCIe slot 5 (processor 2)
12 CFF RAID power connector	32 DIMM 9-16 slots (processor 1)
13 Fan 2 connector	33 Processor 1 socket
14 DIMM 25-32 slots (processor 2)	34 DIMM 1-8 slots (processor 1)
15 PCIe 4 connector ³	35 Intrusion switch connector
16 M.2 signal connector	36 PCIe slot 4 (processor 2)
17 Fan 1 connector	37 PCIe slot 3 (processor 1)
18 Front USB connector	38 PCIe slot 2 (processor 1)
	39 PCIe slot 1 (processor 1)

Table 10. Components on the system board (continued)

19 M.2 power connector	39 PCIe slot 1 (processor 1)
20 SATA 4-7 connector	

Notes:

- ¹ Trusted Platform Module
- ² Trusted Cryptography Module
- ³ **28** PCIe slot 8 is disabled by default. Connect **26** PCIe slot 8 enable connector to **15** NVMe 4 connector to enable PCIe slot 8.

System board LEDs

The illustration in this section shows the LEDs on the system board.

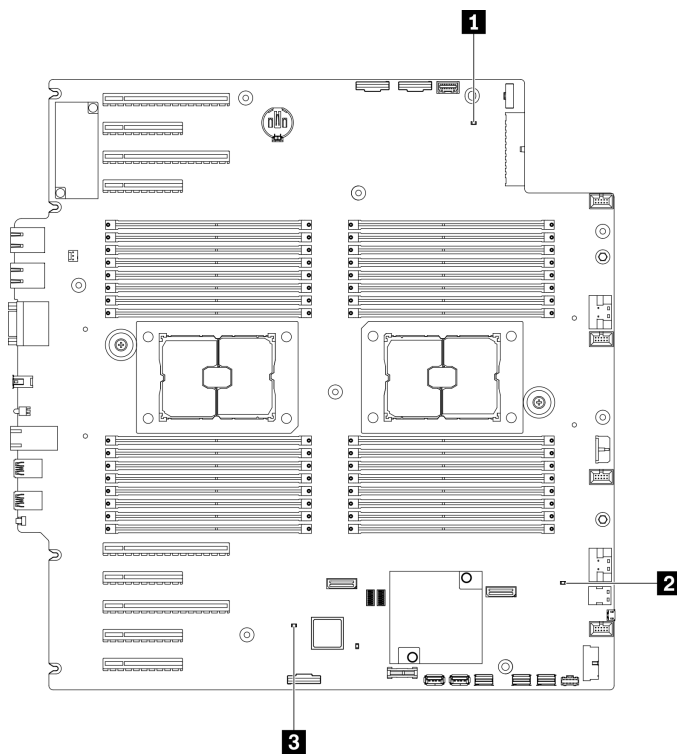

Figure 12. System board LEDs

Table 11. System-board LEDs

1 System power LED	3 XCC heartbeat LED (green)
2 FPGA heartbeat LED (green)	

1 System power LED

The states of the power LED are as follows:

Off: No power supply is properly installed, or the LED itself has failed.

Flashing rapidly (four times per second): The server is turned off and is not ready to be turned on. The power-control button is disabled. This will last approximately 5 to 10 seconds.

Flashing slowly (once per second): The server is turned off and is ready to be turned on. You can press the power-control button to turn on the server.

Lit: The server is turned on.

■ FPGA heartbeat LED (green)

This LED indicates power-on and power-off sequencing.

- **LED blinking:** the system is functioning properly, and no action is necessary.
- **LED not blinking:** (trained technician only) replace the system board. See “System board replacement (trained technician only)” on page 192.

■ XCC heartbeat LED (green)

This LED indicates XCC heartbeat and boot process:

- **LED blinking fast:** XCC code is in the loading process.
- **LED going off momentarily:** XCC code has loaded completely.
- **LED going off momentarily and then starts blinking slowing:** XCC is fully operational. You can now press the power-control button to power on the server.

System board switches

Use this information to locate the system board switches.

Important:

- Read “Installation guidelines” on page 57 to ensure that you work safely.
- Prevent exposure to static electricity, which might lead to system halt and loss of data, by keeping static-sensitive components in their static-protective packages until installation, and handling these devices with an electrostatic-discharge wrist strap or other grounding system.
- Turn off the server before you move the switches; then, disconnect all power cords and external cables. Do not open your server or attempt any repair before reading and understanding the following information:
- Any system board switch that is not shown in the illustrations in this document are reserved.

Note: If there is a clear protective sticker on the top of the switch blocks, you must remove and discard it to access the switches.

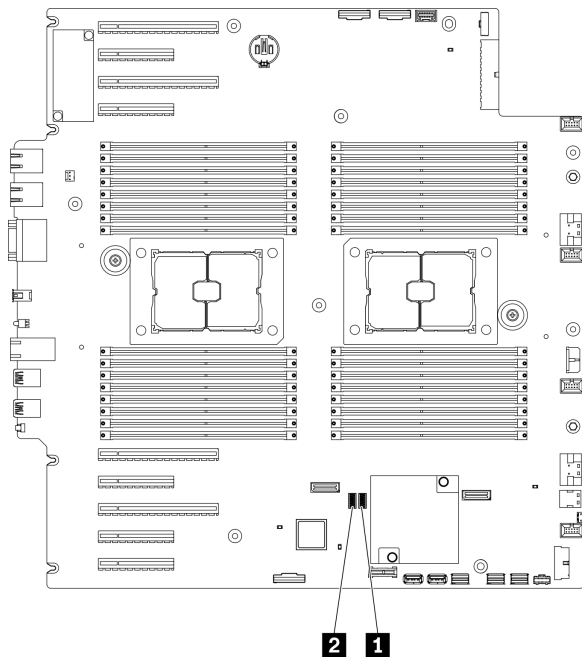

Figure 13. System board switches

Table 12. System board switches

1 SW3 switch block	2 SW2 switch block
---------------------------	---------------------------

Table 13. SW2 switch block definition

Switch number	Default position	Description	Definition
8	Off	Trusted Platform Module (TPM) physical presence	Changing this switch to the On position indicates a physical presence to the TPM.
7	Off	ME recovery	Changing this switch to the On position boots ME to recovery
6	On	Low security	Keeping this switch in the On position allows transitioning between signed official IMM builds and IMM test signed builds, and bypasses CRTM boot check of iMM firmware.
5	Off	Real time clock (RTC) reset	Changing this switch to the On position resets the RTC. A momentary toggle is all that is required. To avoid excessive CMOS battery drain, do not leave this switch in the On position.
4	Off	Password override	Changing this switch to the On position overrides the power-on password.
3	Off	Serial function selection	Off: function as system serial port. On: dump UEFI debug message to serial port.
2	Off	BMC Remote debug	Keeping this switch in the off position enables BMC remote debug.
1	Off	ME security override	Changing this switch to the On position disables ME Security checks.

Table 14. SW3 switch block definition

Switch number	Default position	Description	Definition
8	Off	Force BMC and CPU reset	Changing this switch to the On position forces BMC and CPU reset.
7	On	Power permission override	Changing this switch to the Off position ignores Power Permission and allows the system to power-on.
6	Off	Trusted Platform Module (TPM) physical presence	Changing this switch to the On position indicates a physical presence to the TPM.
5	Off	BMC boot primary	Off: XCC boots from upper half of flash region. On: XCC boots from lower half of flash region.
4	Off	Force XCC reset	Changing this switch to the On position forces XCC into reset.
3	Off	IMM force update	Changing this switch to the On position forces XCC to boot from kernel code only.
2	Off	XCC Trusted Platform Module (TPM) physical presence	Changing this switch to the On position indicates a physical presence to the XCC TPM.
1	Off	Force FPGA reset	Change this switch to the On position forces FPGA into reset.

Server locks

Locking the server cover prevents unauthorized access to the inside of your server and access to the installed drives.

Server cover and front door lock

The server cover and front door lock prevents unauthorized access to the inside of your server and the installed drives in the drive cage. You can remove the key attached on the rear of the server and use it to unlock or lock the server cover and the front door of the server.

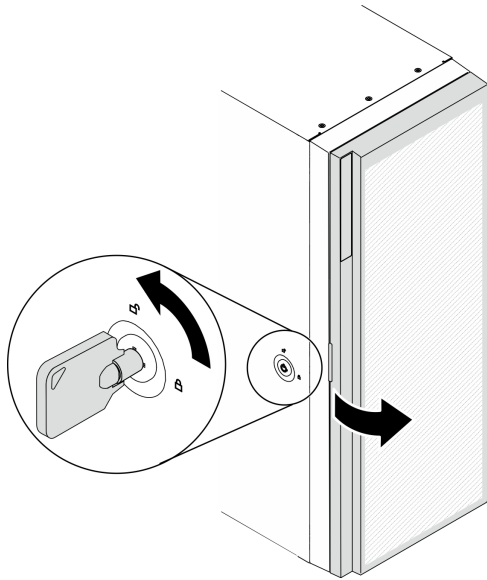

Figure 14. Server cover and front door lock

Backplates and backplanes

Use the section to understand the internal connectors on the backplate or the backplane you use.

2.5-inch drive backplanes

Use this information to locate the connectors on the 2.5-inch drive backplanes.

2.5-inch SAS/SATA 8-bay backplane

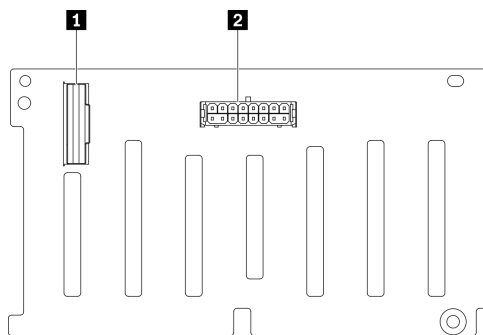

- 1** SAS/SATA connector
- 2** Power connector

Figure 15. 2.5-inch SAS/SATA 8-bay backplane connectors

2.5-inch SAS/SATA/NVMe and NVMe 8-bay backplane

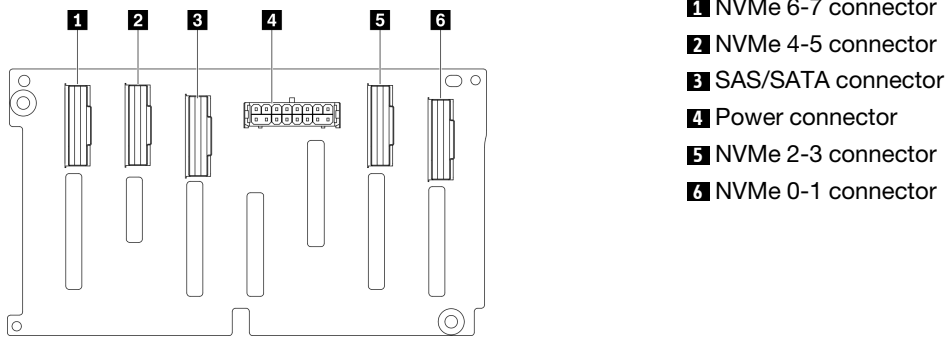

Figure 16. 2.5-inch SAS/SATA/NVMe and NVMe 8-bay backplane connectors

3.5-inch drive backplanes

Use this information to locate the connectors on the 3.5-inch drive backplanes.

3.5-inch SAS/SATA 4-bay backplane

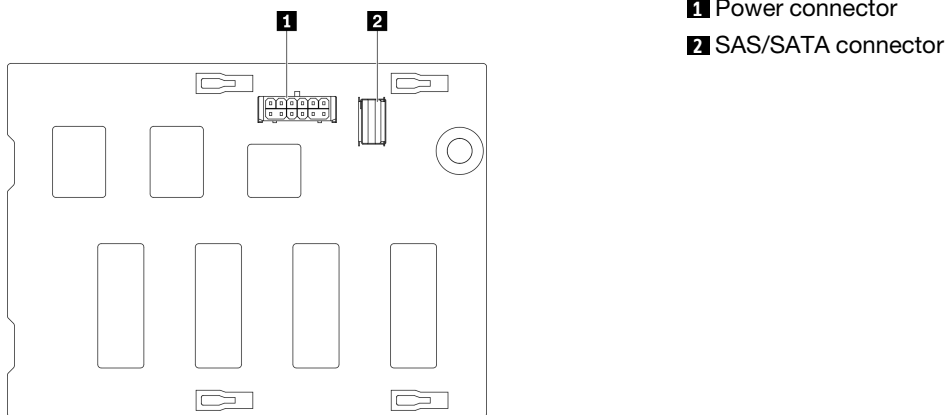
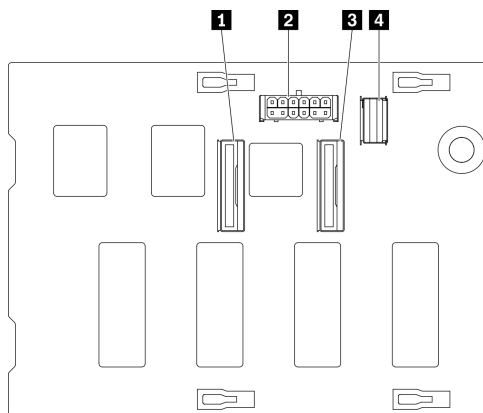

Figure 17. 3.5-inch SAS/SATA 4-bay backplane connectors

3.5-inch SAS/SATA/NVMe and NVMe 4-bay backplane



- 1** NVMe 0-1 connector
- 2** Power connector
- 3** NVMe 2-3 connector
- 4** SAS/SATA connector

Figure 18. 3.5-inch SAS/SATA/NVMe and NVMe 4-bay backplane connectors

3.5-inch drive backplate

Use this information to locate the connectors on the 3.5-inch drive backplate.

3.5-inch SAS/SATA 4-bay backplate

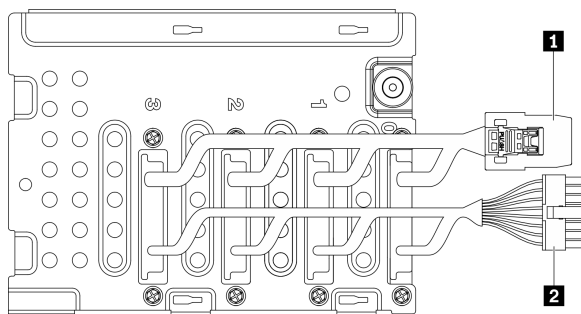

- 1** Signal cable
- 2** Power cable

Figure 19. 3.5-inch SAS/SATA 4-bay backplate cables

Power distribution board connectors

Use this information to locate the connectors on the power distribution board connectors.

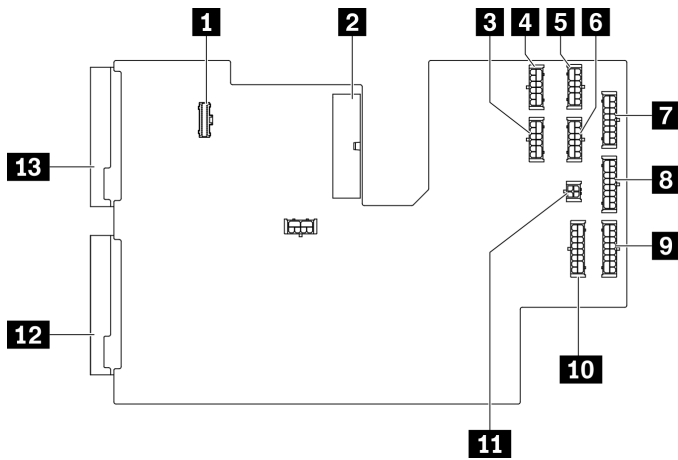

Figure 20. Connectors on the power distribution board

Table 15. Connectors on the power distribution board

1 PDB signal connector	8 BP 3 power connector
2 Main power connector	9 BP 2 power connector
3 GPU 3 power connector	10 BP 1 power connector
4 GPU 1 power connector	11 ODD power connector
5 GPU 2 power connector	12 PSU 2 power connector
6 GPU 4 power connector	13 PSU 1 power connector
7 BP 4 power connector	

Parts list

Use the parts list to identify each of the components that are available for your server.

Note: Depending on the model, your server might look slightly different from the illustration.

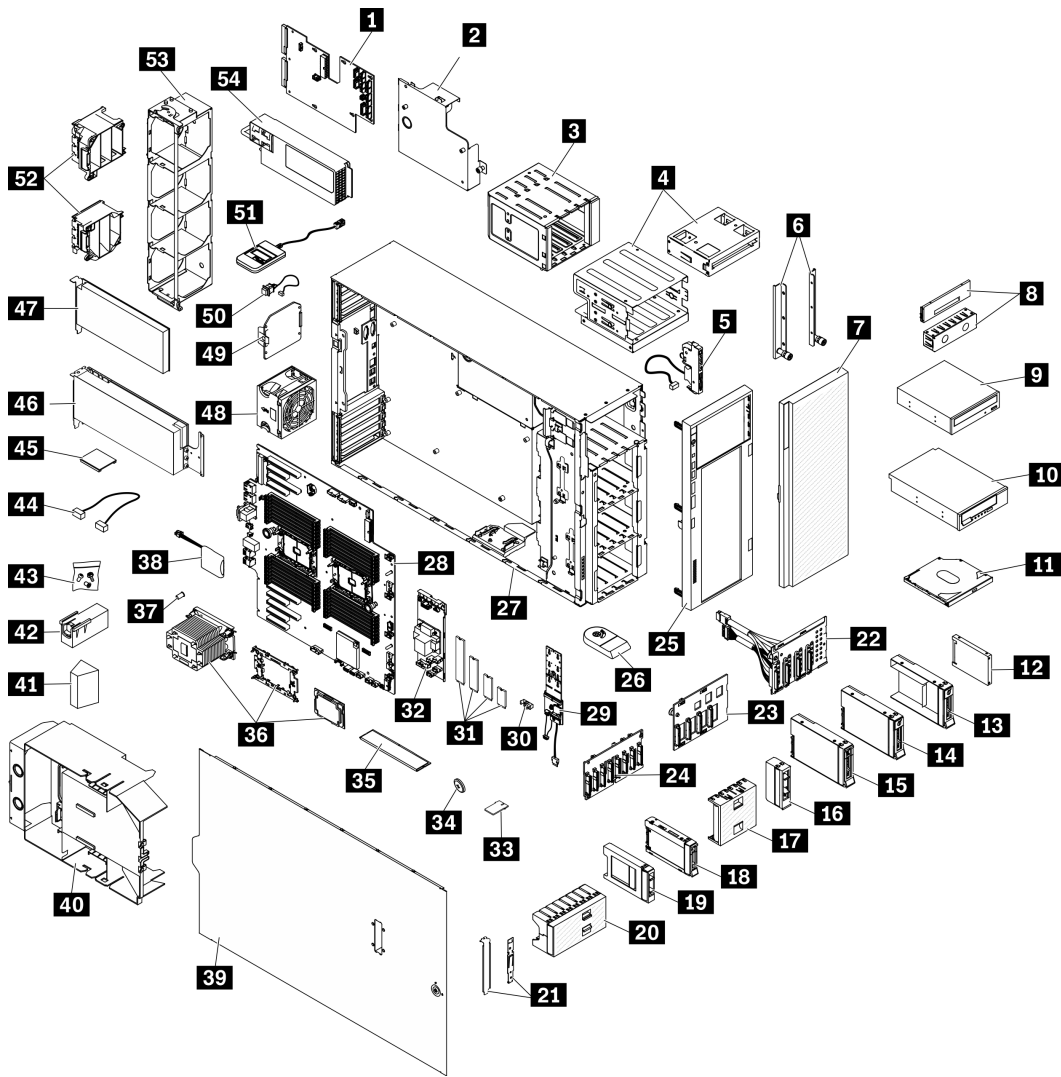

Figure 21. Server components

The parts listed in the following table are identified as one of the following:

- **Tier 1 customer replaceable unit (CRU):** Replacement of Tier 1 CRUs is your responsibility. If Lenovo installs a Tier 1 CRU at your request with no service agreement, you will be charged for the installation.
- **Tier 2 customer replaceable unit (CRU):** You may install a Tier 2 CRU yourself or request Lenovo to install it, at no additional charge, under the type of warranty service that is designated for your server.
- **Field replaceable unit (FRU):** FRUs must be installed only by trained service technicians.
- **Consumable and Structural parts:** Purchase and replacement of consumable and structural parts is your responsibility. If Lenovo acquires or installs a structural component at your request, you will be charged for the service.

Table 16. Parts listing

Index	Description	Tier 1 CRU	Tier 2 CRU	FRU	Consumable and Structural parts
<p>For more information about ordering the parts shown in Figure 21 “Server components” on page 43:</p> <ol style="list-style-type: none"> 1. Go to http://datacentersupport.lenovo.com and navigate to the support page for your server. 2. Click Parts. 					
1	Power distribution board			√	
2	Power distribution board cover			√	
3	Expansion drive cage	√			
4	Optical drive cage and 5.25-inch drive bay adapter	√			
5	Front panel board assembly		√		
6	EIA brackets	√			
7	Front door	√			
8	Tape/Optical drive filler cover and tape drive filler				√
9	5.25-inch optical disk drive	√			
10	5.25-inch LTO/RDX tape drive	√			
11	Slim optical drive	√			
12	2.5-inch drive	√			
13	3.5-inch drive tray with 2.5-inch to 3.5-inch drive adapter	√			
14	3.5-inch simple-swap drive	√			
15	3.5-inch hot-swap drive	√			
16	Filler, 3.5-inch storage drive (single bay)				√
17	Filler, 3.5-inch storage drive (four bay)				√
18	2.5-inch hot-swap drive	√			
19	Filler, 2.5-inch storage drive (single bay)				√
20	Filler, 2.5-inch storage drive (eight bay)				√
21	Bracket kit (drive retainer and PCIe bracket)				√
22	3.5-inch simple-swap drive backplate	√			
23	3.5-inch hot-swap drive backplane	√			
24	2.5-inch hot-swap drive backplane	√			
25	Front bezel	√			

Table 16. Parts listing (continued)

Index	Description	Tier 1 CRU	Tier 2 CRU	FRU	Consumable and Structural parts
26	Foot stand				√
27	Chassis			√	
28	System board			√	
29	M.2 boot adapter	√			
30	M.2 retainer clip	√			
31	M.2 drive	√			
32	Internal CFF RAID adapter	√			
33	TPM card (for Chinese Mainland only)			√	
34	CMOS battery (CR2032)				√
35	DIMM	√			
36	PHM module (heatsink, carrier, processor)			√	
37	Heat sink Torx T30 nut		√		
38	Flash power module	√			
39	Server cover	√			
40	Air baffle				√
41	T4 filler				√
42	GPU filler				√
43	Screw kit				√
44	Cable	√			
45	NVLink bridge	√			
46	Full-length GPU adapter	√			
47	PCIe adapter	√			
48	Fan module	√			
49	Fan filler				√
50	Intrusion switch	√			
51	External LCD diagnostics handset	√			
52	PCIe adapter holder				√
53	Fan cage				√
54	Redundant power supply unit	√			

Power cords

Several power cords are available, depending on the country and region where the server is installed.

To view the power cords that are available for the server:

1. Go to:

<http://dcsc.lenovo.com/#/>

2. Click **Preconfigured Model** or **Configure to order**.

3. Enter the machine type and model for your server to display the configurator page.

4. Click **Power** → **Power Cables** to see all line cords.

Notes:

- For your safety, a power cord with a grounded attachment plug is provided to use with this product. To avoid electrical shock, always use the power cord and plug with a properly grounded outlet.
- Power cords for this product that are used in the United States and Canada are listed by Underwriter's Laboratories (UL) and certified by the Canadian Standards Association (CSA).
- For units intended to be operated at 115 volts: Use a UL-listed and CSA-certified cord set consisting of a minimum 18 AWG, Type SVT or SJT, three-conductor cord, a maximum of 15 feet in length and a parallel blade, grounding-type attachment plug rated 15 amperes, 125 volts.
- For units intended to be operated at 230 volts (U.S. use): Use a UL-listed and CSA-certified cord set consisting of a minimum 18 AWG, Type SVT or SJT, three-conductor cord, a maximum of 15 feet in length and a tandem blade, grounding-type attachment plug rated 15 amperes, 250 volts.
- For units intended to be operated at 230 volts (outside the U.S.): Use a cord set with a grounding-type attachment plug. The cord set should have the appropriate safety approvals for the country in which the equipment will be installed.
- Power cords for a specific country or region are usually available only in that country or region.

Chapter 3. Internal cable routing

Some of the components in the server have internal cables and cable connectors.

To connect cables, observe the following guidelines:

- Turn off the server before you connect or disconnect any internal cables.
- See the documentation that comes with any external devices for additional cabling instructions. It might be easier for you to route cables before you connect the devices to the server.
- Cable identifiers of some cables are printed on the cables that come with the server and optional devices. Use these identifiers to connect the cables to the correct connectors.
- Ensure that the cable is not pinched and does not cover any connectors or obstruct any components on the system board.
- Ensure that the relevant cables pass through the cable clips and guides.

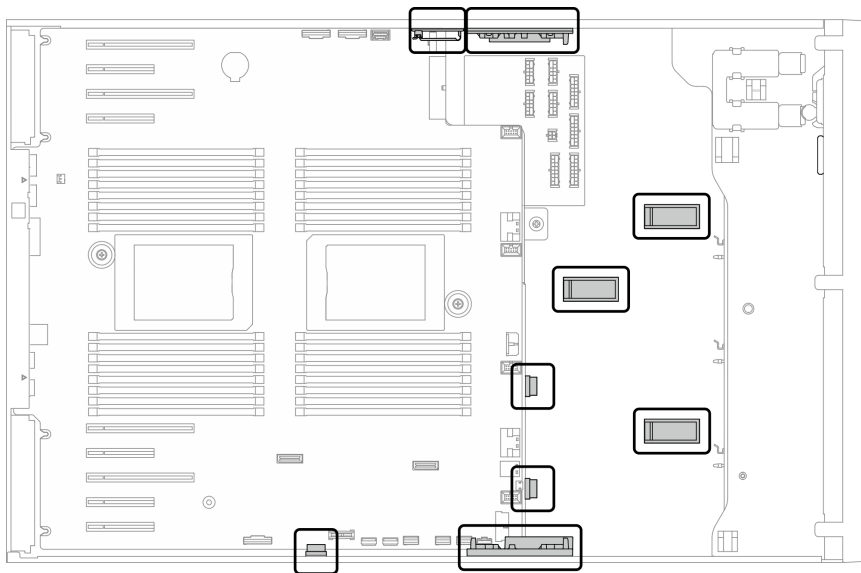

Figure 22. Cable clips and guides on 2.5-inch chassis

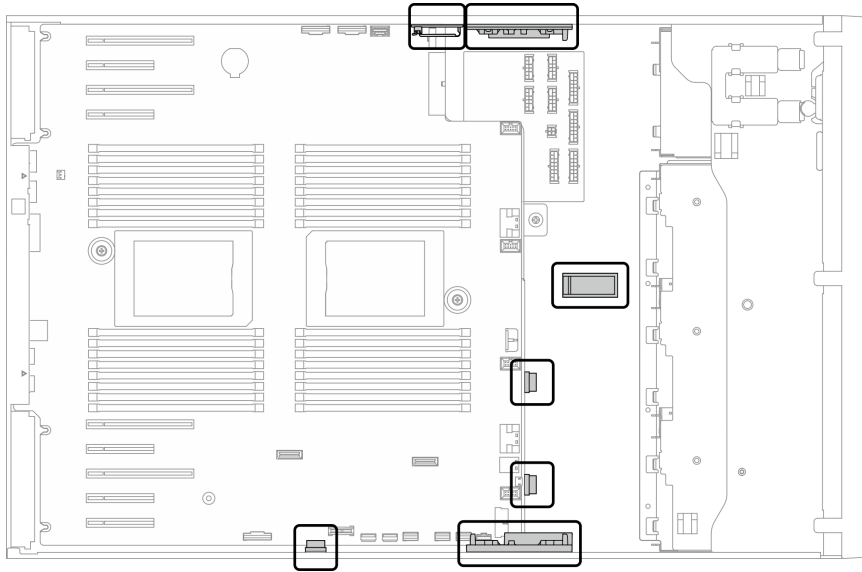
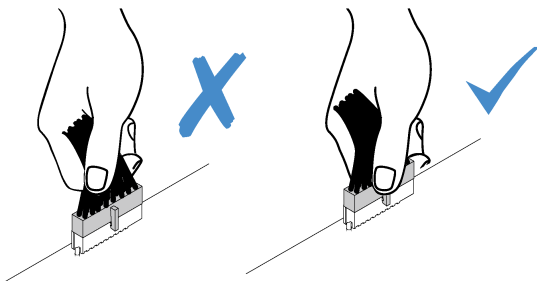

Figure 23. Cable clips and guides on 3.5-inch chassis

Note: Disengage all latches, release tabs, or locks on cable connectors when you disconnect cables from the system board. Failing to release them before removing the cables will damage the cable sockets on the system board, which are fragile. Any damage to the cable sockets might require replacing the system board.



Backplane and backplate cable routing

For more information about the backplane and backplate cable routing, see *ThinkSystem ST650 V2 Backplane/Backplate Cable Routing Guide*.

Front panel cable routing

Use the section to understand the cable routing for the front panel.

From	To
1 Rear of front panel	System board: Operator-information-panel connector

Notes:

- Connections between connectors; **1 ↔ 1, 2 ↔ 2, 3 ↔ 3, ... n ↔ n**
- When routing the cables, ensure that all cables are routed appropriately through the cable guides and cable clips.

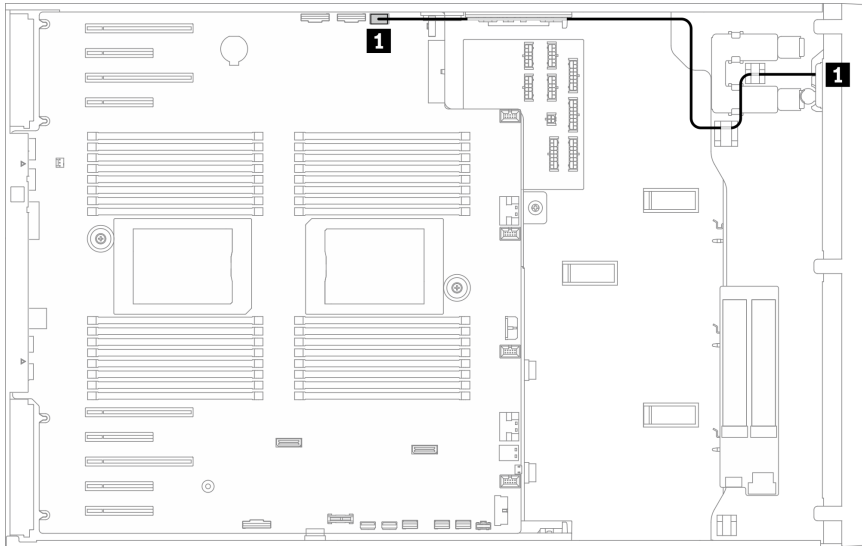

Figure 24. Cable routing for front panel

Front USB cable routing

Use the section to understand the cable routing for the front USB.

From	To
1 Rear of front panel	System board: Front USB connector

Notes:

- Connections between connectors; **1** ↔ **1**, **2** ↔ **2**, **3** ↔ **3**, ... **n** ↔ **n**
- When routing the cables, ensure that all cables are routed appropriately through the cable guides and cable clips.

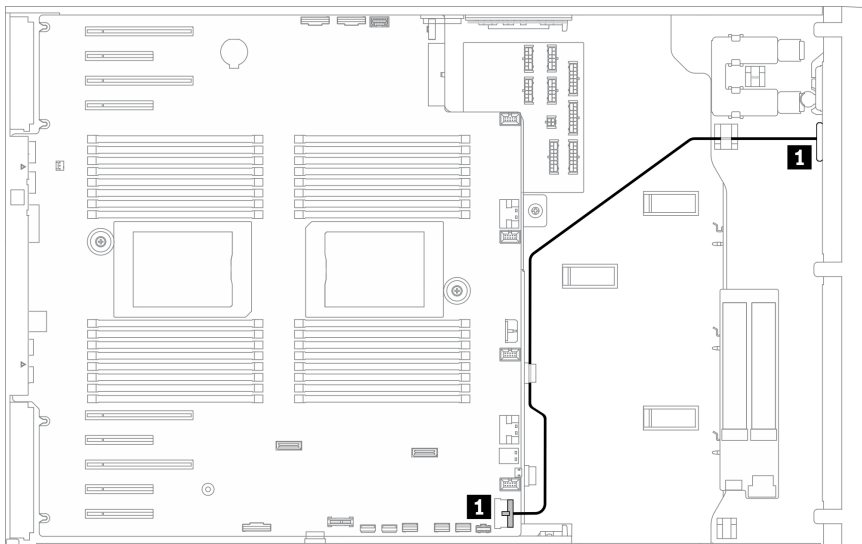

Figure 25. Cable routing for front USB

GPU cable routing

Use this section to understand the cable routing for the GPU.

From	To
1 Power connector on GPU 1	Power distribution board: GPU 3 power connector
5 Power connector on GPU 2	Power distribution board: GPU 1 power connector
3 Power connector on GPU 3	Power distribution board: GPU 2 power connector
4 Power connector on GPU 4	Power distribution board: GPU 4 power connector

Notes:

- Connections between connectors; **1**↔**1**, **2**↔**2**, **3**↔**3**, ... **n**↔**n**
- When routing the cables, ensure that all cables are routed appropriately through the cable guides and cable clips.

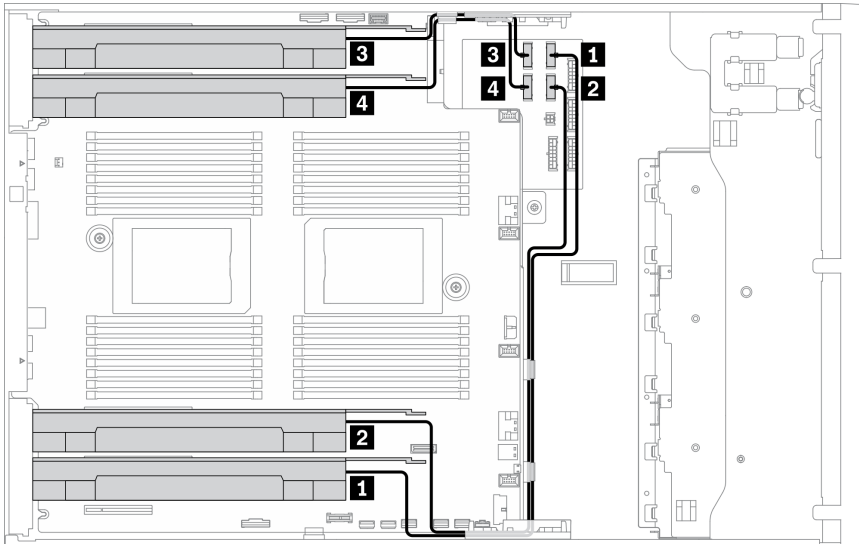

Figure 26. Cable routing for GPU

Internal CFF RAID adapter cable routing

Use this section to understand the cable routing for the CFF RAID adapter.

From	To
1 Signal connector on the CFF RAID adapter	System board: PCIe 3 connector connector
2 Power connector on the CFF RAID adapter	System board: CFF RAID power connector

Notes:

- Connections between connectors; **1**↔**1**, **2**↔**2**, **3**↔**3**, ... **n**↔**n**
- When routing the cables, ensure that all cables are routed appropriately through the cable guides and cable clips.

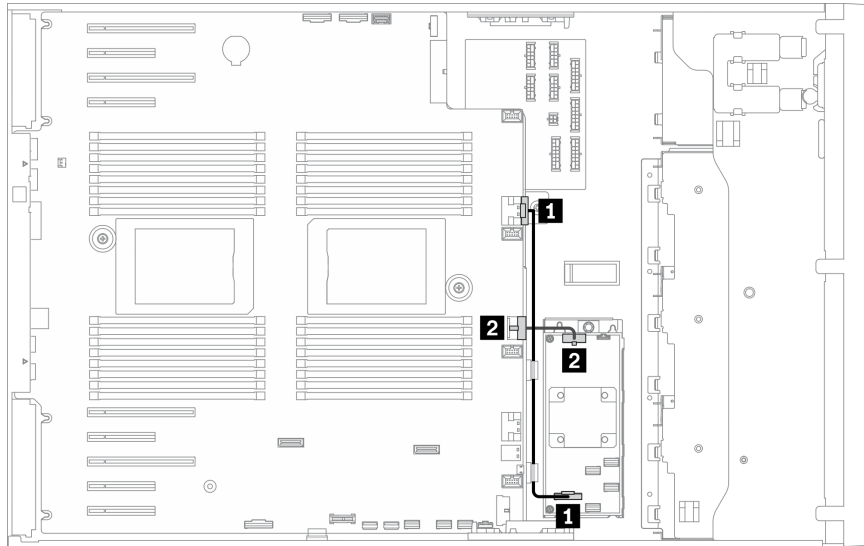

Figure 27. Cable routing for the CFF RAID adapter

M.2 boot adapter cable routing

Use the section to understand the cable routing for the M.2 boot adapter.

From	To
1 M.2 power connector on the M.2 boot adapter	System board: M.2 power connector
2 M.2 signal connector on the M.2 boot adapter	System board: M.2 signal connector

Notes:

- Connections between connectors; **1** ↔ **1**, **2** ↔ **2**, **3** ↔ **3**, ... **n** ↔ **n**
- When routing the cables, ensure that all cables are routed appropriately through the cable guides and cable clips.

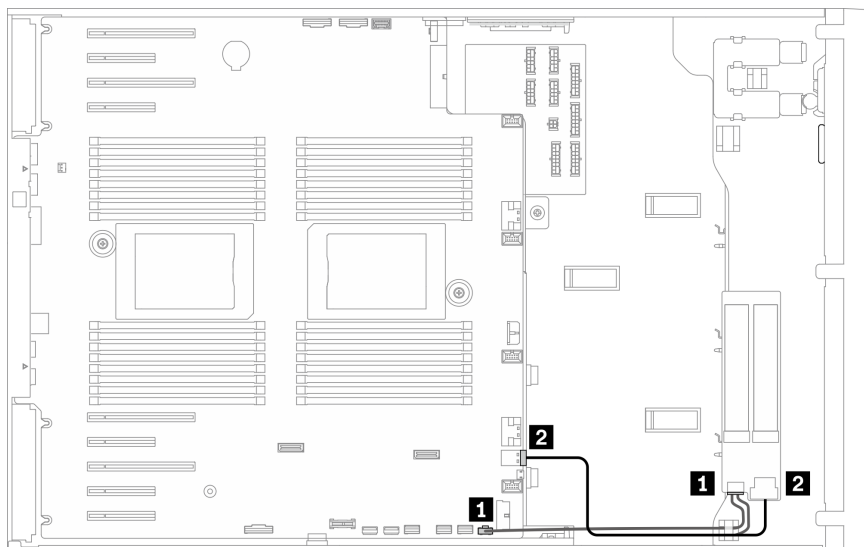

Figure 28. Cable routing for M.2 boot adapter

Optical drive cable routing

Use the section to understand the cable routing for the optical drives.

From	To
1 Power connector on optical drive	Power distribution board: ODD power connector
2 Signal connector on optical drive	System board: Internal USB connector 3

Notes:

- Connections between connectors; **1**↔**1**, **2**↔**2**, **3**↔**3**, ... **n**↔**n**
- When routing the cables, ensure that all cables are routed appropriately through the cable guides and cable clips.

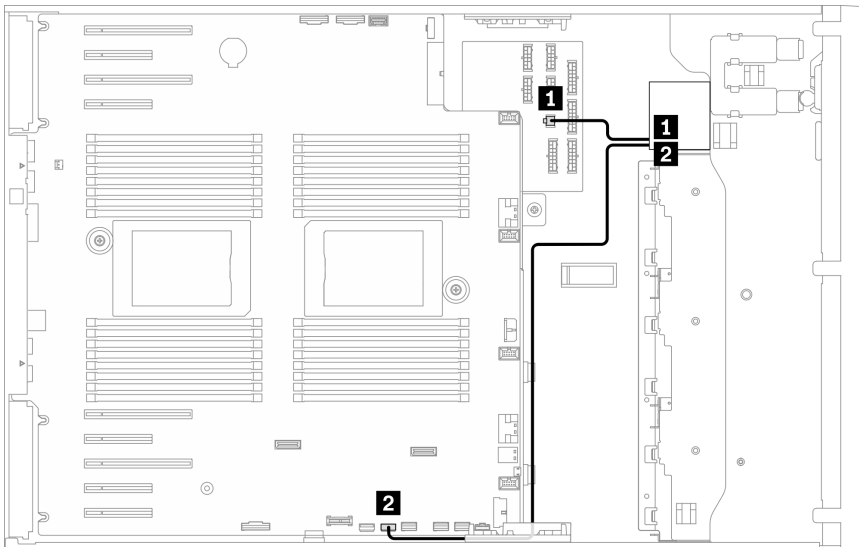

Figure 29. Cable routing for optical drive

PCIe slot 8 cable routing

Use the section to understand the cable routing to enable PCIe slot 8.

From	To
1 System board: PCIe slot 8 enable connector	System board: PCIe 4 connector

Notes:

- Connections between connectors; **1**↔**1**, **2**↔**2**, **3**↔**3**, ... **n**↔**n**
- When routing the cables, ensure that all cables are routed appropriately through the cable guides and cable clips.

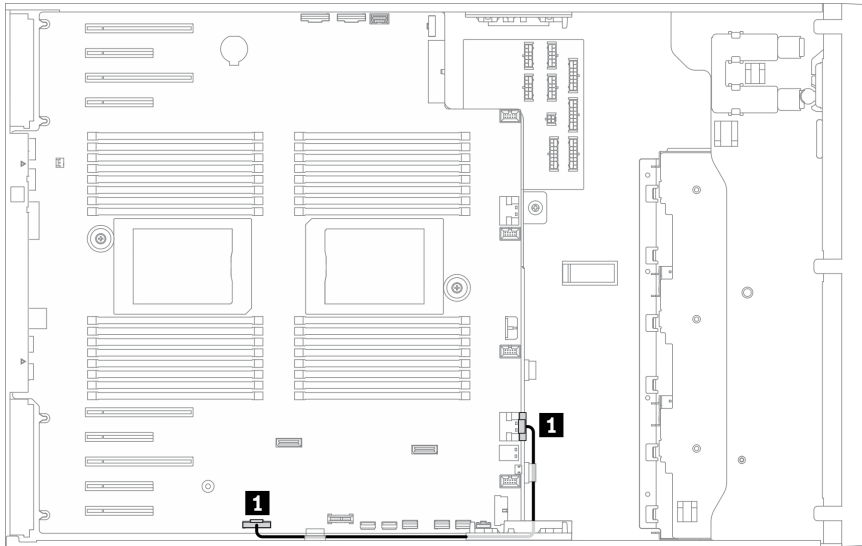

Figure 30. Cable routing to enable PCIe slot 8

Power distribution board cable routing

Use the section to understand the cable routing for the power distribution board.

From	To
1 Power distribution board: Main power connector	System board: Power distribution board power connector
2 Power distribution board: PDB signal connector	System board: Power distribution board signal connector

Notes:

- Connections between connectors; **1** ↔ **1**, **2** ↔ **2**, **3** ↔ **3**, ... **n** ↔ **n**
- When routing the cables, ensure that all cables are routed appropriately through the cable guides and cable clips.

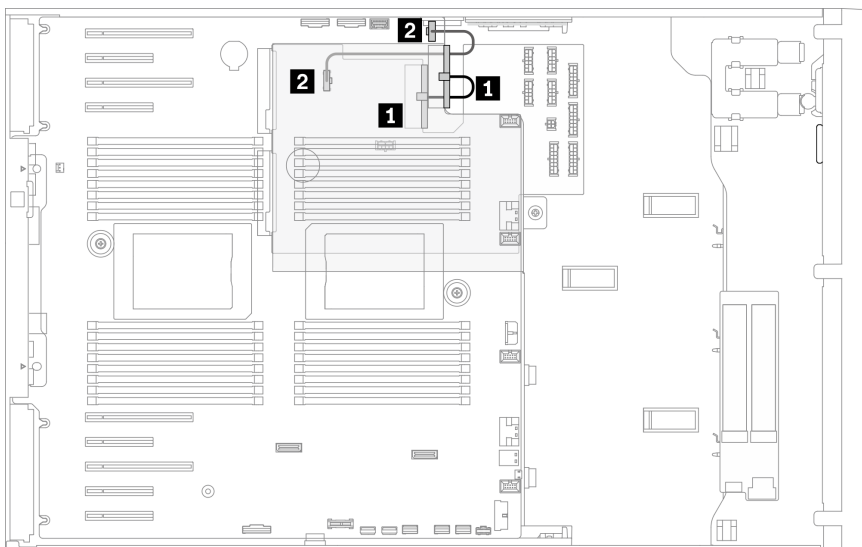

Figure 31. Cable routing for power distribution board

Tape drive cable routing

Use the section to understand the cable routing for the tape drive.

SAS tape drive

From	To
1 Power connector on signal cable	Power distribution board: ODD power connector
2 Signal connector on tape drive	An available connector on the RAID/HBA adapter

Notes:

- Connections between connectors; **1** ↔ **1**, **2** ↔ **2**, **3** ↔ **3**, ... **n** ↔ **n**
- When routing the cables, ensure that all cables are routed appropriately through the cable guides and cable clips.
- The following illustrations show the cable routing for PCIe slot 1 and 9 respectively, the routing for the other PCIe slots are similar.

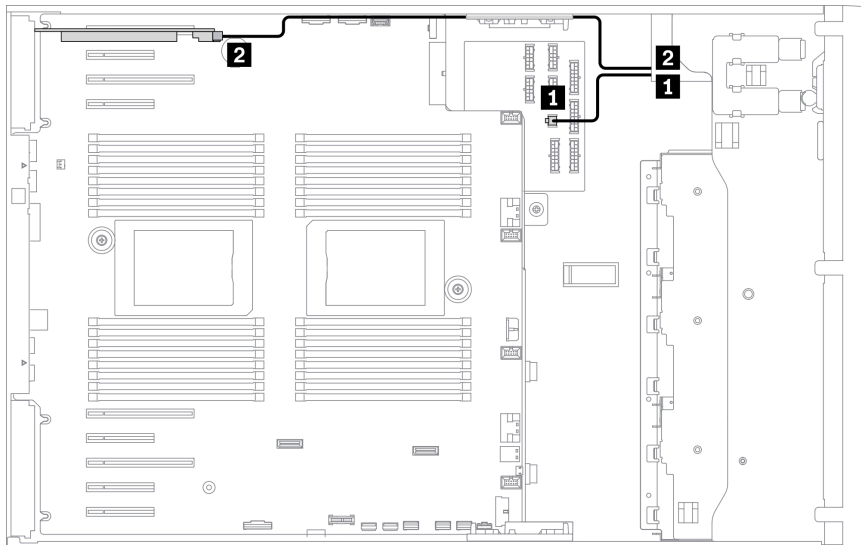

Figure 32. Cable routing for SAS tape drive to PCIe slot 1

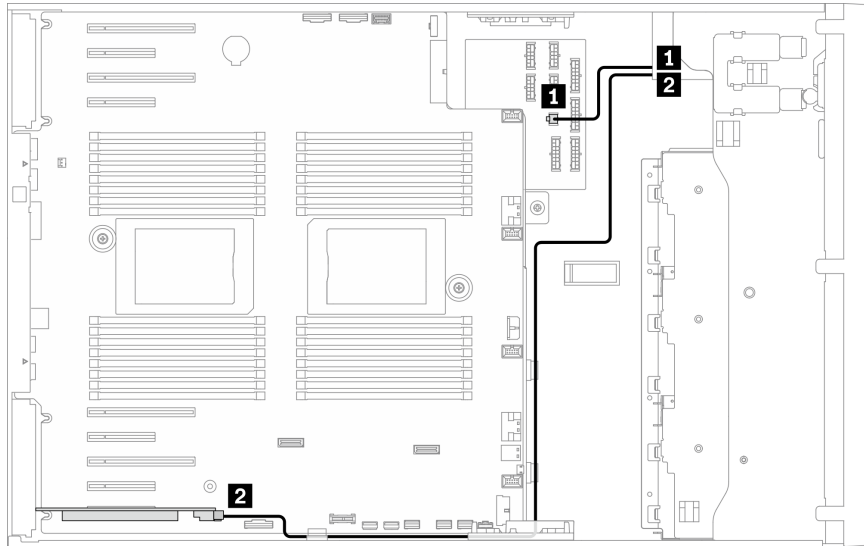

Figure 33. Cable routing for SAS tape drive to PCIe slot 9

USB tape drive

From	To
1 Power connector on tape drive	Power distribution board: ODD power connector
2 Signal connector on tape drive	System board: Internal USB connector 4

Notes:

- Connections between connectors: **1** ↔ **1**, **2** ↔ **2**, **3** ↔ **3**, ... **n** ↔ **n**
- When routing the cables, ensure that all cables are routed appropriately through the cable guides and cable clips.

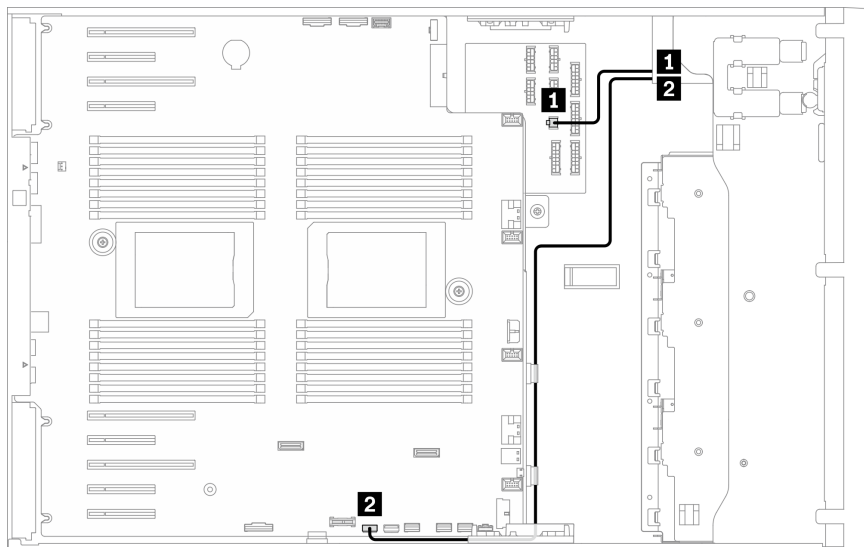

Figure 34. Cable routing for the USB tape drive

Chapter 4. Hardware replacement procedures

This section provides installation and removal procedures for all serviceable system components. Each component replacement procedure references any tasks that need to be performed to gain access to the component being replaced.

For more information about ordering parts:

1. Go to <http://datacentersupport.lenovo.com> and navigate to the support page for your server.
2. Click **Parts**.
3. Enter the serial number to view a listing of parts for your server.

Note: If you replace a part, such as an adapter, that contains firmware, you might also need to update the firmware for that part. For more information about updating firmware, see “Firmware updates” on page 9.

Installation guidelines

Before installing components in your server, read the installation guidelines.

Before installing optional devices, read the following notices carefully:

Attention: Prevent exposure to static electricity, which might lead to system halt and loss of data, by keeping static-sensitive components in their static-protective packages until installation, and handling these devices with an electrostatic-discharge wrist strap or other grounding system.

- Read the safety information and guidelines to ensure that you work safely.
 - A complete list of safety information for all products is available at: http://thinksystem.lenovofiles.com/help/topic/safety_documentation/pdf_files.html
 - The following guidelines are available as well: “Handling static-sensitive devices” on page 60.
- Make sure the components you are installing are supported by the server. For a list of supported optional components for the server, see <https://static.lenovo.com/us/en/serverproven/index.shtml>.
- When you install a new server, download and apply the latest firmware. This will help ensure that any known issues are addressed, and that your server is ready to work with optimal performance. Go to [ThinkSystem ST650 V2 Drivers and Software](#) to download firmware updates for your server.

Important: Some cluster solutions require specific code levels or coordinated code updates. If the component is part of a cluster solution, verify that the latest level of code is supported for the cluster solution before you update the code.

- It is good practice to make sure that the server is working correctly before you install an optional component.
- Keep the working area clean, and place removed components on a flat and smooth surface that does not shake or tilt.
- Do not attempt to lift an object that might be too heavy for you. If you have to lift a heavy object, read the following precautions carefully:
 - Make sure that you can stand steadily without slipping.
 - Distribute the weight of the object equally between your feet.
 - Use a slow lifting force. Never move suddenly or twist when you lift a heavy object.
 - To avoid straining the muscles in your back, lift by standing or by pushing up with your leg muscles.

- Make sure that you have an adequate number of properly grounded electrical outlets for the server, monitor, and other devices.
- Back up all important data before you make changes related to the disk drives.
- Have a small flat-blade screwdriver and a small Phillips screwdriver available.
- You do not have to turn off the server to remove or install hot-swap power supplies or hot-plug USB devices. However, you must turn off the server before you perform any steps that involve removing or installing adapter cables, and you must disconnect the power source from the server before you perform any steps that involve removing or installing a DIMM.
- Blue on a component indicates touch points, where you can grip to remove a component from or install it in the server, open or close a latch, and so on.
- Orange on a component or an orange label on or near a component indicates that the component can be hot-swapped if the server and operating system support hot-swap capability, which means that you can remove or install the component while the server is still running. (Orange can also indicate touch points on hot-swap components.) See the instructions for removing or installing a specific hot-swap component for any additional procedures that you might have to perform before you remove or install the component.
- The Red strip on the drives, adjacent to the release latch, indicates that the drive can be hot-swapped if the server and operating system support hot-swap capability. This means that you can remove or install the drive while the server is still running.

Note: See the system specific instructions for removing or installing a hot-swap drive for any additional procedures that you might need to perform before you remove or install the drive.

- After finishing working on the server, make sure you reinstall all safety shields, guards, labels, and ground wires.

Safety inspection checklist

Use the information in this section to identify potentially unsafe conditions with your server. As each machine was designed and built, required safety items were installed to protect users and service technicians from injury.

CAUTION:

This equipment must be installed or serviced by trained personnel, as defined by the NEC, IEC 62368-1 & IEC 60950-1, the standard for Safety of Electronic Equipment within the Field of Audio/Video, Information Technology and Communication Technology. Lenovo assumes you are qualified in the servicing of equipment and trained in recognizing hazards energy levels in products.

Important: Electrical grounding of the server is required for operator safety and correct system function. Proper grounding of the electrical outlet can be verified by a certified electrician.

Notes:

1. The product is not suitable for use at visual display workplaces according to §2 of the Workplace Regulations.
2. The set-up of the server is made in the server room only.

Use the following checklist to verify that there are no potentially unsafe conditions:

1. Make sure that the power is off and the power cord is disconnected.
2. Check the power cord.
 - Make sure that the third-wire ground connector is in good condition. Use a meter to measure third-wire ground continuity for 0.1 ohm or less between the external ground pin and the frame ground.
 - Make sure that the power cord is the correct type.

To view the power cords that are available for the server:

a. Go to:

<http://dcsc.lenovo.com/#/>

b. In the Customize a Model pane:

1) Click **Select Options/Parts for a Model**.

2) Enter the machine type and model for your server.

c. Click the Power tab to see all line cords.

- Make sure that the insulation is not frayed or worn.
- 3. Check for any obvious non-Lenovo alterations. Use good judgment as to the safety of any non-Lenovo alterations.
- 4. Check inside the server for any obvious unsafe conditions, such as metal filings, contamination, water or other liquid, or signs of fire or smoke damage.
- 5. Check for worn, frayed, or pinched cables.
- 6. Make sure that the power-supply cover fasteners (screws or rivets) have not been removed or tampered with.

System reliability guidelines

Review the system reliability guidelines to ensure proper system cooling and reliability.

Make sure the following requirements are met:

- When the server comes with redundant power, a power supply must be installed in each power-supply bay.
- Adequate space around the server must be spared to allow server cooling system to work properly. Leave approximately 50 mm (2.0 in.) of open space around the front and rear of the server. Do not place any object in front of the fans.
- For proper cooling and airflow, refit the server cover before you turn the power on. Do not operate the server for more than 30 minutes with the server cover removed, for it might damage server components.
- Cabling instructions that come with optional components must be followed.
- A failed fan must be replaced within 48 hours since malfunction.
- A removed hot-swap drive must be replaced within two minutes after removal.
- A removed hot-swap power supply must be replaced within two minutes after removal.
- Every air baffle that comes with the server must be installed when the server starts (some servers might come with more than one air baffle). Operating the server with a missing air baffle might damage the processor.
- All processor sockets must contain either a socket cover or a processor with heat sink.
- When more than one processor is installed, fan population rules for each server must be strictly followed.

Working inside the server with the power on

You might need to keep the power on with the server cover removed to look at system information on the display panel or to replace hot-swap components. Review these guidelines before doing so.

Attention: The server might stop and loss of data might occur when internal server components are exposed to static electricity. To avoid this potential problem, always use an electrostatic-discharge wrist strap or other grounding systems when working inside the server with the power on.

- Avoid loose-fitting clothing, particularly around your forearms. Button or roll up long sleeves before working inside the server.
- Prevent your necktie, scarf, badge rope, or long hair from dangling into the server.
- Remove jewelry, such as bracelets, necklaces, rings, cuff links, and wrist watches.
- Remove items from your shirt pocket, such as pens and pencils, in case they fall into the server as you lean over it.
- Avoid dropping any metallic objects, such as paper clips, hairpins, and screws, into the server.

Handling static-sensitive devices

Review these guidelines before you handle static-sensitive devices to reduce the possibility of damage from electrostatic discharge.

Attention: Prevent exposure to static electricity, which might lead to system halt and loss of data, by keeping static-sensitive components in their static-protective packages until installation, and handling these devices with an electrostatic-discharge wrist strap or other grounding system.

- Limit your movement to prevent building up static electricity around you.
- Take additional care when handling devices during cold weather, for heating would reduce indoor humidity and increase static electricity.
- Always use an electrostatic-discharge wrist strap or other grounding system.
- While the device is still in its static-protective package, touch it to an unpainted metal surface on the outside of the server for at least two seconds. This drains static electricity from the package and from your body.
- Remove the device from the package and install it directly into the server without putting it down. If it is necessary to put the device down, put it back into the static-protective package. Never place the device on the server or on any metal surface.
- When handling a device, carefully hold it by the edges or the frame.
- Do not touch solder joints, pins, or exposed circuitry.
- Keep the device from others' reach to prevent possible damages.

2.5-inch hot-swap drive backplane replacement

Use this information to remove and install a 2.5-inch hot-swap drive backplane.

Note: This topic applies only to server models that have 2.5-inch hot-swap drive backplanes installed.

Remove a 2.5-inch hot-swap drive backplane

Use this information to remove a 2.5-inch hot-swap drive backplane.

About this task

S002



CAUTION:

The power-control button on the device and the power switch on the power supply do not turn off the electrical current supplied to the device. The device also might have more than one power cord. To remove all electrical current from the device, ensure that all power cords are disconnected from the power source.

Attention:

- Read “Installation guidelines” on page 57 to ensure that you work safely.
- Power off the server and disconnect all power cords for this task.
- Prevent exposure to static electricity, which might lead to system halt and loss of data, by keeping static-sensitive components in their static-protective packages until installation, and handling these devices with an electrostatic-discharge wrist strap or other grounding system.
- If the server is in a rack, remove it from the rack.
- If foot stands are installed on the server, rotate them inwards and lay the server on its side for easier operation.

Watch the procedure. A video of the installation and removal process is available:

- YouTube: <https://youtube.com/playlist?list=PLYV5R7hVcs-DoEcXrm2zKNpaK0dZ3f8Qc>
- Youku: https://list.youku.com/albumlist/show/id_59636516

Procedure

Step 1. Make preparations for this task.

- a. Remove the server cover. See “Remove the server cover” on page 188.
- b. Remove all installed hot-swap drives and drive bay fillers (if any) from the drive bays. See “Remove a hot-swap drive” on page 83.

Step 2. Disconnect all the cables from the backplane.

Step 3. Remove the backplane.

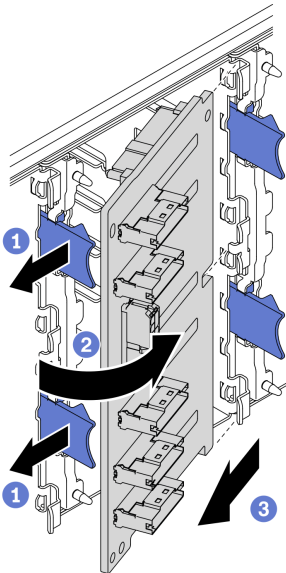

Figure 35. Removal of the 2.5-inch hot-swap drive backplane

- a. ① Lift the release tabs to disengage the backplane.
- b. ② Rotate the backplane away from the drive cage as shown.

- c. 3 Remove the backplane from the drive cage.

After you finish

If you are instructed to return the component or optional device, follow all packaging instructions, and use any packaging materials for shipping that are supplied to you.

Install a 2.5-inch hot-swap drive backplane

Use this information to install a 2.5-inch hot-swap drive backplane.

About this task

S002



CAUTION:

The power-control button on the device and the power switch on the power supply do not turn off the electrical current supplied to the device. The device also might have more than one power cord. To remove all electrical current from the device, ensure that all power cords are disconnected from the power source.

Attention:

- Read “Installation guidelines” on page 57 to ensure that you work safely.
- Power off the server and disconnect all power cords for this task.
- Prevent exposure to static electricity, which might lead to system halt and loss of data, by keeping static-sensitive components in their static-protective packages until installation, and handling these devices with an electrostatic-discharge wrist strap or other grounding system.

Watch the procedure. A video of the installation and removal process is available:

- YouTube: <https://youtube.com/playlist?list=PLYV5R7hVcs-DoEcxrm2zKNpaKOdZ3f8Qc>
- Youku: https://list.youku.com/albumlist/show/id_59636516

Procedure

Step 1. Install the backplane.

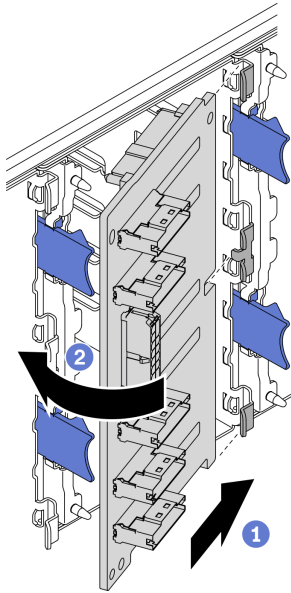

Figure 36. Installation of the 2.5-inch hot-swap drive backplane

- a. 1 Insert the backplane into the backplane slot as shown.
- b. 2 Carefully rotate the edge of the new backplane toward the drive cage until it is secured by the release tabs.

After you finish

- Reconnect the cables to the backplane. See “2.5-inch hot-swap drive backplane cable routing” in the *ThinkSystem ST650 V2 Backplane/Backplate Cable Routing Guide*.
- Reinstall all the hot-swap drives and drive bay fillers (if any) into the drive bays. See “Install a hot-swap drive” on page 84.
- Reinstall the server cover. See “Install the server cover” on page 190.
- Complete the parts replacement. See “Complete the parts replacement” on page 206.

2.5-inch drive replacement from 3.5-inch drive bay

Use this information to remove and install a 2.5-inch drive from a 3.5-inch drive bay.

The EMI integrity and cooling of the server are protected by having all drive bays covered or occupied. The number of the installed drives in your server varies depending on the server model. The vacant bays are occupied by dummy trays. When you install a drive, save the removed dummy tray from the drive bay in case you later remove the drive and need the dummy tray to cover the place.

Attention: An unoccupied drive bay without any other protection might impact the EMI integrity and cooling of the server, which might result in overheating or component damage. To maintain the EMI integrity and cooling of the server, install a new drive as soon as you remove the failing one or the dummy tray.

Before you begin, review the following drive installation rules:

- Follow the order of the drive bays. See Chapter 2 “Server components” on page 15 to locate the drive bays in your server.
- For SSDs with different capacities, install the drive by following the order of the drive bays as well as the order from the lowest capacity to the highest capacity.

Remove a 2.5-inch drive from a 3.5-inch drive bay

Use this information to remove 2.5-inch drive from a 3.5-inch drive bay.

About this task

S002

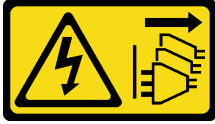

CAUTION:

The power-control button on the device and the power switch on the power supply do not turn off the electrical current supplied to the device. The device also might have more than one power cord. To remove all electrical current from the device, ensure that all power cords are disconnected from the power source.

Attention:

- Read “Installation guidelines” on page 57 to ensure that you work safely.
- Power off the server and disconnect all power cords for this task.
- Prevent exposure to static electricity, which might lead to system halt and loss of data, by keeping static-sensitive components in their static-protective packages until installation, and handling these devices with an electrostatic-discharge wrist strap or other grounding system.

Watch the procedure. A video of the installation and removal process is available:

- YouTube: <https://youtube.com/playlist?list=PLYV5R7hVcs-DoEcxrm2zKNpaKOdZ3f8Qc>
- Youku: https://list.youku.com/albumlist/show/id_59636516

Procedure

- Step 1. Use the key to unlock the server cover; then, open the front door.
- Step 2. Locate the drive you want to remove.
- Step 3. Remove the 3.5-inch drive tray with the 2.5-inch drive. See “Remove a simple-swap drive” on page 80 or “Remove a hot-swap drive” on page 83.
- Step 4. Remove the five screws that secure the 2.5-inch drive and the drive adapter; then, remove the 2.5-inch drive and the drive adapter from the tray.

Figure 37. Removing the screws that secure the 2.5-inch drive and the drive adapter

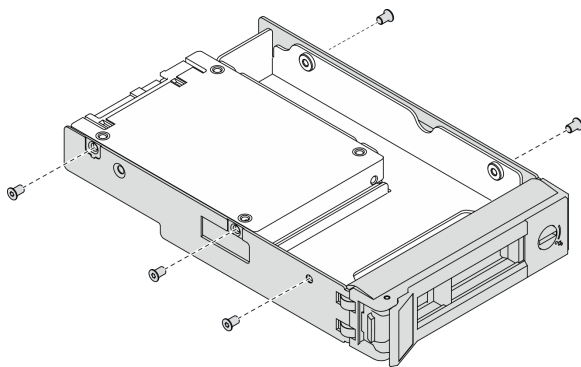

Step 5. Remove the two screws that secure the 2.5-inch drive; then, lift the drive up to remove it from the drive adapter.

Figure 38. 2.5-inch drive removal from the drive adapter

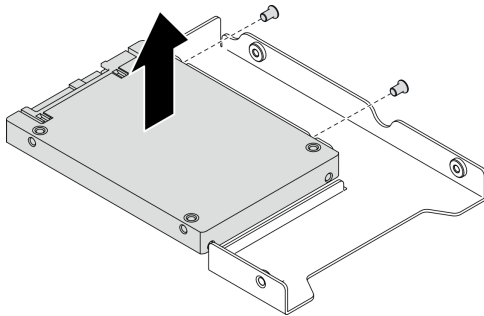

After you finish

If you are instructed to return the component or optional device, follow all packaging instructions, and use any packaging materials for shipping that are supplied to you.

Install a 2.5-inch drive into a 3.5-inch drive bay

Use this information to install a 2.5-inch drive into a 3.5-inch drive bay.

About this task

S002



CAUTION:

The power-control button on the device and the power switch on the power supply do not turn off the electrical current supplied to the device. The device also might have more than one power cord. To remove all electrical current from the device, ensure that all power cords are disconnected from the power source.

Attention:

- Read “Installation guidelines” on page 57 to ensure that you work safely.
- Power off the server and disconnect all power cords for this task.
- Prevent exposure to static electricity, which might lead to system halt and loss of data, by keeping static-sensitive components in their static-protective packages until installation, and handling these devices with an electrostatic-discharge wrist strap or other grounding system.

Watch the procedure. A video of the installation and removal process is available:

- YouTube: <https://youtube.com/playlist?list=PLYV5R7hVcs-DoEcXrm2zKNpaKOdZ3f8Qc>
- Youku: https://list.youku.com/albumlist/show/id_59636516

Procedure

Step 1. Position the 2.5-inch drive into the 2.5-inch to 3.5-inch drive adapter.

- Step 2. Align the two screw holes in the drive with the corresponding holes in the drive adapter; then, install the two screws to secure the drive to the drive adapter.

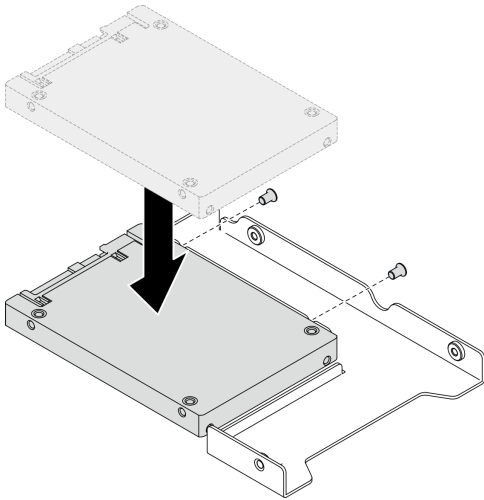
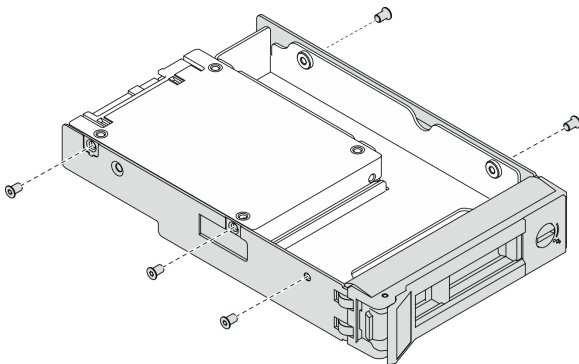

Figure 39. 2.5-inch drive installation to drive adapter

- Step 3. Position the drive adapter with the drive into the 3.5-inch drive tray. Align the screw holes in the drive adapter and the drive with the corresponding holes in the tray; then, install the five screws to secure the drive adapter and the drive into the tray.

Figure 40. Installing the screws that secure the 2.5-inch drive and the drive adapter



- Step 4. Slide the tray with the drive into the drive bay from the front until it snaps into position and then completely close the handle. See “Install a simple-swap drive” on page 81 or “Install a hot-swap drive” on page 84.

After you finish

1. Install other drives if necessary.
2. Close the front door; then, use the key to lock the server cover.
3. Complete the parts replacement. See “Complete the parts replacement” on page 206.

3.5-inch hot-swap drive backplane replacement

Use this information to remove and install a 3.5-inch hot-swap drive backplane.

Note: This topic applies only to server models that have 3.5-inch hot-swap drive backplanes installed.

Remove a 3.5-inch hot-swap drive backplane

Use this information to remove a 3.5-inch hot-swap drive backplane.

About this task

S002

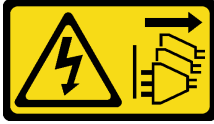

CAUTION:

The power-control button on the device and the power switch on the power supply do not turn off the electrical current supplied to the device. The device also might have more than one power cord. To remove all electrical current from the device, ensure that all power cords are disconnected from the power source.

Attention:

- Read “Installation guidelines” on page 57 to ensure that you work safely.
- Power off the server and disconnect all power cords for this task.
- Prevent exposure to static electricity, which might lead to system halt and loss of data, by keeping static-sensitive components in their static-protective packages until installation, and handling these devices with an electrostatic-discharge wrist strap or other grounding system.
- If the server is in a rack, remove it from the rack.
- If foot stands are installed on the server, rotate them inwards and lay the server on its side for easier operation.

Watch the procedure. A video of the installation and removal process is available:

- YouTube: <https://youtube.com/playlist?list=PLYV5R7hVcs-DoEcxrm2zKNpaKOdZ3f8Qc>
- Youku: https://list.youku.com/albumlist/show/id_59636516

Procedure

Step 1. Make preparations for this task.

- a. Remove the server cover. See “Remove the server cover” on page 188.
- b. Remove all installed hot-swap drives and drive bay fillers (if any) from the drive bays. See “Remove a hot-swap drive” on page 83.

Step 2. Disconnect all the cables from the backplane.

Step 3. Remove the backplane.

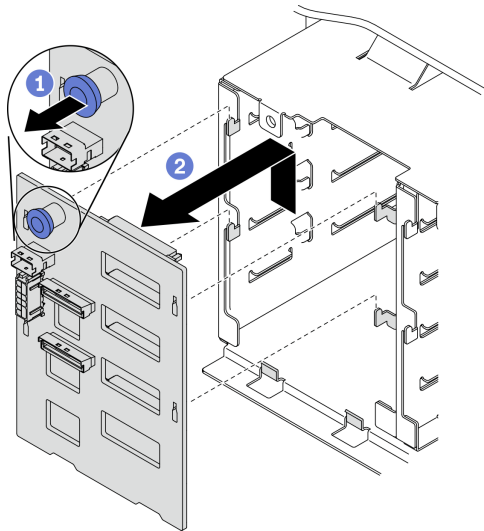

Figure 41. Removal of the 3.5-inch hot-swap drive backplane

- a. ① Open the plunger that secures the backplane.
- b. ② Slightly slide the backplane as shown to disengage it from the drive cage; then, remove the backplane from the drive cage.

After you finish

If you are instructed to return the component or optional device, follow all packaging instructions, and use any packaging materials for shipping that are supplied to you.

Install a 3.5-inch hot-swap drive backplane

Use this information to install a 3.5-inch hot-swap drive backplane.

About this task

S002



CAUTION:

The power-control button on the device and the power switch on the power supply do not turn off the electrical current supplied to the device. The device also might have more than one power cord. To remove all electrical current from the device, ensure that all power cords are disconnected from the power source.

Attention:

- Read “Installation guidelines” on page 57 to ensure that you work safely.
- Power off the server and disconnect all power cords for this task.
- Prevent exposure to static electricity, which might lead to system halt and loss of data, by keeping static-sensitive components in their static-protective packages until installation, and handling these devices with an electrostatic-discharge wrist strap or other grounding system.

Watch the procedure. A video of the installation and removal process is available:

- YouTube: <https://youtube.com/playlist?list=PLYV5R7hVcs-DoEcxrm2zKNpaKOdZ3f8Qc>
- Youku: https://list.youku.com/albumlist/show/id_59636516

Procedure

- Step 1. Position the backplane on the drive cage so that the tabs on the drive cage are inserted into the corresponding holes in the backplane.
- Step 2. Slide the backplane as shown until it is seated into position in the drive cage.

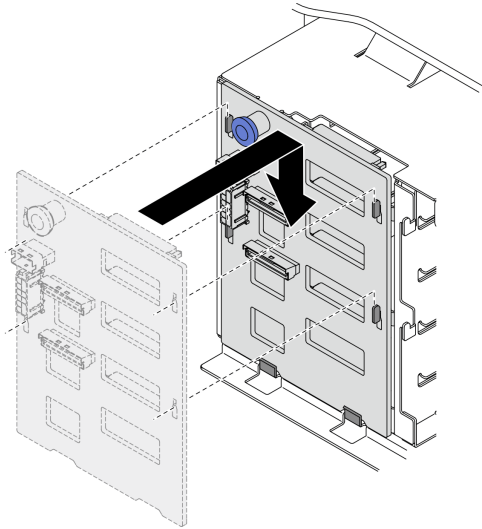

Figure 42. Installation of the 3.5-inch hot-swap drive backplane

After you finish

1. Reconnect the cables to the backplane. See “3.5-inch hot-swap drive backplane cable routing” in the *ThinkSystem ST650 V2 Backplane/Backplane Cable Routing Guide*.
2. Reinstall all the hot-swap drives and drive bay fillers (if any) into the drive bays. See “Install a hot-swap drive” on page 84.
3. Reinstall the server cover. See “Install the server cover” on page 190.
4. Complete the parts replacement. See “Complete the parts replacement” on page 206.

3.5-inch simple-swap drive backplate replacement

Use this information to remove and install a 3.5-inch simple-swap drive backplate.

Note: This section applies only to server models that have 3.5-inch simple-swap drive backplates installed.

Remove a 3.5-inch simple-swap drive backplate

Use this information to remove a 3.5-inch simple-swap drive backplate.

About this task

S002

**CAUTION:**

The power-control button on the device and the power switch on the power supply do not turn off the electrical current supplied to the device. The device also might have more than one power cord. To remove all electrical current from the device, ensure that all power cords are disconnected from the power source.

Attention:

- Read “Installation guidelines” on page 57 to ensure that you work safely.
- Power off the server and disconnect all power cords for this task.
- Prevent exposure to static electricity, which might lead to system halt and loss of data, by keeping static-sensitive components in their static-protective packages until installation, and handling these devices with an electrostatic-discharge wrist strap or other grounding system.
- If the server is in a rack, remove it from the rack.
- If foot stands are installed on the server, rotate them inwards and lay the server on its side for easier operation.

Watch the procedure. A video of the installation and removal process is available:

- YouTube: <https://youtube.com/playlist?list=PLYV5R7hVcs-DoEcxrm2zKNpaKOdZ3f8Qc>
- Youku: https://list.youku.com/albumlist/show/id_59636516

Procedure

Step 1. Make preparations for this task.

- a. Remove the server cover. See “Remove the server cover” on page 188.
- b. Remove all the flash power modules. See “Remove a flash power module” on page 98.
- c. Remove the air baffle. See “Remove the air baffle” on page 72.
- d. Remove all the full-length GPU adapters. See “Remove a full-length GPU adapter” on page 113.
- e. Remove all the fans. See “Remove a hot-swap fan” on page 93.
- f. Remove the fan cage. See “Remove the fan cage assembly” on page 95.
- g. Remove all installed simple-swap drives and drive bay fillers (if any) from the drive bays. See “Remove a simple-swap drive” on page 80.

Step 2. Disconnect all cables connected to the system board.

Step 3. Remove the backplate.

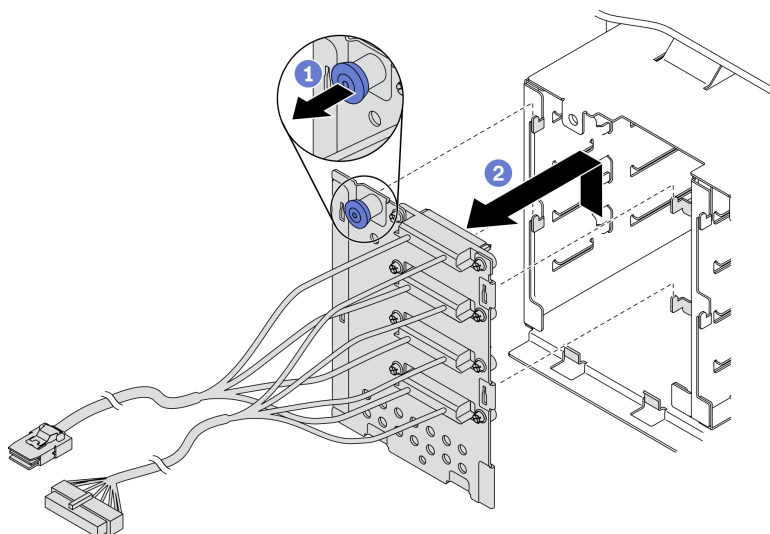

Figure 43. Removal of the 3.5-inch hot-swap drive backplate

- a. ① Open the plunger that secures the backplate.
- b. ② Slightly slide the backplate as shown to disengage it from the drive cage; then, remove the backplate from the drive cage.

After you finish

If you are instructed to return the component or optional device, follow all packaging instructions, and use any packaging materials for shipping that are supplied to you.

Install a 3.5-inch simple-swap drive backplate

Use this information to install a 3.5-inch simple-swap drive backplate.

About this task

S002

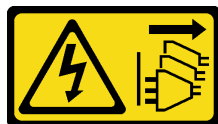

CAUTION:

The power-control button on the device and the power switch on the power supply do not turn off the electrical current supplied to the device. The device also might have more than one power cord. To remove all electrical current from the device, ensure that all power cords are disconnected from the power source.

Attention:

- Read “Installation guidelines” on page 57 to ensure that you work safely.
- Power off the server and disconnect all power cords for this task.
- Prevent exposure to static electricity, which might lead to system halt and loss of data, by keeping static-sensitive components in their static-protective packages until installation, and handling these devices with an electrostatic-discharge wrist strap or other grounding system.

Watch the procedure. A video of the installation and removal process is available:

- YouTube: <https://youtube.com/playlist?list=PLYV5R7hVcs-DoEcXrm2zKNpaKOdZ3f8Qc>
- Youku: https://list.youku.com/albumlist/show/id_59636516

Procedure

- Step 1. Position the backplate on the drive cage so that the tabs on the drive cage are inserted into the corresponding holes in the backplate.
- Step 2. Slide the backplate as shown until it is seated into position in the drive cage.

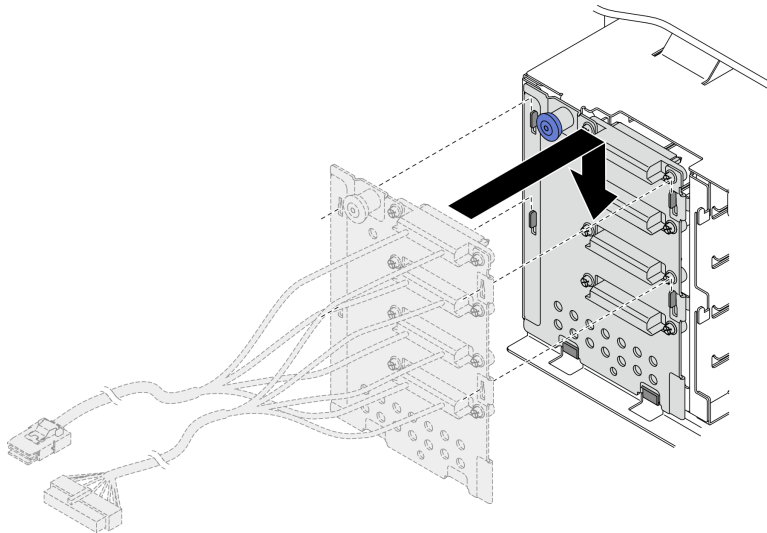

Figure 44. Installation of the 3.5-inch hot-swap drive backplate

- Step 3. Connect the power cable and the signal cable to the system board. See “3.5-inch simple-swap drive backplate cable routing” in the *ThinkSystem ST650 V2 Backplane/Backplate Cable Routing Guide*.

After you finish

1. Reinstall all the simple-swap drives and drive bay fillers (if any) into the drive cage. See “Install a simple-swap drive” on page 81.
2. Reinstall the fan cage. See “Install the fan cage assembly” on page 97.
3. Reinstall all the fans. See “Install a hot-swap fan” on page 94.
4. Reinstall all the full-length GPU adapters. See “Install a full-length GPU adapter” on page 114.
5. Reinstall the air baffle. See “Install the air baffle” on page 74.
6. Reinstall all the flash power modules. See “Install a flash power module” on page 100.
7. Reinstall the server cover. See “Install the server cover” on page 190.
8. Complete the parts replacement. See “Complete the parts replacement” on page 206.

Air baffle replacement

Follow this procedure to remove and install the air baffle.

Remove the air baffle

Follow this procedure to remove the air baffle.

About this task

S033



CAUTION:

Hazardous energy present. Voltages with hazardous energy might cause heating when shorted with metal, which might result in spattered metal, burns, or both.

S017



CAUTION:

Hazardous moving fan blades nearby. Keep fingers and other body parts away.

Attention:

- Read “Installation guidelines” on page 57 to ensure that you work safely.
- Power off the server and disconnect all power cords for this task.
- Prevent exposure to static electricity, which might lead to system halt and loss of data, by keeping static-sensitive components in their static-protective packages until installation, and handling these devices with an electrostatic-discharge wrist strap or other grounding system.
- If the server is in a rack, remove it from the rack.
- If foot stands are installed on the server, rotate them inwards and lay the server on its side for easier operation.

Watch the procedure. A video of the installation and removal process is available:

- YouTube: <https://youtube.com/playlist?list=PLYV5R7hVcs-DoEcxrm2zKNpaKOdZ3f8Qc>
- Youku: https://list.youku.com/albumlist/show/id_59636516

Procedure

Step 1. Make preparations for this task.

- a. Remove the server cover. See “Remove the server cover” on page 188.
- b. Remove all the flash power modules. See “Remove a flash power module” on page 98.

Step 2. Lift the air baffle from the server, and set it aside.

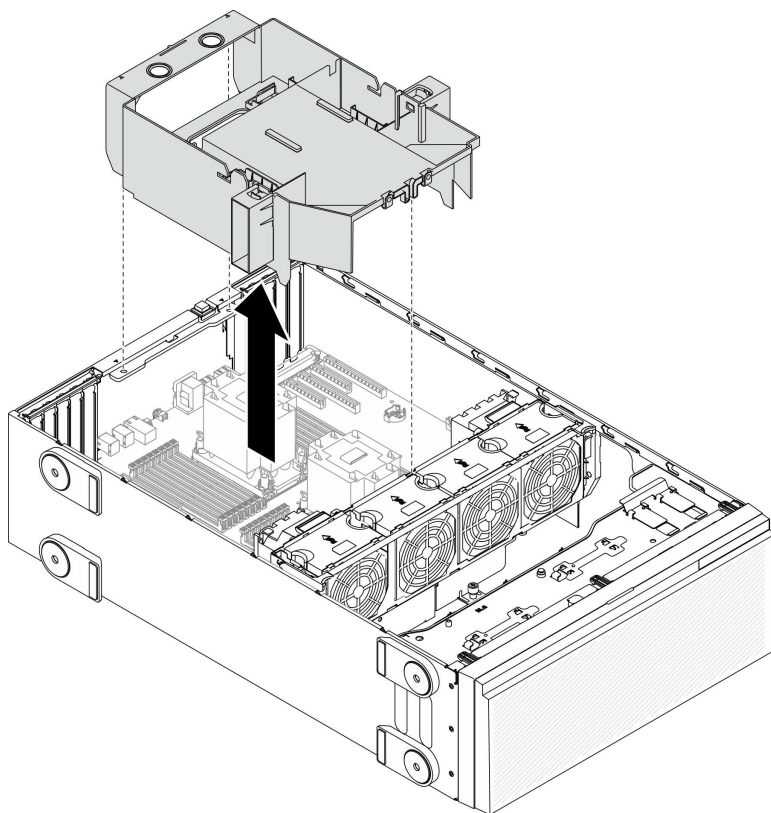

Figure 45. Air baffle removal

Attention: For proper cooling and airflow, install the air baffle before you turn on the server. Operating the server with the air baffle removed might damage server components.

After you finish

If you are instructed to return the component or optional device, follow all packaging instructions, and use any packaging materials for shipping that are supplied to you.

Install the air baffle

Follow this procedure to install the air baffle.

About this task

S033



CAUTION:

Hazardous energy present. Voltages with hazardous energy might cause heating when shorted with metal, which might result in spattered metal, burns, or both.

S017



CAUTION:
Hazardous moving fan blades nearby. Keep fingers and other body parts away.

Attention:

- Read “Installation guidelines” on page 57 to ensure that you work safely.
- Power off the server and disconnect all power cords for this task.
- Prevent exposure to static electricity, which might lead to system halt and loss of data, by keeping static-sensitive components in their static-protective packages until installation, and handling these devices with an electrostatic-discharge wrist strap or other grounding system.

Watch the procedure. A video of the installation and removal process is available:

- YouTube: <https://youtube.com/playlist?list=PLYV5R7hVcs-DoEcXrm2zKNpaK0dZ3f8Qc>
- Youku: https://list.youku.com/albumlist/show/id_59636516

Procedure

- Step 1. Make sure that all cables inside the server have been properly routed so that they will not interfere with the air baffle. See Chapter 3 “Internal cable routing” on page 47.

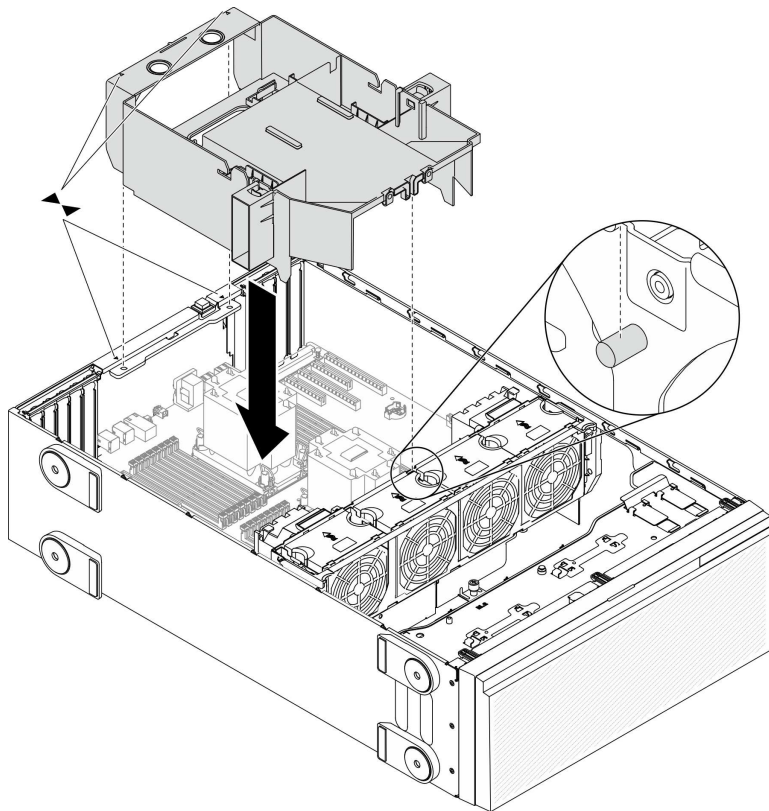

Figure 46. Air baffle installation

Step 2. Align the tabs on the air baffle with the corresponding slots on the rear of the chassis and the fan cage; then, lower the air baffle into the chassis and press the air baffle down until it is securely seated.

After you finish

1. Reinstall all the flash power modules. See “Install a flash power module” on page 100.
2. Reinstall the server cover. See “Install the server cover” on page 190.
3. Complete the parts replacement. See “Complete the parts replacement” on page 206.

CMOS battery (CR2032) replacement

Use this information to remove and install the CMOS battery (CR2032).

Remove the CMOS battery (CR2032)

Use this information to remove the CMOS battery (CR2032).

About this task

S002



CAUTION:

The power-control button on the device and the power switch on the power supply do not turn off the electrical current supplied to the device. The device also might have more than one power cord. To remove all electrical current from the device, ensure that all power cords are disconnected from the power source.

S004



CAUTION:

When replacing the lithium battery, use only Lenovo specified part number or an equivalent type battery recommended by the manufacturer. If your system has a module containing a lithium battery, replace it only with the same module type made by the same manufacturer. The battery contains lithium and can explode if not properly used, handled, or disposed of.

Do not:

- Throw or immerse into water
- Heat to more than 100°C (212°F)
- Repair or disassemble

Dispose of the battery as required by local ordinances or regulations.

S005

**CAUTION:**

The battery is a lithium ion battery. To avoid possible explosion, do not burn the battery. Exchange it only with the approved part. Recycle or discard the battery as instructed by local regulations.

Attention:

- Read “Installation guidelines” on page 57 to ensure that you work safely.
- Power off the server and disconnect all power cords for this task.
- Prevent exposure to static electricity, which might lead to system halt and loss of data, by keeping static-sensitive components in their static-protective packages until installation, and handling these devices with an electrostatic-discharge wrist strap or other grounding system.
- If the server is in a rack, remove it from the rack.
- If foot stands are installed on the server, rotate them inwards and lay the server on its side for easier operation.

Watch the procedure. A video of the installation and removal process is available:

- YouTube: <https://youtube.com/playlist?list=PLYV5R7hVcs-DoEcxrm2zKNpaKOdZ3f8Qc>
- Youku: https://list.youku.com/albumlist/show/id_59636516

Procedure

Step 1. Make preparations for this task.

- a. Remove the server cover. See “Remove the server cover” on page 188.
- b. Remove all the flash power modules. See “Remove a flash power module” on page 98.
- c. Remove the air baffle. See “Remove the air baffle” on page 72.

Step 2. Locate the CMOS battery on the system board. See “System board components” on page 33.

Step 3. Remove the CMOS battery.

Attention: Do not apply excessive force on the CMOS battery. Failing to remove the CMOS battery properly might damage the socket on the system board. Any damage to the socket might require replacing the system board.

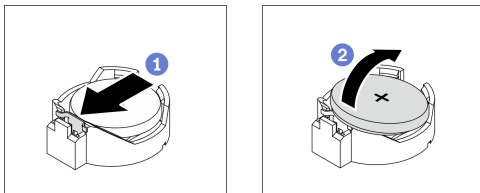

Figure 47. Removing the CMOS battery

- a. ① Press on the nub on the side of the CMOS battery.
- b. ② Pivot the battery away from the socket to remove it.

After you finish

- Install a new CMOS battery. See “Install the CMOS battery (CR2032)” on page 78.

- If you are instructed to return the component or optional device, follow all packaging instructions, and use any packaging materials for shipping that are supplied to you.

Install the CMOS battery (CR2032)

Use this information to install the CMOS battery (CR2032).

About this task

S002

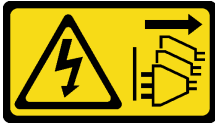

CAUTION:

The power-control button on the device and the power switch on the power supply do not turn off the electrical current supplied to the device. The device also might have more than one power cord. To remove all electrical current from the device, ensure that all power cords are disconnected from the power source.

S004



CAUTION:

When replacing the lithium battery, use only Lenovo specified part number or an equivalent type battery recommended by the manufacturer. If your system has a module containing a lithium battery, replace it only with the same module type made by the same manufacturer. The battery contains lithium and can explode if not properly used, handled, or disposed of.

Do not:

- Throw or immerse into water
- Heat to more than 100°C (212°F)
- Repair or disassemble

Dispose of the battery as required by local ordinances or regulations.

S005



CAUTION:

The battery is a lithium ion battery. To avoid possible explosion, do not burn the battery. Exchange it only with the approved part. Recycle or discard the battery as instructed by local regulations.

Attention:

- Read “Installation guidelines” on page 57 to ensure that you work safely.
- Power off the server and disconnect all power cords for this task.
- Prevent exposure to static electricity, which might lead to system halt and loss of data, by keeping static-sensitive components in their static-protective packages until installation, and handling these devices with an electrostatic-discharge wrist strap or other grounding system.

Consider the following when replacing the CMOS battery in the server:

- When replacing the CMOS battery, you must replace it with another CMOS battery of the same type from the same manufacturer.
- After replacing the CMOS battery, make sure to reconfigure the server and reset system date and time.
- Lenovo has designed this product with your safety in mind. The lithium battery must be handled correctly to avoid possible danger. If you install the CMOS battery, you must adhere to the following instructions.
- If you replace the original lithium battery with a heavy-metal battery or a battery with heavy-metal components, be aware of the following environmental consideration. Batteries and accumulators that contain heavy metals must not be disposed of with normal domestic waste. They will be taken back free of charge by the manufacturer, distributor, or representative, to be recycled or disposed of in a proper manner.

Watch the procedure. A video of the installation and removal process is available:

- YouTube: <https://youtube.com/playlist?list=PLYV5R7hVcs-DoEcxrm2zKNpaK0dZ3f8Qc>
- Youku: https://list.youku.com/albumlist/show/id_59636516

Procedure

Step 1. Install the CMOS battery.

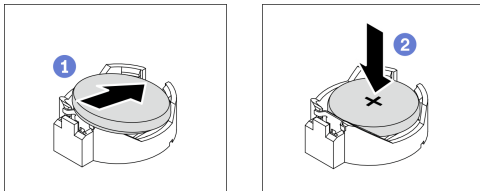

Figure 48. Installing the CMOS battery

- 1 Place the CMOS battery on top of the socket with the positive (+) symbol facing up.
- 2 Push the battery into the socket until it clicks in place.

After you finish

1. Reinstall the air baffle. See “Install the air baffle” on page 74.
2. Reinstall all the flash power modules. See “Install a flash power module” on page 100.
3. Reinstall the server cover. See “Install the server cover” on page 190.
4. Complete the parts replacement. See “Complete the parts replacement” on page 206.
5. Reset date, time, and all the passwords.

Drive replacement

Use the following information to remove and install drives.

The EMI integrity and cooling of the server are protected by having all drive bays covered or occupied. The number of the installed drives in your server varies depending on the server model. The vacant bays are occupied by dummy trays. When you install a drive, save the removed dummy tray from the drive bay in case you later remove the drive and need the dummy tray to cover the place.

Attention: An unoccupied drive bay without any other protection might impact the EMI integrity and cooling of the server, which might result in overheating or component damage. To maintain the EMI integrity and cooling of the server, install a new drive as soon as you remove the failing one or the dummy tray.

Before you begin, review the following drive installation rules:

- Follow the order of the drive bays. See Chapter 2 “Server components” on page 15 to locate the drive bays in your server.
- For SSDs with different capacities, install the drive by following the order of the drive bays as well as the order from the lowest capacity to the highest capacity.

Remove a simple-swap drive

Use this information to remove a simple-swap drive.

About this task

S002



CAUTION:

The power-control button on the device and the power switch on the power supply do not turn off the electrical current supplied to the device. The device also might have more than one power cord. To remove all electrical current from the device, ensure that all power cords are disconnected from the power source.

Attention:

- Read “Installation guidelines” on page 57 to ensure that you work safely.
- Power off the server and disconnect all power cords for this task.
- Prevent exposure to static electricity, which might lead to system halt and loss of data, by keeping static-sensitive components in their static-protective packages until installation, and handling these devices with an electrostatic-discharge wrist strap or other grounding system.

Before removing a simple-swap drive:

- Ensure that you have back up data on your drive, especially if it is part of a RAID array.
- Before you make changes to drives, RAID adapters, drive backplates, or drive cables, back up all important data that is stored on the drives.
- Before you remove any component of a RAID array, back up all RAID configuration information.

Watch the procedure. A video of the installation and removal process is available:

- YouTube: <https://youtube.com/playlist?list=PLYV5R7hVcs-DoEcxrm2zKNpaKOdZ3f8Qc>
- Youku: https://list.youku.com/albumlist/show/id_59636516

Procedure

- Step 1. Use the key to unlock the server cover; then, open the front door.
- Step 2. Locate the simple-swap drive you want to remove.
- Step 3. Remove the simple-swap drive.

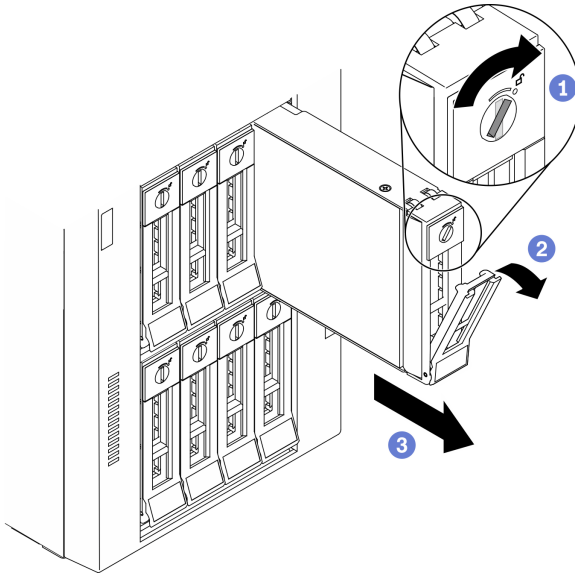

Figure 49. Opening the tray handle of a 3.5-inch simple-swap drive

- a. ① Use a screwdriver to turn the handle lock to the unlocked position.
- b. ② The tray handle opens automatically.
- c. ③ Pull the tray handle and carefully slide the simple-swap drive out of the drive bay.

After you finish

1. Install a new drive or drive filler into the vacant drive bay. See “Install a simple-swap drive” on page 81.

Note: To ensure that there is adequate system cooling, do not operate the server for more than two minutes without either a drive or a drive filler installed in each bay.

2. If you are instructed to return the component or optional device, follow all packaging instructions, and use any packaging materials for shipping that are supplied to you.

Install a simple-swap drive

Use this information to install a simple-swap drive.

About this task

S002



CAUTION:

The power-control button on the device and the power switch on the power supply do not turn off the electrical current supplied to the device. The device also might have more than one power cord. To

remove all electrical current from the device, ensure that all power cords are disconnected from the power source.

Attention:

- Read “Installation guidelines” on page 57 to ensure that you work safely.
- Power off the server and disconnect all power cords for this task.
- Prevent exposure to static electricity, which might lead to system halt and loss of data, by keeping static-sensitive components in their static-protective packages until installation, and handling these devices with an electrostatic-discharge wrist strap or other grounding system.

The following notes describe the type of drives that your server supports and other information that you must consider when you install a drive.

- For a complete list of supported optional devices for the server, see: <https://static.lenovo.com/us/en/serverproven/index.shtml>
- The drive bays are numbered to indicate the installation order (starting from number “0”). Follow the installation order when you install a drive. See “Front view” on page 16.
- The drives in a single RAID array must be the same type, same size, and same capacity.

Watch the procedure. A video of the installation and removal process is available:

- YouTube: <https://youtube.com/playlist?list=PLYV5R7hVcs-DoEcXrm2zKNpaKOdZ3f8Qc>
- Youku: https://list.youku.com/albumlist/show/id_59636516

Procedure

- Step 1. If the drive bay has a drive filler installed, remove it. Keep the drive filler in a safe place for future use.
- Step 2. Install the simple-swap drive.

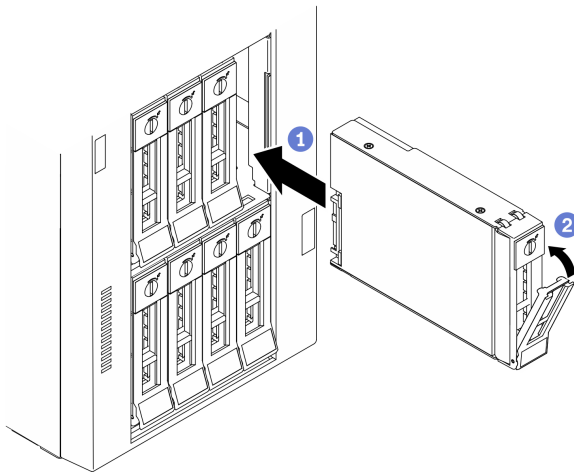

Figure 50. 3.5-inch simple-swap drive installation

- a. ① Ensure that the tray handle is in the open position. Align the drive with the guide rails in the bay; then, gently push the drive into the bay until the drive stops.
- b. ② Close the tray handle to lock the drive in place.

After you finish

1. Install other drives or drive fillers if necessary.

Note: All the drive bays must be occupied. This means that each bay must have a drive or drive filler installed.

2. Close the front door; then, use the key to lock the server cover.
3. Check the drive activity LED on the front panel to verify that the drive is operating correctly.

Simple-swap drive activity LED	Color	Description
Solid on	Green	The simple-swap drive is active.
Off	None	The simple-swap drive is not active.

4. Use the Lenovo XClarity Provisioning Manager to configure the RAID if necessary. For more information, see:

http://sysmgt.lenovofiles.com/help/index.jsp?topic=%2FLXPM%2FRAID_setup.html

5. Complete the parts replacement. See “Complete the parts replacement” on page 206.

Remove a hot-swap drive

Use this information to remove a hot-swap drive.

About this task

S033



CAUTION:

Hazardous energy present. Voltages with hazardous energy might cause heating when shorted with metal, which might result in spattered metal, burns, or both.

Attention:

- Read “Installation guidelines” on page 57 to ensure that you work safely.
- Prevent exposure to static electricity, which might lead to system halt and loss of data, by keeping static-sensitive components in their static-protective packages until installation, and handling these devices with an electrostatic-discharge wrist strap or other grounding system.

Before removing a hot-swap drive:

- Ensure that you have back up data on your drive, especially if it is part of a RAID array.
- Before you make changes to drives, RAID adapters, drive backplanes, or drive cables, back up all important data that is stored on the drives.
- Before you remove any component of a RAID array, back up all RAID configuration information.

Watch the procedure. A video of the installation and removal process is available:

- YouTube: <https://youtube.com/playlist?list=PLYV5R7hVcs-DoEcxrm2zKNpaKOdZ3f8Qc>
- Youku: https://list.youku.com/albumlist/show/id_59636516

Procedure

Step 1. Use the key to unlock the server cover; then, open the front door.

- Step 2. Locate the drive you want to remove.
- Step 3. Remove the hot-swap drive.

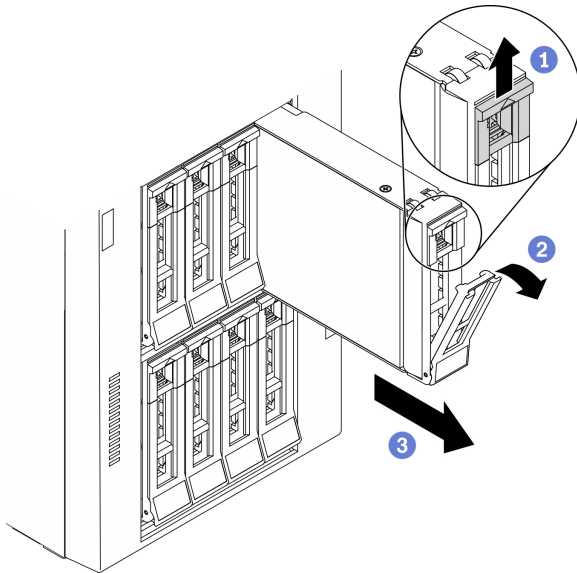

Figure 51. Opening the tray handle

- a. ① Slide the release latch to open the tray handle.
- b. ② The tray handle opens automatically.
- c. ③ Pull the tray handle and carefully slide the drive out of the drive bay.

After you finish

1. Install a new drive or install the drive filler to cover the drive bay. See “Install a hot-swap drive” on page 84.

Attention: To ensure that there is adequate system cooling, do not operate the server for more than two minutes without either a drive or a drive filler installed in each bay.

2. If you are instructed to return the component or optional device, follow all packaging instructions, and use any packaging materials for shipping that are supplied to you.

Install a hot-swap drive

Use this information to install a hot-swap drive.

About this task

S033



CAUTION:

Hazardous energy present. Voltages with hazardous energy might cause heating when shorted with metal, which might result in spattered metal, burns, or both.

Attention:

- Read “Installation guidelines” on page 57 to ensure that you work safely.
- Prevent exposure to static electricity, which might lead to system halt and loss of data, by keeping static-sensitive components in their static-protective packages until installation, and handling these devices with an electrostatic-discharge wrist strap or other grounding system.

The following notes describe the type of drives that your server supports and other information that you must consider when you install a drive.

- For a complete list of supported optional devices for the server, see: <https://static.lenovo.com/us/en/serverproven/index.shtml>
- The drive bays are numbered to indicate the installation order (starting from number “0”). Follow the installation order when you install a drive. See “Front view” on page 16.
- The drives in a single RAID array must be the same type, same size, and same capacity.

Watch the procedure. A video of the installation and removal process is available:

- YouTube: <https://youtube.com/playlist?list=PLYV5R7hVcs-DoEcxrm2zKNpaKOdZ3f8Qc>
- Youku: https://list.youku.com/albumlist/show/id_59636516

Procedure

Step 1. If the drive bay has a drive filler installed, remove it. Keep the drive filler in a safe place for future use.

Step 2. Install the hot-swap drive.

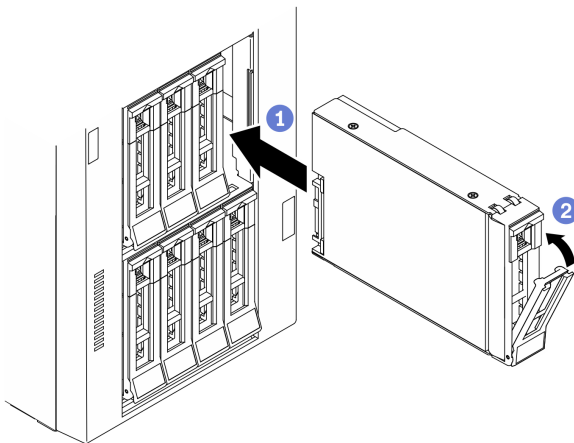

Figure 52. Hot-swap drive installation

- a. ① Ensure that the tray handle is in the open position. Slide the drive into the drive bay until it snaps into position.
- b. ② Close the tray handle to lock the drive in place.

After you finish

1. Install other drives or drive fillers if necessary.

Note: All the drive bays must be occupied. This means that each bay must have a drive or drive filler installed.

2. Close the front door; then, use the key to lock the server cover.

3. Check the drive LEDs to verify that the drive is operating correctly.

Drive LED	Status	Description
Drive activity LED (top)	Solid green	The drive is powered but not active.
	Blinking green	The drive is active.
Drive status LED (bottom)	Solid yellow	The drive has an error.
	Blinking yellow (blinking slowly, about one flash per second)	The drive is being rebuilt.
	Blinking yellow (blinking rapidly, about four flashes per second)	The RAID adapter is locating the drive.

4. Use the Lenovo XClarity Provisioning Manager to configure the RAID if necessary. For more information, see:

http://sysmgt.lenovofiles.com/help/index.jsp?topic=%2FLXPM%2FRAID_setup.html

5. Complete the parts replacement. See “Complete the parts replacement” on page 206.

EIA brackets replacement

Use this information to remove and install the EIA brackets of the server in rack form factor.

Note: This section applies only to server models that have the EIA brackets installed.

Remove the EIA brackets

Use this information to remove the EIA brackets.

About this task

S002



CAUTION:

The power-control button on the device and the power switch on the power supply do not turn off the electrical current supplied to the device. The device also might have more than one power cord. To remove all electrical current from the device, ensure that all power cords are disconnected from the power source.

Attention:

- Read “Installation guidelines” on page 57 to ensure that you work safely.
- Power off the server and disconnect all power cords for this task.
- Prevent exposure to static electricity, which might lead to system halt and loss of data, by keeping static-sensitive components in their static-protective packages until installation, and handling these devices with an electrostatic-discharge wrist strap or other grounding system.
- If the server is in a rack, remove it from the rack.

Watch the procedure. A video of the installation and removal process is available:

- YouTube: <https://youtube.com/playlist?list=PLYV5R7hVcs-DoEcxrm2zKNpaKOdZ3f8Qc>
- Youku: https://list.youku.com/albumlist/show/id_59636516

Procedure

- Step 1. Lay the server on its side.
- Step 2. Use a screwdriver to remove the three screws that secure the right EIA bracket; then, remove the right EIA bracket.

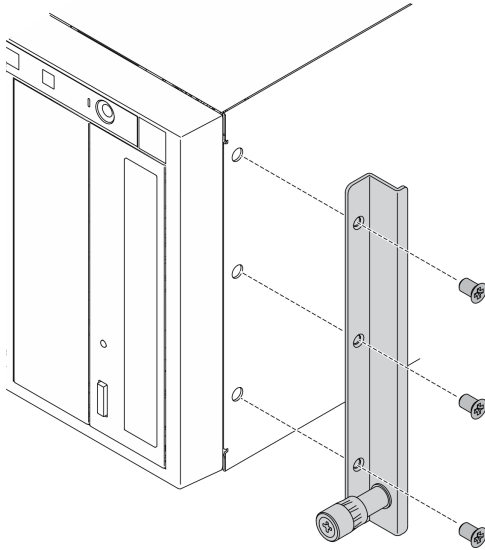

Figure 53. Right EIA bracket removal

- Step 3. Use a screwdriver to remove the three screws that secure the left EIA bracket; then, remove the left EIA bracket.

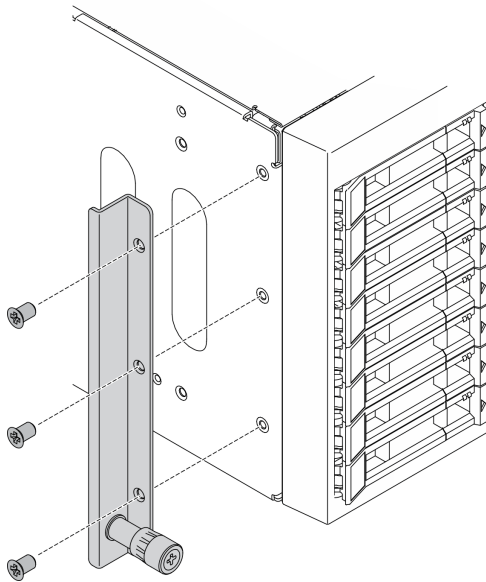

Figure 54. Left EIA bracket removal

After you finish

If you are instructed to return the component or optional device, follow all packaging instructions, and use any packaging materials for shipping that are supplied to you.

Install the EIA brackets

Use this information to install the EIA brackets.

About this task

S002



CAUTION:

The power-control button on the device and the power switch on the power supply do not turn off the electrical current supplied to the device. The device also might have more than one power cord. To remove all electrical current from the device, ensure that all power cords are disconnected from the power source.

Attention:

- Read “Installation guidelines” on page 57 to ensure that you work safely.
- Power off the server and disconnect all power cords for this task.
- Prevent exposure to static electricity, which might lead to system halt and loss of data, by keeping static-sensitive components in their static-protective packages until installation, and handling these devices with an electrostatic-discharge wrist strap or other grounding system.

Watch the procedure. A video of the installation and removal process is available:

- YouTube: <https://youtube.com/playlist?list=PLYV5R7hVcs-DoEcxrm2zKNpaKOdZ3f8Qc>
- Youku: https://list.youku.com/albumlist/show/id_59636516

Procedure

Step 1. Align the holes in the right EIA bracket with the corresponding holes on the top of the chassis; then, use a screwdriver to install the three screws to secure the right EIA bracket

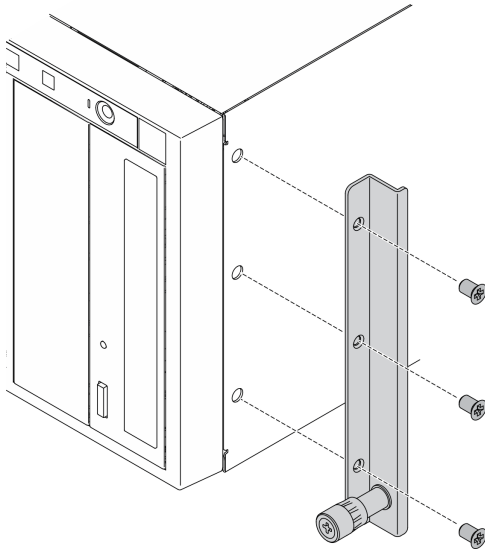

Figure 55. Right EIA bracket installation

Step 2. Align the holes in the left EIA bracket with the corresponding holes on the bottom of the chassis; then, use a screwdriver to install the three screws to secure the left EIA bracket.

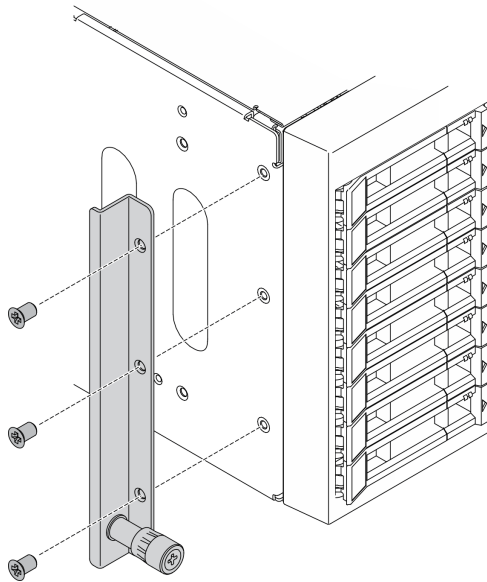

Figure 56. Left EIA bracket installation

After you finish

Complete the parts replacement. See “Complete the parts replacement” on page 206.

Expansion drive cage replacement

Use this information to remove and install the expansion drive cage.

Note: This section applies only to server models that have the expansion drive cage installed.

Remove the expansion drive cage

Use this information to remove the expansion drive cage.

About this task

S002



CAUTION:

The power-control button on the device and the power switch on the power supply do not turn off the electrical current supplied to the device. The device also might have more than one power cord. To remove all electrical current from the device, ensure that all power cords are disconnected from the power source.

Attention:

- Read “Installation guidelines” on page 57 to ensure that you work safely.

- Power off the server and disconnect all power cords for this task.
- Prevent exposure to static electricity, which might lead to system halt and loss of data, by keeping static-sensitive components in their static-protective packages until installation, and handling these devices with an electrostatic-discharge wrist strap or other grounding system.
- If the server is in a rack, remove it from the rack.

Watch the procedure. A video of the installation and removal process is available:

- YouTube: <https://youtube.com/playlist?list=PLYV5R7hVcs-DoEcxrm2zKNpaK0dZ3f8Qc>
- Youku: https://list.youku.com/albumlist/show/id_59636516

Procedure

Step 1. Make preparations for this task.

- Remove the server cover. See “Remove the server cover” on page 188.
- Remove the front door. See “Remove the front door” on page 107.
- Remove the front bezel. See “Remove the front bezel” on page 105.
- Remove all installed hot-swap drives and drive bay fillers (if any) from the drive bays. See “Remove a hot-swap drive” on page 83.

Step 2. Disconnect all the cables from the backplane.

Step 3. Remove the expansion drive cage.

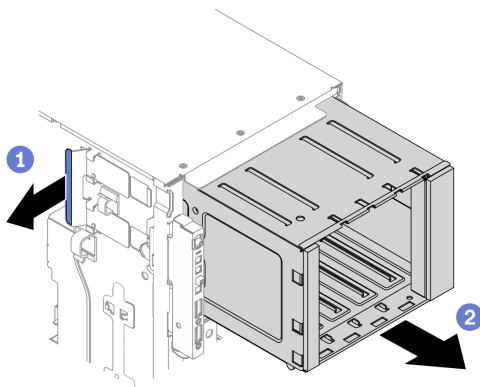

Figure 57. Expansion drive cage removal

- 1 Lift and hold the blue retention tab.
- 2 Carefully pull the expansion drive cage at the same time to slide it out of the opening in the chassis.

After you finish

- Install an expansion drive cage or an optical drive cage. See “Install the expansion drive cage” on page 91 or “Install the optical drive cage” on page 145.
- If you are instructed to return the component or optional device, follow all packaging instructions, and use any packaging materials for shipping that are supplied to you.

Install the expansion drive cage

Use this information to install the expansion drive cage.

About this task

S002

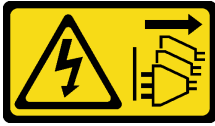

CAUTION:

The power-control button on the device and the power switch on the power supply do not turn off the electrical current supplied to the device. The device also might have more than one power cord. To remove all electrical current from the device, ensure that all power cords are disconnected from the power source.

Attention:

- Read “Installation guidelines” on page 57 to ensure that you work safely.
- Power off the server and disconnect all power cords for this task.
- Prevent exposure to static electricity, which might lead to system halt and loss of data, by keeping static-sensitive components in their static-protective packages until installation, and handling these devices with an electrostatic-discharge wrist strap or other grounding system.

Watch the procedure. A video of the installation and removal process is available:

- YouTube: <https://youtube.com/playlist?list=PLYV5R7hVcs-DoEcxrm2zKNpaKOdZ3f8Qc>
- Youku: https://list.youku.com/albumlist/show/id_59636516

Procedure

Step 1. Install the expansion drive cage.

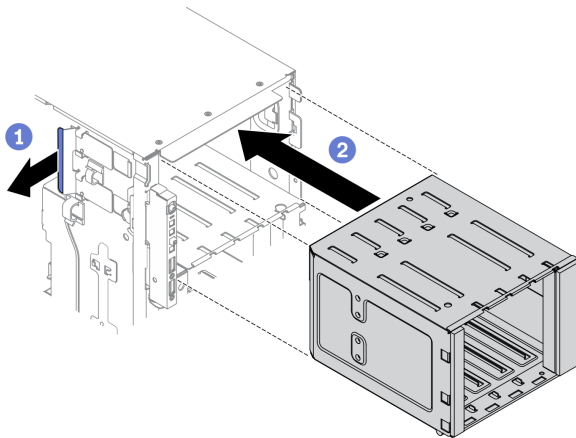

Figure 58. Expansion drive cage installation

- a. ① Lift and hold the blue retention tab.
- b. ② Carefully push the expansion drive cage at the same time to slide it into the bay until it snaps into position.

After you finish

1. Reconnect the cables to the backplane. See “3.5-inch hot-swap drive backplane cable routing” in the *ThinkSystem ST650 V2 Backplane/Backplate Cable Routing Guide*.

2. Reinstall all the hot-swap drives and drive bay fillers (if any) into the drive bays. See “Install a hot-swap drive” on page 84.
3. Reinstall the front bezel. See “Install the front bezel” on page 106.
4. Reinstall the front door. See “Install the front door” on page 109.
5. Reinstall the server cover. See “Install the server cover” on page 190.
6. Complete the parts replacement. See “Complete the parts replacement” on page 206.

Fan and fan cage replacement

Use this procedure to remove or install fan and fan cage assembly.

Remove a hot-swap fan

Use this procedure to remove a hot-swap fan.

About this task

S017



CAUTION:

Hazardous moving fan blades nearby. Keep fingers and other body parts away.

S033



CAUTION:

Hazardous energy present. Voltages with hazardous energy might cause heating when shorted with metal, which might result in spattered metal, burns, or both.

Attention:

- Read “Installation guidelines” on page 57 to ensure that you work safely.
- Prevent exposure to static electricity, which might lead to system halt and loss of data, by keeping static-sensitive components in their static-protective packages until installation, and handling these devices with an electrostatic-discharge wrist strap or other grounding system.
- If the server is in a rack, remove it from the rack.
- If foot stands are installed on the server, rotate them inwards and lay the server on its side for easier operation.

Watch the procedure. A video of the installation and removal process is available:

- YouTube: <https://youtube.com/playlist?list=PLYV5R7hVcs-DoEcXrm2zKNpaKOdZ3f8Qc>
- Youku: https://list.youku.com/albumlist/show/id_59636516

Procedure

Step 1. Remove the server cover. See “Remove the server cover” on page 188.

Step 2. Remove the hot-swap fan.

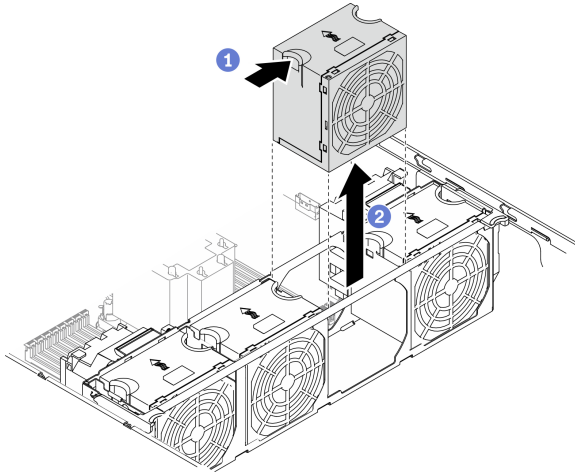

Figure 59. Hot-swap fan removal

- a. ① Pinch on the top of the fan, and press on the latch to release the fan from the connector.
- b. ② Lift the fan out from the fan cage.

After you finish

1. Install a new fan or install a fan filler to cover the place. See “Install a hot-swap fan” on page 94.
2. If you are instructed to return the component or optional device, follow all packaging instructions, and use any packaging materials for shipping that are supplied to you.

Install a hot-swap fan

Use this procedure to install a hot-swap fan.

About this task

S017



CAUTION:
Hazardous moving fan blades nearby. Keep fingers and other body parts away.

S033



CAUTION:

Hazardous energy present. Voltages with hazardous energy might cause heating when shorted with metal, which might result in spattered metal, burns, or both.

Attention:

- Read “Installation guidelines” on page 57 to ensure that you work safely.
- Prevent exposure to static electricity, which might lead to system halt and loss of data, by keeping static-sensitive components in their static-protective packages until installation, and handling these devices with an electrostatic-discharge wrist strap or other grounding system.

Watch the procedure. A video of the installation and removal process is available:

- YouTube: <https://youtube.com/playlist?list=PLYV5R7hVcs-DoEcXrm2zKNpaKOdZ3f8Qc>
- Youku: https://list.youku.com/albumlist/show/id_59636516

Procedure

Step 1. Locate the required fan slot in the fan cage.

Note: Ensure that you observe the installation rules and sequence in “Technical rules for system fans” in the *ThinkSystem ST650 V2 Setup Guide*.

Step 2. Align the fan over the fan slot in the fan cage assembly.

Step 3. Insert the fan into the fan cage assembly until it clicks into place.

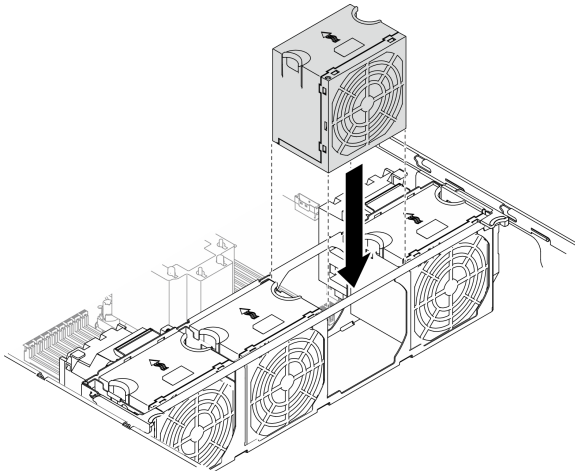

Figure 60. Hot-swap fan installation

After you finish

1. Reinstall the server cover. See “Install the server cover” on page 190.
2. Complete the parts replacement. See “Complete the parts replacement” on page 206.

Remove the fan cage assembly

Use this procedure to remove the fan cage assembly.

About this task

S002

**CAUTION:**

The power-control button on the device and the power switch on the power supply do not turn off the electrical current supplied to the device. The device also might have more than one power cord. To remove all electrical current from the device, ensure that all power cords are disconnected from the power source.

Attention:

- Read “Installation guidelines” on page 57 to ensure that you work safely.
- Power off the server and disconnect all power cords for this task.
- Prevent exposure to static electricity, which might lead to system halt and loss of data, by keeping static-sensitive components in their static-protective packages until installation, and handling these devices with an electrostatic-discharge wrist strap or other grounding system.
- If the server is in a rack, remove it from the rack.
- If foot stands are installed on the server, rotate them inwards and lay the server on its side for easier operation.

Watch the procedure. A video of the installation and removal process is available:

- YouTube: <https://youtube.com/playlist?list=PLYV5R7hVcs-DoEcxrm2zKNpaKOdZ3f8Qc>
- Youku: https://list.youku.com/albumlist/show/id_59636516

Procedure

Step 1. Make preparations for this task.

- a. Remove the server cover. See “Remove the server cover” on page 188.
- b. Remove all the flash power modules. See “Remove a flash power module” on page 98.
- c. Remove the air baffle. See “Remove the air baffle” on page 72.
- d. Remove all the full-length GPU adapters. See “Remove a full-length GPU adapter” on page 113.
- e. Remove all the fans. See “Remove a hot-swap fan” on page 93.

Step 2. Remove the fan cage assembly.

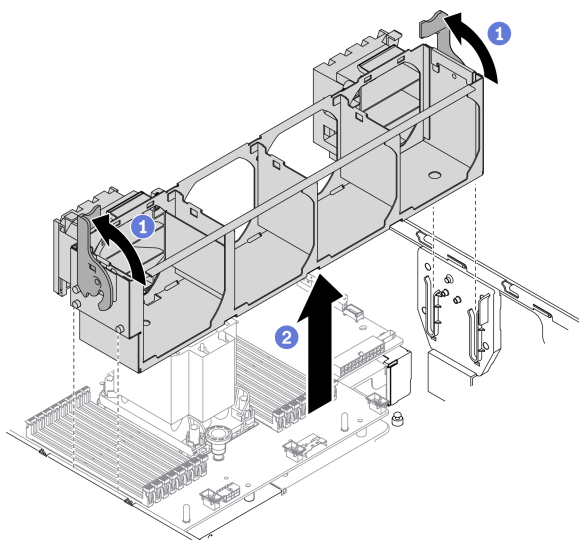

Figure 61. Fan cage assembly removal

- a. ① Lift and rotate the fan cage release latches to disengage the fan cage assembly from the server.
- b. ② Lift the fan cage assembly from the server.

After you finish

If you are instructed to return the component or optional device, follow all packaging instructions, and use any packaging materials for shipping that are supplied to you.

Install the fan cage assembly

Use this procedure to install the fan cage assembly.

About this task

S002



CAUTION:

The power-control button on the device and the power switch on the power supply do not turn off the electrical current supplied to the device. The device also might have more than one power cord. To remove all electrical current from the device, ensure that all power cords are disconnected from the power source.

Attention:

- Read “Installation guidelines” on page 57 to ensure that you work safely.
- Power off the server and disconnect all power cords for this task.
- Prevent exposure to static electricity, which might lead to system halt and loss of data, by keeping static-sensitive components in their static-protective packages until installation, and handling these devices with an electrostatic-discharge wrist strap or other grounding system.

Watch the procedure. A video of the installation and removal process is available:

- YouTube: <https://youtube.com/playlist?list=PLYV5R7hVcs-DoEcxrm2zKNpaKOdZ3f8Qc>
- Youku: https://list.youku.com/albumlist/show/id_59636516

Procedure

Step 1. Install the fan cage assembly.

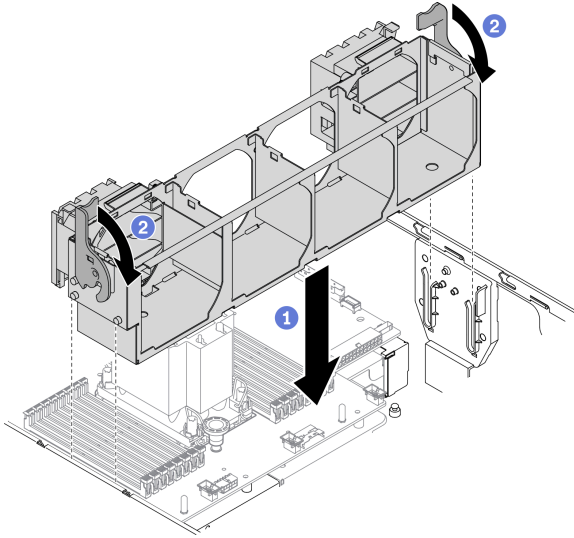

Figure 62. Fan cage assembly installation

- a. ① Align the fan cage assembly to the slots on both sides of the server, and lower it into the server.
- b. ② Rotate the fan cage release latches down until they stop.

After you finish

1. Reinstall all the fans. See “Install a hot-swap fan” on page 94.
2. Reinstall all the full-length GPU adapters. See “Install a full-length GPU adapter” on page 114.
3. Reinstall the air baffle. See “Install the air baffle” on page 74.
4. Reinstall all the flash power modules. See “Install a flash power module” on page 100.
5. Reinstall the server cover. See “Install the server cover” on page 190.
6. Complete the parts replacement. See “Complete the parts replacement” on page 206.

Flash power module replacement

Use this information to remove and install the flash power module.

The flash power module protects the cache memory on the installed RAID adapter. You can purchase a flash power module from Lenovo.

For a list of supported options, see: <https://static.lenovo.com/us/en/serverproven/index.shtml>

Remove a flash power module

Use this information to remove a flash power module.

About this task

S002



CAUTION:

The power-control button on the device and the power switch on the power supply do not turn off the electrical current supplied to the device. The device also might have more than one power cord. To remove all electrical current from the device, ensure that all power cords are disconnected from the power source.

Attention:

- Read “Installation guidelines” on page 57 to ensure that you work safely.
- Power off the server and disconnect all power cords for this task.
- Prevent exposure to static electricity, which might lead to system halt and loss of data, by keeping static-sensitive components in their static-protective packages until installation, and handling these devices with an electrostatic-discharge wrist strap or other grounding system.
- If the server is in a rack, remove it from the rack.
- If foot stands are installed on the server, rotate them inwards and lay the server on its side for easier operation.

Locate the flash power module slot on the air baffle.

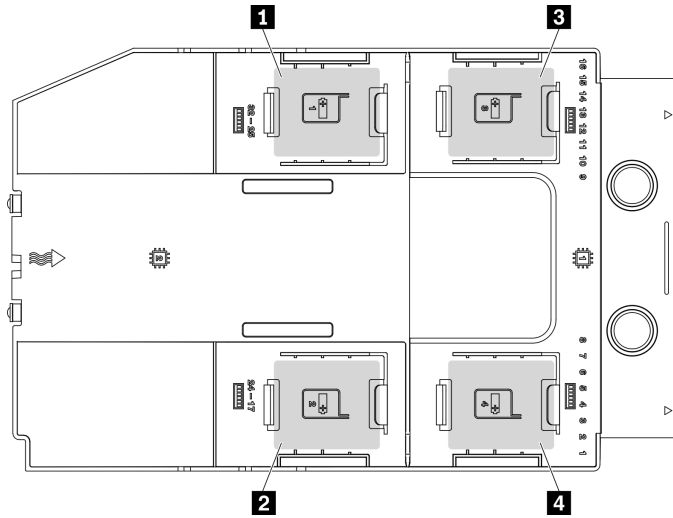

Figure 63. Flash power module slot location

Table 17. Flash power module slot location on air baffle

1 Flash power module slot 1	3 Flash power module slot 3
2 Flash power module slot 2	4 Flash power module slot 4

Watch the procedure. A video of the installation and removal process is available:

- YouTube: <https://youtube.com/playlist?list=PLYV5R7hVcs-DoEcxrm2zKNpaKOdZ3f8Qc>
- Youku: https://list.youku.com/albumlist/show/id_59636516

Procedure

- Step 1. Remove the server cover. See “Remove the server cover” on page 188.
- Step 2. Disconnect the cable of the flash power module from the RAID adapter.
- Step 3. Remove the flash power module.

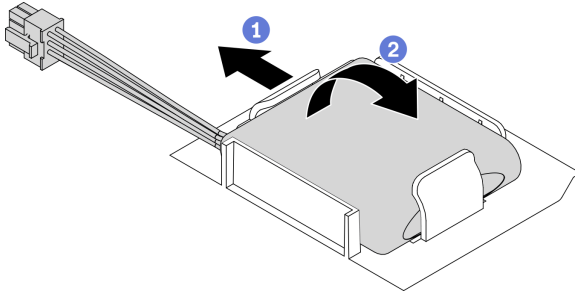

Figure 64. Flash power module removal

- a. ① Gently pivot the retaining clip as shown.
- b. ② Lift the flash power module up and remove it from the holder.

After you finish

If you are instructed to return the component or optional device, follow all packaging instructions, and use any packaging materials for shipping that are supplied to you.

Install a flash power module

Use this information to install a flash power module.

About this task

S002



CAUTION:

The power-control button on the device and the power switch on the power supply do not turn off the electrical current supplied to the device. The device also might have more than one power cord. To remove all electrical current from the device, ensure that all power cords are disconnected from the power source.

Attention:

- Read “Installation guidelines” on page 57 to ensure that you work safely.
- Power off the server and disconnect all power cords for this task.

- Prevent exposure to static electricity, which might lead to system halt and loss of data, by keeping static-sensitive components in their static-protective packages until installation, and handling these devices with an electrostatic-discharge wrist strap or other grounding system.

Locate the flash power module slot on the air baffle.

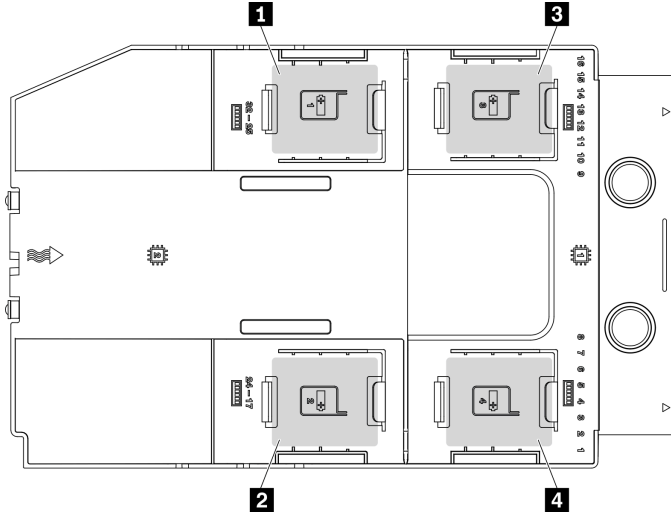

Figure 65. Flash power module slot location

Table 18. Flash power module slot location on air baffle

1 Flash power module slot 1	3 Flash power module slot 3
2 Flash power module slot 2	4 Flash power module slot 4

Watch the procedure. A video of the installation and removal process is available:

- YouTube: <https://youtube.com/playlist?list=PLYV5R7hVcs-DoEcxrm2zKNpaKOdZ3f8Qc>
- Youku: https://list.youku.com/albumlist/show/id_59636516

Procedure

Step 1. Install the flash power module.

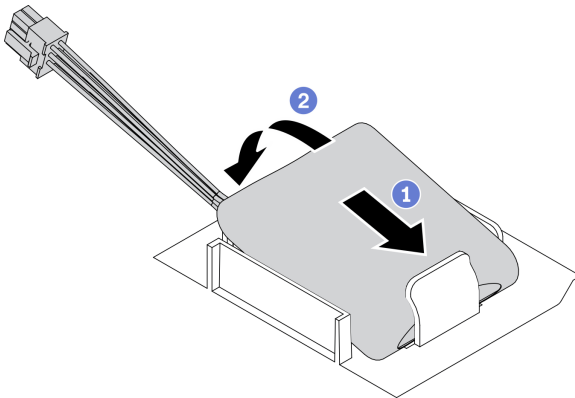

Figure 66. Flash power module installation

- a. ① Note the orientation of the flash power module; then, gently insert the flash power module into the retaining clip at one side as shown.
- b. ② Press the flash power module down on the other side until it snaps into place.

Step 2. Route the flash power module cable and connect it to the RAID adapter.

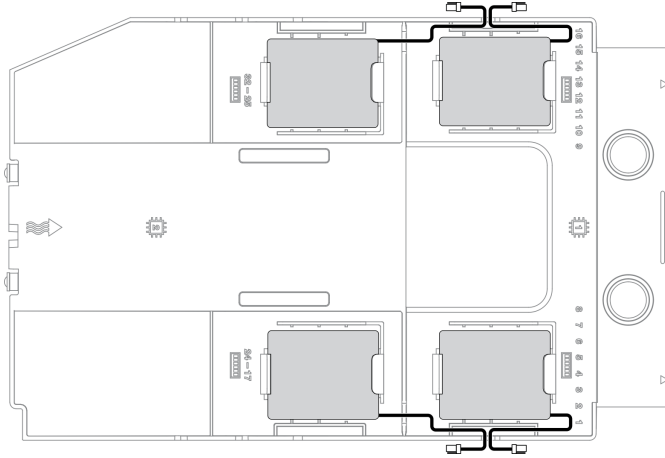

Figure 67. Flash power module cable routing

After you finish

1. Reinstall the server cover. See “Install the server cover” on page 190.
2. Complete the parts replacement. See “Complete the parts replacement” on page 206.

Foot stands replacement

Use this information to remove and install the foot stands.

Note: This section applies only to server models that have foot stands installed.

Remove the foot stands

Use this information to remove the foot stands.

About this task

S033



CAUTION:

Hazardous energy present. Voltages with hazardous energy might cause heating when shorted with metal, which might result in spattered metal, burns, or both.

Attention:

- Read “Installation guidelines” on page 57 to ensure that you work safely.

- Prevent exposure to static electricity, which might lead to system halt and loss of data, by keeping static-sensitive components in their static-protective packages until installation, and handling these devices with an electrostatic-discharge wrist strap or other grounding system.

Watch the procedure. A video of the installation and removal process is available:

- YouTube: <https://youtube.com/playlist?list=PLYV5R7hVcs-DoEcxrm2zKNpaKOdZ3f8Qc>
- Youku: https://list.youku.com/albumlist/show/id_59636516

Procedure

Step 1. For each foot stand, rotate the foot stand inwards; then, lay the server on its side.

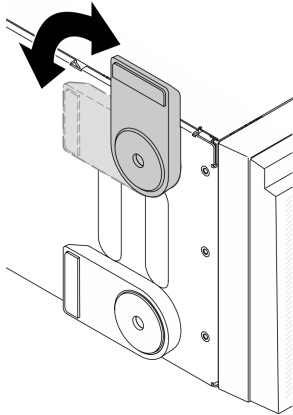

Figure 68. Foot stand adjustment

Step 2. For each foot stand, use a screwdriver to remove the screw that secures the foot stand; then, remove the foot stand from the chassis.

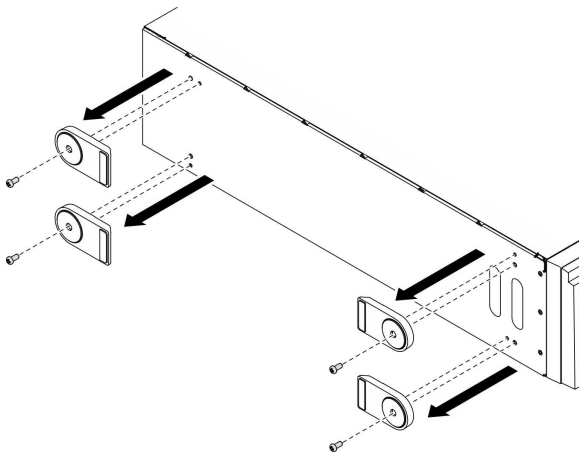

Figure 69. Foot stand removal

After you finish

If you are instructed to return the component or optional device, follow all packaging instructions, and use any packaging materials for shipping that are supplied to you.

Install the foot stands

Use this information to install the foot stands.

About this task

S033



CAUTION:

Hazardous energy present. Voltages with hazardous energy might cause heating when shorted with metal, which might result in spattered metal, burns, or both.

Attention:

- Read “Installation guidelines” on page 57 to ensure that you work safely.
- Prevent exposure to static electricity, which might lead to system halt and loss of data, by keeping static-sensitive components in their static-protective packages until installation, and handling these devices with an electrostatic-discharge wrist strap or other grounding system.

Watch the procedure. A video of the installation and removal process is available:

- YouTube: <https://youtube.com/playlist?list=PLYV5R7hVcs-DoEcXrm2zKNpaKOdZ3f8Qc>
- Youku: https://list.youku.com/albumlist/show/id_59636516

Procedure

Step 1. For each foot stand, carefully align the pin and screw hole on the foot stand with the corresponding hole on the chassis; then, use a screwdriver to install a screw to secure the foot stand.

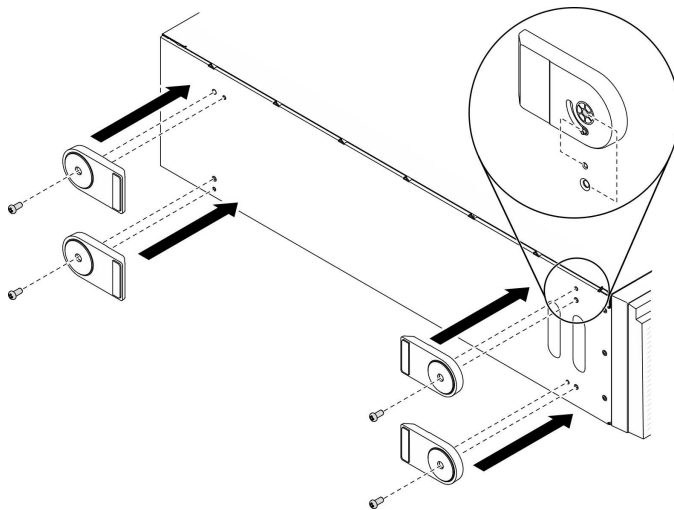

Figure 70. Foot stand installation

Step 2. For each foot stand, rotate the foot stand outwards.

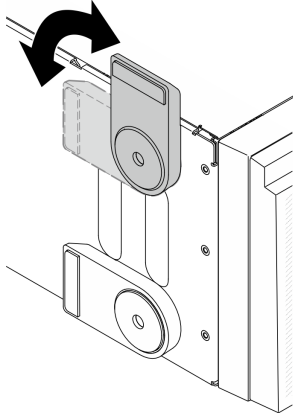

Figure 71. Foot stand adjustment

Important: To help the server stand steadily, ensure that the foot stands are rotated outward.

After you finish

Complete the parts replacement. See “Complete the parts replacement” on page 206.

Front bezel replacement

Use this information to remove and install the front bezel.

Remove the front bezel

Use this information to remove the front bezel.

About this task

S033



CAUTION:

Hazardous energy present. Voltages with hazardous energy might cause heating when shorted with metal, which might result in spattered metal, burns, or both.

Attention:

- Read “Installation guidelines” on page 57 to ensure that you work safely.
- Prevent exposure to static electricity, which might lead to system halt and loss of data, by keeping static-sensitive components in their static-protective packages until installation, and handling these devices with an electrostatic-discharge wrist strap or other grounding system.
- If the server is in a rack, remove it from the rack.
- If foot stands are installed on the server, rotate them inwards and lay the server on its side for easier operation.

Watch the procedure. A video of the installation and removal process is available:

- YouTube: <https://youtube.com/playlist?list=PLYV5R7hVcs-DoEcxrm2zKNpaKOdZ3f8Qc>
- Youku: https://list.youku.com/albumlist/show/id_59636516

Procedure

Step 1. Make preparations for this task.

- Remove the server cover. See “Remove the server cover” on page 188.
- Remove the front door. See “Remove the front door” on page 107.

Step 2. Remove the front bezel.

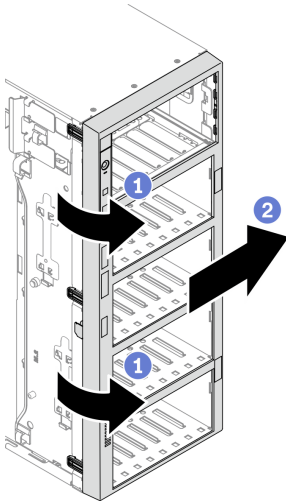

Figure 72. Front bezel removal

- ① Lift the three plastic tabs to release the left side of the bezel from the chassis.
- ② Pivot the bezel as shown to remove it from the chassis.

After you finish

If you are instructed to return the component or optional device, follow all packaging instructions, and use any packaging materials for shipping that are supplied to you.

Install the front bezel

Use this information to install the front bezel.

About this task

S033



CAUTION:

Hazardous energy present. Voltages with hazardous energy might cause heating when shorted with metal, which might result in spattered metal, burns, or both.

Attention:

- Read “Installation guidelines” on page 57 to ensure that you work safely.
- Prevent exposure to static electricity, which might lead to system halt and loss of data, by keeping static-sensitive components in their static-protective packages until installation, and handling these devices with an electrostatic-discharge wrist strap or other grounding system.

Watch the procedure. A video of the installation and removal process is available:

- YouTube: <https://youtube.com/playlist?list=PLYV5R7hVcs-DoEcxm2zKNpaKOdZ3f8Qc>
- Youku: https://list.youku.com/albumlist/show/id_59636516

Procedure

Step 1. Install the front bezel.

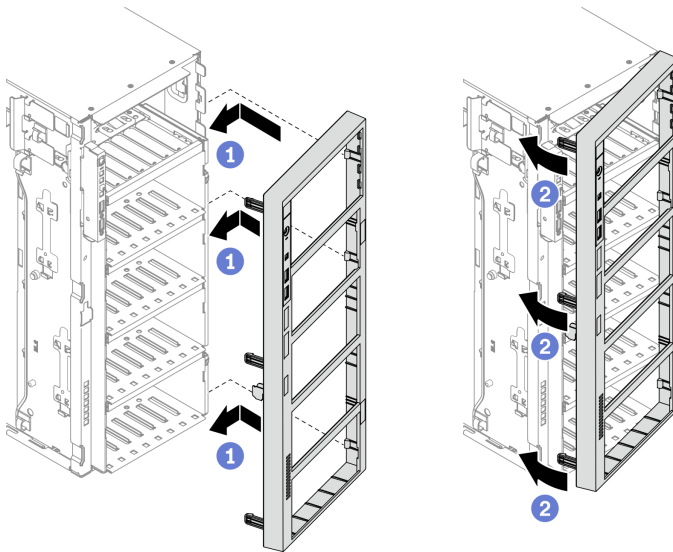

Figure 73. Front bezel installation

- 1 Align the three plastic tabs on the right side of the front bezel with the corresponding holes in the chassis.
- 2 Pivot the front bezel inward until it snaps into position on the left side.

After you finish

1. Reinstall the front door. See “Install the front door” on page 109.
2. Reinstall the server cover. See “Install the server cover” on page 190.
3. Complete the parts replacement. See “Complete the parts replacement” on page 206.

Front door replacement

Use this information to remove and install the front door.

Note: This section applies only to server models that have a front door installed.

Remove the front door

Use this information to remove the front door.

About this task

S033



CAUTION:

Hazardous energy present. Voltages with hazardous energy might cause heating when shorted with metal, which might result in spattered metal, burns, or both.

Attention:

- Read “Installation guidelines” on page 57 to ensure that you work safely.
- Prevent exposure to static electricity, which might lead to system halt and loss of data, by keeping static-sensitive components in their static-protective packages until installation, and handling these devices with an electrostatic-discharge wrist strap or other grounding system.

Watch the procedure. A video of the installation and removal process is available:

- YouTube: <https://youtube.com/playlist?list=PLYV5R7hVcs-DoEcXrm2zKNpaKOdZ3f8Qc>
- Youku: https://list.youku.com/albumlist/show/id_59636516

Procedure

Step 1. Remove the front door.

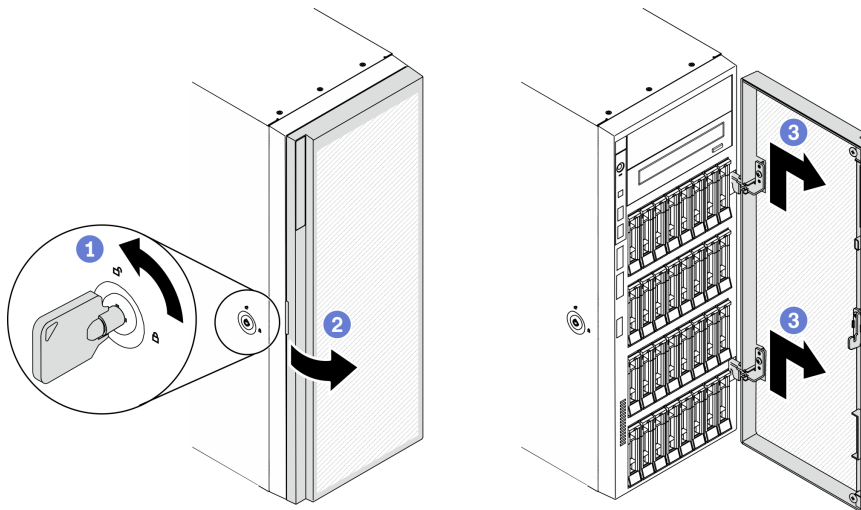

Figure 74. Front door removal

- a. ① Use the key attached on the rear of the server to turn the cover lock to the unlocked position.
- b. ② Open the front door.
- c. ③ Lift the front door slightly upwards until you can completely remove it.

After you finish

If you are instructed to return the component or optional device, follow all packaging instructions, and use any packaging materials for shipping that are supplied to you.

Install the front door

Use this information to install the front door.

About this task

S033



CAUTION:

Hazardous energy present. Voltages with hazardous energy might cause heating when shorted with metal, which might result in spattered metal, burns, or both.

Attention:

- Read “Installation guidelines” on page 57 to ensure that you work safely.
- Prevent exposure to static electricity, which might lead to system halt and loss of data, by keeping static-sensitive components in their static-protective packages until installation, and handling these devices with an electrostatic-discharge wrist strap or other grounding system.

Watch the procedure. A video of the installation and removal process is available:

- YouTube: <https://youtube.com/playlist?list=PLYV5R7hVcs-DoEcxm2zKNpaKODz3f8Qc>
- Youku: https://list.youku.com/albumlist/show/id_59636516

Procedure

Step 1. Install the front door.

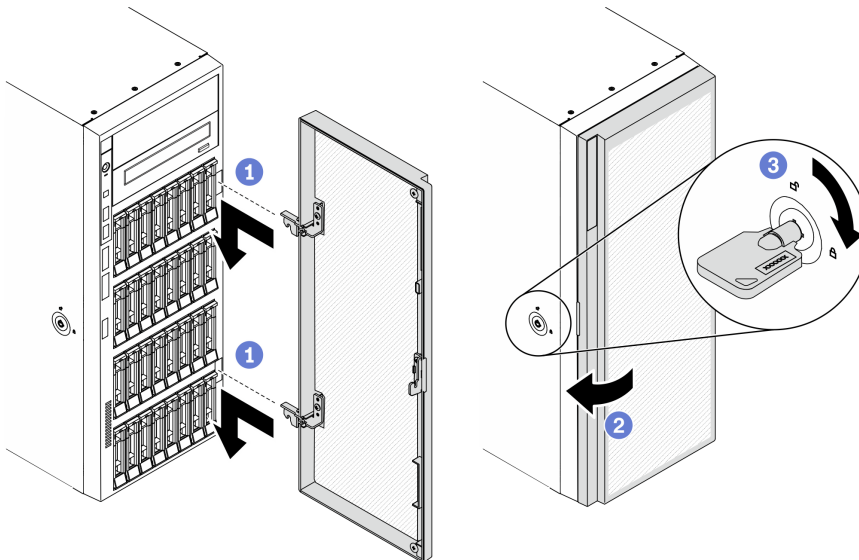

Figure 75. Front door installation

- a. ① Align the two hooks on the front door with the corresponding holes in the front bezel; then, move the front door inwards and then pull it slightly downwards until it is secured in place by the hooks.

- b. ② Close the front door.
- c. ③ Lock the server cover.

After you finish

Complete the parts replacement. See “Complete the parts replacement” on page 206.

Front panel board assembly replacement

Use this information to remove and install the front panel board assembly.

Remove the front panel board assembly

Use this information to remove the front panel board assembly.

About this task

S002



CAUTION:

The power-control button on the device and the power switch on the power supply do not turn off the electrical current supplied to the device. The device also might have more than one power cord. To remove all electrical current from the device, ensure that all power cords are disconnected from the power source.

Attention:

- Read “Installation guidelines” on page 57 to ensure that you work safely.
- Power off the server and disconnect all power cords for this task.
- Prevent exposure to static electricity, which might lead to system halt and loss of data, by keeping static-sensitive components in their static-protective packages until installation, and handling these devices with an electrostatic-discharge wrist strap or other grounding system.
- If the server is in a rack, remove it from the rack.
- If foot stands are installed on the server, rotate them inwards and lay the server on its side for easier operation.

Watch the procedure. A video of the installation and removal process is available:

- YouTube: <https://youtube.com/playlist?list=PLYV5R7hVcs-DoEcxm2zKNpaKOdZ3f8Qc>
- Youku: https://list.youku.com/albumlist/show/id_59636516

Procedure

Step 1. Make preparations for this task.

- a. Remove the server cover. See “Remove the server cover” on page 188.
- b. Remove all the flash power modules. See “Remove a flash power module” on page 98.
- c. Remove the air baffle. See “Remove the air baffle” on page 72.
- d. Remove all the full-length GPU adapters. See “Remove a full-length GPU adapter” on page 113.

- e. Remove all the fans. See “Remove a hot-swap fan” on page 93.
 - f. Remove the fan cage. See “Remove the fan cage assembly” on page 95.
 - g. Remove the front door. See “Remove the front door” on page 107.
 - h. Remove the front bezel. See “Remove the front bezel” on page 105.
- Step 2. Locate the front panel board assembly and disconnect the cables from the system board; then, remove the cable from the cable clips. See “Front panel cable routing” on page 48.
- Step 3. Remove the front panel board assembly .

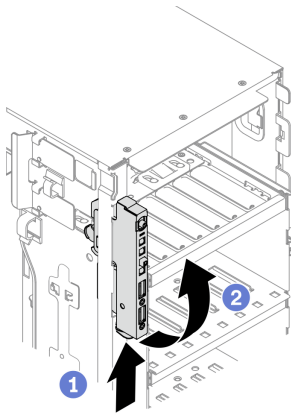

Figure 76. Front panel board assembly removal

- a. ① Press the release tab in the direction as shown.
- b. ② Pivot the front panel board assembly outwards; then, pull the cables out to completely remove the front panel board assembly from the chassis.

After you finish

If you are instructed to return the component or optional device, follow all packaging instructions, and use any packaging materials for shipping that are supplied to you.

Install the front panel board assembly

Use this information to install the front panel board assembly.

About this task

S002



CAUTION:

The power-control button on the device and the power switch on the power supply do not turn off the electrical current supplied to the device. The device also might have more than one power cord. To remove all electrical current from the device, ensure that all power cords are disconnected from the power source.

Attention:

- Read “Installation guidelines” on page 57 to ensure that you work safely.
- Power off the server and disconnect all power cords for this task.
- Prevent exposure to static electricity, which might lead to system halt and loss of data, by keeping static-sensitive components in their static-protective packages until installation, and handling these devices with an electrostatic-discharge wrist strap or other grounding system.

Watch the procedure. A video of the installation and removal process is available:

- YouTube: <https://youtube.com/playlist?list=PLYV5R7hVcs-DoEcXrm2zKNpaKOdZ3f8Qc>
- Youku: https://list.youku.com/albumlist/show/id_59636516

Procedure

Step 1. Route the cables through the corresponding hole in the chassis.

Step 2. Install the front panel board assembly.

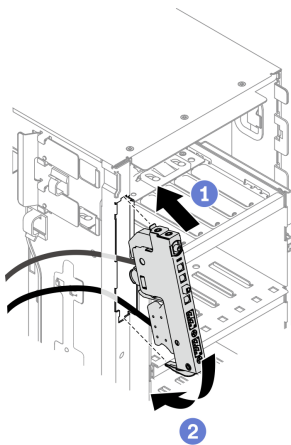

Figure 77. Front panel board assembly installation

- 1 Align the tab on the top side of the front panel board assembly with the side of the corresponding hole in the chassis.
- 2 Pivot the front panel board assembly in until it snaps into position.

Step 3. Carefully route the cable from the secured front panel along the cable clips and connect the cables to the corresponding connectors on the system board. See “Front panel cable routing” on page 48.

After you finish

1. Reinstall the front bezel. See “Install the front bezel” on page 106.
2. Reinstall the front door. See “Install the front door” on page 109.
3. Reinstall the fan cage. See “Install the fan cage assembly” on page 97.
4. Reinstall all the fans. See “Install a hot-swap fan” on page 94.
5. Reinstall all the full-length GPU adapters. See “Install a full-length GPU adapter” on page 114.
6. Reinstall the air baffle. See “Install the air baffle” on page 74.
7. Reinstall all the flash power modules. See “Install a flash power module” on page 100.
8. Reinstall the server cover. See “Install the server cover” on page 190.
9. Complete the parts replacement. See “Complete the parts replacement” on page 206.

Full-length GPU adapter replacement

Use this information to remove and install a full-length GPU adapter.

Your server comes with nine PCIe slots. Depending on your needs, you can install a full-length GPU adapter or remove the full-length GPU adapter if necessary.

Notes:

- For a list of the supported GPU adapters, see: <https://static.lenovo.com/us/en/serverproven/index.shtml>
- For instructions on how to remove and install a half-length GPU adapter or PCIe adapter, see “PCIe adapter replacement” on page 162

Remove a full-length GPU adapter

Use this information to remove a full-length GPU adapter.

About this task

S002



CAUTION:

The power-control button on the device and the power switch on the power supply do not turn off the electrical current supplied to the device. The device also might have more than one power cord. To remove all electrical current from the device, ensure that all power cords are disconnected from the power source.

Attention:

- Read “Installation guidelines” on page 57 to ensure that you work safely.
- Power off the server and disconnect all power cords for this task.
- Prevent exposure to static electricity, which might lead to system halt and loss of data, by keeping static-sensitive components in their static-protective packages until installation, and handling these devices with an electrostatic-discharge wrist strap or other grounding system.
- If the server is in a rack, remove it from the rack.
- If foot stands are installed on the server, rotate them inwards and lay the server on its side for easier operation.

Notes:

- Depending on the specific type, your full-length GPU adapter might look different from the illustration in this topic.
- Use any documentation that comes with the full-length GPU adapter and follow those instructions in addition to the instructions in this topic.

Watch the procedure. A video of the installation and removal process is available:

- YouTube: <https://youtube.com/playlist?list=PLYV5R7hVcs-DoEcxrm2zKNpaK0dZ3f8Qc>
- Youku: https://list.youku.com/albumlist/show/id_59636516

Procedure

- Step 1. Make preparations for this task.
- Remove the server cover. See “Remove the server cover” on page 188.
 - Remove all the flash power modules. See “Remove a flash power module” on page 98.
 - Remove the air baffle. See “Remove the air baffle” on page 72.
- Step 2. Locate the full-length GPU adapter you want to remove.
- Step 3. Remove the full-length GPU adapter.

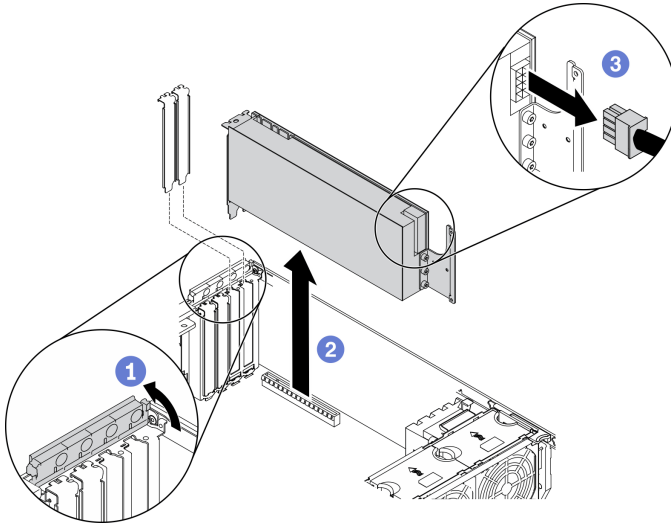

Figure 78. Full-length GPU adapter removal

- ① Open the PCIe adapter retainer.
- ② Grasp the full-length GPU adapter by its edges and carefully pull it out of the PCIe slot.
- ③ Disconnect the power cable from the full-length GPU adapter.

After you finish

- Install another full-length GPU adapter if necessary. See “Install a full-length GPU adapter” on page 114. Otherwise, install a bracket to cover the vacancy and close the PCIe adapter retainer.
- If you need to remove the full-length GPU adapter power cable out of the chassis.
 - Remove all the fans. See “Remove a hot-swap fan” on page 93.
 - Remove the fan cage. See “Remove the fan cage assembly” on page 95.
 - Remove the power cable.
 - Reinstall the fan cage. See “Install the fan cage assembly” on page 97.
 - Reinstall all the fans. See “Install a hot-swap fan” on page 94.
- If you are instructed to return the component or optional device, follow all packaging instructions, and use any packaging materials for shipping that are supplied to you.

Install a full-length GPU adapter

Use this information to install a full-length GPU adapter.

About this task

S002

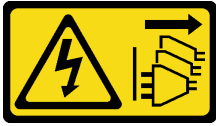

CAUTION:

The power-control button on the device and the power switch on the power supply do not turn off the electrical current supplied to the device. The device also might have more than one power cord. To remove all electrical current from the device, ensure that all power cords are disconnected from the power source.

Attention:

- Read “Installation guidelines” on page 57 to ensure that you work safely.
- Power off the server and disconnect all power cords for this task.
- Prevent exposure to static electricity, which might lead to system halt and loss of data, by keeping static-sensitive components in their static-protective packages until installation, and handling these devices with an electrostatic-discharge wrist strap or other grounding system.

Notes:

- Depending on the specific type, your full-length GPU adapter might look different from the illustration in this topic.
- Use any documentation that comes with the full-length GPU adapter and follow those instructions in addition to the instructions in this topic.

Watch the procedure. A video of the installation and removal process is available:

- YouTube: <https://youtube.com/playlist?list=PLYV5R7hVcs-DoEcXrm2zKNpaKOdZ3f8Qc>
- Youku: https://list.youku.com/albumlist/show/id_59636516

Procedure

Step 1. Locate the applicable PCIe slot. See “Specifications” on page 1 to identify the different types of PCIe slots in your server.

Note: Ensure that you observe the installation rules and sequence in “Technical rules for PCIe adapters” in the *ThinkSystem ST650 V2 Setup Guide*.

Step 2. Make sure you have installed a PCIe adapter holder corresponding to the PCIe slot for your full-length GPU adapter. See “Install a PCIe adapter holder” on page 161.

Step 3. If necessary, route the power cable for the full-length GPU adapter.

- a. Remove all the fans. See “Remove a hot-swap fan” on page 93.
- b. Remove the fan cage. See “Remove the fan cage assembly” on page 95.
- c. Connect the power cable to the power distribution board; then, route the power cable and secure it under the clip. See “GPU cable routing” on page 50.
- d. Reinstall the fan cage. See “Install the fan cage assembly” on page 97.
- e. Reinstall all the fans. See “Install a hot-swap fan” on page 94.

Step 4. If a bracket is installed in the PCIe slot, remove it. Store the bracket for the PCIe slot in case that you later remove the PCIe adapter and need the bracket to cover the place.

Step 5. Install the full-length GPU adapter.

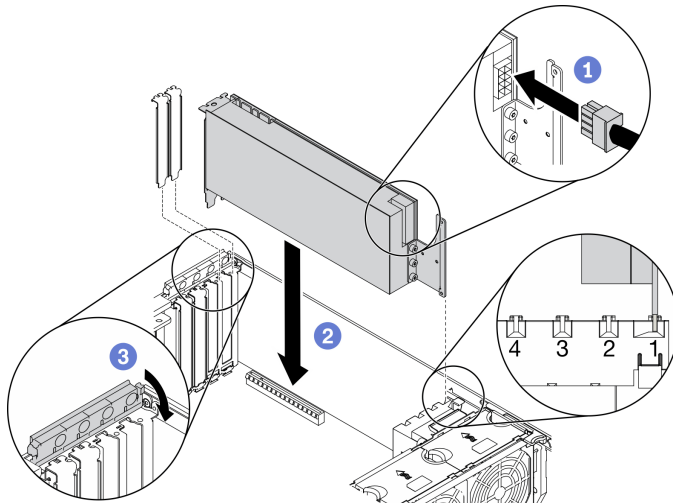

Figure 79. Full-length GPU adapter installation

Note: Make sure the PCIe adapter retainer is in the opened position.

- a. ① Connect the power cable to the full-length GPU adapter.
- b. ② Align the full-length GPU adapter to the PCIe adapter holder and the PCIe slot; then, gently press both ends of the full-length GPU adapter until it is securely seated in the PCIe slot.
- c. ③ Close the PCIe adapter retainer.

After you finish

1. If you have installed one double-wide GPU adapter in PCIe slot 1, or three double-wide GPU adapters in PCIe slot 1, 3, and 7; install a GPU filler. See “Install a GPU filler” on page 118.
2. Reinstall the air baffle. See “Install the air baffle” on page 74.
3. Reinstall all the flash power modules. See “Install a flash power module” on page 100.
4. Reinstall the server cover. See “Install the server cover” on page 190.
5. Complete the parts replacement. See “Complete the parts replacement” on page 206.

GPU filler replacement

Use this information to remove and install a GPU filler.

Remove a GPU filler

Use this information to remove a GPU filler.

About this task

S033



CAUTION:

Hazardous energy present. Voltages with hazardous energy might cause heating when shorted with metal, which might result in spattered metal, burns, or both.

S017



CAUTION:

Hazardous moving fan blades nearby. Keep fingers and other body parts away.

Attention:

- Read “Installation guidelines” on page 57 to ensure that you work safely.
- Prevent exposure to static electricity, which might lead to system halt and loss of data, by keeping static-sensitive components in their static-protective packages until installation, and handling these devices with an electrostatic-discharge wrist strap or other grounding system.
- If the server is in a rack, remove it from the rack.
- If foot stands are installed on the server, rotate them inwards and lay the server on its side for easier operation.

Note: If you have installed one double-wide GPU adapter in PCIe slot 1, or three double-wide GPU adapters in PCIe slot 1, 3, and 7; install a GPU filler for proper cooling and airflow.

Watch the procedure. A video of the installation and removal process is available:

- YouTube: <https://youtube.com/playlist?list=PLYV5R7hVcs-DoEcxrm2zKNpaK0dZ3f8Qc>
- Youku: https://list.youku.com/albumlist/show/id_59636516

Procedure

- Step 1. Remove the server cover. See “Remove the server cover” on page 188.
- Step 2. Press and hold the latch to release the GPU filler from the air baffle; then, remove the GPU filler in the direction as shown.

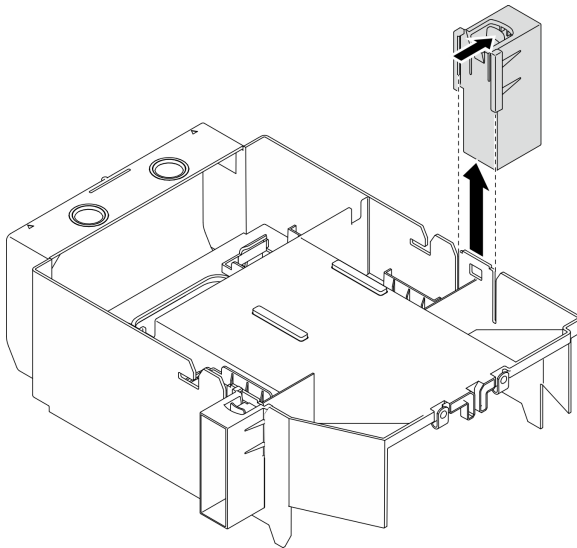

Figure 80. GPU filler removal

After you finish

If you are instructed to return the component or optional device, follow all packaging instructions, and use any packaging materials for shipping that are supplied to you.

Install a GPU filler

Use this information to install a GPU filler.

About this task

S033



CAUTION:

Hazardous energy present. Voltages with hazardous energy might cause heating when shorted with metal, which might result in spattered metal, burns, or both.

S017



CAUTION:

Hazardous moving fan blades nearby. Keep fingers and other body parts away.

Attention:

- Read “Installation guidelines” on page 57 to ensure that you work safely.
- Prevent exposure to static electricity, which might lead to system halt and loss of data, by keeping static-sensitive components in their static-protective packages until installation, and handling these devices with an electrostatic-discharge wrist strap or other grounding system.

Note: If you have installed one double-wide GPU adapter in PCIe slot 1, or three double-wide GPU adapters in PCIe slot 1, 3, and 7; install a GPU filler for proper cooling and airflow.

Watch the procedure. A video of the installation and removal process is available:

- YouTube: <https://youtube.com/playlist?list=PLYV5R7hVcs-DoEcXrm2zKNpaKOdZ3f8Qc>
- Youku: https://list.youku.com/albumlist/show/id_59636516

Procedure

- Step 1. Align the GPU filler with the corresponding slots on the air baffle.
- Step 2. Insert the GPU filler onto the air baffle until it snaps into position

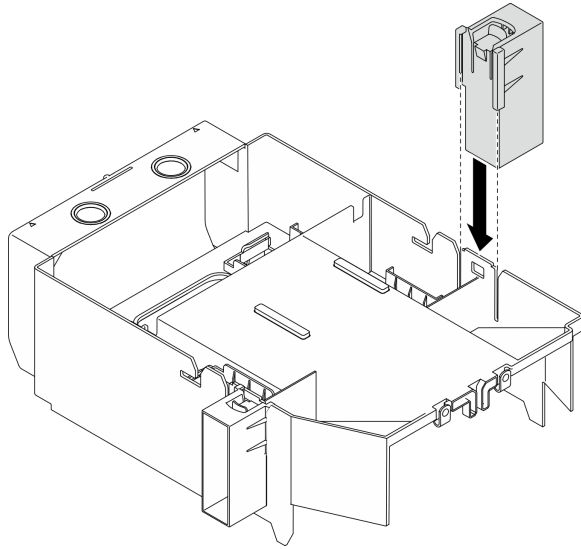

Figure 81. GPU filler installation

After you finish

1. Reinstall the server cover. See “Install the server cover” on page 190.
2. Complete the parts replacement. See “Complete the parts replacement” on page 206.

Heat sink Torx T30 nut replacement

Use this information to remove and install a heat sink Torx T30 nut.

Remove a heat sink Torx T30 nut

This task has instructions for removing a PEEK (Polyether ether ketone) Torx T30 nut on the heat sink.

About this task

S002



CAUTION:

The power-control button on the device and the power switch on the power supply do not turn off the electrical current supplied to the device. The device also might have more than one power cord. To remove all electrical current from the device, ensure that all power cords are disconnected from the power source.

Attention:

- Read “Installation guidelines” on page 57 to ensure that you work safely.
- Power off the server and disconnect all power cords for this task.
- Prevent exposure to static electricity, which might lead to system halt and loss of data, by keeping static-sensitive components in their static-protective packages until installation, and handling these devices with an electrostatic-discharge wrist strap or other grounding system.

- If the server is in a rack, remove it from the rack.
- If foot stands are installed on the server, rotate them inwards and lay the server on its side for easier operation.
- Do not touch the processor contacts. Contaminants on the processor contacts, such as oil from your skin, can cause connection failures.

Note: The heat sink, processor, and processor carrier for your system might be different than those shown in the illustrations.

Watch the procedure. A video of the installation and removal process is available:

- YouTube: <https://youtube.com/playlist?list=PLYV5R7hVcs-DoEcXrm2zKNpaKOdZ3f8Qc>
- Youku: https://list.youku.com/albumlist/show/id_59636516

Procedure

Step 1. Make preparations for this task.

- Remove the hot-swap redundant power supply. See “Remove a hot-swap power supply” on page 170.
- Remove the server cover. See “Remove the server cover” on page 188.
- Remove all the flash power modules. See “Remove a flash power module” on page 98.
- Remove the air baffle. See “Remove the air baffle” on page 72.
- Remove the PHM. See “Remove a processor and heat sink” on page 177.

Step 2. Remove the Torx T30 nut.

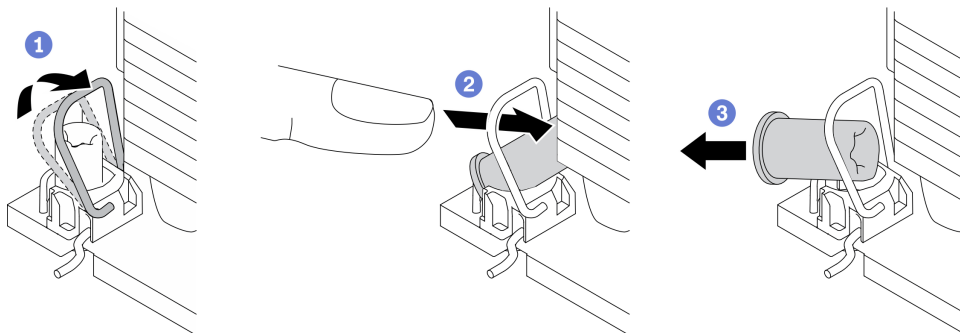

Figure 82. Removing a Torx T30 nut from the heat sink

Note: Do not touch the gold contacts on the bottom of the processor.

- ① Rotate the anti-tilt wire bail inwards.
- ② Push the upper edge of the Torx T30 nut towards the center of the heat sink until it disengages.
- ③ Remove the Torx T30 nut.

Attention: Visually inspect the removed Torx T30 nut, if the nut is cracked or damaged, make sure no debris or broken pieces are left inside your server.

After you finish

1. Install a new Torx T30 nut. See “Install a heat sink Torx T30 nut” on page 121.
2. If you are instructed to return the component or optional device, follow all packaging instructions, and use any packaging materials for shipping that are supplied to you.

Install a heat sink Torx T30 nut

This task has instructions for installing a PEEK (Polyether ether ketone) Torx T30 nut on the heat sink.

About this task

S002



CAUTION:

The power-control button on the device and the power switch on the power supply do not turn off the electrical current supplied to the device. The device also might have more than one power cord. To remove all electrical current from the device, ensure that all power cords are disconnected from the power source.

Attention:

- Read “Installation guidelines” on page 57 to ensure that you work safely.
- Power off the server and disconnect all power cords for this task.
- Prevent exposure to static electricity, which might lead to system halt and loss of data, by keeping static-sensitive components in their static-protective packages until installation, and handling these devices with an electrostatic-discharge wrist strap or other grounding system.
- Do not touch the processor contacts. Contaminants on the processor contacts, such as oil from your skin, can cause connection failures.

Note: The heat sink, processor, and processor carrier for your system might be different than those shown in the illustrations.

Watch the procedure. A video of the installation and removal process is available:

- YouTube: <https://youtube.com/playlist?list=PLYV5R7hVcs-DoEcxrm2zKNpaKOdZ3f8Qc>
- Youku: https://list.youku.com/albumlist/show/id_59636516

Procedure

Step 1. Install the Torx T30 nut.

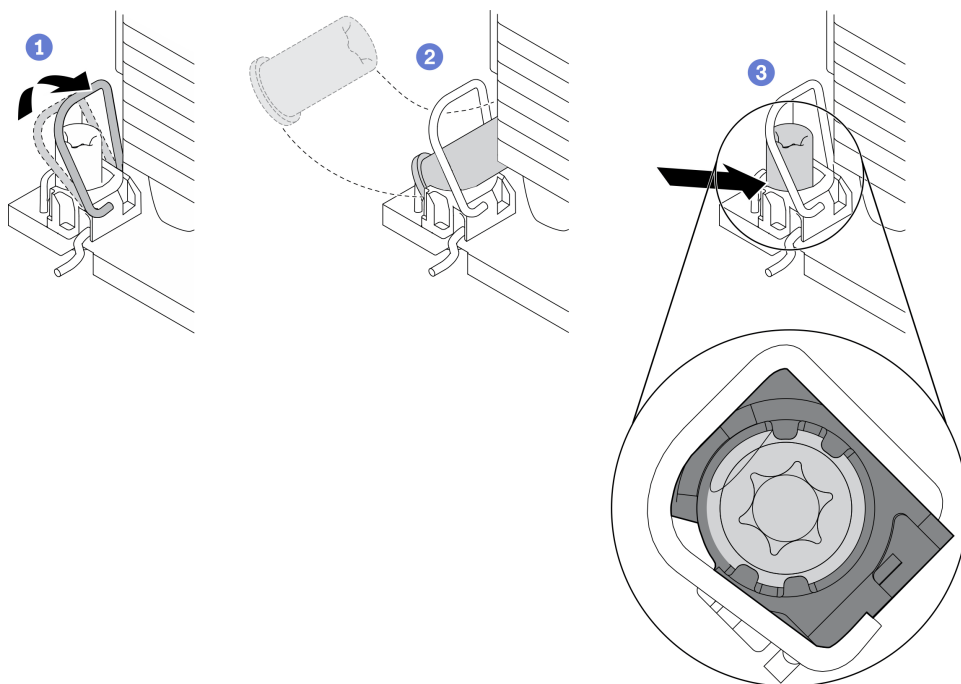

Figure 83. Installing a Torx T30 nut into the heat sink

Note: Do not touch the gold contacts on the bottom of the processor.

- a. ① Rotate the anti-tilt wire bail inwards.
- b. ② Orient the Torx T30 nut under the anti-tilt wire bail; then, align the Torx T30 nut with the socket at an angle as shown.
- c. ③ Push the lower edge of the Torx T30 nut into the socket until it clicks into place. Make sure the Torx T30 nut is secured under the four clips in the socket.

After you finish

1. Reinstall the PHM. See “Install a processor and heat sink” on page 183.
2. Reinstall the air baffle. See “Install the air baffle” on page 74.
3. Reinstall all the flash power modules. See “Install a flash power module” on page 100.
4. Reinstall the server cover. See “Install the server cover” on page 190.
5. Reinstall the hot-swap redundant power supply. See “Install the hot-swap power supply” on page 173.
6. Complete the parts replacement. See “Complete the parts replacement” on page 206.

Internal CFF adapter replacement

Use this information to remove and install the internal CFF RAID adapter, internal CFF HBA adapter, or internal CFF RAID expander adapter.

Remove the internal CFF adapter

Use this information to remove the internal CFF RAID adapter, internal CFF HBA adapter, or internal CFF RAID expander adapter.

About this task

S002

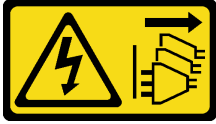
**CAUTION:**

The power-control button on the device and the power switch on the power supply do not turn off the electrical current supplied to the device. The device also might have more than one power cord. To remove all electrical current from the device, ensure that all power cords are disconnected from the power source.

Attention:

- Read “Installation guidelines” on page 57 to ensure that you work safely.
- Power off the server and disconnect all power cords for this task.
- Prevent exposure to static electricity, which might lead to system halt and loss of data, by keeping static-sensitive components in their static-protective packages until installation, and handling these devices with an electrostatic-discharge wrist strap or other grounding system.
- If the server is in a rack, remove it from the rack.
- If foot stands are installed on the server, rotate them inwards and lay the server on its side for easier operation.

Location of the internal CFF adapter.

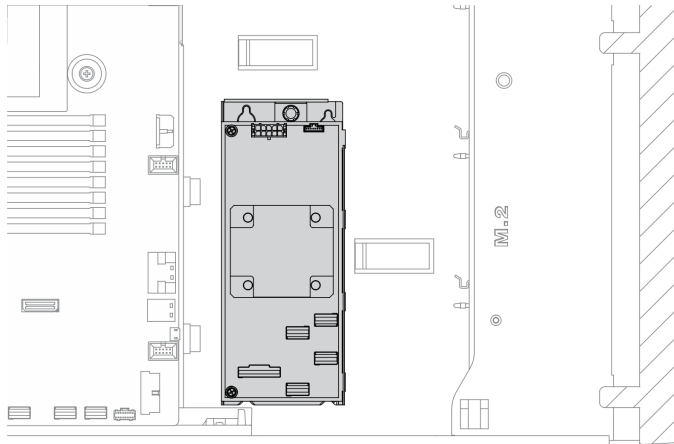

Figure 84. Internal CFF adapter location

Watch the procedure. A video of the installation and removal process is available:

- YouTube: <https://youtube.com/playlist?list=PLYV5R7hVcs-DoEcxm2zKNpaKOdZ3f8Qc>
- Youku: https://list.youku.com/albumlist/show/id_59636516

Procedure

Step 1. Make preparations for this task.

- a. Remove the server cover. See “Remove the server cover” on page 188.
- b. Remove all the flash power modules. See “Remove a flash power module” on page 98.
- c. Remove the air baffle. See “Remove the air baffle” on page 72.
- d. Remove all the full-length GPU adapters. See “Remove a full-length GPU adapter” on page 113.

- e. Remove all the fans. See “Remove a hot-swap fan” on page 93.
- f. Remove the fan cage. See “Remove the fan cage assembly” on page 95.

Step 2. Disconnect all cables from the CFF adapter.

Step 3. Lift the release pin.

Step 4. Slightly slide the CFF adapter as shown and carefully lift it out of the chassis.

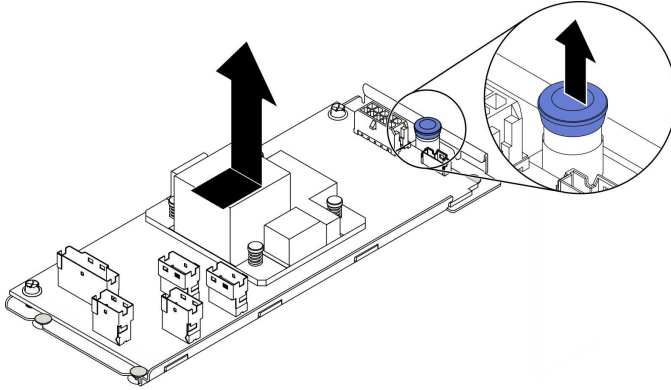

Figure 85. Internal CFF adapter removal

Step 5. Loosen the two screws on the CFF adapter to separate it from its tray if necessary.

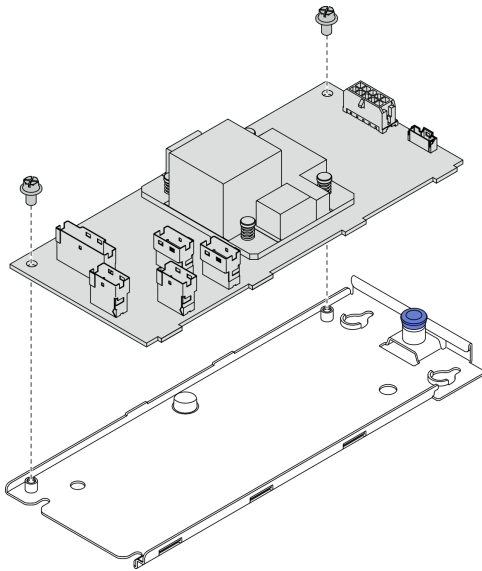

Figure 86. Internal CFF adapter tray removal

After you finish

If you are instructed to return the component or optional device, follow all packaging instructions, and use any packaging materials for shipping that are supplied to you.

Install the internal CFF adapter

Use this information to install the internal CFF RAID adapter, internal CFF HBA adapter, or internal CFF RAID expander adapter.

About this task

S002



CAUTION:

The power-control button on the device and the power switch on the power supply do not turn off the electrical current supplied to the device. The device also might have more than one power cord. To remove all electrical current from the device, ensure that all power cords are disconnected from the power source.

Attention:

- Read “Installation guidelines” on page 57 to ensure that you work safely.
- Power off the server and disconnect all power cords for this task.
- Prevent exposure to static electricity, which might lead to system halt and loss of data, by keeping static-sensitive components in their static-protective packages until installation, and handling these devices with an electrostatic-discharge wrist strap or other grounding system.

Location of the internal CFF adapter.

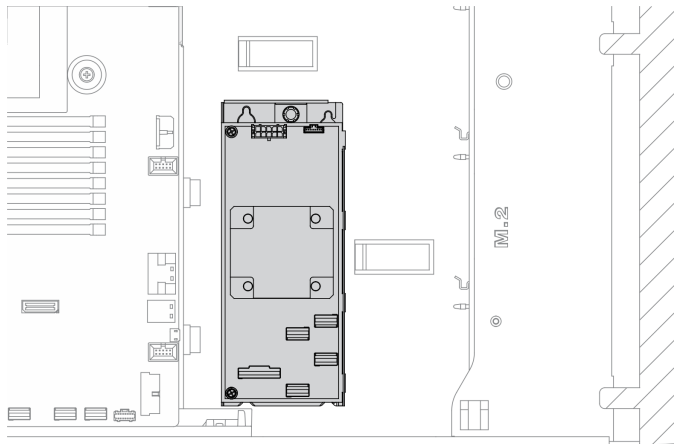

Figure 87. Internal CFF adapter location

Watch the procedure. A video of the installation and removal process is available:

- YouTube: <https://youtube.com/playlist?list=PLYV5R7hVcs-DoEcXrm2zKNpaKOdZ3f8Qc>
- Youku: https://list.youku.com/albumlist/show/id_59636516

Procedure

- Step 1. Align the holes on the CFF adapter with those on its tray, put down the CFF adapter on its tray, and tighten the screws to secure them.

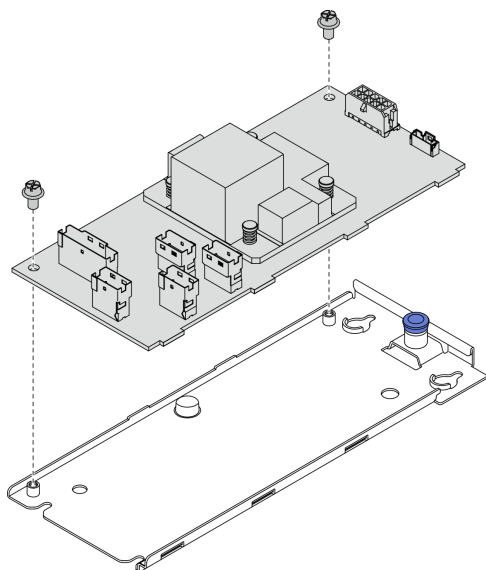

Figure 88. Internal CFF adapter tray installation

- Step 2. Align the notches on the tray with the pins on the chassis, place down the CFF adapter, and slightly slide it as shown to secure it on the chassis.

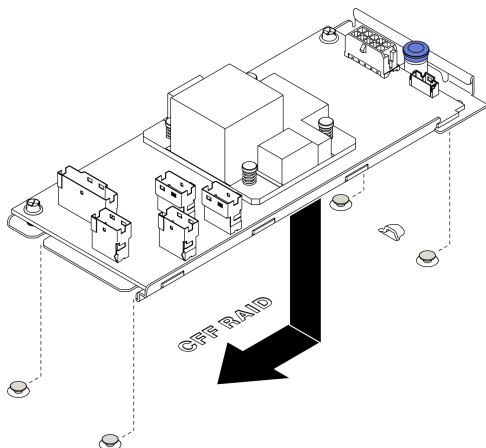

Figure 89. Internal CFF adapter installation

- Step 3. Close the release pin to secure the CFF adapter into position.
 Step 4. Connect the cables to the CFF adapter. See “Internal CFF RAID adapter cable routing” on page 50.

After you finish

1. Connect the cables to the backplane. See *ThinkSystem ST650 V2 Backplane/Backplate Cable Routing Guide*.
2. Reinstall the fan cage. See “Install the fan cage assembly” on page 97.
3. Reinstall all the fans. See “Install a hot-swap fan” on page 94.
4. Reinstall all the full-length GPU adapters. See “Install a full-length GPU adapter” on page 114.
5. Reinstall the air baffle. See “Install the air baffle” on page 74.
6. Reinstall all the flash power modules. See “Install a flash power module” on page 100.

7. Reinstall the server cover. See “Install the server cover” on page 190.
8. Complete the parts replacement. See “Complete the parts replacement” on page 206.

Intrusion switch replacement

Use this information to remove and install the intrusion switch. The intrusion switch informs you that the server cover is not properly installed or closed by creating an event in the system event log (SEL).

Remove the intrusion switch

Use this information to remove the intrusion switch.

About this task

S002



CAUTION:

The power-control button on the device and the power switch on the power supply do not turn off the electrical current supplied to the device. The device also might have more than one power cord. To remove all electrical current from the device, ensure that all power cords are disconnected from the power source.

Attention:

- Read “Installation guidelines” on page 57 to ensure that you work safely.
- Power off the server and disconnect all power cords for this task.
- Prevent exposure to static electricity, which might lead to system halt and loss of data, by keeping static-sensitive components in their static-protective packages until installation, and handling these devices with an electrostatic-discharge wrist strap or other grounding system.
- If the server is in a rack, remove it from the rack.
- If foot stands are installed on the server, rotate them inwards and lay the server on its side for easier operation.

Watch the procedure. A video of the installation and removal process is available:

- YouTube: <https://youtube.com/playlist?list=PLYV5R7hVcs-DoEcxrm2zKNpaKOdZ3f8Qc>
- Youku: https://list.youku.com/albumlist/show/id_59636516

Procedure

Step 1. Make preparations for this task.

- a. Remove the server cover. See “Remove the server cover” on page 188.
- b. Remove all the flash power modules. See “Remove a flash power module” on page 98.
- c. Remove the air baffle. See “Remove the air baffle” on page 72.

Step 2. Disconnect the cable of the intrusion switch from the system board.

Step 3. Press the two tabs on the intrusion switch towards each other and carefully pull out the intrusion switch at the same time to remove it from the frame.

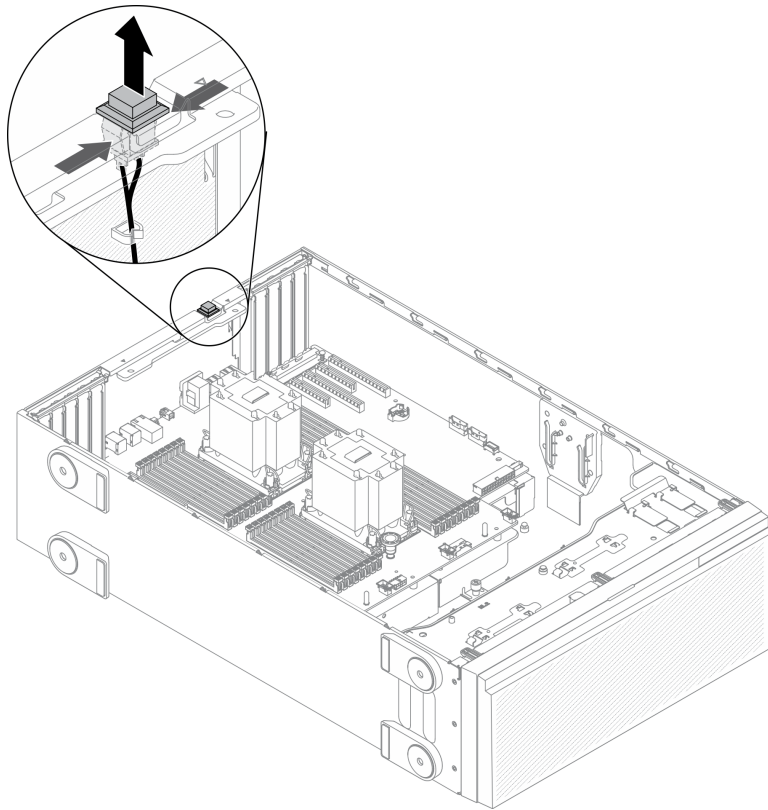

Figure 90. Intrusion switch removal

After you finish

If you are instructed to return the component or optional device, follow all packaging instructions, and use any packaging materials for shipping that are supplied to you.

Install the intrusion switch

Use this information to install the intrusion switch.

About this task

S002



CAUTION:

The power-control button on the device and the power switch on the power supply do not turn off the electrical current supplied to the device. The device also might have more than one power cord. To remove all electrical current from the device, ensure that all power cords are disconnected from the power source.

Attention:

- Read “Installation guidelines” on page 57 to ensure that you work safely.

- Power off the server and disconnect all power cords for this task.
- Prevent exposure to static electricity, which might lead to system halt and loss of data, by keeping static-sensitive components in their static-protective packages until installation, and handling these devices with an electrostatic-discharge wrist strap or other grounding system.

Watch the procedure. A video of the installation and removal process is available:

- YouTube: <https://youtube.com/playlist?list=PLYV5R7hVcs-DoEcxm2zKNpaKOdZ3f8Qc>
- Youku: https://list.youku.com/albumlist/show/id_59636516

Procedure

- Step 1. Insert the cable of the new intrusion switch and then the tab on the intrusion switch frame into the corresponding hole in the chassis. Then, push the intrusion switch in until it is securely seated.

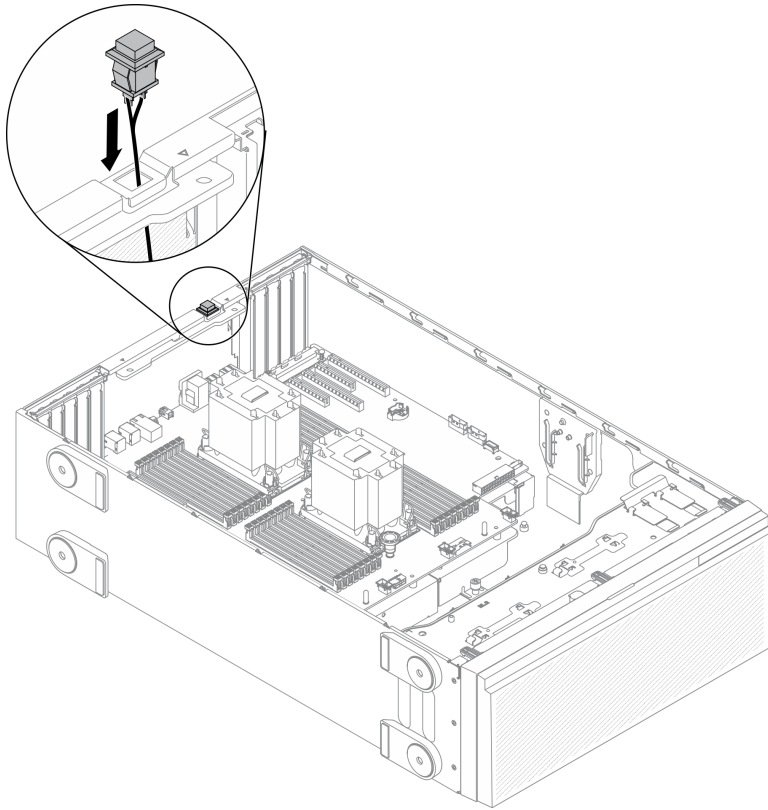

Figure 91. Intrusion switch installation

- Step 2. Connect the intrusion switch cable to the system board. See “System board components” on page 33.

After you finish

1. Reinstall the air baffle. See “Install the air baffle” on page 74.
2. Reinstall all the flash power modules. See “Install a flash power module” on page 100.
3. Reinstall the server cover. See “Install the server cover” on page 190.
4. Complete the parts replacement. See “Complete the parts replacement” on page 206.

M.2 boot adapter replacement

Use this information to remove and install the M.2 boot adapter.

Remove the M.2 boot adapter

Use this information to remove the M.2 boot adapter.

About this task

S002



CAUTION:

The power-control button on the device and the power switch on the power supply do not turn off the electrical current supplied to the device. The device also might have more than one power cord. To remove all electrical current from the device, ensure that all power cords are disconnected from the power source.

Attention:

- Read “Installation guidelines” on page 57 to ensure that you work safely.
- Power off the server and disconnect all power cords for this task.
- Prevent exposure to static electricity, which might lead to system halt and loss of data, by keeping static-sensitive components in their static-protective packages until installation, and handling these devices with an electrostatic-discharge wrist strap or other grounding system.
- If the server is in a rack, remove it from the rack.
- If foot stands are installed on the server, rotate them inwards and lay the server on its side for easier operation.

Watch the procedure. A video of the installation and removal process is available:

- YouTube: <https://youtube.com/playlist?list=PLYV5R7hVcs-DoEcXrm2zKNpaKOdZ3f8Qc>
- Youku: https://list.youku.com/albumlist/show/id_59636516

Procedure

Step 1. Make preparations for this task.

- a. Remove the server cover. See “Remove the server cover” on page 188.
- b. Remove all the flash power modules. See “Remove a flash power module” on page 98.
- c. Remove the air baffle. See “Remove the air baffle” on page 72.
- d. Remove all the full-length GPU adapters. See “Remove a full-length GPU adapter” on page 113.
- e. Remove all the fans. See “Remove a hot-swap fan” on page 93.
- f. Remove the fan cage. See “Remove the fan cage assembly” on page 95.
- g. Remove all the M.2 drives from the M.2 boot adapter. See “Remove an M.2 drive” on page 133

Step 2. Disconnect the cables from the M.2 boot adapter.

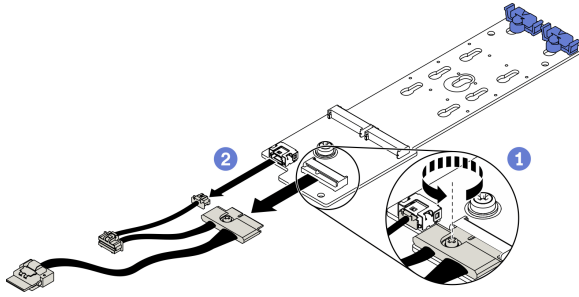

Figure 92. M.2 signal cable screw removal

- a. 1 Loosen the screw that secures the M.2 signal cable to the M.2 boot adapter.
- b. 2 Disconnect all the cables.

Step 3. Remove the M.2 boot adapter.

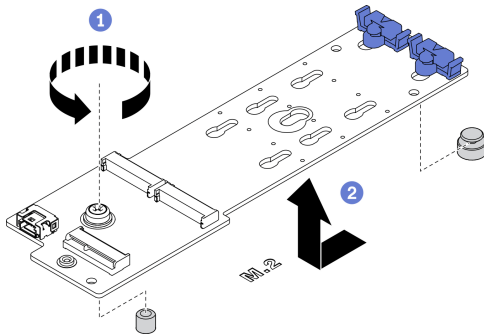

Figure 93. M.2 boot adapter removal

- a. 1 Loosen the screw that secures the M.2 boot adapter to the chassis.
- b. 2 Slightly slide the M.2 boot adapter as shown and carefully lift it out of the chassis.

After you finish

If you are instructed to return the component or optional device, follow all packaging instructions, and use any packaging materials for shipping that are supplied to you.

Install the M.2 boot adapter

Use this information to install the M.2 boot adapter.

About this task

S002



CAUTION:

The power-control button on the device and the power switch on the power supply do not turn off the electrical current supplied to the device. The device also might have more than one power cord. To

remove all electrical current from the device, ensure that all power cords are disconnected from the power source.

Attention:

- Read “Installation guidelines” on page 57 to ensure that you work safely.
- Power off the server and disconnect all power cords for this task.
- Prevent exposure to static electricity, which might lead to system halt and loss of data, by keeping static-sensitive components in their static-protective packages until installation, and handling these devices with an electrostatic-discharge wrist strap or other grounding system.

Watch the procedure. A video of the installation and removal process is available:

- YouTube: <https://youtube.com/playlist?list=PLYV5R7hVcs-DoEcXrm2zKNpaKOdZ3f8Qc>
- Youku: https://list.youku.com/albumlist/show/id_59636516

Procedure

Step 1. Install the M.2 boot adapter.

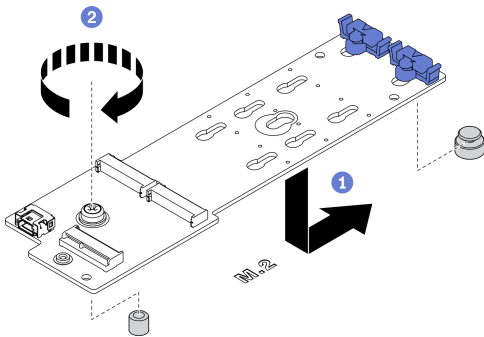

Figure 94. M.2 boot adapter installation

- 1 Insert the M.2 boot adapter into the chassis as shown.
- 2 Tighten the screw to secure the M.2 boot adapter to the chassis.

Step 2. Connect the cables to the M.2 boot adapter.

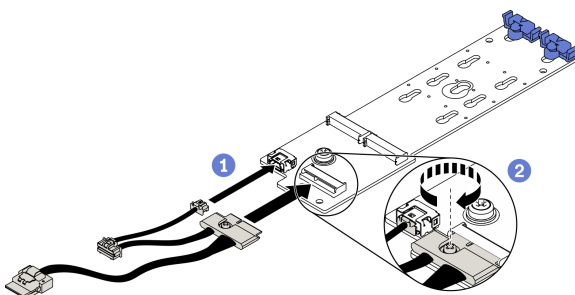

Figure 95. M.2 signal cable screw installation

- 1 Connect all the cables.
- 2 Tighten the screw that secures the M.2 signal cable to the M.2 boot adapter.

Step 3. Connect the power cable and the signal cable to the system board. See “M.2 boot adapter cable routing” on page 51.

After you finish

1. Reinstall the M.2 drives to the M.2 boot adapter. See “Install an M.2 drive” on page 135.
2. Reinstall the fan cage. See “Install the fan cage assembly” on page 97.
3. Reinstall all the fans. See “Install a hot-swap fan” on page 94.
4. Reinstall all the full-length GPU adapters. See “Install a full-length GPU adapter” on page 114.
5. Reinstall the air baffle. See “Install the air baffle” on page 74.
6. Reinstall all the flash power modules. See “Install a flash power module” on page 100.
7. Reinstall the server cover. See “Install the server cover” on page 190.
8. Complete the parts replacement. See “Complete the parts replacement” on page 206.

M.2 drive replacement

Use this information to remove and install the M.2 drive.

Remove an M.2 drive

Use this information to remove an M.2 drive.

About this task

S002



CAUTION:

The power-control button on the device and the power switch on the power supply do not turn off the electrical current supplied to the device. The device also might have more than one power cord. To remove all electrical current from the device, ensure that all power cords are disconnected from the power source.

Attention:

- Read “Installation guidelines” on page 57 to ensure that you work safely.
- Power off the server and disconnect all power cords for this task.
- Prevent exposure to static electricity, which might lead to system halt and loss of data, by keeping static-sensitive components in their static-protective packages until installation, and handling these devices with an electrostatic-discharge wrist strap or other grounding system.
- If the server is in a rack, remove it from the rack.
- If foot stands are installed on the server, rotate them inwards and lay the server on its side for easier operation.

Watch the procedure. A video of the installation and removal process is available:

- YouTube: <https://youtube.com/playlist?list=PLYV5R7hVcs-DoEcXrm2zKNpaK0dZ3f8Qc>
- Youku: https://list.youku.com/albumlist/show/id_59636516

Procedure

Step 1. Remove the server cover. See “Remove the server cover” on page 188.

Step 2. Remove the M.2 drive.

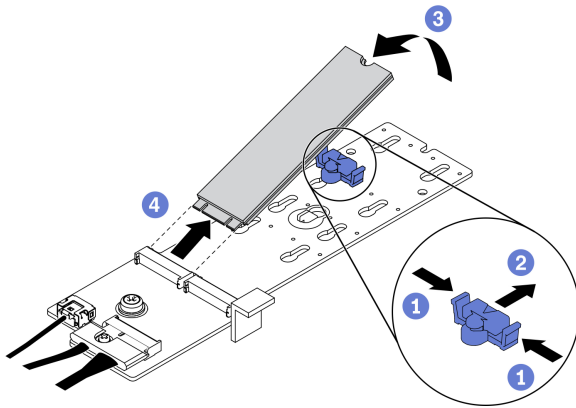

Figure 96. M.2 drive removal

- a. ① Press both sides of the retainer.
- b. ② Slide the retainer backward to loosen the M.2 drive from the M.2 boot adapter.
- c. ③ Pivot the M.2 drive away from the M.2 boot adapter.
- d. ④ Pull the M.2 drive away from the connector at an angle of approximately 30 degrees.

After you finish

If you are instructed to return the component or optional device, follow all packaging instructions, and use any packaging materials for shipping that are supplied to you.

Adjust the retainer on the M.2 boot adapter

Use this information to adjust the retainer on the M.2 boot adapter.

About this task

S002



CAUTION:

The power-control button on the device and the power switch on the power supply do not turn off the electrical current supplied to the device. The device also might have more than one power cord. To remove all electrical current from the device, ensure that all power cords are disconnected from the power source.

Attention:

- Read “Installation guidelines” on page 57 to ensure that you work safely.
- Power off the server and disconnect all power cords for this task.
- Prevent exposure to static electricity, which might lead to system halt and loss of data, by keeping static-sensitive components in their static-protective packages until installation, and handling these devices with an electrostatic-discharge wrist strap or other grounding system.

Before adjusting the retainer on the M.2 boot adapter, locate the correct keyhole that the retainer should be installed into to accommodate the particular size of the M.2 drive you wish to install.

Note: The M.2 boot adapter might be different from the following illustrations, but the adjustment method is the same.

Watch the procedure. A video of the installation and removal process is available:

- YouTube: <https://youtube.com/playlist?list=PLYV5R7hVcs-DoEcxrm2zKNpaK0dZ3f8Qc>
- Youku: https://list.youku.com/albumlist/show/id_59636516

Procedure

Step 1. Adjust the retainer on the M.2 boot adapter.

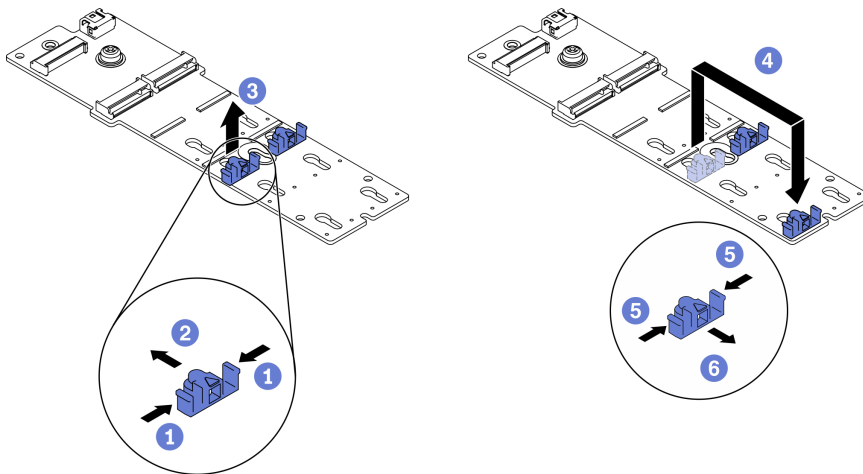

Figure 97. M.2 retainer adjustment

- 1 Press both sides of the retainers.
- 2 Move the retainer forward until it is in the large opening of the keyhole.
- 3 Take the retainer out of the keyhole.
- 4 Insert the retainer into the correct keyhole.
- 5 Press both sides of the retainer.
- 6 Slide the retainer backwards until it is seated in place.

Install an M.2 drive

Use this information to install an M.2 drive.

About this task

S002



CAUTION:

The power-control button on the device and the power switch on the power supply do not turn off the electrical current supplied to the device. The device also might have more than one power cord. To remove all electrical current from the device, ensure that all power cords are disconnected from the power source.

Attention:

- Read “Installation guidelines” on page 57 to ensure that you work safely.
- Power off the server and disconnect all power cords for this task.
- Prevent exposure to static electricity, which might lead to system halt and loss of data, by keeping static-sensitive components in their static-protective packages until installation, and handling these devices with an electrostatic-discharge wrist strap or other grounding system.

Locate the M.2 drive slot on the M.2 adapter.

Note: For some M.2 adapters that support two identical M.2 drives, install the M.2 drive in slot 0 first.

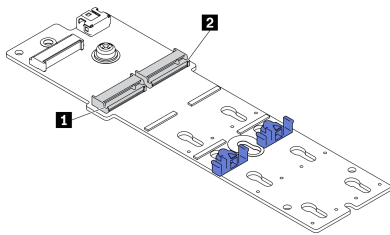

Figure 98. M.2 drive slot

Table 19. M.2 drive slot locations on M.2 boot adapter

1 M.2 boot adapter slot 0	2 M.2 boot adapter slot 1
----------------------------------	----------------------------------

Watch the procedure. A video of the installation and removal process is available:

- YouTube: <https://youtube.com/playlist?list=PLYV5R7hVcs-DoEcxrm2zKNpaKOdZ3f8Qc>
- Youku: https://list.youku.com/albumlist/show/id_59636516

Procedure

Step 1. Install the M.2 drive

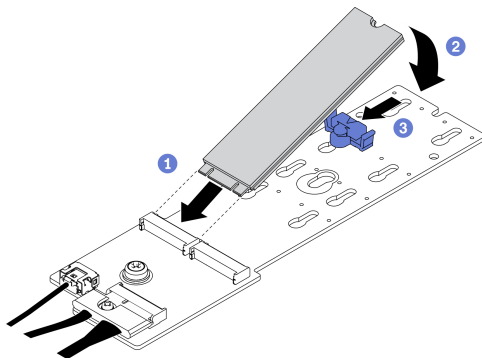

Figure 99. M.2 drive installation

- a. **1** Insert the M.2 drive at an angle of approximately 30 degrees into the connector.

- b. ② Pivot the M.2 drive down until the notch catches on the lip of the retainer.
- c. ③ Slide the retainer forward (towards the connector) to secure the M.2 drive into place.

After you finish

1. Reinstall the server cover. See “Install the server cover” on page 190.
2. Complete the parts replacement. See “Complete the parts replacement” on page 206.

Memory module replacement

Use the following procedures to remove and install a memory module.

Remove a memory module

Use this information to remove a memory module.

About this task

S002



CAUTION:

The power-control button on the device and the power switch on the power supply do not turn off the electrical current supplied to the device. The device also might have more than one power cord. To remove all electrical current from the device, ensure that all power cords are disconnected from the power source.

Attention:

- Read “Installation guidelines” on page 57 to ensure that you work safely.
- Power off the server and disconnect all power cords for this task.
- If the server is in a rack, remove it from the rack.
- If foot stands are installed on the server, rotate them inwards and lay the server on its side for easier operation.
- Memory modules are sensitive to static discharge and require special handling. Refer to the standard guidelines for “Handling static-sensitive devices” on page 60.
 - Always wear an electrostatic-discharge strap when removing or installing memory modules. Electrostatic-discharge gloves can also be used.
 - Never hold two or more memory modules together so that they do not touch each other. Do not stack memory modules directly on top of each other during storage.
 - Never touch the gold memory module connector contacts or allow these contacts to touch the outside of the memory module connector housing.
 - Handle memory modules with care: never bend, twist, or drop a memory module.
 - Do not use any metal tools (such as jigs or clamps) to handle the memory modules, because the rigid metals may damage the memory modules.
 - Do not insert memory modules while holding packages or passive components, which can cause package cracks or detachment of passive components by the high insertion force.

Watch the procedure. A video of the installation and removal process is available:

- YouTube: <https://youtube.com/playlist?list=PLYV5R7hVcs-DoEcxrm2zKNpaKOdZ3f8Qc>
- Youku: https://list.youku.com/albumlist/show/id_59636516

Procedure

Step 1. Make preparations for this task.

- Remove the server cover. See “Remove the server cover” on page 188.
- Remove all the flash power modules. See “Remove a flash power module” on page 98.
- Remove the air baffle. See “Remove the air baffle” on page 72.
- Remove all the full-length GPU adapters. See “Remove a full-length GPU adapter” on page 113.
- Remove all the fans. See “Remove a hot-swap fan” on page 93.
- Remove the fan cage. See “Remove the fan cage assembly” on page 95.

Step 2. Remove the memory module from the slot.

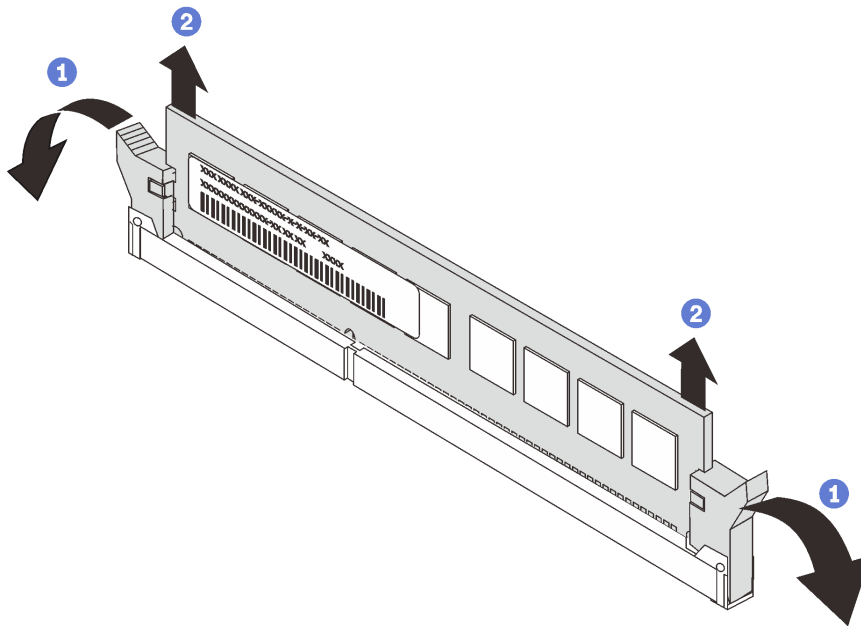

Figure 100. Memory module removal

- ① Open the retaining clip on each end of the memory module slot.

Attention: To avoid breaking the retaining clips or damaging the memory module slots, handle the clips gently.

- ② Grasp the memory module at both ends and carefully lift it out of the slot.

After you finish

- Install a memory module filler or a new memory module to cover the slot. See “Install a memory module” on page 139.
- If you are instructed to return the component or optional device, follow all packaging instructions, and use any packaging materials for shipping that are supplied to you.

Install a memory module

Use this information to install a memory module.

About this task

S002

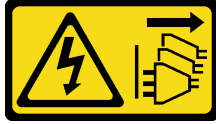

CAUTION:

The power-control button on the device and the power switch on the power supply do not turn off the electrical current supplied to the device. The device also might have more than one power cord. To remove all electrical current from the device, ensure that all power cords are disconnected from the power source.

Attention:

- Read “Installation guidelines” on page 57 to ensure that you work safely.
- Power off the server and disconnect all power cords for this task.
- Memory modules are sensitive to static discharge and require special handling. Refer to the standard guidelines for “Handling static-sensitive devices” on page 60:
 - Always wear an electrostatic-discharge strap when removing or installing memory modules. Electrostatic-discharge gloves can also be used.
 - Never hold two or more memory modules together so that they do not touch each other. Do not stack memory modules directly on top of each other during storage.
 - Never touch the gold memory module connector contacts or allow these contacts to touch the outside of the memory module connector housing.
 - Handle memory modules with care: never bend, twist, or drop a memory module.
 - Do not use any metal tools (such as jigs or clamps) to handle the memory modules, because the rigid metals may damage the memory modules.
 - Do not insert memory modules while holding packages or passive components, which can cause package cracks or detachment of passive components by the high insertion force.

Watch the procedure. A video of the installation and removal process is available:

- YouTube: <https://youtube.com/playlist?list=PLYV5R7hVcs-DoEcxrm2zKNpaKOdZ3f8Qc>
- Youku: https://list.youku.com/albumlist/show/id_59636516

Procedure

- Step 1. Touch the static-protective package that contains the memory module to any unpainted surface on the outside of the server. Then, take the memory module out of the package and place it on a static-protective surface.
- Step 2. Locate the required memory module slot on the system board.

Note: Ensure that you observe the installation rules and sequence in “Technical rules for memory modules” in the *ThinkSystem ST650 V2 Setup Guide*.
- Step 3. Install the memory module into the slot.

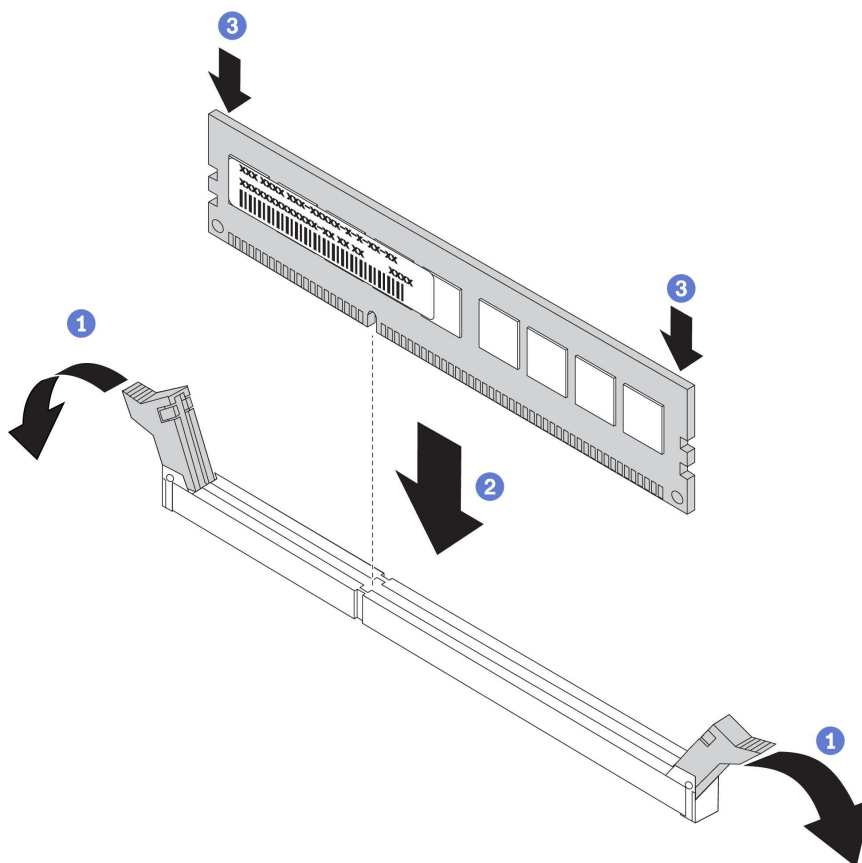

Figure 101. Memory module installation

- a. ① Open the retaining clip on each end of the memory module slot.

Attention: To avoid breaking the retaining clips or damaging the memory module slots, open and close the clips gently.

- b. ② Align the memory module with the slot, and gently place the memory module on the slot with both hands.
- c. ③ Firmly press both ends of the memory module straight down into the slot until the retaining clips snap into the locked position.

Note: If there is a gap between the memory module and the retaining clips, the memory module has not been correctly inserted. In this case, open the retaining clips, remove the memory module, and then reinsert it.

After you finish

1. Reinstall the fan cage. See “Install the fan cage assembly” on page 97.
2. Reinstall all the fans. See “Install a hot-swap fan” on page 94.
3. Reinstall all the full-length GPU adapters. See “Install a full-length GPU adapter” on page 114.
4. Reinstall the air baffle. See “Install the air baffle” on page 74.
5. Reinstall all the flash power modules. See “Install a flash power module” on page 100.
6. Reinstall the server cover. See “Install the server cover” on page 190.
7. Complete the parts replacement. See “Complete the parts replacement” on page 206.

NVLink bridge replacement

Use this information to remove and install an NVLink bridge.

Remove an NVLink bridge

Use this information to remove an NVLink bridge.

About this task

Important: Make sure you have a suction cup available for properly removing the NVLink bridge.

S002



CAUTION:

The power-control button on the device and the power switch on the power supply do not turn off the electrical current supplied to the device. The device also might have more than one power cord. To remove all electrical current from the device, ensure that all power cords are disconnected from the power source.

Attention:

- Read “Installation guidelines” on page 57 to ensure that you work safely.
- Power off the server and disconnect all power cords for this task.
- Prevent exposure to static electricity, which might lead to system halt and loss of data, by keeping static-sensitive components in their static-protective packages until installation, and handling these devices with an electrostatic-discharge wrist strap or other grounding system.
- If the server is in a rack, remove it from the rack.
- If foot stands are installed on the server, rotate them inwards and lay the server on its side for easier operation.

Watch the procedure. A video of the installation and removal process is available:

- YouTube: <https://youtube.com/playlist?list=PLYV5R7hVcs-DoEcxrm2zKNpaK0dZ3f8Qc>
- Youku: https://list.youku.com/albumlist/show/id_59636516

Procedure

Step 1. Make preparations for this task.

- a. Remove the server cover. See “Remove the server cover” on page 188.
- b. Remove all the flash power modules. See “Remove a flash power module” on page 98.
- c. Remove the air baffle. See “Remove the air baffle” on page 72.

Step 2. Press the suction cup against the NVLink bridge until it adheres; then, pull the suction cup and remove the NVLink bridge from the GPUs.

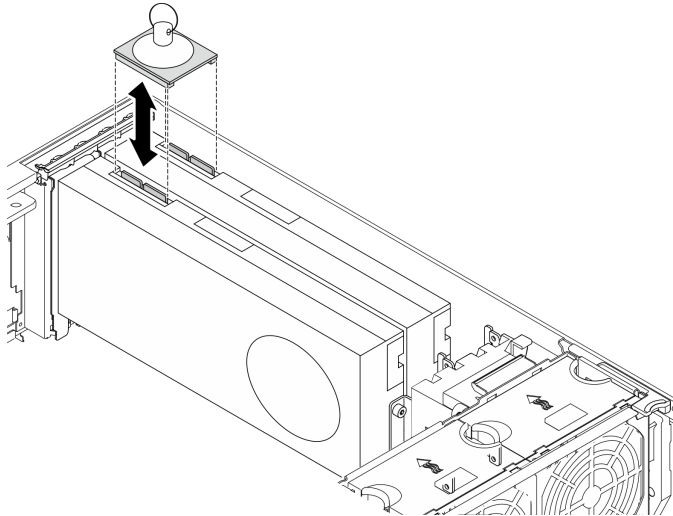

Figure 102. NVLink bridge removal

Step 3. Install the NVLink covers.

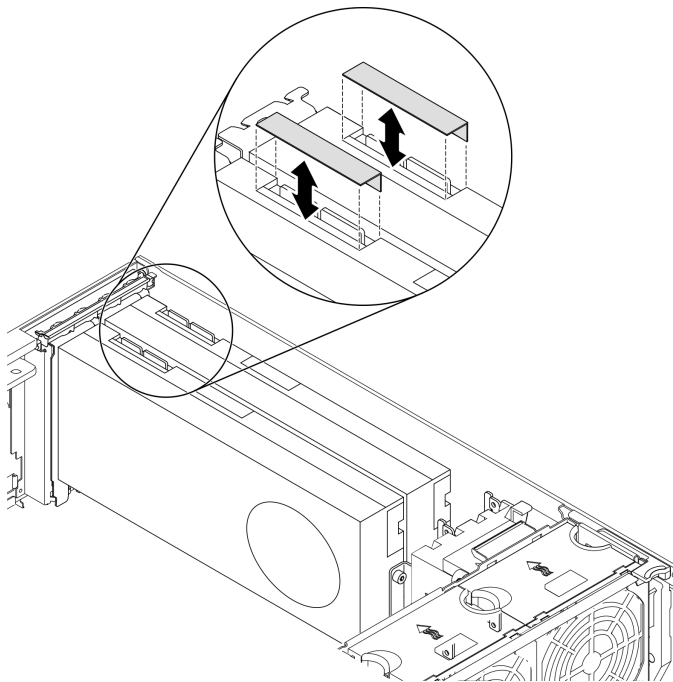

Figure 103. NVLink covers installation

After you finish

If you are instructed to return the component or optional device, follow all packaging instructions, and use any packaging materials for shipping that are supplied to you.

Install an NVLink bridge

Use this information to install an NVLink bridge.

About this task

S002

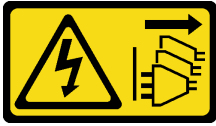

CAUTION:

The power-control button on the device and the power switch on the power supply do not turn off the electrical current supplied to the device. The device also might have more than one power cord. To remove all electrical current from the device, ensure that all power cords are disconnected from the power source.

Attention:

- Read “Installation guidelines” on page 57 to ensure that you work safely.
- Power off the server and disconnect all power cords for this task.
- Prevent exposure to static electricity, which might lead to system halt and loss of data, by keeping static-sensitive components in their static-protective packages until installation, and handling these devices with an electrostatic-discharge wrist strap or other grounding system.

Watch the procedure. A video of the installation and removal process is available:

- YouTube: <https://youtube.com/playlist?list=PLYV5R7hVcs-DoEcxrm2zKNpaKOdZ3f8Qc>
- Youku: https://list.youku.com/albumlist/show/id_59636516

Procedure

Step 1. Remove the NVLink covers.

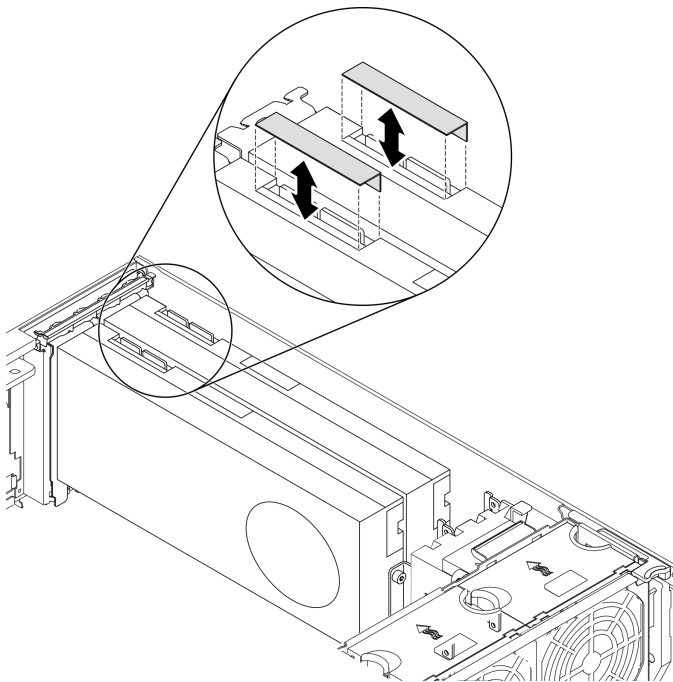

Figure 104. NVLink covers removal

Step 2. Note the orientation of the NVLink bridge; then, install the NVLink bridge as shown.

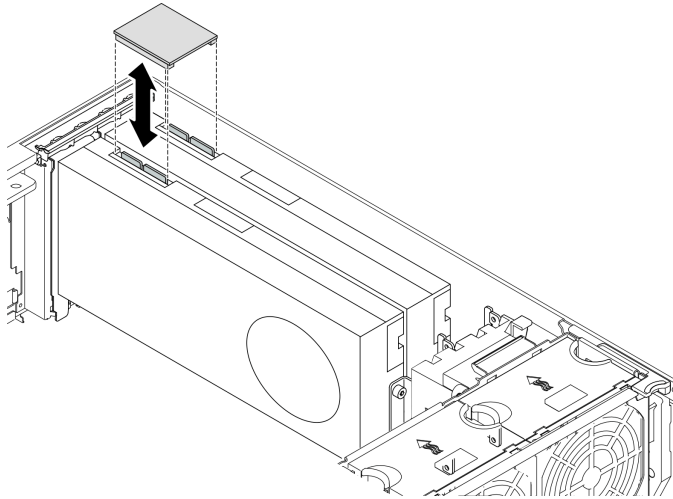

Figure 105. NVLink bridge installation

After you finish

1. Reinstall the air baffle. See “Install the air baffle” on page 74.
2. Reinstall all the flash power modules. See “Install a flash power module” on page 100.
3. Reinstall the server cover. See “Install the server cover” on page 190.
4. Complete the parts replacement. See “Complete the parts replacement” on page 206.

Optical drive cage replacement

Use this information to remove and install the optical drive cage.

Note: This section applies only to server models that have the optical drive cage installed.

Remove the optical drive cage

Use this information to remove the optical drive cage.

About this task

S002



CAUTION:

The power-control button on the device and the power switch on the power supply do not turn off the electrical current supplied to the device. The device also might have more than one power cord. To remove all electrical current from the device, ensure that all power cords are disconnected from the power source.

Attention:

- Read “Installation guidelines” on page 57 to ensure that you work safely.
- Power off the server and disconnect all power cords for this task.

- Prevent exposure to static electricity, which might lead to system halt and loss of data, by keeping static-sensitive components in their static-protective packages until installation, and handling these devices with an electrostatic-discharge wrist strap or other grounding system.
- If the server is in a rack, remove it from the rack.

Watch the procedure. A video of the installation and removal process is available:

- YouTube: <https://youtube.com/playlist?list=PLYV5R7hVcs-DoEcXrm2zKNpaKOdZ3f8Qc>
- Youku: https://list.youku.com/albumlist/show/id_59636516

Procedure

Step 1. Make preparations for this task.

- Remove the server cover. See “Remove the server cover” on page 188.
- Remove the front door. See “Remove the front door” on page 107.
- Remove the front bezel. See “Remove the front bezel” on page 105.
- Remove all installed optical drives, tape drives, and fillers (if any) from the optical drive cage. See “Remove an optical drive or a tape drive” on page 147 and “Remove the 5.25-inch drive bay adapter assembly” on page 153.

Step 2. Remove the optical drive cage.

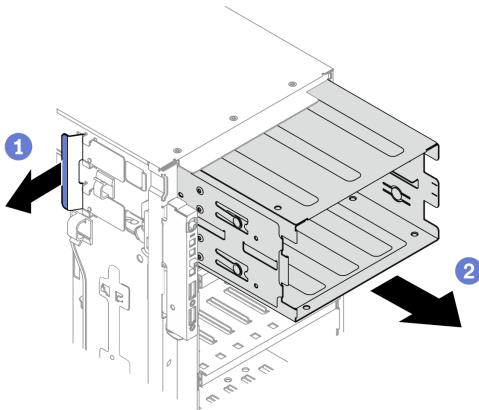

Figure 106. Optical drive cage removal

- ① Lift and hold the blue retention tab.
- ② Carefully pull the optical drive cage at the same time to slide it out of the opening in the chassis.

After you finish

- Install an expansion drive cage or an optical drive cage. See “Install the expansion drive cage” on page 91 or “Install the optical drive cage” on page 145.
- If you are instructed to return the component or optional device, follow all packaging instructions, and use any packaging materials for shipping that are supplied to you.

Install the optical drive cage

Use this information to install the optical drive cage.

About this task

S002

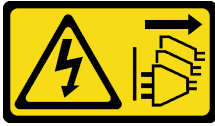

CAUTION:

The power-control button on the device and the power switch on the power supply do not turn off the electrical current supplied to the device. The device also might have more than one power cord. To remove all electrical current from the device, ensure that all power cords are disconnected from the power source.

Attention:

- Read “Installation guidelines” on page 57 to ensure that you work safely.
- Power off the server and disconnect all power cords for this task.
- Prevent exposure to static electricity, which might lead to system halt and loss of data, by keeping static-sensitive components in their static-protective packages until installation, and handling these devices with an electrostatic-discharge wrist strap or other grounding system.

Watch the procedure. A video of the installation and removal process is available:

- YouTube: <https://youtube.com/playlist?list=PLYV5R7hVcs-DoEcxrm2zKNpaKOdZ3f8Qc>
- Youku: https://list.youku.com/albumlist/show/id_59636516

Procedure

Step 1. Install the optical drive cage.

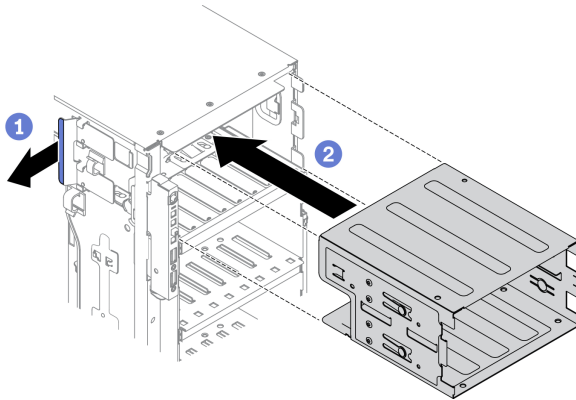

Figure 107. Optical drive cage installation

- a. ① Lift and hold the blue retention tab.
- b. ② Carefully push the optical drive cage at the same time to slide it into the bay until it snaps into position.

After you finish

1. Reinstall all the optical drives, tape drives, and fillers (if any) into the optical drive cage. See “Install an optical drive or a tape drive” on page 150 and “Install the 5.25-inch drive bay adapter assembly” on page 156.
2. Reinstall the front bezel. See “Install the front bezel” on page 106.

3. Reinstall the front door. See “Install the front door” on page 109.
4. Reinstall the server cover. See “Install the server cover” on page 190.
5. Complete the parts replacement. See “Complete the parts replacement” on page 206.

Optical drive or tape drive replacement

Use this information to remove and install the optical drive or tape drive.

Note: This section applies only to server models that have an optical drive or a tape drive installed.

Remove an optical drive or a tape drive

Use this information to remove an optical drive or a tape drive.

About this task

S002



CAUTION:

The power-control button on the device and the power switch on the power supply do not turn off the electrical current supplied to the device. The device also might have more than one power cord. To remove all electrical current from the device, ensure that all power cords are disconnected from the power source.

S006



CAUTION:

When laser products (such as CD-ROMs, DVD drives, fiber optic devices, or transmitters) are installed, note the following:

- Do not remove the covers. Removing the covers of the laser product could result in exposure to hazardous laser radiation. There are no serviceable parts inside the device.
- Use of controls or adjustments or performance of procedures other than those specified herein might result in hazardous radiation exposure.

S007



CAUTION:

This product contains a Class 1M laser. Do not view directly with optical instruments.

Note: This section only applies to server models that come with an optical or tape drive. For those that come with a 5.25-inch drive bay adapter, see “Remove the 5.25-inch drive bay adapter assembly” on page 153.

Attention:

- Read “Installation guidelines” on page 57 to ensure that you work safely.
- Power off the server and disconnect all power cords for this task.
- Prevent exposure to static electricity, which might lead to system halt and loss of data, by keeping static-sensitive components in their static-protective packages until installation, and handling these devices with an electrostatic-discharge wrist strap or other grounding system.
- If the server is in a rack, remove it from the rack.

Note: The following illustrations are based on the scenario that you remove an optical drive. The procedure is similar for removing a tape drive.

Watch the procedure. A video of the installation and removal process is available:

- YouTube: <https://youtube.com/playlist?list=PLYV5R7hVcs-DoEcXrm2zKNpaKOdZ3f8Qc>
- Youku: https://list.youku.com/albumlist/show/id_59636516

Procedure

- Step 1. Make preparations for this task.
- a. Remove the server cover. See “Remove the server cover” on page 188.
 - b. Remove the front door. See “Remove the front door” on page 107.
 - c. Remove the front bezel. See “Remove the front bezel” on page 105.
- Step 2. Disconnect the cables from the rear of the optical drive or tape drive.
- Step 3. Remove the optical drive or tape drive.

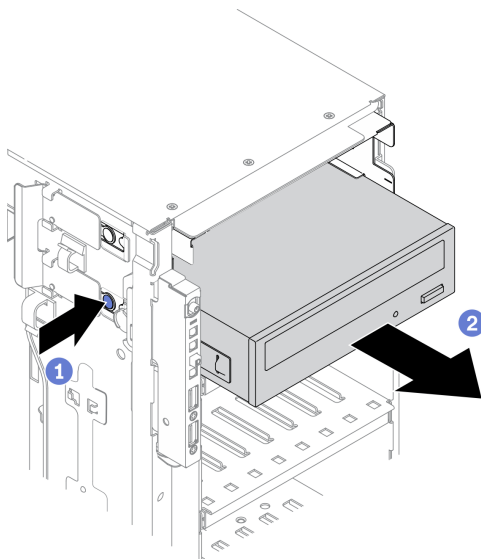

Figure 108. Optical drive removal

- a. ① Press and hold the release tab.
- b. ② Carefully pull the optical drive or tape drive at the same time to remove it from the chassis.

After you finish

1. Install a new optical drive, tape drive, or filler to cover the drive bay. See “Install an optical drive or a tape drive” on page 150. To install a filler, complete the following steps:
 - a. Insert the filler to the vacant drive bay.

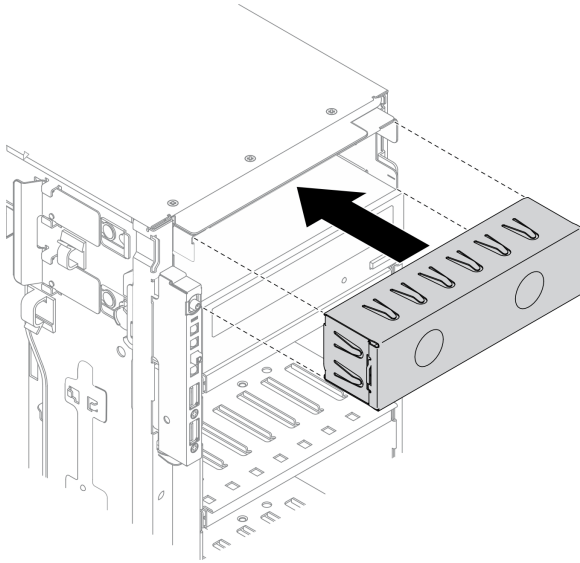

Figure 109. Drive bay filler installation

- b. Install the cover of the drive bay filler to the front bezel. Then, install the front bezel to the chassis.

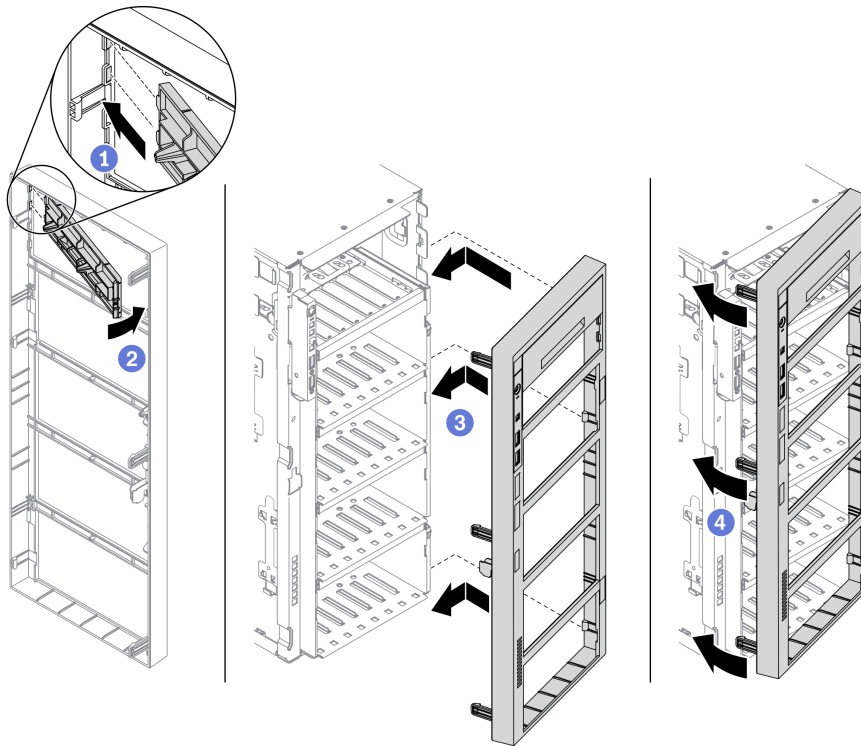

Figure 110. Drive bay filler cover installation

2. Remove the retainer from the removed optical drive or tape drive, and then install the retainer to the chassis.

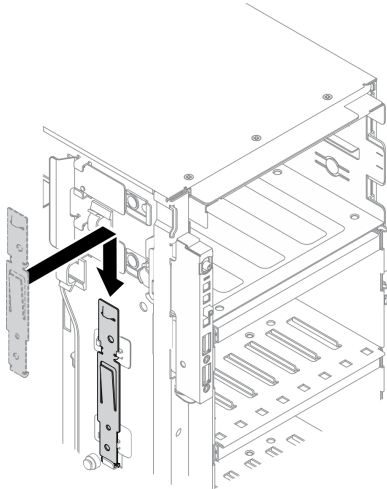

Figure 111. Drive retainer installation

3. If you are instructed to return the component or optional device, follow all packaging instructions, and use any packaging materials for shipping that are supplied to you.

Install an optical drive or a tape drive

Use this information to install an optical drive or a tape drive.

About this task

S002



CAUTION:

The power-control button on the device and the power switch on the power supply do not turn off the electrical current supplied to the device. The device also might have more than one power cord. To remove all electrical current from the device, ensure that all power cords are disconnected from the power source.

S006



CAUTION:

When laser products (such as CD-ROMs, DVD drives, fiber optic devices, or transmitters) are installed, note the following:

- Do not remove the covers. Removing the covers of the laser product could result in exposure to hazardous laser radiation. There are no serviceable parts inside the device.
- Use of controls or adjustments or performance of procedures other than those specified herein might result in hazardous radiation exposure.

S007



CAUTION:

This product contains a Class 1M laser. Do not view directly with optical instruments.

Attention:

- Read “Installation guidelines” on page 57 to ensure that you work safely.
- Power off the server and disconnect all power cords for this task.
- Prevent exposure to static electricity, which might lead to system halt and loss of data, by keeping static-sensitive components in their static-protective packages until installation, and handling these devices with an electrostatic-discharge wrist strap or other grounding system.

Note: The following illustrations are based on the scenario that you install an optical drive. The procedure is similar for installing a tape drive.

Watch the procedure. A video of the installation and removal process is available:

- YouTube: <https://youtube.com/playlist?list=PLYV5R7hVcs-DoEcxrm2zKNpaK0dZ3f8Qc>
- Youku: https://list.youku.com/albumlist/show/id_59636516

Procedure

Step 1. If necessary, remove the cover of the drive bay filler from the front bezel.

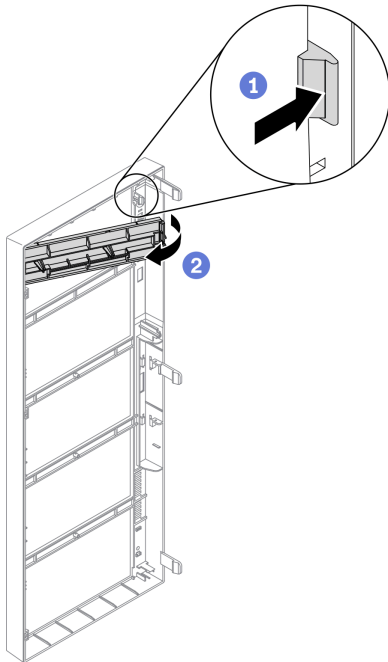

Figure 112. Drive bay filler cover installation

- a. ① Push the tab on the front bezel to release the cover of the drive bay filler.
- b. ② Remove the cover of the drive bay filler as shown.

Step 2. If necessary, remove the drive bay filler out of the chassis.

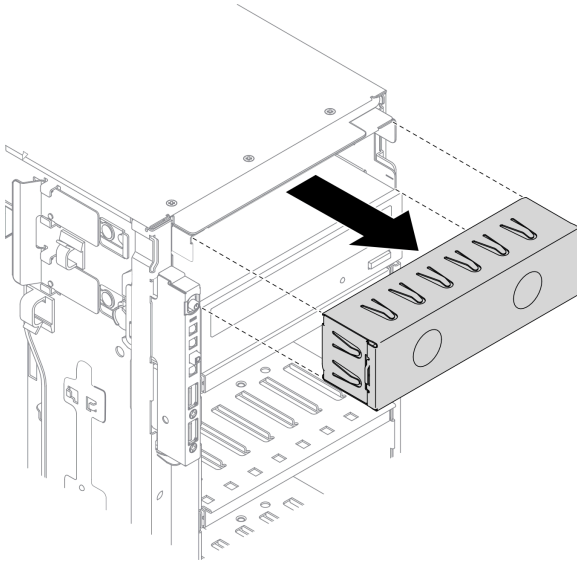

Figure 113. Drive bay filler installation

Step 3. Remove the retainer from the chassis.

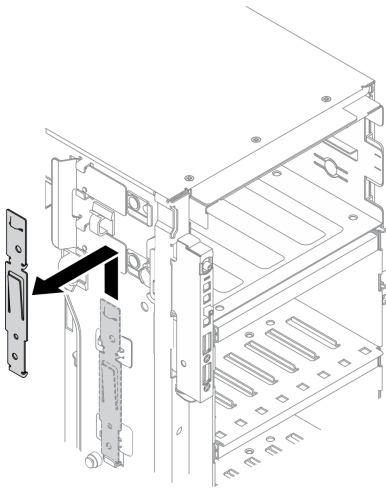

Figure 114. Drive retainer removal

Step 4. Install the retainer to only the left side of the optical drive or tape drive.

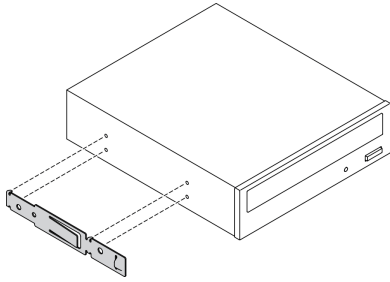

Figure 115. Optical drive retainer installation

- Step 5. Hold the optical drive or tape drive in the correct orientation; then, slide it into the drive bay until it snaps into position.

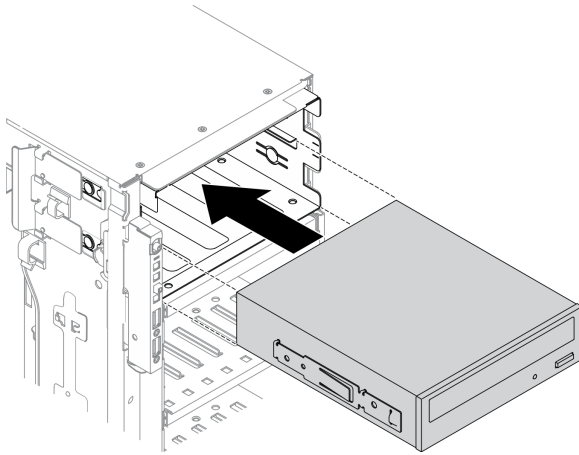

Figure 116. Optical drive installation

- Step 6. Connect the power cable and the signal cable to the rear of the optical drive or tape drive. See “Optical drive cable routing” on page 52 or “Tape drive cable routing” on page 54.

After you finish

1. Reinstall the front bezel. See “Install the front bezel” on page 106.
2. Reinstall the front door. See “Install the front door” on page 109.
3. Reinstall the server cover. See “Install the server cover” on page 190.
4. Complete the parts replacement. See “Complete the parts replacement” on page 206.

Remove the 5.25-inch drive bay adapter assembly

Use this information to remove the 5.25-inch drive bay adapter assembly.

About this task

S002



CAUTION:

The power-control button on the device and the power switch on the power supply do not turn off the electrical current supplied to the device. The device also might have more than one power cord. To remove all electrical current from the device, ensure that all power cords are disconnected from the power source.

S006**CAUTION:**

When laser products (such as CD-ROMs, DVD drives, fiber optic devices, or transmitters) are installed, note the following:

- Do not remove the covers. Removing the covers of the laser product could result in exposure to hazardous laser radiation. There are no serviceable parts inside the device.
- Use of controls or adjustments or performance of procedures other than those specified herein might result in hazardous radiation exposure.

S007**CAUTION:**

This product contains a Class 1M laser. Do not view directly with optical instruments.

Note: This section only applies to server models that come with a 5.25-inch drive bay adapter. For those that come with an optical or tape drive, see “Remove an optical drive or a tape drive” on page 147.

Attention:

- Read “Installation guidelines” on page 57 to ensure that you work safely.
- Power off the server and disconnect all power cords for this task.
- Prevent exposure to static electricity, which might lead to system halt and loss of data, by keeping static-sensitive components in their static-protective packages until installation, and handling these devices with an electrostatic-discharge wrist strap or other grounding system.
- If the server is in a rack, remove it from the rack.

Watch the procedure. A video of the installation and removal process is available:

- YouTube: <https://youtube.com/playlist?list=PLYV5R7hVcs-DoEcxrm2zKNpaKOdZ3f8Qc>
- Youku: https://list.youku.com/albumlist/show/id_59636516

Procedure

Step 1. Make preparations for this task.

- a. Remove the server cover. See “Remove the server cover” on page 188.
- b. Remove the front door. See “Remove the front door” on page 107.
- c. Remove the front bezel. See “Remove the front bezel” on page 105.

- Step 2. Disconnect every cable from the 5.25-inch drive bay adapter assembly.
- Step 3. Remove the 5.25-inch drive bay adapter assembly.

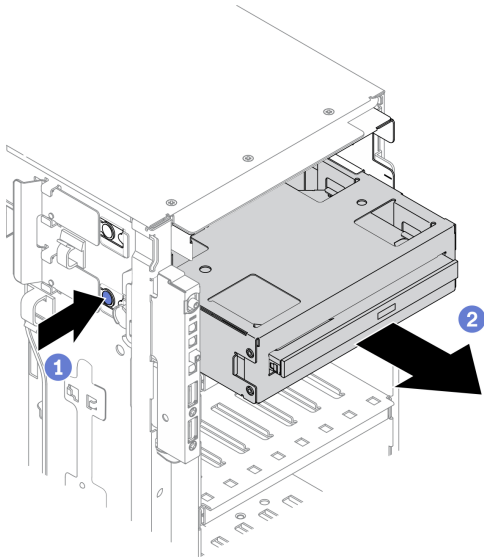

Figure 117. 5.25-inch drive bay adapter assembly removal

- a. 1 Press and hold the release tab.
- b. 2 Carefully pull the 5.25-inch drive bay adapter assembly at the same time to remove it from the chassis.

- Step 4. Remove the slim optical drive out from the adapter.

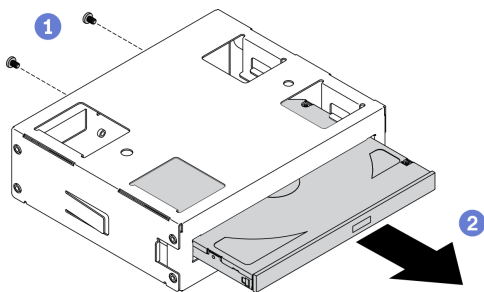

Figure 118. Removing slim optical drive from the drive bay adapter

- a. 1 Remove the two screws that secure the slim optical drive.
- b. 2 Slide the slim optical drive out from the adapter.

After you finish

1. Install a new slim optical drive or install a filler to cover the drive bay. See “Install the 5.25-inch drive bay adapter assembly” on page 156. To install a filler, complete the following steps:
 - a. Insert the filler to the vacant drive bay.

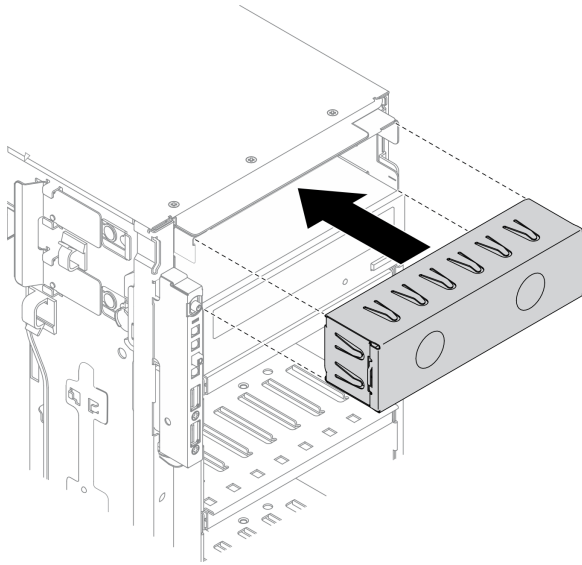

Figure 119. Drive bay filler installation

- b. Install the cover of the drive bay filler to the front bezel. Then, install the front bezel to the chassis.

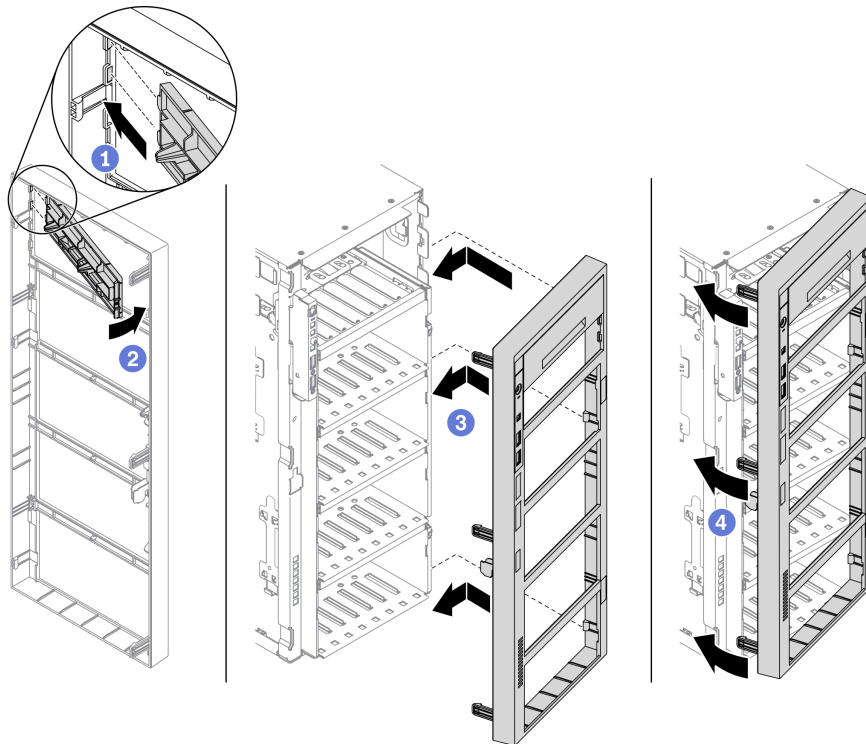

Figure 120. Drive bay filler cover installation

2. If you are instructed to return the component or optional device, follow all packaging instructions, and use any packaging materials for shipping that are supplied to you.

Install the 5.25-inch drive bay adapter assembly

Use this information to install the 5.25-inch drive bay adapter assembly.

About this task

S002



CAUTION:

The power-control button on the device and the power switch on the power supply do not turn off the electrical current supplied to the device. The device also might have more than one power cord. To remove all electrical current from the device, ensure that all power cords are disconnected from the power source.

S006



CAUTION:

When laser products (such as CD-ROMs, DVD drives, fiber optic devices, or transmitters) are installed, note the following:

- Do not remove the covers. Removing the covers of the laser product could result in exposure to hazardous laser radiation. There are no serviceable parts inside the device.
- Use of controls or adjustments or performance of procedures other than those specified herein might result in hazardous radiation exposure.

S007



CAUTION:

This product contains a Class 1M laser. Do not view directly with optical instruments.

Attention:

- Read “Installation guidelines” on page 57 to ensure that you work safely.
- Power off the server and disconnect all power cords for this task.
- Prevent exposure to static electricity, which might lead to system halt and loss of data, by keeping static-sensitive components in their static-protective packages until installation, and handling these devices with an electrostatic-discharge wrist strap or other grounding system.

Watch the procedure. A video of the installation and removal process is available:

- YouTube: <https://youtube.com/playlist?list=PLYV5R7hVcs-DoEcxrm2zKNpaK0dZ3f8Qc>
- Youku: https://list.youku.com/albumlist/show/id_59636516

Procedure

Step 1. If necessary, remove the cover of the drive bay filler from the front bezel.

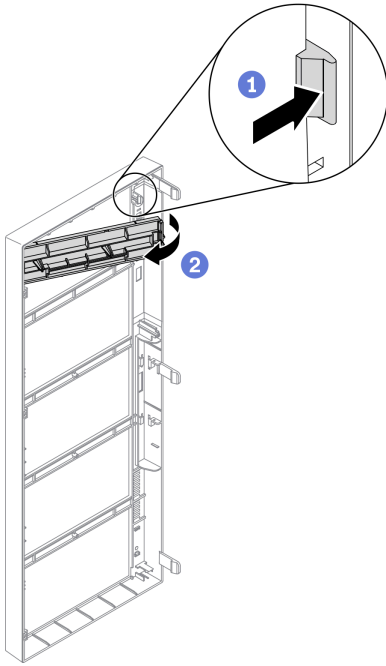

Figure 121. Drive bay filler cover installation

- a. ① Push the tab on the front bezel to release the cover of the drive bay filler.
- b. ② Remove the cover of the drive bay filler as shown.

Step 2. If necessary, remove the drive bay filler out of the chassis.

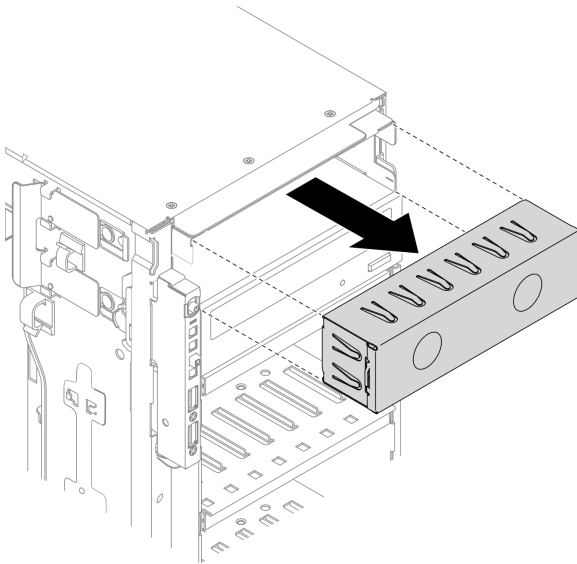

Figure 122. Drive bay filler installation

Step 3. Install the slim optical drive into the adapter.

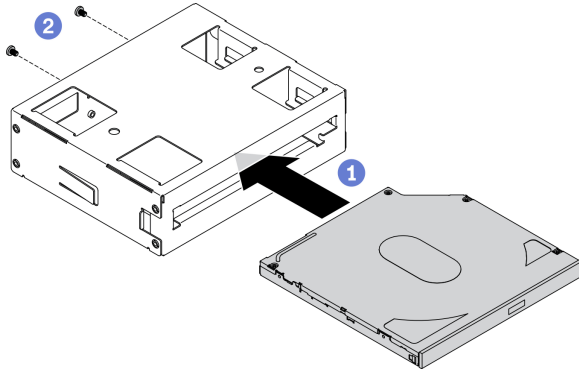

Figure 123. Installing slim optical drive into the drive bay adapter

- a. ① Slide the slim optical drive into the adapter.
- b. ② Secure the slim optical drive with two screws.

Step 4. Hold the 5.25-inch drive bay adapter assembly in the correct orientation; then, slide it into the drive bay until it snaps into position.

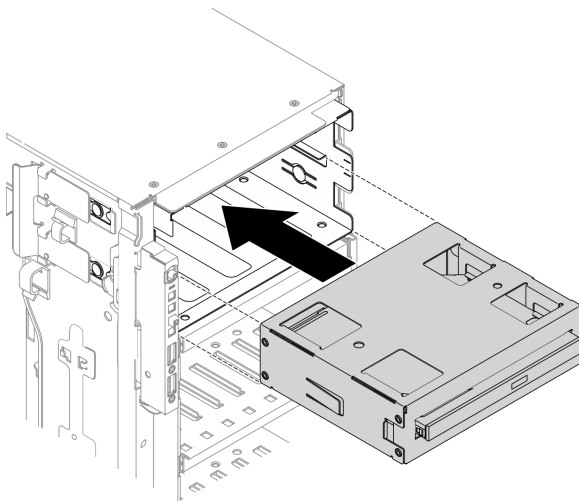

Figure 124. Optical drive installation

Step 5. Connect the power cable and the signal cable to the rear of the 5.25-inch drive bay adapter assembly. For more information about the cable routing. See “Optical drive cable routing” on page 52.

After you finish

1. Reinstall the front bezel. See “Install the front bezel” on page 106.
2. Reinstall the front door. See “Install the front door” on page 109.
3. Reinstall the server cover. See “Install the server cover” on page 190.
4. Complete the parts replacement. See “Complete the parts replacement” on page 206.

PCIe adapter holder replacement

Use this information to remove and install a PCIe adapter holder, which helps to hold the full-length PCIe adapters.

Remove a PCIe adapter holder

Use this information to remove a PCIe adapter holder.

About this task

S002



CAUTION:

The power-control button on the device and the power switch on the power supply do not turn off the electrical current supplied to the device. The device also might have more than one power cord. To remove all electrical current from the device, ensure that all power cords are disconnected from the power source.

Attention:

- Read “Installation guidelines” on page 57 to ensure that you work safely.
- Power off the server and disconnect all power cords for this task.
- Prevent exposure to static electricity, which might lead to system halt and loss of data, by keeping static-sensitive components in their static-protective packages until installation, and handling these devices with an electrostatic-discharge wrist strap or other grounding system.
- If the server is in a rack, remove it from the rack.
- If foot stands are installed on the server, rotate them inwards and lay the server on its side for easier operation.

Watch the procedure. A video of the installation and removal process is available:

- YouTube: <https://youtube.com/playlist?list=PLYV5R7hVcs-DoEcxrm2zKNpaKOdZ3f8Qc>
- Youku: https://list.youku.com/albumlist/show/id_59636516

Procedure

Step 1. Make preparations for this task.

- a. Remove the server cover. See “Remove the server cover” on page 188.
- b. Remove all the flash power modules. See “Remove a flash power module” on page 98.
- c. Remove the air baffle. See “Remove the air baffle” on page 72.
- d. Remove all the full-length GPU adapters. See “Remove a full-length GPU adapter” on page 113.

Step 2. Press and hold the tab to release the PCIe adapter holder from the fan cage; then, remove the PCIe adapter holder in the direction as shown.

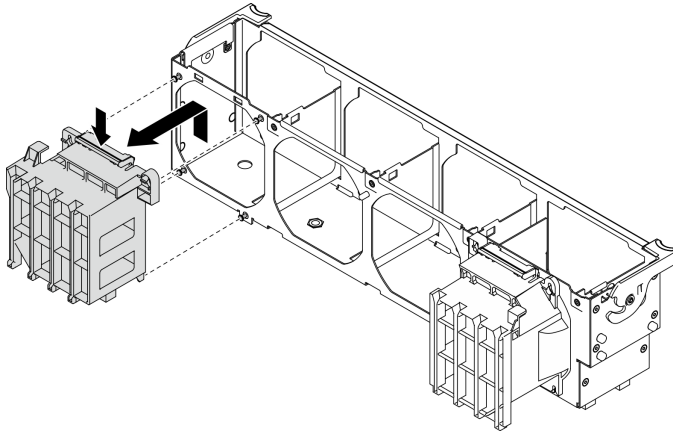

Figure 125. PCIe adapter holder removal

After you finish

If you are instructed to return the component or optional device, follow all packaging instructions, and use any packaging materials for shipping that are supplied to you.

Install a PCIe adapter holder

Use this information to install a PCIe adapter holder.

About this task

S002



CAUTION:

The power-control button on the device and the power switch on the power supply do not turn off the electrical current supplied to the device. The device also might have more than one power cord. To remove all electrical current from the device, ensure that all power cords are disconnected from the power source.

Attention:

- Read “Installation guidelines” on page 57 to ensure that you work safely.
- Power off the server and disconnect all power cords for this task.
- Prevent exposure to static electricity, which might lead to system halt and loss of data, by keeping static-sensitive components in their static-protective packages until installation, and handling these devices with an electrostatic-discharge wrist strap or other grounding system.

Watch the procedure. A video of the installation and removal process is available:

- YouTube: <https://youtube.com/playlist?list=PLYV5R7hVcs-DoEcxrm2zKNpaKOdZ3f8Qc>
- Youku: https://list.youku.com/albumlist/show/id_59636516

Procedure

Step 1. Align the PCIe adapter holder with the corresponding studs on the fan cage.

Note: The studs on the fan cage are positioned differently for the left PCIe adapter holder and right PCIe adapter holder.

Step 2. Insert the PCIe adapter holder onto the fan cage until it snaps into position.

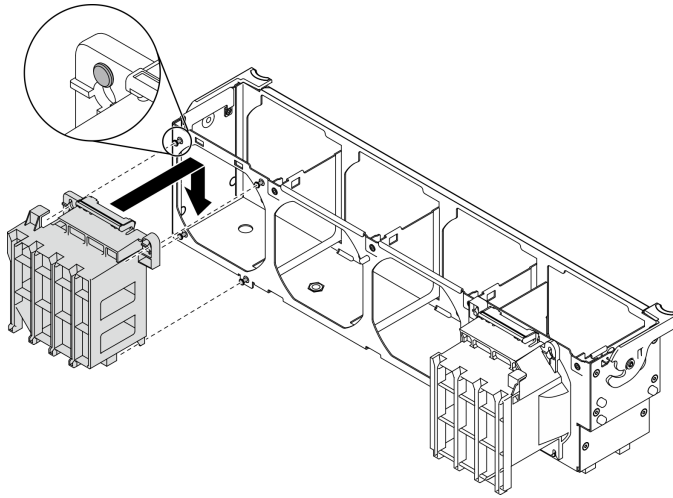

Figure 126. PCIe adapter holder installation

After you finish

1. Reinstall all the full-length GPU adapters. See “Install a full-length GPU adapter” on page 114.
2. Reinstall the air baffle. See “Install the air baffle” on page 74.
3. Reinstall all the flash power modules. See “Install a flash power module” on page 100.
4. Reinstall the server cover. See “Install the server cover” on page 190.
5. Complete the parts replacement. See “Complete the parts replacement” on page 206.

PCIe adapter replacement

Use this information to remove and install a PCIe adapter.

Your server comes with nine PCIe slots. Depending on your needs, you can install a PCIe adapter to obtain the corresponding function or remove the adapter if necessary. The PCIe adapter can be an Ethernet adapter, a host bus adapter, a RAID adapter, a graphics adapter, or any other supported PCIe adapters. PCIe adapters vary by type, but the installation and removal procedures are the same.

Notes:

- For a list of the supported PCIe adapters, see <https://static.lenovo.com/us/en/serverproven/index.shtml>
- For instructions on how to remove and install a full-length GPU adapter, see “Full-length GPU adapter replacement” on page 113

Remove a PCIe adapter

Use this information to remove a PCIe adapter.

About this task

S002

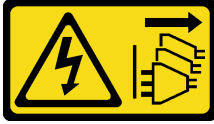
**CAUTION:**

The power-control button on the device and the power switch on the power supply do not turn off the electrical current supplied to the device. The device also might have more than one power cord. To remove all electrical current from the device, ensure that all power cords are disconnected from the power source.

Attention:

- Read “Installation guidelines” on page 57 to ensure that you work safely.
- Power off the server and disconnect all power cords for this task.
- Prevent exposure to static electricity, which might lead to system halt and loss of data, by keeping static-sensitive components in their static-protective packages until installation, and handling these devices with an electrostatic-discharge wrist strap or other grounding system.
- If the server is in a rack, remove it from the rack.
- If foot stands are installed on the server, rotate them inwards and lay the server on its side for easier operation.

Notes:

- Depending on the specific type, your PCIe adapter might look different from the illustration in this topic.
- Use any documentation that comes with the PCIe adapter and follow those instructions in addition to the instructions in this topic.

Watch the procedure. A video of the installation and removal process is available:

- YouTube: <https://youtube.com/playlist?list=PLYV5R7hVcs-DoEcxrm2zKNpaKOdZ3f8Qc>
- Youku: https://list.youku.com/albumlist/show/id_59636516

Procedure

Step 1. Make preparations for this task.

- a. Remove the server cover. See “Remove the server cover” on page 188.
- b. Remove all the flash power modules. See “Remove a flash power module” on page 98.
- c. Remove the air baffle. See “Remove the air baffle” on page 72.

Step 2. Locate the PCIe adapter you want to remove. Depending on the type of PCIe adapter, you might also need to disconnect all cables from the PCIe adapter, the system board, or the drive backplane.

Step 3. Remove the PCIe adapter.

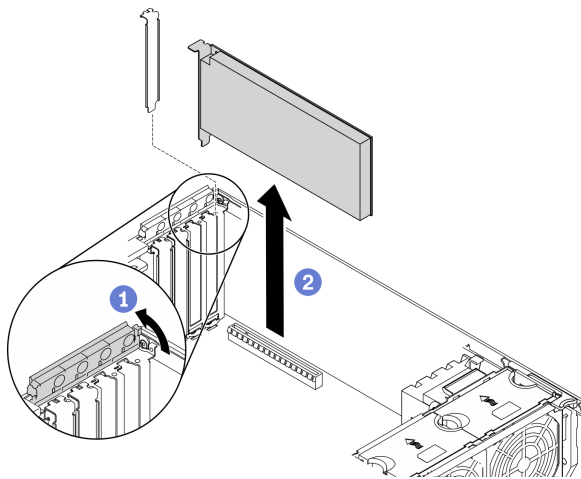

Figure 127. PCIe adapter removal

- a. ① Open the PCIe adapter retainer.
- b. ② Grasp the PCIe adapter by its edges and carefully pull it out of the slot.

After you finish

1. Install another PCIe adapter if necessary. See “Install a PCIe adapter” on page 164. Otherwise, install a bracket to cover the vacancy and close the PCIe adapter retainer.
2. If you are instructed to return the component or optional device, follow all packaging instructions, and use any packaging materials for shipping that are supplied to you.

Install a PCIe adapter

Use this information to install a PCIe adapter.

About this task

S002



CAUTION:

The power-control button on the device and the power switch on the power supply do not turn off the electrical current supplied to the device. The device also might have more than one power cord. To remove all electrical current from the device, ensure that all power cords are disconnected from the power source.

Attention:

- Read “Installation guidelines” on page 57 to ensure that you work safely.
- Power off the server and disconnect all power cords for this task.
- Prevent exposure to static electricity, which might lead to system halt and loss of data, by keeping static-sensitive components in their static-protective packages until installation, and handling these devices with an electrostatic-discharge wrist strap or other grounding system.

Notes:

- Depending on the specific type, your PCIe adapter might look different from the illustration in this topic.
- Use any documentation that comes with the PCIe adapter and follow those instructions in addition to the instructions in this topic.

Watch the procedure. A video of the installation and removal process is available:

- YouTube: <https://youtube.com/playlist?list=PLYV5R7hVcs-DoEcxm2zKNpaKOdZ3f8Qc>
- Youku: https://list.youku.com/albumlist/show/id_59636516

Procedure

Step 1. Locate the applicable PCIe slot. See “Specifications” on page 1 to identify the different types of PCIe slots in your server.

Note: Ensure that you observe the installation rules and sequence in “Technical rules for PCIe adapters” in the *ThinkSystem ST650 V2 Setup Guide*.

Step 2. If a bracket is installed in the PCIe slot, remove it. Store the bracket for the PCIe slot in case that you later remove the PCIe adapter and need the bracket to cover the place.

Step 3. Install the PCIe adapter.

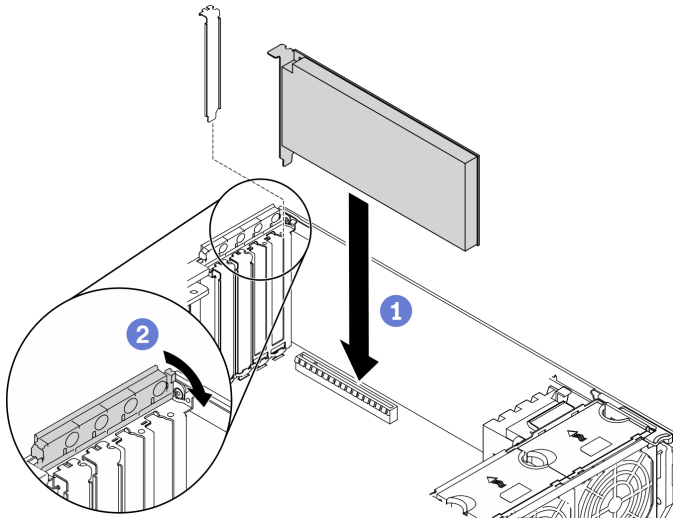

Figure 128. PCIe adapter installation

Note: Make sure the PCIe adapter retainer is in the opened position.

- 1 Align the PCIe adapter to the PCIe slot; then, gently press both ends of the PCIe adapter until it is securely seated in the PCIe slot.
- 2 Close the PCIe adapter retainer.

Step 4. Depending on the type of PCIe adapter, you might need to connect one or more cables. Refer to the documentation that comes with the PCIe adapter for specific information.

After you finish

1. If you have installed a T4 GPU adapter, install a T4 filler onto the server cover. See “Install a T4 filler” on page 204.
2. Reinstall the air baffle. See “Install the air baffle” on page 74.
3. Reinstall all the flash power modules. See “Install a flash power module” on page 100.
4. Reinstall the server cover. See “Install the server cover” on page 190.

5. Complete the parts replacement. See “Complete the parts replacement” on page 206.

Power distribution board replacement

Use this information to remove and install the power distribution board.

Remove the power distribution board

Use this information to remove the power distribution board.

About this task

S002



CAUTION:

The power-control button on the device and the power switch on the power supply do not turn off the electrical current supplied to the device. The device also might have more than one power cord. To remove all electrical current from the device, ensure that all power cords are disconnected from the power source.

Attention:

- Read “Installation guidelines” on page 57 to ensure that you work safely.
- Power off the server and disconnect all power cords for this task.
- Prevent exposure to static electricity, which might lead to system halt and loss of data, by keeping static-sensitive components in their static-protective packages until installation, and handling these devices with an electrostatic-discharge wrist strap or other grounding system.
- If the server is in a rack, remove it from the rack.
- If foot stands are installed on the server, rotate them inwards and lay the server on its side for easier operation.

Watch the procedure. A video of the installation and removal process is available:

- YouTube: <https://youtube.com/playlist?list=PLYV5R7hVcs-DoEcxrm2zKNpaKOdZ3f8Qc>
- Youku: https://list.youku.com/albumlist/show/id_59636516

Procedure

Step 1. Make preparations for this task.

- a. Remove the hot-swap redundant power supply. See “Remove a hot-swap power supply” on page 170.
- b. Remove the server cover. See “Remove the server cover” on page 188.
- c. Remove all the flash power modules. See “Remove a flash power module” on page 98.
- d. Remove the air baffle. See “Remove the air baffle” on page 72.
- e. Remove all the PCIe adapters. See “Remove a PCIe adapter” on page 162.
- f. Remove all the full-length GPU adapters. See “Remove a full-length GPU adapter” on page 113.
- g. Remove all the fans. See “Remove a hot-swap fan” on page 93.

- h. Remove the fan cage. See “Remove the fan cage assembly” on page 95.
- i. Remove the system board. See “Remove the system board” on page 192.

Step 2. Remove the power distribution board cover.

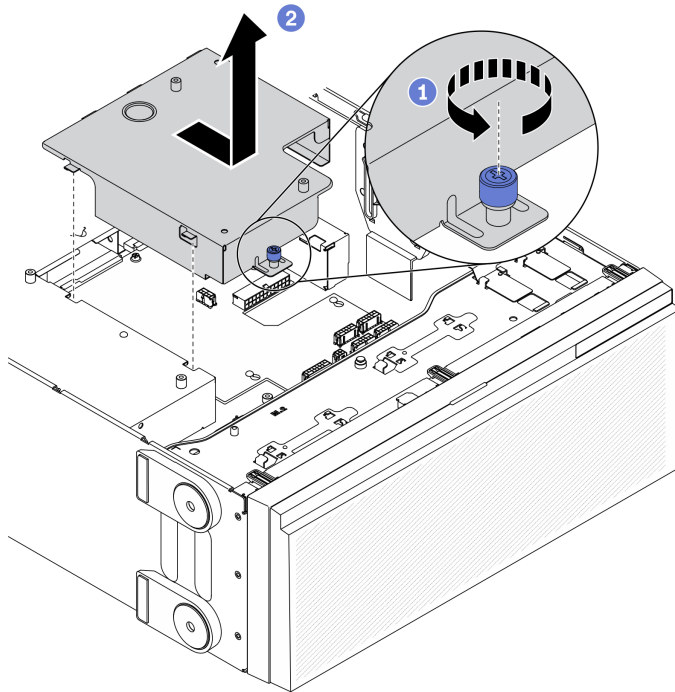

Figure 129. Power distribution board cover removal

- a. ① Loosen the captive screw.
- b. ② Remove the power distribution board cover in the direction as shown.

Step 3. Disconnect all the cables from the power distribution board.

Step 4. Remove the power distribution board.

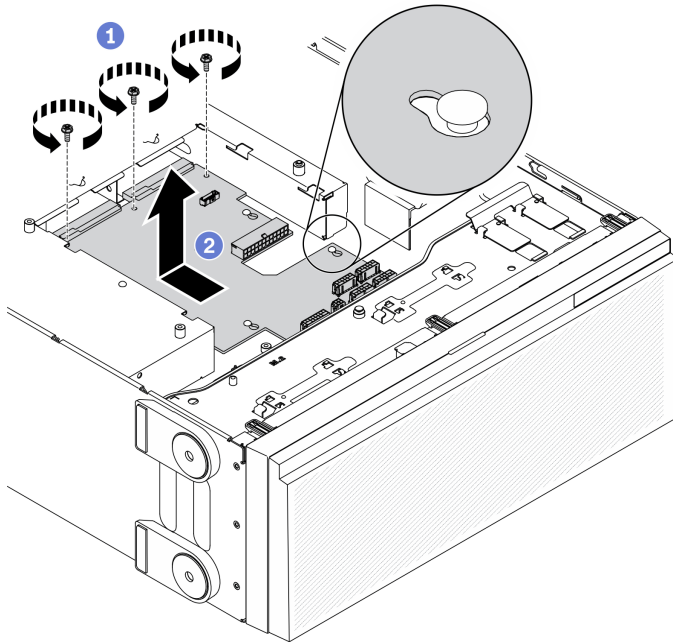

Figure 130. Power distribution board removal

- a. ① Remove the three screws that secure the power distribution board to the chassis.
- b. ② Slide the power distribution board towards the rear of the server to release it from the chassis; then, carefully hold the power distribution board by its edges and lift the power distribution board out of the chassis.

After you finish

- Install a power distribution board. See “Install the power distribution board” on page 168.
- If you are instructed to return the component or optional device, follow all packaging instructions, and use any packaging materials for shipping that are supplied to you.

Install the power distribution board

Use this information to install the power distribution board.

About this task

S002



CAUTION:

The power-control button on the device and the power switch on the power supply do not turn off the electrical current supplied to the device. The device also might have more than one power cord. To remove all electrical current from the device, ensure that all power cords are disconnected from the power source.

Attention:

- Read “Installation guidelines” on page 57 to ensure that you work safely.
- Power off the server and disconnect all power cords for this task.
- Prevent exposure to static electricity, which might lead to system halt and loss of data, by keeping static-sensitive components in their static-protective packages until installation, and handling these devices with an electrostatic-discharge wrist strap or other grounding system.

Watch the procedure. A video of the installation and removal process is available:

- YouTube: <https://youtube.com/playlist?list=PLYV5R7hVcs-DoEcXrm2zKNpaK0dZ3f8Qc>
- Youku: https://list.youku.com/albumlist/show/id_59636516

Procedure

Step 1. Install the power distribution board.

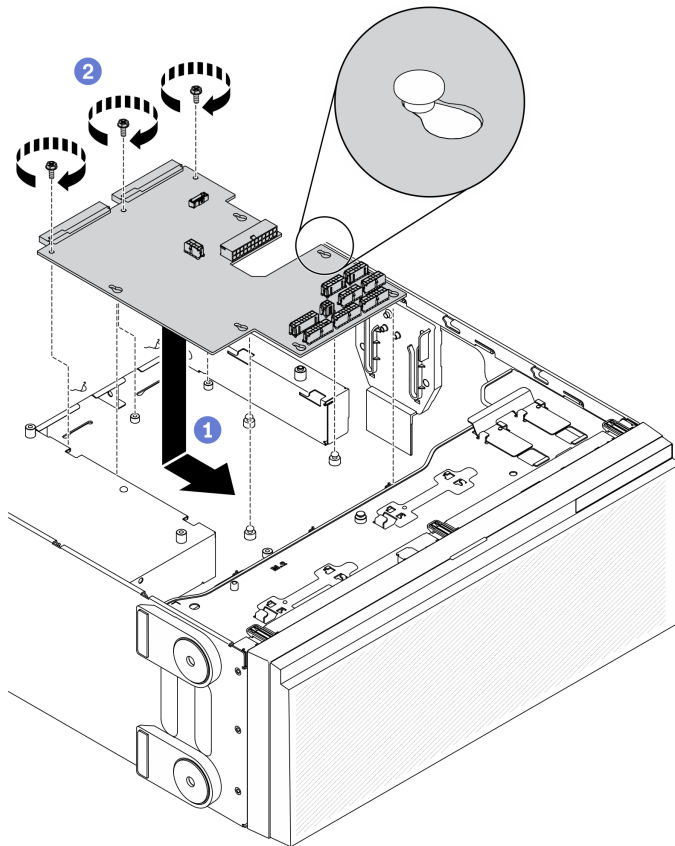

Figure 131. Power distribution board installation

- 1 Carefully hold the power distribution board by its edges and position it to the chassis. Ensure that the tabs on the chassis are inserted into the corresponding holes in the power distribution board; then, slide the power distribution board towards the front of the server.
- 2 Install the three screws to secure the power distribution board to the chassis.

Step 2. Connect the cables to the PDB signal connector and Main power connector on the power distribution board. See “Power distribution board connectors” on page 41.

Step 3. Install the power distribution board cover.

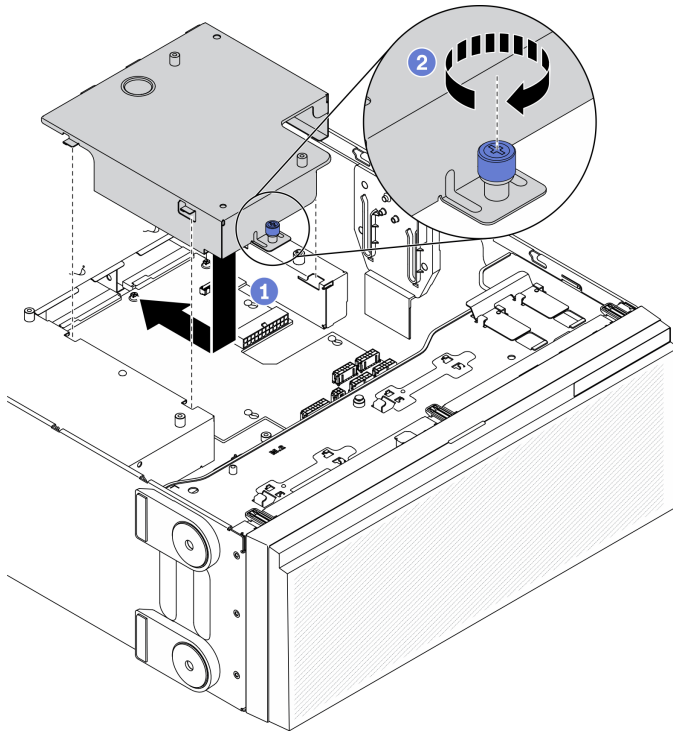

Figure 132. Power distribution board cover installation

- a. ① Install the power distribution board cover in the direction as shown.
- b. ② Fasten the captive screw to secure the power distribution board cover.

After you finish

1. Reinstall the system board. See “Install the system board” on page 196.
2. Connect the cables from the power distribution board to the system board. See “Power distribution board cable routing” on page 53.
3. Reinstall the fan cage. See “Install the fan cage assembly” on page 97.
4. Reinstall all the fans. See “Install a hot-swap fan” on page 94.
5. Reinstall all the full-length GPU adapters. See “Install a full-length GPU adapter” on page 114.
6. Reinstall all the PCIe adapters. See “Install a PCIe adapter” on page 164.
7. Reinstall the air baffle. See “Install the air baffle” on page 74.
8. Reinstall all the flash power modules. See “Install a flash power module” on page 100.
9. Reinstall the server cover. See “Install the server cover” on page 190.
10. Reinstall the hot-swap redundant power supply. See “Install the hot-swap power supply” on page 173.
11. Complete the parts replacement. See “Complete the parts replacement” on page 206.

Power supply unit replacement

Use this information to remove and install the redundant power supply unit.

Remove a hot-swap power supply

Use this information to remove a hot-swap power supply.

About this task

S001



Electrical current from power, telephone, and communication cables is hazardous.

To avoid a shock hazard:

- Connect all power cords to a properly wired and grounded electrical outlet/source.
- Connect any equipment that will be attached to this product to properly wired outlets/sources.
- When possible, use one hand only to connect or disconnect signal cables.
- Never turn on any equipment when there is evidence of fire, water, or structural damage.
- The device might have more than one power cord, to remove all electrical current from the device, ensure that all power cords are disconnected from the power source.

S002



CAUTION:

The power-control button on the device and the power switch on the power supply do not turn off the electrical current supplied to the device. The device also might have more than one power cord. To remove all electrical current from the device, ensure that all power cords are disconnected from the power source.

S033



CAUTION:

Hazardous energy present. Voltages with hazardous energy might cause heating when shorted with metal, which might result in spattered metal, burns, or both.

Attention:

- Read "Installation guidelines" on page 57 to ensure that you work safely.
- Prevent exposure to static electricity, which might lead to system halt and loss of data, by keeping static-sensitive components in their static-protective packages until installation, and handling these devices with an electrostatic-discharge wrist strap or other grounding system.

The following tips describe the information that you must consider when you remove a power supply with dc input.

CAUTION:

1. 240 V dc input (input range: 180-300 V dc) is **ONLY** supported in Chinese Mainland.
2. Power supplies with 240 V dc are not hot-swappable. To remove the power cord, ensure you have turned off the server or disconnected the dc power sources at the breaker panel.
3. In order for the ThinkSystem products to operate error free in both a DC or AC electrical environment, a TN-S earthing system which complies to 60364-1 IEC 2005 standard has to be present or installed.

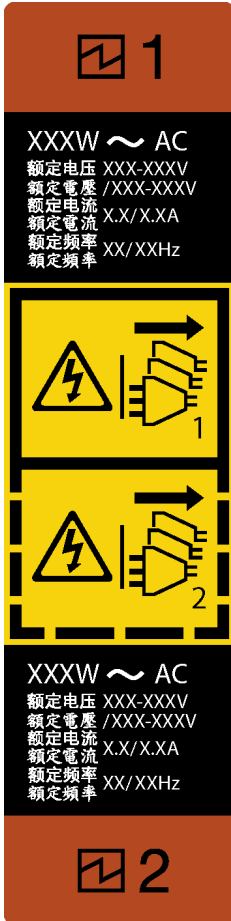

Figure 133. Hot-swap power supply label

Attention: This type of power supply is hot-swap only when two power supplies are installed for redundancy. If only one power supply is installed, you must power off the server first before removing the power supply.



在直流输入状态下，若电源供应器插座不支持热插拔功能，请务必不要对设备电源线进行热插拔，此操作可能导致设备损坏及数据丢失。因错误执行热插拔导致的设备故障或损坏，不属于保修范围。

NEVER CONNECT AND DISCONNECT THE POWER SUPPLY CABLE AND EQUIPMENT WHILE YOUR EQUIPMENT IS POWERED ON WITH DC SUPPLY (hot-plugging). Otherwise you may damage the equipment and result in data loss, the damages and losses result from incorrect operation of the equipment will not be covered by the manufacturers' warranty.

Watch the procedure. A video of the installation and removal process is available:

- YouTube: <https://youtube.com/playlist?list=PLYV5R7hVcs-DoEcxrm2zKNpaK0dZ3f8Qc>
- Youku: https://list.youku.com/albumlist/show/id_59636516

Procedure

- Step 1. Locate the hot-swap power supply in the rear of your server and disconnect the power cord from the power supply.
- Step 2. Remove the hot-swap power supply.

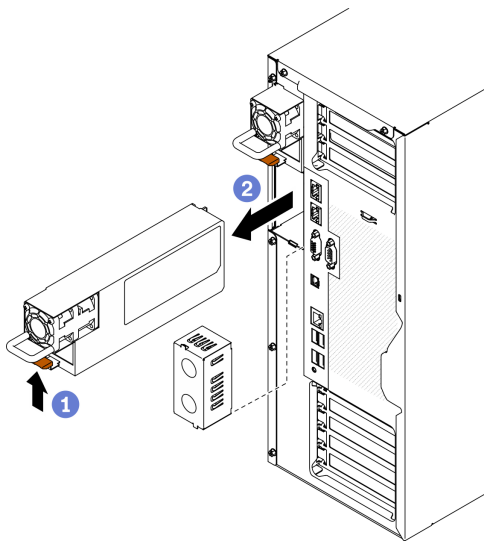

Figure 134. Hot-swap power supply removal

- a. ① Press and hold the release tab in the direction as shown.
- b. ② Carefully pull the handle at the same time to slide the hot-swap power supply out of the chassis.

After you finish

1. Install a power supply or install the power-supply filler to cover the power supply bay. See “Install the hot-swap power supply” on page 173.

Important: To ensure proper cooling during normal server operation, both of the power supply bays must be occupied. This means that each bay must have a power supply installed; or one has a power supply installed and the other has a power-supply filler installed.

2. If you are instructed to return the component or optional device, follow all packaging instructions, and use any packaging materials for shipping that are supplied to you.

Install the hot-swap power supply

Use this information to install the hot-swap power supply.

About this task

S001



Electrical current from power, telephone, and communication cables is hazardous.
To avoid a shock hazard:

- Connect all power cords to a properly wired and grounded electrical outlet/source.
- Connect any equipment that will be attached to this product to properly wired outlets/sources.
- When possible, use one hand only to connect or disconnect signal cables.
- Never turn on any equipment when there is evidence of fire, water, or structural damage.
- The device might have more than one power cord, to remove all electrical current from the device, ensure that all power cords are disconnected from the power source.

S002



CAUTION:

The power-control button on the device and the power switch on the power supply do not turn off the electrical current supplied to the device. The device also might have more than one power cord. To remove all electrical current from the device, ensure that all power cords are disconnected from the power source.

S033



CAUTION:

Hazardous energy present. Voltages with hazardous energy might cause heating when shorted with metal, which might result in spattered metal, burns, or both.

Attention:

- Read “Installation guidelines” on page 57 to ensure that you work safely.
- Prevent exposure to static electricity, which might lead to system halt and loss of data, by keeping static-sensitive components in their static-protective packages until installation, and handling these devices with an electrostatic-discharge wrist strap or other grounding system.

The following tips describe the type of power supply that the server supports and other information that you must consider when you install a power supply:

- The standard shipping has only one power supply installed in the server. For redundancy and hot-swap support, you must install an additional hot-swap power supply. Certain customized models might be shipped with two power supplies installed.
- Ensure that the devices that you are installing are supported. For a list of supported optional devices for the server, go to: <https://static.lenovo.com/us/en/serverproven/index.shtml>

CAUTION:

1. 240 V dc input (input range: 180-300 V dc) is **ONLY** supported in Chinese Mainland.
2. Power supplies with 240 V dc are not hot-swappable. To remove the power cord, ensure you have turned off the server or disconnected the dc power sources at the breaker panel.
3. In order for the ThinkSystem products to operate error free in both a DC or AC electrical environment, a TN-S earthing system which complies to 60364-1 IEC 2005 standard has to be present or installed.

Notes:

- Ensure that the two power supplies installed on the server have the same wattage.
- If you are replacing the existing power supply with a new power supply of different wattage, attach the power information label that comes with this option onto the existing label near the power supply.

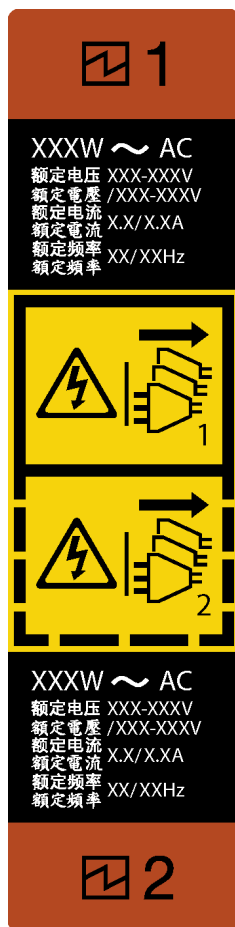

Figure 135. Hot-swap power supply label



在直流输入状态下，若电源供应器插座不支持热插拔功能，请务必不要对设备电源线进行热插拔，此操作可能导致设备损坏及数据丢失。因错误执行热插拔导致的设备故障或损坏，不属于保修范围。

NEVER CONNECT AND DISCONNECT THE POWER SUPPLY CABLE AND EQUIPMENT WHILE YOUR EQUIPMENT IS POWERED ON WITH DC SUPPLY (hot-plugging). Otherwise you may damage the equipment and result in data loss, the damages and losses result from incorrect operation of the equipment will not be covered by the manufacturers' warranty.

Watch the procedure. A video of the installation and removal process is available:

- YouTube: <https://youtube.com/playlist?list=PLYV5R7hVcs-DoEcXrm2zKNpaKOdZ3f8Qc>
- Youku: https://list.youku.com/albumlist/show/id_59636516

Procedure

Step 1. If there is a power-supply-bay filler installed, remove it.

Important: To ensure proper cooling during normal server operation, both of the power supply bays must be occupied. This means that each bay must have a power supply installed; or one has a power supply installed and the other has a power-supply filler installed.

Step 2. Note the orientation of the hot-swap power supply; then, slide it into the chassis until it snaps into position.

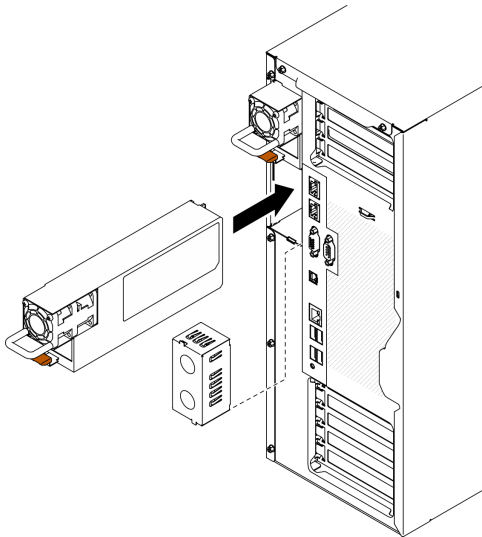

Figure 136. Hot-swap power supply installation

After you finish

1. Connect the power cable to the power supply and a properly grounded electrical outlet.
2. If the server is powered off, power on the server. Ensure that both the power input LED and the power output LED on the power supply are lit, indicating that the power supply is operating properly.
3. Complete the parts replacement. See “Complete the parts replacement” on page 206.

Processor and heat sink replacement

Use this information to remove and install a processor and heat sink.

Attention: Before you begin replacing a processor, make sure that you have an alcohol cleaning pad (part number 00MP352) and thermal grease.

Remove a processor and heat sink

This task has instructions for removing an assembled processor and heat sink, known as a processor-heat-sink module (PHM). This task requires a Torx T30 driver. This procedure must be executed by a trained technician.

About this task

S002



CAUTION:

The power-control button on the device and the power switch on the power supply do not turn off the electrical current supplied to the device. The device also might have more than one power cord. To remove all electrical current from the device, ensure that all power cords are disconnected from the power source.

Attention:

- Read “Installation guidelines” on page 57 to ensure that you work safely.
- Power off the server and disconnect all power cords for this task.
- Prevent exposure to static electricity, which might lead to system halt and loss of data, by keeping static-sensitive components in their static-protective packages until installation, and handling these devices with an electrostatic-discharge wrist strap or other grounding system.
- If the server is in a rack, remove it from the rack.
- Lay the server on its side for easier operation.
- Each processor socket must always contain a cover or a PHM. When removing or installing a PHM, protect empty processor sockets with a cover.
- Do not touch the processor socket or processor contacts. Processor-socket contacts are very fragile and easily damaged. Contaminants on the processor contacts, such as oil from your skin, can cause connection failures.
- Do not allow the thermal grease on the processor or heat sink to come in contact with anything. Contact with any surface can compromise the thermal grease, rendering it ineffective. Thermal grease can damage components, such as the electrical connectors in the processor socket.
- Remove and install only one PHM at a time. If the system board supports multiple processors, install the PHMs starting with the first processor socket.

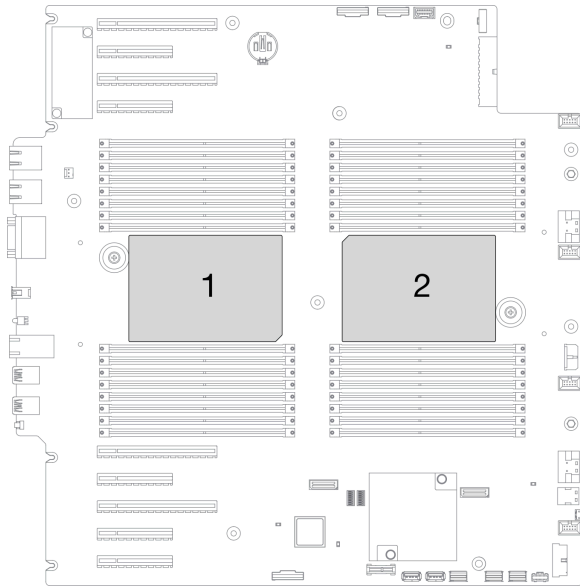

Figure 137. Processor locations on system board

Note: The heat sink, processor, and processor carrier for your system might be different from those shown in the illustrations.

The following illustration shows the components of the PHM.

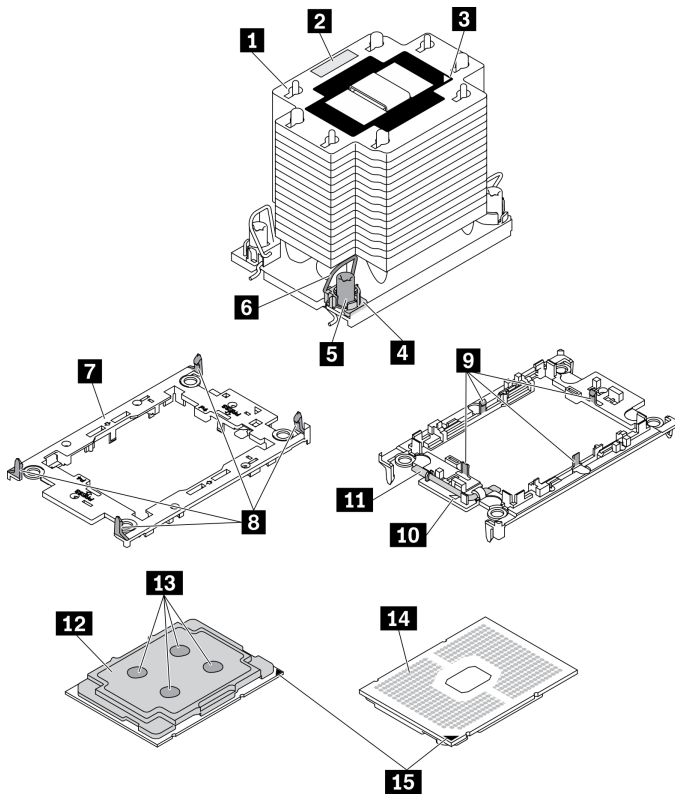

Figure 138. PHM components

1 Heat sink	9 Clips to secure processor in carrier
2 Processor identification label	10 Carrier triangular mark
3 Heat sink triangular mark	11 Processor ejector handle
4 Nut and wire bail retainer	12 Processor heat spreader
5 Torx T30 nut	13 Thermal grease
6 Anti-tilt wire bail	14 Processor contacts
7 Processor carrier	15 Processor triangular mark
8 Clips to secure carrier to heat sink	

Watch the procedure. A video of the installation and removal process is available:

- YouTube: <https://youtube.com/playlist?list=PLYV5R7hVcs-DoEcXrm2zKNpaK0dZ3f8Qc>
- Youku: https://list.youku.com/albumlist/show/id_59636516

Procedure

Step 1. Make preparations for this task.

- Remove the hot-swap redundant power supply. See “Remove a hot-swap power supply” on page 170.
- Remove the server cover. See “Remove the server cover” on page 188.
- Remove all the flash power modules. See “Remove a flash power module” on page 98.
- Remove the air baffle. See “Remove the air baffle” on page 72.

Step 2. Remove the PHM from the system board.

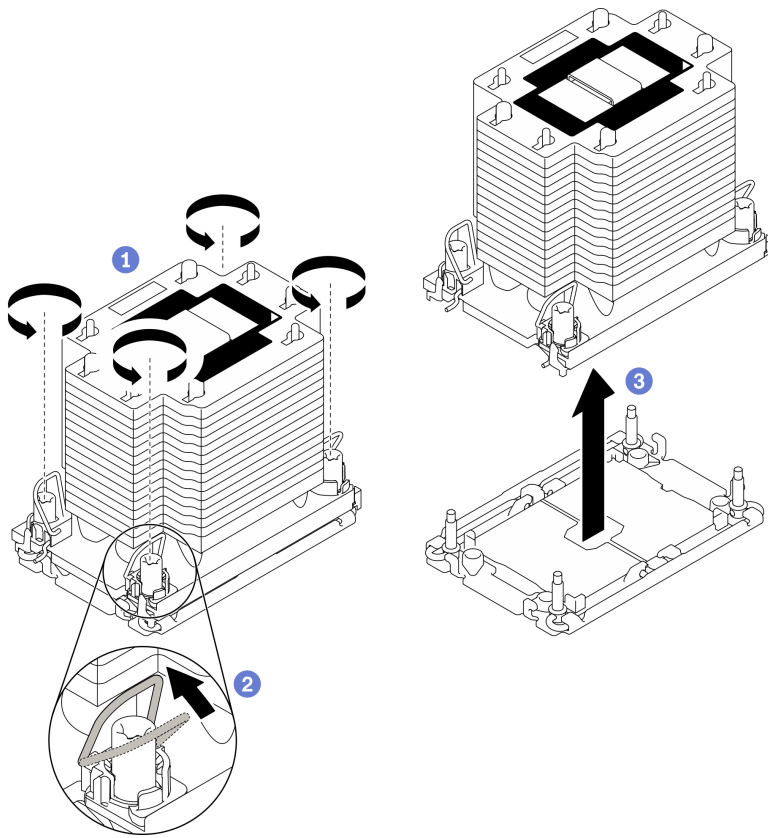

Figure 139. Removing a PHM

- a. ① Fully loosen the Torx T30 nuts on the PHM *in the removal sequence shown* on the heat-sink label.
- b. ② Rotate the anti-tilt wire bails inward.
- c. ③ Carefully lift the PHM from the processor socket. If the PHM cannot be fully lifted out of the socket, further loosen the Torx T30 nuts and try lifting the PHM again.

Notes:

- Do not touch the contacts on the bottom of the processor.
- Keep the processor socket clean from any object to prevent possible damages.

After you finish

- Each processor socket must always contain a cover or a PHM. Protect empty processor sockets with a cover or install a new PHM.
- If you are removing the PHM as part of a system board replacement, set the PHM aside.
- If you are reusing the processor or heat sink, separate the processor from its retainer. See “Separate the processor from carrier and heat sink” on page 181
- If you are instructed to return the component or optional device, follow all packaging instructions, and use any packaging materials for shipping that are supplied to you.

Separate the processor from carrier and heat sink

This task has instructions for separating a processor and its carrier from an assembled processor and heat sink, known as a processor-heat-sink module (PHM). This procedure must be executed by a trained technician.

About this task

S002



CAUTION:

The power-control button on the device and the power switch on the power supply do not turn off the electrical current supplied to the device. The device also might have more than one power cord. To remove all electrical current from the device, ensure that all power cords are disconnected from the power source.

Attention:

- Read “Installation guidelines” on page 57 to ensure that you work safely.
- Power off the server and disconnect all power cords for this task.
- Prevent exposure to static electricity, which might lead to system halt and loss of data, by keeping static-sensitive components in their static-protective packages until installation, and handling these devices with an electrostatic-discharge wrist strap or other grounding system.
- Do not touch the processor contacts. Contaminants on the processor contacts, such as oil from your skin, can cause connection failures.
- Do not allow the thermal grease on the processor or heat sink to come in contact with anything. Contact with any surface can compromise the thermal grease, rendering it ineffective. Thermal grease can damage components, such as the electrical connectors in the processor socket.

Note: The heat sink, processor, and processor carrier for your system might be different from those shown in the illustrations.

Watch the procedure. A video of the installation and removal process is available:

- YouTube: <https://youtube.com/playlist?list=PLYV5R7hVcs-DoEcxrm2zKNpaK0dZ3f8Qc>
- Youku: https://list.youku.com/albumlist/show/id_59636516

Procedure

Step 1. Separate the processor from the heat sink and carrier.

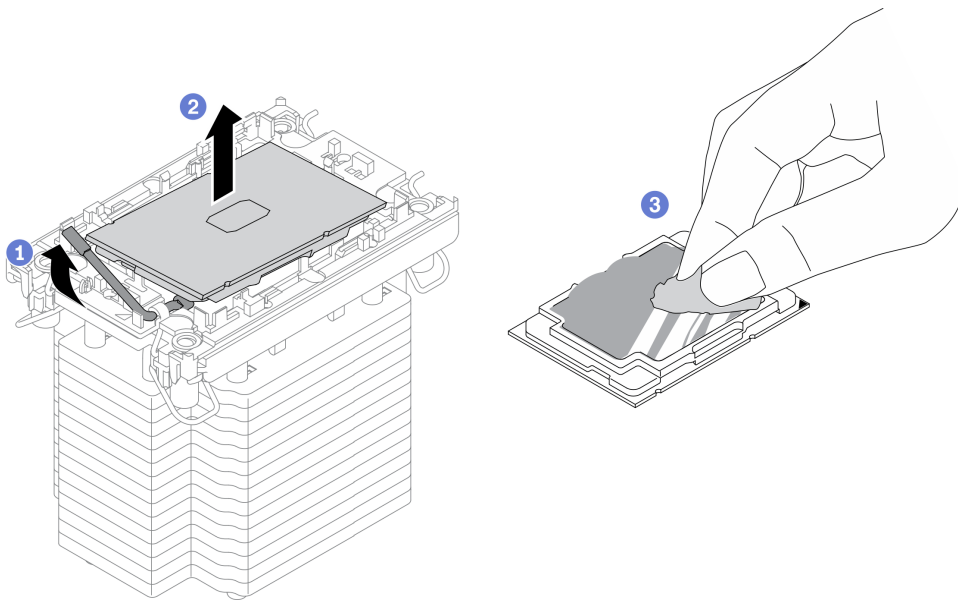

Figure 140. Separating a processor from the heat sink and carrier

Note: Do not touch the contacts on the processor.

- a. ① Lift the handle to release the processor from the carrier.
- b. ② Hold the processor by its edges; then, lift the processor from the heat sink and carrier.
- c. ③ Without putting the processor down, wipe the thermal grease from the top of the processor with an alcohol cleaning pad; then, place the processor on a static protective surface with the processor-contact side up.

Step 2. Separate the processor carrier from the heat sink.

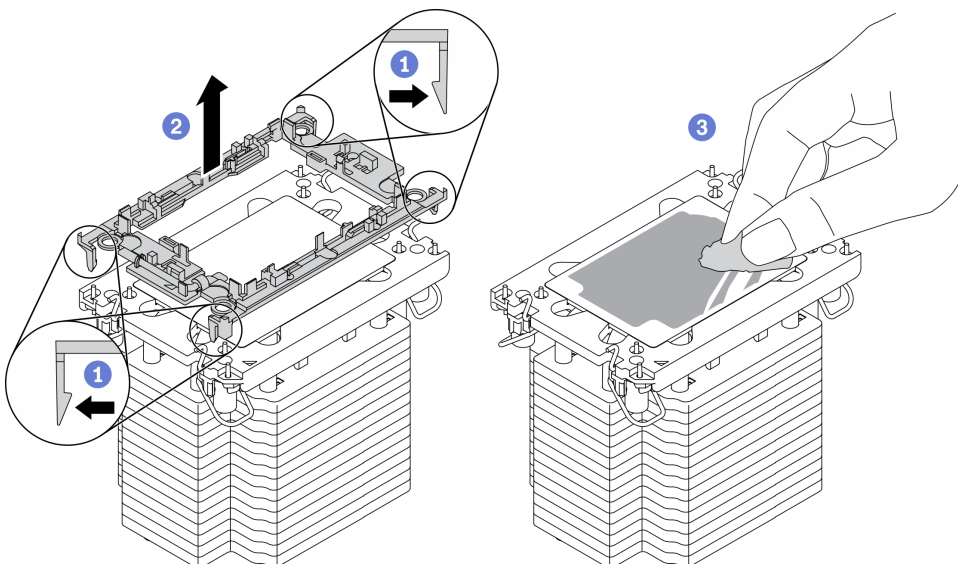

Figure 141. Separating a processor carrier from the heat sink

Note: The processor carrier will be discarded and replaced with a new one.

- a. ① Release the retaining clips from the heat sink.

- b. ② Lift the carrier from the heat sink.
- c. ③ Wipe the thermal grease from the bottom of the heat sink with an alcohol cleaning pad.

After you finish

If you are instructed to return the component or optional device, follow all packaging instructions, and use any packaging materials for shipping that are supplied to you.

Install a processor and heat sink

This task has instructions for installing an assembled processor and heat sink, known as a processor-heat-sink module (PHM). This task requires a Torx T30 driver. This procedure must be executed by a trained technician.

About this task

S002

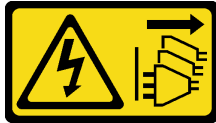

CAUTION:

The power-control button on the device and the power switch on the power supply do not turn off the electrical current supplied to the device. The device also might have more than one power cord. To remove all electrical current from the device, ensure that all power cords are disconnected from the power source.

Attention:

- Read “Installation guidelines” on page 57 to ensure that you work safely.
- Power off the server and disconnect all power cords for this task.
- Prevent exposure to static electricity, which might lead to system halt and loss of data, by keeping static-sensitive components in their static-protective packages until installation, and handling these devices with an electrostatic-discharge wrist strap or other grounding system.
- Each processor socket must always contain a cover or a PHM. When removing or installing a PHM, protect empty processor sockets with a cover.
- Do not touch the processor socket or processor contacts. Processor-socket contacts are very fragile and easily damaged. Contaminants on the processor contacts, such as oil from your skin, can cause connection failures.
- Do not allow the thermal grease on the processor or heat sink to come in contact with anything. Contact with any surface can compromise the thermal grease, rendering it ineffective. Thermal grease can damage components, such as the electrical connectors in the processor socket.
- Remove and install only one PHM at a time. If the system board supports multiple processors, install the PHMs starting with the first processor socket.

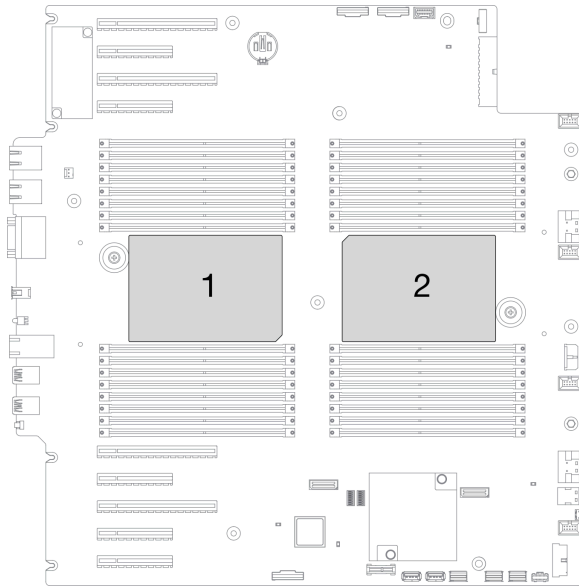

Figure 142. Processor locations on system board

Notes:

- The heat sink, processor, and processor carrier for your system might be different from those shown in the illustrations.
- PHMs are keyed for the socket where they can be installed and for their orientation in the socket.
- See <https://static.lenovo.com/us/en/serverproven/index.shtml> for a list of processors supported for your server. All processors on the system board must have the same speed, number of cores, and frequency.
- Before you install a new PHM or replacement processor, update your system firmware to the latest level. See “Update the firmware” in the *ThinkSystem ST650 V2 Setup Guide*.
- Installing an additional PHM can change the memory requirements for your system. See “Technical rules for memory modules” in the *ThinkSystem ST650 V2 Setup Guide* for a list of processor-to-memory relationships.

The following illustration shows the components of the PHM.

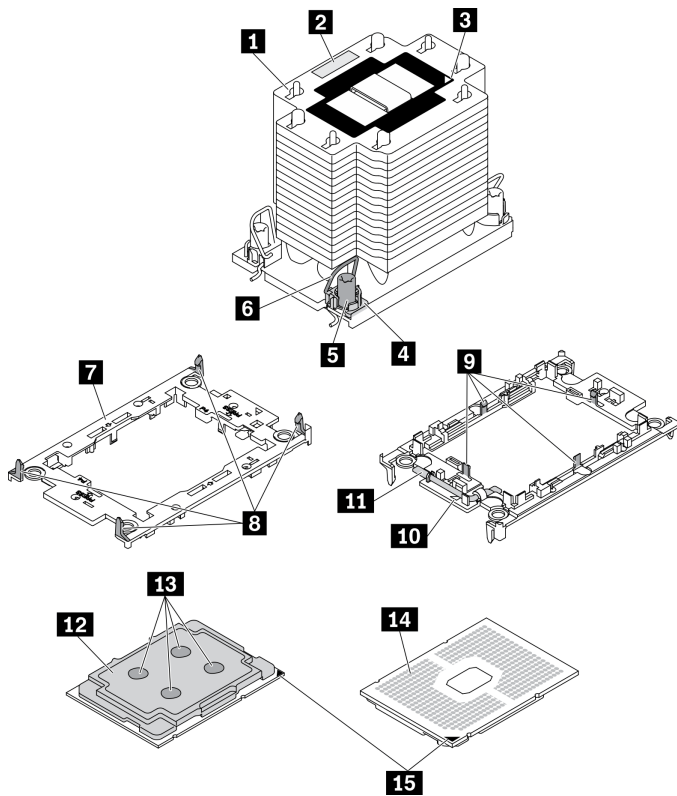

Figure 143. PHM components

1 Heat sink	9 Clips to secure processor in carrier
2 Processor identification label	10 Carrier triangular mark
3 Heat sink triangular mark	11 Processor ejector handle
4 Nut and wire bail retainer	12 Processor heat spreader
5 Torx T30 nut	13 Thermal grease
6 Anti-tilt wire bail	14 Processor contacts
7 Processor carrier	15 Processor triangular mark
8 Clips to secure carrier to heat sink	

Watch the procedure. A video of the installation and removal process is available:

- YouTube: <https://youtube.com/playlist?list=PLYV5R7hVcs-DoEcxrm2zKNpaK0dZ3f8Qc>
- Youku: https://list.youku.com/albumlist/show/id_59636516

Procedure

Step 1. If you are replacing a processor and reusing the heat sink.

- Remove the processor identification label from the heat sink and replace it with the new label that comes with the replacement processor.
- If there is any old thermal grease on the heat sink, wipe the thermal grease from the bottom of the heat sink with an alcohol cleaning pad.

Step 2. If you are replacing a heat sink and reusing the processor.

- a. Remove the processor identification label from the old heat sink and place it on the new heat sink in the same location.

Note: If you are unable to remove the label and place it on the new heat sink, or if the label is damaged during transfer, write the processor serial number from the processor identification label on the new heat sink in the same location as the label would be placed using a permanent marker.

- b. Install processor in new carrier.

Note: Replacement heat sinks come with both gray and black processor carriers. Make sure to use the carrier with the same color as the one you discarded earlier.

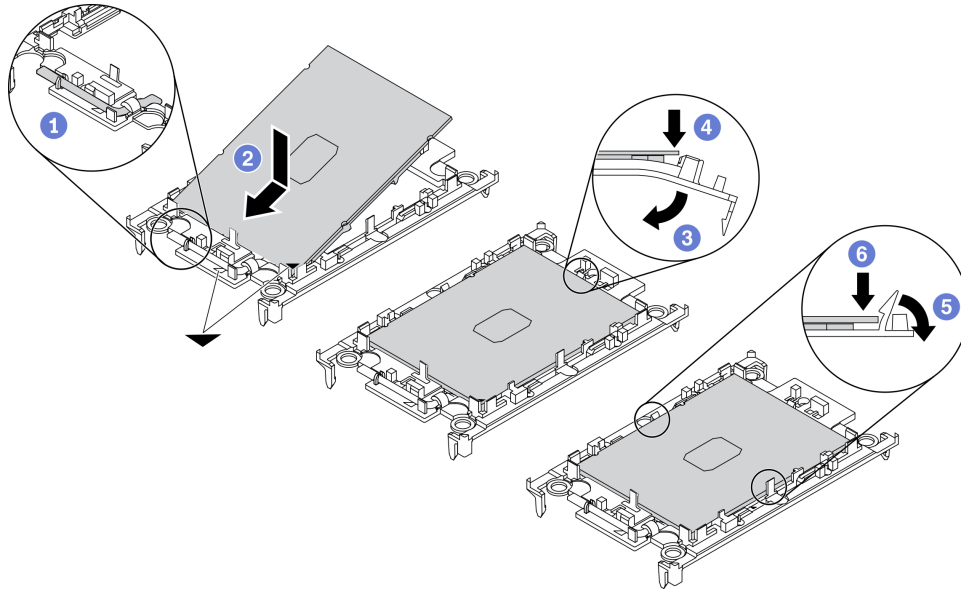

Figure 144. Installing a processor carrier

1. ① Make sure the handle on the carrier is in the closed position.
2. ② Align the processor on the new carrier so that the triangular marks align; then, insert the marked end of the processor into the carrier.
3. ③ Hold the inserted end of the processor in place; then, pivot the unmarked end of the carrier down and away from the processor.
4. ④ Press the processor and secure the unmarked end under the clip on the carrier.
5. ⑤ Carefully pivot the sides of the carrier down and away from the processor.
6. ⑥ Press the processor and secure the sides under the clips on the carrier.

Note: To prevent the processor from falling out of the carrier, keep the processor-contact side up and hold the processor-carrier assembly by the sides of the carrier.

Step 3. Apply thermal grease.

- a. Carefully place the processor and carrier in the shipping tray with the processor-contact side down. Make sure the triangular mark on the carrier is aligned with the triangular mark in the shipping tray.
- b. If there is any old thermal grease on the processor, gently wipe the top of the processor with an alcohol cleaning pad.

Note: Make sure the alcohol has fully evaporated before applying new thermal grease.

- c. Apply the thermal grease on the top of the processor with syringe by forming four uniformly spaced dots, while each dot consists of about 0.1 ml of thermal grease.

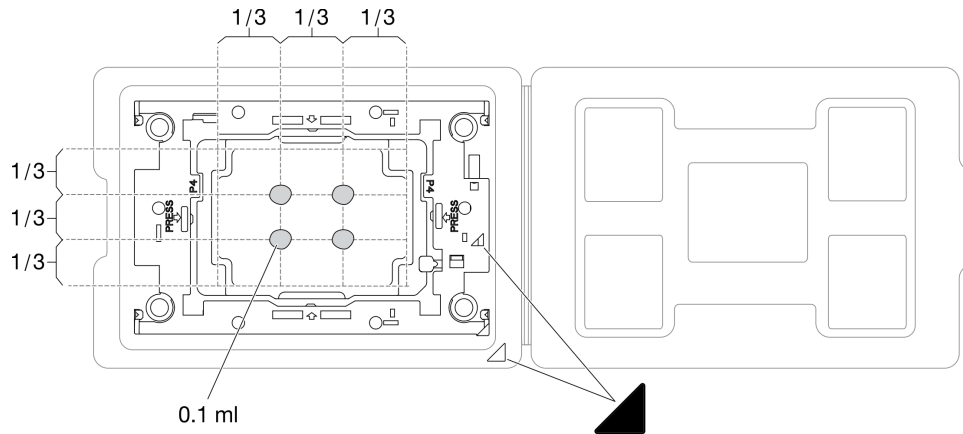

Figure 145. Thermal grease application with processor in shipping tray

- Step 4. Assemble the processor and heat sink.

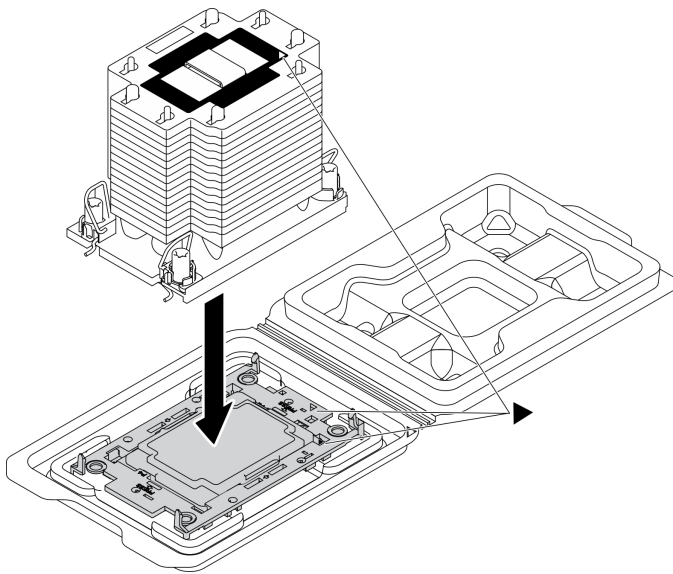

Figure 146. Assembling the PHM with processor in shipping tray

- Align the triangular mark on the heat sink label with the triangular mark on the processor carrier and processor.
 - Install the heat sink onto the processor-carrier.
 - Press the carrier into place until the clips at all four corners engage.
- Step 5. Install the processor-heat-sink module into the system board socket.

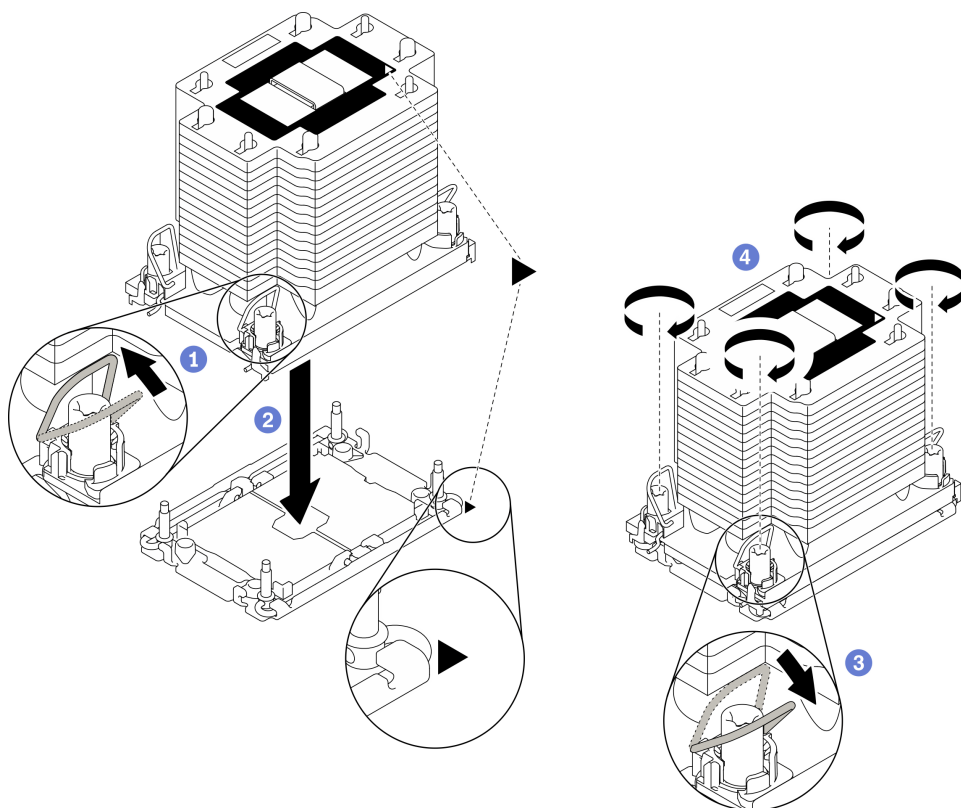

Figure 147. Installing a PHM

- a. ❶ Rotate the anti-tilt wire bails inward.
- b. ❷ Align the triangular mark and four Torx T30 nuts on the PHM with the triangular mark and threaded posts of the processor socket; then, insert the PHM into the processor socket.
- c. ❸ Rotate the anti-tilt wire bails outward until they engage with the hooks in the socket.
- d. ❹ Fully tighten the Torx T30 nuts *in the installation sequence shown* on the heat-sink label. Tighten the screws until they stop; then, visually inspect to make sure that there is no gap between the screw shoulder beneath the heat sink and the processor socket. (For reference, the torque required for the fasteners to fully tighten is 1.1 newton-meters, 10 inch-pounds).

After you finish

1. Reinstall the air baffle. See “Install the air baffle” on page 74.
2. Reinstall all the flash power modules. See “Install a flash power module” on page 100.
3. Reinstall the server cover. See “Install the server cover” on page 190.
4. Reinstall the hot-swap redundant power supply. See “Install the hot-swap power supply” on page 173.
5. Complete the parts replacement. See “Complete the parts replacement” on page 206.

Server cover replacement

Use this information to remove and install the server cover.

Remove the server cover

Use this information to remove the server cover.

About this task

S014



CAUTION:

Hazardous voltage, current, and energy levels might be present. Only a qualified service technician is authorized to remove the covers where the label is attached.

S017



CAUTION:

Hazardous moving fan blades nearby. Keep fingers and other body parts away.

S033



CAUTION:

Hazardous energy present. Voltages with hazardous energy might cause heating when shorted with metal, which might result in spattered metal, burns, or both.

Attention:

- Read “Installation guidelines” on page 57 to ensure that you work safely.
- Prevent exposure to static electricity, which might lead to system halt and loss of data, by keeping static-sensitive components in their static-protective packages until installation, and handling these devices with an electrostatic-discharge wrist strap or other grounding system.
- If the server is in a rack, remove it from the rack.

Watch the procedure. A video of the installation and removal process is available:

- YouTube: <https://youtube.com/playlist?list=PLYV5R7hVcs-DoEcxrm2zKNpaKOdZ3f8Qc>
- Youku: https://list.youku.com/albumlist/show/id_59636516

Procedure

Step 1. Remove the server cover.

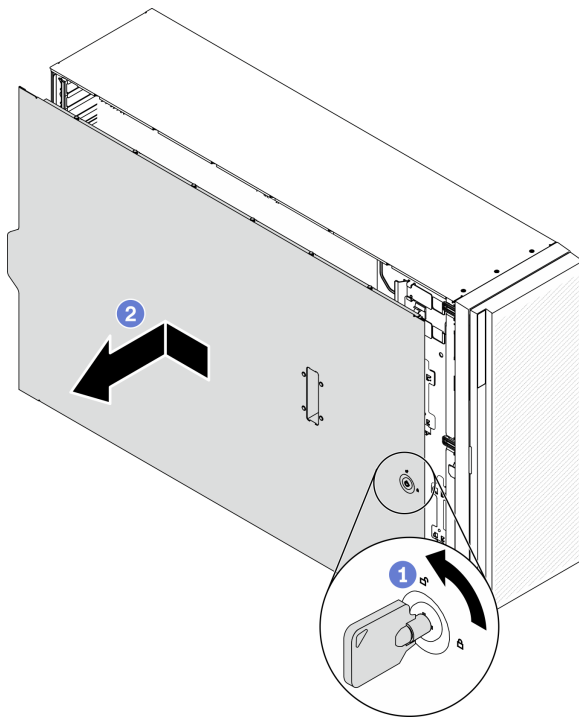

Figure 148. Server cover removal

Attention: For proper cooling, always install the server cover before powering on the server. Operating the server without the cover properly installed might result in server component damage.

- a. ① Use the key attached on the rear of the server to turn the cover lock to the unlocked position.
- b. ② Slide the server cover towards the rear of the server until the server cover is disengaged from the chassis. Then, lift the server cover off the chassis and place it on a flat clean surface.

After you finish

If you are instructed to return the component or optional device, follow all packaging instructions, and use any packaging materials for shipping that are supplied to you.

Install the server cover

Use this information to install the server cover.

About this task

S014



CAUTION:

Hazardous voltage, current, and energy levels might be present. Only a qualified service technician is authorized to remove the covers where the label is attached.

S017



CAUTION:

Hazardous moving fan blades nearby. Keep fingers and other body parts away.

S033



CAUTION:

Hazardous energy present. Voltages with hazardous energy might cause heating when shorted with metal, which might result in spattered metal, burns, or both.

Attention:

- Read “Installation guidelines” on page 57 to ensure that you work safely.
- Prevent exposure to static electricity, which might lead to system halt and loss of data, by keeping static-sensitive components in their static-protective packages until installation, and handling these devices with an electrostatic-discharge wrist strap or other grounding system.
- Ensure that all adapters and other components are installed and seated correctly and that you have not left loose tools or parts inside the server.
- Ensure that all internal cables are correctly routed. See Chapter 3 “Internal cable routing” on page 47.
- If you are installing a new server cover, attach the service label to the inside of the new server cover first if necessary.

Note: A new server cover comes without a service label attached. If you need a service label, order it together with the new server cover. The service label is free of charge.

Watch the procedure. A video of the installation and removal process is available:

- YouTube: <https://youtube.com/playlist?list=PLYV5R7hVcs-DoEcxrm2zKNpaKODz3f8Qc>
- Youku: https://list.youku.com/albumlist/show/id_59636516

Procedure

Step 1. Install the server cover.

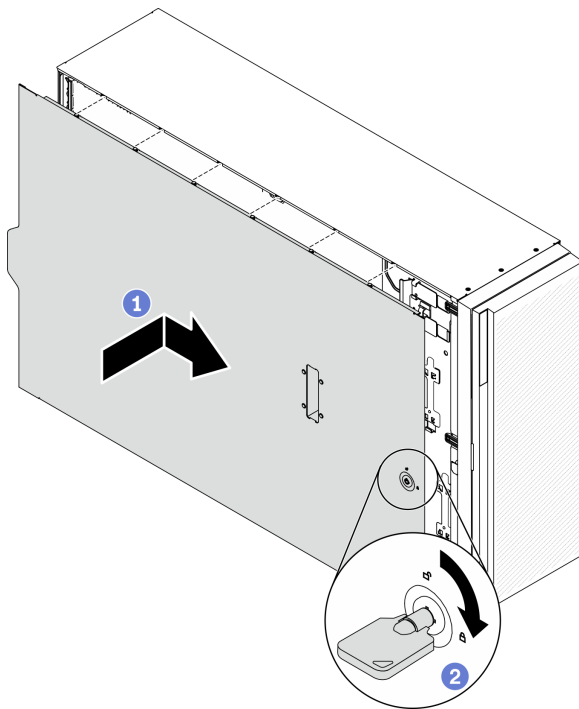

Figure 149. Server cover installation

Note: Before you slide the cover forward, ensure that all the tabs of the cover engage the chassis correctly. If all the tabs do not engage the chassis correctly, it will be very difficult to remove the cover later.

- a. ① Lower the server cover onto the chassis until all tabs on both sides of the server cover engage the chassis. Then, slide the server cover towards the front of the chassis until the server cover stops and the front edge of the cover aligns with the edge of the front bezel.
- b. ② Use the key to turn the cover lock to the locked position.

After you finish

Complete the parts replacement. See “Complete the parts replacement” on page 206.

System board replacement (trained technician only)

Use this information to remove and install the system board.

Note: This task must be operated by trained technicians.

Remove the system board

Use this information to remove the system board.

About this task

S002

**CAUTION:**

The power-control button on the device and the power switch on the power supply do not turn off the electrical current supplied to the device. The device also might have more than one power cord. To remove all electrical current from the device, ensure that all power cords are disconnected from the power source.

Attention:

- Read “Installation guidelines” on page 57 to ensure that you work safely.
- Power off the server and disconnect all power cords for this task.
- Prevent exposure to static electricity, which might lead to system halt and loss of data, by keeping static-sensitive components in their static-protective packages until installation, and handling these devices with an electrostatic-discharge wrist strap or other grounding system.
- If the server is in a rack, remove it from the rack.
- If foot stands are installed on the server, rotate them inwards and lay the server on its side for easier operation.

Watch the procedure. A video of the installation and removal process is available:

- YouTube: <https://youtube.com/playlist?list=PLYV5R7hVcs-DoEcxrm2zKNpaKOdZ3f8Qc>
- Youku: https://list.youku.com/albumlist/show/id_59636516

Procedure

Step 1. Make preparations for this task.

- a. Record all system configuration information, such as Lenovo XClarity Controller IP addresses, vital product data, and the machine type, model number, serial number, Universally Unique Identifier, and asset tag of the server.
- b. Save the system configuration to an external device with Lenovo XClarity Essentials.
- c. Save the system event log to external media.
- d. Remove the server cover. See “Remove the server cover” on page 188.
- e. Remove all the flash power modules. See “Remove a flash power module” on page 98.
- f. Remove the air baffle. See “Remove the air baffle” on page 72.
- g. Remove all the PCIe adapters. See “Remove a PCIe adapter” on page 162.
- h. Remove all the full-length GPU adapters. See “Remove a full-length GPU adapter” on page 113.
- i. Remove all the fans. See “Remove a hot-swap fan” on page 93.
- j. Remove the fan cage. See “Remove the fan cage assembly” on page 95.
- k. Remove the intrusion switch. See “Remove the intrusion switch” on page 127.
- l. Remove the CMOS battery. See “Remove the CMOS battery (CR2032)” on page 76.
- m. Label the slot number on each memory module, then remove all the memory modules from the system board and set them aside on a static-protective surface for reinstallation. See “Remove a memory module” on page 137.
- n. Remove the processor and the heat sink. See “Remove a processor and heat sink” on page 177.

- o. Make note of where the cables are connected to the system board; then, disconnect all the cables.

Note: Disengage all latches, cable clips, release tabs, or locks on cable connectors beforehand. Failing to release them before removing the cables will damage the cable connectors on the system board. Any damage to the cable connectors may require replacing the system board.

Step 2. Remove the nine screws that secure the system board.

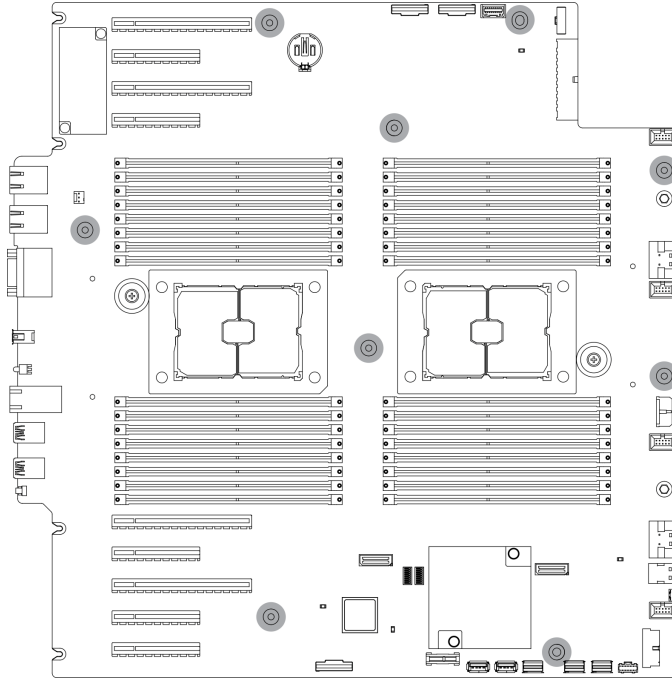

Figure 150. System board screws removal

Step 3. Move the system board towards the front of the server. Ensure that the rear connectors on the system board are disengaged from the corresponding holes in the rear panel.

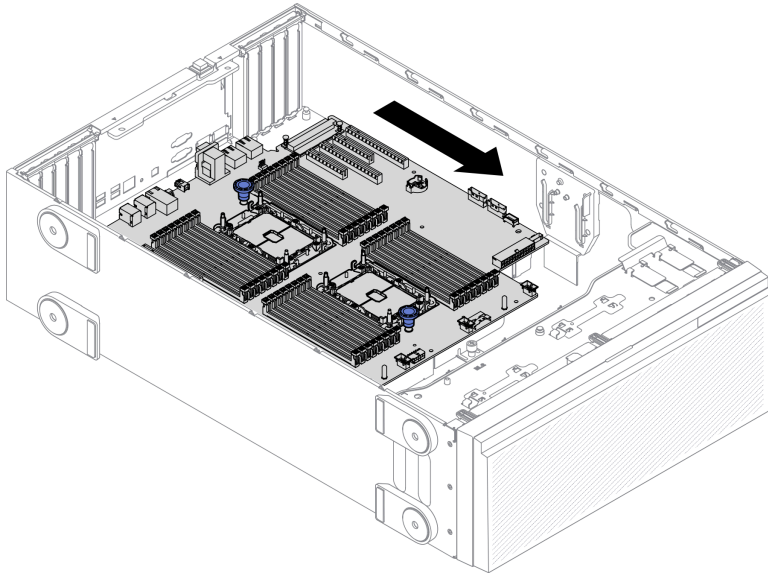

Figure 151. Disengaging the system board from chassis

Step 4. Grasp the plungers and remove the system board in the direction as shown.

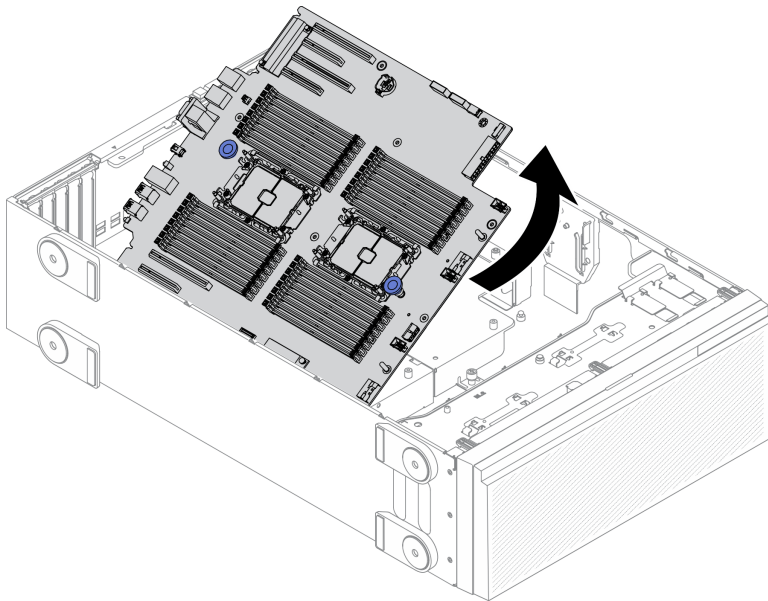

Figure 152. System board removal

Step 5. Place the old system board on a clean, flat, and static-protective surface.

After you finish

- Install a system board. See “Install the system board” on page 196.
- If you are instructed to return the component or optional device, follow all packaging instructions, and use any packaging materials for shipping that are supplied to you.

Important: Before you return the system board, make sure that you install the processor socket dust covers from the new system board. To replace a processor socket dust cover:

1. Take a dust cover from the processor socket assembly on the new system board and orient it correctly above the processor socket assembly on the removed system board.
2. Gently press down the dust cover legs to the processor socket assembly, pressing on the edges to avoid damage to the socket pins. You might hear a click on the dust cover is securely attached.
3. **Make sure** that the dust cover is securely attached to the processor socket assembly.

Install the system board

Use this information to install the system board.

About this task

S002



CAUTION:

The power-control button on the device and the power switch on the power supply do not turn off the electrical current supplied to the device. The device also might have more than one power cord. To remove all electrical current from the device, ensure that all power cords are disconnected from the power source.

Attention:

- Read “Installation guidelines” on page 57 to ensure that you work safely.
- Power off the server and disconnect all power cords for this task.
- Prevent exposure to static electricity, which might lead to system halt and loss of data, by keeping static-sensitive components in their static-protective packages until installation, and handling these devices with an electrostatic-discharge wrist strap or other grounding system.

Watch the procedure. A video of the installation and removal process is available:

- YouTube: <https://youtube.com/playlist?list=PLYV5R7hVcs-DoEcxrm2zKNpaKOdZ3f8Qc>
- Youku: https://list.youku.com/albumlist/show/id_59636516

Procedure

Step 1. Grasp the system board by the plungers and gently lower the system board into the chassis as shown.

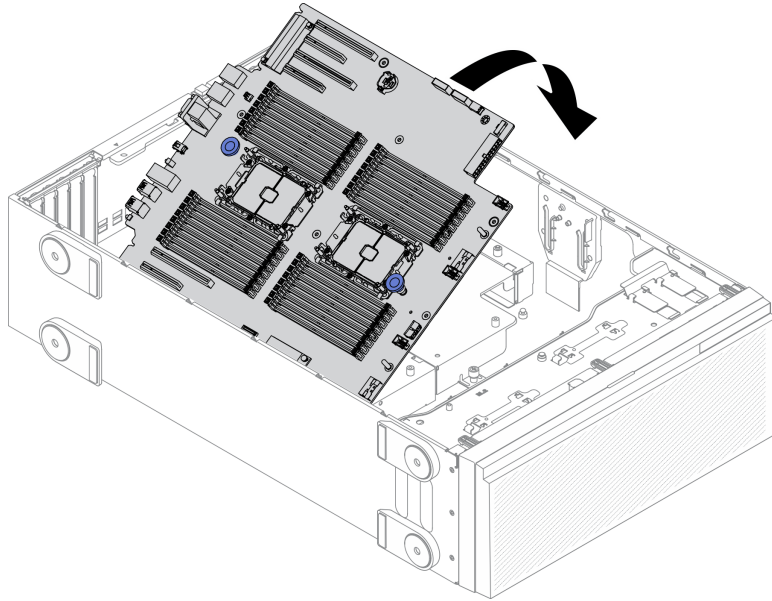

Figure 153. System board installation

- Step 2. Move the system board towards the rear of the server. Ensure that the rear connectors on the new system board are inserted into the corresponding holes in the rear panel.

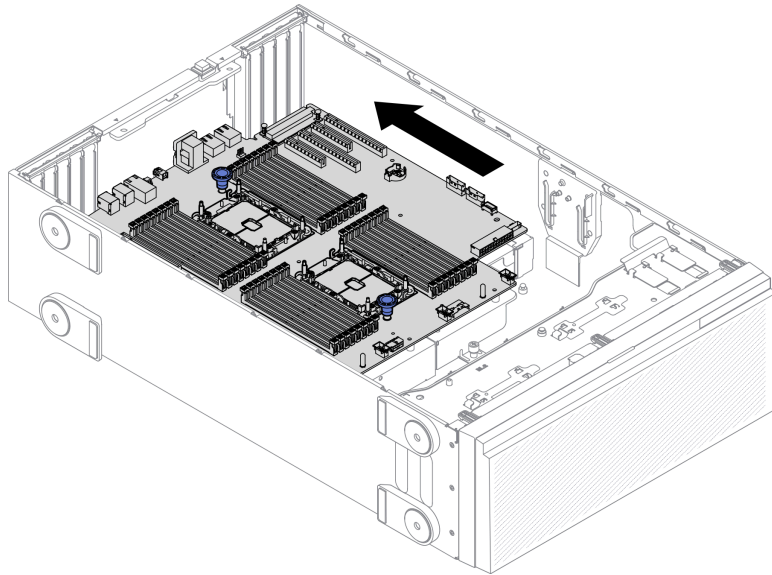

Figure 154. Engaging the system board to chassis

- Step 3. Install the nine screws to secure the system board in place.

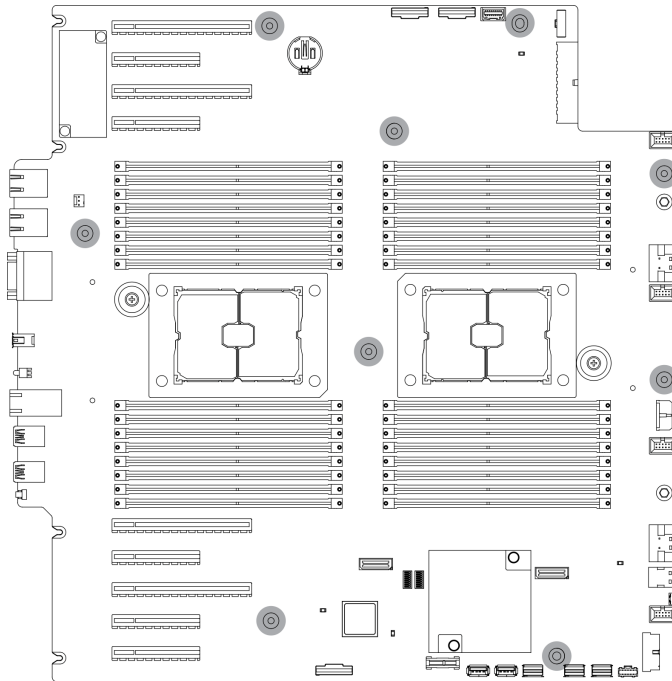

Figure 155. System board screws installation

After you finish

1. Reconnect all the required cables. See Chapter 3 “Internal cable routing” on page 47.
2. Reinstall the processor and the heat sink. See “Install a processor and heat sink” on page 183.
3. Reinstall all the memory modules. See “Install a memory module” on page 139.
4. Reinstall the CMOS battery. See “Install the CMOS battery (CR2032)” on page 78.
5. Reinstall the intrusion switch. See “Install the intrusion switch” on page 128.
6. Reinstall the fan cage. See “Install the fan cage assembly” on page 97.
7. Reinstall all the fans. See “Install a hot-swap fan” on page 94.
8. Reinstall all the full-length GPU adapters. See “Install a full-length GPU adapter” on page 114.
9. Reinstall all the PCIe adapters. See “Install a PCIe adapter” on page 164.
10. Reinstall the air baffle. See “Install the air baffle” on page 74.
11. Reinstall all the flash power modules. See “Install a flash power module” on page 100.
12. Reinstall the server cover. See “Install the server cover” on page 190.
13. Complete the parts replacement. See “Complete the parts replacement” on page 206.
14. Update the machine type and serial number with new vital product data (VPD). Use the Lenovo XClarity Provisioning Manager V3 to update the machine type and serial number. See “Update the machine type and serial number” on page 198.
15. Enable TPM/TCM. See “Enable TPM/TCM” on page 200.
16. Optionally, enable Secure Boot. See “Enable UEFI Secure Boot” on page 202.

Update the machine type and serial number

After the system board is replaced by trained service technicians, the machine type and serial number must be updated.

There are two methods available to update the machine type and serial number:

- From Lenovo XClarity Provisioning Manager V3

To update the machine type and serial number from Lenovo XClarity Provisioning Manager V3:

1. Start the server and press F1 to display the Lenovo XClarity Provisioning Manager V3 interface.
2. If the power-on Administrator password is required, enter the password.
3. From the System Summary page, click **Update VPD**.
4. Update the machine type and serial number.

- From Lenovo XClarity Essentials OneCLI

Lenovo XClarity Essentials OneCLI sets the machine type and serial number in the Lenovo XClarity Controller. Select one of the following methods to access the Lenovo XClarity Controller and set the machine type and serial number:

- Operate from the target system, such as LAN or keyboard console style (KCS) access
- Remote access to the target system (TCP/IP based)

To update the machine type and serial number from Lenovo XClarity Essentials OneCLI:

1. Download and install Lenovo XClarity Essentials OneCLI.

To download Lenovo XClarity Essentials OneCLI, go to the following site:

<https://datacentersupport.lenovo.com/solutions/HT116433>

2. Copy and unpack the OneCLI package, which also includes other required files, to the server. Make sure that you unpack the OneCLI and the required files to the same directory.
3. After you have Lenovo XClarity Essentials OneCLI in place, type the following commands to set the machine type and serial number:

```
onecli config set SYSTEM_PROD_DATA.SysInfoProdName <m/t_model> [access_method]
onecli config set SYSTEM_PROD_DATA.SysInfoSerialNum <s/n> [access_method]
```

Where:

<m/t_model>

The server machine type and model number. Type *m t m xxxxyyy*, where *xxxx* is the machine type and *yyy* is the server model number.

<s/n>

The serial number on the server. Type *sn zzzzzzz*, where *zzzzzzz* is the serial number.

[access_method]

The access method that you select to use from the following methods:

- Online authenticated LAN access, type the command:

```
[--bmc-username xcc_user_id --bmc-password xcc_password]
```

Where:

xcc_user_id

The BMC/IMM/XCC account name (1 of 12 accounts). The default value is USERID.

xcc_password

The BMC/IMM/XCC account password (1 of 12 accounts).

Example commands are as follows:

```
onecli config set SYSTEM_PROD_DATA.SysInfoProdName <m/t_model> --bmc-username xcc_user_id
--bmc-password xcc_password
```

```
onecli config set SYSTEM_PROD_DATA.SysInfoSerialNum <s/n> --bmc-username xcc_user_id
--bmc-password xcc_password
```

- Online KCS access (unauthenticated and user restricted):

You do not need to specify a value for *access_method* when you use this access method.

Example commands are as follows:

```
onecli config set SYSTEM_PROD_DATA.SysInfoProdName <m/t_model>
onecli config set SYSTEM_PROD_DATA.SysInfoSerialNum <s/n>
```

Note: The KCS access method uses the IPMI/KCS interface, which requires that the IPMI driver be installed.

- Remote LAN access, type the command:
[**--bmc** xcc_user_id:xcc_password@xcc_external_ip]

Where:

xcc_external_ip

The BMC/IMM/XCC IP address. There is no default value. This parameter is required.

xcc_user_id

The BMC/IMM/XCC account (1 of 12 accounts). The default value is USERID.

xcc_password

The BMC/IMM/XCC account password (1 of 12 accounts).

Note: BMC, IMM, or XCC internal LAN/USB IP address, account name, and password are all valid for this command.

Example commands are as follows:

```
onecli config set SYSTEM_PROD_DATA.SysInfoProdName <m/t_model>
--bmc xcc_user_id:xcc_password@xcc_external_ip
onecli config set SYSTEM_PROD_DATA.SysInfoSerialNum <s/n>
--bmc xcc_user_id:xcc_password@xcc_external_ip
```

4. Reset the Lenovo XClarity Controller to the factory defaults. Go to https://sysmgt.lenovofiles.com/help/topic/com.lenovo.systems.management.xcc.doc/NN1ia_c_resettingthexcc.html for more information.

Enable TPM/TCM

The server supports Trusted Platform Module (TPM).

Note: For customers in the Chinese Mainland, integrated TPM is not supported. However, customers in the Chinese Mainland can install a Trusted Cryptographic Module (TCM) adapter or a TPM adapter (sometimes called a daughter card).

When a system board is replaced, you must make sure that the TPM/TCM policy is set correctly.

CAUTION:

Take special care when setting the TPM/TCM policy. If it is not set correctly, the system board can become unusable.

Set the TPM policy

By default, a replacement system board is shipped with the TPM policy set to **undefined**. You must modify this setting to match the setting that was in place for the system board that is being replaced.

There are two methods available to set the TPM policy:

- From Lenovo XClarity Provisioning Manager V3

To set the TPM policy from Lenovo XClarity Provisioning Manager V3:

1. Start the server and press F1 to display the Lenovo XClarity Provisioning Manager V3 interface.
2. If the power-on Administrator password is required, enter the password.
3. From the System Summary page, click **Update VPD**.
4. Set the policy to one of the following settings.
 - **NationZ TPM 2.0 enabled - China only**. Customers in the Chinese Mainland should choose this setting if a NationZ TPM 2.0 adapter is installed.
 - **TPM enabled - ROW**. Customers outside of the Chinese Mainland should choose this setting.
 - **Permanently disabled**. Customers in the Chinese Mainland should use this setting if no TPM adapter is installed.

Note: Although the setting **undefined** is available as a policy setting, it should not be used.

- From Lenovo XClarity Essentials OneCLI

Note: Please note that a Local IPMI user and password must be setup in Lenovo XClarity Controller for remote accessing to the target system.

To set the TPM policy from Lenovo XClarity Essentials OneCLI:

1. Read TpmTcmPolicyLock to check whether the TPM_TCM_POLICY has been locked:
`OneCli.exe config show imm.TpmTcmPolicyLock --override --imm <userid>:<password>@<ip_address>`

Note: The imm.TpmTcmPolicyLock value must be 'Disabled', which means TPM_TCM_POLICY is NOT locked and changes to the TPM_TCM_POLICY are permitted. If the return code is 'Enabled' then no changes to the policy are permitted. The planar may still be used if the desired setting is correct for the system being replaced.

2. Configure the TPM_TCM_POLICY into XCC:
 - For customers in Chinese Mainland with no TPM, or customers that require to disable TPM:
`OneCli.exe config set imm.TpmTcmPolicy "NeitherTpmNorTcm" --override --imm <userid>:<password>@<ip_address>`
 - For customers in Chinese Mainland that require to enable TPM:
`OneCli.exe config set imm.TpmTcmPolicy "NationZTPM20Only" --override --imm <userid>:<password>@<ip_address>`
 - For customers outside Chinese Mainland that require to enable TPM:
`OneCli.exe config set imm.TpmTcmPolicy "TpmOnly" --override --imm <userid>:<password>@<ip_address>`
3. Issue reset command to reset system:
`OneCli.exe misc ospower reboot --imm <userid>:<password>@<ip_address>`
4. Read back the value to check whether the change has been accepted:
`OneCli.exe config show imm.TpmTcmPolicy --override --imm <userid>:<password>@<ip_address>`

Notes:

- If the read back value is matched it means the TPM_TCM_POLICY has been set correctly.
imm.TpmTcmPolicy is defined as below:
 - Value 0 use string "Undefined", which means UNDEFINED policy.
 - Value 1 use string "NeitherTpmNorTcm", which means TPM_PERM_DISABLED.
 - Value 2 use string "TpmOnly", which means TPM_ALLOWED.
 - Value 4 use string "NationZTPM20Only", which means NationZ_TPM20_ALLOWED.
 - Below 4 steps must also be used to 'lock' the TPM_TCM_POLICY when using OneCli/ASU commands:
5. Read TpmTcmPolicyLock to check whether the TPM_TCM_POLICY has been locked, command as below:

```
OneCli.exe config show imm.TpmTcmPolicyLock --override --imm <userid>:<password>@<ip_address>
```

The value must be 'Disabled', it means TPM_TCM_POLICY is NOT locked and must be set.

6. Lock the TPM_TCM_POLICY:

```
OneCli.exe config set imm.TpmTcmPolicyLock "Enabled"--override --imm <userid>:<password>@<ip_address>
```

7. Issue reset command to reset system, command as below:

```
OneCli.exe misc ospower reboot --imm <userid>:<password>@<ip_address>
```

During the reset, UEFI will read the value from imm.TpmTcmPolicyLock, if the value is 'Enabled' and the imm.TpmTcmPolicy value is invalid, UEFI will lock the TPM_TCM_POLICY setting.

The valid values for imm.TpmTcmPolicy include 'NeitherTpmNorTcm', 'TpmOnly', and 'NationZTPM20Only'.

If the imm.TpmTcmPolicy is set as 'Enabled' but imm.TpmTcmPolicy value is invalid, UEFI will reject the 'lock' request and change imm.TpmTcmPolicy back to 'Disabled'.

8. Read back the value to check whether the 'Lock' is accepted or rejected. command as below:

```
OneCli.exe config show imm.TpmTcmPolicy --override --imm <userid>:<password>@<ip_address>
```

Note: If the read back value is changed from 'Disabled' to 'Enabled' that means the TPM_TCM_POLICY has been locked successfully. There is no method to unlock a policy once it has been set other than replacing system board.

imm.TpmTcmPolicyLock is defined as below:

Value 1 uses string "Enabled" , which means lock the policy. Other values are not accepted.

Enable UEFI Secure Boot

Optionally, you can enable UEFI Secure Boot.

There are two methods available to enable UEFI Secure Boot:

- From Lenovo XClarity Provisioning Manager V3

To enable UEFI Secure Boot from Lenovo XClarity Provisioning Manager V3:

1. Start the server and press F1 to display the Lenovo XClarity Provisioning Manager V3 interface.
2. If the power-on Administrator password is required, enter the password.
3. From the UEFI Setup page, click **System Settings** → **Security** → **Secure Boot**.
4. Enable Secure Boot and save the settings.

- From Lenovo XClarity Essentials OneCLI

To enable UEFI Secure Boot from Lenovo XClarity Essentials OneCLI:

1. Download and install Lenovo XClarity Essentials OneCLI.

To download Lenovo XClarity Essentials OneCLI, go to the following site:

<https://datacentersupport.lenovo.com/solutions/HT116433>

2. Run the following command to enable Secure Boot:

```
OneCli.exe config set SecureBootConfiguration.SecureBootSetting Enabled  
--bmc <userid>:<password>@<ip_address>
```

where:

- <userid>:<password> are the credentials used to access the BMC (Lenovo XClarity Controller interface) of your server. The default user ID is USERID, and the default password is PASSWORD (zero, not an uppercase o)

– `<ip_address>` is the IP address of the BMC.

For more information about the Lenovo XClarity Essentials OneCLI `set` command, see:

http://sysmgt.lenovofiles.com/help/topic/toolstr_cli_lenovo/onecli_r_set_command.html

T4 filler replacement

Use this information to remove and install the T4 filler.

Remove a T4 filler

Use this information to remove a T4 filler.

About this task

S017



CAUTION:

Hazardous moving fan blades nearby. Keep fingers and other body parts away.

S033



CAUTION:

Hazardous energy present. Voltages with hazardous energy might cause heating when shorted with metal, which might result in spattered metal, burns, or both.

Attention:

- Read “Installation guidelines” on page 57 to ensure that you work safely.
- Prevent exposure to static electricity, which might lead to system halt and loss of data, by keeping static-sensitive components in their static-protective packages until installation, and handling these devices with an electrostatic-discharge wrist strap or other grounding system.
- If the server is in a rack, remove it from the rack.
- If foot stands are installed on the server, rotate them inwards and lay the server on its side for easier operation.

Note: If you have installed a T4 GPU adapter, install a T4 filler onto the server cover for proper cooling and airflow.

Watch the procedure. A video of the installation and removal process is available:

- YouTube: <https://youtube.com/playlist?list=PLYV5R7hVcs-DoEcXrm2zKNpaKOdZ3f8Qc>
- Youku: https://list.youku.com/albumlist/show/id_59636516

Procedure

- Step 1. Remove the server cover. See “Remove the server cover” on page 188.
- Step 2. Turn the server cover over and locate the T4 filler you want to remove.
- Step 3. Remove the T4 filler.

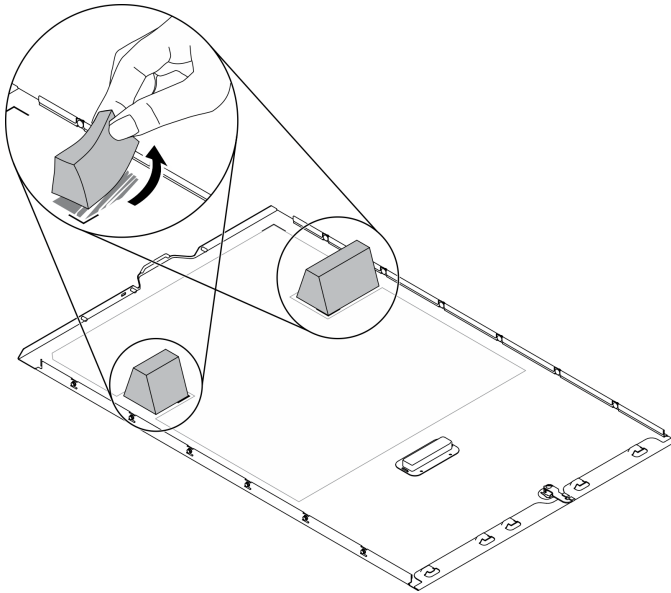

Figure 156. T4 filler removal

After you finish

1. Install a new T4 filler. See “Install a T4 filler” on page 204.
2. If you are instructed to return the component or optional device, follow all packaging instructions, and use any packaging materials for shipping that are supplied to you.

Install a T4 filler

Use this information to install a T4 filler.

About this task

S017



CAUTION:

Hazardous moving fan blades nearby. Keep fingers and other body parts away.

S033



CAUTION:

Hazardous energy present. Voltages with hazardous energy might cause heating when shorted with metal, which might result in spattered metal, burns, or both.

Attention:

- Read “Installation guidelines” on page 57 to ensure that you work safely.
- Prevent exposure to static electricity, which might lead to system halt and loss of data, by keeping static-sensitive components in their static-protective packages until installation, and handling these devices with an electrostatic-discharge wrist strap or other grounding system.

Note: If you have installed a T4 GPU adapter, install a T4 filler onto the server cover for proper cooling and airflow.

Watch the procedure. A video of the installation and removal process is available:

- YouTube: <https://youtube.com/playlist?list=PLYV5R7hVcs-DoEcxrm2zKNpaKOdZ3f8Qc>
- Youku: https://list.youku.com/albumlist/show/id_59636516

Procedure

- Step 1. Locate the corresponding location on the bottom of the server cover for the applicable PCIe slot.
- Step 2. Wipe the surface with an alcohol cleaning pad.

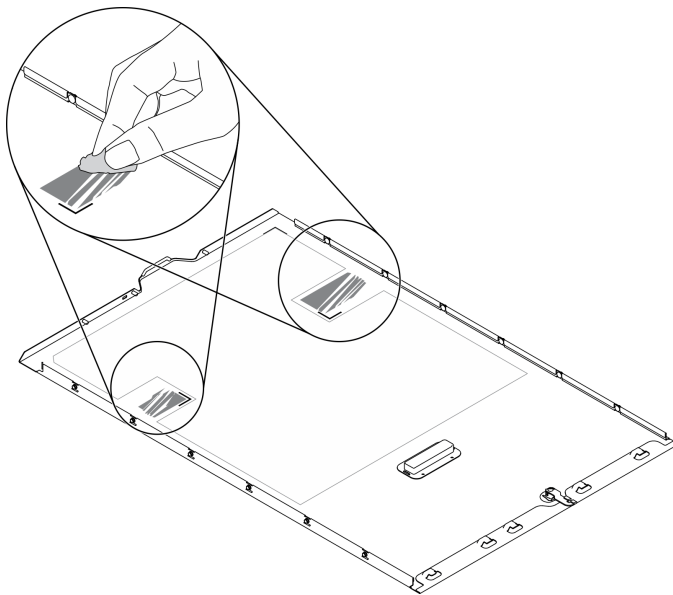



Figure 157. Cleaning surface

- Step 3. Peel away the plastic and apply the T4 filler. Make sure the T4 filler is aligned to the  corner mark.

Note: Make sure the alcohol has fully evaporated before applying the new T4 filler.

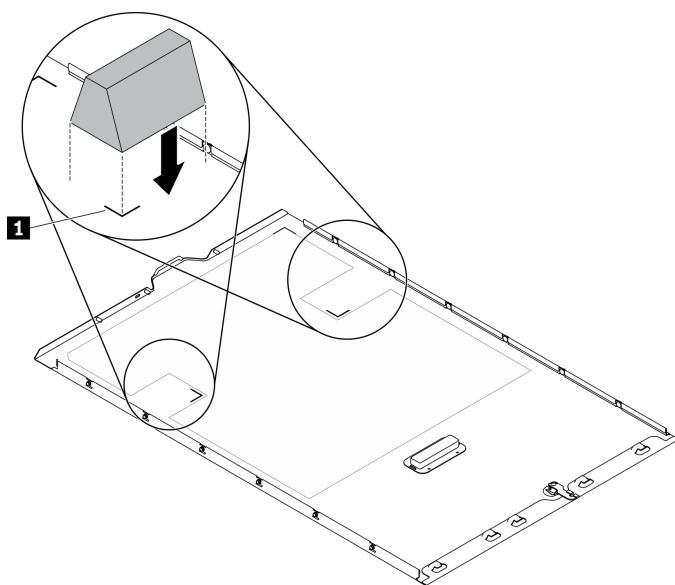

Figure 158. T4 filler installation

After you finish

1. Reinstall the server cover. See “Install the server cover” on page 190.
2. Complete the parts replacement. See “Complete the parts replacement” on page 206.

Complete the parts replacement

Use this information to complete the parts replacement.

To complete the parts replacement, do the following:

1. Ensure that all components have been reassembled correctly and that no tools or loose screws are left inside your server.
2. Properly route and secure the cables in the server. Refer to the cable connecting and routing information for each component.
3. If you have removed the server cover, reinstall it. See “Install the server cover” on page 190.
4. Reconnect external cables and power cords to the server.

Attention: To avoid component damage, connect the power cords last.

5. Update the server configuration.
 - Download and install the latest device drivers: <http://datacentersupport.lenovo.com>.
 - Update the system firmware. See “Firmware updates” on page 9.
 - Update the UEFI configuration.
 - Reconfigure the disk arrays if you have installed or removed a hot-swap drive or a RAID adapter. See the Lenovo XClarity Provisioning Manager V3 User Guide, which is available for download at: <http://datacentersupport.lenovo.com>.

Note: Make sure the latest version of ThinkSystem M.2 with Mirroring Enablement Kit Firmware is applied to avoid virtual disk/array missing after system board replacement.

Chapter 5. Problem determination

Use the information in this section to isolate and resolve issues that you might encounter while using your server.

Lenovo servers can be configured to automatically notify Lenovo Support if certain events are generated. You can configure automatic notification, also known as Call Home, from management applications, such as the Lenovo XClarity Administrator. If you configure automatic problem notification, Lenovo Support is automatically alerted whenever a server encounters a potentially significant event.

To isolate a problem, you should typically begin with the event log of the application that is managing the server:

- If you are managing the server from the Lenovo XClarity Administrator, begin with the Lenovo XClarity Administrator event log.
- If you are using some other management application, begin with the Lenovo XClarity Controller event log.

Event logs

An *alert* is a message or other indication that signals an event or an impending event. Alerts are generated by the Lenovo XClarity Controller or by UEFI in the servers. These alerts are stored in the Lenovo XClarity Controller Event Log. If the server is managed by the Chassis Management Module 2 or by the Lenovo XClarity Administrator, alerts are automatically forwarded to those management applications.

Note: For a listing of events, including user actions that might need to be performed to recover from an event, see the *Messages and Codes Reference*, which is available at:
http://thinksystem.lenovofiles.com/help/topic/7Z74/pdf_files.html

Lenovo XClarity Administrator event log

If you are using Lenovo XClarity Administrator to manage server, network, and storage hardware, you can view the events from all managed devices through the XClarity Administrator.

Logs

Severity	Serviceability	Date and Time	System	Event	System Type	Source Date
Warning	Support	Jan 30, 2017, 7:48:07 AM	Chassis114:...	Node Node 08 device	Chassis	Jan 30, 2017
Warning	Support	Jan 30, 2017, 7:48:07 AM	Chassis114:...	Node Node 02 device	Chassis	Jan 30, 2017
Warning	User	Jan 30, 2017, 7:48:07 AM	Chassis114:...	I/O module IO Module	Chassis	Jan 30, 2017
Warning	User	Jan 30, 2017, 7:48:07 AM	Chassis114:...	Node Node 08 incom	Chassis	Jan 30, 2017

Figure 159. Lenovo XClarity Administrator event log

For more information about working with events from XClarity Administrator, see:

http://sysmgt.lenovofiles.com/help/topic/com.lenovo.lxca.doc/events_vieweventlog.html

Lenovo XClarity Controller event log

The Lenovo XClarity Controller monitors the physical state of the server and its components using sensors that measure internal physical variables such as temperature, power-supply voltages, fan speeds, and component status. The Lenovo XClarity Controller provides various interfaces to systems management software and to system administrators and users to enable remote management and control of a server.

The Lenovo XClarity Controller monitors all components of the server and posts events in the Lenovo XClarity Controller event log.

Severity	Source	Event ID	Message	Date
Error	System	0X4000000E00000000	Remote login successful. Login ID: userid from webguis at IP address: 10.104.194.180.	27 Jul 2015, 08:11:04 AM
Warning	System	0X4000000E00000000	Remote login successful. Login ID: userid from webguis at IP address: 10.104.194.180.	27 Jul 2015, 08:11:04 AM
Info	System	0X4000000E00000000	Remote login successful. Login ID: userid from webguis at IP address: 10.104.194.180.	27 Jul 2015, 08:11:04 AM
Info	System	0X4000000E00000000	Remote login successful. Login ID: userid from webguis at IP address: 10.104.194.180.	27 Jul 2015, 08:11:04 AM

Figure 160. Lenovo XClarity Controller event log

For more information about accessing the Lenovo XClarity Controller event log, see:

http://sysmgt.lenovofiles.com/help/topic/com.lenovo.systems.management.xcc.doc/event_log.html

Light path diagnostics

Light path diagnostics is a system of LEDs on various external and internal components of the server that leads you to the failed component. When an error occurs, LEDs are lit on the front panel on the front of the server and on the rear of the server, then on the failed component. By viewing the LEDs in a particular order, you can often identify the source of the error.

- “Front panel” on page 21
- “External LCD diagnostics handset” on page 27
- “Rear view LEDs” on page 26
- “System board LEDs” on page 35

General problem determination procedures

Use the information in this section to resolve problems if the event log does not contain specific errors or the server is inoperative.

If you are not sure about the cause of a problem and the power supplies are working correctly, complete the following steps to attempt to resolve the problem:

1. Turn off the server.
2. Ensure that the server is cabled correctly.
3. Remove or disconnect the following devices, one at a time, until you find the failure. Turn on and configure the server each time you remove or disconnect a device.
 - Any external devices
 - Surge-suppressor device (on the server)
 - Printer, mouse, and non-Lenovo devices
 - Each adapter
 - Storage drives
 - Memory modules until you reach the minimum configuration that is supported for the server

Note: The minimum configuration required for the server to start is one processor and one 8 GB DIMM.

4. Turn on the server.

If the problem is solved when you remove an adapter from the server, but the problem recurs when you install the same adapter again, suspect the adapter. If the problem recurs when you replace the adapter with a different one, try a different PCIe slot.

If the problem appears to be a networking problem and the server passes all system tests, suspect a network cabling problem that is external to the server.

Resolving suspected power problems

Power problems can be difficult to solve. For example, a short circuit can exist anywhere on any of the power distribution buses. Usually, a short circuit will cause the power subsystem to shut down because of an overcurrent condition.

Complete the following steps to diagnose and resolve a suspected power problem.

Step 1. Check the event log and resolve any errors related to the power.

Note: Start with the event log of the application that is managing the server. For more information about event logs, see “Event logs” on page 207.

- Step 2. Check for short circuits, for example, if a loose screw is causing a short circuit on a circuit board.
- Step 3. Remove the adapters and disconnect the cables and power cords to all internal and external devices until the server is at the minimum configuration that is required for the server to start. See “Specifications” on page 1 to determine the minimum configuration for your server.
- Step 4. Reconnect all ac power cords and turn on the server. If the server starts successfully, reseal the adapters and devices one at a time until the problem is isolated.

If the server does not start from the minimum configuration, replace the components in the minimum configuration one at a time until the problem is isolated.

Resolving suspected Ethernet controller problems

The method that you use to test the Ethernet controller depends on which operating system you are using. See the operating-system documentation for information about Ethernet controllers, and see the Ethernet controller device-driver readme file.

Complete the following steps to attempt to resolve suspected problems with the Ethernet controller.

- Step 1. Make sure that the correct device drivers, which come with the server are installed and that they are at the latest level.
 - Step 2. Make sure that the Ethernet cable is installed correctly.
 - The cable must be securely attached at all connections. If the cable is attached but the problem remains, try a different cable.
 - If you set the Ethernet controller to operate at 100 Mbps or 1000 Mbps, you must use Category 5 cabling.
- Notes:**
- Use CAT6A UTP cables rated at 625 MHz bandwidth for the 10Gb on-board LAN.
 - Wake-on-LAN (WoL) is not supported on 10Gb ethernet connector under Windows OS.
- Step 3. Determine whether the hub supports auto-negotiation. If it does not, try configuring the integrated Ethernet controller manually to match the speed and duplex mode of the hub.
 - Step 4. Check the Ethernet controller LEDs on the rear panel of the server. These LEDs indicate whether there is a problem with the connector, cable, or hub.
 - The Ethernet link status LED is lit when the Ethernet controller receives a link pulse from the hub. If the LED is off, there might be a defective connector or cable or a problem with the hub.
 - The Ethernet transmit/receive activity LED is lit when the Ethernet controller sends or receives data over the Ethernet network. If the Ethernet transmit/receive activity is off, make sure that the hub and network are operating and that the correct device drivers are installed.
 - Step 5. Check the LAN activity LED on the rear of the server. The LAN activity LED is lit when data is active on the Ethernet network. If the LAN activity LED is off, make sure that the hub and network are operating and that the correct device drivers are installed.
 - Step 6. Check for operating-system-specific causes of the problem, and also make sure that the operating system drivers are installed correctly.
 - Step 7. Make sure that the device drivers on the client and server are using the same protocol.

If the Ethernet controller still cannot connect to the network but the hardware appears to be working, the network administrator must investigate other possible causes of the error.

Troubleshooting by symptom

Follow this procedure to find solutions to problems that have identifiable symptoms.

To use the symptom-based troubleshooting information in this section, complete the following steps:

1. Check the event log of the application that is managing the server and follow the suggested actions to resolve any event codes.
 - If you are managing the server from the Lenovo XClarity Administrator, begin with the Lenovo XClarity Administrator event log.
 - If you are using some other management application, begin with the Lenovo XClarity Controller event log.

For more information about event logs, see “Event logs” on page 207.

2. Review this section to find the symptoms that you are experiencing and follow the suggested actions to resolve the issue.
3. If the problem persists, contact support (see “Contacting Support” on page 233).

Drive problems

See this section to resolve issues related to the drives.

- “Server cannot recognize a hard drive” on page 211
- “Multiple hard drives fail” on page 212
- “Multiple hard drives are offline” on page 212
- “A replacement hard disk drive does not rebuild” on page 212
- “Green hard disk drive activity LED does not represent actual state of associated drive” on page 212
- “Yellow hard disk drive status LED does not represent actual state of associated drive” on page 213

Server cannot recognize a hard drive

Complete the following steps until the problem is solved.

1. Observe the associated yellow hard disk drive status LED. If the LED is lit, it indicates a drive fault.
2. If the LED is lit, remove the drive from the bay, wait 45 seconds, and reinsert the drive, making sure that the drive assembly connects to the hard disk drive backplane.
3. Observe the associated green hard disk drive activity LED and the yellow status LED:
 - If the green activity LED is flashing and the yellow status LED is not lit, the drive is recognized by the controller and is working correctly. Run the diagnostics tests for the hard disk drives. When you start a server and press F1, the Lenovo XClarity Provisioning Manager V3 interface is displayed by default. You can perform hard drive diagnostics from this interface. From the Diagnostic page, click **Run Diagnostic → Disk Drive Test**.
 - If the green activity LED is flashing and the yellow status LED is flashing slowly, the drive is recognized by the controller and is rebuilding.
 - If neither LED is lit or flashing, check the hard disk drive backplane.
 - If the green activity LED is flashing and the yellow status LED is lit, replace the drive. If the activity of the LEDs remains the same, go to step Hard disk drive problems. If the activity of the LEDs changes, return to step 1.
4. Make sure that the hard disk drive backplane is correctly seated. When it is correctly seated, the drive assemblies correctly connect to the backplane without bowing or causing movement of the backplane.

5. Reseat the backplane power cable and repeat steps 1 through 3.
6. Reseat the backplane signal cable and repeat steps 1 through 3.
7. Suspect the backplane signal cable or the backplane:
 - Replace the affected backplane signal cable.
 - Replace the affected backplane.
8. Run the diagnostics tests for the hard disk drives. When you start a server and press F1, the Lenovo XClarity Provisioning Manager V3 interface is displayed by default. You can perform hard drive diagnostics from this interface. From the Diagnostic page, click **Run Diagnostic → Disk Drive Test**.

Based on those tests:

- If the adapter passes the test but the drives are not recognized, replace the backplane signal cable and run the tests again.
- Replace the backplane.
- If the adapter fails the test, disconnect the backplane signal cable from the adapter and run the tests again.
- If the adapter fails the test, replace the adapter.

Multiple hard drives fail

Complete the following steps until the problem is solved:

- View the Lenovo XClarity Controller event log for events related to power supplies or vibration issues and resolve those events.
- Make sure that the device drivers and firmware for the hard disk drive and server are at the latest level

Important: Some cluster solutions require specific code levels or coordinated code updates. If the device is part of a cluster solution, verify that the latest level of code is supported for the cluster solution before you update the code.

Multiple hard drives are offline

Complete the following steps until the problem is solved:

- View the Lenovo XClarity Controller event log for events related to power supplies or vibration issues and resolve those events.
- View the storage subsystem log for events related to the storage subsystem and resolve those events.

A replacement hard disk drive does not rebuild

Complete the following steps until the problem is solved:

1. Make sure that the hard disk drive is recognized by the adapter (the green hard disk drive activity LED is flashing).
2. Review the SAS/SATA RAID adapter documentation to determine the correct configuration parameters and settings.

Green hard disk drive activity LED does not represent actual state of associated drive

Complete the following steps until the problem is solved:

1. If the green hard disk drive activity LED does not flash when the drive is in use, run the diagnostics tests for the hard disk drives. When you start a server and press F1, the Lenovo XClarity Provisioning Manager V3 interface is displayed by default. You can perform hard drive diagnostics from this interface. From the Diagnostic page, click **Run Diagnostic → Disk Drive Test**.
2. If the drive passes the test, replace the backplane.

3. If the drive fails the test, replace the drive.

Yellow hard disk drive status LED does not represent actual state of associated drive

Complete the following steps until the problem is solved:

1. Turn off the server.
2. Reseat the SAS/SATA adapter.
3. Reseat the backplane signal cable and backplane power cable.
4. Reseat the hard disk drive.
5. Power on the server and observe the activity of the hard disk drive LEDs.

Fan problems

See this section to resolve issues related the to fans.

- “Abnormally high RPM (revolutions per minute)” on page 213

Abnormally high RPM (revolutions per minute)

Complete the following steps until the problem is solved.

1. Check to see if the system inlet perforation or heatsinks are clogged.
2. Make sure that all air baffles are correctly installed in the server.
3. Check the thermal grease on the processor, and make sure it's not contaminated.

Intermittent problems

See this section to solve intermittent problems.

- “Intermittent external device problems” on page 213
- “Intermittent KVM problems” on page 213
- “Intermittent unexpected reboots” on page 214

Intermittent external device problems

Complete the following steps until the problem is solved.

1. Make sure that the correct device drivers are installed. See the manufacturer's website for documentation.
2. For a USB device:
 - a. Make sure that the device is configured correctly.

Restart the server and press F1 to display the Lenovo XClarity Provisioning Manager V3 system setup interface. Then, click **System Settings** → **Devices and I/O Ports** → **USB Configuration**.
 - b. Connect the device to another port. If using a USB hub, remove the hub and connect the device directly to the server. Make sure that the device is configured correctly for the port.

Intermittent KVM problems

Complete the following steps until the problem is solved.

Video problems:

1. Make sure that all cables and the console breakout cable are properly connected and secure.
2. Make sure that the monitor is working properly by testing it on another server.

3. Test the console breakout cable on a working server to ensure that it is operating properly. Replace the console breakout cable if it is defective.

Keyboard problems:

Make sure that all cables and the console breakout cable are properly connected and secure.

Mouse problems:

Make sure that all cables and the console breakout cable are properly connected and secure.

Intermittent unexpected reboots

Note: Some correctable errors require that the server reboot so that it can disable a device, such as a memory DIMM or a processor to allow the machine to boot up properly.

1. If the reset occurs during POST and the POST watchdog timer is enabled, make sure that sufficient time is allowed in the watchdog timeout value (POST Watchdog Timer).

To check the POST watchdog time, restart the server and press F1 to display the Lenovo XClarity Provisioning Manager V3 system setup interface. Then, click **BMC Settings → POST Watchdog Timer**.

2. If the reset occurs after the operating system starts, disable any automatic server restart (ASR) utilities, such as the Automatic Server Restart IPMI Application for Windows, or any ASR devices that are installed.
3. See the management controller event log to check for an event code that indicates a reboot. See “Event logs” on page 207 for information about viewing the event log.

Keyboard, mouse, or USB-device problems

See this section to solve problems related to a keyboard, mouse, or USB device.

- “All or some keys on the keyboard do not work.” on page 214
- “Mouse does not work.” on page 214
- “USB-device does not work.” on page 215

All or some keys on the keyboard do not work.

1. Make sure that:
 - The keyboard cable is securely connected.
 - The server and the monitor are turned on.
2. If you are using a USB keyboard, run the Setup utility and enable keyboardless operation.
3. If you are using a USB keyboard and it is connected to a USB hub, disconnect the keyboard from the hub and connect it directly to the server.
4. Replace the keyboard.

Mouse does not work.

1. Make sure that:
 - The mouse cable is securely connected to the server.
 - The mouse device drivers are installed correctly.
 - The server and the monitor are turned on.
 - The mouse option is enabled in the Setup utility.
2. If you are using a USB mouse and it is connected to a USB hub, disconnect the mouse from the hub and connect it directly to the server.

3. Replace the mouse.

USB-device does not work.

1. Make sure that:
 - The correct USB device driver is installed.
 - The operating system supports USB devices.
2. Make sure that the USB configuration options are set correctly in system setup.

Restart the server and press F1 to display the Lenovo XClarity Provisioning Manager V3 system setup interface. Then, click **System Settings → Devices and I/O Ports → USB Configuration**.

3. If you are using a USB hub, disconnect the USB device from the hub and connect it directly to the server.

Memory problems

See this section to resolve issues related to memory.

- “Displayed system memory is less than installed physical memory” on page 215
- “Multiple memory modules in a channel identified as failing” on page 216
- “Attempt to change to another PMEM mode fails” on page 217
- “Extra namespace appears in an interleaved region” on page 217
- “Migrated PMEMs are not supported” on page 217
- “Invalid memory population detected” on page 218
- “PMEMs installed in wrong slots after system board replacement” on page 218
- “After PMEMs are reconfigured, error messages and LEDs persist to indicate PMEMs are installed in wrong slots” on page 218
- “Cannot create goal successfully when installing PMEMs to the system for the first time” on page 218

Displayed system memory is less than installed physical memory

Complete the following procedure to solve the problem.

Note: Each time you install or remove a memory module, you must disconnect the server from the power source; then, wait 10 seconds before restarting the server.

1. Make sure that:
 - No error LEDs are lit on the operator information panel.
 - No memory module error LEDs are lit on the system board.
 - Memory mirrored channel does not account for the discrepancy.
 - The memory modules are seated correctly.
 - You have installed the correct type of memory module (see “Memory module installation guideline” in *Setup Guide* for requirements).
 - After changing or replacing a memory module, memory configuration is updated accordingly in the Setup Utility.
 - All banks of memory are enabled. The server might have automatically disabled a memory bank when it detected a problem, or a memory bank might have been manually disabled.
 - There is no memory mismatch when the server is at the minimum memory configuration.
 - When PMEMs are installed:

- a. Refer to “Memory module installation guideline” in *Setup Guide* and see if the displayed memory fits the mode description.
 - b. If the memory is set in App Direct Mode, all the saved data have been backed up, and created namespaces are deleted before any PMEM is replaced or added.
 - c. If PMEMs are recently set in Memory Mode, turn it back to App Direct Mode and examine if there is namespace that has not been deleted.
 - d. Go to the Setup Utility, select **System Configuration and Boot Management → Intel Optane PMEMs → Security**, and make sure security of all the PMEM units is disabled.
2. Reseat the memory modules, and then restart the server.
 3. Check the POST error log:
 - If a memory module was disabled by a systems-management interrupt (SMI), replace the memory module.
 - If a memory module was disabled by the user or by POST, reseat the memory module; then, run the Setup utility and enable the memory module.
 4. Run memory diagnostics. When you start a solution and press F1, the Lenovo XClarity Provisioning Manager V3 interface is displayed by default. You can perform memory diagnostics with this interface. From the Diagnostic page, go to **Run Diagnostic → Memory test** or **PMEM test**.

Notes: When PMEMs are installed, run diagnostics based on the mode that is set presently:

- App Direct Mode:
 - Run Memory Test for DRAM memory modules.
 - Run PMEM Test for PMEMs.
 - Memory Mode:
 - Run both Memory Test and PMEM Test for PMEMs.
5. Reverse the modules between the channels (of the same processor), and then restart the server. If the problem is related to a memory module, replace the failing memory module.

Note: When PMEMs are installed, only adopt this method in Memory Mode.
 6. Re-enable all memory modules using the Setup utility, and then restart the server.
 7. (Trained technician only) Install the failing memory module into a memory module connector for processor 2 (if installed) to verify that the problem is not the processor or the memory module connector.
 8. (Trained technician only) Replace the system board.

Multiple memory modules in a channel identified as failing

Note: Each time you install or remove a memory module, you must disconnect the server from the power source; then, wait 10 seconds before restarting the server.

Complete the following procedure to solve the problem.

1. Reseat the memory modules; then, restart the server.
2. Remove the highest-numbered memory module of those that are identified and replace it with an identical known good memory module; then, restart the server. Repeat as necessary. If the failures continue after all identified memory modules are replaced, go to step 4.
3. Return the removed memory modules, one at a time, to their original connectors, restarting the server after each memory module, until a memory module fails. Replace each failing memory module with an identical known good memory module, restarting the server after each memory module replacement. Repeat step 3 until you have tested all removed memory modules.

4. Replace the highest-numbered memory module of those identified; then, restart the server. Repeat as necessary.
5. Reverse the memory modules between the channels (of the same processor), and then restart the server. If the problem is related to a memory module, replace the failing memory module.
6. (Trained technician only) Install the failing memory module into a memory module connector for processor 2 (if installed) to verify that the problem is not the processor or the memory module connector.
7. (Trained technician only) Replace the system board.

Attempt to change to another PMEM mode fails

After the PMEM mode is changed and the system is successfully restarted, if the PMEM mode stays the same instead of being changed, check the DRAM DIMMs and PMEM capacity to see if it meets the requirement of the new mode (see “Memory module installation guideline” in *Setup Guide*).

Extra namespace appears in an interleaved region

If there are two created namespaces in one interleaved region, VMware ESXi ignores the created namespaces and creates an extra new namespace during system booting. Delete the created namespaces in either the Setup Utility or the operating system before the first booting with ESXi.

Migrated PMEMs are not supported

Intel Optane PMEM interleave set (DIMM X) is migrated from another system (Platform ID: 0x00), these migrated PMEMs are not supported nor warranted in this system.

If this warning message appears, complete the following steps:

1. Move the modules back to the original system with the exact same configuration as the previous one.
2. Back up stored data in PMEM namespaces.
3. Disable PMEM security with one of the following options:
 - **LXPM**
Go to **UEFI Setup → System Settings → Intel Optane PMEMs → Security → Press to Disable Security**, and input passphrase to disable security.
 - **Setup Utility**
Go to **System Configuration and Boot Management → System Settings → Intel Optane PMEMs → Security → Press to Disable Security**, and input passphrase to disable security.
4. Delete namespaces with command corresponding to the operating system that is installed:
 - **Linux** command:
`ndctl destroy-namespace all -f`
 - **Windows** Powershell command
`Get-PmemDisk | Remove-PmemDisk`
5. Clear Platform Configuration Data (PCD) and Namespace Label Storage Area (LSA) with the following `ipmctl` command (for both Linux and Windows).
`ipmctl delete -pcd`

Notes: See the following links to learn how to download and use `ipmctl` in different operating systems:

 - Windows: <https://datacentersupport.lenovo.com/us/en/videos/YTV101407>
 - Linux: <https://datacentersupport.lenovo.com/us/en/solutions/HT508642>
6. Reboot the system, and press F1 to enter Setup Utility.
7. Power off the system.

8. Remove the modules to be reused for a new system or configuration.

Invalid memory population detected

Invalid memory population (unsupported DIMM population) detected. Please verify memory configuration is valid.

If this warning message appears, complete the following steps:

1. See “Memory module installation rules and order” in *Setup Guide* to make sure the present memory module population sequence is supported.
2. If the present sequence is indeed supported, see if any of the modules is displayed as “disabled” in Setup Utility.
3. Reseat the module that is displayed as “disabled,” and reboot the system.
4. If the problem persists, replace the memory module.

PMEMs installed in wrong slots after system board replacement

DIMM X of Intel Optane PMEM persistent interleave set should be moved to DIMM Y.

If this warning message appears, complete the following steps:

1. Record each of the instructions of changing PMEM slot from XCC events.
2. Power off the system, and remove the PMEMs that are mentioned in the warning messages. It is suggested to label these PMEMs to avoid confusion.
3. Install the PMEMs in the correct slot number indicated in the warning messages. Remove the labels to avoid blocking airflow and cooling.
4. Complete replacement and power on the system. Make sure there is no similar warning messages in XCC.

Note: Do not perform any provisioning on PMEM to avoid data lost when the messages are still present in XCC events.

After PMEMs are reconfigured, error messages and LEDs persist to indicate PMEMs are installed in wrong slots

AC the system or restart XCC to solve this problem.

Cannot create goal successfully when installing PMEMs to the system for the first time

When seeing ones of the following messages:

- ERROR: Cannot retrieve memory resources info
- ERROR: One or more PMEM modules do not have PCD data. A platform reboot is recommended to restore valid PCD data.

Complete the following steps to solve the problem.

1. If the PMEMs have been installed in another system with stored data, perform the following steps to erase the data.
 - a. Based on the original population order, install the PMEMs to the original system where they were installed previously, and back up the data from the PMEMs to other storage devices.
 - b. Disable PMEM security with one of the following options:
 - **LXPM**

Go to **UEFI Setup → System Settings → Intel Optane PMEMs → Security → Press to Disable Security**, and input passphrase to disable security.

- **Setup Utility**

Go to **System Configuration and Boot Management → System Settings → Intel Optane PMEMs → Security → Press to Disable Security**, and input passphrase to disable security.

c. Delete namespaces with command corresponding to the operating system that is installed:

- **Linux** command:

```
ndctl destroy-namespace all -f
```

- **Windows** Powershell command

```
Get-PmemDisk | Remove-PmemDisk
```

d. Clear Platform Configuration Data (PCD) and Namespace Label Storage Area (LSA) with the following ipmctl command (for both Linux and Windows).

```
ipmctl delete -pcd
```

Notes: See the following links to learn how to download and use ipmctl in different operating systems:

- Windows: <https://datacentersupport.lenovo.com/us/en/videos/YTV101407>

- Linux: <https://datacentersupport.lenovo.com/us/en/solutions/HT508642>

2. Install the PMEMs back to the target system, and upgrade system firmware to the latest version without entering Setup Utility.

3. If the problem persists, overwrite PMEMs with the following ndctl command.

```
ndctl sanitize-dimm --overwrite all
```

4. Monitor the overwrite status with the following command.

```
watch -n 1 "ipmctl show -d OverwriteStatus -dimm"
```

5. When seeing all PMEM OverwriteStatus=Completed, reboot the system and see if the problem persists.

Monitor and video problems

See this section to solve problems related to a monitor or video.

- “Incorrect characters are displayed” on page 219
- “Screen is blank” on page 219
- “Screen goes blank when you start some application programs” on page 220
- “The monitor has screen jitter, or the screen image is wavy, unreadable, rolling, or distorted.” on page 220
- “The wrong characters appear on the screen” on page 220
- “Management controller remote presence cannot work” on page 220

Incorrect characters are displayed

Complete the following steps:

1. Verify that the language and locality settings are correct for the keyboard and operating system.
2. If the wrong language is displayed, update the server firmware to the latest level. See “Firmware updates” on page 9.

Screen is blank

1. If the server is attached to a KVM switch, bypass the KVM switch to eliminate it as a possible cause of the problem: connect the monitor cable directly to the correct connector on the rear of the server.

2. If the server installed with the graphical adapters while turning on the server, the Lenovo logo displays on the screen after approximately 3 minutes. This is normal operation while the system loads.
3. Make sure that:
 - The server is turned on and there is power supplied to the server.
 - The monitor cables are connected correctly.
 - The monitor is turned on and the brightness and contrast controls are adjusted correctly.
4. Make sure that the correct server is controlling the monitor, if applicable.
5. Make sure that the video output is not affected by corrupted server firmware; see “Firmware updates” on page 9.
6. If the problem remains, contact Lenovo Support.

Screen goes blank when you start some application programs

1. Make sure that:
 - The application program is not setting a display mode that is higher than the capability of the monitor.
 - You installed the necessary device drivers for the application.

The monitor has screen jitter, or the screen image is wavy, unreadable, rolling, or distorted.

1. If the monitor self-tests show that the monitor is working correctly, consider the location of the monitor. Magnetic fields around other devices (such as transformers, appliances, fluorescents, and other monitors) can cause screen jitter or wavy, unreadable, rolling, or distorted screen images. If this happens, turn off the monitor.

Attention: Moving a color monitor while it is turned on might cause screen discoloration.

Move the device and the monitor at least 305 mm (12 in.) apart, and turn on the monitor.

Notes:

- a. To prevent diskette drive read/write errors, make sure that the distance between the monitor and any external diskette drive is at least 76 mm (3 in.).
- b. Non-Lenovo monitor cables might cause unpredictable problems.
2. Reseat the monitor cable.
3. Replace the components listed in step 2 one at a time, in the order shown, restarting the server each time:
 - a. Monitor cable
 - b. Video adapter (if one is installed)
 - c. Monitor
 - d. (Trained technician only) System board.

The wrong characters appear on the screen

Complete the following steps until the problem is solved:

1. Verify that the language and locality settings are correct for the keyboard and operating system.
2. If the wrong language is displayed, update the server firmware to the latest level. See “Firmware updates” on page 9.

Management controller remote presence cannot work

The management controller remote presence function is unable to display the system screen when an optional video adapter is present. To use the management controller remote presence function, remove the optional video adapter or use the onboard VGA as the display device.

Network problems

See this section to resolve issues related to networking.

- “Could not log in using LDAP account with SSL enabled” on page 221

Could not log in using LDAP account with SSL enabled

Complete the following steps until the problem is resolved:

1. Make sure that the license key is valid.
2. Generate a new license key and log in again.

Observable problems

See this section to solve observable problems.

- “The server immediately displays the POST Event Viewer when it is turned on” on page 221
- “Server is unresponsive (POST is complete and operating system is running)” on page 221
- “Server is unresponsive (cannot press F1 to start System Setup)” on page 222
- “Voltage planar fault is displayed in the event log” on page 222
- “Unusual smell” on page 222
- “Server seems to be running hot” on page 222
- “Cracked parts or cracked chassis” on page 223

The server immediately displays the POST Event Viewer when it is turned on

Complete the following steps until the problem is solved.

1. Correct any errors that are indicated by the light path diagnostics LEDs.
2. Make sure that the server supports all the processors and that the processors match in speed and cache size.

You can view processor details from system setup.

To determine if the processor is supported for the server, see <https://static.lenovo.com/us/en/serverproven/index.shtml>.

3. (Trained technician only) Make sure that processor 1 is seated correctly
4. (Trained technician only) Remove processor 2 and restart the server.
5. Replace the following components one at a time, in the order shown, restarting the server each time:
 - a. (Trained technician only) Processor
 - b. (Trained technician only) System board

Server is unresponsive (POST is complete and operating system is running)

Complete the following steps until the problem is solved.

- If you are in the same location as the server, complete the following steps:
 1. If you are using a KVM connection, make sure that the connection is operating correctly. Otherwise, make sure that the keyboard and mouse are operating correctly.
 2. If possible, log in to the server and verify that all applications are running (no applications are hung).
 3. Restart the server.
 4. If the problem remains, make sure that any new software has been installed and configured correctly.
 5. Contact your place of purchase of the software or your software provider.

- If you are accessing the server from a remote location, complete the following steps:
 1. Make sure that all applications are running (no applications are hung).
 2. Attempt to log out of the system and log back in.
 3. Validate the network access by pinging or running a trace route to the server from a command line.
 - a. If you are unable to get a response during a ping test, attempt to ping another server in the enclosure to determine whether it is a connection problem or server problem.
 - b. Run a trace route to determine where the connection breaks down. Attempt to resolve a connection issue with either the VPN or the point at which the connection breaks down.
 4. Restart the server remotely through the management interface.
 5. If the problem remains, verify that any new software has been installed and configured correctly.
 6. Contact your place of purchase of the software or your software provider.

Server is unresponsive (cannot press F1 to start System Setup)

Configuration changes, such as added devices or adapter firmware updates, and firmware or application code problems can cause the server to fail POST (the power-on self-test).

If this occurs, the server responds in either of the following ways:

- The server restarts automatically and attempts POST again.
- The server hangs, and you must manually restart the server for the server to attempt POST again.

After a specified number of consecutive attempts (automatic or manual), the server reverts to the default UEFI configuration and starts System Setup so that you can make the necessary corrections to the configuration and restart the server. If the server is unable to successfully complete POST with the default configuration, there might be a problem with the system board.

You can specify the number of consecutive restart attempts in System Setup. Restart the server and press F1 to display the Lenovo XClarity Provisioning Manager V3 system setup interface. Then, click **System Settings** → **Recovery and RAS** → **POST Attempts** → **POST Attempts Limit**. Available options are 3, 6, 9, and disable.

Voltage planar fault is displayed in the event log

Complete the following steps until the problem is solved.

1. Revert the system to the minimum configuration. See “Specifications” on page 1 for the minimally required number of processors and DIMMs.
2. Restart the system.
 - If the system restarts, add each of the items that you removed one at a time, restarting the system each time, until the error occurs. Replace the item for which the error occurs.
 - If the system does not restart, suspect the system board.

Unusual smell

Complete the following steps until the problem is solved.

1. An unusual smell might be coming from newly installed equipment.
2. If the problem remains, contact Lenovo Support.

Server seems to be running hot

Complete the following steps until the problem is solved.

Multiple servers or chassis:

1. Make sure that the room temperature is within the specified range (see “Specifications” on page 1).
2. Check the management processor event log for rising temperature events. If there are no events, the server is running within normal operating temperatures. Note that you can expect some variation in temperature.

Cracked parts or cracked chassis

Contact Lenovo Support.

Optional-device problems

See this section to solve problems related to optional devices.

- “External USB device not recognized” on page 223
- “PCIe adapter is not recognized or is not functioning” on page 223
- “A Lenovo optional device that was just installed does not work.” on page 223
- “A Lenovo optional device that worked previously does not work now. ” on page 224

External USB device not recognized

Complete the following steps until the problem is resolved:

1. Make sure that the proper drivers are installed on the server. See the product documentation for the USB device for information about device drivers.
2. Use the Setup utility to make sure that the device is configured correctly.
3. If the USB device is plugged into a hub or the console breakout cable, unplug the device and plug it directly into the USB port on the front of the server.

PCIe adapter is not recognized or is not functioning

Complete the following steps until the problem is resolved:

1. Check the event log and resolve any issues related to the device.
2. Validate that the device is supported for the server (see <https://static.lenovo.com/us/en/serverproven/index.shtml>).
3. Make sure that the adapter is installed in a correct slot.
4. Make sure that the proper device drivers are installed for the device.
5. Resolve any resource conflicts if running legacy mode (UEFI).
6. Check <http://datacentersupport.lenovo.com> for any tech tips (also known as retain tips or service bulletins) that might be related to the adapter.
7. Ensure any adapter external connections are correct and that the connectors are not physically damaged.

A Lenovo optional device that was just installed does not work.

1. Check the XCC event log for any events associated with the device.
2. Make sure that the following conditions are met:
 - The device is installed in the correct port.
 - The device is designed for the server (see <https://static.lenovo.com/us/en/serverproven/index.shtml>).
 - You followed the installation instructions that came with the device, and the device is installed correctly.
 - You have not loosened any other installed devices or cables.

- You updated the configuration information in the Setup utility. Whenever memory or any other device is changed, you must update the configuration.
3. Reseat the device that you just installed.
 4. Replace the device that you just installed.

A Lenovo optional device that worked previously does not work now.

1. Check the XCC event log for any events associated with the device.
2. Make sure that all of the cable connections for the device are secure.
3. Reseat the failing device.
4. If the device comes with test instructions, use those instructions to test the device.
5. If the failing device is a SCSI device, make sure that the following conditions are met:
 - The cables for all external SCSI devices are connected correctly.
 - The last device in each SCSI chain, or the end of the SCSI cable, is terminated correctly.
 - Any external SCSI device is turned on. You must turn on an external SCSI device before you turn on the server.
6. Replace the failing device.

Power on and power off problems

Follow this procedure to resolve issues when powering on or powering off the server.

- “Embedded hypervisor is not in the boot list” on page 224
- “The power button does not work (server does not start)” on page 225
- “Server does not power on” on page 225
- “Server does not power off” on page 225

Embedded hypervisor is not in the boot list

Complete the following steps until the problem is solved.

1. If the server has been installed, moved, or serviced recently, or if this is the first time the embedded hypervisor is being used, make sure that the device is connected properly and that there is no physical damage to the connectors.
2. See the documentation that comes with the optional embedded hypervisor flash device for setup and configuration information.
3. Check <https://static.lenovo.com/us/en/serverproven/index.shtml> to validate that the embedded hypervisor device is supported for the server.
4. Make sure that the embedded hypervisor device is listed in the list of available boot options. From the management controller user interface, click **Server Configuration → Boot Options**.

For information about accessing the management controller user interface, see the XClarity Controller product documentation:

http://sysmgmt.lenovofiles.com/help/topic/com.lenovo.systems.management.xcc.doc/dw1lm_c_chapter2_openingandusing.html

5. Check <http://datacentersupport.lenovo.com> for any tech tips (service bulletins) related to the embedded hypervisor and the server.
6. Make sure that other software works on the server to ensure that it is working properly.

The power button does not work (server does not start)

Note: The power button will not function until approximately 1 to 3 minutes after the server has been connected to ac power.

Complete the following steps until the problem is resolved:

1. Make sure that the power button on the server is working correctly:
 - a. Disconnect the server power cords.
 - b. Reconnect the server power cords.
 - c. Reseat the operator information panel cable, and then repeat steps a and b.
 - If the server starts, reseat the operator information panel.
 - If the problem remains, replace the operator information panel.
2. Make sure that:
 - The power cords are correctly connected to the server and to a working electrical outlet.
 - The LEDs on the power supply do not indicate a problem.
3. Reseat the power supplies.
4. Replace each power supply, restarting the server each time:
 - DIMMs
 - Power supplies
5. If you just installed an optional device, remove it, and restart the server. If the server starts, you might have installed more devices than the power supply supports.

Server does not power on

Complete the following steps until the problem is resolved:

1. Check the event log for any events related to the server not powering on.
2. Check for any LEDs that are flashing amber.
3. Check the power LED on the system board.
4. Reseat the power supply.
5. Replace the power supply.

Server does not power off

Complete the following steps until the problem is resolved:

1. Determine whether you are using an Advanced Configuration and Power Interface (ACPI) or a non-ACPI operating system. If you are using a non-ACPI operating system, complete the following steps:
 - a. Press Ctrl+Alt+Delete.
 - b. Turn off the server by pressing the power button and holding it down for 5 seconds.
 - c. Restart the server.
 - d. If the server fails POST and the power button does not work, disconnect the power cord for 20 seconds; then, reconnect the power cord and restart the server.
2. If the problem remains or if you are using an ACPI-aware operating system, suspect the system board.

Processor problems

See this section to solve problems related to a monitor or video.

- “The server goes directly to the POST event viewer when it is turned on.” on page 226

The server goes directly to the POST event viewer when it is turned on.

1. Check the light path diagnostics LEDs and the XCC event log, and resolve any errors that have occurred.
2. Make sure that the server supports all the processors and that the processors match in speed and cache size. You can view processor details from system setup. To determine if the processor is supported for the server, see <https://static.lenovo.com/us/en/serverproven/index.shtml>
3. (Trained technician only) Make sure that processor 1 is seated correctly
4. (Trained technician only) Remove processor 2 and restart the server. (3 and 4)
5. Replace the following components one at a time, in the order shown, restarting the server each time:
 - a. (Trained technician only) Processor
 - b. (Trained technician only) System board

Serial-device problems

See this section to solve problems with serial ports or devices.

- “Number of displayed serial ports is less than the number of installed serial ports” on page 226
- “Serial device does not work” on page 226

Number of displayed serial ports is less than the number of installed serial ports

Complete the following steps until the problem is solved.

1. Make sure that:
 - Each port is assigned a unique address in the Setup utility and none of the serial ports is disabled.
 - The serial-port adapter (if one is present) is seated correctly
2. Reseat the serial port adapter.
3. Replace the serial port adapter.

Serial device does not work

1. Make sure that:
 - The device is compatible with the server.
 - The serial port is enabled and is assigned a unique address.
 - The device is connected to the correct connector.
2. Reseat the following components::
 - a. Failing serial device.
 - b. Serial cable.
3. Replace the following components:
 - a. Failing serial device.
 - b. Serial cable.
4. (Trained technician only) Replace the system board.

Software problems

See this section to solve software problems.

1. To determine whether the problem is caused by the software, make sure that:

- The server has the minimum memory that is needed to use the software. For memory requirements, see the information that comes with the software.

Note: If you have just installed an adapter or memory, the server might have a memory-address conflict.

- The operating system is on the ServerProven list (see <https://static.lenovo.com/us/en/serverproven/index.shtml>) and supported by your hardware.
 - The software is designed to operate on the server.
 - Other software works on the server.
 - The software works on another server.
2. If you receive any error messages while you use the software, see the information that comes with the software for a description of the messages and suggested solutions to the problem.
 3. Check the operating system logs for any events related to your software and attempt to resolve them.
 4. Contact your place of purchase of the software.

Appendix A. Hardware disassembling for recycle

Follow the instructions in this section to recycle components with compliance with local laws or regulations.

Disassemble the server for chassis recycle

Follow the instructions in this section to disassemble the server before recycling the chassis.

About this task

Attention:

- Read “Installation guidelines” on page 57 to ensure that you work safely.
- Power off the server and disconnect all power cords for this task.
- Prevent exposure to static electricity, which might lead to system halt and loss of data, by keeping static-sensitive components in their static-protective packages until installation, and handling these devices with an electrostatic-discharge wrist strap or other grounding system.
- If the server is in a rack, remove it from the rack.
- If foot stands are installed on the server, rotate them inwards and lay the server on its side for easier operation.

- Step 1. Remove the hot-swap redundant power supply. See “Remove a hot-swap power supply” on page 170.
- Step 2. Remove all the installed drives and fillers. See “Remove a hot-swap drive” on page 83 or “Remove a simple-swap drive” on page 80.
- Step 3. Remove the server cover. See “Remove the server cover” on page 188.
- Step 4. Remove the front door. See “Remove the front door” on page 107.
- Step 5. Remove the front bezel. See “Remove the front bezel” on page 105.
- Step 6. Remove the front panel board assembly. See “Remove the front panel board assembly ” on page 110.
- Step 7. Remove the optical drives. See “Remove the 5.25-inch drive bay adapter assembly” on page 153 or “Remove an optical drive or a tape drive” on page 147.
- Step 8. Remove the expansion drive cage. “Remove the expansion drive cage” on page 90.
- Step 9. Remove the optical drive cage. See “Remove the optical drive cage” on page 144.
- Step 10. Remove the T4 fillers. See “Remove a T4 filler” on page 203.
- Step 11. Remove all the flash power modules. See “Remove a flash power module” on page 98.
- Step 12. Remove the GPU filler. See “Remove a GPU filler” on page 116.
- Step 13. Remove the air baffle. See “Remove the air baffle” on page 72.
- Step 14. Remove the NVLink bridges. See “Remove an NVLink bridge” on page 141.
- Step 15. Remove all the full-length GPU adapters. See “Remove a full-length GPU adapter” on page 113.
- Step 16. Remove all the PCIe adapters. See “Remove a PCIe adapter” on page 162.
- Step 17. Remove the PCIe adapter holders. See “Remove a PCIe adapter holder” on page 160.
- Step 18. Remove all the fans. See “Remove a hot-swap fan” on page 93.
- Step 19. Remove the fan cage. See “Remove the fan cage assembly” on page 95.

- Step 20. Remove the backplanes or backplates. See “Remove a 2.5-inch hot-swap drive backplane” on page 60, “Remove a 3.5-inch hot-swap drive backplane” on page 67, or “Remove a 3.5-inch simple-swap drive backplate” on page 69.
- Step 21. Remove all the M.2 drives from the M.2 boot adapter. See “Remove an M.2 drive” on page 133
- Step 22. Remove the M.2 boot adapter. See “Remove the M.2 boot adapter” on page 130.
- Step 23. Remove the Remove the internal CFF adapter. See “Remove the internal CFF adapter” on page 122.
- Step 24. Remove the intrusion switch. See “Remove the intrusion switch” on page 127.
- Step 25. Remove the CMOS battery (CR2032). See “Remove the CMOS battery (CR2032)” on page 76.
- Step 26. Remove all the PHMs. See “Remove a processor and heat sink” on page 177.
- Step 27. Remove the system board. See “Remove the system board” on page 192.
- Step 28. Remove the power distribution board. See “Remove the power distribution board” on page 166.
- Step 29. Remove the foot stands. See “Remove the foot stands” on page 102.
- Step 30. Remove the EIA brackets. See “Remove the EIA brackets” on page 86.

After disassembling the server, recycle the unit in compliance with local regulations.

Appendix B. Getting help and technical assistance

If you need help, service, or technical assistance or just want more information about Lenovo products, you will find a wide variety of sources available from Lenovo to assist you.

On the World Wide Web, up-to-date information about Lenovo systems, optional devices, services, and support are available at:

<http://datacentersupport.lenovo.com>

Note: IBM is Lenovo's preferred service provider for ThinkSystem.

Before you call

Before you call, there are several steps that you can take to try and solve the problem yourself. If you decide that you do need to call for assistance, gather the information that will be needed by the service technician to more quickly resolve your problem.

Attempt to resolve the problem yourself

You can solve many problems without outside assistance by following the troubleshooting procedures that Lenovo provides in the online help or in the Lenovo product documentation. The Lenovo product documentation also describes the diagnostic tests that you can perform. The documentation for most systems, operating systems, and programs contains troubleshooting procedures and explanations of error messages and error codes. If you suspect a software problem, see the documentation for the operating system or program.

You can find the product documentation for your ThinkSystem products at the following location:

<http://thinksystem.lenovofiles.com/help/index.jsp>

You can take these steps to try to solve the problem yourself:

- Check all cables to make sure that they are connected.
- Check the power switches to make sure that the system and any optional devices are turned on.
- Check for updated software, firmware, and operating-system device drivers for your Lenovo product. The Lenovo Warranty terms and conditions state that you, the owner of the Lenovo product, are responsible for maintaining and updating all software and firmware for the product (unless it is covered by an additional maintenance contract). Your service technician will request that you upgrade your software and firmware if the problem has a documented solution within a software upgrade.
- If you have installed new hardware or software in your environment, check <https://static.lenovo.com/us/en/serverproven/index.shtml> to make sure that the hardware and software is supported by your product.
- Go to <http://datacentersupport.lenovo.com> and check for information to help you solve the problem.
 - Check the Lenovo forums at https://forums.lenovo.com/t5/Datacenter-Systems/ct-p/sv_eq to see if someone else has encountered a similar problem.

You can solve many problems without outside assistance by following the troubleshooting procedures that Lenovo provides in the online help or in the Lenovo product documentation. The Lenovo product documentation also describes the diagnostic tests that you can perform. The documentation for most systems, operating systems, and programs contains troubleshooting procedures and explanations of error messages and error codes. If you suspect a software problem, see the documentation for the operating system or program.

Gathering information needed to call Support

If you believe that you require warranty service for your Lenovo product, the service technicians will be able to assist you more efficiently if you prepare before you call. You can also see <http://datacentersupport.lenovo.com/warrantylookup> for more information about your product warranty.

Gather the following information to provide to the service technician. This data will help the service technician quickly provide a solution to your problem and ensure that you receive the level of service for which you might have contracted.

- Hardware and Software Maintenance agreement contract numbers, if applicable
- Machine type number (Lenovo 4-digit machine identifier)
- Model number
- Serial number
- Current system UEFI and firmware levels
- Other pertinent information such as error messages and logs

As an alternative to calling Lenovo Support, you can go to <https://support.lenovo.com/servicerequest> to submit an Electronic Service Request. Submitting an Electronic Service Request will start the process of determining a solution to your problem by making the pertinent information available to the service technicians. The Lenovo service technicians can start working on your solution as soon as you have completed and submitted an Electronic Service Request.

Collecting service data

To clearly identify the root cause of a server issue or at the request of Lenovo Support, you might need collect service data that can be used for further analysis. Service data includes information such as event logs and hardware inventory.

Service data can be collected through the following tools:

- **Lenovo XClarity Provisioning Manager V3**

Use the Collect Service Data function of Lenovo XClarity Provisioning Manager V3 to collect system service data. You can collect existing system log data or run a new diagnostic to collect new data.

- **Lenovo XClarity Controller**

You can use the Lenovo XClarity Controller web interface or the CLI to collect service data for the server. The file can be saved and sent to Lenovo Support.

- For more information about using the web interface to collect service data, see http://sysmgmt.lenovofiles.com/help/topic/com.lenovo.systems.management.xcc.doc/NN1ia_c_servicesandsupport.html.
- For more information about using the CLI to collect service data, see http://sysmgmt.lenovofiles.com/help/topic/com.lenovo.systems.management.xcc.doc/nn1ia_r_ffdcommand.html.

- **Lenovo XClarity Administrator**

Lenovo XClarity Administrator can be set up to collect and send diagnostic files automatically to Lenovo Support when certain serviceable events occur in Lenovo XClarity Administrator and the managed endpoints. You can choose to send diagnostic files to Lenovo Support using Call Home or to another service provider using SFTP. You can also manually collect diagnostic files, open a problem record, and send diagnostic files to the Lenovo Support Center.

You can find more information about setting up automatic problem notification within the Lenovo XClarity Administrator at http://sysmgmt.lenovofiles.com/help/topic/com.lenovo.lxca.doc/admin_setupcallhome.html.

- **Lenovo XClarity Essentials OneCLI**

Lenovo XClarity Essentials OneCLI has inventory application to collect service data. It can run both in-band and out-of-band. When running in-band within the host operating system on the server, OneCLI can collect information about the operating system, such as the operating system event log, in addition to the hardware service data.

To obtain service data, you can run the **getinfor** command. For more information about running the **getinfor**, see http://sysmgt.lenovofiles.com/help/topic/toolctr_cli_lenovo/onecli_r_getinfor_command.html.

Contacting Support

You can contact Support to obtain help for your issue.

You can receive hardware service through a Lenovo Authorized Service Provider. To locate a service provider authorized by Lenovo to provide warranty service, go to <https://datacentersupport.lenovo.com/serviceprovider> and use filter searching for different countries. For Lenovo support telephone numbers, see <https://datacentersupport.lenovo.com/supportphonenumberlist>. In the U.S. and Canada, call 1-800-426-7378.

In the U.S. and Canada, hardware service and support is available 24 hours a day, 7 days a week. In the U.K., these services are available Monday through Friday, from 9 a.m. to 6 p.m.

Chinese Mainland product support

To contact product support in Chinese Mainland, go to: <http://support.lenovo.com.cn/lenovo/wsi/es/ThinkSystem.html>

You can also call 400-106-8888 for product support. The call support is available Monday through Friday, from 9 a.m. to 6 p.m.

Taiwan product support

To contact product support for Taiwan, call 0800-016-888. The call support is available 24 hours a day, 7 days a week.

Appendix C. Notices

Lenovo may not offer the products, services, or features discussed in this document in all countries. Consult your local Lenovo representative for information on the products and services currently available in your area.

Any reference to a Lenovo product, program, or service is not intended to state or imply that only that Lenovo product, program, or service may be used. Any functionally equivalent product, program, or service that does not infringe any Lenovo intellectual property right may be used instead. However, it is the user's responsibility to evaluate and verify the operation of any other product, program, or service.

Lenovo may have patents or pending patent applications covering subject matter described in this document. The furnishing of this document is not an offer and does not provide a license under any patents or patent applications. You can send inquiries in writing to the following:

*Lenovo (United States), Inc.
8001 Development Drive
Morrisville, NC 27560
U.S.A.
Attention: Lenovo Director of Licensing*

LENOVO PROVIDES THIS PUBLICATION "AS IS" WITHOUT WARRANTY OF ANY KIND, EITHER EXPRESS OR IMPLIED, INCLUDING, BUT NOT LIMITED TO, THE IMPLIED WARRANTIES OF NON-INFRINGEMENT, MERCHANTABILITY OR FITNESS FOR A PARTICULAR PURPOSE. Some jurisdictions do not allow disclaimer of express or implied warranties in certain transactions, therefore, this statement may not apply to you.

This information could include technical inaccuracies or typographical errors. Changes are periodically made to the information herein; these changes will be incorporated in new editions of the publication. Lenovo may make improvements and/or changes in the product(s) and/or the program(s) described in this publication at any time without notice.

The products described in this document are not intended for use in implantation or other life support applications where malfunction may result in injury or death to persons. The information contained in this document does not affect or change Lenovo product specifications or warranties. Nothing in this document shall operate as an express or implied license or indemnity under the intellectual property rights of Lenovo or third parties. All information contained in this document was obtained in specific environments and is presented as an illustration. The result obtained in other operating environments may vary.

Lenovo may use or distribute any of the information you supply in any way it believes appropriate without incurring any obligation to you.

Any references in this publication to non-Lenovo Web sites are provided for convenience only and do not in any manner serve as an endorsement of those Web sites. The materials at those Web sites are not part of the materials for this Lenovo product, and use of those Web sites is at your own risk.

Any performance data contained herein was determined in a controlled environment. Therefore, the result obtained in other operating environments may vary significantly. Some measurements may have been made on development-level systems and there is no guarantee that these measurements will be the same on generally available systems. Furthermore, some measurements may have been estimated through extrapolation. Actual results may vary. Users of this document should verify the applicable data for their specific environment.

Trademarks

LENOVO, THINKSYSTEM, Flex System, System x, NeXtScale System, and x Architecture are trademarks of Lenovo.

Intel and Intel Xeon are trademarks of Intel Corporation in the United States, other countries, or both.

Internet Explorer, Microsoft, and Windows are trademarks of the Microsoft group of companies.

Linux is a registered trademark of Linus Torvalds.

All other trademarks are the property of their respective owners.

Important notes

Processor speed indicates the internal clock speed of the microprocessor; other factors also affect application performance.

CD or DVD drive speed is the variable read rate. Actual speeds vary and are often less than the possible maximum.

When referring to processor storage, real and virtual storage, or channel volume, KB stands for 1 024 bytes, MB stands for 1 048 576 bytes, and GB stands for 1 073 741 824 bytes.

When referring to hard disk drive capacity or communications volume, MB stands for 1 000 000 bytes, and GB stands for 1 000 000 000 bytes. Total user-accessible capacity can vary depending on operating environments.

Maximum internal hard disk drive capacities assume the replacement of any standard hard disk drives and population of all hard-disk-drive bays with the largest currently supported drives that are available from Lenovo.

Maximum memory might require replacement of the standard memory with an optional memory module.

Each solid-state memory cell has an intrinsic, finite number of write cycles that the cell can incur. Therefore, a solid-state device has a maximum number of write cycles that it can be subjected to, expressed as total bytes written (TBW). A device that has exceeded this limit might fail to respond to system-generated commands or might be incapable of being written to. Lenovo is not responsible for replacement of a device that has exceeded its maximum guaranteed number of program/erase cycles, as documented in the Official Published Specifications for the device.

Lenovo makes no representations or warranties with respect to non-Lenovo products. Support (if any) for the non-Lenovo products is provided by the third party, not Lenovo.

Some software might differ from its retail version (if available) and might not include user manuals or all program functionality.

Telecommunication regulatory statement

This product may not be certified in your country for connection by any means whatsoever to interfaces of public telecommunications networks. Further certification may be required by law prior to making any such connection. Contact a Lenovo representative or reseller for any questions.

Electronic emission notices

When you attach a monitor to the equipment, you must use the designated monitor cable and any interference suppression devices that are supplied with the monitor.

Additional electronic emissions notices are available at:

<http://thinksystem.lenovofiles.com/help/index.jsp>

Taiwan BSMI RoHS declaration

單元 Unit	限用物質及其化學符號 Restricted substances and its chemical symbols					
	鉛Lead (Pb)	汞Mercury (Hg)	鎘Cadmium (Cd)	六價鉻 Hexavalent chromium (Cr ⁶⁺)	多溴聯苯 Polybrominated biphenyls (PBB)	多溴二苯醚 Polybrominated diphenyl ethers (PBDE)
機架	○	○	○	○	○	○
外部蓋板	○	○	○	○	○	○
機械組零件	-	○	○	○	○	○
空氣傳動設備	-	○	○	○	○	○
冷卻組零件	-	○	○	○	○	○
內存模組	-	○	○	○	○	○
處理器模組	-	○	○	○	○	○
電纜組零件	-	○	○	○	○	○
電源供應器	-	○	○	○	○	○
儲備設備	-	○	○	○	○	○
電路卡	-	○	○	○	○	○
光碟機	-	○	○	○	○	○
<p>備考1. “超出0.1 wt %” 及 “超出0.01 wt %” 係指限用物質之百分比含量超出百分比含量基準值。 Note1 : “exceeding 0.1wt%” and “exceeding 0.01 wt%” indicate that the percentage content of the restricted substance exceeds the reference percentage value of presence condition.</p> <p>備考2. “○” 係指該項限用物質之百分比含量未超出百分比含量基準值。 Note2 : “○” indicates that the percentage content of the restricted substance does not exceed the percentage of reference value of presence.</p> <p>備考3. “-” 係指該項限用物質為排除項目。 Note3 : The “-” indicates that the restricted substance corresponds to the exemption.</p>						

Taiwan import and export contact information

Contacts are available for Taiwan import and export information.

委製商/進口商名稱: 台灣聯想環球科技股份有限公司
進口商地址: 台北市南港區三重路 66 號 8 樓
進口商電話: 0800-000-702

Index

- 2.5-inch drive from 3.5-inch drive bay
 - replacing 63
- 2.5-inch drive from a 3.5-inch drive bay
 - removing 64
- 2.5-inch drive into a 3.5-inch drive bay
 - installing 65

A

- air baffle
 - installing 74
 - removing 72
 - replacing 72

B

- backplane
 - connectors 39–40
 - replacing 60, 66
- backplate
 - connectors 41

C

- cable routing
 - CFF RAID adapter 50
 - front panel 48
 - front USB 49
 - GPU 50
 - M.2 boot adapter 51
 - optical drive 52
 - PCIe slot 8 52
 - power distribution board 53
 - tape drive 54
- carrier 181
- chassis 229
- CMOS battery
 - install 78
 - remove 76
 - replacing 76
- collecting service data 232
- completing
 - parts replacement 206
- connector
 - drive backplane 39
 - drive backplate 39
- connectors
 - backplanes 39–40
 - backplates 41
- contamination, particulate and gaseous 8
- CPU
 - installing 183
 - removing 177
 - separating 181
- CR2032 76
- creating a personalized support web page 231
- custom support web page 231

D

- devices, static-sensitive
 - handling 60
- diagnostics panel

- LCD 27
- DIMM
 - replacing 137
- disassembling 229
- drive
 - replacing 79
- drive backplane connectors 39
- drive backplate connectors 39
- drive problems 211

E

- EIA bracket
 - installing 88
 - removing 86
 - replacing 86
- enable
 - TCM 200
 - TPM 200
- Ethernet
 - controller
 - troubleshooting 210
- Ethernet controller problems
 - solving 210
- expansion drive cage
 - installing 91
 - removing 90
 - replacing 90
- External
 - LCD diagnostics handset 27

F

- fan
 - install 94
 - remove 93
- fan cage
 - install 97
- fan cage assembly
 - remove 95
- fan problems 213
- fan, fan cage
 - replacement 93
- firmware updates 9
- flash power module
 - installing 100
 - removing 98
 - replacing 98
- foot stands
 - installing 104
 - removing 102
 - replacing 102
- form factor 1
- front bezel
 - installing 106
 - removing 105
 - replacing 105
- front door
 - installing 109
 - removing 107
 - replacing 107
- front panel 16, 21
- front panel board assembly
 - installing 111
 - removing 110
 - replacing 110

front view 16
Full-length 113

G

gaseous contamination 8
Getting help 231
GPU adapter
 installing 114
 removing 113
 replacing 113
GPU filler
 installing 118
 removing 116
 replacing 116
guidelines
 options installation 57
 system reliability 59

H

handling static-sensitive devices 60
hardware service and support telephone numbers 233
heat sink 177
 installing 183
 removing 177
 separating 181
heat sink nut 119, 121
 installing 121
 removing 119
help 231
hot-swap drive
 installing 84
 removing 83
hot-swap drive backplane
 installing 62, 68
 removing 60, 67
 replacing 60, 66
hot-swap power supply
 installing 173
 removing 170

I

ID label 1
important notices 236
install
 CMOS battery 78
 fan 94
 fan cage 97
installation
 guidelines 57
installation guidelines 57
installing
 2.5-inch drive into a 3.5-inch drive bay 65
 air baffle 74
 CPU 183
 EIA bracket 88
 expansion drive cage 91
 flash power module 100
 foot stands 104
 front bezel 106
 front door 109
 front panel board assembly 111
 GPU adapter 114
 GPU filler 118
 heat sink 183
 heat sink nut 121
 hot-swap drive 84
 hot-swap drive backplane 62, 68

hot-swap power supply 173
internal CFF adapter 124
intrusion switch 128
memory module 139
microprocessor 183
microprocessor heat sink module 183
optical drive 150
optical drive cage 145
PCIe adapter 164
PCIe adapter holder 161
PEEK T30 nut 121
PHM 183
power distribution board 168
processor 183
processor-heat-sink module 183
server cover 190
simple-swap drive 81
simple-swap drive backplate 71
slim optical drive 156
system board 196
T30 nut 121
T4 filler 204
tape drive 150
intermittent problems 213
internal cable routing 47
internal CFF adapter
 installing 124
 removing 122
internal CFF RAID/HBA/Expander adapter
 replacing 122
introduction 1
intrusion switch
 installing 128
 removing 127
 replacing 127

K

keyboard problems 214

L

LCD
 diagnostics panel 27
LCD diagnostics handset
 External 27

M

M.2 boot adapter
 installing 131
 replacing 130
M.2 drive
 installing 135
 replacing 133
memory module
 removing 137
 replacing 137
memory module, install 139
memory modules
 removal 137
microprocessor
 installing 183
 removing 177
 separating 181
microprocessor heat sink module
 installing 183
 removing 177
 separating 181
monitor problems 219, 225

mouse problems 214

N

network
 problems 221
network access label 1
network activity LED 21
notes, important 236
notices 235
NVLink bridge
 installing 142
 replacing 141

O

observable problems 221
optical drive
 installing 150
 removing 147, 153
 replacing 147
optical drive cage
 installing 145
 removing 144
 replacing 144
optical-drive bay 16
optical-drive eject/close button 16
optical-drive manual-eject hole 16
optical-drive status LED 16
optional-device problems 223

P

particulate contamination 8
parts list 42
parts replacement, completing 206
PCIe adapter
 installing 164
 removing 162
 replacing 162
PCIe adapter holder
 installing 161
 removing 160
 replacing 159
PEEK T30 nut 119, 121
 installing 121
 removing 119
PHM
 installing 183
 removing 177
 separating 181
power button 21
power cords 46
power distribution board
 installing 168
 removing 166
 replacing 166
Power distribution board 41
Power distribution board connectors 41
power off the server 13
power on the server 13
power problems 209
power status LED 21
problem determination 207
problems
 drive 211
 Ethernet controller 210
 fan 213
 intermittent 213
 keyboard 214

monitor 219, 225
mouse 214
network 221
observable 221
optional devices 223
power 209
power on and power off 224
serial-device 226
software 226
USB device 214
video 219, 225
processor 177
 installing 183
 removing 177
processor-heat-sink module
 installing 183
 removing 177

R

rear view 24
rear view LED 26
recycle 229
recycling 229
redundant power supply unit
 replacing 170
remove
 CMOS battery 76
 fan 93
 fan cage assembly 95
 M.2 boot adapter 130
 M.2 drive 133
 NVLink bridge 141
removing
 2.5-inch drive from a 3.5-inch drive bay 64
 air baffle 72
 CPU 177
 EIA bracket 86
 expansion drive cage 90
 flash power module 98
 foot stands 102
 front bezel 105
 front door 107
 front panel board assembly 110
 GPU adapter 113
 GPU filler 116
 heat sink 177
 heat sink nut 119
 hot-swap drive 83
 hot-swap drive backplane 60, 67
 hot-swap power supply 170
 internal CFF adapter 122
 intrusion switch 127
 memory modules 137
 microprocessor 177
 microprocessor heat sink module 177
 optical drive 147, 153
 optical drive cage 144
 PCIe adapter 162
 PCIe adapter holder 160
 PEEK T30 nut 119
 PHM 177
 power distribution board 166
 processor 177
 processor-heat-sink module 177
 server cover 188
 simple-swap drive 80
 simple-swap drive backplate 69
 system board 192
 T30 nut 119
 T4 filler 203
 tape drive 147, 153
removing, memory module 137

- replacement
 - fan, fan cage 93
- replacing
 - 2.5-inch drive from 3.5-inch drive bay 63
 - air baffle 72
 - backplane 60, 66
 - CMOS battery 76
 - DIMM 137
 - drive 79
 - EIA bracket 86
 - expansion drive cage 90
 - flash power module 98
 - foot stands 102
 - front bezel 105
 - front door 107
 - front panel board assembly 110
 - GPU adapter 113
 - GPU filler 116
 - hot-swap drive backplane 60, 66
 - internal CFF RAID/HBA/Expander adapter 122
 - intrusion switch 127
 - M.2 boot adapter 130
 - M.2 drive 133
 - memory module 137
 - NVLink bridge 141
 - optical drive 147
 - optical drive cage 144
 - PCIe adapter 162
 - PCIe adapter holder 159
 - power distribution board 166
 - redundant power supply unit 170
 - server cover 188
 - simple-swap-drive backplate 69
 - system board 192
 - T4 filler 203
 - tape drive 147
- replacing heat sink 177
- replacing heat sink nut 119
- replacing processor 177
- retainer on M.2 boot adapter
 - adjusting 134

S

- safety v
- safety inspection checklist vi, 58
- Secure Boot 202
- security
 - integrated cable lock 38
 - padlock 38
 - security
 - front door lock 38
- security advisories 13
- separating
 - carrier 181
 - CPU 181
 - heat sink 181
 - microprocessor 181
 - microprocessor heat sink module 181
 - PHM 181
- serial number 198
- serial-device problems 226
- server components 15
- server cover
 - installing 190
 - removing 188
 - replacing 188
- server locks
 - locations 38
- server power on or power off problems 224
- service and support
 - before you call 231
 - hardware 233

- software 233
- service data 232
- simple-swap drive 156
 - installing 81
- simple-swap drive backplate
 - installing 71
 - removing 69
- simple-swap drives
 - removing 80
- simple-swap-drive backplate
 - replacing 69
- slim optical drive
 - installing 156
- software problems 226
- software service and support telephone numbers 233
- solving
 - Ethernet controller problems 210
 - solving power problems 209
- Specifications 1
- static-sensitive devices
 - handling 60
- storage-drive bay 16
- support web page, custom 231
- system board
 - installing 196
 - removing 192
 - replacing 192
- system board components 33
- system board LED 35
- system board switches and jumpers 36
- system error LED 21, 35
- system ID button 21
- system ID LED 21, 35
- system power LED 35
- system reliability guidelines 59

T

- T30 nut 119, 121
 - installing 121
 - removing 119
- T4 filler
 - installing 204
 - removing 203
 - replacing 203
- Taiwan BSMI RoHS declaration 237
- Taiwan import and export contact information 237
- tape drive
 - installing 150
 - removing 147, 153
 - replacing 147
- TCM 200
- telecommunication regulatory statement 236
- telephone numbers 233
- Torx T30 nut 119
- TPM 200
- TPM policy 200
- trademarks 236
- troubleshooting 219, 223, 225–226
 - by symptom 211
 - drive problems 211
 - fan problems 213
 - intermittent problems 213
 - keyboard problems 214
 - mouse problems 214
 - network problems 221
 - observable problems 221
 - power on and power off problems 224
 - serial-device problems 226
 - symptoms-based troubleshooting 211
 - USB-device problems 214
 - video 219, 225
- Trusted Cryptographic Module 200

Trusted Platform Module 200

U

UEFI Secure Boot 202
update firmware 9
updating,
 machine type 198
USB-device problems 214

V

video problems 219, 225

W

warranty 1
working inside the server
 power on 59

Lenovo