



**FCC CFR47 PART 22H & 24E
CERTIFICATION TEST REPORT**

FOR

**TABLET WITH CELLULAR GSM/GPRS/EGPRS/WCDMA/HSPA+/DC- HSDPA/LTE
IEEE 802.11A/B/G/N (MIMO 2X2) AND BLUETOOTH RADIO**

MODEL NUMBER: A1491

FCC ID: BCGA1491

REPORT NUMBER: 13U16583-2, REVISION A

ISSUE DATE: FEBRUARY 14, 2014

Prepared for
APPLE, INC.
1 INFINITE LOOP
CUPERTINO, CA 95014, U.S.A

Prepared by
UL VERIFICATION SERVICES INC.
47173 BENICIA STREET
FREMONT, CA 94538, U.S.A.
TEL: (510) 771-1000
FAX: (510) 661-0888



NVLAP LAB CODE 200065-0

Revision History

<u>Rev.</u>	<u>Issue Date</u>	<u>Revisions</u>	<u>Revised By</u>
--	02/06/14	Initial Issue	T. Chan
A	02/14/14	Fixed Section 8.2	C. Pang

TABLE OF CONTENTS

1. ATTESTATION OF TEST RESULTS	5
2. TEST METHODOLOGY	6
3. FACILITIES AND ACCREDITATION	6
4. CALIBRATION AND UNCERTAINTY	6
4.1. MEASURING INSTRUMENT CALIBRATION	6
4.2. SAMPLE CALCULATION	6
4.3. MEASUREMENT UNCERTAINTY	6
5. EQUIPMENT UNDER TEST	7
5.1. DESCRIPTION OF EUT	7
5.2. MAXIMUM OUTPUT POWER	7
5.3. SOFTWARE AND FIRMWARE	9
5.4. MAXIMUM ANTENNA GAIN	9
5.5. WORST-CASE CONFIGURATION AND MODE.....	9
5.6. DESCRIPTION OF TEST SETUP.....	10
6. TEST AND MEASUREMENT EQUIPMENT	12
7. RF POWER OUTPUT VERIFICATION	13
7.1. LTE BAND 2	14
7.2. LTE BAND 5	20
8. CONDUCTED TEST RESULTS	24
8.1. OCCUPIED BANDWIDTH	24
8.1.1. LTE BAND 2	28
8.1.2. LTE BAND 5.....	52
8.2. BANDEDGE	68
8.2.1. LTE BAND 2.....	69
8.2.2. LTE BAND 5.....	117
8.3. OUT OF BAND EMISSIONS	149
8.3.1. LTE BAND 2.....	150
8.3.2. LTE BAND 5.....	174
8.4. FREQUENCY STABILITY	190
9. RADIATED TEST RESULTS	193
9.1. RADIATED POWER (ERP & EIRP)	193

9.1.1. LTE BAND 2.....	197
9.1.2. LTE BAND 5.....	209
9.2. FIELD STRENGTH OF SPURIOUS RADIATION	217
9.2.1. LTE BAND 2.....	218
9.2.1. LTE BAND 5.....	230
10. SETUP PHOTOS.....	238

1. ATTESTATION OF TEST RESULTS

COMPANY NAME: APPLE, INC.
1 INFINITE LOOP
CUPERTINO, CA 95014, U.S.A

EUT DESCRIPTION: Tablet with Cellular GSM/GPRS/EGPRS/WCDMA/HSPA+/DC-HSDPA/LTE/IEEE 802.11a/b/g/n (MIMO 2x2) and Bluetooth Radio

MODEL: A1491

SERIAL NUMBER: 11510

DATE TESTED: NOVEMBER 18, 2013 – FEBRUARY 06, 2014

APPLICABLE STANDARDS	
STANDARD	TEST RESULTS
FCC CFR47 PART 22H AND 24E	Pass

UL Verification Services Inc. tested the above equipment in accordance with the requirements set forth in the above standards. All indications of Pass/Fail in this report are opinions expressed by UL Verification Services Inc. based on interpretations and/or observations of test results. Measurement Uncertainties were not taken into account and are published for informational purposes only. The test results show that the equipment tested is capable of demonstrating compliance with the requirements as documented in this report.

Note: The results documented in this report apply only to the tested sample, under the conditions and modes of operation as described herein. This document may not be altered or revised in any way unless done so by UL Verification Services Inc. and all revisions are duly noted in the revisions section. Any alteration of this document not carried out by UL Verification Services Inc. will constitute fraud and shall nullify the document. This report must not be used by the client to claim product certification, approval, or endorsement by NVLAP, NIST, any agency of the Federal Government, or any agency of any government.

Approved & Released For
UL Verification Services Inc. By:

Tested By:

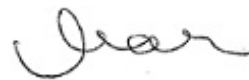

Thu Chan
WiSE Operations Manager
UL Verification Services Inc.

Mona Hua
WiSE Lab Technician
UL Verification Services Inc.

2. TEST METHODOLOGY

The tests documented in this report were performed in accordance with TIA-603-C, FCC CFR 47 Part 2, Part 22 and Part 24.

3. FACILITIES AND ACCREDITATION

The test sites and measurement facilities used to collect data are located at 47173 and 47266 Benicia Street, Fremont, California, USA. Line conducted emissions are measured only at the 47173 address. The following table identifies which facilities were utilized for radiated emission measurements documented in this report. Specific facilities are also identified in the test results sections.

47173 Benicia Street	47266 Benicia Street
<input type="checkbox"/> Chamber A	<input checked="" type="checkbox"/> Chamber D
<input type="checkbox"/> Chamber B	<input checked="" type="checkbox"/> Chamber E
<input type="checkbox"/> Chamber C	<input type="checkbox"/> Chamber F

UL Verification Services Inc. is accredited by NVLAP, Laboratory Code 200065-0. The full scope of accreditation can be viewed at <http://www.ul.com>.

4. CALIBRATION AND UNCERTAINTY

4.1. MEASURING INSTRUMENT CALIBRATION

The measuring equipment utilized to perform the tests documented in this report has been calibrated in accordance with the manufacturer's recommendations, and is traceable to recognized national standards.

4.2. SAMPLE CALCULATION

Where relevant, the following sample calculation is provided:

$$\begin{aligned} \text{Field Strength (dBuV/m)} &= \text{Measured Voltage (dBuV)} + \text{Antenna Factor (dB/m)} + \\ &\text{Cable Loss (dB)} - \text{Preamp Gain (dB)} \\ 36.5 \text{ dBuV} + 18.7 \text{ dB/m} + 0.6 \text{ dB} - 26.9 \text{ dB} &= 28.9 \text{ dBuV/m} \end{aligned}$$

4.3. MEASUREMENT UNCERTAINTY

Where relevant, the following measurement uncertainty levels have been estimated for tests performed on the apparatus:

PARAMETER	UNCERTAINTY
Conducted Disturbance, 0.15 to 30 MHz	3.52 dB
Radiated Disturbance, 30 to 1000 MHz	4.94 dB

Uncertainty figures are valid to a confidence level of 95%

5. EQUIPMENT UNDER TEST

5.1. DESCRIPTION OF EUT

The EUT is a tablet device with cellular GSM/GPRS/EGPRS/WCDMA/HSPA+/DC-HSDPA/LTE/IEEE 802.11a/b/g/n (MIMO 2x2) and bluetooth radio.

5.2. MAXIMUM OUTPUT POWER

The transmitter has a maximum conducted and ERP / EIRP output powers as follows:

LTE BAND 2

Part 24 LTE Band 2						
Bandwidth (MHz)	Frequency Range	Modulation	Conducted (Peak)		EIRP (Peak)	
			dBm	mW	dBm	mW
1.4	1850.7 - 1909.3	QPSK	28.20	660.7	29.37	865.0
		16QAM	27.89	615.2	28.57	719.4
3	1851.5 - 1908.5	QPSK	27.90	616.6	29.15	822.2
		16QAM	27.60	575.4	28.07	641.2
5	1852.5 - 1907.5	QPSK	27.80	602.6	29.17	826.0
		16QAM	27.60	575.4	28.27	671.4
10	1855.0 - 1905.0	QPSK	28.23	665.3	29.07	807.2
		16QAM	28.12	648.6	28.07	641.2
15	1857.5 - 1902.5	QPSK	28.60	724.4	29.32	855.1
		16QAM	28.00	631.0	28.42	695.0
20	1860.0 - 1900.0	QPSK	28.14	651.6	29.19	829.9
		16QAM	28.10	645.7	28.27	671.4

LTE BAND 5

Part 22 LTE Band 5						
Bandwidth (MHz)	Frequency Range	Modulation	Conducted(Average)		ERP(Average)	
			dBm	mW	dBm	mW
1.4	824.7-848.3	QPSK	24.00	251.2	20.98	125.3
		16QAM	23.50	223.9	20.08	101.9
3	825.5-847.5	QPSK	24.00	251.2	20.98	125.3
		16QAM	23.28	212.8	19.98	99.5
5	826.5-846.5	QPSK	24.00	251.2	20.90	123.0
		16QAM	23.30	213.8	19.98	99.5
10	829.0-844.0	QPSK	23.80	239.9	20.88	122.5
		16QAM	23.30	213.8	19.88	97.3

5.3. SOFTWARE AND FIRMWARE

The firmware installed in the EUT during testing was 4324b5_roml.

The EUT is linked CMW500 Test Set.

5.4. MAXIMUM ANTENNA GAIN

Please see table below:

LTE BAND	Antenna Gain (dBi)
LTE Band 2, 1850.7-1909.3MHz	2.15
LTE Band 5, 824.7 - 848.3MHz	- 2.95

5.5. WORST-CASE CONFIGURATION AND MODE

The worst-case scenario for all measurements is based on the investigation results.

The device has both LTE Bands of 2 and 5.

The RB Size was selected to measure for peak or average ERP and EIRP, which was based on the conducted power verification baseline data.

For the fundamental investigation of radiated emissions, the EUT is investigated for vertical and horizontal antenna orientations and X, Y, and Z orientation. It was determined that Y was the worst-case for Cell bands and Y for PCS bands.

5.6. DESCRIPTION OF TEST SETUP

RADIATED TESTS SUPPORT EQUIPMENT

Support Equipment List				
Description	Manufacturer	Model	Serial Number	FCC ID
AC/DC Adapter	Apple	A1357	A/12981EA	DoC
Earphone	Apple	NA	NA	NA

I/O CABLES (RF Conducted Test)

I/O Cable List						
Cable No	Port	# of identical ports	Connector Type	Cable Type	Cable Length (m)	Remarks
1	DC	1	DC	Un-Shielded	0.5m	NA
2	RF In/Out	1	Directional Coupler	Un-Shielded	0.2m	NA
3	RF In/Out	1	Spectrum Analyzer	Un-Shielded	1m	NA
4	RF In/Out	1	Call Box	Un-Shielded	None	NA

I/O CABLES (RF Radiated Test)

I/O Cable List						
Cable No	Port	# of identical ports	Connector Type	Cable Type	Cable Length (m)	Remarks
1	DC	1	DC	Un-Shielded	1.2m	NA
2	Jack	1	Headset	Un-Shielded	1m	NA
3	RF In/Out	1	Horn	Un-Shielded	5m	NA

TEST SETUP

CONDUCTED SETUP DIAGRAM FOR TESTS

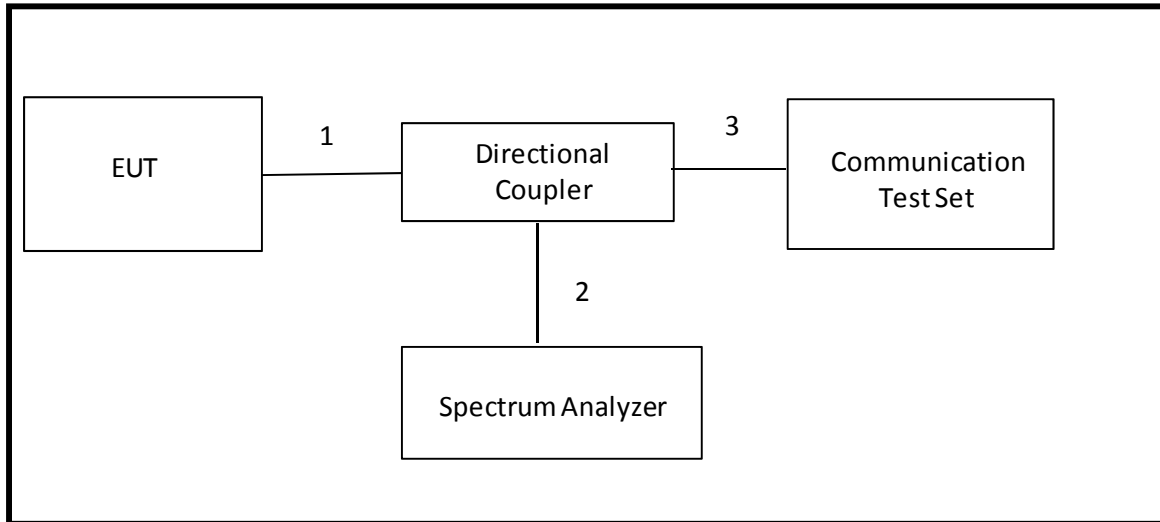

RADIATED SETUP DIAGRAM FOR TESTS

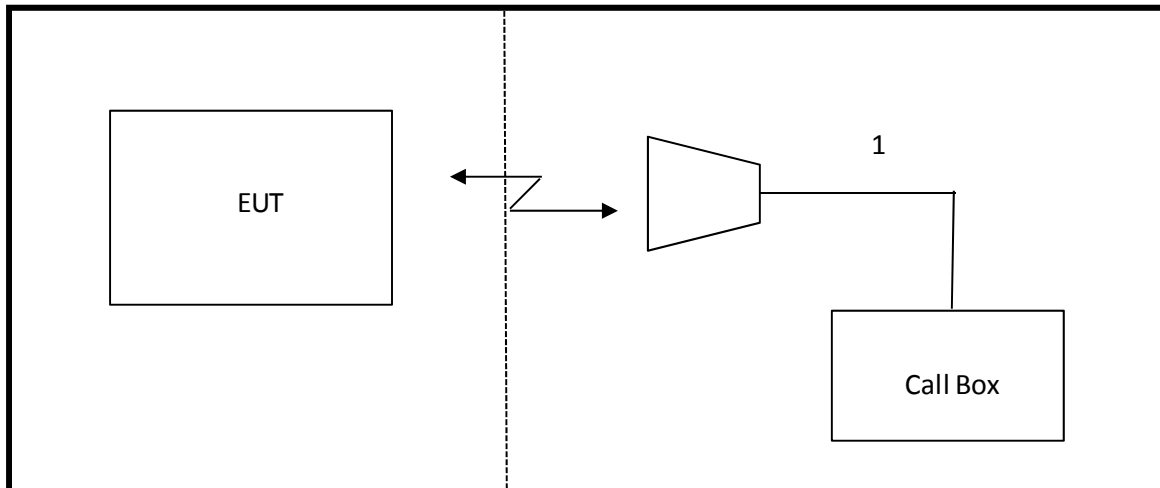

6. TEST AND MEASUREMENT EQUIPMENT

The following test and measurement equipment was utilized for the tests documented in this report:

Test Equipment List				
Description	Manufacturer	Model	Asset	Cal Due
Communication Test Set	R & S	CMW500	F00014	02/21/14
Temperature / Humidity Chamber	Thermotron	SE 600-10-10	C00930	06/27/14
Vector signal generator, 6 GHz	Agilent / HP	E4438C	F00037	07/06/14
Antenna, Tuned Dipole 400~1000 MHz	ETS	3121C DB4	C00993	07/16/13
Horn Antenna	ETS Lindgren	3117	F00131	02/19/14
PreAmp 1-18GHz	Agilent/HP	8449B	C01063	03/18/14
Highpass Filter, 2.7 GHz	Micro-Tronics	HPM13194	N02686	CNR
Highpass Filter, 1.5 GHz	Micro-Tronics	HPM13193	N02688	CNR
Spectrum Analyzer, 44GHz	Agilent	N9030A	F00129	02/21/14
Directional Coupler	Krytar	1817	N02656	CNR
Bilog, 30-1GHz	Sunol Science	A0222813-1	C01011	03/07/14
Peak Power Meter	Boonton	4541	C01189	06/20/14
Peak Power Sensor	Boonton	57006	C01202	05/29/14
PreAmp 30-1000MHz	Sonama	310	981661	11/06/14

7. RF POWER OUTPUT VERIFICATION

LTE Measurement Procedure:

All LTE bands conducted power peak and average are obtained from the CMW500 telecommunication test set.

The following tests were conducted according to the test requirements outlined in section 6.2 of the 3GPP TS36.101 specification.

UE Power Class: 3 (23 +/- 2dBm). The allowed Maximum Power Reduction (MPR) for the maximum output power due to higher order modulation and transmit bandwidth configuration (resource blocks) is specified in Table 6.2.3-1 of the 3GPP TS36.101.

Table 6.2.3-1: Maximum Power Reduction (MPR) for Power Class 3

Modulation	Channel bandwidth / Transmission bandwidth (RB)						MPR (dB)
	1.4 MHz	3.0 MHz	5 MHz	10 MHz	15 MHz	20 MHz	
QPSK	> 5	> 4	> 8	> 12	> 16	> 18	≤ 1
16 QAM	≤ 5	≤ 4	≤ 8	≤ 12	≤ 16	≤ 18	≤ 1
16 QAM	> 5	> 4	> 8	> 12	> 16	> 18	≤ 2

The allowed A-MPR values specified below in Table 6.2.4.-1 of 3GPP TS36.101 are in addition to the allowed MPR requirements. All the measurements below were performed with A-MPR disabled, by using Network Signaling Value of "NS_01".3

Table 6.2.4-1: Additional Maximum Power Reduction (A-MPR)

Network Signalling value	Requirements (sub-clause)	E-UTRA Band	Channel bandwidth (MHz)	Resources Blocks (N_{RB})	A-MPR (dB)
NS_01	6.6.2.1.1	Table 5.5-1	1.4, 3, 5, 10, 15, 20	Table 5.6-1	NA
NS_03	6.6.2.2.1	2, 4, 10, 23, 25, 35, 36	3	>5	≤ 1
			5	>6	≤ 1
			10	>6	≤ 1
			15	>8	≤ 1
			20	>10	≤ 1
NS_04	6.6.2.2.2	41	5	>6	≤ 1
			10, 15, 20	See Table 6.2.4-4	
NS_05	6.6.3.3.1	1	10,15,20	≥ 50	≤ 1
NS_06	6.6.2.2.3	12, 13, 14, 17	1.4, 3, 5, 10	Table 5.6-1	n/a
NS_07	6.6.2.2.3	13	10	Table 6.2.4-2	Table 6.2.4-2
	6.6.3.3.2				
NS_08	6.6.3.3.3	19	10, 15	> 44	≤ 3
NS_09	6.6.3.3.4	21	10, 15	> 40	≤ 1
				> 55	≤ 2
NS_10		20	15, 20	Table 6.2.4-3	Table 6.2.4-3
NS_11	6.6.2.2.1	23 ¹	1.4, 3, 5, 10	Table 6.2.4-5	Table 6.2.4-5
--					
NS_32	-	-	-	-	-

Note 1: Applies to the lower block of Band 23, i.e. a carrier placed in the 2000-2010 MHz region.

7.1. LTE BAND 2

Output power for LTE Band 2 (1.4 MHz)

Bandwidth	UL Channel	Frequency	Modulation	RB Size	RB Offset	Peak Power (dBm)	Average (dBm)
1.4	18607	1850.7	QPSK	1	0	27.36	22.50
				1	2	27.14	22.49
				1	5	27.12	22.46
				3	0	27.47	22.00
				3	1	27.23	22.00
				3	2	27.40	22.00
			16QAM	6	0	27.77	21.50
				1	0	26.90	21.50
				1	2	26.95	21.50
				1	5	27.00	21.35
				3	0	27.10	21.40
				3	1	27.07	21.30
				3	2	27.20	21.30
				6	0	27.89	20.76
1.4	18900	1880.0	QPSK	1	0	27.40	22.50
				1	2	27.24	22.49
				1	5	27.30	22.47
				3	0	27.32	22.40
				3	1	27.33	22.40
				3	2	27.24	22.40
			16QAM	6	0	27.20	21.80
				1	0	27.35	21.50
				1	2	27.21	21.40
				1	5	27.27	21.35
				3	0	27.20	21.30
				3	1	27.23	21.30
				3	2	27.24	21.40
				6	0	27.40	20.70
1.4	19193	1909.3	QPSK	1	0	26.90	22.48
				1	2	26.92	22.46
				1	5	26.85	22.30
				3	0	27.40	22.10
				3	1	27.30	22.10
				3	2	27.26	22.00
			16QAM	6	0	28.20	21.50
				1	0	26.88	21.50
				1	2	26.79	21.46
				1	5	26.77	21.40
				3	0	27.42	21.20
				3	1	27.40	21.30
				3	2	27.30	21.20
				6	0	27.39	20.60

Output power for LTE Band 2 (3.0 MHz)

Bandwidth	UL Channel	Frequency	Modulation	RB Size	RB Offset	Peak Power (dBm)	Average (dBm)
3	18615	1851.5	QPSK	1	0	27.13	22.50
				1	7	27.00	22.47
				1	14	27.23	22.48
				8	0	27.67	21.70
				8	4	27.60	21.70
				8	7	27.70	21.80
				15	0	27.70	21.67
			16QAM	1	0	27.12	21.87
				1	7	27.50	21.40
				1	14	27.20	21.40
				8	0	27.50	20.90
				8	4	27.00	21.10
				8	7	27.60	21.00
				15	0	27.44	20.96
3	18900	1880.0	QPSK	1	0	27.35	22.48
				1	7	27.28	22.47
				1	14	27.27	22.46
				8	0	27.37	21.80
				8	4	27.33	21.86
				8	7	27.26	21.89
				15	0	27.10	21.78
			16QAM	1	0	27.40	21.70
				1	7	27.20	21.47
				1	14	27.25	21.48
				8	0	27.00	20.80
				8	4	27.00	20.86
				8	7	27.24	20.90
				15	0	27.40	20.80
3	19185	1908.5	QPSK	1	0	27.00	22.49
				1	7	26.90	22.47
				1	14	26.73	22.40
				8	0	27.59	21.50
				8	4	27.40	21.60
				8	7	27.72	21.56
				15	0	27.90	21.50
			16QAM	1	0	26.90	21.27
				1	7	26.80	21.26
				1	14	26.68	21.00
				8	0	27.22	20.70
				8	4	26.98	20.58
				8	7	27.10	20.65
				15	0	27.12	20.56

Output power for LTE Band 2 (5.0 MHz)

Bandwidth	UL Channel	Frequency	Modulation	RB Size	RB Offset	Peak Power (dBm)	Average (dBm)
5	18625	1852.5	QPSK	1	0	27.00	22.50
				1	12	27.19	22.46
				1	24	27.20	22.47
				12	0	27.10	21.65
				12	6	27.52	21.78
				12	11	27.50	21.75
			16QAM	25	0	27.75	21.70
				1	0	27.00	21.35
				1	12	27.00	21.50
				1	24	27.00	21.47
				12	0	27.16	20.80
				12	6	27.30	20.70
				12	11	27.13	20.60
				25	0	27.45	20.65
5	18900	1880.0	QPSK	1	0	27.30	22.49
				1	12	27.17	22.49
				1	24	27.12	22.47
				12	0	27.50	21.84
				12	6	27.20	21.80
				12	11	27.30	21.82
			16QAM	25	0	27.70	21.77
				1	0	26.75	21.45
				1	12	26.80	21.50
				1	24	26.70	21.25
				12	0	27.11	20.70
				12	6	27.09	20.80
				12	11	27.00	20.85
				25	0	27.59	20.80
5	19175	1907.5	QPSK	1	0	27.35	22.50
				1	12	27.30	22.49
				1	24	27.08	22.49
				12	0	27.80	21.67
				12	6	27.66	21.58
				12	11	27.60	21.50
			16QAM	25	0	27.64	21.58
				1	0	27.00	22.00
				1	12	27.00	21.88
				1	24	26.65	21.80
				12	0	27.48	20.75
				12	6	27.39	20.67
				12	11	27.26	20.60
				25	0	27.60	20.55

Output power for LTE Band 2 (10 MHz)

Bandwidth	UL Channel	Frequency	Modulation	RB Size	RB Offset	Peak Power (dBm)	Average (dBm)
10	18650	1855.0	QPSK	1	0	27.20	22.50
				1	24	27.30	22.49
				1	49	27.37	22.46
				25	0	27.42	21.78
				25	12	27.40	21.67
				25	24	27.57	21.55
				50	0	27.50	21.50
			16QAM	1	0	27.30	21.60
				1	24	27.50	21.50
				1	49	27.70	21.40
				25	0	27.35	21.00
				25	12	27.75	20.90
				25	24	27.70	20.80
				50	0	27.90	20.60
10	18900	1880.0	QPSK	1	0	27.51	22.50
				1	24	27.33	22.49
				1	49	27.20	22.47
				25	0	27.32	21.90
				25	12	27.30	21.70
				25	24	27.24	21.80
				50	0	27.10	21.60
			16QAM	1	0	27.55	21.50
				1	24	27.32	21.50
				1	49	27.22	21.57
				25	0	27.63	20.86
				25	12	27.43	20.70
				25	24	27.40	20.90
				50	0	27.30	20.60
10	19150	1905.0	QPSK	1	0	27.38	22.49
				1	24	27.25	22.48
				1	49	26.90	22.45
				25	0	28.16	21.68
				25	12	27.60	21.55
				25	24	27.45	21.59
				50	0	28.23	21.50
			16QAM	1	0	27.40	21.36
				1	24	27.00	21.38
				1	49	26.64	21.10
				25	0	28.12	20.80
				25	12	27.90	20.60
				25	24	27.90	20.79
				50	0	27.50	20.65

Output power for LTE Band 2 (15 MHz)

Bandwidth	UL Channel	Frequency	Modulation	RB Size	RB Offset	Peak Power (dBm)	Average (dBm)
15	18675	1857.5	QPSK	1	0	27.25	22.50
				1	37	27.16	22.48
				1	74	27.57	22.46
				36	0	27.50	21.70
				36	16	27.49	21.60
				36	35	27.70	21.54
				75	0	28.60	21.50
			16-QAM	1	0	27.50	21.60
				1	37	27.50	21.50
				1	74	27.20	21.40
				36	0	27.24	21.00
				36	16	27.11	20.83
				36	35	27.30	20.80
				75	0	27.90	20.60
15	18900	1880.0	QPSK	1	0	27.46	22.50
				1	37	27.14	22.49
				1	74	27.13	22.47
				36	0	27.55	21.74
				36	16	27.35	21.65
				36	35	27.30	21.75
				75	0	27.73	21.60
			16-QAM	1	0	27.10	21.50
				1	37	27.27	21.50
				1	74	27.10	21.60
				36	0	27.60	20.80
				36	16	27.32	20.80
				36	35	27.30	20.90
				75	0	27.36	20.58
15	19125	1902.5	QPSK	1	0	27.60	22.49
				1	37	27.56	22.48
				1	74	27.10	22.47
				36	0	27.80	21.70
				36	16	27.80	21.60
				36	35	27.60	21.57
				75	0	28.13	21.50
			16-QAM	1	0	27.40	21.40
				1	37	27.95	21.35
				1	74	27.54	21.10
				36	0	27.97	20.80
				36	16	27.60	20.60
				36	35	27.58	20.80
				75	0	28.00	20.70

Output power for LTE Band 2 (20 MHz)

Bandwidth	UL Channel	Frequency	Modulation	RB Size	RB Offset	Peak Power (dBm)	Average (dBm)
20	18700	1860.0	QPSK	1	0	27.48	22.50
				1	49	27.60	22.47
				1	99	27.97	22.48
				50	0	27.54	21.50
				50	24	27.82	21.40
				50	49	27.83	21.50
				100	0	27.90	21.40
			16-QAM	1	0	26.76	21.87
				1	49	26.80	21.75
				1	99	27.00	21.79
				50	0	27.70	20.90
				50	24	27.37	20.52
				50	49	27.64	20.50
				100	0	28.00	20.60
20	18900	1880.0	QPSK	1	0	27.85	22.50
				1	49	27.60	22.46
				1	99	27.55	22.40
				50	0	27.65	21.70
				50	24	27.72	21.70
				50	49	27.90	21.60
				100	0	28.00	21.60
			16-QAM	1	0	26.80	21.80
				1	49	26.60	21.80
				1	99	27.00	22.10
				50	0	27.77	20.70
				50	24	27.33	20.70
				50	49	27.46	20.76
				100	0	27.43	20.75
20	19100	1900.0	QPSK	1	0	27.80	22.49
				1	49	27.40	22.40
				1	99	27.45	22.30
				50	0	27.79	21.50
				50	24	27.90	21.40
				50	49	27.80	21.40
				100	0	28.14	21.50
			16-QAM	1	0	27.50	21.85
				1	49	27.80	21.80
				1	99	27.33	21.75
				50	0	27.80	20.55
				50	24	27.60	20.40
				50	49	27.89	20.50
				100	0	28.10	20.60

7.2. LTE BAND 5

Output power for LTE Band 5 (1.4 MHz)

Bandwidth	UL Channel	Frequency	Mode	RB Size	RB Offset	Peak Power (dBm)	Average (dBm)
1.4	20407	824.7	QPSK	1	0	27.85	24.00
				1	2	27.93	23.99
				1	5	27.75	23.98
				3	0	28.01	23.95
				3	1	27.84	23.96
				3	2	27.80	23.97
			16QAM	6	0	28.52	23.10
				1	0	27.78	23.40
				1	2	27.80	23.50
				1	5	27.69	23.40
				3	0	28.15	23.36
				3	1	28.01	22.90
				3	2	27.88	22.90
				6	0	28.14	22.10
1.4	20525	836.5	QPSK	1	0	27.80	23.99
				1	2	27.72	23.95
				1	5	27.69	23.98
				3	0	27.78	23.95
				3	1	27.69	23.94
				3	2	27.63	23.95
			16QAM	6	0	28.26	22.90
				1	0	27.67	23.15
				1	2	27.60	23.08
				1	5	27.52	23.16
				3	0	28.03	22.90
				3	1	27.80	22.89
				3	2	27.71	22.89
				6	0	27.94	21.80
1.4	20643	848.3	QPSK	1	0	27.75	23.99
				1	2	27.69	23.95
				1	5	27.52	23.70
				3	0	27.79	23.96
				3	1	27.64	23.89
				3	2	27.62	23.85
			16QAM	6	0	28.28	22.90
				1	0	27.67	23.20
				1	2	27.62	23.20
				1	5	27.47	23.00
				3	0	27.98	22.99
				3	1	27.84	22.90
				3	2	27.77	22.86
				6	0	28.17	21.80

Output power for LTE Band 5 (3.0 MHz)

Bandwidth	UL Channel	Frequency	Mode	RB Size	RB Offset	Peak Power (dBm)	Average (dBm)
3	20415	825.5	QPSK	1	0	27.71	23.99
				1	7	27.74	23.98
				1	14	27.98	24.00
				8	0	28.02	23.10
				8	4	28.05	23.20
				8	7	28.21	23.20
				15	0	28.45	22.89
			16QAM	1	0	27.71	23.28
				1	7	27.82	23.00
				1	14	27.91	23.08
				8	0	27.99	22.00
				8	4	27.95	22.08
				8	7	28.11	22.10
				15	0	28.17	22.29
3	20525	836.5	QPSK	1	0	27.81	23.98
				1	7	27.68	23.90
				1	14	27.63	23.90
				8	0	28.03	23.02
				8	4	27.73	22.87
				8	7	27.72	22.93
				15	0	28.09	22.84
			16QAM	1	0	27.68	23.10
				1	7	27.55	23.15
				1	14	27.56	23.10
				8	0	28.02	22.05
				8	4	27.85	21.99
				8	7	27.78	21.97
				15	0	27.86	21.95
3	20635	847.5	QPSK	1	0	27.71	23.99
				1	7	27.73	23.90
				1	14	27.51	23.60
				8	0	27.99	22.90
				8	4	27.74	22.90
				8	7	27.82	22.90
				15	0	28.33	22.90
			16QAM	1	0	27.61	23.15
				1	7	27.60	23.18
				1	14	27.46	23.00
				8	0	28.06	21.96
				8	4	27.98	22.00
				8	7	28.07	21.89
				15	0	28.16	22.00

Output power for LTE Band 5 (5.0 MHz)

Bandwidth	UL Channel	Frequency	Mode	RB Size	RB Offset	Peak Power (dBm)	Average (dBm)
5	20425	826.5	QPSK	1	0	27.75	24.00
				1	12	27.90	23.98
				1	24	27.97	23.98
				12	0	27.94	23.17
				12	6	27.89	22.99
				12	11	28.06	23.00
				25	0	28.82	22.95
			16QAM	1	0	27.93	23.04
				1	12	28.03	23.20
				1	24	28.15	23.30
				12	0	27.93	22.20
				12	6	27.92	22.10
				12	11	27.89	22.10
				25	0	28.43	21.97
5	20525	836.5	QPSK	1	0	27.71	23.95
				1	12	27.65	23.99
				1	24	27.56	23.94
				12	0	27.77	22.85
				12	6	27.62	22.99
				12	11	27.56	22.90
				25	0	28.60	22.80
			16QAM	1	0	27.85	23.20
				1	12	27.80	23.19
				1	24	27.66	23.20
				12	0	27.68	22.00
				12	6	27.54	22.15
				12	11	27.55	22.05
				25	0	28.26	21.85
5	20625	846.5	QPSK	1	0	27.69	23.99
				1	12	27.50	23.90
				1	24	27.54	23.78
				12	0	27.83	23.00
				12	6	27.67	22.90
				12	11	27.73	22.97
				25	0	28.61	22.80
			16QAM	1	0	27.81	23.08
				1	12	27.65	23.15
				1	24	27.77	23.05
				12	0	27.74	22.09
				12	6	27.56	22.06
				12	11	27.63	22.09
				25	0	28.46	21.80

Output power for LTE Band 5 (10 MHz)

Bandwidth	UL Channel	Frequency	Mode	RB Size	RB Offset	Max Peak Power (dBm)	Average
10	20450	829.0	QPSK	1	0	27.82	23.80
				1	24	28.02	23.70
				1	49	27.92	23.40
				25	0	28.13	23.10
				25	12	28.13	23.00
				25	24	28.34	23.00
				50	0	28.77	23.00
			16QAM	1	0	27.75	23.30
				1	24	27.93	23.27
				1	49	27.79	23.15
				25	0	28.05	21.90
				25	12	28.01	21.90
				25	24	28.21	21.80
				50	0	28.59	21.87
10	20525	836.5	QPSK	1	0	28.13	23.60
				1	24	27.66	23.50
				1	49	27.55	23.80
				25	0	28.03	22.74
				25	12	27.60	23.00
				25	24	27.62	23.00
				50	0	28.43	22.90
			16QAM	1	0	28.02	23.20
				1	24	27.54	23.15
				1	49	27.43	23.29
				25	0	27.99	21.80
				25	12	27.62	21.80
				25	24	27.68	21.80
				50	0	28.31	21.70
10	20600	844.0	QPSK	1	0	27.55	23.80
				1	24	27.66	23.75
				1	49	27.72	23.50
				25	0	27.85	23.00
				25	12	27.63	23.00
				25	24	27.88	22.93
				50	0	28.60	23.00
			16QAM	1	0	27.44	23.07
				1	24	27.60	23.00
				1	49	27.66	23.15
				25	0	27.76	22.00
				25	12	27.61	22.15
				25	24	27.96	22.00
				50	0	28.31	21.70

8. CONDUCTED TEST RESULTS

8.1. OCCUPIED BANDWIDTH

RULE PART(S)

FCC: §2.1049

LIMITS

For reporting purposes only

TEST PROCEDURE

The transmitter output was connected to a calibrated coaxial cable and coupler, the other end of which was connected to a spectrum analyzer. The occupied bandwidth was measured with the spectrum analyzer at the low, middle and high channel in each band. The -26dB bandwidth was also measured and recorded.

MODES TESTED

- LTE Band 2
- LTE Band 5

RESULTS

Band	Mode	RB SIZE / RB OFFSET	f (MHz)	99% BW (MHz)	-26dB BW (MHz)
LTE Band 2	1.4 MHz BAND	6/0	1850.7	1.0841	1.276
	QPSK				
	1.4 MHz BAND	6/0	1880.0	1.0894	1.255
	QPSK				
	1.4 MHz BAND	6/0	1909.3	1.0773	1.216
	QPSK				
	1.4 MHz BAND	6/0	1850.7	1.0890	1.265
	16QAM				
	1.4 MHz BAND	6/0	1880.0	1.0800	1.224
	16QAM				
	1.4 MHz BAND	6/0	1909.3	1.0919	1.184
	16QAM				
	3.0 MHz BAND	15/0	1851.5	2.6684	2.828
	QPSK				
	3.0 MHz BAND	15/0	1880.0	2.6913	2.969
	QPSK				
	3.0 MHz BAND	15/0	1908.5	2.6887	2.878
	QPSK				
	3.0 MHz BAND	15/0	1851.5	2.6933	2.918
	16QAM				
	3.0 MHz BAND	15/0	1880.0	2.6882	2.934
	16QAM				
	3.0 MHz BAND	15/0	1908.5	2.6882	2.914
	16QAM				
5.0 MHz BAND	25/0	1852.5	4.5078	4.813	
QPSK					
5.0 MHz BAND	25/0	1880.0	4.5056	4.827	
QPSK					
5.0 MHz BAND	25/0	1907.5	4.4935	5.004	
QPSK					
5.0 MHz BAND	25/0	1852.5	4.4569	4.774	
16QAM					
5.0 MHz BAND	25/0	1880.0	4.4794	4.807	
16QAM					
5.0 MHz BAND	25/0	1907.5	4.5000	4.765	
16QAM					

Band	Mode	RB SIZE / RB OFFSET	f (MHz)	99% BW (MHz)	-26dB BW (MHz)
LTE Band 2	10 MHz BAND	50/0	1855	8.9509	9.367
	QPSK				
	10 MHz BAND	50/0	1880	8.9711	9.324
	QPSK				
	10 MHz BAND	50/0	1905	8.9768	9.394
	QPSK				
	10 MHz BAND	50/0	1855	8.9825	9.504
	16QAM				
	10 MHz BAND	50/0	1880	8.8648	9.527
	16QAM				
	10 MHz BAND	50/0	1905	8.8475	9.284
	16QAM				
	15 MHz BAND	75/0	1857.5	13.419	13.89
	QPSK				
	15 MHz BAND	75/0	1880	13.351	13.91
	QPSK				
	15 MHz BAND	75/0	1902.5	13.302	13.97
	QPSK				
	15 MHz BAND	75/0	1857.5	13.488	13.99
	16QAM				
	15 MHz BAND	75/0	1880	13.433	14.40
	16QAM				
	15 MHz BAND	75/0	1902.5	13.351	13.96
	16QAM				
	20 MHz BAND	100/0	1860	17.898	18.58
	QPSK				
	20 MHz BAND	100/0	1880	17.889	18.55
	QPSK				
20 MHz BAND	100/0	1900	17.887	18.65	
QPSK					
20 MHz BAND	100/0	1860	17.812	18.48	
16QAM					
20 MHz BAND	100/0	1880	17.774	18.78	
16QAM					
20 MHz BAND	100/0	1900	17.909	18.70	
16QAM					

Band	Mode	RB SIZE/ RB OFFSET	f (MHz)	99% BW (MHz)	(-) 26dB BW (MHz)
LTE BAND 5	1.4 MHz BAND QPSK	6/0	824.7	1.0823	1.223
	1.4 MHz BAND QPSK	6/0	836.5	1.0888	1.256
	1.4 MHz BAND QPSK	6/0	848.3	1.0718	1.153
	1.4 MHz BAND 16QAM	6/0	824.7	1.0854	1.245
	1.4 MHz BAND 16QAM	6/0	836.5	1.0768	1.215
	1.4 MHz BAND 16QAM	6/0	848.3	1.0883	1.213
	3.0 MHz BAND QPSK	15/0	825.5	2.6815	2.844
	3.0 MHz BAND QPSK	15/0	836.5	2.6716	2.879
	3.0 MHz BAND QPSK	15/0	847.5	2.6753	2.807
	3.0 MHz BAND 16QAM	15/0	825.5	2.6793	2.933
	3.0 MHz BAND 16QAM	15/0	836.5	2.6906	2.968
	3.0 MHz BAND 16QAM	15/0	847.5	2.6943	2.947
	5.0 MHz BAND QPSK	25/0	821.5	4.4629	4.672
	5.0 MHz BAND QPSK	25/0	836.5	4.4753	4.784
	5.0 MHz BAND QPSK	25/0	846.5	4.4884	4.716
	5.0 MHz BAND 16QAM	25/0	821.5	4.4807	4.836
	5.0 MHz BAND 16QAM	25/0	836.5	4.4836	4.723
	5.0 MHz BAND 16QAM	25/0	846.5	4.4931	4.830
	10.0 MHz BAND QPSK	50/0	829.0	8.9570	9.614
	10.0 MHz BAND QPSK	50/0	836.5	8.9697	9.472
	10.0 MHz BAND QPSK	50/0	844.0	8.9166	9.401
10.0 MHz BAND 16QAM	50/0	829.0	8.9030	9.353	
10.0 MHz BAND 16QAM	50/0	836.5	9.0040	9.359	
10.0 MHz BAND 16QAM	50/0	844.0	8.9293	9.351	

8.1.1. LTE BAND 2

Band 2 (1.4 MHz Bandwidth)

LTE QPSK

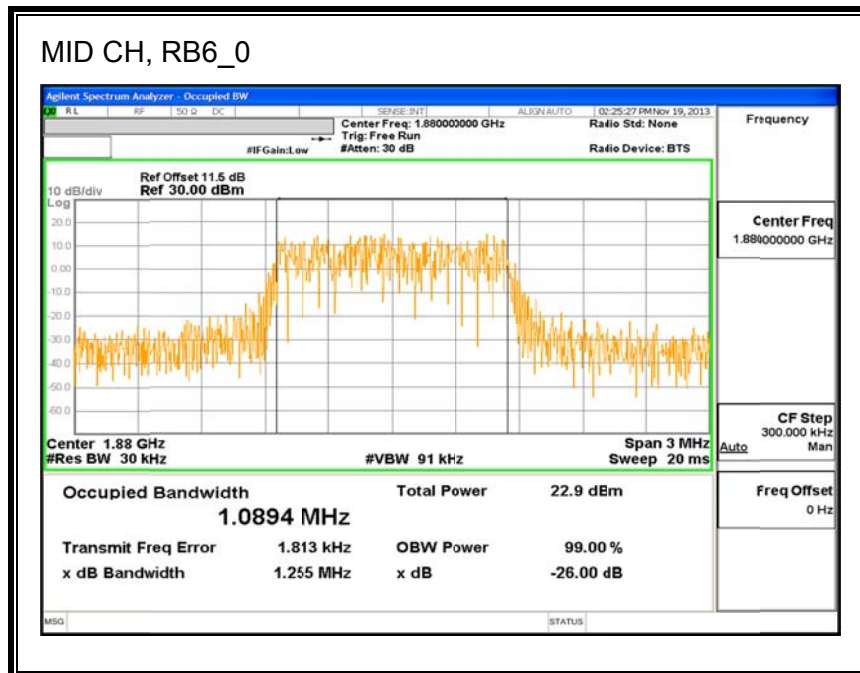
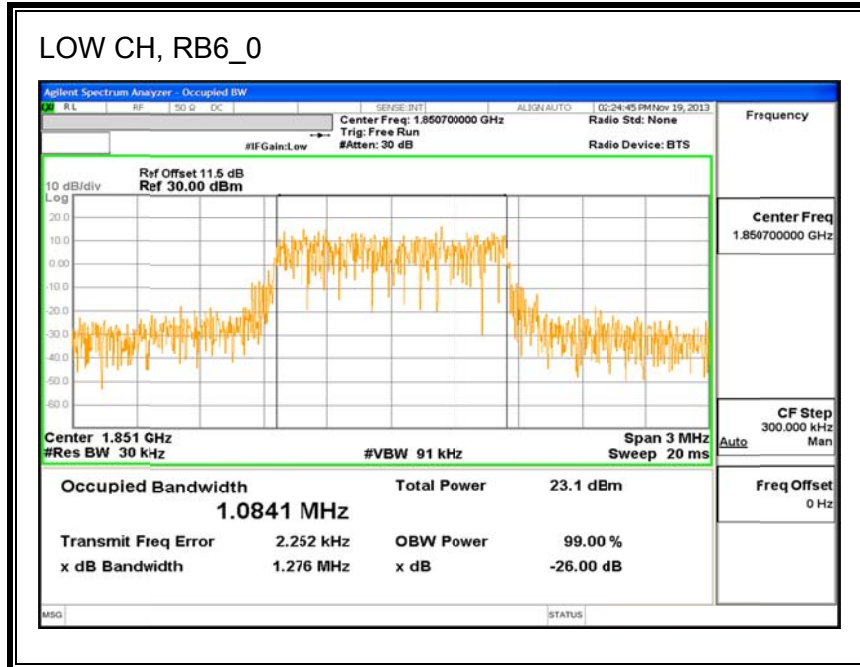

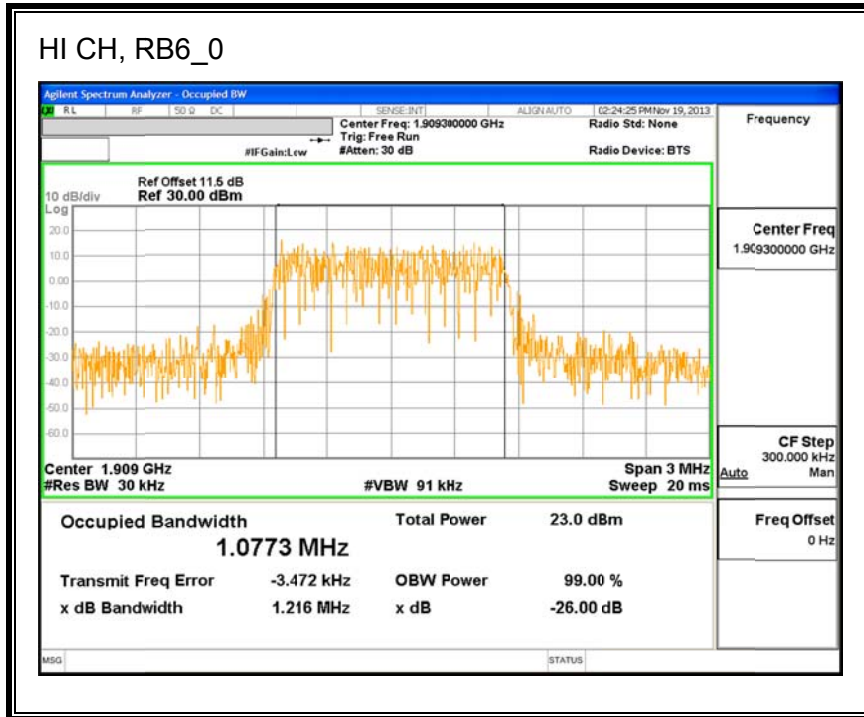

Band 2 (1.4 MHz Bandwidth)

LTE 16QAM

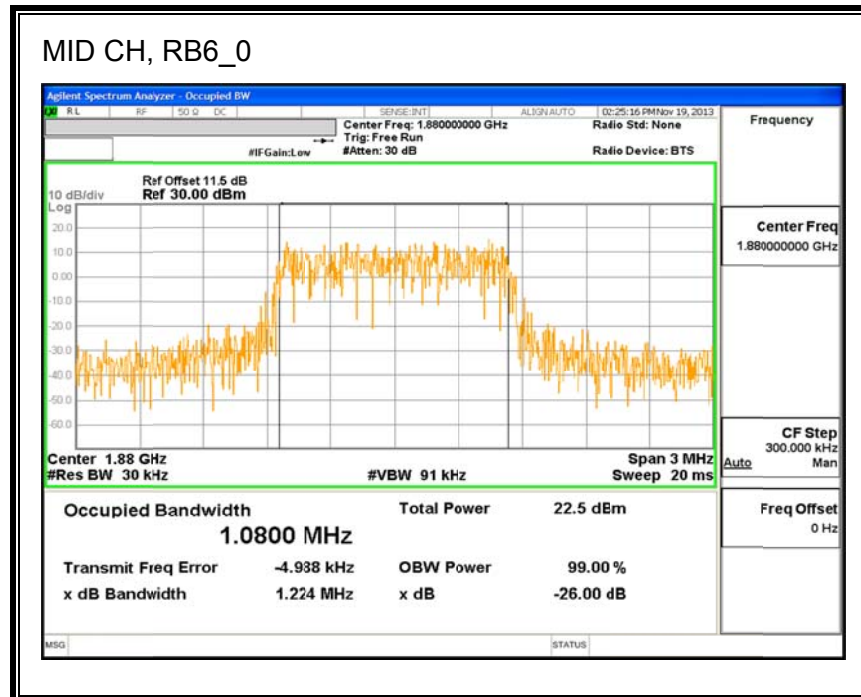
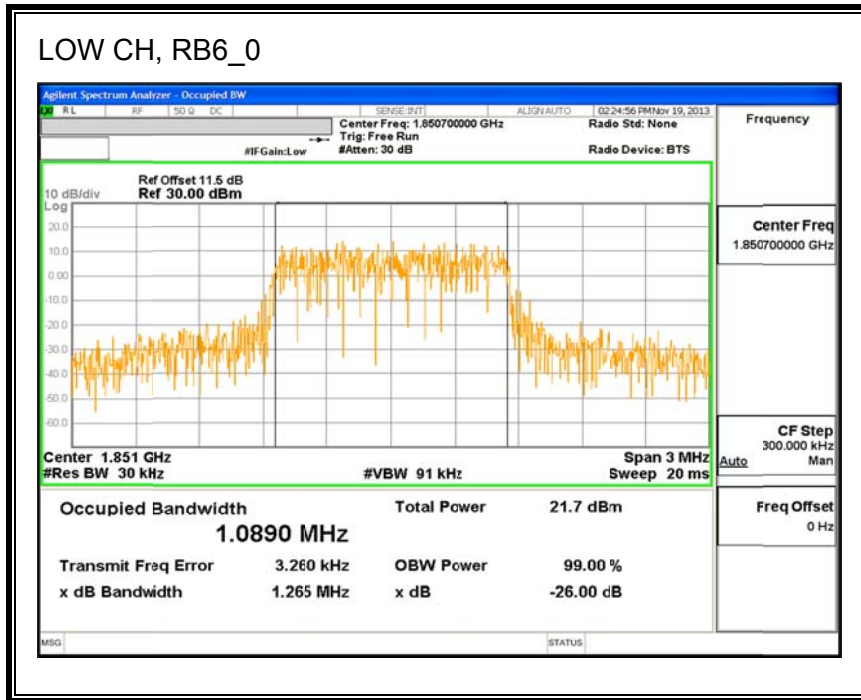

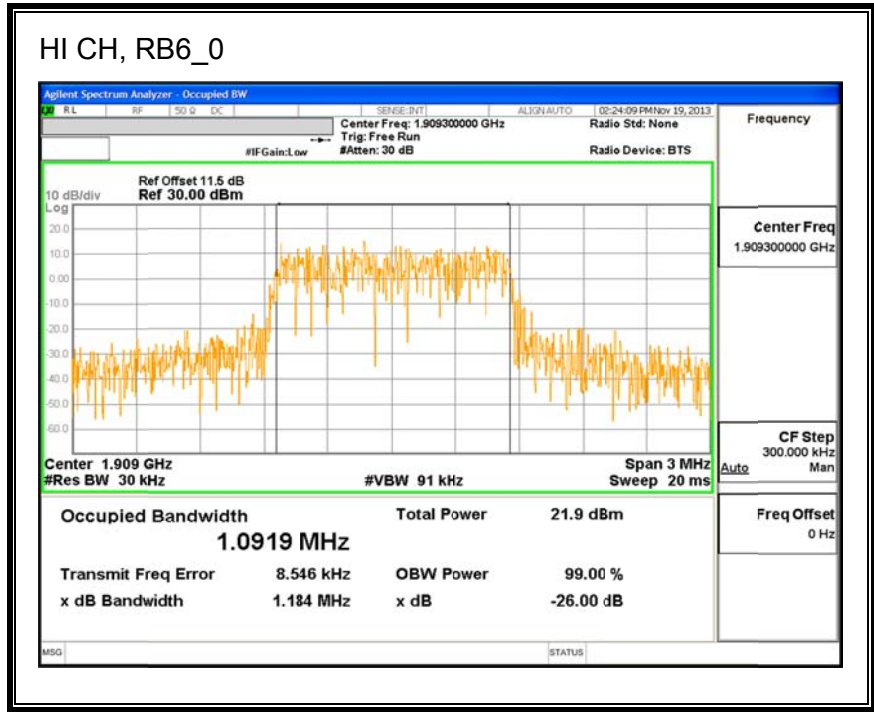

Band 2 (3MHz Bandwidth)

LTE QPSK

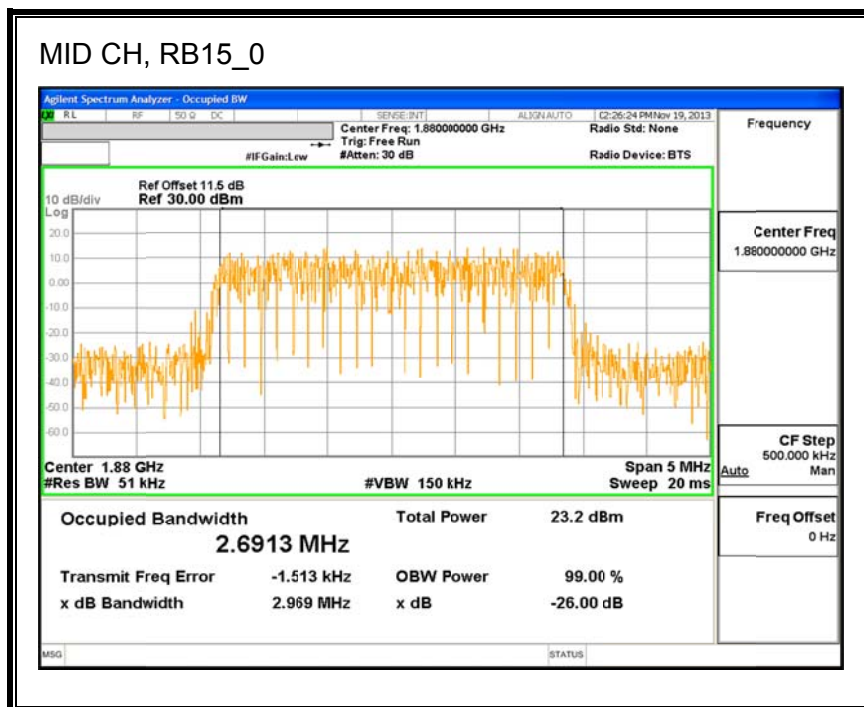
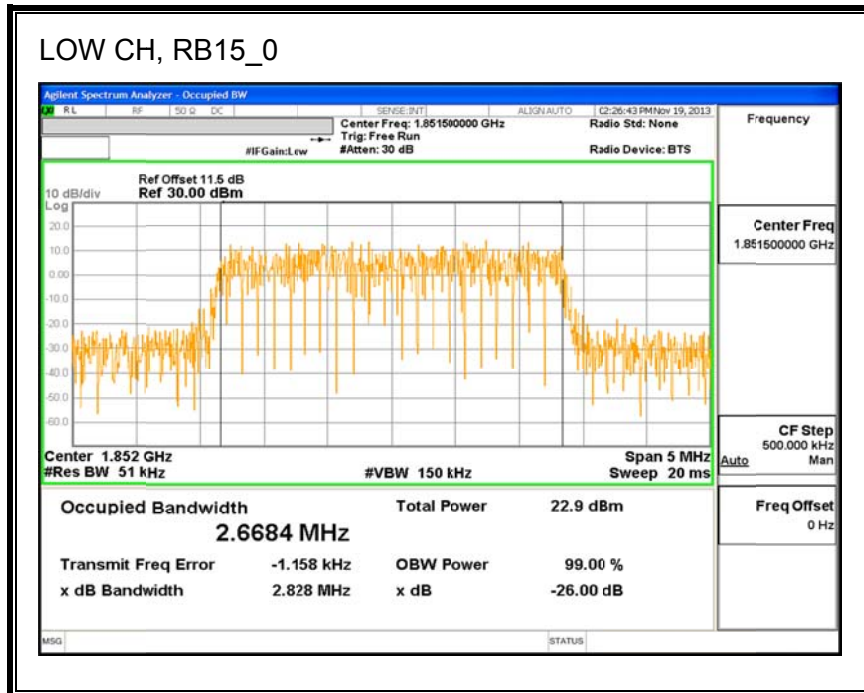

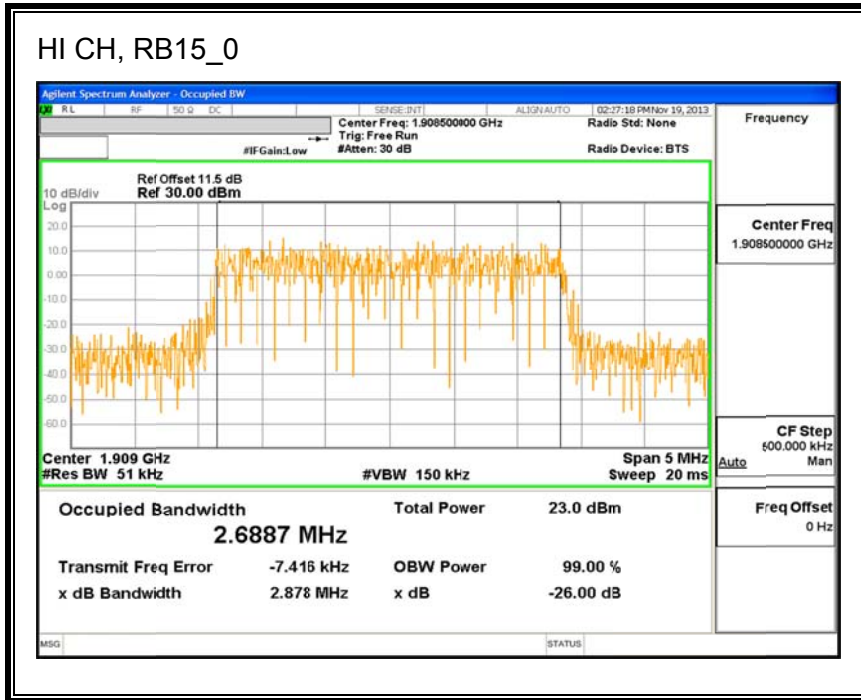

Band 2 (3MHz Bandwidth)

LTE 16QAM

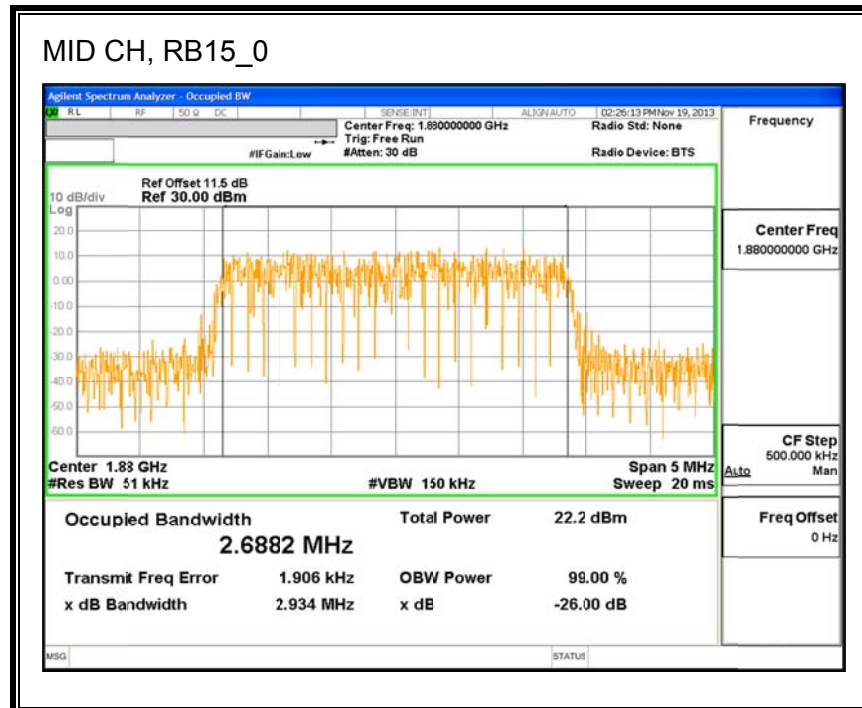
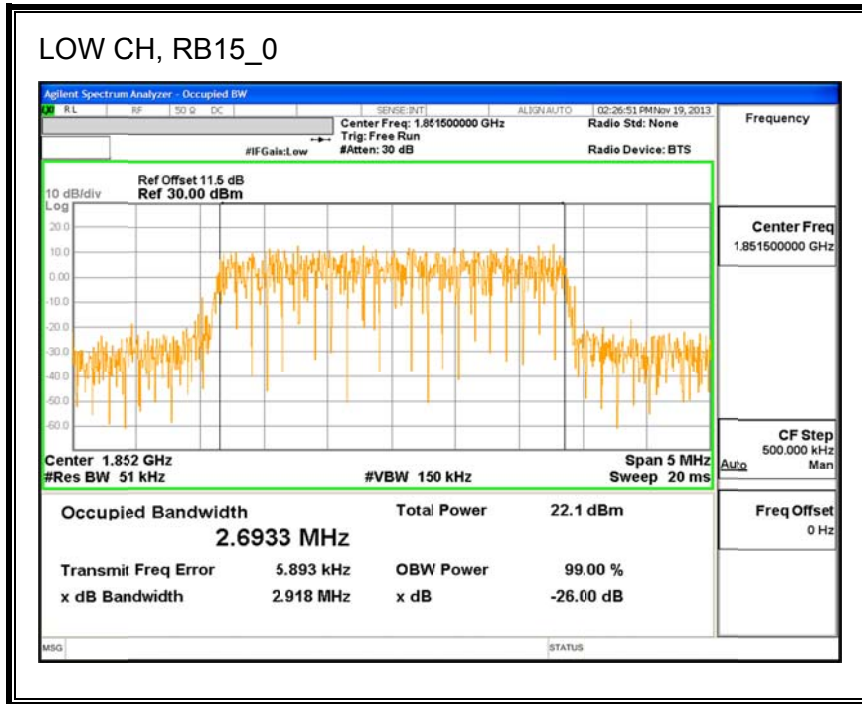

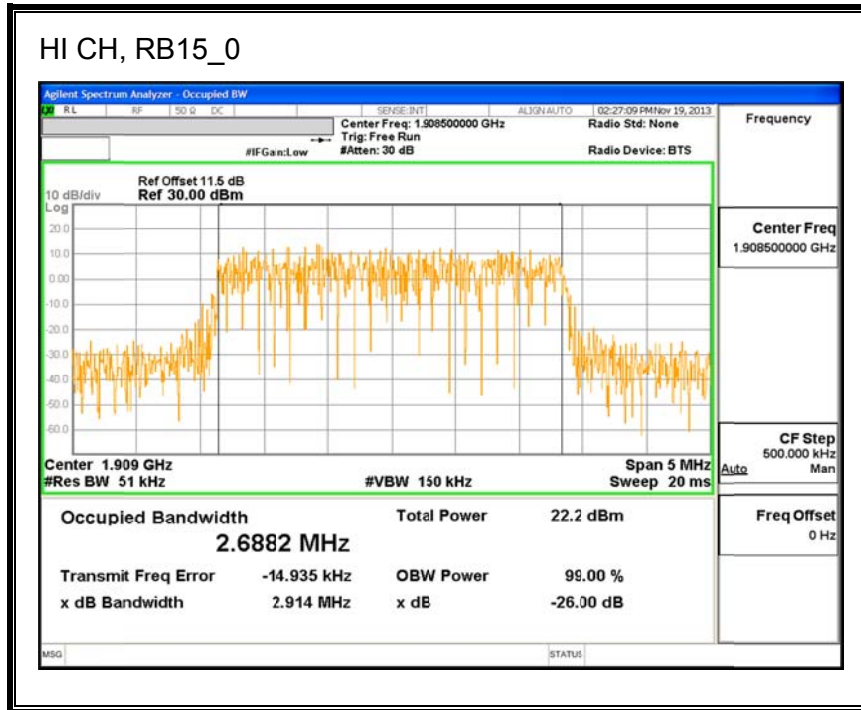

Band 2 (5MHz Bandwidth)

LTE QPSK

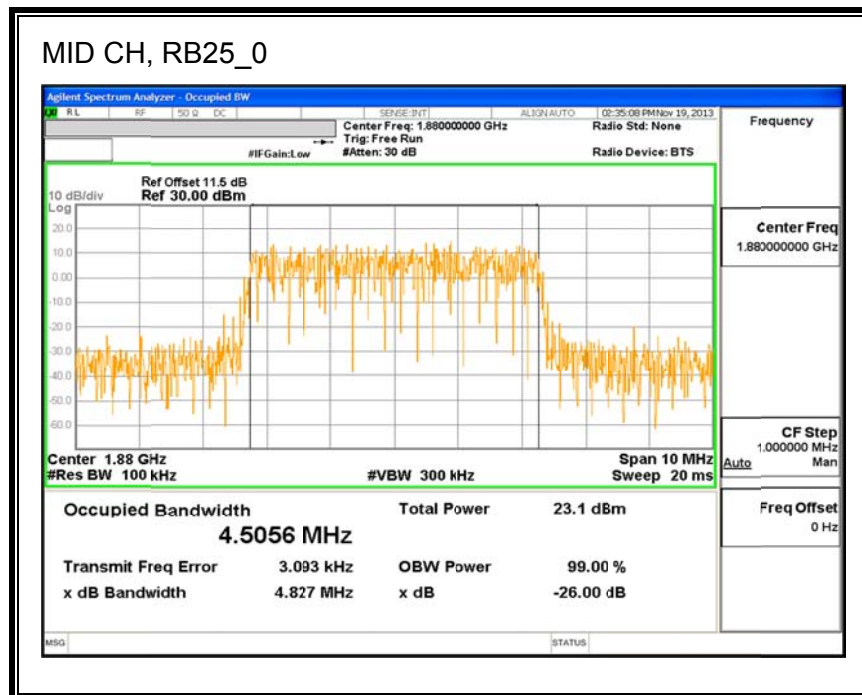
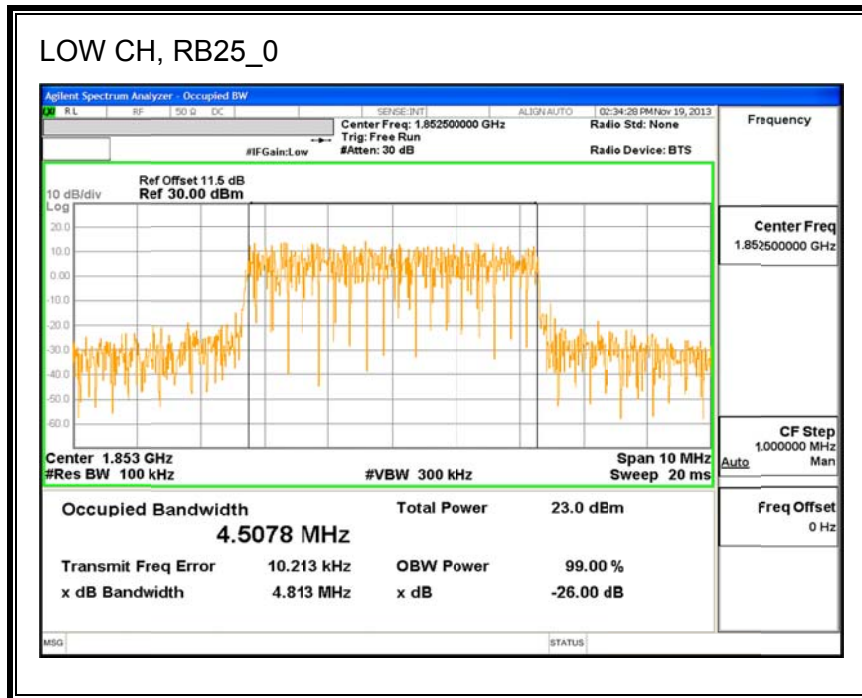

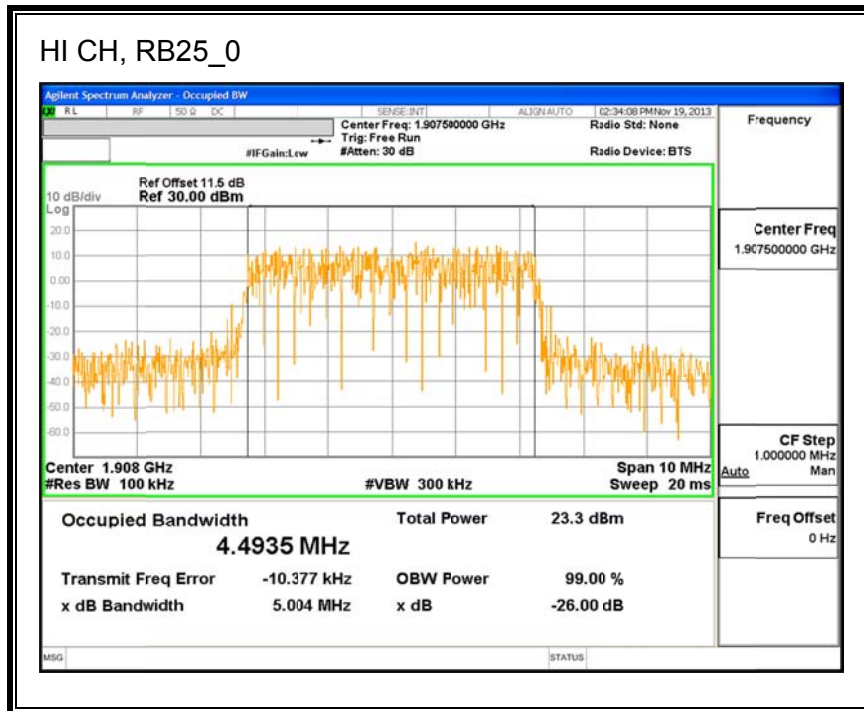

Band 2 (5MHz Bandwidth)

LTE 16QAM

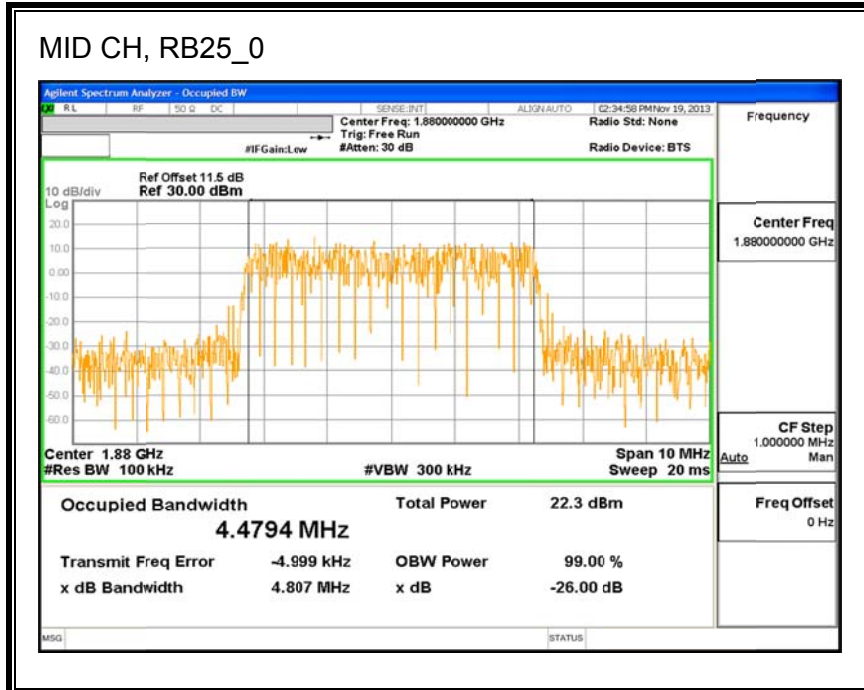
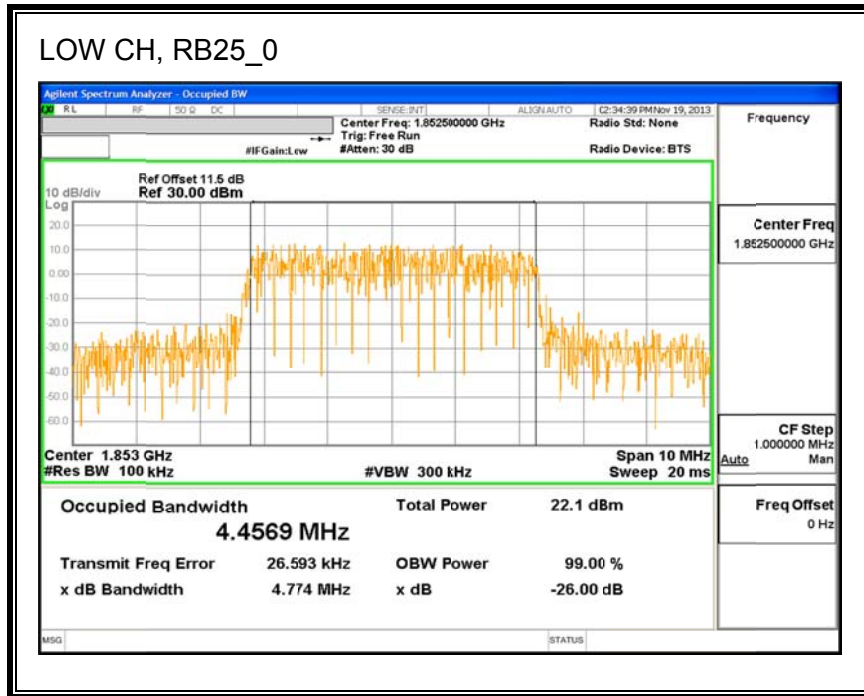

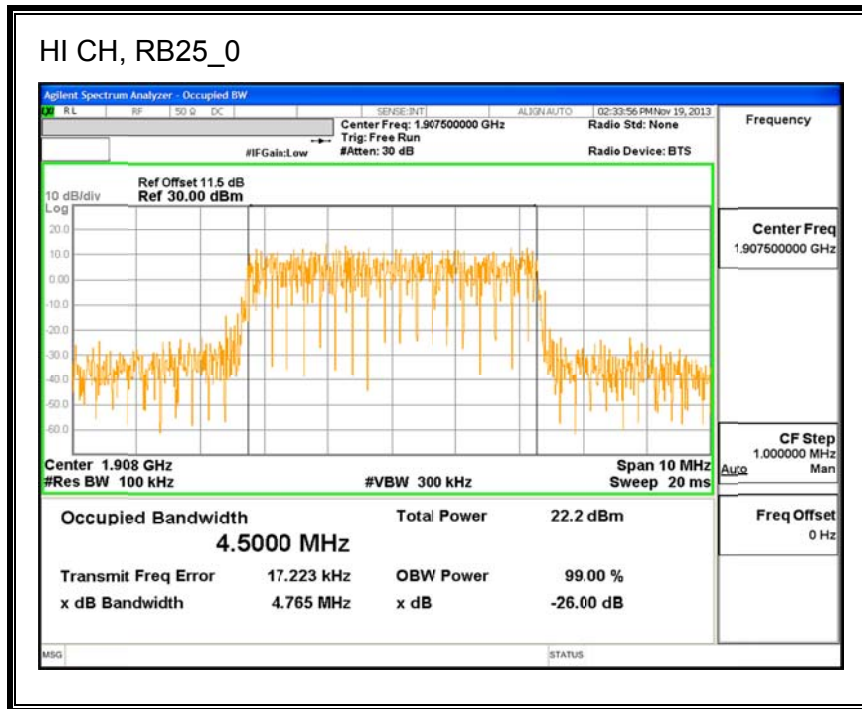

Band 2 (10MHz Bandwidth)

LTE QPSK

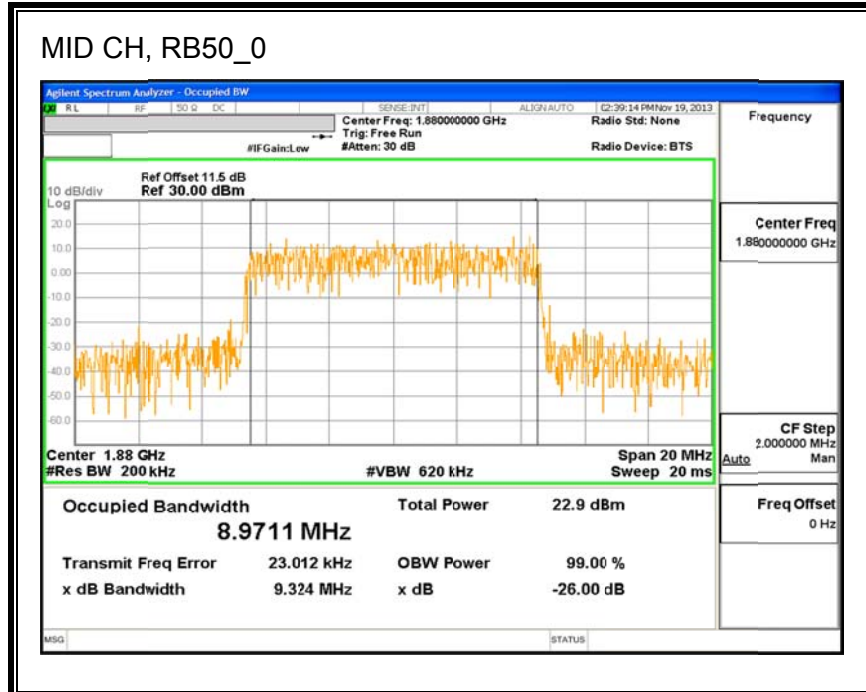
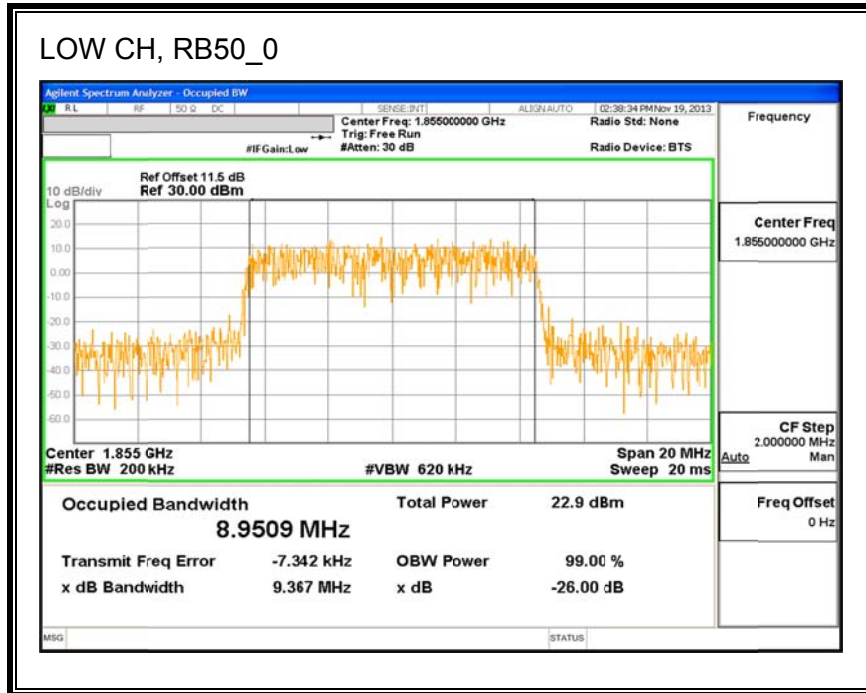



Band 2 (10MHz Bandwidth)

LTE 16QAM

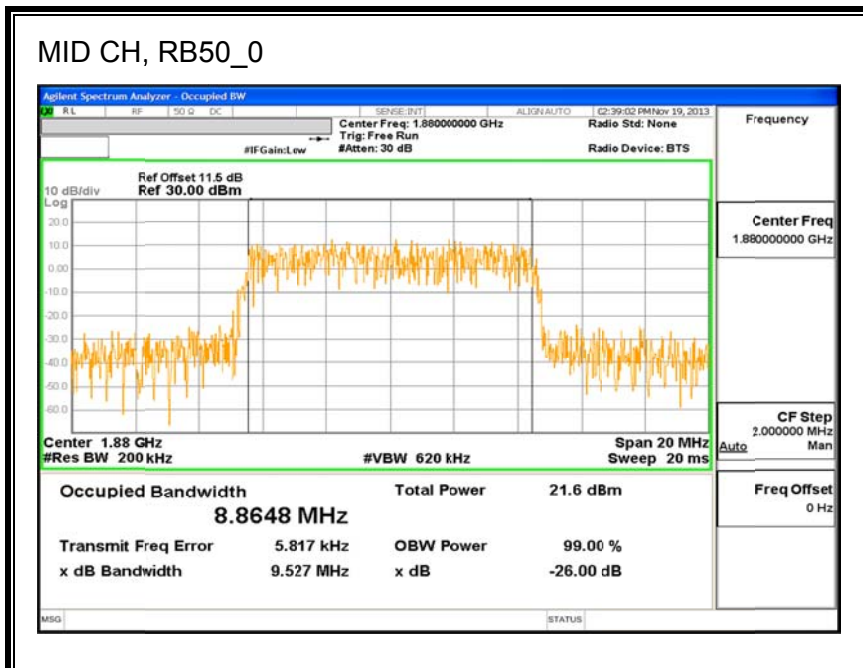
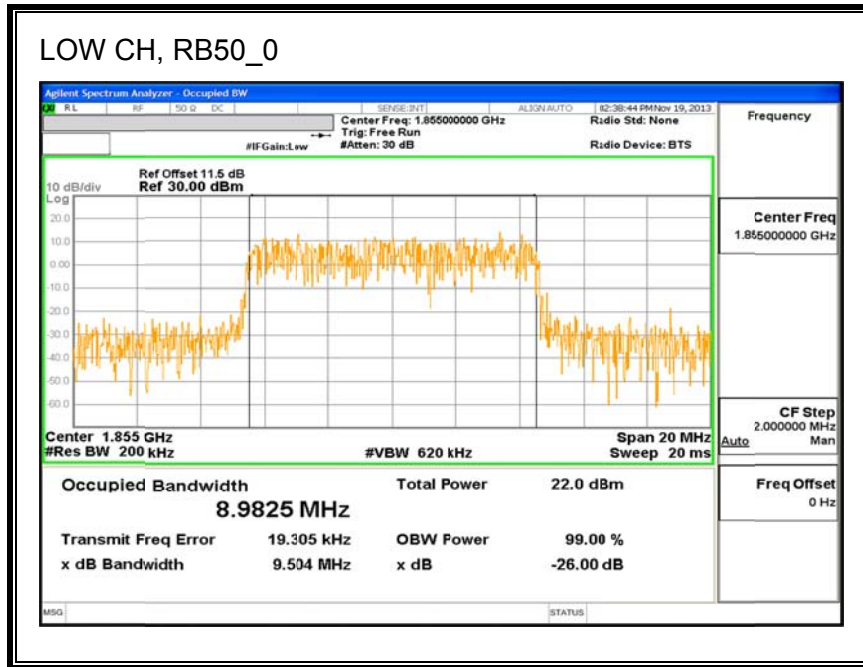

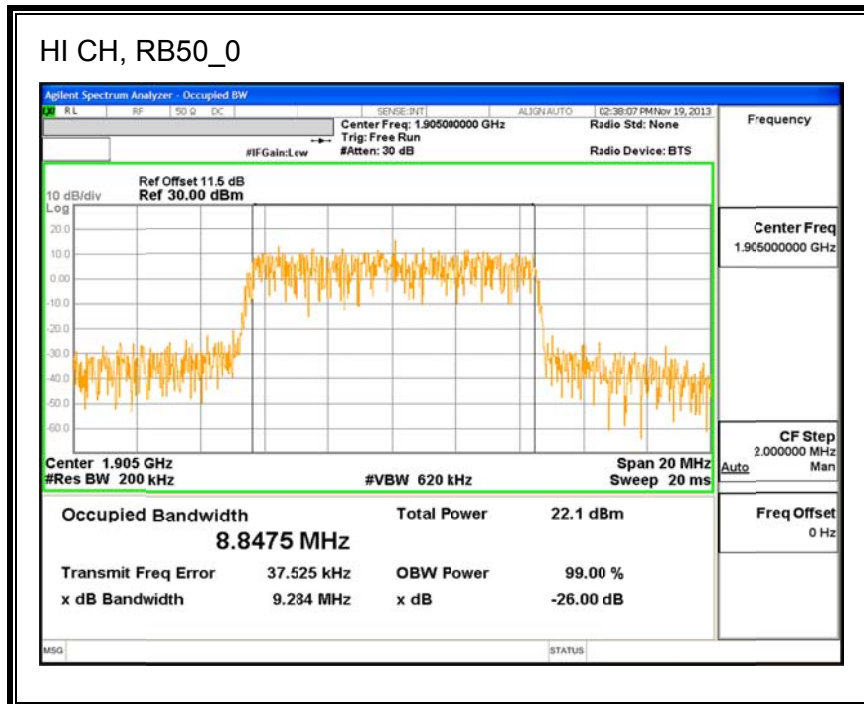

Band 2 (15MHz Bandwidth)

LTE QPSK

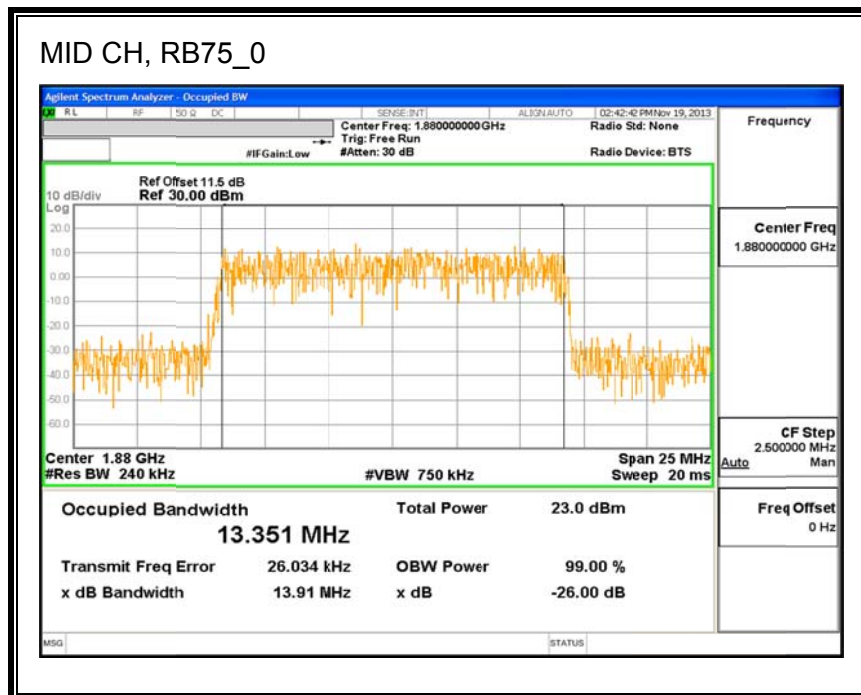
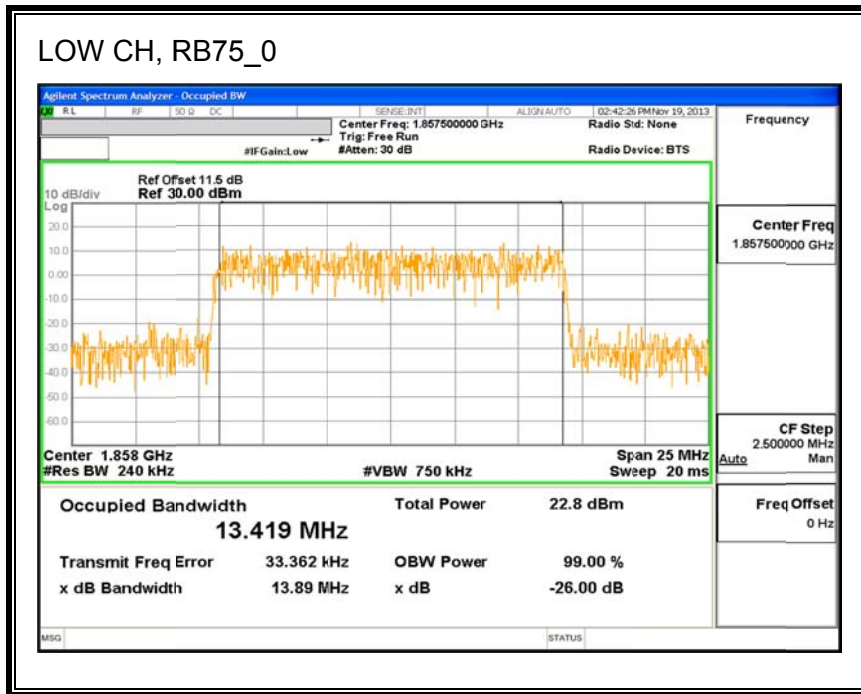

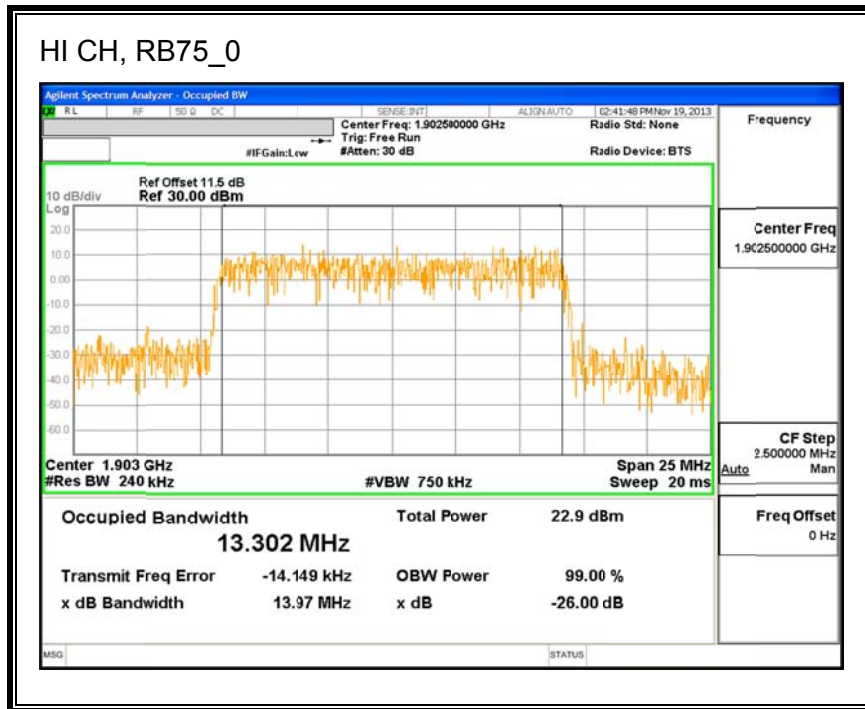

Band 2 (15MHz Bandwidth)

LTE 16QAM

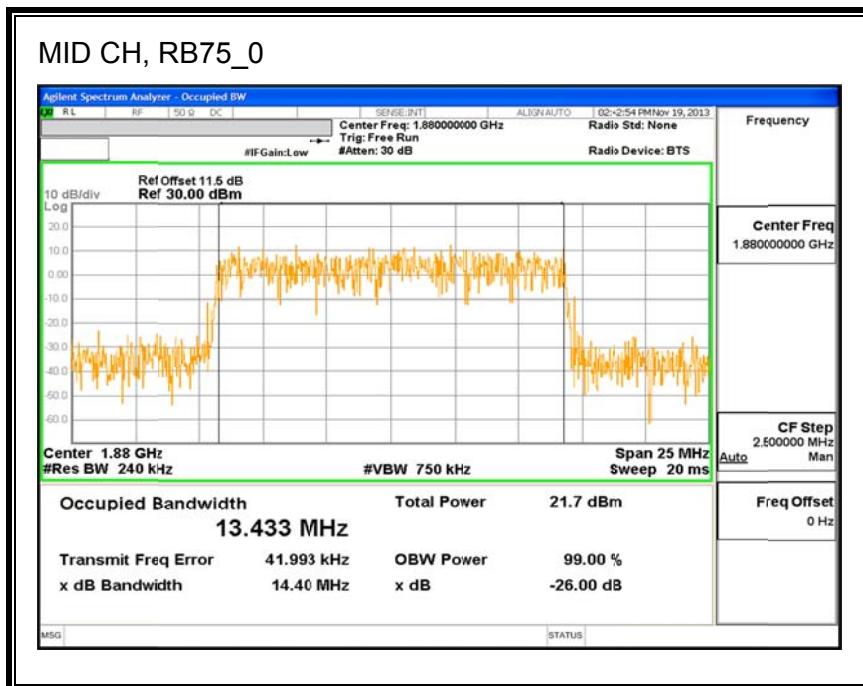
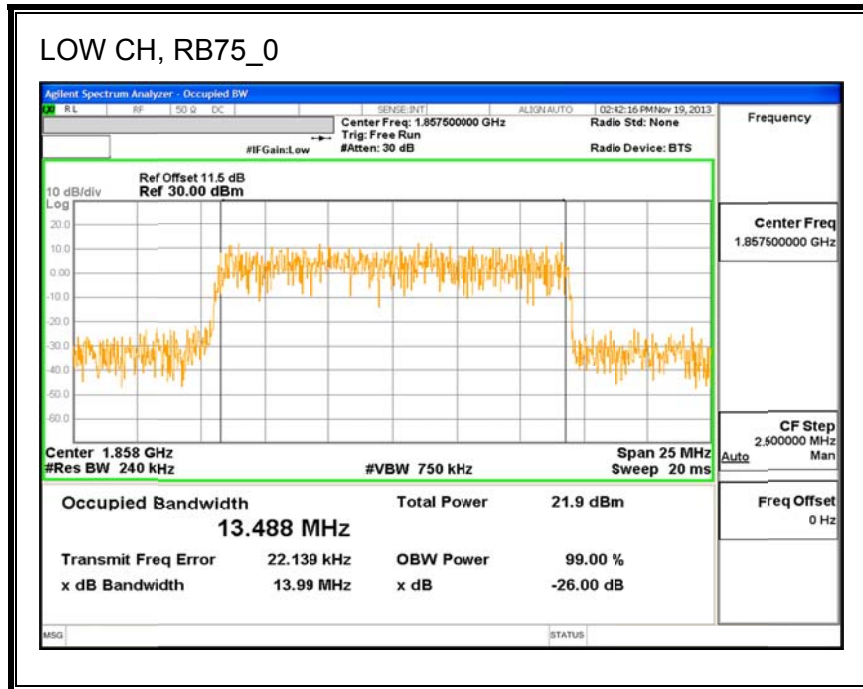

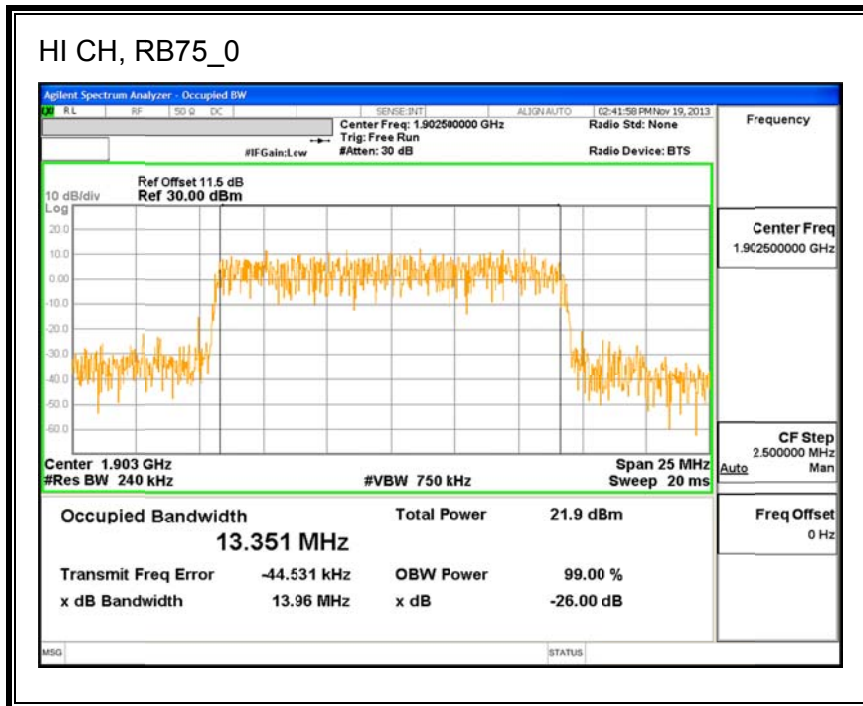

Band 2 (20MHz Bandwidth)

LTE QPSK

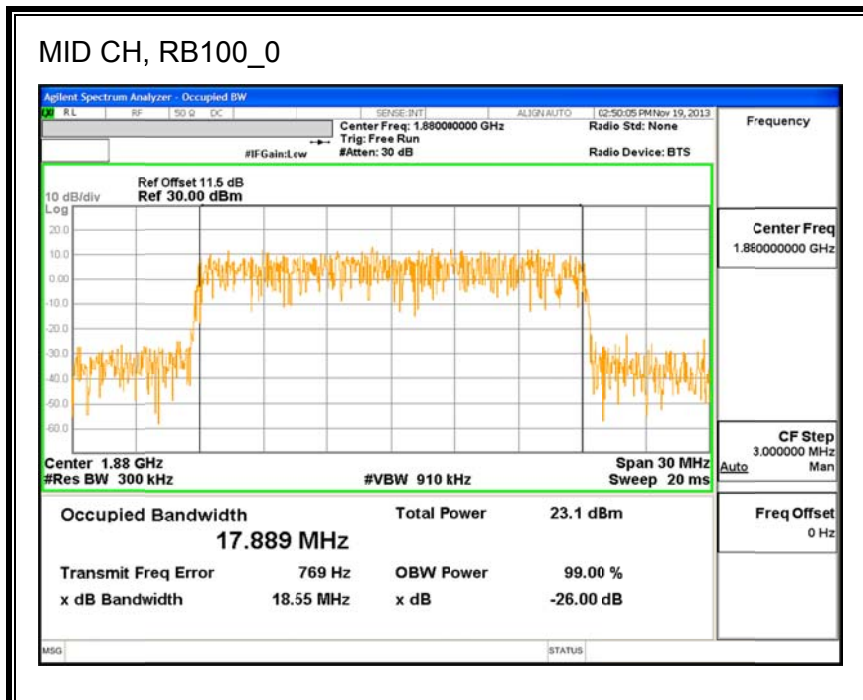
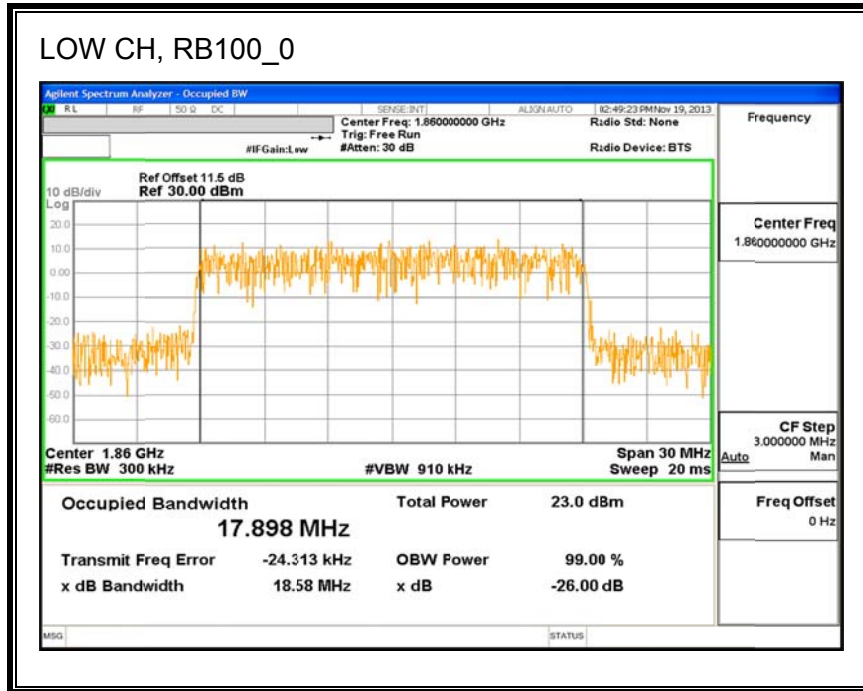

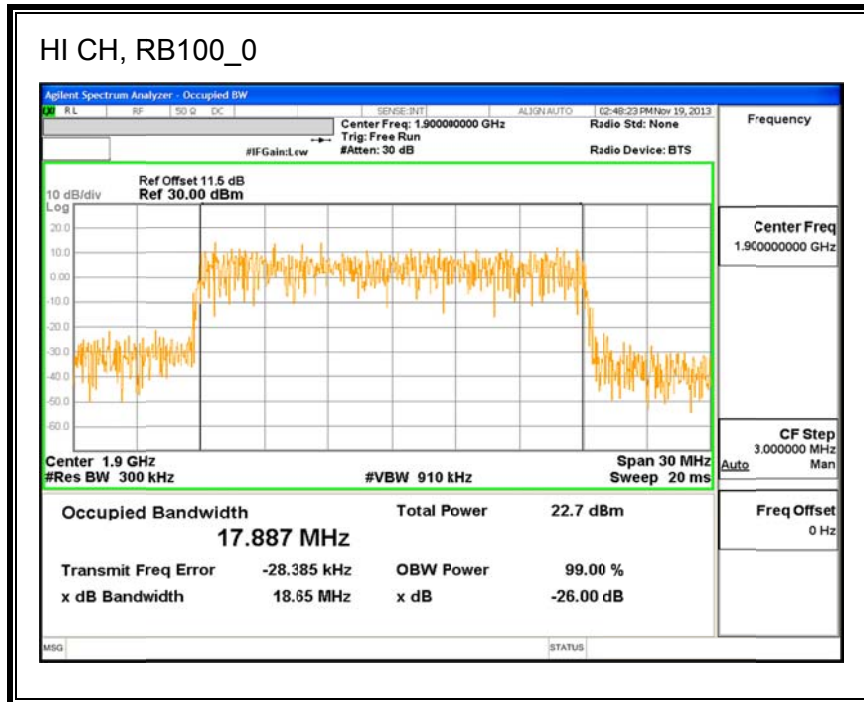

Band 2 (20MHz Bandwidth)

LTE 16QAM

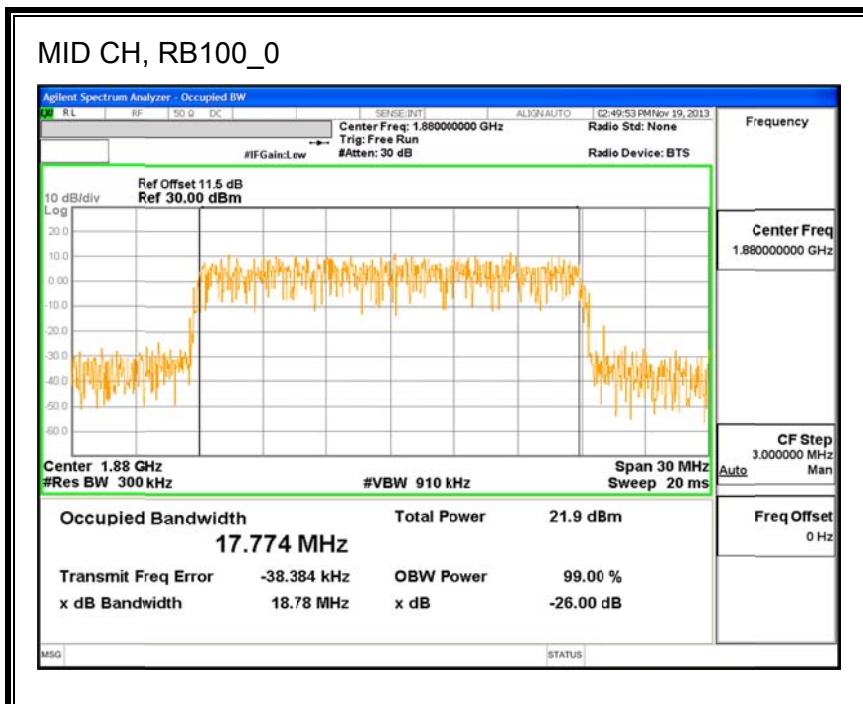
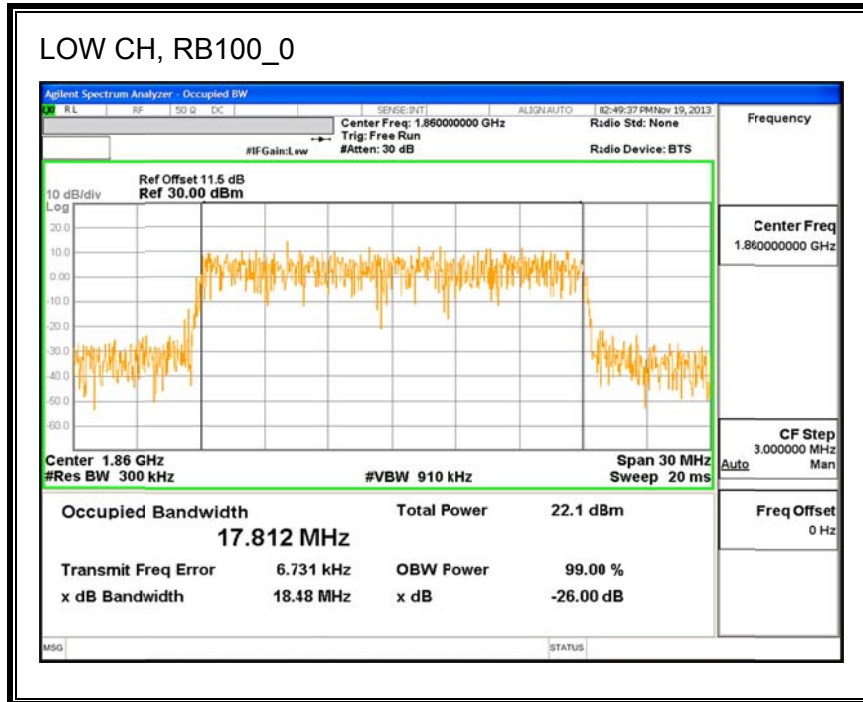

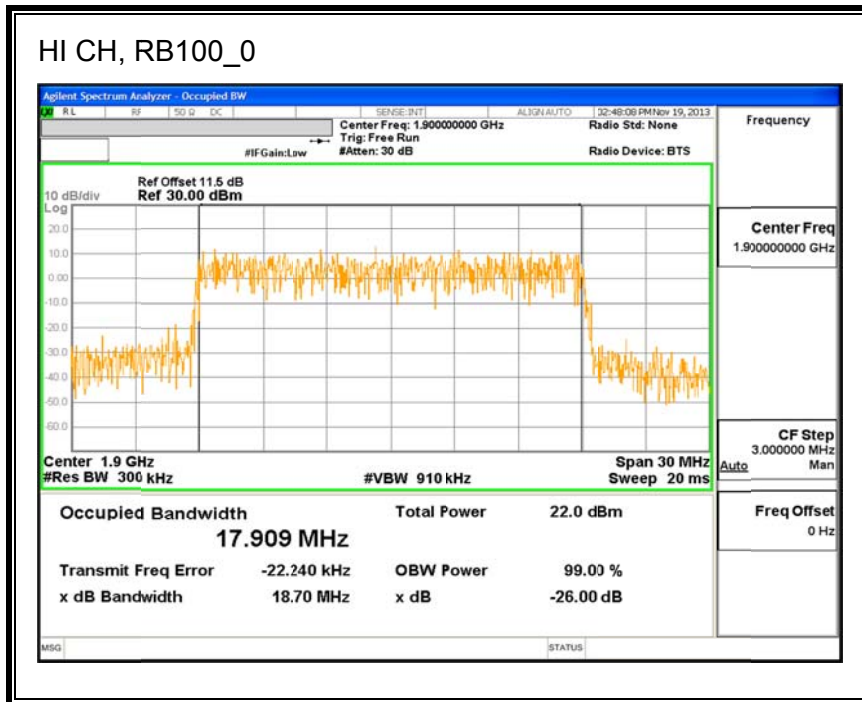

8.1.2. LTE BAND 5

Band 5 (1.4 MHz Bandwidth)

LTE QPSK

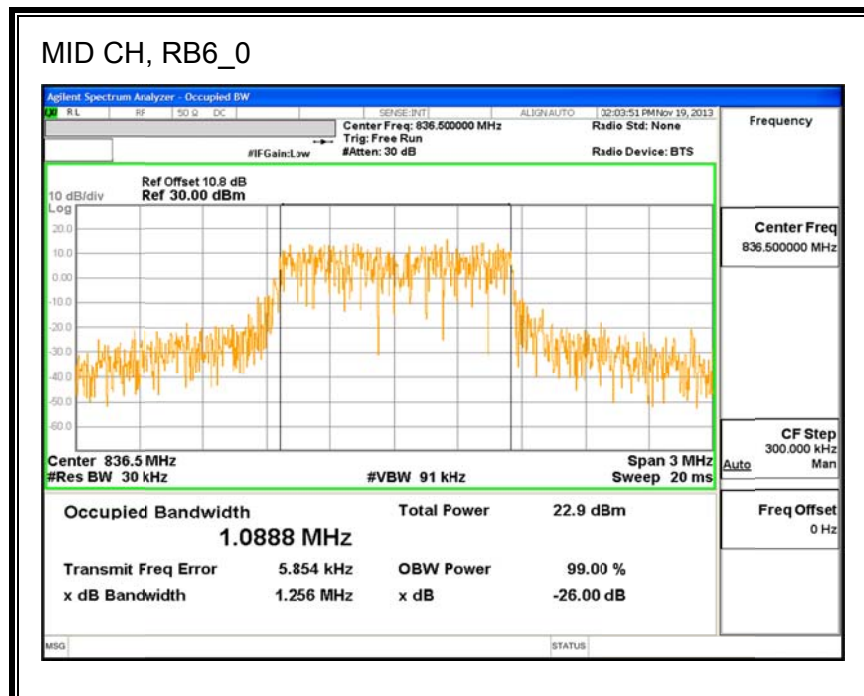
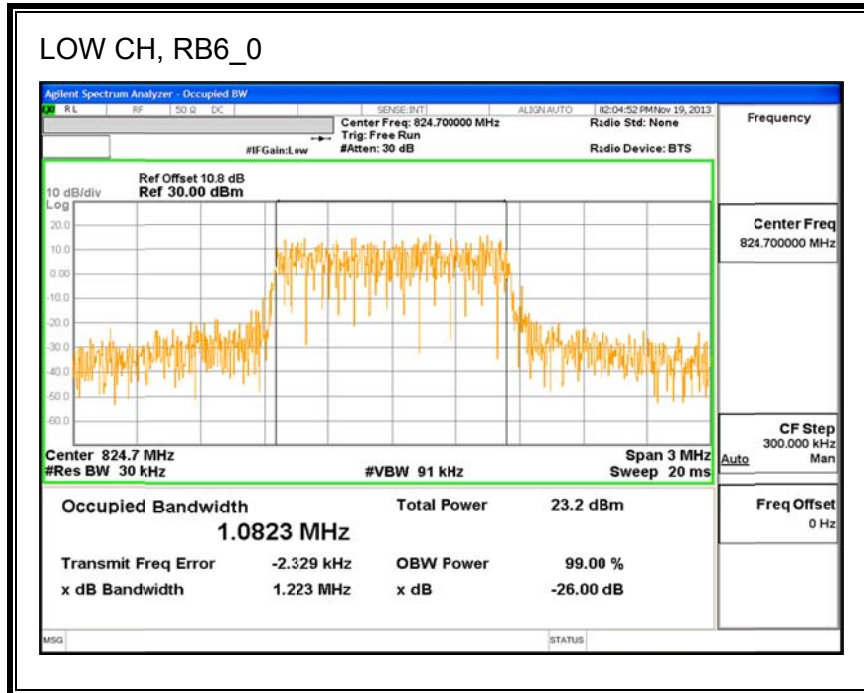

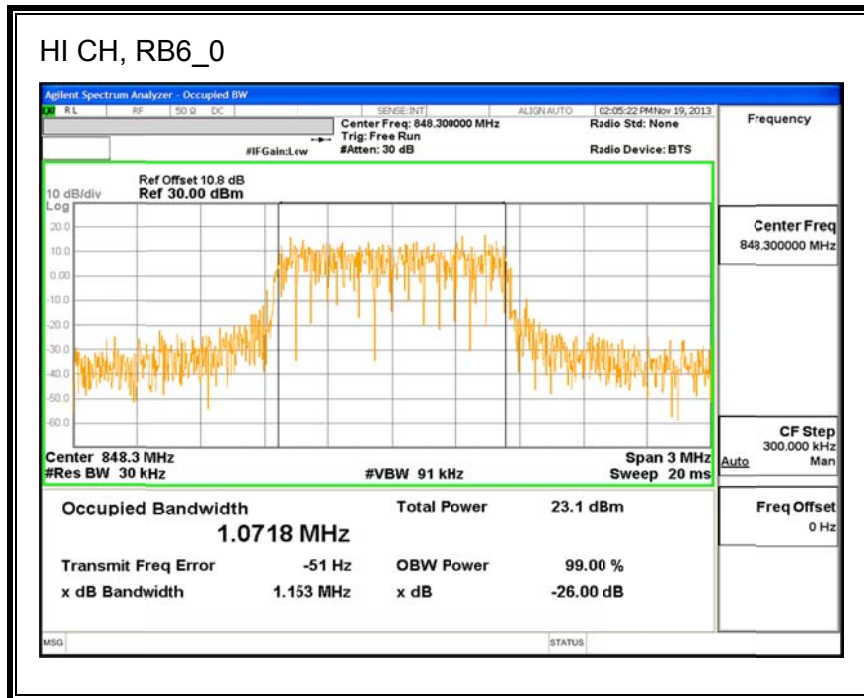

Band 5 (1.4 MHz Bandwidth)

LTE 16QAM

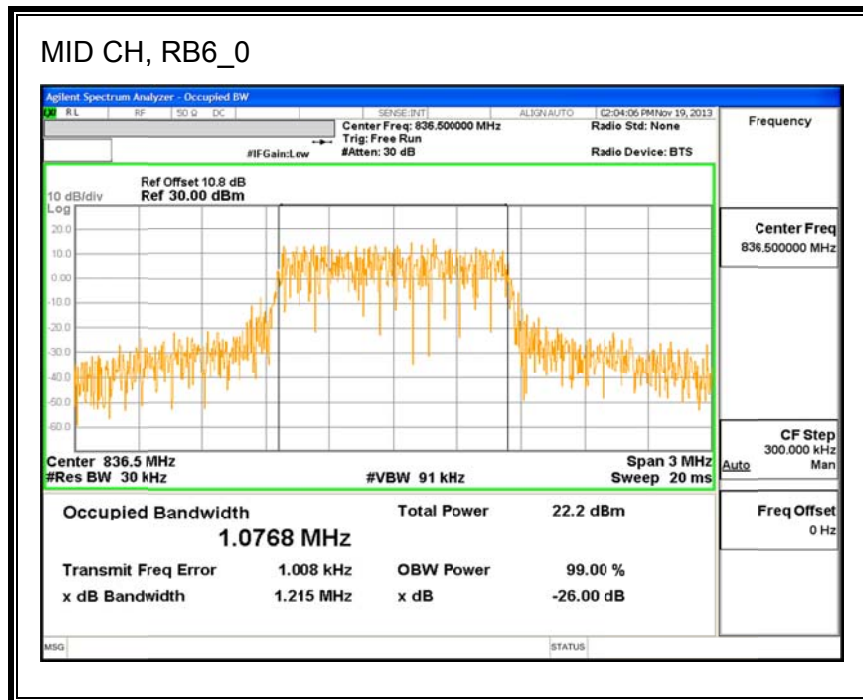
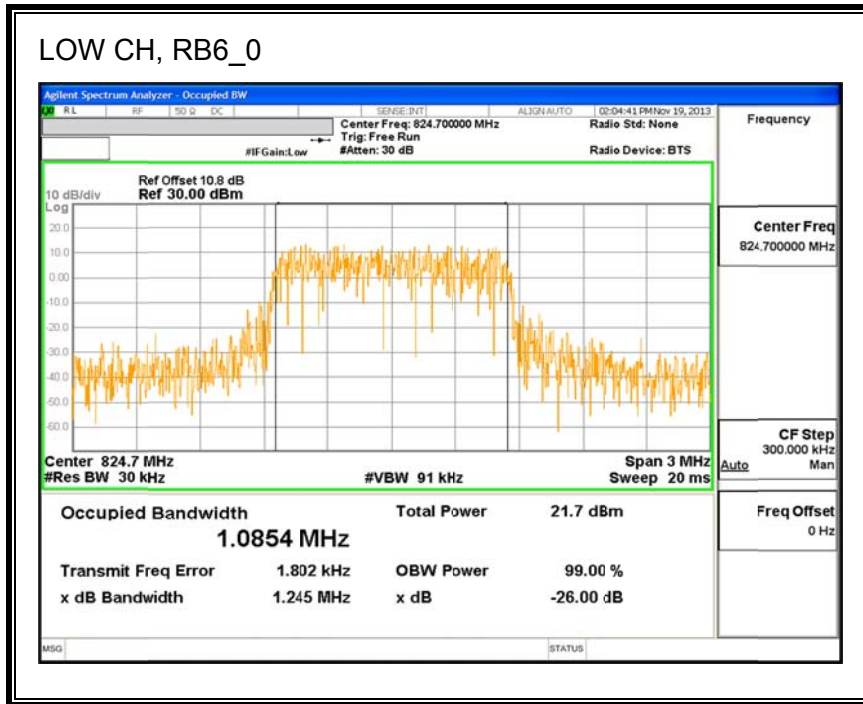

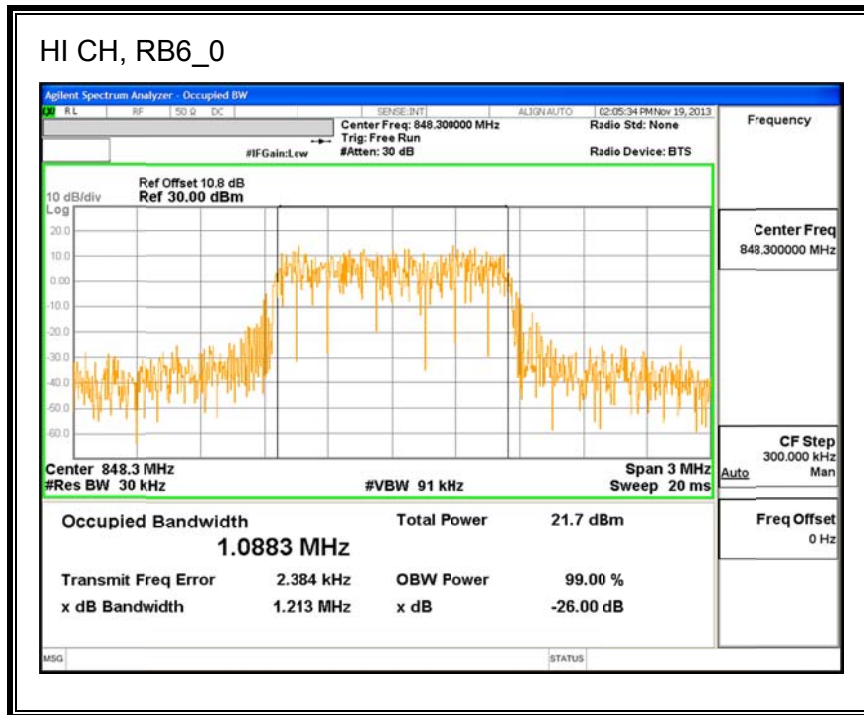

Band 5 (3MHz BANDWIDTH)

LTE QPSK

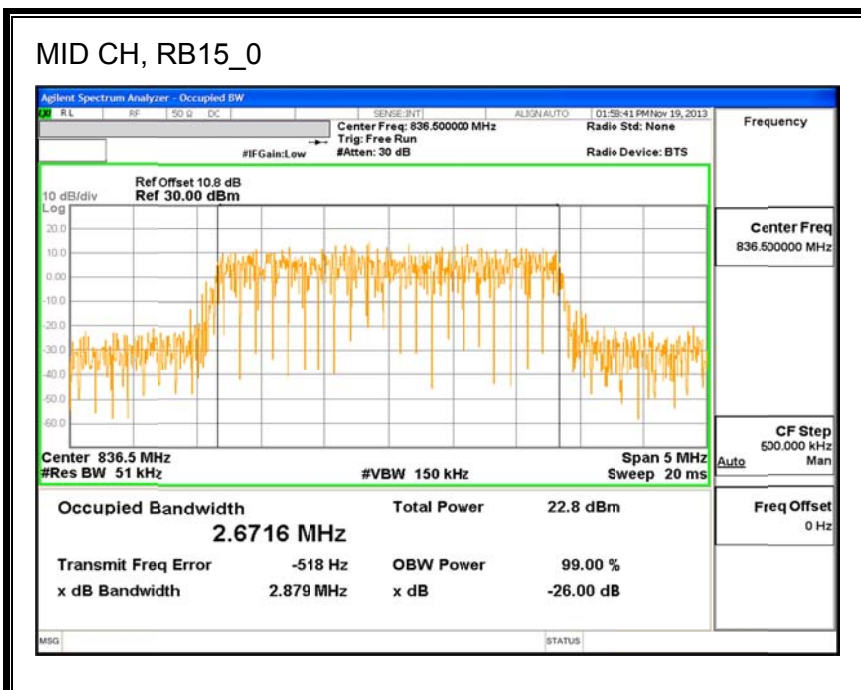
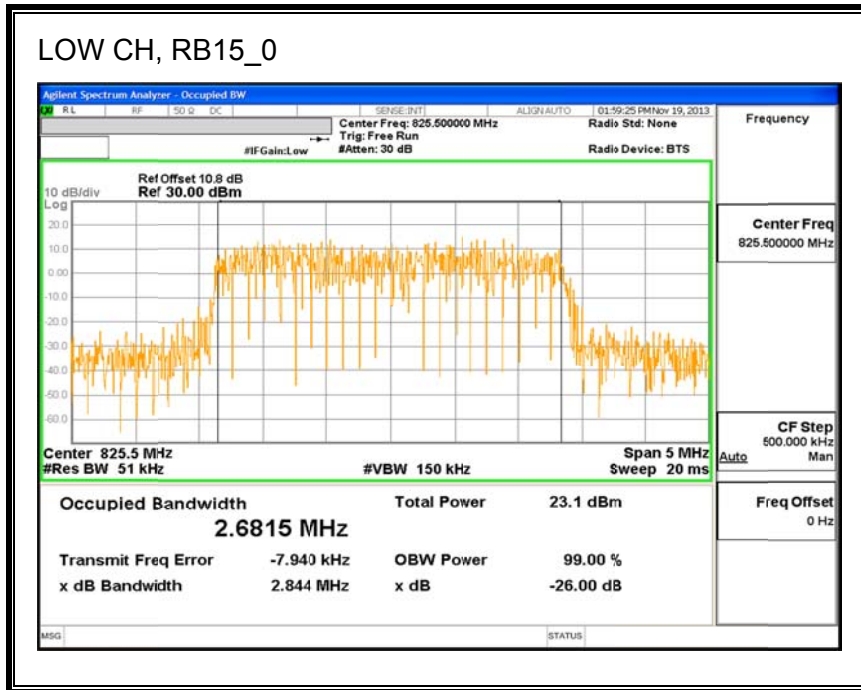

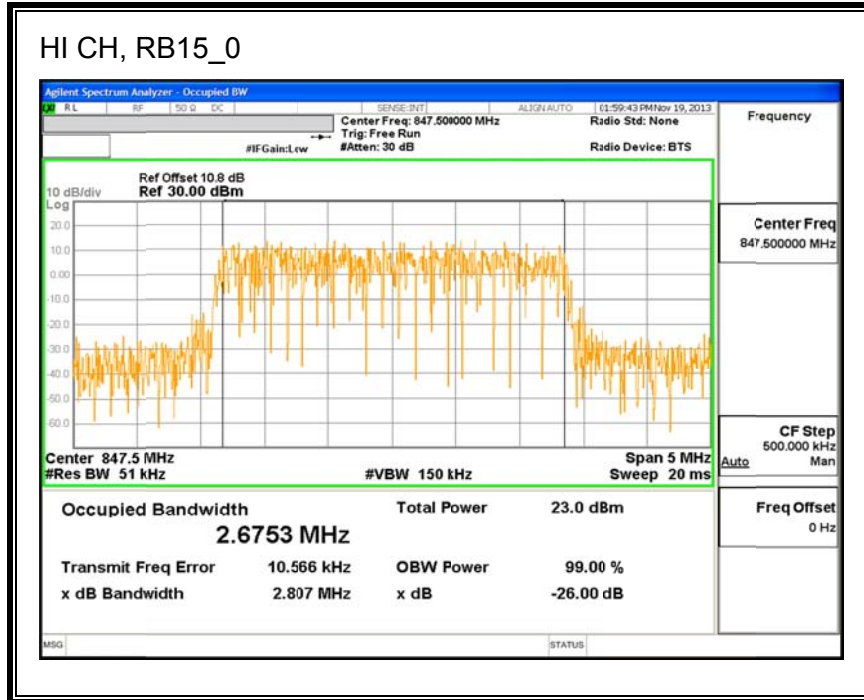

Band 5 (3MHz BANDWIDTH)

LTE 16QAM

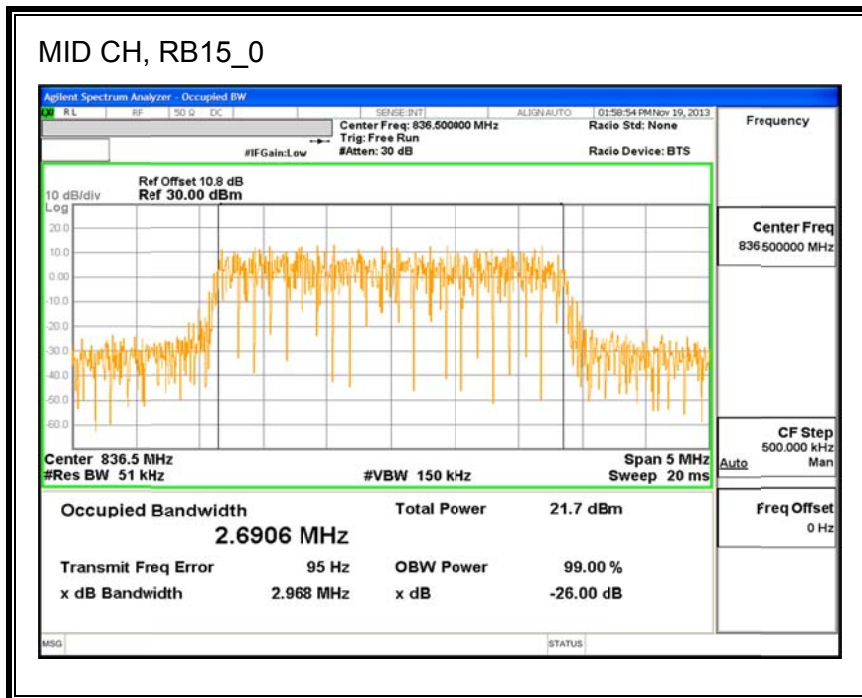
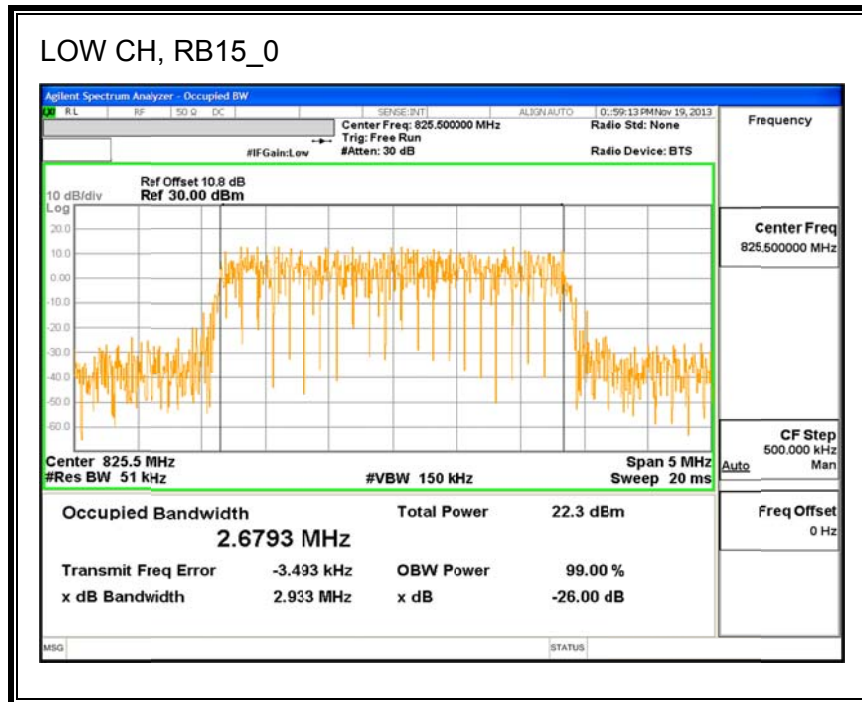

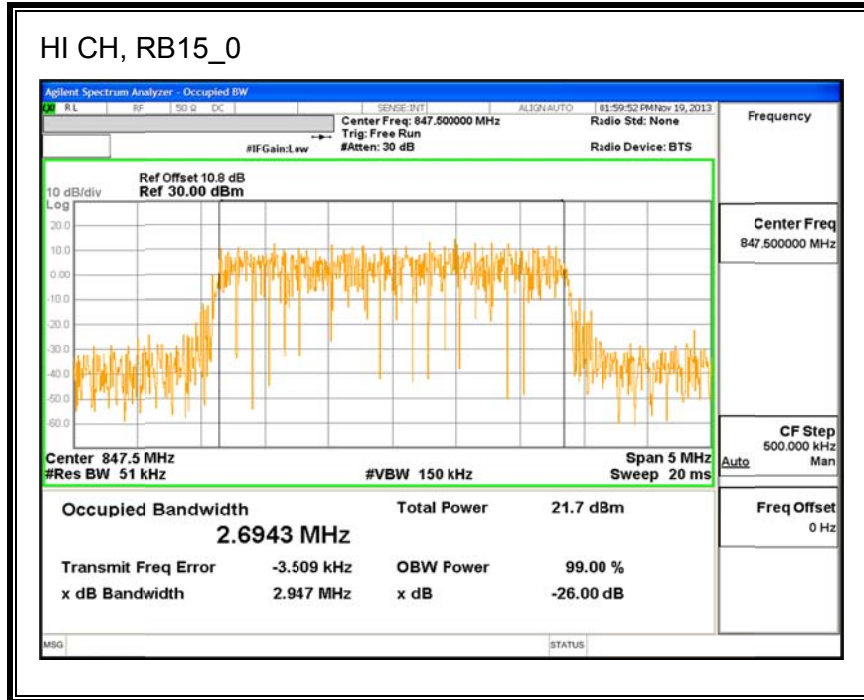

Band 5 (5MHz BANDWIDTH)

LTE QPSK

