

SPECK® Super 90 Series

Designed to suit all domestic pools and spas



speck
pumps 

Flow Rates from 230 - 500 lpm

Quieter, smoother performance

German design & engineering

Available in 1.0 to 2.0 HP

5 Year Warranty*

Easy to remove non-corrosive lid with handle

Robust construction, highest quality material



CONTINENTAL
WATER

Pool Products for Pure Enjoyment

SPECK®

Super 90 Series

The Speck SUPER 90 Series is the ideal choice for all domestic pool and spa applications including heating, salt chlorination and automatic pool cleaning.

Features:

- A high resistance to corrosion and salt water
- Maximum effectiveness at low power input
- The ultimate in reliability
- No contact between motor and pump shaft with pool or spa water
- Highest quality mechanical seal
- Fan cooled - suitable for high ambient temperatures
- Closed impeller
- Stainless steel motor shaft
- Easy to remove clear strainer lid
- Every pump factory wet tested for quality control

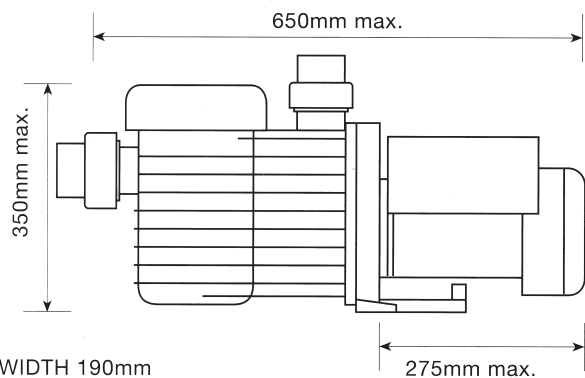
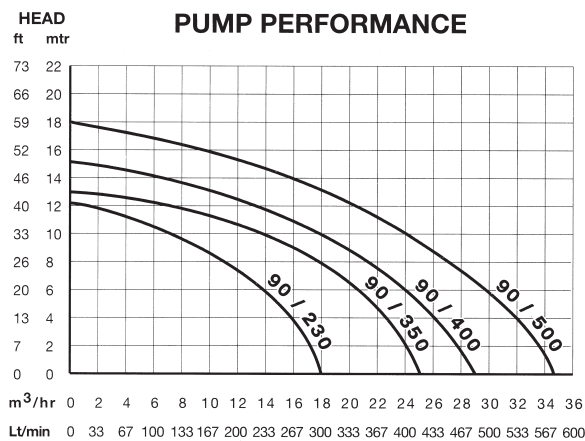

	90/230	90/350	90/400	90/500
Head Max/Min - m	12/4	13/4	15/4	18/4
Inlet Connection - mm	50	50	50	50
Outlet Connection - mm	40	40	40	40
Motor Speed - RPM	2850	2850	2850	2850
Power Input - V	240	240	240	240
Power Output - Kw	650	750	930	1100
AMPS	4.2	4.7	6.0	6.6
Weight - kg	11	13	15	19
Max Water Temp - Deg.C	35	35	35	35

WARRANTY

* Five (5) Year Factory Warranty on the following wet end components: Casing, Diffuser, Gland Housing, Impeller and Mechanical Seal. Two (2) Year Warranty on motor and in all commercial applications. The pouring of salt and chemicals directly into the skimmer box will void full warranty.



1300 166 253 for Sales and Service
 e sales@continentalwater.com.au / accounts@continentalwater.com.au ABN: 71 050 287 735

New South Wales Office
 t (02) 8814 2800
 f (02) 9838 7030

Victorian Office
 t (03) 8794 3800
 f (03) 9702 3941

Queensland Office
 t (07) 3434 1100
 f (07) 3219 2266

New Zealand Office
 t 0011 64 9570 9570
 f 0015 64 9527 7641