



BEVERAGE-AIR

Project: _____

AIA#

Item: _____

Location: _____

SIS#

Approved: _____

DD Draft Beer Equipment-Direct Draw Dispenser

DD94HC Solid Door

Hydrocarbon Series

MODELS:

DD94HC-1-B

DD94HC-1-S



DD94HC-1-B



DD94HC-1-S

3 Year Parts/Labor Warranty
Additional 2 Year Compressor Warranty

CABINET CONSTRUCTION

- Exterior is wear resistant vinyl on steel in black or stainless steel finish
- Top and drip tray are heavy-duty stainless steel
- Interior is galvanized steel on walls and ceiling, reinforced floor is heavy duty stainless steel
- Full electronic control
- Drain tube located at bottom front of cooler for connection to floor drain
- 3" Insulated dispensing towers
- Two (2) dual tap towers
- Self-closing doors with locks
- Magnetic gaskets provide positive door seal
- Field reversible doors
- Compressor available on left or right, specify at time of unit order

OPTIONS & ACCESSORIES

- Stainless steel interior available
- Turbo taps
- Epoxy coated wire shelves
- Wine models
- Wine taps
- Faucet locks
- Glass rinser
- 3"-6" casters or 6" legs with adjustable plate
- Low profile casters
- Foot pedal door opener
- 1-5 Tap tower
- 2,3 & 4 way manifolds
- Special 6/pan option
- No draft/hole cover options

REFRIGERATION SYSTEM

- Refrigeration system uses R290 refrigerant to comply with all environmental concerns
- Models feature forced air refrigeration to keep beer in kegs ice cold for dispensing
- Automatic, non-electric evaporator
- Epoxy coated evaporator coil

DD94HC Direct Draw Dispenser: Standard Model



3779 Champion Blvd., Winston-Salem, NC 27105
1-888-845-9800 Fax: 1-336-245-6453
Beverage-Air.com sales@bevair.com



BEVERAGE-AIR

Bar Equipment-Direct Draw Dispenser Solid Door

Models: DD94HC-1-B, DD94HC-1-S

| MODEL | DD94HC-1-B | DD94HC-1-S |
|----------------------------------|------------|------------|
| EXTERNAL DIMENSIONAL DATA | | |
| Width Overall | 95" | 95" |
| Depth Overall with Handle | 29" | 29" |
| Height Overall | 52 1/2" | 52 1/2" |
| Number of doors | 3 | 3 |
| Depth with Door Open 90° | 50 1/2" | 50 1/2" |
| Door Opening (in) | 21" X 30" | 21" X 30" |
| INTERNAL DIMENSIONAL DATA | | |
| NET Capacity (cubic ft.) | 37.82 | 37.82 |
| Internal Width Overall (in) | 82 1/4" | 82 1/4" |
| Internal Depth Overall (in) | 23 1/8" | 23 1/8" |
| Internal Height Overall (in) | 27 1/4" | 27 1/4" |
| Number of Kegs | 5 | 5 |
| ELECTRICAL DATA | | |
| Full Load Amperes 115/60/1 | 5.5 | 5.5 |
| REFRIGERATION DATA | | |
| Horsepower | 1/3 | 1/3 |
| Capacity (BTU/Hr)* | 2392 | 2392 |
| WEIGHT DATA | | |
| Gross Weight (Crated lbs) | 458 lbs | 458 lbs |
| Height - Crated | 45" | 41 1/4" |
| Width - Crated | 97" | 98" |
| Depth - Crated | 32" | 31 1/4" |

Model Views

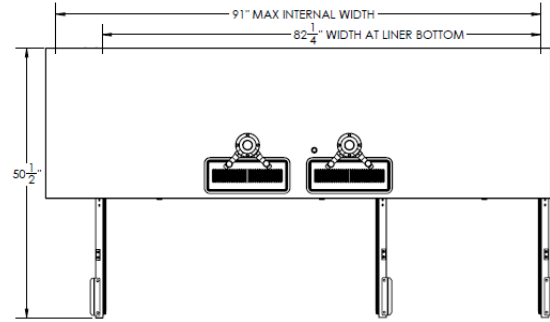

Plan View

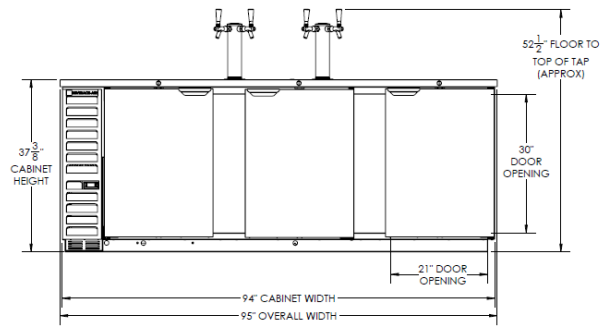

Elevation View

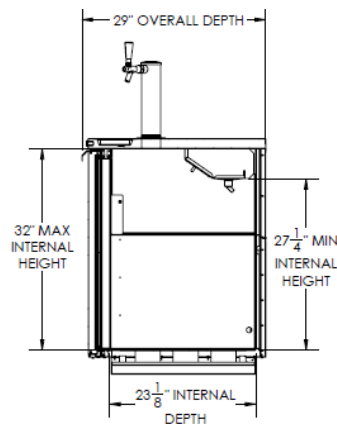

Side View

ELECTRICAL CONNECTION

Units pre-wired at factory and include 8' long cord and plug set.



115/60/1
NEMA-5-15P



an Ali Group Company



The Spirit of Excellence

3779 Champion Blvd., Winston-Salem, NC 27105
1-888-845-9800 Fax: 1-336-245-6453
Beverage-Air.com sales@bevair.com