

SimpleX

Instantaneous water heater (pressure type)

Operation and installation instructions



This water heater must be installed (water and electrical installation), commissioned and serviced by approved service technicians in accordance with these instructions.

PRODUCT CODE : SIMPLE X : 221094

SIZE : A5
MATERIAL : GREEN READ PAPER 75 G.
PLASTIC BAG : 7 x 11 INCH
PART NO. 6901-271094
PART NAME : MANUAL SIMPLEX
REV.02

Installation and operation instructions for the qualified installer

⚠ The installation, electrical connection and first operation of this appliance should be carried out by a qualified installer. The Installation shall comply with AS 3500.4.1 or AS/NZS 3500.4.2 and any other relevant Australian Standards and industry codes relevant to application (eg, AS3500.5 for domestic installation)

The company does not accept liability for failure of any goods supplied which have not been installed and operated in accordance with the manufacturer's instruction.

1 Description of the unit (see fig. 1)

The SimpleX is an automatic instantaneous water heater unit.

- 1) Terminal Block for electrical connection
- 2) Cable Bushing for electric connection cable, concealed and visible.
- 3) 3 - pole manual reset thermal cut-out
- 4) Contactor, 630 VAC, 18A
- 5) Reed (flow) switch
- 6) Cold water connection G 1/2"
- 7) Combination filter/seal
- 8) Hot water connection G 1/2"
- 9) Tank and heating element

2 Specifications and provisions

The specifications and provisions of the local energy supply company and the water supply company concerned are to be complied with.

3 Installation location

The instantaneous water heater should be installed close to the drawing points. When dismantled, the unit is to be stored in a place not subject to frost, because there will always be residual water inside. The unit is to be installed horizontally.

4 Installing the unit

Refer to installation drawing guide in this manual (see fig. 2,3,4)

⚠ Before energising the unit, all the hot water valves connected are to be kept open until the pipe network and the unit are free of air.

Check that the instantaneous water heater is functioning properly.

Important information

- ⚠** Install the unit flush with the wall
- ⚠** The device must be capable of being isolated from the mains, for example by fuses, with an isolating distance of least 3 mm, in all poles
- ⚠** Do not switch the unit on if you suspect it of being frozen.
- ⚠** To guarantee trouble-free operation and safety, only genuine Stiebel Eltron accessories and spare parts should be fitted to this appliance.
- ⚠** The unit must be earthed.
- ⚠** Do not allow children or infirm persons to use this unit without proper adult supervision.
- ⚠** Water temperatures in excess of 50 °C can be produced by the unit. Therefore, a temperature controlling device must be used as part of the installation if hot-water is supplied to sanitary fixtures primarily used for the purposes of personal hygiene.

5 Servicing instructions

Applicable to all maintenance work: Disconnect the unit from the main circuit.

- Clean the filter
- Reset the safety thermal cut-out.

The safety thermal cut-out can be reactivated after a fault has been rectified by means of the reset push button.

For all services:

- ⚠** After any servicing, make sure the earthing screw is tightened properly.
- ⚠** All electrical and plumbing work shall comply to all national/state rules and regulations.

⚠ - This appliance is not intended for use by persons (including children) with reduced physical, sensory or mental capabilities, or lack of experience and knowledge, unless they have been given supervision or instruction concerning use of the appliance by a person responsible for their safety.

⚠ - Children should be supervised to ensure that they do not play with the appliance.

⚠ This appliance is not intended for use by persons (including children) with reduced physical, sensory or mental capabilities, or lack of experience and knowledge, unless they have been given supervision or instruction concerning use of the appliance by a person responsible for their safety

⚠ Children should be supervised to ensure that they don't play with the appliance .

Installation and operation instructions

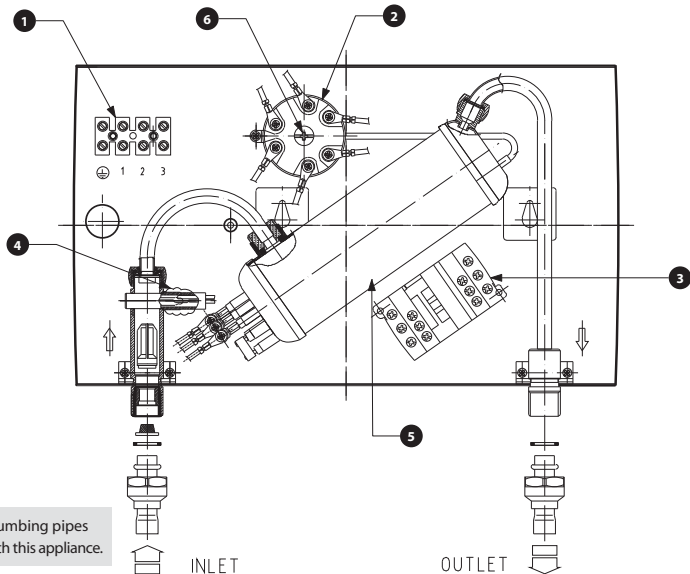

Caution

Plastic (uPVC/HDPE) plumbing pipes must not be used together with this appliance.

Description of the Unit

Fig. 1

- 1 Terminal Block
- 2 Thermal cut-out AS3
- 3 Contactor
- 4 Reed Flow Switch
- 5 Tank and Element
- 6 Reset Switch

Type multi-point type installation Heater unit can also be installed under the sink.

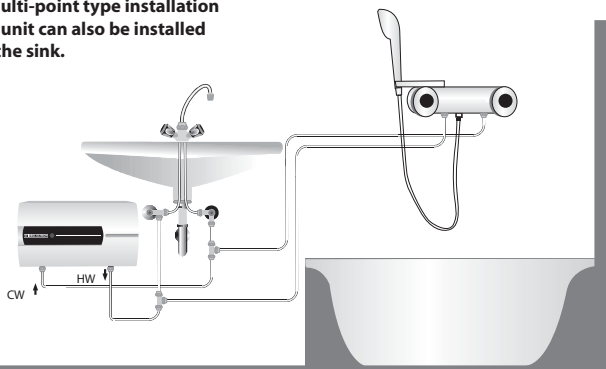
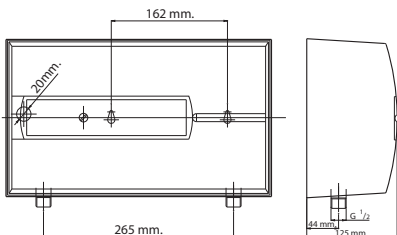
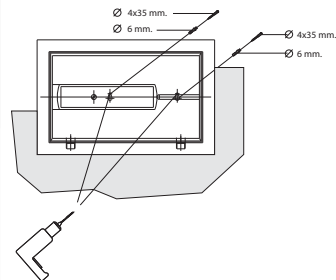
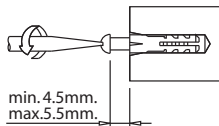

Fig. 2



Mounting Dimensions

Fig. 3

Fixing method

Fig. 4

Installation and operation instructions

Troubleshooting

Elimination of faults by the qualified installer

Fault	Cause	Rectification
The flow switch is not switching the heating on despite the hot water fitting being fully opened.	The water flow rate for the system to switch-on has not been attained. - Dirt contamination or limescale formation in the filter.	- Clean the filter (see fig. 1#7) after shutting the cold water cable entry.
Unit not heating	- The safety thermal cut-out has switched the unit off for safety reasons. - Reed switch defective	- Disconnect the current to the unit. Eliminate the cause of the fault. Press the reset button on the safety thermal cut-out (see Fig.1#3) - Replace the reed switch

Guarantee

For Guarantees please refer to the respective terms and conditions of supply for your country.

⚠ The installation, electrical connection and first operation of this appliance should be carried out by the qualified installer.

The company does not accept liability for failure of any goods supplied which have not been installed and operated in accordance with the manufacturer's instruction.

Environment and recycling

Please help us to protect the environment by disposing of the packaging in accordance with national regulations for waste processing.

Technical data

Type	SimpleX
Design	Pressurized
Rated max. working pressure	1MPa(10 bar)
Capacity	0.5 l.
Protection class	IP24
Water connection	G 1/2"
Electrical connection	3 P/PE - 380 - 415 V.AC.
Rated power @ 3 ph.	
380V	3700 w/ph.
400V	4050 w/ph.
415V	4400 w/ph.
Switch on flow	l/min 4.0

⚠ For water supply higher than rated max working pressure, to install approved pressure reducing device before the water heater

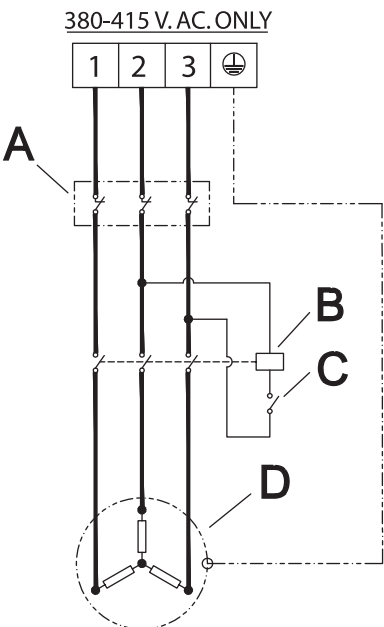

- A - 3 pole manual reset Thermal cut-out
- B - Magnetic Contactor
- C - Flow Switch
- D - Heating Element

fig. 5

Stiebel Eltron Warranty for Water Heaters – Models SimpleX

Who gives the warranty

1. The warranty is given by Stiebel Eltron (Aust) Pty Ltd (A.B.N. 82 066 271 083) of 6 Prohasky Street, Port Melbourne, Victoria, 3207 (“we”, “us” or “our”).

The warranty

2. This warranty applies to Stiebel Eltron Water Heaters – Model SimpleX (the “unit”) manufactured after 1 May 2015.

3. Subject to the warranty exclusions we will repair or replace, at our absolute discretion, a faulty component in your unit free of charge if it fails to operate in accordance with its specifications during the warranty period.

4. If we repair or replace a faulty component to your unit under this warranty, the warranty period is not extended from the time of the repair or replacement.

5. The warranty period commences on the date of completion of the installation of the unit. Where the date of completion of installation is not known, then the warranty period will commence 2 months after the date of manufacture.

6. The warranty period for a unit used for domestic purposes is shown in the table below. Domestic purposes means that the unit is used in a domestic dwelling.

Component	Warranty period
All components	2 years from the date of completion of the installation of the unit.

7. The warranty period for a unit used for commercial purposes is shown in the table below. Commercial purposes means that the unit is used for a non-domestic purpose and includes but not limited to being used in a motel, hotel, mining camp or nursing home.

Component	Warranty period
All components	1 year from the date of completion of the installation of the unit.

Your entitlement to make a warranty claim

8. You are entitled to make a warranty claim if:

8.1. you own the unit or if you have the owner’s consent to represent the owner of the unit;

8.2. you contact us within a reasonable time of discovering the problem with the unit;

How you make a warranty claim

9. To make a warranty claim you must provide us with the following information:

9.1. The model number of the unit;

9.2. A description of the problem with the unit;

9.3. The name, address and contact details (such as phone number and e-mail address) of the owner;

9.4. The address where the unit is installed and the location (e.g. in laundry);

9.5. The serial number of the unit;

9.6. The date of purchase of the unit and the name of the seller of the unit;

9.7. The date of installation of the unit;

9.8. A copy of the certificate of compliance when the unit was installed.

10. The contact details for you to make your warranty claim are:

Name: Stiebel Eltron (Aust) Pty Ltd
Address: 6 Prohasky Street, Port Melbourne, Victoria, 3207
Telephone: 1800 153 351
(8.00 am to 5.00 pm AEST Monday to Friday)
Contact person: Customer Service Representative
E-mail: service@stiebel.com.au

11. We will arrange a suitable time with you to inspect and test the unit.

Warranty exclusions

12. We may reject your warranty claim if:

12.1. The unit was not installed by registered and qualified tradespeople.

12.2. The unit was not installed and commissioned:

(a) in Australia;

(b) in accordance with the Operating and Installation Guide; and

(c) in accordance with the relevant statutory and local requirements of the State or Territory in which the unit is installed.

12.3. The unit has not been operated or maintained in accordance with the Operating and Installation Guide.

12.4. The unit does not bear its original Serial Number or Rating Label.

12.5. The unit was damaged by any or any combination of the following:

(a) normal fair wear and tear;

(b) connection to an incorrect water supply;

(c) connection to water from a bore, dam or swimming pool;

(d) connection to an incorrect power supply;

(e) connection to faulty equipment, such as damaged valves;

(f) foreign matter in the water supply, such as sludge or sediment;

(g) corrosive elements in the water supply;

(h) accidental damage;

(i) act of God, including damage by flood, storm, fire, lightning strike and the like;

(j) excessive water pressure, negative water pressure (partial vacuum) or water pressure pulsation.

12.6. The unit was damaged before it was installed e.g. it was damaged in transit.

12.7. An unauthorised person has modified, serviced, repaired or attempted to repair the unit without our consent.

12.8. Non genuine parts other than those manufactured or approved by us have been used on the unit.

13. We may charge you:

13.1. for any additional transport costs if the unit is installed more than 30 kilometres from our closest authorised service technician.

13.2. for the extra time it takes our authorised service technician to access the unit for inspection and testing if it is not sited in accordance with the Operating and Installation Guide and not readily accessible for inspection.

13.3. for any extra costs of our authorised service technician to make the unit safe for inspection.

14. You must ensure that access to the unit by our authorised service technician is safe and free from obstruction.

15. Our authorised service technician may refuse to inspect and test the unit until you provide safe and free access to it, at your cost.

16. If we reject your warranty claim in accordance with clause 12, we may charge you for our authorised service technician's labour costs to inspect and test the unit.

17. In order to properly test the unit we may remove it to another location for testing.

Australian Consumer Law

18. Our goods come with guarantees that cannot be excluded under the Australian Consumer Law. You are entitled to a replacement or refund for a major failure and compensation for any other reasonably foreseeable loss or damage. You are also entitled to have the goods repaired or replaced if the goods fail to be of acceptable quality and the failure does not amount to a major failure.

19. The Stiebel Eltron warranty for the unit is in addition to any rights and remedies you may have under the Australian Consumer Law.