

## 5. Maximum Conducted Output Power

### 5.1. Test setup

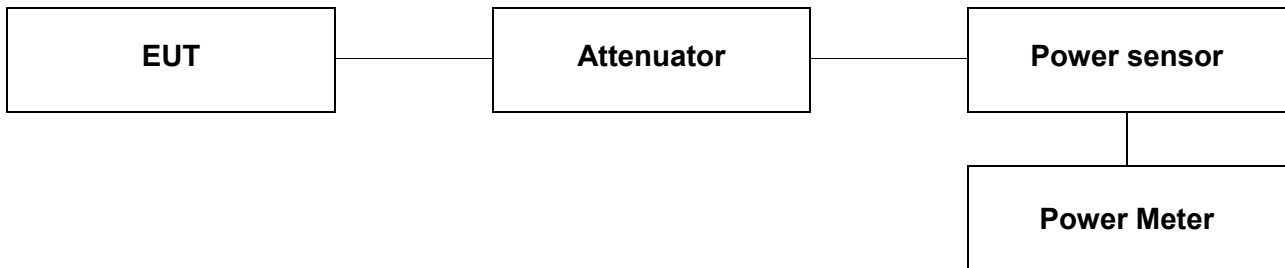

### 5.2. Limit

#### FCC 15.407 (a)(1)(iv)

For mobile and portable client devices in the 5.15-5.25 GHz band, the maximum conducted output power over the frequency band of operation shall not exceed 250 mW provided the maximum antenna gain does not exceed 6 dB i. In addition, the maximum power spectral density shall not exceed 11 dB m in any 1 megahertz band. If transmitting antennas of directional gain greater than 6 dB i are used, both the maximum conducted output power and the maximum power spectral density shall be reduced by the amount in dB that the directional gain of the antenna exceeds 6 dB i.

#### (a)(2)

For the 5.25-5.35 GHz and 5.47-5.725 GHz bands, the maximum conducted output power over the frequency bands of operation shall not exceed the lesser of 250 mW or 11 dB m + 10 log B, where B is the 26 dB emission bandwidth in megahertz. In addition, the maximum power spectral density shall not exceed 11 dB m in any 1 megahertz band. If transmitting antennas of directional gain greater than 6 dB i are used, both the maximum conducted output power and the maximum power spectral density shall be reduced by the amount in dB that the directional gain of the antenna exceeds 6 dB i.

#### (a)(3)

For the band 5.725-5.85 GHz, the maximum conducted output power over the frequency band of operation shall not exceed 1 W. In addition, the maximum power spectral density shall not exceed 30 dB m in any 500-kHz band. If transmitting antennas of directional gain greater than 6 dB i are used, both the maximum conducted output power and the maximum power spectral density shall be reduced by the amount in dB that the directional gain of the antenna exceeds 6 dB i. However, fixed point-to point U-NII devices operating in this band may employ transmitting antennas with directional gain greater than 6 dB i without any corresponding reduction in transmitter conducted power. Fixed, point-to-point operations exclude the use of point-to-multipoint systems, omnidirectional applications, and multiple collocated transmitters transmitting the same information. The operator of the U-NII device, or if the equipment is professionally installed, the installer, is responsible for ensuring that systems employing high gain directional antennas are used exclusively for fixed, point-to-point operations.

*The results shown in this test report refer only to the sample(s) tested unless otherwise stated. This test report cannot be reproduced, except in full, without prior written permission of the Company.*

**SGS Korea Co., Ltd. (Gunpo Laboratory)** 4, LS-ro 182beon-gil, Gunpo-si, Gyeonggi-do, Korea, 15807 <http://www.sgsgroup.kr>

---

### 5.3. Test procedure

1. This measurement settings are specified in section E.3.a of KDB 789033\_v01r02.
2. Measurements may be performed using a wideband RF power meter with a thermocouple detector or equivalent if all of the conditions listed below are satisfied.
  - The EUT is configured to transmit continuously or to transmit with a consistent duty cycle.
  - At all times when the EUT is transmitting, it must be transmitting at its maximum power control level.
  - The integration period of the power meter exceeds the repetition period of the transmitted signal by at least a factor of five.
3. If the transmitter does not transmit continuously, measure the duty cycle,  $x$ , of the transmitter output signal as described in section II.B.
4. Measure the average power of the transmitter. This measurement is an average over both the on and off periods of the transmitter.
5. Adjust the measurement in dB m by adding  $10 \log (1/x)$  where  $x$  is the duty cycle (e.g.,  $10 \log(1/0.25)$  if the duty cycle is 25 percent).
6. In case of band crossing channels 138, 142 and 144, the measurement is complied with section E.2.d of KDB 789033\_D02 v01r02 and section D of KDB 644545\_D03 v01.

---

*The results shown in this test report refer only to the sample(s) tested unless otherwise stated. This test report cannot be reproduced, except in full, without prior written permission of the Company.*

#### 5.4. Test result

Ambient temperature : (23 ± 1) °C

Relative humidity : 47 % R.H.

##### - 11a

U-NII 1	Frequency (MHz)	Conducted Power (dB m)			
		Data Rate [Mbps]	Average Power (dB m)	Duty Correction Factor (dB)	Average Power Result (dB m)
ANT1	5 180	6	7.28	0.09	7.37
	5 200	6	7.94	0.09	8.03
	5 240	6	8.63	0.09	<b>8.72</b>
ANT2	5 180	6	7.78	0.09	7.87
	5 200	6	7.46	0.09	7.55
	5 240	6	7.47	0.09	7.56

U-NII 2A	Frequency (MHz)	Conducted Power (dB m)			
		Data Rate [Mbps]	Average Power (dB m)	Duty Correction Factor (dB)	Average Power Result (dB m)
ANT1	5 260	6	9.11	0.09	9.20
	5 280	6	9.34	0.09	<b>9.43</b>
	5 320	6	8.93	0.09	9.02
ANT2	5 260	6	7.76	0.09	7.85
	5 280	6	8.04	0.09	8.13
	5 320	6	7.32	0.09	7.41

U-NII 2C	Frequency (MHz)	Conducted Power (dB m)			
		Data Rate [Mbps]	Average Power (dB m)	Duty Correction Factor (dB)	Average Power Result (dB m)
ANT1	5 500	6	6.90	0.09	6.99
	5 580	6	4.78	0.09	4.87
	5 720	6	6.29	0.09	6.38
ANT2	5 500	6	7.23	0.09	<b>7.32</b>
	5 580	6	6.12	0.09	6.21
	5 720	6	5.42	0.09	5.51

The results shown in this test report refer only to the sample(s) tested unless otherwise stated. This test report cannot be reproduced, except in full, without prior written permission of the Company.

U-NII 3	Frequency (MHz)	Conducted Power (dB m)			
		Data Rate [Mbps]	Average Power (dB m)	Duty Correction Factor (dB)	Average Power Result (dB m)
ANT1	5 745	6	7.86	0.09	7.95
	5 785	6	7.92	0.09	8.01
	5 825	6	8.22	0.09	<b>8.31</b>
ANT2	5 745	6	5.50	0.09	5.59
	5 785	6	4.73	0.09	4.82
	5 825	6	4.10	0.09	4.19

Band	Conducted Power Limit (dB m)					
	Frequency (MHz)	Fixed Limit (dB m)	26 dB BW (MHz)	11+10LogB (dB m)	Antenna gain (dB i)	Limit (dB m)
U-NII 1	5 180	23.98	/		2.7	23.98
	5 200					
	5 220					
U-NII 2A	5 260	23.98	21.36	24.30	2.7	23.98
	5 280		21.48	24.32		23.98
	5 320		21.59	24.34		23.98
U-NII 2C	5 500	23.98	21.59	24.34	2.7	23.98
	5 580		21.59	24.34		23.98
	5 720		21.48	24.32		23.98
U-NII 3	5 745	30	/		2.7	30
	5 785					
	5 825					

Remark:

1. Result (dB m) = Average Power(dB m) + Duty Correction Factor (dB)

The results shown in this test report refer only to the sample(s) tested unless otherwise stated. This test report cannot be reproduced, except in full, without prior written permission of the Company.

SGS Korea Co., Ltd. (Gunpo Laboratory) 4, LS-ro 182beon-gil, Gunpo-si, Gyeonggi-do, Korea, 15807 <http://www.sgsgroup.kr>

**- 11n\_HT20**

Band	Frequency (MHz)	Conducted Power (dB m)					
		Data Rate [Mbps]	Average Power – ANT1 (dB m)	Average Power – ANT2 (dB m)	ANT1+2 (dB m)	Duty Correction Factor (dB)	Average Power Result (dB m)
U-NII 1	5 180	MCS8	8.38	8.43	11.42	0.13	11.55
	5 200	MCS8	9.03	8.48	11.77	0.13	11.90
	5 240	MCS8	9.63	8.63	12.17	0.13	<b>12.30</b>
U-NII 2A	5 260	MCS8	9.66	8.50	12.13	0.13	12.26
	5 280	MCS8	9.93	8.60	12.33	0.13	<b>12.46</b>
	5 320	MCS8	9.30	7.80	11.62	0.13	11.75
U-NII 2C	5 500	MCS8	7.43	7.74	10.60	0.13	<b>10.73</b>
	5 580	MCS8	5.52	6.46	9.03	0.13	9.16
	5 720	MCS8	7.20	5.72	9.53	0.13	9.66
U-NII 3	5 745	MCS8	8.68	6.57	10.76	0.13	<b>10.89</b>
	5 785	MCS8	8.86	5.39	10.47	0.13	10.60
	5 825	MCS8	9.10	4.09	10.29	0.13	10.42

Band	Conducted Power Limit (dB m)					
	Frequency (MHz)	Fixed Limit (dB m)	26 dB BW (MHz)	11+10LogB (dB m)	Antenna gain (dB i)	Limit (dB m)
U-NII 1	5 180	23.98	/		2.7	23.98
	5 200					
	5 220					
U-NII 2A	5 260	23.98	21.48	24.32	2.7	23.98
	5 280		21.59	24.34		
	5 320		21.71	24.37		
U-NII 2C	5 500	23.98	21.88	24.40	2.7	23.98
	5 580		21.77	24.38		
	5 720		21.48	24.32		
U-NII 3	5 745	30	/		2.7	30
	5 785					
	5 825					

Remark:

- Result (dB m) = Average Power(dB m) + Duty Correction Factor (dB)
- According to KDB 662911 v02r01, power of each port (Ant1 + Ant2) was combined by using below calculation.  
 Power:  $10\log\{10^{(ANT1\ power/10)}+10^{(ANT2\ power/10)}\}$

The results shown in this test report refer only to the sample(s) tested unless otherwise stated. This test report cannot be reproduced, except in full, without prior written permission of the Company.

**- 11n\_HT40**

Band	Frequency (MHz)	Conducted Power (dB m)					
		Data Rate [Mbps]	Average Power – ANT1 (dB m)	Average Power – ANT2 (dB m)	ANT1+2 (dB m)	Duty Correction Factor (dB)	Average Power Result (dB m)
U-NII 1	5 190	MCS8	6.35	6.01	9.19	0.22	<b>9.41</b>
U-NII 2A	5 270	MCS8	7.21	6.22	9.75	0.22	<b>9.97</b>
	5 310	MCS8	7.01	5.60	9.37	0.22	9.59
U-NII 2C	5 510	MCS8	5.35	5.84	8.61	0.22	8.83
	5 550	MCS8	5.62	6.56	9.13	0.22	<b>9.35</b>
	5 710	MCS8	4.84	3.66	7.30	0.22	7.52
U-NII 3	5 755	MCS8	6.16	4.22	8.31	0.22	<b>8.53</b>
	5 795	MCS8	6.47	2.99	8.08	0.22	8.30

Band	Conducted Power Limit (dB m)					
	Frequency (MHz)	Fixed Limit (dB m)	26 dB BW (MHz)	11+10LogB (dB m)	Antenna gain (dB i)	Limit (dB m)
U-NII 1	5 190	23.98			2.7	23.98
U-NII 2A	5 270	23.98	40.29	27.05	2.7	23.98
	5 310		40.41	27.06		
U-NII 2C	5 510	23.98	40.41	27.06	2.7	23.98
	5 550		40.41	27.06		
	5 710		41.04	27.13		
U-NII 3	5 755	30			2.7	30
	5 955					

Remark:

1. Result (dB m) = Average Power (dB m) + Duty Correction Factor (dB)
2. According to KDB 662911 v02r01, power of each port (Ant1 + Ant2) was combined by using below calculation.  
 Power:  $10\log\{10^{(ANT1\ power/10)}+10^{(ANT2\ power/10)}\}$

The results shown in this test report refer only to the sample(s) tested unless otherwise stated. This test report cannot be reproduced, except in full, without prior written permission of the Company.

**- 11ac\_VHT80**

Band	Frequency (MHz)	Conducted Power (dB m)					
		Data Rate [MCS]	Average Power – ANT1 (dB m)	Average Power – ANT2 (dB m)	ANT1+2 (dB m)	Duty Correction Factor (dB)	Average Power Result (dB m)
U-NII 2A	5 290	0	7.51	5.99	9.83	0.41	<b>10.24</b>
U-NII 2C	5 530	0	6.05	6.20	9.14	0.41	<b>9.55</b>
	5 690	0	4.94	3.97	7.49	0.41	7.90
U-NII 3	5 775	0	6.46	3.79	8.34	0.41	<b>8.75</b>

Band	Conducted Power Limit (dB m)					
	Frequency (MHz)	Fixed Limit (dB m)	26 dB BW (MHz)	11+10LogB (dB m)	Antenna gain (dB i)	Limit (dB m)
U-NII 2A	5 290	23.98	82.89	30.19	2.7	23.98
U-NII 2C	5 530	23.98	82.66	30.17	2.7	23.98
	5 690		83.59	30.22		
U-NII 3	5 775	30			2.7	30

Remark:

1. Result (dB m) = Average Power (dB m) + Duty Correction Factor (dB)
2. According to KDB 662911 v02r01, power of each port (Ant1 + Ant2) was combined by using below calculation.  
 Power:  $10\log\{10^{(ANT1\ power/10)}+10^{(ANT2\ power/10)}\}$

The results shown in this test report refer only to the sample(s) tested unless otherwise stated. This test report cannot be reproduced, except in full, without prior written permission of the Company.

**-Band-crossing channels**

Band	Mode	Frequency (MHz)	Conducted Power (dB m)		
			Average Power (dB m)	Duty Correction Factor (dB)	Average Power Result (dB m)
U-NII 2C	11a - ANT1	5 720	5.43	0.09	5.52
U-NII 3			-0.23	0.09	-0.14
U-NII 2C	11a - ANT2		4.79	0.09	4.88
U-NII 3			-1.33	0.09	-1.24

Band	Mode	Frequency (MHz)	Conducted Power (dB m)				
			Average Power - ANT1 (dB m)	Average Power - ANT2 (dB m)	ANT1+2 (dB m)	Duty Correction Factor (dB)	Average Power Result (dB m)
U-NII 2C	11n_HT20	5 720	6.15	5.10	8.67	0.13	8.80
U-NII 3			0.98	-0.29	3.40	0.13	3.53
U-NII 2C	11n_HT40	5 710	4.43	3.24	6.89	0.22	7.11
U-NII 3			-5.20	-6.47	-2.78	0.22	-2.56
U-NII 2C	11ac_VHT80	5 690	4.90	4.15	7.55	0.41	7.96
U-NII 3			-8.52	-9.67	-6.05	0.41	-5.64

Band	Mode	Conducted Power Limit (dB m)					
		Frequency (MHz)	Fixed Limit (dB m)	26 dB BW (MHz)	11+10LogB (dB m)	Antenna gain (dB i)	Limit (dB m)
U-NII 2C	11a	5 720	23.98	15.48	22.90	2.7	22.90
U-NII 3							
U-NII 2C	11n_HT20	5 720	23.98	15.48	22.90	2.7	22.90
U-NII 3							
U-NII 2C	11n_HT40	5 710	23.98	34.93	26.43	2.7	23.98
U-NII 3							
U-NII 2C	11ac_VHT80	5 690	23.98	75.68	29.79	2.7	23.98
U-NII 3							

Remark:

- Result (dB m) = Average Power(dB m) + Duty Correction Factor (dB)
- According to KDB 662911 v02r01, power of each port (Ant1 + Ant2) was combined by using below calculation.  
 Power:  $10\log\{10^{(ANT1\ power/10)}+10^{(ANT2\ power/10)}\}$

The results shown in this test report refer only to the sample(s) tested unless otherwise stated. This test report cannot be reproduced, except in full, without prior written permission of the Company.



## Band-crossing channels

### 802.11a (5 720 MHz)\_ANT 1

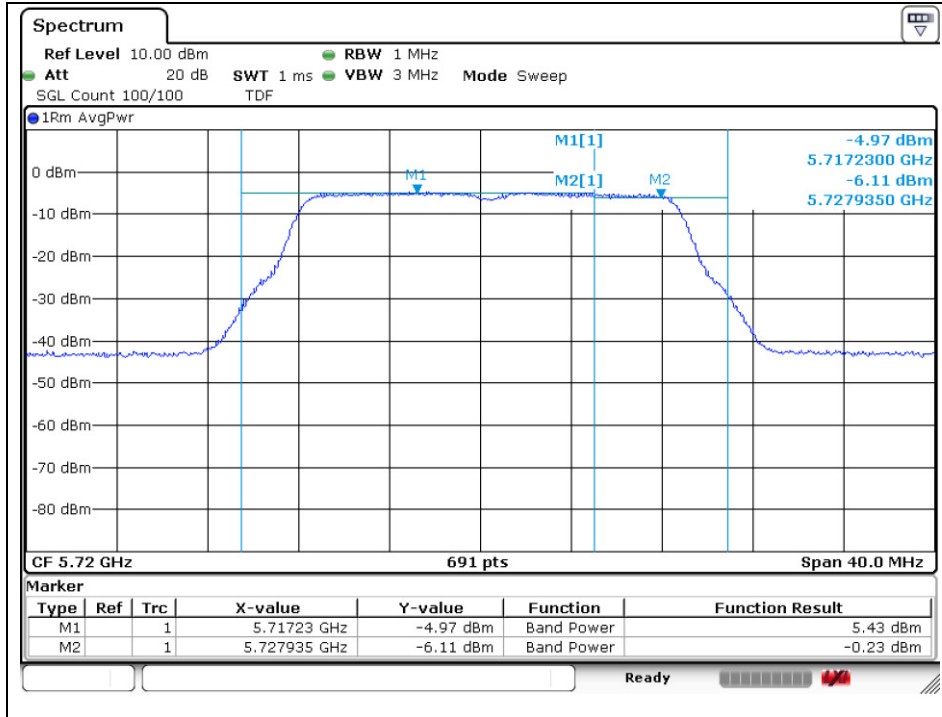

### 802.11a (5 720 MHz)\_ANT 2

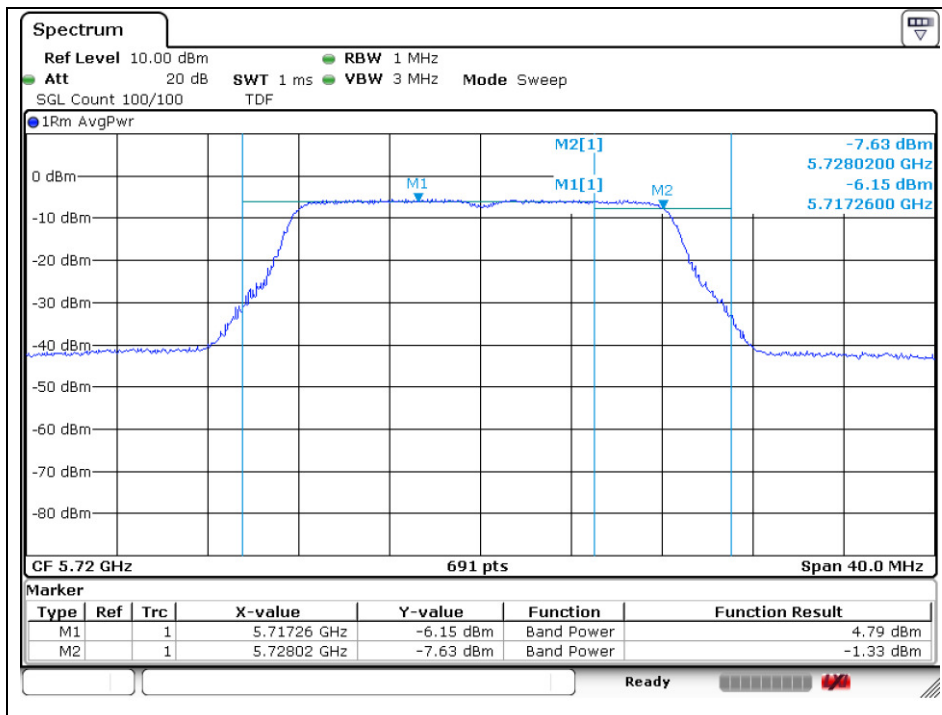

The results shown in this test report refer only to the sample(s) tested unless otherwise stated. This test report cannot be reproduced, except in full, without prior written permission of the Company.

### 802.11n\_HT20 (5 720 MHz)\_ANT1

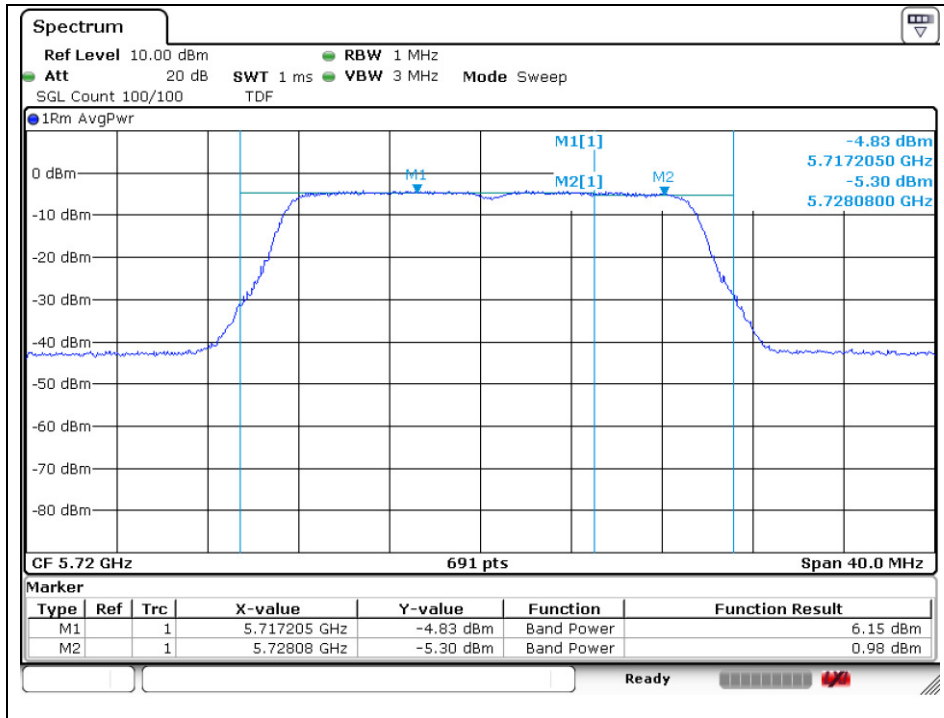

### 802.11n\_HT20 (5 720 MHz)\_ANT2

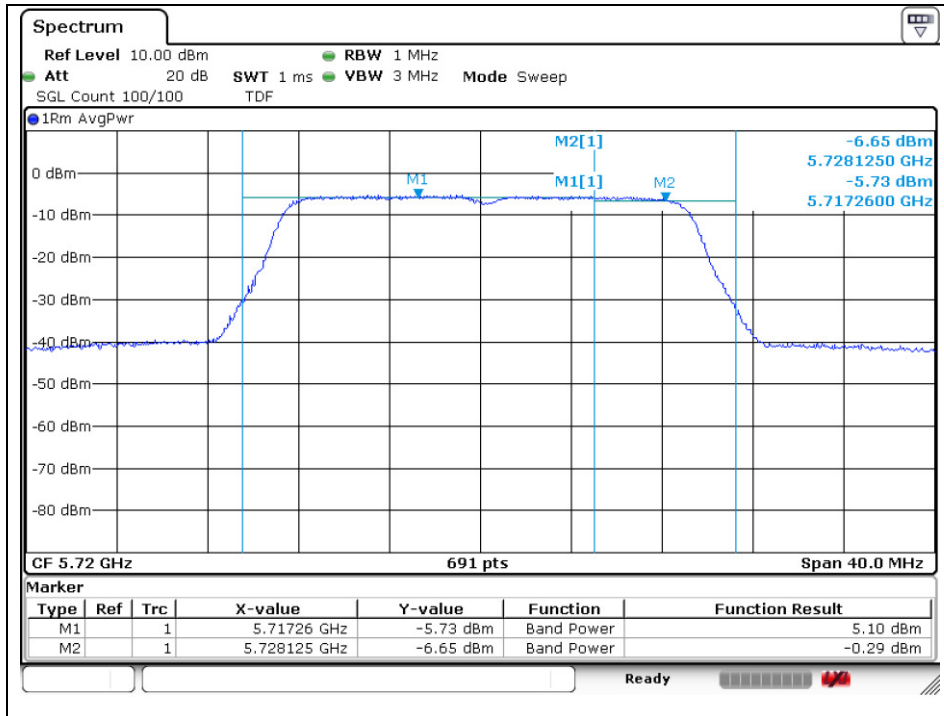

The results shown in this test report refer only to the sample(s) tested unless otherwise stated. This test report cannot be reproduced, except in full, without prior written permission of the Company.

## 802.11n\_HT40 (5 710 MHz)\_ANT1

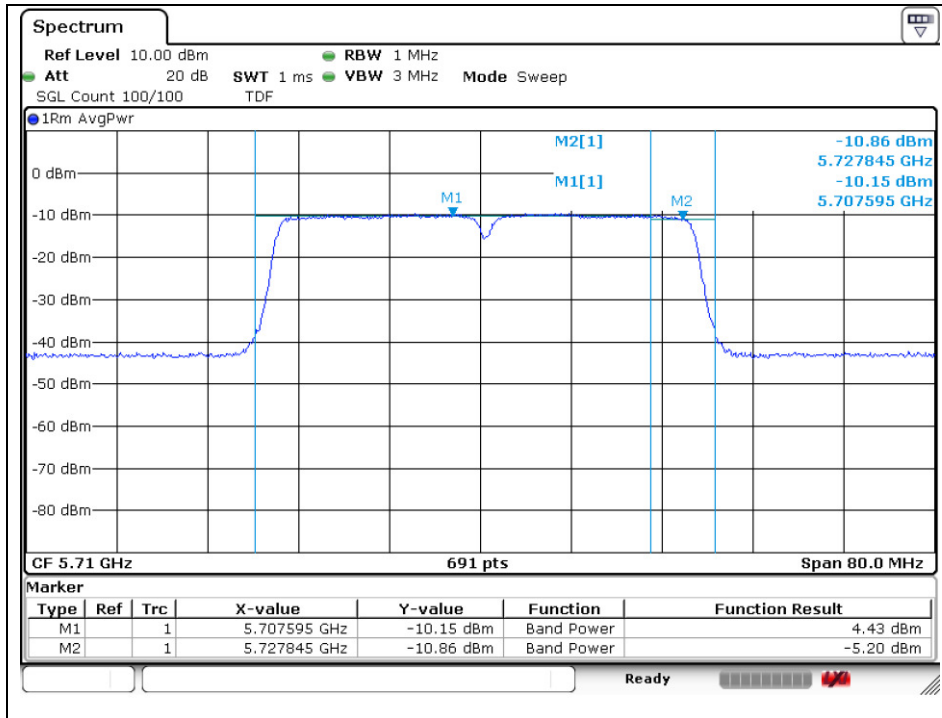

## 802.11n\_HT40 (5 710 MHz)\_ANT2

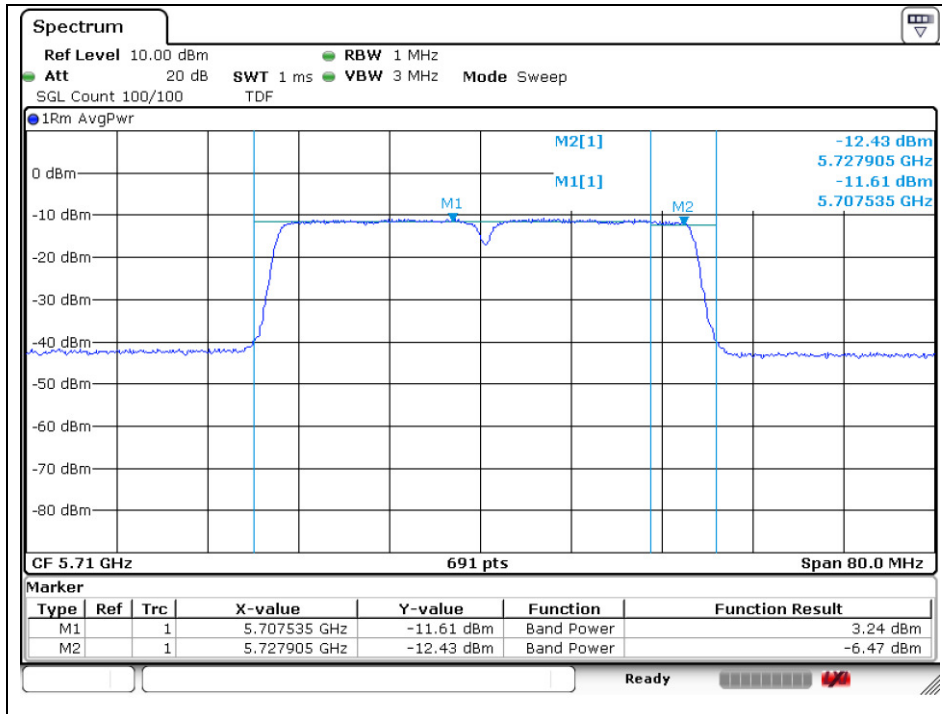

The results shown in this test report refer only to the sample(s) tested unless otherwise stated. This test report cannot be reproduced, except in full, without prior written permission of the Company.

### 802.11ac\_VHT80 (5 690 MHz)\_ANT1

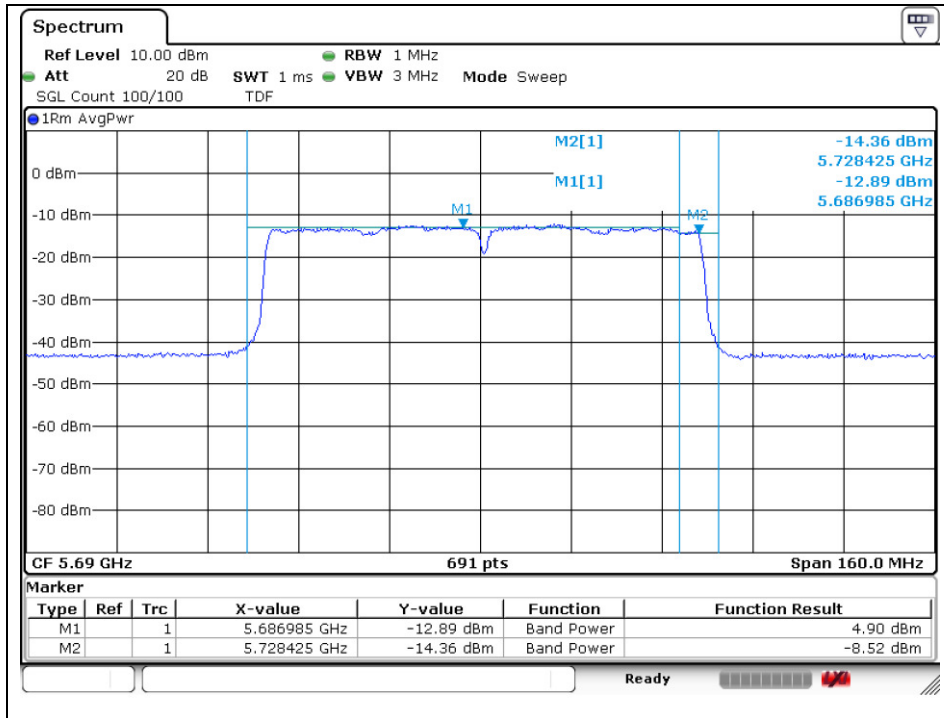

### 802.11ac\_VHT80 (5 690 MHz)\_ANT2

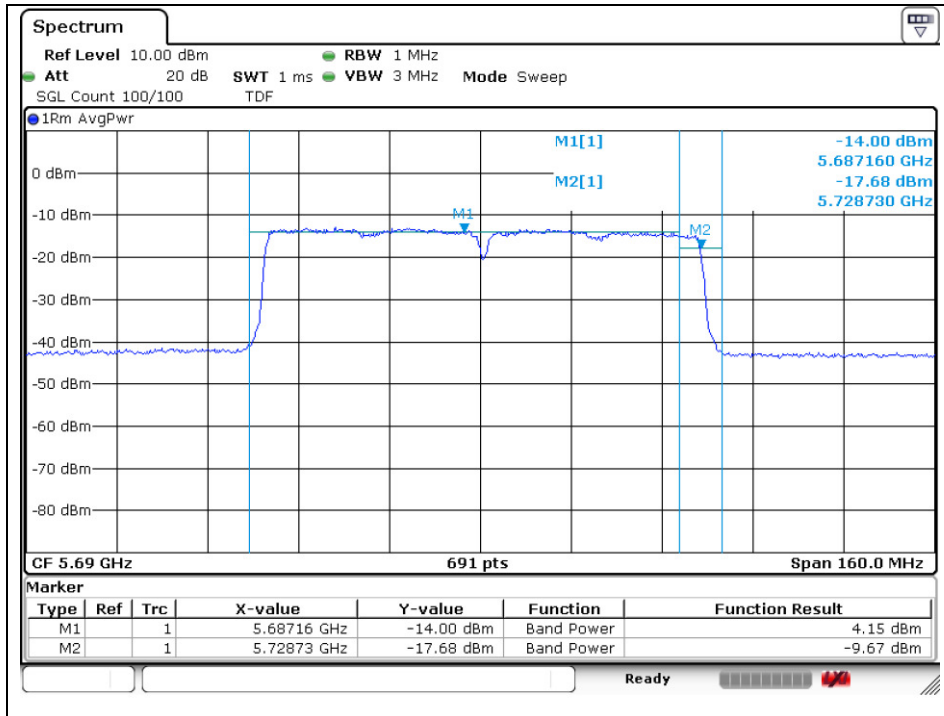

The results shown in this test report refer only to the sample(s) tested unless otherwise stated. This test report cannot be reproduced, except in full, without prior written permission of the Company.

## 6. Peak Power Spectral Density

### 6.1. Test setup



### 6.2. Limit

#### FCC 15.407 (a)(1)(iv)

For mobile and portable client devices in the 5.15-5.25 GHz band, the maximum conducted output power over the frequency band of operation shall not exceed 250 mW provided the maximum antenna gain does not exceed 6 dBi. In addition, the maximum power spectral density shall not exceed 11 dBm in any 1 megahertz band. If transmitting antennas of directional gain greater than 6 dBi are used, both the maximum conducted output power and the maximum power spectral density shall be reduced by the amount in dB that the directional gain of the antenna exceeds 6 dBi.

#### (a)(2)

For the 5.25-5.35 GHz and 5.47-5.725 GHz bands, the maximum conducted output power over the frequency bands of operation shall not exceed the lesser of 250 mW or  $11 \text{ dBm} + 10 \log B$ , where B is the 26 dB emission bandwidth in megahertz. In addition, the maximum power spectral density shall not exceed 11 dBm in any 1 megahertz band. If transmitting antennas of directional gain greater than 6 dBi are used, both the maximum conducted output power and the maximum power spectral density shall be reduced by the amount in dB that the directional gain of the antenna exceeds 6 dBi.

#### (a)(3)

For the band 5.725-5.85 GHz, the maximum conducted output power over the frequency band of operation shall not exceed 1 W. In addition, the maximum power spectral density shall not exceed 30 dBm in any 500-kHz band. If transmitting antennas of directional gain greater than 6 dBi are used, both the maximum conducted output power and the maximum power spectral density shall be reduced by the amount in dB that the directional gain of the antenna exceeds 6 dBi. However, fixed point-to-point U-NII devices operating in this band may employ transmitting antennas with directional gain greater than 6 dBi without any corresponding reduction in transmitter conducted power. Fixed, point-to-point operations exclude the use of point-to-multipoint systems, omnidirectional applications, and multiple collocated transmitters transmitting the same information. The operator of the U-NII device, or if the equipment is professionally installed, the installer, is responsible for ensuring that systems employing high gain directional antennas are used exclusively for fixed, point-to-point operations.

*The results shown in this test report refer only to the sample(s) tested unless otherwise stated. This test report cannot be reproduced, except in full, without prior written permission of the Company.*

**SGS Korea Co., Ltd. (Gunpo Laboratory)** 4, LS-ro 182beon-gil, Gunpo-si, Gyeonggi-do, Korea, 15807 <http://www.sgsgroup.kr>

### 6.3. Test procedure

All data rates and modes were investigated for this test. The full data for the worst case data rate are reported in this section.

1. This measurement settings are specified in section F of KDB 789033\_v01r02.
  2. Create an average power spectrum for the EUT operating mode being tested by following the instructions in section II.E.2. for measuring maximum conducted output power using a spectrum analyzer or EMI receiver: select the appropriate test method (SA-1, SA-2, SA-3, or alternatives to each) and apply it up to, but not including, the step labeled, "Compute power...". (This procedure is required even if the maximum conducted output power measurement was performed using a power meter, method PM.)
  3. Use the peak search function on the instrument to find the peak of the spectrum and record its value.
  4. Make the following adjustments to the peak value of the spectrum, if applicable:
    - a) **If Method SA-2 or SA-2 Alternative was used, add  $10 \log(1/x)$ , where  $x$  is the duty cycle, to the peak of the spectrum.**
    - b) If Method SA-3 Alternative was used and the linear mode was used in step II.E.2.g)(viii), add 1 dB to the final result to compensate for the difference between linear averaging and power averaging.
  5. The result is the Maximum PSD over 1 MHz reference bandwidth.
  6. For devices operating in the bands 5.15-5.25 GHz, 5.25-5.35 GHz, and 5.47-5.725 GHz, the above procedures make use of 1 MHz RBW to satisfy directly the 1 MHz reference bandwidth specified in § 15.407(a)(5). For devices operating in the band 5.725-5.85 GHz, the rules specify a measurement bandwidth of 500 kHz. Many spectrum analyzers do not have 500 kHz RBW, thus a narrower RBW may need to be used. The rules permit the use of a RBWs less than 1 MHz, or 500 kHz, "provided that the measured power is integrated over the full reference bandwidth" to show the total power over the specified measurement bandwidth (*i.e.*, 1 MHz, or 500 kHz). If measurements are performed using a reduced resolution bandwidth ( $< 1$  MHz, or  $< 500$  kHz) and integrated over 1 MHz, or 500 kHz bandwidth, the following adjustments to the procedures apply:
    - a) Set  $RBW \geq 1/T$ , where  $T$  is defined in section II.B.I.a).
    - b) Set  $VBW \geq 3$  RBW.
    - c) If measurement bandwidth of Maximum PSD is specified in 500 kHz, add  $10\log(500 \text{ kHz}/RBW)$  to the measured result, whereas RBW ( $< 500$  kHz) is the reduced resolution bandwidth of the spectrum analyzer set during measurement.
    - d) If measurement bandwidth of Maximum PSD is specified in 1 MHz, add  $10\log(1 \text{ MHz}/RBW)$  to the measured result, whereas RBW ( $< 1$  MHz) is the reduced resolution bandwidth of spectrum analyzer set during measurement.
    - e) Care must be taken to ensure that the measurements are performed during a period of continuous transmission or are corrected upward for duty cycle.
- Note: As a practical matter, it is recommended to use reduced RBW of 100 kHz for the sections 5.c) and 5.d) above, since RBW = 100 kHz is available on nearly all spectrum analyzers.
7. In case of band crossing channels 138, 142 and 144, the measurement is complied with section D of KDB 644545\_D03 v01.

*The results shown in this test report refer only to the sample(s) tested unless otherwise stated. This test report cannot be reproduced, except in full, without prior written permission of the Company.*

## 6.4. Test result

Ambient temperature : (23 ± 1) °C  
 Relative humidity : 47 % R.H.

### 11a - ANT1

Band	Frequency (MHz)	Ch.	Data Rate (Mbps)	Measured PPSD (dB m)	Duty Factor (dB)	Final PPSD (dB m)	Limit (dB m/1 MHz)
U-NII 1	5 180	36	6	-0.47	0.09	-0.38	11
	5 200	40	6	-0.13	0.09	-0.04	
	5 220	44	6	0.59	0.09	0.68	
U-NII 2A	5 260	52	6	-1.95	0.09	-1.86	
	5 280	56	6	-1.67	0.09	-1.58	
	5 320	64	6	-1.97	0.09	-1.88	
U-NII 2C	5 500	100	6	-3.80	0.09	-3.71	
	5 580	116	6	-5.49	0.09	-5.40	
	5 720	144	6	-4.35	0.09	-4.26	
Band	Frequency (MHz)	Ch.	Data Rate (Mbps)	Measured PPSD (dB m)	Duty Factor (dB)	Final PPSD (dB m)	Limit (dB m/500 kHz)
U-NII 3	5 745	149	6	-3.96	0.09	-3.87	30
	5 785	157	6	-4.12	0.09	-4.03	
	5 825	165	6	-3.63	0.09	-3.54	

### 11a - ANT2

Band	Frequency (MHz)	Ch.	Data Rate (Mbps)	Measured PPSD (dB m)	Duty Factor (dB)	Final PPSD (dB m)	Limit (dB m/1 MHz)
U-NII 1	5 180	36	6	-0.35	0.09	-0.26	11
	5 200	40	6	-0.33	0.09	-0.24	
	5 220	44	6	-0.41	0.09	-0.32	
U-NII 2A	5 260	52	6	-3.57	0.09	-3.48	
	5 280	56	6	-3.11	0.09	-3.02	
	5 320	64	6	-4.08	0.09	-3.99	
U-NII 2C	5 500	100	6	-3.30	0.09	-3.21	
	5 580	116	6	-4.20	0.09	-4.11	
	5 720	144	6	-5.22	0.09	-5.13	
Band	Frequency (MHz)	Ch.	Data Rate (Mbps)	Measured PPSD (dB m)	Duty Factor (dB)	Final PPSD (dB m)	Limit (dB m/500 kHz)
U-NII 3	5 745	149	6	-5.99	0.09	-5.90	30
	5 785	157	6	-7.56	0.09	-7.47	
	5 825	165	6	-9.04	0.09	-8.95	

The results shown in this test report refer only to the sample(s) tested unless otherwise stated. This test report cannot be reproduced, except in full, without prior written permission of the Company.

**11n\_HT20**

Band	Frequency (MHz)	Ch.	Data Rate (Mbps)	ANT1	ANT2	ANT1+2	Duty Factor (dB)	Final PPSD (dB m)	Limit (dB m/1 MHz)
				Measured PPSD (dB m)	Measured PPSD (dB m)	Measured PPSD (dB m)			
U-NII 1	5 180	36	MCS8	-0.24	-0.20	2.79	0.13	2.92	11
	5 200	40	MCS8	0.38	-0.09	3.16	0.13	3.29	
	5 220	44	MCS8	1.05	0.10	3.61	0.13	3.74	
U-NII 2A	5 260	52	MCS8	-1.84	-2.83	0.70	0.13	0.83	
	5 280	56	MCS8	-1.49	-2.85	0.89	0.13	1.02	
	5 320	64	MCS8	-1.75	-3.72	0.39	0.13	0.52	
U-NII 2C	5 500	100	MCS8	-3.45	-3.46	-0.44	0.13	-0.31	
	5 580	116	MCS8	-5.01	-3.94	-1.43	0.13	-1.30	
	5 720	144	MCS8	-3.91	-5.03	-1.42	0.13	-1.29	
Band	Frequency (MHz)	Ch.	Data Rate (Mbps)	ANT1	ANT2	ANT1+2	Duty Factor (dB)	Final PPSD (dB m)	Limit (dB m/500 kHz)
				Measured PPSD (dB m)	Measured PPSD (dB m)	Measured PPSD (dB m)			
U-NII 3	5 745	149	MCS8	-3.25	-5.70	-1.29	0.13	-1.16	30
	5 785	157	MCS8	-3.34	-7.34	-1.88	0.13	-1.75	
	5 825	165	MCS8	-3.09	-8.30	-1.95	0.13	-1.82	

**11n\_HT40**

Band	Frequency (MHz)	Ch.	Data Rate (Mbps)	ANT1	ANT2	ANT1+2	Duty Factor (dB)	Final PPSD (dB m)	Limit (dB m/1 MHz)
				Measured PPSD (dB m)	Measured PPSD (dB m)	Measured PPSD (dB m)			
U-NII 1	5 190	38	MCS8	-5.08	-5.34	-2.20	0.22	-1.98	11
U-NII 2A	5 270	54	MCS8	-7.13	-8.13	-4.59	0.22	-4.37	
	5 310	62	MCS8	-7.26	-8.64	-4.89	0.22	-4.67	
U-NII 2C	5 510	102	MCS8	-8.16	-8.08	-5.11	0.22	-4.89	
	5 550	110	MCS8	-8.05	-6.83	-4.39	0.22	-4.17	
	5 710	142	MCS8	-9.33	-10.17	-6.72	0.22	-6.50	
Band	Frequency (MHz)	Ch.	Data Rate (Mbps)	ANT1	ANT2	ANT1+2	Duty Factor (dB)	Final PPSD (dB m)	Limit (dB m/500 kHz)
				Measured PPSD (dB m)	Measured PPSD (dB m)	Measured PPSD (dB m)			
U-NII 3	5 755	151	MCS8	-8.91	-11.47	-6.99	0.22	-6.77	30
	5 795	159	MCS8	-8.64	-12.62	-7.18	0.22	-6.96	

The results shown in this test report refer only to the sample(s) tested unless otherwise stated. This test report cannot be reproduced, except in full, without prior written permission of the Company.



**11ac\_VHT80**

Band	Frequency (MHz)	Ch.	Data Rate (Mbps)	ANT1	ANT2	ANT1+2	Duty Factor (dB)	Final PPSD (dB m)	Limit (dB m/1 MHz)
				Measured PPSD (dB m)	Measured PPSD (dB m)	Measured PPSD (dB m)			
U-NII 2A	5 290	58	MCS0	-9.40	-11.22	-7.21	0.41	-6.80	11
U-NII 2C	5 530	106	MCS0	-9.89	-9.96	-6.91	0.41	-6.50	
	5 690	138	MCS0	-11.98	-12.46	-9.20	0.41	-8.79	
Band	Frequency (MHz)	Ch.	Data Rate (Mbps)	ANT1	ANT2	ANT1+2	Duty Factor (dB)	Final PPSD (dB m)	Limit (dB m/500 kHz)
U-NII 3	5 775	155	MCS0	-11.65	-15.18	-10.06	0.41	-9.65	30

**Band-crossing channels**

Band	Mode	Frequency (MHz)	Ch.	Data Rate (Mbps)	Measured PPSD (dB m)	Duty Factor (dB)	Final PPSD (dB m)	Limit (dB m/500 kHz)
U-NII 3	11a - ANT1	5 720	144	6	-7.61	0.09	-7.52	30
	11a - ANT2	5 720	144	6	-8.29	0.09	-8.20	

Band	Mode	Frequency (MHz)	Ch.	Data Rate (Mbps)	ANT1	ANT2	ANT1+2	Duty Factor (dB)	Final PPSD (dB m)	Limit (dB m/500 kHz)
					Measured PPSD (dB m)	Measured PPSD (dB m)	Measured PPSD (dB m)			
U-NII 3	11n_HT20	5 720	144	MCS8	-7.30	-8.03	-5.82	0.13	-5.69	30
	11n_HT40	5 710	142	MCS8	-12.66	-13.14	-9.88	0.22	-9.66	
	11ac_VHT80	5 690	138	MCS0	-15.54	-16.17	-12.83	0.41	-12.42	

Note :

Final PPSD = Measured PPSD or Measured PPSD (ANT1+2) + Duty Factor

According to KDB 662911 v02r01, power spectral density of each port (ANT1 + ANT2) was combined by using below calculation.

PSD:  $10\log\{10^{(ANT1\ psd/10)}+10^{(ANT2\ psd/10)}\}$

The results shown in this test report refer only to the sample(s) tested unless otherwise stated. This test report cannot be reproduced, except in full, without prior written permission of the Company.

SGS Korea Co., Ltd. (Gunpo Laboratory) 4, LS-ro 182beon-gil, Gunpo-si, Gyeonggi-do, Korea, 15807 <http://www.sgsgroup.kr>

RTT5041-20(2015.10.01)(3)

Tel. +82 31 428 5700 / Fax. +82 31 427 2370

A4(210 mm x 297 mm)

## 802.11a (Band 1) - ANT1

Low Channel (5 180 MHz)

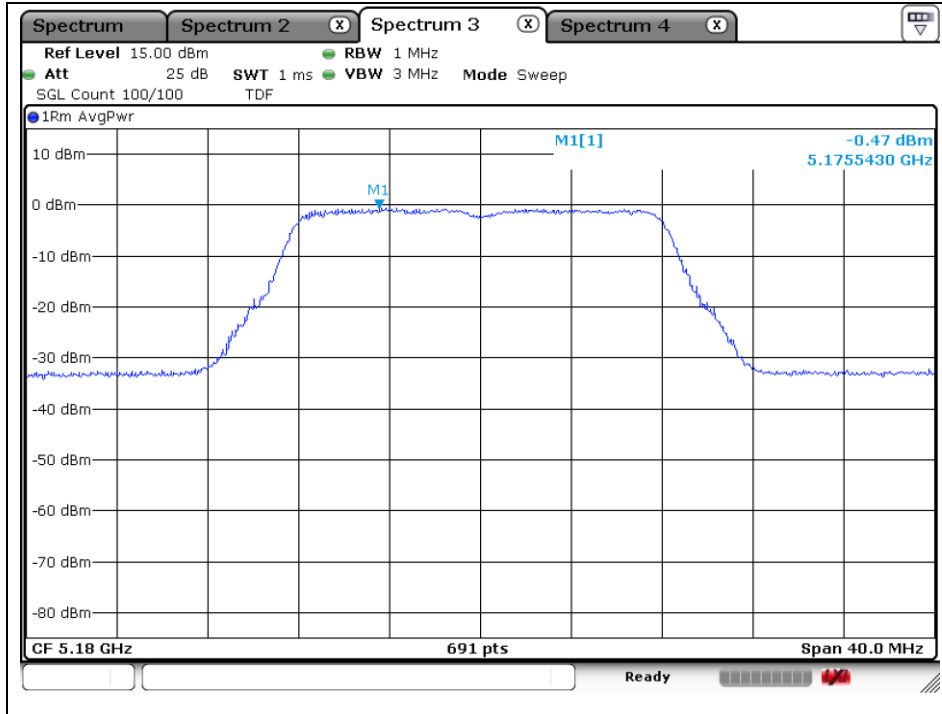

Middle Channel (5 200 MHz)

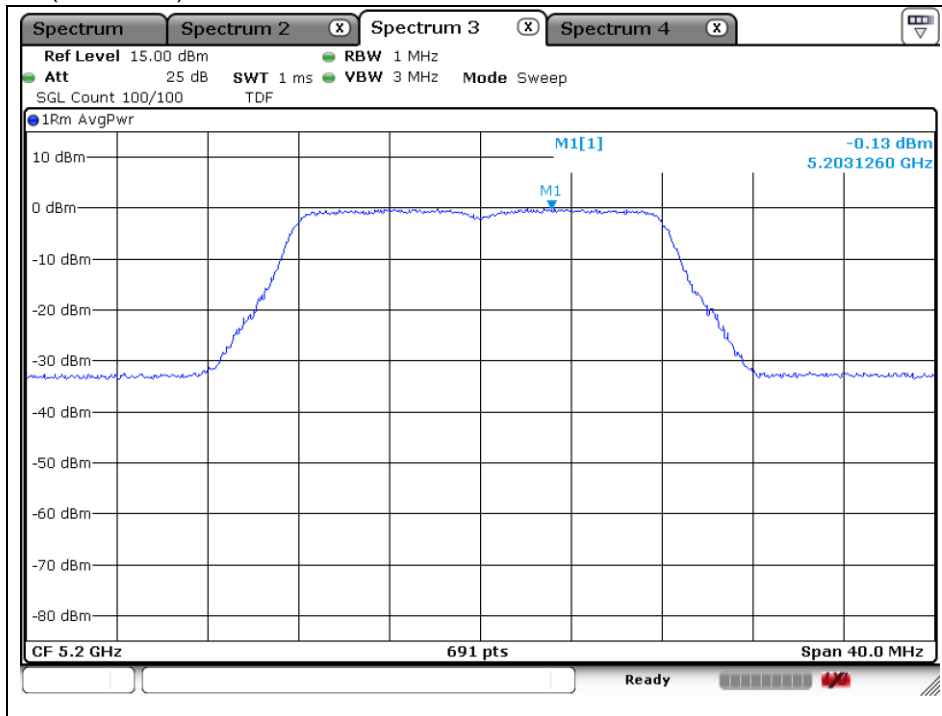

The results shown in this test report refer only to the sample(s) tested unless otherwise stated. This test report cannot be reproduced, except in full, without prior written permission of the Company.

High Channel (5 220 MHz)

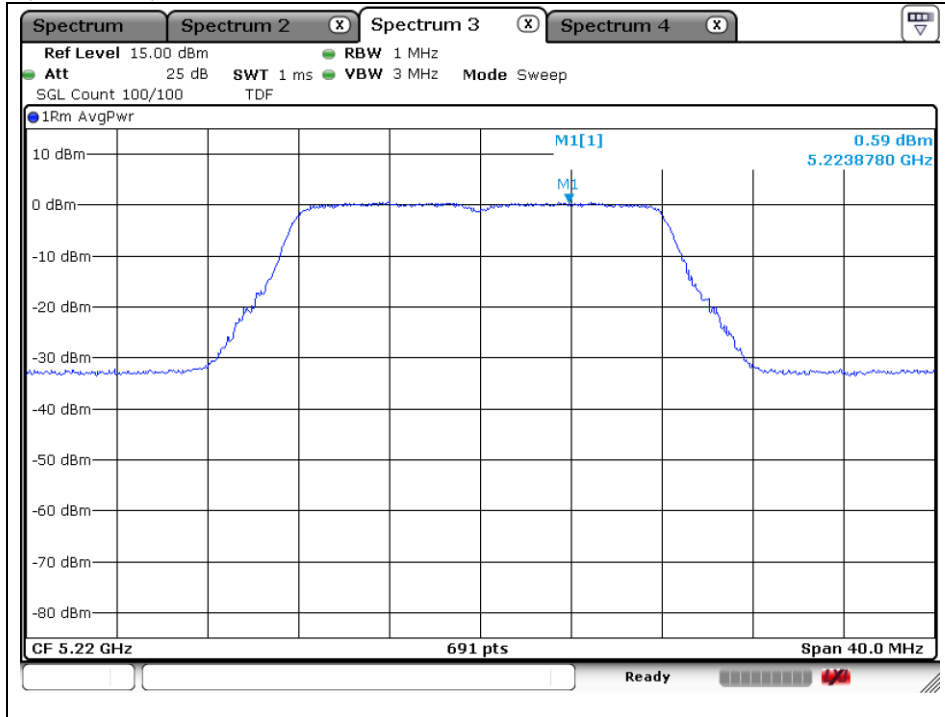

802.11a (Band 2A) - ANT1

Low Channel (5 260 MHz)

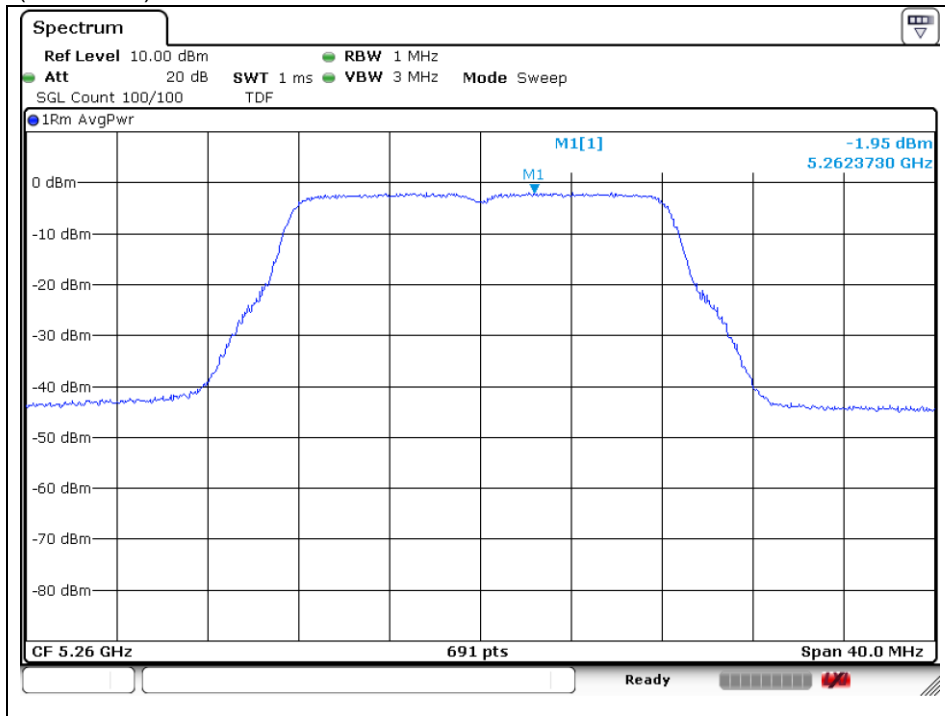

The results shown in this test report refer only to the sample(s) tested unless otherwise stated. This test report cannot be reproduced, except in full, without prior written permission of the Company.

Middle Channel (5 280 MHz)

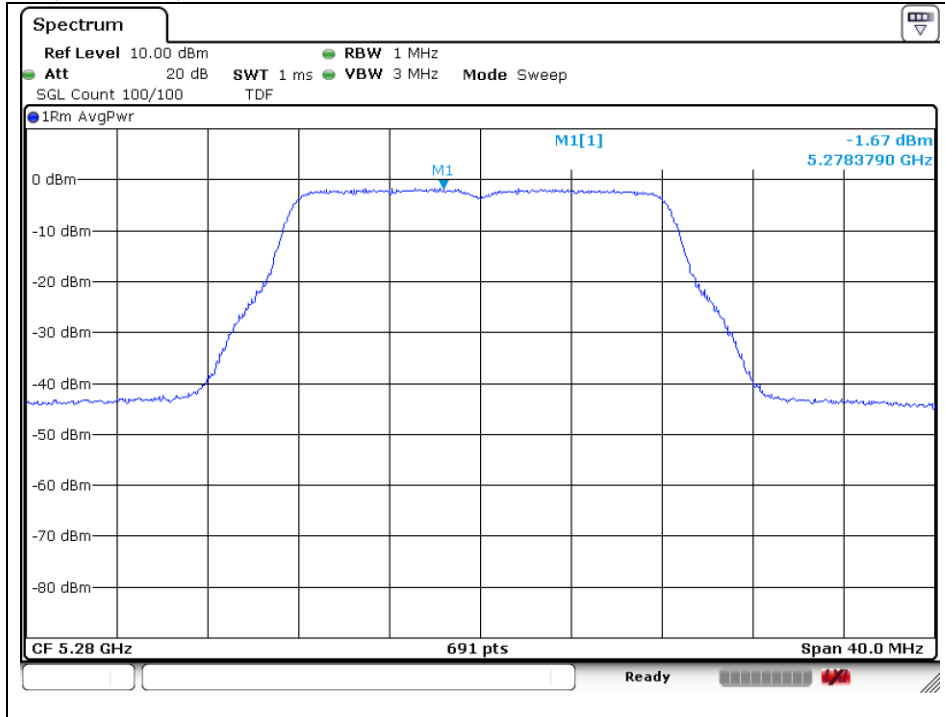

High Channel (5 320 MHz)

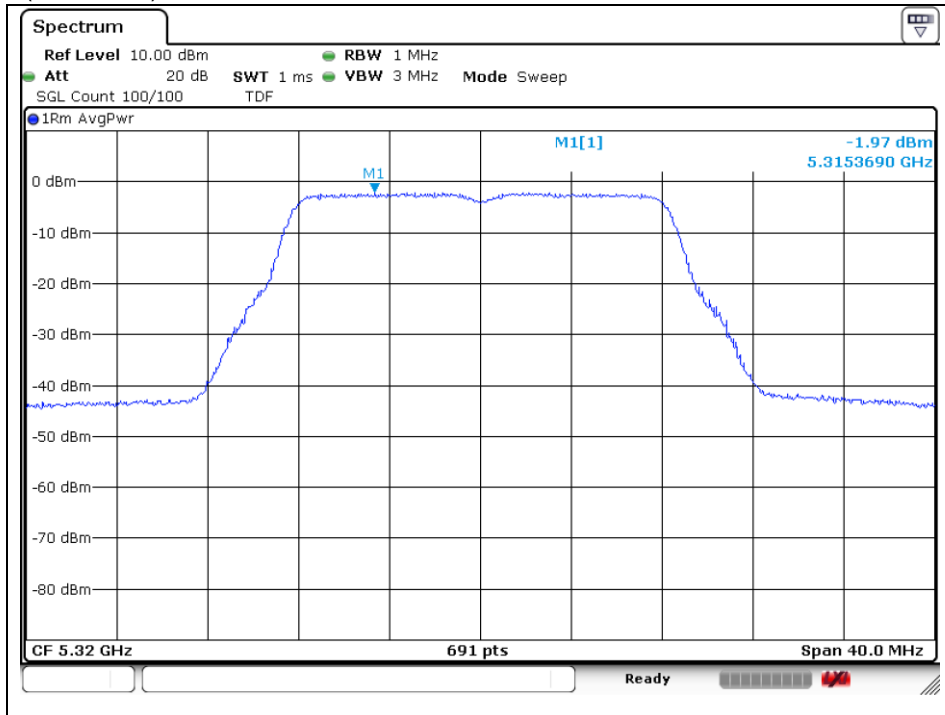

The results shown in this test report refer only to the sample(s) tested unless otherwise stated. This test report cannot be reproduced, except in full, without prior written permission of the Company.

## 802.11a (Band 2C) - ANT1

### Low Channel (5 500 MHz)

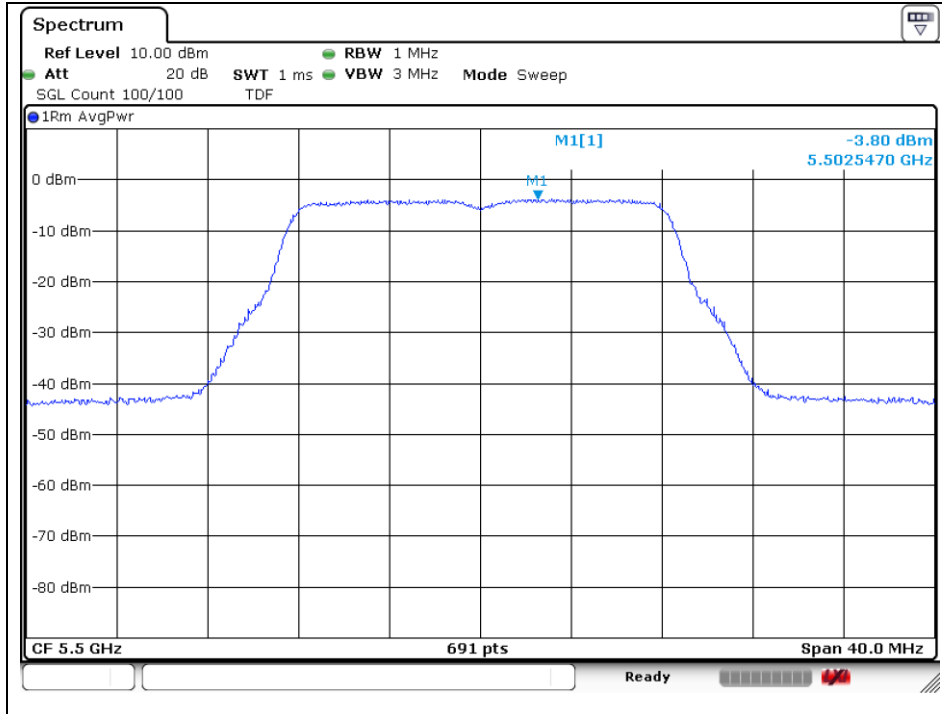

### Middle Channel (5 580 MHz)

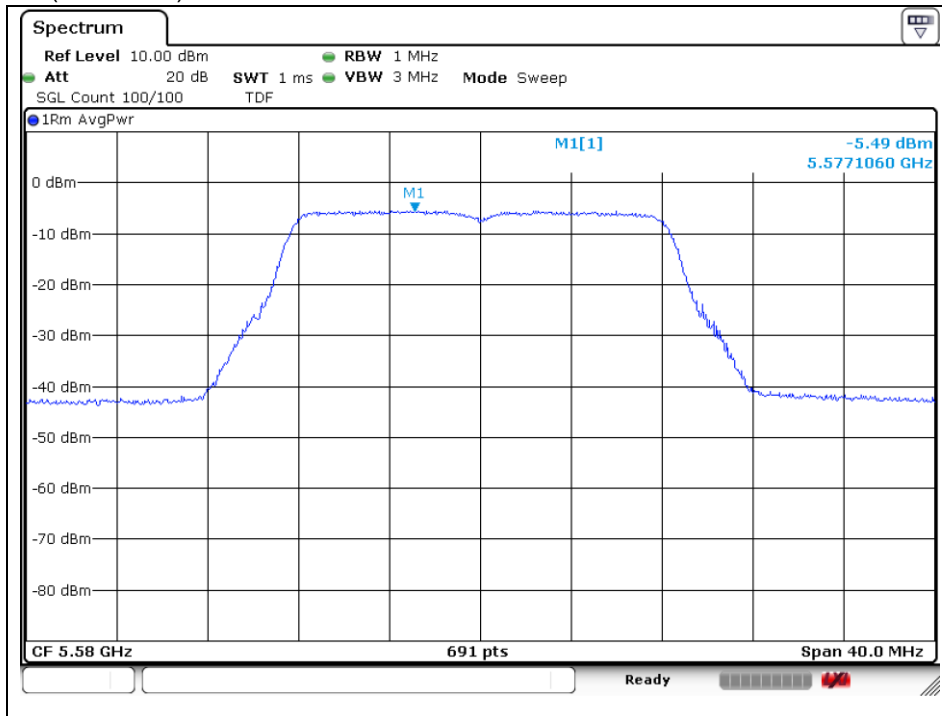

The results shown in this test report refer only to the sample(s) tested unless otherwise stated. This test report cannot be reproduced, except in full, without prior written permission of the Company.

High Channel (5 720 MHz)

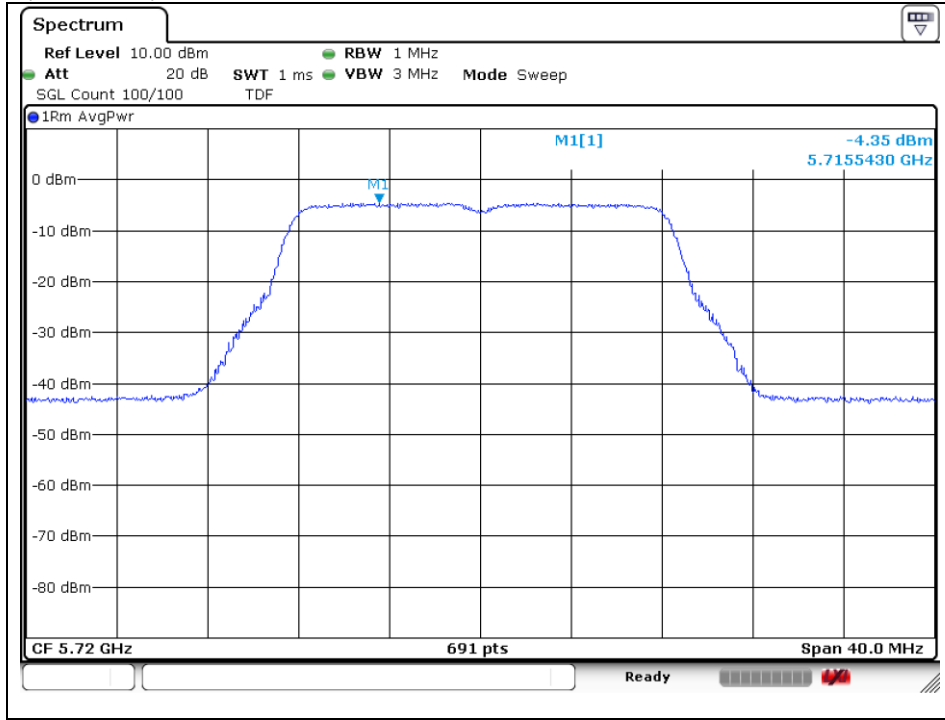

802.11a (Band 3) - ANT1

Low Channel (5 745 MHz)

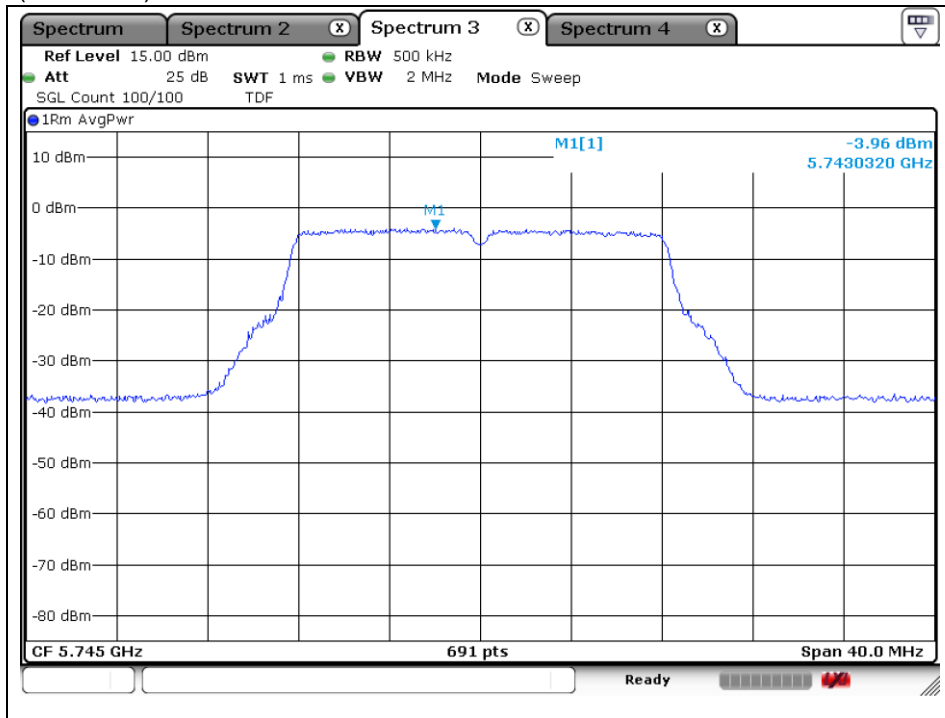

The results shown in this test report refer only to the sample(s) tested unless otherwise stated. This test report cannot be reproduced, except in full, without prior written permission of the Company.

Middle Channel (5 785 MHz)

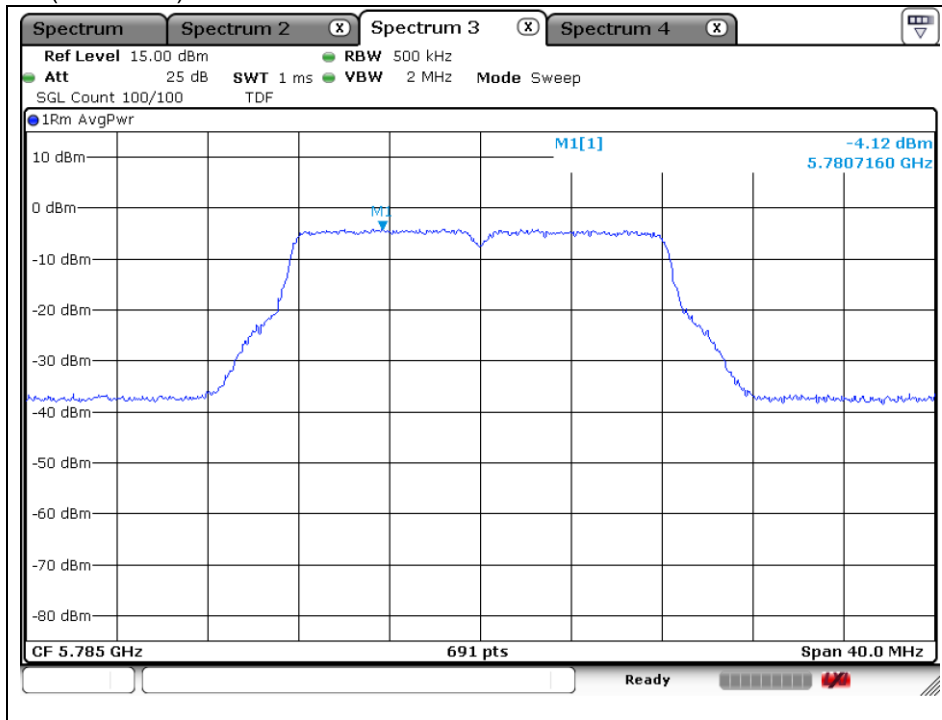

High Channel (5 825 MHz)

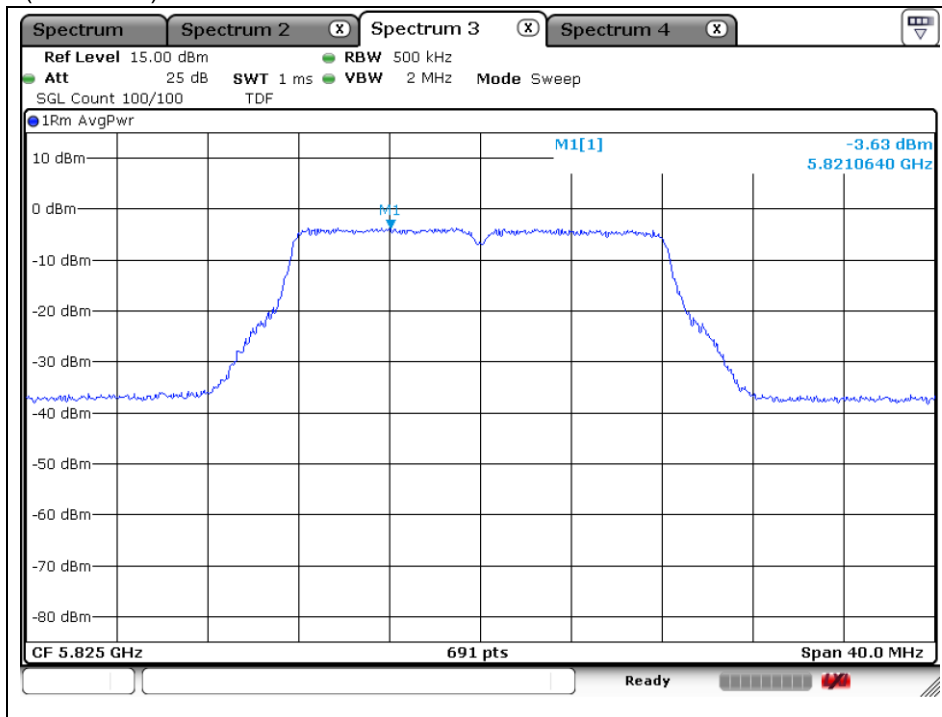

The results shown in this test report refer only to the sample(s) tested unless otherwise stated. This test report cannot be reproduced, except in full, without prior written permission of the Company.

## 802.11a (Band 1) - ANT2

Low Channel (5 180 MHz)

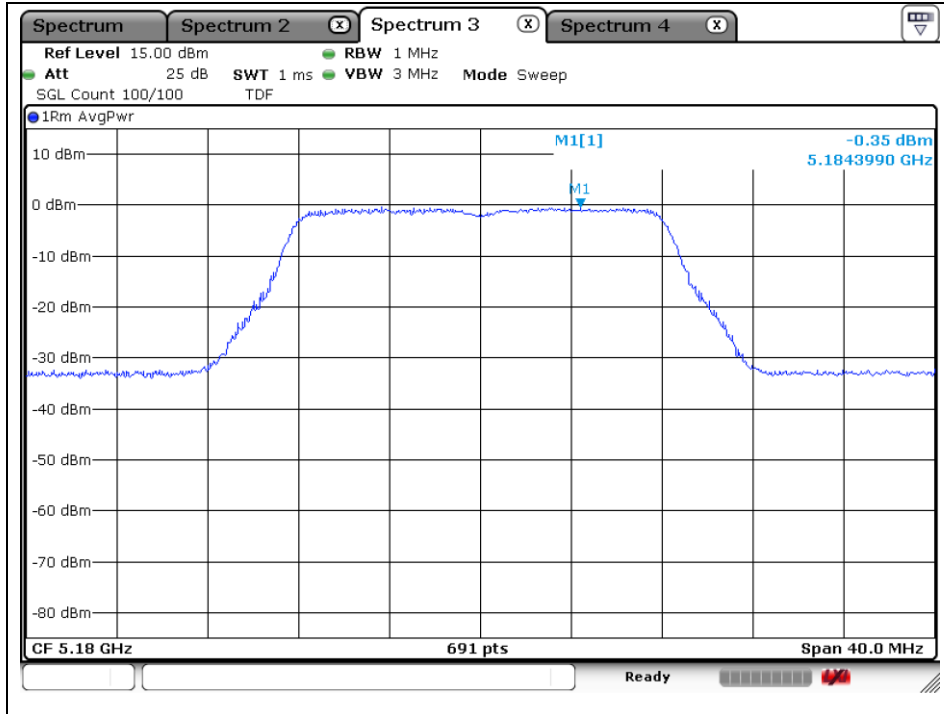

Middle Channel (5 200 MHz)

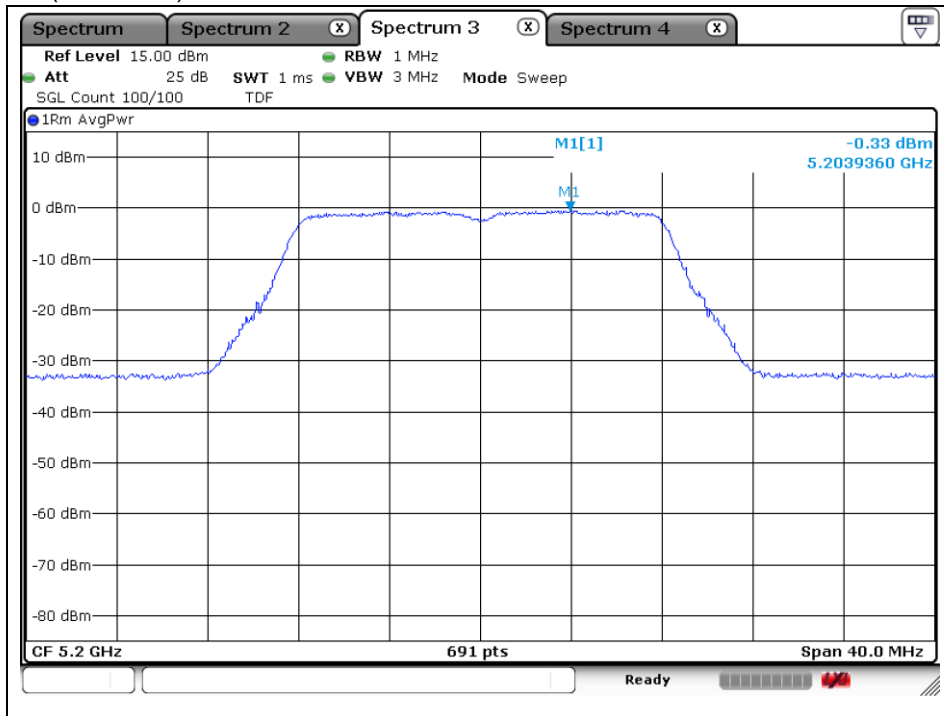

The results shown in this test report refer only to the sample(s) tested unless otherwise stated. This test report cannot be reproduced, except in full, without prior written permission of the Company.



High Channel (5 220 MHz)

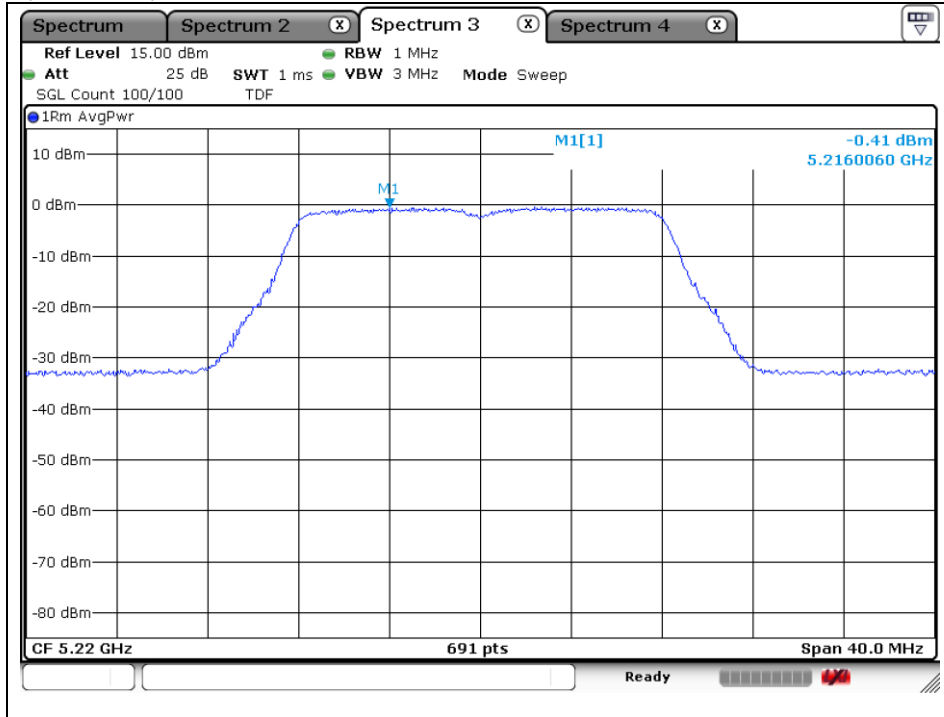

802.11a (Band 2A) - ANT2

Low Channel (5 260 MHz)

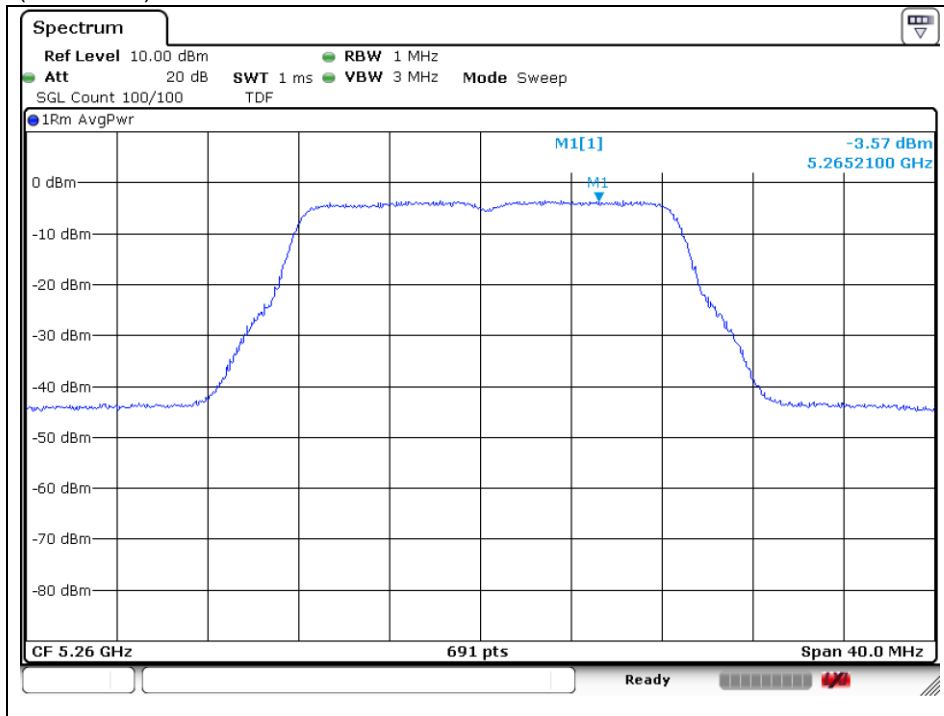

The results shown in this test report refer only to the sample(s) tested unless otherwise stated. This test report cannot be reproduced, except in full, without prior written permission of the Company.

Middle Channel (5 280 MHz)

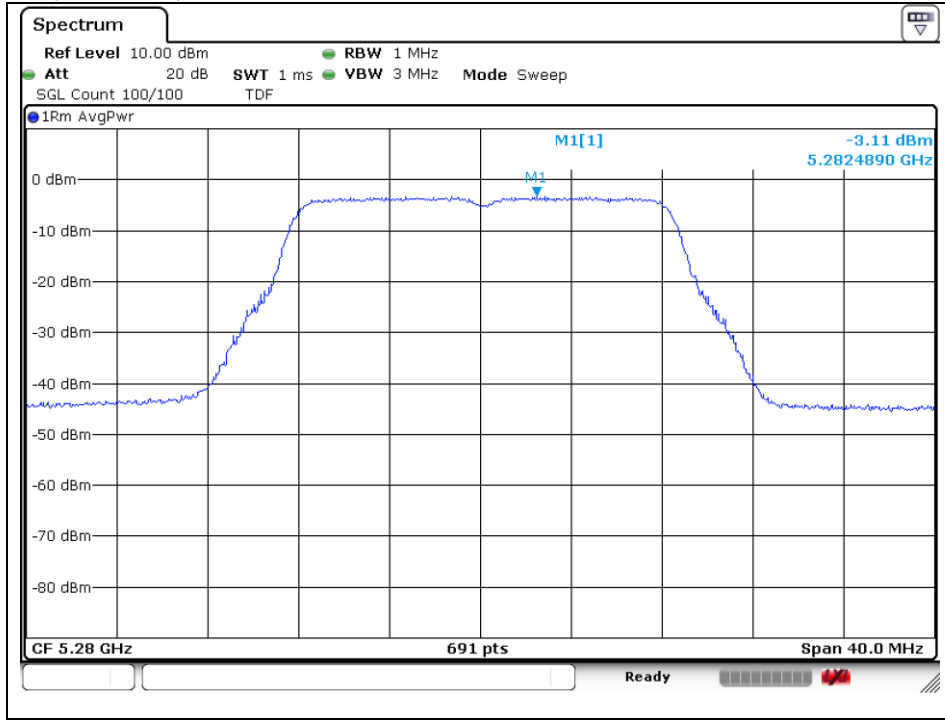

High Channel (5 320 MHz)

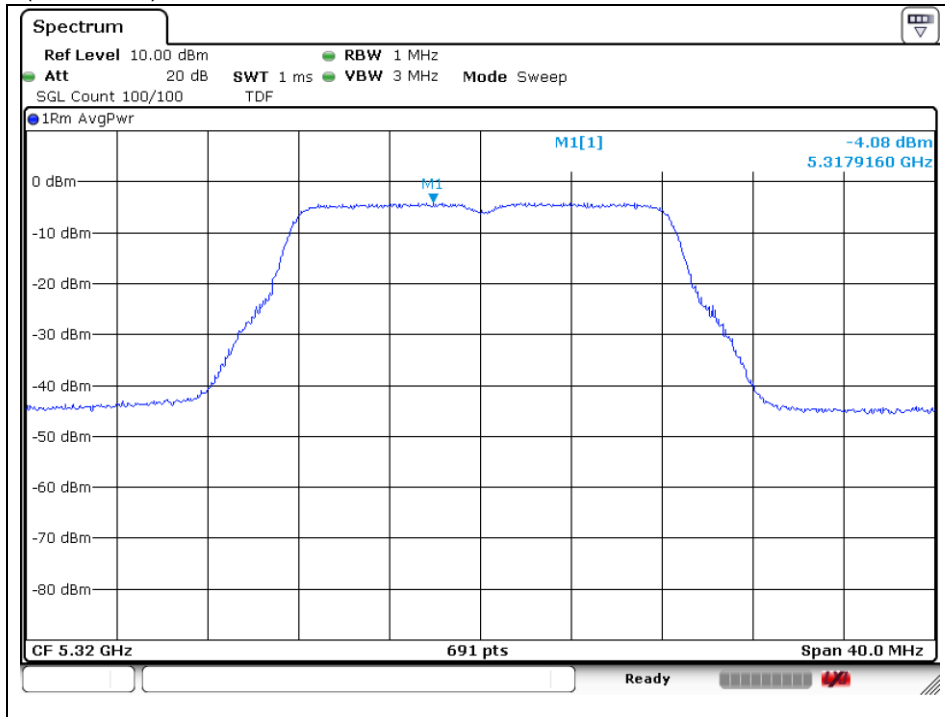

The results shown in this test report refer only to the sample(s) tested unless otherwise stated. This test report cannot be reproduced, except in full, without prior written permission of the Company.

## 802.11a (Band 2C) - ANT2

### Low Channel (5 500 MHz)

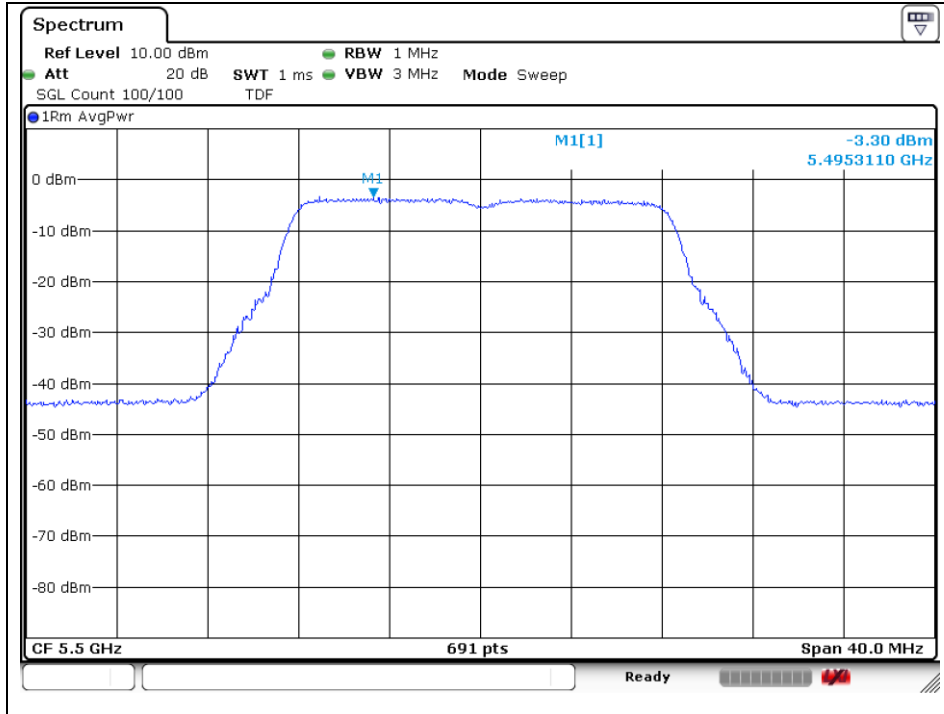

### Middle Channel (5 580 MHz)

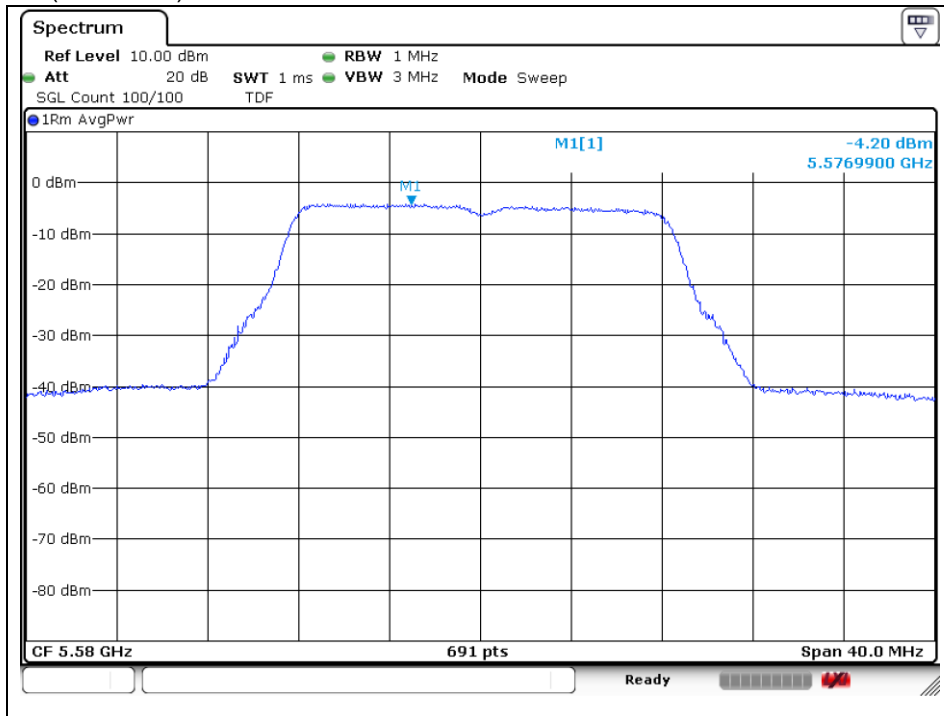

The results shown in this test report refer only to the sample(s) tested unless otherwise stated. This test report cannot be reproduced, except in full, without prior written permission of the Company.

High Channel (5 720 MHz)

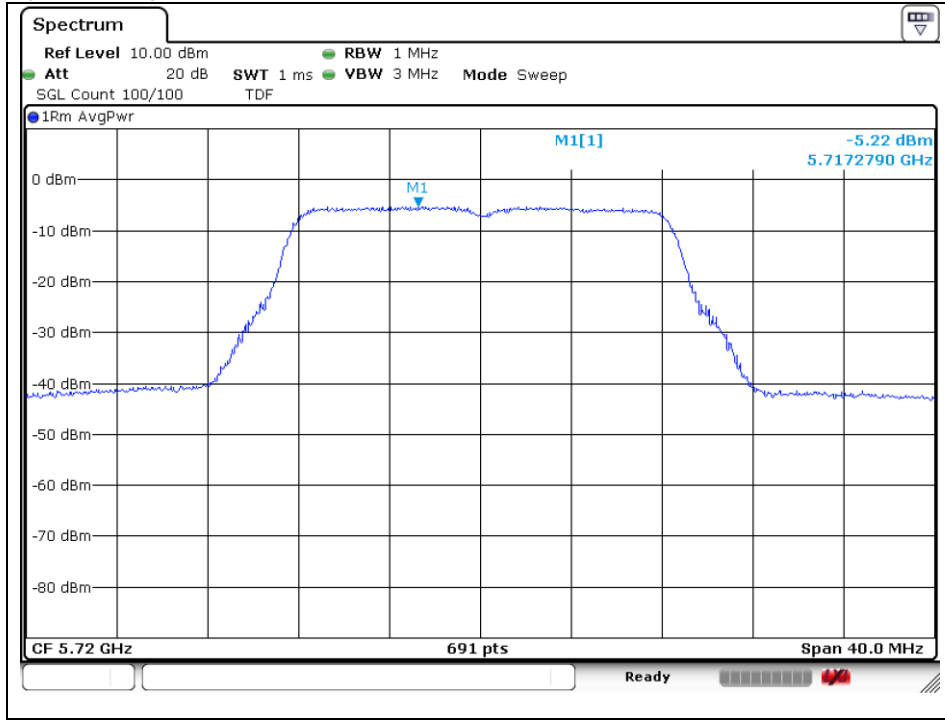

802.11a (Band 3) - ANT2

Low Channel (5 745 MHz)

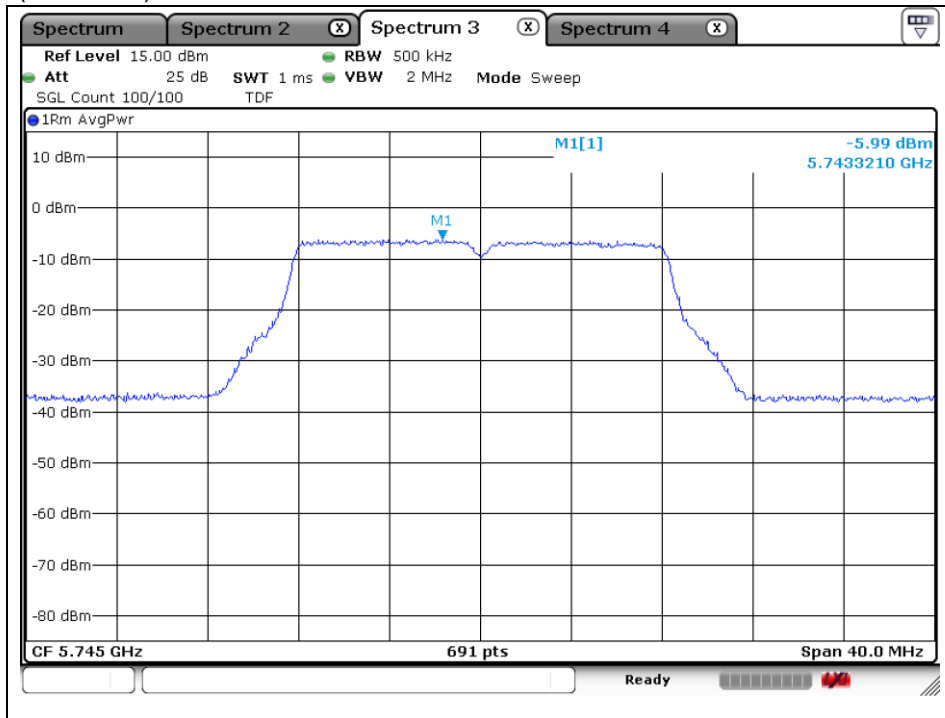

The results shown in this test report refer only to the sample(s) tested unless otherwise stated. This test report cannot be reproduced, except in full, without prior written permission of the Company.

Middle Channel (5 785 MHz)

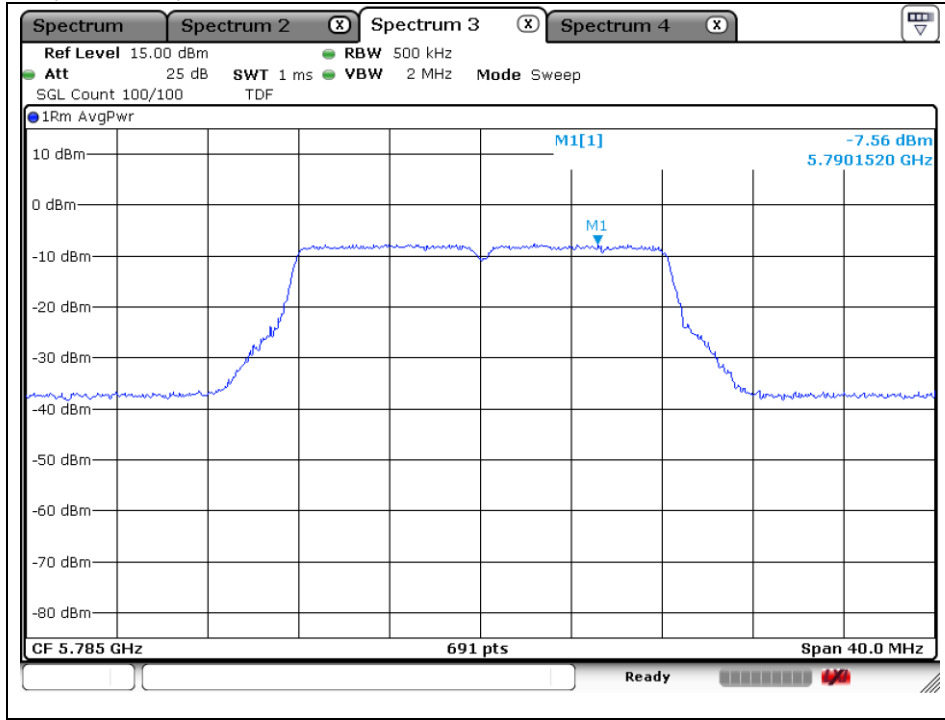

High Channel (5 825 MHz)

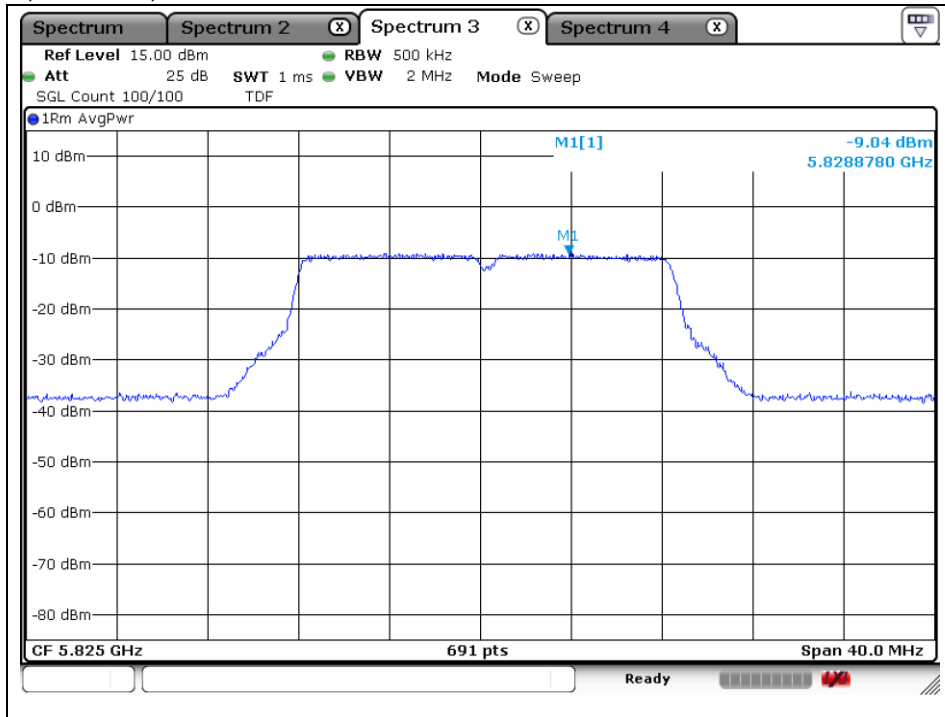

The results shown in this test report refer only to the sample(s) tested unless otherwise stated. This test report cannot be reproduced, except in full, without prior written permission of the Company.

## 802.11n\_HT20 (Band 1) - ANT1

Low Channel (5 180 MHz)

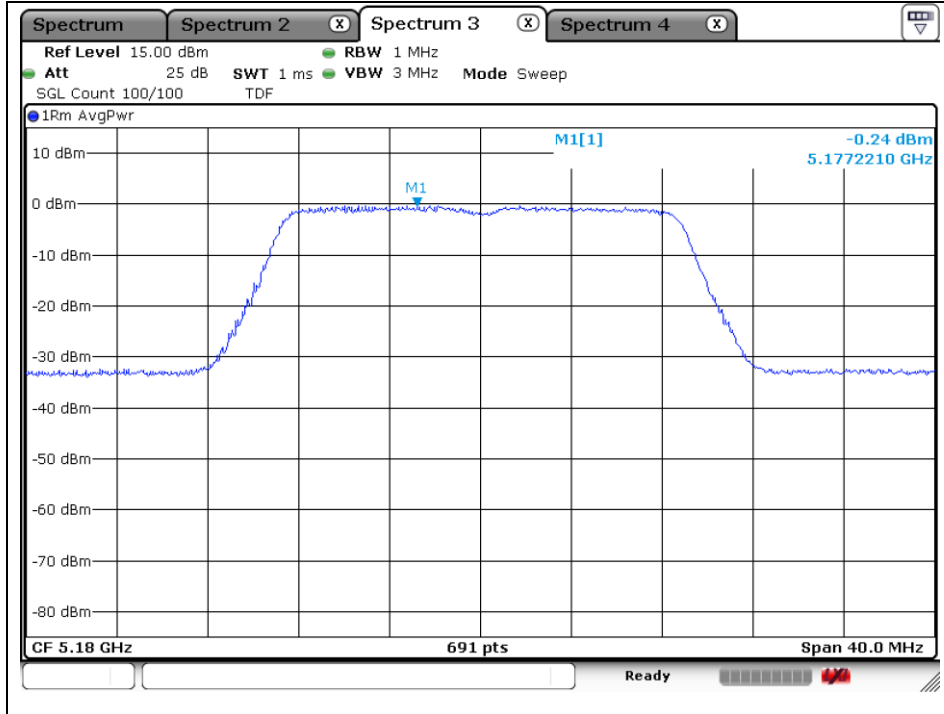

Middle Channel (5 200 MHz)

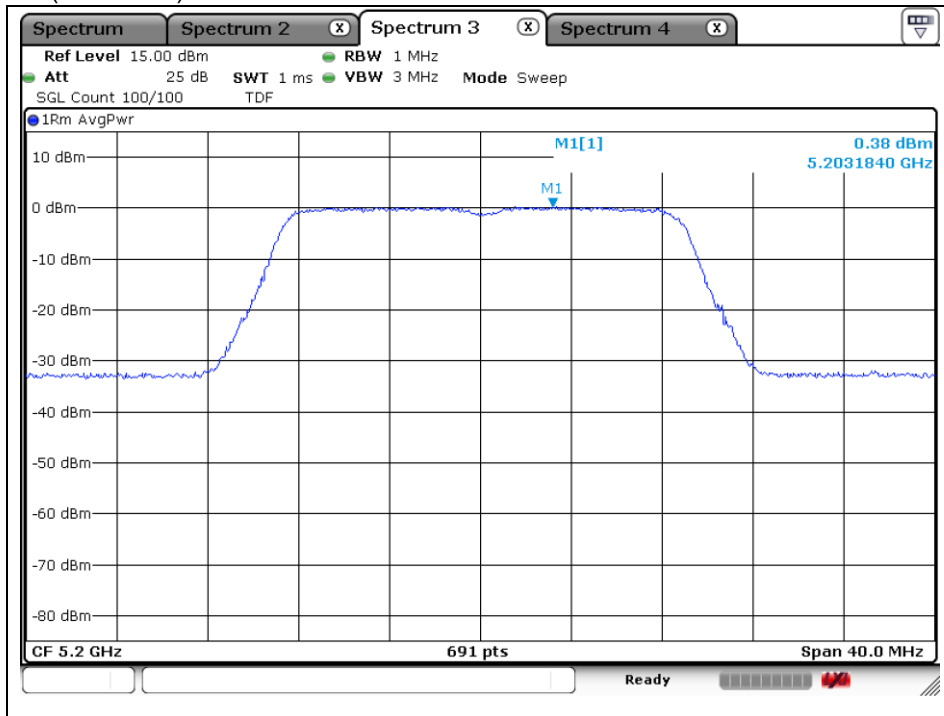

The results shown in this test report refer only to the sample(s) tested unless otherwise stated. This test report cannot be reproduced, except in full, without prior written permission of the Company.

High Channel (5 220 MHz)

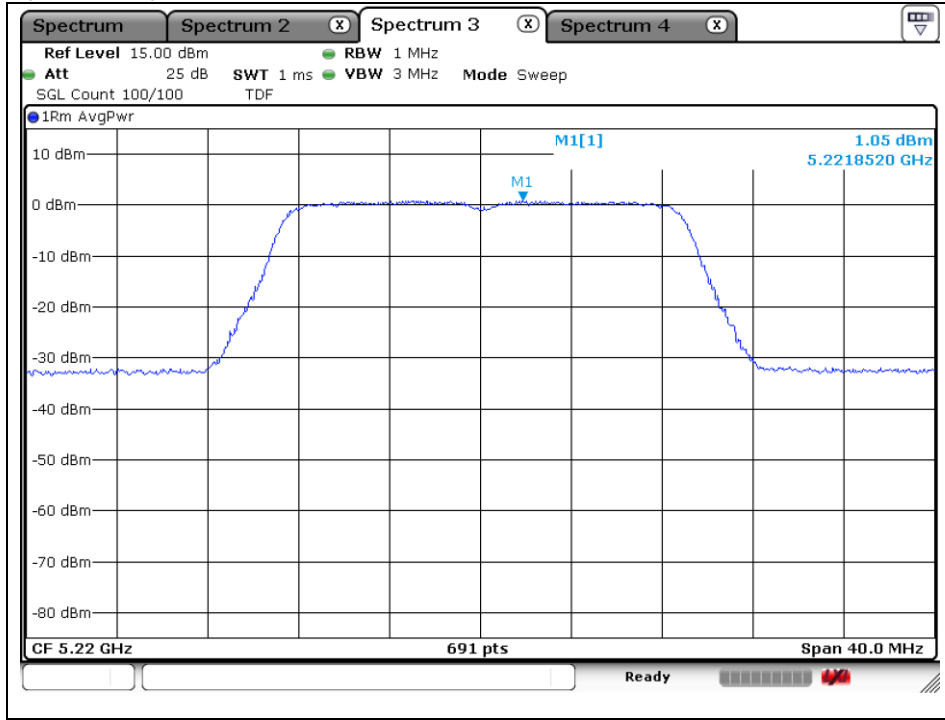

802.11n\_HT20 (Band 2A) - ANT1

Low Channel (5 260 MHz)

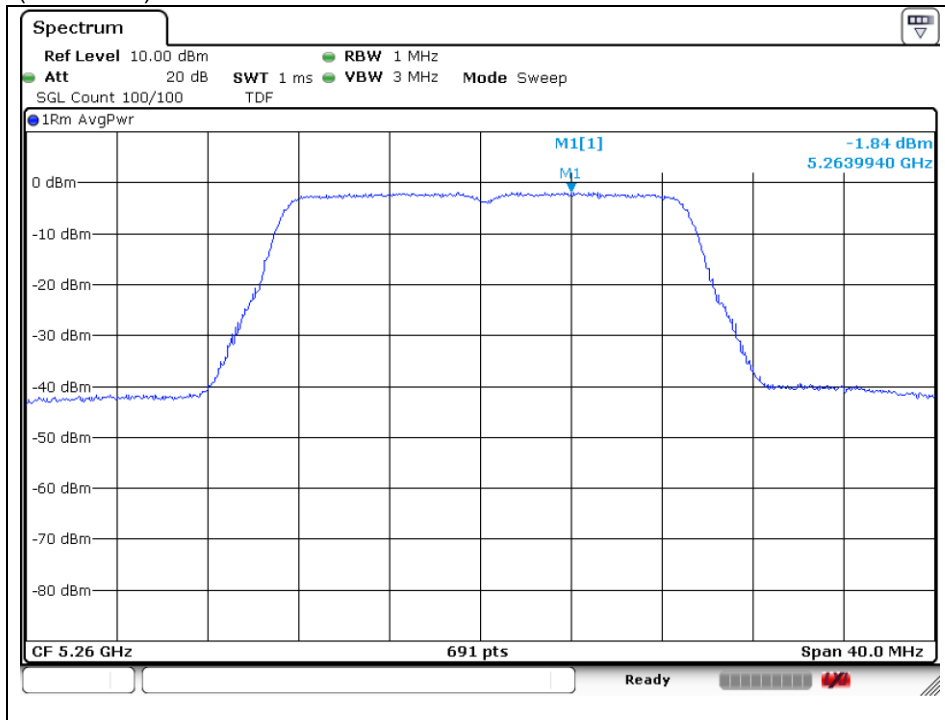

The results shown in this test report refer only to the sample(s) tested unless otherwise stated. This test report cannot be reproduced, except in full, without prior written permission of the Company.

Middle Channel (5 280 MHz)

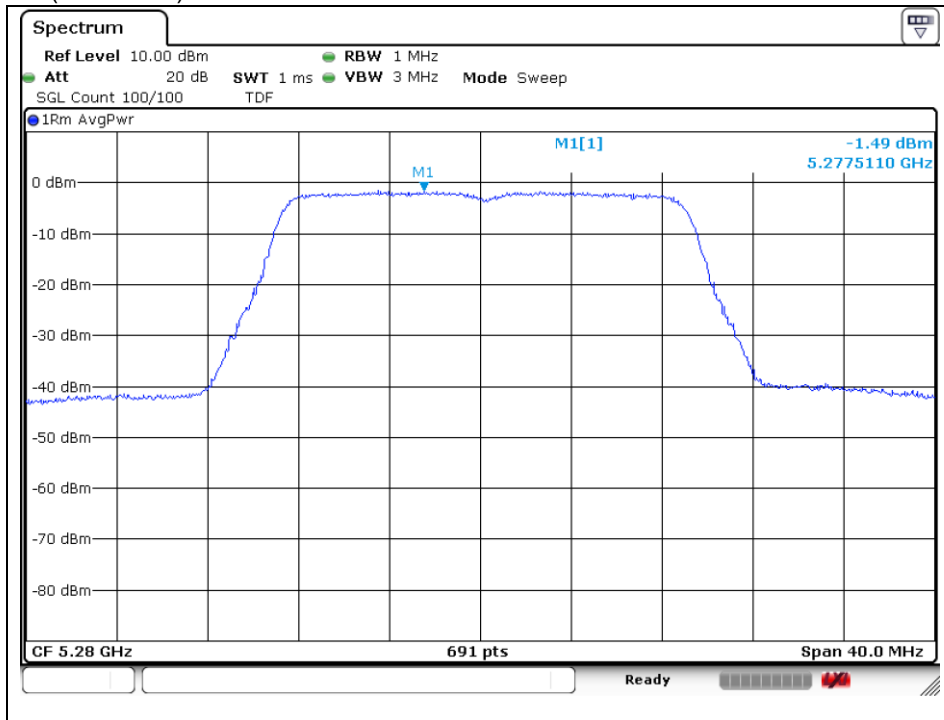

High Channel (5 320 MHz)

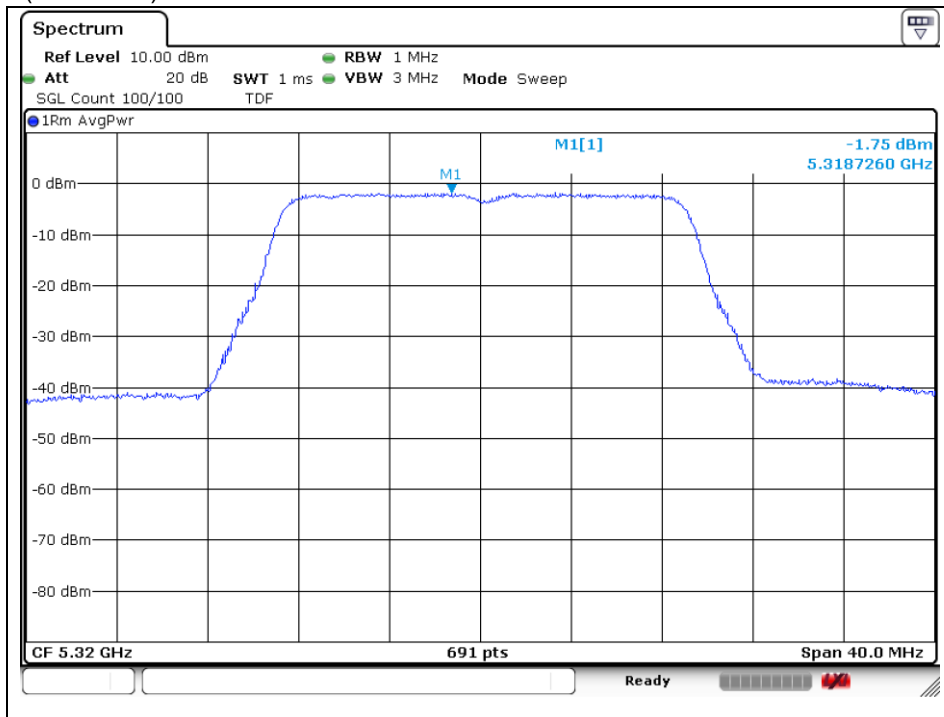

The results shown in this test report refer only to the sample(s) tested unless otherwise stated. This test report cannot be reproduced, except in full, without prior written permission of the Company.



## 802.11n\_HT20 (Band 2C) - ANT1

### Low Channel (5 500 MHz)

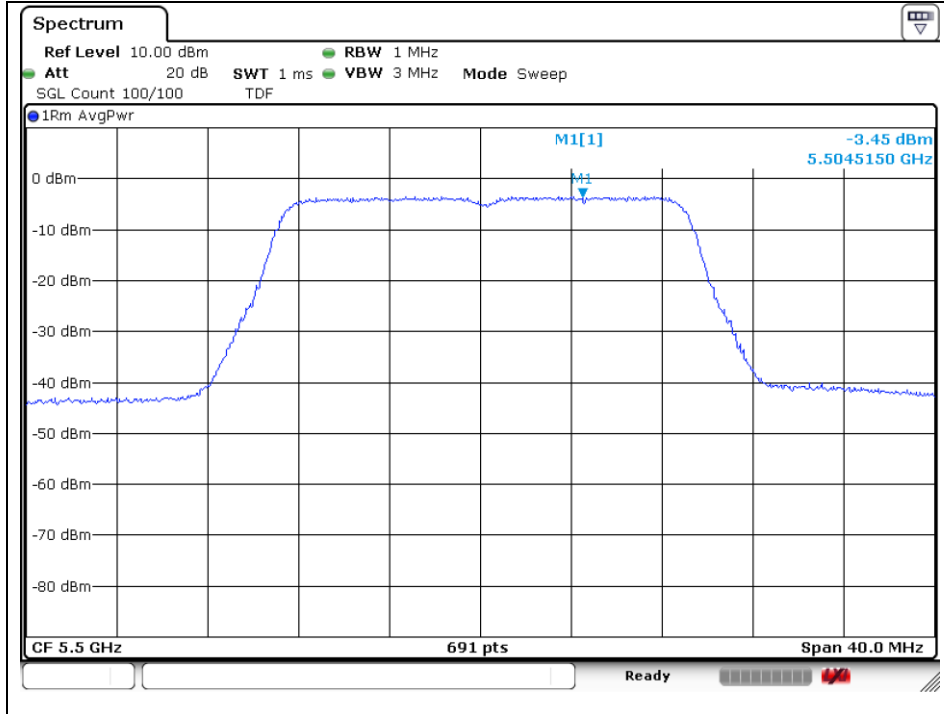

### Middle Channel (5 580 MHz)

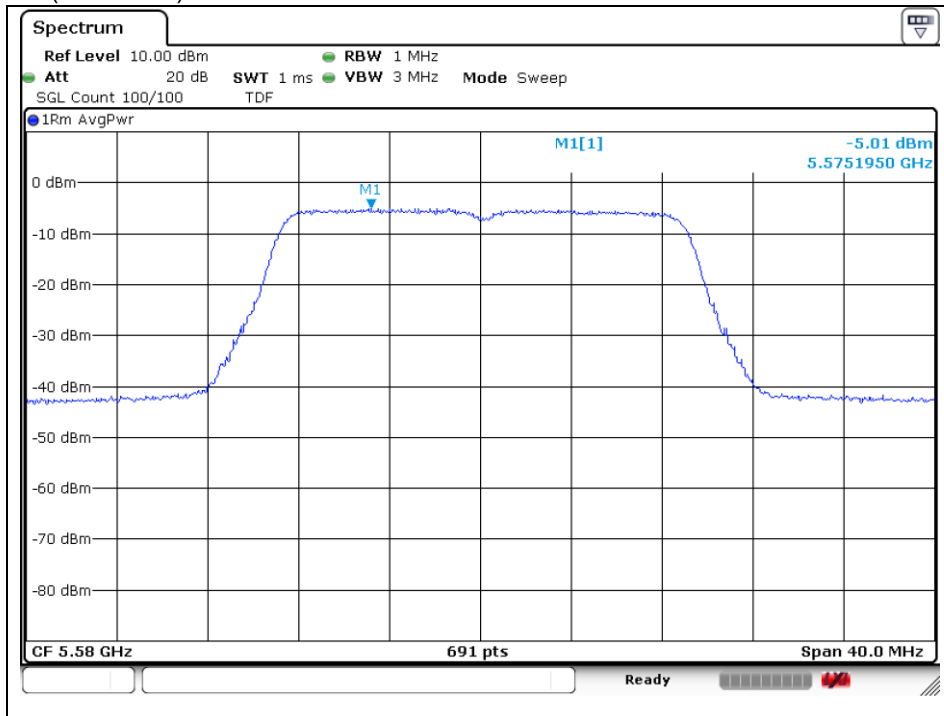

The results shown in this test report refer only to the sample(s) tested unless otherwise stated. This test report cannot be reproduced, except in full, without prior written permission of the Company.

High Channel (5 720 MHz)

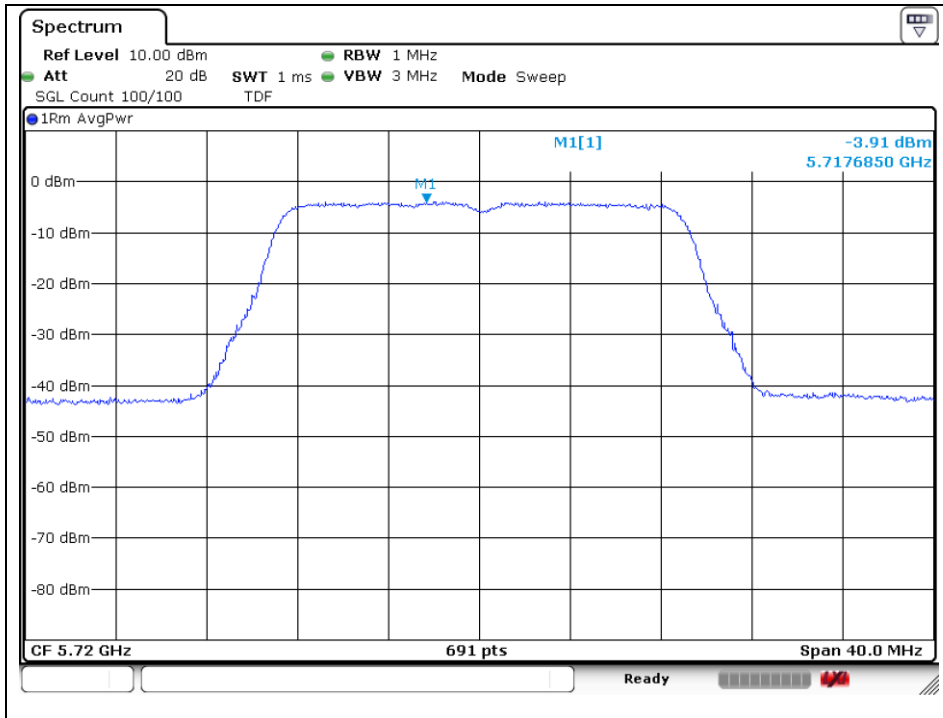

802.11n\_HT20 (Band 3) - ANT1

Low Channel (5 745 MHz)

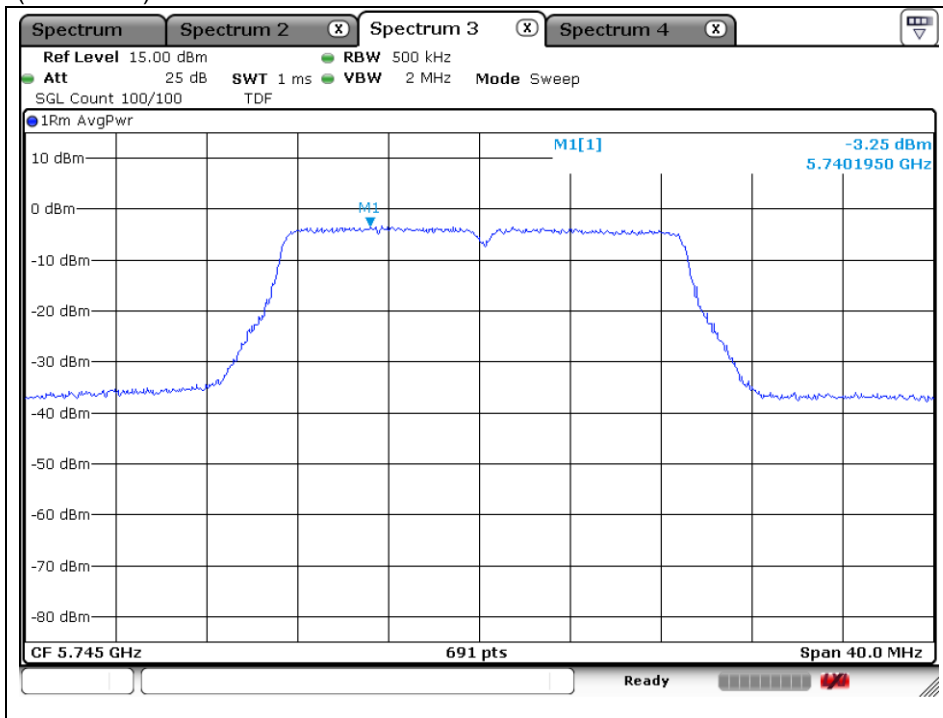

The results shown in this test report refer only to the sample(s) tested unless otherwise stated. This test report cannot be reproduced, except in full, without prior written permission of the Company.

SGS Korea Co., Ltd. (Gunpo Laboratory) 4, LS-ro 182beon-gil, Gunpo-si, Gyeonggi-do, Korea, 15807 <http://www.sgsgroup.kr>

Middle Channel (5 785 MHz)

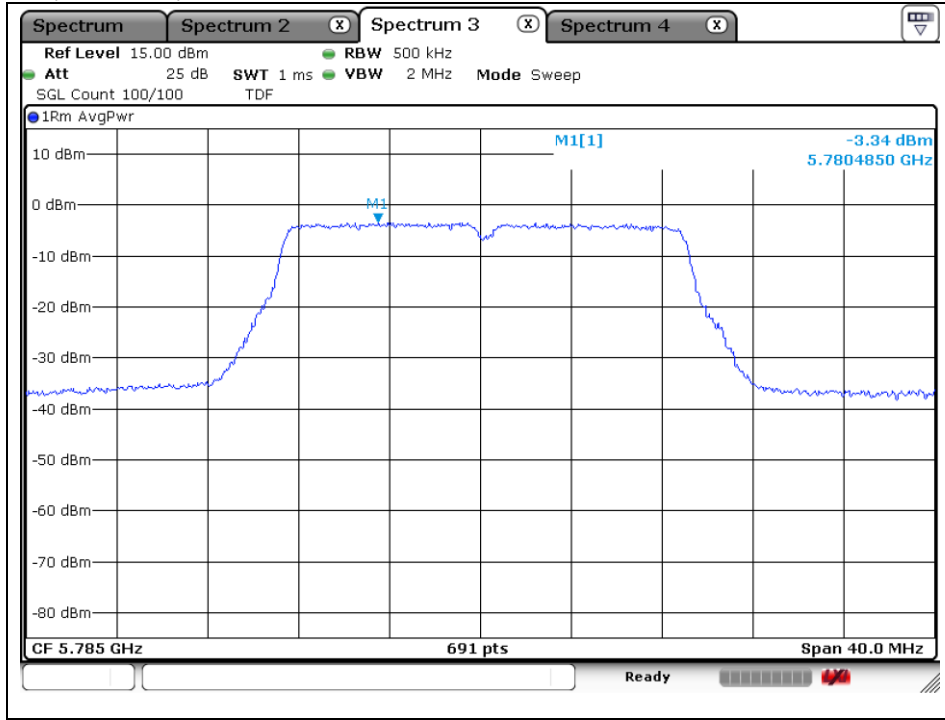

High Channel (5 825 MHz)

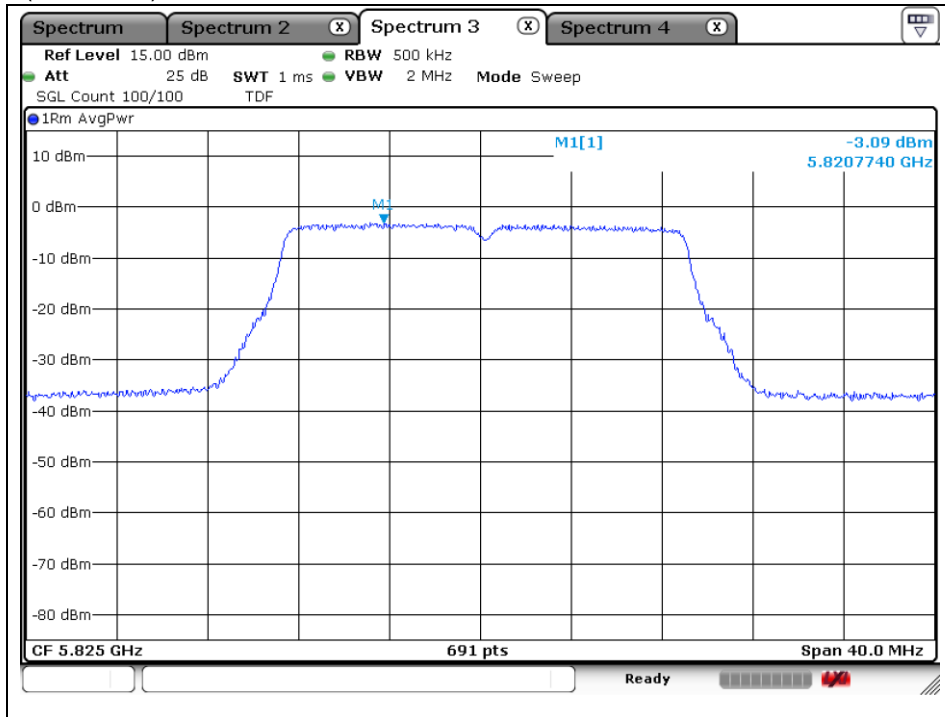

The results shown in this test report refer only to the sample(s) tested unless otherwise stated. This test report cannot be reproduced, except in full, without prior written permission of the Company.

## 802.11n\_HT20 (Band 1) - ANT2

### Low Channel (5 180 MHz)

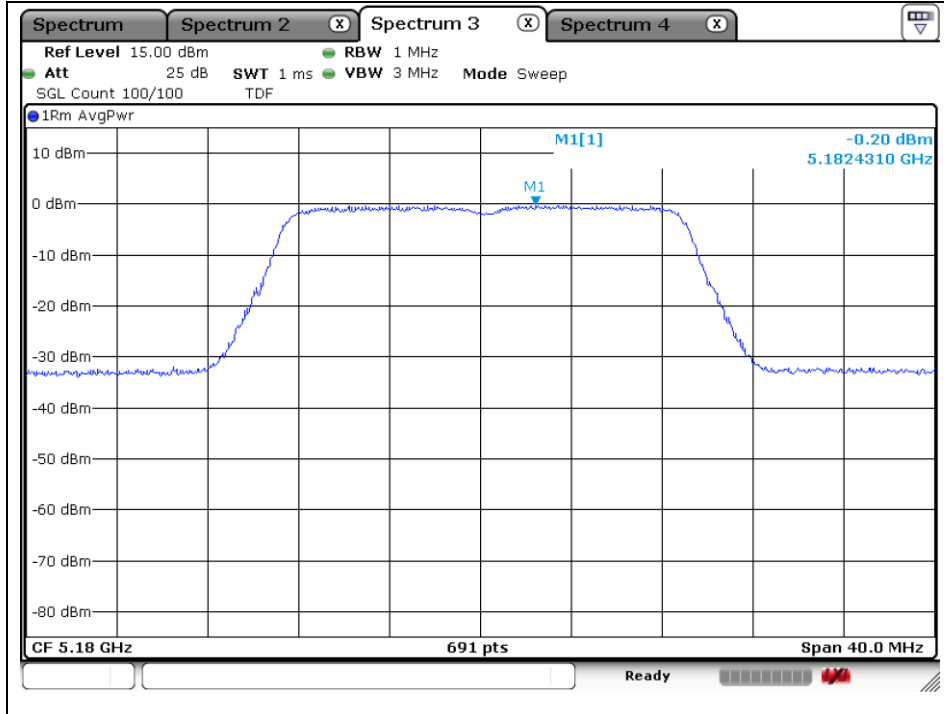

### Middle Channel (5 200 MHz)

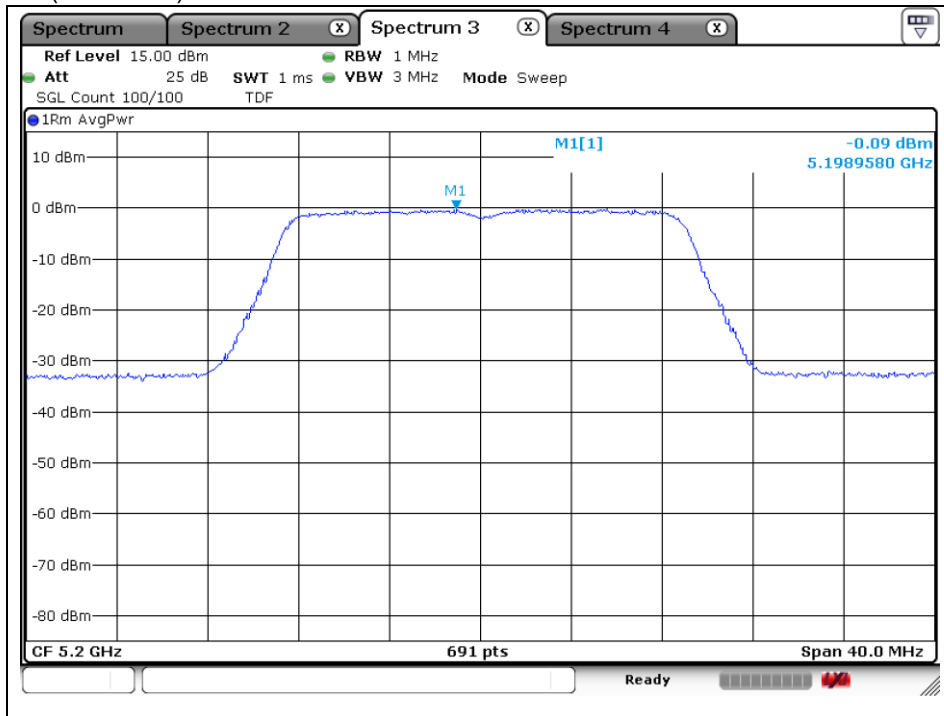

The results shown in this test report refer only to the sample(s) tested unless otherwise stated. This test report cannot be reproduced, except in full, without prior written permission of the Company.

High Channel (5 220 MHz)

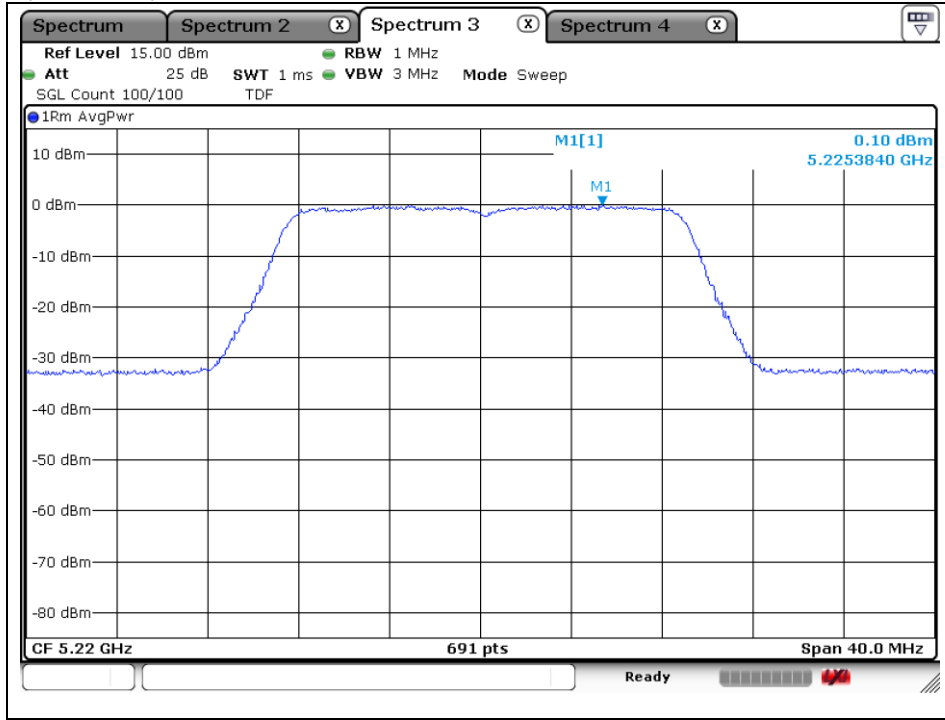

802.11n\_HT20 (Band 2A) - ANT2

Low Channel (5 260 MHz)

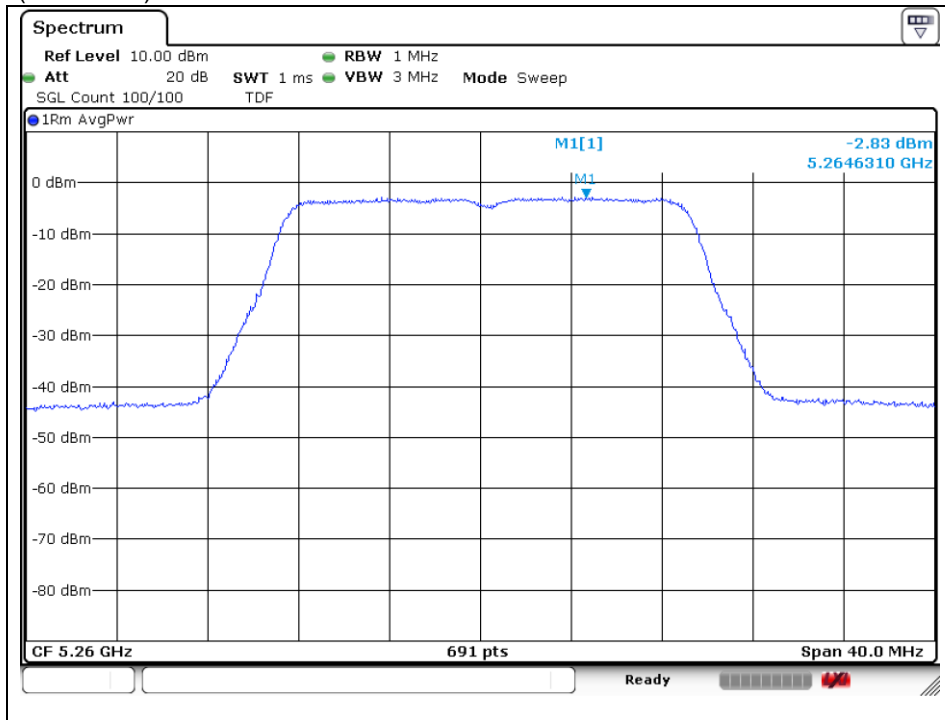

The results shown in this test report refer only to the sample(s) tested unless otherwise stated. This test report cannot be reproduced, except in full, without prior written permission of the Company.

Middle Channel (5 280 MHz)

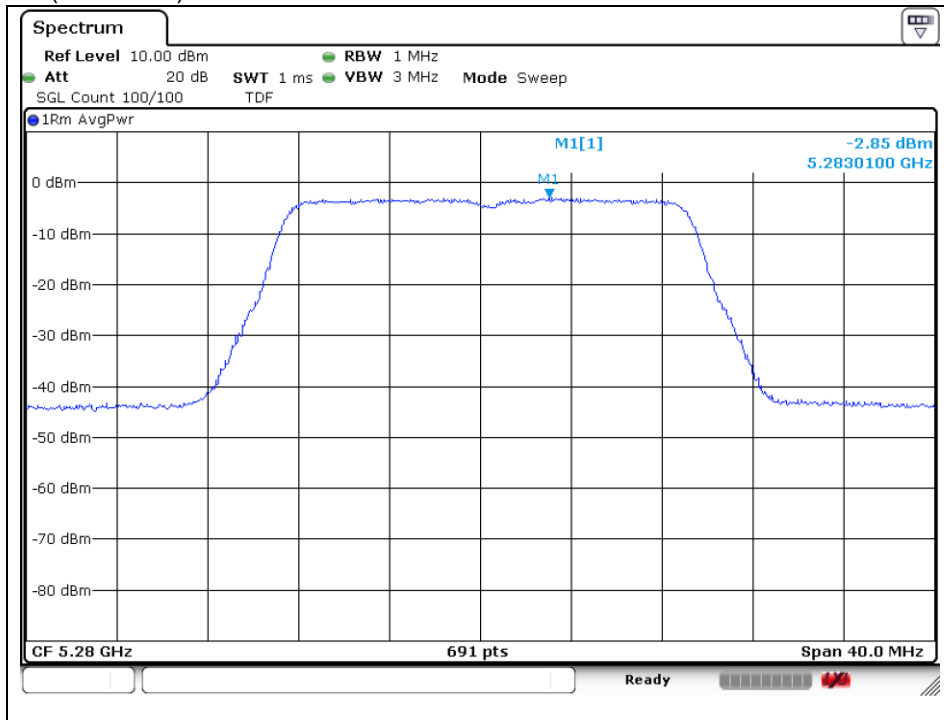

High Channel (5 320 MHz)

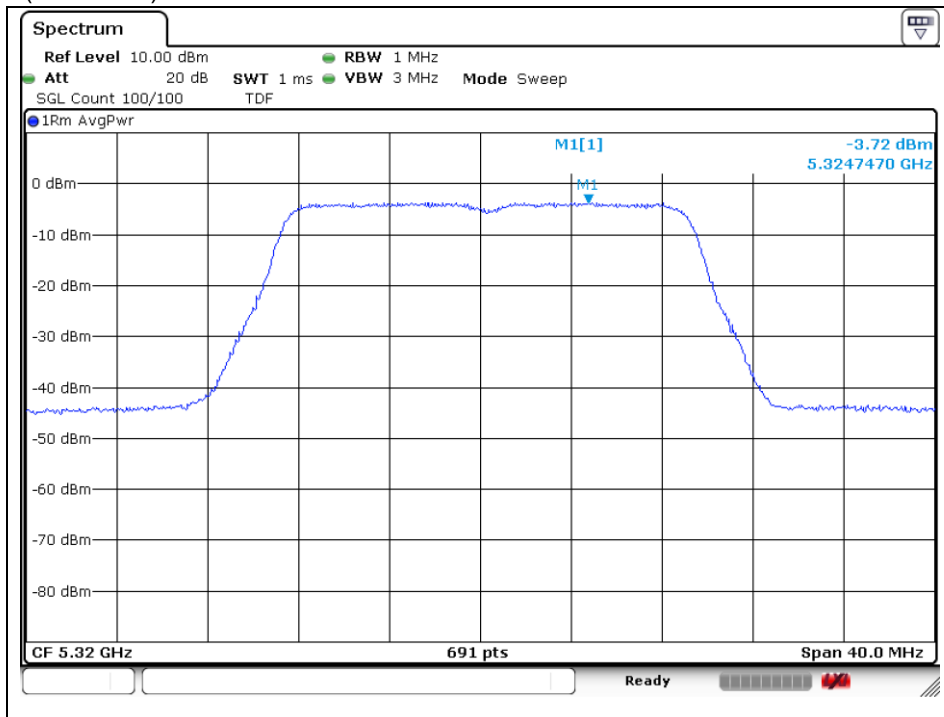

The results shown in this test report refer only to the sample(s) tested unless otherwise stated. This test report cannot be reproduced, except in full, without prior written permission of the Company.

## 802.11n\_HT20 (Band 2C) - ANT2

### Low Channel (5 500 MHz)

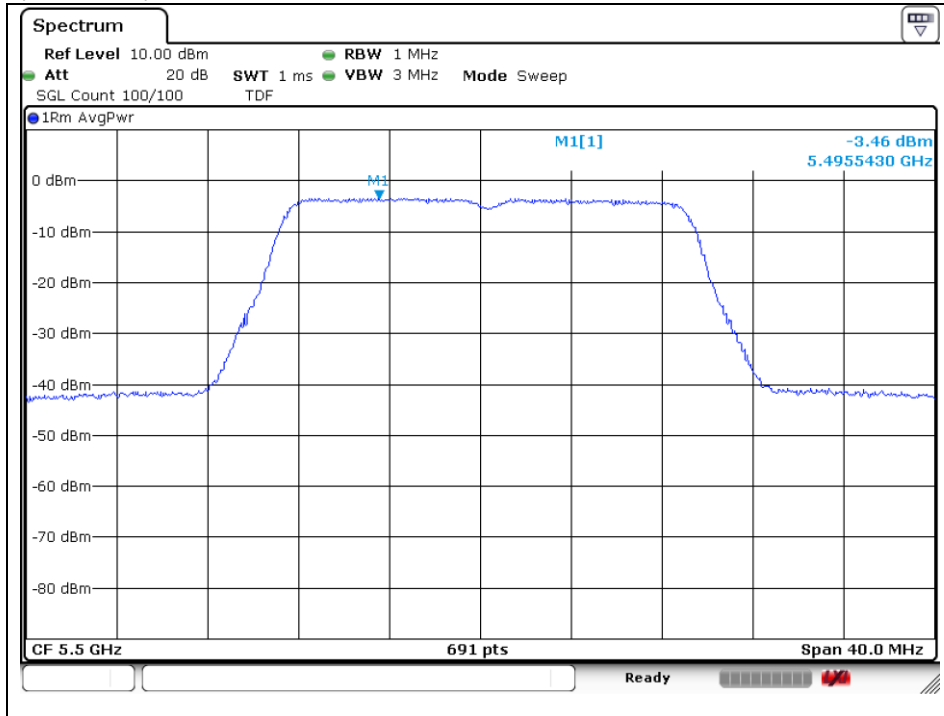

### Middle Channel (5 580 MHz)

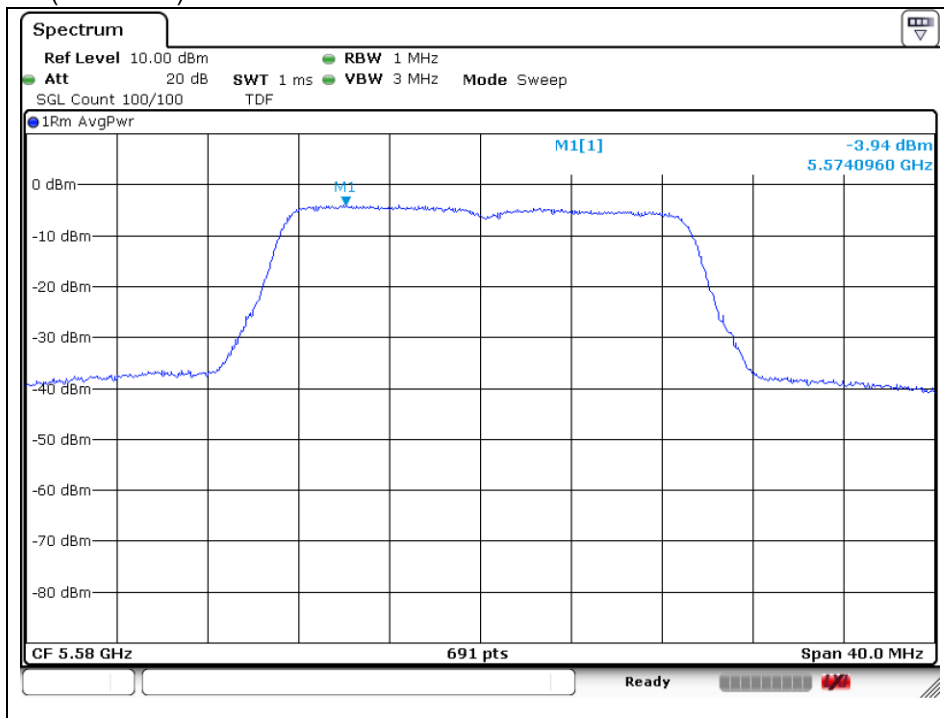

The results shown in this test report refer only to the sample(s) tested unless otherwise stated. This test report cannot be reproduced, except in full, without prior written permission of the Company.

## High Channel (5 720 MHz)

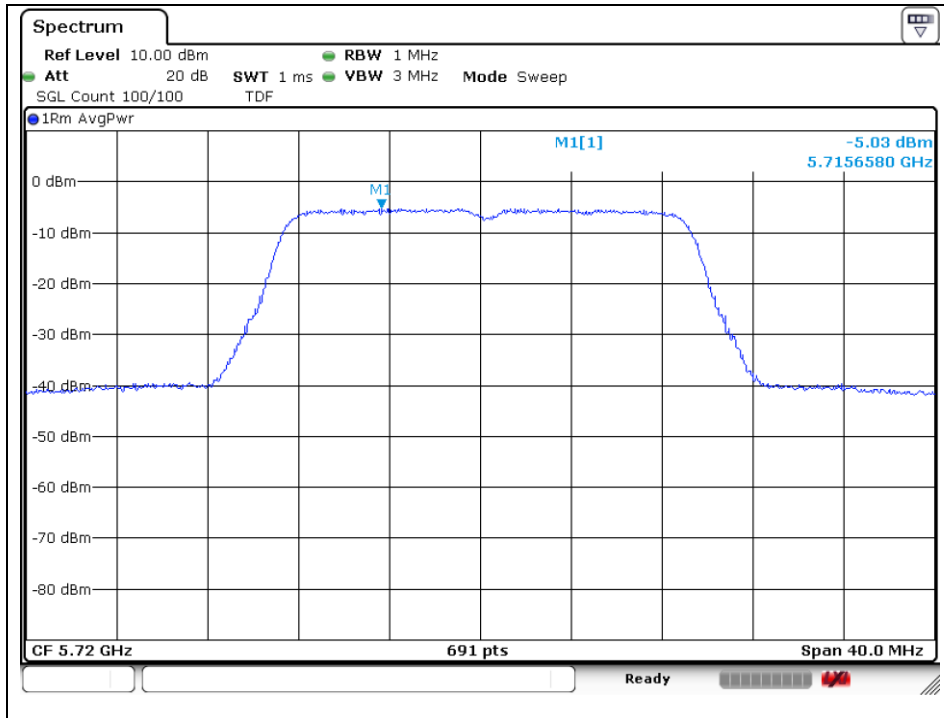

## 802.11n\_HT20 (Band 3) - ANT2

### Low Channel (5 745 MHz)

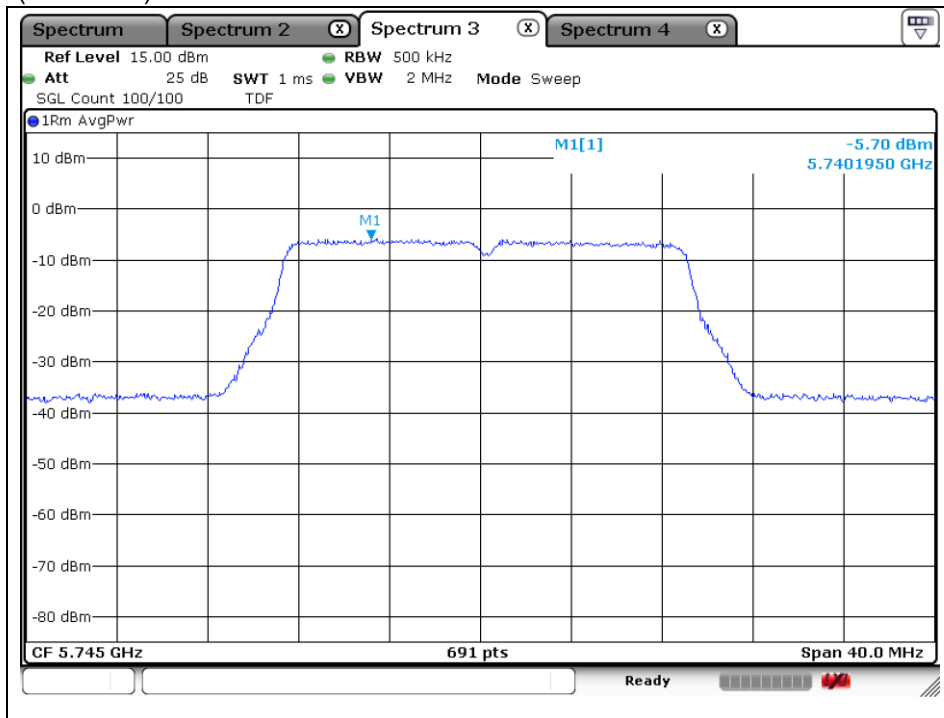

The results shown in this test report refer only to the sample(s) tested unless otherwise stated. This test report cannot be reproduced, except in full, without prior written permission of the Company.

SGS Korea Co., Ltd. (Gunpo Laboratory) 4, LS-ro 182beon-gil, Gunpo-si, Gyeonggi-do, Korea, 15807 <http://www.sgsgroup.kr>



Middle Channel (5 785 MHz)

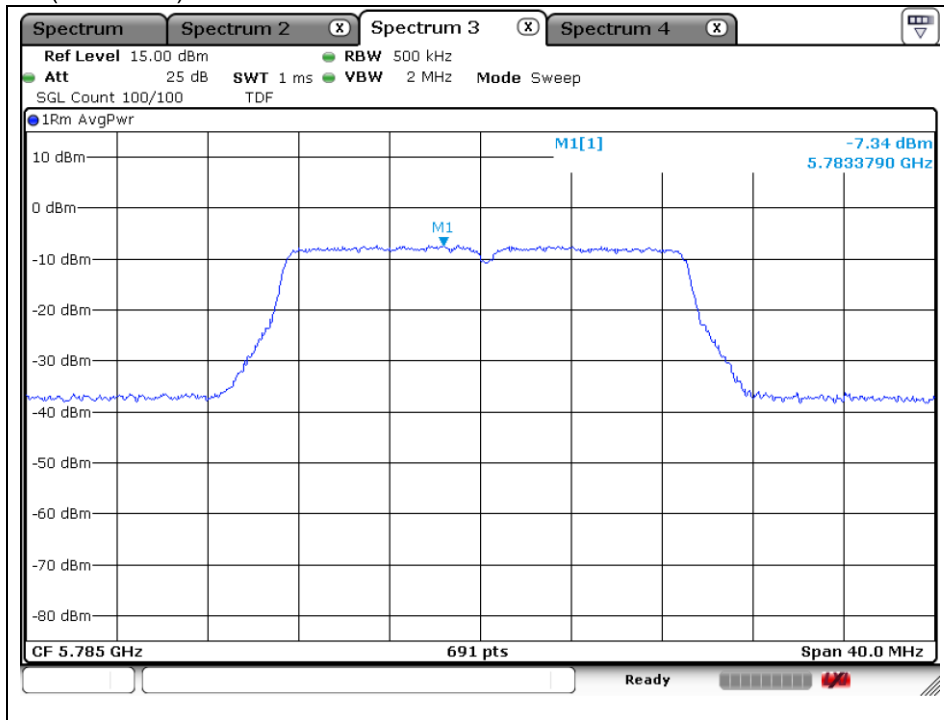

High Channel (5 825 MHz)

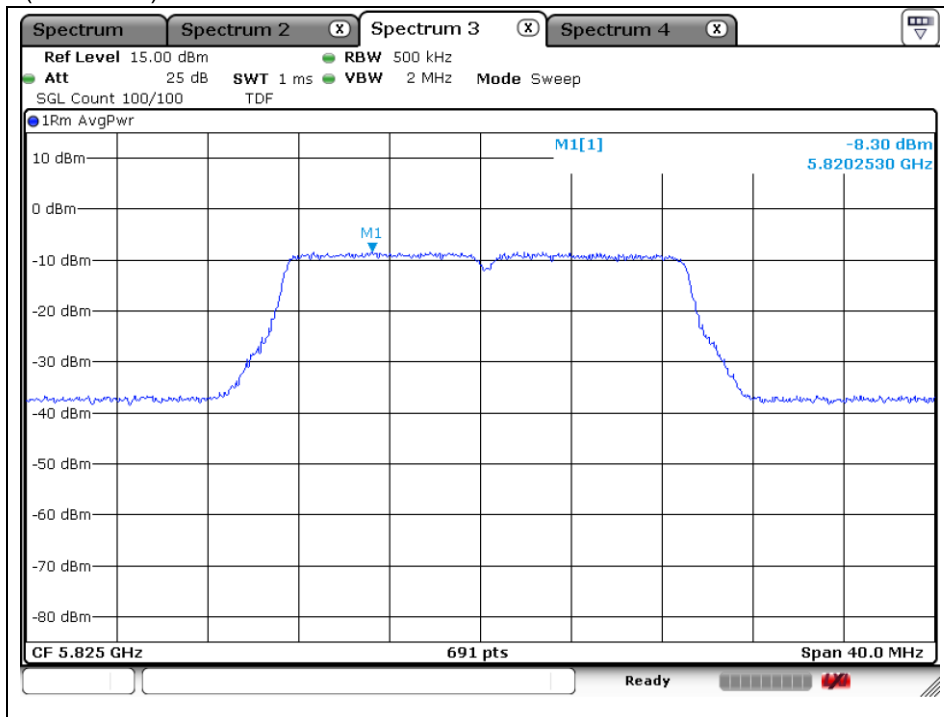

The results shown in this test report refer only to the sample(s) tested unless otherwise stated. This test report cannot be reproduced, except in full, without prior written permission of the Company.

## 802.11n\_HT40 (Band 1) - ANT1

Low Channel (5 190 MHz)

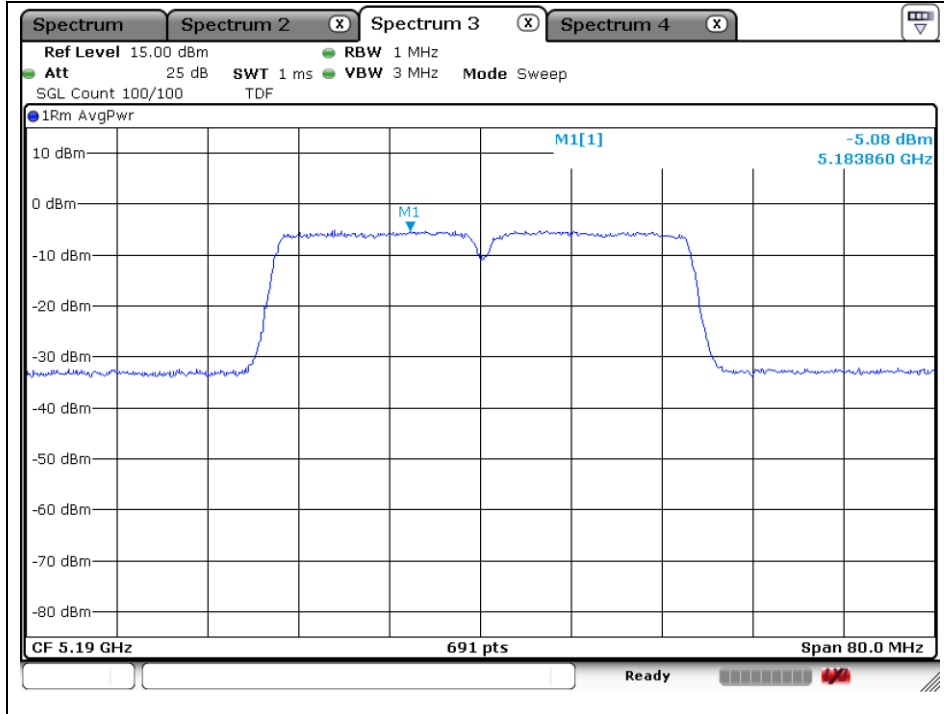

## 802.11n\_HT40 (Band 2A) - ANT1

Low Channel (5 270 MHz)

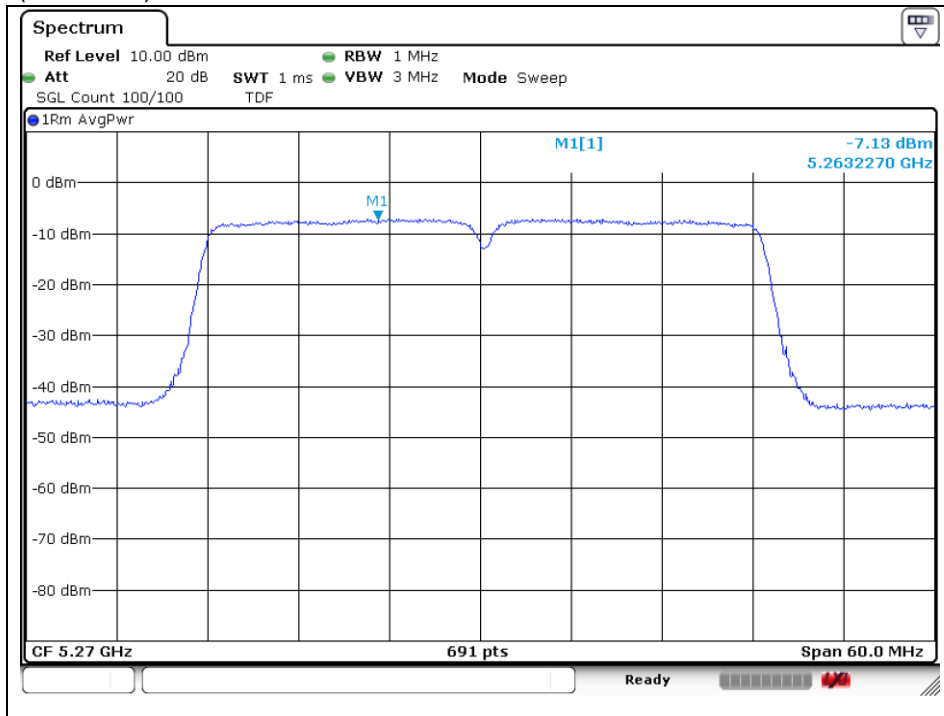

The results shown in this test report refer only to the sample(s) tested unless otherwise stated. This test report cannot be reproduced, except in full, without prior written permission of the Company.

High Channel (5 310 MHz)

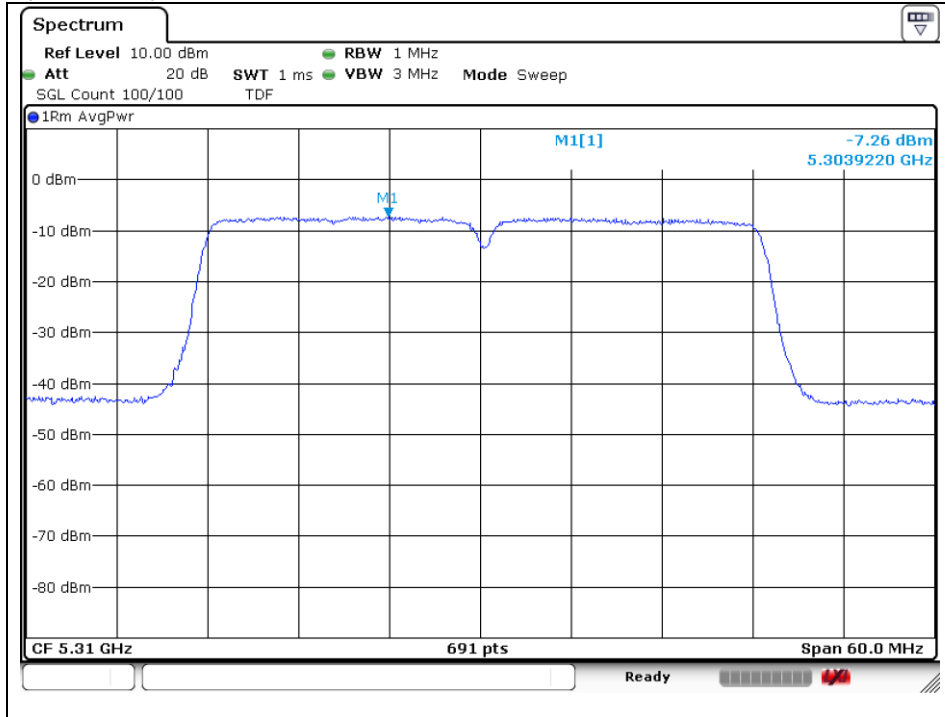

802.11n\_HT40 (Band 2C) - ANT1

Low Channel (5 510 MHz)

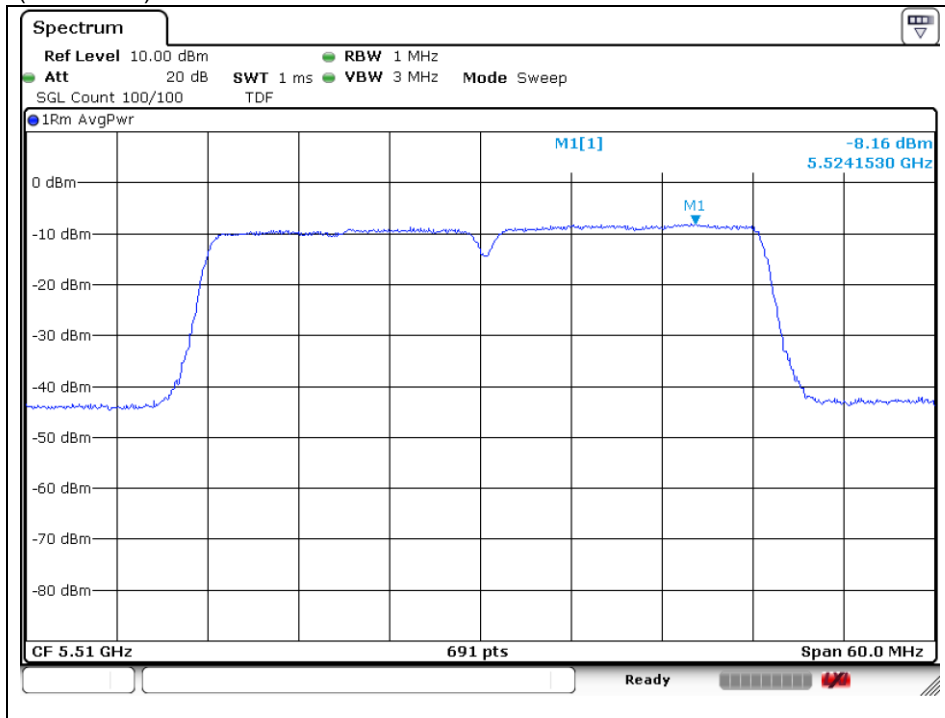

The results shown in this test report refer only to the sample(s) tested unless otherwise stated. This test report cannot be reproduced, except in full, without prior written permission of the Company.

SGS Korea Co., Ltd. (Gunpo Laboratory) 4, LS-ro 182beon-gil, Gunpo-si, Gyeonggi-do, Korea, 15807 <http://www.sgsgroup.kr>

Middle Channel (5 550 MHz)

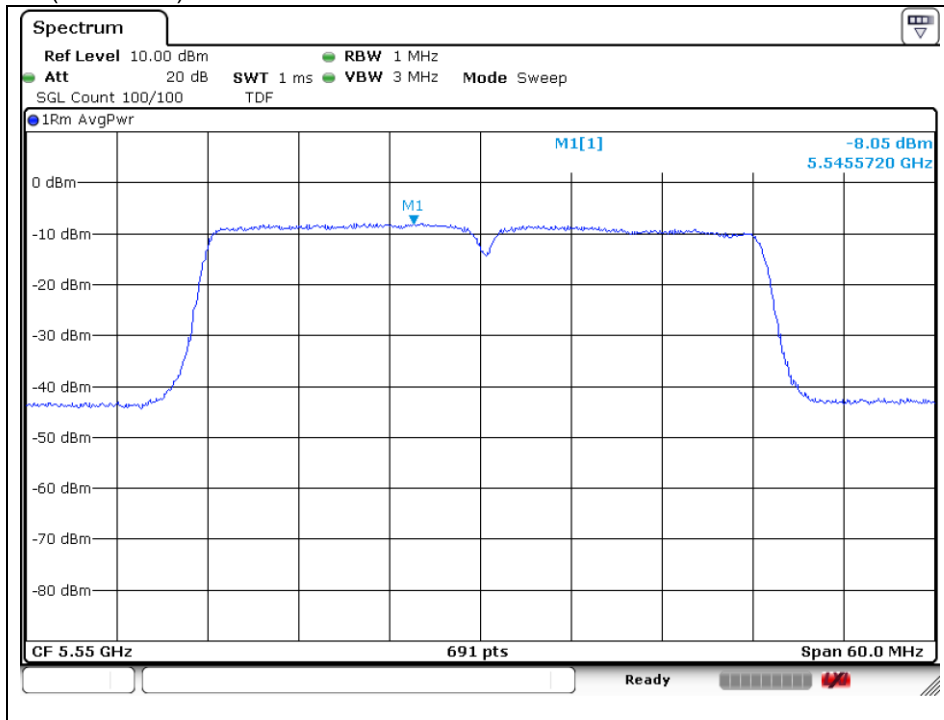

High Channel (5 710 MHz)

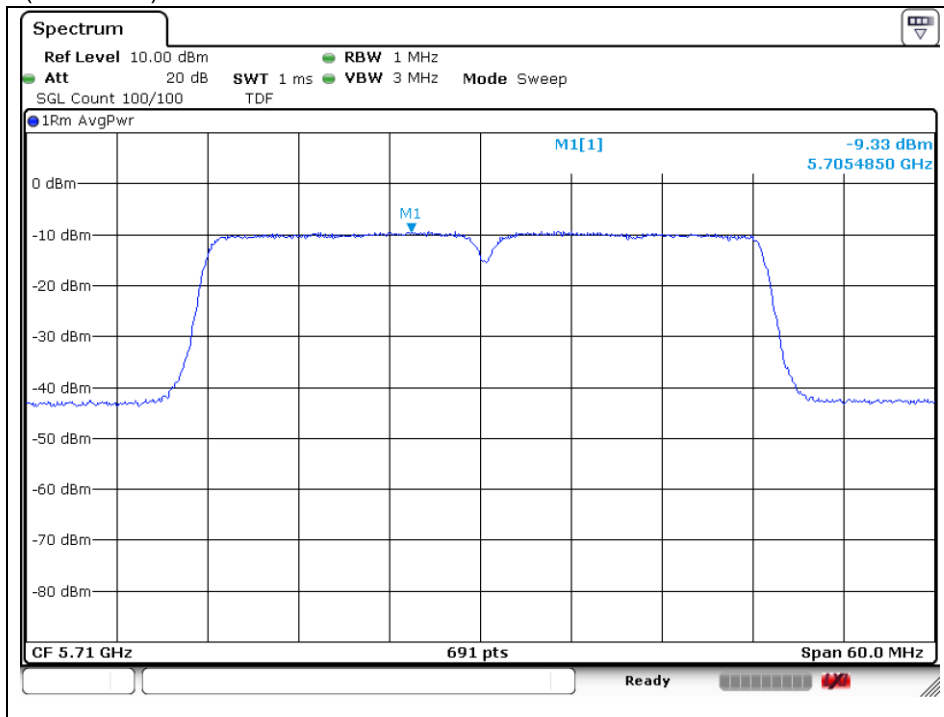

The results shown in this test report refer only to the sample(s) tested unless otherwise stated. This test report cannot be reproduced, except in full, without prior written permission of the Company.

## 802.11n\_HT40 (Band 3) - ANT1

Low Channel (5 755 MHz)

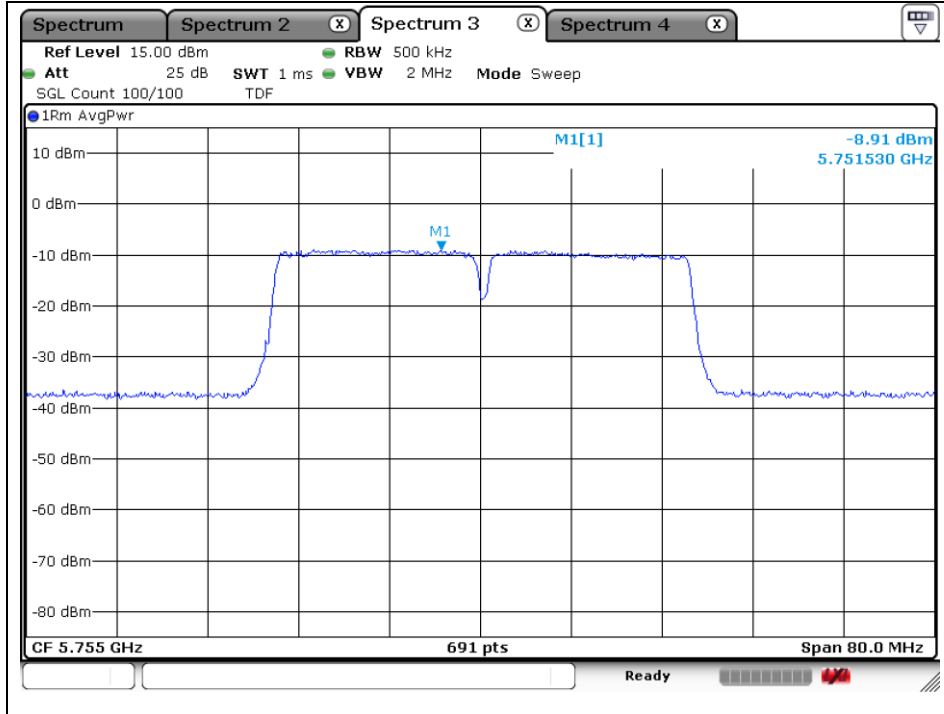

High Channel (5 795 MHz)

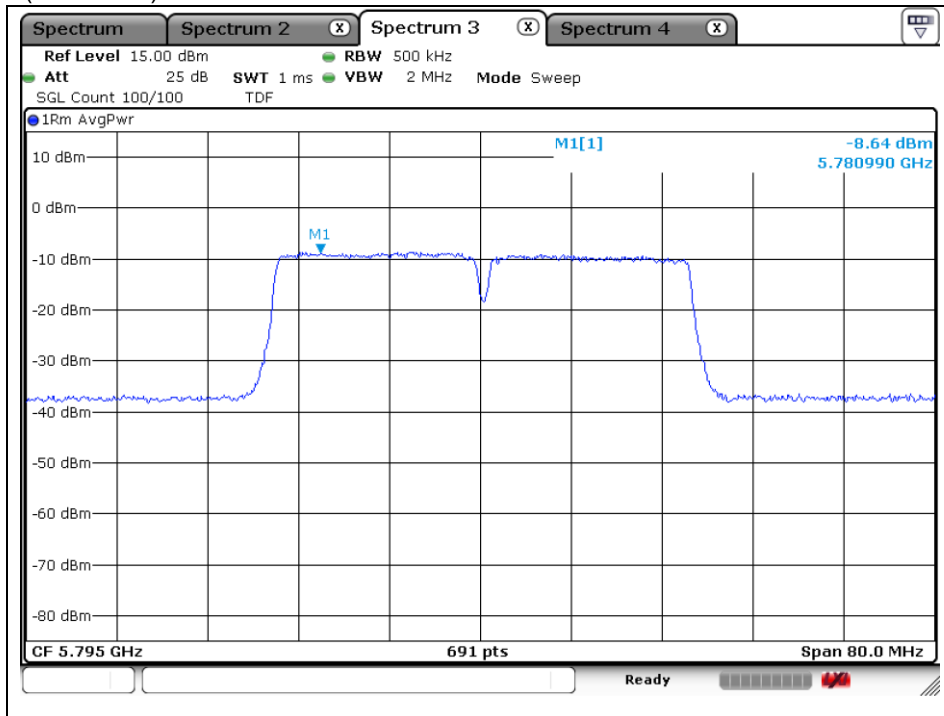

The results shown in this test report refer only to the sample(s) tested unless otherwise stated. This test report cannot be reproduced, except in full, without prior written permission of the Company.

SGS Korea Co., Ltd. (Gunpo Laboratory) 4, LS-ro 182beon-gil, Gunpo-si, Gyeonggi-do, Korea, 15807 <http://www.sgsgroup.kr>

## 802.11n\_HT40 (Band 1) - ANT2

Low Channel (5 190 MHz)

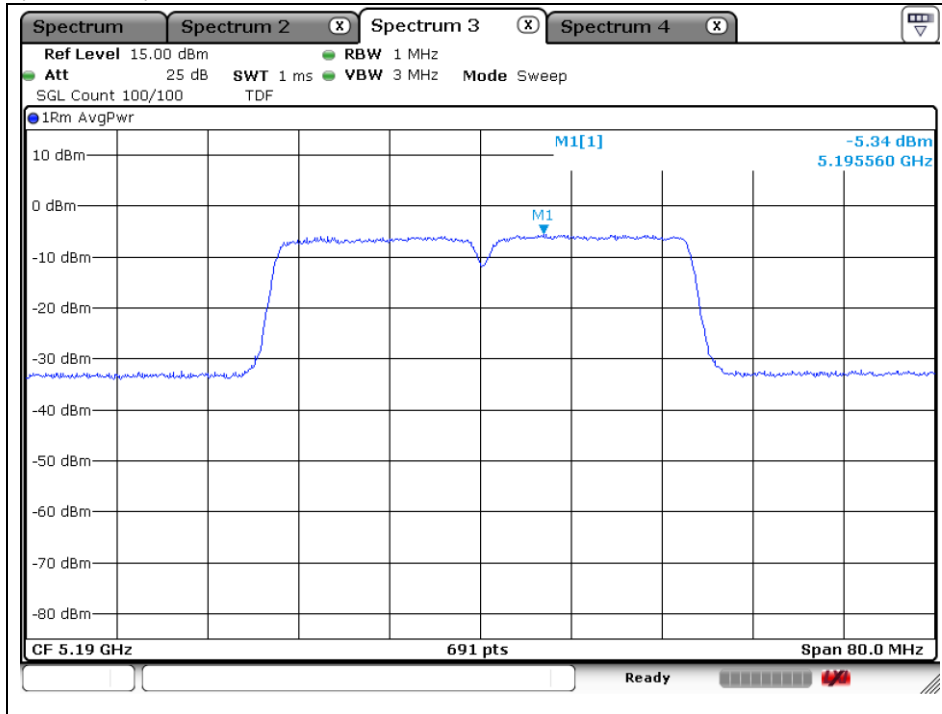

## 802.11n\_HT40 (Band 2A) - ANT2

Low Channel (5 270 MHz)

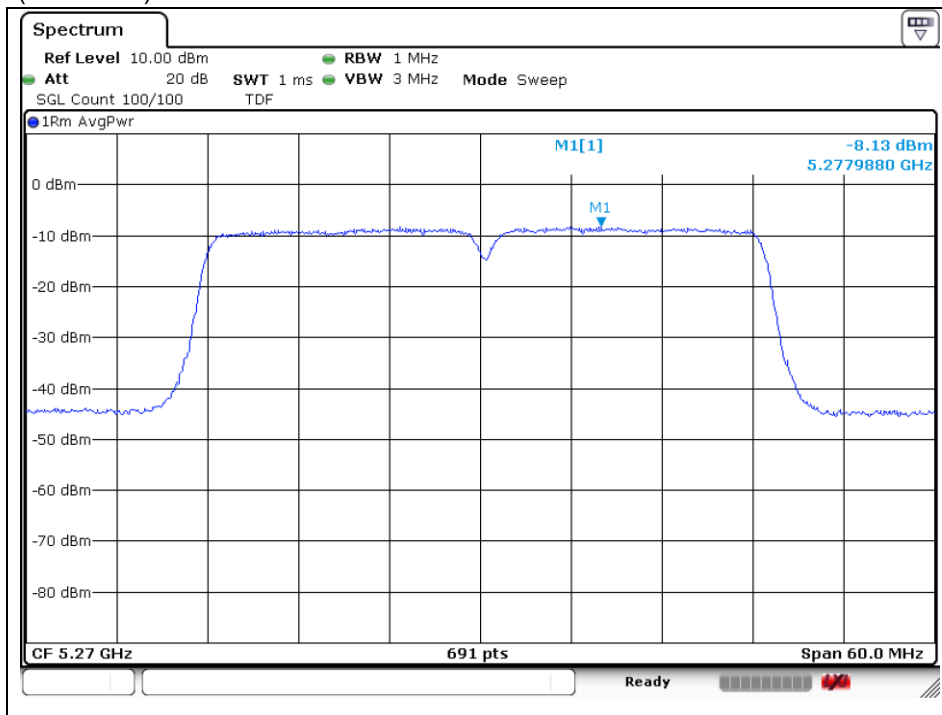

The results shown in this test report refer only to the sample(s) tested unless otherwise stated. This test report cannot be reproduced, except in full, without prior written permission of the Company.

High Channel (5 310 MHz)

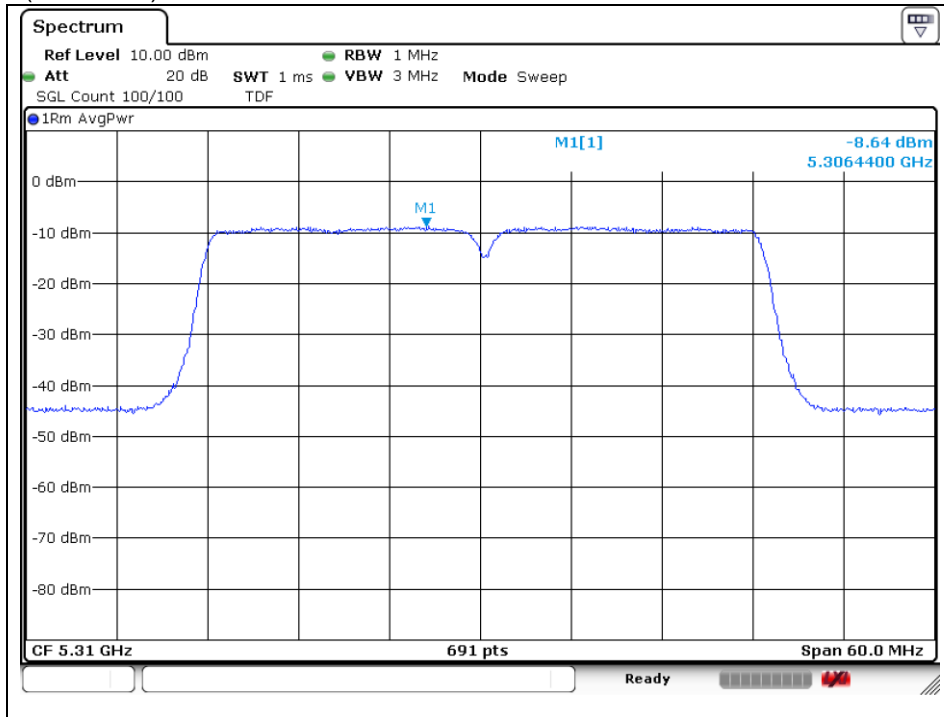

802.11n\_HT40 (Band 2C) - ANT2

Low Channel (5 510 MHz)

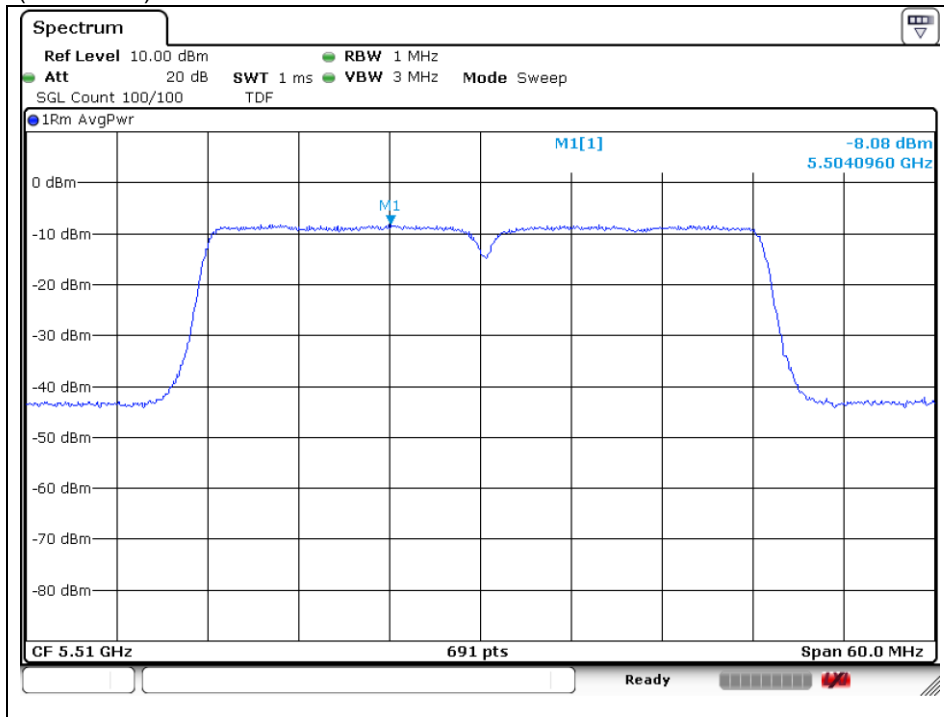

The results shown in this test report refer only to the sample(s) tested unless otherwise stated. This test report cannot be reproduced, except in full, without prior written permission of the Company.

Middle Channel (5 550 MHz)

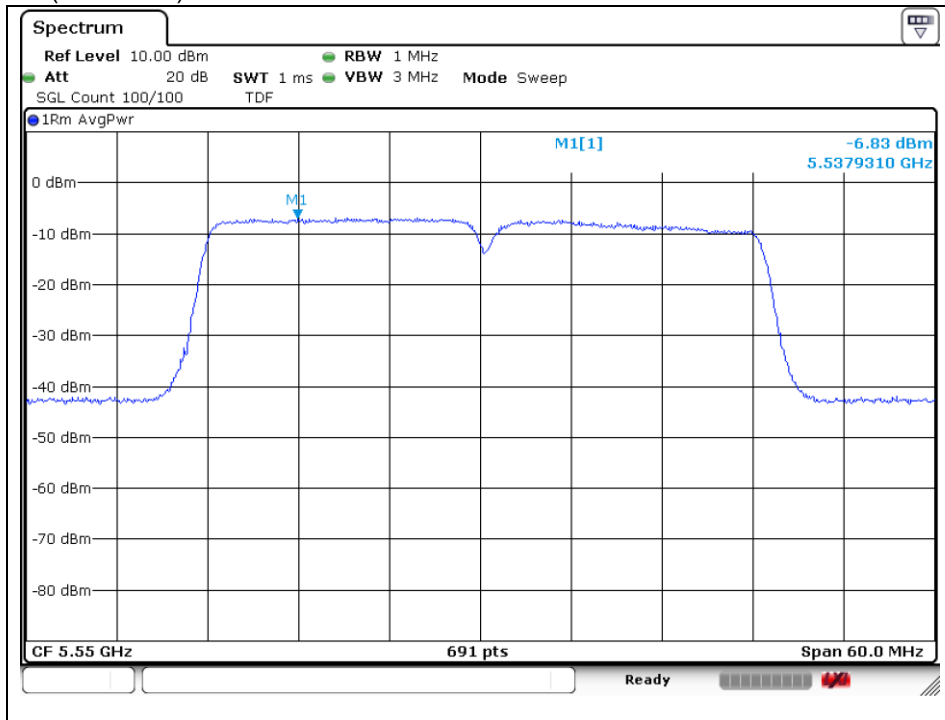

High Channel (5 710 MHz)

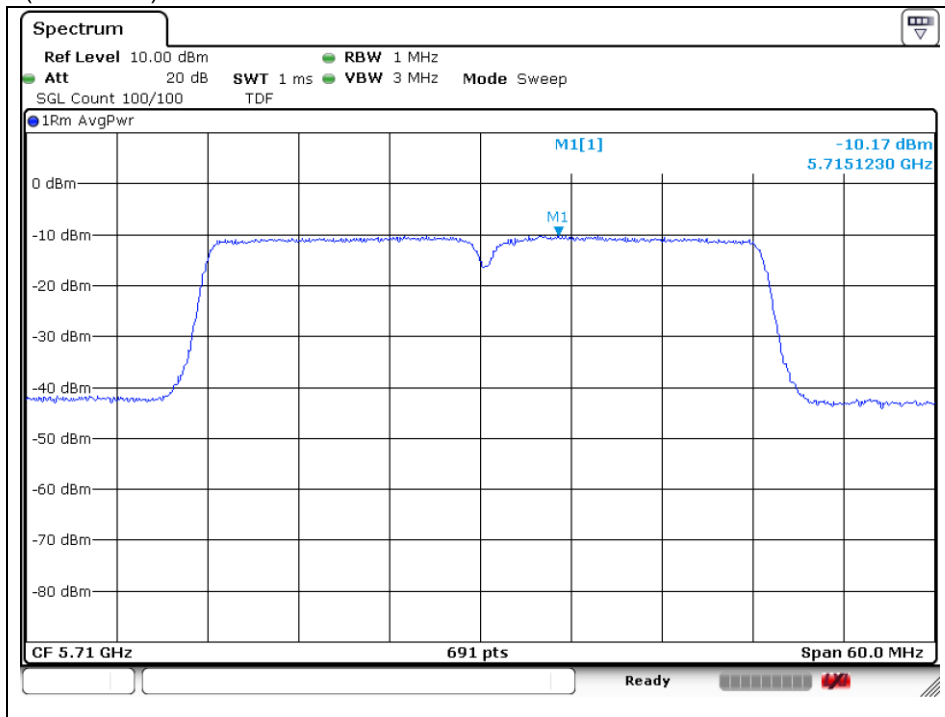

The results shown in this test report refer only to the sample(s) tested unless otherwise stated. This test report cannot be reproduced, except in full, without prior written permission of the Company.



### 802.11n\_HT40 (Band 3) - ANT2

Low Channel (5 755 MHz)

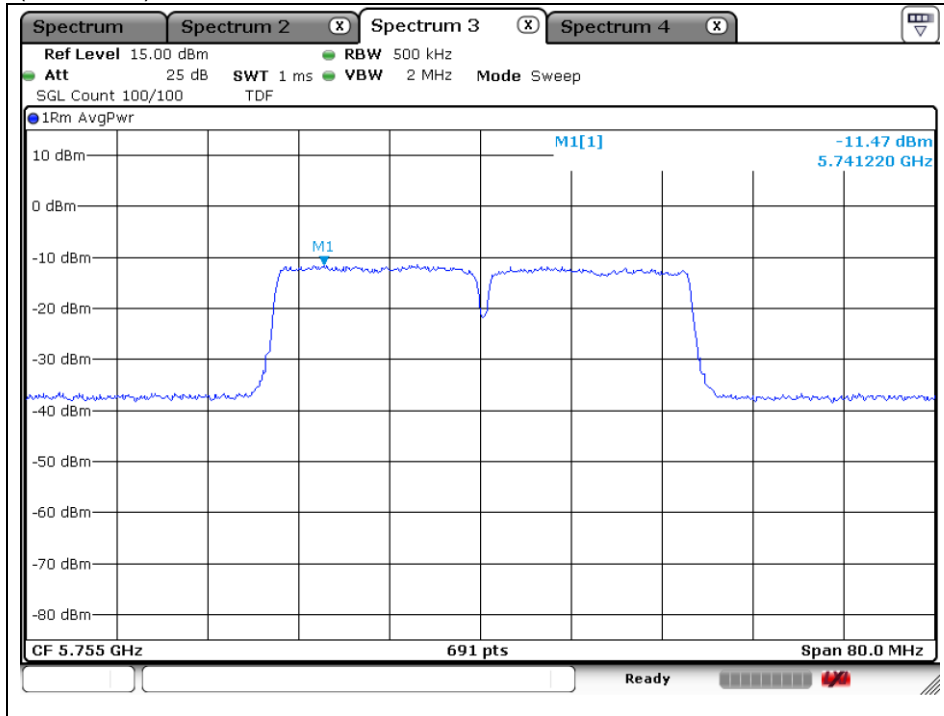

High Channel (5 795 MHz)

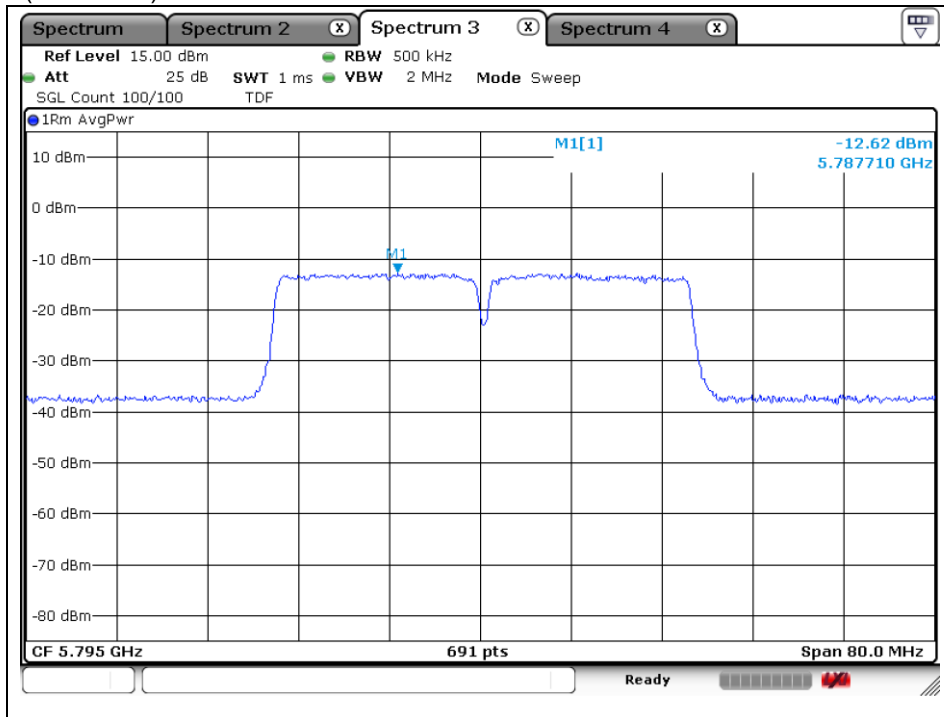

The results shown in this test report refer only to the sample(s) tested unless otherwise stated. This test report cannot be reproduced, except in full, without prior written permission of the Company.

### 802.11ac\_VHT80 (Band 2A) - ANT1

Middle Channel (5 290 MHz)

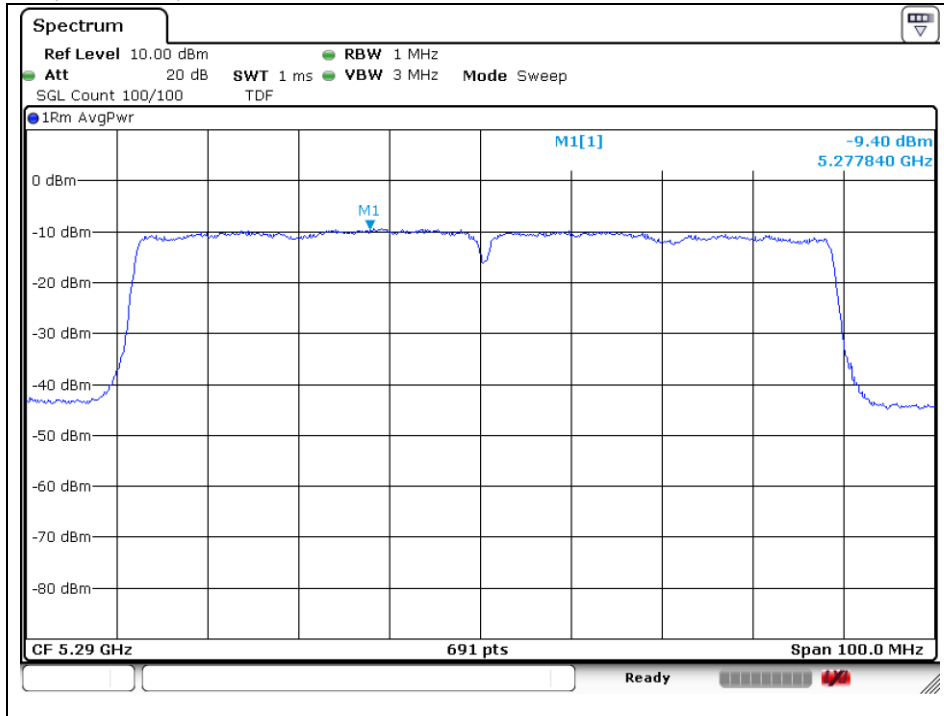

### 802.11ac\_VHT80 (Band 2C) - ANT1

Low Channel (5 530 MHz)

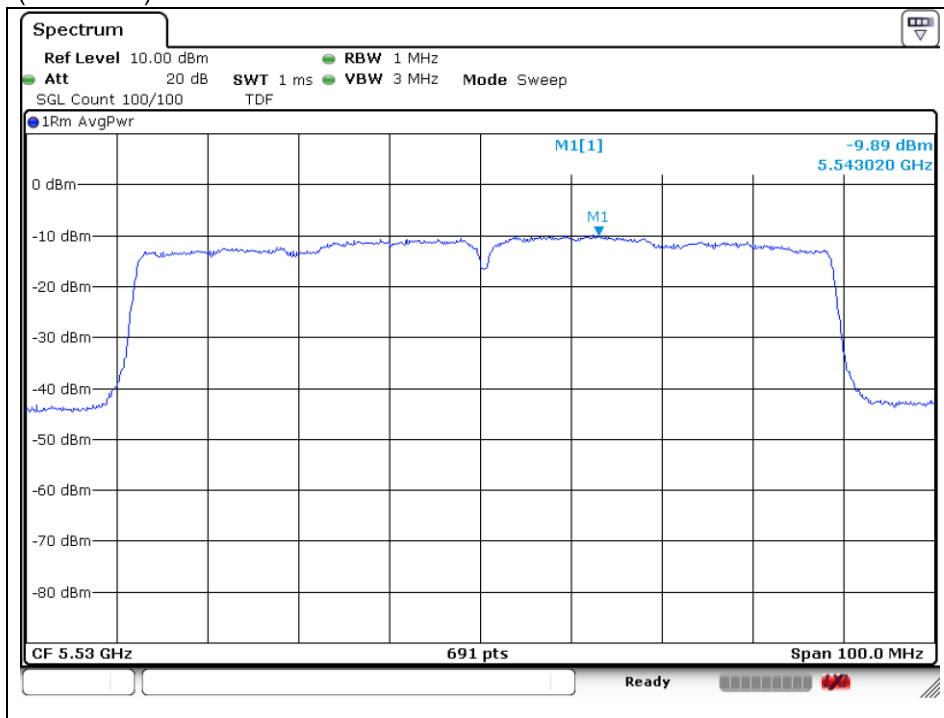

The results shown in this test report refer only to the sample(s) tested unless otherwise stated. This test report cannot be reproduced, except in full, without prior written permission of the Company.

### High Channel (5 690 MHz)

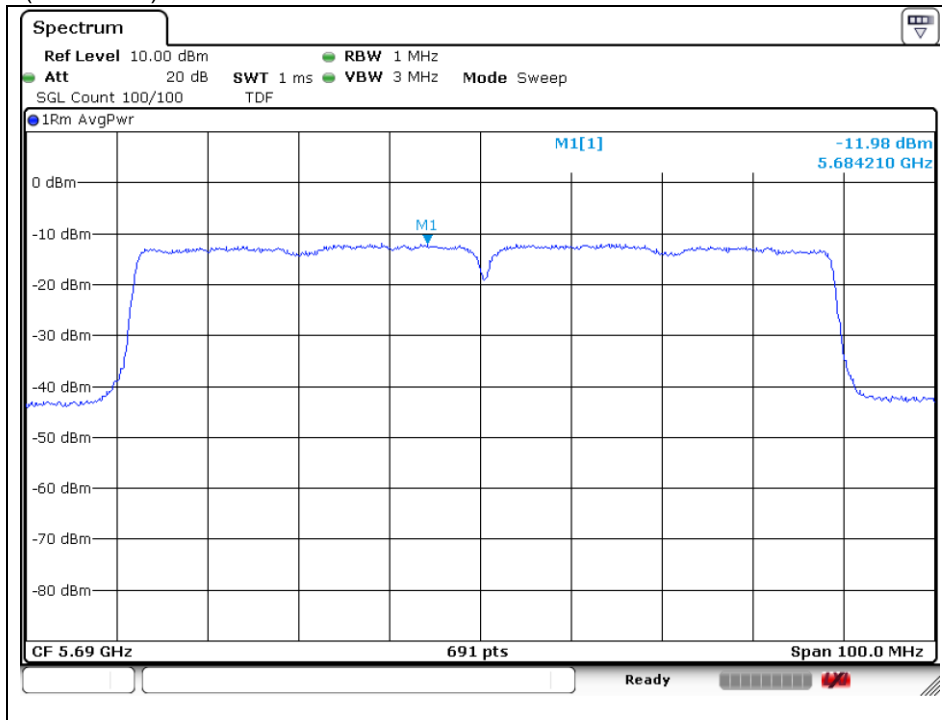

### 802.11ac\_VHT80 (Band 3) - ANT1

#### Middle Channel (5 775 MHz)

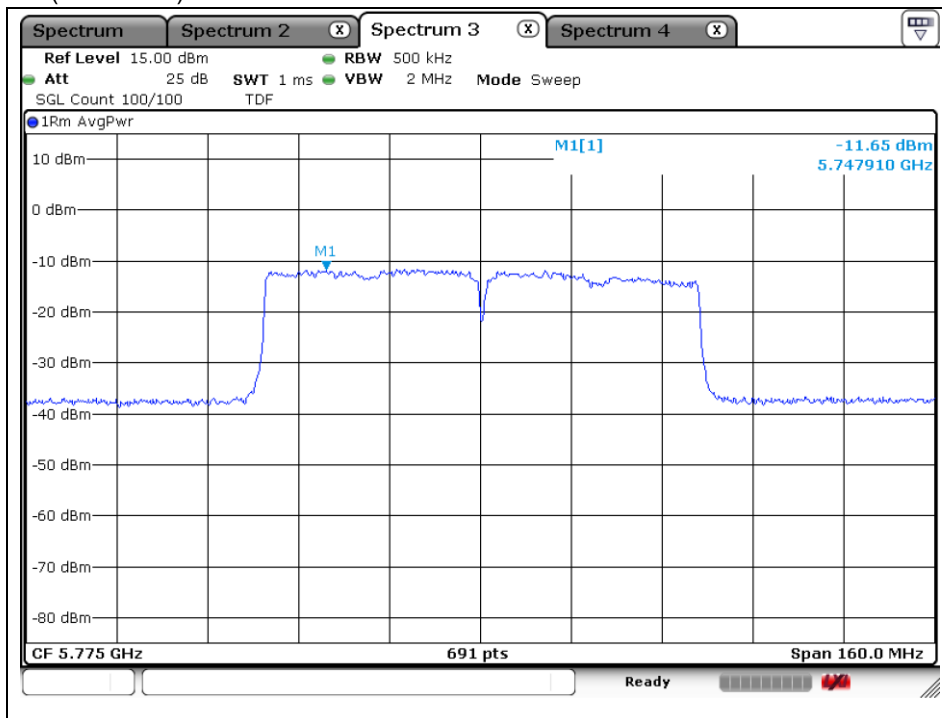

The results shown in this test report refer only to the sample(s) tested unless otherwise stated. This test report cannot be reproduced, except in full, without prior written permission of the Company.

## 802.11ac\_VHT80 (Band 2A) - ANT2

Middle Channel (5 290 MHz)

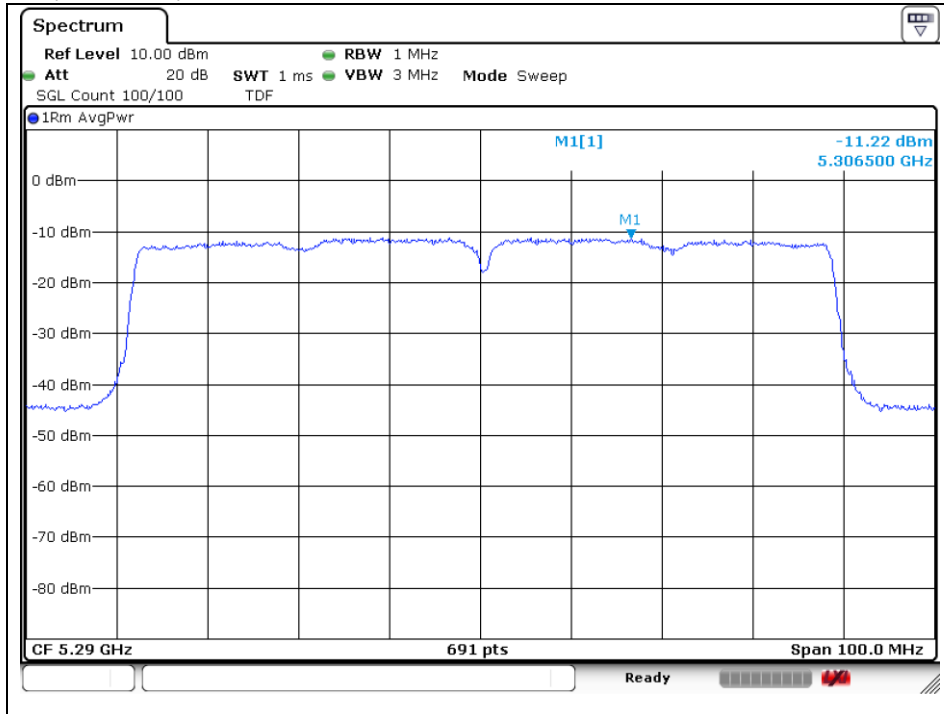

## 802.11ac\_VHT80 (Band 2C) - ANT2

Low Channel (5 330 MHz)

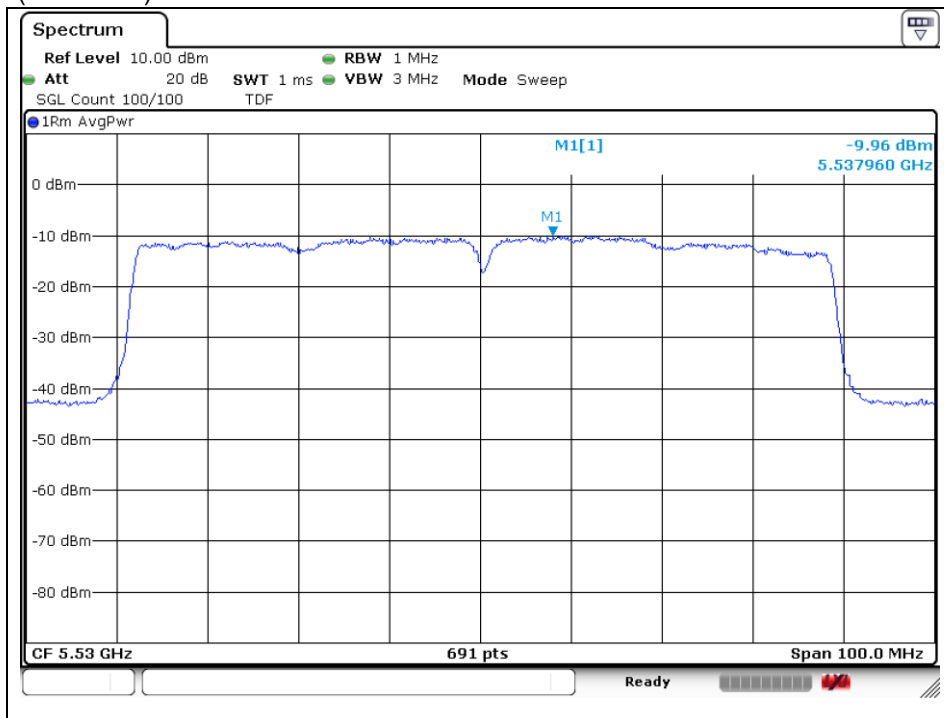

The results shown in this test report refer only to the sample(s) tested unless otherwise stated. This test report cannot be reproduced, except in full, without prior written permission of the Company.

High Channel (5 690 MHz)

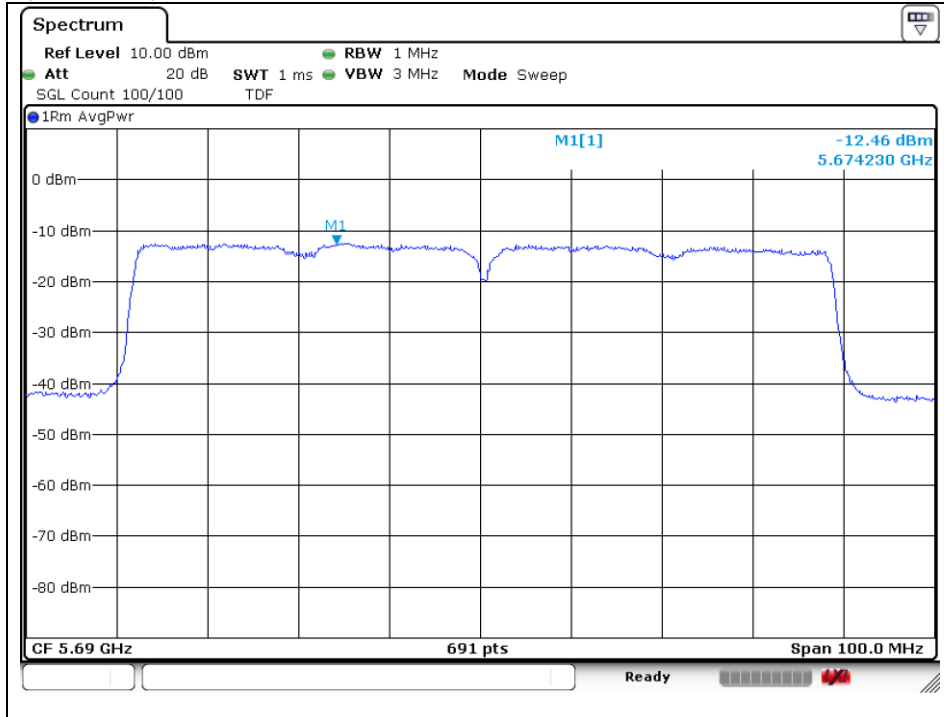

802.11ac\_VHT80 (Band 3) - ANT2

Middle Channel (5 775 MHz)

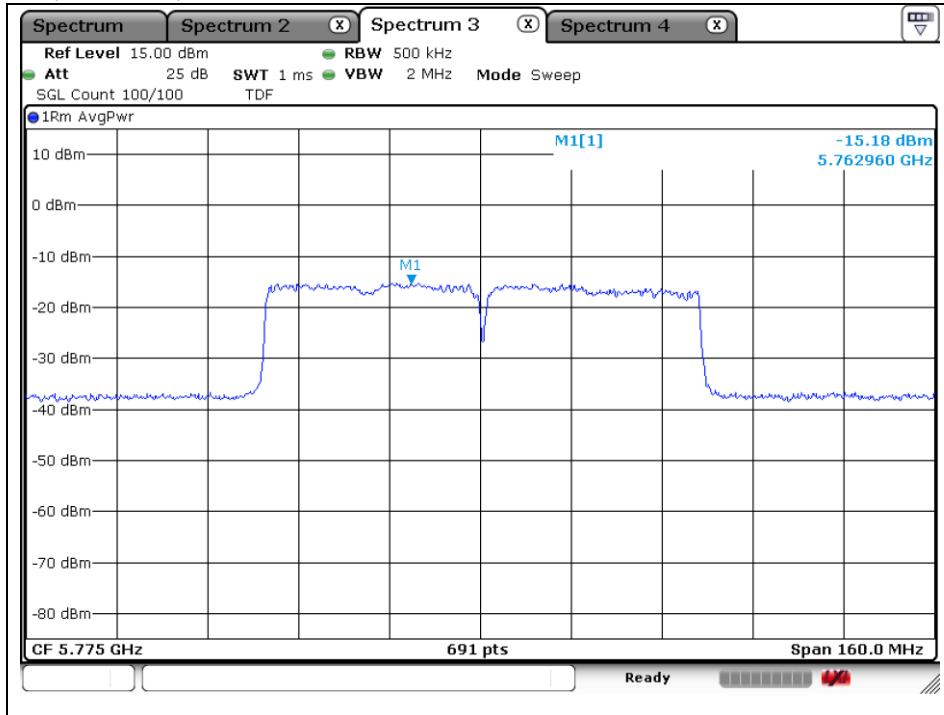

The results shown in this test report refer only to the sample(s) tested unless otherwise stated. This test report cannot be reproduced, except in full, without prior written permission of the Company.

## Band-crossing channels

U-NII 3 11a (5 720 MHz) - ANT1

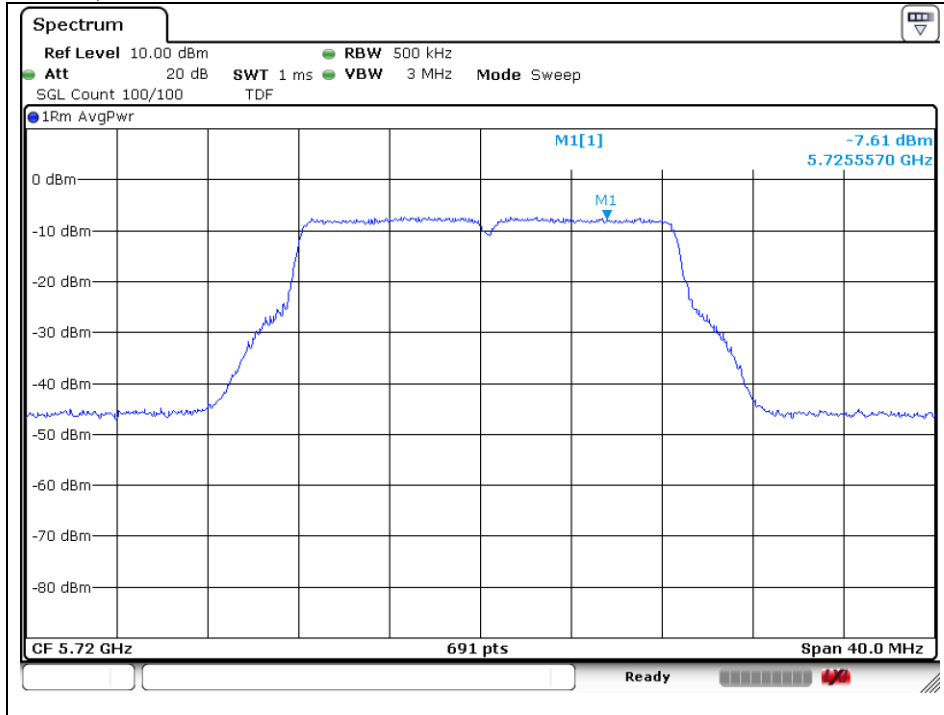

U-NII 3 11a (5 720 MHz) - ANT2

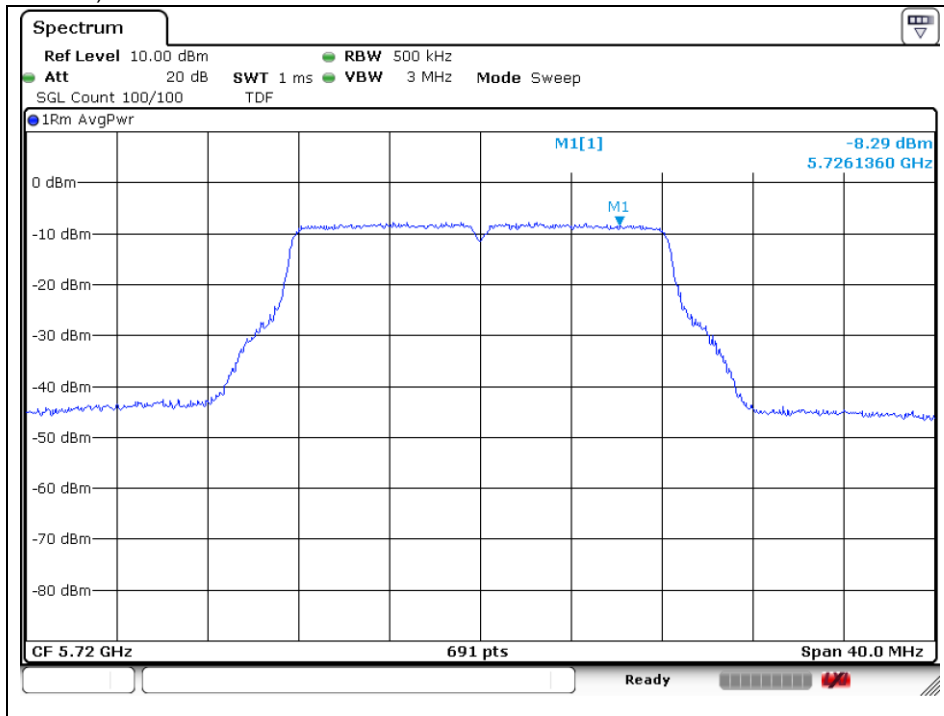

The results shown in this test report refer only to the sample(s) tested unless otherwise stated. This test report cannot be reproduced, except in full, without prior written permission of the Company.

SGS Korea Co., Ltd. (Gunpo Laboratory) 4, LS-ro 182beon-gil, Gunpo-si, Gyeonggi-do, Korea, 15807 <http://www.sgsgroup.kr>

U-NII 3 11n\_HT20 (5 720 MHz) - ANT1

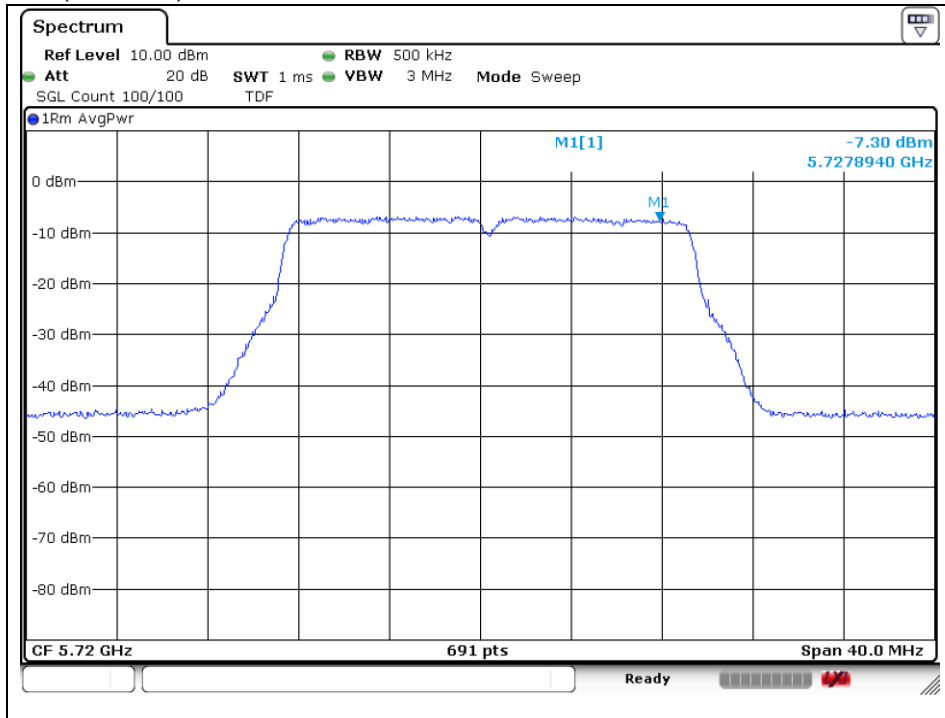

U-NII 3 11n\_HT20 (5 720 MHz) - ANT2

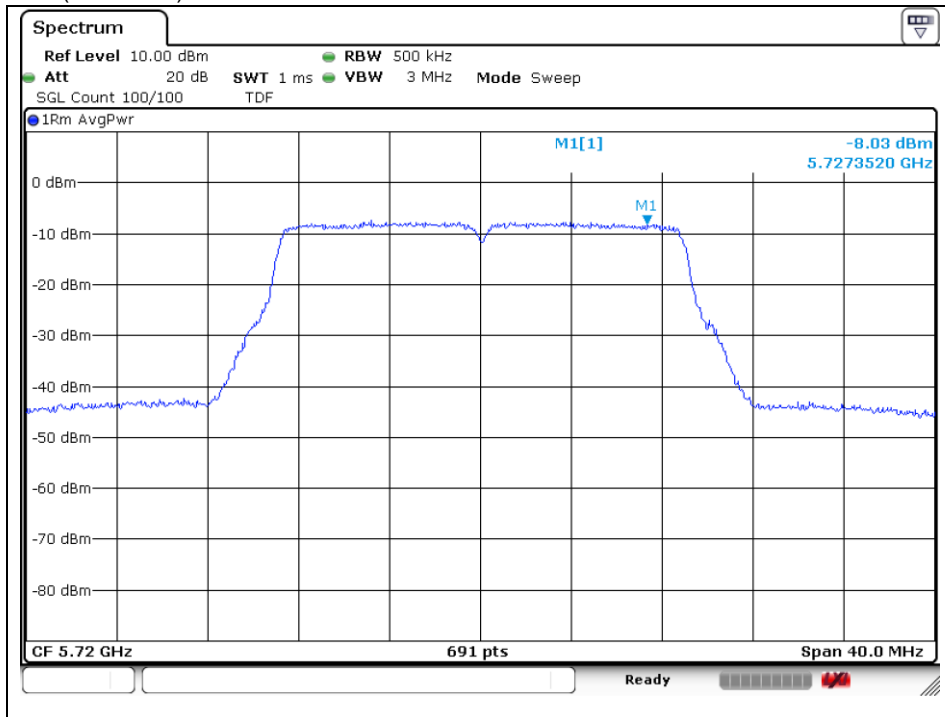

The results shown in this test report refer only to the sample(s) tested unless otherwise stated. This test report cannot be reproduced, except in full, without prior written permission of the Company.

U-NII 3 11n\_HT40 (5 710 MHz) - ANT1

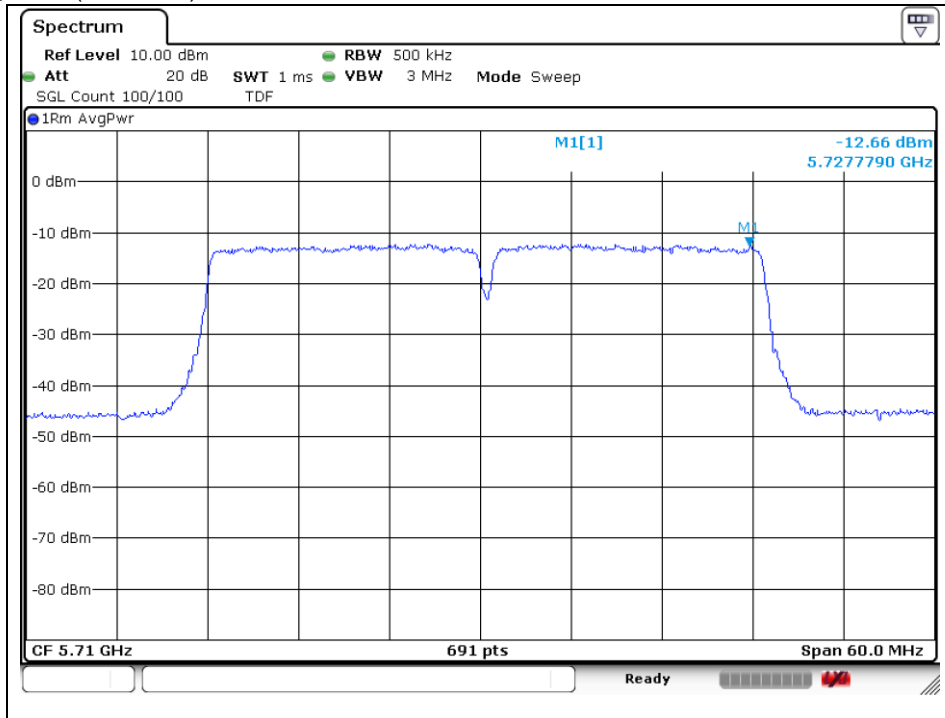

U-NII 3 11n\_HT40 (5 710 MHz) - ANT2

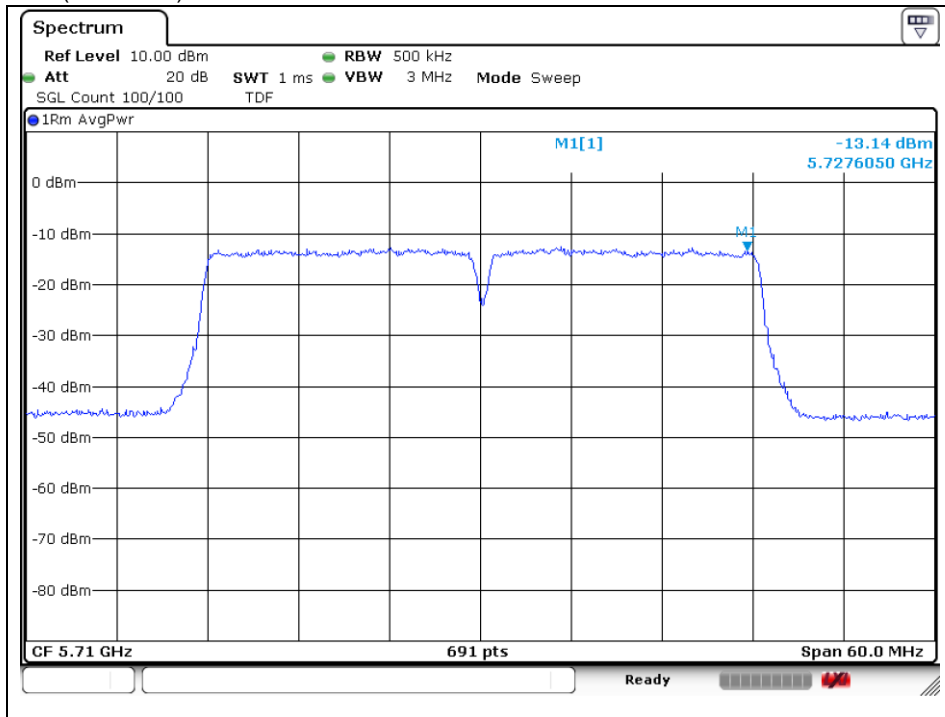

The results shown in this test report refer only to the sample(s) tested unless otherwise stated. This test report cannot be reproduced, except in full, without prior written permission of the Company.



U-NII 3 11ac\_VHT80 (5 690 MHz) - ANT1

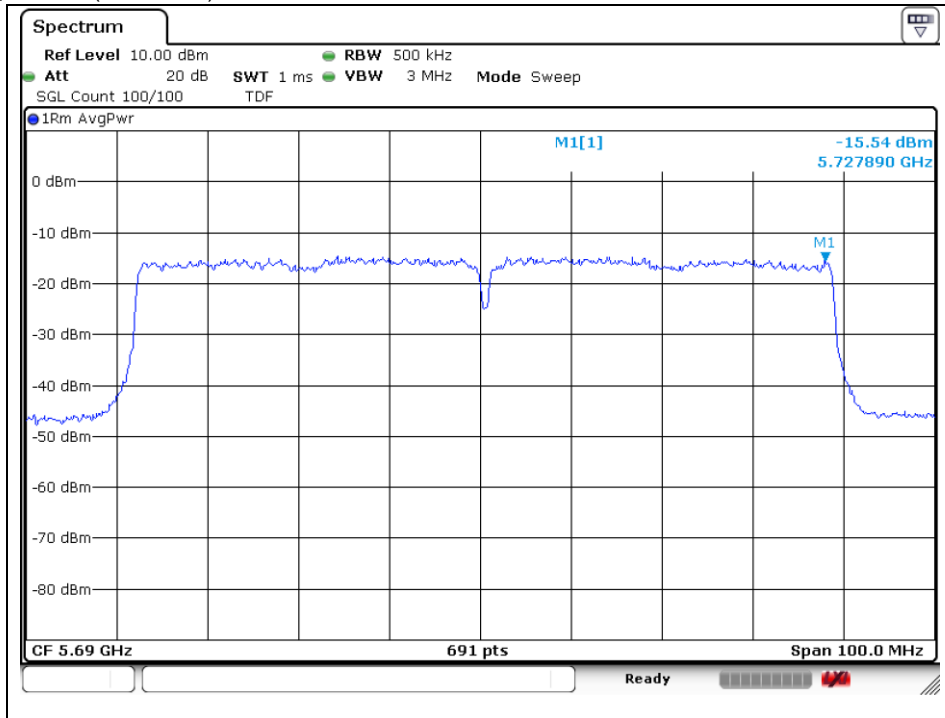

U-NII 3 11ac\_VHT80 (5 690 MHz) - ANT2

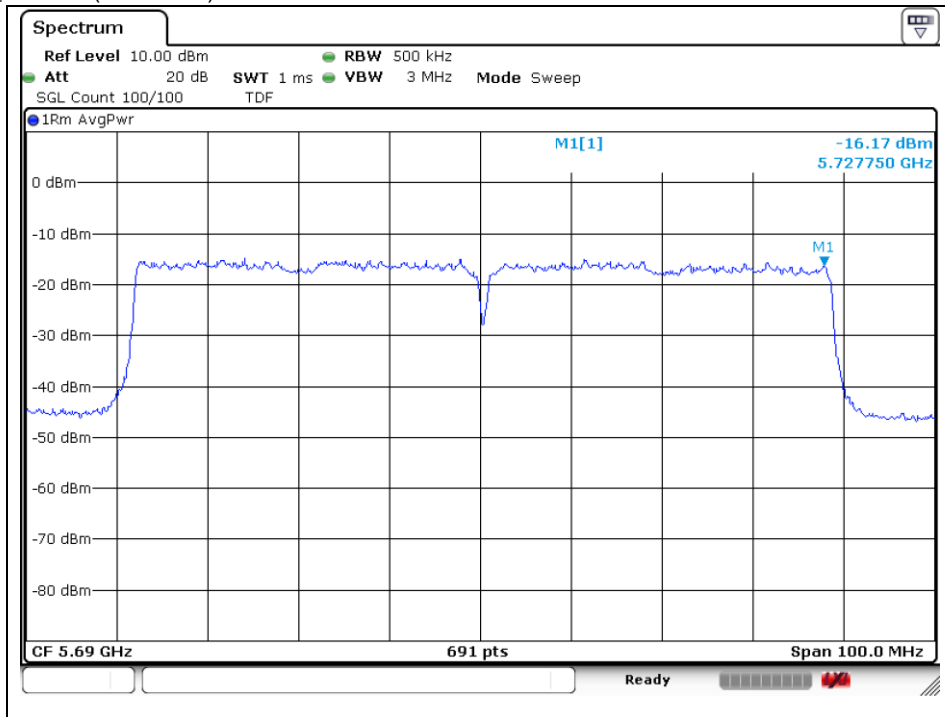

The results shown in this test report refer only to the sample(s) tested unless otherwise stated. This test report cannot be reproduced, except in full, without prior written permission of the Company.

## 7. AC Power Line Conducted Emission

### 7.1. Test Setup

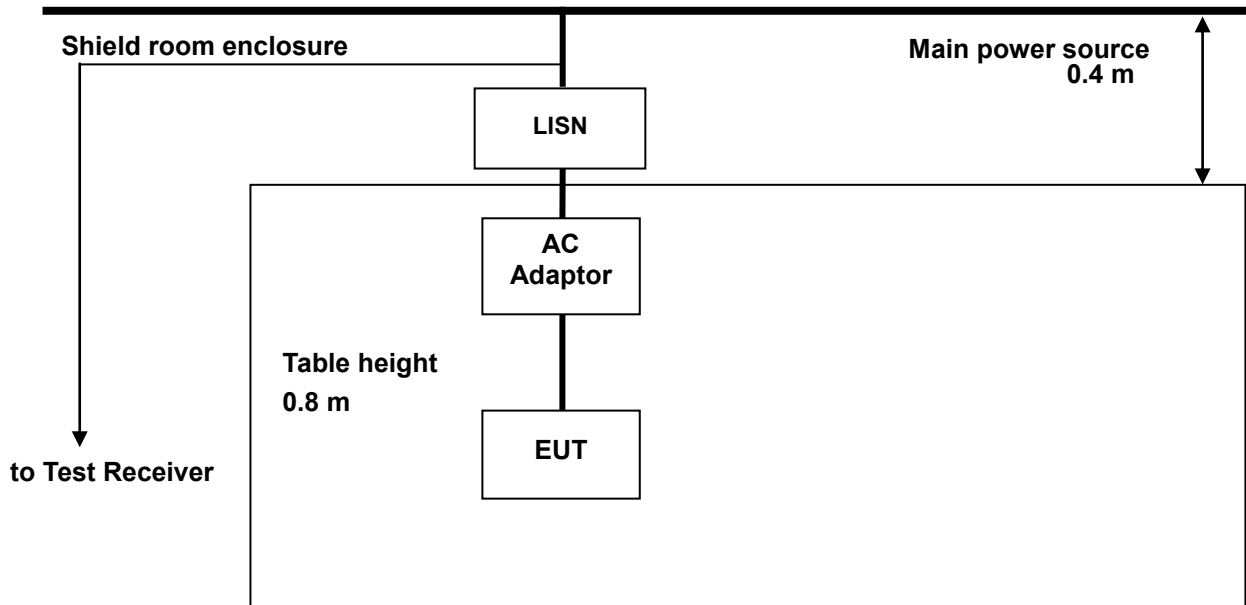

### 7.2. Limit

According to §15.207(a) for an intentional radiator that is designed to be connected to the public utility (AC) power line, the radio frequency voltage that is conducted back onto the AC power line on any frequency or frequencies, within the band 150 kHz to 30 MHz, shall not exceed the limits in the following table, as measured using a 50  $\mu$ H / 50 ohm line impedance stabilization network(LISN).

Compliance with the provision of this paragraph shall on the measurement of the radio frequency voltage between each power line and ground at the power terminal. The lower applies at the boundary between the frequency ranges.

Frequency of Emission (MHz)	Conducted limit (dB $\mu$ V)	
	Quasi-peak	Average
0.15 – 0.50	66 - 56*	56 - 46*
0.50 – 5.00	56	46
5.00 – 30.0	60	50

\* Decreases with the logarithm of the frequency.

The results shown in this test report refer only to the sample(s) tested unless otherwise stated. This test report cannot be reproduced, except in full, without prior written permission of the Company.

SGS Korea Co., Ltd. (Gunpo Laboratory) 4, LS-ro 182beon-gil, Gunpo-si, Gyeonggi-do, Korea, 15807 <http://www.sgsgroup.kr>

---

### 7.3. Test Procedures

All data rates and modes were investigated for this test. The full data for the worst case data rate are reported in this section.

AC line conducted emissions from the EUT were measured according to the dictates of ANSI C63.10-2009

1. The test procedure is performed in a 6.5 m × 3.6 m × 3.6 m (L × W × H) shielded room. The EUT along with its peripherals were placed on a 1.0 m (W) × 1.5 m (L) and 0.8 m in height wooden table and the EUT was adjusted to maintain a 0.4 meter space from a vertical reference plane.
2. The EUT was connected to power mains through a line impedance stabilization network (LISN) which provides 50 ohm coupling impedance for measuring instrument and the chassis ground was bounded to the horizontal ground plane of shielded room.
3. The excess power cable between the EUT and the LISN was bundled. All connecting cables of EUT were moved to find the maximum emission.

---

*The results shown in this test report refer only to the sample(s) tested unless otherwise stated. This test report cannot be reproduced, except in full, without prior written permission of the Company.*

**SGS Korea Co., Ltd. (Gunpo Laboratory)** 4, LS-ro 182beon-gil, Gunpo-si, Gyeonggi-do, Korea, 15807 <http://www.sgsgroup.kr>

## 7.4. Test Results

The following table shows the highest levels of conducted emissions on both phase of Hot and Neutral line

Ambient temperature : (23 ± 1) °C  
 Relative humidity : 47 % R.H.  
  
 Frequency range : 0.15 MHz – 30 MHz  
 Measured Bandwidth : 9 kHz

FREQ. (MHz)	LEVEL(dB $\mu$ V)		LINE	LIMIT(dB $\mu$ V)		MARGIN(dB)	
	Q-Peak	Average		Q-Peak	Average	Q-Peak	Average
0.49	34.80	22.70	N	56.17	46.17	21.37	23.47
4.34	26.30	21.90	N	56.00	46.00	29.70	24.10
5.96	27.30	22.00	N	60.00	50.00	32.70	28.00
10.30	26.30	21.70	N	60.00	50.00	33.70	28.30
14.80	27.10	22.50	N	60.00	50.00	32.90	27.50
27.81	31.70	26.80	N	60.00	50.00	28.30	23.20
0.48	35.00	23.50	H	56.34	46.34	21.34	22.84
0.70	18.00	11.90	H	56.00	46.00	38.00	34.10
6.02	28.50	23.30	H	60.00	50.00	31.50	26.70
9.82	28.40	23.10	H	60.00	50.00	31.60	26.90
14.91	27.40	22.60	H	60.00	50.00	32.60	27.40
27.81	32.30	26.10	H	60.00	50.00	27.70	23.90

### Remark;

- Line ( H ): Hot, Line ( N ): Neutral.
- All modes of operation were investigated and the worst-case emissions were reported using 11n\_HT20 (Band 1) Mode, MCS8, High channel.
- Traces shown in plot mad using a peak detector and average detector.
- The limit for Class B device(s) from 150 kHz to 30 MHz are specified in Section of the Title 47 CFR.
- Deviations to the Specifications: None.

*The results shown in this test report refer only to the sample(s) tested unless otherwise stated. This test report cannot be reproduced, except in full, without prior written permission of the Company.*

## Plots of Conducted Power line

Test mode: (Neutral)

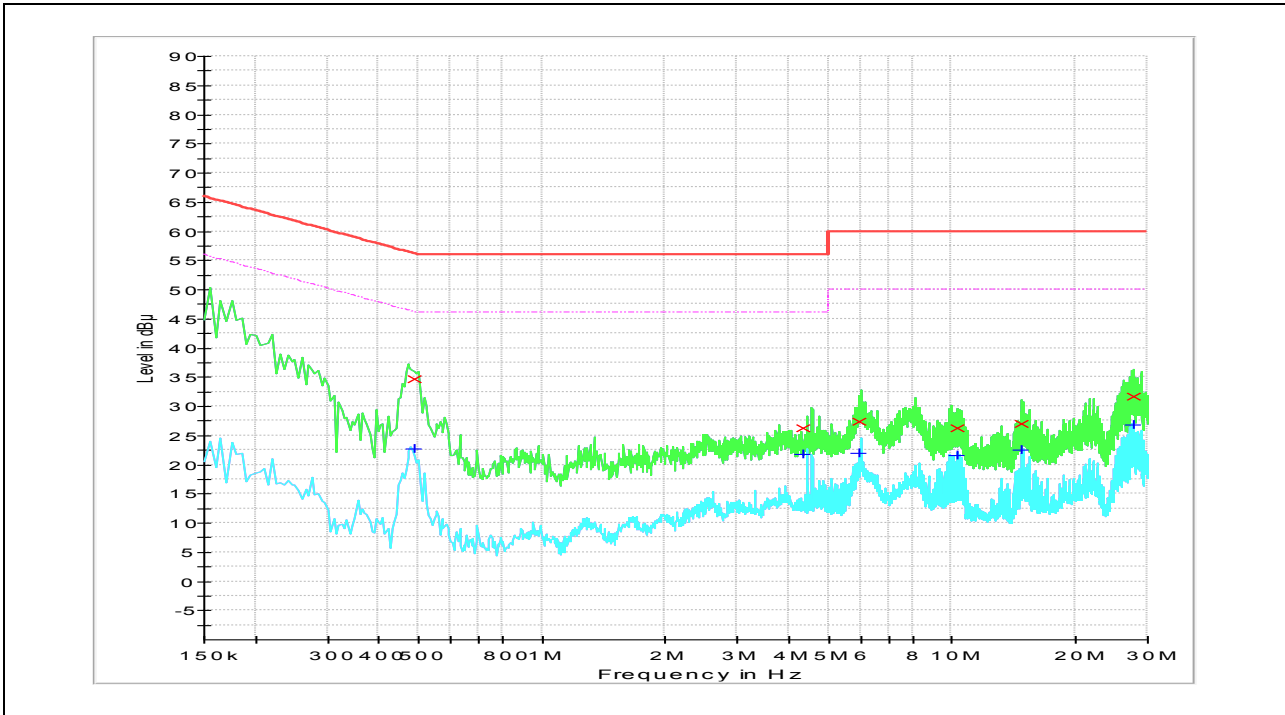

Test mode: (Hot)

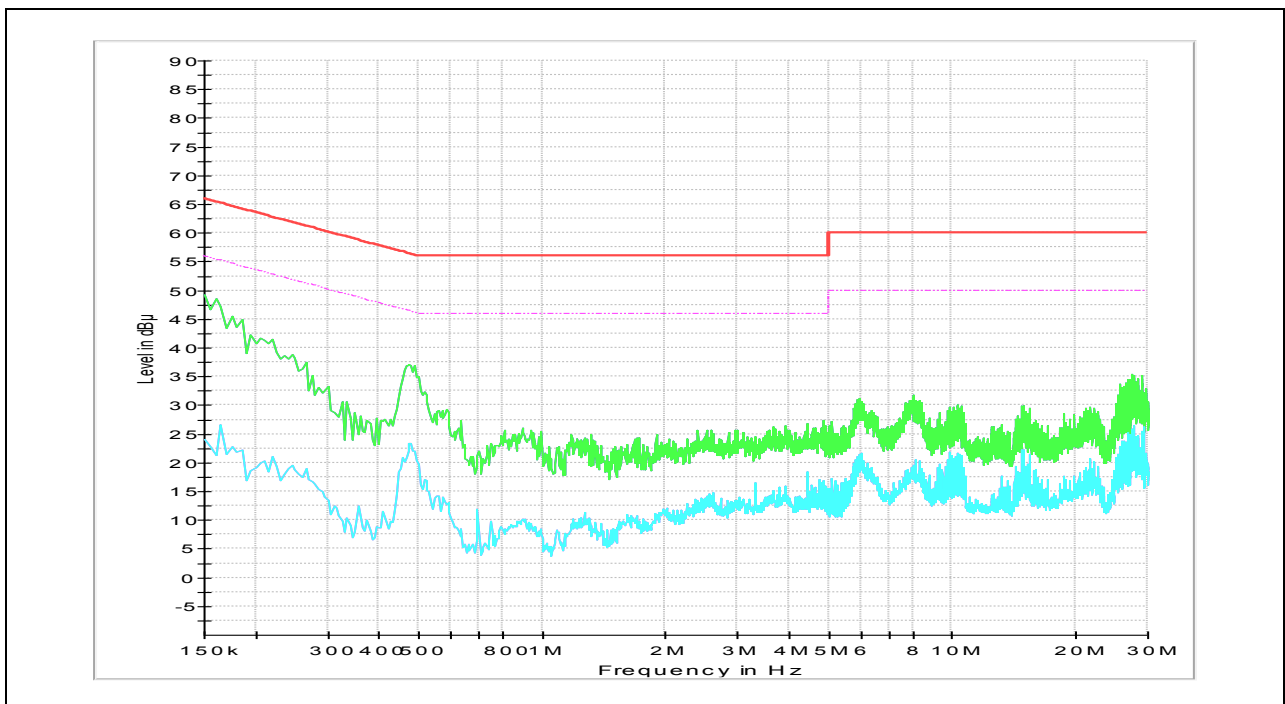

The results shown in this test report refer only to the sample(s) tested unless otherwise stated. This test report cannot be reproduced, except in full, without prior written permission of the Company.

## 8. Antenna Requirement

### 8.1. Standard Applicable

For intentional device, according to FCC 47 CFR Section §15.203, an intentional radiator shall be designed to ensure that no antenna other than that furnished by the responsible party shall be used with the device. And according to FCC 47 CFR Section §15.407 (a) if transmitting antennas of directional gain greater than 6 dB i are used, the power shall be reduced by the amount in dB that the gain of the antenna exceeds 6 dB i.

### 8.2. Antenna Connected Construction

Antenna used in this product is Dipole type and peak max gain of antenna as below.

Band	5 180 MHz – 5 320 MHz	5 500 MHz – 5 720 MHz	5 745 MHz – 5 825 MHz
Mode	11a/n_HT20, HT40, 11ac_VHT20, VHT40, VHT80		
ANT1 Gain	2.7 dB i		
ANT2 Gain	2.7 dB i		

$$\text{Directional gain} = G_{\text{ANT}} + 10 \log(N_{\text{ANT}}) \text{ dB i} = 5.71 \text{ dB i}$$

*The results shown in this test report refer only to the sample(s) tested unless otherwise stated. This test report cannot be reproduced, except in full, without prior written permission of the Company.*

**SGS Korea Co., Ltd. (Gunpo Laboratory)** 4, LS-ro 182beon-gil, Gunpo-si, Gyeonggi-do, Korea, 15807 <http://www.sgsgroup.kr>