

Haier

SERVICE MANUAL

Order No.: TV0902S0027V0

COLOR TV

Model No. HLC22R1

CHASSIS: MTK5380LC



WARNING

This service information is designed for experienced repair technicians only and is not designed for use by the general public. It does not contain warnings or cautions to advise non-technical individuals of potential dangers in attempting to service a product. Products powered by electricity should be serviced or repaired only by experienced professional technicians. Any attempt to service or repair the product dealt with in this service information by anyone else could result in serious injury or death.

©

©2009 (Qingdao Electronics limited company)

All rights reserved. Unauthorized copying and distribution is a violation of law.

CONTENTS

Table of contents	2
1. General Information	3
1-1. General Guidelines.....	3
1-2. Important notice.....	3
1-3. How to read this Service Manual.....	4
2. Specifications	6
3. Location of Controls and Components	7
3-1.Board Location.....	7
3-2. Main Board & AV Board.....	7
3-3. Power Board.....	9
3-4. LCD Panel.....	10
4. Disassemble and assemble	11
4-1 Remove the Pedestal	12
4-2 Remove the Back Cover.....	12
4-3 Remove the adhesive tape.....	12
4-4 Remove the Terminal Bracket.....	12
4-5 Remove the power module.....	13
4-6 Remove the Main board.....	13
4-7 Remove the small power board.....	13
4-8 Remove the speaker	13
4-9 Remove the remote control board	13
5. Installation Instructions	14
5-1 External Equipment Connections	14
5-2 HDMI Connections	16
6. Operation Instructions	19
6-1 Front Panel Controls	19
6-2 Back Panel Controls	19
6-3 Universal Remote Controller.....	19
7. Electrical parts	21
7-1. Block diagram	21
7-2. Circuit Diagram.....	21
7-3 .Wiring Connection Diagram.....	36
8. Measurements and Adjustments	37
8-1. Service Mode	37

8-1-1.How to enter into Service Mode	37
8-1-2.How to exit	37
8-2. Measurements and Adjustments	37
9. Trouble shooting	43
9-1. Simple check	43
9-2. Power Supply Board failure check	44
9-3. Main board failure check	45
9-4. Pannel failure	47

1. General Information

1-1 General Guidelines

When servicing, observe the original lead dress. If a short circuit is found, replace all parts which have been overheated or damaged by the short circuit.

After servicing, see to it that all the protective devices such as insulation barriers, insulation papers shields are properly installed.

After servicing, make the following leakage current checks to prevent the customer from being exposed to shock hazards.

- 1) Leakage Current Cold Check
- 2) Leakage Current Hot Check
- 3) Prevention of Electro Static Discharge(ESD)to Electrostatically Sensitive

1-2 Important notice

1-2-1. Follow the regulations and warnings

Most important thing is to list up the potential hazard or risk for the service personnel to open the units and disassemble the units. For example, we need to describe properly how to avoid the possibility to get electrical shock from the live power supply or charged electrical parts (even the power is off).

This symbol indicates that high voltage is present inside. It is dangerous to make any kind of contact with any inside part of this product.



This symbol indicates that there are important operating and maintenance instructions in the literature accompanying the appliance

1-2-2. Be careful to the electrical shock

To prevent damage which might result in electric shock or fire, do not expose this TV set to rain or excessive moisture. This TV must not be exposed to dripping or splashing water, and objects

Filled with liquid, such as vases, must not be place on top of or above the TV

1-2-3. Electro static discharge (ESD)

Some semiconductor (solid state) devices can be damaged easily by static electricity. Such Components commonly are called Electrostatically Sensitive (ES) Devices. The following tech-niquesshouldbeusedtohelpreducetheincidenceofcomponentdamagecausedbyelectro Static discharge (ESD).

1-2-4. About lead free solder (PbF)

This product is manufactured using lead-free solder as a part of a movement within the consumer products industry at large to be environmentally responsible. Lead-free solder must be used in the servicing and repair of this product.

1-2-5. Use the genuening parts (specified parts)

Special parts which have purposes of fire retardant (resistors),high-quality sound (capacitors), low noise(resistors), etc. are used.

When replacing any of components, be sure to use only manufacture's specified parts shown in the parts list.

Safety Component

- Components identified by  mark have special characteristics important for safety.

1-2-6. Take Care to Deal With The Cathode-Ray Tube

In the condition that an explosion-proof cathode ray tube is set in this equipment, safety is secured against implosion. However, when removing it or serving from backward, it is dangerous to give a shock. Take enough care to deal with it.

1-2-7. Safety Check after Repairment

Confirm that the screws, parts and wiring which were removed in order to service are put in the original positions, or whether there are the portions which are deteriorated around the serviced places serviced or not. Check the insulation between the antenna terminal or external metal and the AC cord plug blades. And be sure the safety of that.

Insulation Test

1. Unplug the plug from the AC outlet.
2. Remove the antenna terminal on TV and turn on the TV.
3. Insulation resistance between the cord plug terminals and the external exposure metal should be more than M ohm by using the 500V insulation resistance meter
4. If the insulation resistance is less than M ohm, the inspection repair should be required. If you have not the 500V insulation resistance meter, use a Tester.
External exposure metal: Antenna terminal Headphone jack

1-2-8. Ordering Spare Parts

Please include the following informations when you order parts. (Particularly the Version letter)

1. Model number and Version letter

The model number can be found on the back of each product and the Version letter can be found at the end of the serial number.

2. Part No. and Description

You can find them in your service manual.

1-2-9. Photo used in this manual

The illustration and photos used in this Manual may not base on the final design of products, which may differ from your products in some way.

1-3. How to read this Service Manual

1-4-1. Using Icons

Icons are used to attract the attention of the reader to specific information. The meaning of each icon is described in the table below:



A "note" provides information that is not indispensable, but may nevertheless be valuable to the reader, such as tips and tricks.

Caution:

A "caution" is used when there is danger that the reader, through incorrect manipulation,



may damage equipment, loose data, get an unexpected result or has to restart(part of) a procedure.

Warning:



A “warning” is used when there is danger of personal injury.

Reference:

A “reference” guides the reader to other places in this binder or in this manual, where he/she will find additional information on a specific topic.



2. Specification

Model	HLC22R1
Screen size	21.6inch
Aspect ratio	16:9
Resolution	1366 x 768
Contrast Ratio	1000:1
Angel of view	H:170/V:160
Color display	16.7M
OSD language	English
Color system	ATSC/NTSC
Color Temperature	Cold/Standard/Warm
Audio output power(Built-in)(W)	3Wx2
Power Consmption(in Standby)	1W
Total power input (W)	50W
Voltage range (V)	120V±10% V
Power frequency (Hz)	60HZ
Time of sleep timer(MINS)	240Min
Net weight(KG)	6.4
Gross weight(KG)	9.25
Net dimension(MM)	461 *180 *361
Packaged dimension(MM)	520 *203 *416

3. LOCATION OF CONTROLS AND COMPONENTS

3-1 Board Location

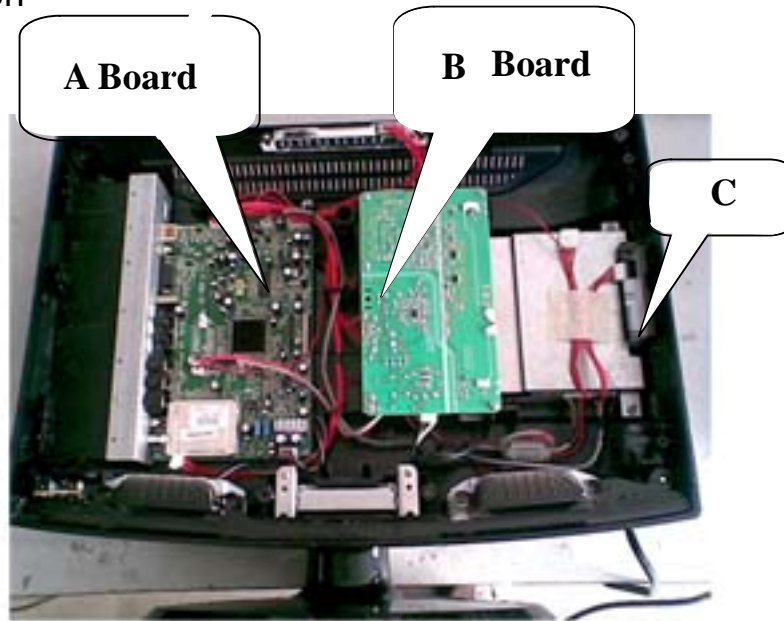

No.	Parts number	Description
A Board		Main Board
B Board		Power Board
C		DVD player

3-2 Main Board & AV Board

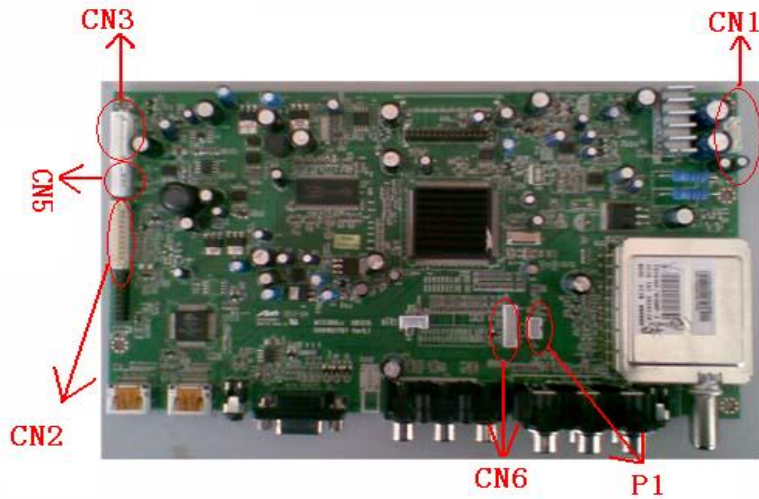

3-2-1 Function Description:

Main Board:

Process signal which incept from exterior equipment, then translate into signal that panel can display.

3-2-2 Connector definition

Main board connector

Power connectors (CN3, CN5)

CN3	CN5
-----	-----

Pin number	Signal name	Pin number	Signal name
1	+12V	1	+12V
2	+12V	2	GND
3	BL	3	GND
4	DIM	4	+5V
5	GND	5	STB
6	GND		
7	SW		

Notes:

CN3-Pin 3: Backlight on/off:

The system can turn on or turn off the backlight of TFT LCD Panel through the power supply unit path.

CN3-Pin 7: System power on / standby

System board will use this pin to control system power.

CN3-Pin 4: Control the luminance of backlight

The system can generate the PWN signal to control the strength of TFT LCD Panel's backlight through this connector.

Keypad and remote connector (CN2)

Pin number	Signal name	Description
1	IR_IN	IR
2	CPU5V	5V
3	LED_G	LAMP GREEN
4	GND	GND
5	LED_R	LAMPRED
6	K7	POWER
7	K6	MENU
8	K5	P_
9	K4	P+
10	K3	V_
11	K2	V+
12	K1	SOURCE

Speaker connector (CN1)

Pin number	Signal name	Description
1	LSPK	LSPK
2	GND	GND
3	GND	GND
4	RSPK	RSPK

DVD VIDEO Connector: CN6

Pin number	Signal name	Description
------------	-------------	-------------

1	GPIO	GPIO
2	PB_IN	PB1 IN
3	Y_IN	Y1_IN
4	GND	GND
5	PR_IN	PR1 IN
6	GND	GND
7	IR	DVD IR

DVD AUDIO Connector: P1

Pin number	Signal name	Description
1	LI	YPBPR1L_IN
2	RI	YPBPR1R_IN
3	GND	GND

Other connectors:

CN19 to Upgrade the program of MTK5380LC (U13) AND FLASH (U17)

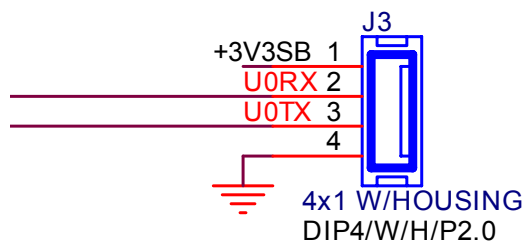

3-3. Power Board



3-3-1 Function Description:

Supply power for Main board, Panel.

3-3-2 Connector definition

INPUT CONNECTOR (CN6)

CN10	Signal name
------	-------------

1	N
2	GND
3	GND
4	DIM
5	EN
6	+12V
7	+12V

3-4. LCD Panel



CMQ V2 1 6 BI- L01)

3-4-1 Function Description: Display the signal.

3-4-2 Connector definition

Pin number	Signal name	Description
1-3	LVDSVDD	Power for panel
4-6	GND	Ground
7	A0N	LVDS EVEN 0 - Signal
8	A0P	LVDS EVEN 0 + Signal
9	A1N	LVDS EVEN 1 - Signal
10	A1P	LVDS EVEN 1 + Signal
11	A2N	LVDS EVEN 2 - Signal
12	A2P	LVDS EVEN 2 + Signal
13,14	GND	Ground
15	CK1N	LVDS EVEN Clock - Signal
16	CK1P	LVDS EVEN Clock + Signal
17	A3N	LVDS EVEN 3 - Signal
18	A3P	LVDS EVEN 3 + Signal
19	A4N	LVDS ODD 0 - Signal
20	A4P	LVDS ODD 0 + Signal
21	A5N	LVDS ODD 1 - Signal

22	A5P	LVDS ODD 1 + Signal
23	A6N	LVDS ODD 2 - Signal
24	A6P	LVDS ODD 2 + Signal
25,26	GND	Ground
27	CK2N	LVDS ODD Clock - Signal
28	CK2P	LVDS ODD Clock + Signal
29	A7N	LVDS ODD 3 - Signal
30	A7P	LVDS ODD 3+ Signal

CN1 (Header):S14B-PH-SM4-TB (D)(LF)(JST) or equivalent.

Pin No.	Symnbol	Description
1	VBL	+5.0V Power input
2		
3		
4	GND	Ground
5		
6		
13		
14		
25		
26	LVDS EVEN	LVDS EVEN Signal
7-12		
15		
16		
17	LVDS ODD	LVDS ODD Signal
18		
19-24		
27		
28		
29		
30		

4. Disassemble and assemble

LX22R1 Knocked-down Show

1.1The first of TV teardown
--Tearing down the base

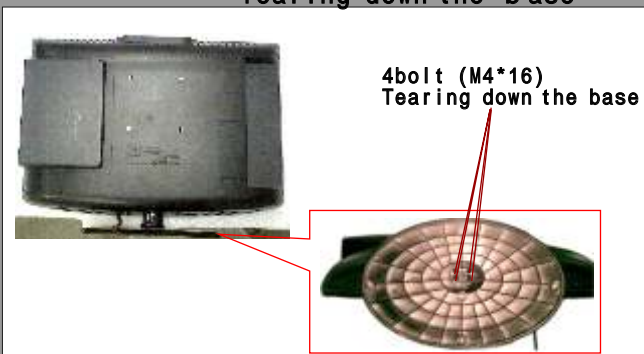

1.2.1The second of TV teardown
--Tearing down the plastic front Cabinet

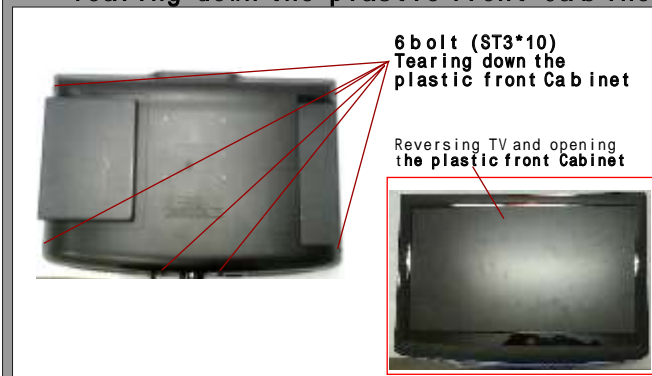

1.2.2The second of TV teardown
--Tearing down the plastic front Cabinet

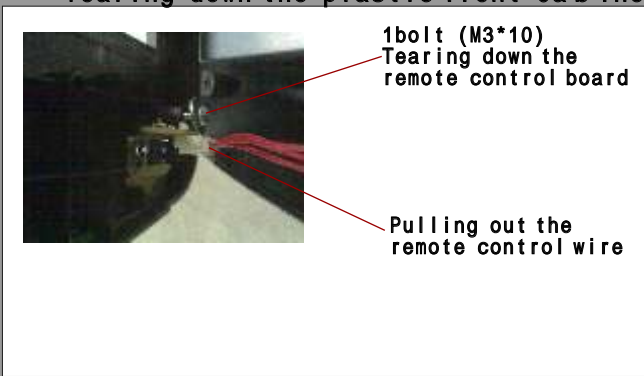

1.3.1The third of TV teardown
--Tearing down the panel

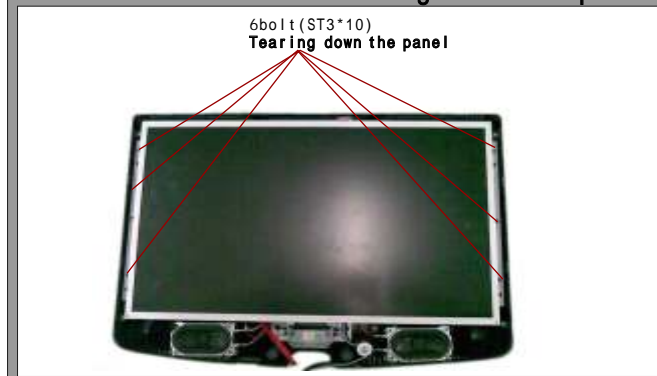

1.3.2The third of TV teardown
--Tearing down the Panel

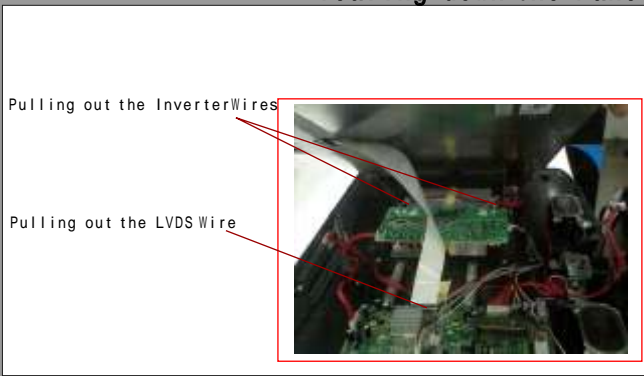

1.4The fourth of TV teardown
--Tearing down the Power Supply

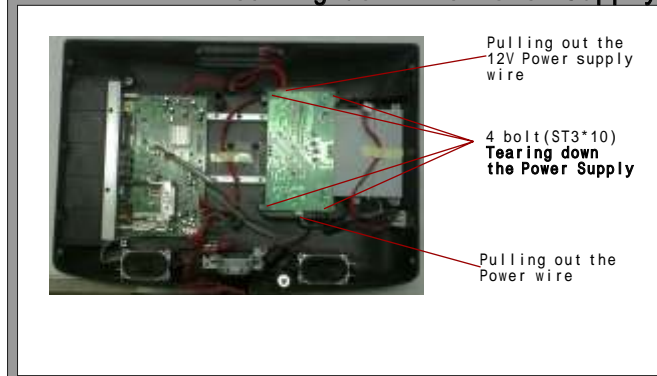

1.5The fifth of TV teardown
--Tearing down the DVD

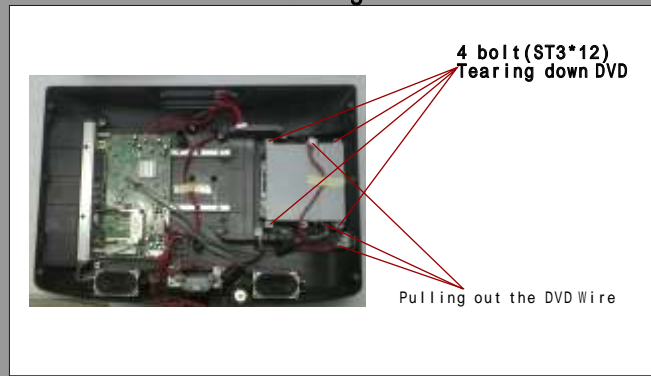

1.6The sixth of TV teardown
--pulling out the Wires

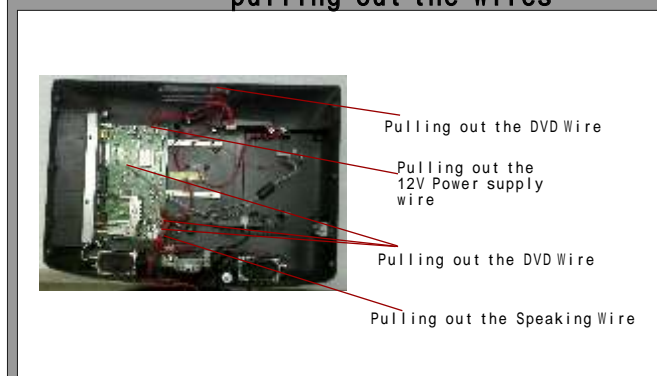

LX22R1 Knocked-down Show

1.7The seventh of TV teardown
--Tearing down the Main board

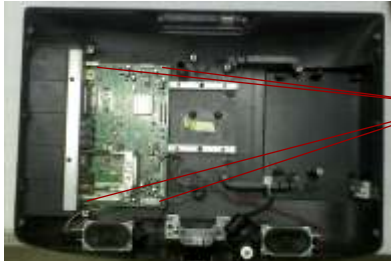

4 bolt (ST3*10)
Tearing down
the Mainboard

1.8The seventh of TV teardown
--Tearing down the speakers



8bolt (ST3*10)
Tearing down the speakers

1.9The seventh of TV teardown
--Tearing down the keypad board



2bolt (ST3*10)
Tearing down the Keypad board

1.10The eighth of TV teardown
--Tearing down the Power Supply Bracket

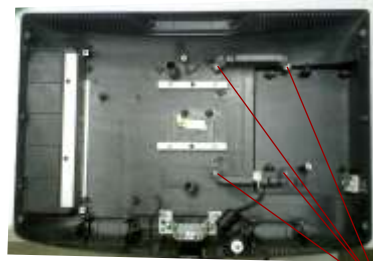

4bolts (ST3*10)
Tearing down the Power Supply Bracket

1.11The ninth of TV teardown
--Tearing down the Power Wire

2 bolt (ST3*10)
Tearing down the terminal board



1bolt (ST4*12)
Tearing down the Power Wire

1.12The ninth of TV teardown
--Tearing down the Power Wire



1bolt (ST4*12)
Tearing down the Power Wire

1.13The ninth of TV teardown
--Tearing down the Base Axis



4bolts (ST3*10)
Tearing down the Base Axis

1.14The ninth of TV teardown
--Tearing down the DVD Keypad Assembly

Opening the Lable



2bolt (ST3*10)
Tearing down the
DVD Keypad assembly



5. Installation Instructions

5-1 External Equipment Connections

Antenna Connection

Connect one end of a coaxial cable (not included) to the ANT IN jack on the back of your TV/DVD combo, then connect the other end of the cable into the antenna or cable TV wall outlet.



To improve picture quality from an antenna in a poor signal area, install a signal amplifier.

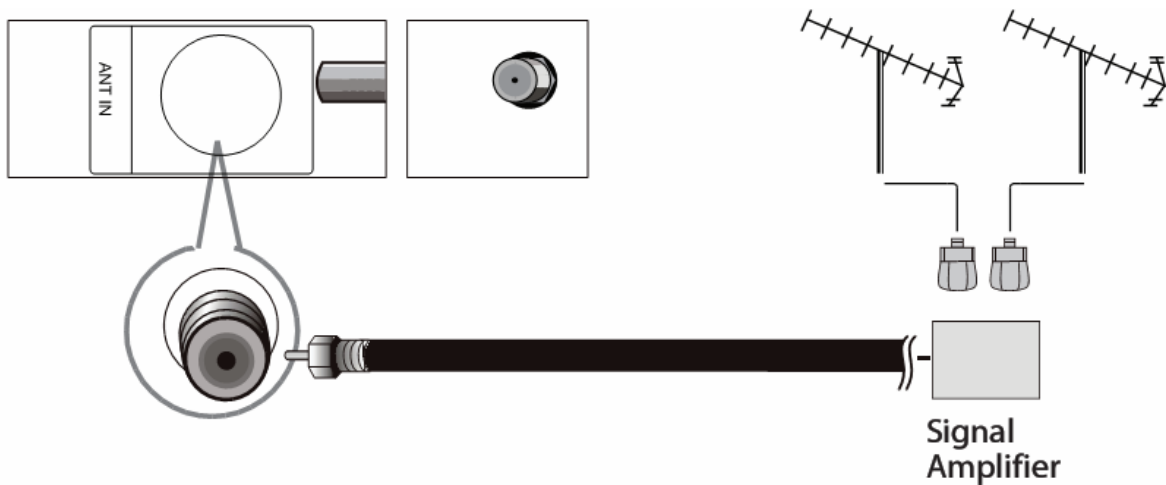

If you need to split the antenna signal to connect two TVs, install a two-way splitter.

Choose Your Connection

There are several ways to connect your television, depending on the components you want to connect

and the quality of the signal you want to achieve. The following are examples of some different ways to connect your TV with different input sources. Choose the connection which is best for you.

VGA Setup

You can use your LCD-TV as a monitor for your personal computer using a VGA cable (not supplied).

Connection and use steps:

1. Read the user guide supplied with your computer and ensure that it has a VGA connector;
2. Make sure that the power of the LCD-TV and the PC are off;
3. Connect a D type 15-pin PC interface cable (not supplied) to the PC video interface connector on the PC. Then connect the other end to the PC video interface connector on the back of the LCD-TV. Tighten the screws on the PC connectors once they are firmly connected;
4. Turn on the power of the LCD-TV first, and then turn on the power of the PC;
5. Press **INPUT** button to set the video input mode of the LCD-TV to PC; Once the input for PC is selected and if you see no image press function F8 on your pc.
6. Check the image on your TV. There may be noise associated with the resolution, vertical pattern, contrast or brightness in PC mode. If noise is present, change the PC mode to another resolution, change the refresh rate to another rate or adjust the brightness and contrast on the menu until the picture is clear. If the refresh rate of the PC graphic card can not be changed, change the PC graphic card or consult the manufacturer of the PC graphic card.

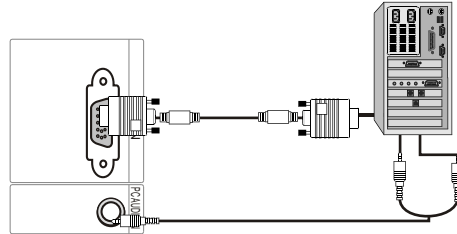

Resolution

Mode	Resolution	Line frequency(KHz)	Frame frequency(Hz)
VGA	640x480	31.5	60
SVGA	800x600	37.9	60
XGA	1024x768	48.4	60

Note: All above listed are subject to VESA criteria.

Component Setup

How to connect

Connect the DVD video outputs (Y, PB, PR) to the Component (Y, Pb, Pr) IN jacks on the TV and connect the DVD audio outputs to the AUDIO IN jacks on the TV, as shown in the figure.

NOTE: If your DVD player does not have component video output, use S-Video.

How to use

1. Turn on the DVD player, insert a DVD.
2. Use **INPUT** button on the remote control to select the proper input.

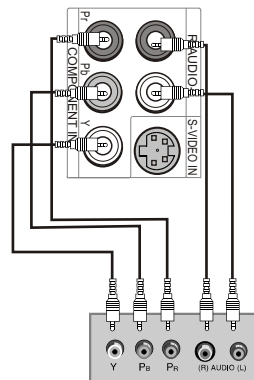

Cable TV Setup

After subscribing to a cable TV service from a local provider you can watch cable TV programming unless a TV tuner device or cable TV converter box is connected to the TV.

For further information regarding cable TV service, contact your local cable TV service provider(s).

Connection Option 1

1. Select 3 or 4 with channel switch on cable box.
2. Tune the TV channel to the same selected output channel on cable box.
3. Select channels at the cable box or with the cable box remote control.

Connection Option 2

1. Connect the audio and video cables from the Cable Box's output jacks to the TV input jacks, as shown in the figure. When connecting the TV to a Cable Box, match the jack colors (Video = yellow, Audio Left = white, and Audio Right = red).
2. Select the input source by using the **INPUT** button on the remote control.
3. Select your desired channel with the remote control for cable box.

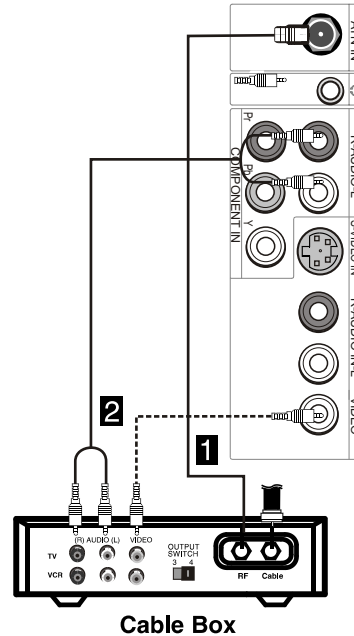

External Component Source Setup

How to connect

Connect the audio and video cables from the external equipment's output jacks to the TV input jacks, as shown in the figure.

When connecting the TV to external equipment, match the jack colors (Video = yellow, Audio Left = white, and Audio Right = red).

How to use

1. Select the input source by using the **INPUT** button on the remote control.
2. Operate the corresponding external equipment. Refer to external equipment operating guide.

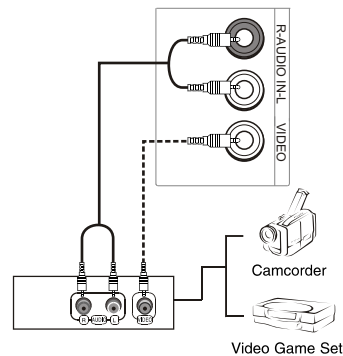

5-2 HDMI Connections

When the source device(DVD player or Set Top Box) supports HDM

How To Connect

1. Connect the source device to HDMI port of this TV with an HDMI cable(not supplied with this product).
2. No separated audio connection is necessary.

How To Use

If the source device supports Auto HDMI function, the output resolution of the source device will be automatically set to 1280x720p.

If the source device does not support Auto HDMI, you need to set the output resolution appropriately.

To get the best picture quality, adjust the output resolution of the source device to 1280x720p. Select HDMI input source in input source option of Select Main source menu.

When the source device(DVD player or Set Top Box) supports DVI

How To Connect

1. Connect the source device to HDMI port of this TV with a HDMI-to-DVI cable(not supplied with this product).
2. A separated audio connection is necessary.
3. If the source device has an analog audio output connector, connect the source device audio output to DVI Audio

In port located on the left side of HDMI port.

How To Use

If the source device supports Auto DVI function, the output resolution of the source device will be automatically set to 1280x720p.

If the source device does not support Auto DVI, you need to set the output resolution appropriately.

To get the best picture quality, adjust the output resolution of the source device to 1280x720p.

Press the INPUT button to select HDMI input source in input source option of Select Main source menu.

Installation

Cable sample

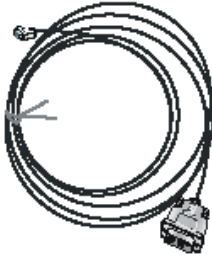
	<p>HDMI Cable (not supplied with the product)</p>
	<p>HDMI to DVI Cable (not supplied with the product)</p>

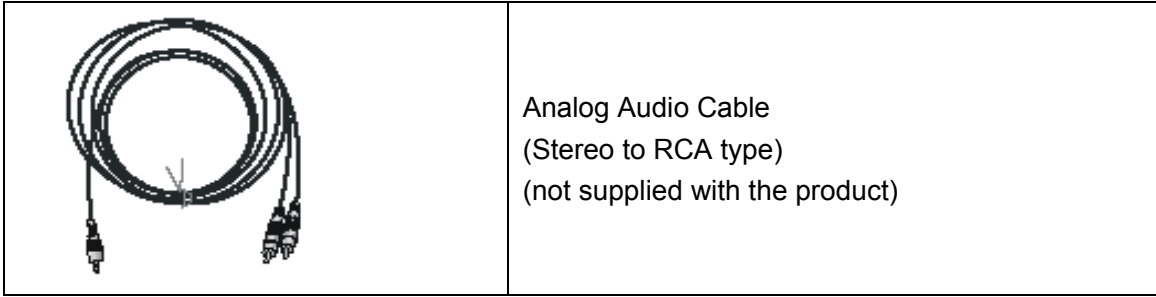

Connecting Headphones

You can connect a set of headphones to your set if you wish to watch a TV programmer without disturbing the other people in the room.

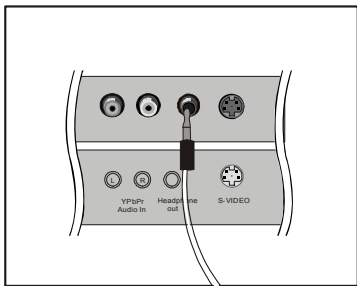

Plug a set of headphones into the 3.5mm mini-jack socket on the rear panel of the set.

Note:

- Prolonged use of headphones at a high volume may damage your hearing.
- You will not receive sound from the speakers when you connect headphones to the system.

Power source

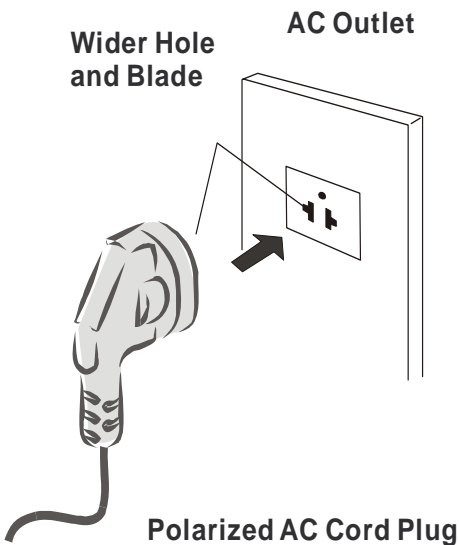

TO USE AC POWER SOURCE

Use the AC polarized line cord provided for operation on AC. Insert the AC cord plug into a standard polarized AC outlet.

NOTES:

- Never connect the AC line cord plug to other than the specified voltage. Use the attached power cord only.
- If the polarized AC cord does not fit into a non-polarized AC outlet, do not attempt to file or cut the blade. It is the user's responsibility to have an electrician replace the obsolete outlet.
- If you cause a static discharge when touching the unit and the unit fails to function, simply unplug the unit from the AC outlet and plug it back in. The unit should return to normal operation.

6. Operation Instructions

Basal information

6-1 Front panel controls

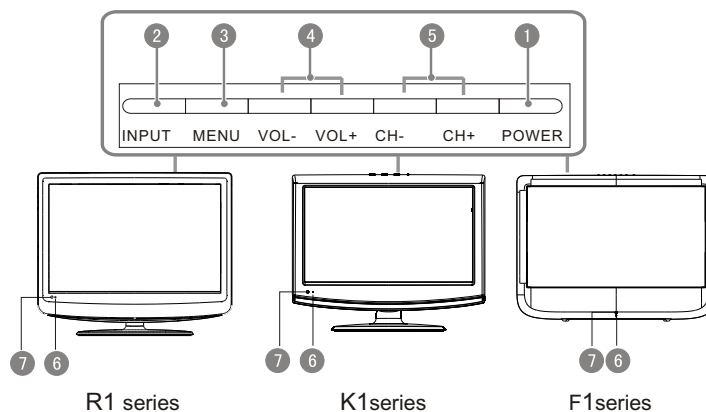

Control Panel Function

- 1. POWER** Press to turn on and off the TV.
- 2. INPUT** Selects the input signals.
- 3. MENU** Menu display. Press to access the on-screen menu display.
- 4. VOL-** Volume down / Left button to adjust the item in the OSD.
VOL+ Volume up/ Right button to adjust the item in the OSD /Press to enter.
- 5. CH-** TV channel down / to select the item in the menu.
CH+ TV channel up / to select the item in the menu.
- 6. Power indicator**
- 7. Remote Sensor** Receivers IR signals from the remote control. Do not put anything near the sensor, which may block the remote control signal.

6-2 Back panel controls

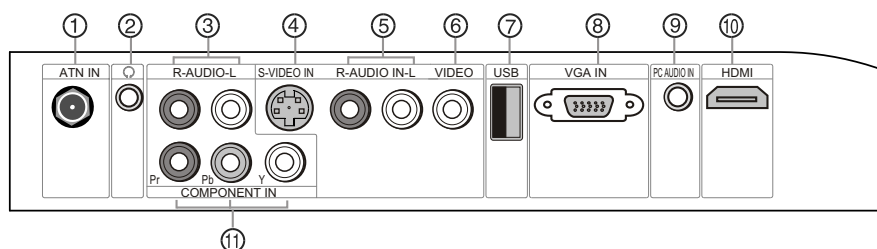

- 1. ANT IN(Antenna Input)** Connect cable or antenna signals to the TV, either directly or through your cable box.
- 2. Headphone jack** : Headphone audio output terminal.
- 3. Audio in** Connect audio output from an external device to these jacks.
- 4. S-VIDEO** Connect S-Video out from an S-Video device to the jacks.
- 5. Audio in** Connect audio output from an external device to these jacks.
- 6. Video in** Connect video output from an external device to this jack.
- 7. USB input** Connect a USB flash drive to view JPEG images or listen to MP3 songs.
- 8. VGA** Connect to the VGA 15PIN analog output connector of a PC graphics card to use set as a PC display.
- 9. PC audio in** Connect the audio output from the pc to the PC audio input port.
- 10. HDMI**: Connect a HDMI device to receive digital audio and uncompressed digital video.
- 11. Component Input** Connect a component video device to these jacks.

6-3 Setting Up Your Remote Control

After it has been set up properly, your remote control can operate in six different modes: TV, VCR, CABLE, DVD, SETBOX or AUDIO. Pressing the corresponding button on the remote control

Remote Control Key Functions

When using the remote control, aim it towards the remote sensor on the TV

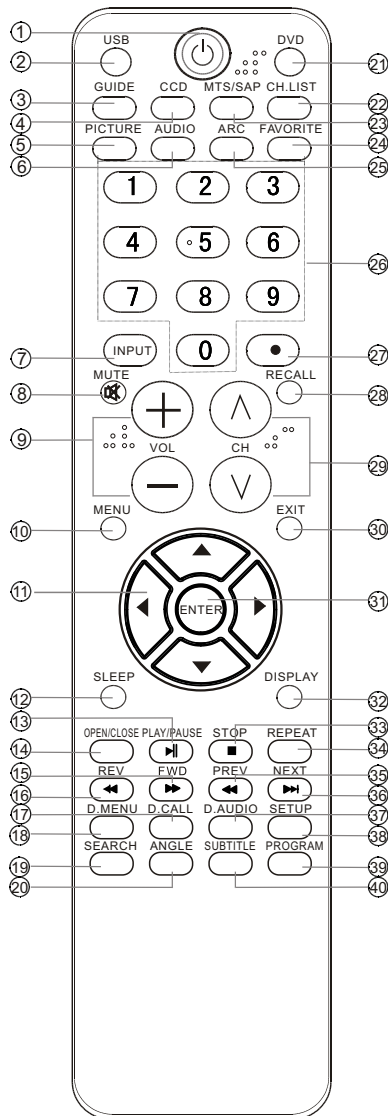

(For TV with DVD)

1. Press to turn on and off the TV
2. Press to switch input source to USB in
3. Display the guide when you are watching analog or digital channels
4. Select a closed caption
5. Press repeatedly to cycle through the available picture modes
6. Press to cycle through different sound settings
7. Show the input source
8. Switches the video sound on or off
9. Press to adjust the volume
10. Press to open the on-screen menu
11. Thumbstick (Up/Down/Left/Right)
Allows you to navigate the on-screen menus and adjust the system settings to your preference.
12. Press to display the sleep timer option
13. DVD PLAY/PAUSE
14. DVD Open/close
15. DVD FAST FORWARD
16. DVD FAST REVERSE
17. DVD CALL
18. DVD MENU
19. DVD SEARCH
20. DVD ANGLE
21. Press to switch input source to DVD in
22. Open the channel list in TV
23. Select MONO, STEREO, SAP in NTSC system
24. Open the favourite channel list in TV
25. Press to change the aspect ratio
26. Press to change a channel
27. Press to select digital channels. For example, to enter "54-3", press "54", " " and "3"
28. Press to jump back and forth between two channels
29. Press to scan through channels. To scan quickly between the last two channels, press and hold down either +/- .
30. Exit On Screen Display
31. Accesses the highlighted item in the on-screen menu
32. Press to display the TV status information on the top of the TV screen
33. DVD STOP
34. DVD REPEAT
35. DVD Previous Chapter
36. DVD Next Chapter
37. DVD AUDIO Mode
38. DVD SETUP
39. DVD PROGRAM
40. DVD SUBTITLE

7. Electrical parts

7-1. Block diagram

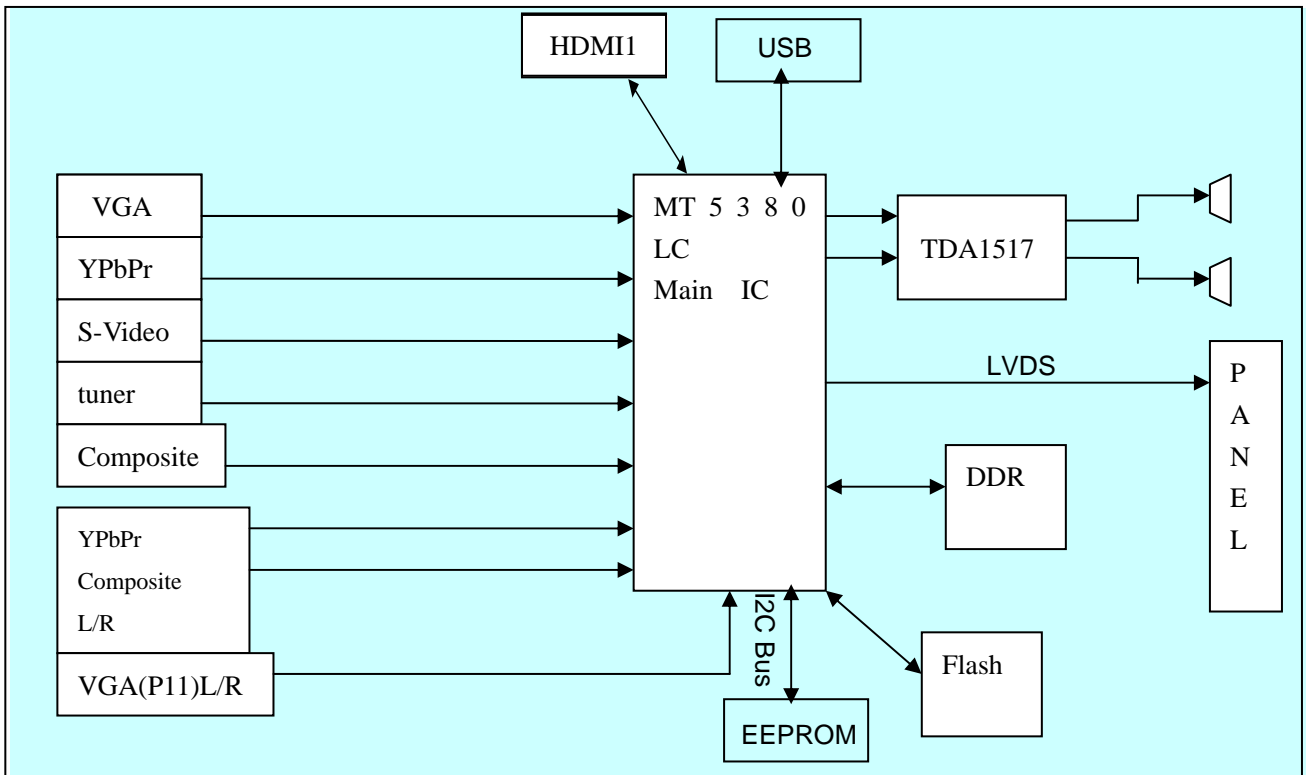

7-2. Circuit Diagram

MT5380 (DDR1) MODEL NAME: MT5380P1-V2

01. INDEX
02. DIGITAL POWER
03. ANALOG POWER
04. PERIPHERAL
05. ANALOG PLL/USB2.0/TUNER
06. DDR1 MEMORY
07. FLASH/JTAG/UART/IR/TRAP
08. HDMI/SPEAKER
09. LVDS/MUTE
10. YPBPR/L/R
11. VGA IN/LR
12. AV IN/LR/CVBSO
13. LINE OUT/HP
14. BACK LIGHT /MAIN POWER

GPIO Definition	
GPIO_0	System EEPROM Write Protect
GPIO_1	Unused
GPIO_3	Unused
GPIO_4	Headphone Detect
GPIO_5	Audio Mute Control
GPIO_6	HDMI EEPROM Write Protect
GPIO_7	HDMI HDP
GPIO_8	Speaker Mute
GPIO_9	LVDS Power Control
GPIO_10	LVDS Panel Control(Reserve)
GPIO_11	LVDS Panel Control(Reserve)
GPIO_12	U2RX
GPIO_13	U2TX
OPCTRL0	CEC Function
OPCTRL1	VGA EEPROM Write Protect
OPCTRL2	Back Light Control
OPCTRL3	Unused
OPCTRL4	Trap
OPCTRL5	Trap
AIN1,2,4	Unused
OPWM0(GPIO 40)	Unused
VCXO(GPIO 67)	Unused

GPIO Definition	
RF_AGC(GPIO 62)	Unused
AIN3_L(GPIO 74)	Unused
AIN3_R(GPIO 75)	Unused

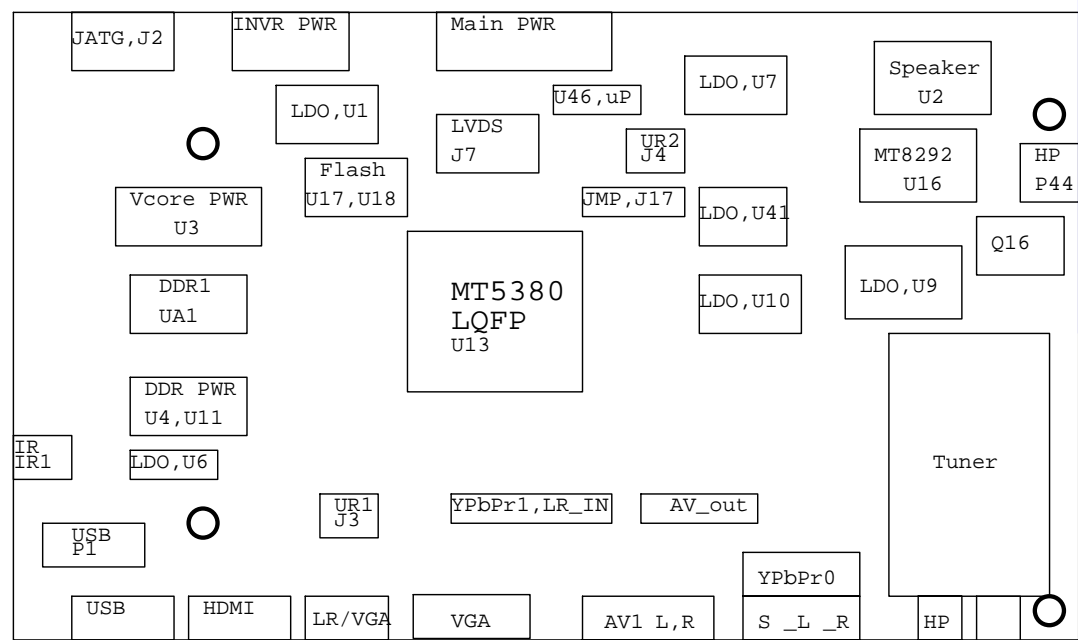

Rev	History	Note	DATE
V1	INITIAL VERSION		2007/04/09
V2	1.Change Vcore Voltage. 2.Add FB for DV33 and AV33 Reserve		
	3. Add R49, R50 for A version IC. 4. Change C20, C21 for crystal capacitors.		2007/06/11
	5.Add DRAM Serial resistors. 6.Add CEC uP. 7. Add U16 MT8292		2007/06/11

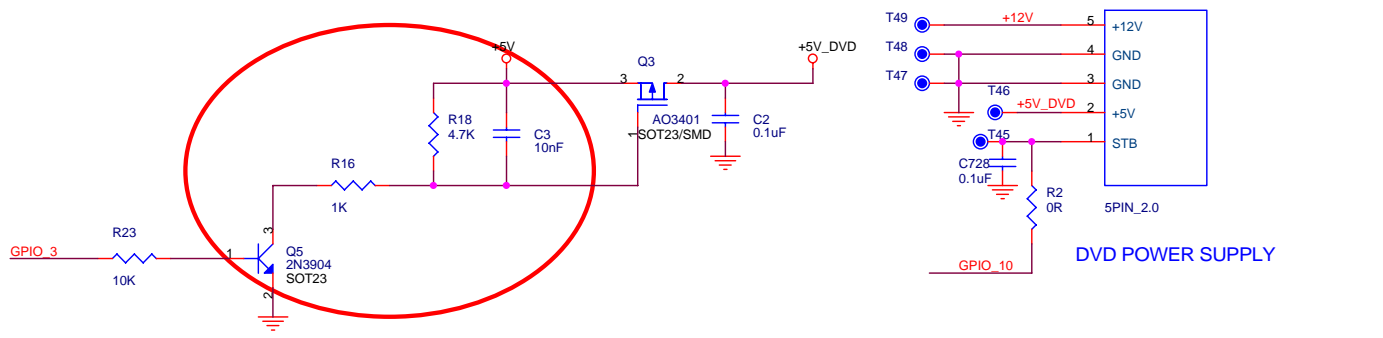
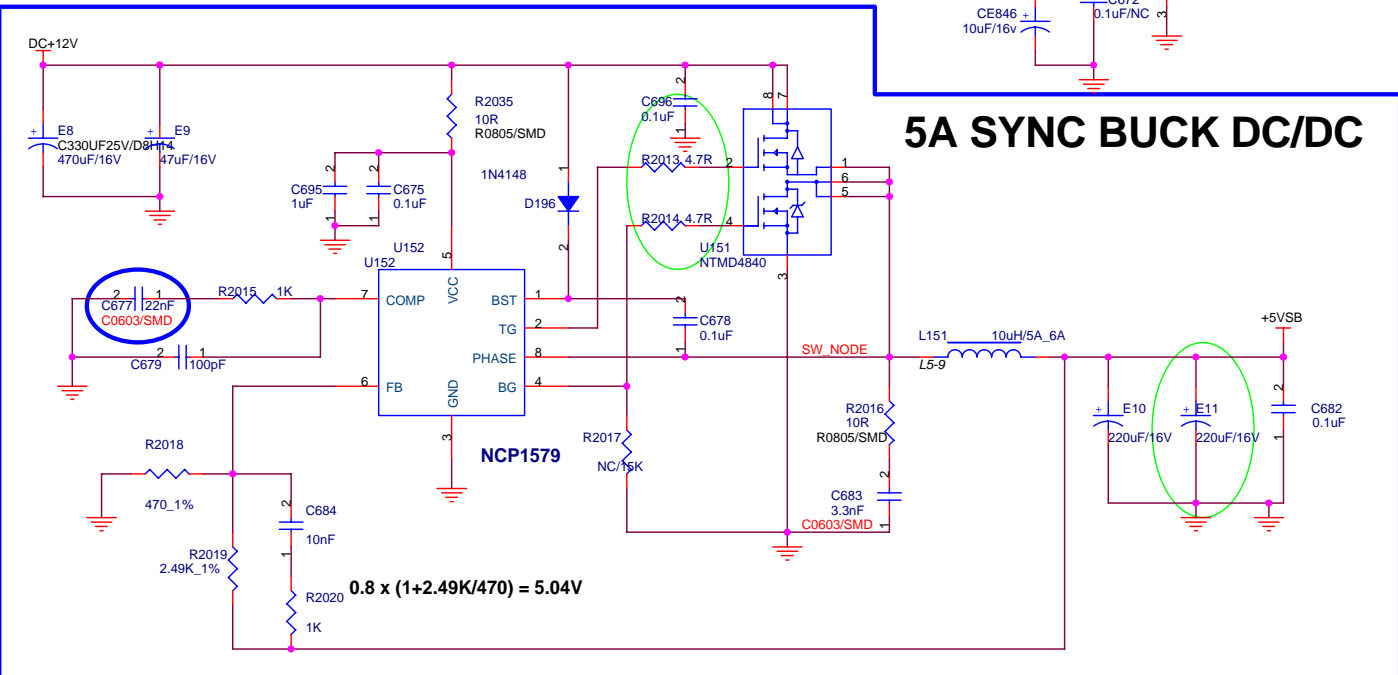
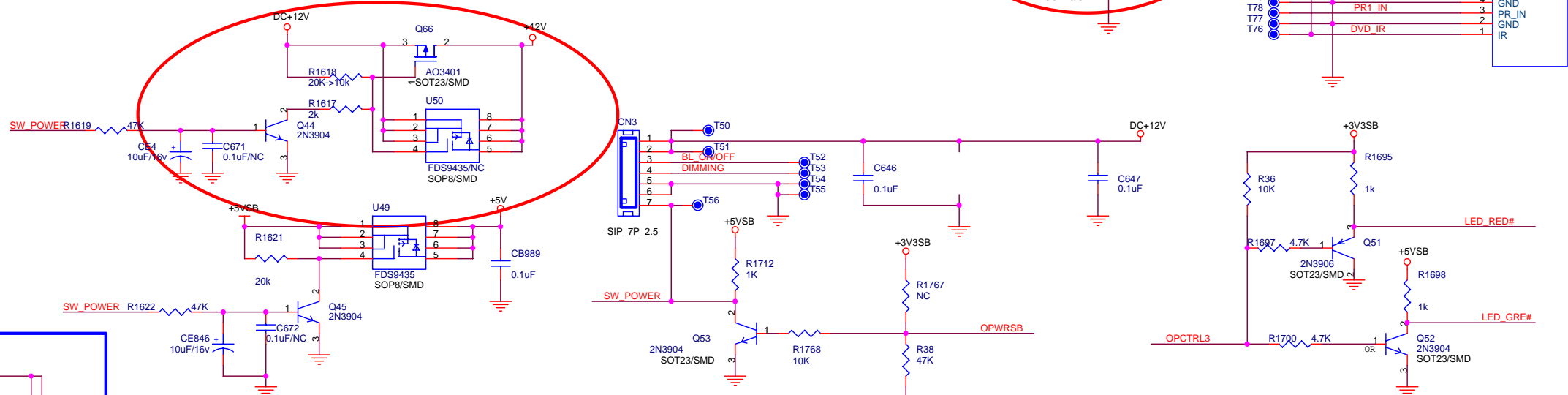
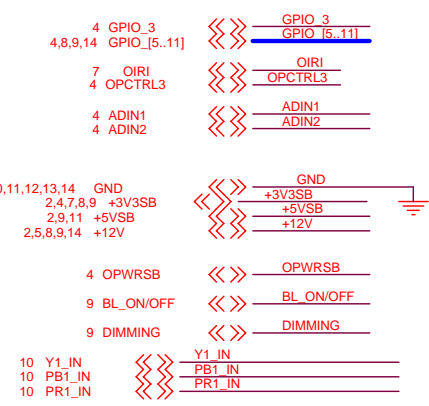
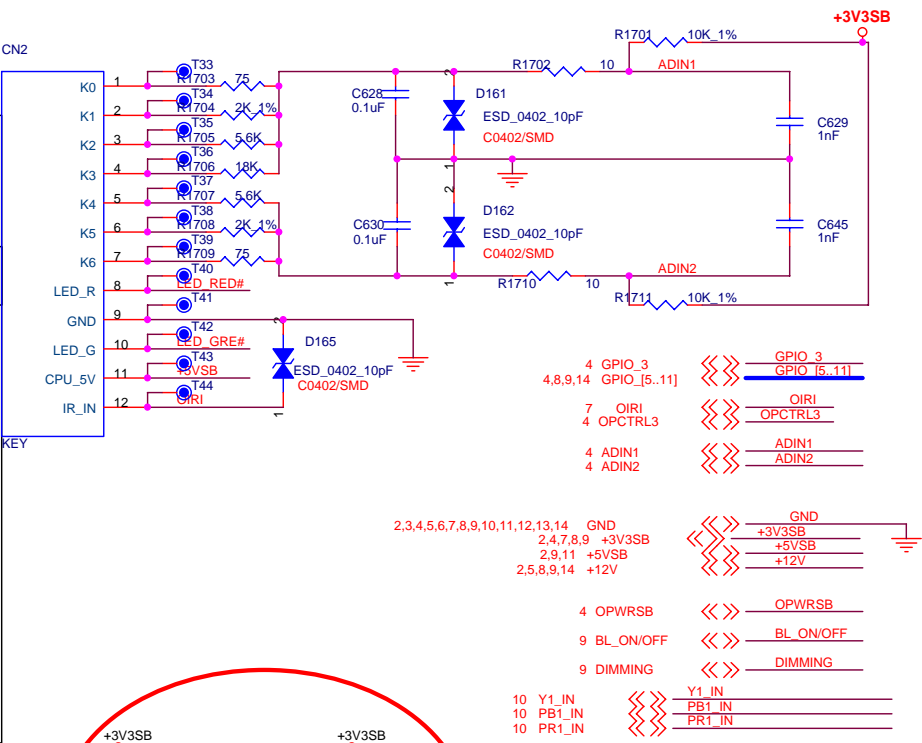

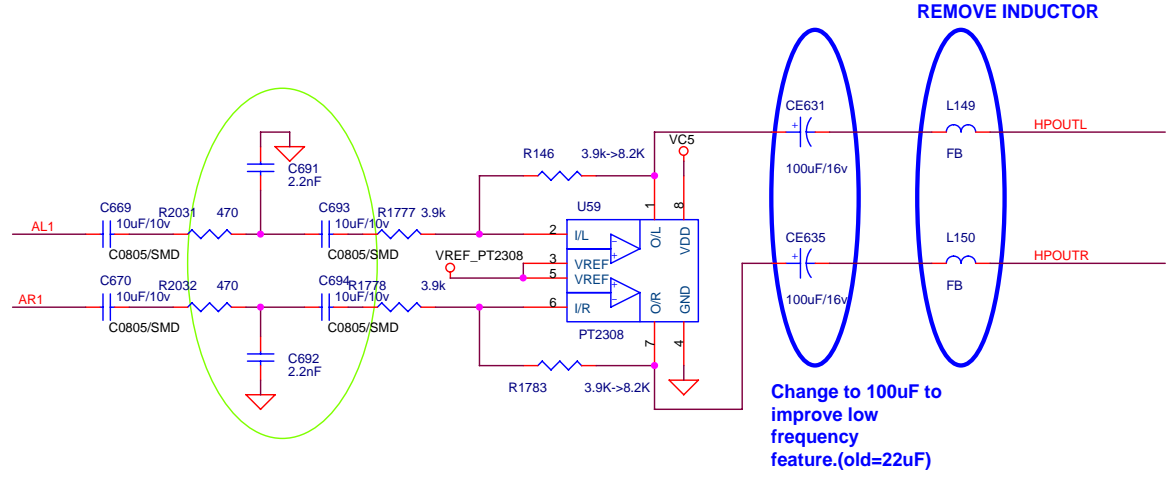
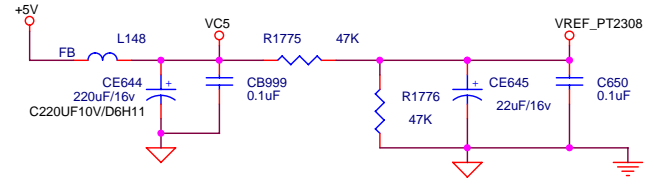
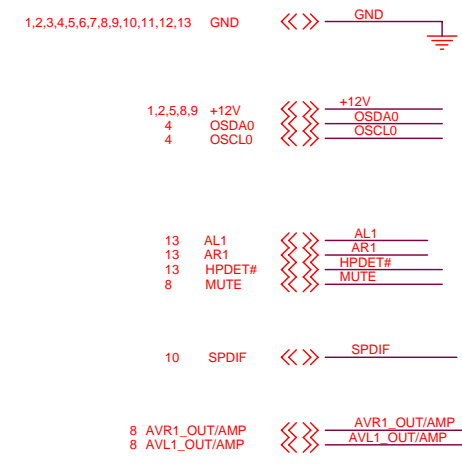
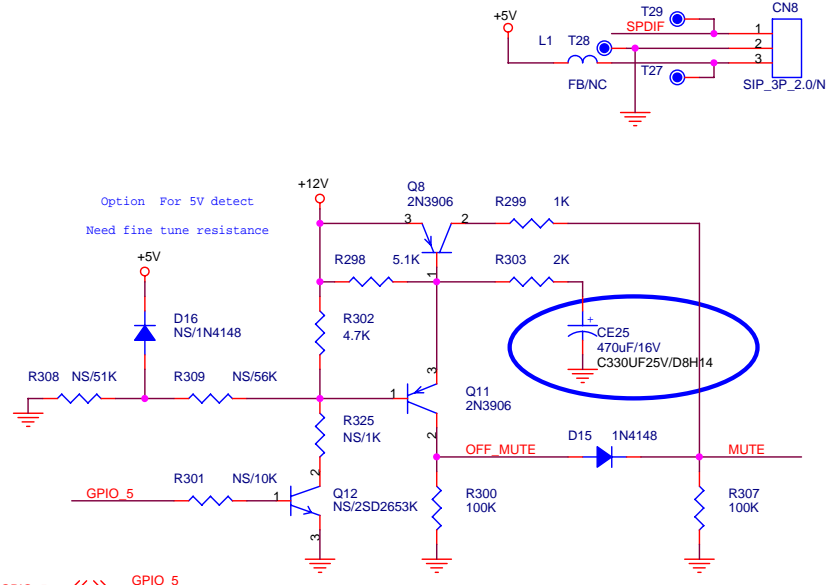
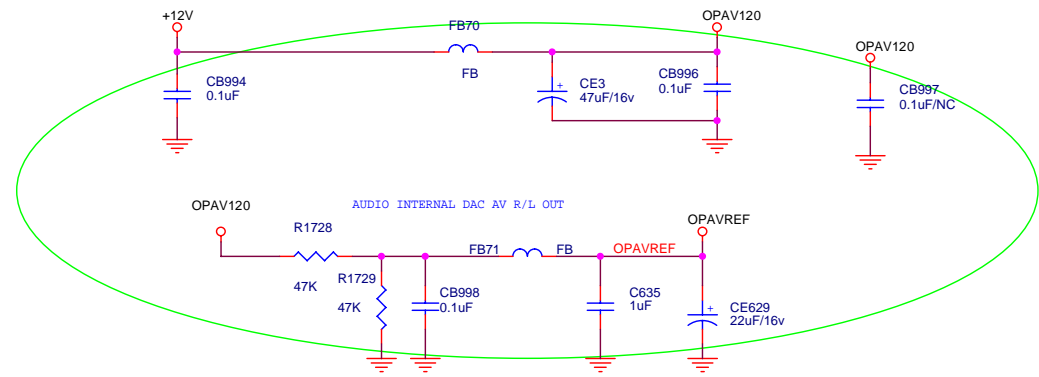

REMOVE INDUCTOR

Change to 100uF to improve low frequency feature.(old=22uF)

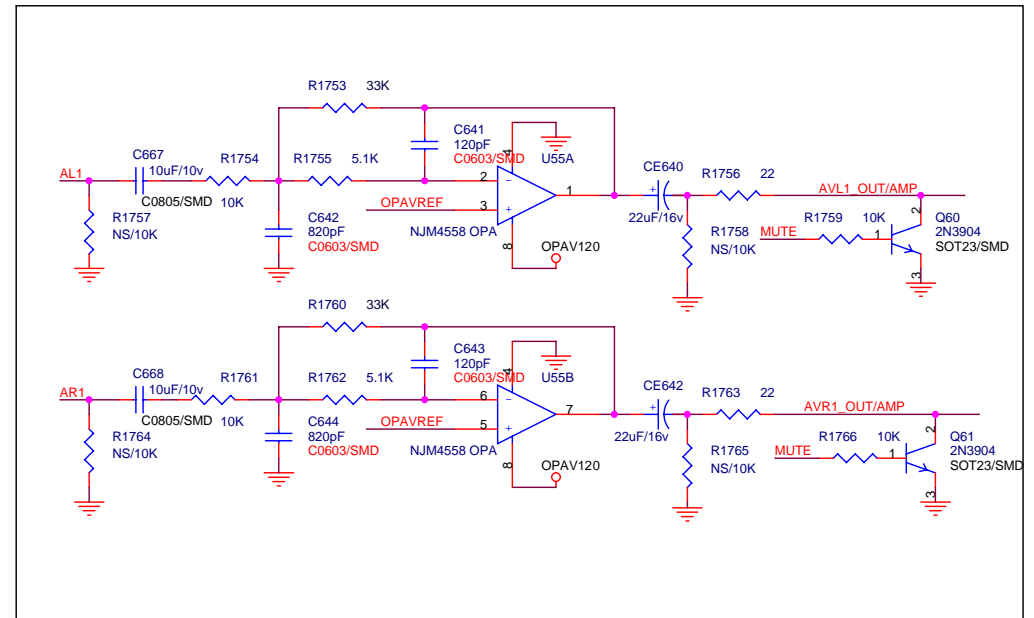
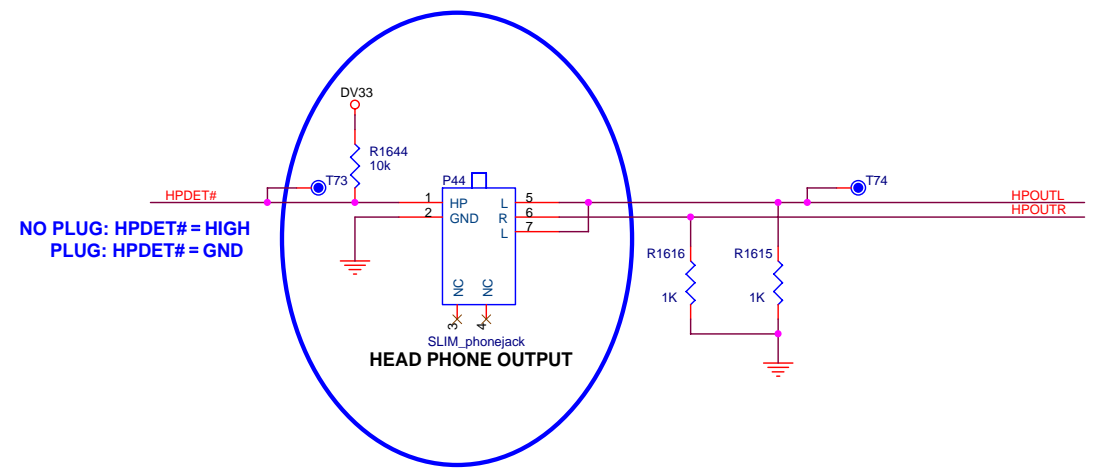

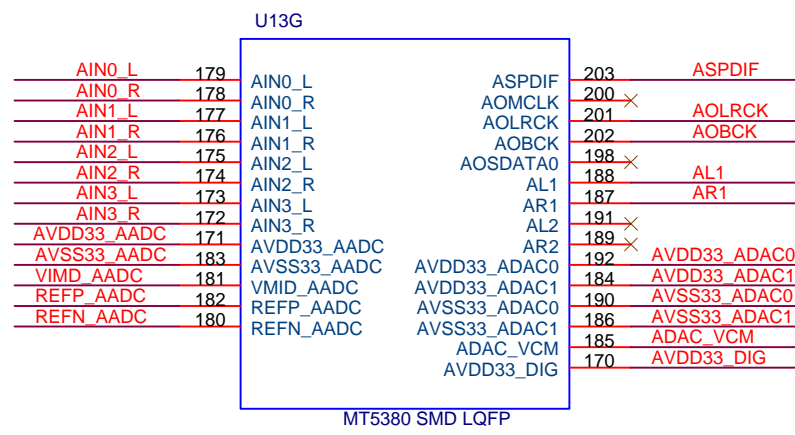

Need fine tune timing

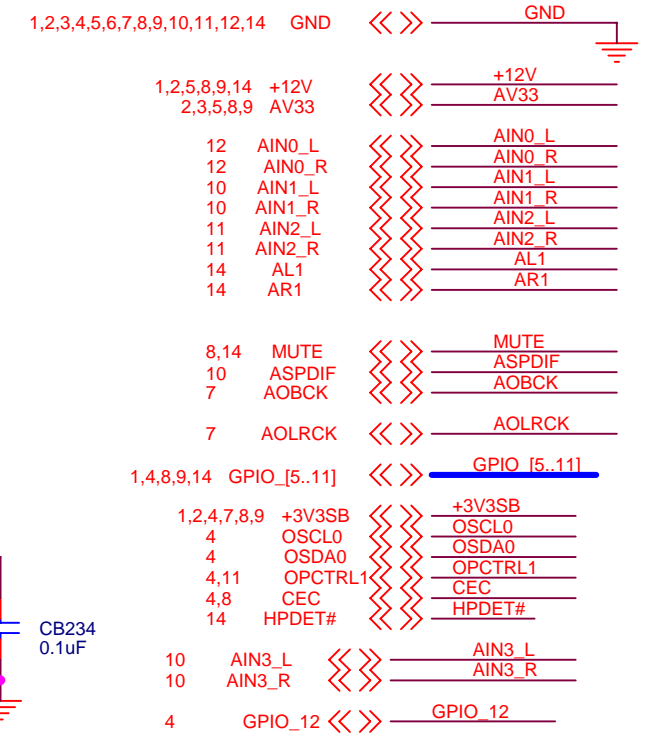
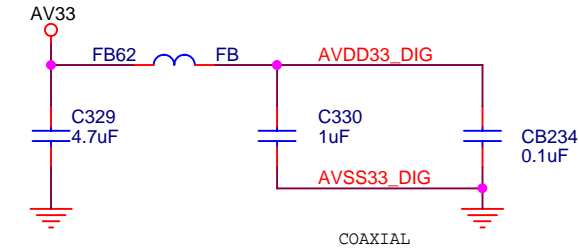
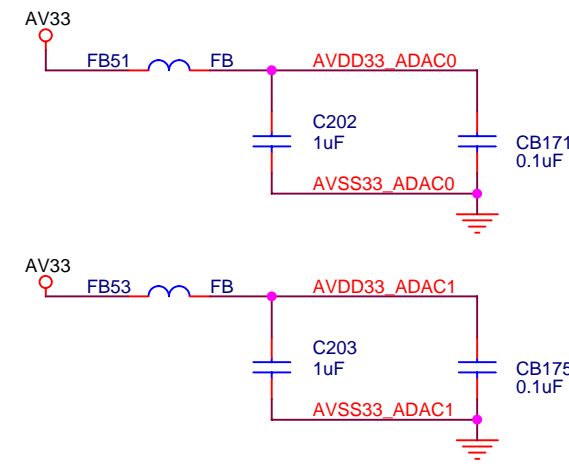
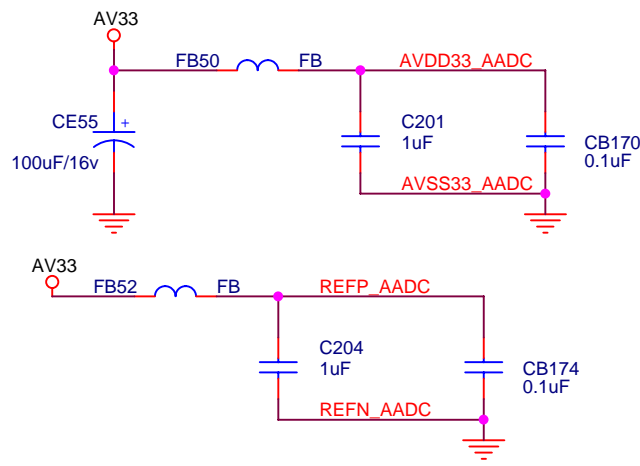
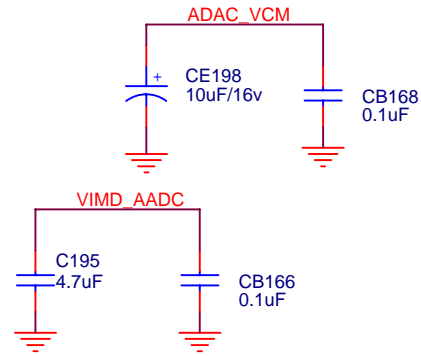

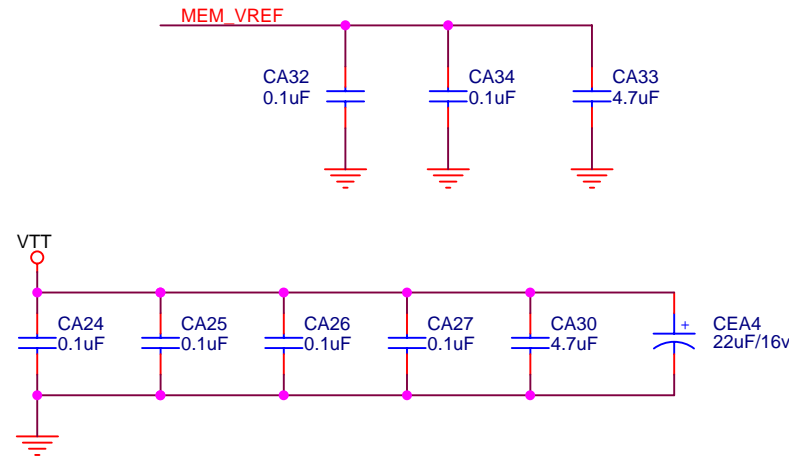
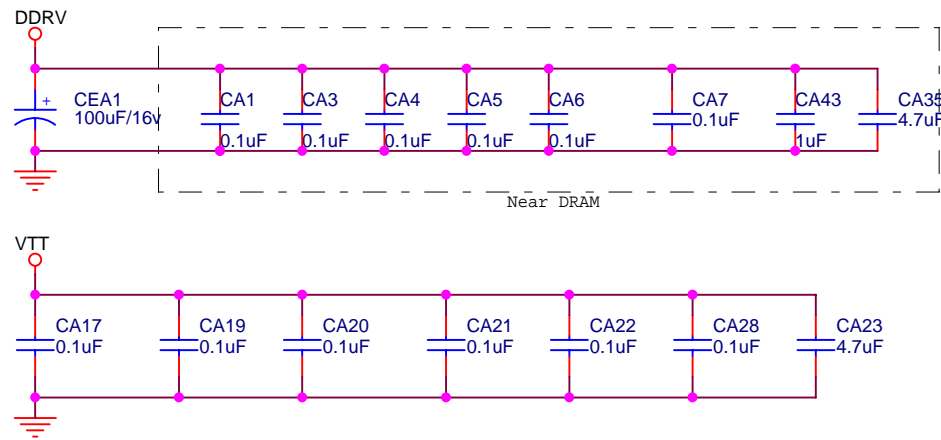
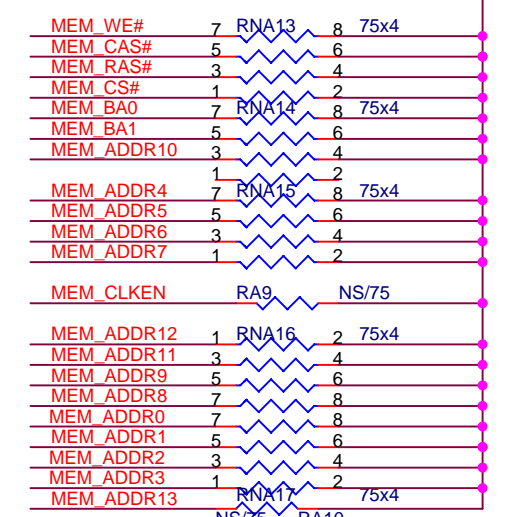
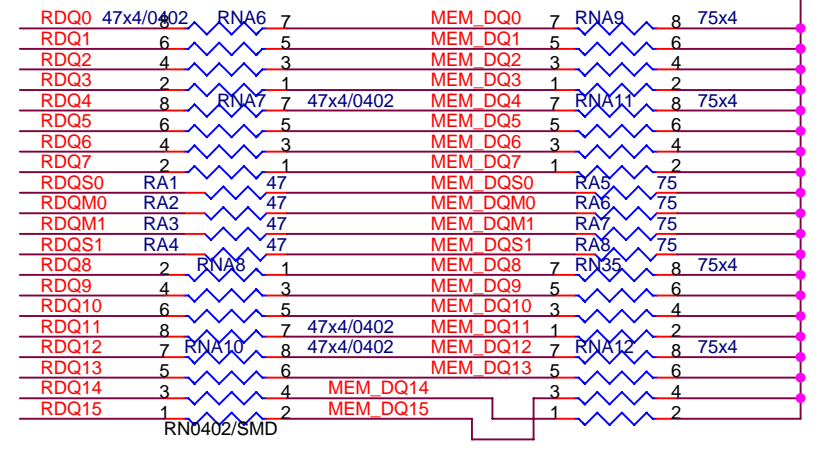
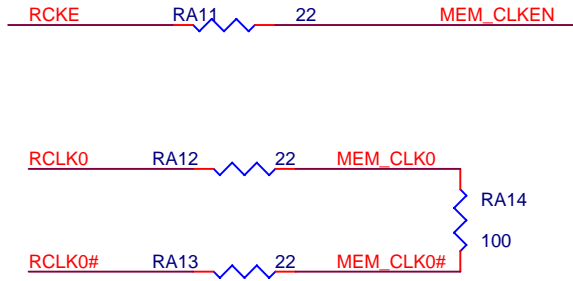
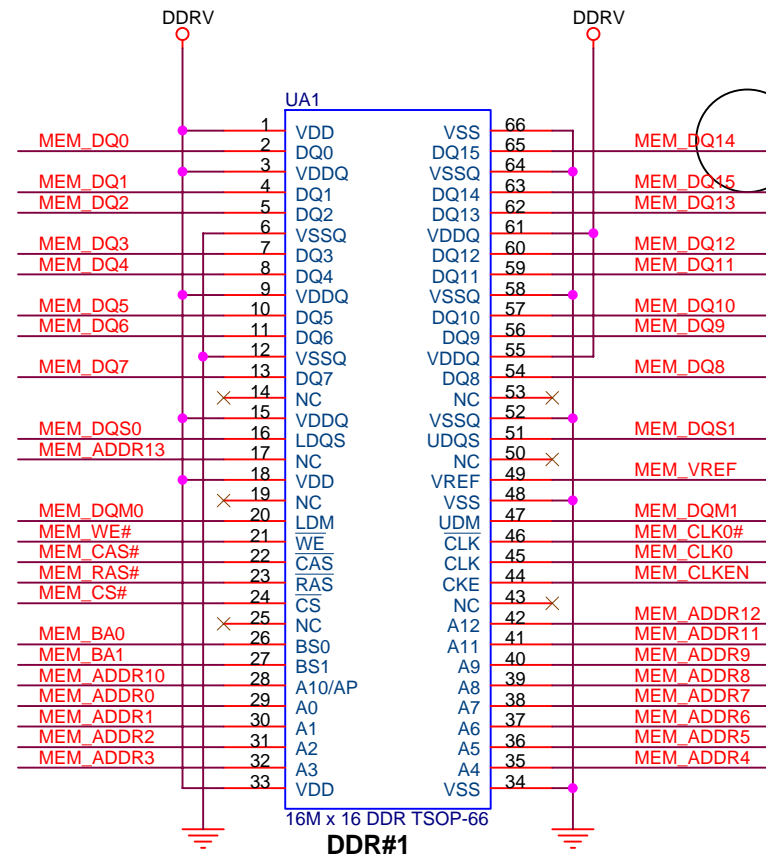
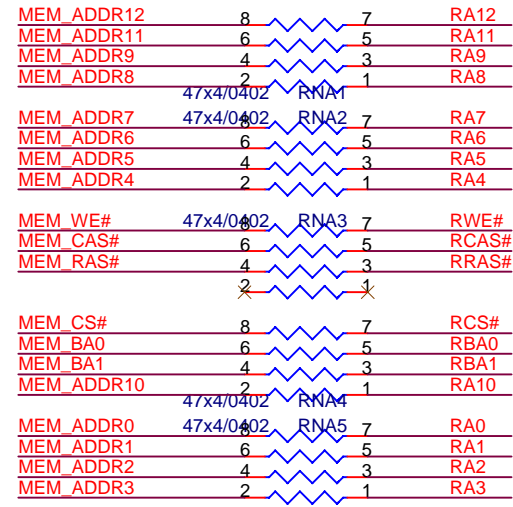
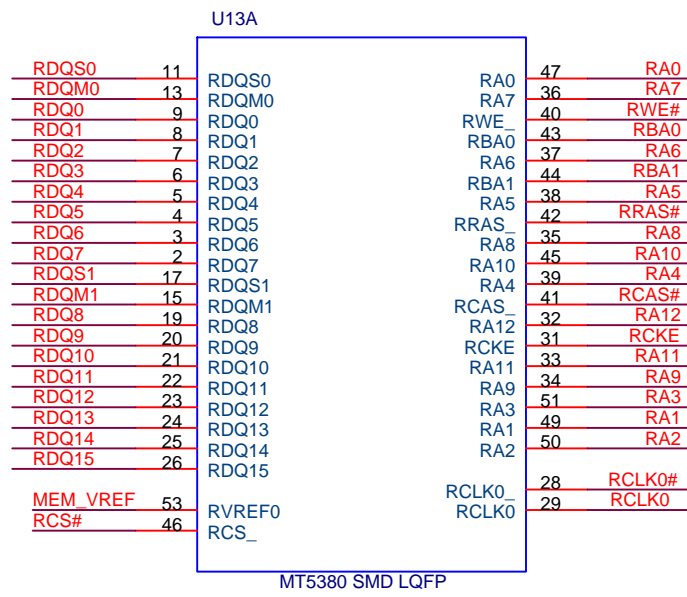

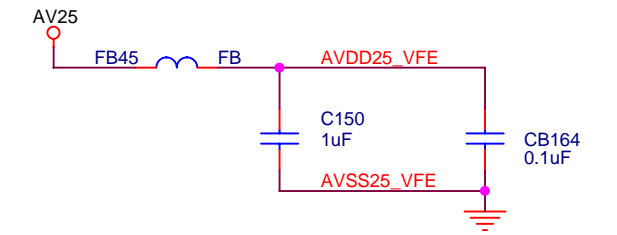
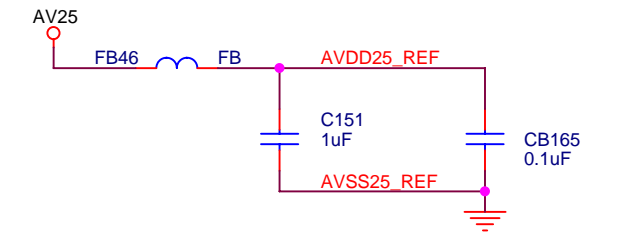
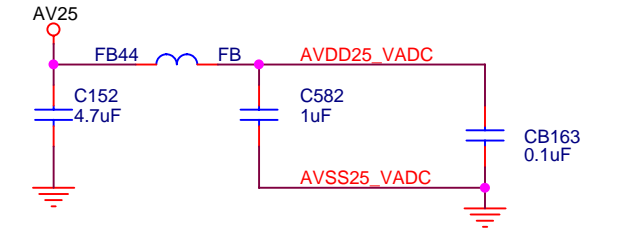
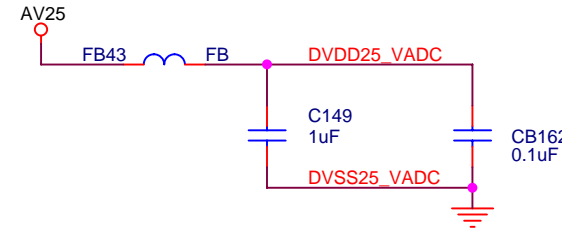
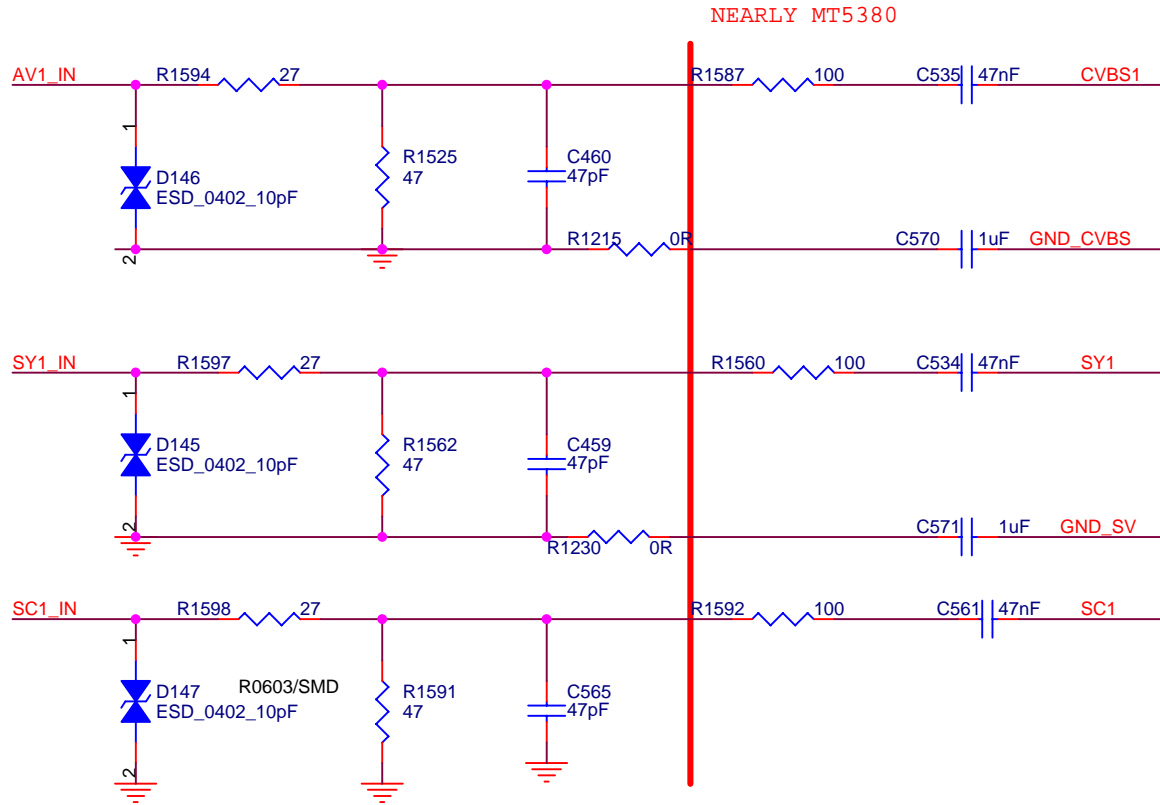
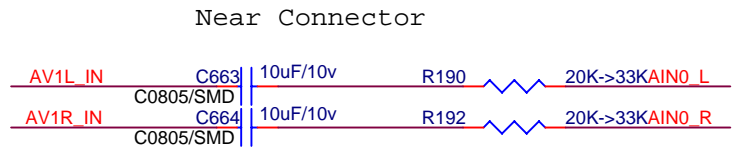
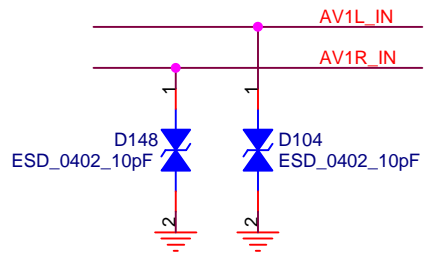
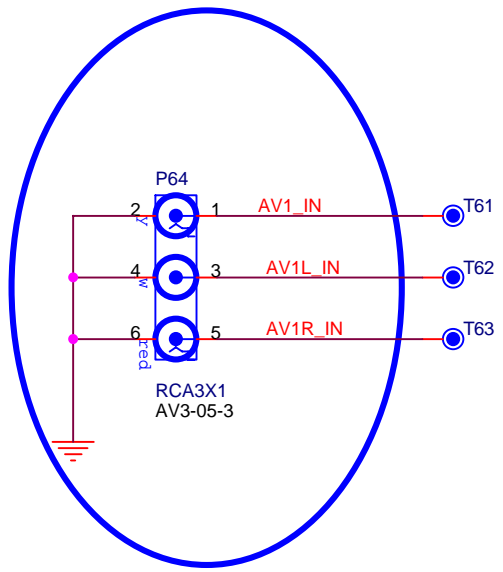
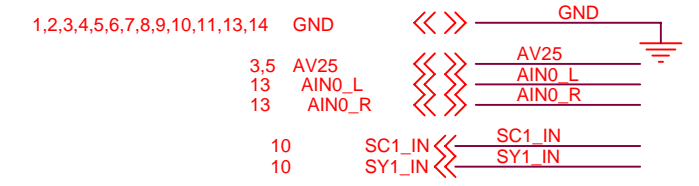
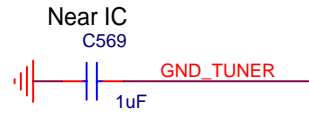
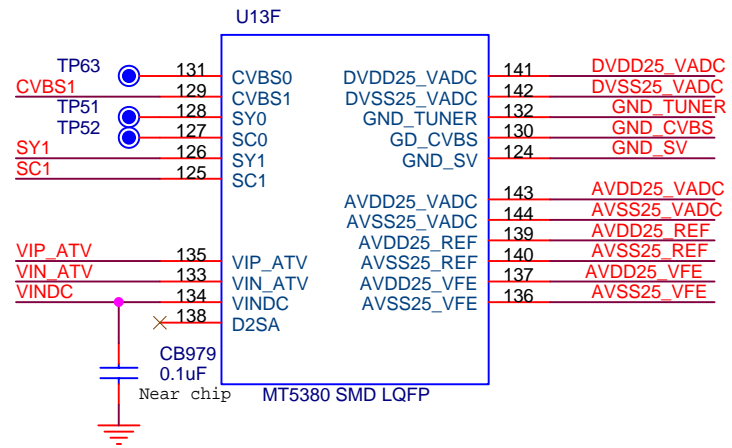

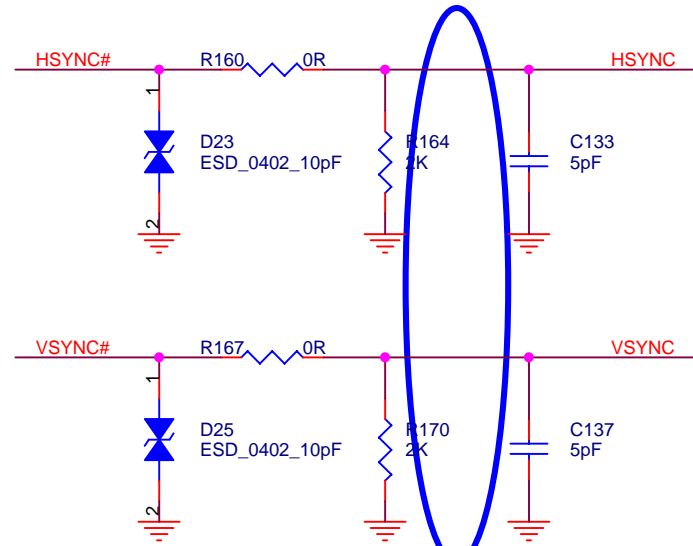
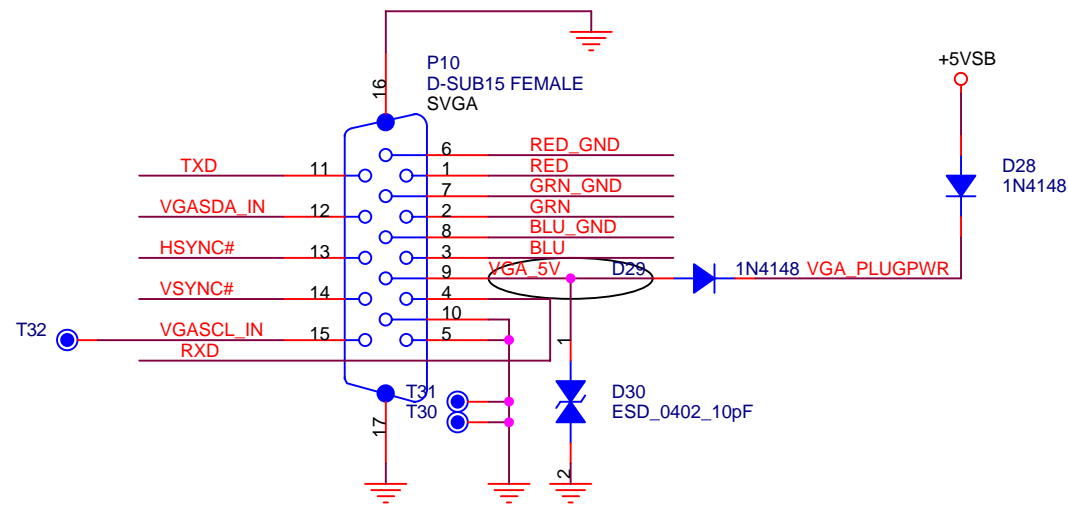

REMOVE INDUCTOR

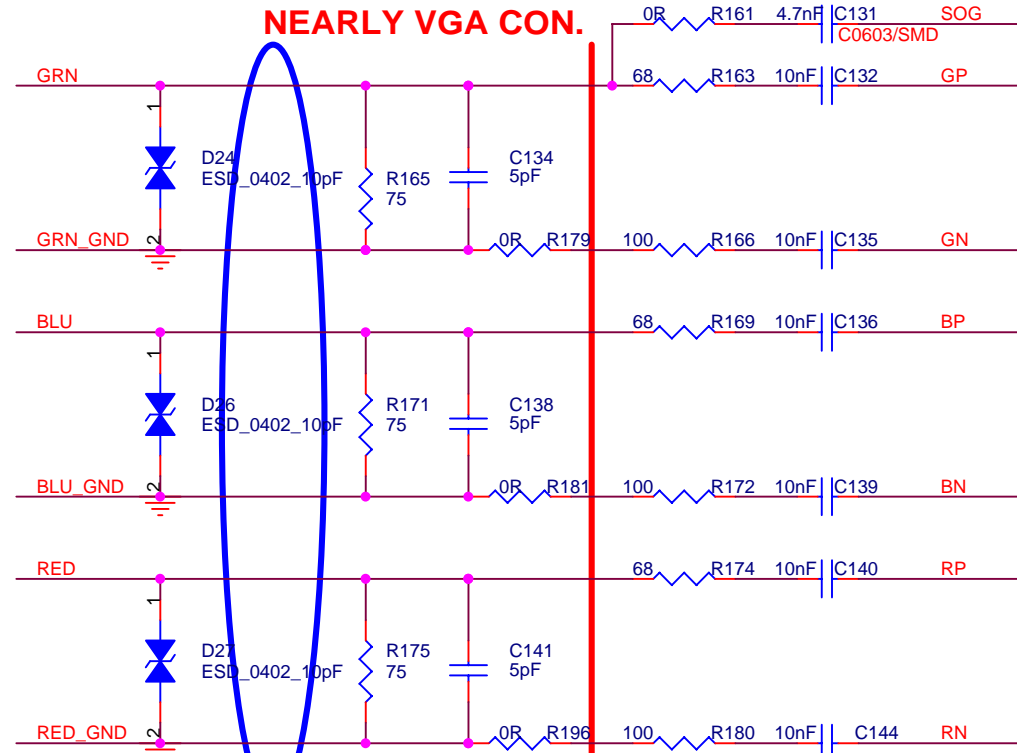
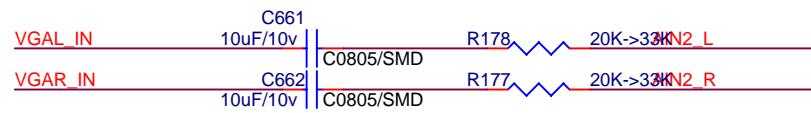

REMOVE INDUCTOR

NEARLY IC

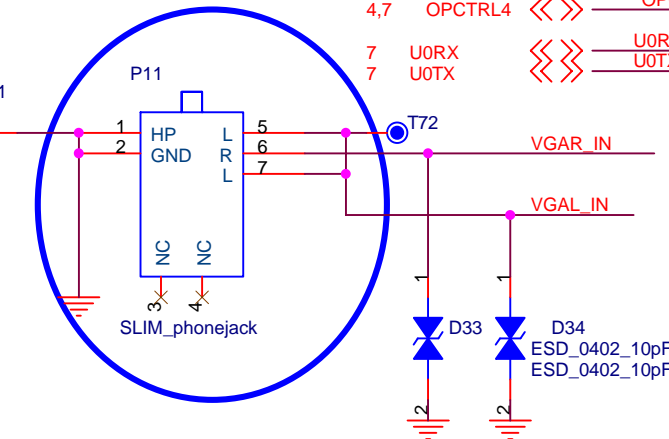
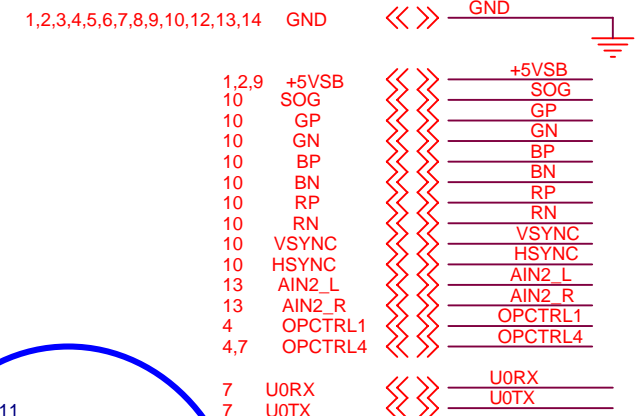

H : WP ENABLE
L : WP DISABLE

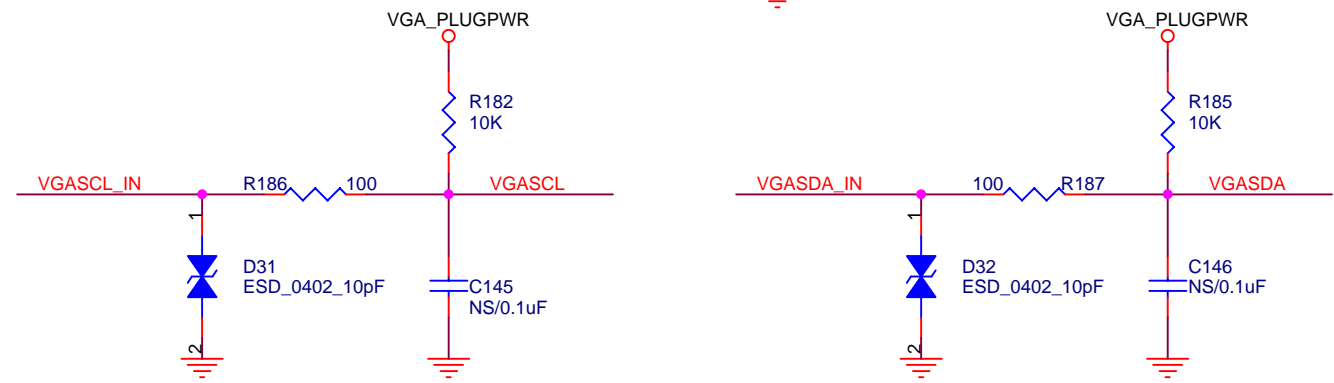
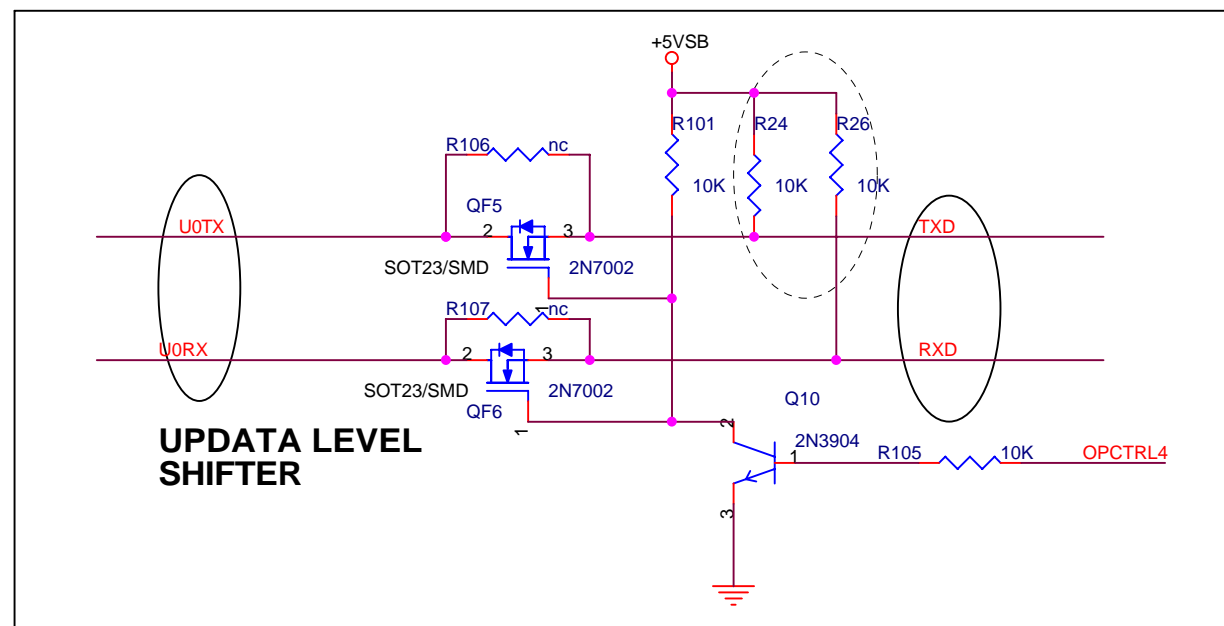
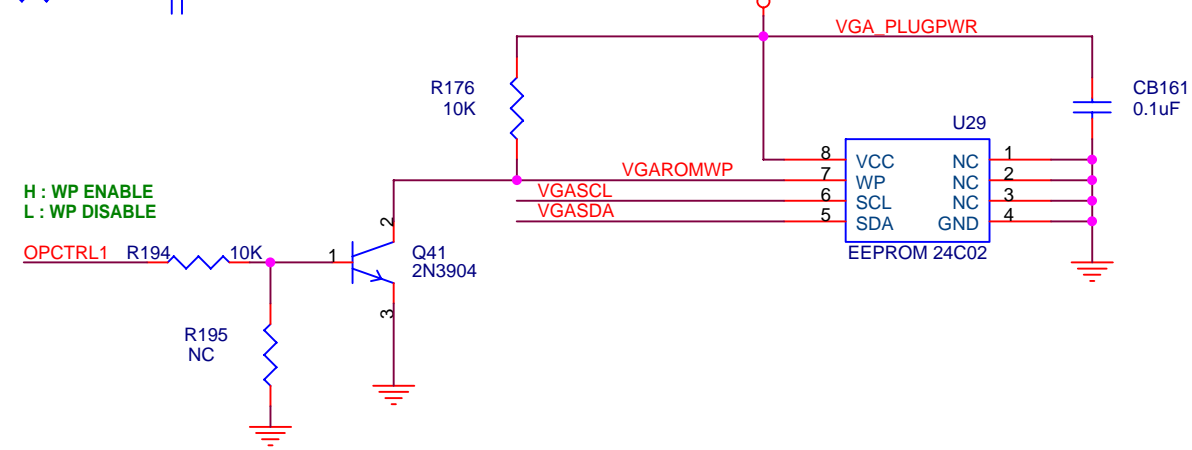

U13E					
SOY0	107	DVDD12_VGA	117	DVDD12_VGA	
Y0P	108	Y0P	113	AVSS12_RGBADC	
Y0N	109	Y0N	110	AVDD12_RGBADC	
PB0P	114	PB0P	105	AVSS12_RGBFE	
PBR0N	115	PBR0N	101	AVDD12_RGBFE	
PRO0P	116	PRO0P			
SOY1	118	SOY1	RP	104	RP
Y1P	119	Y1P	RN	106	RN
Y1N	120	Y1N	BP	98	BP
PB1P	121	PB1P	BN	99	BN
PBR1N	122	PBR1N	GP	102	GP
PR1P	123	PR1P	GN	103	GN
TP47	112	TP47	GN	96	VSYNC
TP48	111	TP48	HSYNC	97	HSYNC
			SOG	100	SOG

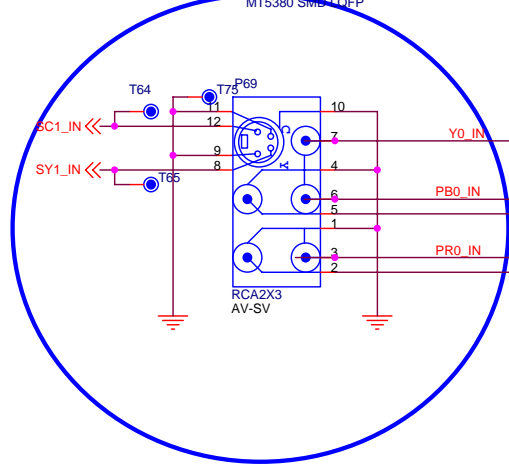

REMOVE INDUCTOR

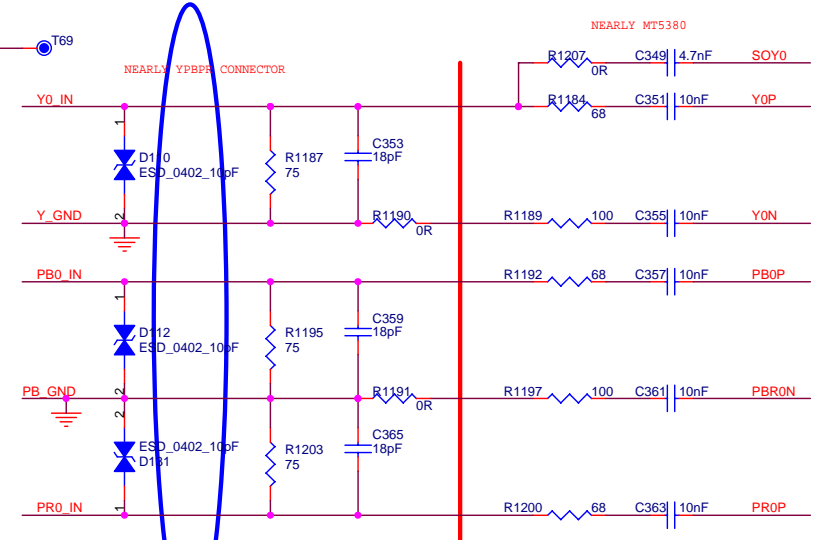

REMOVE INDUCTOR

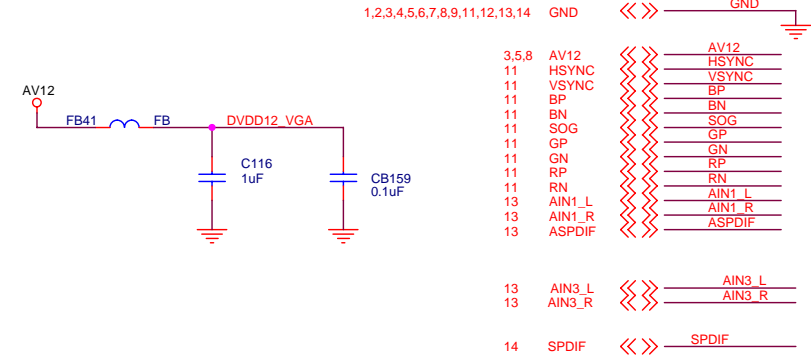
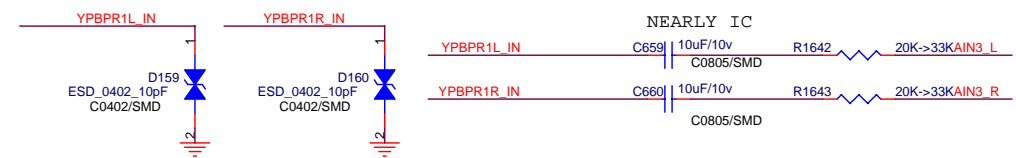
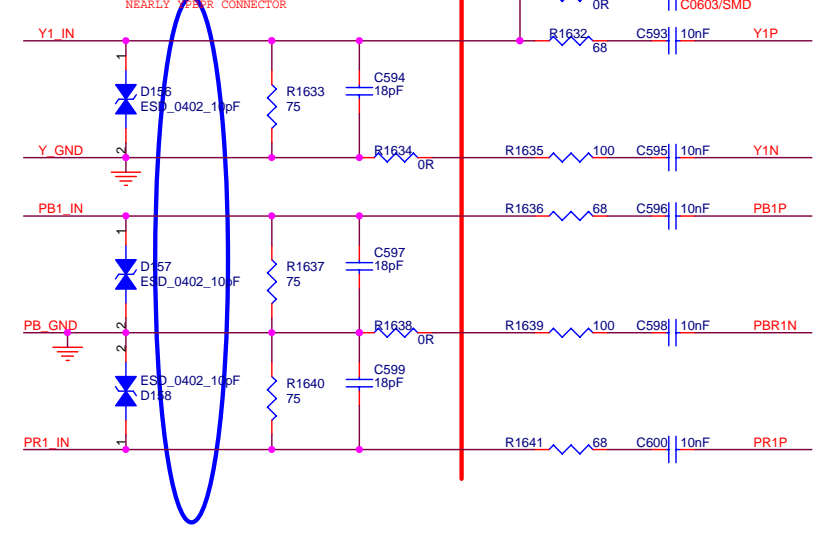

NEARLY IC

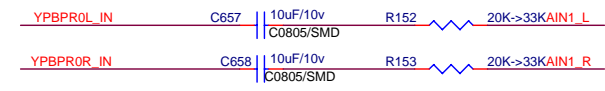

COAXIAL

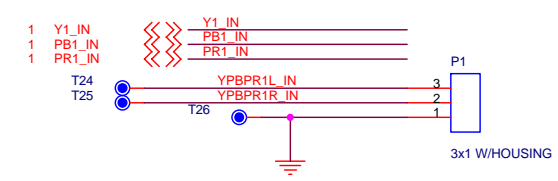
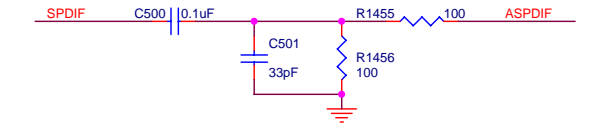

1,2,3,4,5,6,7,8,9,11,12,13,14	GND	<<>	GND
3,5,8	AV12	<<>	AV12
11	HSYNC	<<>	HSYNC
11	VSYNC	<<>	VSYNC
11	BP	<<>	BP
11	BN	<<>	BN
11	SOG	<<>	SOG
11	GP	<<>	GN
11	GN	<<>	RP
11	RP	<<>	RN
11	RN	<<>	AIN1_L
13	AIN1_L	<<>	AIN1_L
13	AIN1_R	<<>	AIN1_R
13	ASPDIF	<<>	ASPDIF
13	AIN3_L	<<>	AIN3_L
13	AIN3_R	<<>	AIN3_R
14	SPDIF	<<>	SPDIF

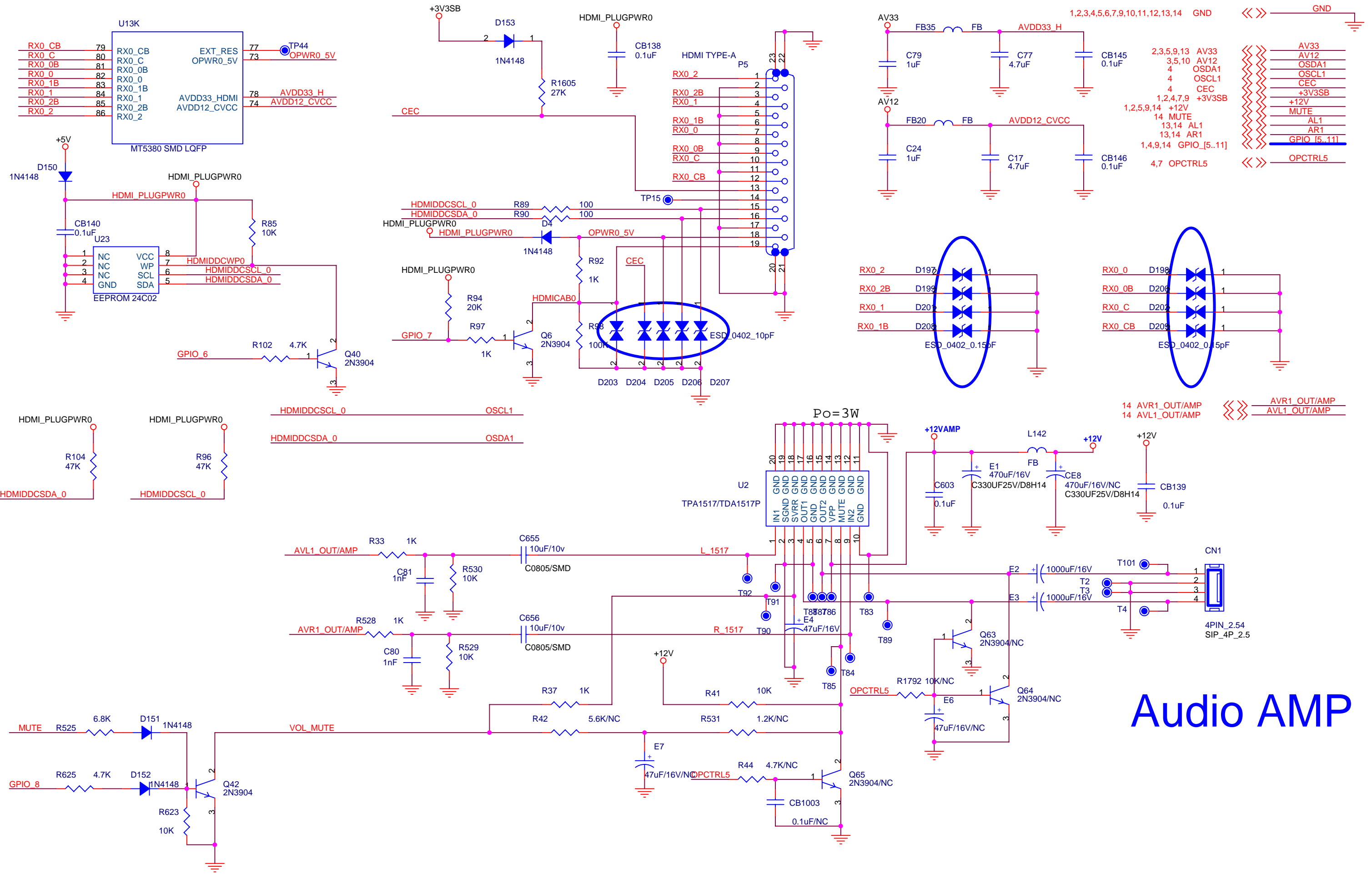

Audio AMP

AV33	2,3,4,5,6,7,9,10,11,12,13,14
AV12	3,5,10
OSDA1	4
OSCL1	4
CEC	4
+3V3SB	1,2,4,7,9
+12V	14
MUTE	14
AL1	13,14
AR1	13,14
GPIO [5..11]	1,4,9,14
OPCTRL5	4,7

AVR1_OUT/AMP	14
AVL1_OUT/AMP	14

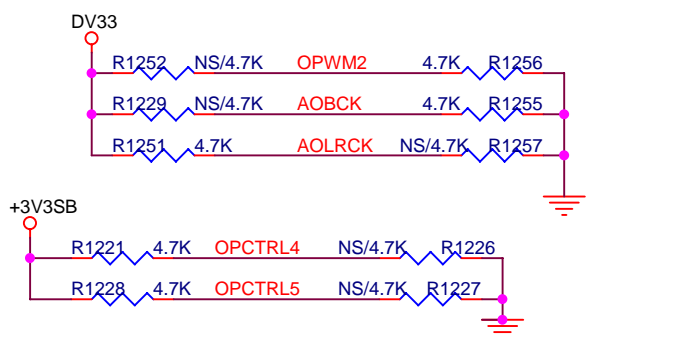
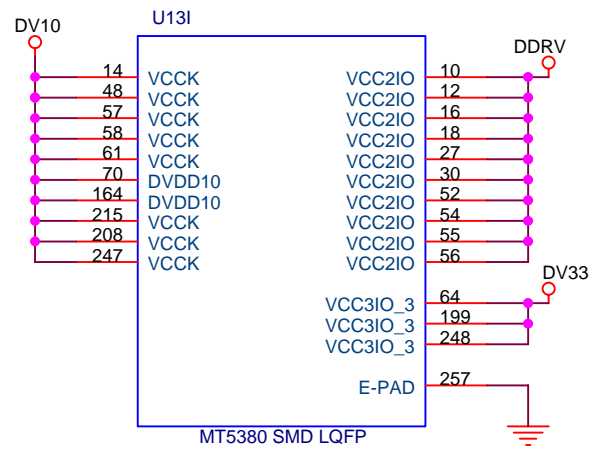
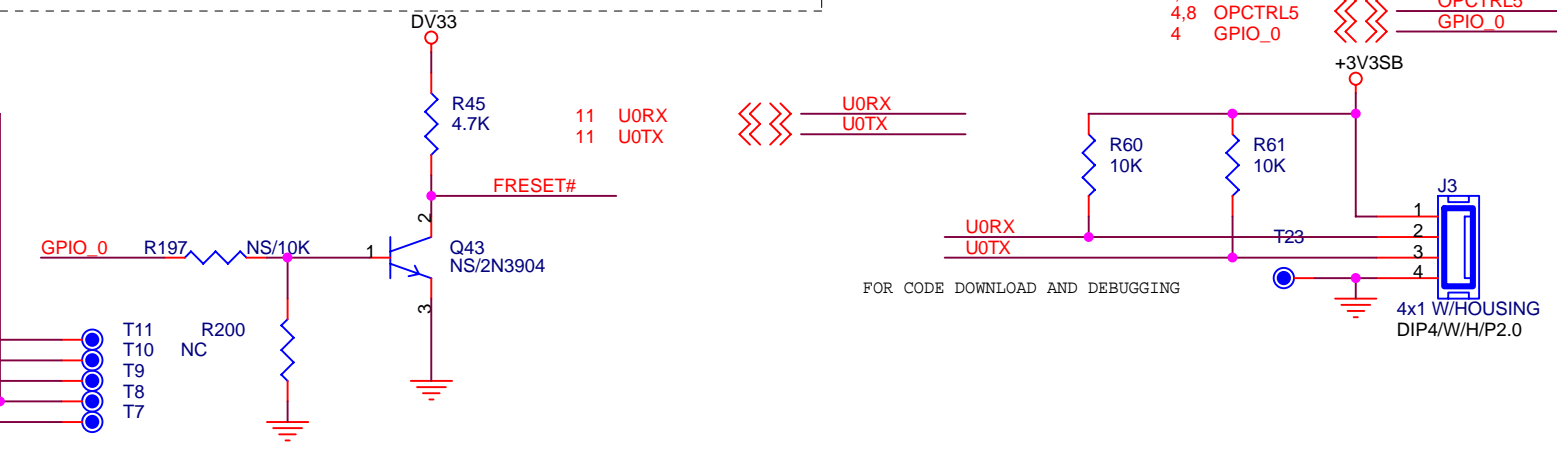
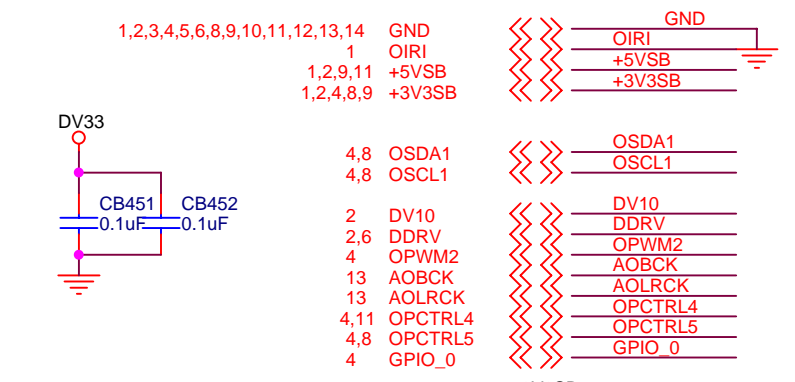
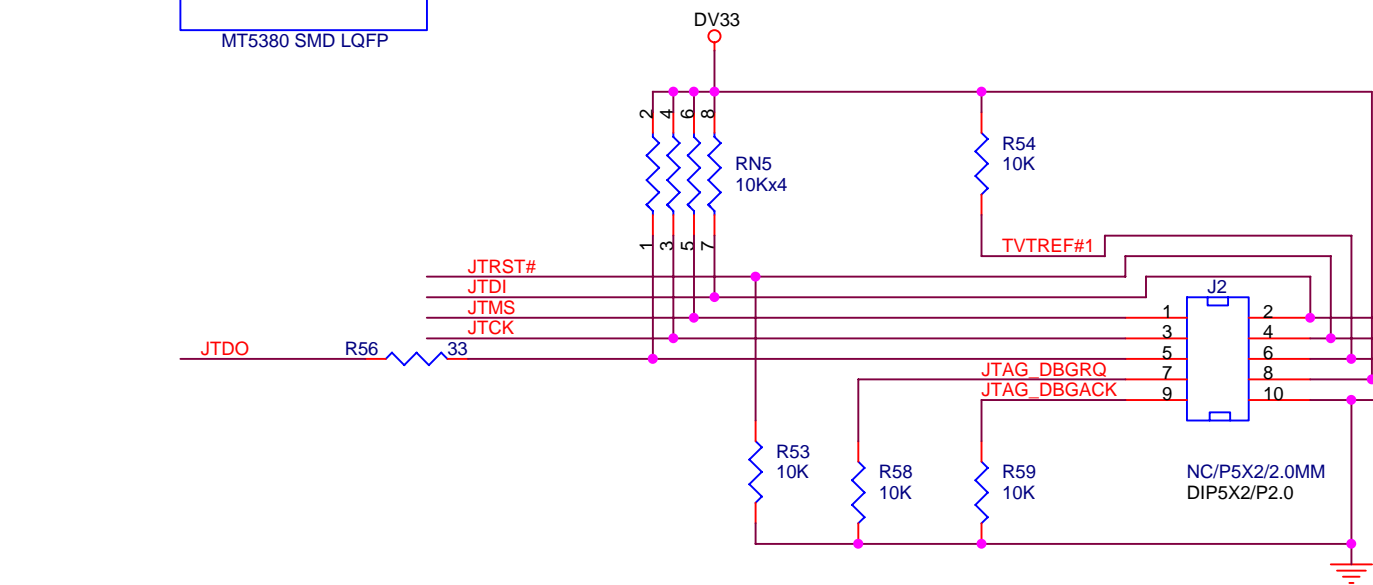
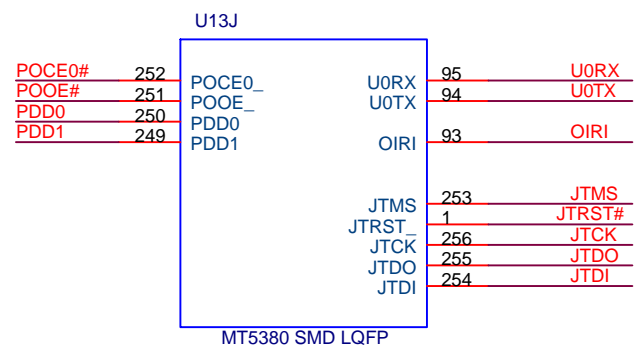

Trap Mode	OPWM2	AOBCK	AOLRCK
Normal mode	0	0	0
ICE mode	0	0	1

Trap Mode	OPCTRL5	OPCTRL4
Core Reset 1 us	1	1

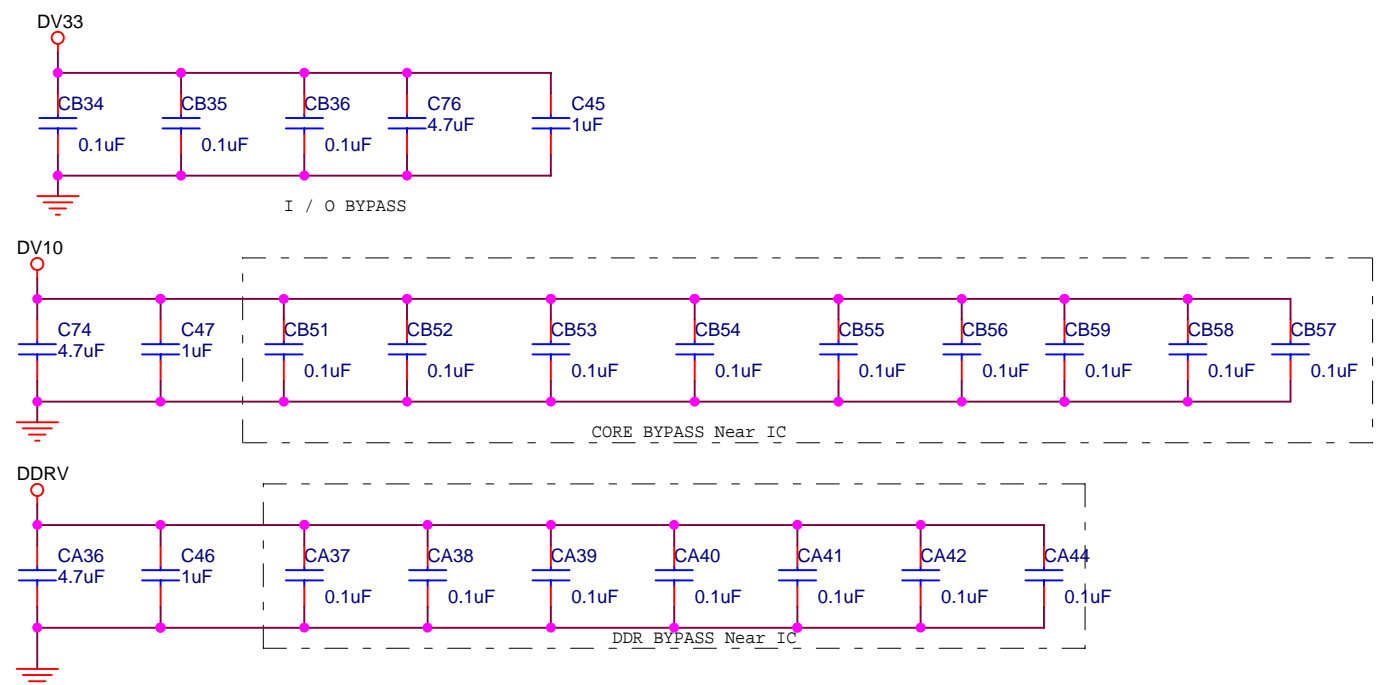

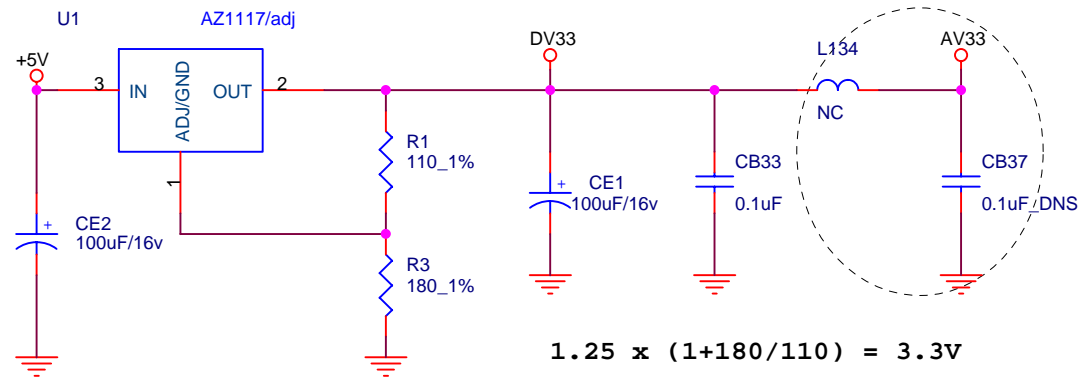

$$1.25 \times (1 + 180/110) = 3.3V$$

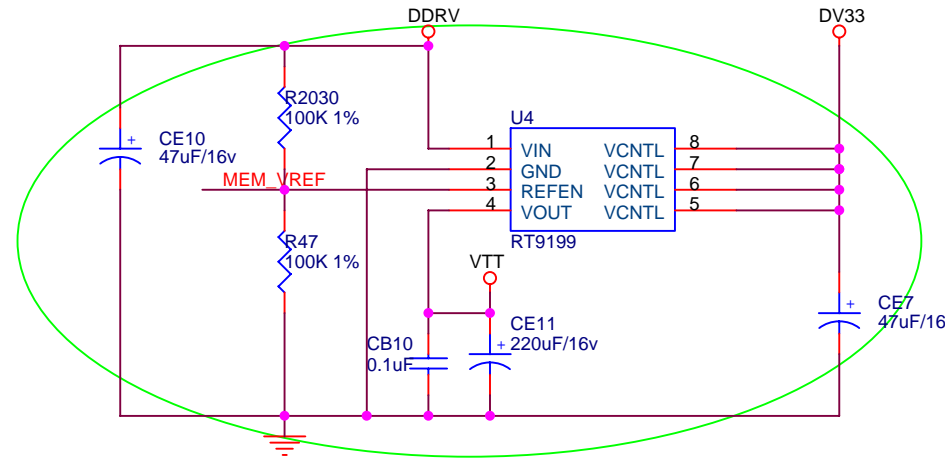

VTT FOR DDR TERMINATOR
MEM_VREF FOR DDR AND MT5381 VREF

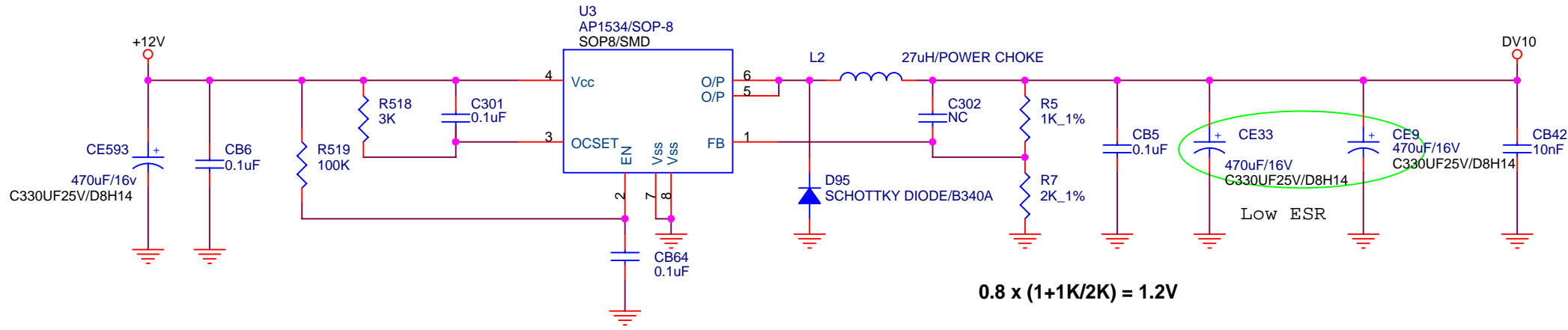

$$0.8 \times (1 + 1K/2K) = 1.2V$$

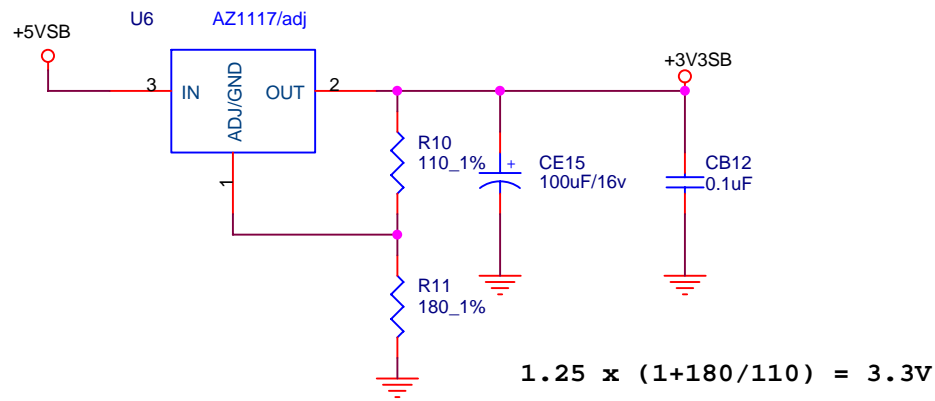

$$1.25 \times (1 + 180/110) = 3.3V$$

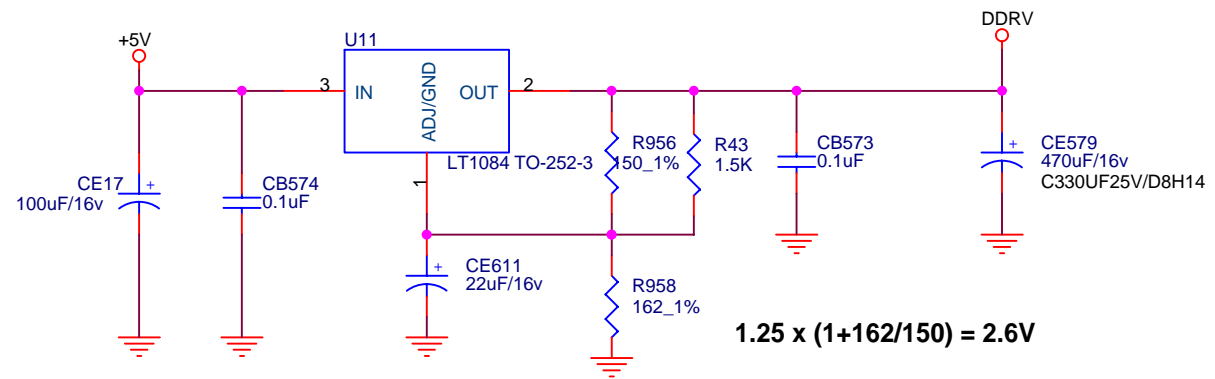

$$1.25 \times (1 + 162/150) = 2.6V$$

A0N	244	A0N	AVDD33_LVDSA	222	AVDD33_LVDS
A0P	243	A0P	AVDD33_LVDSB	231	AVDD33_LVDS
A1N	242	A1N	AVDD33_LVDS	240	AVDD33_LVDS
A1P	241	A1P	AVDD33_VPLL	219	AVDD33_VPLL
A2N	239	A2N			
A2P	238	A2P			
CK1N	237	CK1N			
CK1P	236	CK1P			
A3N	235	A3N			
A3P	234	A3P			
A4N	233	A4N			
A4P	232	A4P			
A5N	230	A5N			
A5P	229	A5P			
A6N	228	A6N			
A6P	227	A6P			
CK2N	226	CK2N			
CK2P	225	CK2P			
A7N	224	A7N			
A7P	223	A7P			

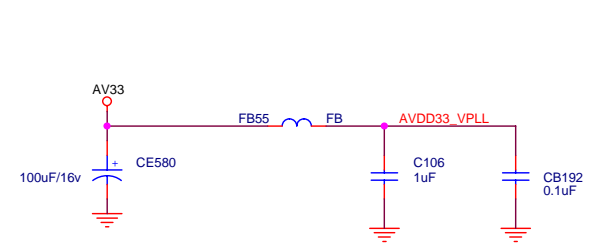

A0N	
A0P	
A1N	
A1P	
A2N	
A2P	
CK1N	
CK1P	
A3N	
A3P	
A4N	
A4P	
A5N	
A5P	
A6N	
A6P	
CK2N	
CK2P	
A7N	
A7P	

1,2,3,4,5,6,7,8,10,11,12,13,14	GND	<<>	GND
1,2,5,8,14	+12V	<<>	+12V
2,3,5,8,13	AV33	<<>	AV33
1,4,8,14	GPIO_[5..11]	<<>	GPIO [5..11]

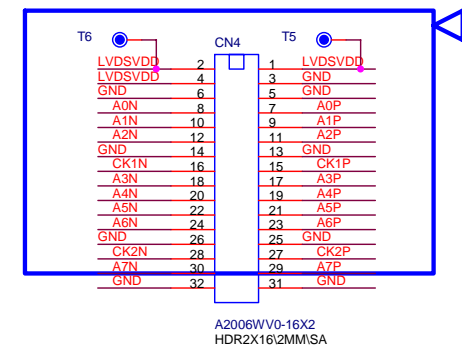

1,2,3,4,5,6,7,8,10,11,12,13,14	GND	<<>	GND
1,2,11	+5VSB	<<>	+5VSB
1,2,5,8,14	+12V	<<>	+12V
4	OPCTRL2	<<>	OPCTRL2
1,2,4,7,8	+3V3SB	<<>	+3V3SB
4,7	OPWM[1..2]	<<>	OPWM1..2
1	BL_ON/OFF	<<>	BL_ON/OFF
1	DIMMING	<<>	DIMMING

REMOVE INDUCTOR

For +5V

For +12V

HI => LVDS POWER ON
LO => LVDS POWER OFF

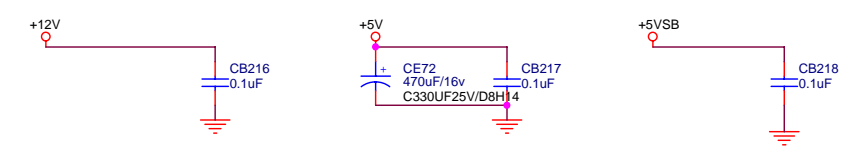
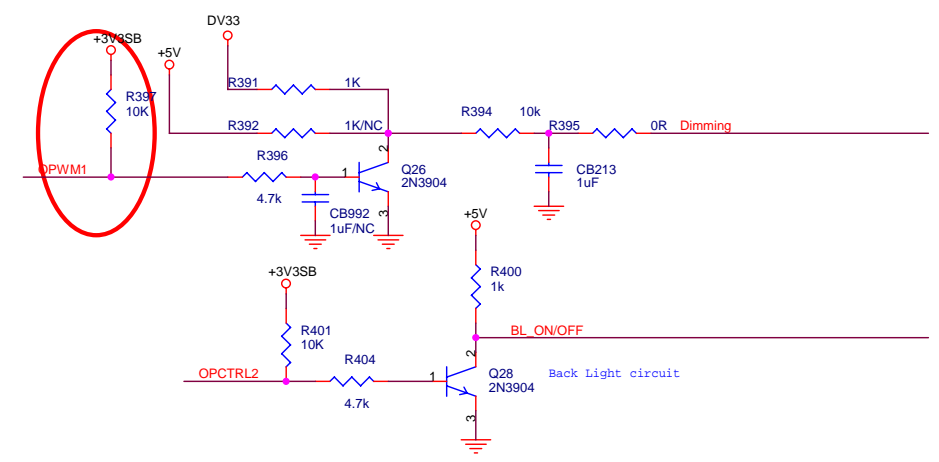
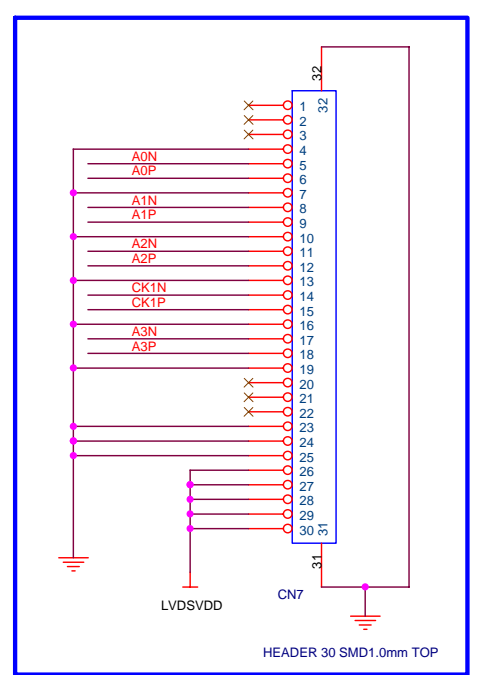
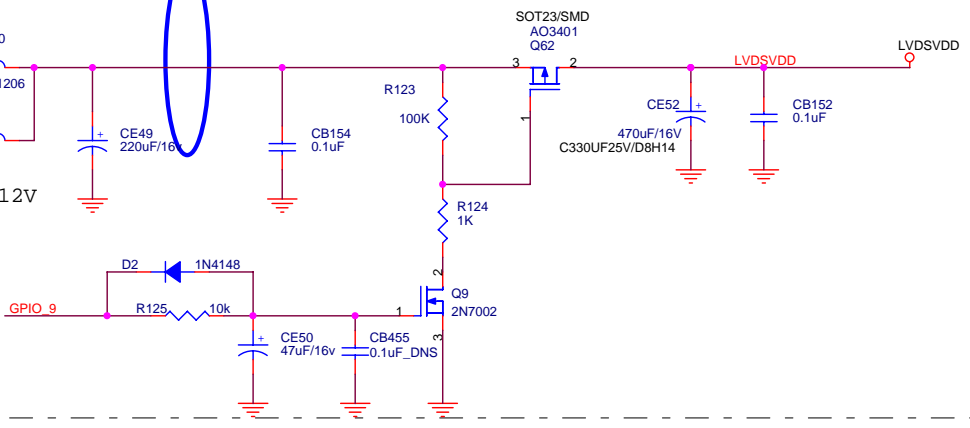

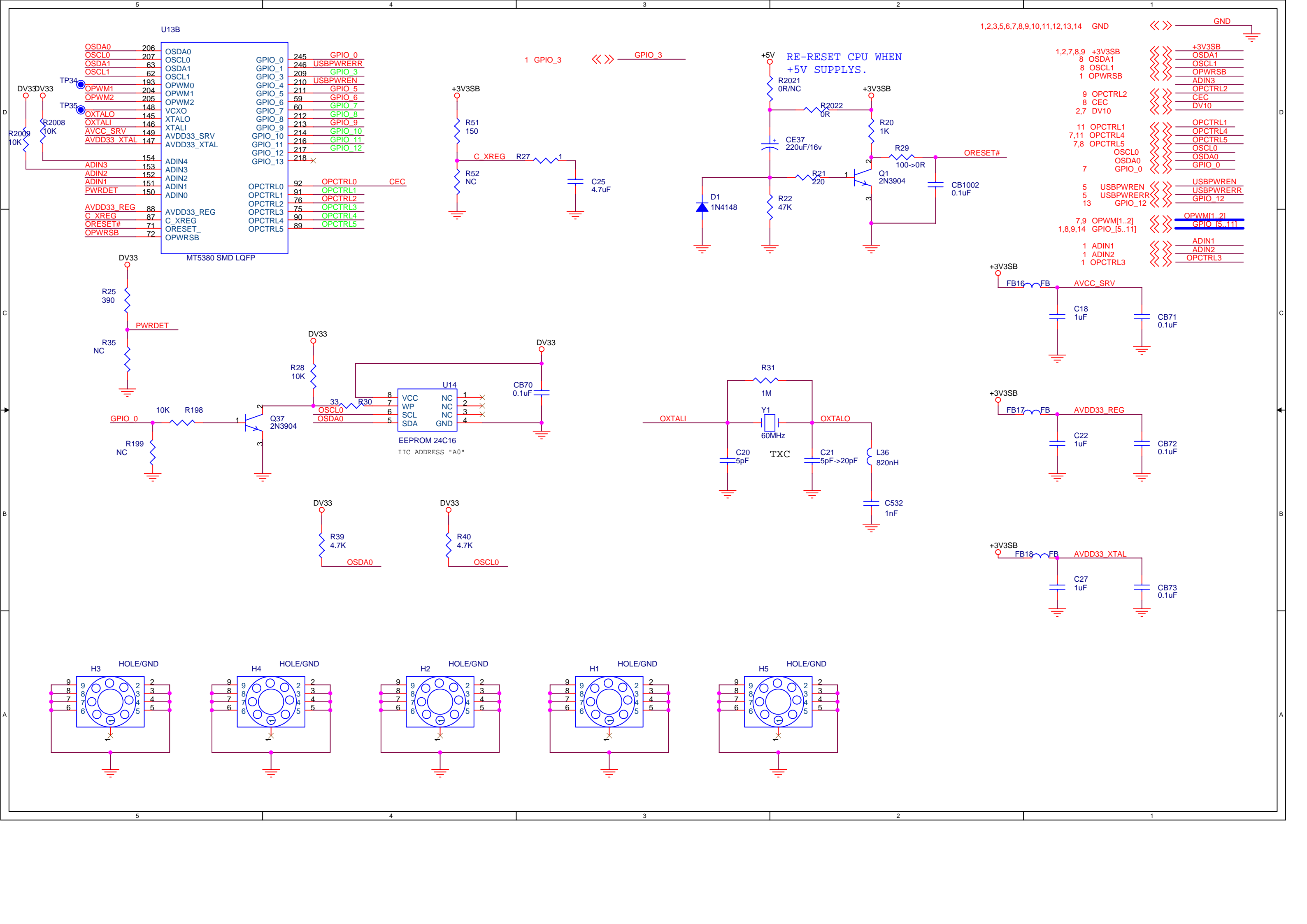

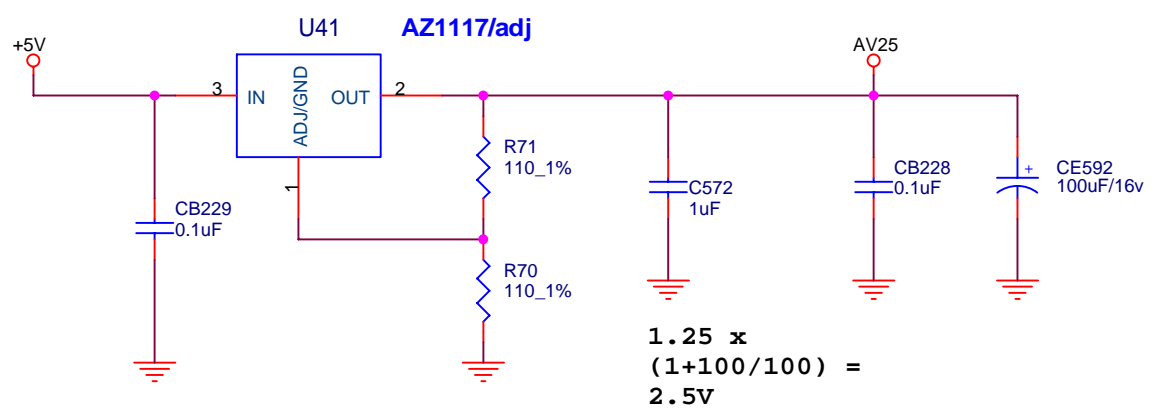
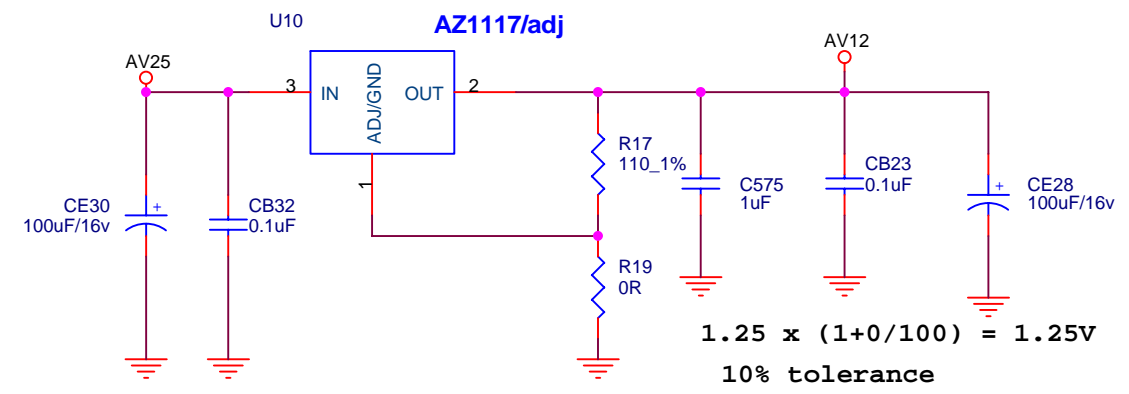
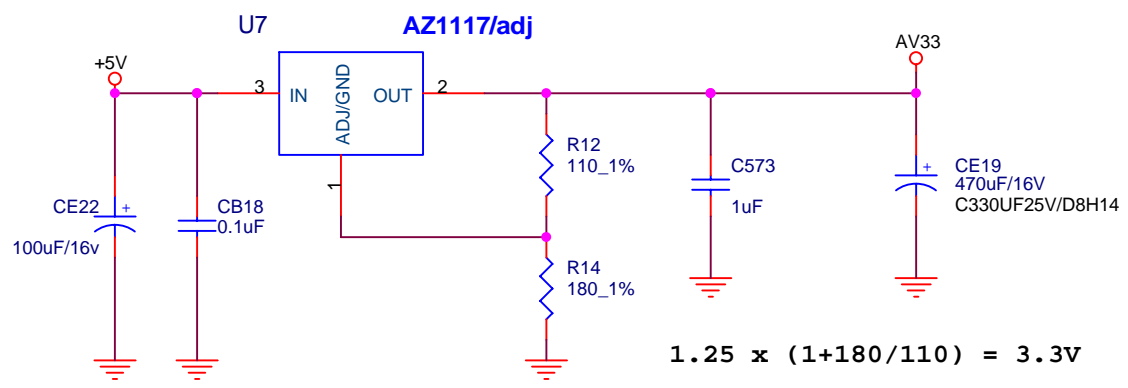

- 1,2,4,5,6,7,8,9,10,11,12,13,14 GND
- 2,5,8,9,13 AV33
- 5,8,10 AV12
- 5,12 AV25
- 1,2,5,8,9,14 +12V

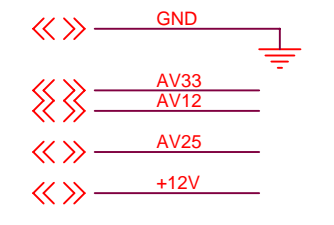

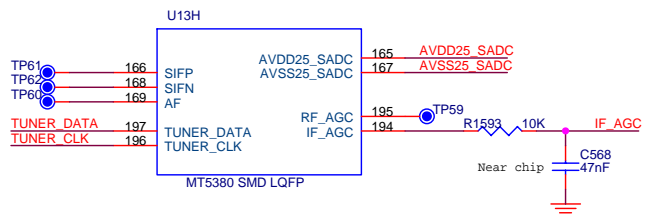
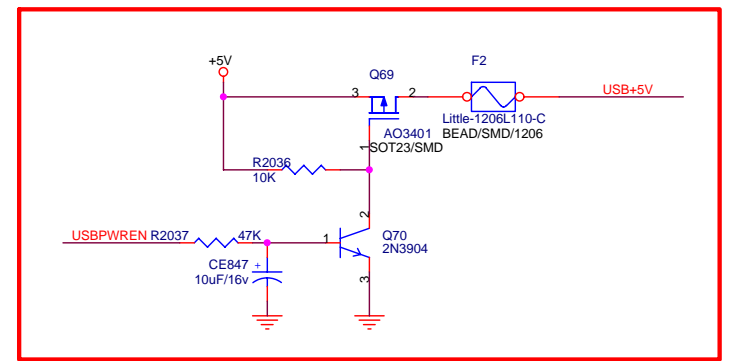
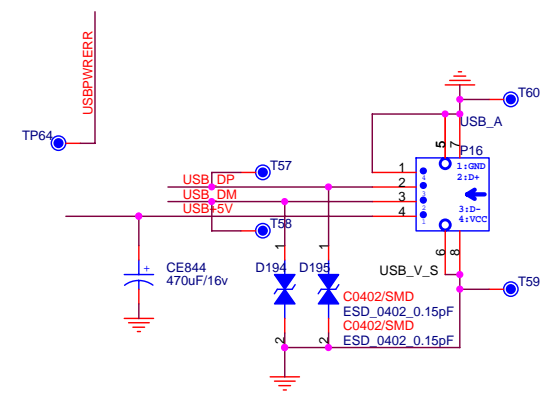
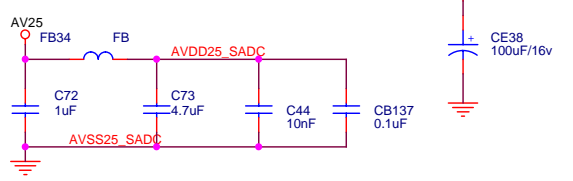
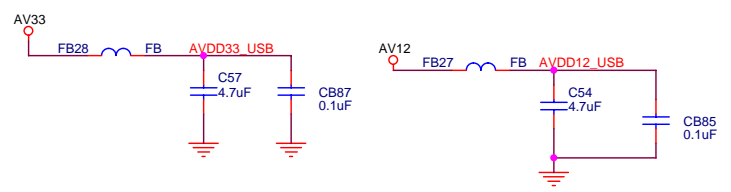
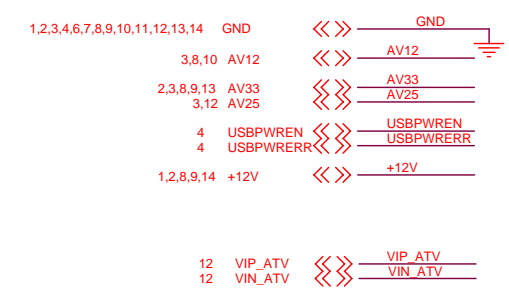
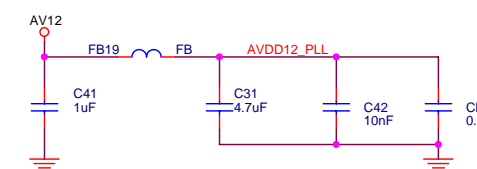
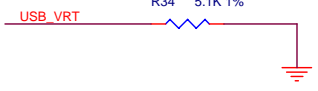
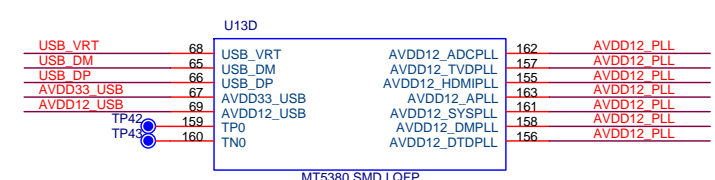

use this POLYSWITCH PTC to avoid over current.

tyco nanoSMDC110F :
 Ihold=0.8A
 Itrip=1.6A @60°C

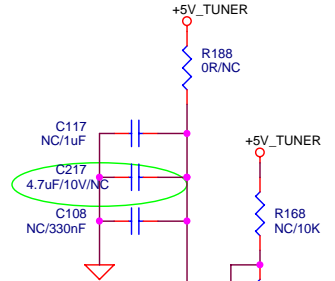
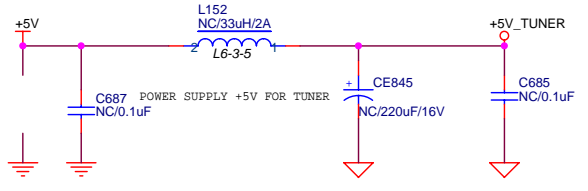

DVT AND NXP OPTION.

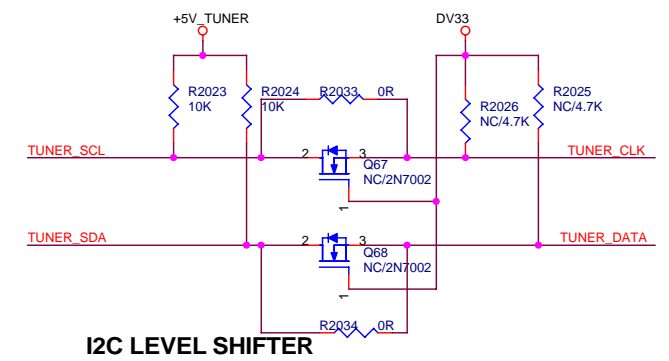
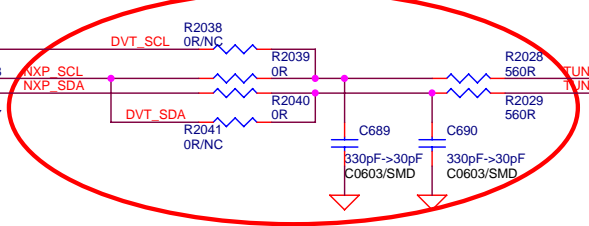

I2C LEVEL SHIFTER

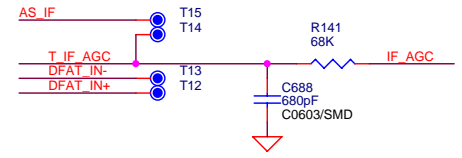
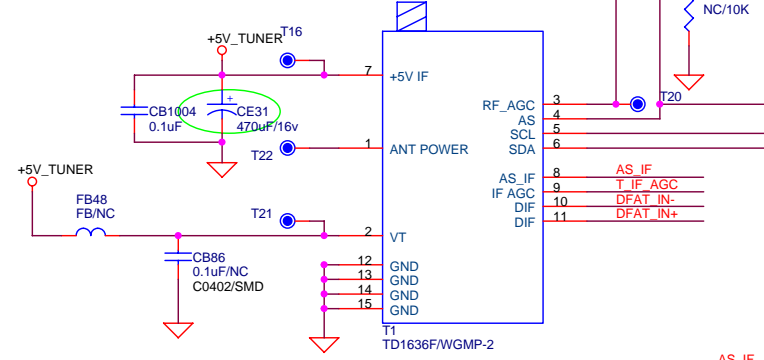

Near Tuner Near MT538X

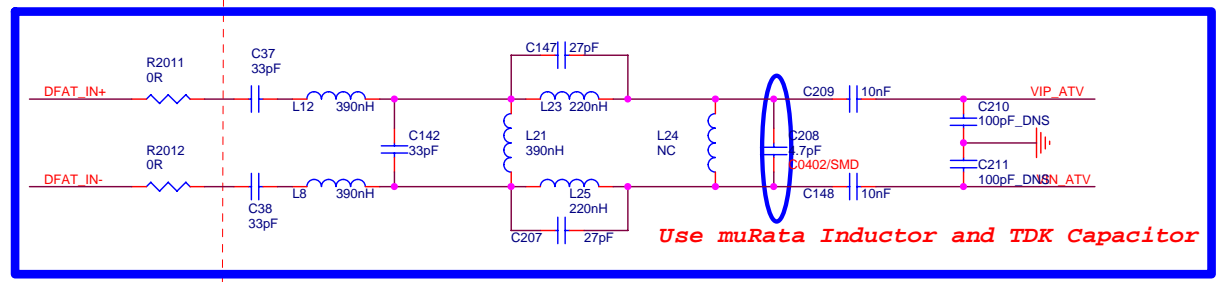

Use muRata Inductor and TDK Capacitor

muRata: LQM18NMR22K00 和 LQM18NMR39K00

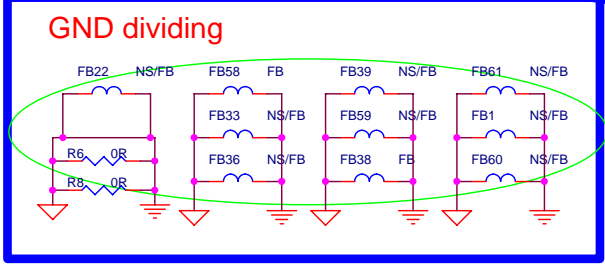
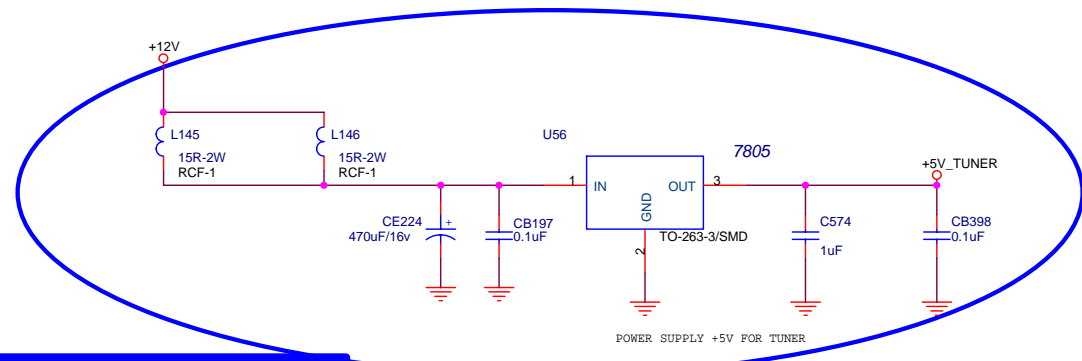

GND dividing

customer type	HLC22R1
Haier type	LX22R1W
special number	DC1480E0100
special technique document number	AT08SR1101US09
export country	AMERICA
customer	HAC
brand	Haier

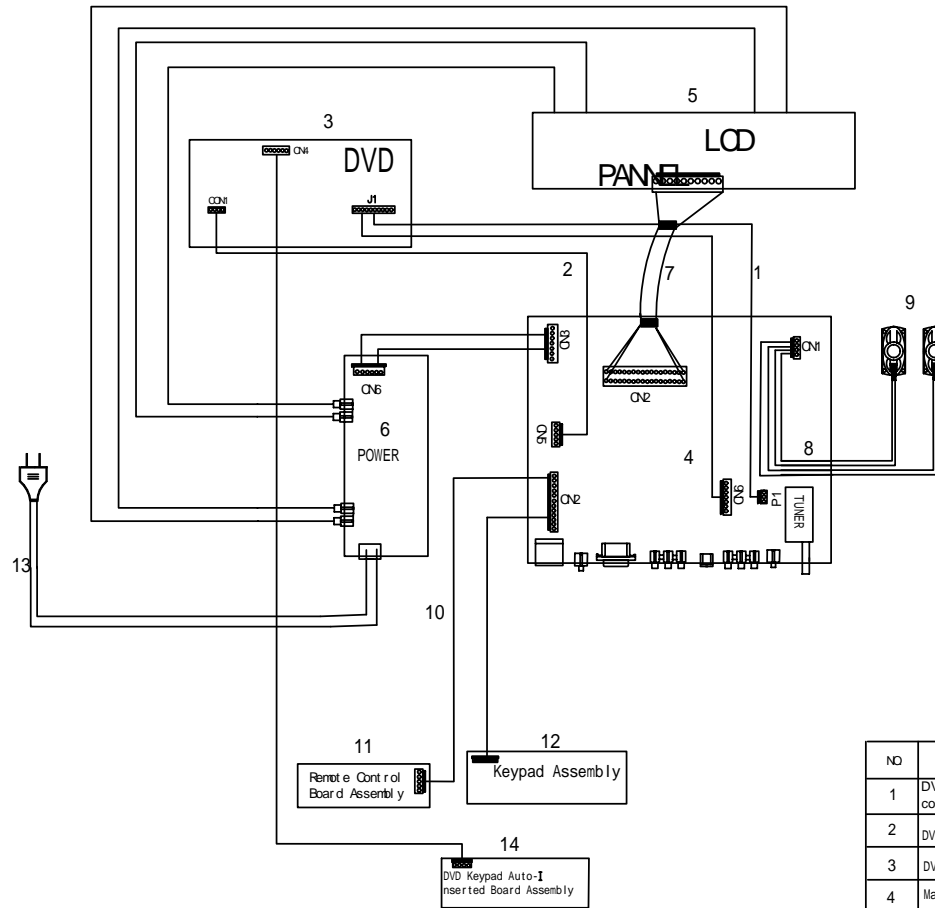

NO	NAME	Serial NO	Spec	Quantity
1	DVD signal connection wire	0090402064		
2	DVD Power wire	0090403161A		
3	DVD(0090810121A)	0090810121A		
4	Main board (0290719615)	DC1480E0100		
5	LCD Panel	0094001227CA		
6	Power Supply	0094001224B		
7	LVDS wire	0090402338		
8	Speaker wire	0090402274		
9	Speaker	0094015071		
10	Combination Wire	0090403157C		
11	Remote Control Board Assembly	0090714708		
12	Keypad Assembly	0090701136		
13	Power cord	0090403211		
14	DVD Keypad Assembly	0090701142		
Workout	Auditing		Standardization	Approval

8. Measurements and Adjustments

8-1. Service Mode

8-1-1. How to enter into Service Mode

The way to the factory mode menu:

1st, press menu,

2en, input 8893,

3rd, press "ok"

Finished these operations , system will be into the factory mode menu.

8-1-2. How to exit

IF want to exit this factory menu, please press the botton "Exit" in the remoter.

8-2 Measurements and Adjustments



8-2-1 Version ,S/N, Panel Resoution

Version: The first line is the model Name and the second line is current software version.

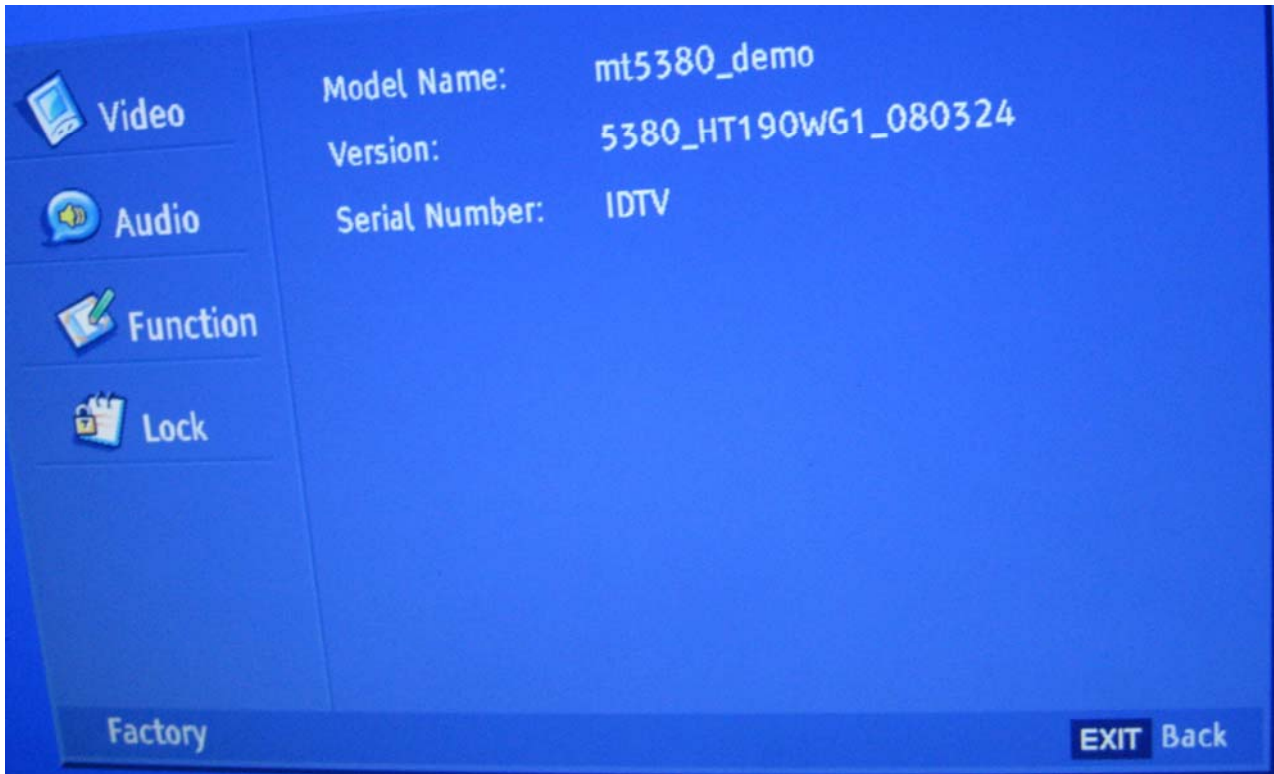

8-2-2 Video

Auto Color

The option could only be used in the VGA and Component model. When we found the color in the two

models was abnormal. Then we can use the function to adjust it automatically.

Color Temperature

The function could adjust the Color Temperature., used when debugging.



8-2-3 Audio

Dolby Banner: When turn it "ON", the model will be in Dolby authentication state.

Compression: Compression style. RF: atv line: AV/S-Video/YPbPr/VGA

Compression Factor: Compression state.

Downmix: output model. MTS System: used when debugging. The parameters only used when debugging, no need to be modified.



8-2-4 Channel

Range Scan: The function could make it to search the channels by differentiation the analog and digital channels.

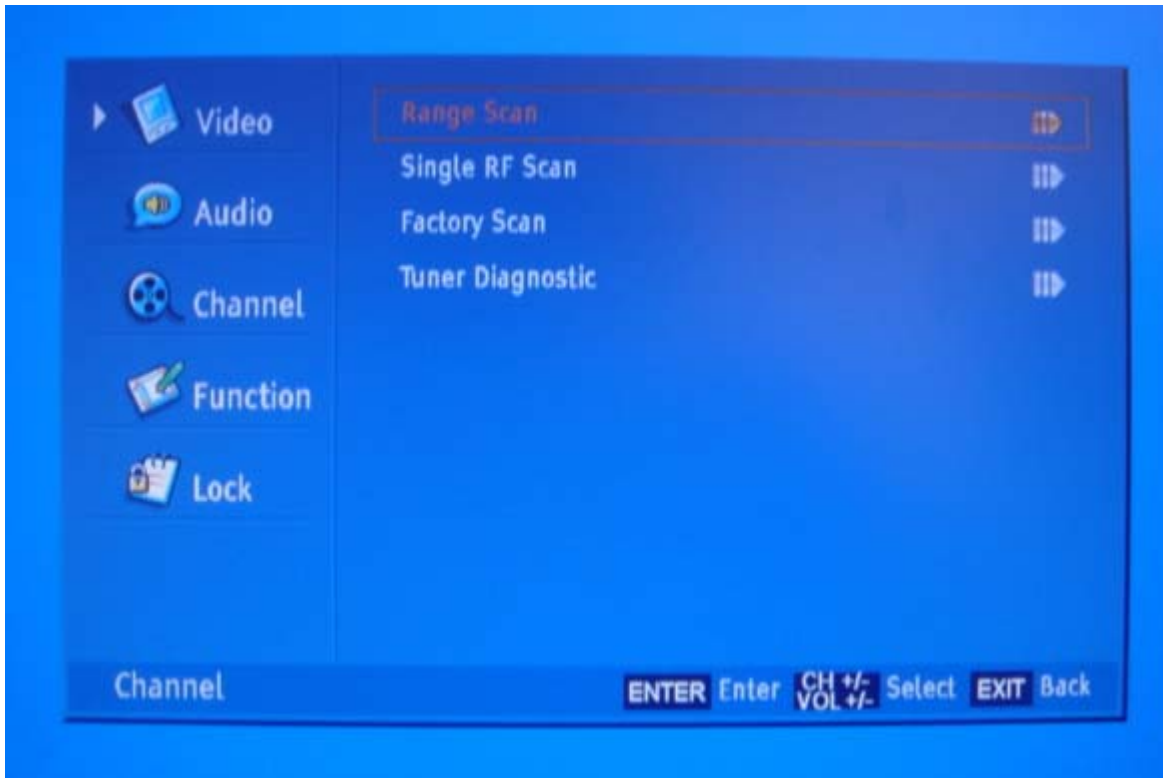

Single RF Scan: Search channels in the frequency scope set in advance.

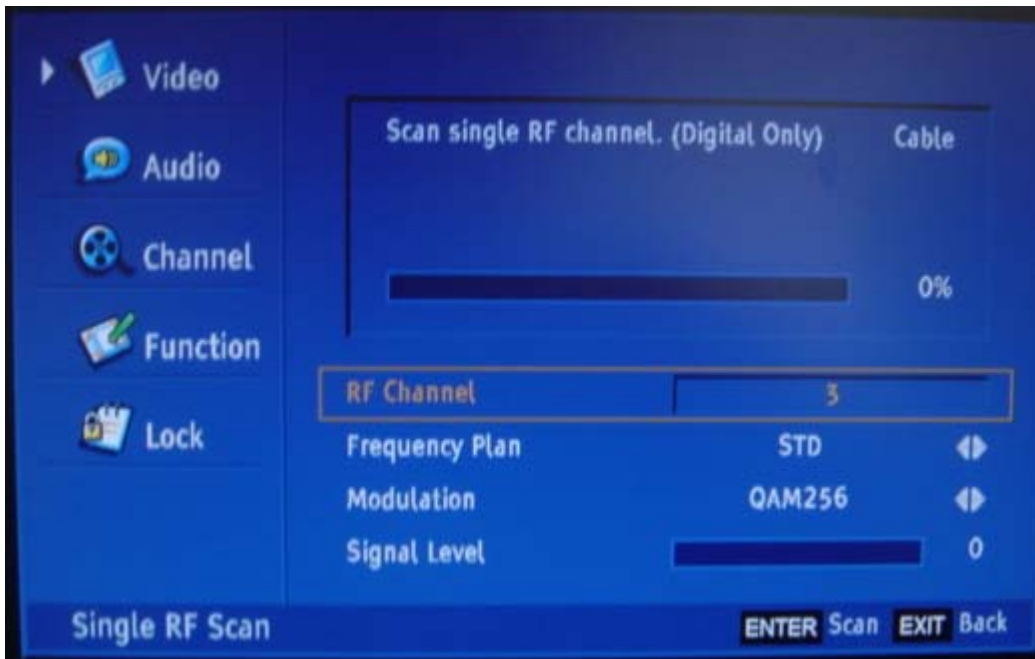

Factory Scan: According to ANTENNA-ANALOG---> ANTENNA-DIGITAL---> CABLE-ANALOG---> CABLE- DIGITAL to search channels, used only in project debugging.



Tuner Diagnostic: Project debugging setting, used to inspect the audio function.

8-2-5Gamma

Gamma:

Bright: GAMMA0.8 Middle: default settings in the program Dark: GAMMA1.2

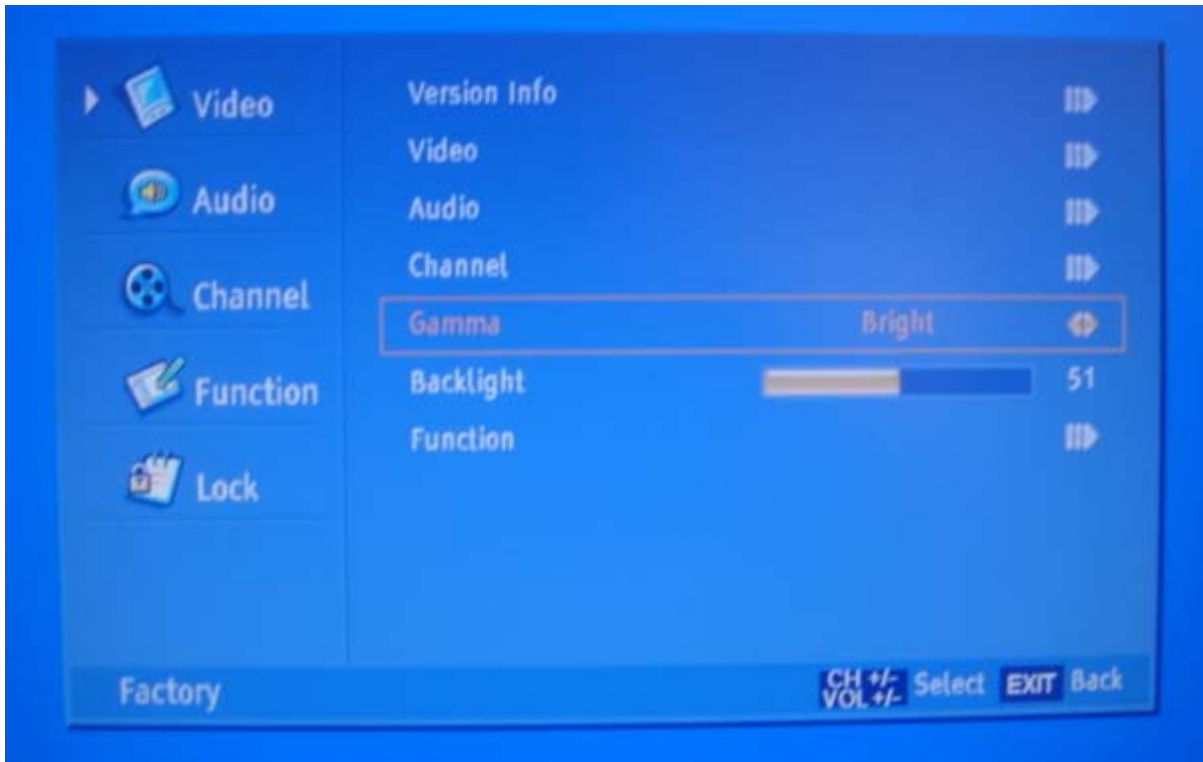

8-2-6 Backlight

Backlight: adjust the backlight.

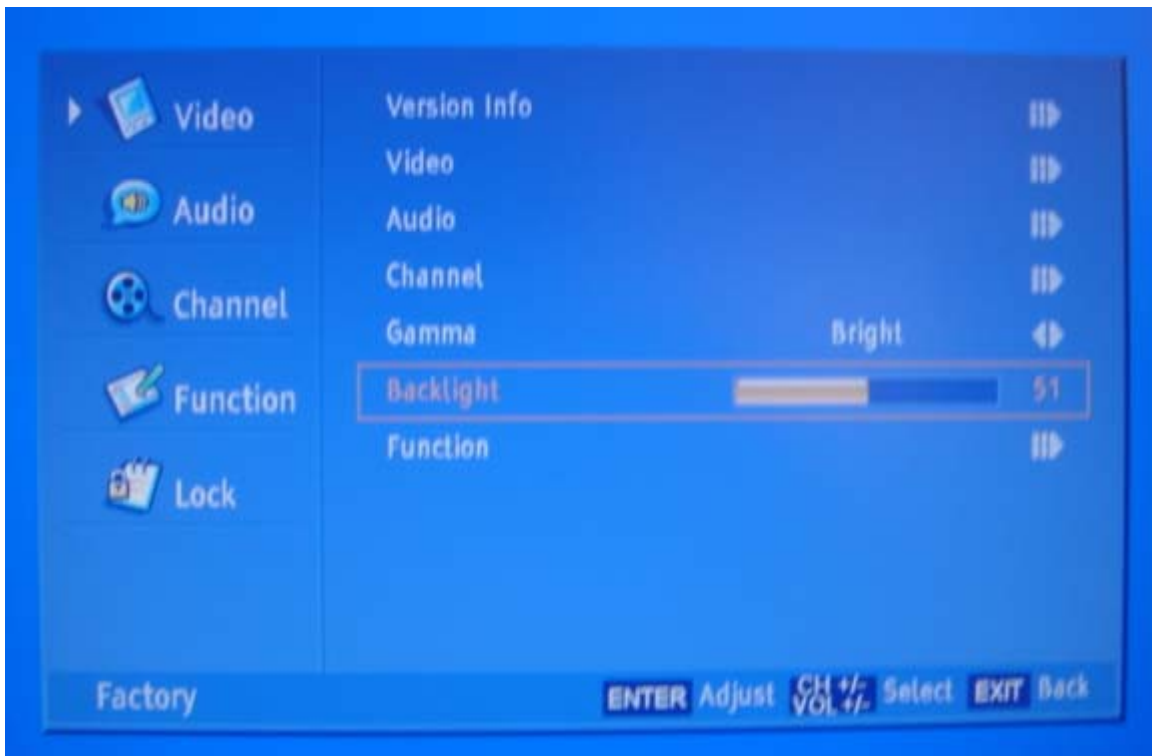

8-2-7 Function

Burning Mode:

Turn it "ON" to enter the aging model, This is for factory run-in testing. The screen would display red, green, blue and black screen repeatedly. Each color screen could be exam at that time.



Clean Storage: The function could make the model turn back to the factory default setting.

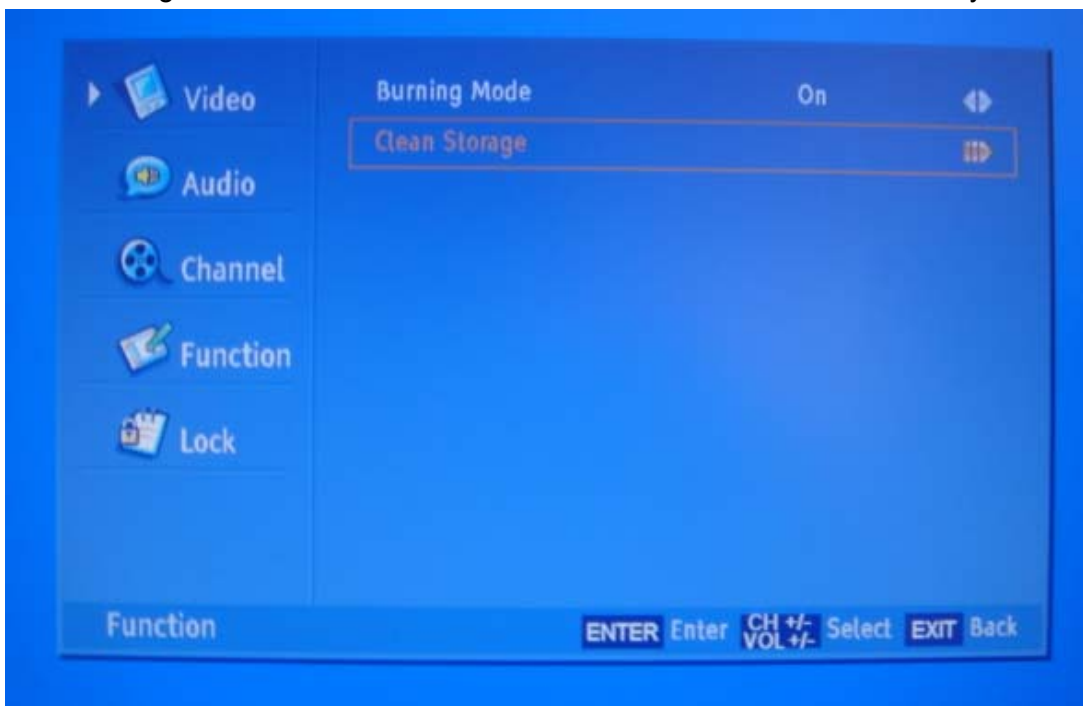

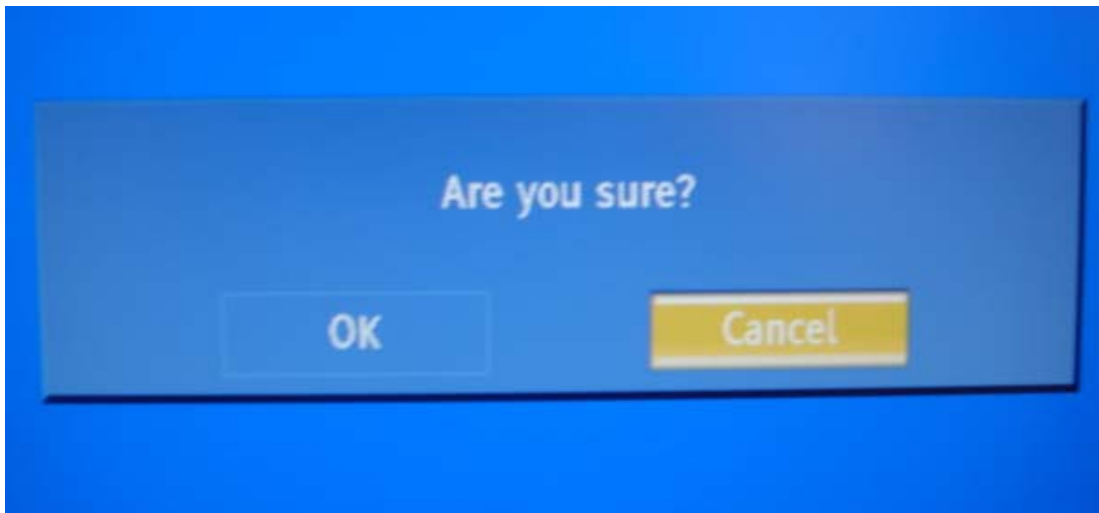

Remark:

The date of the chart only is a example, please don't adjust the factory mode base on it.

9. Trouble shooting

9-1. Simple check

No Picture,no sound	Verify if the television is properly plugged Verify if the television is properly supplied power Verify if electricity is available
Blank screen	Verify if correct signals are input Press INPUT button to change signal input to TV input Restart the television of power supply is interrupted
No sound	Press Mute button and verify if Mute mode is set. Switch to otger channel and verify if the same problem happens. Press VOL+ button to see of he problem can be solved.
Poor sound	Verufy if sound system is correct .Refer to some chapter for adjust.
No picture in some channel	Verify if correct channel is selected. Adjust the antenna. Make adjustments by Fine Tune and MANUAL Scan.
No color for some channel program(black and white)	Verify if the same problem exists in other channels. check out of picture and sound system. Refer to relative instructions in the Manual for color adjust.
Spots with some or all pictures	Verify if the antennal is correctly connected. Verify if the antennal is in good condition. Make fine adjustment of channel.

9-2. Power Supply Board failure check.

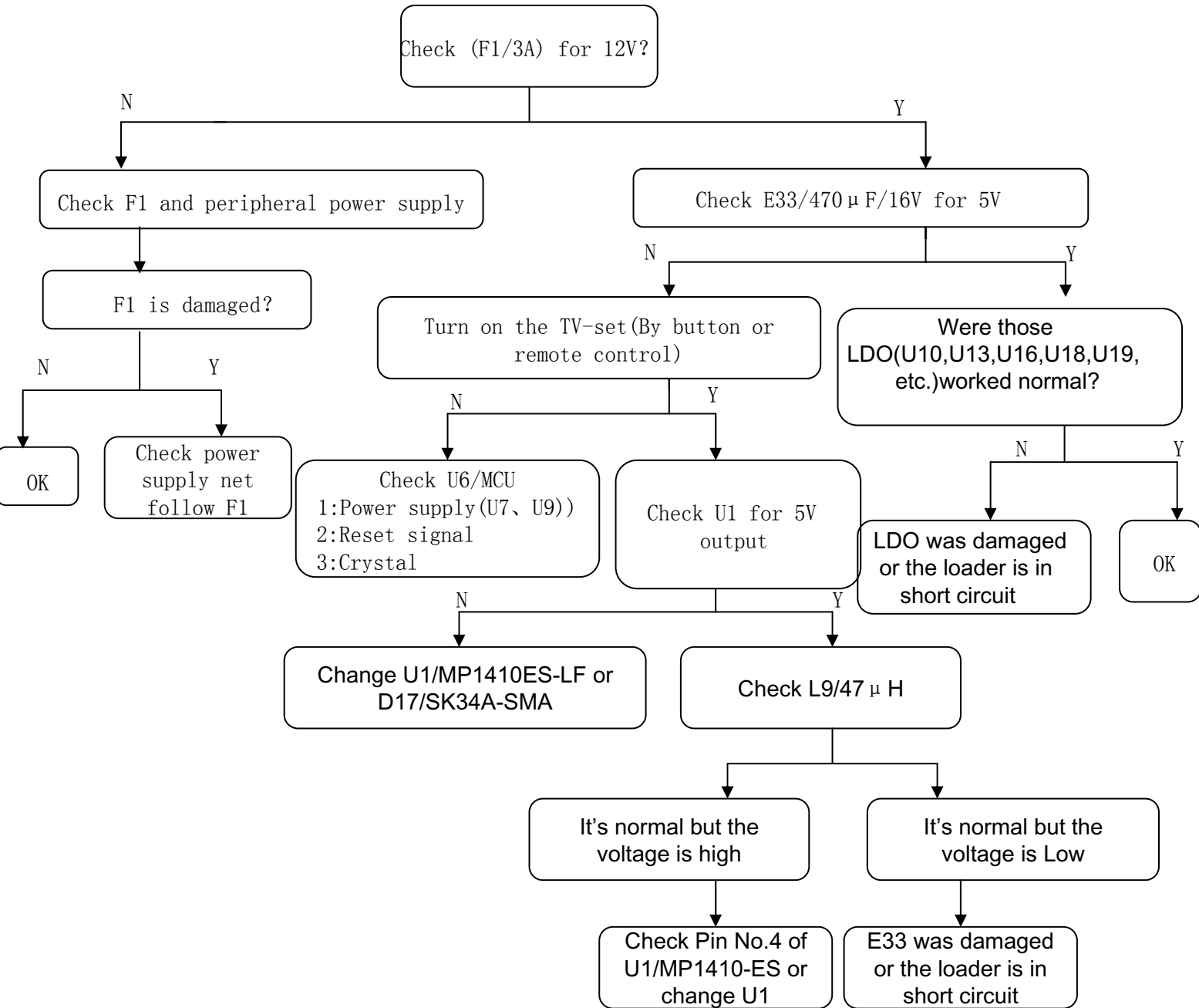

9-3. Main board failure check

State: No Sound

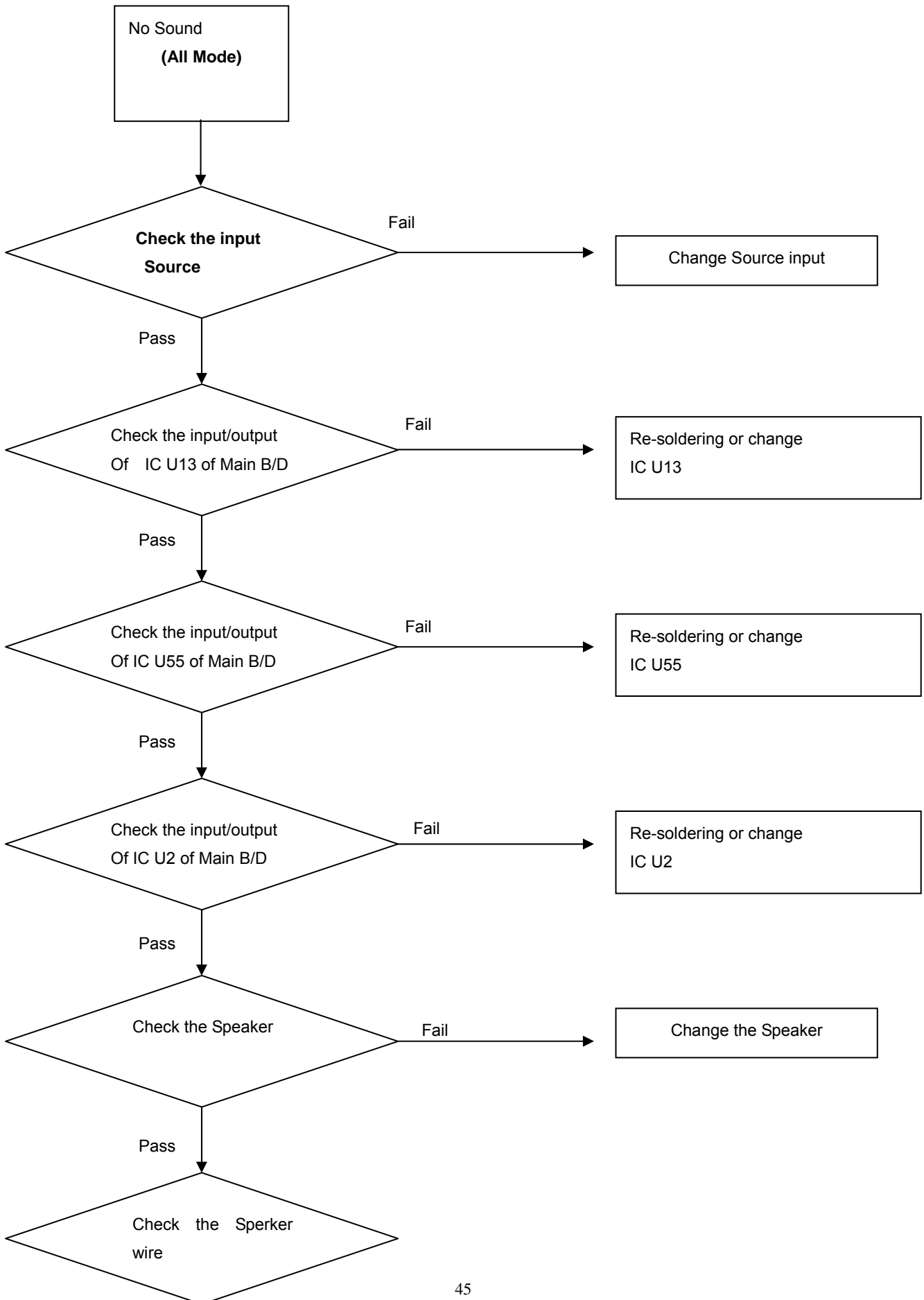



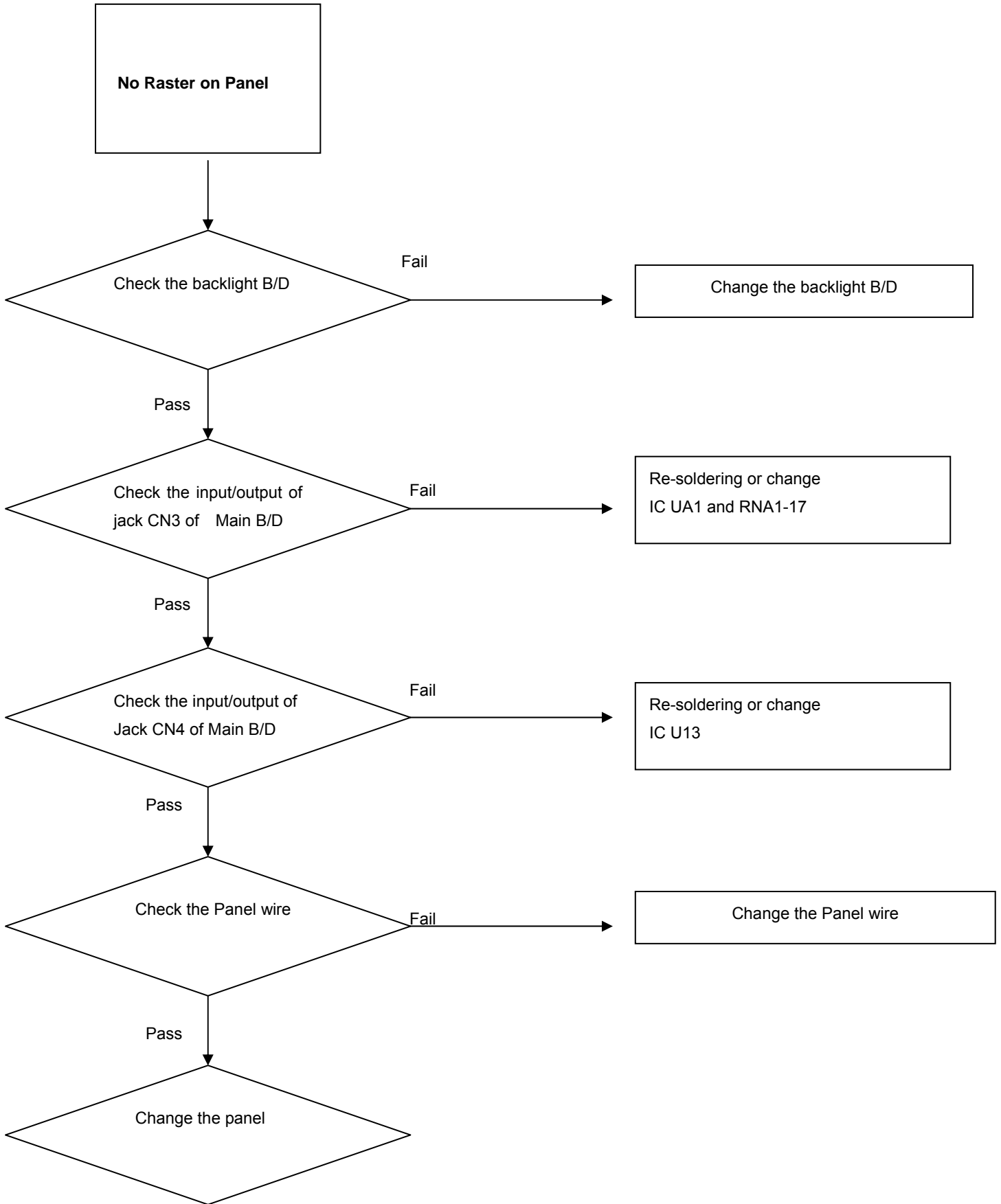

State: No picture



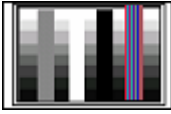
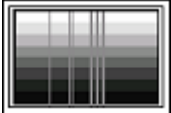
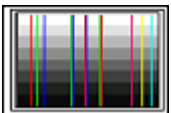

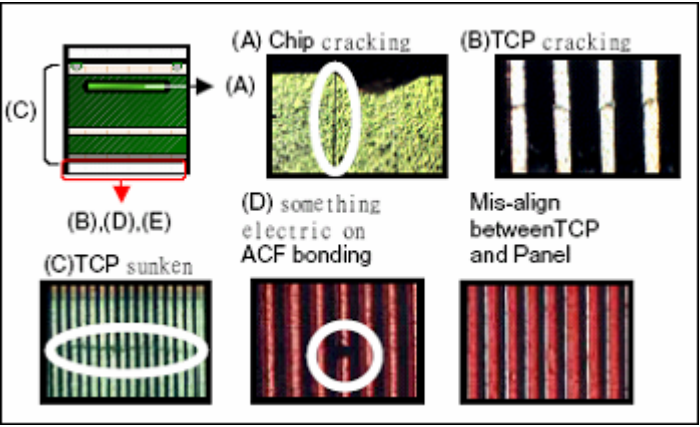

9-4. Pannel failure

Failure Mode





Part	Name	Description	Phenomena	Failure cause
TCP	V B/D	Vertical bar		Block Defect :TCP cracking or cracking Dim or L/D :TCP Sunken :TCP lead cracking :ACF bonding short :Awful environment and something electric enter into LCD :Mis-align between TCP and Panel :Panel failure :TCP failure
	V Dim	Vertical gray line		
	V L/D	Vertical color line(light or dark forever)		
	H B/D	Horizontal bar		
	H Dim	Horizontal gary line		
	H L/D	Horizontal line(light or dark forever)		
				

Failure Mode

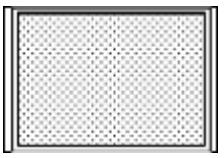

Part	Name	Description	Phenomena	Failure cause
Panel or Polarizer	Dot Defect	Bright dot dark dot in pannel		Incoming Inspection Standard
	Polarizer Bubble	Bladder in Polarizer		Bladder between Polarizer and top glass
	Polarizer Scratch	Polarizer Scratch		Tine or rigidity arose
	F/M inside Polarizer	Eyewinker inside Polarizer		Eyewinker inside Polarizer
Circuit	Abnormal Display	Abnormal Display		1. Chip lose action 2. IC ahort or jointiog bad

	Flashing	Bright and dark display alternately		3. Panel and vsc connect bad
--	----------	-------------------------------------	---	------------------------------

Failure Mode



Part	Name	Description	Phenomena	Failure cause
Circuit	White Screen	B/L normal, only white screen display		Maybe caused by surge current and EDS
	Black Screen	B/L normal, only Black screen display		
	Flicker	Crosstalk		LCD Vcom imbalance
	Abnormal Color	Only abnormal color		Capacitance improper bring crosstalk inside LCD panel
	Abnormal Color	Only abnormal color		1. Chip lose action 2. IC short or joint bad 3. Panel and vsc connect bad

Failure Mode

Part	Name	Description	Phenomena	Failure cause
	Mechanical Noise	When turn panel, appear cacophony		Caused by Mechanical noise of backlight unit
	Ripple	Concentric circle		Caused by between mechanism and panel
	B/L off	B/L lose action		*Connect badness between wire and electrode
	B/L dark	B/L brightness darker than normal		*Connect badness Short between wire and electrode
	B/L wire damaged	B/L wire damaged		Operation abnormal or systemic noise

	B/L wire open	Without backlight		Operation abnormal or systemic noise
	B/L shutdown	B/L shutdown in sometime		Short between lamp housing and wire, Because consume power too much
	F/M	F/M in B/L, white, black Rotundity or wirelike		F/M in B/L unit

Failure Mode

Part	Name	Description	Phenomena	Failure cause
Mechanical or B/L	Light leakage	Brightness at bottom of LCM brighter than normal		B/L unit badness
	Uniformity	B/L brightness asymmetric		Sheet in B/L unit is uneven
	Mount hole	Lack screw or screw damage		*Lack screw Screw damage

Sincere Forever