



FCC 47 CFR PART 15 SUBPART E

**CERTIFICATION TEST REPORT
CLASS II PERMISSIVE CHANGE**

FOR

TABLET WITH IEEE 802.11A/B/G/N (MIMO 2X2) AND BLUETOOTH RADIO

MODEL NUMBER: A1474

FCC ID: BCGA1474

REPORT NUMBER: 15U21850-E9V2

ISSUE DATE: DECEMBER 03, 2015

Prepared for
APPLE, INC.
1 INFINITE LOOP
CUPERTINO, CA 95014, U.S.A.

Prepared by
UL VERIFICATION SERVICES INC.
47173 BENICIA STREET
FREMONT, CA 94538, U.S.A.
TEL: (510) 771-1000
FAX: (510) 661-0888



NVLAP LAB CODE 200065-0

Revision History

<u>Rev.</u>	<u>Issue Date</u>	<u>Revisions</u>	<u>Revised By</u>
V1	11/16/2015	Initial Issue	M. Mekuria
V2	12/03/2015	Revised report to address TCB's questions	T. Chu

TABLE OF CONTENTS

1. ATTESTATION OF TEST RESULTS	5
2. TEST METHODOLOGY	6
3. FACILITIES AND ACCREDITATION	6
4. CALIBRATION AND UNCERTAINTY	7
4.1. MEASURING INSTRUMENT CALIBRATION.....	7
4.2. SAMPLE CALCULATION.....	7
4.3. MEASUREMENT UNCERTAINTY	7
5. EQUIPMENT UNDER TEST.....	8
5.1. DESCRIPTION OF EUT.....	8
5.2. DESCRIPTION OF CLASS II PERMISSIVE CHANGE.....	8
5.3. MAXIMUM OUTPUT POWER.....	8
5.4. DESCRIPTION OF AVAILABLE ANTENNAS.....	8
5.5. SOFTWARE AND FIRMWARE	8
5.6. WORST-CASE CONFIGURATION AND MODE.....	9
5.7. DESCRIPTION OF TEST SETUP	10
6. TEST AND MEASUREMENT EQUIPMENT.....	17
7. ON TIME, DUTY CYCLE AND MEASUREMENT METHODS.....	18
7.1. ON TIME AND DUTY CYCLE.....	18
7.2. MEASUREMENT METHODS.....	21
8. ANTENNA PORT TEST RESULTS.....	22
8.1. 802.11a 1TX MODE IN THE 5.8 GHz BAND.....	22
8.1.1. 6 dB BANDWIDTH	22
8.1.2. 26 dB BANDWIDTH	25
8.1.3. 99% BANDWIDTH.....	28
8.1.4. AVERAGE POWER.....	31
8.1.5. OUTPUT POWER	32
8.1.6. PSD.....	34
8.2. 802.11n HT20 2Tx CDD MODE IN THE 5.8 GHz BAND	37
8.2.1. 6 dB BANDWIDTH	37
8.2.2. 26 dB BANDWIDTH	41
8.2.3. 99% BANDWIDTH.....	45
8.2.4. AVERAGE POWER.....	49
8.2.5. OUTPUT POWER	50
8.2.6. PSD.....	52
8.3. 802.11n HT40 1TX MODE IN THE 5.8 GHz BAND	57
8.3.1. 6 dB BANDWIDTH	57
8.3.2. 26 dB BANDWIDTH	59

8.3.3.	99% BANDWIDTH.....	61
8.3.4.	AVERAGE POWER.....	63
8.3.5.	OUTPUT POWER.....	64
8.3.6.	PSD.....	66
8.4.	<i>802.11n HT40 2Tx CDD MODE IN THE 5.8 GHz BAND</i>	69
8.4.1.	6 dB BANDWIDTH	69
8.4.2.	26 dB BANDWIDTH	72
8.4.3.	99% BANDWIDTH.....	75
8.4.4.	AVERAGE POWER.....	78
8.4.5.	OUTPUT POWER	79
8.4.6.	PSD.....	81
9.	RADIATED TEST RESULTS	85
9.1.	<i>LIMITS AND PROCEDURE.....</i>	85
9.2.	<i>802.11a 1Tx MODE IN THE 5.8 GHz BAND.....</i>	86
9.2.1.	CHAIN 0, RESTRICTED BANDEDGE AND HARMONIC SPURIOUS.....	86
9.2.2.	CHAIN 1, RESTRICTED BANDEDGE AND HARMONIC SPURIOUS.....	96
9.3.	<i>802.11n HT20 2Tx CDD MODE IN THE 5.8 GHz BAND</i>	106
9.4.	<i>802.11n HT40 1Tx MODE IN THE 5.8 GHz BAND.....</i>	116
9.4.1.	CHAIN 0, RESTRICTED BANDEDGE AND HARMONIC SPURIOUS.....	116
9.4.2.	CHAIN 1, RESTRICTED BANDEDGE AND HARMONIC SPURIOUS.....	124
9.5.	<i>802.11n HT40 2Tx CDD MODE IN THE 5.8 GHz BAND</i>	132
9.6.	<i>WORST-CASE BELOW 1 GHz</i>	140
9.7.	<i>WORST-CASE ABOVE 18 GHz.....</i>	142
10.	AC POWER LINE CONDUCTED EMISSIONS	146
10.1.	<i>EUT POWERED BY AC ADAPTER.....</i>	147
10.2.	<i>EUT POWERED BY HOST PC VIA USB CABLE</i>	149
11.	SETUP PHOTOS.....	151

1. ATTESTATION OF TEST RESULTS

COMPANY NAME: APPLE, INC.
1 INFINITE LOOP
CUPERTINO, CA 95014, U.S.A.

EUT DESCRIPTION: TABLET WITH IEEE 802.11A/B/G/N (MIMO 2X2) AND BLUETOOTH RADIO

MODEL: A1474

SERIAL NUMBER: DLXL1006FMN8 (Conducted); DLXKW04FFMN4 (Radiated)

DATE TESTED: OCTOBER 04, 2015 – OCTOBER 22, 2015, DECEMBER 03, 2015

APPLICABLE STANDARDS	
STANDARD	TEST RESULTS
CFR 47 Part 15 Subpart E	Pass

UL Verification Services Inc. tested the above equipment in accordance with the requirements set forth in the above standards. All indications of Pass/Fail in this report are opinions expressed by UL Verification Services Inc. based on interpretations and/or observations of test results. Measurement Uncertainties were not taken into account and are published for informational purposes only. The test results show that the equipment tested is capable of demonstrating compliance with the requirements as documented in this report.

Note: The results documented in this report apply only to the tested sample, under the conditions and modes of operation as described herein. This document may not be altered or revised in any way unless done so by UL Verification Services Inc. and all revisions are duly noted in the revisions section. Any alteration of this document not carried out by UL Verification Services Inc. will constitute fraud and shall nullify the document. This report must not be used by the client to claim product certification, approval, or endorsement by NVLAP, NIST, any agency of the Federal Government, or any agency of any government.

Approved & Released For
UL Verification Services Inc. By:

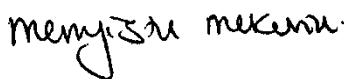

MENGISTU MEKURIA
SENIOR ENGINEER
UL VERIFICATION SERVICES INC.

Tested By:



ERIC YU
EMC LAB ENGINEER
UL VERIFICATION SERVICES INC.

2. TEST METHODOLOGY

The tests documented in this report were performed in accordance with FCC CFR 47 Part 2, FCC CFR 47 Part 15, FCC 14-30, FCC KDB 789033 D02 v01, ANSI C63.10-2013.

3. FACILITIES AND ACCREDITATION

The test sites and measurement facilities used to collect data are located at 47173 and 47266 Benicia Street, Fremont, California, USA. Line conducted emissions are measured only at the 47173 address. The following table identifies which facilities were utilized for radiated emission measurements documented in this report. Specific facilities are also identified in the test results sections.

47173 Benicia Street	47266 Benicia Street
<input type="checkbox"/> Chamber A	<input type="checkbox"/> Chamber D
<input type="checkbox"/> Chamber B	<input checked="" type="checkbox"/> Chamber E
<input type="checkbox"/> Chamber C	<input type="checkbox"/> Chamber F
	<input type="checkbox"/> Chamber G
	<input type="checkbox"/> Chamber H

The above test sites and facilities are covered under FCC Test Firm Registration # 208313. Chambers A through H are covered under Industry Canada company address code 2324B with site numbers 2324B -1 through 2324B-8, respectively.

UL Verification Services Inc. is accredited by NVLAP, Laboratory Code 200065-0. The full scope of accreditation can be viewed at <http://ts.nist.gov/standards/scopes/2000650.htm>.

4. CALIBRATION AND UNCERTAINTY

4.1. MEASURING INSTRUMENT CALIBRATION

The measuring equipment utilized to perform the tests documented in this report has been calibrated in accordance with the manufacturer's recommendations, and is traceable to recognized national standards.

4.2. SAMPLE CALCULATION

Where relevant, the following sample calculation is provided:

$$\begin{aligned} \text{Field Strength (dBuV/m)} &= \text{Measured Voltage (dBuV)} + \text{Antenna Factor (dB/m)} + \text{Cable} \\ &\text{Loss (dB)} - \text{Preamp Gain (dB)} \\ 36.5 \text{ dBuV} + 18.7 \text{ dB/m} + 0.6 \text{ dB} - 26.9 \text{ dB} &= 28.9 \text{ dBuV/m} \end{aligned}$$

4.3. MEASUREMENT UNCERTAINTY

Where relevant, the following measurement uncertainty levels have been estimated for tests performed on the apparatus:

PARAMETER	UNCERTAINTY
Conducted Disturbance, 0.15 to 30 MHz	± 3.52 dB
Radiated Disturbance, 30 to 1000 MHz	± 4.94 dB
Radiated Disturbance, 1 to 6 GHz	± 3.86 dB
Radiated Disturbance, 6 to 18 GHz	± 4.23 dB
Radiated Disturbance, 18 to 26 GHz	± 5.30 dB
Radiated Disturbance, 26 to 40 GHz	± 5.23 dB

Uncertainty figures are valid to a confidence level of 95%.

5. EQUIPMENT UNDER TEST

5.1. DESCRIPTION OF EUT

Tablet with IEEE 802.11a/b/g/n (MIMO 2x2) and Bluetooth radio.

5.2. DESCRIPTION OF CLASS II PERMISSIVE CHANGE

Upgrade EUT to new 5.8GHz band new rule per FCC KDB 789033 D02, v01.

5.3. MAXIMUM OUTPUT POWER

The transmitter has a maximum conducted output power as follows:

Frequency Range (MHz)	Mode	Output Power (dBm)	Output Power (mW)
5745 - 5825	802.11a 1TX	15.96	39.45
5745 - 5825	802.11n HT20 SISO	Covered by 802.11a	
5745 - 5825	802.11a 2TX CDD	Covered by 802.11n HT20 CDD 2TX	
5745 - 5825	802.11n HT20 CDD 2TX	18.98	79.07
5745 - 5825	802.11n HT20 STBC/SDM 2TX	Covered by 802.11n HT20 CDD 2TX	
5755 - 5795	802.11n HT40 SISO	15.97	39.54
5755 - 5795	802.11n HT40 CDD 2TX	18.86	76.91
5755 - 5795	802.11n HT40 STBC/SDM 2TX	Covered by 802.11n HT40 CDD 2TX	

5.4. DESCRIPTION OF AVAILABLE ANTENNAS

Frequency Band (GHz)	Antenna Gain	
	Chain 0	Chain 1
5.8	4.21	3.92

5.5. SOFTWARE AND FIRMWARE

The firmware installed in the EUT during testing was version 6.25 RC55.0.

5.6. WORST-CASE CONFIGURATION AND MODE

The fundamental of the EUT was investigated in three orthogonal orientations X, Y, Z, with AC Adapter and Headset, it was determined that without AC Adapter and Headset was the worst-case and Z orientation was the worst-case orientation for 5.8 GHz band Worst-case.

Data rates as provided by the client were:

802.11a mode: 6 Mbps
802.11n HT20mode: MCS0
802.11n HT40mode: MCS0

Worst-case mode and channel used for 30-1000 MHz radiated and power line conducted emissions was including headset, AC charger and the mode and channel with the highest output power.

For all modes with 1TX, chain 0 was selected per the software provided by the client. Based on the client a preliminary investigation was performed on the two chains and chain 0 was found to be worst-case for the antenna port. However, bandedge and radiated harmonic spurious were tested on both Chain 0 and 1.

5.7. DESCRIPTION OF TEST SETUP

SUPPORT EQUIPMENT

Support Equipment List				
Description	Manufacturer	Model	Serial Number	FCC ID
Laptop	Apple	MacBook Pro	73043BDQAGU	N/A
Laptop AC/DC adapter	Apple	A1172	MV7211FJAX4XA	N/A
Earphone	Apple	NA	NA	N/A
EUT AC/DC adapter	Apple	A1357	W010A051	N/A

I/O CABLES (CONDUCTED TEST)

I/O Cable List						
Cable No	Port	# of identical ports	Connector Type	Cable Type	Cable Length (m)	Remarks
1	Antenna	1	SMA	Un-Shielded	0.2	To spectrum Analyzer
2	USB	1	USB	Shielded	1	N/A
3	AC	1	AC	Un-shielded	3	N/A

I/O CABLES (RADIATED ABOVE 1 GHZ)

I/O Cable List						
Cable No	Port	# of identical ports	Connector Type	Cable Type	Cable Length (m)	Remarks
None Used						

I/O CABLES (RADAITED BELOW 1 GHZ)

I/O Cable List						
Cable No	Port	# of identical	Connector Type	Cable Type	Cable Length (m)	Remarks
1	Headphones Jack	1	3.5mm Audio	Shielded	0.9	N/A
2	AC	1	AC	Un-shielded	3	N/A

I/O CABLES (AC LINE CONDUCTED: AC/DC ADAPTER)

I/O Cable List						
Cable No	Port	# of identical	Connector Type	Cable Type	Cable Length (m)	Remarks
1	Headphones Jack	1	3.5mm Audio	Shielded	0.9	N/A
2	AC	1	AC	Un-shielded	3	N/A

I/O CABLES (AC LINE CONDUCTED: LAPTOP CONFIGUARTION)

I/O Cable List						
Cable No	Port	# of identical	Connector Type	Cable Type	Cable Length (m)	Remarks
1	Headphones Jack	1	3.5mm Audio	Shielded	0.9	N/A
2	USB	1	USB	Shielded	1	N/A
3	AC	1	AC	Un-shielded	3	N/A

TEST SETUP - CONDUCTED TESTS

The EUT was tested connected to a host Laptop via USB cable adapter and spectrum analyzer to antenna port. Test software exercised the EUT.

SETUP DIAGRAM

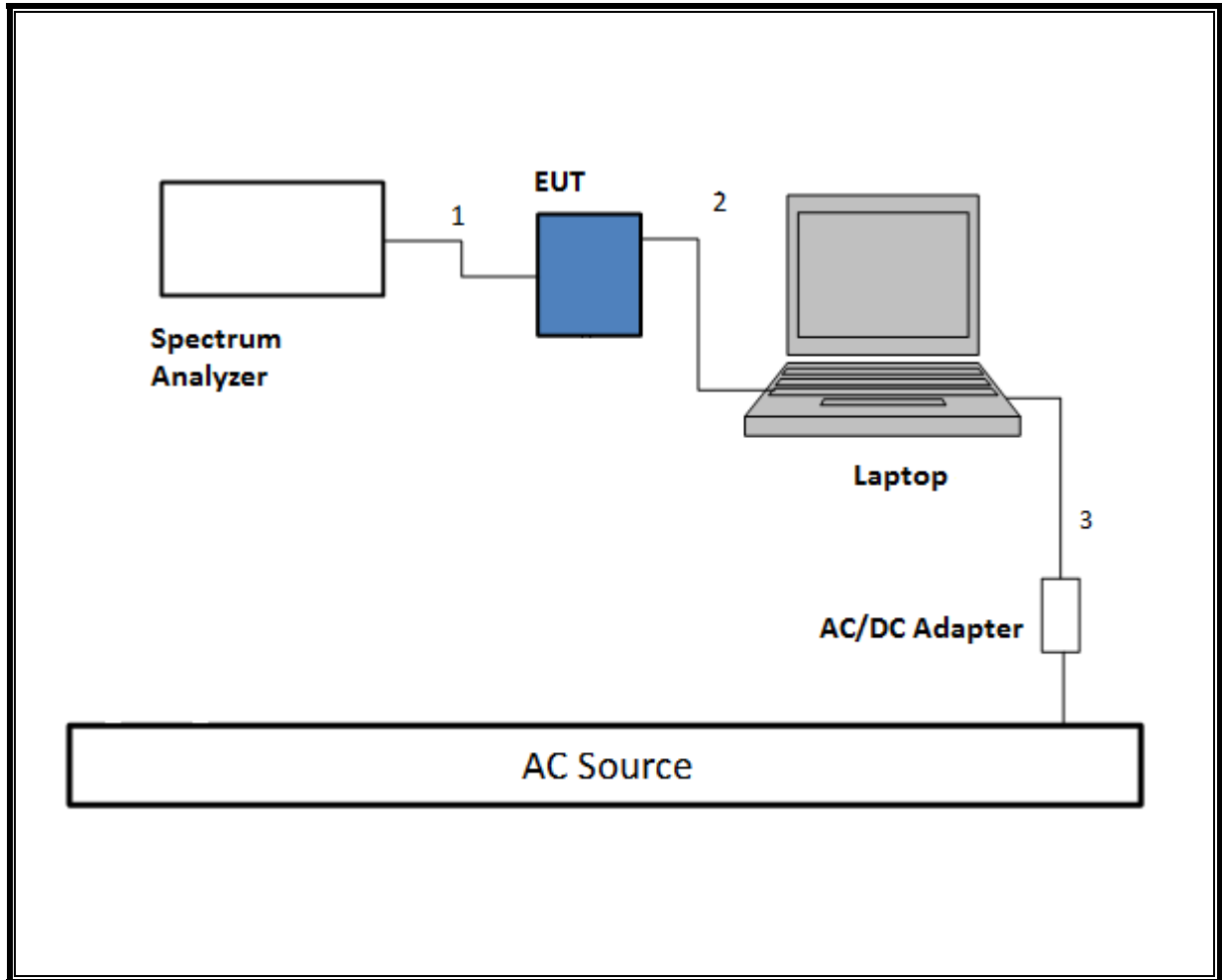

TEST SETUP- RADIATED-ABOVE 1 GHZ

The EUT was tested battery powered. Test software exercised the EUT.

SETUP DIAGRAM

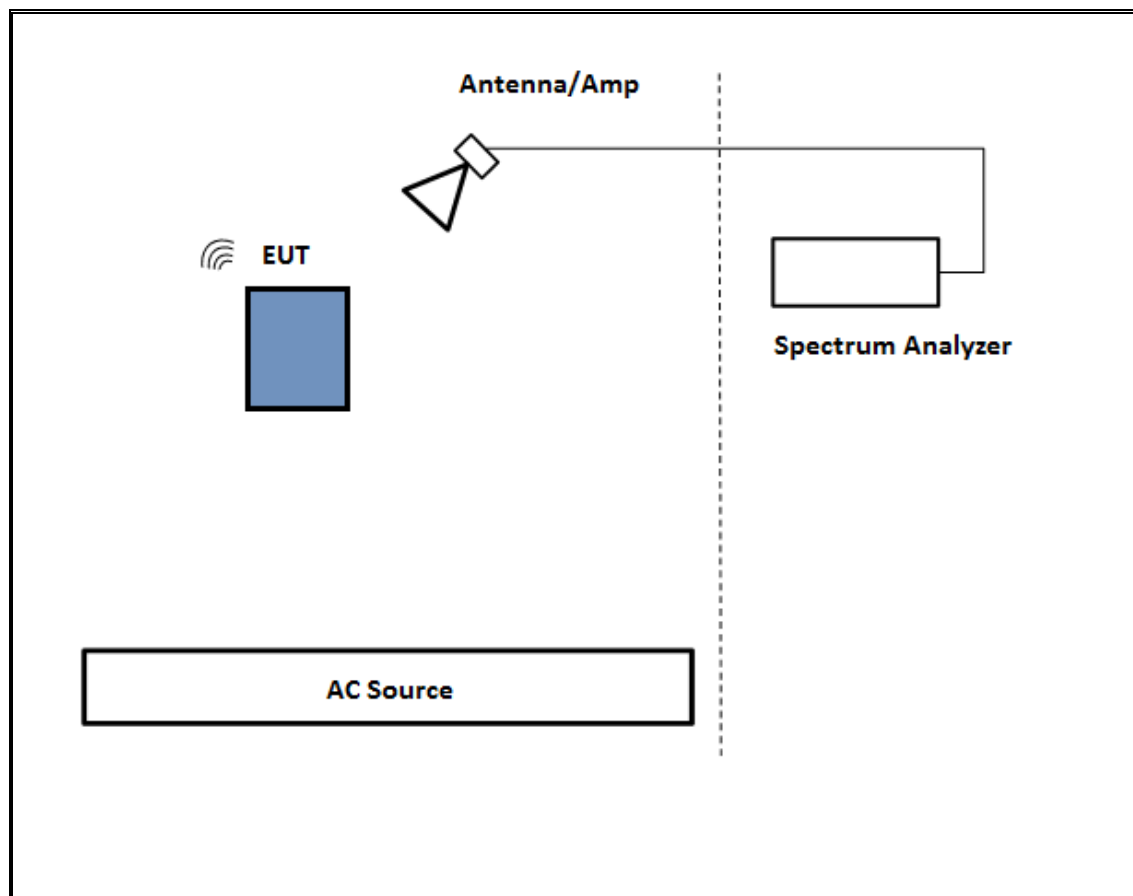

TEST SETUP- BELOW 1GHz

The EUT was tested with earphone connected and powered by AC adapter. Test software exercised the EUT.

SETUP DIAGRAM

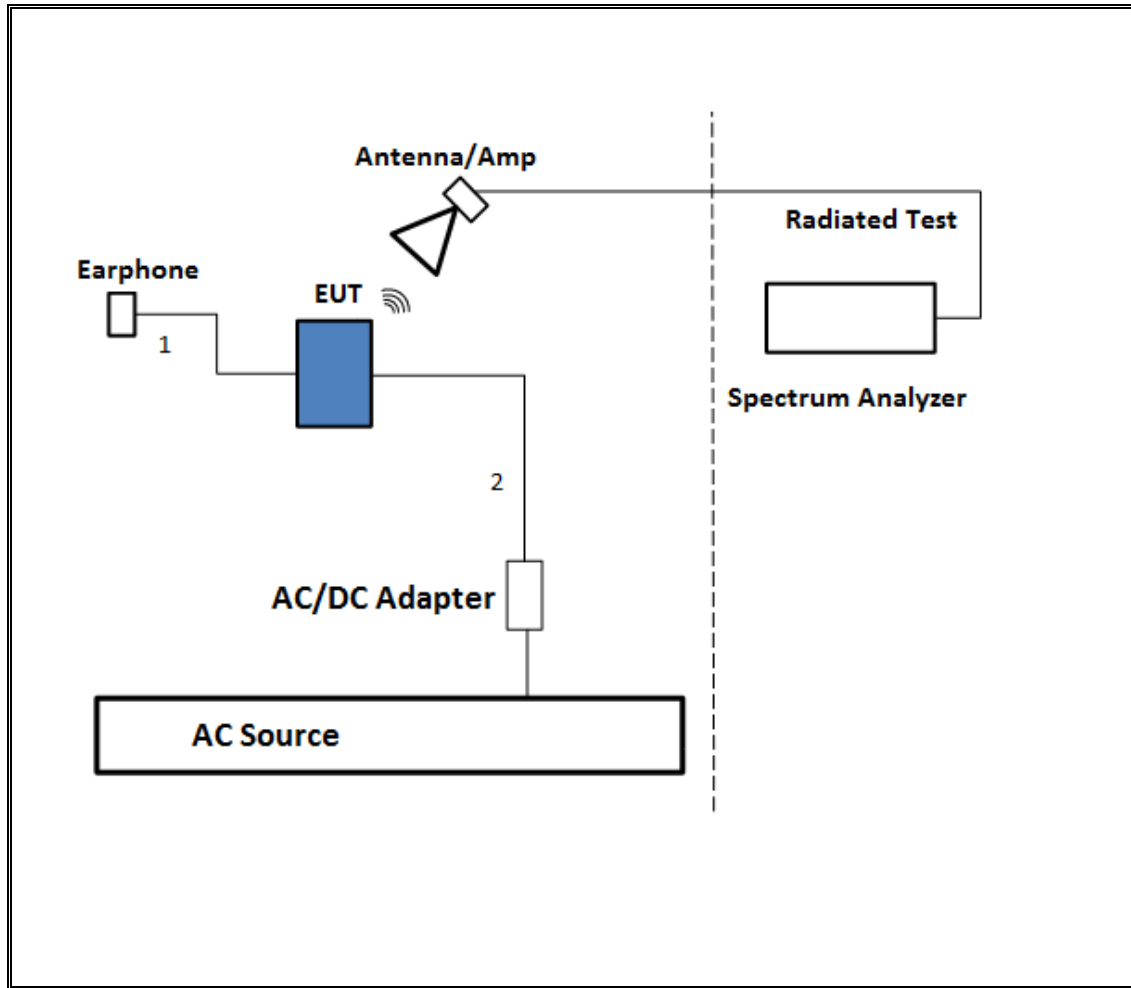

TEST SETUP- AC LINE CONDUCTED: AC/DC ADAPTER

The EUT was tested with earphone connected and powered by AC/DC adapter via USB cable. Test software exercised the EUT.

SETUP DIAGRAM

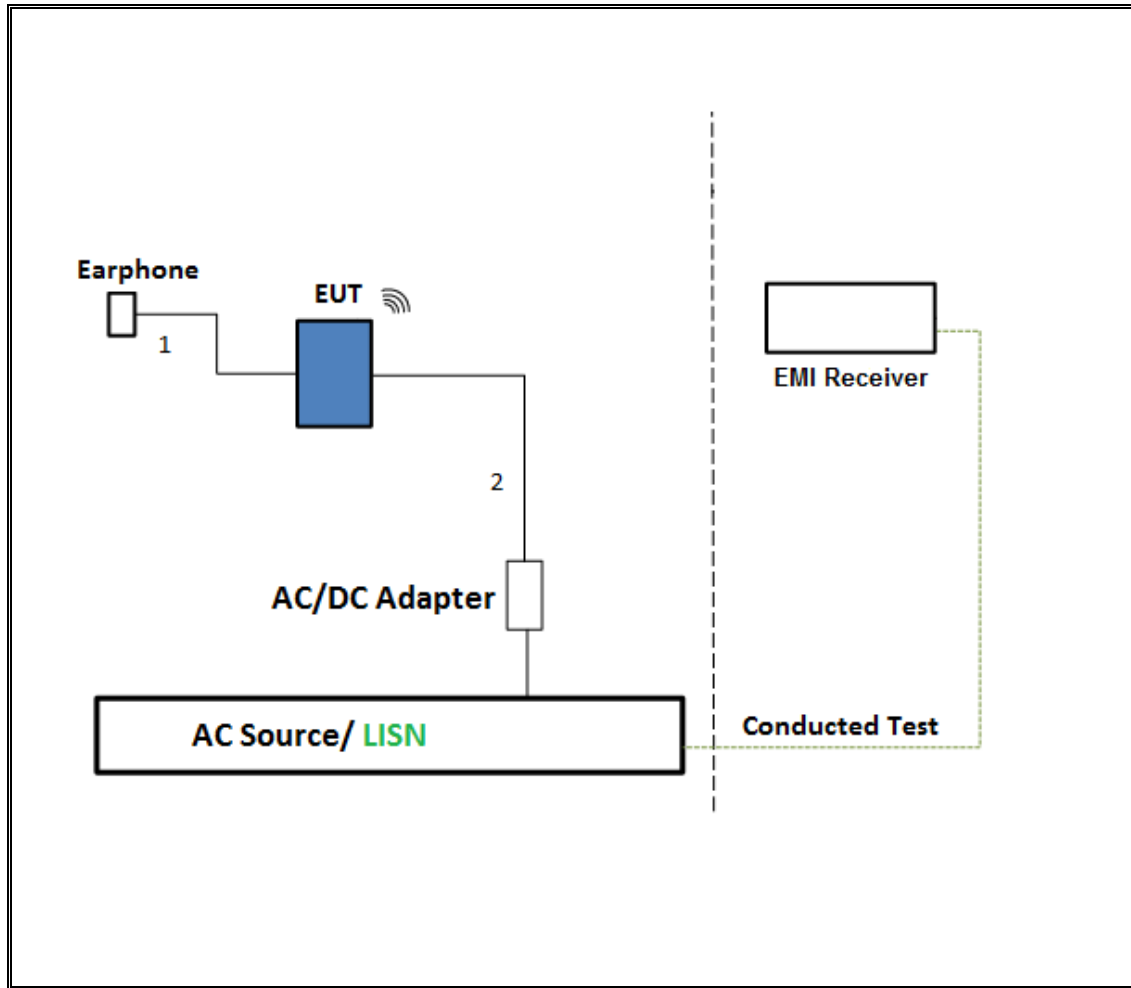

TEST SETUP- AC LINE CONDUCTED: LAPTOP CONFIGURATION

The EUT was tested with earphone connected and powered by host PC via USB cable. Test software exercised the EUT.

SETUP DIAGRAM

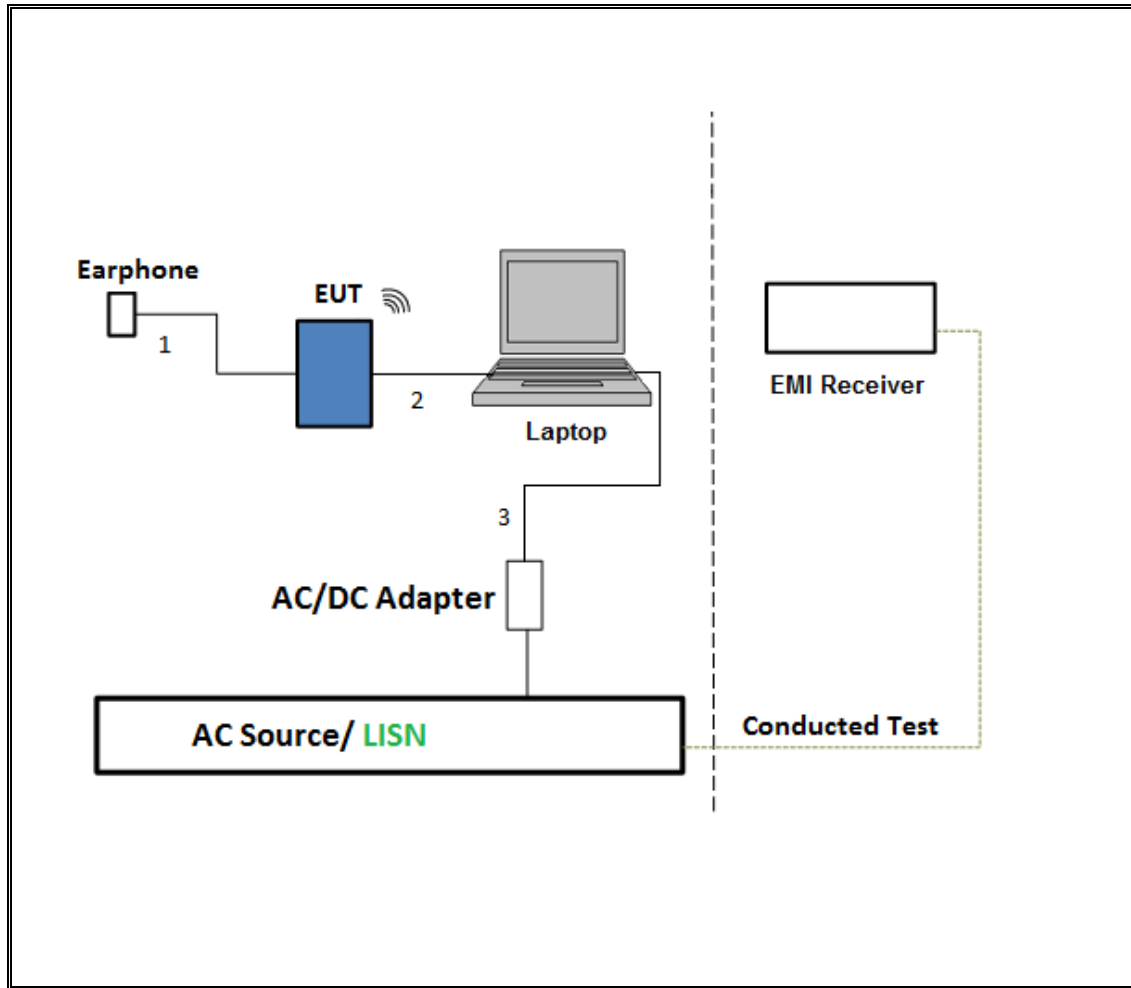

6. TEST AND MEASUREMENT EQUIPMENT

The following test and measurement equipment was utilized for the tests documented in this report:

Test Equipment List				
Description	Manufacturer	Model	Asset	Cal Due
Antenna, Horn 1-18GHz	ETS Lindgren	3117	00143448	2/10/2016
Antenna, Broadband Hybrid, 30MHz to 2000MHz	Sunol Sciences	JB3	A022813-1	1/14/2016
Amplifier, 1 - 18GHz	Miteq	AFS42-00101800-25-S-42	1782158	1/26/2016
Amplifier, 10KHz to 1GHz, 32dB	Sonoma	310N	323561	6/8/2016
Spectrum Analyzer, PXA, 3Hz to 50GHz	Agilent	N9030A	MY52350427	8/4/2016
Amplifier, 10KHz to 1GHz, 32dB	Sonoma	310N	325117	6/9/2016
Spectrum Analyzer, PXA, 3Hz to 44GHz	Agilent	N9030A-544	US51160264	12/23/2015
Power Meter, P-series single channel	Agilent	N1911A	GB45100212	10/9/2015
Power Sensor, P - series, 50MHz to 18GHz, Wideband	Agilent	N1921A	MY53260010	7/12/2016
Antenna, Horn 18 to 26.5GHz	ARA	MWH-1826	1049	12/17/2015
Horn Antenna, 40GHz	ARA	MWH-2640/B	1029	7/15/2016
Spectrum Analyzer, 40 GHz	Agilent	8564E	3943A01643	8/6/2016
Amplifier, 1 to 26.5GHz, 23.5dB Gain minimum	Agilent	8449B	3008A04710	6/29/2016
Amplifier, 26 to 40GHz	Miteq	NSP4000-SP2	88	4/7/2016
AC Line Conducted				
EMI Test Receiver 9KHz-7GHz	Rohde & Schwarz	ESCI7	100773	8/7/2016
LISN for Conducted Emissions CISPR-16	FCC	50/250-25-2	114	1/16/2016
Power Cable, Line Conducted Emissions ANSI 63.4	UL	PG1	N/A	7/28/2016
UL SOFTWARE				
*Radiated Software	UL	UL EMC	Ver 9.5, July 22, 2014	
*Conducted Software	UL	UL EMC	Ver 2.2, March 31, 2015	
*AC Line Conducted Software	UL	UL EMC	Ver 9.5, April 3, 2015	

Note: * indicates automation software version used in the compliance certification testing

7. ON TIME, DUTY CYCLE AND MEASUREMENT METHODS

7.1.ON TIME AND DUTY CYCLE

LIMITS

None; for reporting purposes only.

PROCEDURE

KDB 789033 Zero-Span Spectrum Analyzer Method.

RESULTS

Mode	ON Time B (msec)	Period (msec)	Duty Cycle x (linear)	Duty Cycle (%)	Duty Cycle Correction Factor (dB)	1/B Minimum VBW (kHz)
802.11a 1TX	2.064	2.092	0.987	98.66%	0.00	0.010
802.11n HT20 CDD	1.908	1.936	0.986	98.55%	0.00	0.010
802.11n HT40 1TX	0.932	0.948	0.983	98.31%	0.00	0.010
802.11n HT40 2TX CDD	0.932	0.958	0.973	97.29%	0.12	1.073

DUTY CYCLE PLOTS

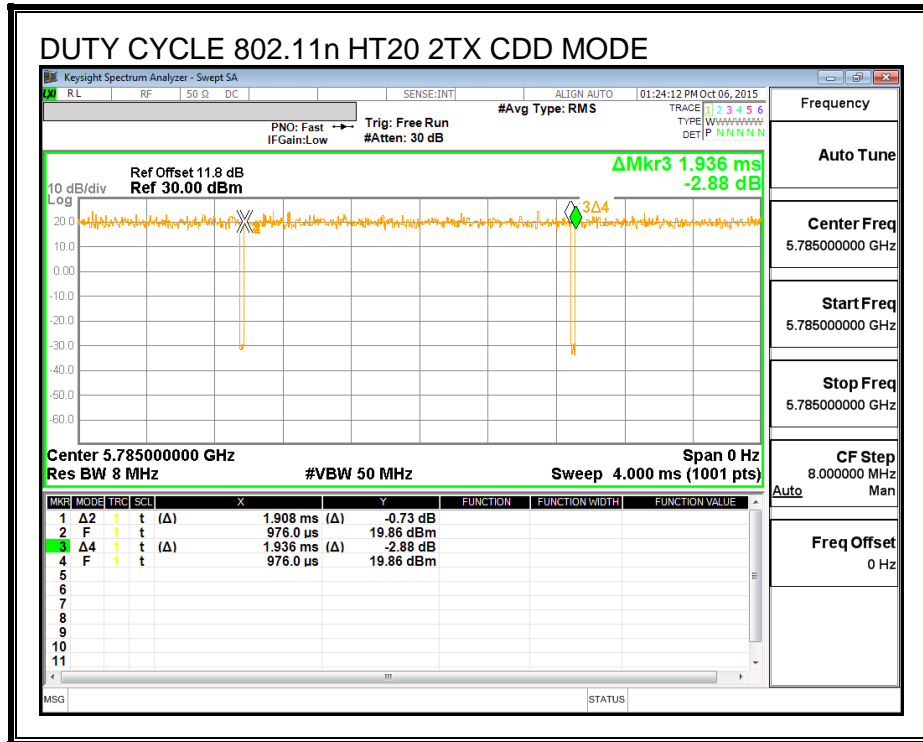
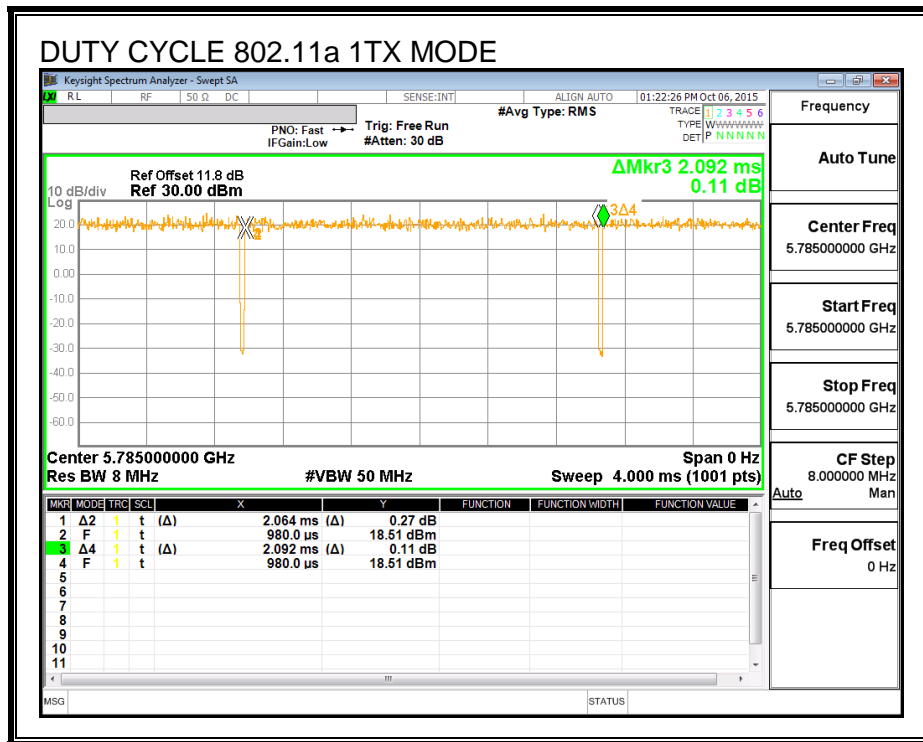

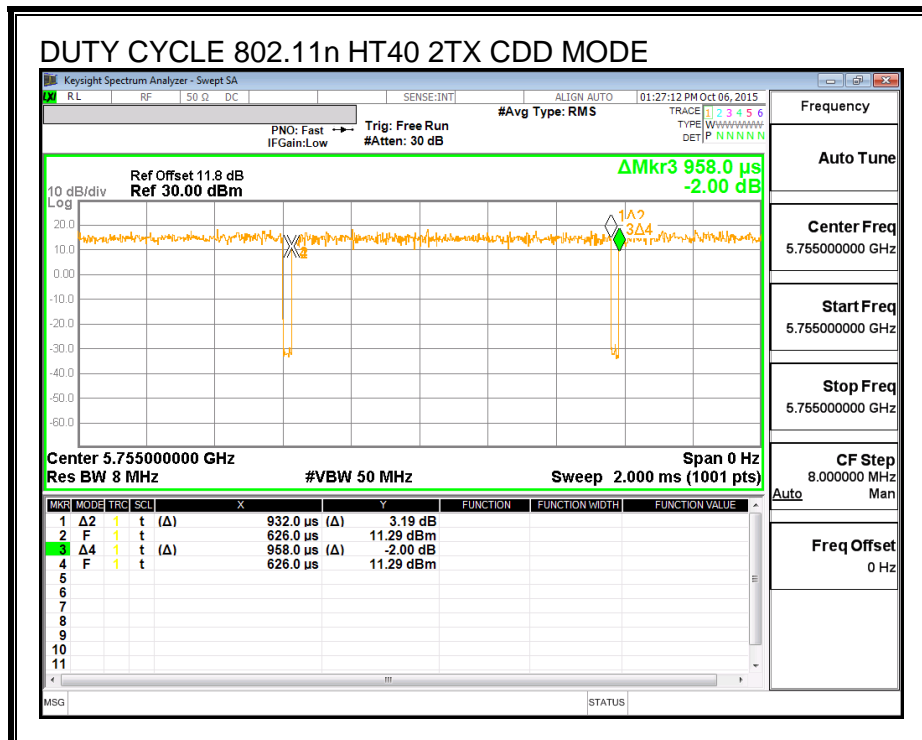
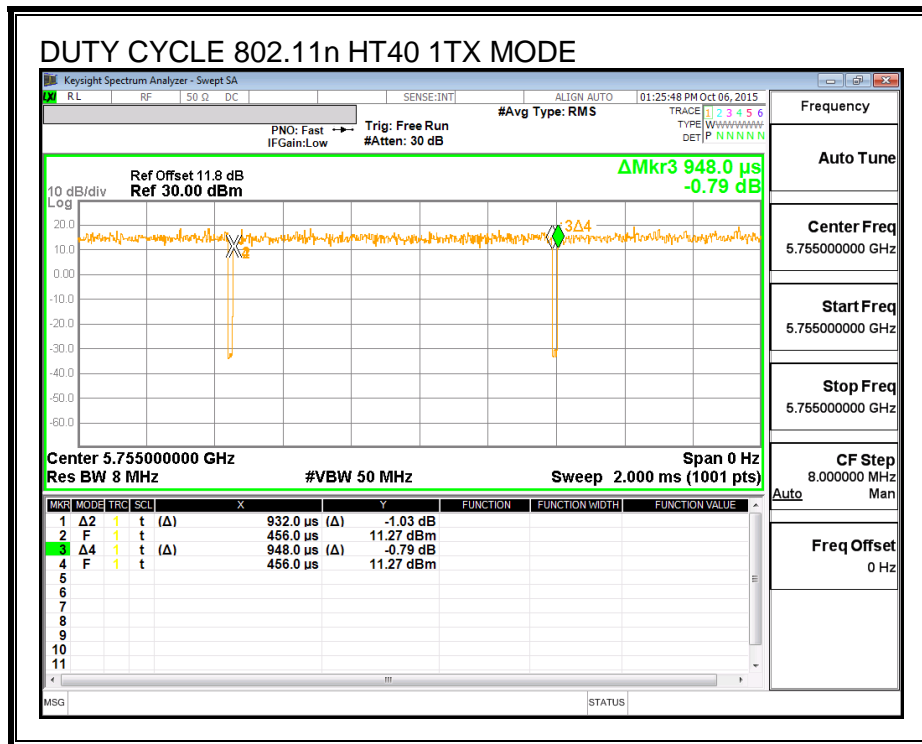

7.2. MEASUREMENT METHODS

26 dB Emission BW & 6 dB Emission BW: KDB 789033 D02 v01, Section C.

99% Occupied BW: KDB 789033 D02 v01, Section D.

Conducted Output Power: KDB 789033 D02 v01, Section E.3.b (Method PM-G).

Power Spectral Density: KDB 789033 D02 v01, Section F.

Unwanted emissions in restricted bands: KDB 789033 D02 v01, Sections G.3, G.4, G.5, and G.6.

Unwanted emissions in non-restricted bands: KDB 789033 D02 v01, Sections G.3, G.4, and G.5.

8. ANTENNA PORT TEST RESULTS

8.1.802.11a 1TX MODE IN THE 5.8 GHz BAND

8.1.1. 6 dB BANDWIDTH

LIMITS

FCC §15.407 (e)

The minimum 6 dB bandwidth shall be at least 500 kHz.

RESULTS

Channel	Frequency (MHz)	6 dB Bandwidth (MHz)	Minimum Limit (MHz)
Low	5745	16.38	0.5
Mid	5785	16.41	0.5
High	5825	16.38	0.5

6 dB BANDWIDTH

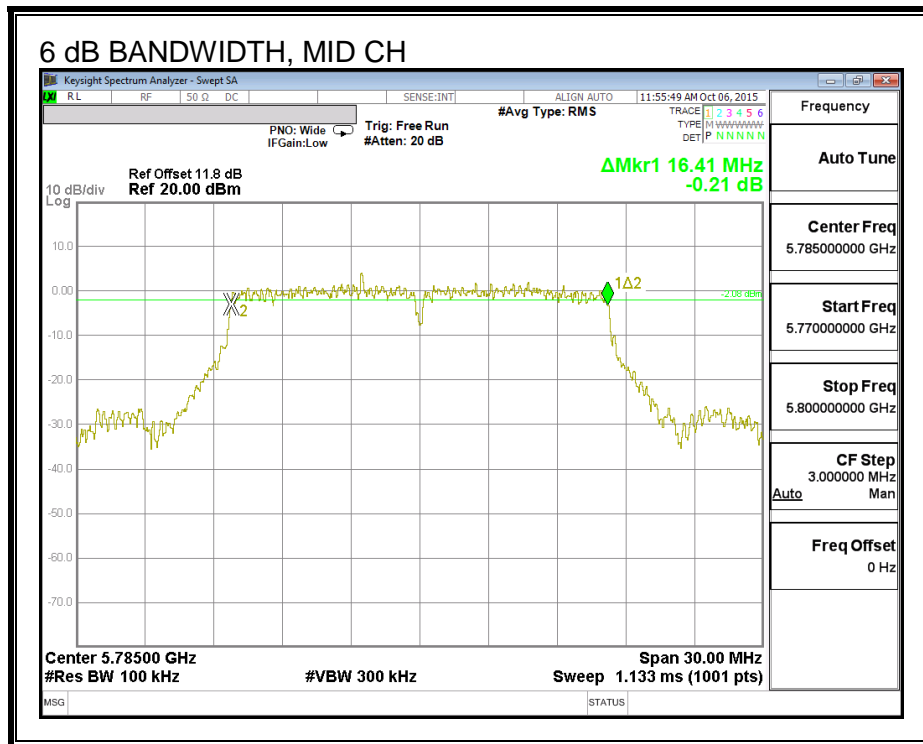
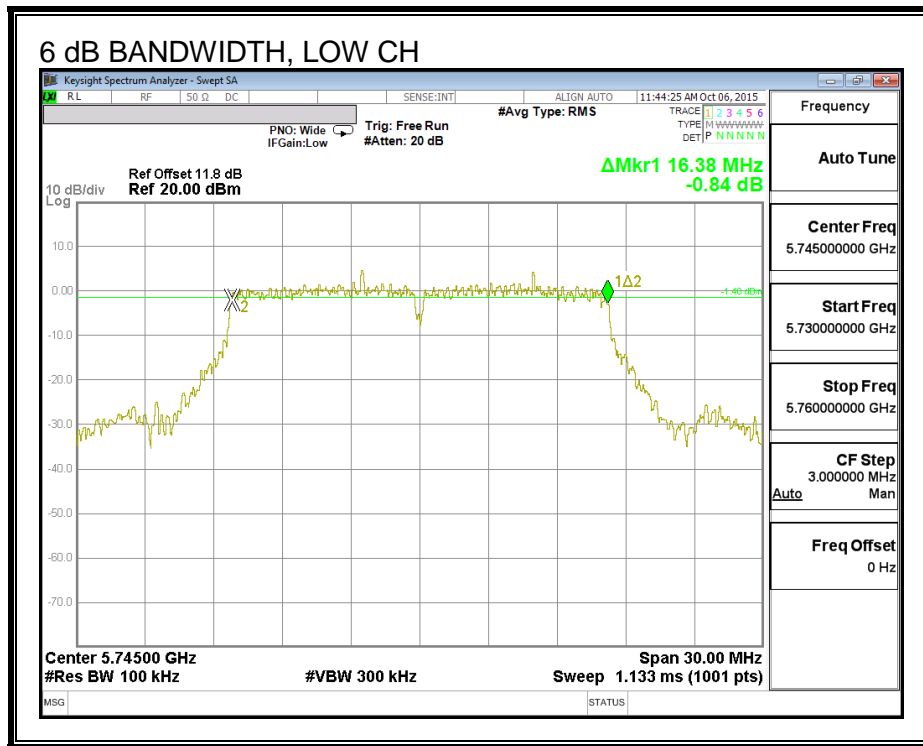

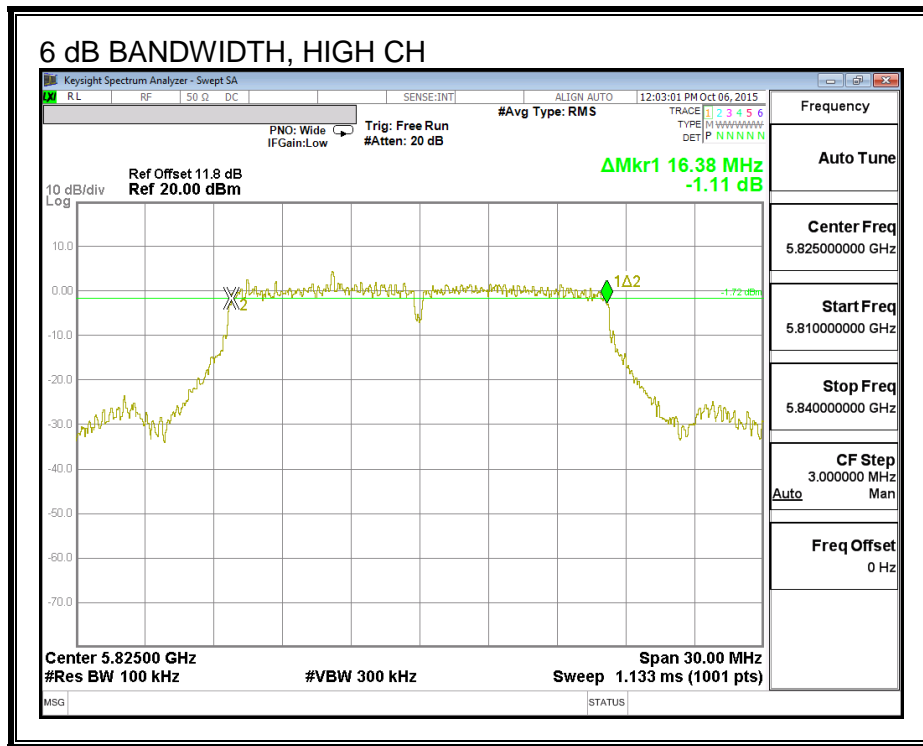

8.1.2. 26 dB BANDWIDTH

LIMITS

None, for reporting purposes only

RESULTS

Channel	Frequency (MHz)	26 dB Bandwidth (MHz)
Low	5745	20.40
Mid	5785	20.31
High	5825	20.37

26 dB BANDWIDTH

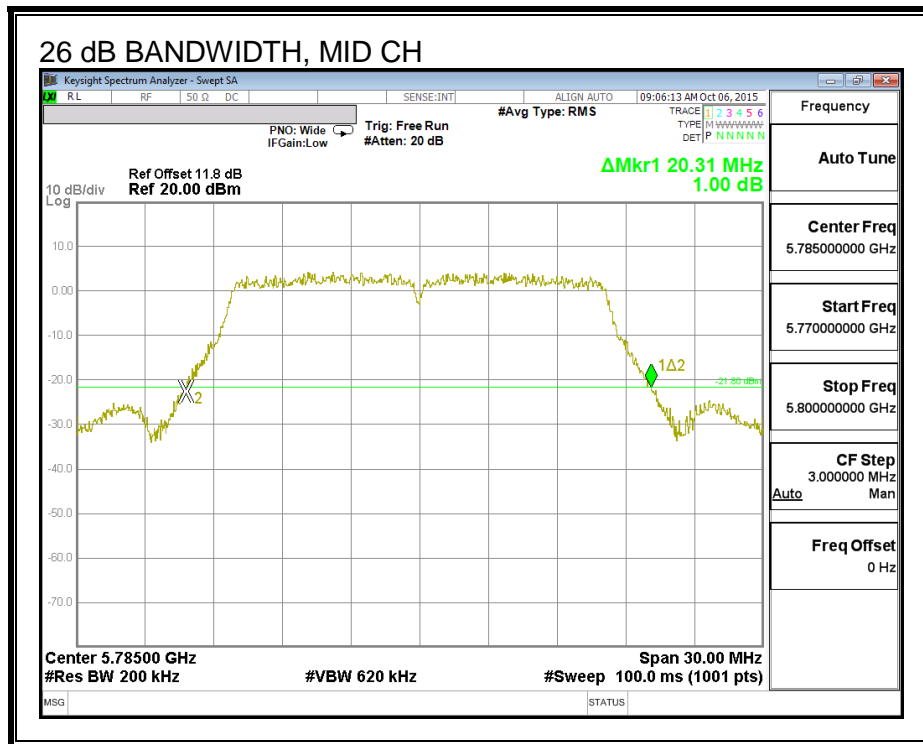
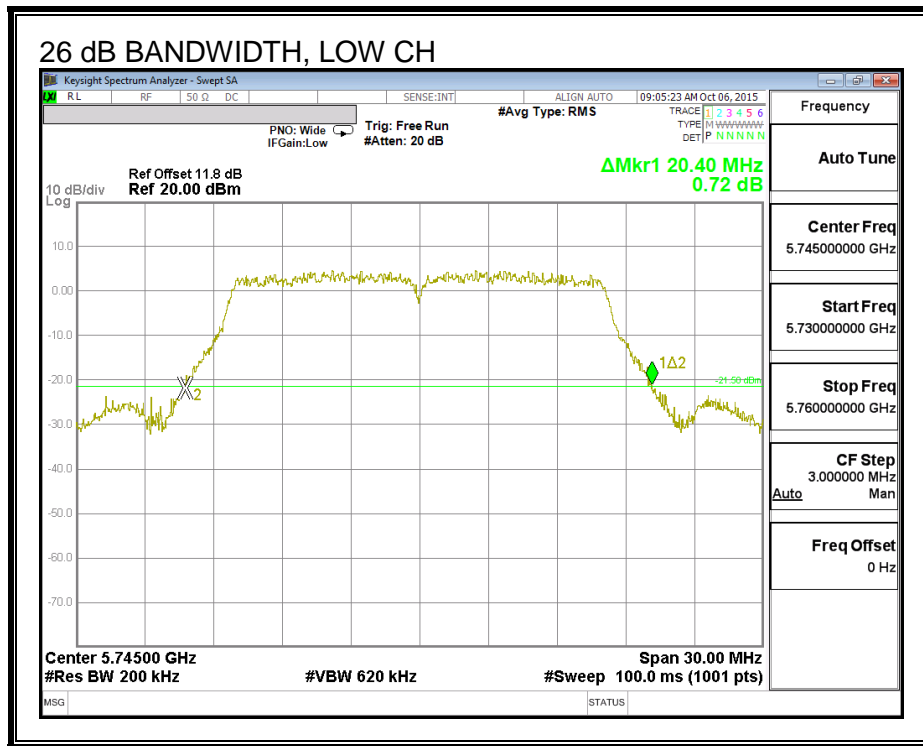

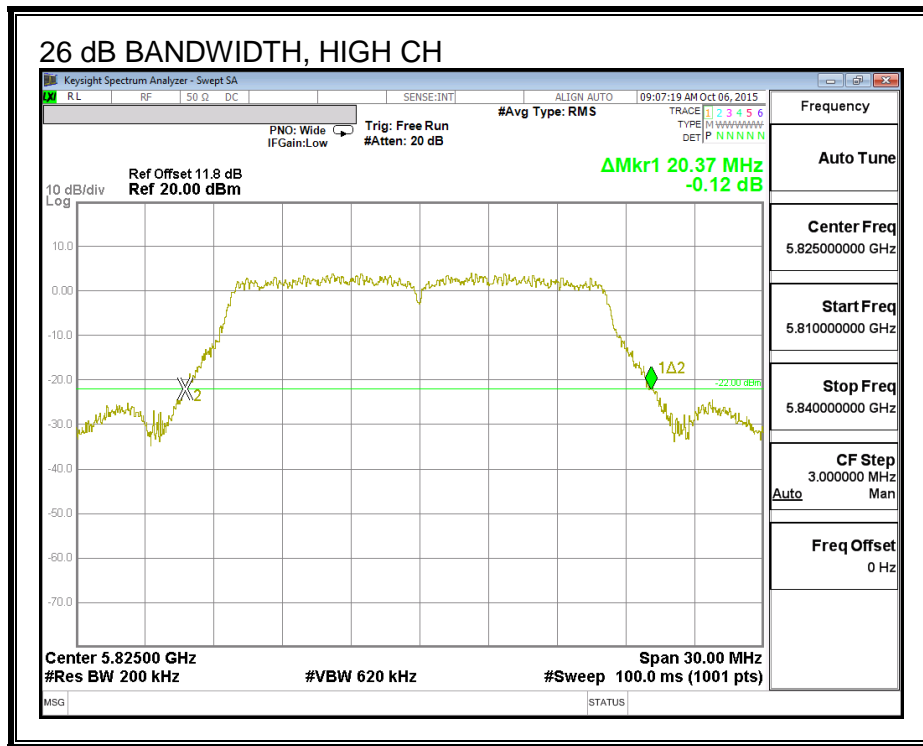

8.1.3. 99% BANDWIDTH

LIMITS

None; for reporting purposes only.

RESULTS

Frequency (MHz)	99% Bandwidth (MHz)
5745	16.395
5785	16.608
5825	16.448

99% BANDWIDTH

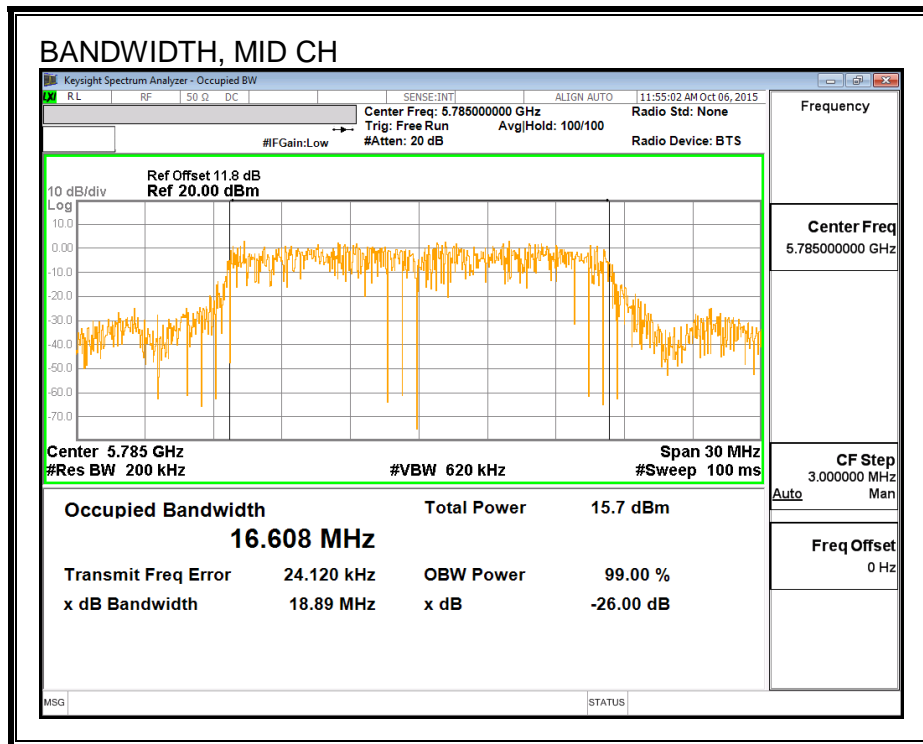
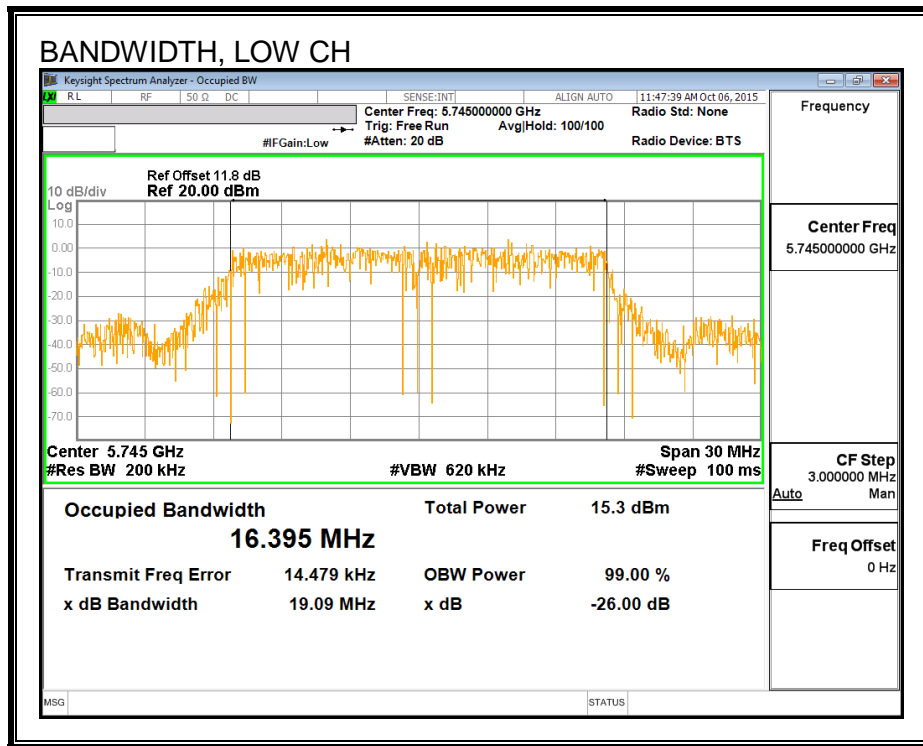

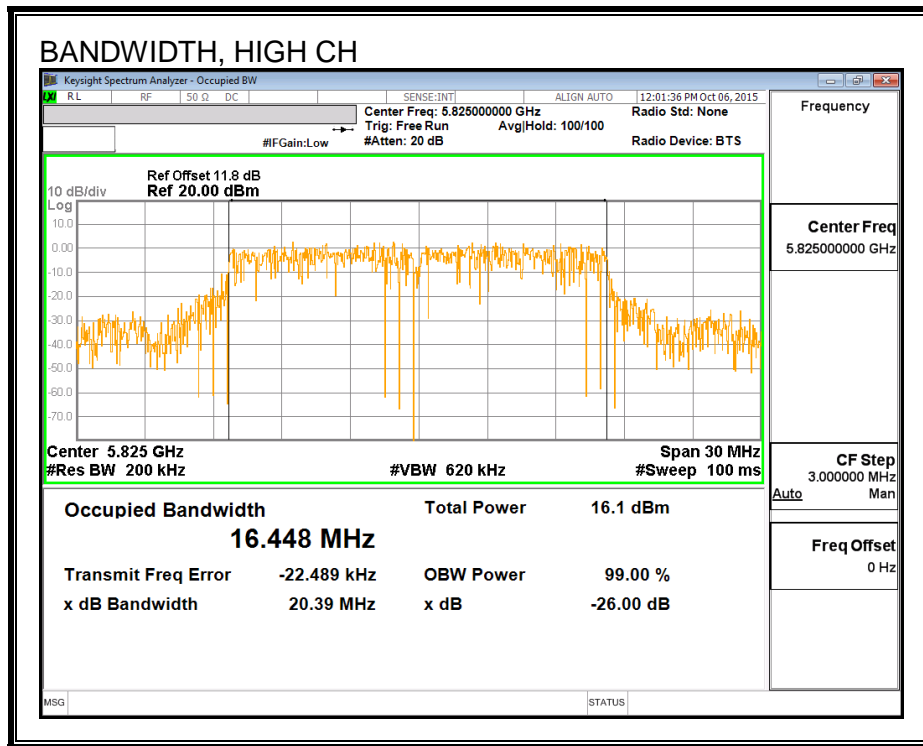

8.1.4. AVERAGE POWER

LIMITS

None; for reporting purposes only.

Test Procedure

Measurements perform using a wideband gated RF power meter.

RESULTS

Channel	Frequency (MHz)	Power (dBm)
Low	5745	14.70
Mid	5785	15.96
High	5825	15.93

8.1.5. OUTPUT POWER

LIMITS

FCC §15.407 (a) (3)

For the band 5.725-5.85 GHz, the maximum conducted output power over the frequency band of operation shall not exceed 1 W. In addition, the maximum power spectral density shall not exceed 30 dBm in any 500-kHz band. If transmitting antennas of directional gain greater than 6 dBi are used, both the maximum conducted output power and the maximum power spectral density shall be reduced by the amount in dB that the directional gain of the antenna exceeds 6 dBi.

Test Procedure

Measurements perform using a wideband gated RF power meter provided that the gate parameters are adjusted such that the power is measured only when the EUT is transmitting at its maximum power control level. Since the measurement is made only during the ON time of the transmitter, no duty cycle correction factor is required.

DIRECTIONAL ANTENNA GAIN

There is only one transmitter output therefore the directional gain is equal to the antenna gain.

RESULTS

Antenna Gain and Limit

Channel	Frequency (MHz)	Directional Gain for Power (dBi)	Power Limit (dBm)
Low	5745	4.21	30.00
Mid	5785	4.21	30.00
High	5825	4.21	30.00

Output Power Results

Channel	Frequency (MHz)	Meas Power (dBm)	Total Corr'd Power (dBm)	Power Limit (dBm)	Power Margin (dB)
Low	5745	14.70	14.70	30.00	-15.30
Mid	5785	15.96	15.96	30.00	-14.04
High	5825	15.93	15.93	30.00	-14.07

8.1.6. PSD

LIMITS

FCC §15.407 (a) (3)

For the band 5.725-5.85 GHz, the maximum conducted output power over the frequency band of operation shall not exceed 1 W. In addition, the maximum power spectral density shall not exceed 30 dBm in any 500-kHz band. If transmitting antennas of directional gain greater than 6 dBi are used, both the maximum conducted output power and the maximum power spectral density shall be reduced by the amount in dB that the directional gain of the antenna exceeds 6 dBi.

DIRECTIONAL ANTENNA GAIN

There is only one transmitter output therefore the directional gain is equal to the antenna gain.

RESULTS

Antenna Gain and Limits

Channel	Frequency (MHz)	Directional Gain (dBi)	PSD Limit (dBm)
Low	5745	4.21	30.00
Mid	5785	4.21	30.00
High	5825	4.21	30.00

Duty Cycle CF (dB)	0.00	Included in Calculations of Corr'd PSD
---------------------------	------	---

PSD Results

Channel	Frequency (MHz)	Meas PSD (dBm)	Total Corr'd PSD (dBm)	PSD Limit (dBm)	PSD Margin (dB)
Low	5745	0.90	0.90	30.00	-29.10
Mid	5785	2.26	2.26	30.00	-27.74
High	5825	2.16	2.16	30.00	-27.84

PSD,

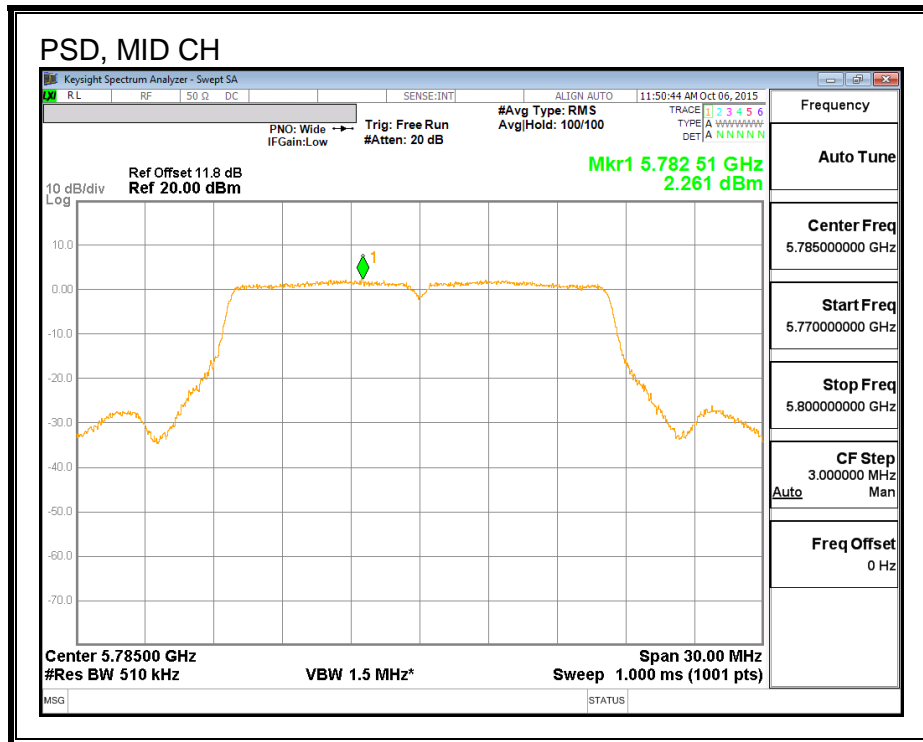
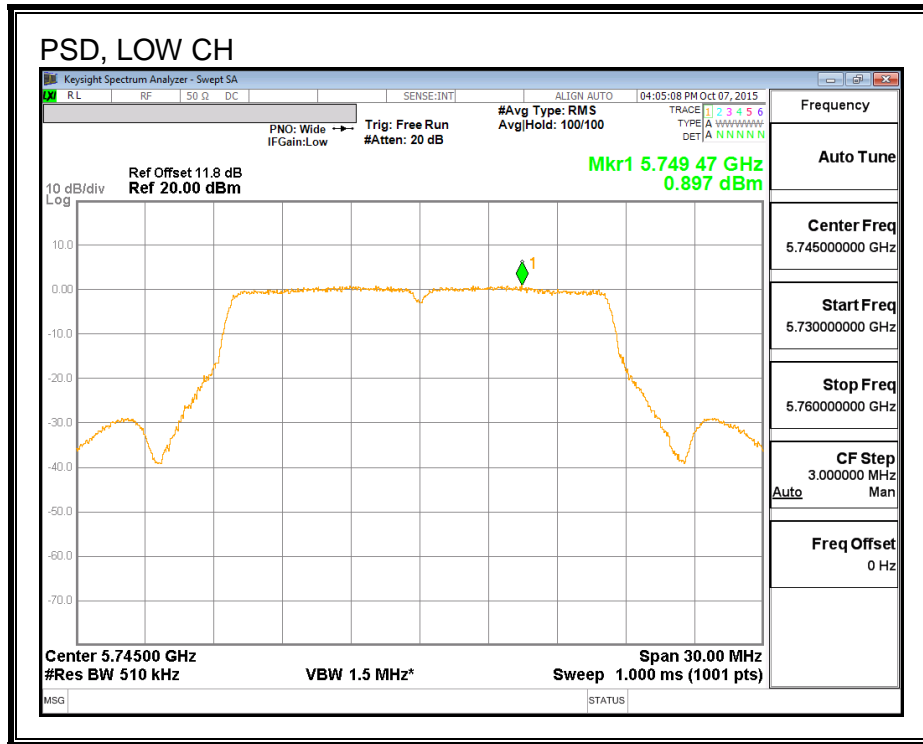

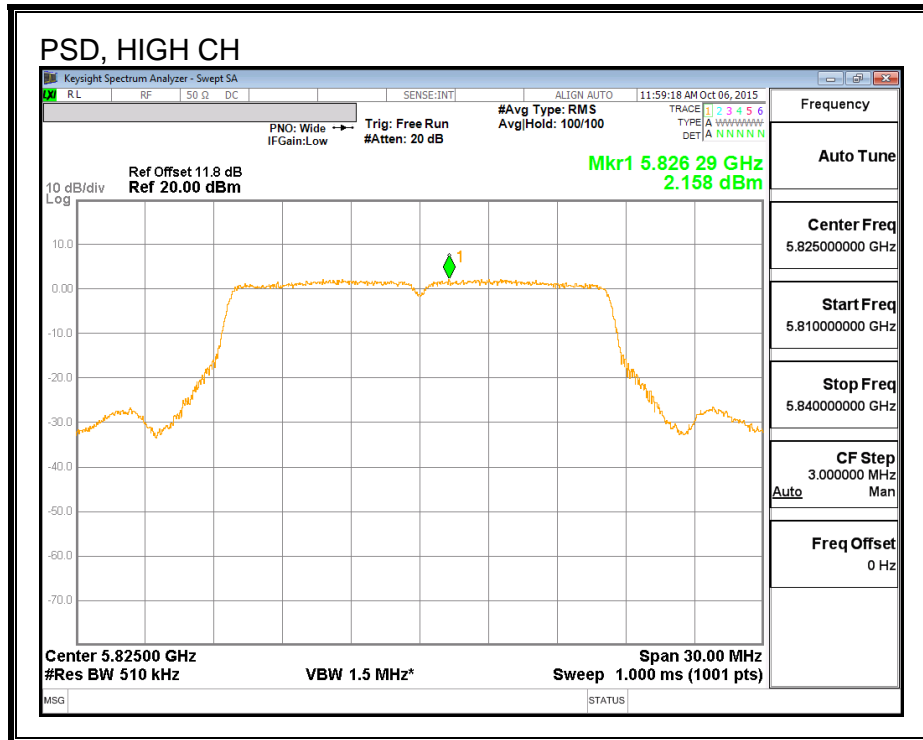

8.2.802.11n HT20 2Tx CDD MODE IN THE 5.8 GHZ BAND

8.2.1. 6 dB BANDWIDTH

LIMITS

FCC §15.407 (e)

The minimum 6 dB bandwidth shall be at least 500 kHz.

RESULTS

Channel	Frequency (MHz)	6 dB BW Chain 0 (MHz)	6 dB BW Chain 1 (MHz)	Minimum Limit (MHz)
Low	5745	17.61	17.61	0.5
Mid	5785	17.61	17.58	0.5
High	5825	17.61	17.61	0.5

6 dB BANDWIDTH, CHAIN 0

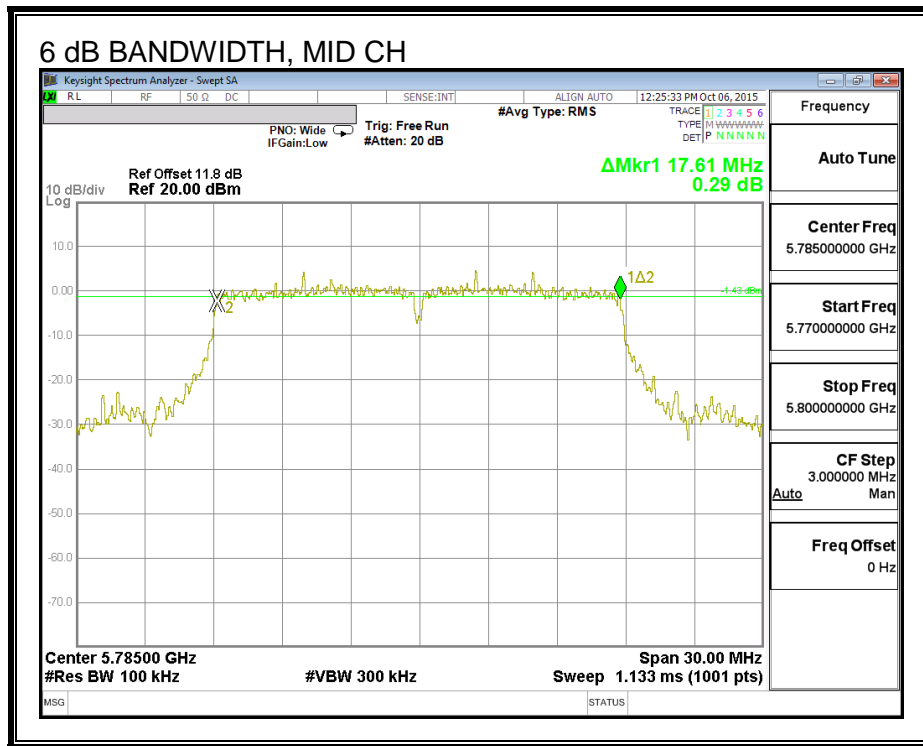
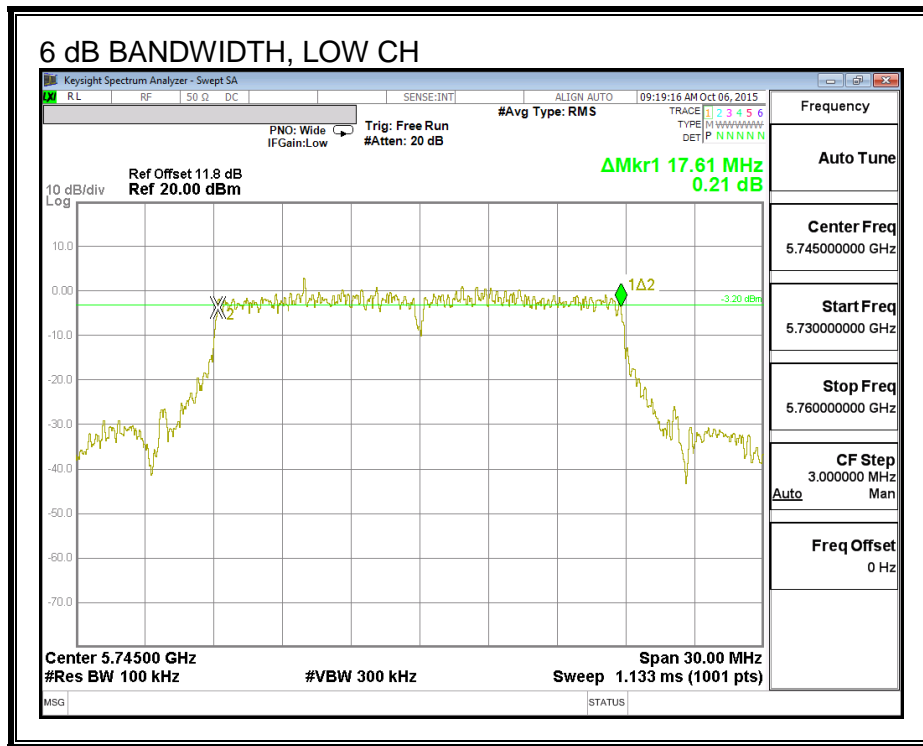

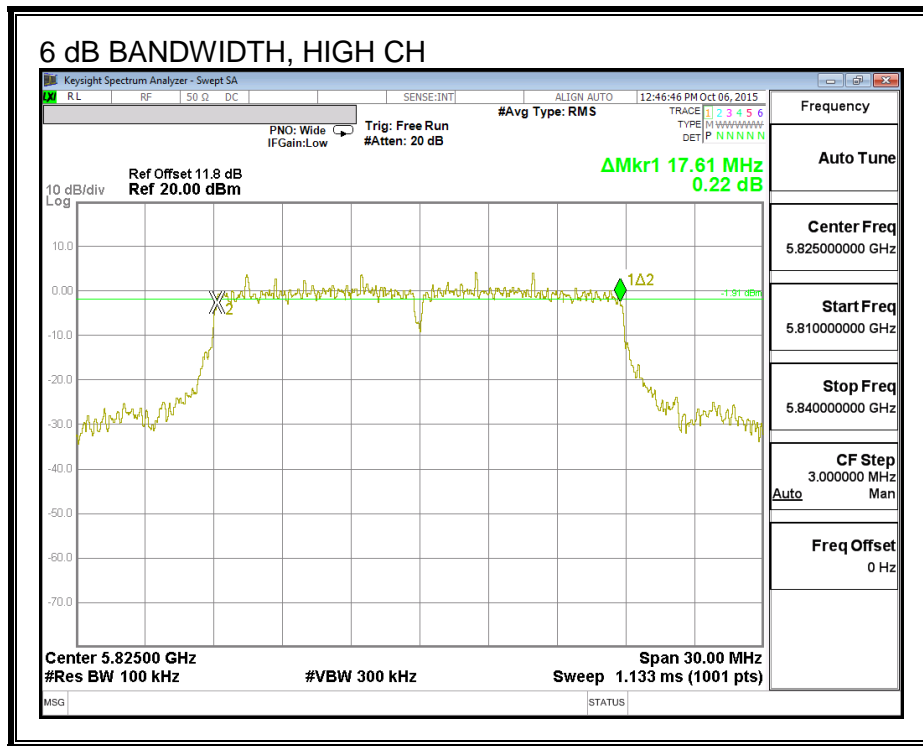

6 dB BANDWIDTH, CHAIN 1

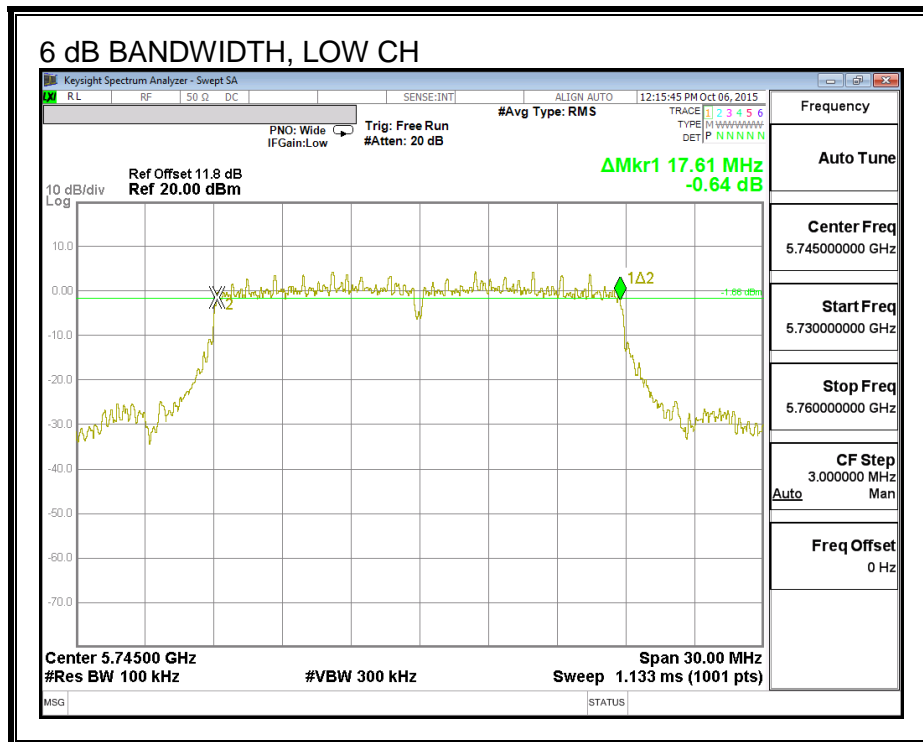

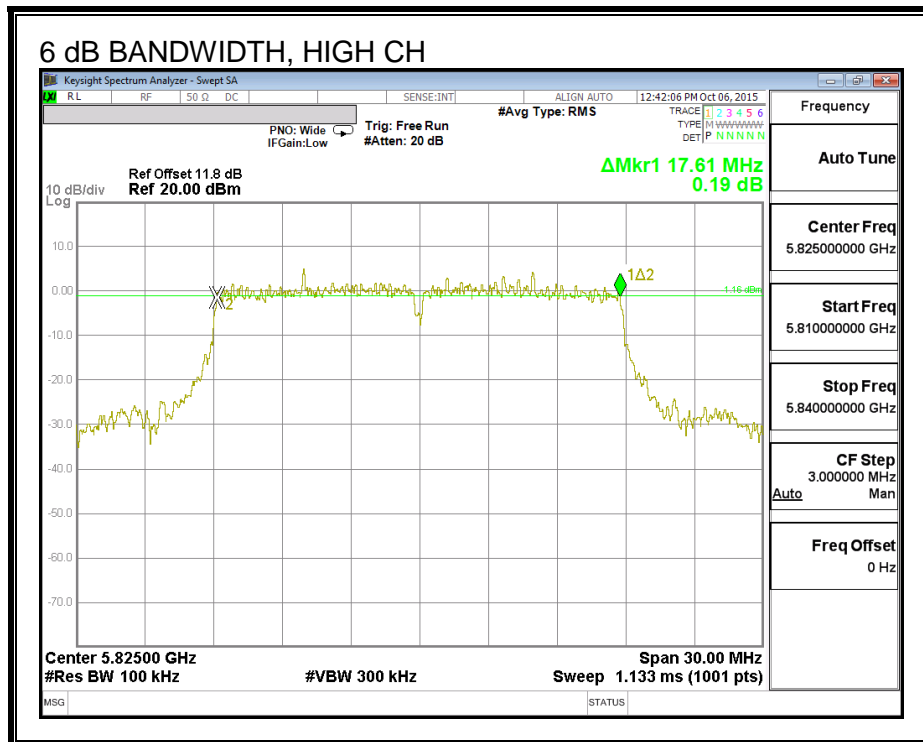
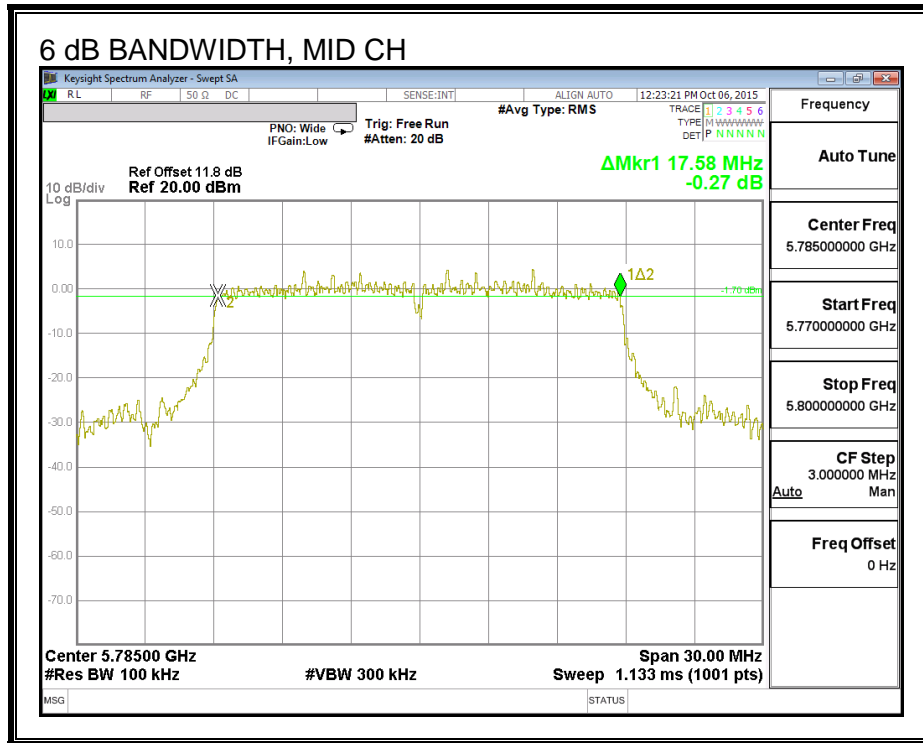

8.2.2. 26 dB BANDWIDTH

LIMITS

None, for reporting purposes only.

RESULTS

Channel	Frequency (MHz)	26 dB BW Chain 0 (MHz)	26 dB BW Chain 1 (MHz)
Low	5745	21.45	20.85
Mid	5785	21.06	20.82
High	5825	20.79	20.85

26 dB BANDWIDTH, CHAIN 0

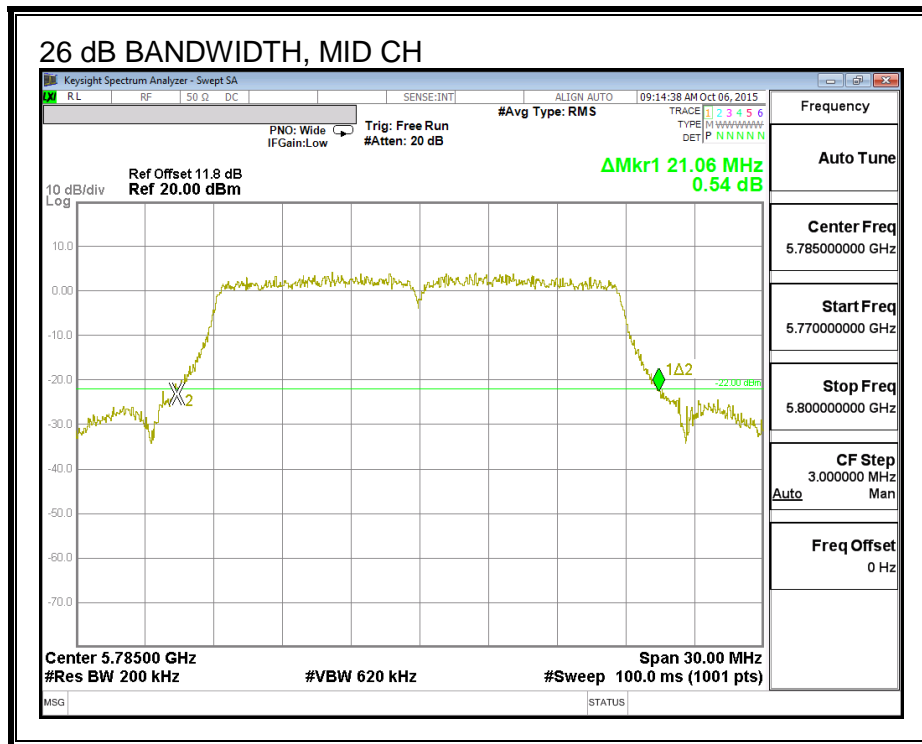
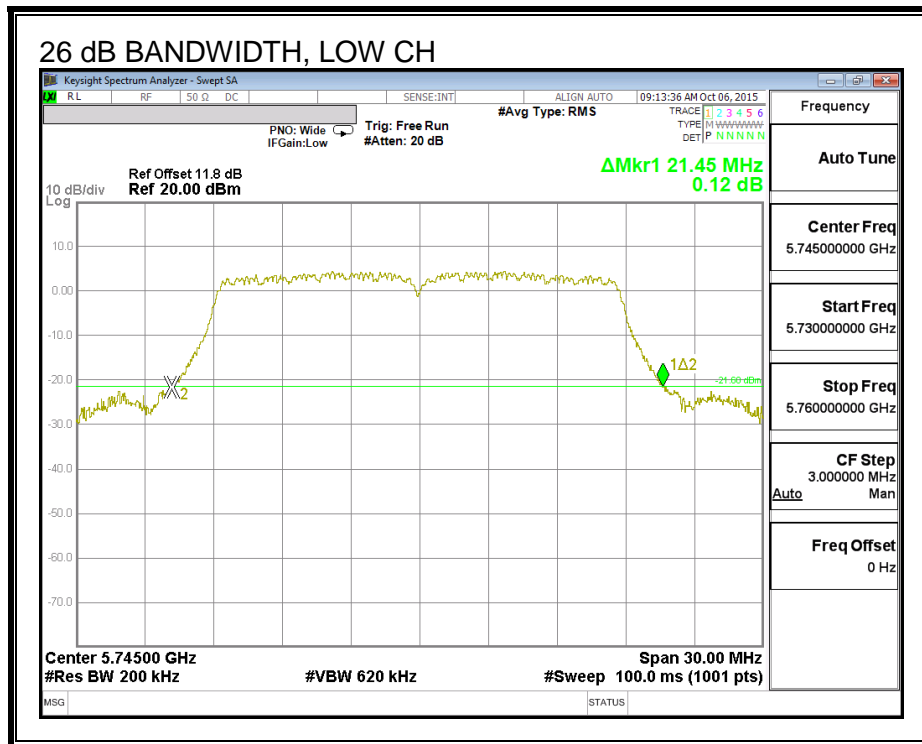

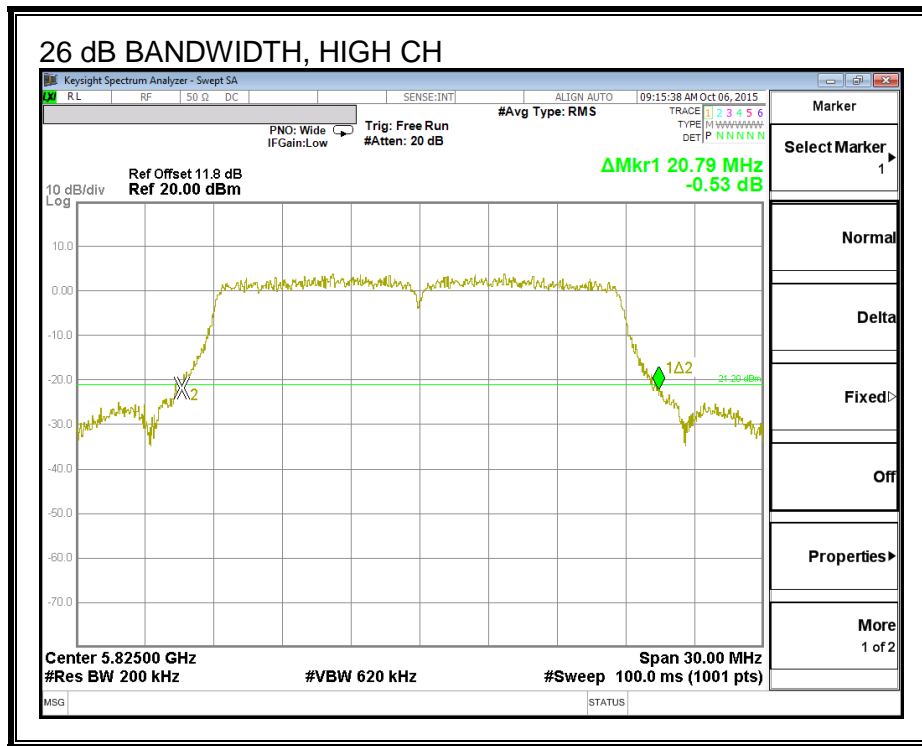

26 dB BANDWIDTH, CHAIN 1

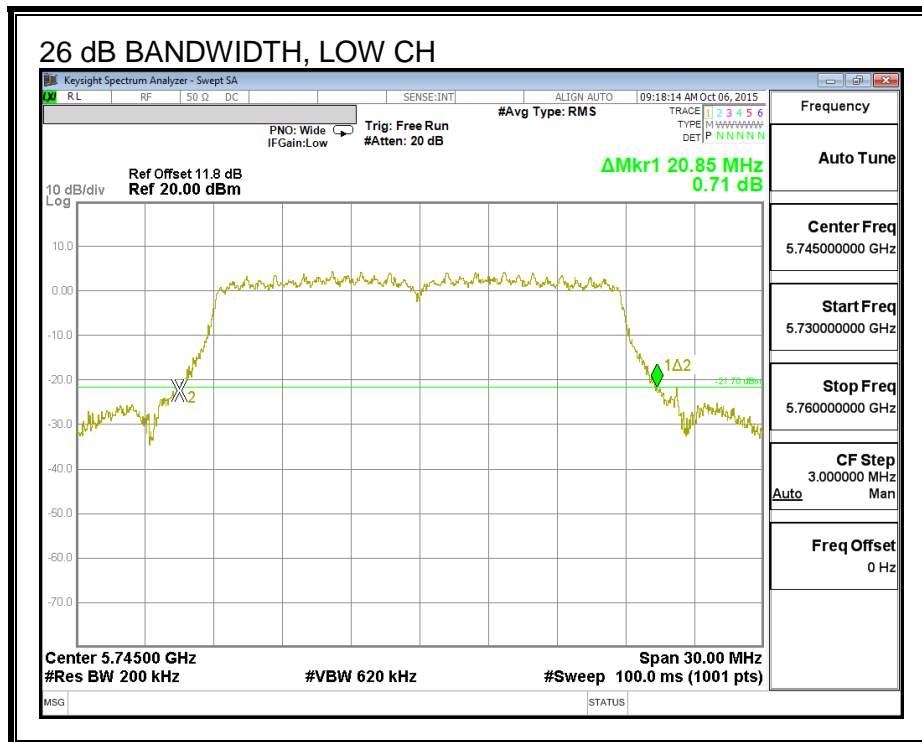

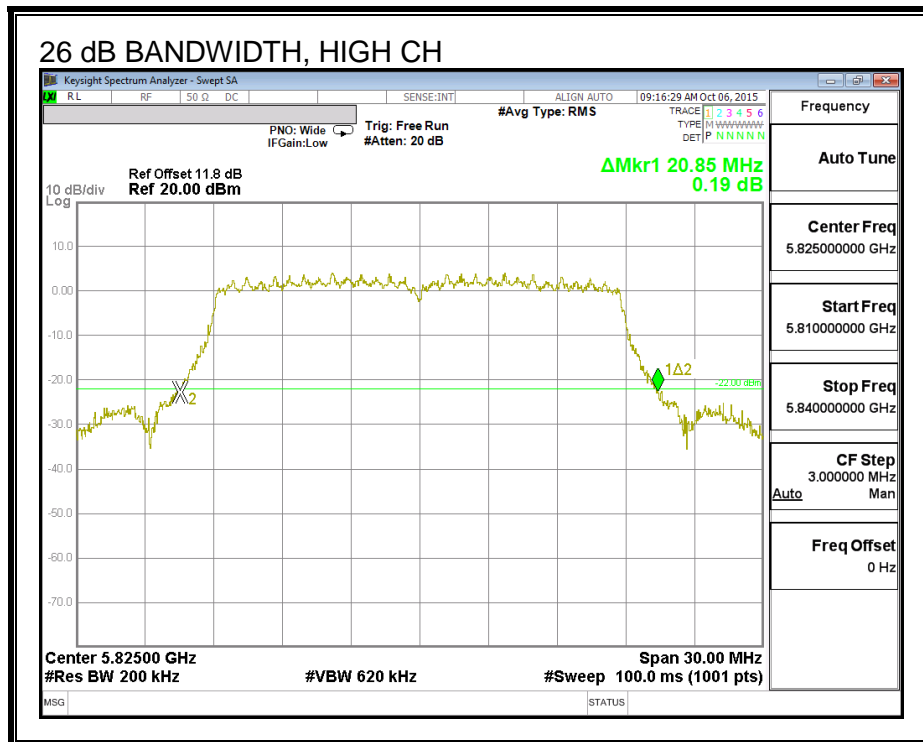
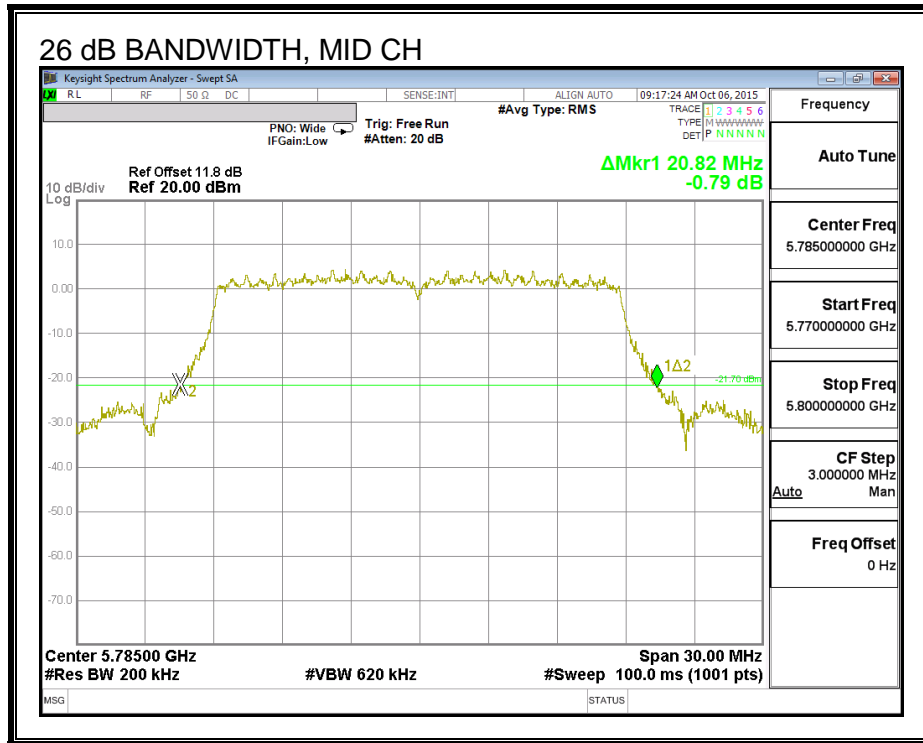

8.2.3. 99% BANDWIDTH

LIMITS

None; for reporting purposes only.

RESULTS

Channel	Frequency (MHz)	99% BW Chain 0 (MHz)	99% BW Chain 1 (MHz)
Low	5745	17.645	17.648
Mid	5785	17.665	17.679
High	5825	17.609	17.673

99% BANDWIDTH, CHAIN 0

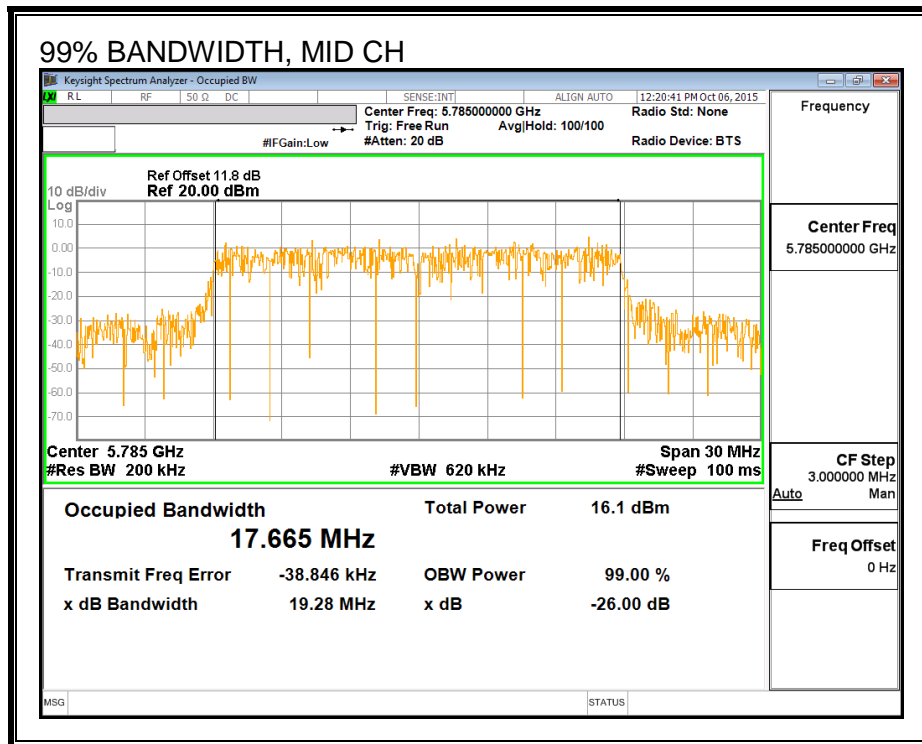
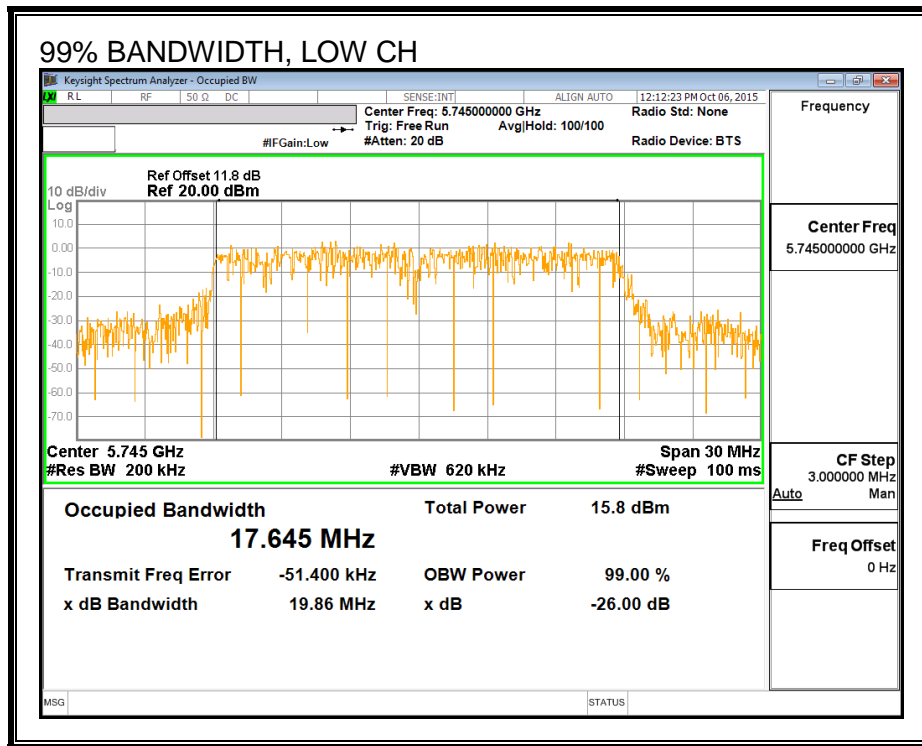

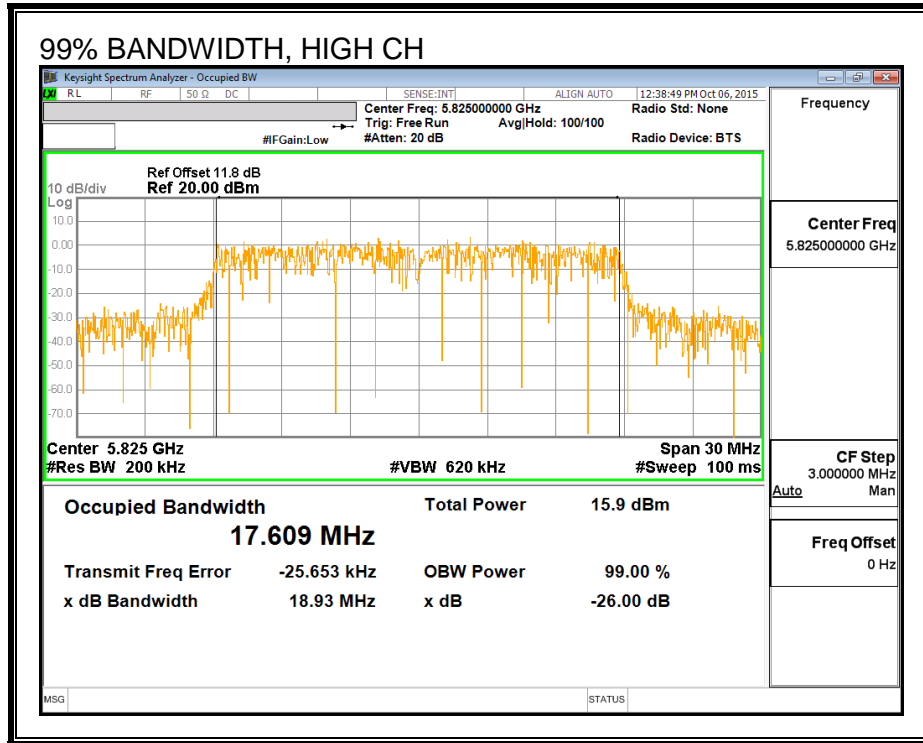

99% BANDWIDTH, CHAIN 1

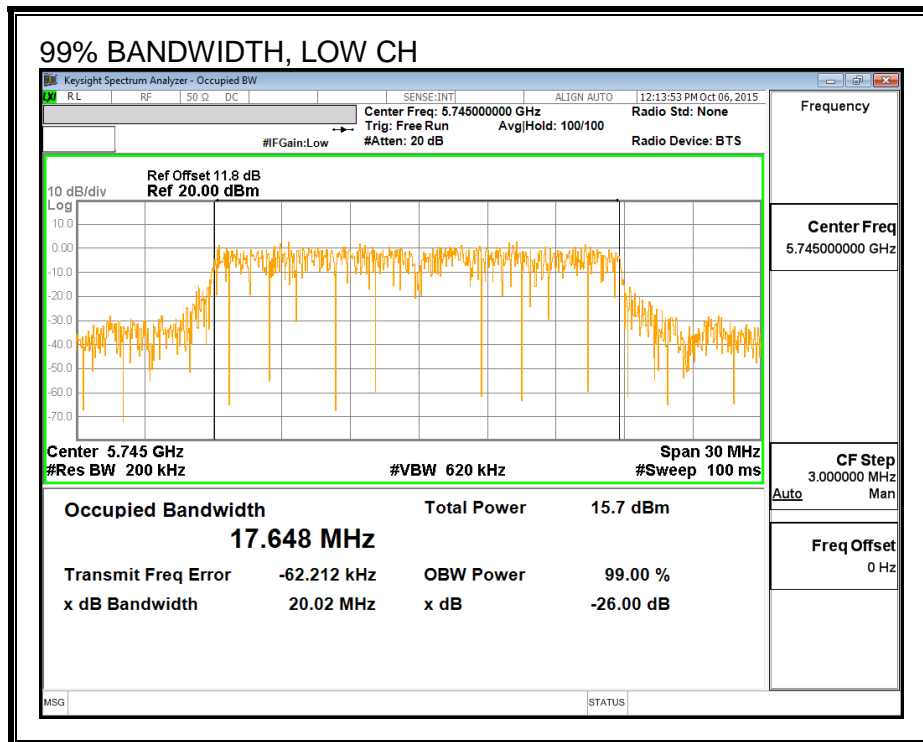

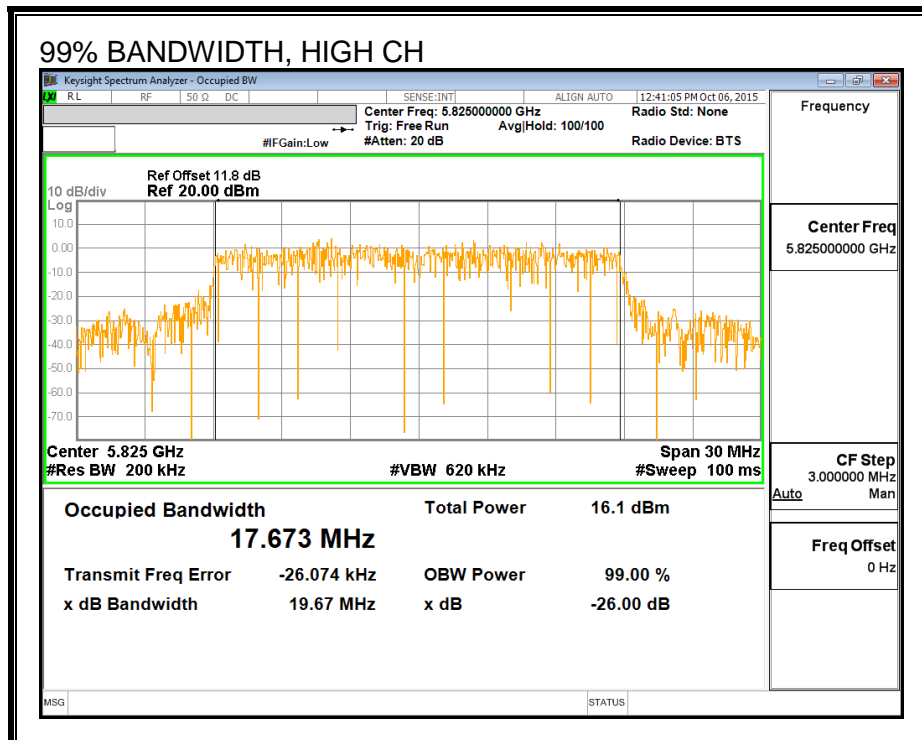
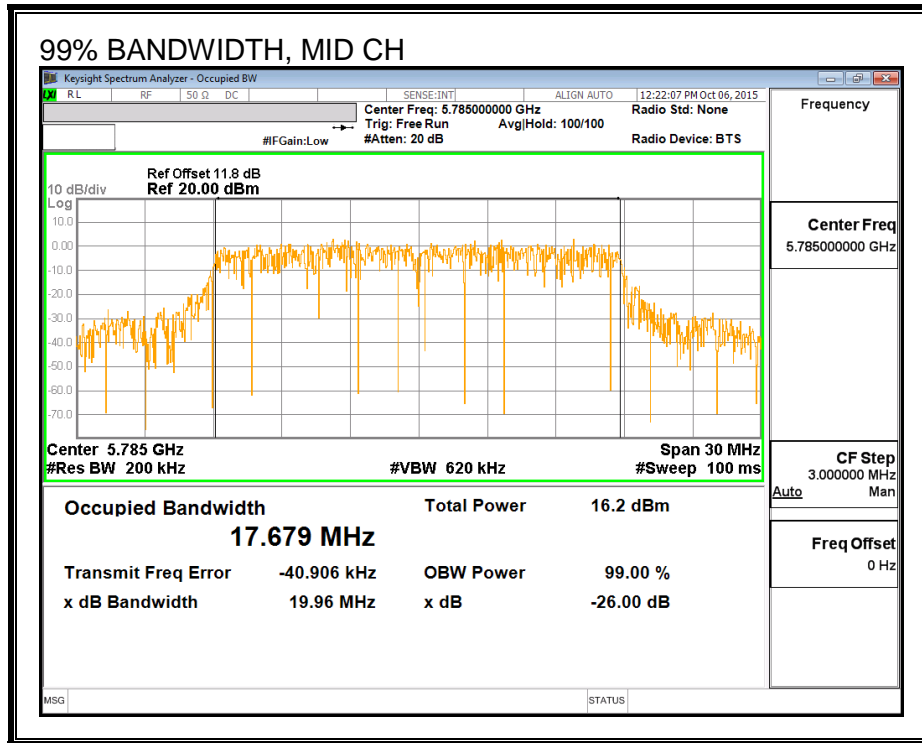

8.2.4. AVERAGE POWER

LIMITS

None; for reporting purposes only.

Test Procedure

Measurements perform using a wideband gated RF power meter.

RESULTS

Channel	Frequency (MHz)	Chain 0 Power (dBm)	Chain 1 Power (dBm)	Total Power (dBm)
Low	5745	14.22	14.28	17.26
Mid	5785	15.93	16.00	18.98
High	5825	15.91	15.99	18.96

8.2.5. OUTPUT POWER

LIMITS

FCC §15.407 (a) (3)

For the band 5.725-5.85 GHz, the maximum conducted output power over the frequency band of operation shall not exceed 1 W. In addition, the maximum power spectral density shall not exceed 30 dBm in any 500-kHz band. If transmitting antennas of directional gain greater than 6 dBi are used, both the maximum conducted output power and the maximum power spectral density shall be reduced by the amount in dB that the directional gain of the antenna exceeds 6 dBi.

Test Procedure

Measurements perform using a wideband gated RF power meter provided that the gate parameters are adjusted such that the power is measured only when the EUT is transmitting at its maximum power control level. Since the measurement is made only during the ON time of the transmitter, no duty cycle correction factor is required.

DIRECTIONAL ANTENNA GAIN

The TX chains are uncorrelated and the antenna gain is unequal among the chains. The directional gain is:

Chain 0 Antenna Gain (dBi)	Chain 1 Antenna Gain (dBi)	Uncorrelated Chains Directional Gain (dBi)
4.21	3.92	4.07

RESULTS

Antenna Gain and Limit

Channel	Frequency (MHz)	Directional Gain for Power (dBi)	Power Limit (dBm)
Low	5745	4.07	30.00
Mid	5785	4.07	30.00
High	5825	4.07	30.00

Output Power Results

Channel	Frequency (MHz)	Chain 0 Meas Power (dBm)	Chain 1 Meas Power (dBm)	Total Corr'd Power (dBm)	Power Limit (dBm)	Power Margin (dB)
Low	5745	14.22	14.28	17.26	30.00	-12.74
Mid	5785	15.93	16.00	18.98	30.00	-11.02
High	5825	15.91	15.99	18.96	30.00	-11.04

8.2.6. PSD

LIMITS

FCC §15.407 (a) (3)

For the band 5.725-5.85 GHz, the maximum conducted output power over the frequency band of operation shall not exceed 1 W. In addition, the maximum power spectral density shall not exceed 30 dBm in any 500-kHz band. If transmitting antennas of directional gain greater than 6 dBi are used, both the maximum conducted output power and the maximum power spectral density shall be reduced by the amount in dB that the directional gain of the antenna exceeds 6 dBi.

DIRECTIONAL ANTENNA GAIN

The TX chains are correlated and the antenna gain is unequal among the chains. The directional gain is:

Chain 0 Antenna Gain (dBi)	Chain 1 Antenna Gain (dBi)	Correlated Chains Directional Gain (dBi)
4.21	3.92	7.08

RESULTS

Antenna Gain and Limits

Channel	Frequency (MHz)	Directional Gain (dBi)	PSD Limit (dBm)
Low	5745	7.08	28.92
Mid	5785	7.08	28.92
High	5825	7.08	28.92

Duty Cycle CF (dB)	0.00	Included in Calculations of Corr'd PSD
---------------------------	------	---

PSD Results

Channel	Frequency (MHz)	Chain 0 Meas PSD (dBm)	Chain 1 Meas PSD (dBm)	Total Corr'd PSD (dBm)	PSD Limit (dBm)	PSD Margin (dB)
Low	5745	-0.39	-0.50	2.57	28.92	-26.35
Mid	5785	1.82	2.13	4.98	28.92	-23.94
High	5825	1.81	2.05	4.94	28.92	-23.98

PSD,

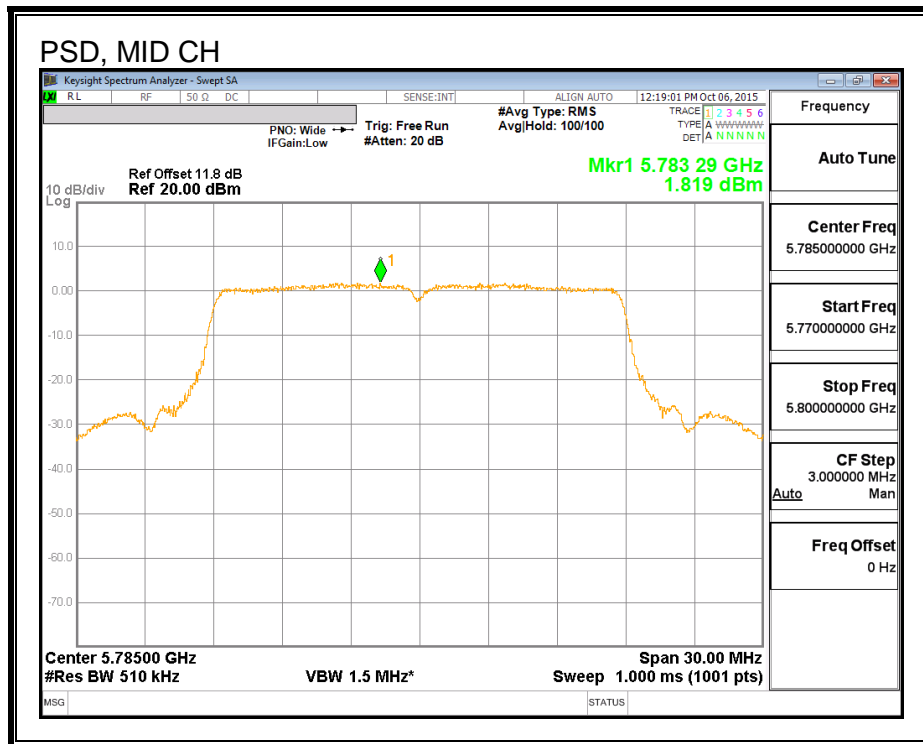
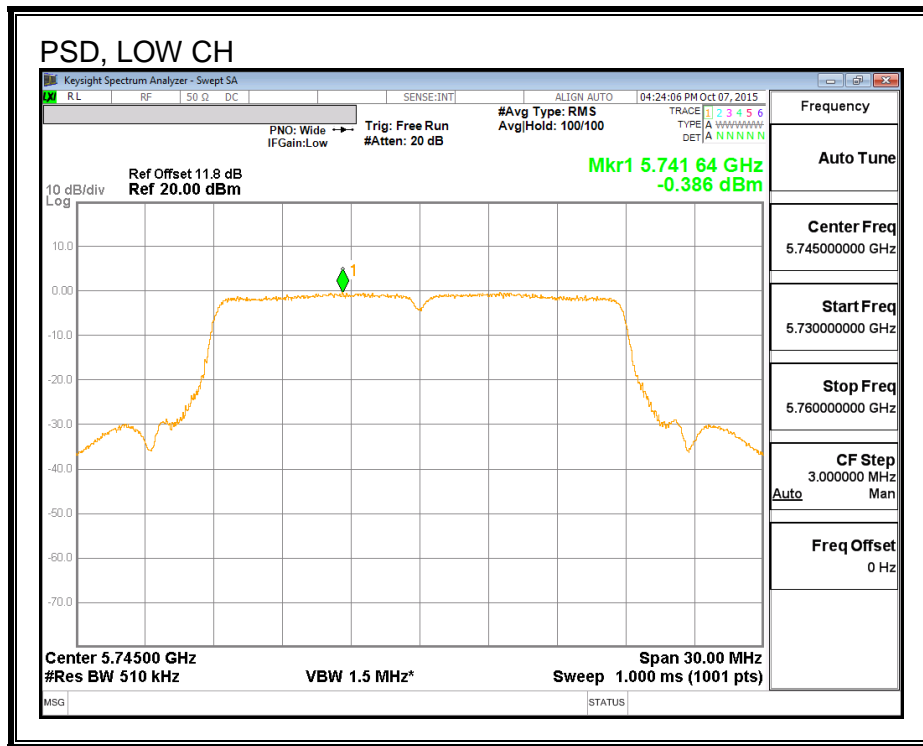

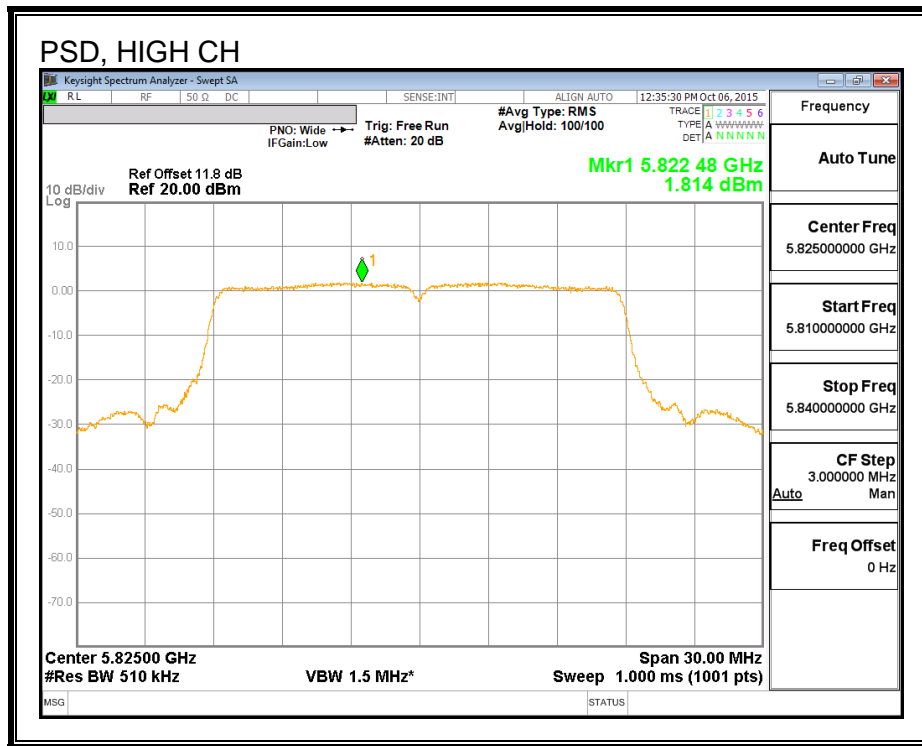

PSD, CHAIN 1

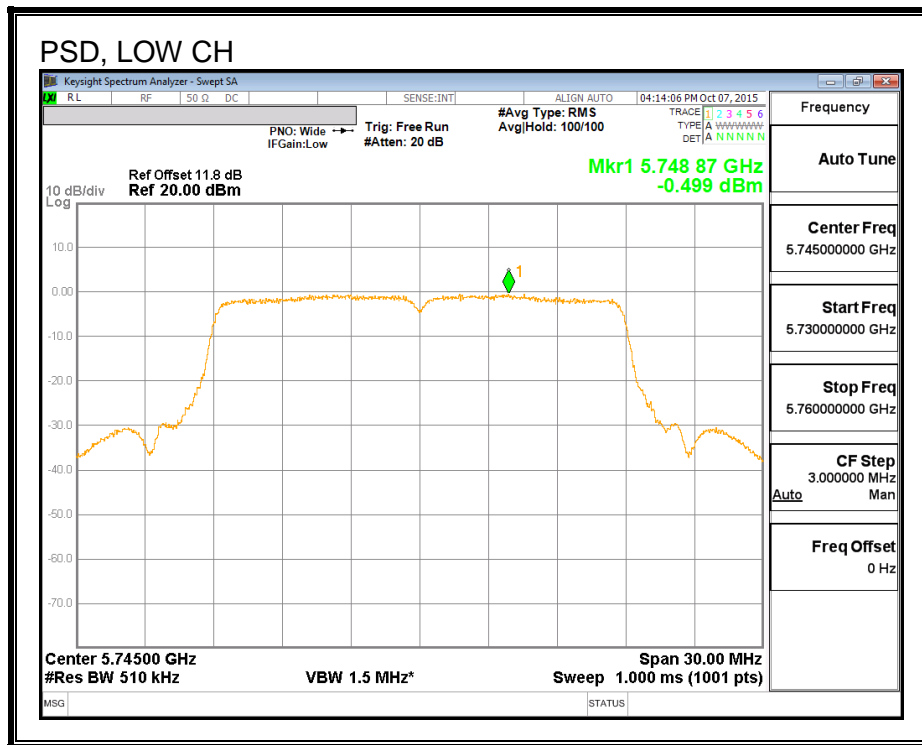

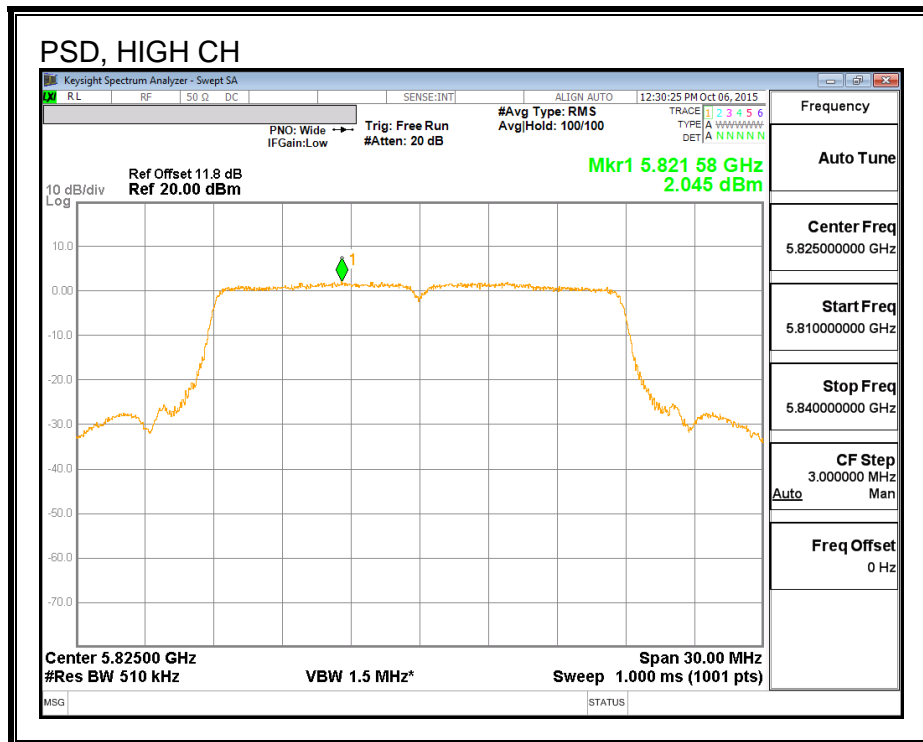
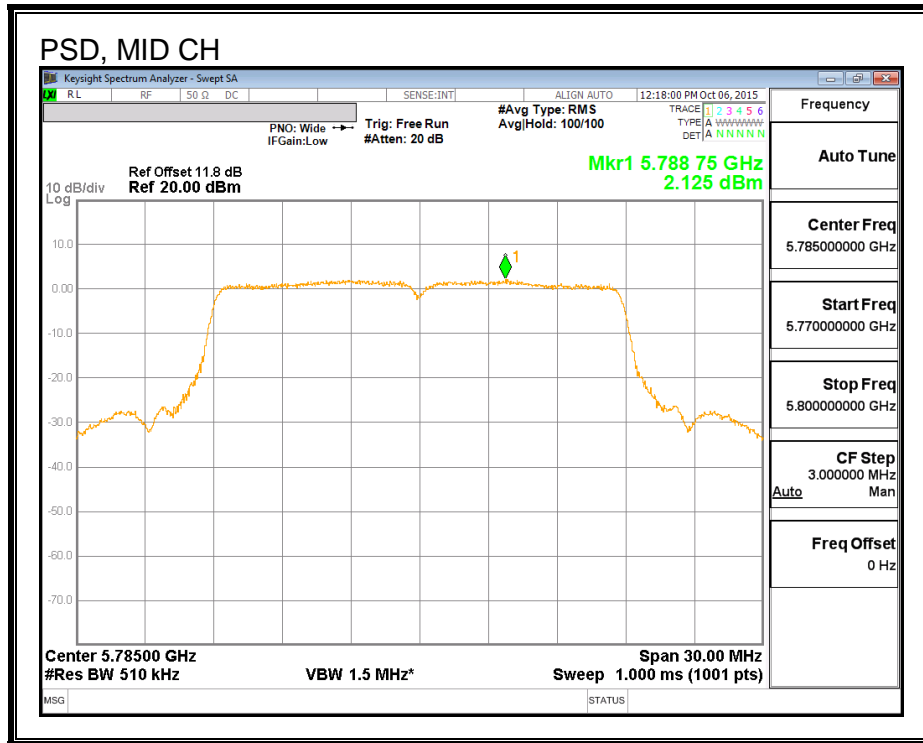

8.3.802.11n HT40 1TX MODE IN THE 5.8 GHz BAND

8.3.1. 6 dB BANDWIDTH

LIMITS

FCC §15.407 (e)

The minimum 6 dB bandwidth shall be at least 500 kHz.

RESULTS

Channel	Frequency (MHz)	6 dB Bandwidth (MHz)	Minimum Limit (MHz)
Low	5755	36.12	0.5
High	5795	36.00	0.5

6 dB BANDWIDTH

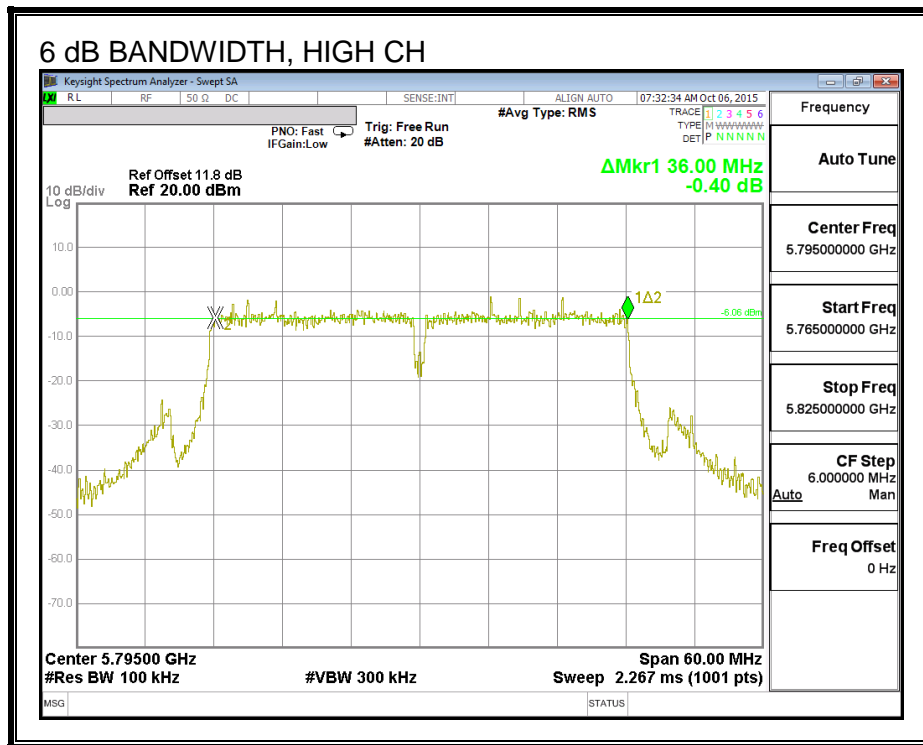
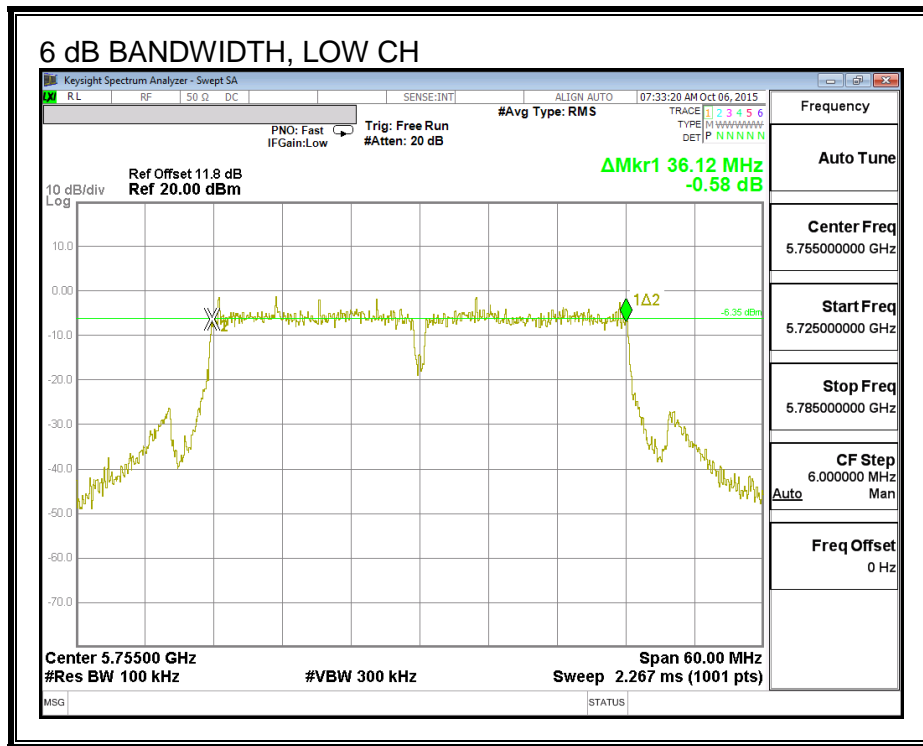

8.3.2. 26 dB BANDWIDTH

LIMITS

None, for reporting purposes only.

RESULTS

Channel	Frequency (MHz)	26 dB Bandwidth (MHz)
Low	5755	39.66
High	5795	39.66

26 dB BANDWIDTH

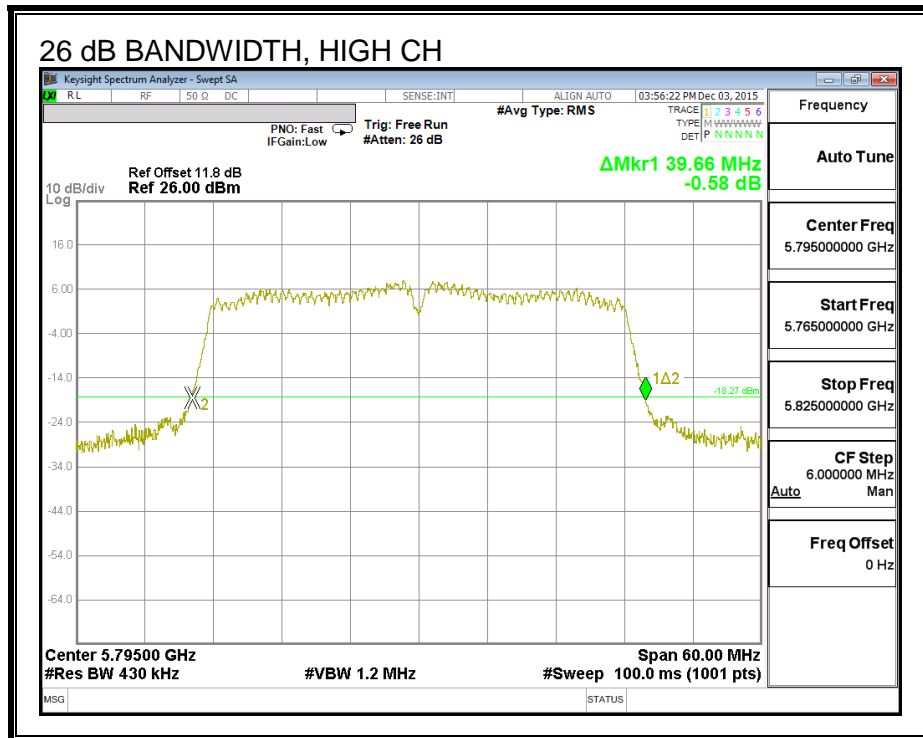
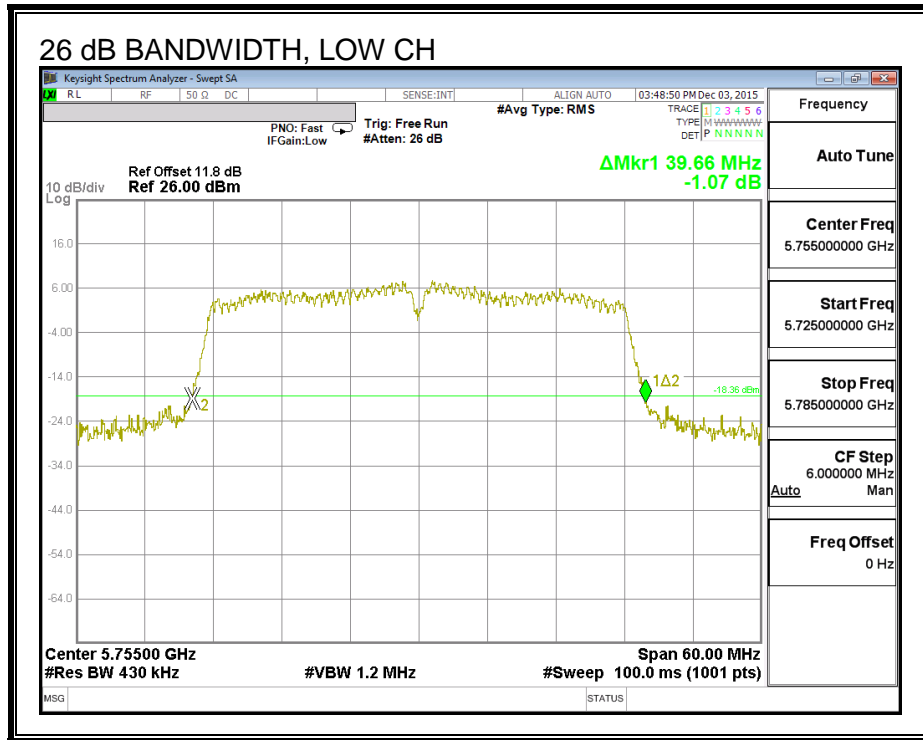

8.3.3. 99% BANDWIDTH

LIMITS

None; for reporting purposes only.

RESULTS

Channel	Frequency (MHz)	99% Bandwidth (MHz)
Low	5755	36.392
High	5795	36.175

99% BANDWIDTH

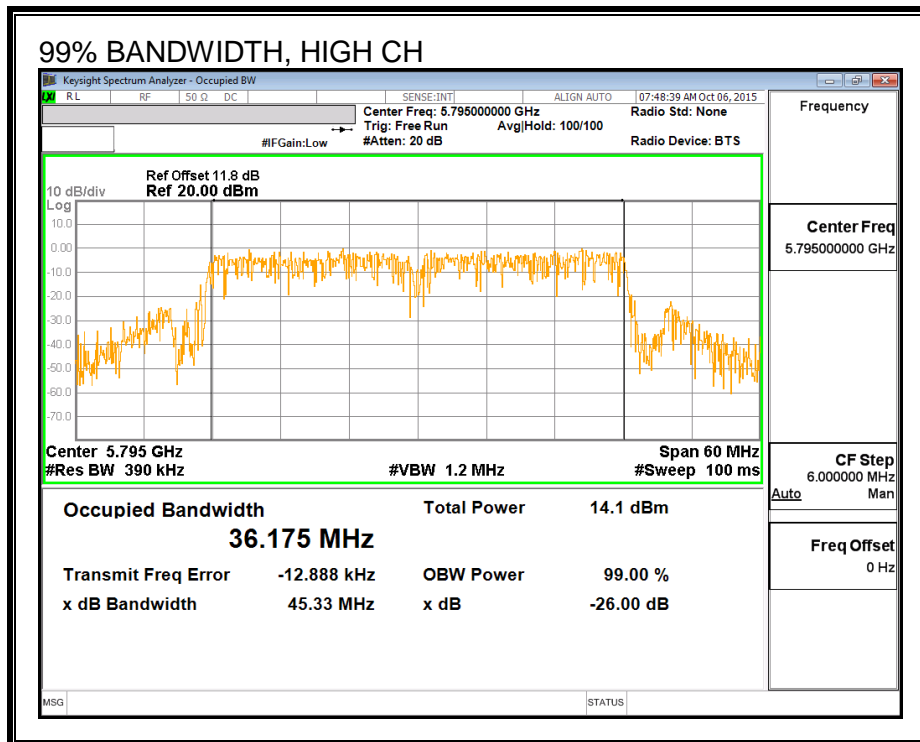
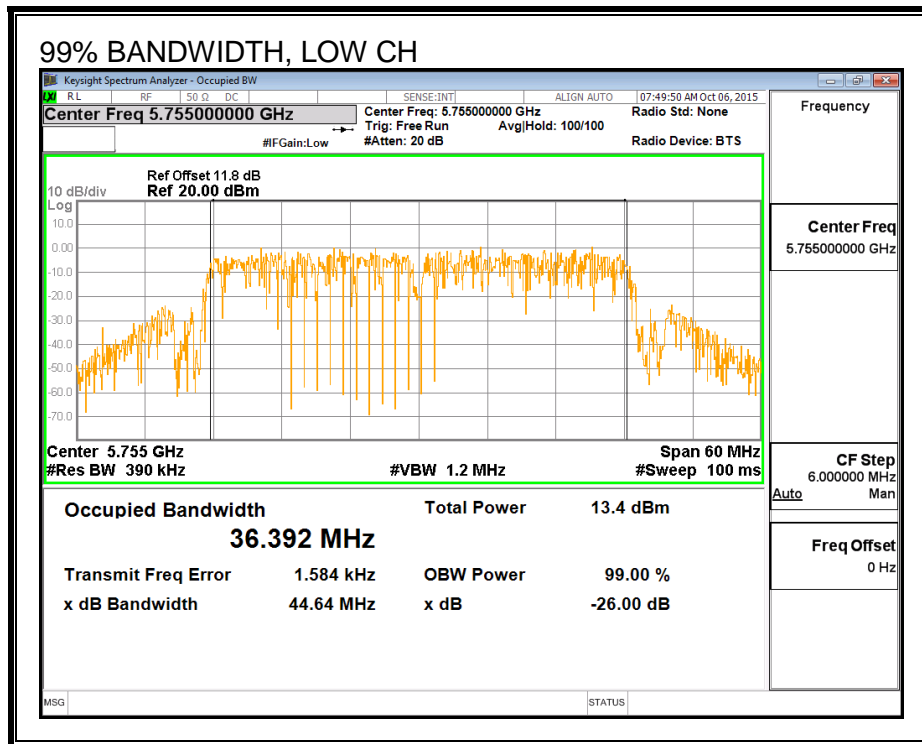

8.3.4. AVERAGE POWER

LIMITS

None; for reporting purposes only.

Test Procedure

Measurements perform using a wideband gated RF power meter.

RESULTS

Channel	Frequency (MHz)	Power (dBm)
Low	5755	12.67
High	5795	15.97

8.3.5. OUTPUT POWER

LIMITS

FCC §15.407 (a) (3)

For the band 5.725-5.85 GHz, the maximum conducted output power over the frequency band of operation shall not exceed 1 W. In addition, the maximum power spectral density shall not exceed 30 dBm in any 500-kHz band. If transmitting antennas of directional gain greater than 6 dBi are used, both the maximum conducted output power and the maximum power spectral density shall be reduced by the amount in dB that the directional gain of the antenna exceeds 6 dBi.

Test Procedure

Measurements perform using a wideband gated RF power meter provided that the gate parameters are adjusted such that the power is measured only when the EUT is transmitting at its maximum power control level. Since the measurement is made only during the ON time of the transmitter, no duty cycle correction factor is required.

DIRECTIONAL ANTENNA GAIN

There is only one transmitter output therefore the directional gain is equal to the antenna gain.

RESULTS

Antenna Gain and Limit

Channel	Frequency (MHz)	Directional Gain (dBi)	Power Limit (dBm)
Low	5755	4.21	30.00
High	5795	4.21	30.00

Output Power Results

Channel	Frequency (MHz)	Meas Power (dBm)	Total Corr'd Power (dBm)	Power Limit (dBm)	Power Margin (dB)
Low	5755	12.67	12.67	30.00	-17.33
High	5795	15.97	15.97	30.00	-14.03

8.3.6. PSD

LIMITS

FCC §15.407 (a) (3)

For the band 5.725-5.85 GHz, the maximum conducted output power over the frequency band of operation shall not exceed 1 W. In addition, the maximum power spectral density shall not exceed 30 dBm in any 500-kHz band. If transmitting antennas of directional gain greater than 6 dBi are used, both the maximum conducted output power and the maximum power spectral density shall be reduced by the amount in dB that the directional gain of the antenna exceeds 6 dBi.

DIRECTIONAL ANTENNA GAIN

There is only one transmitter output therefore the directional gain is equal to the antenna gain.

RESULTS

Antenna Gain and Limits

Channel	Frequency (MHz)	Directional Gain (dBi)	PSD Limit (dBm)
Low	5755	4.21	30.00
High	5795	4.21	30.00

Duty Cycle CF (dB)	0.00	Included in Calculations of Corr'd PSD
---------------------------	------	---

PSD Results

Channel	Frequency (MHz)	Meas PSD (dBm)	Total Corr'd PSD (dBm)	PSD Limit (dBm)	PSD Margin (dB)
Low	5755	-8.21	-8.21	30.00	-38.21
High	5795	-1.19	-1.19	30.00	-31.19

PSD,

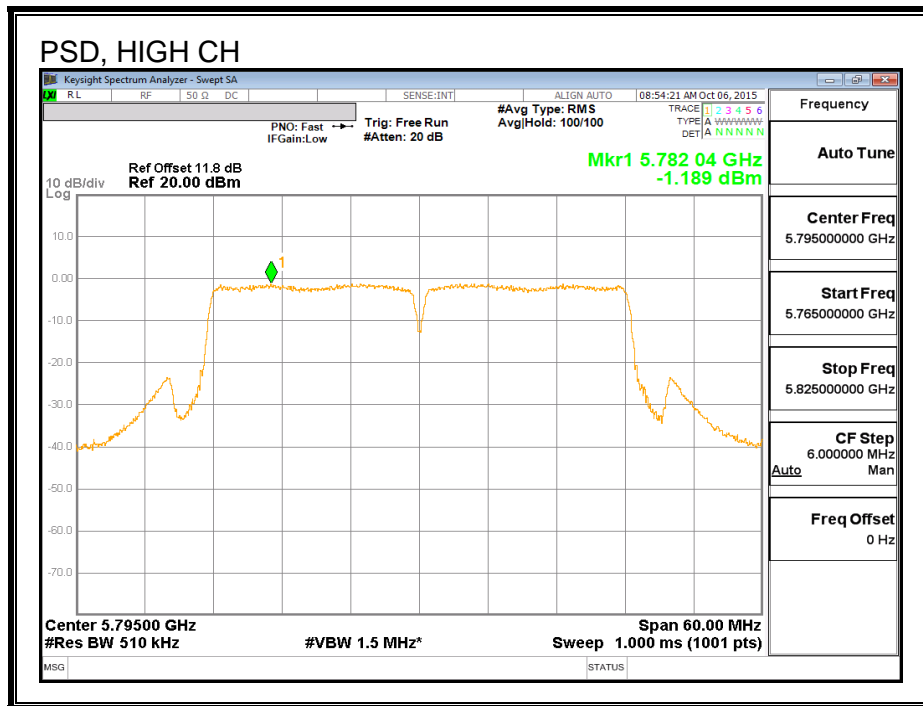
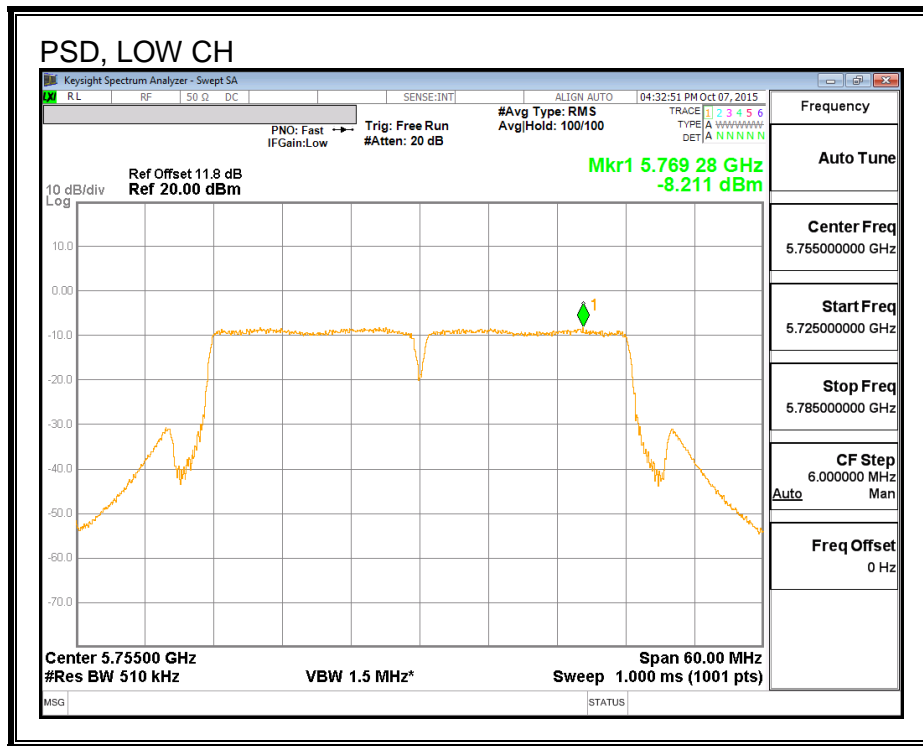

8.4.802.11n HT40 2Tx CDD MODE IN THE 5.8 GHz BAND

8.4.1. 6 dB BANDWIDTH

LIMITS

FCC §15.407 (e)

The minimum 6 dB bandwidth shall be at least 500 kHz.

RESULTS

Channel	Frequency (MHz)	6 dB BW Chain 0 (MHz)	6 dB BW Chain 1 (MHz)	Minimum Limit (MHz)
Low	5755	36.06	36.36	0.5
High	5795	36.00	36.36	0.5

6 dB BANDWIDTH, CHAIN 0

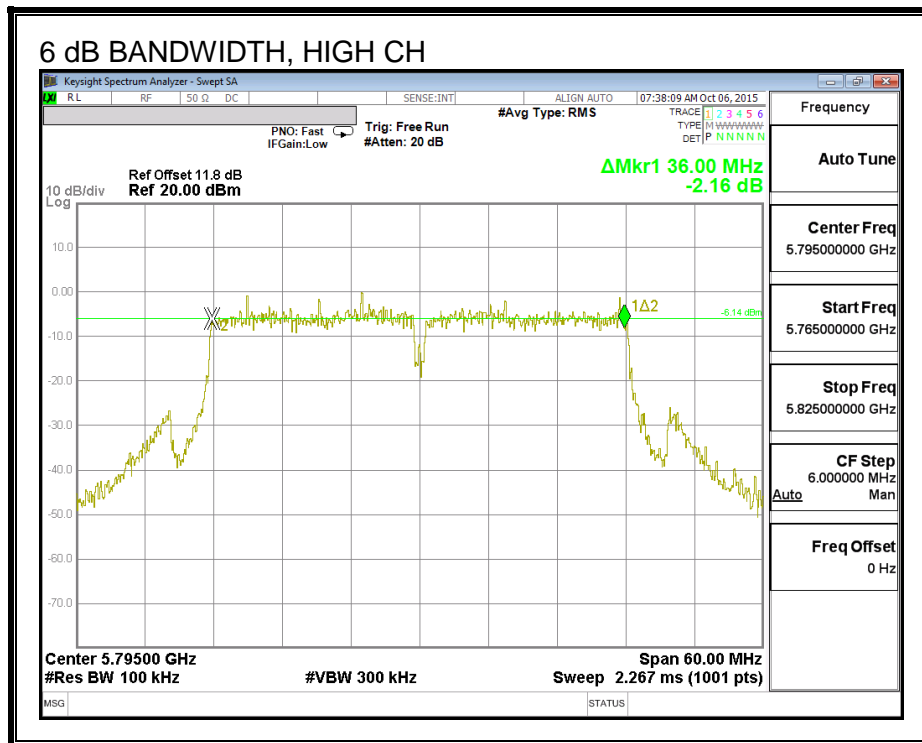
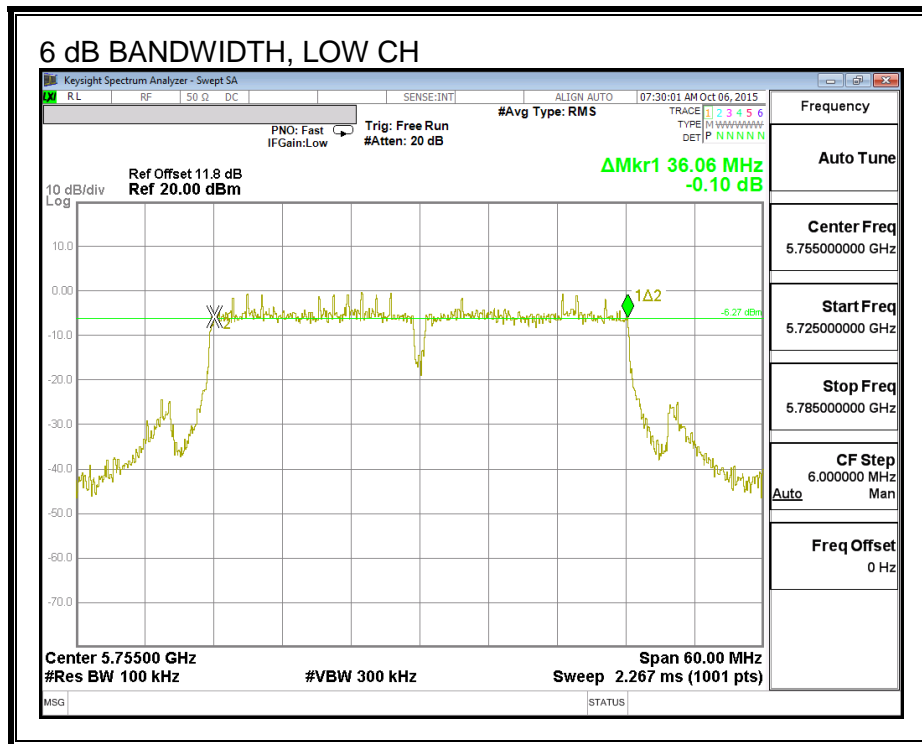

6 dB BANDWIDTH, CHAIN 1

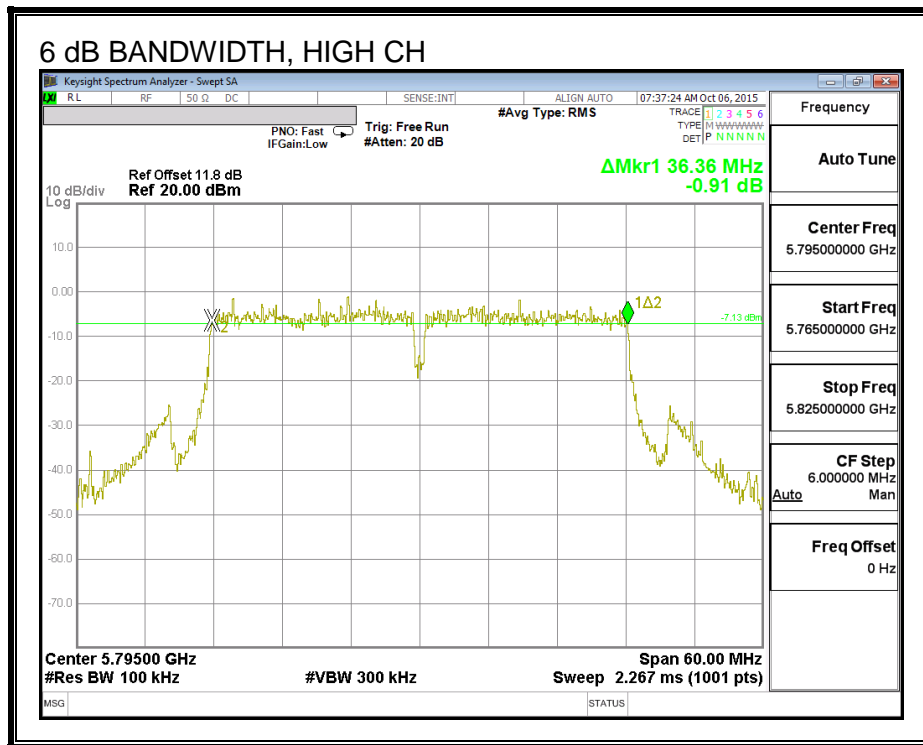
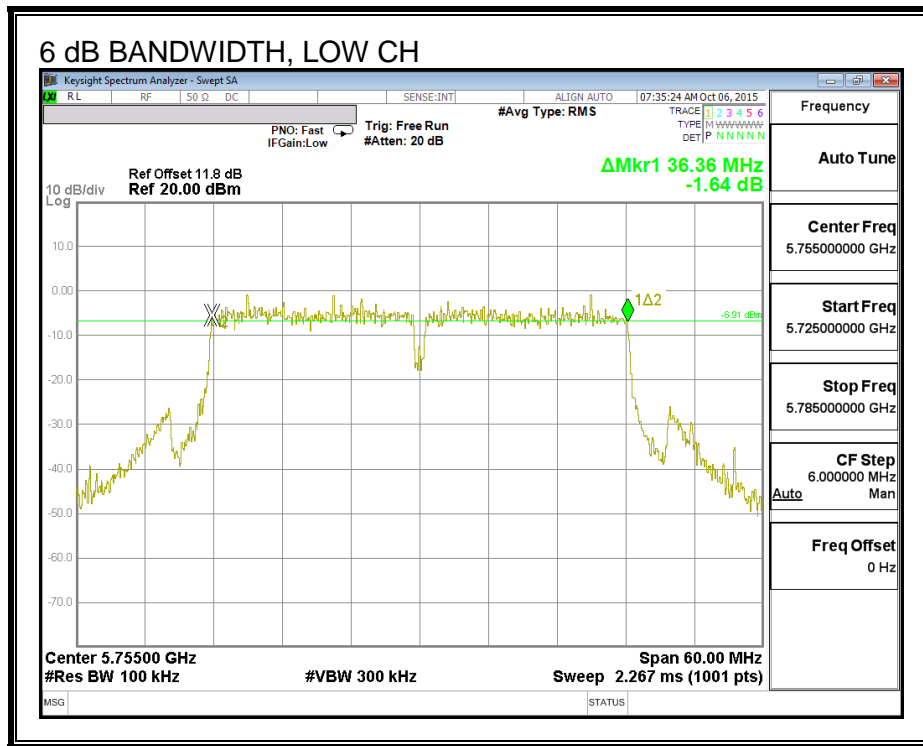

8.4.2. 26 dB BANDWIDTH

LIMITS

None, for reporting purposes only.

RESULTS

Channel	Frequency (MHz)	26 dB BW Chain 0 (MHz)	26 dB BW Chain 1 (MHz)
Low	5755	39.60	39.78
High	5795	39.54	39.72

26 dB BANDWIDTH, CHAIN 0

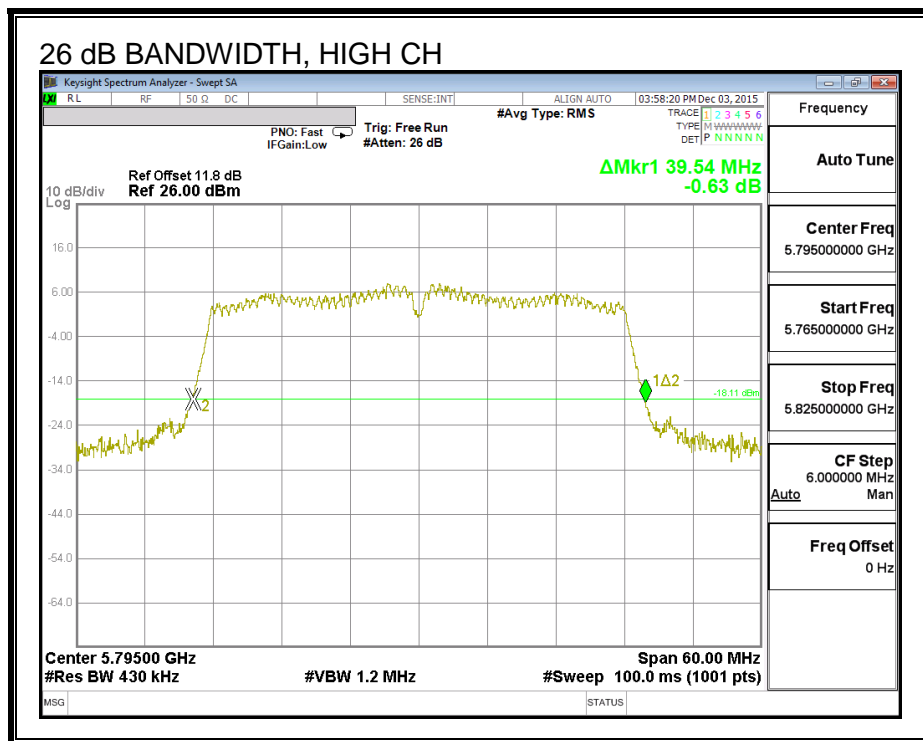
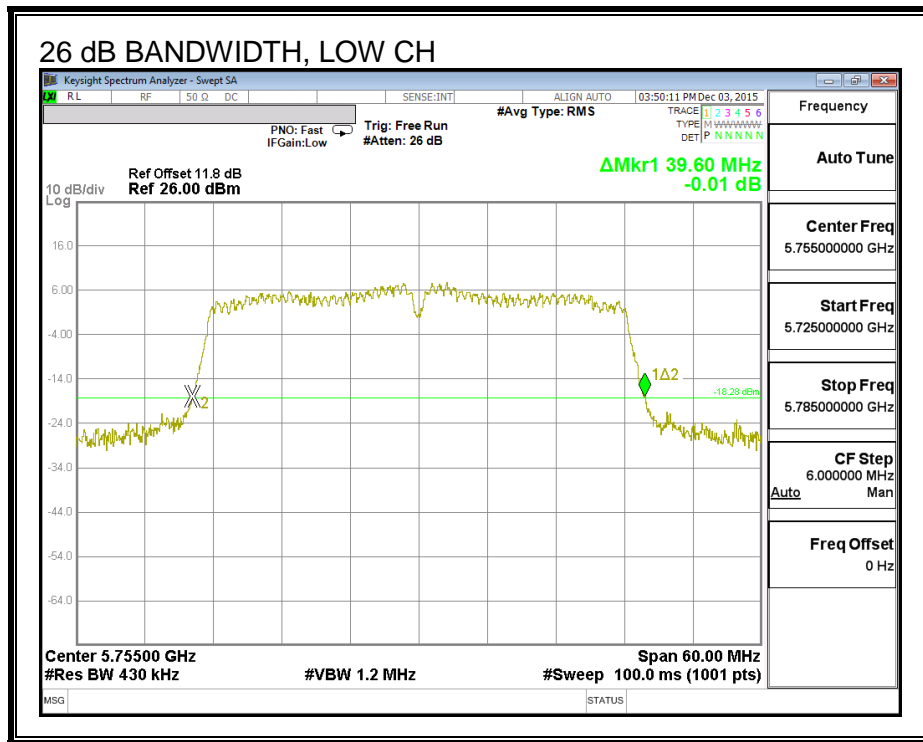

26 dB BANDWIDTH, CHAIN 1

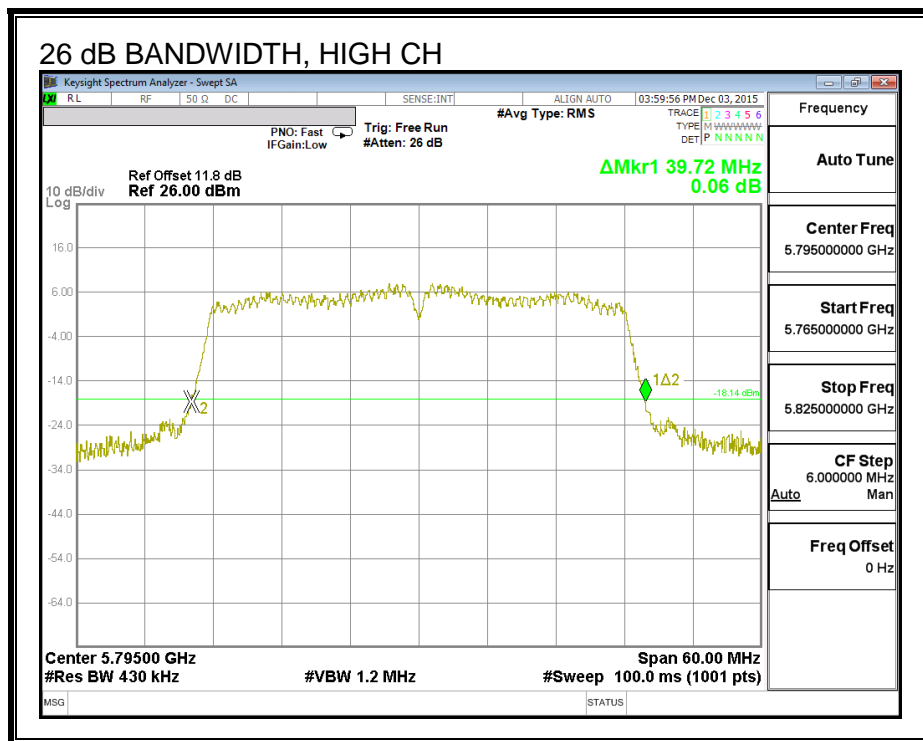
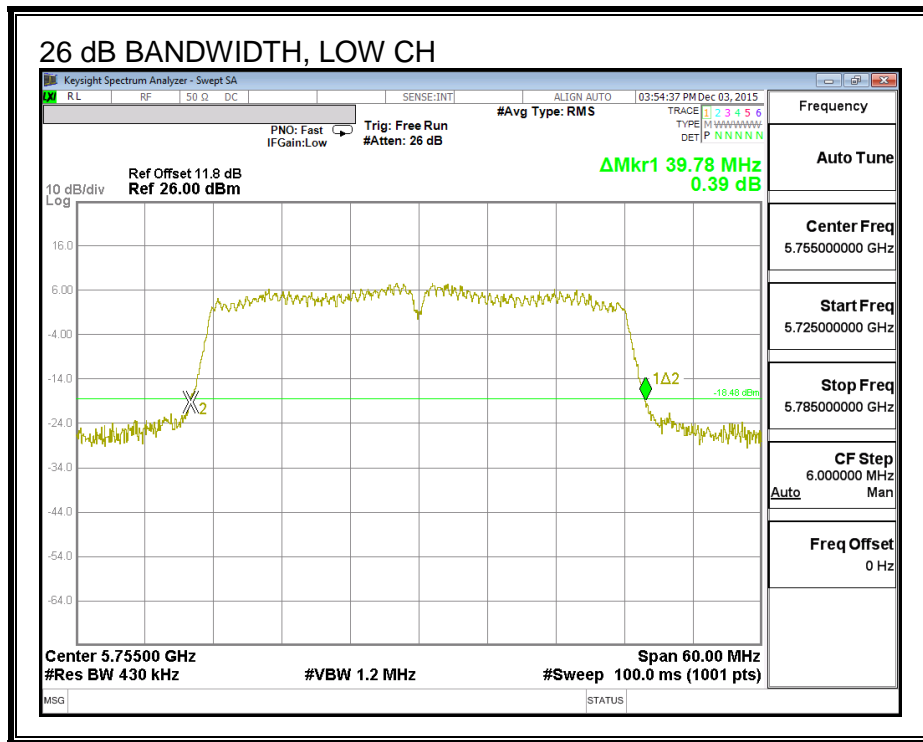

8.4.3. 99% BANDWIDTH

LIMITS

None; for reporting purposes only.

RESULTS

Channel	Frequency (MHz)	99% BW Chain 0 (MHz)	99% BW Chain 1 (MHz)
Low	5755	36.242	36.041
High	5795	36.299	36.355

99% BANDWIDTH, CHAIN 0

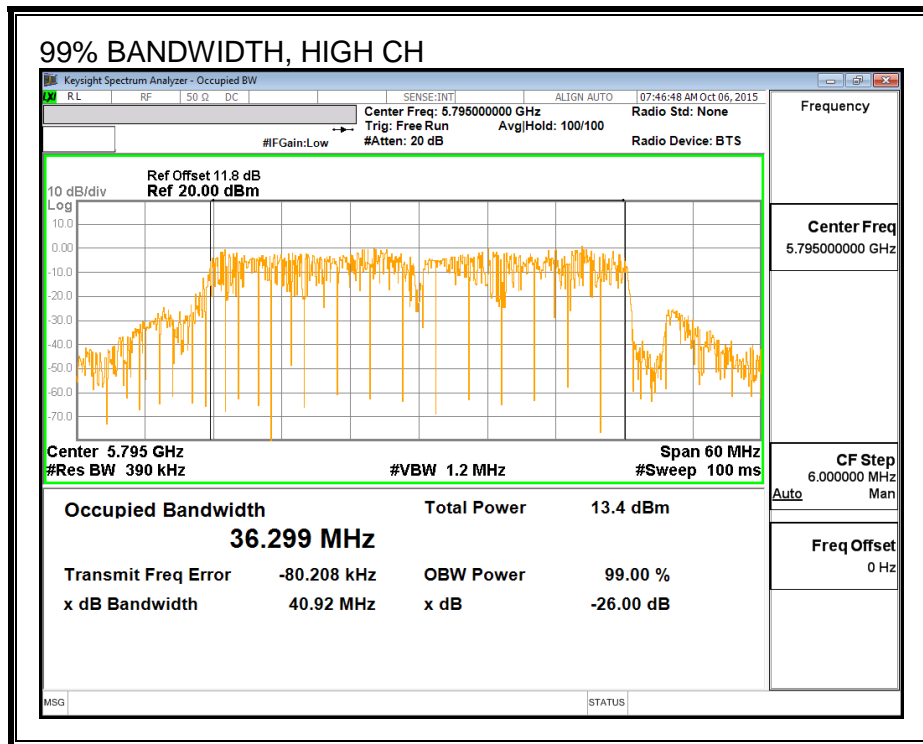
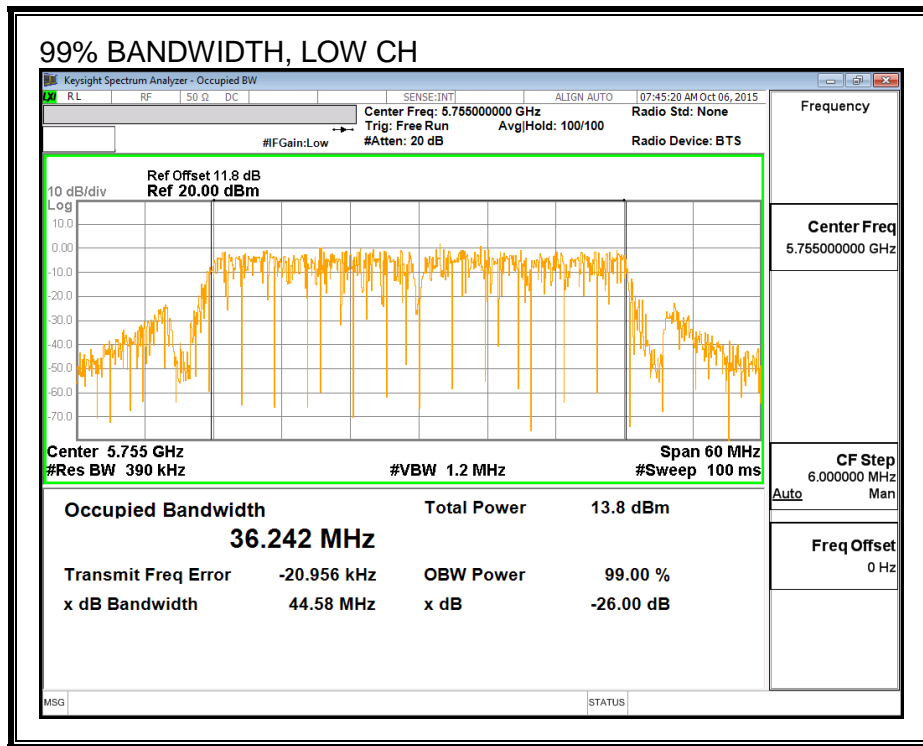

99% BANDWIDTH, CHAIN 1

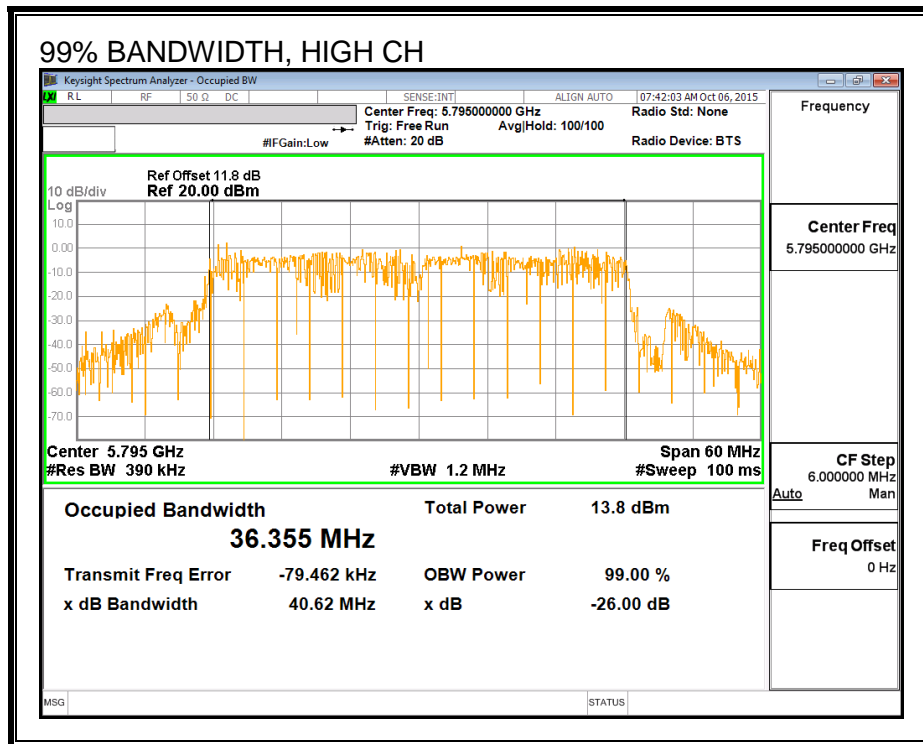
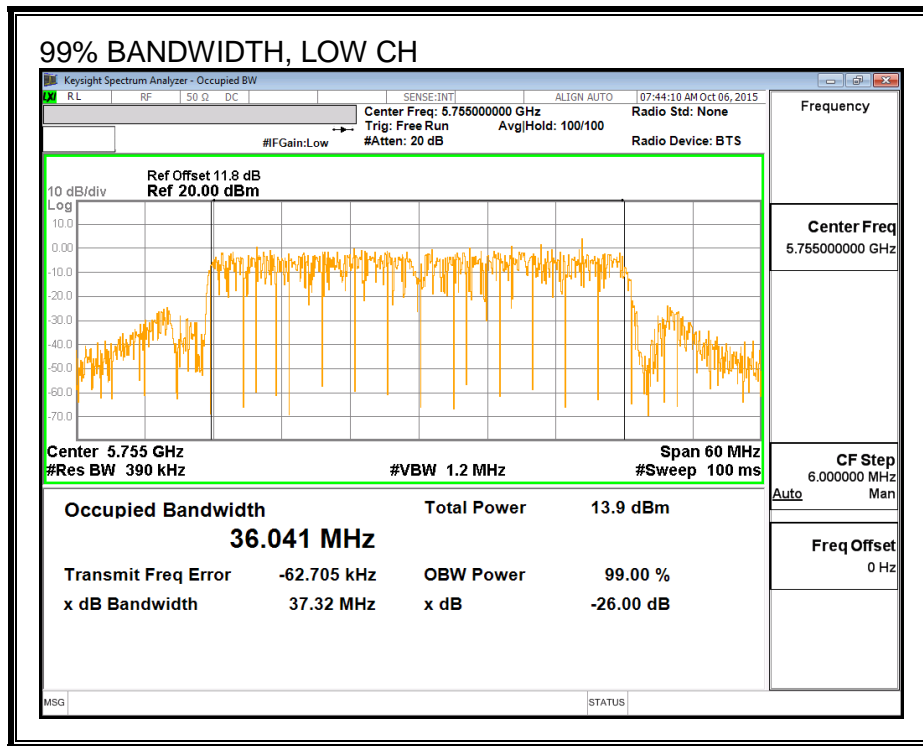

8.4.4. AVERAGE POWER

LIMITS

None; for reporting purposes only.

Test Procedure

Measurements perform using a wideband gated RF power meter.

RESULTS

Channel	Frequency (MHz)	Chain 0 Power (dBm)	Chain 1 Power (dBm)	Total Power (dBm)
Low	5755	10.28	10.40	13.35
High	5795	15.83	15.86	18.86

8.4.5. OUTPUT POWER

LIMITS

FCC §15.407 (a) (3)

For the band 5.725-5.85 GHz, the maximum conducted output power over the frequency band of operation shall not exceed 1 W. In addition, the maximum power spectral density shall not exceed 30 dBm in any 500-kHz band. If transmitting antennas of directional gain greater than 6 dBi are used, both the maximum conducted output power and the maximum power spectral density shall be reduced by the amount in dB that the directional gain of the antenna exceeds 6 dBi.

Test Procedure

Measurements perform using a wideband gated RF power meter provided that the gate parameters are adjusted such that the power is measured only when the EUT is transmitting at its maximum power control level. Since the measurement is made only during the ON time of the transmitter, no duty cycle correction factor is required.

DIRECTIONAL ANTENNA GAIN

The TX chains are uncorrelated and the antenna gain is unequal among the chains. The directional gain is:

Chain 0 Antenna Gain (dBi)	Chain 1 Antenna Gain (dBi)	Uncorrelated Chains Directional Gain (dBi)
4.21	3.92	4.07

RESULTS

Antenna Gain and Limit

Channel	Frequency (MHz)	Directional Gain (dBi)	Power Limit (dBm)
Low	5755	4.07	30.00
High	5795	4.07	30.00

Output Power Results

Channel	Frequency (MHz)	Chain 0 Meas Power (dBm)	Chain 1 Meas Power (dBm)	Total Corr'd Power (dBm)	Power Limit (dBm)	Power Margin (dB)
Low	5755	10.28	10.40	13.35	30.00	-16.65
High	5795	15.83	15.86	18.86	30.00	-11.14

8.4.6. PSD

LIMITS

FCC §15.407 (a) (3)

For the band 5.725-5.85 GHz, the maximum conducted output power over the frequency band of operation shall not exceed 1 W. In addition, the maximum power spectral density shall not exceed 30 dBm in any 500-kHz band. If transmitting antennas of directional gain greater than 6 dBi are used, both the maximum conducted output power and the maximum power spectral density shall be reduced by the amount in dB that the directional gain of the antenna exceeds 6 dBi.

DIRECTIONAL ANTENNA GAIN

The TX chains are correlated and the antenna gain is unequal among the chains. The directional gain is:

Chain 0 Antenna Gain (dBi)	Chain 1 Antenna Gain (dBi)	Correlated Chains Directional Gain (dBi)
4.21	3.92	7.08

RESULTS

Antenna Gain and Limit

Channel	Frequency (MHz)	Directional Gain (dBi)	PSD Limit (dBm)
Low	5755	7.08	28.92
High	5795	7.08	28.92

Duty Cycle CF (dB)	0.12	Included in Calculations of Corr'd PSD
---------------------------	------	---

PSD Results

Channel	Frequency (MHz)	Chain 0 Meas PSD (dBm)	Chain 1 Meas PSD (dBm)	Total Corr'd PSD (dBm)	PSD Limit (dBm)	PSD Margin (dB)
Low	5755	-11.19	-10.73	-7.82	28.92	-36.74
High	5795	-1.35	-1.08	1.92	28.92	-27.00

PSD, CHAIN 0

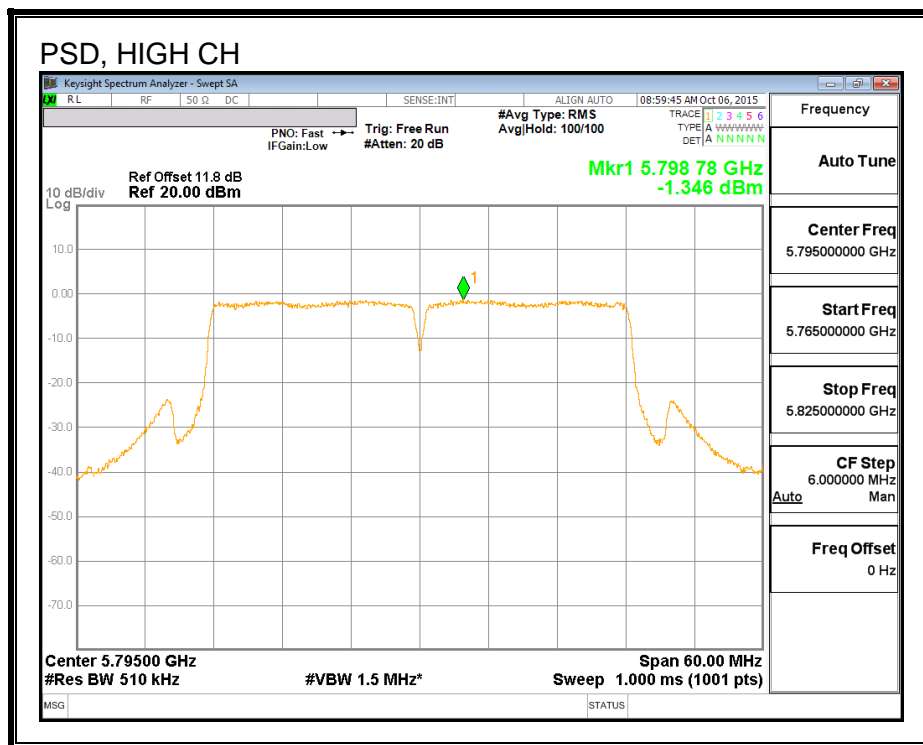
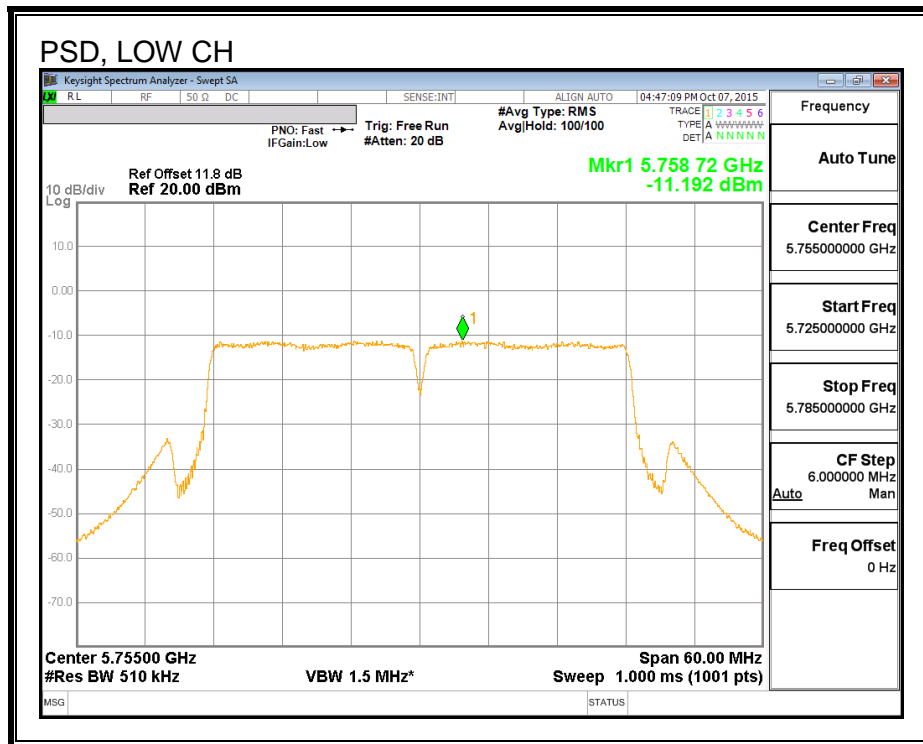

PSD, CHAIN 1

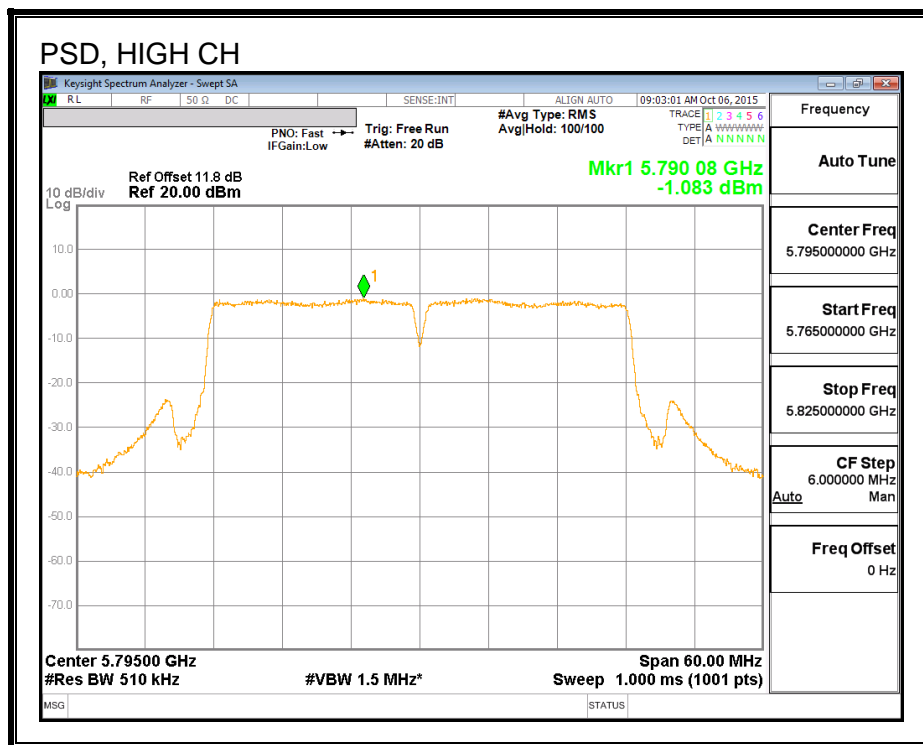
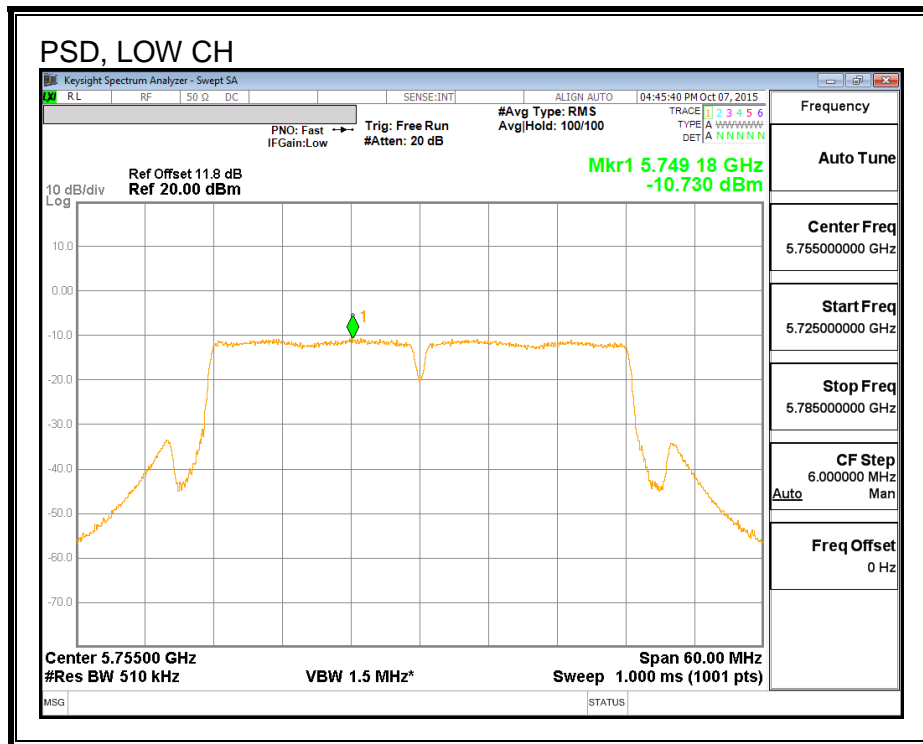

9. RADIATED TEST RESULTS

9.1. LIMITS AND PROCEDURE

LIMITS

FCC §15.205 and §15.209

Frequency Range (MHz)	Field Strength Limit (uV/m) at 3 m	Field Strength Limit (dBuV/m) at 3 m
30 - 88	100	40
88 - 216	150	43.5
216 - 960	200	46
Above 960	500	54

TEST PROCEDURE

The EUT is placed on a non-conducting table 80 cm above the ground plane for measurement below 1GHz; 1.5 m above the ground plane for measurement above 1GHz. The antenna to EUT distance is 3 meters. The EUT is configured in accordance with ANSI C63.10. The EUT is set to transmit in a continuous mode.

For measurements below 1 GHz the resolution bandwidth is set to 100 kHz for peak detection measurements or 120 kHz for quasi-peak detection measurements. Peak detection is used unless otherwise noted as quasi-peak.

For measurements above 1 GHz the resolution bandwidth is set to 1 MHz; the video bandwidth is set to 3 MHz for peak measurements and as applicable for average measurements.

The spectrum from 30 MHz to 40 GHz is investigated with the transmitter set to the lowest, middle, and highest channels in each applicable band.

The frequency range of interest is monitored at a fixed antenna height and EUT azimuth. The EUT is rotated through 360 degrees to maximize emissions received. The antenna is scanned from 1 to 4 meters above the ground plane to further maximize the emission. Measurements are made with the antenna polarized in both the vertical and the horizontal positions.

Radiated emission were performed with the EUT set to transmit at the channel with highest output power as worst-case scenario.

9.2.802.11a 1Tx MODE IN THE 5.8 GHz BAND

9.2.1. CHAIN 0, RESTRICTED BANDEDGE AND HARMONIC SPURIOUS

LOW CHANNEL

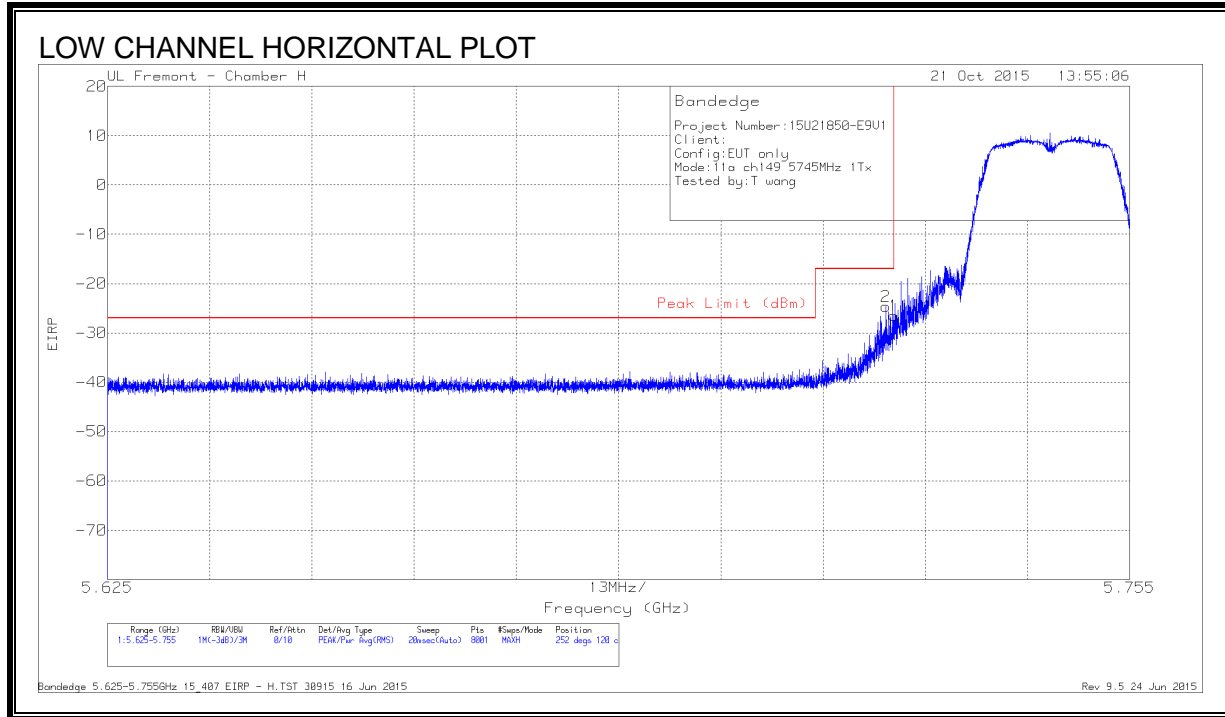

DATA

Marker	Frequency (GHz)	Meter Reading (dBm)	Det	AF T863 (dB/m)	Amp/Cb/ Fitr/Pad (dB)	Conversion Factor (dB)	Corrected Reading EIRP	Peak Limit (dBm)	PK Margin (dB)	Azimuth (Degs)	Height (cm)	Polarity
2	5.724	-49.89	Pk	34.8	-21.3	11.8	-24.59	-17	-7.59	252	120	H
1	5.725	-51.8	Pk	34.8	-21.3	11.8	-26.5	-17	-9.5	252	120	H

Pk - Peak detector

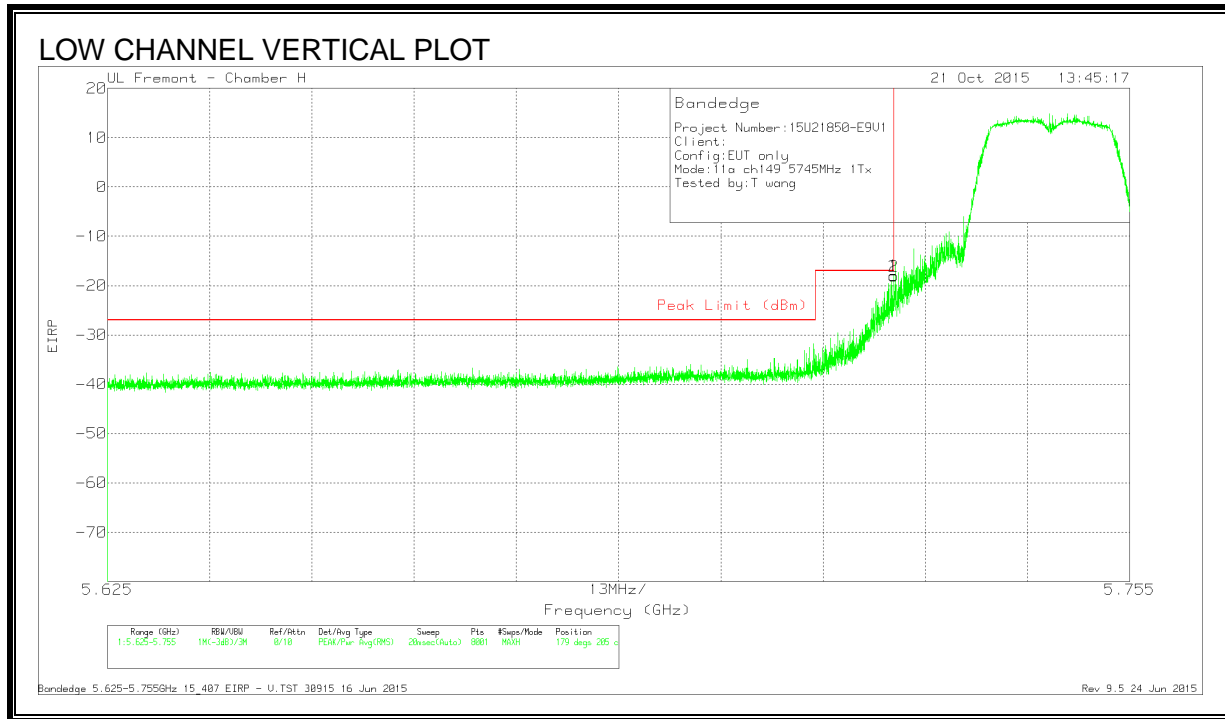

DATA

Marker	Frequency (GHz)	Meter Reading (dBm)	Det	AF T863 (dB/m)	Amp/Cb/Fltr/Pad (dB)	Conversion Factor (dB)	Corrected Reading EIRP	Peak Limit (dBm)	PK Margin (dB)	Azimuth (Degs)	Height (cm)	Polarity
1	5.725	-43.31	Pk	34.8	-21.3	11.8	-18.01	-17	-1.01	179	205	V
2	5.725	-43.43	Pk	34.8	-21.3	11.8	-18.13	-17	-1.13	179	205	V

Pk - Peak detector

RESTRICTED BANDEDGE, Chain 0 (HIGH CHANNEL)

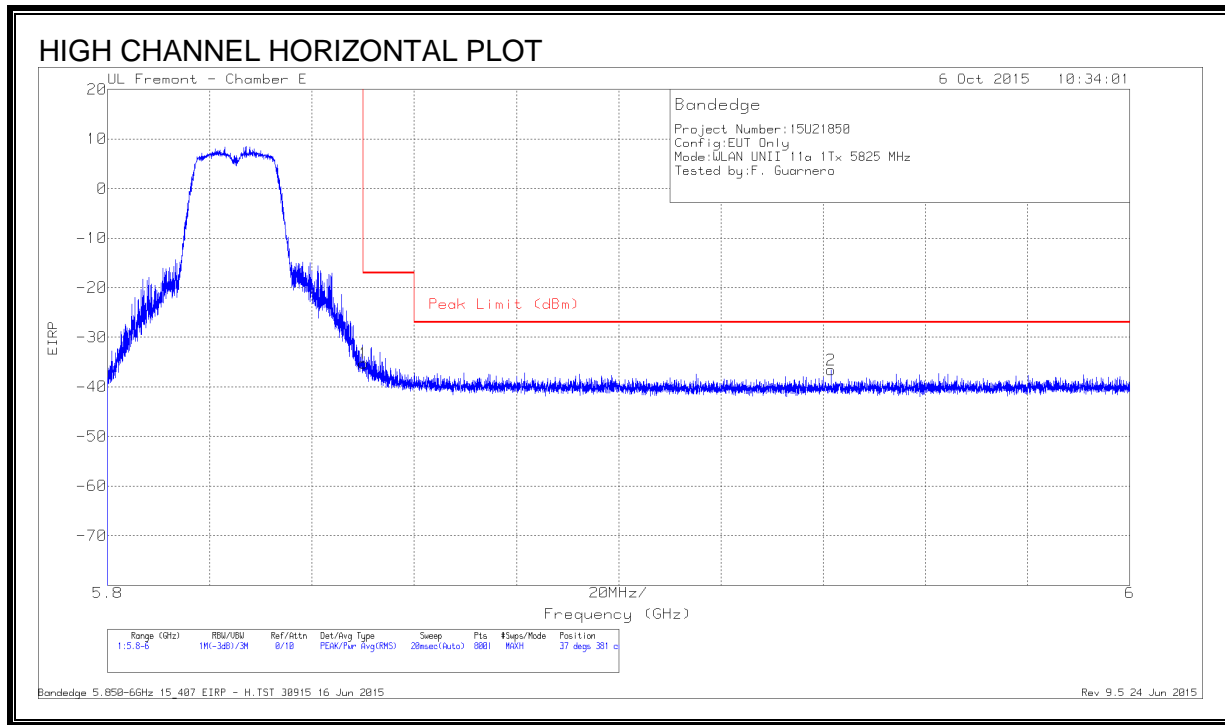

DATA

Marker	Frequency (GHz)	Meter Reading (dBm)	Det	AF T346 (dB/m)	Amp/Cbl/Filtr/ Pad (dB)	Conversion Factor (dB)	Corrected Reading EIRP	Peak Limit (dBm)	PK Margin (dB)	Azimuth (Degs)	Height (cm)	Polarity
1	5.850	-61.67	PK	34.9	-20.3	11.8	-35.27	-17	-18.27	37	381	H
2	5.942	-63.07	PK	35	-20.3	11.8	-36.57	-27	-9.57	37	381	H

Pk - Peak detector

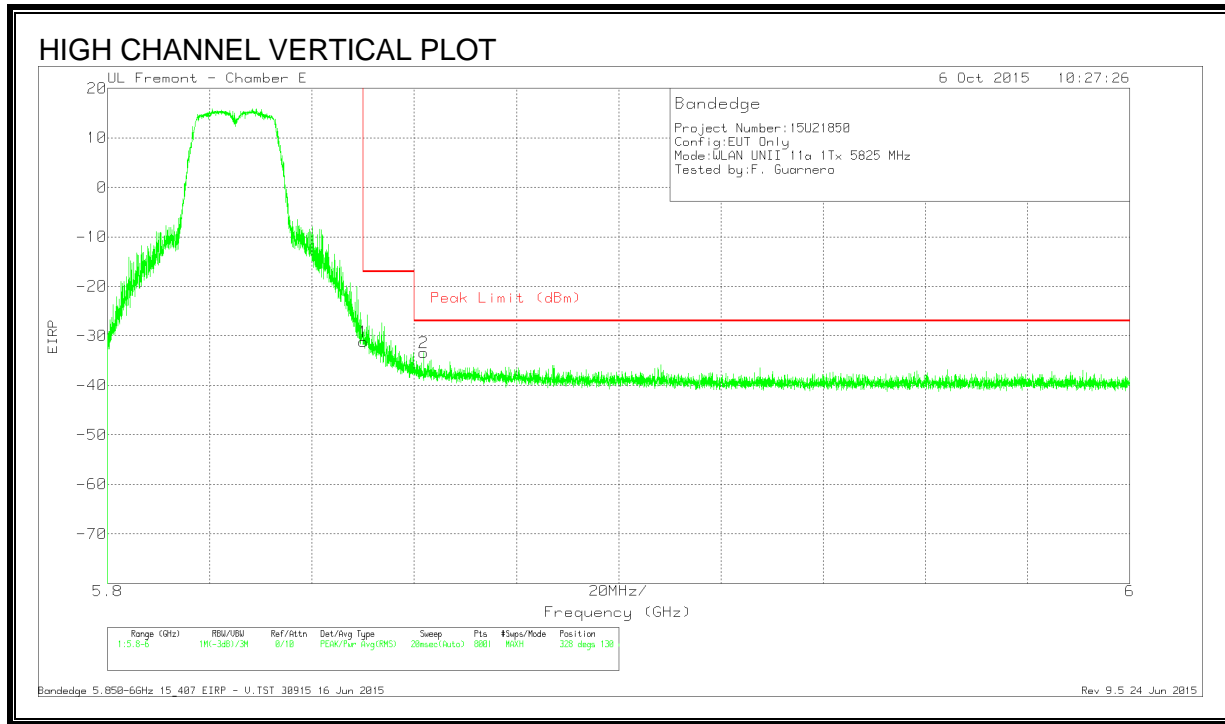

DATA

Marker	Frequency (GHz)	Meter Reading (dBm)	Det	AF T346 (dB/m)	Amp/Cbl/Filtr/ Pad (dB)	Conversion Factor (dB)	Corrected Reading EIRP	Peak Limit (dBm)	PK Margin (dB)	Azimuth (Degs)	Height (cm)	Polarity
1	5.85	-57.63	Pk	34.9	-20.3	11.8	-31.23	-17	-14.23	328	130	V
2	5.862	-59.69	Pk	34.9	-20.4	11.8	-33.39	-27	-6.39	328	130	V

Pk - Peak detector

LOW CHANNEL HARMONICS AND SPURIOUS EMISSIONS

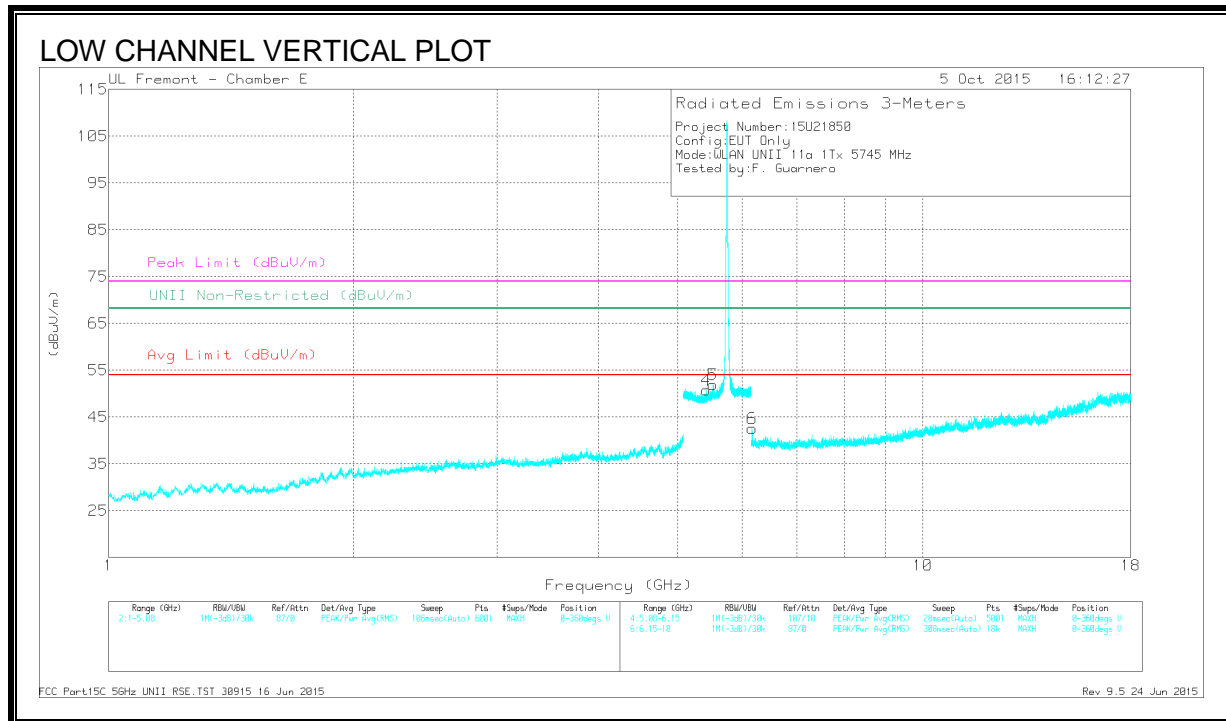
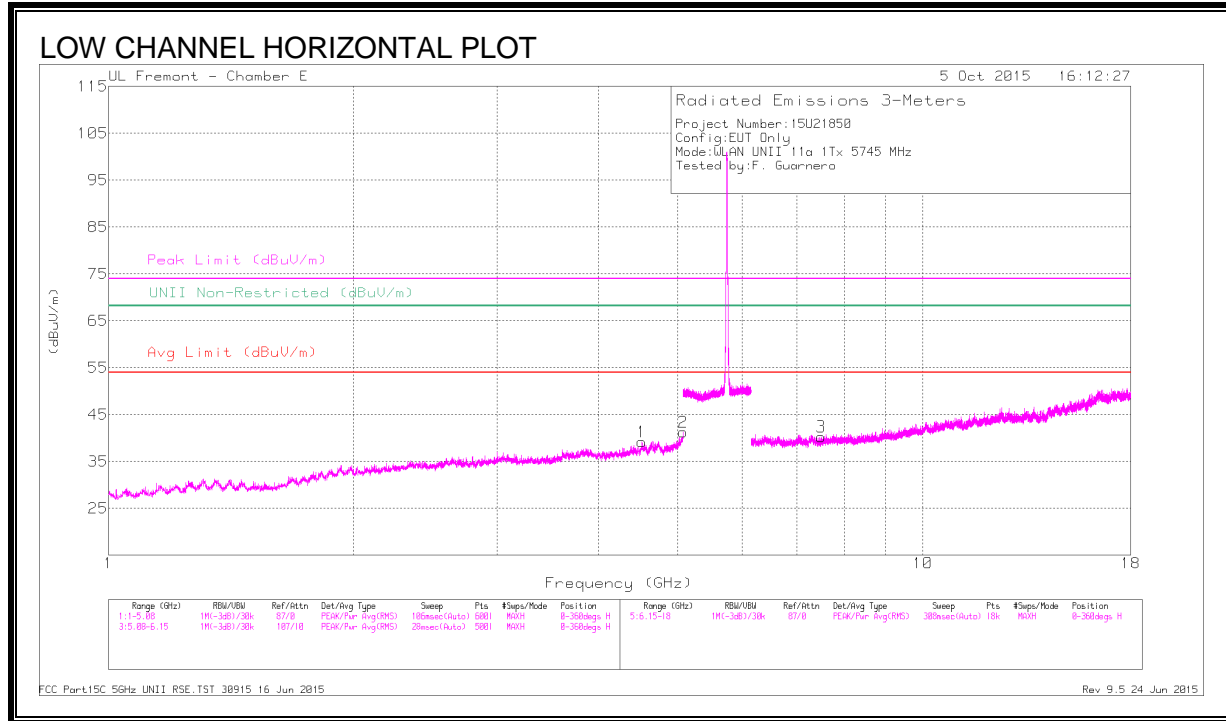

DATA

Marker	Frequency (GHz)	Meter Reading (dBuV)	Det	AF T346 (dB/m)	Amp/Cbl/Fi tr/Pad (dB)	Corrected Reading (dBuV/m)	Avg Limit (dBuV/m)	Margin (dB)	Peak Limit (dBuV/m)	PK Margin (dB)	UNII Non-Restricted (dBuV/m)	PK Margin (dB)	Azimuth (Degs)	Height (cm)	Polarity
1	* 4.515	41.18	PK-U	34	-29.8	45.38	-	-	74	-28.62	-	-	290	223	H
	* 4.514	30.25	ADR	34	-29.8	34.45	54	-19.55	-	-	-	-	290	223	H
2	* 5.079	41.39	PK-U	34.2	-26.9	48.69	-	-	74	-25.31	-	-	258	240	H
	* 5.079	29.91	ADR	34.2	-26.9	37.21	54	-16.79	-	-	-	-	258	240	H
3	* 7.498	38.62	PK-U	35.6	-27.3	46.92	-	-	74	-27.08	-	-	232	193	H
	* 7.498	27.54	ADR	35.6	-27.3	35.84	54	-18.16	-	-	-	-	232	193	H
4	* 5.416	43.43	PK-U	34.6	-20.5	57.53	-	-	74	-16.47	-	-	198	128	V
	* 5.418	31.08	ADR	34.6	-20.5	45.18	54	-8.82	-	-	-	-	198	128	V
5	5.524	45.31	PK-U	34.6	-20.5	59.41	-	-	-	-	68.2	-8.79	226	251	V
	5.527	33.52	ADR	34.6	-20.5	47.62	-	-	-	-	-	-	226	251	V
6	6.171	43.42	PK-U	35.3	-28.2	50.52	-	-	-	-	68.2	-17.68	244	122	V
	6.171	33.49	ADR	35.3	-28.2	40.59	-	-	-	-	-	-	244	122	V

* - indicates frequency in CFR15.205/IC8.10 Restricted Band

PK-U - U-NII: Maximum Peak

ADR - U-NII AD primary method, RMS average

MID CHANNEL HARMONICS AND SPURIOUS EMISSIONS

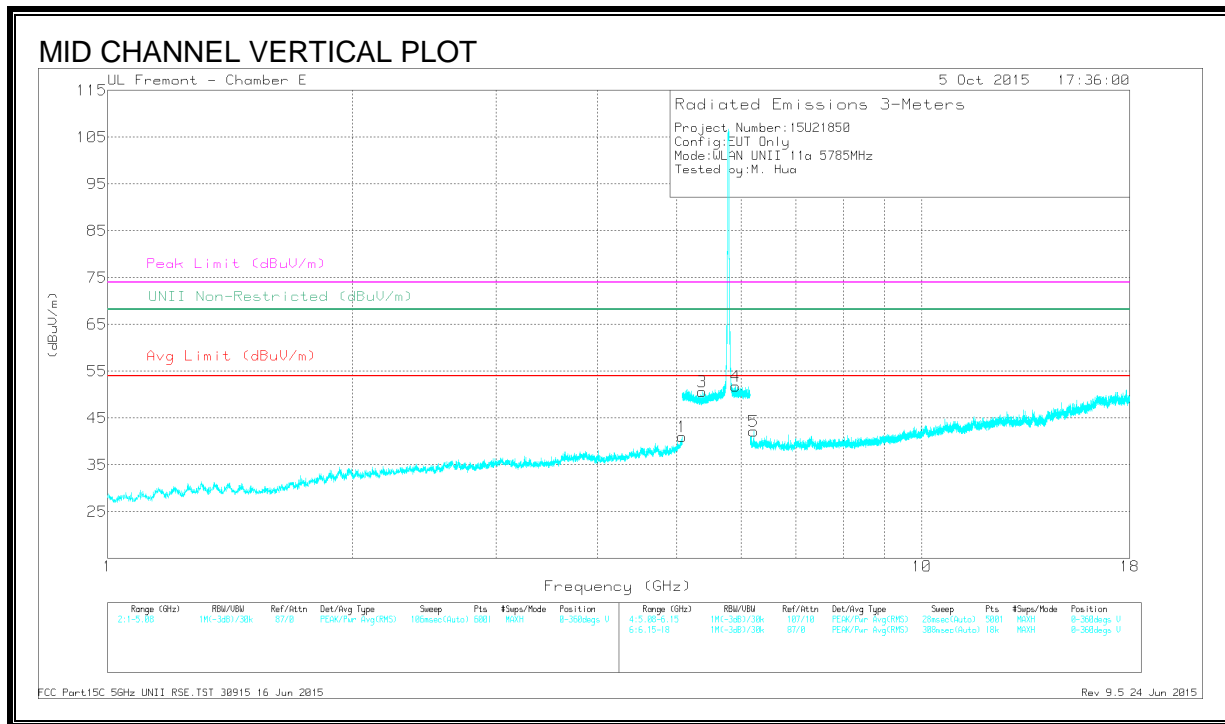
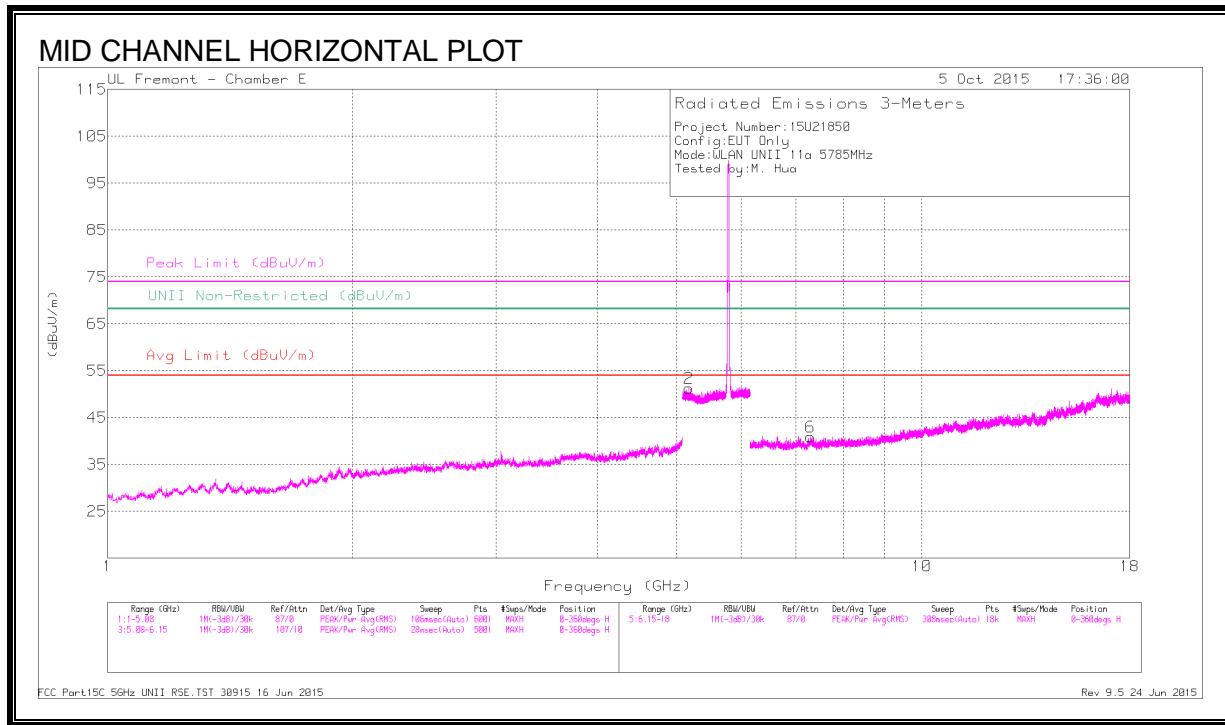

DATA

Marker	Frequency (GHz)	Meter Reading (dBuV)	Det	AF T346 (dB/m)	Amp/Cbl/FI tr/Pad (dB)	Corrected Reading (dBuV/m)	Avg Limit (dBuV/m)	Margin (dB)	Peak Limit (dBuV/m)	PK Margin (dB)	UNII Non-Restricted (dBuV/m)	PK Margin (dB)	Azimuth (Degs)	Height (cm)	Polarity
1	* 5.078	41.22	PK-U	34.2	-27.0	48.42	-	-	74	-25.58	-	-	32	156	V
	* 5.078	29.63	ADR	34.2	-27.0	36.83	54	-17.17	-	-	-	-	32	156	V
2	5.175	40.86	PK-U	34.4	-20.3	54.96	-	-	-	-	68.2	-13.24	117	194	H
3	* 5.370	40.73	PK-U	34.6	-20.6	54.73	-	-	74	-19.27	-	-	47	309	V
	* 5.368	29.12	ADR	34.6	-20.6	43.12	54	-10.88	-	-	-	-	47	309	V
4	5.905	43.02	PK-U	34.9	-20.3	57.62	-	-	-	-	68.2	-10.58	66	255	V
5	6.214	42.58	PK-U	35.4	-28.0	49.98	-	-	-	-	68.2	-18.22	57	106	V
6	* 7.301	38.12	PK-U	35.5	-26.1	47.52	-	-	74	-26.48	-	-	66	362	H
	* 7.298	26.57	ADR	35.5	-26.2	35.87	54	-18.13	-	-	-	-	66	362	H

* - indicates frequency in CFR15.205/IC8.10 Restricted Band

PK-U - U-NII: Maximum Peak

ADR - U-NII AD primary method, RMS average

HIGH CHANNEL HARMONICS AND SPURIOUS EMISSIONS

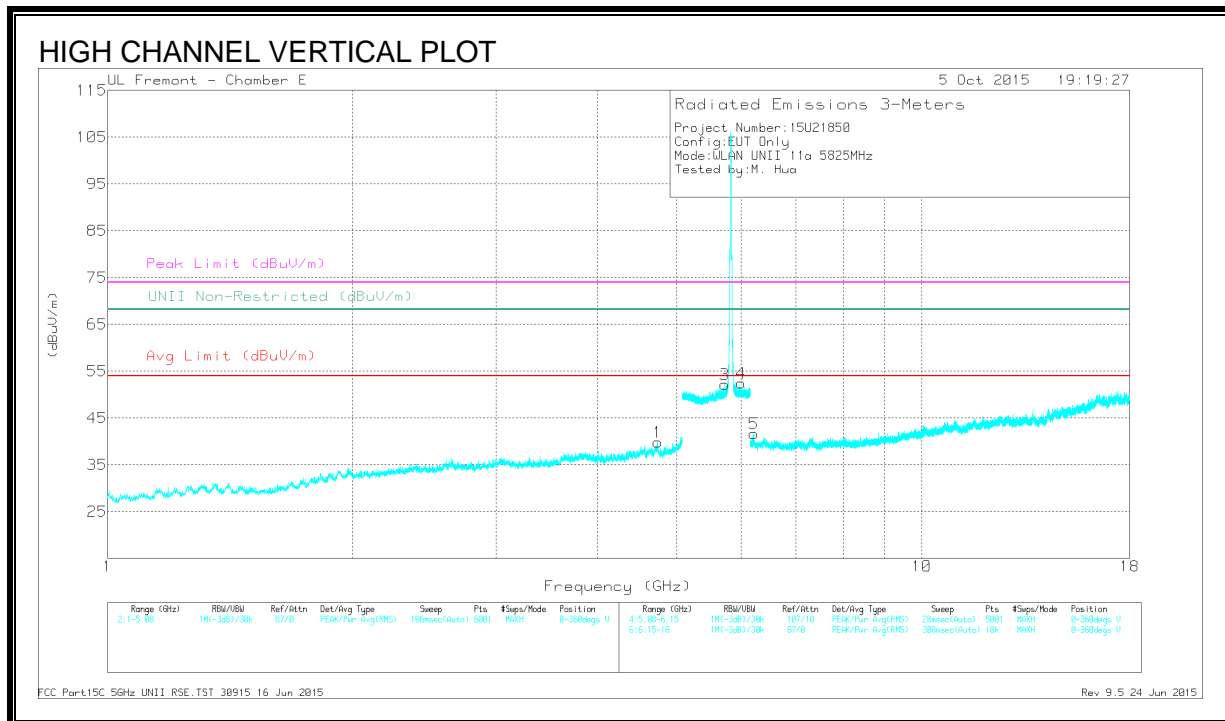
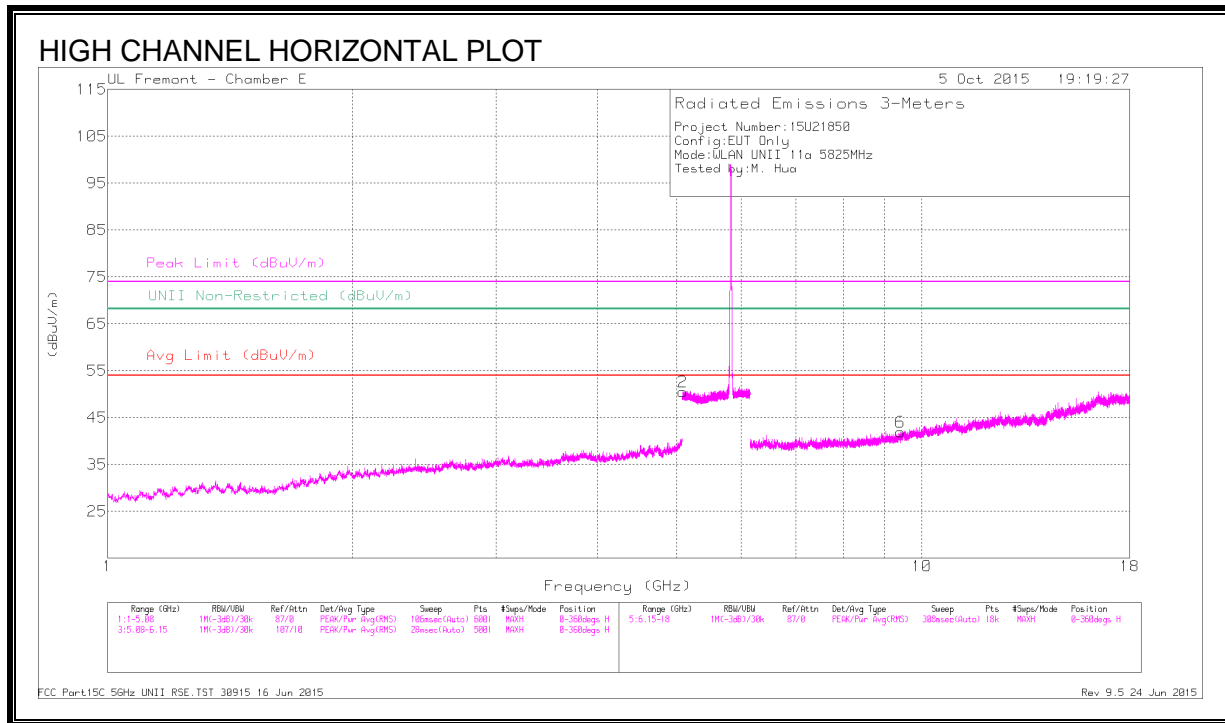

DATA

Markers	Frequency (GHz)	Meter Reading (dBuV)	Det	AF T346 (dB/m)	Amp/Cbl/FI tr/Pad (dB)	Corrected Reading (dBuV/m)	Avg Limit (dBuV/m)	Margin (dB)	Peak Limit (dBuV/m)	PK Margin (dB)	UNII Non-Restricted (dBuV/m)	PK Margin (dB)	Azimuth (Degs)	Height (cm)	Polarity
1	* 4.736	40.60	PK-U	34.1	-28.9	45.80	-	-	74	-28.20	-	-	24	304	V
	* 4.735	29.28	ADR	34.2	-28.9	34.58	54	-19.42	-	-	-	-	24	304	V
2	* 5.087	41.49	PK-U	34.2	-20.6	55.09	-	-	74	-18.91	-	-	87	283	H
	* 5.086	29.56	ADR	34.2	-20.6	43.16	54	-10.84	-	-	-	-	87	283	H
3	5.729	43.49	PK-U	34.7	-20.1	58.09	-	-	-	-	68.2	-10.11	52	318	V
4	5.999	41.20	PK-U	35.1	-19.9	56.40	-	-	-	-	68.2	-11.80	69	142	V
5	6.213	41.98	PK-U	35.4	-28.0	49.38	-	-	-	-	68.2	-18.82	62	176	V
6	* 9.401	37.95	PK-U	36.6	-26.3	48.25	-	-	74	-25.75	-	-	235	158	H
	* 9.402	26.40	ADR	36.6	-26.3	36.70	54	-17.30	-	-	-	-	235	158	H

* - indicates frequency in CFR15.205/IC8.10 Restricted Band

PK-U - U-NII: Maximum Peak

ADR - U-NII AD primary method, RMS average

9.2.2. CHAIN 1, RESTRICTED BANDEGE AND HARMONIC SPURIOUS

LOW CHANNEL

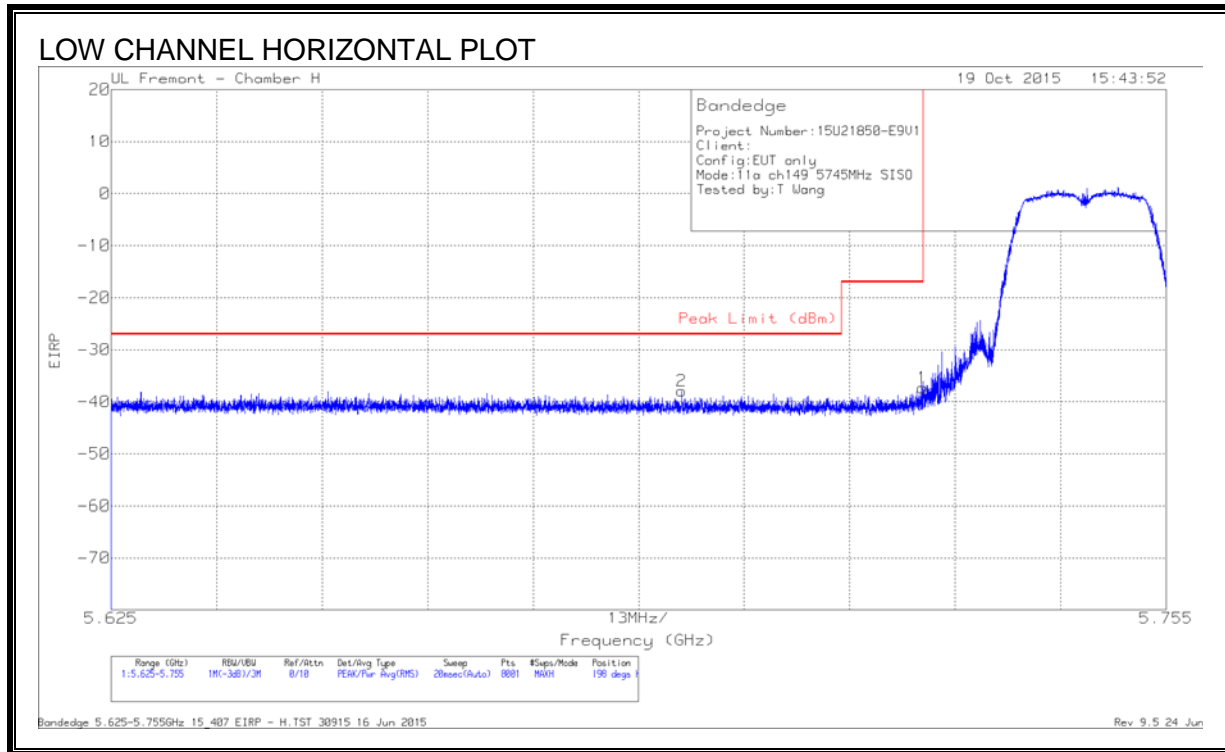

DATA

Marker	Frequency (GHz)	Meter Reading (dBm)	Det	AF T863 (dB/m)	Amp/Cbl/F ltr/Pad (dB)	Conversion Factor (dB)	Corrected Reading EIRP	Peak Limit (dBm)	PK Margin (dB)	Azimuth (Degs)	Height (cm)	Polarity
2	5.695	-63.23	Pk	34.8	-21.3	11.8	-37.93	-27	-10.93	198	310	H
1	5.725	-62.62	Pk	34.8	-21.3	11.8	-37.32	-17	-20.32	198	310	H

Pk - Peak detector

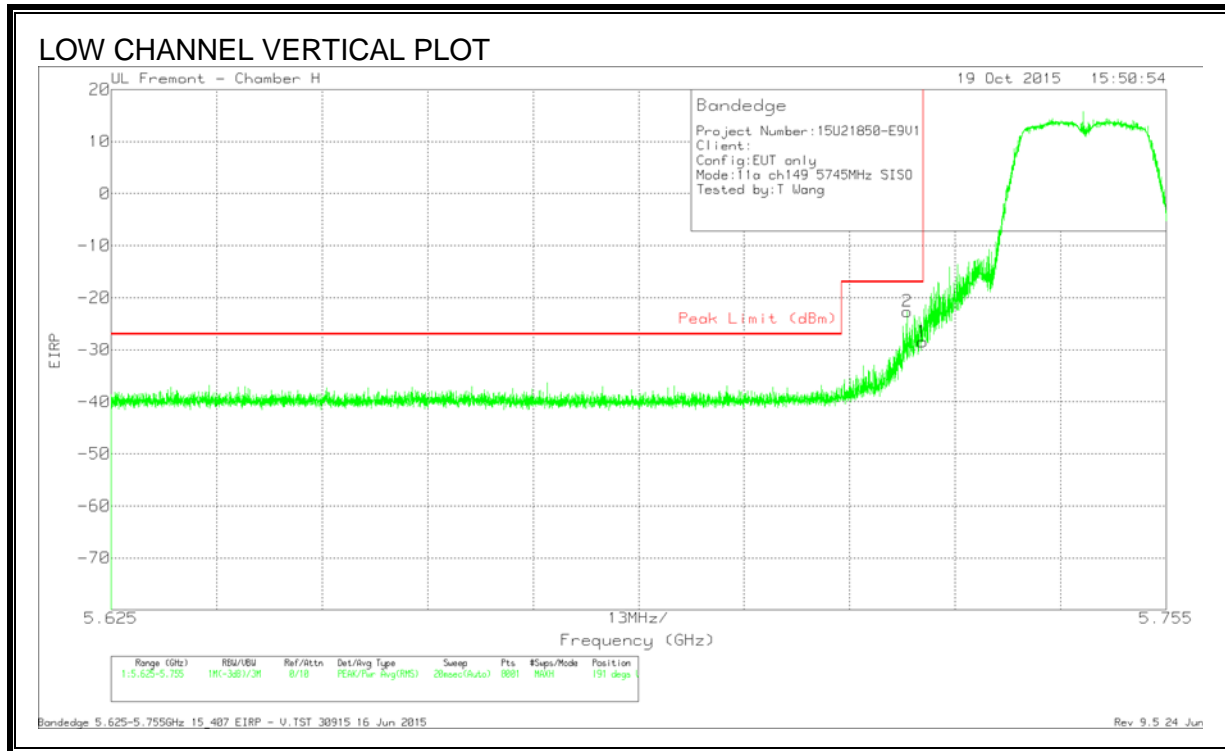

DATA

Marker	Frequency (GHz)	Meter Reading (dBm)	Det	AF T863 (dB/m)	Amp/Cbl/F ltr/Pad (dB)	Conversion Factor (dB)	Corrected Reading EIRP	Peak Limit (dBm)	PK Margin (dB)	Azimuth (Degs)	Height (cm)	Polarity
2	5.723	-47.93	Pk	34.8	-21.3	11.8	-22.63	-17	-5.63	191	299	V
1	5.725	-53.74	Pk	34.8	-21.3	11.8	-28.44	-17	-11.44	191	299	V

Pk - Peak detector

RESTRICTED BANDEDGE, CHAIN 1 (HIGH CHANNEL)

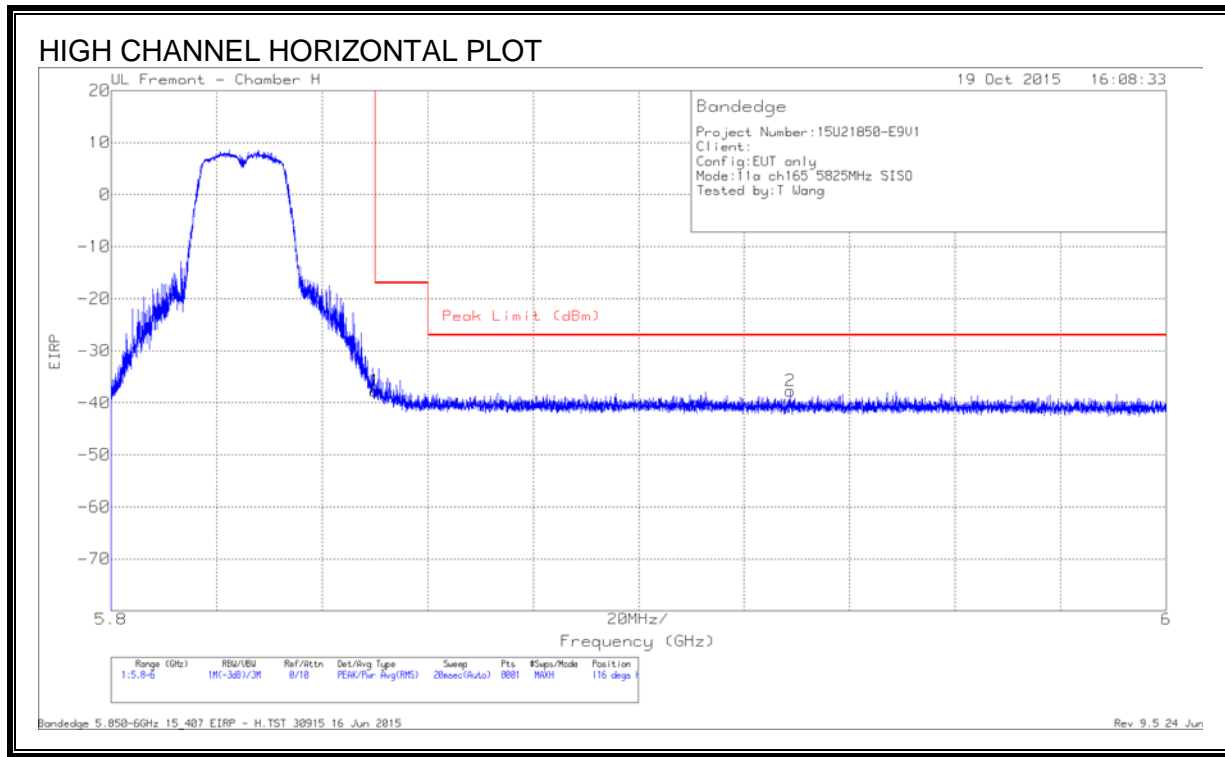

DATA

Marker	Frequency (GHz)	Meter Reading (dBm)	Det	AF T863 (dB/m)	Amp/Cbl/F Itr/Pad (dB)	Conversion Factor (dB)	Corrected Reading EIRP	Peak Limit (dBm)	PK Margin (dB)	Azimuth (Degs)	Height (cm)	Polarity
1	5.85	-63.23	Pk	34.9	-21.2	11.8	-37.73	-17	-20.73	116	128	H
2	5.929	-63.42	Pk	35.1	-21.2	11.8	-37.72	-27	-10.72	116	128	H

Pk - Peak detector

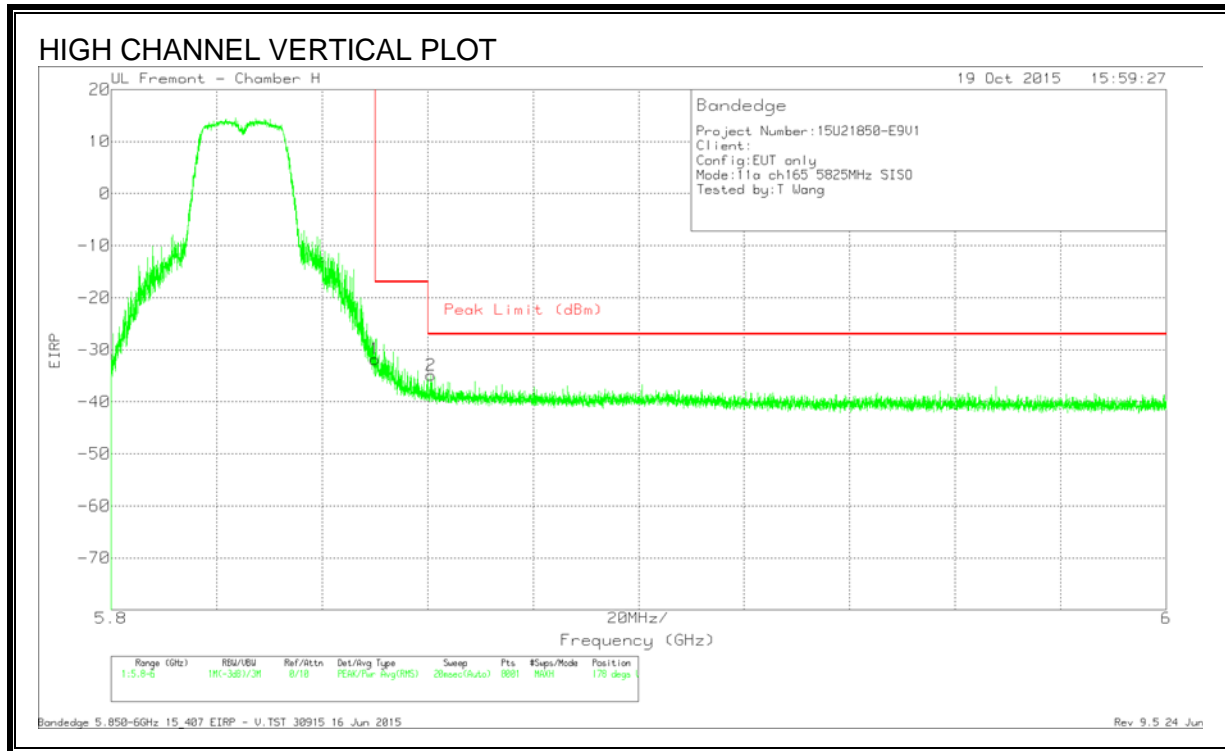

DATA

Marker	Frequency (GHz)	Meter Reading (dBm)	Det	AF T863 (dB/m)	Amp/Cbl/F ltr/Pad (dB)	Conversion Factor (dB)	Corrected Reading EIRP	Peak Limit (dBm)	PK Margin (dB)	Azimuth (Degs)	Height (cm)	Polarity
1	5.85	-57.31	Pk	34.9	-21.2	11.8	-31.81	-17	-14.81	178	189	V
2	5.861	-60.4	Pk	34.9	-21.2	11.8	-34.9	-27	-7.9	178	189	V

Pk - Peak detector

LOW CHANNEL HARMONICS AND SPURIOUS EMISSIONS

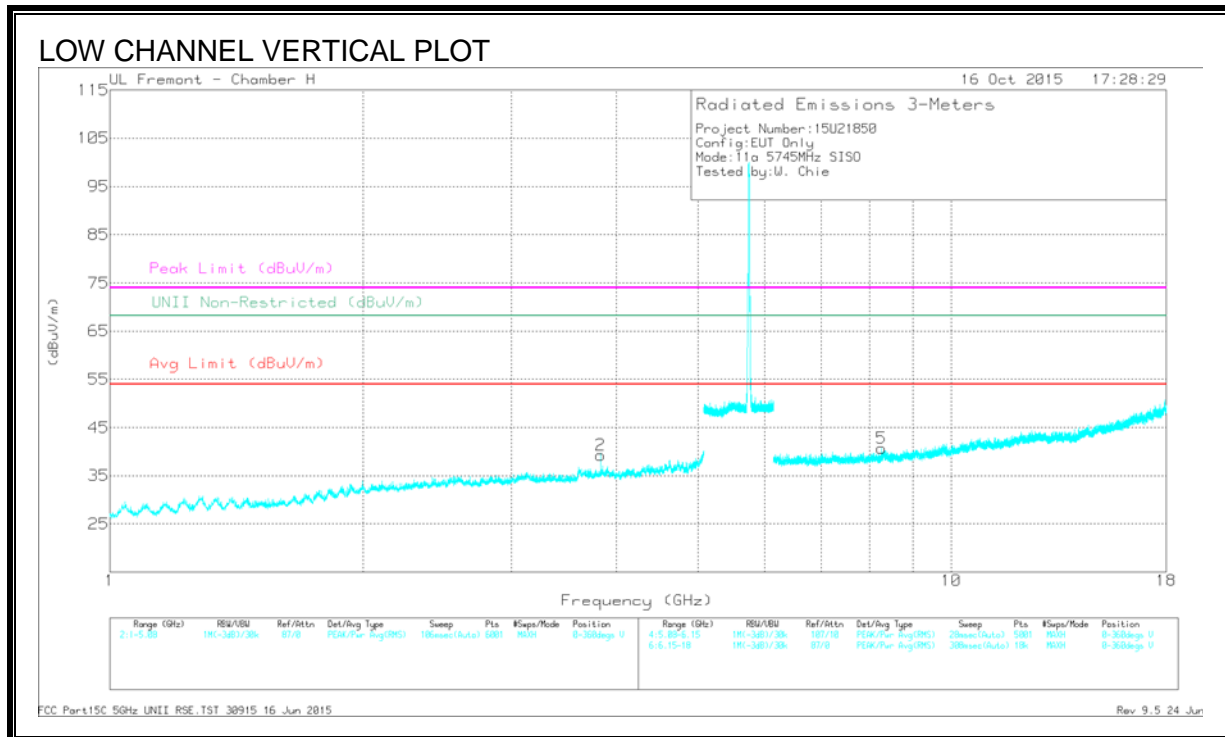
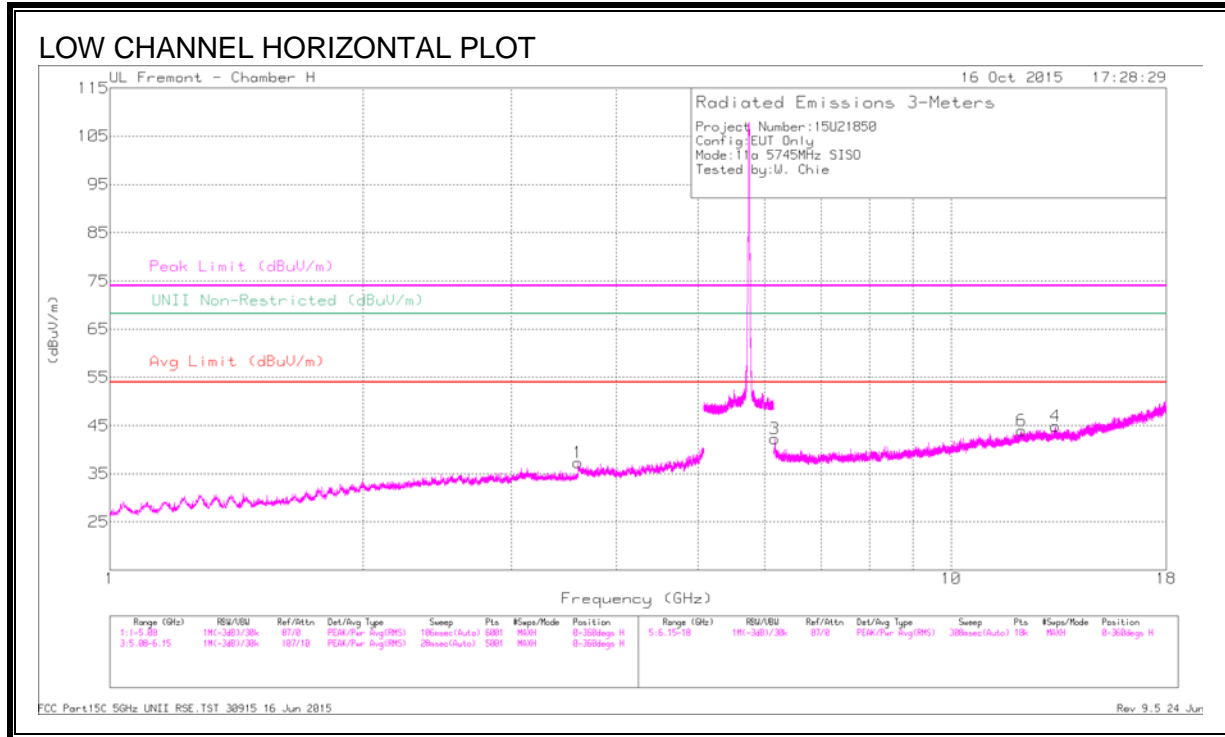

DATA

Marker	Frequency (GHz)	Meter Reading (dBuV)	Det	AF T863 (dB/m)	Amp/Cb/FI tr/Pad (dB)	Corrected Reading (dBuV/m)	Avg Limit (dBuV/m)	Margin (dB)	Peak Limit (dBuV/m)	PK Margin (dB)	UNII Non-Restricted (dBuV/m)	PK Margin (dB)	Azimuth (Degs)	Height (cm)	Polarity
1	* 3.604	41.59	PK-U	33	-31.7	42.89	-	-	74	-31.11	-	-	258	304	H
	* 3.604	30.23	ADR	33	-31.7	31.53	54	-22.47	-	-	-	-	258	304	H
2	* 3.83	44.87	PK-U	33.5	-31.6	46.77	-	-	74	-27.23	-	-	205	218	V
	* 3.83	37.4	ADR	33.5	-31.6	39.3	54	-14.7	-	-	-	-	205	218	V
4	* 13.3	36.13	PK-U	39.5	-24.6	51.03	-	-	74	-22.97	-	-	153	179	H
	* 13.3	24.48	ADR	39.5	-24.6	39.38	54	-14.62	-	-	-	-	153	179	H
6	* 12.117	35.97	PK-U	38.9	-24.1	50.77	-	-	74	-23.23	-	-	216	221	H
	* 12.115	23.99	ADR	38.9	-24.1	38.79	54	-15.21	-	-	-	-	216	221	H
5	* 8.256	38.56	PK-U	35.9	-27.5	46.96	-	-	74	-27.04	-	-	268	201	V
	* 8.254	26.74	ADR	35.9	-27.5	35.14	54	-18.86	-	-	-	-	268	201	V
3	6.171	44.18	PK-U	35.4	-29.3	50.28	-	-	-	-	68.2	-17.92	257	234	H

* - indicates frequency in CFR15.205/IC7.2.2 Restricted Band

PK-U - U-NII: Maximum Peak

ADR - U-NII AD primary method, RMS average

MID CHANNEL HARMONICS AND SPURIOUS EMISSIONS

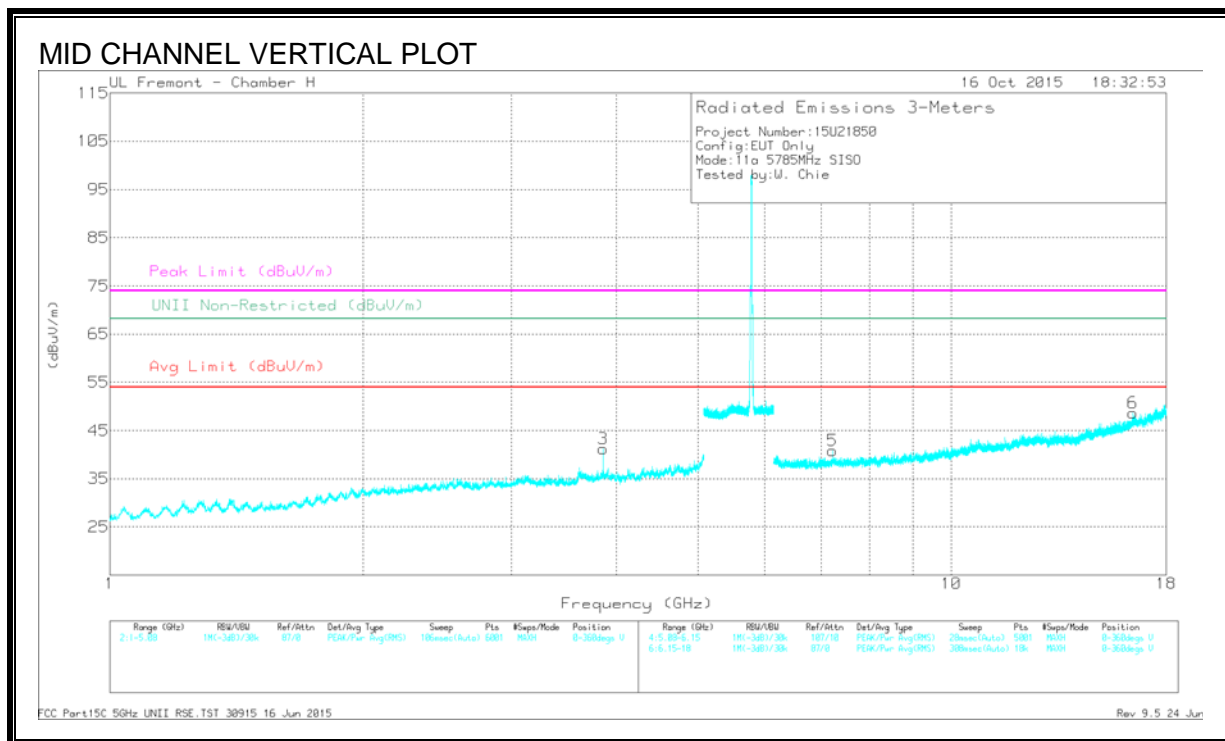
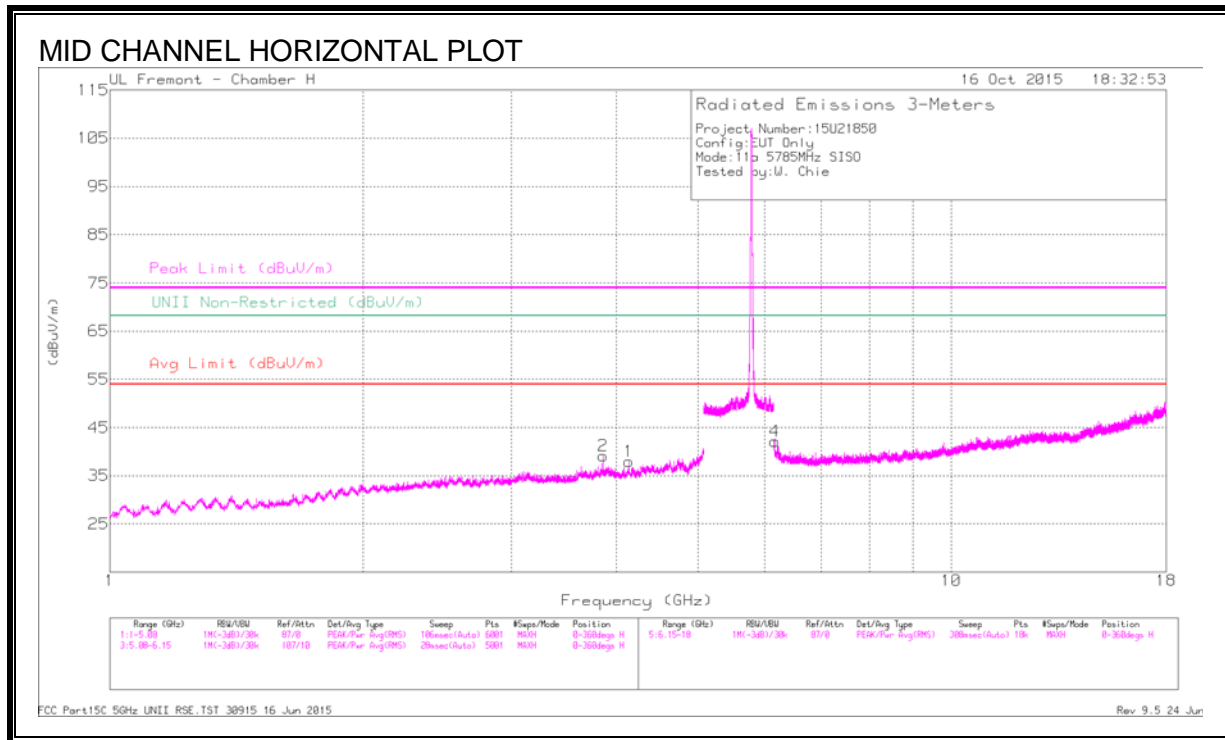

DATA

Marker	Frequency (GHz)	Meter Reading (dBuV)	Det	AFT863 (dB/m)	Amp/Cbl/FI tr/Pad (dB)	Corrected Reading (dBuV/m)	Avg Limit (dBuV/m)	Margin (dB)	Peak Limit (dBuV/m)	PK Margin (dB)	UNII Non-Restricted (dBuV/m)	PK Margin (dB)	Azimuth (Degs)	Height (cm)	Polarity
1	* 4.136	41.69	PK-U	33.5	-30.9	44.29	-	-	74	-29.71	-	-	209	238	H
	* 4.136	29.68	ADR	33.5	-30.9	32.28	54	-21.72	-	-	-	-	209	238	H
2	* 3.857	43.95	PK-U	33.5	-31.6	45.85	-	-	74	-28.15	-	-	116	164	H
	* 3.857	35.76	ADR	33.5	-31.6	37.66	54	-16.34	-	-	-	-	116	164	H
3	* 3.857	45.32	PK-U	33.5	-31.6	47.22	-	-	74	-26.78	-	-	186	206	V
	* 3.857	38.88	ADR	33.5	-31.6	40.78	54	-13.22	-	-	-	-	186	206	V
4	6.164	44.71	PK-U	35.4	-29.4	50.71	-	-	-	-	68.2	-17.49	114	172	H
5	7.222	39.1	PK-U	35.9	-28.4	46.6	-	-	-	-	68.2	-21.6	134	213	V
6	16.415	34.78	PK-U	41.6	-22.2	54.18	-	-	-	-	68.2	-14.02	141	123	V

* - indicates frequency in CFR15.205/IC7.2.2 Restricted Band

PK-U - U-NII: Maximum Peak

ADR - U-NII AD primary method, RMS average

HIGH CHANNEL HARMONICS AND SPURIOUS EMISSIONS

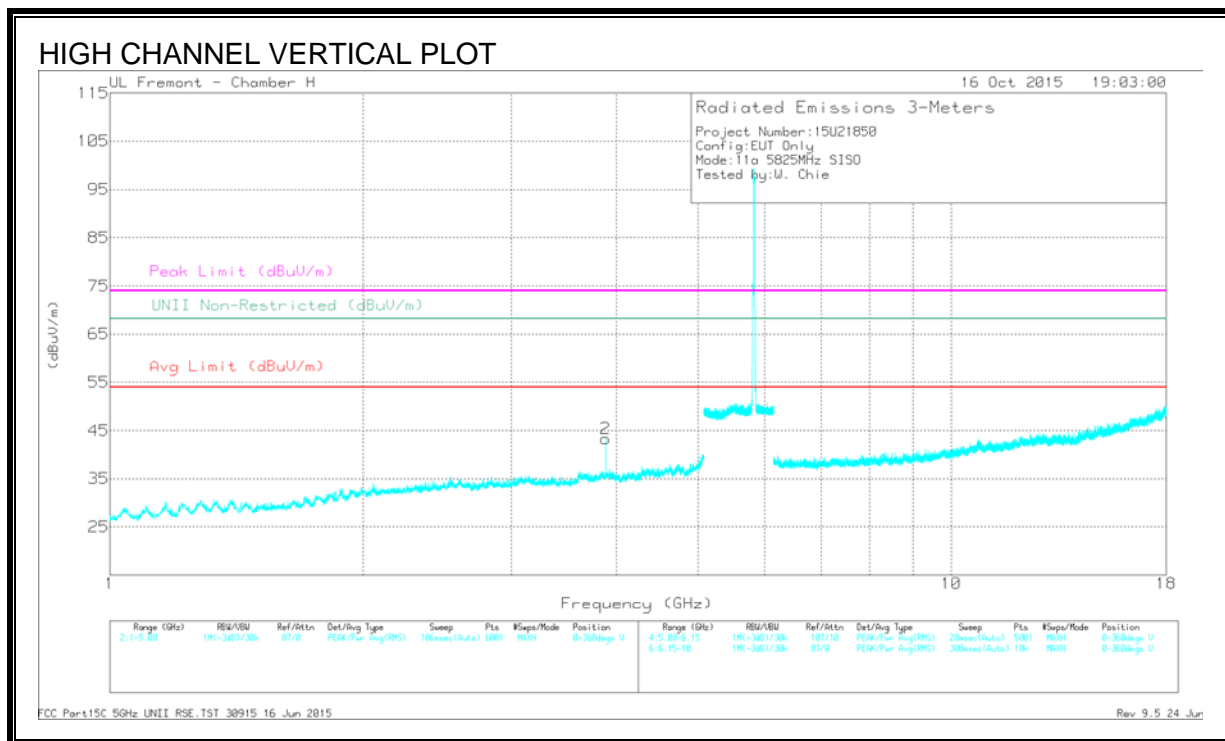
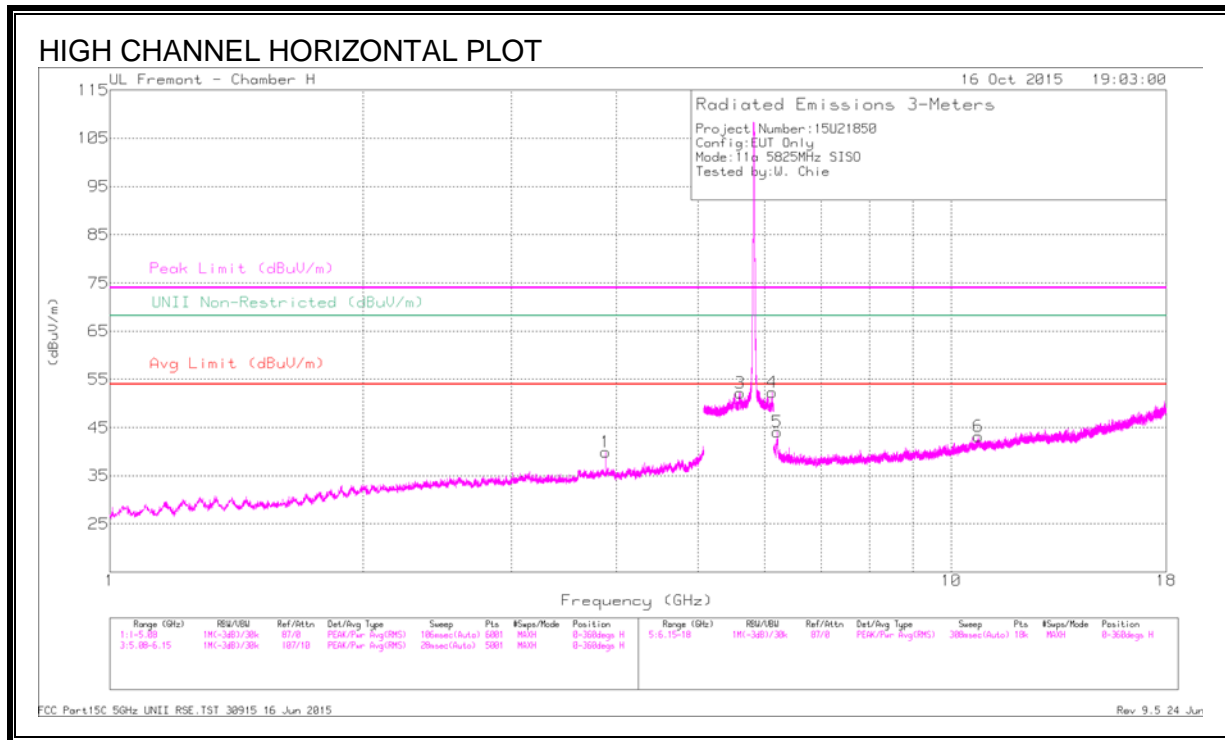

DATA

Marker	Frequency (GHz)	Meter Reading (dBuV)	Det	AFT863 (dB/m)	Amp/Cbl/FI tr/Pad (dB)	Corrected Reading (dBuV/m)	Avg Limit (dBuV/m)	Margin (dB)	Peak Limit (dBuV/m)	PK Margin (dB)	UNII Non-Restricted (dBuV/m)	PK Margin (dB)	Azimuth (Degs)	Height (cm)	Polarity
1	* 3.883	44.87	PK-U	33.6	-31.8	46.67	-	-	74	-27.33	-	-	261	143	H
	* 3.883	37.38	ADR	33.6	-31.8	39.18	54	-14.82	-	-	-	-	261	143	H
2	* 3.883	46.63	PK-U	33.6	-31.8	48.43	-	-	74	-25.57	-	-	166	102	V
	* 3.883	40.94	ADR	33.6	-31.8	42.74	54	-11.26	-	-	-	-	166	102	V
6	* 10.763	35.67	PK-U	37.9	-24.2	49.37	-	-	74	-24.63	-	-	245	399	H
	* 10.763	24.1	ADR	37.9	-24.2	37.8	54	-16.2	-	-	-	-	245	399	H
3	5.608	46.3	PK-U	35	-21.5	59.8	-	-	-	-	68.2	-8.4	207	124	H
4	6.119	44.79	PK-U	35.4	-21	59.19	-	-	-	-	68.2	-9.01	214	236	H
5	6.213	44.63	PK-U	35.5	-29.5	50.63	-	-	-	-	68.2	-17.57	169	231	H

* - indicates frequency in CFR15.205/IC7.2.2 Restricted Band

PK-U - U-NII: Maximum Peak

ADR - U-NII AD primary method, RMS average