



HP Envy Notebook 17
Models 17-s000 – 17-s099
Intel Models

Maintenance and Service Guide

© Copyright 2015 HP Development Company, L.P.

Bluetooth is a trademark owned by its proprietor and used by Hewlett-Packard Company under license. Intel, Core and Pentium are trademarks of Intel Corporation in the U.S. and other countries. Microsoft and Windows are U.S. registered trademarks of the Microsoft group of companies.

The information contained herein is subject to change without notice. The only warranties for HP products and services are set forth in the express warranty statements accompanying such products and services. Nothing herein should be construed as constituting an additional warranty. HP shall not be liable for technical or editorial errors or omissions contained herein.

Second Edition: August 2015

First Edition: June 2015

Document Part Number: 842269-001

Product notice

This guide describes features that are common to most models. Some features may not be available on your computer.

Not all features are available on all editions of Windows. This computer may require upgraded and/or separately purchased hardware, drivers, and/or software to take full advantage of Windows functionality. See <http://www.microsoft.com> for details.

Safety warning notice

 **WARNING!** To reduce the possibility of heat-related injuries or of overheating the device, do not place the device directly on your lap or obstruct the device air vents. Use the device only on a hard, flat surface. Do not allow another hard surface, such as an adjoining optional printer, or a soft surface, such as pillows or rugs or clothing, to block airflow. Also, do not allow the AC adapter to contact the skin or a soft surface, such as pillows or rugs or clothing, during operation. The device and the AC adapter comply with the user-accessible surface temperature limits defined by the International Standard for Safety of Information Technology Equipment (IEC 60950-1).

Table of contents

1 Product description	1
2 External component identification	5
Right side	5
Display	6
Top	7
TouchPad	7
Lights	8
Buttons and speakers	9
Keys	10
Bottom	11
Labels	11
3 Illustrated parts catalog	13
Computer major components	13
Display assembly subcomponents	16
Miscellaneous parts	17
Mass storage devices	18
4 Removal and replacement procedures preliminary requirements	19
Tools required	19
Service considerations	19
Plastic parts	19
Cables and connectors	19
Drive handling	20
Grounding guidelines	20
Electrostatic discharge damage	20
Packaging and transporting guidelines	21
Workstation guidelines	21
5 Removal and replacement procedures for Customer Self-Repair parts	23
Component replacement procedures	23
Battery	23
Optical drive	24

6 Removal and replacement procedures for Authorized Service Provider parts	27
Component replacement procedures	27
Bottom cover	28
Remove Display	30
Hard drive	31
WLAN module	33
RTC battery	35
Memory module	36
Fan	37
Heat sink assembly	38
Optical drive connector	42
System board	43
USB board	46
Speakers	47
Power button board	48
Power connector	49
TouchPad	50
Display assembly, touch	51
7 Using Setup Utility (BIOS)	57
Starting Setup Utility (BIOS)	57
Updating Setup Utility (BIOS)	57
Determining the BIOS version	57
Downloading a BIOS update	58
8 Using HP PC Hardware Diagnostics (UEFI)	59
Downloading HP PC Hardware Diagnostics (UEFI) to a USB device	59
9 Specifications	61
Computer specifications	61
43.9-cm (17.3-in) display specifications	62
Hard drive specifications	63
DVD±RW SuperMulti DL Drive specifications	64
10 Backing up, restoring, and recovering	65
Creating recovery media and backups	65
Creating HP Recovery media (select products only)	65
Using Windows tools	66
Restore and recovery	66
Recovering using HP Recovery Manager	67

What you need to know before you get started	67
Using the HP Recovery partition (select products only)	68
Using HP Recovery media to recover	68
Changing the computer boot order	68
Removing the HP Recovery partition (select products only)	70
11 Power cord set requirements	71
Requirements for all countries	71
Requirements for specific countries and regions	72
12 Recycling	75
Index	77

1 Product description

Category	Description
Product name	HP Envy Notebook 17
Processors	6th generation Intel® Core™ i7 Processor (SKL-H, 2-chip BGA) Intel Core i7-6700U (2.6 GHz, turbo up to 3.5 GHz), 1600 MHz/6 MB L3, quad core 45 W (cTDP to 35 W) 6th generation Intel Core i7 Processor Intel Core i7-6500U (2.5 GHz, SC turbo up to 3.1 GHz), 1600 MHz/4 MB L3, dual core 15 W 6th generation Intel Core i5 Processor Intel Core i5-6200U (2.3 GHz, SC turbo up to 2.8 GHz), 1600 MHz/3 MB L3, dual core 15 W
Chipset	Intel i7 processor 1-chip Integrated SoC PCH Intel HD Graphics Intel HM170
Graphics	Internal graphics: Intel HD Graphics 520 Intel HD Graphics 530 Switchable discrete graphics: NVIDIA N16S-GT (GeForce 940M) with up to 2048 MB or 4096 MB of dedicated video memory (256Mx16 DDR3 900MHz x 4 PCs, 1GHz bridge to 900 MHz) Core i7 Supports HD Decode, DX12, and HDMI
Panel	16:9 Ultra Wide Aspect Ratio (43.9-cm 17.3in), FHD, WLED, SVA, (1920×1080) flat display, 4.0 mm; UWVA eDP. Touch screen with flush glass, multi-touch enabled Supports LVDS (co-layout with eDP1.3+PSR) Non-touch screen with flush glass Supports LVDS (co-layout with eDP1.3+PSR)
Memory	Two SODIMM slots - non-customer accessible / upgradeable DDR3L-1600-MHz Dual Channel Support Supports up to 16 GB of system RAM in the following configurations: <ul style="list-style-type: none">• 16384 MB total system memory (8192×2)• 12288 MB total system memory (8192×1) + (4096×1)• 8192 MB total system memory (8192×1) or (4096×2)
Hard drives	Supports 6.35-cm (2.5-in) SATA hard drives in 9.5 mm (.37 in) and 7.0 mm (.28 in) thicknesses 7/9.5 mm share the same bracket Accelerometer / HDD protection support Single HDD configurations:





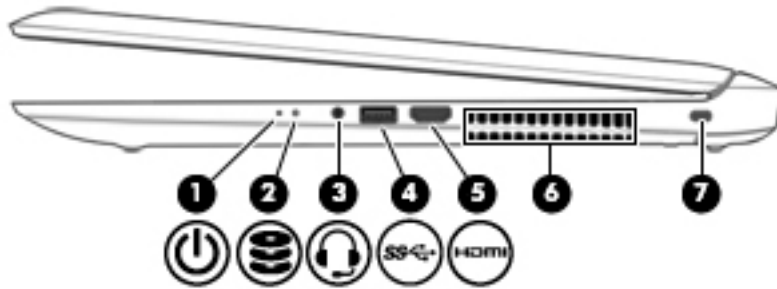

Category	Description
	<ul style="list-style-type: none"> • 2 TB, 5400-rpm, 9.5-mm • 1 TB, 5400-rpm, 9.5-mm <p>Hybrid HDD configurations:</p> <ul style="list-style-type: none"> • 1 TB, 5400-rpm, 9.5-mm SSHD w/8GB NAND
Optical drive	<p>Fixed, serial SATA, 9.5-mm tray load</p> <p>DVD+/-RW Double-Layer SuperMulti</p> <p>Supports zero power optical drive</p> <p>Supports M-disc</p> <p>External USB SATA, ODD (aluminum material)</p>
Audio/video	<p>HP TrueVision HD: HD camera (fixed, no tilt with activity LED, 1280×720 by 30 frames per second)</p> <p>Dual array digital microphone with appropriate software - beam forming, echo cancellation, noise suppression</p> <p>Dual speakers</p> <p>Enable HP Noise Cancellation</p> <p>HD audio</p> <p>Bang & Olufsen</p> <p>Supports Voice Recognition</p>
Sensors	<p>Accelerometer</p> <p>Gyroscope</p> <p>Digital Compass</p> <p>Ambient Light Sensor</p>
Ethernet	<p>Integrated 10/100 network interface card (NIC)</p>
Wireless	<p>Intel WiDi support</p> <p>Integrated Wireless options with dual antenna (M.2/PCIe)</p> <p>Compatible with Miracast-certified devices</p> <p>Intel Dual Band Wireless-AC 3165 802.11 ac 1x1 WiFi + Bluetooth 4.0 Combo Adapter</p>
Internal card expansion	<p>One M.2 slot for WLAN</p>
External media card	<p>HP Multi-Format Digital Media Card Reader</p> <p>Support SD/SDHC/SDXC</p> <p>Push-Push Insertion/Removal</p> <p>SIM slot (populated with WWAN; tool-less user accessible)</p>
Ports	<p>HDMI version 1.4 supporting up to 1920 × 1080 @ 60Hz</p> <p>Hot Plug/unplug and auto detect for correct output to wide-aspect vs. standard aspect video</p> <p>RJ-45 (Ethernet, includes link and activity lights)</p> <p>USB 3.0 (1 on left side, 1 on right side)</p> <p>USB 2.0 (1 on left side)</p> <p>AC Smart Pin adapter plug</p>

Category	Description
	<p>Headphone jack</p> <p>Microphone jack</p> <p>USB 2.0/3.0 Allocation:</p> <ul style="list-style-type: none"> • 3 for unit (2*3.0, 1*2.0) • 1 for camera (2.0) • 1 for WLAN (BT) (2.0) • 1 for touch screen (2.0) • RJ-45/Ethernet • AC Smart Pin adapter plug
Keyboard/ pointing devices	<p>Full size standard three coat paint island-style backlit keyboard with numeric keypad</p> <p>ClickPad with multi-touch gestures, 2-finger scrolling, and pinch-zoom enabled</p> <p>Taps enabled by default</p> <p>Supports modern trackpad gestures</p> <p>Stylus writing support</p>
Power requirements	<p>Battery:</p> <p>4 cell, 41 Whr, 2.8Ah, li-ion battery</p> <p>AC adapters:</p> <p>AC Adapter 65-W Smart nPFC, 3 pin, RC 4.5mm connector (models with discrete graphics only)</p> <p>AC Adapter 65-W EM Smart nPFC, 3 pin, RC 4.5mm connector (models with discrete graphics in India/China only)</p> <p>AC Adapter 45-W Smart nPFC, 3 pin, RC 4.5mm connector (models with UMA graphics only)</p> <p>1 meter power cord</p>
Security	Security Lock
Operating system	<p>Preinstalled:</p> <ul style="list-style-type: none"> • Windows 10 • Windows 10 Home High End ML
Serviceability	<p>End-user replaceable parts:</p> <ul style="list-style-type: none"> • AC adapter • Battery • Optical drive • Memory • Hard drive • MiniCard components • SIM Card (for WWAN)

2 External component identification

Right side



Component	Description
(1)  Power light	<ul style="list-style-type: none">On: The computer is on.Blinking: The computer is in the Sleep state, a power-saving state. The computer shuts off power to the display and other unneeded components.Off: The computer is off or in Hibernation. Hibernation is a power-saving state that uses the least amount of power.
(2)  Hard drive light	<ul style="list-style-type: none">Blinking white: The hard drive is being accessed.
(3)  Audio-out (headphone)/Audio-in (microphone) combo jack	<p>Connects optional powered stereo speakers, headphones, earbuds, a headset, or a television audio cable. Also connects an optional headset microphone. This jack does not support optional microphone-only devices.</p> <p>NOTE: When a device is connected to the jack, the computer speakers are disabled.</p> <p>NOTE: Be sure that the device cable has a 4-conductor connector that supports both audio-out (headphone) and audio-in (microphone).</p>
(4)  USB 3.0 port	Connects an optional USB device, such as a keyboard, mouse, external drive, printer, scanner or USB hub.
(5)  HDMI port	Connects an optional video or audio device, such as a high-definition television, any compatible digital or audio component, or a high-speed High-Definition Multimedia Interface (HDMI) device.
(6) Vent	Enables airflow to cool internal components. NOTE: The computer fan starts up automatically to cool internal components and prevent overheating. It is normal for the internal fan to cycle on and off during routine operation.
(7)  Security cable slot	Attaches an optional security cable to the computer.

NOTE: The security cable is designed to act as a deterrent, but it may not prevent the computer from being mishandled or stolen.

Display

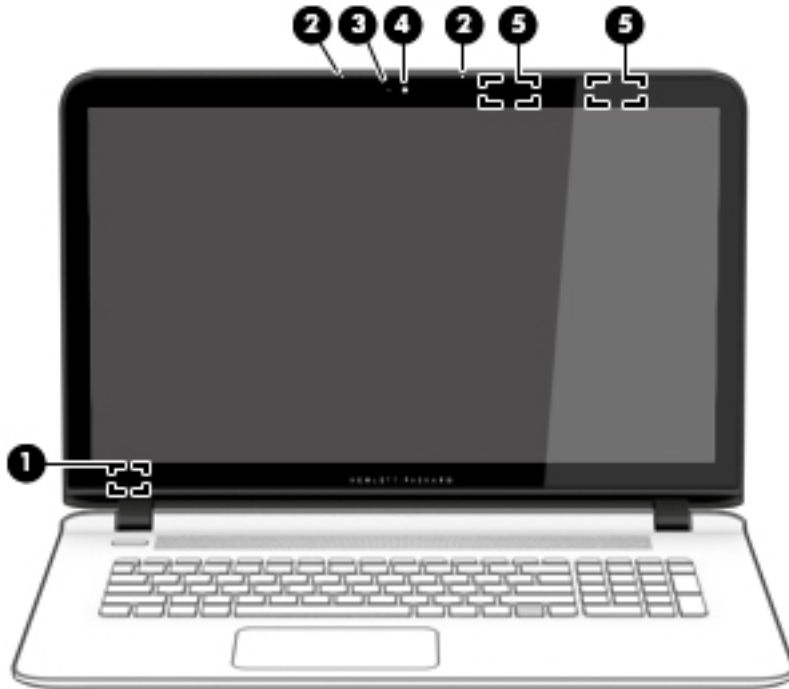

Component	Description
(1) Internal display switch	Turns off the display and initiates Sleep if the display is closed while the power is on. NOTE: The internal display switch is not visible from the outside of the computer.
(2) Internal microphones (2)	Records sound.
(3) Webcam light	On: The webcam is in use.
(4) Webcam	Records video and captures photographs. Some models allow you to video conference and chat online using streaming video.
(5) WLAN antennas* (2)	Sends and receives wireless signals to communicate with wireless local area networks (WLANs).

*The antennas are not visible from the outside of the computer. For optimal transmission, keep the areas immediately around the antennas free from obstructions.

For wireless regulatory notices, see the section of the *Regulatory, Safety, and Environmental Notices* that applies to your country or region.

Top

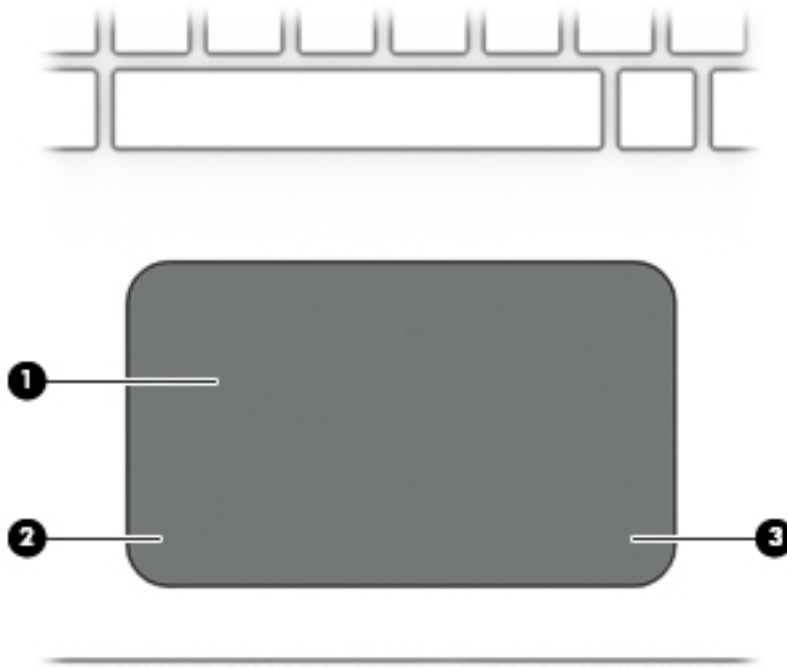

TouchPad

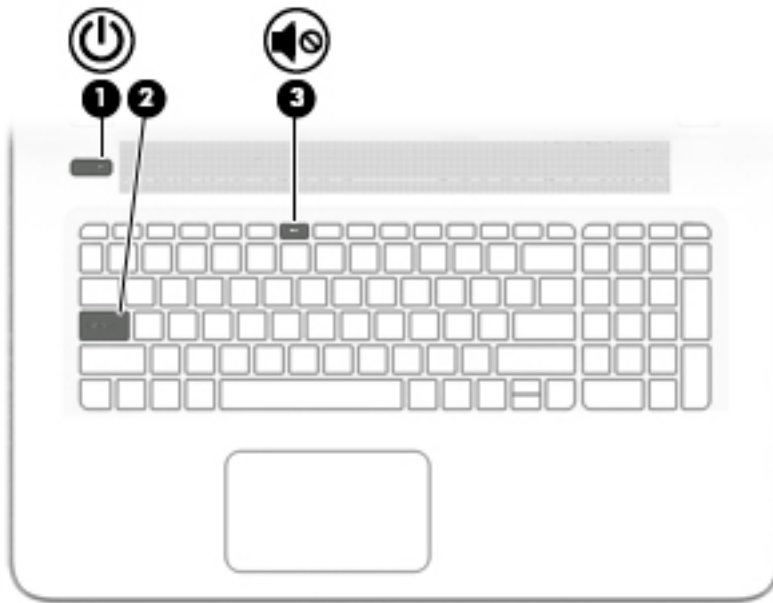

Component	Description
(1) TouchPad zone	Reads your finger gestures to move the pointer or activate items on the screen.
(2) Left TouchPad button	Functions like the left button on an external mouse.
(3) Right TouchPad button	Functions like the right button on an external mouse.

Lights



Component	Description
(1)  Power light	<ul style="list-style-type: none">• On: The computer is on.• Blinking: The computer is in the Sleep state, a power-saving state. The computer shuts off power to the display and other unneeded components.• Off: The computer is off or in Hibernation. Hibernation is a power-saving state that uses the least amount of power.
(2) Caps lock light	On: Caps lock is on, which switches the key input to all capital letters.
(3)  Mute light	<ul style="list-style-type: none">• Amber: Computer sound is off.• Off: Computer sound is on.

Buttons and speakers

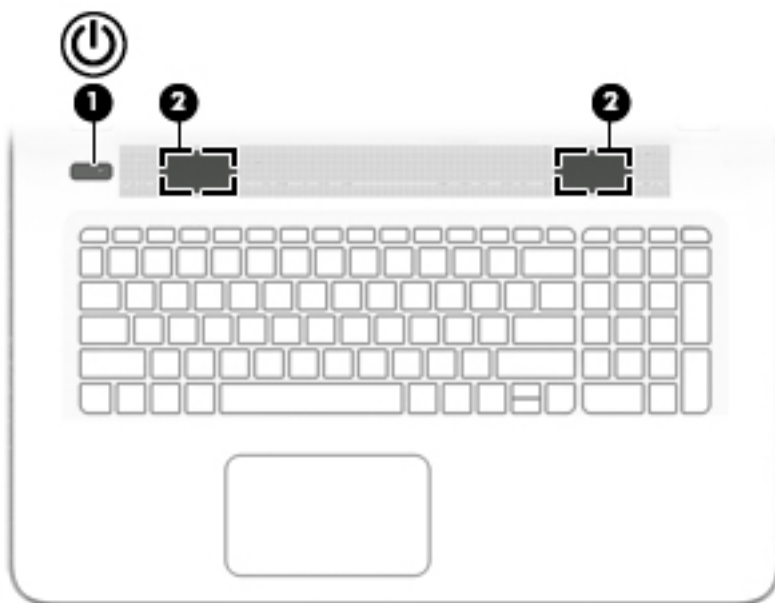

Component	Description
(1)  Power button	<ul style="list-style-type: none">• When the computer is off, press the button to turn on the computer.• When the computer is on, press the button briefly to initiate Sleep.• When the computer is in the Sleep state, press the button briefly to exit Sleep.• When the computer is in Hibernation, press the button briefly to exit Hibernation. <p>CAUTION: Pressing and holding down the power button results in the loss of unsaved information.</p> <p>If the computer has stopped responding and shutdown procedures are ineffective, press and hold the power button down for at least 5 seconds to turn off the computer.</p>
(2) Speakers (2)	Produce sound.

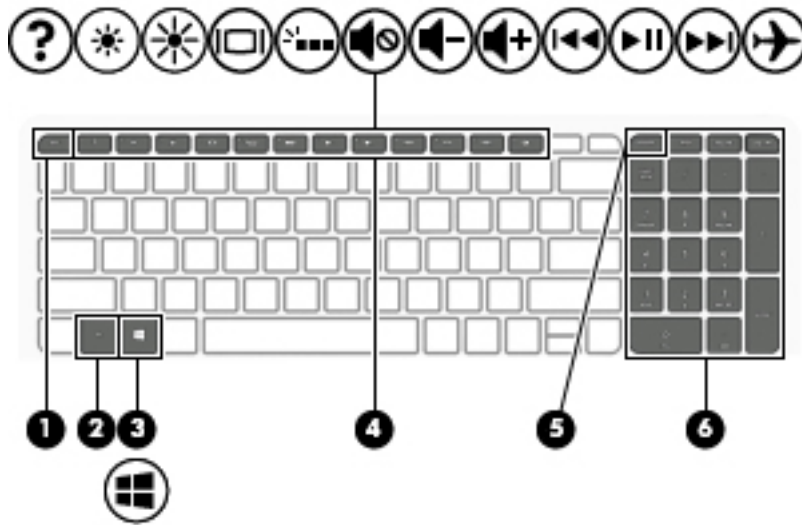

Keys

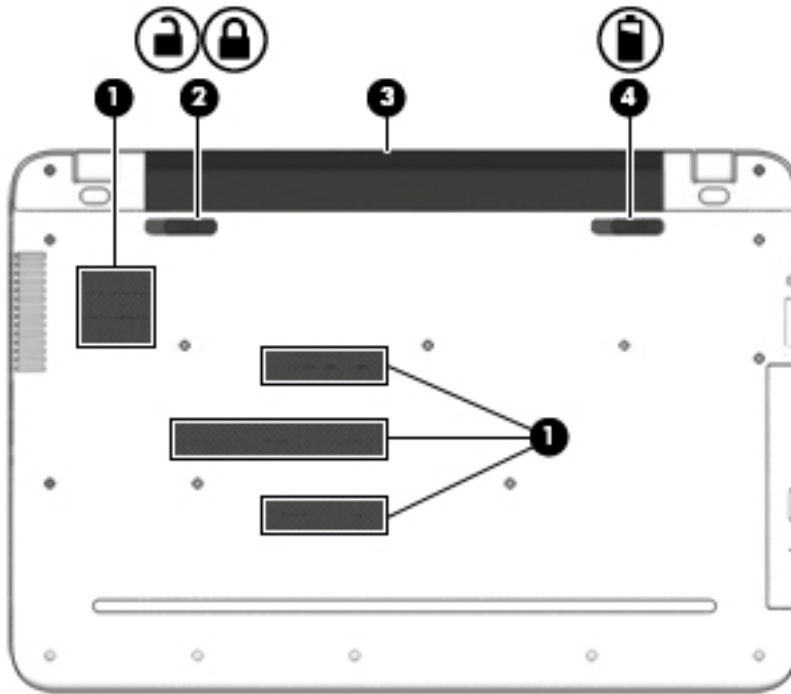

Component	Description
(1) esc key	Displays system information when pressed in combination with the fn key.
(2) fn key	Executes frequently used system functions when pressed in combination with the esc key, action keys, or the spacebar .
(3)  Windows key	Opens the Start menu. NOTE: Pressing the Windows key again will close the Start menu.
(4) Action keys	Execute frequently used system functions. NOTE: On select models, the f5 action key turns the backlight keyboard feature off or on.
(5) num lock key	Alternates between the navigational and numeric functions on the integrated numeric keypad.
(6) Integrated numeric keypad	When num lock is on, the keypad can be used like an external numeric keypad.

Bottom



Component		Description
(1)	Vents (4)	Enable airflow to cool internal components. NOTE: The computer fan starts up automatically to cool internal components and prevent overheating. It is normal for the internal fan to cycle on and off during routine operation.
(2)	 Battery lock	Locks the battery in the battery bay.
(3)	Battery bay	Holds the battery.
(4)	 Battery release latch	Releases the battery.

Labels

The labels affixed to the computer provide information you may need when you troubleshoot system problems or travel internationally with the computer.

 **IMPORTANT:** Check the following locations for the labels described in this section: the bottom of the computer, inside the battery bay, under the service door, or on the back of the display.

- **Service label**—Provides important information to identify your computer. When contacting support, you will probably be asked for the serial number, and possibly for the product number or the model number. Locate these numbers before you contact support.

Your service label will resemble one of the examples shown below. Refer to the illustration that most closely matches the service label on your computer.



Component

- (1) Serial number

- (2) Product number

- (3) Warranty period

- (4) Model number (select products only)

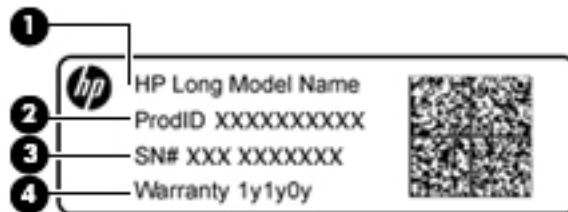

Component

- (1) Model name (select products only)

- (2) Product number

- (3) Serial Number

- (4) Warranty period

- Regulatory label(s)—Provide(s) regulatory information about the computer.
- Wireless certification label(s)—Provide(s) information about optional wireless devices and the approval markings for the countries or regions in which the devices have been approved for use.

3 Illustrated parts catalog

Computer major components

 **NOTE:** HP continually improves and changes product parts. For complete and current information on supported parts for your computer, go to <http://partsurfer.hp.com>, select your country or region, and then follow the on-screen instructions.

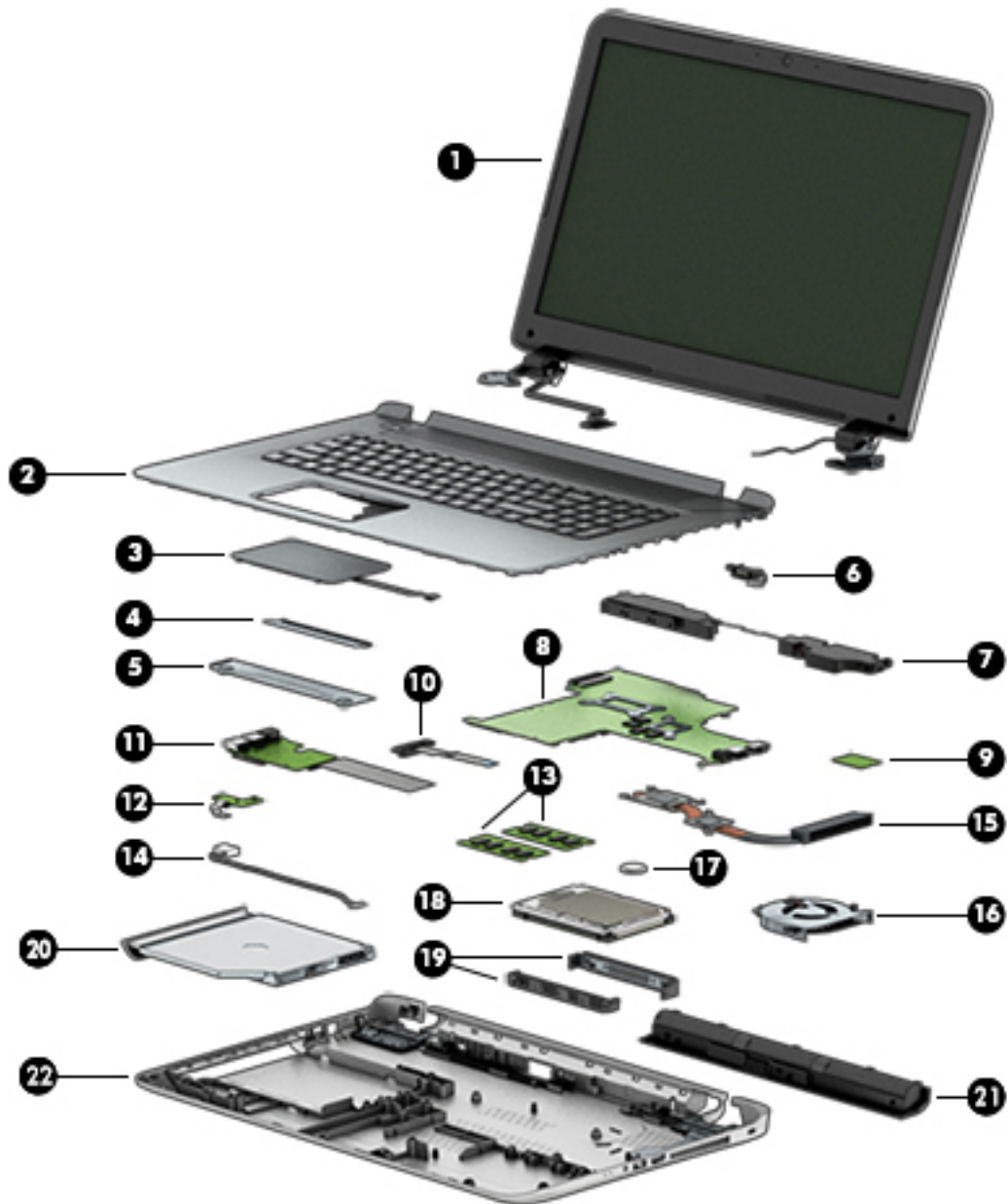

Item	Component	Spare part number
(1)	Display assembly [43.9-cm 17.3-in] HD/FHD, touch screen NOTE: Touch displays are spared both as entire hinge-ups and at the subcomponent level. NOTE: For display assembly spare part information, see Display assembly subcomponents on page 16 .	
	Antiglare FHD+ touch screen	835868-001
	Antiglare FHD+ non-touch screen	846890-001
(2)	Top cover/keyboard (ash silver) (the keyboard and top cover are spared together)	
	For use in the United States	835866-001
	Top cover/keyboard (black)	
	For use in the United States	835867-001
(3)	TouchPad	811552-001
(4)	TouchPad bracket (included with TouchPad)	
(5)	TouchPad rear bracket (included with TouchPad)	
(6)	Battery connector cable (includes the optical drive connector cable)	810928-001
(7)	Speakers (includes left and right speakers and cable)	809316-001
(8)	System board (includes replacement thermal materials): All system boards use the following part numbers: xxxxxx-001: Without the Windows operating system xxxxxx-601: Windows 10	
	For use in models with discrete graphics (NVIDIA N165-GT (GeForce 940M)):	
	• Intel Core i7-6500U WIN processor 4 GB of dedicated video memory	838262-601
	• Intel Core i7-6500U processor and 4 GB of dedicated video memory	838262-001
	• Intel Core i7-6500U WIN processor and 2 GB of dedicated video memory	838261-601
	• Intel Core i7-6500U processor and 2 GB of dedicated video memory	838261-001
	For use in models with UMA graphics	
	• Intel Core i5-6200U WIN processor	838260-601
	• Intel Core i5-6200U processor	838260-001
	• Intel Core i7-6500U WIN processor	841040-601
	• Intel Core i7-6500U processor	841040-001
	• Intel Core i7-6700HQ HM170 WIN processor	835869-601
	• Intel Core i7-6700HQ HM170 processor	835869-001
(9)	WLAN module:	
	Intel Dual Band Wireless-AC 3165 802.11 ac 1x1 WiFi + Bluetooth 4.0 Combo Adapter for Windows 10	806723-005
(10)	Optical Drive Connector Cable Kit (includes the battery connector cable)	810928-001

Item	Component	Spare part number
(11)	USB board for use with 6th generation processors (includes cable)	844489-001
	USB/Audio Cable	844490-001
(12)	Power button board (includes cable)	809310-001
(13)	Memory module (PC3L, 12800, 1600-MHz):	
	8 GB	693374-005
	4 GB	691740-005
(14)	Power connector cable	809295-001
(15)	Heat sink assembly (includes replacement thermal materials):	
	For use in models with discrete graphics 15 W	806827-001
	For use in models with UMA graphics 15 W	806826-001
	For use in models with UMA graphics 35 W	828817-001
(16)	Fan	806747-001
(17)	RTC battery	811080-001
(18)	Hard drive (does not include bracket):	
	2 TB, 5400-rpm, 2.5-inch	801808-005
	1 TB, 5400-rpm, 2.5-inch	778192-005
	1 TB, HDD 5400-rpm, RAW HYBRID 2.5-inch	731999-005
(19)	Hard drive bracket	809296-001
(20)	DVD+/-RW Double-Layer SuperMulti Drive	
	For use in natural silver models	809304-001
(21)	Battery (4-cell, 41-Whr, 2.8-Ah Li-ion)	800049-001
(22)	Bottom cover	
	For use in natural silver models	843589-001
	Base enclosure hinge caps (not pictured), (left and right)	809312-001
	Rubber screw covers (not pictured)	809314-001

Display assembly subcomponents

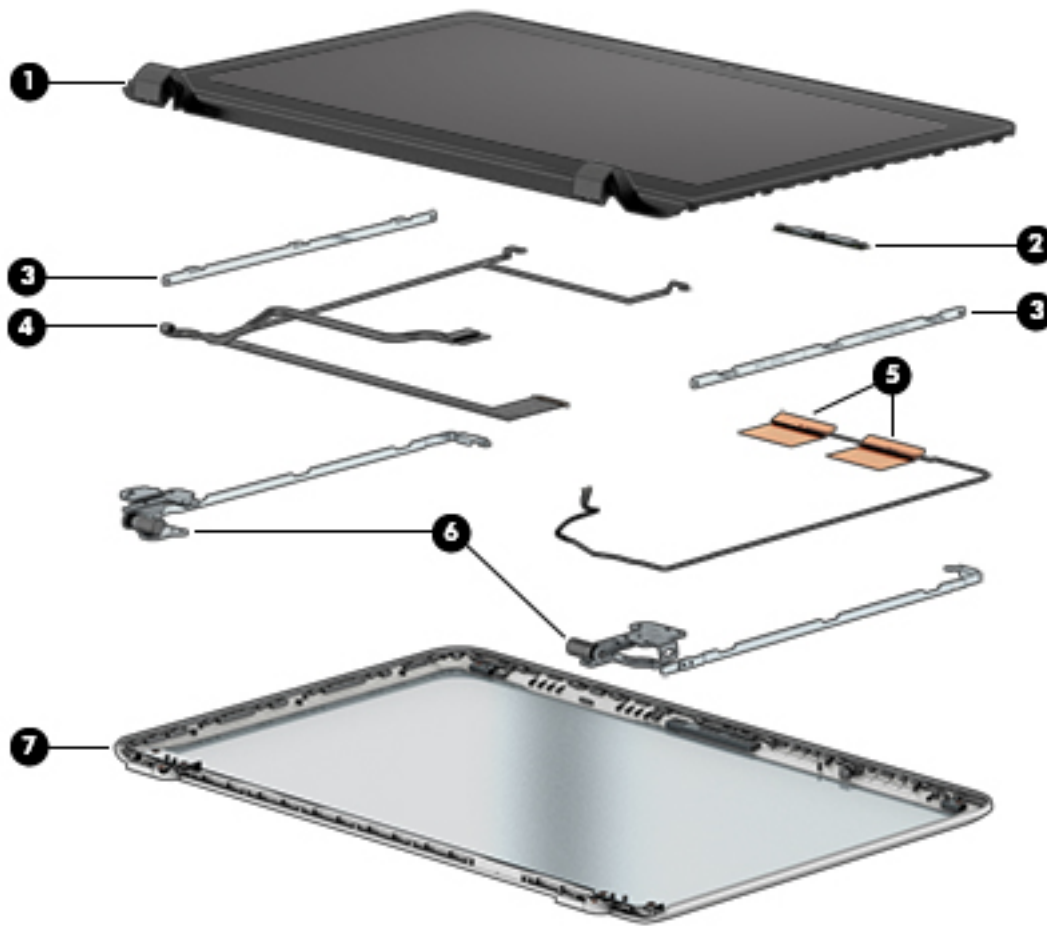

Item	Component	Spare part number
(1)	LCD panel assembly	
	17.3 AG FHD non-touch screen	846890-001
	17.3 AG FHD touch screen	835868-001
(2)	Webcam/microphone module non-touch screen and touch screen	810961-001
(3)	Panel Bracket (included with the Display Panel touch screen)	
(4)	Display cable	
	FHD touch screen	809294-001
	FHD non-touch screen	847874-001
(5)	Antennas touch screen (includes wireless antenna cables and transceivers)	843588-001
(6)	Hinges touch screen (left and right)	809299-001
(7)	Display enclosure :Natural silver version touch screen	835865-001

Miscellaneous parts

Component	Spare part number
HP Smart AC adapter:	
AC adapter, 65-W, non-PFC, 4.5 mm	710412-001
45-W non-PFC, non-slim HP Smart AC adapter (for use in all countries and regions except for the People's Republic of China and India)	741727-001
Power cord (3-pin, black, 1.0-m):	
For use in North America	755530-001
Rubber Kit (includes front and rear feet)	809314-001
Screw Kit	843590-001
HDMI to VGA adapter	701943-001

Mass storage devices



Item	Component	Spare part number
(1)	DVD+-RW Double-Layer SuperMulti Drive	
	For use in natural silver models	809304-001
	Battery/Optical drive cable kit (not illustrated)	810928-001
(2)	Hard drive (does not include bracket):	
	2 TB, 5400-rpm, 2.5-inch	801808-005
	1 TB, 5400-rpm, 2.5-inch, hybrid 8 GB SSD	731999-005
	1 TB, 5400-rpm, 2.5-in	778192-005
	Side brackets (left and right) (not illustrated)	
	Hard driver Connector (not illustrated)	

4 Removal and replacement procedures preliminary requirements

Tools required

You will need the following tools to complete the removal and replacement procedures:

- Flat-bladed screwdriver
- Magnetic screwdriver
- Phillips P0 and P1 screwdrivers

Service considerations

The following sections include some of the considerations that you must keep in mind during disassembly and assembly procedures.

 **NOTE:** As you remove each subassembly from the computer, place the subassembly (and all accompanying screws) away from the work area to prevent damage.

Plastic parts

 **CAUTION:** Using excessive force during disassembly and reassembly can damage plastic parts. Use care when handling the plastic parts. Apply pressure only at the points designated in the maintenance instructions.

Cables and connectors

 **CAUTION:** When servicing the computer, be sure that cables are placed in their proper locations during the reassembly process. Improper cable placement can damage the computer.

Cables must be handled with extreme care to avoid damage. Apply only the tension required to unseat or seat the cables during removal and insertion. Handle cables by the connector whenever possible. In all cases, avoid bending, twisting, or tearing cables. Be sure that cables are routed in such a way that they cannot be caught or snagged by parts being removed or replaced. Handle flex cables with extreme care; these cables tear easily.

Drive handling

⚠ CAUTION: Drives are fragile components that must be handled with care. To prevent damage to the computer, damage to a drive, or loss of information, observe these precautions:

Before removing or inserting a hard drive, shut down the computer. If you are unsure whether the computer is off or in Hibernation, turn the computer on, and then shut it down through the operating system.

Before handling a drive, be sure that you are discharged of static electricity. While handling a drive, avoid touching the connector.

Before removing a diskette drive or optical drive, be sure that a diskette or disc is not in the drive and be sure that the optical drive tray is closed.

Handle drives on surfaces covered with at least one inch of shock-proof foam.

Avoid dropping drives from any height onto any surface.

After removing a hard drive, an optical drive, or a diskette drive, place it in a static-proof bag.

Avoid exposing an internal hard drive to products that have magnetic fields, such as monitors or speakers.

Avoid exposing a drive to temperature extremes or liquids.

If a drive must be mailed, place the drive in a bubble pack mailer or other suitable form of protective packaging and label the package "FRAGILE."

Grounding guidelines

Electrostatic discharge damage

Electronic components are sensitive to electrostatic discharge (ESD). Circuitry design and structure determine the degree of sensitivity. Networks built into many integrated circuits provide some protection, but in many cases, ESD contains enough power to alter device parameters or melt silicon junctions.

A discharge of static electricity from a finger or other conductor can destroy static-sensitive devices or microcircuitry. Even if the spark is neither felt nor heard, damage may have occurred.

An electronic device exposed to ESD may not be affected at all and can work perfectly throughout a normal cycle. Or the device may function normally for a while, then degrade in the internal layers, reducing its life expectancy.

⚠ CAUTION: To prevent damage to the computer when you are removing or installing internal components, observe these precautions:

Keep components in their electrostatic-safe containers until you are ready to install them.

Before touching an electronic component, discharge static electricity by using the guidelines described in this section.

Avoid touching pins, leads, and circuitry. Handle electronic components as little as possible.

If you remove a component, place it in an electrostatic-safe container.

The following table shows how humidity affects the electrostatic voltage levels generated by different activities.

⚠ CAUTION: A product can be degraded by as little as 700 V.

Typical electrostatic voltage levels			
Event	Relative humidity		
	10%	40%	55%
Walking across carpet	35,000 V	15,000 V	7,500 V
Walking across vinyl floor	12,000 V	5,000 V	3,000 V
Motions of bench worker	6,000 V	800 V	400 V
Removing DIPs from plastic tube	2,000 V	700 V	400 V
Removing DIPs from vinyl tray	11,500 V	4,000 V	2,000 V
Removing DIPs from Styrofoam	14,500 V	5,000 V	3,500 V
Removing bubble pack from PCB	26,500 V	20,000 V	7,000 V
Packing PCBs in foam-lined box	21,000 V	11,000 V	5,000 V

Packaging and transporting guidelines

Follow these grounding guidelines when packaging and transporting equipment:

- To avoid hand contact, transport products in static-safe tubes, bags, or boxes.
- Protect ESD-sensitive parts and assemblies with conductive or approved containers or packaging.
- Keep ESD-sensitive parts in their containers until the parts arrive at static-free workstations.
- Place items on a grounded surface before removing items from their containers.
- Always be properly grounded when touching a component or assembly.
- Store reusable ESD-sensitive parts from assemblies in protective packaging or non-conductive foam.
- Use transporters and conveyors made of antistatic belts and roller bushings. Be sure that mechanized equipment used for moving materials is wired to ground and that proper materials are selected to avoid static charging. When grounding is not possible, use an ionizer to dissipate electric charges.

Workstation guidelines

Follow these grounding workstation guidelines:

- Cover the workstation with approved static-shielding material.
- Use a wrist strap connected to a properly grounded work surface and use properly grounded tools and equipment.
- Use conductive field service tools, such as cutters, screwdrivers, and vacuums.
- When fixtures must directly contact dissipative surfaces, use fixtures made only of static-safe materials.
- Keep the work area free of nonconductive materials, such as ordinary plastic assembly aids and Styrofoam.
- Handle ESD-sensitive components, parts, and assemblies by the case or PCM laminate. Handle these items only at static-free workstations.
- Avoid contact with pins, leads, or circuitry.
- Turn off power and input signals before inserting or removing connectors or test equipment.

Equipment guidelines

Grounding equipment must include either a wrist strap or a foot strap at a grounded workstation.

- When seated, wear a wrist strap connected to a grounded system. Wrist straps are flexible straps with a minimum of one megohm $\pm 10\%$ resistance in the ground cords. To provide proper ground, wear a strap snugly against the skin at all times. On grounded mats with banana-plug connectors, use alligator clips to connect a wrist strap.
- When standing, use foot straps and a grounded floor mat. Foot straps (heel, toe, or boot straps) can be used at standing workstations and are compatible with most types of shoes or boots. On conductive floors or dissipative floor mats, use foot straps on both feet with a minimum of one megohm resistance between the operator and ground. To be effective, the conductive must be worn in contact with the skin.

The following grounding equipment is recommended to prevent electrostatic damage:

- Antistatic tape
- Antistatic smocks, aprons, and sleeve protectors
- Conductive bins and other assembly or soldering aids
- Nonconductive foam
- Conductive tabletop workstations with ground cords of one megohm resistance
- Static-dissipative tables or floor mats with hard ties to the ground
- Field service kits
- Static awareness labels
- Material-handling packages
- Nonconductive plastic bags, tubes, or boxes
- Metal tote boxes
- Electrostatic voltage levels and protective materials

The following table lists the shielding protection provided by antistatic bags and floor mats.

Material	Use	Voltage protection level
Antistatic plastics	Bags	1,500 V
Carbon-loaded plastic	Floor mats	7,500 V
Metallized laminate	Floor mats	5,000 V

5 Removal and replacement procedures for Customer Self-Repair parts

 **CAUTION:** The Customer Self-Repair program is not available in all locations. Installing a part not supported by the Customer Self-Repair program may void your warranty. Check your warranty to determine if Customer Self-Repair is supported in your location.

 **NOTE:** HP continually improves and changes product parts. For complete and current information on supported parts for your computer, go to <http://partsurfer.hp.com>, select your country or region, and then follow the on-screen instructions.

Component replacement procedures

 **NOTE:** Please read and follow the procedures described here to access and replace Customer Self-Repair parts successfully.

 **NOTE:** Details about your computer, including model, serial number, product key, and length of warranty, are on the service tag at the bottom of your computer.

This chapter provides removal and replacement procedures for Customer Self-Repair parts.

There are many screws that must be removed, replaced, or loosened when servicing Customer Self- Repair parts. Make special note of each screw size and location during removal and replacement.

Battery

Description	Spare part number
4-cell, 41-Whr, 2.8-Ah Li K104041-CL battery	800049-005

Before disassembling the computer, follow these steps:

1. Shut down the computer. If you are unsure whether the computer is off or in Hibernation, turn the computer on, and then shut it down through the operating system.
2. Disconnect all external devices connected to the computer.
3. Disconnect the power from the computer by first unplugging the power cord from the AC outlet and then unplugging the AC adapter from the computer.

To remove the battery:

1. Position the computer upside down on a flat surface.
2. Slide the battery lock latch **(1)**, and then slide the battery release latch **(2)** to release the battery.

3. Rotate the battery upward **(3)**, and then remove the battery from the computer **(4)**.

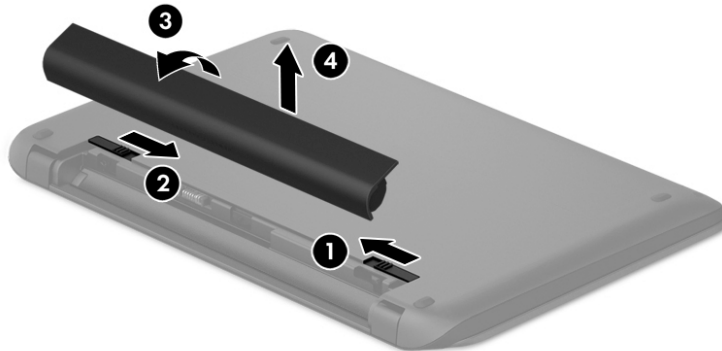

Optical drive

Description	Spare part number
Optical drive (DVD+/-RW Double-Layer SuperMulti) for use in natural silver models	809304-001

Before removing the optical drive, follow these steps:

1. Shut down the computer. If you are unsure whether the computer is off or in Hibernation, turn the computer on, and then shut it down through the operating system.
2. Disconnect all external devices connected to the computer.
3. Disconnect the power from the computer by first unplugging the power cord from the AC outlet and then unplugging the AC adapter from the computer.
4. Remove the battery (see [Battery on page 23](#)).

To remove the optical drive:

1. Remove the Phillips PM2.5×7.0 screw **(1)** that secures the optical drive to the computer.

2. Remove the optical drive **(2)** by sliding it out of the optical drive bay.

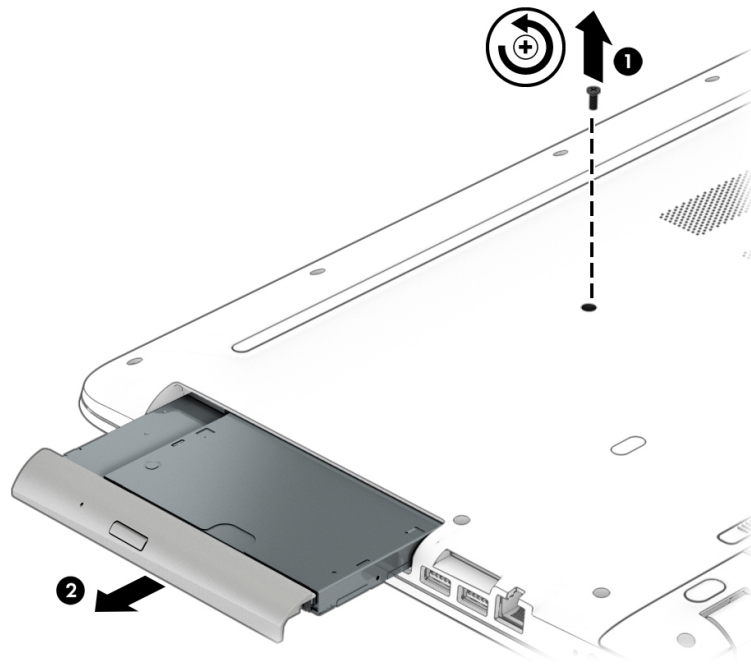

Reverse this procedure to reassemble and install the optical drive.

6 Removal and replacement procedures for Authorized Service Provider parts

 **CAUTION:** Components described in this chapter should only be accessed by an authorized service provider. Accessing these parts can damage the computer or void the warranty.

 **NOTE:** HP continually improves and changes product parts. For complete and current information on supported parts for your computer, go to <http://partsurfer.hp.com>, select your country or region, and then follow the on-screen instructions.

Component replacement procedures

 **NOTE:** Details about your computer, including model, serial number, product key, and length of warranty, are on the service tag at the bottom of your computer.

This chapter provides removal and replacement procedures for Authorized Service Provider only parts.

There are as many as 58 screws that must be removed, replaced, or loosened when servicing Authorized Service Provider only parts. Make special note of each screw size and location during removal and replacement.

Bottom cover

Description	Spare part number
Bottom cover hinge caps	809312-001
Rubber screw covers	809314-001
Bottom cover (for use in natural silver models)	835865-001
Top cover/keyboard/TouchPad ash silver (includes TouchPad brackets) for use in the United States	835866-001
Top cover/keyboard black (for use in the United States)	835867-001

Before removing the bottom cover, follow these steps:

1. Shut down the computer. If you are unsure whether the computer is off or in Hibernation, turn the computer on, and then shut it down through the operating system.
2. Disconnect all external devices connected to the computer.
3. Disconnect the power from the computer by first unplugging the power cord from the AC outlet and then unplugging the AC adapter from the computer.
4. Remove the battery (see [Battery on page 23](#)).
5. Remove the optical drive (see [Optical drive on page 24](#)).

To remove the bottom cover:

1. Position the computer upside down with the front toward you.
2. Remove the four Phillips PM2.5×12.0 screws (1) that secure the hinge covers to the computer, and then lift the covers off the computer (2).

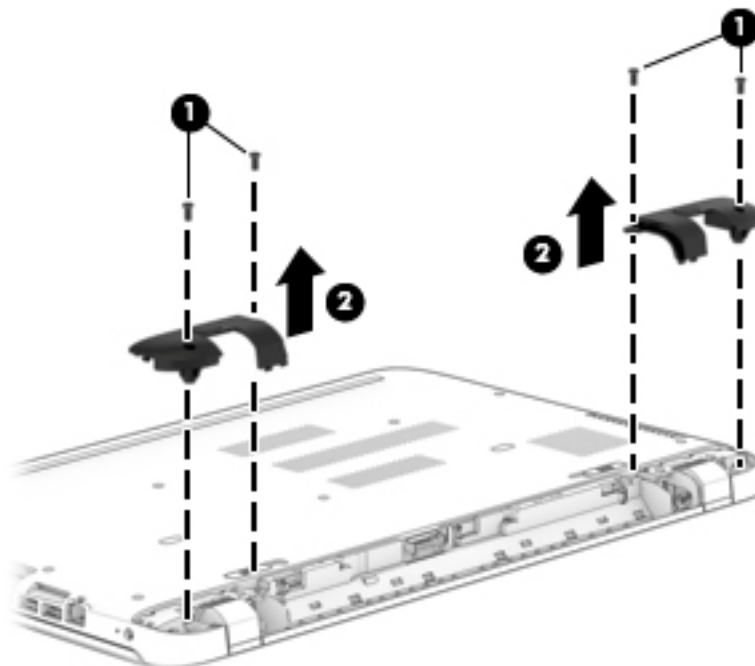

3. Remove the two screw covers **(1)** from near the battery bay.
Remove the two Phillips PM2.5×6.5 screws from near the battery bay **(2)**.
Remove the two Phillips PM2.0×2.0 flat screws from the optical drive bay **(3)**.

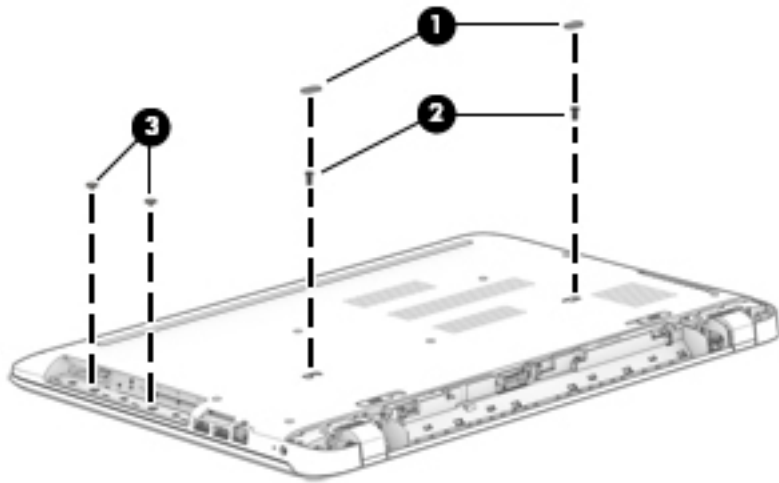

4. Remove the seventeen Phillips PM screws that secure the top cover to the computer.

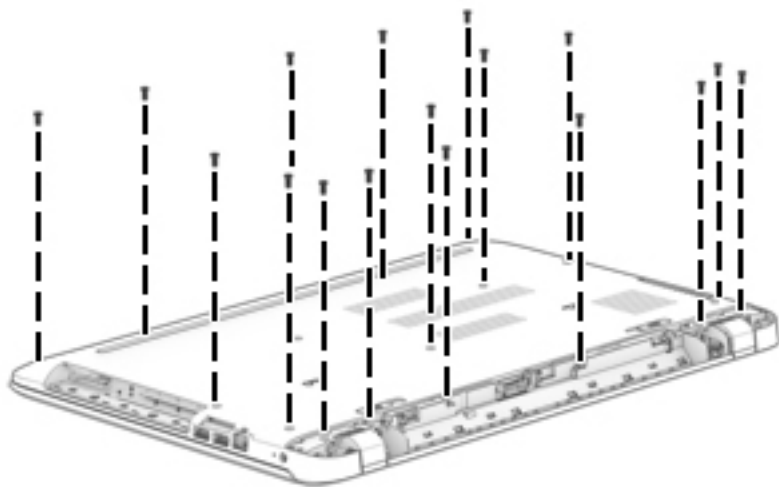

5. Use a non-marking tool to disengage the bottom cover from the computer. Work around the seams on all sides of the computer.

CAUTION: To avoid damaging the cover, do not pry the cover near the optical drive bay.

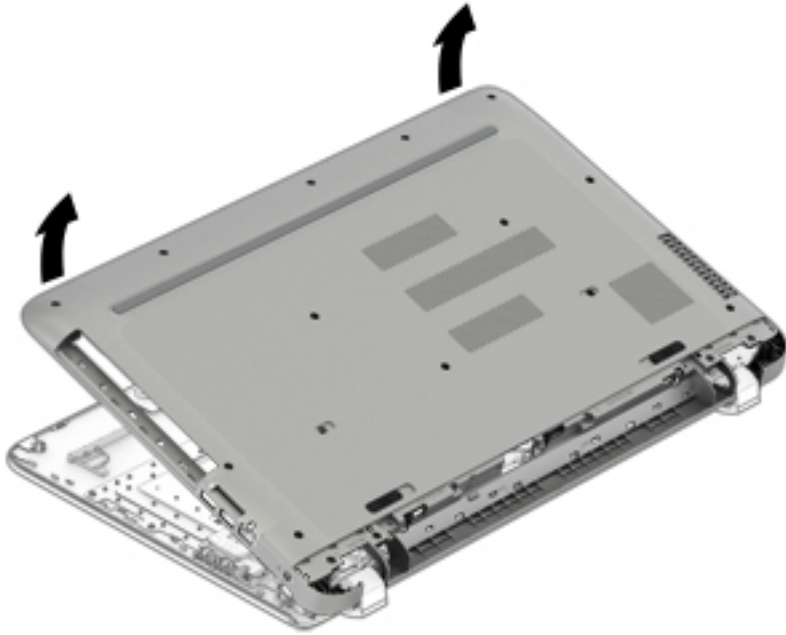

Reverse this procedure to install the bottom cover.

Remove Display

NOTE: The display panel can be removed once the bottom cover is removed. See the [Display assembly, touch on page 51](#) section for disassembling the touch screen display.

Hard drive



NOTE: The hard drive spare part kit does not include the hard drive bracket.

Description	Spare part number
2 TB, 5400-rpm, 2.5-inch	801808-005
1 TB, 5400-rpm, 2.5-in	778192-005
1 TB, 5400-rpm, HDD 2.5-in	731999-005

Before removing the hard drive, follow these steps:

1. Shut down the computer. If you are unsure whether the computer is off or in Hibernation, turn the computer on, and then shut it down through the operating system.
2. Disconnect all external devices connected to the computer.
3. Disconnect the power from the computer by first unplugging the power cord from the AC outlet and then unplugging the AC adapter from the computer.
4. Remove the battery (see [Battery on page 23](#)).
5. Remove the optical drive (see [Optical drive on page 24](#)).
6. Remove the bottom cover (see [Bottom cover on page 28](#)).

To remove the hard drive:

1. Disconnect the hard drive cable from the system board **(1)**.
2. Lift the hard drive from the computer **(2)**.

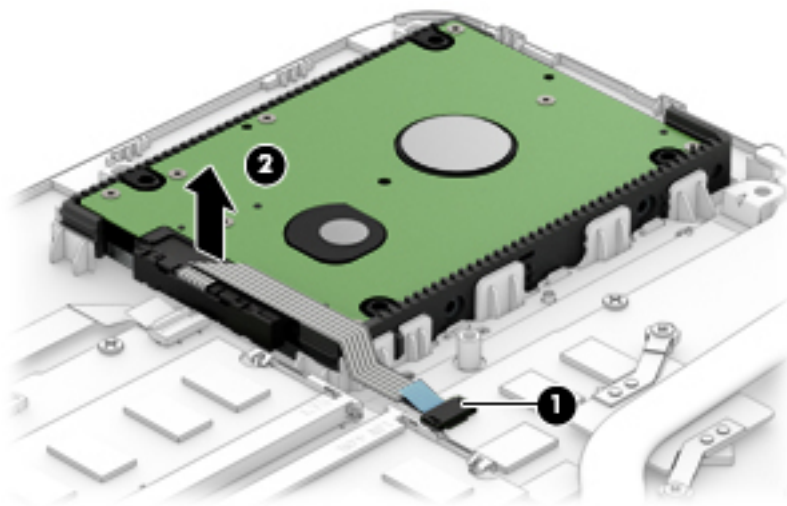

3. Disconnect the hard drive connector and cable **(1)** from the hard drive.

To disassemble the hard drive, pull the brackets away from each side of the hard drive **(2)**.

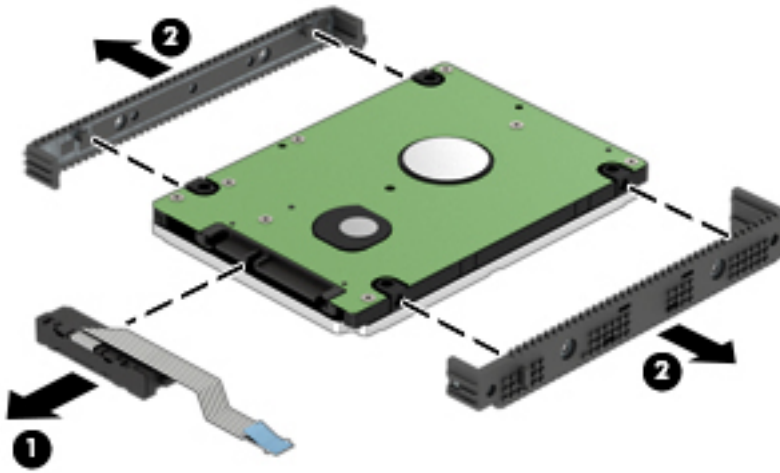

Reverse this procedure to reassemble and install the hard drive.

WLAN module

Description	Spare part number
Intel Dual Band Wireless-AC 3165 802.11 ac 1x1 WiFi + Bluetooth 4.0 Combo Adapter for Windows 10	806723-005

 **CAUTION:** To prevent an unresponsive system, replace the wireless module only with a wireless module authorized for use in the computer by the governmental agency that regulates wireless devices in your country or region. If you replace the module and then receive a warning message, remove the module to restore device functionality, and then contact support.

Before removing the WLAN module, follow these steps:

1. Shut down the computer. If you are unsure whether the computer is off or in Hibernation, turn the computer on, and then shut it down through the operating system.
2. Disconnect all external devices connected to the computer.
3. Disconnect the power from the computer by first unplugging the power cord from the AC outlet and then unplugging the AC adapter from the computer.
4. Remove the battery (see [Battery on page 23](#)).
5. Remove the optical drive (see [Optical drive on page 24](#)).
6. Remove the bottom cover (see [Bottom cover on page 28](#)).

To remove the WLAN module:

1. Disconnect the WLAN antenna cables **(1)** from the terminals on the WLAN module.



NOTE: The #1 WLAN antenna cable is connected to the WLAN module Main terminal. The #2 WLAN antenna cable is connected to the WLAN module Aux terminal.

2. Remove the Phillips PM2.0×3.0 screw **(2)** that secures the WLAN module to the system board. (The WLAN module tilts up.)

3. Remove the WLAN module by pulling the module away from the slot at an angle (3).

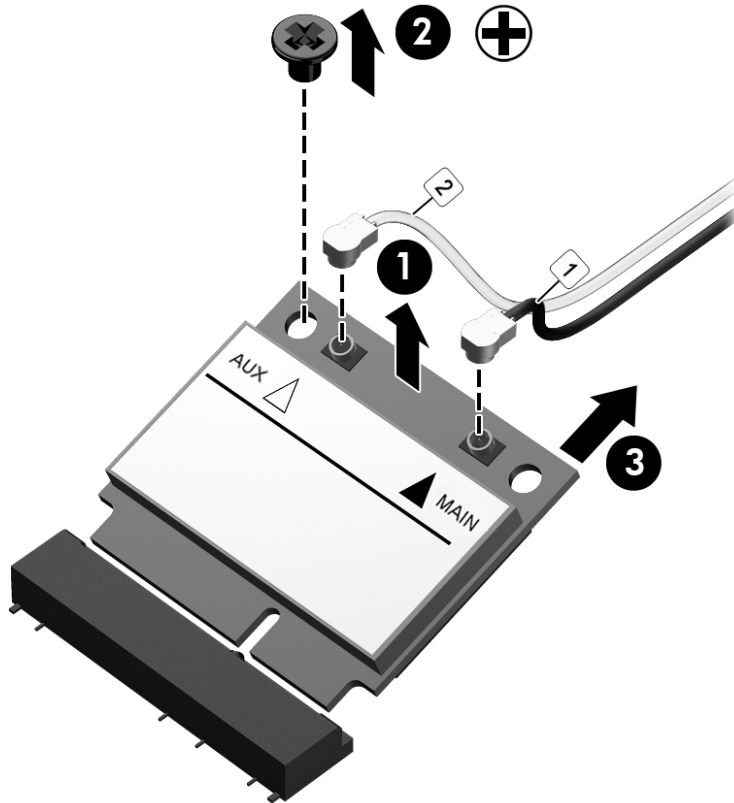

 **NOTE:** If the WLAN antennas are not connected to the terminals on the WLAN module, the protective sleeves must be installed on the antenna connectors, as shown in the following illustration.

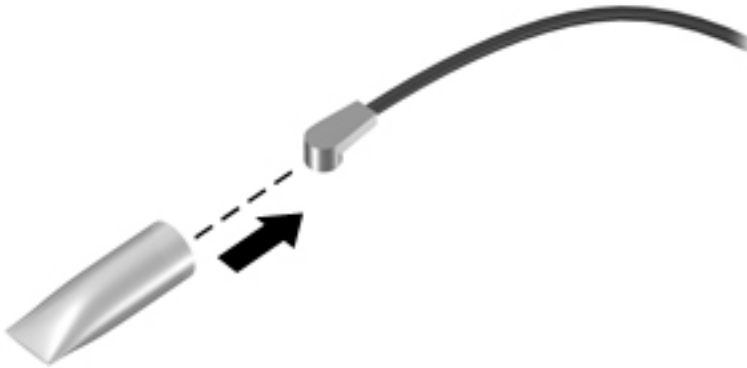

Reverse this procedure to install the WLAN module.

RTC battery

Description	Spare part number
RTC battery	811080-001

Before removing the RTC battery, follow these steps:

1. Shut down the computer. If you are unsure whether the computer is off or in Hibernation, turn the computer on, and then shut it down through the operating system.
2. Disconnect all external devices connected to the computer.
3. Disconnect the power from the computer by first unplugging the power cord from the AC outlet and then unplugging the AC adapter from the computer.
4. Remove the battery (see [Battery on page 23](#)).
5. Remove the optical drive (see [Optical drive on page 24](#)).
6. Remove the bottom cover (see [Bottom cover on page 28](#)).

To remove the RTC battery:

1. Position the system board upside down.
2. Using a thin tool or screwdriver, disengage the battery from the socket **(1)**, and then remove the battery **(2)**.

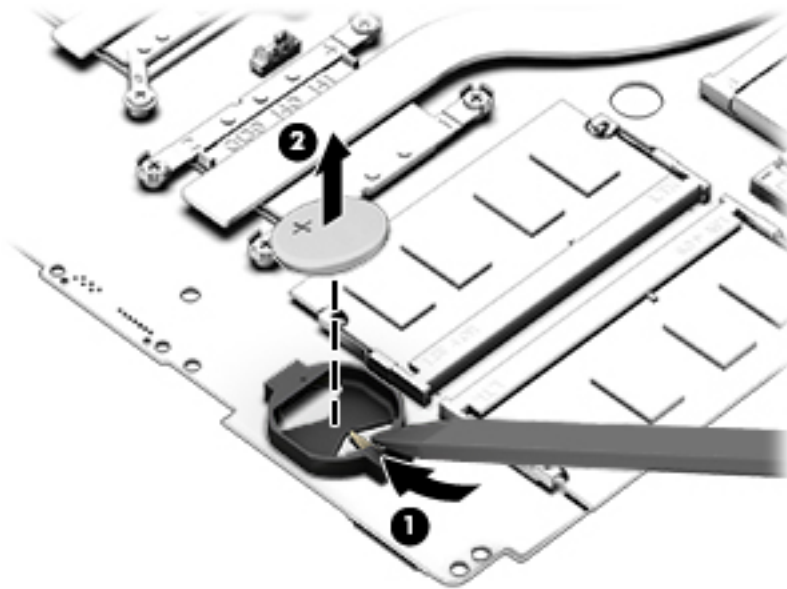

Reverse this procedure to install the RTC battery.

Memory module

Description	Spare part number
8-GB (PC3L, 12800, 1600-MHz)	693374-005
4-GB (PC3L, 12800, 1600-MHz)	691740-005

Before removing a memory module, follow these steps:

1. Shut down the computer. If you are unsure whether the computer is off or in Hibernation, turn the computer on, and then shut it down through the operating system.
2. Disconnect all external devices connected to the computer.
3. Disconnect the power from the computer by first unplugging the power cord from the AC outlet and then unplugging the AC adapter from the computer.
4. Remove the battery (see [Battery on page 23](#)).
5. Remove the optical drive (see [Optical drive on page 24](#)).
6. Remove the bottom cover (see [Bottom cover on page 28](#)).

To remove a memory module:

1. Spread the retaining tabs **(1)** on each side of the memory module slot to release the memory module. (The memory module tilts up.)
2. Remove the memory module **(2)** by pulling it away from the slot at an angle.

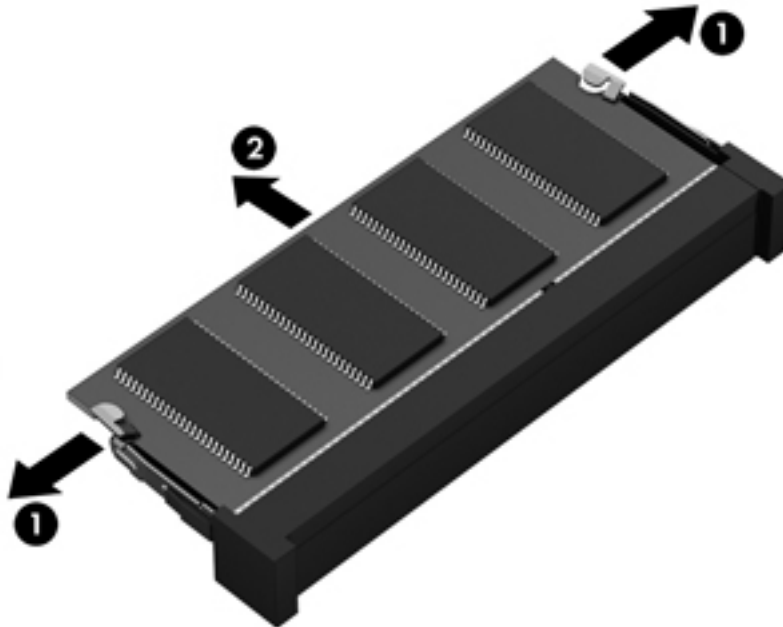

Reverse this procedure to install a memory module.

Fan



NOTE: The fan spare part kit includes replacement thermal materials.

Description	Spare part number
Fan	806747-001



NOTE: To properly ventilate the computer, allow at least **7.6 cm** (3.0 in) of clearance on the left side of the computer. The computer uses an electric fan for ventilation. The fan is controlled by a temperature sensor and is designed to turn on automatically when high temperature conditions exist. These conditions are affected by high external temperatures, system power consumption, power management/battery conservation configurations, battery fast charging, and software requirements. Exhaust air is displaced through the ventilation grill located on the left side of the computer.

Before removing the fan/heat sink assembly, follow these steps:

1. Shut down the computer. If you are unsure whether the computer is off or in Hibernation, turn the computer on, and then shut it down through the operating system.
2. Disconnect all external devices connected to the computer.
3. Disconnect the power from the computer by first unplugging the power cord from the AC outlet and then unplugging the AC adapter from the computer.
4. Remove the battery (see [Battery on page 23](#)).
5. Remove the optical drive (see [Optical drive on page 24](#)).
6. Remove the bottom cover (see [Bottom cover on page 28](#)).

To remove the fan:

1. Position the computer upright and open it.
2. Disconnect the fan cable **(1)** from the system board.
3. Remove the two Phillips PM3.0×3.0 screws **(2)** that secure the fan to the computer.

4. Remove the fan from the computer (3).

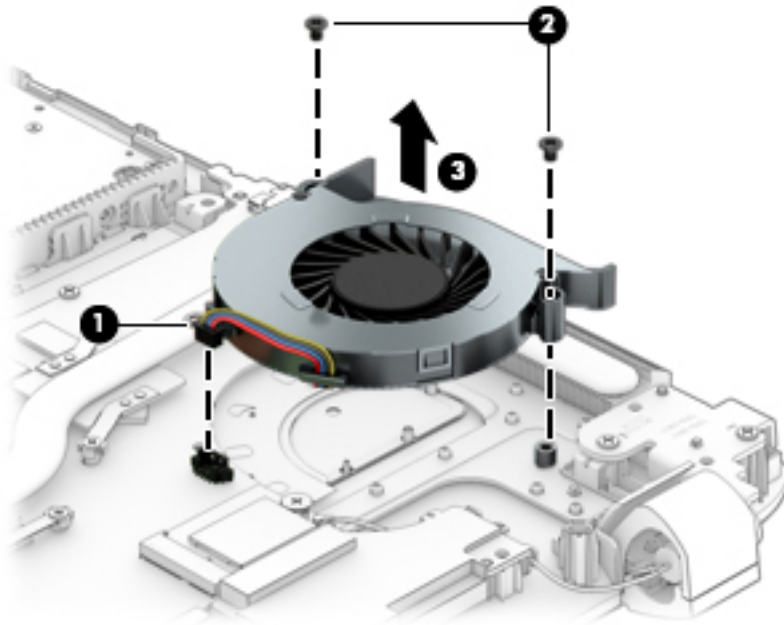

Reverse this procedure to install the fan.

Heat sink assembly

 **NOTE:** The heat sink assembly spare part kit includes replacement thermal materials.

Description	Spare part number
Heat sink for use in models with discrete graphics	806827-001
Heat sink for use in models with UMA graphics 15 W	806826-001
For use in models with UMA graphics 35 W	828817-001

 **NOTE:** To properly ventilate the computer, allow at least **7.6 cm (3.0 in)** of clearance on the left side of the computer. The computer uses an electric fan for ventilation. The fan is controlled by a temperature sensor and is designed to turn on automatically when high temperature conditions exist. These conditions are affected by high external temperatures, system power consumption, power management/battery conservation configurations, battery fast charging, and software requirements. Exhaust air is displaced through the ventilation grill located on the left side of the computer.

Before removing the heat sink assembly, follow these steps:

1. Shut down the computer. If you are unsure whether the computer is off or in Hibernation, turn the computer on, and then shut it down through the operating system.
2. Disconnect all external devices connected to the computer.
3. Disconnect the power from the computer by first unplugging the power cord from the AC outlet and then unplugging the AC adapter from the computer.
4. Remove the battery (see [Battery on page 23](#)).

5. Remove the optical drive (see [Optical drive on page 24](#)).
6. Remove the bottom cover (see [Bottom cover on page 28](#)).
7. Remove the fan (see [Fan on page 37](#)).

To remove the heat sink assembly:

1. Position the computer upright and open it.
2. If you have a model with discrete graphics, in the order indicated, remove the six Phillips PM2.0×3.0 screws **(1)** that secure the heat sink to the system board.
3. Remove the heat sink **(2)** from the system board.

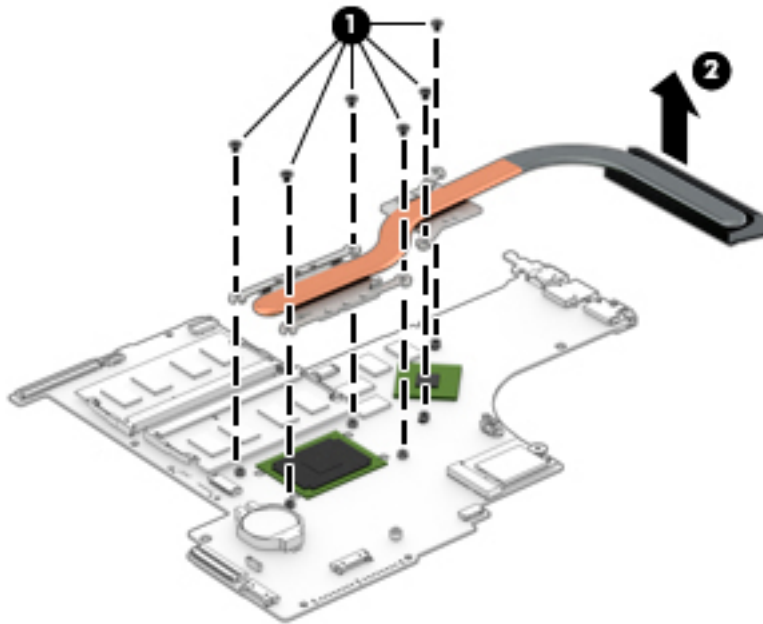

4. If you have a model with UMA graphics, in the order indicated on the screws, remove the six Phillips PM2.0×3.0 screws **(1)** that secure the heat sink to the system board.

5. Remove the heat sink (2) from the system board.

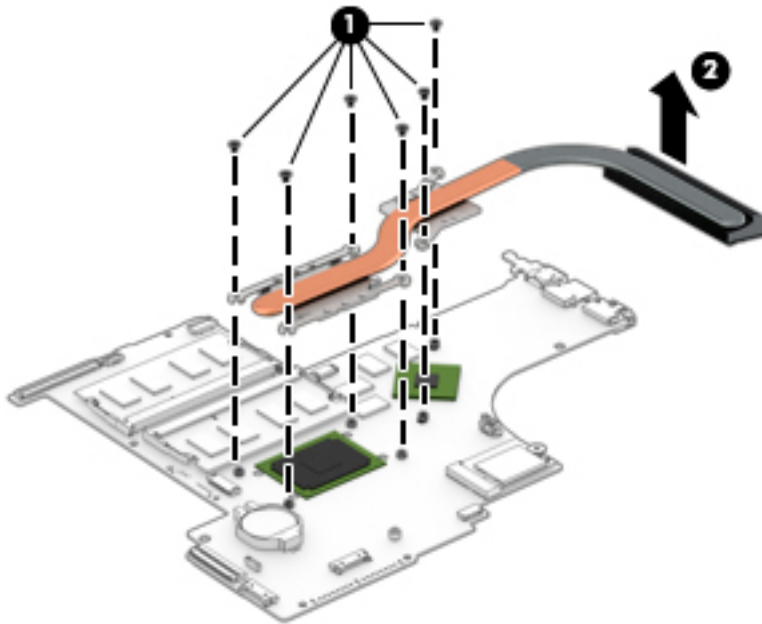

- **Discrete graphics:** Thermal paste is used on the processor and associated heat sink area (1), (2), as well as the graphics chip and associated heat sink area (3), (4).

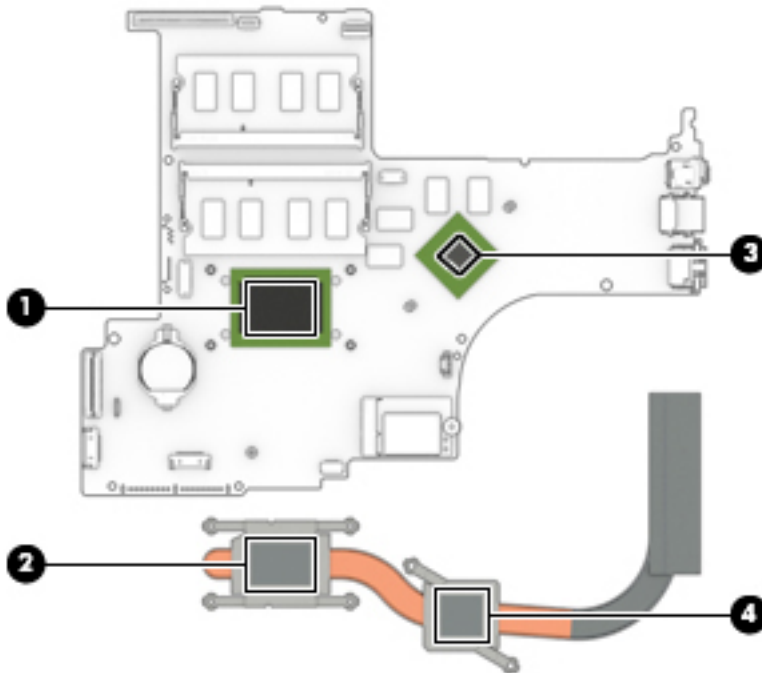

- **UMA graphics:** Thermal paste is used on the heat sink (1) and the processor (2).

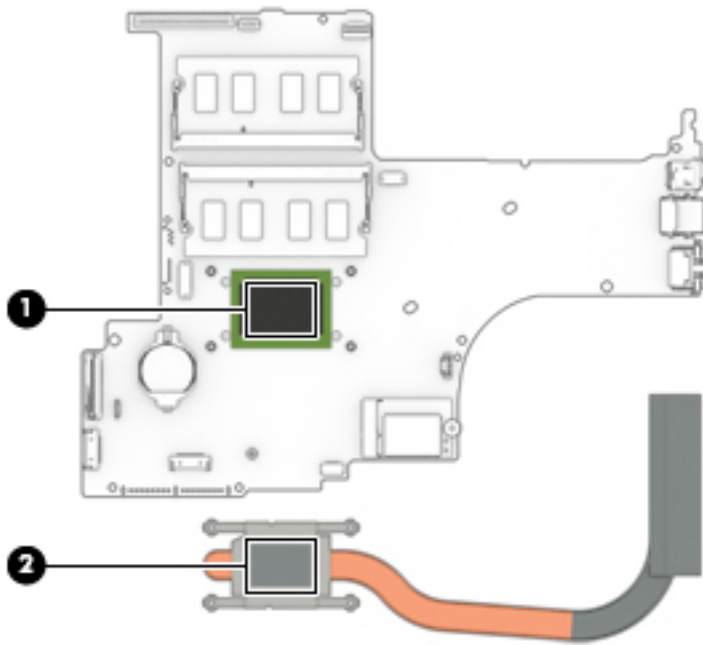

Reverse this procedure to reassemble and install the heat sink assembly.

Optical drive connector

Description	Spare part number
Optical drive connector	810928-001

Before removing the optical drive connector, follow these steps:

1. Shut down the computer. If you are unsure whether the computer is off or in Hibernation, turn the computer on, and then shut it down through the operating system.
2. Disconnect all external devices connected to the computer.
3. Disconnect the power from the computer by first unplugging the power cord from the AC outlet and then unplugging the AC adapter from the computer.
4. Remove the battery (see [Battery on page 23](#)).
5. Remove the optical drive (see [Optical drive on page 24](#)).
6. Remove the bottom cover (see [Bottom cover on page 28](#)).

To remove the optical drive connector:

1. Position the computer upright.
2. Disconnect the optical drive connector cable from the system board **(1)**.
3. Remove the two Phillips PM2.5×3.0 screws **(2)** that secure the optical drive connector to the computer.
4. Remove the optical drive connector and cable **(3)**.

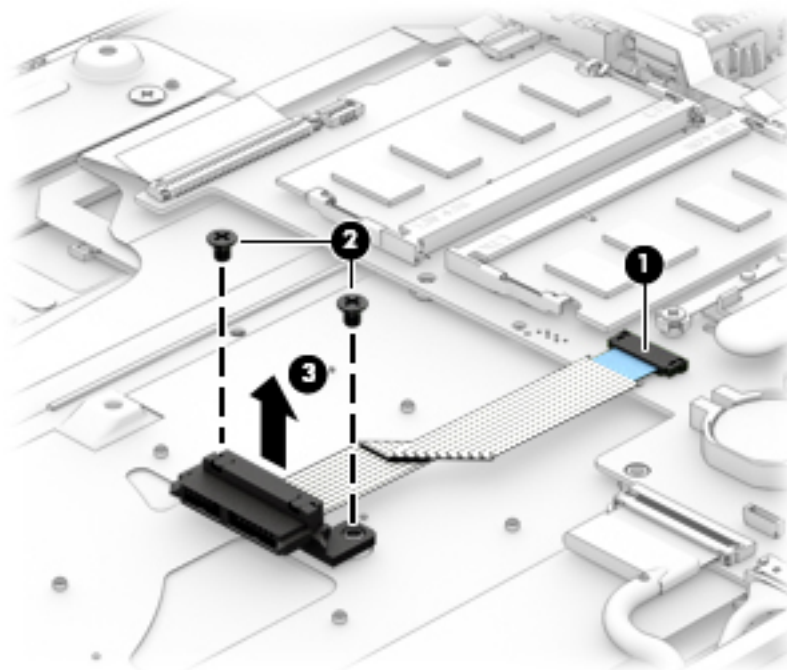

Reverse this procedure to install the optical drive connector.

System board



NOTE: The system board spare part kit includes replacement thermal materials.

Description	Spare part number
System board (includes replacement thermal materials):	
All system boards use the following part numbers:	
xxxxxx-001: Without the Windows operating system	
xxxxxx-601: Windows 10	
For use in models with discrete graphics (NVIDIA N16S-GT (GeForce 940M)):	
<ul style="list-style-type: none">Intel Core i7-6500U WIN processor 4 GB of dedicated video memory	838262-601
<ul style="list-style-type: none">Intel Core i7-6500U processor and 4 GB of dedicated video memory	838262-001
<ul style="list-style-type: none">Intel Core i7-5500U WIN processor and 2 GB of dedicated video memory	838261-601
<ul style="list-style-type: none">Intel Core i7-6500U processor and 2 GB of dedicated video memory	838261-001
For use in models with UMA graphics	
<ul style="list-style-type: none">Intel Core i7-6200U WIN processor	838262-601
<ul style="list-style-type: none">Intel Core i7-6200U processor	838260-001
<ul style="list-style-type: none">Intel Core i5-6500U WIN processor	841040-601
<ul style="list-style-type: none">Intel Core i5-6500U processor	841040-001
<ul style="list-style-type: none">Intel Core i7-6700HQ HM 170 WIN processor	835869-601
<ul style="list-style-type: none">Intel Core i7-6500HQ HM 170 processor	835869-001

Before removing the system board, follow these steps:

1. Shut down the computer. If you are unsure whether the computer is off or in Hibernation, turn the computer on, and then shut it down through the operating system.
2. Disconnect all external devices connected to the computer.
3. Disconnect the power from the computer by first unplugging the power cord from the AC outlet and then unplugging the AC adapter from the computer.
4. Remove the battery (see [Battery on page 23](#)).
5. Remove the optical drive (see [Optical drive on page 24](#)).
6. Remove the bottom cover (see [Bottom cover on page 28](#)).



NOTE: When replacing the system board, be sure that the following components are removed from the defective system board and installed on the replacement system board:

- Memory modules (see [Memory module on page 36](#))
- WLAN module (see [WLAN module on page 33](#))
- Heat sink assembly (see [Heat sink assembly on page 38](#))
- Fan (see [Fan on page 37](#))

To remove the system board:

1. Position the computer upright, and then disconnect the following cables from the system board:

- (1): ClickPad cable
- (2): TouchPad cable
- (3): Hard drive cable
- (4): Optical drive cable
- (5): Keyboard cable
- (6): Power connector cable
- (7): Display cable
- (8): Speaker cable
- (9): Power button board

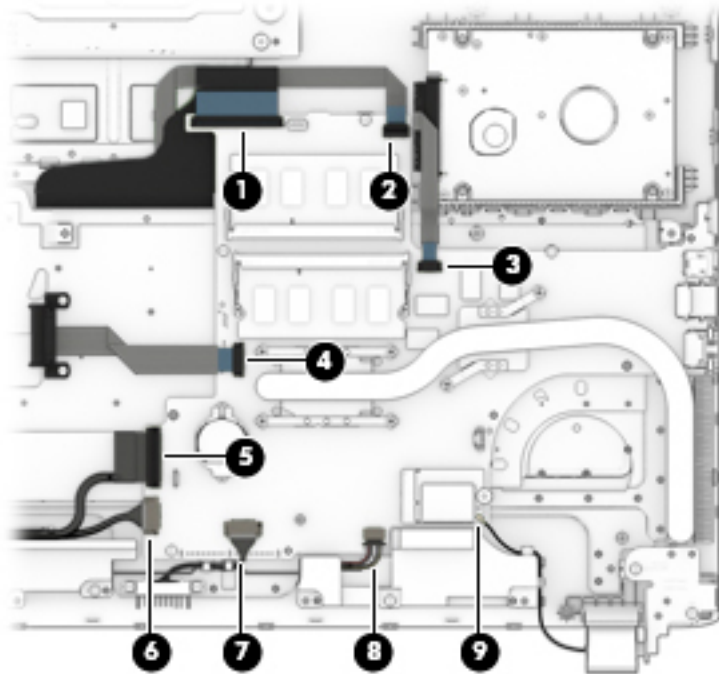

2. Remove the four Phillips PM2.0×3.0 screws (1) that secure the system board to the computer.

3. Lift the right side of the system board, and then lift the right side of the system board up to gain access to the USB board cable and connector underneath (2).

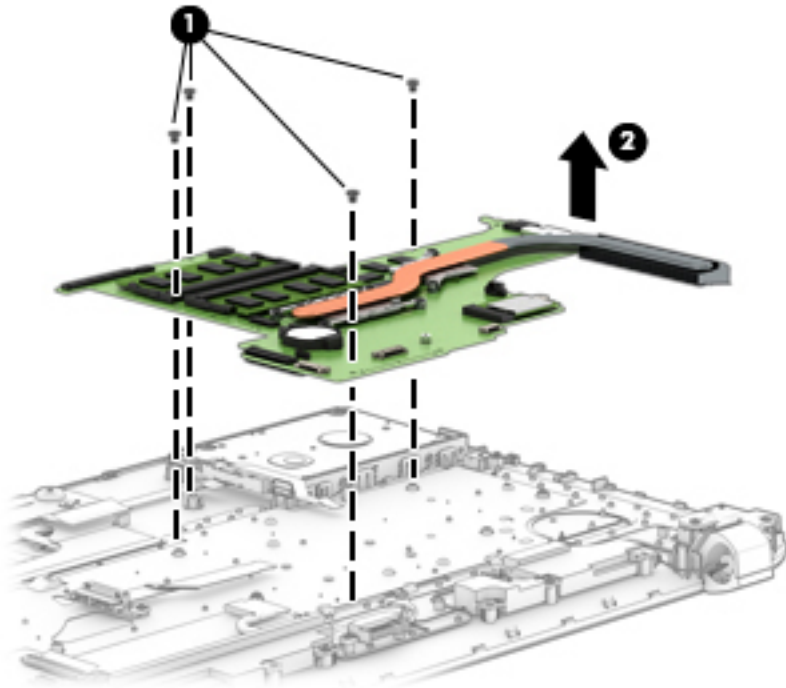

4. Disconnect the USB board cable from the connector under the system board. See [USB board on page 46](#) for cable removal instructions.

Reverse this procedure to install the system board.

USB board

Description	Spare part number
USB board for use with 6th generation processors (includes cable)	844489-001

Before removing the USB board, follow these steps:

1. Shut down the computer. If you are unsure whether the computer is off or in Hibernation, turn the computer on, and then shut it down through the operating system.
2. Disconnect all external devices connected to the computer.
3. Disconnect the power from the computer by first unplugging the power cord from the AC outlet and then unplugging the AC adapter from the computer.
4. Remove the battery (see [Battery on page 23](#)).
5. Remove the optical drive (see [Optical drive on page 24](#)).
6. Remove the bottom cover (see [Bottom cover on page 28](#)).

To remove the USB board:

1. Position the computer upright.
2. Disconnect the larger cable from the system board **(1)**.
3. Disconnect the smaller cable from the USB board that routes to the power button board **(2)**.
4. Remove the two Phillips PM2.5×3.0 screws **(3)** that secure the USB board to the computer.
5. Remove the USB board **(4)**.

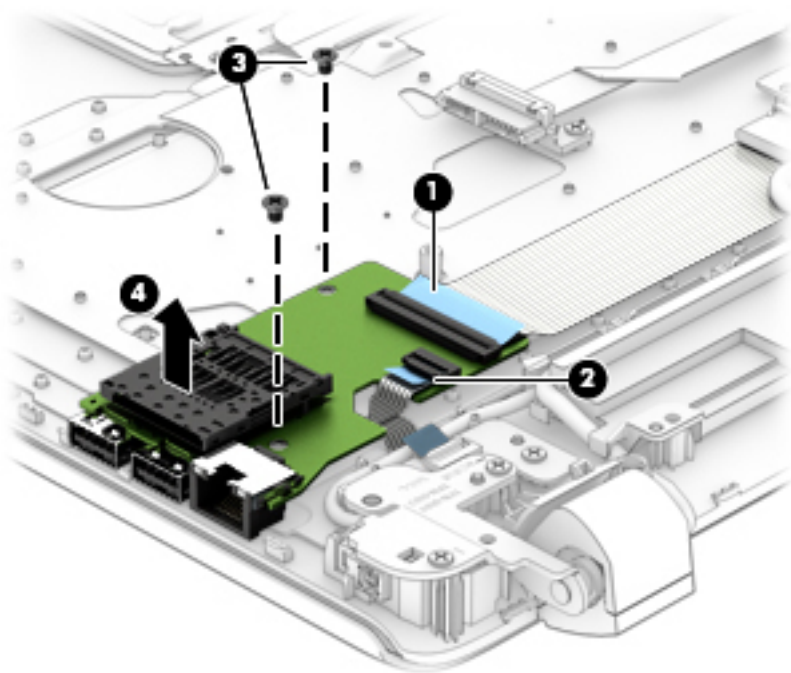

Reverse this procedure to install the USB board.

Speakers

Description	Spare part number
Speakers (includes left and right speakers and cable)	809316-001

Before removing the speakers, follow these steps:

1. Shut down the computer. If you are unsure whether the computer is off or in Hibernation, turn the computer on, and then shut it down through the operating system.
2. Disconnect all external devices connected to the computer.
3. Disconnect the power from the computer by first unplugging the power cord from the AC outlet and then unplugging the AC adapter from the computer.
4. Remove the battery (see [Battery on page 23](#)).
5. Remove the optical drive (see [Optical drive on page 24](#)).
6. Remove the bottom cover (see [Bottom cover on page 28](#)).
7. Remove the system board (see [System board on page 43](#)).

To remove the speakers:

1. Remove the speaker wire from the clips between the speakers **(1)**.
2. Remove the display cable from the channel at the top of the left speaker **(2), (3)**.
3. Remove the two Phillips screws **(4)**
4. Remove the speakers from the computer **(5)**.

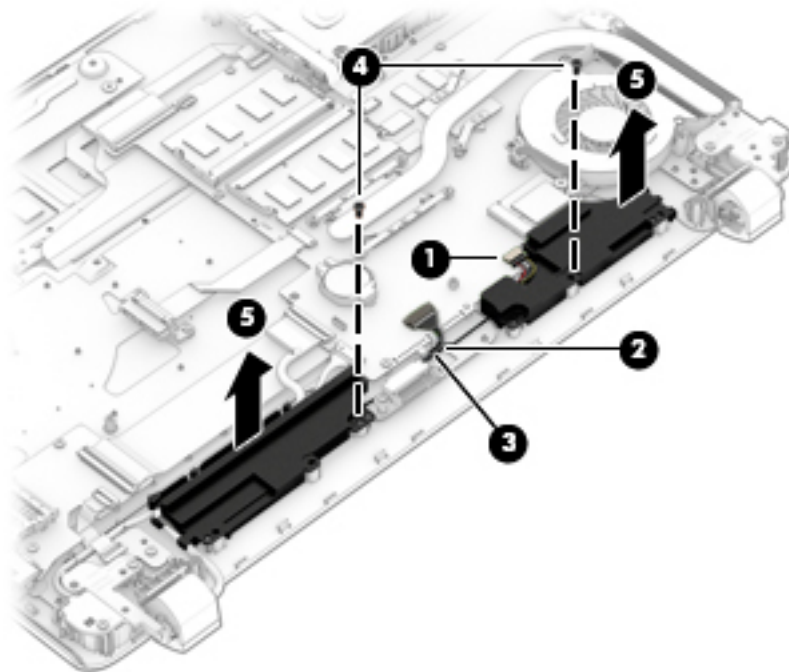

Reverse this procedure to install the speakers.

Power button board

Description	Spare part number
Power button board (includes cable)	809310-001

Before removing the power button board, follow these steps:

1. Shut down the computer. If you are unsure whether the computer is off or in Hibernation, turn the computer on, and then shut it down through the operating system.
2. Disconnect all external devices connected to the computer.
3. Disconnect the power from the computer by first unplugging the power cord from the AC outlet and then unplugging the AC adapter from the computer.
4. Remove the battery (see [Battery on page 23](#)).
5. Remove the optical drive (see [Optical drive on page 24](#)).
6. Remove the bottom cover (see [Bottom cover on page 28](#)).
7. Remove the system board (see [System board on page 43](#)).

To remove the power button board:

1. Disconnect the cable **(1)**.
2. Remove the Phillips PM2.0×2.5 screw **(2)** that secures the power button board to the computer.
3. Remove the power button board from the computer **(3)**.

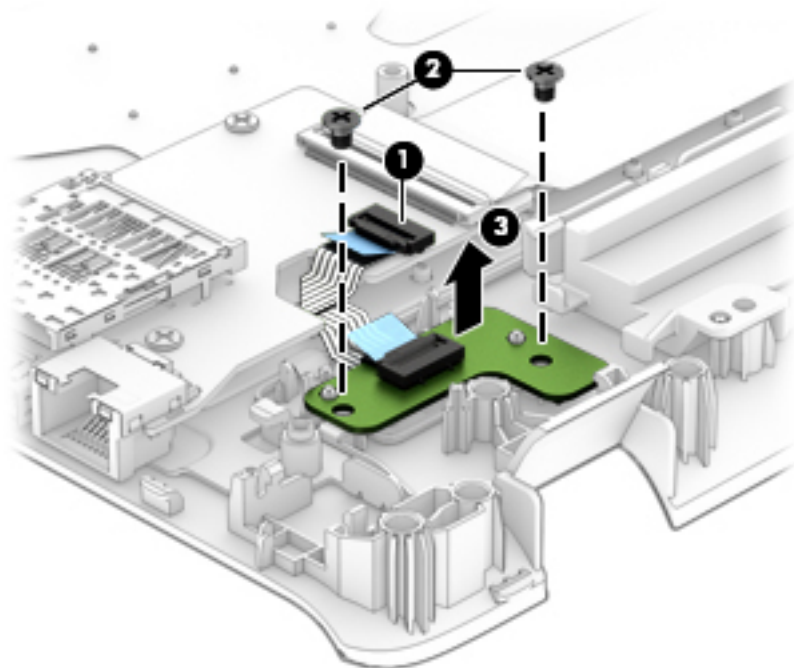

Reverse this procedure to install the power button board and cable.

Power connector

Description	Spare part number
Power connector cable	809295-001

Before removing the power connector cable, follow these steps:

1. Shut down the computer. If you are unsure whether the computer is off or in Hibernation, turn the computer on, and then shut it down through the operating system.
2. Disconnect all external devices connected to the computer.
3. Disconnect the power from the computer by first unplugging the power cord from the AC outlet and then unplugging the AC adapter from the computer.
4. Remove the battery (see [Battery on page 23](#)).
5. Remove the optical drive (see [Optical drive on page 24](#)).
6. Remove the bottom cover (see [Bottom cover on page 28](#)).
7. Remove the system board (see [System board on page 43](#)).

To remove the power connector cable:

1. Pull the tab away from the connector **(1)**.
2. Remove the Phillips PM2.5×3.0 screw **(2)** from the left hinge that sits above the power connector.
3. Remove the power connector **(3)** from the computer.

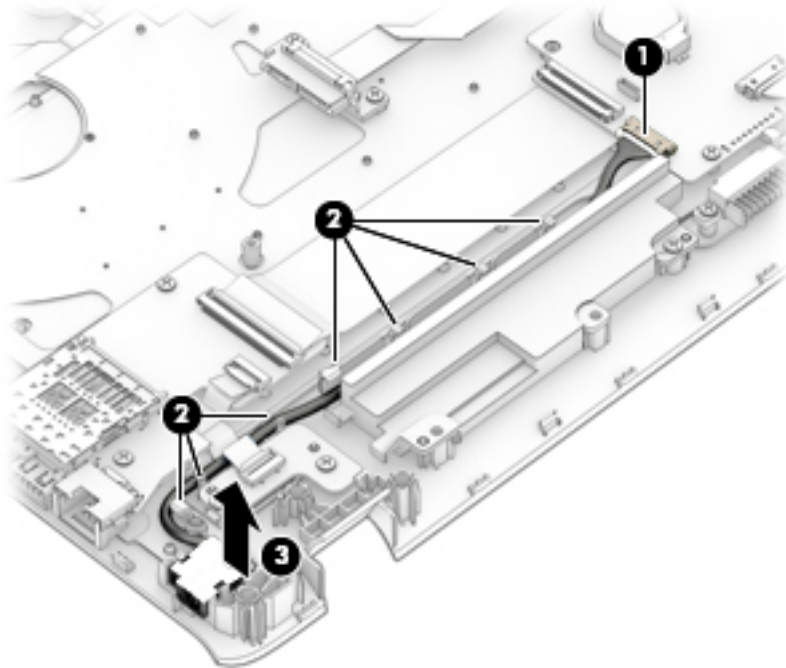

Reverse this procedure to install the power connector cable.

TouchPad

Description	Spare part number
TouchPad board with cable	811552-001

Before removing the TouchPad, follow these steps:

1. Shut down the computer. If you are unsure whether the computer is off or in Hibernation, turn the computer on, and then shut it down through the operating system.
2. Disconnect all external devices connected to the computer.
3. Disconnect the power from the computer by first unplugging the power cord from the AC outlet and then unplugging the AC adapter from the computer.
4. Remove the battery (see [Battery on page 23](#)).
5. Remove the optical drive (see [Optical drive on page 24](#)).
6. Remove the bottom cover (see [Bottom cover on page 28](#)).
7. Remove the system board (see [System board on page 43](#)).

To remove the TouchPad:

1. Remove the three Phillips PM2.5×3.0 screws **(1)** that secure the TouchPad bracket to the computer.
2. Remove the bracket **(2)**.

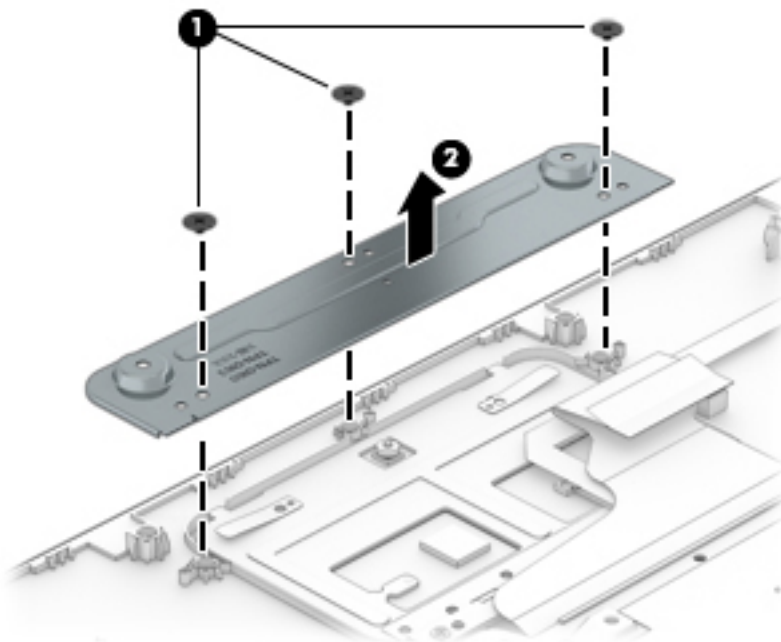

3. Lift the keyboard cable **(1)** to gain access to the TouchPad screws.
4. Remove the three broadhead Phillips PM2.0×2.0 screws **(2)** that secure the rear bracket and the TouchPad to the computer.

5. Lift the bottom of TouchPad and rear bracket up, and then pull it away from computer **(3)**.

 **NOTE:** When installing the TouchPad, note that the metal protrusion that extends from the TouchPad is installed UNDER the keyboard shield **(4)**.

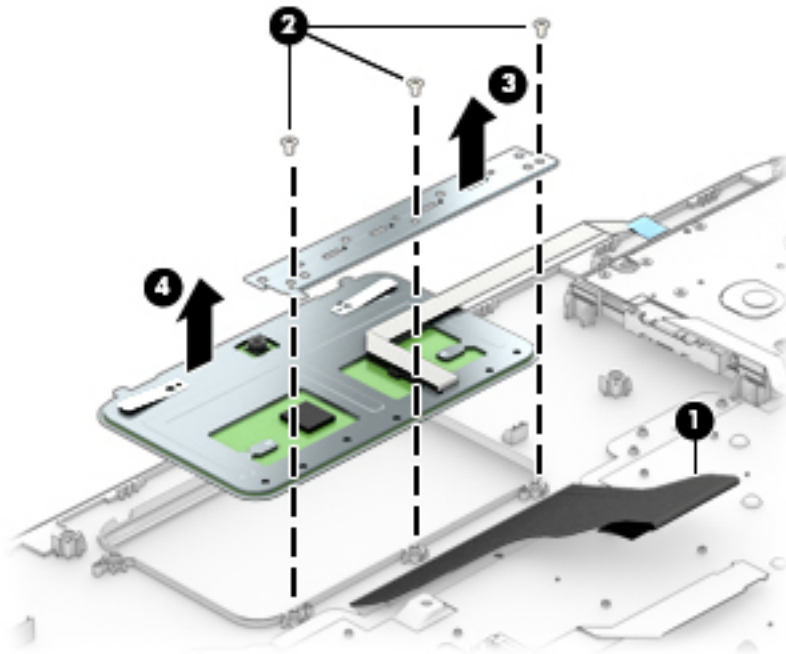

Reverse this procedure to install the TouchPad.

Display assembly, touch

Description	Spare part number
Touch screen connector board included with display	
Webcam/microphone module touch screen	810961-001
Raw display panel (16:9 Ultra Wide Aspect Ratio [43.9-cm 17.3-in]; includes screw covers and touch sensor)	
Antiglare FHD+ touch screen	835868-001
Panel Bracket (included with the Display Panel touch screen)	
Display cable FHD touch screen (includes screw covers)	809294-001
Antennas touch screen (includes wireless antenna cables and transceivers; includes screw covers)	809272-001
Hinges touch screen (left and right, includes screw covers)	809299-001
Display enclosure:	835865-001

Before removing the display assembly, follow these steps:

1. Shut down the computer. If you are unsure whether the computer is off or in Hibernation, turn the computer on, and then shut it down through the operating system.
2. Disconnect all external devices connected to the computer.

3. Disconnect the power from the computer by first unplugging the power cord from the AC outlet and then unplugging the AC adapter from the computer.
4. Remove the battery (see [Battery on page 23](#)).
5. Remove the optical drive (see [Optical drive on page 24](#)).
6. Remove the bottom cover (see [Bottom cover on page 28](#)).

To remove the display assembly:

1. Position the computer on its side, partially open.
2. Remove the four Phillips PM2.5×5.0 screws (1) that secure the display assembly to the computer.
3. Open the display to rotate the hinges upward to an angle (2).
4. Separate the display assembly from the computer (3).

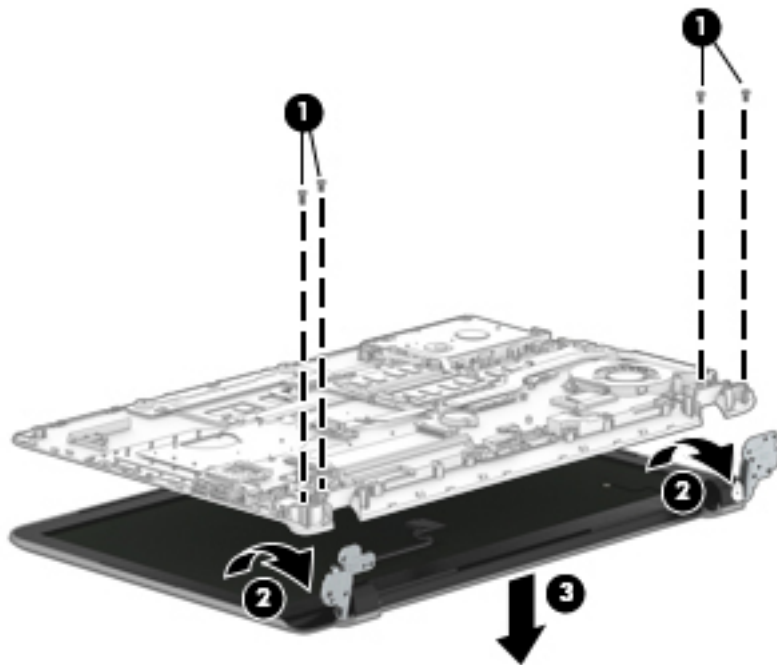

If it is necessary to replace any of the display assembly subcomponents:

1. To remove the display cover:
 - a. Pry up on each side of the display to disengage the cover and remove the back cover.



- b. Turn the display with the bezel down and the back of the panel up. Disconnect the display cables from the panel and bezel **(1)**, **(2)**. Release the connections **(3)**, **(4)** and lift the panel **(5)**.

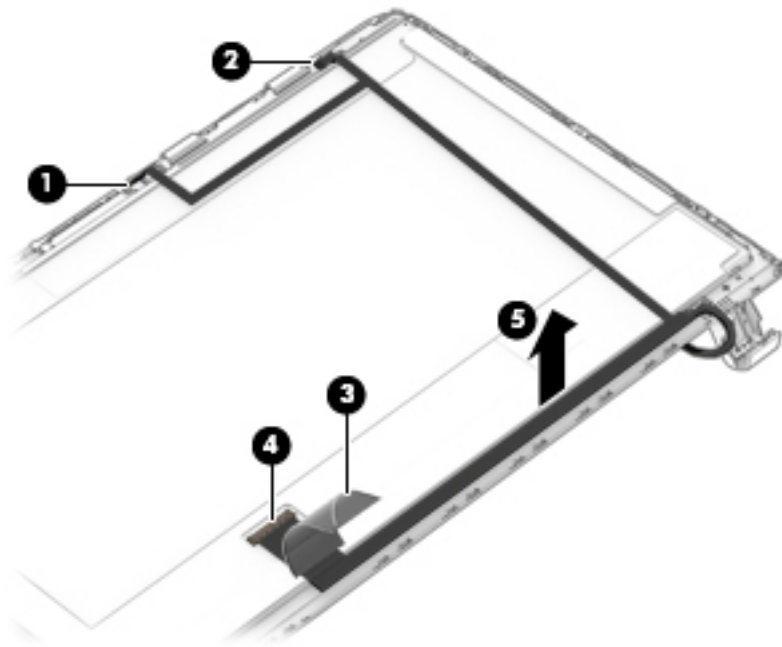

- 2. To remove the webcam/microphone module, position the display assembly with the top edge toward you.
 - a. Disconnect the cable **(1)** from the module.

- b. Remove the webcam/microphone module from the display (2).

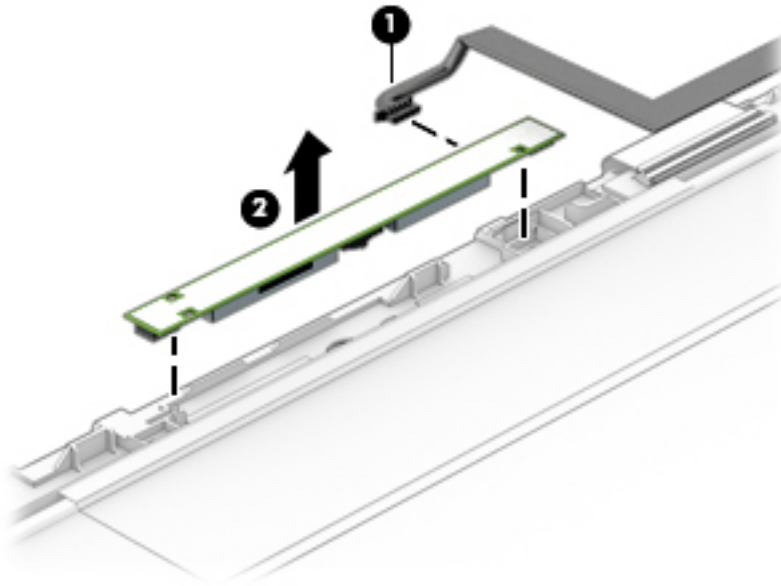

3. To remove the display panel:
- Position the display assembly with the top edge toward you.
 - Remove the six Phillips PM2.0×1.5 screws (1) that secure the display panel to the bezel.
 - Lift the top of the panel (2).

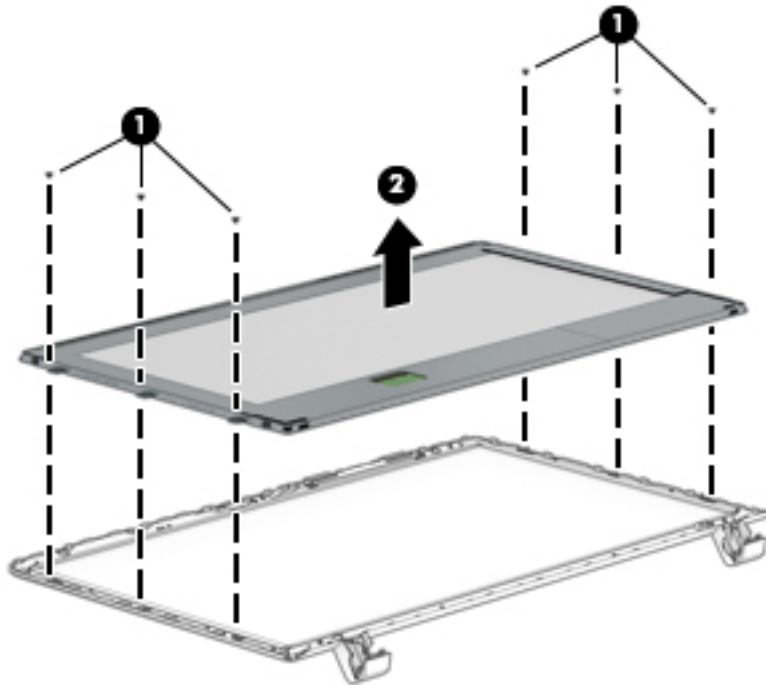

4. To remove the display hinges:
- Remove the six Phillips PM2.5×2.0 screws (1) from the bottom of the hinges, and the two Phillips PM2.0×2.5 screws from the top of the hinges that secure the display hinges to the display.

- b. Remove the display hinges (2).

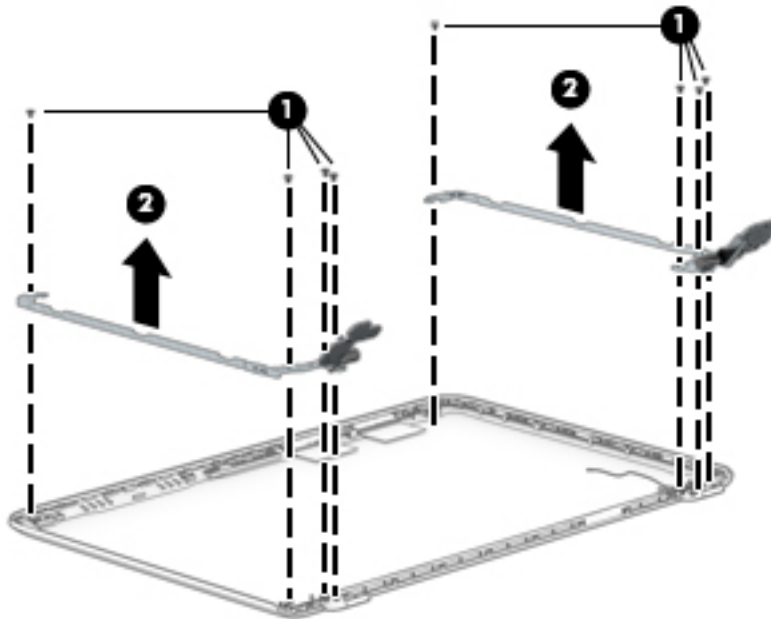

5. To remove the wireless antenna cables and transceivers, release the wireless antenna cables from the clips (1) built into the display enclosure, peel the transceivers from the enclosure (2), and then remove the antenna cables and transceivers.

 **NOTE:** Number of antennas and transceivers may vary.

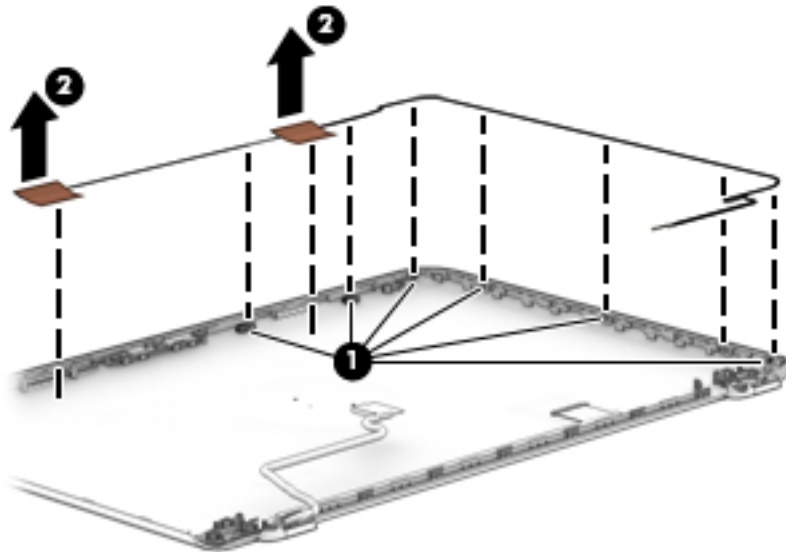

6. To remove the display/webcam cable, disconnect the cable (1).

7. Remove the cable from the clips built into the display panel **(2)**, and then remove the cable from the display **(3)**.

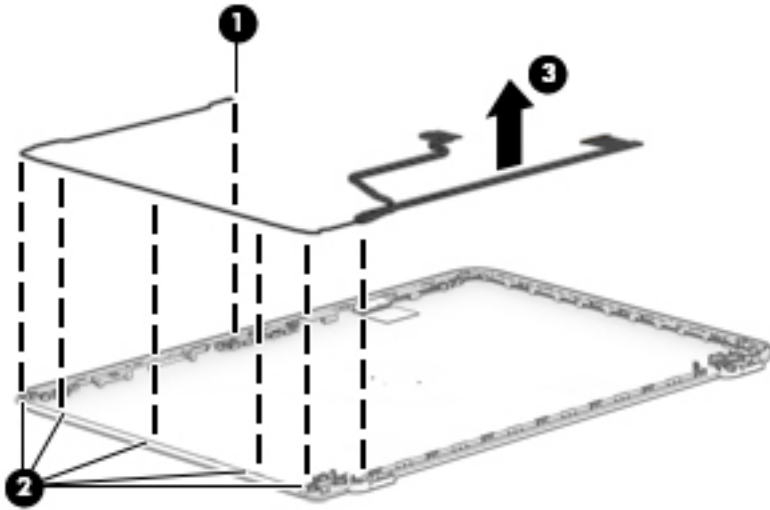

8. If replacing the display enclosure, be sure that the subcomponents (including the webcam/microphone module, the antenna receivers, and all associated cables and hardware) are transferred to the new enclosure.

Reverse this procedure to reassemble and install the display assembly.

7 Using Setup Utility (BIOS)

Setup Utility, or Basic Input/Output System (BIOS), controls communication between all the input and output devices on the system (such as disk drives, display, keyboard, mouse, and printer). Setup Utility (BIOS) includes settings for the types of devices installed, the startup sequence of the computer, and the amount of system and extended memory.

 **NOTE:** To start Setup Utility on convertible computers, your computer must be in notebook mode and you must use the keyboard attached to your notebook.

Starting Setup Utility (BIOS)

 **CAUTION:** Use extreme care when making changes in Setup Utility (BIOS). Errors can prevent the computer from operating properly.

- ▲ Turn on or restart the computer, quickly press **esc**, and then press **f10**.

Updating Setup Utility (BIOS)

Updated versions of Setup Utility (BIOS) may be available on the HP website.

Most BIOS updates on the HP website are packaged in compressed files called *SoftPaqs*.

Some download packages contain a file named *Readme.txt*, which contains information regarding installing and troubleshooting the file.

Determining the BIOS version

To decide whether you need to update Setup Utility (BIOS), first determine the BIOS version on your computer.

To reveal the BIOS version information (also known as *ROM date* and *System BIOS*), use one of these options.

- HP Support Assistant
 1. Type `support` in the taskbar search box, and then select the **HP Support Assistant** app.
– or –
Click the question mark icon in the taskbar.
 2. Select **My PC**, and then select **Specifications**.
- Setup Utility (BIOS)
 1. Start Setup Utility (BIOS) (see [Starting Setup Utility \(BIOS\) on page 57](#)).
 2. Select **Main**, select **System Information**, and then make note of the BIOS version.
 3. Select **Exit**, select **No**, and then follow the on-screen instructions.

To check for later BIOS versions, see [Downloading a BIOS update on page 58](#).

Downloading a BIOS update

 **CAUTION:** To reduce the risk of damage to the computer or an unsuccessful installation, download and install a BIOS update only when the computer is connected to reliable external power using the AC adapter. Do not download or install a BIOS update while the computer is running on battery power, docked in an optional docking device, or connected to an optional power source. During the download and installation, follow these instructions:

- Do not disconnect power from the computer by unplugging the power cord from the AC outlet.
- Do not shut down the computer or initiate Sleep.
- Do not insert, remove, connect, or disconnect any device, cable, or cord.

 **NOTE:** If your computer is connected to a network, consult the network administrator before installing any software updates, especially system BIOS updates.

1. Type `support` in the taskbar search box, and then select the **HP Support Assistant** app.
– or –
Click the question mark icon in the taskbar.
2. Click **Updates**, and then click **Check for updates and messages**.
3. Follow the on-screen instructions.
4. At the download area, follow these steps:
 - a. Identify the most recent BIOS update and compare it to the BIOS version currently installed on your computer. If the update is more recent than your BIOS version, make a note of the date, name, or other identifier. You may need this information to locate the update later, after it has been downloaded to your hard drive.
 - b. Follow the on-screen instructions to download your selection to the hard drive.

Make a note of the path to the location on your hard drive where the BIOS update is downloaded. You will need to access this path when you are ready to install the update.

BIOS installation procedures vary. Follow any instructions that appear on the screen after the download is complete. If no instructions appear, follow these steps:

1. Type `file` in the taskbar search box, and then select **File Explorer**.
2. Click your hard drive designation. The hard drive designation is typically Local Disk (C:).
3. Using the hard drive path you recorded earlier, open the folder that contains the update.
4. Double-click the file that has an `.exe` extension (for example, `filename.exe`).

The BIOS installation begins.
5. Complete the installation by following the on-screen instructions.

 **NOTE:** After a message on the screen reports a successful installation, you can delete the downloaded file from your hard drive.

8 Using HP PC Hardware Diagnostics (UEFI)

HP PC Hardware Diagnostics is a Unified Extensible Firmware Interface (UEFI) that allows you to run diagnostic tests to determine whether the computer hardware is functioning properly. The tool runs outside the operating system so that it can isolate hardware failures from issues that are caused by the operating system or other software components.

When HP PC Hardware Diagnostics (UEFI) detects a failure that requires hardware replacement, a 24-digit Failure ID code is generated. This ID code can then be provided to support to help determine how to correct the problem.

 **NOTE:** To start diagnostics on a convertible computer, your computer must be in notebook mode and you must use the keyboard attached.

To start HP PC Hardware Diagnostics (UEFI), follow these steps:

1. Turn on or restart the computer, and quickly press [esc](#).
2. Press [f2](#).

The BIOS searches three places for the diagnostic tools, in the following order:

- a. Connected USB drive

 **NOTE:** To download the HP PC Hardware Diagnostics (UEFI) tool to a USB drive, see [Downloading HP PC Hardware Diagnostics \(UEFI\) to a USB device on page 59](#).

- b. Hard drive
- c. BIOS

3. When the diagnostic tool opens, select the type of diagnostic test you want to run, and then follow the on-screen instructions.

 **NOTE:** If you need to stop a diagnostic test, press [esc](#).

Downloading HP PC Hardware Diagnostics (UEFI) to a USB device

 **NOTE:** The HP PC Hardware Diagnostics (UEFI) download instructions are provided in English only, and you must use a Windows computer to download and create the HP UEFI support environment because only .exe files are offered.

There are two options to download HP PC Hardware Diagnostics to a USB device.

Download the latest UEFI version

1. Go to <http://www.hp.com/go/techcenter/pcdiags>. The HP PC Diagnostics home page is displayed.
2. In the HP PC Hardware Diagnostics section, click the **Download** link, and then select **Run**.

Download any version of UEFI for a specific product

1. Go to <http://www.hp.com/support>, and then select your country. The HP Support page is displayed.
2. Click **Drivers & Downloads**.

3. Use the categories listed to find your product.

– or –

Click **Find Now** to let HP automatically detect your product.

4. Select your computer, and then select your operating system.
5. In the **Diagnostic** section, follow the on-screen instructions to select and download the UEFI version you want.

9 Specifications

Computer specifications

	Metric	U.S.
Dimensions		
Depth	275 mm	10.89 in
Width	418.8 mm	16.48 in
Height (rear)	28.5 mm	1.15 in
Weight		
	2.9 – 3.2 kg	6.40 – 7.06 lb
Input power		
Operating voltage and current	19.5 V dc @ 2.31 A – 45 W 18.5 V dc @ 3.5 A or 19.5 V dc @ 3.33 A – 65 W	
Temperature		
Operating	5°C to 35°C	41°F to 95°F
Nonoperating	-20°C to 60°C	-4°F to 140°F
Relative humidity (noncondensing)		
Operating	10% to 90%	
Nonoperating	5% to 95%	
Maximum altitude (unpressurized)		
Operating	-15 m to 3,048 m	-50 ft to 10,000 ft
Nonoperating	-15 m to 12,192 m	-50 ft to 40,000 ft

NOTE: Applicable product safety standards specify thermal limits for plastic surfaces. The device operates well within this range of temperatures.

43.9-cm (17.3-in) display specifications

	Metric	U.S.
Active diagonal size	43.9-cm	17.3-in
Thickness	6.0 mm or 4.0 mm	0.157 inch or 0.236 inch
Resolution	1920x1080 (FHD)	
Surface treatment	Antiglare	
Contrast ratio	300:1 (typical)	
Brightness	220 nits (typical)	
Viewing angle	SVA	
Backlight	WLED	
Companion standard	eDP	

Hard drive specifications

	2 TB*	1 TB*	1 TB*
Dimensions			
Height	9.5 mm	9.5 mm	9.5 mm
Length	100.4 mm	100.4 mm	100.4 mm
Width	69.9 mm	69.9 mm	69.9 mm
Weight	115.0 g	115.0 g	115.0 g
Interface type	SATA	SATA	SATA
Transfer rate			
Synchronous (maximum)	300 MB/sec	300 MB/sec	300 MB/sec
Security	ATA security	ATA security	ATA security
Seek times (typical read, including setting)			
Single track	1.4 ms	1.4 ms	1.5 ms
Average (read/write)	10 ms	10 ms	11 ms
Maximum	12 ms	12 ms	14 ms
Logical blocks	3,877,842,922	1,938,921,461	1,465,149,168
Disk rotational speed	5400 rpm	5400 rpm	5400 rpm
Operating temperature	0°C to 60°C (32°F to 140°F)		
*1 TB = 1 billion bytes when referring to hard drive storage capacity. Actual accessible capacity is less.			
NOTE: Certain restrictions and exclusions apply. Contact technical support for details.			

DVD±RW SuperMulti DL Drive specifications

Applicable disc	Read: CD-DA, CD+(E)G, CD-MIDI, CD-TEXT, CD-ROM, CD-ROM XA, MIXED MODE CD, CD-I, CD-I Bridge (Photo-CD, Video CD), Multisession CD (Photo-CD, CD-EXTRA, Portfolio, CD-R, CD-RW), CD-R, CD-RW, DVD-ROM (DVD-5, DVD-9, DVD-10, DVD-18), DVD-R, DVD-RW, DVD+R, DVD+RW, DVD-RAM	Write: CD-R and CD-RW DVD+R, DVD+RW, DVD-R, DVD-RW, DVD-RAM
Center hole diameter	1.5 cm (0.59 in)	
Disc diameter		
Standard disc	12 cm (4.72 in)	
Mini disc	8 cm (3.15 in)	
Disc thickness	1.2 mm (0.047 in)	
Track pitch	0.74 µm	
Access time	CD	DVD
Random	< 175 ms	< 230 ms
Full stroke	< 285 ms	< 335 ms
Audio output level	Line-out, 0.7 Vrms	
Cache buffer	2 MB	
Data transfer rate		
24X CD-ROM	3,600 KB/sec	
8X DVD-ROM	10,800 KB/sec	
24X CD-R	3,600 KB/sec	
16X CD-RW	2,400 KB/sec	
8X DVD+R	10,800 KB/sec	
4X DVD+RW	5,400 KB/sec	
8X DVD-R	10,800 KB/sec	
4X DVD-RW	5,400 KB/sec	
2.4X DVD+R(9)	2,700 KB/sec	
5X DVD-RAM	6,750 KB/sec	
Transfer mode	Multiword DMA Mode	
Startup time	< 15 seconds	
Stop time	< 6 seconds	

10 Backing up, restoring, and recovering

This chapter provides information about the following processes. The information in the chapter is standard procedure for most products.

- Creating recovery media and backups
- Restoring and recovering your system

For additional information, refer to the HP support assistant app.

- ▲ Type `support` in the taskbar search box, and then select the **HP Support Assistant** app.

– or –

Click the question mark icon in the taskbar.

 **IMPORTANT:** If you will be performing recovery procedures on a tablet, the tablet battery must be at least 70% charged before you start the recovery process.

IMPORTANT: For a tablet with a detachable keyboard, connect the keyboard to the keyboard dock before beginning any recovery process.

Creating recovery media and backups

The following methods of creating recovery media and backups are available on select products only. Choose the available method according to your computer model.

- Use HP Recovery Manager to create HP Recovery media after you successfully set up the computer. This step creates a backup of the HP Recovery partition on the computer. The backup can be used to reinstall the original operating system in cases where the hard drive is corrupted or has been replaced.
- Use Windows tools to create system restore points and create backups of personal information.

 **NOTE:** If storage is 32 GB or less, Microsoft System Restore is disabled by default.

Creating HP Recovery media (select products only)

If possible, check for the presence of the Recovery partition and the Windows partition. From the **Start** menu, select **File Explorer**, and then select **This PC**.

- If your computer does not list the Windows partition and the Recovery partition, you can obtain recovery media for your system from support. See the *Worldwide Telephone Numbers* booklet included with the computer. You can also find contact information on the HP website. Go to <http://www.hp.com/support>, select your country or region, and follow the on-screen instructions.
- If your computer does list the Recovery partition and the Windows partition, you can use HP Recovery Manager to create recovery media after you successfully set up the computer. HP Recovery media can be used to perform system recovery if the hard drive becomes corrupted. System recovery reinstalls the original operating system and software programs that were installed at the factory and then configures the settings for the programs. HP Recovery media can also be used to customize the system or restore the factory image if you replace the hard drive.

- Only one set of recovery media can be created. Handle these recovery tools carefully, and keep them in a safe place.
- HP Recovery Manager examines the computer and determines the required storage capacity for the media that will be required.
- To create recovery discs, your computer must have an optical drive with DVD writer capability, and you must use only high-quality blank DVD-R, DVD+R, DVD-R DL, or DVD+R DL discs. Do not use rewritable discs such as CD±RW, DVD±RW, double-layer DVD±RW, or BD-RE (rewritable Blu-ray) discs; they are not compatible with HP Recovery Manager software. Or, instead, you can use a high-quality blank USB flash drive.
- If your computer does not include an integrated optical drive with DVD writer capability, but you would like to create DVD recovery media, you can use an external optical drive (purchased separately) to create recovery discs. If you use an external optical drive, it must be connected directly to a USB port on the computer; the drive cannot be connected to a USB port on an external device, such as a USB hub. If you cannot create DVD media yourself, you can obtain recovery discs for your computer from HP. See the *Worldwide Telephone Numbers* booklet included with the computer. You can also find contact information on the HP website. Go to <http://www.hp.com/support>, select your country or region, and follow the on-screen instructions.
- Be sure that the computer is connected to AC power before you begin creating the recovery media.
- The creation process can take an hour or more. Do not interrupt the creation process.
- If necessary, you can exit the program before you have finished creating all of the recovery DVDs. HP Recovery Manager will finish burning the current DVD. The next time you start HP Recovery Manager, you will be prompted to continue.

To create HP Recovery media:

 **IMPORTANT:** For a tablet with a detachable keyboard, connect the keyboard to the keyboard dock before beginning these steps.

1. Type `recovery` in the taskbar search box, and then select **HP Recovery Manager**.
2. Select **Create recovery media**, and then follow the on-screen instructions.

Using Windows tools

You can create recovery media, system restore points, and backups of personal information using Windows tools.

 **NOTE:** If storage is 32 GB or less, Microsoft System Restore is disabled by default.

For more information and steps, see the Get started app.

- ▲ Select the **Start** button, and then select the **Get started** app.

Restore and recovery

There are several options for recovering your system. Choose the method that best matches your situation and level of expertise:

 **IMPORTANT:** Not all methods are available on all products.

- Windows offers several options for restoring from backup, refreshing the computer, and resetting the computer to its original state. For more information see the Get started app.

- ▲ Select the **Start** button, and then select the **Get started** app.
- If you need to correct a problem with a preinstalled application or driver, use the Reinstall drivers and/or applications option (select products only) of HP Recovery Manager to reinstall the individual application or driver.
 - ▲ Type `recovery` in the taskbar search box, select **HP Recovery Manager**, select **Reinstall drivers and/or applications**, and then follow the on-screen instructions.
- If you want to recover the Windows partition to original factory content, you can choose the System Recovery option from the HP Recovery partition (select products only) or use the HP Recovery media.
- On select products, if you want to recover the computer's original factory partition and content, or if you have replaced the hard drive, you can use the Factory Reset option of HP Recovery media.
- On select products, if you want to remove the recovery partition to reclaim hard drive space, HP Recovery Manager offers the Remove Recovery Partition option.

Recovering using HP Recovery Manager

HP Recovery Manager software allows you to recover the computer to its original factory state by using the HP Recovery media that you either created or that you obtained from HP, or by using the HP Recovery partition (select products only).

What you need to know before you get started

- HP Recovery Manager recovers only software that was installed at the factory. For software not provided with this computer, you must either download the software from the manufacturer's website or reinstall the software from the media provided by the manufacturer.



IMPORTANT: Recovery through HP Recovery Manager should be used as a final attempt to correct computer issues.

- HP Recovery media must be used if the computer hard drive fails.
- To use the Factory Reset option (select products only), you must use HP Recovery media.
- If your computer does not allow the creation of HP Recovery media or if the HP Recovery media does not work, you can obtain recovery media for your system from support. See the *Worldwide Telephone Numbers* booklet included with the computer. You can also find contact information from the HP website. Go to <http://www.hp.com/support>, select your country or region, and follow the on-screen instructions.



IMPORTANT: HP Recovery Manager does not automatically provide backups of your personal data. Before beginning recovery, back up any personal data you want to retain.

Using HP Recovery media, you can choose from one of the following recovery options:



NOTE: Only the options available for your computer display when you start the recovery process.

- System Recovery—Reinstalls the original operating system, and then configures the settings for the programs that were installed at the factory.
- Factory Reset—Restores the computer to its original factory state by deleting all information from the hard drive and re-creating the partitions. Then it reinstalls the operating system and the software that was installed at the factory.

The HP Recovery partition (select products only) allows System Recovery only.

Using the HP Recovery partition (select products only)

The HP Recovery partition allows you to perform a system recovery without the need for recovery discs or a recovery USB flash drive. This type of recovery can be used only if the hard drive is still working.

To start HP Recovery Manager from the HP Recovery partition:

 **IMPORTANT:** For a tablet with a detachable keyboard, connect the keyboard to the keyboard dock before beginning these steps (select products only).

1. Type `recovery` in the taskbar search box, select **Recovery Manager**, and then select **HP Recovery Environment**.

- or -

For computers or tablets with keyboards attached, press **f11** while the computer boots, or press and hold **f11** as you press the power button.

For tablets without keyboards:

Turn on or restart the tablet, and then quickly hold down the volume down button; then select **f11**.

- or -

Turn on or restart the tablet, and then quickly hold down the Windows button; then select **f11**.

2. Select **Troubleshoot** from the boot options menu.
3. Select **Recovery Manager**, and then follow the on-screen instructions.

Using HP Recovery media to recover

You can use HP Recovery media to recover the original system. This method can be used if your system does not have an HP Recovery partition or if the hard drive is not working properly.

1. If possible, back up all personal files.
2. Insert the HP Recovery media, and then restart the computer.
3. Follow the on-screen instructions.

Changing the computer boot order

If your computer does not restart in HP Recovery Manager, you can change the computer boot order, which is the order of devices listed in BIOS where the computer looks for startup information. You can change the selection to an optical drive or a USB flash drive.

To change the boot order:

 **IMPORTANT:** For a tablet with a detachable keyboard, connect the keyboard to the keyboard dock before beginning these steps.

1. Insert the HP Recovery media.
2. Access BIOS:

For computers or tablets with keyboards attached:

▲ Turn on or restart the computer or tablet, quickly press **esc**, and then press **f9** for boot options.

For tablets without keyboards:

▲ Turn on or restart the tablet, and then quickly hold down the volume down button; then select **f9**.

- or -

Turn on or restart the tablet, and then quickly hold down the Windows button; then select **f9**.

3. Select the optical drive or USB flash drive from which you want to boot.
4. Follow the on-screen instructions.

Removing the HP Recovery partition (select products only)

HP Recovery Manager software allows you to remove the HP Recovery partition to free up hard drive space.



IMPORTANT: After you remove the HP Recovery partition, you will not be able to perform System Recovery or create HP recovery media from the HP Recovery partition.



NOTE: The Remove Recovery Partition option is only available on products that support this function.

Follow these steps to remove the HP Recovery partition:

1. Type `recovery` in the taskbar search box, and then select **HP Recovery Manager**.
2. Select **Remove Recovery Partition**, and then follow the on-screen instructions.

11 Power cord set requirements

The wide-range input feature of the computer permits it to operate from any line voltage from 100 to 120 volts ac, or from 220 to 240 volts ac.

The 3-conductor power cord set included with the computer meets the requirements for use in the country or region where the equipment is purchased.

Power cord sets for use in other countries and regions must meet the requirements of the country or region where the computer is used.

Requirements for all countries

The following requirements are applicable to all countries and regions:

- The length of the power cord set must be at least **1.5 m** (5.0 ft) and no more than **2.0 m** (6.5 ft).
- All power cord sets must be approved by an acceptable accredited agency responsible for evaluation in the country or region where the power cord set will be used.
- The power cord sets must have a minimum current capacity of 10 A and a nominal voltage rating of 125 or 250 V ac, as required by the power system of each country or region.
- The appliance coupler must meet the mechanical configuration of an EN 60 320/IEC 320 Standard Sheet C13 connector for mating with the appliance inlet on the back of the computer.

Requirements for specific countries and regions

Country/region	Accredited agency	Applicable note number
Argentina	IRAM	1
Australia	SAA	1
Austria	OVE	1
Belgium	CEBEC	1
Brazil	ABNT	1
Canada	CSA	2
Chile	IMQ	1
Denmark	DEMKO	1
Finland	FIMKO	1
France	UTE	1
Germany	VDE	1
India	ISI	1
Israel	SII	1
Italy	IMQ	1
Japan	JIS	3
The Netherlands	KEMA	1
New Zealand	SANZ	1
Norway	NEMKO	1
The People's Republic of China	CCC	4
Saudi Arabia	SASO	7
Singapore	PSB	1
South Africa	SABS	1
South Korea	KTL	5
Sweden	SEMKO	1
Switzerland	SEV	1
Taiwan	BSMI	6
Thailand	TISI	1
The United Kingdom	ASTA	1
The United States	UL	2

1. The flexible cord must be Type H05VV-F, 3-conductor, 0.75mm² conductor size. Power cord set fittings (appliance coupler and wall plug) must bear the certification mark of the agency responsible for evaluation in the country or region where it will be used.
2. The flexible cord must be Type SVT/SJT or equivalent, No. 18 AWG, 3-conductor. The wall plug must be a two-pole grounding type with a NEMA 5-15P (15 A, 125 V ac) or NEMA 6-15P (15 A, 250 V ac) configuration. CSA or C-UL mark. UL file number must be on each element.

Country/region	Accredited agency	Applicable note number
		3. The appliance coupler, flexible cord, and wall plug must bear a “T” mark and registration number in accordance with the Japanese Dentori Law. The flexible cord must be Type VCTF, 3-conductor, 0.75mm ² or 1.25mm ² conductor size. The wall plug must be a two-pole grounding type with a Japanese Industrial Standard C8303 (7 A, 125 V ac) configuration.
		4. The flexible cord must be Type RVV, 3-conductor, 0.75mm ² conductor size. Power cord set fittings (appliance coupler and wall plug) must bear the CCC certification mark.
		5. The flexible cord must be Type H05VV-F 3X0.75mm ² conductor size. KTL logo and individual approval number must be on each element. Corset approval number and logo must be printed on a flag label.
		6. The flexible cord must be Type HVCTF 3X1.25mm ² conductor size. Power cord set fittings (appliance coupler, cable, and wall plug) must bear the BSMI certification mark.
		7. For 127 V ac, the flexible cord must be Type SVT or SJT 3 x 18 AWG, with plug NEMA 5-15P (15 A, 125 V ac), with UL and CSA or C-UL marks. For 240 V ac, the flexible cord must be Type H05VV-F 3X0.75/1.00mm ² conductor size, with plug BS 1363/A with BSI or ASTA marks.

12 Recycling

When a non-rechargeable or rechargeable battery has reached the end of its useful life, do not dispose of the battery in general household waste. Follow the local laws and regulations in your area for battery disposal.

HP encourages customers to recycle used electronic hardware, HP original print cartridges, and rechargeable batteries. For more information about recycling programs, see the HP Web site at <http://www.hp.com/recycle>.

Index

A

- action keys
 - identifying 10
- antennas
 - illustrated 16, 51
 - removing 55, 56
- audio, product description 2
- audio-out (headphone)/audio-in (microphone) jack, identifying 5

B

- backups 65
- base enclosure hinge caps
 - illustrated 15
- battery
 - illustrated 15
 - removing 23
- battery connector cable
 - spare part number 14
- battery cover, identifying 11
- battery lock, identifying 11
- battery release latch 11
- BIOS
 - determining version 57
 - downloading an update 58
 - starting the Setup Utility 57
 - updating 57

- Bluetooth label 12

- boot order
 - changing 68

- bottom 12

- bottom cover
 - illustrated 15
 - removing 28

- buttons
 - left TouchPad 7
 - power 9
 - right TouchPad 7

C

- cables, service considerations 19
- caps lock light, identifying 8
- chipset, product description 1
- components
 - bottom 11

- right side 5
 - top 7
- computer major components, illustrated 13
- computer specifications 61
- connectors, service considerations 19

D

- display assembly
 - illustrated 14
 - removing 51
 - spare part numbers 14
- display assembly subcomponents
 - illustrated 16
 - removing 51
- display bezel
 - removing 52
- display cable
 - illustrated 16, 51
 - removing 54
- display enclosure
 - illustrated 16, 51
 - removing 56
- display panel
 - illustrated 16, 51
 - product description 1
 - removing 54
- display specifications 62
- DVD±RW SuperMulti DL Drive specifications 64

E

- electrostatic discharge 20
- equipment guidelines 22
- esc key, identifying 10
- Ethernet, product description 2
- external media cards 2

F

- fan
 - illustrated 15
 - removing 37
- fn key, identifying 10

G

- graphics, product description 1
- grounding guidelines 20
- guidelines
 - equipment 22
 - grounding 20
 - packaging 21
 - transporting 21
 - workstation 21

H

- hard drive
 - illustrated 15, 18
 - precautions 20
 - product description 1
 - removing 31
 - specifications 63
- hard drive bracket
 - illustrated 15
 - removing 32
- hard drive light 5
- HDMI port
 - identifying 5
- heat sink assembly
 - illustrated 15
 - removing 15, 38
 - spare part number 38
- hinge caps
 - illustrated 15
- hinges
 - illustrated 16, 51
 - removing 54
- HP PC Hardware Diagnostics (UEFI) using 59
- HP Recovery Manager
 - correcting boot problems 68
 - starting 68
- HP Recovery media
 - creating 65
 - recovery 68
- HP Recovery partition
 - recovery 68
 - removing 70

- I**
- integrated numeric keypad, identifying 10
- internal card expansion 2
- internal display switch, identifying 6
- internal microphones, identifying 6
- J**
- jacks
 - audio-out (headphone)/audio-in (microphone) 5
- K**
- keyboard
 - illustrated 14, 28
 - product description 3
- keys
 - action 10
 - esc 10
 - fn 10
 - Windows 10
- L**
- labels
 - Bluetooth 12
 - regulatory 12
 - serial number 11
 - service 11
 - wireless certification 12
 - WLAN 12
- latch, battery release 11
- lights
 - caps lock 8
 - hard drive 5
 - mute 8
 - power 5, 8
- M**
- mass storage devices
 - illustrated 18
 - precautions 20
- memory module
 - illustrated 15
 - product description 1
 - removing 36
- microphone
 - illustrated 16, 51
 - product description 2
- minimized image recovery 68
- minimized image, creating 67
- model name 1
- mute light, identifying 8
- O**
- operating system 3
- optical drive
 - illustrated 15, 18, 24
 - precautions 20
 - product description 2
 - removing 24
 - specifications 64
- optical drive cable
 - illustrated 14
- optical drive connector
 - removing 42
 - spare part number 42
- original system recovery 67
- P**
- packaging guidelines 21
- plastic parts, service considerations 19
- pointing device 3
- ports
 - HDMI 5
 - product description 2
 - USB 3.0 5
- power button board
 - illustrated 15
 - removing 48
- power button, identifying 9
- power connector cable
 - illustrated 15
 - removing 49
- power cord
 - requirements for all countries 71
 - requirements for specific countries and regions 72
 - set requirements 71
- power lights, identifying 5, 8
- power requirements 3
- processor
 - product description 1
- product description
 - audio 2
 - chipset 1
 - display panel 1
 - Ethernet 2
 - external media cards 2
 - graphics 1
 - hard drive 1
 - internal card expansion 2
 - keyboard 3
 - memory module 1
 - microphone 2
 - operating system 3
 - optical drive 2
 - pointing device 3
 - ports 2
 - power requirements 3
 - processor 1
 - product name 1
 - security 3
 - sensors 2
 - serviceability 3
 - video 2
 - wireless 2
- product name 1
- product name and number, computer 11
- R**
- recover
 - options 66
- recovery
 - discs 66, 68
 - HP Recovery Manager 67
 - media 68
 - starting 68
 - supported discs 66
 - system 67
 - USB flash drive 68
- recovery media
 - creating 65
 - creating using HP Recovery Manager 66
- recovery partition
 - removing 70
- regulatory information
 - regulatory label 12
 - wireless certification labels 12
- removal/replacement
 - preliminaries 19
 - procedures 23, 27
- RTC battery
 - illustrated 15
 - removing 35

S

- security cable slot, identifying 5
- security, product description 3
- sensors, product description 2
- serial number 11
- serial number, computer 11
- service considerations
 - cables 19
 - connectors 19
 - plastic parts 19
- service labels, locating 11
- serviceability, product description 3
- slots
 - security cable 5
- speakers
 - identifying 9
 - illustrated 14
 - removing 47
- specifications
 - computer 61
 - display 62
 - DVD±RW SuperMulti DL Drive 64
 - hard drive 63
 - optical drive 64
- supported discs, recovery 66
- system board
 - removing 43
 - spare part number 14, 43
- system recovery 67
- system restore point
 - creating 66
- system restore point, creating 65

T

- tools required 19
- top cover
 - illustrated 14, 28
- TouchPad
 - buttons 7
 - removing 50
 - spare part number 14, 50
- TouchPad bracket
 - spare part number 14
- TouchPad rear bracket
 - spare part number 14
- TouchPad zone, identifying 7
- transporting guidelines 21
- traveling with the computer 12

U

- USB 3.0 port, identifying 5
- USB board
 - removing 46
 - spare part number 15, 46

V

- vents, identifying 5, 11
- video, product description 2

W

- webcam
 - identifying 6
 - illustrated 16, 51
- webcam light, identifying 6
- webcam/microphone cable
 - illustrated 16, 51
 - removing 54
- webcam/microphone module
 - removing 53
- Windows
 - system restore point 65, 66
- Windows key, identifying 10
- Windows tools
 - using 66
- wireless antennas
 - illustrated 16, 51
 - removing 55, 56
- wireless certification label 12
- wireless, product description 2
- WLAN antennas, identifying 6
- WLAN device 12
- WLAN label 12
- WLAN module
 - illustrated 14
 - removing 33
- workstation guidelines 21

