



User Guide

© Copyright 2019 HP Development Company, L.P.

macOS is a trademark of Apple Computer, Inc., registered in the U.S. and other countries. Android™ is a trademark of Google LLC. HDMI, the HDMI Logo and High-Definition Multimedia Interface are trademarks or registered trademarks of HDMI Licensing LLC. Linux® is the registered trademark of Linus Torvalds in the U.S. and other countries. Windows is either a registered trademark or trademark of Microsoft Corporation in the United States and/or other countries. DisplayPort™, the DisplayPort™ logo, and VESA® are trademarks or registered trademarks owned by the Video Electronics Standards Association (VESA) in the United States and other countries.

The information contained herein is subject to change without notice. The only warranties for HP products and services are set forth in the express warranty statements accompanying such products and services. Nothing herein should be construed as constituting an additional warranty. HP shall not be liable for technical or editorial errors or omissions contained herein.

Product notice





This guide describes features that are common to most models. Some features may not be available on your product. To access the latest user guide, go to <http://www.hp.com/support>, and follow the instructions to find your product. Then select **User Guides**.

First Edition: September 2019

Document Part Number: L72368-001

About this guide

This guide provides technical specifications and information about monitor features, setting up the monitor, using the software, and technical specifications. Depending on the model, your monitor may not have all the features included in this guide.

-
-  **WARNING!** Indicates a hazardous situation that, if not avoided, **could** result in serious injury or death.
 -  **CAUTION:** Indicates a hazardous situation that, if not avoided, **could** result in minor or moderate injury.
 -  **IMPORTANT:** Indicates information considered important but not hazard-related (for example, messages related to property damage). Warns the user that failure to follow a procedure exactly as described could result in loss of data or in damage to hardware or software. Also contains essential information to explain a concept or to complete a task.
 -  **NOTE:** Contains additional information to emphasize or supplement important points of the main text.
 -  **TIP:** Provides helpful hints for completing a task.
-



This product incorporates HDMI technology.

Table of contents

1 Getting started	1
Important safety information	1
Product features and components	2
Features	2
Webcam components	3
Front components	4
Rear components	5
Setting up the monitor	6
Attaching the monitor stand	6
Mounting the monitor head	7
Removing the monitor stand	7
Attaching the monitor head to a mounting device	8
Connecting the cables	9
Connecting USB devices	14
Adjusting the monitor	15
Turning on the monitor	16
HP watermark and image retention policy	16
Installing a security cable	17
2 Using the monitor	18
Downloading software and utilities	18
The Information file	18
The Image Color Matching file	18
Using the OSD menu	19
Using the function buttons	20
Selecting the input source	21
Using the camera	21
Setting up Windows Hello facial recognition	22
Using the computer camera for Windows Hello	22
Using the monitor camera for Windows Hello	23
Using HP Device Bridge	23
Installing HP Device Bridge	24
Stopping HP Device Bridge	24
Adjusting blue light output (select products only)	24
Using Auto-Sleep Mode	24
Changing the Power Mode setting	25

Using PbP	25
3 Support and troubleshooting	27
Solving common issues	27
Video connection combinations	28
Button lockouts	29
Contacting support	29
Preparing to call technical support	30
Locating the serial number and product number	30
4 Maintaining the monitor	31
Maintenance guidelines	31
Cleaning the monitor	31
Shipping the monitor	32
Appendix A Technical specifications	33
110.24 cm (43.4 in) model specifications	33
Preset display resolutions	34
110.24 cm (43.4 in) model	34
Power supply specification	34
Energy saver feature	35
Appendix B Accessibility	36
Accessibility	36
Finding the technology tools you need	36
Our commitment	36
International Association of Accessibility Professionals (IAAP)	36
Finding the best assistive technology	37
Assessing your needs	37
Accessibility for HP products	37
Standards and legislation	38
Standards	38
Mandate 376 – EN 301 549	38
Web Content Accessibility Guidelines (WCAG)	38
Legislation and regulations	38
United States	39
21st Century Communications and Video Accessibility Act (CVAA)	39
Canada	39
Europe	40
United Kingdom	40

Australia	40
Worldwide	40
Useful accessibility resources and links	41
Organizations	41
Educational institutions	41
Other disability resources	41
HP links	41
Contacting support	42

1 Getting started

Important safety information

An AC adapter and power cord might be included with the monitor. If you use another cord, use only a power source and connection appropriate for this monitor. For information about the correct power cord set to use with the monitor, see the *Product Notices* provided in your documentation kit.

 **WARNING!** To reduce the risk of electric shock or damage to the equipment:

- Plug the power cord into an AC outlet that is easily accessible at all times.
- If the power cord has a 3-pin attachment plug, plug the cord into a grounded (earthed) 3-pin outlet.
- Disconnect power from the computer by unplugging the power cord from the AC outlet. When unplugging the power cord from the AC outlet, grasp the cord by the plug.

For your safety, do not place anything on power cords or cables. Care should be taken to route all cords and cables connected to the monitor so that they cannot be stepped on, pulled, grabbed, or tripped over.

To reduce the risk of serious injury, read the *Safety & Comfort Guide* provided with your user guides. It describes proper workstation setup and proper posture, health, and work habits for computer users. The *Safety & Comfort Guide* also provides important electrical and mechanical safety information. The *Safety & Comfort Guide* is also available on the Web at <http://www.hp.com/ergo>.

 **IMPORTANT:** For the protection of the monitor and the computer, connect all power cords for the computer and its peripheral devices (such as a monitor, printer, scanner) to a surge protection device such as a power strip or uninterruptible power supply (UPS). Not all power strips provide surge protection; the power strip must be specifically labeled as having this capability. Use a power strip whose manufacturer offers a damage replacement policy so that you can replace the equipment if surge protection fails.

Use the appropriate and correctly sized furniture designed to properly support your monitor.

 **WARNING!** Monitors that are inappropriately situated on dressers, bookcases, shelves, desks, speakers, chests, or carts may fall over and cause personal injury.

 **NOTE:** This product is suitable for entertainment purposes. Consider placing the monitor in a controlled luminous environment to avoid interference from surrounding light and bright surfaces that might cause disturbing reflections from the screen.

Product features and components

Features

The monitor includes the following features:

- 110.24 cm (43.4 in) curved 1800 mm radius with 3840 × 1200 resolution, ultrawide backlit display, plus full-screen support for lower resolutions
- Antiglare panel with an LED backlight
- Wide viewing angle to allow viewing from a sitting or standing position, or when moving from side to side
- Integrated HP Device Bridge technology that allows you to use a single keyboard and mouse across two connected computers to control applications and transfer files from one computer to the other



NOTE: The integrated HP Device Bridge requires software installation from the included USB flash drive or from <http://www.hp.com/support>.

- Integrated pop-up infrared (IR) and RGB camera with noise cancelling microphones for conferencing and Microsoft Windows Hello support
- Tilt adjustment capability
- Height adjustment capability
- DisplayPort (DP) video input
- High-Definition Multimedia Interface (HDMI) video input (cable provided)
- USB Type-C port with power delivery up to 85 W and DisplayPort Alternate Mode (DP Alt Mode)
- Dynamic power delivery up to 100 W distributed between USB Type-C port #1 and USB Type- C port #2
- USB 3.0 hub with two USB Type-C ports that connect to a computer (upstream); and four USB ports that connect to USB devices (downstream)
- USB cable provided to connect the monitor's USB hub to the USB port on the computer
- Audio-out (headphone) jack
- Plug and Play capability, if supported by your operating system
- Security cable slot provision on rear of monitor for optional security cable
- On-screen display (OSD) adjustments in several languages for easy setup and screen optimization
- HP Display Assistant software for adjusting monitor settings and enabling the theft deterrence features
- High-bandwidth Digital Content Protection (HDCP) copy protection on all digital inputs
- In select regions, USB flash drive with monitor drivers and product documentation
- VESA mounting bracket for attaching the monitor to a wall-mount device or swing arm
- Low blue light mode settings to create a more relaxing and less stimulating image
- Energy saver feature to meet requirements for reduced power consumption



NOTE: For safety and regulatory information, see the *Product Notices* provided in your documentation kit. To access the latest user guide, go to <http://www.hp.com/support> and follow the instructions to find your product. Then select **User Guides**.

Webcam components



Table 1-1 Webcam components and their descriptions

Component	Description	
1	Microphones	Noise-cancelling microphones.
2	IR transmitters	Illuminate objects with IR light.
3	Webcam light	On: The webcam is in use.
4	RGB camera	Transmits your image in a video conference.
5	IR camera	Transmits IR image for Windows Hello.

Front components



Table 1-2 Front components

Control	Function
1 Pop-up webcam	Integrated IR and RGB camera and noise-cancelling microphones.
2 Menu button	Press to open the OSD menu, select a menu item from the OSD, or close the OSD menu.
3 Function buttons	Use these buttons to navigate through the OSD menu based on the indicators above the buttons that are activated while the OSD menu is open. NOTE: The function buttons are located under the monitor's front bezel edge below the power light.
4 Power button	Turns the monitor on or off.
5 Power light	White: The monitor is powered on. Amber: Monitor is in a reduced power state because of inactivity. For more information, see Using Auto-Sleep Mode on page 24 .

Rear components

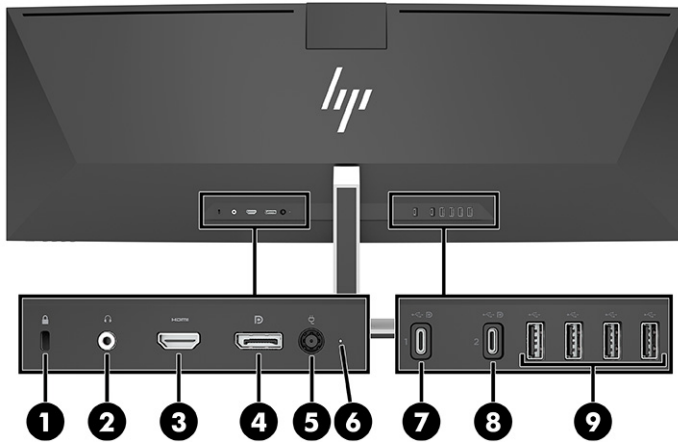



Table 1-3 Rear components

Component	Function
1 Security cable slot	Connects an optional security cable to the monitor.
2 Headphone jack	Connects headphones to the monitor.
3 HDMI port	Connects an HDMI cable from the monitor to a source device such as a computer.
4 DisplayPort connector	Connects the DisplayPort cable from the monitor to a source device such as a computer.
5 Power connector	Connects the power cord.
6 Power light	White: The monitor is connected to power or powered on.
7 USB Type-C #1 port with DP Alt Mode, USB upstream data, and power delivery up to 85 W	<p>Connects a USB Type-C cable to a source device such as a computer or game console. This USB Type-C port can function as a DisplayPort audio/video input or as a USB 3.0 data connection.</p> <p>Charges most USB Type-C devices even when the monitor is in sleep mode.</p> <p>NOTE: The monitor must be set to Performance Mode. For detailed instructions, see Changing the Power Mode setting on page 25.</p>
8 USB Type-C #2 port with DP Alt Mode, USB upstream data, and power delivery up to 85 W	<p>Connects a USB Type-C cable to a source device such as a computer or game console. This USB Type-C port can function as a DisplayPort audio/video input or as a USB 3.0 data connection.</p> <p>Charges most USB Type-C devices even when the monitor is in sleep mode.</p> <p>NOTE: The monitor must be set to Performance Mode. For detailed instructions, see Changing the Power Mode setting on page 25.</p>
9 USB Type-A ports (4) (downstream)	Connect USB cables to peripheral devices, such as a keyboard, mouse, or USB hard drive, and provide data transfer.

 **NOTE:** The USB Type-C port can also function as a USB port when connected to a USB Type-C port on a source device.

The USB Type-C port can function as a DisplayPort audio/video input, a USB 3.0 upstream connection, or it can be used to deliver up to 85 watts of power to a device. Power outputs are 5 V, 9 V, 10 V, 12 V, 15 V, and 20 V with a total maximum output of 85 W.

Only devices accepting Non-limited Power Source (as defined in IEC 60950-1 clause 2.5) can be powered from the USB Type-C port. For a specific equipment list, go to <http://www.hp.com/go/hppc-60950-62368>.

Setting up the monitor

 **WARNING!** To reduce the risk of serious injury, read the *Safety & Comfort Guide*. It describes proper workstation setup and proper posture, health, and work habits for computer users. The *Safety & Comfort Guide* also provides important electrical and mechanical safety information. The *Safety & Comfort Guide* is available on the Web at <http://www.hp.com/ergo>.

 **IMPORTANT:** To prevent damage to the monitor, do not touch the surface of the LCD panel. Pressure on the panel may cause nonuniformity of color or disorientation of the liquid crystals. If this occurs, the screen will not recover to its normal condition.

Attaching the monitor stand

The monitor ships with the stand attached. If you have removed the monitor stand for any reason and need to attach it again, follow these instructions.

 **TIP:** Consider the placement of the monitor, because surrounding light and bright surfaces might cause interfering reflections.

1. Position the monitor upside-down on the top edge on a flat surface covered by a protective sheet made of foam or a clean, dry cloth.

 **IMPORTANT:** To position and stabilize the monitor, HP recommends that two people perform these procedures.

2. Attach the stand to the connector on the back of the monitor head (1).
3. Secure the stand to the monitor head with the three screws included with the monitor (2).

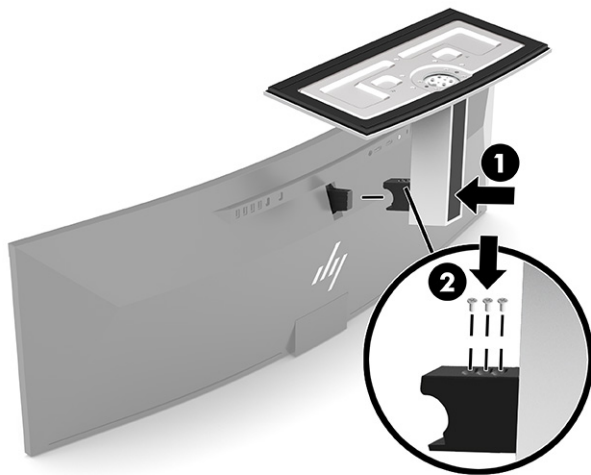

Mounting the monitor head

The monitor head can be attached to a wall, swing arm, or other mounting fixture.

IMPORTANT: This monitor supports the VESA industry-standard 100 mm mounting holes. To attach a third-party mounting solution to the monitor head, four 4 mm, 0.7 pitch, and 10 mm long screws are required. Longer screws might damage the monitor head. Be sure to verify that the manufacturer's mounting solution is compliant with the VESA standard and is rated to support the weight of the monitor head. For best performance, use the power and video cables provided with the monitor.

NOTE: This apparatus is intended to be supported by a UL- or CSA-Listed wall-mount bracket.

Removing the monitor stand

You can remove the monitor head from the stand to install the monitor head on a wall, a swing arm, or other mounting fixture.

IMPORTANT: Before disassembling the monitor, be sure that the monitor is turned off and all cables are disconnected.

1. Disconnect and remove all cables from the monitor.
2. Position the monitor upside-down on the top edge on a flat surface covered by a protective sheet made of foam or a clean, dry cloth.

IMPORTANT: To position and stabilize the monitor, HP recommends that two people perform these procedures.

3. Remove the three screws that attach the stand to the back of the monitor (1).
4. Lift the stand up and out away from the monitor head (2).

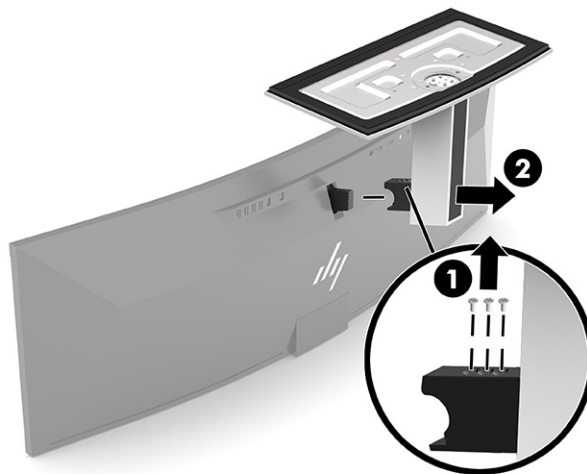

Attaching the monitor head to a mounting device

1. Position the VESA mounting bracket so that the connector slot on the bracket is aligned with the connector slot on the monitor.
2. Press the VESA bracket onto the rear of the monitor until it clicks into place.

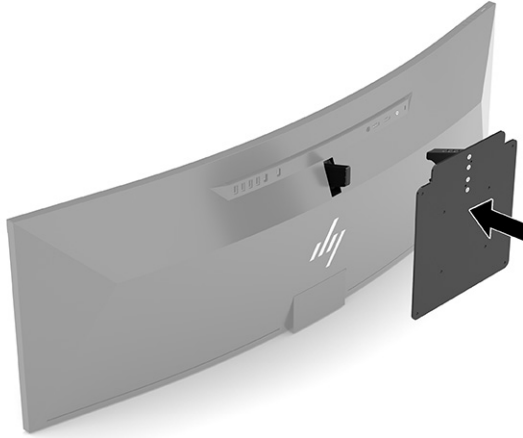

3. Replace the three screws to secure the VESA plate to the monitor.
4. Attach the mounting plate to the wall or swing arm of your choice by inserting the four new VESA screws provided with the VESA mounting bracket.

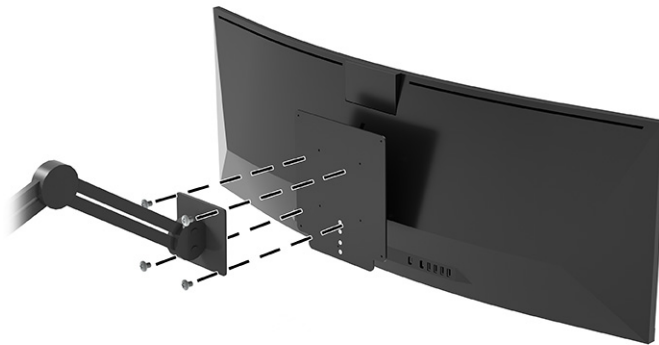

Connecting the cables

 **NOTE:** The monitor ships with select cables. Not all cables shown in this section are included with the monitor.

1. Place the monitor in a convenient, well-ventilated location near the computer.
2. To provide a video signal to the monitor, connect a USB Type-C, DisplayPort, or HDMI video cable between the monitor and source device (computer).

 **NOTE:** Except for USB Type-C inputs, the monitor automatically determines which inputs have valid video signals. USB Type-C input must be manually selected. To select any input, including USB Type-C, open the OSD and select **Input**.

- Connect one end of a USB Type-C to USB Type-C cable (provided) to the USB Type-C port on the rear of the monitor. Then connect the other end to a USB Type-C connector on the source device.

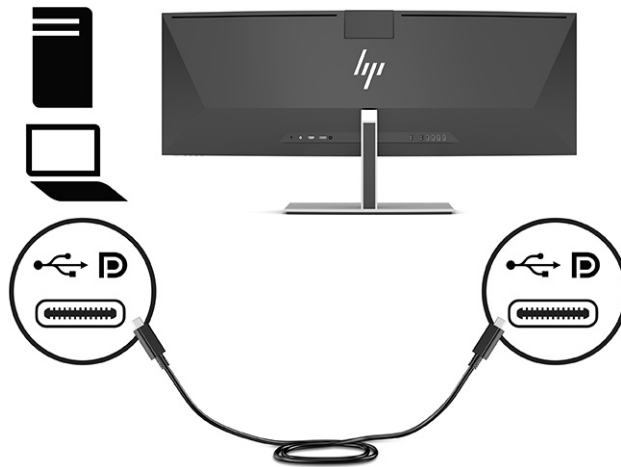

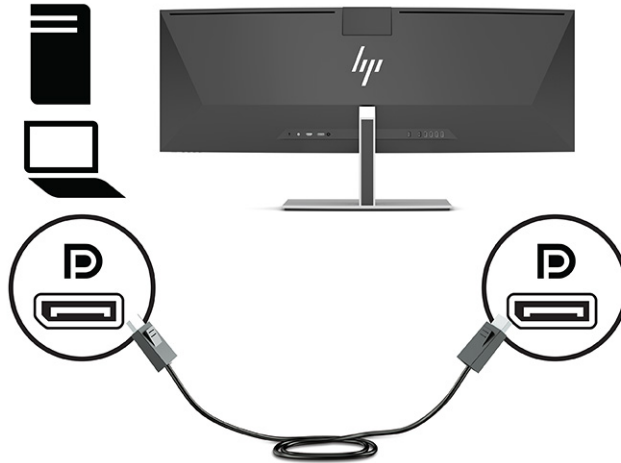

- Connect one end of a DisplayPort cable to the DisplayPort connector on the rear of the monitor and the other end to a DisplayPort connector on the source device.

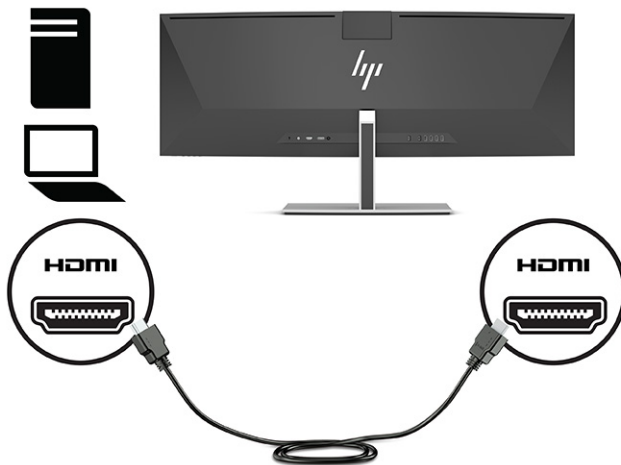

 **NOTE:** If you use a DisplayPort cable for the video signal, you must also connect a USB Type-C to USB Type-A cable or a USB Type-C to USB Type-C cable between the monitor and source device. This connection is required for HP Device Bridge and to provide the upstream connection to enable the monitor hubs on the connected host device.

- Connect one end of an HDMI cable to the HDMI port on the rear of the monitor and the other end to the HDMI port on the source device.



 **NOTE:** If you use an HDMI cable for the video signal, you must also connect a USB Type-C to USB Type-A cable or a USB Type-C to USB Type-C cable between the monitor and source device. This connection is required for HP Device Bridge and to provide the upstream connection to enable the monitor hubs on the connected host device.

3. If you are using a DisplayPort cable for video, you must connect either the provided USB Type-C to USB Type-C cable or USB Type-C to USB Type-A cable between the computer and monitor. Connect the USB Type-C connector to the USB Type-C port on the rear of the monitor. Then connect the USB Type-C connector or the USB Type-A connector to the source device (computer), depending on which cable the source device requires.

 **NOTE:** You must connect either the USB Type-C to USB Type-C cable or the USB Type-C to USB Type-A cable between the monitor and source device (computer) to enable HP Device Bridge and the USB Type-A ports on the monitor.

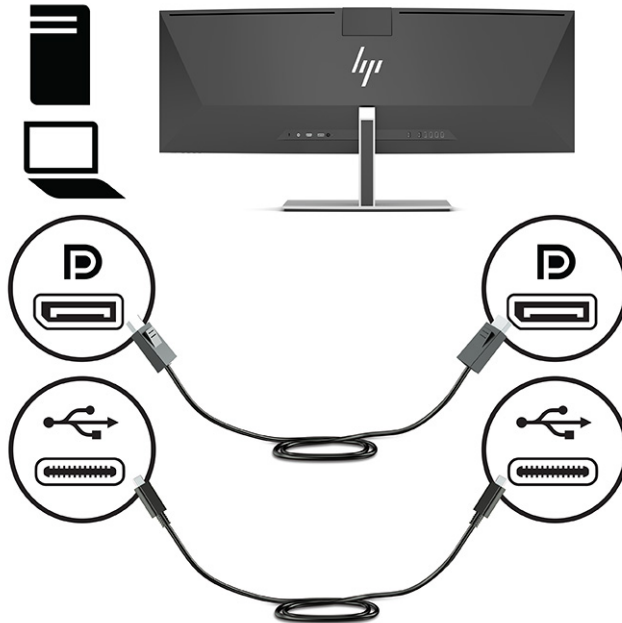

Or

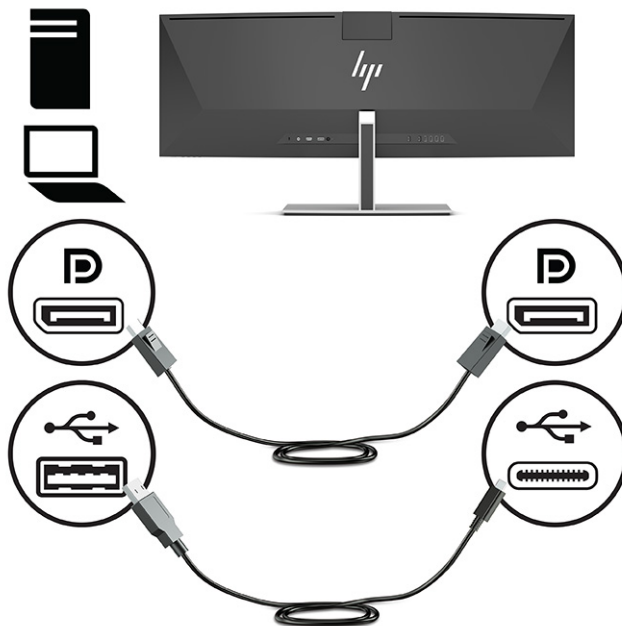

4. If you are using an HDMI cable for video, you must connect either the provided USB Type-C to USB Type-C cable or USB Type-C to USB Type-A cable between the computer and monitor. Connect the USB Type-C connector to the USB Type-C port on the rear of the monitor. Then connect the USB Type-C connector or the USB Type-A connector to the source device (computer), depending on which cable the source device requires.

 **NOTE:** You must connect either the USB Type-C to USB Type-C cable or the USB Type-C to USB Type-A cable between the monitor and source device (computer) to enable HP Device Bridge and the USB Type-A ports on the monitor.

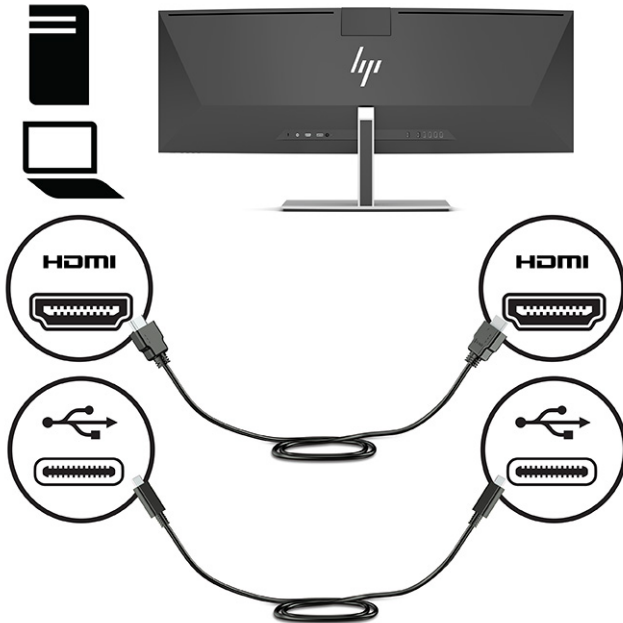

Or

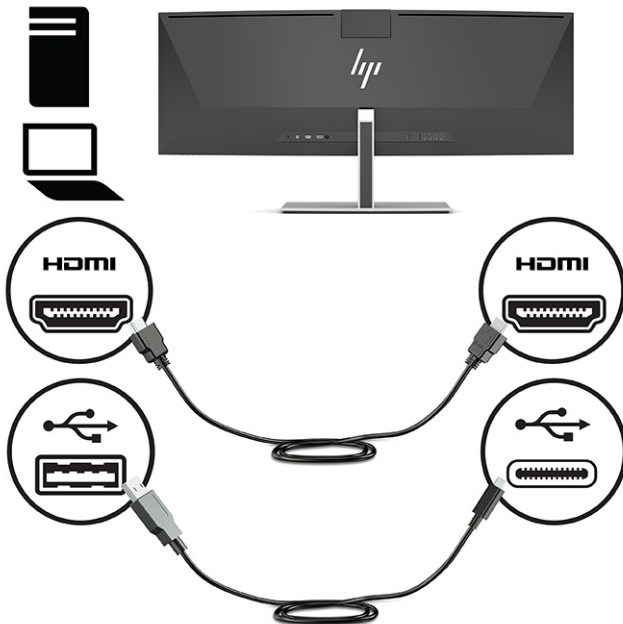

5. Connect one end of the power cord to the AC adapter (1) and the other end to a grounded AC outlet (2). Then connect the AC adapter to the power connector on the rear of the monitor (3).

⚠ WARNING! To reduce the risk of electric shock or damage to the equipment:

Do not disable the power cord grounding plug. The grounding plug is an important safety feature.

Plug the power cord into a grounded (earthed) AC outlet that is easily accessible at all times.

Disconnect power from the equipment by unplugging the power cord from the AC outlet.

For your safety, do not place anything on power cords or cables. Arrange them so that no one may accidentally step on or trip over them. Do not pull on a cord or cable. When unplugging the power cord from the AC outlet, grasp the cord by the plug.

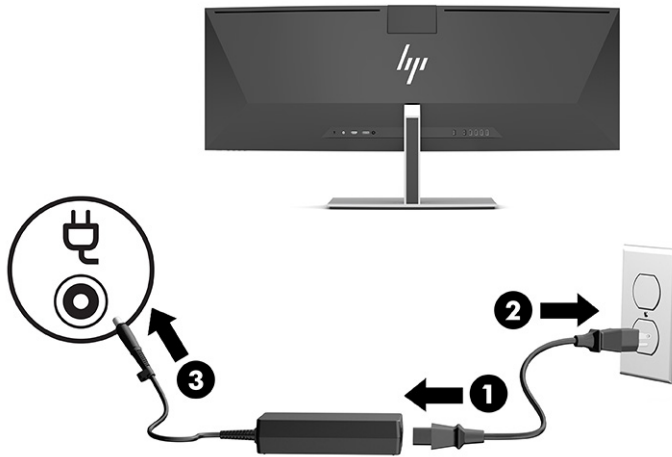

Connecting USB devices

USB ports are used to connect devices such as a USB storage device, USB keyboard, or USB mouse. There are four USB Type-A ports on the rear of the monitor to connect to devices.

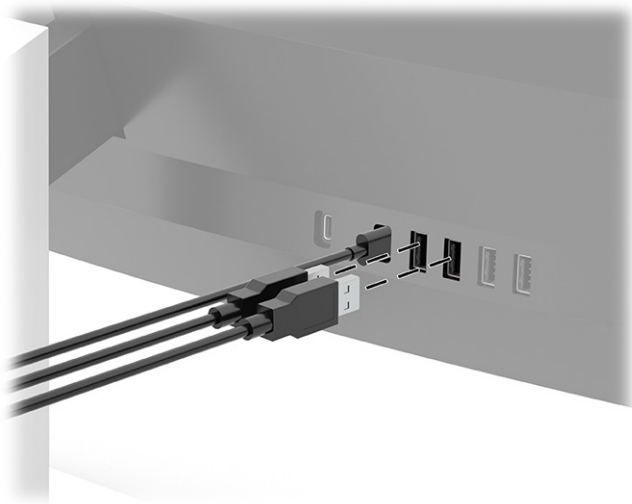

 **NOTE:** If you are using an HDMI or DisplayPort cable for video, you must connect the USB Type-C to USB Type-C cable or the USB Type-C to USB Type-A cable from the source device (computer) to the rear of the monitor to enable the USB Type-A ports to serve as a USB hub for a mouse, keyboards, phones, external hard drives, and practically anything that is USB-connected and can accept 5 V.

Adjusting the monitor

⚠ WARNING! To reduce the risk of serious injury, read the *Safety & Comfort Guide*. It describes proper workstation setup and proper posture, health, and work habits for computer users. The *Safety & Comfort Guide* also provides important electrical and mechanical safety information. The *Safety & Comfort Guide* is available on the Web at <http://www.hp.com/ergo>.

1. Tilt the monitor head forward or backward to set it to a comfortable eye level.

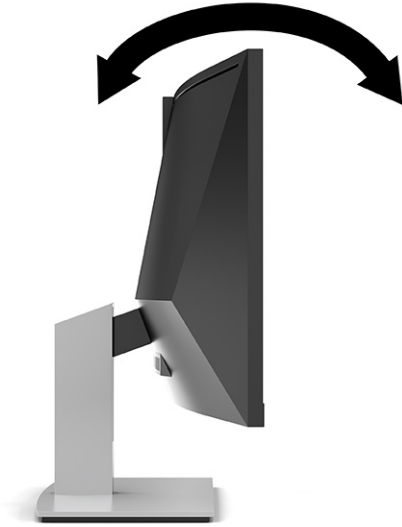

2. Adjust the monitor's height to a comfortable position for your individual workstation. The monitor's top bezel edge should not exceed a height that is parallel to your eye height. A monitor that is positioned low and reclined may be more comfortable for users with corrective lenses. The monitor should be repositioned as you adjust your working posture throughout the work day.

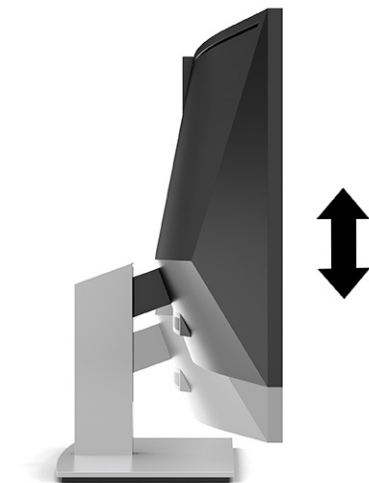

Turning on the monitor

IMPORTANT: Burn-in image damage may occur on monitors that display the same static image on the screen for 12 or more consecutive hours. To avoid burn-in image damage, you should always activate a screen saver application or turn off the monitor when it will not be in use for a prolonged period of time. Image retention is a condition that may occur on all LCD screens. Burn-in damage on the monitor is not covered under the HP warranty.

NOTE: If pressing the power button has no effect, the Power Button Lockout feature might be enabled. To disable this feature, press and hold the monitor power button for 10 seconds.

NOTE: You can disable the power light in the OSD menu. Press the **Menu** button to open the OSD, and then select **Power**, select **Power LED**, and then select **Off**.

1. Press the power button on the computer to turn it on.
2. Press the power button on the bottom of the monitor to turn it on.



When the monitor is first turned on, a monitor status message appears on the screen for 5 seconds. The message shows which input is the current active signal, the status of the auto-switch source setting (On or Off; default setting is On), the current preset screen resolution, and the recommended preset screen resolution.

The monitor automatically scans the signal inputs for an active input and uses that input for the display.

HP watermark and image retention policy

The IPS monitor models are designed with In-Plane Switching (IPS) display technology, which provides ultra-wide viewing angles and advanced image quality. IPS monitors are suitable for a wide variety of advanced image quality applications. This panel technology, however, is not suitable for applications that exhibit static, stationary, or fixed images for long periods of time without the use of screen savers. These types of applications may include camera surveillance, video games, marketing logos, and templates. Static images may cause image retention damage that could look like stains or watermarks on the monitor's screen.

Image retention damage on monitors that are in use 24 hours per day is not covered under the HP warranty. To avoid image retention damage, always turn off the monitor when it is not in use or use the power management setting, if supported on your system, to turn off the monitor when the system is idle.

Installing a security cable

You can secure the monitor to a fixed object with an optional security cable available from HP.

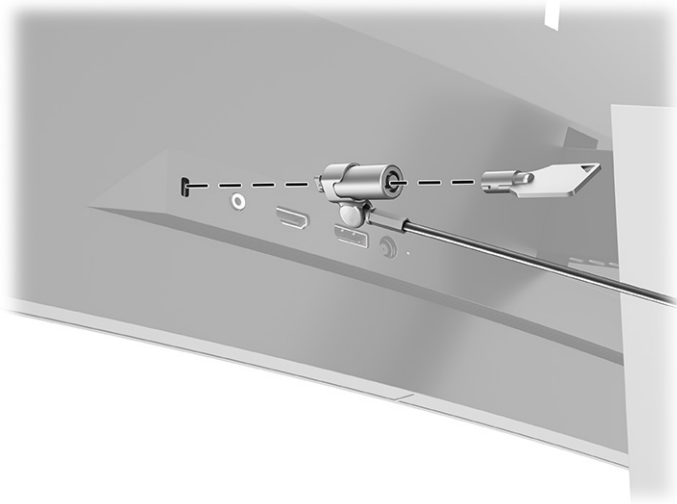

2 Using the monitor

Downloading software and utilities

You can download and install the following files from <http://www.hp.com/support>:

- INF (Information) file
- ICM (Image Color Matching) files
- HP Display Assistant: Adjusts the monitor settings and enables theft deterrence features

To download the files:

1. Go to <http://www.hp.com/support>.
2. Select **Software and Drivers**.
3. Select your product type.
4. Enter your HP monitor model in the search field and follow the on-screen instructions.

The Information file

The INF file defines monitor resources used by Windows® operating systems to ensure monitor compatibility with the computer's graphics adapter.

This monitor is Windows Plug and Play-compatible, and the monitor will work correctly without installing the INF file. Monitor Plug and Play-compatibility requires that the computer's graphics card is VESA® DDC2-compliant and that the monitor connects directly to the graphics card. Plug and Play does not work through separate BNC-type connectors or through distribution buffers or boxes.

The Image Color Matching file

The ICM files are data files that are used in conjunction with graphics programs to provide consistent color matching from monitor screen to printer, or from scanner to monitor screen. This file is activated from within graphics programs that support this feature.



NOTE: The ICM color profile is written in accordance with the International Color Consortium (ICC) Profile Format specification.

Using the OSD menu

Use the OSD menu to adjust the screen image based on your viewing preferences. You can access and make adjustments in the OSD menu using the buttons under the monitor's front bezel edge below the power light. See [Front components on page 4](#) for location.

To access the OSD menu and make adjustments:

1. If the monitor is not already on, press the power button to turn on the monitor.
2. Press the **Menu** button.
3. Use the three function buttons to navigate, select, and adjust the menu choices. The on-screen button labels vary depending on which menu or submenu is active.

The following table lists menu selections in the OSD main menu.

Table 2-1 OSD main menu

Main Menu	Description
Brightness	Adjusts the brightness level of the screen.
Color	Selects and adjusts the screen color.
Image	Adjusts the screen image.
Input	Selects the video input signal.
PbP	Selects and adjusts the PbP image.
USB Host	Selects and adjusts USB host settings.
Power	Adjusts the power settings.
Menu	Adjusts the on-screen display (OSD) and function button controls.
Management	Adjusts the DDC/CI settings and returns all OSD menu settings to the factory default settings.
Information	Selects and displays important information about the monitor.
Exit	Exits the OSD menu screen.

Using the function buttons

Pressing one of the three function buttons activates the buttons and displays the icons above the buttons. The factory default button icons and functions are shown in the following table:



Table 2-2 Default button names and functions

Button	Function
1 Menu button	Opens the OSD main menu, selects a menu item from the OSD, or closes the OSD menu.
2 PbP button	Switches the display mode from full screen to PbP.
3 Brightness button	Opens the Brightness menu where you can adjust the monitor screen to a comfortable brightness level.
4 Next Active Input button	Switches the monitor's input source to the next active input.

When PbP mode is on with two host computers connected to the monitor, the icons above the buttons change as shown in the following table:



Table 2-3 Button names and functions in PbP mode

Button	Function
1 Menu button	Opens the OSD main menu, selects a menu item from the OSD, or closes the OSD menu.
2 L/R button	Switches the display mode from full screen to PbP. NOTE: When monitor is in PbP mode, this button will be disabled.
3 L button	Switches the monitor to full screen mode for the image on the left side of the PbP image.
4 R button	Switches the monitor to full screen mode for the image on the right side of the PbP image.

Selecting the input source

The monitor has four video input connectors:

- USB Type-C #1 (DP Alt Mode)
- USB Type-C #2 (DP Alt Mode)
- DisplayPort
- HDMI

The monitor automatically scans all video input sources to search for an active video input signal. The scan sequence is USB Type-C #1, USB Type-C #2, DisplayPort, and HDMI.

If multiple host computers are connected to the monitor and PbP (Picture by Picture) is off, you can change the video input source by pressing the **Next Active Input** button on the OSD shortcut menu or by going to the OSD menu, selecting **Input**, and choosing your video input source. The following table lists menu options in the **Input** menu:

Table 2-4 Input menu options and functions

Option	Function
USB-C1 Video	Selects USB Type-C #1 as the active video input source.
USB-C2 Video	Selects USB Type-C #2 as the active video input source.
DisplayPort	Selects DisplayPort as the active video input source.
HDMI	Selects HDMI as the active video input source.
Auto-Switch Input	Sets Auto-Switch Input to On or Off.
DP Hot-Plug Detection	Selects Low Power or Always Active.
DisplayPort Mode	Selects DisplayPort 1.1 or DisplayPort 1.2 mode.

Using the camera

Gently pull up the camera to open it using the grips on the back of the camera.

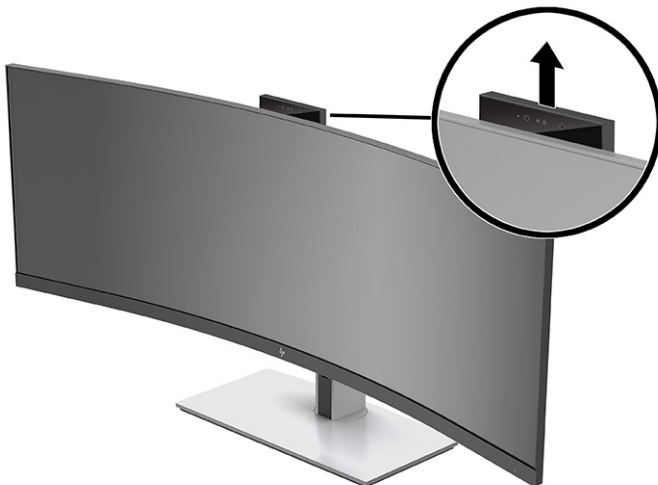

You can use the camera on the monitor in the following ways:

- Stream online video conferences
- Send and receive instant messages
- Schedule meetings
- Maintain security over conversations

When the camera is not in use, you can close the camera by pressing down on it until it clicks into the closed position.

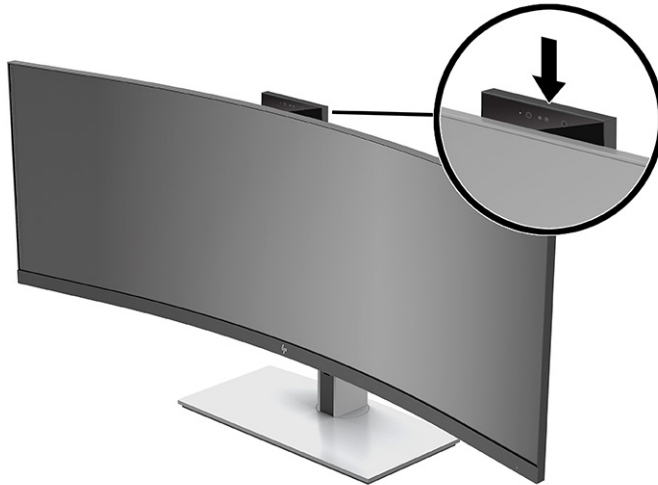

Setting up Windows Hello facial recognition

You can use Windows Hello facial recognition to gain quick, secure access to your computer. Facial recognition can be established using either the camera on your computer or the camera on your monitor.



NOTE: Windows Hello is only supported on the Windows 10 operating system.

Using the computer camera for Windows Hello

To set up Windows Hello facial recognition on a computer with a Windows Hello camera:

1. Download the HP Windows Hello software driver from <http://support.hp.com/us-en/drivers/products>.
2. Connect the monitor to the computer and turn on the computer and monitor.
3. Right-click the Windows desktop and select **Display settings**.
4. Select the 43 inch monitor and scroll down to the **Multiple displays** section.
5. From the drop-down menu, select **Extend desktop to this display**.
6. Select the **Make this my main display** check box.
7. Select the **Start** button, select **Settings**, select **Accounts**, and then select **Sign-in options**.
8. Under **Windows Hello**, select **Set up** under **Face Recognition**.
9. Under **Welcome to Windows Hello**, select **Get Started**, and then follow the on-screen instructions to enroll your facial ID and set up a PIN.

You can now use the IR camera on the monitor to log in when using Windows Hello.

Using the monitor camera for Windows Hello

If your computer does not have a Windows Hello camera, you can set up Windows Hello facial recognition using the IR camera on your monitor:

1. Select the **Start** button, select **Settings**, select **Accounts**, and then select **Sign-in options**.
2. Under **Windows Hello**, select **Set up** under **Face Recognition**.
3. Under **Welcome to Windows Hello**, select **Get Started**, and then follow the on-screen instructions to enroll your facial ID and set up a PIN.

You can now use the IR camera on the monitor to log in when using Windows Hello.

Using HP Device Bridge

HP Device Bridge allows two host computers to connect to a single monitor and enables a single keyboard and mouse to control both host computers by switching seamlessly from one computer to the other. The software also allows you to copy files from one host computer to the other. HP Device Bridge is included on the USB flash drive that shipped with your monitor, or you can download it from <http://www.hp.com/support>.



NOTE: HP Device Bridge must be installed on both host computers to function properly.

HP Device Bridge is available for the following platforms:

- Windows
- macOS
- Linux® Ubuntu
- Android



NOTE: The Android operating system only allows transferring files from an Android device to a non-Android device.

If either of the host computers is disconnected from the monitor:

- The remaining connected host computer automatically is displayed on the monitor in full screen mode.
- The USB upstream connection switches to the remaining connected host computer to enable the USB hub and USB devices.
- The remaining connected host computer can receive up to 85 W of power.

When the disconnected host computer is reconnected:

- HP Device Bridge automatically changes the monitor screen to PbP mode.
- The USB upstream connection switches to the host computer connected to the USB Type-C #1 port to enable the USB hub and USB devices.
- Power delivery to each of the two host computers returns to the original shared levels.

Installing HP Device Bridge

To install HP Device Bridge:

1. Insert the USB flash drive included with your monitor.
2. Select your operating system.
3. Select **HP Device Bridge**.



NOTE: The HP Device Bridge software will run in the background. It must be active for HP Device Bridge to be enabled.

Stopping HP Device Bridge

To stop HP Device Bridge:

1. Right-click the Windows desktop and select **HP Device Bridge**.
2. Select **Quit**.

Adjusting blue light output (select products only)

Decreasing the blue light emitted by the monitor reduces the blue light exposure to your eyes. This monitor allows you to select a setting to reduce blue light output and create a more relaxing and less stimulating image while you read content on the screen.

To adjust the blue light output from the monitor:

1. Press one of the rear panel OSD buttons to activate the buttons, and then press the **Menu** button to open the OSD. Then select **Color Control**.
2. Select a setting:
 - **Low Blue Light:** (Technischer Überwachungsverein, or Technical Inspection Association certified) Reduces blue light for improved eye comfort.
 - **Reading:** Optimizes blue light and brightness for indoor viewing.
 - **Night:** Adjusts to the lowest blue light and reduces the impact on sleep.
3. Select **Back** to return to the OSD menu.
4. In the Main menu, select **Exit** to close the OSD.

Using Auto-Sleep Mode

The monitor supports an on-screen display (OSD) menu option called Auto-Sleep Mode that allows you to enable or disable a reduced power state for the monitor. When Auto-Sleep Mode is enabled, the monitor enters a reduced power state when the host computer signals low power mode, absence of either horizontal or vertical sync signal. Auto-Sleep Mode is enabled by default.

Upon entering this reduced power state (sleep mode), the monitor screen is blanked, the backlight is turned off, and the power light indicator turns amber. The monitor draws less than 0.5 W of power when in this reduced power state. The monitor wakes from the sleep mode when the host device sends an active signal to the monitor (for example, if you activate the mouse or keyboard).

To disable Auto-Sleep Mode:

1. Press the **Menu** button to open the OSD.
2. In the OSD menu, select **Power**, select **Power Mode**, and then select **Performance**.
3. Select **Auto-Sleep Mode** and then select **Off**.

Changing the Power Mode setting

When in sleep mode, to comply with international power standards, the monitor default setting is Power Saver mode. If your display supports Performance mode, then to keep the USB ports enabled even when the monitor is in Auto-Sleep Mode, change the Power Mode setting from Power Saver to Performance.



NOTE: If you are connecting a computer that is not battery powered, the Power Mode setting must be changed to Performance mode.

To change the Power Mode setting:

1. Press the **Menu** button to open the OSD menu.
2. Select **Power**, select **Power Mode**, and then select **Performance**.
3. Select **Save** and close the OSD.

Using PbP

The monitor supports PbP, where one video input source is positioned adjacent to another. The monitor default setting for PbP is **On, Automatic**. When PbP is in automatic mode:

- The host computer attached to the USB Type-C #1 port or HDMI video connector appears on the right side of the PbP image.
- The host computer attached to the USB Type-C #2 port or DisplayPort video connector appears on the left side of the PbP image.
- The default upstream connection is to the host computer connected to the USB Type-C #1 port. This default upstream connection cannot be changed.
- The priority in power negotiation goes to the host computer connected to the USB Type-C #1 port.
- The host computer connected to the USB Type-C #2 port is guaranteed a minimum of 15 W of power, or any watts remaining after power is supplied to the USB Type-C #1 port (100 W minus the power currently being used by the USB Type-C #1 port).



NOTE: When a host computer that does not have battery power is attached to the USB Type-C #1 port on the monitor, the Power Mode setting must be set to Performance mode. For detailed instructions, see [Changing the Power Mode setting on page 25](#).

PbP can be set to **On, Manual** mode in the PbP OSD menu. In this mode, you can control which side of the screen each host computer appears on (left or right), which video source is assigned to each host computer, and which host computer is enabled for the USB upstream connection. To change PbP to manual mode:

1. With two source devices (host computers) connected to the monitor, press one of the OSD buttons under the front bezel to activate the buttons.
2. Press the **Menu** button to open the OSD.
3. In the OSD, select **PbP**, select **On** and then select **Manual**.
4. Under **Set Left Side**, select the video input source to be displayed on the left side of the PbP image.
5. Under **Set Right Side**, select the video input source to be displayed on the right side of the PbP image.



NOTE: If PbP is set to **Off**, the monitor displays the image from the host computer that is selected as the active video input source in the **Image** OSD dialog. For more information about the OSD, see [Using the OSD menu on page 19](#).

If you decide to change PbP back to the default **On, Automatic** mode:

1. With two host computers connected to the monitor, press one of the OSD buttons under the front bezel of the monitor to activate the buttons. Then press the **Menu** button to open the OSD. For the location of the OSD buttons, see [Front components on page 4](#).
2. In the OSD, select **PbP**, and then select **Enable PbP**.

The monitor scans the secondary inputs for a valid video input source and uses that source for the PbP image.

3 Support and troubleshooting

Solving common issues

The following table lists possible issues, the possible cause of each issue, and the recommended solutions.

Table 3-1 Common issues and solutions

Issue	Possible Cause	Solution
Screen is blank or video is flashing.	Power cord is disconnected.	Connect the power cord.
	The monitor is turned off.	Press the front bezel power button. NOTE: If pressing the power button has no effect, press and hold the power button for 10 seconds to disable the Power Button Lockout feature.
	Video cable is improperly connected.	Connect the video cable properly. See Connecting the cables on page 9 for more information.
	System is in sleep mode.	Press any key on the keyboard or move the mouse to exit sleep mode.
	Video card is incompatible.	Open the OSD menu and select the Input menu. Set Auto-Switch Input to Off and manually select the input.
Image appears blurred, indistinct, or too dark.	Brightness is too low.	Open the OSD menu and select Brightness to adjust the brightness scale as needed.
“Check Video Cable” is displayed on the screen.	The monitor video cable is disconnected.	Connect the appropriate video signal cable between the computer and monitor. Be sure that the computer power is off while you connect the video cable.
“Input Signal Out of Range” is displayed on the screen.	Video resolution and/or refresh rate are set higher than what the monitor supports.	Change the settings to a supported setting. See Preset display resolutions on page 34 for more information.
The monitor is off but it did not seem to enter into sleep mode.	Auto-Sleep Mode is not turned on.	Open the OSD menu and select Power . Then select Auto-Sleep Mode and set auto-sleep to On .
“OSD Lockout” is displayed.	The monitor's OSD Lockout function is enabled.	Press and hold the Menu button on the front bezel for 10 seconds to disable the OSD Lockout function.
“Power Button Lockout” is displayed.	The monitor's Power Button Lockout function is enabled.	Press and hold the power button for 10 seconds to disable the Power Button Lockout function.
The camera and USB ports do not work, but the monitor is turned on.	There is no upstream USB connection.	Be sure that the host computer is connected to the monitor with a USB Type-C to USB Type-C cable or a USB Type-C to USB Type-A cable.
No power from the USB Type-C or USB Type-A ports when the monitor is in sleep mode.	The monitor is in Power Saver mode.	Open the OSD menu, select Power , and then change the power mode to Performance .
The desktop computer does not turn on.	The monitor is turned off.	Be sure that the monitor power cord is plugged into an AC outlet and press the monitor power button.

Table 3-1 Common issues and solutions (continued)

Issue	Possible Cause	Solution
	The monitor is in sleep mode.	Press any key on the keyboard or move the mouse to exit sleep mode.
	The monitor is in Power Saver mode.	Open the OSD menu, select Power , and then change the power mode to Performance .
	The desktop computer is not connected to the USB Type-C #1 port on the monitor.	Be sure that the computer is connected to the USB Type-C #1 port on the monitor. NOTE: Desktop host computers must be connected to the USB Type-C #1 port for power delivery.
In PbP mode, the cursor does not move across the two host computer boundaries on the monitor screen.	The two host computers do not have HP Device Bridge installed, or HP Device Bridge is not running on both host computers.	Right-click the Windows desktop and check to see if HP Device Bridge is listed. If HP Device Bridge is not listed, start HP Device Bridge by double-clicking the HP Device Bridge icon on your desktop. Install HP Device Bridge. For detailed instructions, see Installing HP Device Bridge on page 24 .
	The Windows display orientation is not set properly.	Right-click the Windows desktop and select Display settings . Click on Identify and be sure that the host computer displays are oriented left to right as they are physically arranged.
The computer turns off when the monitor enters sleep mode.	The monitor is in Power Saver mode.	Open the OSD menu, select Power , and then change the power mode to Performance .
In PbP mode, the image on the left or right side of the screen is letter boxed.	The monitor is in mirror mode.	Right-click the Windows desktop and select Display settings . Under Multiple displays , select Extend desktop to this display .

Video connection combinations

The following table lists the active video connection, image display location, upstream connection, and power delivery connection for each combination of host computer video connections.

Table 3-2 Video connection combinations

Host computer video connections	USB Type-C #1	USB Type-C #2	DisplayPort	HDMI	Left image	Right image
USB Type-C #1 port and USB Type-C #2 port	Active DisplayPort Alt mode Upstream data connection Power delivery up to 85 W	Active DisplayPort Alt mode Power delivery (minimum 15 W) USB Type-C #2 for HP Device Bridge	Inactive	Inactive	USB Type-C #2 host computer	USB Type-C #1 host computer
USB Type-C #1 port and DisplayPort connector	Active DisplayPort Alt mode Upstream data connection	USB Type-C #2 to DisplayPort host computer for HP Device Bridge	Active	Inactive	DisplayPort host computer	USB Type-C #1 host computer

Table 3-2 Video connection combinations (continued)

Host computer video connections	USB Type-C #1	USB Type-C #2	DisplayPort	HDMI	Left image	Right image
	Power delivery up to 85 W					
USB Type-C #2 port and DisplayPort connector	USB Type-C #1 port to DisplayPort host computer for HP Device Bridge	Active DisplayPort Alt mode Power delivery up to 85 W USB Type-C #2 for HP Device Bridge	Active	Inactive	USB Type-C #2 host computer	DisplayPort host computer
	Upstream data connection					
USB Type-C #1 port and HDMI port	Active DisplayPort Alt mode	USB Type-C #2 to HDMI host computer for HP Device Bridge	Inactive	Active	USB Type-C #1	HDMI
	Upstream data connection					
	Power delivery up to 85 W					
USB Type-C #2 port and HDMI port	USB Type-C #1 port to HDMI host computer for HP Device Bridge	Active DisplayPort Alt mode Power delivery up to 85 W USB Type-C #2 for HP Device Bridge	Inactive	Active	USB Type-C #2	HDMI
	Upstream data connection					
DisplayPort connector and HDMI port	USB Type-C #1 to DisplayPort host computer for HP Device Bridge	USB Type-C #2 to HDMI host computer for HP Device Bridge	Active	Active	DisplayPort	HDMI
	Upstream data connection					

NOTE: Desktop host computers must be connected to the USB Type-C #1 port for power delivery.

Button lockouts

Holding down the power button or **Menu** button for 10 seconds locks out the functionality of the buttons. You can restore the functionality by holding the buttons down again for 10 seconds. This functionality is available only when the monitor is turned on, displaying an active signal, and the OSD is not open.

Contacting support

To resolve a hardware or software problem, go to <http://www.hp.com/support>. Use this site to get more information about your product, including links to discussion forums and instructions on troubleshooting. You can also find information on how to contact HP and open a support case.



NOTE: The monitor user guide, reference material, and drivers are available at <http://www.hp.com/support>.

Preparing to call technical support

If you cannot solve a problem using the troubleshooting tips in this section, you may need to call technical support. Have the following information available when you call:

- Monitor model number
- Monitor serial number
- Purchase date on invoice
- Conditions under which the problem occurred
- Error messages received
- Hardware configuration
- Name and version of the hardware and software you are using

Locating the serial number and product number

The serial number and product number are located on a label on the bottom of the monitor head. You may need these numbers when contacting HP about the monitor model.

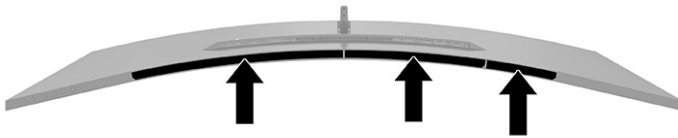

4 Maintaining the monitor

Maintenance guidelines

To enhance the performance and extend the life of the monitor:

- Do not open the monitor cabinet or attempt to service this product yourself. Adjust only those controls that are covered in the operating instructions. If the monitor is not operating properly or has been dropped or damaged, contact an authorized HP dealer, reseller, or service provider.
- Use only a power source and connection appropriate for this monitor, as indicated on the label or back plate of the monitor.
- Be sure that the total ampere rating of the products connected to the outlet does not exceed the current rating of the AC outlet and that the total ampere rating of the products connected to the cord does not exceed the rating of the cord. Look on the power label to determine the ampere rating (AMPS or A) for each device.
- Install the monitor near an outlet that you can easily reach. Disconnect the monitor by grasping the plug firmly and pulling it from the outlet. Never disconnect the monitor by pulling the cord.
- Turn the monitor off when it is not in use and use a screen saver program. Doing this can substantially increase the life expectancy of the monitor.



NOTE: A burned-in image on the monitor is not covered under the HP warranty.

- Never block the slots and openings of the cabinet or push objects into them. These openings provide ventilation.
- Do not drop the monitor or place it on an unstable surface.
- Do not allow anything to rest on the power cord. Do not walk on the cord.
- Keep the monitor in a well-ventilated area, away from excessive light, heat, or moisture.

Cleaning the monitor

1. Turn off the monitor and unplug the power cord from the AC outlet.
2. Disconnect any external devices.
3. Dust the monitor by wiping the screen and the cabinet with a soft, clean antistatic cloth.
4. For more difficult cleaning situations, use a 50/50 mix of water and isopropyl alcohol.



IMPORTANT: Do not use cleaners that contain any petroleum-based materials such as benzene, thinner, or any volatile substance to clean the monitor screen or cabinet. These chemicals may damage the monitor.

IMPORTANT: Spray the cleaner onto a cloth and use the damp cloth to gently wipe the screen surface. Never spray the cleaner directly on the screen surface. It may run behind the bezel and damage the electronics. The cloth should be moist, but not wet. Water dripping into the ventilation openings or other points of entry can cause damage to the monitor. Allow the monitor to air-dry before use.

Shipping the monitor

Keep the original packing box in a storage area. You may need it later if you ship the monitor or move.

A Technical specifications



NOTE: All specifications represent the typical specifications provided by HP's component manufacturers; actual performance may vary either higher or lower.

For the latest specifications or additional specifications on this product, go to <http://www.hp.com/go/quickspecs/> and search for your specific monitor model to find the model-specific QuickSpecs.

110.24 cm (43.4 in) model specifications

Table A-1 110.24 cm (43.4 in) model specifications

Specification	Measurement	
Display	110.24 cm wide screen	43.4 in wide screen
Type	VA	
Viewable image size	110.24 cm diagonal	43.4 in diagonal
Maximum weight (unpacked)	14.3 kg	31.53 lb
Dimensions		
Height	49.1 cm	19.33 in
Depth	25.6 cm	10.08 in
Width	105.7 cm	41.61 in
Tilt	-5° to 20°	
Environmental requirements temperature		
Operating temperature	5°C to 35°C	41°F to 95°F
Storage temperature	-20°C to 60°C	-4°F to 140°F
Storage humidity	5% to 95%	
Power source	100 V ac to 240 V ac 50/60 Hz 2 A	
USB Type-C input	Power outputs are 5 V/9 V/10 V/12 V/15 V/20 V Maximum output 85 W	
Input terminal	One HDMI port, one DisplayPort connector, two USB Type-C connectors, and four USB Type-A connectors	

Preset display resolutions

The display resolutions listed in the following table are the most commonly used modes and are set as factory defaults. The monitor automatically recognizes these preset modes, and they will appear properly sized and centered on the screen.

110.24 cm (43.4 in) model

Table A-2 Preset display resolutions

Preset	Pixel format	Horz freq (kHz)	Vert freq (Hz)
1	640 × 480	31.469	59.940
2	720 × 400	31.469	70.087
3	800 × 600	37.879	60.317
4	1024 × 768	48.363	60.004
5	1280 × 720	45.000	60.000
6	1280 × 800	49.702	59.810
7	1280 × 1024	63.981	60.020
8	1440 × 900	55.935	59.887
9	1600 × 900	60.000	60.000
10	1680 × 1050	65.290	59.954
11	1920 × 1080	67.500	60.000
12	1920 × 1200	74.038	59.950
13	3840 × 1200	74.100	60.000

Table A-3 Preset timing resolutions

Preset	Timing name	Pixel format	Horz freq (kHz)	Vert freq (Hz)
1	480p	720 × 480	31.469	59.940
2	720p60	1280 × 720	45.000	60.000
3	576p	720 × 576	31.250	50.000
4	720p50	1280 × 720	37.500	50.000
5	1080p60	1920 × 1080	67.500	60.000
6	1080p50	1920 × 1080	56.250	50.000

Power supply specification

Table A-4 Power supply technical specifications

Manufacturer	Model number	Power supply rating
Chicony Power Technology	TPC-CA61	19.5 V dc @ 14.36 A-280 W (with USB Type-C port)

Energy saver feature

The monitor supports a reduced power state. The reduced power state is initiated if the monitor detects the absence of either the horizontal sync signal or the vertical sync signal. Upon detecting the absence of these signals, the monitor screen is blanked, the backlight is turned off, and the power light turns amber. When the monitor is in the reduced power state, the monitor uses <0.5 W of power. There is a brief warm-up period before the monitor returns to its normal operating state.

See the computer manual for instructions on setting energy saver features (sometimes called power management features).



NOTE: This power saver feature works only when the monitor is connected to a computer that has energy saver features.

By selecting the settings in the monitor's Energy Saver utility, you can also program the monitor to enter into the reduced power state at a predetermined time. When the monitor's Energy Saver utility causes the monitor to enter the reduced power state, the power light blinks amber.

B Accessibility

Accessibility

HP is working to weave diversity, inclusion and work/life into the fabric of our company, so it is reflected in everything we do. Here are some examples of how we are putting differences to work to create an inclusive environment focused on connecting people to the power of technology throughout the world.

Finding the technology tools you need

Technology can unleash your human potential. Assistive technology removes barriers and helps you create independence at home, at work, and in the community. Assistive technology helps increase, maintain, and improve the functional capabilities of electronic and information technology. For more information, see [Finding the best assistive technology on page 37](#).

Our commitment

HP is committed to providing products and services that are accessible for people with disabilities. This commitment supports our company's diversity objectives and helps us ensure that the benefits of technology are available to all.

Our accessibility goal is to design, produce, and market products and services that can be effectively used by everyone, including people with disabilities, either on a stand-alone basis or with appropriate assistive devices.

To achieve our goal, this Accessibility Policy establishes seven key objectives to guide our actions as a company. All HP managers and employees are expected to support these objectives and their implementation in accordance with their roles and responsibilities:

- Raise the level of awareness of accessibility issues within our company, and provide our employees with the training they need to design, produce, market, and deliver accessible products and services.
- Develop accessibility guidelines for products and services, and hold product development groups accountable for implementing these guidelines where competitively, technically, and economically feasible.
- Involve people with disabilities in the development of accessibility guidelines, and in the design and testing of products and services.
- Document accessibility features and make information about our products and services publicly available in an accessible form.
- Establish relationships with leading assistive technology and solution providers.
- Support internal and external research and development that will improve assistive technology relevant to our products and services.
- Support and contribute to industry standards and guidelines for accessibility.

International Association of Accessibility Professionals (IAAP)

IAAP is a not-for-profit association focused on advancing the accessibility profession through networking, education, and certification. The objective is to help accessibility professionals develop and advance their careers and to better enable organizations to integrate accessibility into their products and infrastructure.

HP is a founding member, and we joined to participate with other organizations to advance the field of accessibility. This commitment supports our company's accessibility goal of designing, producing, and marketing products and services that can be effectively used by people with disabilities.

IAAP will make our profession strong by globally connecting individuals, students, and organizations to learn from one another. If you are interested in learning more, go to <http://www.accessibilityassociation.org> to join the online community, sign up for newsletters, and learn about membership options.

Finding the best assistive technology

Everyone, including people with disabilities or age-related limitations, should be able to communicate, express themselves, and connect with the world using technology. HP is committed to increasing accessibility awareness within HP and with our customers and partners. Whether it's large fonts that are easy on the eyes, voice recognition that lets you give your hands a rest, or any other assistive technology to help with your specific situation—a variety of assistive technologies make HP products easier to use. How do you choose?

Assessing your needs

Technology can unleash your potential. Assistive technology removes barriers and helps you create independence at home, at work, and in the community. Assistive technology (AT) helps increase, maintain, and improve the functional capabilities of electronic and information technology.

You may choose from many AT products. Your AT assessment should allow you to evaluate several products, answer your questions, and facilitate your selection of the best solution for your situation. You will find that professionals qualified to do AT assessments come from many fields, including those licensed or certified in physical therapy, occupational therapy, speech/language pathology, and other areas of expertise. Others, while not certified or licensed, may also provide evaluation information. You will want to ask about the individual's experience, expertise, and fees to determine if they are appropriate for your needs.

Accessibility for HP products

The following links provide information about accessibility features and assistive technology, if applicable, included in various HP products. These resources will help you select the specific assistive technology features and product(s) most appropriate for your situation.

- [HP Elite x3—Accessibility Options \(Windows 10 Mobile\)](#)
- [HP PCs—Windows 7 Accessibility Options](#)
- [HP PCs—Windows 8 Accessibility Options](#)
- [HP PC's—Windows 10 Accessibility Options](#)
- [HP Slate 7 Tablets—Enabling Accessibility Features on Your HP Tablet \(Android 4.1/Jelly Bean\)](#)
- [HP SlateBook PCs—Enabling Accessibility Features \(Android 4.3,4.2/Jelly Bean\)](#)
- [HP Chromebook PCs—Enabling Accessibility Features on Your HP Chromebook or Chromebox \(Chrome OS\)](#)
- [HP Shopping—peripherals for HP products](#)

If you need additional support with the accessibility features on your HP product, see [Contacting support on page 42](#).

Additional links to external partners and suppliers that may provide additional assistance:

- [Microsoft Accessibility information \(Windows 7, Windows 8, Windows 10, Microsoft Office\)](#)
- [Google Products accessibility information \(Android, Chrome, Google Apps\)](#)

- [Assistive Technologies sorted by impairment type](#)
- [Assistive Technologies sorted by product type](#)
- [Assistive Technology vendors with product descriptions](#)
- [Assistive Technology Industry Association \(ATIA\)](#)

Standards and legislation

Standards

Section 508 of the Federal Acquisition Regulation (FAR) standards was created by the US Access Board to address access to information and communication technology (ICT) for people with physical, sensory, or cognitive disabilities. The standards contain technical criteria specific to various types of technologies, as well as performance-based requirements which focus on functional capabilities of covered products. Specific criteria cover software applications and operating systems, web-based information and applications, computers, telecommunications products, video and multi-media, and self-contained closed products.

Mandate 376 – EN 301 549

The EN 301 549 standard was created by the European Union within Mandate 376 as the basis for an online toolkit for public procurement of ICT products. The standard specifies the functional accessibility requirements applicable to ICT products and services, together with a description of the test procedures and evaluation methodology for each accessibility requirement.

Web Content Accessibility Guidelines (WCAG)

Web Content Accessibility Guidelines (WCAG) from the W3C's Web Accessibility Initiative (WAI) helps web designers and developers create sites that better meet the needs of people with disabilities or age-related limitations. WCAG advances accessibility across the full range of web content (text, images, audio, and video) and web applications. WCAG can be precisely tested, is easy to understand and use, and allows web developers flexibility for innovation. WCAG 2.0 has also been approved as [ISO/IEC 40500:2012](#).

WCAG specifically addresses barriers to accessing the web experienced by people with visual, auditory, physical, cognitive, and neurological disabilities, and by older web users with accessibility needs. WCAG 2.0 provides characteristics of accessible content:

- **Perceivable** (for instance, by addressing text alternatives for images, captions for audio, adaptability of presentation, and color contrast)
- **Operable** (by addressing keyboard access, color contrast, timing of input, seizure avoidance, and navigability)
- **Understandable** (by addressing readability, predictability, and input assistance)
- **Robust** (for instance, by addressing compatibility with assistive technologies)

Legislation and regulations

Accessibility of IT and information has become an area of increasing legislative importance. This section provides links to information about key legislation, regulations, and standards.

- [United States](#)
- [Canada](#)
- [Europe](#)

- [United Kingdom](#)
- [Australia](#)
- [Worldwide](#)

United States

Section 508 of the Rehabilitation Act specifies that agencies must identify which standards apply to the procurement of ICT, perform market research to determine the availability of accessible products and services, and document the results of their market research. The following resources provide assistance in meeting Section 508 requirements:

- www.section508.gov
- [Buy Accessible](#)

The U.S. Access Board is currently updating the Section 508 standards. This effort will address new technologies and other areas where the standards need to be modified. For more information, go to [Section 508 Refresh](#).

Section 255 of the Telecommunications Act requires telecommunications products and services to be accessible to people with disabilities. FCC rules cover all hardware and software telephone network equipment and telecommunications equipment used in the home or office. Such equipment includes telephones, wireless handsets, fax machines, answering machines, and pagers. FCC rules also cover basic and special telecommunications services, including regular telephone calls, call waiting, speed dialing, call forwarding, computer-provided directory assistance, call monitoring, caller identification, call tracing, and repeat dialing, as well as voice mail and interactive voice response systems that provide callers with menus of choices. For more information, go to [Federal Communication Commission Section 255 information](#).

21st Century Communications and Video Accessibility Act (CVAA)

The CVAA updates federal communications law to increase the access of persons with disabilities to modern communications, updating accessibility laws enacted in the 1980s and 1990s to include new digital, broadband, and mobile innovations. Regulations are enforced by the FCC and documented as 47 CFR Part 14 and Part 79.

- [FCC Guide on the CVAA](#)

Other U.S. legislation and initiatives

- [Americans with Disabilities Act \(ADA\), Telecommunications Act, the Rehabilitation Act and others](#)

Canada

The Accessibility for Ontarians with Disabilities Act was established to develop and implement accessibility standards to make goods, services, and facilities accessible to Ontarians with disabilities and to provide for the involvement of persons with disabilities in the development of the accessibility standards. The first standard of the AODA is the customer service standard; however, standards for transportation, employment, and information and communication are also being developed. The AODA applies to the Government of Ontario, the Legislative Assembly, every designated public sector organization, and to every other person or organization that provides goods, services, or facilities to the public or other third parties and that has at least one employee in Ontario; and accessibility measures must be implemented on or before January 1, 2025. For more information, go to [Accessibility for Ontarians with Disability Act \(AODA\)](#).

Europe

EU Mandate 376 ETSI Technical Report ETSI DTR 102 612: "Human Factors (HF); European accessibility requirements for public procurement of products and services in the ICT domain (European Commission Mandate M 376, Phase 1)" has been released.

Background: The three European Standardization Organizations have set up two parallel project teams to carry out the work specified in the European Commission "Mandate 376 to CEN, CENELEC and ETSI, in Support of Accessibility Requirements for Public Procurement of Products and Services in the ICT Domain."

ETSI TC Human Factors Specialist Task Force 333 has developed ETSI DTR 102 612. Further details about the work performed by STF333 (e.g., Terms of Reference, specification of the detailed work tasks, time plan for the work, previous drafts, listing of comments received and means to contact the task force) can be found at the [Special Task Force 333](#).

The parts relating to the assessment of suitable testing and conformity schemes were carried out by a parallel project, detailed in CEN BT/WG185/PT. For further information, go to the CEN project team website. The two projects are closely coordinated.

- [CEN project team](#)
- [European Commission mandate for e-accessibility \(PDF 46KB\)](#)

United Kingdom

The Disability Discrimination Act of 1995 (DDA) was enacted to ensure that websites are accessible to blind and disabled users in the United Kingdom.

- [W3C UK Policies](#)

Australia

The Australian government has announced their plan to implement [Web Content Accessibility Guidelines 2.0](#).

All Australian government websites will require Level A compliance by 2012, and Double A by 2015. The new standard replaces WCAG 1.0, which was introduced as a mandated requirement for agencies in 2000.

Worldwide

- [JTC1 Special Working Group on Accessibility \(SWG-A\)](#)
- [G3ict: The Global Initiative for Inclusive ICT](#)
- [Italian accessibility legislation](#)
- [W3C Web Accessibility Initiative \(WAI\)](#)

Useful accessibility resources and links

The following organizations may be good resources for information about disabilities and age-related limitations.



NOTE: This is not an exhaustive list. These organizations are provided for informational purposes only. HP assumes no responsibility for information or contacts you may encounter on the Internet. Listing on this page does not imply endorsement by HP.

Organizations

- American Association of People with Disabilities (AAPD)
- The Association of Assistive Technology Act Programs (ATAP)
- Hearing Loss Association of America (HLAA)
- Information Technology Technical Assistance and Training Center (ITTATC)
- Lighthouse International
- National Association of the Deaf
- National Federation of the Blind
- Rehabilitation Engineering & Assistive Technology Society of North America (RESNA)
- Telecommunications for the Deaf and Hard of Hearing, Inc. (TDI)
- W3C Web Accessibility Initiative (WAI)

Educational institutions

- California State University, Northridge, Center on Disabilities (CSUN)
- University of Wisconsin - Madison, Trace Center
- University of Minnesota computer accommodations program

Other disability resources

- ADA (Americans with Disabilities Act) Technical Assistance Program
- Business & Disability network
- EnableMart
- European Disability Forum
- Job Accommodation Network
- Microsoft Enable
- U.S. Department of Justice - A Guide to disability rights Laws

HP links

[Our contact webform](#)

[HP comfort and safety guide](#)

[HP public sector sales](#)

Contacting support



NOTE: Support is in English only.

- Customers who are deaf or hard of hearing that have questions about technical support or accessibility of HP products:
 - Use TRS/VRS/WebCapTel to call (877) 656-7058 Monday through Friday, 6 a.m. to 9 p.m. Mountain Time.
- Customers with other disabilities or age-related limitations who have questions about technical support or accessibility of HP products, choose one of the following options:
 - Call (888) 259-5707 Monday through Friday, 6 a.m. to 9 p.m. Mountain Time.
 - Complete the [Contact form for people with disabilities or age-related limitations](#).