



SAMSUNG

Samsung Built-in Kitchen Appliances 2018

Samsung Built-in Kitchen Appliances 2018



SAMSUNG





Contents

Leading Innovation	4
Refrigerator	14
Key Innovation	16
Features	18
Models	20
Oven	30
Key Innovation	32
Features	36
Models	38
Accessories	56
Compact Oven	58
Key Innovation	60
Features	62
Models	64
Accessories	74
Cooktop	76
Key Innovation	78
Features	80
Models	82
Accessories	94
Hood	96
Key Innovation	98
Features	100
Models	102
Dishwasher	110
Key Innovation	112
Features	114
Models	116
Specifications	128
Installation Guide	184
Service	208

Leading Innovation

#2

FAST COMPANY
2015
Most Innovative
Companies in IoT

#7

Interbrand
2016
Best Global
Brands

#7

BCG
2016
Most Innovative
Companies

#13

FORTUNE
2016
Global 500

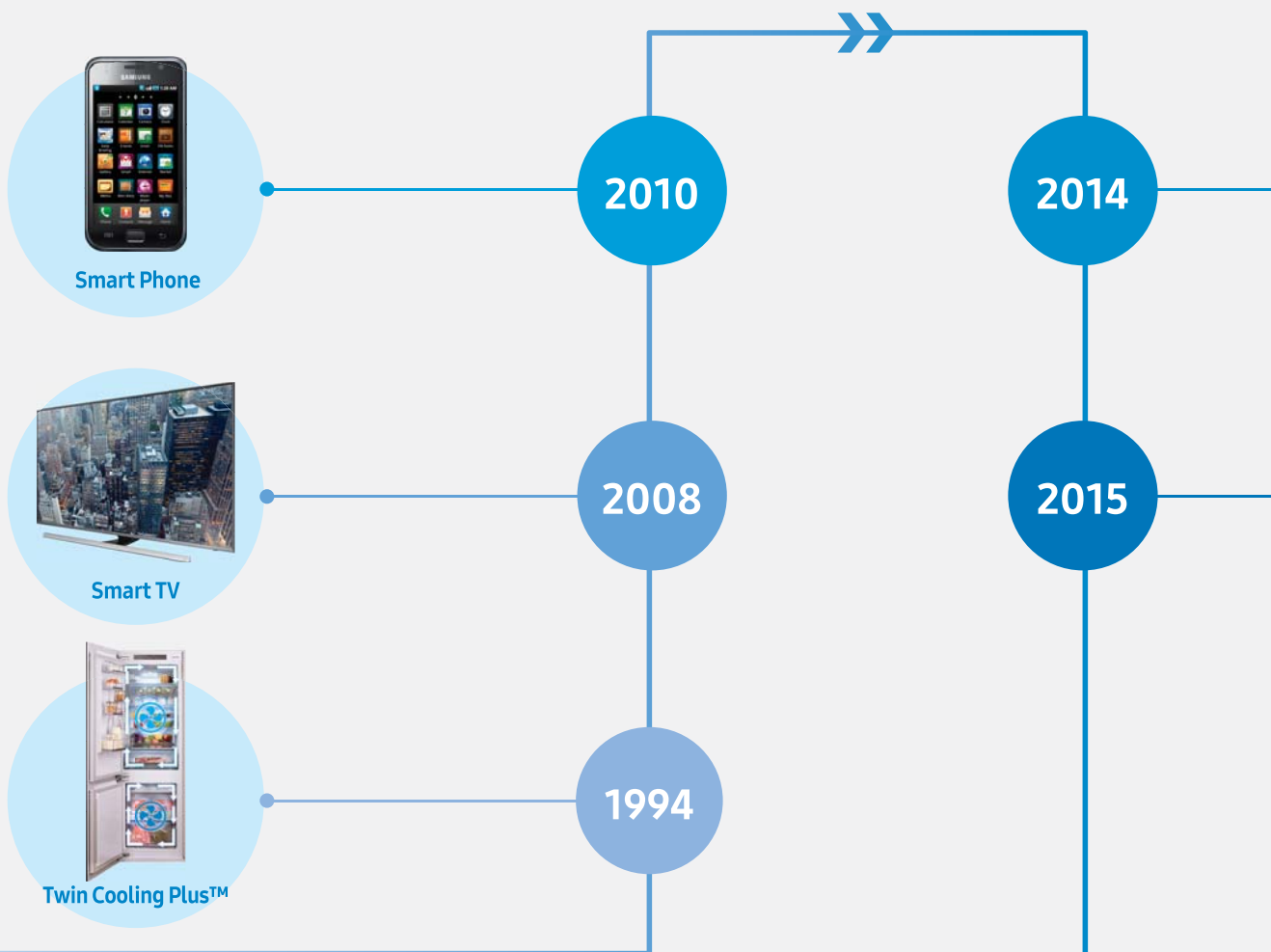

3

REPUTATION
INSTITUTE

2016

Most Reputable
Companies in
the U.S.

17

Forbes

2016

World's Most
Reputable
Companies



POWERbot



Family Hub



AddWash™

Samsung's Heritage of Innovation

Samsung Electronics is a global leader in technology, opening new possibilities for people everywhere. Through relentless innovation and discovery, we are transforming the worlds of TVs, smartphones, wearable devices, tablets, digital appliances, network systems, medical devices and semiconductors. Samsung is also leading in the Internet of Things space through, among others, our Smart Home and Digital Health initiatives. Since being established in Korea in 1969, Samsung Electronics has grown into one of the world's leading technology companies. Today, its global network extends across the world where the creativity, expertise and diverse perspectives of its employees are helping to drive growth.

The digital appliances business offers premium lifestyle appliances for homes that are stylishly designed, eco-friendly, and equipped with convenient and innovative features. Across its refrigerators, air conditioners, washers, cooking appliances, and vacuum cleaners, Samsung has introduced Smart Appliances that are connected, sensory aware and possess the ability to be remotely managed. Samsung plans to continue strengthening basic functions to add value for consumers, such as user convenience and energy-and time-saving features, and expand its sensor and digital technologies.





**What if
the best of
innovation
and design was
concealed in
your kitchen?**



1

2



Introducing new Samsung Built-in Kitchen Appliances

1



A refrigerator that allows you to convert freezer to fridge and vice versa.

Need more room to hold cool beverages for a party? Convert the freezer to an extra fridge compartment at the touch of a button.

See page 16 for more information.

2



An oven that lets you cook two totally different dishes at the same time.

Create two different dishes at different temperatures at the same time.

See page 34 for more information.

3



An induction cooktop that projects a virtual flame onto your cookware.

Enjoy the benefit of seeing a visible flame to better control the heat.

See page 78 for more information.

4



A dishwasher that uses sweeping walls of water to thoroughly wash your dishes.

Say goodbye to tough food residues and say hello to sparkling clean dishes from corner to corner.

See page 112 for more information.





Introducing new Samsung Built-in Kitchen Appliances

The world is full of appliances with "smart technologies." But if those technologies don't improve your day-to-day life, they are not that smart. At Samsung, we don't just design our kitchen appliances around the latest technologies, we design them around you. We strive to understand and solve for aspects of your everyday life. When you see and understand our new built-in kitchen products, you may find yourself asking "Why hasn't anyone thought of this before?" and when you use our appliances, you will know that now there is a better way.

Our products are designed behind four core values:

Innovation

All of our products contain unique new-to-the-world innovations that allow you to cook and clean in new ways that will help make your everyday life easier and your kitchen experience more enjoyable.

Flexibility

Our products are designed to give you maximum flexibility and control over how you choose to cook, clean, and preserve.

Design

Our products are inspired by the designs of premium European kitchens - sleek, minimalist, and modern - while still being practical and easy-to-use.

Reliability

Not only do we take pride in our design and innovations across all our products but we are also committed to ensuring there are no compromises when it comes to dependability and durability of our products.



Smart Technology

① Smarter Control – Wi-Fi Connection

Enjoy simply smarter control anytime and anywhere with a smart phone.

Samsung built-in oven's Wi-Fi Connection lets you **remotely monitor and control** the oven using an app on your smartphone. **From anywhere inside or outside the house**, you can easily check and change settings and adjust cooking times and temperatures. It also helps you to cook like a professional by selecting a Chef Recipe recommended by Michelin 3-Star Chefs.

1. Monitoring & Notification

- Monitor cooking mode, time, temperature.
- Receive notification for preheating, cooking, and error code.
- View the manual on mobile phone.
- Check the temperature of meat probe.

2. Simple Remote Control

- Turn off the power.
- Control cook time and temperature.

3. Recipe Download and Setting

- Find recipes by Michelin 3 star chefs and easily use them at home.

*Available on Android and iOS devices. A network connection is required.

② Smarter Control – Smart Dongle

Control anytime anywhere

Samsung built-in refrigerator is Wi-Fi capable. Using the optional Samsung Smart Dongle and App*, you can check what it's doing remotely on your smartphone, allowing you to control its rapid cooling modes, monitor the temperature and receive alerts if the door is left open. It even diagnoses errors so you don't have to read the manual.

*Sold separately.

*Available on Android and iOS devices. A Wi-Fi connection is required.

Smart Manager

Remote Door Alarm

Accidents happen. Leaving a door open on your refrigerator can result in food spoiling quickly, unnecessary wastage and unwanted expense. But thanks to some clever technology, with the Samsung BRB6000, this becomes a thing of the past. If a door is accidentally left open, the refrigerator will sound an audible alarm. If the door remains open, after 2 minutes, a warning notification is then sent via the App to your smartphone, alerting you to close the door.

Rapid Cooling

Providing the optimum cooling environment for your food means your food will stay fresher and taste better for longer. The Rapid Cooling function enables you to remotely control and set the Fridge and Freezer compartment temperatures to the lowest level before you get home – ideal if you are returning from the Supermarket with your shopping.

Refrigerator

Enjoy ultimate storage capacity and superior cooling technology with Samsung's wide range of 2 door Built-in and Kitchen Fit™ Fridge Freezers.







No Frost 3° Fresh -13° Fresh

SAMSUNG

Metal Cooling

Take-Out T

Fresh Zone

Easy Slide

Full Open Box

Below -18°C

3.2 3.2 3.2

Twin Cooling Plus™

Twin Cooling Plus™ technology creates the optimal temperature and humidity in the fridge and freezer to preserve food in the best condition and protect its natural flavor and aroma. It cools each compartment independently and prevents odors from mixing between them using their own dedicated evaporators and cooling systems. As a result, it retains more moisture and maintains a high humidity level all over the fridge. So, even the most perishable fruits and vegetables are kept fresher for longer, without them drying out or needing to be wrapped, which helps to reduce waste.

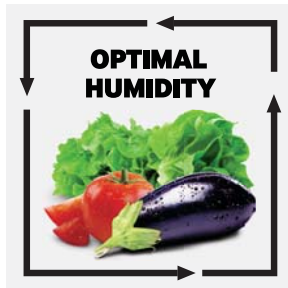

Optimal Humidity

Thanks to the Twin Cooling Plus™, the fridge compartment has its own dedicated supply of cold air, which maintains an optimal level of humidity.

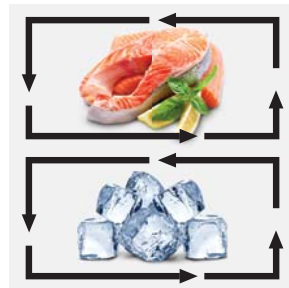

No Odor Mixing

Twin Cooling Plus™ system cools the compartments separately to stop unpleasant odors spreading from fridge to freezer. So frozen food retains more natural flavor without being tainted by smells from the fridge.



Flexibility

The CoolSelect Plus zone provides the ultimate in flexibility, as different foods can be stored at the optimum temperature, so everything stay fresher and tastes great. With one touch it can be easily converted from a freezer to fridge using the optimal pre-set temperatures of 2°C, -1°C, -5°C or -23°C~-15°C.

Features



No Frost

No Frost technology enhances the circulation of air to maintain a constant temperature in every corner of the fridge, which prevents the build up of frost and ice. It also reaches the target temperature much faster, increases the cooling system's durability, and avoids wasting power on defrosting.



CoolSelect Plus Zone

The CoolSelect Plus Zone provides the ultimate in flexibility, as different foods can be stored at the optimum temperature, so everything stays fresher and tastes great. With one touch it can be easily converted from a freezer to fridge using the optimal pre-set temperatures of 2°C, -1°C, -5°C or -15°C~-23°C



Metal Cooling

The Metal Cooling Plate in the rear wall retains the cold and helps to maintain the optimal temperature within the fridge by restoring any heat loss. So your food is preserved better, even if you frequently open and close the door. It also adds a really premium look and is very easy to wipe clean.



The Digital Inverter Compressor

The Digital Inverter Compressor automatically adjusts its speed in response to cooling demand across 7 levels. So it uses less energy, minimises noise and reduces wear and tear for a longer-lasting performance. And for complete peace of mind its performance is backed up by a 10 year warranty*.



Take-out Tray

With a Take-Out Tray, you can easily store and access all of your favorite and frequently used food items, like ice cream, frozen vegetables and pizzas. And you can quickly see what's inside because it's transparent.



Easy Slide Shelf

Reaching into your freezer often means navigating an obstacle course of items, but the Easy Slide Shelf simply slides in and out. So you can efficiently store, organize and access your frozen food – quickly and easily finding and reaching things at the back and in every corner, with no “dead space”.

*10 year warranty is limited to the compressor only.

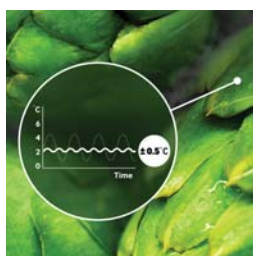

Precise Chef Cooling™

Chefs say that precise and stable temperature control is the key to keeping food at its freshest. Precise Chef Cooling™ minimizes temperature fluctuation, so all your ingredients retain their original textures and flavors.



Fresh Zone

Fresh Zone is a smartly designed drawer that provides the ideal environment preserving meat and fish - keeping them at the optimum temperature so they stay fresh and have the best possible flavor.

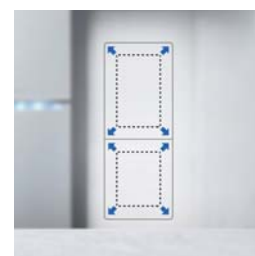

Space Max Technology

The Samsung refrigerator offers up to 30% more storage space than a conventional refrigerator of the same dimensions. Its SpaceMax Technology™ is a slim wall that creates extra internal capacity without increasing the external dimensions or compromising energy efficiency.



Adjustable Door Bin

Four Adjustable Door Bins help you easily organize and flexibly store differently sized items. You can adjust the bins to fit all sizes of bottles, cartons and other items for maximum use of your storage space.



Wifi With Dongle Ready

With Smart Dongle, you can check what the refrigerator is doing from anywhere at any time. You can control its Rapid Cooling modes, monitor the temperature, and receive alerts if the door is left open. And the refrigerator even diagnoses errors, so you don't have to read the manual.

Models

Built-in Fridge Freezers

The Samsung BRB6000 range of Built In Fridge Freezers preserve the original freshness, flavor and texture of food for longer with advanced cooling systems that optimize the temperature and humidity, retain the cold and prevent ice build up. And you can remotely monitor and control it from anywhere at any time with an optional Smart Dongle and App*.



BRB260189WW (BRB2G0189WW)

Key features

- Twin Cooling Plus™
- Cool Select Plus
- Metal Cooling
- 256L Capacity
- SpaceMax Technology™
- Adjustable Door Bin
- Fresh Zone
- Premium Finishing
- No Frost
- Energy Class A+++
- Digital Inverter Technology™
- Fixed door

Included accessories

- Egg Container
- Ice Maker (Tray)
- Wine Rack



BRB260089WW

Key features

- Twin Cooling Plus™
- Cool Select Plus
- Metal Cooling
- 256L Capacity
- SpaceMax Technology™
- Adjustable Door Bin
- Fresh Zone
- Premium Finishing
- No Frost
- Energy Class A+++
- Digital Inverter Technology™
- Slide Door

Included accessories

- Egg Container
- Ice Maker (Tray)
- Wine Rack



BRB260178WW (BRB2G0178WW)

Key features

- Twin Cooling Plus™
- Cool Select Plus
- 257L Capacity
- SpaceMax Technology™
- Adjustable Door Bin
- Fresh Zone
- Premium Finishing
- No Frost
- Energy Class A+++
- Digital Inverter Technology™
- Fixed Door

Included accessories

- Egg Container
- Ice Maker (Tray)
- Wine Rack

*Sold separately.

*Available on Android and iOS devices. A Wi-Fi connection is required.



BRB260187WW (BRB2G0187WW)

Key features

- Twin Cooling Plus™
- Cool Select Plus
- Metal Cooling
- 263L Capacity
- SpaceMax Technology™
- Adjustable Door Bin
- Fresh Zone
- Premium Finishing
- No Frost
- Energy Class A++
- Digital Inverter Technology™
- Fixed Door

Included accessories

- Egg Container
- Ice Maker (Tray)
- Wine Rack



BRB260087WW

Key features

- Twin Cooling Plus™
- Cool Select Plus
- Metal Cooling
- 263L Capacity
- SpaceMax Technology™
- Adjustable Door Bin
- Fresh Zone
- Premium Finishing
- No Frost
- Energy Class A++
- Digital Inverter Technology™
- Slide Door

Included accessories

- Egg Container
- Ice Maker (Tray)
- Wine Rack



BRB260176WW (BRB2G0176WW)

Key features

- Twin Cooling Plus™
- Cool Select Plus
- 264L Capacity
- SpaceMax Technology™
- Adjustable Door Bin
- Fresh Zone
- Premium Finishing
- No Frost
- Energy Class A++
- Digital Inverter Technology™
- Fixed Door

Included accessories

- Egg Container
- Ice Maker (Tray)
- Wine Rack

Models

Built-in Fridge Freezers

The Samsung BRB6000 range of Built In Fridge Freezers preserve the original freshness, flavor and texture of food for longer with advanced cooling systems that optimize the temperature and humidity, retain the cold and prevent ice build up. And you can remotely monitor and control it from anywhere at any time with an optional Smart Dongle and App*.



BRB260076WW

Key features

- Twin Cooling Plus™
- Cool Select Plus
- 264L Capacity
- SpaceMax Technology™
- Adjustable Door Bin
- Fresh Zone
- Premium Finishing
- No Frost
- Energy Class A++
- Digital Inverter Technology™
- Slide Door

Included accessories

- Egg Container
- Ice Maker (Tray)
- Wine Rack



BRB260135WW (BRB2G0135WW)

Key features

- All Around Cooling
- Metal Cooling
- 266L Capacity
- SpaceMax Technology™
- Adjustable Door Bin
- Premium Finishing
- No Frost
- Energy Class A++
- Digital Inverter Technology™
- Fixed Door

Included accessories

- Egg Container
- Ice Maker (Tray)
- Wine Rack



BRB260035WW

Key features

- All Around Cooling
- Metal Cooling
- 266L Capacity
- SpaceMax Technology™
- Adjustable Door Bin
- Premium Finishing
- No Frost
- Energy Class A++
- Digital Inverter Technology™
- Slide Door

Included accessories

- Egg Container
- Ice Maker (Tray)
- Wine Rack

*Sold separately.

*Available on Android and iOS devices. A Wi-Fi connection is required.



BRB260134WW (BRB2G0134WW)

Key features

- All Around Cooling
- 267L Capacity
- SpaceMax Technology™
- Adjustable Door Bin
- Premium Finishing
- No Frost
- Energy Class A++
- Digital Inverter Technology™
- Fixed Door

Included accessories

- Egg Container
- Ice Maker (Tray)
- Wine Rack



BRB260034WW

Key features

- All Around Cooling
- 267L Capacity
- SpaceMax Technology™
- Adjustable Door Bin
- Premium Finishing
- No Frost
- Energy Class A++
- Digital Inverter Technology™
- Slide Door

Included accessories

- Egg Container
- Ice Maker (Tray)
- Wine Rack



BRB260131WW (BRB2G0131WW)

Key features

- All Around Cooling
- Metal Cooling
- 266L Capacity
- SpaceMax Technology™
- Adjustable Door Bin
- Premium Finishing
- No Frost
- Energy Class A+
- Digital Inverter Technology™
- Fixed Door

Included accessories

- Egg Container
- Ice Maker (Tray)
- Wine Rack

Models

Built-in Fridge Freezers

The Samsung BRB6000 range of Built In Fridge Freezers preserve the original freshness, flavor and texture of food for longer with advanced cooling systems that optimize the temperature and humidity, retain the cold and prevent ice build up. And you can remotely monitor and control it from anywhere at any time with an optional Smart Dongle and App*.



BRB260031WW

Key features

- All Around Cooling
- Metal Cooling
- 266L Capacity
- SpaceMax Technology™
- Adjustable Door Bin
- Premium Finishing
- No Frost
- Energy Class A+
- Digital Inverter Technology™
- Slide Door

Included accessories

- Egg Container
- Ice Maker (Tray)
- Wine Rack



BRB260130WW (BRB2G0130WW)

Key features

- All Around Cooling
- 267L Capacity
- SpaceMax Technology™
- Adjustable Door Bin
- Premium Finishing
- No Frost
- Energy Class A+
- Digital Inverter Technology™
- Fixed Door

Included accessories

- Egg Container
- Ice Maker (Tray)
- Wine Rack



BRB260030WW

Key features

- All Around Cooling
- 267L Capacity
- SpaceMax Technology™
- Adjustable Door Bin
- Premium Finishing
- No Frost
- Energy Class A+
- Digital Inverter Technology™
- Slide Door

Included accessories

- Egg Container
- Ice Maker (Tray)
- Wine Rack

*Sold separately.

*Available on Android and iOS devices. A Wi-Fi connection is required.



BRB260010WW

Key features

- All Around Cooling
- 268L Capacity
- SpaceMax Technology™
- Adjustable Door Bin
- No Frost
- Energy Class A+
- Digital Inverter Technology™
- Slide Door

Included accessories

- Egg Container
- Ice Maker (Tray)



BRB260000WW

Key features

- All Around Cooling
- 268L Capacity
- SpaceMax Technology™
- Adjustable Door Bin
- No Frost
- Energy Class A+
- Digital Inverter Technology™
- Slide Door

Included accessories

- Egg Container
- Ice Maker (Tray)

Models

Built-in Fridge

with freezer compartment

The Samsung 1-door refrigerator's advanced technology has been extensively evaluated against strict criteria. It is proven to use less power without losing performance or functionality. And tempered glass shelves with LED lighting can safely hold heavy items and easily find any size item.



BRR19M011WW

Key features

- 183L Capacity
- Tempered Glass Shelves
- LED Lighting
- High Energy Efficient A++

Included accessories

- Egg Container



BRR19M010WW

Key features

- 183L Capacity
- Tempered Glass Shelves
- LED Lighting
- High Energy Efficient A+

Included accessories

- Egg Container



BRR12M001WW

Key features

- 115L Capacity
- Tempered Glass Shelves
- LED Lighting
- High Energy Efficient A++

Included accessories

- Egg Container



BRR12M000WW

Key features

- 115 L Capacity
- Tempered Glass Shelves
- LED Lighting
- High Energy Efficient A⁺

Included accessories

- Egg Container

Models

Kitchen Fit™ Fridge Freezers

You don't have to compromise between capacity and design anymore. The new Samsung Kitchen Fit™ fridge freezer completes a seamless look with a flush integration with your kitchen furniture, while offering more storage space thanks to Samsung SpaceMax Technology™.



RB36J8897S4

Key features

- 350L Capacity
- Precise Chef Cooling™
- Chef Zone™ (Telescopic Rail)
- Twin Cooling Plus™
- Metal Cooling
- SpaceMax Technology™
- Ice Blue Handle Lighting
- Adjustable Door Bin
- Premium Finishing
- No Frost
- Energy Class A++
- Digital Inverter Technology™

Included accessories

- Chef Pan™
- Take Out Box
- Wine Rack
- Egg Container
- Ice Maker (Tray + Ice Cube)



RB36J8799S4 (RL36J8799S4)

Key features

- 350L Capacity
- Precise Chef Cooling™
- Chef Zone™ (Telescopic Rail)
- Twin Cooling Plus™
- Metal Cooling
- SpaceMax Technology™
- Ice Blue Handle Lighting
- Adjustable Door Bin
- Premium Finishing
- No Frost
- Energy Class A+++
- Digital Inverter Technology™

Included accessories

- Chef Pan™
- Take Out Box
- Wine Rack
- Egg Container
- Ice Maker (Tray + Ice Cube)



RB33J8797S4

Key features

- 328L Capacity
- Precise Chef Cooling™
- Chef Zone™ (Telescopic Rail)
- Twin Cooling Plus™
- Metal Cooling
- SpaceMax Technology
- Ice Blue Handle Lighting
- Adjustable Door Bin
- Premium Finishing
- No Frost
- Energy Class A++
- Digital Inverter Technology™

Included accessories

- Chef Pan™
- Take Out Box
- Wine Rack
- Egg Container
- Ice Maker (Tray + Ice Cube)



RB33J8835SR

Key features

- 335L Capacity
- Fresh Zone
- All Around Cooling
- SpaceMax Technology™
- Ice Blue Handle Lighting
- Adjustable Door Bin
- Premium Finishing
- No Frost
- Energy Class A++
- Digital Inverter Technology™

Included accessories

- Egg Container
- Ice Maker (Tray + Ice Cube)



RB36J8797S4

Key features

- 350L Capacity
- Precise Chef Cooling™
- Chef Zone™ (Telescopic Rail)
- Twin Cooling Plus™
- Metal Cooling
- SpaceMax Technology™
- Ice Blue Handle Lighting
- Adjustable Door Bin
- Premium Finishing
- No Frost
- Energy Class A++
- Digital Inverter Technology™

Included accessories

- Chef Pan™
- Take Out Box
- Wine Rack
- Egg Container
- Ice Maker (Tray + Ice Cube)



RB36J8855S4

Key features

- 357L Capacity
- Fresh Zone
- All Around Cooling
- SpaceMax Technology™
- Ice Blue Handle Lighting
- Adjustable Door Bin
- Premium Finishing
- No Frost
- Energy Class A++
- Digital Inverter Technology™

Included accessories

- Slide & Fold Shelf
- Egg Container
- Ice Maker (Tray + Ice Cube)

Models

Kitchen Fit™ Fridge Freezers

You don't have to compromise between capacity and design anymore. The new Samsung Kitchen Fit™ fridge freezer completes a seamless look with a flush integration with your kitchen furniture, while offering more storage space thanks to Samsung SpaceMax Technology™.



RB36J8035SR

Key features

- 357L Capacity
- Fresh Zone
- All Around Cooling
- SpaceMax Technology™
- Ice Blue Handle Lighting
- Adjustable Door Bin
- Premium Finishing
- No Frost
- Energy Class A++
- Digital Inverter Technology™

Included accessories

- Egg Container
- Ice Maker (Tray + Ice Cube)



RB36J8035WW

Key features

- 357L Capacity
- Fresh Zone
- All Around Cooling
- SpaceMax Technology™
- Ice Blue Handle Lighting
- Adjustable Door Bin
- Premium Finishing
- No Frost
- Energy Class A++
- Digital Inverter Technology™

Included accessories

- Egg Container
- Ice Maker (Tray + Ice Cube)



RB33J8035SR

Key features

- 335L Capacity
- Fresh Zone
- All Around Cooling
- SpaceMax Technology™
- Ice Blue Handle Lighting
- Adjustable Door Bin
- Premium Finishing
- No Frost
- Energy Class A++
- Digital Inverter Technology™

Included accessories

- Egg Container
- Ice Maker (Tray + Ice Cube)



RB36J8215SR

Key features

- 357L Capacity
- Fresh Zone
- All Around Cooling
- SpaceMax Technology™
- Ice Blue Handle Lighting
- Adjustable Door Bin
- Premium Finishing
- No Frost
- Energy Class A++
- Digital Inverter Technology™



RB33J8705S4

Key features

- 335L Capacity
- Fresh Zone
- All Around Cooling
- SpaceMax Technology™
- Ice Blue Handle Lighting
- Adjustable Door Bin
- No Frost
- Energy Class A++
- Digital Inverter Technology™



RL33J8039SR

Key features

- Kitchen Fit™ Design
- 332L Capacity
- Twin Cooling Plus™
- Metal Plate
- SpaceMax Technology™
- Adjustable Door Bin
- Hot Stamping
- No Frost
- Energy Class A+++
- Digital Inverter Technology™

Included accessories

- Bottle Rack
- Egg Container
- Ice Maker (Tray + Ice Cube)





Oven

Samsung Built-in Ovens are designed for people who want eye-catching style and great results, with the minimum of effort. With Dual Cook technology, you can cook multiple dishes at once and all with the precision needed for professional-quality food.



Dual Cook Flex™

One Oven. Many combinations. Every taste

The Samsung Dual Cook Flex™ allows you to cook two different dishes simultaneously, at two different temperatures. And with a Flex Door you can access the top compartment without disturbing what's cooking below. No one day is the same, so why should your cooking be?

One flexible door. Opens two ways. Flexible Door

Enjoy complete flexibility to cook various dishes with the flexible door. Open the top half to use the upper zone for smaller meals. Also, easily access the upper zone while cooking different foods without heat loss to the lower zone. Or you can open the entire door when using the whole oven.



Cook more dishes much more efficiently Dual Cook with Flexible Door

You can easily use the upper zone and bottom zone at the same time with different temperature and time settings to get optimal cooking results in both zones without losing heat or hinder cooking in the lower zone. So you can efficiently prepare different dishes and enjoy the best taste.



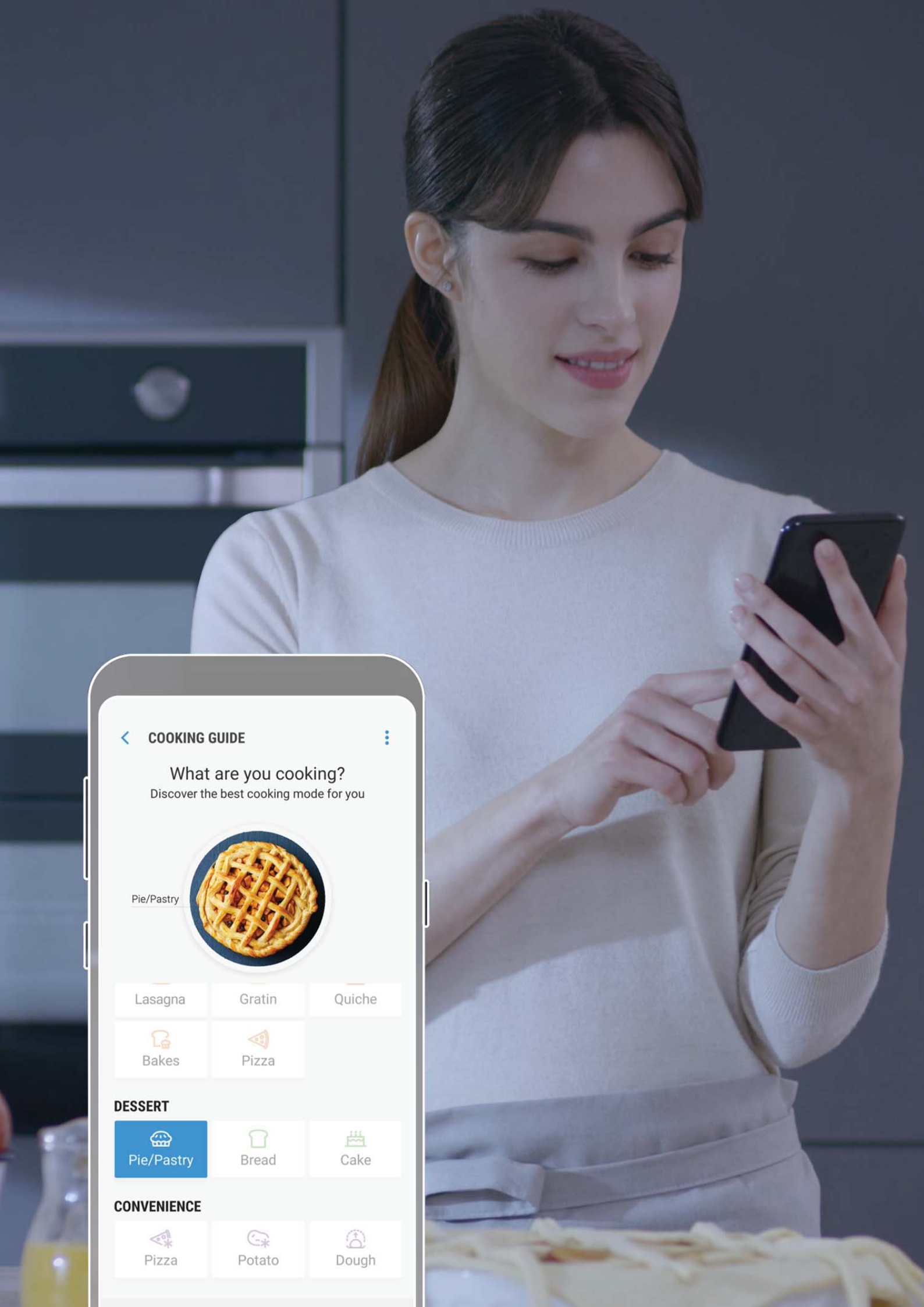

< COOKING GUIDE

What are you cooking?
Discover the best cooking mode for you



Lasagna

Gratin

Quiche



Bakes



Pizza

DESSERT



Pie/Pastry



Bread



Cake

CONVENIENCE



Pizza



Potato



Dough

Wifi-Connection



SmartThings

Easier and intuitive cooking

Cooking Guide recommends optimal cooking mode for a dish, even for simultaneous cooking in upper&lower zone. My Recipe lets you save how you cooked meals, so they're easy to make again. Scrapbook stores recipes, so they are easy to access.

Intuitive Smart Cooking contents



Cooking Guide

Recommends the best oven cooking mode, temperature and cooking time based on the ingredients and type of food you're making. You can also change it to suit your personal preferences.

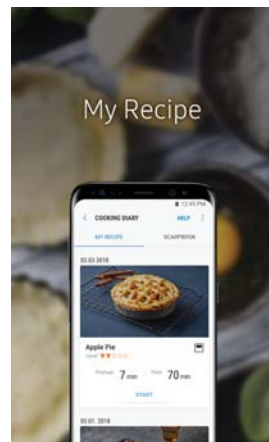

My Recipe

Records your cooking history and notes so you can easily refer back to it. You can also use your camera to take pictures while cooking and save it here.



Scrapbook

Save any recipe you see on the web easily.

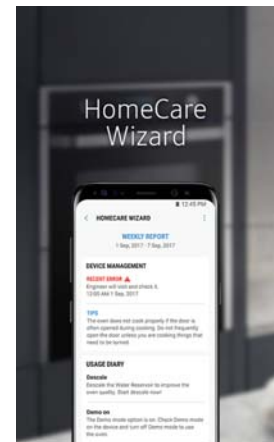

HomeCare Wizard

Receive alerts of potential issues with quick troubleshooting and accurate diagnostics to keep your oven at optimal condition. It even sends reminders when it's time to run the self-cleaning feature and offers helpful guides for better usage.



Dual Cook

Dual Cook technology gives you complete flexibility to cook multiple dishes simultaneously at different temperatures. Its upper and lower cooking zones can be used independently or together – offering flexibility, while saving time and energy. By inserting a divider you can use one zone for smaller meals or create two independently controlled cavities to cook a variety of dishes and different size meals simultaneously, using separate temperature and time settings. And if you remove the divider you can use the whole oven for large dishes, like a holiday turkey.

4 Ovens in 1



Energy Saving

Its upper and lower cooking zones can be used separately to save energy.



Time Saving

It can be divided into two small ovens using a divider that enables you to save time by cooking two different dishes at once.



Large Capacity

The upper and lower cooking zones can be used together for large dishes such as a turkey.

Features



Gourmet Vapour Technology™

Gourmet Vapour Technology™ optimizes the taste and texture of your food, especially during baking or roasting. The technology creates a super-heated vapour that quickly spreads from corner to corner to ensure even cooking, even across multiple levels. So food is deliciously crispy and brown outside.



Meat Probe

A Meat Probe allows you to monitor the internal food temperature without any guesswork by clearly indicating when meat is thoroughly cooked, all without opening the oven door and releasing heat.



Soft Closing Door

The Soft Closing Door smoothly and gently opens and closes with minimal noise. The door's hinge helps it to slowly come to a stop safely, giving you complete peace of mind.



Guide Lighting Control

You can control cooking temperatures and times, select functions and set clean options easily with an intuitive step-by-step display. By following the lights it clearly shows you what to do next, based on the last option you chose, so you can prepare delicious meals without reaching for the instruction manual.

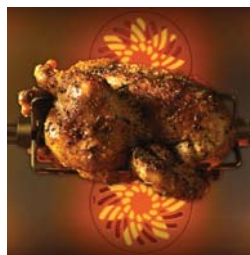

Rotisserie

With rotisserie, meats become more tender, juicier, and easier to baste. Whenever you need it, just put the rotisserie attachment into place.



Wi-fi Connection

Samsung Built-in Oven's Wi-Fi Connection lets you remotely monitor and control the oven using an app on your smartphone. From anywhere inside or outside the house, you can easily check and change settings, and adjust cooking times and temperatures.

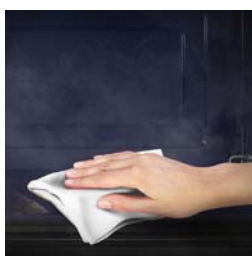

Cleaning (Steam)

Steam Clean helps remove even the most stubborn grime. It uses just a small amount of water inside the oven to create hot steam that loosens grease and food residue, so it's much easier to wipe off.



Real Steam Cooking

Get your meal just right with Real Steam Cooking. It is a healthy way to roast and bake keeping fat and salt levels low, and preventing foods from drying out. Moreover, Real Steam Cooking makes your favorite food have a beautiful golden brown crust with crispy texture while keeping moisture inside.



Full Touch TFT Color LCD Control

A 4.6" full-touch TFT LCD display offers a much simpler and easier way to cook – exactly how you want to. You can select and control a range of functions and settings, such as cooking mode, temperature and time, with the simple touch of your finger.



Telescopic Rail

A Telescopic Rail slides in and out smoothly with hardly any effort, even if you're using large pans or heavy dishes. So you can keep on basting, turning and seasoning your food – without any mess or spills.

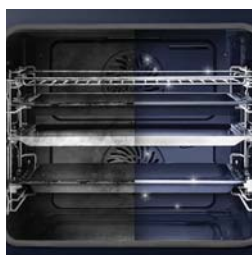

Self Cleaning (Pyrolytic)

A Pyrolytic system keeps your oven neat and clean without any time-consuming scrubbing. It heats the oven cavity to burn off any grease and residue left from cooking, leaving only a few ashes to wipe away.



Cleaning (Catalytic)

Imagine an oven that cleans itself while it's working. With Catalytic cleaning the food remnant tray collects grease and residue and chemically dissolves them, so your oven is always clean.

Models

Dual Cook Flex™

Cook efficiently with less effort and more taste!

A hinged flexible door and Dual Cook system give you the flexibility to cook various types of dishes at the same time, saving time and energy and optimizing results. Wi-Fi Connectivity also lets you monitor and control it anytime, anywhere with an App*.



NV75N7678RS

Key features

- Dual Cook
- Flexible Door
- Wi-Fi Connection
- Intuitive & Easy LED Display Guide Lighting Control
- 75L Large & Useful Capacity
- Energy Class Whole A+
- Upper / Lower A
- Auto Cook 50 Recipes
- Pyrolytic Clean
- Steam Clean
- Child Safety Lock

Included accessories:

- Telescopic (1 Level)
- Meat Probe
- Rotisserie Spit (1 EA)
- Baking Tray (2 EA)
- Wire Rack (1 EA)
- Cookbook (CD)



NV75N7677RS

Key features

- Dual Cook
- Flexible Door
- Wi-Fi Connection
- Intuitive & Easy LED Display Guide Lighting Control
- 75L Large & Useful Capacity
- Energy Class Whole A+
- Upper / Lower A
- Auto Cook 50 Recipes
- Pyrolytic Clean
- Steam Clean
- Child Safety Lock

Included accessories:

- Telescopic (1 Level)
- Rotisserie Spit (1 EA)
- Baking Tray (2 EA)
- Wire Rack (1 EA)
- Cookbook (CD)



NV75N7647RS

Key features

- Dual Cook
- Flexible Door
- Wi-Fi Connection
- Intuitive & Easy LED Display Guide Lighting Control
- 75L Large & Useful Capacity
- Energy Class Whole A+
- Upper / Lower A
- Auto Cook 50 Recipes
- Catalytic Clean
- Steam Clean
- Child Safety Lock

Included accessories:

- Telescopic (1 Level)
- Baking Tray (2 EA)
- Wire Rack (1 EA)
- Cookbook (CD)

* Available on Android and iOS devices. A Wi-Fi connection is required.



NV75N5672RS

Key features

- Dual Cook
- Flexible Door
- 75L Large & Useful Capacity
- Energy Class
Whole A⁺
Upper / Lower A
- Auto Cook 50 Recipes
- Pyrolytic Clean
- Steam Clean
- Child Safety Lock

Included accessories:

- Telescopic (1 Level)
- Meat Probe
- Baking Tray (1 EA)
- Wire Rack (1 EA)
- Wire Inlay (1 EA)
- Cookbook (CD)



NV75N5672RM

Key features

- Dual Cook
- Black Stainless Steel (Matt)
- Flexible Door
- 75L Large & Useful Capacity
- Energy Class
Whole A⁺
Upper / Lower A
- Auto Cook 50 Recipes
- Pyrolytic Clean
- Steam Clean
- Child Safety Lock

Included accessories:

- Telescopic (1 Level)
- Meat Probe
- Baking Tray (1 EA)
- Wire Rack (1 EA)
- Wire Inlay (1 EA)
- Cookbook (CD)



NV75N5671RS

Key features

- Dual Cook
- Flexible Door
- 75L Large & Useful Capacity
- Energy Class
Whole A⁺
Upper / Lower A
- Auto Cook 50 Recipes
- Pyrolytic Clean
- Steam Clean
- Child Safety Lock

Included accessories:

- Telescopic (1 Level)
- Baking Tray (1 EA)
- Wire Rack (1 EA)
- Wire Inlay (1 EA)
- Cookbook (CD)

Models

Dual Cook Flex™

Cook efficiently with less effort and more taste!

A hinged flexible door and Dual Cook system give you the flexibility to cook various types of dishes at the same time, saving time and energy and optimizing results. Wi-Fi Connectivity also lets you monitor and control it anytime, anywhere with an App*.



NV75N567IRM

Key features

- Dual Cook
- Black Stainless Steel (Matt)
- Flexible Door
- 75L Large & Useful Capacity
- Energy Class
Whole A+
- Upper / Lower A
- Auto Cook 50 Recipes
- Pyrolytic Clean
- Steam Clean
- Child Safety Lock

Included accessories:

- Telescopic (1 Level)
- Baking Tray (1 EA)
- Wire Rack (1 EA)
- Wire Inlay (1 EA)
- Cookbook (CD)



NV75N5671BS

Key features

- Dual Cook
- Flexible Door
- 75L Large & Useful Capacity
- Energy Class
Whole A+
- Upper / Lower A
- Auto Cook 50 Recipes
- Pyrolytic Clean
- Steam Clean
- Child Safety Lock

Included accessories:

- Baking Tray (1 EA)
- Wire Rack (1 EA)
- Wire Inlay (1 EA)
- Cookbook (CD)



NV75N5641RS

Key features

- Dual Cook
- Flexible Door
- 75L Large & Useful Capacity
- Energy Class
Whole A+
- Upper / Lower A
- Auto Cook 50 Recipes
- Catalytic Clean
- Steam Clean
- Child Safety Lock

Included accessories:

- Telescopic (1 Level)
- Baking Tray (1 EA)
- Wire Rack (1 EA)
- Wire Inlay (1 EA)
- Cookbook (CD)

* Available on Android and iOS devices. A Wi-Fi connection is required.



NV75N5641RB

Key features

- Dual Cook
- Full Black Glass Design
- Flexible Door
- 75L Large & Useful Capacity
- Energy Class
Whole A⁺
Upper / Lower A
- Auto Cook 50 Recipes
- Catalytic Clean
- Steam Clean
- Child Safety Lock

Included accessories:

- Telescopic (1 Level)
- Baking Tray (1 EA)
- Wire Rack (1 EA)
- Wire Inlay (1 EA)
- Cookbook (CD)



NV75N5642BS

Key features

- Dual Cook
- Flexible Door
- 75L Large & Useful Capacity
- Energy Class
Whole A⁺
Upper / Lower A
- Auto Cook 50 Recipes
- Catalytic Clean
- Steam Clean
- Child Safety Lock

Included accessories:

- Meat Probe
- Baking Tray (1 EA)
- Wire Rack (1 EA)
- Wire Inlay (1 EA)
- Cookbook (CD)



NV75N5641BS

Key features

- Dual Cook
- Flexible Door
- 75L Large & Useful Capacity
- Energy Class
Whole A⁺
Upper / Lower A
- Auto Cook 50 Recipes
- Catalytic Clean
- Steam Clean
- Child Safety Lock

Included accessories:

- Baking Tray (1 EA)
- Wire Rack (1 EA)
- Wire Inlay (1 EA)
- Cookbook (CD)

Models

Gourmet Vapour Technology™

Gourmet Vapour Technology™ optimizes the taste and texture of your food by surrounding it with vapour that quickly and evenly transfers heat and moisture, resulting in food that's deliciously crispy outside, but soft and juicy inside.



NV73J9770RS

Key features

- Gourmet Vapour Technology™
- Intuitive Touch TFT LCD
- Wi-fi Connection
- Energy Class A⁺
- Soft Closing Door
- 73L Capacity
- Pyrolytic Clean
- Steam Clean

Included accessories:

- Meat Probe
- Telescopic (1 Level)
- Baking Tray (2 EA)
- Wire Rack (1 EA)
- Wire Inlay (1 EA)
- Cookbook (CD)



NV73J7740RS

Key features

- Gourmet Vapour Technology™
- Intuitive Touch LED
- Energy Class A⁺
- Soft Closing Door
- 73L Capacity
- Catalytic Clean
- Steam Clean

Included accessories:

- Meat Probe
- Telescopic (1 Level)
- Baking Tray (2 EA)
- Wire Rack (1 EA)
- Wire Inlay (1 EA)
- Cookbook (CD)

Models

Steam Twin™

Enjoy deliciously succulent and healthy steam cooked food. Real Steam Cooking locks in moisture and vital nutrients, while Dual Cook Technology lets you cook different foods simultaneously.



BQ1VD6T131

Key features

- Dual Cook & Steam Cook by Steam Twin™
- Easy Water Supply & Drain System
- Powerful Steam Generator & Descaling System
- 70L Large & Useful Capacity
- Energy Class A
- Auto Cook 25 Recipes, Steam Auto Cook 25 Recipes
- Child Safety Lock
- Catalytic Clean
- Steam Clean

Included accessories:

- Telescopic (2 Level)
- Baking Tray (2 EA)
- Wire Rack (1 EA)
- Wire Inlay (1 EA)



NV70F3984LS

Key features

- Dual Cook & Steam Assist
- Easy Water Supply & Drain System
- Powerful Steam Generator & Descaling System
- 70L Large & Useful Capacity
- Energy Class A
- Auto Cook 25 Recipes, Steam Auto Cook 25 Recipes
- Child Safety Lock
- Catalytic Clean
- Steam Clean

Included accessories:

- Telescopic (2 Level)
- Baking Tray (2 EA)
- Wire Rack (1 EA)
- Wire Inlay (1 EA)

Models

Dual Cook

Dual Cook technology gives you complete flexibility with upper and lower cooking zones that can be used independently, with different temperature and time settings, or you can use the whole oven for large dishes.



NV75M7572RS

Key features

- Dual Cook
- Intuitive & Easy LED Display
- Guide Lighting Control
- 75L Large & Useful Capacity
- Energy Class A
- Auto Cook 50 Recipes
- Pyrolytic Clean
- Steam Clean
- Child Safety Lock

Included accessories:

- Telescopic (1 Level)
- Meat Probe
- Rotisserie Spit (1 EA)
- Baking Tray (2 EA)
- Wire Rack (1 EA)
- Cookbook (CD)



NV75J7570RS

Key features

- Dual Cook
- Intuitive & Easy LED Display
- Guide Lighting Control
- 75L Large & Useful Capacity
- Energy Class A
- Auto Cook 50 Recipes
- Soft Closing Door
- Child Safety Lock
- Pyrolytic Clean
- Steam Clean

Included accessories:

- Telescopic (1 Level)
- Rotisserie Spit (1 EA)
- Baking Tray (2 EA)
- Wire Rack (1 EA)
- Cookbook (CD)



NV75J5540RS

Key features

- Dual Cook
- Intuitive & Easy LED Display
- Guide Lighting Control
- 75L Large & Useful Capacity
- Energy Class A
- Auto Cook 50 Recipes
- Soft Closing Door
- Child Safety Lock
- Catalytic Clean
- Steam Clean

Included accessories:

- Telescopic (1 Level)
- Baking Tray (2 EA)
- Wire Rack (1 EA)
- Cookbook (CD)



NV75M5572RS

Key features

- Dual Cook
- 75L Large & Useful Capacity
- Energy Class A
- Auto Cook 50 Recipes
- Pyrolytic Clean
- Steam Clean
- Child Safety Lock

Included accessories:

- Telescopic (1 Level)
- Meat Probe
- Baking Tray (1 EA)
- Wire Rack (1 EA)
- Wire Inlay (1 EA)
- Cookbook (CD)



NV75K5571RS

Key features

- Dual Cook
- 75L Large & Useful Capacity
- Energy Class A
- Auto Cook 50 Recipes
- Child Safety Lock
- Pyrolytic Clean
- Steam Clean

Included accessories:

- Telescopic (1 Level)
- Baking Tray (1 EA)
- Wire Rack (2 EA)
- Cookbook (CD)



NV75K5571RM

Key features

- Dual Cook
- Black Stainless Steel (Matt)
- 75L Large & Useful Capacity
- Energy Class A
- Auto Cook 50 Recipes
- Child Safety Lock
- Pyrolytic Clean
- Steam Clean

Included accessories:

- Telescopic (1 Level)
- Baking Tray (1 EA)
- Wire Rack (2 EA)
- Cookbook (CD)

Models

Dual Cook

Dual Cook technology gives you complete flexibility with upper and lower cooking zones that can be used independently, with different temperature and time settings, or you can use the whole oven for large dishes.



NV75K5571RG

Key features

- Dual Cook
- Black Stainless Steel (Glossy)
- 75L Large & Useful Capacity
- Energy Class A
- Auto Cook 50 Recipes
- Child Safety Lock
- Pyrolytic Clean
- Steam Clean

Included accessories:

- Telescopic (1 Level)
- Baking Tray (1 EA)
- Wire Rack (2 EA)
- Cookbook (CD)



NV75K5571BS

Key features

- Dual Cook
- 75L Large & Useful Capacity
- Energy Class A
- Auto Cook 50 Recipes
- Child Safety Lock
- Pyrolytic Clean
- Steam Clean

Included accessories:

- Baking Tray (1 EA)
- Wire Rack (2 EA)
- Cookbook (CD)



NV75M5542RS

Key features

- Dual Cook
- 75L Large & Useful Capacity
- Energy Class A
- Auto Cook 50 Recipes
- Catalytic Clean
- Steam Clean
- Child Safety Lock

Included accessories:

- Telescopic (1 Level)
- Meat Probe
- Baking Tray (1 EA)
- Wire Rack (1 EA)
- Wire Inlay (1 EA)
- Cookbook (CD)



NV75K554IRS

Key features

- Dual Cook
- 75L Large & Useful Capacity
- Energy Class A
- Auto Cook 50 Recipes
- Child Safety Lock
- Catalytic Clean
- Steam Clean

Included accessories:

- Telescopic (1 Level)
- Baking Tray (1 EA)
- Wire Rack (2 EA)
- Cookbook (CD)



NV75K554IRM

Key features

- Dual Cook
- Black Stainless Steel (Matt)
- 75L Large & Useful Capacity
- Energy Class A
- Auto Cook 50 Recipes
- Child Safety Lock
- Catalytic Clean
- Steam Clean

Included accessories:

- Telescopic (1 Level)
- Baking Tray (1 EA)
- Wire Rack (2 EA)
- Cookbook (CD)



NV75K554IRG

Key features

- Dual Cook
- Black Stainless Steel (Glossy)
- 75L Large & Useful Capacity
- Energy Class A
- Auto Cook 50 Recipes
- Child Safety Lock
- Catalytic Clean
- Steam Clean

Included accessories:

- Telescopic (1 Level)
- Baking Tray (1 EA)
- Wire Rack (2 EA)
- Cookbook (CD)

Models

Dual Cook

Dual Cook technology gives you complete flexibility with upper and lower cooking zones that can be used independently, with different temperature and time settings, or you can use the whole oven for large dishes.



NV75K5541RB

Key features

- Dual Cook
- Full Black Glass Design
- 75L Large & Useful Capacity
- Energy Class A
- Auto Cook 50 Recipes
- Child Safety Lock
- Catalytic Clean
- Steam Clean

Included accessories:

- Telescopic (1 Level)
- Baking Tray (1 EA)
- Wire Rack (2 EA)
- Cookbook (CD)



NV75K5541BS

Key features

- Dual Cook
- 75L Large & Useful Capacity
- Energy Class A
- Auto Cook 50 Recipes
- Child Safety Lock
- Catalytic Clean
- Steam Clean

Included accessories:

- Baking Tray (1 EA)
- Wire Rack (2 EA)
- Cookbook (CD)



NV75K5541BB

Key features

- Dual Cook
- Full Black Glass Design
- 75L Large & Useful Capacity
- Energy Class A
- Auto Cook 50 Recipes
- Child Safety Lock
- Catalytic Clean
- Steam Clean

Included accessories:

- Baking Tray (1 EA)
- Wire Rack (2 EA)
- Cookbook (CD)



NV70M357IRS

Key features

- Dual Cook
- 70L Large & Useful Capacity
- Energy Class A
- Auto Cook 25 Recipes
- Pyrolytic Clean
- Steam Clean
- Child Safety Lock

Included accessories:

- Telescopic (1 Level)
- Baking Tray (1 EA)
- Wire Rack (1 EA)



NV70M354IRS

Key features

- Dual Cook
- 70L Large & Useful Capacity
- Energy Class A
- Auto Cook 25 Recipes
- Catalytic Clean
- Steam Clean
- Child Safety Lock

Included accessories:

- Telescopic (1 Level)
- Baking Tray (1 EA)
- Wire Rack (1 EA)



NV70M354IRB

Key features

- Dual Cook
- 70L Large & Useful Capacity
- Energy Class A
- Auto Cook 25 Recipes
- Catalytic Clean
- Steam Clean
- Child Safety Lock

Included accessories:

- Telescopic (1 Level)
- Baking Tray (1 EA)
- Wire Rack (1 EA)

Models

Dual Cook

Dual Cook technology gives you complete flexibility with upper and lower cooking zones that can be used independently, with different temperature and time settings, or you can use the whole oven for large dishes.



NV66M357IBS

Key features

- Dual Cook
- 66L Capacity
- Energy Class A
- Auto Cook 25 Recipes
- Pyrolytic Clean
- Steam Clean
- Child Safety Lock

Included accessories:

- Baking Tray (1 EA)
- Wire Rack (1 EA)



NV66M357IBB

Key features

- Dual Cook
- 66L Capacity
- Energy Class A
- Auto Cook 25 Recipes
- Pyrolytic Clean
- Steam Clean
- Child Safety Lock

Included accessories:

- Baking Tray (1 EA)
- Wire Rack (1 EA)



NV66M353IBS

Key features

- Dual Cook
- 66L Capacity
- Energy Class A
- Auto Cook 25 Recipes
- Catalytic Clean
- Steam Clean
- Child Safety Lock

Included accessories:

- Baking Tray (1 EA)
- Wire Rack (1 EA)



NV66M3531BB

Key features

- Dual Cook
- 66L Capacity
- Energy Class A
- Auto Cook 25 Recipes
- Catalytic Clean
- Steam Clean
- Child Safety Lock

Included accessories:

- Baking Tray (1 EA)
- Wire Rack (1 EA)



NV70H5787CB

Key features

- Dual Cook
- All Black Glass Touch Control Panel
- 70L Large & Useful Capacity
- Energy Class A
- Auto Cook 40 Recipes
- Child Safety Lock
- Catalytic Clean
- Steam Clean

Included accessories:

- Telescopic (2 Level)
- Baking Tray (1 EA)
- Wire Rack (1 EA)
- Wire Inlay (1 EA)



NV66H5737LB

Key features

- Dual Cook
- All Black Glass Touch Control Panel
- 66L Large & Useful Capacity
- Energy Class A
- Auto Cook 40 Recipes
- Child Safety Lock
- Pyrolytic Clean
- Steam Clean

Included accessories:

- Baking Tray (1 EA)
- Wire Rack (1 EA)
- Wire Inlay (1 EA)

Models

Convection Cook

Cook your food much faster and with more flavor. Convection Cook uses a fan to actively circulate the hot air and keeps the temperature steady around the food.



NV75J5170BS

Key features

- Fast Ready-to-cook
- 75L Large & Useful Capacity
- Energy Class A⁺
- Auto Cook 20 Recipes
- Soft Closing Door
- Child Safety Lock
- Pyrolytic Clean
- Steam Clean

Included accessories:

- Baking Tray (2 EA)
- Wire Rack (1 EA)
- Cookbook (CD)



NV75J3140RS

Key features

- Fast Ready-to-cook
- 75L Large & Useful Capacity
- Energy Class A
- Soft Closing Door
- Child Safety Lock
- Catalytic Clean

Included accessories:

- Telescopic (1 Level)
- Baking Tray (2 EA)
- Wire Rack (1 EA)



NV75J3140BS

Key features

- Fast Ready-to-cook
- 75L Large & Useful Capacity
- Energy Class A
- Soft Closing Door
- Child Safety Lock
- Catalytic Clean

Included accessories:

- Baking Tray (2 EA)
- Wire Rack (1 EA)



NV75J3140BB

Key features

- Fast Ready-to-cook
- 75L Large & Useful Capacity
- Energy Class A
- Child Safety Lock
- Catalytic Clean

Included accessories:

- Baking Tray (2 EA)
- Wire Rack (1 EA)

Models

Dual Fan

Dual Fans spins opposite directions to spread heat evenly throughout the oven, so all of your dishes are cooked at the same temperature and speed. It also reaches its target temperature faster and is more energy efficient.



NV75K3340RS

Key features

- Even Cook by Twin Fans Airvection
- 75L Large & Useful Capacity
- Energy Class A
- Child Safety Lock
- Catalytic Clean

Included accessories:

- Telescopic (1 Level)
- Baking Tray (1 EA)
- Wire Rack (2 EA)



NV75K3340RG

Key features

- Even Cook by Twin Fans Airvection
- Black Stainless Steel (Glossy)
- 75L Large & Useful Capacity
- Energy Class A
- Child Safety Lock
- Catalytic Clean

Included accessories:

- Telescopic (1 Level)
- Baking Tray (1 EA)
- Wire Rack (2 EA)



NV75K3340RB

Key features

- Even Cook by Twin Fans Airvection
- 75L Large & Useful Capacity
- Energy Class A
- Child Safety Lock
- Catalytic Clean

Included accessories:

- Telescopic (1 Level)
- Baking Tray (1 EA)
- Wire Rack (2 EA)



NV75K3340RW

Key features

- Even Cook by Twin Fans Airvection
- 75L Large & Useful Capacity
- Energy Class A
- Child Safety Lock
- Catalytic Clean

Included accessories:

- Telescopic (1 Level)
- Baking Tray (1 EA)
- Wire Rack (2 EA)



NV70M3372RS

Key features

- Even Cook by Twin Fans Airvection
- 70L Large & Useful Capacity
- Energy Class A
- Auto Cook 20 Recipes
- Pyrolytic Clean
- Steam Clean
- Child Safety Lock

Included accessories:

- Telescopic (1 Level)
- Meat Probe
- Baking Tray (1 EA)
- Wire Rack (1 EA)



NV70M3372BS

Key features

- Even Cook by Twin Fans Airvection
- 70L Large & Useful Capacity
- Energy Class A
- Auto Cook 20 Recipes
- Pyrolytic Clean
- Steam Clean
- Child Safety Lock

Included accessories:

- Meat Probe
- Baking Tray (1 EA)
- Wire Rack (1 EA)

Models

Dual Fan

Dual Fans spins opposite directions to spread heat evenly throughout the oven, so all of your dishes are cooked at the same temperature and speed. It also reaches its target temperature faster and is more energy efficient.



NV70M3373BS

Key features

- Even Cook by Twin Fans Airvection
- 70L Large & Useful Capacity
- Energy Class A
- Auto Cook 20 Recipes
- Pyrolytic Clean
- Steam Clean
- Child Safety Lock

Included accessories:

- Meat Probe
- Baking Tray (2 EA)
- Wire Rack (1 EA)



NV70M3372BB

Key features

- Even Cook by Twin Fans Airvection
- 70L Large & Useful Capacity
- Energy Class A
- Auto Cook 20 Recipes
- Pyrolytic Clean
- Steam Clean
- Child Safety Lock

Included accessories:

- Meat Probe
- Baking Tray (1 EA)
- Wire Rack (1 EA)



NV70K3370RS

Key features

- Even Cook by Twin Fans Airvection
- 70L Large & Useful Capacity
- Energy Class A
- Auto Cook 20 Recipes
- Child Safety Lock
- Pyrolytic Clean
- Steam Clean

Included accessories:

- Telescopic (1 Level)
- Baking Tray (1 EA)
- Wire Rack (1 EA)



NV70K3370BS

Key features

- Even Cook by Twin Fans Airvection
- 70L Large & Useful Capacity
- Energy Class A
- Auto Cook 20 Recipes
- Child Safety Lock
- Pyrolytic Clean
- Steam Clean

Included accessories:

- Baking Tray (1 EA)
- Wire Rack (1 EA)



NV70K3370BB

Key features

- Even Cook by Twin Fans Airvection
- 70L Large & Useful Capacity
- Energy Class A
- Auto Cook 20 Recipes
- Child Safety Lock
- Pyrolytic Clean
- Steam Clean

Included accessories:

- Baking Tray (1 EA)
- Wire Rack (1 EA)



NV70K2340RS

Key features

- Even Cook by Twin Fans Airvection
- 70L Large & Useful Capacity
- Energy Class A
- Auto Cook 20 Recipes
- Child Safety Lock
- Catalytic Clean
- Steam Clean

Included accessories:

- Telescopic (1 Level)
- Baking Tray (1 EA)
- Wire Rack (1 EA)

Models

Dual Fan

Dual Fans spins opposite directions to spread heat evenly throughout the oven, so all of your dishes are cooked at the same temperature and speed. It also reaches its target temperature faster and is more energy efficient.



NV70K2340RM

Key features

- Even Cook by Twin Fans Airvection
- Black Stainless Steel (Matt)
- 70L Large & Useful Capacity
- Energy Class A
- Auto Cook 20 Recipes
- Child Safety Lock
- Catalytic Clean
- Steam Clean

Included accessories:

- Telescopic (1 Level)
- Baking Tray (1 EA)
- Wire Rack (1 EA)



NV70K2340RG

Key features

- Even Cook by Twin Fans Airvection
- Black Stainless Steel (Glossy)
- 70L Large & Useful Capacity
- Energy Class A
- Auto Cook 20 Recipes
- Child Safety Lock
- Catalytic Clean
- Steam Clean

Included accessories:

- Telescopic (1 Level)
- Baking Tray (1 EA)
- Wire Rack (1 EA)



NV70K2340RB

Key features

- Even Cook by Twin Fans Airvection
- 70L Large & Useful Capacity
- Energy Class A
- Auto Cook 20 Recipes
- Child Safety Lock
- Catalytic Clean
- Steam Clean

Included accessories:

- Telescopic (1 Level)
- Baking Tray (1 EA)
- Wire Rack (1 EA)



NV70K1340BS

Key features

- Even Cook by Twin Fans Airvection
- 70L Large & Useful Capacity
- Energy Class A
- Child Safety Lock
- Catalytic Clean

Included accessories:

- Baking Tray (1 EA)
- Wire Rack (1 EA)



NV70K1340BG

Key features

- Even Cook by Twin Fans Airvection
- Black Stainless Steel (Glossy)
- 70L Large & Useful Capacity
- Energy Class A
- Child Safety Lock
- Catalytic Clean

Included accessories:

- Baking Tray (1 EA)
- Wire Rack (1 EA)



NV70K1340BB

Key features

- Even Cook by Twin Fans Airvection
- 70L Large & Useful Capacity
- Energy Class A
- Child Safety Lock
- Catalytic Clean

Included accessories:

- Baking Tray (1 EA)
- Wire Rack (1 EA)

Models

Dual Fan

Dual Fans spins opposite directions to spread heat evenly throughout the oven, so all of your dishes are cooked at the same temperature and speed. It also reaches its target temperature faster and is more energy efficient.



NV70K1340BW

Key features

- Even Cook by Twin Fans Airvection
- 70L Large & Useful Capacity
- Energy Class A
- Child Safety Lock
- Catalytic Clean

Included accessories:

- Baking Tray (1 EA)
- Wire Rack (1 EA)



NV70K1310BS

Key features

- Even Cook by Twin Fans Airvection
- 70L Large & Useful Capacity
- Energy Class A
- Child Safety Lock

Included accessories:

- Baking Tray (1 EA)
- Wire Rack (1 EA)



NV70K1310BB

Key features

- Even Cook by Twin Fans Airvection
- 70L Large & Useful Capacity
- Energy Class A
- Child Safety Lock

Included accessories:

- Baking Tray (1 EA)
- Wire Rack (1 EA)



NV72M1010BS

Key features

- 72L Large & Useful Capacity
- Energy Class A
- Child Safety Lock

Included accessories:

- Baking Tray (1 EA)
- Wire Rack (1 EA)



NV70H5587BB

Key features

- Even Cook by Twin Fans Airvection
- All Black Glass Touch Control Panel
- 70L Large & Useful Capacity
- Energy Class A
- Auto Cook 25 Recipes
- Child Safety Lock
- Catalytic Clean
- Steam Clean

Included accessories:

- Telescopic (1 Level)
- Baking Tray (1 EA)
- Wire Rack (1 EA)
- Wire Inlay (1 EA)



NV70H5587CB

Key features

- Even Cook by Twin Fans Airvection
- All Black Glass Touch Control Panel
- 70L Large & Useful Capacity
- Energy Class A
- Auto Cook 25 Recipes
- Child Safety Lock
- Catalytic Clean
- Steam Clean

Included accessories:

- Telescopic (2 Level)
- Baking Tray (2 EA)
- Wire Rack (1 EA)
- Wire Inlay (1 EA)

Models

Dual Fan

Dual Fans spins opposite directions to spread heat evenly throughout the oven, so all of your dishes are cooked at the same temperature and speed. It also reaches its target temperature faster and is more energy efficient.



NV70H5557LB

Key features

- Even Cook by Twin Fans Airvection
- All Black Glass Touch Control Panel
- 70L Large & Useful Capacity
- Energy Class A
- Auto Cook 25 Recipes
- Child Safety Lock
- Catalytic Clean
- Steam Clean

Included accessories:

- Baking Tray (2 EA)
- Wire Rack (1 EA)
- Wire Inlay (1 EA)



NV70H3350CB

Key features

- Classic Retro Style
- Even Cook by Twin Fans Airvection
- 70L Large & Useful Capacity
- Energy Class A
- Child Safety Lock
- Catalytic Clean

Included accessories:

- Telescopic (1 Level)
- Baking Tray (2 EA)
- Wire Rack (1 EA)
- Wire Inlay (1 EA)



NV70H3350CE

Key features

- Classic Retro Style
- Even Cook by Twin Fans Airvection
- 70L Large & Useful Capacity
- Energy Class A
- Child Safety Lock
- Catalytic Clean

Included accessories:

- Telescopic (1 Level)
- Baking Tray (2 EA)
- Wire Rack (1 EA)
- Wire Inlay (1 EA)

Oven Accessories (option)

Telescopic Rail



MA-RS772

Key features

- Compatible with 75L Dual Cook Oven
- Full Extension Type (Level 2, 4)

Applicable models

- NV75K5571**
- NV75K5541**



MA-RS572

Key features

- Compatible with 75L Dual Fan Oven
- Full Extension Type (Level 2, 4)

Applicable models

- NV75*9770**
- NV75*3340**



MA-RS272

Key features

- Compatible with 70L Dual Fan Oven
- Full Extension Type (Level 2,4)

Applicable models

- NV70K3370**
- NV70K2340**
- NV70K1340**

Oven Accessories

Samsung Oven Accessories make life in the kitchen much easier, by providing more practical, professional and convenient ways to cook, so you always achieve the best possible results.

Baking Tray (20mm)



The 20mm Baking Tray is ideal for cooking cakes, cookies and other pastries. With the slanted side to the front you can easily slide them off.

Baking Tray (30mm)



The 30mm Baking Tray can be used for cooking cakes and pastries or for roasting. Insert the wire tray and it will collect melted fat or meat juices, so they don't go all over the oven.

Extra Deep Tray (50mm)



This 50mm Extra Deep Tray is great for roasting large portions of meat, especially if they create a lot of fat and juices. With the wire tray inserted it will also prevent any liquids from dropping onto the bottom of the oven.

Telescopic Rail



Using the Telescopic Rail you can quickly slide food out of the oven, so it's easy to check or take out without having to bend over so much or risk getting close to the hot oven. Using it is easy – just slide out the Telescopic Rail at the level you want, place the shelf or tray you're using on them and then push it back completely into the oven.

Meat Probe



When you're cooking a large piece of meat the inside is usually very slow to cook. With the Meat Probe you can quickly measure the internal temperature to ensure your meat is properly cooked. Just stick the probe into the meat and it shows the temperature.

Wire Rack



The Wire Rack is ideal for grilling, roasting or baking, especially when you're using tins, casserole dishes or other baking pots, as heat can easily circulate around the base, so food is cooked thoroughly. The bent up side of the frame should be placed at the rear of the oven in order to provide extra support when cooking large amounts.

Wire Inlay



When combined with the Baking Tray the Wire Inlay is great for grilling or roasting meals and can also be used to prevent liquids from dropping onto the bottom of the oven.

Rotisserie Spit



With the Rotisserie Spit you don't have to continually turn over food, like chicken, that you're grilling or roasting. Instead it ensures that food is always cooked evenly. The Rotisserie Spit can only be used in single mode on Level 3 shelf, because it needs to be attached to an adapter on the back. And please remember to remove the black plastic handle while cooking.

Steam Tray (12L)

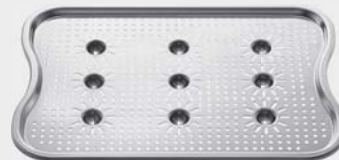

The Steam Tray helps retain steam, so steaming food is much faster and more economical. The glass lid can also be turned upside down and used as a dish for roasting or baking. The Steam Tray is only for use with the Steam Cook function and should be placed on the Level 1 shelf, so that it touches the rear of the oven. It consists of 4 parts: glass lid, metal pan, steam tray and steam nozzle.





Compact Oven

Samsung Compact Ovens are small in size, but big on result. Despite their compact design they boast a 50L capacity, which is more than capable of handling multiple dishes - and even the holiday turkey! Add in their speed and steam cooking abilities and they really are a great choice for a busy home.

COLLECTION



11:30 AM

Microwave

For fast efficient cooking without changing the colour or form of food

30 sec
Start



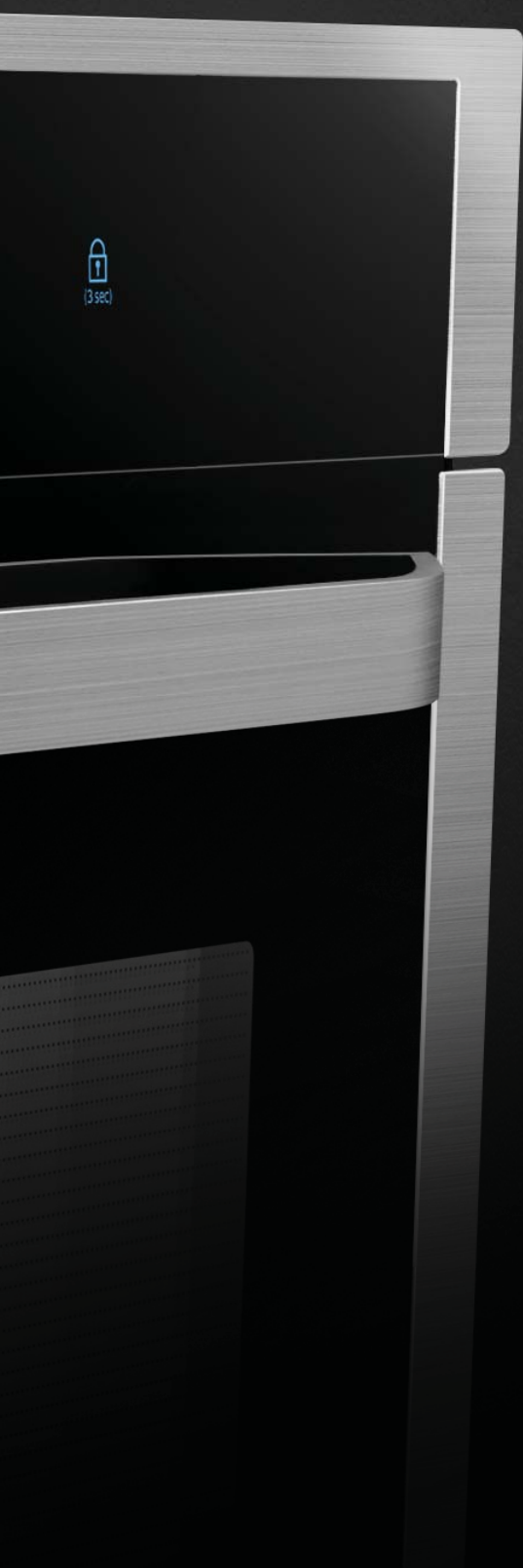

Full touch TFT-LCD Display

A 4.6" full-touch TFT LCD display offers a much simpler and easier way to cook – exactly how you want to. You can select and control a range of functions and settings, such as cooking mode, temperature and time, with the simple touch of your finger. And it also gives you plenty of useful information to help you cook like a professional.

Features

Compact Oven



Speed Cooking

Speed Cooking cooks food deeply and evenly. It also features multiple heating systems, including a fan-assisted convection that circulates heat evenly.



Guide Lighting Control

The Guide Lighting Control is a digital dashboard that acts as a culinary assistant. You can control cooking temperatures and times, select functions and set cleaning options by following the lights on its display.



A Pre-stop Hinge Door

A Pre-stop hinge door ensures that the door can be quietly and safely closed. It automatically stops at a preset level, so it doesn't shut too quickly and create a loud noise or cause spills or accidents.



Steam Cleaning

Steam Cleaning lets you loosen and remove food particles and stubborn stains in the oven cavity easily. Simply fill the cup inside the oven with water and it quickly bathes the cavity, so residue can be wiped away.



Massive 50 Liter Capacity

Massive 50 liter capacity enables you to cook much more or much larger food. You can prepare multiple dishes at once, like trays of cookies, or easily accommodate large items, like a big roast or holiday turkey.



Dual Fans Convection

Dual Fans spins the opposite directions to spread heat evenly throughout the oven, so all of your dishes are cooked at the same temperature and speed. It also reaches its target temperature faster and is more energy efficient.

Microwave Oven



Smart Moisture Sensor

With the push of a button the Smart Moisture Sensor determines the interior air humidity, so the cooking mode and time can be automatically adjusted to ensure meals are always cooked perfectly.



Browning Plus

The Browning Plus button achieves the ideal texture and color for your food, so it looks and tastes delicious. It increases the cooking time by 30 seconds to brown and crisp food exquisitely with the grill heater.



Keep Warm

Preparing lots of dishes or a whole meal can be a real juggling act as you need to keep everything warm and ready to serve together. With one touch the Samsung microwave oven's Keep Warm function keeps food at the proper temperature without over-cooking, so it stays deliciously warm and tasty just like freshly cooked food-no matter when you serve it.

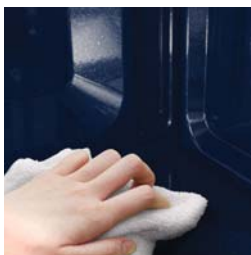

Ceramic Enamel

The durable Ceramic Enamel is easy to keep clean and scratch-free. Its smooth surface can be cleaned without scrubbing and won't discolor over time. It's also highly rust and scratch-resistant, so it lasts longer.

Models

Compact Oven

A Samsung Compact Oven is the perfect choice when space is limited, but you like to speed cooking a lot! With a huge 50 liter capacity and speed cooking option you simply don't need anything more.



NQ50C7935ES

Key features

- Steam and Steam Combination Cooking
- Pop-up Dial and Touch Buttons
- 50L Large Capacity
- Steam Clean
- Auto Cook 35 Recipes
- Auto Defrost 5 Programmes
- Grill, Hot Air, Top and Bottom Heat
- Child Safety Lock

Included accessories:

- Baking Tray (2 EA)
- Wire Rack (1 EA)
- Wire Tray Insert (1 EA)
- Steam Rack (1 EA)



NQ50J9530BS

Key features

- MWO Combination Cooking
- Intuitive Touch TFT LCD
- 50L Large Capacity
- Pro-Roasting
- Auto Cook 35 Recipes
- Auto Defrost 5 Programmes
- Steam Clean
- Pre-stop Hinge

Included accessories:

- Ceramic Tray (1 EA)
- Baking Tray (2 EA)
- Wire Rack (1 EA)
- Wire Tray Insert (1 EA)



NQ50J5530BS

Key features

- MWO Combination Cooking
- Intuitive & Easy LED Display
- Guide Lighting Control
- 50L Large Capacity
- Pro-Roasting
- Auto Cook 20 Recipes
- Auto Defrost 5 Programmes
- Steam Clean
- Pre-stop Hinge

Included accessories:

- Ceramic Tray (1 EA)
- Baking Tray (2 EA)
- Pure Steam Bowl



NQ50J3530BS

Key features

- MWO Combination Cooking
- Pop-up Dial with Touch Buttons
- 50L Large Capacity
- Steam Clean
- Auto Cook 20 Recipes
- Auto Defrost 5 Programmes
- Child Safety Lock

Included accessories:

- Ceramic Tray (1 EA)
- Baking Tray (1 EA)
- Pure Steam Bowl



NQ50K3530BG

Key features

- MWO Combination Cooking
- Pop-up Dial with Touch Buttons
- 50L Large Capacity
- Steam Clean
- Auto Cook 20 Recipes
- Auto Defrost 5 Programmes
- Child Safety Lock

Included accessories:

- Ceramic Tray (1 EA)
- Baking Tray (1 EA)
- Pure Steam Bowl



NQ50H5537KB

Key features

- MWO Combination Cooking
- Glass Touch
- Pop-up Dial with Touch Buttons
- 50L Large Capacity
- Steam Clean
- Auto Cook 20 Recipes
- Auto Defrost 5 Programmes
- Child Safety Lock

Included accessories:

- Ceramic Tray (1 EA)
- Baking Tray (1 EA)
- Pure Steam Bowl

Models

Compact Oven

A Samsung Compact Oven is the perfect choice when space is limited, but you like to speed cooking a lot! With a huge 50 liter capacity and speed cooking option you simply don't need anything more.



NQ50K5130BS

Key features

- MWO Solo
- Pop-up Dial with Touch Buttons
- 50L Large Capacity
- Steam Clean
- Auto Cook 15 Recipes
- Auto Defrost 5 Programmes
- Child Safety Lock

Included accessories:

- Ceramic Tray (1 EA)



NQ50K3130BS

Key features

- MWO Solo
- Pop-up Dial with Touch Buttons
- 50L Large Capacity
- Steam Clean
- Auto Cook 15 Recipes
- Auto Defrost 5 Programmes
- Child Safety Lock

Included accessories:

- Ceramic Tray (1 EA)



NQ50K3130BM

Key features

- MWO Solo
- Pop-up Dial with Touch Buttons
- 50L Large Capacity
- Steam Clean
- Auto Cook 15 Recipes
- Auto Defrost 5 Programmes
- Child Safety Lock

Included accessories:

- Ceramic Tray (1 EA)



NQ50H7535DS

Key features

- MWO Combination Cooking
- Pop-up Dial with Touch Buttons
- 50L Large Capacity
- Steam Clean
- Auto Cook 35 Recipes
- Auto Defrost 5 Programmes
- Child Safety Lock

Included accessories:

- Ceramic Tray (1 EA)
- Baking Tray (2 EA)
- Wire Rack (1 EA)
- Wire Tray Insert (1 EA)



NQ50H5533KS

Key features

- MWO Combination Cooking
- Pop-up Dial with Touch Buttons
- 50L Large Capacity
- Steam Clean
- Auto Cook 20 Recipes
- Auto Defrost 5 Programmes
- Child Safety Lock

Included accessories:

- Ceramic Tray (1 EA)
- Baking Tray (1 EA)
- Wire Tray Insert (1 EA)
- Pure Steam Bowl



NQ50H7235AS

Key features

- MWO Solo
- Pop-up Dial with Touch Buttons
- 50L Large Capacity
- Steam Clean
- Auto Cook 15 Recipes
- Auto Defrost 5 Programmes
- Child Safety Lock

Included accessories:

- Ceramic Tray (1 EA)

Models

Warmer

Samsung's Warmer which is matched with Compact Oven keeps food at the perfect temperature until dinner is ready.



NL20J7100WB

(matching: NQ50J9530BS, NQ50J5530BS, NQ50J3530BS, NQ50K5130BS, NQ50K3130BS)

Key features

- Complementary design to compact oven
- Defrosting (Temp. Ranges 30°C~80°C)
- Plate Warming
- Food Kept Warm
- Loading Weight : 20kg
- Fits a 60cm niche
- Stores accessories when not in use



NL20F7100WB

(matching: NQ50C7935ES, NQ50H7535DS, NQ50H5533KS, NQ50H7235AS)

Key features

- Complementary design to compact oven
- Defrosting (Temp. Ranges 30°C~80°C)
- Plate Warming
- Food Kept Warm
- Loading Weight : 20kg
- Fits a 60cm niche
- Stores accessories when not in use

Models

Microwave Oven

Provides a seamless look that is perfectly harmonized with modern built-in kitchens.



MG22M8074CT

Key features

- Smart Moisture Sensor
- Browning Plus
- Keep Warm
- Ceramic Enamel
- Type : MWO + Grill
- 22L Capacity
- Touch (Control Type)
- Side Opening Door
- Ice Blue LED (Display)

Included accessories:

- Round Grill Rack
- Crusty Plate



MG22M8074AT

Key features

- Smart Moisture Sensor
- Browning Plus
- Keep Warm
- Ceramic Enamel
- Type : MWO + Grill
- 22L Capacity
- Touch (Control Type)
- Side Opening Door
- Ice Blue LED (Display)

Included accessories:

- Round Grill Rack



MG22M8054AK

Key features

- Browning Plus
- Keep Warm
- Ceramic Enamel
- Type : MWO + Grill
- 22L Capacity
- Touch (Control Type)
- Side Opening Door
- Ice Blue LED (Display)

Included accessories:

- Round Grill Rack

Models

Microwave Oven

Provides a seamless look that is perfectly harmonized with modern built-in kitchens.



MG22M8054AW

Key features

- Browning Plus
- Keep Warm
- Ceramic Enamel
- Type : MWO + Grill
- 22L Capacity
- Touch (Control Type)
- Side Opening Door
- Ice Blue LED (Display)

Included accessories:

- Round Grill Rack

MS22M8074AT

Key features

- Smart Moisture Sensor
- Keep Warm
- Deodorization
- Ceramic Enamel
- Type : Solo MWO
- 22L Capacity
- Touch (Control Type)
- Side Opening Door
- Ice Blue LED (Display)

MS22M8054AK

Key features

- Keep Warm
- Deodorization
- Memory Cook
- Ceramic Enamel
- Type : Solo MWO
- 22L Capacity
- Touch (Control Type)
- Side Opening Door
- Ice Blue LED (Display)



MS22M8054AW

Key features

- Keep Warm
- Deodorization
- Memory Cook
- Ceramic Enamel
- Type : Solo MWO
- 22L Capacity
- Touch (Control Type)
- Side Opening Door
- Ice Blue LED (Display)



FG87SUST

Key features

- Crusty Cook
- Steam Clean
- Ceramic Enamel
- Type : MWO + Grill
- 23L Capacity
- Tact (Control Type)
- Side Opening Door
- Ice Blue LED (Display)

Included accessories:

- Crusty Plate
- Steam Clean



FG87SUB

Key features

- Crusty Cook
- Steam Clean
- Ceramic Enamel
- Type : MWO + Grill
- 23L Capacity
- Tact (Control Type)
- Side Opening Door
- Ice Blue LED (Display)

Included accessories:

- Crusty Plate
- Steam Clean

Models

Microwave Oven

Provides a seamless look that is perfectly harmonized with modern built-in kitchens.



FG77SUST

Key features

- Crusty Cook
- Steam Clean
- Ceramic Enamel
- Type : MWO + Grill
- 20L Capacity
- Tact (Control Type)
- Side Opening Door
- Ice Blue LED (Display)

Included accessories:

- Crusty Plate
- Steam Clean



FG77SUB

Key features

- Crusty Cook
- Steam Clean
- Ceramic Enamel
- Type : MWO + Grill
- 20L Capacity
- Tact (Control Type)
- Side Opening Door
- Ice Blue LED (Display)

Included accessories:

- Crusty Plate
- Steam Clean



FW87SUST

Key features

- Steam Cook
- Deodorization
- Ceramic Enamel
- Type : Solo MWO
- 23L Capacity
- Tact (Control Type)
- Side Opening Door
- Ice Blue LED (Display)

Included accessories:

- Power Steam Bowl



FW87SUB

Key features

- Steam Cook
- Deodorization
- Ceramic Enamel
- Type : Solo MWO
- 23L Capacity
- Tact (Control Type)
- Side Opening Door
- Ice Blue LED (Display)

Included accessories:

- Power Steam Bowl

Compact Oven Accessories

Samsung Compact Oven Accessories are carefully designed to enhance your cooking life by providing simpler and more convenient ways to cook perfectly delicious food.

Baking Tray (20mm)



The 20mm Baking Tray is ideal for cooking cakes, cookies and other pastries. With the slanted side to the front you can easily slide them off.

Ceramic Tray



Specially designed for cooking with microwaves, the Ceramic Tray is extremely robust and scratch-proof. It's also easy to clean and also extremely hygienic as it is made of an anti-bacterial material.

Steam Tray



The Steam Tray helps you steam all sorts of food, including large items, so that they come out thoroughly and deliciously cooked.

Wire Rack

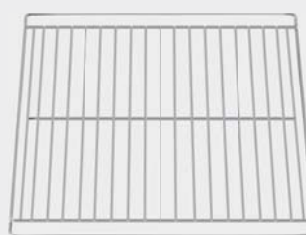

The Wire Rack is ideal for grilling, roasting or baking, especially when you're using tins, casserole dishes or other baking pots, as heat can easily circulate around the base, so food is cooked thoroughly. The bent up side of the frame should be placed at the rear of the oven in order to provide extra support when cooking large amounts.

Wire Tray Insert



When combined with the Ceramic Tray the Wire Tray Insert is great for quickly cooking meals when using the Microwave mode.

Microwave Oven Accessories

Samsung Compact Microwave Oven Accessories are carefully designed to enhance your cooking life by providing simpler and more convenient ways to cook perfectly delicious food.

Crusty Plate



Worried about how to use the pizza leftover from yesterday? The Samsung Crusty Plate heats frozen foods, such as pizza, so it tastes just like when it was originally cooked. This amazing feature ensures a tasty and crispy texture for perfect results every time.

Steam Clean



The unique surface inside the microwave is made of ceramic enamel; a non-stick and highly scratch-resistant surface that also has an anti-bacterial coating. In conjunction with the Steam Clean system, bacteria and food particles can be wiped away easily, keeping your oven hygienically clean.

Power Steam Bowl



Compared to traditional ones, the upgraded Power Steam Bowl has a round shape with a large space. The special feature of this remodeled Steam Bowl is that the top and bottom levels are separate, so you can enjoy a greater variety of foods without them becoming dry.

Round Grill Rack

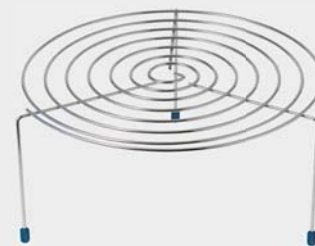

Round Grill Rack can be used to cook two dishes at the same time. A small dish can be placed on the turntable and a second dish on the rack. The metal racks can be used in grill, convection and combination cooking.

Cooktop

Samsung Induction Cooktop's modern design is complemented by a brilliant Ice blue LED display that adds an extra touch of style. It provides extremely clear and simple to understand information about the selected functions, so it's much easier to control how you cook.







Virtual Flame Technology™

With the Virtual Flame Technology™ you can enjoy the instinctive feel and visual control of flames and clearly see if the burner is on or off. LED lighting is located in front of one burner, which glows like a real gas flame to show how high it is turned up – the brighter the flame the greater the power level of the burner. So, just like a Gas Range, you can enjoy a more intuitive way to cook with the added peace of mind of instantly knowing if burners are turned up too much or have been accidentally left on.



Intuitive Interface

Virtual Flame Technology™ provides natural and intuitive visual control of the cooktop as LED lighting located in front of the burner glows like a real gas flame.



Interactive Cooking

Unlike conventional induction cooktops, you can quickly react to the power level with Virtual Flame Technology™, allowing you to enjoy a more interactive cooking experience.



Safety Measures

LED lighting that glows in accordance to the power level not only prevents accidental burns, but also allows you to instantly check if the burner have been left on.

Features

Induction Cooktop



Magnetic Knob

A movable Magnetic Knob lets you control the power of each ring more simply and precisely. It can be completely detached, so the entire surface can be cleaned more easily.



Auto Connectivity

The hood also wirelessly connects to the cooktop, so they turn on and off together. You can also remotely control of hood through mobile. (Power on/off, fan speed control, lamp on/off).



Flex Zone Plus

Flex Zone Plus is a large, open space on the cooktop that is specially designed for cooking multiple dishes. It is divided into 4 zones for greater flexibility and is wide and spacious enough to accommodate different sizes and shapes of cookware at once or cook large meals.



Ice-blue Display

The modern and brilliant Ice-blue LED Display provides extremely clear information about the selected functions, so it's easier to control how you cook. It also adds an extra touch of style.



Wi-Fi Control

You can remotely check the cooktop to see if any burners have been left on or to set the timer.



Keep Warm

The Keep Warm button is handy for when you're preparing several dishes, as it lets you keep your food at the perfect temperature without overcooking. Your food will taste freshly prepared.



Quick Start

The Quick Start button reduces the number of steps and time it takes to start cooking by providing high heat instantly with simply one touch. The heat can be gradually reduced, if desired.



Pause

The Pause button provides greater convenience by allowing you to switch all cooking zones to a low power setting with just one touch. Just touch it again to instantly return the heat to original power levels.



Sliding Control

The extra wide and intuitive Sliding Control LED display panel enables fast and precise control of your cooking temperatures. Simply touch and glide your finger across it to instantly set or adjust the heat levels.

Ceramic Cooktop



Easy To Clean

With the Samsung Ceramic Cooktop there's no need to worry about messy spills and splatters. Even after the greasiest cooking, the smooth, ergonomic surface will quickly wipe clean.

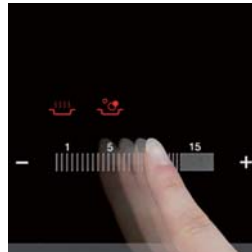

Sliding Control

Enjoy effortless control of your cooking using the Sliding Control panel. Simply touch and glide your finger across the panel to instantly and precisely set or adjust the cooking temperature.



Automatic Safety

Enjoy complete peace of mind with an automatic safety shut-off function that ensures that the cooktop is always off when you want it to be. It also features a child safety lock to prevent children from turning the cooktop on.

Gas Cooktop



Triple Crown

Cook every dish perfectly with a Triple Crown gas burner, which produces searing, instantaneous heat, so it's ideal for woks, large pans and rapid cooking like making stir fry.



Endless Rail Grate

Even the heaviest pots and pans will slide along seamless rails, eliminating the need to lift them. Simple indicator marks also show if they're properly centered over the optimum heat. And the whole grate can be easily cleaned in a dishwasher.



Flame Failure Safety Device

There's no need to worry about gas leaks, as the automatic shut-down sensor provides instant protection if any stray gas is detected.

Models

Induction Cooktop

For a simple, clean and efficient way to get things done fast, look no further than a Samsung Induction Cooktop. It heats food extremely quickly and provides effortless fingertip control.



NZ84J9770EK

Key features

- Virtual Flame Technology™ & Lighting Bar
- Precise Control with Magnetic Knob
- 1~15 Power Level with Booster
- Wide Flex Zone
- Keep Warm
- Quick Start / Quick Stop / Pause
- 2 Stage Residual Heat Indicator
- Display Color: Ice Blue
- 3-side Bevelled Frame
- Left 38 x 20cm 3.3 (3.6kW)
- Center Rear 21cm 2.2 (3.2kW)
- Right Front 14.5cm 1.2 (2.0kW)
- Total Max. Power 7.0kW

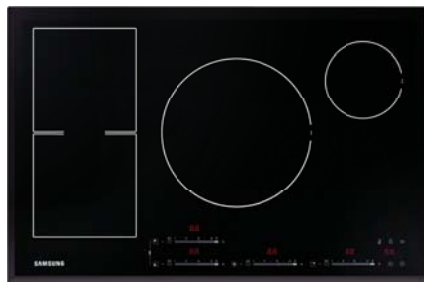

NZ84F7NC6AB

Key features

- Sliding Control
- 1~15 Power Level with Booster
- Flex Zone
- Keep Warm
- Quick Stop / Pause
- 2 Stage Residual Heat Indicator
- Display Color : New Amber
- 3-side Bevelled Frame
- Left 38 x 20cm 3.3 (3.6kW)
- Center 28cm 2.4 (3.6kW)
- Right Rear 14.5cm 1.2 (2.0kW)
- Total Max. Power 7.2kW



NZ63N9777GK

Key features

- Virtual Flame Technology™
- Flex Zone Plus
- Auto Connectivity (with Hood) & Wi-Fi
- Sliding & DirectAccess Control
- 1~15 Power Level with Booster
- Keep Warm
- Quick Start / Quick Stop / Pause
- 2 Stage Residual Heat Indicator
- Display Color: Ice Blue
- Front Bevelled Frame
- Flex Zone 38 x 24cm 3.3 (3.6kW)
- Right Center 21cm 2.2 (3.2kW)
- Total Max. Power 6.8kW



NZ64N9777GK

Key features

- Virtual Flame Technology™
- Flex Zone Plus
- Auto Connectivity (with Hood) & Wi-Fi
- Sliding & DirectAccess Control
- 1~15 Power Level with Booster
- Keep Warm
- Quick Start / Quick Stop / Pause
- 2 Stage Residual Heat Indicator
- Display Color: Ice Blue
- Front Bevelled Frame
- Flex Zone 38 x 24cm 3.3 (3.6kW)
- Right Front 21cm 2.2 (3.2kW)
- Right Rear 14.5cm 1.2 (2.0kW)
- Total Max. Power 7.2kW



NZ64N9777BK

Key features

- Virtual Flame Technology™
- Flex Zone Plus
- Auto Connectivity (with Hood) & Wi-Fi
- Sliding & DirectAccess Control
- 1~15 Power Level with Booster
- Keep Warm
- Quick Start / Quick Stop / Pause
- 2 Stage Residual Heat Indicator
- Display Color: Ice Blue
- Front Bevelled Frame
- Flex Zone 38 x 24cm 3.3 (3.6kW)
- Right Front 21cm 2.2 (3.2kW)
- Right Rear 14.5cm 1.2 (2.0kW)
- Total Max. Power 7.2kW

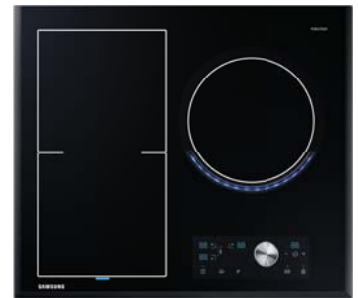

NZ63J9770EK

Key features

- Virtual Flame Technology™
- & Lighting Bar
- Precise Control with Magnetic Knob
- 1~15 Power Level with Booster
- Wide Flex Zone
- Keep Warm
- Quick Start / Quick Stop / Pause
- 2 Stage Residual Heat Indicator
- Display Color : Ice Blue
- 3-side Bevelled Frame
- Left 43 x 22cm 3.3 (3.6kW)
- Right 22cm 2.2 (3.2kW)
- Total Max. Power 6.8kW

Models

Induction Cooktop

For a simple, clean and efficient way to get things done fast, look no further than a Samsung Induction Cooktop. It heats food extremely quickly and provides effortless fingertip control.



NZ64N7777GK

Key features

- Virtual Flame Technology™
- Flex Zone Plus
- Auto Connectivity (with Hood) & Wi-Fi
- Sliding & DirectAccess Control
- 1~15 Power Level with Booster
- Keep Warm
- Quick Start / Quick Stop / Pause
- 2 Stage Residual Heat Indicator
- Display Color: Amber
- Front Bevelled Frame
- Flex Zone 38 x 24cm 3.3 (3.6kW)
- Right Front 21cm 2.2 (3.2kW)
- Right Rear 14.5cm 1.2 (2.0kW)
- Total Max. Power 7.2kW



NZ63K7777BK

Key features

- Virtual Flame Technology™
- Sliding Control
- 1~15 Power Level with Booster
- Flex Zone Plus
- Keep Warm
- Quick Start / Quick Stop / Pause
- 2 Stage Residual Heat Indicator
- Display Color : New Amber
- Front Bevelled Frame
- Left 38 x 24cm 3.3 (3.6kW)
- Right 22cm 2.2 (3.2kW)
- Total Max. Power 6.8kW



NZ64N7757GK

Key features

- Flex Zone Plus
- Auto Connectivity (with Hood) & Wi-Fi
- Sliding & DirectAccess Control
- 1~15 Power Level with Booster
- Keep Warm
- Quick Start / Quick Stop / Pause
- 2 Stage Residual Heat Indicator
- Display Color: Ice Blue
- Front Bevelled Frame
- Flex Zone 38 x 24cm 3.3 (3.6kW)
- Right Front 21cm 2.2 (3.2kW)
- Right Rear 14.5cm 1.2 (2.0kW)
- Total Max. Power 7.2kW



NZ64N7757FK

Key features

- Flex Zone Plus
- Auto Connectivity (with Hood) & Wi-Fi
- Sliding & DirectAccess Control
- 1~15 Power Level with Booster
- Keep Warm
- Quick Start / Quick Stop / Pause
- 2 Stage Residual Heat Indicator
- Display Color: Ice Blue
- Cut Edge Frame
- Flex Zone 38 x 24cm 3.3 (3.6kW)
- Right Front 21cm 2.2 (3.2kW)
- Right Rear 14.5cm 1.2 (2.0kW)
- Total Max. Power 7.2kW



NZ64K7757BK

Key features

- Sliding Control
- 1~15 Power Level with Booster
- Flex Zone Plus
- Keep Warm
- Quick Start / Quick Stop / Pause
- 2 Stage Residual Heat Indicator
- Display Color : New Amber
- Front Bevelled Frame
- Left 38 x 24cm 3.3 (3.6kW)
- Right Front 21cm 2.2 (3.2kW)
- Right Rear 14.5cm 1.4 (2.0kW)
- Total Max. Power 7.2kW



NZ63K5727BK

Key features

- Sliding Control
- 1~15 Power Level with Booster
- Dual Power Zone
- Keep Warm
- Quick Start / Quick Stop / Pause
- 2 Stage Residual Heat Indicator
- Display Color : New Amber
- Front Bevelled Frame
- Left 28cm 3.6 (5.0kW)
- Right Front 21cm 2.2 (3.2kW)
- Right Rear 14.5cm 1.4 (2.0kW)
- Total Max. Power 7.2kW

Models

Induction Cooktop

For a simple, clean and efficient way to get things done fast, look no further than a Samsung Induction Cooktop. It heats food extremely quickly and provides effortless fingertip control.



NZ64K5747BK

Key features

- Sliding Control
- 1~15 Power Level with Booster
- Flex Zone
- Keep Warm
- Quick Start / Quick Stop / Pause
- 2 Stage Residual Heat Indicator
- Display Color : New Amber
- Front Bevelled Frame
- Left 38 x 20cm 3.3 (3.6kW)
- Right Front 21cm 2.2 (3.2kW)
- Right Rear 14.5cm 1.4 (2.0kW)
- Total Max. Power 7.2kW



NZ63H57470K

Key features

- Sliding Control
- 1~15 Power Level with Booster
- Keep Warm
- Quick Start / Quick Stop / Pause
- 2 Stage Residual Heat Indicator
- Display Color : New Amber
- Cut Edge Frame
- Left 38 x 20cm 3.3 (3.6kW)
- Right 28cm 2.4 (3.6kW)
- Total Max. Power 7.2kW



NZ64H37075K

Key features

- Sliding Control
- 1~9 Power Level with Booster
- Quick Stop
- Residual Heat Indicator
- Display Color : New Amber
- All Around Stainless Frame
- Left Front 14cm 1.25 (1.5kW)
- Left Rear 22cm 2.35 (2.6kW)
- Right Front 22cm 2.35 (2.6kW)
- Right Rear 14cm 1.25 (1.5kW)
- Total Max. Power 7.2kW

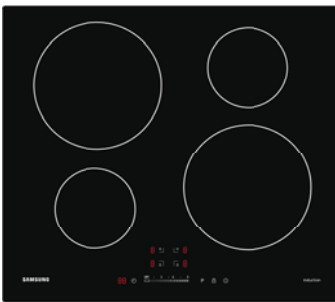

NZ64H37070K

Key features

- Sliding Control
- 1~9 Power Level with Booster
- Quick Stop
- Residual Heat Indicator
- Display Color : New Amber
- Cut Edge Frame
- Left Front 14cm 1.25 (1.5kW)
- Left Rear 22cm 2.35 (2.6kW)
- Right Front 22cm 2.35 (2.6kW)
- Right Rear 14cm 1.25 (1.5kW)
- Total Max. Power 7.2kW



NZ63H37070K

Key features

- Sliding Control
- 1~9 Power Level with Booster
- Quick Stop
- Residual Heat Indicator
- Display Color : New Amber
- Cut Edge Frame
- Left Front 14cm 1.2 (1.5kW)
- Left Rear 18cm 2.3 (2.6kW)
- Right 28cm 3.0 (4.0kW)
- Total Max. Power 7.2kW

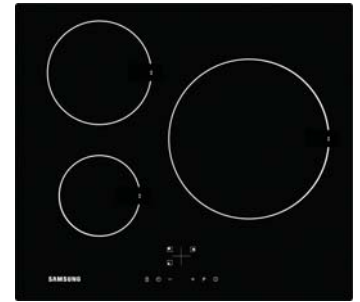

NZ63F3NM1AB

Key features

- +/- Touch Control
- 1~9 Power Level with Booster
- Quick Stop
- Residual Heat Indicator
- Display Color : New Amber
- Cut Edge Frame
- Left Front 14cm 1.2 (1.5kW)
- Left Rear 18cm 2.3 (2.6kW)
- Right 28cm 3.0 (4.0kW)
- Total Max. Power 7.2kW

Models

Induction Cooktop

For a simple, clean and efficient way to get things done fast, look no further than a Samsung Induction Cooktop. It heats food extremely quickly and provides effortless fingertip control.



NZ64F3NMIAB

Key features

- +/- Touch Control
- 1~9 Power Level with Booster
- Quick Stop
- Residual Heat Indicator
- Display Color : New Amber
- Cut Edge Frame
- Left Front 14cm 1.25 (1.5kW)
- Left Rear 22cm 2.35 (2.6kW)
- Right Front 22cm 2.35 (2.6kW)
- Right Rear 14cm 1.25 (1.5kW)
- Total Max. Power 7.2kW



NZ63M3707AK

Key features

- Sliding Control
- 1~9 Power Level with Booster
- Quick Stop
- Residual Heat Indicator
- Cut Edge Frame
- Left Front 14cm 1.2 (1.5kW)
- Left Rear 18cm 2.3 (2.6kW)
- Right Center 28cm 3.0 (4.0kW)
- Total Max. Power 7.2kW



NZ64M3707AK

Key features

- Sliding Control
- 1~9 Power Level with Booster
- Quick Stop
- Residual Heat Indicator
- Cut Edge Frame
- Left Front 14cm 1.25 (1.5kW)
- Left Rear 22cm 2.35 (2.6kW)
- Right Front 22cm 2.35 (2.6kW)
- Right Rear 14cm 1.25 (1.5kW)
- Total Max. Power 7.2kW



NZ63M3NM1BB

Key features

- +/- Touch Control
- 1~9 Power Level with Booster
- Quick Stop
- Residual Heat Indicator
- Cut Edge Frame
- Left Front 14cm 1.2 (1.5kW)
- Left Rear 18cm 2.3 (2.6kW)
- Right Center 28cm 3.0 (4.0kW)
- Total Max. Power 7.2kW



NZ64M3NM1BB

Key features

- +/- Touch Control
- 1~9 Power Level with Booster
- Quick Stop
- Residual Heat Indicator
- Cut Edge Frame
- Left Front 14cm 1.25 (1.5kW)
- Left Rear 22cm 2.35 (2.6kW)
- Right Front 22cm 2.35 (2.6kW)
- Right Rear 14cm 1.25 (1.5kW)
- Total Max. Power 7.2kW

Models

Ceramic Cooktop

Add a great look to your kitchen with a Samsung Ceramic Cooktop. Their fast and powerful radiant heating, fingertip control and expansive and easy to clean surface also makes them effortless to use.



CTR164NC01

Key features

- Oval & Double Burner
- Sliding Control
- 1~9 Power Level
- Built-in Timer
- Display Color : New Amber
- 4-side Bevelled Frame
- Left Front 12 / 21cm 0.75 / 2.2kW
- Left Rear 14.5cm 1.2kW
- Right Front 14.5cm 1.2kW
- Right Rear 17 / 26.5cm 1.6 / 2.4kW
- Total Max. Power 7.0kW



CTR364NC01

Key features

- Touch Control
- 1~9 Power Level
- Built-in Timer
- Display Color : New Amber
- 3-side Bevelled Frame
- Left Front 12/21cm 0.75/2.2kW
- Left Rear 14.5cm 1.2kW
- Right Front 14.5cm 1.2kW
- Right Rear 12/18.3cm 0.8/2.0kW
- Total Max. Power 7.0kW



CTR464NC01

Key features

- Touch Control
- 1~9 Power Level
- Built-in Timer
- Display Color : New Amber
- 3-side Bevelled Frame
- Left Front 12/21cm 0.75/2.2kW
- Left Rear 14.5cm 1.2kW
- Right Front 14.5cm 1.2kW
- Right Rear 17/26.5cm 1.6/2.4kW
- Total Max. Power 7.0kW



CTR464NB01

Key features

- Touch Control
- 1~9 Power Level
- Built-in Timer
- Display Color : New Amber
- 3-side Bevelled Frame
- Left Front 18cm 1.8kW
- Left Rear 14.5cm 1.2kW
- Right Front 14.5cm 1.2kW
- Right Rear 18cm 1.8kW
- Total Max. Power 6.0kW

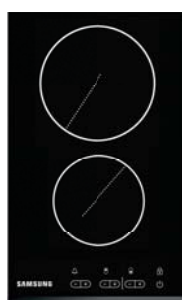

CTR432NB02

Key features

- Touch Control
- 1~9 Power Level
- Built-in Timer
- Display Color : New Amber
- Front Bevelled Frame
- Right 18cm 1.8kW
- Front 14.5cm 1.2kW
- Total Max. Power 3.0kW

Models

Gas Cooktop

Push back the limits of style and performance with a Samsung Gas Cooktop. Their powerful performance, effortless controllability and advanced safety features make cooking a real pleasure.



NA75J3030AS

Key features

- High Power Triple Crown (3.8kW)
- Easy to Clean Stainless Steel Surface
- 3 Cast Iron Grate & Wok Support
- Burner Types
 - 1 Triple Crown
 - 1 Rapid
 - 2 Semi-rapid
 - 1 Auxiliary
- Mechanic Dial Type Knob
- Electronic Ignition (One Touch Ignition)
- Safety Device (Flame Failure Device)
- LNG / LPG Convergence Kit Incl.

Included accessories:

- Wok Support



NA75M3130AS

Key features

- High Power Triple Crown (3.8kW)
- Easy to Clean Stainless Steel Surface
- 3 Enamel Grate
- Burner Types
 - 1 Triple Crown
 - 1 Rapid
 - 2 Semi-rapid
 - 1 Auxiliary
- Mechanic Dial Type Knob
- Electronic Ignition (One Touch Ignition)
- Safety Device (Flame Failure Device)
- LNG / LPG Convergence Kit Incl.



NA64H3040AS

Key features

- High Power Triple Crown (4.0kW)
- Easy to Clean Stainless Steel Surface
- 4 Cast Iron Grate & Wok Support
- Burner Types
 - 1 Triple Crown
 - 1 Rapid
 - 1 Semi-rapid
 - 1 Auxiliary
- Mechanic Dial Type Knob
- Electronic Ignition (One Touch Ignition)
- Safety Device (Flame Failure Device)
- LNG / LPG Convergence Kit Incl.

Included accessories:

- Wok Support

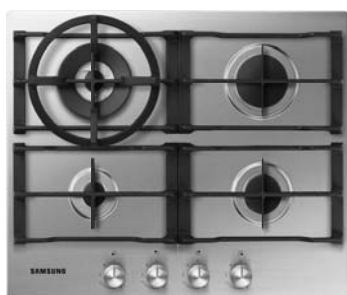

NA64H3030AS

Key features

- High Power Triple Crown (3.8kW)
- Easy to Clean Stainless Steel Surface
- 4 Cast Iron Grate & Wok Support
- Burner Types
 - 1 Triple Crown
 - 1 Rapid
 - 1 Semi-rapid
 - 1 Auxiliary
- Mechanic Dial Type Knob
- Electronic Ignition (One Touch Ignition)
- Safety Device (Flame Failure Device)
- LNG / LPG Convergence Kit Incl.

Included accessories:

- Wok Support



NA64H3010AS

Key features

- Rapid Burner (3.3kW)
- Easy to Clean Stainless Steel Surface
- 4 Cast Iron Grate
- Burner Types
 - 2 Rapid
 - 1 Semi-rapid
 - 1 Auxiliary
- Mechanic Dial Type Knob
- Electronic Ignition (One Touch Ignition)
- Safety Device (Flame Failure Device)
- LNG / LPG Convergence Kit Incl.



NA64H3110AS

Key features

- Rapid Burner (3.3kW)
- Easy to Clean Stainless Steel Surface
- 4 Enamel Grate
- Burner Types
 - 2 Rapid
 - 1 Semi-rapid
 - 1 Auxiliary
- Mechanic Dial Type Knob
- Electronic Ignition (One Touch Ignition)
- Safety Device (Flame Failure Device)
- LNG / LPG Convergence Kit Incl.

Models

Gas Cooktop

Push back the limits of style and performance with a Samsung Gas Cooktop. Their powerful performance, effortless controllability and advanced safety features make cooking a real pleasure.



NA64H3040BS

Key features

- High Power Triple Crown (4.0kW)
- Diamond Layout for More Space Usability
- 3 Cast Iron Grate & Wok Support
- Burner Types
 - 1 Triple Crown
 - 1 Rapid
 - 1 Semi-rapid
 - 1 Auxiliary
- Mechanic Dial Type Knob
- Electronic Ignition (One Touch Ignition)
- Safety Device (Flame Failure Device)
- LNG / LPG Convergence Kit Incl.

Included accessories:

- Wok Support



NA64H3030BS

Key features

- High Power Triple Crown (3.8kW)
- Diamond Layout for More Space Usability
- 3 Cast Iron Grate & Wok Support
- Burner Types
 - 1 Triple Crown
 - 1 Rapid
 - 1 Semi-rapid
 - 1 Auxiliary
- Mechanic Dial Type Knob
- Electronic Ignition (One Touch Ignition)
- Safety Device (Flame Failure Device)
- LNG / LPG Convergence Kit Incl.

Included accessories:

- Wok Support



NA64H3010BS

Key features

- Rapid Burner (3.3kW)
- Diamond Layout for More Space Usability
- 3 Cast Iron Grate
- Burner Types
 - 2 Rapid
 - 1 Semi-rapid
 - 1 Auxiliary
- Mechanic Dial Type Knob
- Electronic Ignition (One Touch Ignition)
- Safety Device (Flame Failure Device)
- LNG / LPG Convergence Kit Incl.



NA64H3110BS

Key features

- Rapid Burner (3.3kW)
- Diamond Layout for More Space Usability
- 3 Enamel Grate
- Burner Types
 - 2 Rapid
 - 1 Semi-rapid
 - 1 Auxiliary
- Mechanic Dial Type Knob
- Electronic Ignition (One Touch Ignition)
- Safety Device (Flame Failure Device)
- LNG / LPG Convergence Kit Incl.



NA64H3030AK

Key features

- High Power Triple Crown (3.8kW)
- Easy to Clean Tempered Glass Surface
- 4 Cast Iron Grate & Wok Support
- Burner Types
 - 1 Triple Crown
 - 2 Semi-rapid
 - 1 Auxiliary
- Mechanic Dial Type Knob
- Electronic Ignition (One Touch Ignition)
- Safety Device (Flame Failure Device)
- LNG / LPG Convergence Kit Incl.

Included accessories:

- Wok Support



NA64H3010AK

Key features

- Rapid Burner (3.3kW)
- Easy to Clean Tempered Glass Surface
- 4 Cast Iron Grate & Wok Support
- Burner Types
 - 1 Rapid
 - 2 Semi-rapid
 - 1 Auxiliary
- Mechanic Dial Type Knob
- Electronic Ignition (One Touch Ignition)
- Safety Device (Flame Failure Device)
- LNG / LPG Convergence Kit Incl.

Included accessories:

- Wok Support

Models

Gas Cooktop

Push back the limits of style and performance with a Samsung Gas Cooktop. Their powerful performance, effortless controllability and advanced safety features make cooking a real pleasure.



NA64H3000AK

Key features

- Rapid Burner (3.0kW)
- Easy to Clean Tempered Glass Surface
- 4 Cast Iron Grate
- Burner Types
 - 1 Rapid
 - 2 Semi-rapid
 - 1 Auxiliary
- Mechanic Dial Type Knob
- Electronic Ignition (One Touch Ignition)
- Safety Device (Flame Failure Device)
- LNG / LPG Convergence Kit Incl.



NA64H3010CK

Key features

- Rapid Burner (3.3kW)
- Classic Retro Style Fitting into Traditional Kitchen
- 4 Cast Iron Grate & Wok Support
- Burner Types
 - 1 Rapid
 - 2 Semi-rapid
 - 1 Auxiliary
- Mechanic Dial Type Knob
- Electronic Ignition (One Touch Ignition)
- Safety Device (Flame Failure Device)
- LNG / LPG Convergence Kit Incl.

Included accessories:

- Wok Support



NA64H3030BK

Key features

- High Power Triple Crown (3.8kW)
- Diamond Layout for More Space Usability
- 3 Cast Iron Grate & Wok Support
- Burner Types
 - 1 Triple Crown
 - 2 Semi-rapid
 - 1 Auxiliary
- Mechanic Dial Type Knob
- Electronic Ignition (One Touch Ignition)
- Safety Device (Flame Failure Device)
- LNG / LPG Convergence Kit Incl.

Included accessories:

- Wok Support



NA64H3010BK

Key features

- Rapid Burner (3.3kW)
- Diamond Layout for More Space Usability
- 3 Cast Iron Grate & Wok Support
- Burner Types
 - 1 Rapid
 - 2 Semi-rapid
 - 1 Auxiliary
- Mechanic Dial Type Knob
- Electronic Ignition (One Touch Ignition)
- Safety Device (Flame Failure Device)
- LNG / LPG Convergence Kit Incl.

Included accessories:

- Wok Support

Gas Cooktop Accessories

Wok Support



The circular Wok Support ensures your wok is always in exactly the right place, so that heat is quickly and evenly distributed, and you can enjoy delicious stir fried food.







Hood

Samsung Hood brings pure convenience to your kitchen. With their high suction power and choice of speeds they will quickly, quietly and efficiently remove steam, vapor and smoke - even if you should burn the toast. And a carbon air filter also eliminates bad odors, so your kitchen always smells fresh.





Power Ventilation System

Proper ventilation is essential to a comfortable and healthy cooking environment, so a near-silent Power Ventilation with Booster system refreshes the air in a flash. Its 729 cubic meters an hour suction capacity gets rid of steam, fumes and odors from the kitchen extremely quickly and quietly.

Features



Power Ventilation System

Ensure a comfortable and healthy cooking environment with proper ventilation. A near-silent Power Ventilation System refreshes the air in a flash. Using the Booster, it has an amazing 737 cubic meters an hour suction capacity. So it gets rid of steam, fumes and odors extremely quickly and quietly.



Auto Connectivity

Save the time and effort of controlling the hood and cooktop separately. Auto Connectivity* wirelessly aligns and shows their status. It allows you to control the hood using the one-touch controls of the cooktop. You can instantly turn them on and off together and enjoy the ultimate in convenience



Auto Sensor

Enjoy a pleasant cooking environment without having to control the hood. An Auto Sensor* optimizes the ventilation speed by sensing the vapors from the cooktop. It also keeps the fan working for 10 minutes to remove any residual fumes. So you never need to worry that it's working at the right speed.



Premium Design

Upgrade your home and create an elegant modern looking kitchen. The Premium Design has a slim profile and striking black stainless steel finish. Its will harmonize well with your kitchen furniture and other appliances, including Samsung products. So it creates a seamless and streamlined look.



Washable Aluminum Filter

Make sure that your hood delivers a powerful ventilation performance for longer. A durable and easy to maintain Aluminum Filter captures oil and dust before it clogs the motor or hinders the airflow. It only needs cleaning every 3-4 weeks. And it is washable and small enough to go in a dishwasher.



Touch Control

Enjoy much simpler control with the Touch Control. The bright LED panel is clear and easy to read. It also has the same intuitive touchscreen control as a smartphone. So you can quickly adjust the settings with a gentle touch. And its stylish and exclusive look will enhance your kitchen.



Models

Perfect for almost any space, a Samsung Hood is designed to keep your kitchen cleaner and fresher. They quickly remove smoke and steam, as well as any lingering odors.



NK36N9804VB (90cm)

Key features

- Auto Connectivity (with Hob)
- Auto Sensing Control
- Black Glass
- High Suction Power (737m³/h)
- Touch Control
- LED Bar Lighting
- 4 Speed Extraction Modes (3 Level x 1 Booster)
- Washable Aluminum Metallic Filters
- Saturation Indicator
- Timer Function
- Energy Class A⁺

Included accessories:

- Charcoal Filter



NK24N9804VB (60cm)

Key features

- Auto Connectivity (with Hob)
- Auto Sensing Control
- Black Glass
- High Suction Power (737m³/h)
- Touch Control
- LED Bar Lighting
- 4 Speed Extraction Modes (3 Level x 1 Booster)
- Washable Aluminum Metallic Filters
- Saturation Indicator
- Timer Function
- Energy Class A⁺

Included accessories:

- Charcoal Filter



NK36M7070VS (90cm)

Key features

- Stainless Steel
- Touch Control
- High Suction Power (729m³/h)
- 2 LED Lighting
- 4 Speed Extraction Modes (3 Level x 1 Booster)
- Washable Aluminum Metallic Filters
- Saturation Indicator
- Timer Function

Included accessories:

- Charcoal Filter



NK24M7070VS (60cm)

Key features

- Stainless Steel
- Touch Control
- High Suction Power (729m³/h)
- 2 LED Lighting
- 4 Speed Extraction Modes (3 Level x 1 Booster)
- Washable Aluminum Metallic Filters
- Saturation Indicator
- Timer Function

Included accessories:

- Charcoal Filter



NK36M7070VB (90cm)

Key features

- Black Glass
- Touch Control
- High Suction Power (729m³/h)
- 2 LED Lighting
- 4 Speed Extraction Modes (3 Level x 1 Booster)
- Washable Aluminum Metallic Filters
- Saturation Indicator
- Timer Function

Included accessories:

- Charcoal Filter



NK24M7070VB (60cm)

Key features

- Black Glass
- Touch Control
- High Suction Power (729m³/h)
- 2 LED Lighting
- 4 Speed Extraction Modes (3 Level x 1 Booster)
- Washable Aluminum Metallic Filters
- Saturation Indicator
- Timer Function

Included accessories:

- Charcoal Filter

Models

Perfect for almost any space, a Samsung Hood is designed to keep your kitchen cleaner and fresher. They quickly remove smoke and steam, as well as any lingering odors.



NK36N5703BS (90cm)

Key features

- Auto Connectivity (with Hob)
- Stylish Front Black Glass
- High Suction Power (722m³/h)
- Touch Control
- 2 LED Lighting
- 4 Speed Extraction Modes (3 Level x 1 Booster)
- Washable Aluminum Metallic Filters
- Saturation Indicator
- Timer Function
- Energy Class A

Included accessories:

- Charcoal Filter



NK24N5703BS (60cm)

Key features

- Auto Connectivity (with Hob)
- Stylish Front Black Glass
- High Suction Power (722m³/h)
- Touch Control
- 2 LED Lighting
- 4 Speed Extraction Modes (3 Level x 1 Booster)
- Washable Aluminum Metallic Filters
- Saturation Indicator
- Timer Function
- Energy Class A

Included accessories:

- Charcoal Filter



NK24N5703BM (60cm)

Key features

- Auto Connectivity (with Hob)
- Black Stainless with Stylish Front Black Glass
- High Suction Power (722m³/h)
- Touch Control
- 2 LED Lighting
- 4 Speed Extraction Modes (3 Level x 1 Booster)
- Washable Aluminum Metallic Filters
- Saturation Indicator
- Timer Function
- Energy Class A

Included accessories:

- Charcoal Filter



NK36M5070BS (90cm)

Key features

- Stylish Front Black Glass
- Touch Control
- High Suction Power (668m³/h)
- 2 LED Lighting
- 4 Speed Extraction Modes (3 Level x 1 Booster)
- Washable Aluminum Metallic Filters
- Saturation Indicator
- Timer Function

Included accessories:

- Charcoal Filter



NK24M5070BS (60cm)

Key features

- Stylish Front Black Glass
- Touch Control
- High Suction Power (668m³/h)
- 2 LED Lighting
- 4 Speed Extraction Modes (3 Level x 1 Booster)
- Washable Aluminum Metallic Filters
- Saturation Indicator
- Timer Function

Included accessories:

- Charcoal Filter



NK36M5070BG (90cm)

Key features

- Black Stainless with Stylish Front Black Glass
- Touch Control
- High Suction Power (668m³/h)
- 2 LED Lighting
- 4 Speed Extraction Modes (3 Level x 1 Booster)
- Washable Aluminum Metallic Filters
- Saturation Indicator
- Timer Function

Included accessories:

- Charcoal Filter

Models

Perfect for almost any space, a Samsung Hood is designed to keep your kitchen cleaner and fresher. They quickly remove smoke and steam, as well as any lingering odors.



NK24M5070BG (60cm)

Key features

- Black Stainless with Stylish Front Black Glass
- Touch Control
- High Suction Power (668m³/h)
- 2 LED Lighting
- 4 Speed Extraction Modes (3 Level x 1 Booster)
- Washable Aluminum Metallic Filters
- Saturation Indicator
- Timer Function

Included accessories:

- Charcoal Filter



NK36M5070BM (90cm)

Key features

- Black Stainless with Stylish Front Black Glass
- Touch Control
- High Suction Power (668m³/h)
- 2 LED Lighting
- 4 Speed Extraction Modes (3 Level x 1 Booster)
- Washable Aluminum Metallic Filter
- Saturation Indicator
- Timer Function

Included accessories:

- Charcoal Filter



NK24M5070BM (60cm)

Key features

- Black Stainless with Stylish Front Black Glass
- Touch Control
- High Suction Power (668m³/h)
- 2 LED Lighting
- 4 Speed Extraction Modes (3 Level x 1 Booster)
- Washable Aluminum Metallic Filter
- Saturation Indicator
- Timer Function

Included accessories:

- Charcoal Filter



NK36M5070FS (90cm)

Key features

- Stainless Steel Glass Construction
- Touch Control
- High Suction Power (670m³/h)
- 2 LED Lighting
- 4 Speed Extraction Modes (3 Level x 1 Booster)
- Washable Aluminum Metallic Filters
- Saturation Indicator
- Timer Function

Included accessories:

- Charcoal Filter



NK24M5070FS (60cm)

Key features

- Stainless Steel Glass Construction
- Touch Control
- High Suction Power (670m³/h)
- 2 LED Lighting
- 4 Speed Extraction Modes (3 Level x 1 Booster)
- Washable Aluminum Metallic Filters
- Saturation Indicator
- Timer Function

Included accessories:

- Charcoal Filter



NK36M5070CS (90cm)

Key features

- Stainless Steel Glass Construction
- Touch Control
- High Suction Power (670m³/h)
- 2 LED Lighting
- 4 Speed Extraction Modes (3 Level x 1 Booster)
- Washable Aluminum Metallic Filters
- Saturation Indicator
- Timer Function

Included accessories:

- Charcoal Filter

Models

Perfect for almost any space, a Samsung Hood is designed to keep your kitchen cleaner and fresher. They quickly remove smoke and steam, as well as any lingering odors.



NK24M5070CS (60cm)

Key features

- Stainless Steel Glass Construction
- Touch Control
- High Suction Power (670m³/h)
- 2 LED Lighting
- 4 Speed Extraction Modes (3 Level x 1 Booster)
- Washable Aluminum Metallic Filters
- Saturation Indicator
- Timer Function

Included accessories:

- Charcoal Filter



NK36M5060SS (90cm)

Key features

- Stainless Steel
- Touch Control
- High Suction Power (668m³/h)
- 2 LED Lighting
- 4 Speed Extraction Modes (3 Level x 1 Booster)
- Washable Aluminum Metallic Filters
- Saturation Indicator
- Timer Function

Included accessories:

- Charcoal Filter



NK24M5060SS (60cm)

Key features

- Stainless Steel
- Touch Control
- High Suction Power (668m³/h)
- 2 LED Lighting
- 4 Speed Extraction Modes (3 Level x 1 Booster)
- Washable Aluminum Metallic Filters
- Saturation Indicator
- Timer Function

Included accessories:

- Charcoal Filter



NK36M3050PS (90cm)

Key features

- Stainless Steel
- Button Control
- 512m³/h Suction Power
- Bulb Lighting Lamp
- 3 Speed Extraction Modes
- Washable Aluminum Metallic Filters

Included accessories:

- Charcoal Filter



NK24M3050PS (60cm)

Key features

- Stainless Steel
- Button Control
- 512m³/h Suction Power
- Bulb Lighting Lamp
- 3 Speed Extraction Modes
- Washable Aluminum Metallic Filters

Included accessories:

- Charcoal Filter



NK36M1030IS (90cm)

Key features

- Stainless Steel
- Button Control
- 392m³/h Suction Power
- 2 Bulb Lighting Lamp
- 3 Speed Extraction Modes
- Washable Aluminum Metallic Filters

Included accessories:

- Charcoal Filter

Dishwasher

Life couldn't be easier or simpler than with a Samsung Dishwasher. Engineered with Samsung's advanced technology, it provides a never before seen cleaning and drying performance, as well as superior energy efficiency and low noise. And it also has a large, flexible capacity so you can simply do a halfload if there's not much to wash.







Waterwall™ Technology

The Samsung WaterWall™ dishwasher perfectly cleans all of your dishes from corner to corner even if they are heavily soiled. WaterWall™ technology creates a high pressure wall of water that glides back and forth, so there are no more missed dishes or leftover dirt.

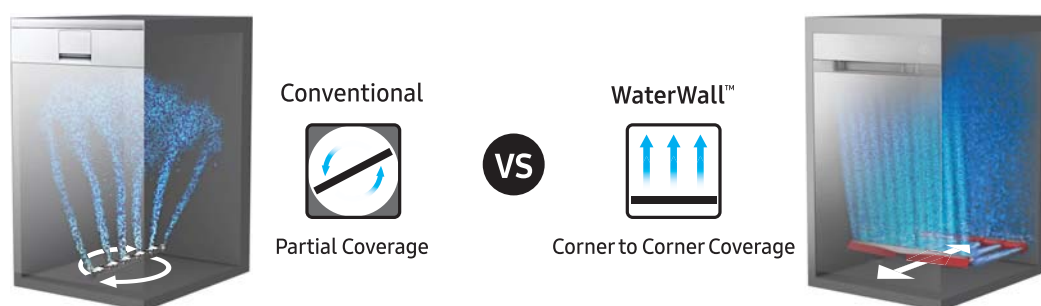

Unlike conventional circular water jets, the first-of-its-kind spray bar moves back and forth to create a sweeping wall of water, eliminating the need for time-consuming and water-wasting pre-rinse. It harnesses the power of high-pressure water to cover hard-to-reach places in the bottom rack.

Features

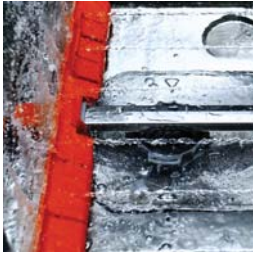

WaterWall™

WaterWall™ technology cleans every dish in every corner, without wasting time or water on pre-rinsing. It provides a revolutionary cleaning performance by creating a sweeping wall of high pressure water that covers the hard to reach places in the bottom rack, where you often put the dirtiest dish.

*The Products in the video may vary by region.



Zone Booster™

The Zone Booster™ area removes stubborn leftover food effectively. Unlike conventional dishwashers, it's the industry's widest targeted cleaning zone with 5 nozzles on the left, as well as 3 more on the right. So it gets rid of stuck-on remains and cleans really dirty dishes in a single wash.

*The Products in the video may vary by region.



Air Flow Drying with Auto Open

Enjoy sparkling clean dishes every time with the Air Flow Drying with Auto Open feature. At the end of a cycle the door automatically opens to allow steam to escape, giving you better drying results. A fan on the top also creates a protective curtain of air to ensure that your worktop isn't damaged.



Premium Design

Premium styling that fits seamlessly with your kitchen furniture to enhance your home with a harmonious and modern appearance. Its recessed handle gives the front a clean and flush appearance and, because there is no handle protruding out, it also makes it easier to move around the kitchen.



Daily 55™ Cycle

A 55" Daily Cycle saves you time by getting your dishes clean and dry much faster. It's ideal for smaller loads of lightly soiled items that don't need really intensive cleaning, such as cups and cutlery, as it will put them through a complete washing and drying cycle within just 55 minutes.



Easy Load Racking System

An Easy Load Racking System makes it easy to load and unload all sizes of dishes. The tines in the lower rack can fully folded down to make space for large items. And its newly designed wheels move more easily and comfortably. Its height adjustable upper rack can also be quickly raised up or down.

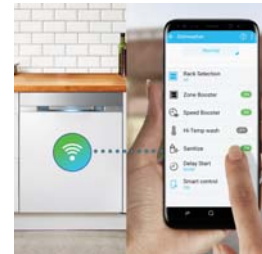

Wi-Fi Connectivity (Smart Control)

Wi-Fi Connectivity lets you remotely monitor and control what it's doing from anywhere at any time using an App* on your smartphone. You can monitor the progress of a cleaning cycle, remotely turn it on and off, select or adjust the cycles to use and receive diagnostics information wherever you are.

* 'Premium +' model only. App for iPhones & Android. Wi-Fi connection required.

Models

Fullsize Dishwasher (Fully Built-in)

If you like to keep things neat then the Fully Built-in Samsung Dishwasher is perfect for you. And despite its large capacity it's extremely quiet, so you might even forget it's there.



DW60M9550BB

Key features

- WaterWall™ Cleaning System
- Zone Booster™ Targeted Cleaning
- 55min Wash & Dry Cycle
- Air Flow Drying with Auto Open
- Easy Load Racking System
- 14 Place Settings
- Energy Class A+++
- Water Consumption:
Annual 2716L (9.7L / Cycle)
- 42dBA Noise Level
- 7 Programs : Intensive, Auto, Eco, Daily 55', Quick, Delicate, Self Clean



DW60M9530BB

Key features

- WaterWall™ Cleaning System
- Zone Booster™ Targeted Cleaning
- 55min Wash & Dry Cycle
- Easy Load Racking System
- 14 Place Settings
- Energy Class A++
- Water Consumption:
Annual 2716L (9.7L / Cycle)
- 44dBA Noise Level
- 6 Programs : Intensive, Auto, Eco, Daily 55', Quick, Delicate



DW60M6050BB

Key features

- Flexible 3rd Rack
- Easy Height Adjustment
- Hygiene Option
- 60min Express Wash
- Full Stainless Steel Tub
- 14 Place Settings
- Energy Class A++
- Water Consumption:
Annual 2940L (10.5L / Cycle)
- 44dBA Noise Level
- 7 Programs : Intensive, Auto, Express, Eco, Quick, Delicate, Pre-wash



DW60M6040BB

Key features

- Easy Height Adjustment
- Hygiene Option
- 60min Express Wash
- Full Stainless Steel Tub
- 13 Place Settings
- Energy Class A⁺⁺
- Water Consumption:
Annual 2940L (10.5L / Cycle)
- 44dBA Noise Level
- 6 Programs : Intensive, Auto, Express,
Eco, Delicate, Pre-wash

Models

Fullsize Dishwasher (Semi Built-in)

For the ultimate in integrated style and convenience you can't beat the Semi Built-in Samsung Dishwasher. Its eco- and user-friendly design will also save you time and energy.



DW60M9970SS

Key features

- WaterWall™ Cleaning System
- Zone Booster™ Targeted Cleaning
- 55min Wash & Dry Cycle
- Smart Wi-Fi Control
- Air Flow Drying with Auto Open
- Easy Load Racking System
- 14 Place Settings
- Energy Class A+++
- Water Consumption:
Annual 2716L (9.7L / Cycle)
- 41dBA Noise Level
- 7 Programs : Intensive, Auto, Eco, Daily 55', Quick, Delicate, Self Clean



DW60M9550SS

Key features

- WaterWall™ Cleaning System
- Zone Booster™ Targeted Cleaning
- 55min Wash & Dry Cycle
- Air Flow Drying with Auto Open
- Easy Load Racking System
- 14 Place Settings
- Energy Class A+++
- Water Consumption:
Annual 2716L (9.7L / Cycle)
- 42dBA Noise Level
- 7 Programs : Intensive, Auto, Eco, Daily 55', Quick, Delicate, Self Clean



DW60M6050SS

Key features

- Flexible 3rd Rack
- Easy Height Adjustment
- Hygiene Option
- 60min Express Wash
- Full Stainless Steel Tub
- 14 Place Settings
- Energy Class A++
- Water Consumption:
Annual 2940L (10.5L / Cycle)
- 44dBA Noise Level
- 7 Programs : Intensive, Auto, Express, Eco, Quick, Delicate, Pre-wash



DW60M6040SS

Key features

- Easy Height Adjustment
- Hygiene Option
- 60min Express Wash
- Full Stainless Steel Tub
- 13 Place Settings
- Energy Class A++
- Water Consumption:
Annual 2940L (10.5L / Cycle)
- 44dBA Noise Level
- 7 Programs : Intensive, Auto, Express,
Eco, Quick, Delicate, Pre-wash

Models

Fullsize Dishwasher (Built Under)

Add an extra touch of style with a Built Under Samsung Dishwasher. Its elegant, user-friendly design will complement any modern kitchen perfectly, while also delivering a brilliant cleaning performance.



DW60M9970US

Key features

- WaterWall™ Cleaning System
- Zone Booster™ Targeted Cleaning
- 55min Wash & Dry Cycle
- Smart Wi-Fi Control
- Air Flow Drying with Auto Open
- Easy Load Racking System
- 14 Place Settings
- Energy Class A+++
- Water Consumption:
Annual 2716L (9.7L / Cycle)
- 42dBA Noise Level
- 7 Programs : Intensive, Auto, Eco, Daily 55', Quick, Delicate, Self Clean



DW60M9550US

Key features

- WaterWall™ Cleaning System
- Zone Booster™ Targeted Cleaning
- 55min Wash & Dry Cycle
- Air Flow Drying with Auto Open
- Easy Load Racking System
- 14 Place Settings
- Energy Class A+++
- Water Consumption:
Annual 2716L (9.7L / Cycle)
- 42dBA Noise Level
- 7 Programs : Intensive, Auto, Eco, Daily 55', Quick, Delicate, Self Clean



DW60M6050US

Key features

- Flexible 3rd Rack
- Easy Height Adjustment
- Hygiene Option
- 60min Express Wash
- Full Stainless Steel Tub
- 14 Place Settings
- Energy Class A++
- Water Consumption:
Annual 2940L (10.5L / Cycle)
- 44dBA Noise Level
- 7 Programs : Intensive, Auto, Express, Eco, Quick, Delicate, Pre-wash



DW60M6050UW

Key features

- Flexible 3rd Rack
- Easy Height Adjustment
- Hygiene Option
- 60min Express Wash
- Full Stainless Steel Tub
- 14 Place Settings
- Energy Class A⁺⁺
- Water Consumption:
Annual 2940L (10.5L / cycle)
- 44dBA Noise Level
- 7 Programs : Intensive, Auto, Express, Eco, Quick, Delicate, Pre-wash



DW60M6051US

Key features

- Flexible 3rd Rack
- Easy Height Adjustment
- Hygiene Option
- 60min Express Wash
- Full Stainless Steel Tub
- 14 Place Settings
- Energy Class A⁺⁺
- Water Consumption:
Annual 2940L (10.5L / Cycle)
- 44dBA Noise Level
- 7 Programs : Intensive, Auto, Express, Eco, Quick, Delicate, Pre-wash



DW60M6051UW

Key features

- Flexible 3rd Rack
- Easy Height Adjustment
- Hygiene Option
- 60min Express Wash
- Full Stainless Steel Tub
- 14 Place Settings
- Energy Class A⁺⁺
- Water Consumption:
Annual 2940L (10.5L / cycle)
- 44dBA Noise Level
- 7 Programs : Intensive, Auto, Express, Eco, Quick, Delicate, Pre-wash

Models

Fullsize Dishwasher (Built Under)

Add an extra touch of style with a Built Under Samsung Dishwasher. Its elegant, user-friendly design will complement any modern kitchen perfectly, while also delivering a brilliant cleaning performance.



DW60M6040US

Key features

- Easy Height Adjustment
- Hygiene Option
- 60min Express Wash
- Full Stainless Steel Tub
- 13 Place Settings
- Energy Class A++
- Water Consumption:
Annual 2940L (10.5L / Cycle)
- 44dBA Noise Level
- 7 Programs : Intensive, Auto, Express, Eco, Quick, Delicate, Pre-wash



DW60M6040UW

Key features

- Easy Height Adjustment
- Hygiene Option
- 60min Express Wash
- Full Stainless Steel Tub
- 13 Place Settings
- Energy Class A++
- Water Consumption:
Annual 2940L (10.5L / Cycle)
- 44dBA Noise Level
- 7 Programs : Intensive, Auto, Express, Eco, Quick, Delicate, Pre-wash

Models

Fullsize Dishwasher (Freestanding)

Enjoy complete flexibility with a Freestanding Samsung Dishwasher. Its sleek, modern styling will enhance any space, while delivering a powerful and efficient washing performance.



DW60M9550FS

Key features

- WaterWall™ Cleaning System
- Zone Booster™ Targeted Cleaning
- 55min Wash & Dry Cycle
- Air Flow Drying with Auto Open
- Easy Load Racking System
- 14 Place Settings
- Energy Class A+++
- Water Consumption:
Annual 2716L (9.7L / Cycle)
- 42dBA Noise Level
- 7 Programs : Intensive, Auto, Eco,
Daily 55', Quick, Delicate, Self Clean



DW60M9550FW

Key features

- WaterWall™ Cleaning System
- Zone Booster™ Targeted Cleaning
- 55min Wash & Dry Cycle
- Air Flow Drying with Auto Open
- Easy Load Racking System
- 14 Place Settings
- Energy Class A+++
- Water Consumption:
Annual 2716L (9.7L / Cycle)
- 42dBA Noise Level
- 7 Programs : Intensive, Auto, Eco,
Daily 55', Quick, Delicate, Self Clean





Models

Refrigerator

Built-in Fridge Freezers



Model Code		BRB260189WW (BRB2G0189WW)	BRB260089WW	BRB260178WW (BRB2G0178WW)	BRB260187WW (BRB2G0187WW)
Energy Class		A+++	A+++	A+++	A++
Actual Capacity					
Total:		256L	256L	257L	263L
Refrigerator:		191L	191L	192L	191L
Freezer:		65L	65L	65L	72L
Volt/Amps		220-240V / 50Hz	220-240V / 50Hz	220-240V / 50Hz	220-240V / 50Hz
Physical Specifications					
Net Width	Width (label)	540 mm	540 mm	540 mm	540 mm
Net Height	W/ Hinge (label)	1,775 mm	1,775 mm	1,775 mm	1,775 mm
	W/O hinge (label)	1,775 mm	1,775 mm	1,775 mm	1,775 mm
Net Depth	W/ Handle	550 mm	550 mm	550 mm	550 mm
	W/O Handles (label)	550 mm	550 mm	550 mm	550 mm
Weight		69.5 kg	67.5 kg	68.5 kg	63 kg
Length of the Cable		2.5m	2.5m	2.5m	2.5m
Cooling Features					
Cooling Technology		Twin Cooling Plus™	Twin Cooling Plus™	Twin Cooling Plus™	Twin Cooling Plus™
Cool Select Plus		Yes	Yes	Yes	Yes
Precise Cooling (Fridge / Freezer / FleNoZone)		Yes / No / No	Yes / No / No	Yes / No / No	No / No / No
Noise		38dBA	38dBA	38dBA	38dBA
Temperature Control		Digital	Digital	Digital	Digital
Metal Cooling (Duct)		Yes	Yes	No	Yes
Refrigerant		R600a	R600a	R600a	R600a
Freezing Capacity		9.0kg	9.0kg	9.0kg	9.0kg
Autonomy Hour (Temp Rising)		18hr	18hr	18hr	14hr
Smart WiFi Dongle-Ready		Yes	Yes	Yes	Yes
Fridge Features					
Interior Color		White	White	White	White
Shelves	Quantity	4 EA	4 EA	4 EA	4 EA
	Deco	Yes	Yes	Yes	Yes
	Spill Proof	Yes	Yes	Yes	Yes
Take Out Tray		1 EA	1 EA	No	1 EA
Crispers	Quantity	1 EA	1 EA	1 EA	1 EA
	Deco	Premium Finishing	Premium Finishing	Premium Finishing	Premium Finishing
Fresh Zone	Quantity	1 EA	1 EA	1 EA	1 EA
	Deco	Premium Finishing	Premium Finishing	Premium Finishing	Premium Finishing
Door	Full Flushed Door	Fixed Hinge	Slide Hinge	Fixed Hinge	Fixed Hinge
	Reversible	Yes	Yes	Yes	Yes
	Door Alarm	Yes	Yes	Yes	Yes
Door Bins	TOTAL (ALL) Quantity	5 EA	5 EA	5 EA	5 EA
	Color	Transparent Blue	Transparent Blue	Transparent Blue	Transparent Blue
	Deco	Premium Finishing	Premium Finishing	Premium Finishing	Premium Finishing
Dairy Bin	Quantity	1 EA	1 EA	1 EA	1 EA
	Color	Transparent Blue	Transparent Blue	Transparent Blue	Transparent Blue
	Deco	Premium Finishing	Premium Finishing	Premium Finishing	Premium Finishing
Included Accessories	Wine Rack (Stainless Steel)	1 EA	1 EA	1 EA	1 EA
	Egg Container	1 EA	1 EA	1 EA	1 EA
LED Lighting		Upper1EA - Pillar LED	Upper1EA - Pillar LED	Upper1EA - Pillar LED	Upper1EA - Pillar LED
Freezer Features					
Easy Open Handle™		No	No	No	No
Handle Type		No	No	No	No
Drawer	Quantity	2 EA	2 EA	2 EA	2 EA
	Soft Closing	No	No	No	No
Shelves	Quantity	1 EA	1 EA	1 EA	1 EA
	Easy Slide	Yes	Yes	Yes	Yes
Cool Select Plus (Freezer)					
Cool Select Plus		Yes	Yes	Yes	Yes
Temperature zone		Fridge (41°F / 2°C)	Fridge (41°F / 2°C)	Fridge (41°F / 2°C)	Fridge (41°F / 2°C)
		Chilled (30°F / -1°C)	Chilled (30°F / -1°C)	Chilled (30°F / -1°C)	Chilled (30°F / -1°C)
		Soft Freezing (23°F / -5°C)	Soft Freezing (23°F / -5°C)	Soft Freezing (23°F / -5°C)	Soft Freezing (23°F / -5°C)
		Frozen (-9~-1°F / -23~-15°C)	Frozen (-9~-1°F / -23~-15°C)	Frozen (-9~-1°F / -23~-15°C)	Frozen (-9~-1°F / -23~-15°C)

Models

Refrigerator

Built-in Fridge Freezers



Model Code	BRB260087WW	BRB260176WW (BRB2G0176WW)	BRB260076WW	BRB260135WW (BRB2G0135WW)
Energy Class	A ⁺⁺	A ⁺⁺	A ⁺⁺	A ⁺⁺
Actual Capacity				
Total:	263L	264L	264L	266L
Refrigerator:	191L	192L	192L	194L
Freezer:	72L	72L	72L	72L
Volt/Amps	220-240V / 50Hz	220-240V / 50Hz	220-240V / 50Hz	220-240V / 50Hz
Physical Specifications				
Net Width	Width (label)	540 mm	540 mm	540 mm
Net Height	W/ Hinge (label)	1,775 mm	1,775 mm	1,775 mm
	W/O Hinge (label)	1,775 mm	1,775 mm	1,775 mm
Net Depth	W/ Handle	550 mm	550 mm	550 mm
	W/O Handles (label)	550 mm	550 mm	550 mm
Weight		62 kg	62 kg	59 kg
Length of the Cable		2.5m	2.5m	2.5m
Cooling Features				
Cooling Technology	Twin Cooling Plus™	Twin Cooling Plus™	Twin Cooling Plus™	All Around Cooling
Cool Select Plus	Yes	Yes	Yes	No
Precise Cooling (Fridge / Freezer / FleNoZone)	No / No / No	No / No / No	No / No / No	No / No / No
Noise	38dBA	38dBA	38dBA	38dBA
Temperature Control	Digital	Digital	Digital	Digital
Metal Cooling (Duct)	Yes	No	No	Yes
Refrigerant	R600a	R600a	R600a	R600a
Freezing Capacity	9.0kg	9.0kg	9.0kg	9.0kg
Autonomy Hour (Temp Rising)	14hr	14hr	14hr	14hr
Smart	WiFi Dongle-Ready	Yes	Yes	N/A
Fridge Features				
Interior Color	White	White	White	White
Shelves	Quantity	4 EA	4 EA	4 EA
	Deco	Yes	Yes	Yes
	Spill Proof	Yes	Yes	Yes
Take Out Tray	Quantity	1 EA	No	No
Crispers	Quantity	1 EA	1 EA	2 EA
	Deco	Premium Finishing	Premium Finishing	Premium Finishing
Fresh Zone	Quantity	1 EA	1 EA	No
	Deco	Premium Finishing	Premium Finishing	Premium Finishing
Door	Full Flushed Door	Slide Hinge	Fixed Hinge	Fixed Hinge
	Reversible	Yes	Yes	Yes
	Door Alarm	Yes	Yes	Yes
Door Bins	TOTAL (ALL) Quantity	5 EA	5 EA	5 EA
	Color	Transparent Blue	Transparent Blue	Transparent Blue
	Deco	Premium Finishing	Premium Finishing	Premium Finishing
Dairy Bin	Quantity	1 EA	1 EA	1 EA
	Color	Transparent Blue	Transparent Blue	Transparent Blue
	Deco	Premium Finishing	Premium Finishing	Premium Finishing
Included Accessories	Wine Rack (Stainless Steel)	1 EA	1 EA	1 EA
	Egg Container	1 EA	1 EA	1 EA
LED Lighting		Upper1EA - Pillar LED	Upper1EA - Pillar LED	Upper1EA - Pillar LED
Freezer Features				
Easy Open Handle™		No	No	No
Handle Type		No	No	No
Drawer	Quantity	2 EA	2 EA	2 EA
	Soft Closing	No	No	No
Shelves	Quantity	1 EA	1 EA	1 EA
	Easy Slide	Yes	Yes	Yes
Cool Select Plus (Freezer)				
Cool Select Plus		Yes	Yes	No
	Temperature Zone	Fridge (41°F / 2°C)	Fridge (41°F / 2°C)	Fridge (41°F / 2°C)
		Chilled (30°F / -1°C)	Chilled (30°F / -1°C)	Chilled (30°F / -1°C)
		Soft Freezing (23°F / -5°C)	Soft Freezing (23°F / -5°C)	Soft Freezing (23°F / -5°C)
		Frozen (-9~-1°F / -23~-15°C)	Frozen (-9~-1°F / -23~-15°C)	Frozen (-9~-1°F / -23~-15°C)

Models

Refrigerator

Built-in Fridge Freezers



Model Code		BRB260035WW	BRB260134WW (BRB2G0134WW)	BRB260034WW	BRB260131WW (BRB2G0131WW)
Energy Class		A ⁺⁺	A ⁺⁺	A ⁺⁺	A ⁺
Actual Capacity					
Total:		266L	267L	267L	266L
Refrigerator:		194L	195L	195L	194L
Freezer:		72L	72L	72L	72L
Volt/Amps		220-240V / 50Hz	220-240V / 50Hz	220-240V / 50Hz	220-240V / 50Hz
Physical Specifications					
Net Width	Width (label)	540 mm	540 mm	540 mm	540 mm
Net Height	W/ Hinge (label)	1,775 mm	1,775 mm	1,775 mm	1,775 mm
	W/O Hinge (label)	1,775 mm	1,775 mm	1,775 mm	1,775 mm
Net Depth	W/ Handle	550 mm	550 mm	550 mm	550 mm
	W/O Handles (label)	550 mm	550 mm	550 mm	550 mm
Weight		58.5 kg	58.5 kg	58 kg	60.5 kg
Length of the Cable		2.5m	2.5m	2.5m	2.5m
Cooling Features					
Cooling Technology		All Around Cooling	All Around Cooling	All Around Cooling	All Around Cooling
Cool Select Plus		No	No	No	No
Precise Cooling	(Fridge / Freezer / FleNoZone)	No / No / No	No / No / No	No / No / No	No / No / No
Noise		38dBA	38dBA	38dBA	37dBA
Temperature Control		Digital	Digital	Digital	Digital
Metal Cooling (Duct)		Yes	No	No	Yes
Refrigerant		R600a	R600a	R600a	R600a
Freezing Capacity		9.0kg	9.0kg	9.0kg	9.0kg
Autonomy Hour (Temp Rising)		14hr	14hr	14hr	14hr
Smart	WiFi Dongle-Ready	N/A	N/A	N/A	N/A
Fridge Features					
Interior Color		White	White	White	White
Shelves	Quantity	4 EA	4 EA	4 EA	4 EA
	Deco	Yes	Yes	Yes	Yes
	Spill Proof	Yes	Yes	Yes	Yes
Take Out Tray		No	No	No	No
Crispers	Quantity	2 EA	2 EA	2 EA	2 EA
	Deco	Premium Finishing	Premium Finishing	Premium Finishing	Premium Finishing
Fresh Zone	Quantity	No	No	No	No
	Deco	Premium Finishing	Premium Finishing	Premium Finishing	Premium Finishing
Door	Full Flushed Door	Slide Hinge	Fixed Hinge	Slide Hinge	Fixed Hinge
	Reversible	Yes	Yes	Yes	Yes
	Door Alarm	Yes	Yes	Yes	Yes
Door Bins	TOTAL (ALL) Quantity	5 EA	5 EA	5 EA	5 EA
	Color	Transparent Blue	Transparent Blue	Transparent Blue	Transparent Blue
Dairy Bin	Deco	Premium Finishing	Premium Finishing	Premium Finishing	Premium Finishing
	Quantity	1 EA	1 EA	1 EA	1 EA
	Color	Transparent Blue	Transparent Blue	Transparent Blue	Transparent Blue
Included Accessories	Deco	Premium Finishing	Premium Finishing	Premium Finishing	Premium Finishing
	Wine Rack (Stainless Steel)	1 EA	1 EA	1 EA	1 EA
LED Lighting	Egg Container	1 EA	1 EA	1 EA	1 EA
		Upper1EA - Pillar LED	Upper1EA - Pillar LED	Upper1EA - Pillar LED	Upper1EA - Pillar LED
Freezer Features					
Easy Open Handle™		No	No	No	No
Handle Type		No	No	No	No
Drawer	Quantity	2 EA	2 EA	2 EA	2 EA
	Soft Closing	No	No	No	No
Shelves	Quantity	1 EA	1 EA	1 EA	1 EA
	Easy Slide	Yes	Yes	Yes	Yes
Cool Select Plus (Freezer)					
Cool Select Plus		No	No	No	No
Temperature Zone		No	No	No	No
		No	No	No	No
		No	No	No	No
		No	No	No	No

Models

Refrigerator

Built-in Fridge Freezers



Model Code		BRB260031WW	BRB260130WW (BRB2G0130WW)	BRB260030WW
Energy Class		A ⁺	A ⁺	A ⁺
Actual Capacity				
Total:		266L	267L	267L
Refrigerator:		194L	195L	195L
Freezer:		72L	72L	72L
Volt/Amps		220-240V / 50Hz	220-240V / 50Hz	220-240V / 50Hz
Physical Specifications				
Net Width	Width (label)	540 mm	540 mm	540 mm
Net Height	W/ Hinge (label)	1,775 mm	1,775 mm	1,775 mm
	W/O Hinge (label)	1,775 mm	1,775 mm	1,775 mm
Net Depth	W/ Handle	550 mm	550 mm	550 mm
	W/O Handles (label)	550 mm	550 mm	550 mm
Weight		60 kg	60.5 kg	59.5 kg
Length of the Cable		2.5m	2.5m	2.5m
Cooling Features				
Cooling Technology		All Around Cooling	All Around Cooling	All Around Cooling
Cool Select Plus		No	No	No
Precise Cooling	(Fridge / Freezer / FleNoZone)	No / No / No	No / No / No	No / No / No
Noise		37dBA	37dBA	37dBA
Temperature Control		Digital	Digital	Digital
Metal Cooling (Duct)		Yes	No	No
Refrigerant		R600a	R600a	R600a
Freezing Capacity		9.0kg	9.0kg	9.0kg
Autonomy Hour (Temp Rising)		14hr	14hr	14hr
Smart	WiFi Dongle-Ready	N/A	N/A	N/A
Fridge Features				
Interior Color		White	White	White
Shelves	Quantity	4 EA	4 EA	4 EA
	Deco	Yes	Yes	Yes
	Spill Proof	Yes	Yes	Yes
Take Out Tray		No	No	No
Crispers	Quantity	2 EA	2 EA	2 EA
	Deco	Premium Finishing	Premium Finishing	Premium Finishing
Fresh Zone	Quantity	No	No	No
	Deco	Premium Finishing	Premium Finishing	Premium Finishing
Door	Full Flushed Door	Slide Hinge	Fixed Hinge	Slide Hinge
	Reversible	Yes	Yes	Yes
	Door Alarm	Yes	Yes	Yes
Door Bins	TOTAL (ALL) Quantity	5 EA	5 EA	5 EA
	Color	Transparent Blue	Transparent Blue	Transparent Blue
	Deco	Premium Finishing	Premium Finishing	Premium Finishing
Dairy Bin	Quantity	1 EA	1 EA	1 EA
	Color	Transparent Blue	Transparent Blue	Transparent Blue
	Deco	Premium Finishing	Premium Finishing	Premium Finishing
Included Accessories	Wine Rack (Stainless Steel)	1 EA	1 EA	1 EA
	Egg Container	1 EA	1 EA	1 EA
LED Lighting		Upper1EA - Pillar LED	Upper1EA - Pillar LED	Upper1EA - Pillar LED
Freezer Features				
Easy Open Handle™		No	No	No
Handle Type		No	No	No
Drawer	Quantity	2 EA	2 EA	2 EA
	Soft Closing	No	No	No
Shelves	Quantity	1 EA	1 EA	1 EA
	Easy Slide	Yes	Yes	Yes
Cool Select Plus (Freezer)				
Cool Select Plus		No	No	No
	Temperature Zone	No	No	No
		No	No	No
		No	No	No
		No	No	No

Models

Refrigerator

Built-in Fridge Freezers



Model Code		BRB260010WW	BRB260000WW
Energy Class		A+	A+
Actual Capacity			
Total:		268L	268L
Refrigerator:		196L	196L
Freezer:		72L	72L
Volt/Amps		220-240V / 50Hz	220-240V / 50Hz
Physical Specifications			
Net Width	Width (label)	540 mm	540 mm
Net Height	W/ Hinge (label)	1,775 mm	1,775 mm
	W/O Hinge (label)	1,775 mm	1,775 mm
Net Depth	W/ Handle	550 mm	550 mm
	W/O Handles (label)	550 mm	550 mm
Weight		57 kg	57 kg
Length of the Cable		2.5m	2.5m
Cooling Features			
Cooling Technology		All Around Cooling	All Around Cooling
Cool Select Plus		No	No
Precise Cooling	(Fridge / Freezer / FleNoZone)	No / No / No	No / No / No
Noise		37dBA	37dBA
Temperature Control		Digital	Digital
Metal Cooling (Duct)		No	No
Refrigerant		R600a	R600a
Freezing Capacity		9.0kg	9.0kg
Autonomy Hour (Temp Rising)		14hr	14hr
Smart	WiFi Dongle-Ready	N/A	N/A
Fridge Features			
Interior Color		White	White
Shelves	Quantity	4 EA	3 EA
	Deco	No	No
	Spill Proof	Yes	Yes
Take Out Tray		No	No
Crispers	Quantity	1 EA	1 EA
	Deco	No	No
Fresh Zone	Quantity	No	No
	Deco	No	No
Door	Full Flushed Door	Slide Hinge	Slide Hinge
	Reversible	Yes	Yes
	Door Alarm	Yes	Yes
Door Bins	TOTAL (ALL) Quantity	5 EA	4 EA
	Color	Transparent Blue	Transparent Blue
	Deco	No	No
Dairy Bin	Quantity	1 EA	1 EA
	Color	Transparent Blue	Transparent Blue
	Deco	No	No
Included Accessories	Wine Rack (Stainless Steel)	No	No
	Egg Container	1 EA	1 EA
LED Lighting		Upper 1EA - Pillar LED	Upper 1EA - Pillar LED
Freezer Features			
Easy Open Handle™		No	No
Handle Type		No	No
Drawer	Quantity	2 EA	2 EA
	Soft Closing	No	No
Shelves	Quantity	1 EA	1 EA
	Easy Slide	Yes	Yes
Cool Select Plus (Freezer)			
Cool Select Plus		No	No
Temperature Zone		No	No
		No	No
		No	No

Models

Refrigerator

Built-in Fridge with freezer compartment



147

Model Code	BRR19M011WW	BRR19M010WW	BRR12M001WW	BRR12M000WW
Capacity				
Net Total (Liter)	183L	183L	115L	115L
Gross Total (Liter)	184L	184L	116L	116L
Gross for Freezer (Liter)	14L	14L	14L	14L
Gross for Fridge (Liter)	170L	170L	102L	102L
Net for Freezer (Liter)	14L	14L	14L	14L
Net for Fridge (Liter)	169L	169L	101L	101L
Physical Specifications				
Net Width	540 mm	540 mm	540 mm	540 mm
Net Case Height with Top Decorative Plate Edge	1227 mm	1227 mm	882 mm	882 mm
Net Case Height with Top Decorative Plate	1218 mm	1218 mm	876 mm	876 mm
Net Case Height without Top Decorative Plate	1215 mm	1215 mm	871 mm	871 mm
Net Depth without Door Handle	540 mm	540 mm	534 mm	534 mm
Net Depth without Door	500.5 mm	500.5 mm	493 mm	493 mm
Packing Dimension (W x H x D)	575 x 1293 x 565 mm	575 x 1293 x 565mm	570 x 974 x 560 mm	570 x 974 x 560 mm
Net Weight	40 kg	40 kg	32 kg	32 kg
Packing Weight	44 kg	44 kg	34.5 kg	34.5 kg
20 / 40 / 40H (Container)	56 / 120 / 166 / NA	56 / 120 / 166 / NA	80 / 168 / 216 / NA	80 / 168 / 216 / NA
Cooling Features				
Cooling Type	Direct Cooling	Direct Cooling	Direct Cooling	Direct Cooling
No Frost	No	No	No	No
Multi Flow	No	No	No	No
Refrigerator Feature				
Number of Shelf (Total)	3 EA	3 EA	1 EA	1 EA
Wine Rack	Yes	Yes	Yes	Yes
Number of Door Pocket	3 EA	3 EA	3 EA	3 EA
Egg Container (Egg Tray)	Yes	Yes	Yes	Yes
Interior LED Light	LED	LED	LED	LED
Hot Stamping	Yes	Yes	No	No
Shelf Material	Tempered Glass	Tempered Glass	Tempered Glass	Tempered Glass
Number of Vegetable & Fruit Drawer	1 EA	1 EA	1 EA	1 EA
General Feature				
Door Reversible	Yes	Yes	Yes	Yes
Door Alarm	Yes	Yes	No	No
Refrigerant	R600a	R600a	R600a	R600a
Autonomy Hour (Temp Rising)	12h	12h	12h	12h
Compressor	AC	AC	AC	AC
Exterior Feature				
Dispenser with Water Filter	No	No	No	No
Display & Control (Fridge and Freezer)	Button	Button	Dial	Dial
Door Handle	Recess	Recess	Recess	Recess
Color	White	White	White	White
Performance				
Energy Efficiency Class	A ⁺⁺	A ⁺	A ⁺⁺	A ⁺
Noise Level	41dBA	41dBA	41dBA	41dBA
Climate Class	N,ST	N,ST	N,ST	N,ST
Freezing Capacity (Kg / 24h)	2 kg / 24h	2 kg / 24h	2 kg / 24h	2 kg / 24h
Energy Consumption	166kWh / year	198kWh / year	129kWh / year	159kWh / year
Installation				
Built-In	Yes	Yes	Yes	Yes
Door Hinge Type	Slide Hinge	Slide Hinge	Slide Hinge	Slide Hinge
Cabinet Dimensions				
Min. Width	560 mm	560 mm	560 mm	560 mm
Recomm. Width	562 mm	562 mm	562 mm	562 mm
Min. Height	1221 mm	1221 mm	879 mm	879 mm
Recomm. Height	1223 mm	1223 mm	881 mm	881 mm
Max. Height	1227 mm	1227 mm	884 mm	884 mm
Min. Depth	550 mm	550 mm	550 mm	550 mm
Recomm. Depth	570 mm	570 mm	570 mm	570 mm

Models

Refrigerator

Kitchen Fit™ Fridge Freezers



Model Code		RB36J8897S4	RB36J8799S4 (RL36J8799S4)	RB33J8797S4	RB33J8835SR
Energy Class		A ⁺⁺	A ⁺⁺⁺	A ⁺⁺	A ⁺⁺
Capacity					
Total		350	350	328	335
Refrigerator		240	240	218	225
Freezer		110	110	110	110
Physical Specifications					
Net Width		595	595	595	595
Net Case Height with Hinge		2017	2017	1927	1927
Net Case Height without Hinge		2017	2017	1927	1927
Net Depth with Door Handle (Recess)		590	590	590	590
Net Depth without Door Handle (Recess)		590	590	590	590
Net Depth without Door		535	535	535	535
Length of the Cable		2.5m	2.5m	2.5m	2.5m
Cooling Features					
No Frost		Yes	Yes	Yes	Yes
Cooling Technology		Twin Cooling Plus™	Twin Cooling Plus™	Twin Cooling Plus™	All Around Cooling
Exterior Features					
Dispenser		No	No	No	No
Display & Control (Ice Blue)		ENoternal	Internal	Internal	ENoternal
Handle Type		Recess	Recess	Recess	Recess
Handle Lighting		Yes	Yes	Yes	Yes
Color		Art Hairline (Stainless Steel)	Art Hairline (Stainless Steel)	Art Hairline (Stainless Steel)	Stainless Steel
Fridge Features					
Drawer	Chef Zone™ (Telescopic Rail)	Yes	Yes	Yes	No
	Chef Zone™	No	No	No	No
	Fresh Zone	No	No	No	1 EA
	Veg Box	1 EA	1 EA	1 EA	1 EA
	Hot Stamping	Yes	Yes	Yes	Yes
Number of Shelf	Total	3 EA	3 EA	3 EA	3 EA
(Including Drawer Cover)	Hot Stamping	Yes	Yes	Yes	Yes
	Bottle Rack (Stainless Steel)	1 EA	1 EA	1 EA	1 EA
	Chef Pan (Stainless Steel) + Cover	Yes	Yes	Yes	No
	Slide & Fold Shelf	No	No	No	No
Door Guard	Dairy Guard	1 EA	1 EA	1 EA	1 EA
	Guard Variety	4 EA	4 EA	4 EA	4 EA
	Bottle Guard	1 EA	1 EA	1 EA	1 EA
	Hot Stamping	Yes	Yes	Yes	Yes
	Water Tank	No	No	No	No
	Egg Container	1 EA (10 Eggs)	1 EA (10 Eggs)	1 EA (10 Eggs)	1 EA (10 Eggs)
	Metal Plate (Twin Cooling Plus Print)	Yes	Yes	Yes	No
Power Cool		Yes	Yes	Yes	Yes
LED Lighting		Top	Top	Top	Top
Freezer Features					
Ice Maker (Tray + Support Tray Ice)		Tray + Ice Cube	Tray + Ice Cube	Tray + Ice Cube	Tray + Ice Cube
Number of Shelf (Glass)		1 EA	1 EA	1 EA	1 EA
Drawer		3 EA	3 EA	3 EA	3 EA
Hot Stamping		Yes	Yes	Yes	Yes
Freeze Star Rating		4 Star	4 Star	4 Star	4 Star
Power Freeze		Yes	Yes	Yes	Yes
Others					
Construction		Freestanding	Freestanding	Freestanding	Freestanding
Kitchen Fit™		Yes	Yes	Yes	Yes
Door Reversible		Yes	Yes	Yes	Yes
Door Alarm		Yes	Yes	Yes	Yes

Models

Refrigerator

Kitchen Fit™ Fridge Freezers



Model Code	RB36J8797S4	RB36J8855S4	RB36J8035SR	RB36J8035WW
Energy Class	A ⁺⁺	A ⁺⁺	A ⁺⁺	A ⁺⁺
Capacity				
Total	350	357	357	357
Refrigerator	240	247	247	247
Freezer	110	110	110	110
Physical Specifications				
Net Width	595	595	595	595
Net Case Height with Hinge	2017	2017	2017	2017
Net Case Height without Hinge	2017	2017	2017	2017
Net Depth with Door Handle (Recess)	590	590	590	590
Net Depth without Door Handle (Recess)	590	590	590	590
Net Depth without Door	535	535	535	535
Length of the Cable	2.5m	2.5m	2.5m	2.5m
Cooling Features				
No Frost	Yes	Yes	Yes	Yes
Cooling Technology	Twin Cooling Plus™	All Around Cooling	All Around Cooling	All Around Cooling
Exterior Features				
Dispenser	No	No	No	No
Display & Control (Ice Blue)	Internal	External	Internal	Internal
Handle Type	Recess	Recess	Recess	Recess
Handle Lighting	Yes	Yes	No	No
Color	Art Hairline (Stainless Steel)	Art Hairline (Stainless Steel)	Stainless Steel	White
Fridge Features				
Drawer	Chef Zone™ (Telescopic Rail)	Yes	No	No
	Chef Zone™	No	No	No
	Fresh Zone	No	1 EA	1 EA
	Veg Box	1 EA	1 EA	1 EA
	Hot Stamping	Yes	Yes	Yes
Number of Shelf (Including Drawer Cover)	Total	3 EA	3 EA	3 EA
	Hot Stamping	Yes	Yes	Yes
	Bottle Rack (Stainless Steel)	1 EA	1 EA	1 EA
	Chef Pan (Stainless Steel) + Cover	Yes	No	No
	Slide & Fold Shelf	No	1 EA	No
Door Guard	Dairy Guard	1 EA	1 EA	1 EA
	Guard Variety	4 EA	4 EA	4 EA
	Bottle Guard	1 EA	1 EA	1 EA
	Hot Stamping	Yes	Yes	Yes
	Water Tank	No	No	No
	Egg Container	1 EA (10 Eggs)	1 EA (10 Eggs)	1 EA (10 Eggs)
	Metal Plate (Twin Cooling Plus Print)	Yes	No	No
	Power Cool	Yes	Yes	Yes
	LED Lighting	Top	Top	Top
Freezer Features				
	Ice Maker (Tray + Support Tray Ice)	Tray + Ice Cube	Tray + Ice Cube	Tray + Ice Cube
	Number of Shelf (Glass)	1 EA	1 EA	1 EA
	Drawer	3 EA	3 EA	3 EA
	Hot Stamping	Yes	Yes	Yes
	Freeze Star Rating	4 Star	4 Star	4 Star
	Power Freeze	Yes	Yes	Yes
Others				
	Construction	Freestanding	Freestanding	Freestanding
	Kitchen Fit™	Yes	Yes	Yes
	Door Reversible	Yes	Yes	Yes
	Door Alarm	Yes	Yes	Yes

Models

Refrigerator

Kitchen Fit™ Fridge Freezers



Model Code	RB33J8035SR	RB36J8215SR
Energy Class	A++	A++
Capacity		
Total	335	357
Refrigerator	225	247
Freezer	110	110
Physical Specifications		
Net Width	595	595
Net Case Height with Hinge	1927	2017
Net Case Height without Hinge	1927	2017
Net Depth with Door Handle (Recess)	590	590
Net Depth without Door Handle (Recess)	590	590
Net Depth without Door	535	535
Length of the Cable	2.5m	2.5m
Cooling Features		
No Frost	Yes	Yes
Cooling Technology	All Around Cooling	All Around Cooling
Exterior Features		
Dispenser	No	No
Display & Control (Ice Blue)	Internal	External
Handle Type	Recess	Recess
Handle Lighting	No	No
Color	Stainless Steel	Stainless Steel
Fridge Features		
Drawer	Chef Zone™ (Telescopic Rail)	No
	Chef Zone™	No
	Fresh Zone	1 EA
	Veg Box	1 EA
	Hot Stamping	Yes
Number of Shelf	Total	3 EA
(Including Drawer Cover)	Hot Stamping	Yes
	Bottle Rack (Stainless Steel)	1 EA
	Chef Pan (Stainless Steel) + Cover	No
	Slide & Fold Shelf	No
Door Guard	Dairy Guard	1 EA
	Guard Variety	4 EA
	Bottle Guard	1 EA
	Hot Stamping	Yes
	Water Tank	No
	Egg Container	1 EA (10 Eggs)
	Metal Plate (Twin Cooling Plus Print)	No
	Power Cool	Yes
	LED Lighting	Top
Freezer Features		
	Ice Maker (Tray + Support Tray Ice)	Tray + Ice Cube
	Number of Shelf (Glass)	1 EA
	Drawer	3 EA
	Hot Stamping	Yes
	Freeze Star Rating	4 Star
	Power Freeze	Yes
Others		
	Construction	Freestanding
	Kitchen Fit™	Yes
	Door Reversible	Yes
	Door Alarm	Yes

Models

Refrigerator

Kitchen Fit™ Fridge Freezers



Model Code	RB33J8705S4	RL33J8039SR
Energy Class	A ⁺⁺	A ⁺⁺⁺
Capacity		
Total	335	332
Refrigerator	225	222
Freezer	110	110
Physical Specifications		
Net Width	595	595
Net Case Height with Hinge	1927	1927
Net Case Height without Hinge	1927	1927
Net Depth with Door Handle (Recess)	590	590
Net Depth without Door Handle (Recess)	590	590
Net Depth without Door	535	535
Length of the Cable	2.5m	2.5m
Cooling Features		
No Frost	Yes	Yes
Cooling Technology	All Around Cooling	Twin Cooling Plus™
Exterior Features		
Dispenser	No	No
Display & Control (Ice Blue)	Internal	Internal
Handle Type	Recess	Recess
Handle Lighting	Lighting	No
Color	Art Hairline (Stainless Steel)	Stainless Steel
Fridge Features		
Drawer	Chef Zone™ (Telescopic Rail)	No
	Chef Zone™	No
	Fresh Zone	1 EA
	Veg Box	1 EA
	Hot Stamping	No
Number of Shelf	Total	3 EA
(Including Drawer Cover)	Hot Stamping	No
	Bottle Rack (Stainless Steel)	No
	Chef Pan (Stainless Steel) + Cover	No
	Slide & Fold Shelf	No
Door Guard	Dairy Guard	1 EA
	Guard Variety	4 EA
	Bottle Guard	1 EA
	Hot Stamping	No
	Water Tank	No
	Egg Container	1 EA (10 Eggs)
	Metal Plate (Twin Cooling Plus Print)	No
	Power Cool	Yes
	LED Lighting	Top
Freezer Features		
Ice Maker (Tray + Support Tray Ice)	Tray + Ice Cube	Tray + Ice Cube
Number of Shelf (Glass)	1 EA	1 EA
Drawer	3 EA	3 EA
Hot Stamping	No	Yes
Freeze Star Rating	4 Star	4 Star
Power Freeze	Yes	Yes
Others		
Construction	Freestanding	Freestanding
Kitchen Fit™	Yes	Yes
Door Reversible	Yes	Yes
Door Alarm	Yes	Yes

Models

Dual Cook Flex



Model Code		NV75N7678RS	NV75N7677RS	NV75N7647RS	NV75N5672RS
Project Name		NV7000N	NV7000N	NV7000N	NV7000N
Oven Features					
Energy Class	Single Mode	A+	A+	A+	A+
	Dual Cook Mode (Upper / Lower)	A / A	A / A	A / A	A / A
Cavity Wall		Flat / Side Racks	Flat / Side Racks	Flat / Side Racks	Flat / Side Racks
Oven Colors		Stainless Steel	Stainless Steel	Stainless Steel	Stainless Steel
Door	Glass panes	Quadruple	Quadruple	Double	Quadruple
	Opening	Drop Down	Drop Down	Drop Down	Drop Down
	Soft Closing Door	No	No	No	No
Interior Lamp (W)		25W / 40W (Halogen)	25W / 40W (Halogen)	25W / 40W (Halogen)	25W / 40W (Halogen)
Interior Lights (Position)		Top / Side	Top / Side	Top / Side	Top / Side
Control	Control Panel Height	85mm	85mm	85mm	85mm
	Display	LED / Ice Blue	LED / Ice Blue	LED / Ice Blue	LED / Ice Blue
Cleaning Method	Control Method	Pop-up Dial (with Touch Buttons)	Pop-up Dial (with Touch Buttons)	Pop-up Dial (with Touch Buttons)	Pop-up Dial (with Touch Buttons)
	Wi-Fi	Yes	Yes	Yes	No
	Pyrolytic	Pyrolytic	Pyrolytic	No	Pyrolytic
Cleaning Method	Catalytic	No	No	Yes (Back Wall)	No
	Steam	Steam Cleaning	Steam Cleaning	Steam Cleaning	Steam Cleaning
	Grill Heater	Fixed	Fixed	Swing	Fixed
Electric Features					
Temp Ranges	Single Convection	30~275°C	30~275°C	30~275°C	30~250°C
	Single Grill	100~300°C	100~300°C	100~300°C	100~270°C
	Upper or Lower	40~250°C	40~250°C	40~250°C	40~250°C
	Twin	40~250°C	40~250°C	40~250°C	40~250°C
Upper Grill (Small / Large)		1600W / 1100W	1600W / 1100W	1600W / 1100W	1600W / 1100W
Bottom Heater		1100W	1100W	1100W	1100W
Convection (Upper / Lower)		1200W / 1200W	1200W / 1200W	1200W / 1200W	1200W / 1200W
Input Power		3650~3950W	3650~3950W	3650~3950W	3650~3950W
Over Voltage Protection		Yes	Yes	Yes	Yes
Cooking Modes					
Single Mode	Oven Modes				
	Conventional	30~275°C	30~275°C	30~275°C	30~250°C
	Convection	30~275°C	30~275°C	30~275°C	30~250°C
	Eco Convection	30~275°C	30~275°C	30~275°C	30~250°C
	Large Grill	100~300°C	100~300°C	100~300°C	100~270°C
	Eco Grill	100~300°C	100~300°C	100~300°C	100~270°C
	Fan Grill	No	No	No	No
	Bottom Heat + Convection	40~275°C	40~275°C	40~275°C	40~250°C
	Top Heat + Convection	40~275°C	40~275°C	40~275°C	40~250°C
	Bottom Heat	100~230°C	100~230°C	100~230°C	100~230°C
	Intensive Cook	No	No	No	No
	Pro-roasting	80~200°C	80~200°C	80~200°C	80~200°C
	Special Function				
	Fast Preheat	Yes	Yes	Yes	Yes
	Keep Warm	40~100°C	40~100°C	40~100°C	40~100°C
	Plate Warm	30~80°C	30~80°C	30~80°C	30~80°C
	Defrost	No	No	No	No
	Prove Dough	No	No	No	No
	Slow Cook	No	No	No	No
	Drying	No	No	No	No
	Auto Cook Recipes	40 EA (Twin Mode 10 EA)	40 EA (Twin Mode 10 EA)	40 EA (Twin Mode 10 EA)	40 EA (Twin Mode 10 EA)
	Favorite (=Memory Cook)	No	No	No	No
Upper Mode	Convection	40~250°C	40~250°C	40~250°C	40~250°C
	Top Heat + Convection	40~250°C	40~250°C	40~250°C	40~250°C
	Large Grill	40~250°C	40~250°C	40~250°C	200~250°C
	Eco Convection	40~250°C	40~250°C	40~250°C	40~250°C
Lower Mode	Convection	40~250°C	40~250°C	40~250°C	40~250°C
	Bottom Heat	40~250°C	40~250°C	40~250°C	100~230°C
	Bottom Heat + Convection	40~250°C	40~250°C	40~250°C	40~250°C
	Eco Convection	40~250°C	40~250°C	40~250°C	40~250°C
Twin Mode (Upper) Mode x (Lower) Mode		3 Mode x 3 Mode = 9 EA	3 Mode x 3 Mode = 9 EA	3 Mode x 3 Mode = 9 EA	3 Mode x 3 Mode = 9 EA
Control Features					
Clock		Yes	Yes	Yes	Yes
Child Safety Lock		Yes	Yes	Yes	Yes
Count Timer		Yes	Yes	Yes	Yes
Cook Time		Yes	Yes	Yes	Yes
End Time		Yes	Yes	Yes	Yes
Sound		Yes	Yes	Yes	Yes
Equipment Supplied					
Accessory	Telescopic	1 Level	1 Level	1 Level	1 Level
	Tray	Baking Tray 2 EA	Baking Tray 2 EA	Baking Tray 2 EA	Baking Tray 1 EA
	Rack	Wire Rack 1 EA	Wire Rack 1 EA	Wire Rack 1 EA	Wire Rack 1 EA, Wire Inlay 1 EA
	BBQ Spit	Yes	Yes	No	No
	Meat Probe	Yes	No	No	Yes
	Cookbook (CD)	Yes	Yes	Yes	Yes
Application Dimensions					
Dimension (W x H x D)	Outside	595 x 595 x 570	595 x 595 x 570	595 x 595 x 570	595 x 595 x 570
	Cutout	560 x 572 x 549	560 x 572 x 549	560 x 572 x 549	560 x 572 x 549
	Shipping	694 x 660 x 660	694 x 660 x 660	694 x 660 x 660	694 x 660 x 660
Capacity	Net Volume	75L	75L	75L	75L
	Net Volume (Upper or Lower)	34 / 32L	34 / 32L	34 / 32L	34 / 32L
Loading Quantity	40ft HQ	216	216	216	216
	40ft	162	162	162	162
	20ft	72	72	72	72

Models

Dual Cook Flex



Model Code		NV75N5672RM	NV75N5671RS	NV75N5671RM	NV75N5671BS
Project Name		NV7000N	NV7000N	NV7000N	NV7000N
Oven Features					
Energy Class	Single Mode	A+	A+	A+	A+
	Dual Cook Mode (Upper / Lower)	A / A	A / A	A / A	A / A
Cavity Wall		Flat / Side Racks	Flat / Side Racks	Flat / Side Racks	Flat / Side Racks
Oven Colors		Black Stainless Steel (Matt)	Stainless Steel	Black Stainless Steel (Matt)	Stainless Steel
Door	Glass panes	Quadruple	Quadruple	Quadruple	Quadruple
	Opening	Drop Down	Drop Down	Drop Down	Drop Down
	Soft Closing Door	No	No	No	No
Interior Lamp (W)		25W / 40W (Halogen)	25W / 40W (Halogen)	25W / 40W (Halogen)	25W / 40W (Halogen)
Interior Lights (Position)		Top / Side	Top / Side	Top / Side	Top / Side
Control	Control Panel Height	85mm	85mm	85mm	85mm
	Display	LED / Ice Blue	LED / Ice Blue	LED / Ice Blue	LED / Ice Blue
	Control Method	Pop-up Dial (with Touch Buttons)	Pop-up Dial (with Touch Buttons)	Pop-up Dial (with Touch Buttons)	Pop-up Dial (with Touch Buttons)
Cleaning Method	Wi-Fi	No	No	No	No
	Pyrolytic	Pyrolytic	Pyrolytic	Pyrolytic	Pyrolytic
	Catalytic	No	No	No	No
	Steam	Steam Cleaning	Steam Cleaning	Steam Cleaning	Steam Cleaning
	Grill Heater	Fixed	Fixed	Fixed	Fixed
Electric Features					
Temp Ranges	Single Convection	30~250°C	30~250°C	30~250°C	30~250°C
	Single Grill	100~270°C	100~270°C	100~270°C	100~270°C
	Upper or Lower	40~250°C	40~250°C	40~250°C	40~250°C
	Twin	40~250°C	40~250°C	40~250°C	40~250°C
Upper Grill (Small / Large)		1600W / 1100W	1600W / 1100W	1600W / 1100W	1600W / 1100W
Bottom Heater		1100W	1100W	1100W	1100W
Convection (Upper / Lower)		1200W / 1200W	1200W / 1200W	1200W / 1200W	1200W / 1200W
Input Power		3650~3950W	3650~3950W	3650~3950W	3650~3950W
Over Voltage Protection		Yes	Yes	Yes	Yes
Cooking Modes					
Single Mode	Oven Modes				
	Conventional	30~250°C	30~250°C	30~250°C	30~250°C
	Convection	30~250°C	30~250°C	30~250°C	30~250°C
	Eco Convection	30~250°C	30~250°C	30~250°C	30~250°C
	Large Grill	100~270°C	100~270°C	100~270°C	100~270°C
	Eco Grill	100~270°C	100~270°C	100~270°C	100~270°C
	Fan Grill	No	No	No	No
	Bottom Heat + Convection	40~250°C	40~250°C	40~250°C	40~250°C
	Top Heat + Convection	40~250°C	40~250°C	40~250°C	40~250°C
	Bottom Heat	100~230°C	100~230°C	100~230°C	100~230°C
	Intensive Cook	No	No	No	No
	Pro-roasting	80~200°C	80~200°C	80~200°C	80~200°C
	Special Function				
	Fast Preheat	Yes	Yes	Yes	Yes
	Keep Warm	40~100°C	40~100°C	40~100°C	40~100°C
	Plate Warm	30~80°C	30~80°C	30~80°C	30~80°C
	Defrost	No	No	No	No
	Prove Dough	No	No	No	No
	Slow Cook	No	No	No	No
	Drying	No	No	No	No
	Auto Cook Recipes	40 EA (Twin Mode 10 EA)	40 EA (Twin Mode 10 EA)	40 EA (Twin Mode 10 EA)	40 EA (Twin Mode 10 EA)
Favorite (=Memory Cook)	No	No	No	No	
Upper Mode	Convection	40~250°C	40~250°C	40~250°C	40~250°C
	Top Heat + Convection	40~250°C	40~250°C	40~250°C	40~250°C
	Large Grill	200~250°C	200~250°C	200~250°C	200~250°C
Lower Mode	Eco Convection	40~250°C	40~250°C	40~250°C	40~250°C
	Convection	40~250°C	40~250°C	40~250°C	40~250°C
	Bottom Heat	100~230°C	100~230°C	100~230°C	100~230°C
Twin Mode	Bottom Heat + Convection	40~250°C	40~250°C	40~250°C	40~250°C
	Eco Convection	40~250°C	40~250°C	40~250°C	40~250°C
	(Upper) Mode x (Lower) Mode	3 Mode x 3 Mode = 9 EA	3 Mode x 3 Mode = 9 EA	3 Mode x 3 Mode = 9 EA	3 Mode x 3 Mode = 9 EA
Control Features					
	Clock	Yes	Yes	Yes	Yes
	Child Safety Lock	Yes	Yes	Yes	Yes
	Count Timer	Yes	Yes	Yes	Yes
	Cook Time	Yes	Yes	Yes	Yes
	End Time	Yes	Yes	Yes	Yes
	Sound	Yes	Yes	Yes	Yes
Equipment Supplied					
Accessory	Telescopic	1 Level	1 Level	1 Level	No
	Tray	Baking Tray 1 EA	Baking Tray 1 EA	Baking Tray 1 EA	Baking Tray 1 EA
	Rack	Wire Rack 1EA, Wire Inlay 1 EA	Wire Rack 1EA, Wire Inlay 1 EA	Wire Rack 1EA, Wire Inlay 1 EA	Wire Rack 1EA, Wire Inlay 1 EA
	BBQ Spit	No	No	No	No
	Meat Probe	Yes	No	No	No
	Cookbook (CD)	Yes	Yes	Yes	Yes
Application Dimensions					
Dimension (W x H x D)	Outside	595 x 595 x 570	595 x 595 x 570	595 x 595 x 570	595 x 595 x 570
	Cutout	560 x 572 x 549	560 x 572 x 549	560 x 572 x 549	560 x 572 x 549
	Shipping	694 x 660 x 660	694 x 660 x 660	694 x 660 x 660	694 x 660 x 660
Capacity	Net Volume	75L	75L	75L	75L
	Net Volume (Upper or Lower)	34 / 32L	34 / 32L	34 / 32L	34 / 32L
Loading Quantity	40ft HQ	216	216	216	216
	40ft	162	162	162	162
	20ft	72	72	72	72

Models

Dual Cook Flex



Model Code		NV75N5641RS	NV75N5641RB	NV75N5642BS	NV75N5641BS
Project Name		NV7000N	NV7000N	NV7000N	NV7000N
Oven Features					
Energy Class	Single Mode	A+	A+	A+	A+
	Dual Cook Mode (Upper / Lower)	A / A	A / A	A / A	A / A
Cavity Wall		Flat / Side Racks	Flat / Side Racks	Flat / Side Racks	Flat / Side Racks
Oven Colors		Stainless Steel	Black Glass	Stainless Steel	Stainless Steel
Door	Glass panes	Double	Double	Double	Double
	Opening	Drop Down	Drop Down	Drop Down	Drop Down
	Soft Closing Door	No	No	No	No
Interior Lamp (W)		25W / 40W (Halogen)	25W / 40W (Halogen)	25W / 40W (Halogen)	25W / 40W (Halogen)
Interior Lights (Position)		Top / Side	Top / Side	Top / Side	Top / Side
Control	Control Panel Height	85mm	85mm	85mm	85mm
	Display	LED / Ice Blue	LED / Ice Blue	LED / Ice Blue	LED / Ice Blue
	Control Method	Pop-up Dial (with Touch Buttons)	Pop-up Dial (with Touch Buttons)	Pop-up Dial (with Touch Buttons)	Pop-up Dial (with Touch Buttons)
	Wi-Fi	No	No	No	No
Cleaning Method	Pyrolytic	No	No	No	No
	Catalytic	Yes (Back Wall)	Yes (Back Wall)	Yes (Back Wall)	Yes (Back Wall)
	Steam	Steam Cleaning	Steam Cleaning	Steam Cleaning	Steam Cleaning
	Grill Heater	Swing	Swing	Swing	Swing
Electric Features					
Temp Ranges	Single Convection	30~250°C	30~250°C	30~250°C	30~250°C
	Single Grill	100~270°C	100~270°C	100~270°C	100~270°C
	Upper or Lower	40~250°C	40~250°C	40~250°C	40~250°C
	Twin	40~250°C	40~250°C	40~250°C	40~250°C
Upper Grill (Small / Large)		1600W / 1100W	1600W / 1100W	1600W / 1100W	1600W / 1100W
Bottom Heater		1100W	1100W	1100W	1100W
Convection (Upper / Lower)		1200W / 1200W	1200W / 1200W	1200W / 1200W	1200W / 1200W
Input Power		3650~3950W	3650~3950W	3650~3950W	3650~3950W
Over Voltage Protection		Yes	Yes	Yes	Yes
Cooking Modes					
Single Mode	Oven Modes				
	Conventional	30~250°C	30~250°C	30~250°C	30~250°C
	Convection	30~250°C	30~250°C	30~250°C	30~250°C
	Eco Convection	30~250°C	30~250°C	30~250°C	30~250°C
	Large Grill	100~270°C	100~270°C	100~270°C	100~270°C
	Eco Grill	100~270°C	100~270°C	100~270°C	100~270°C
	Fan Grill	No	No	No	No
	Bottom Heat + Convection	40~250°C	40~250°C	40~250°C	40~250°C
	Top Heat + Convection	40~250°C	40~250°C	40~250°C	40~250°C
	Bottom Heat	100~230°C	100~230°C	100~230°C	100~230°C
	Intensive Cook	No	No	No	No
	Pro-roasting	80~200°C	80~200°C	80~200°C	80~200°C
	Special Function				
	Fast Preheat	Yes	Yes	Yes	Yes
	Keep Warm	40~100°C	40~100°C	40~100°C	40~100°C
	Plate Warm	30~80°C	30~80°C	30~80°C	30~80°C
	Defrost	No	No	No	No
	Prove Dough	No	No	No	No
	Slow Cook	No	No	No	No
	Drying	No	No	No	No
	Auto Cook Recipes	40 EA (Twin Mode 10 EA)	40 EA (Twin Mode 10 EA)	40 EA (Twin Mode 10 EA)	40 EA (Twin Mode 10 EA)
	Favorite (=Memory Cook)	No	No	No	No
Upper Mode	Convection	40~250°C	40~250°C	40~250°C	40~250°C
	Top Heat + Convection	40~250°C	40~250°C	40~250°C	40~250°C
	Large Grill	200~250°C	200~250°C	200~250°C	200~250°C
Lower Mode	Eco Convection	40~250°C	40~250°C	40~250°C	40~250°C
	Convection	40~250°C	40~250°C	40~250°C	40~250°C
	Bottom Heat	100~230°C	100~230°C	100~230°C	100~230°C
	Bottom Heat + Convection	40~250°C	40~250°C	40~250°C	40~250°C
Twin Mode	Eco Convection	40~250°C	40~250°C	40~250°C	40~250°C
	(Upper) Mode x (Lower) Mode	3 Mode x 3 Mode = 9 EA	3 Mode x 3 Mode = 9 EA	3 Mode x 3 Mode = 9 EA	3 Mode x 3 Mode = 9 EA
Control Features					
	Clock	Yes	Yes	Yes	Yes
	Child Safety Lock	Yes	Yes	Yes	Yes
	Count Timer	Yes	Yes	Yes	Yes
	Cook Time	Yes	Yes	Yes	Yes
	End Time	Yes	Yes	Yes	Yes
	Sound	Yes	Yes	Yes	Yes
Equipment Supplied					
Accessory	Telescopic	1 Level	1 Level	No	No
	Tray	Baking Tray 1 EA	Baking Tray 1 EA	Baking Tray 1 EA	Baking Tray 1 EA
	Rack	Wire Rack 1EA, Wire Inlay 1 EA	Wire Rack 1EA, Wire Inlay 1 EA	Wire Rack 1EA, Wire Inlay 1 EA	Wire Rack 1EA, Wire Inlay 1 EA
	BBQ Spit	No	No	No	No
	Meat Probe	No	No	Yes	No
	Cookbook (CD)	Yes	Yes	Yes	Yes
Application Dimensions					
Dimension (W x H x D)	Outside	595 x 595 x 570	595 x 595 x 570	595 x 595 x 570	595 x 595 x 570
	Cutout	560 x 572 x 549	560 x 572 x 549	560 x 572 x 549	560 x 572 x 549
	Shipping	694 x 660 x 660	694 x 660 x 660	694 x 660 x 660	694 x 660 x 660
Capacity	Net Volume	75L	75L	75L	75L
	Net Volume (Upper or Lower)	34 / 32L	34 / 32L	34 / 32L	34 / 32L
Loading Quantity	40ft HQ	216	216	216	216
	40ft	162	162	162	162
	20ft	72	72	72	72



Model Code		NV73J9770RS	NV73J7740RS
Project Name		Vapour Cook	Vapour Cook
Oven Features			
Energy Class		A ⁺	A ⁺
Cavity Wall		Flat / Side Racks	Flat / Side Racks
Oven Colors		Stainless Steel	Stainless Steel
Door	Glass panes	Quadruple	Triple
	Opening	Drop Down	Drop Down
	Soft Closing Door	Soft Close	Soft Close
Interior Lamp (W)		40W (Halogen)	40W (Halogen)
Interior Lights (Position)		Top	Top
Control	Control Panel Height	85mm	85mm
	Display	4.6" Touch LCD	LED / Ice Blue
	Control Method	Touch LCD	Full Touch
Cleaning Method	Wi-Fi	Yes	No
	Pyrolytic	Pyrolytic	No
	Catalytic	No	Yes (Back Wall)
	Steam	Steam Cleaning	Steam Cleaning
	Grill Heater	Fixed	Swing
Electric Features			
Temp Ranges	Single Convection	30~275°C	30~275°C
	Single Grill	100~300°C	100~300°C
	Upper or Lower	No	No
	Twin	No	No
Upper Grill (Small / Large)		1600W / 1100W	1600W / 1100W
Bottom Heater		1100W	1100W
Convection (Upper / Lower)		1800W	1800W
Input Power		3500~3850W	3500~3850W
Over Voltage Protection		Yes	Yes
Cooking Modes			
Single Mode	Oven Modes		
	Conventional	30~275°C	30~275°C
	Convection	30~275°C	30~275°C
	Eco Convection	30~275°C	30~275°C
	Large Grill	100~300°C	100~300°C
	Eco Grill	100~300°C	100~300°C
	Fan Grill	100~275°C	No
	Bottom Heat + Convection	40~275°C	40~275°C
	Top Heat + Convection	40~275°C	40~275°C
	Bottom Heat	100~230°C	No
	Intensive Cook	40~275°C	No
	Pro-roasting	80~200°C	80~200°C
	Special Function		
	Vapour + Convection	120~275°C	120~275°C
	Vapour Top Heat + Convection	120~275°C	120~275°C
	Vapour Bottom Heat + Convection	120~275°C	120~275°C
	Steam Cook	No	No
	Steam Assist	No	No
	Keep Warm	40~100°C	40~100°C
	Plate Warm	30~80°C	30~80°C
	Defrost	No	No
	Prove Dough	No	No
	Slow Cook	70~120°C	No
	Drying	40~90°C	No
	Auto Cook Recipes	80 EA	40 EA
	Favorite (=Memory Cook)	10 EA	No
	Upper Mode	Convection	No
Top Heat + Convection		No	No
Large Grill		No	No
Lower Mode	Convection	No	No
	Bottom Heat	No	No
	Bottom Heat + Convection	No	No
	Steam Cook	No	No
	Steam Assist	No	No
Twin Mode	(Upper) Mode x (Lower) Mode	No	No
Control Features			
	Clock	Yes	Yes
	Child Safety Lock	Yes	Yes
	Count Timer	Yes	Yes
	Cook Time	Yes	Yes
	End Time	Yes	Yes
	Language Option	11 EA	No
	Sound	Yes	Yes
Equipment Supplied			
Accessory	Telescopic	1 Level	1 Level
	Tray	Baking Tray 2 EA	Baking Tray 2 EA
	Rack	Wire Rack 1 EA, Wire Inlay 1 EA	Wire Rack 1 EA, Wire Inlay 1 EA
	Rotisserie Spit	No	No
	Meat Probe	Meat Probe	Meat Probe
	Cookbook (CD)	Yes	Yes
Application Dimensions			
Dimension (W x H x D)	Outside	595 x 595 x 566	595 x 595 x 566
	Cutout	560 x 572 x 545	560 x 572 x 545
	Shipping	682 x 645.5 x 656	682 x 645.5 x 656
Capacity	Net Volume	73L	73L
	Net Volume (Upper or Lower)	No	No
Loading Quantity	40ft HQ / 40ft / 20ft	216 / 162 / 72	216 / 162 / 72

Models Steam Twin™



Model Code		BQ1VD6T131	NV70F3984LS
Project Name		Jupiter	Jupiter
Oven Features			
Energy Class		A	A
Cavity Wall		Flat / Side Racks	Flat / Side Racks
Oven Colors		Stainless Steel	Stainless Steel
Door	Glass panes	Triple	Triple
	Opening	Drop Down	Drop Down
	Soft Closing Door	No	No
Interior Lamp (W)		25W / 40W (Blub / Halogen)	25W / 40W (Blub / Halogen)
Interior Lights (Position)		Rear / Side	Rear / Side
Control	Control Panel Height	115mm	115mm
	Display	LED / Blue	LED / Blue
	Control Method	Pop-up Dial	Pop-up Dial
	Wi-Fi	No	No
Cleaning Method	Pyrolytic	No	No
	Catalytic	Yes (Back Wall)	Yes (Back Wall)
	Steam	Steam Cleaning	Steam Cleaning
	Grill Heater	Swing	Swing
Electric Features			
Temp Ranges	Single Convection	40~250°C	40~250°C
	Single Grill	40~270°C	40~270°C
	Upper or Lower	40~250°C	40~250°C
Twin		170~250°C	170~250°C
	Upper Grill (Small / Large)	1600W / 1100W	1600W / 1100W
Bottom Heater		1100W	1100W
Convection (Upper / Lower)		1200W / 1200W	1200W / 1200W
Input Power		3650W	3650W
Over Voltage Protection		No	No
Cooking Modes			
Single Mode	Oven Modes		
	Conventional	40~250°C	40~250°C
	Convection	40~250°C	40~250°C
	Eco Convection	No	No
	Large Grill	40~270°C	40~270°C
	Eco Grill	40~270°C	40~270°C
	Fan Grill	No	No
	Bottom Heat + Convection	40~250°C	40~250°C
	Top Heat + Convection	40~250°C	40~250°C
	Bottom Heat	No	No
	Intensive Cook	No	No
	Pro-roasting	No	No
	Special Function		
	Vapour + Convection	No	No
	Vapour Top Heat + Convection	No	No
	Vapour Bottom Heat + Convection	No	No
	Steam Cook	1 / 2 / 3	No
	Steam Assist	130~250°C	130~250°C
	Keep Warm	No	No
	Plate Warm	No	No
	Defrost	No	No
	Prove Dough	No	No
	Slow Cook	No	No
	Drying	No	No
	Auto Cook Recipes	50 EA	50 EA
	Favorite (=Memory Cook)	No	No
	Upper Mode	Convection	40~250°C
Top Heat + Convection		40~250°C	40~250°C
Large Grill		40~250°C	40~250°C
Lower Mode	Convection	40~250°C	40~250°C
	Bottom Heat	No	No
	Bottom Heat + Convection	40~250°C	40~250°C
	Steam Cook	1 / 2 / 3	No
Twin Mode	Steam Assist	130~250°C	130~250°C
	(Upper) Mode x (Lower) Mode	3 Mode x 3 Mode = 9 EA	3 Mode x 3 Mode = 9 EA
Control Features			
Clock		Yes	Yes
Child Safety Lock		Yes	Yes
Count Timer		Yes	Yes
Cook Time		Yes	Yes
End Time		Yes	Yes
Language Option		No	No
Sound		Yes	Yes
Equipment Supplied			
Accessory	Telescopic	2 Level	2 Level
	Tray	2 EA	2 EA
	Rack	Wire Rack 1 EA, Wire Inlay 1 EA	Wire Rack 1 EA, Wire Inlay 1 EA
	Rotisserie Spit	No	No
	Meat Probe	No	No
	Cookbook (CD)	No	No
Application Dimensions			
Dimension (W x H x D)	Outside	595 x 595 x 566	595 x 595 x 566
	Cutout	560 x 572 x 545	560 x 572 x 545
	Shipping	682 x 645.5 x 656	682 x 645.5 x 656
Capacity	Net Volume	70L	70L
	Net Volume (Upper or Lower)	30 / 32L	30 / 32L
Loading Quantity	40ft HQ / 40ft / 20ft	216 / 162 / 72	216 / 162 / 72

Models Dual Cook



Model Code	NV75M7572RS	NV75J7570RS	NV75J5540RS	NV75M5572RS	
Project Name	NV9900J	NV9900J	NV9900J	NV9900J	
Oven Features					
Energy Class	A	A	A	A	
Cavity Wall	Flat / Side Racks	Flat / Side Racks	Flat / Side Racks	Flat / Side Racks	
Oven Colors	Stainless Steel	Stainless Steel	Stainless Steel	Stainless Steel	
Door	Glass panes	Quadruple	Triple	Quadruple	
	Opening	Drop Down	Drop Down	Drop Down	
	Soft Closing Door	Soft Close	Soft Close	No	
Interior Lamp (W)	40W / 40W (Halogen)	40W / 40W (Halogen)	40W / 40W (Halogen)	40W / 40W (Halogen)	
Interior Lights (Position)	Top / Side	Top / Side	Top / Side	Top / Side	
Control	Control Panel Height	85mm	85mm	85mm	
	Display	LED / Ice Blue	LED / Ice Blue	LED / Ice Blue	
	Control Method	Pop-up Dial (with Touch Buttons)	Pop-up Dial (with Touch Buttons)	Pop-up Dial (with Touch Buttons)	Pop-up Dial
Cleaning Method	Wi-Fi	No	No	No	
	Pyrolytic	Pyrolytic	Pyrolytic	No	
	Catalytic	No	No	Yes (Back Wall)	No
	Steam	Steam Cleaning	Steam Cleaning	Steam Cleaning	Steam Cleaning
Grill Heater	Fixed	Fixed	Swing	Fixed	
Electric Features					
Temp Ranges	Single Convection	30~275°C	30~275°C	30~275°C	
	Single Grill	100~300°C	100~300°C	100~300°C	
	Upper or Lower	40~250°C	40~250°C	40~250°C	
Upper Grill (Small / Large)	Twin	40~250°C	40~250°C	40~250°C	
	Upper Grill (Small / Large)	1600W / 1100W	1600W / 1100W	1600W / 1100W	
Bottom Heater	1100W	1100W	1100W	1100W	
Convection (Upper / Lower)	1200W / 1200W	1200W / 1200W	1200W / 1200W	1200W / 1200W	
Input Power	3650~3950W	3650~3950W	3650~3950W	3650~3950W	
Over Voltage Protection	Yes	Yes	Yes	Yes	
Cooking Modes					
Single Mode	Oven Modes				
	Conventional	30~275°C	30~275°C	30~275°C	
	Convection	30~275°C	30~275°C	30~275°C	
	Eco Convection	30~275°C	30~275°C	30~275°C	
	Large Grill	100~300°C	100~300°C	100~300°C	
	Eco Grill	100~300°C	100~300°C	100~300°C	
	Fan Grill	No	No	No	
	Bottom Heat + Convection	40~275°C	40~275°C	40~275°C	
	Top Heat + Convection	40~275°C	40~275°C	40~275°C	
	Bottom Heat	100~230°C	100~230°C	100~230°C	
	Intensive Cook	No	No	No	
	Pro-roasting	80~200°C	80~200°C	80~200°C	
	Special Function				
	Vapour + Convection	No	No	No	
	Vapour Top Heat + Convection	No	No	No	
	Vapour Bottom Heat + Convection	No	No	No	
	Steam Cook	No	No	No	
	Steam Assist	No	No	No	
	Keep Warm	40~100°C	40~100°C	40~100°C	
	Plate Warm	30~80°C	30~80°C	30~80°C	
	Defrost	No	No	No	
	Prove Dough	No	No	No	
	Slow Cook	No	No	No	
	Drying	No	No	No	
	Auto Cook Recipes	40 EA (Twin Mode 10 EA)	40 EA (Twin Mode 10 EA)	40 EA (Twin Mode 10 EA)	40 EA (Twin Mode 10 EA)
	Favorite (=Memory Cook)	No	No	No	No
	Upper Mode	Convection	40~250°C	40~250°C	40~250°C
Top Heat + Convection		40~250°C	40~250°C	40~250°C	
Large Grill		200~250°C	200~250°C	200~250°C	
Lower Mode	Convection	40~250°C	40~250°C	40~250°C	
	Bottom Heat	100~230°C	100~230°C	100~230°C	
	Bottom Heat + Convection	40~250°C	40~250°C	40~250°C	
	Steam Cook	No	No	No	
Twin Mode	Steam Assist	No	No	No	
	(Upper) Mode x (Lower) Mode	3 Mode x 3 Mode = 9 EA	3 Mode x 3 Mode = 9 EA	3 Mode x 3 Mode = 9 EA	
Control Features					
Clock	Clock	Yes	Yes	Yes	
	Child Safety Lock	Yes	Yes	Yes	
	Count Timer	Yes	Yes	Yes	
	Cook Time	Yes	Yes	Yes	
	End Time	Yes	Yes	Yes	
	Language Option	No	No	No	
	Sound	Yes	Yes	Yes	
Equipment Supplied					
Accessory	Telescopic	1 Level	1 Level	1 Level	
	Tray	2 EA	2 EA	2 EA	
	Rack	Wire Rack 1 EA	Wire Rack 1 EA	Wire Rack 1 EA	
	Rotisserie Spit	Yes	Yes	No	
	Meat Probe	Yes	No	No	
	Cookbook (CD)	Yes	Yes	Yes	
Application Dimensions					
Dimension (W x H x D)	Outside	595 x 595 x 566	595 x 595 x 566	595 x 595 x 566	
	Cutout	560 x 572 x 545	560 x 572 x 545	560 x 572 x 545	
	Shipping	682 x 645.5 x 656	682 x 645.5 x 656	682 x 645.5 x 656	
Capacity	Net Volume	75L	75L	75L	
	Net Volume (Upper or Lower)	34 / 32L	34 / 32L	34 / 32L	
Loading Quantity	40ft HQ / 40ft / 20ft	216 / 162 / 72	216 / 162 / 72	216 / 162 / 72	

Models

Dual Cook



Model Code		NV75K5571RS	NV75K5571RM	NV75K5571RG	NV75K5571BS
Project Name		NV9900J VE	NV9900J VE	NV9900J VE	NV9900J VE
Oven Features					
Energy Class		A	A	A	A
Cavity Wall		Flat / Side Racks	Flat / Side Racks	Flat / Side Racks	Flat / Side Racks
Oven Colors		Staninless Steel	Black Staninless Steel	Black Staninless Steel	Staninless Steel
Door	Glass panes	Quadruple	Quadruple	Quadruple	Quadruple
	Opening	Drop Down	Drop Down	Drop Down	Drop Down
	Soft Closing Door	No	No	No	No
Interior Lamp (W)		40W / 40W (Halogen)	40W / 40W (Halogen)	40W / 40W (Halogen)	40W / 40W (Halogen)
Interior Lights (Position)		Top / Side	Top / Side	Top / Side	Top / Side
Control	Control Panel Height	85mm	85mm	85mm	85mm
	Display	LED / Ice Blue	LED / Ice Blue	LED / Ice Blue	LED / Ice Blue
Control Method		Pop-up Dial	Pop-up Dial	Pop-up Dial	Pop-up Dial
Cleaning Method	Wi-Fi	No	No	No	No
	Pyrolytic	Pyrolytic	Pyrolytic	Pyrolytic	Pyrolytic
	Catalytic	No	No	No	No
	Steam	Steam Cleaning	Steam Cleaning	Steam Cleaning	Steam Cleaning
Grill Heater		Fixed	Fixed	Fixed	Fixed
Electric Features					
Temp Ranges	Single Convection	30~250°C	30~250°C	30~250°C	30~250°C
	Single Grill	100~270°C	100~270°C	100~270°C	100~270°C
Upper or Lower	Upper or Lower	40~250°C	40~250°C	40~250°C	40~250°C
	Twin	40~250°C	40~250°C	40~250°C	40~250°C
Upper Grill (Small / Large)		1600W / 1100W	1600W / 1100W	1600W / 1100W	1600W / 1100W
Bottom Heater		1100W	1100W	1100W	1100W
Convection (Upper / Lower)		1200W / 1200W	1200W / 1200W	1200W / 1200W	1200W / 1200W
Input Power		3650~3950W	3650~3950W	3650~3950W	3650~3950W
Over Voltage Protection		Yes	Yes	Yes	Yes
Cooking Modes					
Single Mode	Oven Modes				
	Conventional	30~250°C	30~250°C	30~250°C	30~250°C
	Convection	30~250°C	30~250°C	30~250°C	30~250°C
	Eco Convection	30~250°C	30~250°C	30~250°C	30~250°C
	Large Grill	100~270°C	100~270°C	100~270°C	100~270°C
	Eco Grill	100~270°C	100~270°C	100~270°C	100~270°C
	Fan Grill	No	No	No	No
	Bottom Heat + Convection	40~250°C	40~250°C	40~250°C	40~250°C
	Top Heat + Convection	40~250°C	40~250°C	40~250°C	40~250°C
	Bottom Heat	100~230°C	100~230°C	100~230°C	100~230°C
	Intensive Cook	No	No	No	No
	Pro-roasting	80~200°C	80~200°C	80~200°C	80~200°C
	Special Function				
	Vapour + Convection	No	No	No	No
	Vapour Top Heat + Convection	No	No	No	No
	Vapour Bottom Heat + Convection	No	No	No	No
	Steam Cook	No	No	No	No
	Steam Assist	No	No	No	No
	Keep Warm	40~100°C	40~100°C	40~100°C	40~100°C
	Plate Warm	30~80°C	30~80°C	30~80°C	30~80°C
	Defrost	No	No	No	No
	Prove Dough	No	No	No	No
	Slow Cook	No	No	No	No
	Drying	No	No	No	No
	Auto Cook Recipes	40 EA (Twin Mode 10 EA)	40 EA (Twin Mode 10 EA)	40 EA (Twin Mode 10 EA)	40 EA (Twin Mode 10 EA)
	Favorite (=Memory Cook)	No	No	No	No
	Upper Mode	Convection	40~250°C	40~250°C	40~250°C
Top Heat + Convection		40~250°C	40~250°C	40~250°C	40~250°C
Large Grill		200~250°C	200~250°C	200~250°C	200~250°C
Lower Mode	Convection	40~250°C	40~250°C	40~250°C	40~250°C
	Bottom Heat	100~230°C	100~230°C	100~230°C	100~230°C
	Bottom Heat + Convection	40~250°C	40~250°C	40~250°C	40~250°C
	Steam Cook	No	No	No	No
Twin Mode	Steam Assist	No	No	No	No
	(Upper) Mode x (Lower) Mode	3 Mode x 3 Mode = 9 EA	3 Mode x 3 Mode = 9 EA	3 Mode x 3 Mode = 9 EA	3 Mode x 3 Mode = 9 EA
Control Features					
Clock		Yes	Yes	Yes	Yes
Child Safety Lock		Yes	Yes	Yes	Yes
Count Timer		Yes	Yes	Yes	Yes
Cook Time		Yes	Yes	Yes	Yes
End Time		Yes	Yes	Yes	Yes
Language Option		No	No	No	No
Sound		Yes	Yes	Yes	Yes
Equipment Supplied					
Accessory	Telescopic	1 Level	1 Level	1 Level	No
	Tray	1 EA	1 EA	1 EA	1 EA
	Rack	Wire Rack 2 EA	Wire Rack 2 EA	Wire Rack 2 EA	Wire Rack 2 EA
	Rotisserie Spit	No	No	No	No
	Meat Probe	No	No	No	No
	Cookbook (CD)	Yes	Yes	Yes	Yes
Application Dimensions					
Dimension (W x H x D)	Outside	595 x 595 x 566	595 x 595 x 566	595 x 595 x 566	595 x 595 x 566
	Cutout	560 x 572 x 545	560 x 572 x 545	560 x 572 x 545	560 x 572 x 545
	Shipping	682 x 645.5 x 656	682 x 645.5 x 656	682 x 645.5 x 656	682 x 645.5 x 656
Capacity	Net Volume	75L	75L	75L	75L
	Net Volume (Upper or Lower)	35 / 32L	35 / 32L	35 / 32L	35 / 32L
Loading Quantity		216 / 162 / 72	216 / 162 / 72	216 / 162 / 72	216 / 162 / 72

Models Dual Cook



Model Code		NV75M5542RS	NV75K5541RS	NV75K5541RM	NV75K5541RG
Project Name		NV9900J	NV9900J VE	NV9900J VE	NV9900J VE
Oven Features					
Energy Class		A	A	A	A
Cavity Wall		Flat / Side Racks	Flat / Side Racks	Flat / Side Racks	Flat / Side Racks
Oven Colors		Stainless Steel	Staninless Steel	Black Staninless Steel	Black Staninless Steel
Door	Glass panes	Triple	Triple	Triple	Triple
	Opening	Drop Down	Drop Down	Drop Down	Drop Down
	Soft Closing Door	Soft Close	No	No	No
Interior Lamp (W)		40W / 40W (Halogen)	40W / 40W (Halogen)	40W / 40W (Halogen)	40W / 40W (Halogen)
Interior Lights (Position)		Top / Side	Top / Side	Top / Side	Top / Side
Control	Control Panel Height	85mm	85mm	85mm	85mm
	Display	LED / Ice Blue	LED / Ice Blue	LED / Ice Blue	LED / Ice Blue
	Control Method	Pop-up Dial (with Touch Buttons)	Pop-up Dial	Pop-up Dial	Pop-up Dial
	Wi-Fi	No	No	No	No
Cleaning Method	Pyrolytic	No	No	No	No
	Catalytic	Yes (Back Wall)	Yes (Back Wall)	Yes (Back Wall)	Yes (Back Wall)
	Steam	Steam Cleaning	Steam Cleaning	Steam Cleaning	Steam Cleaning
	Grill Heater	Swing	Swing	Swing	Swing
Electric Features					
Temp Ranges	Single Convection	30~275°C	30~250°C	30~250°C	30~250°C
	Single Grill	100~300°C	100~270°C	100~270°C	100~270°C
	Upper or Lower	40~250°C	40~250°C	40~250°C	40~250°C
Upper Grill (Small / Large)	Twin	40~250°C	40~250°C	40~250°C	40~250°C
	Bottom Heater	1600W / 1100W	1600W / 1100W	1600W / 1100W	1600W / 1100W
Convection (Upper / Lower)		1100W	1100W	1100W	1100W
Input Power		1200W / 1200W	1200W / 1200W	1200W / 1200W	1200W / 1200W
Over Voltage Protection		3650~3950W	3650~3950W	3650~3950W	3650~3950W
		Yes	Yes	Yes	Yes
Cooking Modes					
Single Mode		Oven Modes			
		Conventional	30~275°C	30~250°C	30~250°C
		Convection	30~275°C	30~250°C	30~250°C
		Eco Convection	30~275°C	30~250°C	30~250°C
		Large Grill	100~300°C	100~270°C	100~270°C
		Eco Grill	100~300°C	100~270°C	100~270°C
		Fan Grill	No	No	No
		Bottom Heat + Convection	40~275°C	40~250°C	40~250°C
		Top Heat + Convection	40~275°C	40~250°C	40~250°C
		Bottom Heat	100~230°C	100~230°C	100~230°C
		Intensive Cook	No	No	No
		Pro-roasting	80~200°C	80~200°C	80~200°C
		Special Function			
		Vapour + Convection	No	No	No
		Vapour Top Heat + Convection	No	No	No
		Vapour Bottom Heat + Convection	No	No	No
		Steam Cook	No	No	No
		Steam Assist	No	No	No
		Keep Warm	40~100°C	40~100°C	40~100°C
		Plate Warm	30~80°C	30~80°C	30~80°C
		Defrost	No	No	No
		Prove Dough	No	No	No
		Slow Cook	No	No	No
		Drying	No	No	No
		Auto Cook Recipes	40 EA (Twin Mode 10 EA)	40 EA (Twin Mode 10 EA)	40 EA (Twin Mode 10 EA)
		Favorite (=Memory Cook)	No	No	No
Upper Mode	Convection	40~250°C	40~250°C	40~250°C	40~250°C
	Top Heat + Convection	40~250°C	40~250°C	40~250°C	40~250°C
	Large Grill	200~250°C	200~250°C	200~250°C	200~250°C
Lower Mode	Convection	40~250°C	40~250°C	40~250°C	40~250°C
	Bottom Heat	100~230°C	100~230°C	100~230°C	100~230°C
	Bottom Heat + Convection	40~250°C	40~250°C	40~250°C	40~250°C
	Steam Cook	No	No	No	No
		Steam Assist	No	No	No
Twin Mode		(Upper) Mode x (Lower) Mode	3 Mode x 3 Mode = 9 EA	3 Mode x 3 Mode = 9 EA	3 Mode x 3 Mode = 9 EA
Control Features					
		Clock	Yes	Yes	Yes
		Child Safety Lock	Yes	Yes	Yes
		Count Timer	Yes	Yes	Yes
		Cook Time	Yes	Yes	Yes
		End Time	Yes	Yes	Yes
		Language Option	No	No	No
		Sound	Yes	Yes	Yes
Equipment Supplied					
Accessory		Telescopic	1 Level	1 Level	1 Level
		Tray	2 EA	1 EA	1 EA
		Rack	Wire Rack 1 EA	Wire Rack 2 EA	Wire Rack 2 EA
		Rotisserie Spit	No	No	No
		Meat Probe	Yes	No	No
		Cookbook (CD)	Yes	Yes	Yes
Application Dimensions					
Dimension (W x H x D)		Outside	595 x 595 x 566	595 x 595 x 566	595 x 595 x 566
		Cutout	560 x 572 x 545	560 x 572 x 545	560 x 572 x 545
		Shipping	682 x 645.5 x 656	682 x 645.5 x 656	682 x 645.5 x 656
Capacity	Net Volume		75L	75L	75L
	Net Volume (Upper or Lower)		34 / 32L	35 / 32L	35 / 32L
Loading Quantity		40ft HQ / 40ft / 20ft	216 / 162 / 72	216 / 162 / 72	216 / 162 / 72

Models

Dual Cook



Model Code		NV75K5541RB	NV75K5541BS	NV75K5541BB	NV70M3571RS	
Project Name		NV9900J VE	NV9900J VE	NV9900J VE	Defeature Dual Cook	
Oven Features						
Energy Class		A	A	A	A	
Cavity Wall		Flat / Side Racks	Flat / Side Racks	Flat / Side Racks	Flat / Side Racks	
Oven Colors		Black Glass	Stainless Steel	Black Glass	Stainless Steel	
Door	Glass panes	Triple	Triple	Triple	Triple	
	Opening	Drop Down	Drop Down	Drop Down	Drop Down	
	Soft Closing Door	No	No	No	No	
Interior Lamp (W)		40W / 40W (Halogen)	40W / 40W (Halogen)	40W / 40W (Halogen)	25W / 40W (Halogen)	
Interior Lights (Position)		Top / Side	Top / Side	Top / Side	Rear / Side	
Control	Control Panel Height	85mm	85mm	85mm	115mm	
	Display	LED / Ice Blue	LED / Ice Blue	LED / Ice Blue	LED / Ice Blue	
	Control Method	Pop-up Dial	Pop-up Dial	Pop-up Dial	Pop-up Dial	
Cleaning Method	Wi-Fi	No	No	No	No	
	Pyrolytic	No	No	No	Yes	
	Catalytic	Yes (Back Wall)	Yes (Back Wall)	Yes (Back Wall)	No	
	Steam	Steam Cleaning	Steam Cleaning	Steam Cleaning	Steam Cleaning	
	Grill Heater	Swing	Swing	Swing	Fixed	
Electric Features						
Temp Ranges	Single Convection	30~250°C	30~250°C	30~250°C	40~250°C	
	Single Grill	100~270°C	100~270°C	100~270°C	100~270°C	
Upper or Lower	Upper or Lower	40~250°C	40~250°C	40~250°C	No	
	Twin	40~250°C	40~250°C	40~250°C	No	
Upper Grill (Small / Large)		1600W / 1100W	1600W / 1100W	1600W / 1100W	1600W / 1100W	
Bottom Heater		1100W	1100W	1100W	1100W	
Convection (Upper / Lower)		1200W / 1200W	1200W / 1200W	1200W / 1200W	1200W / 1200W	
Input Power		3650~3950W	3650~3950W	3650~3950W	3650~3950W	
Over Voltage Protection		Yes	Yes	Yes	Yes	
Cooking Modes						
Single Mode	Oven Modes					
	Conventional	30~250°C	30~250°C	30~250°C	40~250°C	
	Convection	30~250°C	30~250°C	30~250°C	40~250°C	
	Eco Convection	30~250°C	30~250°C	30~250°C	No	
	Large Grill	100~270°C	100~270°C	100~270°C	100~270°C	
	Eco Grill	100~270°C	100~270°C	100~270°C	100~270°C	
	Fan Grill	No	No	No	100~270°C	
	Bottom Heat + Convection	40~250°C	40~250°C	40~250°C	40~250°C	
	Top Heat + Convection	40~250°C	40~250°C	40~250°C	40~250°C	
	Bottom Heat	100~230°C	100~230°C	100~230°C	100~230°C	
	Intensive Cook	No	No	No	No	
	Pro-roasting	80~200°C	80~200°C	80~200°C	80~200°C	
	Special Function					
	Vapour + Convection	No	No	No	No	
	Vapour Top Heat + Convection	No	No	No	No	
	Vapour Bottom Heat + Convection	No	No	No	No	
	Steam Cook	No	No	No	No	
	Steam Assist	No	No	No	No	
	Keep Warm	40~100°C	40~100°C	40~100°C	No	
	Plate Warm	30~80°C	30~80°C	30~80°C	No	
	Defrost	No	No	No	No	
	Prove Dough	No	No	No	No	
	Slow Cook	No	No	No	No	
	Drying	No	No	No	No	
	Auto Cook Recipes	40 EA (Twin Mode 10 EA)	40 EA (Twin Mode 10 EA)	40 EA (Twin Mode 10 EA)	25 EA	
	Upper Mode	Favorite (=Memory Cook)	No	No	No	No
		Convection	40~250°C	40~250°C	40~250°C	40~250°C
		Top Heat + Convection	40~250°C	40~250°C	40~250°C	40~250°C
	Lower Mode	Large Grill	200~250°C	200~250°C	200~250°C	200~250°C
		Convection	40~250°C	40~250°C	40~250°C	40~250°C
Bottom Heat		100~230°C	100~230°C	100~230°C	100~230°C	
Twin Mode	Bottom Heat + Convection	40~250°C	40~250°C	40~250°C	40~250°C	
	Steam Cook	No	No	No	No	
	Steam Assist	No	No	No	No	
(Upper) Mode x (Lower) Mode		3 Mode x 3 Mode = 9 EA	3 Mode x 3 Mode = 9 EA	3 Mode x 3 Mode = 9 EA	3 Mode x 3 Mode = 9 EA	
Control Features						
Clock		Yes	Yes	Yes	Yes	
Child Safety Lock		Yes	Yes	Yes	Yes	
Count Timer		Yes	Yes	Yes	Yes	
Cook Time		Yes	Yes	Yes	Yes	
End Time		Yes	Yes	Yes	Yes	
Language Option		No	No	No	No	
Sound		Yes	Yes	Yes	Yes	
Equipment Supplied						
Accessory	Telescopic	1 Level	No	No	1 Level	
	Tray	1 EA	1 EA	1 EA	1 EA	
	Rack	Wire Rack 2 EA	Wire Rack 2 EA	Wire Rack 2 EA	Wire Rack 1 EA	
	Rotisserie Spit	No	No	No	No	
	Meat Probe	No	No	No	No	
	Cookbook (CD)	Yes	Yes	Yes	No	
Application Dimensions						
Dimension (W x H x D)	Outside	595 x 595 x 566	595 x 595 x 566	595 x 595 x 566	595 x 595 x 566	
	Cutout	560 x 572 x 545	560 x 572 x 545	560 x 572 x 545	560 x 572 x 545	
	Shipping	682 x 645.5 x 656	682 x 645.5 x 656	682 x 645.5 x 656	682 x 645.5 x 656	
Capacity	Net Volume	75L	75L	75L	66L	
	Net Volume (Upper or Lower)	35 / 32L	35 / 32L	35 / 32L	30 / 32L	
Loading Quantity		216 / 162 / 72	216 / 162 / 72	216 / 162 / 72	216 / 162 / 72	

Models Dual Cook



Model Code		NV70M3541RS	NV70M3541RB	NV66M3571BS	NV66M3571BB	
Project Name		Defeature Dual Cook	Defeature Dual Cook	Defeature Dual Cook	Defeature Dual Cook	
Oven Features						
Energy Class		A	A	A	A	
Cavity Wall		Flat / Side Racks	Flat / Side Racks	Forming	Forming	
Oven Colors		Stainless Steel	Black	Stainless Steel	Black	
Door	Glass panes	Triple	Triple	Triple	Triple	
	Opening	Drop Down	Drop Down	Drop Down	Drop Down	
	Soft Closing Door	No	No	No	No	
Interior Lamp (W)		25W / 40W (Halogen)	25W / 40W (Halogen)	25W (Bulb)	25W (Bulb)	
Interior Lights (Position)		Rear / Side	Rear / Side	Rear	Rear	
Control	Control Panel Height	115mm	115mm	115mm	115mm	
	Display	LED / Ice Blue	LED / Ice Blue	LED / Ice Blue	LED / Ice Blue	
	Control Method	Pop-up Dial	Pop-up Dial	Pop-up Dial	Pop-up Dial	
	Wi-Fi	No	No	No	No	
Cleaning Method	Pyrolytic	No	No	Yes	Yes	
	Catalytic	Yes (Back Wall)	Yes (Back Wall)	No	No	
	Steam	Steam Cleaning	Steam Cleaning	Steam Cleaning	Steam Cleaning	
	Grill Heater	Fixed	Fixed	Fixed	Fixed	
Electric Features						
Temp Ranges	Single Convection	40~250°C	40~250°C	40~250°C	40~250°C	
	Single Grill	100~270°C	100~270°C	100~270°C	100~270°C	
	Upper or Lower	No	No	No	No	
Upper Grill (Small / Large)	Twin	No	No	No	No	
	Bottom Heater	1600W / 1100W	1600W / 1100W	1600W / 1100W	1600W / 1100W	
Convection (Upper / Lower)		1100W	1100W	1100W	1100W	
Input Power		1200W / 1200W	1200W / 1200W	1200W / 1200W	1200W / 1200W	
Over Voltage Protection		3650~3950W	3650~3950W	3650~3950W	3650~3950W	
		Yes	Yes	Yes	Yes	
Cooking Modes						
Single Mode	Oven Modes					
	Conventional	40~250°C	40~250°C	40~250°C	40~250°C	
	Convection	40~250°C	40~250°C	40~250°C	40~250°C	
	Eco Convection	No	No	No	No	
	Large Grill	100~270°C	100~270°C	100~270°C	100~270°C	
	Eco Grill	100~270°C	100~270°C	100~270°C	100~270°C	
	Fan Grill	100~270°C	100~270°C	100~270°C	100~270°C	
	Bottom Heat + Convection	40~250°C	40~250°C	40~250°C	40~250°C	
	Top Heat + Convection	40~250°C	40~250°C	40~250°C	40~250°C	
	Bottom Heat	100~230°C	100~230°C	100~230°C	100~230°C	
	Intensive Cook	No	No	No	No	
	Pro-roasting	80~200°C	80~200°C	80~200°C	80~200°C	
	Special Function					
	Vapour + Convection	No	No	No	No	
	Vapour Top Heat + Convection	No	No	No	No	
	Vapour Bottom Heat + Convection	No	No	No	No	
	Steam Cook	No	No	No	No	
	Steam Assist	No	No	No	No	
	Keep Warm	No	No	No	No	
	Plate Warm	No	No	No	No	
	Defrost	No	No	No	No	
	Prove Dough	No	No	No	No	
	Slow Cook	No	No	No	No	
	Drying	No	No	No	No	
	Auto Cook Recipes	25 EA	25 EA	25 EA	25 EA	
	Favorite (=Memory Cook)	No	No	No	No	
	Upper Mode	Convection	40~250°C	40~250°C	40~250°C	40~250°C
		Top Heat + Convection	40~250°C	40~250°C	40~250°C	40~250°C
		Large Grill	200~250°C	200~250°C	200~250°C	200~250°C
	Lower Mode	Convection	40~250°C	40~250°C	40~250°C	40~250°C
		Bottom Heat	100~230°C	100~230°C	100~230°C	100~230°C
		Bottom Heat + Convection	40~250°C	40~250°C	40~250°C	40~250°C
Steam Cook		No	No	No	No	
Steam Assist		No	No	No	No	
Twin Mode	(Upper) Mode x (Lower) Mode	3 Mode x 3 Mode = 9 EA	3 Mode x 3 Mode = 9 EA	3 Mode x 3 Mode = 9 EA	3 Mode x 3 Mode = 9 EA	
Control Features						
Clock		Yes	Yes	Yes	Yes	
Child Safety Lock		Yes	Yes	Yes	Yes	
Count Timer		Yes	Yes	Yes	Yes	
Cook Time		Yes	Yes	Yes	Yes	
End Time		Yes	Yes	Yes	Yes	
Language Option		No	No	No	No	
Sound		Yes	Yes	Yes	Yes	
Equipment Supplied						
Accessory	Telescopic	1 Level	1 Level	No	No	
	Tray	1 EA	1 EA	1 EA	1 EA	
	Rack	Wire Rack 1 EA	Wire Rack 1 EA	Wire Rack 1 EA	Wire Rack 1 EA	
	Rotisserie Spit	No	No	No	No	
	Meat Probe	No	No	No	No	
	Cookbook (CD)	No	No	No	No	
Application Dimensions						
Dimension (W x H x D)	Outside	595 x 595 x 566	595 x 595 x 566	595 x 595 x 566	595 x 595 x 566	
	Cutout	560 x 572 x 545	560 x 572 x 545	560 x 572 x 545	560 x 572 x 545	
	Shipping	682 x 645.5 x 656	682 x 645.5 x 656	682 x 645.5 x 656	682 x 645.5 x 656	
Capacity	Net Volume	70L	70L	66L	66L	
	Net Volume (Upper or Lower)	30 / 32L	30 / 32L	30 / 32L	30 / 32L	
Loading Quantity	40ft HQ / 40ft / 20ft	216 / 162 / 72	216 / 162 / 72	216 / 162 / 72	216 / 162 / 72	

Models

Dual Cook



Model Code		NV66M3531BS	NV66M3531BB	NV70H5787CB	NV66H5737LB
Project Name		Defeature Dual Cook	Defeature Dual Cook	Prezzo	Prezzo
Oven Features					
Energy Class		A	A	A	A
Cavity Wall		Forming	Forming	Flat / Side Racks	Forming
Oven Colors		Stainless Steel	Black	Black Glass	Black Glass
Door	Glass panes	Triple	Triple	Triple	Triple
	Opening	Drop Down	Drop Down	Drop Down	Drop Down
Soft Closing Door		No	No	No	No
Interior Lamp (W)		25W (Bulb)	25W (Bulb)	40W / 40W (Halogen)	40W / 40W (Halogen)
Interior Lights (Position)		Rear	Rear	Top / Side	Top / Side
Control	Control Panel Height	115mm	115mm	115mm	115mm
	Display	LED / Ice Blue	LED / Ice Blue	LED / Ice Blue	LED / Ice Blue
Control Method		Pop-up Dial	Pop-up Dial	Touch Glass	Touch Glass
Cleaning Method	Wi-Fi	No	No	No	No
	Pyrolytic	No	No	No	No
	Catalytic	Yes (Back Wall)	Yes (Back Wall)	Yes (Back Wall)	Yes (Back Wall)
	Steam	Steam Cleaning	Steam Cleaning	Steam Cleaning	Steam Cleaning
Grill Heater		Fixed	Fixed	Swing	Swing
Electric Features					
Temp Ranges	Single Convection	40~250°C	40~250°C	40~250°C	40~250°C
	Single Grill	100~270°C	100~270°C	40~270°C	40~270°C
Upper or Lower	Upper or Lower	No	No	40~250°C	40~250°C
	Twin	No	No	170~250°C	170~250°C
Upper Grill (Small / Large)		1600W / 1100W	1600W / 1100W	1600W / 1100W	1600W / 1100W
Bottom Heater		1100W	1100W	1100W	1100W
Convection (Upper / Lower)		1200W / 1200W	1200W / 1200W	1200W / 1200W	1200W / 1200W
Input Power		3650~3950W	3650~3950W	3650W	3650W
Over Voltage Protection		Yes	Yes	Yes	Yes
Cooking Modes					
Single Mode	Oven Modes				
	Conventional	40~250°C	40~250°C	40~250°C	40~250°C
Convection		40~250°C	40~250°C	40~250°C	40~250°C
Eco Convection		No	No	No	No
Large Grill		100~270°C	100~270°C	40~270°C	40~270°C
Eco Grill		100~270°C	100~270°C	40~270°C	40~270°C
Fan Grill		100~270°C	100~270°C	No	No
Bottom Heat + Convection		40~250°C	40~250°C	40~250°C	40~250°C
Top Heat + Convection		40~250°C	40~250°C	40~250°C	40~250°C
Bottom Heat		100~230°C	100~230°C	No	No
Intensive Cook		No	No	No	No
Pro-roasting		80~200°C	80~200°C	No	No
Special Function					
Vapour + Convection		No	No	No	No
Vapour Top Heat + Convection		No	No	No	No
Vapour Bottom Heat + Convection		No	No	No	No
Steam Cook		No	No	No	No
Steam Assist		No	No	No	No
Keep Warm		No	No	No	No
Plate Warm		No	No	No	No
Defrost		No	No	No	No
Prove Dough		No	No	No	No
Slow Cook		No	No	No	No
Drying		No	No	No	No
Auto Cook Recipes		25 EA	25 EA	40 EA	40 EA
Favorite (=Memory Cook)		No	No	No	No
Upper Mode	Convection	40~250°C	40~250°C	40~250°C	40~250°C
	Top Heat + Convection	40~250°C	40~250°C	40~250°C	40~250°C
Large Grill		200~250°C	200~250°C	40~250°C	40~250°C
Lower Mode	Convection	40~250°C	40~250°C	40~250°C	40~250°C
	Bottom Heat	100~230°C	100~230°C	No	No
Bottom Heat + Convection		40~250°C	40~250°C	40~250°C	40~250°C
Steam Cook		No	No	No	No
Steam Assist		No	No	No	No
Twin Mode	(Upper) Mode x (Lower) Mode	3 Mode x 3 Mode = 9 EA	3 Mode x 3 Mode = 9 EA	3 Mode x 3 Mode = 9 EA	3 Mode x 2 Mode = 6 EA
Control Features					
Clock		Yes	Yes	Yes	Yes
Child Safety Lock		Yes	Yes	Yes	Yes
Count Timer		Yes	Yes	Yes	Yes
Cook Time		Yes	Yes	Yes	Yes
End Time		Yes	Yes	No	No
Language Option		No	No	No	No
Sound		Yes	Yes	Yes	Yes
Equipment Supplied					
Accessory	Telescopic	No	No	2 Level	No
	Tray	1 EA	1 EA	1 EA	1 EA
	Rack	Wire Rack 1 EA	Wire Rack 1 EA	Wire Rack 1 EA, Wire Inlay 1 EA	Wire Rack 1 EA, Wire Inlay 1 EA
	Rotisserie Spit	No	No	No	No
	Meat Probe	No	No	No	No
	Cookbook (CD)	No	No	No	No
Application Dimensions					
Dimension (W x H x D)	Outside	595 x 595 x 566	595 x 595 x 566	595 x 595 x 566	595 x 595 x 566
	Cutout	560 x 572 x 545	560 x 572 x 545	560 x 572 x 545	560 x 572 x 545
	Shipping	682 x 645.5 x 656	682 x 645.5 x 656	682 x 645.5 x 656	682 x 645.5 x 656
Capacity	Net Volume	66L	66L	70L	66L
	Net Volume (Upper or Lower)	30 / 32L	30 / 32L	30 / 32L	30 / 32L
Loading Quantity	40ft HQ / 40ft / 20ft	216 / 162 / 72	216 / 162 / 72	216 / 162 / 72	216 / 162 / 72

Models

Convection Cook



Model Code		NV75J5170BS	NV75J3140RS	NV75J3140BS	NV75J3140BB	
Project Name		NV9900J	NV9900J	NV9900J	NV9900J	
Oven Features						
Energy Class		A+	A	A	A	
Cavity Wall		Flat / Side Racks	Flat / Side Racks	Flat / Side Racks	Flat / Side Racks	
Oven Colors		Stainless Steel	Stainless Steel	Stainless Steel	Black Coated	
Door	Glass panes	Quadruple	Triple	Triple	Triple	
	Opening	Drop Down	Drop Down	Drop Down	Drop Down	
	Soft Closing Door	Soft Close	Soft Close	Soft Close	Soft Close	
Interior Lamp (W)		40W (Halogen)	25W (Halogen)	25W (Halogen)	25W (Halogen)	
Interior Lights (Position)		Top	Top	Top	Top	
Control	Control Panel Height	85mm	85mm	85mm	85mm	
	Display	LED / Ice Blue	LED / Ice Blue	LED / Ice Blue	LED / Ice Blue	
	Control Method	Pop-up Dial (with Touch Buttons)	Pop-up Dial (with Touch Buttons)	Pop-up Dial (with Touch Buttons)	Pop-up Dial (with Touch Buttons)	
Cleaning Method	Wi-Fi	No	No	No	No	
	Pyrolytic	Pyrolytic	No	No	No	
	Catalytic	No	Yes (Back Wall)	Yes (Back Wall)	Yes (Back Wall)	
	Steam	Steam Cleaning	No	No	No	
	Grill Heater	Fixed	Swing	Swing	Swing	
Electric Features						
Temp Ranges	Single Convection	30~275°C	50~250°C	50~250°C	50~250°C	
	Single Grill	100~300°C	1 / 2 / 3	1 / 2 / 3	1 / 2 / 3	
	Upper or Lower	No	No	No	No	
Upper Grill (Small / Large)	Twin	No	No	No	No	
		1600W / 1100W	1600W / 1100W	1600W / 1100W	1600W / 1100W	
Bottom Heater		1100W	1100W	1100W	1100W	
Convection (Upper / Lower)		1800W	1800W	1800W	1800W	
Input Power		3500~3850W	3500~3850W	3500~3850W	3500~3850W	
Over Voltage Protection		Yes	Yes	Yes	Yes	
Cooking Modes						
Single Mode	Oven Modes					
	Conventional	30~275°C	50~250°C	50~250°C	50~250°C	
	Convection	30~275°C	50~250°C	50~250°C	50~250°C	
	Eco Convection	30~275°C	No	No	No	
	Large Grill	100~300°C	1 / 2 / 3	1 / 2 / 3	1 / 2 / 3	
	Eco Grill	100~300°C	No	No	No	
	Fan Grill	No	No	No	No	
	Bottom Heat + Convection	40~275°C	50~250°C	50~250°C	50~250°C	
	Top Heat + Convection	40~275°C	50~250°C	50~250°C	50~250°C	
	Bottom Heat	100~230°C	No	No	No	
	Intensive Cook	No	No	No	No	
	Pro-roasting	80~200°C	No	No	No	
	Special Function					
	Vapour + Convection	No	No	No	No	
	Vapour Top Heat + Convection	No	No	No	No	
	Vapour Bottom Heat + Convection	No	No	No	No	
	Steam Cook	No	No	No	No	
	Steam Assist	No	No	No	No	
	Keep Warm	40~100°C	No	No	No	
	Plate Warm	30~80°C	No	No	No	
	Defrost	No	No	No	No	
	Prove Dough	No	No	No	No	
	Slow Cook	No	No	No	No	
	Drying	No	No	No	No	
	Auto Cook Recipes	20 EA	No	No	No	
	Favorite (=Memory Cook)	No	No	No	No	
	Upper Mode	Convection	No	No	No	No
		Top Heat + Convection	No	No	No	No
		Large Grill	No	No	No	No
	Lower Mode	Convection	No	No	No	No
Bottom Heat		No	No	No	No	
Bottom Heat + Convection		No	No	No	No	
Steam Cook		No	No	No	No	
Twin Mode	Steam Assist	No	No	No	No	
	(Upper) Mode x (Lower) Mode	No	No	No	No	
Control Features						
Accessories	Clock	Yes	Yes	Yes	Yes	
	Child Safety Lock	Yes	Yes	Yes	Yes	
	Count Timer	Yes	No	No	No	
	Cook Time	Yes	No	No	No	
	End Time	Yes	No	No	No	
	Language Option	No	No	No	No	
	Sound	Yes	Yes	Yes	Yes	
Equipment Supplied						
Accessory	Telescopic	No	1 Level	No	No	
	Tray	2 EA	2 EA	2 EA	2 EA	
	Rack	Wire Rack 1 EA	Wire Rack 1 EA	Wire Rack 1 EA	Wire Rack 1 EA	
	Rotisserie Spit	No	No	No	No	
	Meat Probe	No	No	No	No	
	Cookbook (CD)	Yes	No	No	No	
Application Dimensions						
Dimension (W x H x D)	Outside	595 x 595 x 566	595 x 595 x 566	595 x 595 x 566	595 x 595 x 566	
	Cutout	560 x 572 x 545	560 x 572 x 545	560 x 572 x 545	560 x 572 x 545	
	Shipping	682 x 645.5 x 656	682 x 645.5 x 656	682 x 645.5 x 656	682 x 645.5 x 656	
Capacity	Net Volume	75L	75L	75L	75L	
	Net Volume (Upper or Lower)	No	No	No	No	
Loading Quantity	40ft HQ / 40ft / 20ft	216 / 162 / 72	216 / 162 / 72	216 / 162 / 72	216 / 162 / 72	

Models

Dual Fan



Model Code		NV75K3340RS	NV75K3340RG	NV75K3340RB	NV75K3340RW
Project Name		Dual Fan	Dual Fan	Dual Fan	Dual Fan
Oven Features					
Energy Class		A	A	A	A
Cavity Wall		Flat / Side Racks	Flat / Side Racks	Flat / Side Racks	Flat / Side Racks
Oven Colors		Stainless Steel	Black Stainless Steel	Black Coated	White Coated
Door	Glass panes	Triple	Triple	Triple	Triple
	Opening	Drop Down	Drop Down	Drop Down	Drop Down
Soft Closing Door		No	No	No	No
Interior Lamp (W)		40W (Halogen)	40W (Halogen)	40W (Halogen)	40W (Halogen)
Interior Lights (Position)		Top	Top	Top	Top
Control	Control Panel Height	85mm	85mm	85mm	85mm
	Display	LED / Ice Blue	LED / Ice Blue	LED / Ice Blue	LED / Ice Blue
Control Method		Pop-up Dial	Pop-up Dial	Pop-up Dial	Pop-up Dial
Cleaning Method	Wi-Fi	No	No	No	No
	Pyrolytic	No	No	No	No
	Catalytic	Yes (Back Wall)	Yes (Back Wall)	Yes (Back Wall)	Yes (Back Wall)
	Steam	No	No	No	No
Grill Heater		Fixed	Fixed	Fixed	Fixed
Electric Features					
Temp Ranges	Single Convection	50~250°C	50~250°C	50~250°C	50~250°C
	Single Grill	1 / 2 / 3	1 / 2 / 3	1 / 2 / 3	1 / 2 / 3
Upper or Lower	Upper	No	No	No	No
	Lower	No	No	No	No
Twin		No	No	No	No
Upper Grill (Small / Large)		1600W / 1100W	1600W / 1100W	1600W / 1100W	1600W / 1100W
Bottom Heater		1100W	1100W	1100W	1100W
Convection (Upper / Lower)		1200W / 1200W	1200W / 1200W	1200W / 1200W	1200W / 1200W
Input Power		3500~3850W	3500~3850W	3500~3850W	3500~3850W
Over Voltage Protection		Yes	Yes	Yes	Yes
Cooking Modes					
Single Mode		Oven Modes	Oven Modes	Oven Modes	Oven Modes
Conventional		50~250°C	50~250°C	50~250°C	50~250°C
Convection		50~250°C	50~250°C	50~250°C	50~250°C
Eco Convection		No	No	No	No
Large Grill		1 / 2 / 3	1 / 2 / 3	1 / 2 / 3	1 / 2 / 3
Eco Grill		No	No	No	No
Fan Grill		No	No	No	No
Bottom Heat + Convection		50~250°C	50~250°C	50~250°C	50~250°C
Top Heat + Convection		50~250°C	50~250°C	50~250°C	50~250°C
Bottom Heat		No	No	No	No
Intensive Cook		No	No	No	No
Pro-roasting		No	No	No	No
Special Function					
Vapour + Convection		No	No	No	No
Vapour Top Heat + Convection		No	No	No	No
Vapour Bottom Heat + Convection		No	No	No	No
Steam Cook		No	No	No	No
Steam Assist		No	No	No	No
Keep Warm		No	No	No	No
Plate Warm		No	No	No	No
Defrost		No	No	No	No
Prove Dough		No	No	No	No
Slow Cook		No	No	No	No
Drying		No	No	No	No
Auto Cook Recipes		No	No	No	No
Favorite (=Memory Cook)		No	No	No	No
Upper Mode	Convection	No	No	No	No
	Top Heat + Convection	No	No	No	No
	Large Grill	No	No	No	No
Lower Mode	Convection	No	No	No	No
	Bottom Heat	No	No	No	No
	Bottom Heat + Convection	No	No	No	No
Steam Cook		No	No	No	No
Steam Assist		No	No	No	No
Twin Mode		(Upper) Mode x (Lower) Mode	No	No	No
Control Features					
Clock		Yes	Yes	Yes	Yes
Child Safety Lock		Yes	Yes	Yes	Yes
Count Timer		Yes	Yes	Yes	Yes
Cook Time		Yes	Yes	Yes	Yes
End Time		Yes	Yes	Yes	Yes
Language Option		No	No	No	No
Sound		Yes	Yes	Yes	Yes
Equipment Supplied					
Accessory		Telescopic	Telescopic	Telescopic	Telescopic
Tray		1 Level	1 Level	1 Level	1 Level
Rack		1 EA	1 EA	1 EA	1 EA
Wire Rack 2 EA		Wire Rack 2 EA	Wire Rack 2 EA	Wire Rack 2 EA	Wire Rack 2 EA
Rotisserie Spit		No	No	No	No
Meat Probe		No	No	No	No
Cookbook (CD)		No	No	No	No
Application Dimensions					
Dimension (W x H x D)		Outside	595 x 595 x 566	595 x 595 x 566	595 x 595 x 566
Cutout		560 x 572 x 545	560 x 572 x 545	560 x 572 x 545	560 x 572 x 545
Shipping		682 x 645.5 x 656	682 x 645.5 x 656	682 x 645.5 x 656	682 x 645.5 x 656
Capacity	Net Volume	75L	75L	75L	75L
	Net Volume (Upper or Lower)	No	No	No	No
Loading Quantity		40ft HQ / 40ft / 20ft	216 / 162 / 72	216 / 162 / 72	216 / 162 / 72

Models Dual Fan



Model Code		NV70M3372RS	NV70M3372BS	NV70M3373BS	NV70M3372BB
Project Name		New Metro	New Metro	New Metro	New Metro
Oven Features					
Energy Class		A	A	A	A
Cavity Wall		Flat / Side Racks	Flat / Side Racks	Flat / Side Racks	Flat / Side Racks
Oven Colors		Stainless Steel	Stainless Steel	Stainless Steel	Black
Door	Glass panes	Triple	Triple	Triple	Triple
	Opening	Drop Down	Drop Down	Drop Down	Drop Down
	Soft Closing Door	No	No	No	No
Interior Lamp (W)		25W (Halogen)	25W (Halogen)	25W (Halogen)	25W (Halogen)
Interior Lights (Position)		Side	Side	Side	Side
Control	Control Panel Height	115mm	115mm	115mm	115mm
	Display	LED / Ice Blue	LED / Ice Blue	LED / Ice Blue	LED / Ice Blue
	Control Method	Pop-up Dial	Pop-up Dial	Pop-up Dial	Pop-up Dial
Cleaning Method	Wi-Fi	No	No	No	No
	Pyrolytic	Pyrolytic	Pyrolytic	Pyrolytic	Pyrolytic
	Catalytic	No	No	No	No
	Steam	Steam Cleaning	Steam Cleaning	Steam Cleaning	Steam Cleaning
Grill Heater		Fixed	Fixed	Fixed	Fixed
Electric Features					
Temp Ranges	Single Convection	30~250°C	30~250°C	30~250°C	30~250°C
	Single Grill	100~250°C	100~250°C	100~250°C	100~250°C
	Upper or Lower	No	No	No	No
	Twin	No	No	No	No
Upper Grill (Small / Large)		1600W / 1100W	1600W / 1100W	1600W / 1100W	1600W / 1100W
Bottom Heater		1100W	1100W	1100W	1100W
Convection (Upper / Lower)		1700W	1700W	1700W	1700W
Input Power		3400~3600W	3400~3600W	3400~3600W	3400~3600W
Over Voltage Protection		Yes	Yes	Yes	Yes
Cooking Modes					
Single Mode	Oven Modes				
	Conventional	30~250°C	30~250°C	30~250°C	30~250°C
	Convection	30~250°C	30~250°C	30~250°C	30~250°C
	Eco Convection	30~250°C	30~250°C	30~250°C	30~250°C
	Large Grill	100~250°C	100~250°C	100~250°C	100~250°C
	Eco Grill	100~250°C	100~250°C	100~250°C	100~250°C
	Fan Grill	No	No	No	No
	Bottom Heat + Convection	40~250°C	40~250°C	40~250°C	40~250°C
	Top Heat + Convection	40~250°C	40~250°C	40~250°C	40~250°C
	Bottom Heat	100~230°C	100~230°C	100~230°C	100~230°C
	Intensive Cook	No	No	No	No
	Pro-roasting	80~200°C	80~200°C	80~200°C	80~200°C
	Special Function				
	Vapour + Convection	No	No	No	No
	Vapour Top Heat + Convection	No	No	No	No
	Vapour Bottom Heat + Convection	No	No	No	No
	Steam Cook	No	No	No	No
	Steam Assist	No	No	No	No
	Keep Warm	No	No	No	No
	Plate Warm	No	No	No	No
	Defrost	No	No	No	No
	Prove Dough	No	No	No	No
	Slow Cook	No	No	No	No
	Drying	No	No	No	No
	Auto Cook Recipes	20 EA	20 EA	20 EA	20 EA
	Favorite (=Memory Cook)	No	No	No	No
	Upper Mode	Convection	No	No	No
Top Heat + Convection		No	No	No	No
Large Grill		No	No	No	No
Lower Mode	Convection	No	No	No	No
	Bottom Heat	No	No	No	No
	Bottom Heat + Convection	No	No	No	No
	Steam Cook	No	No	No	No
	Steam Assist	No	No	No	No
Twin Mode	(Upper) Mode x (Lower) Mode	No	No	No	No
Control Features					
	Clock	Yes	Yes	Yes	Yes
	Child Safety Lock	Yes	Yes	Yes	Yes
	Count Timer	Yes	Yes	Yes	Yes
	Cook Time	Yes	Yes	Yes	Yes
	End Time	Yes	Yes	Yes	Yes
	Language Option	No	No	No	No
	Sound	Yes	Yes	Yes	Yes
Equipment Supplied					
Accessory	Telescopic	1 Level	No	No	No
	Tray	1 EA	1 EA	2 EA	1 EA
	Rack	Wire Rack 1 EA	Wire Rack 1 EA	Wire Rack 1 EA	Wire Rack 1 EA
	Rotisserie Spit	No	No	No	No
	Meat Probe	Yes	Yes	Yes	Yes
	Cookbook (CD)	No	No	No	No
Application Dimensions					
Dimension (W x H x D)	Outside	595 x 595 x 566	595 x 595 x 566	595 x 595 x 566	595 x 595 x 566
	Cutout	560 x 572 x 545	560 x 572 x 545	560 x 572 x 545	560 x 572 x 545
	Shipping	682 x 645.5 x 656	682 x 645.5 x 656	682 x 645.5 x 656	682 x 645.5 x 656
Capacity	Net Volume	70L	70L	70L	70L
	Net Volume (Upper or Lower)	No	No	No	No
Loading Quantity	40ft HQ / 40ft / 20ft	216 / 162 / 72	216 / 162 / 72	216 / 162 / 72	216 / 162 / 72

Models

Dual Fan



Model Code		NV70K3370RS	NV70K3370BS	NV70K3370BB
Project Name		New Metro	New Metro	New Metro
Oven Features				
Energy Class		A	A	A
Cavity Wall		Flat / Side Racks	Flat / Side Racks	Flat / Side Racks
Oven Colors		Stainless Steel	Stainless Steel	Black
Door	Glass panes	Triple	Triple	Triple
	Opening	Drop Down	Drop Down	Drop Down
Soft Closing Door		No	No	No
Interior Lamp (W)		25W (Halogen)	25W (Halogen)	25W (Halogen)
Interior Lights (Position)		Side	Side	Side
Control	Control Panel Height	115mm	115mm	115mm
	Display	LED / Ice Blue	LED / Ice Blue	LED / Ice Blue
	Control Method	Pop-up Dial	Pop-up Dial	Pop-up Dial
	Wi-Fi	No	No	No
Cleaning Method	Pyrolytic	Pyrolytic	Pyrolytic	Pyrolytic
	Catalytic	No	No	No
	Steam	Steam Cleaning	Steam Cleaning	Steam Cleaning
	Grill Heater	Fixed	Fixed	Fixed
Electric Features				
Temp Ranges	Single Convection	30~250°C	30~250°C	30~250°C
	Single Grill	100~250°C	100~250°C	100~250°C
	Upper or Lower	No	No	No
	Twin	No	No	No
Upper Grill (Small / Large)		1600W / 1100W	1600W / 1100W	1600W / 1100W
Bottom Heater		1100W	1100W	1100W
Convection (Upper / Lower)		1700W	1700W	1700W
Input Power		3400~3600W	3400~3600W	3400~3600W
Over Voltage Protection		Yes	Yes	Yes
Cooking Modes				
Single Mode	Oven Modes			
	Conventional	30~250°C	30~250°C	30~250°C
	Convection	30~250°C	30~250°C	30~250°C
	Eco Convection	30~250°C	30~250°C	30~250°C
	Large Grill	100~250°C	100~250°C	100~250°C
	Eco Grill	100~250°C	100~250°C	100~250°C
	Fan Grill	No	No	No
	Bottom Heat + Convection	40~250°C	40~250°C	40~250°C
	Top Heat + Convection	40~250°C	40~250°C	40~250°C
	Bottom Heat	100~230°C	100~230°C	100~230°C
	Intensive Cook	No	No	No
	Pro-roasting	80~200°C	80~200°C	80~200°C
	Special Function			
	Vapour + Convection	No	No	No
	Vapour Top Heat + Convection	No	No	No
	Vapour Bottom Heat + Convection	No	No	No
	Steam Cook	No	No	No
	Steam Assist	No	No	No
	Keep Warm	No	No	No
	Plate Warm	No	No	No
	Defrost	No	No	No
	Prove Dough	No	No	No
	Slow Cook	No	No	No
	Drying	No	No	No
	Auto Cook Recipes	20 EA	20 EA	20 EA
	Favorite (=Memory Cook)	No	No	No
	Upper Mode	Convection	No	No
Top Heat + Convection		No	No	No
Large Grill		No	No	No
Lower Mode	Convection	No	No	No
	Bottom Heat	No	No	No
	Bottom Heat + Convection	No	No	No
	Steam Cook	No	No	No
	Steam Assist	No	No	No
Twin Mode	(Upper) Mode x (Lower) Mode	No	No	No
Control Features				
	Clock	Yes	Yes	Yes
	Child Safety Lock	Yes	Yes	Yes
	Count Timer	Yes	Yes	Yes
	Cook Time	Yes	Yes	Yes
	End Time	Yes	Yes	Yes
	Language Option	No	No	No
	Sound	Yes	Yes	Yes
Equipment Supplied				
Accessory	Telescopic	1 Level	No	No
	Tray	1 EA	1 EA	1 EA
	Rack	Wire Rack 1 EA	Wire Rack 1 EA	Wire Rack 1 EA
	Rotisserie Spit	No	No	No
	Meat Probe	No	No	No
	Cookbook (CD)	No	No	No
Application Dimensions				
Dimension (W x H x D)	Outside	595 x 595 x 566	595 x 595 x 566	595 x 595 x 566
	Cutout	560 x 572 x 545	560 x 572 x 545	560 x 572 x 545
	Shipping	682 x 645.5 x 656	682 x 645.5 x 656	682 x 645.5 x 656
Capacity	Net Volume	70L	70L	70L
	Net Volume (Upper or Lower)	No	No	No
Loading Quantity	40ft HQ / 40ft / 20ft	216 / 162 / 72	216 / 162 / 72	216 / 162 / 72

Models Dual Fan



Model Code		NV70K2340RS	NV70K2340RM	NV70K2340RG	NV70K2340RB	
Project Name		New Metro	New Metro	New Metro	New Metro	
Oven Features						
Energy Class		A	A	A	A	
Cavity Wall		Flat / Side Racks	Flat / Side Racks	Flat / Side Racks	Flat / Side Racks	
Oven Colors		Stainless Steel	Black Stainless Steel	Black Stainless Steel	Black Coated	
Door	Glass panes	Triple	Triple	Triple	Triple	
	Opening	Drop Down	Drop Down	Drop Down	Drop Down	
	Soft Closing Door	No	No	No	No	
Interior Lamp (W)		25W (Halogen)	25W (Halogen)	25W (Halogen)	25W (Halogen)	
Interior Lights (Position)		Side	Side	Side	Side	
Control	Control Panel Height	115mm	115mm	115mm	115mm	
	Display	LED / Ice Blue	LED / Ice Blue	LED / Ice Blue	LED / Ice Blue	
	Control Method	Pop-up Dial	Pop-up Dial	Pop-up Dial	Pop-up Dial	
Cleaning Method	Wi-Fi	No	No	No	No	
	Pyrolytic	No	No	No	No	
	Catalytic	Yes (Back Wall)	Yes (Back Wall)	Yes (Back Wall)	Yes (Back Wall)	
	Steam	Steam Cleaning	Steam Cleaning	Steam Cleaning	Steam Cleaning	
Grill Heater		Swing	Swing	Swing	Swing	
Electric Features						
Temp Ranges	Single Convection	30~250°C	30~250°C	30~250°C	30~250°C	
	Single Grill	100~250°C	100~250°C	100~250°C	100~250°C	
	Upper or Lower	No	No	No	No	
Twin		No	No	No	No	
Upper Grill (Small / Large)		1600W / 1100W	1600W / 1100W	1600W / 1100W	1600W / 1100W	
Bottom Heater		1100W	1100W	1100W	1100W	
Convection (Upper / Lower)		1700W	1700W	1700W	1700W	
Input Power		3400~3600W	3400~3600W	3400~3600W	3400~3600W	
Over Voltage Protection		Yes	Yes	Yes	Yes	
Cooking Modes						
Single Mode	Oven Modes					
	Conventional	30~250°C	30~250°C	30~250°C	30~250°C	
	Convection	30~250°C	30~250°C	30~250°C	30~250°C	
	Eco Convection	30~250°C	30~250°C	30~250°C	30~250°C	
	Large Grill	100~250°C	100~250°C	100~250°C	100~250°C	
	Eco Grill	100~250°C	100~250°C	100~250°C	100~250°C	
	Fan Grill	No	No	No	No	
	Bottom Heat + Convection	40~250°C	40~250°C	40~250°C	40~250°C	
	Top Heat + Convection	40~250°C	40~250°C	40~250°C	40~250°C	
	Bottom Heat	100~230°C	100~230°C	100~230°C	100~230°C	
	Intensive Cook	No	No	No	No	
	Pro-roasting	80~200°C	80~200°C	80~200°C	80~200°C	
	Special Function					
	Vapour + Convection	No	No	No	No	
	Vapour Top Heat + Convection	No	No	No	No	
	Vapour Bottom Heat + Convection	No	No	No	No	
	Steam Cook	No	No	No	No	
	Steam Assist	No	No	No	No	
	Keep Warm	No	No	No	No	
	Plate Warm	No	No	No	No	
	Defrost	No	No	No	No	
	Prove Dough	No	No	No	No	
	Slow Cook	No	No	No	No	
	Drying	No	No	No	No	
	Auto Cook Recipes	20 EA	20 EA	20 EA	20 EA	
	Favorite (=Memory Cook)	No	No	No	No	
	Upper Mode	Convection	No	No	No	No
		Top Heat + Convection	No	No	No	No
		Large Grill	No	No	No	No
	Lower Mode	Convection	No	No	No	No
		Bottom Heat	No	No	No	No
		Bottom Heat + Convection	No	No	No	No
		Steam Cook	No	No	No	No
Steam Assist		No	No	No	No	
Twin Mode	(Upper) Mode x (Lower) Mode		No	No	No	
			No	No	No	
Control Features						
Clock		Yes	Yes	Yes	Yes	
Child Safety Lock		Yes	Yes	Yes	Yes	
Count Timer		Yes	Yes	Yes	Yes	
Cook Time		Yes	Yes	Yes	Yes	
End Time		Yes	Yes	Yes	Yes	
Language Option		No	No	No	No	
Sound		Yes	Yes	Yes	Yes	
Equipment Supplied						
Accessory	Telescopic	1 Level	1 Level	1 Level	1 Level	
	Tray	1 EA	1 EA	1 EA	1 EA	
	Rack	Wire Rack 1 EA	Wire Rack 1 EA	Wire Rack 1 EA	Wire Rack 1 EA	
	Rotisserie Spit	No	No	No	No	
	Meat Probe	No	No	No	No	
	Cookbook (CD)	No	No	No	No	
Application Dimensions						
Dimension (W x H x D)	Outside	595 x 595 x 566	595 x 595 x 566	595 x 595 x 566	595 x 595 x 566	
	Cutout	560 x 572 x 545	560 x 572 x 545	560 x 572 x 545	560 x 572 x 545	
	Shipping	682 x 645.5 x 656	682 x 645.5 x 656	682 x 645.5 x 656	682 x 645.5 x 656	
Capacity	Net Volume	70L	70L	70L	70L	
	Net Volume (Upper or Lower)	No	No	No	No	
Loading Quantity	40ft HQ / 40ft / 20ft	216 / 162 / 72	216 / 162 / 72	216 / 162 / 72	216 / 162 / 72	

Models

Dual Fan



Model Code		NV70K1340BS	NV70K1340BG	NV70K1340BB	NV70K1340BW
Project Name		New Metro	New Metro	New Metro	New Metro
Oven Features					
Energy Class		A	A	A	A
Cavity Wall		Flat / Side Racks	Flat / Side Racks	Flat / Side Racks	Flat / Side Racks
Oven Colors		Stainless Steel	Black Stainless Steel	Black Coated	White Coated
Door	Glass panes	Triple	Triple	Triple	Triple
	Opening	Drop Down	Drop Down	Drop Down	Drop Down
Soft Closing Door		No	No	No	No
Interior Lamp (W)		25W (Halogen)	25W (Halogen)	25W (Halogen)	25W (Halogen)
Interior Lights (Position)		Side	Side	Side	Side
Control	Control Panel Height	115mm	115mm	115mm	115mm
	Display	LED / Ice Blue	LED / Ice Blue	LED / Ice Blue	LED / Ice Blue
	Control Method	Non Pop-up Dial	Non Pop-up Dial	Non Pop-up Dial	Non Pop-up Dial
Cleaning Method	Wi-Fi	No	No	No	No
	Pyrolytic	No	No	No	No
	Catalytic	Yes (Back Wall)	Yes (Back Wall)	Yes (Back Wall)	Yes (Back Wall)
	Steam	No	No	No	No
Grill Heater		Fixed	Fixed	Fixed	Fixed
Electric Features					
Temp Ranges	Single Convection	50~250°C	50~250°C	50~250°C	50~250°C
	Single Grill	1 / 2 / 3 Level	1 / 2 / 3 Level	1 / 2 / 3 Level	1 / 2 / 3 Level
	Upper or Lower	No	No	No	No
	Twin	No	No	No	No
Upper Grill (Small / Large)		1600W / 700W	1600W / 700W	1600W / 700W	1600W / 700W
Bottom Heater		600W	600W	600W	600W
Convection (Upper / Lower)		1700W	1700W	1700W	1700W
Input Power		3400~3600W	3400~3600W	3400~3600W	3400~3600W
Over Voltage Protection		No	No	No	No
Cooking Modes					
Single Mode	Oven Modes				
	Conventional	50~250°C	50~250°C	50~250°C	50~250°C
	Convection	50~250°C	50~250°C	50~250°C	50~250°C
	Eco Convection	No	No	No	No
	Large Grill	1 / 2 / 3	1 / 2 / 3	1 / 2 / 3	1 / 2 / 3
	Eco Grill	No	No	No	No
	Fan Grill	No	No	No	No
	Bottom Heat + Convection	50~250°C	50~250°C	50~250°C	50~250°C
	Top Heat + Convection	50~250°C	50~250°C	50~250°C	50~250°C
	Bottom Heat	No	No	No	No
	Intensive Cook	No	No	No	No
	Pro-roasting	No	No	No	No
	Special Function				
	Vapour + Convection	No	No	No	No
	Vapour Top Heat + Convection	No	No	No	No
	Vapour Bottom Heat + Convection	No	No	No	No
	Steam Cook	No	No	No	No
	Steam Assist	No	No	No	No
	Keep Warm	No	No	No	No
	Plate Warm	No	No	No	No
	Defrost	No	No	No	No
	Prove Dough	No	No	No	No
	Slow Cook	No	No	No	No
	Drying	No	No	No	No
	Auto Cook Recipes	No	No	No	No
	Favorite (=Memory Cook)	No	No	No	No
	Upper Mode	Convection	No	No	No
Top Heat + Convection		No	No	No	No
Large Grill		No	No	No	No
Lower Mode	Convection	No	No	No	No
	Bottom Heat	No	No	No	No
	Bottom Heat + Convection	No	No	No	No
	Steam Cook	No	No	No	No
Twin Mode	Steam Assist	No	No	No	No
	(Upper) Mode x (Lower) Mode	No	No	No	No
Control Features					
Clock		Yes	Yes	Yes	Yes
Child Safety Lock		Yes	Yes	Yes	Yes
Count Timer		Yes	Yes	Yes	Yes
Cook Time		Yes	Yes	Yes	Yes
End Time		No	No	No	No
Language Option		No	No	No	No
Sound		Yes	Yes	Yes	Yes
Equipment Supplied					
Accessory	Telescopic	No	No	No	No
	Tray	1 EA	1 EA	1 EA	1 EA
	Rack	Wire Rack 1 EA	Wire Rack 1 EA	Wire Rack 1 EA	Wire Rack 1 EA
	Rotisserie Spit	No	No	No	No
	Meat Probe	No	No	No	No
	Cookbook (CD)	No	No	No	No
Application Dimensions					
Dimension (W x H x D)	Outside	595 x 595 x 566	595 x 595 x 566	595 x 595 x 566	595 x 595 x 566
	Cutout	560 x 572 x 545	560 x 572 x 545	560 x 572 x 545	560 x 572 x 545
	Shipping	682 x 645.5 x 656	682 x 645.5 x 656	682 x 645.5 x 656	682 x 645.5 x 656
Capacity	Net Volume	70L	70L	70L	70L
	Net Volume (Upper or Lower)	No	No	No	No
Loading Quantity	40ft HQ / 40ft / 20ft	216 / 162 / 72	216 / 162 / 72	216 / 162 / 72	216 / 162 / 72

Models Dual Fan



Model Code		NV70K1310BS	NV70K1310BB	NV72M1010BS	NV70H5587BB
Project Name		New Metro	New Metro	Conventional (W/O Fan)	Prezio
Oven Features					
Energy Class		A	A	A	A
Cavity Wall		Flat / Side Racks	Flat / Side Racks	Forming	Flat / Side Racks
Oven Colors		Stainless Steel	Black Cotaed	Stainless Steel	Black Glass
Door	Glass panes	Triple	Triple	Triple	Triple
	Opening	Drop Down	Drop Down	Drop Down	Drop Down
	Soft Closing Door	No	No	No	No
Interior Lamp (W)		25W (Halogen)	25W (Halogen)	25W (Bulb)	25W (Bulb)
Interior Lights (Position)		Side	Side	Rear	Rear
Control	Control Panel Height	115mm	115mm	115mm	115mm
	Display	LED / Ice Blue	LED / Ice Blue	LED / Ice Blue	LED / Ice Blue
	Control Method	Non Pop-up Dial	Non Pop-up Dial	Non Pop-up Dial	Touch Glass
	Wi-Fi	No	No	No	No
Cleaning Method	Pyrolytic	No	No	No	No
	Catalytic	No	No	No	Yes (Back Wall)
	Steam	No	No	No	Steam Cleaning
	Grill Heater	Fixed	Fixed	Fixed	Swing
Electric Features					
Temp Ranges	Single Convection	50~250°C	50~250°C	N.A.	40~250°C
	Single Grill	1 / 2 / 3 Level	1 / 2 / 3 Level	1 / 2 / 3 Level	40~300°C
	Upper or Lower	No	No	No	No
	Twin	No	No	No	No
Upper Grill (Small / Large)		1600W / 700W	1600W / 700W	1600W / 700W	1600W / 1100W
Bottom Heater		600W	600W	600W	1100W
Convection (Upper / Lower)		1700W	1700W	No	1700W
Input Power		3400~3600W	3400~3600W	2950~3200W	3400W
Over Voltage Protection		No	No	No	Yes
Cooking Modes					
Single Mode	Oven Modes				
	Conventional	50~250°C	50~250°C	50~250°C	40~250°C
	Convection	50~250°C	50~250°C	No	40~250°C
	Eco Convection	No	No	No	No
	Large Grill	1 / 2 / 3	1 / 2 / 3	1 / 2 / 3	40~300°C
	Eco Grill	No	No	1 / 2 / 3	40~300°C
	Fan Grill	No	No	No	No
	Bottom Heat + Convection	50~250°C	50~250°C	No	40~250°C
	Top Heat + Convection	50~250°C	50~250°C	No	40~250°C
	Bottom Heat	No	No	No	No
	Intensive Cook	No	No	No	No
	Pro-roasting	No	No	No	No
	Special Function				
	Vapour + Convection	No	No	No	No
	Vapour Top Heat + Convection	No	No	No	No
	Vapour Bottom Heat + Convection	No	No	No	No
	Steam Cook	No	No	No	No
	Steam Assist	No	No	No	No
	Keep Warm	No	No	No	No
	Plate Warm	No	No	No	No
	Defrost	No	No	Yes	No
	Prove Dough	No	No	Yes	No
	Slow Cook	No	No	No	No
	Drying	No	No	No	No
	Auto Cook Recipes	No	No	No	25 EA
	Favorite (=Memory Cook)	No	No	No	No
Upper Mode	Convection	No	No	No	No
	Top Heat + Convection	No	No	No	No
	Large Grill	No	No	No	No
Lower Mode	Convection	No	No	No	No
	Bottom Heat	No	No	No	No
	Bottom Heat + Convection	No	No	No	No
	Steam Cook	No	No	No	No
	Steam Assist	No	No	No	No
Twin Mode	(Upper) Mode x (Lower) Mode	No	No	No	No
Control Features					
	Clock	Yes	Yes	Yes	Yes
	Child Safety Lock	Yes	Yes	Yes	Yes
	Count Timer	Yes	Yes	Yes	Yes
	Cook Time	Yes	Yes	Yes	Yes
	End Time	No	No	No	Yes
	Language Option	No	No	No	No
	Sound	Yes	Yes	Yes	No
Equipment Supplied					
Accessory	Telescopic	No	No	No	1 Level
	Tray	1 EA	1 EA	1 EA	1 EA
	Rack	Wire Rack 1 EA	Wire Rack 1 EA	Wire Rack 1 EA	Wire Rack 1 EA, Wire Inlay 1 EA
	Rotisserie Spit	No	No	No	No
	Meat Probe	No	No	No	No
	Cookbook (CD)	No	No	No	No
Application Dimensions					
Dimension (W x H x D)	Outside	595 x 595 x 566	595 x 595 x 566	595 x 595 x 566	595 x 595 x 566
	Cutout	560 x 572 x 545	560 x 572 x 545	560 x 572 x 545	560 x 572 x 545
	Shipping	682 x 645.5 x 656	682 x 645.5 x 656	682 x 645.5 x 656	682 x 645.5 x 656
Capacity	Net Volume	70L	70L	72L	70L
	Net Volume (Upper or Lower)	No	No	No	No
Loading Quantity	40ft HQ / 40ft / 20ft	216 / 162 / 72	216 / 162 / 72	216 / 162 / 72	216 / 162 / 72

Models

Dual Fan



Model Code		NV70H5587CB	NV70H557LB
Project Name		Prezio	Prezio
Oven Features			
Energy Class		A	A
Cavity Wall		Flat / Side Racks	Flat / Side Racks
Oven Colors		Black Glass	Black Glass
Door	Glass panes	Triple	Triple
	Opening	Drop Down	Drop Down
	Soft Closing Door	No	No
Interior Lamp (W)		25W (Bulb)	25W (Bulb)
Interior Lights (Position)		Rear	Rear
Control	Control Panel Height	115mm	115mm
	Display	LED / Ice Blue	LED / Ice Blue
	Control Method	Touch Glass	Touch Glass
	Wi-Fi	No	No
Cleaning Method	Pyrolytic	No	No
	Catalytic	Yes (Back Wall)	Yes (Back Wall)
	Steam	Steam Cleaning	Steam Cleaning
	Grill Heater	Swing	Swing
Electric Features			
Temp Ranges	Single Convection	40~250°C	40~250°C
	Single Grill	40~300°C	40~300°C
	Upper or Lower	No	No
	Twin	No	No
Upper Grill (Small / Large)		1600W / 1100W	1600W / 1100W
Bottom Heater		1100W	1100W
Convection (Upper / Lower)		1700W	1700W
Input Power		3400W	3400W
Over Voltage Protection		Yes	Yes
Cooking Modes			
Single Mode	Oven Modes		
	Conventional	40~250°C	40~250°C
	Convection	40~250°C	40~250°C
	Eco Convection	No	No
	Large Grill	40~300°C	40~300°C
	Eco Grill	40~300°C	40~300°C
	Fan Grill	No	No
	Bottom Heat + Convection	40~250°C	40~250°C
	Top Heat + Convection	40~250°C	40~250°C
	Bottom Heat	No	No
	Intensive Cook	No	No
	Pro-roasting	No	No
	Special Function		
	Vapour + Convection	No	No
	Vapour Top Heat + Convection	No	No
	Vapour Bottom Heat + Convection	No	No
	Steam Cook	No	No
	Steam Assist	No	No
	Keep Warm	No	No
	Plate Warm	No	No
	Defrost	No	No
	Prove Dough	No	No
	Slow Cook	No	No
	Drying	No	No
	Auto Cook Recipes	25 EA	25 EA
	Favorite (=Memory Cook)	No	No
	Upper Mode	Convection	No
Top Heat + Convection		No	No
Large Grill		No	No
Lower Mode	Convection	No	No
	Bottom Heat	No	No
	Bottom Heat + Convection	No	No
	Steam Cook	No	No
Twin Mode	Steam Assist	No	No
	(Upper) Mode x (Lower) Mode	No	No
Control Features			
Clock		Yes	Yes
Child Safety Lock		Yes	Yes
Count Timer		Yes	Yes
Cook Time		Yes	Yes
End Time		Yes	Yes
Language Option		No	No
Sound		No	No
Equipment Supplied			
Accessory	Telescopic	2 Level	No
	Tray	2 EA	2 EA
	Rack	Wire Rack 1 EA, Wire Inlay 1 EA	Wire Rack 1 EA, Wire Inlay 1 EA
	Rotisserie Spit	No	No
	Meat Probe	No	No
	Cookbook (CD)	No	No
	Application Dimensions		
Dimension (W x H x D)	Outside	595 x 595 x 566	595 x 595 x 566
	Cutout	560 x 572 x 545	560 x 572 x 545
	Shipping	682 x 645.5 x 656	682 x 645.5 x 656
Capacity	Net Volume	70L	70L
	Net Volume (Upper or Lower)	No	No
Loading Quantity	40ft HQ / 40ft / 20ft	216 / 162 / 72	216 / 162 / 72

Models

Dual Fan



Model Code		NV70H3350CB	NV70H3350CE	
Project Name		Retro	Retro	
Oven Features				
Energy Class		A	A	
Cavity Wall		Flat / Side Racks	Flat / Side Racks	
Oven Colors		Black	White	
Door	Glass panes	Triple	Triple	
	Opening	Drop Down	Drop Down	
	Soft Closing Door	No	No	
Interior Lamp (W)		25W (Bulb)	25W (Bulb)	
Interior Lights (Position)		Rear	Rear	
Control	Control Panel Height	115mm	115mm	
	Display	LED New Amber	LED New Amber	
	Control Method	Non Pop-up Dial	Non Pop-up Dial	
Cleaning Method	Wi-Fi	No	No	
	Pyrolytic	No	No	
	Catalytic	Yes (Back Wall)	Yes (Back Wall)	
	Steam	No	No	
Grill Heater		Fixed	Fixed	
Electric Features				
Temp Ranges	Single Convection	50-250°C	50-250°C	
	Single Grill	1 / 2 / 3 Level	1 / 2 / 3 Level	
	Upper or Lower	No	No	
	Twin	No	No	
Upper Grill (Small / Large)		1600W / 1100W	1600W / 1100W	
Bottom Heater		1100W	1100W	
Convection (Upper / Lower)		1700W	1700W	
Input Power		3400W	3400W	
Over Voltage Protection		No	No	
Cooking Modes				
Single Mode	Oven Modes			
	Conventional	50-250°C	50-250°C	
	Convection	50-250°C	50-250°C	
	Eco Convection	No	No	
	Large Grill	1 / 2 / 3	1 / 2 / 3	
	Eco Grill	No	No	
	Fan Grill	No	No	
	Bottom Heat + Convection	50-250°C	50-250°C	
	Top Heat + Convection	50-250°C	50-250°C	
	Bottom Heat	No	No	
	Intensive Cook	No	No	
	Pro-roasting	No	No	
	Special Function			
	Vapour + Convection	No	No	
	Vapour Top Heat + Convection	No	No	
	Vapour Bottom Heat + Convection	No	No	
	Steam Cook	No	No	
	Steam Assist	No	No	
	Keep Warm	No	No	
	Plate Warm	No	No	
	Defrost	No	No	
	Prove Dough	No	No	
	Slow Cook	No	No	
	Drying	No	No	
	Auto Cook Recipes	No	No	
	Favorite (=Memory Cook)	No	No	
	Upper Mode	Convection	No	No
		Top Heat + Convection	No	No
		Large Grill	No	No
	Lower Mode	Convection	No	No
Bottom Heat		No	No	
Bottom Heat + Convection		No	No	
Steam Cook		No	No	
Twin Mode	Steam Assist	No	No	
	(Upper) Mode x (Lower) Mode	No	No	
Control Features				
Clock		Yes	Yes	
Child Safety Lock		Yes	Yes	
Count Timer		Yes	Yes	
Cook Time		No	No	
End Time		No	No	
Language Option		No	No	
Sound		No	No	
Equipment Supplied				
Accessory	Telescopic	1 Level	1 Level	
	Tray	2 EA	2 EA	
	Rack	Wire Rack 1 EA, Wire Inlay 1 EA	Wire Rack 1 EA, Wire Inlay 1 EA	
	Rotisserie Spit	No	No	
	Meat Probe	No	No	
	Cookbook (CD)	No	No	
Application Dimensions				
Dimension (W x H x D)	Outside	595 x 595 x 566	595 x 595 x 566	
	Cutout	560 x 572 x 545	560 x 572 x 545	
	Shipping	682 x 645.5 x 656	682 x 645.5 x 656	
Capacity	Net Volume	70L	70L	
	Net Volume (Upper or Lower)	No	No	
Loading Quantity	40ft HQ / 40ft / 20ft	216 / 162 / 72	216 / 162 / 72	

Models

Compact Oven



Model Code		NQ50C7935ES	NQ50J9530BS	NQ50J5530BS	NQ50J3530BS
Oven Features					
Type		Steam Combi	Combi MWO	Combi MWO	Combi MWO
Cavity Material		Ceramic Enamel	Ceramic Enamel	Ceramic Enamel	Ceramic Enamel
Oven Color (Con-panel / Door)		Stainless Steel	Stainless Steel	Stainless Steel	Stainless Steel
Door	Glass	Triple	Triple	Triple	Triple
	Opening	Drop Down	Drop Down	Drop Down	Drop Down
	Handle Color	Stainless Steel	Stainless Steel	Stainless Steel	Stainless Steel
	Prestop Hinge	No	Yes	Yes	Yes
Interior Lamp (Watts)		2 x 25W (Normal)	40W (Halogen)	40W (Halogen)	40W (Halogen)
Interior Lights		Upper Right & Left	Left (Side)	Left (Side)	Left (Side)
Control	Control Panel Height	85 mm	85 mm	85 mm	85 mm
	Display	LED / Ice Blue	4.6" Touch LCD	LED / Ice Blue	LED / Ice Blue
	Control Method	Pop-up Dial (with Touch Buttons)	Touch LCD	Pop-up Dial (with Touch Buttons)	Pop-up Dial (with Touch Buttons)
Cleaning Method	Steam	Yes	Yes	Yes	Yes
	Grill Heater	Fixed	Fixed	Fixed	Fixed
Electric Features					
MWO Watts		No	900 W	800 W	800 W
Oven Temp Ranges		Convection : 40~250°C Grill : 150~250°C	Convection : 40~250°C Grill : 150~250°C	Convection : 40~230°C Grill : 150~230°C	Convection : 40~230°C Grill : 150~230°C
Upper Grill (In / Out)		1400W / 1100W	1400W / 1100W	1400W / 1100W	1400W / 1100W
Lower Grill		1000W	1000W	1000W	1000W
Convection (Upper / Lower)		1000W	1000W	No	No
Fan		2	2	1	1
Input Power		3200W	3200W	3000W	3000W
Cooking Modes					
MWO Mode	MWO	No	Yes	Yes	Yes
	Auto Defrost	No	Yes (5 EA)	Yes (5 EA)	Yes (5 EA)
	Auto Reheat	No	No	No	No
	Keep Warm (MWO)	No	No	No	No
	Power Level (MWO)	No	100/180/300/450/600/750/900	100/180/300/450/600/700/800	100/180/300/450/600/700/800
Combi-MWO Mode (MWO + Oven)	MWO + Grill	No	Yes	Yes	Yes
	MWO + Convection	No	Yes	Yes	Yes
	MWO + Roast	No	Yes	No	No
Oven Mode	Steam Generator	Yes	No	No	No
	Steam + Convection	Yes	No	No	No
	Steam + Reheat	Yes	No	No	No
	Convection	Yes	Yes	Yes	Yes
	Roasting (Convection + Top) Heat	Yes	Yes	No	No
	Conventional	Yes	Yes	No	No
	Grill	Yes	Yes	Yes	Yes
	Fan Grill	Yes	Yes	No	No
	Pizza (Convection + Bottom)	Yes	Yes	No	No
	Intensive (Top + Bottom + Convection)	Yes	Yes	No	No
	Pro-Roasting	Yes	Yes	No	No
	Eco Convection	Yes	No	No	No
Vegetable Function		No	No	Yes	Yes
Multi-level Cook Mode		Yes	Yes	No	No
Keep Warm Mode		Yes	Yes	Yes	Yes
Deodorization		No	No	No	No
Auto Cook Recipes		40 EA (Auto Cook 35 EA, Auto Defrost 5 EA)	40 EA (Auto Cook 31 EA, Speed Cook 4 EA, Auto Defrost 5 EA)	25 EA (Auto Cook 10 EA, Auto Defrost 5 EA, Vegetable 10 EA)	25 EA (Auto Cook 10 EA, Auto Defrost 5 EA, Vegetable 10 EA)
Control Features					
	Clock	Yes	Yes	Yes	Yes
	Child Safety Lock	Yes	Yes	Yes	Yes
	Cook Time	Yes	Yes	Yes	Yes
	End Timer	Yes	Yes	Yes	Yes
	Oven Temp	Yes	Yes	Yes	Yes
	Sound	Buzzer	Buzzer	Buzzer	Buzzer
	Sound On / Off (Hidden)	Yes	Yes	Yes	Yes
	Demo Mode	Yes (Hidden)	Yes (Hidden)	Yes (Hidden)	Yes (Hidden)
Equipment Supplied					
Accessory	Ceramic Tray		1 EA	1 EA	1 EA
	Baking Tray	2 EA	2 EA	1 EA	1 EA
	Wire Rack	1 EA	1 EA	No	No
	Wire Tray Insert	1 EA	1 EA	1 EA	1 EA
	Steam Tray	Yes (Steam Rack 1)	No	1 EA (Pure Steam Bowl)	1 EA (Pure Steam Bowl)
Application Dimensions					
Dimension (W x H x D)	Outside	595 x 454.2 x 570	595 x 454.2 x 570	595 x 454.2 x 570	595 x 454.2 x 570
	Cutout	555 x 445 x 548.8	555 x 445 x 548.8	555 x 445 x 548.8	555 x 445 x 548.8
	Shipping	700 x 578 x 663	700 x 578 x 663	700 x 578 x 663	700 x 578 x 663
Capacity	Usable Capacity	50 L	50 L	50 L	50 L

Models

Compact Oven



Model Code	NQ50K3530BG	NQ50H5537KB	NQ50K5130BS	NQ50K3130BS
Oven Features				
Type	Combi MWO	Combi MWO	MWO Solo	MWO Solo
Cavity Material	Ceramic Enamel	Ceramic Enamel	Ceramic Enamel	Ceramic Enamel
Oven Color (Con-panel / Door)	Black Stainless Steel (Caviar Black)	Black Glass	Stainless Steel	Stainless Steel
Door	Glass	Triple	Triple	Triple
Opening	Drop Down	Drop Down	Drop Down	Drop Down
Handle Color	Stainless Steel	Titanium BLK	Stainless Steel	Stainless Steel
Prestop Hinge	Yes	Yes	No	No
Interior Lamp (Watts)	40W (Halogen)	40W (Halogen)	1 x 25W (Wide)	1 x 25W (Wide)
Interior Lights	Left (Side)	Left (Side)	Left (Side)	Left (Side)
Control Panel Height	85 mm	85 mm	85 mm	85 mm
Display	LED / Ice Blue	LED / Ice Blue	LED / Ice Blue	LED / Ice Blue
Control Method	Pop-up Dial (with Touch Buttons)	Glass Touch	Pop-up Dial (with Touch Buttons)	Pop-up Dial (with Touch Buttons)
Cleaning Method	Steam	Yes	Yes	Yes
Grill Heater	Fixed	Fixed	No	No
Electric Features				
MWO Watts	800 W	800 W	900 W	900 W
Oven Temp Ranges	Convection : 40~230°C Grill : 150~230°C	Convection : 40~230°C Grill : 150~230°C	No	No
Upper Grill (In / Out)	1400W / 1100W	1400W / 1100W	No	No
Lower Grill	1000W	1000W	No	No
Convection (Upper / Lower)	No	No	No	No
Fan	1	1	No	No
Input Power	3000W	3000W	1650W	1650W
Cooking Modes				
MWO Mode	MWO	Yes	Yes	Yes
Auto Defrost	Yes (5 EA)	Yes (5 EA)	Yes	Yes
Auto Reheat	No	No	Yes	Yes
Keep Warm (MWO)	No	No	Yes	Yes
Power Level (MWO)	100/180/300/450/600/700/800	100/180/300/450/600/700/800	100/180/300/450/600/750/900	100/180/300/450/600/750/900
Combi-MWO Mode (MWO + Oven)	MWO + Grill	Yes	No	No
MWO + Convection	Yes	Yes	No	No
MWO + Roast	No	Yes	No	No
Oven Mode	Steam Generator	No	No	No
Steam + Convection	No	No	No	No
Steam + Reheat	No	No	No	No
Convection	Yes	Yes	No	No
Roasting (Convection + Top) Heat	No	No	No	No
Conventional	No	No	No	No
Grill	Yes	Yes	No	No
Fan Grill	No	No	No	No
Pizza (Convection + Bottom)	No	No	No	No
Intensive (Top + Bottom + Convection)	No	No	No	No
Pro-Roasting	No	No	No	No
Eco Convection	No	No	No	No
Vegetable Function	Yes	Yes (10 EA)	No	No
Multi-level Cook Mode	No	No	No	No
Keep Warm Mode	Yes	No	No	No
Deodorization	No	No	Yes	Yes
Auto Cook Recipes	25 EA (Auto Cook 10 EA, Auto Defrost 5 EA, Vegetable 10 EA)	25 EA (Auto Cook 10 EA, Auto Defrost 5 EA, Vegetable 10 EA)	20 EA (Auto Cook 15 EA, Auto Defrost 5 EA)	20 EA (Auto Cook 15 EA, Auto Defrost 5 EA)
Control Features				
Clock	Yes	Yes	Yes	Yes
Child Safety Lock	Yes	Yes	Yes	Yes
Cook Time	Yes	Yes	No	No
End Timer	Yes	Yes	No	No
Oven Temp	Yes	Yes	No	No
Sound	Buzzer	Buzzer	Buzzer	Buzzer
Sound On / Off (Hidden)	Yes	Yes	No	No
Demo Mode	Yes (Hidden)	Yes (Hidden)	Yes (Hidden)	Yes (Hidden)
Equipment Supplied				
Accessory	Ceramic Tray	1 EA	1 EA	1 EA
Baking Tray	1 EA	1 EA	No	No
Wire Rack	No	No	No	No
Wire Tray Insert	1 EA	1 EA	No	No
Steam Tray	1 EA (Pure Steam Bowl)	1 EA (Pure Steam Bowl)	No	No
Application Dimensions				
Dimension (W x H x D)	Outside	595 x 454.2 x 570	595 x 454.2 x 570	595 x 454.2 x 570
Cutout	555 x 445 x 548.8	555 x 445 x 548.8	555 x 445 x 548.8	555 x 445 x 548.8
Shipping	700 x 578 x 663	700 x 578 x 663	700 x 578 x 663	700 x 578 x 663
Capacity	Usable Capacity	50 L	50 L	50 L

Models

Compact Oven



Model Code		NQ50K3130BM	NQ50H7535DS	NQ50H5533KS	NQ50H7235AS
Oven Features					
Type		MWO Solo	Combi MWO	Combi MWO	MWO Solo
Cavity Material		Ceramic Enamel	Ceramic Enamel	Ceramic Enamel	Ceramic Enamel
Oven Color (Con-panel / Door)		Black Stainless Steel (Matt Black)	Stainless Steel	Stainless Steel	Stainless Steel
Door	Glass	Triple	Triple	Triple	Triple
	Opening	Drop Down	Drop Down	Drop Down	Drop Down
	Handle Color	Stainless Steel	Stainless Steel	Stainless Steel	Stainless Steel
	Prestop Hinge	No	No	Yes	No
Interior Lamp (Watts)		1 x 25W (Wide)	1 x 25W (Wide)	40W (Halogen)	1 x 25W (Wide)
Interior Lights		Left (Side)	Left (Side)	Left (Side)	Left (Side)
Control	Control Panel Height	85 mm	85 mm	85 mm	85 mm
	Display	LED / Ice Blue	LED / Ice Blue	LED / Ice Blue	LED / Ice Blue
	Control Method	Pop-up Dial (with Touch Buttons)	Pop-up Dial (with Touch Buttons)	Pop-up Dial (with Touch Buttons)	Pop-up Dial (with Touch Buttons)
Cleaning Method	Steam	Yes	Yes	Yes	Yes
	Grill Heater	No	Fixed	Fixed	No
Electric Features					
MWO Watts		900 W	900 W	800 W	900 W
Oven Temp Ranges		No	Convection : 40~250°C	Convection : 40~230°C	No
		No	Grill : 150~250°C	Grill : 150~230°C	No
Upper Grill (In / Out)		No	1400W / 1100W	1400W / 1100W	No
Lower Grill		No	1000W	1000W	No
Convection (Upper / Lower)		No	1000W	No	No
Fan		No	2	1	No
Input Power		1650W	3200W	3000W	1650W
Cooking Modes					
MWO Mode	MWO	Yes	Yes	Yes	Yes
	Auto Defrost	Yes	Yes	Yes (5 EA)	Yes
	Auto Reheat	Yes	Yes	No	Yes
	Keep Warm (MWO)	Yes	No	No	No
	Power Level (MWO)	100/180/300/450/600/750/900	100/180/300/450/600/750/900	100/180/300/450/600/700/800	100/180/300/450/600/750/900
Combi-MWO Mode (MWO + Oven)	MWO + Grill	No	Yes	Yes	No
	MWO + Convection	No	Yes	Yes	No
	MWO + Roast	No	Yes	No	No
Oven Mode	Steam Generator	No	No	No	No
	Steam + Convection	No	No	No	No
	Steam + Reheat	No	No	No	No
	Convection	No	Yes	Yes	No
	Roasting (Convection + Top) Heat	No	Yes	No	No
	Conventional	No	Yes	No	No
	Grill	No	Yes	Yes	No
	Fan Grill	No	Yes	No	No
	Pizza (Convection + Bottom)	No	Yes	No	No
	Intensive (Top + Bottom + Convection)	No	Yes	No	No
	Pro-Roasting	No	Yes	No	No
	Eco Convection	No	Yes	No	No
Vegetable Function		No	No	Yes (10 EA)	No
Multi-level Cook Mode		No	Yes	No	No
Keep Warm Mode		No	Yes	No	No
Deodorization		Yes	No	No	Yes
Auto Cook Recipes		20 EA (Auto Cook 15 EA, Auto Defrost 5 EA)	40 EA (Auto Cook 35 EA, Auto Defrost 5 EA)	25 EA (Auto Cook 10 EA, Auto Defrost 5 EA, Vegetable 10 EA)	20 EA (Auto Cook 15 EA, Auto Defrost 5 EA)
Control Features					
	Clock	Yes	Yes	Yes	Yes
	Child Safety Lock	Yes	Yes	Yes	Yes
	Cook Time	No	Yes	Yes	No
	End Timer	No	Yes	Yes	No
	Oven Temp	No	Yes	Yes	No
	Sound	Buzzer	Buzzer	Buzzer	Buzzer
	Sound On / Off (Hidden)	No	Yes	Yes	No
	Demo Mode	Yes (Hidden)	Yes (Hidden)	Yes (Hidden)	Yes (Hidden)
Equipment Supplied					
Accessory	Ceramic Tray	1 EA	1 EA	1 EA	1 EA
	Baking Tray	No	2 EA	1 EA	No
	Wire Rack	No	1 EA	No	No
	Wire Tray Insert	No	1 EA	1 EA	No
	Steam Tray	No	No	1 EA (Pure Steam Bowl)	No
Application Dimensions					
Dimension (W x H x D)	Outside	595 x 454.2 x 570	595 x 454.2 x 570	595 x 454.2 x 570	595 x 454.2 x 570
	Cutout	555 x 445 x 548.8	555 x 445 x 548.8	555 x 445 x 548.8	555 x 445 x 548.8
	Shipping	700 x 578 x 663	700 x 578 x 663	700 x 578 x 663	700 x 578 x 663
Capacity	Usable Capacity	50 L	50 L	50 L	50 L



Model Code	NL20J7100WB	NL20F7100WB
Design	Glass / Stainless Steel Frame	Glass / Stainless Steel Frame
Features		
Size	600 x 150	600 x 150
Cut-out	560 x 550 x 150	560 x 550 x 150
Handle	Push & Pull Door	Push & Pull Door
Rail	Telescopic Rail	Telescopic Rail
Weight Capacity	25kg	25kg
	Mechanic Knob	Mechanic Knob
Temp Range	30-80°C	30-80°C
Energy Consumption	420W	420W
Safe Opening & Closing	Anti-slip Mat	Anti-slip Mat
Control	LED Status Lamp	LED Status Lamp
Dimension	595 x 545 x 140	595 x 545 x 140
Remark	Push-pull Tolerance : 21mm	Push-pull Tolerance : 21mm
	Door Gap Between Compact and Warmer : 8mm	Door Gap Between Compact and Warmer : 8mm

Models

Microwave Oven



Model Code		MG22M8074CT	MG22M8074AT	MG22M8054AK	MG22M8054AW
General					
Capacity		0.7 cu.ft. / 22 Liter	0.7 cu.ft. / 22 Liter	0.7 cu.ft. / 22 Liter	0.7 cu.ft. / 22 Liter
Type	Installation	Built-in	Built-in	Built-in	Built-in
	Heat Source	Grill	Grill	Grill	Grill
Power	Power Source	230V / 50Hz	230V / 50Hz	230V / 50Hz	230V / 50Hz
	Output Power (Microwave)	850W	850W	850W	850W
	Output Power (Grill)	1100W	1100W	1100W	1100W
	Output Power (Convection)	N/A	N/A	N/A	N/A
	Power Consumption	1300W	1300W	1300W	1300W
	Max Output Power	2400W	2400W	2400W	2400W
Display	Type	LED / Ice Blue	LED / Ice Blue	LED / Ice Blue	LED / Ice Blue
	Language Option	N/A	N/A	N/A	N/A
Sensor	Control Method	Yes (Moisture)	Yes (Moisture)	No	No
	Door Open Mechanism	Push button	Push button	Push button	Push button
	MW Distribution Mechanism	Turntable	Turntable	Turntable	Turntable
Features					
Keep Warm (Food)		Yes	Yes	Yes	Yes
Power Level		6	6	6	6
Time Control		Touch (+/-)	Touch (+/-)	Touch (+/-)	Touch (+/-)
Weight / Serving Control		Touch (+/-)	Touch (+/-)	Touch (+/-)	Touch (+/-)
One Minute / 30 secs Plus		30 secs Plus	30 secs Plus	30 secs Plus	30 secs Plus
Turntable on / off		No	No	No	No
Defrost (Auto / Power / Sensor)		Yes	Yes	Yes	Yes
Auto Reheat/cook		Yes	Yes	Yes	Yes
Auto Crusty cook		No	No	No	No
Auto Power Steam Cook		No	No	No	No
Sensor Cook		Yes	Yes	No	No
Child Lock		Yes	Yes	Yes	Yes
Materials & Finishes					
Cabinet Color		Black	Black	Black	Black
Door Color		Stainless Steel	Stainless Steel	Black	White
Cavity Interior		Ceramic Enamel	Ceramic Enamel	Ceramic Enamel	Ceramic Enamel
Turntable	Material	Glass	Glass	Glass	Glass
	Size	Diameter 255mm	Diameter 255mm	Diameter 255mm	Diameter 255mm
Grill Heater		Sheath	Sheath	Sheath	Sheath
Accessory					
Grill Rack		Yes	Yes	Yes	Yes
Crusty Plate		Yes	N/A	N/A	N/A
Physical Specification					
Dimension (W x H x D)	Cavity	330 x 224 x 292	330 x 224 x 292	330 x 224 x 292	330 x 224 x 292
	Outside	595 x 380 x 320	595 x 380 x 320	595 x 380 x 320	595 x 380 x 320
	Shipping	706 x 466 x 434	706 x 466 x 434	706 x 466 x 434	706 x 466 x 434
Weight (Kg)	Weight (Net)	15.5 Kg	15.5 Kg	15.5 Kg	15.5 Kg
	Weight (Shipping)	18.5 Kg	18.5 Kg	18.5 Kg	18.5 Kg
Loading Quantity	20ft / 40HQ	210 / 440	210 / 440	210 / 440	210 / 440

Models

Microwave Oven



Model Code		MS22M8074AT	MS22M8054AK	MS22M8054AW
General				
Capacity		0.7 cu.ft. / 22 Liter	0.7 cu.ft. / 22 Liter	0.7 cu.ft. / 22 Liter
Type	Installation	Built-in	Built-in	Built-in
	Heat Source	Solo	Solo	Solo
Power	Power Source	230V / 50Hz	230V / 50Hz	230V / 50Hz
	Output Power (Microwave)	850W	850W	850W
	Output Power (Grill)	N/A	N/A	N/A
	Output Power (Convection)	N/A	N/A	N/A
	Power Consumption	1250W	1250W	1250W
	Max Output Power	1250W	1250W	1250W
Display	Type	LED / Ice Blue	LED / Ice Blue	LED / Ice Blue
	Language Option	N/A	N/A	N/A
Sensor		Yes (Moisture)	No	No
Control Method		Touch	Touch	Touch
Door Open Mechanism		Push button	Push button	Push button
MW Distribution Mechanism		Turntable	Turntable	Turntable
Features				
Keep Warm (Food)		Yes	Yes	Yes
Power Level		6	6	6
Time Control		Touch (+/-)	Touch (+/-)	Touch (+/-)
Weight / Serving Control		Touch (+/-)	Touch (+/-)	Touch (+/-)
One Minute / 30 secs Plus		30 secs Plus	30 secs Plus	30 secs Plus
Turntable on / off		No	No	No
Defrost (Auto / Power / Sensor)		Yes	Yes	Yes
Auto Reheat/cook		Yes	Yes	Yes
Auto Crusty cook		No	No	No
Auto Power Steam cook		No	No	No
Sensor Cook		Yes	No	No
Child Lock		Yes	Yes	Yes
Materials & Finishes				
Cabinet Color		Black	Black	Black
Door Color		Black	Black	White
Cavity Interior		Ceramic Enamel	Ceramic Enamel	Ceramic Enamel
Turntable	Material	Glass	Glass	Glass
	Size	Diameter 255mm	Diameter 255mm	Diameter 255mm
Grill Heater		N/A	N/A	N/A
Accessory				
Grill Rack		N/A	N/A	N/A
Crusty Plate		N/A	N/A	N/A
Physical Specification				
Dimension (W x H x D)	Cavity	330 x 224 x 292	330 x 224 x 292	330 x 224 x 292
	Outside	595 x 380 x 320	595 x 380 x 320	595 x 380 x 320
	Shipping	706 x 466 x 434	706 x 466 x 434	706 x 466 x 434
Weight (Kg)	Weight (Net)	14.5 Kg	14.5 Kg	14.5 Kg
	Weight (Shipping)	17.8 Kg	17.8 Kg	17.8 Kg
Loading Quantity	20ft / 40HQ	210 / 440	210 / 440	210 / 440

Models

Microwave Oven



Model Code		FG87SUST	FG87SUB	FG77SUST	FG77SUB
General					
Capacity		0.8 cu.ft. / 23 Liter	0.8 cu.ft. / 23 Liter	0.7 cu.ft. / 20 Liter	0.7 cu.ft. / 20 Liter
Type	Installation	Built-in	Built-in	Built-in	Built-in
	Heat Source	Grill	Grill	Grill	Grill
Power	Power Source	230V / 50Hz	230V / 50Hz	230V / 50Hz	230V / 50Hz
	Output Power (Microwave)	800W	800W	850W	850W
	Output Power (Grill)	1100W	1100W	1100W	1100W
	Output Power (Convection)	N/A	N/A	N/A	N/A
	Power Consumption	1200W	1200W	1300W	1300W
	Max Output Power	2300W	2300W	2400W	2400W
Display	Type	LED / Ice Blue	LED / Ice Blue	LED / Ice Blue	LED / Ice Blue
	Language Option	N/A	N/A	N/A	N/A
Sensor		No	No	No	No
Control Method		Tact	Tact	Tact	Tact
Door Open Mechanism		Push button	Push Button	Push Button	Push Button
MW Distribution Mechanism		Turntable	Turntable	Turntable	Turntable
Features					
Cooking Modes	Microwave Oven	Yes	Yes	Yes	Yes
	Brown / Grill	Yes	Yes	Yes	Yes
Clock		Yes	Yes	Yes	Yes
Warm		No	No	No	No
Max Cooking Time		99min	99min	99min	99min
Kitchen Timer / Hold Timer		No	No	No	No
More / Less		No	No	No	No
Memory Cook		No	No	No	No
Power Level		6	6	6	6
Cooking Stages		No	No	No	No
Time Control		Button (+/-)	Button (+/-)	Button (+/-)	Button (+/-)
Weight / Serving Control		Button (+/-)	Button (+/-)	Button (+/-)	Button (+/-)
One Minute / 30 secs Plus		30 secs Plus	30 secs Plus	30 secs Plus	30 secs Plus
Turntable On / Off		No	No	No	No
Defrost (Auto / Power / Sensor)	Power Defrost (4)	1.Meat	1.Meat	1.Meat	1.Meat
		2.Poultry	2.Poultry	2.Poultry	2.Poultry
		3.Fish	3.Fish	3.Fish	3.Fish
		4.Bread / Cake	4.Bread / Cake	4.Bread / Cake	4.Bread / Cake
		1.Ready Meal	1.Ready Meal	1.Ready Meal	1.Ready Meal
Auto Reheat / Cook		2.Soup / Sauce	2.Soup / Sauce	2.Soup / Sauce	2.Soup / Sauce
		3.Pasta Gratin	3.Pasta Gratin	3.Pasta Gratin	3.Pasta Gratin
		4.Drinks	4.Drinks	4.Drinks	4.Drinks
		Crusty Cook (4)	Crusty Cook (4)	Crusty Cook (4)	Crusty Cook (4)
Auto Crusty Cook		1.Frozen Pizza	1.Frozen Pizza	1.Frozen Pizza	1.Frozen Pizza
		2.Frozen Baguettes	2.Frozen Baguettes	2.Frozen Baguettes	2.Frozen Baguettes
		3.Frozen Quiche / Pie	3.Frozen Quiche / Pie	3.Frozen Quiche / Pie	3.Frozen Quiche / Pie
		4.Frozen Chicken Nuggets	4.Frozen Chicken Nuggets	4.Frozen Chicken Nuggets	4.Frozen Chicken Nuggets
Auto Power Steam Cook		No	No	No	No
		-	-	-	-
		-	-	-	-
		-	-	-	-
Sensor Cook		No	No	No	No
Deodorization		No	No	No	No
Setting (My Choice)	Weight Option	No	No	No	No
	Sound Option	Yes	Yes	Yes	Yes
	Reminder End Signal	Yes	Yes	Yes	Yes
	Clock System Option (12H / 24H)	Yes	Yes	Yes	Yes
Child Lock		Yes (Hidden)	Yes (Hidden)	Yes (Hidden)	Yes (Hidden)
Materials & Finishes					
Cabinet Color		Stainless Steel	Black	Stainless Steel	Stainless Steel
Door Color		Stainless Steel	Black	Stainless Steel	Stainless Steel
Cavity Interior		Ceramic Enamel	Ceramic Enamel	Ceramic Enamel	Ceramic Enamel
Turntable	Material	Glass	Glass	Glass	Glass
	Size	Diameter 288mm	Diameter 288mm	Diameter 255mm	Diameter 255mm
Grill Heater		Sheath	Sheath	Sheath	Sheath
Carton Box		Yellow	Yellow	Yellow	Yellow
Accessory					
Rack	Round	Yes	Yes	Yes	Yes
Steam Clean		Yes	Yes	Yes	Yes
Power Steam Bowl		No	No	No	No
Crusty Plate		Yes	Yes	Yes	Yes
Cooking Guide Label		Yes	Yes	Yes	Yes
Physical Specification					
Dimension (W x H x D) Cavity		330 x 211 x 324	330 x 211 x 324	330 x 211 x 291	330 x 211 x 291
	Outside	489 x 275 x 392	489 x 275 x 392	489 x 275 x 326	489 x 275 x 326
	Shipping	654 x 441 x 455	654 x 441 x 455	654 x 455 x 441	654 x 455 x 441
Weight	Net	14.5kg	14.5kg	13.5kg	13.5kg
	Shipping	19.0kg	19.0kg	17.5kg	17.5kg
Loading Quantity	20ft / 40ft	209 / 448 sets	209 / 448 sets	220 / 440 sets	220 / 440 sets

Models

Microwave Oven



Model Code		FW87SUST	FW87SUB
General			
Capacity		0.8 cu.ft. / 23 Liter	0.8 cu.ft. / 23 Liter
Type	Installation	Built-in	Built-in
	Heat Source	Solo	Solo
Power	Power Source	230V / 50Hz	0
	Output Power (Microwave)	800W	800W
	Output Power (Grill)	NA	NA
	Output Power (Convection)	N/A	N/A
	Power Consumption	1150W	1150W
	Max Output Power	1150W	1150W
Display	Type	LED / Ice Blue	LED / Ice Blue
	Language Option	N/A	N/A
Sensor		No	No
Control Method		Tact	Tact
Door Open Mechanism		Push Button	Push Button
MW Distribution Mechanism		Turntable	Turntable
Features			
Cooking Modes	Microwave Oven	Yes	Yes
	Brown / Grill	No	No
Clock		Yes	Yes
Warm		No	No
Max Cooking Time		99min	99min
Kitchen Timer / Hold Timer		Yes	Yes
More / Less		No	No
Memory Cook		Yes	Yes
Power Level		6	6
Cooking Stages		No	No
Time Control		Button (+/-)	Button (+/-)
Weight / Serving Control		Button (+/-)	Button (+/-)
One Minute / 30 secs Plus		30 secs Plus	30 secs Plus
Turntable On / Off		No	No
Defrost (Auto / Power / Sensor)		Power Defrost (1) Meat, Poultry, Fish	Power Defrost (1) Meat, Poultry, Fish
		-	-
		-	-
Auto Reheat / Cook		1.Ready Meal (Chilled) 2.Ready Meal (Frozen) 3 Drinks	1.Ready Meal (Chilled) 2.Ready Meal (Frozen) 3 Drinks
		-	-
Auto Crusty Cook		No	No
		-	-
		-	-
		-	-
Auto Power Steam Cook		Power Steam Cook (4) 1.Rice 2.Peeled Potatoes 3.Fresh Vegetables 4. Fruit Compote	Power Steam Cook (4) 1.Rice 2.Peeled Potatoes 3.Fresh Vegetables 4. Fruit Compote
Sensor Cook		No	No
Deodorization		Yes	Yes
Setting (My Choice)	Weight Option	No	No
	Sound Option	Yes	Yes
	Reminder End Signal	Yes	Yes
	Clock System Option (12H / 24H)	Yes	Yes
	Child Lock	Yes (Hidden)	Yes (Hidden)
Materials & Finishes			
Cabinet Color		Stainless Steel	Black
Door Color		Stainless Steel	Black
Cavity Interior		Ceramic Enamel	Ceramic Enamel
Turntable	Material	Glass	Glass
	Size	Diameter 288mm	Diameter 288mm
Grill Heater		N/A	N/A
Carton Box		Yellow	Yellow
Accessory			
Rack	Round	No	No
Steam Clean		No	No
Power Steam Bowl		Yes	Yes
Crusty Plate		No	No
Cooking Guide Label		Yes	Yes
Physical Specification			
Dimension (W x H x D)	Cavity	330 x 211 x 291	330 x 211 x 291
	Outside	489 x 275 x 326	489 x 275 x 326
	Shipping	654 x 455 x 441	654 x 455 x 441
Weight	Net	12.5kg	12.5kg
	Shipping	17.0kg	17.0kg
Loading Quantity	20ft / 40ft	209 / 448 sets	209 / 448 sets

Models

Induction Cooktop



Model Code		NZ84J9770EK	NZ84F7NC6AB	NZ63N9777GK	NZ64N9777GK	
Type		NZ9900J	NZ-F700G	NZ6000K Smart	NZ6000K Smart	
Dimensions (W x D x H)						
	Outside (Max.)	800 x 520 x 56	800 x 520 x 56	600 x 520 x 56	600 x 520 x 56	
	Packing	902 x 594 x 139	900 x 582 x 146	712 x 594 x 149	712 x 594 x 149	
	Cut-out Size	750 x 490	750 x 490	560 x 490	560 x 490	
Features						
Surface	Frame	3 Bevel	3 Bevel	1 Bevel	1 Bevel	
Packing Case Color		Yellow	Yellow	Yellow	Yellow	
Display	Control Method	Magnetic Knob	Dedicated Control	Common Control	Common Control	
	Type	Integrated Knob Dial	Sliding & Direct Access	Sliding & Direct Access	Sliding & Direct Access	
Power	LED Color	Ice Blue	New Amber	Ice Blue	Ice Blue	
	Virtual Flame	Ice Blue	N/A	Ice Blue	Ice Blue	
	140mm	No	No	No	No	
	145mm	No	1.2 / 2.0K(B)	No	1.4 / 2.0K(B)	
	160mm	1.2 / 2.0K(B)	No	No	No	
	180mm	No	No	No	No	
	210mm	No	No	2.2 / 3.2K(B)	2.2 / 3.2K(B)	
	220mm	2.2 / 3.2K(B)	No	No	No	
	280mm	No	2.4 / 3.6K(B)	No	No	
Safety Function	Flex Zone (Front)	1.8 / 2.6K(B)	1.8 / 2.6K(B)	1.8 / 2.6K(B)	1.8 / 2.6K(B)	
	Flex Zone (Center)	No	No	1.8 / 3.0K(B)	1.8 / 3.0K(B)	
	Flex Zone (Rear)	1.8 / 2.6K(B)	1.8 / 2.6K(B)	1.8 / 2.6K(B)	1.8 / 2.6K(B)	
	Flex Zone TOT	3.3 / 3.6K(B)	3.3 / 3.6K(B)	3.3 / 3.6K(B)	3.3 / 3.6K(B)	
	Total Power	7.0kW	7.2kW	6.8kW	7.2kW	
	Q'ty of Booster	4	4	3	4	
	Residual Heat Indicator	2 Stage	2 Stage	2 Stage	2 Stage	
	Small Utensil Detection	Yes	Yes	Yes	Yes	
	Auto Pan Detection	Yes	Yes	Yes	Yes	
Control Feature	Safety Time Shut Off	Yes	Yes	Yes	Yes	
	Safety Shut Off	Yes	Yes	Yes	Yes	
	Child Safety Lock	Yes	Yes	Yes	Yes	
	High Temp Limit	Yes	Yes	Yes	Yes	
	Wifi	No	No	Yes	Yes	
	Bluetooth	No	No	Yes	Yes	
	Sound On / Off Hidden Lock	Yes	Yes	Yes	Yes	
	Power Level	15 + Booster	15 + Booster	15 + Booster	15 + Booster	
	Timer	99min	99min	99min	99min	
	Power Control	Yes	Yes	Yes	Yes	
	Direct Access	Yes	Yes	Yes	Yes	
	Power On / Off	Yes	Yes	Yes	Yes	
Energy Eff.	Pan Grilling	No	No	No	No	
	Pause	Yes	Yes	Yes	Yes	
	Quick Start	Yes	No	Yes	Yes	
	Demo Mode	Yes	Yes	Yes	Yes	
	Quick Stop	Yes	Yes	Yes	Yes	
	Keep Warm	Yes	Yes	Yes	Yes	
	Up Timer	Yes	No	No	No	
	Down Timer	Yes	No	Yes	Yes	
	Stand by Power Consumption	Under 0.5W	Under 0.5W	Under 0.5W	Under 0.5W	
	Network STAND BY	No	No	Under 2W	Under 2W	
	Noise	Noise Level (Operating)	Under 43dB	Under 43dB	Under 43dB	Under 43dB
	Power Cable	Power Cable Type	5 Wire	5 Wire	5 Wire	5 Wire
Power Cable Length		1.5m	1.5m	1.5m	1.5m	
Power	Max. Power Limit	No	No	Yes (3000W / 4000W / MAX.)	Yes (3000W / 4000W / MAX.)	
Shipping	L/Q/TY (20 / 40 / 40High Cuft)	336 / 736 / 736	384 / 832 / 936	405 / 900 / 1020	405 / 900 / 1020	
Weight	Net / Gross	16.5Kg / 19.5Kg	15.5Kg / 18.7Kg	12.6Kg / 15.5Kg	13.2Kg / 16.1Kg	
Dimension	Flex Size	225 x 435mm	195 x 390mm	240 x 380mm	240 x 380mm	

Models Induction Cooktop



Model Code		NZ64N9777BK	NZ63J9770EK	NZ64N7777GK	NZ63K7777BK
Type		NZ6000K Smart	NZ9900J	NZ6000K Smart	NZ6000K
Dimensions (W x D x H)					
	Outside (Max.)	600 x 520 x 56	600 x 520 x 56	600 x 520 x 56	600 x 520 x 56
	Packing	712 x 594 x 149	712 x 594 x 142	712 x 594 x 149	712 x 594 x 142
	Cut-out Size	560 x 490	560 x 490	560 x 490	560 x 490
Features					
Surface	Frame	1 Bevel	3 Bevel	1 Bevel	1 Bevel
Packing Case Color		Yellow	Yellow	Yellow	Yellow
Display	Control Method	Common Control	Magnetic Knob	Common Control	Common Control
	Type	Sliding & Direct Access	Integrated Knob Dial	Sliding & Direct Access	Sliding & Direct Access
	LED Color	Ice Blue	Ice Blue	New Amber	Amber
Power	Virtual Flame	Ice Blue	Ice Blue	Amber	Amber
	140mm	No	No	No	No
	145mm	1.4 / 2.0K(B)	No	1.4 / 2.0K(B)	No
	160mm	No	No	No	No
	180mm	No	No	No	No
	210mm	2.2 / 3.2K(B)	No	2.2 / 3.2K(B)	No
	220mm	No	2.2 / 3.2K(B)	No	2.2 / 3.2K(B)
	280mm	No	No	No	No
	Flex Zone (Front)	1.8 / 2.6K(B)	1.8 / 2.6K(B)	1.8 / 2.6K(B)	1.8 / 2.6K(B)
	Flex Zone (Center)	1.8 / 3.0K(B)	No	1.8 / 3.0K(B)	1.8 / 3.0K(B)
	Flex Zone (Rear)	1.8 / 2.6K(B)	1.8 / 2.6K(B)	1.8 / 2.6K(B)	1.8 / 2.6K(B)
	Flex Zone TOT	3.3 / 3.6K(B)	3.3 / 3.6K(B)	3.3 / 3.6K(B)	3.3 / 3.6K(B)
	Total Power	7.2kW	6.8kW	7.2kW	6.8kW
	Q'ty of Booster	4	3	4	3
Safety Function	Residual Heat Indicator	2 Stage	2 Stage	2 Stage	2 Stage
	Small Utensil Detection	Yes	Yes	Yes	Yes
	Auto Pan Detection	Yes	Yes	Yes	Yes
	Safety Time Shut Off	Yes	Yes	Yes	Yes
	Safety Shut Off	Yes	Yes	Yes	Yes
	Child Safety Lock	Yes	Yes	Yes	Yes
	High Temp Limit	Yes	Yes	Yes	Yes
Control Feature	Wifi	Yes	No	Yes	No
	Bluetooth	Yes	No	Yes	No
	Sound On / Off Hidden Lock	Yes	Yes	Yes	Yes
	Power Level	15 + Booster	15 + Booster	15 + Booster	15 + Booster
	Timer	99min	99min	99min	99min
	Power Control	Yes	Yes	Yes	Yes
	Direct Access	Yes	Yes	Yes	Yes
	Power On / Off	Yes	Yes	Yes	Yes
	Pan Grilling	No	No	No	No
	Pause	Yes	Yes	Yes	Yes
	Quick Start	Yes	Yes	Yes	Yes
	Demo Mode	Yes	Yes	Yes	Yes
	Quick Stop	Yes	Yes	Yes	Yes
	Keep Warm	Yes	Yes	Yes	Yes
	Up Timer	No	Yes	No	Yes
	Down Timer	Yes	Yes	Yes	Yes
Energy Eff.	Stand by Power Consumption	Under 0.5W	Under 0.5W	Under 0.5W	Under 0.5W
	Network STAND BY	No	No	Under 2W	No
Noise	Noise Level (Operating)	Under 43dB	Under 43dB	Under 43dB	Under 43dB
Power Cable	Power Cable Type	5 Wire	5 Wire	5 Wire	5 Wire
	Power Cable Length	1.5m	1.5m	1.5m	1.5m
Power	Max. Power Limit	Yes (3000W / 4000W / MAX.)	No	Yes (3000W / 4000W / MAX.)	Yes (3000W / 4000W / MAX.)
Shipping	L/Q'TY (20 / 40 / 40High Cuft)	405 / 900 / 1020	432 / 960 / 960	405 / 900 / 1020	432 / 960 / 1080
Weight	Net / Gross	13.2Kg / 16.1Kg	13.4Kg / 15.9Kg	13.2Kg / 16.1Kg	12.8Kg / 15.6Kg
Dimension	Flex Size	240 x 380mm	225 x 435mm	240 x 380mm	240 x 380mm

Models

Induction Cooktop



		NZ64N7757GK	NZ64N7757FK	NZ64K7757BK	NZ63K5727BK
Type		NZ6000K Smart	NZ6000K Smart	NZ6000K	NZ6000K
Dimensions (W x D x H)					
	Outside (Max.)	600 x 520 x 56	600 x 520 x 56	600 x 520 x 56	600 x 520 x 56
	Packing	712 x 594 x 149	712 x 594 x 149	712 x 594 x 142	712 x 594 x 142
	Cut-out Size	560 x 490	560 x 490	560 x 490	560 x 490
Features					
Surface	Frame	1 Bevel	Cut Edge	1 Bevel	1 Bevel
Packing Case Color		Yellow	Yellow	Yellow	Yellow
Display	Control Method	Common Control	Common Control	Common Control	Common Control
	Type	Sliding & Direct Access	Sliding & Direct Access	Sliding & Direct Access	Sliding & Direct Access
	LED Color	New Amber	New Amber	Amber	Amber
Power	Virtual Flame	N/A	N/A	No	No
	140mm	No	No	No	No
	145mm	1.4 / 2.0K(B)	1.4/2.0K(B)	1.4 / 2.0K(B)	1.4 / 2.0K(B)
	160mm	No	No	No	No
	180mm	No	No	No	No
	210mm	2.2 / 3.2K(B)	2.2/3.2K(B)	2.2 / 3.2K(B)	2.2 / 3.2K(B)
	220mm	No	No	No	No
	280mm	No	No	No	3.6 / 5.0K(B)
	Flex Zone (Front)	1.8 / 2.6K(B)	1.8 / 2.6K(B)	1.8 / 2.6K(B)	No
	Flex Zone (Center)	1.8 / 3.0K(B)	1.8 / 3.0K(B)	1.8 / 3.0K(B)	No
	Flex Zone (Rear)	1.8 / 2.6K(B)	1.8 / 2.6K(B)	1.8 / 2.6K(B)	No
	Flex Zone TOT	3.3 / 3.6K(B)	3.3 / 3.6K(B)	3.3 / 3.6K(B)	No
	Total Power	7.2kW	7.2kW	7.2kW	7.2kW
	Q'ty of Booster	4	4	4	3
Safety Function	Residual Heat Indicator	2 Stage	2 Stage	2 Stage	2 Stage
	Small Utensil Detection	Yes	Yes	Yes	Yes
	Auto Pan Detection	Yes	Yes	Yes	Yes
	Safety Time Shut Off	Yes	Yes	Yes	Yes
	Safety Shut Off	Yes	Yes	Yes	Yes
	Child Safety Lock	Yes	Yes	Yes	Yes
	High Temp Limit	Yes	Yes	Yes	Yes
	Control Feature	Wifi	Yes	Yes	No
	Bluetooth	Yes	Yes	No	No
	Sound On / Off Hidden Lock	Yes	Yes	Yes	Yes
	Power Level	15 + Booster	15 + Booster	15 + Booster	15 + Booster
	Timer	99min	99min	99min	99min
	Power Control	Yes	Yes	Yes	Yes
	Direct Access	Yes	Yes	Yes	Yes
	Power On / Off	Yes	Yes	Yes	Yes
	Pan Grilling	No	No	No	No
	Pause	Yes	Yes	Yes	Yes
	Quick Start	Yes	Yes	Yes	Yes
	Demo Mode	Yes	Yes	Yes	Yes
	Quick Stop	Yes	Yes	Yes	Yes
	Keep Warm	Yes	Yes	Yes	Yes
	Up Timer	No	No	Yes	Yes
	Down Timer	Yes	Yes	Yes	Yes
Energy Eff.	Stand by Power Consumption	Under 0.5W	Under 0.5W	Under 0.5W	Under 0.5W
	Network STAND BY	Under 2W	Under 2W	No	No
Noise	Noise Level (Operating)	Under 43dB	Under 43dB	Under 43dB	Under 43dB
Power Cable	Power Cable Type	5 Wire	5 Wire	5 Wire	5 Wire
	Power Cable Length	1.5m	1.5m	1.5m	1.5m
Power	Max. Power Limit	Yes (3000W / 4000W / MAX.)	Yes (3000W / 4000W / MAX.)	Yes (3000W / 4000W / MAX.)	No
Shipping	L/Q/TY (20 / 40 / 40High Cuft)	405 / 900 / 1020	405 / 900 / 1020	432 / 960 / 1080	432 / 960 / 1080
Weight	Net / Gross	13Kg / 15.9Kg	13Kg / 15.9Kg	13.2Kg / 16.0Kg	12.3Kg / 15.1Kg
Dimension	Flex Size	240 x 380mm	240 x 380mm	240 x 380mm	Dual Power Zone

Models Induction Cooktop



Model Code		NZ64K5747BK	NZ63H57470K	NZ64H37075K	NZ64H37070K	
Type		NZ6000K	NZ5000H	NZ3000H	NZ3000H	
Dimensions (W x D x H)						
	Outside (Max.)	600 x 520 x 56	600 x 520 x 56	590 x 520 x 57	590 x 520 x 57	
	Packing	712 x 594 x 142	710 x 582 x 137	690 x 645 x 115	690 x 645 x 115	
	Cut-out Size	560 x 490	560 x 490	560 x 490	560 x 490	
Features						
Surface	Frame	1 Bevel	Cut Edge	4 Stainless Steel	Cut Edge	
Packing Case Color		Yellow	Yellow	Yellow	Yellow	
Display	Control Method	Common Control	Common Control	Common Control	Common Control	
	Type	Sliding & Direct Access	Sliding & Direct Access	Sliding	Sliding	
	LED Color	Amber	New Amber	New Amber	New Amber	
Power	Virtual Flame	No	N/A	N/A	N/A	
	140mm	No	No	1.25 / 1.5K(B) x 2	1.25 / 1.5K(B) x 2	
	145mm	1.4 / 2.0K(B)	No	No	No	
	160mm	No	No	No	No	
	180mm	No	No	No	No	
	210mm	2.2 / 3.2K(B)	No	No	No	
	220mm	No	No	2.35 / 2.6K(B) x 2	2.35 / 2.6K(B) x 2	
	280mm	No	2.4 / 3.6K(B)	No	No	
	Flex Zone (Front)	1.8 / 2.6K(B)	1.8 / 2.6K(B)	No	No	
	Flex Zone (Center)	No	No	No	No	
	Flex Zone (Rear)	1.8 / 2.6K(B)	1.8 / 2.6K(B)	No	No	
	Flex Zone TOT	3.3 / 3.6K(B)	3.3 / 3.6K(B)	No	No	
	Total Power	7.2kW	7.2kW	7.2kW	7.2kW	
	Q'ty of Booster	4	3	4	4	
Safety Function	Residual Heat Indicator	2 Stage	2 Stage	1 Stage	1 Stage	
	Small Utensil Detection	Yes	Yes	Yes	Yes	
	Auto Pan Detection	Yes	Yes	Yes	Yes	
	Safety Time Shut Off	Yes	Yes	Yes	Yes	
	Safety Shut Off	Yes	Yes	Yes	Yes	
	Child Safety Lock	Yes	Yes	Yes	Yes	
	High Temp Limit	Yes	Yes	Yes	Yes	
	Wifi	No	No	No	No	
Control Feature	Bluetooth	No	No	No	No	
	Sound On / Off Hidden Lock	Yes	Yes	No	No	
	Power Level	15 + Booster	15 + Booster	9 + Booster	9 + Booster	
	Timer	99min	99min	99min	99min	
	Power Control	Yes	Yes	Yes	Yes	
	Direct Access	Yes	Yes	Boost Level Only	Boost Level Only	
	Power On / Off	Yes	Yes	Yes	Yes	
	Pan Grilling	No	Yes	No	No	
	Pause	Yes	Yes	No	No	
	Quick Start	Yes	Yes	No	No	
	Demo Mode	Yes	Yes	No	No	
	Quick Stop	Yes	Yes	Yes	Yes	
	Keep Warm	Yes	Yes	No	No	
	Up Timer	Yes	Yes	No	No	
	Down Timer	Yes	Yes	Yes	Yes	
	Energy Eff.	Stand by Power Consumption	Under 0.5W	Under 0.5W	Under 0.5W	Under 0.5W
		Network STAND BY	No	No	No	No
Noise	Noise Level (Operating)	Under 43dB	Under 43dB	Under 43dB	Under 43dB	
Power Cable	Power Cable Type	5 Wire	5 Wire	5 Wire	5 Wire	
	Power Cable Length	1.5m	1.5m	1.5m	1.5m	
Power	Max. Power Limit	Yes (3000W / 4000W / MAX.)	No	No	No	
Shipping	L/Q'TY (20 / 40 / 40High Cuft)	432 / 960 / 1080	512 / 1072 / 1072	459 / 918 / 918	459 / 918 / 918	
Weight	Net / Gross	12.7Kg / 15.5Kg	13.1Kg / 15.3Kg	10.7Kg / 12.2Kg	10.5Kg / 12.0Kg	
Dimension	Flex Size	200 x 380mm	200 x 380mm	No	No	

Models

Induction Cooktop



		NZ63H37070K	NZ63F3NM1AB	NZ64F3NM1AB	NZ63M3707AK
Type		NZ3000H	NZ-F300G	NZ-F300G	NZ3000H
Dimensions (W x D x H)					
	Outside (Max.)	590 x 520 x 57	590 x 520 x 57	590 x 520 x 57	590 x 520 x 57
	Packing	690 x 645 x 115	690 x 645 x 115	690 x 645 x 115	690 x 645 x 115
	Cut-out Size	560 x 490	560 x 490	560 x 490	560 x 490
Features					
Surface	Frame	Cut Edge	Cut Edge	Cut Edge	Cut Edge
Packing Case Color		Yellow	Yellow	Yellow	Yellow
Display	Control Method	Common Control	Common Control	Common Control	Common Control
	Type	Sliding	Glass Touch (+/-)	Glass Touch (+/-)	Sliding
	LED Color	New Amber	New Amber	New Amber	New Amber
	Virtual Flame	N/A	N/A	N/A	N/A
Power	140mm	1.2 / 1.5K(B)	1.2 / 1.5K(B)	1.25 / 1.5K(B) x 2	1.2 / 1.5K(B)
	145mm	No	No	No	No
	160mm	No	No	No	No
	180mm	2.3 / 2.6K(B)	2.3 / 2.6K(B)	No	2.3 / 2.6K(B)
	210mm	No	No	No	No
	220mm	No	No	2.35 / 2.6K(B) x 2	No
	280mm	3.0 / 4.0K(B)	3.0 / 4.0K(B)	No	3.0 / 4.0K(B)
	Flex Zone (Front)	No	No	No	No
	Flex Zone (Center)	No	No	No	No
	Flex Zone (Rear)	No	No	No	No
	Flex Zone TOT	No	No	No	No
	Total Power	7.2kW	7.2kW	7.2kW	7.2kW
	Q'ty of Booster	3	3	4	3
Safety Function	Residual Heat Indicator	1 Stage	1 Stage	1 Stage	1 Stage
	Small Utensil Detection	Yes	Yes	Yes	Yes
	Auto Pan Detection	Yes	Yes	Yes	Yes
	Safety Time Shut Off	Yes	Yes	Yes	Yes
	Safety Shut Off	Yes	Yes	Yes	Yes
	Child Safety Lock	Yes	Yes	Yes	Yes
	High Temp Limit	Yes	Yes	Yes	Yes
Control Feature	Wifi	No	No	No	No
	Bluetooth	No	No	No	No
	Sound On / Off Hidden Lock	No	No	No	No
	Power Level	9 + Booster	9 + Booster	9 + Booster	9 + Booster
	Timer	99min	99min	99min	99min
	Power Control	Yes	Yes	Yes	Yes
	Direct Access	Boost Level Only	Boost Level Only	Boost Level Only	Boost Level Only
	Power On / Off	Yes	Yes	Yes	Yes
	Pan Grilling	No	No	No	No
	Pause	No	No	No	No
	Quick Start	No	No	No	No
	Demo Mode	No	No	No	No
	Quick Stop	Yes	Yes	Yes	Yes
	Keep Warm	No	No	No	No
	Up Timer	No	No	No	No
	Down Timer	Yes	Yes	Yes	Yes
Energy Eff.	Stand by Power Consumption	Under 0.5W	Under 0.5W	Under 0.5W	Under 0.5W
	Network STAND BY	No	No	No	No
Noise	Noise Level (Operating)	Under 43dB	Under 43dB	Under 43dB	Under 43dB
Power Cable	Power Cable Type	5 Wire	5 Wire	5 Wire	5 Wire
	Power Cable Length	1.5m	1.5m	1.5m	1.5m
Power	Max. Power Limit	No	No	No	No
Shipping	L/Q/TY (20 / 40 / 40High Cuft)	459 / 918 / 918	459 / 918 / 918	459 / 918 / 918	459 / 918 / 918
Weight	Net / Gross	10.6Kg / 12.1Kg	10.6Kg / 12.1Kg	10.5Kg / 12.0Kg	10.6Kg / 12.1Kg
Dimension	Flex Size	No	No	No	No

Models Induction Cooktop



Model Code		NZ64M3707AK	NZ63M3NM1BB	NZ64M3NM1BB
Type		NZ3000H	NZ-F300G	NZ-F300G
Dimensions (W x D x H)				
	Outside (Max.)	590 x 520 x 57	590 x 520 x 57	590 x 520 x 57
	Packing	690 x 645 x 115	690 x 645 x 115	690 x 645 x 115
	Cut-out Size	560 x 490	560 x 490	560 x 490
Features				
Surface	Frame	Cut Edge	Cut Edge	Cut Edge
Packing Case Color		Yellow	Yellow	Yellow
Display	Control Method	Common Control	Common Control	Common Control
	Type	Sliding	Glass Touch (+/-)	Glass Touch (+/-)
	LED Color	New Amber	New Amber	New Amber
	Virtual Flame	N/A	N/A	N/A
Power	140mm	1.25 / 1.5K(B) x 2	1.2 / 1.5K(B)	1.25 / 1.5K(B) x 2
	145mm	No	No	No
	160mm	No	No	No
	180mm	No	2.3 / 2.6K(B)	No
	210mm	No	No	No
	220mm	2.35 / 2.6K(B) x 2	No	2.35 / 2.6K(B) x 2
	280mm	No	3.0 / 4.0K(B)	No
	Flex Zone (Front)	No	No	No
	Flex Zone (Center)	No	No	No
	Flex Zone (Rear)	No	No	No
	Flex Zone TOT	No	No	No
	Total Power	7.2kW	7.2kW	7.2kW
	Q'ty of Booster	4	3	4
Safety Function	Residual Heat Indicator	1 Stage	1 Stage	1 Stage
	Small Utensil Detection	Yes	Yes	Yes
	Auto Pan Detection	Yes	Yes	Yes
	Safety Time Shut Off	Yes	Yes	Yes
	Safety Shut Off	Yes	Yes	Yes
	Child Safety Lock	Yes	Yes	Yes
	High Temp Limit	Yes	Yes	Yes
Control Feature	Wifi	No	No	No
	Bluetooth	No	No	No
	Sound On / Off Hidden Lock	No	No	No
	Power Level	9 + Booster	9 + Booster	9 + Booster
	Timer	99min	99min	99min
	Power Control	Yes	Yes	Yes
	Direct Access	Boost Level Only	Boost Level Only	Boost Level Only
	Power On / Off	Yes	Yes	Yes
	Pan Grilling	No	No	No
	Pause	No	No	No
	Quick Start	No	No	No
	Demo Mode	No	No	No
	Quick Stop	Yes	Yes	Yes
	Keep Warm	No	No	No
	Up Timer	No	No	No
	Down Timer	Yes	Yes	Yes
Energy Eff.	Stand by Power Consumption	Under 0.5W	Under 0.5W	Under 0.5W
	Network STAND BY	No	No	No
Noise	Noise Level (Operating)	Under 43dB	Under 43dB	Under 43dB
Power Cable	Power Cable Type	5 Wire	5 Wire	5 Wire
	Power Cable Length	1.5m	1.5m	1.5m
Power	Max. Power Limit	No	No	No
Shipping	L/Q/TY (20 / 40 / 40High Cuft)	459 / 918 / 918	459 / 918 / 918	459 / 918 / 918
Weight	Net / Gross	10.5Kg / 12.0Kg	10.6Kg / 12.1Kg	10.5Kg / 12.0Kg
Dimension	Flex Size	No	No	No

Models

Ceramic Cooktop



Model Code		CTR164NC01	CTR364NC01	CTR464NC01	CTR464NB01
Model Type Install		Built-in	Built-in	Built-in	Built-in
Mode		2 Single, Double, Oval	2 Single, Double, Oval	2 Single, Double, Oval	2 Single, 2 Fast
Appearance (Frame)		Bevelled Edge	Bevelled Edge	Bevelled Edge	Bevelled Edge
Application Dimensions					
Dimension (W x D x H mm)	Glass	575 x 505 x 4	575 x 505 x 4	575 x 505 x 4	575 x 505 x 4
	Outside (Max.)	575 x 505 x 52.6	575 x 505 x 52.6	575 x 505 x 52.6	575 x 505 x 52.6
	Shipping	692 x 622 x 130	692 x 622 x 130	692 x 622 x 130	692 x 622 x 130
	Cut-out Size	560 x 490	560 x 490	560 x 490	560 x 490
Weight (Net / Gross)		8.0 / 10.5kg	8.0 / 10.5kg	8.0 / 10.5kg	7.5 / 10.0kg
L / QTY (20 / 40ft)		459 / 918	459 / 918	459 / 918	459 / 918
Features					
	Control Method	Sliding Control	Touch Control	Touch Control	Touch Control
	Display	LED	LED	LED	LED
Heating Element	Single 148mm	1.2kW	1.2kW	1.2kW	1.2kW
	Single 180mm	No	No	No	1.8kW
	Double (120 / 210mm)	0.75 / 2.2kW	0.75 / 2.2kW	0.75 / 2.2kW	No
	Oval (170 / 265mm)	1.5-1.6 / 2.4kW	1.5-1.6 / 2.4kW	1.5-1.6 / 2.4kW	No
	Double (120 / 183mm)	No	No	No	No
	Triple (120 / 175 / 215mm)	No	No	No	No
	Total Power	7.0kW	7.0kW	7.0kW	6.0kW
Residual Heat Indicator		Yes	Yes	Yes	Yes
Scraper		Yes	Yes	Option	NA
Control Feature	Child Safety Lock	Yes	Yes	Yes	Yes
	Power Level	9	9	9	9
	Timer	99min	99min	99min	NA
	Power Control	Yes	Yes	Yes	Yes
	High Temp. Protector	Yes	Yes	Yes	Yes
	Power On / Off	Yes	Yes	Yes	Yes

Models

Ceramic Cooktop



Model Code		CTR432NB02
Model Type Install		Built-in
Mode		1 Single, 1 Fast
Appearance (Frame)		2-Bevelled Edge
Application Dimensions		
Dimension (W x D x H mm)	Glass	288 x 505 x 4
	Outside (Max.)	288 x 505 x 50
	Shipping	430 x 640 x 160
	Cut-out Size	273 x 490
Weight (Net / Gross)		4.3 / 6.0kg
L / Q'TY (20 / 40ft)		719 / 1477
Features		
Heating Element	Control Method	Touch Control
	Display	LED
	Single 148mm	1.2kW
	Single 180mm	1.8kW
	Double (120 / 210mm)	No
	Oval (170 / 265mm)	No
	Double (120 / 183mm)	No
	Triple (120 / 175 / 215mm)	No
Residual Heat Indicator	Total Power	3.0kW
Scraper		Yes
Control Feature	Child Safety Lock	Yes
	Power Level	9
	Timer	99min
	Power Control	Yes
	High Temp. Protector	Yes
	Power On / Off	Yes

Models

Gas Cooktop



Model Code		NA75J3030AS	NA75M3130AS	NA64H3040AS	NA64H3030AS
		Square	Square	Square	Square
Main Specifications					
Width (cm)		75	75	60	60
Gas Cooking Zones		5	5	4	4
Color		Stainless Steel	Stainless Steel	Stainless Steel	Stainless Steel
Pan Supports		Cast-iron	Enamel Grate	Cast-iron	Cast-iron
		(Wok Pansupport Included)		(Wok Pansupport Included)	(Wok pansupport included)
Wok Grate		Wok	No	Wok	Wok
Knob Design		Neo	Neo	Neo	Neo
Burner Features					
Gas	Triple Crown	3.8kW x 1	3.8kW x 1	4.0kW x 1	3.8kW x 1
	Rapid	3.0kW x 1	3.0kW x 1	3.3kW x 1	3.3kW x 1
	Semi-rapid	2.0kW x 1	2.0kW x 2	2.0kW x 1	2.0kW x 1
	Auxiliary	1.0kW x 1	1.0kW x 1	1.0kW x 1	1.0kW x 1
	Total	11.8kW	11.8kW	10.3kW	10.1kW
Safety Functions					
Flame Failure Device		Yes	Yes	Yes	Yes
Convenience					
One Hand Ignition		Yes	Yes	Yes	Yes
Installation / Connection					
Gas Power Consumption (W)		1.0W	1.0W	1.0W	1.0W
Power Cord without Plug		Yes	Yes	Yes	Yes
Power Supply		220~240V, 50 / 60Hz	220~240V, 50 / 60Hz	220~240V, 50 / 60Hz	220~240V, 50 / 60Hz
Delivery Status		Natural Gas	Natural Gas	Natural Gas	Natural Gas
Additional Injectors		LPG Conversion	LPG Conversion	LPG Conversion	LPG Conversion
		Injectors Included	Injectors Included	Injectors Included	Injectors Included
Dimensions / Weight					
Net Weight (kg)		15.6 (Include Wok)	10.5	11.8 (Include Wok)	11.8 (Include Wok)
Cut-out Size (W x L mm)		560 x 490	560 x 490	560 x 490	560 x 490
Net Dimension (W x D x H mm)		750 x 510 x 98	750 x 510 x 98	600 x 510 x 90	600 x 510 x 90

Models Gas Cooktop



Model Code		NA64H3010AS	NA64H3110AS	NA64H3040BS	NA64H3030BS
		Square	Square	Diamond	Diamond
Main Specifications					
Width (cm)		60	60	60	60
Gas Cooking Zones		4	4	4	4
Color		Stainless Steel	Stainless Steel	Stainless Steel	Stainless Steel
Pan Supports		Cast-iron	Enamel	Cast-iron	Cast-iron
				(Wok Pansupport Included)	(Wok pansupport included)
Wok Grate		No	No	Wok	Wok
Knob Design		Neo	Neo	Neo	Neo
Burner Features					
Gas	Triple Crown	No	No	4.0kW x 1	3.8kW x 1
	Rapid	3.3kW x 2	3.3kW x 2	3.3kW x 1	3.3kW x 1
	Semi-rapid	2.0kW x 1	2.0kW x 1	2.0kW x 1	2.0kW x 1
	Auxiliary	1.0kW x 1	1.0kW x 1	1.0kW x 1	1.0kW x 1
	Total	9.6kW	9.6kW	10.3kW	10.1kW
Safety Functions					
Flame Failure Device		Yes	Yes	Yes	Yes
Convenience					
One Hand Ignition		Yes	Yes	Yes	Yes
Installation / Connection					
Gas Power Consumption (W)		1.0W	1.0W	1.0W	1.0W
Power Cord without Plug		Yes	Yes	Yes	Yes
Power Supply		220~240V, 50 / 60Hz	220~240V, 50 / 60Hz	220~240V, 50 / 60Hz	220~240V, 50 / 60Hz
Delivery Status		Natural Gas	Natural Gas	Natural Gas	Natural Gas
Additional Injectors		LPG Conversion Injectors Included	LPG Conversion Injectors Included	LPG Conversion Injectors Included	LPG Conversion Injectors Included
Dimensions / Weight					
Net Weight (kg)		10.6	9.1	12.4 (Include Wok)	12.4 (Include Wok)
Cut-out Size (W x L mm)		560 x 490	560 x 490	560 x 490	560 x 490
Net Dimension (W x D x H mm)		600 x 510 x 90	600 x 510 x 91	600 x 510 x 90	600 x 510 x 90

Models

Gas Cooktop



Model Code	NA64H3010BS	NA64H3110BS	NA64H3030AK	NA64H3010AK
	Diamond	Diamond	Square	Square
Main Specifications				
Width (cm)	60	60	60	60
Gas Cooking Zones	4	4	4	4
Color	Stainless Steel	Stainless Steel	Black Tempered Glass	Black Tempered Glass
Pan Supports	Cast-iron	Enamel	Cast-iron	Cast-iron
Wok Grate	No	No	(Wok Pansupport Included) Wok	(Wok Pansupport Included) Wok
Knob Design	Neo	Neo	Neo	Neo
Burner Features				
Gas	Triple Crown	No	No	3.8kW x 1
	Rapid	3.3kW x 2	3.3kW x 2	No
	Semi-rapid	2.0kW x 1	2.0kW x 1	2.0kW x 2
	Auxiliary	1.0kW x 1	1.0kW x 1	1.0kW x 1
	Total	9.6kW	9.6kW	8.8kW
Safety Functions				
Flame Failure Device	Yes	Yes	Yes	Yes
Convenience				
One Hand Ignition	Yes	Yes	Yes	Yes
Installation / Connection				
Gas Power Consumption (W)	1.0W	1.0W	1.0W	1.0W
Power Cord without Plug	Yes	Yes	Yes	Yes
Power Supply	220~240V, 50 / 60Hz	220~240V, 50 / 60Hz	220~240V, 50 / 60Hz	220~240V, 50 / 60Hz
Delivery Status	Natural Gas	Natural Gas	Natural Gas	Natural Gas
Additional Injectors	LPG Conversion Injectors Included	LPG Conversion Injectors Included	LPG Conversion Injectors Included	LPG Conversion Injectors Included
Dimensions / Weight				
Net Weight (kg)	11.2	9.5	16.6 (Include Wok)	15.7 (Include Wok)
Cut-out Size (W x L mm)	560 x 490	560 x 490	560 x 490	560 x 490
Net Dimension (W x D x H mm)	600 x 510 x 90	600 x 510 x 91	600 x 520 x 99	600 x 520 x 99

Models Gas Cooktop



Model Code		NA64H3000AK	NA64H3010CK	NA64H3030BK	NA64H3010BK
		Square	Square	Diamond	Diamond
Main Specifications					
Width (cm)		60	60	60	60
Gas Cooking Zones		4	4	4	4
Color		Black Tempered Glass	Black Tempered Glass	Black Tempered Glass	Black Tempered Glass
Pan Supports		Cast-iron	Cast-iron	Cast-iron	Cast-iron
Wok Grate		No	(Wok Pansupport Included)	(Wok Pansupport Included)	(Wok Pansupport Included)
Knob Design		Neo	Retro	Neo	Neo
Burner Features					
Gas	Triple Crown	No	No	3.8kW x 1	No
	Rapid	3.0kW x 1	3.3kW x 1	No	3.3kW x 1
	Semi-rapid	2.0kW x 2	2.0kW x 2	2.0kW x 2	2.0kW x 2
	Auxiliary	1.0kW x 1	1.0kW x 1	1.0kW x 1	1.0kW x 1
	Total	8.0kW	8.3kW	8.8kW	8.3kW
Safety Functions					
Flame Failure Device		Yes	Yes	Yes	Yes
Convenience					
One Hand Ignition		Yes	Yes	Yes	Yes
Installation / Connection					
Gas Power Consumption (W)		1.0W	1.0W	1.0W	1.0W
Power Cord without Plug		Yes	Yes	Yes	Yes
Power Supply		220~240V, 50 / 60Hz	220~240V, 50 / 60Hz	220~240V, 50 / 60Hz	220~240V, 50 / 60Hz
Delivery Status		Natural Gas	Natural Gas	Natural Gas	Natural Gas
Additional Injectors		LPG Conversion Injectors Included	LPG Conversion Injectors Included	LPG Conversion Injectors Included	LPG Conversion Injectors Included
Dimensions / Weight					
Net Weight (kg)		14.8	15.7 (Include Wok)	17.2 (Include Wok)	16.3 (Include Wok)
Cut-out Size (W x L mm)		560 x 490	560 x 490	560 x 490	560 x 490
Net Dimension (W x D x H mm)		600 x 520 x 99	600 x 520 x 99	600 x 520 x 99	600 x 520 x 99

Models Hood



Model Code	NK36N9804VB	NK24N9804VB
Type	Vertical (Glass)	Vertical (Glass)
Main Specifications		
References	Glass / Painted Body	Glass / Painted Body
Size (cm)	90	60
Model Type Install	Wall-mount	Wall-mount
Technical Specifications		
Type of Controls	Touch control (DGT)	Touch control (DGT)
Energy Efficiency Class	A ⁺	A ⁺
Display Color	Ice Blue	Ice Blue
Extraction Type	Ducting or Recirculating	Ducting or Recirculating
Number of Motors / Fans	1 / 1	1 / 1
Number of Extraction speeds	4 (3 + Booster)	4 (3 + Booster)
Max Extraction (m ³ / hr)	560	560
Boost Extraction (m ³ / hr)	737	737
Max Sound Power (dBA)	66	66
Boost Sound Power (dBA)	72	72
Lighting	1 x 7W LED Bar	1 x 7W LED Bar
Number of Metallic Filter (Aluminium)	2	1
Number of Charcoal Filter	2	2
Total Power of Connection (W)	167	167
Ducting Diameter (mm)	150	150
Clean Air	No	No
Saturation Filter Lamps	Yes	Yes
Timer	Yes	Yes
Booster	Yes	Yes
Air Diverter	No	No
Charcoal Filter	Yes	Yes
Bluetooth	Yes	Yes
Automatic Control (Sensor)	Yes (Vapor)	Yes (Vapor)
Accessories (Optional)		
Charcoal Filter Reference	CFC0038668	CFC0038668
Dimensions		
Gross Weight	30.8	24.5
Net Weight	23.3	19.2
Gross Dimensions (W x D x H)	1034 x 915 x 433	759 x 915 x 433
Net Dimensions (W x D x H)	Min. 1,050~	Min. 1,050~
	Max. 1,486 x 898 x 386	Max. 1,486 x 598 x 386
Loading		
80m ³ Truck (loose Carton)	168	252
20F Container	60	90
40F Container	130	195
40HC Container	156	234



Model Code	NK36M7070VS	NK24M7070VS	NK36M7070VB	NK24M7070VB
Type	Vertical (Inox)	Vertical (Inox)	Vertical (Black Glass)	Vertical (Black Glass)
Main Specifications				
References	Stainless Steel A430	Stainless Steel A430	Glass / Painted Body	Glass / Painted Body
Size (cm)	90	60	90	60
Model Type Install	Wall-mount	Wall-mount	Wall-mount	Wall-mount
Technical Specifications				
Type of Controls	Touch Control (DGT)	Touch Control (DGT)	Touch Control (DGT)	Touch Control (DGT)
Energy Efficiency Class	B	B	B	B
Display Color	Ice Blue	Ice Blue	Ice Blue	Ice Blue
Extraction Type	Ducting or Recirculating	Ducting or Recirculating	Ducting or Recirculating	Ducting or Recirculating
Number of Motors / Fans	1 / 1	1 / 1	1 / 1	1 / 1
Number of Extraction speeds	4 (3 + Booster)	4 (3 + Booster)	4 (3 + Booster)	4 (3 + Booster)
Max Extraction (m ³ / hr)	585	585	585	585
Boost Extraction (m ³ / hr)	729	729	729	729
Max Sound Power (dBA)	68	68	68	68
Boost Sound Power (dBA)	73	73	73	73
Lighting	2 x 2.5W LED	2 x 2.5W LED	2 x 2.5W LED	2 x 2.5W LED
Number of Metallic Filter (Aluminium)	2	1	1	1
Number of Charcoal Filter	2	2	2	2
Total Power of Connection (W)	265	265	265	265
Ducting Diameter (mm)	150	150	150	150
Clean Air	No	No	No	No
Saturation Filter Lamps	Yes	Yes	Yes	Yes
Timer	Yes	Yes	Yes	Yes
Booster	Yes	Yes	Yes	Yes
Air Diverter	Yes	Yes	Yes	Yes
Charcoal Filter	No	No	No	No
Bluetooth	No	No	No	No
Automatic Control (Sensor)	No	No	No	No
Accessories (Optional)				
Charcoal Filter Reference	DG81-02279A	DG81-02279A	DG81-02279A	DG81-02279A
Dimensions				
Gross Weight	30.8	24.5	30.7	23.6
Net Weight	23.3	19.2	23	17.5
Gross Dimensions (W x D x H)	1034 x 915 x 433	759 x 915 x 433	1034 x 915 x 433	759 x 915 x 433
Net Dimensions (W x D x H)	Min. 1,040~	Min. 1,040~	Min. 1,040~	Min. 1,040~
	Max. 1,440 x 898 x 137	Max. 1,440 x 598 x 137	Max. 1,440 x 898 x 137	Max. 1,440 x 598 x 137
Loading				
80m3 Truck (loose Carton)	168	252	168	252
20F Container	60	90	60	90
40F Container	130	195	130	195
40HC Container	156	234	156	234

Models Hood



Model Code	NK36N5703BS	NK24N5703BS	NK24N5703BM
Type	T- type (Black Glass)	T- type (Black Glass)	T- type (Black Glass)
Main Specifications			
References	Stainless Steel A430 + Black Glass	Stainless Steel A430 + Black Glass	Stainless Steel A430 + Black Glass
Size (cm)	90	60	60
Model Type Install	Wall-mount	Wall-mount	Wall-mount
Technical Specifications			
Type of Controls	Touch Control (DGT)	Touch Control (DGT)	Touch Control (Elica)
Energy Efficiency Class	A	A	A
Display Color	Ice Blue	Ice Blue	Ice Blue
Extraction Type	Ducting or Recirculating	Ducting or Recirculating	Ducting or Recirculating
Number of Motors / Fans	1 / 1	1 / 1	1 / 1
Number of Extraction speeds	4 (3 + Booster)	4 (3 + Booster)	4 (3 + Booster)
Max Extraction (m ³ / hr)	622	622	622
Boost Extraction (m ³ / hr)	722	722	722
Max Sound Power (dBA)	72	72	72
Boost Sound Power (dBA)	75	75	75
Lighting	2 x 2.5W LED	2 x 2.5W LED	2 x 2.5W LED
Number of Metallic Filter (Aluminium)	3	2	2
Number of Charcoal Filter	1	1	1
Total Power of Connection (W)	315	315	315
Ducting Diameter (mm)	150	150	150
Clean Air	No	No	No
Saturation Filter Lamps	Yes	Yes	Yes
Timer	Yes	Yes	Yes
Booster	Yes	Yes	Yes
Air Diverter	No	No	No
Charcoal Filter	Yes	Yes	Yes
Bluetooth	Yes	Yes	Yes
Automatic Control (Sensor)	No	No	No
Accessories (Optional)			
Charcoal Filter Reference	F00333/S	F00333/S	F00333/S
Dimensions			
Gross Weight	17.9	15.7	15.7
Net Weight	14.5	13.2	13.2
Gross Dimensions (W x D x H)	945 x 375 x 575	645 x 375 x 575	645 x 375 x 575
Net Dimensions (W x D x H)	Min. 619 ~	Min. 619 ~	Min. 619 ~
	Max. 1147 x 900 x 450	Max. 1147 x 600 x 450	Max. 1147 x 900 x 450
Loading			
80m ³ Truck (loose Carton)	336	504	336
20F Container	144	204	144
40F Container	296	444	296
40HC Container	296	444	296

Models Hood



Model Code	NK36M5070BS	NK24M5070BS	NK36M5070BG	NK24M5070BG
Type	T- type (Black Glass)	T- type (Black Glass)	T- type (Black Glass, Black Stainless Steel Caviar)	T- type (Black Glass, Black Stainless Steel Caviar)
Main Specifications				
References	Stainless Steel A430 + Black Glass	Stainless Steel A430 + Black Glass	Caviar Black + Black Glass	Caviar Black + Black Glass
Size (cm)	90	60	90	60
Model Type Install	Wall-mount	Wall-mount	Wall-mount	Wall-mount
Technical Specifications				
Type of Controls	Touch Control	Touch Control	Touch Control	Touch Control
Energy Efficiency Class	B	B	B	B
Display Color	Ice Blue	Ice Blue	Ice Blue	Ice Blue
Extraction Type	Ducting or Recirculating	Ducting or Recirculating	Ducting or Recirculating	Ducting or Recirculating
Number of Motors / Fans	1 / 1	1 / 1	1 / 1	1 / 1
Number of Extraction speeds	4 (3 + Booster)	4 (3 + Booster)	4 (3 + Booster)	4 (3 + Booster)
Max Extraction (m ³ / hr)	531	531	531	531
Boost Extraction (m ³ / hr)	668	668	668	668
Max Sound Power (dBA)	70	70	70	70
Boost Sound Power (dBA)	75	75	75	75
Lighting	2 x 2.5W LED	2 x 2.5W LED	2 x 2.5W LED	2 x 2.5W LED
Number of Metallic Filter (Aluminium)	3	2	3	2
Number of Charcoal Filter	1	1	1	1
Total Power of Connection (W)	265	265	265	265
Ducting Diameter (mm)	150	150	150	150
Clean Air	No	No	No	No
Saturation Filter Lamps	Yes	Yes	Yes	Yes
Timer	Yes	Yes	Yes	Yes
Booster	Yes	Yes	Yes	Yes
Air Diverter	Yes	Yes	Yes	Yes
Charcoal Filter	No	No	No	No
Bluetooth	No	No	No	No
Automatic Control (Sensor)	No	No	No	No
Accessories (Optional)				
Charcoal Filter Reference	DG81-02294A	DG81-02294A	DG81-02294A	DG81-02279A
Dimensions				
Gross Weight	17.9	15.7	20	16.8
Net Weight	14.5	13.2	17.2	14.8
Gross Dimensions (W x D x H)	945 x 375 x 575	645 x 375 x 575	945 x 375 x 575	645 x 375 x 575
Net Dimensions (W x D x H)	Min. 619~	Min. 619~	Min. 619~	Min. 619~
	Max. 1,147 x 900 x 450	Max. 1,147 x 600 x 450	Max. 1,147 x 900 x 500	Max. 1,147 x 600 x 500
Loading				
80m3 Truck (loose Carton)	336	504	336	504
20F Container	144	204	144	204
40F Container	296	444	296	444
40HC Container	296	444	296	444

Models Hood



Model Code	NK36M5070BM	NK24M5070BM	NK36M5070FS	NK24M5070FS
Type	T- type (Black Glass, Black Stainless Steel Matt)	Box (Black Glass, Black Stainless Steel Matt)	Glass (Flat)	Glass (Flat)
Main Specifications				
References	Matt Black + Black Glass	Matt Black + Black Glass	Stainless Steel A430	Stainless Steel A430
Size (cm)	90	60	90	60
Model Type Install	Wall-mount	Wall-mount	Wall-mount	Wall-mount
Technical Specifications				
Type of Controls	Touch Control	Touch Control	Touch Control	Touch Control
Energy Efficiency Class	B	B	B	B
Display Color	Ice Blue	Ice Blue	Ice Blue	Ice Blue
Extraction Type	Ducting or Recirculating	Ducting or Recirculating	Ducting or Recirculating	Ducting or Recirculating
Number of Motors / Fans	1 / 1	1 / 1	1 / 1	1 / 1
Number of Extraction speeds	4 (3 + Booster)	4 (3 + Booster)	4 (3 + Booster)	4 (3 + Booster)
Max Extraction (m ³ / hr)	531	531	558	558
Boost Extraction (m ³ / hr)	668	668	670	670
Max Sound Power (dBA)	70	70	69	69
Boost Sound Power (dBA)	75	75	73	73
Lighting	2 x 2.5W LED	2 x 2.5W LED	2 x 2.5W LED	2 x 2.5W LED
Number of Metallic Filter (Aluminium)	3	2	1	1
Number of Charcoal Filter	1	1	1	1
Total Power of Connection (W)	265	265	255	255
Ducting Diameter (mm)	150	150	150	150
Clean Air	No	No	No	No
Saturation Filter Lamps	Yes	Yes	Yes	Yes
Timer	Yes	Yes	Yes	Yes
Booster	Yes	Yes	Yes	Yes
Air Diverter	Yes	Yes	Yes	Yes
Charcoal Filter	No	No	No	No
Bluetooth	No	No	No	No
Automatic Control (Sensor)	No	No	No	No
Accessories (Optional)				
Charcoal Filter Reference	DG81-02294A	DG81-02294A	DG81-02294A	DG81-02294A
Dimensions				
Gross Weight	20	16.3	20.2	18.8
Net Weight	17	13.9	15.5	14.7
Gross Dimensions (W x D x H)	945 x 375 x 575	645 x 375 x 575	945 x 375 x 575	645 x 375 x 575
Net Dimensions (W x D x H)	Min. 619~	Min. 619~	Min. 739~	Min. 739~
	Max. 1,147 x 900 x 500	Max. 1,147 x 600 x 500	Max. 1,061 x 898 x 450	Max. 1,061 x 598 x 450
Loading				
80m ³ Truck (loose Carton)	336	504	336	504
20F Container	144	204	144	204
40F Container	296	444	296	444
40HC Container	296	444	296	444

Models Hood



Model Code	NK36M5070CS	NK24M5070CS	NK36M5060SS	NK24M5060SS
Type	Glass (Curved)	Glass (Curved)	T- type (Stainless Steel)	T- type (Stainless Steel)
Main Specifications				
References	Stainless Steel A430	Stainless Steel A430	Stainless Steel A430	Stainless Steel A430
Size (cm)	90	60	90	60
Model Type Install	Wall-mount	Wall-mount	Wall-mount	Wall-mount
Technical Specifications				
Type of Controls	Touch Control	Touch Control	Touch Control	Touch Control
Energy Efficiency Class	B	B	B	B
Display Color	Ice Blue	Ice Blue	Ice Blue	Ice Blue
Extraction Type	Ducting or Recirculating	Ducting or Recirculating	Ducting or Recirculating	Ducting or Recirculating
Number of Motors / Fans	1 / 1	1 / 1	1 / 1	1 / 1
Number of Extraction speeds	4 (3 + Booster)	4 (3 + Booster)	4 (3 + Booster)	4 (3 + Booster)
Max Extraction (m ³ / hr)	558	558	531	531
Boost Extraction (m ³ / hr)	670	670	668	668
Max Sound Power (dBA)	69	69	70	70
Boost Sound Power (dBA)	73	73	75	75
Lighting	2 x 2.5W LED	2 x 2.5W LED	2 x 2.5W LED	2 x 2.5W LED
Number of Metallic Filter (Aluminium)	1	1	3	2
Number of Charcoal Filter	1	1	1	1
Total Power of Connection (W)	255	255	265	265
Ducting Diameter (mm)	150	150	150	150
Clean Air	No	No	No	No
Saturation Filter Lamps	Yes	Yes	Yes	Yes
Timer	Yes	Yes	Yes	Yes
Booster	Yes	Yes	Yes	Yes
Air Diverter	Yes	Yes	Yes	Yes
Charcoal Filter	No	No	No	No
Bluetooth	No	No	No	No
Automatic Control (Sensor)	No	No	No	No
Accessories (Optional)				
Charcoal Filter Reference	DG81-02294A	DG81-02294A	DG81-02294A	DG81-02294A
Dimensions				
Gross Weight	17.3	16	16.5	15.3
Net Weight	14.5	13.3	13.2	12.8
Gross Dimensions (W x D x H)	945 x 415 x 575	645 x 375 x 575	945 x 375 x 575	645 x 375 x 575
Net Dimensions (W x D x H)	Min. 603~	Min. 603~	Min. 619~	Min. 619~
	Max. 1,130 x 900 x 450	Max. 1,130 x 600 x 450	Max. 1,147 x 900 x 450	Max. 1,147 x 600 x 450
Loading				
80m3 Truck (loose Carton)	280	504	336	504
20F Container	144	204	144	204
40F Container	296	444	296	444
40HC Container	296	444	296	444

Models Hood



Model Code	NK36M3050PS	NK24M3050PS
Type	Chimney	Chimney
Main Specifications		
References	Stainless Steel A430	Stainless Steel A430
Size (cm)	90	60
Model Type Install	Wall-mount	Wall-mount
Technical Specifications		
Type of Controls	Push Button	Push Button
Energy Efficiency Class	D	D
Display Color	No	No
Extraction Type	Ducting or Recirculating	Ducting or Recirculating
Number of Motors / Fans	1 / 1	1 / 1
Number of Extraction speeds	3	3
Max Extraction (m ³ / hr)	512	512
Boost Extraction (m ³ / hr)	No	No
Max Sound Power (dBA)	70	70
Boost Sound Power (dBA)	No	No
Lighting	2 x 28W Bulbs	2 x 28W Bulbs
Number of Metallic Filter (Aluminium)	3	2
Number of Charcoal Filter	2	2
Total Power of Connection (W)	236	236
Ducting Diameter (mm)	150	150
Clean Air	No	No
Saturation Filter Lamps	No	No
Timer	No	No
Booster	No	No
Air Diverter	Yes	Yes
Charcoal Filter	No	No
Bluetooth	No	No
Automatic Control (Sensor)	No	No
Accessories (Optional)		
Charcoal Filter Reference	DG81-02329A	DG81-02329A
Dimensions		
Gross Weight	10.2	8.7
Net Weight	8	6.9
Gross Dimensions (W x D x H)	940 x 263 x 510	652 x 293 x 510
Net Dimensions (W x D x H)	Min. 739~	Min. 739~
	Max. 1,061 x 900 x 450	Max. 1,061 x 600 x 450
Loading		
80m ³ Truck (loose Carton)	560	800
20F Container	192	236
40F Container	400	512
40HC Container	500	640



Model Code		NK24M1030IS
Type	Slide-In	
Main Specifications		
References	Body / Bottom Grey the Front Stainless Steel A430	
Size (cm)	60	
Model Type Install	Wall-mount	
Technical Specifications		
Type of Controls	Push Button	
Energy Efficiency Class	C	
Display Color	No	
Extraction Type	Ducting or Recirculating	
Number of Motors / Fans	1 / 1	
Number of Extraction speeds	3	
Max Extraction (m ³ / hr)	392	
Boost Extraction (m ³ / hr)	-	
Max Sound Power (dBA)	71	
Boost Sound Power (dBA)	-	
Lighting	2xLED 3W (Bulbs)	
Number of Metallic Filter (Aluminium)	2	
Number of Charcoal Filter	1	
Total Power of Connection (W)	136	
Ducting Diameter (mm)	120	
Clean Air	No	
Saturation Filter Lamps	No	
Timer	No	
Booster	No	
Air Diverter	No	
Charcoal Filter	Optional	
Bluetooth	No	
Automatic Control (Sensor)	No	
Accessories (Optional)		
Charcoal Filter Reference	CFC0038000	
Dimensions		
Gross Weight	6 / 7.5	
Net Weight	6 / 7.5	
Gross Dimensions (W x D x H)	354 x 241 x 634	
Net Dimensions (W x D x H)	180 x 600 x 280	
Loading		
80m ³ Truck (loose Carton)	1296	
20F Container	486	
40F Container	972	
40HC Container	1080	

Models

Dishwasher

Fully Built-in



Model Code		DW60M9550BB	DW60M9530BB
Project Name		DW9000M	DW9000M
Design			
Control Panel Location		Hidden	Hidden
Control Type		Touch	Touch
Color		N/A	N/A
Performance			
Capacity (Place Setting)		14	14
Energy Efficiency Class		A+++	A++
Energy consumption (annual)		237 kWh / year	266 kWh / year
Energy consumption (cycle)		0.83 kWh / cycle	0.93 kWh / cycle
Wash Performance		A	A
Drying Performance		A	A
Dry System		Auto Open	Auto Open
Water Consumption (L/ annual)		2716	2716
Water Consumption (L/ cycle)		9.7	9.7
Noise Level (dBA)		42 dBA	44 dBA
Function			
Programs		7	6
Intensive		Yes	Yes
Auto		Yes	Yes
Normal		No	No
Delicate		Yes	Yes
Eco		Yes	Yes
Daily 55' (or Express)		Yes	Yes
Quick (38min)		Yes	Yes
Self Clean		Yes	No
Pre Wash		No	No
Delay Start		Yes	Yes
Half Load		Yes	Yes
Sanitize		Yes	Yes
Hi-temp wash		Yes	Yes
Child Lock		Yes	Yes
Zone Booster		Yes	Yes
(Targeted cleaning)			
Speed Booster		Yes	No
Wi-Fi		No	No
Safety		Aqua Stop	Yes
Inner System			
Interior		Tub Material	Stainless Steel
		Number of Wash Arm	3
Upper		Basket handle	Yes
		Foldable cup shelves	Yes
		Adjustable Height	Yes
		Fold down tines	Yes
Lower		Basket handle	Yes
		Fold down tines	Yes
Cutlery		Cutlery Tray	Yes
		Cutlery Basket	No
Dimensions			
Net		Width (mm)	598
		Height (mm)	817
		Depth (mm)	555
		Weight (Kg)	45
Installation			
Electrical(Volts/Hertz)		220-240V / 50Hz	220-240V / 50Hz
Heater Watts		2000-2300W	2000-2300W
Circulation Motor		60 to 100W	60 to 100W
Drain Pump		30W	30W
Levelling screws		60mm	60mm

Models

Dishwasher

Fully Built-in



Model Code	DW60M6050BB	DW60M6040BB
Project Name	DW5500MM	DW5500MM
Design		
Control Panel Location	Hidden	Hidden
Control Type	Touch	Touch
Color	N/A	N/A
Performance		
Capacity (Place Setting)	14	13
Energy Efficiency Class	A++	A++
	Energy consumption (annual)	266 kWh / year
	Energy consumption (cycle)	0.93 kWh / cycle
Wash Performance	A	A
Drying Performance	A	A
	Dry System	Condensing
Water Consumption (L/ annual)	2940	2940
Water Consumption (L/ cycle)	10.5	10.5
Noise Level (dBA)	44 dBA	44 dBA
Function		
Programs	Number of programs	7
	Intensive	Yes
	Auto	Yes
	Normal	No
	Delicate	Yes
	Eco	Yes
	Daily 55' (or Express)	Yes
	Quick (38min)	Yes
	Self Clean	No
	Pre Wash	Yes
Options	Delay Start	1-24h
	Half Load	Yes
	Sanitize	Yes
	Hi-temp wash	No
	Child Lock	Yes
	Zone Booster	No
	(Targeted cleaning)	
	Speed Booster	No
	Wi-Fi	No
Safety	Aqua Stop	Yes
Inner System		
Interior	Tub Material	Stainless Steel
	Number of Wash Arm	3
Upper	Basket handle	Yes
	Foldable cup shelves	Yes
	Adjustable Height	Yes
	Fold down tines	No
Lower	Basket handle	Yes
	Fold down tines	Yes
Cutlery	Cutlery Tray	Yes
	Cutlery Basket	No
Dimensions		
Net	Width (mm)	598
	Height (mm)	815
	Depth (mm)	550
	Weight (Kg)	43
Installation		
	Electrical(Volts/Hertz)	220-240V / 50Hz
	Heater Watts	1760-2100W
	Circulation Motor	85W
	Drain Pump	30W
	Levelling screws	50mm

Models

Dishwasher

Semi Built-in



Model Code		DW60M9970SS	DW60M9550SS	DW60M6050SS	DW60M6040SS
Project Name		DW9000M	DW9000M	DW5500MM	DW5500MM
Design					
Control Panel Location		Hidden	Hidden	Front	Front
Control Type		Touch	Touch	Button	Button
Color		Silver	Silver	Silver	Silver
Performance					
Capacity (Place Setting)		14	14	14	13
Energy Efficiency Class		A+++	A+++	A++	A++
Energy consumption (annual)		237 kWh/year	237 kWh/year	266 kWh/year	262 kWh/year
Energy consumption (cycle)		0.83 kWh/cycle	0.83 kWh/cycle	0.93 kWh/cycle	0.92 kWh/cycle
Wash Performance		A	A	A	A
Drying Performance		A	A	A	A
Dry System		Auto Open	Auto Open	Condensing	Condensing
Water Consumption (L/ annual)		2716	2716	2940	2940
Water Consumption (L/ cycle)		9.7	9.7	10.5	10.5
Noise Level (dBA)		41 dBA	42 dBA	44 dBA	44 dBA
Function					
Programs		Number of programs	7	7	6
		Intensive	Yes	Yes	Yes
		Auto	Yes	Yes	Yes
		Normal	No	No	No
		Delicate	Yes	Yes	Yes
		Eco	Yes	Yes	Yes
		Daily 55' (or Express)	Yes	Yes	Yes
		Quick (38min)	Yes	Yes	No
		Self Clean	Yes	Yes	No
		Pre Wash	No	No	Yes
Options		Delay Start	Yes	Yes	1-24h
		Half Load	Yes	Yes	Yes
		Sanitize	Yes	Yes	Yes
		Hi-temp wash	Yes	Yes	No
		Child Lock	Yes	Yes	Yes
		Zone Booster	Yes	Yes	No
		(Targeted cleaning)			
		Speed Booster	Yes	Yes	No
		Wi-Fi	Yes	No	No
Safety		Aqua Stop	Yes	Yes	Yes
Inner System					
Interior		Tub Material	Stainless Steel	Stainless Steel	Stainless Steel
		Number of Wash Arm	3	3	2
Upper		Basket handle	Yes	Yes	Yes
		Foldable cup shelves	Yes	Yes	Yes
		Adjustable Height	Yes	Yes	Yes
		Fold down tines	Yes	Yes	No
Lower		Basket handle	Yes	Yes	Yes
		Fold down tines	Yes	Yes	Yes
Cutlery		Cutlery Tray	Yes	Yes	No
		Cutlery Basket	No	No	Yes
Dimensions					
Net		Width (mm)	598	598	598
		Height (mm)	817	817	815
		Depth (mm)	575	575	570
		Weight (Kg)	45	45	43
Installation					
Electrical(Volts/Hertz)		220-240V / 50Hz	220-240V / 50Hz	220-240V / 50Hz	220-240V / 50Hz
Heater Watts		2000-2300W	2000-2300W	1760-2100W	1760-2100W
Circulation Motor		60 to 100W	60 to 100W	85W	85W
Drain Pump		30W	30W	30W	30W
Levelling screws		60mm	60mm	50mm	50mm

Models

Dishwasher

Built Under



Model Code		DW60M9970US	DW60M9550US	DW60M6050US	DW60M6050UW
Project Name		DW9000M	DW9000M	DW5500MM	DW5500MM
Design					
Control Panel Location		Hidden	Hidden	Condensing	Front
Control Type		Touch	Touch	Button	Button
Color		Silver	Silver	Silver	White
Performance					
Capacity (Place Setting)		14	14	14	14
Energy Efficiency Class		A+++	A+++	A++	A++
	Energy consumption (annual)	237 kWh / year	237 kWh / year	266 kWh / year	266 kWh / year
	Energy consumption (cycle)	0.83 kWh / cycle	0.83 kWh / cycle	0.93 kWh / cycle	0.93 kWh / cycle
Wash Performance		A	A	A	A
Drying Performance		A	A	A	A
	Dry System	Auto Open	Auto Open	Condensing	Condensing
Water Consumption (L / annual)		2716	2716	2940	2940
Water Consumption (L / cycle)		9.7	9.7	10.5	10.5
Noise Level (dBA)		42 dBA	42 dBA	44 dBA	44 dBA
Function					
Programs	Number of programs	7	7	7	7
	Intensive	Yes	Yes	Yes	Yes
	Auto	Yes	Yes	Yes	Yes
	Normal	No	No	No	No
	Delicate	Yes	Yes	Yes	Yes
	Eco	Yes	Yes	Yes	Yes
	Daily 55' (or Express)	Yes	Yes	Yes	Yes
	Quick (38min)	Yes	Yes	Yes	Yes
	Self Clean	Yes	Yes	No	No
	Pre Wash	No	No	Yes	Yes
Options	Delay Start	Yes	Yes	1-24h	1-24h
	Half Load	Yes	Yes	Yes	Yes
	Sanitize	Yes	Yes	Yes	Yes
	Hi-temp wash	Yes	Yes	No	No
	Child Lock	Yes	Yes	Yes	Yes
	Zone Booster	Yes	Yes	No	No
	(Targeted cleaning)				
	Speed Booster	Yes	Yes	No	No
	Wi-Fi	Yes	No	No	No
Safety	Aqua Stop	Yes	Yes	Yes	Yes
Inner System					
Interior	Tub Material	Stainless Steel	Stainless Steel	Stainless Steel	Stainless Steel
	Number of Wash Arm	3	3	3	3
Upper	Basket handle	Yes	Yes	Yes	Yes
	Foldable cup shelves	Yes	Yes	Yes	Yes
	Adjustable Height	Yes	Yes	Yes	Yes
	Fold down tines	Yes	Yes	No	No
Lower	Basket handle	Yes	Yes	Yes	Yes
	Fold down tines	Yes	Yes	Yes	Yes
Cutlery	Cutlery Tray	Yes	Yes	Yes	Yes
	Cutlery Basket	No	No	No	No
Dimensions					
Net	Width (mm)	598	598	598	598
	Height (mm)	817	817	815	815
	Depth (mm)	575	575	570	570
	Weight (Kg)	46	46	43	43
Installation					
	Electrical(Volts/Hertz)	220-240V / 50Hz	220-240V / 50Hz	220-240V / 50Hz	220-240V / 50Hz
	Heater Watts	2000-2300W	2000-2300W	1760-2100W	1760-2100W
	Circulation Motor	60 to 100W	60 to 100W	85W	85W
	Drain Pump	30W	30W	30W	30W
	Levelling screws	60mm	60mm	50mm	50mm

Models

Dishwasher

Built Under



Model Code		DW60M6051US	DW60M6051UW	DW60M6040US	DW60M6040UW
Project Name		DW5500MM	DW5500MM	DW5500MM	DW5500MM
Design					
Control Panel Location		Front	Front	Front	Front
Control Type		Button	Button	Button	Button
Color		Silver	White	Silver	Silver
Performance					
Capacity (Place Setting)		14	14	13	13
Energy Efficiency Class		A++	A++	A++	A++
Energy consumption (annual)		266 kWh / year	266 kWh / year	262 kWh / year	262 kWh / year
Energy consumption (cycle)		0.93 kWh / cycle	0.93 kWh / cycle	0.92 kWh / cycle	0.92 kWh / cycle
Wash Performance		A	A	A	A
Drying Performance		A	A	A	A
Dry System		Condensing	Condensing	Condensing	Condensing
Water Consumption (L/ annual)		2940	2940	2940	2940
Water Consumption (L/ cycle)		10.5	10.5	10.5	10.5
Noise Level (dBA)		44 dBA	44 dBA	44 dBA	44 dBA
Function					
Programs		7	7	6	6
Intensive		Yes	Yes	Yes	Yes
Auto		Yes	Yes	Yes	Yes
Normal		No	No	No	No
Delicate		Yes	Yes	Yes	Yes
Eco		Yes	Yes	Yes	Yes
Daily 55' (or Express)		Yes	Yes	Yes	Yes
Quick (38min)		Yes	Yes	No	No
Self Clean		No	No	No	No
Pre Wash		Yes	Yes	Yes	Yes
Options		1-24h	1-24h	1-24h	1-24h
Half Load		Yes	Yes	Yes	Yes
Sanitize		Yes	Yes	Yes	Yes
Hi-temp wash		No	No	No	No
Child Lock		Yes	Yes	Yes	Yes
Zone Booster (Targeted cleaning)		No	No	No	No
Speed Booster		No	No	No	No
Wi-Fi		No	No	No	No
Safety		Aqua Stop	Yes	Yes	Yes
Inner System					
Interior		Tub Material	Stainless Steel	Stainless Steel	Stainless Steel
Number of Wash Arm		3	3	2	2
Upper		Basket handle	Yes	Yes	Yes
Foldable cup shelves		Yes	Yes	Yes	Yes
Adjustable Height		Yes	Yes	Yes	Yes
Fold down tines		No	No	No	No
Lower		Basket handle	No	Yes	Yes
Fold down tines		Yes	Yes	Yes	Yes
Cutlery		Cutlery Tray	Yes	No	No
Cutlery Basket		No	No	Yes	Yes
Dimensions					
Net		Width (mm)	598	598	598
Height (mm)		815	815	815	815
Depth (mm)		570	570	570	570
Weight (Kg)		43	43	43	43
Installation					
Electrical(Volts/Hertz)		220-240V / 50Hz	220-240V / 50Hz	220-240V / 50Hz	220-240V / 50Hz
Heater Watts		1760-2100W	1760-2100W	1760-2100W	1760-2100W
Circulation Motor		85W	85W	85W	85W
Drain Pump		30W	30W	30W	30W
Levelling screws		50mm	50mm	50mm	50mm

Models

Dishwasher

Freestanding



Model Code		DW60M9550FS	DW60M9550FW
Project Name		DW9000M	DW9000M
Design			
Control Panel Location		Hidden	Hidden
Control Type		Touch	Touch
Color		Silver	White
Performance			
Capacity (Place Setting)		14	14
Energy Efficiency Class		A+++	A+++
Energy consumption (annual)		237 kWh / year	237 kWh / year
Energy consumption (cycle)		0.83 kWh / cycle	0.83 kWh / cycle
Wash Performance		A	A
Drying Performance		A	A
Dry System		Auto Open	Auto Open
Water Consumption (L / annual)		2716	2716
Water Consumption (L / cycle)		9.7	9.7
Noise Level (dBA)		42 dBA	42 dBA
Function			
Programs		Number of programs	7
		Intensive	Yes
		Auto	Yes
		Normal	No
		Delicate	Yes
		Eco	Yes
		Daily 55' (or Express)	Yes
		Quick (38min)	Yes
		Self Clean	Yes
		Pre Wash	No
Options		Delay Start	Yes
		Half Load	Yes
		Sanitize	Yes
		Hi-temp wash	Yes
		Child Lock	Yes
		Zone Booster	Yes
		(Targeted cleaning)	
		Speed Booster	Yes
		Wi-Fi	No
Safety		Aqua Stop	Yes
Inner System			
Interior		Tub Material	Stainless Steel
		Number of Wash Arm	3
Upper		Basket handle	Yes
		Foldable cup shelves	Yes
		Adjustable Height	Yes
		Fold down tines	Yes
Lower		Basket handle	Yes
		Fold down tines	Yes
Cutlery		Cutlery Tray	Yes
		Cutlery Basket	No
Dimensions			
Net		Width (mm)	598
		Height (mm)	845
		Depth (mm)	600
		Weight (Kg)	54
Installation			
		Electrical(Volts/Hertz)	220-240V / 50Hz
		Heater Watts	2000-2300W
		Circulation Motor	60 to 100W
		Drain Pump	30W
		Levelling screws	30mm

Models / Refrigerator

INSTALLATION GUIDE

BRB260189WW, BRB260178WW, BRB260187WW, BRB260176WW, BRB260135WW, BRB260134WW, BRB260131WW, BRB260130WW

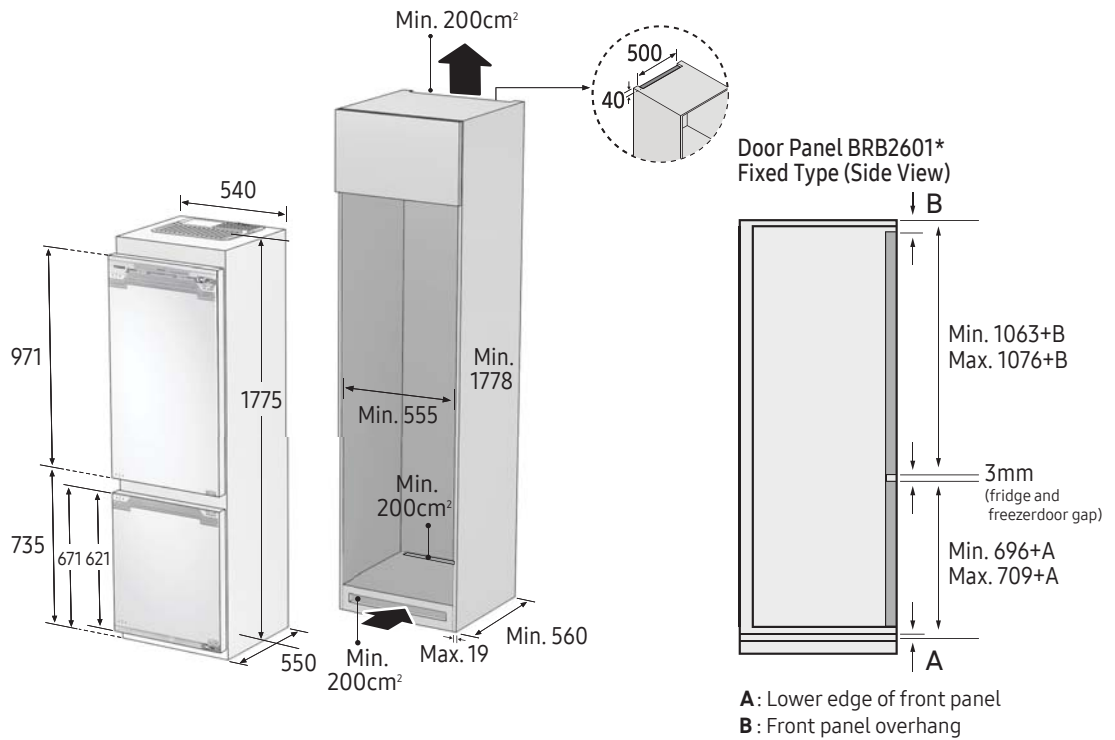

BRB260089WW, BRB260087WW, BRB260076WW, BRB260035WW, BRB260034WW, BRB260031WW, BRB260030WW, BRB260010WW
BRB60000WW

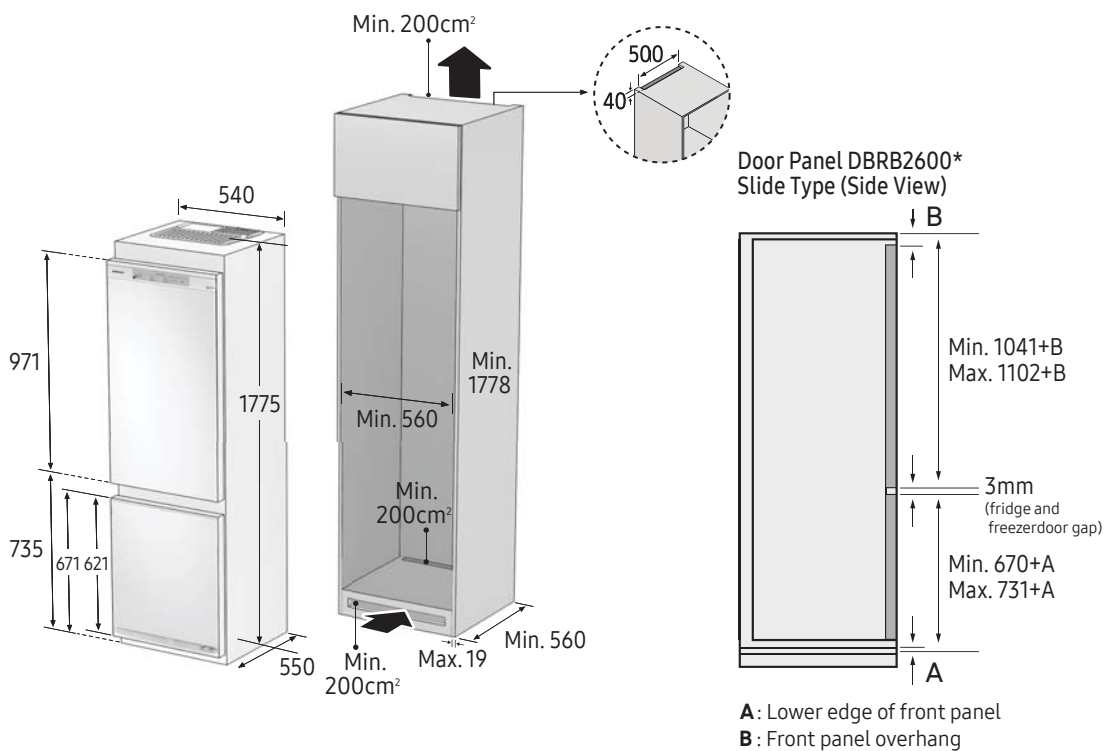

BRR19M011WW, BRR19M010WW

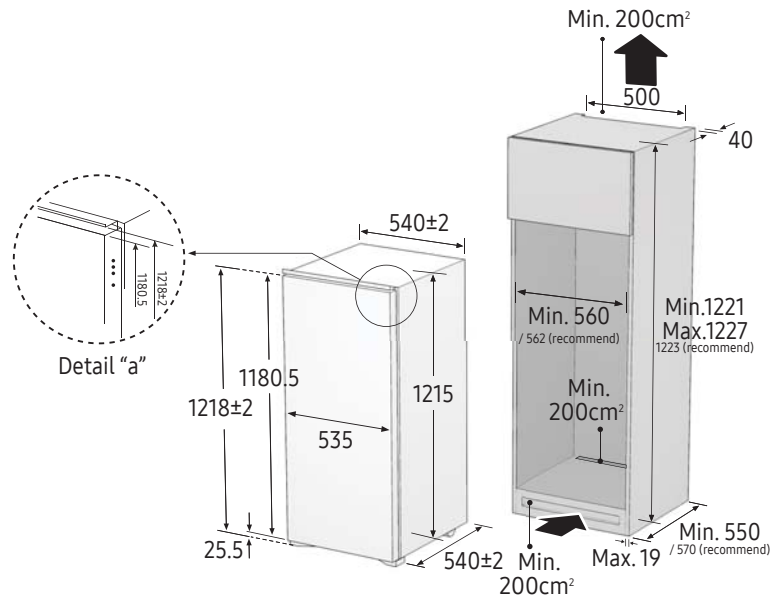

BRR12M001WW, BRR12M000WW

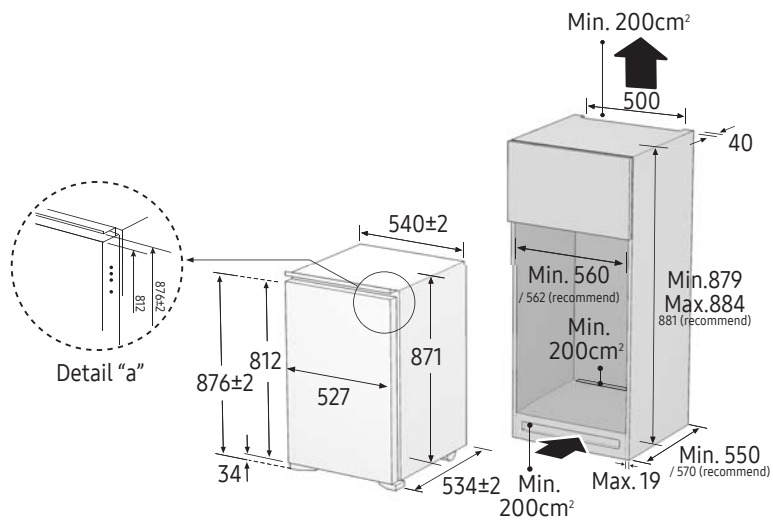

Models / Refrigerator

INSTALLATION GUIDE

RB36J8897S4, RB36J8799S4, RB36J8797S4, RB36J8855S4, RB36J8035SR, RB36J8035WW, RB36J8215SR



RB33J8797S4, RB33J8835SR, RB33J8035SR, RB33J8705S4

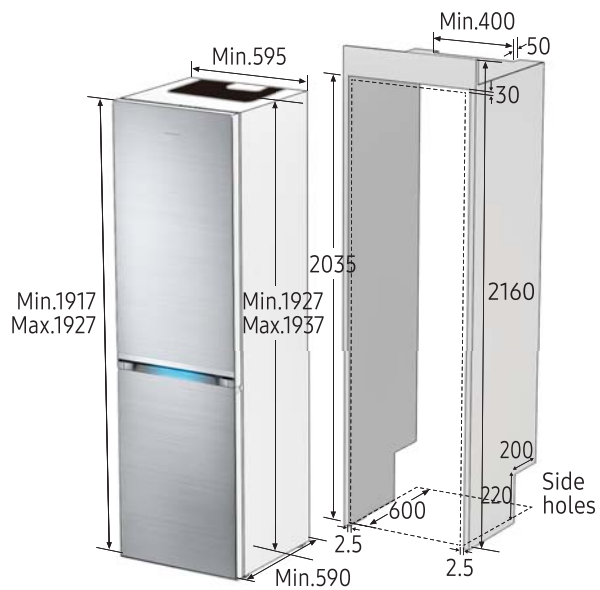

Models / oven

INSTALLATION GUIDE

NV75N7678RS, NV75N7677RS, NV75N7647RS, NV75N5672RS, NV75N5672RM, NV75N5671RS, NV75N5671RM, NV75N5671BS, NV75N5641RS, NV75N5641RB, NV75N5642BS, NV75N5641BS

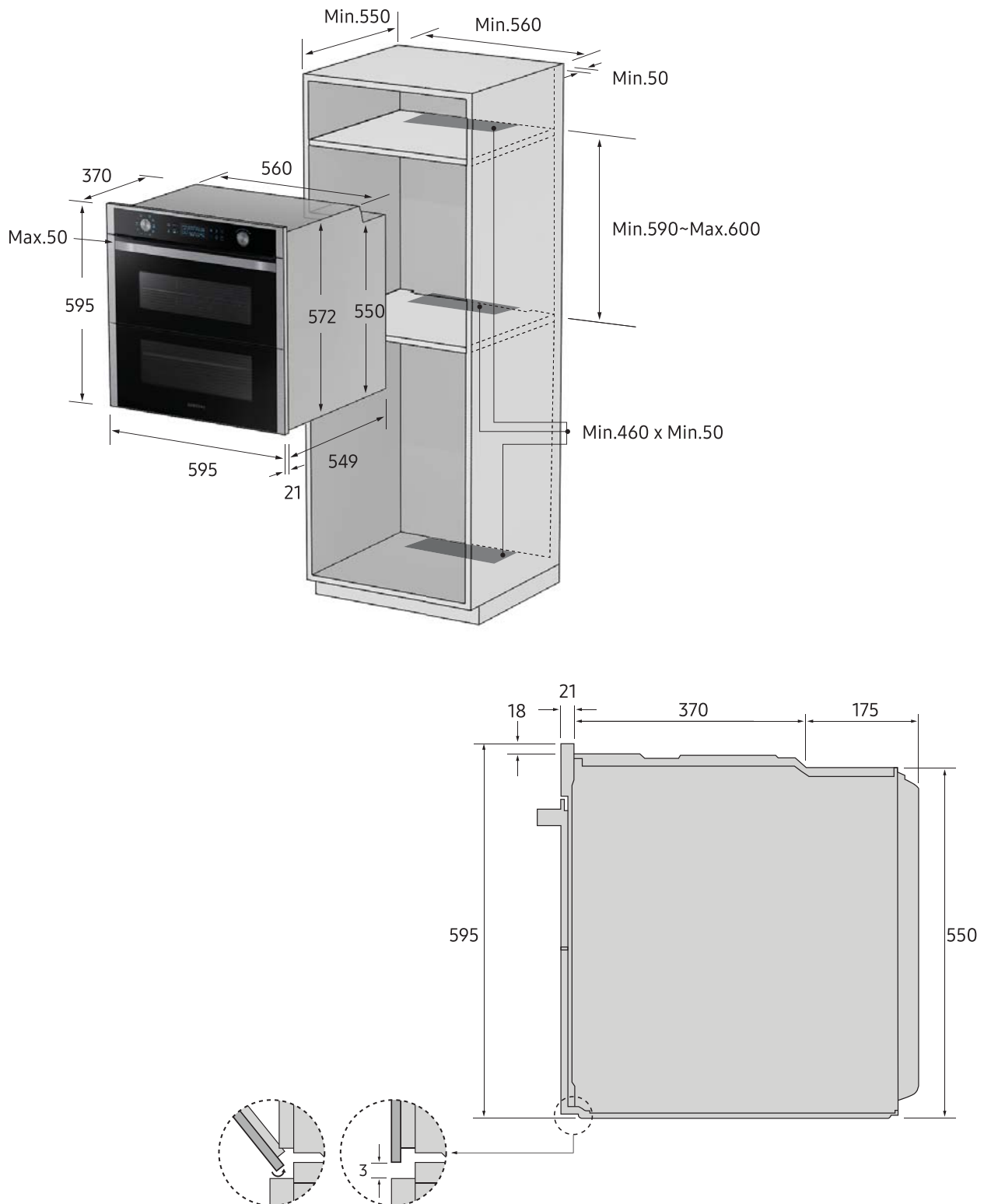

Secure at least 3mm of gap so that the door opens and closes smoothly

Models / oven

INSTALLATION GUIDE

NV73J9770RS,NV73J7740RS,BQ1VD6T131,NV70F3984LS,NV75M7572RS,NV757570RS,NV75J5540RS,NV75M5572RS,NV75K5571RS,NV75K5571RM,NV75K5571RG,NV75K5571BS,NV75M5542RS,NV75K5541RS,NV75K5541RM,NV75K5541RG,NV75K5541RB,NV75K5541BS,NV75K5541BB,NV70M3571RS,NV70M3541RS,NV70M3541RB,NV66M3571BS,NV66M3571BB,NV66M3531BS,NV66M3531BB,NV70H5787CB,NV66H5737LB,NV75J5170BS,NV75J3140RS,NV75J3140BS,NV75J3140BB,NV75K3340RS,NV75K3340RG,NV75K3340RB,NV75K3340RW,NV70M3372RS,NV70M3372BS,NV70M3373BS,NV70M3372BB,NV70K3370RS,NV70K3370BS,NV70K3370BB,NV70K2340RS,NV70K2340RM,NV70K2340RG,NV70K2340RB,NV70K1340BS,NV70K1340BG,NV70K1340BB,NV70K1340BW,NV70K1310BS,NV70K1310BB,NV72M1010BS,NV70H5587BB,NV70H5587CB,NV70H5557LB,NV70H3350CB,NV70H3350CE

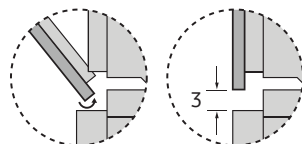
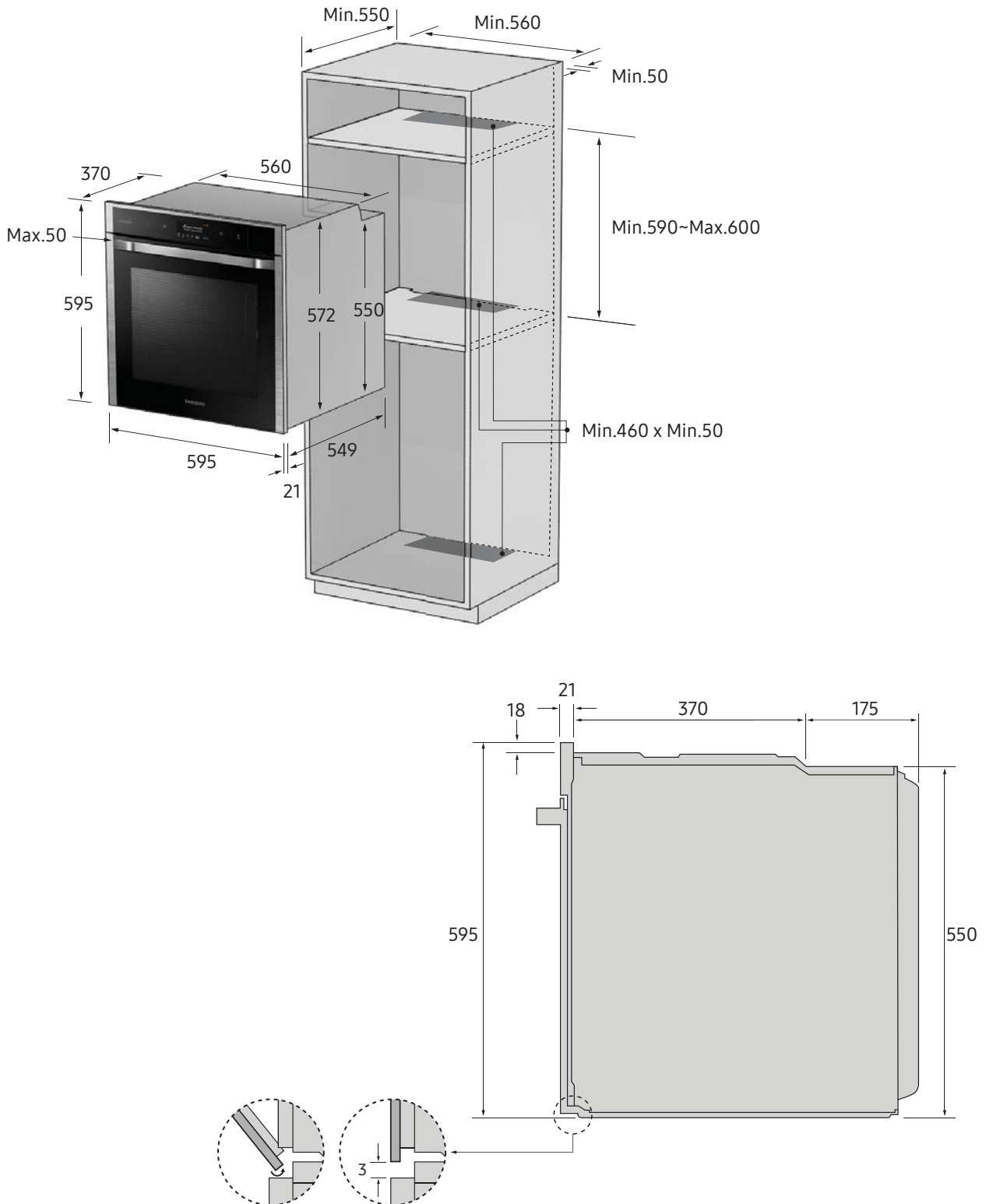

Secure at least 3mm of gap so that the door opens and closes smoothly

Models / Compact Oven

INSTALLATION GUIDE

NQ50C7935ES, NQ50J9530BS, NQ50J5530BS, NQ50J3530BS, NQ50K3530BG, NQ50H5537KB, NQ50K5130BS, NQ50K3130BS, NQ50K3130BM, NQ50H7535DS, NQ50H5533KS, NQ50H7235AS

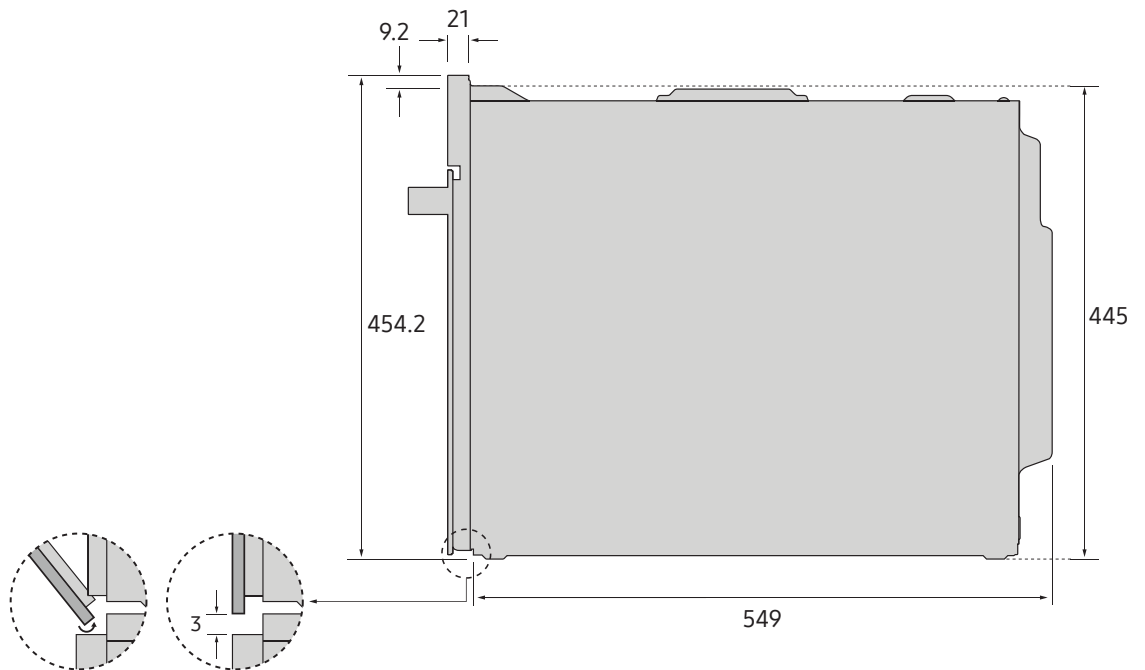
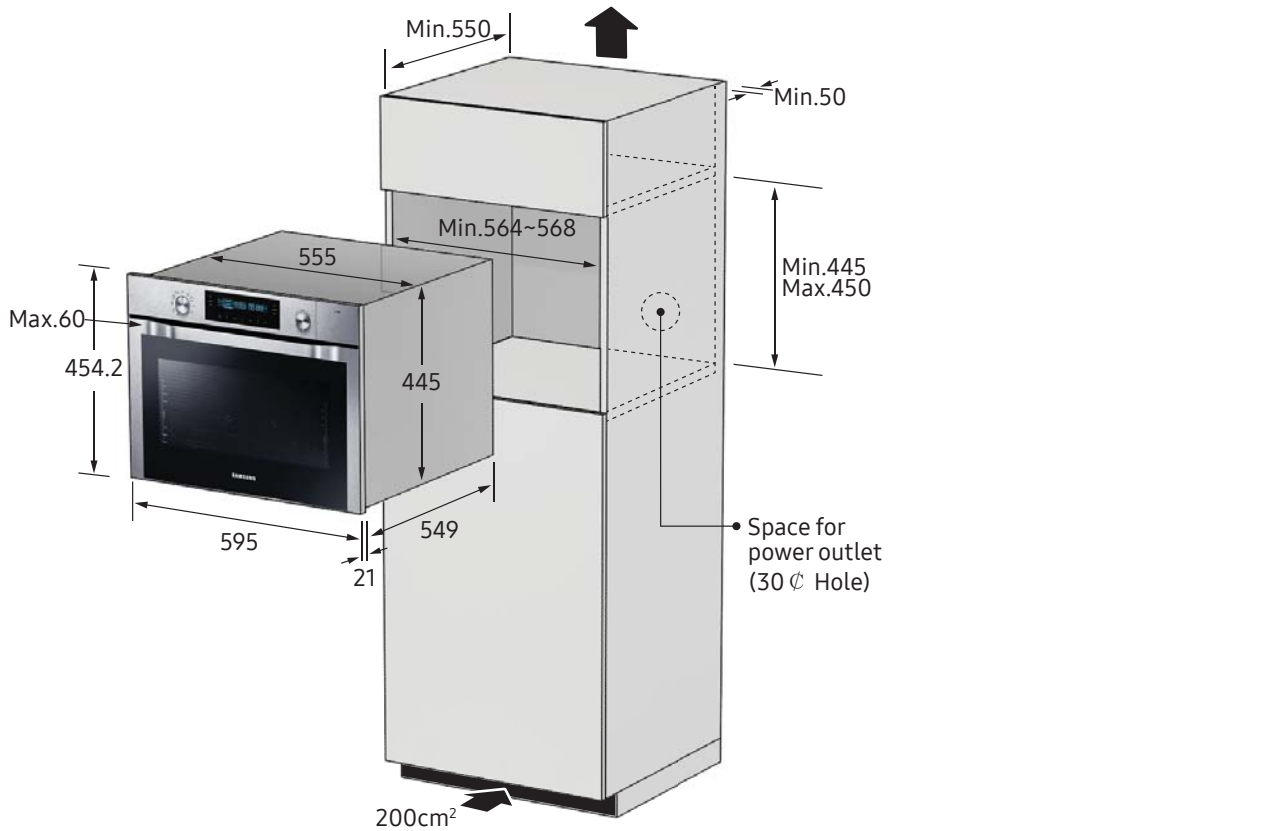

Secure at least 3mm of gap so that the door opens and closes smoothly

Models / Warmer

INSTALLATION GUIDE

NL20J7100WB, NL20F7100WB, NL20N7100WM

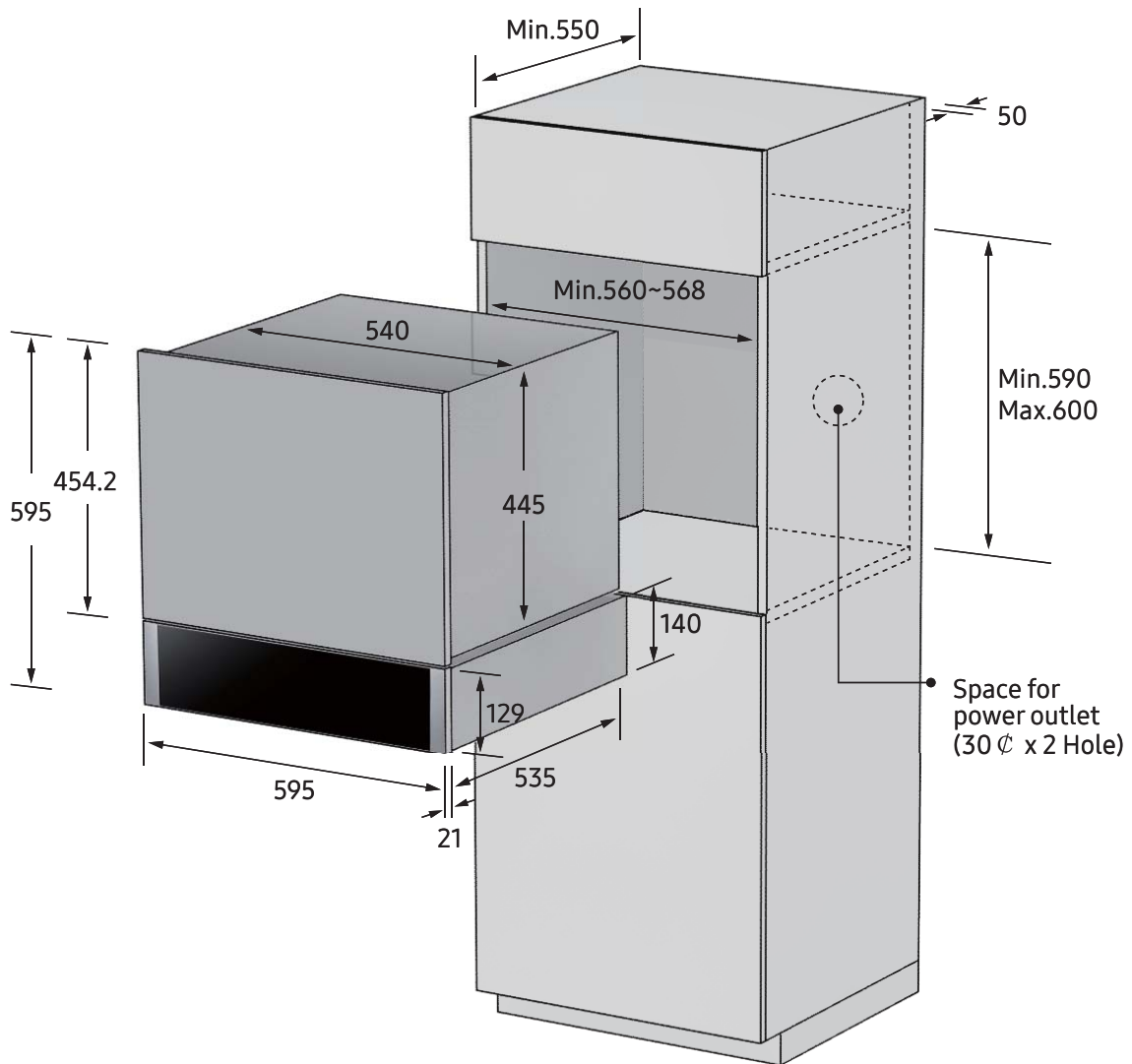

MG22M8074CT, MG22M8074AT, MG22M8054AK, MG22M8054AW, MS22M8074AT, MS22M8054AK, MS22M8054AW

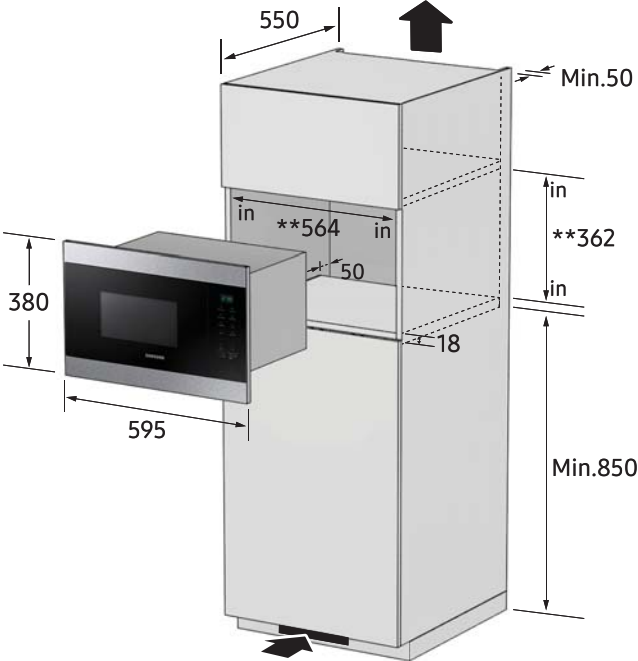

FG87SUST, FG87SUB, FG77SUST, FG77SUB, FW87SUST, FW87SUB

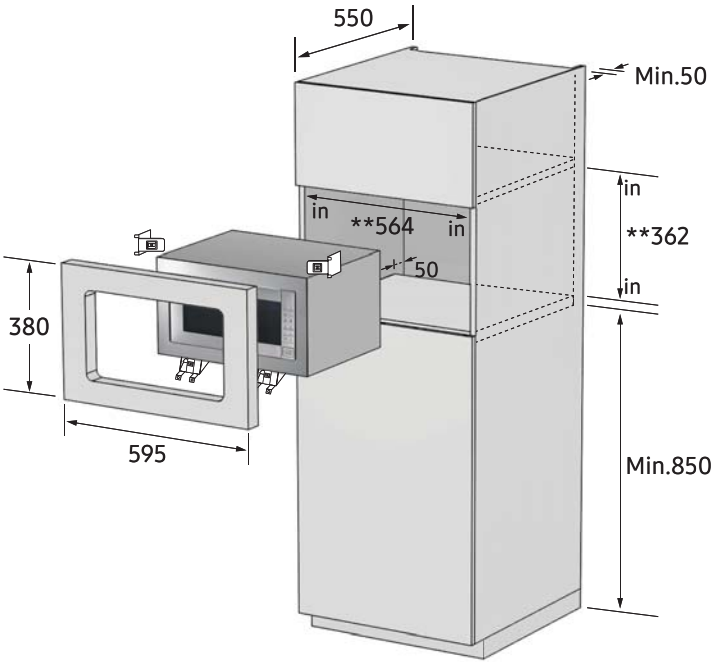

Models / Induction Cooktop

INSTALLATION GUIDE

NZ84J9770EK

NZ84F7NC6AB

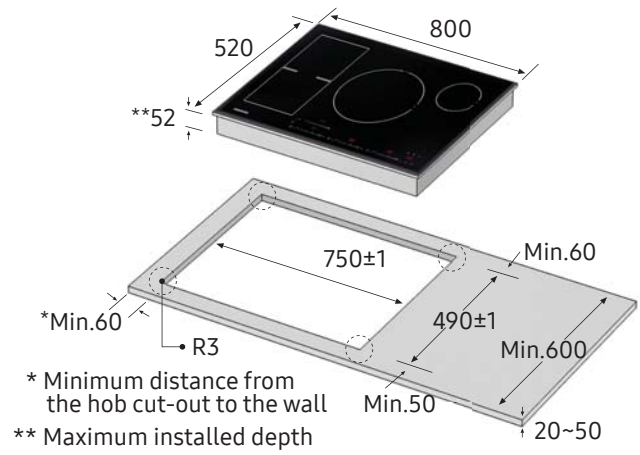
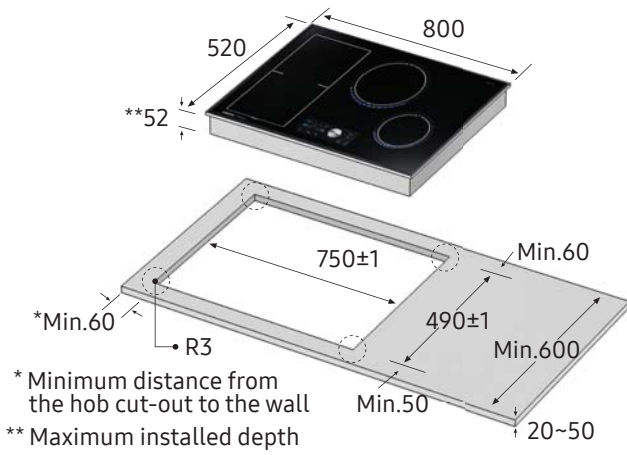

NZ63N9777GK

NZ64N9777GK

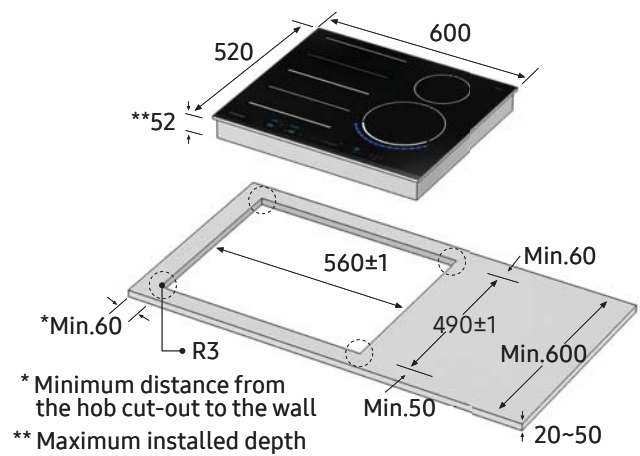
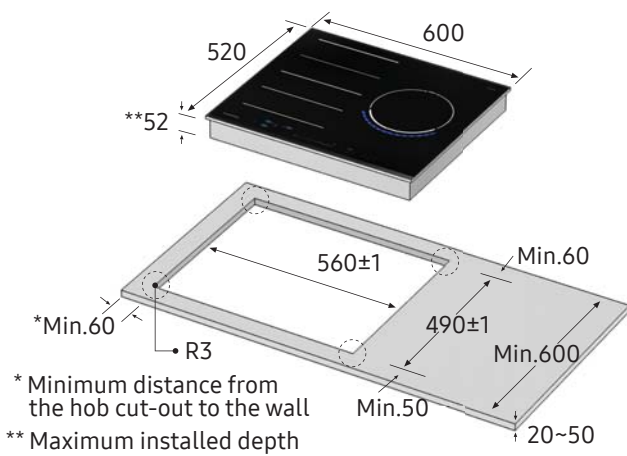

NZ64N9777BK

NZ63J9770EK

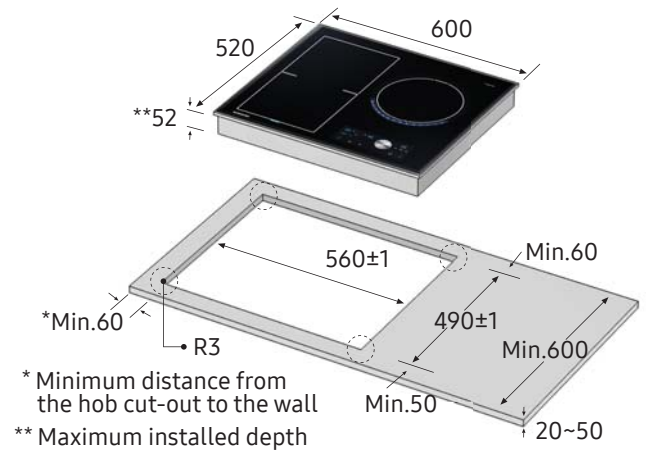
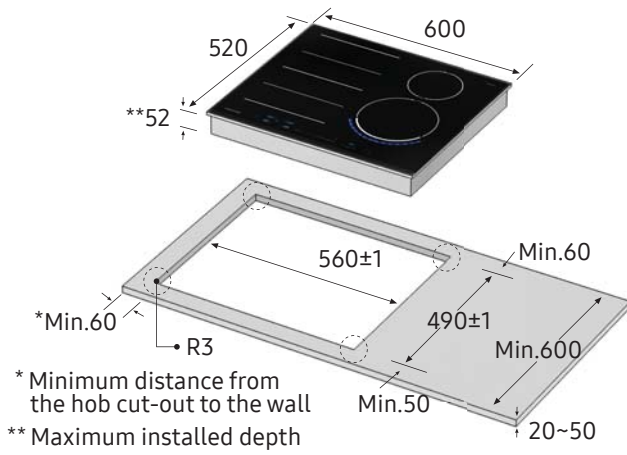

NZ64N7777GK

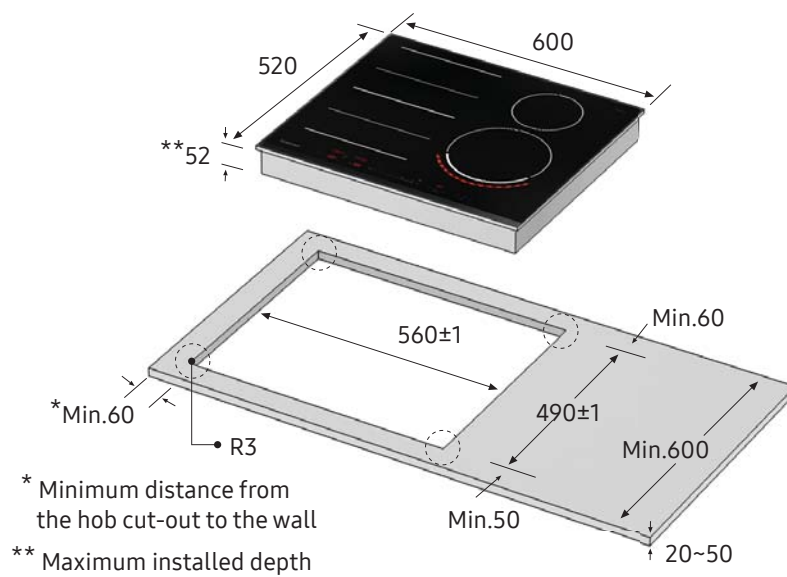

Models / Induction Cooktop

INSTALLATION GUIDE

NZ63K7777BK

NZ64N7757GK

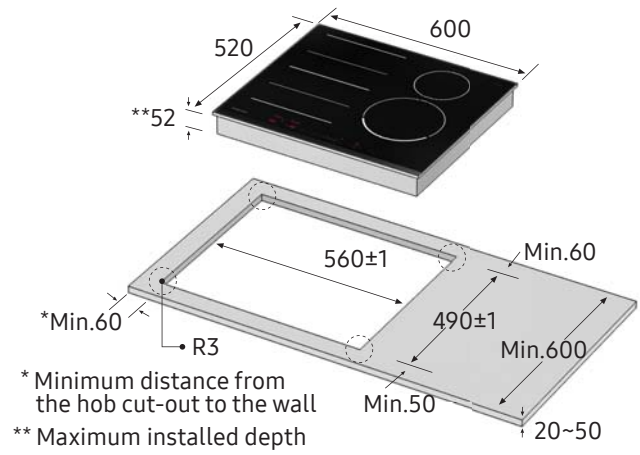
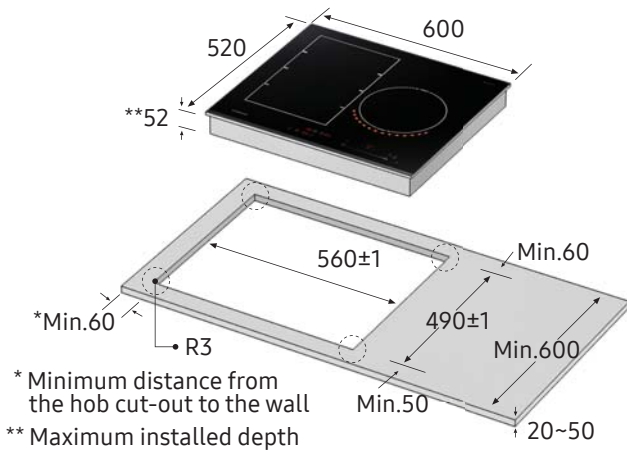

NZ64N7757FK

NZ64K7757BK

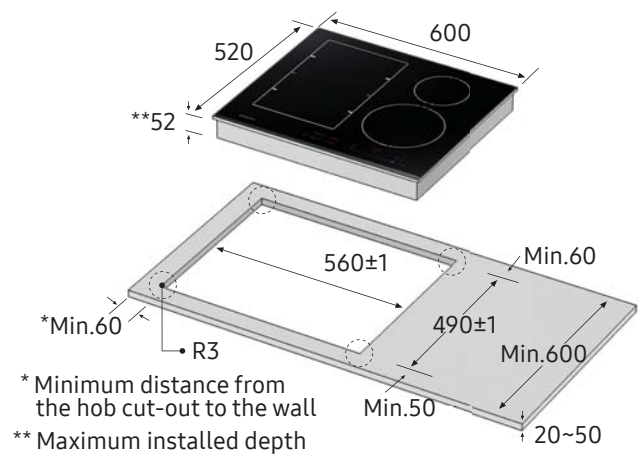
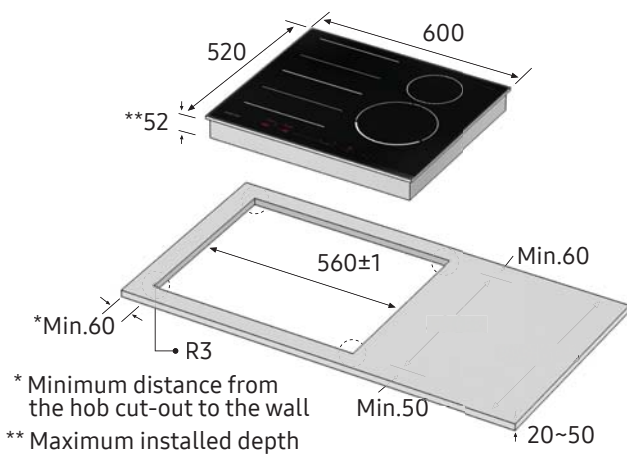

NZ63K5727BK

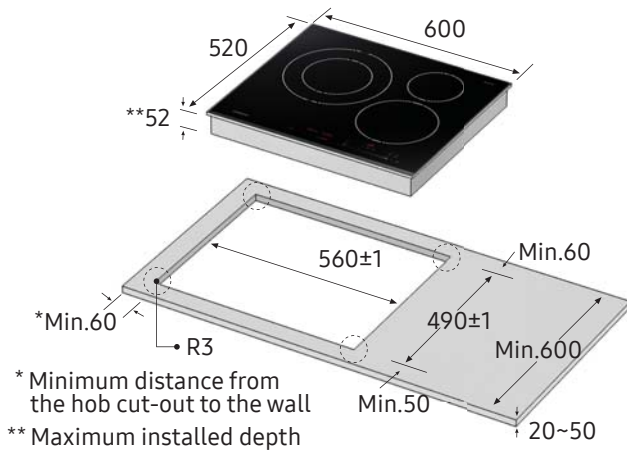

NZ64K5747BK

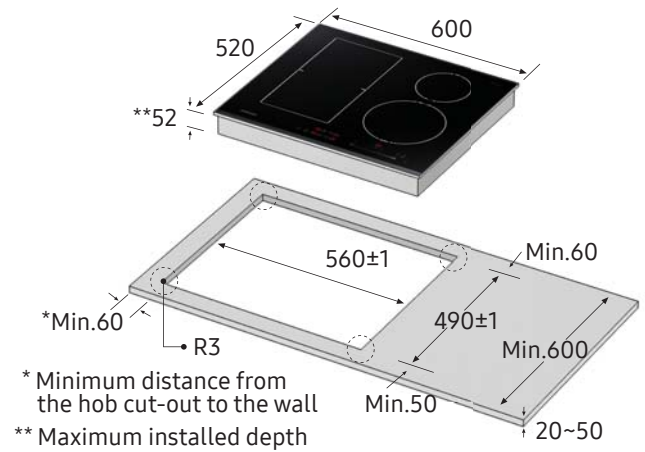

NZ63H57470K

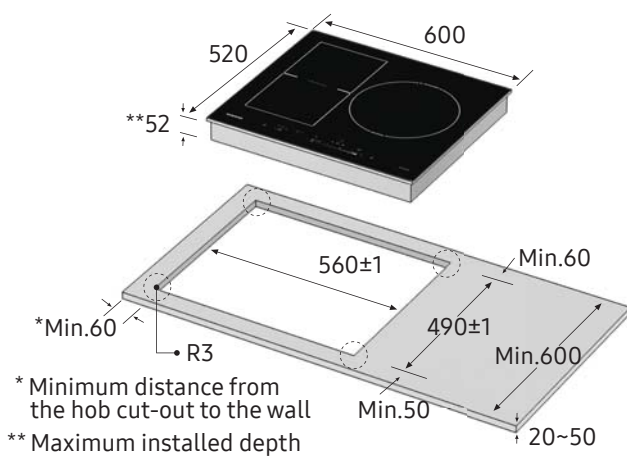

NZ64H37075K

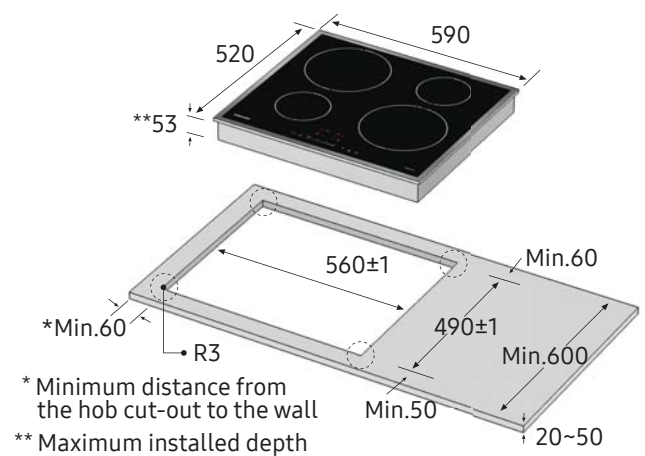

Models / Induction Cooktop

INSTALLATION GUIDE

NZ64H37070K

NZ63H37070K

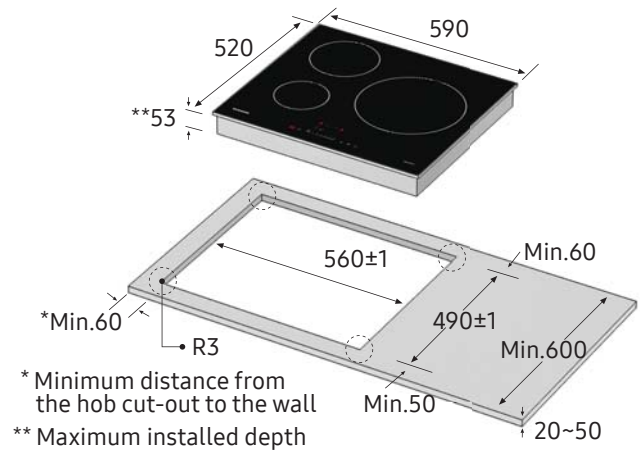
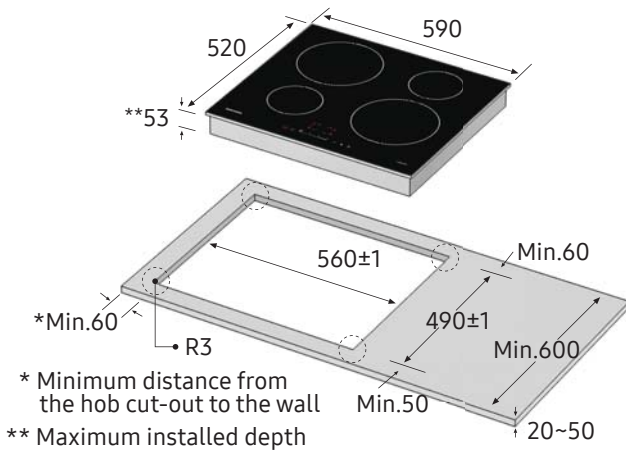

NZ63F3NM1AB

NZ64F3NM1AB

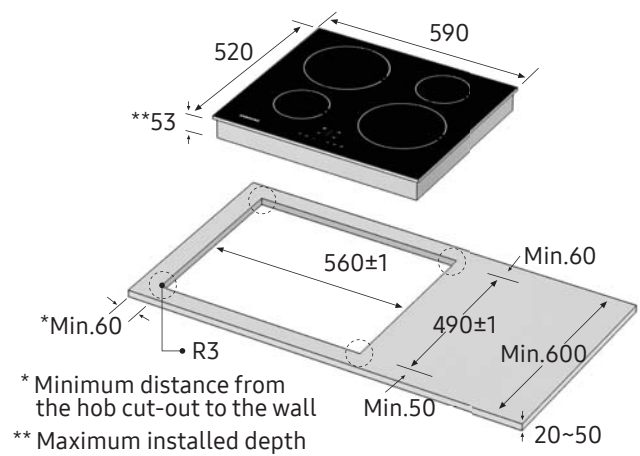
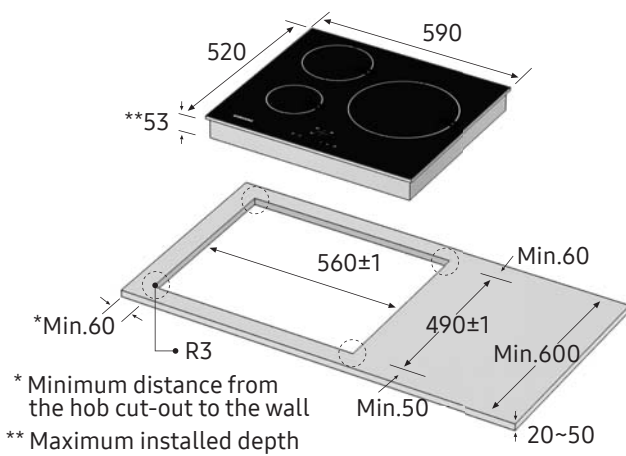

NZ63M3707AK

NZ64M3707AK

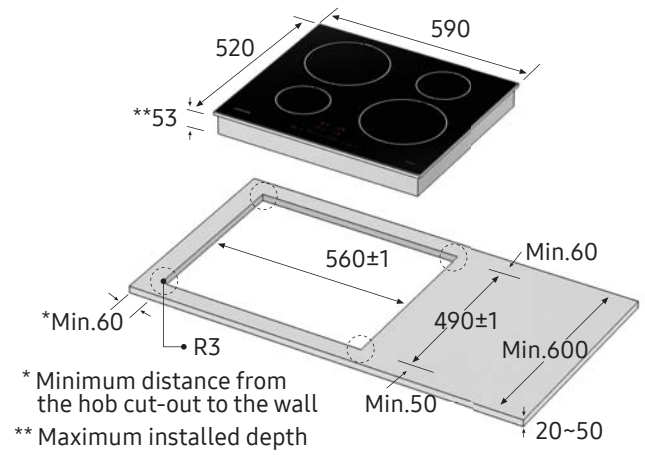
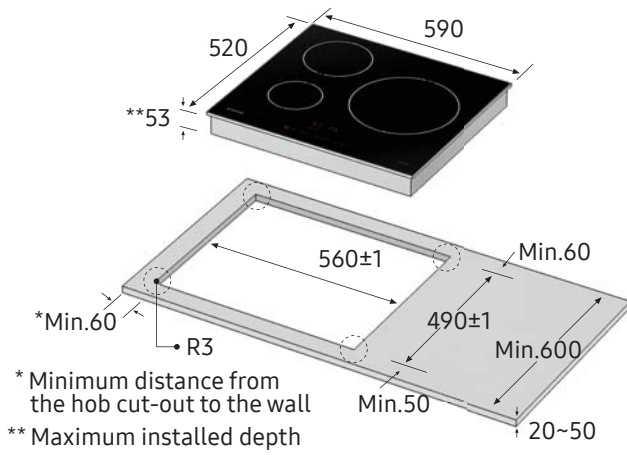

NZ63M3NM1BB

NZ64M3NM1BB

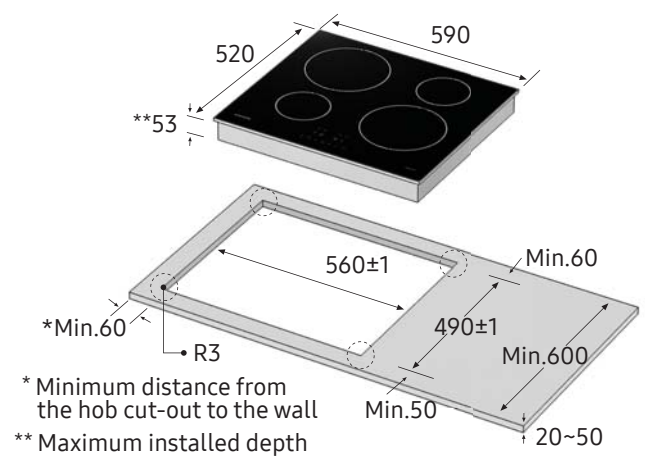
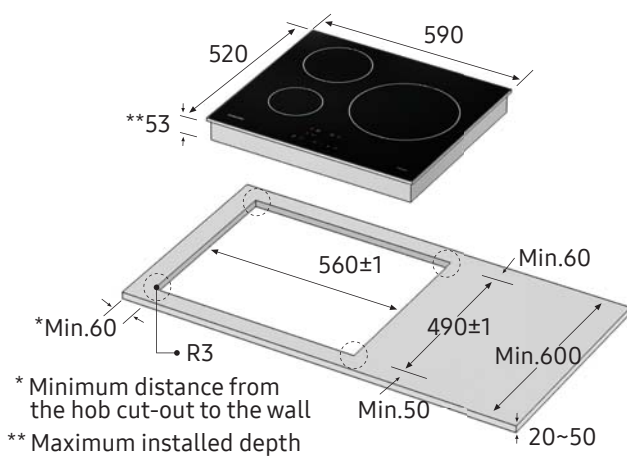

Models / Ceramic Cooktop

INSTALLATION GUIDE

CTR164NC01

CTR364NC01

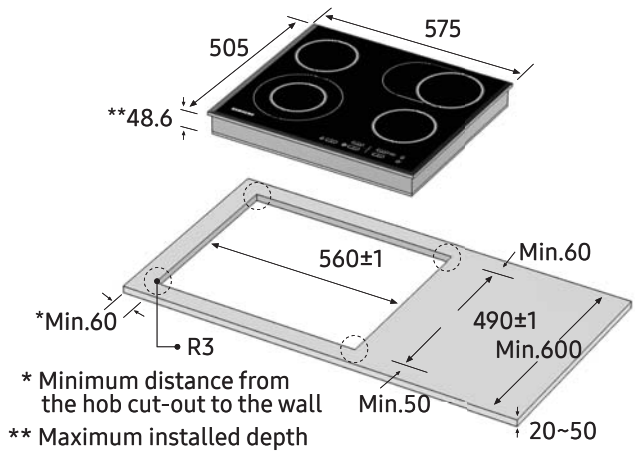
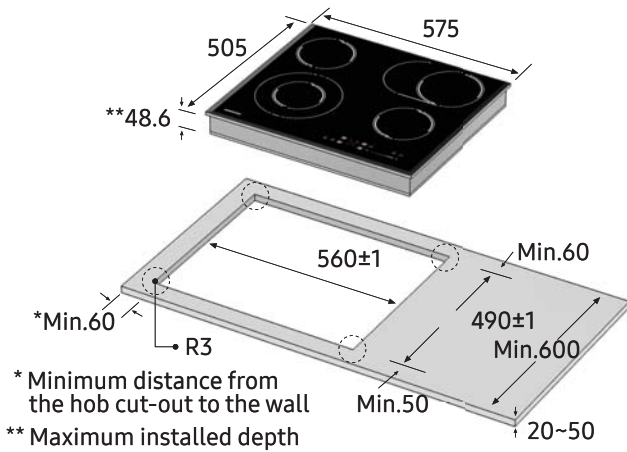

CTR464NC01

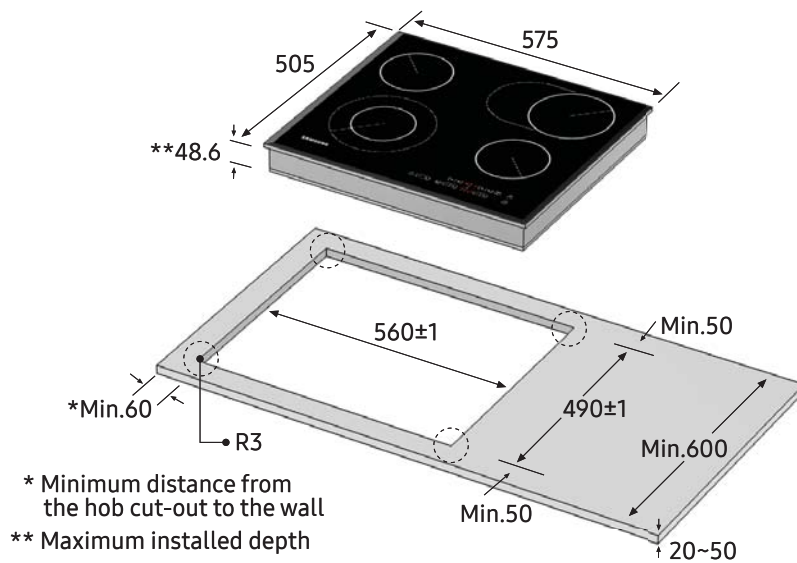

CTR464NB01

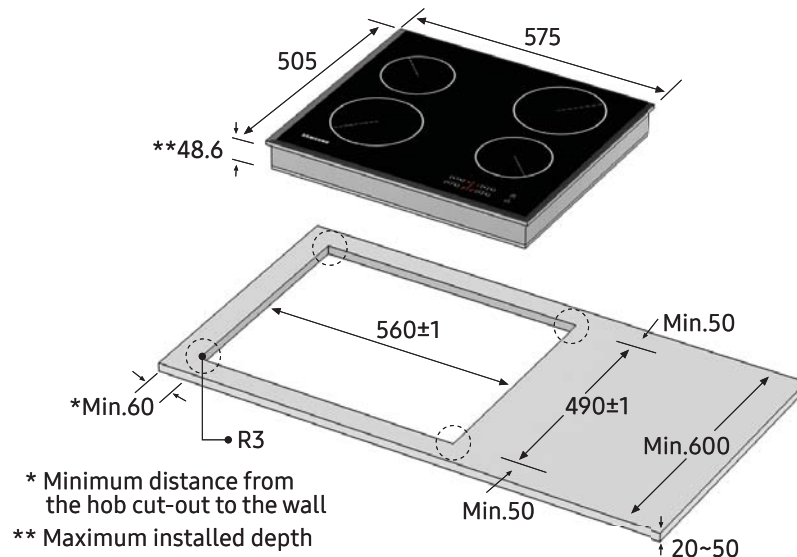

CTR432NB02

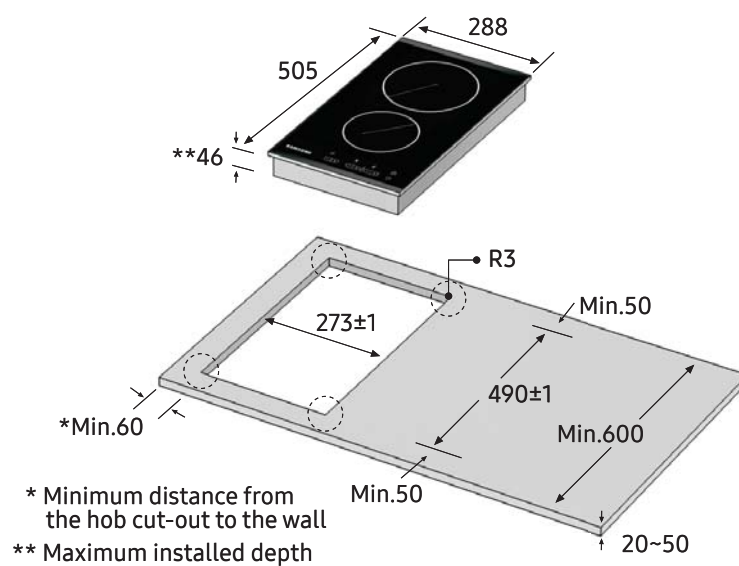

Models / Gas Cooktop

INSTALLATION GUIDE

NA75J3030AS

NA75M3130AS

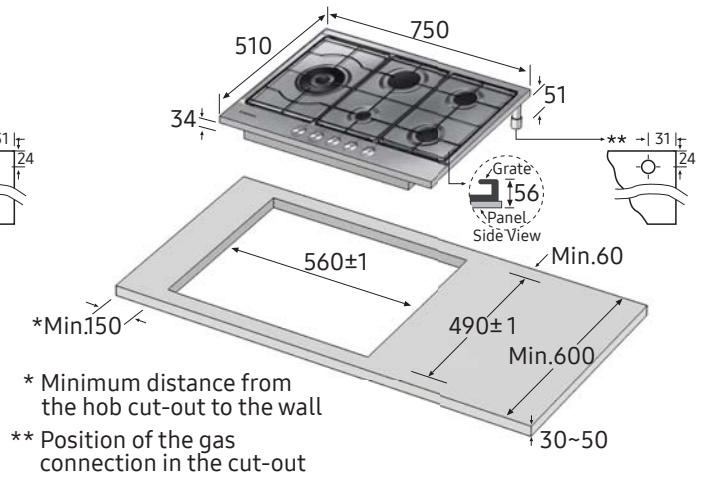
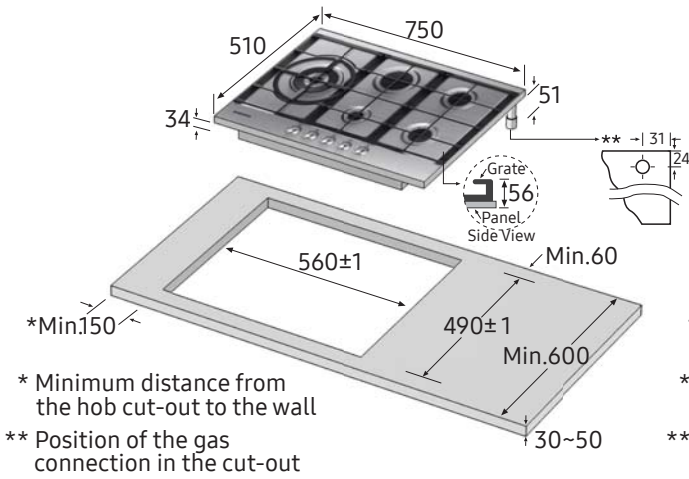

NA64H3040AS

NA64H3030AS

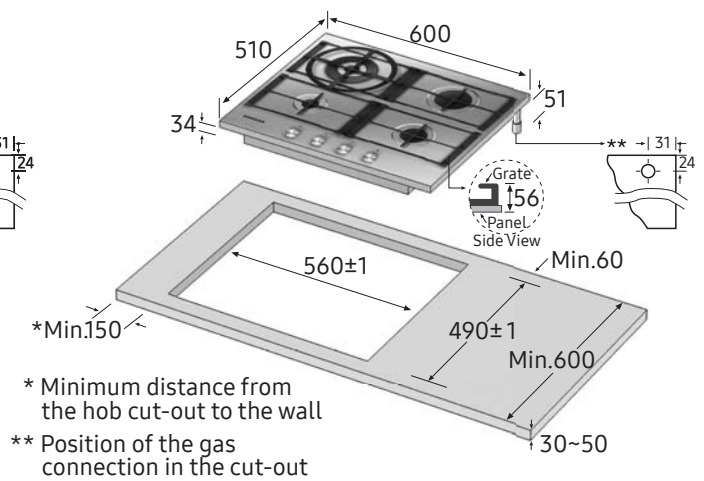
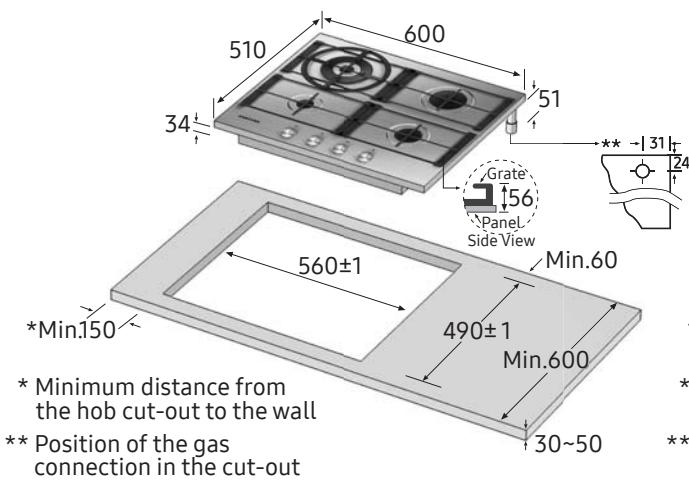

Models / Gas Cooktop

INSTALLATION GUIDE

NA64H3010BS

NA64H3110BS

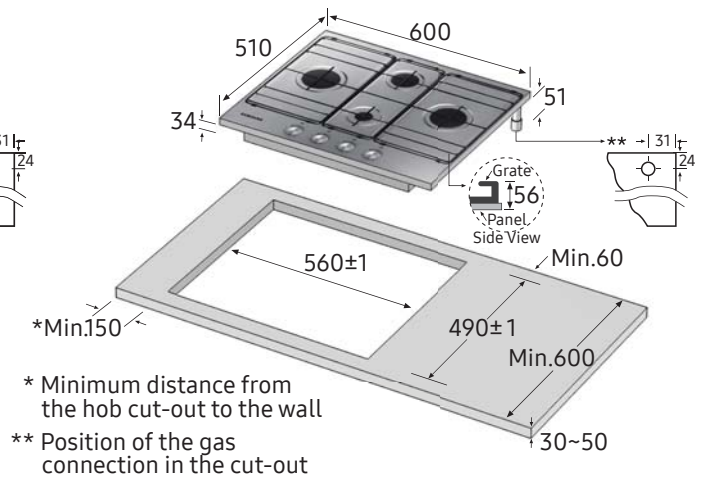
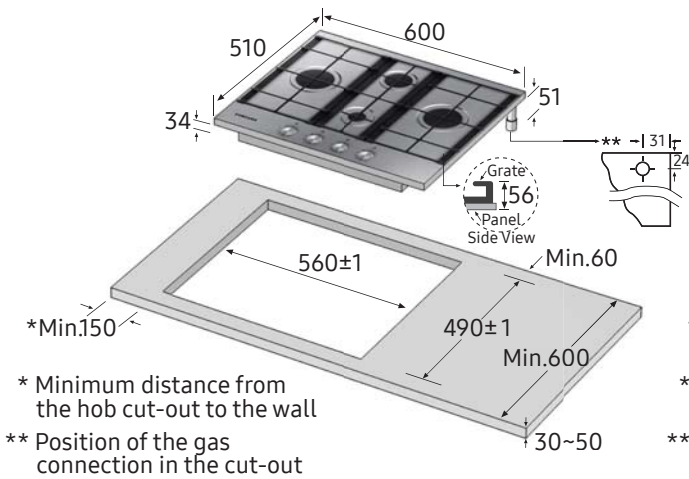

NA64H3030AK

NA64H3010AK

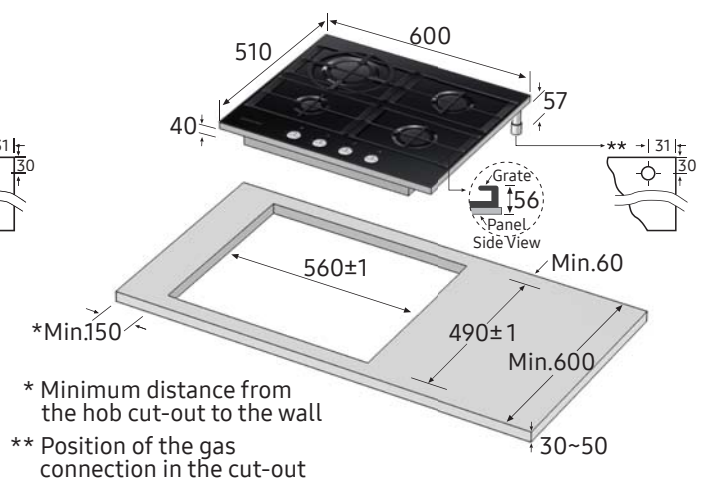
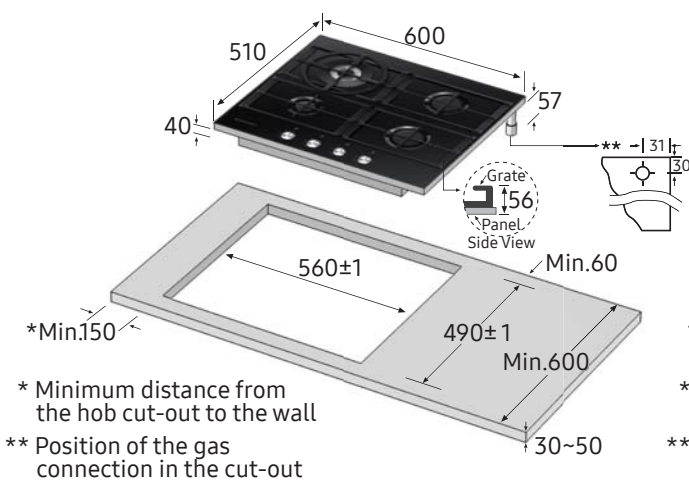

NA64H3000AK

NA64H3010CK

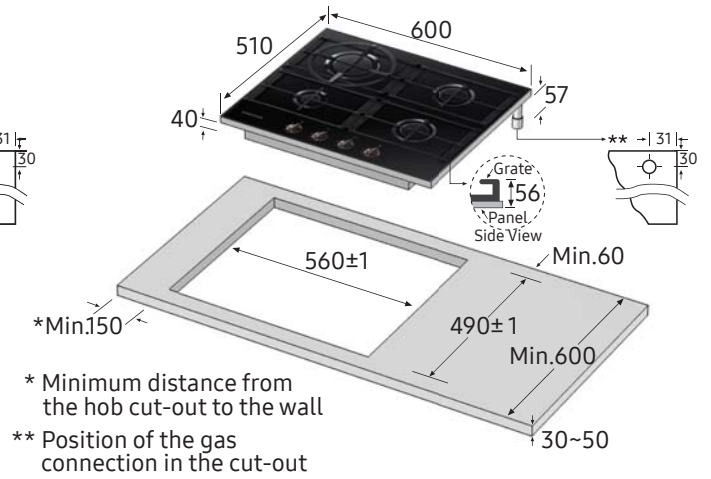
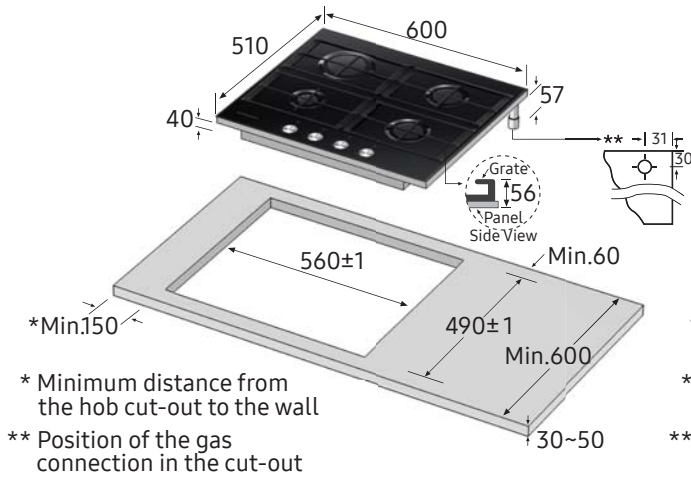

NA64H3030BK

NA64H3010BK

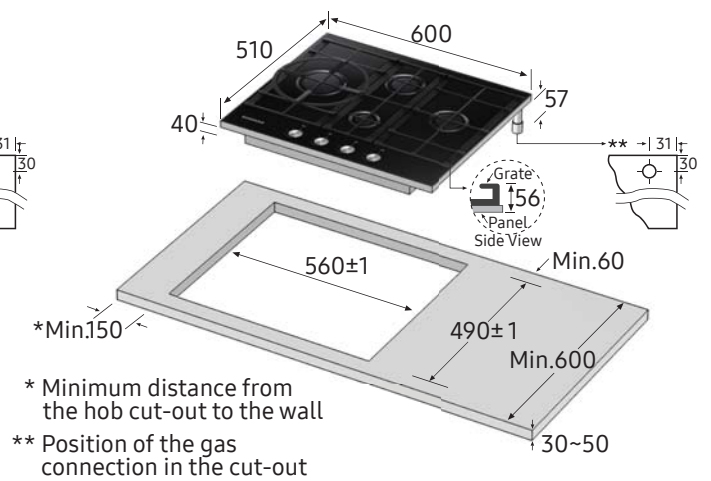
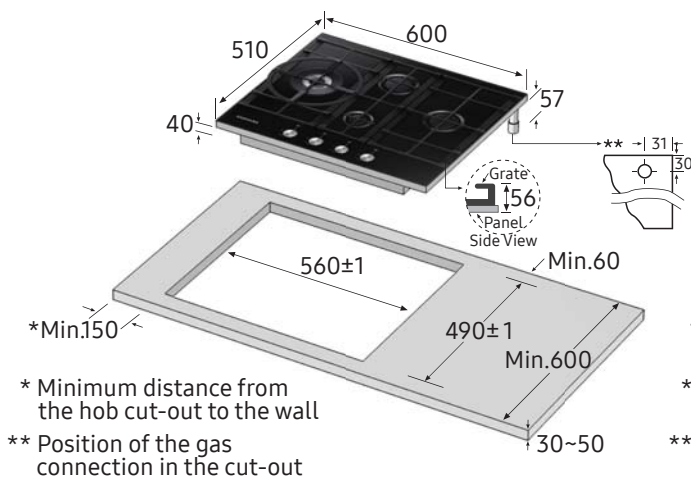

Models / Hood

INSTALLATION GUIDE

NK36N9804VB, NK24N9804VB / 90cm, 60cm
NK36M7070VS, NK24M7070VS / 90cm, 60cm
NK36M7070VB, NK24M7070VB / 90cm, 60cm

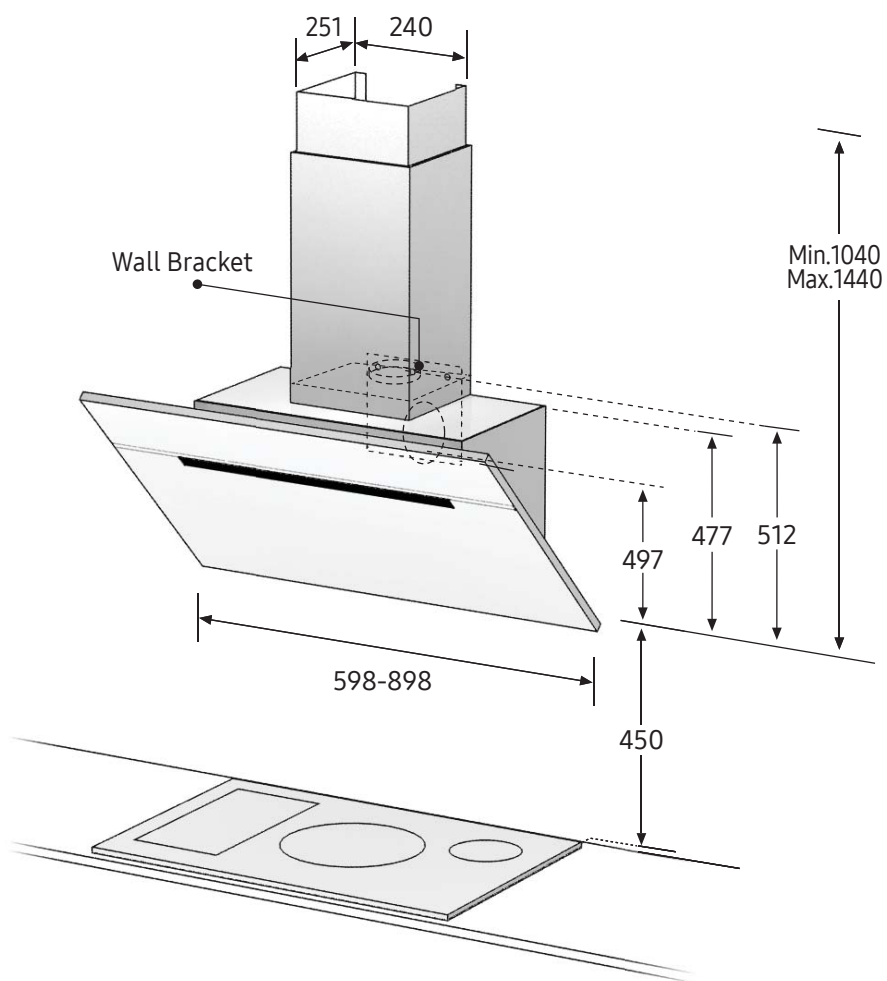

Models / Hood

INSTALLATION GUIDE

NK36N5703BS, NK24N5703BS / 90cm, 60cm
NK36M5070BS, NK24M5070BS / 90cm, 60cm
NK36M5060SS, NK24M5060SS / 90cm, 60cm

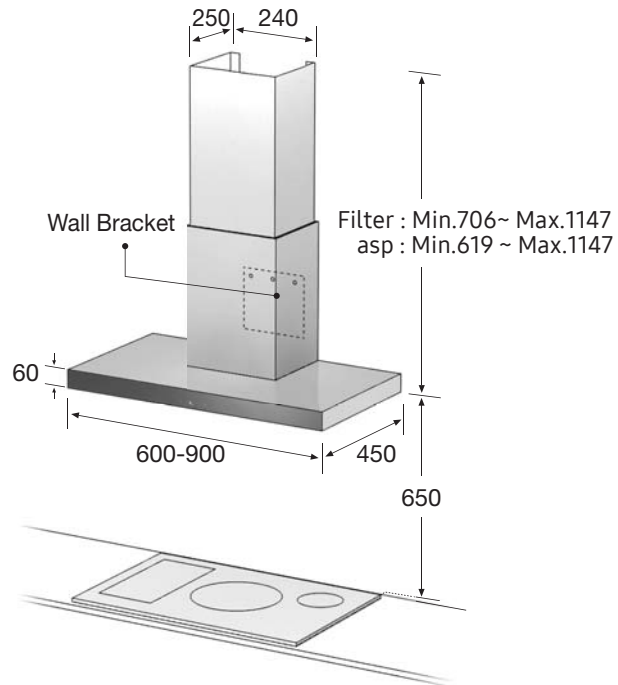

NK24N5703BM / 60cm
NK36M5070BG, NK24M5070BG / 90cm, 60cm
NK36M5070BM, NK24M5070BM / 90cm, 60cm

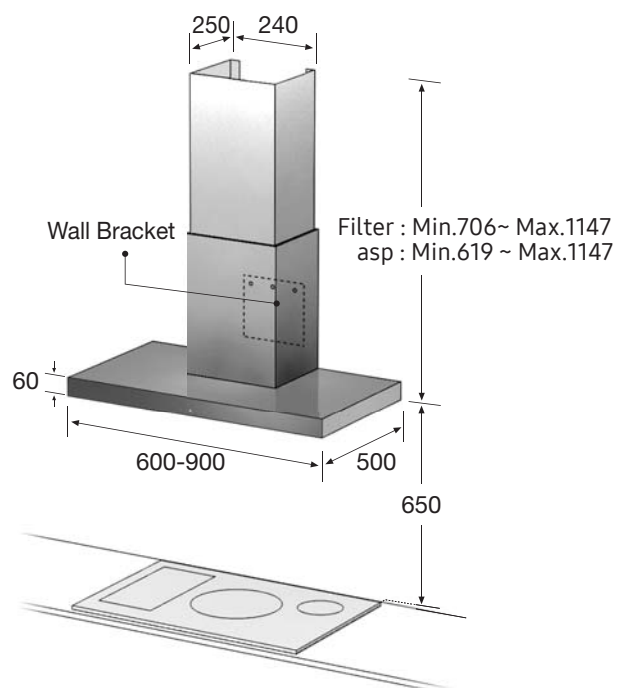

Models / Hood

INSTALLATION GUIDE

NK36M5070FS, NK24M5070FS / 90cm, 60cm

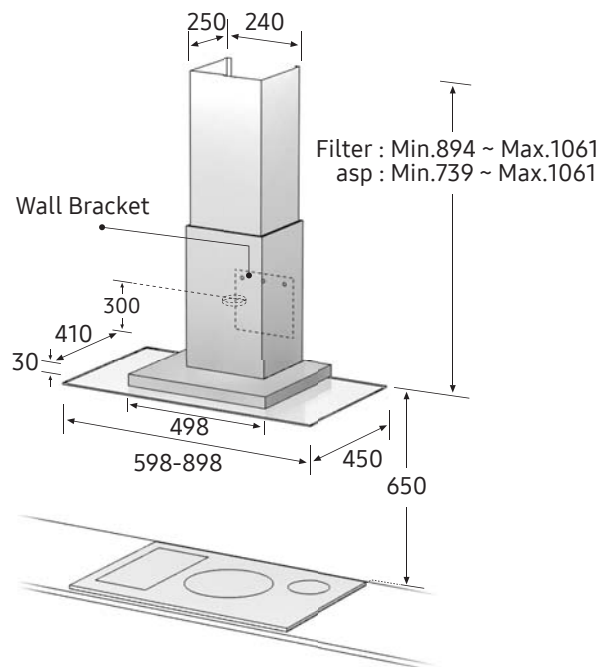

NK36M5070CS, NK24M5070CS / 90cm, 60cm

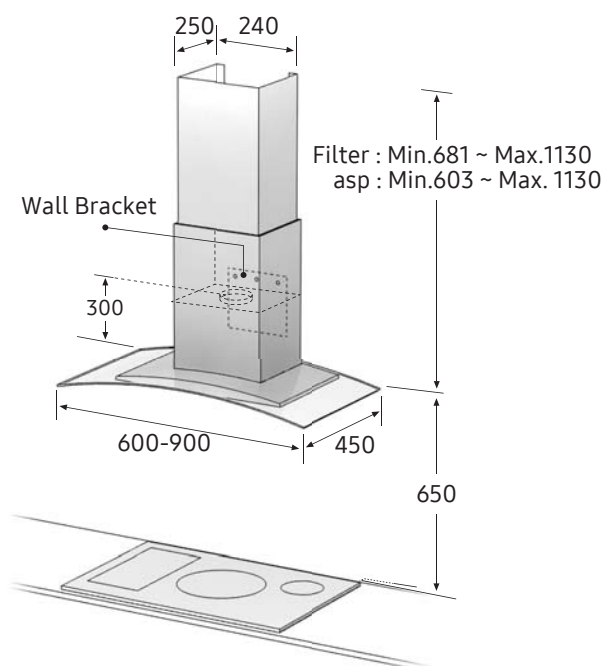

NK36M3050PS, NK24M3050PS / 90cm, 60cm

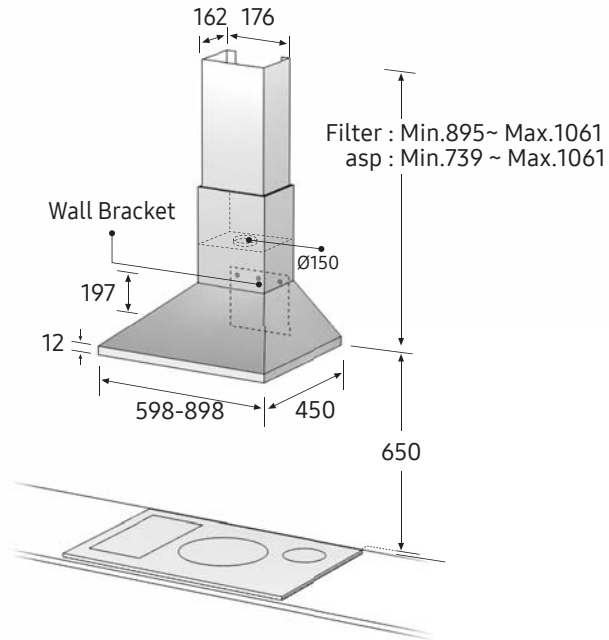

NK36M1030IS, NK24M1030IS / 90cm, 60cm
NK24M1030IB / 60cm
NK24N1331IS / 60cm

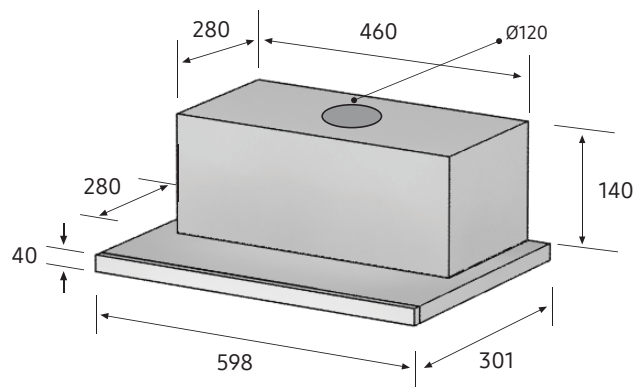

Models / Fullsize Dishwasher (Fully Built-in)

INSTALLATION GUIDE

DW60M9550BB, DW60M9530BB

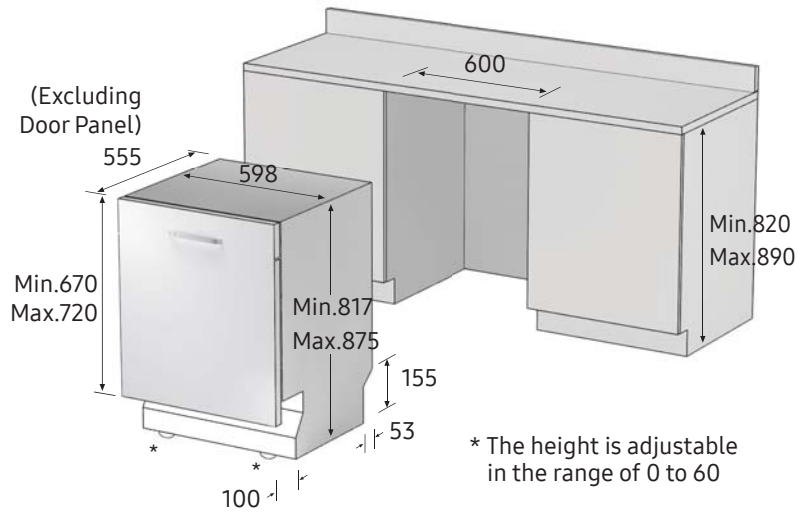

DW60M6050BB, DW60M6040BB

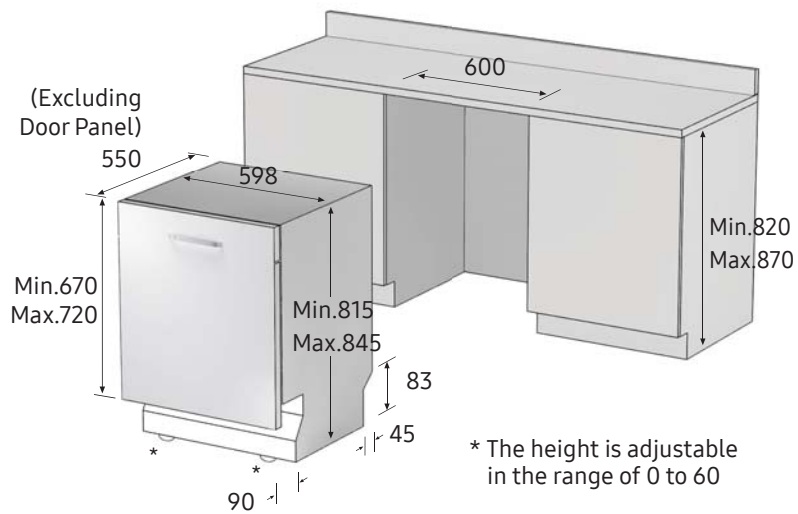

Models / Fullsize Dishwasher (Semi Built-in)

INSTALLATION GUIDE

DW60M9970SS, DW60M9550SS

DW60M6050SS

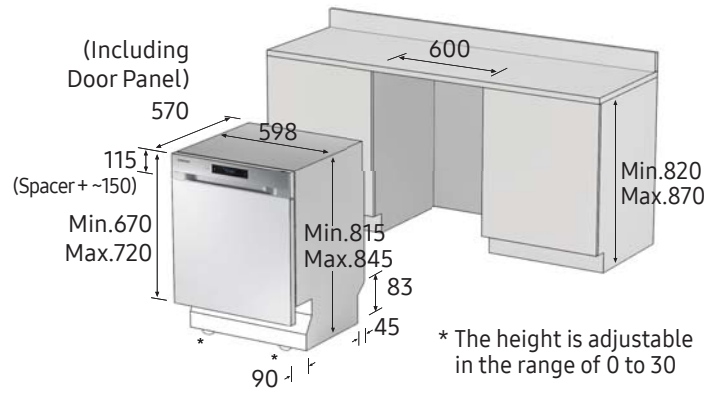
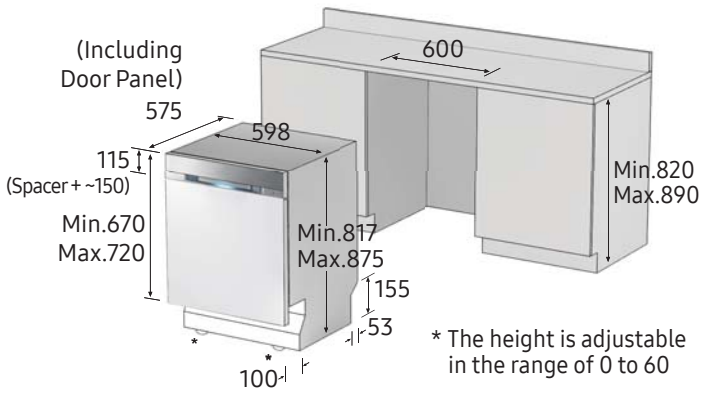

DW60M6040SS

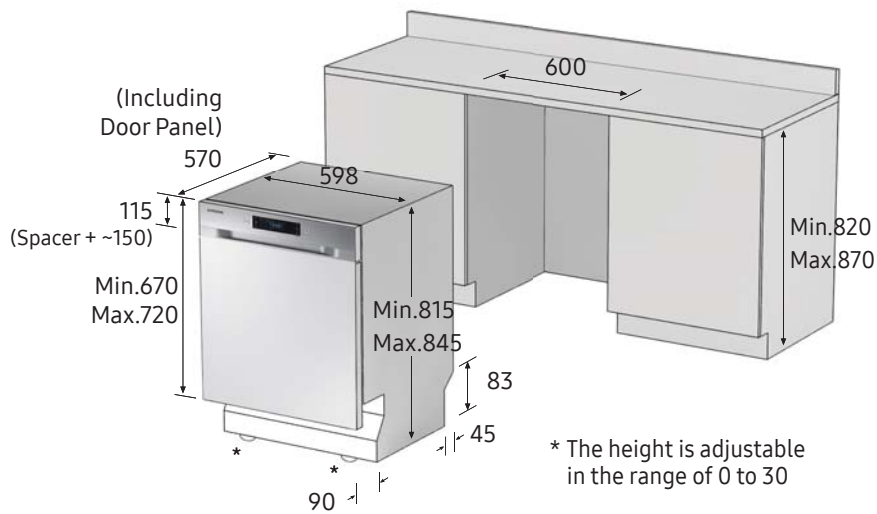

Models / Fullsize Dishwasher (Built Under)

INSTALLATION GUIDE

DW60M9970US, DW60M9550US

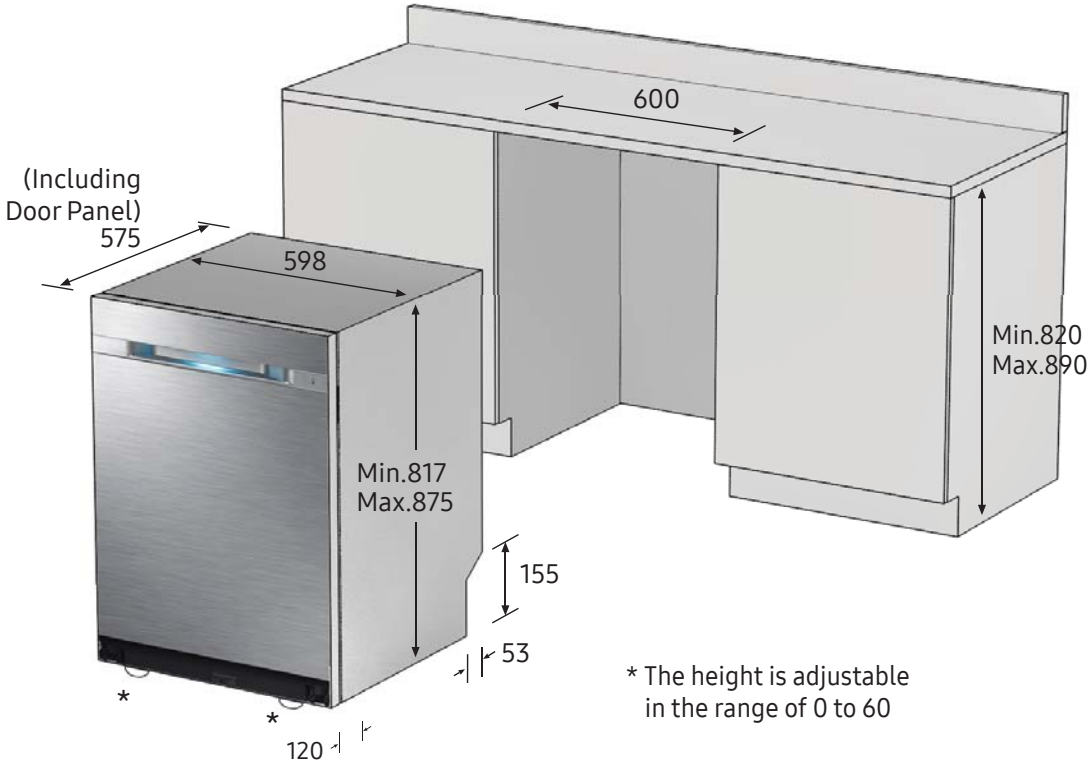

Models / Fullsize Dishwasher (Built Under)
INSTALLATION GUIDE

DW60M6050US, DW60M6050UW, DW60M6051US, DW60M6051UW

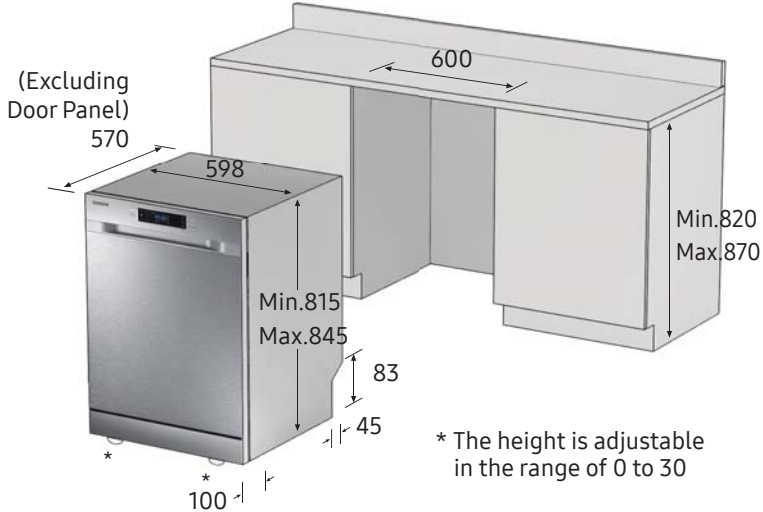

DW60M6040US, DW60M6040UW

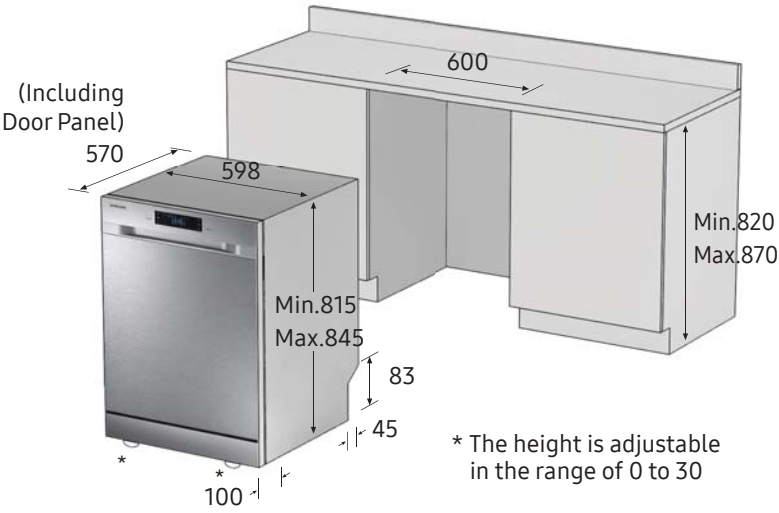





Samsung Service

Samsung Customer Service is here to help you throughout the lifetime of your appliance. We provide everything from an expert repair service to helpful advice – giving you the level of service you expect from Samsung.

Repair

When you buy a Samsung appliance you choose reliability and the best in quality. If, however, you require any help, Samsung Service can provide rapid and reliable assistance.

Online Support

Many common issues can be easily solved with the correct advice. Our online FAQs give you helpful hints and tips to keep your appliance performing at its best.
www.samsung.com

Contact us

Our customer service advisors are here to help 24 hours a day, seven days a week.

Register your appliance and warranty

You should register all your appliances and warranties with Samsung to ensure we have full records in the event of any important product updates.

[insert where a customer should go to register their appliance e.g. www.samsung.com]

