

# USER MANUAL

## AP 5.4 Label Printer



# Using the Documentation

Copyright.....	2	Text appearance .....	10
Documentation structure.....	3	Title page .....	11
Datapool, documentation object.....	3	Abbreviations .....	12
Documentation concept.....	3	Printer names.....	12
Documentation format .....	6	Parameters .....	12
Printing the documentation .....	7	Index.....	13
Navigation aids .....	8		
Symbols and note signs.....	9		
Warning notes .....	9		
Symbols .....	10		



## CAUTION!

Read the user manual before operating the device for the first time.  
The user manual is an essential part of the device it belongs to.  
The user manual is to be stored at the machine operating location and made accessible to the operator.

## Copyright

© 2015 by Novexx Solutions GmbH. All rights reserved.

Reprinting and reproduction of these documents, including extracts, is only allowed with the express permission of the manufacturer. More detailed information is available from your supplier.

### Copyright

The documentation is subject to copyright. The copyright claims include all forms and types of material and information which may be protected by current copyright laws. No part of the documentation may be copied, reproduced in any other manner, processed or translated into another language, irrespective of the manner and fashion or with which means this takes place.

### Copy

Electronically stored device information (CD ROM, Internet) supplied by the manufacturer may be printed out by the user, provided that the print medium serves the use or servicing of the described product.

### Protected rights

Names are generally given without any mention of existing patents, registered designs or trademarks. The absence of a corresponding remark does not give any implication that the name can be used at will. All trademarks are recognised.

### Alterations

No liability is assumed for the accuracy of the contents of this documentation. The manufacturer reserves the right to alter technical or other specifications with no prior notice. Deviations in the documentation from prevailing conditions do not represent an obligation to redeliver.

### Guarantee

The manufacturer does not guarantee the existence or non-existence of properties with the description of subject contents. Nor does the manufacturer give any express or tacit guarantee declarations whatsoever.

## Documentation structure

### Datapool, documentation object

The overall documentation is a part of the datapool, which is provided for the printer user and the service personnel on CD or other electronic media.

#### Datapool

This datapool includes:

- this printer documentation,
- the printer drivers

#### Printer doc

Here the overall documentation (abbr.: documentation) is to be understood as the printer documentation.

The printer documentation contains all the information which is required for using the product. Using the product means preparing it for use, putting it into operation, setting it up, the operation, servicing and maintenance, fault searching and the service for optional extensions, settings and repairs.

#### Doc object

The documentation object includes

- various printer families (printer series), consisting of different printer models (devices),
- standard and optional additions for the printer (options) and
- the printer language Easy Plug.

### Documentation concept

The wide range of products which must be documented and the demand for documentation distribution and use, both in electronic form (CD/Internet, PC) as well as in paper form, have resulted in the following documentation concept:

#### Structure

The documentation consists of

- topic sections (generally comparable to chapters),
- manuals (handbooks, instructions),
- link pages and the
- start page (start page of the CD documentation).



**Subject section**

Thematically-related subject contents are described in each topic section. A topic section is the smallest unit of information with its own

- page numbering,
- header bar,
- list of contents,
- index,
- device classification and
- its own revision status.

Subject sections form the basis of the manual. A topic section can be simultaneously assigned to several manuals. Subject sections are in one, in some cases two, languages.

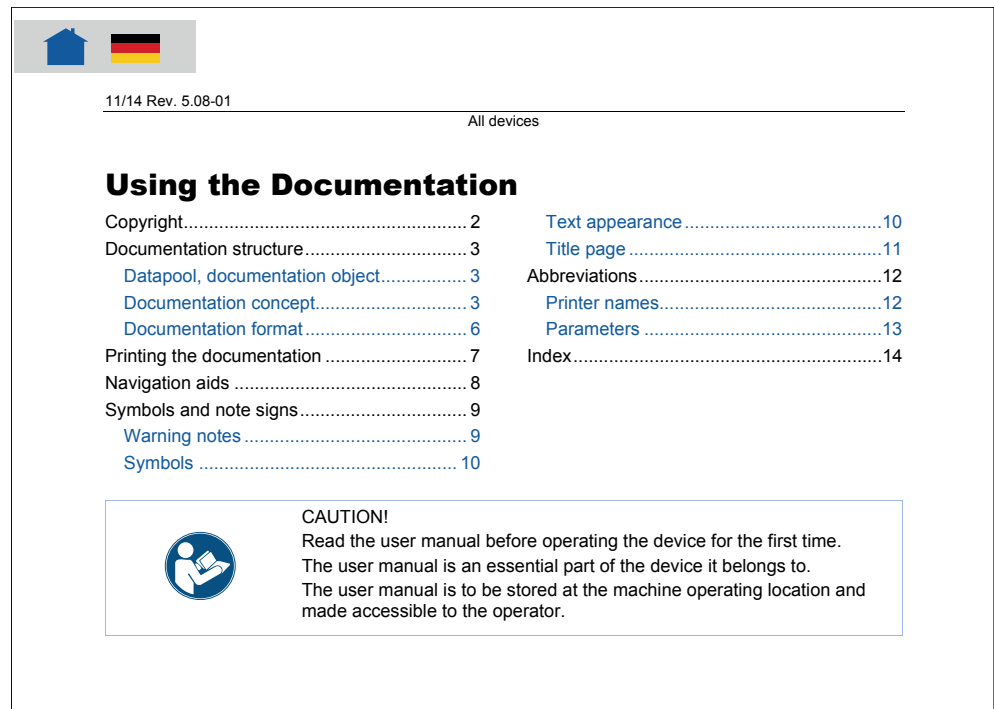

Fig. 1 Example: First page of topic section "Using the Documentation"

**Manual**

A manual is composed of different topic sections. The following features characterize a manual:

- Title page with a list of contents, device classification and revision status (see Fig. 1).
- The list of contents contains the designations of the topic sections and also serves as a link distributor to these topic sections.
- The contents of a manual refer to a certain device, a device family or an option (documentation object).
- A manual is assigned to a certain language and only contains topic sections in this language.
- A manual is assigned to a certain user group. There are *Service Manuals* (mainly for the Service), *User Manuals* (mainly for the user) and just *Manuals* (for Service and user).



Fig. 1 Each Manual title page provides a list of topic section in its right half.

To a certain extent manuals are only virtual, as the same topic section can be simultaneously assigned to different manuals (the topic section physically only exists once).

Subject sections which are only assigned to a single manual are colour-coded on the title page of the manual (in the same colour as the title of the manual, see "Symbols and note signs").

## Link page

A link page is only an organisational component of the datapool available on electronic media. The following features characterize a link page:

- Assignment to a single language
- Function as a link distributor to the individual manuals (access to the overall documentation of the corresponding language)
- Function as a link distributor to other components of the datapool provided on the electronic medium (e. g. printer drivers and print and design software in the corresponding language)

**Start page**

The start page is also only an organisational component and is displayed when the CD starts, or on the Internet on the link to the printer datapool. The following features characterize a start page:

- Assignment is irrespective of the language or multilingual
- Function for the language selection made by the user
- Function as a link distributor to the link page with the selected language.

This gives the following documentation hierarchy:

**Hierarchy**

1. Start page (selection of the language)
2. Link page (selection of the manual)
3. Manual title page (selection of the topic section)
4. Subject section contents page (selection of the subtheme)

In most cases, the subtheme selected in step 4 equates to the information being searched for. For instance, the selection of the status number in the list of contents of the topic section leads straight to the description of this status number.

**Documentation format**

All elements of the printer overall documentation are in Adobe PDF (Portable Document Format). This has the following practical advantages:

**Printing**

- The documents can be printed in the required quality irrespective of the printer type and the fonts which are used.

**Memory**

- Less memory is required for saving the document due to differentiated data compression (faster loading, faster printing).

**Internet**

- Internet compatibility due to the relatively small amount of data.

**License**

- Simple distribution without the need to purchase licenses (Adobe Reader licenses are provided free of charge by Adobe worldwide and in many languages).

**Platform**

- Can run on different platforms (Windows/Macintosh/Linux)

**Links**

- Links within and between Acrobat documents, as well as links to documents in other formats and executable files.
- Other Acrobat Reader functions such as page returns, bookmarks, thumbnails, document-overlapping search function with an automated index, etc.
- More detailed information about the Acrobat Reader is contained in the Acrobat online help.

## Printing the documentation

In order to make the documentation readable without a PC, the documents can be printed in A4 as well as in Letter format. For printing, the Acrobat Reader uses the print capabilities of the platform it is run on. The layout of the printed documents equals the appearance on the monitor screen.

Mind the following hints before you start to print:

When printing several manuals, it is not necessary to print out all topic sections starting with the title page.

- Only print out the topic sections marked in black once. These topic sections are referenced from different Manuals. Physically, they consist of the same data.
- Always print out all subjects marked in purple. Reference is only made once in the respective manual to each purple topic section.

When printing all of only one manual, it is necessary to print out all topic sections in this manual starting from the title page.

### Example

- In order to print a *user manual*, proceed as follows:
  1. Print the title page.
  2. Click the topic sections on the right half of the title page one after the other. Print each topic section completely.
- In order to print the *service manual* additionally, switch to the title page of the service manual and only click the topic sections written in purple. Print those topic sections. The remaining black topic sections are already printed with the user manual.

### Text integration

It is also possible to integrate documentation text (and images) in other documents using the Windows clipboard. As a result, e. g. order information (spare part designations and part numbers) can be used simply and with no additional effort.

- ▶ Pay attention to copyright restrictions. Information on this subject can be found under "Copyright".



## Navigation aids



### Info search

The following options are available for quickly searching for information in the paper documentation:

- The title page of each manual with a list of contents of the topic section
- The detailed list of contents with page numbers on the first page of each topic section
- The own page numbering of each topic section
- The index at the end of each topic section.

### Links

In the top left corner of each title page and on the first page of each topic section, you find small graphics, which ease the change back to higher levels of the documentation (see Tab. 1).

Symbol	Meaning
	<i>Triangle</i> : Link to the last opened page.
	<i>Triangle</i> : Link to the last opened page. <i>House</i> : Link to the menu page. <i>Flag</i> : Link to the german page of identical content. On the corresponding german page, a british flag symbolizes the cross-reference to the british page.
	<i>Houses with flags</i> : Links to the menu pages in different languages. Is used in bilingual topic sections (e.g. spare parts lists).

Tab. 1 Navigation aids can be found on the first pages of the PDF-documents.

## Symbols and note signs

### Warning notes

Warning notes warn of a possibly dangerous situation. Personal injury, material damage or data loss are possible, if care is not taken.

Depending on the dimension of possible damages, the warning notes look different:

- Warning note, which warns of a danger that can lead to injuries, if the dangerous situation is not avoided. Appearance: Exclamation mark in a triangle, signal word "WARNING", blue frame, blue shaded text field (see below).



WARNING!

Description of the *danger source*.

Description of *possible personal injury*.

→ Measure to avoid personal injury.

→ Further measure to avoid personal injury.

→ ...

- Warning note, which warns of a danger that can lead to material damage or data loss, if the dangerous situation is not avoided. Appearance: Exclamation mark in a triangle, signal word "CAUTION", blue frame (see below)..



CAUTION!







Description of the *danger source*.

Description of *possible material damage*.



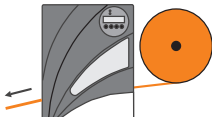
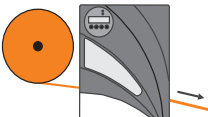



→ Measure to avoid material damage.

→ ...

## Symbols

	Warning of the risk of injury due to moving or rapidly rotating parts! Long hair, loose jewellery, long sleeves, etc. are not admissible when operating the machine. Wear sufficient personal protection gear.
	Tools required for the described service action.
	Marks additional information, which has not necessarily to be read to operate the machine, but which improves the understanding for the described function.
	Lefthand version (LH version): Symbol marking a text section which refers to the LH version of a device. (Only important for DPM, PEM and ALX 92x)
	Righthand version (RH version): Symbol marking a text section which refers to the RH version of a device. (Only important for DPM, PEM and ALX 92x)
	CE label: Documents the EC conformity of the device.
	Recycling: Notes about disposal. Pay attention to environmental protection!
	Arrow at the right bottom corner: paragraph is continued on the following page. 

## Text appearance

	1. (Numbered) Action instructions, introductory text: 2. follow the sequence!
	Focus arrow: action instructions, sequence not stipulated.
	Note arrow: special note. Pay attention!
	Focus point: feature, extra paragraph.
	Focus circle: Reference to another text position or info source.
	Exists. Completed. Yes. Applies.
<a href="#">Blue text with link symbol</a> 	Link to other positions in the documentation (click). Exception: In lists of contents, the black text is also linked.

## Title page

**Link**

Black text in the blue frame:  
link to topic sections which occur several times in different manuals (click).

**Link**

Purple text in the blue frame:  
link to a topic section which only occurs once and belongs specifically to the manual (click).

**Link**

Blue text in the blue frame:  
A click on the text starts an executable program, e.g. the printer driver unpacking program starting from the "Manual printer driver" title page.

## Abbreviations

### Printer names

If there is not enough space to call all printers by their full names, the abbreviated spellings listed in Tab. 2 are used.

Spelling	Meaning	Example, note
64-04/05	64-04, 64-05	
64bit series	Printer/Print-Dispenser with 64bit electronics	64-xx, DPM, PEM, ALX 92x
64-xx	Tabletop printer with 64bit electronics	64-04, 64-05, 64-06, 64-08
ALX 92x	Print-Dispenser of the ALX 92x series	ALX 924, ALX 925, ALX 926

Tab. 2 Abbreviated spelling of printers.

### Parameters

The notation of parameters is done as follows:

MENU > Parameter name

Example:

INTERF. PARAM. > Interface

(Parameter "Interface" in the menu "INTERF. PARAM.")

# Index

## A

Abbreviations .....	12
Alterations, technical .....	2

## C

Copy .....	2
Copyright.....	2

## D

Datapool .....	3
Documentation	
concept.....	3
format .....	6
object.....	3
structure .....	3

## H

Hierarchy.....	6
----------------	---

## L

Link page .....	5
-----------------	---

## P

Paper documentation.....	7
Patents.....	2
Pinch Point.....	10

## R

Redelivery, documentation .....	2
Registered designs .....	2
Reservation.....	2

## S

Safety notes .....	9
Start page .....	6
Subject section .....	4

## T

Trademarks.....	2
-----------------	---



## Safety Notes

Note about printer names .....	2
Information and qualifications .....	3
Follow the instructions .....	3
Information must be made available .....	3
Ensure necessary qualifications .....	3
Machine operating safety .....	4
Conditions for safe use .....	4
Protect against injuries that can result from electrical current .....	4
Protect against injuries that can result from mechanical actions .....	4

## Note about printer names

The protective measures described in the following count for all printers (e. g. 64-xx), print-and-apply machines (e. g. ALX 92x) and print-and-apply modules (DPM) distributed by Novexx Solutions.

▣ In this document, all above mentioned printer types are referred to as „machine“.



## Information and qualifications



### Follow the instructions

Safe and efficient operation of the printer can only be guaranteed if you observe all necessary information.

Product liability and warranty can only be claimed, if the printer was operated according to the notes and instructions in the user manual.

→ Before operating the device, read the operating instructions and all other notes carefully.

→ Observe the additional safety and warning notes on the device.

### Information must be made available

This operating manual...

→ is to be stored at the printer operating location and made accessible to the operator.

→ is to be maintained in legible condition.

→ If the machine is sold, it must be made available to the new owner

→ Safety and warning notices attached to the machine must be kept clean and legible. Missing or damaged warning labels and plates are to be replaced.

### Ensure necessary qualifications

#### Operation

→ Only allow the printer to be operated, adjusted and serviced by instructed and authorised personnel.

Instruction of the operating personnel must ensure

- that operating personnel can use the machine independently and without posing a danger.
- that operating personnel can remedy minor operational malfunctions themselves.

→ Train at least 2 persons to operate the machine.

→ Make label materials for test purposes available in sufficient quantities.

→ Moreover, personnel are to be regularly instructed about work safety and environmental protection issues.

→ The responsibilities for operation, adjustment and servicing of the machine must be clearly defined and consistently maintained.

→ Only make adjustments to the machine in accordance with this manual and with all due care.

#### Service

Special servicing, fault searching and fault correction are to be carried out by the manufacturer, his appointees or other authorised service agents. This also includes the optional installation and refitting of components.

## Machine operating safety



### Conditions for safe use

- Only use the machine in enclosed areas with environmental conditions matching the values given in the technical specifications.
- Only operate the machine on a plane, solid support.
- Only trained and authorized personnel should operate the printer!
- During operation, the printhead can become hot! Care should be taken when touching the printhead!
- Do not make any modifications or any additional casing for the machine!
- Do not allow any liquids to enter into the machine!
- Repairs to the machine may only be performed by authorized specialists who are aware of the risks involved!
- Make sure that the power supply socket for the machine is readily accessible!
- Lay the power supply cable, data cables and compressed air hoses (if applicable) in a way that nobody can stumble over it.
- In case of emergency, switch off the machine and pull off the power supply cable!
- Only use original accessories!



### Protect against injuries that can result from electrical current

- Only put the machine into operation when installed in a correctly installed housing.
- Only operate the machine using the system voltage indicated on the nameplate!
- Only connect the machine to a grounded power socket fitted to authorized standards!
- Only connect devices to the interfaces at the machine that fulfil SELV (safety extra-low voltage) circuit requirements according to EN 60950!



### Protect against injuries that can result from mechanical actions

- Only operate the printer when the cover is closed!
- Don't wear loose long hair (if necessary, wear a hairnet).
- Keep loose jewellery, long sleeves, etc. away from rotating parts or the printer.
- Wear sufficient personal protective equipment.

### Applicator operation

The following printers can be operated with an applicator:

- 64-xx
- ALX 92x
- DPM

Operation with an applicator causes additional hazards, which must be safeguarded by the following additional protective measure:

- Only operate the printer, if it is equipped with an appropriate safeguarding device<sup>1</sup>. This device must stop the printer, if it is opened.

1) Movable interlocking guard according to EN ISO 12100-1, 3.25.4



# Technical Data

Dimensions .....	2	Thermotransfer Ribbon .....	10
Measures .....	2	Ribbon Roll .....	10
Weight .....	2	Connections, device data .....	11
Performance Data .....	3	Protection class .....	11
Print Technology .....	3	Mains Voltage .....	11
Printhead Type .....	3	Mains Frequency .....	11
Printhead characteristics .....	3	Power Consumption .....	11
Label sensor .....	4	Current Consumption .....	11
Max. print length .....	4	Interfaces .....	12
Zero line .....	4	Electronic Configuration .....	13
Fonts .....	4	Specifications only for AP 5.4/5.6 dispenser	14
Modifying Fonts .....	5	Environmental Conditions .....	15
Impression accuracy .....	5	Operating Temperature .....	15
Image formats .....	6	Storage Temp. ....	15
Bar codes .....	6	Relative Humidity .....	15
2-dimensional bar codes .....	6	Protection category .....	15
GS1 Databar & CC bar codes .....	6	Noise .....	15
Printer emulation .....	7	Test Marks, certificates .....	16
Label Stock .....	8	CE .....	16
Material Types .....	8	CTÜVUS-Mark .....	16
Material Thickness .....	8	TÜV-Mark .....	16
Material Width .....	8	CB .....	16
Label Length .....	8	FCC .....	16
Gap size .....	8	GOST R .....	16
Label Roll .....	9	Limitations .....	17
		Print width limitations at AP 5.6 .....	17

## Dimensions

### Measures

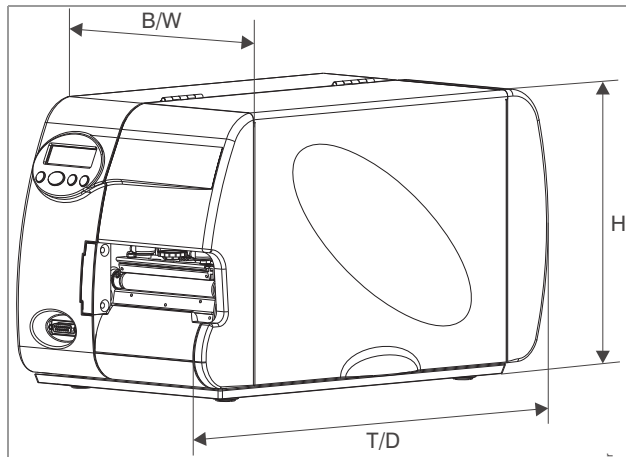

[1] Dimensions of the AP 5.6 and AP 5.4 (H=Height, W=Width, D=Depth).

Printer	Measures (H x W x D)
AP 5.4	272 x 260 x 462 mm
AP 5.6	272 x 335,5 x 462 mm

[Tab. 1] Measures

### Weight

Printer	Weight
AP 5.4/5.6	14 kg
AP 5.4 basic / peripheral	14 kg
AP 5.4 dispenser / internal rewinder	16 kg

[Tab. 2] Printer weight

## Performance Data

### Print Technology

Thermodyrect and thermotransfer printing

### Printhead Type

- “Flat Head” type (ceramic thin film flat head)
- 8.0 dot/mm (203 dpi)
- 11.8 dot/mm (300 dpi)

### Printhead characteristics



#### CAUTION!

The maximum achievable print width of the AP 5.6 is limited by print speed and print contrast.

→ Pay attention to the limitations, see [Print width limitations at AP 5.6](#) on page 17.

Printer	Resolution (Dot/mm)	Resolution (dpi)	Print-speed (mm/s)	Print-speed (Inch/s)	Max. printwidth (mm)
AP 5.4	8.0	203	50-200	2-8	104
	11.8	300	50-150	2-6	105.7
AP 5.6	8.0	203	50-200	2-8	168
	11.8	300	50-150	2-6	

[Tab. 3] Important printhead data.

## Label sensor

Sensor type	Setting range (Size c)	Punch length (Size b)	Punch width (Size a)
Transmission sensor (Standard)	0–60 mm	0.8–14 mm	min. 4 mm
Reflex-sensor (optional)	6–66 mm	4 mm (recommended)	12 mm (recommended)

[Tab. 4] Required punch measures.

➡ The dark/light change at the reflex sensor is taken as the *label beginning* (= end of the reflex mark)

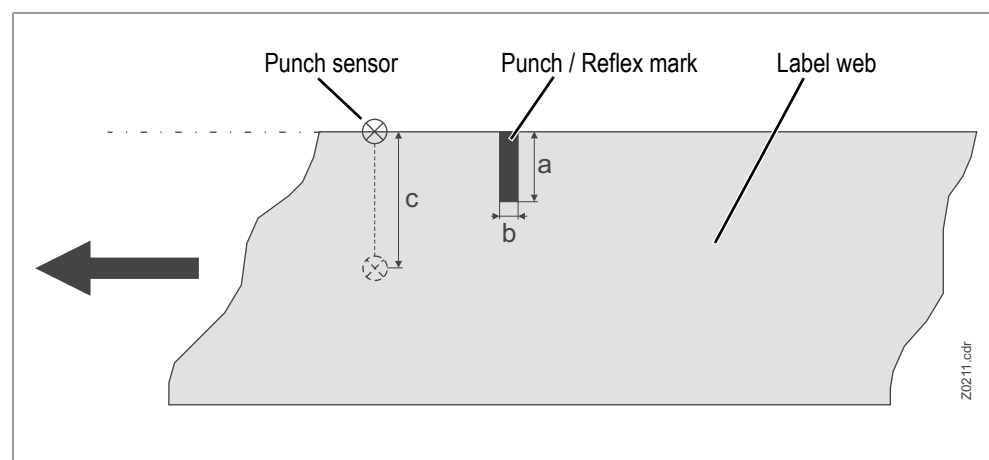

[2] Measures and setting range of the punch / reflex mark.

## Max. print length

The maximum print length depends on the following:

- Printer type
- Printer resolution
- Firmware version
- Parameter settings regarding memory allocation (e.g. `SYSTEM PARAMETERS > Free store size`)

## Zero line

Offset of the material zero line to the print zero line: 1 mm (what means that a stripe of 1 mm width at the inner label margin is unprintable)

## Fonts

- 17 Fixsize fonts , including OCR-A and OCR-B
- 3 scalable fonts (Speedo fonts)
- Truetype fonts are supported
- Optionally can Truetype, Speedo and Fixsize fonts be stored on SD-card

## Modifying Fonts

- Up to factor 8 scaling in x/y direction
- Rotation by 0, 90, 180 and 270 degrees

## Impression accuracy

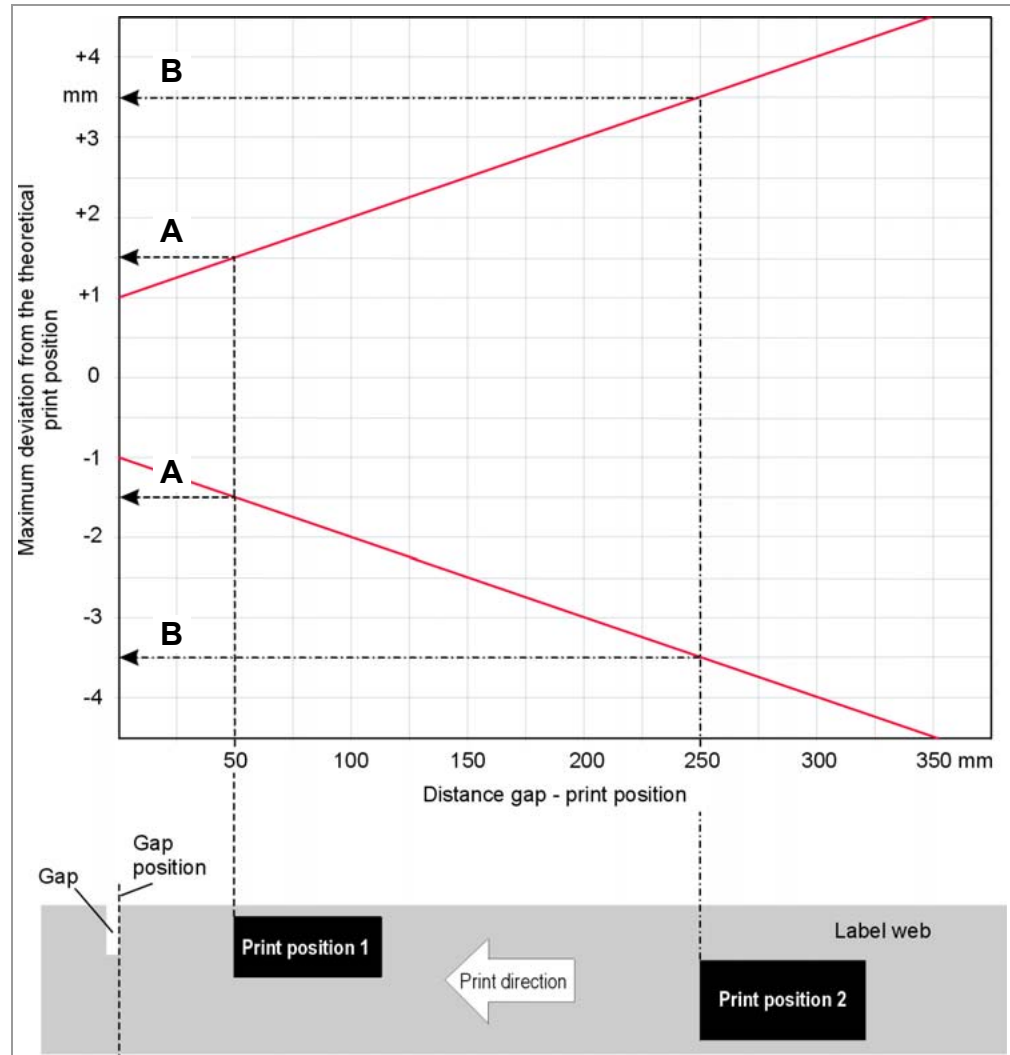

[3] The impression accuracy depends on the print position on the label: the longer the distance to the gap is, the lower is the impression accuracy. The maximum impression accuracy is at the gap position with +/- 1 mm.

Reading examples:

A: Print position 1 is located 50 mm behind the gap position. The maximum possible deflection from the theoretical print position is +/- 1.5 mm.

B: Print position 1 is located 250 mm behind the gap position. The maximum possible deflection from the theoretical print position is +/- 3.5 mm.

▣▣▣▣ Those values are empirical for typical applications with common label stock / foil combinations. Since the deflection of the print position strongly depends on the applied label stock / foil combination, it can turn out higher if unfavorable combinations are used.

## Image formats

BMP, PCX, JPEG, TIFF, GIF, Easy Plug logos

## Bar codes

Codabar	Code 128 A, B, C
Code 128	Code 128 UPS
Code 128 pharmacy	ITF
Code 2/5 matrix	MSI
Code 2/5 interleaved	EAN 8
Code 2/5 5-line	EAN 13 add-on 2
Code 2/5 interleaved ratio 1:3	EAN 13 add-on 5
Code 2/5 matrix ratio 1:2,5	EAN 128
Code 2/5 matrix ratio 1:3	Postcode (guide and identity code)
Code 39	UPC A
Code 39 extended	UPC E
Code 39 ratio 2,5:1	Code 93
Code 39 ratio 3:1	

All bar codes scalable in 30 different width and in the height.

## 2-dimensional bar codes

Data Matrix Code (code according to ECC200)
Maxi Code
PDF 417
Codablock F
Code 49
QR matrix code

## GS1 Databar & CC bar codes

Reduced Space Symbology (GS1 Databar) und Composite Component (CC) bar codes:

GS1 Databar-14	UPC-A + CC-A/CC-B
GS1 Databar-14 truncated	UPC-E + CC-A/CC-B
GS1 Databar-14 stacked	EAN 13 + CC-A/CC-B
GS1 Databar-14 stacked omnidirectional	EAN 8 + CC-A/CC-B
GS1 Databar limited	UCC/EAN 128 + CC-A/CC-B
GS1 Databar expanded	UCC/EAN 128 + CC-C



## **Printer emulation**

Easy-Plug

## Label Stock

### Material Types

Thermodirect material, thermotransfer material, synthetic ribbons: PE, PP, PVC, PA in rolls or fan-folded.

### Material Thickness

- *Self-adhesive labels*: 60 - 160 g/m<sup>2</sup>
- *Cardboard labels*:
  - AP 5.4: max. 240 g/m<sup>2</sup>
  - AP 5.6: max. 190 g/m<sup>2</sup>

### Material Width

Printer type	Material width
AP 5.4	15 - 120 mm
AP 5.4 dispenser	30 - 110 mm <sup>a</sup>
AP 5.6	50 - 185 mm
AP 5.6 dispenser	50 - 170 mm <sup>a</sup>

[Tab. 5] Overview material width.

- a) The material passage width is limited by the dispensing sensor, which is mounted at the side. If a dispensing edge without a sensor is applied (foot switch operation), the passage width is as large as at the standard printer.

### Label Length

Printer	Min. length	Max. length
AP 5.4	5 mm	max. print width <sup>a</sup>
AP 5.4 dispenser	30 mm	200 mm
AP 5.4 dispenser <sup>b</sup>	5 mm	200 mm
AP 5.6	5 mm	max. print width <sup>a</sup>
AP 5.6 dispenser	30 mm	200 mm

[Tab. 6] Overview label length.

- a) See [Max. print length](#) on page 4.  
 b) With optional label sensor for short labels.

### Gap size

Gap size between the labels on the backing material:

- min.: 1.0 mm
- max.: Label length - 15 mm

## Label Roll

- *Winding Direction*: Labels facing inward or outward, internal rewinder: labels facing outwards
- *Roll diameter*:

Roll / Conditions	Roll Ø
Label roll for normal printing operation	max. 210 mm
Label roll for dispensing operation (with 100 mm core-Ø)	max. 190 mm
Take-up roll for winding/dispenser operation	max. 120 mm

[Tab. 7] Diameter of material and winding roll

- *Core diameter*: 38.1 mm (1.5"), 76.2 mm (3") oder 101.6 mm(4"); cores with 76.2 (3") or 101.6 mm (4") can be applied with the core adapter supplied with the printer.

# Thermotransfer Ribbon

## Ribbon Roll

- *Winding Direction*: Colour-side rolled inwards or outwards
- *Roll dimensions*:

Variable	Dimensions
External Ø	max. 80 mm <sup>a</sup>
Core Ø	25 mm (1")
Width <sup>b</sup>	AP 5.4: 25 -114 mm
	AP 5.6: 54 -172 mm

- a) Corresponds for example to 450 m standard ribbon type Novexx 4903
- b) Generally counts: The thermal transfer ribbon must overlap the label 2 mm on each side.  
For labels width > max. print width count the foil width:  
AP 5.4: 110 mm, AP 5.6: 172 mm.

## Connections, device data

### Protection class

„I“

### Mains Voltage

100-240 V (AC)

### Mains Frequency

50-60 Hz

### Power Consumption

- Max. 320 W
- In standby mode depending on the equipment 30-40 W

### Current Consumption

3.0-1.5 A

## Interfaces

Interface	Details
RS-232	Baud: 1200-115200, 8- bit; suitable connection cord: 1:1 D-Sub 9 extension lead (connector-jack)
RS-422/485	On optional I/O board, D-Sub 15, Baud: 1200-115200, 8-bit
Ethernet	10/100 Base T with TCP/IP, LPD, RawIP printing, DHCP, HTTPD, FTPD, SNMP
USB (V1.1)	USB-A host port, USB-B device port, Transmission rate 12 Mbps
Signal interface	On optional I/O board, D-Sub 15

[Tab. 8] Data interfaces at AP 5.4/5.6

Detailed information on the interfaces can be found in the Service Manual, topic section [Service Electronics](#) , chapter “CPU boards”, “Interfaces”.

## Electronic Configuration

Feature	Details
CPU	32 bit (NetLogic)
RAM	64 MB SDRAM
ROM	4 MB Flash
Memory card	SD
Realtime-clock	Present
Control Panel	4 buttons; LCD graphics display with 128x32 pixels; typically used to display two text lines with 16 characters each

[Tab. 9] Electronic configuration of the AP 5.4/5.6.

## **Specifications only for AP 5.4/5.6 dispenser**

- Speed, while the rewinding-Ø is calculated: 75 mm/s (3"/s)
- Speed, while the material is fed back: 75 mm/s (3"/s)
- Distance dispensing edge - print zero line: 25 mm
- Distance punch sensor - print zero line: 71 mm
- Max. admissible outer diameter of the rewound backing paper roll: 120 mm



## **Environmental Conditions**

### **Operating Temperature**

5 to 35°C

### **Storage Temp.**

-4 to 60°C

### **Relative Humidity**

35-75% (non-condensing)

### **Protection category**

IP 21

### **Noise**

< 70dB(A)

## Test Marks, certificates

### CE

EU conformity: The devices fulfil the requirements of the following EU directives:

- Machinery Directive
- EMC Directive

For details refer to [EC Declaration of conformity](#) 

### cTÜV<sub>US</sub>-Mark

TÜV test mark for USA and Canada:

- USA: tested according to UL 60950-1
- Canada: tested according to CAN/CSA-C22.2 No 60950-1

### TÜV-Mark

TÜV test mark for EU: tested according to EN 60950-1

### CB

CB test certificate: tested according to IEC 60950-1

### FCC

Declaration of conformity: FCC rules, part 15 class B devices

### GOST R

Meets the requirements of the following GOST R standards:

- MEK 60950-1-2005
- 51318.22-2006
- 51318.24-99
- 51317.3.2-2006
- 51317.3.3-2008

## Limitations

### Print width limitations at AP 5.6

If the max. values given in the following tables are exceeded, malfunction of the power supply will be most probably the consequence, followed by a restart of the printer.

#### 203 dpi printhead

Print speed		Limitations
mm/s	Inch/s	
51	2	Max. admissible print contrast: 120%
76/102	3/4	Max. admissible print contrast at print width > 100 mm: 110% Max. admissible print width at print contrast > 110%: 100 mm
127/152	5/6	Max. admissible print contrast at print width > 75 mm: 85% Max. admissible print width at print contrast > 85%: 75 mm
178/203	7/8	Max. admissible print contrast at print width > 55 mm: 67% Max. admissible print width at print contrast > 67%: 55 mm

[Tab. 10] Print width limitations for AP 5.6 with 203 dpi printheads.

#### 300 dpi printhead

Print speed		Limitations
mm/s	Inch/s	
51/76	2/3	Max. admissible print contrast: 120%
102	4	Max. admissible print contrast at print width > 100 mm: 105% Max. admissible print width at print contrast > 105%: 100 mm
127	5	Max. admissible print contrast at print width > 75 mm: 88% Max. admissible print width at print contrast > 88%: 75 mm
152	6	Max. admissible print contrast at print width > 65 mm: 74% Max. admissible print width at print contrast > 74%: 65 mm

[Tab. 11] Print width limitations for AP 5.6 with 300 dpi printheads.



# Product description

- Intended Use ..... 2
- Device types ..... 3
  - Basic ..... 3
  - Peripheral ..... 3
  - „Basic dispenser“ or „peripheral dispenser“ ..... 3
- Options ..... 4
  - Internal Options ..... 4
  - External Options ..... 4
- Functionality ..... 5
  - AP 5.4/5.6 without dispenser ..... 5
  - AP 5.4/5.6 dispenser ..... 6
- Operating controls ..... 7
  - AP 5.4/5.6 “basic” and “peripheral” ..... 7
  - AP 5.4/5.6 dispenser ..... 9
  - Operation panel ..... 11
- Ports and connections ..... 13
- Warning signs on printer ..... 15
- Operating modes ..... 16
  - Offline mode ..... 16
  - Online mode ..... 16
  - Message mode ..... 16
  - Standalone mode ..... 17

## Intended Use

AP 5.4 and AP 5.6 printers are designed for printing label material, using the thermal or thermal transfer printing process. In addition, the dispenser versions of both printer types can dispense self-adhesive labels and can rewind the remaining backing paper (or alternatively the complete label material). It is possible to use a wide range of label materials and thermal transfer ribbons. Label stock must be in roll shape or fan-folded. The label web can optionally be pulled-in from outside the printer through the slots in the rear side or bottom plate.

Any other use or use going beyond this shall be regarded as abnormal use.

Novexx Solutions assumes no liability for damage due to abnormal use of the printer.

## Device types

AP 5.4 and AP 5.6 are available in 4 versions:

### Basic

AP 5.4/5.6 equipped with serial, USB and Ethernet interface and SD-card slot. Possible upgrade to „peripheral“ version.

The following options can be integrated:

- Reflex sensor (top and/or bottom)
- I/O board (signal interface and additional serial interface)

### Peripheral

Like the AP 5.4/5.6 basic, but with capability to add the following options:

- External rewinder (for AP 5.4 only)
- Cutter

### „Basic dispenser“ or „peripheral dispenser“

AP 5.4/5.6 with additional built-in internal rewinder. In connection with an optional dispensing edge, this printer can also be used as a dispenser. If the dispensing edge is replaced by a deflection plate, the printed labels are not dispensed, but rewound together with the backing paper.

## Options

### Internal Options

...should be factory-fitted or installed by a service engineer:

- *Reflex Sensor Kit*: Light barrier fitting that apart from the transmission sensor, also contains a reflex sensor.
- *Label sensor for short labels*. Recommended for label length < 30 mm.
- *Internal rewinder kit*: To retrofit the internal rewinder; contains the rewinder as well as the driver board and material guide
- *I/O board*: RS-422/485 interface, signal interface

### External Options

...do not require any special alterations to the printer:

- *Cutter* (required printer: AP 5.4/5.6 peripheral)
- AP 5.4 only: *(External) rewinder* for material rolls with 38 mm (1.5"), 75 mm (3") or 100 mm (4") cores (required printer: AP 5.4 peripheral)
- *Keyboard* for standalone operation
- *Foot switch* for foot-operated label dispensing
- *Dispensing edge* (required printer: AP 5.4/5.6 „basic“ or „peripheral“ with internal rewinder)

## Functionality

### AP 5.4/5.6 without dispenser

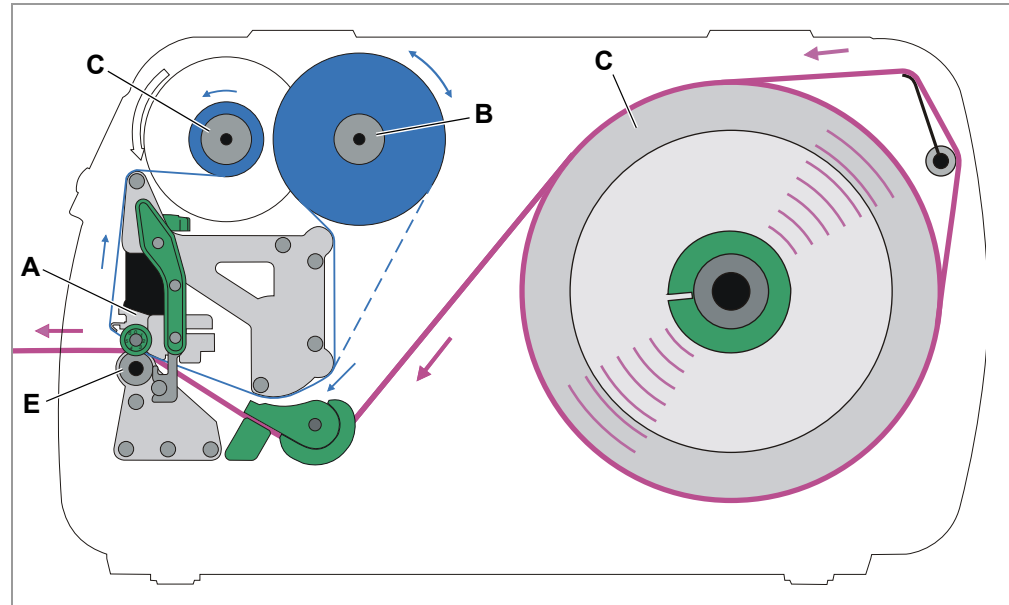

[1] Material and foil path inside the AP 5.4/AP 5.6.

- A Printhead
- B Foil unwind mandrel
- C Foil rewind mandrel
- D Material unwinder
- E Print roller

The label printers AP 5.4 and AP 5.6 only differ in the print width. The functionality is the same for both printers.

The printing principle is based on the thermal printhead [1A]. The core piece of the printhead, the thermal edge, consists of a row of dot elements, which can be controlled and heated separately. Each heated dot element leaves a black dot on the label material.

With thermo printing, the black dot results from the reaction of the thermosensitive label material. With thermo transfer printing, the black colour is transferred from the thermotransfer foil to the label material.

In order to add the dot lines to an image, the label material has to be passed underneath the printhead during printing. This material feeding is accomplished by the print roller [1E], which is motor driven. By moving the label material, it is unwound from the label roll [1C].

When using thermotransfer printing, the thermotransfer foil is fed together with the label material underneath the printhead. The foil position is between label material and printhead, the colour side facing the label material. The full foil roll is plugged on the foil unwinder [1B]. After passing the printhead, the used foil is wound onto the foil re-winder [1C], which is motor driven. If the foil roll is completely rewound, a new roll has to be inserted.

Material end and foil end are detected by sensors and are displayed on the operation panel (optionally by a sound signal).

The label beginning is detected by a light transmission sensor with punched label material and by a reflex sensor (option) with endless material.



## AP 5.4/5.6 dispenser

The AP 5.4/5.6 dispenser allows freshly printed labels to be dispensed (via the dispensing edge) or rewound in the printer enclosure (via the defelector).

- When used as a *dispenser*, the label material is drawn around the dispensing edge and only the backing paper is rewound.
- When used as a *rewinder*, the printed label is guided across a baffle plate and rewound together with the backing paper.

The electronic components in the rewinder control the tensile force on the release paper so that the same force is applied for all winding diameters. This is controlled independently of the material width and printing speed. The controller can be set automatically or manually depending on the settings in the parameter menu.

▮► The manual setting is only necessary in special cases and may only be performed by qualified, authorised service personnel.

After switching on the printer, the rewinder is initialised and the backing paper is tightened.

Once a print job is received, the printer searches for the first label start marking at reduced printing speed. To do this, the label material is moved by at least the distance between the label sensor and the printhead (70 mm). This distance is used by the rewinder controller to calculate the diameter of the previously wound backing paper. To allow the controller to calculate the diameter even with endless material, in this case printing also does not start until the material has moved 70 mm. The print job is carried out at the speed that has been set in the parameter menu or as specified by the print job.

If a fault occurs during operation, the rewinder shuts off automatically.

Once the maximum diameter of the backing paper has been reached, a message appears on the display and the rewinder shuts off automatically.

### Dispenser operating modes

The following operating modes are available for the dispenser:

- *Dispenser mode with dispenser sensor:*

The material feed ends at the dispensing edge, i.e., the label to be dispensed remains hanging on the dispensing edge (set dispensing position). The printer waits until the label is removed before moving the next empty label beneath the printhead and then printing and dispensing it.
- *Dispenser mode with foot switch:*

Pressing the foot switch releases the label for printing and dispensing. Afterwards, the next empty label is positioned beneath the printhead.

See topic section [\(De\)activating the dispensing edge](#) , page 9.

## Operating controls

### AP 5.4/5.6 “basic” and “peripheral”



[2] Outside view of AP 5.4/5.6 “peripheral”.

**A** Control panel

LCD screen; 4 buttons; displays operating status of printer; allows parameter menu settings.

**B** Connection for additional devices:

(Only to AP 5.4/5.6 “peripheral”). This is where the optional cutter or rewinder (AP 5.4 only) is connected.

**C** Front cover:

Open this to insert material and the ribbon.

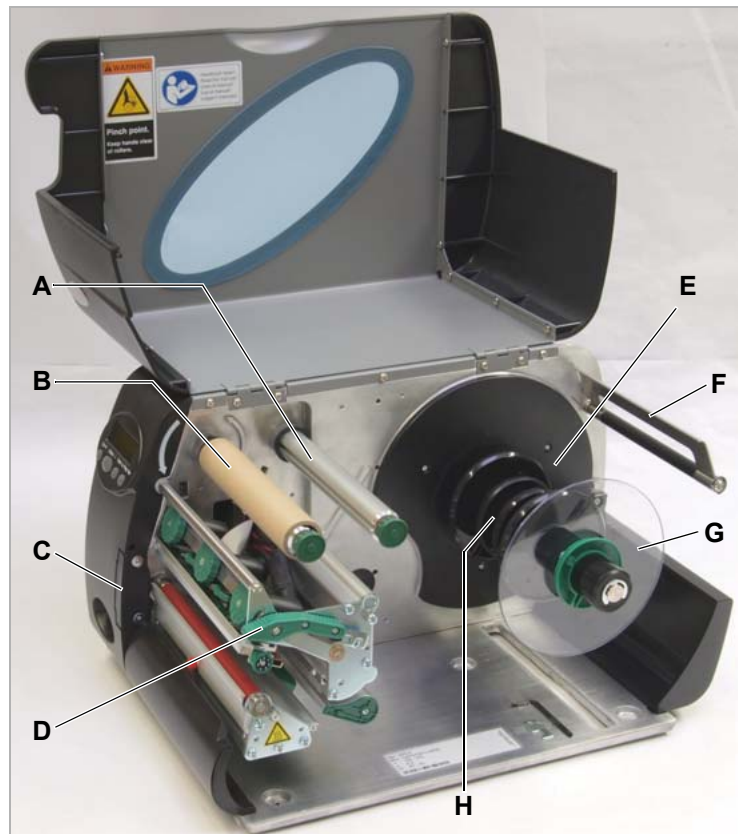

[3] Operating controls of AP 5.4/5.6.

- A** Ribbon unwinding mandrel:  
Holds the new ribbon roll
- B** Ribbon winding mandrel  
Holds the cardboard core that rewinds the spent ribbon.
- C** Connection flange for additional devices  
You can fasten either a cutter or rewriter (AP 5.4 only) here. To do this, you first have to remove the plastic cover.
- D** Pressure lever  
Opening the pressure lever lifts the printhead. You do this to insert material/ribbon or to clean the printhead/print roller.
- E** Material unwinder  
This is where you install the roll with the label material.
- F** Material strain relief  
Allows the label material to unroll evenly.
- G** Guiding disk  
Prevents material roll from sliding out sideways.
- H** Adapter rings  
For adapting unwinder to core diameter of material roll.

## AP 5.4/5.6 dispenser

AP 5.4/5.6 “basic” or  
“peripheral” dispenser

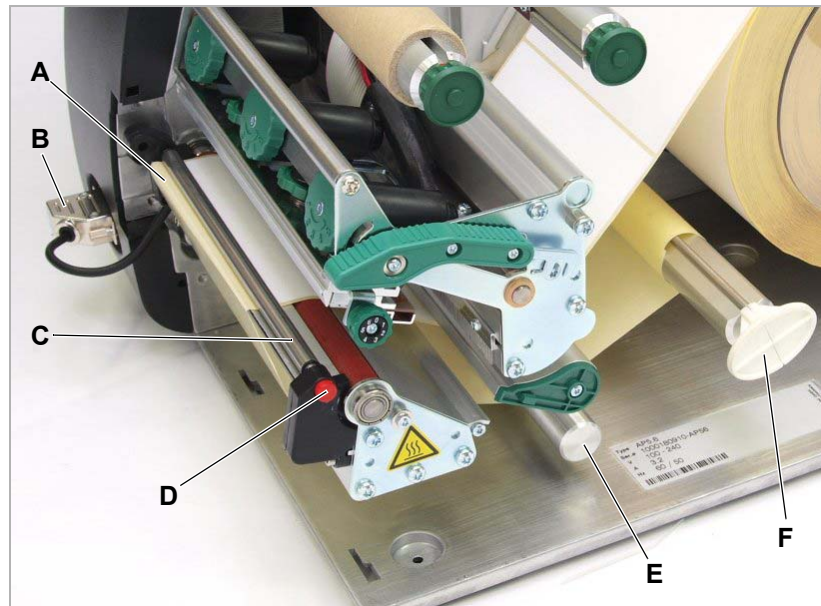

[4] Additional operating controls on AP 5.4/5.6 dispenser.

- A** Dispensing edge:  
This is where the labels are separated from the backing paper.
- B** Plugs:  
Connector for dispensing edge sensor.
- C** Dispensing roll:  
This holds the material ribbon taut over the dispensing edge.
- D** Button for dispensing roll:  
Press the red button to remove the dispensing roll.
- E** Deflecting shaft:  
This deflects the backing paper.
- F** Rewinder:  
This rewinds the backing paper.

**AP 5.4/5.6 “basic” or  
“peripheral” dispenser  
in rewinder mode**

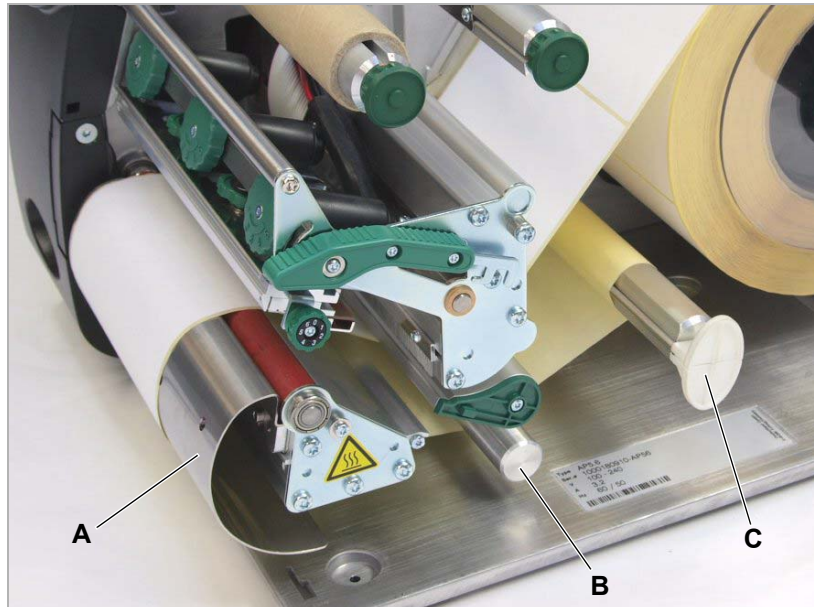

[5] Additional operating controls of AP 5.4/5.6 dispenser in rewinding mode.

- A** Baffle plate:  
Deflects the printed labels without dispensing any of them.
- B** Deflecting shaft:  
This deflects the labels.
- C** Rewinder  
Rewinds the label web.

## Operation panel



[6] Operation panel of AP 5.4/5.6.

### A Display

The display contains two rows of 32 digits for displaying operating modes, parameters, values, statuses and messages. Users can adjust the display language so that the text appears in their native language. The backlighting ensures that the screen is easily legible.

### B Cut button

- *Offline*: Starts a cut (prerequisite: cutter is installed and activated)
- *Parameters menu*: navigates to deeper menu levels or selects menu options.
- *Parameters menu*: Decreases values

### C Online button

- Switches between online and offline mode.
- Confirms entries, menu options or status messages.
- Selects print job and enters field data for printer in standalone mode.

### D Feed button

- *Offline*: Starts material feed
- *Online*: Starts printing process after it has been paused
- *Parameters menu*: Navigates to higher menu levels or selects menu options.
- *Parameters menu*: Increases values.

**E** Prog button

- *Offline*: Opens Parameters menu
- *Parameter menu*: Moves back one step in Parameters menu or quits the menu.

For more functions and more details, see

- section [Offline mode](#) auf Seite 16 and section [Online mode](#) auf Seite 16
- topic section [InfoPrintouts and Parameters](#)

## Ports and connections



### WARNING!

This unit operates at mains voltage! Contacting electrically live components can cause potentially lethal electrical shocks and burns.

→ Only connect the printer to devices that fulfil the SELV (safety extra-low voltage) circuit requirements in accordance with EN 60950.



### CAUTION!

Using poor quality auxiliary equipment can damage the printer.

→ Only connect original accessories.

For instructions on how to use the network connections, see topic section “Advanced Applications” chapter [Data Transmission with Ethernet](#) , page 17.

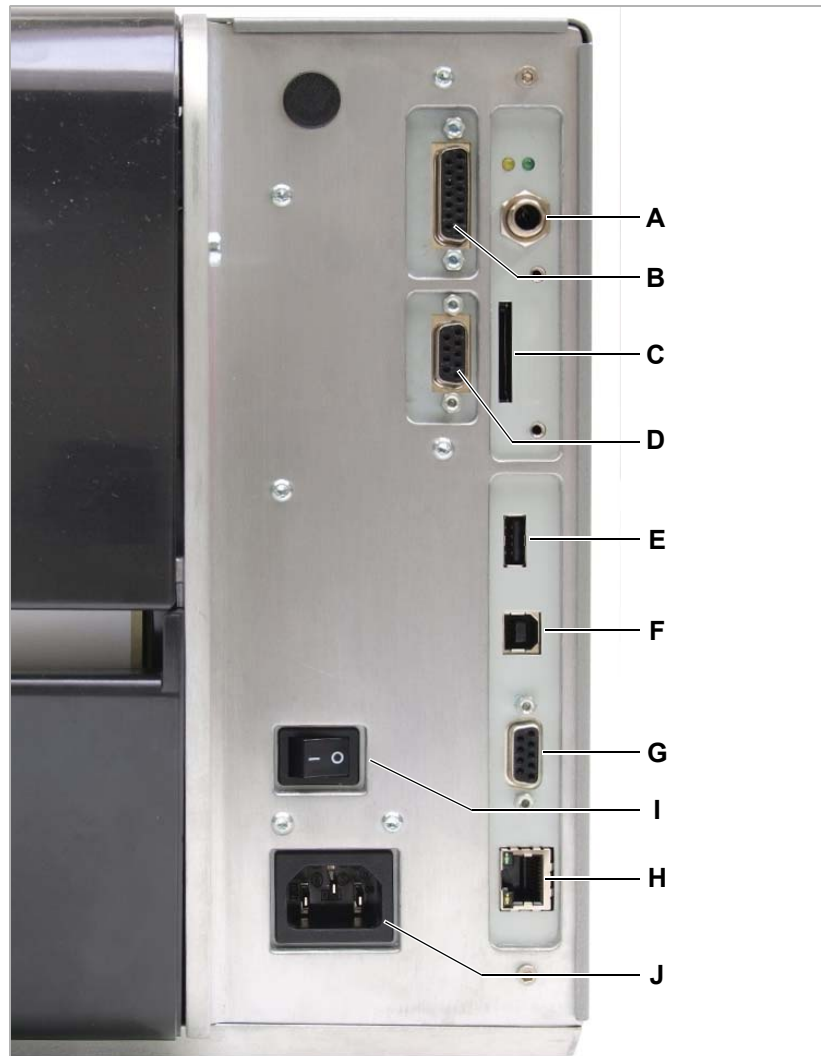

[7] The rear side of the AP 5.4/5.6 with I/O board (option) installed.

#### A Start/stop signal input

Connections for a foot switch (signal starts printer) or stacker (signal stops printer)

#### B Signal port (option)

4 inputs / 3 outputs on optionally available I/O board



- C** Memory card slot  
For SD cards where you can store fonts, logos, graphics, etc.
- D** Serial port (option):  
RS232 or RS422/485 on optionally available I/O board
- E** USB port (host)  
For USB sticks, keyboards, etc.
- F** USB port (device)  
For serial transfer of printer data.
- G** RS232 port  
For serial transfer of printer data.
- H** Ethernet port  
Interface for “Ethernet 10/100 Base T” network
- I** Mains power switch  
On/Off switch for printer
- J** Mains socket  
Mains socket for connection to mains using supplied cable.

## Warning signs on printer





### WARNING!

If warning signs are missing on the printer, possible hazards may not be noticed in time.

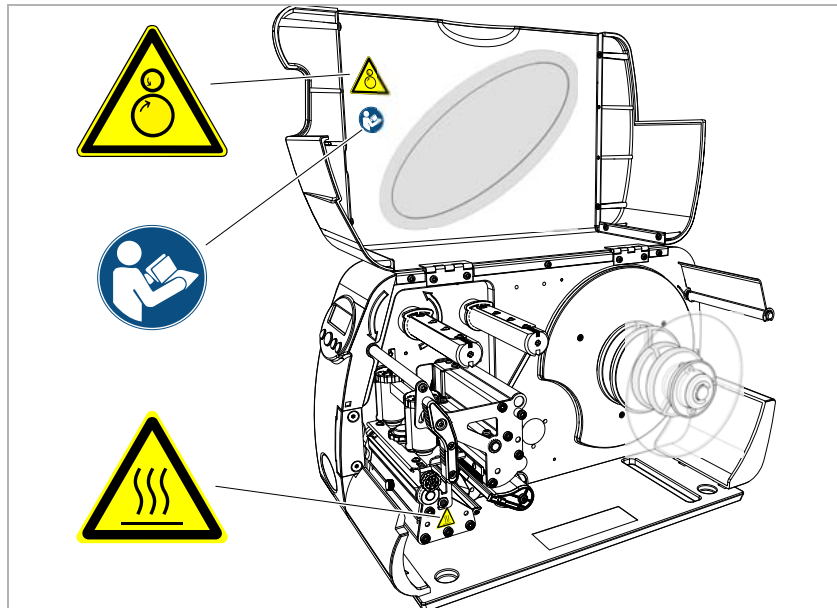
- Do not remove warning stickers.
- Replace any warning stickers if they become lost or illegible.



[8] Warning signs on AP 5.4/5.6.

Warning note	Meaning	Article no.
	The 'Pinch point' warning note warns you of the danger posed by the machine's rotating parts; they can trap items and draw them in.	A5346
	The "Hot surface" symbol warns of a burn hazard if the surface is touched. Allow the device to cool off before touching it.	A5640
	The blue label 'Read manual' demands that operators read the user manual.	A5331

[Tab. 1] Meaning of the warning notes.

## Operating modes

### Offline mode

```
OFFLINE  0 JOBS
```

No print jobs are queued.

In *Offline* mode, you can change the printer settings. This operating mode is normally active when the printer is first turned on. Print jobs are received at the selected port but not processed.

☛ To set the printer so that it immediately switches to online mode after being turned on, set `SYSTEM PARAMETER > Turn-on mode` to „Online”.

### Online mode

In *Online* mode, printjobs are received and immediately processed.

- No print jobs are queued.

```
ONLINE  0 JOBS
```

- If data is currently being transferred to the printer, this is indicated by a single dot to the lower right of the displayed number of current jobs.

```
ONLINE  0: JOBS
```

An additional dot at mid-line height indicates when the interpreter is active.

- *No dot*: no data to interpret.
- *Dot*: The interpreter is currently running (there is still data in the spooler)
- *Flashing dot*: The interpreter is waiting for more data in order to complete a command (no data in spooler).

- During printing, the number of received jobs (13) are displayed as well as the remaining quantity (25) of labels to be printed in the current job.

```
ONLINE  13 JOBS
Restcount: 25
```

- If a print job has been specified as continuous, the remaining quantity for this job will be endless.

```
ONLINE  13 JOBS
Restcount: endles
```

☛ To stop the printing process, press the Online button.

### Message mode

Status messages are used to indicate errors or certain operating statuses. When status messages appear, the background colour of the display becomes red. When a status message is present, the printer waits until the error has been eliminated and/or acknowledged. When the error is acknowledged, the printer switches from message mode to offline mode (depending on the error and state of previous process).

Status messages consist of the status number together with a brief description:

```
Status num:  5001
No gap found
```

For instance, status message 5001 (see above) appears when the printer is configured for punched label material but continuous material (unpunched) is inserted. In this case, the printer continues to transport the material for a few more seconds until the error message appears.

For more on the status messages as well as a detailed list of all status messages, see [Status Reports](#) .

### **Standalone mode**

In standalone mode (operation without data connection to computer), print jobs are not transferred via data cable but are instead stored on a SD card. From there, you can access them from the control panel or using a connected keyboard.

For more information on standalone mode, see topic section “Advanced Applications”, chapter [Standalone Operation](#)  on page 8.



# Commissioning and Operation

Installation .....	2
Unpacking the printer .....	2
Setting up the printer .....	3
Scope of delivery .....	4
Assembly .....	5
Connecting the printer .....	6
Main operating steps .....	7
Configuring the data interface .....	7
(De)activating the internal rewinder .....	7
(De)activating the dispensing edge .....	9
Setting the dispenser .....	9
Operating in offline mode .....	10
Online operation .....	11
Creating a print job .....	12
Transferring a print job .....	13
Using SD cards .....	15
Setting the real-time clock .....	16

## Installation

### Unpacking the printer



#### CAUTION!

To avoid damage to the printer, observe the following:

- Do *not* lift the printer using the plastic components on the front and rear.
- To lift the printer, do *not* reach below the front hood.



[1] AP 5.4 in the original packaging.

1. Remove all loose objects from the shipping box.
2. Carefully lift the printer out of the box together with the styrofoam packaging.
  - ▮▮▮ Have a second person hold the box tightly.
3. Remove the styrofoam and plastic film from the printer.
  - ▮▮▮ Store the original packaging for possible shipping at a later date!
4. Place the printer on a flat surface.
  - ▮▮▮ To carry the printer, reach below the baseplate at the front and rear.
5. Open the front cover. Remove the foamed shipping lock from the printhead.
6. Check that the shipment is complete, see [Scope of delivery](#) □ on page 4.

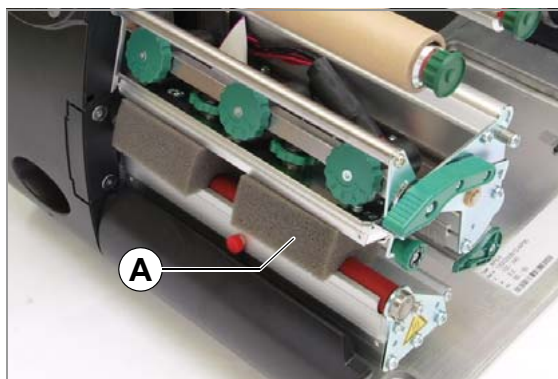

[2] Shipping lock at the printhead.

## Setting up the printer



### WARNING!

Lethal hazard from mains power, if any liquid gets into the printer!

→ Protect the printer from liquid penetration!



### CAUTION!

The printer and printing materials will be damaged by moisture and wetness!

→ Only operate the printer in enclosed room, in which the ambient conditions match the values given in the [Technical Specifications](#) .

The setup location of the printer must match the following requirements:

- The location must be in an enclosed room.
- The ambient conditions must match the values given in the [Technical Specifications](#) .
- The printer must stand secure against tilting on an even surface.
- The power supply socket for the printer must be readily accessible, in order that the mains connector can be pulled in an emergency case.
- Possibility to lay all connection cables without producing any tripping hazard.
- Enough space for the operator, both, in front (operation panel) and sideways of the printer.

## Scope of delivery

- Printer AP 5.4/5.6 including 2 pairs of core adapters [3B] and one paper core [3A] for rewinding thermotransfer ribbon.
- Mains power cable
- Documentation CD
  - Contains detailed operating manual for printer as well as Windows drivers and Servicing manual.
- Instructions (multilingual)
- Torx screwdriver [3C] size 10 (fastened to baseplate using adhesive tape)
- Support hooks [2D] for optional cutter (fastened to baseplate using adhesive tape)
- Cover for the mounting flange for peripheral devices with two fixing bolts [4C]
- AP 5.4/5.6 basic only:
  - Cover for the connector for peripheral devices [4B]
- AP 5.4/5.6 basic dispenser and AP 5.4/5.6 peripheral dispenser only:
  - Baffle plate with fixing screws [4A]

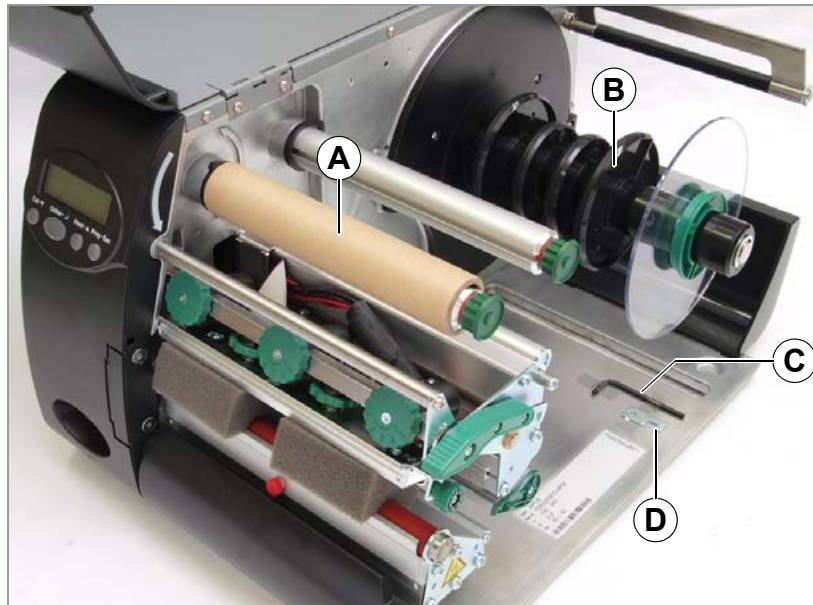

[3] AP 5.6 "peripheral" in delivered state.

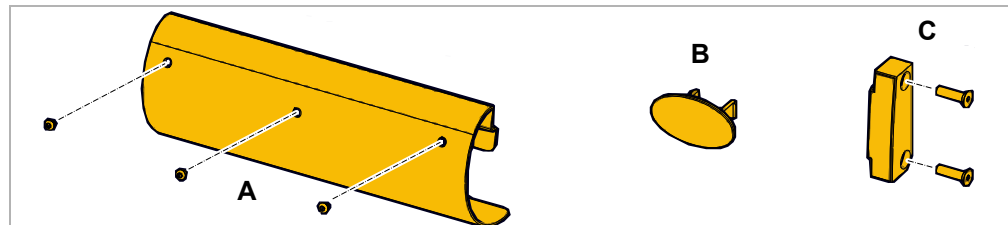

[4] Separately delivered parts.



## Assembly

### Housing parts

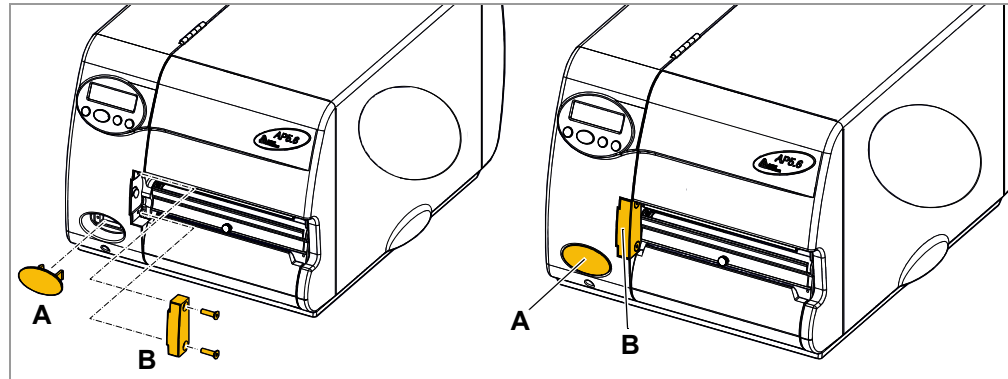

[5] Assembly of the separately shipped housing parts.

1. Press the cover for the peripheral connector [5A] into the housing opening, until it is flush with the housing.
2. Scew the mounting flange cover [5B] onto the mounting flange. Use the screwdriver that came with the printer.

### Baffle plate

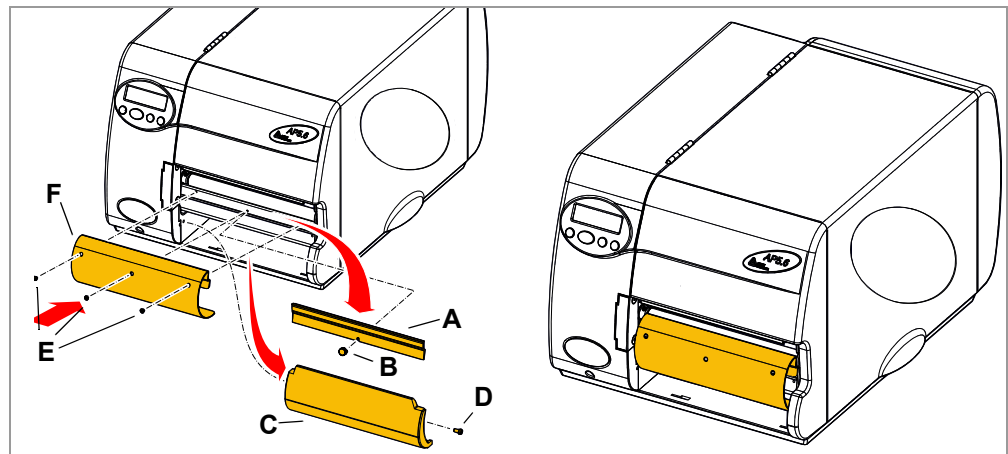

[6] Mounting the baffle plate.

The baffle plate [6F] can be mounted instead of the dispensing edge in order to rewind the printed material inside the printer. Assembling the baffle plate:

1. Remove the tear-off edge [6A]. To do so, turn out the thumb screw [6B].
2. Remove the front side bottom housing part [6C]. To do so, turn out the screw [6D].
3. Turn in the screws [6E] that came with the baffle plate some rotations. Hang the baffle plate [6F] with the buttonhole openings on the rear side of the plate onto the screws. Tighten the screws.

### Cutter

If you have ordered an AP 5.4/5.6 peripheral with cutter, the cutter will be shipped separately.

For instructions on how to assemble the cutter, see manual [Cutter 2000](#), “Fastening, Setting Up, Servicing”.

## Connecting the printer



### WARNING!

This unit operates at mains voltage! Contacting electrically live components can cause potentially lethal electrical shocks and burns.

- Make sure that the machine has been switched off before connecting the mains cable.
- Only operate the printer at the mains voltage given on the type plate.
- Only connect the printer to a properly installed mains socket with protective earth.
- When installing the mains cable, ensure the following:
  - a) Nobody can stumble over the cable
  - b) Mains plug can be pulled in case of emergency

In case of danger, the printer can only be disconnected from the power supply by removing the power plug from the power supply.

- Make sure that the power supply socket for the printer is readily accessible.

Risk of stumbling over cables.

- Lay the power supply cable, data cables and compressed air hoses (if applicable) in a way that nobody can stumble over it.

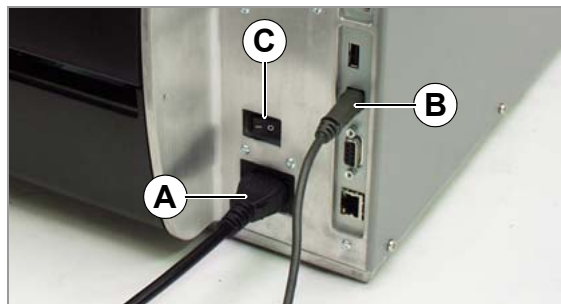

[7] Rear side of AP 5.6.

1. Make sure that the printer is switched off (mains switch [7C] at "0" position).
2. Connect the mains cable [7A] to the mains connector at the printer.
3. Connect the mains cable into a mains socket.
4. Connect the printer and computer or printer and network using suitable data cable (example: USB cable to USB (device) port [7B] of printer and to USB port of host computers).
5. Turn on the unit using the mains power switch (position "1").

As soon as the printer is ready, the following appears:

OFFLINE 0 JOBS

► If **SYSTEM PARAMETERS > Turn-on mode** is set to "Online", the printer switches directly into online mode after turning on the printer!

## Main operating steps

### Switching on/off

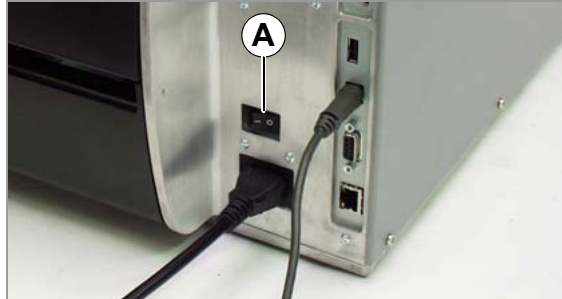

[8] Rear side of the AP 5.6.

→ Switch on the printer by the mains switch (position „I“).

Display, if the printer is ready:

OFFLINE 0 JOBS

With unchanged factory settings, the printer starts in offline mode.

If the printer is supposed to start in online mode:

→ Set SYSTEM PARAMETER > Turn-on mode to „Online“.



#### CAUTION!

Switching the printer off and on again without a pause can cause malfunctioning.

→ Wait at least 20 seconds between switching the printer off and on again.

### Configuring the data interface

The AP 5.4/5.6 has been pre-configured at our factory for data transmission through the USB port. Alternatively, printer data can also be transmitted via RS232, RS422/485 (only with optional I/O board), USB or Ethernet port.

→ Choosing the port: INTERFACE PARA > EASYPLUGINTERPR > Interface

→ Configuring the port:

- RS232 (COM1): INTERFACE PARA > COM1 PORT > ...
- RS232/422/485 (COM3): INTERFACE PARA > COM3 PORT > ...
- Ethernet: INTERFACE PARA > NETWORK PARAM. > ...

▮▮▮ We recommend that your network administrator configures the network settings.

- USB: no configuration required

For more information on how to set the parameters, see topic section “Info Printouts and Parameters”, [Operating the Parameter Menu](#) ▮.

The order numbers for network and data cables are given in topic section [Accessories](#) ▮.

For more information on how to use the Ethernet port, see topic section “Advanced Applications”, chapter [Data Transmission with Ethernet](#) ▮ on page 18.

## (De)activating the internal rewinder

► Only applies to AP 5.4/5.6 dispensers with baffle plate installed.

### Activate

► Ensure that material has been inserted before you activate the rewinding function, otherwise a fault message will appear!

For information on inserting material, see topic section “Setup”, chapter [Inserting Label Material](#) on page 6.

Set

1. SYSTEM PARAMETER > Periph. device to “Intern Rewinder”.

► Do not confuse this with “Rewinder” because this setting activates the external rewinder (additional device)!

After being activated, the system checks the direction of rotation of the rewinder.

Rewinder direct. Facing outside
------------------------------------

“Facing outside” is set by default.

2. If required, press the cut/feed button to change the direction of rotation.
3. Press the ENTER button to confirm your selection.

The printer restarts. Afterwards, an additional menu `REWINDER PARA` can be opened from the main menu, and this contains the `Rewind direction` parameter. Using this parameter, you can change the direction of rotation.

During the initialisation, the printer attempts to tighten the label strip.

### Deactivate

→ Set SYSTEM PARAMETER > Perip. device to “None”.

### Possible fault

The following error message may appear briefly after activating the internal rewinder:

Status	5004
Rewinder mat. tear	

Possible causes include:

- No material has been inserted or end of material has not been fastened to rewinder. Fasten end of material to rewinder and press Online button.
- The material strip is sagging in front of the rewinder. Press the Online button.

### Modifying main initialisation

After this, the printer is ready for the first job. As soon as a job is received, the rewinder controller calculates the main initialisation values for the rewinding process on the basis of the given material width and printing speed. These values are suitable for a wide range of applications.

However, these settings may cause too much printer offset in certain special applications. In these cases, the main initialisation values will have to be modified. Such applications include printing on:

- Very narrow labels
- Very coarse backing paper
- Very thick backing paper compared to the label
- Labels stuck on the backing paper
- Backing paper perforated along label contour

► Only qualified service technicians are permitted to edit the main initialisation values!

## (De)activating the dispensing edge

☛ Only applies to AP 5.4/5.6 dispensers with dispensing edge installed!

### Activating

Set

→ SYSTEM PARAMETER > Periph. device to “Dispenser”.

The printer restarts. Afterwards, an additional menu DISPENSER PARA can be accessed that contains all of the parameters required for dispensing mode:

Parameters	Possible settings
Dispenser mode	True 1:1 mode (default), Batch mode, Normal 1:1 mode
Dispensing position	Configurable in millimetres (default: 0.0 mm)
Display mode	Remaining qty. in job (default), dispenser counter
Dispense counter	Quantity presetting (default = 0)
Application mode	Safe mode (default), immediate mode
Start source	Foot switch, light sensor (default)

[Tab. 1] Parameters in DISPENSER PARA menu.

For more on the listed parameters, see [Info Printouts and Parameters](#).

### Deactivating

Set

→ SYSTEM PARAMETER > Periph. device to “None”.

## Setting the dispenser

### Application A

The label should be dispensed to that a narrow strip still sticks to the backing paper above the dispensing edge. After manually removing the dispensed label, the next label is printed and dispensed.

Set

→ DISPENSER PARA > Dispenseposition to -6.0 mm (for strong adhesives, this may have to be reduced to -8.0 mm).

Set

→ DISPENSER PARA > Start source to “Light barrier”.

### Application B

The label should be printed and dispensed after receiving a signal from the connected foot switch.

Set

→ SYSTEM PARAMETER > External signal to “Singlestart”.

Set

→ DISPENSER PARA > Dispenseposition to -6.0 mm (for strong adhesives, this may have to be reduced to -8.0 mm).

Set

→ DISPENSER PARA > Start source to “Foot switch”.

### Label length < 40 mm

☛ If very short labels are to be printed (PRINT PARAMETERS > Material length is set to < 40 mm), the printer is automatically initialised for the material before printing.

For more information, see the parameter description DISPENSER PARA > Calibration mode under [Info Printouts and Parameters](#).

## Operating in offline mode

- Changing from offline to online mode:



- Switching into online mode when print job is stopped



- Slow material and ribbon feed:

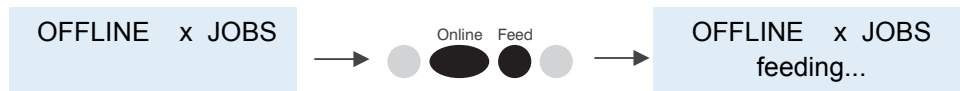

- Material is reversing below the printhead:



- Reset

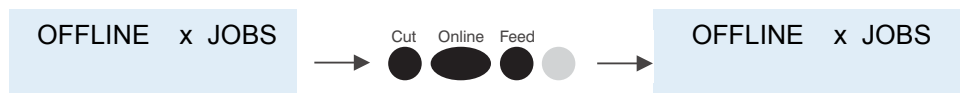

- Opening the parameter menu



- Feeding material to next punch or while button is pressed:



- Setting the label length automatically:

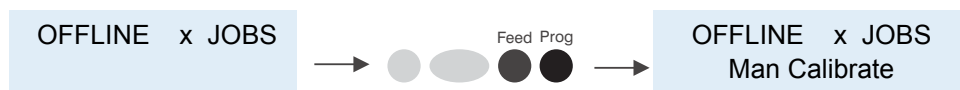

For more information, see topic section “Setup”, chapter [Setting the label length automatically](#).

## Online operation

- Switching to offline mode:



- Adjusting the print contrast: press Feed button to increase, press Cut button to decrease the print contrast



- Stopping a print job: The label currently being printed will be completed before the printer stops.



a) The message “Stopped xxx” alternates with “Press Feed”.

- Switching to offline mode when print job is stopped



- Continuing a print job



- Standalone mode: select a print job stored on an SD card (example: *Testdat.FOR*)



For more information, see topic section “Advanced Applications”, chapter [Standalone Operation](#) on page 8.

## Creating a print job

There are basically two ways of generating a print job: You can use a label layout program together with a Windows printer driver or create a simple text file containing printer commands.

**Windows printer driver** There are different printer drivers available for the various versions of Windows. Using the printer drivers, you can print from nearly any Windows application. The functionality depends heavily on the layout software you use. We recommend using a special label layout program such as NiceLabel (test version included on Documentation CD, see [Layout program](#) on page 12).

Printer drivers can be found here:

- Internet: [www.novexx.com](http://www.novexx.com)
- Documentation CD (also contains this operating manual)

Installing the printer driver:

1. Insert the documentation CD

The language selection menu [9] opens.

2. Depending on the version of Windows in use, click one of the areas A [9A], B [9B] or C [9C].

▮ Drivers for older versions of Windows (see area C [9C]) are only available for AP 5.4.

3. Follow the instructions given by the Installation Wizard.

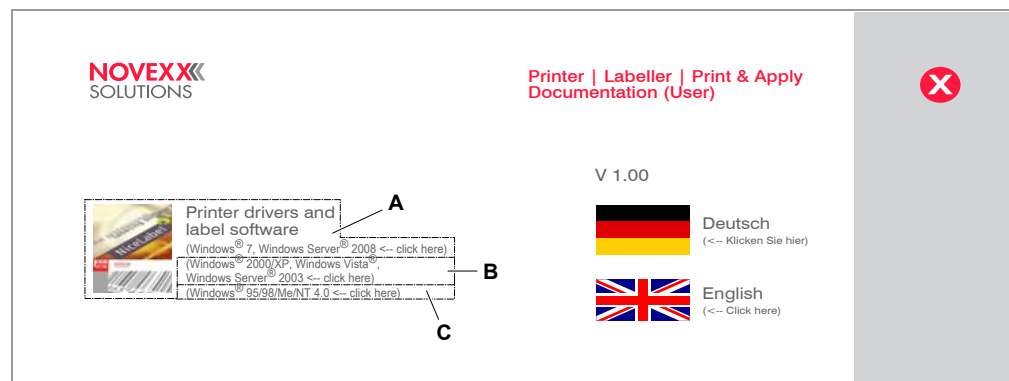

[9] The language selection menu appears after you insert the Documentation CD.

## Layout program

The Documentation CD contains a test version of the “NiceLabel” layout program.

Installing:

1. Insert the Documentation CD
2. Click “Printer drivers and label software” [9A].
3. Follow the instructions given by the Installation Wizard.



**Command file**

Enter a sequence of printer commands into a text file and send this file to the printer. To do this, you require a simple text editor and the copy command in MS-DOS. Easy-Plug is a special command language for formulating print jobs. However, writing a print job in text file format does require some programming knowledge. Furthermore, you will not be able to preview the resulting printout on screen. Instead, you will have to create a test printout in order to view the final results of your print job.

For a practical example of a print job together with instructions for testing purposes, see *Easy-Plug Manual*, topic section “General Notes, Definitions and Command Overview”, section [Programming Example](#).

**Transferring a print job**

The printer cannot process the print job until it has been loaded into RAM. This can be accomplished in two ways:

- Using a *data cable* from the PC
- Using the card slot and a *SD card*

**Data cable and layout program**

If you are using a label layout program, the appropriate print command has to be triggered. The data port is set when you install the printer driver.

**Data cable and Easy Plug file**

Requirements:

- Data cable has been connected between printer and PC or between printer and network
- Command file was created (here: “testjob.txt”) and stored in computer or on SD card
- The command line (DOS prompt) has been started in Windows

Enter the following command:

- Serial port (COM1): `copy testjob.txt com1`
- USB port: `copy testjob.txt \\computer name\share name`, with
  - *Computer name* = name of computer. In Windows XP for instance, this can be found under START > SETTINGS > CONTROL PANEL > SYSTEM > COMPUTER NAME
  - In Windows XP, the *share name* can be found under START > SETTINGS > PRINTERS AND FAXES after right-clicking PROPERTIES > SHARE. The share name is a printer connected to a specific port, such as the USB port for USB transfer or the TCP/IP port for Ethernet transfer.
- Ethernet port: as described above for the USB port. For more information on transmitting data via Ethernet, see topic section “Advanced Applications”, chapter [Data Transmission with Ethernet](#) on page 18.

Tips on transferring data via USB or Ethernet:

- ▣► The procedure described here does not apply to Windows 98, Windows ME or Windows NT 4.0.
- ▣► The share name must comply with MS-DOS conventions (max. 8 characters long, no special characters or spaces)

**SD card and  
Easy-Plug file**

Printing starts immediately after switching on

1. Rename print job file on SD card (root directory) as *autostrt.for*.
2. Insert SD card into card slot on printer (see next section).
3. Switch on printer.

The printer processes the print job as soon as it is in online mode.

Alternatively, the print job can be started in standalone mode; for more details, see topic section “Advanced Applications”, [Standalone Operation](#) on page 8.

## Using SD cards



### CAUTION!

To prevent malfunctions, observe the following.

- Only use SD cards that have been approved by the manufacturer.
- Only insert or remove SD cards after the printer has been switched off.
- After switching off, do not remove the SD cards until the backlighting on the screen has gone out.

Recommended card type:

Xmore industrial 2 GB (item no. A101465) [10]



[10] Recommended SD card.

Inserting the SD card:

1. Switch off the printer.
2. Insert the SD card into the card slot as shown [11].
  - ▣▣▣▣ The contacts point to the front left side.
  - ▣▣▣▣ Once the card is inserted two-thirds of the way [11A], a mechanical resistance becomes apparent. Apply a little more force to overcome the resistance, insert the card until it stops and then release it. The card springs back a little ways towards its final resting position [11B].



[11] Insert the SD card.

Removing the card:

1. Insert the card into the slot until it stops [11B] and release it.  
The card springs back out of the card slot [11A].
2. Remove the card fully from the slot.

For more on using memory cards, refer to the Plug-in Card Manual, topic section “Application”, chapter [CF/SD Cards](#).

## Setting the real-time clock

The real-time clock of the AP 5.4/5.6 can be used, for example, to calculate and print the expiry date of a perishable product.

Setting the real-time clock:

1. Choose `SYSTEM PARAMETERS > Realtime clock`.

Realtime clock  
dd.mm.yyyy hh:mm

dd=day, mm=month, yyyy=year, hh=hour,  
mm=minute

2. Enter the date and time:
  - *Cut button*: moves the cursor
  - *Feed button*: modified the setting
  - *Online button*: stores the setting



## Setup

Choosing the Materials .....	2	Inserting Ribbon .....	11
Label Material .....	2	Inserting a New Ribbon Roll .....	12
Thermal Transfer Ribbon .....	3	Replacing the Ribbon Roll .....	12
Insertion Diagrams .....	4	Exchanging the Ribbon Roll .....	13
AP 5.4/AP 5.6 Standard .....	4	When the Roll is Empty .....	14
AP 5.4/AP 5.6 with Internal Rewinder .....	4	End of Material .....	14
AP 5.4/AP 5.6 Dispenser .....	5	End of Ribbon .....	14
Inserting Label Material .....	6	Settings .....	15
AP 5.4/AP 5.6 Standard .....	7	Mechanic settings .....	15
AP 5.4/AP 5.6 with Internal Rewinder .....	9	Parameter settings .....	17
AP 5.4/AP 5.6 Dispenser .....	10	Setting the degree of blackness .....	18

# Choosing the Materials

## Label Material

**Material specification** The AP 5.4/AP 5.6 can process rolls as well as leporello fold (= fold-out or accordion fold material).

▮▮▮▮▶ The label rolls must be wound with the printable side facing outwards.

For more information on the material specifications, refer to topic section “Technical Data”, chapter [Label Stock](#) on page 8.

### Punches/reflex markings

In general, one distinguishes between converted and unconverted material.

- The start of each label is usually marked on converted material. With self-adhesive labels, this can be a gap [1A] between the labels or, with cardboard labels, a small punch [1B] on the edge. If the printer is equipped with the optional reflex sensor, it will be able to detect reflex markings [1C] on the rolls.
- Unconverted material is referred to as “continuous form material” and does not have any label markings. The length of the label is determined through the length setting in the Parameter menu.

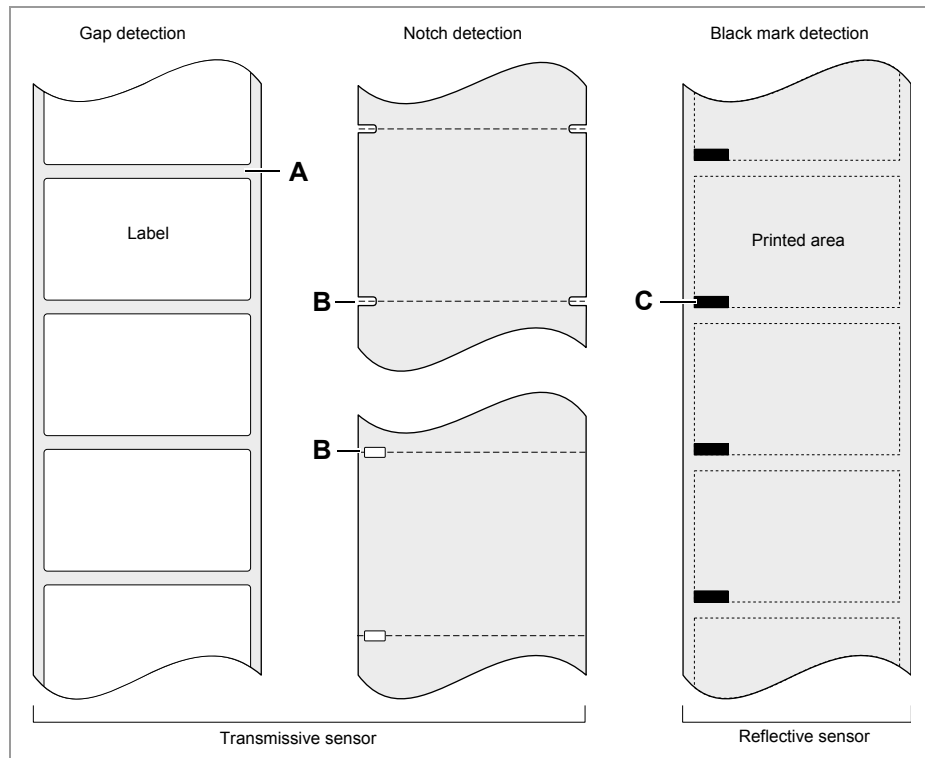

[1] Various types and positions of “start of label” markings.

- Quality criteria** Pay attention to the following 3 factors when selecting the quality of label material:
- The abrasive behaviour of the surface structure of the material
  - The chemical properties of the material that affect how ink is printed
  - Temperature required for ink transfer
- Abrasiveness** If the material is very rough (= strong sanding effect), the printhead will wear down more quickly than with smooth material. This is an important aspect of thermal printing. With thermal transfer printing, this does not pose much of a problem because you can select a ribbon that is wider than the material.
- Cleaning the printhead** Similarly, excessively high printhead temperatures can also cause problems. The material and the ribbon require more time to cool down, the printing quality becomes more critical and the printhead will wear down more quickly.

**Thermal Transfer Ribbon**

We recommend the following for ribbons:

- The ribbon must have a anti-static back coating with low friction.
- The ribbon must be designed for “Flat Head” printheads.
- The ribbons must be able to handle winding speeds of up to 200 mm/s (8 inch/sec).



**CAUTION!**

Ribbons that do not have these properties can reduce the printer performance and damage the printhead!

## Insertion Diagrams

These diagrams display how the material and ribbon moves through the printer under the following conditions:

- Label material must be wound with printed side facing outwards
- Thermal transfer ribbon:
  - Solid line = printed side wound inwards
  - Dashed line = printed side wound outwards

### AP 5.4/AP 5.6 Standard

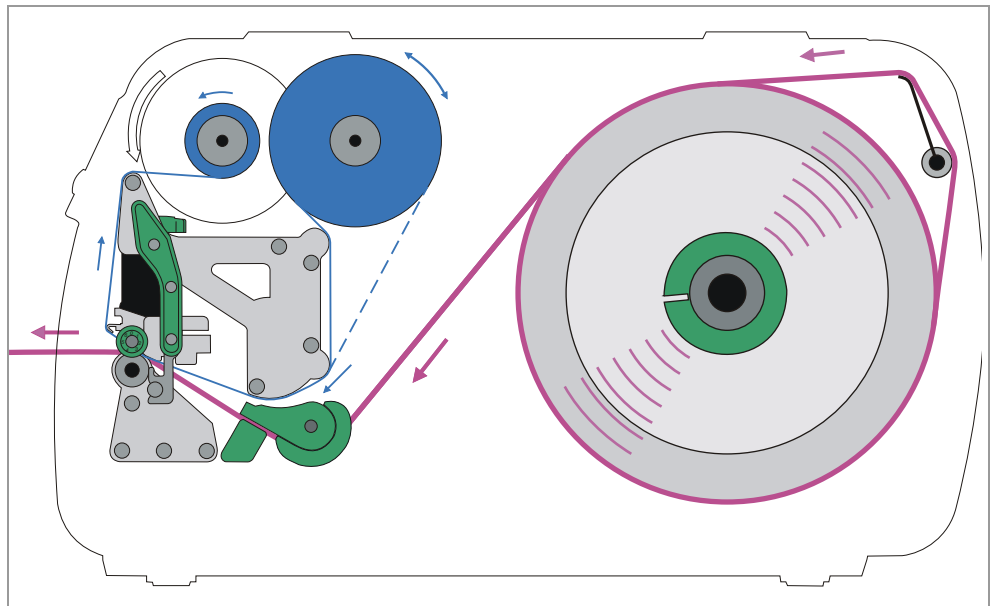

[2] Material and ribbon movement in AP 5.4/AP 5.6.

### AP 5.4/AP 5.6 with Internal Rewinder

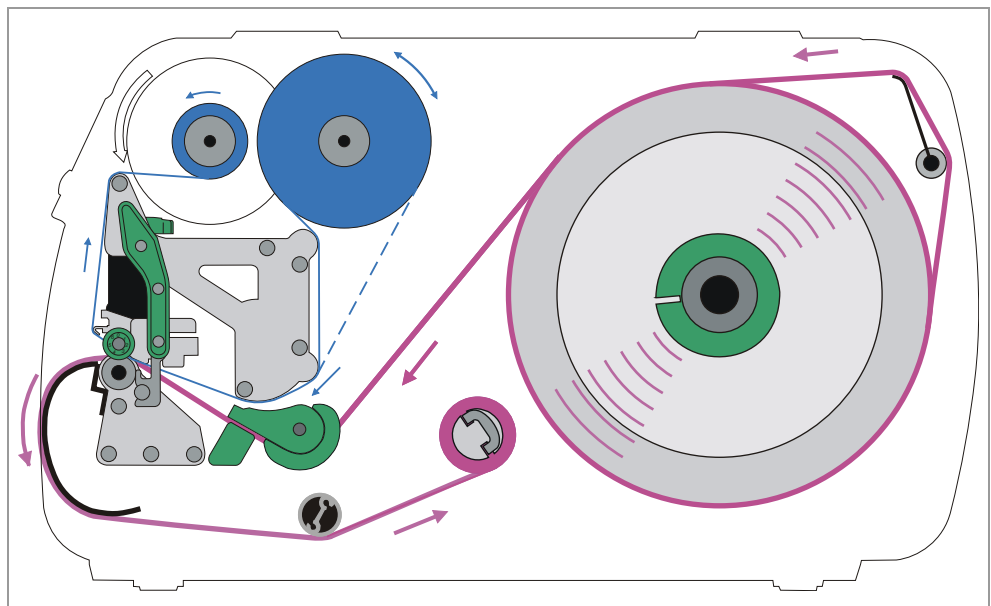

[3] Material and ribbon movement in AP 5.4/AP 5.6 with internal rewinder.



### AP 5.4/AP 5.6 Dispenser

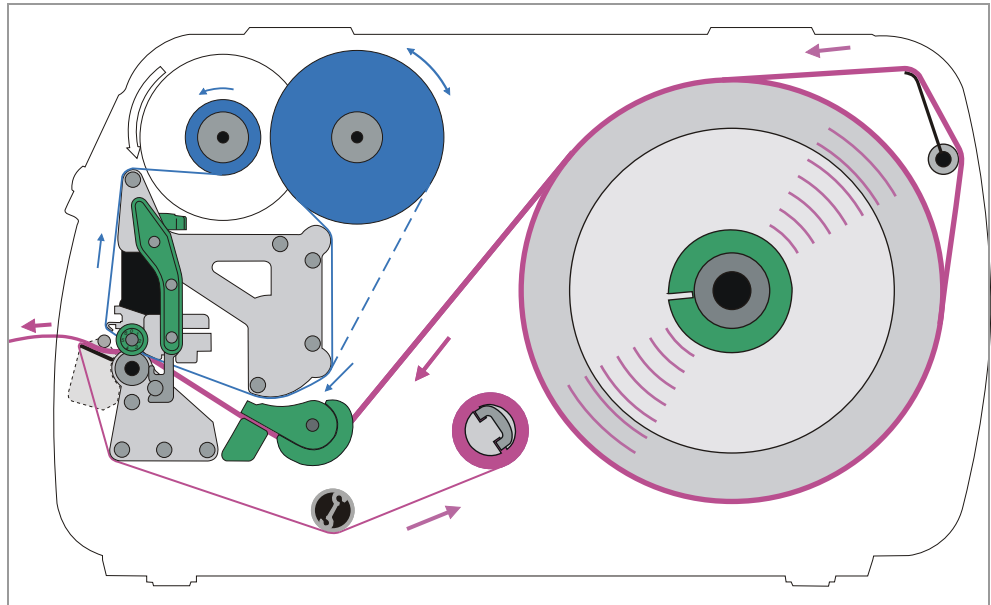

[4] Material and ribbon movement in AP 5.4/AP 5.6 dispenser.

## Inserting Label Material



### WARNING!

Danger of crushing fingers when closing the front hood.

→ Always use the grip [5A] to open or close the front hood.

Danger of rotating parts drawing items in.

→ Don't wear loose long hair (if necessary, wear a hairnet).

→ Keep loose jewellery, long sleeves, etc. away from rotating parts of the printer.

→ Always close the front hood before printing.

Label rolls/stacks may weight several kilograms. Rolls/stacks which are falling down can cause injuries.

→ Wear safety shoes when handling label rolls/stacks.

→ Store label rolls/stacks safely.

During operation, the printhead can become hot!

→ Be careful whenever touching the printer.



[5] Grip (A) at the front hood.

### AP 5.4/AP 5.6 Standard

#### Inserting a label roll

1. Open the front hood.
2. Open the pressure lever [6A] on the print-head.
3. Remove the guiding disk [6B] of the material roller.
4. If necessary, insert two properly fitting adapter disks onto the unwinder.
  - ▣▣▣▣ Choose the spacing between the adapter disks so that the roll of material is supported evenly.
5. Push the roll of material onto the unwinder. Re-attach the guiding disk and push it up to the roll of material.
  - ▣▣▣▣ The roll of material must rotate counter-clockwise while unwinding!
6. Insert the material as shown [7].
  - ▣▣▣▣ Also make sure to push the material around the material strain-relief [7A]!

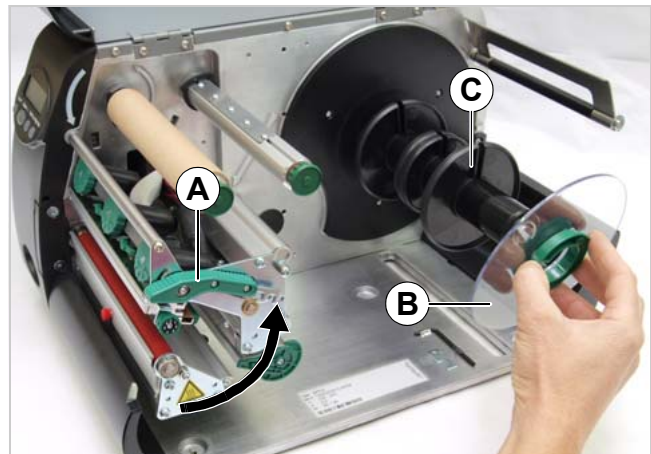

[6] Preparing the material unwinder on AP 5.6.

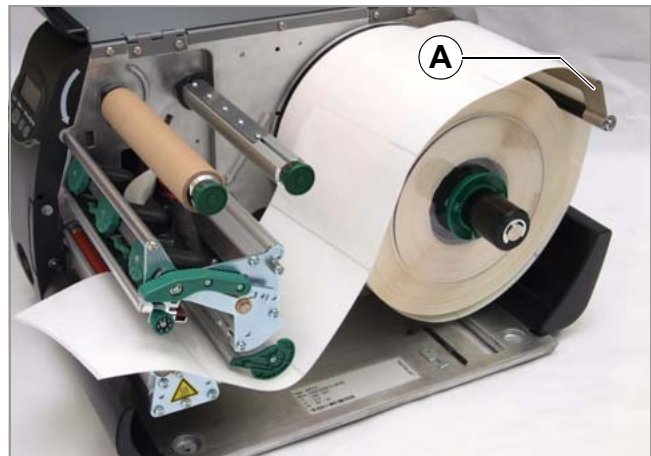

[7] Inserting the label material.

7. Push the material guiding [8A] up to the edge of the material without clamping the material.

Continued overleaf.

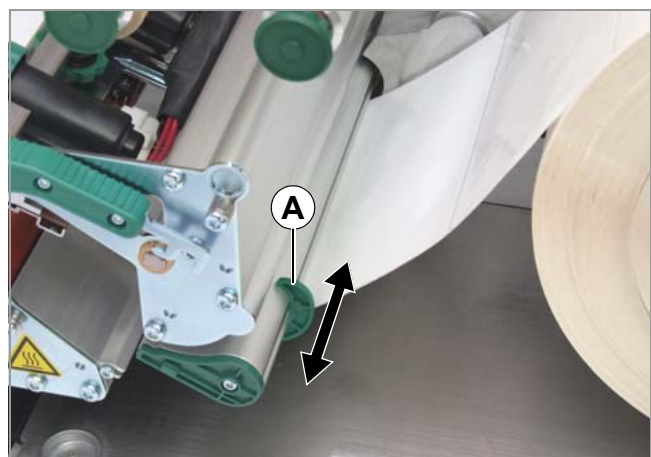

[8] Adjusting the material guide (A).

8. Push the sensor arm using the handle [9A] until the indicator [9B] is above the punches on the material.

▮▮▮▮ The optional *reflex light sensor* is located 6 mm to the right of the indicator!

9. *Direct thermal* printing: Close the pressure lever. *Thermal transfer* printing: Insert ribbon, see chapter [Inserting Ribbon](#) on page 11.

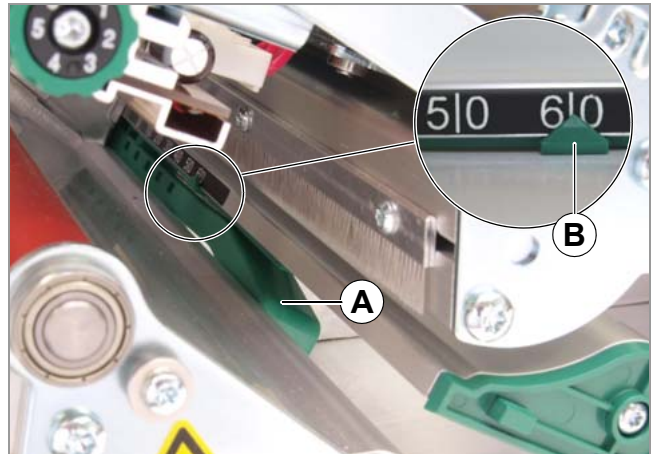

[9] Adjusting the label sensor (figure w/o material).

### Inserting Leporello Fold

Alternatively to the roller material, you can also use leporello fold (accordion fold):

1. Open the front hood.
2. Open the pressure lever on the printhead.
3. Place the leporello fold [10A] behind the printer.
4. Push the material over the material unwinder. Push the guiding disk up to the edge of the material without clamping the material.
5. Continue as described in steps 6 to 8 in [Inserting a label roll](#) on page 7.

▮▮▮▮ Alternatively, the material can be fed through the slot [10B] in the printer bottom.

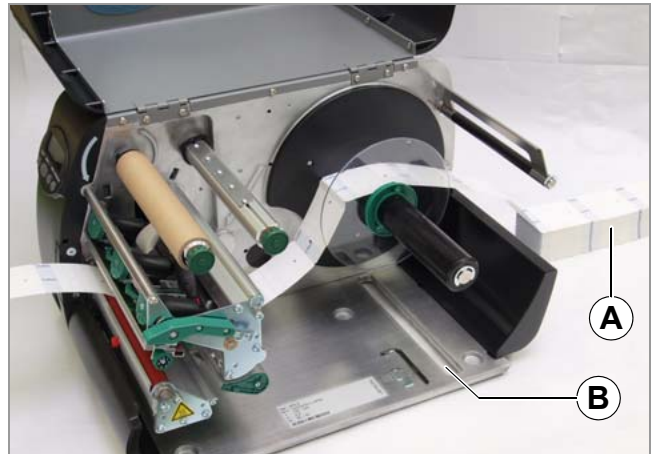

[10] Inserting the leporello fold (A).

## AP 5.4/AP 5.6 with Internal Rewinder

1. Insert the label material, see [Inserting a label roll](#) on page 7.
2. As shown, move the end of the label strip towards the rewriter [11A] and fasten it to the clasp [11B].
  - ▮▮▮▮▮ The short side of the stay bolt fits into the groove [13A].
3. Choose the direction of rotation for the rewriter (printout facing inwards or outwards): Choose the **REWINDER PARA > Rewind direction** parameter.

After switching on the printer, the rewriter slowly rotates in the configured direction until the material ribbon becomes taut.

The following error message might appear until the material ribbon is taut.

Status	5004
Rewriter mat. tear	

→ If this happens, press the Online key (repeatedly if necessary) to acknowledge the message.

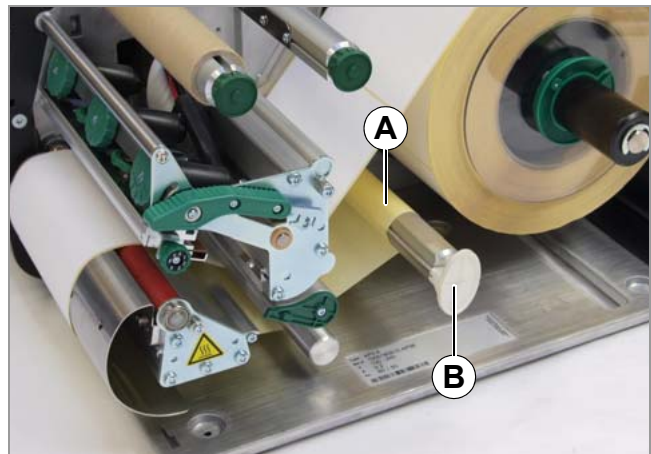

[11] Material path through an AP 5.6 with internal rewriter.

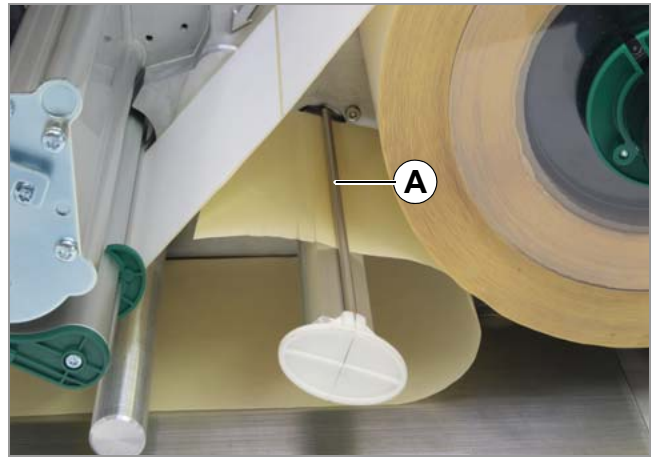

[12] Fix the label strip on the rewriter.

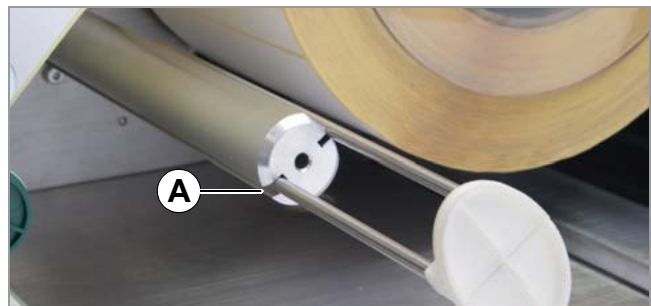

[13] Insert the clasp with the short side into the groove (A).

### AP 5.4/AP 5.6 Dispenser

1. Inserting the label material, see [Inserting a label roll](#) on page 7.
2. Remove the release paper from the labels to approx. 30 cm away from the end of the label strip [15].
3. Press the red button [14A] on the dispensing edge to unlock the dispensing roll. Remove the dispensing roll [14B]
4. As shown, move the backing paper towards the rewinder [15A].

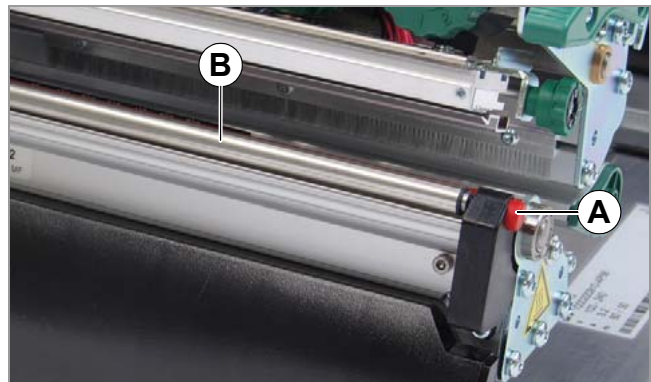

[14] Dispenser roll (B) above dispenser edge.

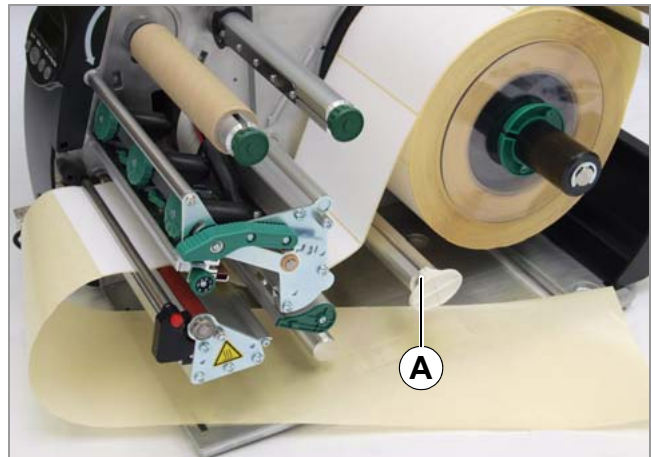

[15] Move the covering paper towards the rewinder (A).

5. Fasten the end of the backing paper strip to the clasp [16A].
  - ▮ The short side of the clasp fits into the groove [17A].
6. Manually rotate the rewinder in a counter-clockwise direction until the backing paper is taut.
7. Reconnect the dispensing roll.

After switching on the printer, the rewinder slowly rotates until the material ribbon becomes taut.

The following error message might appear until the release paper is taut.

Status	5004
Rewinder mat. tear	

→ Press the Online key (repeatedly if necessary) to acknowledge the message.

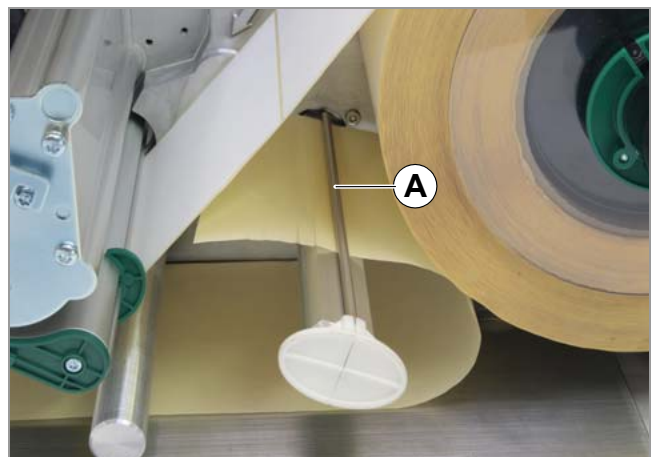

[16] Fasten the covering paper to the rewinder.

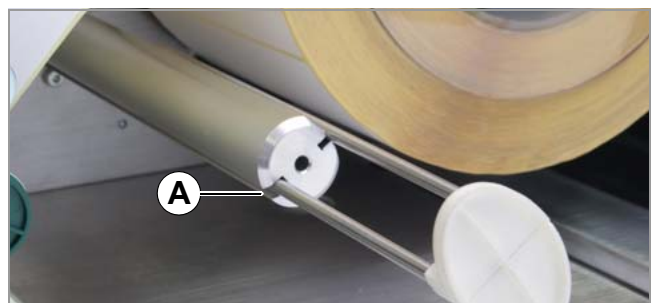

[17] Insert the clasp with the short side into the groove (A).

## Inserting Ribbon



### WARNING!

Danger of crushing fingers when closing the front hood.

→ Always use the grip to open or close the front hood.

Danger of rotating parts drawing items in.

→ Don't wear loose long hair (if necessary, wear a hairnet).

→ Keep loose jewellery, long sleeves, etc. away from rotating parts of the printer.

→ Always close the front hood before printing.

During operation, the printhead can become hot!

→ Be careful whenever touching the printer.



### CAUTION!

Poor printing quality.

→ The thermal transfer ribbon must overlap the label width 2 mm on each side (ribbon width = label width + 2 mm)<sup>a</sup>.

a) Exception: The label material width exceeds the printhead width. In this case, ribbon must not be wider as the printhead (= max. ribbon width).



[18] Grip (A) at the front hood.

▮▮▮▮▶ Ribbon only has to be inserted for thermal transfer printing.

## Inserting a New Ribbon Roll

1. Open the front hood.
2. Open the pressure lever [19A] on the printhead.
3. Push the ribbon roll [19B] onto the unwinding mandrel until it stops. Push the empty ribbon sleeve onto the rewinding mandrel [19C].

▮▮▮▮ The ribbon rotates in a counter-clockwise direction with the coloured side facing inwards (see fig.)!

4. As shown, insert the ribbon into the printer [19] [20]. Fasten the end of the ribbon with adhesive tape to the empty ribbon sleeve.
5. Rotate the rewinding mandrel a few turns in a counter-clockwise direction until the ribbon is free of folds.

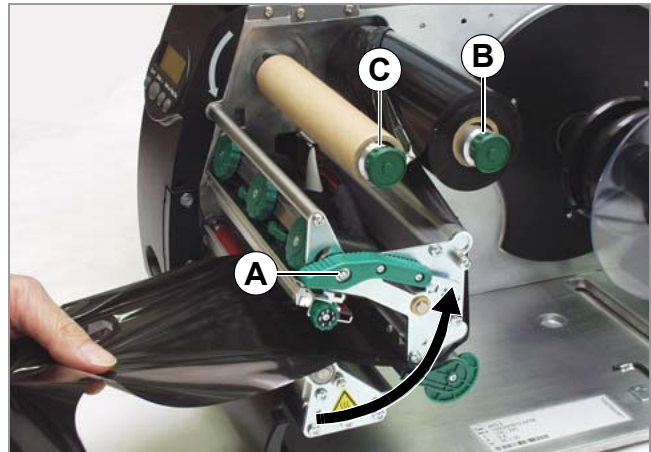

[19] Insert the ribbon.

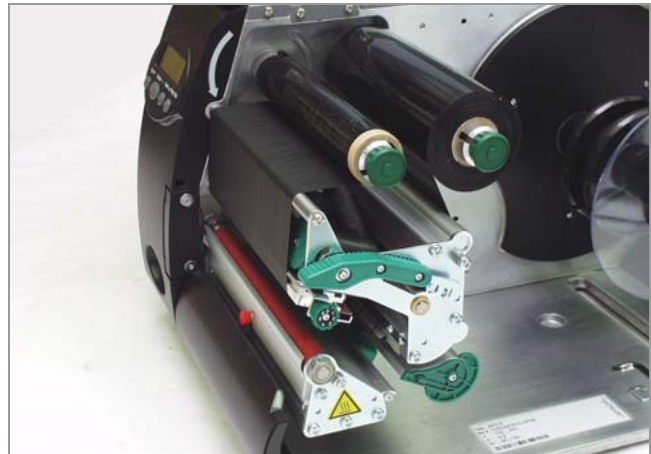

[20] Fasten the ribbon and tighten the ribbon.

## Replacing the Ribbon Roll

1. Open the pressure lever on the printhead.
2. Remove the wound roll of ribbon from the rewinding mandrel.
3. Remove the empty core of ribbon from the unwinding mandrel and place this onto the rewinding mandrel.
4. Clean the printhead.  
See topic section „Maintenance and cleaning“, chapter [Cleaning the Printhead](#) on page 6.
5. Insert a new roll of ribbon as described above.



## Exchanging the Ribbon Roll

To switch between *different types of ribbons*, there is no need to cut off the ribbon each time and then insert it and fasten it to the ribbon re-winder.

It's easier as follows:

1. Open the pressure lever [21].
2. Remove both rolls of ribbon from the mandrels. Pull away the ribbon sideways from the printhead [22].

▣▣▣▣▶ Store your frequently used ribbons as pairs of rolls [23].

You can insert another pair of rolls as follows:

1. Push the ribbon between the rolls sideways below the printhead [22].
2. Push the ribbon rolls onto the mandrels and tighten the ribbon [21].

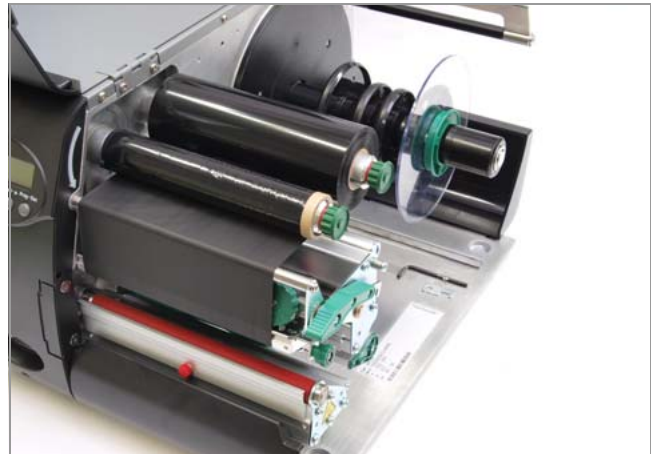

[21] AP 5.4 with inserted ribbon, pressure lever is open.



[22] Remove both ribbon rolls.

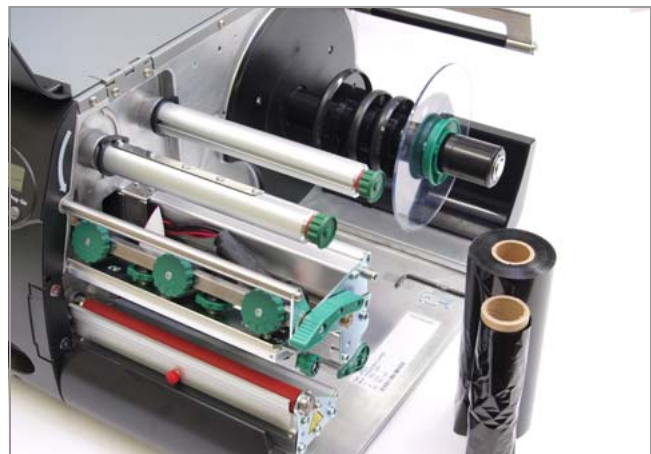

[23] Store the ribbon rolls in pairs.

## When the Roll is Empty

### End of Material

After the end of the material roll passes by the punch sensor, the following status message appears:

Status	5002
Material end	

→ Open the pressure lever and pull the end of the material forwards out of the printer.

### End of Ribbon

Once the end of the ribbon has been wound away and the unwinding mandrel no longer rotates, the following message will appear:

Status	5008
Ribbon end	

→ Proceed as described under [Inserting a New Ribbon Roll](#) on page 12.

▮▮▮▮ End-of-ribbon detection can be shut off when required, e.g. for direct thermal printing:

→ To do this, set `SYSTEM PARAMETERS > Foil mode` to “Thermal printing”.

For more detailed information on how to set the parameters, see [Info Printouts and Parameters](#).

## Settings

### Mechanic settings

#### Ribbon brake (AP 5.6)

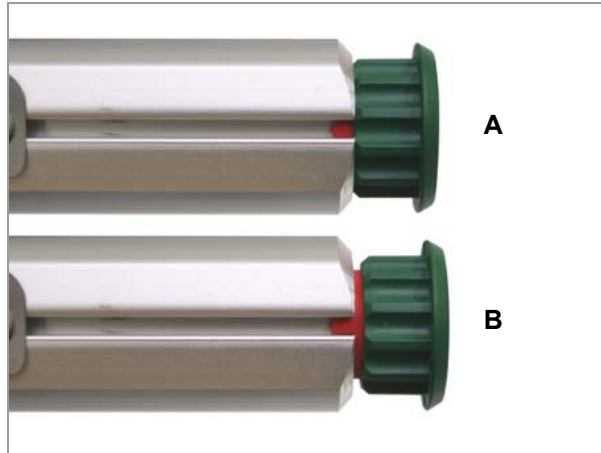

[24] Adjusting knob at the ribbon mandrels

- A Setting for low braking torque
- B Setting for high braking torque

The braking torque of the AP 5.6 ribbon mandrels can be set in two strengths.

- High braking torque = red ring is visible [24B]
- Low braking torque = red ring is *not* visible [24A]

Changing the braking torque:

→ Pull at the green adjusting knob and turn it  $\frac{1}{4}$  rotation, until it snaps in.

- Increasing the braking torque: turn *clockwise*
- Decreasing the braking torque: turn *anti-clockwise*

⚠ Always keep the unwinding mandrel set to „low braking torque“. Exception: printing with long backward movement stretch (PRINT PARAMETERS > Cut mode = „Real 1:1 mode“ or DISPENSER PARA > Dispense Mode = „Real 1:1 mode“)

Ribbon width	Setting rewinding mandrel
50-90 mm	low braking torque [24A]
90-110 mm	both settings possible
110-172 mm	high braking torque [24B]

[Tab. 1] Typical values for setting the ribbon brake.

**Printhead pressure**

Increasing the printhead (contact) pressure increases the blackness of the printout.

*Increasing* the printhead pressure:

→ Turn each knob [25A] until a *higher* number is placed opposite of the edge [25B]

*Decreasing* the printhead pressure:

→ Turn each knob [25A] until a *lower* number is placed opposite of the edge [25B]

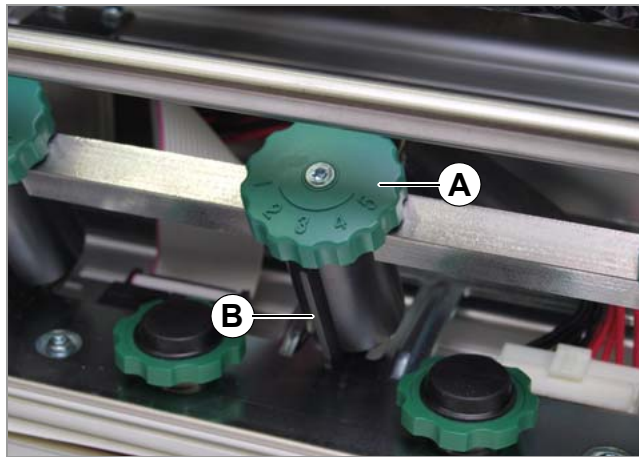

[25] Adjusting knob (A) for the printhead contact pressure.

**Printhead Support**

When printing narrow labels, the printhead can come into direct contact with the print roller in areas where no material is present. This can cause preliminary wear and tear on the printhead and can lead to varying printing intensities between the two label edges.

▮▮▮▮ When using narrow labels, activate the printhead support!

*Narrow = material width < printhead width.*

The printhead support setting is indicated by the position of the thumb wheel [5A]. For wide labels, we recommend the “0” setting.

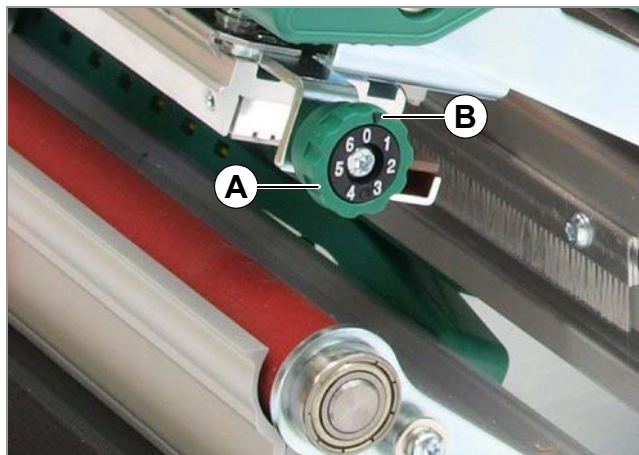

[26] Thumb wheel (A) for printhead support.

1. For narrow labels, turn the thumb wheel clockwise until the marking [5B] points to “1”. The printhead is lifted on the outside.

2. Make a test printout and check the evenness of the printed results. If the printing intensity is not even, turn the thumb wheel even further.
3. Repeat steps 1 to 3 until the print intensity is even across the entire label width.

### Parameter settings

For more information on how to set the parameters, see “Info Printouts and Parameters”, section [Operating the Parameter Menu](#) .

#### Material Parameters

Using the following three parameters, you can enter the properties of the label material to be printed on the printer:

Parameter	Function
PRINT PARAMETERS > Material type	Sets the material type (punched or continuous)
PRINT PARAMETERS > Material length	Sets the label length (start of label to end of label)
PRINT PARAMETERS > Material width	Sets the material width
SYSTEM PARAMETER > Light sens. type	Sets the sensor type (reflex or transmission) according to material type (reflex markings or punches)

#### Setting the label length automatically

→ In offline mode, press the feed+prog buttons simultaneously.

After pressing the button, the printer transports the label material forwards until two start-of-label markings have passed by the label sensor. The label length thus determined will be displayed and applied to

PRINT PARAMETERS > Material length. Furthermore, PRINT PARAMETERS > Material type is set to “Punched”.

Display of the measured label length:

```
OFFLINE  x JOBS
          198.5 mm
```

▮ This function measures the label length without punches, i.e., from the start of the label to the end of the label. For label material with very large punches, we recommend measuring the label length manually and then entering this value (label length + punch).

#### Ribbon Parameters

Using this parameter, you can configure whether to use direct thermal printing (without ribbon) or thermal transfer printing (with ribbon).

Parameter	Function
SYSTEM PARAMETER > Foil mode	Set to thermal transfer or direct thermal printing.

## Print contrast



### CAUTION!

The maximum achievable print width of the AP 5.6 is limited by print speed and print contrast.

→ Pay attention to the limitations, see [Print width limitations at AP 5.6](#) on page 16.

The setting of the print contrast is done in the parameter menu with `SYSTEM PARAMETER > Print contrast` or, in online mode, by pressing the Prog button.

■▶ AP5.6: Due to certain limitations in operating conditions, the maximum setable print contrast value of the AP 5.6 is limited by the following two factors:

- Printhead resolution
- Print speed

Print speed	Max. print contrast
51mm/s (2 inch/s)	120%
76mm/s (3inch/s)	117%
102mm/s (4inch/s)	115%
127mm/s (5inch/s)	100%
152mm/s (6inch/s)	85%
178mm/s (7inch/s)	76%
203mm/s (8inch/s)	67%

[Tab. 2] Max. setable print contrast with 203 dpi print heads (AP 5.6).

Print speed	Max. print contrast
<= 76mm/s (3inch/s)	120%
102mm/s (4inch/s)	105%
127mm/s (5inch/s)	88%
152mm/s (6inch/s)	74%

[Tab. 3] Max. setable print contrast with 300 dpi print heads (AP 5.6).

### Parameters for Dispenser Mode

■▶ Setting only for AP 5.4/AP 5.6 “basic” dispenser and for AP 5.4/AP 5.6 “peripheral” dispenser.

Parameter	Function
SYSTEM PARAMETER > Periph. device	Set to “Dispenser”



### Parameters for Rewinding Mode

■▶ Setting only for AP 5.4/AP 5.6 “basic” dispenser and for AP 5.4/AP 5.6 “peripheral” dispenser.

Parameter	Function
SYSTEM PARAMETER > Periph. device	Set to “Intern rewinder”.
REWINDER PARA > Rewind. direction	Select the direction of rotation (print-out facing inwards or outwards).

### **Setting the degree of blackness**

In some cases, the blackness of the printout is not sufficient with the standard setting, e. g. when printing on cardboard material. If this happens, the blackness can be increased by the following measures:

- Increasing the *print contrast*, see chapter [Print contrast](#)  on page 18.
- Increase the *printhead (contact) pressure*, see chapter [Printhead pressure](#)  on page 16.



# Advanced Applications

Printing with temperature compensation .....	2	Access via Web/FTP server .....	21
Requirements .....	2	Web server .....	21
Function description .....	2	FTP server .....	26
Printing with start signal .....	4	Data transmission with WLAN .....	29
Application notes .....	4	Requirements .....	29
Available interfaces .....	4	Notes .....	29
Connecting the signal source .....	5	Printer setup .....	30
Settings in the parameter menu .....	7	Connecting .....	30
Standalone Operation .....	8	PC setup .....	31
Requirements .....	8	Testing the connection .....	32
Functional Description .....	9	Sending a printjob .....	32
Selecting files from memory card .....	10	Storing and transferring parameter settings	33
Executing printjobs .....	11	Recommendations .....	33
Executing firmware files .....	13	Application cases .....	33
Automatic file execution .....	13	Storing settings on memory card .....	34
Additionally usable keys on a keyboard ..	13	Loading settings from memory card .....	35
Insert Input Field in Printjob .....	14	Automatic setup loading .....	35
Example Application .....	14	Verifying Bar Codes with OLV .....	36
Data input by interface .....	16	System Requirements .....	36
Data Transmission with Ethernet .....	17	Functional Description .....	36
System Requirements .....	17	Setup .....	37
Integration of Ethernet Interface .....	18	Appendix .....	39
Setting the IP Parameters .....	19	Example: Setup file for AP 5.4 .....	39
Transmission with Raw Socket Interface	19		
Transmission with LPD Server .....	20		
Troubleshooting .....	20		



# Printing with temperature compensation

## Requirements

- Suitable printers: All devices listed in the headline of this document
- Firmware: All versions

## Function description

The print contrast is heavily dependent on the temperature of the printhead. This can be set using the parameter SYSTEM PARAMETERS > Print contrast or in the online mode after pressing the Esc button.

When the printer is being used for a big print job, the temperature of the printhead and the print contrast increase during printing. This increase is greater, the larger the print-job and the larger the amount of black to be printed.

In extreme cases, this rise in temperature can lead to smearing in fine structures when printed, e.g. barcodes arranged crosswise to the printing direction. To avoid this, the firmware constantly checks and corrects the printhead temperature. The precondition for this is that the parameter SYSTEM PARAMETERS > Temp. reduction is set to a value > 0 (Default: 20%).

► The temperature compensation is the greater, the higher the setting of the parameter SYSTEM PARAMETERS > Temp. reduction is [1].

Parameter	Function
SYSTEM PARAMETERS > Print contrast	Sets the print contrast, i.e. indirectly, the printhead temperature (actually adjusts the driving power of the printhead).
SYSTEM PARAMETERS > Temp. reduction	Sets the correction factor for the temperature compensation. The higher the selected setting, the greater the reduction of the driving power when the printhead temperature rises.

[Tab. 1] Parameters for setting the temperature compensation.

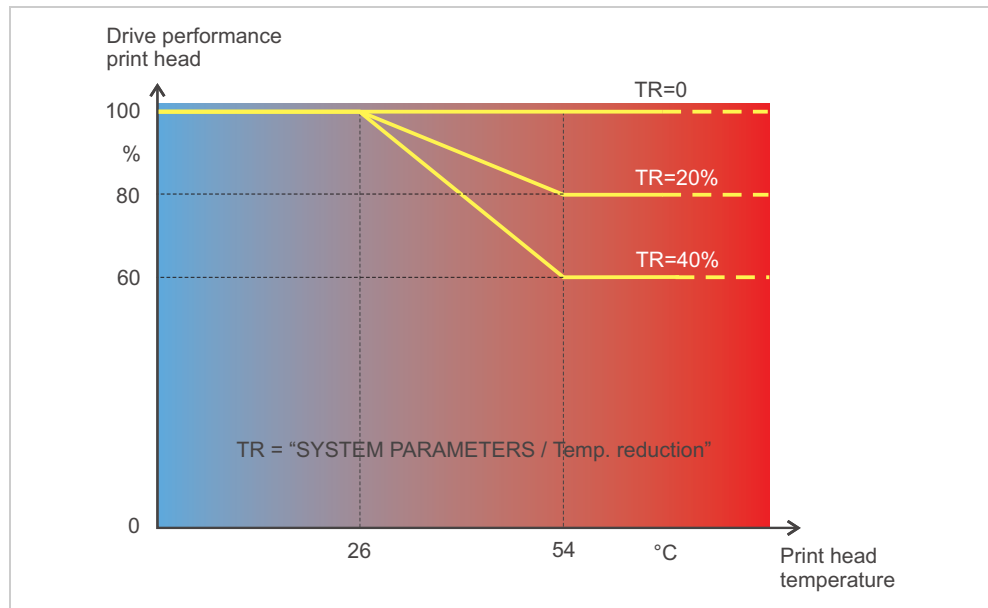

[1] With the parameter SYSTEM PARAMETERS > Temp. reduction activated, the driving power of the printhead – and therefore indirectly the print contrast – are reduced. Reduction starts at a temperature of 26°C. The maximum value is maintained at 54°C and above.

**Readout example**

The driving power of the printhead is 100% (setable in online mode after pressing the Prog button).

The printing layout contains a lot of black areas. For this reason, the temperature reduction is activated with 40%.

→ SYSTEM PARAMETERS > Temp. reduction = 40%.

Now, if the printhead temperature rises above 26°C, the driving power will be reduced automatically.

Reading out the diagram results in: With a given printhead temperature of approx. 40°C, the driving power is reduced to approx. 80%; with a supposed printhead temperature of 54°C or above, it is reduced to 60%.

## Printing with start signal

### Application notes

Print-and-Apply systems are normally triggered by an external start signal, which typically comes from a product sensor placed at the conveyor. In most cases, after a start signal arrived, a label is printed, dispensed and applied on the product.

This chapter describes...

- different ways of connecting a start signal source
- required settings in the printer parameter menu

### Available interfaces

Depending on the printer type and configuration, different interfaces for start signal input are available (Tab. 2).

Printer	Singlestart <sup>a</sup>	USI <sup>b</sup>	AI <sup>c</sup>	E/A <sup>d</sup>
64-xx Dispenser	S	O	--	--
64-xx	O	O	--	--
AP 5.4 Dispenser	S	--	--	O
AP 4.4	O	--	--	--
AP 5.4	O	--	--	O
AP 5.4 Gen. 2	S	--	--	O
AP 5.6	S	--	--	O
AP 7.t	O	--	--	O
ALX 92x	O	O	O	--

[Tab. 2] Interfaces for start signal input for the different printer types  
(S = Standard; O = Optional; -- = No option)

- Singlestart connector on the devices rear side
- USI board with signal interface
- Applicator Interface with signal interface
- I/O board with signal interface

## Connecting the signal source

### Product sensor

The 3 accessory boards USI, AI and I/O provide each a signal interface shaped as a D-Sub connector [2B] [3A]. To those connectors, a start signal source can be connected. As signal source serves usually a product sensor (photoelectric switch).

For detailed information on connecting a signal source see (Tab. 3):

Printer	Board	Article no. product sensor
ALX 92x, DPM, PEM	USI <sup>a</sup>	A2682
ALX 92x	AI	A7112 (Light sensor) N100136 (Connection cable)
AP 5.4, AP 5.4 Gen. 2, AP 5.6	I/O	No pre-assembled product sensor available.

[Tab. 3] Article numbers for product sensors.

a) USI in the 24 V version

► For details about the connector pinout, refer to the Service Manual of the relevant printer, topic section „Electronics“.

### Footswitch

Footswitches are available as accessory for both, 64-xx and AP 5.4/5.6 printers and are shipped ready configured (see topic section [Accessories](#) ).

Printer	Article no. foot switch
AP 5.4, AP 5.4 Gen. 2, AP 5.6	A4053
64-xx Dispenser with LTSI	A4053 + A7268 <sup>a</sup>
64-xx Dispenser	97685

[Tab. 4] Article numbers for foot switches.

a) Adapter cable for connection to a USI.

→ Connect the footswitch to the singlestart connector [2A].

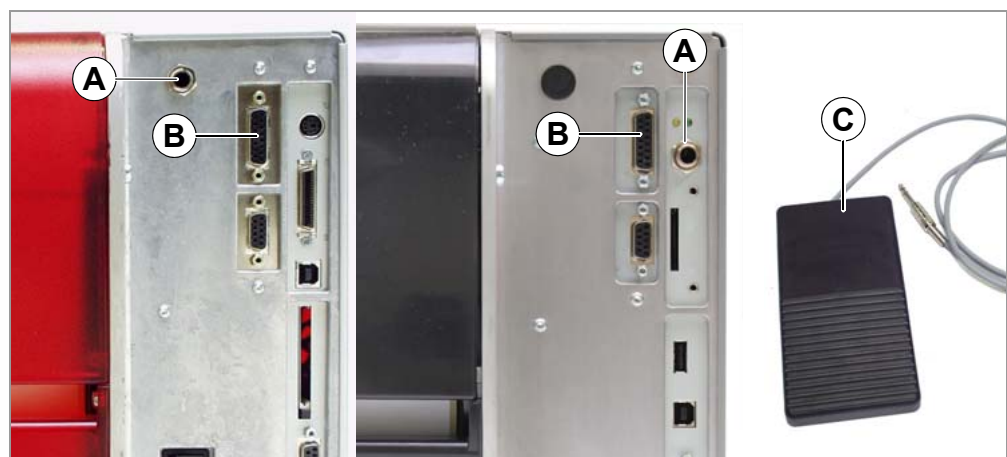

[2] Single-start connector (A) and I/O board signal connector (B) at AP 5.4 (left) and at AP 5.4 Gen. 2 or AP 5.6 (right) respectively. Matching footswitch (C) with 3-point plug.

AP 4.4 – DPM – PEM – ALX 92x



[3] USI signal connector (A) and singlestart connector (B) at a 64-xx.  
If the printer is operated with a LTSI applicator, the footswitch has to be connected to the USI!

**Light barrier**

(64-xx Dispenser type M and AP 5.4/5.6 Dispenser only) This printer type is shipped with a short dispensing edge [4B] with a light barrier, which serves as signal source. After printing and dispensing, the label blocks the light barrier and stops the printer until the label is taken off. As soon as the light barrier is clear again, the next label is printed.

→ Connect the light barrier to the D-Sub connector at the printer front side [4A].

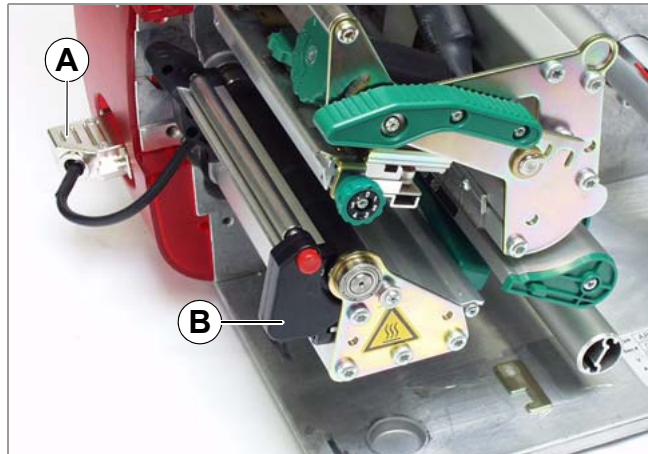

[4] AP 5.4 Dispenser.

## Settings in the parameter menu

Setting	Interface	Printer	Parameter	Value
Accept start signals	--	All	SYSTEM PARAMETER > External signal	Singlestart
Signal source	Singlestart input	64-xx	-- <sup>a</sup>	--
		64-xx Dispenser, AP 5.4 Dispenser, AP 5.6 Dispenser	DISPENSER PARA > Start source	Foot switch
		AP 5.4, AP 5.6, AP 7.t	--	--
	Disp. edge light barrier	64-xx Dispenser, AP 5.4 Dispenser, AP 5.6 Dispenser	DISPENSER PARA > Start source	Light barrier
		USI	DISPENSER PARA > Start source	USI interface
	I/O	64-xx, ALX 92x, ALX 73x	--	--
		AP 5.4, AP 5.6, AP 7.t	--	--
AI	ALX 92x, ALX 73x	--	--	
Signal flange	Singlestart input	64-xx, AP 5.4, AP 7.t, AP 5.4 Gen II, AP 5.6	SYSTEM PARAMETER > Start print mode	„Pulse rising“
	USI	64-xx, ALX 92x	DP INTERFACE > Start print mode	„Pulse rising“
	I/O	AP 5.4, AP 5.6, AP 7.t	I/O BOARD > Start print mode	„Pulse rising“
	AI	ALX 92x, ALX 73x	APPLICATOR PARA > Start print mode	„Pulse rising“
Start delay	Singlestart input	AP 5.4 Gen II Dispenser, AP 5.6 Dispenser	DISPENSER PARA > Start offset	Enter distance between start sensor and dispensing edge
	USI	64-xx, ALX 92x, ALX 73x	DP INTERFACE > Start delay	
	I/O	AP 5.4 Gen II Dispenser, AP 5.6 Dispenser	DISPENSER PARA > Start offset	
	AI	ALX 92x, ALX 73x	APPLICATOR PARA > Start delay	

[Tab. 5] Overview on the most important settings for start signal application (Firmware versions 3.52/6.52/7.52).

a) „--“ = No setting required.

► Further settings for 64-xx Dispenser see user manual 64-xx, topic section „Setup“, chapter [Settings at 64-xx dispensers](#) on page 17.

► Settings for application of ALX 92x with applicator see service manual ALX 92x, topic section „Applicator Interface“, chapter [Selecting an applicator type](#) on page 5.

## Standalone Operation

### Requirements

#### Printer

Suitable printers: all devices listed in the headline of this document, except for AP 4.4 (which has no card slot)

#### Firmware

Printer	Feature	Firmware version
64-xx, DPM, PEM, ALX 92x	Gen. 2 <sup>a</sup>	3.0
64-xx, DPM, PEM, ALX 92x	Gen. 3 <sup>b</sup>	5.02
ALX 73x	--	6.36
AP 5.4, AP 7.t	--	1.10
AP 5.4 Gen II, AP 5.6	MLK	3.34

[Tab. 6] Minimum firmware requirement for standalone operation.

- a) Characteristic feature: No USB interfaces, but Centronics as standard.  
 b) Characteristic feature: USB interfaces, Centronics optional.

#### CPU board

Printer	Feature	CPU board number
64-xx, DPM, PEM, ALX 92x	Gen. 2	A2292/A2293
64-xx, DPM, PEM, ALX 92x	Gen. 3	A6621
PM 3000	--	A6621
AP 5.4, AP 7.t	--	A3927
AP 5.4 Gen II, AP 5.6	MLK	A100150

[Tab. 7] Minimum CPU board requirement for standalone operation.

#### Options board

Is required for the printer types listed below to be able to connect a keyboard. The order number for the options board can be found in topic section [Accessories](#) .

- 64-xx Gen. 2
- DPM Gen. 2
- PEM Gen. 2
- ALX 92x Gen. 2

#### Memory card

For order number, see the Plugin Card Manual, topic [Available Cards](#) .

#### Card reader

PC or laptop with card reader

## Keyboard

On request, a keyboard can be connected to the printer. This considerably simplifies entry of variable data, especially when dealing with text.

➡ 64-xx, DPM, PEM and ALX 92x of Generation 2 require an additional board for connecting the keyboard, see chapter [Options board](#) on page 8. The Options board provides a PS/2 connector; an USB-to-PS/2 adapter comes with the offered keyboards.

Keyboard type	Order #
USB-keyboard <sup>a</sup> without numeric keypad, German layout	A8407
USB-keyboard <sup>a</sup> without numeric keypad, US layout	A8406

[Tab. 8] Keyboards available as accessory.

a) Comes with USB-to-PS/2 adapter (required for „AP 5.4 red“ and for „64-xx Gen. 2“)

The matching keyboard layout is set with parameter `SYSTEM PARAMETER > keyboard`.

➡ Before first use, check if the intended keyboard really works with the printer.

## Functional Description

Standalone operation means the printer can be operated without it needing to be connected to a host computer. For this purpose, a PC is used to store the print job on a CompactFlash card (memory card). After this card is plugged into the card slot at the printer, the operator can start the print jobs on demand. For this, he uses the printer control panel or a keyboard connected to the printer. Variable data can also be entered via the control panel or the external keyboard.

The standalone mode can always be accessed from the „normal“ printer operation (with online/offline mode and message mode). To do so, press the Online and Esc buttons simultaneously.

It is helpful to imagine two consoles, between which can be switched by pressing Online+Esc.

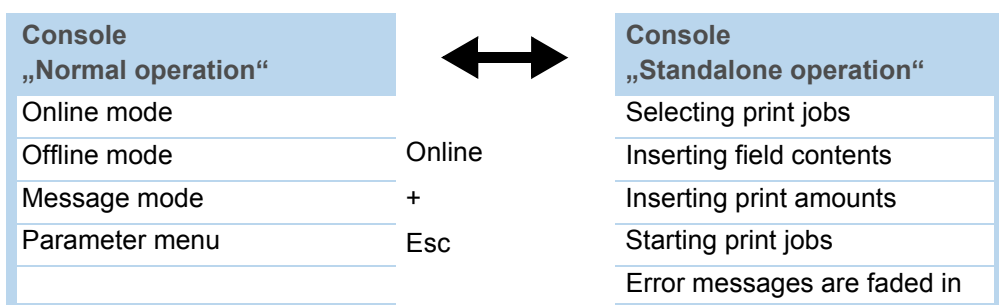

[Tab. 9] Functions and display texts in normal and in standalone operation mode.



**Features**

Standalone operation in brief:

- Printing without computer connection
- Data entry via control panel or keyboard
- Reading print job from the memory card
- Entry or selection of field content
- Updating Firmware from memory card

**Selecting files from memory card****Requirements**

The card slot which is used for standalone operation must provide the drive letter C. 64-xx, DPM, PEM, ALX 92x <sup>1</sup>:

→ Set INTERF.PARAM. > DRIVEASSIGNMENT > Drive C to „Compact flash“ or „Compact flash 2“ („Compact flash 2“ appears only with the optional 2<sup>nd</sup> card slot).

AP 5.4 Gen. 2, AP 5.6:

→ Set INTERF.PARAM. > DRIVEASSIGNMENT > Drive C to „SD/MMC card“ (= factory setting).

Other printers: No setting required

Selectable are files with the following extensions:

- „\*.FOR“ (printjob)
- „\*.S3B“ (firmware)

▣▣▣▣ The files must be stored on memory card in folder \FORMATS.

▣▣▣▣ If no file with one of the above listed endings is found in folder \FORMATS, or if no memory card is inserted, the following message appears:

Standalone  
No files!

▣▣▣▣ If a huge amount of printjob files is stored in folder \FORMATS, this can lead to the following status message:

Status num: 8857  
Wrong mem config

To remedy the cause of this message, take one (or both) of the following measures:

- Reduce the number of files in the \FORMATS folder
- Increase the amount of assigned memory in SYSTEM PARAMETER > Free store size

**Selecting a file**

1. Press the *Online* + *Esc* buttons to get into the standalone mode. The following is displayed:

Choose a file  
Novexx.for

„Novexx.for“ stands for any printjob file, which is stored in the \FORMATS folder.

Assumption: More than one file is stored in the \FORMATS folder: In this case the first file in alphabetical order is displayed.

2. Press the *Cut* or *Feed button* to step to the next file.

▣▣▣▣ Press the *Esc button* to jump back to the first entry of the list.

1) With firmware version 5.32 or higher (each Gen. 3)

3. Press the *Online button* to start proceeding the file

In case of a printjob file, the printjob is started, in case of a firmware file, the firmware upload starts.

The following message appears after selecting a printjob:

```
Novexx.for
Executing .
```

„Novexx.for“ = printjob file

The point after „Executing“ moves as long as the interpreter works.

Afterwards, input data are requested. If no input fields are provided, only the print amount is queried:

```
Enter quantity
1
```

The initial print amount is set in the printjob.

4. Change the print
5. Press the *buttons Online+Esc* to get back to the Online mode.

#### Key/button functions

Operation	Printer button	Keyboard key
Go to previous file	Feed	Cursor Up
Go to next file	Cut (or Apply)	Cursor Down
Confirm the selection	Online	Enter
More than one file: jump back to the first file in the list	Esc	Esc

[Tab. 10] Keys for file selection

#### Quick selection

▣ If an external keyboard is connected, the file can be selected by typing in the first letter of the file name.

Example:

After changing to the standalone mode, the following is displayed:

```
Choose a file
Novexx.for
```

„Novexx.for“ stands for any printjob file, which is stored in the \FORMATS folder.

1. Press the key for the first letter of the wanted file name , e. g. „D“. Display:

```
D
Default.for
```

D stands for the typed-in character.

„Default.for“ is in alphabetical order the first file with a „D“ as first letter.

2. Press the enter key to select the file, or  
Press the esc key to undo the input.

### Executing printjobs

All input fields are polled, which are defined as such in the print job (see [Example Application](#) □ on page 14). Next, the print quantity is requested. As soon as the print quantity is confirmed (online button), the print job is executed. From now on, all infor-

mation about the job is displayed in the "Print control" console. While the print job is processed, it is started newly in the „Standalone“ console. The input fields are polled again, with the previous entries as default. Alternating with the first input field, the text „Start next job“ is displayed.

- ▣▣▣▣ Each printjob file may contain *only one* printjob. If any printjob file contains more than one printjobs, only the first printjob is executed.
- ▣▣▣▣ The new start of the print job can be avoided by setting the parameter SYSTEM PARAMETER > Single job mode to „deactivated“.
- ▣▣▣▣ Press the Esc button to go back to the file selection.

Operation	Printer button	Keyboard key
Increase by 1	Feed	Cursor Up
Decrease by 1 (the predecessor of 0 is 9)	Cut (or Apply)	Cursor Down
Enter	Online	Enter
Delete/Cancel	Esc	Esc

[Tab. 11] Keys for entering variable data

- ▣▣▣▣ It's also possible to enter a single „\*“ for the print quantity. This makes the print quantity „endless“.

## Executing firmware files

Files with the extension `.S3B` are firmware files. Selecting a firmware file means starting a firmware download. As this is a fundamental intervention to the system, firmware files are not executed immediately. The query "Firmwaredownload ? No/Yes" demands explicit confirmation of the operator.

► The same firmware file renamed to the extension `.FOR` is executed without querying.

Operation	Printer button	Keyboard key
Switch between Yes/No	Feed	Cursor Up
Switch between Yes/No	Cut (or Apply)	Cursor Down
Confirm the selection	Online	Enter
More than one file: jump back to the first file in the list	Esc	Esc

[Tab. 12] Keys for loading firmware files

## Automatic file execution

If the file `DEFAULT.FOR` (All letters lower case or all upper case; „Default.for“ doesn't work) exists on memory card in the folder `\FORMATS`, this file is executed automatically at system start. Display during power up, until the file is executed:

Standalone  
Initializing

► If a file `\AUTOSTRT.FOR` is also existing (in the root directory, not case-sensitive), it will be executed first. But be aware that standalone-printjobs are only executed properly, if the relevant file is stored in `\FORMATS`, as described above.

## Additionally usable keys on a keyboard

With an external keyboard connected, the printer can be operated without touching the buttons of the operation panel. The function keys F5-F8 can be used alternatively to the operation panel buttons:

Operation	Keyboard key
Delete the current print job (works in both consoles)	Ctrl+Del
Jump to the start (e.g. start of a file selection list)	Ctrl+Home
Jump to the end (e.g. end of a file selection list)	Ctrl+End
Change between Standalone and standard console	Ctrl+Ins
Delete backwards	Backspace
Same function as <i>cut/apply</i> printer button	F5
Same function as <i>online</i> printer button	F6
Same function as <i>feed</i> printer button	F7
Same function as <i>prog/esc</i> printer button	F8

[Tab. 13] Additional keys for operating the printer with an external keyboard.

## Insert Input Field in Printjob

Input fields can be defined in the following Easy Plug field types:

- Text field
- Counting field
- Barcode field

These field types can be defined through the following Easy Plug commands: YT, YN, YB, IDM, PDF, MXC, CBF, YC, YS, YG.

Using a special syntax it is made clear in these commands that the text dealt with here is not a fixed text, but text requested at the time of implementation.

Further information on the input field syntax can be found in the description of the respective command in the Easy Plug Manual, topic section [Description of commands](#) □

## Example Application

1. Generate two text files with the content shown in the tables below.

▣▣▣▣ Tip: Cut out the content using the Acrobat Reader text selection tool and copy it to a text file.

### Example

```
#!A1#IMN100/60#ER
#J40#T5#YT107/0///Simple test for
#J30#T5#YN100/0/60///STANDALONE Mode
#Q3/
```

[Tab. 14] File „TEST1.FOR“

### Example

```
#J10#T5#YT107/0///Fixtext#G
#J40#T5#YN100/0/60///$<Color:>,Lightred
#J40#T5#YN100/0/60///$<Color:>,Lightred
#J20#T5#YT107/0///$<Article number:>,
#!A1#IMN100/60#ER
#Q3/
```

[Tab. 15] File „NOVEXX.FOR“

2. Create a directory on the memory card called \FORMATS.
3. Store the two text files as TEST1.FOR and NOVEXX.FOR on the memory card in the directory \FORMATS.
  - ▣▣▣▣ The file ending must be \*.FOR!
  - ▣▣▣▣ There is no difference made between uppercase and lowercase letters!
4. Switch off printer.
5. Insert memory card into the printer's card slot.
6. Turn on printer and switch to online mode.

AP 4.4 – AP 5.4 – AP 5.6 – AP 7.t – 64-xx – DPM – PEM – ALX 92x

7. Simultaneously press the Online and ESC keys.

The first file on the memory card is displayed:

```
Choose a file
NOVEXX.FOR
```

8. Call up the file `TEST1.FOR` by pressing the Cut or Feed keys.

▣▣▣▣ On DPM or ALX 92x, please press the Apply instead of the Cut key!

9. Confirm selection by pressing the Online button.

Now you are asked for the quantity of labels to be printed:

```
Enter quantity
3
```

Quantity 3 appears as default, as this was already preset in the printjob. To increase the quantity to 10, for instance, please perform the following procedure:

10. Press the ESC key. This erases the 3.
11. Press the Feed button in order to incrementally increase (up to a max. of 9) the quantity of labels to be printed.
- ▣▣▣▣ Quantity 0 = infinite printing!
12. Press the Online button to move forward by one position. Should you wish to enter a number with two or more digits, simply increase the second digit using the Feed button. Should the number only have one digit, press the Online button again.
- The printer will now print the stipulated number of labels.

## NOVEXX.FOR

In case of the `NOVEXX.FOR` file, this works somewhat differently. Once the file is called up, the following is displayed:

```
ONLINE      1 JOBS
Color: Lightred
```

In the second line the printer will ask for the content for the first data field. "Color" is a prompt and therefore not printed. The preset content of the printjob is called "Lightred".

- *Without keyboard* you can enter the desired text in characters. Entering letters works in the same way as digit entry (see example `TEST1.FOR`). Using the Cut or Feed buttons, you can scroll through the available set of characters until the required character appears. Use the Online button to move forward by one position. After entering the last character, press the Online button twice.
- *With a keyboard* you can, after the input prompt "Color:", simply enter a different content.

▣▣▣▣ The entry may only have a length that ensures the printout does not extend over the label edge! - otherwise a printer error message is displayed!

The next input field is displayed and then the next etc., until all input fields have been processed.

At the end you may change the quantity of labels to be printed if required.

## Data input by interface

Available with firmware x.33 or a later version.

Apart from putting in data by operation panel or by external keyboard, the data can be sent via interface.

Application example: Reading in data from a RS232 barcode scanner via serial interface.

**Selecting the interface** → INTERF.PARAM. > OPTIONS > StandAlone Input

▣▣▣▣ Listed are only interfaces, which are available in the printer and are not already occupied by another function.

### Application notes

The following characters or character sequences are replaced by *respectively one* „Enter“ action, if received.

- <CR> <sup>1</sup>
- <CR><LF>
- <LF> <sup>2</sup>
- <LF><CR>

▣▣▣▣ Data received at the interface are processed *only then*, if the printer is switched to standalone operation.

### Example

Example of a standalone printjob on the memory card:

```
#!A1#DC
#IMSR100.08/100.08
#HV50
#PR8/8/
#RX0
#ERN/1//0
#R0/0
#VTS/Var1//10///Test Var1#G
#VTS/Var2//10///Test Var2#G
#T34.16 #J90.75 #FD/0/L #SS100/BVUN/42X42/0 #VW/L/Var1#G
#T34.08 #J79.58 #FD/0/L #SS100/BVUN/42X42/0 #VW/L/Var2#G
#Q1#G
#!P1
```

The following data is received via the data interface:

```
Content1<cr><lf>
Content2<cr><lf>
3<cr><lf>
```

The first two lines assign the content „Content1“ to the variable „Var1“ and the content „Content2“ to the variable „Var2“. The third line assigns the print quantity „3“.

---

1) <cr> = 0x0D  
2) <lf> = 0x0A

## Data Transmission with Ethernet

### System Requirements



CAUTION! - Unqualified manipulations of a data network can disturb or stop its proper functioning.

Connecting a device to a network requires network administrator knowledge.

→ Consult your network administrator for assistance, if you don't have knowledge on this level!

#### Hardware

- Printer

Printer	Feature	Ethernet connection by
AP 4.4	–	Ethernet connection <i>not possible!</i>
AP 5.4	–	Integrated Ethernet interface
AP 5.6	–	
AP 7.t	–	
64-xx		
DPM	Gen. 2	CPU board A2292 with integrated Ethernet interface (optional)
PEM		
ALX 92x		
64-xx		
DPM	Gen. 3	Integrated Ethernet interface
PEM		
ALX 92x		
ALX 73x		

[Tab. 16] Equipment of the different printer types with Ethernet interfaces.

- Ethernet cable: must have quality „Cat. 5E“ and be shielded.

#### Software

- Firmware:

Printer	Feature	Firmware version
64-xx, DPM, PEM, ALX 92x	Gen. 2	3.0
64-xx, DPM, PEM, ALX 92x	Gen. 3	5.02
ALX 73x	--	6.36 <sup>a</sup>
AP 5.4, AP 5.6, AP 7.t	--	alle Versionen

[Tab. 17] Minimum firmware requirement if it is to apply the Ethernet function.

a) Printer firmware

- Network protocol: TCP/IP



## Integration of Ethernet Interface

The Ethernet interface of the printers is laid out as 10/100 Base T. The transmission speed is set by autonegotiation. LEDs are located above the RJ 45 plug, showing the network situation [5][6][7].

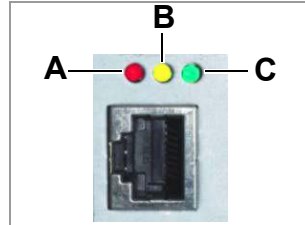

[5] Position of the signal LEDs at 64-xx, DPM, PEM, ALX 92x (each Gen. 2).

- A LED red lights = Printer is connected to network
- B LED yellow flashes = Network traffic
- C LED green lights = High transmission rate (100 Mbit/s)

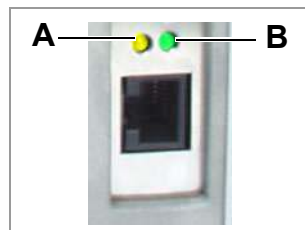

[6] Position of the signal LEDs at AP 5.4, AP 7.t, ALX 73x and 64-xx, DPM, PEM, ALX 92x (each Gen. 3)

- A LED yellow lights = Printer is connected to network; LED flashes = Network traffic
- B LED green lights = High transmission rate (100 Mbit/s)

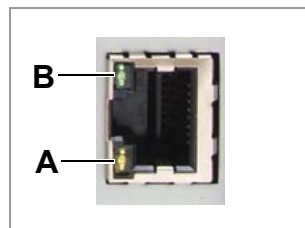

[7] Position of the signal LEDs at AP 5.4 Gen. II and AP 5.6.

- A LED yellow lights = Printer is connected to network; LED flashes = Network traffic
- B LED green lights = High transmission rate (100 Mbit/s)

### MAC Address

An internationally unique MAC (Media Access Control) address is required for Ethernet operation. It consists of 6 bytes and is usually separated by colons or hyphens (hexadecimal, e.g. 00:0a:44:02:00:49 or 00-0a-44-02-00-49). The first 3 bytes are constant 00:0A:44 (Novexx code), the last 3 bytes vary for each device. The product manufacturer is responsible for the allocation of the MAC addresses.

### IP Address

In the printer software a TCP/IP protocol stack is implemented, i.e. for network purposes the device requires an IP address along with the MAC address. IP-addresses are always displayed as 4 bytes separated by dots (e.g. 192.168.1.99). IP addresses are assigned by the network operator, as a rule the network administrator.

▣▣▣▣ MAC and IP addresses originate from different protocol layers and are generally independent of each other.

Further information about TCP/IP can be found in the abundance of literature on the subject.

## Setting the IP Parameters

The IP-parameter settings can either be set fix, or they can be requested from a DHCP server with every start of the printer. To assist the system administrator, the DHCP server is provided a device name on request, which consists of a combination of printer type + 3 digits from the MAC address. (e.g. AP\_5.4\_\_\_300dpi\_020049). The following values have been preset:

- IP address: 192.168.1.99
- Net mask: 255.255.255.0
- Default gateway: 0.0.0.0

▣▣▣▣ Connection to a name server is not required.

Menu	Parameter	Description
INTERF. PARAM. > NETWORK PARAM	IP addressassign	Here, please set "fixed IP address" or "DHCP".
	IP address	IP parameter input fields, in case "fixed IP address" was set for the address assign type.
	Net mask	
	Gateway address	

[Tab. 18] Setting the IP parameters in the printer menu

▣▣▣▣ **WARNING:** The address allocation for each device must be clear and unambiguous. Ask your network administrator for assistance!

## Transmission with Raw Socket Interface

Printing data can be transmitted using a parameterisable socket interface (TCP server socket on port number > 1024).

This protocol is supported by

- all Unix derivatives; a connection similar to that of terminal servers can be established.
- Windows 2000, Windows XP

A software package from external providers is required for Windows 95, Windows 98 and Windows NT (e.g. Serial/IP by Tactical Software, <http://www.tacticalsoftware.com>).

In this way you can set the Port address in the printer's parameter menu:

Parameter	Description
INTERF. PARAM. > NETWORK PARAM. > Port address	Here you can select the port number of the service in section 1024-65535
INTERF. PARAM. > EASYPLUGINTERPR > Interface	Here a TCP/IP socket must be set in order to receive printing data at the set port number.

[Tab. 19] Setting the port address in the printer's parameter menu

## Transmission with LPD Server

Printing data can be transmitted to the printer using the LPR/LPD (Line Printer Daemon) protocol (“BSD Spooler”).

This protocol is supported by

- all Unix derivatives
- Windows NT, Windows 2000 und Windows XP
  - ▮ The print queue of the host must be named „lp“!

### Example

1. Set parameter INTERF.PARAM. > EASYPLUGINTERPR > Interface to „LPD server“.
2. Send the printjob file (here: „test.txt“) as illustrated using the „lpr“ command [8].

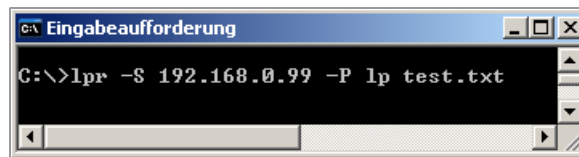

[8] Sending a printjob with the „lpr“ command.

- ▮ Enter „lpr ?“ to get a list of the admissible command options.
- ▮ For the use of LPD server under Windows NT or Windows 2000, please refer to the following link:

<http://support.microsoft.com/default.aspx?scid=kb;EN-US;179156>

- ▮ For the use of LPD server under Windows 95 and Windows 98, a software package from external providers is required (e.g. Windows LPR Spooler, see the following link).

<http://home.arcor.de/Heil-Consulting/>

## Troubleshooting

The following should be checked if a problem occurs:

- Ethernet connection: The yellow LED belonging to the printer network socket must be illuminated. If this is not the case, possible sources of error are:
  - that the network is not connected to the outlet.
  - ISDN outlet: Erroneous, the network cable was connected to an ISDN instead of a network outlet. Both outlet types do not differ mechanically.
  - an incorrect cable (ISDN cable?) is used to connect the printer to the network outlet.
  - a defective hub/switch.
  - a defective printer board.
- IP parameter: The defined parameters or parameters set via DHCP are displayed in the “Printer Status” printout. A “ping” to the set IP address must return an echo. This also works if a different interface is set in the Easy Plug Interpreter parameter. Possible source of error: Incorrect configuration of a network participant.
- On the printer, either “TCP/IP socket” or “LPD server” must be set in the Easy Plug Interpreter parameter.

## Access via Web/FTP server

### Web server

#### Applications

The web server makes it possible

- to set or read the values of parameters from the parameter menu via a web browser
  - to control the operator panel of the labeller resp. the printer via a web browser.
- ▣▣▣▣ The web server is *not* multi-session compatible, i.e. only one user can be logged in at any time.
- ▣▣▣▣ The web server is a setup utility, not an operational one. The web server should not be heavily used during a high performance application of the dispenser, otherwise this could result in losses in machine performance.

#### Prerequisites

- Suitable printers: All printers listed in the headline, apart from the AP 4.4
- Required firmware:

Printer	Feature	Min. firmware vers.
64-xx, DPM, PEM, ALX 92x	Gen. 2	3.40
64-xx, DPM, PEM, ALX 92x	Gen. 3	5.02
AP 5.4, AP 7.t	--	3.0
AP 5.4 Gen II, AP 5.6	MLK	3.34

- The printer is connected to a network
- A valid IP address is assigned to the printer (by the network administrator or by a DHCP server)
- INTERFACE PARA > NETWORK PARAM. > WEB server must be set to "On".

#### Starting the web server

1. Note down the IP address of the printer.
  - ▣▣▣▣ This is shown under INTERFACE PARA > NETWORK PARAM. > IP address
2. Start the internet browser.
3. Enter the following in the address bar:
 

http://[IP address without initial zeroes]

Example: IP address = 144.093.029.031

Enter: http://144.93.29.31

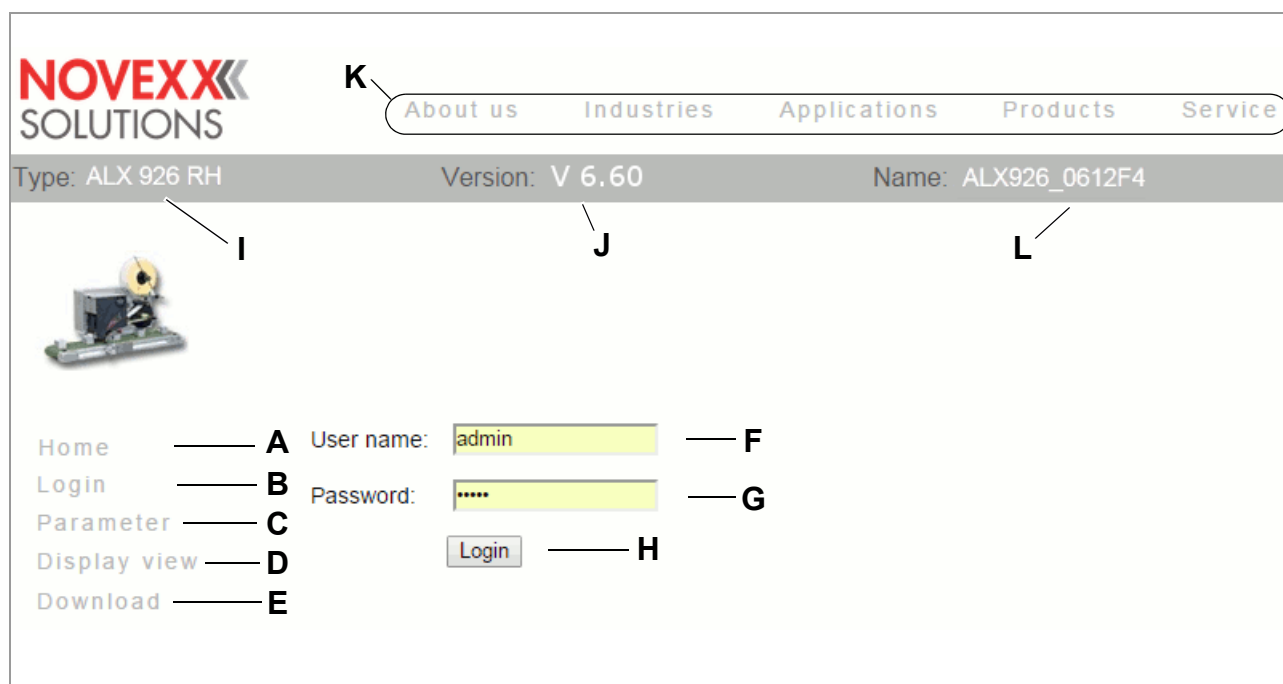

[9] Login dialogue of the web server

- A** Link to the web server home
- B** Opens input fields for user name and password [9]
- C** Calls the parameter menu  
Enables settings in the labeller parameter menu to be changed.
- D** Calls the operator panel display  
Gives access to all the parameters of the real operator panel
- E** Starts the FTP server in a new browser window  
See chapter [FTP server](#) on page 26.
- F** Input field for user name  
Preset: “admin”
- G** Input field for password  
Preset: “admin”  
The password can be changed under `INTERFACE PARA >NETWORK PARAM. > WEB server`
- H** Click on this button after entering user name and password
- I** Displays the machine model
- J** Displays the firmware version
- K** Links to the Avery Dennison Machinery website
- L** DHCP host name (see `INTERFACE PARA >NETWORK PARAM. > DHCP host name`)

### Logging in to the web server

1. Click on the “Login” link [9B]
2. Enter user name and password [9F, G]  
Preset in both cases: admin
3. Click on the “Login” button [9H]

### Changing a setting in the parameter menu

Click on the names of submenus and parameters to open them so that you can change the settings they contain.

Example

Making a change to PRINT PARAMETERS > Materiallength:

1. Click on “Parameter” link [9C].
2. Click on “PRINT PARAMETERS” link.
3. Click on “Materiallength” link.
4. A dialog box opens: [10].
5. Enter the required value in the entry field.
6. Click on the “Save” button.

The value is now transferred to the labeller.

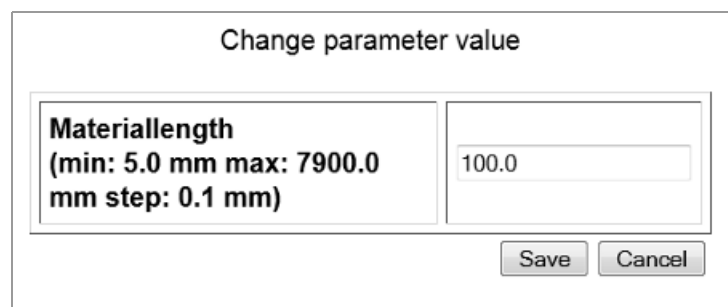

The screenshot shows a dialog box with the title "Change parameter value". Inside the dialog, there is a section for "Materiallength" with the following text: "(min: 5.0 mm max: 7900.0 mm step: 0.1 mm)". To the right of this text is an input field containing the value "100.0". At the bottom right of the dialog, there are two buttons: "Save" and "Cancel".

[10] Example: Dialog box for entering value for the parameter PRINT PARAMETERS > Materiallength

 Some parameters trigger a reset of the labeller, if they have been changed on the labeller via the operator panel. However, if any of these parameters is changed via the web server, the reset does not occur automatically. The changes only come into effect after the next time the labeller is reset. In these cases, the “Reset” button [11A] appears after the setting has been changed.

**NOVEXX SOLUTIONS**      About us      Industries      Applications      Pr

Type: ALX 926      Version: V6.60-SR1      Name: ALX92

**A** — **Some parameters were changed**     



Home

Logout

**PRINT PARAMETERS**

**INTERFACE PARA**

- >EASYPLUGINTERPR
- >COM1 PORT
- >COM3 PORT
- >COM4 PORT
- >CENTRONICS
- >NETWORK PARAM.
- >OPTIONS
- >DRIVEASSIGNMENT

**SYSTEM PARAMETER**

**PRINT PARAMETERS**

Print speed:      12.0 Inch/s

Feed speed:      16.0 Inch/s

Materialtype:      Punched

Materiallength:      160.0 mm

Materialwidth:      100.0 mm

Print direction:      Foot first

[11] Information (A): Changes made to the parameter setting do not come into effect until after a reset.

The virtual operator

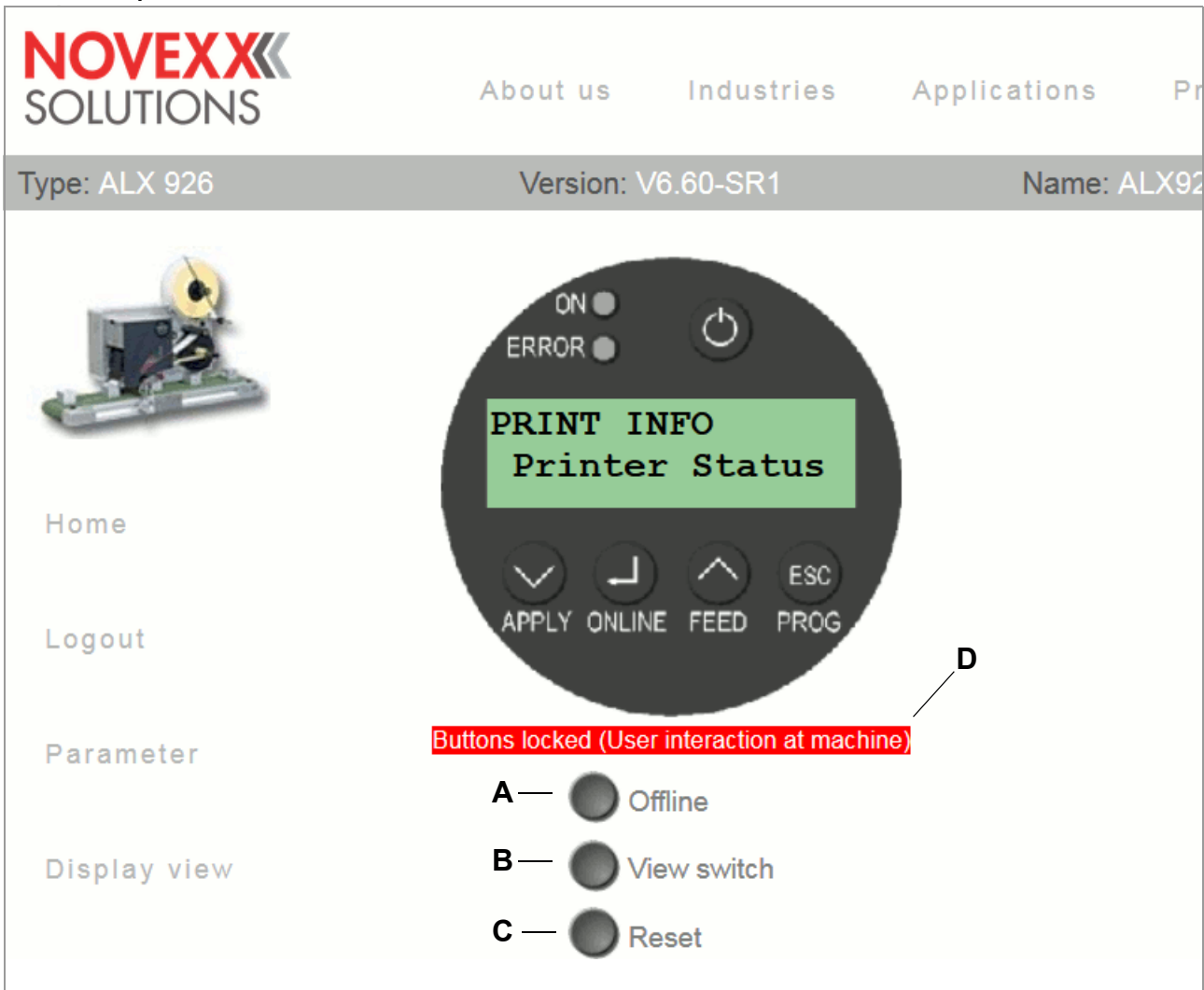

[12] The virtual operator panel

After the “Display view” link is clicked, an image of the operator panel (= virtual operator panel) appears on the screen [12]. All of the buttons on the real operator panel can also be operated by mouse-click on the virtual operator panel.

The buttons [12A-C] underneath the virtual operator panel are equivalent to key combinations on the real operator panel

- A** “Offline” button  
Sets the machine offline during dispensing mode  
Equals pressing the ONLINE button
- B** “View switch” button  
Switches into standalone mode  
Equivalent to pressing the buttons ONLINE + ESC
- C** “Reset” button  
Triggers a reset  
Equivalent to pressing the buttons APPLY + ONLINE + FEED



**D** Status line [13E]

In order to avoid putting an operating person at the machine at risk by sudden starting up of the machine, the virtual operator panel is locked as soon as a button at the machine operator panel is pressed. The status line indicates the current status:

Message	Meaning
No	A user is logged in at the virtual operator panel. The virtual operator panel is unlocked.
„Buttons locked (not logged in)“	No user is logged in at the virtual operator panel. The virtual operator panel is locked.
„Buttons locked (User interaction at machine)“	A user is logged in at the virtual operator panel. The virtual operator panel is blocked, because an operator at the machine operator panel has pressed a button Reactivate the virtual operator panel: → Switch from „Offline“ to „Online“ at the machine operator panel.

**FTP server****Applications**

The file transfer protocol (FTP) server (RFC959) enables access to the internal RAM disk and to the memory card in the card slot of the LMA/PMA (as long as there is a memory card in the slot).

In this way, files (configuration or firmware files) can be saved to the memory card or the internal RAM disk, or existing files renamed or deleted.

- ▣▣▣▣ The FTP server is multi-session compatible.
- ▣▣▣▣ The FTP server should not be heavily used during a high performance application of the labeller.

**Prerequisites**

- The printer is connected to a network
- A valid IP address is assigned to the printer (by the network administrator or by a DHCP server)
- INTERFACE PARA >NETWORK PARAM. > FTP server is set to “On”.
- A FTP client <sup>1</sup> is installed on the host computer.
- The FTP connection is *not* blocked by a firewall

**Establishing a FTP connection**

1. Note down the IP address of the printer.
  - ▣▣▣▣ The IP address is shown under INTERFACE PARA >NETWORK PARAM. > IP address
2. Start the FTP client.
3. Enter the following in the address bar:
 

```
ftp://[IP address without initial zeroes]
```

 Example: IP address = 144.093.029.047  
 Enter: ftp://144.93.29.47  
 An input field for the user name and password appears.

1) e. g. WS-FTP, Internet Explorer, Midnight Commander, Firefox

4. Enter user name and password.

A user name can be chosen at will; preset password = "avery"

Change the password under INTERFACE PARA >NETWORK PARAM. > FTP Password

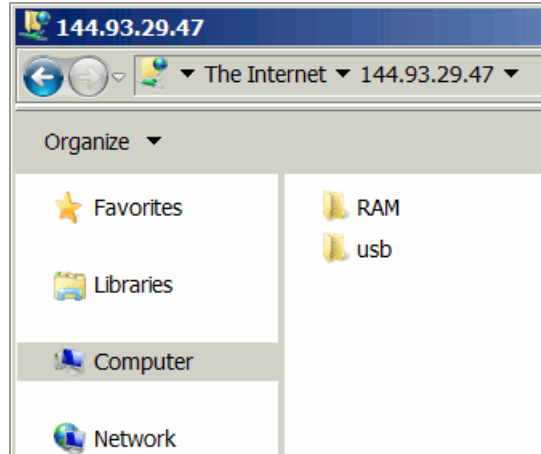

[13] User interface of the FTP server in the Windows Explorer.  
RAM = internal machine memory; usb = connected USB stick.

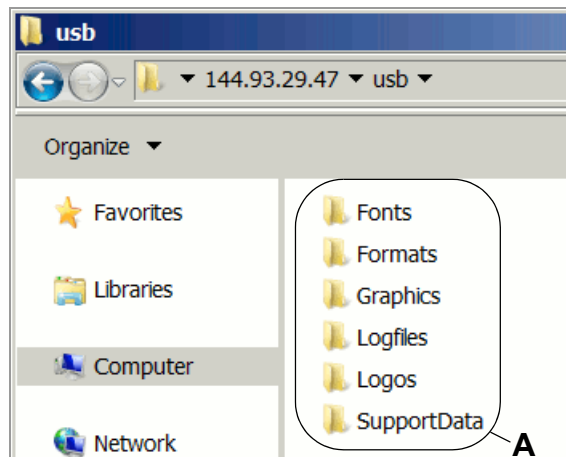

[14] Folders on the USB stick (A).

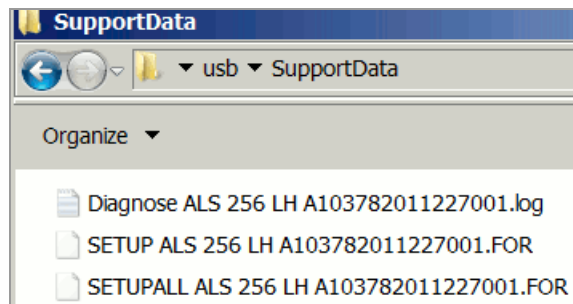

[15] Files in folder „SupportData“.

If the login was successful, separate folders appear in the FTP client, one for the internal RAM disk and one for each connected memory medium [13]:

• RAM:

The content of the RAM disk is without matter for the user.

• USB:

If one of the functions for storing setup or diagnosis data on a memory medium was already processed, the following subfolders can be found here <sup>1)</sup>:

Subfolder	Comment
Formats	<ul style="list-style-type: none"> <li>• Location for setup files (see MASCHINEN SETUP &gt; Param. speichern)</li> <li>• Location for firmware files to be uploaded in standalone mode</li> </ul>
Logfiles	Location for diagnosis files (see SERVICE/DIAGNOS. > Diagnose speich.)
SupportData	Location for setup and diagnosis files (see SERVICE/DIAGNOS. > Gen.SupportDaten) [15]
Fonts	
Graphics	Without function
Logos	

1) Depending on the applied memory medium appears SD, CF or USB.

## Data transmission with WLAN

According to standard IEEE 802.11b

### Requirements

#### Suitable printers

Printer	Firmware
AP 5.4, AP 7.t	3.00
64-xx, DPM, PEM, ALX 92x (each Gen. 3)	5.31
ALX 73x	6.36

[Tab. 20] Minimum firmware versions for use of WLAN.

#### Revision number CPU board

- AP 5.4, AP 7.t: at least 3 (A3927-03)
  - 64-xx, DPM, PEM, ALX 92x, ALX 73x: at least 4 (A6621-04)
- Displaying the revision number: SERVICE DATA > CPU BOARD DATA > CPU identifier

#### WLAN CF cards

- D-Link „DCF-660W“ (article number A7456)
- Linksys „WCF12“ (no longer available)
- Pretec „OC-WLBXX-A“ (no longer available) [16A]

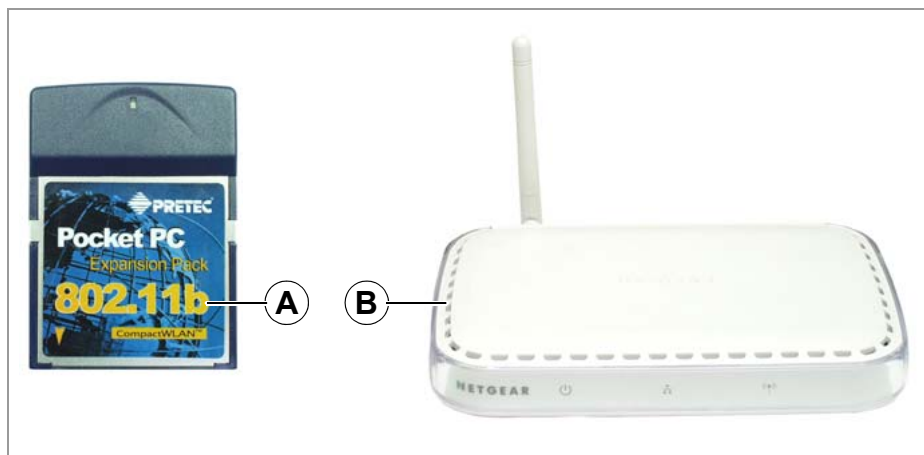

[16] WLAN CF card (A) ; Wireless Access Point (B)

#### Further requirements

- Access point according to standard IEEE 802.11b station mode „infrastructure“ (e. g. „Netgear Wireless Access Point WG602“ [16B])
- Ethernet crossed link cable (1:1 cable), to connect the access point to the host computer
- PC with operating system Windows XP

### Notes

WLAN = Wireless Local Area Network

This section describes a simple setup, with which data transmission from a host computer (e. g. PC) via an access point to a label printer can be tested. This setup doesn't suit for real network operation.

## Printer setup



CAUTION! - Network manipulations can disturb or avoid proper network operation.

→ Before connecting any device to a network, always ensure the approval of the network administrator.

1. Insert the WLAN CF card into the printers card slot. Switch the printer on.  
In the printer menu `INTERF. PARAM. > NETWORK PARAM.`, additional parameters for WLAN operation show up.

The LED at the card is flashing as long as the card is not logged in at the access point.

2. Make the following settings in the `INTERF. PARAM. > NETWORK PARAM.` menu:

Parameter	Setting	Note
IP addressassign	Fixed IP address	
IP address	e. g. 192.168.000.999	ask the network administrator for it; the initial three bytes must equal the PC address
Net mask	255.255.255.000	= default setting
WLAN SSID	idt	use lower case letters
WLAN WEP	disabled	
WLAN default key	0	or any other setting
FTP server		arbitrary setting
WEB Server		arbitrary setting

[Tab. 21] Required parameter settings in the printer menu.

3. Set parameter `INTERF. PARAM. > EASYPLUGINTERPR > Interface` to „LPD Server“.
4. Restart printer to activate the settings.

## Connecting

1. Connect the access point to the PC using a crossed link cable. Connect the access point to the mains supply and switch it on.
2. Check, if the LED at the WLAN CF card lights up permanent. If it does not, check the following points:
  - Is the card plugged firmly into the card slot?
  - Does the card match one of the supported card types?
  - Is the parameter `INTERF. PARAM. > NETWORK PARAM. > WLAN SSID` set to „idt“ (small letters!)?

## PC setup

1. In Windows XP call: *Start > Settings > System > Network*.
2. Click on *Configuration*, click the right mouse button and select *Properties*.  
Window [17] shows up.

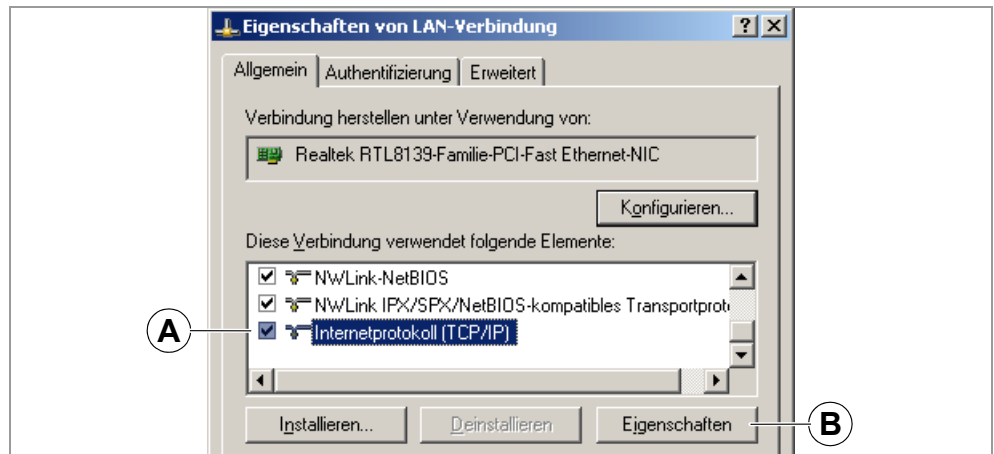

[17] „Properties of LAN connection“ window.

3. Select the item „Internet protocol (TCP/IP)“ [17A] and click on the „Properties“ button [17B].

Window [18] appears.

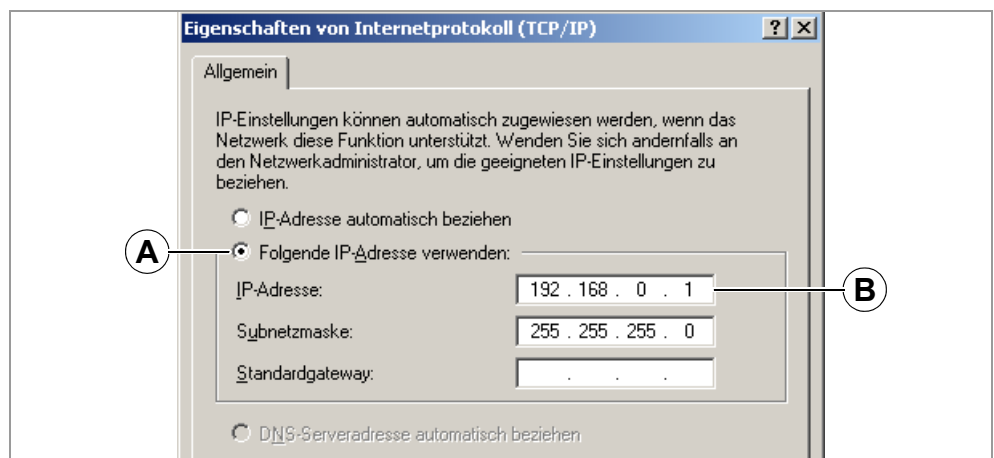

[18] „Properties of internet protocol (TCP/IP)“ window.

4. Activate the input field for fixed IP addresses [18A].
5. Ask the network administrator for suitable IP addresses. Type the IP address into field [18B] (e. g. 192.168.0.1).
6. Restart the PC to activate the settings.

## Testing the connection

1. Call the input window: *Start > Programs > Accessories > Input prompt*.
2. Enter the command „ping“ with the printers IP address, e.g. „ping 192.168.0.99“.
3. If the connection works properly, four answer lines appear in the input prompt window [19].

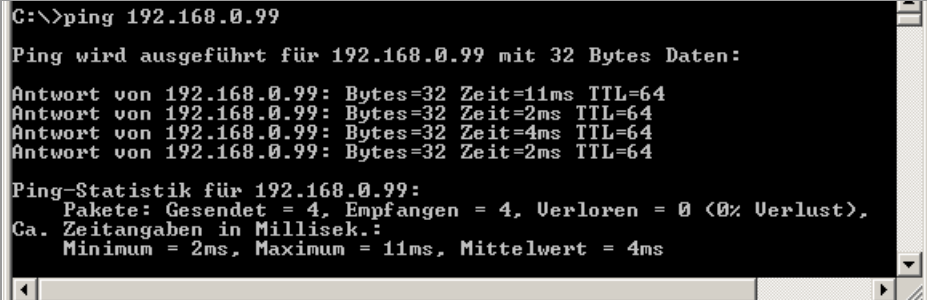

```
C:\>ping 192.168.0.99

Ping wird ausgeführt für 192.168.0.99 mit 32 Bytes Daten:

Antwort von 192.168.0.99: Bytes=32 Zeit=11ms TTL=64
Antwort von 192.168.0.99: Bytes=32 Zeit=2ms TTL=64
Antwort von 192.168.0.99: Bytes=32 Zeit=4ms TTL=64
Antwort von 192.168.0.99: Bytes=32 Zeit=2ms TTL=64

Ping-Statistik für 192.168.0.99:
    Pakete: Gesendet = 4, Empfangen = 4, Verloren = 0 (0% Verlust),
    Ca. Zeitangaben in Millisek.:
        Minimum = 2ms, Maximum = 11ms, Mittelwert = 4ms
```

[19] Input prompt window after proceeding ping with the printers IP address.

➡ As an additional test, „ping“ can also be called with the IP address of the access point. The default IP address of the Netgear WG602 is 192.168.0.227

If the printer doesn't send back an answer, the connection doesn't work properly. Measures in this case are:

- ➔ Check all the above mentioned settings.
- ➔ Contact the network administrator for advice.

## Sending a printjob

1. Have an Easy-Plug printjob ready (in this example: „test.txt“).
2. Send the printjob using the command „lpr“ [20].

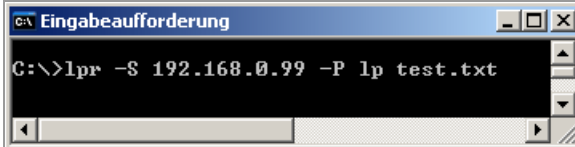

```
C:\>lpr -S 192.168.0.99 -P lp test.txt
```

[20] Sending a printjob using the lpr command

After some seconds, the printer should start printing.

➡ During data transmission, the LED at the WLAN CF card flashes.

## Storing and transferring parameter settings

### Recommendations

- Suitable printers: All printers listed in the headline, apart from the AP 4.4 (which has no card slot)
- Firmware:

Printer	Feature	Firmware version
64-xx, DPM, PEM, ALX 92x	Gen. 2	3.40
64-xx, DPM, PEM, ALX 92x	Gen. 3	5.02
ALX 73x	--	6.36
AP 5.4, AP 7.t	--	3.00
AP 5.4 Gen II, AP 5.6	MLK	7.34

[Tab. 22] Minimum firmware requirement if it is to store or transfer parameter settings.

### Application cases

Sometimes, it will be necessary to reinstall all parameter settings of a printer at a time or to transfer the settings to another printer. In those cases, the operator can save time, money and nerves by loading all the parameter settings completely. The following cases are possible:

- After a printer is being serviced, it is supposed to get the same settings as before.
- The parameter settings of one printer are supposed to be transferred to another printer of the same type.
- Several printers of the same type should be provided with the same settings.

It is advisable to read out and to store the parameter settings completely, to be able to restore them later. To do so, there are two ways:

#### Easy-Plug

Reading out via the interface by means of appropriate Easy-Plug commands. This requires sound knowledge of the command language Easy-Plug and is not further discussed here.

Further information: refer to the Easy-Plug manual, topic section [Description of commands](#) □, commands #!PG and #PC.

#### Memory card

Storing the parameter settings on a memory card in a text file („setup file“) (see description below).



### Storing settings on memory card

1. Call parameter SPECIAL FUNCTION > Store parameters <sup>1</sup>.
  - ▣▣▣▣ This parameter is only visible, if a memory card is plugged into the printer card slot.
2. Select a storing option: „With adjust para“ or „Without adj. par“.
  - „With adjust para“  
(Default setting) Parameters, which carry device specific settings, are also saved. Examples for this type of settings are the printhead resistance and the sensor settings.  
  
The relevant parameter names are marked with a „\*“ in the setup file. This option is recommended, if the settings are supposed to be reinstalled on the same printer.
  - „Without adj. par“  
Parameters, which carry device specific settings, are not saved.  
  
This option is recommended, if settings are supposed to be transferred to another printer of the same type.
3. After having chosen the storing option, the default file name is displayed (storing location: directory \FORMATS on memory card):
  - SETUPALL.FOR for storing option „With adjust para“
  - SETUP.FOR for storing option „Without adj. par“
  - ▣▣▣▣ File names and directory can be modified with the printer operation buttons or with a connected keyboard.
  - ▣▣▣▣ If a file with the given name already exists, it will be overwritten without further inquiry.

Command ID	Parameter name	Setting
#G Printer System Menu		
#PC2001/24.50	#G Head disp dist.	: 24.5 mm
#PC2002/0	#G Speed unit	: Inch/s
#PC2003/36.40	#G Foil end warning	: 36.4 mm
#PC2004/0	#G Display mode	: Job rest quant.
#PC2005/0	#G *Dispense counter	: 0
#PC2006/0	#G w/wo magazine	: with
#PC2007/0	#G Autom. dot check	: Off
#PC2008/10	#G Earliest dottest	: after 10 label
#PC2009/0	#G Latest dotcheck	: after 0 label
#PC2010/0	#G Dottestarea from	: 0 mm
#PC2011/104	#G Dottestarea to	: 104 mm
#PC2012/0	#G Print emulation	: Easyplug
#PC2013/9	#G Character Sets	: IBM

[Tab. 23] Example: Detail of a setup file.

For an example of a complete listing of a setup file, refer to .

1) Older printers: call SPECIAL FUNCTION > Parameter to CF

## Loading settings from memory card

All files with parameter settings, which are stored in the \FORMATS directory, can be read out using the standalone mode.

▣▣▣▣▣ The file extension must be „.FOR“, see [Selecting files from memory card](#) on page 10.

## Automatic setup loading

→ Save the setup file as \AUTOSTRT.FOR (in the root directory on memory card).

Loading the settings:

1. Switch the printer off.
2. Insert the memory card.
3. Switch the printer on. The setup loading starts automatically. Display text when the settings are loaded:

Switch off.  
Remove card

## Verifying Bar Codes with OLV

### System Requirements

#### Printer

- Suitable printers: 64-xx / DPM / PEM / ALX 92x.
- Printer firmware: at least version 3.30
  - ▣ With firmware v. 3.30, the OLV can only be connected to Com2, that is, the option board A2294 must be installed in the printer.

#### OLV

- SV100 with power supply, interface cable and mounting plate.

Part	Order # (RJS)
Scanner/OLV	002-7973
Installation kit with PC software and power supply	002-8107
Mounting plate with scanner bracket	002-4608

[Tab. 24] Ordering numbers of the manufacturer for the SV 100.

- Firmware version: X302
- Manufacturer: RJS [www.RJS1.com](http://www.RJS1.com) 
- Serial data cable (1:1) to connect printer and OLV.
- For use outside of the USA, a country specific power cable is required.

Cable	Order # (Novexx)
Serial cable	A1207
Power cable euro norm	90600
Power cable UK	A0635
Power cable switzerland	A0842
Power cable denmark	A3598

[Tab. 25] Accessories for the SV 100 available at Novexx Solutions

### Functional Description

An OLV is a bar code scanner, which is able to rate the scanned bar code in quality (according to ANSI grades). The OLV is placed in front of the printer, so that it can read the bar codes directly after printing [21].

- ▣ Only the OLV „SV100“ by RJS can be used.
- ▣ Only bar codes can be verified, which are printed with a rotation of 0° or 180°.

## Setup

1. Place the printer on the OLV mounting plate as illustrated.
  - ▮ Operating the OLV at a DPM / PEM / ALX 92x requires a support stand matching the respective installation situation
2. Connect the OLV to the serial interface of the printer.
  - ▮ After the printer has been switched on, initialization commands are sent to the OLV. Therefore, the OLV has first to be switched on. These initialization commands switch on the laser beam (among other things).
  - ▮ The sending of the initialization commands can be repeated at any time by pressing the Feed and Esc buttons (at the printer) simultaneously. This may be necessary, if the OLV was switched off.
3. Switch on the OLV.
4. Switch on the printer.
5. Set the printer parameter `INTERF. PARAM. > OPTIONS > OLV` option to „Serial Com1“ or „Serial Com2“, depending on the port on which the OLV is connected.
  - ▮ (Firmware 3.30: Set the printer parameter `INTERF. PARAM. > COM2 PORT > Function Option` to „Barcode OLV“.)

The data transfer parameters of the interface are automatically set to the default values required by the SV100 (115 200 baud, 8 data bits, no parity, 2 stop bits, hardware handshake).
6. Position the OLV so, that the distance between laser beam (on the label) and print-head is as short as possible.
  - ▮ For detailed information on setting the OLV please refer to the SV100 manual.
7. Set the parameters in the `OLV PARAMETERS` menu (at the printer).

Information about the parameters can be found in topic section [Info-Printouts and Parameters](#) .

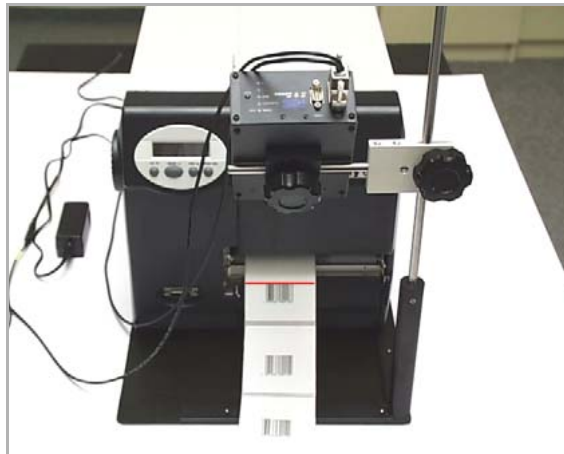

[21] 64-05 with OLV mounted (front view).

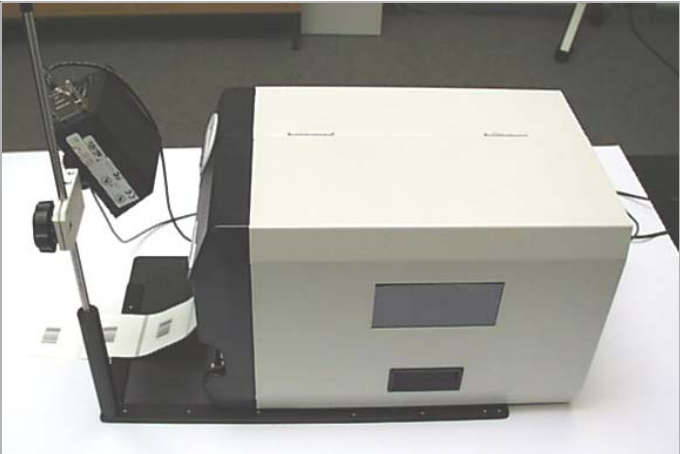

[22] 64-05 with OLV mounted (side view).

# Appendix

## Example: Setup file for AP 5.4

```

#!A1
#G Machine Setup for AP 5.4 300 Dpi Version: V3.10
#G Serial number : A424904304797
#G MAC Address : 000a.44.02.13.8c
#G Creation date : 05.05.2006 16:01

#G-----
#G Printer Parameter Menu
#G-----
#PC1001/1 #G Infeed no. : Nr. 1
#PC1002/8 #G Inf. change spd. : 8 Inch/s
#PC1003/4.0 #G Print speed : 4 Inch/s
#PC1004/4.0 #G Feed speed : 4 Inch/s
#PC1005/1 #G Materialtype : Punched
#PC1006/200.0 #G Materiallength : 200.0 mm
#PC1007/48.0 #G Materialwidth : 48.0 mm
#PC1027/0 #G Print direction : Foot first
#PC1008/0.0 #G Punch offset : 0.0 mm
#PC1009/1 #G Bar code multip. : * 1
#PC1010/0 #G UPC plain-copy : In line
#PC1011/0 #G EAN Readline : Standard
#PC1012/0 #G EAN sep. lines : With readl. only
#PC1013/0 #G Rotated barcodes : Normal
#PC1014/0 #G Cut mode : Real 1:1 mode
#PC1015/3 #G Cut speed : 3 Inch/s
#PC1016/105 #G Cut width : 105 mm
#PC1017/0.0 #G Cut position : 0.0 mm
#PC1018/0.0 #G Double cut : 0.0 mm
#PC1019/1 #G Rewind direction : Printing outside
#PC1020/0.0 #G *X - Printadjust : 0.0 mm
#PC1021/0.0 #G *Y - Printadjust : 0.0 mm
#PC1022/0 #G Punchmode : Automatic
#PC1023/128 #G Punchlevel : 128
#PC1024/30 #G Matend : 30
#G-----
#G Easyplug Interpreter
#G-----
#PC1101/2 #G Interface : TCP/IP SOCKET
#PC1102/0 #G Spooler mode : Mult. print jobs
#PC1103/1 #G *Printer ID no. : 1
#PC1104/64 #G Spooler size : 64 KBytes
#G-----
#G COM1 Port Parameter
#G-----
#PC1201/5 #G Baud rate : 9600 Baud
#PC1202/8 #G No. of data bits : 8
#PC1203/2 #G Parity : None
#PC1204/1 #G Stop bits : 1 Bit
#PC1205/0 #G Data synch. : RTS/CTS
#PC1206/0 #G Serial port mode : RS232
#PC1207/1 #G Frame error : Display

```

AP 4.4 – AP 5.4 – AP 5.6 – AP 7.t – 64-xx – DPM – PEM – ALX 92x

```

#G-----
#G COM2 Port Parameter
#G-----
#PC1302/5          #G Baud rate       : 9600 Baud
#PC1303/8          #G No. of data bits : 8
#PC1304/2          #G Parity           : None
#PC1305/1          #G Stop bits        : 1 Bit
#PC1306/0          #G Data synch.      : RTS/CTS
#PC1307/0          #G Serial port mode : RS232
#PC1308/1          #G Frame error      : Display
#G-----
#G COM3 Port Parameter
#G-----
#PC1351/2          #G Baud rate       : 9600 Baud
#PC1354/1          #G Parity           : None
#PC1356/0          #G Data synch.      : RTS/CTS
#PC1358/1          #G Frame error      : Display
#G-----
#G COM4 Port Parameter
#G-----
#PC1361/2          #G Baud rate       : 9600 Baud
#PC1364/1          #G Parity           : None
#PC1366/0          #G Data synch.      : RTS/CTS
#PC1368/1          #G Frame error      : Display
#G-----
#G Centronics Port Parameter
#G-----
#PC1401/1          #G PnP function     : On
#G-----
#G Ethernet Parameter
#G-----
#PC1501/0          #G IP Addressassign : DHCP
#PC1502/-1872945967 #G *IP address      : 144.093.028.209
#PC1503/-65536     #G *Net mask         : 255.255.000.000
#PC1504/0          #G *Gateway address : 000.000.000.000
#PC1505/9100       #G Port address      : 9100
#PC1506/0          #G Ethernet speed    : Auto negotiation
#PC1521/1          #G SNMP Agent        : Enabled
#PC1522/public#G   #G SNMP password     : public
#PC1507/1          #G FTP server        : Enabled
#PC1508/novexx#G   #G FTP Password      : novexx
#PC1509/1          #G WEB server        : Enabled
#PC1510/5          #G WEB display refr  : 5 s
#PC1511/admin#G    #G WEB admin passw.  : admin
#PC1512/supervisor#G #G WEB supervisor p.: supervisor
#PC1513/AP5.4_300dpi_02138C#G#G DHCP host name : AP5.4_300dpi_02138C
#PC1514/idt#G      #G WLAN SSID         : idt
#PC1515/0          #G WLAN WEP          : Disabled
#PC1516/1          #G WLAN default key  : 1
#PC1517/123456789aBCd123456789AbcD#G#G WLAN key 1 : 123456789aB-
Cd123456789AbcD
#PC1518/123456789aBCd123456789AbcD#G#G WLAN key 2 : 123456789aB-
Cd123456789AbcD
#PC1519/123456789aBCd123456789AbcD#G#G WLAN key 3 : 123456789aB-
Cd123456789AbcD
#PC1520/123456789aBCd123456789AbcD#G#G WLAN key 4 : 123456789aB-
Cd123456789AbcD

```

## AP 4.4 – AP 5.4 – AP 5.6 – AP 7.t – 64-xx – DPM – PEM – ALX 92x

```

#G-----
#G Options Parameter
#G-----
#PC5300/0          #G Remote Display   : Disabled
#G-----
#G Printer System Menu
#G-----
#PC2001/24.5      #G Head disp dist.  : 24.5 mm
#PC2002/0          #G Speed unit       : Inch/s
#PC2003/36.4      #G Foil end warning : 36.4 mm
#PC2060/0          #G Foil warn stop   : Disabled
#PC2004/0          #G Display mode     : Job rest quant.
#PC2005/372       #G *Dispense counter : 372
#PC2006/0          #G w/wo magazine    : with
#PC2012/0          #G Print emulation  : Easyplug
#PC2013/3          #G Character sets    : Germany
#PC2014/0          #G Character filter  : Chars >= 20Hex
#PC2015/0          #G Light sens. type : Punched
#PC2016/0          #G Head-sensor dist : 0 mm
#PC2017/50        #G Sens. punch-LS   : 50 %
#PC2018/0          #G Foil mode         : Thermo transfer
#PC2019/9.9       #G Ribb. eco. limit : 9.9 mm
#PC2058/0          #G Feed mode         : Head up
#PC2020/1          #G Turn-on mode      : Online
#PC2021/0          #G Interface delay   : 0 ms
#PC2022/1          #G Error reprint     : Enabled
#PC2023/0          #G Single-job mode   : Disabled
#PC2025/1106      #G *Head resistance  : 1106 Ohm / 12 Dot
#PC2026/20        #G Temp. reduction  : 20 %
#PC2066/1          #G Thin line emphas  : On
#PC2027/0          #G Voltage offset    : 0 %
#PC2028/1          #G Logo expansion    : Yes
#PC2029/0          #G Miss. label tol. : 0
#PC2031/1          #G Periph. device    : Cutter
#PC2032/2          #G Infeed module     : 2 infeeds
#PC2033/1          #G Singlestartquant  : 1
#PC2035/0          #G Application mode  : Save mode
#PC2036/0          #G Appl. waitpos.    : 0 mm
#PC2037/10        #G Applicator speed  : 10 Inch/s
#PC2038/0          #G Start mode        : Edge
#PC2039/0          #G Start source      : Light barrier
#PC2057/0          #G Calibration mode  : Automatic
#PC2042/0          #G External signal   : Disabled
#PC2043/0          #G Signal edge       : Falling edge
#PC2044/1          #G Apply key         : Enabled
#PC2045/99        #G Print contrast    : 99 %
#PC2046/512       #G Ram disk size     : 512 KBytes
#PC2047/256       #G Font downl. area  : 256 KBytes
#PC2048/1024      #G Free store size   : 1024 KBytes
#PC2049/2          #G Print info mode   : Compact right
#PC2050/0          #G Reprint function  : Disabled
#PC2051/1          #G Language          : English
#PC2063/1          #G Keyboard          : English
#PC2053/0          #G Access authoriz.  : Deactivated
#PC2059/80        #G Max InitFeedback  : 80 mm
#PC1026/0         #G Material feed     : for- / backwards

```



## AP 4.4 – AP 5.4 – AP 5.6 – AP 7.t – 64-xx – DPM – PEM – ALX 92x

```

#G-----
#G Peripheral Parameter Menu
#G-----
#PC2512/1          #G Rewinder Motor   : Generation 2
#PC2501/0          #G Current mode     : Table values
#PC2502/100        #G Min rew. current : 100
#PC2503/250        #G Max rew. current : 250
#PC2504/170        #G Min rew. current : 170 %
#PC2505/170        #G Max rew. current : 170 %
#PC2506/0          #G Start rew. curr.  : 0 %
#PC2507/30         #G Start cur. len.   : 30 mm
#PC2508/95         #G Pullback current : 95
#PC2509/50         #G Back diameter    : 50 mm
#PC2510/0          #G Break current    : 0
#PC2511/120        #G Break diameter   : 120 mm
#G-----
#G Dispenser Interface
#G-----
#PC3001/0          #G Interface type   : USI interface
#PC3002/0.0        #G Start delay      : 0.0 mm
#PC3003/0          #G Start print mode : Pulse falling
#PC3004/0          #G End print mode   : Mode 0
#PC3005/0          #G Reprint signal   : Disabled
#PC3006/1          #G Ribbon signal    : Enabled
#PC3007/0          #G Material signal  : Disabled
#PC3013/60.0       #G Diam. mat. end   : 60.0 mm
#PC3008/0          #G Feed input       : Standard
#PC3012/0          #G Pause input      : Standard
#PC3009/0          #G Start error stop : Off
#PC3010/1          #G Internal inputs  : Enabled
#PC3011/0          #G Apply mode       : After start sig.
#G-----
#G Textile Parameter Menu
#G-----
#PC3301/1          #G Changelabel Mode : Always at jobend
#PC3302/1          #G Changelab Print  : With print
#PC3303/10         #G Changelab Length : + 10 mm
#PC3304/1          #G Label Eject Mode : Yes, at job end
#PC3305/0          #G Head lift autom. : after 0 labels
#G-----
#G Applicator Parameter Menu
#G-----
#PC3101/0          #G Applicator type  : LTP - LTPV
#PC3102/0          #G Apply mode       : After start sig.
#PC3110/2          #G Start print mode : Pulse rising
#PC3103/0          #G Start error stop : Off
#PC3104/0          #G APSF sensor res. : 0 pulses/m
#PC3105/0.0        #G Start delay      : 0.0 mm
#PC3106/1          #G Dwell time       : 1 ms
#PC3107/1          #G Blow on time     : 1 ms
#PC3108/0          #G Restart delay    : 0 ms
#PC3109/2000       #G Position timeout : 2000 ms
#PC3212/0          #G Start error stop : Off
#G-----
#G I/O Board Parameter Menu
#G-----
#PC3201/0.0        #G Start delay      : 0.0 mm
#PC3202/0          #G APSF sensor res. : 0 pulses/m
#PC3203/0          #G Start print mode : Pulse falling
#PC3204/0          #G Reprint signal   : Disabled
#PC3205/0          #G Feed input       : Disabled
#PC3206/0          #G Pause input      : Disabled
#PC3207/0          #G Error output      : Printer error
#PC3208/0          #G Error polarity   : Level low active
#PC3209/1          #G Status output    : Low ribbon warn.
#PC3210/0          #G Status polarity  : Level low active
#PC3211/0          #G End print mode   : Mode0 inactive
#G-----

```

## AP 4.4 – AP 5.4 – AP 5.6 – AP 7.t – 64-xx – DPM – PEM – ALX 92x

## #G MLI Parameter Menu

```

#G-----
#PC4002/15          #G Darkness           : 15
#PC4003/126        #G Control Prefix    : 7EH
#PC4004/94         #G Format Prefix     : 5EH
#PC4005/44         #G Delimiter Char    : 2CH
#PC4006/0          #G Label Top         : 0 Dots
#PC4007/0          #G Left Position     : 0 Dots
#PC4009/0          #G Resolution        : 300 DPI
#PC4010/0          #G Error Indication  : OFF
#PC4011/0          #G Error Checking    : YES
#PC4012/0          #G 305 DPI Scaling   : YES
#PC4013/0          #G Image Save Path   : Internal RAM
#PC4014/1          #G Command ^PR       : Enable
#PC4015/1          #G Command ^MT       : Enable
#PC4017/0          #G Label Invert      : Disable
#PC4016/1          #G Command ^JM       : Enable

```

## #G Printer Special Menu

```

#G-----
#PC5001/1          #G *Printer type     : AP 5
#PC5002/1          #G *Printhead type   : KPA 300 DPI
#PC5004/0          #G Command sequence  : ,#G`
#PC5005/0          #G EasyPl. file log  : Disabled

```

## #G Printer Service Menu

```

#G-----
#PC5111/0          #G Spec parameter 1  : 0
#PC5112/0          #G Spec parameter 2  : 0
#PC5113/0          #G EasyPlug Monitor  : Disabled
#PC5125/0          #G EP Monitor Mode   : Interpreter data
#PC5116/127        #G *Punch adjust     : 127
#PC5117/128        #G *Reflex adjust    : 128
#PC5119/234        #G *Foil adjust      : 234
#PC5120/170        #G *Head sens adjust : 170
#PC5121/0          #G *Optn.1           : 0
#PC5122/0          #G *Optn.2 adjust    : 0
#PC5101/35         #G Matend tolerance  : 35 mm
#PC5102/0.0        #G Feed adjust       : 0.0 %
#PC5103/0.0        #G Foil feed adjust  : 0.0 %
#PC5104/0.0        #G *Punch y calibr.  : 0.0 mm
#PC5123/31775      #G *Rewinder adjust  : 31775
#PC5127/1          #G Debug interface   : Serial Com1
#PC5124/0          #G Debug mask        : 0
#PC5128/-1872945986 #G Debug IP address  : 144.093.028.190

```

## #G Module Firmware Versions

```

#G-----
#G readonly ID=30004 #G System version    : V3.10
#G readonly ID=30052 #G Peripheraldriver  : V 3 - T 3
#G readonly ID=30057 #G Intern. rewinder  : V 4 - T 36

```

AP 4.4 – AP 5.4 – AP 5.6 – AP 7.t – 64-xx – DPM – PEM – ALX 92x

```

#G-----
#G Operational Data
#G-----
#G readonly ID=30014 #G Serv. operations : 0
#G readonly ID=30015 #G Head number : 0
#G readonly ID=30016 #G Roll number : 0
#G readonly ID=30017 #G Cutter number : 0
#G readonly ID=30018 #G Head run length : 441 m
#G readonly ID=30019 #G Roll run length : 401 m
#G readonly ID=30020 #G Cuts on knife : 881
#G readonly ID=30021 #G Tot. mat. length : 401 m
#G readonly ID=30022 #G Tot. foil length : 358 m
#G readonly ID=30023 #G Total cuts : 881
#G readonly ID=30025 #G Head strobes : 3978688
#G readonly ID=30026 #G Foil diameter : 67.8 mm
#G readonly ID=30028 #G Operation time : 209 hours 46 min
#G-----
#G Power supply data
#G-----
#G readonly ID=30029 #G Type : Blue Mountain
#G-----
#G CPU board data
#G-----
#G readonly ID=30034 #G CPU identifier : 25-0
#G readonly ID=30036 #G PCB Revision : REV03
#G readonly ID=30037 #G FPGA version : 5817
#G readonly ID=30039 #G MAC Address : 000a.44.02.13.8c
#G readonly ID=30040 #G Serial number : A424904304797
#G readonly ID=30041 #G Production date : 03.08.2004
#G readonly ID=30042 #G PCB part number : A3407-03
#G readonly ID=30043 #G Board part numb. : A4249-01
#G readonly ID=30044 #G Manufacturer : Multitech Sys
#G readonly ID=30045 #G Work place : FCT Test Station
#G readonly ID=30046 #G Company name : Novexx Solutions
#G-----
#G CF card slot status
#G-----
#G readonly ID=30047 #G Card in slot : Yes
#G readonly ID=30048 #G Card typ : 3.3 Volt
#G-----
#G Internal Memory Configuration
#G-----
#G readonly ID=30010 #G Space for Jobs : 7.8 MB
#G readonly ID=30007 #G Ram memory size : 16 MB
#G readonly ID=30008 #G Flash mem size : 4 MB FUJ
#G readonly ID=30009 #G Compact flash : 32 MB
#G readonly ID=30010 #G Space for Jobs : 7.8 MB
#G readonly ID=30011 #G Max. Labellength : 1984 mm
#G readonly ID=30013 #G Default values : User defined
#G-----
#G Printer Debug Menu
#G-----
#PC5403/0 #G Pctrl communica. : Disabled
#PC5402/0 #G Variables : Disabled
#PC5400/0 #G Label generation : Disabled
#PC5401/0 #G Print handling : Disabled
#G-----
#G Execute system restart ( 217 parameters )
#G-----
#PC999999/-1#G

```



# Maintenance and Cleaning

- General Notice ..... 2
  - Maintenance by Qualified Personnel ..... 2
  - Safety ..... 2
  - Troubleshooting ..... 2
  - Ordering Spare Parts ..... 3
  - Note on Cleaning ..... 3
  - Cleaning Agents ..... 3
- Printhead ..... 5
  - Important Handling Notes ..... 5
  - Finding out the printhead resolution ..... 5
  - Cleaning the Printhead ..... 6
  - Changing the Printhead ..... 8
- Print Roller ..... 9
  - Cleaning the Print Roller ..... 9
  - Changing the Print Roller ..... 10
- Punch Sensor ..... 11
- Material guiding: setting the movability ..... 12

## General Notice

### Maintenance by Qualified Personnel

Regular technical maintenance is required to ensure that the device is always in operating order.

#### Qualifications

Maintenance work should only be carried out by qualified personnel. The safety, reliability and longevity of the device depend on correct maintenance.

▣▣▣▣ Persons causing damage as a result of unqualified maintenance, repair and care are liable for these costs.

#### Manufacturer Service

For reliable maintenance, servicing, diagnosis and troubleshooting, please contact your supplier, nearest dealer or another service supplier authorized by the manufacturer.

### Safety



#### WARNING!

Maintenance and cleaning may result in hazardous situations. Accidents can occur by mechanical or electrical means if safety instructions are not observed!

→ Turn off the device and disconnect the power cable prior to cleaning or maintenance work!

→ On no account should liquid be allowed to enter the device!

→ Do not use any of kind of spray directly on the printer! Moisten a cloth with a cleaning agent to clean the device!

→ Repairs to the printer may only be carried out by a trained service technician!

### Troubleshooting

#### Status

If device malfunctions occur, analyze the device messages first. Please read the relevant chapter contained in this documentation.

#### Calling for Service

If you are not authorized to carry out a diagnosis and repair of problems, please call your technician or authorized service supplier. The service personnel have the required information and replacement parts to correctly carry out the repairs.

### Ordering Spare Parts



CAUTION! - Using parts that do not meet the manufacturer’s high standards may damage the machine.

→ Only use original spare parts supplied by the manufacturer.

The following information is required when ordering spare parts:

#### Order Specifications

- Model
- Device serial number
- Optional device configuration
- Description and part number of the spare part
- Number of parts required

### Note on Cleaning

#### Frequency of Care

Frequent maintenance and cleaning is required to ensure that the device operates safely and provides a high level of performance. The frequency with which maintenance checks are required depends on operating and environmental conditions, the length of operation daily, and the print media used.

▣ In particular, the printhead and feed roller need to be checked regularly for paper, adhesives and ink residues.

### Cleaning Agents



CAUTION!

The printer can be damaged by aggressive cleaning agents.

→ Do not use any cleaning agent that could damage or destroy the resin surface, labelling, display, nameplates, electrical components, etc.

→ Do not use any cleaning agents that are abrasive or solvent to plastics. Avoid acid or alkaline solutions.

Dirty component	Cleaning agent	Order number
Printhead	Printhead Cleaning pen [1A]	95327
	Cleaning paper	5030
	Ethyl or isopropyl alcohol	
Print roller and other rubber rollers	Roller cleaner [1B]	98925
Metal deflection axis or -guide tube	Cleaning fuel	
	Label remover	90073
External parts	Common neutral cleaning liquid	

[Tab. 1] Recommended cleaning agents.



[1] Printhead cleaning pen (A) and roller cleaner (B).

## Printhead

### Important Handling Notes



#### CAUTION!

Printhead can be damaged.

- Protect the printhead [1] from electrostatic discharges when performing maintenance work or cleaning.<sup>a</sup>
- Do not touch the thermal edge [1C].
- Do not use sharp or hard objects to clean the printhead.

a) If you do not have any professional ESD protection equipment (ESD wristband, ESD shoes, ...): place one hand on an earthed object near to you (e.g. a radiator) before touching the device, to discharge any static charge your body may be carrying.

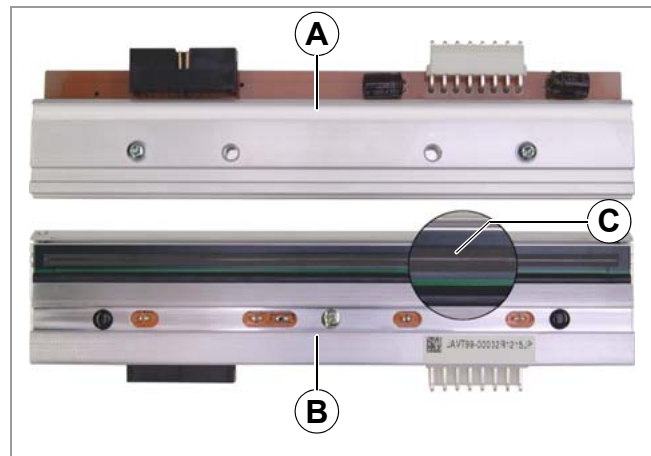

[1] Printhead viewed at from the top (A) and bottom (B).

### Finding out the printhead resolution

By means of the resistance values given in the following table, it can be determined if the printhead has a resolution of 8.0 or 11.8 Dot/mm. Resolution value: see label on the printhead.

Resolution	Resistance
8.0 Dot/mm	560-760 Ohm
11.8 Dot/mm	960-1300 Ohm



## Cleaning the Printhead



### WARNING!

Risk of burning injuries from a hot printhead.

→ Ensure that the printhead has cooled down before cleaning it.

Impurities such as lint and color particles from the thermotransfer foil may collect on the printhead during printing. This can lead to a noticeable detrimental effect on the printed image, shown by:

- Differing contrast on the labels
- Light stripes in the printing direction

▮ Clean printhead regularly to ensure optimal print head condition.

### Cleaning intervals

- Thermal transfer printing: after each used up ribbon roll
- Direct thermal printing: after each used up label roll

### Preparation

1. Switch off the printer.
2. Open the printhead pressure lever. The printhead folds upwards.
3. Remove material and foil from the printer.

### Cleaning with a cleaning pen

→ Applying light pressure, go over the thermal edge [2B] a few times with the cleaning pen [2A].

Cleaning pen: see chapter [Cleaning Agents](#) on page 3.

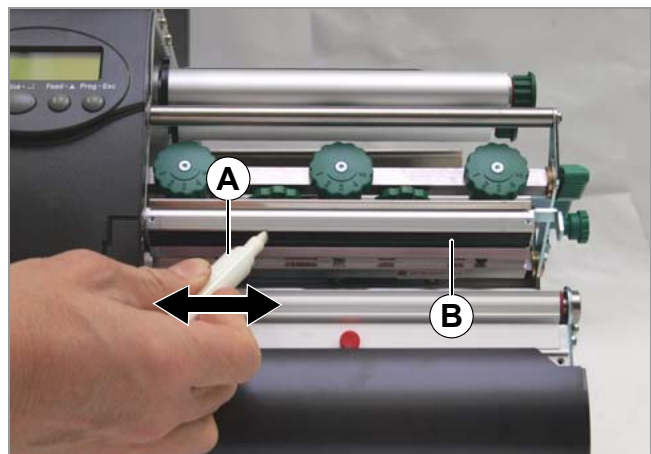

[2] Cleaning the thermal edge with a cleaning pen (A).

### Cleaning with cleaning paper

1. Cut a strip of cleaning paper matching the printhead width.
2. Insert the cleaning paper [3A] into the printer with the rough side facing upwards.
3. Close the pressure lever.
4. Move the cleaning paper back and forth repeatedly [3].

Cleaning paper: see chapter [Cleaning Agents](#) on page 3.

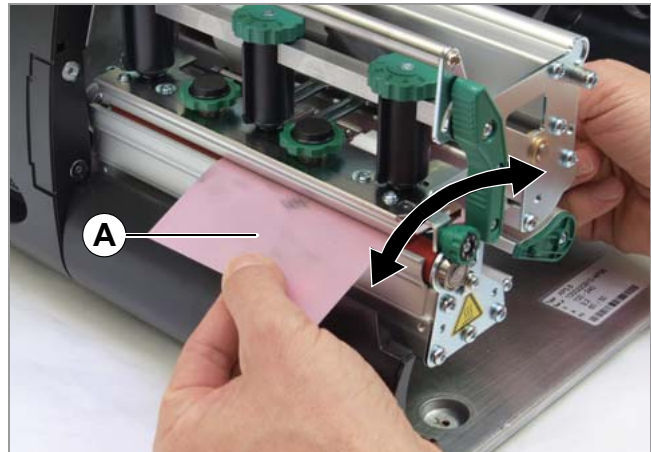

[3] Cleaning the thermal edge with cleaning paper (A).

### Cleaning with alcohol



#### CAUTION!

Risk of fire due to a flammable liquid.

- Observe the safety instructions on the alcohol bottle.
- Don't smoke.

⚠️ Only use alcohol-based solvents<sup>1</sup> when the other two cleaning agents are not available!

→ Moisten a lint-free cloth with alcohol; wipe the thermal edge with the cloth.

→ Allow printhead to dry for several minutes.

1) For example ethyl or isopropyl alcohol.

## Changing the Printhead



### WARNING!

Risk of burning injuries from a hot printhead.

→ Ensure that the printhead has cooled down before cleaning it.



### CAUTION!

Printhead misalignment.

→ Don't loosen the screws [4C] fixing the printhead on the bracket.

Dismantling the printhead:

1. Switch off the printer and disconnect from the power.
2. Remove material and foil from the printer.
3. Open the pressure lever.
4. Press the printhead onto the print roller. At the same time remove the 2 knurled screws [5A].

The printhead is released from the fastener and remains on the print roller [6].

5. Remove both printhead cables [7A] from the printhead.
6. Remove the printhead.

Fitting the printhead:

1. Note the resistance of the new printhead. You can read this on a sticker directly on the printhead!
2. Affix the printhead cable.
3. Press the printhead against the fastener from below and tighten the knurled screws.
  - ⚠ Don't touch the thermal bar while doing so!
4. Call up the parameter `SYSTEM PARAMETERS > Head resistance` and enter the printhead resistance you noted earlier.

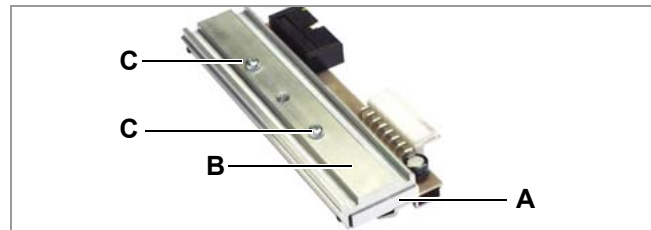

[4] Printhead (A) and bracket (B) were adjusted exactly by means of special positioning tools.

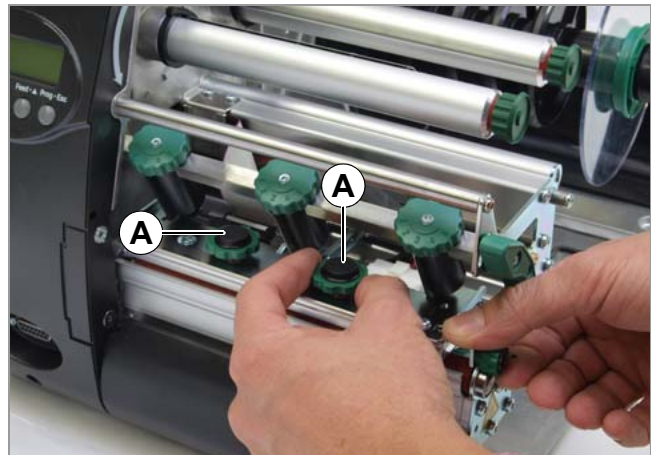

[5] Turning out the thumb screws (A).

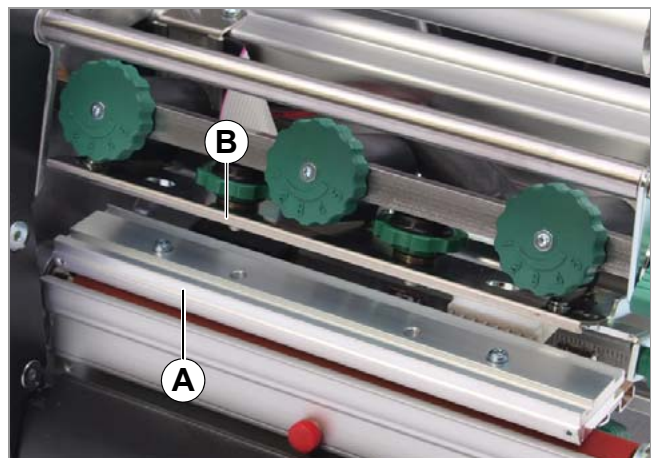

[6] Printhead (A) removed from the holder (B).

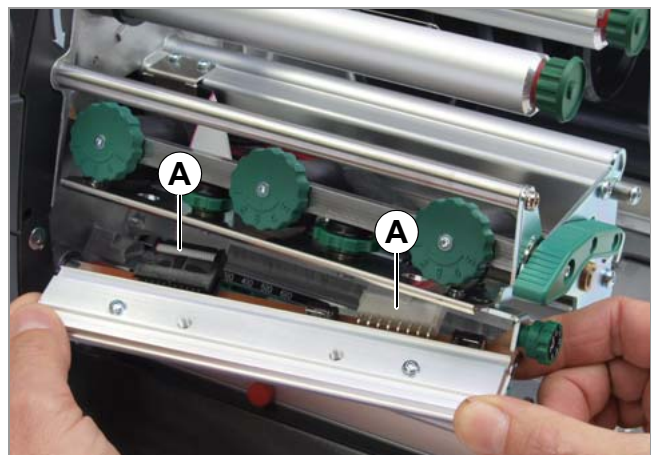

[7] Pulling off the printhead cables (A).

## Print Roller

### Cleaning the Print Roller



#### WARNING!

Risk of burning injuries from a hot printhead.

→ Ensure that the printhead has cooled down before cleaning it.

Contamination on the print roller can degrade the quality of the print and the transport of the material.

1. Switch off the printer and disconnect from the power
2. Remove material and foil from the printer.
  - ▮▮▮ You can access the print roller more easily if you remove the tear-off edge [8A] beforehand.
3. To do this, unfasten the screw [8B] in the middle of the tear-off edge. Remove the tear-off edge [9].
4. Moisten a lint-free cloth with roller cleaner and wipe the printer roller [10]. Gradually rotate the roller until it is completely clean.
5. Refit the tear-off edge.

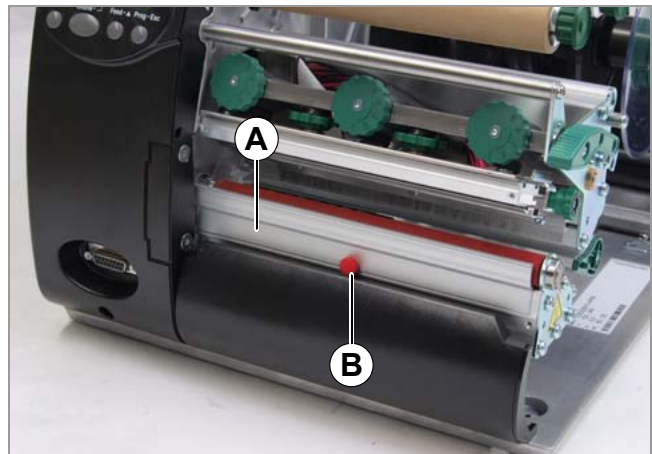

[8] Abreißkante (A) am AP 5.6.

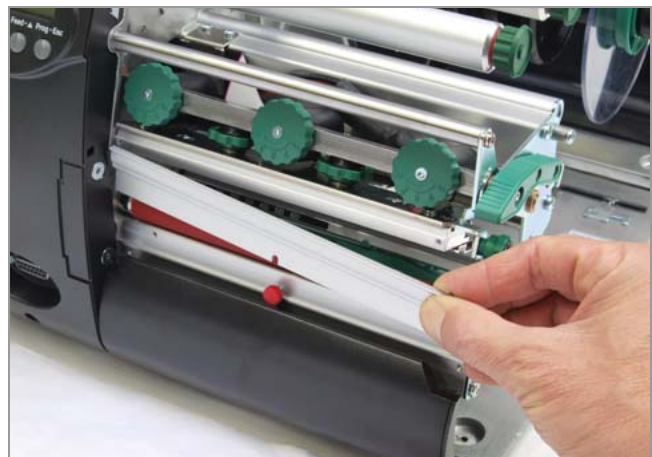

[9] Abreißkante abnehmen.

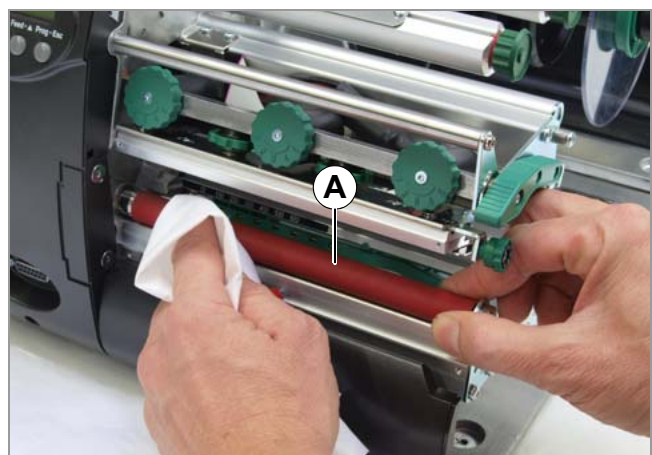

[10] Druckwalze abwischen.

## Changing the Print Roller



### WARNING!

Risk of burning injuries from a hot printhead.

→ Ensure that the printhead has cooled down before cleaning it.

### Tool

2,5 mm hex screwdriver (comes with the printer).

### Disassembly:

1. Switch off the printer and disconnect from the power.
2. Remove material and foil from the printer.
3. Unfasten the screw [11B] in the middle of the tear-off edge [11A]. Remove the tear-off edge.
4. Release the set screw [11C].
5. Remove the print roller sideways [12].

### Fitting:

1. Push the print roller through the external bearing plate.  
The printer roller axle is flattened on the end.
2. Place the axle in the socket [12B] and gently rotate until the flat part [12C] of the axle is under the set screw.
3. Press the print roller firmly into the socket.  
▶▶▶ Ball bearing [13B] and bearing plate [13A] must flush on the inner side!
4. Fasten the set screw.

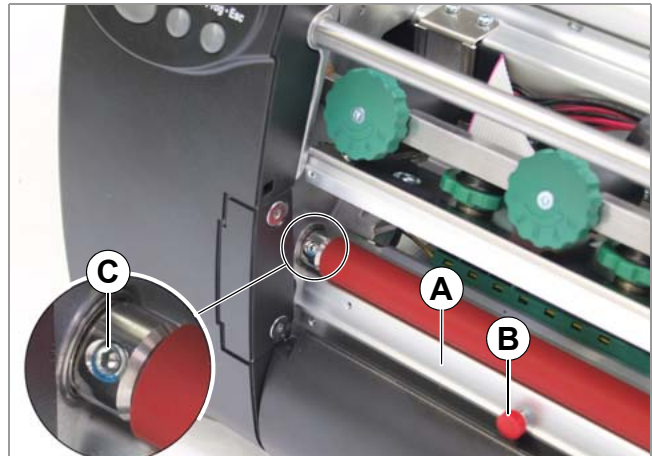

[11] Print roller at an AP 5.6.

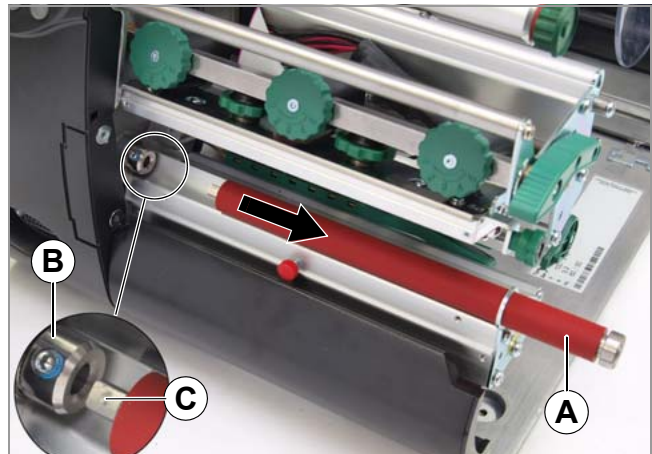

[12] Pull out the print roller (A).

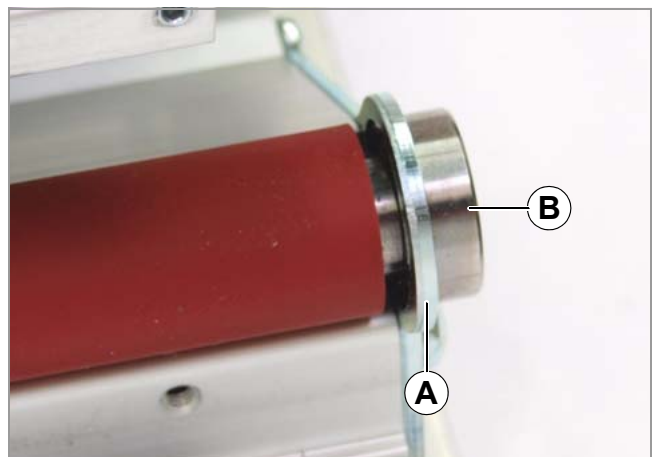

[13] The ball bearing (B) and bearing plate (A) must flush at the inner side.

## Punch Sensor

During printing the punch sensor can become contaminated with lint. Large amounts of dirt can lead to problems with perforation recognition.

To free the punch sensor from dust and abraded particles:

1. Remove the cover [14A] gently and swivel downwards.
2. Remove the sensor arm [15A].
3. Clean the opening [15B] with compressed air.



### CAUTION!

Label sensor can be damaged.

→ Do *not* use sharp or hard objects or solvents to clean the label sensors.

▮▮▮ The light transmission sensor is situated in the upper and the lower part of the sensor arm on a level with the indicator [15C]. The reflex sensor is situated about 5 mm further out in the lower part.

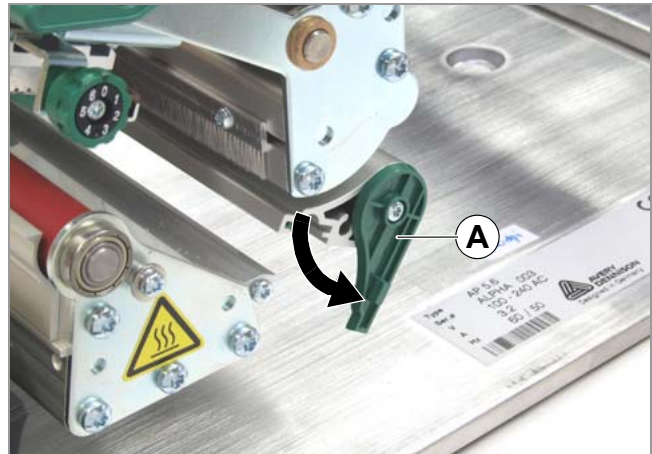

[14] Open the cover (A).

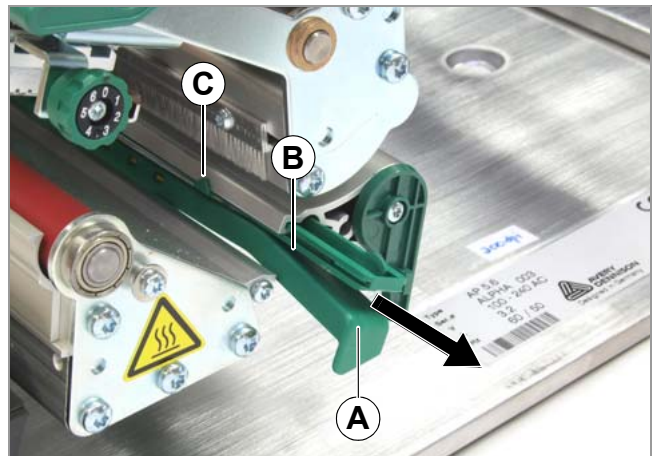

[15] Pull out the label sensor fork (A)..

## Material guiding: setting the movability

### Tools

Torx screwdriver of size 10 (supplied with printer) [17B]

If the material guiding [16A] shifts during the printing, the sliding friction has to be increased:

1. Unscrew the cover [17C].
2. Tighten the set screw [17A] in the material guide to increase the driving force.
3. Check the movability of the material guide. If necessary, repeat step 2.
4. Reassemble the cover.

▮▮▮▮ Adjusting the friction according to the factory settings: see service manual, topic section „Service Mechanics“, chapter „Material transport“, [Adjusting the friction of the material guide](#) □ on page 24.

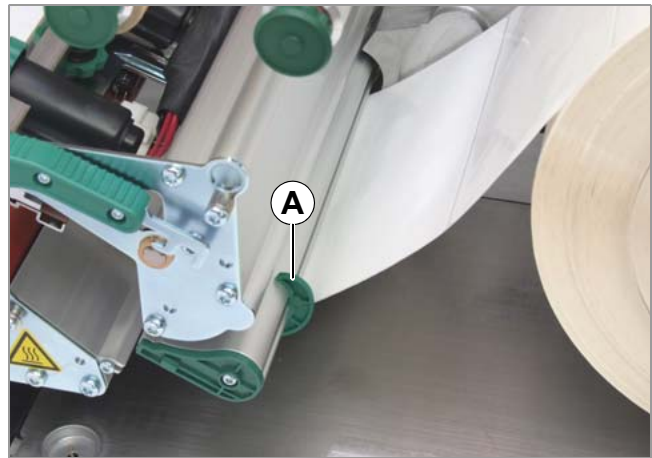

[16] Adjusting the material guide (A).

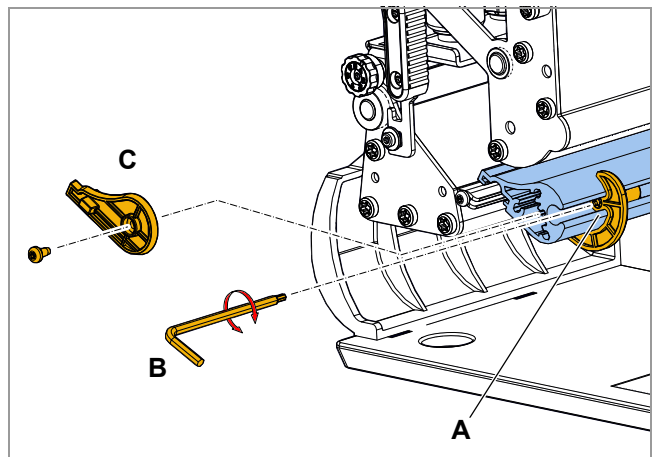

[17] Tighten the set screw (A) to increase the driving force.



# Info Printouts & Parameters

- General Information ..... 5
  - Important setting instructions ..... 5
  - Area of application ..... 5
- Operating the parameter menu ..... 7
  - Example ..... 7
  - Parameter Menu ..... 8
- Overview Parameter Menus ..... 9
  - Understanding the Parameter Overviews . 9
  - AP 5.4 all parameters ..... 10
  - AP 5.4/5.6 operator parameters ..... 13
- Alphabetical Parameter List ..... 14

## PRINT INFO

- Printer status ..... 17
- Memory status..... 18
- Font status ..... 19
- Flashdata status..... 22
- Service Status ..... 23
- Dottest endless ..... 24
- Dottest punched ..... 24
- Reference label ..... 25
- RFID Status..... 26

## PRINT PARAMETERS

- Print speed ..... 27
- Feed speed ..... 27
- Material type ..... 28
- Material length..... 28
- Material width ..... 28
- Print direction ..... 29
- Punch offset ..... 29
- Bar code multip. .... 30
- Tradit. Imaging ..... 30
- UPC plain-copy ..... 31
- EAN Readline..... 31
- EAN sep. lines..... 31
- Dispense Mode ..... 31
- Dispenseposition..... 33
- Cut mode ..... 34
- Cut speed..... 36
- Cut position ..... 36
- Double cut ..... 36

- Cut width ..... 37
- Rewind direction ..... 37
- Rotated Barcodes ..... 37
- X - Printadjust ..... 38
- Y – Printadjust ..... 38
- Punch mode..... 38
- Punch level ..... 39

## INTERFACE PARA

### > EASYPLUGINTERPR

- Interface..... 40
- Spooler mode ..... 40
- Printer ID No..... 41
- Spooler size ..... 41
- Offline mode ..... 41
- Interface delay ..... 41

### > COM1 PORT

- Baud rate ..... 42
- No. of data bits..... 42
- Parity..... 42
- Stop bits..... 42
- Data synch..... 43
- Frame error..... 43

### > COM3 PORT

- Baud rate ..... 43
- No. of data bits..... 43
- Parity..... 43
- Stop bits..... 44
- Data synch..... 44
- Frame error..... 44
- Serial Port Mode ..... 44

### > COM4 PORT

- Baud rate ..... 45
- No. of data bits..... 45
- Parity..... 45
- Stop bits..... 45
- Data synch..... 45
- Frame error..... 45

### > USB

- USB select..... 46



> NETWORK PARAM.

IP address assign..... 46  
 IP address ..... 46  
 Net mask ..... 46  
 Gateway address ..... 47  
 Port address ..... 47  
 Ethernet speed ..... 47  
 MAC address ..... 47  
 SNMP agent ..... 47  
 SNMP password ..... 47  
 FTP server ..... 48  
 FTP password ..... 48  
 WEB server ..... 48  
 WEB display refr ..... 49  
 WEB admin passw. .... 50  
 WEB supervisor p. .... 50  
 WEB operator p..... 51  
 Time client ..... 51  
 Time server IP ..... 52  
 Sync. interval..... 52  
 Time zone ..... 52  
 DHCP host name ..... 52  
 > OPTIONS  
 RFID Option ..... 53  
 StandAlone Input..... 53  
 #VW/I Interface ..... 54  
 > DRIVEASSIGNMENT  
 Drive C ..... 54

SYSTEM PARAMETER

Foil end warning ..... 55  
 Foil warn stop ..... 55  
 Print Interpret. .... 55  
 Character sets ..... 56  
 Character filter ..... 57  
 Light sens. type ..... 57  
 Head-sensor dist. .... 57  
 Foil mode ..... 57  
 Turn-on mode ..... 58  
 Error reprint ..... 58  
 EasyPlug error ..... 58  
 Single job mode ..... 58  
 Head resistance ..... 59

Temp. reduction ..... 60  
 Thin line emphas ..... 60  
 Voltage offset..... 60  
 Miss. label tol..... 60  
 Gap detect mode ..... 61  
 Periph. device ..... 61  
 Singlestartquant..... 62  
 External signal ..... 62  
 Print contrast..... 62  
 Ram disk size ..... 63  
 Font downl. area ..... 63  
 Free store size ..... 64  
 Print info mode ..... 65  
 Reprint function..... 65  
 Language..... 65  
 Keyboard ..... 66  
 Access authoriz. .... 66  
 Realtime clock ..... 67

DISPENSER PARA

Dispense Mode..... 68  
 Dispenseposition ..... 69  
 Display mode ..... 70  
 Dispense counter..... 70  
 Application mode ..... 70  
 Start source ..... 71  
 Calibration mode..... 71  
 Start offset ..... 71  
 Start error stop..... 72  
 Product length..... 72  
 Current mode..... 72  
 Min. rew. current..... 73  
 Max. rew. current ..... 73  
 Start rew. current ..... 74  
 Start cur. len. .... 74  
 Pullback current..... 74  
 Back diameter..... 75  
 Brake current ..... 75  
 Brake diameter ..... 75

REWINDER PARA

Rewind direction ..... 76  
 Current mode..... 76

Min. rew. current .....	76
Max rew. current .....	76
Start rew. curr.....	76
Start cur. len.....	77
Pullback current .....	77
Back diameter .....	77
Brake current.....	77
Break diameter.....	77

## I/O BOARD

Start print mode.....	78
Reprint Signal.....	78
Feed input .....	79
Pause input .....	79
Error output .....	79
Error Polarity .....	80
Status output.....	80
Status polarity .....	80
End print mode.....	81

## ZPL PARAMETERS

Darkness .....	82
Control Prefix .....	82
Format Prefix.....	82
Delimiter Char .....	82
Label Top .....	83
Left Position .....	83
Manual Calibrate .....	83
Resolution .....	83
Error Indication .....	84
Error Checking .....	84
Image Save Path.....	84
Command ^PR.....	84
Command ^MT.....	84
Label Invert .....	85
Command ^JM.....	85
Command ^MD/~SD.....	85

## SPECIAL FUNCTION

Printer type.....	86
Default Values.....	86
Command sequence .....	86
Delete job.....	86

Delete spooler.....	86
Factory settings .....	87
Custom defaults.....	87
Store Parameters.....	87
Store Diagnosis .....	88
Gen.Support Data.....	88
EasyPl. file log .....	88
Log files delete.....	89
Data blocks del. ....	89
RFID stat. del. ....	90

## SERVICE FUNCTION

Service.....	91
Head exchange.....	91
Roller exchange.....	91
Cutter exchange .....	91
Serv. data reset .....	92
EasyPlug monitor.....	92
EP Monitor Mode .....	92
Sensor adjust.....	92
Sensor test .....	93
Cutter test .....	93
Matend adjust.....	93
Matend tolerance .....	93
Feedadjust label .....	94
Feed adjust.....	94
Punch y calibr. ....	94
Memory card test.....	94
Send test .....	96
Receive test.....	97
Printtest.....	97
Rewinder adjust.....	97
Rewinder values .....	98

## SERVICE DATA

### > MODULE FW VERS.

System version .....	99
System revision .....	99
System date.....	99
Bootloader .....	99
uMon.....	99
Peripheraldriver .....	99
Intern. rewinder.....	100

<b>&gt; OPERATION DATA</b>		PCB revision.....	103
Serv. operations .....	100	FPGA version .....	103
Headnumber .....	100	MAC address.....	103
Roll number.....	100	Serial number .....	103
Cutter number .....	100	Production date.....	104
Head run length.....	100	PCB part number .....	104
Roll run length .....	101	Board part numb.....	104
Cuts on knife .....	101	Manufacturer.....	104
Tot. mat. length .....	101	Work place.....	104
Tot. foil length.....	101	Company name .....	104
Total cuts.....	101	<b>&gt; DISPLAY DATA</b>	
Head strobes.....	101	Display version .....	104
Head temperature .....	102	Display SerialNr .....	105
Foil diameter .....	102	<b>&gt; MEMORY DATA</b>	
Dispensing cycl. ....	102	Ram memory size.....	105
Operation time.....	102	Flash mem size.....	105
<b>&gt; POWERSUPPLYDATA</b>		SD card.....	105
Type .....	103	USB stick .....	105
PS temperature .....	103	Space for Jobs.....	106
<b>&gt; CPU BOARD DATA</b>		Max. Labellength .....	106
CPU identifier .....	103	Default values.....	106

# General Information

## Important setting instructions

Starting in offline mode, you get to the parameter menu by pressing the prog button. There you can set/alter the different parameters of the printer and activate/deactivate options.

Many Parameters provide a range within the setting can be changed with a standard step width. By this step width, the setting is changed, if the Cut-(Apply-) or Feed button is pressed once.

▣▣▣▣► The step width can be increased ten times, if the Online button is pressed simultaneously (Cut+Online or Feed+Online).

▣▣▣▣► Wait at least 10 seconds between switching the device off and on again, otherwise any modified parameter settings are not saved.

▣▣▣▣► With some parameters, false settings can result in the device being damaged (e. g. if the print head temperature is too high). Data and/or print orders are also deleted during formatting and with other settings.

▣▣▣▣► Pay attention to the corresponding notes in the following description to ensure that no damage occurs!



## Area of application

The description counts for all devices listed in the headline of this document. All status printouts and parameters are described in the same order as they *may appear* in the parameter menu of the respective printer.

▣▣▣▣► Not all of the parameters appear in each of the listed printers!

At the beginning of each parameter description can be found information about the availability of the parameter:

AP 5.4      AP 5.6
▣▣▣▣► Only with installed I/O board.

Fig. 1: At the beginning of each parameter description, the availability of the parameter is specified: Between the two lines is a list of the concerned printer types; the remark below (arrow) quotes further conditions.

If a parameter appears in the menu of a certain printer type or not, depends on the following, which can be read from this bar:

- The *printer type*:  
Printers, which have the parameter available in the parameter menu, are listed between the lines. Example (see fig. 1): AP 5.4, AP 5.6.
- The configuration with *options* and/or certain *parameter settings*:  
Example (see fig. 1): The parameter only appears in the menu of an AP 5.4/5.6, if the device is equipped with an board. If the remark is not assigned to a special printer type, it is valid for all listed printers.

**Firmware**

This description applies to all printers which are equipped with the following firmware version:

7.60

- The paragraph „Overview Parameter Menues“ in this topic section contains an overview of all available parameters of the respective printer.

## Operating the parameter menu

The illustrations on the following pages clarify the operating principle of the parameter menu. The return path shown on the left of the screen, called up using the Prog. button, also applies for parameters in the middle of the screen.

### Setting values

The setting of a parameter always follows this scheme:

1. Select the parameter.
2. Press the Online button.
3. Set the parameter to the intended value by pressing the Cut or Feed button.
4. Confirm by pressing the Online button.

### Example

Setting the parameter `PRINT PARAMETERS > Material type` to punched material.

1. Press prog button.

OFFLINE 0 JOBS	Initial state: off-line mode
----------------	------------------------------

2. Press prog button.

PRINT INFO
------------

3. Press cut button.

PRINT PARAMETERS
------------------

4. Press online button.

PRINT PARAMETERS Print speed	First parameter in the <code>PRINT PARAMETERS</code> menu.
---------------------------------	--

5. Press cut button repeatedly, until the following is displayed:

Material type Endless
--------------------------

6. Press feed button.

Material type Punched	Setting the parameter to the intended value by pressing the Cut or Feed button.
--------------------------	---

7. Press online button.

PRINT PARAMETERS Material type	Confirm with Online button.
-----------------------------------	-----------------------------

8. Press prog button 2x.

OFFLINE 0 JOBS	"Way back" by pressing the Prog button.
----------------	---

### Parameter Menu

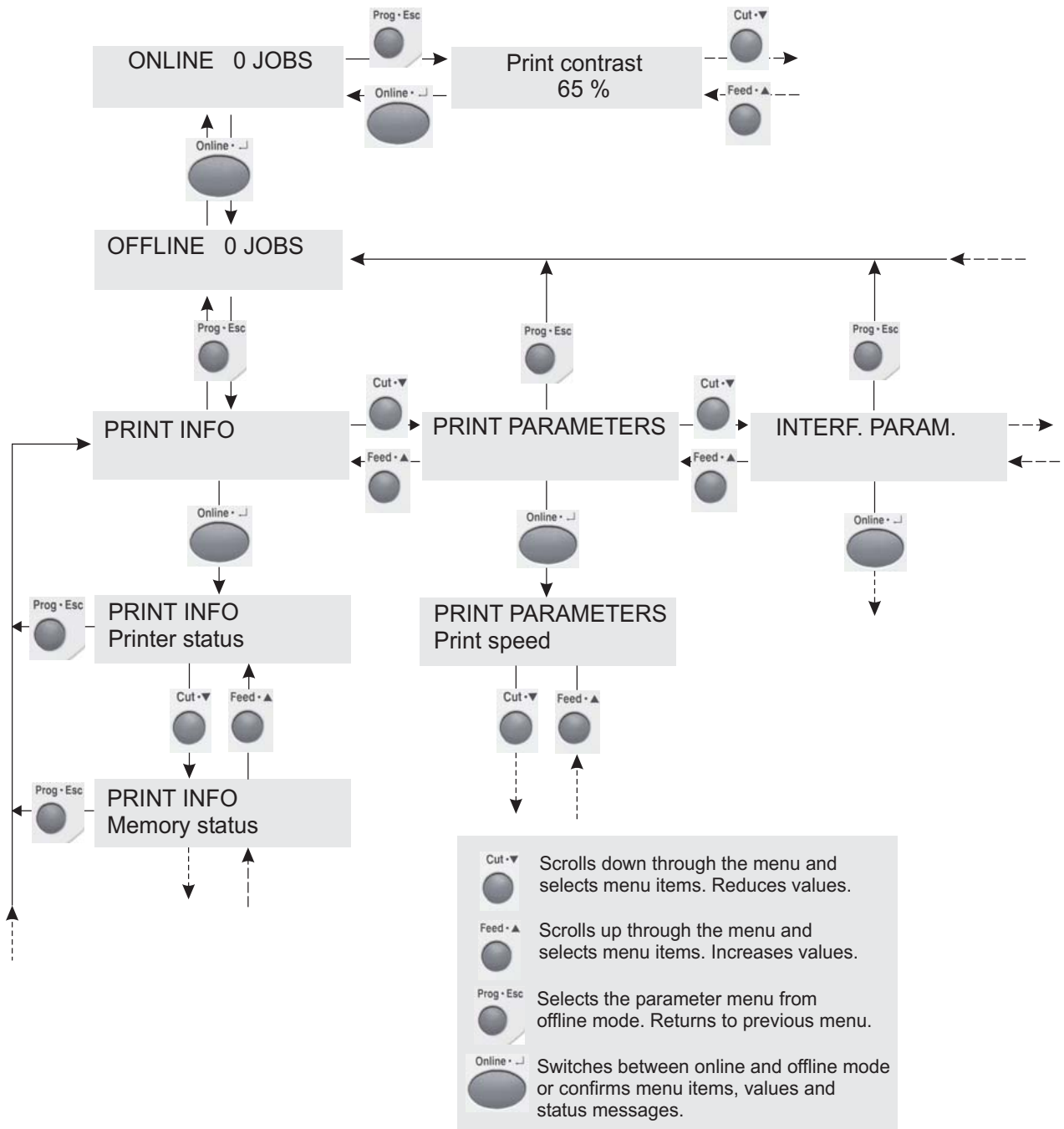

Fig. 1: Guideline through the parameter menu. Start into it by pressing the Prog button in off-line mode.

## Overview Parameter Menus

### Understanding the Parameter Overviews

The charts in the following show all of the parameters implemented in the printer firmware. Some parameters are only visible in the parameter menu under specific preconditions. These parameters are provided with a gray background and a digit at the right column edge. The digit refers to a footnote describing the precondition under which the parameter is visible.



AP 5.4 Gen II – AP 5.6

PRINT INFO	PRINT PARAMETERS	INTERFACE PARA	(INTERFACE PARA cont.)	(INTERFACE PARA cont.)	SYSTEM PARAMETER
Printer status	Print speed	> EASYPLUGINTERPR	Parity	DHCP host name	Foil end warning
Memory status	Feed speed	Interface	Stop bits		Foil warn stop
Font status	Material type	Spooler mode	Data synch.	> OPTIONS	Print Interpret.
Flashdata status 4	Material length	Printer ID No.	Frame error	RFID Option	Character sets
Service status	Material width	Spooler size		StandAlone Input	Character filter
Dottest endless	Print direction	Offline mode	> USB	#VW/I Interface	Light sens. type
Dottest punched	Punch offset	Interface delay	USB select		Head-sensor dist 13/14
Reference label	Bar code Multi.			> DRIVEASSIGNMENT	Foil mode
RFID status 22	Tradit. Imaging 13	> COM1 PORT	> NETWORK PARAM.	Drive C	Turn-on mode
	UPC plain-copy	Baud rate	IP Addressassign	Drive D	Error reprint
	EAN Readline	No. of data bits	IP Address		EasyPlug errors
	EAN sep. lines	Parity	Net mask		Single job mode
	Cut mode 6	Stop bits	Gateway address		Head resistance
	Cut position 6	Data synch.	Port address		Temp. reduction
	Double cut 6	Frame error	Ethernet speed		Thin line emphas 13
	Rewind direction 5		MAC address		Voltage offset
	Rotated barcodes	> COM3 PORT 23	SNMP agent		Miss. label tol.
	Dispenseposition 8	Baud rate 23	SNMP password 13		Gap detect mode
	X – Printadjust	No. of data bits 23	FTP server		Periph. device
	Y – Printadjust	Parity 23	FTP password 13		Singlestartquant
	Punch mode	Stop bits 23	WEB server		External signal
	Punch level 12	Data synch. 23	WEB display refr 1		Start print mode 24
		Serial Port Mode 23	WEB admin passw. 13		Print contrast
		Frame error 23	WEB supervisor p. 13		Ram disk size
			Time client		Font downl. area
		> COM4 PORT	Time server IP 3		Free store size
		Baud rate	Sync. intervall 3		Print info mode
		No. of data bits	Time zone 3		Reprint function

1. Only with INTERF.PARAM. > NETWORK PARAM. > WEB Server = „enabled“ 2. Only with BLDC firmware version V4-T36 or higher 3. Only with INTERF.PARAM. > NETWORK PARAM. > Time client = „Enabled“ 4. Only with at least one data block stored in the flash memory 5. Only with rewinder 6. Only with cutter 7. Only with „AP 5.4 peripheral“ 8. Only if SYSTEM PARAMETER > Periph. device = „Tear-off edge“ or „Tear off + sensor“ 10. Only with SYSTEM PARAMETER > Druck Interpret. = „ZPL Emulation“ 12. Only if PRINT PARAMETERS > Punch mode = „Manual“ 13. Only in production mode 14. As in 13. or with a setting value > 0 18. Only with installed RFID option 20. Only if SYSTEM PARAMETER > Periph. device = „Dispenser“ 21. Only if SYSTEM PARAMETER > Periph. device = „Int Rewinder“ 22. Only with an activated RFID option 23. Only with I/O board 24. Not with I/O board 29. Availability depends on device configuration 30. Only with the appropriate memory medium plugged in

AP 5.4 Gen II – AP 5.6

(SYSTEM PARAM. cont.)

Language
Keyboard
Access authoriz.
Realtime Clock

I/O BOARD PARA	23
Start delay	23
Start print mode	23
Reprint Signal	23
Feed input	23
Pause input	23
Error output	23
Error polarity	23
Status output	23
Status polarity	23
End print mode	23

ZPL PARAMETERS	10
Version	10
Darkness	10
Control Prefix	10
Format Prefix	10
Delimiter Char	10
Label Top	10
Left Position	10
Manual Calibrate	10
Resolution	10
Error Indication	10
Error Checking	10
305 DPI Scaling	10
Image Save Path	10
Command ^PR	10
Command ^MT	10
Label Invert	10
Command ^JM	10

DISPENSER PARA	20
Dispense Mode	20
Dispenseposition	20
Display mode	20
Dispense counter	20
Application mode	20
Start source	20
Calibration mode	20
Start offset	20
Start error stop	20
Product length	20
Speed Adaption	20
Current mode	13+20
Min rew. current	13+20
Max rew. current	13+20
Start rew. curr.	13+20
Start cur. len.	13+20
Pullback current	13+20
Back diameter	13+20
Break current	13+20
Break diameter	13+20

REWINDER PARA	21
Rewind direction	21
Current mode	13+21
Min rew. current	13+21
Max rew. current	13+21
Start rew. curr.	13+21
Start cur. len.	13+21
Pullback current	13+21
Back diameter	13+21
Break current	13+21
Break diameter	13+21

SPECIAL FUNCTION	
Printer type	13
Command sequence	13
Delete job	
Delete spooler	
Factory settings	
Custom defaults	13
Store parameters	
Store diagnosis	
Gen.Support Data	
EasyPI. file log	30
Log files delete	30
Data blocks del.	4
RFID stat. del.	22

1. Only with INTERF.PARAM. > NETWORK PARAM. > WEB Server = „enabled“ 2. Only with BLDC firmware version V4-T36 or higher 3. Only with INTERF.PARAM. > NETWORK PARAM. > Time client = „Enabled“  
 4. Only with at least one data block stored in the flash memory 5. Only with rewinder 6. Only with cutter 7. Only with „AP 5.4 peripheral“ 8. Only if SYSTEM PARAMETER > Periph. device = „Tear-off edge“ or „Tear off + sensor“ 10. Only with SYSTEM PARAMETER > Druck Interpret. = „ZPL Emulation“ 12. Only if PRINT PARAMETERS > Punch mode = „Manual“ 13. Only in production mode 14. As in 13. or with a setting value > 0 18. Only with installed RFID option 20. Only if SYSTEM PARAMETER > Periph. device = „Dispenser“ 21. Only if SYSTEM PARAMETER > Periph. device = „Int Rewinder“ 22. Only with an activated RFID option 23. Only with I/O board 24. Not with I/O board 29. Availability depends on device configuration 30. Only with the appropriate memory medium plugged in

AP 5.4 Gen II – AP 5.6

AP 5.4 Parameters

FW 7.60

SERVICE FUNCTION	
Service	13
Head exchange	13
Roller exchange	13
Cutter exchange	13+6
Serv. data reset	13
EasyPlug monitor	23
EP Monitor Mode	13
Sensor adjust	13
Sensor test	
Cutter test	
Matend adjust	
Matend tolerance	
Feedadjust label	
Feed adjust	
Punch y calibr.	13
Memory card test	
Send test	
Receive test	
Rewinder adjust	5
Print test	

SERVICE DATA	
> MODULE FW VERS.	
System version	
System revision	
System date	
Bootloader	
uMon	
Peripheraldriver	7
Intern. rewinder	21
> OPERATION DATA	
Serv. operations	
Headnumber	
Roll number	
Cutter number	6
Head run length	
Roll run length	
Cuts on knife	6
Tot. mat. length	
Tot. foil length	
Total cuts	6
Head strobes	
Head temperature	
Foil diameter	
Operation time	
> POWERSUPPLYDATA	
Type	
PS temperature	

(Service Data cont.)

> CPU BOARD DATA	
CPU identifier	
PCB revision	
FPGA version	
MAC address	
Serial number	
Production date	
PCB part number	
Board part numb.	
Manufacturer	13
Work place	13
Company name	13

> DISPLAY DATA	
Display version	
Display SerialNr	

> MEMORY DATA	
Ram memory size	
Flash mem size	
SD card	30
USB stick	30
Space for Jobs	
Max. Labellength	
Default values	

1. Only with INTERF.PARAM. > NETWORK PARAM. > WEB Server = „enabled“ 2. Only with BLDC firmware version V4-T36 or higher 3. Only with INTERF.PARAM. > NETWORK PARAM. > Time client = „Enabled“ 4. Only with at least one data block stored in the flash memory 5. Only with rewinder 6. Only with cutter 7. Only with „AP 5.4 peripheral“ 8. Only if SYSTEM PARAMETER > Periph. device = „Tear-off edge“ or „Tear off + sensor“ 10. Only with SYSTEM PARAMETER > Druck Interpret. = „ZPL Emulation“ 12. Only if PRINT PARAMETERS > Punch mode = „Manual“ 13. Only in production mode 14. As in 13. or with a setting value > 0 18. Only with installed RFID option 20. Only if SYSTEM PARAMETER > Periph. device = „Dispenser“ 21. Only if SYSTEM PARAMETER > Periph. device = „Int Rewinder“ 22. Only with an activated RFID option 23. Only with I/O board 24. Not with I/O board 29. Availability depends on device configuration 30. Only with the appropriate memory medium plugged in

AP 5.4 Gen II – AP 5.6

AP 5.4/5.6 Operator Parameters

FW 7.60

PRINT PARAMETERS	SYSTEM PARAMETER	SPECIAL FUNCTION	SERVICE FUNCTION	SERVICE DATA	(Service Data cont.)
Print speed	Light sens. type	Delete job	Print test	> MODULE FW VERS.	> CPU BOARD DATA
Feed speed	Foil mode	Delete spooler		System version	CPU identifier
Material type	Print contrast	Store parameters		System revision	PCB revision
Material length		Store diagnosis		System date	FPGA version
Material width				Bootloader	MAC address
Print direction				uMon	Serial number
Cut mode 6				Peripheraldriver 7	Production date
Cut position 6				Intern. rewinder 21	PCB part number
Double cut 6					Board part numb.
Rewind direction 5				> OPERATION DATA	Manufacturer 13
X – Printadjust				Serv. operations	Work place 13
Y – Printadjust				Headnumber	Company name 13
				Roll number	
				Cutter number 6	> DISPLAY DATA
				Head run length	Display version
				Roll run length	Display SerialNr
				Cuts on knife 6	
				Tot. mat. length	> MEMORY DATA
				Tot. foil length	Ram memory size
				Total cuts 6	Flash mem size
				Head strobes	SD card 30
				Head temperature	USB stick 30
				Foil diameter	Space for Jobs
				Operation time	Max. Labellength
					Default values
				> POWERSUPPLYDATA	
				Type	
				PS temperature	

1. Only with INTERF.PARAM. > NETWORK PARAM. > WEB Server = „enabled“ 2. Only with BLDC firmware version V4-T36 or higher 3. Only with INTERF.PARAM. > NETWORK PARAM. > Time client = „Enabled“ 4. Only with at least one data block stored in the flash memory 5. Only with rewinder 6. Only with cutter 7. Only with „AP 5.4 peripheral“ 8. Only if SYSTEM PARAMETER > Periph. device = „Tear-off edge“ or „Tear off + sensor“ 10. Only with SYSTEM PARAMETER > Druck Interpret. = „ZPL Emulation“ 12. Only if PRINT PARAMETERS > Punch mode = „Manual“ 13. Only in production mode 14. As in 13. or with a setting value > 0 18. Only with installed RFID option 20. Only if SYSTEM PARAMETER > Periph. device = „Dispenser“ 21. Only if SYSTEM PARAMETER > Periph. device = „Int Rewinder“ 22. Only with an activated RFID option 23. Only with I/O board 24. Not with I/O board 29. Availability depends on device configuration 30. Only with the appropriate memory medium plugged in

## Alphabetical Parameter List

#VW/I Interface . . . . .	<a href="#">54</a>	Data synch. . . . .	<a href="#">43</a>	Feed speed . . . . .	<a href="#">27</a>
Access authoriz. . . . .	<a href="#">66</a>	Data synch. . . . .	<a href="#">44</a>	Feedadjust label . . . . .	<a href="#">94</a>
Application mode . . . . .	<a href="#">70</a>	Data synch. . . . .	<a href="#">45</a>	Flash mem size . . . . .	<a href="#">105</a>
Back diameter. . . . .	<a href="#">75</a>	Default values. . . . .	<a href="#">106</a>	Flashdata status . . . . .	<a href="#">22</a>
Back diameter. . . . .	<a href="#">77</a>	Default Values . . . . .	<a href="#">86</a>	Foil diameter . . . . .	<a href="#">102</a>
Bar code multip. . . . .	<a href="#">30</a>	Delete job . . . . .	<a href="#">86</a>	Foil end warning . . . . .	<a href="#">55</a>
Baud rate . . . . .	<a href="#">42</a>	Delete spooler . . . . .	<a href="#">86</a>	Foil mode . . . . .	<a href="#">57</a>
Baud rate . . . . .	<a href="#">43</a>	Delimiter Char . . . . .	<a href="#">82</a>	Foil warn stop . . . . .	<a href="#">55</a>
Baud rate . . . . .	<a href="#">45</a>	DHCP host name . . . . .	<a href="#">52</a>	Font downl. area . . . . .	<a href="#">63</a>
Board part numb. . . . .	<a href="#">104</a>	Dispense counter . . . . .	<a href="#">70</a>	Font status. . . . .	<a href="#">19</a>
Bootloader . . . . .	<a href="#">99</a>	Dispense Mode . . . . .	<a href="#">31</a>	Format Prefix . . . . .	<a href="#">82</a>
Brake current . . . . .	<a href="#">75</a>	Dispense Mode . . . . .	<a href="#">68</a>	FPGA version . . . . .	<a href="#">103</a>
Brake current . . . . .	<a href="#">77</a>	Dispenseposition . . . . .	<a href="#">33</a>	Frame error . . . . .	<a href="#">43</a>
Brake diameter . . . . .	<a href="#">75</a>	Dispenseposition . . . . .	<a href="#">69</a>	Frame error . . . . .	<a href="#">44</a>
Break diameter . . . . .	<a href="#">77</a>	Dispensing cycl. . . . .	<a href="#">102</a>	Frame error . . . . .	<a href="#">45</a>
Calibration mode. . . . .	<a href="#">71</a>	Display mode . . . . .	<a href="#">70</a>	Free store size. . . . .	<a href="#">64</a>
Character filter . . . . .	<a href="#">57</a>	Display SerialNr . . . . .	<a href="#">105</a>	FTP password . . . . .	<a href="#">48</a>
Character sets . . . . .	<a href="#">56</a>	Display version. . . . .	<a href="#">104</a>	FTP server. . . . .	<a href="#">48</a>
Command ^JM. . . . .	<a href="#">85</a>	Dottest endless. . . . .	<a href="#">24</a>	Gap detect mode. . . . .	<a href="#">61</a>
Command ^MT . . . . .	<a href="#">84</a>	Dottest punched . . . . .	<a href="#">24</a>	Gateway address. . . . .	<a href="#">47</a>
Command ^PR . . . . .	<a href="#">84</a>	Double cut . . . . .	<a href="#">36</a>	Gen.Support Data . . . . .	<a href="#">88</a>
Command ^MD/~SD . . . . .	<a href="#">85</a>	Drive C . . . . .	<a href="#">54</a>	Head exchange . . . . .	<a href="#">91</a>
Command sequence. . . . .	<a href="#">86</a>	EAN Readline. . . . .	<a href="#">31</a>	Head resistance. . . . .	<a href="#">59</a>
Company name . . . . .	<a href="#">104</a>	EAN sep. lines . . . . .	<a href="#">31</a>	Head run length. . . . .	<a href="#">100</a>
Control Prefix . . . . .	<a href="#">82</a>	EasyPl. file log . . . . .	<a href="#">88</a>	Head strobes . . . . .	<a href="#">101</a>
CPU identifier . . . . .	<a href="#">103</a>	EasyPlug error . . . . .	<a href="#">58</a>	Head temperature . . . . .	<a href="#">102</a>
Current mode . . . . .	<a href="#">72</a>	EasyPlug monitor. . . . .	<a href="#">92</a>	Headnumber . . . . .	<a href="#">100</a>
Current mode . . . . .	<a href="#">76</a>	End print mode. . . . .	<a href="#">81</a>	Head-sensor dist.. . . . .	<a href="#">57</a>
Custom defaults . . . . .	<a href="#">87</a>	EP Monitor Mode . . . . .	<a href="#">92</a>	Image Save Path . . . . .	<a href="#">84</a>
Cut mode . . . . .	<a href="#">34</a>	Error Checking . . . . .	<a href="#">84</a>	Interface delay . . . . .	<a href="#">41</a>
Cut position. . . . .	<a href="#">36</a>	Error Indication . . . . .	<a href="#">84</a>	Interface . . . . .	<a href="#">40</a>
Cut speed . . . . .	<a href="#">36</a>	Error output . . . . .	<a href="#">79</a>	Intern. rewinder . . . . .	<a href="#">100</a>
Cut width. . . . .	<a href="#">37</a>	Error Polarity . . . . .	<a href="#">80</a>	IP address . . . . .	<a href="#">46</a>
Cuts on knife. . . . .	<a href="#">101</a>	Error reprint . . . . .	<a href="#">58</a>	IP addressassign . . . . .	<a href="#">46</a>
Cutter exchange . . . . .	<a href="#">91</a>	Ethernet speed. . . . .	<a href="#">47</a>	Keyboard . . . . .	<a href="#">66</a>
Cutter number. . . . .	<a href="#">100</a>	External signal . . . . .	<a href="#">62</a>	Label Invert . . . . .	<a href="#">85</a>
Cutter test . . . . .	<a href="#">93</a>	Factory settings . . . . .	<a href="#">87</a>	Label Top. . . . .	<a href="#">83</a>
Darkness. . . . .	<a href="#">82</a>	Feed adjust. . . . .	<a href="#">94</a>	Language . . . . .	<a href="#">65</a>
Data blocks del. . . . .	<a href="#">89</a>	Feed input . . . . .	<a href="#">79</a>	Left Position. . . . .	<a href="#">83</a>

## AP 5.4 Gen II – AP 5.6

Light sens. type . . . . .	<a href="#">57</a>	Printer status . . . . .	<a href="#">17</a>	Service . . . . .	<a href="#">91</a>
Log files delete . . . . .	<a href="#">89</a>	Printer type . . . . .	<a href="#">86</a>	Single job mode . . . . .	<a href="#">58</a>
MAC address . . . . .	<a href="#">103</a>	Printtest . . . . .	<a href="#">97</a>	Singlestartquant . . . . .	<a href="#">62</a>
MAC address . . . . .	<a href="#">47</a>	Product length . . . . .	<a href="#">72</a>	SNMP agent . . . . .	<a href="#">47</a>
Manual Calibrate . . . . .	<a href="#">83</a>	Production date . . . . .	<a href="#">104</a>	SNMP password . . . . .	<a href="#">47</a>
Manufacturer . . . . .	<a href="#">104</a>	PS temperature . . . . .	<a href="#">103</a>	Space for Jobs . . . . .	<a href="#">106</a>
Matend adjust . . . . .	<a href="#">93</a>	Pullback current . . . . .	<a href="#">74</a>	Spooler mode . . . . .	<a href="#">40</a>
Matend tolerance . . . . .	<a href="#">93</a>	Pullback current . . . . .	<a href="#">77</a>	Spooler size . . . . .	<a href="#">41</a>
Material length . . . . .	<a href="#">28</a>	Punch level . . . . .	<a href="#">39</a>	StandAlone Input . . . . .	<a href="#">53</a>
Material type . . . . .	<a href="#">28</a>	Punch mode . . . . .	<a href="#">38</a>	Start cur. len. . . . .	<a href="#">74</a>
Material width . . . . .	<a href="#">28</a>	Punch offset . . . . .	<a href="#">29</a>	Start cur. len. . . . .	<a href="#">77</a>
Max rew. current . . . . .	<a href="#">76</a>	Punch y calibr. . . . .	<a href="#">94</a>	Start error stop . . . . .	<a href="#">72</a>
Max. Labellength . . . . .	<a href="#">106</a>	Ram disk size . . . . .	<a href="#">63</a>	Start offset . . . . .	<a href="#">71</a>
Max. rew. current . . . . .	<a href="#">73</a>	Ram memory size . . . . .	<a href="#">105</a>	Start print mode . . . . .	<a href="#">78</a>
Memory card test . . . . .	<a href="#">94</a>	Realtime clock . . . . .	<a href="#">67</a>	Start rew. curr. . . . .	<a href="#">76</a>
Memory status . . . . .	<a href="#">18</a>	Receive test . . . . .	<a href="#">97</a>	Start rew. current . . . . .	<a href="#">74</a>
Min. rew. current . . . . .	<a href="#">73</a>	Reference label . . . . .	<a href="#">25</a>	Start source . . . . .	<a href="#">71</a>
Min. rew. current . . . . .	<a href="#">76</a>	Reprint function . . . . .	<a href="#">65</a>	Status output . . . . .	<a href="#">80</a>
Miss. label tol. . . . .	<a href="#">60</a>	Reprint Signal . . . . .	<a href="#">78</a>	Status polarity . . . . .	<a href="#">80</a>
Net mask . . . . .	<a href="#">46</a>	Resolution . . . . .	<a href="#">83</a>	Stop bits . . . . .	<a href="#">42</a>
No. of data bits . . . . .	<a href="#">42</a>	Rewind direction . . . . .	<a href="#">37</a>	Stop bits . . . . .	<a href="#">44</a>
No. of data bits . . . . .	<a href="#">43</a>	Rewind direction . . . . .	<a href="#">76</a>	Stop bits . . . . .	<a href="#">45</a>
No. of data bits . . . . .	<a href="#">45</a>	Rewinder adjust . . . . .	<a href="#">97</a>	Store Diagnosis . . . . .	<a href="#">88</a>
Offline mode . . . . .	<a href="#">41</a>	Rewinder values . . . . .	<a href="#">98</a>	Store Parameters . . . . .	<a href="#">87</a>
Operation time . . . . .	<a href="#">102</a>	RFID Option . . . . .	<a href="#">53</a>	Sync. interval . . . . .	<a href="#">52</a>
Parity . . . . .	<a href="#">42</a>	RFID stat. del. . . . .	<a href="#">90</a>	System date . . . . .	<a href="#">99</a>
Parity . . . . .	<a href="#">43</a>	RFID Status . . . . .	<a href="#">26</a>	System revision . . . . .	<a href="#">99</a>
Parity . . . . .	<a href="#">45</a>	Roll number . . . . .	<a href="#">100</a>	System version . . . . .	<a href="#">99</a>
Pause input . . . . .	<a href="#">79</a>	Roll run length . . . . .	<a href="#">101</a>	Temp. reduction . . . . .	<a href="#">60</a>
PCB part number . . . . .	<a href="#">104</a>	Roller exchange . . . . .	<a href="#">91</a>	Thin line emphas . . . . .	<a href="#">60</a>
PCB revision . . . . .	<a href="#">103</a>	Rotated Barcodes . . . . .	<a href="#">37</a>	Time client . . . . .	<a href="#">51</a>
Periph. device . . . . .	<a href="#">61</a>	SD card . . . . .	<a href="#">105</a>	Time server IP . . . . .	<a href="#">52</a>
Peripheraldriver . . . . .	<a href="#">99</a>	Send test . . . . .	<a href="#">96</a>	Time zone . . . . .	<a href="#">52</a>
Port address . . . . .	<a href="#">47</a>	Sensor adjust . . . . .	<a href="#">92</a>	Tot. foil length . . . . .	<a href="#">101</a>
Print contrast . . . . .	<a href="#">62</a>	Sensor test . . . . .	<a href="#">93</a>	Tot. mat. length . . . . .	<a href="#">101</a>
Print direction . . . . .	<a href="#">29</a>	Serial number . . . . .	<a href="#">103</a>	Total cuts . . . . .	<a href="#">101</a>
Print info mode . . . . .	<a href="#">65</a>	Serial Port Mode . . . . .	<a href="#">44</a>	Tradit. Imaging . . . . .	<a href="#">30</a>
Print Interpret . . . . .	<a href="#">55</a>	Serv. data reset . . . . .	<a href="#">92</a>	Turn-on mode . . . . .	<a href="#">58</a>
Print speed . . . . .	<a href="#">27</a>	Serv. operations . . . . .	<a href="#">100</a>	Type . . . . .	<a href="#">103</a>
Printer ID No. . . . .	<a href="#">41</a>	Service Status . . . . .	<a href="#">23</a>	uMon . . . . .	<a href="#">99</a>

UPC plain-copy . . . . . [31](#)  
USB select . . . . . [46](#)  
USB stick . . . . . [105](#)  
Voltage offset . . . . . [60](#)  
WEB admin passw.. . . . . [50](#)  
WEB display refr. . . . . [49](#)  
WEB operator p. . . . . [51](#)  
WEB server. . . . . [48](#)  
WEB supervisor p. . . . . [50](#)  
Work place . . . . . [104](#)  
X - Printadjust. . . . . [38](#)  
Y – Printadjust . . . . . [38](#)

## PRINT INFO

A material width of 100 mm is necessary to print the reports. The status print-out is approx. 200 mm long.

### Printer status

AP 5.4    AP 5.6

A protocol can be printed to get an overview of customer-specific parameter settings, see [1].

▣▣▣▣▣ Which parameters are listed, depends on the printer type.

Printer Status	Printer Status	Printer Status	Printer Status
<b>Printer type</b> : ALX 926 RH <b>Printhead type</b> : KCE 6Inch <b>System version</b> : V6.35 : May 4 2010 <hr/> <b>Printer Parameter Menu</b> <hr/> <b>Print speed</b> : 8.0 Inch/s <b>Feed speed</b> : 8.0 Inch/s <b>Materialtype</b> : Endless <b>Materiallength</b> : 25.0 mm <b>Materialwidth</b> : 100.0 mm <b>Print direction</b> : Foot first <b>Punch offset</b> : 0.0 mm <b>Bar code multip.</b> : * 1 <b>UPC plain-copy</b> : In line <b>EAN Readline</b> : Standard <b>EAN sep. lines</b> : With readl. only <b>Rotated barcodes</b> : Optimized <b>Dispense Mode</b> : Real 1:1 mode <b>Dispenseposition</b> : 0.0 mm <b>X - Printadjust</b> : 0.0 mm <b>Y - Printadjust</b> : 0.0 mm <b>Punchmode</b> : Automatic <b>Punchlevel</b> : 128 <hr/> <b>Printer Interface Menu</b> <hr/> <b>Easyplug Interpreter</b> <hr/> <b>Interface</b> : TCP/IP SOCKET <b>Spooler mode</b> : Mult. print jobs <b>Printer ID no.</b> : 1 <b>Spooler size</b> : 64 KBytes <b>Offline mode</b> : Interf. disabled <b>Interface delay</b> : 0 ms <hr/> <b>COM1 Port Parameter</b> <hr/> <b>Baud rate</b> : 115200 Baud <b>No. of data bits</b> : 8 <b>Parity</b> : None <b>Stop bits</b> : 1 Bit	<b>Data synch.</b> : RTS/CTS <b>Frame error</b> : Display <hr/> <b>COM2 Port Parameter</b> <hr/> <b>Baud rate</b> : 115200 Baud <b>No. of data bits</b> : 8 <b>Parity</b> : None <b>Stop bits</b> : 1 Bit <b>Data synch.</b> : RTS/CTS <b>Frame error</b> : Display <hr/> <b>Centronics Port Parameter</b> <hr/> <b>PnP function</b> : On <hr/> <b>Ethernet Parameter</b> <hr/> <b>IP Addressassign</b> : DHCP <b>IP address</b> : 144.093.029.062 <b>Net mask</b> : 255.255.254.000 <b>Gateway address</b> : 144.093.028.001 <b>Port address</b> : 9100 <b>Ethernet speed</b> : Auto negotiation <b>SNMP Agent</b> : Disabled <b>FTP server</b> : Enabled <b>WEB server</b> : Enabled <b>WEB display refr</b> : 5 s <b>Time client</b> : Disabled <b>DHCP host name</b> : PEM06_050131 <b>MAC Address</b> : 00.0a.44.05.01.31 <hr/> <b>Options Parameter</b> <hr/> <b>OLV Option</b> : Disabled <b>RFID Option</b> : Disabled <b>StandAlone Input</b> : None <hr/> <b>Printer System Menu</b> <hr/> <b>Head disp dist.</b> : 24.5 mm <b>Speed unit</b> : Inch/s <b>Cover open error</b> : Immediately <b>Foil end warning</b> : 36.4 mm	<b>Foil warn stop</b> : Disabled <b>Display mode</b> : Job rest quant. <b>Dispense counter</b> : 0 <b>Autom. dot check</b> : Off <b>Print Interpret.</b> : Easyplug <b>Character sets</b> : IBM <b>Character filter</b> : Chars > = 20Hex <b>Light sens. type</b> : Punched <b>Ribbon autoecon.</b> : Disabled <b>Ribb. eco. limit</b> : 10.0 mm <b>Feed mode</b> : Head up <b>Turn-on mode</b> : Online <b>Error reprint</b> : Enabled <b>EasyPlug errors</b> : Tolerant handl. <b>Single-job mode</b> : Disabled <b>Head resistance</b> : 1000 Ohm <b>Temp. reduction</b> : 20 % <b>Voltage offset</b> : 0 % <b>Miss. label tol.</b> : 2 <b>Gap detect. mode</b> : Autom. forward <b>Mat. end detect.</b> : Transparent <b>Periph. device</b> : Tear-off edge <b>Singlestartquant</b> : 1 <b>Dispensing mode</b> : fast <b>Application mode</b> : Save mode <b>External signal</b> : Singlestart <b>Start print mode</b> : Pulse falling <b>Print contrast</b> : 60 % <b>Ram disk size</b> : 512 KBytes <b>Font downl. area</b> : 256 KBytes <b>Free store size</b> : 3072 KBytes <b>Print info mode</b> : Par.values right <b>Reprint function</b> : Disabled <b>Language</b> : English <b>Keyboard</b> : English <b>Signal / buzzer</b> : Off <b>Access authoriz.</b> : Deactivated <b>Realtime Clock</b> : 16.09.2010 09:54 <b>Material feed</b> : for- / backwards	<hr/> <b>Applicator Parameter Menu (AI B</b> <hr/> <b>Applicator type</b> : <b>Start print mode</b> : <b>Restart delay</b> : <hr/> <b>Internal Options</b> <hr/> <b>Default values</b> : <b>Com2 Option</b> :

[1] Example of printout „Printer status“.

#### Listed items:

- System version:
  - Shows the installed firmware version as well as the release date of this version.
  - Firmware version: R = firmware RISC processor, H = firmware H8 processor.
- Printer type:
  - Shows the printer type, which has been set using parameter `SERVICE FUNCTIONS > printer type` (e.g. AP 5.4)
  - "USA" displayed after the printer type indicates that the USA font is loaded.
  - "8DOT" displayed after the printer type indicates that the 8-Dot emulation is loaded.



- **Printer Parameter Menu**  
Shows the setting of the parameters in the `PRINT PARAMETERS` menu.
- **Printer Interface Menu**  
Shows the setting of the parameters in the `INTERFACE PARA` menu.
- **Printer system menu**  
Shows the setting of the parameters in the `SYSTEM PARAMETER` menu.
- **Dispenser Interface**  
Shows the setting of the parameters in the `DP INTERFACE` menu.
- **Internal Options**
  - **Default values:** Shows the values which are used in case of a factory reset (Standard or Default). See parameter `SPECIAL FUNCTION > Default Values`.
  - **Realtime Clock:** Shows the set time and date, if a realtime clock is installed. In case of a too low battery, the line "Battery empty" is added.
  - **2. com port:** Shows if an additional serial Interface is installed (not supported).

## Memory status

AP 5.4    AP 5.6

A memory protocol can be printed to provide an overview of the distribution of the available memory capacity (one page).

▣▣▣▣➔ The entries differ depending on printer type and configuration.

MEMORY STATUS	
<u>Internal Memory Configuration</u>	
Ram memory size	: 64 MB
Flash mem size	: 4 MB AMD
CompactFlash	: 117 MB / 128 MB
Space for Jobs	: 51.2 MB
Max. Labellength	: 8167 mm
Default values	: Standard
Space for spooler	: 64 KB
Space for RAM disc	: 512 KB
Font downl. area	: 256 KB
Free store size	: 3072 KB
<u>Logos on RAM disc</u>	
<u>Graphics on RAM disc</u>	
<u>Easyplug formats on Memory Card (C:)</u>	
Testjob.for	407 Bytes
<u>Logos on Memory Card (C:)</u>	
<u>Graphics on Memory Card (C:)</u>	

[2] Example of a „Memory status“ printout.

### Listed items:

- Internal Memory Configuration
- See paragraph > [MEMORY DATA](#) □ on page 105.

- Logos on RAM disc
  - Graphics on RAM disc
  - Fonts on RAM disc
- See „Plugin card manual“, topic section „Application“, chapter [CF/SD cards](#)

### Font status

AP 5.4    AP 5.6

Print samples of all installed characters, bar codes and line samples (several pages).

Page „Font Library“ shows a list of the internal fonts and line styles.

#### Internal Fonts

- ➔ Use the Easy-Plug commands listed in the first column of the report (e.g. #YT100), to print using the appropriate font.
- Easy Plug commands: Refer to the Easy Plug Manual, topic section [Description of Commands](#) .
- For a list of all characters contained in the internal fonts, refer to the User Manual, topic section [Internal Fonts](#) .

FONT LIBRARY		
Number of Fonts : 20 (internal)		
EP. Cmd	High	Font Sample
Y1100	0.83	0123456789ABCDEF0123456789ABCDEF0123456789ABCDEF
Y1101	1.33	0123456789ABCDEF0123456789ABCDEF0123456789ABCDEF
Y1102	1.50	0123456789ABCDEF0123456789ABCDEF0123456789ABCDEF
Y1103	2.00	0123456789ABCDEF0123456789ABCDEF0123456789ABCDEF
Y1104	2.92	0123456789ABCDEF
Y1105	1.50	0123456789ABCDEF0123456789ABCDEF0123456789ABCDEF
Y1106	2.00	0123456789ABCDEF0123456789ABCDEF0123456789ABCDEF
Y1107	2.92	0123456789ABCDE
Y1108	3.25	0123456789ABCDEF
Y1109	5.16	0123456789
Y1110	2.75	0123456789ABCDEF
Y1111	1.41	0123456789ABCDEF0123456789ABCDEF0123456789ABCDEF
Y1112	1.92	0123456789ABCDEF0123456789ABCDEF0123456789ABCDEF
Y1113	1.92	0123456789ABCDEF0123456789ABCDEF0123456789ABCDEF
Y1114	2.33	0123456789ABCDEF0123456789ABCDEF0123456789ABCDEF
Y1115	2.33	0123456789ABCDEF0123456789ABCDEF0123456789ABCDEF
Y1116	2.38	0123456789ABCDEF
Y1100	40 P	0123456789ABCDEF
Y1101	40 P	0123456789ABCDEF
Y1102	40 P	0123456789ABCDEF
Line Style	Line Sample	
Typ 0	—————	
Typ 1	- - - - -	
Typ 2	- - - - -	
Typ 3	.....	
Typ 4	- - - - -	
Typ 5	- - - - -	
Typ 6	- - - - -	
Typ 7	- - - - -	
Typ 8	- - - - -	
Typ 9	- - - - -	
Typ 10	.....	
Typ 11	.....	
Typ 12	.....	

[3] Print sample „Font Status“, section „Font Library“.

**Internal Line Styles**

➔ Use the line style number (first column) with one of the Easy Plug commands #YL or #YR to print lines in the matching style.

○ Easy Plug commands: Refer to the Easy Plug Manual, topic section [Description of Commands](#) .





























➔ Additionally, the following line styles are available:

- 13: Checked pattern with 3 dot edge length
- 14: Checked pattern with 1 mm edge length
- 15: Checked pattern with 5 mm edge length

➔ The line width has to be defined as a multiple of the edge length of the checked pattern!

**Internal bar codes**

The pages titled „Barcode Library“ show print samples of the internal bar codes (see [4], [5]).

BARCODE LIBRARY			BARCODE LIBRARY			BARCODE LIBRARY		
EasyPlug Nr.	Barcode Sample		EasyPlug Nr.	Barcode Sample		EasyPlug Nr.	Barcode Sample	
Number of Barcodes : 31 (internal)								
0		EAN 8	14		HSI	27		COEE 128 Pharmacy
1		EAN 13	15		EAN 128			
2		UPICA	16		COEE 38 (2:1)			
3		COEE 93	17		POSTCODE (flatcode)			
4		COEE 2/5 Interleaved			POSTCODE (flatcode)			
5		COEE 2/5 Matrix	18		COEE 128 (UPSI)			
6		COEE 2/5 5 Sturche	19		COEE 38 (2.5:1)			
7		COEE 38	20		COEE 2/5 Interleaved Ratio (1:3)			
8		COEABAR	21		COEE 2/5 Matrix Ratio (1:2.5)			
9		UPICE	22		COEE 2/5 Matrix Ratio (1:3)			
10		ADD DN 2	23		COEE 38 Extended			
11		ADD DN 5	24		COEE 128 A			
12		ITF	25		COEE 128 B			
13		COEE 128	26		COEE 128 C			

[4] Print sample „Font Status“, section „Barcode Library“.

- *Onedimensional bar codes* are printed with the Easy-Plug command #YB, see manual Easy-Plug, topic section [Description of Commands](#) .
- *Two-dimensional bar codes* are printed by means of special Easy-Plug commands:

AP 5.4 Gen II – AP 5.6

Easy-Plug command	Bar code
#IDM	Data Matrix Code
#MXC	Maxi Code
#PDF	PDF 417
#CBF	Codabar F
#CFN	Code 49
#SQR	QR Matrix Code

[1] Internal, two-dimensional bar codes.

- **GS1 DataBar (formerly RSS) and Composite Component (CC) bar codes** are printed by means of the Easy-Plug command #RSS. The bar code is determined by the number in the first column of the subsequent table. This number is added to the command as a parameter.

**BARCODE LIBRARY**

EasyPlug Nr.	Barcode Sample	
#RSS1		GS1 Databar Omnidr.
#RSS2		GS1 Databar Truncated
#RSS3		GS1 Databar Stacked
#RSS4		GS1 Databar Stacked Omnidirectional
#RSS5		GS1 Databar Limited
#RSS6		GS1 Databar Expanded
#RSS7		UPC-A + CC-A/CC-B
#RSS8		UPC-E + CC-A/CC-B
#RSS9		EAN-13 + CC-A/CC-B
#RSS10		EAN-8 + CC-A/CC-B
#RSS11		UCC/EAN-128 + CC-A/CC-B
#RSS12		UCC/EAN-128 + CC-C

**BARCODE LIBRARY**

EasyPlug Nr.	Barcode Sample	
		Data Matrix Code
		Maxi Code
		PDF 417
		Codablock F
		Code 49
		QR Code

[5] Print sample „Font Status“, section „Font Library“: Listing of RSS-Codes and 2-dim. bar codes.

## Flashdata status

AP 5.4    AP 5.6

Prints a list of all fonts stored in the flash memory. This can be e. g. customized fonts or diagnose data.

- For details see topic section [Internal Fonts](#) , paragraph „Customized fonts“.
- For detailed information about diagnosis data refer to the service manual, topic section „Fault location“, „Reading out diagnosis data“.

FLASH DATA BLOCKS	
Total flash for data blocks	: 1872 KByte
Flash data block partition size	: 16 KByte
Number of flash data blocks	: 2
Remaining flash for data blocks	: 1104 KByte
<hr/>	
Block 0    Diagnostics information	128 KByte
<hr/>	
Block 1    MPCL Block	128 KByte
<hr/>	

[6] Example printout „Flashdata status“.

## Service Status

AP 5.4    AP 5.6

Print the Service status report to read about operation time, no. of services, no. of exchanged parts and other matters of service interest (one page).

Use the parameter `SERVICE FUNCTION > Serv. data reset`, to set all the counters to zero, which are listed on the printout.

Service Status	
<b>Operational Data</b>	
Service operations	: 4294967295
Head number	: 0
Roll number	: 0
Knife number	: 0
Head run length	: 0 m
Roll run length	: 0 m
Cuts on knife	: 9
Total material length	: 358429 m
Total foil length	: 358150 m
Total cuts	: 2187
Total head moves	: 2414
Head strokes	: 1922179
Foil diameter	: 44.5 mm
Operation time	: 20 hours 16 min
<b>Power supply data</b>	
Type:	: CME PSupply
<b>CPU board data</b>	
CPU identifier	: 34-16
System controller	: GT-64111
Board Revision	: REV04
<b>Peripheraldriver</b>	
Feed driver	: V3 - T3
Foil driver	: V3 - T3
Head driver	: V3 - T3
Peripheraldriver	: V3 - T3
USI interface	: V2 - T1

[7] Example of a „Service Status“ printout.

- For information on the operational data on the service status printout refer to paragraph > [OPERATION DATA](#) on page 100.
- For information on the power supply data on the service status printout refer to paragraph > [POWERSUPPLYDATA](#) on page 103.
- For information on the CPU board data on the service status printout refer to paragraph > [CPU BOARD DATA](#) on page 103.
- For information on the peripheral driver data on the service status printout refer to paragraph > [MODULE FW VERS.](#) on page 99.

## **Dottest endless**

---

AP 5.4    AP 5.6

---

Dottest for application with endless label stock.

This function prints a pattern which enables trained personnel to check the adjustment as well as the function of the printhead.

### **Test pattern**

The „Dottest endless“ or „Dottest punched“ prints a pattern consisting of 33 rows filled with vertical lines on the upper label area. All lines have a constant distance of 4 dot. With every new row, the line pattern is shifted one dot. The resulting line-pattern repeats every four rows.

The test pattern shows missing dots clearly as white vertical lines running through the pattern.

The lower label area is filled with testpatterns, which are kept close to those used by Kyocera. The patterns are useful for printout comparison.

The bars underneath the test pattern allow the adjustment of the different zero lines.

## **Dottest punched**

---

AP 5.4    AP 5.6

---

Dottest for application with punched material.

- See parameter [Dottest endless](#)  on page 24.

### Reference label

AP 5.4    AP 5.6

Prints a label with some examples of barcodes, fonts, logos... just try out!

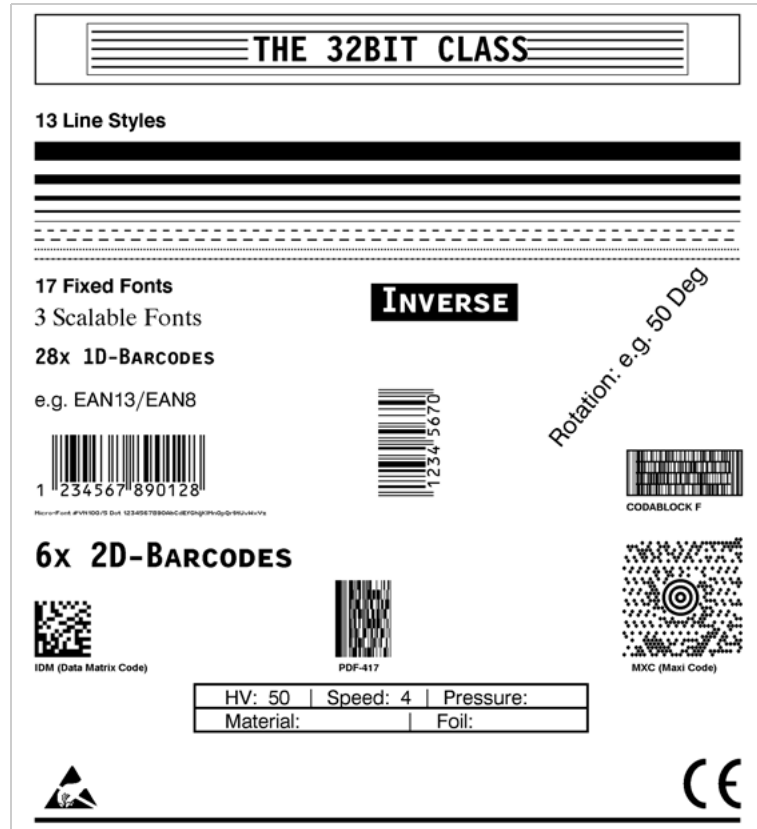

[8] Example of a Reference label printout (INFO AUSDRUCKEN > Reference label).



## RFID Status

▣► Only with activated RFID option.

---

AP 5.4      AP 5.6

---

Prints a status printout with RFID specific data:

RFID Status	
System version	: V4.00 Jun 23 2005 [R4.00 PE2.50 H4.00Q]
Printer type	: 64-05
Nr CMD retries	: 3
Nr invalid tags	: 3
<hr/>	
Statistics	
<hr/>	
Nr of Tags	: 7043
Nr. invalid tags	: 2788
Total Nr. SELECT	: 7803
Invalid SELECT	: 16%
Total Nr. READ	: 1189
Invalid READ	: 29%
Total Nr. WRITES	: 5483
Invalid WRITE	: 37%
Rate READ	: 45
Rate WRITE	: 46

[2] Example of a RFID status printout ( INFO AUSDRUCKEN > RFID Status).

## PRINT PARAMETERS

### Print speed

---

 AP 5.4    AP 5.6
 

---

The print speed (material feed) can be adjusted according to the ribbon and material combination being used in order to optimise the contrast depth and the density of the print image.

x Inch/s

Setting range: see table (tab. 3); Unit interval: 0,2 inch/s;  
Default setting: 8 Inch/s

Printer	Print speed / feed speed (Inch/s)
AP 5.4/5.6 (8-Dot-Druckkopf)	2-8
AP 5.4/5.6 (12-Dot-Druckkopf)	2-6

[3] The setting range of the print/feed speed depends on the printhead.

### Feed speed

---

 AP 5.4    AP 5.6
 

---

Setting:

The value for the feed speed should not be set too high for print applications with long calculating units (e. g. consecutive numbering). This can help to avoid alternating between abrupt braking to 0 (zero) and acceleration to print speed.

▣► When altering the print speed, the feed speed is equal to the print speed. If a different feed speed is required, this must be set again.

x Inch/s

Setting range: see table (tab. 3); Unit interval: 0,2 inch/s;  
Default setting: 8 Inch/s

## Material type

---

AP 5.4    AP 5.6

---

Definition of the materials used. A distinction is made between reel material and gapped material (hole gaps, self-adhesive material with register gaps). The detected gap position corresponds to the start of the label.

▣▣▣▣ The value is overwritten by the appropriate Easy Plug command when sending label formats.

**Endless**

If material is to be used without gaps.

**Punched**

If material is to be used with gaps (default setting).

## Material length

---

AP 5.4    AP 5.6

---

The material length (label length) is the distance between the gaps, measured from the front edge (beginning) of a label to the front edge of the next label.

▣▣▣▣ The value is overwritten by the appropriate Easy Plug command when sending label formats.

**xxx mm**

Setting range: 5 mm to "max. length entry"; Unit interval: 0.1 mm

Default setting: 100 mm

Maximum length entry: dependent on the print head width and memory configuration.

## Material width

---

AP 5.4    AP 5.6

---

Zero position of the left border. If the printer is working in line-printer mode, alterations can be made in millimetre units.

**xxx mm**

Setting range: "min. width" to "max. width"; Unit interval: 0.1 mm

Default setting: 100 mm

- Min. width: dependent on the printer type
  - Max. width: dependent on print head width and memory configuration.
- For detailed material width information, refer to topic section „Specifications“.

## Print direction

AP 5.4    AP 5.6

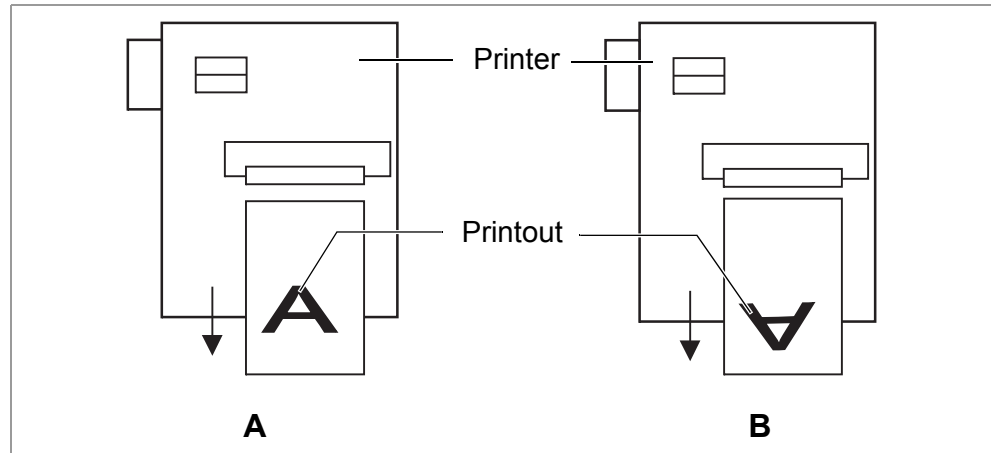

[9] Orientation of the printout „Foot first“ (A) or „Head first“ (B).

**Foot first**

(Default) Orientation of the printout according to [9A].

**Head first**

Orientation of the printout according to [9B]. Mind the following:

▣ Define the „true“ label length (without gap length) in parameter `PRINT PARAMETERS > Material length`. If the label gap is wider than 5 mm, the parameter `SYSTEM PARAMETER > Miss. label tol.` must be set to a value more than zero.

▣ The distance between material base line and the first printable dot is 1 mm. To keep this distance while printing „head first“, the material width must be calculated as follows::

$$b_{Mat} = b_{Bp} - 2mm , \text{ with}$$

$b_{Mat}$ : Material width

$b_{Bp}$ : Backing paper width

## Punch offset

AP 5.4    AP 5.6

The zero position can be determined offset in millimetre units from the detected gap position.

▣ The value is overwritten by the appropriate Easy Plug command when sending label formats.

**xxx mm**

Setting range: -8 to +max. label length; Unit interval: 0,1 mm

Default setting: 0 mm

Maximum offset in feed direction: -8 mm

Minimum offset against feed direction: +max. label length

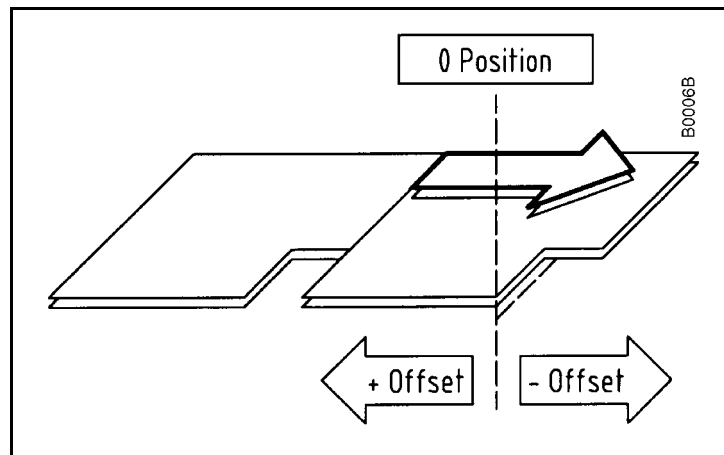

[10] Positive and negative offset in relation to the feed direction (arrow).

### Bar code multip.

AP 5.4    AP 5.6

Bar code height scaling factor

Increases the bar code height defined in the label layout (Easy-Plug) by multiplication by a factor of 1 to 10.

x

Setting range: 1 to 10; Unit interval: 1; Default setting: 1

The printed bar code height calculates starting with the value defined in the label layout multiplied by the scaling factor x.

### Tradit. Imaging

AP 5.4    AP 5.6

▣ In production mode only.

Up to firmware version x.31, the barcode height was calculated with the formula:

$$\text{Barcodeheight}_{Print} = (\text{Barcodeheight}_{Layout} + 1) \cdot x$$

with x = PRINT PARAMETERS > Barcode Multi.

By doing so, the printed barcode height in millimeters was by 1 higher than the value defined in the layout (1 --> 2 mm, 2 --> 3 mm, etc.)<sup>1)</sup>.

From firmware version x.31 on, the printed barcode is exactly as high in millimeters, as the value in the layout is (1 --> 1 mm, 2 --> 2 mm, etc.)<sup>1)</sup>.

No

New height calculation (1 --> 1 mm, 2 --> 2 mm, etc.) is applied (default setting).

The plain copy line is printed with OCR-B font.

Yes

Setting for customers with print layouts based on the *old* height calculation scheme.

1) Assumed that PRINT PARAMETERS > Barcode Multi. = „1“.

The plain copy line of the barcodes EAN8, EAN13, UPC-A and UPC-E is printed with the same fonts, which older printer types like TTK or TTX x50 have used.

### UPC plain-copy

---

AP 5.4    AP 5.6

---

The position of the first and last digit in the plain-copy line - underneath the bar code - can be adjusted as required.

#### Raised

First and last digit of the UPCA or first digit with the UPCE are raised (default setting).

#### In line

All digits in the decoded line are in line under the code.

### EAN Readline

---

AP 5.4    AP 5.6

---

#### <> Signs

Readline enclosed in "<>" signs or terminated by a ">"-Sign (EAN 13).

#### Standard

Readline without "<>" or ">" signs (default).

### EAN sep. lines

---

AP 5.4    AP 5.6

---

EAN separation lines. Parameter for controlling of EAN or UPC barcodes if they are printed without readline.

#### With readl. only

(Default) The separation bars at the beginning, middle, and the end of the barcode are only long, if the barcode is printed with a readline.

#### Always long

The separation bars at the beginning, middle, and the end of the barcode are always long, regardless if the barcode is printed with or without readline. The position of the barcode is the same as with the readline option switched on.

### Dispense Mode

---

AP 5.4    AP 5.6

---

Governs the run of the print-dispense procedure.

▣ Only if `SYSTEM PARAMETER > Periph. device = „Tear-off edge“`.

#### Dispense only

With this setting, the printer can be used as a mere dispenser without processing print jobs. Set the material length before you use this function.

See parameter `PRINT PARAMETERS > Material length`.

After calling "Dispense only", the printer restarts; afterwards, the following is displayed:

Dispense only  
Labels

0

0 = Number of dispensed labels.

The parameters menu can be activated as usual after having switched to the offline mode by pressing the Online button two times.

#### Normal 1:1 Mode

- The printer cannot print on the whole label surface. A stripe at the label beginning stays unprinted.
- The label is being dispensed while printing.
- The output volume is at its maximum level.

▣ The width of the unprintable stripe is calculated as follows:

*Distance print line to dispensing edge + Dispense position* (see [4])

Printer	Distance print line - dispensing edge
64-xx	39.8 mm (long dispensing edge) 24.2 mm (short dispensing edge)
AP 5.4	25.0 mm

[4] Distances between print line and dispensing edge for some printers.

- Also refer to parameter PRINT PARAMETERS > Dispense position.
- A graphic can be found under PRINT PARAMETERS > Cut mode > Normal 1:1 mode.

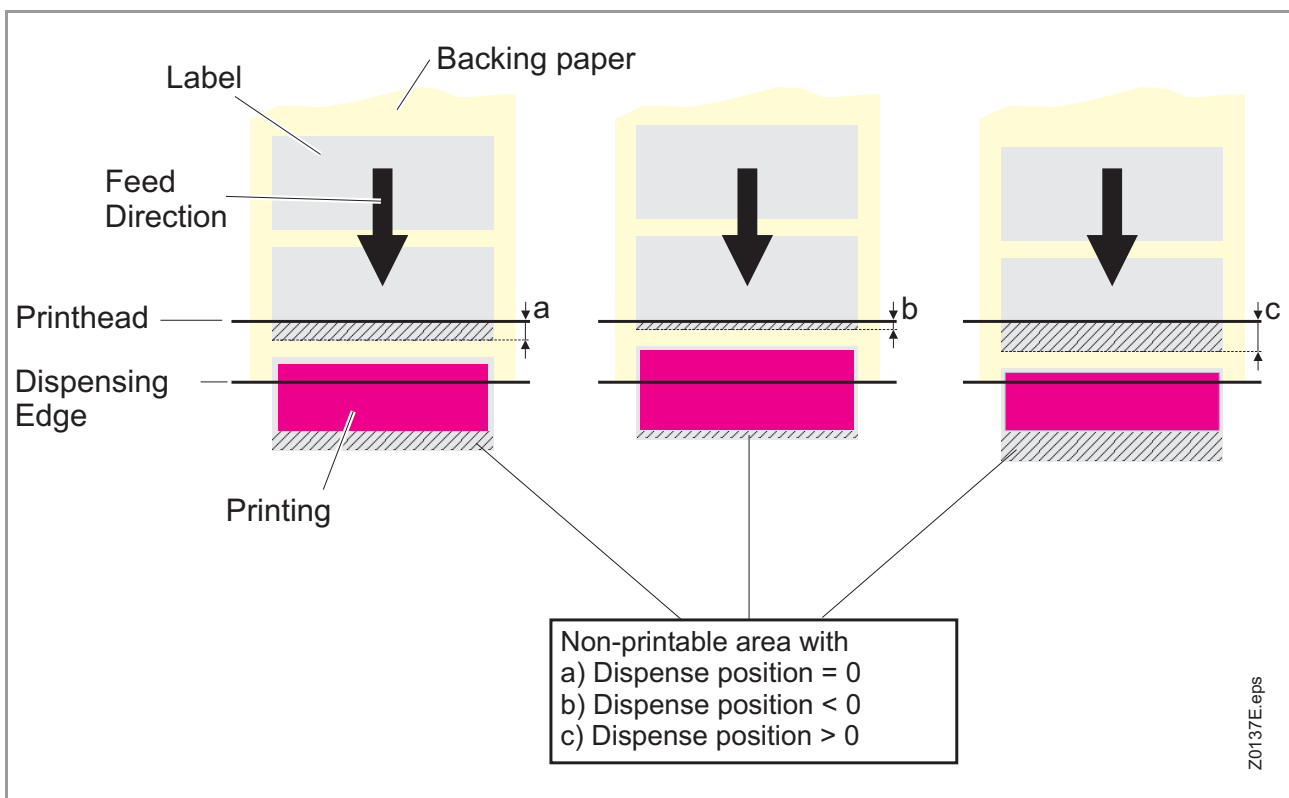

[11] The size of the not imprintable area in Normal 1:1 depends of the setting of parameter SYSTEM PARAMETER > Dispense Position.

**Batch Mode**

- The printer can print the whole label surface.
- Dispensing of the label takes place during printing. Printing of the next label is interrupted until the label is completely dispensed.
- The output volume is at its maximum level.

▣▣▣▣ The *Batch mode* is optimised for printing and dispensing at high speeds. Due to this, it is not possible to use all features available in modes *Normal 1:1* or *Real 1:1*. Also consider, that printing data must be available on time and in sufficient quantity.

▣▣▣▣ The following Job/Parameter-combinations must not be used:

- Jobs with counter fields
  - Jobs with variable fields
  - SYSTEM PARAMETER > Dispensing mode must be set to "fast".
- A graphic can be found under PRINT PARAMETERS > Cut mode > Batch mode.

**Real 1:1 Mode**

(Default setting)

- The printer can print the whole label surface.
- After dispensing a label, the beginning of the next label is drawn back under the print head.
- The output volume is lower than in *Batch Mode* or *Normal 1:1 Mode*.

○ A graphic can be found under PRINT PARAMETERS > Cut mode > Real 1:1 mode.

**Dispenseposition**

AP 5.4    AP 5.6

▣▣▣▣ Only with SYSTEM PARAMETER > Periph. device = „Tear-off edge“.

Dispense position

Adjusts the dispense position in or against the feed direction. Depending on the set dispense position, the dispensed label sticks to the backing paper with a more or less wide strip [12]. The required width of this strip depends on the further processing.

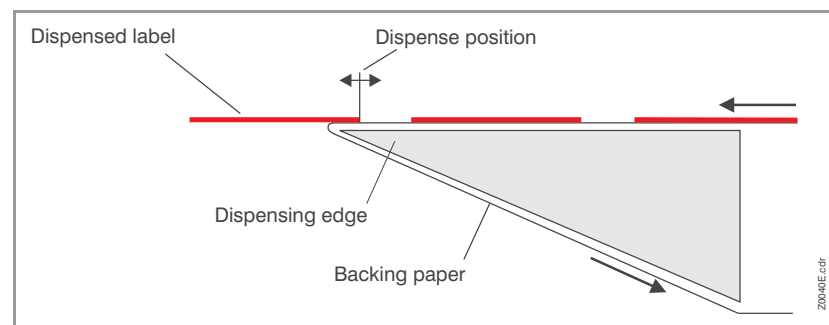

[12] Dispense position (= stop position) of the dispensed label.

x.x mm

Setting range: -30.0 to +20.0 mm; Unit interval: 0.1 mm; Default setting: -6.0 mm



### Cut mode

AP 5.4    AP 5.6

Only with mounted and activated cutter (SYSTEM PARAMETER > Periph. device = „Cutter“).

This is where the procedure for the label output and cut is defined.

#### Real 1:1 mode

The whole surface of the label is printable. The label is pushed forward to the cutter for cutting. After the cut, the beginning of the next label is drawn back under the print head. This reduces the output volume (in relation to a certain time).

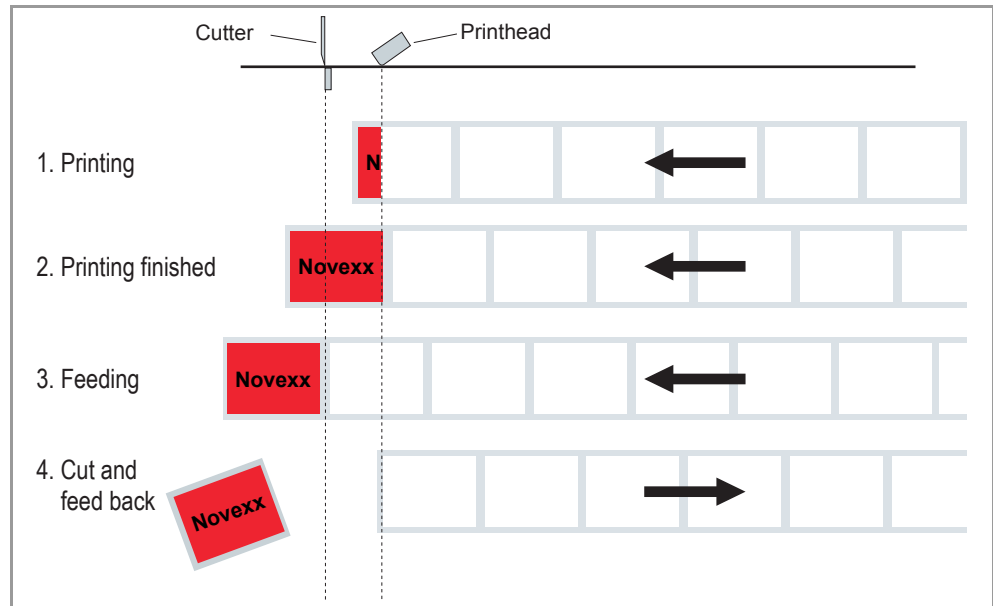

[13] Printing process (schematic) in „Real 1:1 Mode“.

**Batch mode**

The whole surface of the label is printable. Cutting takes place during printing. This can result in brief interruptions within the print zone of the following label. The output volume is at its maximum level.

Requirements for the batch mode are:

- Ribbon economy is not active (parameter `SYSTEM PARAMETER > Ribbon autoecon. = "Off"`)
- Material length >18 mm (>14 mm on the TTX 350)
- Number of cuts for a print job - at least 2 or more

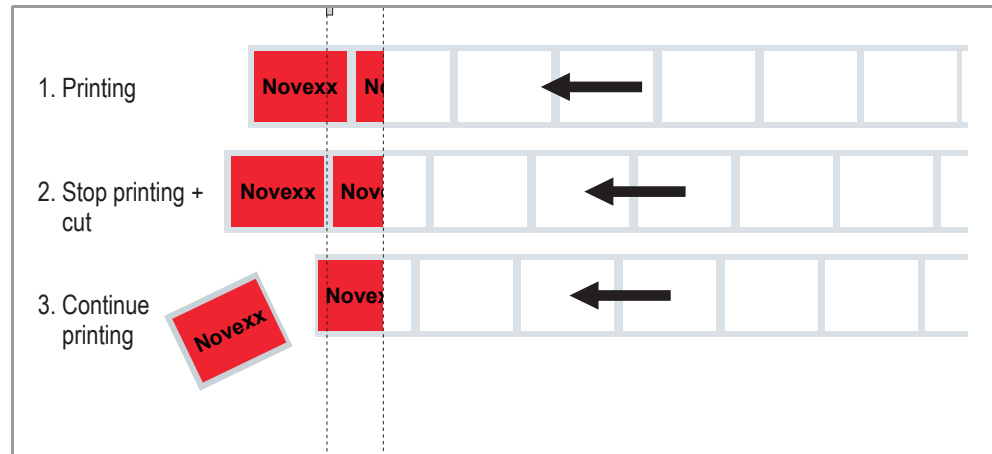

[14] Printing process in Batch mode (schematic).

**Normal 1:1 mode**

In N1:1 mode, cutting takes place during printing. The zero-line of the printing is shifted 18 mm in y-direction. This offset equals the distance cutter-print-head. Caused by this shifting, the first 18 mm of the label are not printable. These measurement corresponds to the distance between print head and cutter. The output volume is at its maximum level.

(The offset of the zero-line is caused historically and serves the compatibility of older printer models).

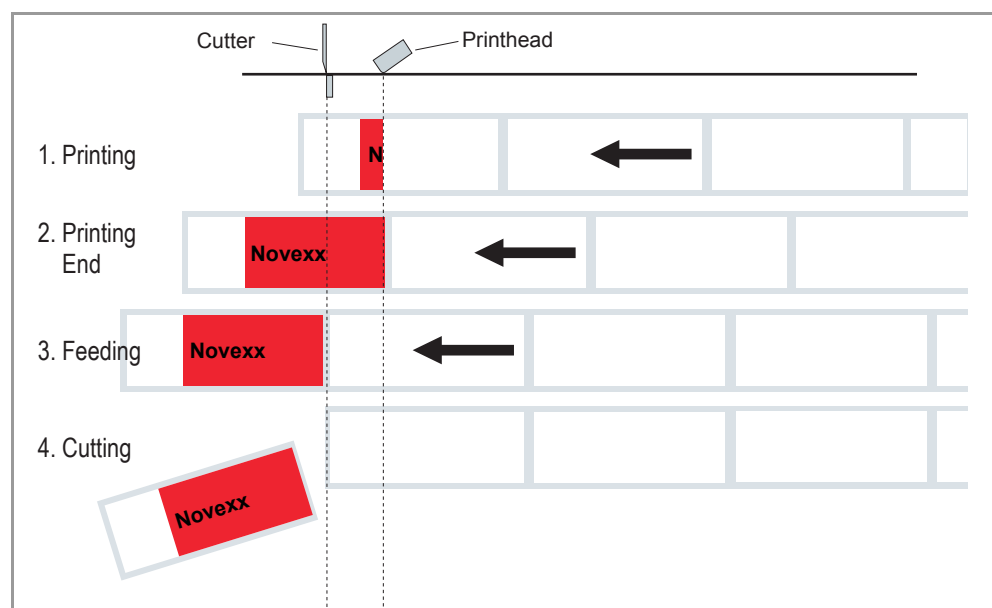

[15] Printing process in Normal 1:1 mode (schematic).

## Cut speed

---

AP 5.4    AP 5.6

---

▣▣▣▣► Only with mounted and activated cutter (SYSTEM PARAMETER > Periph. device = „Cutter“).

The cut speed is to be adjusted to the material thickness and strength.

x

Setting range: 2 to 5; Unit interval: 1

- 2: extremely slow; for thick and strong material
- 5: extremely fast; for thin material

## Cut position

---

AP 5.4    AP 5.6

---

▣▣▣▣► Only with mounted and activated cutter (SYSTEM PARAMETER > Periph. device = „Cutter“).

The cut position is identical to the detected gap position, i. e. with the start of the label. Fine settings to meet specific customer requirements can be programmed using the parameter PRINT PARAMETER > Cut position.

x inch/s

Setting range: -2.0 to +2.0 mm; Unit interval: 0.1mm

- Maximum offset in feed direction: -2.0 mm
- No offset: 0 mm
- Minimum offset against feed direction: -2.0 mm

## Double cut

---

AP 5.4    AP 5.6

---

▣▣▣▣► Only with mounted and activated cutter (SYSTEM PARAMETER > Periph. device = „Cutter“).

Joining grids or the gap area between the labels can be removed using a double cut, thereby improving the outline.

The first cut is offset by the distance set from the recognized gap position away in the feed direction, the second cut is made at the gap position.

A possible correction of the cut position ("Cut position" function) is calculated for both cuts and must be taken into consideration.

x inch/s

Setting range: 0.0 to 5.0 mm; Unit interval: 0.1mm

Normal simple cut: 0.0 mm

▣▣▣▣► The smallest possible double cut distance of 1.0 mm must be adhered to!

### Cut width

AP 5.4    AP 5.6

Only with mounted and activated cutter (SYSTEM PARAMETER > Periph. device = „Cutter“).

xxx

Setting range: 0 to MAX\_CUT\_WIDTH;  
Default setting: MAX\_CUT\_WIDTH

The values for MAX\_CUT\_WIDTH depend on printer type and printhead:

Printer	MAX_CUT_WIDTH
64-04	106
64-05	128
64-06	160
64-08	213
AP 5.4 with 203 dpi	104
AP 5.4 with 300 dpi	105
AP 5.6 with 203 dpi	168
AP 5.6 with 300 dpi	167

The values for MAX\_CUT\_WIDTH don't equate to the real cut width (no linear relation between value and cut width). The proper setting value has to be determined by trying.

### Rewind direction

AP 5.4    AP 5.6

Only with mounted and activated (external) rewinder (SYSTEM PARAMETERS > Periph. device = „Rewinder“).  
Determines the sense of rotation of the optional Rewinder.

Printing outside

Rewind direction: The printed label is facing *outside*.

Printing inside

Rewind direction: The printed label is facing *inside*.

### Rotated Barcodes

AP 5.4    AP 5.6

Improves readability of rotated (90° and 270°) bar codes.

Normal

„Normal“ printing without special processing of rotated bar codes.

Optimized

(Default setting) The line and gap widths of rotated bar codes are modified to improve readability.

## X - Printadjust

---

AP 5.4    AP 5.6

---

The zero point of the mask is moved in relation to the edge of the label on the X- axis, i. e. lengthways to the material.

▣▣▣▣ If the setting is changed, while the print job is stopped, the printer recalculates the format using the changed values.

▣▣▣▣ Caution with graphics, which are generated via one of the Easy Plug commands #YI, #YIR or #YIB! If the graphics is shifted beyond the label border as a consequence of changing the parameter "X-Printadjust", the part of the graphics which "juts out" will get lost.

x.x mm

Setting range: -15.0 to +15.0 mm; Unit interval: 0.1mm

Default setting: 0.0 mm

- Maximum offset away from the edge of the label: +15.0 mm
- No offset: 0.0mm
- Maximum offset towards the edge of the label: -15.0 mm

## Y – Printadjust

---

AP 5.4    AP 5.6

---

The zero point of the mask is moved in relation to the gap position on the Y-axis, i. e. in the feed direction.

▣▣▣▣ If the setting is changed, while the print job is stopped, the printer recalculates the format using the changed values.

▣▣▣▣ Caution with graphics, which are generated via one of the Easy Plug commands #YI, #YIR or #YIB! If the graphics is shifted beyond the label border as a consequence of changing the parameter "Y-Printadjust", the part of the graphics which "juts out" will get lost.

x.x mm

Setting range: -15.0 to +15.0 mm; Unit interval: 0.1mm

Default setting: 0.0 mm

- Maximum offset in feed direction: +15.0 mm
- No offset: 0.0mm
- Minimum offset against feed direction: -15.0 mm

## Punch mode

---

AP 5.4    AP 5.6

---

Automatic

Automatic mode, for material with a contrast zone = gap in the label.

"Automatic" is the default setting, suitable for all materials with which there is a difference in the transparency between the label and gap of more than 2 values (see Description, sensor check).

Manual

Manual setting, for material with several varying contrast zones. Settings are made using the parameter `PRINT PARAMETER > Punch level`.

The range of the value automatically measured by the gap detection can be defined specifically for the label material. This allows materials with high-contrast proof points within the label to be processed, which would otherwise be measured as 'false' gaps by the system. The corresponding setting value is then equal to, or smaller than, the value measured at the actual gap.

## Punch level

---

AP 5.4    AP 5.6

---

▣▣▣▣➔ Only if PRINT PARAMETERS > Punch mode = „Manual“.

**xxx**

Setting range: 0 to 255; Unit interval: 1

The value xxx stands for the current contrast within the photoelectric switch of the material which has just been inserted. This serves to determine a threshold value for the inserted material.

```
Punchlevel
Punch xxx Val yyy
```

xxx = current measurement at the punch sensor

yyy = set threshold value

### Example

Self-adhesive material with black bars lengthways across the label

- Reading:
  - Masking paper: 30
  - Masking paper + label: 60
  - Masking paper + label + black bars: 190
- Setting value: 60
 

A setting value of 60 means that all readings over 60 are ignored, therefore also the reading 190 at the black bar.

## INTERFACE PARA

Interface parameter

### > EASYPLUGINTERPR

#### Interface

---

AP 5.4    AP 5.6

---

This parameter sets the interface, by which the printer will receive data.

**Serial Com1**

Serial interface Com1.

**Only for Ethernet interface (10/100 Base T):**

**TCP/IP Socket**

Print data can be sent to the printer via a TCP/IP socket

**LPD Server**

Print data can be sent to the printer via the LPR/LPD-protocol

**USB**

USB interface

**Serial Com3**

Serial interface Com3.

▣▣▣▣ Only with optional I/O board mounted.

▣▣▣▣ Selection of the type of serial interface is done with parameter `INTERFACE PARA > >COM3 PORT > Serial Port Mode`

**Automatic**

All interfaces are enabled to receive data, but *not simultaneously*.

▣▣▣▣ Don't send data to more than one interface at a time.

▣▣▣▣ Except are interfaces, which are being used by an option (e.g. OLV).

#### Spooler mode

---

AP 5.4    AP 5.6

---

The operating mode of the spooler determines whether print series are processed individually, or whether the spooler can receive print data when printing several series.

**Single print job**

Single print series mode (the interface can only receive data after printing the required number of labels of a single series)

**Mult. print jobs**

Multiple print series mode (the interface can receive data while the series is being printed)

## Printer ID No.

---

AP 5.4    AP 5.6

---

Printer identification number

Determines the identification number of the printer. In such a way, the printer can be addressed by the Easy Plug command #!An (n=printer ID).

The use of ID numbers is in particular reasonable for data transfer by RS422/485 interface, if several printers are connected by one data line. Each of the connected printers then only incorporates the data mapped to him by #!An command.

xx

Setting range: 0 to 31; Unit interval: 1

## Spooler size

---

AP 5.4    AP 5.6

---

The memory capacity of the printer buffer can be set according to the requirements of each customer.

xxx Kbyte

Unit interval: 16-2048 kBytes; step width: 16 kBytes; default setting: 64 kBytes

## Offline mode

---

AP 5.4    AP 5.6

---

Interf. disabled

Easy-Plug commands are *not* accepted, while the machine is in offline mode (default setting).

Interf. enabled

Easy-Plug commands *are* accepted in offline mode.

## Interface delay

---

AP 5.4    AP 5.6

---

▣► Only visible, if INTERFACE PARA >EASYPLUGINTERPR > Offline mode = „Interf. enabled“

After switching from online to offline mode, the printer interface is deactivated. This parameter offers a setable delay time before deactivating the interface.

xxxx ms

Setting range: 0-1000; Unit interval: 100; Default setting: 0



## &gt; COM1 PORT

**Baud rate**

AP 5.4    AP 5.6

## Data transfer speed

Speed of data transfer using the serial interface.

xxxxxx Baud

Setting range: 300 to 115200 Baud; Unit interval: 300/600/1200/2400/4800/9600/19200/38400/115200 (default)

**No. of data bits**

AP 5.4    AP 5.6

This parameter can be defined in connection with both the serial and the parallel interface.

7

7 Data bits

8

8 Data bits

**Parity**

AP 5.4    AP 5.6

Defines the parity check of serial transmitted data.

The parity bit is for checking data transmission. If the check shows an error, a corresponding message is displayed. The setting must be identical at the sender and the receiver. Normally transmission is set without a parity bit.

Odd

Odd parity.

A parity bit is added so that there is an odd number of 1 Bits.

Even

Even parity.

A parity bit is added so that there is an even number of 1 Bits.

None

No check bit. Sending and receiving without check bit.

Always zero

Check bit is always 0 (zero). Sending and receiving without parity check.

**Stop bits**

AP 5.4    AP 5.6

## Number of stop bits

1 Bit

1 stop bit

2 Bit

2 stop bits

**Data synch.**

AP 5.4    AP 5.6

Data synchronisation at the serial interface.

**RTS/CTS**

Data synchronisation through hardware

**XON/XOFF**

Data synchronisation through software

**None**

Handshake signals are ignored

**Frame error**

AP 5.4    AP 5.6

**Display**

(Default) An error message is displayed, if a framing error is detected while the printer is receiving serial data.

**Ignore**

Framing errors will be ignored, no error messages are displayed.

**> COM3 PORT**

▣▣▣▣► This menu only appears, if the optional I/O board is installed.

**Baud rate**

AP 5.4    AP 5.6

▣▣▣▣► With mounted and connected I/O board only.  
Speed of data transfer using the serial interface.

**xxxxxx Baud**

Setting range: 2400 to 115200 Baud; Unit interval: 2400/4800/9600/19200/38400/115200 (default)

**No. of data bits**

AP 5.4    AP 5.6

▣▣▣▣► With mounted and connected I/O board only.  
The number of data bits is always 8.

**Parity**

AP 5.4    AP 5.6

▣▣▣▣► With mounted and connected I/O board only.  
Defines the parity check of serial transmitted data.

The parity bit is for checking data transmission. If the check shows an error, a corresponding message is displayed. The setting must be identical at the sender and the receiver. Normally transmission is set without a parity bit.

<b>Even</b>	Even parity. A parity bit is added so that there is an even number of 1 Bits.
<b>None</b>	No check bit. Sending and receiving without check bit.

### Stop bits

---

AP 5.4    AP 5.6

---

▣▣▣▣▶ With mounted and connected I/O board only.  
The number of stop bits is 2 and cannot be changed.

### Data synch.

---

AP 5.4    AP 5.6

---

- ▣▣▣▣▶ With mounted and connected I/O board only.  
○ See parameter [Data synch.](#)  on page 43.

### Frame error

---

AP 5.4    AP 5.6

---

- ▣▣▣▣▶ With mounted and connected I/O board only.  
○ See parameter [Frame error](#)  on page 43.

### Serial Port Mode

---

AP 5.4    AP 5.6

---

▣▣▣▣▶ With mounted and connected I/O board only.  
Setting of the serial interface type.

<b>RS232</b>	Sets Com2 to RS 232. Data synchronisation may be done by hardware (RTS/CTS) or by software (XON/XOFF). Maximum cable length is 15 m.
<b>RS422</b>	Sets Com2 to RS 422. RS 422 is a 4 wire point to point connection, suitable for only one device. Receiver and driver of the printer are always enabled. Data synchronization is only possible by software (XON/XOFF). Maximum cable length is 1 km with twisted telecommunication cable.
<b>RS485</b>	Sets Com2 to RS 485. RS 485 is a 2 or 4 wire bus system for up to 30 devices. The printer's receiver is always enabled, the printer's driver is only enabled, if the printer sends data to the host. Data synchronization is only possible by software (XON/XOFF). Maximum cable length is 1 km with twisted telecommunication cable.

**> COM4 PORT**

Internal interface, to which the optional RFID read/write unit can be connected.

**Baud rate**

---

AP 5.4    AP 5.6

---

- See parameter [Baud rate](#)  on page 42.

**No. of data bits**

---

AP 5.4    AP 5.6

---

Fixed setting of 8 Bits.

**Parity**

---

AP 5.4    AP 5.6

---

- See parameter [Parity](#)  on page 42.

**Stop bits**

---

AP 5.4    AP 5.6

---

Fixed setting of 2 Bits.

**Data synch.**

---

AP 5.4    AP 5.6

---

- See parameter [Data synch.](#)  on page 43.

**Frame error**

---

AP 5.4    AP 5.6

---

- See parameter [Frame error](#)  on page 43.

## &gt; USB

**USB select**

AP 5.4    AP 5.6

<b>External Device</b>	(Default setting) Setting for the connection of a USB device (e. g. USB-Stick).
<b>Internal Device</b>	Setting for the use of the USB port for internal communication (as device).
<b>Internal Host</b>	Setting for the use of the USB port for internal communication (as host).

## &gt; NETWORK PARAM.

**IP address assign**

AP 5.4    AP 5.6

<b>Fixed IP address</b>	<p>▣▣▣▣ A change of this parameter setting forces a printer restart.</p> <p>This setting activates the parameters "Net mask" and "Gateway address" (see below).</p>
<b>DHCP</b>	IP address is assigned automatically. The assigned IP address is displayed for a moment on the printer display, while the printer is starting.

**IP address**

AP 5.4    AP 5.6

<b>xxx.xxx.xxx.xxx</b>	<p>Setting range per xxx value: 0 to 255</p> <p>Change between the digits by pressing the Cut or Feed button; Acknowledge the setting by pressing the Online button. After a change of the IP address, the printer will reset automatically.</p>
------------------------	--

**Net mask**

AP 5.4    AP 5.6

<b>xxx.xxx.xxx.xxx</b>	<p>Setting range per xxx value: 0 to 255</p> <p>Depending on the set IP address appears a default value.</p> <p>▣▣▣▣ We recommend to use the default value!</p>
------------------------	---

## Gateway address

---

AP 5.4    AP 5.6

---

xxx.xxx.xxx.xxx

Setting range per xxx value: 0 to 255  
000.000.000.000 = no gateway is used

## Port address

---

AP 5.4    AP 5.6

---

Setting range: 1024 to 65535. Default: 9100.

## Ethernet speed

---

AP 5.4    AP 5.6

---

Auto negotioation

The communication speed is selected automatically.

10M half duplex

The communication speed is set to 10 MBit/s *half duplex*.

10M full duplex

The communication speed is set to 10 MBit/s *full duplex*.

100M half duplex

The communication speed is set to 100 MBit/s *half duplex*.

100M full duplex

The communication speed is set to 100 MBit/s *full duplex*.

## MAC address

---

AP 5.4    AP 5.6

---

Displays the MAC address of the CPU board. This address can not be changed in the parameter menu.

## SNMP agent

---

AP 5.4    AP 5.6

---

||||➡ Function is not released yet.

## SNMP password

---

AP 5.4    AP 5.6

---

||||➡ Only in production mode.

||||➡ Function is not released yet.

## FTP server

---

AP 5.4    AP 5.6

---

The File Transfer Protocol (FTP) server (RFC959) allows access to the internal RAM disk of the printer and, if available, to the memory card. The FTP server is capable of multisesion mode, without evaluating the user name when logging in. The password must match the set password (see below).

- For further information read the user manual, topic section „Advanced Applications“, chapter „Data transmission with FTP“.

**On**

Switches the FTP server *on*.

**Off**

Switches the FTP server *off*.

## FTP password

---

AP 5.4    AP 5.6

---

▣▣▣▣▶ Parameter only appears in production mode.

Input of the FTP server password by means of a connected keyboard or the printers operation panel. Default setting: „novexx“.

Changing the password:

1. Press the Esc button. The cursor jumps to the first character.
2. Press the Cut- or Feed button until the wanted character appears. Acknowledge by pressing the Online button.
3. Put in the next character.
4. Acknowledge the new password by pressing the Online button.

## WEB server

---

AP 5.4    AP 5.6

---

The web server may be used to

- read out or change parameter settings of the printer with a web browser
- operate the printer via a web browser.

▣▣▣▣▶ The WEB server is not multi-session capable, what means that only one user at a time can be logged in.

### Requirements for use of the web server function:

- Printer is connected to network
- A valid IP address is assigned to the printer (by the network administrator or by a DHCP server)
- `INTERFACE PARA > NETWORK PARAM. > WEB server` must be set to „On“.

### Starting the web server:

1. Write down the printers IP address (`INTERFACE PARA > NETWORK PARAM. > IP address`).
2. Start the web browser.

3. Insert into the address field:

http://[IP address without leading zeros]

Example: IP address = 144.093.029.031

Input: http://144.93.29.31

4. Click „Login“.
5. Type in user name (admin) and password (admin).

If the login was successful, you will find the following menu items at the left window margin:

Menu item	Function
Home	Jump to the home page
Logout	Interrupt the connection to the printer
Parameter	<p>Opens the parameter menu. By clicking on submenus and parameters, those can be opened and the parameter settings be changed.</p> <p>▣▣▣▣ Some parameters force the printer to reset, if their setting is modified by means of the operation panel. If the parameters are changed via the web server, this doesn't happen automatically. Therefore, the modifications only become effective after the next printer restart. A restart can be triggered remote in the „Display view“.</p>
Display view	Opens the display operation panel. Enables remote operation of the printer.
Download	<p>Opens another browser window with the URL of the FTP server. For more information read the description of <code>INTERFACE PARA &gt; NETWORK PARAM. &gt; FTP server</code>.</p>
Help	Help texts

[5] Functions of the web server.

- On** Switches the web server *on*.
- Off** Switches the web server *off*.

## WEB display refr

(WEB display refresh)

AP 5.4 AP 5.6

▣▣▣▣ Only appears, if `INTERF.PARAM > NETWORK PARAM. > Time client = „On“`.

Automatic updating of the web browser display. The setting determines the time in seconds between two updates.

▣▣▣▣ Setting 0 = „no automatic updating“.

- xx s** Setting range: 0 to 20; Default setting: 5



**WEB admin passw.**

(WEB administrator password)

---

AP 5.4    AP 5.6

---

■ Only in production mode.

Modifying the password for web server access as admin.

Default setting: „admin“

■ The user name is also „admin“.

■ If the user logs in as admin to the web server, he/she has access to all parameters, which are *not* marked with the footmark „only in production mode“.

Changing the password at the operating panel:

1. Press the Esc button. The cursor jumps to the first character.
2. Press the Cut- or Feed button until the wanted character appears. Acknowledge by pressing the Online button.
3. Type in the next character.
4. Acknowledge the new password by pressing the Online button.

■ Alternatively, the password can be typed in using a keyboard, or via the web server.

**WEB supervisor p.**

(WEB supervisor password)

---

AP 5.4    AP 5.6

---

■ Only in production mode.

Modifying the password for web server access as supervisor.

Default setting: „supervisor“

■ The user name is also „supervisor“.

■ If the user logs in as supervisor to the web server, he/she has access to *all* parameters.

Changing the password at the operating panel:

1. Press the Esc button. The cursor jumps to the first character.
2. Press the Cut- or Feed button until the wanted character appears. Acknowledge by pressing the Online button.
3. Type in the next character.
4. Acknowledge the new password by pressing the Online button.

■ Alternatively, the password can be typed in using a keyboard, or via the web server.

## WEB operator p.

(WEB operator password)

---

AP 5.4    AP 5.6

---

▣▣▣▣➔ Only in production mode.

Modifying the password for web server access as supervisor.

Default setting: „operator“

▣▣▣▣➔ The user name is also „operator“.

▣▣▣▣➔ If the user logs in as operator to the web server, he/she has access to a selection of parameters, which are necessary for settings during labelling operation.

- For details see paragraph [AP 5.4/5.6 operator parameters](#)  on page 13.

Changing the password at the operating panel:

1. Press the Esc button. The cursor jumps to the first character.
2. Press the Cut- or Feed button until the wanted character appears. Acknowledge by pressing the Online button.
3. Type in the next character.
4. Acknowledge the new password by pressing the Online button.

▣▣▣▣➔ Alternatively, the password can be typed in using a keyboard, or via the web server.

## Time client

---

AP 5.4    AP 5.6

---

Loads the current time from a time server.

Off

The time client is switched off.

On

The time client is switched on. The time is loaded with the frequency set under *Sync. interval* from a time server with the IP address *Time server IP*.

If there is no valid time server response within 2 s after system start, an error message appears:

```
Statusnum:      9040
No Time Server
```

 With the time client service, the current date and time can be obtained from a time server using RFC868 time protocol on UDP port 37. For this purpose, a time server IP address needs to be given. Date and time are initially requested at start up an optional in a setable update interval during operation time. It is also stored in the internal real time clock. There is no time offset or daylight saving hour, so the server time must exactly match the local time of the printer.

## Time server IP

---

AP 5.4    AP 5.6

---

IP address of the time server.

▣▣▣▣ Only appears if INTERFACE PARA > NETWORK PARAM. > Time client = „On“.

xxx.xxx.xxx.xxx

Enter the IP address following the xxx.xxx.xxx.xxx schema.  
Setting range for each xxx value: [0...255].

## Sync. interval

---

AP 5.4    AP 5.6

---

Determines the frequency for time requests.

▣▣▣▣ Only appears if INTERFACE PARA > NETWORK PARAM. > Time client = „On“.

xxxx

Setting range: [0...9999] s; Default setting: 3600 s.

## Time zone

---

AP 5.4    AP 5.6

---

Correction of the time received by the time server by a value expressed in hours (hh) and minutes (mm).

▣▣▣▣ Only appears if INTERFACE PARA > NETWORK PARAM. > Time client = „On“.

+/- hh:mm

Setting range: [-12:00...+12:00]; Default setting: 00:00; Step width: 00:30

## DHCP host name

---

AP 5.4    AP 5.6

---

Host name of the printer. Default setting: „Device name“ + the last 3 figures of the MAC adress.

Typing in the host name at the operating panel:

1. Press the Esc button. The cursor jumps to the first character.
2. Press the Cut- or Feed button until the wanted character appears.  
Acknowledge by pressing the Online button.

▣▣▣▣ Valid characters: A-Z, a-z, 0-9, -

3. Type in the next character.

4. Acknowledge the new password by pressing the Online button.

▣▣▣▣ Alternatively, the password can be typed in using a keyboard, or via the web server.

> OPTIONS

**RFID Option**

AP 5.4    AP 5.6

- Off** RFID-Option is *not* activated (RFID = Radio Frequency Identification).
- Serial Com1** This setting option is not relevant for application of the RFID option.  
 ■■■► This setting option is only visible, if Com1 is not activated for any other option.
- Serial Com4** Com4 is activated for application of the RFID option (Setting for AP 5.4 Gen II, AP 5.6).  
 ■■■► This setting option is only visible, if Com4 is not activated for any other option.

**StandAlone Input**

AP 5.4    AP 5.6

- Defines an interface for data input in standalone mode.  
 ■■■► Interfaces are only selectable, if installed and not used by another function (e. g. as data interface). If `INTERFACE PARA >EASYPLUGINTERPR > Interface = „Automatic“`, all interfaces besides Com3 are blanked out.
- None** No data input via interface.
- Serial Com1** Com1 is activated for data input in standalone mode.
- Serial Com3** Com3 is activated for data input in standalone mode.
- TCP/IP SOCKET** Ethernet interface is activated for data input in standalone mode.

## #VW/I Interface

---

AP 5.4    AP 5.6

---

<b>Easyplug</b>	Defines the output interface belonging to the Easy-Plug command #VW/I. (Default) Interface that is defined in <code>INTERFACE PARA &gt;EASYPLUGINTERPR &gt; Interface</code> as input interface for print data.
<b>Serial Com1</b>	Serial interface Com 1. <ul style="list-style-type: none"> <li>▣▣▣▣ Only available for selection, if the interface is not occupied by another function.</li> </ul>
<b>USB</b>	USB interface <ul style="list-style-type: none"> <li>▣▣▣▣ Only available for selection, if the interface is not occupied by another function.</li> </ul>
<b>TCP/IP SOCKET</b>	Ethernet interface <ul style="list-style-type: none"> <li>▣▣▣▣ Only available for selection, if the interface is not occupied by another function.</li> </ul>
<b>Serial Com3</b>	Serial interface Com 3. <ul style="list-style-type: none"> <li>▣▣▣▣ Only available for selection, if the optional I/O board is installed and if the interface is not occupied by another function.</li> </ul>

## > DRIVEASSIGNMENT

- For detailed information read the Easy-Plug manual, topic section [General Notes, Definitions and Command Overview](#) , chapter „Drive names“.

### Drive C

---

AP 5.4    AP 5.6

---

Assigns drive letter C: to the card slot or to the USB port.

<b>None</b>	C: is not assigned
<b>SD card</b>	(Default setting) C: is assigned to the SD card slot.
<b>USB-stick</b>	C: is assigned to the USB host port.

## SYSTEM PARAMETER

### Foil end warning

---

 AP 5.4    AP 5.6
 

---

Setting of a limit diameter for the ribbon roll. If the ribbon roll diameter falls below the set value, the displayed message changes from...

ONLINE    X JOBS    ...to...

FOLIE    X JOBS    ...while the display is blinking.

- For details refer to the parameters [DP INTERFACE > Ribbon signal](#) and [SERVICE DATA > OPERATION DATA > Foil diameter](#)

x.xx mm

Setting range: 25.4 to 50.0 mm; Unit interval: 0.1 mm;  
Default setting: 25.4 mm

### Foil warn stop

---

 AP 5.4    AP 5.6
 

---

Off

(Default setting) Printer does *not* stop in case of a „Foil end warning“.

On

If a „Foil end warning“ occurs, the printer stops after the current label and shows the status message:

```
PrintStatus: 5110
Foil low
```

- ➔ Press the online button to acknowledge the message, then the feed button to continue printing.

### Print Interpret.

---

 AP 5.4    AP 5.6
 

---

Easyplug

Printjobs written in the Easy-Plug command language can be interpreted.

Lineprinter

Lineprinter (or similar to Lineprinter), print-out of the print command.

Hex Dump

Print-out in hexadecimal format.

In Lineprinter and Hex Dump, commands are printed out in the form of a list with the character set 12.

▣▣▣▣ ➔ When setting Lineprinter or Hex Dump, Easy Plug commands which have not yet been processed are deleted!

ZPL Emulation

Printjobs written in the ZPL II<sup>®1)</sup> command language („ZPL“) can be interpreted.

▣▣▣▣ ➔ Firmware loading requires changing into EasyPlug first.

---

1) ZPL II is a registered trademark of ZIH Corp.

## Character sets

AP 5.4    AP 5.6

Setting the character set:

- **16bit:** UTF-8 coding.
- **8bit:** Choose between IBM and ANSI character set.
- **7Bit:** Additionally to the IBM and ANSI character sets, some country specific character sets are provided, which have some characters allocated differently (see table below)

▣▣▣▣▶ The country specific character sets are only suitable for older 7bit applications!

Decimal	35	36	64	91	92	93	94	96	123	124	125	126	>127
ASCII	#	\$	@	[	\	]	^	'	{		}	~	
UTF-8	#	\$	@	[	\	]	^	'	{		}	~	print
ISO 8859-2	#	\$	@	[	\	]	^	'	{		}	~	print
ANSI (CP 1250)	#	\$	@	[	\	]	^	'	{		}	~	print
ANSI (CP 1252) <sup>a</sup>	#	\$	@	[	\	]	^	'	{		}	~	print
IBM	#	\$	@	[	\	]	^	'	{		}	~	print
Special	f	¢	blank	blank	¼	½	blank	blank	«	•	»	±	blank
Norway	#	\$	@	Æ	¥	Å	^	'	æ	¢	å	~	blank
Spain	#	\$	@	i	Ñ	Ç	^	'	¿	ñ	ç	~	blank
Sweden	#	•	É	Ä	Ö	Å	Ü	é	ä	ö	å	ü	blank
Italy	Š	\$	§	°	ç	é	^	ù	à	ò	è	'	blank
Germany	#	\$	§	Ä	Ö	Ü	^	'	ä	ö	ü	ß	blank
France	£	\$	à	°	ç	§	^	'	é	ù	è	~	blank
United Kingdom	£	\$	@	[	\	]	^	'	{		}	½	blank
USA	#	\$	@	[	\	]	^	'	{		}	~	blank
blank = space, print = printable													

[6] Country settings for applications, which base on 7bit ASCII code.

a) Covering ISO 8859-1.

- For complete tables of all fixfonts characters available with setting "IBM" refer to the User Manual, topic section "Internal Fonts". You also find there a comparison of the IBM and ANSI character sets.

## Character filter

---

AP 5.4    AP 5.6

---

<b>Character &gt;= 20Hex</b>	Filter function is activated. Characters smaller than 20H are filtered out of the data flow.
<b>All character</b>	Filter function is deactivated. Characters smaller than 20H are treated as normal characters.

## Light sens. type

---

AP 5.4    AP 5.6

---

Light sensor type

The optional reflex photoelectric switch for labels with reflecting length markings, or the normal factory-fitted photoelectric switch for labels with transparent or register gaps (self-adhesive labels), must be defined according to the application.

<b>Short label opt.</b>	Activates the optional short label sensor. ■■■► Appears only in AP 5.4 printers which are equipped with the short label sensor.
<b>Reflex</b>	Reflex photoelectric switch (for reflecting markings)
<b>Punched</b>	Transparent photoelectric switch (for gaps)

## Head-sensor dist.

(Distance between printline and label sensor)

---

AP 5.4    AP 5.6

---

■■■► Parameter appears only in production mode or if a value > 0 is set.  
 Printhead-sensor distance

Special function for setting non-standard punch sensors. Such sensors can be applied in special application devices ("Nistan"). The value x is the distance between thermal edge and punch sensor in millimeters.

<b>x mm</b>	Setting range: 0 to 400 mm ■■■► A „non standard sensor“ must be installed and connected instead of the regular punch sensor. ■■■► 0 = disabled (the regular punch sensor is used).
-------------	--

## Foil mode

---

AP 5.4    AP 5.6

---

<b>Thermo transfer</b>	Thermo transfer printing (Ribbon sensor activated)
<b>Thermal printing</b>	Thermo direct printing (Ribbon sensor deactivated)



## Turn-on mode

---

AP 5.4    AP 5.6

---

Operating mode of the printer after it has been switched on.

<b>Online</b>	Printer starts in on-line mode.
<b>Offline</b>	Printer starts in off-line mode.
<b>Standalone</b>	Printer starts in standalone mode.

## Error reprint

---

AP 5.4    AP 5.6

---

If an error occurs while a label is printed, the last printed label is reprinted. For label layouts containing variable data (for example, count fields), disable the reprint function.

<b>On</b>	Reprint in error cases (default setting)
<b>Off</b>	No reprint in error cases.

## EasyPlug error

---

AP 5.4    AP 5.6

---

Handling of errors caused by faulty Easy-Plug commands.

<b>Tolerant handl.</b>	The label is printed, after the Easy-Plug/Bitimage error was acknowledged (default setting).
<b>Strict handling</b>	<p>The Easy-Plug command, which caused the error, is displayed after approx. 2 seconds in the lower display line. The displayed text is up to 30 characters long and is scrolled automatically.</p> <p>If a single character caused the error, this character is marked with „&gt;&gt; &lt;&lt;„ in the display text, to facilitate the detection.</p> <p>By pressing the cut button, the display can be toggled between error message and Easy-Plug command text.</p> <p>After acknowledging the first occurred Easy-Plug error, the printjob and the spooler are deleted (as by #!CA). This prevents the printing of labels with format errors.</p>

## Single job mode

---

AP 5.4    AP 5.6

---

In single job mode (also stop mode) the printer stops after every job and waits until the operator restarts the print process.

<b>Off</b>	Single job mode is switched off (default setting).
------------	--

**On**

Single job mode is switched on. The printer always displays "Start next job", before starting a new print job. This requests the user to acknowledge by pressing the Online button.

### Head resistance

---

AP 5.4    AP 5.6

---

For optimum print quality, the individual print head resistance of the thermo head employed in the device must be set once with this parameter.

When replacing the print head, the resistance value of the print head (to be read off from the print head) must be entered again.



#### CAUTION!

Entering a false value can damage the print head.

→ Read off the correct value from the print head and set it accordingly.

xxxx Ohm

▣▣▣▣ The value set here remains when the factory settings are carried out.  
Setting range: 1000 to 1500 Ohm; Unit interval: 1 Ohm

Setting the print head resistance:

#### Setting:

1. From the print head, read off the resistance value to be set and make a note of it (1000 to 1500).
2. In off-line mode press the Prog. button, display: *PRINT INFO*.
3. Press the Cut button until *SYSTEM PARAMETER* is displayed.
4. Press the Online button, display:

SYSTEM PARAMETER  
Foil end warning

5. Press the Cut button until the following is displayed:

SYSTEM PARAMETER  
Head resistance

6. Press the Online button, set value is displayed.
7. Set the previously noted resistance value of the print head using the Feed and Cut buttons.
8. Press the Online button to confirm the set value.
9. Press the Prog. button to return to the display *OFFLINE 0 JOBS*.

## Temp. reduction

---

AP 5.4    AP 5.6

---

Reduction in the print head temperature

The parameter `SYSTEM PARAMETER > Temperature reduct.` allows the power supply to be reduced in the event of an increase in the print head temperature, thereby ensuring an evenly good print image.

xxx%

Setting range: 0 to 100%; Unit interval: 5%

The following setting alternatives are available:

- 0%: No temperature reduction.
  - xx%: Up to xx% temperature reduction with a hot print head.
  - Default setting: 20%.
- For further information refer to the user manual, topic section „Advanced Application“, chapter „Printing with Temperature Compensation“

## Thin line emphas

---

AP 5.4    AP 5.6

---

▣► Only in production mode

Thin line emphasis. Print emphasis for thin lines in order to get a better print result.

On

(Default) Print emphasis for thin lines is switched on.

Thin lines in the printout, which run crossways to the printing direction, are printed approx. 1.5 times wider. This may have the effect, that small white patches are closed with color (e.g. in the „e“ with very small fonts).

Off

Print emphasis for thin lines is switched off.

## Voltage offset

---

AP 5.4    AP 5.6

---

The voltage offset increases the head voltage and therefore the head temperature which e.g. was set by Easy Plug command (HV).

xx%

Setting range: 0 to 20%; Unit interval: 1%; Default setting: 0%

## Miss. label tol.

---

AP 5.4    AP 5.6

---

Missing label tolerance

The maximum search path for gaps which cannot be found can be varied. In cases of difficult gap detection (i. e. minimum variation in the light transparency, gap to label), shortening the search path is to be recommended. Label loss resulting from gaps not being detected can be reduced in this way. Printing does not take place during the search process.

- xx** Setting range: 0 to 50; Unit interval: 1
- Example 0 (Zero label length):  
A gap must be found after a printed label otherwise an error message is given. This setting is for detecting every missing label.
  - Example 5 (Five label lengths):  
A gap must be found after a maximum of 5 label lengths otherwise an error message is given.

### Gap detect mode

---

AP 5.4    AP 5.6

---

After one of the following events, the printer must always search for the punch, that is initialize the label material:

- After switching the printer on
- After changing the label material

**Manual** The operator has to initialize the material the first time always manually by pressing the feed key several times.

■▶ After a change of material, the printer has to initialize the rewinder. For this reason, approx. 70 mm label material are fed forward. If the initialization is prevented (e. g. by switching off or resetting the printer), the following status message will appear after switching on next time: „5301 BLDC rewinder Ø“.

**Autom. Forward** (Default for printers) The material initialization is always done automatically, if necessary. There is no backward movement of the material during the initialization.

**Autom. feed back** AP 5.4 / AP 5.6: Setting is visible, but has no effect.

### Periph. device

---

AP 5.4    AP 5.6

---

After installation, options must be selected under "Peripheral device" in order to be assured of the corresponding sensor queries and printer reactions.



#### CAUTION!

Selecting an incorrect option can lead to malfunctions or damage.

- None** No peripheral device is installed.
- Cutter** Sets the printer firmware to the cutter option. Selection permits access to the cut parameters.
- Rewinder** Sets the printer firmware to the rewinder option. Selection permits access to the rewinder setting parameters.
- Tear-off edge** Sets the printer firmware to the tear-off edge option. The punch is fed forward to the tear-off edge.

<b>Dispenser</b>	Setting for AP 5.4/5.6 dispenser version.
<b>Intern Rewinder</b>	AP 5.4/5.6 dispenser only: Setting for printer operation in „internal rewinder“ mode, that is operation with a deflector and without dispensing edge.
<b>Tear-off + sensor</b>	AP 5.4 only: Setting for using the dispensing edge as tear-off edge. The punch is fed forward to the dispensing edge.
<b>Disp. with LTSI</b>	Setting for operation of a LTSI applicator, see <a href="#">Technical Manual LTSI</a> 

### Singlestartquant

---

AP 5.4    AP 5.6

---

Determines the label quantity, which will be printed after a start signal.

**xx**                      Setting range: 1 to 10; Unit interval: 1; Default setting: 1

### External signal

---

AP 5.4    AP 5.6

---

The parameter determines, if and how an incoming signal at the - optional - single start connector will be interpreted.

**Off**                      Signal interpretation disabled.

**Singlestart**                      The signal triggers the printing of a single label. This setting may be used e.g. for printing single labels by means of a foot switch.

**Stacker full**                      The signal triggers the display of a status report and stops the printer. This setting may be used when using a stacker (= stacker full signal).

- Detailed information about using start signals can be found in the user manual, topic section „Advanced Applications“, chapter „Printing with start signal“, [Settings in the parameter menu](#) 

▮▮▮▮➔ Only appears here, when *no* I/O board is installed. Otherwise, this parameter appears in the **I/O BOARD** menu.

- For details see paragraph [Start print mode](#)  on page 78.

### Print contrast

---

AP 5.4    AP 5.6

---

**xxx%**                      Setting range: 1 to 120%; Unit interval: 1; Default setting: 60



#### CAUTION!

The parameter **Print contrast** affects directly the life durance of the printhead. It counts: „The higher the setting of **Print contrast** is, the lower is the life durance of the printhead“. This counts even more for settings above 100%. Therefore mind:

- ➔ Always choose the lowest possible setting necessary to produce an acceptable print result.

- The highest setable print contrast depends on two factors:
- Printhead resolution
  - Print speed

Print speed	Max. print contrast
51 mm/s (2 inch/s)	120%
76 mm/s (3 inch/s)	117%
102 mm/s (4 inch/s)	115%
127 mm/s (5 inch/s)	100%
152 mm/s (6 inch/s)	85%
178 mm/s (7 inch/s)	76%
203 mm/s (8 inch/s)	67%

[7] Max. print contrast for printheads with 203 dpi resolution.

Print speed	Max. print contrast
<= 76 mm/s (3 inch/s)	120%
102 mm/s (4 inch/s)	105%
127 mm/s (5 inch/s)	88%
152 mm/s (6 inch/s)	74%

[8] Max. print contrast for printheads with 300 dpi resolution.

## Ram disk size

AP 5.4    AP 5.6

A part of the printer memory can be identified as a RAM disk. The RAM disk can be used in the same way as the Compact Flash Card, e.g. for storage of logos or fonts.

With the parameter Ram disk size, the customer can set the size of the RAM disk to his needs. Be aware, that RAM disk memory is not available for print picture buildup. Use of much RAM disk memory reduces the picture buildup rate of the printer.

☛ Switching the printer off extinguishes the memory content! Fonts, logos etc., which were loaded on the RAM disk, must be loaded again after switching the printer off.

xxxx KBytes

Setting range: 128 KBytes to the maximum size, which depends on the memory configuration and allocation of the printer; Unit interval: 128 KBytes; Default setting: 512 KBytes.

- See also parameter PRINT INFO > Memory status.

## Font downl. area



AP 5.4    AP 5.6

If speedo-fonts are supposed to be used, they have first to be copied to a reserved RAM disk area. Use parameter „Font downl. area“ to reserve the RAM disk area in the required size.

The size of the required RAM disk area depends on the size of the font files to be loaded.

▮▮▮▮ Mind to reserve a big enough RAM disk area!

There are two ways to copy the font files to the RAM disk:

- Copy from SD-card:  
The font files must be placed in a folder named \fonts on the SD-card during system startup. The files must be named fontxxx.spd (xxx = No. from 200 up to 999).
- For details refer to the „Plugin-card manual“, topic section „Application“, paragraph [CF/SD-cards](#) .
- Copy via Easy Plug command #DF (download file).
- More information about the #DF command: See manual „Easy Plug“, topic section [Description of Commands](#) .

**xxx KBytes**

Setting range: 128 KBytes to the maximum size, which depends on the memory configuration and allocation of the printer; Unit interval: 128 KBytes; Default setting: 256 KBytes

▮▮▮▮ Switching the printer off extinguishes the memory content! Fonts, logos etc., which were loaded on the RAM disk, must be loaded again after switching the printer off.

### Free store size

---

AP 5.4    AP 5.6



---

By setting this parameter, a part of the memory is reserved, which the printer firmware can use if necessary (dynamic memory allocation). If this memory area is dimensioned too small, the printer firmware can not work and the error message „8856 Free store size“ shows up.

▮▮▮▮ The more memory is allocated using this parameter, the less memory is available for print jobs.

**xxx KBytes**

Setting range: 4 MB to the maximum size, which depends on the memory configuration and allocation of the printer; Unit interval: 128 KBytes; Default setting: 4 MB.

- ➔ A good advice is to increase the set value step by step, starting with the minimum of 4 MB, until the status message 8856 ("Free store size", what means the memory area is low) does no longer appear during data conversion.
- Use with the Easy Plug command #YG, see manual [Easy Plug](#) .
- See parameter [Memory status](#)  on page 18.

## Print info mode

---

AP 5.4    AP 5.6

---

Structure option for info printouts.

### Par. values right

Setting for 100 mm material width. The parameter values are printed on the right side of the parameter names:

*Parameter name: Value*

### Par. values left

Setting for 100 mm material width. The parameter values are printed on the left side of the parameter names:

*Value: Parameter name*

### Compact right

Setting for 50 mm material width. The parameter values are printed on the right side of the parameter names:

*Parameter name: Value*

### Compact left

Setting for 50 mm material width. The parameter values are printed on the left side of the parameter names:

*Value: Parameter name*

## Reprint function

---

AP 5.4    AP 5.6

---

### Off

(Default setting) Reprinting is not possible.

### On

The last printed label can be reprinted by pressing the feed button in online mode, if the printer is not printing at that moment.

## Language

---

AP 5.4    AP 5.6

---

Setting the display language.

Russian  
 Turkish  
 Polish  
 Italian  
 Danish  
 Dutch  
 Spanish  
 French  
 English  
 German



## Keyboard

---

 AP 5.4    AP 5.6
 

---

Setting the keyboard layout country version for standalone operation.

Polish  
 Swedish  
 Finish  
 Danish  
 Spanish  
 French  
 English  
 German

## Access authoriz.

---

 AP 5.4    AP 5.6
 

---

Access authorization

Limits the access either to all printer functions (Power-up code) or only to the parameter menu (user or supervisor mode). Changed settings become active after the next switch-on.

### Key codes

Regardless when the code is prompted, can three different key codes be typed in tab. 9.

Enter code

Entering a key code: Type the corresponding buttons of the control panel in succession. A valid key code switches the printer into the appropriate mode.

Mode	Key code	Impact
User	2x Cut Feed, Online	Access only to the submenus PRINT INFO and SERVICE DATA
Operator	Cut, Online, Feed, Prog	Access to reduced parameter menu
Supervisor	2x Online, Feed, Cut, 2x Online	Access to all parameters except production parameters
Production	Cut, Online, Feed, Cut, 3x Online	Access to all parameters

[9] Permissible key codes.



### CAUTION!

Production mode: Input errors to certain parameters can make the printer inoperable or can damage it.

→ The production code may only be applied by *trained service technicians*.

▮▮▮▮ Especially service technicians may use the direct access into production mode, even if the parameter *Access authoriz.* is set to „Off“, what means that no password will be queried at all. To do so, proceed as follows:

1. Switch printer off.
2. Switch printer on, simultaneously press the Feed+Prog-key until the printer type is displayed.

After the printer was powered up, the key code will be queried:

3. Enter the production code.

### Possible Settings

<b>Off</b>	Password interrogation switched off (default)
<b>Power-up code</b>	Activates the password interrogation directly after switching the printer on. After the input of a valid key code, the printer switches into offline mode. Depending on the entered key code, the printer starts in user, supervisor or production mode.
<b>User</b>	Activates the password interrogation when accessing the parameter menu. <ul style="list-style-type: none"> <li>• The printer is in the offline mode after switch-on</li> <li>• Change to the online mode is possible without restriction</li> <li>• To reach the parameters-menu, enter a valid key code</li> <li>• Valid key codes: all</li> </ul>
<b>Operator</b>	Access to reduced parameter menu; contains only parameters which are necessary for daily use of the printer. <ul style="list-style-type: none"> <li>○ For details see paragraph <a href="#">AP 5.4/5.6 operator parameters</a> on page 13.</li> </ul>
<b>Supervisor</b>	As setting „User“, with different valid key codes: <ul style="list-style-type: none"> <li>• Valid key codes: Supervisor, Production</li> </ul>
<b>User auto start</b>	Printer starts without password interrogation. Only the menus PRINT INFO and SERVICE DATA are accessible.

## Realtime clock

---

AP 5.4      AP 5.6

---

The realtime clock provides actual date and time. Those data can be processed using the Easy-Plug #YC, #YS or #DM commands.

Realtime Clock dd.mm.yyyy hh:mm	dd=Day, mm=Month, yyyy=Year, hh=Hour, mm=Minute (Example: 19.02.2001 14:41)
------------------------------------	--

Setting date / time:

1. Press the CUT button repeatedly, until the digit blinks which you want to alter.
2. Set the intended value to the digit by pressing the FEED button (repeatedly).
3. Repeat steps 1 and 2 until date / time is set correctly.
4. Press the ONLINE button.
  - ▣▶ Press the ESC button to leave the parameter without altering the setting.

## DISPENSER PARA

▣▣▣▣ This menu appears only, if **SYSTEM PARAMETER > Periph. device** is set to „Dispenser“.

### Dispense Mode

AP 5.4

AP 5.6

Governs the run of the print-dispense procedure.

▣▣▣▣ Only if **SYSTEM PARAMETER > Periph. device** = „Dispenser“.

#### Normal 1:1 Mode

- The printer cannot print on the whole label surface. A stripe at the label beginning stays unprinted.
- The label is being dispensed while printing.
- The output volume is at its maximum level.

▣▣▣▣ The width of the unprintable stripe is calculated as follows:

*Distance print line to dispensing edge (25 mm) + Dispense position (tab. 10)*

Printer	Distance print line - dispensing edge
64-xx	39.8 mm (long dispensing edge) 24.2 mm (short dispensing edge)
AP 5.4	25.0 mm

[10] Distances between print line and dispensing edge for some printers.

- Also refer to parameter **PRINT PARAMETERS > Dispense position**.
- A graphic can be found under **PRINT PARAMETERS > Cut mode > Normal 1:1 mode**.

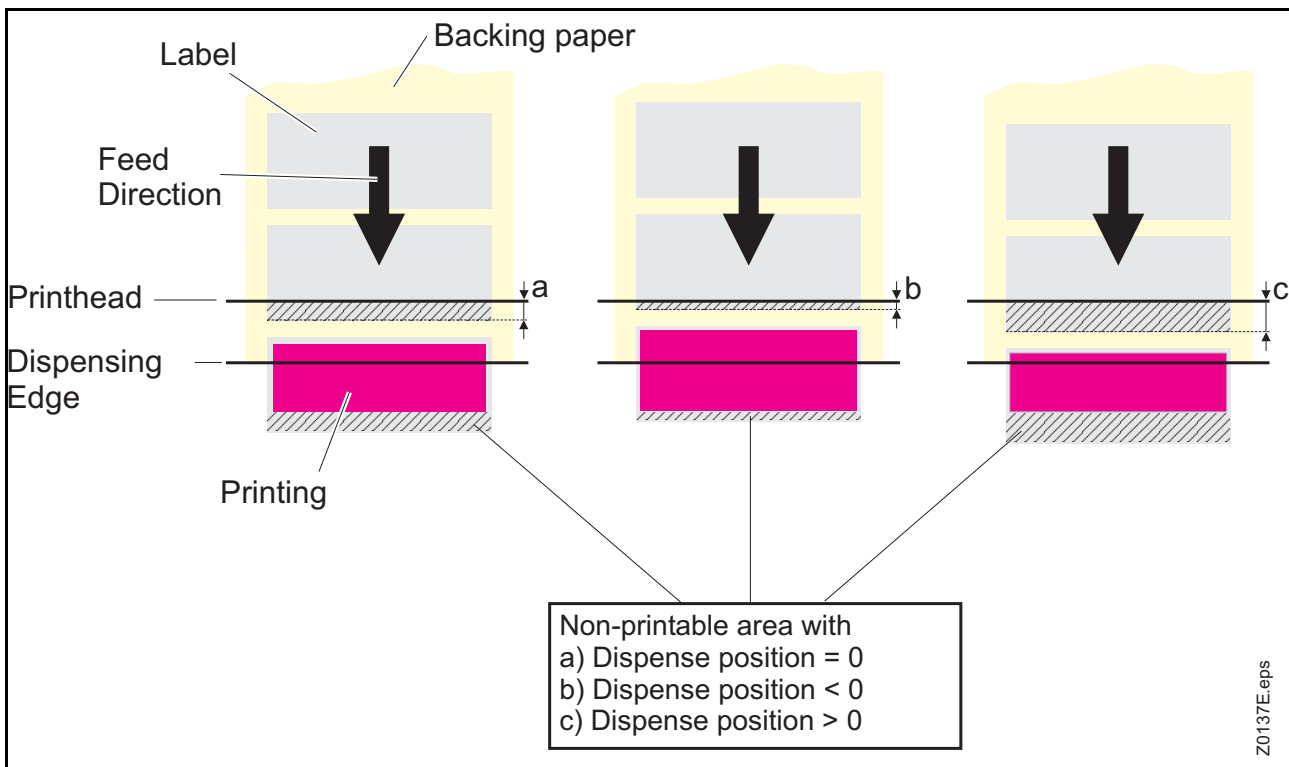

[16] The size of the not imprintable area in Normal 1:1 depends of the setting of parameter **DISPENSE PARAMETERS > Dispense Position**.

**Batch Mode**

- The printer can print the whole label surface.
- Dispensing of the label takes place during printing. Printing of the next label is interrupted until the label is completely dispensed.
- The output volume is at its maximum level.

▣▣▣▣ The *Batch mode* is optimised for printing and dispensing at high speeds. Due to this, it is not possible to use all features available in modes *Normal 1:1* or *Real 1:1*. Also consider, that printing data must be available on time and in sufficient quantity.

▣▣▣▣ The following must be considered in batch mode:

- Printjobs must not contain counter fields or variable fields
  - DISPENSE PARAMETER > Dispensing mode must be set to "fast".
- A graphic can be found under PRINT PARAMETERS > Cut mode > Batch mode.

**Real 1:1 Mode**

(Default setting)

- The printer can print the whole label surface.
  - After dispensing a label, the beginning of the next label is drawn back under the print head.
  - The output volume is lower than in *Batch Mode* or *Normal 1:1 Mode*.
- A graphic can be found under PRINT PARAMETERS > Cut mode > Real 1:1 mode.

**Dispenseposition**

AP 5.4

AP 5.6

▣▣▣▣ Only if SYSTEM PARAMETER > Periph. device = „Dispenser“.

Adjusts the dispense position in or against the feed direction. Depending on the set dispense position, the dispensed label sticks to the backing paper with a more or less wide strip [17]. The required width of this strip depends on the further processing.

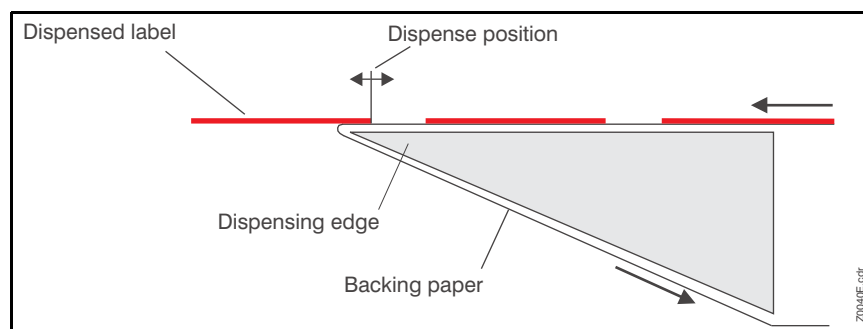

[17] Dispense position of the dispensed label.

x.x mm

Setting range: -30.0 to +20.0 mm; Unit interval: 0.1 mm; Default setting: -6.0 mm

## Display mode

AP 5.4

AP 5.6

Only if `SYSTEM PARAMETER > Periph. device = „Dispenser“`.

Makes the *already* printed labels appear in the display instead of the *not yet* printed ones.

### Job rest quant.

Display of the *not yet* printed labels of a print job.

Only if `SYSTEM PARAMETER > Periph. device = „Dispenser“`.

### Dispense counter

Counting of start pulses. Activate the counter by selecting "Dispense counter". The counted number appears on the display after the parameter *Dispense counter* (see below) has been selected.

## Dispense counter

AP 5.4

AP 5.6

Only if `SYSTEM PARAMETER > Periph. device = „Dispenser“`.

Dispense counter  
xxxxxx

xxxxxx = Number of dispensed labels.

Only if `SYSTEM PARAMETER > Periph. device = „Dispenser“`.  
The displayed value can be varied by pressing the Cut or Feed button. There are two ways of setting back the counter:

- Set the parameter `Display mode` (see above) to "Job rest quant." , then back to "Dispense counter" and confirm by pressing the Online button.
- Reduce the displayed number by pressing the Cut button.

## Application mode

AP 5.4

AP 5.6

Only if `SYSTEM PARAMETER > Periph. device = „Dispenser“`.

### Save Mode

A start signal is required to draw the next label back under the print head. This setting bears advantages for label material with a strong adhesive, which would not stay attached to the applicator when the backing paper is fed backwards.

### Immediate Mode

After the just printed label has reached the dispense position, the following label is drawn back under the print head. The dispensed label stays attached to the applicator (default setting).

### Synchronous mode

Drawing back of the next label to be printed is triggered by the *not* active edge of the start signal. The active edge is defined with `Start print mode`. *Not* active is the opposite signal edge.

Requirements:

- `SYSTEM PARAMETER > Start print mode = „Pulse rising“` or `„Pulse falling“`
- With I/O board installed: `I/O BOARD PARA > Start print mode = „Pulse rising“` or `„Pulse falling“`

## Start source

---

AP 5.4    AP 5.6

---

☛ Only if `SYSTEM PARAMETER > Periph. device = „Dispenser“`.

Choose a signal source for the start signal:

**Foot switch**

Optional foot switch is used to generate the start signal.

**Light barrier**

(Default setting) Photoelectric switch at the dispensing edge which detects the taking off of the dispensed label.

☛ The setting "Light barrier" is unsuitable for product sensors! Product sensors must be connected to the I/O board!

## Calibration mode

---

AP 5.4    AP 5.6

---

☛ Only if `SYSTEM PARAMETER > Periph. device = „Dispenser“`.

☛ Is only effective with label material shorter than 40 mm!

 If label material shorter than 40 mm is used, the printer automatically initializes before printing. This measuring of the label material improves the impression accuracy. The initialization occurs in the following cases:

- After switching the printer on
- After opening and closing the printhead pressure lever.

☛ *Advice:* Start the material initialization manually before printing. This is done by pressing the feed button in offline mode.

Selecting a material initialization procedure:

**Automatic**

(Default) Material initialization is done automatically. Therefore, the label material is fed forwards and backwards several times.

☛ There is a risk of the dispensing edge roller getting jammed by labels sticking to it, which were dispensed by the forward/backward movement. If this happens, use the setting „Manual“ instead.

**Manual**

The label material is fed two or three label lengths forwards. If this is done, dispense two labels by pressing the feed button - only afterwards, the initialization is complete.

## Start offset

---

AP 5.4    AP 5.6

---

Function for operation with product sensor.

Use this parameter to set the distance between product sensor (light barrier) and dispensing edge. The recommended delay time is calculated of the "Start delay" distance and the conveyor speed (= print speed in cases of direct application).

**xxx.x mm**

Setting range: 15.0 bis 2999.9 mm; Unit interval: 0.1 mm;  
Default setting: 15.0 mm

### Start error stop

AP 5.4    AP 5.6

Function for operation with product sensor.

Determines the reaction of the machine on a product start error. A product start error occurs in the following cases:

- If a further start signal arrives, before the current label is completely printed.
- *With mounted I/O board or USI board only:* If a reprint is requested, before the first label after powering on is printed.
- If a start signal arrives and no printjob is loaded.

If a product start error occurs, the machine stops and displays the appropriate status message. If an I/O board or an USI is installed, the following output signals are activated (set low):

- ERROR\
- MACHINE STATUS\

**On** (Default) Start errors are worked up (the machine stops!)

**Off** Start errors are being ignored.

### Product length

AP 5.4    AP 5.6

Function for operation with product sensor.

If this function is activated, the printer ignores all start signals until the product has passed the dispensing edge.

**0.0 mm** Setting range: [0.0...1999.9] mm; Default setting.: 0.0

### Current mode

AP 5.4    AP 5.6

▣▣▣▣➔ Only in production mode.

▣▣▣▣➔ Only if `SYSTEM PARAMETER > Periph. device = „Dispenser“`.

The setting of this parameter influences the impact of the parameters *Min rew. current* and *Max rew. current*.

**Table values** Display of the automatically calculated motor current chart PWM values (in %). On the base of this setting, the printer calculates the motor current values for *Min rew. current* and *Max rew. current* out of print speed and material width. The calculated values appear as default 100%.

**Absolute values** With this setting, the printer doesn't calculate and doesn't adapt to material width and print speed. The set values for *Min rew. current* and *Max rew. current* are given to the output stage without a modification. The values appear as absolute values.

▣▣▣▣➔ The setting "Absolute values" should only be applied by qualified personell!

## Min. rew. current

AP 5.4 AP 5.6

- ▣▣▣▣ Only in production mode.
  - ▣▣▣▣ Only if SYSTEM PARAMETER > Periph. device = „Dispenser“.
- Minimal rewinder current

This parameter influences the rewinder current with 25 mm rewinder diameter (min. rewinder diameter).

Problem	Solution
The label web runs too loose around the dispensing edge during printer operation. The label roll is wound up too loose.	Increase the setting
The label web runs too tight around the dispensing edge during printer operation. The label roll is wound up too tight.	Decrease the setting

[11] Cases, in which the setting of the minimal rewinder current has to be corrected.

XXX%

Setting range: 50-200%; Default setting: 110%  
Precondition for the setting in percent:

Parameter DISPENSER PARA > Current mode = Table values (see above).

XXX

Setting range: 0-750; Default setting: 110;  
Precondition for the setting in absolute values:

Parameter DISPENSER PARA > Current mode = Absolute values (see above).

## Max. rew. current

AP 5.4 AP 5.6

- ▣▣▣▣ Only in production mode.
  - ▣▣▣▣ Only if SYSTEM PARAMETER > Periph. device = „Dispenser“.
- Maximum rewinder current

This parameter influences the rewinder current with 120 mm rewinder diameter (max. rewinder diameter).

XXX%

Setting range: 50-200%; Default setting: 110%  
Precondition for the setting in percent:

Parameter DISPENSER PARA > Current mode = Table values (see above).

XXX

Setting range: 0-750; Default setting: 250;  
Precondition for the setting in absolute values:

Parameter DISPENSER PARA > Current mode = Absolute values (see above).

 The two parameter values *Min. rew. current* and *Max. rew. current* are used by the motor output stage to calculate all other current values for diameters lying in between.



Problem	Solution
The label web runs too loose around the dispensing edge during printer operation. The label roll is wound up too loose.	Increase the setting
The label web runs too tight around the dispensing edge during printer operation. The label roll is wound up too tight.	Decrease the setting

[12] Cases, in which the setting of the minimal rewinder current has to be corrected.

### Start rew. current

AP 5.4 AP 5.6

■ Only in production mode.

■ Only if SYSTEM PARAMETER > Periph. device = „Dispenser“.

Start rewinder current

Setting of the start-up current super-elevation in % or the normal motor current.

XXX%

Setting range: 0-100%; Default setting: 0%

### Start cur. len.

AP 5.4 AP 5.6

■ Only in production mode.

■ Only if SYSTEM PARAMETER > Periph. device = „Dispenser“.

Start current length

Duration of the start-up current super-elevation. To be set is the feed length, during which the increased current is supposed to flow.

XX mm

Setting range: 10-40 mm; Default setting: 30 mm

### Pullback current

AP 5.4 AP 5.6

■ Only in production mode.

■ Only if SYSTEM PARAMETER > Periph. device = „Dispenser“.

 After a label was dispensed, the label web has to be pulled back under the printhead. To reach this, the rewinder is rotated slightly in the opposite direction. The braking torque of the rewinder against this rotation may not be too strong, otherwise this could decrease the impression accuracy. Because of the brake torque depending on the diameter of the wound up label web, it has to be corrected at the beginning (min. diameter) and at the end (max. diameter) of the winding-up process. This is done by the *Pullback current* (supports the backwards rotation in case of low diameter) and the *Brake current* (amplifies the brake torque in case of high diameter). Additionally can be set: The diameter up to which the Pullback current is throttled down to zero (parameter *Back diameter*), and the diameter, from which on the brake current starts (parameter *Brake diameter*).

The parameter *Pullback current* sets the support current for the rewinder at the minimum diameter of 25 mm. When the diameter of the rewound label web reaches the set value (Back diameter), the support current will be throttled down to a minimum.

### Back diameter

---

AP 5.4    AP 5.6

---

- ▣ Only in production mode
- ▣ Only appears if SYSTEM PARAMETER > Periph. device = „Dispenser“

Pullback current diameter

- See parameter [Pullback current](#) on page 74.
  - ▣ If the label web is *loose*, while it is fed back under the printhead, *decrease* this value in small steps. If the material is *tightened* too much, *increase* the value in small steps.

XX mm

Setting range: 0-120 mm; Default setting: 50 mm

### Brake current

---

AP 5.4    AP 5.6

---

- ▣ Only in production mode.
  - ▣ Only if SYSTEM PARAMETER > Periph. device = „Dispenser“.
- Sets the brake current

- See parameter [Pullback current](#) on page 74.
  - Setting range: 0-100; Default setting: 0

XXX

### Brake diameter

---

AP 5.4    AP 5.6

---

- ▣ Only in production mode.
  - ▣ Only if SYSTEM PARAMETER > Periph. device = „Dispenser“.
- Sets the break diameter.

- See parameter [Pullback current](#) on page 74.
  - Setting range: 0-120; Default setting: 120

XXX

## REWINDER PARA

☛ This menu appears only in AP 5.4 und AP 5.6, and only, if **SYSTEM PARAMETER > Periph. device** is set to „Intern Rewinder“.

### Rewind direction

---

AP 5.4    AP 5.6

---

☛ Only if **SYSTEM PARAMETER > Periph. device** = „Intern Rewinder“.  
(Internal) Rewinder rotation direction

Printing inside

The label face shows *inwards*, when the label stock is wound up.

Printing outside

The label face shows *outwards*, when the label stock is wound up.

### Current mode

---

AP 5.4    AP 5.6

---

☛ Only in production mode.

☛ Only if **SYSTEM PARAMETER > Periph. device** = „Intern Rewinder“.

- See parameter [Current mode](#)  on page 72.

### Min. rew. current

---

AP 5.4    AP 5.6

---

☛ Only in production mode.

☛ Only if **SYSTEM PARAMETER > Periph. device** = „Intern Rewinder“.

- See parameter [Min. rew. current](#)  on page 73.

### Max rew. current

---

AP 5.4    AP 5.6

---

☛ Only in production mode.

☛ Only if **SYSTEM PARAMETER > Periph. device** = „Intern Rewinder“.

- See parameter [Max. rew. current](#)  on page 73.

### Start rew. curr.

---

AP 5.4    AP 5.6

---

☛ Only in production mode.

☛ Only if **SYSTEM PARAMETER > Periph. device** = „Intern Rewinder“.

- See parameter [Start rew. current](#)  on page 74.

## Start cur. len.

---

 AP 5.4 AP 5.6
 

---

- ▣ Only in production mode.
- ▣ Only if SYSTEM PARAMETER > Periph. device = „Intern Rewinder“.
- See parameter [Start cur. len.](#) on page 74.

## Pullback current

---

 AP 5.4 AP 5.6
 

---

- ▣ Only in production mode.
- ▣ Only if SYSTEM PARAMETER > Periph. device = „Intern Rewinder“.
- See parameter [Pullback current](#) on page 74.

## Back diameter

---

 AP 5.4 AP 5.6
 

---

- ▣ Only in production mode.
- ▣ Only if SYSTEM PARAMETER > Periph. device = „Intern Rewinder“.
- See parameter [Back diameter](#) on page 75.

## Brake current

---

 AP 5.4 AP 5.6
 

---

- ▣ Only in production mode.
- ▣ Only if SYSTEM PARAMETER > Periph. device = „Intern Rewinder“.
- See parameter [Brake current](#) on page 75.

## Break diameter

---

 AP 5.4 AP 5.6
 

---

- ▣ Only in production mode.
- ▣ Only if SYSTEM PARAMETER > Periph. device = „Intern Rewinder“.
- See parameter [Brake diameter](#) on page 75.

## I/O BOARD

▣▣▣▣ This menu appears only if the optional I/O Board is mounted.

### Start print mode

---

AP 5.4    AP 5.6

---

▣▣▣▣ Only with an I/O board mounted.

Selecting a print mode. Depending on the selected mode, the input signal START\_PRINT will be interpreted differently by the I/O Board signal interface. The parameter is also used for the device connected to the foot switch jack.

- Make sure to select SYSTEM PARAMETER > External Signal = „Single Start“.
- See parameter [External signal](#) on page 62.
- Note: The parameter Start Print Mode replaces the parameter Signal Edge in the SYSTEM PARAMETER menu.
- Preconditions: Print job is available (DATA READY), printer is in “Online” mode, no error messages.

<b>Pulse falling</b>	(Default setting) The printing of a label is triggered by a high-to-low change of the signal at the input START PRINT. The printing occurs only after the set delay time.
<b>Pulse rising</b>	The printing of a label is triggered by a low-high change of the signal at the input START PRINT. The printing occurs only after the set delay time.
<b>Pulse fall/ris</b>	The printing of a label is triggered by a low-high-change as well as by a high-low change of the signal at the input START PRINT. The printing occurs only after the set delay time.
<b>Level low active</b>	Labels will be printed as long as the signal at input START PRINT is held low.
<b>Level high activ</b>	Labels will be printed as long as the signal at input START PRINT is held high.

### Reprint Signal

---

AP 5.4    AP 5.6

---

<b>Off</b>	▣▣▣▣ Only with an I/O board mounted. The input signal is disabled
<b>On</b>	The last printed label will be reprinted on the falling edge of the REPRINT signal.  Preconditions: <ul style="list-style-type: none"> <li>• The label to be reprinted, should be printed and dispensed.</li> <li>• Printer is in online mode.</li> </ul> <p>▣▣▣▣ If a REPRINT is triggered while the printer is in “I/O-Board Pause” mode, the reprint will proceed as soon as the printer is switched back in online mode. Precondition: in level mode START PRINT must be inactive.</p>

## Feed input

---

AP 5.4    AP 5.6

---

☐➡ Only with an I/O board mounted.  
Concerns the input signal FEED at the signal interface.

**On**

(Default setting) Feeding of one label on the falling signal edge. The display shows „I/O board feed“ during feeding. Requirements are:

- Offline mode, „stopped mode“ or „pause mode“
- Online mode and no print job loaded.

**Off**

Signals at the FEED input are ignored.

## Pause input

---

AP 5.4    AP 5.6

---

☐➡ Only with an I/O board mounted.  
Concerns the input signal PAUSE at the signal interface.

**Off**

Signals at the PAUSE input are ignored.

**Pause**

A high-to-low transition switches the printer into the „I/O-Board Pause“ mode. The next high-low-transition switches the printer back into the online mode. If parameter *I/O-Board > Start print mode* is set to „Level high active“ or „Level low active“, any activating of the PAUSE signal stops the printing after the current label.

Features:

- Printer display shows „I/O-Board pause“
- ERROR is active (only if *I/O Board > Error output* is set to „Printer err+Off“)
- If a print job is available: DATA READY becomes inactive (if *I/O Board > Status output* is set to „Print job ready“)
- START PRINT signals are suppressed
- REPRINT requests are processed after switching into online mode.

A "low" signal for 20 ms switches the printer into the pause mode. The pause mode is the same as the "Online stopped" mode and can be switched to the "Online" mode by pressing the feed button.

## Error output

---

AP 5.4    AP 5.6

---

☐➡ Only with an I/O board mounted.  
This parameter defines different events, which activate the output signal ERROR.

**Printer error**

ERROR will be activated in all of the following cases:

- Material end
- Ribbon end (only if *SYSTEM PARAMETER > Foil mode* = „Thermo transfer“)
- No punch recognized (only if *PRINT PARAMETERS > Material type* = „punched“)
- Printhead pressure lever was opened during the printing of a label.

- Start print error
- Other errors, which keep the printer from printing
  - ▣▣▣▣► During the initialization (powering up) of the printer, the ERROR-signal is instable!

**Printererr + Offl**

In addition to the above mentioned cases activate the following events the ERROR-signal:

- The printer is in offline mode
- The printhead pressure lever is open
- „I/O board pause“ mode
- Stopped mode (the printing was stopped)

**Error Polarity**

---

AP 5.4    AP 5.6

---

▣▣▣▣► Only with an I/O board mounted.  
Switches the polarity of the ERROR signal.

**Level high activ**

The output is high when it is active, otherwise low.

**Level low active**

The output is low when it is active, otherwise high. (Default)

**Status output**

---

AP 5.4    AP 5.6

---

▣▣▣▣► Only with an I/O board mounted.  
This parameter defines different events, which activate the output signal MACHINE STATUS.

**Low ribbon warn**

The signal is activated, if the ribbon roll diameter is less than the limit.

- See parameter [Foil end warning](#)  on page 55.

**Print job ready**

(Default setting) The signal is activated, if the printer has finished image processing and is ready to start printing.

The signal is *not activated*, if:

- the print job is done,
- the print job was stopped,
- the printer was switched to offline mode,
- the printer is in pause mode.

**Status polarity**

---

AP 5.4    AP 5.6

---

▣▣▣▣► Only with an I/O board mounted.  
Switches the polarity of the MACHINE STATUS signal.

**Level high activ**

The output is high when it is active, otherwise low.

**Level low active**

(Default setting)The output is low when it is active, otherwise high.

## End print mode

---

AP 5.4    AP 5.6

---

■ Only with an I/O board mounted.

■ Not available in batch mode.

Concerns the output signal PRINT\_END at the I/O board signal interface.  
Determines the signal response after printing of a label.

### Mode0 inactive

No print end signal.

### Mode1 low level

Low, if the print module is just printing a label, otherwise high.  
The output is also deactivated (= low) as long as labels are fed with "Feed Button" or "Feed Signal".

### Mode2 high level

High, if the print module is just printing a label, otherwise low.  
The output is also deactivated (= high) as long as labels are fed with "Feed Button" or "Feed Signal".

### Mode3 low pulse

(Default setting) Low for 20 ms after printing and dispensing a label.  
The output is also activated (= low) after a label is fed with "Feed Button" or "Feed Signal".

### Mode4 high pulse

High for 20 ms after printing and dispensing a label.  
The output is also activated (= high) after a label is fed with "Feed Button" or "Feed Signal".

SYSTEM PARAMETER



## ZPL PARAMETERS

This section lists the ZPL II® commands that the printer can interpret with any special notes, if applicable.

▣▣▣▣ This menu appears only with SYSTEM PARAMETER > Print Interpret. set to „ZPL Emulation“ or „EasyPlug/ZPL Emu“.

▣▣▣▣ ZPL is not supported in Standalone Mode.

▣▣▣▣ Recommended settings:

SYSTEM PARAMETER > RAM disk size at least 2048 Kbytes

SYSTEM PARAMETER > Free store size at least 4 MB

### Darkness

---

AP 5.4    AP 5.6

---

Print contrast for ZPL printjobs. This setting is modified by printjobs which contain print contrast information. The print contrast set by SYSTEM PARAMETERS > Print contrast is not influenced by this setting.

xx

Setting range: 0-30; Step width: 1; Default setting: the Easy-Plug setting is overtaken.

### Control Prefix

---

AP 5.4    AP 5.6

---

Indicates the start of a ZPL control instruction.

xxH

Default: xx = 7E (0x7E = „Tilde“)

### Format Prefix

---

AP 5.4    AP 5.6

---

Indicates the start of a ZPL format instruction.

xxH

Default: xx = 5E (0x5E = „Caret“)

### Delimiter Char

---

AP 5.4    AP 5.6

---

Used as a parameter place marker in ZPL format instructions.

xxH

Default: xx = 2C (0x2C = „Comma“)

## Label Top

---

AP 5.4    AP 5.6

---

Label top offset (y-offset) in dots. Equals the parameter `PRINT PARAMETERS > Y-Printadjust`, which will be ignored, when ZPL printjobs are printed.

xxx Dots

Setting range: -240 - +240; Default: 0; Step width: 1

## Left Position

---

AP 5.4    AP 5.6

---

Left position offset (x-offset) in dots. Equals the parameter `PRINT PARAMETERS > X-Printadjust`, which will be ignored, when ZPL printjobs are printed.

xxx Dots

Setting range: -9999 - +9999; Default: 0; Step width: 1

## Manual Calibrate

---

AP 5.4    AP 5.6

---

For endless material, the label length information is sent in the printjob. For punched material, the label length has to be detected by activating this function.

YES

Label length calculation for punched material.

- ▣▣▣▣▶ Activate this function, if label material has changed.
- ▣▣▣▣▶ Calibration should be done after changing material, when there are no printjobs loaded in the printer.
- ▣▣▣▣▶ Shortcut (in offline mode): press the feed + prog buttons simultaneously to activate the calibration.

## Resolution

---

AP 5.4    AP 5.6

---

Print resolution in dpi. A 200 dpi graphic printjob can be printed with a 300 dpi printhead.

xxx DPI

Setting range: 200/300 dpi; Default: 300 dpi;

**Error Indication**

AP 5.4 AP 5.6

Selects the way, in which the printer responds in the event of error occurring during printing.

Low  
High  
Off

Error Level	Setting		
	LOW	HIGH	OFF
0	Ignore	Ignore	Ignore
1	Ignore	Flash on the display	Ignore
2	Prompt user for action	Prompt user for action	Ignore

[13] Error handling settings.

**Error Checking**

AP 5.4 AP 5.6

Enables or disables error checking, when the printer is handling print fields.

YES

Error checking is enabled. (Default)

NO

Error checking is disabled.

**Image Save Path**

AP 5.4 AP 5.6

Selects the memory to be used by the ^IS and ^IL commands.

☐➡ Interpreter version: 1.10 or higher.

CF Card

Optional CompactFlash card

Internal RAM

The printer's internal RAM. (Default)

**Command ^PR**

AP 5.4 AP 5.6

Disable

The print rate sent in the ZPL printjob is ignored.

Enable

The print rate is not ignored.

**Command ^MT**

AP 5.4 AP 5.6

Disable

The material type sent in the ZPL printjob is ignored (thermo-transfer or thermo-direct).

Enable

The material type is not ignored.

### Label Invert

AP 5.4    AP 5.6

Rotates the printout by 180°. Equals the parameter `PRINT PARAMETERS > Print direction`, which will be ignored, when ZPL printjobs are printed.

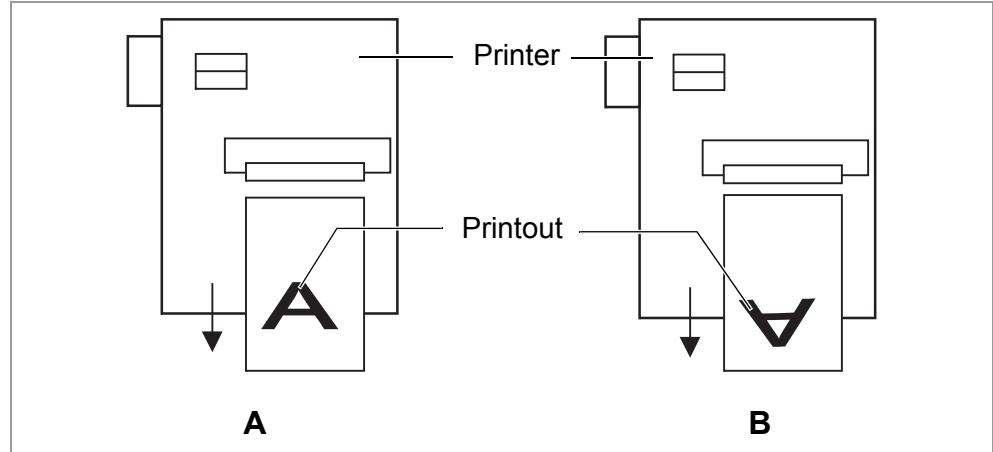

[18] Orientation of the printout: Setting „Disable“ (A) or „Enable“ (B).

**Disable**

The label is printed with „normal“ orientation [18A].

**Enable**

The label printout is rotated by 180° [18B].

### Command ^JM

AP 5.4    AP 5.6

Interpreter version: 1.32 or higher

The ^JM command changes the printer resolution:

- ^JMA sets the resolution to the default value = printhead resolution.
- ^JMB sets the resolution to 200 dpi, if the actual resolution is 300 dpi. If the actual resolution is 200 dpi, this command is ignored.

**Disable**

The resolution setting sent in the ZPL printjob is ignored.

**Enable**

The resolution setting is not ignored.

### Command ^MD/~SD

AP 5.4    AP 5.6

The ZPL commands ^MD and ~SD (set printhead darkness value) are processed optionally.

**Enable**

^MD- and ~SD are processed.

**Disable**

^MD- and ~SD are ignored.

## SPECIAL FUNCTION

### Printer type

---

AP 5.4    AP 5.6

---

▣▣▣▣▶ Only in production mode.

Selection of the machine type. Must be set after the CPU board was replaced or after new firmware was loaded.

AP5

AP 5.4AP 5.6

AP7

AP 7.t

### Default Values

---

AP 5.4    AP 5.6

---

▣▣▣▣▶ Parameter appears only in production mode.

User defined

The presently selected settings of all parameters will be taken as default values. That is you will get those settings back even after a firmware update. All you have to do is to call the parameter "Factory settings".

Standard

Calling the parameter "Factory settings" will set all parameters to the factory preset values.

### Command sequence

---

AP 5.4    AP 5.6

---

▣▣▣▣▶ Parameter appears only in production mode.

~

„~“ is used as start sign for Easy-Plug command sequences.

#

(Default setting) „#“ is used as start sign for Easy-Plug command sequences.

### Delete job

---

AP 5.4    AP 5.6

---

Press the Online-key to cancel the active print job.

Delete Job  
Clearing . . .

### Delete spooler

---

AP 5.4    AP 5.6

---

Press the Online-key to delete all print jobs contained in the spooler.

Delete Spooler  
Clearing . . .

## Factory settings

---

AP 5.4    AP 5.6

---

All parameters are preset ex works to values specific to each device type. These factory settings can be restored at any time.

- ▣▣▣▣ All parameters are then overwritten by the factory settings.
- ▣▣▣▣ All data present in the spooler, including data belonging to an interrupted print job, is deleted!

**No**

(Default) No factory setting.

**Custom defaults**

If custom parameter settings were stored before (see parameter *Custom defaults*), those are restored.

- ▣▣▣▣ „Custom defaults“ only appears, if custom settings have already been stored.

**Factory defaults**

The parameters are set to factory defaults.

## Custom defaults

---

AP 5.4    AP 5.6

---

- ▣▣▣▣ Parameter appears only in production mode.

**Apply current**

Stores the current parameter settings as values for the default setup. Those settings are restored by calling parameter *SPECIAL FUNCTION > Factory settings = „Custom defaults“*.

**Delete**

Deletes the stored custom default settings. „Delete“ is only visible, if settings have already been stored.

## Store Parameters

---

AP 5.4    AP 5.6

---

Parameter settings are saved in a text file on memory card (directory FORMATS\). Considered are also parameters which belong to options, which are not activated.

**Without adj. par**

(Default) Parameters, which contain device specific settings, are *not* saved.  
(Default file name: SETUP.FOR).

*Application example:* Transfer of printer settings to another printer (device specific settings as printhead resistance or sensor settings should not be overwritten).

**With adjust para**

Parameters, which contain device specific settings, are *also* saved. The relevant parameter names are marked with a \* in the text file.

(Default file name: SETUPALL.FOR).

*Application example:* Service

- For more information about saving and reading parameter settings read topic section „Advanced Applications“, chapter „Saving and Transferring parameter settings“.

## Store Diagnosis

---

AP 5.4    AP 5.6

---

Stores the diagnostic data on memory card. The default file name composes as follows:

„Diagnose AP 5.4 203 Dpi A429403110613.log“

- *AP 5.4 203 Dpi*: printer type and printhead resolution
  - *A429403110613*: serial number of the CPU board; equals the value displayed under `SERVICE DATA > CPU board data > Serial number`
- For details read the service manual, topic section „Fault Location“, chapter „Reading out diagnostic data“.

## Gen.Support Data

---

AP 5.4    AP 5.6

---

Generate support data

Generates the folder „SupportData“ on the selected memory medium and stores the following diagnosis files therein:

- Setup.for (for details see `SPECIAL FUNCTION > Store Parameters`)
- SetupAll.for (for details see `SPECIAL FUNCTION > Store Parameters`)
- Diagnose.log (for details see `SPECIAL FUNCTION > Store diagnosis`)

Each of the file names is completed by the printer type and the serial number of the CPU board. The file content is english, regardless of the language setting at the printer.

Those data are very helpful for the technical support for fault diagnosis purposes.

## EasyPI. file log

Easy-Plug file log

---

AP 5.4    AP 5.6

---

- ▣ Only visible, if a memory card is inserted.
- ▣ Activating this parameter may slow down the label rate. Therefore disable the function after error analysis.
- ▣ Activating this parameter may cause error messages, which may be difficult to understand. Therefore disable the function after error analysis. If an error occurs, disable the function and restart the printer.

Off

The file log function is switched off.

All data

All received data, including immediate commands, are written into the log file.

**Interpreter data**

All data is written into the log file, which the Easy-Plug interpreter reads out of the reception spooler. Immediate commands are *not* included.

**Log files delete**

---

AP 5.4    AP 5.6

---

**No**

▣▣▣▣ Only visible, if a memory card is inserted.  
(Default setting) No function.

**Yes**

Deletes all log files on the inserted memory card, which fulfil the following conditions:

- Filename matches the scheme „EPxxxxxx.log“  
xxxxxx = number from 1 to 999999, preceding digits filled with „0“. Example: „EP000001.log“.
- Location: folder \LOGFILES on memory card

Those conditions are matched by logfiles, which are automatically generated by SPECIAL FUNCTION > EasyPl. file log.

**Data blocks del.**

Delete data blocks

---

AP 5.4    AP 5.6

---

**Bxx**

▣▣▣▣ Only appears, if at least one data block is in the flash memory.  
(Default setting) After calling the parameter, data block number 01 is displayed:

```
Data blocks del.
B01 diagnose inf
```

„B01“: block number 01

„diagnose inf“: name of the data block, is contained in the data block header.

If the flash memory contains more than one data block:

→ Press the cut button several times, until the wanted data block appears.

Deleting a data block:

→ Press the online button.

```
Data blocks del.
Delete? --> no
```

→ Press the feed button to change to „yes“.

→ Press the online button to delete the block.

**All**

All data blocks contained in the flash memory are deleted.



**RFID stat. del.**

---

AP 5.4    AP 5.6

---

▣▶ Only with activated RFID option.

Sets all RFID counters to zero.

○ See PRINT INFO > RFID status.

## SERVICE FUNCTION

### Service

---

AP 5.4    AP 5.6

---

▣▶ Parameter only appears in production mode.

Increases the counter level of the "Service" counter on the "Service Status" printout by one.

- See parameter [Service Status](#)  on page 23.

yes

Increases the counter "Services" by one

no

Doesn't increase the counter

### Head exchange

---

AP 5.4    AP 5.6

---

▣▶ Parameter only appears in production mode.

Increases the counter „Head number“ on the info printout „Service Status“ by one.

- See parameter [Service Status](#)  on page 23.

yes

Increases the counter "Head number" by one

no

Doesn't increase the counter

### Roller exchange

---

AP 5.4    AP 5.6

---

▣▶ Parameter only appears in production mode.

Increases the counter „Roll number“ on the info printout „Service Status“ by one.

- See parameter [Service Status](#)  on page 23.

yes

Increases the counter "Roll number" by one

no

Doesn't increase the counter

### Cutter exchange

---

AP 5.4    AP 5.6

---

▣▶ Parameter only appears in production mode and only with a cutter mounted and activated.

Increases the counter „Cutter number“ on the info printout „Service Status“ by one.

- See parameter [Service Status](#)  on page 23.

yes	Increases the counter "Cutter number" by one
no	Doesn't increase the counter

### Serv. data reset

---

AP 5.4    AP 5.6

---

▣▣▣▣▶ Parameter only appears in production mode.  
Sets all counters on the info printout „Service Status“ to zero.

- See parameter [Service Status](#)  on page 23.

### EasyPlug monitor

---

AP 5.4    AP 5.6

---

▣▣▣▣▶ Parameter only appears in production mode.

The parameter activates the logging of received Easy Plug data. Data is transmitted to COM1 or COM2.

▣▣▣▣▶ Activating this parameter may slow down the label rate. Therefore disable the function after error analysis.

▣▣▣▣▶ To keep the influence of the monitoring function on the data rate as low as possible, the baud rate should be set to 115,000!  
(Default setting) The monitor function is disabled.

Off

Serial Com1

The Easy-Plug monitor data is transmitted to Com1.

Serial Com2

The Easy-Plug monitor data is transmitted to Com2.

### EP Monitor Mode

---

AP 5.4    AP 5.6

---

▣▣▣▣▶ Parameter only appears in production mode.

▣▣▣▣▶ Activating this parameter may slow down the label rate. Therefore disable the function after error analysis.

Interpreter data

(Default setting) All received Easy-Plug data, apart from immediate commands, are transmitted.

All data

All received Easy-Plug data, including immediate commands, are transmitted.

### Sensor adjust

---

AP 5.4    AP 5.6

---

▣▣▣▣▶ Parameter only appears in production mode.

- For detailed instructions sensor adjustment, please refer to the service manual, topic section "Service Electronics", paragraph "Settings".

## Sensor test

---

AP 5.4    AP 5.6

---

- The description of the sensor test can be found in the printer service manual, topic section „Service Electronics“, chapter [Sensor test](#).

The values displayed are for checking the sensors (sensor check) and can be adjusted by service personnel.

## Cutter test

---

AP 5.4    AP 5.6

---

Makes it possible to test the cutter function without having to set the parameter `SYSTEM PARAMETER > Periph. device` to „cutter“.

Press Cut Key

Triggers a cut, if a cutter is installed. Without a cutter nothing will happen.

## Matend adjust

---

AP 5.4    AP 5.6

---

These printer types are equipped with a single light sensor which is designed to detect both, punches and material end. The sensor must be able to detect three different states:

- No material
- Only backing paper
- Backing paper + label face

The parameter `SERVICE FUNCTION > Matend adjust` can set the limit between being recognized as „only backing paper“ or as „material end“.

- For further information read the Service Manual, topic section „Service Electronics“, chapter „Sensor settings“ > „Setting the material end sensor“.

yy Level : xx

Setting range: 0 to 255; Step width: 1; Default setting: 20

## Matend tolerance

---

AP 5.4    AP 5.6

---

Material end tolerance

This is relevant for label stock with very long punches. To avoid those punches being recognized as material end by mistake, can here the distance be set, after which the gap over the light sensor is interpreted as material end.

▮ By choosing a very high material end tolerance, you loose the protection of the print roller against being printed on!

xxx mm

Setting range: 20-300 mm; Default setting: 35 mm

## Feedadjust label

---

AP 5.4    AP 5.6

---

Prints a scale, which enables to calculate the feed adjust value (see next parameter).

For application instructions, refer to the Service Manual, topic section „Electronics Gen. 3“, chapter [Adjusting the imprint position](#) .

## Feed adjust

---

AP 5.4    AP 5.6

---

Corrects the material feed length. Such a correction can be necessary when printing on very long labels, to compensate slippage-related feeding inaccuracy.

For application instructions, refer to the Service Manual, topic section „Electronics Gen. 3“, chapter [Adjusting the imprint position](#) .

**x.x% [ribbon]**

Setting for *thermal transfer printing*

Setting range: -10.0 to +10.0; Step width: 0.1%; Default setting: 0%

▣▣▣▣▶ Only appears if thermal transfer printing was selected (see **SYSTEM PARAMETER** > Ribbon autoecon.)

**x.x% [direct]**

Setting for *thermal direct printing*

Setting range: -10.0 to +10.0; Step width: 0.1%; Default setting: 0%

▣▣▣▣▶ Only appears if thermal direct printing was selected (see **SYSTEM PARAMETER** > Ribbon autoecon.)

## Punch y calibr.

---

AP 5.4    AP 5.6

---

▣▣▣▣▶ Only in production mode

Compensating the variation of distance between punch sensor and thermal bar of the printhead.

**x.x mm**

Setting range: -3.0 to 3.0; Default setting: 0.0; Unit interval: 0.1

## Memory card test

---

AP 5.4    AP 5.6

---

Pressing the online button starts a test routine for the Compact Flash Card memory. The following display shows up after successful testing:

```
Memory card test
Card Test O.K.
```

If the memory card is defective or not available, a corresponding error report shows up.

For test purposes, the printer creates a file named TESTXXXX.TXT in the root directory of the card. An already existing file with this name will be overwritten.

### Send test

AP 5.4    AP 5.6

#### Serial connection

Carrying out the send test requires a terminal program, e.g. the Hyper Terminal contained in Windows95.

Start send test as follows:

1. Start the terminal program and set it to the transmission parameters used by the printer.
2. Press the Online-key to start the send test.

Send test running . . .

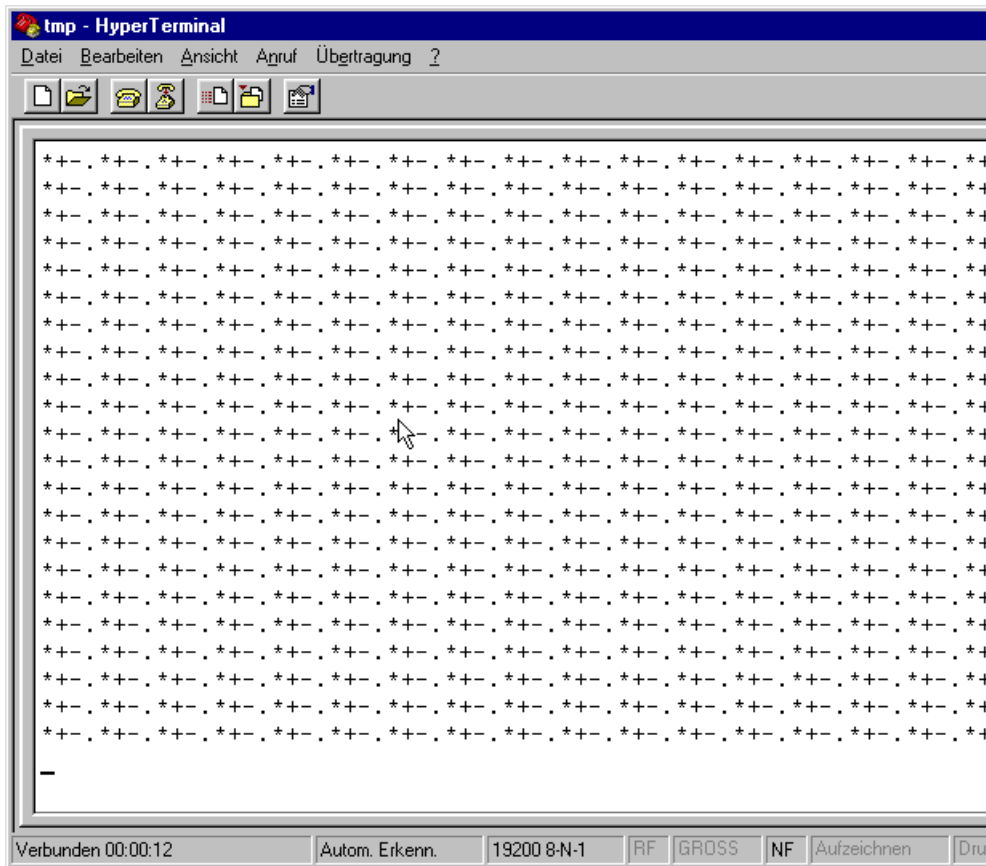

[19] Pattern in the terminal window.

The terminal window should show a regular pattern of four repeating characters. Those characters are continuous sent by the printer.

A transfer fault would be recognizable as irregularity of the pattern. Press the Prog-key to stop testing.

## Receive test

---

AP 5.4    AP 5.6

---

### Serial connection

Assumption is a serial data line between PC and printer; the parameter `INTERF.PARAM. > Interface` must be set to „Serial Com1“.

1. Start the MS-DOS-prompt (using Windows).
2. Set the interface to the values adjusted at the printer by means of MS-DOS command `MODE`:

Example of printer settings:

- Baud rate: 19200
- No. of data bits: 8
- Parity: none
- Stop Bits: 1
- Data synch.: RTS/CTS

DOS-Command: `mode COM1 baud=19200 parity=n data=8 stop=1`  
(if com1 is the serial port)

3. Press the Online-key to start Receive test.

```
Receive test
0 Bytes
```

4. Send any file to the printer (Condition: com1 = Printer port; anyfile.txt = any file ):

`copy anyfile.txt com1` (add `/b` for binary files)

The following shows up on the printer display:

```
Receive test
xxxxx Bytes
```

xxxxxx is the size of the sent file in bytes. This value is being counted up during the test. The test is complete if the file size does not vary any more. If the bytes announced at the printer match the size visible in the MS-DOS window, transfer was successful. Otherwise, transmission errors occurred.

## Printtest

---

AP 5.4    AP 5.6

---

General printtest, prints line by line the set printer type and the firmware version. Material settings (Material type, length, width) are considered.

Stop the printtest by pressing the Online button.

## Rewinder adjust

---

AP 5.4    AP 5.6

---

▣▣▣▣▶ AP 5.4 Only with „Rewinder 2000“ installed.



Setting up the rewinder.

The rewinder setup compensates differences in characteristic or assembly of the light barrier.

▣▣▣▣ This parameter counts for both, the external *rewinder option* for AP 5.4 and the *backing paper rewinder* of the ALX 92x. But mind that the setting values are different!

- A setting description for the *rewinder option* is given in the „User Manual Rewinder 2000“, topic section „Attachment, Setup“, chapter „Settings“ > „Setting up 64-xx“ > [Adjusting the sensor](#) .

loose xxx

Setup of the loose dancer arm (xxx = actual sensor value).

tightened xxx

Setup of the tightened dancer arm (xxx = actual sensor value).

The setting follows in both cases this scheme:

1. Bring the dancer arm to its loose position.
2. Press the cut button
3. Pull the dancer arm tight.
4. Press the Online button.

## Rewinder values

---

AP 5.4      AP 5.6

---

▣▣▣▣ AP 5.4 Only with „Rewinder 2000“ installed.

Shows the values of the position sensor at the rewinder dancer arm in middle/tightened and in loose position.

Rewinder values

xxx <----- text -----> yyy

- xxx = Sensor value in *loose* position
- text = Sensor type (Opto = light barrier; Hall = hall sensor; ???? = no explicit sensor type)
- yyy = Sensor value in one of the following positions:
  - *Middle* for 64-xx with „Rewinder 2000“ and for ALX 92x with R04A rewinder motor output stage (--> 01/2012, recognizable with SYSTEM PARAMETER >MODULE FW VERS. > Rewinder driver = „V2-T36“)
  - *Tightened* for ALX 92x with M5A rewinder motor output stage (01/2012-->, recognizable with SYSTEM PARAMETER >MODULE FW VERS. > Rewinder driver = „V4-T5“)
- For detailed information about setting the rewinder dancer arm refer to:
  - Rewinder 2000: Technical Manual Rewinder 2000, topic section „Attachment, Setup“, chapter „Settings“ > „Setting up 64-xx“ > [Adjusting the sensor](#) 

## SERVICE DATA

### > MODULE FW VERS.

#### System version

---

AP 5.4    AP 5.6

---

Shows the firmware version number.

#### System revision

---

AP 5.4    AP 5.6

---

Shows a consecutive revision number.

▣▣▣▣▶ Only for factory-internal use.

#### System date

---

AP 5.4    AP 5.6

---

Shows the date, at which the firmware was generated.

#### Bootloader

---

AP 5.4    AP 5.6

---

Shows the bootloader version number.

#### uMon

---

AP 5.4    AP 5.6

---

Shows the bootloader version number.

#### Peripheraldriver

---

AP 5.4    AP 5.6

---

▣▣▣▣▶ Only with mounted (optional) peripheral output stage board.  
Applied PIC version on the output stage board driving the peripheral motor.

**Intern. rewinder**

(Internal rewinder)

AP 5.4    AP 5.6

▣▣▣▣ „AP 5.4/5.6 peripheral with internal rewinder“ only.  
Applied PIC version on the internal rewinder motor output stage board.

**> OPERATION DATA****Serv. operations**

AP 5.4    AP 5.6

Shows the number of service operations. The counter is increased by calling the parameter SERVICE FUNCTION > Service = yes. Maximum value: 4 billions.

**Headnumber**

AP 5.4    AP 5.6

Shows the number of printhead changes. The counter is increased by calling the parameter SERVICE FUNCTION > Cutter exchange = yes. Maximum value: 4 billions.

**Roll number**

AP 5.4    AP 5.6

Shows the number of exchanged print rollers. The counter is increased by calling the parameter SERVICE FUNCTION > Roller exchange > yes. Maximum value: 4 billions.

**Cutter number**

AP 5.4    AP 5.6

▣▣▣▣ Only with mounted and activated cutter.  
Shows the number of exchanged cutters. The counter is increased by calling the parameter SERVICE FUNCTION > Cutter exchange = yes. Maximum value: 4 billions.

**Head run length**

AP 5.4    AP 5.6

Shows the total "covered distance" of the printhead. The counter is reset with each calling of the parameter SERVICE FUNCTION > Cutter exchange = yes. Maximum value: 4 billions.

---

## Roll run length

---

AP 5.4    AP 5.6

---

Shows the total "covered distance" of the print roller. The counter is reset with each calling of the parameter SERVICE FUNCTION > Roller exchange = yes. Maximum value: 4 billions.

---

## Cuts on knife

---

AP 5.4    AP 5.6

---

▣▣▣▣▶ Only with mounted and activated cutter.

Shows the number of cuts done by one knife. The counter is reset with each calling of the parameter SERVICE FUNCTION > Cutter exchange = yes. Maximum value: 4 billions.

---

## Tot. mat. length

---

AP 5.4    AP 5.6

---

Shows the total "covered distance" of the feed roller. In comparison to the counter Roll run length, this counter is not reset after a roller exchange. Maximum value: 4 billions.

---

## Tot. foil length

---

AP 5.4    AP 5.6

---

Shows the total "covered distance" of the ribbon roller.

---

## Total cuts

---

AP 5.4    AP 5.6

---

▣▣▣▣▶ Only with mounted and activated cutter.

Shows the number of cuts done by all knives. In comparison to the counter Cuts on knife, this counter is not reset after a knife exchange. Maximum value: 4 billions.

---

## Head strobes

---

AP 5.4    AP 5.6

---

Shows the counted head strobes, which are a measure for the service life of the printhead. A strobe is counted for each line in which at least one dot is printed. Maximum value: 4 billions.

---

## Head temperature

---

AP 5.4    AP 5.6

---

Shows the current printhead temperature in °C.

---

## Foil diameter

---

AP 5.4    AP 5.6

---

Shows the calculated foil diameter: A measurement routine calculates the actual ribbon roll diameter with an exactness of 7.5%.

The parameter `SYSTEM PARAMETER > Foil end warning` can be used to set a critical foil roll diameter. If the foil roll diameter equals this value, a message appears on the printer display.

- See parameter [Foil end warning](#)  on page 55.

---

## Dispensing cycl.

(Dispensing cycles)

---

AP 5.4    AP 5.6

---

▣▶ AP 5.4/5.6: Dispenser version only.  
Shows the number of dispensed labels.

---

## Operation time

---

AP 5.4    AP 5.6

---

Shows the elapsed time since the last switch-on of the machine.

**> POWERSUPPLYDATA****Type**

AP 5.4    AP 5.6

Shows the type of power supply, e.g. „Blue Mountain“.

**PS temperature**

AP 5.4    AP 5.6

Shows the current power supply temperature in °C. If for any reason the function is not supported, „??? °C“ is displayed.

**> CPU BOARD DATA****CPU identifier**

AP 5.4    AP 5.6

Shows the designation of the applied processor.

**PCB revision**

AP 5.4    AP 5.6

Shows the layout revision and part number of the CPU board.

**FPGA version**

AP 5.4    AP 5.6

Shows the FPGA version.

**MAC address**

AP 5.4    AP 5.6

Shows the MAC Address, an unchanging board address, which is programmed by the board manufacturer.

**Serial number**

AP 5.4    AP 5.6

Serial number: Is programmed by the board manufacturer.

**Production date**

AP 5.4    AP 5.6

Production date: Is programmed by the board manufacturer.

**PCB part number**

AP 5.4    AP 5.6

Shows the part number of the board without components.

**Board part numb.**

AP 5.4    AP 5.6

Shows the part number of the board with components.

**Manufacturer**

AP 5.4    AP 5.6

▣▣▣▣▶ Parameter appears only in production mode.  
Shows the board manufacturer.

**Work place**

AP 5.4    AP 5.6

▣▣▣▣▶ Parameter appears only in production mode.  
Shows the printer work place.

**Company name**

AP 5.4    AP 5.6

▣▣▣▣▶ Parameter appears only in production mode.  
Shows the company name.

**> DISPLAY DATA****Display version**

AP 5.4    AP 5.6

Shows the *version number* of the operation panel.

## Display SerialNr

---

 AP 5.4    AP 5.6
 

---

Shows the *serial number* of the operation panel.

## > MEMORY DATA

### Ram memory size

---

 AP 5.4    AP 5.6
 

---

Shows the available RAM memory size.

### Flash mem size

---

 AP 5.4    AP 5.6
 

---

Shows the available Flash memory size. The abbreviation which is displayed behind the memory size indicates the manufacturer of the applied Flash-RAM:

Abbreviation	Manufacturer
MX	Macronix
AMD	AMD
FUJ	Fuji

[14] The displayed abbreviations indicate the manufacturer of the Flash-RAM.

### SD card

---

 AP 5.4    AP 5.6
 

---

☛ Only with plugged-in SD card

Shows the memory size of the SD card:

SD card  
 971 MB / 1024 MB (c:)

- 971 MB of 1024 MB are free
  - Drive letter, which is assigned to the SD card (here: „C:“)
- Assigning a drive letter: see chapter > [DRIVEASSIGNMENT /](#) on page 54.

### USB stick

---

 AP 5.4    AP 5.6
 

---

☛ Only with plugged-in USB stick

Shows the memory size of the USB stick:



USB stick  
971 MB / 1024 MB (c:)

- 971 MB of 1024 MB are free
  - Drive letter, which is assigned to the USB stick (here: „C:“)
- Assigning a drive letter: see chapter > [DRIVEASSIGNMENT](#) / on page 54.

### Space for Jobs

---

AP 5.4    AP 5.6

---

Shows the memory size, which is available for print jobs.

### Max. Labellength

---

AP 5.4    AP 5.6

---

Shows the maximum printable label length, which results from the memory allocation.

### Default values

---

AP 5.4    AP 5.6

---

Shows the setting of parameter [SPECIAL FUNCTION](#) > Default values.



# Status Reports

General information about status reports..... 7	1033	Uninit flash par ..... 14
Area of application ..... 7	1034	Uninit restrict ..... 14
Display of status reports..... 7	1035	Uninit combi ..... 14
Acknowledging status reports ..... 7	1036	Wrong combi para..... 14
General software errors..... 8	1037	Software error ..... 14
Easy-Plug errors..... 8	1038	Software error ..... 14
Unspecific errors ..... 8	1087	OLV not active ..... 14
Not listed status reports..... 9	1088	No realltimeclock ..... 14
Listing of all Status reports..... 10	1089	Seek Fkt. Error ..... 15
1000 No new command ..... 10	1090	Incomplete Job..... 15
1001 Parameter Table..... 10	1091	Wrong var field..... 15
1002 Comm. sorting ..... 10	1092	Rename file..... 15
1003 Too many slashes ..... 10	1093	Delete file ..... 15
1004 Slash w/o param..... 10	1094	More than 3 figs ..... 15
1005 2 same commands ..... 10	1097	Out of memory ..... 15
1006 Letter incorrect ..... 10	1099	File end ..... 15
1007 Command incorr..... 10	1101	Wrong time/date..... 16
1008 Subcomm. incorr. .... 10	1102	Counter offset ..... 16
1009 Param. tab inc. .... 11	1110	Opening Bracket ..... 16
1010 #ER x #Q !..... 11	1111	Closing Bracket..... 16
1011 #ER missing ..... 11	1112	Para: No Value..... 16
1012 #IM x #Q !..... 11	1113	No Default Value..... 16
1013 Comm. flag inc. .... 11	1114	< Limit value..... 16
1014 Uninit integer ..... 11	1115	> Limit value..... 17
1015 Uninit float ..... 11	1120	Incorr. logo no. .... 17
1016 Uninit string ..... 11	1121	Logo exists..... 17
1017 Uninit discr..... 12	1122	Creating logo..... 17
1018 Too many discr..... 12	1123	Rename logo..... 17
1019 Uninit BCD para. .... 12	1124	Logo file ..... 17
1020 Too much image..... 12	1125	Delete error ..... 17
1021 Uninit image par ..... 12	1126	File creation ..... 18
1022 Too many files ..... 12	1127	File format..... 18
1023 Uninit File Para..... 12	1128	File exists ..... 18
1024 Com. too long ..... 12	1130	Float overflow..... 18
1025 Com twice there ..... 13	1131	Logo cache full..... 18
1026 Comm. w/o. flag ..... 13	1140	Line too long ..... 18
1027 Uninit parameter..... 13	1141	Para. incorr. Bl ..... 18
1028 Parameter uninit..... 13	1150	Integer overflow ..... 18
1029 Param. incorr..... 13	1160	String too long..... 19
1030 Command incorr..... 13	1170	X Pos > width ..... 19
1031 Too many slashes ..... 13	1171	X Pos < zero ..... 19
1032 Incorrect char. .... 13	1172	Y Pos > length ..... 19

1173	Y Pos < zero.....	19	1333	Logo not there.....	24
1174	Max width: right.....	19	1334	#YV Data incorr.....	24
1175	Max width: left.....	20	1335	#YV Field cont.....	25
1176	Max length: top.....	20	1336	#YV no. incorr.....	25
1177	Max length: bot.....	20	1390	Web width zero.....	25
1178	x Dots < zero.....	20	1391	Web > Width.....	25
1200	GetRLE reset st.....	20	1392	Job memory full.....	25
1201	GetRLE error st.....	20	1393	Job struct creat.....	25
1210	itoa Short Strin.....	20	1394	Invalidation.....	25
1240	New FS>E.....	20	1395	Label too wide.....	26
1241	New Read Pointer.....	21	1396	Label too long.....	26
1242	New FE in job.....	21	1397	Label too short.....	26
1243	New delete order.....	21	1398	Label too small.....	26
1244	New wrong pos.....	21	1404	UTF8 data wrong.....	26
1245	New no space.....	21	1470	X-Offset.....	26
1246	New HP no space.....	21	1471	Y-Offset.....	27
1247	Out of memory.....	21	<b>1501-1535 Messages, which can occur in ZPL emulation mode.....</b>		<b>27</b>
1260	TimeDate string.....	21	1501	Unknown MLI Cmd.....	27
1270	#-comm. invalid.....	21	1502	MLI Hash Error.....	27
1272	Wrong #!.....	21	1503	Filename Too Long.....	27
1273	Wrong #!C.....	22	1504	Param > Max.....	27
1276	#!P wrong number.....	22	1505	Param < Min.....	27
1277	Wrong #!S.....	22	1506	No Previous.....	27
1278	Wrong #!X.....	22	1507	Not enough data.....	28
1279	#!X wrong number.....	22	1508	String Too Long.....	28
1282	Spooler FB > L.....	22	1509	Wrong Byte Cnts.....	28
1285	#!-comm. incorr.....	22	1510	Wrong Param.....	28
1290	Label limit.....	23	1511	Bar Parm Error.....	28
1291	Draw field.....	23	1512	Code128 Mode Err.....	28
1300	Invalid Command.....	23	1513	Wrong Mode.....	28
1301	Table full.....	23	1514	^BX Parm Err.....	29
1310	Wrong Field ID.....	23	1515	Conv to ECC200.....	29
1320	No Default Value.....	23	1516	Bad Drive: x.....	29
1321	Bar Code Object.....	23	1517	Mask String: x.....	29
1322	Logo Object.....	23	1518	Bad Format: x.....	29
1323	Line Object.....	23	1519	Cmd Init Error.....	29
1324	Rectangle Object.....	23	1520	Unsupported Cmd.....	29
1325	Truedoc Object.....	24	1521	Unsupported: x.....	29
1326	Fix Field Creati.....	24	1522	Bad Char Set x.....	30
1327	Update Field Cre.....	24	1523	Cmd Parm Error.....	30
1328	Var Field Creati.....	24	1524	d/mm not chg x.....	30
1329	Count Field Crea.....	24	1525	USI not exist.....	30
1330	Create clk. field.....	24	1526	Can't Off CV.....	30
1331	Field type inv.....	24	1527	Offset illegal.....	30
1332	Field length inc.....	24			

1528	Language illegal .....	30	5006	Head-fault .....	39
1529	Invalid Prn Mode .....	31	5008	Ribbon end.....	39
1530	Inc free str mem .....	31	5009	USI start error .....	40
1531	Inc RAM disc .....	31	5012	Delete H8 loader .....	40
1532	No Fixfont.....	31	5013	Prog H8 loader.....	40
1533	No Speedo Font .....	31	5015	Scanner.....	41
1534	^XA missing.....	31	5016	ALX Rewinder .....	41
1535	^XZ missing.....	31	5017	Power Supply.....	41
<b>2000-2009 Messages caused by Easy-Plug variables.....</b>		<b>32</b>	5018	Dot check area.....	42
2000	Double var name.....	32	5020	I2C Timeout xx.....	42
2002	Var. data length.....	32	5021	I2C Conf. xx .....	42
2003	Expr. bracket .....	32	5022	I2C Busy xx.....	42
2004	Exp. quotemark .....	32	5023	I2C LAB xx.....	42
2005	Exp. comma pos.....	32	5024	I2C BER xx .....	42
2006	Exp.functionname.....	32	5025	I2C Polling xx.....	42
2007	Exp.fct.paratype .....	32	5026	Motorprotect CPU .....	43
2008	Exp.fct.paraCnt.....	32	5028	PS overheat .....	43
2009	Exp. name wrong .....	32	5029	I2C checksum xx.....	43
2010	Fct. para value.....	33	<b>5051-5058 Messages which can only occur with a TT4 printer .....</b>		<b>44</b>
2011	OLV variable.....	33	5051	Barcode Infeed 1.....	44
2111	Invalid Date .....	33	5052	Barcode Infeed 2.....	44
2500	Multiple texts .....	33	5053	Barcode Infeed 3.....	44
<b>3000/3003/3006/3012/3015 Com x Overrun .....</b>		<b>33</b>	5054	Barcode Infeed 4.....	44
<b>3001/3004/3007/3013/3016 Com x Parity .....</b>		<b>33</b>	5055	Infeed 1 empty .....	44
<b>3002/3005/3008/3015/3017 Com x Frame .....</b>		<b>33</b>	5056	Infeed 2 empty .....	44
3010	Spooler Overflow.....	34	5057	Infeed 3 empty .....	45
3011	Send buffer full .....	34	5058	Infeed 4 empty .....	45
<b>4100-4106 Message, which can only occur with OLV-Option .....</b>		<b>35</b>	5059	Stacker full .....	45
4100	No OLV data.....	35	5060	Stacker full .....	45
4101	OLV limit exceed .....	35	5061	Dispenser motor.....	46
4103	OLV barcode type .....	35	5062	Disp. lift motor.....	46
4104	OLV Timeout .....	35	5063	Press roll .....	46
4105	No OLV response.....	36	5063	Lever open .....	46
4106	OLV Software .....	36	5064	Backing paper .....	46
5000	Bus device.....	36	5071	Material end unw.....	46
5001	No gap found.....	38	5072	Material end unw.....	47
5002	Material end.....	38	5100	No H8 response .....	47
5003	Cover open.....	38	5100	Printengine lock .....	47
5004	Rewinder mat. tear.....	39	5101	Headadjust error .....	47
5005	Knife-fault .....	39	5102	Dot Defective .....	47
			5110	Foil low.....	48
			5120	Home position .....	48
			5121	Touch down .....	48
			5122	PLC not ready.....	48

5123	USI Material low .....	48	5541	ISO error #2 .....	58
5125	Vn for USI req.....	49	5542	ISO error #3 .....	59
5130	PSU xxxxxxxx.....	50	5543	ISO error #15 .....	59
5131	PSU communicat.....	52	5544	ISO error #16 .....	59
5140	Rewinder control .....	52	5545	ISO error #17 .....	59
5144	Rewinder Init .....	52	5546	ISO error #18 .....	59
5145	Rewinder full.....	53	5547	ISO error #19 .....	59
5150	No USI interface.....	53	5548	ISO error #20 .....	59
5151	Applic. interf.....	53	5549	ISO error ??? .....	59
5152	Winding direct.....	53	5550	Wrong tag type.....	59
5200	Home position .....	53	5551	Max Tags failed.....	59
5201	Touch down.....	54	5560	TCS full / cover .....	59
5203	Touch down sens. ....	54	5590	Odd hex string.....	60
5204	Appl. Startererror .....	54	5600	Job without #Q.....	60
5205	Applicator gen. ....	54	5601	Job memory full.....	60
5206	Applicator resp. ....	54	6000	Param. incorrect.....	60
5207	Appl. driver 1 .....	54	6001	Nov. prog. err. ....	60
5208	Appl. driver 2 .....	55	6002	New prog. vers.....	60
5209	Appl. driver 3 .....	55	6003	Memory error .....	60
5210	Appl. driver 4 .....	55	6004	Load H8 program .....	61
5212	Vx.x for AI rec.....	55	6005	Fixfont data .....	61
5300	BLDC EEPROM err.....	55	6006	Speedofont data.....	61
5301	BLDC rewinder Ø .....	56	6007	Print ctrl. stop .....	61
5500	Unknown .....	56	6008	ZPL Fixfont data.....	61
5501	General.....	56	6009	ZPL Speedo data .....	62
<b>5502-5551 Messages, which can only occur with RFID option .....</b>		<b>56</b>	6010	Printengine soft.....	62
5502	RFID internal .....	56	6012	Start next job.....	62
5504	No RFID job.....	56	6030	Param. checksum .....	62
5510	RFID COM timeout.....	56	6031	New Parameters .....	62
5512	COM open failed .....	56	6101	No sensor found.....	62
5513	Get baud failed .....	57	6200	Filesystem regis .....	62
5521	No transponder.....	57	6201	File sys. format.....	62
5522	Tag write err .....	57	6202	Drive open.....	62
5523	Tag address err .....	57	6203	Filesystem close .....	63
5524	CMD not applicable .....	57	6204	Disk directory .....	63
5525	Tag read err.....	57	6205	Write disk .....	63
5526	Tag select first.....	57	6206	Read disk .....	63
5527	Tag RF comm err .....	58	6207	No file card.....	63
5528	EEPROM failure .....	58	6208	Drive xx full .....	63
5529	Parameter range .....	58	6300	Out of memory .....	64
5530	Unknown CMD .....	58	6301	Incomplete job.....	64
5531	Protocol length .....	58	6310	Centr. Timeout .....	64
5532	CMD not avail.....	58	6311	Centr. Timeout .....	64
5540	ISO error #1.....	58	8001	Shared Memory .....	64
			8002	Stream Buffer.....	64

8103	TrueDoc Font .....	64	8804	Maxi. Sec. mess.....	69
8104	Speedo alloc.....	64	8805	Maxicode Country .....	69
8105	Load TrueType .....	64	8830	Cod49 Datalength.....	70
8106	Fonttype wrong.....	65	8031	Cod49 wrong data.....	70
8107	Character set.....	65	8850	Unknown filetype.....	70
8108	Symbol set.....	65	8851	Graphic open .....	70
8109	TT-specifications .....	65	8852	Graphic header .....	70
8110	Unknown char. ....	65	8853	Graphic palette.....	70
8111	Stream type .....	65	8854	Graphic read .....	70
8112	Font not supp. ....	65	8856	Free store size .....	71
8200	Fixfont number .....	65	8857	Wrong mem config.....	71
8201	Font downl. full .....	66	8900	Codablock columns.....	71
8202	Font deleted .....	66	8901	Codablock rows .....	71
8300	Bar code corr.....	66	8902	Codablock softw.....	71
8301	Bar code data .....	66	8903	Codablock infogr .....	71
8302	Barcode checksum.....	66	8950	Logo open .....	71
8303	Bar code sample .....	66	8951	File format .....	72
8304	Bar c. plain-copy.....	66	8952	Not installed .....	72
8305	Bar code print.....	67	9000	Wrong errornum.....	72
8306	Plain-copy len.....	67	9001	Software Error.....	72
8307	Readline dist.....	67	9003	Print head type.....	72
8308	Bar code ratio .....	67	9005	No Printhead .....	72
8309	Module range .....	67	9007	Bad MAC Address .....	72
8310	Bar code element .....	67	9008	Powerfail signal.....	73
8311	Barcode table .....	67	9009	Temporary MAC.....	73
8400	PDF417 ECC.....	67	9011	Bootloader ext.....	73
8401	PDF417 Lines.....	67	9013	Head voltage.....	73
8402	PDF417 Columns .....	68	9014	Motor voltage .....	74
8403	PDF417 Style .....	68	9015	Network init. ....	74
8404	PDF417 Command.....	68	9016	DHCP Failed .....	74
8405	PDF417 Size .....	68	9017	RTC read failed.....	74
8406	PDF417 Details .....	68	9018	#!CA wrong Pos.....	74
8407	PDF417 Coding.....	68	9022	No network link .....	75
8500	Code 25Int len. ....	68	9023	Filename: Functionname() Line: xxx.....	75
8501	Postcode length.....	68	9024	Not possible ! .....	75
8600	EAN Length .....	68	9030	Log file:CF full .....	75
8601	UPCE Numbers sys. ....	68	9031	Log file: nnnn .....	75
8705	IDM rows/columns.....	69	9032	EP file log stop .....	75
8760	EAN128 field len.....	69	9034	Use min 16MB RAM .....	76
8761	EAN128 Data type.....	69	9035	No printpr. stop .....	76
8762	EAN128 Ident. ....	69	9039	Ribbon mode chg.....	76
8800	Maxicode Mode .....	69	9040	No Time Server.....	76
8801	Maxicode Sys no.....	69			
8802	Maxicode Zipcode .....	69			
8803	Maxicode Class .....	69			
				<b>9100-9119 Messages during firmware update .....</b>	<b>76</b>

9100	Invalid format.....	76	9112	PIC missing.....	77
9101	Invalid Header .....	76	9113	RFID Update Fail.....	77
9102	Inv.Board Rev.....	76	9114	RFID missing .....	78
9103	Inval. firmware .....	76	9115	AWID missing .....	78
9104	Inv. Data Size .....	77	9116	Ser. Disp. Missing.....	78
9107	Flash Overflow .....	77	9117	Device Unknown.....	78
9108	Flash Ovf. Diag.....	77	9118	H8 Update Fail.....	78
9109	Flash Ovf. Params.....	77	9119	H8 missing .....	78
9110	Flash Write Err. ....	77	9122	Checksum error .....	78
9111	PIC Update Fail.....	77	9123	Memory unavailable.....	79

## General information about status reports

### Area of application

This description of the status reports is valid for the print components of all the devices listed in the header bar and their options.

### Display of status reports

During operation, tests are continually carried out to determine whether a malfunction has occurred. If a malfunction is detected, the corresponding status report appears on the display.

- 64-xx / ALX 92x / DPM / PEM / PM 3000 only:  
If the parameter `SYSTEM PARAMETER > Signal buzzer` is set to *On*, an additional tone signal is given.
- 64-xx / ALX 92x / DPM / PEM / PM 3000 with “Gen. 3” electronics only:  
During a status message, the background light changes from green to red.  
The status can be requested using the serial interface (see Easy-Plug command `#!Xn`).

### Display

The status report shown on the display is assembled as follows:

```
Status      xxxx
TextTextTextTextTextTe
```

- *Status*: Is replaced by either „PrintStatus“ or „QueueStatus“.  
-- *PrintStatus* means, the error is caused by malfunction of the printer, independent of the sent print job. This is a message of the printer control.  
-- *QueueStatus* means, the error is caused by a faulty Easy-Plug command in the print job. This is a message of the Easy-Plug interpreter.
- *xxxx* signifies a status number in the range from 0001 to 9999. Using this number the user can look up the status of the printer in the following directory of status reports.
- *TextTextTextText* stands for a short display text which belongs to each status number. In many cases, the status of the printer can be identified just on the basis of this short display text.

More detailed information about the status reports and any measures which may need to be taken is given in the descriptions of the status reports which follow the list of status reports.

### Example

```
PrintStatus      8704
IDM Init. Error
```

### Acknowledging status reports

#### Self-acknowledging

Self-acknowledging status reports only show an event taking place in the device, and are simply for informing the operator about this event. The message appears for a short period on the display and is accompanied by



a short signal tone. The device continues to operate without any intervention from the user.

▶ Pay attention to each message in order to punctually prevent malfunctions.

**Acknowledging**

Status reports which are to be acknowledged must be confirmed by the operator as the activating event or malfunction endangers normal operation. The message appears on the display for so long until the malfunction has been corrected and acknowledged with the Enter button. A short signal tone is also given when the message appears.

**Disabling**

Messages which are shown following serious errors. This condition can be ended with a "warm start" (press Cut+Online+Feed buttons) or by switching off the printer.

<b>Self-acknowledging</b>	Header not underlined
<b><u>Acknowledging</u></b>	Header underlined once
<b><u><u>Disabling</u></u></b>	Header underlined twice

Tab. 1 The way of acknowledgment, a status message requires, can be detected by the text format used for the header. The gravity of a status message increases with the number of underlines.

**General software errors**

Errors in the firmware can never be completely ruled out. Such errors are described in the error directory as "General software errors". They can only be corrected by the manufacturer.

→ If errors which are described in the error directory as "General software errors" repeatedly occur, please notify the manufacturer, quoting the error number and the circumstances in which the error occurred.

**Easy-Plug errors**

Errors in the Easy-Plug code can be detected much easier with firmware version x.33 or higher. This requires the following setting:

SYSTEM PARAMETERS > EasyPlug error = "Strict handling"

The Easy-Plug command, which caused the error, is displayed after approx. 2 seconds in the lower display line. The displayed text is up to 30 characters long and is scrolled automatically.

If a single character caused the error, this character is marked with „>> <<„, in the display text, to facilitate the detection.

By pressing the cut button, the display can be toggled between error message and Easy-Plug command text.

**Unspecific errors**

Some errors can have more than one cause. To be able to find the specific reason for such an error, it is important that it can be reproduced.

→ Send the following items of information as complete as possible to the manufacturer – preferably as files:

- *Layout and/or printjob*, which makes the status message appear
  - *Parameter configuration* of the printer, when the error occurs
  - *Log file* of the printjob until the error occurs
- Use parameter **SPECIAL FUNCTION > Parameter to CF**, to save the current parameter configuration.
- Use parameter **SERVICE FUNCTION > EasyPlug monitor**, to send the received Easy-Plug data to a serial interface. Alternatively, with some printer types, log files of the printjob can be saved on memory card (**SPECIAL FUNCTION > Parameter to CF**).

Our Technical Support will try hard to find a solution by reproducing the situation which caused the error.

### **Not listed status reports**

Some status reports are not shown in the list of status reports. They provide developers of the printer firmware and trained service personnel with information about special conditions, particularly with regards to the printer firmware.

- ▣▣▣▣▶ If your printer displays status reports which are not included in the following list, please refer to the authorised service office. Make a note of the status number and the circumstances in which the message occurred.

## Listing of all Status reports

### **1000 No new command**

- Status** General software error
- Measure** → Switch printer off and then back on again after thirty seconds.  
→ Please read the notes in section [General software errors](#) .

### **1001 Parameter Table**

- Status** General software error
- Measure** → Switch printer off and then back on again after thirty seconds.  
→ Please read the notes in section [General software errors](#) .

### **1002 Comm. sorting**

- Status** General software error
- Measure** → Switch printer off and then back on again after thirty seconds.  
→ Please read the notes in section [General software errors](#) .

### **1003 Too many slashes**

- Status** General software error
- Measure** → Please read the notes in section [General software errors](#) .

### **1004 Slash w/o param.**

- Status** General software error
- Measure** → Acknowledge by pressing the on-line button.  
→ Please read the notes in section [General software errors](#) .

### **1005 2 same commands**

- Status** General software error
- Measure** → Acknowledge by pressing the on-line button.  
→ Please read the notes in section [General software errors](#) .

### **1006 Letter incorrect**

- Status** General software error: self-acknowledging
- Measure** → Please read the notes in section [General software errors](#) .

### **1007 Command incorr.**

- Status** Unknown command.
- Measure** → Check Easy Plug sequence.

### **1008 Subcomm. incorr.**

- Status** Unknown letter in a subcommand.
- Measure** → Check Easy Plug sequence.

**1009 Param. tab inc.**

**Status** General software error

**Measure** → Acknowledge by pressing the on-line button.  
→ Please read the notes in section [General software errors](#) .

**1010 #ER x #Q !**

**Status** One or more illegal commands between #ER and #Q.

**Measure** → Check transmitted Easy Plug sequence.  
→ Please read the notes in section [Easy-Plug errors](#) .

**1011 #ER missing**

**Status** One or more format commands without leading #ER (self-acknowledging)

**Measure** → None. The command is still carried out.  
→ Please read the notes in section [Easy-Plug errors](#) .

**1012 #IM x #Q !**

**Status** One or more illegal commands between #IM and #Q.

**Measure** → Check Easy Plug sequence.  
→ Please read the notes in section [Easy-Plug errors](#) .

**1013 Comm. flag inc.**

**Status** General software error

**Measure** → Switch printer off and then back on again after thirty seconds.  
→ Please read the notes in section [General software errors](#) .

**1014 Uunit integer**

**Status** General software error

**Measure** → Switch printer off and then back on again after thirty seconds.  
→ Please read the notes in section [General software errors](#) .

**1015 Uunit float**

**Status** General software error

**Measure** → Switch printer off and then back on again after thirty seconds.  
→ Please read the notes in section [General software errors](#) .

**1016 Uunit string**

**Status** General software error

**Measure** → Switch printer off and then back on again after thirty seconds.  
→ Please read the notes in section [General software errors](#) .

**1017    Unit discr**

**Status**                    General software error

**Measure**                → Switch printer off and then back on again after thirty seconds.  
                                 → Please read the notes in section [General software errors](#) .

**1018    Too many discr**

**Status**                    General software error

**Measure**                → Switch printer off and then back on again after thirty seconds.  
                                 → Please read the notes in section [General software errors](#) .

**1019    Unit BCD para.**

**Status**                    General software error

**Measure**                → Switch printer off and then back on again after thirty seconds.  
                                 → Please pay attention to the notes in chapter [General software errors](#) .

**1020    Too much image**

**Status**                    General software error

**Measure**                → Switch printer off and then back on again after thirty seconds.  
                                 → Please pay attention to the notes in chapter [General software errors](#) .

**1021    Unit image par**

**Status**                    General software error

**Measure**                → Switch printer off and then back on again after thirty seconds.  
                                 → Please pay attention to the notes in chapter [General software errors](#) .

**1022    Too many files**

**Status**                    General software error

**Measure**                → Switch printer off and then back on again after thirty seconds.  
                                 → Pay attention to the notes in section [General software errors](#) .

**1023    Unit File Para**

**Status**                    General software error

**Measure**                → Switch printer off and then back on again after thirty seconds.  
                                 → Please pay attention to the notes in chapter [General software errors](#) .

**1024    Com. too long**

**Status**                    General software error

**Measure**                → Switch printer off and then back on again after thirty seconds.  
                                 → Please pay attention to the notes in chapter [General software errors](#) .

**1025 Com twice there**

- Status** General software error
- Measure** → Switch printer off and then back on again after thirty seconds.  
→ Please pay attention to the notes in chapter [General software errors](#) .

**1026 Comm. w/o. flag**

- Status** General software error
- Measure** → Switch printer off and then back on again after thirty seconds.  
→ Please read the notes in section [General software errors](#) .

**1027 Uinit parameter**

- Status** Parameter could not be initialised.
- Measure** → Acknowledge by pressing the Online button.

**1028 Parameter uninit**

- Status** General software error
- Measure** → Acknowledge by pressing the Online button.  
→ Please read the notes in section [General software errors](#) .

**1029 Param. incorr.**

- Status** Incorrect parameter in the command.
- Measure** → Check Easy Plug sequence.  
→ Please read the notes in section [Easy-Plug errors](#) .

**1030 Command incorr.**







- Status** Error during the command interpretation.
- Measure** → Check Easy Plug sequence.  
→ Please read the notes in section [Easy-Plug errors](#) .

**1031 Too many slashes**

- Status** Too many parameters between two slashes.
- Measure** → Check Easy Plug sequence.  
→ Please read the notes in section [Easy-Plug errors](#) .

**1032 Incorrect char.**

- Status** Parameter contains an invalid character.
- Measure** → Check Easy Plug sequence.  
→ Please read the notes in section [Easy-Plug errors](#) .

**1033    Uninit flash par****Status**                    General software error**Measure**                → Switch printer off and then back on again after thirty seconds.  
                                  → Please read the notes in section [General software errors](#) .**1034    Uninit restrict****Status**                    A „restricted string“ parameter could not be initialized.**Measure**                → Switch printer off and then back on again after thirty seconds.  
                                  → Please read the notes in section [General software errors](#) .**1035    Uninit combi****Status**                    General software error. A combi parameter could not be initialized.**Measure**                → Confirm by pressing the Online button.  
                                  → Please read the notes in section [General software errors](#) .**1036    Wrong combi para****Status**                    General software error. A combi parameter could not be initialized.**Measure**                → Confirm by pressing the Online button.  
                                  → Please read the notes in section [General software errors](#) .**1037    Software error****Status**                    General software error**Measure**                → Switch printer off and then back on again after thirty seconds.  
                                  → Please read the notes in section [General software errors](#) .**1038    Software error****Status**                    General software error**Measure**                → Switch printer off and then back on again after thirty seconds.  
                                  → Please read the notes in section [General software errors](#) .**1087    OLV not active****Status**                    OLV- specific Easy Plug commands have been used (#OLVI or #OLVD), *without* having set the printer to OLV use at first.**Measure**                → Set the printer to OLV use.  
                                  ○ See parameter INTERF. PARAM > COM2 PORT > Function Option.**1088    No realtimeclock****Status**                    RTC-specific Easy Plug commands have been used (#YS or #YC), *without* having a RTC installed.**Measure**                → Install a RTC.  
                                  ○ For details refer to the Service Manual, topic section "General Service", chapter "Assembling accessories" / "Option board".

**1089 Seek Fkt. Error**

- Status** General software error. An error occurred while processing the function „seek“ in the internal file system of the printer.
- Measure** → Confirm by pressing the Online button.  
→ Please read the notes in section [General software errors](#) .

**1090 Incomplete Job**

- Status** The actual print job was not terminated by the #Q command. In other words, after a start command #ER for a label format follows another #ER command without the first format being terminated by #Q.
- Measure** → Confirm by pressing the Online button.  
→ Terminate the print job with a #Q command.

**1091 Wrong var field**

- Status** An error occurred while interpreting the text string of a variable data field. The error could e.g. be caused by a #YT or a #YB command (Easy Plug). Self-acknowledging error.
- Measure** → Check the text strings of variable data fields.

**1092 Rename file**

- Status** General software error
- Measure** → Please read the notes in section [General software errors](#) .

**1093 Delete file**

- Status** File cannot be deleted.
- Measure** → Check whether the file name is written correctly; check whether the file is write-protected.

**1094 More than 3 figs**

- Status** General software error
- Measure** → Switch printer off and then back on again after thirty seconds.  
→ Please read the notes in section [General software errors](#) .

**1097 Out of memory**

- Status** General software error
- Measure** → Switch printer off and then back on again after thirty seconds.  
→ Please read the notes in section [General software errors](#) .

**1099 File end**

- Status** General software error
- Measure** → Please read the notes in section [General software errors](#) .



**1101 Wrong time/date**

**Status** Easy-Plug command #RTC (set realtime clock): invalid date or wrong date/time format.

**Measure** → Check command #RTC in the current printjob.  
→ Please read the notes in section [Easy-Plug errors](#) .

**1102 Counter offset**

**Status** Applies to all Easy-Plug commands with counter function, e. g. #YT: A non-valid digit was used in the offset.

**Measure** → Check all commands with counter function in the current printjob.  
→ Please read the notes in section [Easy-Plug errors](#) .

**1110 Opening Bracket**

**Status** General software error

**Measure** → Switch printer off and then back on again after thirty seconds.  
→ Please read the notes in section [General software errors](#) .

**1111 Closing Bracket**

**Status** General software error

**Measure** → Switch printer off and then back on again after thirty seconds.  
→ Please read the notes in section [General software errors](#) .

**1112 Para: No Value**

**Status** General software error

**Measure** → Switch printer off and then back on again after thirty seconds.  
→ Please read the notes in section [General software errors](#) .

**1113 No Default Value**

**Status** General software error

**Measure** → Switch printer off and then back on again after thirty seconds.  
→ Please read the notes in section [General software errors](#) .

**1114 < Limit value**

**Status** A sent Easy Plug command contains a value which exceeds the admissible range at the bottom limit. The faulty value is replaced automatically by a default value matching the limits.

Example: #YT109/-1/. The value -1 has been assigned to the parameter d. Admissible for d are the values 0, 1, 2, 3. Therefore, -1 exceeds the value range at the bottom limit.

**Measure** → Check the Easy Plug command on admissible values and correct them if necessary.  
→ Please read the notes in section [Easy-Plug errors](#) .

**1115 > Limit value**

**Status** A sent Easy Plug command contains a value which exceeds the admissible range at the top limit. The faulty value is replaced automatically by a default value matching the limits.

Example: #YT109/5/. The value 5 has been assigned to the parameter d. Admissible for d are the values 0, 1, 2, 3. Therefore, 5 exceeds the value range at the top limit.

**Measure** → Check the Easy Plug command on admissible values and correct them if necessary.

→ Please read the notes in section [Easy-Plug errors](#) .

**1120 Incorr. logo no.**

**Status** Logo no. is invalid because it is outside of the address field. (self-acknowledging)

**Measure** → Check whether the logo no. has been given as being smaller than 0 (zero) or larger than 255.

**1121 Logo exists**

**Status** Logo already exists.

**Measure** → Change the designation of the logo; repeat saving.

**1122 Creating logo**

**Status** General software error

**Measure** → Please read the notes in section [General software errors](#) .

**1123 Rename logo**

**Status** General software error

**Measure** → Please read the notes in section [General software errors](#) .

**1124 Logo file**

**Status** General software error

**Measure** → Please read the notes in section [General software errors](#) .

**1125 Delete error**

**Status** General software error

**Measure** → Switch printer off and then back on again after thirty seconds.

→ Please read the notes in section [General software errors](#) .

**1126 File creation**

**Status** Faulty Easy-Plug code. A file could not be created. The error may e.g. be caused by a faulty filename or by too less printer memory.

- Measure**
- Check all used filenames for length, applied characters, etc. Change the name if faulty.
  - Check the printer for enough memory.
  - Please read the notes in section [Easy-Plug errors](#) .

**1127 File format**

**Status** A file name doesn't match the (DOS-) filename convention.

- Measure**
- Check all used filenames for length, applied characters, etc. Change the name if faulty.

**1128 File exists**

**Status** Faulty Easy-Plug code. A file is ought to be loaded into the printer memory via #DF command. The command was used without adding the parameter "O" for "Overwrite", but a file already exists under the given name.

- Measure**
- Rename one of both files or set the parameter "O".
  - Please read the notes in section [Easy-Plug errors](#) .

**1130 Float overflow**

**Status** Number of figures is too high for a floating comma variable.

- Measure**
- Switch printer off and then back on again after thirty seconds.
  - Reduce the number of figures.

**1131 Logo cache full**

**Status** A logo or several logos was/were sent which is/are too huge for the logo buffer.

- Measure**
- Switch printer off and then back on again after thirty seconds.
  - Reduce the logo size.

**1140 Line too long**

**Status** Error during conversion from EPT into BIN: permitted line length exceeded.

- Measure**
- Reduce line length.

**1141 Para. incorr. BI**

**Status** Error during processing of a Bit Image parameter.

- Measure**
- Acknowledge by pressing the on-line button.

**1150 Integer overflow**

**Status** Too many figures for an integer variable.

- Measure**
- Switch printer off and then back on again after thirty seconds.
  - Reduce the number of figures.

**1160 String too long**

**Status** A string parameter exceeds the maximum string length of 256 characters (1024 characters in 2-dimensional bar codes respectively).

**Measure** → Reduce the number of characters in the string.

**1170 X Pos > width**

**Status** Faulty Easy-Plug code. X position exceeds permitted maximum value.

**Result** The previously set print offset is retained.

**Measure** → Reduce value for X position.  
→ Please read the notes in section [Easy-Plug errors](#) .

**1171 X Pos < zero**

**Status** Faulty Easy-Plug code. Value for X position < zero.

**Result** The previously set print offset is retained.

**Measure** → Check value for X position for signs.  
→ Please read the notes in section [Easy-Plug errors](#) .

**1172 Y Pos > length**

**Status** Faulty Easy-Plug code. Y position exceeds the label length.

**Result** The previously set print offset is retained.

**Measure** → Reduce value for Y position.  
→ Select a longer label.  
→ Please read the notes in section [Easy-Plug errors](#) .

**1173 Y Pos < zero**

**Status** Faulty Easy-Plug code. Value for Y position < zero.

**Result** The previously set print offset is retained.

**Measure** → Check value for Y position for signs.  
→ Please read the notes in section [Easy-Plug errors](#) .

**1174 Max width: right**

**Status** Maximum label width, right, reached. Elements such as character, line or logo do not fit into the physical print format (self-acknowledging)

**result** Only elements which completely fit into the print format are printed.

**Measure** → Alter value for width or position of elements.  
→ Please read the notes in section [Easy-Plug errors](#) .

**1175 Max width: left**

**Status** Faulty Easy-Plug code. Maximum label width, left, reached. Elements such as character, line or logo do not fit into the physical print format (self-acknowledging)

**result** Only elements which completely fit into the print format are printed.

**Measure** → Alter value for width or position of elements.  
→ Please read the notes in section [Easy-Plug errors](#) .

**1176 Max length: top**

**Status** Faulty Easy-Plug code. Maximum label length, top, reached.

**Measure** → Correct label layout: Position the drawing elements in a way that they fit on the label or modify the label length.  
→ Please read the notes in section [Easy-Plug errors](#) .

**1177 Max length: bot.**

**Status** Faulty Easy-Plug code. Maximum label length, bottom, reached.

**Measure** → Correct label layout: Position the drawing elements in a way that they fit on the label.  
→ Please read the notes in section [Easy-Plug errors](#) .

**1178 x Dots < zero**

**Status** Bit Image:

**Measure** → Switch printer off and then back on again after thirty seconds.

**1200 GetRLE reset st**

**Status** (number of bytes) \* (number of lines) does not correspond to the file length.

**Measure** → Switch printer off and then back on again after thirty seconds.

**1201 GetRLE error st**

**Status** GetRLE byte has error status.

**Measure** → Switch printer off and then back on again after thirty seconds.

**1210 itoa Short Strin**

**Status** General software error

**Measure** → Please read the notes in section [General software errors](#) .

**1240 New FS>E**

**Status** General software error

**Measure** → Please read the notes in section [General software errors](#) .

**1241 New Read Pointer**

**Status** Faulty memory assignment for print jobs.

**Measure** → Please read the notes in section [Unspecific errors](#) .

**1242 New FE in job**

**Status** Faulty memory assignment for print jobs.

**Measure** → Please read the notes in section [Unspecific errors](#) .

**1243 New delete order**

**Status** Faulty memory assignment for print jobs.

**Measure** → Please read the notes in section [Unspecific errors](#) .

**1244 New wrong pos.**

**Status** Faulty memory assignment for print jobs.

**Measure** → Please read the notes in section [Unspecific errors](#) .

**1245 New no space**

**Status** Faulty memory assignment for print jobs.

**Measure** → Please read the notes in section [Unspecific errors](#) .

**1246 New HP no space**

**Status** Faulty memory assignment for print jobs.

**Measure** → Please read the notes in section [Unspecific errors](#) .

**1247 Out of memory**

**Status** Faulty memory assignment for print jobs.

**Measure** → Please read the notes in section [Unspecific errors](#) .

**1260 TimeDate string**

**Status** General software error

**Measure** → Acknowledge by pressing the on-line button.

→ Please read the notes in section [General software errors](#) .

**1270 #-comm. invalid**

**Status** General software error

**Measure** → Please read the notes in section [General software errors](#) .

**1272 Wrong #!..**

**Status** Faulty Easy-Plug code. Faulty use of the immediate command "#!A..". The specified parameter value exceeds the admissible value range (0 to 31).

**Measure** → Specify an admissible parameter value.

→ Please read the notes in section [Easy-Plug errors](#) .

**1273 Wrong #!C..**

**Status** Faulty Easy-Plug code. Faulty use of the immediate command "#!C..". The specified parameter value exceeds the admissible value range (A, F).

**Measure** → Specify an admissible parameter value.  
→ Please read the notes in section [Easy-Plug errors](#) .

**1276 #!P wrong number**

**Status** Faulty Easy-Plug code. Faulty use of the immediate command "#!P..". The specified parameter value exceeds the admissible value range (0 to 31).

**Measure** → Specify an admissible parameter value.  
→ Please read the notes in section [Easy-Plug errors](#) .

**1277 Wrong #!S..**

**Status** Faulty Easy-Plug code. Faulty use of the immediate command "#!S..". The specified parameter value exceeds the admissible value range (P, R).

**Measure** → Specify an admissible parameter value.  
→ Please read the notes in section [Easy-Plug errors](#) .

**1278 Wrong #!X..**

**Status** Faulty Easy-Plug code. Faulty use of the immediate command "#!X..". The specified parameter value exceeds the admissible value range (S, B, P).

**Measure** → Specify an admissible parameter value.  
→ Please read the notes in section [Easy-Plug errors](#) .

**1279 #!X wrong number**

**Status** Faulty Easy-Plug code. Faulty use of the immediate command "#!X..". The specified parameter value exceeds the admissible value range.

**Measure** → Specify an admissible parameter value.  
→ Please read the notes in section [Easy-Plug errors](#) .

**1282 Spooler FB > L**

**Status** General software error

**Measure** → Switch printer off and then back on again after thirty seconds.  
→ Please read the notes in section [General software errors](#) .

**1285 #!-comm. incorr.**

**Status** Faulty Easy-Plug code. Faulty use of the immediate command "#!..!". The specified letter is unknown.

**Measure** → Specify an admissible letter.  
→ Please read the notes in section [Easy-Plug errors](#) .

**1290 Label limit**

**Status** Faulty Easy-Plug code. Value for x or y position exceeds the label limit.

**Measure** → Reduce the value for the x or y position.  
→ Please read the notes in section [Easy-Plug errors](#) .

**1291 Draw field**

**Status** Faulty Easy-Plug code. Function call, drawing object, unsuccessful.

→ Please read the notes in section [Easy-Plug errors](#) .

**1300 Invalid Command**

**Status** General software error

**Measure** → Please read the notes in section [General software errors](#) .

**1301 Table full**

**Status** General software error

**Measure** → Please read the notes in section [General software errors](#) .

**1310 Wrong Field ID**

**Status** The error can have several causes.

**Measure** → Please read the notes in section [Unspecific errors](#) .

**1320 No Default Value**

**Status** Faulty Easy-Plug code.

**Measure** → Please read the notes in section [Easy-Plug errors](#) .

**1321 Bar Code Object**

**Status** Faulty Easy-Plug code regarding the declaration of a bar code.

**Measure** → Please read the notes in section [Easy-Plug errors](#) .

**1322 Logo Object**

**Status** Faulty Easy-Plug code regarding the declaration of a logo.

**Measure** → Please read the notes in section [Easy-Plug errors](#) .

**1323 Line Object**

**Status** Faulty Easy-Plug code regarding the declaration of a line.

**Measure** → Please read the notes in section [Easy-Plug errors](#) .

**1324 Rectangle Object**

**Status** Faulty Easy-Plug code regarding the declaration of a rectangle.

**Measure** → Please read the notes in section [Easy-Plug errors](#) .



**1325 Truedoc Object**

**Status** The error can have several causes.

**Measure** → Please read the notes in section [Unspecific errors](#) .

**1326 Fix Field Creati**

**Status** Faulty Easy-Plug code regarding the declaration of a field.

**Measure** → Please read the notes in section [Easy-Plug errors](#) .

**1327 Update Field Cre**

**Status** Faulty Easy-Plug code regarding the declaration of a field.

**Measure** → Please read the notes in section [Easy-Plug errors](#) .

**1328 Var Field Creati**

**Status** Faulty Easy-Plug code regarding the declaration of a field.

**Measure** → Please read the notes in section [Easy-Plug errors](#) .

**1329 Count Field Crea**

**Status** Faulty Easy-Plug code regarding the declaration of a counting field.

**Measure** → Please read the notes in section [Easy-Plug errors](#) .

**1330 Create clk. field**

**Status** General software error

**Measure** → Please read the notes in section [General software errors](#) .

**1331 Field type inv.**

**Status** Invalid field type

**Measure** → Acknowledge by pressing the Online button.

**1332 Field length inc.**

**Status** General software error

**Measure** → Switch printer off and then back on again after thirty seconds.

→ Please read the notes in section [General software errors](#) .

**1333 Logo not there**

**Status** Selected logo does not exist.

**Measure** → Check file name / existence of the logo.

**1334 #YV Data incorr.**

**Status** Illegal entries for a #YV field (variables data field).

**Measure** → Acknowledge by pressing the Online button.

→ Correct data.

→ Please read the notes in section [Easy-Plug errors](#) .

**1335 #YV Field cont.**

- Status** Content of the #YV field (variables data field) could not be pasted.
- Measure** → Acknowledge by pressing the Online button.  
→ Please read the notes in section [Easy-Plug errors](#) .

**1336 #YV no. incorr.**

- Status** #YV field (variables data field) with the given no. not found.
- Measure** → Acknowledge by pressing the Online button.  
→ Check the number of the #YV field.  
→ Please read the notes in section [Easy-Plug errors](#) .

**1390 Web width zero**

- Status** The printer was set to printing several label rows (Easy Plug command #ER,  $n > 1$ ); but the label width was by fault set to zero ( $b = 0$ ).
- Measure** → Correct the #ER command regarding the setting of parameter b.  
→ Please read the notes in section [Easy-Plug errors](#) .

**1391 Web > Width**

- Status** The printer was set to printing several label rows (Easy Plug command #ER,  $n > 1$ ); but both or one of the parameters  $n$  and  $b$  are set in a way that  $n * b$  (label row width \* no. of rows) exceeds the material width.
- Measure** → Correct the #ER command regarding the setting of parameters  $n$  and  $b$ .  
→ Please read the notes in section [Easy-Plug errors](#) .

**1392 Job memory full**

- Status** The error can have several causes.
- Measure** → Please read the notes in section [Unspecific errors](#) .

**1393 Job struct creat**

- Status** The error can have several causes.
- Measure** → Please read the notes in section [Unspecific errors](#) .

**1394 Invalidation**

- Status** General software error
- Measure** → Switch printer off and then back on again after thirty seconds.  
→ Please read the notes in section [General software errors](#) .

**1395 Label too wide****Status**

A printjob contains an #IM-command which sets the label width to a measure exceeding the maximum print width. The maximum print width depends on the printer type.

- Refer to the user manual, topic section „Specifications“ for the maximum label width.

**Measure**

- Reduce the label width set by the #IM-command in the concerned print job, until the label width matches the maximum print width.
- Please read the notes in section [Easy-Plug errors](#) .

**1396 Label too long****Status**

Label length setting exceeds the maximum label length. The maximum label length depends on the memory configuration of the printer.

- The info-printout „Memory Status“ shows among other data the maximum label length. Read more about info-printouts in topic section „Info-Printouts and Parameters“.

**Measure**

- Reduce the label width setting.
- Please read the notes in section [Easy-Plug errors](#) .

**1397 Label too short****Status**

The label length defined in the #IM command is smaller than the minimum admissible length. The label length is set to the minimum value.

**Measure**

- Correct the length value in the label layout definition.
- Please read the notes in section [Easy-Plug errors](#) .

**1398 Label too small****Status**

The label width defined in the #IM command is smaller than the minimum admissible width. The label width is set to the minimum value.

**Measure**

- Correct the width value in the label layout definition.
- Please read the notes in section [Easy-Plug errors](#) .

**1404 UTF8 data wrong****Status**

Character code > 0xffff

**Measure**

- Check/change the character code.

**1470 X-Offset****Status**

The x-position of a layout element (graphics, text, ...) is beyond the label margin. The element is shifted automatically to the first admissible position at the correct side of the margin.

**Measure**

- Check the x-positions of the layout elements and change them, if necessary.
- Please read the notes in section [Easy-Plug errors](#) .

**1471 Y-Offset**

**Status** The y-position of a layout element (graphics, text, ...) is beyond the label margin. The element is shifted automatically to the first admissible position at the correct side of the margin.

**Measure** → Check the y-positions of the layout elements and change them, if necessary.  
→ Please read the notes in section [Easy-Plug errors](#) .

**1501-1535 Messages, which can occur in ZPL emulation mode**

This section lists all error messages that may appear when using the ZPL II<sup>®</sup> interpreter function.

**1501 Unknown MLI Cmd**

**Error level** 1

**Status** An uninterpretable command was encountered.

**Measure** → Check, if the printjob was proceeded correctly. If yes, ignore the message, if no, modify the printjob.

**1502 MLI Hash Error**

**Error level** 1

**Status** General software error.

**Measure** Read chapter [General software errors](#)  on page 8.

**1503 Filename Too Long**

**Error level** 1

**Status** Filename is too long.

**Measure** → Rename the file with a shorter name.

**1504 Param > Max**

**Error level** 1

**Status** Parameter exceeds the maximum value defined

**Measure** → Shorten the parameter.

**1505 Param < Min**

**Error level** 1

**Status** Parameter is shorter than the admissible minimum value allowed.

**Measure** → Modify the parameter.

**1506 No Previous**

**Error level** 1

**Status** Graphics command is to set current row data to previous row data, but previous row data doesn't exist.

**Measure** →

**1507 Not enough data****Error level** 1**Status** Data for graphics command is not enough.**Measure** → Check and modify graphics data.**1508 String Too Long****Error level** 1**Status** String characters exceeds the maximum number of characters which the particular string parameter can take.**Measure** → Check and modify the command.**1509 Wrong Byte Cnts****Error level** 1**Status** The row size or total size parameters is not valid (equals 0). Occurs when download graphic or download font commands in process.**Measure** → Check and modify the command.**1510 Wrong Param****Error level** 1**Status** Control characters are not allowed for discrete parameter (single letter parameter).**Measure** → Check and modify the command.**1511 Bar Parm Error****Error level** 1**Status** Parameters to a barcode command is wrong or does not conform with specs.**Measure** → Modify the bar code command.**1512 Code128 Mode Err****Error level** 1**Status** Code128 barcode command specifying mode type other than 'AUTO'.**Measure** → Modify the bar code command.**1513 Wrong Mode****Error level** 2**Status** Coda block barcode command specifying mode type other than 'F'.**Measure** → Modify the bar code command.

**1514    ^BX Parm Err.**

Error level            2

Status                    Data Matrix bar code command specified an escape sequence character.  
This is not supported in this printer.

Measure                → Modify the bar code command.

**1515    Conv to ECC200**

Error level            1

Status                    Data Matrix barcode command specified non ECC200 level. Program is  
attempting to convert to ECC200.

Measure                → Modify the bar code command.

**1516    Bad Drive: x**

Error level            2

Status                    The drive selected is not a valid drive. (We support only 'R' and 'B').

Measure                → Select a valid drive.

**1517    Mask String: x**

Error level            2

Status                    The mask string used in ^SF command is not supported.

Measure                → Modify the print job.

**1518    Bad Format: x**

Error level            2

Status                    The graphic format selected is not supported by Avery ZPL Emulation  
(Compressed binary and PNG format).

Measure                → Convert graphic into a supported format.

**1519    Cmd Init Error**

Error level            1

Status                    General software error.

Measure                Read chapter [General software errors](#) □ on page 8.**1520    Unsupported Cmd**

Error level            1

Status                    Non critical commands that is not supported by this printer.

Measure                → Check and modify the commands in the printjob.

**1521    Unsupported: x**

Error level            2

Status                    Critical commands that is not supported by this printer.

Measure                → Check and modify the commands in the printjob.

**1522 Bad Char Set x**

**Error level** 2  
**Status** The character set selected by ^CI command is not supported.  
**Measure** → Replace the character set by a supported set.

**1523 Cmd Parm Error**

**Error level** 1  
**Status** Error encountered while parsing command parameter.  
**Measure** → Check and modify the commands in the printjob.

**1524 d/mm not chg x**

**Error level** 2  
**Status** Command attempting to lower print density assuming a 200 dpi printer.  
**Measure** → Check and modify the commands in the printjob.

**1525 USI not exist**

**Error level** 1  
**Status** The printer is not equipped with a USI board.  
**Measure** → Modify the printjob.  
→ Install a USI board.

**1526 Can't Off CV**

**Error level** 1  
**Status** Command attempting to turn off barcode validations.  
**Measure** → Check and modify the commands in the printjob.

**1527 Offset illegal**

**Error level** 2  
**Status** RTC command specified a clock offset not supported by this printer (possibly a negative offset).  
**Measure** → Correct the command.

**1528 Language illegal**

**Error level** 2  
**Status** Language specified by RTC command is not English or German.  
**Measure** → Correct the command.

**1529 Invalid Prn Mode**

Error level 1

Status Print modes other than cutter mode are selected (Tear-off, Rewind or Peel-off modes in ^MM command).

Measure → Correct the command.

**1530 Inc free str mem**

Error level 2

Status Not enough free store memory.

Measure → Increase the value set in SYSTEM PARAMETER &gt; Free store size (at least 2048 Kbytes).

**1531 Inc RAM disc**

Error level 2

Status Not enough RAM disc.

Measure → Increase the value set in SYSTEM PARAMETER &gt; Ram disk size (at least 2048 Kbytes).

**1532 No Fixfont**

Error level 2

Status No fixfonts in Flash.

Measure → Load fixfont.

**1533 No Speedo Font**

Error level 2

Status No Speedo font in Flash.

Measure → Load speedo font.

**1534 ^XA missing**

Error level 1

Status Command should be placed inside of ^XA...^XZ pair.

Measure → Modify the printjob.

**1535 ^XZ missing**

Error level 1

Status Command should be placed outside of ^XA...^XZ pair.

Measure → Modify the printjob.



## **2000-2009 Messages caused by Easy-Plug variables**

### **2000 Double var name**

**Status** Attempt to define a variable with an already existing name.

**Measure** → Choose another name for the variable.

### **2002 Var. data length**

**Status** The maximum allowed length of a variable was exceeded.

**Measure** → Correct the variable length.

### **2003 Expr. bracket**

**Status** The number of open and close brackets in the expression is not equal.

**Measure** → Check the brackets in the expression and correct their number.

### **2004 Exp. quotemark**

**Status** The number of quotemarks in the expression is *not* a multiple of two.

**Measure** → Check the quotemarks in the expression and correct their number.

### **2005 Exp. comma pos.**

**Status** Unexpected comma in the expression.

**Measure** → Check the syntax of the expression regarding commas.

### **2006 Exp.functionname**

**Status** A wrong function name is used in the expression.

**Measure** → Check, if the function names used in the expression are spelled correctly and if the functions exist. Change the function name.

### **2007 Exp.fct.paratype**

**Status** A wrong parameter type in an expression was detected.

Example: SubStr("Text",o,"A") would provoke this message, because "A" is not a number.

**Measure** → Check the expressions. Correct the wrong expression.

### **2008 Exp.fct.paraCnt**

**Status** Wrong number of function parameters in the expression.

**Measure** → Check the expressions. Correct the wrong expression.

### **2009 Exp. name wrong**

**Status** A not defined variable name is used in an expression.

**Measure** → Check the variable names. Correct the spelling if necessary or define a new variable.

**2010 Fct. para value**

**Status** The error is caused by the Easy-Plug function chr(). The argument, which was assigned to the function, exceeds the admissible value range 0...255.

**Measure** → Change the argument (details see Easy-Plug manual)

**2011 OLV variable**

**Status** Wrong naming of the variable in Easy-Plug command #VDO (details see Easy-Plug manual)

**Measure** → Check the Easy-Plug command #VDO in the current printjob.

**2111 Invalid Date**

**Status** Invalid date specification in a string.  
Example: Function call *DayOfYear*("31", "6", "2005") would produce this error message (because the date did not exist).

**Measure** → Correct the date specification.

- See Easy-Plug Manual, topic section "Description of commands", chapter "Easy-Plug variables".

**2500 Multiple texts**

**Status** This status number may be combined with variety of texts, which all are generated by the Basic interpreter. The Basic interpreter is a function which is not released nor supported.

**Measure** → Switch off the Basic interpreter (SYSTEM PARAMETERS > Print Interpret.).

**3000/3003/3006/3012/3015 Com x Overrun**

**Status** Receive error at the RS232 interface COMx (x = [1...5]).

**Measure** → Acknowledge by pressing the Online button.

**3001/3004/3007/3013/3016 Com x Parity**

**Status** Receive error at the RS232 interface COMx (x = [1...5]).

**Measure** → Acknowledge by pressing the Online button.

→ Check parameter setting at printer (INTERF. PARAM. > COM1 PORT > Parity) and PC.

- Notes about setting the printer parameters are given in the chapter "Info Print-outs and Parameters" in the User Manual.

**3002/3005/3008/3015/3017 Com x Frame**

**Status** Receive error at the RS232 interface COMx (x = [1...5]).

**Measure** → Acknowledge by pressing the Online button.

→ Check parameter setting at printer (INTERF. PARAM. > COM1 PORT > Baud rate and INTERF. PARAM. > COM1 PORT > stop bits) and PC.

- Notes about setting the printer parameters are given in the chapter "Info Print-outs and Parameters" in the User Manual.

**3010 Spooler Overflow**

**Status** Fault which is caused by a faulty handshake at an interface. The consequence is an overflowing data buffer at the printer, because the host doesn't stop to send data to the printer.

**Measure**

- Acknowledge by pressing the Online button.
- Check the connections of the data line, especially the signal wires belonging to the handshake.
- Check the interface settings, especially the handshake settings.

**3011 Send buffer full**

**Status** The send buffer is full. This error may happen, if the printer status was requested several times (#!Xn), but the status reply was not read out.

**Measure** → Make sure that the status reply is read out.

## **4100-4106      Message, which can only occur with OLV-Option**

### **4100      No OLV data**

**Status**                      The OLV found out, that the bar code type and/or the bar code data, which was just printed and read, doesn't match the bar code specified in the print job. The error may have one of the following causes:

- OLV is not connected/switched on
- The bar code has not been printed
- The bar code has been printed poorly, so that the OLV can not detect it.

**Measure**                    → Check, if the OLV is connected correctly

→ Check the printout quality. If the printout is poor, change the print parameters and/or use a different material/ribbon-combination.

→ Make a dot check. May be, that a dot is defective, which was ought to print an important line of the bar code.

→ If the bar code has not been printed at all: check the print job.

### **4101      OLV limit exceed**

**Status**                      The read bar code exceeds a user-specified limit. The limits, e.g. contrast or readability, can be set via the parameter menu or via Easy Plug command.

**Measure**                    → Check the printout quality.

→ Change the limit.

→ Eventually modify the print parameters or the material/ribbon combination.

### **4103      OLV barcode type**

**Status**                      The OLV found out, that the bar code type, which was just printed and read, doesn't match the bar code specified in the print job.

**Measure**                    → Check the printout.

### **4104      OLV Timeout**

**Status**                      General software error

**Measure**                    ○ Please read the notes in section [General software errors](#) .

**4105 No OLV response**

**Status** This error may occur shortly after switching on the printer with the OLV device already switched on. It indicates, that the OLV version number was not successfully read.

Possible causes are:

- Wrong connection cable between OLV and printer
- Faulty interface parameter setting for Com2
- Power supply of the OLV interrupted or not available
- Defective I/O board (Com2)

**Measure** → Check the possible causes of failure and exchange defective parts.

**4106 OLV Software**

**Status** General software error

**Measure** ○ Please read the notes in section [General software errors](#) .

**5000 Bus device**

**Status** One of the devices connected to the I<sup>2</sup>C bus (e.g. output stage boards) does not respond. This message appears mostly first in a sequence of two or three status messages, which help to isolate the error source.

**Measure** → Acknowledge by pressing the Online button.  
→ Switch printer off and back on again after 30 sec. If the error message continues to appear, please contact the manufacturer.

**Example** The parameter `SYSTEM PARAMETERS > Periph. device` is set to "Cutter" without an output stage board for a cutter being installed. The following status messages appear one after another:

1. 

Status	5000
Bus device	

 Generally tells, that something went wrong with I<sup>2</sup>C bus communication.

→ Press Online button.

2. 

Status	5005
Knife-fault	

 Either no output stage board is prepared to drive a cutter, or the I<sup>2</sup>C bus data cable is not connected to the output stage board (this message appears only in one of those two cases, alternative status messages see Tab. 2)

→ Press Online button.

3. 

Status	5020
I2C Timeout	4

 Time limit exceeded without getting an answer from device no. 4 (4 = Cutter, see Tab. 4) (alternative status messages see Tab. 3)

→ Press Online button

One of the following status messages may follow second:

Status #	Text	Missing output stage for the following
----------	------	--

		<b>device:</b>
5005	Knife-fault	Cutter motor
5006	Head-fault	Print head liftmotor
5008	Ribbon end	Ribbon motor

Tab. 2 Those status messages indicate, that the device is not connected to the I<sup>2</sup>C bus.

Third may follow one of the status messages listed below:

<b>Status #</b>	<b>Text</b>
5020	I2C Timeout xx
5021	I2C Conf. xx
5022	I2C Busy xx
5023	I2C LAB xx
5024	I2C BER xx
5025	I2C Polling xx

Tab. 3 Status messages, which help to further locate the I<sup>2</sup>C bus error. xx = Device ID of the concerned device (see 0)

#	Device	64-xx	DPM / PEM	ALX 92x	AP 5.4	AP 7.t
0	CPU	X	X	X	X	X
1	Feed motor	X	X	X		X
2	Foil motor	X	X	X		
3	Printhead motor	X	X	X		X
4	Peripheral motor	X				X
5	Dispenser motor	X				
5	Rewinder motor			X		
8	Rewinder (internal)			X	X	
12	(Reserved)					
13	USI board	X	X	X		
15	I/O board	X	X	X	X	X
16	EEPROM	X	X	X	X	X
17	Realtime-clock	X	X	X	X	X
18	Power supply	X <sup>1)</sup>	X	X		

Tab. 4 Assignment of device IDs as used in status messages related to the I<sup>2</sup>C bus.

1) Only with the power supply types HME and ME 500.

**5001 No gap found**

- Status** No gap found or several blank labels fed.
- Measure**
- Acknowledge by pressing the Online button.
  - Check the print mask for gap definition (material length).
  - Check whether the correct material has been inserted.
  - Check that the photoelectric switch is clean.
  - Check material feed and position of photoelectric switch.
  - Check sensitivity of the photoelectric switch (Parameter SYSTEM PARAMETERS > Sens. punch-LS). Materials providing a poor contrast between label and backing paper or between reflex mark and label require a higher sensitivity setting.
  - After confirmation using the Online button, the material is fed forward automatically and the next gap is sought.

**5002 Material end**

- Status** Material end. Material no longer in the gap LS.
- Measure**
1. Press Online button in order to acknowledge the status report.  
Display: *OFFLINE x JOBS*
  2. Insert material and check the position of the photoelectric switch, correct if necessary.
  3. Press Online button: processing of the job continues, gap is reinitialised.

**5003 Cover open**

- Status** 64-xx / DPM / PEM / ALX 92x: *Cover open*
- Housing cover is open. Opening the cover causes all other eventually waiting status messages (e.g. ribbon end) to be deleted and the "Cover open" message immediately to be displayed. Closing the cover automatically acknowledges the message.
- AP 4.4 / 5.4: *Printhead pressure lever open*
- The printhead pressure lever was opened, during:
- the feeding of material or
  - printing.
- The error message is automatically acknowledged with the closing of the printhead pressure lever.
- Measure** → Close the cover or printhead lever respectively.

**5004 Rewinder mat. tear**

- Status** Label material at the backing paper rewinder is torn off.  
The *AP 5.4 Dispenser* shows this message also if the backing paper sleeve was too large during material initialization; the backing paper web could not be tightened.
- Measure** → Acknowledge by pressing the Online button.  
→ Secure label material to the rewinder.

**5005 Knife-fault**

- Status** Faults at the cutter.
- Measure** → Acknowledge by pressing the Online button.

**5006 Head-fault**

- Status** Print head lifting malfunction (head sensor).
- Measure** → Check whether dirt is preventing the head contact lever from moving freely, if necessary clean.  
→ If not successful, call Service.

**5008 Ribbon end**

- Status** Ribbon end
- Measure**
- When using thermal printing:
    1. Check whether the parameter `SYSTEM PARAMETER > Ribbonautoecon.` is set to "deactivated".
    2. Acknowledge by pressing the Online button.
    3. Switch off the ribbon end detection, parameter: `SYSTEM PARAMETER > Ribbonautoecon.`
    4. Press the Online button: processing of the job continues, gap LS is reinitialised.
  - When using heat transfer printing:
 

Measure 1

    1. Tighten ribbon or set the spring plate on the ribbon unwind mandrel so that the ribbon core turns the mandrel with it and the ribbon core can still be removed.
    2. Press the Feed button in order to acknowledge the status report.  
Display: OFFLINE x JOBS
    3. Press the Online button: processing of the job continues, gap LS is reinitialised.



**Measure 2**

1. Press the Cut button to deactivate the acoustic signal.
2. Press the Feed button in order to acknowledge the status report.  
Display: OFFLINE x JOBS
3. Insert a new ribbon.
4. Press the Online button: processing of the job continues, gap LS is reinitialised.

**5009 USI start error**

**Status** This status message can only be triggered with activated parameter DP INTERFACE > Start error stop. It occurs, if another start signal is given while printing a label.

**Measure** → Acknowledge by pressing the Online button. Press the Feed button afterwards to proceed with the print job.

**5012 Delete H8 loader**

**Status** Error while loading the H8 firmware: the old firmware on the machine could not be deleted.

**Measure**

- Acknowledge by pressing the Online button.
- Retry loading the firmware.
- If the error occurs repeatedly, the bootloader must be loaded newly.

**5013 Prog H8 loader**

**Status** Error while loading the H8 firmware: the new firmware could not be written.

**Measure**

- Acknowledge by pressing the Online button.
- Retry loading the firmware.
- If the error occurs repeatedly, the bootloader must be loaded newly.

**5015 Scanner****Status**

Faults at the scanner.

The scanner is tested during printer initialization by switching it on for a moment. A properly working scanner will afterwards send a reply signal to the printer. A missing reply signal provokes the status message. The missing of the reply signal can have several reasons.

**Measure**

- Acknowledge by pressing the Online button.
- Red scanner LED lights up? – If not, there is a lack of power supply. Check, if the scanner connection cable is plugged in correctly and if the connection cable is damaged.
- Yellow scanner LED lights up shortly after switching the printer on. – If not, the scanner test was faulty.

**5016 ALX Rewinder****Status**

(Only ALX 92x)

The output stage board belonging to the Rewinder motor is not connected or damaged.

**Measure**

- Check, if the board is connected properly.
- Exchange the board to verify if it is damaged.

**5017 Power Supply****Status**

Communication fault of the power supply during the running of the service function "Head dot test".

The power supply didn't succeed in switching to the dot check mode (that is, reducing the head voltage to 10 V). Also in this case, temporary disturbances on the measurement line of the H8 processor, caused by the power supply, are a possible reason. Even if the switchover is defective (the status message is displayed continuously), can the printer be used in normal operation mode.

**Measure**

- Acknowledge by pressing the Online button.
- Try again. If the error message continues to appear, exchange the power supply.
- For detailed information refer to the appropriate service manual, topic section "General Service", chapter "Connections and electrics", "Powerpack".

**5018 Dot check area**

**Status** A value is measured at the AD transformer, which should not occur with a proper working printer. That means, the current measurement circuit inside the power supply delivers a value which is too high. This can be a sporadically occurring fault of the power supply (noise voltages) or a durable defect. Another possibility is, that a dot of the printhead has a much too low resistance – a rather unlikely option, because this dot would be quickly overheated while printing, what would damage it and lead to a high resistance.

**Measure** → Acknowledge by pressing the Online button.  
→ Try again. If the error message continues to appear, please contact the manufacturer.

**5020 I2C Timeout xx**

**Status** Timeout error during communication via the I<sup>2</sup>C bus with the device xx (see Tab. 4 on page 37).

**Measure** → Switch printer off and then back on again after 30 sec. If the error message continues to appear, please contact the manufacturer.

**5021 I2C Conf. xx**

**Status** Confirmation error during communication via the I<sup>2</sup>C bus with the device xx (see Tab. 4 on page 37).

**Measure** → Switch printer off and then back on again after 30 sec. If the error message continues to appear, please contact the manufacturer.

**5022 I2C Busy xx**

**Status** Error during communication via the I<sup>2</sup>C bus with the device xx (see Tab. 4 on page 37). Device always reports that it is busy.

**Measure** → Switch printer off and then back on again after 30 sec. If the error message continues to appear, please contact the manufacturer.

**5023 I2C LAB xx**

**Status** Error during communication via the I<sup>2</sup>C bus with the device xx (see Tab. 4 on page 37).

**Measure** → Switch printer off and then back on again after 30 sec. If the error message continues to appear, please contact the manufacturer.

**5024 I2C BER xx**

**Status** Error during communication via the I<sup>2</sup>C bus with the device xx (see Tab. 4 on page 37).

**Measure** → Switch printer off and then back on again after 30 sec. If the error message continues to appear, please contact the manufacturer.

**5025 I2C Polling xx**

**Status** Polling error during communication via the I<sup>2</sup>C bus with the device xx (see Tab. 4 on page 37).

**Measure** → Switch printer off and then back on again after 30 sec. If the error message continues to appear, please contact the manufacturer.

### **5026 Motorprotect CPU**

**Status** (AP x.x only) The motor driver board (output stage board) is overheated or defective.

**Measure** → Switch printer off and then back on again after 30 sec.  
If the error message continues to appear:  
→ Replace the motordriver board.

### **5028 PS overheat**

(AP x.x only)

**Status** The temperature inside of the power supply exceeded the admissible range.

**Measure** → Let the power supply cool down for some minutes.

### **5029 I2C checksum xx**

**Status** During I<sup>2</sup>C communication with device xx occurred a checksum error.  
xx = I<sup>2</sup>C device number (see Tab. 4 on page 37).

**Measure** → Switch printer off and then back on again after 30 sec. If the error message continues to appear, please contact the manufacturer.

## **5051-5058 Messages which can only occur with a TT4 printer**

### **5051 Barcode Infeed 1**

- Status** (TT4 only) Error while reading the bar code on the material in infeed 1
- Measure**
- Check, whether material in infeed 1 is inserted correctly. The bar code must be in front (in advance direction) on the material bottom. Insert material correctly, if necessary.
  - Check, whether the bar code print is erroneous on material in infeed 1. Exchange material, if necessary.

### **5052 Barcode Infeed 2**

- Status** (TT4 only) Error while reading the bar code on the material in infeed 2
- Measure**
- Check, whether material in infeed 2 is inserted correctly. The bar code must be in front (in advance direction) on the material bottom. Insert material correctly, if necessary.
  - Check, whether the bar code print is erroneous on material in infeed 2. Exchange material, if necessary.

### **5053 Barcode Infeed 3**

- Status** (TT4 only) Error while reading the bar code on the material in infeed 3
- Measure**
- Check, whether material in infeed 3 is inserted correctly. The bar code must be in front (in advance direction) on the material bottom. Insert material correctly, if necessary.
  - Check, whether the bar code print is erroneous on material in infeed 3. Exchange material, if necessary.

### **5054 Barcode Infeed 4**

- Status** (TT4 only) Error while reading the bar code on the material in infeed 4
- Measure**
- Check, whether material in infeed 4 is inserted correctly. The bar code must be in front (in advance direction) on the material bottom. Insert material correctly, if necessary.
  - Check, whether the bar code print is erroneous on material in infeed 4. Exchange material, if necessary.

### **5055 Infeed 1 empty**

- Status** (TT4 only) While initializing, TT4 reports no material in infeed 1.
- ▶ Precondition for this status message is, that parameter `SYSTEM PARAMETERS > w/wo magazine` is set to „with“.
- Measure**
- Check, if the material in infeed 1 is loaded correctly, respectively if it's loaded at all. Acknowledge by pressing the Online button.

### **5056 Infeed 2 empty**

- Status** (TT4 only) While initializing, TT4 reports no material in infeed 1.

- ▶▶▶▶ Precondition for this status message is, that parameter `SYSTEM PARAMETERS > w/wo magazine` is set to „with“.

**Measure** → Check, if the material in infeed 1 is loaded correctly, respectively if it's loaded at all. Acknowledge by pressing the Online button.

### **5057 Infeed 3 empty**

**Status** (TT4 only) While initializing, TT4 reports no material in infeed 1.

- ▶▶▶▶ Precondition for this status message is, that parameter `SYSTEM PARAMETERS > w/wo magazine` is set to „with“.

**Measure** → Check, if the material in infeed 1 is loaded correctly, respectively if it's loaded at all. Acknowledge by pressing the Online button.

### **5058 Infeed 4 empty**

**Status** (TT4 only) While initializing, TT4 reports no material in infeed 1.

- ▶▶▶▶ Precondition for this status message is, that parameter `SYSTEM PARAMETERS > w/wo magazine` is set to „with“.

**Measure** → Check, if the material in infeed 1 is loaded correctly, respectively if it's loaded at all. Acknowledge by pressing the Online button.

### **5059 Stacker full**

**Status** (AP 7.t only) This message can only appear if a TCS is applied as peripheral device. It indicates, that the stacker is full or the protection cover is opened.

**Measure**

- Empty stacker
- Close cover
- If the message appears in spite of a closed cover and an emptied stacker, check the function of lid switch and microswitch.

### **5060 Stacker full**

**Status** This message can only appear if a TCS is applied as peripheral device. It indicates, that the stacker is full or the protection cover is opened.

**Measure**

- Empty stacker
- Close cover
- If the message appears in spite of a closed cover and an emptied stacker, check the function of lid switch and microswitch.

**5061 Dispenser motor**

- Status** The output stage board for the dispenser motor is not present or defective.
- Measure** → Press the Online button to acknowledge.
- Check the output stage board for the dispenser motor and eventually exchange it.

**5062 Disp. lift motor**

- Status** The output stage board for the dispenser lift motor is not present or defective.
- Measure** → Press the Online button to acknowledge.
- Check the output stage board for the dispenser lift motor and eventually exchange it.

**5063 Press roll**

64-xx dispenser / DPM / PEM / ALX 92x

- Status** The press roll lever is not closed. Opening the lever causes the immediate deletion of all potentially queued status messages (e. g. ribbon end) and display of the “Press roll” message. Closing the lever automatically acknowledges the status message..
- Measure** → Close the press roll lever.

**5063 Lever open**

AP 5.4/5.6

- Status** The printhead lever is not closed. Opening the lever causes the immediate deletion of all potentially queued status messages (e. g. ribbon end) and display of the “Lever open” message. Closing the lever automatically acknowledges the status message.
- Measure** → Close the printhead lever.

**5064 Backing paper**

- Status** Happens with dispenser version printers: Shows up, when the diameter of the rewinded backing paper roll has become too large.
- Measure** → Clear the rewinding mandrel.
- Press the Online button to acknowledge.

**5071 Material end unw**

- Status** Occurs during operation with activated *internal* OD control. The message appears, if the material roll diameter has reached the critical value (setable by MACHINE SETUP >Materialend err).
- Measure** → Replenish the material roll.

**5072 Material end unw**

**Status** Occurs during operation with activated *internal* OD control. The message appears, if no rotation of the material roll has been registered during at least 600 mm of material feeding.

**Measure** → Check the material feeding; if necessary, replenish the material roll.

**5100 No H8 response**

**Status** Communication fault with H8 processor (occurs only at devices with Gen. 2 electronics).

**Measure** → Acknowledge by pressing the Online button.  
→ Switch device off and on again.

If the message continues to appear:

→ Contact service technician.

Instructions for service technicians:

The error can occur in connection with the exchange of the CPU board of an ALX 92x machine.

→ Acknowledge error, set all sensors, restart.

→ If the error message still appears: Reload firmware and/or carry out a forced bootloader start with "Clear params".

→ If the error continues to appear: send CPU board with a fault description to the manufacturer.

**5100 Printengine lock**

**Status** Printengine error (occurs only at devices with Gen. 3 electronics).

**Measure** → Acknowledge by pressing the Online button.  
→ Switch device off and on again.

If the message continues to appear:

→ Contact service technician.

**5101 Headadjust error**

**Status** Error during the running of the "Head Alignment" service function.

**Measure** → Acknowledge by pressing the Online button.  
→ Contact service technician.

**5102 Dot Defective**

**Status** Defective dot detected during the running of the "Head dot test" service function.

**Measure** → Acknowledge by pressing the Online button.



**5110 Foil low**

**Status** The diameter of the foil roll fell below the set warning diameter (see SYSTEM PARAMETER > Foil warning).

The message is caused by a foil warning in addition with the following setting: SYSTEM PARAMETER > Foil warn stop = „Enabled“.

**Measure** → Acknowledge by pressing the Online button, then press the Feed button to continue printing.

**5120 Home position**

**Status** The applied applicator cannot reach the home position; this can be caused by an impact from outside (e.g. extending it manually), which has moved the applicator. In those cases, the stepper motor loses steps and doesn't regain its home position.

Preconditions for this error to occur:

- The parameter DP INTERFACE > Interface type is set to *USI Applicator*.
- Internal inputs are enabled.

**Measure** → Take care not to move the applicator by force.  
→ Acknowledge by pressing the Online button.

**5121 Touch down**

**Status** The applied applicator doesn't reach the Touch Down Position, what means that it extends completely without reaching any product or other resistance. .

Preconditions for this error to occur:

- The parameter DP INTERFACE > Interface type is set to *USI Applicator*.
- Internal inputs are enabled.

**Measure** → Correct the applicator position. The applicator must reach the product before it is completely extended.  
→ Acknowledge by pressing the Online button.

**5122 PLC not ready**

Situation:

- The parameter DP INTERFACE > Interface type is set to *USI Applicator*.
- Internal inputs are enabled.

**Status** The connected PLC is not on line.

**Measure** → Check if the PLC is powered on.  
→ Check if the PLC shows any error status.  
→ Acknowledge by pressing the Online button.

**5123 USI Material low**

The error can only occur with an ALX 92x with optional OD control sensor.

**Status** The outer diameter of the material roll has reached the set minimum value.

**Measure** → Insert a new material roll.  
→ Acknowledge by pressing the Online button.

**5125 Vn for USI req.****Status**

This message shows up, if the firmware of the USI doesn't match the printer firmware.

n = Required USI firmware version

- USI firmware version is higher than the required version:

Message is automatically quit after approx. 2 s. This combination should work without problems.

**Measure**

- USI firmware version is older than the required version:  
→ Update the USI firmware.
- See service manual, topic section [Firmware Gen. 3](#) 

**5130 PSU xxxxxxxx**

**Status**

Failure of the power supply. "xxxxxxx" = four byte long error code in hexadecimal form. Every bit stands for a certain status of the power supply. The bit is set to "1", if the status occurred.

- Byte 1: xxxxxxXX

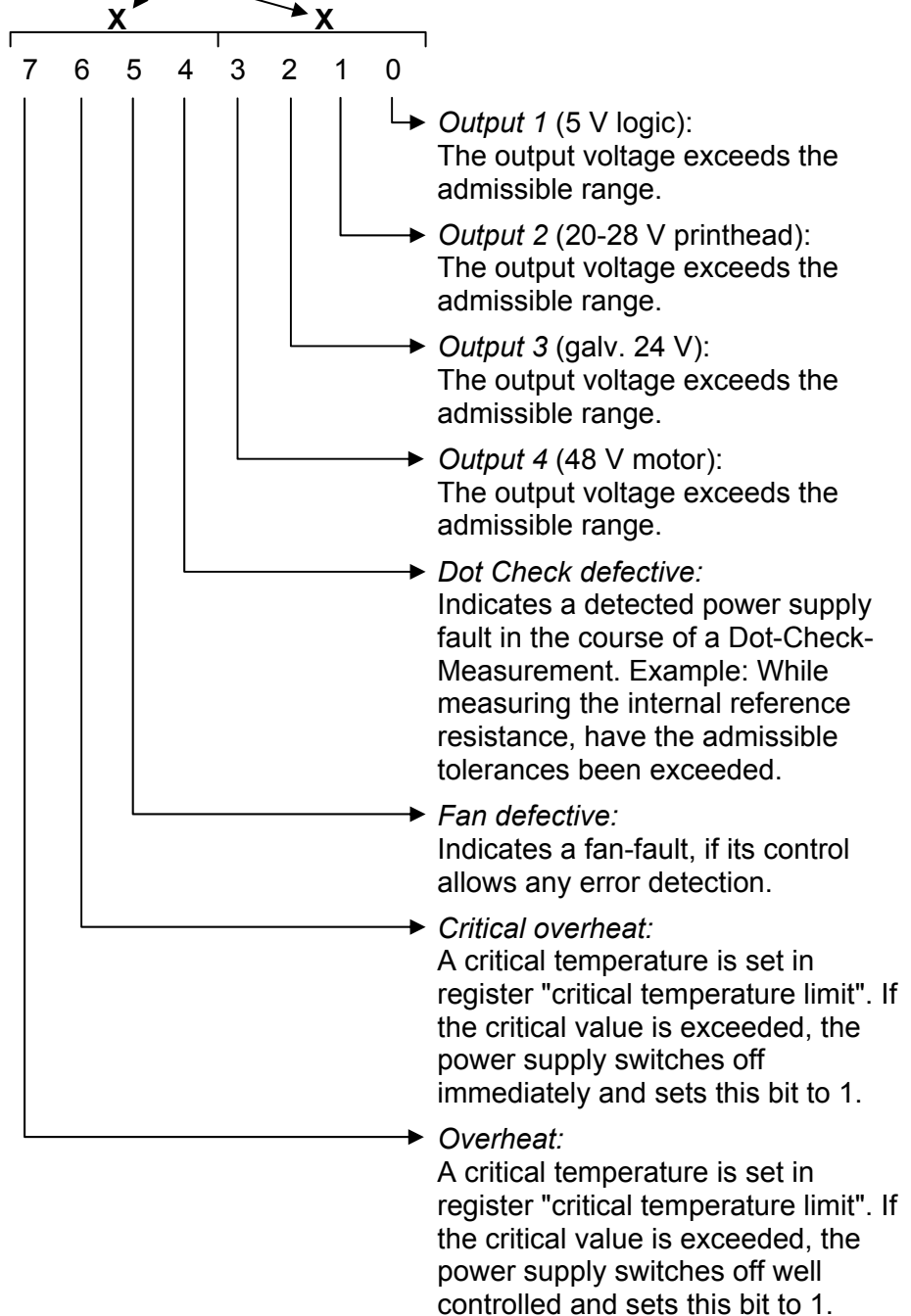

- Byte 2: xxxx**XX**xx

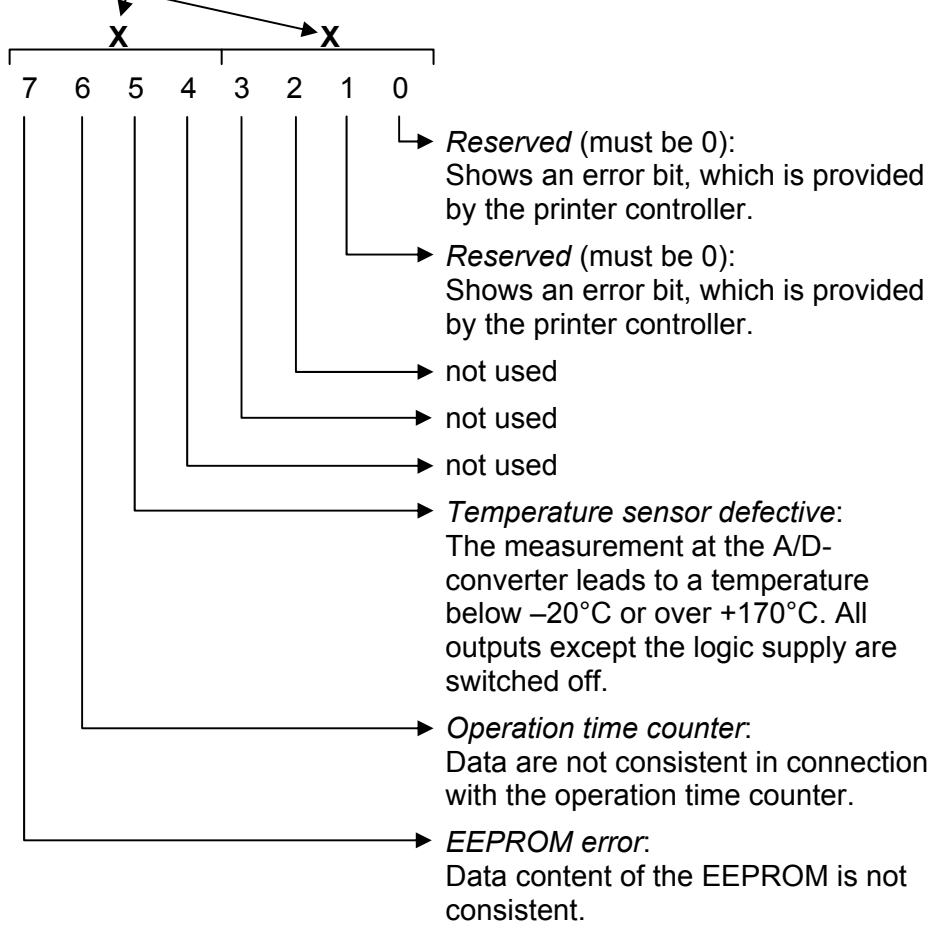

- Byte 3: xx**XX**xxxx

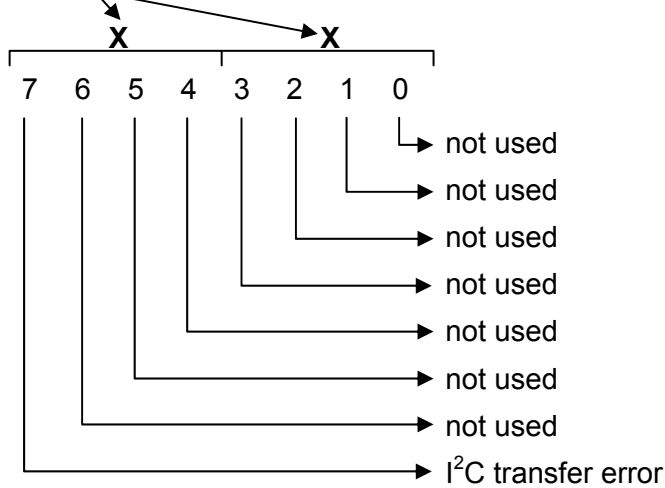

- Byte 4: **XX**xxxxxx (is not being used yet)



Example: 0000F020

Bit no.	7	6	5	4	3	2	1	0	Meaning
Byte 1 (here: 20)	0	0	1	0	0	0	0	0	Fan defective
Byte 2 (here: F0)	1	1	1	1	0	0	0	0	Temperature sensor defective, operation time counter is not consistent, EEPROM error
Byte 3	0	0	0	0	0	0	0	0	
Byte 4	0	0	0	0	0	0	0	0	

### **5131 PSU communicat.**

Power supply communication  
(64-xx / DPM / PEM / ALX 92x / PM 3000 only)

**Status** A fault occurred during communication with the power supply via I<sup>2</sup>C bus.

**Measure** → Switch the printer off and after 30 seconds on again. If the message continues to appear, contact the manufacturer.

### **5140 Rewinder control**

(ALX 92x with M5A motor output stages only)

 During problem-free operation, the rewind unit dancer arm only moves a minimal distance around the "control position". This is the position the dancer arm takes up after initialisation of the machine.

**Status** *Cause:* Any force applied that moves the dancer arm from its control position.

Example: The feed motor is blocked; the backing paper is not conveyed quickly enough; as a result the dancer arm is pulled upwards.

Example: The backing paper is torn; the dancer arm springs downwards.

**Measure** → Press the Enter-key.  
This reinitialises the dancer arm control; the dancer arm moves back into the control position.

### **5144 Rewinder Init**

(ALX 92x with M5A motor output stages only)

**Status** The message has a couple of possible causes:

- No label material inserted.
- Rewinder sensors are not or not properly connected.
- Sensor board position is faulty.
- Sensor defective.

→ Insert material.

→ Check the connection. Connect the sensors properly.

→ Correct the position of the sensor board.

→ Exchange the sensor board.

**5145 Rewinder full**

(ALX 92x with M5A motor output stages only)

**Status** The maximum permitted diameter (205mm) for the rewinder roll has been reached.



This error can only occur if the end of a new label roll was glued on to backing paper that had already been wound onto the rewinder.

**Measure** → Remove the rewound backing paper.  
→ Press the Enter-key to confirm the error message.

**5150 No USI interface**

**Status** (DPM / PEM / ALX 92x only)  
This error appears, if no USI is detected while the printer is powering up.

**Measure** → Check, if the USI is defective or not built in.

**5151 Applic. interf.**

Applicator interface

**Status** (DPM / PEM / ALX 92x only)  
Neither Applicator Interface (AI), nor USI are connected to the device.

**Measure** → Connect a USI or AI to the device.

**5152 Winding direct.**

(ALX 92x with M5A motor output stages only)

**Status** The backing paper end is not correctly attached to the rewinder mandrel.  
Wrong machine type selected (SPECIAL FUNCTION > Printer type).

- Attach the backing paper web to the rewinding mandrel as described in the user manual.  
→ Setting „RH“ at a LH machine or vice versa.

**5200 Home position**

**Status** The applicator did not reach its home position within the given time frame.  
Possible causes:

- The applicator is jammed
- Applicators driven by compressed air: The air supply may be interrupted or switched off
- Cable not connected properly

**Measure** → Check cable and compressed air connections; reconnect them properly, if necessary.  
→ May the applicator move unhindered? – remove any obstacles.

**5201 Touch down**

**Status** The applicator did not reach its touch down position within the given time frame.

**Measure** → Check cable and compressed air connections; reconnect them properly, if necessary.  
→ May the applicator move unhindered? – remove any obstacles.

**5203 Touch down sens.**

**Status** The touchdown sensor(s) was/were already triggered before the application.

**Measure** → Check cable and compressed air connections; reconnect them properly, if necessary.

**5204 Appl. Startererror**

**Status** The device received another start signal during printing/applying a label.

Precondition: Parameter `APPLICATOR PARA > Start error stop` or `DP INTERFACE > Start error stop` is set to *On*.

**Measure** → Check the labelling procedure; increase the product distance.  
→ Set parameter *Start error stop* to *Off*.

**5205 Applicator gen.**

**Status** General software error

**Measure** ○ Please read the notes in section [General software errors](#) □.

**5206 Applicator resp.**

**Status** Communication with the AI exceeded a given time frame.

**Measure** → Switch the printer off and on again after half a minute. If the error still occurs after several tries, please contact our technical support.

**5207 Appl. driver 1**

**Status** Shortcut or overheat at power output 1 at the applicator connector (CN603) on the AI board. The power output 1 comprises the following output signals:

- Cylinder
- Vacuum
- Airstream Support
- Blow On

**Measure** → Check the connections.

**5208 Appl. driver 2**

**Status** Shortcut or overheat at power output 2 at the applicator connector (CN603) on the AI board. The power output 2 comprises the following output signals:

- BTS
- Reserved 1
- Reserved 2
- Reserved 3

**Measure** → Check the connections.

**5209 Appl. driver 3**

**Status** Shortcut or overheat at power output 3 at the machine status connector (CN602) on the AI board. The power output 3 comprises the following output signals:

- Error
- Warning
- Ready

**Measure** → Check the connections.

**5210 Appl. driver 4**

**Status** Shortcut or overheat at power output 4 at the machine status connector (CN602) on the AI board. The power output 4 comprises the following output signals:

- Cycle
- OD-Foil
- OD-Sensor
- Offline

**Measure** → Check the connections.

**5212 Vx.x for AI rec**

**Status** The required AI firmware (version x.x) is not installed.

**Measure** If the installed AI firmware is older than the required version:

→ Acknowledge message. Load AI firmware version x.x.

If the installed AI firmware is newer than the required version:

The message is acknowledged automatically.

**5300 BLDC EEPROM err.**

**Status** General EEPROM read/write error on the BLDC driver board (AP 5.4 with internal rewinder).

**Measure** → Switch printer off and then on again after 30 seconds. If the status message continues to appear, change the BLDC board.



**5301 BLDC rewinder Ø**

- Status** The stored rewinder diameter exceeds the admissible range (AP 5.4 with internal rewinder).
- Measure**
- Acknowledge the status message by pressing the online button.
  - Switch to offline mode and feed the label web for approx. 200 mm. This re-initializes the rewinder diameter.
  - ▣▣▣▣→ If the printer is switched off and on again *without prior initialization*, the status message will be displayed again.

**5500 Unknown**

- Status** General software error
- Measure** ○ Please read the notes in section [General software errors](#) .

**5501 General**

- Status** General software error
- Measure** ○ Please read the notes in section [General software errors](#) .

**5502-5551 Messages, which can only occur with RFID option****5502 RFID internal**

- Status** General software error
- Measure** ○ Please read the notes in section [General software errors](#) .

**5504 No RFID job**

- Status** A print job, which is not declared as RFID printjob, contains RFID-specific Easy-Plug commands (e. g. #RT, #RFW, ...).
- RFID printjobs are declared in the #IM command by defining the distance between label edge and optimum of transponder antenna (parameter "d").
- Measure** → Modify the print job.

**5510 RFID COM timeout**

- Status** Timeout error. There was no communication between reader module and COM2 in the time slot where it should be performed.
- Measure**
- Repeat the operation, in the course of which the error occurred.
  - Check, if the reader module board is connected correctly.
  - Check if the reader module board is defective.

**5512 COM open failed**

- Status** There was a communication problem at COM2 while powering up the printer. The interface cannot be opened by the printer firmware – or it is used by another firmware part.
- Measure**
- Check, if COM2 is available (that is, if it is built-in).
  - Check the function of the COM2 interface.

**5513 Get baud failed**

**Status** There was a communication problem between COM2 and reader module while powering up the printer. The baud rate of the reader module is not detected correctly by the printer firmware. Baud rate and/or parity and/or another setting of transmission parameters at the reader module is faulty.

**Measure**

- Check, if the reader module board is connected correctly.
- Check if the reader module board is defective.
- Check the setting of the transmission parameters at the reader module.

**5521 No transponder**

**Status** Either there is no transponder (=tag) or more than one transponder within reach of the antenna.

**Measure** → Check the label material feeding; remove paper jam, if necessary.

**5522 Tag write err**

**Status** A transponder (=tag) cannot be written on for one of the following reasons:

- Faulty address: e.g. an attempt to write into a protected area.
- The tag is out of reach of the antenna, after it has already been recognized.
- Noise signals avoid the transmission.

**Measure** → Check the system for the mentioned error causes and correct them.

**5523 Tag address err**

**Status** Faulty address: The address data targets beyond the logical or physical address range of the transponder.

**Measure** → Change the address.

**5524 CMD not applicable**

**Status** A command cannot be interpreted by the transponder.

**Measure** → Change or remove the command.

**5525 Tag read err**

**Status** The plausibility test of the read data failed. Possible reasons are:

- The tag is out of reach of the antenna, after it has already been recognized.
- Noise signals avoid the transmission.

**Measure** → Check the system for the mentioned error causes and correct them.

**5526 Tag select first**

**Status** A read or write command was given without selecting the transponder at first.

**Measure** → Add a select command before using the read/write command.

**5527 Tag RF comm err**

**Status** Transponder and reader are unable to communicate. Possible reasons are:

- More than one transponder is within reach of the antenna.
- No transponder is within reach of the antenna.

**Measure** → Check the label material feeding; eventually remove paper jam.

**5528 EEPROM failure**

**Status**

- The reader cannot write on the transponder EEPROM.
- A faulty checksum was detected before writing on the EEPROM.

**Measure** → Repeat the writing attempt.

→ Try another transponder

**5529 Parameter range**

**Status** Faulty address. Transponders of the same type may have memory ranges of different sizes; according to this, the admissible addresses differ too.

The fault occurs, if a block address targets beyond the address range of the transponder.

**Measure** → Change the address.

→ Use a transponder with a wider address range.

**5530 Unknown CMD**

**Status** The reader doesn't support the used command.

**Measure** → Change or replace the command.

**5531 Protocol length**

**Status** General software error

**Measure** ○ Please read the notes in section [General software errors](#) .

**5532 CMD not avail.**

**Status** The sent command cannot be executed at the moment.

**Measure** → Check, if all system components match the specifications.

**5540 ISO error #1**

**Status** Faulty system configuration. Possible reasons may be:

- Faulty firmware version of the reader
- The applied transponders doesn't match the reader.

**Measure** → Check if the reader has the correct firmware version installed.

→ Compare the applied transponder type with the specification of the reader. If necessary, use another transponder type.

**5541 ISO error #2**

○ See [ISO error #1](#) .

**5542 ISO error #3**

○ See [ISO error #1](#).

**5543 ISO error #15**

○ See [ISO error #1](#).

**5544 ISO error #16**

○ See [ISO error #1](#).

**5545 ISO error #17**

○ See [ISO error #1](#).

**5546 ISO error #18**

○ See [ISO error #1](#).

**5547 ISO error #19**

○ See [ISO error #1](#).

**5548 ISO error #20**

○ See [ISO error #1](#).

**5549 ISO error ???**

○ See [ISO error #1](#).

**5550 Wrong tag type**

**Status** A transponder type was detected, which is not known by the reader – it cannot be used.

**Measure** → Use another transponder type, which is known to the reader.

**5551 Max Tags failed**

**Status** The maximum permissible number of invalid labels was reached. This value is to be set via parameter `RFID PARAMETERS > Max Tags To Stop`.

||||▶ Invalid labels are being printed on with diagonal stripes.

**Measure** → Find out, why the labels are invalid; put things right.

→ Increase the maximum value.

**5560 TCS full / cover**

**Status** This message can only appear, if a TCS is applied as peripheral device. The message shows up, if:

- the stacker is full
- the stacker cover is open

**Measure** → Empty the stacker, or

→ close the cover

**5590 Odd hex string**

**Status** A character string was sent to the transponder (Easy Plug command #RFS) and was ought to be interpreted hexadecimal (use #RFS with parameter "B"). For this, the character string must consist of an equal number of characters. This was not the case, what triggered this error message.

**Measure** → Send an equal number of characters.

**5600 Job without #Q**

**Status** The print job misses the declaration of the print amount (Easy-Plug command #Q).

**Measure** → Insert a #Q command with the print amount.

**5601 Job memory full**

**Status** The job memory for Easy-Plug printjobs is full.

**Measure** → Reduce the reserved memory for one or more of the following memory areas:

- Free store size (SYSTEM PARAMETER > Free store size)
- RAM disk size (SYSTEM PARAMETER > Ram disk size)
- Font download size (SYSTEM PARAMETER > Font downl. area)

→ If there are already some printjobs in the printer queue: wait until those are processed.

**6000 Param. incorrect**

**Status** Novram check sum error.

||||▶ Check the setting of the printhead resistance (parameter SYSTEM PARAMETER > Head resistance) , before you press the Online button – possibly the value is faulty.

**Measure** → Confirm error by pressing the Online button. All parameters are set back to the factory settings.

**6001 Nov. prog. err.**

**Status** Error during allocation of main memory.

**Measure** → Switch printer off and then back on again after 30 sec. If the error message continues to appear, please contact the manufacturer.

**6002 New prog. vers.**

**Status** Occurs after firmware update. The printer hereby reports that new firmware is available.

**Measure** → Confirm by pressing the Online button. All parameters are set back to the factory settings.

**6003 Memory error**

**Status** Error during partitioning of the main memory.

**Measure** → Switch printer off and back on again after 30 sec. If the error message continues to appear, please contact the manufacturer.

**6004 Load H8 program**

**Status** Appears, when  
 a) no valid H8 firmware is loaded  
 b) after a forced start of the boot loader

**Measure** Case a)  
 1. Press the Online button to confirm.  
 2. Load H8 firmware.  
 ○ For details, refer to the service manual, topic section "Firmware", section "Loading the H8 system".  
 Case b)  
 → Press the Online button to confirm.  
 ○ For details, refer to the service manual, topic section "Firmware", section "Loading the Firmware (using boot loader)".

**6005 Fixfont data**

**Status** Defective fixfonts.

**Measure** → Load the firmware new.  
 ○ Refer to the service manual, topic section "Firmware".

**6006 Speedofont data**

**Status** Defective speedo fonts.

**Measure** → Load the firmware new.  
 ○ Refer to the service manual, topic section "Firmware".

**6007 Print ctrl. stop**

**Status** The print control doesn't start, what means that the printer doesn't finish the initialization phase after switching it on.

**Measure** → Read in the service manual, what to do:  
 ○ Refer to the service manual, topic section "Firmware" or "Firmware Gen. 3", chapter "Error messages".

**6008 ZPL Fixfont data**

**Status** Defective fixfonts.

**Measure** → Load the firmware new.  
 ○ Refer to the service manual, topic section "Firmware".

**6009 ZPL Speedo data**

**Status** Defective speedo fonts.

**Measure** → Load the firmware new.

○ Refer to the service manual, topic section "Firmware".

**6010 Printengine soft**

**Status** General software error.

**Measure** → Switch printer off and then back on again after thirty seconds.

○ Please read the notes in section [General software errors](#) .

**6012 Start next job**

**Status** The message appears at the end of a printjob, if the single job mode (SYSTEM PARAMETERS > Single job mode) is activated. It indicates, that the next printjob should be started.

**Measure** → Acknowledge by pressing the online button. Start next printjob.

**6030 Param. checksum**

**Status** Wrong parameter checksum.

**Measure** → None. The message is merely informativ.

**6031 New Parameters**

**Status** By loading a new firmware version, some new parameters have been added to the parameter menu.

**Measure** → None. The message is merely informativ.

**6101 No sensor found**

**Status** Error during the running of the "Sensor Test" service function.

**Measure** → Acknowledge by pressing the online button.

→ Contact service technician.

**6200 Filesystem regis**

**Status** General software error.

**Measure** → Switch printer off and then back on again after thirty seconds.

○ Please read the notes in section [General software errors](#) .

**6201 File sys. format**

**Status** Error during formatting of the RAM disk or the memory card.

**Measure** → Switch printer off and then back on again after thirty seconds. If the error message continues to appear, please contact the manufacturer.

**6202 Drive open**

**Status** Accessing the memory card failed.

- Measure** → Format the memory card using the PC card drive. Try again to write onto the card.
- Try another memory card.

### **6203 Filesystem close**

**Status** Accessing the memory card failed.

- Measure** → Format the memory card using the PC card drive. Try again to write onto the card.
- Try another memory card.

### **6204 Disk directory**

**Status** Work directory cannot be opened.

- Measure** → Acknowledge by pressing the Online button.
- Check designation existence of the work directory.

### **6205 Write disk**

**Status** Error during writing on RAM disk or memory card.

- Measure** → Acknowledge by pressing the Online button.

### **6206 Read disk**

**Status** Error during reading from RAM disk or memory card.

- Measure** → Acknowledge by pressing the Online button.

### **6207 No file card**

**Status** No CompactFlash-card found.

- Measure** → Acknowledge by pressing the Online button.
- Check, if a memory card is inserted.
- If the memory card was inserted after switching on the printer: switch the printer off and on again.

### **6208 Drive xx full**

**Status** Writing on drive xx failed, because there is not enough free space.

- Measure** → Acknowledge by pressing the Online button.
- Free space on the drive.



**6300 Out of memory**

**Status** Not enough free memory available, to load additional print jobs. The job buffer is completely filled with print jobs.

**Measure** → Delete spooler using the parameter `SPECIAL FUNCTION > Delete spooler`.

**6301 Incomplete job**

**Status** The Easy Plug interpreter failed interpreting a certain print job to the end. The print job has possibly not been terminated by a #Q-command.

**Measure** → Check, if the print job is properly terminated with #Q.

**6310 Centr. Timeout**

**Status** The Easy Plug command #!Xn triggers a status acknowledgement via centronics Interface. But the PC doesn't pick up the supplied data.

**Measure** → Check the data line connecting printer and PC.

**6311 Centr. Timeout**

**Status** The Easy Plug command #!Xn triggers a status acknowledgement via centronics Interface. But the PC doesn't pick up the supplied data.

**Measure** → Check the data line connecting printer and PC.

**8001 Shared Memory**

**Status** General software error.

**Measure** → Switch printer off and then back on again after thirty seconds.  
○ Please read the notes in section [General software errors](#) .

**8002 Stream Buffer**

**Status** General software error.

**Measure** → Switch printer off and then back on again after thirty seconds.  
○ Please read the notes in section [General software errors](#) .

**8103 TrueDoc Font**

**Status** Error: font with the number given is not contained in the system.

**Measure** → Check font no., if necessary select another font.

**8104 Speedo alloc**

**Status** Fault while initializing the speedo fonts.

**Measure** → Load firmware new.  
○ Refer to the service manual, topic section "Firmware".

**8105 Load TrueType**

**Status** Damaged font file.

**Measure** → Switch printer off and then back on again after thirty seconds.  
→ Reload font file, if necessary select another font.

**8106 Fonttype wrong**

**Status** General software error.

**Measure** → Switch printer off and then back on again after thirty seconds.  
○ Please read the notes in section [General software errors](#) .

**8107 Character set**

**Status** General software error.

**Measure** → Switch printer off and then back on again after thirty seconds.  
○ Please read the notes in section [General software errors](#) .

**8108 Symbol set**

**Status** General software error.

**Measure** → Switch printer off and then back on again after thirty seconds.  
○ Please read the notes in section [General software errors](#) .

**8109 TT-specifications**

**Status** General software error.

**Measure** → Switch printer off and then back on again after thirty seconds.  
○ Please read the notes in section [General software errors](#) .

**8110 Unknown char.**

**Status** Character is not included in the character set (character set does not support all characters).

**Measure** → Select another character / character set.

**8111 Stream type**

**Status** General software error.

**Measure** → Switch printer off and then back on again after thirty seconds.  
○ Please read the notes in section [General software errors](#) .

**8112 Font not supp.**

**Status** The applied TrueType font is not supported by the system. Text, which uses this font, is ignored.

**Measure** → Use another TrueType font.

**8200 Fixfont number**

**Status** Incorrect fix font no.

**Measure** → Check fix font no., alter if necessary.

**8201 Font downl. full**

**Status** The font download buffer is full.

- Measure**
- Allocate more memory for the download buffer using the parameter SYSTEM PARAMETERS > Font downl. area.
  - Rename some speedo-fonts on the CompactFlash-Card, you actually don't use. All speedo-fonts named fontxxx.spd (xxx = font no.) are being loaded into the font download buffer while system startup.
  - For Details refer to the manual „Cards“, subject section „Using cards“, paragraph „memory card“.

**8202 Font deleted**

**Status** Attempt to access a font, which is no longer available on memory card or on RAM disk (font was deleted or renamed).

- Measure**
- Check the label layout. Load the not available font or use another, available, font.

**8300 Bar code corr.**

**Status** Error: a bar code correction factor greater than +/- 25% has been selected.

- Measure**
- Reduce correction factor.

**8301 Bar code data**

**Status** Incorrect bar code data. The bar code data is not permitted for the selected bar code type.

- Measure**
- Use data permitted for the bar code type.

**8302 Barcode checksum**

**Status** Error during calculation of the bar code check sum.

- Measure**
- Check transmitted data.
  - If the error continues to occur please contact the manufacturer. Send the transmitted Easy Plug data.

**8303 Bar code sample**

**Status** Error during calculation of the bar code sample.

- Measure**
- Check whether the transmitted data is permitted for the bar code type; if necessary alter the data.

**8304 Bar c. plain-copy**

**Status** Error during integration of the plain-copy line in the bar code sample.

- Measure**
- Check whether the transmitted data is permitted for the bar code type; if necessary alter the data.

**8305 Bar code print**

- Status** Error during calculation of the bar code print image.
- Measure** → Acknowledge by pressing the Online button.
- Measure** → Check whether the transmitted data is permitted for the bar code type; if necessary alter the data.

**8306 Plain-copy len.**

- Status** Illegal: bar code plain-copy line has more than 300 characters.
- Measure** → Reduce line length.

**8307 Readline dist.**

- Status** General software error.
- Measure** → Switch printer off and then back on again after thirty seconds.  
○ Please read the notes in section [General software errors](#) .

**8308 Bar code ratio**

- Status** Illegal bar code ratio.
- Measure** → Select another ratio.

**8309 Module range**

- Status** Maximum range of the bar code module exceeded.
- Measure** → Reduce module range.

**8310 Bar code element**

- Status** Bar code element exceeds the maximum permitted size of 253 dots (21 mm).
- Measure** → Reduce size of the bar code element.

**8311 Barcode table**

- Status** General software error.
- Measure** → Switch printer off and then back on again after thirty seconds.  
○ Please read the notes in section [General software errors](#) .

**8400 PDF417 ECC**

- Status** Bar code PDF417: incorrect ECC level (Error Correction Level).
- Measure** → Alter ECC level.

**8401 PDF417 Lines**

- Status** Bar code PDF417: illegal number of lines.
- Measure** → Alter number of lines.

**8402 PDF417 Columns**

**Status** Bar code PDF417: illegal number of columns.

**Measure** → Alter number of columns.

**8403 PDF417 Style**

**Status** Bar code PDF417: incorrect style.

**Measure** → Alter style.

**8404 PDF417 Command**

**Status** Bar code PDF417: incorrect command.

**Measure** → Acknowledge by pressing the on-line button.

→ Check and alter commands.

**8405 PDF417 Size**

**Status** Bar code PDF417: incorrect size.

**Measure** → Alter size.

**8406 PDF417 Details**

**Status** Bar code PDF417: incorrect details.

**Measure** → Alter details.

**8407 PDF417 Coding**

**Status** Bar code PDF417: coding error.

**Measure** → Switch printer off and then back on again after thirty seconds.

→ Acknowledge by pressing the Online button.

**8500 Code 25Int len.**

**Status** Bar code Code 25 Interleaved: input line too long.

**Measure** → Shorten input line.

**8501 Postcode length**

**Status** Bar code postcode: illegal data length.

**Measure** → Check length of the transmitted data and set it to the permitted length.

**8600 EAN Length**

**Status** Bar code EAN: illegal data length.

**Measure** → Check length of the transmitted data and set it to the permitted length.

**8601 UPCE Numbers sys.**

**Status** Error: First data character of the transmitted data is not 0 or 1.

**Measure** → Alter first data character to 0 or 1.

**8705 IDM rows/columns**

**Status** The input data does not match the given matrix or the number of rows/columns is invalid.

**Measure** → Change the number of rows/columns or the input data.

**8760 EAN128 field len**

**Status** The number of data after a data identifier does not correspond to the definition for this data identifier.

**Measure** → Change the number of data.

**8761 EAN128 Data type**

**Status** The data type (alphanumeric, numeric) after a data identifier does not correspond to the definition for this data identifier.

**Measure** → Change the data type.

**8762 EAN128 Ident.**

**Status** Invalid data identifier.

**Measure** → Change the data identifier.

**8800 Maxicode Mode**

**Status** Maxicode: faulty mode

**Measure** → Change mode.

**8801 Maxicode Sys no**

**Status** Maxicode: incorrect system no.

**Measure** → Correct system no.

**8802 Maxicode Zipcode**

**Status** Maxicode: incorrect zipcode.

**Measure** → Correct zipcode.

**8803 Maxicode Class**

**Status** Maxicode: faulty class code.

**Measure** → Correct class code.

**8804 Maxi. Sec. mess.**

**Status** Maxicode: secondary message has an illegal length.

**Measure** → Correct length of secondary message.

**8805 Maxicode Country**

**Status** Maxicode: faulty country code.

**Measure** → Correct country code.

**8830 Cod49 Datalength**

**Status** The user data string is too long. Not all characters can be coded in the bar code. The bar code is not printed.

**Measure** → Shorten the data string.

**8031 Cod49 wrong data**

**Status** The data string contains wrong characters. The bar code is not printed.

**Measure** → Correct the content of the data string.

**8850 Unknown filetype**

Graphic files with the extension declared in the Easy Plug command #YG are not supported.

**Measure** → Transform the graphics file into another file format or use another graphic in a supported format. Check, if the spelling of the file extension is correct.

**8851 Graphic open**

**Status** The graphics file declared in the Easy Plug #YG command cannot be found on the compactflash card. Possible reasons are:

- Path and/or designation of the graphics file stored on the compactflash card doesn't match the path and/or designation declared by the #YG command.
- The file is not available on the compactflash card.

**Measure** → Check if the spelling of the graphics file is the same both in the #YG command and on the compactflash card.

**8852 Graphic header**

**Status** A graphics file declared by a Easy Plug #YG command should be proceeded. The file header doesn't match the file.

**Measure** → The graphics file is possibly faulty. Check the file and replace it if necessary.

**8853 Graphic palette**

**Status** A graphics file declared by a Easy Plug #YG command should be proceeded. Error reading the graphics palette.

**Measure** → The graphics file is possibly faulty. Check the file and replace it if necessary.

**8854 Graphic read**

**Status** A graphics file declared by a Easy Plug #YG command should be proceeded. Error reading the file.

**Measure** → The graphics file is possibly faulty. Check the file and replace it if necessary.

**8856 Free store size**

- Status** By setting parameter `SYSTEM PARAMETER > Free store size`, a part of the memory is reserved, which the printer firmware can use if necessary (dynamic memory allocation). If this memory area is dimensioned too small, the printer firmware can not work and this error message shows up. One cause may for example be, that data are supposed to be loaded, whose size exceeds the reserved memory (e. g. graphics).
- Measure** → Enlarging the reserved memory partition, that is increasing the value of `SYSTEM PARAMETER > Free store size`.

**8857 Wrong mem config**

Wrong memory configuration

- Status** Too much memory requested by parameters. The following parameters request more or less memory:
- `SYSTEM PARAMETER > Font downl. area`
  - `SYSTEM PARAMETER > Ram disk size`
  - `SYSTEM PARAMETER > Free store size`

The fault occurs, if the sum of requested memory space exceeds the amount of available memory.

After error confirmation, the relevant parameters are set back to their default values. Furthermore, a restart is triggered.

- Measure** → Change the settings of the relevant parameters.

**8900 Codablock columns**

- Status** Bar code Codablock: illegal number of columns.
- Measure** → Correct number of columns.

**8901 Codablock rows**

- Status** Bar code Codablock: illegal number of rows.
- Measure** → Correct number of rows.

**8902 Codablock softw.**

- Status** Bar code Codablock: software error.
- Measure** →

**8903 Codablock infogr**

- Status** Bar code Codablock: info not in line.
- Measure** →

**8950 Logo open**

- Status** Failure when attempting to read a logo, which has previously been copied on RAM disk or on memory card (thus using Easy Plug command #DK).
- Measure** → Repeat loading the logo via #DK command.



- In cases of continuous occurrence of this error, please contact the technical support.

### **8951 File format**

**Status** General software error.

- Measure**
- Switch printer off and then back on again after thirty seconds.
  - Please read the notes in section [General software errors](#) .

### **8952 Not installed**

**Status** General software error.

- Measure**
- Switch printer off and then back on again after thirty seconds.
  - Please read the notes in section [General software errors](#) .

### **9000 Wrong errornum**

**Status** General software error.

- Measure**
- Switch printer off and then back on again after thirty seconds.
  - Please read the notes in section [General software errors](#) .

### **9001 Software Error**

**Status** General software error.

- Measure**
- Switch printer off and then back on again after thirty seconds.
  - Please read the notes in section [General software errors](#) .

### **9003 Print head type**

**Status** A wrong printhead type is selected in the printer menu.

- Measure**
- Correct the setting of the printhead type.
  - Set the printhead type using parameter `SPECIAL FUNCTION > Printhead type`.

### **9005 No Printhead**

**Status** Printhead could not be detected. Possible causes:

- Printhead cable not connected
- Wrong printhead type
- Defective printhead cable
- Defective CPU board
- Printhead cable plugged into wrong connector on the CPU board

- Measure**
- Check printhead cable, printhead and CPU board and replace defective parts.

### **9007 Bad MAC Address**

**Status** This error message is displayed, if an invalid MAC address is programmed to the CPU board. Valid means, the MAC address matches the range `00.0a.44.xx.xx.xx`.

In this case, the network will not be initialised. To enable work with the network, a valid (Avery-) MAC address must be programmed on the board.

This can only be done by an authorized service technician or by the manufacturer.

- Measure**
- Acknowledge the status message by pressing the Online button. The printer will be starting, but cannot be used with a network.
  - Contact the technical support for a new programming of the board's MAC address.
  - If a new programming is not possible, exchange the CPU board.

### **9008 Powerfail signal**

"powerfail" is a signal at the power supply, which is normally activated for a short time, after the printer has been switched off. It triggers the storing of parameter settings and counter values, using the leftover of supply voltage.

**Status** The powerfail signal is already active after switching the printer on. The following causes are possible:

- Defektive power supply
- Defektive data cable
- Defektive board

- Measure**
- Switch the printer off and on again. If the error occurs repeatedly:
  - Check the hardware (see above).
  - ▶▶▶▶ After acknowledging the message (pressing the online button), the printer works normal. But be aware that the powerfail signal is deactivated, what means, that no parameter settings and counter values are stored, when the printer is switched off.

### **9009 Temporary MAC**

Temporary MAC address.

**Status** This error message is displayed, if the MAC address has the value 00.0a.44.00.00.00. This MAC address is used only during production.

- Measure**
- Acknowledge the status message by pressing the Online button. The printer will be starting and the network can be used.
  - Contact the technical support for a new programming of the board's MAC address.
  - If a new programming is not possible, exchange the CPU board.

### **9011 Bootloader ext.**

Bootloader external device.

**Status** At least one external device (e.g. AI, BLDC output stage) has no valid (e.g. an incomplete) application program loaded. This is the reason, why the device remains in the bootloading status and signalizes this status message. The error can only occur, until now (05/04), if an AI is applied.

- Measure** → Load a valid application program.

### **9013 Head voltage**

**Status** Faulty 5 V print head supply voltage. Possible causes are:

- *Only AP 5.4:* Printhead was connected to the wrong connector on the CPU board.
- Short circuit, possibly is the printhead defective.

**Measure** → *Only AP 5.4:* Check if the printhead is connected to the correct connector on the CPU board. Change the connector, if necessary.

→ Replace the printhead

### **9014 Motor voltage**

**Status** Faulty 45 V motor supply voltage. A possible cause is a short circuit, that is the printhead is defective.

**Measure** → Replace the printhead

### **9015 Network init.**

**Status** Error during the network initialization.

**Measure** → Contact your network administrator.

### **9016 DHCP Failed**

**Status** DHCP failed. This may happen, if parameter `INTERF. PARAM. > ETHERNET PARAM. > IP Adressassign` is set to *DHCP*, but no IP-address can be drawn.

**Measure** → Contact your network administrator.

### **9017 RTC read failed**

**Status** Error, while trying to read the realtime clock (RTC). Happens, if an Easy-Plug command to read out the RTC is sent, but no RTC is built in.

**Measure** → Check, if the printer is supplied with a RTC. To do so, print a status printout.

- See parameter `INFO PRINTOUT > Printer status`

You find the actual date on the printout, below the header „Systemversion“, if a RTC is installed.

→ Check, if the error occurs repeatedly or sometimes.

If it occurs repeatedly:

→ *AP 5.4:* replace the CPU board.

*64-xx / ALX 92x / DPM / PEM:* Replace the RTC. If the error still occurs, replace the CPU board.

- If the error occurs sometimes, please refer to the notes in section [General software errors](#) □.

### **9018 #!CA wrong Pos.**

**Status** The #!CA command is placed at an inadmissible position – the Easy-Plug interpreter can not proceed the command at this position (e. .g during the loading of files onto a memory card).

**Measure** → Call the #!CA command at an admissible position.

**9022 No network link**

**Status** This message can only occur, if the Ethernet address assign is set to DHCP. The cause is nearly always a badly connected network connector.

**Measure** → Check, if the network connector is plugged in properly.

**9023 Filename: Functionname() Line: xxx**

**Status** This status message indicates a software error. The error source is located in the source file "Filename" in function "Functionname()" in line xxx.

**Measure** → Switch device off and on again.

If the error occurs repeatedly:

→ Contact the manufacturer.

When doing so, it is important to be able to reproduce the error. Gather the following informations before calling the technical support of the manufacturer:

-- Displayed information about the error source

-- Label layout, logfiles, etc. as described in chapter [Unspecific errors](#) 

**9024 Not possible !**

**Status** Detecting the material length (a function, which is normally used with MLI) is not possible, because a printjob is currently processed.

**Measure** → Retry as soon as the printjob is processed.

**9030 Log file:CF full**

**Status** An attempt to store data on the memory card was not successful, because of a full card.

**Measure** → Clear some storage space on the memory card, or

→ Insert an empty memory card.

**9031 Log file: nnnn**

**Status** File access error. *nnnn* = error code of the operating system.

**Measure** → Repeat the operation, which led to this message. If it comes to this message repeatedly, send a message to the Technical Support, including the error code.

**9032 EP file log stop**

**Status** Internal error during Easy-Plug file logging (SPECIAL PARAMETER > EasyPl. file log).

**Measure** → Repeat operation. If the error occurs repeatedly: switch off the file logging.

▣▣▣▣➔ Use parameter SPECIAL PARAMETER > EasyPl. file log only for error analysis purposes. Using the parameter in continuous operation can cause error messages, which are hard to understand.

**9034 Use min 16MB RAM**

**Status** The printer has not enough RAM. The applied firmware version needs at least 16 MB RAM for faultless operation.

**Measure** → Extend the printers RAM.

**9035 No printpr. stop**

**Status** This status message may appear during the loading of new firmware onto the H8 (64 Bit) or onto boards, which are connected to the H8 (e.g. Applikator Interface).

**Measure** → Switch the printer off and on again and retry the firmware loading.

**9039 Ribbon mode chg.**

**Status** The ribbon mode was changed between two consecutive printjobs via Easy-Plug command (from thermal transfer to thermo or vice-versa).

**Measure** → Check the ribbon mode setting and, if necessary, change the setting (SYSTEM PARAMETERS > Ribbon autoecon.).

**9040 No Time Server**

**Status** Comes up one times at startup, if INTERFACE PARA > NETWORK PARAM. > Time client is set to "On" and there is no response from the set time server.

**Measure** → Check the time server availability respectively the time server settings.

**9100-9119 Messages during firmware update****9100 Invalid format**

**Status** Occurs during a download. The sent data is faulty, e. g. regarding an

- invalid data format
- invalid check sum
- invalid address
- invalid record type

**Measure** → Switch printer off and on again. Check the download data.

**9101 Invalid Header**

**Status** Occurs during a download. The sent files have a format error in the header.

**Measure** → Switch printer off and on again. Check the download data.

**9102 Inv.Board Rev.**

**Status** Occurs during a firmware download. The sent firmware does not match the *version* of the CPU board.

**Measure** → Switch printer off and on again. Check the download data.

**9103 Inval. firmware**

**Status** Occurs during a firmware download. The sent firmware does not match the installed CPU board.

**Measure** → Switch printer off and on again. Check the firmware file.

**9104 Inv. Data Size**

**Status** Occurs during a download. The size of the sent data doesn't match the file size indicated in the header.

**Measure** → Switch printer off and on again. Check the download data.

**9107 Flash Overflow**

**Status** Occurs during a download. The flash memory on the CPU board is full. No more data can be loaded.

**Measure** → Switch printer off and on again.

**9108 Flash Ovf. Diag.**

**Status** Occurs during a download. The flash memory on the CPU board has not enough free memory space left for diagnose data.

**Measure** → Delete data blocks in the flash memory or reduce max. size of the diagnose data.

**9109 Flash Ovf. Params.**

**Status** Occurs during a download. The flash memory on the CPU board has not enough free memory space left to store the current parameter settings.

||||▶ After a restart, the parameters are set to "Factory setting".

**Measure** → Delete data blocks in the flash memory.

**9110 Flash Write Err.**

**Status** Occurs during a download. The flash memory can't be accessed for writing.

**Measure** → Switch printer off and on again.

**9111 PIC Update Fail.**

**Status** Occurs during a firmware update or a PIC-controlled device, if the update failed.

**Measure** → Switch printer off and on again.

**9112 PIC missing**

**Status** Occurs during a firmware update of a PIC-controlled device, if no such device was found.

**Measure** → Check the configuration.  
The status message is cancelled automatically. The download continues.

**9113 RFID Update Fail.**

**Status** Occurs during a firmware update of a RFID module, if the update failed.

**Measure** → Switch printer off and on again.

**9114 RFID missing**

**Status** Occurs during a firmware update of a RFID module, if no such device was found.

**Measure** → Check the configuration.  
The status message is cancelled automatically. The download continues.

**9115 AWID missing**

**Status** Occurs during a firmware update of an AWID RFID module, if a RFID module of another manufacturer was found.

**Measure** → Check the configuration.  
The status message is cancelled automatically. The download continues.

**9116 Ser. Disp. Missing**

**Status** Occurs during a firmware update of a serial operation panel, if no such device was found.

**Measure** → Check the configuration.  
The status message is cancelled automatically. The download continues.

**9117 Device Unknown**

**Status** Occurs during a firmware update, if the device information in the header is missing.

**Measure** → Switch printer off and on again. Check the configuration.

**9118 H8 Update Fail.**

**Status** The update of a H8 device failed.

**Measure** → Switch printer off and on again.

**9119 H8 missing**

**Status** Occurs during a firmware update of a H8 device, if no such device was found.

**Measure** → Check the configuration.  
The status message is cancelled automatically. The download continues.

**9122 Checksum error**

**Status** Checksum error while loading a firmware file. The checksum of the loaded data doesn't match the calculated checksum.

**Measure** → Repeat the download.  
→ If the error continues to occur, the file is probably damaged or corrupted. Check/ exchange the firmware file.

**9123 Memory unavailable**

**Status** Error while loading a firmware file. There is not enough free memory available.

**Measure**

- Restart machine and repeat the download.
- If the error continues to occur: Reduce the memory which is assigned by the following parameters:
  - SYSTEM PARAMETERS > Ram disc size
  - SYSTEM PARAMETERS > Font downl. area
  - SYSTEM PARAMETERS > Free store size





# Internal Fonts

General notes .....	2
System Requirements .....	2
Font size .....	2
OCR-fonts .....	2
Parameter settings .....	3
Fixfonts and Speedo fonts .....	3
Customized Fonts .....	3
Font presentation .....	6
Font coding comparison .....	7
Font tables .....	11
Fixfonts .....	11
Speedo fonts .....	62

## General notes

### System Requirements

The internal fonts are available in the following printer types:

- TTX 450/650/674/675/950/1050
- TDI
- TTK
- 64-04/05/06/08
- DPM/PEM
- PM 3000
- ALX 73x/92x
- AP 4.4/5.4
- AP 5.6
- AP 7.t

### Font size

This topic section lists all internal fonts, fixfonts as well as Speedo fonts, provided by printer types listed above. The pictured fonts were printed with a 300dpi printhead. If a printer with a 200dpi printhead is used instead, the same fonts are available, but with a different print size. An exception are the OCR fonts (YT 110 and YT 116), whose size is standardized. Printed on a label, they appear always in the same size, independent of the printhead resolution.

Fixfonts cannot be scaled, Speedo fonts can.

### OCR-fonts

OCR-font	Internal font
A	YT110
B	YT116

[Tab. 1] Internal fonts which equal the OCR fonts.

### Parameter settings

- The font parameter must be set to „IBM“ (=default setting) (Tab. 2).
- The optional character filter suppresses characters < 20 hex. If you want to print those characters, switch the character filter off (Tab. 2).

Printer	Parameter	Setting
TTX x50	SYSP > NACH	IBM
TTX 67x TDI	IFAC > <20H	No
64-xx DPM PEM ALX 92x	SYSTEM PARAMETERS > Character sets	IBM
ALX 73x (printer) AP 4.4 AP 5.4 AP 7.t	SYSTEM PARAMETERS > Character filter	All character

[Tab. 2] Necessary parameter-settings to get all listed characters printed.

Refer to topic section „Info-printouts and parameters“ for detailed information on parameters.

### Fixfonts and Speedo fonts

Use the Easy Plug command „YT“ for fixfonts and „YN“ for Speedo fonts to print text with internal fonts.

For more information on Easy Plug commands refer to the Easy Plug Manual, topic section [Description of commands](#).

### Customized Fonts

#### Prerequisites

➡ Only with 64-xx Gen. 3

Starting with firmware version 5.02, customized fonts can be loaded separately into the flash memory.

Prerequisites:

- At least 4 MB flash memory are available.
- Free flash memory of the required amount.

#### Loading fonts

Files with customized fonts can be ordered at Avery Dennison. Such font files carry the extension \*.s3b (as firmware files) and have to be loaded in the same way as firmware files.

➡ Firmware version before 3.00 (32Bit) or 4.00 (64Bit) respectively provided the internal fonts in separate \*.s3b files. Those files can *not* be used with firmware versions 5.02 and above!

Refer to the service manual, topic section [Firmware](#).

After successfully loading a font file, the following message appears:

```
Data done
KBytes: xx
```

➔ Restart the printer to activate the fonts.

If not enough unused flash memory is available, the following message appears:

```
Data update
Flash full
```

Followed by:

```
Data update
Loader Error
```

➔ Restart the printer.

## Numbering

Customized fonts can override the standard fonts included in the firmware partially or fully, or they can supplement the standard fonts. In the latter case, font numbers of the customized fonts start with 400.

## Overview loaded fonts

A list of sample printouts of the loaded fonts can be generated with the status printout `PRINT INFO > Flashdata status [1]`.

▮➔ This parameter only appears, if any fonts are already loaded into the flash memory.

**FLASH DATA BLOCKS**

---

Total flash for data blocks : 1856 KByte  
Flash data block partition size : 16 KByte  
Number of flash data blocks : 3  
Remaining flash for data blocks : 1344

---

**Block 0 Diagnostics information 128 KByte**

---

Diagnose record 1 - created at 2008.11.25 08:20:02  
Diagnose record 2 - created at 2008.11.25 09:04:34  
Diagnose record 3 - created at 2008.11.28 10:46:24

---

**Block 1 Custom fonts (Scaleable) 128 KByte**

---

EP. Cmd	Hight	Font Sample
YN400	40p	0123456789ABC

---

**Block 2 Custom fonts (Scaleable) 128 KByte**

---

EP. Cmd	Hight	Font Sample
YN401	40p	0123456789ABC
YN402	40p	0123456789ABC
YN403	40p	0123456789ABC

---

**Block 3 Custom fonts (Scaleable) 128 KByte**

---

EP. Cmd	Hight	Font Sample
YN404	40p	0123456789ABC
YN405	40p	0123456789ABC
YN406	40p	0123456789ABC

[1] Example of status printout „Flashdata status“ - in this case, the same font file was loaded twice. The result is, that in Block 2 and Block 3 are the same fonts, but with different font numbers.

**Deleting fonts**

Fonts can be deleted from the flash memory by calling parameter SPECIAL FUNCTION > Data blocks del..

☛ This parameter only appears, if any fonts are already loaded into the flash memory.

See topic section [Info-Printouts and Parameters](#) ☐.

# Font presentation

A →	0	1	2	3	4	5	6	7	8	9	A	B
	0	1	2	3	4	5	6	7	8	9	10	11
B →		☺	☹	♥	♦	♣	♠	●	◼	◯	◐	♂
	C	D	E	F	10	11	12	13	14	15	16	17
12	13	14	15	16	17	18	19	20	21	22	23	
♀	♪	♫	☀	▶	◀	↕	!!	¶	§	—	↕	
18	19	1A	1B	1C	1D	1E	1F	20	21	22	23	
24	25	26	27	28	29	30	31	32	33	34	35	
↑	↓	→	←	└	↔	▲	▼		!	"	#	
24	25	26	27	28	29	2A	2B	2C	2D	2E	2F	
36	37	38	39	40	41	42	43	44	45	46	47	
\$	%	&	'	(	)	*	+	,	-	.	/	
30	31	32	33	34	35	36	37	38	39	3A	3B	
48	49	50	51	52	53	54	55	56	57	58	59	
0	1	2	3	4	5	6	7	8	9	:	;	
3C	3D	3E	3F	40	41	42	43	44	45	46	47	
60	61	62	63	64	65	66	67	68	69	70	71	
<	=	>	?	@	A	B	C	D	E	F	G	
48	49	4A	4B	4C	4D	4E	4F	50	51	52	53	
72	73	74	75	76	77	78	79	80	81	82	83	
H	I	J	K	L	M	N	O	P	Q	R	S	
54	55	56	57	58	59	5A	5B	5C	5D	5E	5F	
84	85	86	87	88	89	90	91	92	93	94	95	
T	U	V	W	X	Y	Z	[	\	]	^	_	

[2] Each character of the font is depicted with its hexadecimal (first line) and decimal (second line) code.  
**A** Hexadecimal code.  
**B** Decimal code.

## Font coding comparison

Not valid for TTX 67x, TTK, TDI

Selecting the font coding:

- Parameter menu: SYSTEM PARAMETERS > Character sets
- Easy-Plug: #N

	0	1	2	3	4	5	6	7	8	9	A	B	C	D	E	F
0x00		☺	☹	♥	♦	♣	♠	●	○	◐	♂	♀	⊙	♪	◐	
0x10	▶	◀	↕	!!	¶	§	-	↕	↑	↓	→	←	↳	↔	▲	▼
0x20		!	"	#	\$	%	&	'	(	)	*	+	,	-	.	/
0x30	0	1	2	3	4	5	6	7	8	9	:	;	<	=	>	?
0x40	@	A	B	C	D	E	F	G	H	I	J	K	L	M	N	O
0x50	P	Q	R	S	T	U	V	W	X	Y	Z	[	\	]	^	_
0x60	'	a	b	c	d	e	f	g	h	i	j	k	l	m	n	o
0x70	p	q	r	s	t	u	v	w	x	y	z	{		}	~	⏏
0x80	€	ü	é	â	ä	à	å	ç	ê	ë	è	ï	î	ì	Ä	Å
0x90	É	æ	Æ	ô	ö	ò	û	ù	ÿ	Ö	Ü	ø	£	Ø	Pt	f
0xA0	á	í	ó	ú	ñ	Ñ	ª	º	¿	¬	½	¼	¡	«	»	
0xB0	⋮	⊞	⊠		┌	┐	└	┘	┌	┐	└	┘	┌	┐	└	┘
0xC0	┌	└	┐	┘	┌	└	┐	┘	┌	└	┐	┘	┌	└	┐	┘
0xD0	┌	└	┐	┘	┌	└	┐	┘	┌	└	┐	┘	┌	└	┐	┘
0xE0	α	β	Γ	π	Σ	σ	μ	τ	Φ	Θ	Ω	δ	∞	φ	ε	∩
0xF0	≡	±	≥	≤	¡	¡	÷	≈	°	•	·	√	η	²	■	

[3] Speedo font 101 (#YN101) with coding „similar IBM“ (#N9).

All printers

	0	1	2	3	4	5	6	7	8	9	A	B	C	D	E	F
0x00																
0x10																
0x20		!	"	#	\$	%	&	'	(	)	*	+	,	-	.	/
0x30	0	1	2	3	4	5	6	7	8	9	:	;	<	=	>	?
0x40	@	A	B	C	D	E	F	G	H	I	J	K	L	M	N	O
0x50	P	Q	R	S	T	U	V	W	X	Y	Z	[	\	]	^	_
0x60	`	a	b	c	d	e	f	g	h	i	j	k	l	m	n	o
0x70	p	q	r	s	t	u	v	w	x	y	z	{		}	~	
0x80	€		,	f	„	...	†	‡	^	%	Š	<	œ	Ž		
0x90		'	'	“	”	.	-	-	~	™	š	>	œ	ž	ÿ	
0xA0		ı	ç	£	¤	¥	¦	§	¨	©	ª	«	¬	-	®	¯
0xB0	°	±	²	³	´	µ	¶	·	¸	¹	º	»	¼	½	¾	¿
0xC0	À	Á	Â	Ã	Ä	Å	Æ		È	É	Ê	Ë	Ì	Í	Î	Ï
0xD0	Ð	Ñ	Ò	Ó	Ô	Õ	Ö	×	Ø	Ù	Ú	Û	Ü	Ý	Þ	ß
0xE0	à	á	â	ã	ä	å	æ	ç	è	é	ê	ë	ì	í	î	ï
0xF0	ð	ñ	ò	ó	ô	õ	ö	÷	ø	ù	ú	û	ü	ý	þ	ÿ

[4] Speedo font 101 (#YN101) with coding ANSI CP1252 (#N10).



All printers

	0	1	2	3	4	5	6	7	8	9	A	B	C	D	E	F
0x00																
0x10																
0x20		!	"	#	\$	%	&	'	(	)	*	+	,	-	.	/
0x30	0	1	2	3	4	5	6	7	8	9	:	;	<	=	>	?
0x40	@	A	B	C	D	E	F	G	H	I	J	K	L	M	N	O
0x50	P	Q	R	S	T	U	V	W	X	Y	Z	[	\	]	^	_
0x60	`	a	b	c	d	e	f	g	h	i	j	k	l	m	n	o
0x70	p	q	r	s	t	u	v	w	x	y	z	{		}	~	
0x80	€		,	„	...	†	‡		%	Š	<	Š		Ž	Ž	
0x90		'	'	“	”	.	-	-		™	š	>	š		ž	ž
0xA0		˘	˘	ł	ꝛ	Ą	ı	§	”	©	§	«	¬	-	®	Ž
0xB0	°	±	˙	ł	´	μ	¶	·	˘	ą	ş	»	Ł	”	ł	ż
0xC0		Á	Â	Ã	Ä	Í	Ć		Č	É	Ě	Ě	Ě	Í	Î	
0xD0	Đ	Ń	Ň	Ó	Ô	Õ	Ö	×	Ř	Ů	Ú	Ů	Ů	Ů	Ý	Ť
0xE0		á	â	ã	ä	í	ć	ç	č	é	ę	ě	ě	í	î	
0xF0	ď	ń	ň	ó	ô	õ	ö	÷	ř	ů	ú	ů	ů	ů	ý	ť

[5] Speedo font 101 (#YN101) with coding ANSI CP1250 (#N11)

All printers

	0	1	2	3	4	5	6	7	8	9	A	B	C	D	E	F
0x00																
0x10																
0x20		!	"	#	\$	%	&	'	(	)	*	+	,	-	.	/
0x30	0	1	2	3	4	5	6	7	8	9	:	;	<	=	>	?
0x40	@	A	B	C	D	E	F	G	H	I	J	K	L	M	N	O
0x50	P	Q	R	S	T	U	V	W	X	Y	Z	[	\	]	^	_
0x60	`	a	b	c	d	e	f	g	h	i	j	k	l	m	n	o
0x70	p	q	r	s	t	u	v	w	x	y	z	{		}	~	
0x80																
0x90																
0xA0		À	Á	Â	Ã	Ä	Å	Ş	Ş	Š	Š	Ž	-	Ž	Ž	
0xB0	°	ą	ć	ł	ł	ś	ś	š	š	ž	ž	ž	ž	ž	ž	
0xC0		Á	Â	Ã	Ä	Å	Ł	Ć	Č	É	Ě	Ě	Ě	Í	Î	
0xD0	Đ	Ń	Ň	Ó	Ô	Õ	Ö	×	Ř	Ů	Ú	Ů	Ů	Ů	Ý	Ť
0xE0		á	â	ã	ä	å	ł	ć	č	é	ě	ě	ě	í	î	
0xF0	đ	ń	ň	ó	ô	õ	ö	÷	ř	ů	ú	ů	ů	ů	ý	ť

[6] Speedo font 101 (#YN101) with coding ISO 8859-2 (#N12)

All printers

# Font tables

Coding: IBM

## Fixfonts

YT100

0	1	2	3	4	5	6	7	8	9	A	B
0	1	2	3	4	5	6	7	8	9	10	11
C	D	E	F	10	11	12	13	14	15	16	17
12	13	14	15	16	17	18	19	20	21	22	23
			“						§		
18	19	1A	1B	1C	1D	1E	1F	20	21	22	23
24	25	26	27	28	29	30	31	32	33	34	35
									ı	”	#
24	25	26	27	28	29	2A	2B	2C	2D	2E	2F
36	37	38	39	40	41	42	43	44	45	46	47
§	%	&	'	(	)	^	+	,	-	.	/
30	31	32	33	34	35	36	37	38	39	3A	3B
48	49	50	51	52	53	54	55	56	57	58	59
o	ı	2	3	4	5	6	7	B	9	:	;
3C	3D	3E	3F	40	41	42	43	44	45	46	47
60	61	62	63	64	65	66	67	68	69	70	71
<	=	>	?	@	A	B	C	D	E	F	G
48	49	4A	4B	4C	4D	4E	4F	50	51	52	53
72	73	74	75	76	77	78	79	80	81	82	83
H	I	J	K	L	M	N	O	P	Q	R	S
54	55	56	57	58	59	5A	5B	5C	5D	5E	5F
84	85	86	87	88	89	90	91	92	93	94	95
T	U	V	W	X	Y	Z	[	\	]	^	_

[7] Fixfont YT100 (IBM), ASCII no. 000-095.

All printers

60	61	62	63	64	65	66	67	68	69	6A	6B
96	97	98	99	100	101	102	103	104	105	106	107
'	a	b	c	d	e	f	g	h	i	j	k

6C	6D	6E	6F	70	71	72	73	74	75	76	77
108	109	110	111	112	113	114	115	116	117	118	119
l	m	n	o	p	q	r	s	t	u	v	w

78	79	7A	7B	7C	7D	7E	7F	80	81	82	83
120	121	122	123	124	125	126	127	128	129	130	131
x	y	z	{		}	~		€	ü	ó	ä

84	85	86	87	88	89	8A	8B	8C	8D	8E	8F
132	133	134	135	136	137	138	139	140	141	142	143
š	à	á	ç	ø	â	ä	γ	τ	ι	κ	Å

90	91	92	93	94	95	96	97	98	99	9A	9B
144	145	146	147	148	149	150	151	152	153	154	155
É	œ	Æ	ß	ö	ö	ü	ü	y	ø	U	ø

9C	9D	9E	9F	A0	A1	A2	A3	A4	A5	A6	A7
156	157	158	159	160	161	162	163	164	165	166	167
£	ø	Pe	f	á	f	ó	ú	ñ	ñ	á	o

A8	A9	AA	AB	AC	AD	AE	AF	B0	B1	B2	B3
168	169	170	171	172	173	174	175	176	177	178	179
é			‰	‰	i	“	”		⌘		

B4	B5	B6	B7	B8	B9	BA	BB	BC	BD	BE	BF
180	181	182	183	184	185	186	187	188	189	190	191
									“	”	

[8] Fixfont YT100 (IBM), ASCII no. 096-191.

All printers

C0	C1	C2	C3	C4	C5	C6	C7	C8	C9	CA	CB
192	193	194	195	196	197	198	199	200	201	202	203
				-							

CC	CD	CE	CF	D0	D1	D2	D3	D4	D5	D6	D7
204	205	206	207	208	209	210	211	212	213	214	215

D8	D9	DA	DB	DC	DD	DE	DF	E0	E1	E2	E3
216	217	218	219	220	221	222	223	224	225	226	227
									ò		

E4	E5	E6	E7	E8	E9	EA	EB	EC	ED	EE	EF
228	229	230	231	232	233	234	235	236	237	238	239
		µ							ø		

F0	F1	F2	F3	F4	F5	F6	F7	F8	F9	FA	FB
240	241	242	243	244	245	246	247	248	249	250	251
	z				¸			.	»		

FC	FD	FE	FF								
252	253	254	255								
		™									

[9] Fixfont YT100 (IBM), ASCII no. 192-255.

All printers

YT101

0	1	2	3	4	5	6	7	8	9	A	B
0	1	2	3	4	5	6	7	8	9	10	11
C	D	E	F	10	11	12	13	14	15	16	17
12	13	14	15	16	17	18	19	20	21	22	23
			π						§		
18	19	1A	1B	1C	1D	1E	1F	20	21	22	23
24	25	26	27	28	29	30	31	32	33	34	35
									!	"	#
24	25	26	27	28	29	2A	2B	2C	2D	2E	2F
36	37	38	39	40	41	42	43	44	45	46	47
\$	%	&	'	[	]	*	+	,	-	.	/
30	31	32	33	34	35	36	37	38	39	3A	3B
48	49	50	51	52	53	54	55	56	57	58	59
0	1	2	3	4	5	6	7	8	9	:	;
3C	3D	3E	3F	40	41	42	43	44	45	46	47
60	61	62	63	64	65	66	67	68	69	70	71
<	=	>	?	@	A	B	C	D	E	F	G
48	49	4A	4B	4C	4D	4E	4F	50	51	52	53
72	73	74	75	76	77	78	79	80	81	82	83
H	I	J	K	L	M	N	O	P	Q	R	S
54	55	56	57	58	59	5A	5B	5C	5D	5E	5F
84	85	86	87	88	89	90	91	92	93	94	95
T	U	V	W	X	Y	Z	[	\	]	^	_

[10] Fixfont YT101(IBM), ASCII no. 000-095.

All printers

60	61	62	63	64	65	66	67	68	69	6A	6B
96	97	98	99	100	101	102	103	104	105	106	107
'	a	b	c	d	e	f	g	h	i	j	k

6C	6D	6E	6F	70	71	72	73	74	75	76	77
108	109	110	111	112	113	114	115	116	117	118	119
l	m	n	o	p	q	r	s	t	u	v	w

78	79	7A	7B	7C	7D	7E	7F	80	81	82	83
120	121	122	123	124	125	126	127	128	129	130	131
x	y	z	<		>	~		€	ü	ë	ä

84	85	86	87	88	89	8A	8B	8C	8D	8E	8F
132	133	134	135	136	137	138	139	140	141	142	143
ä	à	å	ç	ê	ë	è	ï	î	í	Ë	Å

90	91	92	93	94	95	96	97	98	99	9A	9B
144	145	146	147	148	149	150	151	152	153	154	155
É	æ	Æ	ó	ö	õ	ú	ù	ÿ	Ü	Û	ø

9C	9D	9E	9F	A0	A1	A2	A3	A4	A5	A6	A7
156	157	158	159	160	161	162	163	164	165	166	167
£	Ø	Pt	f	á	í	ó	ú	ñ	Ñ	ª	º

A8	A9	AA	AB	AC	AD	AE	AF	B0	B1	B2	B3
168	169	170	171	172	173	174	175	176	177	178	179
¿			½	¼	¡	«	»		⌘		

B4	B5	B6	B7	B8	B9	BA	BB	BC	BD	BE	BF
180	181	182	183	184	185	186	187	188	189	190	191
									€	¥	

[11] Fixfont YT101 (IBM), ASCII no. 096-191.

All printers

C0	C1	C2	C3	C4	C5	C6	C7	C8	C9	CA	CB
192	193	194	195	196	197	198	199	200	201	202	203
				-							

CC	CD	CE	CF	D0	D1	D2	D3	D4	D5	D6	D7
204	205	206	207	208	209	210	211	212	213	214	215

D8	D9	DA	DB	DC	DD	DE	DF	E0	E1	E2	E3
216	217	218	219	220	221	222	223	224	225	226	227
									ß		

E4	E5	E6	E7	E8	E9	EA	EB	EC	ED	EE	EF
228	229	230	231	232	233	234	235	236	237	238	239
									ø		

F0	F1	F2	F3	F4	F5	F6	F7	F8	F9	FA	FB
240	241	242	243	244	245	246	247	248	249	250	251
	±							°	ø		

FC	FD	FE	FF								
252	253	254	255								
		▪									

[12] Fixfont YT101 (IBM), ASCII no. 192-255.



All printers

YT102

0	1	2	3	4	5	6	7	8	9	A	B
0	1	2	3	4	5	6	7	8	9	10	11
C	D	E	F	10	11	12	13	14	15	16	17
12	13	14	15	16	17	18	19	20	21	22	23
			α						§		
18	19	1A	1B	1C	1D	1E	1F	20	21	22	23
24	25	26	27	28	29	30	31	32	33	34	35
									!	"	#
24	25	26	27	28	29	2A	2B	2C	2D	2E	2F
36	37	38	39	40	41	42	43	44	45	46	47
\$	%	&	'	(	)	*	+	,	-	.	/
30	31	32	33	34	35	36	37	38	39	3A	3B
48	49	50	51	52	53	54	55	56	57	58	59
0	1	2	3	4	5	6	7	8	9	:	;
3C	3D	3E	3F	40	41	42	43	44	45	46	47
60	61	62	63	64	65	66	67	68	69	70	71
<	=	>	?	@	A	B	C	D	E	F	G
48	49	4A	4B	4C	4D	4E	4F	50	51	52	53
72	73	74	75	76	77	78	79	80	81	82	83
H	I	J	K	L	M	N	O	P	Q	R	S
54	55	56	57	58	59	5A	5B	5C	5D	5E	5F
84	85	86	87	88	89	90	91	92	93	94	95
T	U	V	W	X	Y	Z	[	\	]	^	_

[13] Fixfont YT102 (IBM), ASCII no. 000-095.

## All printers

60	61	62	63	64	65	66	67	68	69	6A	6B
96	97	98	99	100	101	102	103	104	105	106	107
'	a	b	c	d	e	f	g	h	i	j	k

6C	6D	6E	6F	70	71	72	73	74	75	76	77
108	109	110	111	112	113	114	115	116	117	118	119
l	m	n	o	p	q	r	s	t	u	v	w

78	79	7A	7B	7C	7D	7E	7F	80	81	82	83
120	121	122	123	124	125	126	127	128	129	130	131
x	y	z	{		}	~		€	ü	é	â

84	85	86	87	88	89	8A	8B	8C	8D	8E	8F
132	133	134	135	136	137	138	139	140	141	142	143
ä	à	å	ç	ê	ë	è	ï	î	ì	Ä	Å

90	91	92	93	94	95	96	97	98	99	9A	9B
144	145	146	147	148	149	150	151	152	153	154	155
É	æ	Æ	ô	ö	ò	û	ù	ÿ	Ö	Ü	ø

9C	9D	9E	9F	A0	A1	A2	A3	A4	A5	A6	A7
156	157	158	159	160	161	162	163	164	165	166	167
£	Ø	Pt	f	á	í	ó	ú	ñ	Ñ	ª	º

A8	A9	AA	AB	AC	AD	AE	AF	B0	B1	B2	B3
168	169	170	171	172	173	174	175	176	177	178	179
¿			½	¼	í	«	»		☒		

B4	B5	B6	B7	B8	B9	BA	BB	BC	BD	BE	BF
180	181	182	183	184	185	186	187	188	189	190	191
									¢	¥	

[14] Fixfont YT102 (IBM), ASCII no. 096-191.

All printers

C0	C1	C2	C3	C4	C5	C6	C7	C8	C9	CA	CB
192	193	194	195	196	197	198	199	200	201	202	203
				-							

CC	CD	CE	CF	D0	D1	D2	D3	D4	D5	D6	D7
204	205	206	207	208	209	210	211	212	213	214	215

D8	D9	DA	DB	DC	DD	DE	DF	E0	E1	E2	E3
216	217	218	219	220	221	222	223	224	225	226	227
									β		

E4	E5	E6	E7	E8	E9	EA	EB	EC	ED	EE	EF
228	229	230	231	232	233	234	235	236	237	238	239
									∅		

F0	F1	F2	F3	F4	F5	F6	F7	F8	F9	FA	FB
240	241	242	243	244	245	246	247	248	249	250	251
	±							°	∅		

FC	FD	FE	FF								
252	253	254	255								
		▪									

[15] Fixfont YT102 (IBM), ASCII no. 192-255.

All printers

YT103

0	1	2	3	4	5	6	7	8	9	A	B
0	1	2	3	4	5	6	7	8	9	10	11
C	D	E	F	10	11	12	13	14	15	16	17
12	13	14	15	16	17	18	19	20	21	22	23
			⌘						§		
18	19	1A	1B	1C	1D	1E	1F	20	21	22	23
24	25	26	27	28	29	30	31	32	33	34	35
									!	"	#
24	25	26	27	28	29	2A	2B	2C	2D	2E	2F
36	37	38	39	40	41	42	43	44	45	46	47
\$	%	&	'	(	)	*	+	,	-	.	/
30	31	32	33	34	35	36	37	38	39	3A	3B
48	49	50	51	52	53	54	55	56	57	58	59
0	1	2	3	4	5	6	7	8	9	:	;
3C	3D	3E	3F	40	41	42	43	44	45	46	47
60	61	62	63	64	65	66	67	68	69	70	71
<	=	>	?	@	A	B	C	D	E	F	G
48	49	4A	4B	4C	4D	4E	4F	50	51	52	53
72	73	74	75	76	77	78	79	80	81	82	83
H	I	J	K	L	M	N	O	P	Q	R	S
54	55	56	57	58	59	5A	5B	5C	5D	5E	5F
84	85	86	87	88	89	90	91	92	93	94	95
T	U	V	W	X	Y	Z	[	\	]	^	_

[16] Fixfont YT103 (IBM), ASCII no. 000-095.

All printers

60	61	62	63	64	65	66	67	68	69	6A	6B
96	97	98	99	100	101	102	103	104	105	106	107
'	a	b	c	d	e	f	g	h	i	j	k

6C	6D	6E	6F	70	71	72	73	74	75	76	77
108	109	110	111	112	113	114	115	116	117	118	119
l	m	n	o	p	q	r	s	t	u	v	w

78	79	7A	7B	7C	7D	7E	7F	80	81	82	83
120	121	122	123	124	125	126	127	128	129	130	131
x	y	z	{		}	~		€	ü	é	â

84	85	86	87	88	89	8A	8B	8C	8D	8E	8F
132	133	134	135	136	137	138	139	140	141	142	143
ä	à	å	ç	ê	ë	è	ï	î	ì	Ä	Å

90	91	92	93	94	95	96	97	98	99	9A	9B
144	145	146	147	148	149	150	151	152	153	154	155
É	æ	Æ	ô	ö	ò	û	ù	ÿ	Ö	Ü	ø

9C	9D	9E	9F	A0	A1	A2	A3	A4	A5	A6	A7
156	157	158	159	160	161	162	163	164	165	166	167
£	Ø	Pt	f	á	í	ó	ú	ñ	Ñ	ª	º

A8	A9	AA	AB	AC	AD	AE	AF	B0	B1	B2	B3
168	169	170	171	172	173	174	175	176	177	178	179
¿			½	¼	¡	«	»		☒		

B4	B5	B6	B7	B8	B9	BA	BB	BC	BD	BE	BF
180	181	182	183	184	185	186	187	188	189	190	191
									¢	¥	

[17] Fixfont YT103 (IBM), ASCII no. 096-191.

All printers

C0	C1	C2	C3	C4	C5	C6	C7	C8	C9	CA	CB
192	193	194	195	196	197	198	199	200	201	202	203
				–							

CC	CD	CE	CF	D0	D1	D2	D3	D4	D5	D6	D7
204	205	206	207	208	209	210	211	212	213	214	215

D8	D9	DA	DB	DC	DD	DE	DF	E0	E1	E2	E3
216	217	218	219	220	221	222	223	224	225	226	227
									β		

E4	E5	E6	E7	E8	E9	EA	EB	EC	ED	EE	EF
228	229	230	231	232	233	234	235	236	237	238	239
									∅		

F0	F1	F2	F3	F4	F5	F6	F7	F8	F9	FA	FB
240	241	242	243	244	245	246	247	248	249	250	251
	±							°	∅		

FC	FD	FE	FF								
252	253	254	255								
		▪									

[18] Fixfont YT103 (IBM), ASCII no. 192-255.

All printers

YT104

0	1	2	3	4	5	6	7	8	9	A	B
0	1	2	3	4	5	6	7	8	9	10	11
C	D	E	F	10	11	12	13	14	15	16	17
12	13	14	15	16	17	18	19	20	21	22	23
			⌘						§		
18	19	1A	1B	1C	1D	1E	1F	20	21	22	23
24	25	26	27	28	29	30	31	32	33	34	35
									!	"	#
24	25	26	27	28	29	2A	2B	2C	2D	2E	2F
36	37	38	39	40	41	42	43	44	45	46	47
\$	%	&	'	(	)	*	+	,	-	.	/
30	31	32	33	34	35	36	37	38	39	3A	3B
48	49	50	51	52	53	54	55	56	57	58	59
0	1	2	3	4	5	6	7	8	9	:	;
3C	3D	3E	3F	40	41	42	43	44	45	46	47
60	61	62	63	64	65	66	67	68	69	70	71
<	=	>	?	@	A	B	C	D	E	F	G
48	49	4A	4B	4C	4D	4E	4F	50	51	52	53
72	73	74	75	76	77	78	79	80	81	82	83
H	I	J	K	L	M	N	O	P	Q	R	S
54	55	56	57	58	59	5A	5B	5C	5D	5E	5F
84	85	86	87	88	89	90	91	92	93	94	95
T	U	V	W	X	Y	Z	[	\	]	^	_

[19] Fixfont YT104 (IBM), ASCII no. 000-095.

All printers

60	61	62	63	64	65	66	67	68	69	6A	6B
96	97	98	99	100	101	102	103	104	105	106	107
'	a	b	c	d	e	f	g	h	i	j	k

6C	6D	6E	6F	70	71	72	73	74	75	76	77
108	109	110	111	112	113	114	115	116	117	118	119
l	m	n	o	p	q	r	s	t	u	v	w

78	79	7A	7B	7C	7D	7E	7F	80	81	82	83
120	121	122	123	124	125	126	127	128	129	130	131
x	y	z	{		}	~		€	ü	é	â

84	85	86	87	88	89	8A	8B	8C	8D	8E	8F
132	133	134	135	136	137	138	139	140	141	142	143
ä	à	å	ç	ê	ë	è	ï	î	ì	Ä	Å

90	91	92	93	94	95	96	97	98	99	9A	9B
144	145	146	147	148	149	150	151	152	153	154	155
É	æ	Æ	ô	ö	ò	û	ù	ÿ	Ö	Ü	ø

9C	9D	9E	9F	A0	A1	A2	A3	A4	A5	A6	A7
156	157	158	159	160	161	162	163	164	165	166	167
£	Ø	Pt	f	á	í	ó	ú	ñ	Ñ	a	o

A8	A9	AA	AB	AC	AD	AE	AF	B0	B1	B2	B3
168	169	170	171	172	173	174	175	176	177	178	179
¿			½	¼	¡	«	»		☒		

B4	B5	B6	B7	B8	B9	BA	BB	BC	BD	BE	BF
180	181	182	183	184	185	186	187	188	189	190	191
									¢	¥	

[20] Fixfont YT104 (IBM), ASCII no. 096-191.



All printers

C0	C1	C2	C3	C4	C5	C6	C7	C8	C9	CA	CB
192	193	194	195	196	197	198	199	200	201	202	203
				—							

CC	CD	CE	CF	D0	D1	D2	D3	D4	D5	D6	D7
204	205	206	207	208	209	210	211	212	213	214	215

D8	D9	DA	DB	DC	DD	DE	DF	E0	E1	E2	E3
216	217	218	219	220	221	222	223	224	225	226	227
									β		

E4	E5	E6	E7	E8	E9	EA	EB	EC	ED	EE	EF
228	229	230	231	232	233	234	235	236	237	238	239
									∅		

F0	F1	F2	F3	F4	F5	F6	F7	F8	F9	FA	FB
240	241	242	243	244	245	246	247	248	249	250	251
	±							◦	∅		

FC	FD	FE	FF								
252	253	254	255								
		■									

[21] Fixfont YT104 (IBM), ASCII no. 192-255.

All printers

YT105

0	1	2	3	4	5	6	7	8	9	A	B
0	1	2	3	4	5	6	7	8	9	10	11
C	D	E	F	10	11	12	13	14	15	16	17
12	13	14	15	16	17	18	19	20	21	22	23
			¤						§		
18	19	1A	1B	1C	1D	1E	1F	20	21	22	23
24	25	26	27	28	29	30	31	32	33	34	35
									!	"	#
24	25	26	27	28	29	2A	2B	2C	2D	2E	2F
36	37	38	39	40	41	42	43	44	45	46	47
\$	%	&	'	(	)	*	+	,	-	.	/
30	31	32	33	34	35	36	37	38	39	3A	3B
48	49	50	51	52	53	54	55	56	57	58	59
0	1	2	3	4	5	6	7	8	9	:	;
3C	3D	3E	3F	40	41	42	43	44	45	46	47
60	61	62	63	64	65	66	67	68	69	70	71
<	=	>	?	@	A	B	C	D	E	F	G
48	49	4A	4B	4C	4D	4E	4F	50	51	52	53
72	73	74	75	76	77	78	79	80	81	82	83
H	I	J	K	L	M	N	O	P	Q	R	S
54	55	56	57	58	59	5A	5B	5C	5D	5E	5F
84	85	86	87	88	89	90	91	92	93	94	95
T	U	V	W	X	Y	Z	[	\	]	^	_

[22] Fixfont YT105 (IBM), ASCII no. 000-095.

All printers

60	61	62	63	64	65	66	67	68	69	6A	6B
96	97	98	99	100	101	102	103	104	105	106	107
'	a	b	c	d	e	f	g	h	i	j	k

6C	6D	6E	6F	70	71	72	73	74	75	76	77
108	109	110	111	112	113	114	115	116	117	118	119
l	m	n	o	p	q	r	s	t	u	v	w

78	79	7A	7B	7C	7D	7E	7F	80	81	82	83
120	121	122	123	124	125	126	127	128	129	130	131
x	y	z	{		}	~		€	ü	é	â

84	85	86	87	88	89	8A	8B	8C	8D	8E	8F
132	133	134	135	136	137	138	139	140	141	142	143
ä	à	å	ç	ê	ë	è	ï	î	ì	Ä	Å

90	91	92	93	94	95	96	97	98	99	9A	9B
144	145	146	147	148	149	150	151	152	153	154	155
É	æ	Æ	ô	ö	ò	û	ù	ÿ	Ö	Ü	ø

9C	9D	9E	9F	A0	A1	A2	A3	A4	A5	A6	A7
156	157	158	159	160	161	162	163	164	165	166	167
£	Ø	Pt	f	á	í	ó	ú	ñ	Ñ	ª	º

A8	A9	AA	AB	AC	AD	AE	AF	B0	B1	B2	B3
168	169	170	171	172	173	174	175	176	177	178	179
¿			½	¼	í	«	»		☒		

B4	B5	B6	B7	B8	B9	BA	BB	BC	BD	BE	BF
180	181	182	183	184	185	186	187	188	189	190	191
									¢	¥	

[23] Fixfont YT105 (IBM), ASCII no. 096-191.

All printers

C0	C1	C2	C3	C4	C5	C6	C7	C8	C9	CA	CB
192	193	194	195	196	197	198	199	200	201	202	203
				-							

CC	CD	CE	CF	D0	D1	D2	D3	D4	D5	D6	D7
204	205	206	207	208	209	210	211	212	213	214	215

D8	D9	DA	DB	DC	DD	DE	DF	E0	E1	E2	E3
216	217	218	219	220	221	222	223	224	225	226	227
									ß		

E4	E5	E6	E7	E8	E9	EA	EB	EC	ED	EE	EF
228	229	230	231	232	233	234	235	236	237	238	239
									ø		

F0	F1	F2	F3	F4	F5	F6	F7	F8	F9	FA	FB
240	241	242	243	244	245	246	247	248	249	250	251
	±							°	ø		

FC	FD	FE	FF								
252	253	254	255								
		▪									

[24] Fixfont YT105 (IBM), ASCII no. 192-255.

All printers

YT106

0	1	2	3	4	5	6	7	8	9	A	B
0	1	2	3	4	5	6	7	8	9	10	11
C	D	E	F	10	11	12	13	14	15	16	17
12	13	14	15	16	17	18	19	20	21	22	23
			⌘						§		
18	19	1A	1B	1C	1D	1E	1F	20	21	22	23
24	25	26	27	28	29	30	31	32	33	34	35
									!	"	#
24	25	26	27	28	29	2A	2B	2C	2D	2E	2F
36	37	38	39	40	41	42	43	44	45	46	47
\$	%	&	'	(	)	*	+	,	-	.	/
30	31	32	33	34	35	36	37	38	39	3A	3B
48	49	50	51	52	53	54	55	56	57	58	59
0	1	2	3	4	5	6	7	8	9	:	;
3C	3D	3E	3F	40	41	42	43	44	45	46	47
60	61	62	63	64	65	66	67	68	69	70	71
<	=	>	?	@	A	B	C	D	E	F	G
48	49	4A	4B	4C	4D	4E	4F	50	51	52	53
72	73	74	75	76	77	78	79	80	81	82	83
H	I	J	K	L	M	N	O	P	Q	R	S
54	55	56	57	58	59	5A	5B	5C	5D	5E	5F
84	85	86	87	88	89	90	91	92	93	94	95
T	U	V	W	X	Y	Z	[	\	]	^	_

[25] Fixfont YT106 (IBM), ASCII no. 000-095.

All printers

60	61	62	63	64	65	66	67	68	69	6A	6B
96	97	98	99	100	101	102	103	104	105	106	107
'	a	b	c	d	e	f	g	h	i	j	k

6C	6D	6E	6F	70	71	72	73	74	75	76	77
108	109	110	111	112	113	114	115	116	117	118	119
l	m	n	o	p	q	r	s	t	u	v	w

78	79	7A	7B	7C	7D	7E	7F	80	81	82	83
120	121	122	123	124	125	126	127	128	129	130	131
x	y	z	{		}	~		€	ü	é	â

84	85	86	87	88	89	8A	8B	8C	8D	8E	8F
132	133	134	135	136	137	138	139	140	141	142	143
ä	à	å	ç	ê	ë	è	ï	î	ì	Ä	Å

90	91	92	93	94	95	96	97	98	99	9A	9B
144	145	146	147	148	149	150	151	152	153	154	155
É	æ	Æ	ô	ö	ò	û	ù	ÿ	Ö	Ü	ø

9C	9D	9E	9F	A0	A1	A2	A3	A4	A5	A6	A7
156	157	158	159	160	161	162	163	164	165	166	167
£	Ø	Pt	f	á	í	ó	ú	ñ	Ñ	ª	º

A8	A9	AA	AB	AC	AD	AE	AF	B0	B1	B2	B3
168	169	170	171	172	173	174	175	176	177	178	179
¿			½	¼	¡	«	»		☒		

B4	B5	B6	B7	B8	B9	BA	BB	BC	BD	BE	BF
180	181	182	183	184	185	186	187	188	189	190	191
									¢	¥	

[26] Fixfont YT106 (IBM), ASCII no. 096-191.

All printers

C0	C1	C2	C3	C4	C5	C6	C7	C8	C9	CA	CB
192	193	194	195	196	197	198	199	200	201	202	203
				–							

CC	CD	CE	CF	D0	D1	D2	D3	D4	D5	D6	D7
204	205	206	207	208	209	210	211	212	213	214	215

D8	D9	DA	DB	DC	DD	DE	DF	E0	E1	E2	E3
216	217	218	219	220	221	222	223	224	225	226	227
									β		

E4	E5	E6	E7	E8	E9	EA	EB	EC	ED	EE	EF
228	229	230	231	232	233	234	235	236	237	238	239
									∅		

F0	F1	F2	F3	F4	F5	F6	F7	F8	F9	FA	FB
240	241	242	243	244	245	246	247	248	249	250	251
	±							◦	∅		

FC	FD	FE	FF								
252	253	254	255								
		■									

[27] Fixfont YT106 (IBM), ASCII no. 192-255.

All printers

YT107

0	1	2	3	4	5	6	7	8	9	A	B
0	1	2	3	4	5	6	7	8	9	10	11
C	D	E	F	10	11	12	13	14	15	16	17
12	13	14	15	16	17	18	19	20	21	22	23
			œ						§		
18	19	1A	1B	1C	1D	1E	1F	20	21	22	23
24	25	26	27	28	29	30	31	32	33	34	35
									!	"	#
24	25	26	27	28	29	2A	2B	2C	2D	2E	2F
36	37	38	39	40	41	42	43	44	45	46	47
\$	%	&	'	(	)	*	+	,	-	.	/
30	31	32	33	34	35	36	37	38	39	3A	3B
48	49	50	51	52	53	54	55	56	57	58	59
0	1	2	3	4	5	6	7	8	9	:	;
3C	3D	3E	3F	40	41	42	43	44	45	46	47
60	61	62	63	64	65	66	67	68	69	70	71
<	=	>	?	@	A	B	C	D	E	F	G
48	49	4A	4B	4C	4D	4E	4F	50	51	52	53
72	73	74	75	76	77	78	79	80	81	82	83
H	I	J	K	L	M	N	O	P	Q	R	S
54	55	56	57	58	59	5A	5B	5C	5D	5E	5F
84	85	86	87	88	89	90	91	92	93	94	95
T	U	V	W	X	Y	Z	[	\	]	^	_

[28] Fixfont YT107 (IBM), ASCII no. 000-095.



All printers

60	61	62	63	64	65	66	67	68	69	6A	6B
96	97	98	99	100	101	102	103	104	105	106	107
'	a	b	c	d	e	f	g	h	i	j	k

6C	6D	6E	6F	70	71	72	73	74	75	76	77
108	109	110	111	112	113	114	115	116	117	118	119
l	m	n	o	p	q	r	s	t	u	v	w

78	79	7A	7B	7C	7D	7E	7F	80	81	82	83
120	121	122	123	124	125	126	127	128	129	130	131
x	y	z	{		}	~		€	ü	é	â

84	85	86	87	88	89	8A	8B	8C	8D	8E	8F
132	133	134	135	136	137	138	139	140	141	142	143
ä	à	å	ç	ê	ë	è	ï	î	ì	Ä	Å

  

90	91	92	93	94	95	96	97	98	99	9A	9B
144	145	146	147	148	149	150	151	152	153	154	155
É	æ	Æ	ô	ö	ò	û	ù	ÿ	Ö	Ü	ø

9C	9D	9E	9F	A0	A1	A2	A3	A4	A5	A6	A7
156	157	158	159	160	161	162	163	164	165	166	167
£	Ø	Pt	f	á	í	ó	ú	ñ	Ñ	a	o

A8	A9	AA	AB	AC	AD	AE	AF	B0	B1	B2	B3
168	169	170	171	172	173	174	175	176	177	178	179
¿			½	¼	í	«	»				

B4	B5	B6	B7	B8	B9	BA	BB	BC	BD	BE	BF
180	181	182	183	184	185	186	187	188	189	190	191
									¢	¥	

[29] Fixfont YT107 (IBM), ASCII no. 096-191.

All printers

C0	C1	C2	C3	C4	C5	C6	C7	C8	C9	CA	CB
192	193	194	195	196	197	198	199	200	201	202	203
				—							

CC	CD	CE	CF	D0	D1	D2	D3	D4	D5	D6	D7
204	205	206	207	208	209	210	211	212	213	214	215

D8	D9	DA	DB	DC	DD	DE	DF	E0	E1	E2	E3
216	217	218	219	220	221	222	223	224	225	226	227
									ß		

E4	E5	E6	E7	E8	E9	EA	EB	EC	ED	EE	EF
228	229	230	231	232	233	234	235	236	237	238	239
									Ø		

F0	F1	F2	F3	F4	F5	F6	F7	F8	F9	FA	FB
240	241	242	243	244	245	246	247	248	249	250	251
	±							°	ø		

FC	FD	FE	FF								
252	253	254	255								
		■									

[30] Fixfont YT107 (IBM), ASCII no. 192-255.

All printers

YT108

0	1	2	3	4	5	6	7	8	9	A	B
0	1	2	3	4	5	6	7	8	9	10	11
C	D	E	F	10	11	12	13	14	15	16	17
12	13	14	15	16	17	18	19	20	21	22	23
			⌘					¶	§		
18	19	1A	1B	1C	1D	1E	1F	20	21	22	23
24	25	26	27	28	29	30	31	32	33	34	35
									!	"	#
24	25	26	27	28	29	2A	2B	2C	2D	2E	2F
36	37	38	39	40	41	42	43	44	45	46	47
\$	%	&	'	(	)	*	+	,	-	.	/
30	31	32	33	34	35	36	37	38	39	3A	3B
48	49	50	51	52	53	54	55	56	57	58	59
0	1	2	3	4	5	6	7	8	9	:	;
3C	3D	3E	3F	40	41	42	43	44	45	46	47
60	61	62	63	64	65	66	67	68	69	70	71
<	=	>	?	@	A	B	C	D	E	F	G
48	49	4A	4B	4C	4D	4E	4F	50	51	52	53
72	73	74	75	76	77	78	79	80	81	82	83
H	I	J	K	L	M	N	O	P	Q	R	S
54	55	56	57	58	59	5A	5B	5C	5D	5E	5F
84	85	86	87	88	89	90	91	92	93	94	95
T	U	V	W	X	Y	Z	[	\	]	^	_

[31] Fixfont YT108 (IBM), ASCII no. 000-095.

All printers

60	61	62	63	64	65	66	67	68	69	6A	6B
96	97	98	99	100	101	102	103	104	105	106	107
'	A	B	C	D	E	F	G	H	I	J	K

6C	6D	6E	6F	70	71	72	73	74	75	76	77
108	109	110	111	112	113	114	115	116	117	118	119
L	M	N	O	P	Q	R	S	T	U	V	W

78	79	7A	7B	7C	7D	7E	7F	80	81	82	83
120	121	122	123	124	125	126	127	128	129	130	131
X	Y	Z	{		}	~		€	Ü	É	Â

84	85	86	87	88	89	8A	8B	8C	8D	8E	8F
132	133	134	135	136	137	138	139	140	141	142	143
Ä	À	Å	Ç	Ê	Ë	È	Ï	Î	Ì	Ï	Å

90	91	92	93	94	95	96	97	98	99	9A	9B
144	145	146	147	148	149	150	151	152	153	154	155
É	Æ	Æ	Ô	Ö	Ò	Û	Ù	ÿ	Ö	Ü	ø

9C	9D	9E	9F	A0	A1	A2	A3	A4	A5	A6	A7
156	157	158	159	160	161	162	163	164	165	166	167
£	Ø	PT	f	Á	Í	Ó	Ù	Ñ	Ñ	A	O

A8	A9	AA	AB	AC	AD	AE	AF	B0	B1	B2	B3
168	169	170	171	172	173	174	175	176	177	178	179
¿			½	¼	i	«	»		☒		

B4	B5	B6	B7	B8	B9	BA	BB	BC	BD	BE	BF
180	181	182	183	184	185	186	187	188	189	190	191
									¢	¥	

[32] Fixfont YT108 (IBM), ASCII no. 096-191.

All printers

C0	C1	C2	C3	C4	C5	C6	C7	C8	C9	CA	CB
192	193	194	195	196	197	198	199	200	201	202	203
				—							

CC	CD	CE	CF	D0	D1	D2	D3	D4	D5	D6	D7
204	205	206	207	208	209	210	211	212	213	214	215

D8	D9	DA	DB	DC	DD	DE	DF	E0	E1	E2	E3
216	217	218	219	220	221	222	223	224	225	226	227
									ß		

E4	E5	E6	E7	E8	E9	EA	EB	EC	ED	EE	EF
228	229	230	231	232	233	234	235	236	237	238	239
		μ							ø		

F0	F1	F2	F3	F4	F5	F6	F7	F8	F9	FA	FB
240	241	242	243	244	245	246	247	248	249	250	251
	±				¾			°	ø	.	

FC	FD	FE	FF								
252	253	254	255								
		■									

[33] Fixfont YT108 (IBM), ASCII no. 192-255.

All printers

YT109

0	1	2	3	4	5	6	7	8	9	A	B
0	1	2	3	4	5	6	7	8	9	10	11
C	D	E	F	10	11	12	13	14	15	16	17
12	13	14	15	16	17	18	19	20	21	22	23
			⌘					¶	§		
18	19	1A	1B	1C	1D	1E	1F	20	21	22	23
24	25	26	27	28	29	30	31	32	33	34	35
									!	"	#
24	25	26	27	28	29	2A	2B	2C	2D	2E	2F
36	37	38	39	40	41	42	43	44	45	46	47
\$	%	&	'	(	)	*	+	,	-	.	/
30	31	32	33	34	35	36	37	38	39	3A	3B
48	49	50	51	52	53	54	55	56	57	58	59
0	1	2	3	4	5	6	7	8	9	:	;
3C	3D	3E	3F	40	41	42	43	44	45	46	47
60	61	62	63	64	65	66	67	68	69	70	71
<	=	>	?	@	A	B	C	D	E	F	G
48	49	4A	4B	4C	4D	4E	4F	50	51	52	53
72	73	74	75	76	77	78	79	80	81	82	83
H	I	J	K	L	M	N	O	P	Q	R	S
54	55	56	57	58	59	5A	5B	5C	5D	5E	5F
84	85	86	87	88	89	90	91	92	93	94	95
T	U	V	W	X	Y	Z	[	\	]	^	_

[34] Fixfont YT109 (IBM), ASCII no. 000-095.

All printers

60	61	62	63	64	65	66	67	68	69	6A	6B
96	97	98	99	100	101	102	103	104	105	106	107
'	A	B	C	D	E	F	G	H	I	J	K

6C	6D	6E	6F	70	71	72	73	74	75	76	77
108	109	110	111	112	113	114	115	116	117	118	119
L	M	N	O	P	Q	R	S	T	U	V	W

78	79	7A	7B	7C	7D	7E	7F	80	81	82	83
120	121	122	123	124	125	126	127	128	129	130	131
X	Y	Z	{		}	~		€	Ü	É	Â

84	85	86	87	88	89	8A	8B	8C	8D	8E	8F
132	133	134	135	136	137	138	139	140	141	142	143
Ä	À	Å	Ç	Ê	Ë	È	Ï	Î	Ì	Ã	Ä

90	91	92	93	94	95	96	97	98	99	9A	9B
144	145	146	147	148	149	150	151	152	153	154	155
Ê	Æ	Æ	Ô	Ö	Ò	Û	Ù	ÿ	Ï	Ü	Ø

9C	9D	9E	9F	A0	A1	A2	A3	A4	A5	A6	A7	
156	157	158	159	160	161	162	163	164	165	166	167	
£	Ø	P	T	f	Á	Í	Ó	Ú	Ñ	Ñ	À	Ó

A8	A9	AA	AB	AC	AD	AE	AF	B0	B1	B2	B3
168	169	170	171	172	173	174	175	176	177	178	179
¿			½	¼	í	«	»		☒		

B4	B5	B6	B7	B8	B9	BA	BB	BC	BD	BE	BF
180	181	182	183	184	185	186	187	188	189	190	191
									¢	¥	

[35] Fixfont YT109 (IBM), ASCII no. 096-191.





All printers

YT110

0	1	2	3	4	5	6	7	8	9	A	B
0	1	2	3	4	5	6	7	8	9	10	11

C	D	E	F	10	11	12	13	14	15	16	17
12	13	14	15	16	17	18	19	20	21	22	23

18	19	1A	1B	1C	1D	1E	1F	20	21	22	23
24	25	26	27	28	29	30	31	32	33	34	35
										¶	#

24	25	26	27	28	29	2A	2B	2C	2D	2E	2F
36	37	38	39	40	41	42	43	44	45	46	47
¢	%	&	'	(	)	*	+	¬	-	.	/

30	31	32	33	34	35	36	37	38	39	3A	3B
48	49	50	51	52	53	54	55	56	57	58	59
0	1	2	3	4	5	6	7	8	9	:	;

3C	3D	3E	3F	40	41	42	43	44	45	46	47
60	61	62	63	64	65	66	67	68	69	70	71
	=	>	?		A	B	C	D	E	F	G

48	49	4A	4B	4C	4D	4E	4F	50	51	52	53
72	73	74	75	76	77	78	79	80	81	82	83
H	I	J	K	L	M	N	O	P	Q	R	S

54	55	56	57	58	59	5A	5B	5C	5D	5E	5F
84	85	86	87	88	89	90	91	92	93	94	95
T	U	V	W	X	Y	Z					

[37] Fixfont YT110 (IBM), ASCII no. 000-095.

All printers

60	61	62	63	64	65	66	67	68	69	6A	6B
96	97	98	99	100	101	102	103	104	105	106	107

6C	6D	6E	6F	70	71	72	73	74	75	76	77
108	109	110	111	112	113	114	115	116	117	118	119

78	79	7A	7B	7C	7D	7E	7F	80	81	82	83
120	121	122	123	124	125	126	127	128	129	130	131
			{		}			€			

84	85	86	87	88	89	8A	8B	8C	8D	8E	8F
132	133	134	135	136	137	138	139	140	141	142	143
										À	Ã

90	91	92	93	94	95	96	97	98	99	9A	9B
144	145	146	147	148	149	150	151	152	153	154	155
		Æ							Ö	Ü	Ø

9C	9D	9E	9F	A0	A1	A2	A3	A4	A5	A6	A7
156	157	158	159	160	161	162	163	164	165	166	167
£	¥								Ñ		

A8	A9	AA	AB	AC	AD	AE	AF	B0	B1	B2	B3
168	169	170	171	172	173	174	175	176	177	178	179
¿											

B4	B5	B6	B7	B8	B9	BA	BB	BC	BD	BE	BF
180	181	182	183	184	185	186	187	188	189	190	191

[38] Fixfont YT110 (IBM), ASCII no. 096-191.



All printers

YT111

0	1	2	3	4	5	6	7	8	9	A	B
0	1	2	3	4	5	6	7	8	9	10	11
C	D	E	F	10	11	12	13	14	15	16	17
12	13	14	15	16	17	18	19	20	21	22	23
			π						§		
18	19	1A	1B	1C	1D	1E	1F	20	21	22	23
24	25	26	27	28	29	30	31	32	33	34	35
									!	"	#
24	25	26	27	28	29	2A	2B	2C	2D	2E	2F
36	37	38	39	40	41	42	43	44	45	46	47
\$	%	&	'	(	)	*	+	,	-	.	/
30	31	32	33	34	35	36	37	38	39	3A	3B
48	49	50	51	52	53	54	55	56	57	58	59
0	1	2	3	4	5	6	7	8	9	:	;
3C	3D	3E	3F	40	41	42	43	44	45	46	47
60	61	62	63	64	65	66	67	68	69	70	71
<	=	>	?	@	A	B	C	D	E	F	G
48	49	4A	4B	4C	4D	4E	4F	50	51	52	53
72	73	74	75	76	77	78	79	80	81	82	83
H	I	J	K	L	M	N	O	P	Q	R	S
54	55	56	57	58	59	5A	5B	5C	5D	5E	5F
84	85	86	87	88	89	90	91	92	93	94	95
T	U	V	W	X	Y	Z	[	\	]	^	_

[40] Fixfont YT111 (IBM), ASCII no. 000-095.

All printers

60	61	62	63	64	65	66	67	68	69	6A	6B
96	97	98	99	100	101	102	103	104	105	106	107
'	a	b	c	d	e	f	g	h	i	j	k

6C	6D	6E	6F	70	71	72	73	74	75	76	77
108	109	110	111	112	113	114	115	116	117	118	119
l	m	n	o	p	q	r	s	t	u	v	w

78	79	7A	7B	7C	7D	7E	7F	80	81	82	83
120	121	122	123	124	125	126	127	128	129	130	131
x	y	z	{		}	~		€	ü	é	â

84	85	86	87	88	89	8A	8B	8C	8D	8E	8F
132	133	134	135	136	137	138	139	140	141	142	143
ä	à	å	ç	ê	ë	è	ï	î	ì	Ä	Å

90	91	92	93	94	95	96	97	98	99	9A	9B
144	145	146	147	148	149	150	151	152	153	154	155
É	æ	Æ	ð	ö	ò	ú	ù	ÿ	Ö	Ü	ø

9C	9D	9E	9F	A0	A1	A2	A3	A4	A5	A6	A7
156	157	158	159	160	161	162	163	164	165	166	167
£	Ø	Pt	f	á	í	ó	ú	ñ	Ñ	ª	º

A8	A9	AA	AB	AC	AD	AE	AF	B0	B1	B2	B3
168	169	170	171	172	173	174	175	176	177	178	179
¿			½	¼	;	«	»		☒		

B4	B5	B6	B7	B8	B9	BA	BB	BC	BD	BE	BF
180	181	182	183	184	185	186	187	188	189	190	191
									€	¥	

[41] Fixfont YT111 (IBM), ASCII no. 096-191.

All printers

C0	C1	C2	C3	C4	C5	C6	C7	C8	C9	CA	CB
192	193	194	195	196	197	198	199	200	201	202	203
				-							

CC	CD	CE	CF	D0	D1	D2	D3	D4	D5	D6	D7
204	205	206	207	208	209	210	211	212	213	214	215

D8	D9	DA	DB	DC	DD	DE	DF	E0	E1	E2	E3
216	217	218	219	220	221	222	223	224	225	226	227
									ß		

E4	E5	E6	E7	E8	E9	EA	EB	EC	ED	EE	EF
228	229	230	231	232	233	234	235	236	237	238	239
									Ø		

F0	F1	F2	F3	F4	F5	F6	F7	F8	F9	FA	FB
240	241	242	243	244	245	246	247	248	249	250	251
	±							°	ø		

FC	FD	FE	FF								
252	253	254	255								
		▪									

[42] Fixfont YT111 (IBM), ASCII no. 192-255.

All printers

YT112

0	1	2	3	4	5	6	7	8	9	A	B
0	1	2	3	4	5	6	7	8	9	10	11
C	D	E	F	10	11	12	13	14	15	16	17
12	13	14	15	16	17	18	19	20	21	22	23
			⌘						§		
18	19	1A	1B	1C	1D	1E	1F	20	21	22	23
24	25	26	27	28	29	30	31	32	33	34	35
									!	"	#
24	25	26	27	28	29	2A	2B	2C	2D	2E	2F
36	37	38	39	40	41	42	43	44	45	46	47
\$	%	&	'	(	)	*	+	,	-	.	/
30	31	32	33	34	35	36	37	38	39	3A	3B
48	49	50	51	52	53	54	55	56	57	58	59
0	1	2	3	4	5	6	7	8	9	:	;
3C	3D	3E	3F	40	41	42	43	44	45	46	47
60	61	62	63	64	65	66	67	68	69	70	71
<	=	>	?	@	A	B	C	D	E	F	G
48	49	4A	4B	4C	4D	4E	4F	50	51	52	53
72	73	74	75	76	77	78	79	80	81	82	83
H	I	J	K	L	M	N	O	P	Q	R	S
54	55	56	57	58	59	5A	5B	5C	5D	5E	5F
84	85	86	87	88	89	90	91	92	93	94	95
T	U	V	W	X	Y	Z	[	\	]	^	_

[43] Fixfont YT112 (IBM), ASCII no. 000-095.

All printers

60	61	62	63	64	65	66	67	68	69	6A	6B
96	97	98	99	100	101	102	103	104	105	106	107
‘	a	b	c	d	e	f	g	h	i	j	k

6C	6D	6E	6F	70	71	72	73	74	75	76	77
108	109	110	111	112	113	114	115	116	117	118	119
l	m	n	o	p	q	r	s	t	u	v	w

78	79	7A	7B	7C	7D	7E	7F	80	81	82	83
120	121	122	123	124	125	126	127	128	129	130	131
x	y	z	{		}	~		€	ü	é	â

84	85	86	87	88	89	8A	8B	8C	8D	8E	8F
132	133	134	135	136	137	138	139	140	141	142	143
ä	à	å	ç	ê	ë	è	ï	î	ì	Ä	Å

90	91	92	93	94	95	96	97	98	99	9A	9B
144	145	146	147	148	149	150	151	152	153	154	155
É	æ	Æ	ô	ö	ò	û	ù	ÿ	Ö	Ü	ø

9C	9D	9E	9F	A0	A1	A2	A3	A4	A5	A6	A7
156	157	158	159	160	161	162	163	164	165	166	167
£	Ø	Pt	f	á	í	ó	ú	ñ	Ñ	a	o

A8	A9	AA	AB	AC	AD	AE	AF	B0	B1	B2	B3
168	169	170	171	172	173	174	175	176	177	178	179
¿			½	¼	í	«	»		☒		

B4	B5	B6	B7	B8	B9	BA	BB	BC	BD	BE	BF
180	181	182	183	184	185	186	187	188	189	190	191
									ç	¥	

[44] Fixfont YT112 (IBM), ASCII no. 096-191.



All printers

C0	C1	C2	C3	C4	C5	C6	C7	C8	C9	CA	CB
192	193	194	195	196	197	198	199	200	201	202	203
				-							

CC	CD	CE	CF	D0	D1	D2	D3	D4	D5	D6	D7
204	205	206	207	208	209	210	211	212	213	214	215

D8	D9	DA	DB	DC	DD	DE	DF	E0	E1	E2	E3
216	217	218	219	220	221	222	223	224	225	226	227
									ß		

E4	E5	E6	E7	E8	E9	EA	EB	EC	ED	EE	EF
228	229	230	231	232	233	234	235	236	237	238	239
									Ø		

F0	F1	F2	F3	F4	F5	F6	F7	F8	F9	FA	FB
240	241	242	243	244	245	246	247	248	249	250	251
	±							°	ø		

FC	FD	FE	FF								
252	253	254	255								
		■									

[45] Fixfont YT112 (IBM), ASCII no. 192-255.

All printers

YT113

0	1	2	3	4	5	6	7	8	9	A	B
0	1	2	3	4	5	6	7	8	9	10	11
C	D	E	F	10	11	12	13	14	15	16	17
12	13	14	15	16	17	18	19	20	21	22	23
			α						§		
18	19	1A	1B	1C	1D	1E	1F	20	21	22	23
24	25	26	27	28	29	30	31	32	33	34	35
									!	"	#
24	25	26	27	28	29	2A	2B	2C	2D	2E	2F
36	37	38	39	40	41	42	43	44	45	46	47
\$	%	&	'	(	)	*	+	,	-	.	/
30	31	32	33	34	35	36	37	38	39	3A	3B
48	49	50	51	52	53	54	55	56	57	58	59
0	1	2	3	4	5	6	7	8	9	:	;
3C	3D	3E	3F	40	41	42	43	44	45	46	47
60	61	62	63	64	65	66	67	68	69	70	71
<	=	>	?	@	A	B	C	D	E	F	G
48	49	4A	4B	4C	4D	4E	4F	50	51	52	53
72	73	74	75	76	77	78	79	80	81	82	83
H	I	J	K	L	M	N	O	P	Q	R	S
54	55	56	57	58	59	5A	5B	5C	5D	5E	5F
84	85	86	87	88	89	90	91	92	93	94	95
T	U	V	W	X	Y	Z	[	\	]	^	_

[46] Fixfont YT113 (IBM), ASCII no. 000-095.

## All printers

60	61	62	63	64	65	66	67	68	69	6A	6B
96	97	98	99	100	101	102	103	104	105	106	107
‘	a	b	c	d	e	f	g	h	i	j	k

6C	6D	6E	6F	70	71	72	73	74	75	76	77
108	109	110	111	112	113	114	115	116	117	118	119
l	m	n	o	p	q	r	s	t	u	v	w

78	79	7A	7B	7C	7D	7E	7F	80	81	82	83
120	121	122	123	124	125	126	127	128	129	130	131
x	y	z	{		}	~		€	ü	é	â

84	85	86	87	88	89	8A	8B	8C	8D	8E	8F
132	133	134	135	136	137	138	139	140	141	142	143
ä	à	å	ç	ê	ë	è	ï	î	ì	Ä	Å

90	91	92	93	94	95	96	97	98	99	9A	9B
144	145	146	147	148	149	150	151	152	153	154	155
É	æ	Æ	ô	ö	ò	û	ù	ÿ	Ö	Ü	ø

9C	9D	9E	9F	A0	A1	A2	A3	A4	A5	A6	A7
156	157	158	159	160	161	162	163	164	165	166	167
£	Ø	Pt	f	á	í	ó	ú	ñ	Ñ	ª	º

A8	A9	AA	AB	AC	AD	AE	AF	B0	B1	B2	B3
168	169	170	171	172	173	174	175	176	177	178	179
¿			½	¼	¡	«	»		☒		

B4	B5	B6	B7	B8	B9	BA	BB	BC	BD	BE	BF
180	181	182	183	184	185	186	187	188	189	190	191
									¢	¥	

[47] Fixfont YT113 (IBM), ASCII no. 096-191.

All printers

C0	C1	C2	C3	C4	C5	C6	C7	C8	C9	CA	CB
192	193	194	195	196	197	198	199	200	201	202	203
				-							

CC	CD	CE	CF	D0	D1	D2	D3	D4	D5	D6	D7
204	205	206	207	208	209	210	211	212	213	214	215

D8	D9	DA	DB	DC	DD	DE	DF	E0	E1	E2	E3
216	217	218	219	220	221	222	223	224	225	226	227
									ß		

E4	E5	E6	E7	E8	E9	EA	EB	EC	ED	EE	EF
228	229	230	231	232	233	234	235	236	237	238	239
									Ø		

F0	F1	F2	F3	F4	F5	F6	F7	F8	F9	FA	FB
240	241	242	243	244	245	246	247	248	249	250	251
	±							°	ø		

FC	FD	FE	FF								
252	253	254	255								
		■									

[48] Fixfont YT113 (IBM), ASCII no. 192-255.

All printers

YT114

0	1	2	3	4	5	6	7	8	9	A	B
0	1	2	3	4	5	6	7	8	9	10	11
C	D	E	F	10	11	12	13	14	15	16	17
12	13	14	15	16	17	18	19	20	21	22	23
			☒						§		
18	19	1A	1B	1C	1D	1E	1F	20	21	22	23
24	25	26	27	28	29	30	31	32	33	34	35
									!	"	#
24	25	26	27	28	29	2A	2B	2C	2D	2E	2F
36	37	38	39	40	41	42	43	44	45	46	47
\$	%	&	'	(	)	*	+	,	-	.	/
30	31	32	33	34	35	36	37	38	39	3A	3B
48	49	50	51	52	53	54	55	56	57	58	59
0	1	2	3	4	5	6	7	8	9	:	;
3C	3D	3E	3F	40	41	42	43	44	45	46	47
60	61	62	63	64	65	66	67	68	69	70	71
<	=	>	?	@	A	B	C	D	E	F	G
48	49	4A	4B	4C	4D	4E	4F	50	51	52	53
72	73	74	75	76	77	78	79	80	81	82	83
H	I	J	K	L	M	N	O	P	Q	R	S
54	55	56	57	58	59	5A	5B	5C	5D	5E	5F
84	85	86	87	88	89	90	91	92	93	94	95
T	U	V	W	X	Y	Z	[	\	]	^	_

[49] Fixfont YT114 (IBM), ASCII no. 000-095.

All printers

60	61	62	63	64	65	66	67	68	69	6A	6B
96	97	98	99	100	101	102	103	104	105	106	107
‘	a	b	c	d	e	f	g	h	i	j	k

6C	6D	6E	6F	70	71	72	73	74	75	76	77
108	109	110	111	112	113	114	115	116	117	118	119
l	m	n	o	p	q	r	s	t	u	v	w

78	79	7A	7B	7C	7D	7E	7F	80	81	82	83
120	121	122	123	124	125	126	127	128	129	130	131
x	y	z	{		}	~		€	ü	é	â

84	85	86	87	88	89	8A	8B	8C	8D	8E	8F
132	133	134	135	136	137	138	139	140	141	142	143
ä	à	å	ç	ê	ë	ò	ï	î	ì	Ä	Å

90	91	92	93	94	95	96	97	98	99	9A	9B
144	145	146	147	148	149	150	151	152	153	154	155
É	æ	Æ	ô	ö	ò	û	ù	ÿ	Ö	Ü	ø

9C	9D	9E	9F	A0	A1	A2	A3	A4	A5	A6	A7
156	157	158	159	160	161	162	163	164	165	166	167
£	Ø	Pt	f	á	í	ó	ú	ñ	Ñ	a	o

A8	A9	AA	AB	AC	AD	AE	AF	B0	B1	B2	B3
168	169	170	171	172	173	174	175	176	177	178	179
¿			½	¼	¡	«	»		☒		

B4	B5	B6	B7	B8	B9	BA	BB	BC	BD	BE	BF
180	181	182	183	184	185	186	187	188	189	190	191
									¢	¥	

[50] Fixfont YT114 (IBM), ASCII no. 096-191.

All printers

C0	C1	C2	C3	C4	C5	C6	C7	C8	C9	CA	CB
192	193	194	195	196	197	198	199	200	201	202	203
				–							

CC	CD	CE	CF	D0	D1	D2	D3	D4	D5	D6	D7
204	205	206	207	208	209	210	211	212	213	214	215

D8	D9	DA	DB	DC	DD	DE	DF	E0	E1	E2	E3
216	217	218	219	220	221	222	223	224	225	226	227
									ß		

E4	E5	E6	E7	E8	E9	EA	EB	EC	ED	EE	EF
228	229	230	231	232	233	234	235	236	237	238	239
									Ø		

F0	F1	F2	F3	F4	F5	F6	F7	F8	F9	FA	FB
240	241	242	243	244	245	246	247	248	249	250	251
	±							°	∅		

FC	FD	FE	FF								
252	253	254	255								
		■									

[51] Fixfont YT114 (IBM), ASCII no. 192-255.

All printers

YT115

0	1	2	3	4	5	6	7	8	9	A	B
0	1	2	3	4	5	6	7	8	9	10	11
C	D	E	F	10	11	12	13	14	15	16	17
12	13	14	15	16	17	18	19	20	21	22	23
			¤						§		
18	19	1A	1B	1C	1D	1E	1F	20	21	22	23
24	25	26	27	28	29	30	31	32	33	34	35
									!	"	#
24	25	26	27	28	29	2A	2B	2C	2D	2E	2F
36	37	38	39	40	41	42	43	44	45	46	47
\$	%	&	'	(	)	*	+	,	-	.	/
30	31	32	33	34	35	36	37	38	39	3A	3B
48	49	50	51	52	53	54	55	56	57	58	59
0	1	2	3	4	5	6	7	8	9	:	;
3C	3D	3E	3F	40	41	42	43	44	45	46	47
60	61	62	63	64	65	66	67	68	69	70	71
<	=	>	?	@	A	B	C	D	E	F	G
48	49	4A	4B	4C	4D	4E	4F	50	51	52	53
72	73	74	75	76	77	78	79	80	81	82	83
H	I	J	K	L	M	N	O	P	Q	R	S
54	55	56	57	58	59	5A	5B	5C	5D	5E	5F
84	85	86	87	88	89	90	91	92	93	94	95
T	U	V	W	X	Y	Z	[	\	]	^	_

[52] Fixfont YT115 (IBM), ASCII no. 000-095.



All printers

60	61	62	63	64	65	66	67	68	69	6A	6B
96	97	98	99	100	101	102	103	104	105	106	107
'	a	b	c	d	e	f	g	h	i	j	k

6C	6D	6E	6F	70	71	72	73	74	75	76	77
108	109	110	111	112	113	114	115	116	117	118	119
l	m	n	o	p	q	r	s	t	u	v	w

78	79	7A	7B	7C	7D	7E	7F	80	81	82	83
120	121	122	123	124	125	126	127	128	129	130	131
x	y	z	{		}	~		€	ü	é	â

84	85	86	87	88	89	8A	8B	8C	8D	8E	8F
132	133	134	135	136	137	138	139	140	141	142	143
ä	à	å	ç	ê	ë	è	ï	î	ì	Ä	Å

90	91	92	93	94	95	96	97	98	99	9A	9B
144	145	146	147	148	149	150	151	152	153	154	155
É	æ	Æ	ô	ö	ò	û	ù	ÿ	Ö	Ü	ø

9C	9D	9E	9F	A0	A1	A2	A3	A4	A5	A6	A7
156	157	158	159	160	161	162	163	164	165	166	167
£	Ø	Pt	f	á	í	ó	ú	ñ	Ñ	a	o

A8	A9	AA	AB	AC	AD	AE	AF	B0	B1	B2	B3
168	169	170	171	172	173	174	175	176	177	178	179
¿			½	¼	¡	«	»		☒		

B4	B5	B6	B7	B8	B9	BA	BB	BC	BD	BE	BF
180	181	182	183	184	185	186	187	188	189	190	191
									¢	¥	

[53] Fixfont YT115 (IBM), ASCII no. 096-191.

All printers

C0	C1	C2	C3	C4	C5	C6	C7	C8	C9	CA	CB
192	193	194	195	196	197	198	199	200	201	202	203
				—							

CC	CD	CE	CF	D0	D1	D2	D3	D4	D5	D6	D7
204	205	206	207	208	209	210	211	212	213	214	215

D8	D9	DA	DB	DC	DD	DE	DF	E0	E1	E2	E3
216	217	218	219	220	221	222	223	224	225	226	227
									ß		

E4	E5	E6	E7	E8	E9	EA	EB	EC	ED	EE	EF
228	229	230	231	232	233	234	235	236	237	238	239
									Ø		

F0	F1	F2	F3	F4	F5	F6	F7	F8	F9	FA	FB
240	241	242	243	244	245	246	247	248	249	250	251
	±							°	ø		

FC	FD	FE	FF								
252	253	254	255								
		■									

[54] Fixfont YT115 (IBM), ASCII no. 192-255.

All printers

YT116

0	1	2	3	4	5	6	7	8	9	A	B
0	1	2	3	4	5	6	7	8	9	10	11
C	D	E	F	10	11	12	13	14	15	16	17
12	13	14	15	16	17	18	19	20	21	22	23
									§		
18	19	1A	1B	1C	1D	1E	1F	20	21	22	23
24	25	26	27	28	29	30	31	32	33	34	35
									!	"	#
24	25	26	27	28	29	2A	2B	2C	2D	2E	2F
36	37	38	39	40	41	42	43	44	45	46	47
\$	%	&	'	(	)	*	+	,	-	.	/
30	31	32	33	34	35	36	37	38	39	3A	3B
48	49	50	51	52	53	54	55	56	57	58	59
0	1	2	3	4	5	6	7	8	9	:	;
3C	3D	3E	3F	40	41	42	43	44	45	46	47
60	61	62	63	64	65	66	67	68	69	70	71
<	=	>	?	@	A	B	C	D	E	F	G
48	49	4A	4B	4C	4D	4E	4F	50	51	52	53
72	73	74	75	76	77	78	79	80	81	82	83
H	I	J	K	L	M	N	O	P	Q	R	S
54	55	56	57	58	59	5A	5B	5C	5D	5E	5F
84	85	86	87	88	89	90	91	92	93	94	95
T	U	V	W	X	Y	Z	[	\	]	^	_

[55] Fixfont YT116 (IBM), ASCII no. 000-095.

All printers

60	61	62	63	64	65	66	67	68	69	6A	6B
96	97	98	99	100	101	102	103	104	105	106	107
'	a	b	c	d	e	f	g	h	i	j	k

6C	6D	6E	6F	70	71	72	73	74	75	76	77
108	109	110	111	112	113	114	115	116	117	118	119
l	m	n	o	p	q	r	s	t	u	v	w

78	79	7A	7B	7C	7D	7E	7F	80	81	82	83
120	121	122	123	124	125	126	127	128	129	130	131
x	y	z	{		}	~		€	ü	é	

84	85	86	87	88	89	8A	8B	8C	8D	8E	8F
132	133	134	135	136	137	138	139	140	141	142	143
ä	à	â				è				À	Ā

90	91	92	93	94	95	96	97	98	99	9A	9B
144	145	146	147	148	149	150	151	152	153	154	155
	æ	Æ		ö	ò		ù		õ	ü	ø

9C	9D	9E	9F	A0	A1	A2	A3	A4	A5	A6	A7
156	157	158	159	160	161	162	163	164	165	166	167
£	Ø							ñ	Ñ		

A8	A9	AA	AB	AC	AD	AE	AF	B0	B1	B2	B3
168	169	170	171	172	173	174	175	176	177	178	179

B4	B5	B6	B7	B8	B9	BA	BB	BC	BD	BE	BF
180	181	182	183	184	185	186	187	188	189	190	191

[56] Fixfont YT116 (IBM), ASCII no. 096-191.

All printers

C0	C1	C2	C3	C4	C5	C6	C7	C8	C9	CA	CB
192	193	194	195	196	197	198	199	200	201	202	203

CC	CD	CE	CF	D0	D1	D2	D3	D4	D5	D6	D7
204	205	206	207	208	209	210	211	212	213	214	215

D8	D9	DA	DB	DC	DD	DE	DF	E0	E1	E2	E3
216	217	218	219	220	221	222	223	224	225	226	227
									β		

E4	E5	E6	E7	E8	E9	EA	EB	EC	ED	EE	EF
228	229	230	231	232	233	234	235	236	237	238	239

F0	F1	F2	F3	F4	F5	F6	F7	F8	F9	FA	FB
240	241	242	243	244	245	246	247	248	249	250	251

FC	FD	FE	FF								
252	253	254	255								

[57] Fixfont YT116 (IBM), ASCII no. 192-255.

All printers

### Speedo fonts

YN100

0	1	2	3	4	5	6	7	8	9	A	B
0	1	2	3	4	5	6	7	8	9	10	11
	☺	☻	♥	♦	♣	♠	●	◼	◯	◐	♂
C	D	E	F	10	11	12	13	14	15	16	17
12	13	14	15	16	17	18	19	20	21	22	23
♀	♪	♫	☀	▶	◀	↕	!!	¶	§	—	↕
18	19	1A	1B	1C	1D	1E	1F	20	21	22	23
24	25	26	27	28	29	30	31	32	33	34	35
↑	↓	→	←	└	↔	▲	▼		!	"	#
24	25	26	27	28	29	2A	2B	2C	2D	2E	2F
36	37	38	39	40	41	42	43	44	45	46	47
\$	%	&	'	(	)	*	+	,	-	.	/
30	31	32	33	34	35	36	37	38	39	3A	3B
48	49	50	51	52	53	54	55	56	57	58	59
0	1	2	3	4	5	6	7	8	9	:	;
3C	3D	3E	3F	40	41	42	43	44	45	46	47
60	61	62	63	64	65	66	67	68	69	70	71
<	=	>	?	@	A	B	C	D	E	F	G
48	49	4A	4B	4C	4D	4E	4F	50	51	52	53
72	73	74	75	76	77	78	79	80	81	82	83
H	I	J	K	L	M	N	O	P	Q	R	S
54	55	56	57	58	59	5A	5B	5C	5D	5E	5F
84	85	86	87	88	89	90	91	92	93	94	95
T	U	V	W	X	Y	Z	[	\	]	^	_

[58] Speedo font YN100 (IBM), ASCII no. 000-095.

All printers

60	61	62	63	64	65	66	67	68	69	6A	6B
96	97	98	99	100	101	102	103	104	105	106	107
‘	a	b	c	d	e	f	g	h	i	j	k

6C	6D	6E	6F	70	71	72	73	74	75	76	77
108	109	110	111	112	113	114	115	116	117	118	119
l	m	n	o	p	q	r	s	t	u	v	w

78	79	7A	7B	7C	7D	7E	7F	80	81	82	83
120	121	122	123	124	125	126	127	128	129	130	131
x	y	z	{		}	~	⏏	€	ü	é	â

84	85	86	87	88	89	8A	8B	8C	8D	8E	8F
132	133	134	135	136	137	138	139	140	141	142	143
ä	à	å	ç	ê	ë	è	ï	î	ì	Ä	Å

90	91	92	93	94	95	96	97	98	99	9A	9B
144	145	146	147	148	149	150	151	152	153	154	155
É	æ	Æ	ô	ö	ò	û	ù	ÿ	Ö	Ü	ø

9C	9D	9E	9F	A0	A1	A2	A3	A4	A5	A6	A7
156	157	158	159	160	161	162	163	164	165	166	167
£	Ø	Pt	f	á	í	ó	ú	ñ	Ñ	ª	º

A8	A9	AA	AB	AC	AD	AE	AF	B0	B1	B2	B3
168	169	170	171	172	173	174	175	176	177	178	179
¿	┌	┐	½	¼	¡	«	»	⋮	⦿	⦿	

B4	B5	B6	B7	B8	B9	BA	BB	BC	BD	BE	BF
180	181	182	183	184	185	186	187	188	189	190	191
└	≡	≡	⌋	≡	≡		└	└	¢	¥	└

[59] Speedo font YN100 (IBM), ASCII no. 096-191.

All printers

C0	C1	C2	C3	C4	C5	C6	C7	C8	C9	CA	CB
192	193	194	195	196	197	198	199	200	201	202	203
⌒	⊥	⊥	⊥	—	⊕	⊕	⊕	⊕	⊕	⊕	⊕

CC	CD	CE	CF	D0	D1	D2	D3	D4	D5	D6	D7
204	205	206	207	208	209	210	211	212	213	214	215
⊕	⊕	⊕	⊕	⊕	⊕	⊕	⊕	⊕	⊕	⊕	⊕

D8	D9	DA	DB	DC	DD	DE	DF	E0	E1	E2	E3
216	217	218	219	220	221	222	223	224	225	226	227
⊕	⊥	⊥	■	■	■	■	■	α	β	Γ	π

E4	E5	E6	E7	E8	E9	EA	EB	EC	ED	EE	EF
228	229	230	231	232	233	234	235	236	237	238	239
Σ	σ	μ	τ	Φ	Θ	Ω	δ	∞	φ	ε	∩

F0	F1	F2	F3	F4	F5	F6	F7	F8	F9	FA	FB
240	241	242	243	244	245	246	247	248	249	250	251
≡	±	≥	≤	∫	∫	÷	≈	°	•	•	√

FC	FD	FE	FF								
252	253	254	255								
η	²	■									

[60] Speedo font YN100 (IBM), ASCII no. 192-255.



All printers

YN101

0	1	2	3	4	5	6	7	8	9	A	B
0	1	2	3	4	5	6	7	8	9	10	11
	☺	☹	♥	♦	♣	♠	●	◼	◯	◐	♂
C	D	E	F	10	11	12	13	14	15	16	17
12	13	14	15	16	17	18	19	20	21	22	23
♀	♪	♫	☀	▶	◀	↕	!!	¶	§	—	↕
18	19	1A	1B	1C	1D	1E	1F	20	21	22	23
24	25	26	27	28	29	30	31	32	33	34	35
↑	↓	→	←	└	↔	▲	▼		!	"	#
24	25	26	27	28	29	2A	2B	2C	2D	2E	2F
36	37	38	39	40	41	42	43	44	45	46	47
\$	%	&	'	(	)	*	+	,	-	.	/
30	31	32	33	34	35	36	37	38	39	3A	3B
48	49	50	51	52	53	54	55	56	57	58	59
0	1	2	3	4	5	6	7	8	9	:	;
3C	3D	3E	3F	40	41	42	43	44	45	46	47
60	61	62	63	64	65	66	67	68	69	70	71
<	=	>	?	@	A	B	C	D	E	F	G
48	49	4A	4B	4C	4D	4E	4F	50	51	52	53
72	73	74	75	76	77	78	79	80	81	82	83
H	I	J	K	L	M	N	O	P	Q	R	S
54	55	56	57	58	59	5A	5B	5C	5D	5E	5F
84	85	86	87	88	89	90	91	92	93	94	95
T	U	V	W	X	Y	Z	[	\	]	^	_

[61] Speedo font YN101 (IBM), ASCII no. 000-095.

All printers

60	61	62	63	64	65	66	67	68	69	6A	6B
96	97	98	99	100	101	102	103	104	105	106	107
'	a	b	c	d	e	f	g	h	i	j	k
6C	6D	6E	6F	70	71	72	73	74	75	76	77
108	109	110	111	112	113	114	115	116	117	118	119
l	m	n	o	p	q	r	s	t	u	v	w
78	79	7A	7B	7C	7D	7E	7F	80	81	82	83
120	121	122	123	124	125	126	127	128	129	130	131
x	y	z	{		}	~	⏏	€	ü	é	â
84	85	86	87	88	89	8A	8B	8C	8D	8E	8F
132	133	134	135	136	137	138	139	140	141	142	143
ä	à	å	ç	ê	ë	è	ï	î	ì	Ä	Å
90	91	92	93	94	95	96	97	98	99	9A	9B
144	145	146	147	148	149	150	151	152	153	154	155
É	æ	Æ	ô	ö	ò	û	ù	ÿ	Ö	Ü	ø
9C	9D	9E	9F	A0	A1	A2	A3	A4	A5	A6	A7
156	157	158	159	160	161	162	163	164	165	166	167
£	Ø	Pt	f	á	í	ó	ú	ñ	Ñ	ª	º
A8	A9	AA	AB	AC	AD	AE	AF	B0	B1	B2	B3
168	169	170	171	172	173	174	175	176	177	178	179
¿	┌	┐	½	¼	ı	«	»	⋮	⋱	⏏	
B4	B5	B6	B7	B8	B9	BA	BB	BC	BD	BE	BF
180	181	182	183	184	185	186	187	188	189	190	191
└	═	≡	⌋	⌌	⌍	∥	⌎	⌏	¢	¥	┘

[62] Speedo font YN101 (IBM), ASCII no. 096-191.

All printers

C0	C1	C2	C3	C4	C5	C6	C7	C8	C9	CA	CB
192	193	194	195	196	197	198	199	200	201	202	203
⌒	⊥	⊥	⊥	—	⊕	≡	∥	⌒	⌒	≡	≡
CC	CD	CE	CF	D0	D1	D2	D3	D4	D5	D6	D7
204	205	206	207	208	209	210	211	212	213	214	215
∥	≡	≡	⊥	⊥	≡	≡	⌒	⌒	≡	≡	≡
D8	D9	DA	DB	DC	DD	DE	DF	E0	E1	E2	E3
216	217	218	219	220	221	222	223	224	225	226	227
≡	⌒	⌒	■	■	■	■	■	α	β	Γ	π
E4	E5	E6	E7	E8	E9	EA	EB	EC	ED	EE	EF
228	229	230	231	232	233	234	235	236	237	238	239
Σ	σ	μ	τ	Φ	Θ	Ω	δ	∞	φ	ε	∩
F0	F1	F2	F3	F4	F5	F6	F7	F8	F9	FA	FB
240	241	242	243	244	245	246	247	248	249	250	251
≡	±	≥	≤	∫	∫	÷	≈	°	•	•	√
FC	FD	FE	FF								
252	253	254	255								
η	²	■									

[63] Speedo font YN101 (IBM), ASCII no. 192-255.

All printers

YN102

0	1	2	3	4	5	6	7	8	9	a	b
0	1	2	3	4	5	6	7	8	9	10	11
	☺	☻	♥	♦	♣	♠	●	◼	◯	◐	♂
c	d	e	f	10	11	12	13	14	15	16	17
12	13	14	15	16	17	18	19	20	21	22	23
♀	♪	♫	☀	▶	◀	↕	!!	¶	§	—	⬇
18	19	1a	1b	1c	1d	1e	1f	20	21	22	23
24	25	26	27	28	29	30	31	32	33	34	35
↑	↓	→	←	└	↔	▲	▼		!	"	#
24	25	26	27	28	29	2a	2b	2c	2d	2e	2f
36	37	38	39	40	41	42	43	44	45	46	47
\$	%	&	'	(	)	*	+	,	-	.	/
30	31	32	33	34	35	36	37	38	39	3a	3b
48	49	50	51	52	53	54	55	56	57	58	59
<b>0</b>	<b>1</b>	<b>2</b>	<b>3</b>	<b>4</b>	<b>5</b>	<b>6</b>	<b>7</b>	<b>8</b>	<b>9</b>	<b>:</b>	<b>;</b>
3c	3d	3e	3f	40	41	42	43	44	45	46	47
60	61	62	63	64	65	66	67	68	69	70	71
<	=	>	?	@	<b>A</b>	<b>B</b>	<b>C</b>	<b>D</b>	<b>E</b>	<b>F</b>	<b>G</b>
48	49	4a	4b	4c	4d	4e	4f	50	51	52	53
72	73	74	75	76	77	78	79	80	81	82	83
<b>H</b>	<b>I</b>	<b>J</b>	<b>K</b>	<b>L</b>	<b>M</b>	<b>N</b>	<b>O</b>	<b>P</b>	<b>Q</b>	<b>R</b>	<b>S</b>
54	55	56	57	58	59	5a	5b	5c	5d	5e	5f
84	85	86	87	88	89	90	91	92	93	94	95
<b>T</b>	<b>U</b>	<b>V</b>	<b>W</b>	<b>X</b>	<b>Y</b>	<b>Z</b>	[	\	]	^	_

[64] Speedo font YN102 (IBM), ASCII no. 000-095.

All printers

60	61	62	63	64	65	66	67	68	69	6a	6b
96	97	98	99	100	101	102	103	104	105	106	107
'	a	b	c	d	e	f	g	h	i	j	k

6c	6d	6e	6f	70	71	72	73	74	75	76	77
108	109	110	111	112	113	114	115	116	117	118	119
l	m	n	o	p	q	r	s	t	u	v	w

78	79	7a	7b	7c	7d	7e	7f	80	81	82	83
120	121	122	123	124	125	126	127	128	129	130	131
x	y	z	{		}	~	☐	€	ü	é	â

84	85	86	87	88	89	8a	8b	8c	8d	8e	8f
132	133	134	135	136	137	138	139	140	141	142	143
ä	à	â	ç	ê	ë	è	ï	î	ì	Ä	Å

90	91	92	93	94	95	96	97	98	99	9a	9b
144	145	146	147	148	149	150	151	152	153	154	155
É	æ	Æ	ô	ö	ò	û	ù	ÿ	Ö	Ü	ø

9c	9d	9e	9f	a0	a1	a2	a3	a4	a5	a6	a7
156	157	158	159	160	161	162	163	164	165	166	167
£	Ø	Pt	f	á	í	ó	ú	ñ	Ñ	ª	º

a8	a9	aa	ab	ac	ad	ae	af	b0	b1	b2	b3
168	169	170	171	172	173	174	175	176	177	178	179
¿	┌	┐	½	¼	ı	«	»	⋮	⊞	⊞	

b4	b5	b6	b7	b8	b9	ba	bb	bc	bd	be	bf
180	181	182	183	184	185	186	187	188	189	190	191
└	≡	≡	└	≡	≡		└	└	ç	¥	└

[65] Speedo font YN102 (IBM), ASCII no. 096-191.

All printers

c0	c1	c2	c3	c4	c5	c6	c7	c8	c9	ca	cb
192	193	194	195	196	197	198	199	200	201	202	203
cc	cd	ce	cf	d0	d1	d2	d3	d4	d5	d6	d7
204	205	206	207	208	209	210	211	212	213	214	215
d8	d9	da	db	dc	dd	de	df	e0	e1	e2	e3
216	217	218	219	220	221	222	223	224	225	226	227
								α	β	Γ	π
e4	e5	e6	e7	e8	e9	ea	eb	ec	ed	ee	ef
228	229	230	231	232	233	234	235	236	237	238	239
Σ	σ	μ	τ	Φ	Θ	Ω	δ	∞	φ	ε	∩
f0	f1	f2	f3	f4	f5	f6	f7	f8	f9	fa	fb
240	241	242	243	244	245	246	247	248	249	250	251
≡	±	≥	≤	∫	J	÷	≈	°	•	•	√
fc	fd	fe	ff								
252	253	254	255								
η	2	■									
8	9	a	b	c	d	e	f	10	11	12	13
8	9	10	11	12	13	14	15	16	17	18	19
14	15	16	17	18	19	1a	1b	1c	1d	1e	1f
20	21	22	23	24	25	26	27	28	29	30	31
	§	—									

[66] Speedo font YN102 (IBM), ASCII no. 192-255.



## Zubehör

Fußschalter, Tastatur .....
Netzkabel .....
Datenkabel .....
USI-Testbox .....

## Accessories

Foot switch, Keyboard .....	2
Power Cables.....	3
Data Cables .....	4
USI Testbox .....	5

## Fußschalter, Tastatur / Foot switch, Keyboard



1



3

ID	Bezeichnung	Designation	Teilenummer / Part Number
1	Fußschalter	Foot switch	A4053 <sup>1</sup> (AP4.4/5.4) A104186 <sup>2</sup>
2	Adapterkabel (Fußschalter - USI)	Adapter cable (foot switch - USI)	A7268
3	Tastatur	Keyboard	A8407 <sup>3</sup> (German layout) A8406 <sup>4</sup> (US layout)

1) Stecker wie abgebildet.  
Plug as illustrated.

2) Fußschalter mit Adapterkabel für den Anschluss an USI.  
Foot switch with adapter cable for connection to USI.

3) Adapter USB-zu-PS/2 wird mitgeliefert.

4) USB-to-PS/2 adapter is included.



## Netzkabel / Power Cables



1



2



3



4



5



6

ID	Bezeichnung	Designation	Teilenummer / Part Number
1	Netzkabel UK	Power cable UK	A0635
2	Netzkabel EU	Power cable EU	A4254
3	Netzkabel USA	Power cable USA	A4255
4	Netzkabel China	Power cable China	A5451
5	Netzkabel DK	Power cable Denmark	A3598
6	Netzkabel Schweiz	Power cable Swiss	A0842

## Datenkabel / Data Cables



ID	Bezeichnung	Designation	Teilenummer / Part Number
1	RS 232-Kabel	RS 232 cable	A1207
2	Centronics-Kabel (3m lang, bidirektional)	Centronics cable (length: 3m, bidirectional)	A2480 (64-xx)
3	Centronics-Kabel (IEEE 1284 CA)	Centronics cable (IEEE 1284 CA)	A4253 (AP 4.4/5.4/7.t)
4	USB-Kabel 2.0 A zu B	USB cable 2.0 A to B	126738

## USI-Testbox / USI Testbox

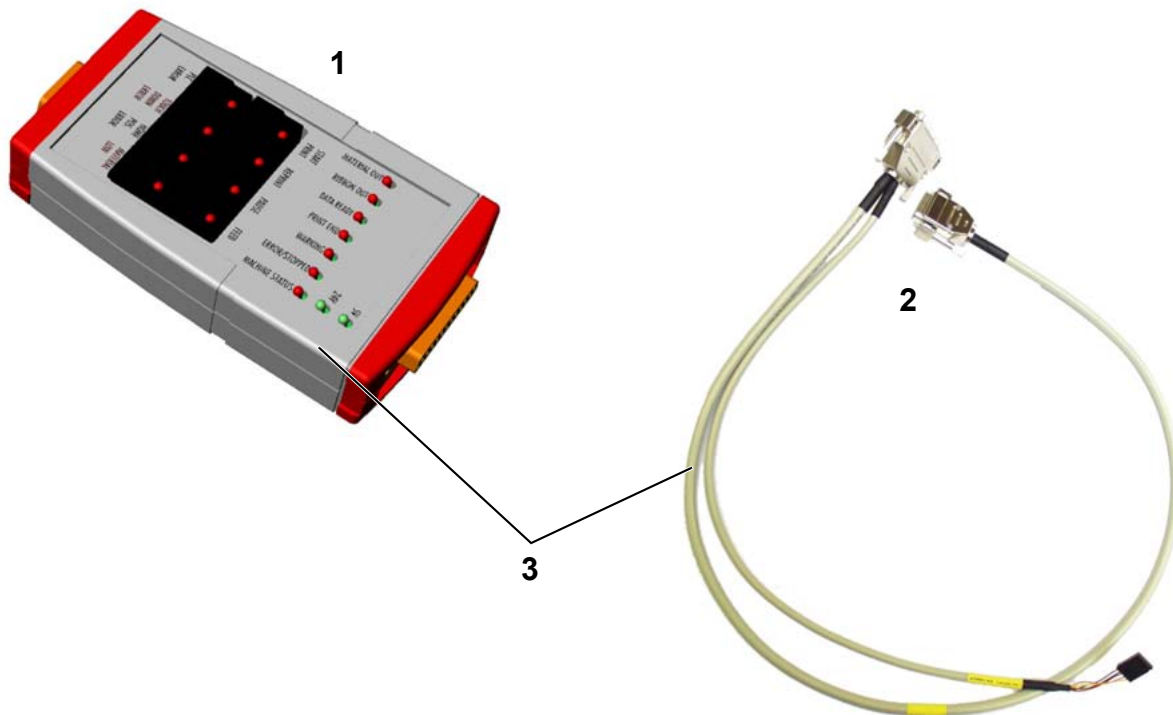

ID	Bezeichnung	Designation	Teilenummer / Part Number
1	USI-Testbox	USI test box	A2739
2	Anschlußkabel für Testbox	Connection cable test box	A2842
3	USI-Testbox + Rundkabel	USI test box + connection cable	A2843



## Disposal

Disposing of the printer .....	2
Before disposal .....	2
Disposal measures .....	2

## Disposing of the printer

### Before disposal



#### WARNING!

This unit operates at mains voltage! Contacting electrically live components can cause potentially lethal electrical shocks and burns.

→ Before disposing of the printer, disconnect all cables.



### Disposal measures

During the production of the individual components, the manufacturer ensures that as little an impact is made on the environment as possible. When it comes to disposal, you as the user have a considerable influence in helping to reduce the strain on the environment.

For details about the disposal of material (e. g. ribbon) please consult the respective manufacturer. Please heed the following notes regarding the disposal of packaging, defect components after maintenance or repair work, or even the disposal of the printer after the end of the product's service life:

→ Dispose of waste properly, i.e. sorted according to the material groups of the parts to be disposed of. The aim should always be to achieve a maximum possible reutilisation of the basic materials combined with the minimum possible environmental impact.

Therefore, pay attention to the following:

- First of all, remove problem materials from the device and dispose of them separately. Problem materials are e.g. batteries, LCD displays and parts containing mercury.
- Then separate the remaining parts as much as possible according to material for recycling.

→ Pay attention to the material and disposal instructions which may be included on certain individual parts.

→ Under no circumstances should you simply throw electrical or electronic scrap into the rubbish bin.

→ Use environmentally compatible alternatives such as returning waste to the suppliers or the manufacturer, disposal by specialised waste disposal firms, exchange services, etc.

→ Fundamentally dispose of waste in as environmentally compatible a manner as today's environmental protection, reprocessing and disposal systems allow.

→ Refer to your supplier, the appropriate disposal firms or directly to the manufacturer if you have any disposal problems. The manufacturer can provide you with information and help you to dispose of components from the printer range in a modern and environmentally compatible manner.

▮▮▮▮ WEEE-Reg.-Nr. DE 46850411

