



Panasonic



COMMERCIAL FOOD SERVICE PRODUCTS

2019

WELCOME

to the range of Commercial Food Service Products from Panasonic.

Whilst you are probably aware of the Panasonic brand, what you probably didn't know is that Panasonic have been supplying commercial kitchens with products for over 50 years. We have been supplying international customers with a wide range of Commercial Food Service products, specifically design to meet the needs of the Hospitality industry.

Based on our success globally including Europe, North America, Japan, China and other parts of Asia. Panasonic is now bringing some of these ranges to Australia for the Food Service and Hospitality market.

Panasonic has a long history of producing quality products and in 2018 celebrated our 100 year anniversary since foundation. This longevity has been built on the back of long relationships with the market and working pro-actively with our customers to build a better future.

The new Commercial Food Services division has a dedicated B2B team that will manage the launch of an exciting new future for the Panasonic brand.

We will be talking to you, our customers on expanding the range in the future and hope you enjoy using our products.



WHY PANASONIC

Panasonic prides itself on producing premium products that are built to last, essential in a commercial kitchen environment. We build-in unique design features, conduct extensive testing and manage strict quality assessment procedures, that have resulted in a solid track record of performing in any conditions. We don't compromise on quality.

To ensure a dedicated B2B approach, we operate from within the Hussmann Australia Pty Ltd (a Panasonic company), a market leader in the manufacture and supply of supermarket fridge and freezer cabinets across Australia. In Sydney we have over 17,000 sq metres of factory/warehouse where we keep a vast range of parts and extensive stock to support fast turnaround orders and speedy repairs. It is this network and warehousing capacity that enables us to maximise our reach for service and support.

We are dedicated to the long term position of Panasonic Commercial Food Service products, so much so that we offer a 2 year warranty on parts for our commercial series refrigeration range, backed up with a nation-wide service team and a unique in-field warranty on our microwaves, where any issues or delays in repairing your microwave will be covered by a loan machine until the repairs can be completed!

So with this network and experience we promise to deliver: Quality, Innovation and Experience.

And we guarantee it!

MICROWAVES



FEATURES

- Internationally used across the Food Service sector
- NE1853 is still made in Japan and comes with a 2 year warranty
- Manufacturer of Magnetrons and microwaves
- Range of heavy duty and light duty options
- Extensive pre-sale testing
- Stackable and compact

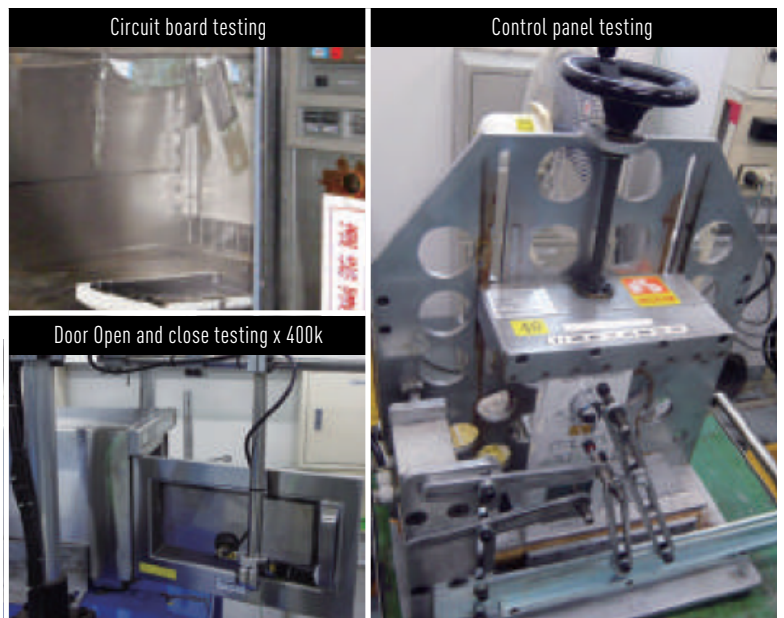

Panasonic

COMMERCIAL MICROWAVE OVENS NE-1853



- 1800W of cooking power
- Compact size, heavy-duty performance
- 15 power levels & 5 stage cooking
- Dual power feed for more consistent even cooking
- Energy efficient LED lighting and LCD display
- Easy extension pad +10s/+20s heating

NE-1853 COMMERCIAL MICROWAVE OVEN

- 1800W of cooking power
- 2 magnetrons
- Dual power feed for more consistent even cooking
- Side Open
- Programmable memory pads
- 15 power levels
- 5 stage cooking
- Easy extension pad +10s/+20s
- 30 preset menu programs
- Programmable lock
- Easy to clean air filter
- Stainless steel cabinet & cavity
- Removable ceiling splatter shield
- Energy efficient LED lighting and LCD display
- Stackable

Technical Specifications

| | | |
|----------------------------------|---|---|
| Model No. | NE-1853 | |
| Capacity | 18L (0.6cft) | |
| Output Power | 1800W | |
| Power Source | 240V, 50Hz Single Phase | |
| Plug Type | AS/NS4417  | |
| Required Power | 12.3A 2830W | |
| Material | Face of Door/Base | Stainless Steel |
| | Cabinet | Stainless Steel |
| | Cavity | Stainless Steel |
| | Base plate | Sealed-in ceramic |
| Door Design | Side Open | |
| Program | Power Level | 15 Levels |
| | Memory | 30 programs |
| | Stage Cooking | 5 stages |
| | Memory lock | Yes |
| | Multiple quantity keys | Yes (X2 for 2 dishes, X 3 for 3 dishes) |
| | Extension Pad | Yes (+10s/+20s) |
| Display | LCD | |
| Oven Lamp | LED | |
| Stackable | Yes | |
| Outer Dimensions (WxDxH) | 422 x 508 x 337 mm | |
| Cavity Dimensions (WxDxH) | 330 x 310 x 175 mm | |
| Weight | Net | 30 kg |

* Specifications are subject to change without notice for further improvement.

* 15A plug required

OPTIONAL ACCESSORY

Microsave® Liner - Minimises cleaning time and extends the microwave's lifespan by providing total protection for the cavity, roof, sides, back and base.

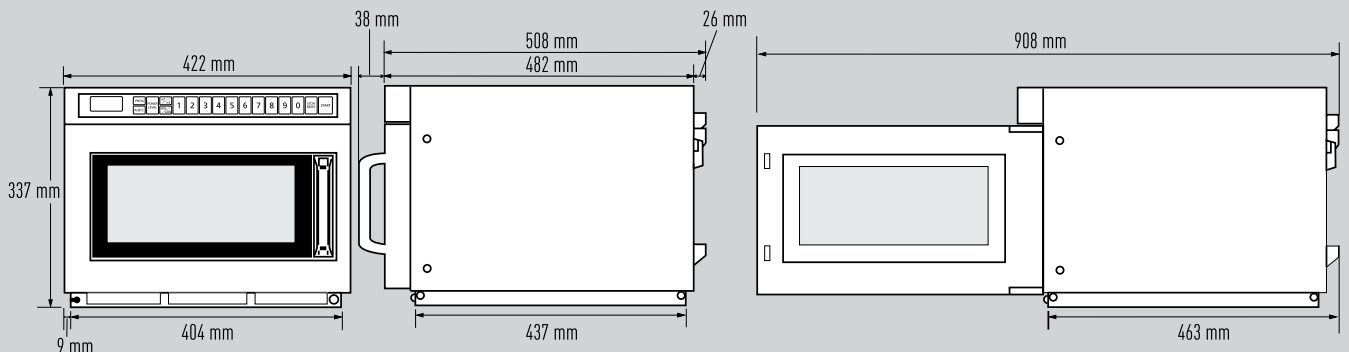

Panasonic

**SEMI-COMMERCIAL
MICROWAVE OVENS
NE-1037**



Simple to use, programmable, designed to withstand the rigours of commercial use, meeting the demands of busy caterers who have medium out put requirement



NE-1037

1000 Watt Medium Duty Microwave Oven



- Side Open
- Programmable memory pads
- 3 power levels
- 3 stage cooking
- x2 Double quantity pad
- 10 preset menu programs
- Programmable lock
- Stainless steel cabinet & cavity
- Increased durability of door hinge
- Flat cavity
- Space saving with only 360mm depth

Technical Specifications

| | | |
|----------------------------------|--|-----------------------|
| Model No. | NE-1037 | |
| Capacity | 22L (0.8cft) | |
| Output Power | 1000W | |
| Power Source | 240V, 50Hz Single Phase | |
| Plug Type | AS/NZS3112  | |
| Required Power | 6.6A 1490W | |
| Material | Face of Door/Base | Stainless Steel |
| | Cabinet | Stainless Steel |
| | Cavity | Stainless Steel |
| | Base plate | Sealed-in ceramic |
| Door Design | Side Open | |
| Program | Power Level | 3 Levels |
| | Memory | 10 programs |
| | Stage Cooking | 3 stages |
| | Memory lock | Yes |
| | Multiple quantity keys | Yes (X2 for 2 dishes) |
| Outer Dimensions (WxDxH) | 510 x 360 x 306 mm | |
| Cavity Dimensions (WxDxH) | 330 x 330 x 2005 mm | |
| Weight | Net | 18.6 kg |

* Specifications are subject to change without notice for further improvement.

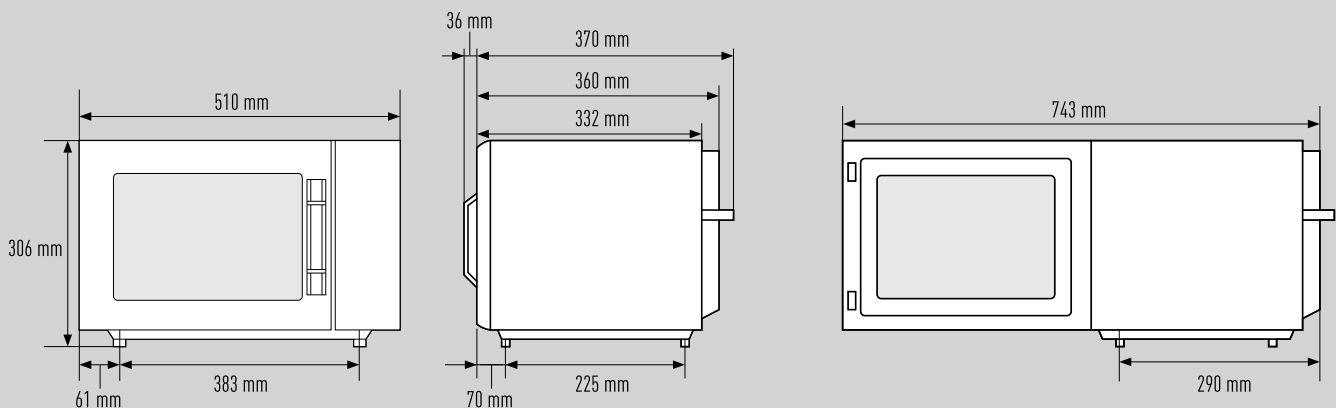

Panasonic

**COMBINATION
MICROWAVE OVEN
NE-C1275**



**SPEED AND VERSATILITY
WITH A 2-YEAR WARRANTY**

The NE-C1275 Combination Oven features Microwave, Grill and Convection Oven - which is versatile enough to cook anything from hearty pies to delicious paninis - fast and to perfection. Downloaded cooking programs can be easily transferred via SD Card - making it an ideal choice for use in hotels, clubs and restaurants with set menus, where consistent results and ease of operation are essential.

NE-C1275

3 WAY COMBINATION OVEN



- 1800W Convection Oven, 1800W Grill, 1150W Microwave
- High speed Fan Grill and Grill Convection functions for faster browning results
- Combination Options include: Microwave + Grill; Microwave + Convection; Microwave + Fan Grill; and Microwave + Grill Convection
- Preset Combi keys offer 5 popular combination options which can be selected with one touch
- Microwave has 6 power levels. Dual emission bottom energy feed ensures even heating
- Convection oven settings range from 100°C – 250°C
- 4 element Quartz Grill with 2 power levels and recessed elements
- Three fast “Preheat” settings – up to 240°C on continuous standby (will maintain temperature for up to 4 hours of non use).
- 2 shelf positions
- Up to 99 programs available, each can be preset with up to 3 stages of combination or single cooking cycles
- Programmable manually or via SD Memory Card and your Personal Computer
- Fast cool feature to quickly reduce oven temperature for easy cleaning and low temperature cooking
- Beep tone option and clean air filter reminder
- Program lock

PLACEMENT OF YOUR OVEN

- Oven must be placed on a flat, stable surface.
- For proper operation, the oven must have sufficient air flow.
- A gap of at least 5cm (2”) must be available at the right and left hand sides and back wall of the oven.
- A minimum space of 20cm (8”) must be left above the oven and the 2 exhaust vents at the rear.
- Do not place the oven on a shelf directly above or beside a gas or electric hob or cooker. This may cause damage to the oven.
- It is dangerous to position this oven on a shelf which is so high that food and accessories cannot be safely removed by the user.
- Do NOT attempt to stack these ovens.

ACCESSORIES INCLUDED

Wire Rack Shelf and Ceramic Insulating Tray

Dual shelf positions enable food to achieve traditional browning from the oven or the grill.

TECHNICAL SPECIFICATIONS

| | |
|-----------------------------|----------------------------------|
| Model: NE-C1275 | |
| Power Source | 230-240V / 50Hz, Single phase |
| Plug/Outlet | 13 amp |
| Power Requirement | 2900W 12.2A |
| Power Supply | Single phase 13 amp power supply |
| Frequency | 2450 MHz |
| Outer Dimensions (WxDxH) | 600x484x383mm |
| Oven Dimensions (WxDxH) | 406x336x217mm |
| Net Weight | 41kg (inc accessories) |
| Cubic Capacity | 29.6 litres (1 cu.ft) |
| Output Power (W) | |
| Microwave | 1150w |
| Grill | 1800w |
| Convection Oven | 1800w |
| MICROWAVE | |
| 6 Power Levels | |
| High | 1150w |
| Medium | 850w |
| Low | 560w |
| Simmer | 420w |
| Defrost | 180w |
| Stand | Zero w |
| Timer (min) | |
| High, Medium | Up to 15 mins |
| Low, Simmer, Defrost, Stand | Up to 1 hour |
| CONVECTION OVEN | |
| Temperature Range | 100°C – 250°C |
| Timer (min) | Up to 1 hour 40 mins |
| GRILL | |
| Timer (min) | Up to 1 hour |
| 2 Power Levels | |
| High (Hi) | 1,800W |
| Low (Lo) | 1,450W |



SD Card Technology

Panasonic[®]

Husmann Australia Pty Ltd.
66 Glendenning Road, Glendenning NSW 2761
+61 2 8805-0400

COMMERCIAL FOOD SERVICE PRODUCTS

2019

COMING SOON



Professional Microwave Convection Oven
(For Reheating)

NE-SCV2

NEW

A variety of heating patterns offer tasty results quickly.

1 Offering versatile menus quickly

- Combining Convection, Grill, and Microwave functions for speedy heating of frozen, refrigerated, or room-temperature dishes.
- 3-step continuous heat setting (3-Step setting) is possible.
- Fan speed adjustable from 30 to 100%.

Oven interior image

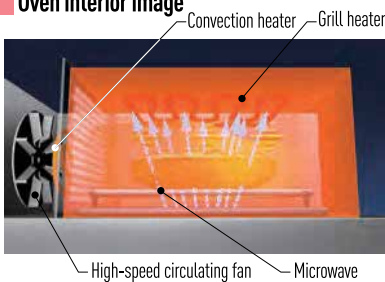

2 A compact design that fits on store counters

- The compact design fits on counters that are 60 cm deep.
- A heat-insulated body with safety in mind.



3 Easy-to-see, easy-to-operate touch panel system

- Touch panel system is easy to operate. With the Memory function, you just press a number to start heating.



Professional Microwave Convection Oven
(For Reheating)

NE-SCV2

| | |
|---------------------------|---|
| Dimensions: | 474 x 565 x 412 mm (W x D x H) |
| Power Consumption: | Single Phase 100 V, 3750 W |
| High-Frequency Output: | 1200 to 0 W / Switchable in 9 Steps |
| Convection Heater Output: | 1350 W, Temperature Adjustable 180 to 250°C |
| Grill Heater Output: | 1800 W (2-Step Switchable) |
| Preheat Adjustment Range: | 150°C (Stand-by Preheat), 180°C, 250°C |
| Oven Capacity: | 10 L |
| Memory Capacity: | 10 to 1,000 |
| Product Weight: | Approx. 37.4 kg |



You can combine Convection, Grill, and Microwave functions into 6 versatile heating patterns for frozen, refrigerated, and room-temperature dishes.

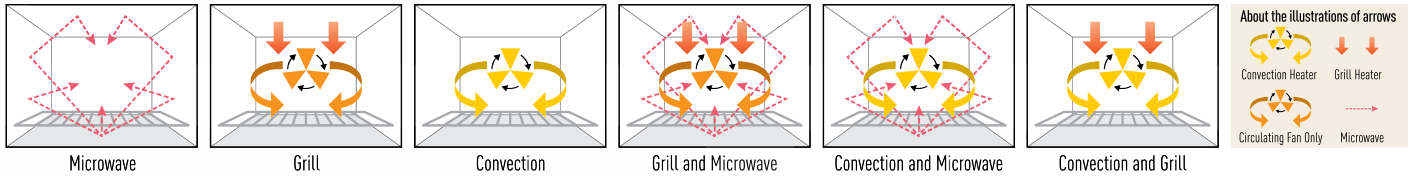

Fan Speed Settings (30% to 100%)

Circulates the heat around the oven interior, browns food, and crisps the outside.

Menu Examples



Pizza

Hot dog

Fondant chocolate

3-Step Setting Possible

You can combine 6 heating patterns, and cook continuously for up to 3 steps.

Cooking Time Example (with Preheating)

| Heating Method | Menu | Amount | Time | Fan |
|--|----------------------------|--------------------------|---|-----|
| ① Grill and Microwave ② Grill | Pizza (frozen) | One 8-inch pizza (220 g) | Approx. 2 min 20 sec (① approx. 1 min 30 sec, ② approx. 50 sec) | 30% |
| ① Convection and Microwave ② Convection | Hot dog (refrigerated) | One (110 g) | Approx. 40 sec (① approx. 32 sec, ② approx. 8 sec) | 40% |
| Grill and Microwave | Fondant chocolate (frozen) | One (90 g) | Approx. 30 sec | 50% |

Dimensions

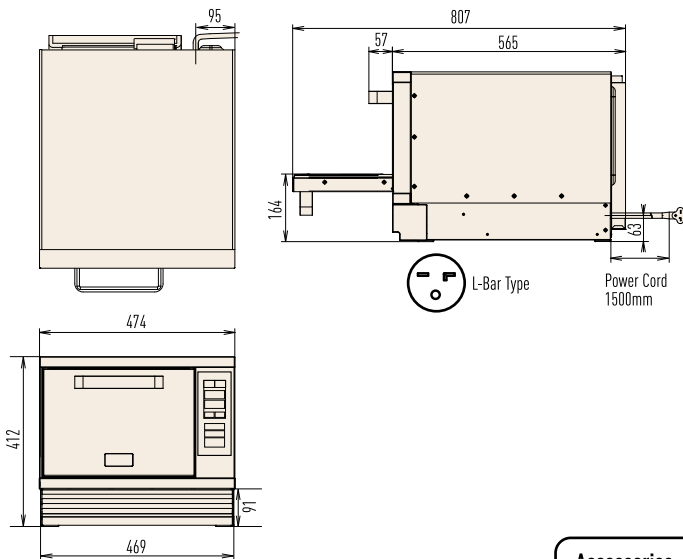

Specifications

| | | |
|--------------------------|---------------------|--|
| Dimensions | Exterior (mm) | 474 x 565 x 412 (W x D x H) |
| | Interior (mm) | 270 x 330 x 110 (W x D x H) |
| Interior Capacity | | 10 L |
| High-Frequency Output | | 1200 to 0 W, 9-Step Switchable |
| Power Supply | | Bottom (2-Duct) Power Supply Method |
| Grill | Heater Output | 1800 W (2-Step Switchable) |
| Convection | Heater Output | 1350 W, Temperature Adjustment: 180 to 250°C |
| Preheat Adjustment Range | | 150°C (Stand-by Preheat), 180°C, 250°C |
| Memory Capacity | | 10 to 1,000 (100 When Shipped) |
| Rating | Power Supply | Inverter Power Supply (Single Phase 200 V), 50 Hz/60 Hz Common (Hz Free) |
| | Power Consumption | 3750 W |
| Applicable | Power Supply Outlet | L-Bar Type, 20 A, 250 V |
| Door Opening Direction | | Vertical |
| Accessories | | Ceramic Tray, Wire Rack, Ceramic Plate White, Specified SD Memory Card |
| Product Weight | | Approx. 37.4 kg |

Accessories



Ceramic Tray



Wire Rack



Ceramic Plate White



Specified SD Memory Card

eco ideas

The Panasonic Group takes the environment into full consideration when manufacturing products.

Saving Energy

We thoroughly pursue energy-saving efficiency in the products that we deliver to our customers, and aim to reduce the amount of CO₂ emitted during product use.

Saving Resources

We reduce the amount of new resources used in new products, and recycle resources from end-of-life products, to promote resource recycling.

Chemical Substances

Panasonic products comply globally with the standard values for using substances* designated by the RoHS Directive as impacting the environment.
* Lead, cadmium, mercury, hexavalent chromium, polybrominated biphenyls, and polybrominated diphenyl ethers.

Contact Details

**Husmann Australia Pty. Ltd. (ACN: 002 366 887)
a Panasonic Company**

Address

66 Glendenning Road, Glendenning, NSW 2761

Phone

02 8805 0400

Product Manager

0474 440 083

Panasonic@husmann.com

Customer Service

02 8805 0400

Panasonic@husmann.com

Accounts & Administration

02 8805 0400

au_accounts@husmann.com

Warranty

1300 720 660(Bevwizz)

warranty.aus@husmann.com



Panasonic