

Versatec® VS

VARIABLE SPEED

Commercial

Water Source/Geothermal Heat Pump

- R-410A Refrigerant
- 3-6 Tons

Installation Information

Water Piping Connections

Hot Water Connections

Electrical

Startup Procedures

Troubleshooting

Preventive Maintenance



Table of Contents

Model Nomenclature	4
Electrical Availability	4
General Installation Information	5
Vertical Dimensional Data.	6-7
Horizontal Dimensional Data	8-9
Installation Notes	10-12
Hanger Bracket Locations.	13
Duct System, Water Piping, and Condensate Drain.	14
Water Quality	15
System Cleaning and Flushing.	16
Open Loop Ground Water Systems	17
Hot Water Generator Connections	18-19
Freeze Detection	20
Electrical Connections.	20
Electrical Data.	21
Blower Performance Data.	22
Setting Blower Speed - Variable Speed ECM - UPC Controls	23
Wiring Schematics	24-29
Controls - Aurora Advanced Variable Speed Control	30-39
Controls - UPC DDC Control (optional).	40-48
Unit Startup	49
Operating Limits.	50
Operating Parameters	51
Pressure Drop	52
Reference Calculations and Legend	53
Refrigerant Circuit Guideline	54
Compressor and Thermistor Resistance	55
Troubleshooting	56
Startup/Troubleshooting Form	57-58
Preventive Maintenance	59
Replacement Procedures	59
Revision Guide.	61

Model Nomenclature

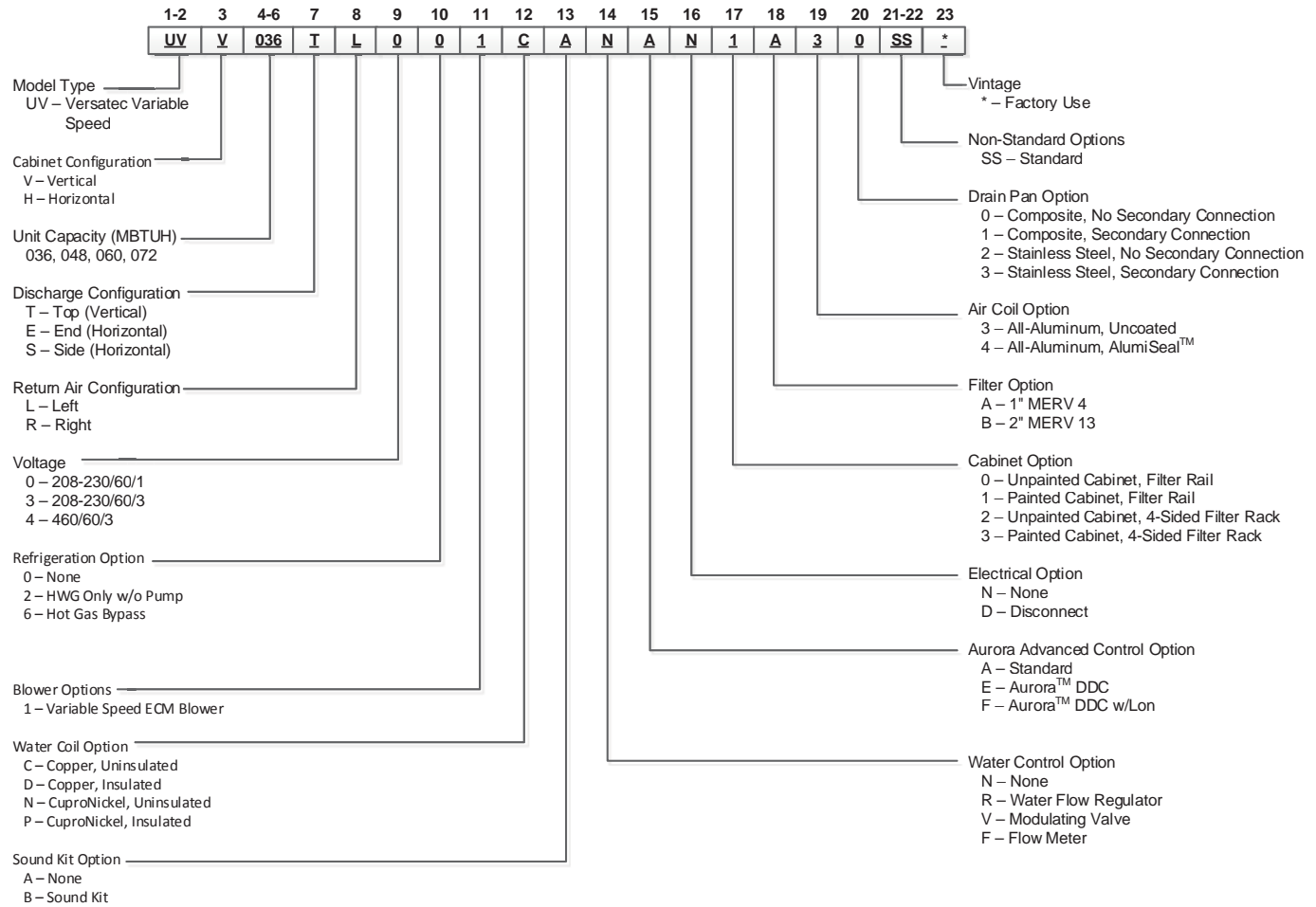

Rev.: 05 May 2017

Electrical Availability

VS ECM

Voltage	Model			
	036	048	060	072
208-230/60/1	•	•	•	•
208-230/60/3	•	•	•	•
460/60/3	•	•	•	•
575/60/3	N/A	N/A	N/A	N/A

Legend:

NA = Not Available

• = Voltage available in this size

8/25/2016

General Installation Information

Safety Considerations



WARNING: Before performing service or maintenance operations on a system, turn off main power switches to the indoor unit. If applicable, turn off the accessory heater power switch. Electrical shock could cause personal injury.

Installing and servicing heating and air conditioning equipment can be hazardous due to system pressure and electrical components. Only trained and qualified service personnel should install, repair or service heating and air conditioning equipment. Untrained personnel can perform the basic maintenance functions of cleaning coils and cleaning and replacing filters. All other operations should be performed by trained service personnel. When working on heating and air conditioning equipment, observe precautions in the literature, tags and labels attached to the unit and other safety precautions that may apply.

Follow all safety codes. Wear safety glasses and work gloves. Use a quenching cloth for brazing operations and have a fire extinguisher available.

Moving and Storage

Move units in the normal “up” orientation. Horizontal units may be moved and stored per the information on the packaging. Do not stack more than three units in total height. Vertical units may be stored one upon another to a maximum height of two units. Do not attempt to move units while stacked. When the equipment is received, all items should be carefully checked against the bill of lading to be sure all crates and cartons have been received. Examine units for shipping damage, removing the units from the packaging if necessary. Units in question should also be internally inspected. If any damage is noted, the carrier should make the proper notation on the delivery receipt, acknowledging the damage.

Unit Location

Locate the unit in an indoor area that allows for easy removal of the filter and access panels. Location should have enough space for service personnel to perform maintenance or repair. Provide sufficient room to make water, electrical and duct connection(s). If the unit is located in a confined space, such as a closet, provisions must be made for return air to freely enter the space by means of a louvered door, etc. Any access panel screws that would be difficult to remove after the unit is installed should be removed prior to setting the unit. On horizontal units, allow adequate room below the unit for a condensate drain trap and do not locate the unit above supply piping. **Care should be taken when units are located in unconditioned spaces to prevent damage from frozen water lines and excessive heat that could damage electrical components.**

Installing Vertical Units

Prior to setting the unit in place, remove and discard the compressor hold down shipping bolt located at the front of the compressor mounting bracket.

Vertical units are available in left or right air return configurations. Top flow vertical units should be mounted level on a vibration absorbing pad slightly larger than the base to provide isolation between the unit and the floor. It is not necessary to anchor the unit to the floor (see figure below).

Vertical Unit Mounting

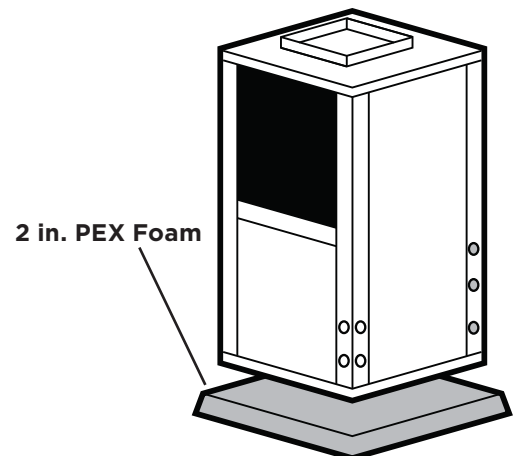

Vertical Dimensional Data

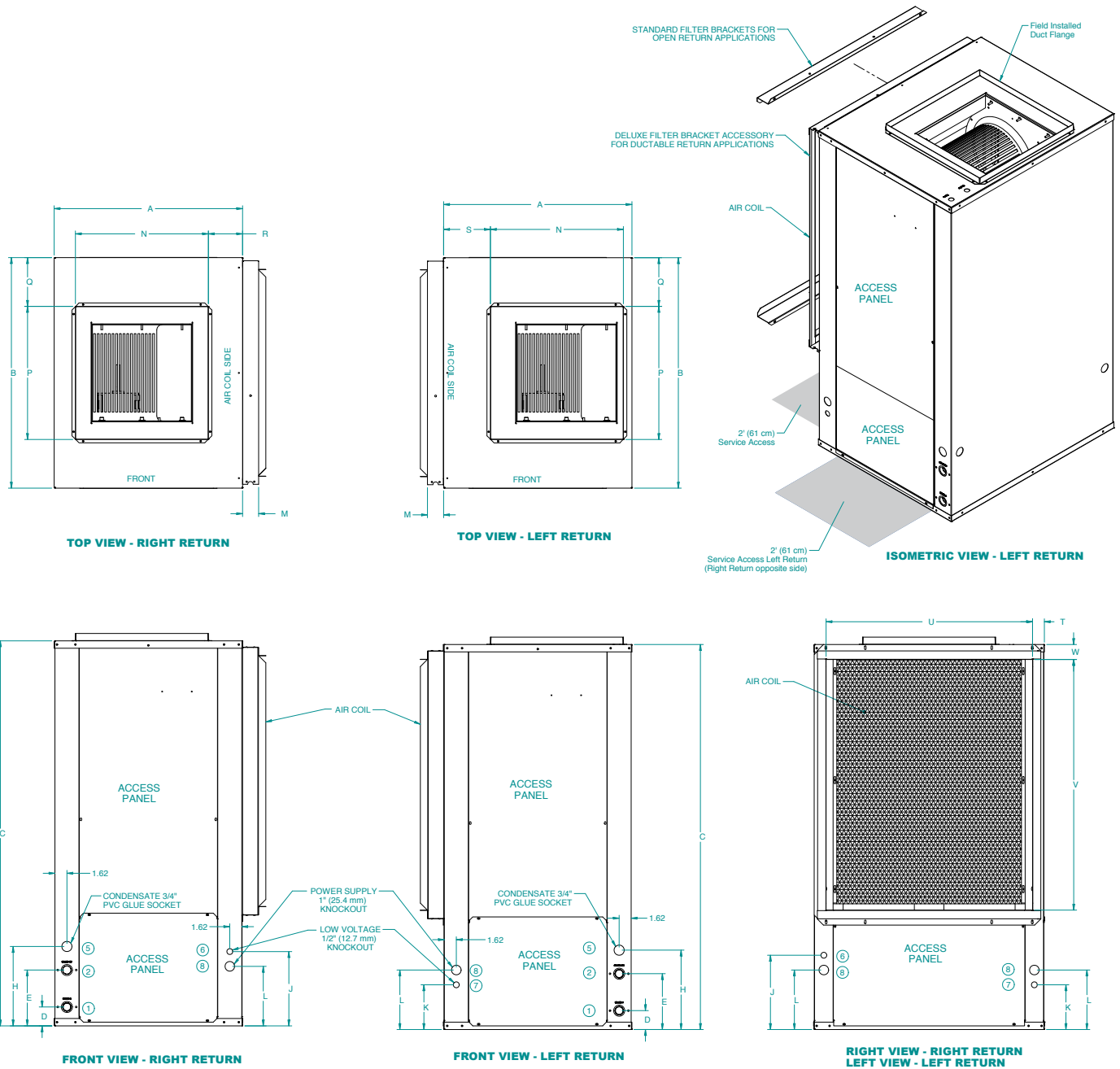

Vertical Dimensional Data cont.

Vertical Models	Overall Cabinet			Water Connections								Electrical Knockouts			M	Discharge Connection duct flange installed (±0.10 in)					**Return Connection using deluxe filter rack (±0.10 in)			
												6	7	8		Discharge Connection					**Return Connection			
	A	B	C	1	2	3	4	5	Loop	Knockout	J	K	L	N		P	Q	R	S	T	U	V	W	
	Width	Depth	Height*	In	Out	HWG In	HWG Out	Condensate	Water FPT	HWG Provisions	1/2" cond	1/2" cond	1" cond	Supply Width		Supply Depth					Return Depth	Return Height		
036	in.	25.5	31.2	44.2	2.6	7.6	1.4	4.4	10.8	1"	0.875	10.1	6.1	8.1	2.2	18.0	18.0	6.6	4.6	6.3	1.6	28.1	26.1	2.0
	cm.	64.8	79.2	112.3	6.6	19.3	3.6	11.2	27.4	25.4 mm	22.2 mm	25.7	15.5	20.6	5.6	45.7	45.7	16.8	11.7	16.0	4.1	71.4	66.3	5.1
048	in.	25.5	31.2	48.2	2.6	7.6	1.4	4.4	10.8	1"	0.875	10.1	6.1	8.1	2.2	18.0	18.0	6.6	4.6	6.3	1.6	28.1	30.0	2.0
	cm.	64.8	79.2	122.4	6.6	19.3	3.6	11.2	27.4	25.4 mm	22.2 mm	25.7	15.5	20.6	5.6	45.7	45.7	16.8	11.7	16.0	4.1	71.4	76.2	5.1
060-072	in.	25.5	31.2	52.2	2.6	7.6	1.4	4.4	10.8	1"	0.875	10.1	6.1	8.1	2.2	18.0	18.0	6.6	5.0	6.4	1.6	28.1	34.0	2.0
	cm.	64.8	79.2	132.6	6.6	19.3	3.6	11.2	27.4	25.4 mm	22.2 mm	25.7	15.5	20.6	5.6	45.7	45.7	16.8	12.7	16.3	4.1	71.4	86.4	5.1

Vertical Disconnect

When using disconnect, do not use dimension L from the standard vertical dimensional data. Use dimension LL from the vertical disconnect dimensional data.

Vertical Models	LL
036	15.3 [38.9]
048	14.3 [36.3]
060	14.3 [36.3]
072	14.3 [36.3]

Dimensions in inches [cm]

08/25/16

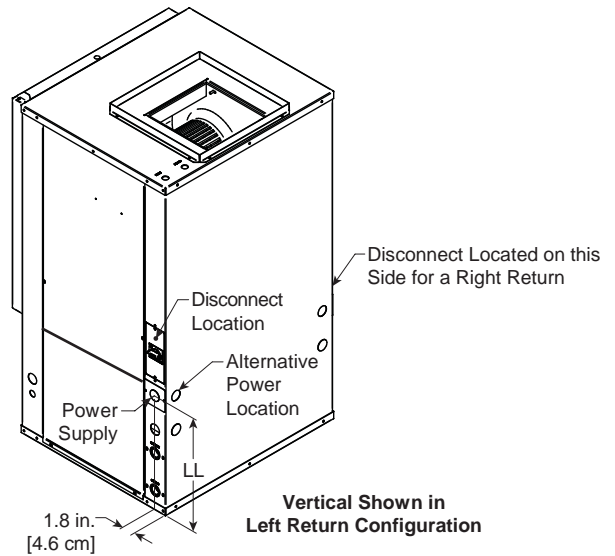

Horizontal Dimensional Data

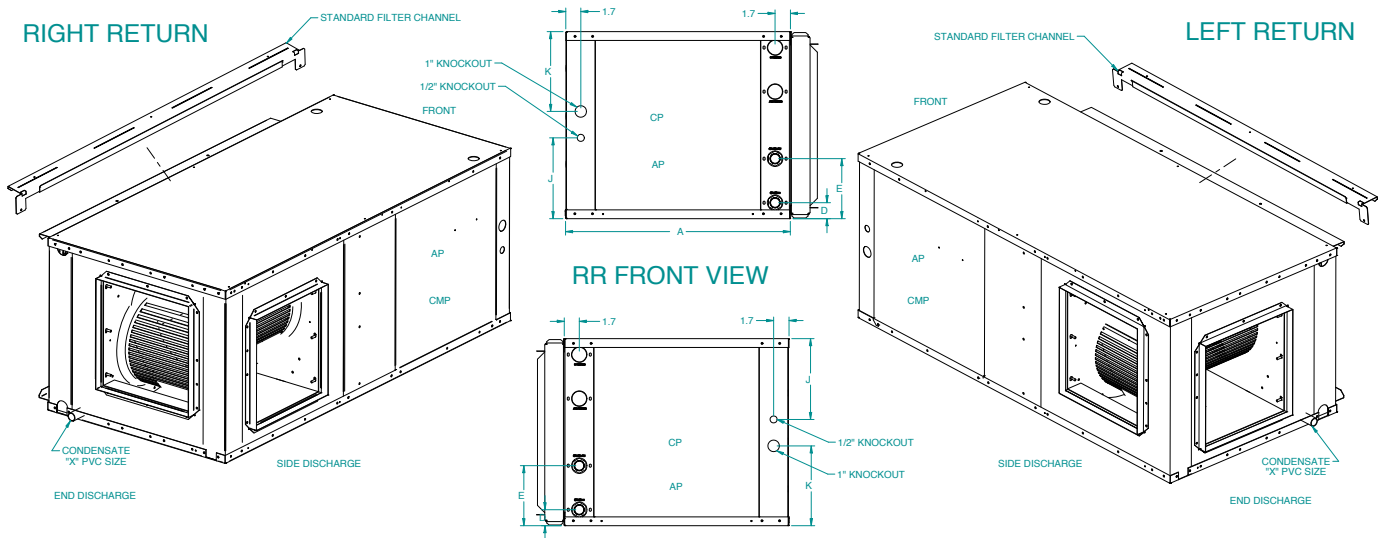

LR FRONT VIEW

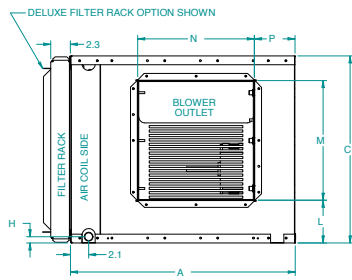

RIGHT RETURN END DISCHARGE

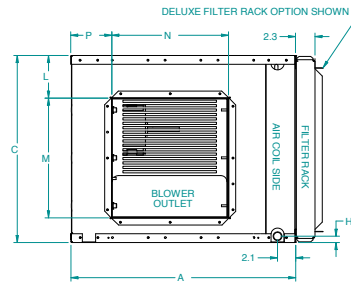

LEFT RETURN END DISCHARGE

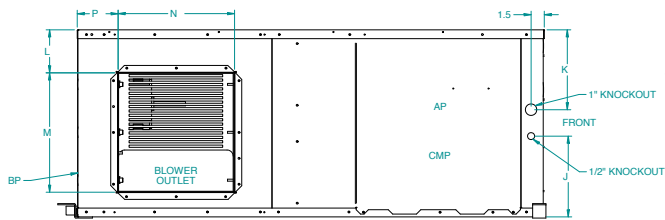

RIGHT RETURN SIDE DISCHARGE

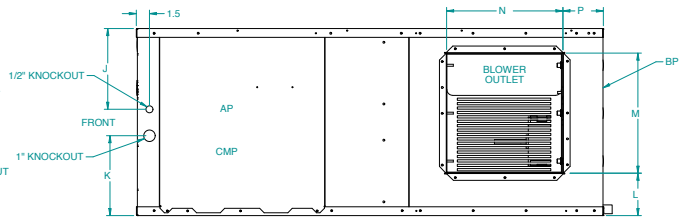

LEFT RETURN SIDE DISCHARGE

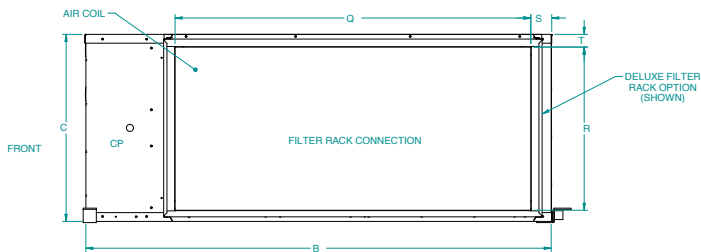

RIGHT RETURN SIDE VIEW

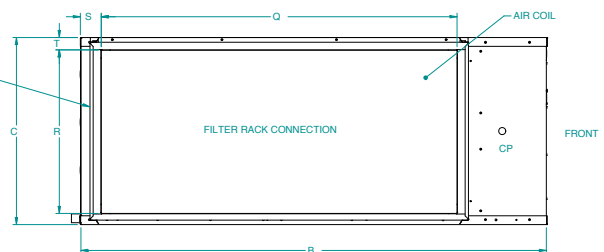

LEFT RETURN SIDE VIEW

Horizontal Dimensional Data cont.

Horizontal Models	Overall Cabinet			Water Connections				Electrical Knockouts		Discharge Connection duct flange installed (±0.10 in)				Return Connection using deluxe filter rack option (±0.10 in)				PVC Size	
	A	B	C	1	2	3		J	K	L	M	N	P	Q	R	S	T	X	
	Width	Depth	Height*	In	Out	Condensate	Water FPT	1/2" cond Low Voltage	1" cond Power Supply		Supply Width	Supply Depth		Return Depth	Return Height				
036	in.	25.5	57.0	21.2	1.8	6.8	0.8	1"	9.2	9.1	4.9	13.6	13.2	4.6	40.4	18.6	2.3	1.4	3/4"
	cm.	64.8	144.8	53.8	4.6	17.3	2.0	25.4 mm	23.4	23.1	12.4	34.5	33.5	11.7	102.6	47.2	5.8	3.6	1.9
048	in.	25.5	63.0	21.2	1.8	6.8	0.8	1"	9.2	9.1	4.9	13.6	13.2	4.6	45.4	18.6	2.3	1.4	3/4"
	cm.	64.8	160.0	53.8	4.6	17.3	2.0	25.4 mm	23.4	23.1	12.4	34.5	33.5	11.7	115.3	47.2	5.8	3.6	1.9
060	in.	25.5	70.0	21.2	1.8	6.8	0.8	1"	9.2	9.1	4.9	13.6	13.2	4.6	45.4	18.6	2.3	1.4	3/4"
	cm.	64.8	177.8	53.8	4.6	17.3	2.0	25.4 mm	23.4	23.1	12.4	34.5	33.5	11.7	115.3	47.2	5.8	3.6	1.9
072	in.	25.5	75.0	21.2	1.8	6.8	0.8	1"	9.2	9.1	4.9	13.6	13.2	4.6	45.4	18.6	2.3	1.4	3/4"
	cm.	64.8	190.5	53.8	4.6	17.3	2.0	25.4 mm	23.4	23.1	12.4	34.5	33.5	11.7	115.3	47.2	5.8	3.6	1.9

Horizontal Disconnect

When using disconnect, do not use dimension K from the standard horizontal dimensional data. Use dimension KK from the horizontal disconnect dimensional data.

Horizontal Models	KK
036	10.2 [25.9]
048-72	11.2 [28.4]

Dimensions in inches [cm]

08/25/16

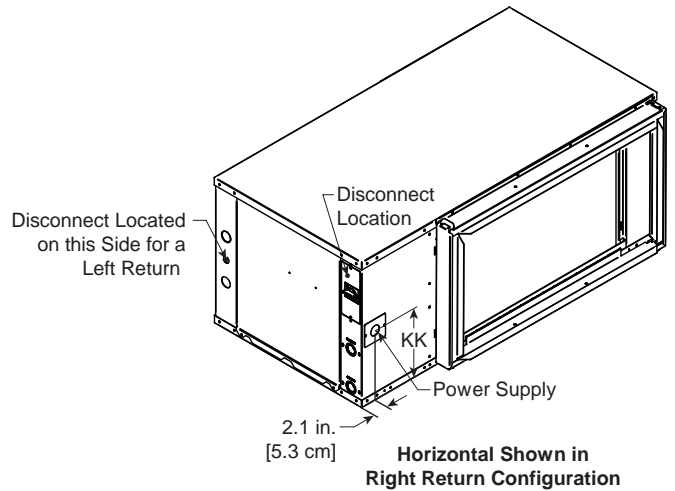

Installation Notes

Typical Unit Installation

Unit Location

Locate the unit in an indoor area that allows for easy removal of the filter and access panels. Location should have enough space for service personnel to perform maintenance or repair. Provide sufficient room to make water, electrical and duct connection(s). If the unit is located in a confined space, such as a closet, provisions must be made for return air to freely enter the space by means of a louvered door, etc. Any access panel screws that would be difficult to remove after the unit is installed should be removed prior to setting the unit. On horizontal units, allow adequate room below the unit for a condensate drain trap and do not locate the unit above supply piping. Care should be taken when units are located in unconditioned spaces to prevent damage from frozen water lines and excessive heat that could damage electrical components.

Water Piping

Piping is usually design as 'reverse return' to equalize flow paths through each unit. A short flexible pressure rated hose is used to make connection to the fixed building

piping system. This hose is typically stainless steel braid and includes a swivel fitting on one end for easy removal and is flexible to help isolate the unit for quieter operation. Isolation valves for servicing, y-strainers for filtering and memory-stop flow valve or a balancing valve can be provided for consistent water flow through the unit.

All unit source water connections are fittings that accept a male pipe thread (MPT). Insert the connectors by hand, then tighten the fitting with a wrench to provide a leakproof joint. The open and closed loop piping system should include pressure/temperature ports for serviceability. The proper water flow must be provided to each unit whenever the unit operates. To assure proper flow, use pressure/temperature ports to determine the flow rate. These ports should be located at the supply and return water connections on the unit. The proper flow rate cannot be accurately set without measuring the water pressure drop through the refrigerant-to-water heat exchanger. Never use flexible hoses smaller than the inside diameter of the water connection at the unit. Limit hose length to 10 feet per connection. Check carefully for water leaks.

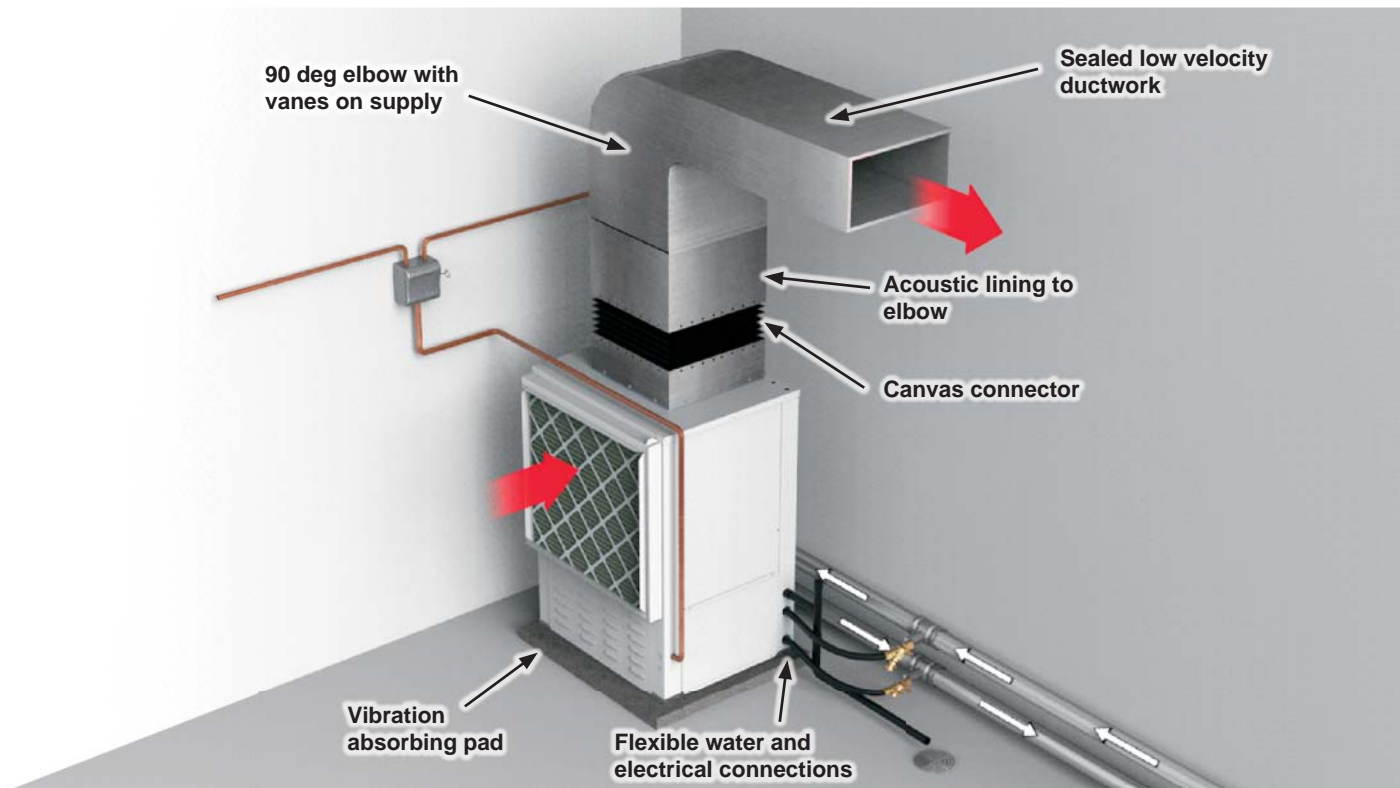

Installation Notes cont.

Installing Horizontal Units

Remove and discard the compressor hold down shipping bolt located at the front of the compressor mounting bracket prior to setting the unit in place. Horizontal units are available with side or end discharge.

NOTE: Left (Right) Return Side Discharge cannot be converted to Left (Right) Return End Discharge or vice versa, without additional custom sheet metal parts. Horizontal units are normally suspended from a ceiling by four (O36-O60 models) or five (O72 models) 3/8 in. diameter threaded rods. The rods are usually attached to the unit by hanger bracket kits furnished with each unit.

Lay out the threaded rods per the Hanger Bracket Dimensions table. Assemble the hangers to the unit as shown. Securely tighten the brackets to the unit using the weld nuts located on the underside of the bottom panel. When attaching the hanger rods to the bracket, a double nut is required since vibration could loosen a single nut.

To allow filter access, install hanger brackets as illustrated in the Hanger Bracket Locations section. The unit should be pitched approximately 1/4 in. towards the drain in both directions to facilitate the removal of condensate. Use only the bolts provided in the kit to attach hanger brackets. The use of longer bolts could damage internal parts.

Some applications require the installation of horizontal units on an attic floor. In this case, the unit should be set in a full size secondary drain pan on top of a vibration absorbing pad. The secondary drain pan prevents possible condensate overflow or water leakage damage to the ceiling. The secondary drain pan is usually placed on a plywood base isolated from the ceiling joists by additional layers of vibration absorbing material.



CAUTION: Do not use rods smaller than 3/8 in. diameter since they may not be strong enough to support the unit. The rods must be securely anchored to the ceiling.

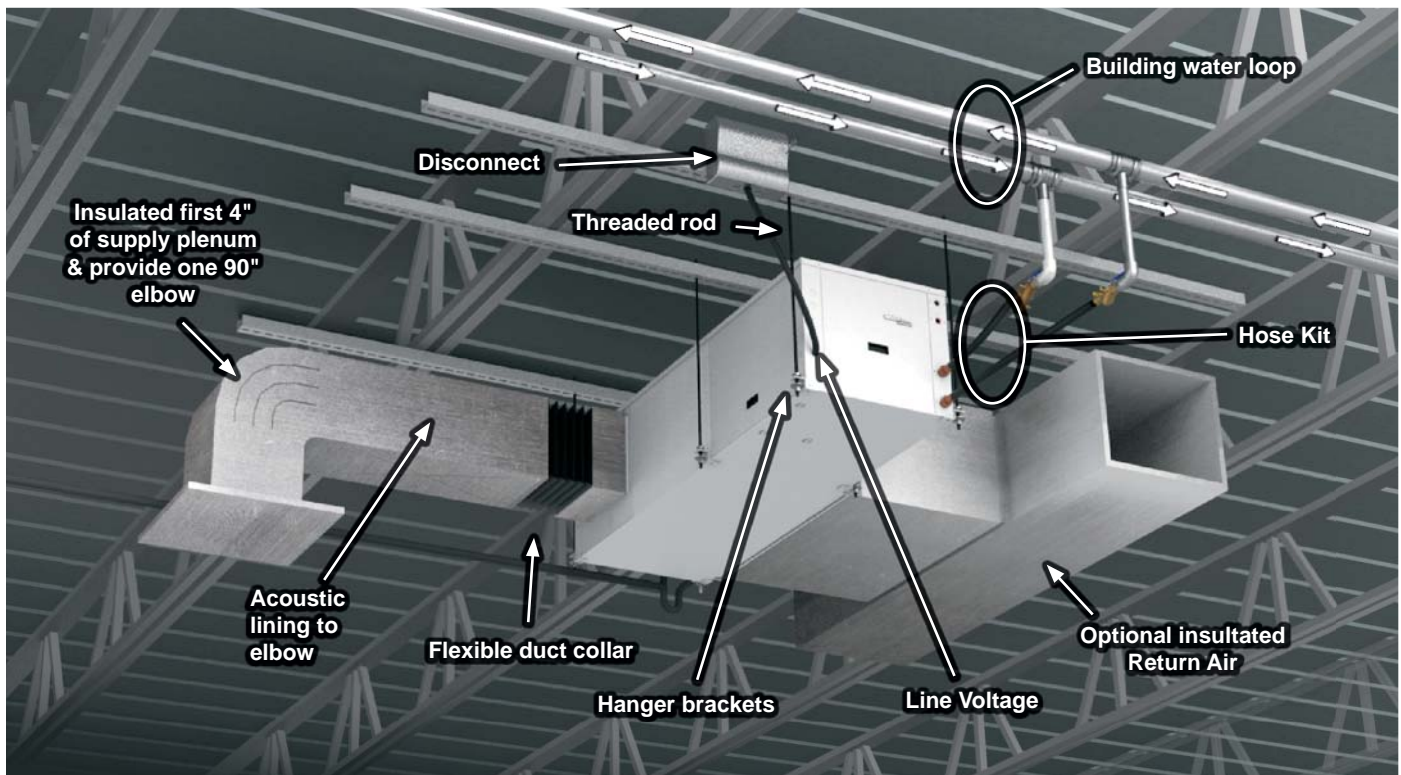

Installation Notes cont.

Acoustical Considerations and Equipment Sound Performance

Sound Performance

The Versatec Variable Speed is third party sound rated in accordance with ARI 260. Please consult WaterFurnace Sound Performance Data Catalog for details on the AHRI standard and sound performance data.

Recommendations for Noise Reduction

Horizontal Unit Location

- Specify equipment with quietest sound power ratings
- Do not locate units above areas with a required NC 40 or less
- Space WSHP at least 10 ft (3m) apart to avoid noise summing of multiple units in a space.
- Maximize the height of the unit above the ceiling (horizontal).
- Suspend unit with isolation grommets that are appropriately rated to reduce vibrations (horizontal).

Vertical Unit Location

- Specify equipment with quietest sound power ratings
- Space WSHP at least 10 ft (3m) apart to avoid noise summing of multiple units in a space.
- Acoustic ceiling coatings can greatly reduce noise levels in mechanical rooms.
- Mount unit on a sound absorbing pad, extruded polystyrene, rubber or cork pad.

Ductwork

- Ensure return air grilles will not allow line of site noise to transfer to adjacent space. Use a sound barrier or some other material to isolate the grille from the unit. A supply grille, boot and short piece of flex duct pointed away from the unit can greatly attenuate equipment noise.
- Use a canvas isolation duct connector at the supply and return duct connection of the unit.
- Internally line the discharge and return duct within the first 4-8 feet of unit with acoustic insulation. Install an internally lined 'L' shaped return duct elbow at return grille. Face the elbow away from adjacent units.
- Always install at least one 90° elbow in the discharge duct to eliminate line of sight noise transmission of the blower.
- Use turning vanes at all elbows and tees to reduce turbulence.
- Limit supply duct velocities to less than 1,000 fpm
- Design and install ductwork as stiff as possible
- Allow 3 duct diameters both up and down stream of the unit before any fittings or transitions are installed.
- Use duct sealant on all duct joints.
- Install a short (2-4') of flex duct on all branch ducts just prior to discharge boot or diffuser to reduce vibration and duct sound prior to delivery in the room.
- Locate the branch duct balancing damper as far away from the diffuser as possible.
- In ceiling plenum systems, install an internally lined 'L' shaped return duct elbow at unit. Face the elbow away from adjacent units (horizontal).

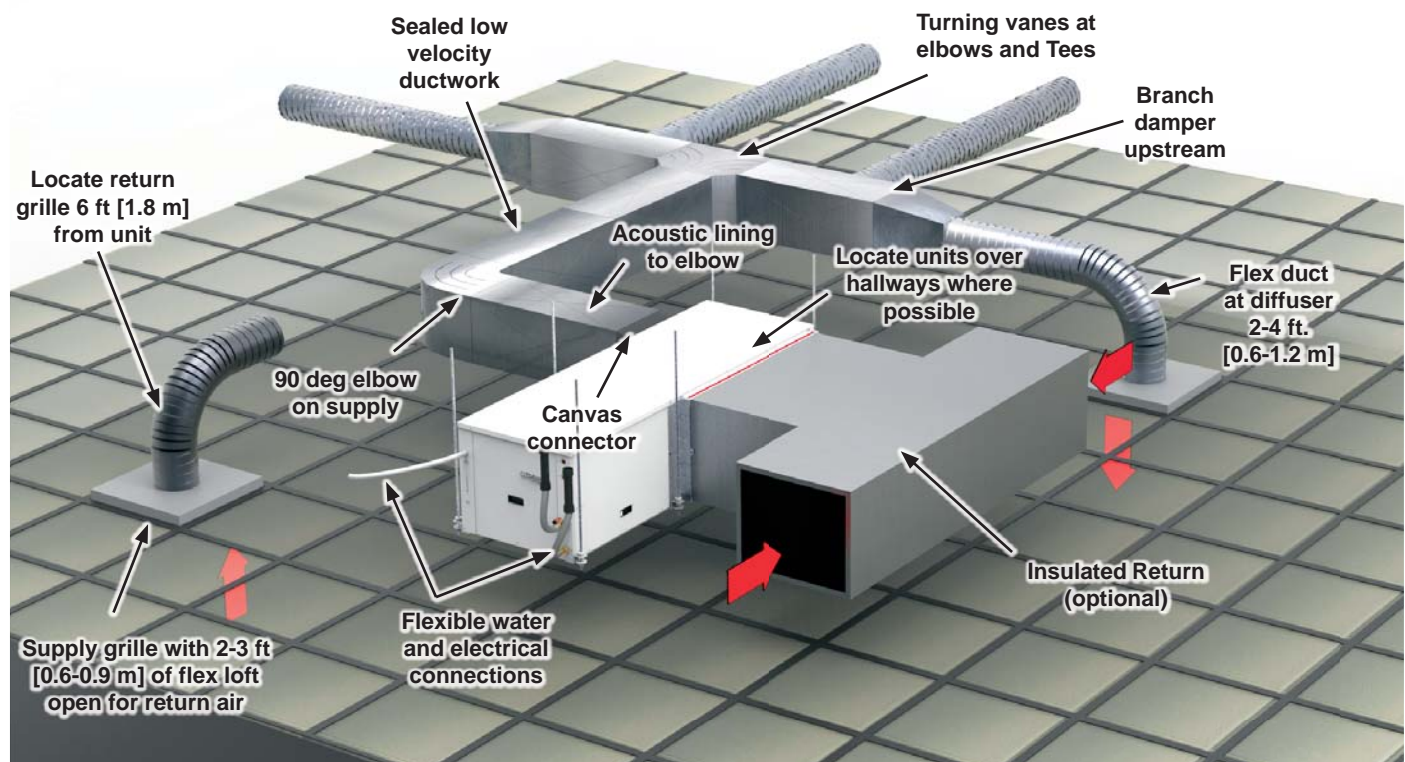

Hanger Bracket Locations

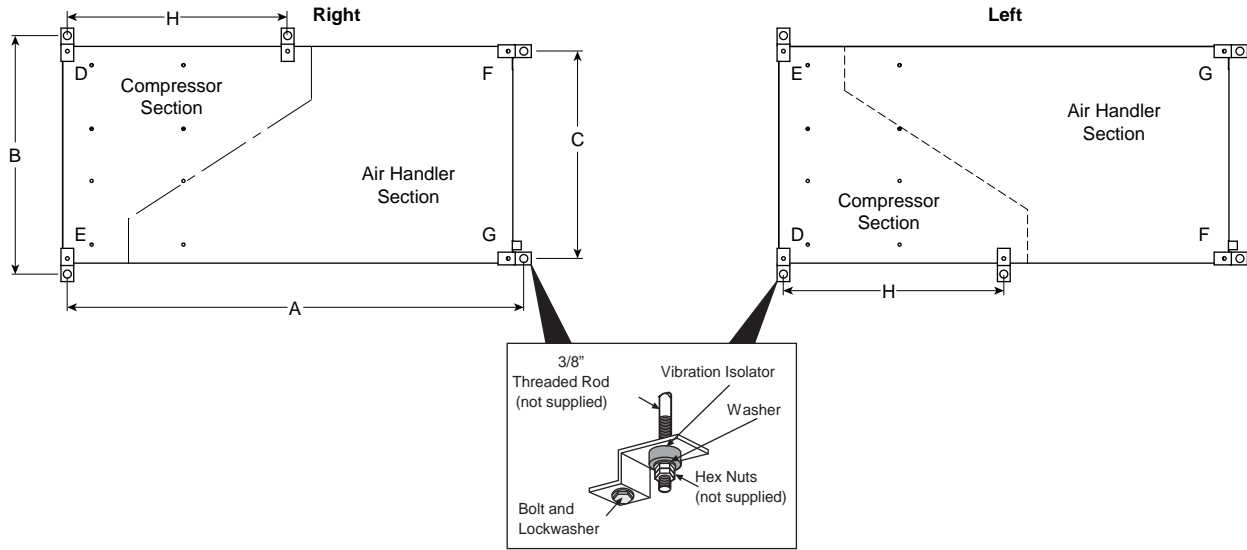

Hanger Dimensions

Model	Hanger Kit Part Number	Unit Hanger Dimensions			
		A	B	C	H
036	in.	53.8	28.1	24.4	n/a
	cm	136.7	71.4	62.0	n/a
048	in.	61.8	28.1	24.4	n/a
	cm	157.0	71.4	62.0	n/a
060	in.	68.8	28.1	24.4	36.0
	cm	174.8	71.4	62.0	91.4
072	in.	68.8	28.1	24.4	42.0
	cm	174.8	71.4	62.0	106.7

8/25/16

Weight Distribution

Model	Vertical Shipping Weight	Horizontal Shipping Weight	Horizontal Weight Distribution				
			Front		Back		
			D	E	F	G	
036	lb.	400	415	155	105	80	65
	kg	[181]	[188]	[70]	[48]	[36]	[30]
048	lb.	410	420	165	110	85	70
	kg	[186]	[191]	[75]	[50]	[39]	[32]
060	lb.	450	460	140	120	100	85
	kg	[204]	[209]	[64]	[54]	[45]	[39]
072	lb.	485	495	155	130	105	90
	kg	[220]	[225]	[70]	[59]	[48]	[41]

8/25/16

Duct System

An air outlet collar is provided on vertical top flow units and all horizontal units to facilitate a duct connection. A flexible connector is recommended for discharge and return air duct connections on metal duct systems. Uninsulated duct should be insulated with a minimum of 1-inch duct insulation. Application of the unit to uninsulated ductwork in an unconditioned space is not recommended as the unit's performance will be adversely affected.

If the unit is connected to existing ductwork, check the duct system to ensure that it has the capacity to accommodate the air required for the unit application. If the duct is too small, as in the replacement of heating only systems, larger ductwork should be installed. All existing ductwork should be checked for leaks and repaired if necessary.

The duct system should be sized to handle the design airflow quietly and efficiently. To maximize sound attenuation of the unit blower, the supply and return plenums should include an internal duct liner of fiberglass or constructed of ductboard for the first few feet. On systems employing a sheet metal duct system, canvas connectors should be used between the unit and the ductwork. If air noise or excessive airflow is a problem, the blower speed can be changed.

Water Piping

The proper water flow must be provided to each unit whenever the unit operates. To assure proper flow, use pressure/temperature ports to determine the flow rate. These ports should be located at the supply and return water connections on the unit. The proper flow rate cannot be accurately set without measuring the water pressure drop through the refrigerant-to-water heat exchanger.

All source water connections on commercial units are fittings that accept a male pipe thread (MPT). Insert the connectors by hand, then tighten the fitting with a wrench to provide a leakproof joint. When connecting to an open loop (groundwater) system, thread any copper MPT fitting into the connector and tighten in the same manner as described above.

Condensate Drain

On vertical units, the internal condensate drain assembly consists of a drain tube which is connected to the drain pan, a 3/4 in. PVC female adapter and a flexible connecting hose. The female adapter may exit either the front or the side of the cabinet. The adapter should be glued to the field-installed PVC condensate piping. On vertical units, a condensate hose is inside all cabinets as a trapping loop; therefore, an external trap is not necessary.

On horizontal units, a PVC stub or stainless steel tube is provided for condensate drain piping connection. An external trap is required (see below). If a vent is necessary, an open stand pipe may be applied to a tee in the field-installed condensate piping.

Horizontal Drain Connection (Composite Drain Pan)

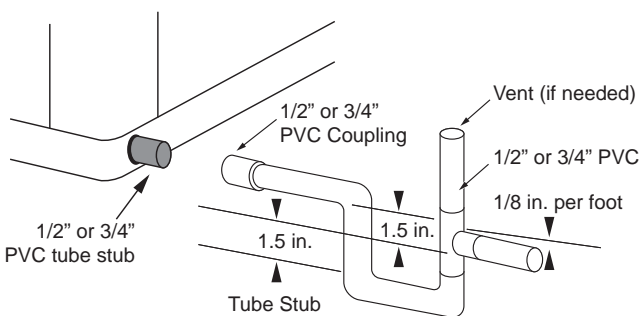

Unit Pitch for Drain

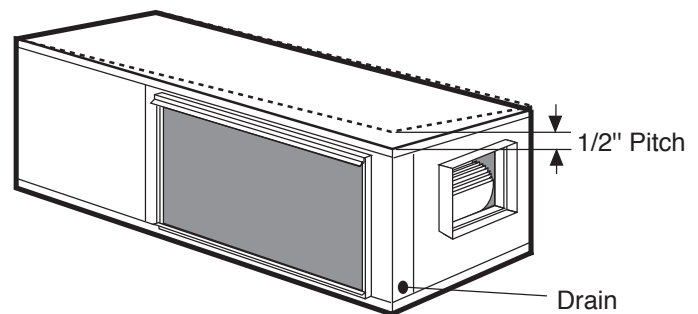

Water Quality

It is the responsibility of the system designer and installing contractor to ensure that acceptable water quality is present and that all applicable codes have been met in these installations. Failure to adhere to the guidelines in the water quality table could result in loss of warranty. In ground water situations where scaling could be heavy or where biological growth such as iron bacteria will be present, a closed loop system is recommended. The heat exchanger coils in ground water systems may, over a period of time, lose heat exchange capabilities due to a buildup of mineral deposits inside. These can be cleaned, but only by a qualified service mechanic, as special solutions and pumping equipment are required. Hot water generator coils can likewise become scaled and possibly plugged. In areas with extremely hard water, the owner should be informed that the heat exchanger may require occasional flushing.

Units with cupronickel heat exchangers are recommended for open loop applications due to the increased resistance to build-up and corrosion, along with reduced wear caused by acid cleaning. Failure to adhere to the guidelines in the water quality table could result in the loss of warranty.

Water Treatment

Do not use untreated or improperly treated water. Equipment damage may occur. The use of improperly treated or untreated water in this equipment may result in scaling, erosion, corrosion, algae or slime. Purchase of a pre-mix antifreeze could significantly improve system reliability if the water quality is controlled and there are additives in the mixture to inhibit corrosion. There are many examples of such fluids on the market today such as Environol™ 1000 (pre-mix ethanol), and others. The services of a qualified water treatment specialist should be engaged to determine what treatment, if any, is required. The product warranty specifically excludes liability for corrosion, erosion or deterioration of equipment.

The heat exchangers and water lines in the units are copper or cupronickel tube. There may be other materials in the buildings piping system that the designer may need to take into consideration when deciding the parameters of the water quality. If antifreeze or water treatment solution is to be used, the designer should confirm it does not have a detrimental effect on the materials in the system.

Contaminated Water

In applications where the water quality cannot be held to prescribed limits, the use of a secondary or intermediate heat exchanger is recommended to separate the unit from the contaminated water. The table above outlines the water quality guidelines for unit heat exchangers. If these conditions are exceeded, a secondary heat exchanger is required. Failure to supply a secondary heat exchanger where needed will result in a warranty exclusion for primary heat exchanger corrosion or failure.

Material		Copper	90/10 Cupronickel	316 Stainless Steel
pH	Acidity/Alkalinity	7 - 9	7 - 9	7 - 9
Scaling	Calcium and Magnesium Carbonate	(Total Hardness) less than 350 ppm	(Total Hardness) less than 350 ppm	(Total Hardness) less than 350 ppm
Corrosion	Hydrogen Sulfide	Less than 0.5 ppm (rotten egg smell appears at 0.5 ppm)	10 - 50 ppm	Less than 1 ppm
	Sulfates	Less than 125 ppm	Less than 125 ppm	Less than 200 ppm
	Chlorine	Less than 0.5 ppm	Less than 0.5 ppm	Less than 0.5 ppm
	Chlorides	Less than 20 ppm	Less than 125 ppm	Less than 300 ppm
	Carbon Dioxide	Less than 50 ppm	10 - 50 ppm	10 - 50 ppm
	Ammonia	Less than 2 ppm	Less than 2 ppm	Less than 20 ppm
	Ammonia Chloride	Less than 0.5 ppm	Less than 0.5 ppm	Less than 0.5 ppm
	Ammonia Nitrate	Less than 0.5 ppm	Less than 0.5 ppm	Less than 0.5 ppm
	Ammonia Hydroxide	Less than 0.5 ppm	Less than 0.5 ppm	Less than 0.5 ppm
	Ammonia Sulfate	Less than 0.5 ppm	Less than 0.5 ppm	Less than 0.5 ppm
Iron Fouling (Biological Growth)	Total Dissolved Solids (TDS)	Less than 1000 ppm	1000 - 1500 ppm	1000 - 1500 ppm
	LSI Index	+0.5 to -0.5	+0.5 to -0.5	+0.5 to -0.5
Iron Fouling (Biological Growth)	Iron, FE ²⁺ (Ferrous) Bacterial Iron Potential	< 0.2 ppm	< 0.2 ppm	< 0.2 ppm
	Iron Oxide	Less than 1 ppm, above this level deposition will occur	Less than 1 ppm, above this level deposition will occur	Less than 1 ppm, above this level deposition will occur
Erosion	Suspended Solids	Less than 10 ppm and filtered for max. of 600 micron size	Less than 10 ppm and filtered for max. of 600 micron size	Less than 10 ppm and filtered for max. of 600 micron size
	Threshold Velocity (Fresh Water)	< 6 ft/sec	< 6 ft/sec	< 6 ft/sec

NOTES: Grains = ppm divided by 17
mg/L is equivalent to ppm

2/22/12

System Cleaning and Flushing

Cleaning and Flushing

Prior to start up of any heat pump, the water circulating system must be cleaned and flushed of all dirt and debris.

If the system is equipped with water shutoff valves, the supply and return runouts must be connected together at each unit location (This will prevent the introduction of dirt into the unit, see Flushing with Water Shutoff Valve Equipped Systems illustration). The system should be filled at the water make-up connection with all air vents open. After filling, vents should be closed.

Flushing with Water Shutoff Valve Equipped Systems

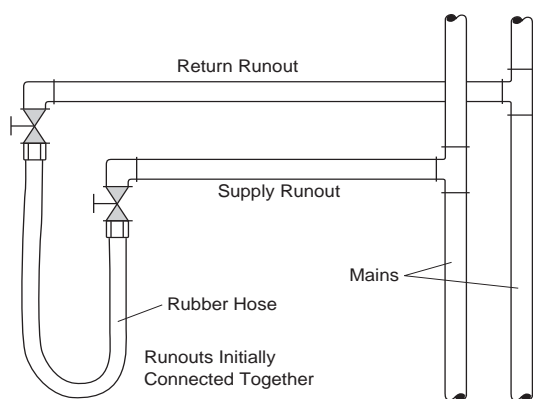

The contractor should start the main circulator with the pressure reducing valve makeup open. Vents should be checked in sequence to bleed off any trapped air and to verify circulation through all components of the system.

As water circulates through the system, the contractor should check and repair any leaks found in the piping system. Drain(s) at the lowest point(s) in the system should be opened for initial flush and blowdown, making sure water fill valves are set at the same rate. Check the pressure gauge at the pump suction and manually adjust the make-up water valve to hold the same positive pressure both before and after opening the drain valves. Flushing should continue for at least two hours, or longer if required, until drain water is clean and clear.

The supplemental heater and/or circulator pump, if used, should be shut off. All drains and vents should be opened to completely drain the system. Short-circuited supply and return runouts should now be connected to the unit supply and return connections.

Refill the system with clean water. Test the system water for acidity and treat as required to leave the water slightly alkaline (pH 7.5 to 8.5). The specified percentage of antifreeze may also be added at this time. Use commercial grade antifreeze designed for HVAC systems only. Environol™ brand antifreeze is recommended.

Once the system has been filled with clean water and antifreeze (if used), precautions should be taken to protect the system from dirty water conditions. Dirty water will result in system-wide degradation of performance, and solids may clog valves, strainers, flow regulators, etc. Additionally, the heat exchanger may become clogged which reduces compressor service life and can cause premature unit failure.

In boiler/tower application, set the loop control panel set points to desired temperatures. Supply power to all motors and start the circulating pumps. After full flow has been established through all components including the heat rejector (regardless of season), air vented and loop temperatures stabilized, each of the units will be ready for check, test and start up and for air and water balancing.

Ground Source Loop System Checkout

Once piping is completed between the unit pumping system and ground loop, final purging and charging of the loop is needed. A high pressure pump is needed to achieve adequate flow velocity in the loop to purge air and dirt particles from the loop itself. Antifreeze solution is used in most areas to prevent freezing. Flush the system adequately to remove as much air as possible; then pressurize the loop to a static pressure of 40-50 PSI (summer) or 50-75 PSI (winter). This is normally adequate for good system operation. Loop static pressure may decrease soon after initial installation, due to pipe expansion and loop temperature change. Running the unit for at least 30 minutes after the system has been completely purged of air will allow for the "break-in" period. It may be necessary to adjust static loop pressure (by adding water) after the unit has run for the first time. Loop static pressure will also fluctuate with the seasons. Pressures will be higher in the winter months than during the cooling season. This fluctuation is normal and should be considered when charging the system initially.

Ensure the pump provides adequate flow through the unit by checking pressure drop across the heat exchanger. Usually 2.25-3.0 gpm of flow per ton of cooling capacity is recommended in earth loop applications.

Open Loop Ground Water Systems

Typical open loop piping is shown below. Always maintain water pressure in the heat exchanger by placing water control valves at the outlet of the unit to prevent mineral precipitation. Use a closed, bladder-type expansion tank to minimize mineral formation due to air exposure. Insure proper water flow through the unit by checking pressure drop across the heat exchanger and comparing it to the figures in unit capacity data tables in the specification catalog. 1.5-2 gpm of flow per ton of cooling capacity is recommended in open loop applications. Due to only minor differences in flow rate from low to high, only one solenoid valve should be used. The valve should be sized for full flow.

Discharge water from the unit is not contaminated in any manner and can be disposed of in various ways, depending on local codes, i.e. recharge well, storm sewer, drain field, adjacent stream or pond, etc. Most local codes forbid the use of sanitary sewer for disposal. Consult your local building and zoning departments to assure compliance in your area.

Open System - Groundwater Application

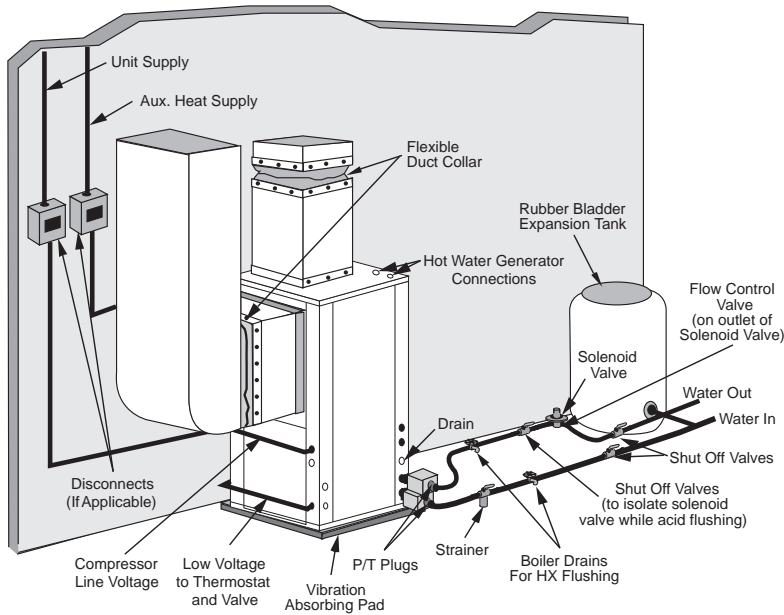

Hot Water Generator Connections

The heat reclaiming hot water generator coil is of vented double-wall copper construction and is suitable for potable water.

To maximize the benefits of the hot water generator a minimum 50-gallon water heater is recommended. For higher demand applications, use an 80-gallon water heater or two 50-gallon water heaters connected in a series as shown below. Electric water heaters are recommended. Make sure all local electrical and plumbing codes are met for installing a hot water generator. A water softener is recommended with hard water (greater than 10 grains or 170 total hardness).

Water Tank Preparation

To install a unit with a hot water generator, follow these installation guidelines.

1. Turn off the power to the water heater.
2. Attach a water hose to the water tank drain connection and run the other end of the hose to an open drain or outdoors.
3. Close the cold water inlet valve to the water heater tank.
4. Drain the tank by opening the valve on the bottom of the tank, then open the pressure relief valve or hot water faucet.
5. Flush the tank by opening the cold water inlet valve to the water heater to free the tank of sediments. Close when draining water is clear.
6. Disconnect the garden hose and remove the drain valve from the water heater.
7. Refer to Plumbing Installation and Hot Water Generator Startup.

Plumbing Installation

1. Inspect the dip tube in the water heater cold inlet for a check valve. If a check valve is present it must be removed or damage to the hot water generator circulator will occur.
2. Remove drain valve and fitting.
3. Thread the 3/4-inch NPT x 3-1/2-inch brass nipple into the water heater drain port.
4. Attach the center port of the 3/4-inch FPT tee to the opposite end of the brass nipple.
5. Attach the 1/2-inch copper to 3/4-inch NPT adaptor to the side of the tee closest to the unit.
6. Install the drain valve on the tee opposite the adaptor.
7. Run interconnecting tubing from the tee to HWG water out.

Typical Hot Water Generator Installation

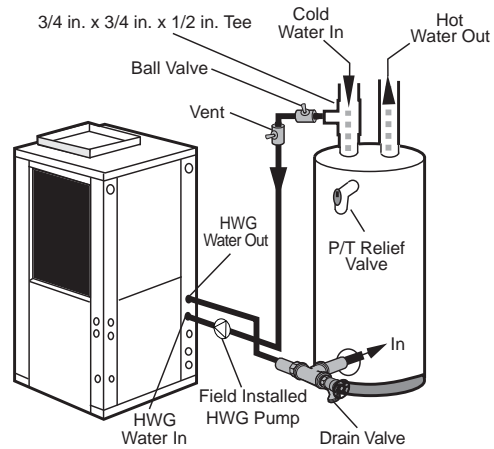

Hot Water Generator Installation In Preheat Tank

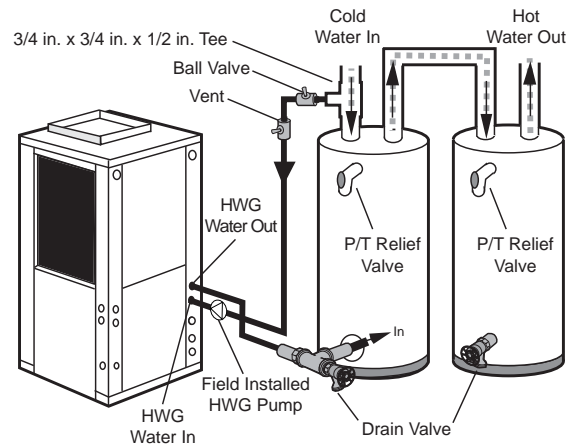

NOTE: This configuration maximizes hot water generator capability.



CAUTION: Elements will burn out if energized dry.

8. Cut the cold water "IN" line going to the water heater.
9. Insert the reducing solder tee in line with cold water "IN" line as shown.
10. Run interconnecting copper tubing between the unit DHW water "IN" and the tee (1/2-inch nominal). The recommended maximum distance is 50 feet.
11. To prevent air entrapment in the system, install a vent coupling at the highest point of the interconnecting lines.
12. Insulate all exposed surfaces of both connecting water lines with 3/8-inch wall closed cell insulation.

NOTE: All plumbing and piping connections must comply with local plumbing codes.

Hot Water Generator Connections cont.

Hot Water Generator Startup

1. Make sure the power is off to the heat pump. Connect the wire from the hot water generator pump to T1 on the contactor.
2. Close the drain valve to the water heater.
3. Open the cold water supply to the tank.
4. Open a hot water faucet in the building to bleed air from the system. Close when full.
5. Open the pressure relief valve to bleed any remaining air from the tank, then close.
6. If so equipped, turn the venting (burping) screw in the center of the pump two (2) turns open (water will drip out), wait until all air is purged from the pump, then tighten the plug. Use vent couplings to bleed air from the lines.
7. Carefully inspect all plumbing for water leaks and correct as required.
8. Before restoring electrical supply to the water heater, adjust the temperature setting on the tank.
 - On tanks with both upper and lower elements, the lower element should be turned down to the lowest setting, approximately 100°F. The upper element should be adjusted to 120°F to 130°F. Depending upon the specific needs of the customer, you may want to adjust the upper element differently.
 - On tanks with a single element, lower the thermostat setting to 120°F.
9. After the thermostat(s) is adjusted, replace the access cover and restore electrical supply to the water heater.
10. Make sure that any valves in the hot water generator circuit are open.
11. Turn on the unit to heating.
12. The HWG pump should be running. When the pump is first started, turn the venting (burping) screw (if equipped) in the center of the pump two (2) turns open until water dribbles out, then replace. Allow the pump to run for at least five minutes to ensure that water has filled the circulator properly.
13. The temperature difference between the water entering and leaving the hot water generator should be 5°F to 15°F. The water flow should be approximately 0.4 gpm per ton of nominal cooling.
14. Allow the unit to heat water for 15 to 20 minutes to be sure operation is normal.



CAUTION: Never operate the HWG circulating pump while dry. If the unit is placed in operation before the hot water generator piping is connected, be sure that the pump wires are disconnected from the contactor.

Freeze Detection

For Aurora Base Control, set SW2-1, FP1, on the printed circuit board for applications using a closed loop antifreeze solution to 15°F [-9.4°C]. On applications using an open loop/ground water system (or closed loop no antifreeze), set this dip switch to 30°F [-1.1°C], the factory default setting. (Refer to the Dip Switch Field Selection table).

Electrical Connections

General

Be sure the available power is the same voltage and phase as that shown on the unit serial plate. Line and low voltage wiring must be done in accordance with local codes or the National Electric Code, whichever is applicable.

Power Connection

Connect the incoming line voltage wires to L1 and L2 of the contactor for single-phase unit. Consult the Electrical Data tables for correct fuse sizes.

Aurora Base Control Box

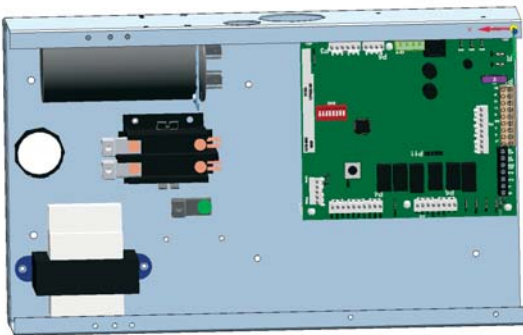

208 Volt Operation

All 208/230 volt units are factory wired for 230 volt operation. For 208 volt operation, the red and blue transformer wires must be switched on terminal strip PS.



CAUTION: When installing a unit with an ECM blower motor in 460/60/3 voltage, a neutral wire is required to allow proper unit operation.

Electrical Data

Model	Rated Voltage	Voltage Min/Max	Compressor			Blower Motor FLA	Total Unit FLA	Min Circ Amp	Max Fuse/HACR Breaker
			MCC	RLA	LRA*				
036	208-230/60/1	187/253	26.0	16.7	60.0	4.3	21.0	25.2	40
	208-230/60/3	187/253	18.0	11.5	60.0	4.3	15.8	18.7	30
	460/60/3	414/506	12.0	7.7	25.0	4.3	12.0	13.0	20
048	208-230/60/1	187/253	26.0	16.7	60.0	7.7	24.4	28.6	60
	208-230/60/3	187/253	18.0	11.5	60.0	6.7	18.2	21.1	30
	460/60/3	414/506	12.0	7.7	25.0	6.0	13.7	15.6	20
060	208-230/60/1	187/253	38.0	24.4	60.0	7.7	32.1	38.2	60
	208-230/60/3	187/253	24.0	15.4	60.0	6.7	22.1	26.0	40
	460/60/3	414/506	15.0	9.6	25.0	6.0	15.6	18.0	25
072	208-230/60/1	187/253	38.0	24.4	60.0	7.7	32.1	38.2	60
	208-230/60/3	187/253	24.0	15.4	60.0	6.7	22.1	26.0	40
	460/60/3	414/506	15.0	9.6	25.0	6.0	15.6	18.0	25

HACR circuit breaker in USA only

* - Based on AC input current protection to compressor drive.

8/25/16

Blower Performance Data

VS ECM Blower Performance Versatec Variable Speed Series

Model	Max ESP	Air Flow Speed Settings											
		1	2	3	4	5	6	7	8	9	10	11	12
036	0.50	285	380	525	675	815	980	1100	1220	1330	1440	1540	1575
			G	L							H	Aux	
048	0.75	475	620	730	850	1020	1140	1270	1400	1520	1650	1790	1925
			G	L								H	Aux
060	0.75	400	600	830	1050	1230	1400	1560	1700	1870	2010	2140	2265
			G	L								H	Aux
072	0.75	400	600	830	1050	1230	1400	1560	1700	1870	2010	2140	2265
			G	L									H-Aux
				*1-2	*3-4	*5-6	*5-6	*7-8		*9-10	*11-12		*11-12

*VS Compressor speed is given for the factory default cfm settings. When the cfm default settings are changed it will change the relationship to the compressor speed that is shown in the table.

1/25/17

Factory settings are at recommended L, H, and Aux positions
 "G" may be located anywhere within the airflow table
 "L" setting should be located < or = to "H" setting
 "H" setting MUST be located within the shaded cfm range
 "Aux" setting MUST be equal to or greater than "H" setting
 "Aux" setting MUST be equal to or greater than the minimum allowable cfm for the auxiliary heater kit (see auxiliary heat ratings)
 CFM is controlled within 5% up to the maximum ESP
 Max ESP includes allowance for wet coil and 1" MERV 4

Setting Blower Speed - Variable Speed ECM

The ABC board's Yellow Config LED will flash the current ECM blower speed selections for G, low, and high continuously with a short pause in between. The speeds can also be confirmed with the AID Tool under the Setup/ECM Setup screen. The Aux will not be flashed but can be viewed in the AID Tool. The ECM blower motor speeds can be field adjusted with or without using an AID Tool.

Variable speed ECM Setup without an AID Tool

The blower speeds for G only, Low (Y1), and High (Y2/Aux) can be adjusted directly at the Aurora ABC board which utilizes the push button (SW1) on the ABC board. This procedure is outlined in the ECM Configuration Mode portion of the Aurora 'Base' Control System section. The Aux cannot be set manually without an AID Tool.

Variable speed ECM Setup with an AID Tool

A much easier method utilizes the AID Tool to change the airflow using the procedure below. First navigate to the Setup screen and then select ECM Setup. This screen displays the current ECM settings. It allows the technician to enter the setup screens to change the ECM settings.

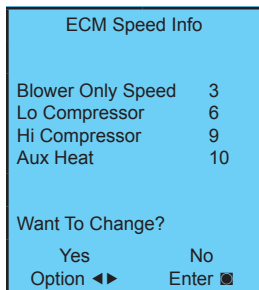

Change the highlighted item using the ◀ and ▶ buttons and then press the ◻ button to select the item.

Selecting YES will enter ECM speed setup, while selecting NO will return to the previous screen.

ECM Speed Setup - These screens allow the technician to select the G, low, high, and auxiliary heat blower speed for the ECM blower motor. Change the highlighted item using the ▲ and ▼ buttons. Press the ◻ button to select the speed.

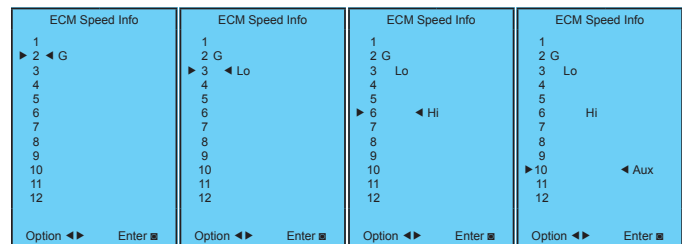

After the auxiliary heat speed setting is selected the AID Tool will automatically transfer back to the ECM Setup screen.

Cooling Airflow Setup - These screens allow the technician to select -15%, -10%, -5%, None or +5% change from the heating airflow. Change the adjustment percentage using the ▲ and ▼ buttons. Press the ◻ button to save the change.

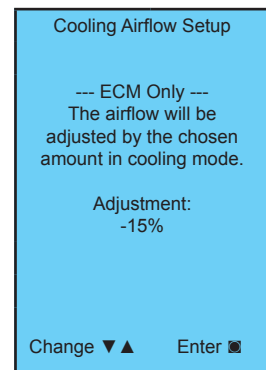
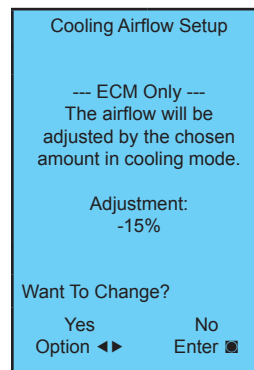

Setting Blower Speed - Variable Speed ECM - UPC Controls

Variable speed ECM blower motors have 12 selectable speeds and are factory set for optimum performance. When applicable, the speed settings may also be adjusted through the Building Automation System (BAS).



CAUTION: Disconnect all power before performing this operation.

Wiring Schematics

Commercial Variable Speed - 208-230/60/1

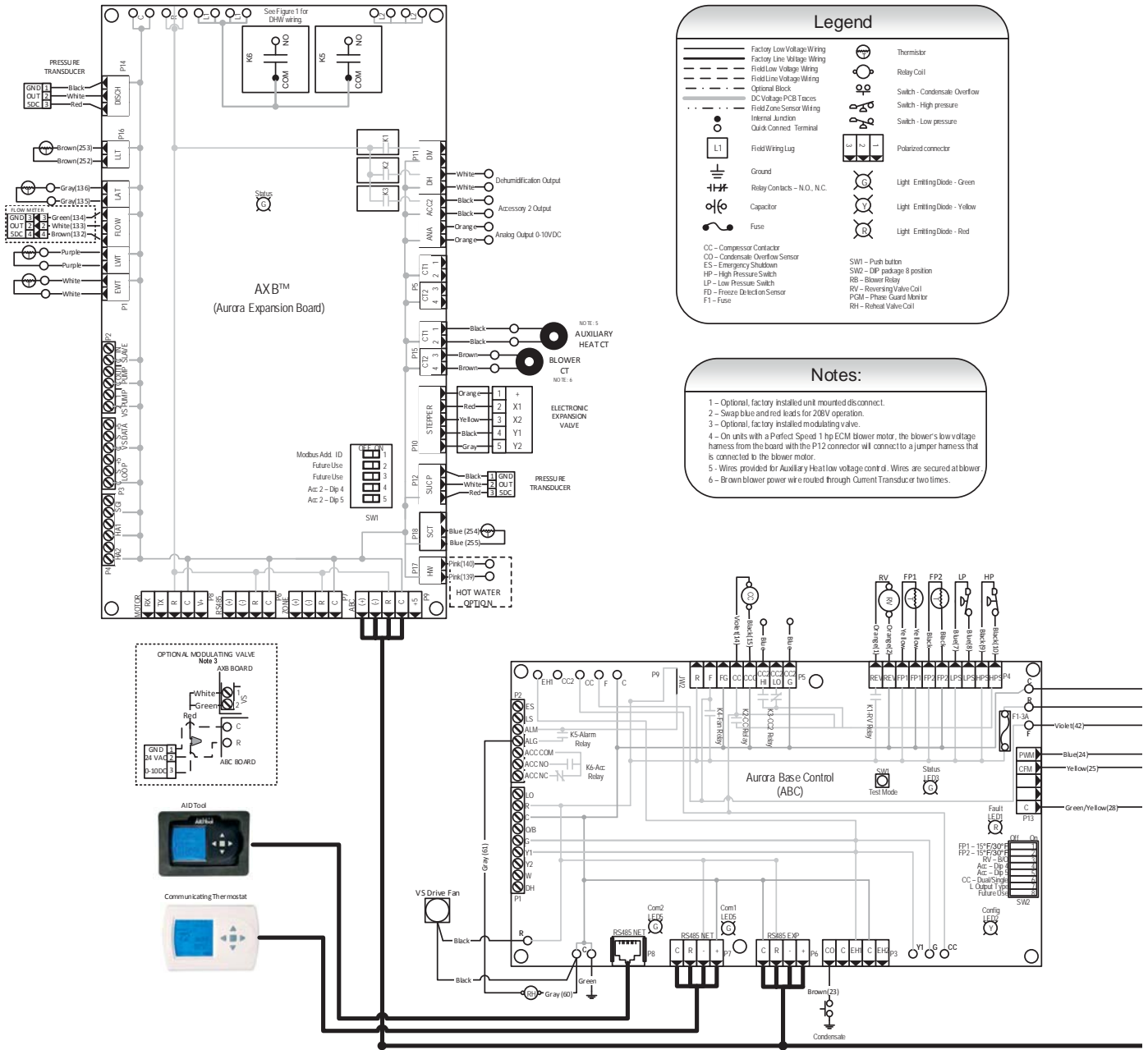

Wiring Schematics cont.

Commercial Variable Speed - 208-230/60/1

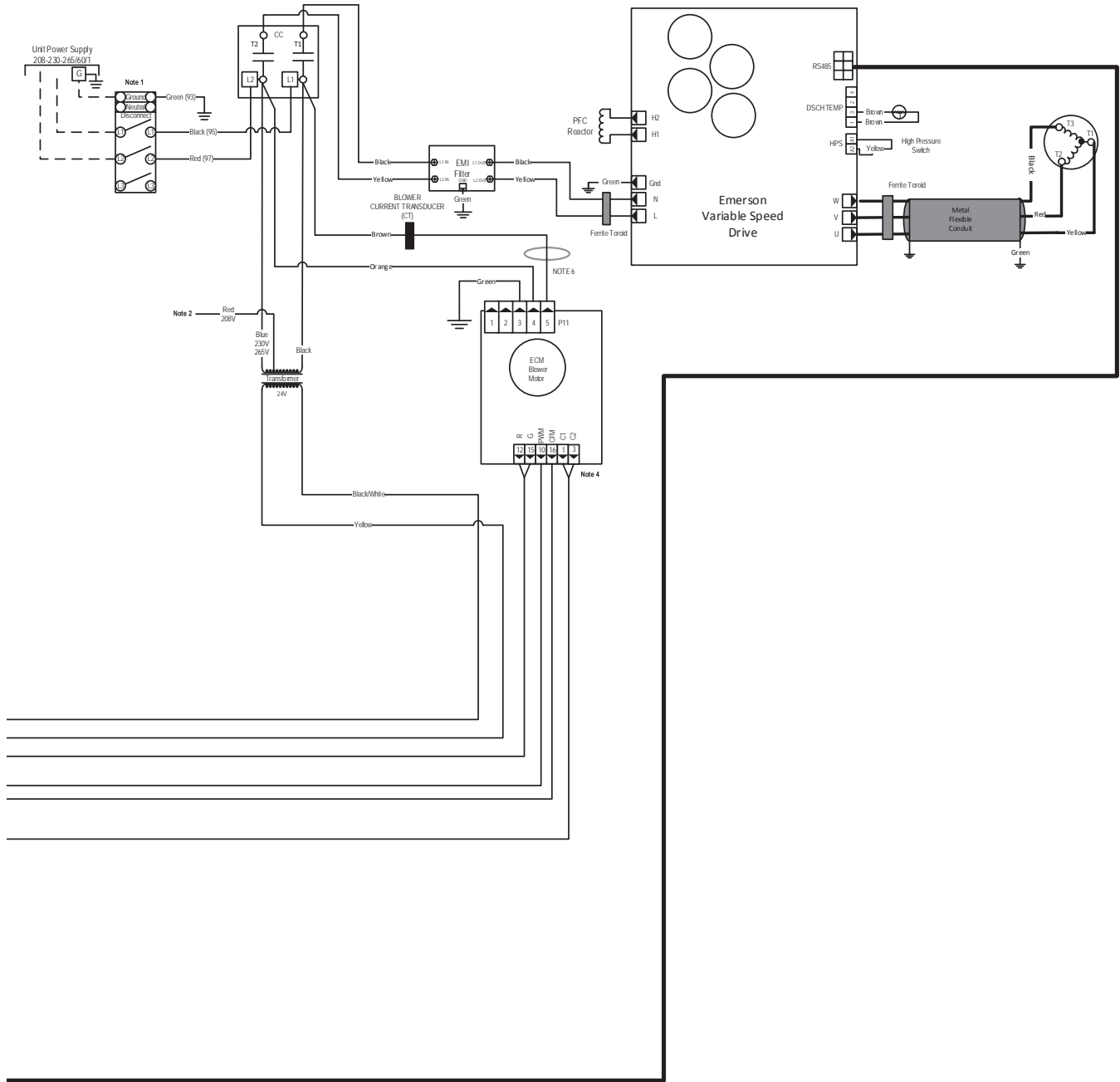

Wiring Schematics cont.

Commercial Variable Speed - 460/60/3

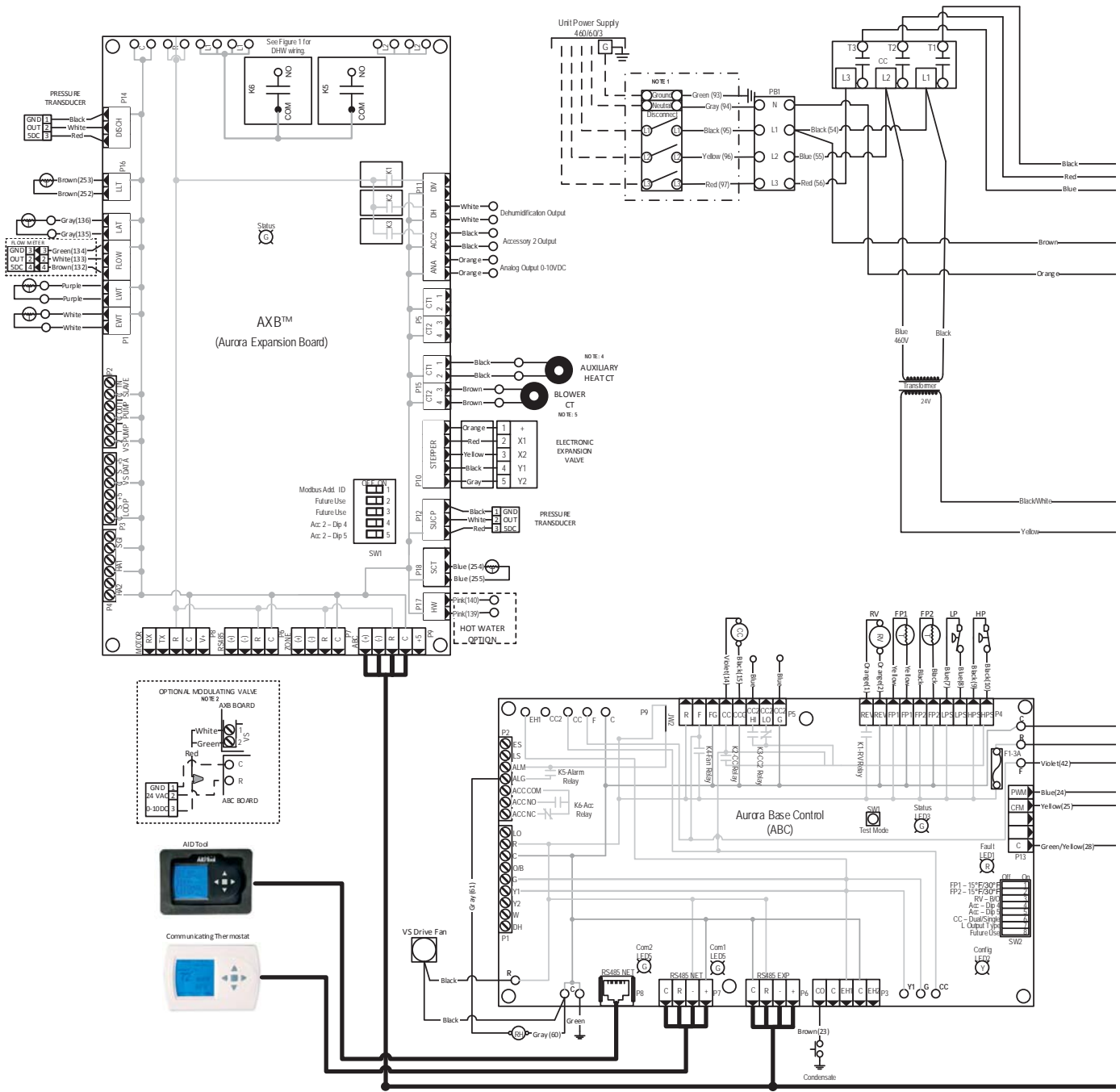

Wiring Schematics cont.

Commercial Variable Speed - 460/60/3

09/15/16

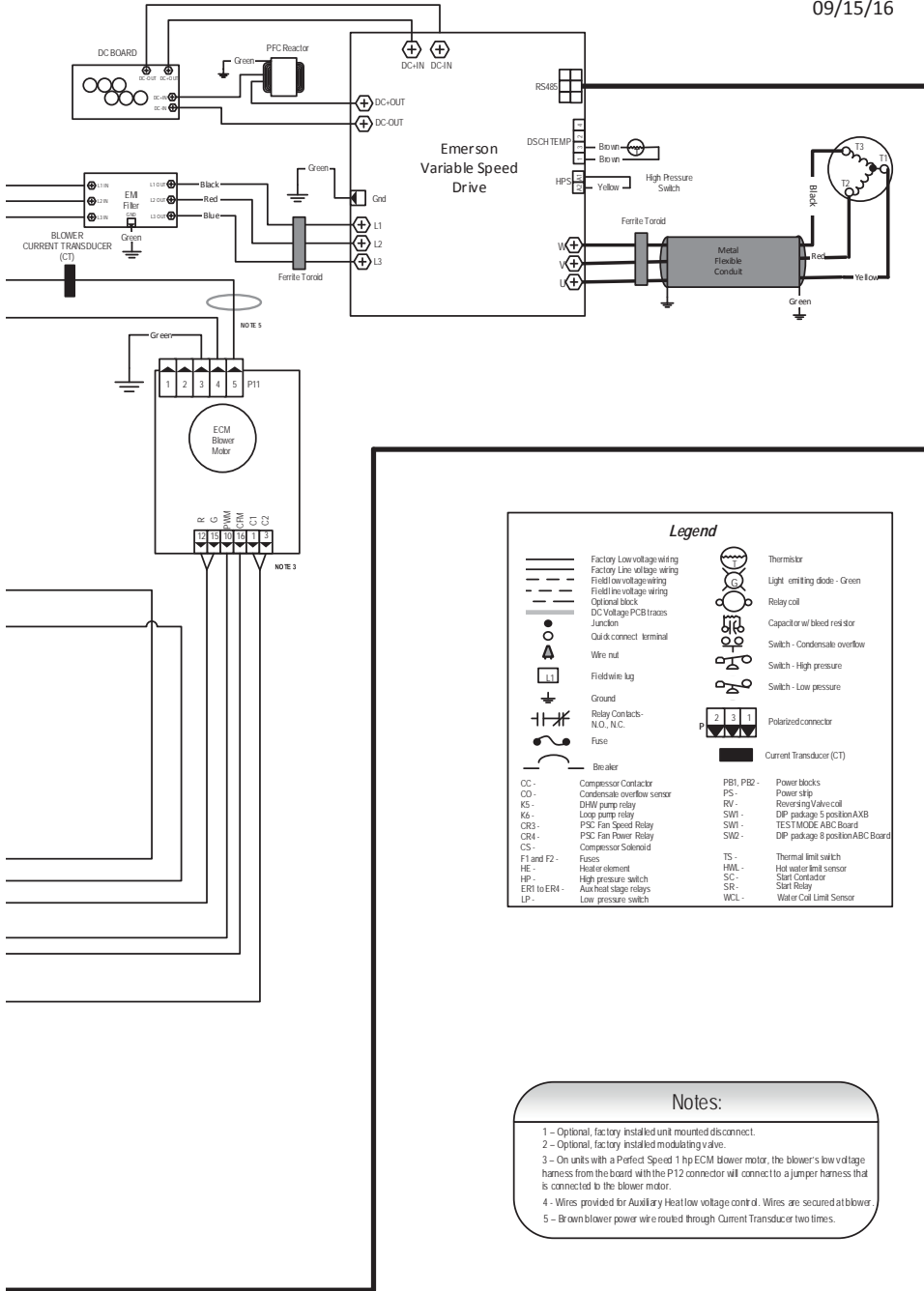

Wiring Schematics cont.

Commercial Variable Speed

Red Fault LED	LED Flash Code *	Lockout	Reset/Remove	Fault Condition Summary	ABC Action		AID Tool Display and History	IntelliZone 2 and Thermostat Display
					ABC Green Status LED	ABC Red Fault LED		
Normal - No Faults	Off	-						
Fault-Input	1	No	Auto	Tstat input error. Autoreset upon condition removal.	Normal	Code 1		
Fault-High Pressure	2	Yes	Hard or Soft	HP switch has tripped (>600 psi)	Lockout	Code 2	Lockout - E2 High Press	Lockout - E2 High Press
Fault-Low Pressure	3	Yes	Hard or Soft	Low Pressure Switch has tripped (<40 psi for 30 continuous sec.)	Lockout	Code 3	Lockout - E3 Low Press	Lockout - E3 Low Press
Fault-Freeze Detection FP2	4	Yes	Hard or Soft	Freeze protection sensor has tripped (<30 degF for 30 continuous sec.)	Lockout	Code 4	Lockout - E4 Freeze Detection FP2	Lockout - E4 Freeze Detection FP2
Fault-Freeze Detection FPI	5	Yes	Hard or Soft	Freeze protection sensor has tripped (<15 or 30 degF for 30 continuous sec.)	Lockout	Code 5	Lockout - E5 Freeze Detection FPI	Lockout - E5 Freeze Detection FPI
Fault-Condensate Overflow	7	Yes	Hard or Soft	Condensate switch has shown continuity for 30 continuous sec.	Lockout	Code 7	Lockout - E7 Condensate	Lockout - E7 Condensate
Fault-Over/Under Voltage	8	No**	Auto	Instantaneous Voltage is out of range. **Controls shut down until resolved.	Lockout	Code 8	Lockout - E8 Over/Under voltage	Lockout - E8 Over/Under voltage
Fault-FPI & 2 Snsr Error	11	Yes	Hard or Soft	If FPI or 2 Sensor Err	Lockout	Code 11	Lockout - E11 FPI/FP2 Sensor Error	Lockout - E11 FPI/FP2 Sensor Error
Non-Critical AXB Snsr Err	13	No	Auto	Any Other Sensor Err	Normal	Code 13	Alert - E13 Non-Critical AXB Sensor Error	Alert - E13 Non-Critical AXB Sensor Error
Critical XBSnsr Err	14	Yes	Hard or Soft	Sensor Err for EEV or HW	Lockout	Code 14	Lockout - E14 Critical AXB Sensor Error	Lockout - E14 Critical AXB Sensor Error
Alarm-HotWtr	15	No	Auto	HW over limit or logic lockout. HW pump deactivated.	Normal	Code 15	Alert - E15 Hot Water Temp Limit	No Display
Fault-VarSpdPump	16	No	Auto	Alert is read from PWM feedback.	Normal	Code 16	Alert - E16 Var Spd Pump Err	Alert - E16 Var Spd Pump Err
Not Used	17	No	Auto	IZZ Com Fault. Autoreset upon condition removal.	Normal	Code 17	Warning - E17 IZZ Comm Error	Warning - E17 IZZ Comm Error
Non-Crit Com Err	18	No	Auto	Any non-critical com error	Normal	Code 18	Alert - E18 Non-Critical Communication Error	Alert - E18 Non-Critical Communication Error
Fault-ChkComErr	19	No	Auto	Any critical com error. Auto reset upon condition removal	Normal	Code 19	Alert - E19 Critical Communication Error	Alert - E19 Critical Communication Error
Alarm - Low Loop Pressure	21	No	Auto	Loop pressure is below 3 psi for more than 3 minutes	Normal	Code 21	Alert - E21 Low Loop Pressure	No Display
Alarm - Home Automation 1	23	No	Auto	Closed contact input is present on Dig 2 input. - Text is configurable	Normal	Code 23	Alert - E23 Selected choice	Alert - E23 Selected choice
Alarm - Home Automation 2	24	No	Auto	Closed contact input is present on Dig 3 input. - Text is configurable	Normal	Code 24	Alert - E24 Selected Choice	Alert - E24 Selected Choice
Derate-DriveTemp	41	No	Auto	Drive Temp has reached critical High Temp	Derated	Code 41	Warning! Derated - E41 Drive Temp	Warning! Derated - E41 Drive Temp
Derate-OutPwrLmt	46	No	Auto	Supply Voltage is low or Max Pwr is reached due to high pressure	Derated	Code 46	Warning! Derated - E46 OutPwrLmt	Warning! Derated - E46 OutPwrLmt
Fault-DistTpsSnr	51	Yes	Hard or Soft	Discharge Sensor (SD) is > 280 F or invalid (-76 to 392 F)	Lockout	Code 51	Lockout! - E51 DistTpsSnr	Lockout! - E51 DistTpsSnr
Fault-SucPrsSnr	52	Yes	Hard or Soft	Suction Pressure (PO) is invalid (0 to 290 psi)	Lockout	Code 52	Lockout! - E52 SucPrsSnr	Lockout! - E52 SucPrsSnr
Fault-ConPrsSnr	53	10x then Yes	Hard or Soft	Jumper missing from drive pin A1 to A2	Norm then Lockout	Code 53	Lockout! - E53 ConPrsSnr	Lockout! - E53 ConPrsSnr
Fault-LowSupVolt	54	Yes	Hard or Soft	Supply Voltage is <175 V (190V to reset) or powered off/on too quickly (<30 sec.).	Lockout	Code 54	Lockout! - E54 LowSupVolt	Lockout! - E54 LowSupVolt
Fault-OutEnvelop	55	10x then Yes	Hard or Soft	Comp Operating out of envelope more than 90 sec. Retry 10x.	Norm then Lockout	Code 55	Lockout! - E55 OutEnvelop	Lockout! - E55 OutEnvelop
Fault-OverCurrnt	56	Yes	Hard or Soft	Over current tripped by phase loss, earth fault, short circuit. Check motor windings/wiring connectors	Lockout	Code 56	Lockout! - E56 OverCurrnt	Lockout! - E56 OverCurrnt
Fault-Over/UnderVolt	57	Yes	Hard or Soft	Over/Under AC input voltage or Over/Under DC Bus Voltage	Lockout	Code 57	Lockout! - E57 Over/Under Volt	Lockout! - E57 Over/Under Volt
Fault-HDrivTemp	58	Yes	Hard or Soft	Over temperature of PFC/IGBT/Power Module. Check drive airflow/compressor operation	Lockout	Code 58	Lockout! - E58HDrivTemp	Lockout! - E58HDrivTemp
Fault-DrivErr_MOC/AOC	59	Yes	Hard or Soft	Microelectronic/EEPROM fault has occurred. Check communications/Power Cycle/DC Bus Volt	Lockout	Code 59	Lockout! - E59 DrvntErr	Lockout! - E59 DrvntErr
Fault-MultSafeMd	61	Yes	Hard or Soft	Communication/Configuration Error has occurred	Lockout	Code 61	Lockout! - E61 MultSafeMd	Lockout! - E61 MultSafeMd
Fault-PFC-IGBT/OpenSensor	62	Yes	Hard or Soft	Power Module Temp Low/Open Sensor Fault/PFC-IGBT Temp Low	Lockout	Code 62	Lockout! - E62 LowTemp	Lockout! - E62 LowTemp
Fault-Limit Lockout	63	Yes	Hard or Soft	Discharge Temp/High Drive Temp/OverSensor fault limits have been reached	Lockout	Code 63	Lockout! - E63 FaultLimit	Lockout! - E63 FaultLimit
System Reset	99	No	Auto	System Reset Counter History	NA	Code 99	Fault History - E99 SysReset	No Display

Note: *All codes >11 use long flash for tens digit and short flash for the ones digit. 20, 30, 40, 50 etc. are skipped! Alert! is a noncritical sensor or function that has failed. Normal operation of the heat pump is maintained but service is desired at some point.

Wiring Schematics cont.

Commercial Variable Speed

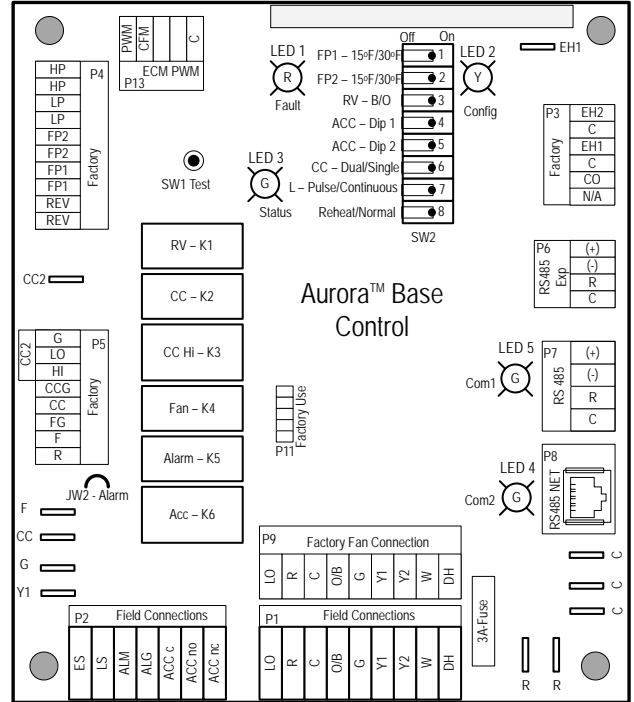
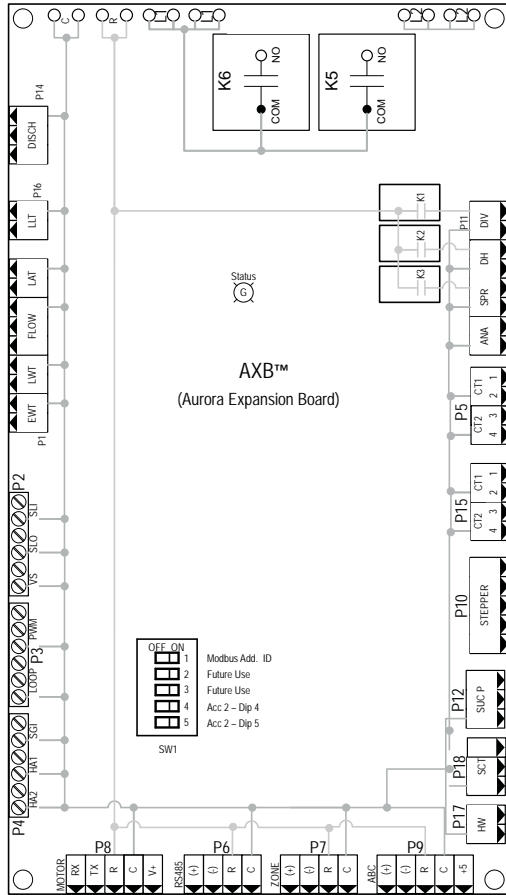

AXB Accessory 2 DIP Settings		
SW1-4	SW1-5	DESCRIPTION
ON	ON	Cycles with Blower
OFF	ON	Cycles with CC first stage compressor or compressor spd 1-12
ON	OFF	Cycles with CC2 second stage of compressor or comp spd 7-12
OFF	OFF	Cycles with DH from ABC board

ABC SW2 Accessory Relay		
DESCRIPTION	SW2-4	SW2-5
Cycle with Blower	ON	ON
Cycle with Compressor	OFF	OFF
Water Valve Slow Opening	ON	OFF
Cycle with Comm. T-stat Hum Cmd	OFF	ON

Legend

		Thermistor
		Relay Coil
		Switch - Condensate Overflow
		Switch - High pressure
		Switch - Low pressure
		Polarized connector
		Light Emitting Diode - Green
		Light Emitting Diode - Yellow
		Light Emitting Diode - Red





CC - Compressor Contactor
 CO - Condensate Overflow Sensor
 ES - Emergency Shutdown
 HP - High Pressure Switch
 LP - Low Pressure Switch
 FD - Freeze Detect on Sensor
 F1 - Fuse

SW1 - Push button
 SW2 - DIP package 8 position
 RB - Blower Relay
 RV - Reversing Valve Coil
 PGM - Phase Guard Monitor
 RH - Reheat Valve Coil

Controls - Aurora Advanced Variable Speed Control

Aurora Controls

The Aurora Control System is a complete commercial comfort system that can bring all aspects of the HVAC system into one cohesive module network. The Aurora System is available in two configurations: Aurora Base Control and Aurora Advanced Control both with optional Aurora UPC for DDC applications.

Control	General Description	Application	Display/Interface	Protocol
<p>Aurora Base Control</p> 	<p>The ABC microprocessor provides all the features necessary to operate today's standard WSHPs that utilize dual capacity compressors and variable speed ECM/5 speed ECM blower motors. This control can communicate to a handheld diagnostic tool to help the installing contractor or service technician with equipment setup and service. By utilizing Modbus RTU communication protocol, the ABC board can communicate with additional devices on the Aurora network</p>	<p>Used for residential and commercial applications that use single or dual capacity compressors with PSC, 5-speed ECM, or variable speed ECM blower motors. This base control can also communicate to the AID Tool to display faults, inputs/outputs, and software revision. Commercial features such as slow opening water valve and random start are also capable with the ABC board.</p>	<p>Optional AID tool can be used for field service.</p>	<p>Standalone</p>
<p>Aurora Advanced Control (ABC/AXB)</p> 	<p>Aurora Advanced Control adds the Aurora AXB expansion board and provides added I/O and standard features such as refrigerant, performance or energy monitoring.</p>	<ul style="list-style-type: none"> • Refrigeration Monitoring - provides Suction and discharge pressure, Suction, liquid line temps and superheat and subcooling. • Performance Monitoring - provides entering and leaving loop water temperatures, loop flow rate as well as heat of extraction or rejection rate into the loop. • Energy Monitoring - provides real-time power measurement (Watt) of compressor, fan, auxiliary heat and zone pump. • Plus many more I/O options 	<p>Optional AID tool can be used for field service.</p>	<p>Standalone</p>
<p>Aurora Base/Aurora Advanced Control w/UPC BACnet or N2</p> 	<p>The Aurora Unitary Protocol Converter (UPC) is an integrated solution and communicates directly with the Aurora Heat Pump Controls and allows access/control of a variety of internal Aurora heat pump operations such as sensors, relay operation, faults and other information. In turn, the UPC then converts internal Aurora Modbus protocol to BACnet MS/TP, or N2 protocols and communicates to the BAS system. This provides the great benefit of complete control integration and a myriad of information available to the BAS from the heat pump control. Plus it also allows individual unit configuration such as ECM fan speeds or freeze protection setting directly over the BAS without the need for access to the actual heat pump.</p>	<p>The Aurora UPC is implemented with the Aurora heat pump control into our latest water source heat pumps. All Internal Aurora points are accessible to the UPC via firmware providing an integrated solution. All zone temperatures and zone sensors are connected to the UPC on an RNet bus, simplifying hook up at the unit. RNet sensors can include a combination of zone temperature and humidity, CO2, and VOC sensors. The UPC includes built-in support for a custom configurable keypad/display unit.</p>	<p>Optional Aurora Touch Interface</p>	<p>BACnet MS/TP or N2 Open (DIP selectable)</p>
<p>Aurora Base/Aurora Advanced Control w/UPC LonWorks</p> 	<p>The Aurora Unitary Protocol Converter (UPC) is an integrated solution and communicates directly with the Aurora Heat Pump Controls and allows access/control of a variety of internal Aurora heat pump operations such as sensors, relay operation, faults and other information. In turn, the UPC then converts internal Aurora Modbus protocol to LONWorks protocol and communicates to the BAS system.</p>	<p>The Aurora UPC is implemented with the heat pump control into our latest water source heat pumps. All Internal Aurora points are accessible to the UPC via firmware providing an integrated solution. All zone temperatures and zone sensors are connected to the UPC on an RNet bus, simplifying hook up at the unit. RNet sensors can include a combination of zone temperature and humidity, CO2, and VOC sensors. The UPC includes built-in support for a custom configurable keypad/display unit.</p>	<p>Optional Aurora Touch Interface</p>	<p>LonWorks</p>

Controls - Aurora Advanced Variable Speed Control cont.

Aurora 'Advanced Variable Speed' Control



NOTE: Refer to the Aurora Base Control Application and Troubleshooting Guide and the Instruction Guide: Aurora Interface and Diagnostics (AID) Tool for additional information.

The Aurora Advanced VS Control provides all baseline operation of 7 faults (HP, LP, and LOC, coax freeze protection, air coil freeze protection, over/under voltage, and condensate overflow), as well as compressor speed, fan speed, and lockout management through a single Aurora Base Control board (ABC). The control features all heat pump operational timings, configurations, sensors, and fault history that can be viewed using the AID tool.

In addition to the baseline operation, Aurora Advanced VS Control adds the extended I/O of the Aurora Expansion Board (AXB) to the mix. This extended I/O includes energy monitoring as a standard feature where current transducers measure current and power of the fan motor. Compressor power is monitored by the compressor drive and communicated to the Aurora Controls. Refrigerant monitoring is standard on all variable speed models and reports refrigerant temperatures and pressures in order to calculate superheat and subcooling. The optional performance monitoring kit includes entering and leaving water temperatures along with source water flow rate via a vortex shedding flow meter.

The Aurora Advanced VS Control uses an internal PID control and communicates via Modbus to the variable speed compressor drive and electronic expansion valve to provide capacity and superheat control of the system. All faults codes from the compressor drive are mapped to the Aurora system which are then displayed through the AID tool.

Optional Aurora UPC

When coupled with the optional Aurora UPC, the system can communicate all of these same heat pump parameters to the BAS as network points using either BACnet, N2 or Lon protocols. This means that not only are heat pump parameters visible by the BAS, many configuration settings, such as airflow and freeze detection settings, can also be changed from the BAS system saving commissioning costs. This provides both cost advantages and features not typically found on WSHP controls. All configuration, sensor and servicing can be accessed thru the AuroraTouch color service tool. This integration allows heat pump monitoring sensors, status and service diagnosis faults to be communicated thru the DDC direct to the building automation system (BAS), giving building supervisors detailed and accurate information on every piece of equipment without removing an access panel!



Control Features

Software ABC Standard Version 3.0

Variable Speed Compressors

Only Copeland EV2 Variable Speed compressors can be operated.

Aurora Advanced VS Control Features

NOTE: Refer to the Aurora Advanced VS Control Application and Troubleshooting Guide and the Instruction Guide: Aurora Interface and Diagnostics (AID) Tool for additional information.

Control Features

Software ABC VS Version 3.0 Variable Capacity Compressors

- Random start at power up
- Anti-short cycle protection
- High and low pressure cutouts
- Loss of charge
- Water coil freeze detection
- Air coil freeze detection
- Over/under voltage protection
- Condensate overflow sensor
- Load shed
- Dehumidification (where applicable)
- Emergency shutdown
- Diagnostic LED
- Test mode push button switch
- Two auxiliary electric heat outputs
- Alarm output
- Accessory output with N.O. and N.C.
- Modbus communication

Controls - Aurora Advanced Variable Speed Control cont.

Variable Speed ECM Blower Motor

A variable speed ECM blower motor is driven directly using the onboard PWM output. Multiple blower speeds are available based upon requirements of the compressor and electric heat. The blower speeds can be changed either by the variable speed ECM manual configurations mode method or by using the Aurora AID Tool directly, or with the Aurora/UPC via BAS.

Advanced Hot Water Generator Control (Domestic Hot Water Option)

An AID Tool selectable temperature limit and microprocessor control of the process is featured. This will maximize hot water generation and prevent undesirable energy use. An alert will occur when the hot water input temperature is at or above the set point (130°F default) for 30 continuous seconds. This alert will appear as an E15 on the AID Tool and the hot water pump de-energizes. Hot water pump operations resume on the next compressor cycle or after 15 minutes of continuous compressor operation during the current thermostat demand cycle. Since compressor hot gas temperature is dependent on loop temperature in cooling mode, loop temperatures may be too low to allow proper heating of water. The control will monitor water and refrigerant temperatures to determine if conditions are satisfactory for heating water.

VS Drive and Envelope Control

The VS drive operates the compressor between 25 and 100% capacity. The VS drive communicates any out of refrigerant envelope conditions to the Aurora and will attempt to adjust the compressor speed to keep within the envelope. These conditions are measured using discharge temperature and current sensors of the drive.

Electronic Expansion Valve (EEV)

The electronic expansion valve (EEV) is operated by the AXB board and is set to maintain optimal superheat setting for maximum efficiency. All operation parameters are communicated to the Aurora system.

Variable Speed Pump

This input and output are provided to drive and monitor a variable speed pump. The VS pump output is a PWM signal to drive the variable speed pump. The minimum and maximum level are set using the AID Tool. 50% and 100% are the default settings respectively. The VS data input allows a separate PWM signal to return from the pump giving fault and performance information. Fault received from the variable speed pump will be displayed as E16.

Modulating Water Valve

This output is provided to drive a modulating water valve. Through advanced design the 0-10VDC valve can be driven directly from the VS Pump output. The minimum and maximum level are set in the same way as the VS pump using the AID Tool. 50% and 100% are the default settings respectively.

Loop Pump Linking

This input and output are provided so that two units can be linked together with a common flow center. When either unit has a call for loop outputs, both unit's loop pump relays and variable speed pumps are energized. The flow center then can simply be wired to either unit. The output from one unit should be routed to the input of the other. If daisy chained, up to 16 heat pumps can be wired and linked together in this fashion.

Advanced Communication Ports

AXB Communication ports P6 and P8 will provide future expansion via dedicated protocols. These are for future use.

Monitoring Sensors

Energy Monitoring

Energy Monitoring is standard in all models and includes two current transducers (blower and electric heat) so that the complete power usage of the heat pump can be measured. Compressor power is measured by the variable speed drive. The AID Tool provides configuration detail for the type of blower motor and a line voltage calibration procedure to improve the accuracy. This information can be displayed on the AID Tool, selected communicating thermostats or communicated thru the optional Aurora UPC BAS communications board.

Refrigerant Monitoring

Refrigerant Monitoring is standard in all models includes two pressure transducers, and three temperature sensors, heating liquid line, suction temperature and existing cooling liquid line (FP1). These sensors allow the measurement of discharge and suction pressures, suction and liquid line temperatures as well as superheat and subcooling. This information can be displayed on the AID Tool or communicated thru the optional Aurora UPC BAS communications board.

Performance Monitoring (Requires Flow Meter)

The optional Performance Monitoring includes three temperature sensors, entering and leaving water, leaving air temperature and a water flow rate sensor. Heat of extraction and rejection will be calculated. This requires configuration using the AID Tool for selection of water or antifreeze and is displayed on the AID tool or communicated thru the optional Aurora UPC BAS communications board.

Controls - Aurora Advanced Variable Speed Control cont.

Special Modes and Applications Communicating Digital Thermostats

The Aurora Advanced VS controls system also requires either the monochromatic or color touch screen graphic display thermostats for user interface. These displays not only feature easy to use graphical interface but display alerts and faults in plain English.

Dehumidification - Active

Active dehumidification will only activate during cooling operation and is based upon the humidity setpoint of the thermostat being at least 5% below the actual relative humidity and being within the temperature parameters described here. The green status LED will flash code 2 when active. The unit can operate a maximum of 2°F below the cooling setpoint. The compressor will ramp up and airflow will begin at a low level. Airflow is then reduced periodically until air coil temperature setpoint is reached. If coil temperature continues to drop, the airflow is increased until air coil setpoint is maintained. After 20 minutes of operation in the Active Dehumidification mode, normal cooling operation will resume for 5 minutes. This cycle continues until the dehumidification setpoint is reached, room temperature is more than 2°F below cooling setpoint, or more than 1°F above cooling setpoint (normal cooling takes over). In IntelliZone2 systems, active dehumidification is only enabled when system is operating on compressor speeds 4 or lower. Once active dehumidification is activated the main zone and any other active cooling zone will remain open.

Field Hardware Selectable Options

ABC Field Selectable Options via Button (SW1)

Test/Configuration Button (See SW1 Operation Table)

Test Mode

The control is placed in the test mode by holding the push button switch on the ABC SW1 for 2 - 5 seconds. In test mode most of the control timings will be shortened by a factor of sixteen (16). LED3 (green) will flash at 1 second on and 1 second off. Additionally, when entering test mode LED1 (red) will flash the last lockout one time. Test mode will automatically time out after 30 minutes. Test mode can be exited by pressing and holding the SW1 button for 2 to 5 seconds or by cycling the power. **NOTE:** Test mode will automatically be exited after 30 minutes.

Variable Speed ECM Configuration Mode

The control is placed in the variable speed ECM configuration mode by holding the push-button switch SW1 for 5 to 10 seconds, the high, low, and G variable speed ECM speeds can be selected by following the LED display lights. LED2 (yellow) will fast flash when entering the variable speed ECM configuration. When setting G speed LED3 (green) will be continuously lit, for low speed LED1 (red) will be continuously lit, and for high speed both LED3 (green)

and LED1 (red) will be continuously lit. During the variable speed ECM configuration mode LED2 (yellow) will flash each of the 12 possible blower speeds 3 times. When the desired speed is flashed press SW1, LED2 will fast flash until SW1 is released. G speed has now been selected. Next select low speed, and high speed blower selections following the same process above. After third selection has been made, the control will exit the variable speed ECM configuration mode. Aux blower speed will remain at default or current setting and requires the AID Tool for adjustment.

Reset Configuration Mode

The control is placed in reset configuration mode by holding the push button switch SW1 on the ABC for 50 to 60 seconds. This will reset all configuration settings and the EEPROM back to the factory default settings. LED3 (green) will turn off when entering reset configuration mode. Once LED3 (green) turns off, release SW1 and the control will reset.

ABC DIP Switch (SW2)

- SW2-1** FP1 Selection - Low water coil temperature limit setting for freeze detection. On = 30°F; Off = 15°F.
- SW2-2** FP2 Selection - Low air coil temperature limit setting for freeze detection. On = 30°F; Off = Not Used
- SW2-3** RV - O/B - thermostat type. Heat pump thermostats with "O" output in cooling or "B" output in Heating can be selected. On = O; Off = B.
- SW2-4** Access Relay Operation (P2) and 2-5

Access Relay Operation	SW2-4	SW2-5
Cycle with Blower	ON	ON
Cycle with Compressor	OFF	OFF
Water Valve Slow Opening	ON	OFF
Cycle with Comm. T-stat Hum Cmd	OFF	ON

- SW2-6** CC Operation - selection of single or dual capacity compressor. On = Single Stage; Off = Dual Capacity
NOTE: SW2-6 is not applicable to the 7 Series
- SW2-7** Lockout and Alarm Outputs (P2) - selection of a continuous or pulsed output for both the LO and ALM Outputs. On = Continuous; Off = Pulsed
NOTE: SW2-7 is not applicable to the 7 Series
- SW2-8** Future Use

Alarm Jumper Clip Selection

From the factory, ALM is connected to 24 VAC via JW2. By cutting JW2, ALM becomes a dry contact connected to ALG.

Controls - Aurora Advanced Variable Speed Control cont.

Variable Speed ECM Blower Speeds

The blower speeds can be changed either by using the variable speed ECM manual configurations mode method or by using the Aurora AID Tool directly (see Instruction Guide: Aurora Interface and Diagnostics (AID) Tool topic).

AXB DIP Switch (SW1)

DIP 1 - ID: This is the AXB ModBus ID and should always read On.

DIP 2 & 3 - Future Use

DIP 4 & 5 - Accessory Relay2: A second, DIP configurable, accessory relay is provided that can be cycled with the compressor 1 or 2, blower, or the Dehumidifier (DH) input. This is to complement the Accessory 1 Relay on the ABC board.

Position	DIP 4	DIP 5	Description
1	ON	ON	Cycles with blower or ECM (or G)
2	OFF	ON	Cycles with CC1 first stage of compressor or compressor spd 1-12
3	ON	OFF	Cycles with CC2 second stage of compressor or compressor spd 7-12
4	OFF	OFF	Cycles with DH input from ABC board

Field Selectable Options via Software (Selectable via the Aurora AID Tool)

Many options are field selectable and configurable in Aurora software via the AID Tool. Consult the installation manual or Aurora documentation for further details.

Basic Aurora Safety Features

The following safety features are provided to protect the compressor, heat exchangers, wiring and other components from damage caused by operation outside of design conditions.

Fuse - a 3 amp automotive type plug-in fuse provides protection against short circuit or overload conditions. Anti-Short Cycle Protection - 4 minute anti-short cycle protection for the compressor.

Random Start - 5 to 80 second random start upon power up.

Fault Retry - in the fault condition, the control will stage off the outputs and then “try again” to satisfy the thermostat VS call. Once the thermostat input calls are satisfied, the control will continue on as if no fault occurred. If 3 consecutive faults occur without satisfying the thermostat VS call, then the control will go to Lockout mode.

Lockout - when locked out, the blower will operate continuously in “G” blower speed setting. The Alarm output (ALM) and Lockout output (L) will be turned on. The fault type identification display LED1 (Red) shall flash the fault code. To reset lockout conditions with SW2-8 On, the demand call must be removed for at least 30 seconds. To reset lockout conditions with SW2-8 Off, the demand call must be removed for at least 30 seconds. Lockout may also be reset by turning power off for at least 30 seconds or by enabling the emergency shutdown input for at least 30 seconds.



CAUTION: Frequent cycling of power to the drive can damage the drive! Wait at least 5 minutes between cycles (connecting and disconnecting power to the drive).

Lockout With Emergency Heat - if the control is locked out in the heating mode, and a call for emergency heat is received, the control will operate in the emergency heat mode while the compressor is locked out. The first emergency heat output will be energized 10 seconds after the W input is received, and the blower will shift to high speed. If the control remains locked out, and the W input is present, additional stage of emergency heat will stage on after 2 minutes. When the W input is removed, all of the emergency heat outputs will turn off, and the variable speed ECM blower will shift to low speed.

High Pressure - fault is recognized when the Normally Closed High Pressure Switch, P4-9/10 opens, no matter how momentarily. The High Pressure Switch is electrically in series with the Compressor Contactor and serves as a hardwired limit switch if an overpressure condition should occur.

Low Pressure - fault is recognized when the Normally Closed Low Pressure Switch, P4-7/8 is continuously open for 30 seconds. Closure of the LPS any time during the 30 second recognition time restarts the 30 second continuous open requirement. A continuously open LPS shall not be recognized during the 2 minute startup bypass time.

Loss of Charge - fault is recognized when the Normally Closed Low Pressure Switch, P4-7/8 is open prior to the compressor starting.

Condensate Overflow - fault is recognized when the impedance between this line and 24 VAC common or chassis ground drops below 100K ohms for 30 seconds continuously.

Controls - Aurora Advanced Variable Speed Control cont.

Freeze Detection-(Coax) - set points shall be either 30°F or 15°F. When the thermistor temperature drops below the selected set point, the control shall begin counting down the 30 seconds delay. If the thermistor value rises above the selected set point, then the count should reset. The resistance value must remain below the selected set point for the entire length of the appropriate delay to be recognized as a fault. This fault will be ignored for the initial 2 minutes of the compressor run time.

Freeze Detection-(Air Coil) - Air Coil Freeze Detection will use the FP2 input to protect against ice formation on the air coil. The FP2 input will operate exactly like FP1 except that the set point is 30 degrees and is not field adjustable.

Over/Under Voltage Shutdown - An over/under voltage condition exists when the control voltage is outside the range of 18 VAC to 30 VAC. If the over/under voltage shutdown lasts for 15 minutes, the lockout and alarm relay will be energized. Over/under voltage shutdown is self-resetting in that if the voltage comes back within range of 18 VAC to 30 VAC for at least 0.5 seconds, then normal operation is restored.

Other Lockouts and Alarms

Several other lockouts and alarms are shown in the Status LED1 (LED1, Red) table with the associated codes visible on the thermostat, ABC Fault LED, and in text in the AID Tool.

Operation Description

Power Up - The unit will not operate until all the inputs and safety controls are checked for normal conditions. The unit has a 5 to 80 second random start delay at power up. Then the compressor has a 4 minute anti-short cycle delay after the random start delay.

Standby - In standby mode the compressor, pump, and blower motor are not active. The RV may be active. The blower and compressor will be off.

Heating Operation - The unit will operate based upon demand as calculated by the room setpoint algorithm. The resulting compressor speed (1-12) will also select an appropriate blower speed for the selected compressor speed. Aux Heat will not be available (on IntelliZone2 Aux Heat is available on compressor speeds 10-12) until after the 12th compressor speed has been operational and still is not satisfying the thermostat, then auxiliary electric heat will be activated.

Emergency Heat (W) - The blower will be started on G speed, 10 seconds later the first stage of electric heat will be turned on. 5 seconds after the first stage of electric heat is energized the blower will shift to Aux speed. If the emergency heat demand is not satisfied after 2 minutes the second electric heat stage will be energized.

Cooling Operation - The unit will operate based upon demand as calculated by the room setpoint algorithm. The resulting compressor speed, speeds 1-12, will also select an appropriate blower speed. The blower mode will also have the cooling airflow adjustment applied. In all cooling operations, the reversing valve directly tracks the O input. Thus, anytime the O input is present, the reversing valve will be energized.

Controls - Aurora Advanced Variable Speed Control cont.

Blower (G) - The blower will start immediately upon receiving a thermostat G command. If there are no other commands from the thermostat the variable speed ECM will run on low speed until the G command is removed. Regardless of blower input (G) from the thermostat, the blower will remain on low speed for 30 seconds at the end of each heating, cooling, and emergency heat cycle.

Emergency Shutdown - Four (4) seconds after a valid ES input, P2-7 is present, all control outputs will be turned off and remain off until the emergency shutdown input is no longer present. The first time that the compressor is started after the control exits the emergency shutdown mode, there will be an anti-short cycle delay followed by a random start delay. Input must be tied to common to activate.

Continuous Blower Operation - The blower output will be energized any time the control has a G input present, unless the control has an emergency shutdown input present. The blower output will be turned off when G input is removed.

Load Shed - The LS input disables all outputs with the exception of the blower output. When the LS input has been cleared, the anti-short cycle timer and random start timer will be initiated. Input must be tied to common to activate.

Aurora Advanced VS Control LED Displays

These three LEDs display the status, configuration, and fault codes for the control. These can also be read in plain English via the Aurora AID Tool. See the LED tables for further explanation.

Aurora Interface and Diagnostics (AID) Tool

The Aurora Interface and Diagnostics (AID) Tool is a device that is a member of the Aurora network. The AID Tool is used to troubleshoot equipment which uses the Aurora control via Modbus RTU communication. The AID Tool provides diagnostics, fault management, variable speed ECM setup, and system configuration capabilities to the Aurora family of controls. An AID Tool is recommended, although not required, for variable speed ECM airflow settings. The AID Tool simply plugs into the exterior of the cabinet in the AID Tool port.



Status LED (LED3, Green)

Description of Operation	Fault LED, Green
Normal Mode	ON
Control is Non-functional	OFF
Test Mode	Slow Flash
Lockout Active	Fast Flash
Dehumidification Mode	Flash Code 2
Load Shed	Flash Code 5
Emergency Shutdown	Flash Code 6
On Peak Mode	Flash Code 7
Warning! VS Derated	Flash Code 8
Warning! VS SafeMode	Flash Code 9

Configuration LED (LED2, Yellow)

Description of Operation	Configuration LED, Yellow
No Software Overwritten	ECM Setting
DIP Switch Overwritten	Slow Flash
ECM Configuration Mode	Fast Flash
Reset Configuration Mode	OFF

Controls - Aurora Advanced Variable Speed Control cont.

Red Fault LED	LED Flash Code	Lockout	Reset/Remove	Fault Condition Summary	ABC Action		AID Tool Display and History	Intellizone2 and Thermostat Display
					ABC Green Status LED	ABC Red Fault LED		
ABC & AXB Basic Faults								
Normal - No Faults	Off	-						
Fault-Input	1	No	Auto	Tstat input error. Autoreset upon condition removal.	Normal	Code 1		
Fault-High Pressure	2	Yes	Hard or Soft	HP switch has tripped (>600 psi)	Lockout	Code 2	Lockout - E2 High Press	Lockout - E2 High Press
Fault-Low Pressure	3	Yes	Hard or Soft	Low Pressure Switch has tripped (<40 psi for 30 continuous sec)	Lockout	Code 3	Lockout - E3 Low Press	Lockout - E3 Low Press
Fault-Freeze Detection FP2	4	Yes	Hard or Soft	Freeze protection sensor has tripped (<30 degF for 30 continuous sec)	Lockout	Code 4	Lockout - E4 Freeze Detection FP2	Lockout - E4 Freeze Detection FP2
Fault-Freeze Detection FPI	5	Yes	Hard or Soft	Freeze protection sensor has tripped (<15 or 30 degF for 30 continuous sec)	Lockout	Code 5	Lockout - E5 Freeze Detection FPI	Lockout - E5 Freeze Detection FPI
Fault-Condensate Overflow	7	Yes	Hard or Soft	Condensate switch has shown continuity for 30 continuous sec.	Lockout	Code 7	Lockout - E7 Condensate	Lockout - E7 Condensate
Fault-Over/Under Voltage	8	No**	Auto	Instantaneous Voltage is out of range. **Controls shut down until resolved.	Lockout	Code 8	Lockout - E8 Over/Under voltage	Lockout - E8 Over/Under voltage
Fault-FPI & 2 Snsr Error	11	Yes	Hard or Soft	If FPI or 2 Snsr Err	Lockout	Code 11	Lockout - E11 FPI/FP2 Sensor Error	Lockout - E11 FPI/FP2 Sensor Error
Miscellaneous								
Non-Critical AXBSnsrErr	13	No	Auto	Any Other Sensor Err	Normal	Code 13	Alert - E13 Non-Critical AXB Sensor Error	Alert - E13 Non-Critical AXB Sensor Error
Critical AXBSnsrErr	14	Yes	Hard or Soft	Sensor Err for EEV or HW	Lockout	Code 14	Lockout - E14 Critical AXB Sensor Error	Lockout - E14 Critical AXB Sensor Error
Alarm-HotWtr	15	No	Auto	HW over limit or logic lockout. HW pump deactivated.	Normal	Code 15	Alert - E15 Hot Water Temp Limit	No Display
Fault-VarSpdPump	16	No	Auto	Alert is read from PWM feedback.	Normal	Code 16	Alert - E16 Var Spd Pump Err	Alert - E16 Var Spd Pump Err
Not Used	17	No	Auto	I22 Com Fault. Autoreset upon condition removal.	Normal	Code 17	Warning - E17 I22 Comm Error	Warning - E17 I22 Comm Error
Non-CritComErr	18	No	Auto	Any non-critical com error	Normal	Code 18	Alert - E18 Non-Critical Communication Error	Alert - E18 Non-Critical Communication Error
Fault-CritComErr	19	No	Auto	Any critical com error. Auto reset upon condition removal	Normal	Code 19	Alert - E19 Critical Communication Error	Alert - E19 Critical Communication Error
Alarm - Low Loop Pressure	21	No	Auto	Loop pressure is below .3 psi for more than 3 minutes	Normal	Code 21	Alert - E21 Low Loop Pressure	No Display
Alarm - Home Automation 1	23	No	Auto	Closed contact input is present on Dig 2 input - Text is configurable	Normal	Code 23	Alert - E23 Selected choice	Alert - E23 Selected choice
Alarm - Home Automation 2	24	No	Auto	Closed contact input is present on Dig 3 input - Text is configurable	Normal	Code 24	Alert - E24 Selected Choice	Alert - E24 Selected Choice
Derate-DriveTemp	41	No	Auto	Drive Temp has reached critical High Temp	Derated	Code 41	Warning/ Derated - E41 DriveTemp	Warning/ Derated - E41 DriveTemp
Derate-DrivePwrLmt	46	No	Auto	Supply Voltage is low or Max Pwr is reached due to high pressure	Derated	Code 46	Warning/ Derated - E46 OutPwrLmt	Warning/ Derated - E46 OutPwrLmt
Fault-DistmpSnr	51	Yes	Hard or Soft	Discharge Sensor (SD) is > 280 F or invalid (<76 to 392 F)	Lockout	Code 51	Lockout - E51 DistmpSnr	Lockout - E51 DistmpSnr
Fault-SucPrsSnr	52	Yes	Hard or Soft	Suction Pressure (PO) is invalid (0 to 290 psi)	Lockout	Code 52	Lockout - E52 SucPrsSnr	Lockout - E52 SucPrsSnr
Fault-ConPrsSnr	53	IOx, then Yes	Hard or Soft	Jumper missing from drive pin A1 to A2	Norm then Lockout	Code 53	Lockout - E53 ConPrsSnr	Lockout - E53 ConPrsSnr
Fault-LowSupVolt	54	Yes	Hard or Soft	Supply Voltage is <175 V (190V to reset) or powered off/on too quickly (<30 sec.)	Lockout	Code 54	Lockout - E54 LowSupVolt	Lockout - E54 LowSupVolt
Fault-OutEnvelop	55	IOx, then Yes	Hard or Soft	Comp Operating out of envelope more than 90 sec. Retry IOx.	Norm then Lockout	Code 55	Lockout - E55 OutEnvelop	Lockout - E55 OutEnvelop
Fault-OverCurrnt	56	Yes	Hard or Soft	Over current tripped by phase loss, earth fault, short circuit. Check motor windings/wiring connections	Lockout	Code 56	Lockout - E56 OverCurrnt	Lockout - E56 OverCurrnt
Fault-Over/UnderVolt	57	Yes	Hard or Soft	Over/Under AC input voltage or Over/Under DC Bus Voltage	Lockout	Code 57	Lockout - E57 Over/Under Volt	Lockout - E57 Over/Under Volt
Fault-HIDrivTemp	58	Yes	Hard or Soft	Over temperature of PFC-IGBT/Power Module. Check drive airflow/compressor operation	Lockout	Code 58	Lockout - E58 HIDrivTemp	Lockout - E58 HIDrivTemp
Fault-DrivErr MOC/AOC	59	Yes	Hard or Soft	Microelectronic/EEPROM fault has occurred. Check communications/power cycle/DC Bus Volt	Lockout	Code 59	Lockout - E59 DrvIntErr	Lockout - E59 DrvIntErr
Fault-MultSafeMtd	61	Yes	Hard or Soft	Communication/Configuration Error has occurred	Lockout	Code 61	Lockout - E61 MultSafeMtd	Lockout - E61 MultSafeMtd
Fault-PFC-IGBT/OpenSensor	62	Yes	Hard or Soft	Power Module Temp Low/Open Sensor Fault/PFC-IGBT Temp Low	Lockout	Code 62	Lockout - E62 LowTemp	Lockout - E62 LowTemp
Fault-Limit Lockout	63	Yes	Hard or Soft	Discharge Temp/orHigh Drive Temp/orOpenSensor fault limits have been reached	Lockout	Code 63	Lockout - E63 FaultLmt	Lockout - E63 FaultLmt
System Reset	99	No	Auto	System Reset Counter History	NA	Code 99	Fault History - E99 SysReset	No Display
Counter								

Note: *All codes >11 use long flash for tens digit and short flash for the ones digit. 20, 30, 40, 50 etc. are skipped.
 Alert* is a noncritical sensor or function that has failed. Normal operation of the heat pump is maintained but service is desired at some point.

Controls - Aurora Advanced Variable Speed Control cont.

ABC Control Board Layout

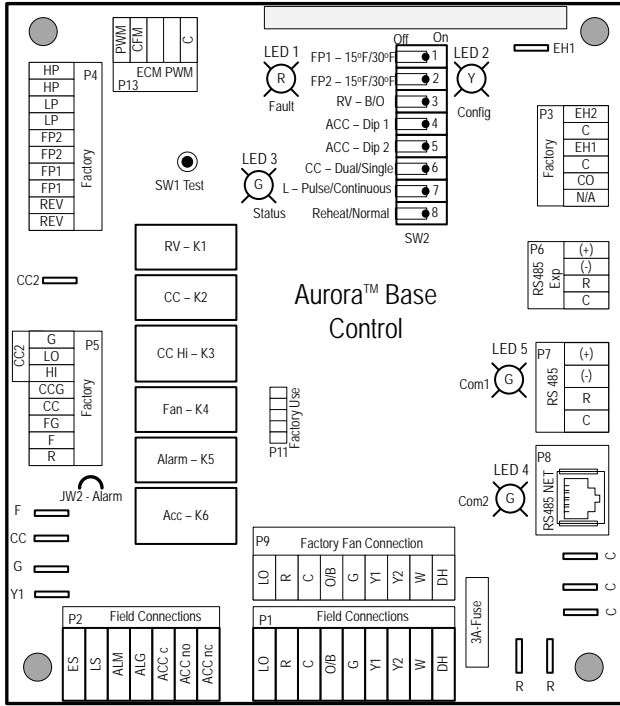

AXB Control Board Layout

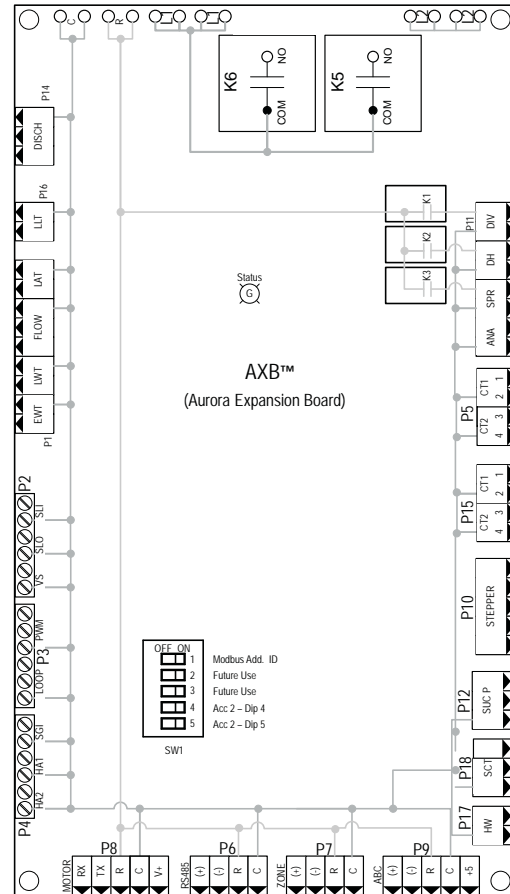

EMI Filter

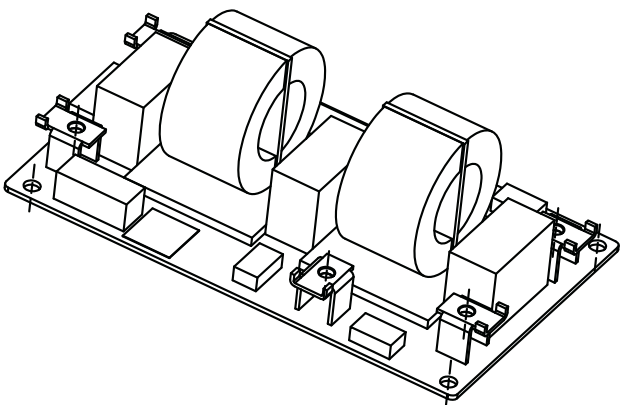

Controls - Aurora Advanced Variable Speed Control cont.

Compressor Drive

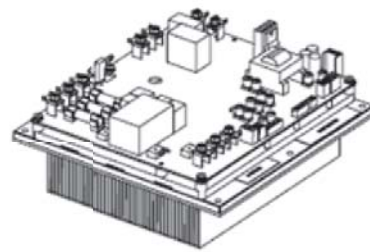
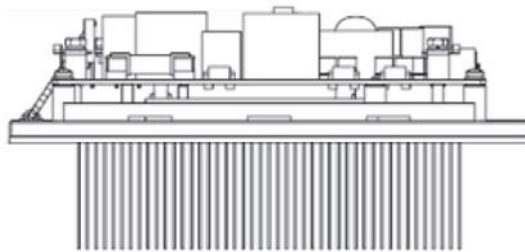
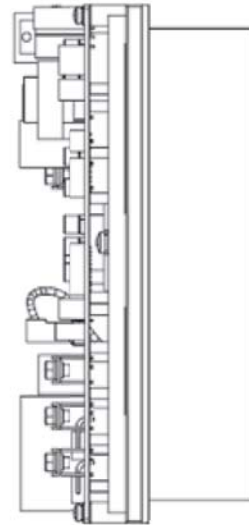
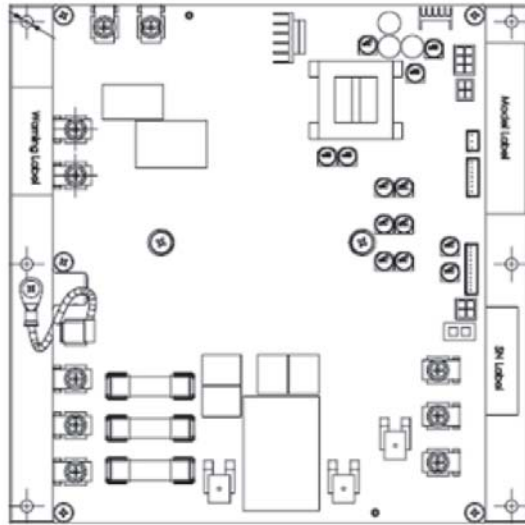

Capacitor Board

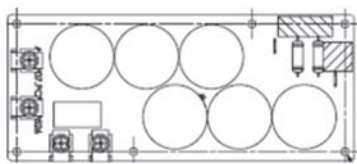

Choke

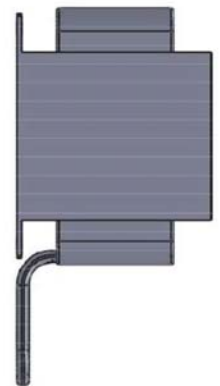
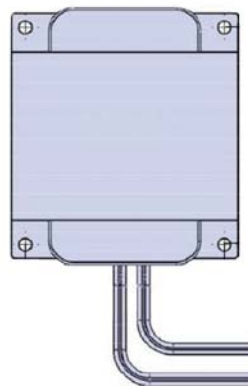

Controls - UPC DDC Control (optional)

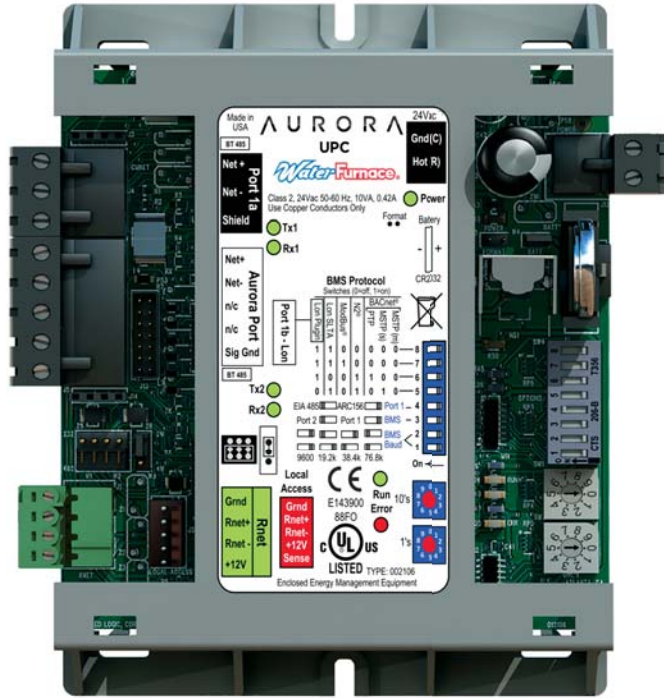

Aurora UPC Controller

The Aurora Unitary Protocol Converter (UPC) is designed to add-on to any Aurora based heat pump control. The Aurora Unitary Protocol Converter (UPC) is designed to allow water source heat pumps to be integrated into Building Automation Systems (BAS) with ease. The Aurora UPC is an integrated solution and communicates directly with the Aurora Heat Pump Controls and allows access/control of a variety of internal Aurora heat pump operations such as sensors, relay operation, faults and other information. In turn, the UPC then converts internal Aurora Modbus protocol to BACnet MS/TP, LON, or N2 protocols and communicates to the BAS system. This provides the great benefit of complete control integration and a myriad of information available to the BAS from the heat pump control. Plus it also allows individual unit configuration such as ECM fan speeds or freeze protection setting directly over the BAS without the need for access to the actual heat pump. The Aurora UPC is programmed using the powerful Eikon object oriented.

The Aurora UPC is implemented with the Aurora Base Controller (ABC) heat pump control into our latest water source heat pumps. This will allow for a BAS to integrate

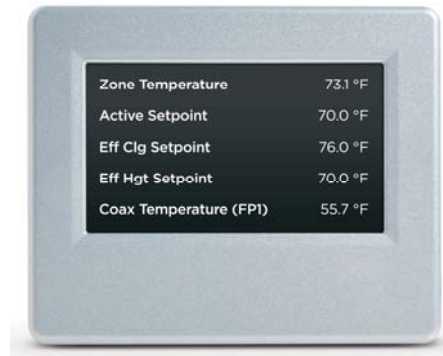

Aurora Touch Interface



ZS Series Sensors

and communicate to the heat pump thru a choice of 3 different communication protocols. The Aurora UPC has the ability to communicate BACnet MS/TP, N2 open, or LonWorks (requires LON Plugin card). This flexibility is possible due to the onboard dipswitches which allow for the desired protocol and baud rate to be selected in the field. All zone temperatures and zone sensors are connected to the UPC on an RNet bus, simplifying hook up at the unit. RNet sensors can include a combination of zone temperature and humidity, CO₂, and VOC sensors. The UPC includes built-in support for a custom configurable keypad/display unit - BACview6 (4-line by 40 character per line display) or BACview5 (2-line by 16 character per line display). Up to 2 Keypad/display units can be mounted remotely for configuration and troubleshooting.

There are an extensive number of points that the UPC has available over the network for integration into the BAS. Control programmers need to carefully determine which points they want to add into the BAS database. A list of the BACnet points, N2 points, and LON SNVTs are available along with their individual point descriptions by contacting a factory service representative.

Controls - UPC DDC Control (optional) cont.

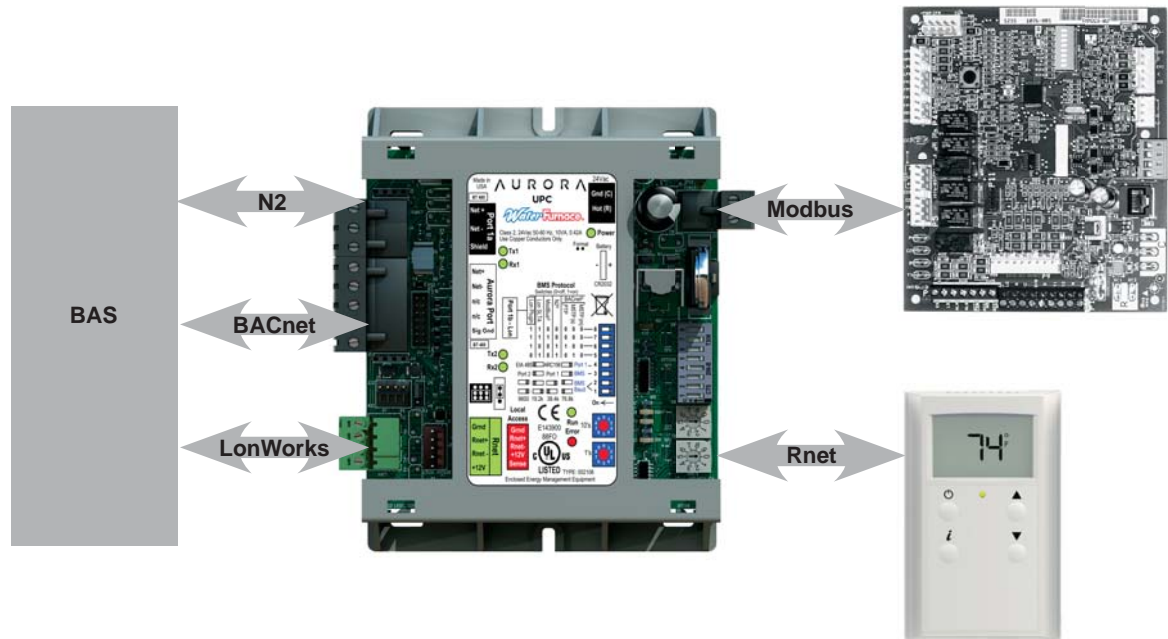

Aurora UPC Features

- Rugged enclosure made of GE C2950 Cycloy plastic
- Built-in surge transient protection circuitry
- Operating range of -20° to 140°F; 10 to 95% relative humidity, non-condensing
- Onboard CR123A battery has a life of 10 years with 720 hours of cumulative power outage
- Multi-Protocol field selectable communication port that supports:
 - EIA-485 BACnet MS/TP @ 9600, 19.2k, 38.4k, 76.8k baud
 - Metasys N2 Open
 - LonWorks TP/FT-10 (Requires optional LON plug-in communication card)
- Status of all unit operating conditions and fault lockouts
- Visual LED's for status of power, network communication, processor operation, and errors
- Provides gateway into Aurora heat pump controls for unsurpassed control flexibility
 - Network point for commanding unit into load shed
 - Network point for commanding unit into emergency shutdown
 - Network points to assist in fan speed selection
 - Network points for freeze protection settings
- Heating and cooling control from a remotely located zone sensor
- Rnet communication port which allows for multiple Rnet zone sensors (5) to be connected for space temperature averaging if desired.
- Local laptop or BACview connection for field service
- FCC, UL and CE listed. BTL Certification is pending

Aurora UPC Optional Features

- BACview handheld display, needed for field configuration of fan speeds, set points, etc.
- AID Tool for Aurora ABC configuration and troubleshooting.
- Aurora Advanced Control adds the Aurora AXB expansion board and provides added I/O and standard features
 - **Refrigeration Monitoring** - provides Suction and discharge pressure, Suction, liquid line temps and superheat and subcooling.
 - **Performance Monitoring** - provides entering and leaving loop water temperatures, loop flow rate as well as heat of extraction or rejection rate into the loop.
 - **Energy Monitoring** - provides real-time power measurement (Watt) of compressor, fan, auxiliary heat and zone pump.
- Graphics packages available in the future

Controls - UPC DDC Control (optional) cont.

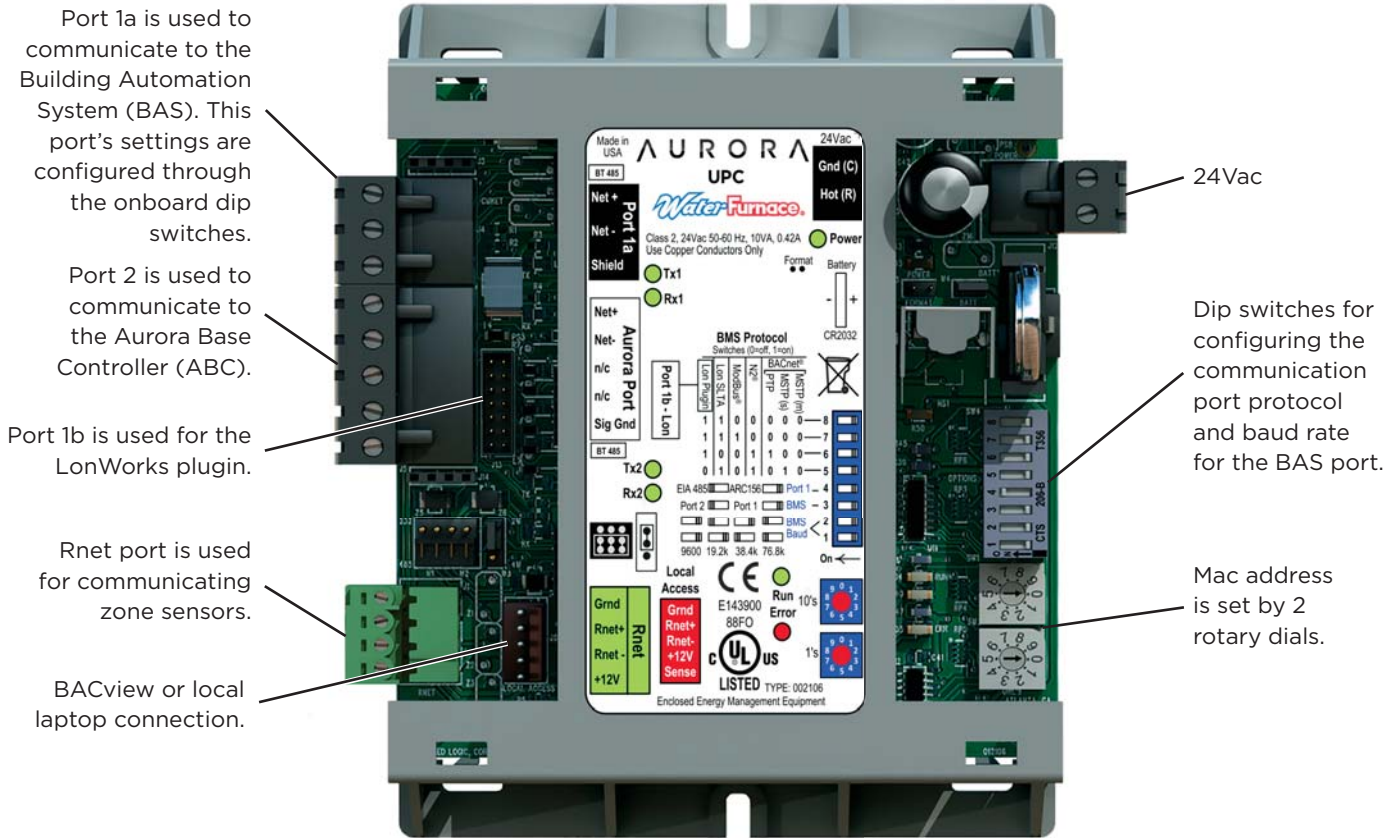

Controls - UPC DDC Control (optional) cont.

1. **Leaving Air Temperature (LAT) Sensor** - This 10 kOhm NTC sensor is factory installed on all UPC equipped heat pumps. It typically is attached to wiring inside the blower cabinet on the suction side of the blower. This sensor is attached on ABC FP2 pins available as LAT AU-30.
2. **Valve End Switch** - This optional input is setup for a field installed flow valve end switch. This end switch input is attached at ABC Y2 and available at point BV-67.
3. **Fan Proving Sensors** - This optional factory installed current sensor is connected to confirm fan operation via the power wires. The sensor is attached at ABC G and available at point BV-33.
4. **Occupancy Sensor** - This standard feature includes a field installed and wired room sensor with occupancy sensor typically found in DDC systems. The RNet room sensors can be found thru your commercial representative. The occupancy Sensors are attached at ABC O and can be found at point BV-49.
5. **Dirty Filter Switch** - This optional field installed switch is connected to confirm dirty filter operation. The dirty filter switch can be found thru your commercial representative. The sensor is attached at ABC W and available at point BV-63.
6. **Fault, Configuration, and Status Codes** - The codes can be visible to the BAS if desired

Aurora Advanced Fault Codes (ABC + AXB Expansion Board) Variable Speed

Variable Speed Drive Additions

	Red Fault LED	LED Flash Code *	Lockout	Reset/Remove	Fault Condition Summary
ABC & AXB Basic Faults	Normal - No Faults	Off	-		
	Fault-Input	1	No	Auto	Tstat input error. Autoreset upon condition removal.
	Fault-High Pressure	2	Yes	Hard or Soft	HP switch has tripped (>600 psi)
	Fault-Low Pressure	3	Yes	Hard or Soft	Low Pressure Switch has tripped (<40 psi for 30 continuous sec.)
	Fault-Freeze Detection FP2	4	Yes	Hard or Soft	Freeze protection sensor has tripped (<30 degF for 30 continuous sec.)
	Fault-Freeze Detection FP1	5	Yes	Hard or Soft	Freeze protection sensor has tripped (<15 or 30 degF for 30 continuous sec.)
	Fault-Condensate Overflow	7	Yes	Hard or Soft	Condensate switch has shown continuity for 30 continuous sec.
	Fault-Over/Under Voltage	8	No**	Auto	Instantaneous Voltage is out of range. **Controls shut down until resolved.
	Fault-FP1 & 2 Snsr Error	11	Yes	Hard or Soft	If FP1 or 2 Sensor Err

Note: *All codes >11 use long flash for tens digit and short flash for the ones digit. 20, 30, 40, 50 etc. are skipped!
Alert' is a noncritical sensor or function that has failed. Normal operation of the heat pump is maintained but service is desired at some point.

Controls - UPC DDC Control (optional) cont.

Aurora Base or Advanced Control Configuration and Status Codes

Status LED (LED3, Green)

Description of Operation	Fault LED, Green
Normal Mode	ON
Control is Non-functional	OFF
Test Mode	Slow Flash
Lockout Active	Fast Flash
Dehumidification Mode	Flash Code 2
Load Shed	Flash Code 5
Emergency Shutdown	Flash Code 6
On Peak Mode	Flash Code 7
(Future Use)	Flash Code 8
(Future Use)	Flash Code 9

Configuration LED (LED2, Yellow)

Description of Operation	Configuration LED, Yellow
No Software Overwritten	ECM Setting
DIP Switch Overwritten	Slow Flash
ECM Configuration Mode	Fast Flash
Reset Configuration Mode	OFF

9. Alarm Relay - The Alarm relay (ALM) is factory connected to 24 VAC via jumper JW2. By cutting JW2, ABC ALM becomes a dry contact connected to ABC ALG. The Relay is field switchable between Factory setting as an Alarm output or available for other uses.

10. Accessory Relay1 - A configurable, accessory relay on the ABC is provided that can be cycled with the compressor, blower, or the Dehumidifier (DH) input. A third (factory) setting cycles the relay with the compressor but delays the compressor and blower output for 90 sec. Source pump or slow opening solenoid valves in well systems or variable speed primary pumping systems would be a prime use of this feature.

Access Relay Operation	SW2-4	SW2-5
Cycle with Blower	ON	ON
Cycle with Compressor	OFF	OFF
Water Valve Slow Opening	ON	OFF
Cycle with Comm. T-stat Hum Cmd	OFF	ON

11. Electric Heat EH1 - A digital 24VDC output is provided for electric heat powering. UPC's Default programming has EH1 set for AUX/ELEC Heat operation and will be controlled using the UPC's internal P.I.D. logic. However it can be changed by the BAS to be network controlled.

12. Electric Heat EH2 - A digital VDC output is provided for field options converted from the original EH2 output. Default UPC program has the EH2 output set for Network Control but can be changed by the BAS to be controlled by the UPC's internal P.I.D. logic.

Controls - UPC DDC Control (optional) cont.

Aurora Advanced Control Configuration and Options

1. **Accessory Relay2** - A second, configurable, accessory relay on the AXB is provided that can be cycled with the compressor 1 or 2, blower, or the Dehumidifier (DH) input. This is to complement the Accessory 1 Relay on the ABC board.

Position	DIP 4	DIP 5	Description
1	ON	ON	Cycles with Fan or ECM (or G)
2	OFF	ON	Cycles with CC1 first stage of compressor or compressor spd 1-12
3	ON	OFF	Cycles with CC2 second stage of compressor or compressor spd 7-12
4	OFF	OFF	Cycles with DH input from ABC board

2. **Analog Out** - A standard 0-10VDC analog output is provided. This output can be used to drive modulating dampers etc.
3. **Variable Speed Pump or Modulating Water Valve (If applicable)** - This input and output are provided to drive and monitor a variable speed pump. The VS pump output is a PWM signal to drive the variable speed pump. The minimum and maximum level are set using the AID Tool. 75% and 100% are the default settings respectively. The VS data input allows a separate PWM signal to return from the pump giving fault and performance information. Fault received from the variable speed pump will be displayed as E16. **Modulating Water Valve** - This Variable speed PWM output is provided to optionally drive a modulating water valve. Through advanced design a 0-10VDC valve can be driven directly from the VS pump output. The minimum and maximum level are set in the same way as the VS pump using the AID Tool. 75% and 100% are the default settings respectively.
4. **Loop Pump Linking (If applicable)** - This input and output are provided so that two units can be linked together with a common flow center. When either unit has a call for loop pump, both unit's loop pump relays and variable speed pumps are energized. The flow center then can simply be wired to either unit. The output from one unit should be routed to the input of the other. If daisy chained up to 16 heat pumps can be wired and linked together in this fashion.

Controls - UPC DDC Control (optional) cont.

Aurora Advanced Control Optional Sensor Kits

- 1. Energy Monitoring (Standard)** - Energy Monitoring includes two current transducers (blower and electric heat). The BACview Tool provides configuration detail for the type of blower motor and a line voltage calibration procedure to improve the accuracy. This real time power usage information can be displayed on the AID Tool and is available thru network points when using BACnet or N2 Open.
 - Compressor Current
 - Fan Current
 - Aux Heat Current
 - Pump Selection
 - Voltage
 - Compressor Watts
 - Fan Watts
 - Aux Heat Watts
 - Pump Watts (VS Only)

- 2. Refrigerant Monitoring** - The optional Refrigerant Monitoring Kit includes two pressure transducers, and three temperature sensors, heating liquid line, suction temperature and existing cooling liquid line (FP1). These sensors allow the measurement of discharge and suction pressures, suction and liquid line temperatures as well as superheat and subcooling. This information can be displayed on the BACview Tool, or the network when using BACnet and N2.
 - Htg Liquid Line
 - Clg Liquid Line
 - Discharge pressure
 - Suction Pressure
 - Discharge Saturated Temp
 - Suction Saturated Temperature
 - Superheat
 - SubCooling

- 3. Performance Monitoring (Requires flow meter)** - Performance Monitoring includes: three temperature sensors, entering and leaving water, leaving air temperature and a water flow rate sensor. With this kit, heat of extraction and rejection will be calculated. This requires configuration using the BACview Tool for selection of water or antifreeze.
 - Leaving Air Temperature (supply)
 - Alt Leaving Air Temperature (Supply)
 - Entering Water Temperature
 - Leaving Water Temperature
 - Water Flow Meter
 - Entering Air Temperature (from zone sensor)
 - Brine Selection (water/antifreeze)
 - Heat of Extraction/Rejection

Controls - UPC DDC Control (optional) cont.

ZS Series RNet Sensor Overview

The ZS Series line of intelligent zone sensors provides the function and flexibility you need to manage the conditions important to the comfort and productivity of the zone occupants. The ZS sensors are available in a variety of zone sensing combinations to address your application needs. These combinations include temperature, relative humidity, and indoor air quality (carbon dioxide or VOCs (Volatile Organic Compounds)). They are built to be flexible allowing for easy customization of what the user/technician sees. Designed to work with the Aurora UPC controllers the ZS sensor line includes the ZS Base, ZS Plus, ZS Pro and ZS Pro-F.

The UPC uses a proprietary communication called Rnet to receive the space temperature from the zone sensor.

This is done using (2) 18 AWG twisted pair unshielded cables for a total of 4 wires connected to the Rnet port. The sensor gets its power from the UPC controller and connecting multiple sensors to one UPC will allow for space temperature averaging. The UPC can support one ZS Pro or ZS Pro F with up to four ZS standard sensors wired to the Rnet port on the UPC for a total of 5 zone sensors. The sensors use a precise 10k ohm thermistor with less than 0.18°F drift over a ten year span, this allows for less maintenance or re-calibration after installation. The sensors also have a hidden communication port for connecting a BACview or local laptop that provides access to the equipment for commissioning and maintenance. The table below shows the features of each of the four sensors that are currently available.



Features	ZS Base	ZS Plus	ZS Pro	ZS Pro-F
Temp, CO ² , Humidity, and VOC Options	✓	✓	✓	✓
Neutral Color	✓	✓	✓	✓
Addressable/supports daisy chaining	✓	✓	✓	✓
Hidden communication port	✓	✓	✓	✓
Mounts on a standard 2" by 4" electrical box	✓	✓	✓	✓
Occupancy Status indicator LED		✓	✓	✓
Push button occupancy override		✓	✓	✓
Setpoint adjust		✓	✓	✓
Large, easy to read LCD			✓	✓
Alarm indicator			✓	✓
°F to °C conversion button				✓

Options	Part Number	Part Number	Part Number	Part Number
Temperature Only	ZSU	ZSUPL	ZSUP	ZSUPF
Temp with CO ²	ZSU-C	ZSUPL-C	ZSUP-C	ZSUPF-C
Temp with Humidity	ZSU-H	ZSUPL-H	ZSUP-H	ZSUPF-H
Temp with Humidity, CO ²	ZSU-HC	ZSUPL-HC	ZSUP-HC	ZSUPF-HC
Temp, Humidity, VOC	ZSU-HV	ZSUPL-HV	ZSUP-HV	ZSUPF-HV
Temp with VOC	ZSU-V	ZSUPL-V	ZSUP-V	ZSUPF-V

Controls - UPC DDC Control (optional) cont.

RNet Sensor Physical and Electrical Data

Sensing Element	Range	Accuracy
Temperature (on non-Humidity models)	-4° to 122° F (-20° C to 50° C)	30.35° F (0.2° C)
Temperature (on Humidity models)	50° F to 104° F (10° C to 40° C)	30.5° F (0.3° C)
Humidity	10% to 90%	31.8% typical
CO2	400 to 1250 PPM 1250 to 2000 PPM	330PPM or +/-3% of reading (greater of two) 35% of reading plus 30 PPM
VOC	0 to 2,000 PPM	3100 PPM
Power Requirements	Sensor Type	Power Required
Temperature Only	All Models	12 Vdc @ 8 mA
Temperature with Humidity	All Models	12 Vdc @ 15 mA (idle) to 190 mA (CO2 measurement cycle)
Temp with VOC, or Temp/VOC/Humidity	All Models	12 Vdc @ 60 mA
Temp with CO2 , or Temp/ CO2/Humidity	All Models	12 Vdc @ 15 mA (idle) to 190 mA (CO2 measurement cycle)
Power Supply	A controller supplies the Rnet sensor network with 12 Vdc @ 210 mA. Additional power may be required for your application. See sensor ZS Installation Guide	
Communication	115 kbps Rnet connection between sensor(s) and controller 15 sensors max per Rnet network; 5 sensors max per control program	
Local Access Port	For connecting a laptop computer to the local equipment for maintenance and commissioning	
Environmental Operating Range	32° to 122° F (0° - 50° C), 10% to 90% relative humidity, non-condensing	
Mounting Dimensions	Standard 4"x 2" electrical box using provided 6/32" x 1/2" mounting screws	

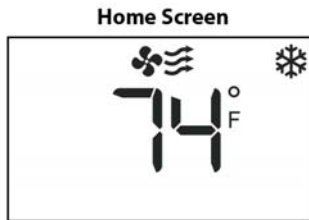
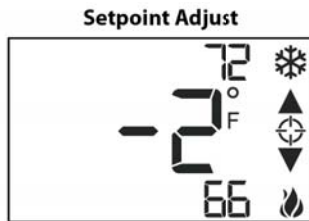
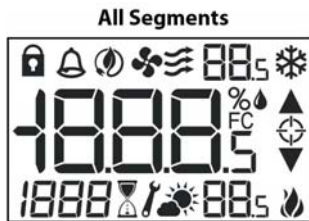

Temperature Only or Temperature with Humidity

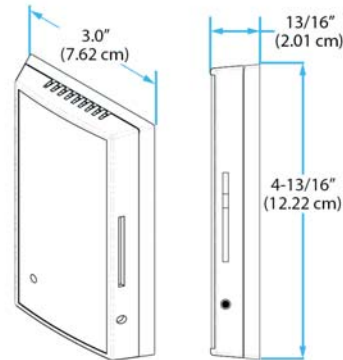

Sensor with CO2 or VOC

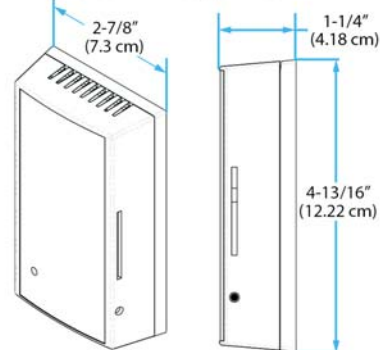

Unit Startup

Before Powering Unit, Check The Following:

NOTE: Remove and discard the compressor shipping bolts. The bolts can then be discarded.

- High voltage is correct and matches nameplate.
- Fuses, breakers and wire size correct.
- Low voltage wiring complete.
- Piping completed and water system cleaned and flushed.
- Air is purged from closed loop system.
- Isolation valves are open, water control valves or loop pumps wired.
- Condensate line open and correctly pitched.
- Transformer switched to 208V if applicable.
- Dip switches are set correctly.
- Blower rotates freely – foam shipping support has been removed.
- Blower speed correct.
- Air filter/cleaner is clean and in position.
- Service/access panels are in place.
- Return air temperature is between 50-80°F heating and 60-95°F cooling.
- Check air coil cleanliness to insure optimum performance. Clean as needed according to maintenance guidelines. To obtain maximum performance the air coil should be cleaned before startup. A 10-percent solution of dishwasher detergent and water is recommended for both sides of coil, a thorough water rinse should follow.

Startup Steps

NOTE: Complete the Equipment Start-Up/Commissioning Check Sheet during this procedure. Refer to thermostat operating instructions and complete the startup procedure.

1. Initiate a control signal to energize the blower motor. Check blower operation.
2. Initiate a control signal to place the unit in the cooling mode. Cooling setpoint must be set below room temperature.
3. Cooling will energize after a time delay. Check for correct rotation of scroll compressors in 3 phase applications. Incorrect rotation will cause low refrigerant pressures and possibly unusual noise. Switch any two power leads at the compressor or contactor to reverse rotation.
4. Be sure that the compressor and water control valve or loop pump(s) are activated.
5. Verify that the water flow rate is correct by measuring the pressure drop through the heat exchanger using the P/T plugs and comparing to the pressure drop table.
6. Check the temperature of both the supply and discharge water (Refer to Operating Parameters tables).
7. Check for an air temperature drop of 15°F to 25°F across the air coil, depending on the blower speed and entering water temperature.
8. Decrease the cooling set point several degrees and verify high-speed blower operation (ECM only).
9. Adjust the cooling setpoint above the room temperature and verify that the compressor and water valve or loop pumps deactivate.
10. Initiate a control signal to place the unit in the heating mode. Heating set point must be set above room temperature.
11. Heating will energize after a time delay.
12. Check the temperature of both the supply and discharge water (Refer to Unit Operating Parameters tables).
13. Check for an air temperature rise of 20°F to 35°F across the air coil, depending on the blower speed and entering water temperature.
14. If auxiliary electric heaters are installed, increase the heating setpoint until the electric heat banks are sequenced on. All stages of the auxiliary heater should be sequenced on when the thermostat is in the Emergency Heat mode. Check amperage of each element.
15. Adjust the heating setpoint below room temperature and verify that the compressor and water valve or loop pumps deactivate.
16. During all testing, check for excessive vibration, noise or water leaks. Correct or repair as required.
17. Set system to desired normal operating mode and set temperature to maintain desired comfort level.
18. Instruct the owner/operator in the proper operation of the thermostat and system maintenance.

NOTE: Be certain to fill out and forward all warranty registration papers.

Operating Limits

Operating Limits	Cooling		Heating	
	(°F)	(°C)	(°F)	(°C)
Air Limits				
Min. Ambient Air	45	7.2	45	7.2
Rated Ambient Air	80	26.7	70	21.1
Max. Ambient Air	100	37.8	85	29.4
Min. Entering Air	50	10.0	40	4.4
Rated Entering Air db/wb	80.6/66.2	27/19	68	20.0
Max. Entering Air db/wb	110/83	43/28.3	80	26.7
Water Limits				
Min. Entering Water	30	-1.1	20	-6.7
Normal Entering Water	50-110	10-43.3	30-70	-1.1
Max. Entering Water	120	48.9	90	32.2

NOTE: Minimum/maximum limits are only for start-up conditions, and are meant for bringing the space up to occupancy temperature. Units are not designed to operate at the minimum/maximum conditions on a regular basis. The operating limits are dependent upon three primary factors: 1) water temperature, 2) return air temperature, and 3) ambient temperature. When any of the factors are at the minimum or maximum levels, the other two factors must be at the normal level for proper and reliable unit operation.

Cooling Capacity Corrections

Entering Air WB °F	Total Clg Cap	Sensible Cooling Capacity Multipliers - Entering DB °F										Power Input	Heat of Rejection
		60	65	70	75	80	80.6	85	90	95	100		
55	0.898	0.723	0.866	1.048	1.185	*	*	*	*	*	*	0.985	0.913
60	0.912		0.632	0.880	1.078	1.244	1.260	*	*	*	*	0.994	0.927
65	0.967			0.694	0.881	1.079	1.085	1.270	*	*	*	0.997	0.972
66.2	0.983			0.655	0.842	1.040	1.060	1.232	*	*	*	0.999	0.986
67	1.000			0.616	0.806	1.000	1.023	1.193	1.330	*	*	1.000	1.000
70	1.053			0.693	0.879	0.900	1.075	1.250	1.404	*	*	1.003	1.044
75	1.168				0.687	0.715	0.875	1.040	1.261	1.476		1.007	1.141

NOTE: * Sensible capacity equals total capacity at conditions shown.

11/10/09

Heating Corrections

Ent Air DB °F	Htg Cap	Power	Heat of Ext
45	1.062	0.739	1.158
50	1.050	0.790	1.130
55	1.037	0.842	1.096
60	1.025	0.893	1.064
65	1.012	0.945	1.030
68	1.005	0.976	1.012
70	1.000	1.000	1.000
75	0.987	1.048	0.970
80	0.975	1.099	0.930

11/10/09

Airflow Corrections

Airflow		Cooling				Heating		
cfm Per Ton of Clg	% of Nominal	Total Cap	Sens Cap	Power	Heat of Rej	Htg Cap	Power	Heat of Ext
240	60	0.922	0.786	0.910	0.920	0.943	1.150	0.893
275	69	0.944	0.827	0.924	0.940	0.958	1.105	0.922
300	75	0.959	0.860	0.937	0.955	0.968	1.078	0.942
325	81	0.971	0.894	0.950	0.967	0.977	1.053	0.959
350	88	0.982	0.929	0.964	0.978	0.985	1.031	0.973
375	94	0.992	0.965	0.982	0.990	0.993	1.014	0.988
400	100	1.000	1.000	1.000	1.000	1.000	1.000	1.000
425	106	1.007	1.034	1.020	1.010	1.007	0.990	1.011
450	113	1.012	1.065	1.042	1.018	1.013	0.983	1.020
475	119	1.017	1.093	1.066	1.026	1.018	0.980	1.028
500	125	1.019	1.117	1.092	1.033	1.023	0.978	1.034
520	130	1.020	1.132	1.113	1.038	1.026	0.975	1.038

11/10/09

Operating Parameters

Entering Water Temp °F	Load	Cooling -- No Hot Water Generation					
		Suction Pressure psig	Discharge Pressure psig	Superheat	Subcooling	Water Temp Rise °F	Air Temp Drop °F DB
30	Min	120 - 125	115 - 130	12 - 16	3 - 8	4 - 8	17 - 23
	Max	100 - 115	115 - 130	15 - 20	8 - 12	8 - 12	17 - 23
50	Min	140 - 150	160 - 180	12 - 16	3 - 8	4 - 8	17 - 23
	Max	120 - 135	180 - 200	8 - 12	8 - 14	8 - 12	17 - 23
70	Min	145 - 155	210 - 230	8 - 12	6 - 12	4 - 8	17 - 23
	Max	133 - 143	250 - 260	8 - 12	8 - 14	8 - 12	17 - 23
90	Min	150 - 160	295 - 305	8 - 12	6 - 12	4 - 8	17 - 23
	Max	140 - 150	330 - 340	8 - 12	8 - 14	8 - 12	17 - 23
110	Min	155 - 165	370 - 400	4 - 8	6 - 12	4 - 8	17 - 23
	Max	148 - 153	390 - 420	8 - 12	8 - 14	8 - 12	17 - 23

Entering Water Temp °F	Load	Heating -- No Hot Water Generation					
		Suction Pressure psig	Discharge Pressure psig	Superheat	Subcooling	Water Temp Drop °F	Air Temp Rise °F DB
30	Min	90 - 95	220 - 230	4 - 8	3 - 8	2 - 5	9 - 12
	Max	80 - 88	275 - 290	8 - 12	3 - 10	3 - 7	14 - 18
50	Min	130 - 145	235 - 260	8 - 12	3 - 5	5 - 9	9 - 12
	Max	105 - 120	290 - 315	8 - 12	3 - 10	5 - 9	20 - 24
70	Min	155 - 170	250 - 280	8 - 12	3 - 5	5 - 9	15 - 20
	Max	140 - 155	315 - 330	8 - 12	3 - 10	6 - 10	22 - 30
90	Min	180 - 190	270 - 300	8 - 12	3 - 5	5 - 9	15 - 20
	Max	160 - 170	340 - 380	8 - 12	3 - 10	6 - 10	22 - 30
110	Min						
	Max						

Note: Cooling performance based on entering air temperatures of 80° F DB, 67° F WB.
 Heating performance based on entering air temperature of 70° F DB.

8/25/16

Pressure Drop

Model	gpm	Pressure Drop (psi)				
		30°F	50°F	70°F	90°F	110°F
036	5.0	1.5	1.2	0.9	0.5	0.2
	7.0	2.2	1.9	1.6	1.2	0.9
	9.0	3.0	2.7	2.3	2.0	1.7
	11.0	4.9	4.6	4.3	4.0	3.7
048	6.0	1.6	1.3	1.0	0.6	0.3
	9.0	2.4	2.1	1.7	1.4	1.1
	12.0	3.4	3.1	2.7	2.4	2.1
	15.0	5.7	5.3	5.0	4.7	4.3
060	8.0	1.8	1.6	1.3	1.1	0.8
	12.0	3.8	3.3	2.9	2.4	1.9
	16.0	6.5	6.0	5.6	5.1	4.6
	20.0	9.7	9.1	8.5	8.0	7.4
072	12.0	3.2	3.0	2.8	2.6	2.4
	15.0	4.5	4.1	3.8	3.4	3.0
	18.0	6.0	5.6	5.3	4.9	4.5
	21.0	7.8	7.4	7.1	6.7	6.3

8/25/16

Valve	gpm	Cv	Pressure Drop (psi)
1"	6.0	16.1	0.14
	9.0	16.8	0.29
	12.0	17.4	0.47
	15.0	18.1	0.69
1"	6.0	16.1	0.14
	9.0	16.8	0.29
	12.0	17.4	0.47
	15.0	18.1	0.69
1"	9.0	16.8	0.29
	12.0	17.4	0.47
	16.0	18.3	0.76
	20.0	19.2	1.09
1"	12.0	17.4	0.47
	15.0	18.1	0.69
	18.0	18.7	0.92
	24.0	20.1	1.43

8/25/16

Reference Calculations

Heating Calculations:	Cooling Calculations:
$LWT = EWT - \frac{HE}{gpm \times 500}$	$LWT = EWT + \frac{HR}{gpm \times 500}$
$LAT = EAT + \frac{HC}{cfm \times 1.08}$	$LAT(DB) = EAT(DB) - \frac{SC}{cfm \times 1.08}$
$TH = HC + HWC$	$LC = TC - SC$
	$S/T = \frac{SC}{TC}$

Legend and Notes

ABBREVIATIONS AND DEFINITIONS:

cfm = airflow, cubic feet/minute	HE = total heat of extraction, MBtu/h
EWT = entering water temperature, Fahrenheit	HWC = hot water generator capacity, MBtu/h
gpm = water flow in gallons/minute	EER = Energy Efficient Ratio = BTU output/Watt input
WPD = water pressure drop, psi and feet of water	COP = Coefficient of Performance = Btu output/Btu input
EAT = entering air temperature, Fahrenheit (dry bulb/wet bulb)	LWT = leaving water temperature, °F
HC = air heating capacity, MBtu/h	LAT = leaving air temperature, °F
TC = total cooling capacity, MBtu/h	TH = total heating capacity, MBtu/h
SC = sensible cooling capacity, MBtu/h	LC = latent cooling capacity, MBtu/h
kW = total power unit input, kilowatts	S/T = sensible to total cooling ratio
HR = total heat of rejection, MBtu/h	

Notes (Refer to Performance Data tables)

- Performance ratings are based on 80°F DB / 67°F WB EAT for cooling and 70°F DB EAT for heating.
- Three flow rates are shown for each unit. The lowest flow rate shown is used for geothermal open loop/well water systems with a minimum of 50°F EWT. The middle flow rate shown is the minimum geothermal closed loop flow rate. The highest flow rate shown is optimum for geothermal closed loop systems and the suggested flow rate for boiler/tower applications.
- The hot water generator numbers are based on a flow rate of 0.4 gpm/ton of rated capacity with an EWT of 90°F.
- Entering water temperatures below 40°F assumes 15% antifreeze solution.
- For non-standard EAT conditions, apply the appropriate correction factors on (Refer to Correction Factor Tables).
- Interpolation between EWT, gpm, and cfm data is permissible.

Refrigerant Circuit Guideline

Symptom	Head Pressure	Suction Pressure	Compressor Amp Draw	Superheat	Subcooling	Air Temp. Differential	Water Temp. Differential
Under Charged System (Possible Leak)	Low	Low	Low	High	Low	Low	Low
Over Charged System	High	High	High	Normal	High	Normal/Low	Normal
Low Air Flow Heating	High	High	High	High/Normal	Low	High	Low
Low Air Flow Cooling	Low	Low	Low	Low/Normal	High	High	Low
Low Water Flow Heating	Low/Normal	Low/Normal	Low	Low	High	Low	High
Low Water Flow Cooling	High	High	High	High	Low	Low	High
High Air Flow Heating	Low	Low	Low	Low	High	Low	Low
High Air Flow Cooling	Low	High	Normal	High	Low	Low	Normal
High Water Flow Heating	Normal	Low	Normal	High	Normal	Normal	Low
High Water Flow Cooling	Low	Low	Low	Low	High	Normal	Low
Low Indoor Air Temperature Heating	Low	Low	Low	Normal	High	Normal	Normal/High
Low Indoor Air Temperature Cooling	Low	Low	Low	Normal/Low	High	Low	Low
High Indoor Air Temperature Heating	High	High	High	Normal/High	Normal/Low	Low	Normal
High Indoor Air Temperature Cooling	High	High	High	High	Low	Low	High
Restricted EEC (Check Service Advisory)	High	Low	Normal/Low	High	High	Low	Low
Insufficient Compressor (Possible Bad Valves)	Low	High	Low	High	Normal/High	Low	Low
Scaled Coaxial Heat Exchanger Heating	Low	Low	Low	Normal/Low	High	Low	Low
Scaled Coaxial Heat Exchanger Cooling	High	High	High	Normal/Low	Low	Low	Low
Restricted Filter Drier	Check temperature difference (delta T) across filter drier.						

8/25/16

Compressor and Thermistor Resistance

Compressor Resistance Chart

Model	208-230/60/1
036	0.681
048	0.203
060	0.203
072	0.203

8/25/16

Thermistor Resistance Chart

Thermistor Resistance (10k Ohm) for FP1, FP2, HWL, LWT, LLT, and EWT		Thermistor Resistance (1k Ohm) for compressor discharge line, suction line, LAT, and compressor ambient	
Temperature (°F)	Resistance (Ohms)	Temperature (°F)	Resistance (Ohms)
5	75757-70117	20	974.4-973.4
14	57392-53234	25	985.4-984.4
23	43865-40771	30	996.1-995.1
32	33809-31487	35	1007.0-1006.0
41	26269-24513	40	1017.8-1016.8
50	20570-19230	45	1028.6-1027.6
59	16226-15196	50	1039.5-1038.5
68	12889-12093	55	1050.2-1049.2
77	10310-9688	60	1061.2-1060.2
86	8300-7812	65	1072.9-1071.9
95	6723-6337	70	1082.7-1081.7
104	5480-5172	75	1093.4-1092.4
113	4490-4246	80	1103.0-1102.0
122	3700-3504	85	1115.5-1114.5
131	3067-2907	90	1126.2-1125.2
140	2554-2424	95	1136.6-1135.6
149	2149-2019	100	1147.2-1146.2
		105	1158.1-1157.1
		110	1168.8-1167.8
		115	1179.4-1178.4
		120	1190.1-1189.1
		125	1200.3-1199.3
		130	1212.2-1211.2

8/25/16

Troubleshooting

Should a major problem develop, refer to the following information for possible causes and corrective steps.

If compressor won't run:

1. The fuse may be open or the circuit breaker is tripped. Check electrical circuits and motor windings for shorts or grounds. Investigate for possible overloading. Replace fuse or reset circuit breakers after fault is corrected.
2. Supply voltage may be too low. Check it with a volt meter.
3. Control system may be faulty. Check control for correct wiring of thermostat or aquastat and check the 24 volt transformer for proper voltage.
4. Wires may be loose or broken. Replace or tighten.
5. The low pressure switch may have tripped due to one or more of the following:
 - a) Heating
 - 1) Plugged heat exchanger on source side
 - 2) Water flow source side - (Low)
 - 3) Water too cold source side
 - 4) Low refrigerant
 - b) Cooling
 - 1) Plugged heat exchanger on load side
 - 2) Water flow load side - (Low)
 - 3) Water too cold load side
 - 4) Low refrigerant
6. The high pressure switch may have tripped due to one or more of the following:
 - a) Heating
 - 1) Plugged heat exchanger on load side
 - 2) Low water flow load side
 - 3) Water too warm load side
 - b) Cooling
 - 1) Plugged heat exchanger on source side
 - 2) Low water flow on source side
 - 3) Water too warm source side
7. The compressor overload protection may be open.
8. The internal winding of the compressor motor may be grounded to the compressor shell. If so, replace the compressor.
9. The compressor winding may be open or shorted. Disconnect power. Check continuity with ohm meter. If the winding is open, replace the compressor.

If sufficient cooling or heating is not obtained:

1. Check control for improper location or setting.
2. Check for restriction in water flow.
3. Check refrigerant subcooling and superheat for proper refrigerant charge and expansion valve operation.
4. The reversing valve may be defective and creating a bypass of refrigerant. If the unit will not heat, check the reversing valve coil.

If the unit operation is noisy:

1. Check compressor for loosened mounting bolts. Make sure compressor is floating free on its isolator mounts. Check for tubing contact with the compressor or other surfaces. Readjust it by bending slightly.
2. Check screws on all panels.
3. Check for chattering or humming in the contactor or relays due to low voltage or a defective holding coil. Replace the component.
4. Check for proper installation of vibration absorbing material under the unit.
5. Check for abnormally high discharge pressures.
6. Compressor rotation incorrect

Refrigerant Systems

To maintain sealed circuit integrity, do not install service gauges unless unit operation appears abnormal. Compare the change in temperature on the air side as well as the water side to the Operating Parameters tables. If the unit's performance is not within the ranges listed, and the airflow and water flow are known to be correct, gauges should then be installed and superheat and subcooling numbers calculated. If superheat and subcooling are outside recommended ranges, an adjustment to the refrigerant charge may be necessary.

NOTE: Refrigerant tests must be made with hot water generator turned "OFF". Verify that air and water flow rates are at proper levels before servicing the refrigerant circuit.

Startup and Troubleshooting Form

Company Name: _____ Company Phone No: _____
 Technician Name: _____ Date: _____
 Model No: _____ Serial No: _____
 Owner's Name: _____ Open or Closed Loop: _____
 Installation Address: _____ Installation Date: _____

Check One

Start up/Check-out for new installation Troubleshooting Problem: _____

1. FLOW RATE IN GPM (COAXIAL HEAT EXCHANGER)

Water In Pressure: a. _____ PSI
 Water Out Pressure: b. _____ PSI
 Pressure Drop = a - b c. _____ PSI
 Convert Pressure Drop to Flow Rate
 (refer to *Pressure Drop* table) d. _____ GPM

2. TEMPERATURE RISE OR DROP ACROSS COAXIAL HEAT EXCHANGER

	COOLING	HEATING
Water In Temperature:	e. _____ °F	e. _____ °F
Water Out Temperature:	f. _____ °F	f. _____ °F
Temperature Difference:	g. _____ °F	g. _____ °F

3. TEMPERATURE RISE OR DROP ACROSS AIR COIL

	COOLING	HEATING
Air In Temperature:	h. _____ °F	h. _____ °F
Air Out Temperature:	i. _____ °F	i. _____ °F
Temperature Difference:	j. _____ °F	j. _____ °F

4. HEAT OF REJECTION (HR) / HEAT OF EXTRACTION (HE) CALCULATION

HR or HE = Flow Rate x Temperature Difference x Brine Factor*
 d. (above) x g. (above) x 485 for Methanol or Environol, 500 for water*
 Heat of Extraction (Heating Mode) = _____ btu/hr
 Heat of Rejection (Cooling Mode) = _____ btu/hr
 Compare results to Capacity Data Tables

Note: Steps 5 through 8 need only be completed if a problem is suspected

5. WATTS

	COOLING	HEATING
Volts:	m. _____ VOLTS	m. _____ VOLTS
Total Amps (Comp. + Fan):	n. _____ AMPS	n. _____ AMPS
Watts = m. x n. x 0.85	o. _____ WATTS	o. _____ WATTS

6. CAPACITY

Cooling Capacity = HR. - (o. x 3.413) p. _____ btu/hr
 Heating Capacity= HE. + (o. x 3.413) p. _____ btu/hr

7. EFFICIENCY

Cooling EER = p. / o. q. _____ EER
 Heating COP = p. / (o. x 3.413) q. _____ COP

8. SUPERHEAT (S.H.) / SUBCOOLING (S.C.)

	COOLING	HEATING
Suction Pressure:	r. _____ PSI	r. _____ PSI
Suction Saturation Temperature:	s. _____ °F	s. _____ °F
Suction Line Temperature:	t. _____ °F	t. _____ °F
Superheat = t. - s.	u. _____ °F	u. _____ °F
Head Pressure:	v. _____ PSI	v. _____ PSI
High Pressure Saturation Temp.:	w. _____ °F	w. _____ °F
Liquid Line Temperature*:	x. _____ °F	x. _____ °F
Subcooling = w. - x.	y. _____ °F	y. _____ °F

* Note: Liquid line is between the coaxial heat exchanger and the expansion valve in the cooling mode; between the air coil and the expansion valve in the heating mode.

DEALER: _____
 PHONE #: _____ DATE: _____
 PROBLEM: _____
 MODEL #: _____
 SERIAL #: _____



Commercial Solutions

Startup/Troubleshooting Form

COOLING CYCLE ANALYSIS

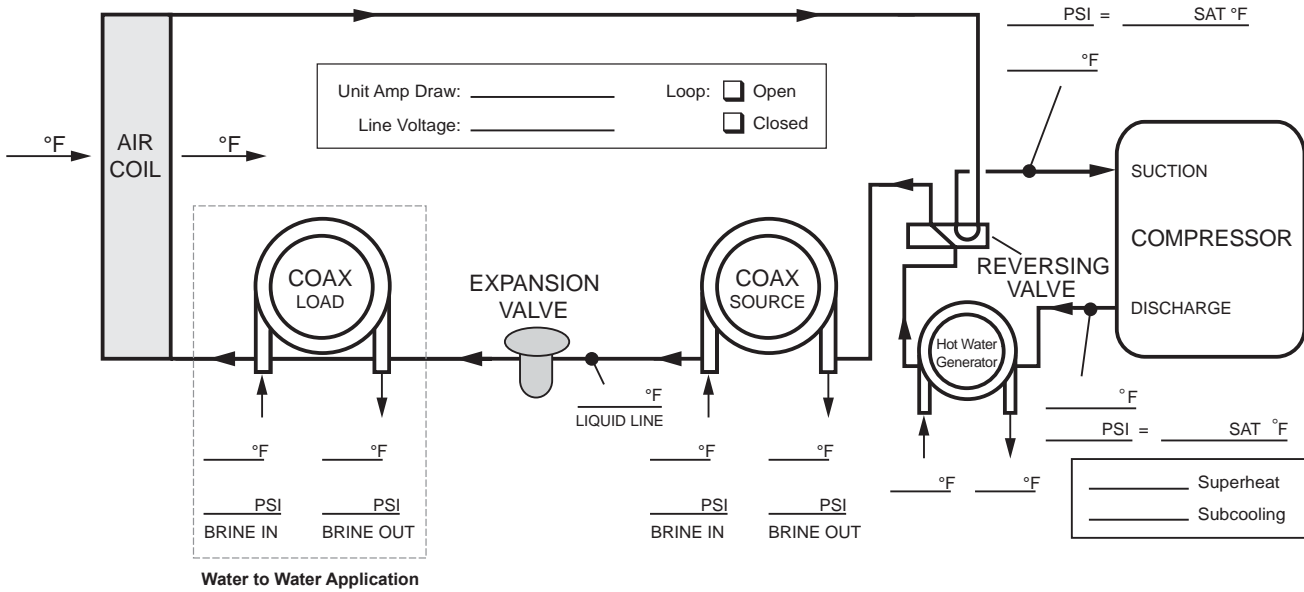

Heat of Extraction/Rejection = GPM x 500 (485 for water/antifreeze) x ΔT

Note: DO NOT hook up pressure gauges unless there appears to be a performance problem.

HEATING CYCLE ANALYSIS

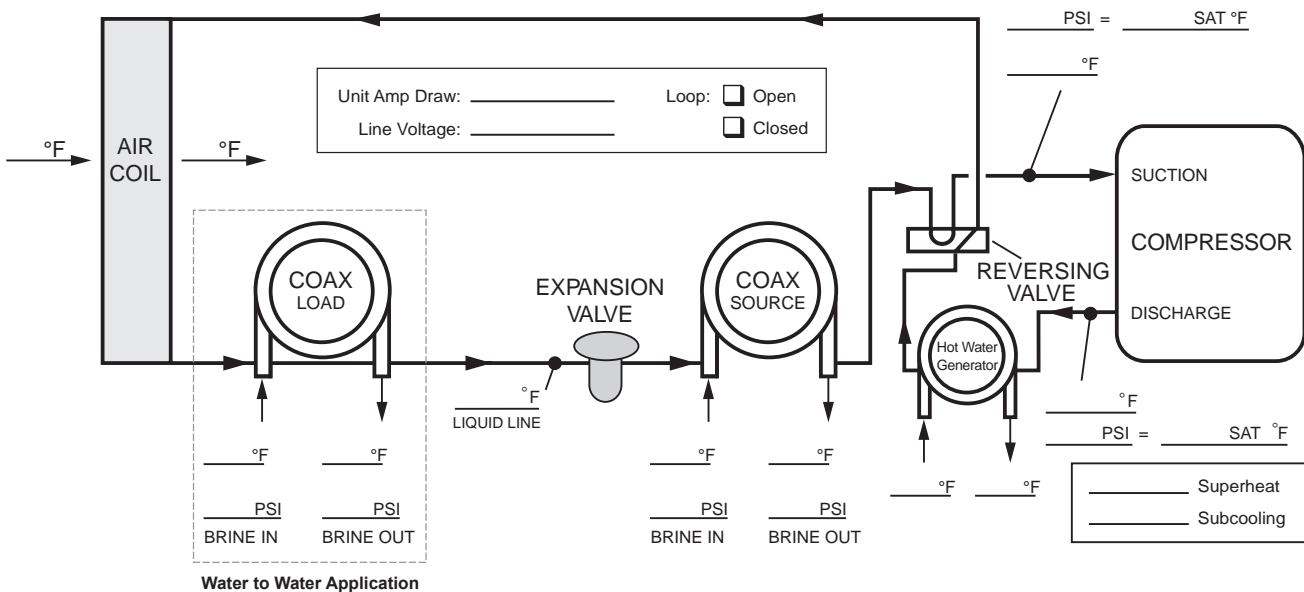

Preventive Maintenance

Water Coil Maintenance

1. Keep all air out of the water. An open loop system should be checked to ensure that the well head is not allowing air to infiltrate the water line. Lines should always be airtight.
2. Keep the system under pressure at all times. It is recommended in open loop systems that the water control valve be placed in the discharge line to prevent loss of pressure during off cycles. Closed loop systems must have positive static pressure.

NOTE: On open loop systems, if the installation is in an area with a known high mineral content (125 PPM or greater) in the water, it is best to establish with the owner a periodic maintenance schedule so the coil can be checked regularly. Should periodic coil cleaning be necessary, use standard coil cleaning procedures which are compatible with either the cupronickel or copper water lines. Generally, the more water flowing through the unit the less chance for scaling.

Other Maintenance

Filters

Filters must be clean to obtain maximum performance. They should be inspected monthly under normal operating conditions and be replaced when necessary. Units should never be operated without a filter.

Condensate Drain

In areas where airborne bacteria produce a slime in the drain pan, it may be necessary to treat chemically to minimize the problem. The condensate drain can pick up lint and dirt, especially with dirty filters. Inspect twice a year to avoid the possibility of overflow.

Blower Motors

Blower motors are equipped with sealed ball bearings and require no periodic oiling.

Hot Water Generator Coil

See Water Coil Maintenance section above.

Air Coil

The air coil must be cleaned to obtain maximum performance. Check once a year under normal operating conditions and, if dirty, brush or vacuum (with a brush attachment) clean. Care must be taken not to damage the aluminum fins while cleaning.



CAUTION: Fin edges are sharp.

Replacement Procedures

Obtaining Parts

When ordering service or replacement parts, refer to the model number and serial number of the unit as stamped on the serial plate attached to the unit. If replacement parts are required, mention the date of installation of the unit and the date of failure, along with an explanation of the malfunctions and a description of the replacement parts required.

In-Warranty Material Return

Material may not be returned except by permission of authorized warranty personnel. Contact your local distributor for warranty return authorization and assistance.

Notes

Revision Guide

Pages:	Description:	Date:	By:
22	Made Correction in Blower Performance Data Notes	14 Sept 2018	MA
Misc.	Removed Waterside Economizer Option, Hot Gas Bypass/Reheat Option	11 July 2017	MA
All	Document Creation	20 Dec., 2016	JM



Manufactured by
WaterFurnace International, Inc.
9000 Conservation Way
Fort Wayne, IN 46809
www.waterfurnace.com



IM2750AU 09/18

Product:	Versatec Variable Speed Series
Type:	Water Source/Geothermal Heat Pump
Size:	3-6 Tons
Document:	Installation Manual