



## FCC TEST REPORT FOR

Shanghai SmartPeak Technology Co.,Ltd.

POS Terminal

Test Model: P600

Additional Model No.: P600 Countertop

Prepared for : Shanghai SmartPeak Technology Co.,Ltd.  
Address : Room 1, No.3 Building, NO.295, Qianqiao Road, Fengxian District, Shanghai, China

Prepared by : Shenzhen LCS Compliance Testing Laboratory Ltd.  
Address : 101, 201 Bldg A & 301 Bldg C, Juji Industrial Park Yabianxueziwei, Shajing Street, Baoan District, Shenzhen, 518000, China

Tel : (+86)755-82591330  
Fax : (+86)755-82591332  
Web : www.LCS-cert.com  
Mail : webmaster@LCS-cert.com

Date of receipt of test sample : December 10, 2022  
Number of tested samples : 2  
Sample No. : A120822082-1, A120822082-2  
Serial number : Prototype  
Date of Test : December 10, 2022 ~ December 15, 2022  
Date of Report : December 23, 2022



Shenzhen LCS Compliance Testing Laboratory Ltd.

Add: 101, 201 Bldg A & 301 Bldg C, Juji Industrial Park Yabianxueziwei, Shajing Street, Baoan District, Shenzhen, 518000, China

Tel: +(86) 0755-82591330 | E-mail: webmaster@lcs-cert.com | Web: www.lcs-cert.com

Scan code to check authenticity



| <b>FCC TEST REPORT</b><br><b>FCC Part 22 /Part 24</b>   |   |
|---|---|
| <b>Report Reference No.</b> ..... :   | <b>LCSA120822082EE</b>  |
| <b>FCC ID</b> ..... :   | <b>2A73S-P600</b>   |
| <b>Date of Issue</b> ..... :  | <b>December 23, 2022</b>  |
| <b>Testing Laboratory Name</b> ..... :  | <b>Shenzhen LCS Compliance Testing Laboratory Ltd.</b>  |
| Address..... :  | 101, 201 Bldg A & 301 Bldg C, Juji Industrial Park Yabianxueziwei, Shajing Street, Baoan District, Shenzhen, 518000, China  |
| <b>Applicant's name</b> ..... :   | <b>Shanghai SmartPeak Technology Co.,Ltd.</b>   |
| Address..... :  | Room 1, No.3 Builiding, NO.295, Qianqiao Road, Fengxian District, Shanghai, China   |
| <b>Test specification</b> ..... :   |   |
| Standard..... :   | <b>FCC Part 22: Public Mobile Services</b><br><b>FCC Part 24: Personal Communication Services</b>   |
| Test Report Form No..... :  | LCSEMC-1.0  |
| TRF Originator..... :   | Shenzhen LCS Compliance Testing Laboratory Ltd.   |
| Master TRF..... :   | Dated 2011-03   |
| <b>Shenzhen LCS Compliance Testing Laboratory Ltd. All rights reserved.</b><br>This publication may be reproduced in whole or in part for non-commercial purposes as long as the Shenzhen LCS Compliance Testing Laboratory Ltd. is acknowledged as copyright owner and source of the material. Shenzhen LCS Compliance Testing Laboratory Ltd. takes no responsibility for and will not assume liability for damages resulting from the reader's interpretation of the reproduced material due to its placement and context. |   |
| <b>Test item description</b> ..... :  | <b>POS Terminal</b>   |
| Trade Mark..... :   | SmartPeak   |
| Test Model..... :   | P600  |
| Ratings..... :  | Input: 5V $\overline{=}$ 2A<br>For Adapter Input: 100-240V~, 50/60Hz, 0.40A<br>For Adapter Output: 5.0V $\overline{=}$ 2.0A, 10.0W<br>DC 7.4V by Rechargeable Li-ion Battery, 2600mAh |
| Hardware version..... :   | /   |
| Software version..... :   | V0.70.7506  |
| Frequency..... :  | GSM 850MHz; PCS 1900MHz   |
| Result..... :   | <b>PASS</b>   |

**Compiled by:**

Vera Deng/ Administrator

**Supervised by:**

Cary Luo/ Technique principal

**Approved by:**

Gavin Liang/ Manager





# TEST REPORT

|  |                                    |
|--|------------------------------------|
| <b>Test Report No. :</b> LCSA120822082EE | December 23, 2022<br>Date of issue |
|--|------------------------------------|

|                          |  |
|--------------------------|--|
| EUT.....                 | : POS Terminal   |
| Test Model.....          | : P600   |
| <b>Applicant.....</b>    | <b>: Shanghai SmartPeak Technology Co.,Ltd.</b>                                    |
| Address.....             | : Room 1, No.3 Building, NO.295, Qianqiao Road, Fengxian District, Shanghai, China |
| Telephone.....           | : /  |
| Fax.....                 | : /  |
| <b>Manufacturer.....</b> | <b>: Shanghai SmartPeak Technology Co.,Ltd.</b>                                    |
| Address.....             | : Room 1, No.3 Building, NO.295, Qianqiao Road, Fengxian District, Shanghai, China |
| Telephone.....           | : /  |
| Fax.....                 | : /  |
| <b>Factory.....</b>      | <b>: Shanghai SmartPeak Technology Co.,Ltd.</b>                                    |
| Address.....             | : Room 1, No.3 Building, NO.295, Qianqiao Road, Fengxian District, Shanghai, China |
| Telephone.....           | : /  |
| Fax.....                 | : /  |

|                     |             |
|---------------------|-------------|
| <b>Test Result:</b> | <b>PASS</b> |
|---------------------|-------------|

The test report merely corresponds to the test sample.  
It is not permitted to copy extracts of these test result without the written permission of the test laboratory.





### Revision History

| Report Version | Issue Date        | Revision Content | Revised By |
|----------------|-------------------|------------------|------------|
| 000            | December 23, 2022 | Initial Issue    | ---        |
|                |                   |                  |            |
|                |                   |                  |            |





# Contents

|          |   |                  |
|----------|---|------------------|
| <b>1</b> | <b><u>TEST STANDARDS .....</u></b>                  | <b><u>6</u></b>  |
| <b>2</b> | <b><u>SUMMARY .....</u></b>                         | <b><u>7</u></b>  |
| 2.1      | Product Description                                 | 7                |
| 2.2      | Equipment under Test                                | 9                |
| 2.3      | Short description of the Equipment under Test (EUT) | 10               |
| 2.4      | Internal Identification of AE used during the test  | 10               |
| 2.5      | Normal Accessory setting                            | 10               |
| 2.6      | EUT configuration                                   | 10               |
| 2.7      | Related Submittal(s) / Grant (s)                    | 10               |
| 2.8      | Modifications                                       | 10               |
| 2.9      | General Test Conditions/Configurations              | 11               |
| <b>3</b> | <b><u>TEST ENVIRONMENT .....</u></b>                | <b><u>12</u></b> |
| 3.1      | Address of the test laboratory                      | 12               |
| 3.2      | Test Facility                                       | 12               |
| 3.3      | Environmental conditions                            | 12               |
| 3.4      | Test Description                                    | 13               |
| 3.5      | Equipments Used during the Test                     | 14               |
| 3.6      | Measurement uncertainty                             | 15               |
| <b>4</b> | <b><u>TEST CONDITIONS AND RESULTS .....</u></b>     | <b><u>16</u></b> |
| 4.1      | Radiated Spurious Emission                          | 16               |
| <b>5</b> | <b><u>TEST SETUP PHOTOGRAPHS OF EUT .....</u></b>   | <b><u>20</u></b> |
| <b>6</b> | <b><u>EXTERIOR PHOTOGRAPHS OF THE EUT .....</u></b> | <b><u>20</u></b> |
| <b>7</b> | <b><u>INTERIOR PHOTOGRAPHS OF THE EUT .....</u></b> | <b><u>20</u></b> |





# 1 TEST STANDARDS

The tests were performed according to following standards:

[FCC Part 22 \(10-1-16 Edition\)](#): Cellular Radiotelephone Service.

[FCC Part 24\(10-1-16 Edition\)](#): Broadband PCS.

[ANSI/TIA-603-E-2016](#): Land Mobile FM or PM Communications Equipment Measurement and Performance Standards.

[47 CFR FCC Part 15 Subpart B](#): Unintentional Radiators.

[FCC Part 2](#): Frequency Allocations And Radio Treaty Matters: General Rules And Regulations.

[ANSI C63.4:2014](#): Methods of Measurement of Radio-Noise Emissions from Low-Voltage Electrical and Electronic Equipment in the Range of 9 kHz to 40 GHz.

[ANSI C63.26-2015](#): Compliance Testing of Transmitters Used in Licensed Radio Services.

[FCC KDB971168 D01](#) Power Meas License Digital Systems v03r01.



Shenzhen LCS Compliance Testing Laboratory Ltd.

Add: 101, 201 Bldg A & 301 Bldg C, Juji Industrial Park Yabianxueziwei, Shajing Street, Baoan District, Shenzhen, 518000, China

Tel: +(86) 0755-82591330 | E-mail: webmaster@lcs-cert.com | Web: www.lcs-cert.com

Scan code to check authenticity



## 2 SUMMARY

### 2.1 Product Description

The **Shanghai SmartPeak Technology Co.,Ltd.**'s Model: P600 or the "EUT" as referred to in this report; more general information as follows, for more details, refer to the user's manual of the EUT.

|                      |  |
|----------------------|--|
| EUT                  | : POS Terminal   |
| Test Model           | : P600   |
| Additional Model No. | : P600 Countertop  |
| Model Declaration    | : PCB board, structure and internal of these model(s) are the same, So no additional models were tested  |
| Power Supply         | : Input: 5V $\overline{=}$ 2A<br>For Adapter Input: 100-240V~, 50/60Hz, 0.40A<br>For Adapter Output: 5.0V $\overline{=}$ 2.0A, 10.0W<br>DC 7.4V by Rechargeable Li-ion Battery, 2600mAh                      |
| Hardware Version     | : /  |
| Software Version     | : V0.70.7506   |
| Bluetooth            | :  |
| Frequency Range      | : 2402MHz ~ 2480MHz  |
| Channel Number       | : 79 channels for Bluetooth V4.1(DSS)<br>40 channels for Bluetooth V4.1 (DTS)  |
| Channel Spacing      | : 1MHz for Bluetooth V4.1 (DSS)<br>2MHz for Bluetooth V4.1 (DTS)   |
| Modulation Type      | : GFSK, $\pi/4$ -DQPSK, 8-DPSK for Bluetooth V4.1(DSS)<br>GFSK for Bluetooth V4.1 (DTS)  |
| Bluetooth Version    | : V4.1   |
| Antenna Description  | : PIFA Antenna, 0.5dBi(Max.)   |
| WIFI(2.4G Band)      | :  |
| Frequency Range      | : 2412MHz ~ 2462MHz  |
| Channel Spacing      | : 5MHz   |
| Channel Number       | : 11 Channels for 20MHz bandwidth (2412~2462MHz)   |
| Modulation Type      | : IEEE 802.11b: DSSS (CCK, DQPSK, DBPSK)<br>IEEE 802.11g: OFDM (64QAM, 16QAM, QPSK, BPSK)<br>IEEE 802.11n: OFDM (64QAM, 16QAM, QPSK, BPSK)   |
| Antenna Description  | : PIFA Antenna, 0.5dBi(Max.)   |
| 2G                   | :  |
| Support Band         | : <input type="checkbox"/> GSM 900 (EU-Band) <input type="checkbox"/> DCS 1800 (EU-Band)<br><input checked="" type="checkbox"/> GSM 850 (U.S.-Band) <input checked="" type="checkbox"/> PCS 1900 (U.S.-Band) |
| Release Version      | : R99  |
| GPRS Class           | : Class 12   |
| EGPRS Class          | : Class 12   |
| Type Of Modulation   | : GMSK for GSM/GPRS; GMSK/8PSK for EGPRS   |
| Antenna Description  | : PIFA Antenna   |



Shenzhen LCS Compliance Testing Laboratory Ltd.

Add: 101, 201 Bldg A & 301 Bldg C, Juji Industrial Park Yabianxueziwei, Shajing Street, Baoan District, Shenzhen, 518000, China

Tel: +(86) 0755-82591330 | E-mail: webmaster@lcs-cert.com | Web: www.lcs-cert.com

Scan code to check authenticity



0.5dBi (max.) For GSM 850  
0.5dBi (max.) For PCS 1900

**3G**

Support Band :  WCDMA Band II (U.S.-Band)  
 WCDMA Band V (U.S.-Band)  
 WCDMA Band IV (U.S.-Band)  
 WCDMA Band I (EU-Band)  
 WCDMA Band VIII (EU-Band)

Release Version : R9

Type Of Modulation : QPSK, 16QAM

Antenna Description : PIFA Antenna  
0.5dBi (max.) For WCDMA Band II  
0.5dBi (max.) For WCDMA Band V

**LTE**

Support Band :  E-UTRA Band 2(U.S.-Band)  
 E-UTRA Band 4(U.S.-Band)  
 E-UTRA Band 7(U.S.-Band)

LTE Release Version : R9

Type Of Modulation : QPSK/16QAM

Antenna Description : PIFA Antenna  
0.5dBi (max.) For E-UTRA Band 2  
0.5dBi (max.) For E-UTRA Band 4  
0.5dBi (max.) For E-UTRA Band 7

Power Class : Class 3

**NFC**

Operating Frequency : 13.56MHz

Modulation Type : ASK

Antenna Description : Internal, 0.5dBi(Max.)

GPS function : Support and only RX

Extreme temp. Tolerance : -30°C to +50°C

Extreme vol. Limits : 6.4VDC to 8.4VDC (nominal: 7.4VDC)



Shenzhen LCS Compliance Testing Laboratory Ltd.

Add: 101, 201 Bldg A & 301 Bldg C, Juji Industrial Park Yabianxueziwei, Shajing Street, Baoan District, Shenzhen, 518000, China

Tel: +(86) 0755-82591330 | E-mail: webmaster@lcs-cert.com | Web: www.lcs-cert.com

Scan code to check authenticity





## 2.2 Equipment under Test

### Power supply system utilised

|                      |   |   |                                   |
|----------------------|---|---|-----------------------------------|
| Power supply voltage | : | <input type="radio"/> 120V / 60 Hz  | <input type="radio"/> 115V / 60Hz |
|                      |   | <input type="radio"/> 12 V DC   | <input type="radio"/> 24 V DC     |
|                      |   | <input checked="" type="radio"/> Other (specified in blank below) 7.4V DC |                                   |

### Test frequency list

| Test Mode | TX/RX | RF Channel  |             |             |
|-----------|-------|-------------|-------------|-------------|
|           |       | Low(L)      | Middle (M)  | High (H)    |
| GSM850    | TX    | Channel 128 | Channel 190 | Channel 251 |
|           |       | 824.2 MHz   | 836.6 MHz   | 848.8 MHz   |
|           | RX    | Channel 128 | Channel 190 | Channel 251 |
|           |       | 869.2 MHz   | 881.6 MHz   | 893.8 MHz   |
| Test Mode | TX/RX | RF Channel  |             |             |
| PCS1900   | TX    | Channel 512 | Channel 661 | Channel 810 |
|           |       | 1850.2 MHz  | 1880.0 MHz  | 1909.8 MHz  |
|           | RX    | Channel 512 | Channel 661 | Channel 810 |
|           |       | 1930.2 MHz  | 1960.0 MHz  | 1989.8 MHz  |





## 2.3 Short description of the Equipment under Test (EUT)

### 2.3.1 General Description

P600 is subscriber equipment in the BT/BLE/2.4GWIFI/GSM/WCDMA/LTE/NFC/GPS system. GSM/GPRS/EGPRS frequency band is Band II/V. The HSPA/UMTS frequency band is Band II/V. LTE frequency band is band 2/4/7. The HSPA/UMTS frequency band II and Band V test data included in this report. The P600 implements such functions as RF signal receiving/transmitting, GSM/GPRS/EGPRS/ HSPA/UMTS/LTE protocol processing, video MMS service and etc. Externally it provides SIM card interface.

### 2.4 Internal Identification of AE used during the test

| AE ID* | Description                     |
|--------|---------------------------------|
| AE1    | Rechargeable Li-Polymer Battery |
| AE2    | Switching Adapter               |
| AE3    | Power Adapter                   |

#### AE1

Battery Model: P600-18650

DC 7.4V by Rechargeable Li-ion Battery, 2600mAh

#### AE2

Adapter Model: GLH50D2000HW

Adapter Input: 100-240V~, 50/60Hz, 0.4A

Adapter Output: 5.0V $\overline{\text{---}}$ 2.0A, 10.0W

### 2.5 Normal Accessory setting

Fully charged battery was used during the test.

### 2.6 EUT configuration

The following peripheral devices and interface cables were connected during the measurement:

- - supplied by the manufacturer
- - supplied by the lab

|               |                |   |
|---------------|----------------|---|
| ○ Power Cable | Length (m) :   | / |
|               | Shield :       | / |
|               | Detachable :   | / |
| ○ Multimeter  | Manufacturer : | / |
|               | Model No. :    | / |

### 2.7 Related Submittal(s) / Grant (s)

This submittal(s) (test report) is intended for **FCC ID: 2A73S-P600** filing to comply with FCC Part 22 and Part 24 Rules.

### 2.8 Modifications

No modifications were implemented to meet testing criteria.



Shenzhen LCS Compliance Testing Laboratory Ltd.

Add: 101, 201 Bldg A & 301 Bldg C, Juji Industrial Park Yabianxueziwei, Shajing Street, Baoan District, Shenzhen, 518000, China

Tel: +(86) 0755-82591330 | E-mail: webmaster@lcs-cert.com | Web: www.lcs-cert.com

Scan code to check authenticity



## 2.9 General Test Conditions/Configurations

### 2.9.1 Test Modes

NOTE: The test mode(s) are selected according to relevant radio technology specifications.

| Test Mode | Test Modes Description            |
|-----------|-----------------------------------|
| SM/TM1    | GSM system, GSM, GMSK modulation  |
| GSM/TM2   | GSM system, GPRS, GMSK modulation |
| GSM/TM3   | GSM system, EDGE, 8PSK modulation |

Note:

- As GSM and GPRS with the same emission designator, test result recorded in this report at the worst case GSM/TM1 only after exploratory scan.

### 2.9.2 Test Environment

| Environment Parameter | Selected Values During Tests |         |
|-----------------------|------------------------------|---------|
| Relative Humidity     | Ambient                      |         |
| Temperature           | TN                           | Ambient |
| Voltage               | VL                           | DC 6.4V |
|                       | VN                           | DC 7.4V |
|                       | VH                           | DC 8.4V |

NOTE: VL=lower extreme test voltage VN=nominal voltage  
VH=upper extreme test voltage TN=normal temperature





### 3 TEST ENVIRONMENT

#### 3.1 Address of the test laboratory

##### Shenzhen LCS Compliance Testing Laboratory Ltd

101, 201 Bldg A & 301 Bldg C, Juji Industrial Park Yabianxueziwei, Shajing Street, Baoan District, Shenzhen, 518000, China  
The sites are constructed in conformance with the requirements of ANSI C63.4 (2014) and CISPR Publication 32.

#### 3.2 Test Facility

The test facility is recognized, certified, or accredited by the following organizations:

NVLAP Accreditation Code is 600167-0.

FCC Designation Number is CN5024.

CAB identifier is CN0071.

CNAS Registration Number is L4595.

Test Firm Registration Number: 254912.

#### 3.3 Environmental conditions

During the measurement the environmental conditions were within the listed ranges:

|                       |              |
|-----------------------|--------------|
| Temperature:          | 15-35 ° C    |
| Humidity:             | 30-60 %      |
| Atmospheric pressure: | 950-1050mbar |





### 3.4 Test Description

#### 3.4.1 Cellular Band (824-849MHz paired with 869-894MHz)

| Test Item   | FCC Rule No.        | Requirements     | Verdict |
|---|---------------------|------------------|---------|
| Field Strength of Spurious Radiation  | §2.1053,<br>§22.917 | ≤ -13dBm/100kHz. | Pass    |
| NOTE 1: For the verdict, the "N/A" denotes "not applicable", the "N/T" de notes "not tested". |                     |                  |         |

#### 3.4.2 PCS Band (1850-1910MHz paired with 1930-1990MHz)

| Test Item   | FCC Rule No.        | Requirements   | Verdict |
|---|---------------------|----------------|---------|
| Field Strength of Spurious Radiation  | §2.1053,<br>§24.238 | ≤ -13dBm/1MHz. | Pass    |
| NOTE 1: For the verdict, the "N/A" denotes "not applicable", the "N/T" de notes "not tested". |                     |                |         |

Remark: The measurement uncertainty is not included in the test result.





### 3.5 Equipments Used during the Test

| Item | Equipment                           | Manufacturer      | Model No.  | Serial No.      | Cal Date   | Due Date   |
|------|-------------------------------------|-------------------|------------|-----------------|------------|------------|
| 1    | Power Meter                         | R&S               | NRVS       | 100444          | 2022-06-16 | 2023-06-15 |
| 2    | Power Sensor                        | R&S               | NRV-Z81    | 100458          | 2022-06-16 | 2023-06-15 |
| 3    | Power Sensor                        | R&S               | NRV-Z32    | 10057           | 2022-06-16 | 2023-06-15 |
| 4    | LTE Test Software                   | Tonscend          | JS1120-1   | N/A             | N/A        | N/A        |
| 5    | RF Control Unit                     | Tonscend          | JS0806-1   | 158060009       | 2022-10-29 | 2023-10-28 |
| 6    | MXA Signal Analyzer                 | Agilent           | N9020A     | MY512509<br>05  | 2022-10-29 | 2023-10-28 |
| 7    | WIDEBAND RADIO COMMUNICATION TESTER | R&S               | CMW 500    | 103818          | 2022-06-16 | 2023-06-15 |
| 8    | DC Power Supply                     | Agilent           | E3642A     | N/A             | 2022-10-29 | 2023-10-28 |
| 9    | EMI Test Software                   | AUDIX             | E3         | /               | N/A        | N/A        |
| 10   | 3m Semi Anechoic Chamber            | SIDT FRANKONIA    | SAC-3M     | 03CH03-<br>HY   | 2022-06-16 | 2023-06-15 |
| 11   | Positioning Controller              | Max-Full          | MF7802BS   | MF780208<br>586 | N/A        | N/A        |
| 12   | Active Loop Antenna                 | SCHWARZBECK       | FMZB 1519B | 00005           | 2021-08-29 | 2024-08-28 |
| 13   | By-log Antenna                      | SCHWARZBECK       | VULB9163   | 9163-470        | 2021-09-12 | 2024-09-11 |
| 14   | Horn Antenna                        | SCHWARZBECK       | BBHA 9120D | 9120D-<br>1925  | 2021-09-05 | 2024-09-04 |
| 15   | Broadband Horn Antenna              | SCHWARZBECK       | BBHA 9170  | 791             | 2021-08-29 | 2024-08-28 |
| 16   | Broadband Preamplifier              | SCHWARZBECK       | BBV9719    | 9719-025        | 2022-06-16 | 2023-06-15 |
| 17   | EMI Test Receiver                   | R&S               | ESR 7      | 101181          | 2022-06-16 | 2023-06-15 |
| 18   | RS SPECTRUM ANALYZER                | R&S               | FSP40      | 100503          | 2022-10-29 | 2023-10-28 |
| 19   | Broadband Preamplifier              | /                 | BP-01M18G  | P190501         | 2022-06-16 | 2023-06-15 |
| 20   | 6dB Attenuator                      | /                 | 100W/6dB   | 1172040         | 2022-06-16 | 2023-06-15 |
| 21   | 3dB Attenuator                      | /                 | 2N-3dB     | /               | 2022-10-29 | 2023-10-28 |
| 22   | Temperature & Humidity Chamber      | GUANGZHOU GOGNWEN | GDS-100    | 70932           | 2022-10-06 | 2023-10-05 |
| 23   | EMI Test Software                   | Farad             | EZ         | /               | N/A        | N/A        |
| 24   | RADIO COMMUNICATION TESTER          | R&S               | CMU 200    | 105988          | 2022-10-29 | 2023-10-28 |



Shenzhen LCS Compliance Testing Laboratory Ltd.

Add: 101, 201 Bldg A & 301 Bldg C, Juji Industrial Park Yabianxueziwei, Shajing Street, Baoan District, Shenzhen, 518000, China

Tel: +(86) 0755-82591330 | E-mail: webmaster@lcs-cert.com | Web: www.lcs-cert.com

Scan code to check authenticity



### 3.6 Measurement uncertainty

The data and results referenced in this document are true and accurate. The reader is cautioned that there may be errors within the calibration limits of the equipment and facilities. The measurement uncertainty was calculated for all measurements listed in this test report acc. to ETSI TR 100 028 “ Electromagnetic compatibility and Radio spectrum Matters (ERM); Uncertainties in the measurement of mobile radio equipment characteristics” and is documented in the Shenzhen LCS Compliance Testing Laboratory Ltd. quality system acc. to DIN EN ISO/IEC 17025. Furthermore, component and process variability of devices similar to that tested may result in additional deviation. The manufacturer has the sole responsibility of continued compliance of the device.

Hereafter the best measurement capability for Shenzhen LCS Compliance Testing Laboratory Ltd. is reported:

| Test                                | Range      | Measurement Uncertainty | Notes |
|-------------------------------------|------------|-------------------------|-------|
| Radiated Emission                   | 30~1000MHz | 3.10 dB                 | (1)   |
| Radiated Emission                   | 1~18GHz    | 3.80 dB                 | (1)   |
| Radiated Emission                   | 18-40GHz   | 3.90 dB                 | (1)   |
| Conducted Disturbance               | 0.15~30MHz | 1.63 dB                 | (1)   |
| Conducted Power                     | 9KHz~18GHz | 0.61 dB                 | (1)   |
| Spurious RF Conducted Emission      | 9KHz~40GHz | 1.22 dB                 | (1)   |
| Band Edge Compliance of RF Emission | 9KHz~40GHz | 1.22 dB                 | (1)   |
| Occupied Bandwidth                  | 9KHz~40GHz | -                       | (1)   |

This uncertainty represents an expanded uncertainty expressed at approximately the 95% confidence level using a coverage factor of k=1.96.



## 4 TEST CONDITIONS AND RESULTS

### 4.1 Radiated Spurious Emission

#### TEST APPLICABLE

According to the TIA/EIA 603D:2010 and FCC Part 2.1033 test method, The Receiver or Spectrum was scanned from lowest frequency frequency generated within the equipment to the 10<sup>th</sup> harmonic of the highest frequency generated within the equipment, which is the transmitted carrier that can be as high as 1910 MHz. The resolution bandwidth is set as outlined in Part 24.238, Part 22.917, RSS-132 §5.5 and RSS-133 §6.5. The spectrum is scanned with the mobile station transmitting at carrier frequencies that pertain to low, mid and high channels of PCS1900 and GSM850.

#### TEST CONFIGURATION

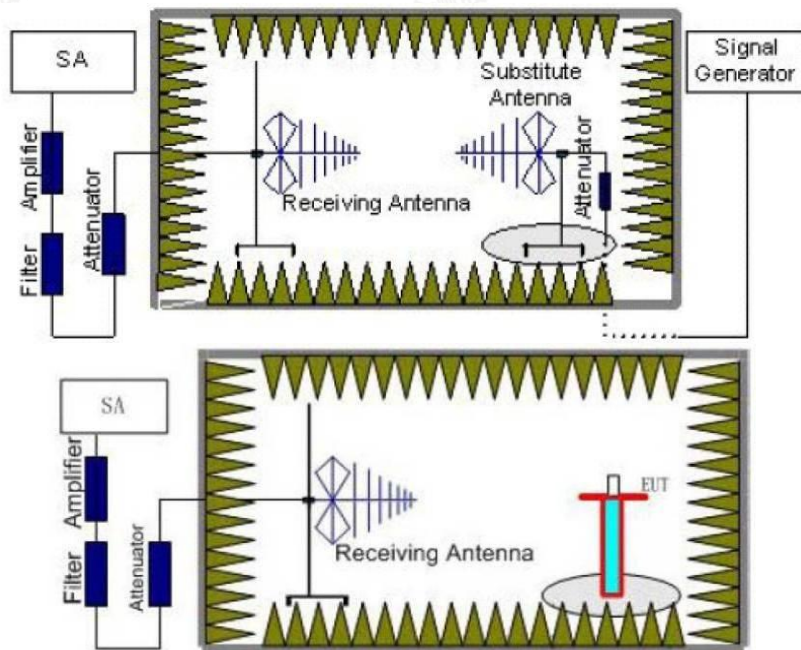

#### TEST PROCEDURE

1. EUT was placed on a 1.50 meter high non-conductive stand at a 3 meter test distance from the receive antenna. A receiving antenna was placed on the antenna mast 3 meters from the EUT for emission measurements. The height of receiving antenna is 1.50 m. Detected emissions were maximized at each frequency by rotating the EUT through 360° and adjusting the receiving antenna polarization. The radiated emission measurements of all transmit frequencies in three channels (High, Middle, Low) were measured with peak detector.
2. A log-periodic antenna or double-ridged waveguide horn antenna shall be substituted in place of the EUT. The log-periodic antenna will be driven by a signal generator and the level will be adjusted till the same power value on the spectrum analyzer or receiver. The level of the spurious emissions can be calculated through the level of the signal generator, cable loss, the gain of the substitution antenna and the reading of the spectrum analyzer or receiver.
3. The EUT is then put into continuously transmitting mode at its maximum power level during the test. Set Test Receiver or Spectrum RBW=1MHz, VBW=3MHz, And the maximum value of the receiver should be recorded as (P<sub>r</sub>).
4. The EUT shall be replaced by a substitution antenna. In the chamber, an substitution antenna for the frequency band of interest is placed at the reference point of the chamber. An RF Signal source for the frequency band of interest is connected to the substitution antenna with a cable that has been constructed to not interfere with the radiation pattern of the antenna. A power (P<sub>Mea</sub>) is applied to the input of the substitution antenna, and adjust the level of the signal generator output until the value of the receiver







reach the previously recorded ( $P_r$ ). The power of signal source ( $P_{Mea}$ ) is recorded. The test should be performed by rotating the test item and adjusting the receiving antenna polarization.

5. A amplifier should be connected to the Signal Source output port. And the cable should be connect between the Amplifier and the Substitution Antenna. The cable loss ( $P_{cl}$ ), the Substitution Antenna Gain ( $G_a$ ) and the Amplifier Gain ( $P_{Ag}$ ) should be recorded after test.

The measurement results are obtained as described below:

$$\text{Power(EIRP)} = P_{Mea} + P_{Ag} - P_{cl} + G_a$$

6. This value is EIRP since the measurement is calibrated using an antenna of known gain (2.15 dBi) and known input power.
7. ERP can be calculated from EIRP by subtracting the gain of the dipole,  $ERP = EIRP - 2.15\text{dBi}$ .
8. In order to make sure test results more clearly, we set frequency range and sweep time for difference frequency range as follows table:

| Working Frequency | Subrange (GHz) | RBW    | VBW    | Sweep time (s) |
|-------------------|----------------|--------|--------|----------------|
| TM1/GSM 850       | 0.00009~0.15   | 1KHz   | 3KHz   | 30             |
|                   | 0.00015~0.03   | 10KHz  | 30KHz  | 10             |
|                   | 0.03~1         | 100KHz | 300KHz | 10             |
|                   | 1~2            | 1 MHz  | 3 MHz  | 2              |
|                   | 2~5            | 1 MHz  | 3 MHz  | 3              |
|                   | 5~8            | 1 MHz  | 3 MHz  | 3              |
|                   | 8~10           | 1 MHz  | 3 MHz  | 3              |
| TM1/GSM 1900      | 0.00009~0.15   | 1KHz   | 3KHz   | 30             |
|                   | 0.00015~0.03   | 10KHz  | 30KHz  | 10             |
|                   | 0.03~1         | 100KHz | 300KHz | 10             |
|                   | 1~2            | 1 MHz  | 3 MHz  | 2              |
|                   | 2~5            | 1 MHz  | 3 MHz  | 3              |
|                   | 5~8            | 1 MHz  | 3 MHz  | 3              |
|                   | 8~11           | 1 MHz  | 3 MHz  | 3              |
|                   | 11~14          | 1 MHz  | 3 MHz  | 3              |
|                   | 14~18          | 1 MHz  | 3 MHz  | 3              |
|                   | 18~20          | 1 MHz  | 3 MHz  | 2              |

## TEST LIMITS

According to 24.238 and 22.917 specify that the power of any emission outside of the authorized operating frequency ranges must be attenuated below the transmitting power ( $P$ ) by a factor of at least  $43 + 10 \log(P)$  dB. The specification that emissions shall be attenuated below the transmitter power ( $P$ ) by at least  $43 + 10 \log(P)$  dB, translates in the relevant power range (1 to 0.001 W) to -13 dBm. At 1 W the specified minimum attenuation becomes 43 dB and relative to a 30 dBm (1 W) carrier becomes a limit of -13 dBm. At 0.001 W (0 dBm) the minimum attenuation is 13 dB, which again yields a limit of -13 dBm. In this way a translation of the specification from relative to absolute terms is carried out.

| Frequency    | Channel | Frequency Range | Verdict |
|--------------|---------|-----------------|---------|
| TM1/GSM 850  | Low     | 9KHz -10GHz     | PASS    |
|              | Middle  | 9KHz -10GHz     | PASS    |
|              | High    | 9KHz -10GHz     | PASS    |
| TM1/GSM 1900 | Low     | 9KHz -20GHz     | PASS    |
|              | Middle  | 9KHz -20GHz     | PASS    |
|              | High    | 9KHz -20GHz     | PASS    |

## TEST RESULTS

Remark:

1. We were tested all refer 3GPP TS151 010.
2.  $EIRP = P_{Mea}(dBm) - P_{cl}(dB) + G_a(dBi)$
3. We were not recorded other points as values lower than limits.
4.  $Margin = EIRP - Limit$



Shenzhen LCS Compliance Testing Laboratory Ltd.

Add: 101, 201 Bldg A & 301 Bldg C, Juji Industrial Park Yabianxueziwei, Shajing Street, Baoan District, Shenzhen, 518000, China

Tel: +(86) 0755-82591330 | E-mail: webmaster@lcs-cert.com | Web: www.lcs-cert.com

Scan code to check authenticity

*GSM/TM1/GSM850\_ Low Channel*

| Frequency (MHz) | P <sub>Mea</sub> (dBm) | P <sub>cl</sub> (dB) | Diatance | G <sub>a</sub> Antenna Gain(dB) | Peak EIRP (dBm) | Limit (dBm) | Margin (dB) | Polarization |
|-----------------|------------------------|----------------------|----------|---------------------------------|-----------------|-------------|-------------|--------------|
| 1648.40         | -43.19                 | 3.86                 | 3.00     | 8.56                            | -38.49          | -13.00      | -25.49      | H            |
| 2472.60         | -44.39                 | 4.29                 | 3.00     | 6.98                            | -41.70          | -13.00      | -28.70      | H            |
| 1648.40         | -39.35                 | 3.86                 | 3.00     | 8.56                            | -34.65          | -13.00      | -21.65      | V            |
| 2472.60         | -42.28                 | 4.29                 | 3.00     | 6.98                            | -39.59          | -13.00      | -26.59      | V            |

*GSM/TM1/GSM850\_ Middle Channel*

| Frequency (MHz) | P <sub>Mea</sub> (dBm) | P <sub>cl</sub> (dB) | Diatance | G <sub>a</sub> Antenna Gain(dB) | Peak EIRP (dBm) | Limit (dBm) | Margin (dB) | Polarization |
|-----------------|------------------------|----------------------|----------|---------------------------------|-----------------|-------------|-------------|--------------|
| 1673.20         | -42.12                 | 3.9                  | 3.00     | 8.58                            | -37.44          | -13.00      | -24.44      | H            |
| 2509.80         | -46.28                 | 4.32                 | 3.00     | 6.8                             | -43.80          | -13.00      | -30.80      | H            |
| 1673.20         | -37.22                 | 3.9                  | 3.00     | 8.58                            | -32.54          | -13.00      | -19.54      | V            |
| 2509.80         | -43.05                 | 4.32                 | 3.00     | 6.8                             | -40.57          | -13.00      | -27.57      | V            |

*GSM/TM1/GSM850\_ High Channel*

| Frequency (MHz) | P <sub>Mea</sub> (dBm) | P <sub>cl</sub> (dB) | Diatance | G <sub>a</sub> Antenna Gain(dB) | Peak EIRP (dBm) | Limit (dBm) | Margin (dB) | Polarization |
|-----------------|------------------------|----------------------|----------|---------------------------------|-----------------|-------------|-------------|--------------|
| 1697.60         | -46.58                 | 3.91                 | 3.00     | 9.06                            | -41.43          | -13.00      | -28.43      | H            |
| 2546.40         | -49.11                 | 4.32                 | 3.00     | 6.65                            | -46.78          | -13.00      | -33.78      | H            |
| 1697.60         | -43.13                 | 3.91                 | 3.00     | 9.06                            | -37.98          | -13.00      | -24.98      | V            |
| 2546.40         | -44.96                 | 4.32                 | 3.00     | 6.65                            | -42.63          | -13.00      | -29.63      | V            |

*GSM/TM3/EDGE850\_ Low Channel*

| Frequency (MHz) | P <sub>Mea</sub> (dBm) | P <sub>cl</sub> (dB) | Diatance | G <sub>a</sub> Antenna Gain(dB) | Peak EIRP (dBm) | Limit (dBm) | Margin (dB) | Polarization |
|-----------------|------------------------|----------------------|----------|---------------------------------|-----------------|-------------|-------------|--------------|
| 1648.40         | -45.38                 | 3.86                 | 3.00     | 8.56                            | -40.68          | -13.00      | -27.68      | H            |
| 2472.60         | -46.17                 | 4.29                 | 3.00     | 6.98                            | -43.48          | -13.00      | -30.48      | H            |
| 1648.40         | -41.96                 | 3.86                 | 3.00     | 8.56                            | -37.26          | -13.00      | -24.26      | V            |
| 2472.60         | -44.15                 | 4.29                 | 3.00     | 6.98                            | -41.46          | -13.00      | -28.46      | V            |

*GSM/TM3/EDGE850\_ Middle Channel*

| Frequency (MHz) | P <sub>Mea</sub> (dBm) | P <sub>cl</sub> (dB) | Diatance | G <sub>a</sub> Antenna Gain(dB) | Peak EIRP (dBm) | Limit (dBm) | Margin (dB) | Polarization |
|-----------------|------------------------|----------------------|----------|---------------------------------|-----------------|-------------|-------------|--------------|
| 1673.20         | -44.14                 | 3.9                  | 3.00     | 8.58                            | -39.46          | -13.00      | -26.46      | H            |
| 2509.80         | -48.31                 | 4.32                 | 3.00     | 6.8                             | -45.83          | -13.00      | -32.83      | H            |
| 1673.20         | -39.39                 | 3.9                  | 3.00     | 8.58                            | -34.71          | -13.00      | -21.71      | V            |
| 2509.80         | -45.38                 | 4.32                 | 3.00     | 6.8                             | -42.90          | -13.00      | -29.90      | V            |

*GSM/TM3/EDGE850\_ High Channel*

| Frequency (MHz) | P <sub>Mea</sub> (dBm) | P <sub>cl</sub> (dB) | Diatance | G <sub>a</sub> Antenna Gain(dB) | Peak EIRP (dBm) | Limit (dBm) | Margin (dB) | Polarization |
|-----------------|------------------------|----------------------|----------|---------------------------------|-----------------|-------------|-------------|--------------|
| 1697.60         | -49.05                 | 3.91                 | 3.00     | 9.06                            | -43.90          | -13.00      | -30.90      | H            |
| 2546.40         | -51.47                 | 4.32                 | 3.00     | 6.65                            | -49.14          | -13.00      | -36.14      | H            |
| 1697.60         | -45.42                 | 3.91                 | 3.00     | 9.06                            | -40.27          | -13.00      | -27.27      | V            |
| 2546.40         | -46.71                 | 4.32                 | 3.00     | 6.65                            | -44.38          | -13.00      | -31.38      | V            |



Shenzhen LCS Compliance Testing Laboratory Ltd.

Add: 101, 201 Bldg A &amp; 301 Bldg C, Juji Industrial Park Yabianxueziwei, Shajing Street, Baoan District, Shenzhen, 518000, China

Tel: +(86) 0755-82591330 | E-mail: webmaster@lcs-cert.com | Web: www.lcs-cert.com

Scan code to check authenticity

*GSM/TM1/GSM1900\_ Low Channel*

| Frequency (MHz) | P <sub>Mea</sub> (dBm) | P <sub>cl</sub> (dB) | Diatance | G <sub>a</sub> Antenna Gain(dB) | Peak EIRP (dBm) | Limit (dBm) | Margin (dB) | Polarization |
|-----------------|------------------------|----------------------|----------|---------------------------------|-----------------|-------------|-------------|--------------|
| 3700.40         | -45.70                 | 5.26                 | 3.00     | 9.88                            | -41.08          | -13.00      | -28.08      | H            |
| 5550.60         | -46.37                 | 6.11                 | 3.00     | 11.36                           | -41.12          | -13.00      | -28.12      | H            |
| 3700.40         | -41.93                 | 5.26                 | 3.00     | 9.88                            | -37.31          | -13.00      | -24.31      | V            |
| 5550.60         | -43.72                 | 6.11                 | 3.00     | 11.36                           | -38.47          | -13.00      | -25.47      | V            |

*GSM/TM1/GSM1900\_ Middle Channel*

| Frequency (MHz) | P <sub>Mea</sub> (dBm) | P <sub>cl</sub> (dB) | Diatance | G <sub>a</sub> Antenna Gain(dB) | Peak EIRP (dBm) | Limit (dBm) | Margin (dB) | Polarization |
|-----------------|------------------------|----------------------|----------|---------------------------------|-----------------|-------------|-------------|--------------|
| 3760.00         | -43.73                 | 5.32                 | 3.00     | 10.03                           | -39.02          | -13.00      | -43.73      | H            |
| 5640.00         | -48.72                 | 6.19                 | 3.00     | 11.41                           | -43.50          | -13.00      | -48.72      | H            |
| 3760.00         | -39.79                 | 5.32                 | 3.00     | 10.03                           | -35.08          | -13.00      | -39.79      | V            |
| 5640.00         | -45.07                 | 6.19                 | 3.00     | 11.41                           | -39.85          | -13.00      | -45.07      | V            |

*GSM/TM1/GSM1900\_ High Channel*

| Frequency (MHz) | P <sub>Mea</sub> (dBm) | P <sub>cl</sub> (dB) | Diatance | G <sub>a</sub> Antenna Gain(dB) | Peak EIRP (dBm) | Limit (dBm) | Margin (dB) | Polarization |
|-----------------|------------------------|----------------------|----------|---------------------------------|-----------------|-------------|-------------|--------------|
| 3819.60         | -48.52                 | 5.36                 | 3.00     | 9.62                            | -44.26          | -13.00      | -48.52      | H            |
| 5729.40         | -51.20                 | 6.24                 | 3.00     | 11.46                           | -45.98          | -13.00      | -51.20      | H            |
| 3819.60         | -45.28                 | 5.36                 | 3.00     | 9.62                            | -41.02          | -13.00      | -45.28      | V            |
| 5729.40         | -46.74                 | 6.24                 | 3.00     | 11.46                           | -41.52          | -13.00      | -46.74      | V            |

*GSM/TM3/EDGE1900\_ Low Channel*

| Frequency (MHz) | P <sub>Mea</sub> (dBm) | P <sub>cl</sub> (dB) | Diatance | G <sub>a</sub> Antenna Gain(dB) | Peak EIRP (dBm) | Limit (dBm) | Margin (dB) | Polarization |
|-----------------|------------------------|----------------------|----------|---------------------------------|-----------------|-------------|-------------|--------------|
| 3700.40         | -47.15                 | 5.26                 | 3.00     | 9.88                            | -42.53          | -13.00      | -29.53      | H            |
| 5550.60         | -48.14                 | 6.11                 | 3.00     | 11.36                           | -42.89          | -13.00      | -29.89      | H            |
| 3700.40         | -43.74                 | 5.26                 | 3.00     | 9.88                            | -39.12          | -13.00      | -26.12      | V            |
| 5550.60         | -45.67                 | 6.11                 | 3.00     | 11.36                           | -40.42          | -13.00      | -27.42      | V            |

*GSM/TM3/EDGE1900\_ Middle Channel*

| Frequency (MHz) | P <sub>Mea</sub> (dBm) | P <sub>cl</sub> (dB) | Diatance | G <sub>a</sub> Antenna Gain(dB) | Peak EIRP (dBm) | Limit (dBm) | Margin (dB) | Polarization |
|-----------------|------------------------|----------------------|----------|---------------------------------|-----------------|-------------|-------------|--------------|
| 3760.00         | -45.64                 | 5.32                 | 3.00     | 10.03                           | -40.93          | -13.00      | -27.93      | H            |
| 5640.00         | -50.39                 | 6.19                 | 3.00     | 11.41                           | -45.17          | -13.00      | -32.17      | H            |
| 3760.00         | -41.80                 | 5.32                 | 3.00     | 10.03                           | -37.09          | -13.00      | -24.09      | V            |
| 5640.00         | -47.29                 | 6.19                 | 3.00     | 11.41                           | -42.07          | -13.00      | -29.07      | V            |

*GSM/TM3/EDGE1900\_ High Channel*

| Frequency (MHz) | P <sub>Mea</sub> (dBm) | P <sub>cl</sub> (dB) | Diatance | G <sub>a</sub> Antenna Gain(dB) | Peak EIRP (dBm) | Limit (dBm) | Margin (dB) | Polarization |
|-----------------|------------------------|----------------------|----------|---------------------------------|-----------------|-------------|-------------|--------------|
| 3819.60         | -51.16                 | 5.36                 | 3.00     | 9.62                            | -46.90          | -13.00      | -33.90      | H            |
| 5729.40         | -53.26                 | 6.24                 | 3.00     | 11.46                           | -48.04          | -13.00      | -35.04      | H            |
| 3819.60         | -47.29                 | 5.36                 | 3.00     | 9.62                            | -43.03          | -13.00      | -30.03      | V            |
| 5729.40         | -48.96                 | 6.24                 | 3.00     | 11.46                           | -43.74          | -13.00      | -30.74      | V            |



Shenzhen LCS Compliance Testing Laboratory Ltd.

Add: 101, 201 Bldg A &amp; 301 Bldg C, Juji Industrial Park Yabianxueziwei, Shajing Street, Baoan District, Shenzhen, 518000, China

Tel: +(86) 0755-82591330 | E-mail: webmaster@lcs-cert.com | Web: www.lcs-cert.com

Scan code to check authenticity



## **5 TEST SETUP PHOTOGRAPHS OF EUT**

Please refer to separated files for Test Setup Photos of the EUT.

## **6 EXTERIOR PHOTOGRAPHS OF THE EUT**

Please refer to separated files for External Photos of the EUT.

## **7 INTERIOR PHOTOGRAPHS OF THE EUT**

Please refer to separated files for Internal Photos of the EUT.

.....**End of Report**.....

