

FCC Radio Test Report

FCC ID:2AM8GCHAMELEON7

Original Grant

Report No. : TBR-C-202202-0108-314
Applicant : Guangzhou Lie Dun Electronics Technology CO., Ltd
Equipment Under Test (EUT)
EUT Name : RUGGEDIZED HAND-HELD DEVICE
Model No. : CHAMELEON 7
Brand Name : CHAMELEON
Sample ID : 202202_0108-01-1& 202202_0108-01-2
Receipt Date : 2022-07-13
Test Date : 2022-07-13 to 2022-09-22
Issue Date : 2022-12-30
Standards : FCC Part 2, FCC Part 22 Subpart H, FCC Part 24 Subpart E,
FCC Part 27, ANSI/TIAC63.26: 2015
Conclusions : **PASS**

In the configuration tested, the EUT complied with the standards specified above,

The EUT technically complies with the FCC requirements

Test/Witness Engineer :

Camille Li

Camille Li

Engineer Supervisor :

IVAN SU

Ivan Su

Engineer Manager :

Ray Lai

Ray Lai



This report details the results of the testing carried out on one sample. The results contained in this test report do not relate to other samples of the same product. The manufacturer should ensure that all products in series production are in conformity with the product sample detailed in the report.

Contents

| | |
|---|-----------|
| CONTENTS | 2 |
| 1. GENERAL INFORMATION ABOUT EUT | 6 |
| 1.1 Client Information..... | 6 |
| 1.2 General Description of EUT (Equipment Under Test) | 6 |
| 1.3 Block Diagram Showing the Configuration of System Tested..... | 7 |
| 1.4 Description of Support Units | 7 |
| 1.5 Description of Test Mode..... | 8 |
| 1.6 Measurement Uncertainty | 10 |
| 1.7 Test Facility..... | 10 |
| 2. TEST SUMMARY | 11 |
| 3. TEST EQUIPMENT | 13 |
| 4. FREQUENCY STABILITY | 15 |
| 4.1 Test Standard and Requirement..... | 15 |
| 4.2 Test Setup..... | 15 |
| 4.3 Test Procedure..... | 16 |
| 4.4 EUT Operating Condition | 16 |
| 4.5 Deviation From Test Standard..... | 16 |
| 4.6 Test Data..... | 16 |
| 5. CONDUCTED RF OUTPUT POWER | 17 |
| 5.1 Test Standard and Limit..... | 17 |
| 5.2 Test Setup..... | 17 |
| 5.3 Test Procedure..... | 17 |
| 5.4 EUT Operating Condition | 17 |
| 5.5 Deviation From Test Standard..... | 17 |
| 5.6 Test Data..... | 17 |
| 6. PEAK-AVERAGE RATIO | 18 |
| 6.1 Test Standard and Limit..... | 18 |
| 6.2 Test Setup..... | 18 |
| 6.3 Test Procedure..... | 18 |
| 6.4 EUT Operating Condition | 18 |
| 6.5 Deviation From Test Standard..... | 18 |
| 6.6 Test Data..... | 18 |

| | | |
|------------|--|-----------|
| 7. | RADIATED OUTPUT POWER | 19 |
| | 7.1 Test Standard and Limit..... | 19 |
| | 7.2 Test Setup..... | 19 |
| | 7.3 Test Procedure..... | 20 |
| | 7.4 EUT Operating Condition | 20 |
| | 7.5 Deviation From Test Standard..... | 20 |
| | 7.6 Test Data..... | 21 |
| 8. | OCCUPIED BANDWIDTH | 22 |
| | 8.1 Test Standard and Limit..... | 22 |
| | 8.2 Test Setup..... | 22 |
| | 8.3 Test Procedure..... | 22 |
| | 8.4 EUT Operating Condition | 23 |
| | 8.5 Deviation From Test Standard..... | 23 |
| | 8.6 Test Data..... | 23 |
| 9. | CONDUCTED OUT OF BAND EMISSIONS | 24 |
| | 9.1 Test Standard and Limit..... | 24 |
| | 9.2 Test Setup..... | 24 |
| | 9.3 Test Procedure..... | 24 |
| | 9.4 EUT Operating Condition | 24 |
| | 9.5 Deviation From Test Standard..... | 24 |
| | 9.6 Test Data..... | 24 |
| 10. | BAND EDGE TEST..... | 25 |
| | 10.1 Test Standard and Limit | 25 |
| | 10.2 Test Setup..... | 25 |
| | 10.3 Test Procedure..... | 25 |
| | 10.4 EUT Operating Condition | 25 |
| | 10.5 Deviation From Test Standard..... | 25 |
| | 10.6 Test Data..... | 25 |
| 11. | RADIATED OUT BAND OF EMISSIONS..... | 27 |
| | 11.1 Test Standard and Limit | 27 |
| | 11.2 Test Setup..... | 27 |
| | 11.3 Test Procedure..... | 27 |
| | 11.4 EUT Operating Condition | 28 |
| | 11.5 Deviation From Test Standard..... | 28 |
| | 11.6 Test Data..... | 28 |

ATTACHMENT A-- RADIATED OUTPUT POWER.....29

1. General Information about EUT

1.1 Client Information

| | | |
|---------------------|---|---|
| Applicant | : | Guangzhou Lie Dun Electronics Technology CO., Ltd |
| Address | : | No.4 plant of No.43 South International Trade Avenue, Hualong Town, Panyu District, Guangzhou, Guangdong, China |
| Manufacturer | : | Guangzhou Lie Dun Electronics Technology CO., Ltd |
| Address | : | No.4 plant of No.43 South International Trade Avenue, Hualong Town, Panyu District, Guangzhou, Guangdong, China |

1.2 General Description of EUT (Equipment Under Test)

| | | | |
|----------------------------|---|--|--|
| EUT Name | : | RUGGEDIZED HAND-HELD DEVICE | |
| HVIN/Model | : | CHAMELEON 7 | |
| Product Description | : | FCC Operating Frequency: | UMTS Band II: 1852.40MHz-1907.60MHz UMTS Band IV: TX:1712.4MHz-1752.6MHz UMTS Band V:826.40MHz-846.60MHz |
| | | Antenna Gain: | 1.65dBi WCDMA Band II/VI/V |
| | | Modulation Type: | EDGE: 8PSK UMTS: QPSK |
| Power Rating | : | For adapter: (Model:MX15W-0502000UX) Input: AC 100V-240V, 50/60Hz 0.3A Output: DC 5V ⁺ , 2000mA DC 3.85V by 7100mAh Li-ion battery | |
| Software Version | : | ---- | |
| Hardware Version | : | QH6601_MB_V1.1 | |
| Remark | : | The antenna gain and adapter provided by the applicant, the verified for the RF conduction test provided by TOBY test lab. | |

Note:

For a more detailed features description, please refer to the manufacturer's specifications or the User's Manual.

1.3 Block Diagram Showing the Configuration of System Tested

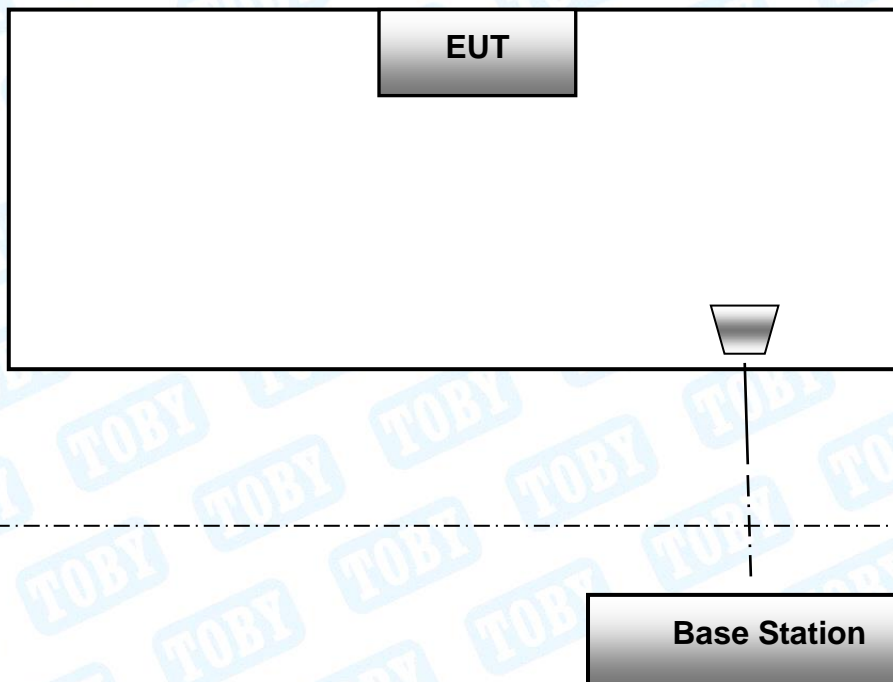

The above block diagram of setup is the normal mode. And more detail please refer to the test setup of each test item of bellow.

1.4 Description of Support Units

The EUT has been tested as an independent unit.

1.5 Description of Test Mode

To investigate the maximum EMI emission characteristics generates from EUT, the test system was pre-scanning tested base on the consideration of following EUT operation mode or test configuration mode which possible have effect on EMI emission level. Each of these EUT operation mode(s) or test configuration mode(s) mentioned follow was evaluated respectively.

During all testing, EUT is link mode with base station at maximum power level. The spurious emission measurements were carried out in semi-anechoic chamber with 3-meter test range. Frequency range investigated for radiated emission as below:

1. 9kHz~10GHz for UMTS Band V.
2. 9kHz~20GHz for UMTS Band II/IV.

| Test Channel | | |
|--------------|---------|----------------|
| Mode | Channel | Frequency(MHz) |
| UMTS Band II | 9262 | 1852.40 |
| | 9400 | 1880.00 |
| | 9538 | 1907.60 |
| UMTS Band IV | 1312 | 1712.40 |
| | 1413 | 1732.60 |
| | 1513 | 1752.60 |
| UMTS Band V | 4132 | 826.40 |
| | 4183 | 836.60 |
| | 4233 | 846.60 |

| Test Mode | Description |
|--------------------|-----------------------------------|
| RMC UMTS Band II | highest , middle, lowest channels |
| HSDPA UMTS Band II | highest , middle, lowest channels |
| HSUPA UMTS Band II | highest , middle, lowest channels |
| RMC UMTS Band IV | highest , middle, lowest channels |
| HSDPA UMTS Band IV | highest , middle, lowest channels |
| HSUPA UMTS Band IV | highest , middle, lowest channels |
| RMC UMTS Band V | highest , middle, lowest channels |
| HSDPA UMTS Band V | highest , middle, lowest channels |
| HSUPA UMTS Band V | highest , middle, lowest channels |

Note:

- (1) The measurements are performed at the highest, middle, lowest available channels.
- (2) During the testing procedure, the EUT is in link mode with base station emulator at maximum power level in each test mode.
- (3) The EUT has RMC, HSDPA, HSUPA functions in UMTS band II and UMTS band V, and after pre-testing, RMC mode is the worst case for all the emission tests.
- (4) The EUT is considered a portable unit; it was pre-tested on the positioned of each 3 axis, X-plane, Y-plane and Z-plane. The worst case was found positioned on Z-plane as the normal use. Therefore only the test data of this Z-plane was used for radiated emission measurement test.

1.6 Measurement Uncertainty

| Test Item | Parameters | Expanded Uncertainty (U_{Lab}) |
|-------------------|--------------------------------------|------------------------------------|
| Radiated Emission | Level Accuracy: 9kHz to 30 MHz | ± 4.60 dB |
| Radiated Emission | Level Accuracy: 30MHz to 1000 MHz | ± 4.50 dB |
| Radiated Emission | Level Accuracy: Above 1000MHz | ± 4.20 dB |

1.7 Test Facility

The testing report were performed by the Shenzhen Toby Technology Co., Ltd., in their facilities located at 1/F., Building 6, Rundongsheng Industrial Zone, Longzhu, Xixiang, Bao'an District, Shenzhen, Guangdong, China. At the time of testing, the following bodies accredited the Laboratory:

CNAS (L5813)

The Laboratory has been accredited by CNAS to ISO/IEC 17025: 2017 General Requirements for the Competence of Testing and Calibration Laboratories for the competence in the field of testing. And the Registration No.: CNAS L5813.

A2LA Certificate No.: 4750.01

The laboratory has been accredited by American Association for Laboratory Accreditation(A2LA) to ISO/IEC 17025: 2017 General Requirements for the Competence of Testing and Calibration Laboratories for the technical competence in the field of Electrical Testing. And the A2LA Certificate No.: 4750.01.FCC Accredited Test Site Number: 854351. Designation Number: CN1223.

IC Registration No.: (11950A)

The Laboratory has been registered by Certification and Engineering Bureau of Industry Canada for radio equipment testing. The site registration: Site# 11950A. CAB identifier: CN0056.

2. Test Summary

| Test Standards and Test Results | | | |
|--|---|----------|--------|
| Standard | Document Title | | |
| FCC Part 2 (10-1-05 Edition) | Frequency Allocations and Radio Treaty Matters; General Rules and Regulations | | |
| FCC Part 22/ FCC Part 27 10-1-05 Edition) | Public Mobile Services | | |
| FCC Part 24 (10-1-05 Edition) | Personal Communications Services | | |
| Standard Section | Test Item | Judgment | Remark |
| 2.1046;27.50(d) RSS-132 Section 5.4 | Conducted RF Output Power | PASS | N/A |
| 24.232(d); 27.50(d) RSS-132 Section 5.4 | Peak-Average Ratio | PASS | N/A |
| 2.1049; 22.917; 24.238; RSS-Gen | 99% & -26 dB Occupied Bandwidth | PASS | N/A |
| 2.1055; 22.355; 24.235; RSS-132 Section 5.3 RSS-133 Section 6.3 RSS-139 Section 6.4 | Frequency Stability | PASS | N/A |
| 2.1051; 2.1057; 22.917; 24.238; 27.53(h) | Conducted Out of Band Emissions | PASS | N/A |
| 2.1051; 2.1057; 22.917; 24.238; 27.53(h) RSS-132 Section 5.5 RSS-133 Section 6.5 RSS-139 Section 6.6 | Band Edge | PASS | N/A |
| 22.913; 24.238,27.50(d) RSS-132 Section 5.4 RSS-133 Section 6.4 RSS-139 Section 6.5 | Transmitter Radiated Power (EIRP/ERP) | PASS | N/A |
| 2.1051; 2.1057; 22.917; 24.238; 27.53(h) | Radiated Out of Band Emissions | PASS | N/A |

| | | |
|---------------------|--|--|
| RSS-132 Section 5.5 | | |
|---------------------|--|--|

Note: N/A is an abbreviation for Not Applicable.

3. Test Equipment

| Radiation Emission Test | | | | | |
|---|-----------------------|-----------------------|---------------|---------------|---------------|
| Equipment | Manufacturer | Model No. | Serial No. | Last Cal. | Cal. Due Date |
| Spectrum Analyzer | Agilent | E4407B | MY45106456 | Jun. 23, 2022 | Jun. 22, 2023 |
| EMI Test Receiver | Rohde & Schwarz | ESPI | 100010/007 | Jun. 23, 2022 | Jun. 22, 2023 |
| Spectrum Analyzer | Rohde & Schwarz | FSV40-N | 102197 | Jun. 23, 2022 | Jun. 22, 2023 |
| Wideband Radio Communication Tester | Rohde & Schwarz | CMW500 | 144382 | Jun. 23, 2022 | Jun. 22, 2023 |
| Universal Radio Communication Tester | Rohde&Schwarz | CMU200 | 103903 | Jun. 23, 2022 | Jun. 22, 2023 |
| Bilog Antenna | ETS-LINDGREN | 3142E | 00117537 | Feb. 27, 2022 | Feb.26, 2024 |
| Horn Antenna | ETS-LINDGREN | 3117 | 00143207 | Feb. 26, 2022 | Feb.25, 2024 |
| Horn Antenna | ETS-LINDGREN | BBHA 9170 | BBHA9170582 | Feb. 26, 2022 | Feb.25, 2024 |
| Loop Antenna | SCHWARZBECK | FMZB 1519 B | 1519B-059 | Feb. 26, 2022 | Feb.25, 2024 |
| Pre-amplifier | Sonoma | 310N | 185903 | Feb. 26, 2022 | Feb.25, 2023 |
| Pre-amplifier | HP | 8449B | 3008A00849 | Feb. 26, 2022 | Feb.25, 2023 |
| Pre-amplifier | SKET | LNPA_1840G-50 | SK201904032 | Feb. 26, 2022 | Feb.25, 2023 |
| Cable | HUBER+SUHNER | 100 | SUCOFLEX | Feb. 26, 2022 | Feb.25, 2023 |
| Positioning Controller | ETS-LINDGREN | 2090 | N/A | N/A | N/A |
| Antenna Conducted Emission | | | | | |
| Equipment | Manufacturer | Model No. | Serial No. | Last Cal. | Cal. Due Date |
| Spectrum Analyzer | Agilent | E4407B | MY45106456 | Jun. 23, 2022 | Jun. 22, 2023 |
| Wideband Radio Communication Tester | Rohde & Schwarz | CMW500 | 144382 | Jun. 23, 2022 | Jun. 22, 2023 |
| Universal Radio Communication Tester | Rohde&Schwarz | CMU200 | 103903 | Jun. 23, 2022 | Jun. 22, 2023 |
| Spectrum Analyzer | Rohde & Schwarz | ESPI | 100010/007 | Jun. 23, 2022 | Jun. 22, 2023 |
| MXA Signal Analyzer | Agilent | N9020A | MY47380425 | Sep. 01, 2022 | Aug. 31, 2023 |
| Vector Signal Generator | Agilent | N5182A | MY50141294 | Sep. 01, 2022 | Aug. 31, 2023 |
| Analog Signal Generator | Agilent | N5181A | MY48180463 | Sep. 01, 2022 | Aug. 31, 2023 |
| RF Power Sensor | DARE!! Instruments | RadiPowerRPR300 6W | 17100015SNO26 | Sep. 01, 2022 | Aug. 31, 2023 |
| | DARE!! | RadiPowerRPR300 | 17100015SNO29 | Sep. 01, 2022 | Aug. 31, 2023 |

| | | | | | |
|-------------------------------------|-----------------------|-----------------------|---------------|---------------|---------------|
| | Instruments | 6W | | | |
| | DARE!! Instruments | RadiPowerRPR300 6W | 17I00015SNO31 | Sep. 01, 2022 | Aug. 31, 2023 |
| | DARE!! Instruments | RadiPowerRPR300 6W | 17I00015SNO33 | Sep. 01, 2022 | Aug. 31, 2023 |
| Temperature and Humidity Chamber | ZhengHang | ZH-QTH-1500 | ZH2107264 | Jun. 22, 2022 | Jun. 21, 2023 |

4. Frequency Stability

4.1 Test Standard and Requirement

4.1.1 Test Standard

FCC Part 2.1055

FCC Part 22.355

FCC Part 24.235

FCC Part 27.54

4.1.2 Requirement

According to FCC section 22.355 and FCC section 24.235, the frequency stability shall be sufficient to ensure that the fundamental emission stays within the authorized frequency block.

According to FCC section 2.1055, the test conditions are:

(1) Temperature:

The temperature is varied from -30°C to $+50^{\circ}\text{C}$ at intervals of not more than 10°C .

(2) Primary Supply Voltage:

For hand carried battery powered equipment, the primary supply voltage is reduced to the battery operating end point which shall be specified by the manufacture. The supply voltage shall be measured at input to the cable normally provide with the equipment, or at the power supply terminals if cables are not normally provided.

4.2 Test Setup

For Temperature Test:

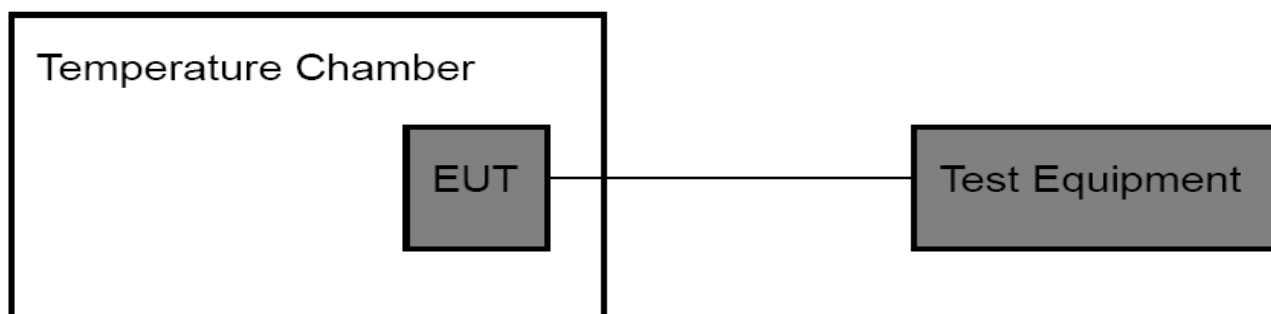

For Voltage Test:

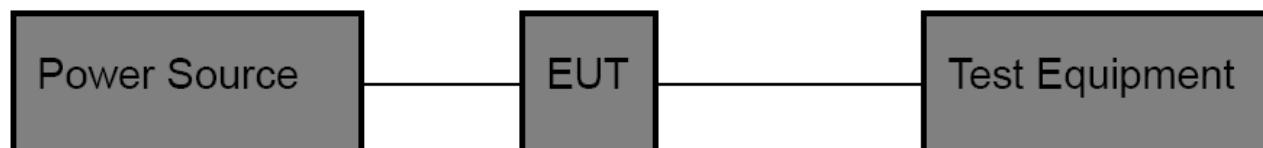

4.3 Test Procedure

Test Procedures for Temperature Variation:

- (1) The EUT was set up in the thermal chamber and connected with the base station.
- (2) With power off, the temperature was decreased to -30°C and the EUT was stabilized for three hours. Power was applied and the maximum change in frequency was recorded within one minute.
- (3) With power off, the temperature was raised in 10°C set up to 50°C and the EUT was stabilized for three hours. Power was applied and the maximum change in frequency was recorded within one minute.
- (4) If the EUT cannot be turned on at -30°C , the testing lowest temperature will be raised in 10°C step until the EUT can be turned on.

Test Procedures for Voltage Variation:

- (1) The EUT was placed in a temperature chamber at $25 \pm 5^{\circ}\text{C}$ and connected with the base station.
- (2) Reduce the input voltage to specify extreme voltage variation ($\pm 15\%$) and endpoint, record the maximum frequency change.
- (3) The variation in frequency was measured for the worst case.

4.4 EUT Operating Condition

The Equipment Under Test was set to Communication with the Base Station.

4.5 Deviation From Test Standard

No deviation

4.6 Test Data

Please refer to the Appendix WCDMA Test Data - **Frequency Stability**.

5. Conducted RF Output Power

5.1 Test Standard and Limit

5.1.1 Test Standard

FCC Part 2: 2.1046

FCC Part 22H : 22.913 (a)

FCC Part 24E: 24.232 (c)

FCC Part 27.54

5.1.2 Test Limit

| GSM850/UMTS Band V | UMTS Band IV | PCS 1900/UMTS Band II |
|--------------------|---------------|-----------------------|
| 38.5 dBm (ERP) | 30 dBm (EIRP) | 33 dBm (EIRP) |

5.2 Test Setup

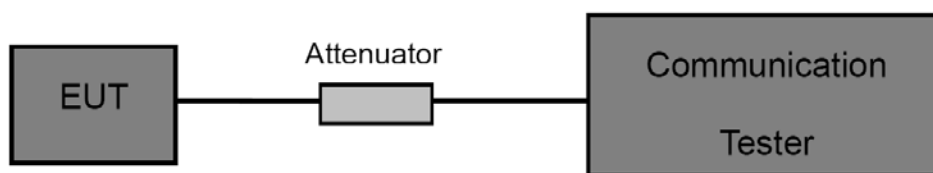

5.3 Test Procedure

- (1) The EUT is coupled to the Base Station with the suitable Attenuator, the path loss is calibrated to correct the reading.
- (2) A call is set up by the Base Station to the generic call set up procedure.
- (3) Set EUT at maximum power level through base station by power level command.
- (4) Then read record the power value from the Base Station in dBm.

5.4 EUT Operating Condition

The EUT was continuously connected with the Base station and transmitting in the max power during the test.

5.5 Deviation From Test Standard

No deviation

5.6 Test Data

Please refer to the Appendix WCDMA Test Data - **Conducted RF Output Power**.

6. Peak-Average Ratio

6.1 Test Standard and Limit

6.1.1 Test Standard

FCC Part 24E: 24.232 (d)

FCC Part 27E: 50(d)

6.1.2 Test Limit

Peak-to-Average Ratio

The peak-to-average ratio (PAR) of the transmission may not exceed 13 dB.

6.2 Test Setup

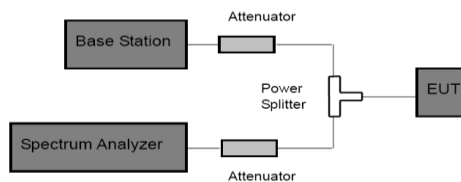

6.3 Test Procedure

According with KDB 971168

- (1) The signal analyzer's CCDF measurement profile is enabled.
- (2) Frequency = carrier center frequency.
- (3) Measurement BW > Emission bandwidth of signal.
- (4) The signal analyzer was set to collect one million samples to generate the CCDF curve.
- (5) The measurement interval was set depending on the type of signal analyzed. For continuous signals (>98% duty cycle), the measurement interval was set to 1ms. For burst transmissions, the spectrum analyzer is set to use an internal "RF Burst" trigger that is synced with an incoming pulse and the measurement interval is set to less than the duration of the "on time" of one burst to ensure that energy is only captured during a time in which of the transmitter is operating at maximum power.

6.4 EUT Operating Condition

The EUT was continuously connected with the Base station and transmitting in the max power during the test.

6.5 Deviation From Test Standard

No deviation

6.6 Test Data

Please refer to the Appendix WCDMA Test Data - **Peak-to-Average Ratio**.

7. Radiated Output Power

7.1 Test Standard and Limit

7.1.1 Test Standard

FCC Part 22H: 22.913 (a)

FCC Part 24E: 24.232 (c)

FCC Part 24E: 27.50 (d)

7.1.2 Test Limit

According to FCC Part 22.913 (a), the ERP of Cellular mobile transmitters must not exceed 7 Watts(38.5 dBm).

According to FCC Part 24.232 (c), the Mobile/portable stations are limited to 2 Watts(33 dBm) EIRP peak power.

According to FCC Part 27.50 (d)(4), Fixed, mobile, and portable (hand-held) stations operating in the 1710-1755 MHz band and mobile and portable stations operating in the 1695-1710 MHz and 1755-1780 MHz bands are limited to 1 watt EIRP. Fixed stations operating in the 1710-1755 MHz band are limited to a maximum antenna height of 10 meters above ground. Mobile and portable stations operating in these bands must employ a means for limiting power to the minimum necessary for successful communications.

| GSM850/UMTS Band V | UMTS Band IV | PCS 1900/UMTS Band II |
|--------------------|---------------|-----------------------|
| 38.5 dBm (ERP) | 30 dBm (EIRP) | 33 dBm (EIRP) |

7.2 Test Setup

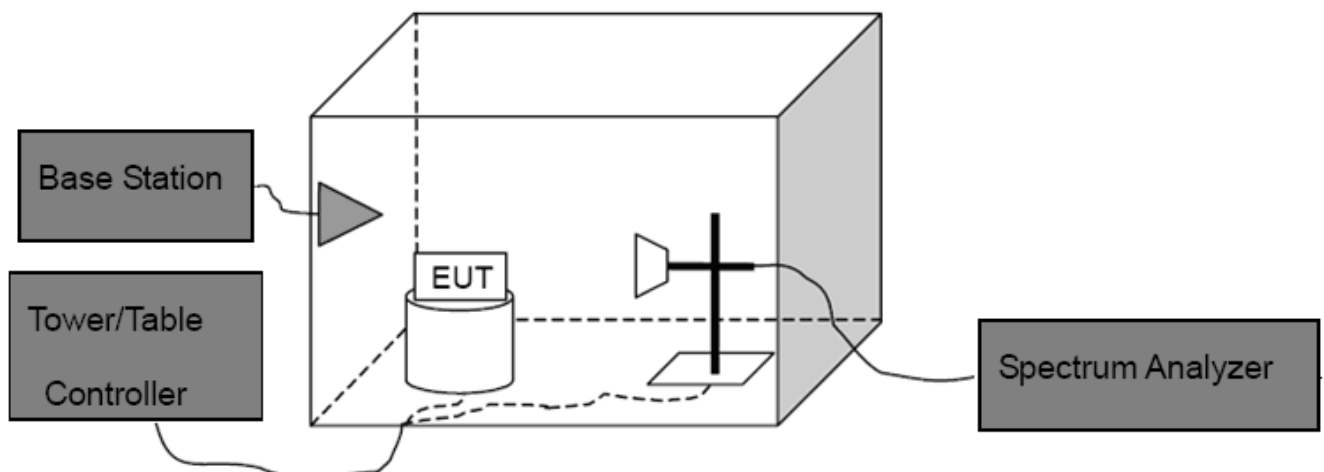

Above 1G

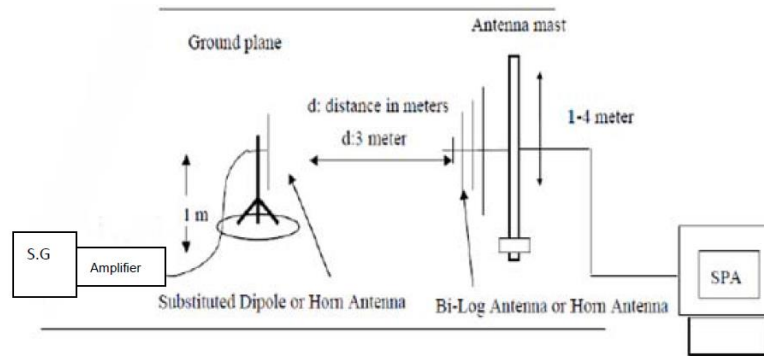

Substituted Method

7.3 Test Procedure

- (1) The EUT was placed on a non-conductive rotating platform with 0.8 meter height in an anechoic chamber. The radiated emission at the fundamental frequency was measured at 3 m with a test antenna and a spectrum analyzer with RBW=3 MHz, VBW=3 MHz and peak detector settings.
- (2) During the measurement, the EUT was enforced in maximum power and linked with the Base Station. The highest was recorded from analyzer power level (LVT) from the 360 degrees rotation of the turntable and the test antenna raised and lowered over a range from 1 to 4 meters in both horizontally and vertically polarized orientations.
- (3) Effective Isotropic Radiated Power (EIRP) was measured by substitution method according to C63.26. The EUT was replaced by dipole antenna (for frequency below 1 GHz) or Horn antenna (for frequency above 1 GHz) at same location with same polarize of receiver antenna and then a known power of each measure frequency from S.G. was applied into the dipole antenna or Horn antenna through a TX cable, and then recorded the maximum Analyzer reading through raised and lowered the test antenna.

Note: In test, the S.G. Connect the Pre-amplifier(Sonoma 310N Pre-amplifier for frequency below 1 GHz, HP 8449B Pre-amplifier for frequency above 1 GHz)

Then the EUT's EIRP and ERP was calculated with the correction factor:

$$\text{ERP} = \text{S.G. Level} + \text{Antenna Gain Cord. (dBd)} - \text{Cable Loss (dB)}$$

$$\text{EIRP} = \text{S.G. Level} + \text{Antenna Gain Cord. (dBi)} - \text{Cable Loss (dB)}$$

7.4 EUT Operating Condition

The EUT was continuously connected with the Base station and transmitting in the max power during the test.

7.5 Deviation From Test Standard

No deviation

7.6 Test Data

Please refer to the Attachment A.

8. Occupied Bandwidth

8.1 Test Standard and Limit

8.1.1 Test Standard

FCC Part 2: 2.1049

8.1.2 Test Requirement

According to FCC section 2.1049, the occupied bandwidth is the frequency bandwidth such that below its lower and above its upper frequency limits, the mean powers radiated are each equal to 0.5 percent of the total mean power radiated by a given emission.

Occupied bandwidth is also known as 99% power and -26dB occupied bandwidths.

8.2 Test Setup

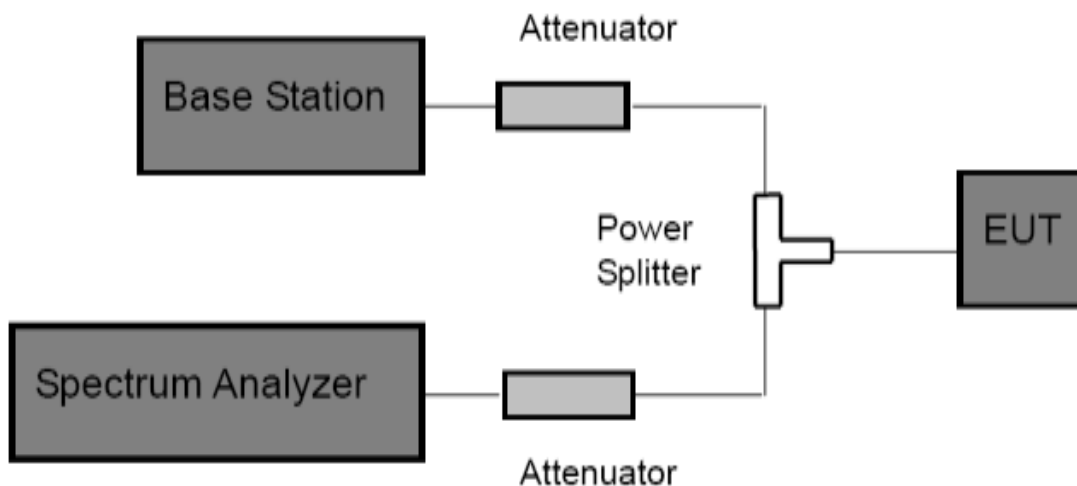

8.3 Test Procedure

- (1) The EUT was directly connected to the spectrum analyzer and Base station via power splitter as show in the block diagram above.
- (2) The resolution bandwidth of the Spectrum Analyzer is set to at least 1% of the occupied bandwidth.
- (3) The low, middle and the high channels are selected to perform tests respectively.
- (4) Set the frequency range of the Spectrum Analyzer suitably to capture the waveform; search peak; make a line whose value is 26dB lower than the peak; mark two points which the line intersected the waveform at; finally record the delta of the two points as the occupied bandwidth and the plot.
- (5) Set the Spectrum Analyzer Occupied bandwidth function to measure the 99% occupied

bandwidth.

8.4 EUT Operating Condition

The EUT was continuously connected with the Base station and transmitting in the max power during the test.

8.5 Deviation From Test Standard

No deviation

8.6 Test Data

Please refer to the Appendix WCDMA Test Data - **26dB Bandwidth and Occupied Bandwidth.**

9. Conducted Out of Band Emissions

9.1 Test Standard and Limit

9.1.1 Test Standard

FCC Part 2: 2.1051, 2.1057

FCC Part 22H: 22.917(a)

FCC Part 24E: 24.238(a)

FCC Part 27: 53 (h)

9.1.2 Test Limit

The power of any emission outside of the authorized operating frequency ranges must be attenuated below the transmitting power(P) by a factor of at least $43+10\log(P)$ dB. For all power levels +30 dBm to 0 dBm, this becomes a constant specification limit of -13 dBm.

9.2 Test Setup

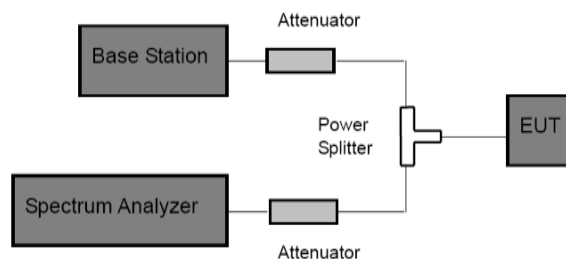

9.3 Test Procedure

- (1) The EUT was directly connected to the spectrum analyzer and Base station via power splitter as show in the block diagram above.
- (2) Spectrum Setting:
Frequency bellow 1 GHz: RBW=100 kHz, VBW=300 kHz.
Frequency above 1 GHz: RBW=1 MHz, VBW=3 MHz.
- (3) The low, middle and high channels of each band and mode's spurious emissions for 30 MHz to 10th Harmonic were measured by Spectrum analyzer.

9.4 EUT Operating Condition

The EUT was continuously connected with the Base station and transmitting in the max power during the test.

9.5 Deviation From Test Standard

No deviation

9.6 Test Data

Please refer to the Appendix WCDMA Test Data - **Conducted Spurious Emission.**

10. Band Edge Test

10.1 Test Standard and Limit

10.1.1 Test Standard

FCC Part 2: 2.1051, 2.1057

FCC Part 22H: 22.917(a)

FCC Part 24E: 24.238(a)

FCC Part 27: 53 (h)

10.1.2 Test Limit

The power of any emission outside of the authorized operating frequency ranges must be attenuated below the transmitting power(P) by a factor of at least $43+10\log(P)$ dB. For all power levels +30 dBm to 0 dBm, this becomes a constant specification limit of -13 dBm.

10.2 Test Setup

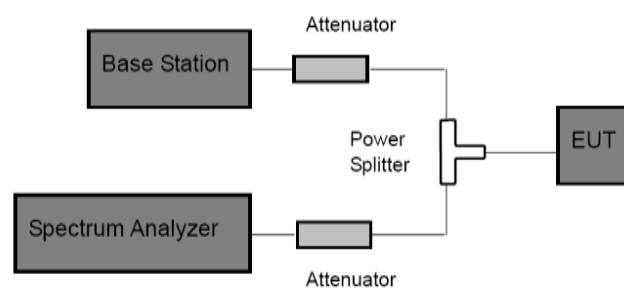

10.3 Test Procedure

(1) The EUT was directly connected to the spectrum analyzer and Base station via power splitter as show in the block diagram above.

(2) Spectrum Setting:

GSM and PCS: $RBW \geq 1\%$ 26db bandwidth, $VBW=3$ RBW, Span 1 MHz, Detector: Peak Mode.

WCDMA: $RBW \geq 1\%$ 26db bandwidth, $VBW=3$ RBW, Span 10 MHz, Detector: Peak Mode.

(3) The band edges of low and high channels for the highest RF powers were measured.

10.4 EUT Operating Condition

The EUT was continuously connected with the Base station and transmitting in the max power during the test.

10.5 Deviation From Test Standard

No deviation

10.6 Test Data

Please refer to the Appendix WCDMA Test Data - **Band Edge**.

11. Radiated Out Band of Emissions

11.1 Test Standard and Limit

11.1.1 Test Standard

FCC Part 2: 2.1053, 2.1057

FCC Part 22H: 22.917

FCC Part 24E: 24.238

FCC Part 27: 53 (h)

11.1.2 Test Limit

The power of any emission outside of the authorized operating frequency ranges must be attenuated below the transmitting power(P) by a factor of at least $43+10\log(P)$ dB. For all power levels +30 dBm to 0 dBm, this becomes a constant specification limit of -13 dBm.

11.2 Test Setup

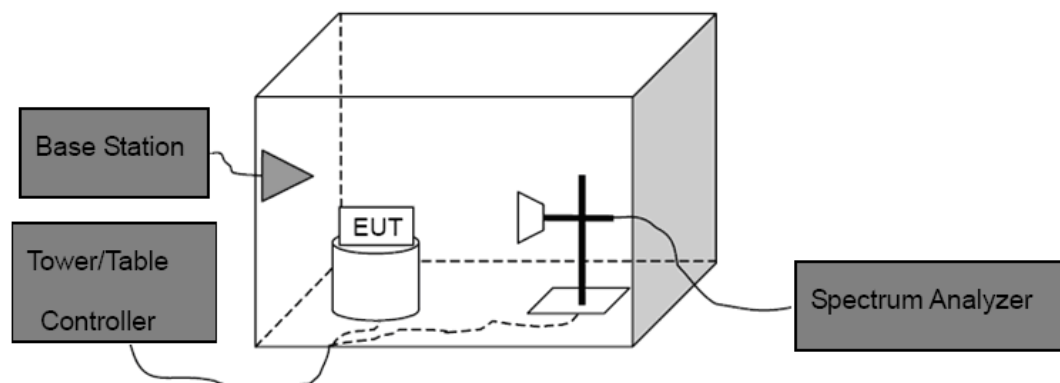

11.3 Test Procedure

- (1) The test system setup as show in the block diagram above.
- (2) The EUT was placed on an non-conductive rotating platform in an anechoic chamber. The radiated spurious emissions from 30MHz to 10th harmonious of fundamental frequency were measured at 3 m with a test antenna and a spectrum analyzer with RBW=1 MHz, VBW=1 MHz, peak detector settings.
- (3) During the measurement, the EUT was enforced in maximum power and linked with a base station. All the spurious emissions at 3m were measured by rotation of the turntable and the test antenna raised and lowered over a range from 1 to 4 meters in both horizontally and vertically polarized orientations.
- (4) When found the maximum level of emissions from the EUT. Remove the EUT and replace it with substitution antenna. A signal generator was connected to the substitution antenna by a non-radiating cable. The absolute levels of the spurious emissions were measured by the

substitution.

Spurious emissions in $\text{dB}=10 \log(\text{TX power in Watts}/0.001)$ -the absolute level

Spurious attenuation limit in $\text{dB}=43+10 \log(\text{power out in Watts})$

11.4 EUT Operating Condition

The EUT was continuously connected with the Base station and transmitting in the max power during the test.

11.5 Deviation From Test Standard

No deviation

11.6 Test Data

Please refer to the Attachment B.

Attachment A-- Radiated Output Power

| UMTS Band II | | | | | | | | |
|--------------|---------|-----------------|---------------|----------------|----------------------|-----------------|------------------|----------------|
| Mode | Channel | Frequency (MHz) | Antenna (H&V) | SG Level (dBm) | Antenna Factor (dBi) | Cable Loss (dB) | EIRP Power (dBm) | EIRP Power (W) |
| RMC | 9262 | 1852.4 | H | 20.65 | 5.01 | 2.59 | 23.07 | 0.2029 |
| | | | V | 15.18 | 5.01 | 2.59 | 17.60 | 0.0576 |
| | 9400 | 1880.0 | H | 20.11 | 4.82 | 2.59 | 22.34 | 0.1714 |
| | | | V | 19.54 | 4.82 | 2.59 | 21.77 | 0.1504 |
| | 9538 | 1907.6 | H | 18.79 | 4.45 | 2.59 | 20.65 | 0.1161 |
| | | | V | 18.51 | 4.45 | 2.59 | 20.37 | 0.1090 |
| Limit | | | | | | | 33 | 2 |

| UMTS Band IV | | | | | | | | |
|--------------|---------|-----------------|---------------|----------------|----------------------|-----------------|-----------------|---------------|
| Mode | Channel | Frequency (MHz) | Antenna (H&V) | SG Level (dBm) | Antenna Factor (dBi) | Cable Loss (dB) | ERP Power (dBm) | ERP Power (W) |
| RMC | 4132 | 826.4 | H | 20.50 | 5.01 | 2.59 | 22.92 | 0.1959 |
| | | | V | 13.77 | 5.01 | 2.59 | 16.19 | 0.0416 |
| | 4183 | 836.6 | H | 18.35 | 4.82 | 2.59 | 20.58 | 0.1142 |
| | | | V | 13.88 | 4.82 | 2.59 | 16.11 | 0.0408 |
| | 4233 | 846.6 | H | 19.39 | 4.45 | 2.59 | 21.25 | 0.1335 |
| | | | V | 18.50 | 4.45 | 2.59 | 20.36 | 0.1087 |
| Limit | | | | | | | 30 | 1 |

| UMTS Band V | | | | | | | | |
|--------------|---------|-----------------|---------------|----------------|----------------------|-----------------|-----------------|---------------|
| Mode | Channel | Frequency (MHz) | Antenna (H&V) | SG Level (dBm) | Antenna Factor (dBi) | Cable Loss (dB) | ERP Power (dBm) | ERP Power (W) |
| RMC | 4132 | 826.4 | H | 16.86 | 5.01 | 2.59 | 19.28 | 0.0846 |
| | | | V | 15.26 | 5.01 | 2.59 | 17.68 | 0.0587 |
| | 4183 | 836.6 | H | 20.80 | 4.82 | 2.59 | 23.03 | 0.2009 |
| | | | V | 15.64 | 4.82 | 2.59 | 17.87 | 0.0613 |
| | 4233 | 846.6 | H | 20.09 | 4.45 | 2.59 | 21.95 | 0.1565 |
| | | | V | 17.54 | 4.45 | 2.59 | 19.40 | 0.0871 |
| Limit | | | | | | | 38.5 | 7 |

Attachment B--Radiated Out Band of Emissions

Measurement Data (worst case)

| Test mode: | UMTS Band II RMC | | | | | | |
|-----------------|--------------------|------------------|------------------------------|-----------------|----------------------|-------------|--------|
| Channel: | Middle | | | | | | |
| Frequency (MHz) | Spurious Emission | | | | | Limit (dBm) | Result |
| | Polarization (H&V) | Read Level (dBm) | Antenna Correct Factor (dBi) | Cable Loss (dB) | Emission Level (dBm) | | |
| 3760.40 | Horizontal | -55.82 | 14.94 | 6.12 | -34.76 | -13.00 | Pass |
| 5640.30 | H | -66.93 | 13.87 | 7.86 | -45.20 | | |
| 7520.40 | H | -68.53 | 14.49 | 9.54 | -44.50 | | |
| 9400.00 | H | --- | --- | --- | --- | | |
| 11280.00 | H | --- | --- | --- | --- | | |
| 13160.00 | H | --- | --- | --- | --- | | |
| 3760.40 | Vertical | -39.97 | 8.02 | 3.97 | -27.98 | -13.00 | Pass |
| 5640.30 | V | -47.39 | 10.47 | 5.05 | -31.87 | | |
| 7520.40 | V | -58.36 | 16.92 | 5.98 | -35.46 | | |
| 9400.00 | V | --- | --- | --- | --- | | |
| 11280.00 | V | --- | --- | --- | --- | | |
| 13160.00 | V | --- | --- | --- | --- | | |

Remark: 1, The testing has been conformed to $10 \times 1880.0\text{MHz} = 18,800\text{MHz}$.
 2, All other emissions more than 30 dB below the limit.
 3, Emission Level= Read Level+ Antenna Correct Factor +Cable Loss

| Test mode: | UMTS Band IV RMC | | | | | | |
|-------------------|-------------------------|------------------|------------------------------|-----------------|----------------------|-------------|--------|
| Channel: | Middle | | | | | | |
| Frequency (MHz) | Spurious Emission | | | | | Limit (dBm) | Result |
| | Polarization (H&V) | Read Level (dBm) | Antenna Correct Factor (dBi) | Cable Loss (dB) | Emission Level (dBm) | | |
| 3465.25 | Horizontal | -54.72 | 14.94 | 6.12 | -33.66 | -13.00 | Pass |
| 5197.82 | H | -66.53 | 13.87 | 7.86 | -44.80 | | |
| 6930.44 | H | -70.75 | 14.49 | 9.54 | -46.72 | | |
| 8663.00 | H | --- | --- | --- | --- | | |
| 10395.60 | H | --- | --- | --- | --- | | |
| 3465.25 | H | --- | --- | --- | --- | | |
| 5197.82 | Vertical | -39.20 | 8.02 | 3.97 | -27.21 | -13.00 | Pass |
| 6930.44 | V | -47.25 | 10.47 | 5.05 | -31.73 | | |
| 8663.00 | V | -57.46 | 16.92 | 5.98 | -34.56 | | |
| 10395.60 | V | --- | --- | --- | --- | | |
| 3465.25 | V | --- | --- | --- | --- | | |
| 5197.82 | V | --- | --- | --- | --- | | |

Remark: 1, The testing has been conformed to $10 \times 1732.6\text{MHz} = 17326\text{MHz}$.
2, All other emissions more than 30 dB below the limit.
3, Emission Level= Read Level+ Antenna Correct Factor +Cable Loss

| Test mode: | UMTS Band V RMC | | | | | | |
|-------------------|------------------------|------------------|------------------------------|-----------------|----------------------|-------------|--------|
| Channel: | Middle | | | | | | |
| Frequency (MHz) | Spurious Emission | | | | | Limit (dBm) | Result |
| | Polarization (H&V) | Read Level (dBm) | Antenna Correct Factor (dBi) | Cable Loss (dB) | Emission Level (dBm) | | |
| 1673.20 | Horizontal | -57.88 | 14.94 | 6.12 | -36.82 | -13.00 | Pass |
| 2509.80 | H | -63.00 | 13.87 | 7.86 | -41.27 | | |
| 3346.40 | H | -70.01 | 14.49 | 9.54 | -45.98 | | |
| 4183.00 | H | --- | --- | --- | --- | | |
| 5019.60 | H | --- | --- | --- | --- | | |
| 5856.20 | H | --- | --- | --- | --- | | |
| 1673.20 | Vertical | -35.62 | 8.02 | 3.97 | -23.63 | -13.00 | Pass |
| 2509.80 | V | -49.84 | 10.47 | 5.05 | -34.32 | | |
| 3346.40 | V | -57.18 | 16.92 | 5.98 | -34.28 | | |
| 4183.00 | V | --- | --- | --- | --- | | |
| 5019.60 | V | --- | --- | --- | --- | | |
| 5856.20 | V | --- | --- | --- | --- | | |

Remark: 1, The testing has been conformed to $10 \times 836.6\text{MHz} = 8,366\text{MHz}$.
 2, All other emissions more than 30 dB below the limit.
 3, Emission Level= Read Level+ Antenna Correct Factor +Cable Loss

-----End of the Report-----