

# Service Manual



## Colour Television

**TX-32PS12**  
**TX-28PS12**

## EURO- 9L Chassis

### SPECIFICATIONS

(Information in brackets [ ] refers to model TX-28PS12)

<b>Power Source:</b>	220-240V a.c., 50Hz	AV3 IN	S-Video IN (4-pin)	Y: 1V p-p 75Ω C:0,3V p-p 75Ω
<b>Power Consumption:</b>	114W [105W]		Audio (RCAx2)	500mV rms 10kΩ
<b>Stand-by Power Consumption:</b>	0,6W		Video (RCAx1)	1V p-p 75Ω
<b>Aerial Impedance:</b>	75Ω unbalanced, Coaxial Type	AV4 IN	Video (21 pin)	1V p-p 75Ω
<b>Receiving System:</b>	PAL-I M.NTSC (AV only) NTSC (AV only)		Audio (21 pin)	500mV rms 10kΩ
<b>Receiving Channels:</b>	UHF E21-E68		RGB (21 pin)	0,7V p-p 75Ω
<b>Intermediate Frequency:</b>			S-Video IN (21-pin)	Y: 1V p-p 75Ω C:0,3V p-p 75Ω
<b>Video/Audio</b>		AV4 OUT	Video (21 pin)	1V p-p 75Ω
Video	39,5MHz		Audio (21 pin)	500mV rms 1kΩ
Audio	33,5MHz 32,95MHz (NICAM)	<b>High Voltage:</b>		32kV ± 1kV [30,5kV ± 1kV]
Colour	35,07MHz	<b>Picture Tube:</b>	W76ELE50X71	76cm
<b>Terminals:</b>			[W66EKT50X71	66cm]
AUDIO MONITOR OUT	Audio (RCAx2) 500mV rms 1kΩ	<b>Audio Output:</b>		2x10W RMS, 2x20W MPO, 8Ω impedance
AV1 IN	Video (21 pin) 1V p-p 75Ω Audio (21 pin) 500mV rms 10kΩ RGB (21 pin) 0,7V p-p 75Ω	<b>Headphones:</b>		8Ω Impedance
AV1 OUT	Video (21 pin) 1V p-p 75Ω Audio (21 pin) 500mV rms 1kΩ	<b>Accessories supplied :</b>		Remote Control 2 x R6 (UM3) Batteries
AV2 IN	Video (21 pin) 1V p-p 75Ω Audio (21 pin) 500mV rms 10kΩ S-Video IN (21-pin) Y: 1V p-p 75Ω C:0,3V p-p 75Ω	<b>Dimensions:</b>		
AV2 OUT	Video (21 pin) 1V p-p 75Ω Audio (21 pin) 500mV rms 1kΩ	Height:	567mm	[510mm]
		Width:	902mm	[805mm]
		Depth:	551mm	[533mm]
		<b>Net weight:</b>	55,5kg	[43,3kg]

Specifications are subject to change without notice.  
Weights and dimensions shown are approximate.

# CONTENTS

SAFETY PRECAUTIONS .....	2
SERVICE HINTS .....	3
SERVICE POSITION .....	4
ADJUSTMENT PROCEDURE AND SELF-CHECK .....	5
WAVEFORM PATTERN TABLE .....	6
ALIGNMENT SETTINGS .....	7
BLOCK DIAGRAMS .....	8
PARTS LOCATION .....	13
REPLACEMENT PARTS LIST .....	14
SCHEMATIC DIAGRAMS .....	27
CONDUCTOR VIEWS .....	32

## SAFETY PRECAUTION

### GENERAL GUIDE LINES

1. It is advisable to insert an isolation transformer in the a.c. supply before servicing a hot chassis.
2. When servicing, observe the original lead dress in the high voltage circuits. If a short circuit is found, replace all parts that have been overheated or damaged by the short circuit.
3. After servicing, see that all the protective devices such as insulation barriers, insulation papers, shields and isolation R-C combinations are correctly installed.
4. When the receiver is not being used for a long period of time, unplug the power cord from the a.c. outlet.
5. Potentials as high as 33kV [31,5kV] are present when this receiver is in operation. Operation of the receiver without the rear cover involves the danger of a shock hazard from the receiver power supply. Servicing should not be attempted by anyone who is not familiar with the precautions necessary when working on high voltage equipment. Always discharge the anode of the tube.
6. After servicing make the following leakage current checks to prevent the customer from being exposed to shock hazard.

### LEAKAGE CURRENT COLD CHECK

1. Unplug the a.c. cord and connect a jumper between the two prongs of the plug.
2. Turn on the receiver's power switch.
3. Measure the resistance value with an ohmmeter, between the jumpered a.c. plug and each exposed metallic cabinet part on the receiver, such as screw heads, aerials, connectors, control shafts etc. When the exposed metallic part has a return path to the chassis, the reading should be between 4M ohm and 20M ohm. When the exposed metal does not have a return path to the chassis, the reading must be infinite.

### LEAKAGE CURRENT HOT CHECK

1. Plug the a.c. cord directly into the a.c. outlet. Do not use an isolation transformer for this check.
2. Connect a 2k $\Omega$  10W resistor in series with an exposed metallic part on the receiver and an earth, such as a water pipe.
3. Use an a.c. voltmeter with high impedance to measure the potential across the resistor.

4. Check each exposed metallic part and check the voltage at each point.
5. Reverse the a.c. plug at the outlet and repeat each of the previous measurements.
6. The potential at any point should not exceed 1,4 Vrms. In case a measurement is outside the limits specified, there is a possibility of a shock hazard, and the receiver should be repaired and rechecked before it is returned to the customer.

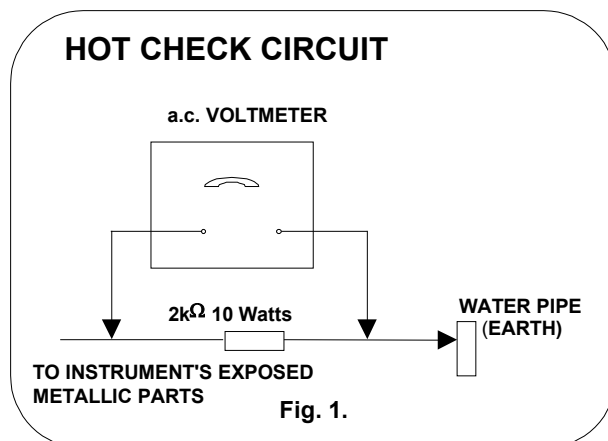

### X-RADIATION WARNING

1. The potential sources of X-Radiation in TV sets are the high voltage section and the picture tube.
2. When using a picture tube test jig for service, ensure that the jig is capable of handling 33kV [31,5kV] without causing X-Radiation.

**NOTE:** It is important to use an accurate periodically calibrated high voltage meter.

1. Set the brightness to minimum.
2. Measure the high voltage. The meter should indicate: 32kV  $\pm$  1kV [30,5kV  $\pm$  1kV]. If the meter indication is out of tolerance, immediate service and correction is required to prevent the possibility of premature component failure.
3. To prevent any X-Radiation possibility, it is essential to use the specified tube.

# SERVICE HINTS

## How to remove the rear cover

1. Remove the 12 screws as shown in Fig.2.



Fig. 2

# LOCATION OF CONTROLS

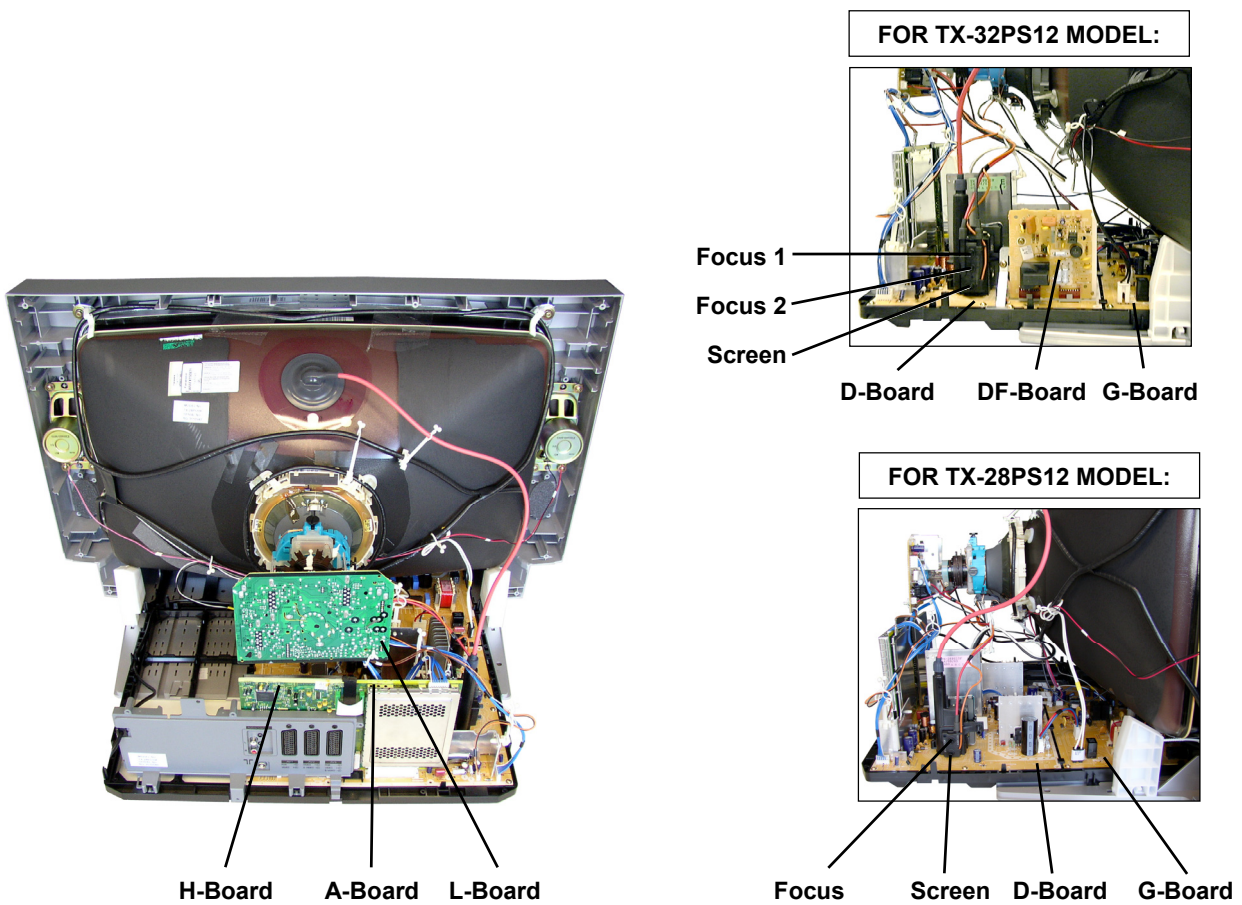
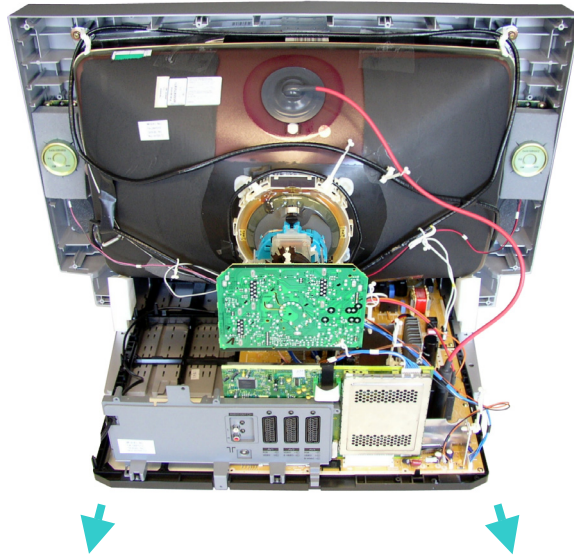

Fig. 3

## HOW TO MOVE THE CHASSIS INTO SERVICE POSITION

1. Remove the bead clumper from the mains lead.
2. Hold and lift the rear of the chassis and gently pull the chassis towards you, as shown in **Fig.4.**
3. Release the respective wiring clips and rotate the chassis horizontally through 90° anti-clockwise.
4. Locate the chassis to position **Fig .5.** :
5. After servicing ensure all wiring is returned to its original position before returning the receiver to the customer.



**Fig.4 .**

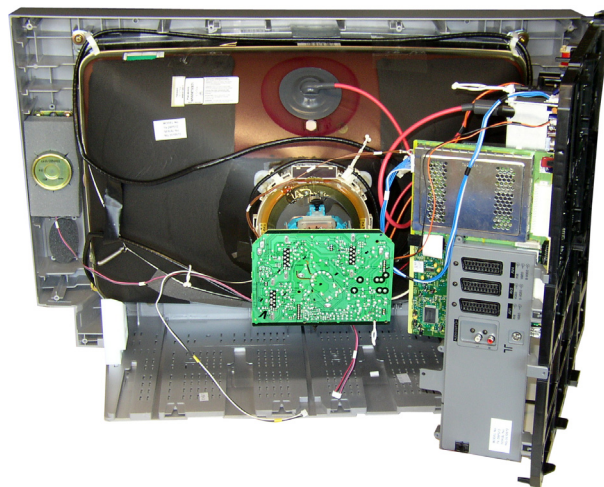

**Fig. 5.**

# ADJUSTMENT PROCEDURE

Item / Preparation	Adjustments																																																																								
<b>+B SET-UP</b> 1. Receive a Window pattern. 2. Set the controls :  Brightness      Minimum  Contrast         Minimum  Volume           Minimum	Confirm the following voltages:  <table> <tr> <td><b>TPD1</b></td> <td>205</td> <td>±</td> <td>10V</td> <td><b>TPD11</b></td> <td>5</td> <td>±</td> <td>0,5V</td> </tr> <tr> <td><b>TPD2</b></td> <td>137</td> <td>±</td> <td>2V</td> <td><b>TPD12</b></td> <td>3,3</td> <td>±</td> <td>0,1V</td> </tr> <tr> <td><b>TPD3</b></td> <td>42</td> <td>±</td> <td>2V</td> <td><b>TPD13</b></td> <td>2,5</td> <td>±</td> <td>0,1V</td> </tr> <tr> <td><b>TPD5</b></td> <td>42</td> <td>±</td> <td>2V</td> <td><b>TPD14</b></td> <td>3,3</td> <td>±</td> <td>0,1V</td> </tr> <tr> <td><b>TPD6</b></td> <td>12,5</td> <td>±</td> <td>1V</td> <td><b>TPD15</b></td> <td>5</td> <td>±</td> <td>0,5V</td> </tr> <tr> <td><b>TPD7</b></td> <td>-12,5</td> <td>±</td> <td>1V</td> <td><b>TPD16</b></td> <td>5</td> <td>±</td> <td>0,5V</td> </tr> <tr> <td><b>TPD8</b></td> <td>30,5</td> <td>±</td> <td>1V</td> <td><b>TPG3</b></td> <td>7,5</td> <td>±</td> <td>0,5V</td> </tr> <tr> <td><b>TPD9</b></td> <td>9</td> <td>±</td> <td>1V</td> <td><b>TPG5</b></td> <td>300</td> <td>±</td> <td>10V</td> </tr> <tr> <td><b>TPD10</b></td> <td>8</td> <td>±</td> <td>0,5V</td> <td></td> <td></td> <td></td> <td></td> </tr> </table>	<b>TPD1</b>	205	±	10V	<b>TPD11</b>	5	±	0,5V	<b>TPD2</b>	137	±	2V	<b>TPD12</b>	3,3	±	0,1V	<b>TPD3</b>	42	±	2V	<b>TPD13</b>	2,5	±	0,1V	<b>TPD5</b>	42	±	2V	<b>TPD14</b>	3,3	±	0,1V	<b>TPD6</b>	12,5	±	1V	<b>TPD15</b>	5	±	0,5V	<b>TPD7</b>	-12,5	±	1V	<b>TPD16</b>	5	±	0,5V	<b>TPD8</b>	30,5	±	1V	<b>TPG3</b>	7,5	±	0,5V	<b>TPD9</b>	9	±	1V	<b>TPG5</b>	300	±	10V	<b>TPD10</b>	8	±	0,5V				
<b>TPD1</b>	205	±	10V	<b>TPD11</b>	5	±	0,5V																																																																		
<b>TPD2</b>	137	±	2V	<b>TPD12</b>	3,3	±	0,1V																																																																		
<b>TPD3</b>	42	±	2V	<b>TPD13</b>	2,5	±	0,1V																																																																		
<b>TPD5</b>	42	±	2V	<b>TPD14</b>	3,3	±	0,1V																																																																		
<b>TPD6</b>	12,5	±	1V	<b>TPD15</b>	5	±	0,5V																																																																		
<b>TPD7</b>	-12,5	±	1V	<b>TPD16</b>	5	±	0,5V																																																																		
<b>TPD8</b>	30,5	±	1V	<b>TPG3</b>	7,5	±	0,5V																																																																		
<b>TPD9</b>	9	±	1V	<b>TPG5</b>	300	±	10V																																																																		
<b>TPD10</b>	8	±	0,5V																																																																						
<b>CUT OFF / Ug2 Test</b> 1. Receive a Window pattern. 2. Normalize the TV set. 3. Set brightness: minimum.	To adjust Cutoff connect an oscilloscope to the Blue cathode. Adjust the screen VR until the black level is 170V +0V/-5V.  <div style="text-align: center;"> <p>Black Level 170V+0V/-5V GND</p> </div>																																																																								

## SELF CHECK

Self-check is used to automatically check the bus lines and hexadecimal code of the TV set. To enter Self-Check mode, press the **STATUS** button on the remote control and at the same time press the down **(-V)** button on the customer controls at the front the TV set. To exit Self Check, switch off the TV set at the power button.

E2	O.K.	SUM	****
DDP	O.K.		
VSP	O.K.		
AVSW	O.K.		
TUN	O.K.		
MSP	O.K.		
DPL	---		
MAS	---		
OPTION 1	0D		
OPTION 2	00		
OPTION 3	10		
OPTION 4	10		
OPTION 5	00		
OPTION 6	11		
OPTION 7	0C		
OPTION 8	40		
OPTION 9	00		
OPTION 10	80		
OPTION 11	19		
OPTION 12	08		
OPTION 13	08		
CHECK	33		

If the CCU ports have been checked and found to be incorrect or not located then " - - " will appear in place of "O.K.".

# WAVEFORM PATTERN TABLE

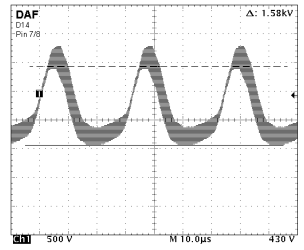
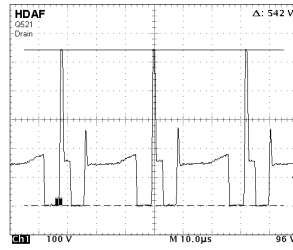
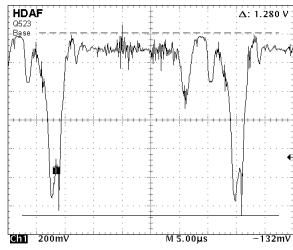
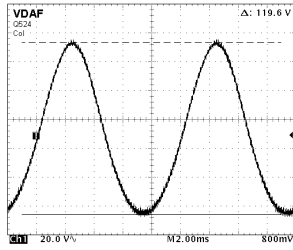
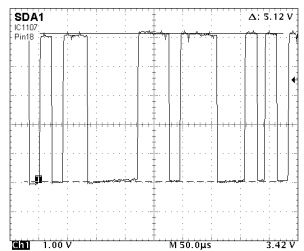
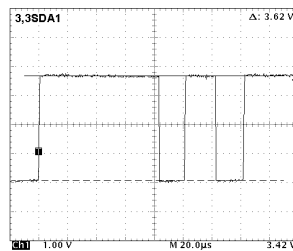
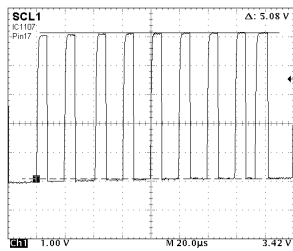
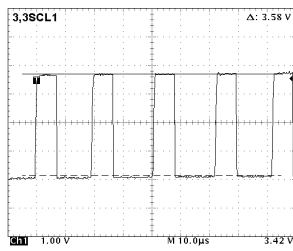
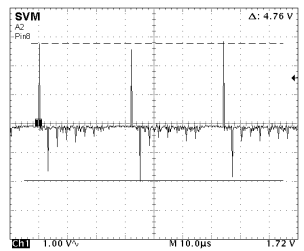
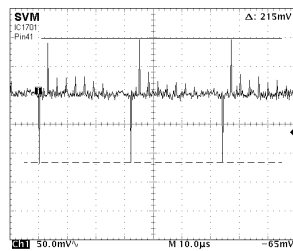
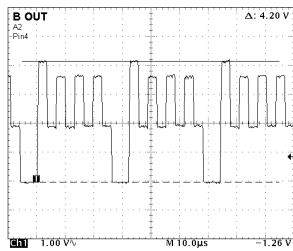
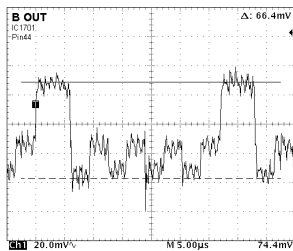
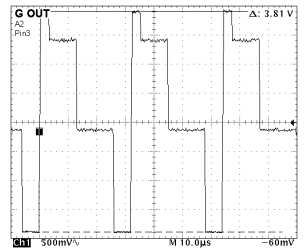
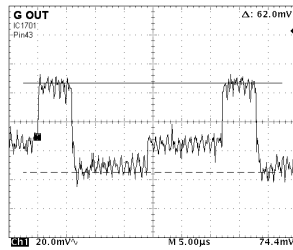
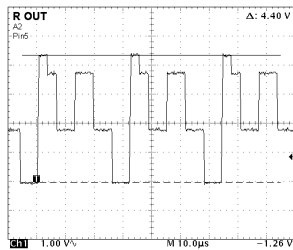
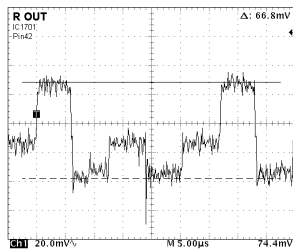
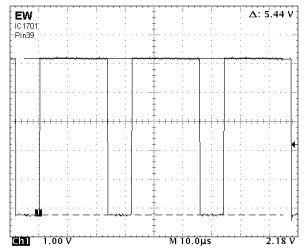
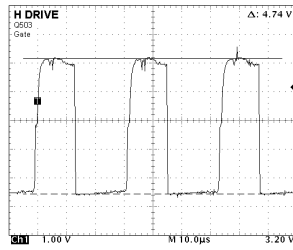
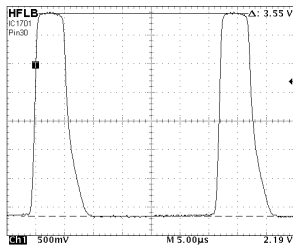
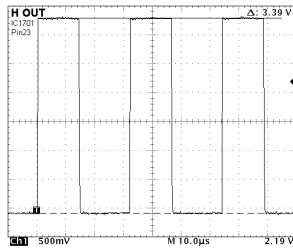
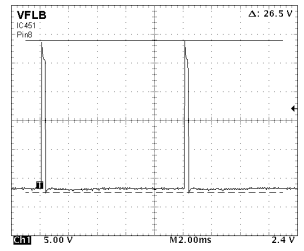
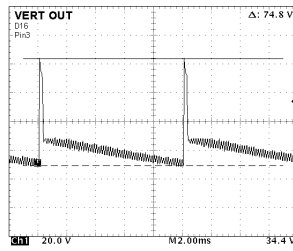
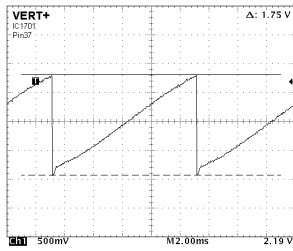
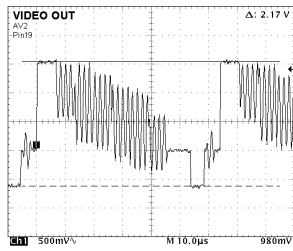

**CONDITIONS:** CONTRAST...MAX, BRIGHTNESS...MID, COLOUR...MID, SHARPNESS...MID

# ALIGNMENT SETTINGS

(The figures below are nominal and used for representative purposes only.)

1. Set the Bass to maximum position, set the Treble to minimum position, set the Volume to minimum then press the down button (-V) on the customer controls at the front of the TV and at the same time press the **INDEX** button on the remote control, this will place the TV into the Service Mode 1.
2. Press the **RED / GREEN** buttons to step up / down through the functions.
3. Press the **YELLOW / BLUE** buttons to alter the function values.
4. Press the **STR** button after each adjustment has been made to store the required values.
5. To exit the Service Mode, press the "**N**" button.

Alignment Function	Setting indication Note: All setting values are approximate	Settings / Special features
Horizontal Position	H-Pos 21	Optimum setting.
Vertical Position	V-Pos 27	Optimum setting.
Horizontal Amplitude	H-Amp 41	Optimum setting.
Vert. Amplitude	V-Amp -66	Optimum setting.
EW-amplitude	EW-Amp 1 - 25	Optimum setting.
Lower Corner	Lower Corner 2	Optimum setting.
Trapezium-comp	Trapez 1 -7	Optimum setting.
Upper Corner	Upper Corner -2	Optimum setting.
Vertical Symmetry	V-Sym -4	Optimum setting.
Vertical Linearity	V-Lin 40	Optimum setting.
Angle	Angle -2	Optimum setting.
Bow	Bow 0	Optimum setting.
DVCO	DVCO -1	Receive a PAL Colour Bar Pattern. For DVCO alignment press " <b>Blue</b> " button, wait until the colours are changing slowly and press " <b>STR</b> ".
Highlight Lowlight	High 0403 0318 0350 Low 0071 0132 0160	Optimum setting.
Sub-Brightness	Sub-Brightness 20	Optimum setting.

# VIDEO BLOCK DIAGRAM

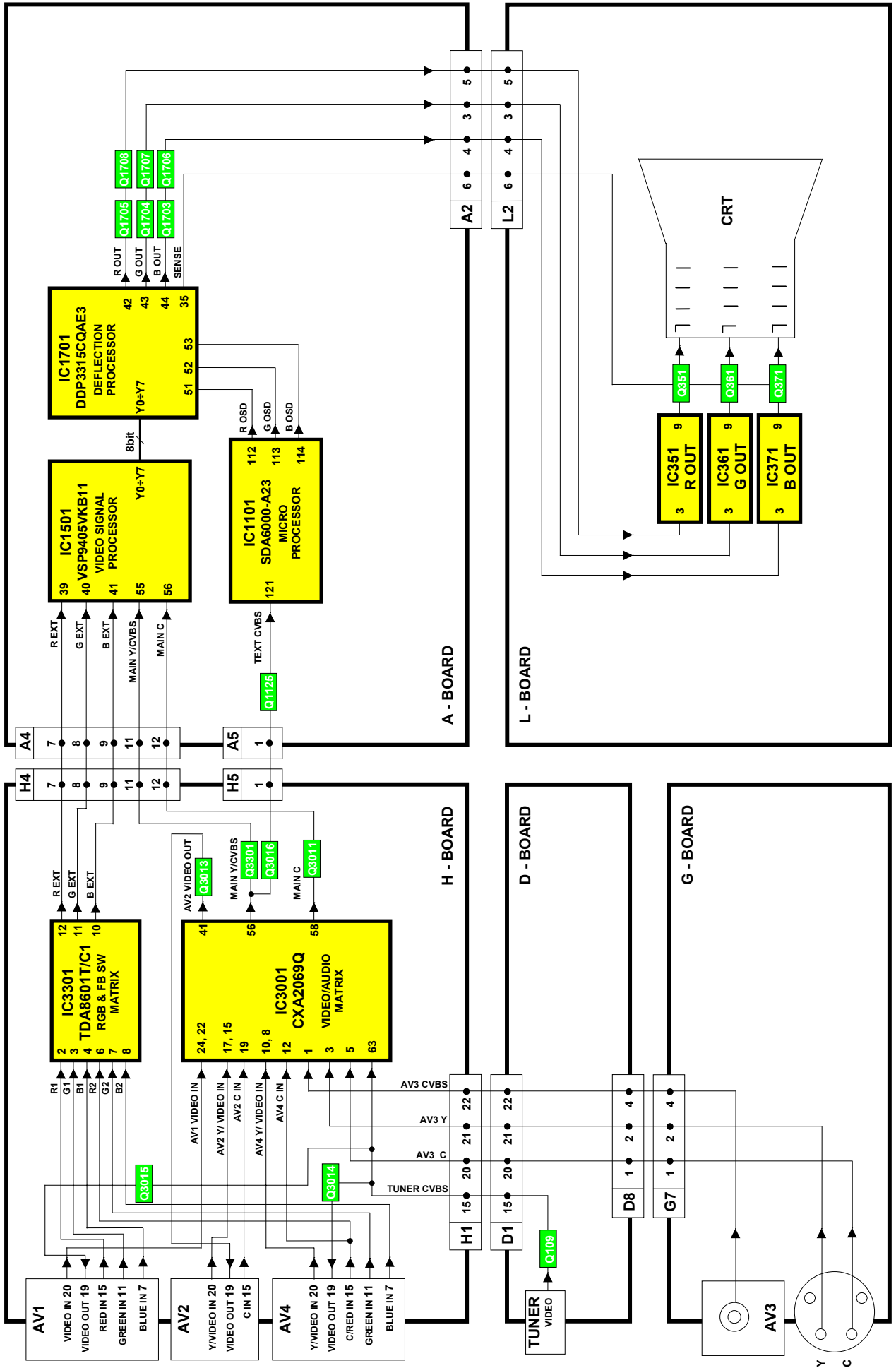



# AUDIO BLOCK DIAGRAM

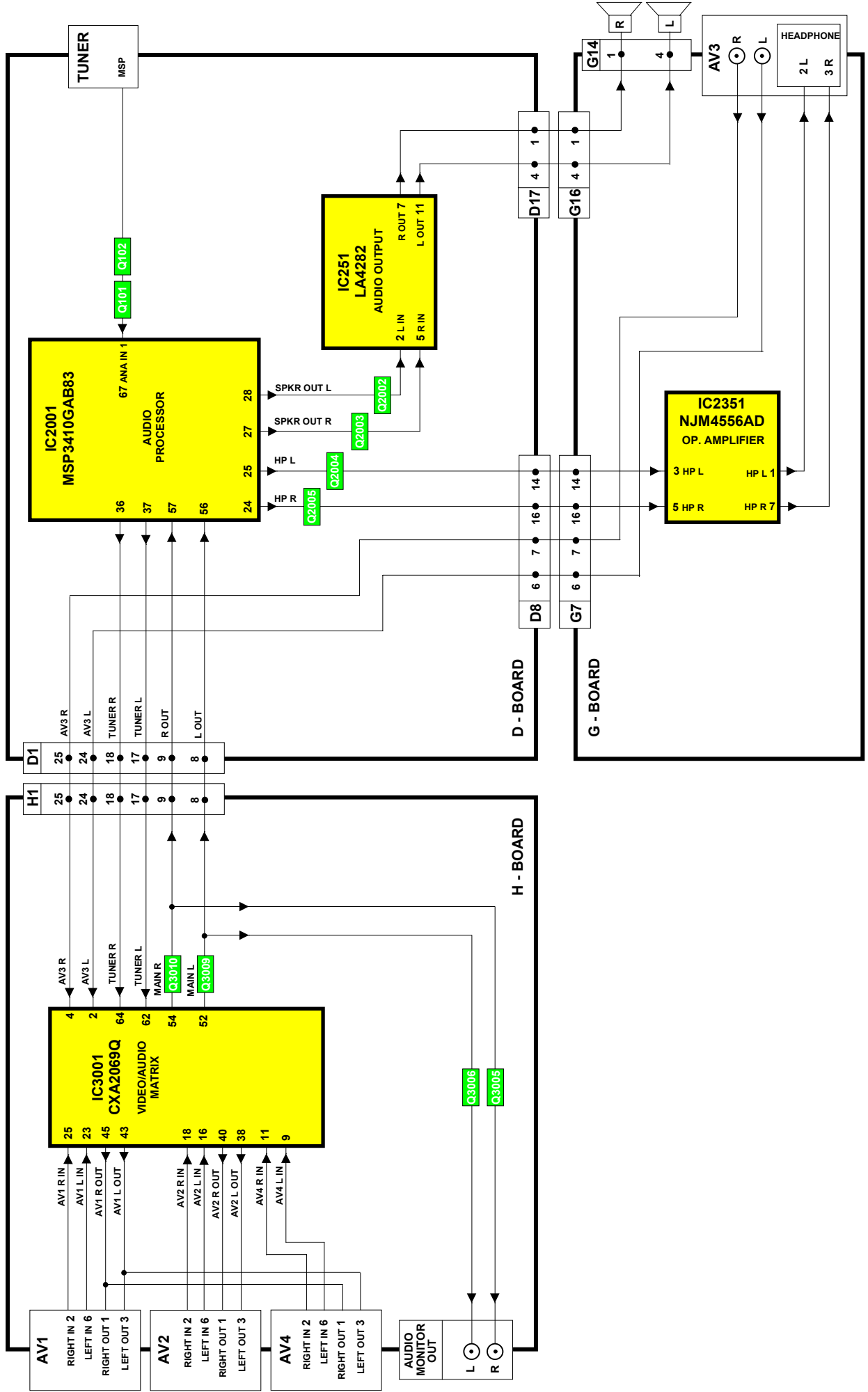



# DEFLECTION BLOCK DIAGRAM

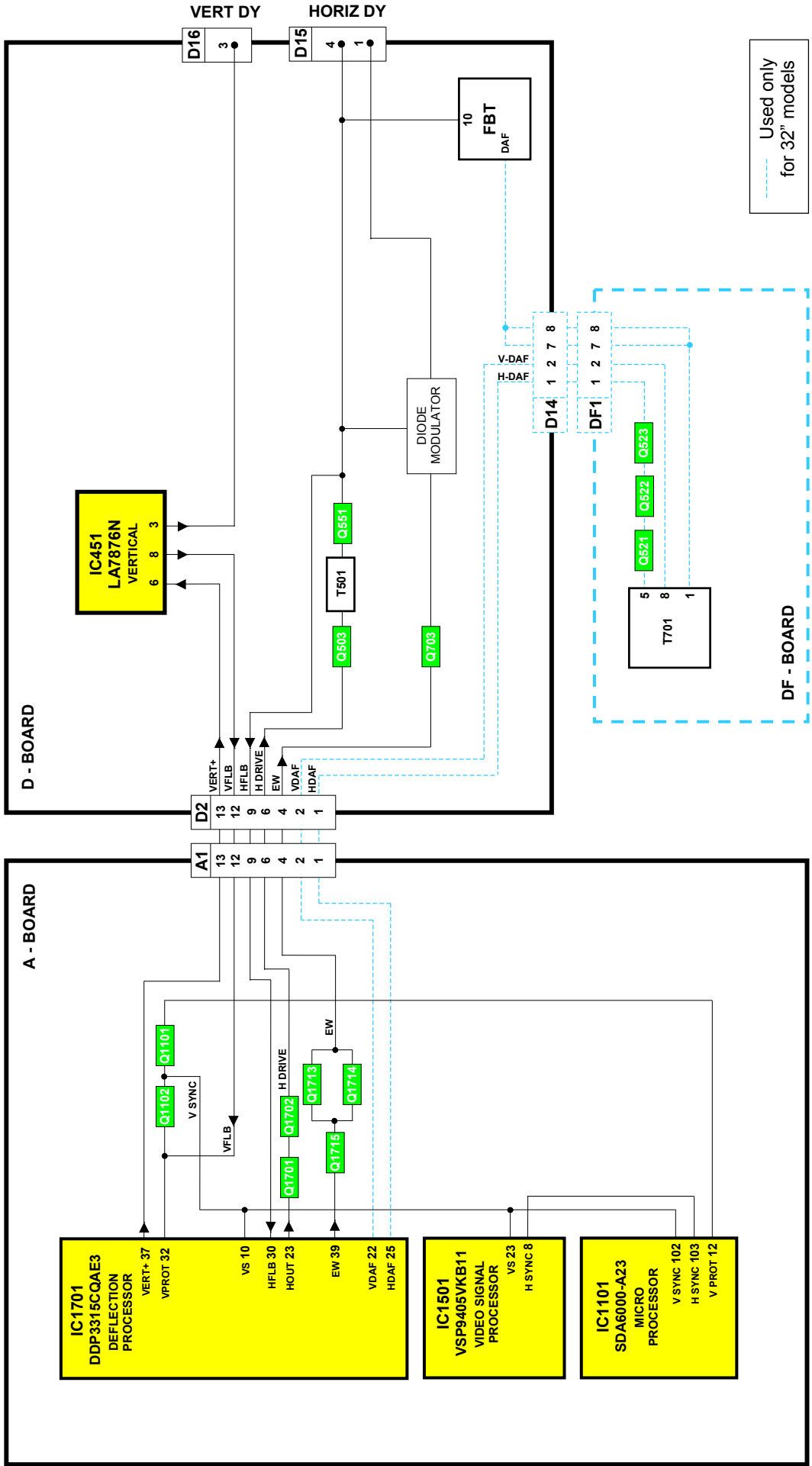

# POWER SUPPLY BLOCK DIAGRAM

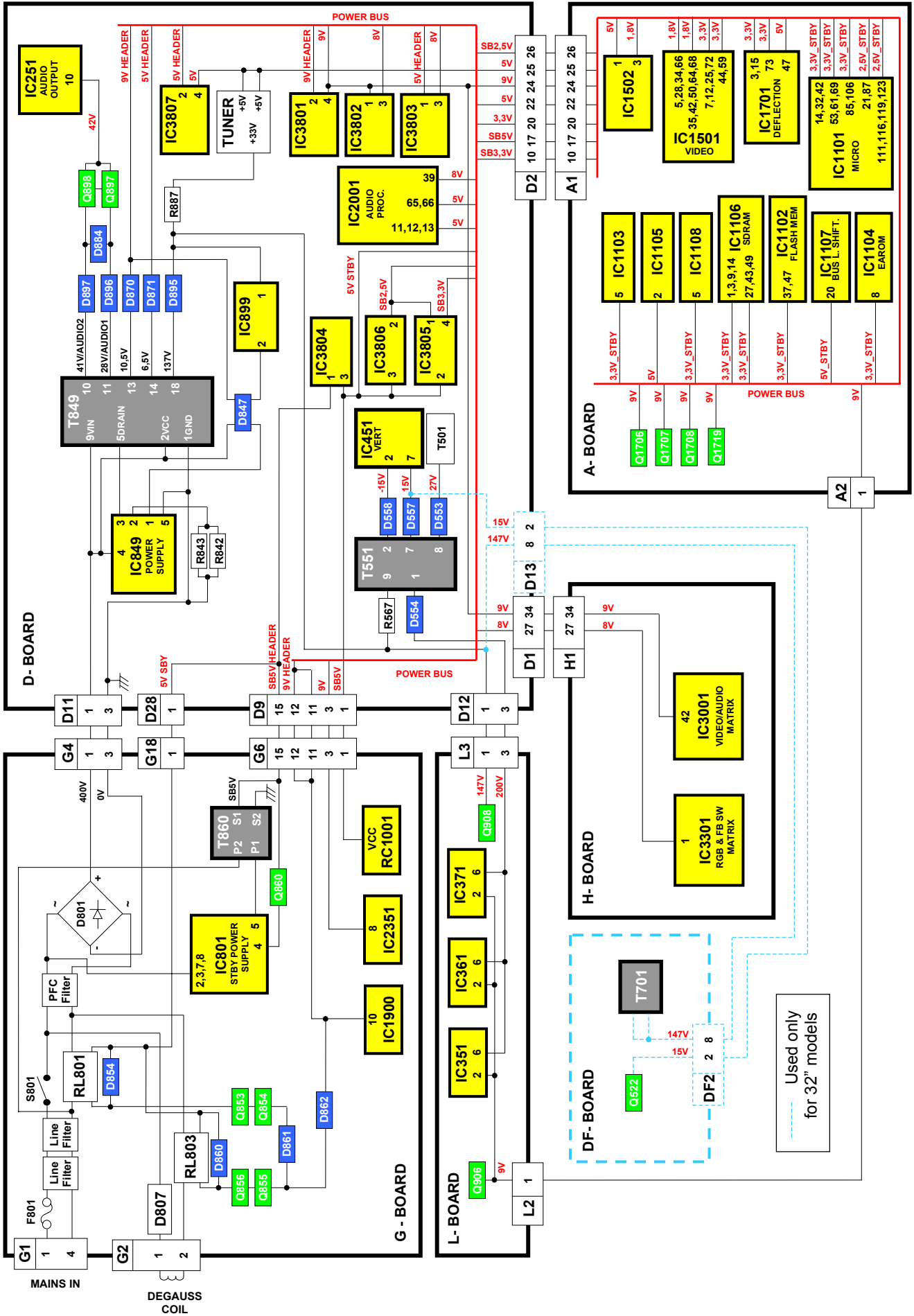

# PARTS LOCATION

**NOTE:**



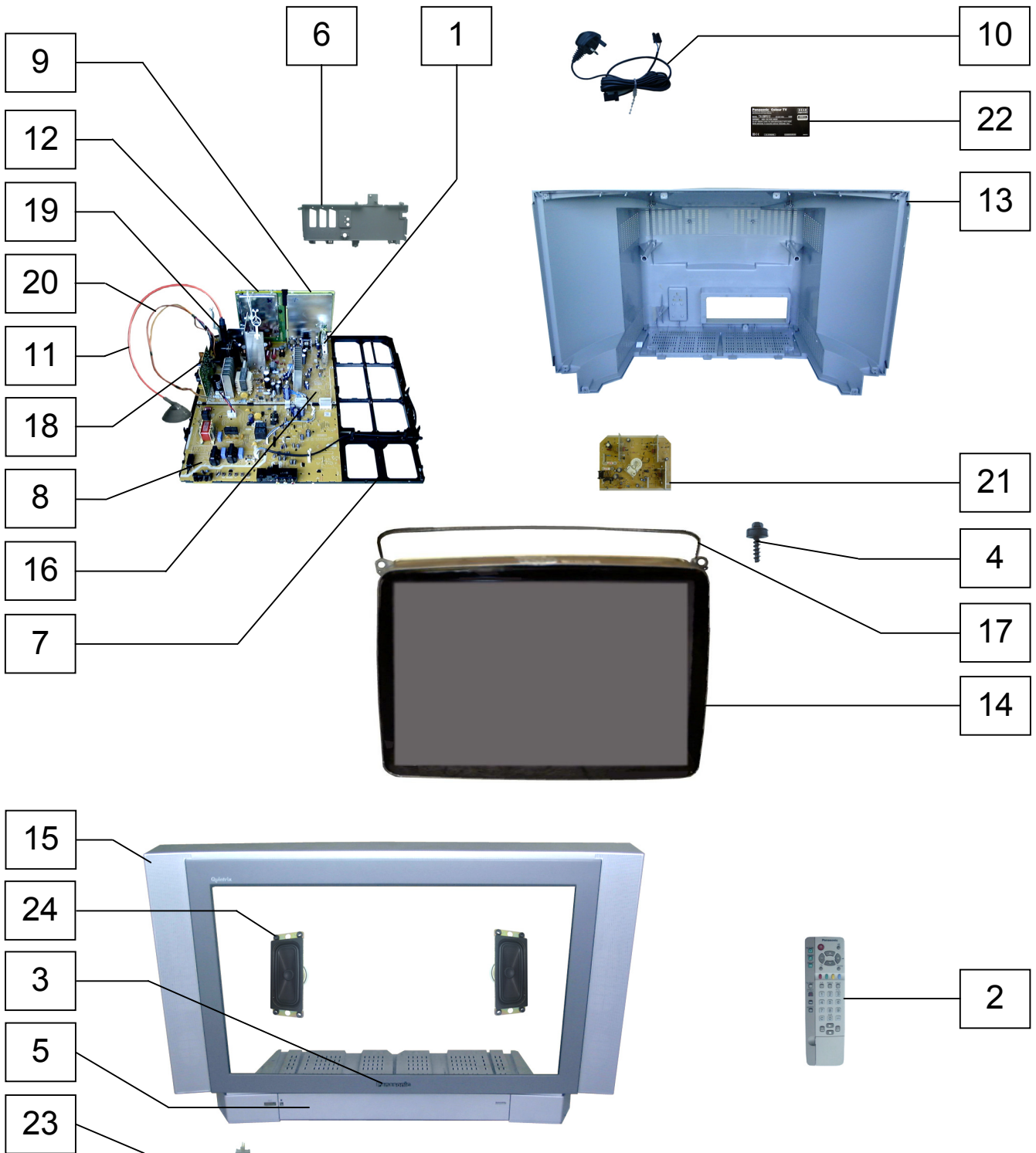

The numbers on the exploded view below refer to the exploded view section of the Replacement Parts List.





# REPLACEMENT PARTS LIST

## Important Safety Notice

Components Identified by  mark have special characteristics important for safety.  
 \* When replacing any of these components, use only manufacturers specified parts.  
 In case of ordering these spare parts, please always add the complete Model-Type number to your order.

Cct Ref	Parts Number	Description
<b>COMMON PARTS</b>		
<b>EXPLODED VIEW</b>		
1	ENG27519G	TUNER
2	EUR511212A	REMOTE CONTROL
3	TBMA060	PANASONIC BADGE
4	THT1062	CRT FIXING SCREW
5	TKP0E10604	DOOR LID
6	TKP8E1497-D	AV PANEL
7	TMX8E058-1	CHASSIS FRAME
8	TNP8EG005AT	G P.C.B. 
9	TNP8EH008AM	H P.C.B. 
10	TXASX01DBZG	AC CORD S5Y 
11	ZTBZAD550A	ANODE LEAD 
<b>MISCELLANEOUS COMPONENTS</b>		
.	R6RC/2P	BATTERY
.	TBLG3019	SET FOOT (FRONT)
.	TBLG3020	SET FOOT (REAR)
.	TBM0E0033	PRESET LABEL
.	TBM0E0034	PRESET LABEL
.	TEK6935	LID SWITCH
.	TKK0E9507	CRT SUPPORT BRACKET R
.	TKK0E9508	CRT SUPPORT BRACKET L
.	TKP0E10701	IR WINDOW
.	TLK8E05177	ROTATION COIL
.	TMW8E050-2	LED HOLDER
.	TMW8E056-1	PCB CLIP
CKN2	TMM8E18027	SPACER
RK401	TXF5B09W09	ROPE
<b>INSTRUCTION BOOKS</b>		
.	TQB8E3820-M	ENGLISH
<b>I.C.s</b>		
IC251	LA4282	AUDIO OUTPUT
IC351	TDA6111Q/N4	RGB OUTPUT
IC361	TDA6111Q/N4	RGB OUTPUT
IC371	TDA6111Q/N4	RGB OUTPUT
IC451	LA7876N	VERTICAL OUTPUT
IC801	MIP0254SPSCF	STANDBY CONTROL IC
IC849	STRF6656LF57	POWER SUPPLY
IC899	SE130N	ERROR AMPLIFIER
IC1101	SDA6000-A23	MICRO PROCESSOR
IC1102	EDF1/020/0F	8MEG FLASH 29LV800BTC7
IC1103	PST9128NR	SYSTEM RESET
IC1105	C0EAH0000067	MOS LOGIC
IC1106	C3ABPG000102	64M SDRAM

Cct Ref	Parts Number	Description
IC1107	TC7MBD3245FK	BUS LEVEL SHIFTER
IC1108	74LVC1GU04GW	INVERTER
IC1501	VSP9405VKB11	VIDEO PROCESSOR
IC1502	BA18BC0FP	REGULATOR
IC1701	DDP3315CQAG3	DEFLECTION PROCESSOR
IC1900	LA6515	EARTH CORRECTION
IC2001	MSP3410GAB83	AUDIO PROCESSOR
IC2351	NJM4556AD	HEADPHONE AMPLIFIER
IC3001	CXA2069Q	A/V MATRIX SWITCH
IC3301	TDA8601T/C1	RGB, FB MATRIX
IC3801	BA09ST-V5	REGULATOR
IC3802	BA08T	REGULATOR
IC3803	BA033T	3.3V REGULATOR
IC3804	BA05T	REGULATOR
IC3805	BA033ST-V5	REGULATOR
IC3806	LD1117V25C	REGULATOR
IC3807	BA05ST-V5	REGULATOR
RC1001	RPM-6937	LED RECEIVER
<b>FUSES</b>		
F801-L	EYF52BC	FUSE HOLDER
F801-R	EYF52BC	FUSE HOLDER
F801	S5055AC	FUSE 
R2810	TSF19252	FS LINK 
<b>DIODES</b>		
D103	1SS355TE-17	DIODE
D251	MA700ATA	DIODE
D252	MA700ATA	DIODE
D351	ERA15-04V3	DIODE
D352	ERA15-04V3	DIODE
D361	ERA15-04V3	DIODE
D362	ERA15-04V3	DIODE
D371	ERA15-04V3	DIODE
D372	ERA15-04V3	DIODE
D376	1SS355TE-17	DIODE
D377	1SS355TE-17	DIODE
D378	1SS355TE-17	DIODE
D387	MA2160LFS	DIODE
D454	EU02V0	DIODE
D456	MTZJT-776.8B	DIODE
D457	1SS133T-77	DIODE
D458	EU02V0	DIODE
D501	1SS133T-77	DIODE
D502	EU02V0	DIODE
D503	1SS133T-77	DIODE
D504	1SS133T-77	DIODE
D505	MTZJT-7710D	DIODE
D553	EU02V0	DIODE
D554	EU02V0	DIODE
D555	1SS133T-77	DIODE
D556	UDZSTE-1722B	DIODE
D557	ERB93-02E	DIODE

Cct Ref	Parts Number	Description
D558	ERB93-02E	DIODE
D559	1SS133T-77	DIODE
D560	RH3GLF102	DIODE
D563	EU02V0	DIODE
D565	EU02V0	DIODE
D575	MTZJT-775.1C	DIODE
D576	EU02V0	DIODE
D580	FMV-3GULF730	DIODE
D706	EU02V0	DIODE
D707	EU02V0	DIODE
D710	MTZJT-7716C	DIODE
D711	MTZJT-775.1A	DIODE
D712	1SS133T-77	DIODE
D713	MTZJT-777.5B	DIODE
D714	MTZJT-772.7B	DIODE
D801	RBV-608LF-B	DIODE
D807	59890T60B110	THERMISTOR
D808	ERZV10D621CS	SURGE ABSORBER
D809	ERC0510E3	DIODE
D810	ERC0510E3	DIODE
D811	TVSSR2KLV1	DIODE
D812	RY24V1	DIODE
D814	ERA22-10G1	DIODE
D815	MA2082-ALFS	DIODE
D841	1SR124-4AT82	DIODE
D843	1SR124-4AT82	DIODE
D844	1SR124-4AT82	DIODE
D847	PC123FY2	PHOTO COUPLER
D854	1SS133T-77	DIODE
D860	1SS133T-77	DIODE
D861	1SS133T-77	DIODE
D862	1SS133T-77	DIODE
D866	EU02V0	DIODE
D867	1SS133T-77	DIODE
D868	MA4056HTA	DIODE
D870	RK46LF-L1	DIODE
D871	RK46LF-L1	DIODE
D884	MTZJT-7727A	DIODE
D887	BZX79B75A26A	DIODE
D888	1SS133T-77	DIODE
D889	1SS133T-77	DIODE
D890	1SS133T-77	DIODE
D891	1SS133T-77	DIODE
D892	MA2180TP	DIODE
D893	MTZJT-776.2B	DIODE
D894	1SS133T-77	DIODE
D895	RU4BLF-L1	DIODE
D896	FMGG26S	DIODE
D897	1SR124-4AT82	DIODE
D899	MTZJT-7736A	DIODE
D910	R2KNLFA1	DIODE
D1001	LNH201RFCF6	L.E.D.
D1004	MTZJT-778.2C	DIODE
D1101	1SS355TE-17	DIODE
D1104	1SS355TE-17	DIODE
D1701	DAN217T146	DIODE
D1702	DAN217T146	DIODE
D1703	1SS355TE-17	DIODE
D1901	MTZJT-777.5B	DIODE
D1902	1SS133T-77	DIODE
D2001	MTZJT-774.7C	DIODE
D2002	MA723TA	DIODE
D2003	MA723TA	DIODE
D2004	MA723TA	DIODE
D2005	MA723TA	DIODE
D2006	MA723TA	DIODE

Cct Ref	Parts Number	Description
D2007	MA723TA	DIODE
D2008	MA723TA	DIODE
D2351	1SS355TE-17	DIODE
D2352	1SS355TE-17	DIODE
D2353	1SS355TE-17	DIODE
D2354	1SS355TE-17	DIODE
D2355	1SS355TE-17	DIODE
D3201	MTZJT-778.2C	DIODE
D3202	MTZJT-778.2C	DIODE
D3204	UDZSTE-1716B	DIODE
D3351	1SS355TE-17	DIODE
D3352	1SS355TE-17	DIODE
D3353	1SS355TE-17	DIODE
D3354	1SS355TE-17	DIODE
D3801	1SS133T-77	DIODE
D3802	1SS133T-77	DIODE
D3803	MTZJT-775.6B	DIODE
D3804	1SS133T-77	DIODE
D3805	1SS133T-77	DIODE
D3806	1SS133T-77	DIODE
D3807	1SS133T-77	DIODE
D3808	1SS133T-77	DIODE
D3809	1SS133T-77	DIODE
D3812	1SR124-4AT82	DIODE
Q860	PC123FY2	PHOTO COUPLER
<b>TRANSISTORS</b>		
Q101	BC847B	TRANSISTOR
Q102	BC847B	TRANSISTOR
Q103	BC857B	TRANSISTOR
Q109	BC847B	TRANSISTOR
Q251	2SD1328STX	TRANSISTOR
Q252	2SD1328STX	TRANSISTOR
Q253	BC847B	TRANSISTOR
Q254	BC847B	TRANSISTOR
Q351	2SA1767QTA	TRANSISTOR
Q361	2SA1767QTA	TRANSISTOR
Q371	2SA1767QTA	TRANSISTOR
Q503	2SK2231TE16L	TRANSISTOR
Q551	2SC5905000RK	TRANSISTOR
Q552	2SC1473ATA	TRANSISTOR
Q556	BC847B	TRANSISTOR
Q701	BC847B	TRANSISTOR
Q702	BC847B	TRANSISTOR
Q703	2SK2231TE16L	TRANSISTOR
Q704	BC847B	TRANSISTOR
Q705	BC547B/126	TRANSISTOR
Q706	BC847B	TRANSISTOR
Q853	BC847B	TRANSISTOR
Q854	BC847B	TRANSISTOR
Q855	BC847B	TRANSISTOR
Q856	BC847B	TRANSISTOR
Q893	2SA1018QTA	TRANSISTOR
Q894	BC847B	TRANSISTOR
Q895	BC847B	TRANSISTOR
Q896	BC857B	TRANSISTOR
Q897	2SA1534A-RTA	TRANSISTOR
Q898	BC557B/126	TRANSISTOR
Q906	BC847B	TRANSISTOR
Q907	BC857B	TRANSISTOR
Q908	2SA1535ARLB	TRANSISTOR
Q909	2SC3944ARLB	TRANSISTOR
Q1002	BC847B	TRANSISTOR
Q1101	BC857B	TRANSISTOR
Q1102	BC847B	TRANSISTOR
Q1104	BC847B	TRANSISTOR
Q1106	BC857B	TRANSISTOR

Cct Ref	Parts Number	Description
Q1108	BC847B	TRANSISTOR
Q1109	BC847B	TRANSISTOR
Q1110	BC847B	TRANSISTOR
Q1111	BC847B	TRANSISTOR
Q1112	BC847B	TRANSISTOR
Q1113	BC847B	TRANSISTOR
Q1115	BC847B	TRANSISTOR
Q1116	BC847B	TRANSISTOR
Q1125	BC847B	TRANSISTOR
Q1701	BC847B	TRANSISTOR
Q1702	BC847B	TRANSISTOR
Q1703	BC847B	TRANSISTOR
Q1704	BC847B	TRANSISTOR
Q1705	BC847B	TRANSISTOR
Q1706	FMY4AT148	TRANSISTOR
Q1707	FMY4AT148	TRANSISTOR
Q1708	FMY4AT148	TRANSISTOR
Q1710	BC847B	TRANSISTOR
Q1712	BC847B	TRANSISTOR
Q1713	FDV301N	TRANSISTOR
Q1714	FDV302P	TRANSISTOR
Q1715	FDV301N	TRANSISTOR
Q1717	BC857B	TRANSISTOR
Q1718	BC847B	TRANSISTOR
Q1719	BC847B	TRANSISTOR
Q1901	BC847B	TRANSISTOR
Q1902	BC847B	TRANSISTOR
Q1903	BC847B	TRANSISTOR
Q1904	BC847B	TRANSISTOR
Q1905	2SA1534A-RTA	TRANSISTOR
Q2001	BC857B	TRANSISTOR
Q2002	BC857B	TRANSISTOR
Q2003	BC857B	TRANSISTOR
Q2004	BC857B	TRANSISTOR
Q2005	BC857B	TRANSISTOR
Q2006	BC857B	TRANSISTOR
Q2351	BC847B	TRANSISTOR
Q2352	BC847B	TRANSISTOR
Q2353	BC857B	TRANSISTOR
Q2354	BC847B	TRANSISTOR
Q3000	BC847B	TRANSISTOR
Q3001	BC847B	TRANSISTOR
Q3003	BC847B	TRANSISTOR
Q3004	BC847B	TRANSISTOR
Q3005	BC857B	TRANSISTOR
Q3006	BC857B	TRANSISTOR
Q3007	BC847B	TRANSISTOR
Q3008	BC847B	TRANSISTOR
Q3009	BC847B	TRANSISTOR
Q3010	BC847B	TRANSISTOR
Q3011	BC847B	TRANSISTOR
Q3013	BC847B	TRANSISTOR
Q3014	BC847B	TRANSISTOR
Q3015	BC847B	TRANSISTOR
Q3016	BC847B	TRANSISTOR
Q3017	BC847B	TRANSISTOR
Q3018	BC847B	TRANSISTOR
Q3301	BC847B	TRANSISTOR
Q3352	BC857B	TRANSISTOR
Q3802	2SD2396/K	TRANSISTOR
<b>TRANSFORMERS</b>		
T501	ETH19Y187AY	TRANSFORMER
T849	10783850	TRANSFORMER
T860	ETS19AB1G6AG	TRANSFORMER
<b>COILS</b>		
L107	TALV35VB100K	COIL



Cct Ref	Parts Number	Description
L116	ELESN6R8KA	COIL
L381	TLT220K991R	COIL
L382	ELESN6R8KA	COIL
L551	EXCELD35C	COIL
L557	EXCELD35C	COIL
L558	EXCELSA35B	COIL
L701	ELC18B221E	COIL
L704	ELC18B182F	COIL
L804	R39264	PFC COIL
L883	TALL08T181KA	COIL
L892	ELEIE470KA	COIL
L893	EXCELSA35T	COIL
L894	EXCELSA35T	COIL
L895	EXCELSA35T	COIL
L896	EXCELSA35T	COIL
L897	EXCELSA35T	COIL
L898	EXCELSA35T	COIL
L899	EXCELSA35T	COIL
L1061	TLT331K991R	COIL
L1104	TALC325T4R7M	COIL
L1109	TALC325T4R7M	COIL
L1115	TALC168T8R2K	COIL
L1701	EXC3BB221H	COIL
L2001	TALV35VB100K	COIL
L2004	ELESN101KA	COIL
L2005	TALV35VB100K	COIL
L2351	EXCELD35V	COIL
L2352	EXCELD35V	COIL
L3001	ELESN1R5KA	COIL
L3003	ELESN1R5KA	COIL
L3005	ELESN1R5KA	COIL
L3007	ELESN1R5KA	COIL
L3009	ELESN1R5KA	COIL
L3011	ELESN1R5KA	COIL
L3015	EXCELD35V	COIL
L3016	EXCELD35V	COIL
L3078	ELESN2R2KA	COIL
L3201	ELEBR6R8KA	COIL
L3202	ELEBR6R8KA	COIL
L3203	EXCELSA35T	COIL
L3204	ELEBR6R8KA	COIL
L3205	ELEBR6R8KA	COIL
L3206	EXCELSA35T	COIL
L3301	ELESN2R7KA	COIL
L3302	ELESN2R7KA	COIL
L3303	ELESN2R7KA	COIL
L3304	ELESN2R2KA	COIL
<b>FILTERS</b>		
L801	ELF20N013A	LINE FILTER
L802	ELF20N013A	LINE FILTER
LC1107	ELKE103FA	FILTER
LC1109	ELKE103FA	FILTER
LC1117	ELKE103FA	FILTER
LC1120	ELKE103FA	FILTER
LC1129	ELKE103FA	FILTER
LC1130	ELKE103FA	FILTER
LC1131	ELKE103FA	FILTER
LC1140	ELKE103FA	FILTER
LC1147	ELKE103FA	FILTER
LC1151	ELKE103FA	FILTER
LC1152	ELKE103FA	FILTER
LC1153	ELKE103FA	FILTER
LC1154	ELKE103FA	FILTER
LC1155	ELKE103FA	FILTER
LC1156	ELKE103FA	FILTER
LC1157	ELKE103FA	FILTER



Cct Ref	Parts Number	Description
LC1504	TLK212T256AL	FILTER
LC1505	TLK212T256AL	FILTER
LC1506	TLK212T256AL	FILTER
LC1507	TLK212T256AL	FILTER
LC1508	TLK212T256AL	FILTER
LC1510	ELKE103FA	FILTER
LC1511	ELKE103FA	FILTER
LC1512	ELKE103FA	FILTER
LC1513	ELKE103FA	FILTER
LC1702	TLK212T256AL	FILTER
LC1705	ELKE103FA	FILTER
LC1706	ELKE103FA	FILTER
LC1713	TLK212T256AL	FILTER
<b>CRYSTALS</b>		
X1101	H0J600400006	CRYSTAL
X1501	AI202504E	CRYSTAL
X1701	4730007823	CRYSTAL
X2001	4730007158	CRYSTAL
<b>RESISTORS</b>		
JA1	ERJ6GEY0R00V	S.M.CARB 0.1W 0 Ω
JA2	ERJ6GEY0R00V	S.M.CARB 0.1W 0 Ω
JA3	ERJ6GEY0R00V	S.M.CARB 0.1W 0 Ω
JA4	ERJ6GEY0R00V	S.M.CARB 0.1W 0 Ω
JA5	ERJ6GEY0R00V	S.M.CARB 0.1W 0 Ω
JA6	ERJ6GEY0R00V	S.M.CARB 0.1W 0 Ω
JA7	ERJ6GEY0R00V	S.M.CARB 0.1W 0 Ω
JA7	ERJ8GEY0R00V	S.M.CARB 0.125 0 Ω
JA8	ERJ6GEY0R00V	S.M.CARB 0.1W 0 Ω
JA9	ERJ8GEY0R00V	S.M.CARB 0.125 0 Ω
JA11	ERJ6GEY0R00V	S.M.CARB 0.1W 0 Ω
JA12	ERJ8GEY0R00V	S.M.CARB 0.125 0 Ω
JA13	ERJ8GEY0R00V	S.M.CARB 0.125 0 Ω
JA14	ERJ8GEY0R00V	S.M.CARB 0.125 0 Ω
JA15	ERJ8GEY0R00V	S.M.CARB 0.125 0 Ω
JA16	ERJ6GEY0R00V	S.M.CARB 0.1W 0 Ω
JA17	ERJ6GEY0R00V	S.M.CARB 0.1W 0 Ω
JA20	ERJ8GEY0R00V	S.M.CARB 0.125 0 Ω
JA21	ERJ8GEY0R00V	S.M.CARB 0.125 0 Ω
JA22	ERJ6GEY0R00V	S.M.CARB 0.1W 0 Ω
JA23	ERJ6GEY0R00V	S.M.CARB 0.1W 0 Ω
JA27	ERJ8GEY0R00V	S.M.CARB 0.125 0 Ω
JA32	ERJ6GEY0R00V	S.M.CARB 0.1W 0 Ω
JSA003	ERJ3GEY0R00V	S.M.CARB 0.1W 0 Ω
JSA004	ERJ3GEY0R00V	S.M.CARB 0.1W 0 Ω
JSA005	ERJ3GEY0R00V	S.M.CARB 0.1W 0 Ω
JSA045	ERJ3GEY0R00V	S.M.CARB 0.1W 0 Ω
JSA046	ERJ3GEY0R00V	S.M.CARB 0.1W 0 Ω
JSA047	ERJ3GEY0R00V	S.M.CARB 0.1W 0 Ω
JSA049	ERJ3GEY0R00V	S.M.CARB 0.1W 0 Ω
JSA050	ERJ3GEY0R00V	S.M.CARB 0.1W 0 Ω
JSA058	ERJ3GEY0R00V	S.M.CARB 0.1W 0 Ω
JSA060	ERJ3GEY0R00V	S.M.CARB 0.1W 0 Ω
JSA061	ERJ6GEY0R00V	S.M.CARB 0.1W 0 Ω
JSA062	ERJ6GEY0R00V	S.M.CARB 0.1W 0 Ω
JSA063	ERJ6GEY0R00V	S.M.CARB 0.1W 0 Ω
JSA066	ERJ6GEY0R00V	S.M.CARB 0.1W 0 Ω
JSD010	ERJ6GEY0R00V	S.M.CARB 0.1W 0 Ω
JSD016	ERJ6GEY0R00V	S.M.CARB 0.1W 0 Ω
JSD035	ERJ6GEY0R00V	S.M.CARB 0.1W 0 Ω
JSG017	ERJ6GEY0R00V	S.M.CARB 0.1W 0 Ω
JSG031	ERJ6GEY0R00V	S.M.CARB 0.1W 0 Ω
JSH004	ERJ3GEY0R00V	S.M.CARB 0.1W 0 Ω
JSH11	ERJ6GEY0R00V	S.M.CARB 0.1W 0 Ω
JSH12	ERJ6GEY0R00V	S.M.CARB 0.1W 0 Ω
JSH13	ERJ6GEY0R00V	S.M.CARB 0.1W 0 Ω
JSH15	ERJ6GEY0R00V	S.M.CARB 0.1W 0 Ω

Cct Ref	Parts Number	Description
JSL4	ERJ6GEY0R00V	S.M.CARB 0.1W 0 Ω
JSL11	ERJ6GEY0R00V	S.M.CARB 0.1W 0 Ω
R111	ERJ6GEY0R00V	S.M.CARB 0.1W 0 Ω
R112	ERJ6GEYJ101V	S.M.CARB 0.1W 5% 100 Ω
R113	ERJ6GEYJ223V	S.M.CARB 0.1W 5% 22K Ω
R114	ERJ6GEYJ471V	S.M.CARB 0.1W 5% 470 Ω
R115	ERJ6GEYJ102V	S.M.CARB 0.1W 5% 1K Ω
R116	ERJ6GEYJ101V	S.M.CARB 0.1W 5% 100 Ω
R117	ERJ6GEYJ332V	S.M.CARB 0.1W 5% 3K3 Ω
R118	ERJ6GEYJ681V	S.M.CARB 0.1W 5% 680 Ω
R120	ERJ6GEYJ222V	S.M.CARB 0.1W 5% 2K2 Ω
R121	ERJ6GEYJ103V	S.M.CARB 0.1W 5% 10K Ω
R122	ERJ6GEY0R00V	S.M.CARB 0.1W 0 Ω
R129	ERJ6GEYJ101V	S.M.CARB 0.1W 5% 100 Ω
R130	ERJ6GEYJ472V	S.M.CARB 0.1W 5% 4K7 Ω
R134	ERJ6GEYJ101V	S.M.CARB 0.1W 5% 100 Ω
R135	ERJ6GEYJ101V	S.M.CARB 0.1W 5% 100 Ω
R136	ERJ6GEY0R00V	S.M.CARB 0.1W 0 Ω
R141	ERJ6GEYJ102V	S.M.CARB 0.1W 5% 1K Ω
R142	ERJ6GEY0R00V	S.M.CARB 0.1W 0 Ω
R250	ERJ6GEYJ103V	S.M.CARB 0.1W 5% 10K Ω
R251	ERJ6GEYJ471V	S.M.CARB 0.1W 5% 470 Ω
R252	ERJ6GEYJ103V	S.M.CARB 0.1W 5% 10K Ω
R253	ERJ6GEYJ471V	S.M.CARB 0.1W 5% 470 Ω
R254	ERJ6GEYJ103V	S.M.CARB 0.1W 5% 10K Ω
R255	ERJ6GEYJ103V	S.M.CARB 0.1W 5% 10K Ω
R256	ERJ6GEYJ103V	S.M.CARB 0.1W 5% 10K Ω
R257	ERJ6GEYJ151V	S.M.CARB 0.1W 5% 150 Ω
R258	ERJ6GEYJ151V	S.M.CARB 0.1W 5% 150 Ω
R259	ERJ6GEYJ201V	S.M.CARB 0.1W 5% 200 Ω
R260	ERJ6GEYJ201V	S.M.CARB 0.1W 5% 200 Ω
R261	ERJ6GEYJ392V	S.M.CARB 0.1W 5% 3K9 Ω
R262	ERJ6GEYJ392V	S.M.CARB 0.1W 5% 3K9 Ω
R263	ERDS2TJ2R2T	CARBON 0.25W 5% 2R2 Ω
R264	ERDS2TJ2R2T	CARBON 0.25W 5% 2R2 Ω
R265	ERJ6GEYJ103V	S.M.CARB 0.1W 5% 10K Ω
R266	ERJ6GEYJ473V	S.M.CARB 0.1W 5% 47K Ω
R267	ERJ6GEYJ103V	S.M.CARB 0.1W 5% 10K Ω
R268	ERQ14AJ101P	METAL 0.25W 5% 100 Ω
R269	ERJ6GEY0R00V	S.M.CARB 0.1W 0 Ω
R350	ERQ12AJ151P	FUSIBLE 0.5W 5% 150 Ω
R352	ERJ6GEYJ202V	S.M.CARB 0.1W 5% 2K Ω
R356	ERJ6GEYJ181V	S.M.CARB 0.1W 5% 180 Ω
R358	ERDS1TJ821V	CARBON 0.5W 5% 820 Ω
R361	ERJ6GEYJ183V	S.M.CARB 0.1W 5% 18K Ω
R362	ERJ6GEYJ202V	S.M.CARB 0.1W 5% 2K Ω
R366	ERJ6GEYJ181V	S.M.CARB 0.1W 5% 180 Ω
R368	ERDS1TJ821V	CARBON 0.5W 5% 820 Ω
R370	ERQ1CJPR56S	METAL 1W 5% R56 Ω
R372	ERJ6GEYJ202V	S.M.CARB 0.1W 5% 2K Ω
R376	ERJ6GEYJ181V	S.M.CARB 0.1W 5% 180 Ω
R378	ERDS1TJ821V	CARBON 0.5W 5% 820 Ω
R380	ERJ6GEYJ392V	S.M.CARB 0.1W 5% 3K9 Ω
R381	ERJ6GEYJ102V	S.M.CARB 0.1W 5% 1K Ω
R382	ERJ6GEY0R00V	S.M.CARB 0.1W 0 Ω
R383	ERJ6GEY0R00V	S.M.CARB 0.1W 0 Ω
R391	ERDS2TJ274T	CARBON 0.25W 5% 270K Ω
R392	ERJ6GEYJ684V	S.M.CARB 0.1W 5% 680K Ω
R451	ERJ6GEYJ223V	S.M.CARB 0.1W 5% 22K Ω
R454	ERJ6GEYJ223V	S.M.CARB 0.1W 5% 22K Ω
R455	ERDS2TJ223T	CARBON 0.25W 5% 22K Ω
R458	ERDS1TJ1R0T	CARBON 0.5W 5% 1 Ω
R460	ERG3SJS271H	METAL 3W 5% 270 Ω
R461	ERX2SJS1R0H	METAL 2W 5% 1 Ω
R463	ERJ6GEYJ821V	S.M.CARB 0.1W 5% 820 Ω
R464	ERJ6GEYJ512V	S.M.CARB 0.1W 5% 5K1 Ω

Cct Ref	Parts Number	Description			
R465	ERJ6GEYJ621V	S.M.CARB	0.125	5%	620 Ω
R467	ERJ6GEY0R00V	S.M.CARB	0.1W		0 Ω
R501	ERJ6GEYJ392V	S.M.CARB	0.1W	5%	3K9 Ω
R503	ERJ6GEYJ104V	S.M.CARB	0.1W	5%	100K Ω
R507	ERG3FJ820H	METAL	3W	5%	82 Ω
R509	ERG1SJ222E	METAL	0.5W	5%	2K2 Ω
R510	ERG1SJ222E	METAL	0.5W	5%	2K2 Ω
R553	ERX3SJSR68H	METAL	3W	5%	R68 Ω
R555	ERJ6GEY0R00V	S.M.CARB	0.1W		0 Ω
R556	ERJ6GEYJ563V	S.M.CARB	0.1W	5%	56K Ω
R557	ERJ6GEYJ101V	S.M.CARB	0.1W	5%	100 Ω
R558	ERDS1TJ124T	CARBON	0.5W	5%	120K Ω
R559	ERJ6GEY0R00V	S.M.CARB	0.1W		0 Ω
R560	ERJ6GEYJ434V	S.M.CARB	0.125	5%	430K Ω
R561	ERJ6GEYJ303V	S.M.CARB	0.1W	5%	30K Ω
R562	ERJ6GEYJ104V	S.M.CARB	0.1W	5%	100K Ω
R563	ERJ6GEYJ564V	S.M.CARB	0.1W	5%	560K Ω
R564	ERJ6GEYJ363V	S.M.CARB	0.125	5%	36K Ω
R566	ERJ6GEYJ102V	S.M.CARB	0.1W	5%	1K Ω
R567	343-23R3AY	METAL	10W	5%	3R3 Ω
R568	ERDS1TJ120T	CARBON	0.5W	5%	12 Ω
R569	ERJ6GEYJ102V	S.M.CARB	0.1W	5%	1K Ω
R578	ERQ12HKR39P	FUSIBLE	0.5W	10%	R39 Ω
R581	ERG3FJ561H	METAL	3W	5%	560 Ω
R701	ERJ6GEYJ101V	S.M.CARB	0.1W	5%	100 Ω
R702	ERX2SJS1R0H	METAL	2W	5%	1 Ω
R704	ERDS1FJ472V	CARBON	0.5W	5%	4K7 Ω
R705	ERG3FJ151H	METAL	3W	5%	150 Ω
R706	ERG3FJ151H	METAL	3W	5%	150 Ω
R707	ERJ6GEYJ272V	S.M.CARB	0.1W	5%	2K7 Ω
R708	ERJ6GEYJ103V	S.M.CARB	0.1W	5%	10K Ω
R709	ERJ6GEYJ473V	S.M.CARB	0.1W	5%	47K Ω
R711	ERDS1TJ133T	CARBON	0.5W	5%	13K Ω
R712	ERJ6GEYJ203V	S.M.CARB	0.1W	5%	20K Ω
R715	ERDS2TJ272T	CARBON	0.25W	5%	2K7 Ω
R716	ERQ12AJ680P	METAL	0.5W	5%	68 Ω
R717	ERJ6GEYJ272V	S.M.CARB	0.1W	5%	2K7 Ω
R718	ERJ6GEYJ203V	S.M.CARB	0.1W	5%	20K Ω
R720	ERJ6GEYJ302V	S.M.CARB	0.1W	5%	3K Ω
R721	ERJ6GEYJ681V	S.M.CARB	0.1W	5%	680 Ω
R722	ERJ6GEYJ332V	S.M.CARB	0.1W	5%	3K3 Ω
R723	ERJ6GEYJ473V	S.M.CARB	0.1W	5%	47K Ω
R724	ERG2FJ680H	METAL	2W	5%	68 Ω
R725	ERG1FJ202P	METAL	1W	5%	2K Ω
R801	ERC12ZGK105C	SOLID	0.5W	10%	1M Ω $\Delta$
R807	ERF2AJ560P	WOUND	2W	5%	56 Ω
R808	ERG1FJS104D	METAL	1W	5%	100K Ω
R809	ERDS2TJ101T	CARBON	0.25W	5%	100 Ω
R836	ERD75TAJ825	CARBON	1W	5%	8M2 Ω $\Delta$
R837	ERDS2TJ100T	CARBON	0.25W	5%	10 Ω
R838	ERDS2TJ332T	CARBON	2W	5%	3K2 Ω
R839	ERDS2TJ202T	CARBON	0.25W	5%	2K Ω
R841	ERDS2TJ681T	CARBON	0.25W	5%	680 Ω
R842	D0D2R27KA003	WOUND	2W	10%	R27 Ω
R843	D0D2R27KA003	WOUND	2W	10%	R27 Ω
R853	ERDS1TJ103T	CARBON	0.5W	5%	10K Ω
R854	ERDS2TJ473T	CARBON	0.25W	5%	47K Ω
R855	ERJ6GEY0R00V	S.M.CARB	0.1W		0 Ω
R856	ERJ6GEYJ203V	S.M.CARB	0.1W	5%	20K Ω
R859	ERJ6GEYJ123V	S.M.CARB	0.1W	5%	12K Ω
R860	ERJ6GEYJ473V	S.M.CARB	0.1W	5%	47K Ω
R861	ERJ6GEYJ203V	S.M.CARB	0.1W	5%	20K Ω
R862	ERJ6GEYJ153V	S.M.CARB	0.1W	5%	15K Ω
R863	ERDS1TJ122T	CARBON	0.5W	5%	1K2 Ω
R864	ERDS1TJ102T	CARBON	0.5W	5%	1K Ω
R868	ERG3FJ183H	METAL	3W	5%	18K Ω

Cct Ref	Parts Number	Description			
R869	ERG3FJ183H	METAL	3W	5%	18K Ω
R870	ERJ6GEYJ104V	S.M.CARB	0.1W	5%	100K Ω
R877	ERJ6GEYJ473V	S.M.CARB	0.1W	5%	47K Ω
R879	ERG1SJ223P	METAL	1W	5%	22K Ω
R880	ERG1SJ183P	METAL	1W	5%	18K Ω
R881	ERJ6GEYJ153V	S.M.CARB	0.1W	5%	15K Ω
R882	ERDS2TJ681T	CARBON	0.25W	5%	680 Ω
R883	ERJ6GEYJ752V	S.M.CARB	0.1W	5%	7K5 Ω
R884	ERDS1TJ103T	CARBON	0.5W	5%	10K Ω
R885	ERJ6GEYJ753V	S.M.CARB	0.1W	5%	75K Ω
R886	ERG3FJ101H	METAL	3W	5%	100 Ω
R887	ERDS1TJ683T	CARBON	0.5W	5%	68K Ω
R888	ERG3FJ101H	METAL	3W	5%	100 Ω
R889	ERJ6GEYJ752V	S.M.CARB	0.1W	5%	7K5 Ω
R890	ERDS2TJ202T	CARBON	0.25W	5%	2K Ω
R892	ERDS2TJ101T	CARBON	0.25W	5%	100 Ω
R893	ERJ6GEYJ752V	S.M.CARB	0.1W	5%	7K5 Ω
R894	ERDS1TJ2R2T	CARBON	0.5W	5%	2R2 Ω
R895	ERJ6GEYJ102V	S.M.CARB	0.1W	5%	1K Ω
R897	ERJ6GEYJ511V	S.M.CARB	0.1W	5%	510 Ω
R898	ERJ6GEY0R00V	S.M.CARB	0.1W		0 Ω
R914	ERJ6GEYJ102V	S.M.CARB	0.1W	5%	1K Ω
R918	ERJ6GEY0R00V	S.M.CARB	0.1W		0 Ω
R921	ERJ6GEY0R00V	S.M.CARB	0.1W		0 Ω
R922	ERDS2TJ683T	CARBON	2W	5%	68K Ω
R923	ERDS2TJ683T	CARBON	2W	5%	68K Ω
R925	ERJ6GEY0R00V	S.M.CARB	0.1W		0 Ω
R926	ERJ6GEY0R00V	S.M.CARB	0.1W		0 Ω
R927	ERDS2TJ681T	CARBON	0.25W	5%	680 Ω
R928	ERDS2TJ130T	CARBON	0.25W	5%	13 Ω
R929	ERDS1FVJ331T	CARBON	0.5W	5%	330 Ω
R935	ERQ14AJW3R9E	FUSIBLE	0.25W	5%	3R9 Ω
R936	ERQ1CJP331S	FUSIBLE	1W	5%	330 Ω
R938	ERDS2TJ681T	CARBON	0.25W	5%	680 Ω
R941	ERDS1TJ130T	CARBON	0.5W	5%	13 Ω
R942	ERJ6GEY0R00V	S.M.CARB	0.1W		0 Ω
R943	ERJ6GEY0R00V	S.M.CARB	0.1W		0 Ω
R944	ERJ6GEYJ102V	S.M.CARB	0.1W	5%	1K Ω
R945	ERJ6GEYJ102V	S.M.CARB	0.1W	5%	1K Ω
R948	ERG5FJ152H	METAL	5W	5%	1K5 Ω
R949	ERJ6GEY0R00V	S.M.CARB	0.1W		0 Ω
R1005	ERJ6GEYJ332V	S.M.CARB	0.1W	5%	3K3 Ω
R1007	ERJ6GEYJ103V	S.M.CARB	0.1W	5%	10K Ω
R1017	ERJ6GEYJ103V	S.M.CARB	0.1W	5%	10K Ω
R1043	ERJ6GEYJ682V	S.M.CARB	0.1W	5%	6K8 Ω
R1044	ERJ6GEYJ123V	S.M.CARB	0.1W	5%	12K Ω
R1045	ERJ6GEYJ223V	S.M.CARB	0.1W	5%	22K Ω
R1046	ERJ6GEYJ683V	S.M.CARB	0.1W	5%	68K Ω
R1047	ERDS2TJ102T	CARBON	0.25W	5%	1K Ω
R1101	ERJ3GEYJ562V	S.M.CARB	0.1W	5%	5K6 Ω
R1102	ERJ3GEYJ562V	S.M.CARB	0.1W	5%	5K6 Ω
R1103	ERJ3GEYJ103V	S.M.CARB	0.1W	5%	10K Ω
R1104	ERJ3GEYJ101V	S.M.CARB	0.1W	5%	100 Ω
R1105	ERJ3GEYJ103V	S.M.CARB	0.1W	5%	10K Ω
R1106	ERJ3GEYJ103V	S.M.CARB	0.1W	5%	10K Ω
R1107	ERJ3GEYJ103V	S.M.CARB	0.1W	5%	10K Ω
R1108	ERJ3GEYJ103V	S.M.CARB	0.1W	5%	10K Ω
R1109	ERJ3GEYJ103V	S.M.CARB	0.1W	5%	10K Ω
R1110	ERJ3GEYJ103V	S.M.CARB	0.1W	5%	10K Ω
R1111	ERJ3GEYJ101V	S.M.CARB	0.1W	5%	100 Ω
R1112	ERJ3GEYJ101V	S.M.CARB	0.1W	5%	100 Ω
R1113	ERJ3GEYJ103V	S.M.CARB	0.1W	5%	10K Ω
R1115	ERJ3GEYJ101V	S.M.CARB	0.1W	5%	100 Ω
R1116	ERJ3GEYJ103V	S.M.CARB	0.1W	5%	10K Ω
R1117	ERJ3GEYJ103V	S.M.CARB	0.1W	5%	10K Ω
R1118	ERJ3GEYJ103V	S.M.CARB	0.1W	5%	10K Ω

Cct Ref	Parts Number	Description				
R1119	ERJ3GEYJ103V	S.M.CARB	0.1W	5%	10K Ω	
R1120	ERJ3GEYJ101V	S.M.CARB	0.1W	5%	100 Ω	
R1121	ERJ3GEYJ101V	S.M.CARB	0.1W	5%	100 Ω	
R1122	ERJ3GEYJ103V	S.M.CARB	0.1W	5%	10K Ω	
R1123	ERJ3GEYJ101V	S.M.CARB	0.1W	5%	100 Ω	
R1124	ERJ3GEYJ101V	S.M.CARB	0.1W	5%	100 Ω	
R1125	ERJ3GEYJ103V	S.M.CARB	0.1W	5%	10K Ω	
R1126	ERJ3GEYJ101V	S.M.CARB	0.1W	5%	100 Ω	
R1127	ERJ3GEY0R00V	S.M.CARB	0.1W		0 Ω	
R1128	ERJ3GEYJ273V	S.M.CARB	0.1W	5%	27K Ω	
R1129	ERJ3GEYJ101V	S.M.CARB	0.1W	5%	100 Ω	
R1131	ERJ3GEYJ101V	S.M.CARB	0.1W	5%	100 Ω	
R1132	ERJ3GEYJ562V	S.M.CARB	0.1W	5%	5K6 Ω	
R1133	ERJ3GEYJ102V	S.M.CARB	0.1W	5%	1K Ω	
R1134	ERJ3GEYJ473V	S.M.CARB	0.1W	5%	47K Ω	
R1135	ERJ3GEYJ224V	S.M.CARB	0.1W	5%	220K Ω	
R1136	ERJ3GEYJ473V	S.M.CARB	0.1W	5%	47K Ω	
R1137	ERJ3GEYJ104V	S.M.CARB	0.1W	5%	100K Ω	
R1138	ERJ3GEYJ223V	S.M.CARB	0.1W	5%	22K Ω	
R1139	ERJ3GEYJ104V	S.M.CARB	0.1W	5%	100K Ω	
R1140	ERJ3GEYJ225V	S.M.CARB	0.1W	5%	2M2 Ω	
R1141	ERJ3GEYJ101V	S.M.CARB	0.1W	5%	100 Ω	
R1142	ERJ3GEYJ221V	S.M.CARB	0.1W	5%	220 Ω	
R1144	ERJ3GEYJ472V	S.M.CARB	0.1W	5%	4K7 Ω	
R1145	ERJ3GEYJ331V	S.M.CARB	0.1W	5%	330 Ω	
R1146	ERJ3GEYJ103V	S.M.CARB	0.1W	5%	10K Ω	
R1147	ERJ3GEYJ101V	S.M.CARB	0.1W	5%	100 Ω	
R1148	ERJ3GEYJ273V	S.M.CARB	0.1W	5%	27K Ω	
R1149	ERJ3GEYJ103V	S.M.CARB	0.1W	5%	10K Ω	
R1150	ERJ3GEY0R00V	S.M.CARB	0.1W		0 Ω	
R1151	ERJ3GEY0R00V	S.M.CARB	0.1W		0 Ω	
R1152	ERJ3GEY0R00V	S.M.CARB	0.1W		0 Ω	
R1153	ERJ3GEYJ223V	S.M.CARB	0.1W	5%	22K Ω	
R1154	ERJ3GEYJ104V	S.M.CARB	0.1W	5%	100K Ω	
R1155	ERJ3GEYJ102V	S.M.CARB	0.1W	5%	1K Ω	
R1157	ERJ3GEYJ103V	S.M.CARB	0.1W	5%	10K Ω	
R1158	ERJ3GEYJ101V	S.M.CARB	0.1W	5%	100 Ω	
R1160	ERJ3GEY0R00V	S.M.CARB	0.1W		0 Ω	
R1161	ERJ3GEYJ103V	S.M.CARB	0.1W	5%	10K Ω	
R1162	ERJ3GEYJ123V	S.M.CARB	0.1W	5%	12K Ω	
R1164	ERJ3GEY0R00V	S.M.CARB	0.1W		0 Ω	
R1166	ERJ3GEYJ222V	S.M.CARB	0.1W	5%	2K2 Ω	
R1168	ERJ3GEYJ101V	S.M.CARB	0.1W	5%	100 Ω	
R1169	ERJ3GEYJ103V	S.M.CARB	0.1W	5%	10K Ω	
R1170	ERJ3GEYJ103V	S.M.CARB	0.1W	5%	10K Ω	
R1171	ERJ3GEYJ153V	S.M.CARB	0.1W	5%	15K Ω	
R1172	ERJ3GEYJ472V	S.M.CARB	0.1W	5%	4K7 Ω	
R1178	ERJ3GEYJ101V	S.M.CARB	0.1W	5%	100 Ω	
R1180	ERJ3GEY0R00V	S.M.CARB	0.1W		0 Ω	
R1181	ERJ3GEYJ683V	S.M.CARB	0.1W	5%	68K Ω	
R1182	ERJ3GEY0R00V	S.M.CARB	0.1W		0 Ω	
R1183	ERJ3GEYJ101V	S.M.CARB	0.1W	5%	100 Ω	
R1186	ERJ3GEYJ102V	S.M.CARB	0.1W	5%	1K Ω	
R1187	ERJ3GEYJ683V	S.M.CARB	0.1W	5%	68K Ω	
R1188	ERJ3GEYJ101V	S.M.CARB	0.1W	5%	100 Ω	
R1189	ERJ3GEYJ101V	S.M.CARB	0.1W	5%	100 Ω	
R1191	ERJ3GEYJ103V	S.M.CARB	0.1W	5%	10K Ω	
R1194	ERJ3GEY0R00V	S.M.CARB	0.1W		0 Ω	
R1195	ERJ3GEYJ101V	S.M.CARB	0.1W	5%	100 Ω	
R1196	EXB38V680JV	S.M.RES	0.063	5%	68 Ω	
R1197	ERJ3GEYJ472V	S.M.CARB	0.1W	5%	4K7 Ω	
R1199	ERJ3GEYJ223V	S.M.CARB	0.1W	5%	22K Ω	
R1200	ERJ3GEYJ473V	S.M.CARB	0.1W	5%	47K Ω	
R1202	EXB38V680JV	S.M.RES	0.063	5%	68 Ω	
R1205	EXB38V680JV	S.M.RES	0.063	5%	68 Ω	
R1209	EXB38V680JV	S.M.RES	0.063	5%	68 Ω	

Cct Ref	Parts Number	Description				
R1210	ERJ3GEYJ224V	S.M.CARB	0.1W	5%	220K Ω	
R1211	ERJ3GEYJ223V	S.M.CARB	0.1W	5%	22K Ω	
R1212	ERJ3GEYJ472V	S.M.CARB	0.1W	5%	4K7 Ω	
R1214	EXB38V680JV	S.M.RES	0.063	5%	68 Ω	
R1217	EXB38V680JV	S.M.RES	0.063	5%	68 Ω	
R1221	EXB38V680JV	S.M.RES	0.063	5%	68 Ω	
R1225	EXB38V680JV	S.M.RES	0.063	5%	68 Ω	
R1232	EXB38V390JV	S.M.RES	0.063	5%	39 Ω	
R1233	EXB38V680JV	S.M.RES	0.063	5%	68 Ω	
R1236	EXB38V680JV	S.M.RES	0.063	5%	68 Ω	
R1251	ERJ6GEY0R00V	S.M.CARB	0.1W		0 Ω	
R1255	ERJ3GEYJ392V	S.M.CARB	0.1W	5%	3K9 Ω	
R1257	ERJ3GEY0R00V	S.M.CARB	0.1W		0 Ω	
R1258	ERJ3GEYJ153V	S.M.CARB	0.1W	5%	15K Ω	
R1264	ERJ3GEYJ471V	S.M.CARB	0.1W	5%	470 Ω	
R1265	ERJ6GEY0R00V	S.M.CARB	0.1W		0 Ω	
R1268	ERJ6GEY0R00V	S.M.CARB	0.1W		0 Ω	
R1269	ERJ6GEY0R00V	S.M.CARB	0.1W		0 Ω	
R1270	ERJ6GEY0R00V	S.M.CARB	0.1W		0 Ω	
R1271	ERJ6GEY0R00V	S.M.CARB	0.1W		0 Ω	
R1272	ERJ6GEY0R00V	S.M.CARB	0.1W		0 Ω	
R1273	ERJ6GEY0R00V	S.M.CARB	0.1W		0 Ω	
R1278	ERJ6GEY0R00V	S.M.CARB	0.1W		0 Ω	
R1280	ERJ6GEY0R00V	S.M.CARB	0.1W		0 Ω	
R1285	ERJ6GEY0R00V	S.M.CARB	0.1W		0 Ω	
R1286	ERJ6GEY0R00V	S.M.CARB	0.1W		0 Ω	
R1287	ERJ6GEY0R00V	S.M.CARB	0.1W		0 Ω	
R1288	ERJ6GEY0R00V	S.M.CARB	0.1W		0 Ω	
R1289	ERJ6GEY0R00V	S.M.CARB	0.1W		0 Ω	
R1292	ERJ6GEY0R00V	S.M.CARB	0.1W		0 Ω	
R1293	ERJ6GEY0R00V	S.M.CARB	0.1W		0 Ω	
R1501	ERJ3GEY0R00V	S.M.CARB	0.1W		0 Ω	
R1502	ERJ3GEYJ103V	S.M.CARB	0.1W	5%	10K Ω	
R1503	ERJ3GEYJ222V	S.M.CARB	0.1W	5%	2K2 Ω	
R1504	ERJ3GEYJ222V	S.M.CARB	0.1W	5%	2K2 Ω	
R1505	ERJ3GEYJ222V	S.M.CARB	0.1W	5%	2K2 Ω	
R1511	ERJ6GEYJ750V	S.M.CARB	0.1W	5%	75 Ω	
R1512	ERJ6GEYJ750V	S.M.CARB	0.1W	5%	75 Ω	
R1513	ERJ6GEYJ750V	S.M.CARB	0.1W	5%	75 Ω	
R1514	ERJ3GEYJ101V	S.M.CARB	0.1W	5%	100 Ω	
R1515	ERJ3GEYJ101V	S.M.CARB	0.1W	5%	100 Ω	
R1516	ERJ3GEYJ101V	S.M.CARB	0.1W	5%	100 Ω	
R1519	ERJ3GEYJ101V	S.M.CARB	0.1W	5%	100 Ω	
R1521	ERJ6GEYJ750V	S.M.CARB	0.1W	5%	75 Ω	
R1522	ERJ6GEYJ750V	S.M.CARB	0.1W	5%	75 Ω	
R1523	ERJ6GEYJ750V	S.M.CARB	0.1W	5%	75 Ω	
R1524	ERJ6GEYJ750V	S.M.CARB	0.1W	5%	75 Ω	
R1540	ERJ3GEYJ101V	S.M.CARB	0.1W	5%	100 Ω	
R1701	ERJ3GEY0R00V	S.M.CARB	0.1W		0 Ω	
R1704	ERJ3GEY0R00V	S.M.CARB	0.1W		0 Ω	
R1705	ERJ3GEYJ221V	S.M.CARB	0.1W	5%	220 Ω	
R1706	ERJ3GEYJ471V	S.M.CARB	0.1W	5%	470 Ω	
R1707	ERJ3GEYJ471V	S.M.CARB	0.1W	5%	470 Ω	
R1708	ERJ3GEYJ473V	S.M.CARB	0.1W	5%	47K Ω	
R1709	ERJ3GEYJ103V	S.M.CARB	0.1W	5%	10K Ω	
R1710	ERJ3GEYJ563V	S.M.CARB	0.1W	5%	56K Ω	
R1712	ERJ3GEYJ103V	S.M.CARB	0.1W	5%	10K Ω	
R1713	ERJ3GEYJ332V	S.M.CARB	0.1W	5%	3K3 Ω	
R1714	ERJ3GEYJ102V	S.M.CARB	0.1W	5%	1K Ω	
R1716	ERJ3GEYJ103V	S.M.CARB	0.1W	5%	10K Ω	
R1717	ERJ3GEYJ271V	S.M.CARB	0.1W	5%	270 Ω	
R1719	ERJ3GEYJ223V	S.M.CARB	0.1W	5%	22K Ω	
R1720	ERJ3GEYJ822V	S.M.CARB	0.1W	5%	8K2 Ω	
R1721	ERJ3GEYJ682V	S.M.CARB	0.1W	5%	6K8 Ω	
R1723	ERJ3GEYJ750V	S.M.CARB	0.1W	5%	75 Ω	
R1724	ERJ3GEYJ223V	S.M.CARB	0.1W	5%	22K Ω	

Cct Ref	Parts Number	Description				
R1725	ERJ3GEYJ223V	S.M.CARB	0.1W	5%	22K Ω	
R1726	ERJ3GEYJ223V	S.M.CARB	0.1W	5%	22K Ω	
R1727	ERJ3GEYJ101V	S.M.CARB	0.1W	5%	100 Ω	
R1728	ERJ3GEYJ101V	S.M.CARB	0.1W	5%	100 Ω	
R1732	ERJ3GEYJ151V	S.M.CARB	0.1W	5%	150 Ω	
R1733	ERJ3GEYJ151V	S.M.CARB	0.1W	5%	150 Ω	
R1734	ERJ3GEYJ151V	S.M.CARB	0.1W	5%	150 Ω	
R1735	ERJ3GEYJ821V	S.M.CARB	0.1W	5%	820 Ω	
R1736	ERJ3GEYJ103V	S.M.CARB	0.1W	5%	10K Ω	
R1737	ERJ3GEYJ560V	S.M.CARB	0.1W	5%	56 Ω	
R1738	ERJ6GEYJ621V	S.M.CARB	0.125	5%	620 Ω	
R1739	ERJ3GEYJ103V	S.M.CARB	0.1W	5%	10K Ω	
R1740	ERJ3GEYJ560V	S.M.CARB	0.1W	5%	56 Ω	
R1741	ERJ6GEYJ621V	S.M.CARB	0.125	5%	620 Ω	
R1742	ERJ3GEYJ103V	S.M.CARB	0.1W	5%	10K Ω	
R1743	ERJ3GEYJ560V	S.M.CARB	0.1W	5%	56 Ω	
R1744	ERJ6GEYJ621V	S.M.CARB	0.125	5%	620 Ω	
R1745	ERJ6GEYJ471V	S.M.CARB	0.1W	5%	470 Ω	
R1746	ERJ3GEYJ472V	S.M.CARB	0.1W	5%	4K7 Ω	
R1747	ERJ3GEYJ102V	S.M.CARB	0.1W	5%	1K Ω	
R1748	ERJ3GEYJ472V	S.M.CARB	0.1W	5%	4K7 Ω	
R1749	ERJ3GEYJ223V	S.M.CARB	0.1W	5%	22K Ω	
R1750	ERJ3GEYJ102V	S.M.CARB	0.1W	5%	1K Ω	
R1751	ERJ3GEYJ334V	S.M.CARB	0.1W	5%	330K Ω	
R1752	ERJ6GEYJ560V	S.M.CARB	0.1W	5%	56 Ω	
R1755	ERJ3GEYJ102V	S.M.CARB	0.1W	5%	1K Ω	
R1758	ERJ3GEYJ101V	S.M.CARB	0.1W	5%	100 Ω	
R1759	ERJ3GEYJ101V	S.M.CARB	0.1W	5%	100 Ω	
R1760	ERJ3GEY0R00V	S.M.CARB	0.1W		0 Ω	
R1761	ERJ3GEY0R00V	S.M.CARB	0.1W		0 Ω	
R1762	ERJ3GEY0R00V	S.M.CARB	0.1W		0 Ω	
R1763	ERJ3GEY0R00V	S.M.CARB	0.1W		0 Ω	
R1766	ERJ3GEY0R00V	S.M.CARB	0.1W		0 Ω	
R1767	ERJ3GEY0R00V	S.M.CARB	0.1W		0 Ω	
R1768	ERJ3GEY0R00V	S.M.CARB	0.1W		0 Ω	
R1769	ERJ3GEY0R00V	S.M.CARB	0.1W		0 Ω	
R1770	ERJ3GEY0R00V	S.M.CARB	0.1W		0 Ω	
R1771	ERJ3GEYJ103V	S.M.CARB	0.1W	5%	10K Ω	
R1772	ERJ3GEYJ103V	S.M.CARB	0.1W	5%	10K Ω	
R1774	ERJ3GEYJ222V	S.M.CARB	0.1W	5%	2K2 Ω	
R1775	ERJ3GEYJ102V	S.M.CARB	0.1W	5%	1K Ω	
R1776	ERJ3GEYJ102V	S.M.CARB	0.1W	5%	1K Ω	
R1777	ERJ3GEYJ473V	S.M.CARB	0.1W	5%	47K Ω	
R1780	ERJ3GEYJ331V	S.M.CARB	0.1W	5%	330 Ω	
R1781	ERJ3GEYJ101V	S.M.CARB	0.1W	5%	100 Ω	
R1782	ERJ3GEYJ102V	S.M.CARB	0.1W	5%	1K Ω	
R1901	ERJ6GEYJ472V	S.M.CARB	0.1W	5%	4K7 Ω	
R1902	ERJ6GEYJ392V	S.M.CARB	0.1W	5%	3K9 Ω	
R1903	ERJ6GEYJ103V	S.M.CARB	0.1W	5%	10K Ω	
R1904	ERDS1TJ2R2T	CARBON	0.5W	5%	2R2 Ω	
R1905	ERJ6GEYJ273V	S.M.CARB	0.1W	5%	27K Ω	
R1906	ERJ6GEYJ273V	S.M.CARB	0.1W	5%	27K Ω	
R1907	ERJ6GEYJ273V	S.M.CARB	0.1W	5%	27K Ω	
R1908	ERJ6GEY0R00V	S.M.CARB	0.1W		0 Ω	
R1909	ERDS1TJ2R2T	CARBON	0.5W	5%	2R2 Ω	
R1912	ERDS2TJ102T	CARBON	0.25W	5%	1K Ω	
R1913	ERJ6GEYJ222V	S.M.CARB	0.1W	5%	2K2 Ω	
R1914	ERJ6GEYJ333V	S.M.CARB	0.1W	5%	33K Ω	
R1915	ERJ6GEYJ331V	S.M.CARB	0.1W	5%	330 Ω	
R1916	ERJ6GEYJ103V	S.M.CARB	0.1W	5%	10K Ω	
R1917	ERJ6GEYJ472V	S.M.CARB	0.1W	5%	4K7 Ω	
R1918	ERJ6GEYJ121V	S.M.CARB	0.1W	5%	120 Ω	
R1919	ERJ6GEYJ332V	S.M.CARB	0.1W	5%	3K3 Ω	
R1920	ERJ6GEYJ103V	S.M.CARB	0.1W	5%	10K Ω	
R1921	ERJ6GEYJ103V	S.M.CARB	0.1W	5%	10K Ω	
R1923	ERJ6GEYJ472V	S.M.CARB	0.1W	5%	4K7 Ω	

Cct Ref	Parts Number	Description				
R1926	ERJ6GEYJ102V	S.M.CARB	0.1W	5%	1K Ω	
R2001	ERJ6GEYJ101V	S.M.CARB	0.1W	5%	100 Ω	
R2002	ERJ6GEYJ101V	S.M.CARB	0.1W	5%	100 Ω	
R2011	ERJ6GEYJ183V	S.M.CARB	0.1W	5%	18K Ω	
R2012	ERJ6GEY0R00V	S.M.CARB	0.1W		0 Ω	
R2013	ERJ6GEYJ101V	S.M.CARB	0.1W	5%	100 Ω	
R2014	ERJ6GEYJ101V	S.M.CARB	0.1W	5%	100 Ω	
R2015	ERJ6GEYJ101V	S.M.CARB	0.1W	5%	100 Ω	
R2016	ERJ6GEYJ101V	S.M.CARB	0.1W	5%	100 Ω	
R2021	ERJ6GEYJ562V	S.M.CARB	0.1W	5%	5K6 Ω	
R2022	ERJ6GEYJ221V	S.M.CARB	0.1W	5%	220 Ω	
R2023	ERJ6GEYJ222V	S.M.CARB	0.1W	5%	2K2 Ω	
R2024	ERJ6GEY0R00V	S.M.CARB	0.1W		0 Ω	
R2025	ERJ6GEYJ562V	S.M.CARB	0.1W	5%	5K6 Ω	
R2026	ERJ6GEYJ102V	S.M.CARB	0.1W	5%	1K Ω	
R2027	ERJ6GEYJ101V	S.M.CARB	0.1W	5%	100 Ω	
R2028	ERJ6GEYJ222V	S.M.CARB	0.1W	5%	2K2 Ω	
R2029	ERJ6GEYJ101V	S.M.CARB	0.1W	5%	100 Ω	
R2030	ERJ6GEYJ222V	S.M.CARB	0.1W	5%	2K2 Ω	
R2031	ERJ6GEYJ101V	S.M.CARB	0.1W	5%	100 Ω	
R2032	ERJ6GEYJ101V	S.M.CARB	0.1W	5%	100 Ω	
R2033	ERJ6GEYJ102V	S.M.CARB	0.1W	5%	1K Ω	
R2034	ERJ6GEYJ102V	S.M.CARB	0.1W	5%	1K Ω	
R2035	ERJ6GEY0R00V	S.M.CARB	0.1W		0 Ω	
R2036	ERJ6GEY0R00V	S.M.CARB	0.1W		0 Ω	
R2037	ERJ6GEYJ102V	S.M.CARB	0.1W	5%	1K Ω	
R2038	ERJ6GEYJ562V	S.M.CARB	0.1W	5%	5K6 Ω	
R2222	ERJ6GEY0R00V	S.M.CARB	0.1W		0 Ω	
R2240	ERJ6GEY0R00V	S.M.CARB	0.1W		0 Ω	
R2351	ERJ6GEYJ103V	S.M.CARB	0.1W	5%	10K Ω	
R2352	ERJ6GEYJ103V	S.M.CARB	0.1W	5%	10K Ω	
R2353	ERJ6GEYJ473V	S.M.CARB	0.1W	5%	47K Ω	
R2354	ERJ6GEYJ104V	S.M.CARB	0.1W	5%	100K Ω	
R2355	ERJ6GEYJ681V	S.M.CARB	0.1W	5%	680 Ω	
R2356	ERJ6GEYJ332V	S.M.CARB	0.1W	5%	3K3 Ω	
R2357	ERJ6GEYJ103V	S.M.CARB	0.1W	5%	10K Ω	
R2358	ERJ6GEYJ473V	S.M.CARB	0.1W	5%	47K Ω	
R2359	ERJ6GEYJ681V	S.M.CARB	0.1W	5%	680 Ω	
R2360	ERJ6GEYJ332V	S.M.CARB	0.1W	5%	3K3 Ω	
R2361	ERJ6GEYJ104V	S.M.CARB	0.1W	5%	100K Ω	
R2362	ERJ6GEYJ473V	S.M.CARB	0.1W	5%	47K Ω	
R2363	ERJ6GEYJ103V	S.M.CARB	0.1W	5%	10K Ω	
R2364	ERJ6GEYJ473V	S.M.CARB	0.1W	5%	47K Ω	
R2367	ERJ6GEY0R00V	S.M.CARB	0.1W		0 Ω	
R2368	ERJ6GEYJ102V	S.M.CARB	0.1W	5%	1K Ω	
R2369	ERJ6GEYJ562V	S.M.CARB	0.1W	5%	5K6 Ω	
R2370	ERJ6GEYJ472V	S.M.CARB	0.1W	5%	4K7 Ω	
R3001	ERJ6ENF82R0V	S.M.CARB	0.1W	1%	82 Ω	
R3002	ERJ6ENF82R0V	S.M.CARB	0.1W	1%	82 Ω	
R3003	ERJ6ENF82R0V	S.M.CARB	0.1W	1%	82 Ω	
R3004	ERJ6GEYJ750V	S.M.CARB	0.1W	5%	75 Ω	
R3005	ERJ6GEYJ561V	S.M.CARB	0.1W	5%	560 Ω	
R3006	ERJ6GEYJ333V	S.M.CARB	0.1W	5%	33K Ω	
R3007	ERJ6GEYJ561V	S.M.CARB	0.1W	5%	560 Ω	
R3008	ERJ6GEYJ333V	S.M.CARB	0.1W	5%	33K Ω	
R3009	ERJ6ENF1802V	S.M.CARB	0.1W	1%	18K Ω	
R3010	ERJ6ENF9101V	S.M.CARB	0.1W	1%	9K1 Ω	
R3011	ERJ3GEYJ101V	S.M.CARB	0.1W	5%	100 Ω	
R3012	ERJ3GEYJ103V	S.M.CARB	0.1W	5%	10K Ω	
R3013	ERJ3GEYJ103V	S.M.CARB	0.1W	5%	10K Ω	
R3014	ERJ3GEYJ101V	S.M.CARB	0.1W	5%	100 Ω	
R3015	ERJ6GEYJ561V	S.M.CARB	0.1W	5%	560 Ω	
R3016	ERJ6GEYJ333V	S.M.CARB	0.1W	5%	33K Ω	
R3017	ERJ6GEYJ561V	S.M.CARB	0.1W	5%	560 Ω	
R3018	ERJ6GEYJ333V	S.M.CARB	0.1W	5%	33K Ω	
R3019	ERJ6ENF1802V	S.M.CARB	0.1W	1%	18K Ω	

Cct Ref	Parts Number	Description				
R3020	ERJ6ENF9101V	S.M.CARB	0.1W	1%	9K1 Ω	
R3021	ERJ3GEYJ101V	S.M.CARB	0.1W	5%	100 Ω	
R3022	ERJ6ENF82R0V	S.M.CARB	0.1W	1%	82 Ω	
R3023	ERJ6ENF82R0V	S.M.CARB	0.1W	1%	82 Ω	
R3024	ERJ6ENF82R0V	S.M.CARB	0.1W	1%	82 Ω	
R3025	ERJ6GEYJ750V	S.M.CARB	0.1W	5%	75 Ω	
R3026	ERJ6GEYJ561V	S.M.CARB	0.1W	5%	560 Ω	
R3028	ERJ6GEYJ333V	S.M.CARB	0.1W	5%	33K Ω	
R3029	ERJ6GEYJ561V	S.M.CARB	0.1W	5%	560 Ω	
R3031	ERJ6GEYJ333V	S.M.CARB	0.1W	5%	33K Ω	
R3032	ERJ6ENF1802V	S.M.CARB	0.1W	1%	18K Ω	
R3033	ERJ6ENF9101V	S.M.CARB	0.1W	1%	9K1 Ω	
R3034	ERJ3GEYJ391V	S.M.CARB	0.1W	5%	390 Ω	
R3035	ERJ3GEYJ391V	S.M.CARB	0.1W	5%	390 Ω	
R3036	ERJ3GEYJ103V	S.M.CARB	0.1W	5%	10K Ω	
R3037	ERJ3GEYJ104V	S.M.CARB	0.1W	5%	100K Ω	
R3038	ERJ3GEYJ103V	S.M.CARB	0.1W	5%	10K Ω	
R3039	ERJ3GEYJ104V	S.M.CARB	0.1W	5%	100K Ω	
R3040	ERJ3GEYJ221V	S.M.CARB	0.1W	5%	220 Ω	
R3041	ERJ3GEYJ221V	S.M.CARB	0.1W	5%	220 Ω	
R3042	ERJ3GEYJ102V	S.M.CARB	0.1W	5%	1K Ω	
R3043	ERJ3GEYJ102V	S.M.CARB	0.1W	5%	1K Ω	
R3044	ERJ3GEY0R00V	S.M.CARB	0.1W		0 Ω	
R3047	ERJ3GEYJ102V	S.M.CARB	0.1W	5%	1K Ω	
R3048	ERJ3GEYJ102V	S.M.CARB	0.1W	5%	1K Ω	
R3051	ERJ6GEYJ750V	S.M.CARB	0.1W	5%	75 Ω	
R3052	ERJ3GEYJ562V	S.M.CARB	0.1W	5%	5K6 Ω	
R3053	ERJ6GEYJ750V	S.M.CARB	0.1W	5%	75 Ω	
R3054	ERJ3GEYJ562V	S.M.CARB	0.1W	5%	5K6 Ω	
R3055	ERJ6GEYJ750V	S.M.CARB	0.1W	5%	75 Ω	
R3056	ERJ6GEYJ750V	S.M.CARB	0.1W	5%	75 Ω	
R3057	ERJ3GEYJ102V	S.M.CARB	0.1W	5%	1K Ω	
R3059	ERJ3GEYJ102V	S.M.CARB	0.1W	5%	1K Ω	
R3061	ERJ6GEYJ750V	S.M.CARB	0.1W	5%	75 Ω	
R3062	ERJ3GEYJ102V	S.M.CARB	0.1W	5%	1K Ω	
R3064	ERJ3GEYJ102V	S.M.CARB	0.1W	5%	1K Ω	
R3065	ERJ6GEYJ750V	S.M.CARB	0.1W	5%	75 Ω	
R3066	ERJ6GEYJ750V	S.M.CARB	0.1W	5%	75 Ω	
R3067	ERJ3GEYJ102V	S.M.CARB	0.1W	5%	1K Ω	
R3069	ERJ6GEYJ102V	S.M.CARB	0.1W	5%	1K Ω	
R3074	ERJ3GEYJ101V	S.M.CARB	0.1W	5%	100 Ω	
R3075	ERJ3GEYJ101V	S.M.CARB	0.1W	5%	100 Ω	
R3084	ERJ6GEY0R00V	S.M.CARB	0.1W		0 Ω	
R3085	ERJ6GEY0R00V	S.M.CARB	0.1W		0 Ω	
R3088	ERJ3GEY0R00V	S.M.CARB	0.1W		0 Ω	
R3089	ERJ3GEYJ102V	S.M.CARB	0.1W	5%	1K Ω	
R3091	ERJ3GEYJ750V	S.M.CARB	0.1W	5%	75 Ω	
R3092	ERJ3GEY0R00V	S.M.CARB	0.1W		0 Ω	
R3093	ERJ3GEYJ391V	S.M.CARB	0.1W	5%	390 Ω	
R3094	ERJ3GEY0R00V	S.M.CARB	0.1W		0 Ω	
R3095	ERJ3GEYJ391V	S.M.CARB	0.1W	5%	390 Ω	
R3105	ERJ3GEYJ153V	S.M.CARB	0.1W	5%	15K Ω	
R3106	ERJ3GEYJ682V	S.M.CARB	0.1W	5%	6K8 Ω	
R3107	ERJ3GEY0R00V	S.M.CARB	0.1W		0 Ω	
R3108	ERJ6GEYJ102V	S.M.CARB	0.1W	5%	1K Ω	
R3109	ERJ6GEYJ750V	S.M.CARB	0.1W	5%	75 Ω	
R3110	ERJ3GEYJ123V	S.M.CARB	0.1W	5%	12K Ω	
R3111	ERJ3GEYJ682V	S.M.CARB	0.1W	5%	6K8 Ω	
R3112	ERJ3GEYJ101V	S.M.CARB	0.1W	5%	100 Ω	
R3114	ERJ3GEY0R00V	S.M.CARB	0.1W		0 Ω	
R3115	ERJ6GEYJ102V	S.M.CARB	0.1W	5%	1K Ω	
R3116	ERJ6GEYJ750V	S.M.CARB	0.1W	5%	75 Ω	
R3117	ERJ3GEYJ101V	S.M.CARB	0.1W	5%	100 Ω	
R3118	ERJ3GEY0R00V	S.M.CARB	0.1W		0 Ω	
R3119	ERJ6GEYJ102V	S.M.CARB	0.1W	5%	1K Ω	
R3120	ERJ6GEYJ750V	S.M.CARB	0.1W	5%	75 Ω	

Cct Ref	Parts Number	Description				
R3121	ERJ3GEYJ103V	S.M.CARB	0.1W	5%	10K Ω	
R3122	ERJ3GEYJ103V	S.M.CARB	0.1W	5%	10K Ω	
R3123	ERJ3GEYJ474V	S.M.CARB	0.1W	5%	470K Ω	
R3124	ERJ3GEYJ474V	S.M.CARB	0.1W	5%	470K Ω	
R3125	ERJ3GEYJ103V	S.M.CARB	0.1W	5%	10K Ω	
R3126	ERJ3GEYJ103V	S.M.CARB	0.1W	5%	10K Ω	
R3127	ERJ3GEYJ474V	S.M.CARB	0.1W	5%	470K Ω	
R3128	ERJ3GEYJ474V	S.M.CARB	0.1W	5%	470K Ω	
R3201	ERJ6GEYJ103V	S.M.CARB	0.1W	5%	10K Ω	
R3202	ERJ6GEYJ103V	S.M.CARB	0.1W	5%	10K Ω	
R3203	ERDS1TJ151T	CARBON	0.5W	5%	150 Ω	
R3208	ERDS1TJ151T	CARBON	0.5W	5%	150 Ω	
R3212	ERJ6GEYJ101V	S.M.CARB	0.1W	5%	100 Ω	
R3213	ERJ6GEYJ101V	S.M.CARB	0.1W	5%	100 Ω	
R3214	ERJ6GEYJ153V	S.M.CARB	0.1W	5%	15K Ω	
R3215	ERJ6GEYJ153V	S.M.CARB	0.1W	5%	15K Ω	
R3301	ERJ6GEY0R00V	S.M.CARB	0.1W		0 Ω	
R3303	ERJ3GEY0R00V	S.M.CARB	0.1W		0 Ω	
R3304	ERJ3GEYJ221V	S.M.CARB	0.1W	5%	220 Ω	
R3305	ERJ3GEYJ750V	S.M.CARB	0.1W	5%	75 Ω	
R3306	ERJ3GEYJ102V	S.M.CARB	0.1W	5%	1K Ω	
R3307	ERJ3GEYJ221V	S.M.CARB	0.1W	5%	220 Ω	
R3308	ERJ3GEYJ750V	S.M.CARB	0.1W	5%	75 Ω	
R3309	ERJ3GEYJ102V	S.M.CARB	0.1W	5%	1K Ω	
R3311	ERJ6ENF82R0V	S.M.CARB	0.1W	1%	82 Ω	
R3312	ERJ6ENF82R0V	S.M.CARB	0.1W	1%	82 Ω	
R3313	ERJ6ENF82R0V	S.M.CARB	0.1W	1%	82 Ω	
R3354	ERJ6GEYJ102V	S.M.CARB	0.1W	5%	1K Ω	
R3355	ERJ6GEYJ391V	S.M.CARB	0.1W	5%	390 Ω	
R3356	ERJ6GEYJ681V	S.M.CARB	0.1W	5%	680 Ω	
R3357	ERJ6GEYJ681V	S.M.CARB	0.1W	5%	680 Ω	
R3358	ERJ6GEYJ681V	S.M.CARB	0.1W	5%	680 Ω	
R3362	ERJ6GEYJ102V	S.M.CARB	0.1W	5%	1K Ω	
R3363	ERJ6GEYJ102V	S.M.CARB	0.1W	5%	1K Ω	
R3364	ERJ6GEYJ102V	S.M.CARB	0.1W	5%	1K Ω	
R3801	ERJ6GEYJ123V	S.M.CARB	0.1W	5%	12K Ω	
R3803	ERDS1TJ751V	CARBON	0.5W	5%	750 Ω	
R3805	ERG2SJS270H	METAL	2W	5%	27 Ω	
R3810	ERJ6GEYJ822V	S.M.CARB	0.1W	5%	8K2 Ω	
<b>CAPACITORS</b>						
C107	ECJ2VF1H104Z	S.M.CAP	50V		100nF	
C108	ECA1CM100B	ELECT	16V		10μF	
C110	ECJ2VB1H103K	S.M.CAP	50V		10nF	
C111	ECA1HMR33B	ELECT	50V		330nF	
C117	ECJ2VB1H103K	S.M.CAP	50V		10nF	
C118	ECJ2VF1H104Z	S.M.CAP	50V		100nF	
C119	ECA1CM221B	ELECT	16V		220μF	
C122	ECJ2FB1H104K	S.M.CAP	50V		100nF	
C130	ECJ2VB1H103K	S.M.CAP	50V		10nF	
C131	ECJ2VB1C104K	S.M.CAP	16V		100nF	
C137	ECJ2VC1H100D	S.M.CAP	50V		10pF	
C138	ECJ2VC1H220J	S.M.CAP	50V		22pF	
C141	ECJ2VB1H103K	S.M.CAP	50V		10nF	
C142	ECJ2FB1H104K	S.M.CAP	50V		100nF	
C251	ECA1HM010B	ELECT	50V		1μF	
C252	ECA1HM010B	ELECT	50V		1μF	
C253	ECA1HM4R7B	ELECT	50V		4.7μF	
C254	ECJ2VB1H472K	S.M.CAP	50V		4.7nF	
C255	ECA1HM4R7B	ELECT	50V		4.7μF	
C256	ECJ2VB1H472K	S.M.CAP	50V		4.7nF	
C259	ECA1EM220B	ELECT	25V		22μF	
C260	ECA1EM220B	ELECT	25V		22μF	
C261	ECQV1H154JL3	FILM	50V		150nF	
C262	ECQV1H154JL3	FILM	50V		150nF	
C263	ECA1HM101B	ELECT	50V		100μF	
C264	ECQV1H683JL3	FILM	50V		68nF	

Cct Ref	Parts Number	Description			
C265	ECQV1H683JL3	FILM	50V	68nF	
C266	ECJ2FB1H104K	S.M.CAP	50V	100nF	
C267	ECJ2FB1H104K	S.M.CAP	50V	100nF	
C269	ECA1HM332E	ELECT	50V	3300µF	
C350	ECJ2VC1H102J	S.M.CAP	50V	1nF	
C352	ECJ2VF1H224Z	S.M.CAP	50V	220nF	
C353	ECJ2YB1H104K	S.M.CAP	50V	100nF	
C354	ECQE2104KF3	FILM	250V	100nF	
C355	ECKR2H102KB5	CERAMIC	500V	1nF	
C358	ECJ2VC1H222J	S.M.CAP	50V	2.2nF	
C359	CL21C030CBNC	CERAMIC	50V	3pF	
C360	ECJ2VC1H102J	S.M.CAP	50V	1nF	
C362	ECJ2VF1H224Z	S.M.CAP	50V	220nF	
C363	ECJ2YB1H104K	S.M.CAP	50V	100nF	
C364	ECQE2104KF3	FILM	250V	100nF	
C365	ECKR2H102KB5	CERAMIC	500V	1nF	
C368	ECJ2VC1H222J	S.M.CAP	50V	2.2nF	
C369	CL21C220JBNC	CERAMIC	50V	22pF	
C370	ECJ2VC1H102J	S.M.CAP	50V	1nF	
C372	ECJ2VF1H224Z	S.M.CAP	50V	220nF	
C373	ECJ2YB1H104K	S.M.CAP	50V	100nF	
C374	ECQE2104KF3	FILM	250V	100nF	
C375	ECKR2H102KB5	CERAMIC	500V	1nF	
C378	ECJ2VC1H222J	S.M.CAP	50V	2.2nF	
C381	SMG1CV101MT5	ELECT	16V	100µF	
C382	ECA1CM471B	ELECT	16V	470µF	
C383	ECJ2VB1H103K	S.M.CAP	50V	10nF	
C384	ECQE2104KFW	FILM	250V	100nF	
C385	ECA2EM220B	ELECT	250V	22µF	
C386	ECKW3D152JBR	CERAMIC	2KV	1.5nF	
C395	ECA1HMR47B	ELECT	50V	470nF	
C451	ECJ2VB1H102K	S.M.CAP	50V	1nF	
C456	KMG1HV221MT5	ELECT	50V	220µF	
C459	ECQB1224KFW	FILM	100V	220nF	
C463	ECA1HM221B	ELECT	50V	220µF	
C501	ECA1EM101B	ELECT	25V	100µF	
C508	ECQB1H103JF3	FILM	50V	10nF	
C509	SMG1VV470MT5	ELECT	35V	47µF	
C551	ECKW3D271JBR	CERAMIC	2kV	270pF	
C552	ECWH20102JVY	FILM	2kV	1nF	
C557	ECKR2H471KB5	CERAMIC	500V	470pF	
C558	ECA1HHG471B	ELECT	50V	470µF	
C559	ECJ2FB1H104K	S.M.CAP	50V	100nF	
C560	ECQE2683KFW	FILM	250V	68nF	
C561	ECA1EM222E	ELECT	25V	2200µF	
C562	ECKR2H101KB5	CERAMIC	500V	100pF	
C563	ECA2EM220B	ELECT	250V	22µF	
C564	ECEA2AU2R2B	ELECT	100V	2.2µF	
C565	ECQB1H273JF3	FILM	50V	27nF	
C566	ECKR2H471KB5	CERAMIC	500V	470pF	
C567	ECA1HM102E	ELECT	50V	1000µF	
C568	ECKR2H471KB5	CERAMIC	500V	470pF	
C569	ECKR2H102KB5	CERAMIC	500V	1nF	
C573	CL21C221JBNC	CERAMIC	50V	220pF	
C574	CL21C221JBNC	CERAMIC	50V	220pF	
C588	ECWF4824JBB	FILM	400V	820nF	
C701	ECKR2H152KB5	CERAMIC	500V	1.5nF	
C702	ECQE1335KFB	FILM	100V	3.3µF	
C703	ECJ2VB1H333K	S.M.CAP	50V	33nF	
C704	ECQV1H474JL3	FILM	50V	470nF	
C706	ECKR2H471KB5	CERAMIC	500V	470pF	
C707	ECJ2VB1H471K	S.M.CAP	50V	470pF	
C708	ECJ2VB1H333K	S.M.CAP	50V	33nF	
C709	ECJ2VB1H333K	S.M.CAP	50V	33nF	
C801	222233820224	FILM	275V	220nF	⚠
C802	222233820224	FILM	275V	220nF	⚠

Cct Ref	Parts Number	Description			
C804	222233820154	FILM	275V	150nF	⚠
C806	ECKWNA101MB	CERAMIC	400V	100µF	⚠
C807	ECKW2H472PU7	CERAMIC	500V	4.7nF	
C808	ECKW2H472PU7	CERAMIC	500V	4.7nF	
C809	ECKW2H472PU7	CERAMIC	500V	4.7nF	
C810	ECKW2H472PU7	CERAMIC	500V	4.7nF	
C812	ECQE6823KFB	FILM	630V	82nF	
C813	ECKWAE472ZE	CERAMIC	500V	4.7nF	
C814	ECA2WM100E	ELECT	450V	10µF	
C815	ECKW3D392KBP	CERAMIC	2kV	3.9nF	
C816	ECQV1H104JL3	FILM	50V	0.1µF	
C817	ECKR1H101KB5	CERAMIC	50V	100pF	
C838	ECJ2VC1H151J	S.M.CAP	50V	150pF	
C839	ECKCWS332MEB	CERAMIC	250V	3.3nF	⚠
C842	ECQB1H821JF3	FILM	50V	820pF	
C843	ECKR1H471KB5	CERAMIC	50V	470pF	
C844	ECKW3D152KBP	CERAMIC	2KV	1.5nF	
C847	ECA1EM101B	ELECT	25V	100µF	
C849	43303S9227M5	ELECT	400V	220µF	
C855	ECJ2VB1H103K	S.M.CAP	50V	10nF	
C856	ECJ2VB1H103K	S.M.CAP	50V	10nF	
C865	ECA1HM100B	ELECT	50V	10µF	
C866	ECA1HM100B	ELECT	50V	10µF	
C867	ECA1CM222B	ELECT	16V	2200µF	
C868	ECA1CM471B	ELECT	16V	470µF	
C870	EEUFC1E102B	ELECT	25V	1000µF	
C871	ECKR2H471KB5	CERAMIC	500V	470pF	
C873	EEUFC1E102B	ELECT	25V	1000µF	
C874	ECKR2H471KB5	CERAMIC	500V	470pF	
C891	ECA1HM010B	ELECT	50V	1µF	
C892	ECA1CM100B	ELECT	16V	10µF	
C893	ECA2CHG101E	ELECT	160V	100µF	
C894	EEUEB2D101E	ELECT	200V	100µF	
C895	ECKW3D471KBP	CERAMIC	2KV	470pF	
C896	ECA1HHG102E	ELECT	50V	1nF	
C897	ECA1VHG331B	ELECT	35V	330pF	
C899	ECKR2H471KB5	CERAMIC	500V	470pF	
C902	ECA1VM101B	ELECT	35V	100µF	
C904	ECJ2VF1H103Z	S.M.CAP	50V	10nF	
C909	ECKR2H472MD5	CERAMIC	500V	4.7nF	
C910	ECKR2H472MD5	CERAMIC	500V	4.7nF	
C912	ECA2CM220B	ELECT	160V	22µF	
C917	ECA1HM100B	ELECT	50V	10µF	
C918	ECJ2VF1H103Z	S.M.CAP	50V	10nF	
C1002	SMG1CV101MT5	ELECT	16V	100µF	
C1003	ECJ2YB1H104K	S.M.CAP	50V	100nF	
C1004	ECJ2VB1H103K	S.M.CAP	50V	10nF	
C1005	SMG1CV101MT5	ELECT	16V	100µF	
C1006	ECJ2YB1H104K	S.M.CAP	50V	100nF	
C1007	ECJ2VC1H270J	S.M.CAP	50V	27pF	
C1101	ECJ1VF1E104Z	S.M.CAP	25V	100nF	
C1102	ECJ1VF1E104Z	S.M.CAP	25V	100nF	
C1103	ECJ1VF1E104Z	S.M.CAP	25V	100nF	
C1104	ECJ1VF1E104Z	S.M.CAP	25V	100nF	
C1105	F1J1A1050020	CERAMIC	16V	2.2µF	
C1106	ECJ1VF1E104Z	S.M.CAP	25V	100nF	
C1107	ECJ1VF1E104Z	S.M.CAP	25V	100nF	
C1108	ECJ1VF1E104Z	S.M.CAP	25V	100nF	
C1109	ECJ1VF1E104Z	S.M.CAP	25V	100nF	
C1110	F1J1A1050020	CERAMIC	16V	2.2µF	
C1111	ECJ1VC1H271J	S.M.CAP	50V	270pF	
C1112	ECJ1VF1E104Z	S.M.CAP	25V	100nF	
C1113	ECEA1AKA101B	ELECT	10V	100µF	
C1114	ECEA1CKA100B	ELECT	16V	10µF	
C1115	ECJ1VF1E104Z	S.M.CAP	25V	100nF	
C1116	ECJ1VF1E104Z	S.M.CAP	25V	100nF	

Cct Ref	Parts Number	Description		
C1117	ECJ1VF1E104Z	S.M.CAP	25V	100nF
C1118	ECJ1VB1H472K	S.M.CAP	50V	4.7nF
C1119	ECJ1VF1E104Z	S.M.CAP	25V	100nF
C1120	ECJ1VF1E104Z	S.M.CAP	25V	100nF
C1121	ECJ1VF1E104Z	S.M.CAP	25V	100nF
C1122	ECJ1VF1E104Z	S.M.CAP	25V	100nF
C1123	ECJ1VF1E104Z	S.M.CAP	25V	100nF
C1124	ECJ1VF1E104Z	S.M.CAP	25V	100nF
C1125	ECJ1VF1E104Z	S.M.CAP	25V	100nF
C1126	ECJ1VF1E104Z	S.M.CAP	25V	100nF
C1127	ECJ1VF1E104Z	S.M.CAP	25V	100nF
C1128	ECJ1VF1E104Z	S.M.CAP	25V	100nF
C1129	ECJ1VF1E104Z	S.M.CAP	25V	100nF
C1130	ECJ1VF1E104Z	S.M.CAP	25V	100nF
C1131	ECJ1VC1H220J	S.M.CAP	50V	22pF
C1132	ECJ1VC1H220J	S.M.CAP	50V	22pF
C1133	ECJ1VF1E104Z	S.M.CAP	25V	100nF
C1134	ECJ1VF1E104Z	S.M.CAP	25V	100nF
C1135	ECJ1VF1E104Z	S.M.CAP	25V	100nF
C1136	ECJ1VF1E104Z	S.M.CAP	25V	100nF
C1138	ECJ1VC1H221J	S.M.CAP	50V	220pF
C1139	ECJ1VC1H221J	S.M.CAP	50V	220pF
C1140	ECJ1VF1E104Z	S.M.CAP	25V	100nF
C1142	ECJ1VC1H151J	S.M.CAP	50V	150pF
C1145	ECJ1VF1E104Z	S.M.CAP	25V	100nF
C1146	ECEA1CKA100B	ELECT	16V	10μF
C1150	ECJ1VF1E104Z	S.M.CAP	25V	100nF
C1151	ECJ1VB1H102K	S.M.CAP	50V	1nF
C1155	ECJ1VB1C473K	S.M.CAP	16V	47nF
C1156	ECJ1VF1E104Z	S.M.CAP	25V	100nF
C1157	ECJ2VF1C105Z	S.M.CAP	16V	1μF
C1159	ECEA1CKA100B	ELECT	16V	10μF
C1160	ECEA1AKA101B	ELECT	10V	100μF
C1161	ECEA1AKA101B	ELECT	10V	100μF
C1162	ECEA1AKA101B	ELECT	10V	100μF
C1163	ECEA1AKA221Q	ELECT	10V	220μF
C1164	ECEA1AKA101B	ELECT	10V	100μF
C1165	ECJ2VF1C105Z	S.M.CAP	16V	1μF
C1166	ECJ1VF1E104Z	S.M.CAP	25V	100nF
C1167	ECEA1AKA101B	ELECT	10V	100μF
C1168	ECJ1VF1E104Z	S.M.CAP	25V	100nF
C1169	ECEA1AKA101B	ELECT	10V	100μF
C1170	ECEA1AKA101B	ELECT	10V	100μF
C1171	F1J1A1050020	CERAMIC	16V	2.2μF
C1177	ECJ1VB1H102K	S.M.CAP	50V	1nF
C1178	ECJ1VB1H102K	S.M.CAP	50V	1nF
C1179	ECJ1VB1H102K	S.M.CAP	50V	1nF
C1180	ECJ1VC1H271J	S.M.CAP	50V	270pF
C1181	ECJ1VC1H271J	S.M.CAP	50V	270pF
C1182	ECJ1VC1H271J	S.M.CAP	50V	270pF
C1183	ECJ1VC1H271J	S.M.CAP	50V	270pF
C1184	ECJ1VC1H271J	S.M.CAP	50V	270pF
C1185	ECJ1VC1H271J	S.M.CAP	50V	270pF
C1188	ECJ1VF1H103Z	S.M.CAP	50V	10nF
C1189	ECJ1VF1H103Z	S.M.CAP	50V	10nF
C1190	ECJ1VF1H103Z	S.M.CAP	50V	10nF
C1191	ECJ1VF1H103Z	S.M.CAP	50V	10nF
C1192	ECJ1VF1H103Z	S.M.CAP	50V	10nF
C1501	ECJ1VC1H220J	S.M.CAP	50V	22pF
C1502	ECJ1VC1H220J	S.M.CAP	50V	22pF
C1503	ECJ1VF1E104Z	S.M.CAP	25V	100nF
C1504	ECJ2VF1C105Z	S.M.CAP	16V	1μF
C1505	ECJ2VF1C105Z	S.M.CAP	16V	1μF
C1506	ECJ1VF1E104Z	S.M.CAP	25V	100nF
C1507	ECJ1VF1E104Z	S.M.CAP	25V	100nF
C1508	ECJ2VF1C105Z	S.M.CAP	16V	1μF

Cct Ref	Parts Number	Description		
C1509	ECJ2VF1C105Z	S.M.CAP	16V	1μF
C1510	ECJ1VF1E104Z	S.M.CAP	25V	100nF
C1511	ECJ1VF1E104Z	S.M.CAP	25V	100nF
C1512	ECJ1VF1E104Z	S.M.CAP	25V	100nF
C1513	ECJ2VF1C105Z	S.M.CAP	16V	1μF
C1514	ECJ1VF1E104Z	S.M.CAP	25V	100nF
C1515	ECEA1CKA100B	ELECT	16V	10μF
C1516	ECJ1VB1H103K	S.M.CAP	50V	10nF
C1517	ECJ2VF1C105Z	S.M.CAP	16V	1μF
C1518	ECJ1VF1E104Z	S.M.CAP	25V	100nF
C1519	ECEA1CKA100B	ELECT	16V	10μF
C1520	ECJ1VB1H103K	S.M.CAP	50V	10nF
C1521	ECJ2VF1C105Z	S.M.CAP	16V	1μF
C1522	ECJ1VF1E104Z	S.M.CAP	25V	100nF
C1523	ECJ2VF1C105Z	S.M.CAP	16V	1μF
C1524	ECJ1VF1E104Z	S.M.CAP	25V	100nF
C1525	ECJ1VF1E104Z	S.M.CAP	25V	100nF
C1526	ECJ2VF1C105Z	S.M.CAP	16V	1μF
C1527	ECJ2VF1C105Z	S.M.CAP	16V	1μF
C1528	ECJ1VF1E104Z	S.M.CAP	25V	100nF
C1529	ECJ2VF1C105Z	S.M.CAP	16V	1μF
C1530	ECJ1VF1E104Z	S.M.CAP	25V	100nF
C1531	ECJ2VF1C105Z	S.M.CAP	16V	1μF
C1532	ECJ1VF1E104Z	S.M.CAP	25V	100nF
C1533	ECJ1VB1H103K	S.M.CAP	50V	10nF
C1534	ECJ2VF1C105Z	S.M.CAP	16V	1μF
C1535	ECJ1VF1E104Z	S.M.CAP	25V	100nF
C1536	ECJ2VF1C105Z	S.M.CAP	16V	1μF
C1537	ECJ1VF1E104Z	S.M.CAP	25V	100nF
C1538	ECJ2VF1C105Z	S.M.CAP	16V	1μF
C1539	ECJ1VF1E104Z	S.M.CAP	25V	100nF
C1543	ECJ2YB1H104K	S.M.CAP	50V	100nF
C1544	ECJ2YB1H104K	S.M.CAP	50V	100nF
C1545	ECEA1AKA101B	ELECT	10V	100μF
C1562	ECEA1HKAR33B	ELECT	50V	0.33μF
C1563	ECEA1CKA220B	ELECT	16V	22μF
C1573	ECJ1VB1C473K	S.M.CAP	16V	47nF
C1574	ECJ1VB1C473K	S.M.CAP	16V	47nF
C1575	ECJ1VB1C473K	S.M.CAP	16V	47nF
C1577	ECJ1VB1H103K	S.M.CAP	50V	10nF
C1701	ECJ1VC1H270J	S.M.CAP	50V	27pF
C1702	ECJ1VC1H270J	S.M.CAP	50V	27pF
C1703	ECJ1VC1H271J	S.M.CAP	50V	270pF
C1704	ECJ1VC1H561J	S.M.CAP	50V	560pF
C1705	ECJ1VB1H222K	S.M.CAP	50V	2.2nF
C1706	ECEA1AKA101B	ELECT	10V	100μF
C1707	ECJ1VC1H270J	S.M.CAP	50V	27pF
C1709	ECJ2VF1C105Z	S.M.CAP	16V	1μF
C1710	ECJ1VB1H153K	S.M.CAP	50V	15nF
C1711	ECJ1VB1H682K	S.M.CAP	50V	6.8nF
C1713	ECEA1CKA100B	ELECT	16V	10μF
C1714	ECJ1VF1E104Z	S.M.CAP	25V	100nF
C1715	ECEA1AKA101B	ELECT	10V	100μF
C1716	ECJ1VB1H222K	S.M.CAP	50V	2.2nF
C1717	ECJ1VC1H561J	S.M.CAP	50V	560pF
C1718	ECJ1VC1H271J	S.M.CAP	50V	270pF
C1719	ECJ1VB1H103K	S.M.CAP	50V	10nF
C1720	ECJ1VB1H103K	S.M.CAP	50V	10nF
C1721	ECJ1VB1H103K	S.M.CAP	50V	10nF
C1722	ECJ1VB1H103K	S.M.CAP	50V	10nF
C1723	ECEA1CKA101B	ELECT	16V	100μF
C1724	ECJ1VB1H222K	S.M.CAP	50V	2.2nF
C1725	ECJ1VB1H103K	S.M.CAP	50V	10nF
C1726	ECJ1VB1H103K	S.M.CAP	50V	10nF
C1727	ECJ1VB1H103K	S.M.CAP	50V	10nF
C1728	ECJ1VB1H222K	S.M.CAP	50V	2.2nF











Cct Ref	Parts Number	Description		
C1729	ECJ1VC1H561J	S.M.CAP	50V	560pF
C1730	ECJ1VC1H271J	S.M.CAP	50V	270pF
C1731	ECJ1VF1E104Z	S.M.CAP	25V	100nF
C1732	ECJ1VF1E104Z	S.M.CAP	25V	100nF
C1733	ECJ1VF1E104Z	S.M.CAP	25V	100nF
C1734	ECJ1VC1H391J	S.M.CAP	50V	390pF
C1735	ECJ1VC1H391J	S.M.CAP	50V	390pF
C1736	ECJ1VC1H391J	S.M.CAP	50V	390pF
C1737	ECJ2VB1C224K	S.M.CAP	16V	220nF
C1738	ECJ2VF1C105Z	S.M.CAP	16V	1µF
C1739	ECEA1AKA221Q	ELECT	10V	220µF
C1740	ECJ1VB1H103K	S.M.CAP	50V	10nF
C1741	ECA1AM101B	ELECT	10V	100µF
C1742	ECEA1HKA3R3B	ELECT	50V	3.3µF
C1743	ECEA1HKA3R3B	ELECT	50V	3.3µF
C1752	ECJ1VB1H471K	S.M.CAP	50V	470pF
C1783	ECJ1VC1H151J	S.M.CAP	50V	150pF
C1901	ECJ2VB1H103K	S.M.CAP	50V	10nF
C1902	ECJ2YB1H104K	S.M.CAP	50V	100nF
C1905	ECA1CM470B	ELECT	16V	47µF
C1906	ECJ2VB1H103K	S.M.CAP	50V	10nF
C1907	ECA1CM470B	ELECT	16V	47µF
C1908	ECJ2YB1H104K	S.M.CAP	50V	100nF
C1909	ECJ2YB1H104K	S.M.CAP	50V	100nF
C2001	ECA1CM100B	ELECT	16V	10µF
C2002	ECJ2VB1H152K	S.M.CAP	50V	1.5nF
C2003	ECJ2VC1H471J	S.M.CAP	50V	470pF
C2004	CL21C221JBNC	CERAMIC	50V	220pF
C2005	ECJ2FB1H104K	S.M.CAP	50V	100nF
C2006	ECJ2VB1H102K	S.M.CAP	50V	1nF
C2007	ECJ2VB1H102K	S.M.CAP	50V	1nF
C2009	ECJ2VB1H102K	S.M.CAP	50V	1nF
C2010	ECJ2VB1H102K	S.M.CAP	50V	1nF
C2011	ECJ2VB1H102K	S.M.CAP	50V	1nF
C2012	ECA1CM100B	ELECT	16V	10µF
C2013	ECA1CM100B	ELECT	16V	10µF
C2014	ECJ2VC1H471J	S.M.CAP	50V	470pF
C2015	ECJ2VB1H152K	S.M.CAP	50V	1.5nF
C2016	ECA1HM100B	ELECT	50V	10µF
C2017	ECJ2VB1H102K	S.M.CAP	50V	1nF
C2018	ECJ2VB1H102K	S.M.CAP	50V	1nF
C2019	ECJ2VB1H102K	S.M.CAP	50V	1nF
C2020	ECJ2VB1H102K	S.M.CAP	50V	1nF
C2021	ECA1HM3R3B	ELECT	50V	3.3µF
C2022	ECJ2FB1H104K	S.M.CAP	50V	100nF
C2023	CL21C221JBNC	CERAMIC	50V	220pF
C2024	CL21C221JBNC	CERAMIC	50V	220pF
C2025	ECA1CM100B	ELECT	16V	10µF
C2026	ECJ2FB1H104K	S.M.CAP	50V	100nF
C2027	CL21C221JBNC	CERAMIC	50V	220pF
C2028	ECA1CM100B	ELECT	16V	10µF
C2029	ECJ2VB1H152K	S.M.CAP	50V	1.5nF
C2030	ECJ2VC1H471J	S.M.CAP	50V	470pF
C2031	ECJ2VC1H560J	S.M.CAP	50V	56pF
C2032	ECJ2VC1H470J	S.M.CAP	50V	47pF
C2034	ECJ2VC1H010C	S.M.CAP	50V	1pF
C2035	ECJ2VC1H010C	S.M.CAP	50V	1pF
C2037	ECA1CM102B	ELECT	16V	1000µF
C2038	ECA1CM471B	ELECT	16V	470µF
C2039	ECJ2VB1H103K	S.M.CAP	50V	10nF
C2040	ECJ2VB1H103K	S.M.CAP	50V	10nF
C2041	ECJ2VF1C334Z	S.M.CAP	16V	330nF
C2042	ECJ2VF1C334Z	S.M.CAP	16V	330nF
C2043	ECJ2VB1H103K	S.M.CAP	50V	10nF
C2044	ECA1CM102B	ELECT	16V	1000µF
C2045	ECA1CM331B	ELECT	16V	330µF

Cct Ref	Parts Number	Description		
C2351	ECA1CM470B	ELECT	16V	47µF
C2352	ECA1HM010B	ELECT	50V	1µF
C2353	ECA1HM010B	ELECT	50V	1µF
C2355	ECJ2VC1H101J	S.M.CAP	50V	100pF
C2356	ECJ2VC1H101J	S.M.CAP	50V	100pF
C2357	ECJ2VB1H103K	S.M.CAP	50V	10nF
C2358	ECA1HM100B	ELECT	50V	10µF
C2359	ECA1HM010B	ELECT	50V	1µF
C2360	ECA1HM010B	ELECT	50V	1µF
C2361	ECA1VM102B	ELECT	35V	1000µF
C2362	ECA1VM102B	ELECT	35V	1000µF
C2363	ECJ2VC1H102J	S.M.CAP	50V	1nF
C2364	ECJ2VC1H102J	S.M.CAP	50V	1nF
C2369	ECA1CM331B	ELECT	16V	330µF
C2370	ECA1CM102B	ELECT	16V	1000µF
C2371	SMG1CV101MT5	ELECT	16V	100µF
C3001	ECJ1VC1H561J	S.M.CAP	50V	560pF
C3002	ECJ1VC1H561J	S.M.CAP	50V	560pF
C3003	ECJ1VC1H561J	S.M.CAP	50V	560pF
C3005	ECJ1VC1H561J	S.M.CAP	50V	560pF
C3006	ECJ1VC1H561J	S.M.CAP	50V	560pF
C3007	ECJ1VC1H561J	S.M.CAP	50V	560pF
C3009	ECJ1VC1H561J	S.M.CAP	50V	560pF
C3010	ECJ1VC1H561J	S.M.CAP	50V	560pF
C3011	ECEA1CKA100B	ELECT	16V	10µF
C3012	ECJ1VC1H561J	S.M.CAP	50V	560pF
C3014	ECJ1VC1H561J	S.M.CAP	50V	560pF
C3015	ECJ1VC1H561J	S.M.CAP	50V	560pF
C3016	ECEA1CKA100B	ELECT	16V	10µF
C3017	ECJ1VC1H561J	S.M.CAP	50V	560pF
C3019	ECJ1VC1H561J	S.M.CAP	50V	560pF
C3020	ECJ1VC1H561J	S.M.CAP	50V	560pF
C3021	ECJ1VC1H561J	S.M.CAP	50V	560pF
C3023	ECJ1VC1H561J	S.M.CAP	50V	560pF
C3024	ECJ1VC1H561J	S.M.CAP	50V	560pF
C3025	ECJ1VC1H561J	S.M.CAP	50V	560pF
C3027	ECEA1CKA100B	ELECT	16V	10µF
C3028	ECEA1CKA100B	ELECT	16V	10µF
C3029	ECEA1CKA100B	ELECT	16V	10µF
C3030	ECEA1CKA100B	ELECT	16V	10µF
C3035	ECEA1CKA470B	ELECT	16V	47µF
C3036	ECEA1CKA470B	ELECT	16V	47µF
C3037	ECJ1VC1H101J	S.M.CAP	50V	100pF
C3038	ECJ1VC1H101J	S.M.CAP	50V	100pF
C3039	ECJ1VC1H101J	S.M.CAP	50V	100pF
C3040	ECJ1VC1H561J	S.M.CAP	50V	560pF
C3041	ECJ1VC1H561J	S.M.CAP	50V	560pF
C3042	ECJ1VC1H561J	S.M.CAP	50V	560pF
C3043	ECJ1VC1H561J	S.M.CAP	50V	560pF
C3044	ECJ1VB1C104K	S.M.CAP	16V	100nF
C3045	ECEA1CKA100B	ELECT	16V	10µF
C3046	ECEA1CKA100B	ELECT	16V	10µF
C3047	ECEA1CKA100B	ELECT	16V	10µF
C3048	ECEA1CKA100B	ELECT	16V	10µF
C3051	ECJ2VF1C105Z	S.M.CAP	16V	1µF
C3052	ECJ2VF1C105Z	S.M.CAP	16V	1µF
C3053	ECJ2VF1C105Z	S.M.CAP	16V	1µF
C3054	ECJ2VF1C105Z	S.M.CAP	16V	1µF
C3055	ECJ2VF1C105Z	S.M.CAP	16V	1µF
C3056	ECJ2VF1C105Z	S.M.CAP	16V	1µF
C3057	ECJ2VF1C105Z	S.M.CAP	16V	1µF
C3058	ECJ2VF1C105Z	S.M.CAP	16V	1µF
C3059	ECJ2VF1C105Z	S.M.CAP	16V	1µF
C3060	ECJ2VF1C105Z	S.M.CAP	16V	1µF
C3061	ECJ2VF1C105Z	S.M.CAP	16V	1µF
C3062	ECJ2VF1C105Z	S.M.CAP	16V	1µF



Cct Ref	Parts Number	Description		
C3063	ECJ2VF1C105Z	S.M.CAP	16V	1µF
C3064	ECJ2VF1C105Z	S.M.CAP	16V	1µF
C3065	ECJ2VF1C105Z	S.M.CAP	16V	1µF
C3066	ECJ2VF1C105Z	S.M.CAP	16V	1µF
C3067	ECJ2VF1C105Z	S.M.CAP	16V	1µF
C3068	ECJ2VF1C105Z	S.M.CAP	16V	1µF
C3069	ECJ2VF1C105Z	S.M.CAP	16V	1µF
C3071	ECJ2VF1C105Z	S.M.CAP	16V	1µF
C3072	ECJ2VF1C105Z	S.M.CAP	16V	1µF
C3073	ECJ2VF1C105Z	S.M.CAP	16V	1µF
C3074	ECJ2VF1C474Z	S.M.CAP	16V	470nF
C3076	ECEA1CKA100B	ELECT	16V	10µF
C3077	ECEA1CKA100B	ELECT	16V	10µF
C3078	ECEA1CKA470B	ELECT	16V	47µF
C3079	ECJ1VB1H103K	S.M.CAP	50V	10nF
C3080	ECEA1CKA100B	ELECT	16V	10µF
C3081	ECEA1CKA100B	ELECT	16V	10µF
C3083	ECEA1CKA100B	ELECT	16V	10µF
C3084	CL21B473KBNC	CERAMIC	50V	47nF
C3085	CL21B473KBNC	CERAMIC	50V	47nF
C3086	CL21B473KBNC	CERAMIC	50V	47nF
C3087	CL21B473KBNC	CERAMIC	50V	47nF
C3088	CL21B473KBNC	CERAMIC	50V	47nF
C3089	CL21B473KBNC	CERAMIC	50V	47nF
C3092	ECJ2VF1C105Z	S.M.CAP	16V	1µF
C3093	ECJ2VF1C105Z	S.M.CAP	16V	1µF
C3094	ECJ2VF1C105Z	S.M.CAP	16V	1µF
C3201	ECJ2VB1H103K	S.M.CAP	50V	10nF
C3202	ECJ2VB1H103K	S.M.CAP	50V	10nF
C3203	ECJ2VC1H561J	S.M.CAP	50V	560pF
C3204	ECJ2VC1H561J	S.M.CAP	50V	560pF
C3205	SMG1HV470MT5	ELECT	50V	47µF
C3206	SMG1HV470MT5	ELECT	50V	47µF
C3207	CL21C271JBNC	CERAMIC	50V	270pF
C3211	CL21C271JBNC	CERAMIC	50V	270pF
C3213	ECJ2VC1H561J	S.M.CAP	50V	560pF
C3214	ECJ2VC1H561J	S.M.CAP	50V	560pF
C3215	SMG1HV470MT5	ELECT	50V	47µF
C3216	SMG1HV470MT5	ELECT	50V	47µF
C3217	ECJ2VC1H561J	S.M.CAP	50V	560pF
C3218	ECJ2VC1H561J	S.M.CAP	50V	560pF
C3301	ECJ1VB1H103K	S.M.CAP	50V	10nF
C3302	ECEA1AKA330B	ELECT	10V	33µF
C3303	ECJ1VC1H271J	S.M.CAP	50V	270pF
C3304	ECJ1VC1H271J	S.M.CAP	50V	270pF
C3305	ECJ1VC1H221J	S.M.CAP	50V	220pF
C3306	ECJ1VC1H221J	S.M.CAP	50V	220pF
C3307	ECJ1VC1H221J	S.M.CAP	50V	220pF
C3308	ECJ1VC1H271J	S.M.CAP	50V	270pF
C3309	ECJ1VC1H271J	S.M.CAP	50V	270pF
C3310	ECJ1VC1H271J	S.M.CAP	50V	270pF
C3314	ECKR1H271KB5	CERAMIC	50V	270pF
C3315	ECKR1H271KB5	CERAMIC	50V	270pF
C3351	ECA1CM221B	ELECT	16V	220µF
C3801	ECJ2FB1H104K	S.M.CAP	50V	100nF
C3802	ECA1CM221B	ELECT	16V	220µF
C3803	ECJ2FB1H104K	S.M.CAP	50V	100nF
C3804	ECA1CM470B	ELECT	16V	47µF
C3806	ECA1HM101B	ELECT	50V	100µF
C3807	ECA1AHG332B	ELECT	10V	3.3nF
C3808	ECJ2FB1H104K	S.M.CAP	50V	100nF
C3809	ECA0JM221B	ELECT	6.3V	220µF
C3811	ECJ2FB1H104K	S.M.CAP	50V	100nF
C3812	SMG1CV101MT5	ELECT	16V	100µF
C3813	ECJ2VB1H103K	S.M.CAP	50V	10nF
C3814	ECJ2FB1H104K	S.M.CAP	50V	100nF

Cct Ref	Parts Number	Description			
C3815	SMG1CV101MT5	ELECT	16V	100µF	
C3816	ECJ2FB1H104K	S.M.CAP	50V	100nF	
C3817	SMG1CV101MT5	ELECT	16V	100µF	
C3818	ECJ2YB1H104K	S.M.CAP	50V	100nF	
C3819	ECA1AM472E	ELECT	10V	4700µF	
<b>TERMINALS AND LINKS</b>					
JK3001	350536400	SCART SOCKET			
JK3002	350536400	SCART SOCKET			
JK3003	350536400	SCART SOCKET			
JK3004	YKC21-5861N	RCA SOCKET			
JK3201	TJB8E027	AV TERMINAL			
<b>SWITCHES</b>					
S801	ESB92S11B	SWITCH			△
S1003	EVQ21405R	SWITCH			
S1004	EVQ21405R	SWITCH			
S1005	EVQ21405R	SWITCH			
S1006	EVQ21405R	SWITCH			
S1007	EVQ21405R	SWITCH			
<b>RELAYS</b>					
RL801	K6B1ADA00010	RELAY			△
RL803	K6B1ADA00010	RELAY			△
<b>DIFFERENCES FOR MODEL TX--28PS12</b>					
<b>EXPLODED VIEW</b>					
12	TNP8EA007BA	A P.C.B.			△
13	TKU0E0112	BACK COVER			△
14	W66EKT50X71	C.R.T.			△
15	TKY0E0116-1	CABINET			
16	TNP8ED005AQ	D P.C.B.			△
17	TLK8E05183	DEGAUSS COIL			△
19	ZTFN65004A	F.B.T.			△
20	TXJ/FC0DEG1	FOCUS LEAD ASSY			△
21	TNP8EL020AH	L P.C.B.			△
22	TBM0E0076	MODEL LABEL			
23	TBX0E80401	POWER BUTTON			
24	EASG12S500C2	SPEAKER			
<b>MISCELLANEOUS COMPONENTS</b>					
.	TPC0E42301	CARTON			
.	TPD0E0026	BOTTOM CUSHION			
.	TPD0E0027	TOP CUSHION			
<b>I.C.s</b>					
IC1104	D00/3EA	32K EAROM 24C3210PI2.7			
<b>COILS</b>					
L501	EXCELDR35C	COIL			
L582	ELC18B221L	COIL			
L584	ELH5L7727	COIL			
<b>RESISTORS</b>					
R355	ERG1FJ683P	METAL	1W	5%	68K Ω
R365	ERG1FJ683P	METAL	1W	5%	68K Ω
R375	ERG1FJ683P	METAL	1W	5%	68K Ω
R394	ERJ6GEYJ621V	S.M.CARB	0.125	5%	620 Ω
R396	ERJ6GEYJ621V	S.M.CARB	0.125	5%	620 Ω
R398	ERJ6GEYJ621V	S.M.CARB	0.125	5%	620 Ω
<b>CAPACITORS</b>					
C581	ECWF4624JBB	FILM	400V		620nF
C582	ECWF4514JBB	FILM	400V		510nF
C583	ECWH20512JVB	FILM	2kV		5.1nF
C584	ECWH20562JVB	FILM	2KV		5.6nF
C586	ECQF4153JZH	FILM	400V		15nF
C587	ECQF4153JZH	FILM	400V		15nF
C916	ECA2CM100B	ELECT	160V		10µF

Cct Ref	Parts Number	Description
<b>TERMINALS AND LINKS</b>		
JK381	330550049	CRT SOCKET 
<b>DIFFERENCES FOR MODEL TX--32PS12</b>		
<b>EXPLODED VIEW</b>		
12	TNP8EA007AY	A P.C.B. 
13	TKU8E00780	BACK COVER 
14	W76ELE50X71	C.R.T. 
15	TKY8E661-1	CABINET 
16	TNP8ED005AP	D P.C.B. 
17	TLK8E05186	DEGAUSS COIL 
18	TNPA1806AT	DF P.C.B. 
19	ZTFN56004A	F.B.T. 
20	TXJ/FCOCJEG	FOCUS LEAD ASSY 
21	TNP8EL020AG	L P.C.B. 
22	TBM0E0078	MODEL LABEL
23	TBX8E101	POWER BUTTON
24	EASG12S500A2	SPEAKER
<b>MISCELLANEOUS COMPONENTS</b>		
.	TPC0E42001-1	CARTON
.	TPD0E0032	BOTTOM CUSHION
.	TPD0E0033	TOP CUSHION
.	TPD0E1007	SUB CUSHION
<b>I.C.s</b>		
IC1104	D00/3DA	32K EAROM 24C3210PI2.7
<b>DIODES</b>		
D521	AU02AV0	DIODE
D522	AU02AV0	DIODE
D523	MA165TA5VT	DIODE
D524	MA165TA5VT	DIODE
D525	RP1HLFA5	DIODE
D526	RP1HLFA5	DIODE
<b>TRANSISTORS</b>		
Q521	2SK1006RF122	TRANSISTOR
Q522	2SC3311ASTA	TRANSISTOR
Q523	2SC3311ASTA	TRANSISTOR
Q524	2SC5460LB	TRANSISTOR
Q525	2SC3311ATA	TRANSISTOR
<b>TRANSFORMERS</b>		
T701	ETF18L101A	TRANSFORMER
<b>COILS</b>		
L521	LHL13NB182JB	COIL
L582	ELC18B331E	COIL
L584	ELH5L7719	COIL
<b>RESISTORS</b>		
R353	ERJ6GEY0R00V	S.M.CARB 0.1W 0 Ω
R355	ERG1SJ823P	METAL 1W 5% 82K Ω
R363	ERJ6GEY0R00V	S.M.CARB 0.1W 0 Ω
R365	ERG1SJ823P	METAL 1W 5% 82K Ω
R373	ERJ6GEY0R00V	S.M.CARB 0.1W 0 Ω
R375	ERG1SJ823P	METAL 1W 5% 82K Ω
R394	ERJ6GEYJ751V	S.M.CARB 0.1W 5% 750 Ω
R396	ERJ6GEYJ751V	S.M.CARB 0.1W 5% 750 Ω
R398	ERJ6GEYJ751V	S.M.CARB 0.1W 5% 750 Ω
R520	ERDS2TJ153T	CARBON 0.25W 5% 15K Ω
R521	ERG2FJS123D	METAL 2W 5% 12K Ω
R522	ERDS2TJ101T	CARBON 0.25W 5% 100 Ω
R523	ERDS2TJ103T	CARBON 0.25W 5% 10K Ω
R524	ERDS2TJ103T	CARBON 0.25W 5% 10K Ω
R525	ERDS2TJ102T	CARBON 0.25W 5% 1K Ω
R526	ERC14GK184V	SOLID 0.25W 10% 180K Ω
R527	ERC14GK224V	SOLID 0.25W 10% 220K Ω

Cct Ref	Parts Number	Description
R530	ERDS2TJ101T	CARBON 0.25W 5% 100 Ω
R531	ERC14GK334V	SOLID 0.25W 10% 330K Ω
R532	ERDS2TJ473T	CARBON 0.25W 5% 47K Ω
R533	ERG3FJS561D	METAL 3W 5% 560 Ω
R534	ERDS2TJ333T	CARBON 0.25W 5% 33K Ω
R535	ERG1FJS332D	METAL 1W 5% 3K3 Ω
R536	ERG3FJS681D	METAL 3W 5% 680 Ω
R537	ERC12GK104D	SOLID 0.5W 10% 100K Ω
R538	ERC14GK225V	SOLID 0.25W 10% 2M2 Ω
R540	ERDS2TJ560T	CARBON 0.25W 5% 56 Ω
R1793	ERJ3GEYJ153V	S.M.CARB 0.1W 5% 15K Ω
<b>CAPACITORS</b>		
C351	ECJ2VC1H070D	S.M.CAP 50V 7pF
C361	ECJ2VC1H070D	S.M.CAP 50V 7pF
C371	ECJ2VC1H070D	S.M.CAP 50V 7pF
C521	ECKR3A182KBP	CERAMIC 1KV 1.8nF
C522	ECKW3A272KBP	CERAMIC 1kV 2.7nF
C523	ECKR3A151KBP	CERAMIC 1KV 150pF
C524	ECQM6223JZW	FILM 630V 22nF
C525	ECQM4223JZW	FILM 400V 22nF
C526	ECKW3D101KBP	CERAMIC 2kV 100pF
C527	ECA1HM010B	ELECT 50V 1μF
C528	ECKW3D471KBP	CERAMIC 2KV 470pF
C529	ECA1HM100B	ELECT 50V 10μF
C530	ECKR3A681KBP	CERAMIC 1kV 680pF
C531	ECKW3D102KBP	CERAMIC 2KV 1nF
C581	ECWF4684JBB	FILM 400V 680nF
C582	ECWF4474JBB	FILM 400V 470nF
C583	ECWH20562JVB	FILM 2KV 5.6nF
C584	ECWH20622JVB	FILM 2KV 6.2nF
C586	ECQF4103JZH	FILM 400V 10nF
C587	ECQF4103JZH	FILM 400V 10nF
C916	ECA2CM220B	ELECT 160V 22μF
C1784	ECJ1VB1H103K	S.M.CAP 50V 10nF
<b>TERMINALS AND LINKS</b>		
JK381	330770044	CRT SOCKET 

# SCHEMATIC DIAGRAMS FOR MODELS TX-32PS12, TX-28PS12 (EURO-9L CHASSIS)



## IMPORTANT SAFETY NOTICE

Components identified by  mark have special characteristics important for safety. When replacing any of these components, use only manufacturers' specified parts.



### NOTE

1. RESISTOR  
All resistors are carbon 1/4W resistor, unless marked otherwise.  
Unit of resistance is OHM ( $\Omega$ ) (k=1,000, M=1,000,000)
2. CAPACITORS  
All capacitors are ceramic 50V unless marked otherwise.  
Unit of capacitance is  $\mu$ F unless otherwise stated.
3. COIL  
Unit of inductance is  $\mu$ H, unless otherwise stated.

4. TEST POINT  
 Test Point Position

5. EARTH SYMBOL  
 Chassis Earth (Cold)  
 Line Earth (Hot)

6. VOLTAGE MEASUREMENT  
Voltage is measured by a d.c. voltmeter.  
Measurement conditions are as follows:  
Power source            a.c. 220V-240V, 50Hz  
Receiving Signal        Colour Bar signal (RF)  
All customer controls    Maximum position

7.  
 Indicates the Video signal path  
 Indicates the Audio signal path

These schematic diagrams are the latest at time of printing and are subject to change without notice.

### REMARKS

- a. Do not touch the hot part, or the hot and cold parts at the same time, as you are liable to a shock hazard.
- b. Do not short circuit the hot and cold circuits as electrical components may be damaged.
- c. Do not connect an instrument, such as an oscilloscope, to the hot and cold circuits simultaneously as this may cause fuse failure. Connect the earth of the instruments to the earth connection of the circuit being measured.
- d. Make sure to disconnect the power plug before removing the chassis.

### NOTE

1. The Power Supply Circuit contains a circuit area, which uses a separate power supply to isolate the earth connection. The circuit is defined by HOT and COLD indications in the schematic diagram. All circuits, except the Power Circuit, are COLD.

NOTE :

DF BOARD IS USED ONLY FOR TX-32PS12 MODEL.

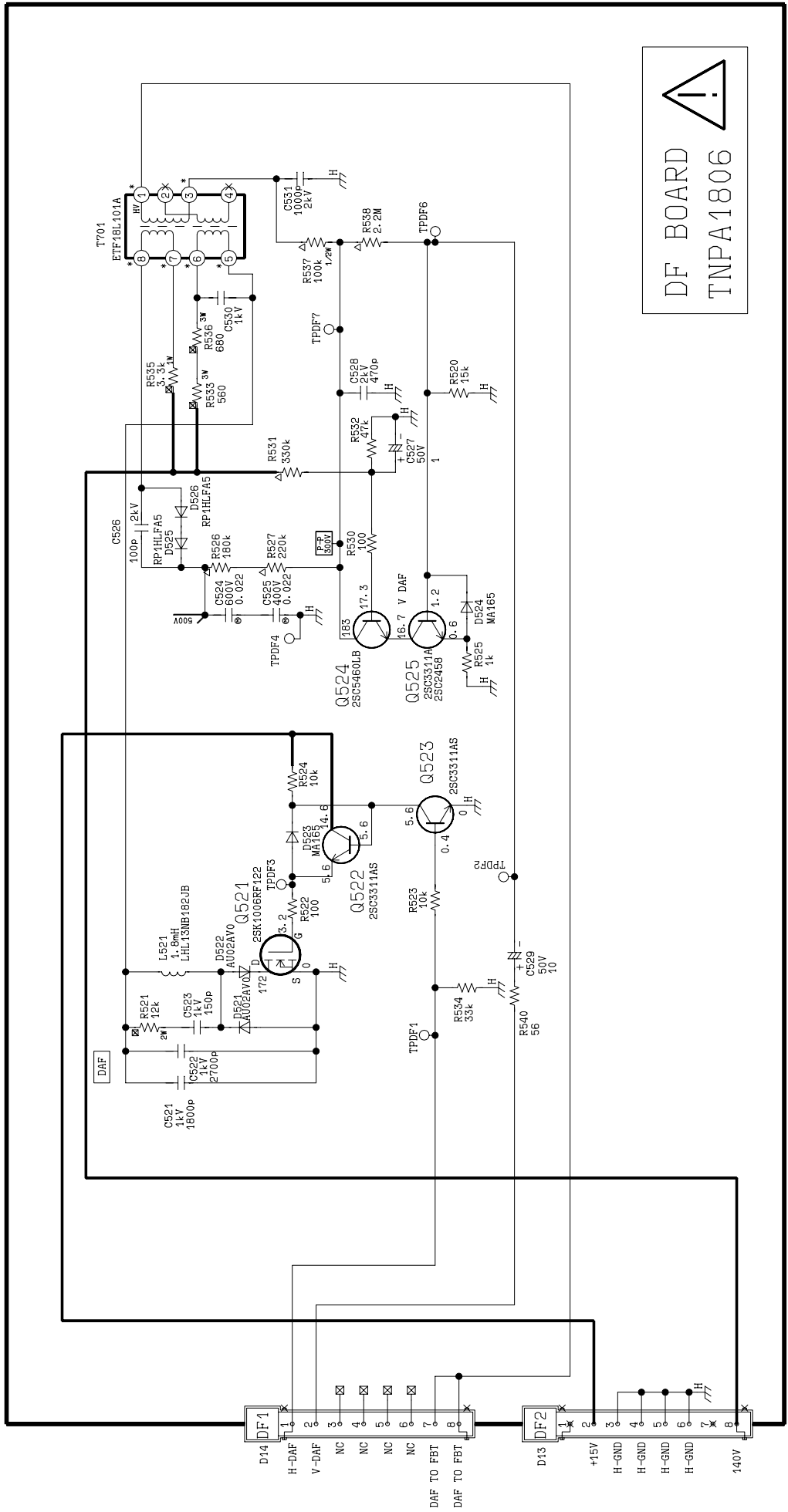

DF BOARD  
TNPA1806







NOTE :  
THE VALUES IN BRACKETS ( ) REFER TO TX-28PS12 MODEL.

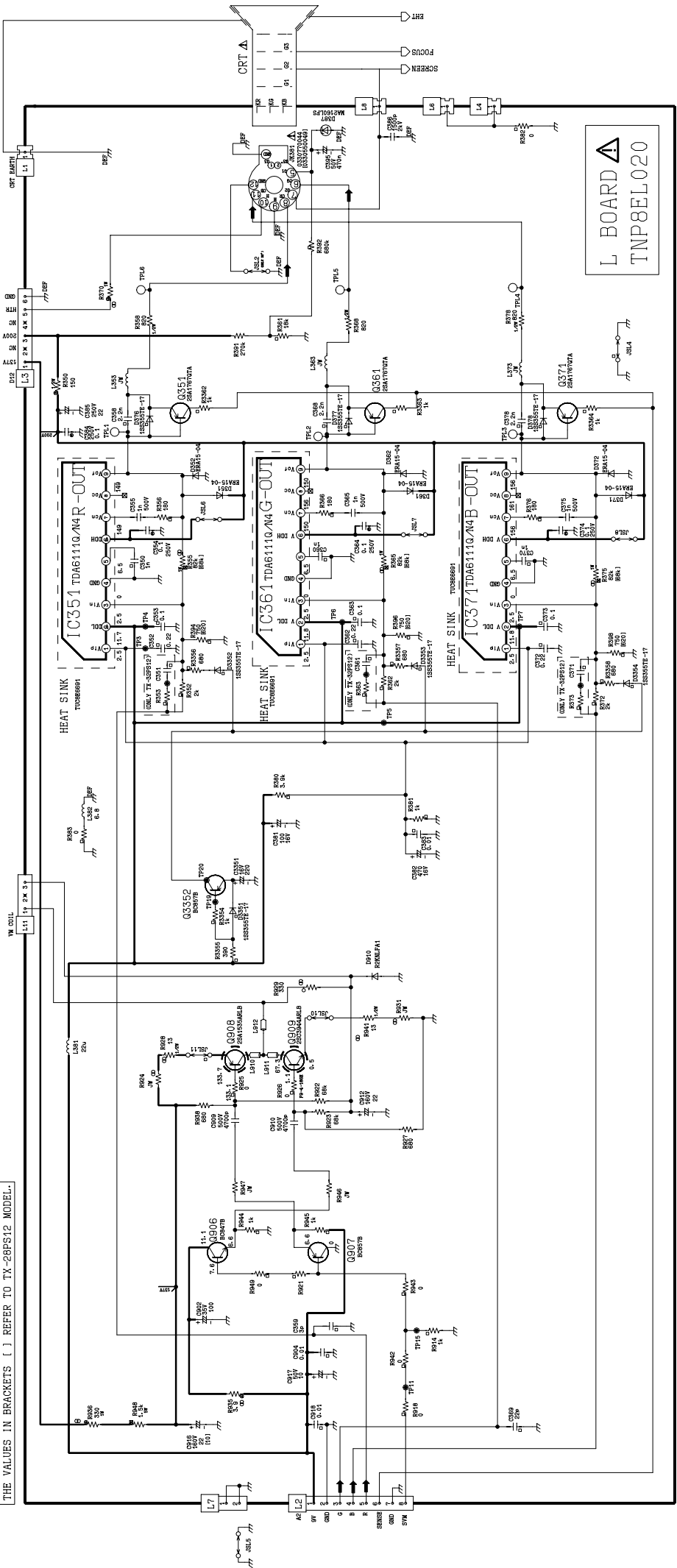

NOTE:  
THE VALUES IN BRACKETS ( ) REFER TO TX-28P812 MODEL.

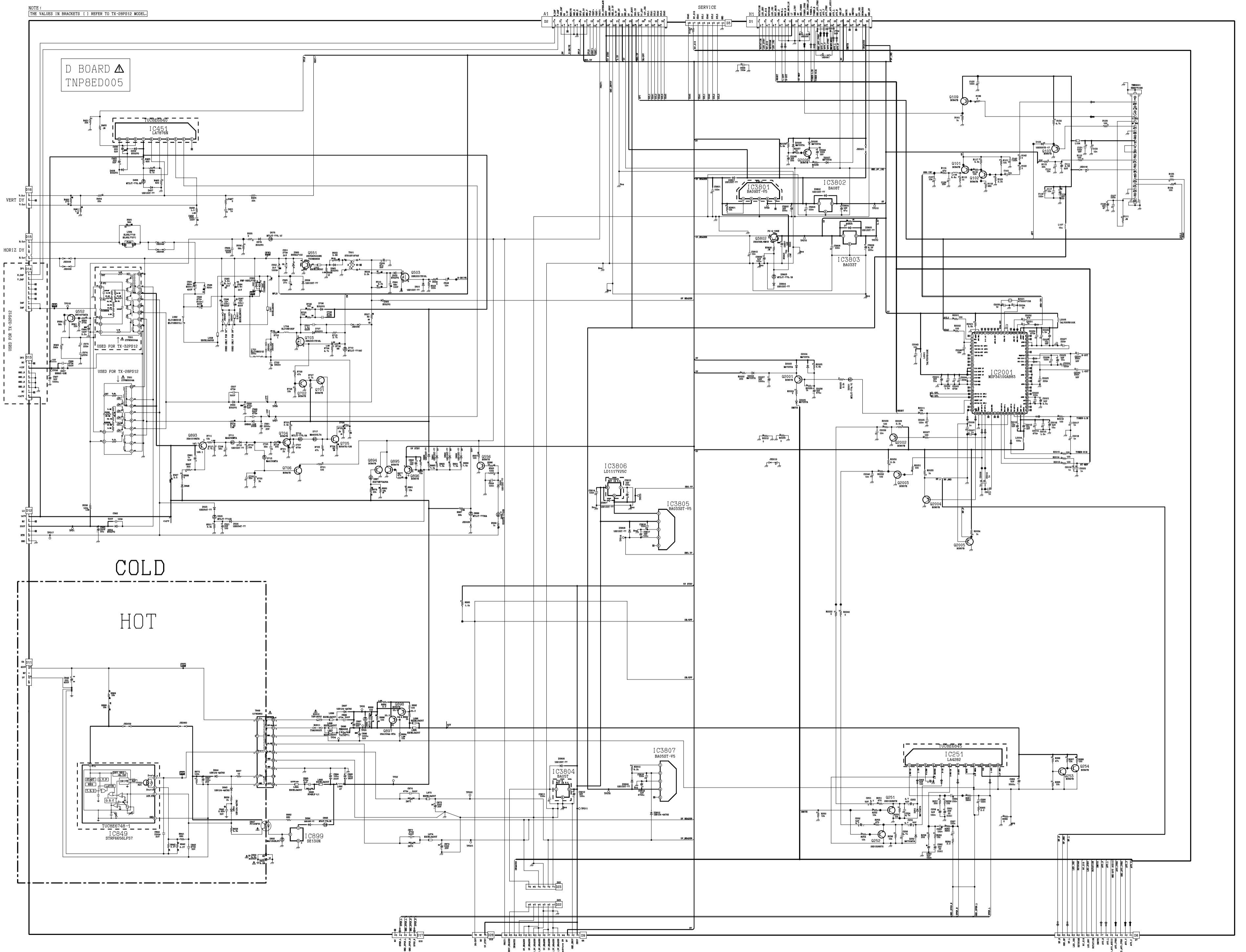

D BOARD  $\Delta$   
TNP8ED005

COLD

HOT

IC251  
LA4282

IC3804  
BA93ST

IC3807  
BA93ST-V5

IC3806  
LD117V25C

IC3805  
BA933ST-V5

IC2001  
MP9410GAB93

IC3802  
BA93ST

IC3801  
BA93ST-V5

IC451  
LA78763

IC849  
STRF6656LFS7

IC899  
SE130N

VERT DY

HORIZ DY

USED FOR TX-32P812

USED FOR TX-28P812

USED FOR TX-32P812

SERVICE

A1

D1

100V

100V



TNP8EG005  
G-BOARD

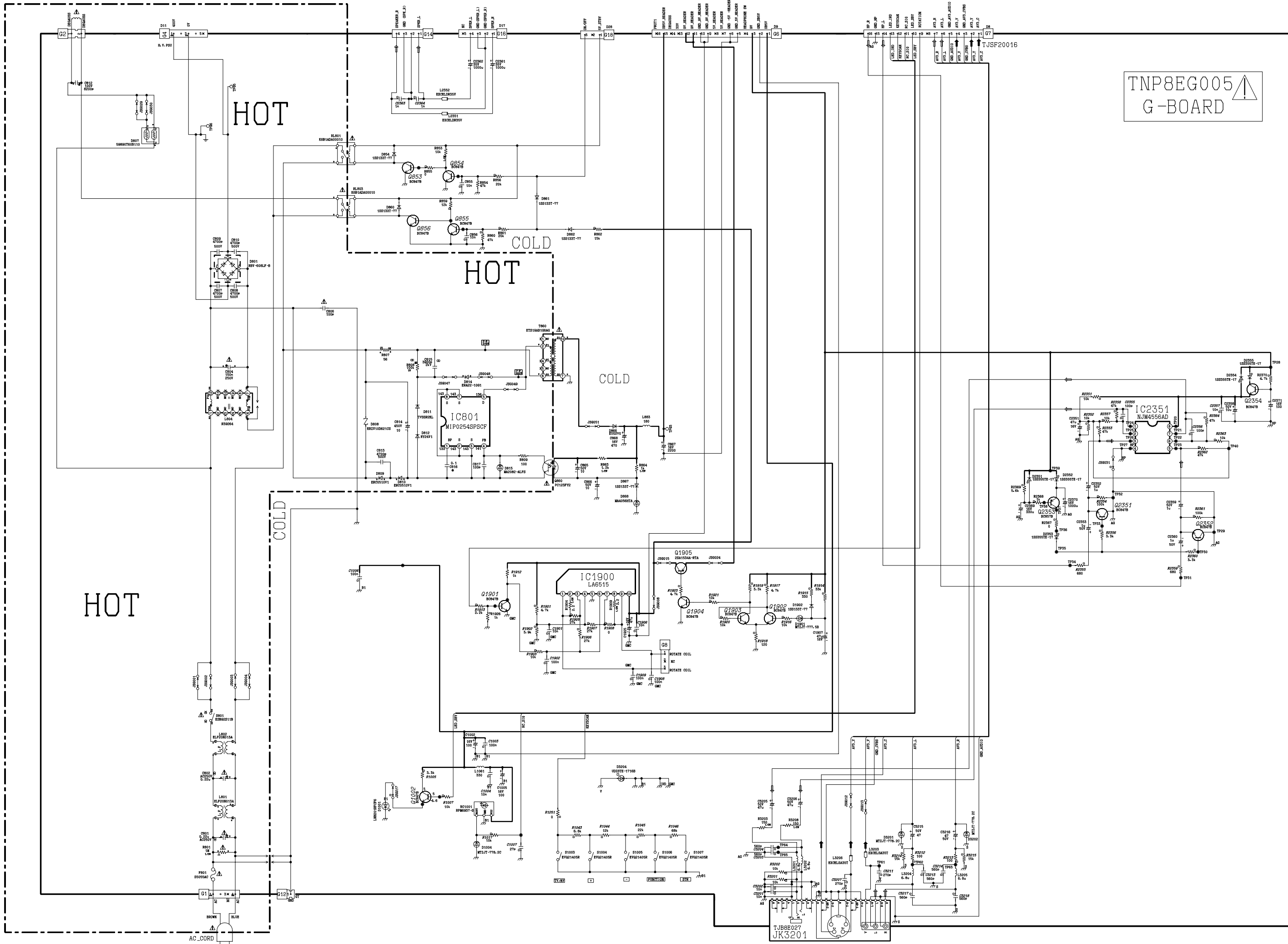

# CONDUCTOR VIEWS FOR MODELS TX-32PS12, TX-28PS12

## G - BOARD TNP8EG005

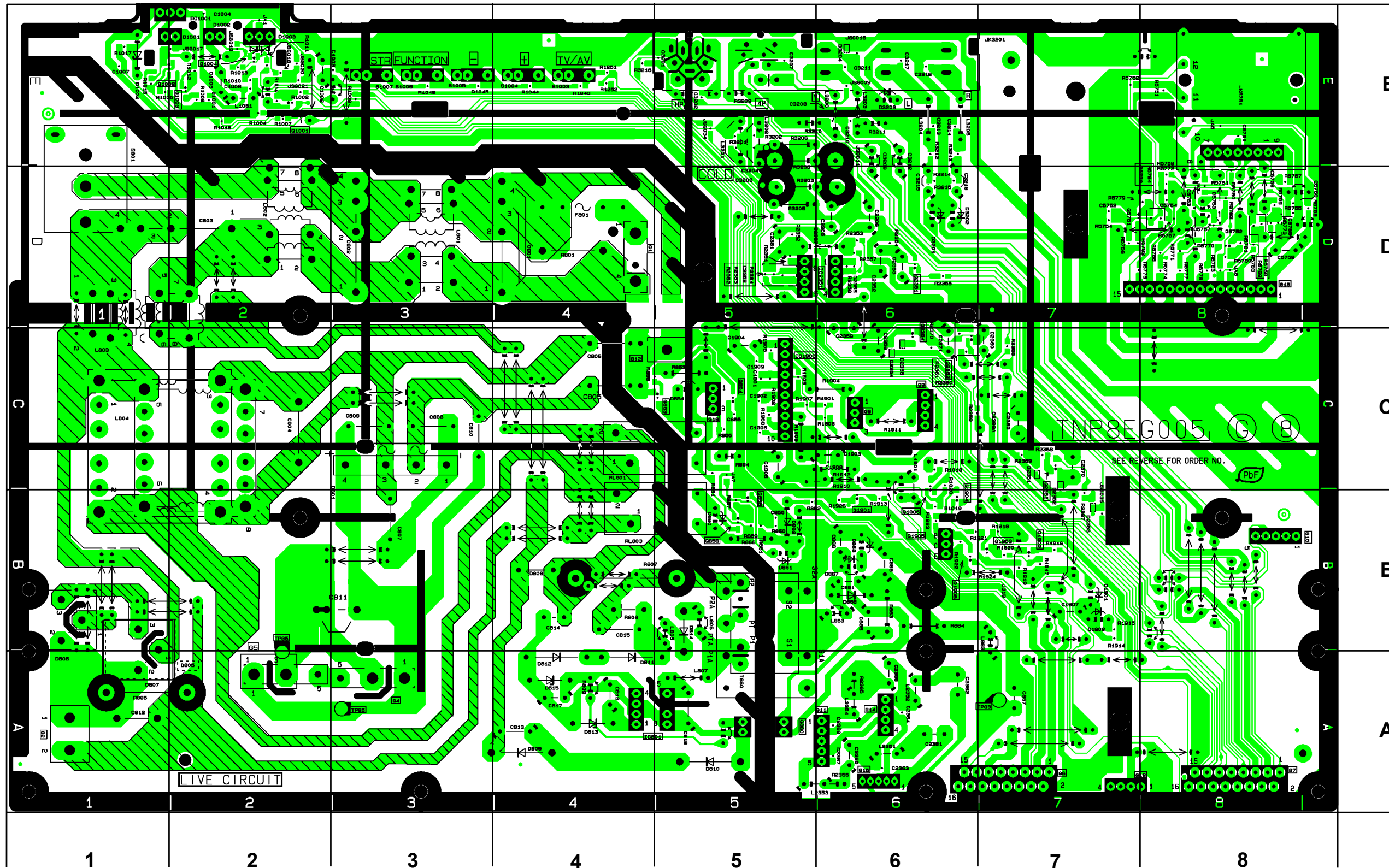

<b>TRAN'S</b>		D3201	D6
Q1002	E1	D3202	D6
Q1901	B6	D3204	E6
Q1902	B7	D801	C3
Q1903	B7	D807	A1
Q1904	B7	D808	B4
Q1905	B6	D809	A4
Q2351	D6	D811	A4
Q2352	C6	D812	A4
Q2353	C7	D815	A4
Q2354	C6	D854	C5
Q853	C5	D860	B5
Q854	C5	D861	B5
Q855	B5	D862	B5
Q856	B5	D866	B6
Q860	A5	D867	B6
		D868	B6
<b>DIODE</b>		<b>IC'S</b>	
D1001	E2	IC1900	C5
D1004	E1	IC2351	D6
D1901	B7	IC801	A4
D1902	B7		
D2351	C7	<b>TP'S</b>	
D2352	B7	TPG3	A7
D2353	B7	TPG5	A3
D2354	C6		
D2355	C6		

D - BOARD TNP8ED005

TRAN'S		D707	B7
Q101	C2	D710	B6
Q102	C2	D711	D6
Q103	C2	D712	D6
Q109	C1	D713	D5
Q2001	F2	D714	A6
Q2002	E2	D841	E7
Q2003	E1	D843	E7
Q2004	E1	D844	E7
Q2005	E1	D847	E6
Q2006	A1	D848	D6
Q251	E4	D870	F5
Q252	E4	D871	F5
Q253	F4	D884	F4
Q254	F4	D887	E4
Q3802	B3	D888	B4
Q503	D4	D889	B3
Q551	D5	D890	B3
		D891	B3
DIODE		D892	E6
D103	C2	D893	E5
D2001	E2	D894	E5
D2002	E2	D895	E5
D2003	E2	D896	F5
D2004	E2	D897	F5
D2005	F2	D899	E4
D2006	A1		
D2007	A2	IC'S	
D2008	A2	IC2001	D2
D251	E4	IC251	E3
D252	E4	IC3801	B2
D3801	B2	IC3802	B3
D3802	B3	IC3803	B4
D3803	B2	IC3804	C3
D3804	B3	IC3805	C3
D3805	B5	IC3806	C3
D3806	C3	IC3807	C3
D3807	C3	IC451	A7
D3808	D3	IC849	E7
D3809	C3	IC899	E5
D3812	C3		
D454	B7	TP'S	
D456	A7	TPD1	A8
D457	A7	TPD10	B3
D458	B7	TPD11	D3
D501	D4	TPD12	B3
D502	D4	TPD13	C3
D503	A8	TPD14	C3
D504	A6	TPD15	B2
D505	A6	TPD16	C3
D553	B7	TPD17	A8
D554	D8	TPD18	D8
D555	A8	TPD19	F2
D556	A8	TPD2	E5
D557	B7	TPD20	F2
D558	B7	TPD21	F4
D559	D4	TPD22	F4
D560	D6	TPD3	F4
D563	D5	TPD4	F4
D565	D5	TPD5	F4
D575	A8	TPD6	F8
D576	A8	TPD7	B8
D580	C6	TPD8	B7
D706	A6	TPD9	B2

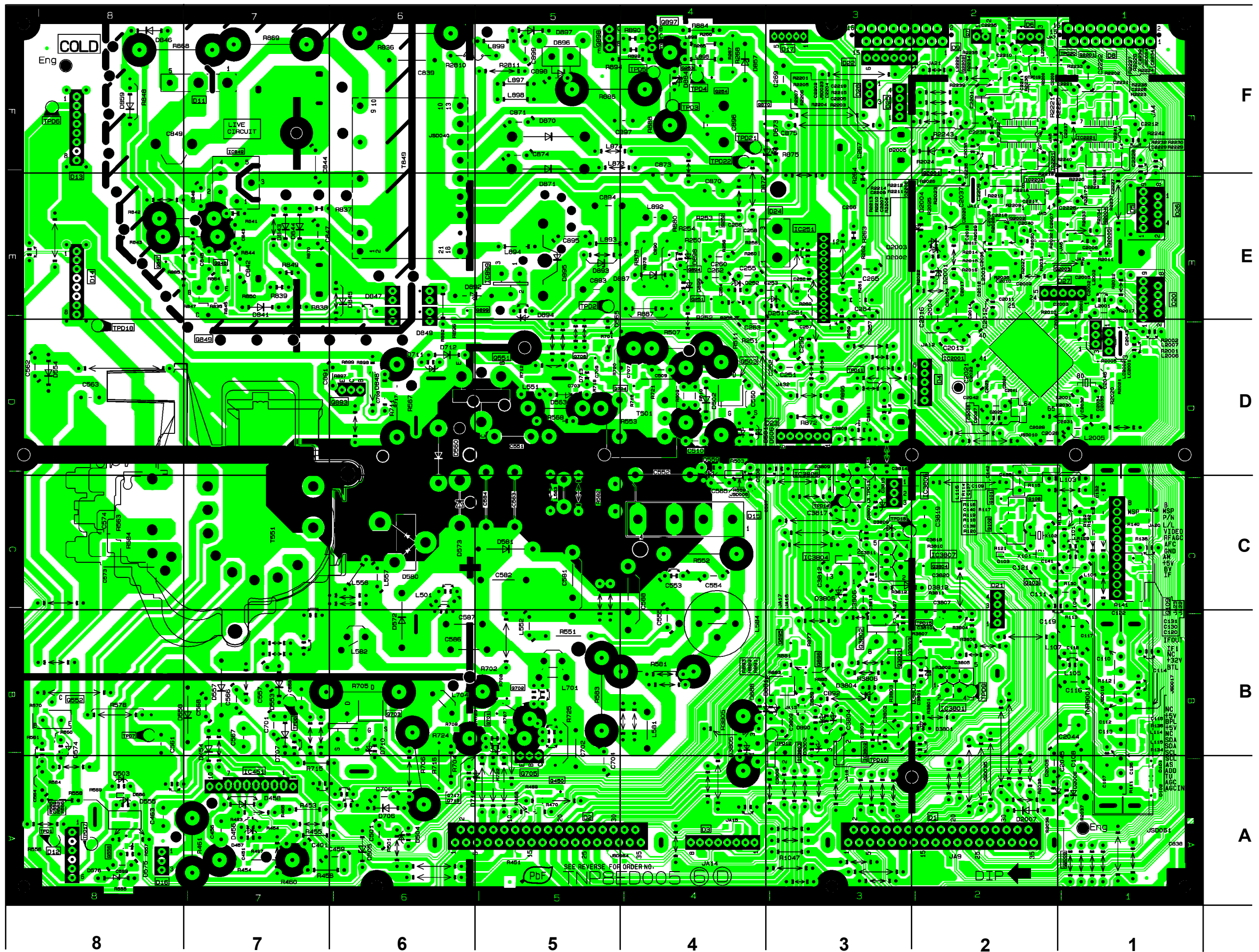

H - BOARD TNP8EH008 - TOP

TRAN'S		IC'S	
Q3000	B4	IC3001	E3
Q3001	B4	IC3301	E2
Q3015	D2		
Q3018	E4		

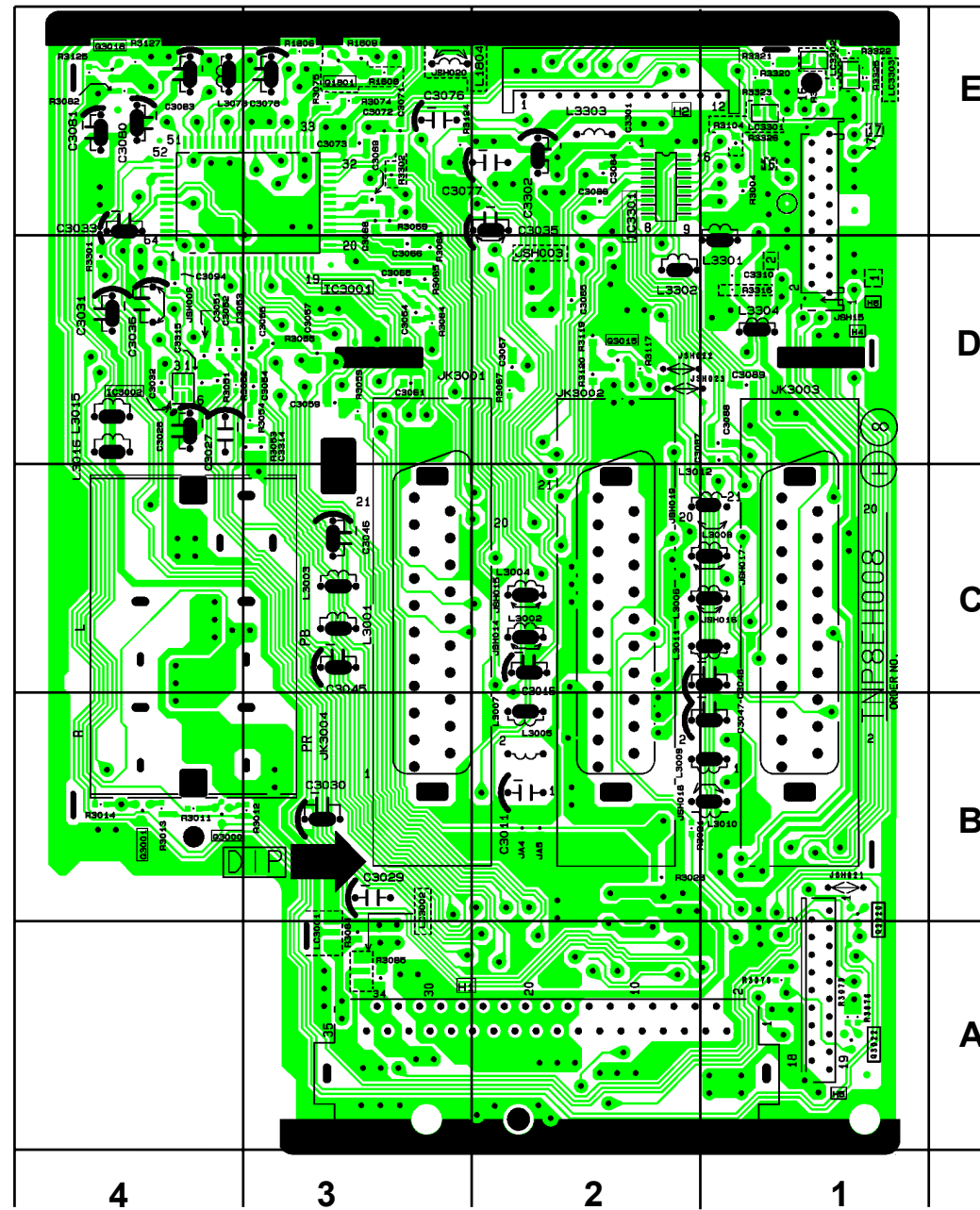

H - BOARD TNP8EH008 - BOTTOM

TRAN'S		Q3007	E3	Q3013	E3
Q3003	B2	Q3008	E2	Q3014	D4
Q3004	B4	Q3009	B4	Q3016	D2
Q3005	B3	Q3010	A3	Q3017	E1
Q3006	B3	Q3011	E2	Q3301	D2

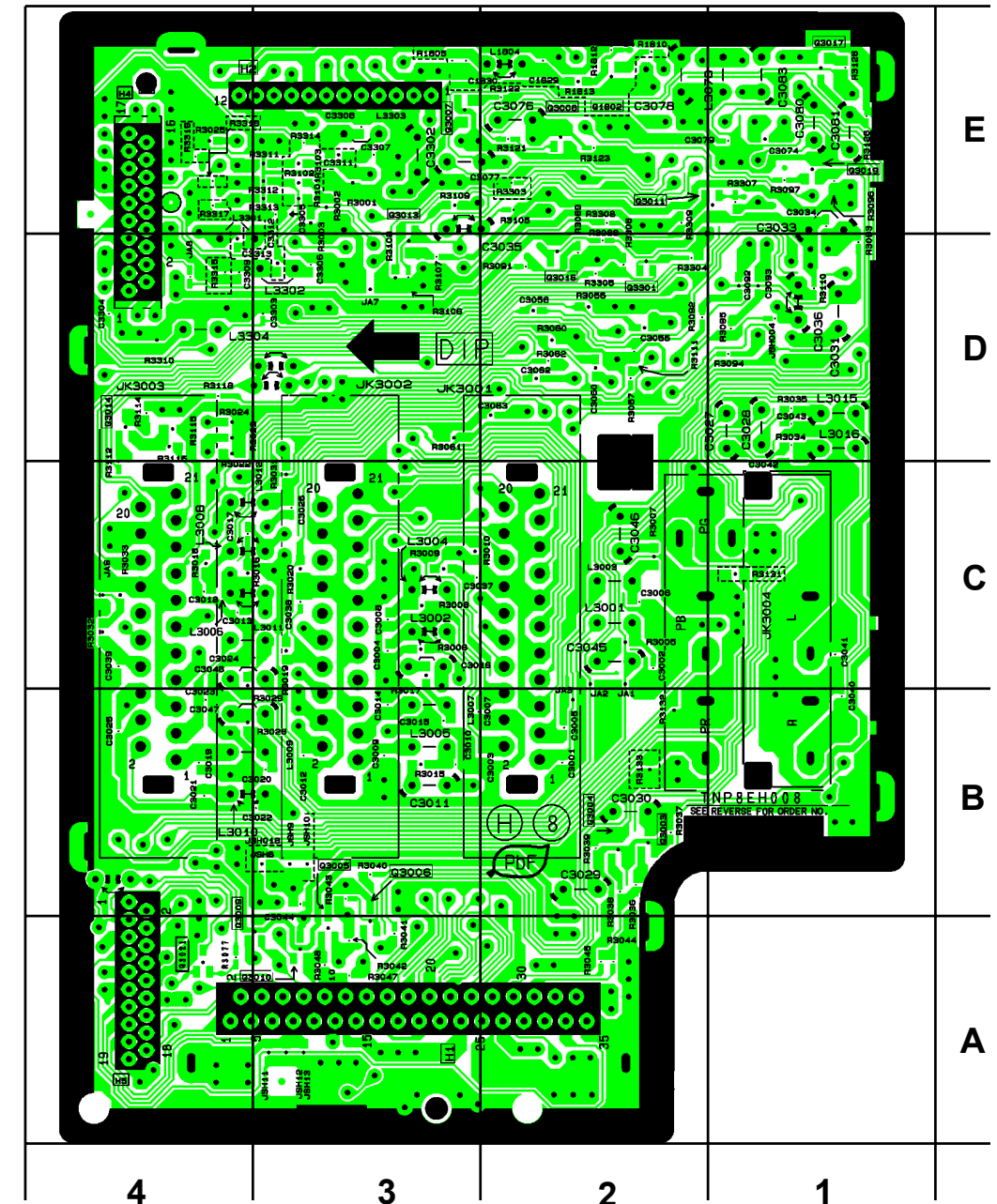

## A - BOARD TNP8EA007 - BOTTOM

TRAN'S		Q1115	D2
Q1101	D3	Q1116	C2
Q1102	D3	Q1703	A6
Q1104	D2	Q1704	B6
Q1108	B2	Q1705	A6
Q1109	C3	Q1719	A6
Q1110	C3		
Q1111	B3	<b>IC'S</b>	
Q1112	B4	IC1108	B3

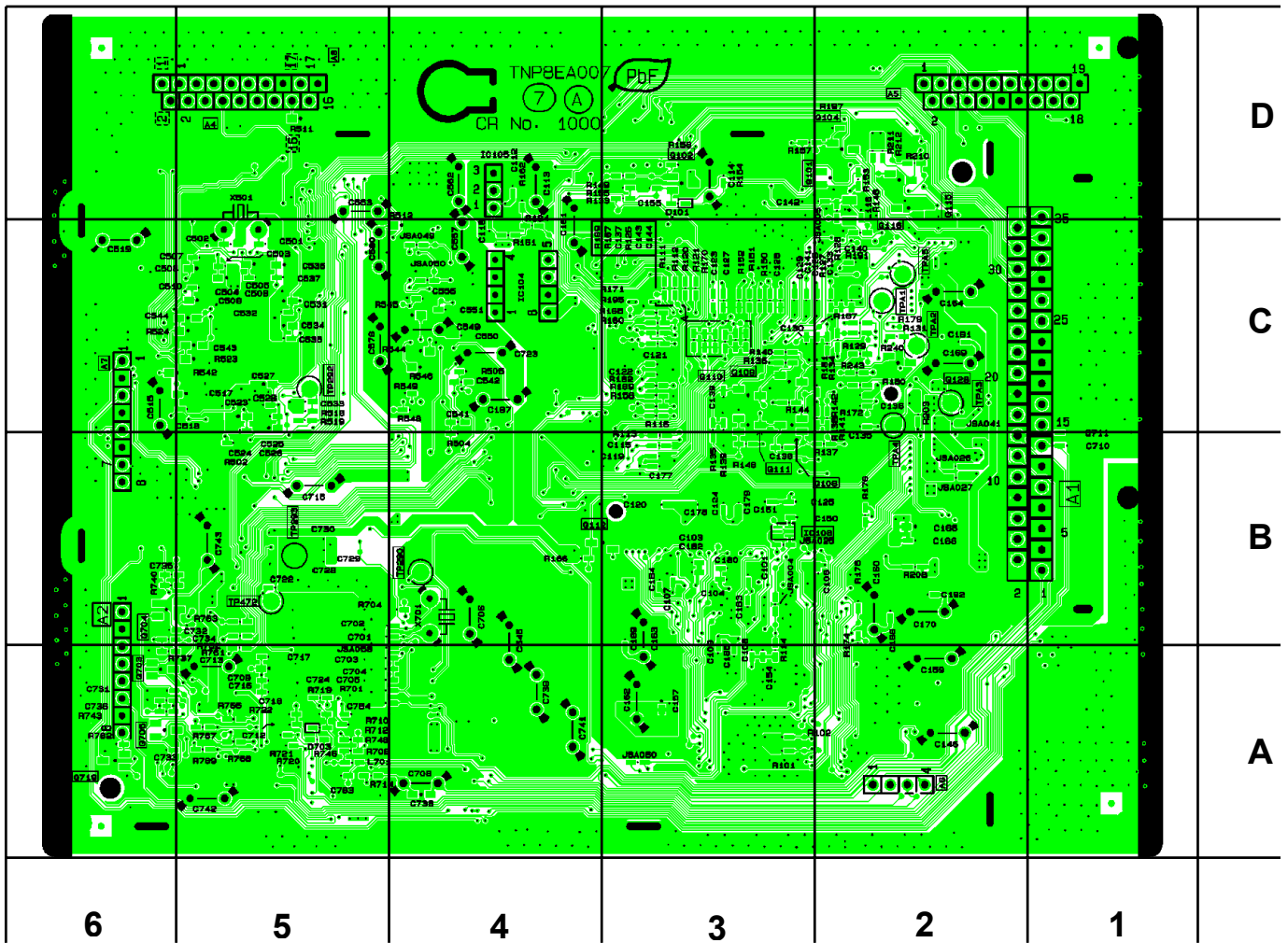

## A - BOARD TNP8EA007 - TOP

TRAN'S				DIODE		IC'S		TP'S	
Q1106	D5	Q1713	A2	D1101	D3	IC1101	C4	TPA1	C2
Q1113	D5	Q1714	A2	D1104	D5	IC1102	A4	TPA2	C2
Q1125	D4	Q1715	A2	D1701	A3	IC1103	A5	TPA3	C2
Q1701	A2	Q1717	A3	D1702	A3	IC1104	C3	TPA4	C2
Q1702	A2	Q1718	A3	D1703	A5	IC1105	D3	TPA5	C2
Q1706	A1					IC1106	B4		
Q1707	B1					IC1107	C4		
Q1708	A1					IC1501	C2		
Q1710	A3					IC1502	D3		
Q1712	A1					IC1701	B2		

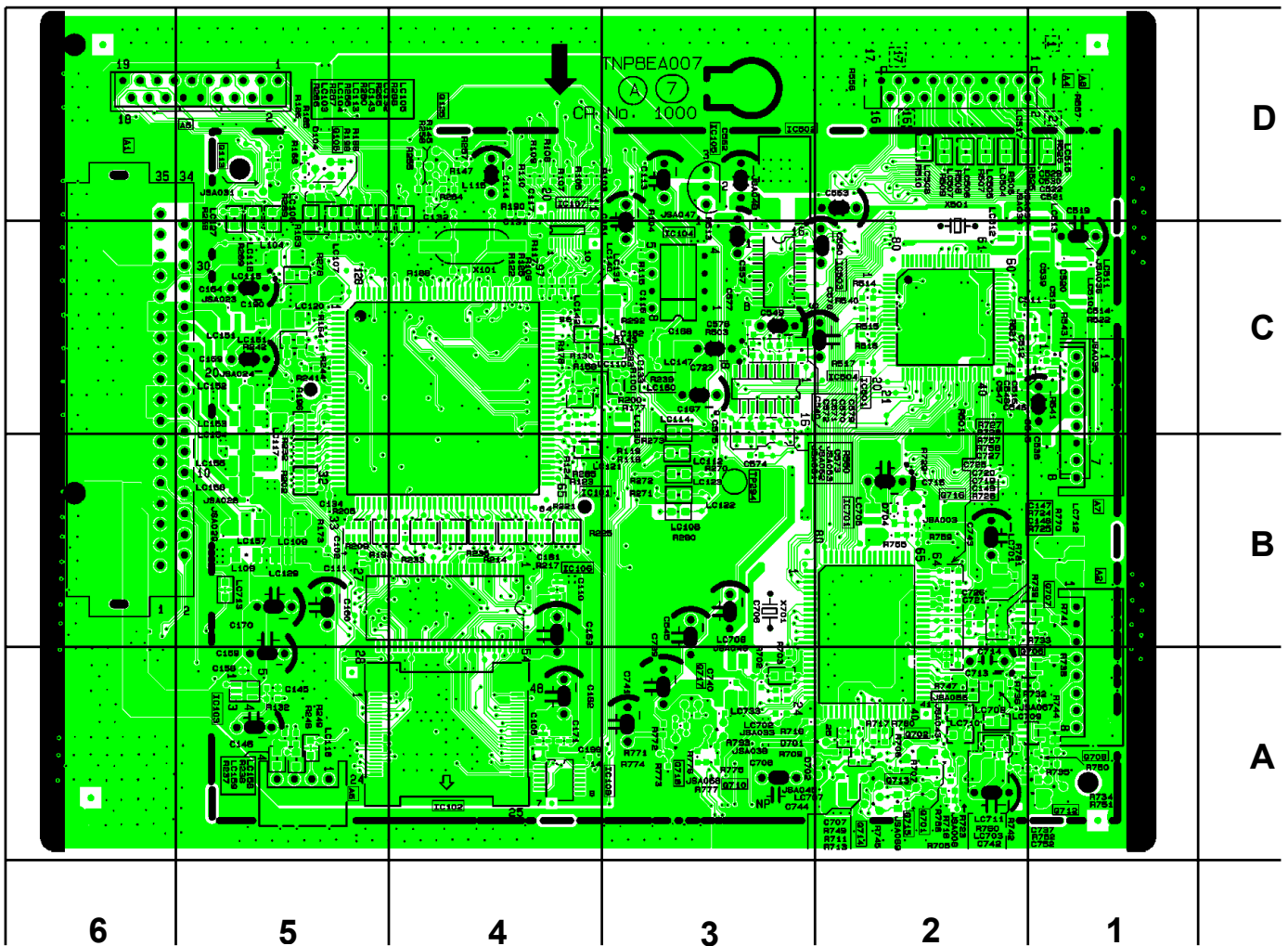

**DF - BOARD TNPA1806  
(USED ONLY FOR TX-32PS12 MODEL)**

TRAN'S		DIODE		TP'S	
Q521	A3	D521	B3	TPDF1	A3
Q522	A3	D522	A3	TPDF2	B3
Q523	A3	D523	A3	TPDF3	A3
Q524	C2	D524	B3	TPDF4	A1
Q525	B3	D525	C3	TPDF5	B3
		D526	C3	TPDF6	B3

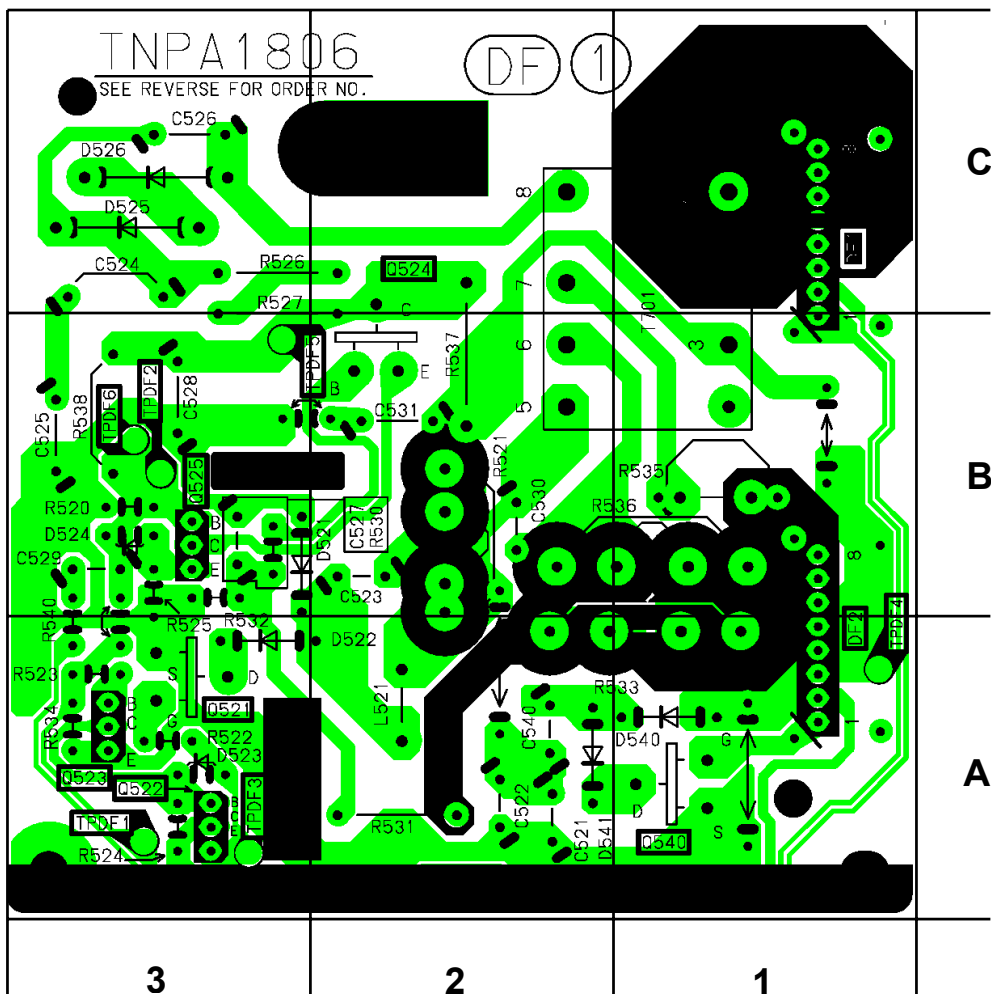

## L - BOARD TNP8EL020

TRAN'S	DIODE	D371	C1	IC361	B4		
Q3352	C4	D3351	C4	D372	C2	IC371	D2
Q351	D3	D3352	C4	D376	D3	<b>TP'S</b>	
Q361	B4	D3353	A4	D377	B4	TPL1	D3
Q371	C2	D3354	D2	D378	C2	TPL2	B4
Q906	A2	D351	D3	D387	B3	TPL3	C2
Q907	A3	D352	D3	D910	A2	TPL4	C2
Q908	B1	D361	B3	<b>IC'S</b>		TPL5	B3
Q909	A1	D362	B4	IC351	D2	TPL6	C3

