



FCC DOC TEST REPORT

According to

FCC CFR 47 Part 15 Subpart B: 2013

CISPR 22 : 1997

ICES 003 Issue 5:2012(Class B Limit)

Applicant : ASUSTEK COMPUTER INC.
Address : 4F, No. 150, LI-TE Rd., PEITOU, TAIPEI 112,
: TAIWAN
Equipment : Motherboard
Model No. : Z170-K,H170-PRO,Z170-P
Brand name : ASUS

I HEREBY CERTIFY THAT :

The sample was received on Jun. 08, 2015 and the testing was carried out on Jun. 16, 2015 at CerpPASS Technology Corp. The test result refers exclusively to the test presented test model / sample. Without written approval of CerpPASS Technology Corp., the test report shall not be reproduced except in full.

Approved by:

Hill Chen
EMC/RF B.U. Manager



FCC TEST REPORT

Issued by:

CerpPASS Technology Co.,Ltd

No.10, Lane 2, Lianfu Street, Luzhu Township, Taoyuan County 33848, Taiwan(R.O.C.)

Tel: 886-3-3226-888

Fax: 886-3-3226-881

The test record, data evaluation & Equipment. Under Test configurations represented herein are true and accurate accounts of the measurements of the samples EMC characteristics under the conditions specified in this report.

Laboratory Accreditation:

CerpPASS Technology Corporation Test Laboratory

NVLAP LAB Code:	200954-0
TAF LAB Code:	1439



Contents

1. Summary of Test Procedure and Test Result.....	5
1.1. Applicable Standards	5
2. Test Configuration of Equipment under Test	6
2.1. Feature of Equipment under Test.....	6
2.2. Test Manner	8
2.3. Description of Test System.....	10
2.4. Connection Diagram of Test System.....	11
2.5. General Information of Test.....	12
2.6. Measurement Uncertainty	12
3. Test of Conducted Emission.....	13
3.1. Test Limit	13
3.2. Test Procedures	13
3.3. Typical test Setup.....	14
3.4. Measurement Equipment.....	14
3.5. Test Result and Data	15
3.6. Test Photographs	17
4. Test of Radiated Emission	18
4.1. Test Limit	18
4.2. Test Procedures	18
4.3. Typical test Setup.....	19
4.4. Measurement Equipment.....	20
4.5. Test Result and Data (30MHz ~ 1000MHz)	21
4.6. Test Result and Data (1000MHz ~ 18000MHz)	25
4.7. Test Photographs (30MHz ~ 1000MHz).....	29
4.8. Test Photographs (1000MHz ~ 18000MHz).....	31
5. Photographs of EUT	33



1. Summary of Test Procedure and Test Result

1.1. Applicable Standards

The measurements shown in this test report were made in accordance with the procedures given in ANSI C63.4 – 2009 and the energy emitted by this equipment was passed Part 2, Part 15, CISPR PUB. 22.

The energy emitted by this equipment was passed both Radiated and Conducted Emissions Class B limits.

Test Item	Normative References	Test Result	Remarks
Conducted Emission	ANSI C63.4-2009 FCC Part 15 Subpart B CISPR 22 : 1997 ICES 003 Issue 5:2012	PASS	Meets Class B Limit Minimum passing margin(AV) is -10.44 dB at 3.6780MHz
Radiated Emission	ANSI C63.4-2009 FCC Part 15 Subpart B CISPR 22 : 1997 ICES 003 Issue 5:2012	PASS	Meets Class B Limit Minimum passing margin(QP) is -6.08 dB at 935.0099 MHz



2. Test Configuration of Equipment under Test

2.1. Feature of Equipment under Test

Motherboard	Model No.:	Z170-K,H170-PRO,Z170-P
Remark	The model name Z170-P less VGA port and SATA Express than Z170-K& H170-PRO.	
Switching Power Supply	Model No.:	FSP350-60HHN(85)
	Input	AC 200V~240V~3A 50Hz
	Output:	DC(+3.3V/21A; +5V/20A; +12V1/15A; +12V2/15A; -12V/0.5A; +5Vsb/2.5A)

Key component List			
Item	Manufactory	Model	Specification
CPU	Intel	QJE9	3.40GHz
RAM	SAMSUNG	M378A5143DB0-CPB	4GB
HDD	WD	WD3200AAKX-001CA0	320GB

Model Number	Z170-K		
CPU	Intel CPU Support Type	LGA 1151	
Chipset	PCH Vendor	Intel	
	PCH Type	Z170	
Memory	Memory Type	DDR4	
	Memory size	Min: 1042MB Max: 16GB	
resolutin	D-sub Max.resolutin:	1920*1200 60Hz	
	DVI Max.resolutin:	1920*1200 60Hz	
	HDMI Max.resolutin:	1920*1080 60Hz	
Network:	10M/bps,100M/bps,1000M/bps		
I/O Ports:	1	PS-2 port:	2
	2	USB1.1&2.0 port	2
	3	USB3.0 port	2
	4	DVI port	1
	5	D-sub port	1
	6	HDMI port	1
	7	RJ-45 port(10M/bps,100M/bps,1000M/bps)	1
	8	Audio port	3



Model Number	H170-PRO		
CPU	Intel CPU Support Type	LGA 1151	
Chipset	PCH Vendor	Intel	
	PCH Type	H170	
Memory	Memory Type	DDR4	
	Memory size	Min: 1042MB	
		Max: 16GB	
resolutin	D-sub Max.resolutin:	1920*1200 60Hz	
	DVI Max.resolutin:	1920*1200 60Hz	
	HDMI Max.resolutin:	1920*1080 60Hz	
Network:	10M/bps,100M/bps,1000M/bps		
I/O Ports:	1	PS-2 port:	2
	2	USB1.1&2.0 port	2
	3	USB3.0 port	2
	4	DVI port	1
	5	D-sub port	1
	6	HDMI port	1
	7	RJ-45 port(10M/bps,100M/bps,1000M/bps)	1
	8	Audio port	3

Model Number	Z170-P		
CPU	Intel CPU Support Type	LGA 1151	
Chipset	PCH Vendor	Intel	
	PCH Type	Z170	
Memory	Memory Type	DDR4	
	Memory size	Min: 1042MB	
		Max: 16GB	
resolutin	DVI Max.resolutin:	1920*1200 60Hz	
	HDMI Max.resolutin:	1920*1080 60Hz	
Network:	10M/bps,100M/bps,1000M/bps		
I/O Ports:	1	PS-2 port:	2
	2	USB1.1&2.0 port	2
	3	USB3.0 port	2
	4	DVI port	1
	5	D-sub port	0
	6	HDMI port	1
	7	RJ-45 port(10M/bps,100M/bps,1000M/bps)	1
	8	Audio port	3



2.2. Test Manner

- a. During testing, the interface cables and equipment positions were varied according to ANSI C63.4.
- b. The complete test system included the Notebook PC, PS/2 Keyboard, PS/2 Mouse, LCD Monitor, iPod, HDD, Earphone and EUT for EMI test.
- c. During the test, setup up the EUT and all system, turn on the power of all Equipments.
- d. An executive program, "BurnInTest professional V6", run the EMC test software "H", "H" font size No. is 11, CPU+RAM+2D+3D 100%.
- e. An executive program, "WINTHRAX.EXE" was executed to read and write data from IPOD, HDD.
- f. During the disturbances at telecommunication port test, the condition of LAN utilization in excess of 10%.

The pre-test modes for CE

Mode 1: Full System with DVI (1920*1200@60Hz) and HDMI (1920*1200@60Hz) for Z170-K with Status 1

Mode 2: Full System with DVI (1920*1200@60Hz) and HDMI (1920*1200@60Hz) for Z170-K with Status 2

Mode 3: Full System with DVI (1920*1200@60Hz) and HDMI (1920*1200@60Hz) for Z170-K with Status 3

Mode 4: Full System with DVI (1920*1200@60Hz) and HDMI (1920*1200@60Hz) for Z170-K with Status 4

Mode 5: Full System with DVI (1920*1200@60Hz) and HDMI (1920*1200@60Hz) for Z170-K with Status 5

Mode 6: Full System with VGA (1920*1200@60Hz) and HDMI (1920*1200@60Hz) for Z170-K with Status 1

Mode 7: Full System with VGA (1920*1200@60Hz) and DVI (1920*1200@60Hz) for Z170-K with Status 1

Mode 8: Full System with DVI (1920*1200@60Hz) and HDMI (1920*1200@60Hz) for H170-PRO with Status 1

Mode 9: Full System with DVI (1920*1200@60Hz) and HDMI (1920*1200@60Hz) for Z170-P with Status 1

Mode 10: Full System with DVI (1280*1024@75Hz) and HDMI (1280*1024@75Hz) for Z170-K with Status 1

Mode 11: Full System with DVI (640*480@60Hz) and HDMI (640*480@60Hz) for Z170-K with Status 1

The final test mode for CE

Mode 1: Full System with DVI (1920*1200@60Hz) and HDMI (1920*1200@60Hz) for Z170-K with Status 1

The pre-test modes for RE

Mode 1: Full System with DVI (1920*1200@60Hz) and HDMI (1920*1200@60Hz) for Z170-K with Status 1 for close case

Mode 2: Full System with DVI (1920*1200@60Hz) and HDMI (1920*1200@60Hz) for Z170-K with Status 2 for close case



- Mode 3: Full System with DVI (1920*1200@60Hz) and HDMI (1920*1200@60Hz) for Z170-K with Status 3 for close case
- Mode 4: Full System with DVI (1920*1200@60Hz) and HDMI (1920*1200@60Hz) for Z170-K with Status 4 for close case
- Mode 5: Full System with DVI (1920*1200@60Hz) and HDMI (1920*1200@60Hz) for Z170-K with Status 5 for close case
- Mode 6: Full System with VGA (1920*1200@60Hz) and HDMI (1920*1200@60Hz) for Z170-K with Status 1 for close case
- Mode 7: Full System with VGA (1920*1200@60Hz) and DVI (1920*1200@60Hz) for Z170-K with Status 1 for close case
- Mode 8: Full System with DVI (1920*1200@60Hz) and HDMI (1920*1200@60Hz) for H170-PRO with Status 1 for close case
- Mode 9: Full System with DVI (1920*1200@60Hz) and HDMI (1920*1200@60Hz) for Z170-P with Status 1 for close case
- Mode 10: Full System with DVI (1280*1024@75Hz) and HDMI (1280*1024@75Hz) for Z170-K with Status 1 for close case
- Mode 11: Full System with DVI (640*480@60Hz) and HDMI (640*480@60Hz) for Z170-K with Status 1 for close case
- Mode 12: Full System with DVI (1920*1200@60Hz) and HDMI (1920*1200@60Hz) for Z170-K with Status 1 for open case

The final test mode for RE

- Mode 1: Full System with DVI (1920*1200@60Hz) and HDMI (1920*1200@60Hz) for Z170-K with Status 1 for close case
- Mode 12: Full System with DVI (1920*1200@60Hz) and HDMI (1920*1200@60Hz) for Z170-K with Status 1 for open case

g. The maximum operating frequency is above 108MHz, the test frequency range is from 30MHz to 18GHz.



2.3. Description of Test System

No.	Device	Manufacturer	Model No.	Description
1	Notebook PC	SONY	PCG-71811P	Non-Shielded, 1.5m R33021
2	PS/2 Keyboard	DELL	SK-8115	T3A002
3	PS/2 Mouse	DELL	G0K02XYK	N/A
4	LCD Monitor	DELL	3008WFPT	Non-Shielded, 1.8m R3A002
5	LCD Monitor	Lenovo	L2364wA	Non-Shielded, 1.8m R33B65
6	iPod	APPLE	A1373	N/A
7	iPod	APPLE	A1373	N/A
8	iPod	APPLE	3409A	N/A
9	iPod	APPLE	3409A	N/A
10	HDD	WD	WDBPCK5000ABK-01	N/A
11	HDD	WD	WDBPCK5000ABK-02	N/A
12	HDD	WD	WD4711.A	N/A
13	HDD	WD	WD4711.A	N/A
14	Earphone	SALAR	V18	N/A
15	Earphone	SALAR	V18	N/A

2.4. Connection Diagram of Test System

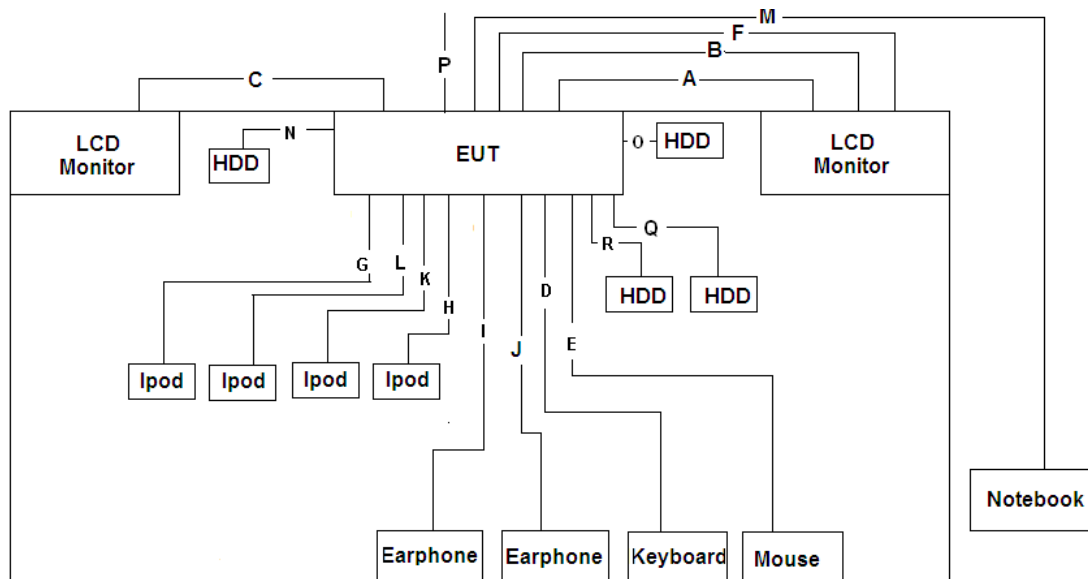

Item	Cable	Quantity	Description
A	VGA Cable	1	Shielded, 1.8m,with two ferrites core bonded
B	DVI Cable	1	Shielded, 1.8m,with two ferrites core bonded
C	HDMI Cable	1	Non-Shielded, 1.5m
D	PS/2 Cable	1	Shielded, 1.8m,with a ferrite core bonded
E	PS/2 Cable	1	Shielded, 1.2m
F	Audio Cable	1	Shielded, 1.8m
I	USB Cable	1	Shielded, 1.0m
J	USB Cable	1	Shielded, 1.0m
K	Audio Cable	1	Non-Shielded, 1.8m
H	Audio Cable	1	Non-Shielded, 1.8m
O	USB Cable	1	Shielded, 1.0m
G	USB Cable	1	Shielded,1.0m
L	USB Cable	1	Shielded,0.6m
P	LAN Cable	1	Non-Shielded, >3.0m
Q	USB Cable	1	Shielded,0.6m
N	Mini HDMI Cable	1	Shielded, 1.0m
S	USB Cable	1	Shielded,0.6m
R	USB Cable	1	Shielded, 0.6m



2.5. General Information of Test

Test Site :	CerpPASS Technology Corporation Test Laboratory Address: No.10, Ln. 2, Lianfu St., Luzhu Dist., Taoyuan City 33848, Taiwan (R.O.C.) Tel:+886-3-3226-888 Fax:+886-3-3226-881 Address: No.68-1, Shihbachongsi, Shihding Township, New Taipei City 223, Taiwan, R.O.C. Tel: +886-2-2663-8582
FCC Registration Number :	TW1079, TW1061,390316, 228391, 641184
IC Registration Number :	4934B-1, 4934E-1, 4934E-2
VCCI	T-2205 for Telecommunication Test C-4463 for Conducted emission test R-3428, R-4128 for Radiated emission test G-812, G-813 for radiated disturbance above 1GHz
Frequency Range Investigated :	Conducted Emission Test: from 150 kHz to 30 MHz Radiated Emission Test: from 30 MHz to 18,000 MHz
Test Distance :	The test distance of radiated emission below 1GHz from antenna to EUT is 3 M. The test distance of radiated emission above 1GHz from antenna to EUT is 3 M.

2.6. Measurement Uncertainty

Measurement Item	Measurement Frequency	Polarization	Uncertainty
Conducted Emission	9 kHz ~ 30 MHz	LINE / NEUTRAL	3.25 dB
Radiated Emission	30 MHz ~ 1,000 MHz	Vertical / Horizontal	3.93 dB
	1,000 MHz ~ 18,000 MHz	Vertical / Horizontal	5.18 dB

The measurement uncertainty will be considered, when test result margin to the limit.



3. Test of Conducted Emission

3.1. Test Limit

Conducted Emissions were measured from 150 kHz to 30 MHz with a bandwidth of 9 KHz on the 120 VAC power and return leads of the EUT according to the methods defined in ANSI C63.4-2009 Section 3.1. The EUT was placed on a nonmetallic stand in a shielded room 0.8 meters above the ground plane as shown in section 2.2. The interface cables and equipment positioning were varied within limits of reasonable applications to determine the position produced maximum conducted emissions.

Conducted Emission Limits:

Frequency (MHz)	Quasi Peak (dB μ V)	Average (dB μ V)
0.15 – 0.5	66-56*	56-46*
0.5 – 5.0	56	46
5.0 – 30.0	60	50

3.2. Test Procedures

- a. The EUT was placed 0.4 meter from the conducting wall of the shielding room was kept at least 80 centimeters from any other grounded conducting surface.
- b. Connect EUT to the power mains through a line impedance stabilization network (LISN).
- c. All the support units are connecting to the other LISN.
- d. The LISN provides 50 ohm coupling impedance for the measuring instrument.
- e. The FCC states that a 50 ohm, 50 micro-Henry LISN should be used.
- f. Both sides of AC line were checked for maximum conducted interference.
- g. The frequency range from 150 kHz to 30 MHz was searched.
- h. Set the test-receiver system to Peak Detect Function and Specified Bandwidth with Maximum Hold Mode.

3.3. Typical test Setup

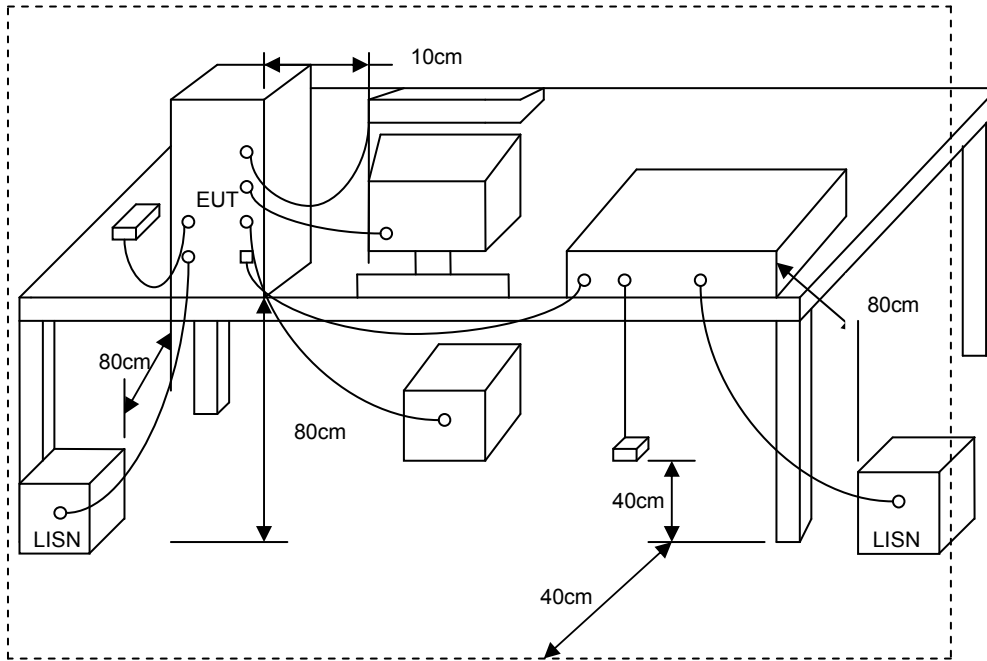

3.4. Measurement Equipment

Instrument/Ancillary	Manufacturer	Model No.	Serial No.	Calibration Date	Valid Date.
Test Receiver	R&S	ESCI	100565	2015.03.29	2016.03.28
AMN	R&S	ESH2-Z5	100182	2014.09.04	2015.09.03
Two-Line V-Network	R&S	ENV216	100325	/	/
ISN	FCC	FCC-TLISN-T2-02	20379	2015.03.29	2016.03.28
ISN	FCC	FCC-TLISN-T4-02	20380	2015.03.29	2016.03.28
ISN	FCC	FCC-TLISN-T8-02	20381	2015.03.29	2016.03.28
ISN	TESEQ	ISN ST08	30175	2015.03.29	2016.03.28
Current Probe	R&S	EZ-17	100303	2015.03.29	2016.03.28
Passive Voltage Probe	R&S	ESH2-Z3	100026	2015.03.29	2016.03.28
Pulse Limiter	R&S	ESH3-Z2	100529	2015.03.29	2016.03.28
Temperature/ Humidity Meter	Zhicheng	ZC1-11	CEP-TH-004	2015.04.02	2016.04.01
EZ-EMC	Fala	Ver CT3A1	N/A	N/A	N/A



3.5. Test Result and Data

Test Mode :	Mode 1: Full System with DVI (1920*1200@60Hz) and HDMI (1920*1200@60Hz) for Z170-K with Status 1		
AC Power :	AC 120V/60Hz	Phase :	LINE
Temperature :	24°C	Humidity :	48%
Pressure(mbar) :	1002	Date :	2015/06/16

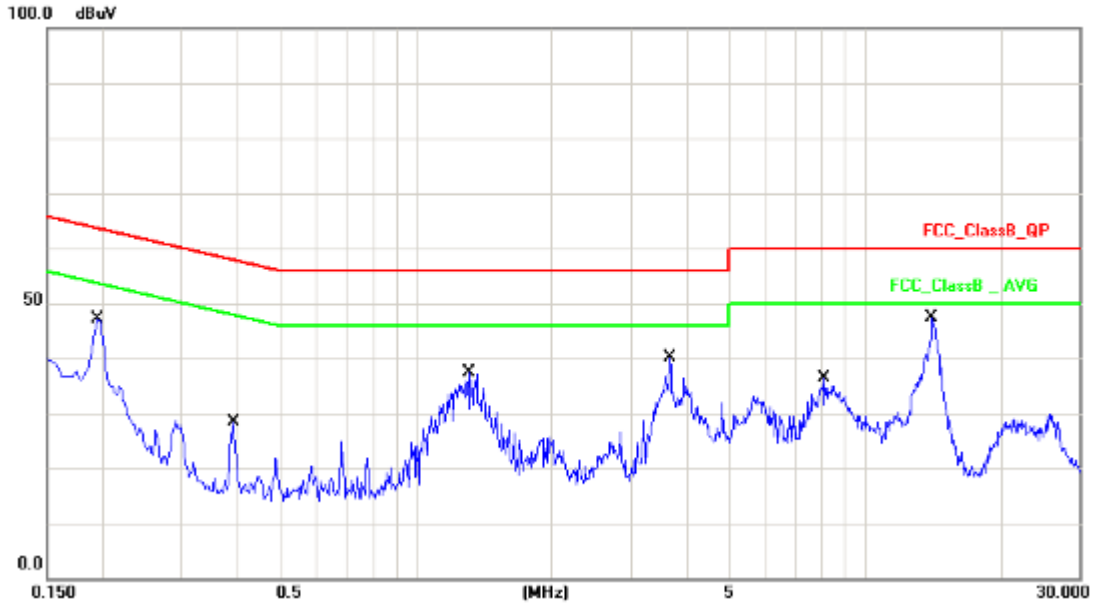

No.	Frequency (MHz)	Factor (dB)	Reading (dBuV)	Level (dBuV)	Limit (dBuV)	Margin (dB)	Detector
1	0.1940	10.12	35.22	45.34	63.86	-18.52	QP
2	0.1940	10.12	28.24	38.36	53.86	-15.50	AVG
3	0.3899	10.15	15.73	25.88	58.06	-32.18	QP
4	0.3899	10.15	15.26	25.41	48.06	-22.65	AVG
5	1.3140	10.16	20.93	31.09	56.00	-24.91	QP
6	1.3140	10.16	7.10	17.26	46.00	-28.74	AVG
7	3.6780	10.20	27.56	37.76	56.00	-18.24	QP
8	3.6780	10.20	25.36	35.56	46.00	-10.44	AVG
9	8.0940	10.25	22.60	32.85	60.00	-27.15	QP
10	8.0940	10.25	20.04	30.29	50.00	-19.71	AVG
11	14.1180	10.48	26.62	37.10	60.00	-22.90	QP
12	14.1180	10.48	17.18	27.66	50.00	-22.34	AVG

Note: Measurement Level = Reading Level + Correct Factor



Test Mode :	Mode 1: Full System with DVI (1920*1200@60Hz) and HDMI (1920*1200@60Hz) for Z170-K with Status 1		
AC Power :	AC 120V/60Hz	Phase :	NEUTRAL
Temperature :	24°C	Humidity :	48%
Pressure(mbar) :	1002	Date :	2015/06/16

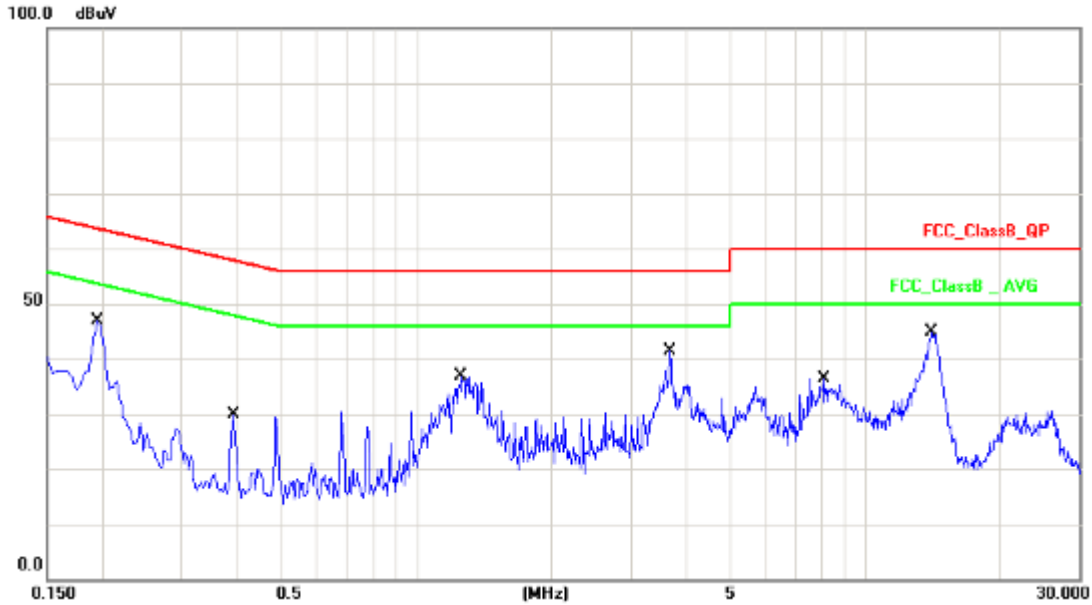

No.	Frequency (MHz)	Factor (dB)	Reading (dBuV)	Level (dBuV)	Limit (dBuV)	Margin (dB)	Detector
1	0.1940	10.13	35.41	45.54	63.86	-18.32	QP
2	0.1940	10.13	27.17	37.30	53.86	-16.56	AVG
3	0.3899	10.15	17.25	27.40	58.06	-30.66	QP
4	0.3899	10.15	16.97	27.12	48.06	-20.94	AVG
5	1.2620	10.18	21.61	31.79	56.00	-24.21	QP
6	1.2620	10.18	15.81	25.99	46.00	-20.01	AVG
7	3.6780	10.21	27.14	37.35	56.00	-18.65	QP
8	3.6780	10.21	24.31	34.52	46.00	-11.48	AVG
9	8.0900	10.26	23.50	33.76	60.00	-26.24	QP
10	8.0900	10.26	21.34	31.60	50.00	-18.40	AVG
11	14.1140	10.48	26.94	37.42	60.00	-22.58	QP
12	14.1140	10.48	17.51	27.99	50.00	-22.01	AVG

Note: Measurement Level = Reading Level + Correct Factor

Test engineer: Dian



3.6. Test Photographs

Front View



Rear View





4. Test of Radiated Emission

4.1. Test Limit

Radiated emissions were measured with a bandwidth according to the methods defines in ANSI C63.4-2009. The EUT was placed on a nonmetallic stand in the open-field site, 0.8 meter above the ground plane, as shown in section 3.2. The interface cables and equipment positions were varied within limits of reasonable applications to determine the positions producing maximum radiated emissions.

For unintentional device, according to § 15.109(a), except for Class A digital devices, the field strength of radiated emissions from unintentional radiators at a distance of 3 meters shall not exceed the following values:

Frequency (MHz)	Distance Meters	Radiated ($\mu\text{V} / \text{M}$)	Radiated (dB $\mu\text{V} / \text{M}$)
30-88	3	100	40.0
88-216	3	150	43.5
216-960	3	200	46.0
Above 960	3	500	54.0

For unintentional device, according to CISPR PUB.22, for Class B digital devices, the general requirement of field strength of radiated emissions from intentional radiators at a distance of 10 meters shall not exceed the below table.

Frequency (MHz)	Distance Meters	Radiated (dB $\mu\text{V} / \text{M}$)
30-230	10	30
230-1000	10	37

4.2. Test Procedures

- The EUT was placed on a Rota table top 0.8 meter above ground.
- The EUT was set 3/10 meters from the interference receiving antenna which was mounted on the top of a variable height antenna tower.
- The table was rotated 360 degrees to determine the position of the highest radiation.
- The antenna is a half wave dipole and its height is varied between one meter and four meters above ground to find the maximum value of the field strength both horizontal polarization and vertical polarization of the antenna are set to make the measurement.
- For each suspected emission the EUT was arranged to its worst case and then tune the antenna tower (from 1 M to 4 M) and turn table (from 0 degree to 360 degrees) to find the maximum reading.
- Set the test-receiver system to Peak Detect Function and specified bandwidth with Maximum Hold Mode.
- If the emission level of the EUT in peak mode was 6 dB lower than the limit specified, then testing will be stopped and peak values of EUT will be reported, otherwise, the emissions which do not have 6 dB margin will be repeated one by one using the quasi-peak method and reported.

4.3. Typical test Setup

Below 1GHz Test Setup

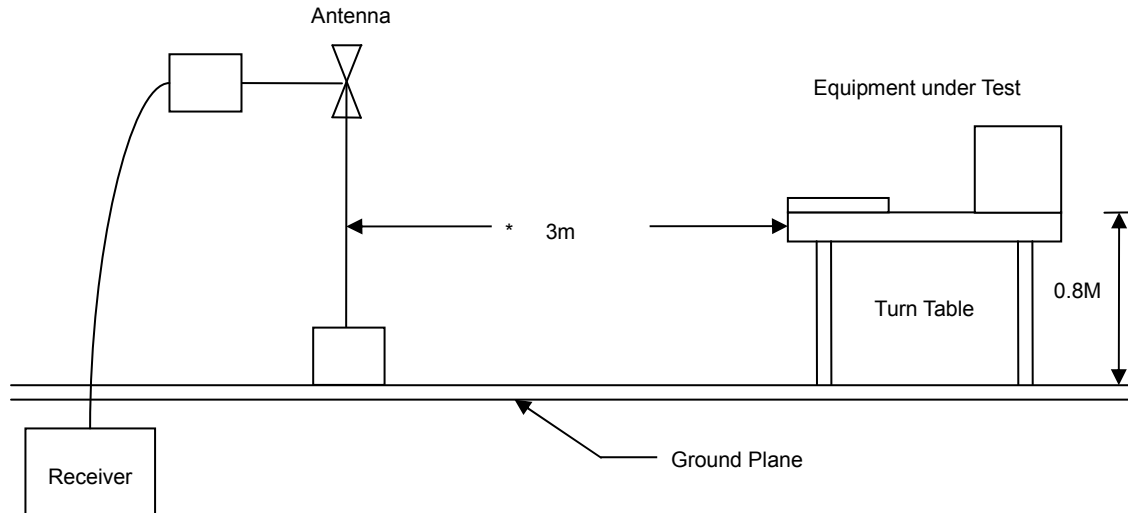

Above 1GHz Test Setup

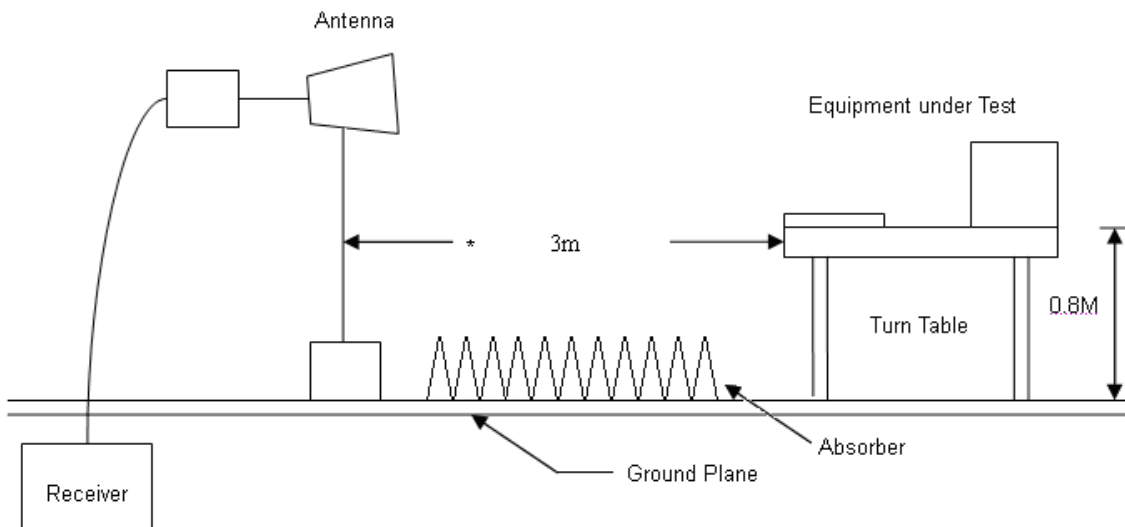



4.4. Measurement Equipment

Instrument	Manufacturer	Model No.	Serial No.	Calibration Date	Valid Date
EMI Test Receiver	R&S	ESCI	101183	2015.03.29	2016.03.28
Preamplifier	songyi	EM330	60618	2014.07.28	2015.07.27
Preamplifier	Agilent	8449B	3008A02342	2015.03.29	2016.03.28
Bilog Antenna	Sunol Science	JB1	A072414-2	2014.08.05	2015.08.04
Broad-Band Horn Antenna	Schwarzbeck	BBHA9120D	9120D-619	2015.04.20	2016.04.19
Broad-Band Horn Antenna	Schwarzbeck	BBHA9170	9170-347	2015.04.20	2016.04.19
Preamplifier	COM-POWER	PA-840	711885	2015.03.29	2016.03.28
Spectrum Analyzer	R&S	FSP40	100324	2015.03.29	2016.03.28
Temperature/ Humidity Meter	Zhicheng	ZC1-11	CEP-TH-002	2015.04.02	2016.04.01
EZ-EMC	Fala	Ver CT3A1	N/A	N/A	N/A



4.5. Test Result and Data (30MHz ~ 1000MHz)

Test Mode :	Mode 1: Full System with DVI (1920*1200@60Hz) and HDMI (1920*1200@60Hz) for Z170-K with Status 1 for close case		
AC Power :	AC 120V/60Hz	Ant. Polarization:	Horizontal
Temp :	24°C	Humidity :	42%
Pressure(mbar) :	1002	Date :	2015/06/13



No.	Frequency (MHz)	Factor (dB/m)	Reading (dBuV)	Level (dBuV/m)	Limit (dBuV/m)	Margin (dB)	Det.	Height (cm)	Azimuth (deg)
1	53.2800	-11.53	38.86	27.33	40.00	-12.67	QP	100	231
2	162.8900	-7.51	43.07	35.56	43.50	-7.94	QP	100	51
3	338.4600	-6.55	44.06	37.51	46.00	-8.49	QP	100	56
4	359.8000	-6.85	40.46	33.61	46.00	-12.39	QP	100	148
5	417.0300	-3.65	33.22	29.57	46.00	-16.43	QP	200	351
6	913.6700	2.34	35.82	38.16	46.00	-7.84	QP	100	87

Note: Measurement Level = Reading Level + Correct Factor



Test Mode :	Mode 1: Full System with DVI (1920*1200@60Hz) and HDMI (1920*1200@60Hz) for Z170-K with Status 1 for close case		
AC Power :	AC 120V/60Hz	Ant. Polarization:	Vertical
Temp :	24°C	Humidity :	42%
Pressure(mbar) :	1002	Date :	2015/06/13

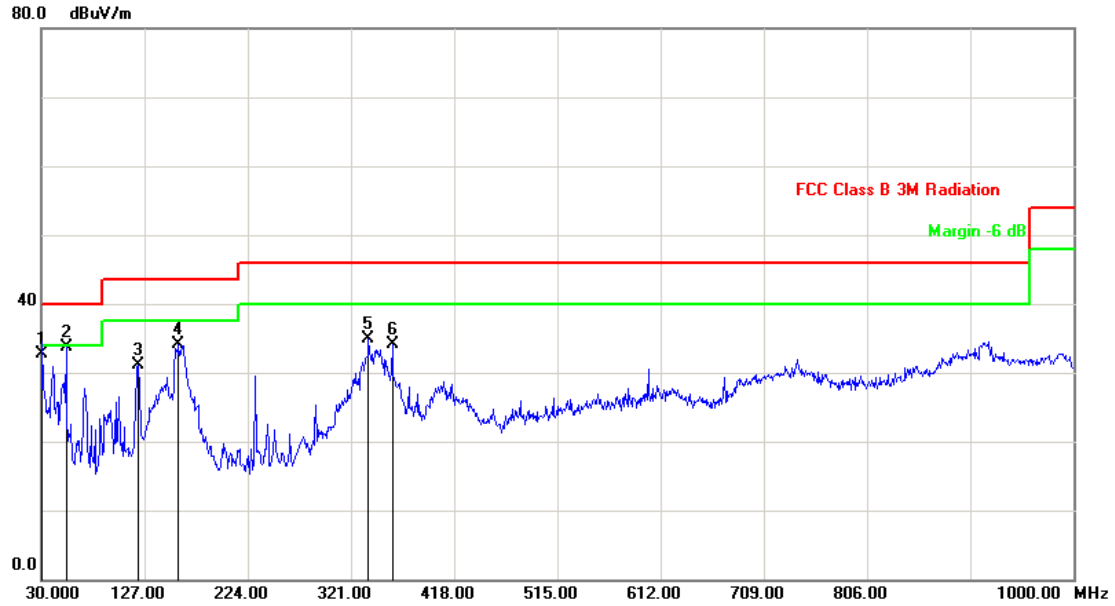

No.	Frequency (MHz)	Factor (dB/m)	Reading (dBuV)	Level (dBuV/m)	Limit (dBuV/m)	Margin (dB)	Det.	Height (cm)	Azimuth (deg)
1	30.9700	-2.85	35.47	32.62	40.00	-7.38	QP	100	54
2	53.2800	-11.53	45.23	33.70	40.00	-6.30	QP	200	42
3	121.1800	-9.70	40.81	31.11	43.50	-12.39	QP	100	266
4	159.0100	-7.50	41.52	34.02	43.50	-9.48	QP	100	75
5	337.4900	-6.54	41.35	34.81	46.00	-11.19	QP	200	52
6	359.8000	-6.85	40.87	34.02	46.00	-11.98	QP	200	54

Note: Measurement Level = Reading Level + Correct Factor



Test Mode :	Mode 12: Full System with DVI (1920*1200@60Hz) and HDMI (1920*1200@60Hz) for Z170-K with Status 1 for open case		
AC Power :	AC 120V/60Hz	Ant. Polarization:	Horizontal
Temp :	24°C	Humidity :	42%
Pressure(mbar) :	1002	Date :	2015/06/13

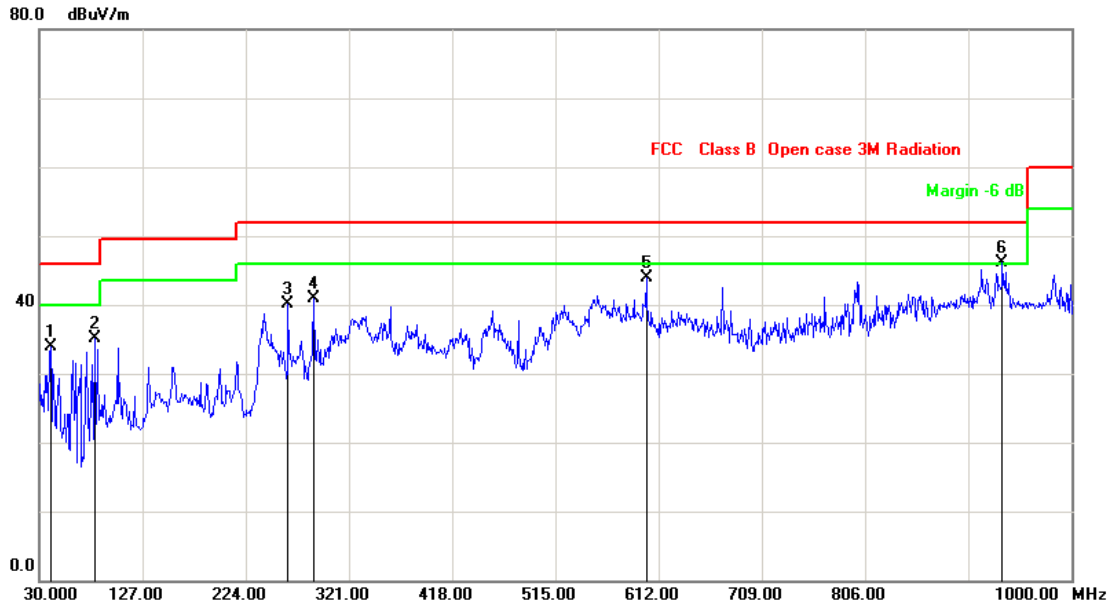

No.	Frequency (MHz)	Factor (dB/m)	Reading (dBuV)	Level (dBuV/m)	Limit (dBuV/m)	Margin (dB)	Det.	Height (cm)	Azimuth (deg)
1	40.6699	-6.86	40.78	33.92	46.00	-12.08	QP	100	19
2	82.3799	-15.44	50.61	35.17	46.00	-10.83	QP	100	263
3	263.7699	-12.22	52.25	40.03	52.00	-11.97	QP	100	24
4	288.0199	-11.34	52.23	40.89	52.00	-11.11	QP	100	43
5	600.3600	-2.64	46.59	43.95	52.00	-8.05	QP	200	98
6	935.0099	3.50	49.42	45.92	52.00	-6.08	QP	100	38

Note: Measurement Level = Reading Level + Correct Factor



Test Mode :	Mode 12: Full System with DVI (1920*1200@60Hz) and HDMI (1920*1200@60Hz) for Z170-K with Status 1 for open case		
AC Power :	AC 120V/60Hz	Ant. Polarization:	Vertical
Temp :	24°C	Humidity :	42%
Pressure(mbar) :	1002	Date :	2015/06/13

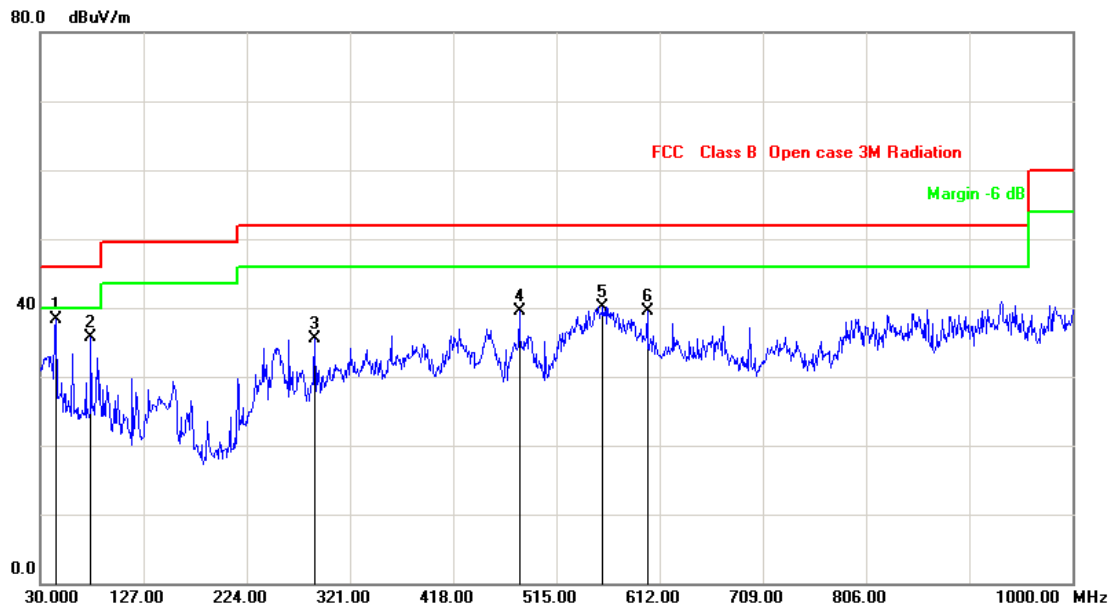

No.	Frequency (MHz)	Factor (dB/m)	Reading (dBuV)	Level (dBuV/m)	Limit (dBuV/m)	Margin (dB)	Det.	Height (cm)	Azimuth (deg)
1	44.5500	-9.03	47.37	38.34	46.00	-7.66	QP	200	244
2	77.5300	-15.93	51.62	35.69	46.00	-10.31	QP	200	330
3	288.0200	-11.34	46.77	35.43	52.00	-16.57	QP	200	76
4	480.0800	-5.36	44.83	39.47	52.00	-12.53	QP	100	72
5	558.6500	-3.55	43.67	40.12	52.00	-11.88	QP	100	84
6	600.3600	-2.64	42.12	39.48	52.00	-12.52	QP	100	79

Note: Measurement Level = Reading Level + Correct Factor



4.6. Test Result and Data (1000MHz ~ 18000MHz)

Test Mode :	Mode 1: Full System with DVI (1920*1200@60Hz) and HDMI (1920*1200@60Hz) for Z170-K with Status 1 for close case		
AC Power :	AC 120V/60Hz	Ant. Polarization:	Horizontal
Temp :	24°C	Humidity :	42%
Pressure(mbar) :	1002	Date :	2015/06/13

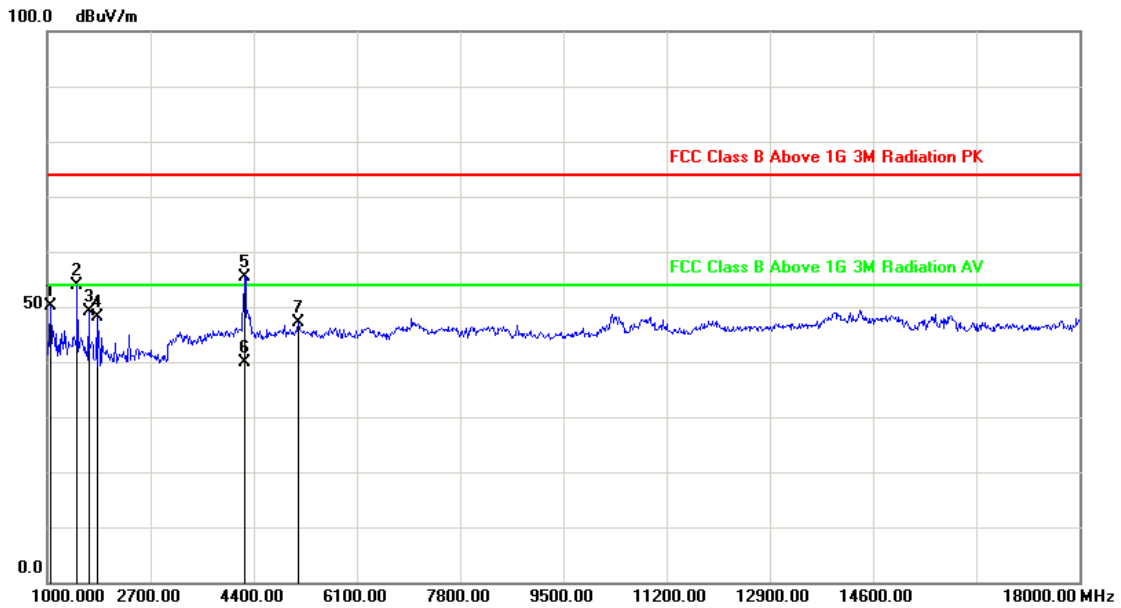

No.	Frequency (MHz)	Factor (dB/m)	Reading (dBuV)	Level (dBuV/m)	Limit (dBuV/m)	Margin (dB)	Det.	Height (cm)	Azimuth (deg)
1	1051.000	-6.66	56.68	50.02	74.00	-23.98	peak	176	360
2	1493.000	-4.81	58.68	53.87	74.00	-20.13	peak	100	3
3	1680.000	-4.03	53.22	49.19	74.00	-24.81	peak	102	360
4	1816.000	-3.47	51.59	48.12	74.00	-25.88	peak	100	0
5	4247.000	4.98	50.44	55.42	74.00	-18.58	peak	100	217
6	4247.000	4.98	34.87	39.85	54.00	-14.15	AVG	100	217
7	5131.000	7.07	40.00	47.07	74.00	-26.93	peak	100	280

Note: Measurement Level = Reading Level + Correct Factor



Test Mode :	Mode1:Full System with DVI (1920*1200@60Hz) and HDMI (1920*1200@60Hz) for Z170-K with Status 1 for close case		
AC Power :	AC 120V/60Hz	Ant. Polarization:	Vertical
Temp :	24°C	Humidity :	42%
Pressure(mbar) :	1002	Date :	2015/06/13

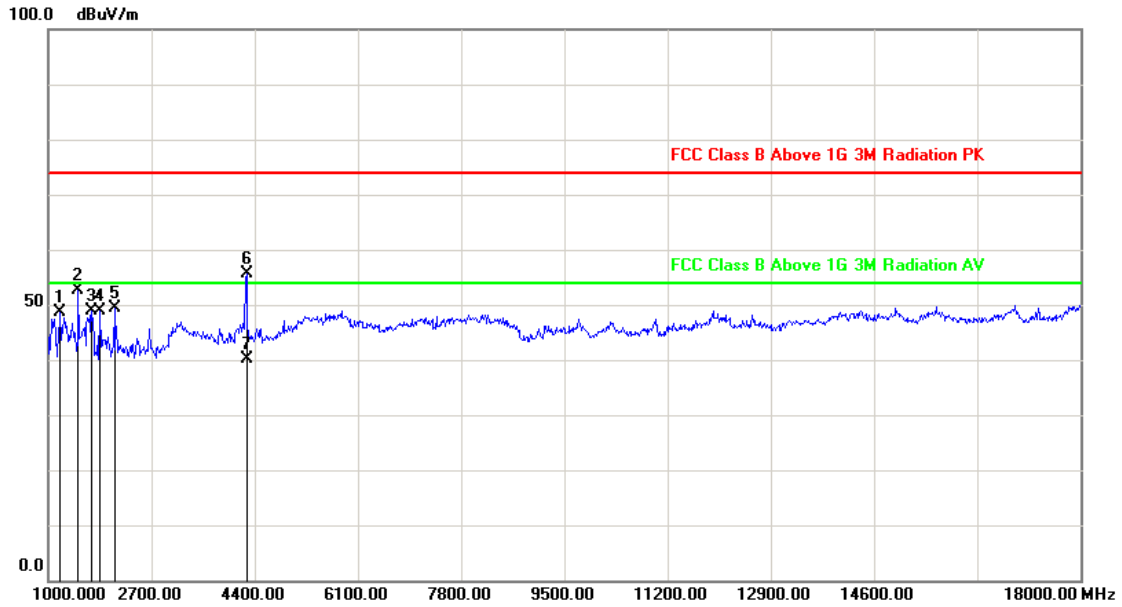

No.	Frequency (MHz)	Factor (dB/m)	Reading (dBuV)	Level (dBuV/m)	Limit (dBuV/m)	Margin (dB)	Det.	Height (cm)	Azimuth (deg)
1	1187.000	-6.09	54.60	48.51	74.00	-25.49	peak	112	360
2	1493.000	-4.81	57.33	52.52	74.00	-21.48	peak	100	333
3	1714.000	-3.89	52.89	49.00	74.00	-25.00	peak	200	342
4	1850.000	-3.33	52.22	48.89	74.00	-25.11	peak	200	165
5	2088.000	-2.41	51.88	49.47	74.00	-24.53	peak	100	147
6	4264.000	5.02	50.57	55.59	74.00	-18.41	peak	100	2
7	4264.000	5.02	35.22	40.24	54.00	-13.76	AVG	100	2

Note: Measurement Level = Reading Level + Correct Factor



Test Mode :	Mode 12: Full System with DVI (1920*1200@60Hz) and HDMI (1920*1200@60Hz) for Z170-K with Status 1 for open case		
AC Power :	AC 120V/60Hz	Ant. Polarization:	Horizontal
Temp :	24°C	Humidity :	42%
Pressure(mbar) :	1002	Date :	2015/06/13

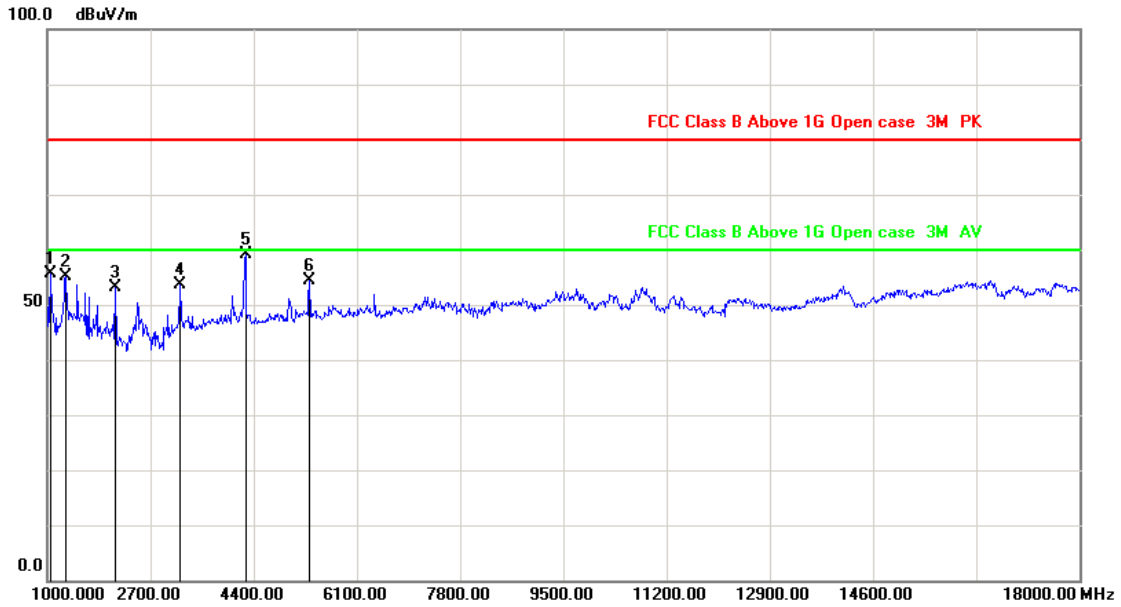

No.	Frequency (MHz)	Factor (dB/m)	Reading (dBuV)	Level (dBuV/m)	Limit (dBuV/m)	Margin (dB)	Det.	Height (cm)	Azimuth (deg)
1	1051.000	-6.66	62.30	55.64	80.00	-24.36	peak	200	98
2	1306.000	-5.59	60.60	55.01	80.00	-24.99	peak	100	47
3	2122.000	-2.29	55.34	53.05	80.00	-26.95	peak	200	98
4	3193.000	1.37	52.34	53.71	80.00	-26.29	peak	200	108
5	4264.000	5.02	54.13	59.15	80.00	-20.85	peak	200	113
6	5318.000	7.38	46.99	54.37	80.00	-25.63	peak	100	90

Note: Measurement Level = Reading Level + Correct Factor



Test Mode :	Mode 12: Full System with DVI (1920*1200@60Hz) and HDMI (1920*1200@60Hz) for Z170-K with Status 1 for open case		
AC Power :	AC 120V/60Hz	Ant. Polarization:	Vertical
Temp :	24°C	Humidity :	42%
Pressure(mbar) :	1002	Date :	2015/06/13

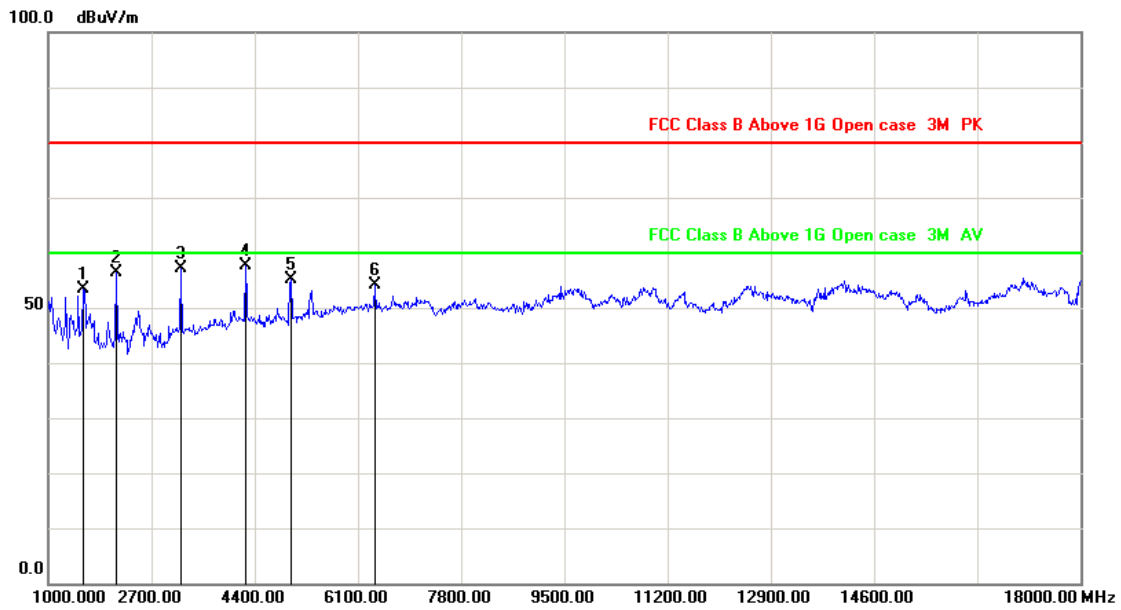

No.	Frequency (MHz)	Factor (dB/m)	Reading (dBuV)	Level (dBuV/m)	Limit (dBuV/m)	Margin (dB)	Det.	Height (cm)	Azimuth (deg)
1	1578.000	-4.46	57.77	53.31	80.00	-26.69	peak	100	31
2	2122.000	-2.29	58.72	56.43	80.00	-23.57	peak	100	54
3	3176.000	1.30	55.88	57.18	80.00	-22.82	peak	200	54
4	4247.000	4.98	52.66	57.64	80.00	-22.36	peak	100	40
5	4995.000	6.84	48.22	55.06	80.00	-24.94	peak	100	99
6	6372.000	9.81	44.21	54.02	80.00	-25.98	peak	100	51

Note: Measurement Level = Reading Level + Correct Factor

Test engineer: Karp



4.7. Test Photographs (30MHz ~ 1000MHz)

Close case

Front View

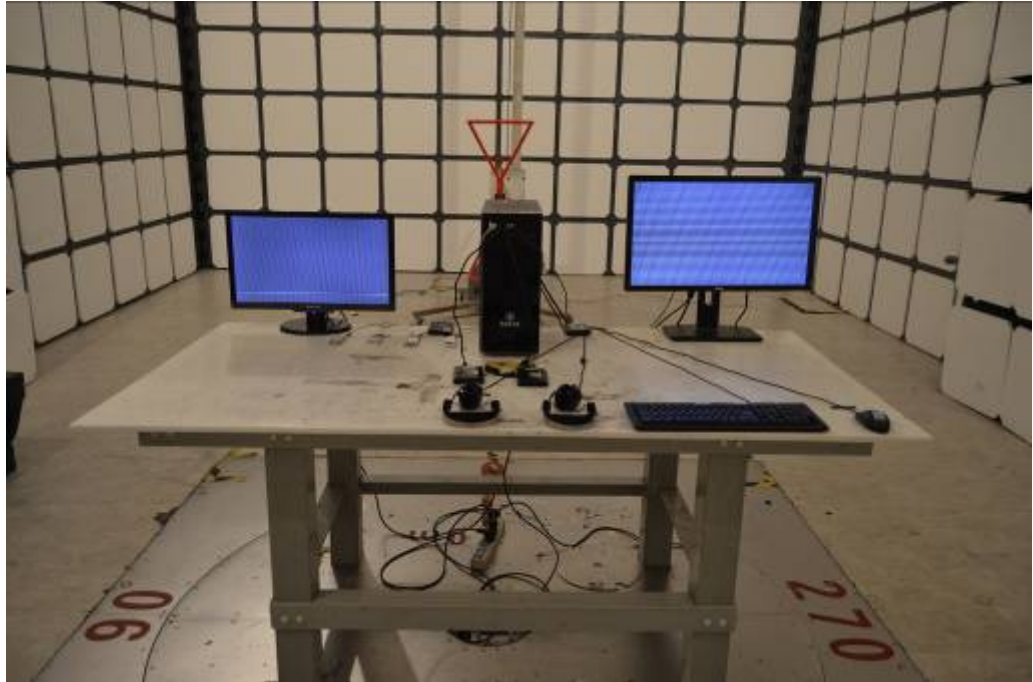

Rear View

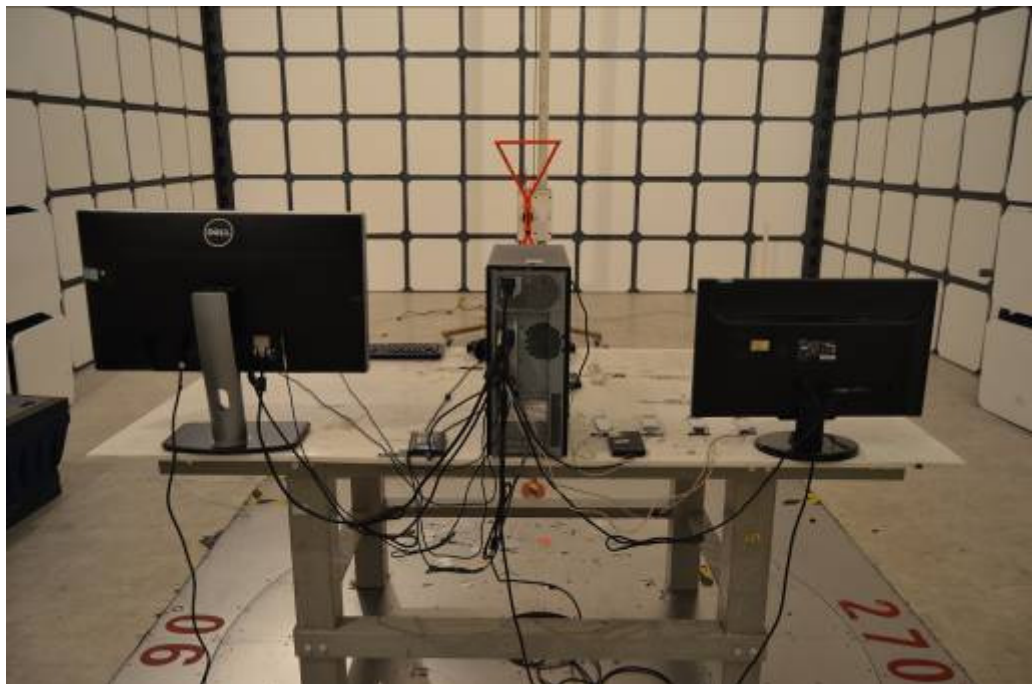



Open case

Front View

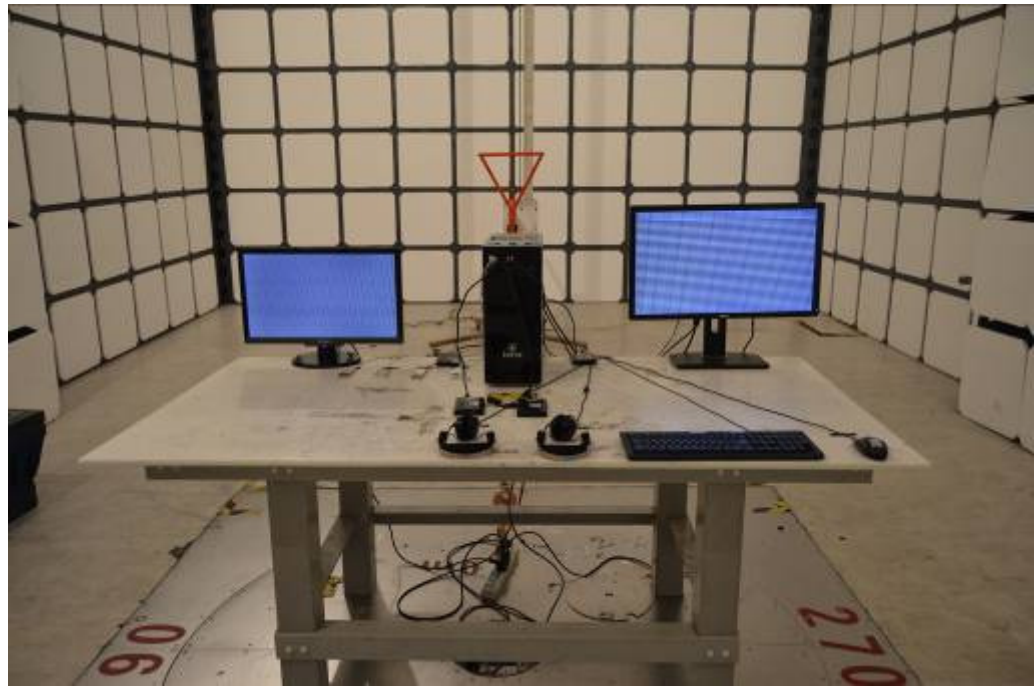

Rear View

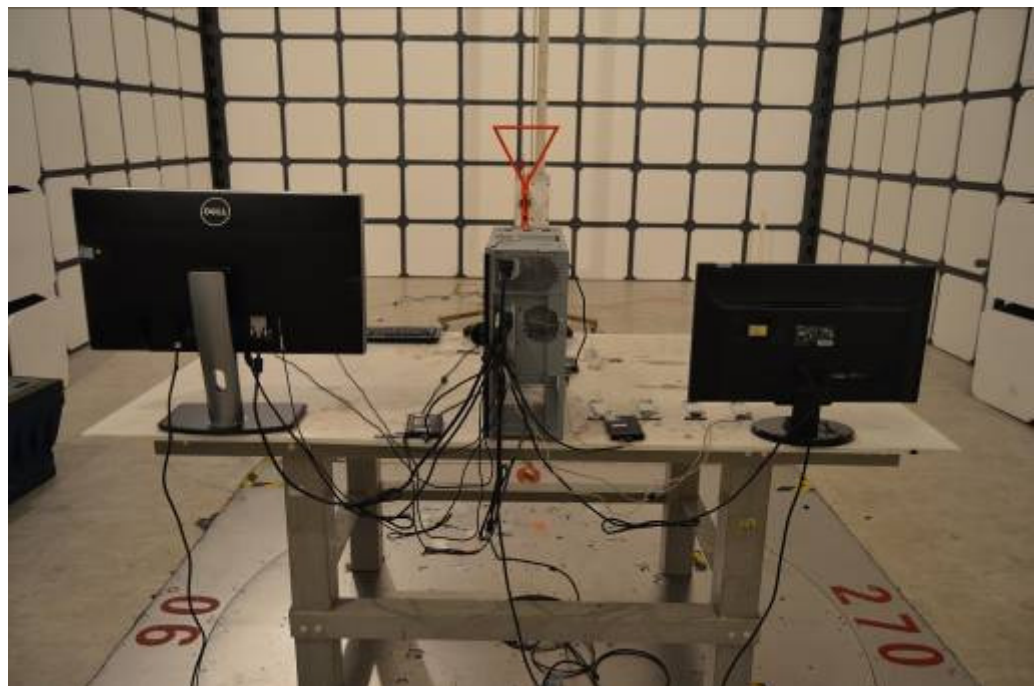



4.8. Test Photographs (1000MHz ~ 18000MHz)

Close case

Front View

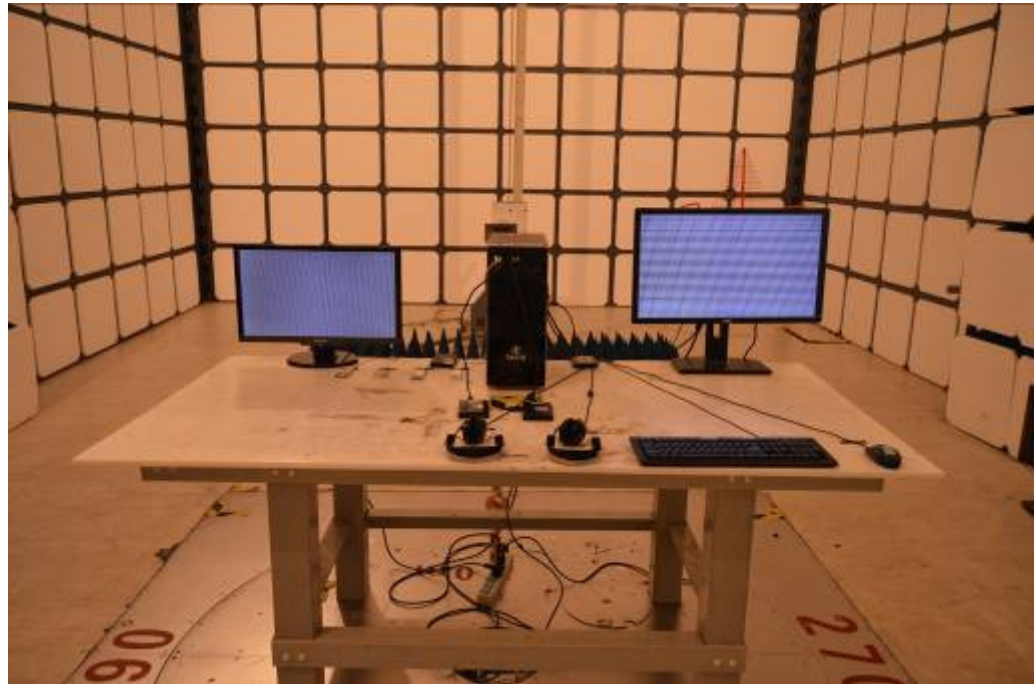

Rear View

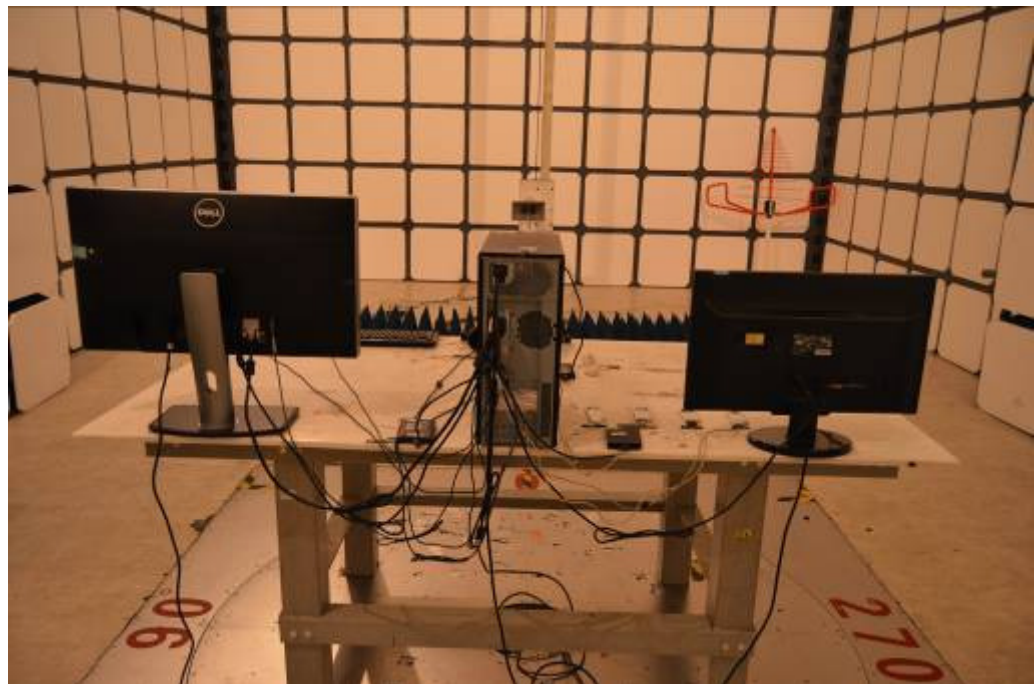



Open case

Front View

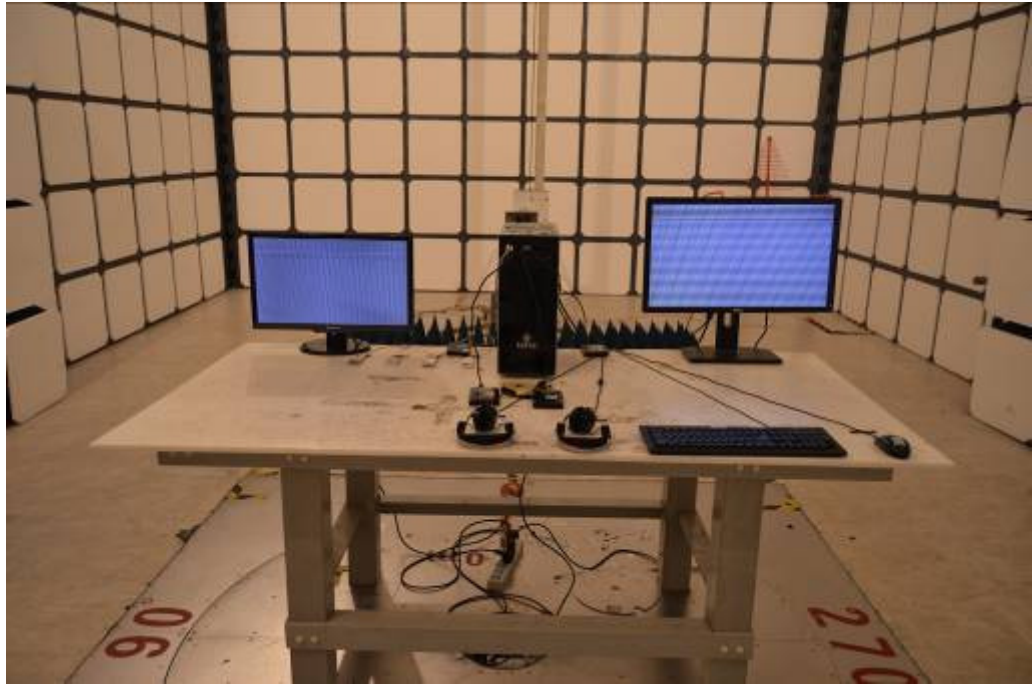

Rear View

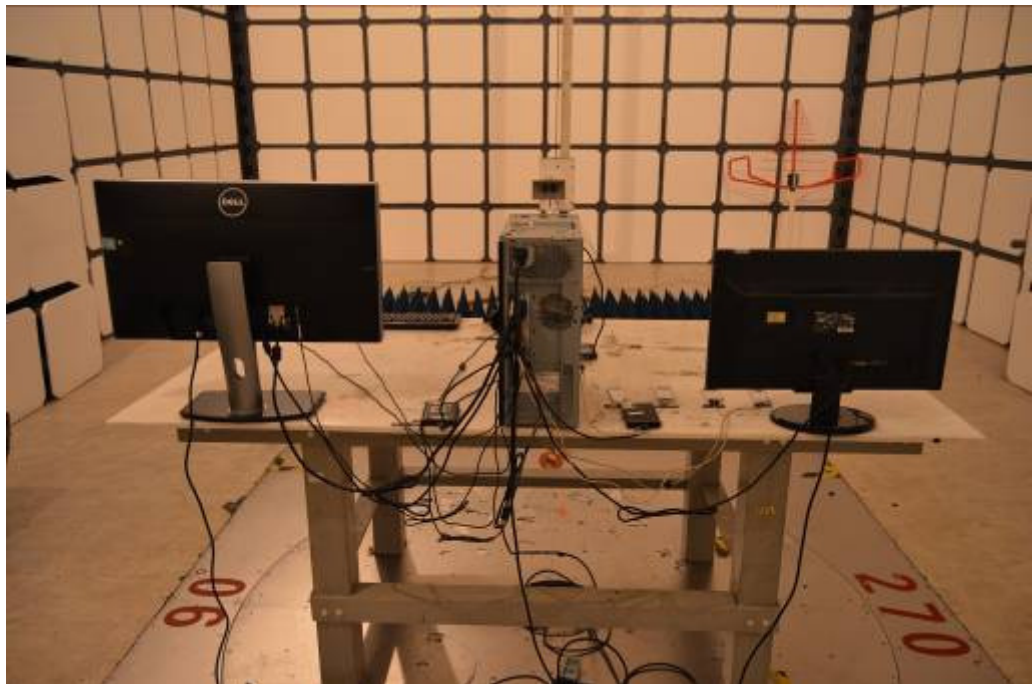



5. Photographs of EUT

1) EUT Photo



2) EUT Photo

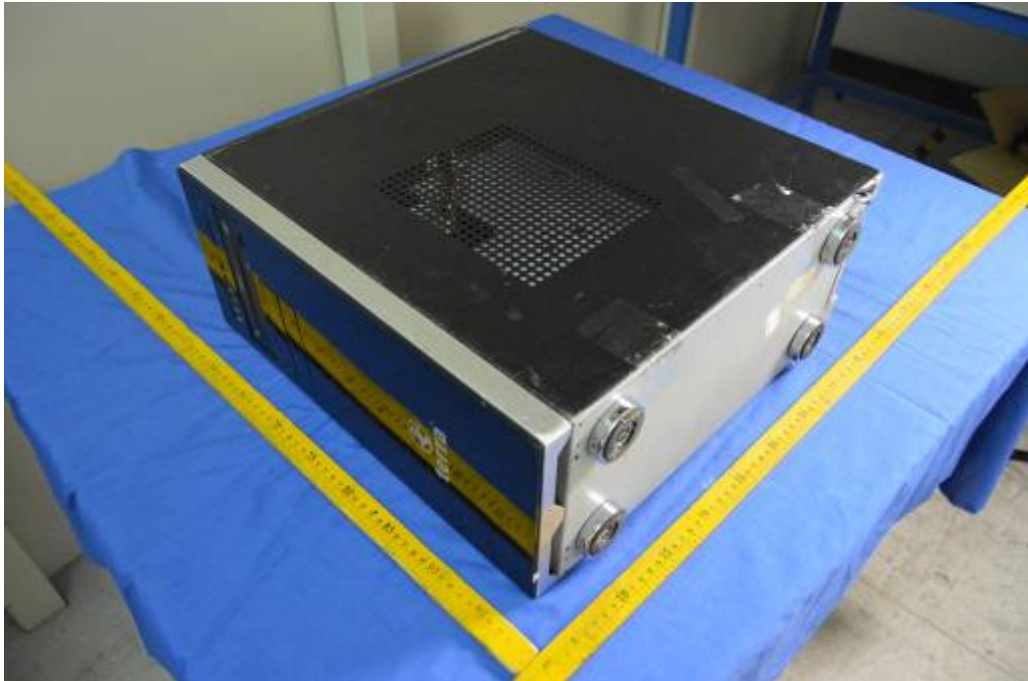



3) EUT Photo



4) EUT Photo

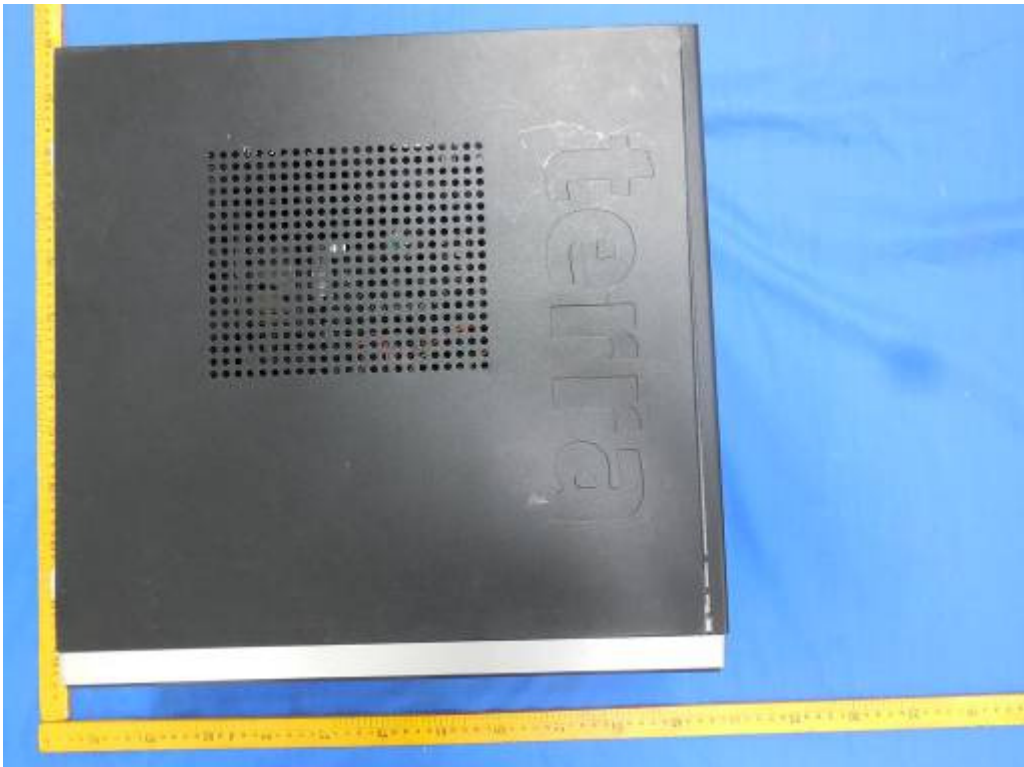



5) EUT Photo



6) EUT Photo(Z170-K,H170-PRO)





7) EUT Photo(Z170-K,H170-PRO)



8) EUT Photo(Z170-P)

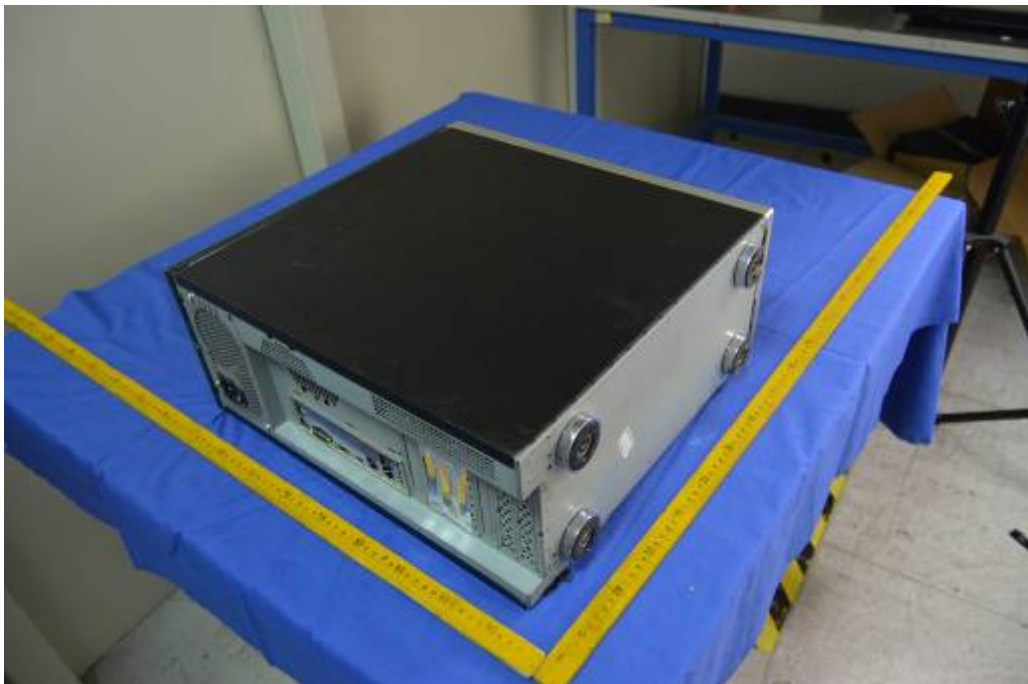



9) EUT Photo(Z170-P)



10) EUT Photo(Z170-P)





11) EUT Photo



12) EUT Photo





13) EUT Photo



14) EUT Photo





15) EUT Photo



16) EUT Photo(Z170-K)





17) EUT Photo(Z170-K)



18) EUT Photo(H170-PRO)





19) EUT Photo(H170-PRO)



20) EUT Photo(Z170-P)





21) EUT Photo (Z170-P)



22) EUT Photo

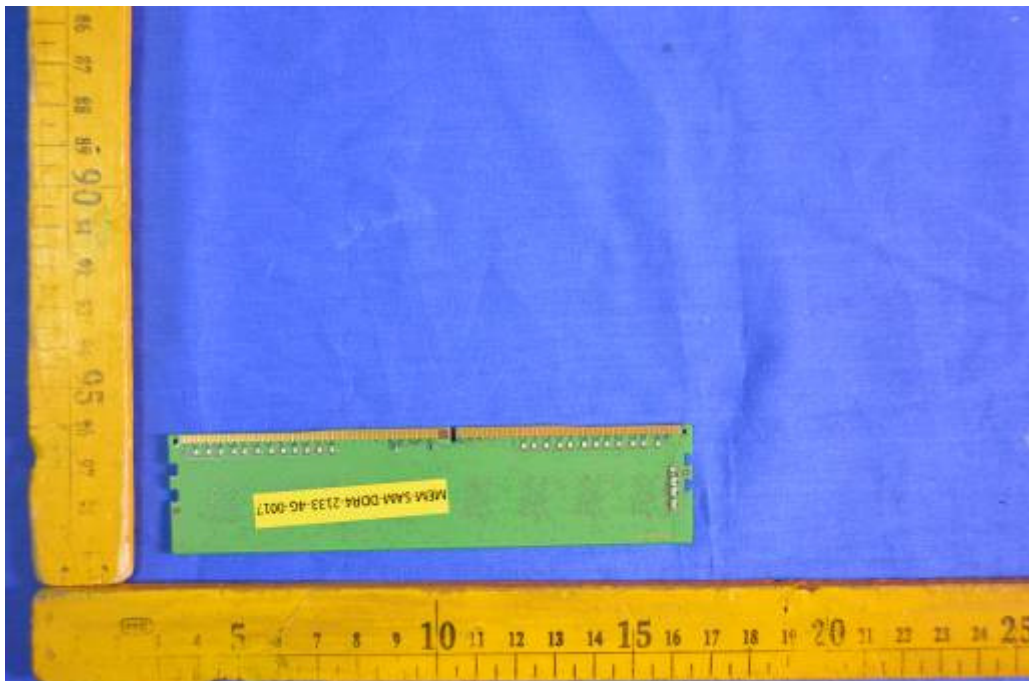

23) EUT Photo



24) EUT Photo





25) EUT Photo

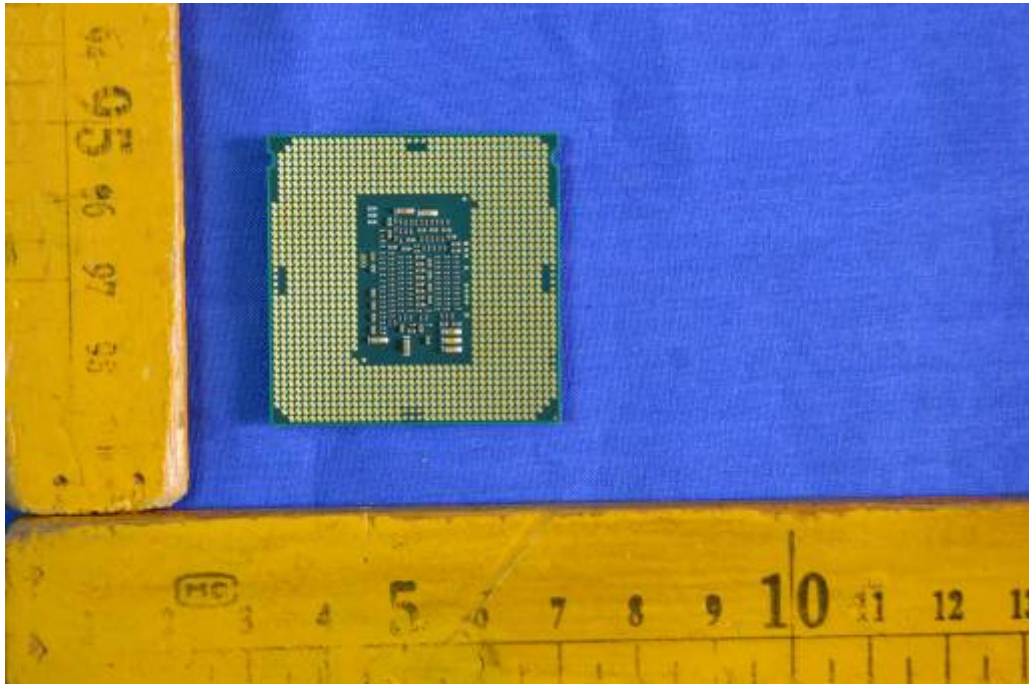

26) EUT Photo





27) EUT Photo



28) EUT Photo





29) EUT Photo

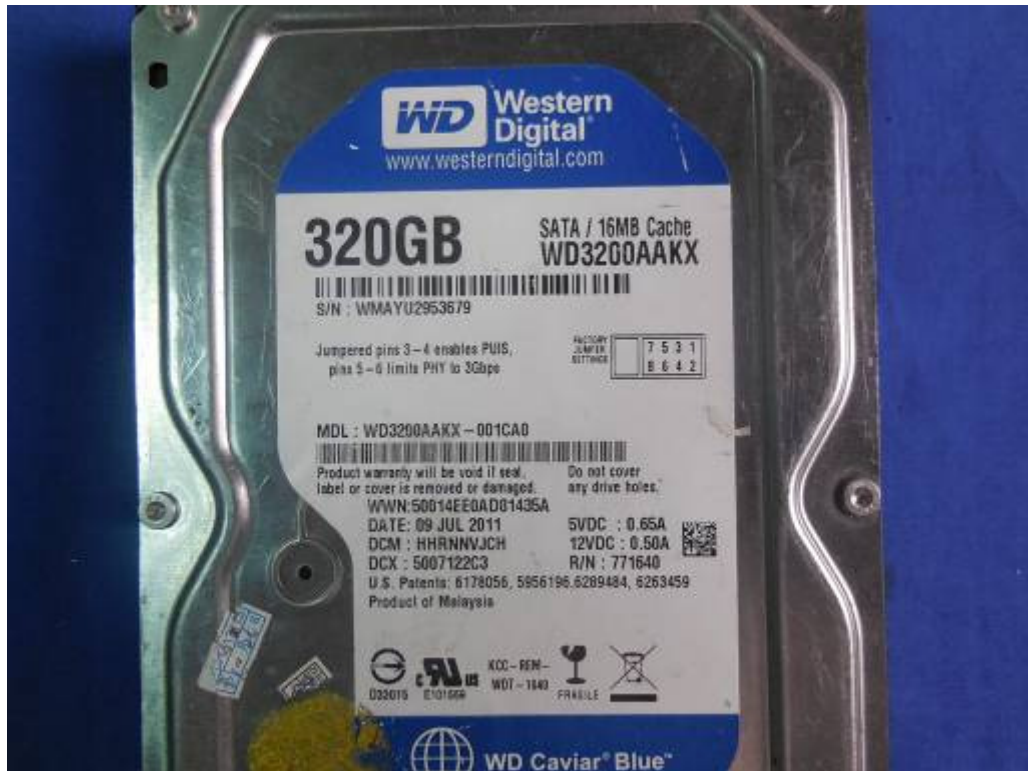

30) EUT Photo

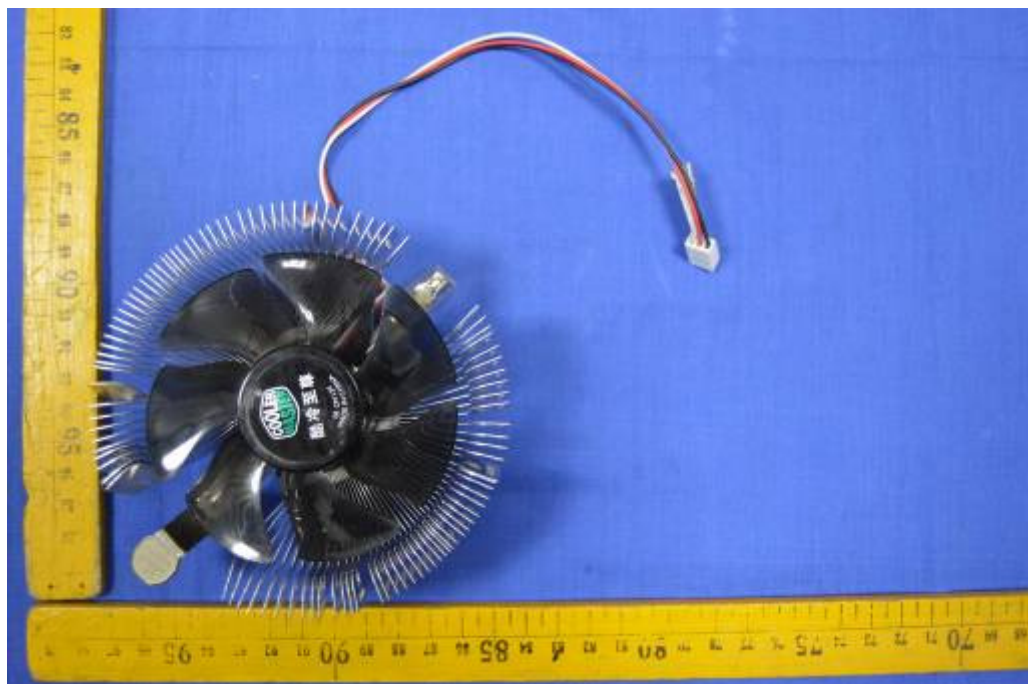



31) EUT Photo

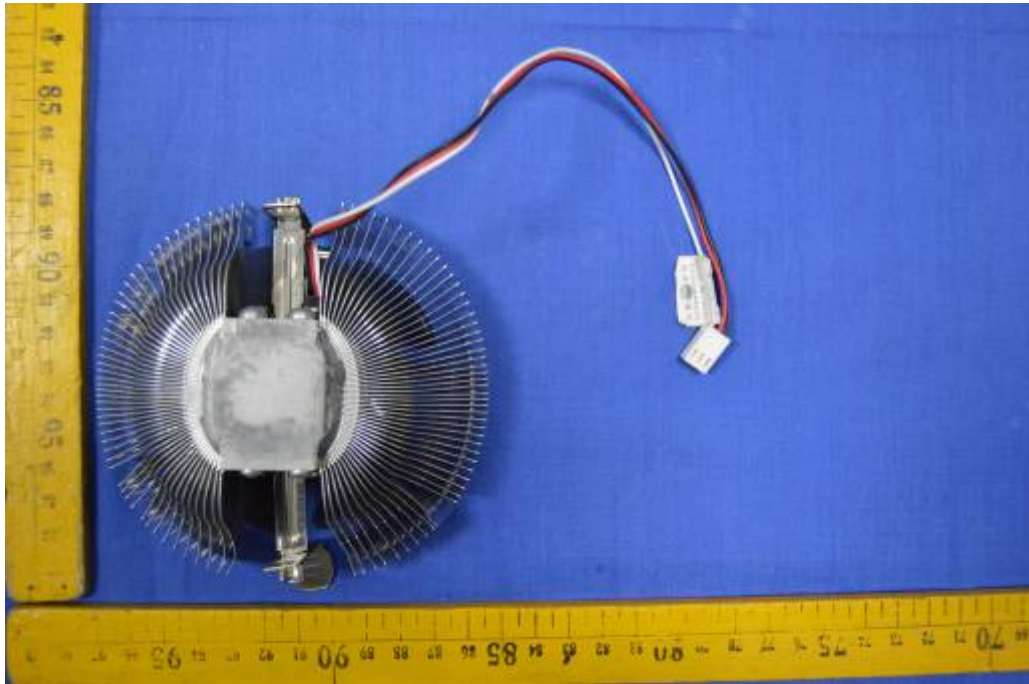

32) EUT Photo





33) EUT Photo



34) EUT Photo

