

# SIEMENS



## SINAMICS Drives

### SINAMICS S120

Chassis Format Converter Units  
Cabinet Modules

### SINAMICS S150















Converter Cabinet Units

Catalog  
D 21.3

Edition  
2017  
PDF Update  
11/2017

[siemens.com/drives](http://siemens.com/drives)

## Related catalogs

<p><b>SINAMICS G130</b> D 11 Drive Converter Chassis Units <b>SINAMICS G150</b> Drive Converter Cabinet Units</p> <p>E86060-K5511-A101-A6-7600</p>		<p><b>Industrial Controls</b> IC 10 SIRIUS</p> <p>E86060-K1010-A101-A7-7600</p>	
<p><b>SINAMICS GM150/SINAMICS SM150</b> D 12 Medium-Voltage Converters</p> <p>E86060-K5512-A101-A3-7600</p>		<p><b>Industrial Communication</b> IK PI SIMATIC NET</p> <p>E86060-K6710-A101-B8-7600</p>	
<p><b>SINAMICS G180</b> D 18.1 Converters – Compact Units, Cabinet Systems, Cabinet Units Air-Cooled and Liquid-Cooled</p> <p>E86060-K5518-A111-A2-7600</p>		<p><b>Low-Voltage Power Distribution and Electrical Installation Technology</b> LV 10 SENTRON • SIVACON • ALPHA Protection, Switching, Measuring and Monitoring Devices, Switchboards and Distribution Systems PDF (E86060-K8280-A101-A4-7600) Print (E86060-K8280-A101-A3-7600)</p>	
<p><b>Motion Control Drives</b> D 31 SINAMICS Inverters for Single-Axis Drives and SIMOTICS Motors</p> <p>E86060-K5531-A101-A2-7600</p>		<p><b>Products for Automation and Drives</b> CA 01 Interactive Catalog DVD</p> <p>E86060-D4001-A510-D8-7600</p>	
<p><b>SINAMICS Drives</b> D 35 SINAMICS G120P and SINAMICS G120P Cabinet pump, fan, compressor converters</p> <p>E86060-K5535-A101-A4-7600</p>		<p><b>Industry Mall</b> Information and Ordering Platform on the Internet:</p> <p><a href="http://www.siemens.com/industrymall">www.siemens.com/industrymall</a></p>	
<p><b>Motion Control Drives</b> D 21.4 SINAMICS S120 and SIMOTICS</p> <p>E86060-K5521-A141-A1-7600</p>			
<p><b>SIMOTICS GP, SD, XP, DP</b> D 81.1 <b>Low-Voltage Motors</b> Type series 1FP1, 1LE1, 1MB1 and 1PC1 Frame sizes 71 to 315 Power range 0.09 to 200 kW E86060-K5581-A111-A9-7600</p>			
<p><b>SIMOTICS FD</b> D 81.8 <b>Low-Voltage Motors</b> Frame sizes 315 to 450 Power range 200 to 1800 kW</p> <p>PDF (E86060-K5581-A181-A5-7600)</p>			
<p><b>LOHER Low-Voltage Motors</b> D 83.1 Type series 1MD5, 1PS0, 1PS1, 1PS4 and 1PS5 Frame sizes 71 to 500 Power range 0.12 to 1400 kW</p> <p>E86060-K5583-A111-A3-7600</p>			

## The Engineering Manual

### SINAMICS Low Voltage Engineering Manual

Engineering Manual for

- SINAMICS G130 Drive Converter Chassis Units,
- SINAMICS G150 Drive Converter Cabinet Units,
- SINAMICS S120 Chassis Format Units,
- SINAMICS S120 Cabinet Modules,
- SINAMICS S150 Converter Cabinet Units



This manual offers users comprehensive support with the configuring of drives and associated system components.

The first three chapters are devoted primarily to the fundamental physical principles of variable-speed electric drives and include EMC Installation Guidelines as well as general system descriptions and planning information which relate to all products in the SINAMICS range.

The other chapters then discuss in detail questions relating to the dimensioning of drives with converters of specific types as well as the selection of suitable motors.

#### Note:

**The manual is not available in hard copy form, but only as an electronic file in PDF format.**





**SIEMENS**

## SINAMICS S120

Chassis Format Converter Units, Cabinet Modules

## SINAMICS S150

Converter Cabinet Units

Catalog D 21.3 · 2017

Dear Customer,

We are pleased to present you with the new Catalog D 21.3 · 2017. This catalog provides a comprehensive overview of the powerful drive systems SINAMICS S120 chassis format converter units, SINAMICS S120 Cabinet Modules and SINAMICS S150 with the associated system components.

We would like to draw your attention to the following product innovations:

- SINAMICS S120 chassis format converter units in water-cooled version

These built-in units are specially designed for the operation of shared cooling circuits for the plant, motor and converter.

The products listed in this Catalog are also included in the new edition of the Interactive Catalog CA 01 on DVD-ROM and in the Industry Mall. Please contact your local Siemens office for additional information.

Up-to-date information about SINAMICS S120 and SINAMICS S150 is available on the Internet at:

[www.siemens.com/sinamics-s120](http://www.siemens.com/sinamics-s120)

[www.siemens.com/sinamics-s150](http://www.siemens.com/sinamics-s150)

You can access our Interactive Catalog and our Industry Mall on the Internet at:

[www.siemens.com/industrymall](http://www.siemens.com/industrymall)

We are keen to receive your suggestions and recommendations for improvement (please make reference to Catalog D 21.3 · 2017) at

[catalogs.industry@siemens.com](mailto:catalogs.industry@siemens.com)

We hope that you will often enjoy using Catalog D 21.3 · 2017 as a selection and ordering reference document and wish you every success with our products and solutions.

With kind regards,



Franz-Peter Petz

Vice President

Sales

Siemens AG, Process Industries and Drives, Large Drives





# SINAMICS S120 Chassis Format Converter Units

## SINAMICS S120 Cabinet Modules

## SINAMICS S150 Converter Cabinet Units

### SINAMICS Drives



#### Catalog D 21.3 · 2017 – PDF Update 11/2017

Supersedes:  
Catalog D 21.3 · 2015 (PDF)

Refer to the Industry Mall for current updates of  
this catalog:

[www.siemens.com/industrymall](http://www.siemens.com/industrymall)

The products contained in this catalog can also be found  
in the Interactive Catalog CA 01.

Article No.: E86060-D4001-A510-D8-7600

Please contact your local Siemens branch.

© Siemens AG 2017

### System Overview

1

### Highlights

2

### SINAMICS S120 Chassis Format Converter Units

75 kW to 5700 kW

3

### SINAMICS S120 Cabinet Modules

4,8 kW to 5700 kW

4

### SINAMICS S150 Converter Cabinet Units

75 kW to 1200 kW

5

### Tools and Engineering

6

### Services and Documentation

7

### Appendix

8



The products and systems described in  
this catalog are manufactured/distributed  
under application of a certified quality  
management system in accordance with  
EN ISO 9001 (Certified Registration  
No. 002241 QM UM). The certificate is  
recognized by all IQNet countries.

# Integrated Drive Systems

Faster on the market and in the black with Integrated Drive Systems

SINAMICS is an important element of a Siemens Integrated Drive System, contributing significantly to increased efficiency, productivity, and availability in industrial production processes.

Integrated Drive Systems are Siemens' trendsetting answer to the high degree of complexity that characterizes drive and automation technology today. The world's only true one-stop solution for entire drive systems is characterized in particular by its threefold integration: Horizontal, vertical,

and lifecycle integration ensure that every drive system component fits seamlessly into the whole system, into any automation environment, and even into the entire lifecycle of a plant.

The outcome is an optimal workflow – from engineering all the way to service that entails more productivity, increased efficiency, and better availability. That's how Integrated Drive Systems reduce time to market and time to profit.

## Horizontal integration

**Integrated drive portfolio:** The core elements of a fully integrated drive portfolio are frequency converters, motors, couplings, and gear units. At Siemens, they're all available from a single source. Perfectly integrated, perfectly interacting. For all power and performance classes. As standard solutions or fully customized. No other player in the market can offer a comparable portfolio. Moreover, all Siemens drive components are perfectly matched, so they are optimally interacting.

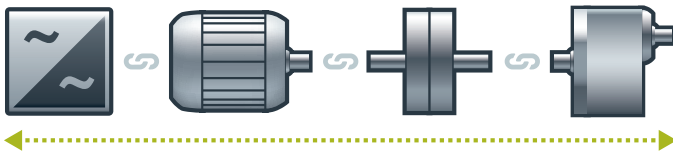

You can boost the availability of your application or plant to up to

**99%\***

\*e.g., conveyor application

## Vertical integration

Thanks to **vertical integration**, the complete drive train is seamlessly integrated in the entire automation environment – an important prerequisite for production with maximum value added. Integrated Drive Systems are part of Totally Integrated Automation (TIA), which means that they are perfectly embedded into the system architecture of the entire industrial production process. This enables optimal processes through maximum communication and control.

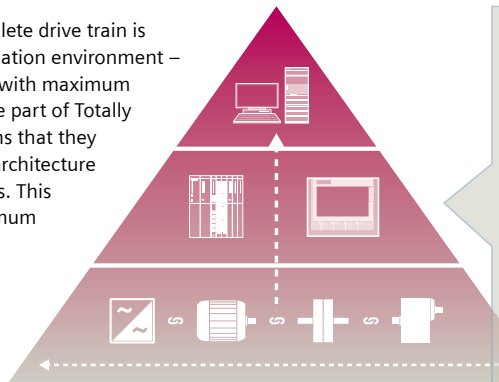

With TIA Portal you can cut your engineering time by up to

**30%**

## Lifecycle integration

**Lifecycle integration** adds the factor of time: Software and service are available for the entire lifecycle of an Integrated Drive System. That way, important optimization potential for maximum productivity, increased efficiency, and highest availability can be leveraged throughout the system's lifecycle – from planning, design, and engineering to operation, maintenance, and all the way even to modernization.

With Integrated Drive Systems, assets become important success factors. They ensure shorter time to market, maximum productivity and efficiency in operation, and shorter time to profit.

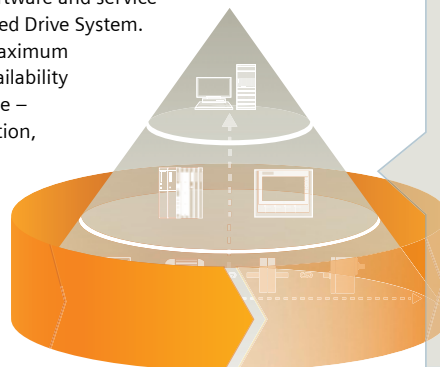

With Integrated Drive Systems you can reduce your maintenance costs by up to

**15%**

## System Overview



<b>1/2</b>	<b>The SINAMICS drive family</b>
1/2	Integration in automation
1/2	Applications
1/3	Energy efficiency
1/4	Variants
1/4	Platform concept
1/4	Quality management according to EN ISO 9001
1/6	System properties
1/6	Application areas
<b>1/7</b>	<b>Drive selection</b>
1/7	SINAMICS selection guide – typical applications
<b>1/8</b>	<b>SIMOTICS motors</b>
<b>1/9</b>	<b>SINAMICS S120</b>
	The flexible, modular drive system for demanding drive tasks
<b>1/12</b>	<b>SINAMICS S150</b>
	The drive solution for demanding single-motor drives



# System Overview

## The SINAMICS drive family

### Overview

#### Integration in automation

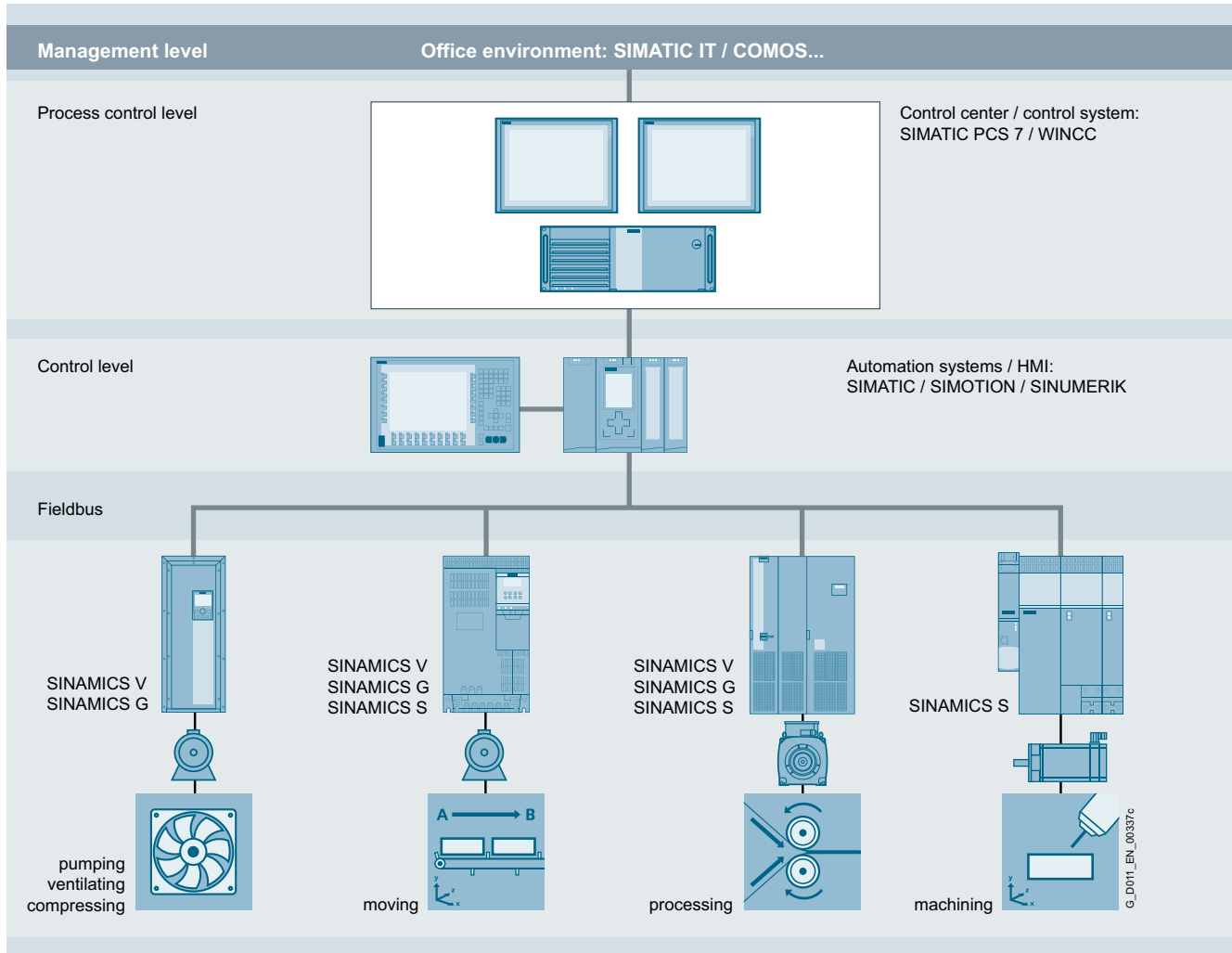

SINAMICS in the automation environment

#### Totally Integrated Automation and communication

SINAMICS is an integral component of Siemens Totally Integrated Automation. The integrated and seamless SINAMICS system covering engineering, data management, and communication at the automation level ensures solutions with low associated costs in conjunction with the SIMATIC, SIMOTION, and SINUMERIK control systems.

Depending on the application, the appropriate converter can be selected and incorporated in the automation concept. With this in mind, the converters are clearly subdivided into their different applications. A wide range of communication options (depending on the drive type) are available for establishing a communication link to the automation system:

- PROFINET
- PROFIBUS
- EtherNet/IP
- Modbus TCP
- Modbus RTU
- AS-Interface
- CANopen
- BACnet MS/TP
- Web server

#### Applications

SINAMICS is the comprehensive family of drives from Siemens designed for machine and plant engineering applications. SINAMICS offers solutions for all drive tasks:

- Simple pump and fan applications in the process industry
- Demanding single drives in centrifuges, presses, extruders, elevators, as well as conveyor and transport systems
- Drive line-ups in textile, plastic film, and paper machines as well as in rolling mill plants
- High-precision servo drives for the manufacture of wind turbines
- Highly dynamic servo drives for machine tools, as well as packaging and printing machines

## Overview (continued)



G\_D211\_XX\_00395

SINAMICS as part of the Siemens modular automation system

***Innovative, energy-efficient and reliable drive systems and applications as well as services for the entire drive train***

The solutions for drive technology place great emphasis on the highest productivity, energy efficiency and reliability for all torque ranges, performance and voltage classes.

Siemens offers not only the right innovative variable frequency drive for every drive application, but also a wide range of energy-efficient low voltage motors, geared motors, explosion-protected motors and high-voltage motors for combination with SINAMICS.

Furthermore, Siemens supports its customers with global pre-sales and after-sales services, with over 295 service points in 130 countries – and with special services e.g. application consulting or motion control solutions.

***Energy efficiency***

***Energy management process***

Efficient energy management consultancy identifies the energy flows, determines the potential for making savings and implements them with focused activities.

Almost two thirds of the industrial power requirement is from electric motors. This makes it all the more important to use drive technology permitting energy consumption to be reduced effectively even in the configuration phase, and consequently to optimize plant availability and process stability. With SINAMICS, Siemens offers powerful energy efficient solutions which, depending on the application, enable a significant reduction in electricity costs.

***Up to 70 % potential for savings using variable speed operation***

SINAMICS enables great potential for savings to be realized by controlling the motor speed. In particular, huge potential savings can be recovered from pumps, fans and compressors which are operated with mechanical throttle and valves. Here, changing to variable-speed drives brings enormous economic advantages. In contrast to mechanical control systems, the power consumption at partial load operation is always immediately adjusted to the demand at that time. So energy is no longer wasted, permitting savings of up to 60 % – in exceptional cases even up to 70 %. Variable-speed drives also offer clear advantages over mechanical control systems when it comes to maintenance and repair. Current spikes when powering up the motor and strong torque surges become things of the past – and the same goes for pressure waves in pipelines, cavitation or vibrations which cause sustainable damage to the plant. Smooth starting and ramp-down relieve the load on the mechanical system, ensuring a significantly longer service life of the entire drive train.

# System Overview

1

## The SINAMICS drive family

### Overview (continued)

#### Regenerative feedback of braking energy

In conventional drive systems, the energy produced during braking is converted to heat using braking resistors. Energy produced during braking is efficiently recovered to the supply system by versions of SINAMICS G and SINAMICS S drives with regenerative feedback capability and these devices do not therefore need a braking resistor. This permits up to 60 % of the energy requirement to be saved, e.g. in lifting applications. Energy which can be reused at other locations on a machine. Furthermore, this reduced power loss simplifies the cooling of the system, enabling a more compact design.

#### Variants

Depending on the application, the SINAMICS range offers the ideal variant for any drive task.

#### Energy transparency in all configuration phases

Early on, in the configuration phase, the SIZER for Siemens Drives engineering tool provides information on the specific energy requirement. The energy consumption across the entire drive train is visualized and compared with different plant concepts.

#### SINAMICS in combination with energy-saving motors

Engineering integration stretches beyond the SINAMICS drive family to higher-level automation systems, and to a broad spectrum of energy-efficient motors with a wide range of performance classes, which, compared to previous motors, are able to demonstrate up to 10 % greater efficiency.

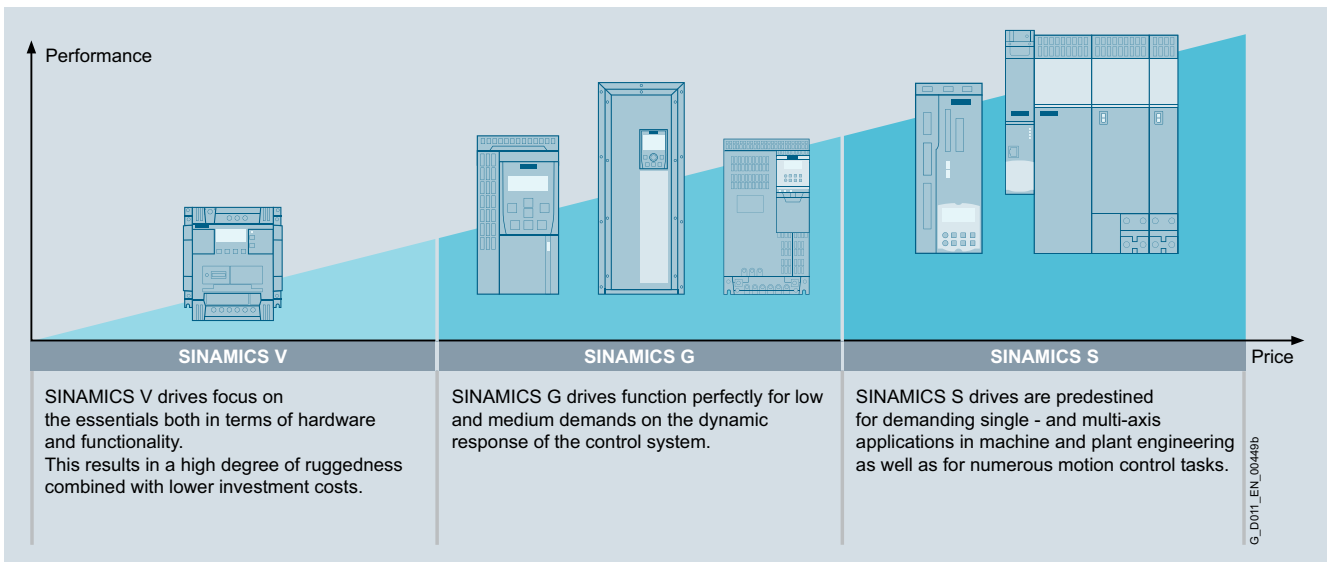

#### Platform concept

All SINAMICS variants are based on a platform concept. Joint hardware and software components, as well as standardized tools for dimensioning, configuration, and commissioning tasks ensure high-level integration across all components. SINAMICS handles a wide variety of drive tasks with no system gaps. The different SINAMICS variants can be easily combined with each other.

#### Quality management according to EN ISO 9001













SINAMICS conforms to the most exacting quality requirements. Comprehensive quality assurance measures in all development and production processes ensure a consistently high level of quality.

Of course, our quality management system is certified by an independent authority in accordance with EN ISO 9001.



## Overview (continued)

## The SINAMICS drive family

Low voltage										DC voltage	Medium voltage	
Basic performance		General performance					High performance			DC applications	Applications with high outputs	
												
SINAMICS V20	SINAMICS V90	SINAMICS G120C G120 G120P G120P Cabinet	SINAMICS G110D G120D G120P G110M SIMATIC ET 200pro FC-2	SINAMICS G130 G150	SINAMICS G180	SINAMICS S110	SINAMICS S210	SINAMICS S120 S120M	SINAMICS S150	SINAMICS DCM	SINAMICS GH150 GH180 GM150 SM150 GL150 SL150 SM120CM	
0.12 kW to 30 kW	0.05 kW to 7 kW	0.37 kW to 630 kW	0.37 kW to 7.5 kW	75 kW to 2700 kW	2.2 kW to 6600 kW	0.55 kW to 132 kW	0.05 kW to 0.75 kW	0.55 kW to 5700 kW	75 kW to 1200 kW	6 kW to 30 MW	0.15 MW to 85 MW	
Pumps, fans, compressors, conveyor belts, mixers, mills, spinning machines, textile machines, refrigerated display counters, fitness equipment, ventilation systems	Handling machines, packaging machines, automatic assembly machines, metal forming machines, printing machines, winding and unwinding units	Pumps, fans, compressors, conveyor belts, mixers, mills, extruders, building management systems, process industry, HVAC, single-axis positioning applications in machine and plant engineering	Conveyor technology, single-axis positioning applications (G120D)	Pumps, fans, compressors, conveyor belts, mixers, mills, extruders	Sector-specific for pumps, fans, compressors, conveyor belts, extruders, mixers, mills, kneaders, centrifuges, separators	Single-axis positioning applications in machine and plant engineering	Packaging machines, handling equipment, feed and withdrawal devices, stacking units, automatic assembly machines, laboratory automation, wood, glass and ceramics industry, digital printing machines	Production machines (packaging, textile and printing machines, paper machines, plastic processing machines), machine tools, plants, process lines and rolling mills, marine drives, test bays	Test bays, cross cutters, centrifuges	Rolling mill drives, wire-drawing machines, extruders and cableways and lifts, test bay drives	Pumps, fans, compressors, mixers, crushers, mills, extruders, rolling mills, conveyor technology, excavators, test bays, marine drives, blast furnace fans, retrofit	
Catalog D 31.1	Brochure V90	Catalogs D 31.1, D 35	Catalog D 31.2	Catalog D 11	Catalog D 18.1	Catalog D 31.1	Brochure S210	Catalogs D 21.3, D 21.4 NC 62	Catalog D 21.3	Catalog D 23.1	Catalogs D 15.1, D 12	
Engineering tools (e.g. Drive Technology Configurator, SIZER for Siemens Drives, STARTER and SINAMICS Startdrive)												

G\_D011\_EN\_004501

# System Overview

1

## The SINAMICS drive family

### Overview (continued)

#### System properties

The SINAMICS range is characterized by the following system properties:

- Standard and seamless functionality based on a platform concept
- Standardized engineering
- High degree of flexibility and combination capability
- Wide range of power ratings
- Designed for global use
- SINAMICS Safety Integrated
- Increased economic efficiency and effectiveness
- High energy efficiency
- Wide range of options when interfacing to higher-level control systems
- Totally Integrated Automation

#### Application areas

Tailored to suit different application areas, the SINAMICS range encompasses the following products:

#### AC low-voltage converters (line supply voltage < 1000 V)

- SINAMICS G110
  - The versatile drive for low power ratings
- SINAMICS G110D
  - The distributed, compact single-motor drive in a high degree of protection for basic applications
- SINAMICS G120
  - The modular single drive for low up to medium power ratings
- SINAMICS G120C
  - The compact drive with high power density
- SINAMICS G120D
  - The distributed, modular single-motor drive in a high degree of protection for sophisticated applications
- SINAMICS G120P
  - The specialist for pumps, fans, and compressors
- SINAMICS G130 and SINAMICS G150
  - The universal drive solution for high-performance single-motor drives
- SINAMICS G180
  - The specific drive solution for the oil & gas, chemical and process industries
- SINAMICS S110
  - The basic positioning drive for single-axis applications
- SINAMICS S120
  - The flexible, modular drive system for demanding drive tasks
- SINAMICS S150
  - The drive solution for demanding single-motor drives with energy recovery

#### DC converter (line supply voltage < 1000 V)

- SINAMICS DCM
  - The scalable drive system for both basic and demanding applications

#### AC medium-voltage converters (line supply voltage > 1000 V)

- SINAMICS GM150
  - The universal drive solution for single-motor drives
- SINAMICS SM150
  - The drive solution for demanding single-motor and multi-motor drives
- SINAMICS GL150
  - The drive solution for synchronous motors up to 120 MW
- SINAMICS SL150
  - The drive solution for rotors with a high number of poles (slow speed) for the highest torques and overloads
- SINAMICS PERFECT HARMONY GH150
  - Excellent versatility for cell-based medium-voltage converters
- SINAMICS PERFECT HARMONY GH180
  - Striking harmony between performance, process and technology.

More information about SINAMICS is available online at [www.siemens.com/sinamics](http://www.siemens.com/sinamics)

## Overview

## SINAMICS selection guide – typical applications

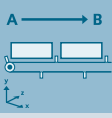
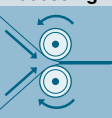
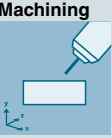
Use	Requirements for torque accuracy/speed accuracy/position accuracy/coordination of axes/functionality					
	Continuous motion			Non-continuous motion		
	Basic	Medium	High	Basic	Medium	High
<b>Pumping, ventilating, compressing</b> 	Centrifugal pumps Radial / axial fans Compressors V20 G120C G120P	Centrifugal pumps Radial / axial fans Compressors G120P G130/G150 G180 <sup>1)</sup>	Eccentric screw pumps <b>S120</b>	Hydraulic pumps Metering pumps G120	Hydraulic pumps Metering pumps S110	Descaling pumps Hydraulic pumps <b>S120</b>
<b>Moving</b> 	Conveyor belts Roller conveyors Chain conveyors V20 G110D G110M G120C ET 200pro FC-2 <sup>2)</sup>	Conveyor belts Roller conveyors Chain conveyors Lifting/lowering devices Elevators Escalators/moving walkways Indoor cranes Marine drives Cable railways G120 G120D G130/G150 G180 <sup>1)</sup>	Elevators Container cranes Mining hoists Excavators for open-cast mining Test bays <b>S120</b> <b>S150</b> DCM	Acceleration conveyors Storage and retrieval machines V90 G120 G120D	Acceleration conveyors Storage and retrieval machines Cross cutters Reel changers S110 DCM	Storage and retrieval machines Robotics Pick & place Rotary indexing tables Cross cutters Roll feeds Engagers/disengagers <b>S120</b> DCM
<b>Processing</b> 	Mills Mixers Kneaders Crushers Agitators Centrifuges V20 G120C	Mills Mixers Kneaders Crushers Agitators Centrifuges Extruders Rotary furnaces G120 G130/G150 G180 <sup>1)</sup>	Extruders Winders/unwinders Lead/follower drives Calenders Main press drives Printing machines <b>S120</b> <b>S150</b> DCM	Tubular bagging machines Single-axis motion control such as • Position profiles • Path profiles V90 G120	Tubular bagging machines Single-axis motion control such as • Position profiles • Path profiles S110	Servo presses Rolling mill drives Multi-axis motion control such as • Multi-axis positioning • Cams • Interpolations <b>S120</b> DCM
<b>Machining</b> 	Main drives for • Turning • Milling • Drilling S110	Main drives for • Drilling • Sawing <b>S110</b> <b>S120</b>	Main drives for • Turning • Milling • Drilling • Gear cutting • Grinding <b>S120</b>	Axis drives for • Turning • Milling • Drilling S110	Axis drives for • Drilling • Sawing <b>S110</b> <b>S120</b>	Axis drives for • Turning • Milling • Drilling • Lasering • Gear cutting • Grinding • Nibbling and punching <b>S120</b>

Using the SINAMICS selection guide

The varying range of demands on modern variable frequency drives requires a large number of different types. Selecting the optimum drive has become a significantly more complex process. The application matrix shown simplifies this selection process considerably, by suggesting the ideal SINAMICS drive for examples of typical applications and requirements.

- The application type is selected from the vertical column
  - Pumping, ventilating, compressing
  - Moving
  - Processing
  - Machining
- The quality of the motion type is selected from the horizontal row
  - Basic
  - Medium
  - High

## More information

Further information about SINAMICS is available on the Internet at [www.siemens.com/sinamics](http://www.siemens.com/sinamics)

Practical application examples and descriptions are available on the Internet at [www.siemens.com/sinamics-applications](http://www.siemens.com/sinamics-applications)

<sup>1)</sup> Industry-specific drives.





<sup>2)</sup> Information on the SIMATIC ET 200pro FC-2 frequency converter is available at [www.siemens.com/et200pro-fc](http://www.siemens.com/et200pro-fc)

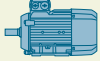
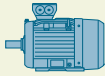
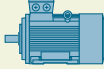
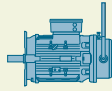
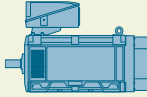
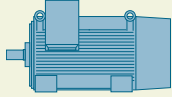
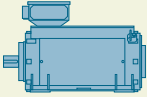

# System Overview

## SIMOTICS motors

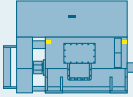
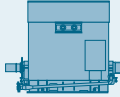
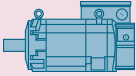
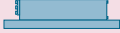
### Overview

SIMOTICS						
Low-voltage motors for line and converter operation						
General Purpose SIMOTICS GP	Severe Duty SIMOTICS SD	Explosion-proof SIMOTICS XP	Definite Purpose SIMOTICS DP	Flexible Duty SIMOTICS FD	Non standard SIMOTICS TN	High Torque SIMOTICS HT
						
DC motors		High-voltage motors				
Direct current SIMOTICS DC		High Voltage SIMOTICS HV				
						
Motors for motion control						
SIMOTICS S servomotors		SIMOTICS M main motors		SIMOTICS L linear motors		SIMOTICS T torque motors
Servomotors	Servo geared motors					

G\_DD01\_EN\_00401

#### SIMOTICS stands for

- 150 years of experience in building electric motors
- The most comprehensive range of motors worldwide
- Optimum solutions in all industries, regions and power/performance classes
- Innovative motor technologies of the highest quality and reliability
- Highest dynamic performance, precision and efficiency together with the optimum degree of compactness
- Our motors can be integrated into the drive train as part of the overall system
- A global network of skill sets and worldwide service around the clock

#### A clearly structured portfolio

The entire SIMOTICS product portfolio is transparently organized according to application-specific criteria in order to help users select the optimum motor for their application.

The product range extends from standard motors for pumps, fans and compressors to highly dynamic, precise motion control motors for positioning tasks and motion control in handling applications, as well as production machinery and machine tools, to DC motors and powerful high-voltage motors. Whatever it is that you want to move – we can supply the right motor for the task.

#### An outstanding performance for any job

A key characteristic of all SIMOTICS motors is their quality. They are robust, reliable, dynamic and precise to assure the requisite performance level for any process and deliver exactly the capabilities demanded by the application in hand. Thanks to their compact design, they can be integrated as space-saving units into installations. Furthermore, their impressive energy efficiency makes them effective as a means of reducing operating costs and protecting the environment.

#### A dense network of skill sets and servicing expertise around the world

SIMOTICS offers not only a wealth of sound experience gleaned from a development history which stretches back over around 150 years, but also the know-how of hundreds of engineers. This knowledge and our worldwide presence form the basis for a unique proximity to industries which feeds through in tangible terms to the specific motor configuration which is tailored to suit your application.

Our specialists are available to answer all your queries regarding any aspect of motor technology. At any time - wherever you are in the world. When you choose SIMOTICS, therefore, you reap the benefits of a global service network which is continuously accessible, thereby helping to optimize response times and minimize downtimes.

#### Perfection of the complete drive train

SIMOTICS is perfectly coordinated with other Siemens product families. In combination with the SINAMICS integrated drives family and the SIRIUS complete portfolio of industrial controls, SIMOTICS fits seamlessly as part of the complete drive train into automation solutions which are based on the SIMATIC, SIMOTION and SINUMERIK control systems.

## Overview

### *The flexible, modular drive system for demanding drive tasks*

SINAMICS S120 is the modular drive system with vector and servo control that is ideal for sophisticated drive tasks in plant and machine construction.

Multi-axis drive solutions with higher-level motion control can be implemented with the modular SINAMICS S120 system just the same as solutions for single-axis drives.

Covering a power range from 0.12 kW to 5700 kW and various control modules with a graduated range of functions, the modular SINAMICS S120 system can be used to simply and quickly create a precisely tailored drive configuration – for almost any sophisticated drive application.

On the SINAMICS S120, the drive intelligence is combined with closed-loop control functions into Control Units.

These units are capable of controlling drives in the vector, servo and V/f modes. They also perform the speed and torque control functions plus other intelligent drive functions for all axes on the drive.

Using the available closed-loop control techniques, both synchronous as well as induction motors can be operated, and therefore the complete range of low-voltage motors from Siemens.

Integrated PROFINET or PROFIBUS DP interfaces ensure easy integration into complete automation solutions. SINAMICS S120 also supports many other fieldbus interfaces.

SINAMICS S120 Cabinet Modules are available as a cabinet system specifically for use in plant construction. These can be combined to form drive cabinet line-ups with a total power rating of up to 5700 kW. Standardized interfaces enable the modules to be linked quickly to create a ready-to-connect drive solution for multi-motor applications.

## Benefits

SINAMICS S120 is characterized by the following properties:

- Can be universally used in high-performance single and multi-axis applications
- Can be freely combined to create customized solutions
- Wide range of power ratings
- Wide range of functions
- SINAMICS Safety Integrated functions
- Supports various cooling types (air/liquid-cooled)
- Supports various infeed concepts
- Can be simply integrated into higher-level automation and IT environments
- User-friendly engineering
- Ease of handling
- Simple installation
- Practical connection system
- Auto-configuration with electronic type plates

## Application

SINAMICS S120 vector control is recommended for drive solutions with continuous material webs, for example, wire-drawing machines, film and paper machines, as well as for hoisting gear, centrifuges and marine drives with harmonic, circular motion.

SINAMICS S120 with servo control and servo motors is employed for cyclic processes with both precise and highly dynamic closed-loop position control.

With SINAMICS S120, more performance is integrated into machines that are used in many industries, for instance in:

- Packaging machines
- Plastics processing machines
- Textile machines
- Presses and punches
- Printing and paper machines
- Machines used in the woodworking, glass and ceramics industries
- Hoisting gear
- Handling and assembly systems
- Machine tools
- Rolling mill drives
- Vehicle and gearbox test bays
- Text bay applications
- Marine applications

# System Overview

## SINAMICS S120

### Design

SINAMICS S120 built-in units are available as Power Modules, Line Modules and Motor Modules with the appropriate line-side and motor-side components.

#### Cooling types

There are various cooling options available depending on the type of construction:

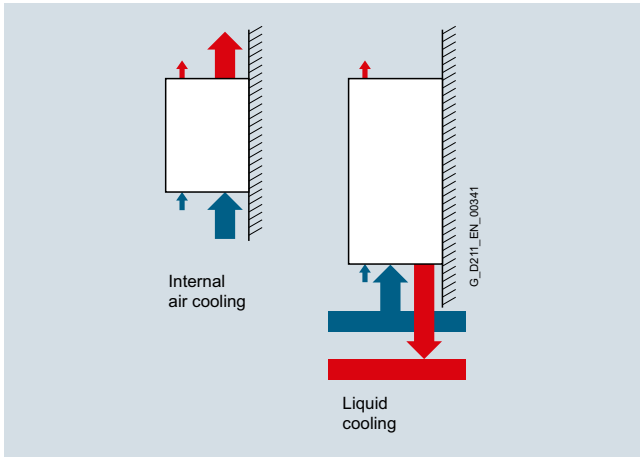

#### Internal air cooling

In this standard solution, the power loss from the electronics and power units of the drive components is removed by natural cooling or by a forced-ventilation system and routed to the interior of the control cabinet.

#### Liquid cooling

On liquid-cooled units, the power semiconductors are mounted on a heat sink through which the cooling medium flows. Most of the heat produced by the unit is absorbed by the cooling medium and can be dissipated outside the control cabinet.

#### Water cooling for shared circuits

With water cooling for shared circuits, the water that is available at the plant can be used. This results in a shared cooling circuit for the plant, motor, and converter. The requirements for the water quality are low in this case. Additives are not needed in the water circuit which simplifies environmentally friendly commissioning and maintenance. Furthermore, the converter is resistant to the addition of oxygen to the cooling water. The advantages of liquid cooling, such as high energy savings and efficient heat recovery, are also available with water cooling.

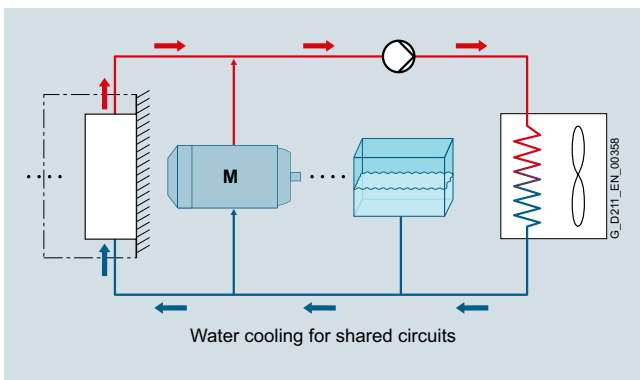

#### Types of construction

Power Modules are available in blocksize and chassis formats. Motor Modules and Line Modules are available in booksize, booksize compact and chassis formats.

Precise details and ordering data on the booksize, booksize compact and blocksize formats are found in Catalog D 21.4.

#### Booksize format

Booksize format units are optimized for multi-axis applications and are mounted adjacent to one another. The connection for the common DC link is an integral feature.

The units are cooled by an internal air cooling circuit.

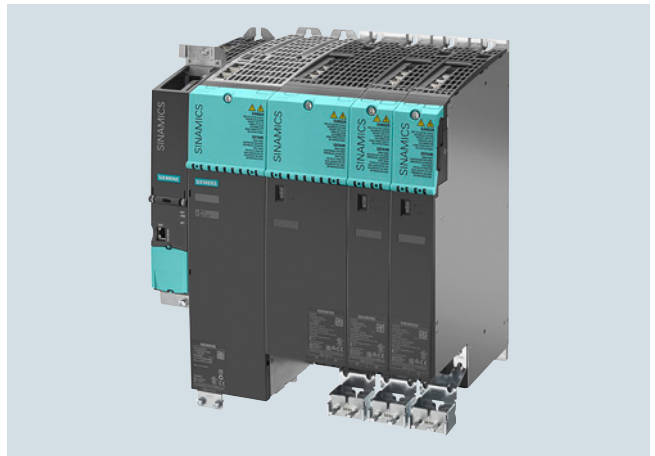

#### Booksize compact format

Derived from the booksize format we developed the booksize compact format for machines with particularly high requirements for the compactness of their drives.

The booksize compact format combines all benefits of the booksize format and provides the same performance with an even smaller overall height and an extended overload capability.

The booksize compact format is thus particularly suitable for integration into machines requiring a high dynamic performance and where installation space is restricted.

The units are cooled by an internal air cooling circuit.



**Design** (continued)**Blocksize format**

Blocksize format units are optimized for single-axis applications and are supplied only as Power Modules. The CU310-2 can be directly snap-mounted. The units are cooled by an internal air cooling circuit.

**Chassis format**

Higher-output units (approximately 100 kW and above) are constructed in chassis format. These drive units are available as:

- Power Modules
- Basic Line Modules
- Smart Line Modules (air-cooled only)
- Active Line Modules
- Active Interface Modules
- Motor Modules

Chassis format units are cooled by an internal air cooling circuit, liquid cooling, or water cooling for shared circuits. The CU310-2 Control Unit can be integrated in the Power Modules.



Liquid-cooled units and water-cooled units for shared circuits are used primarily for applications where installation space is restricted (up to a 60 % smaller footprint when compared to air cooling) or where low noise emissions are important. They are also suitable for applications in tough ambient conditions.

**Cabinet Modules**

SINAMICS S120 Cabinet Modules are a modular cabinet system for multi-motor drives with a central supply infeed and a common DC busbar, for example, as used in paper machines, rolling mills, test bays, and hoisting gear. Cabinet Modules are available with a total power rating of up to 4500 kW in the air-cooled version and up to 5700 kW in the liquid-cooled version. The main components of the system are as follows:

- Line Connection Modules
- Basic Line Modules
- Smart Line Modules
- Active Line Modules including Active Interface Modules
- Central Braking Modules
- Motor Modules
- Auxiliary Power Supply Modules



# System Overview

1

## SINAMICS S150

### Overview

*The drive solution for demanding single-motor drives*



SINAMICS S150 cabinet units are designed for variable-speed drives in plant and machinery construction.

They are especially suitable where high demands are placed on dynamic performance and speed precision, as well as for frequent braking cycles with high braking energies and four-quadrant operation. The drive converter cabinet units provide high performance speed control with a high precision and dynamic performance, and are available for a power range extending from 75 kW up to 1200 kW.

### Design

SINAMICS S150 systems are ready-to-connect converters accommodated in a standard control cabinet.

They can be optimally adapted to specific requirements as a result of a wide range of options.

Different variants allow the line and the motor connection to be made at the top or bottom. This ensures a high degree of flexibility regarding how the drive is installed.

The drive units are available with cabinet widths starting from 1400 mm in grid dimension increments of 200 mm. As standard, the cabinets have degree of protection IP20, and can be optionally increased up to IP54. The AOP30 Advanced Operator Panel is fitted as standard in the cabinet door.

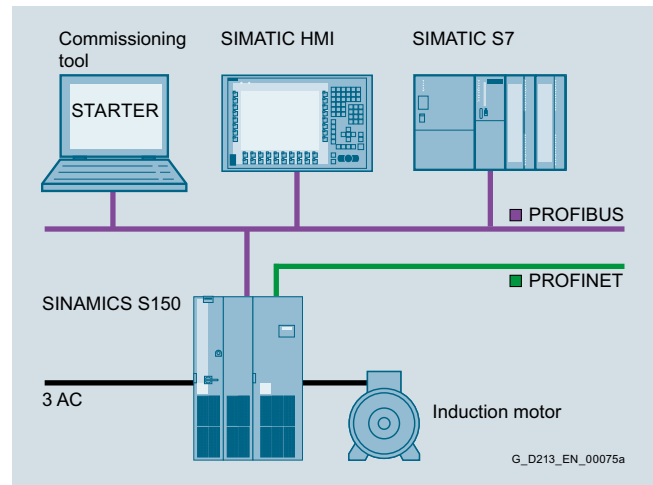

## Highlights



### 2/2 **Safety Integrated**

2/2 Overview  
2/3 Functions

### 2/12 **Safety Integrated for SINAMICS S120 Chassis Format Converter Units, SINAMICS S120 Cabinet Modules and SINAMICS S150 Drive Converter Cabinet Units**

2/12 Overview  
2/13 Benefits  
2/14 Functions

### 2/15 **Communication**

2/15 Overview  
2/16 PROFINET  
2/21 PROFIdrive  
2/22 PROFIBUS  
2/23 Industrial Ethernet  
2/24 EtherNet/IP  
2/24 Modbus TCP  
2/24 CANopen  
2/24 USS



## Highlights

### Safety Integrated

#### Overview



#### Legal framework

Machine manufacturers and manufacturing plants must ensure that their machines or plants cannot cause danger due to malfunctions in addition to the general risks of electric shock, heat or radiation.

In Europe, for example, compliance with the Machinery Directive 2006/42/EC is legally stipulated by the EU work safety directive. In order to ensure compliance with this directive, it is recommended that the corresponding harmonized European standards are applied. This triggers the "assumption of conformity" and gives manufacturers and operators the legal security in terms of compliance with both national regulations and EU directives. The machine manufacturer uses the CE marking to document the compliance with all relevant directives and regulations in the free movement of goods.

#### Safety-related standards

Functional safety is specified in various standards. For example, EN ISO 12100 specifies standards pertaining to machine safety (risk assessment and risk reduction). IEC 61508 specifies basic requirements for electronic and programmable safety-related systems. EN 62061 (only applicable for electrical and electronic control systems) and EN ISO 13849-1, which has replaced EN 954-1, define the functional and safety-related requirements of safety-oriented control systems.

The above-mentioned standards define different safety requirements that the machine has to satisfy in accordance with the risk, frequency of a dangerous situation, probability of occurrence and the opportunities for recognizing impending danger.

- EN ISO 13849-1:  
Performance Level PL a ... e;  
Category B, 1 ... 4
- EN 62061:  
Safety Integrity Level SIL 1 ... 3

#### Trend toward integrated safety systems

The trend toward greater complexity and higher modularity of machines has seen a shift in safety functions away from the classical central safety functions (for example, shutdown of the complete machine using a main switch) and into the machine control system and the drives. This is often accompanied by a significant increase in productivity because the equipping times are shortened. Depending on the type of machine, it may even be possible to continue manufacturing other parts while equipping is in progress.

Integrated safety functions act much faster than those of a conventional design. The safety of a machine is increased further with Safety Integrated. Furthermore, thanks to the faster method of operation, safety measures controlled by integrated safety systems are perceived as less of a hindrance by the machine operator, therefore significantly reducing the motivation to consciously bypass safety functions.

## Function

### Safety functions integral to the SINAMICS drives

SINAMICS drives are characterized by a large number of integrated safety functions. In combination with the sensors and safety control required for the safety functionality, they ensure that highly-effective protection for persons and machines is implemented in a practice-oriented manner.

They comply with the requirements of the following safety categories:

- PL d and Category 3 according to EN ISO 13849-1
- SIL 2 according to IEC 61508 and IEC 61800-5-2

#### Note:

The Safe Brake Test (SBT) diagnostic function meets the requirements for Category 2 according to EN ISO 13849-1.

The Safety Integrated functions of the SINAMICS drives are generally certified by independent institutes. You can obtain the corresponding test certificates and manufacturer's declarations from your Siemens contacts.

The integrated safety functions that are currently available in the SINAMICS drive system are described below. Their functional safety satisfies the requirements defined in the international standard IEC 61800-5-2 for variable-speed drive systems.

The safety functions integrated into the SINAMICS drive system can be roughly divided into four categories:

- **Functions for safely stopping a drive**
  - Safe Torque Off (STO)
  - Safe Stop 1 (SS1)
  - Safe Stop 2 (SS2)
  - Safe Operating Stop (SOS)
- **Functions for safe brake management**
  - Safe Brake Control (SBC)
  - Safe Brake Test (SBT) (this diagnostic function exceeds the scope of IEC 61800-5-2)
- **Functions for safely monitoring the motion of a drive**
  - Safely-Limited Speed (SLS)
  - Safe Speed Monitor (SSM)
  - Safe Direction (SDI)
- **Functions for safely monitoring the position of a drive**
  - Safely-Limited Position (SLP)
  - Safe Position (SP) (this function exceeds the scope of IEC 61800-5-2)

The Safety Integrated Function Manual contains detailed information about the safety functions.

<https://support.industry.siemens.com/cs/document/109740018>

Further manuals pertaining to Safety Integrated in drive systems can be found on the Internet at

<https://support.industry.siemens.com/cs/ww/en/ps/13231/man>

Further information about Safety Integrated can be found on the Internet at

[www.siemens.com/safety-drives](http://www.siemens.com/safety-drives)

### Safe Torque Off (STO)

The STO function is the most common and basic drive-integrated safety function. It ensures that no torque-generating energy can continue to affect a motor and prevents unintentional start-ups.

#### Effect

This function is a mechanism that prevents the drive from restarting unexpectedly, in accordance with EN 60204-1, Section 5.4. The STO function suppresses the drive pulses (corresponds to Stop Category 0 according to EN 60204-1). The drive is reliably torque-free. This state is monitored internally in the drive.

#### Application

STO has the immediate effect that the drive cannot supply any torque-generating energy. STO can be used wherever the drive will naturally reach a standstill due to load torque or friction in a sufficiently short time or when "coasting down" of the drive will not have any relevance for safety.

STO makes it possible for persons to work safely when the protective door is open (restart interlock) and is used on machines/installations with moving axes, e.g. on handling or conveyor systems.

#### Customer benefits

Some of the advantages of the integrated STO safety function over conventional safety technology with electromechanical switchgear include the elimination of separate components as well as of the work that would be required to wire and service them, i.e. no wearing parts as a result of the electronic shutdown. Because of the fast electronic switching times, the function provides a shorter reaction time than the conventional solution comprising electromechanical components. When STO is triggered, the converter remains connected to the network and can be fully diagnosed.

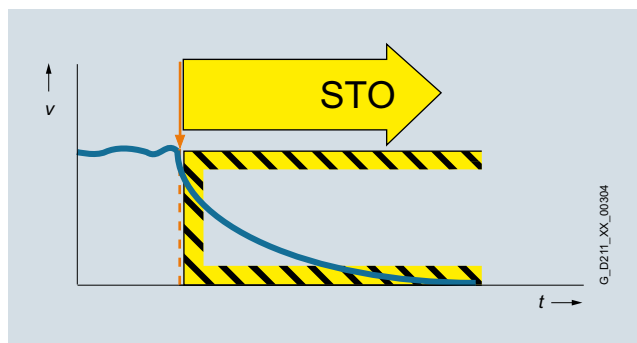

## Highlights

### Safety Integrated

#### Function (continued)

##### Safe Stop 1 (SS1)

The SS1 function causes a motor to stop rapidly and safely and switches the motor to torque-free mode after coming to a standstill by activating STO.

##### Effect

The SS1 function can safely stop the drive in accordance with EN 60204-1, Stop Category 1. When the SS1 function is selected, the drive brakes autonomously along a quick stop ramp and automatically activates the Safe Torque Off and Safe Brake Control functions (if configured) when the parameterized safety delay time expires.

##### Application

The SS1 function is used when, in the event of a safety-relevant incident, the drive must stop as quickly as possible with a subsequent transition into the STO state (e.g. EMERGENCY STOP). It is thus used to bring large centrifugal masses to a stop as quickly as possible for the safety of the operating personnel, or to brake motors at high speeds as quickly as possible. Examples of typical applications are saws, grinding machine spindles, centrifuges, winders and storage and retrieval machines.

##### Customer benefits

The targeted stopping of a drive by means of SS1 reduces the risk of danger, increases the productivity of a machine, and allows the safety clearances in a machine to be reduced. The principle is to bring the drive actively to a standstill, compared with just using the STO function. Complex mechanical brakes that are susceptible to wear are not normally required to brake the motor.

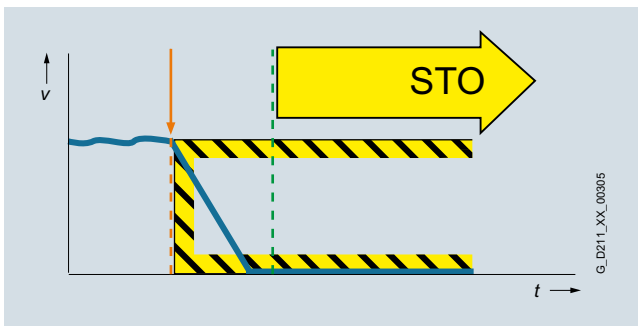

##### Safe Stop 2 (SS2)

The SS2 function brings the motor to a standstill quickly and safely and then activates the SOS function once the motor has stopped.

##### Effect

The Safe Stop 2 function can safely stop the drive in accordance with EN 60204-1, Stop Category 2. When the SS2 function is selected, the drive brakes autonomously along a quick stop ramp. In contrast to SS1, the drive control remains operational afterwards, i.e. the motor can supply the full torque required to maintain zero speed. Standstill is safely monitored (Safe Operating Stop function).

##### Application

As with SS1, the SS2 function ensures the quickest possible deceleration of the motor. However, the motor power is not switched off. Instead, a control system prevents it from leaving the standstill position – even if it is affected by external forces. Typical applications for SS2 include machine tools, for example.

##### Customer benefits

The SS2 function ensures a rapid axis stop. Because the control remains active, after the safety function is deselected, productive operation can continue without referencing. This ensures short setup and standstill times and high productivity.

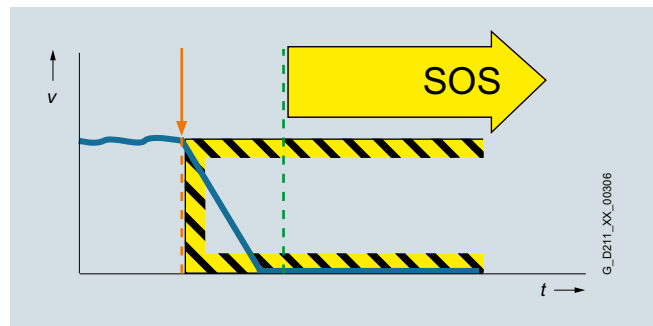

**Function** (continued)**Safe Operating Stop (SOS)**

With the SOS function, the stopped motor is held in position by the drive control system and its position monitored.

Effect

The SOS function constitutes safe standstill monitoring. The drive control remains in operation. The motor can therefore deliver the full torque to hold the current position. The actual position is reliably monitored. In contrast to safety functions SS1 and SS2, the speed setpoint is not influenced autonomously. After SOS has been activated, the higher-level control must bring the drive to a standstill within a parameterized time and then hold the position setpoint.

Application

SOS is an ideal solution for all those applications for which the machine or parts of the machine must be at a safe standstill for certain steps, but the drive must also supply a holding torque. It is ensured that despite counter torque the drive remains in its current position. In contrast to SS1 and SS2, the drive does not brake autonomously in this case. It expects the higher-level controller to ramp down the relevant axes as a coordinated group within an adjustable delay time. This can be used to prevent any damage to the machine or product. Typical applications for SOS include winders, converting and packaging machines and machine tools.

Customer benefits

No mechanical components are necessary to keep the axis in position despite any counterforce that may occur. Due to the short switching times and the fact that the drive control always remains active, setup and downtimes are reduced. Recalibration of the axis after exiting the SOS function is not necessary. The axis can immediately be moved again after deactivation of the SOS function.

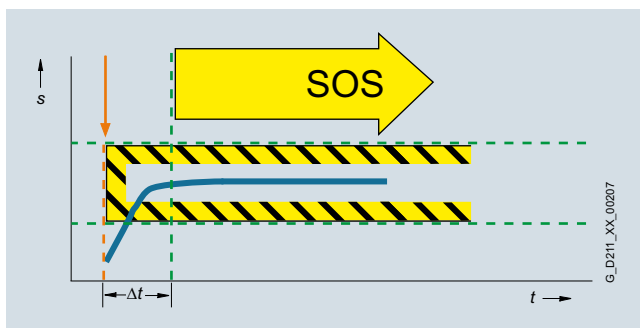
**Safe Brake Control (SBC)**

The SBC function permits the safe control of a holding brake. SBC is always activated in parallel with STO.

Effect

A holding brake which is active in a de-energized state is controlled and monitored using safe two-channel technology. Due to the two-channel control, the brake may still be activated in the event of an insulation fault in the control cable. Errors of this kind are detected early by means of test pulses.

Note:

An additional Safe Brake Relay is required for power units in blocksize format. An additional Safe Brake Adapter is necessary for power units in chassis format.

Application

The SBC function is used in conjunction with the functions STO or SS1 to prevent the movement of an axis in the torque-free state, e.g. because of gravity.

Customer benefits

Again, the function saves the use of external hardware and the associated wiring.

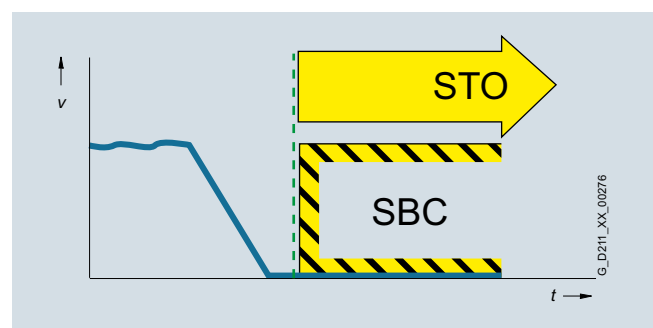

## Highlights

### Safety Integrated

#### Function (continued)

##### Safe Brake Test (SBT)

The SBT diagnostic function carries out a brake function test at regular intervals or before personnel enter the danger zone.

##### Effect

A good way to check the proper functioning of brakes that have become worn is to apply a torque to the closed brake. Drive systems that have two brakes, e.g. motor brake and external brake, can be tested with different torque values.

##### Application

The SBT diagnostic function is suitable for implementing a safe brake in combination with the SBC function.

##### Customer benefits

The function detects faults or wear in the brake mechanics. Automatically testing the effectiveness of brakes reduces maintenance costs and increases the safety and availability of the machine or plant.

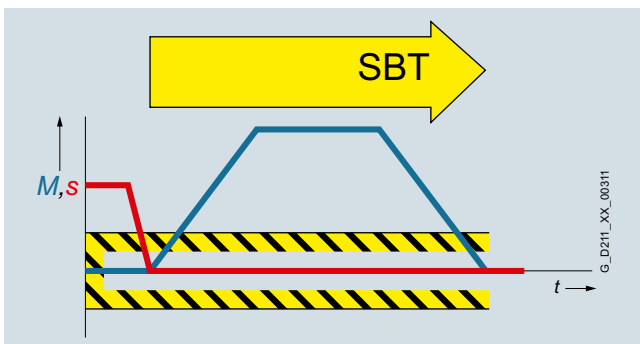

##### Safely-Limited Speed (SLS)

The SLS function monitors the drive to ensure that it does not exceed a preset speed or velocity limit.

##### Effect

The SLS function monitors the drive against a parameterized speed limit. Four different limit values can be selected. As in the case of SOS, the speed setpoint is not influenced independently. After SLS has been selected, the higher-level control must bring the drive down below the selected speed limit within a parameterizable time. If the speed limit is exceeded, a customizable drive-integrated fault reaction occurs.

The SLS limit stage 1 can be multiplied by a factor that is transferred in 16-bit resolution via PROFIsafe. This allows an almost unlimited number of limits to be specified.

##### Application

The SLS function is used if people are in the danger zone of a machine and their safety can only be guaranteed by reduced speed. Typical application cases include those in which an operator must enter the danger zone of the machine for the purposes of maintenance or setting up, such as a winder in which the material is manually threaded by the operator. To prevent injury to the operator, the roller may only spin at a safely reduced speed. SLS is often also used as part of a two-stage safety concept. While a person is in a less critical zone, the SLS function is activated, and the drives are only stopped in a smaller area with higher potential risk. SLS can be used not only for operator protection, but also for machinery protection, e.g. if a maximum speed must not be exceeded.

##### Customer benefits

The SLS function can contribute to a significant reduction in downtime, or greatly simplify or even accelerate setup. The overall effect achieved is a higher availability of the machine. Moreover, external components such as speed monitors can be omitted.

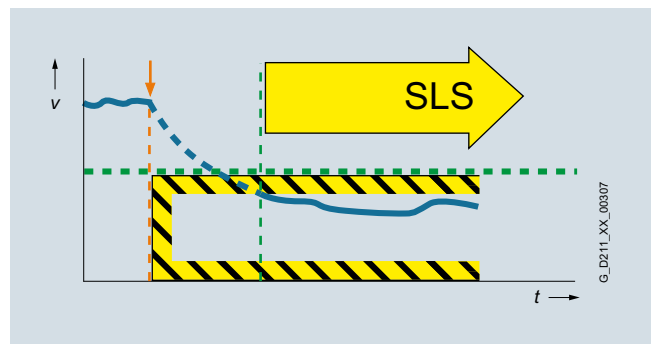

**Function** (continued)**Safe Speed Monitor (SSM)**

The SSM function warns when a drive is working below an adjustable speed limit. As long as it remains below the threshold, the function issues a safety-related signal.

Effect

If a speed value drops below a parameterized limit, a safety-related signal is generated. This can, for example, be processed in a safety controller to respond to the event by programming, depending on the situation.

Application

With the SSM function, in the simplest case, a safety door can be unlocked if the speed drops below a non-critical level. Another typical example is that of a centrifuge that may be filled only when it is operating below a configured speed limit.

Customer benefits

Unlike SLS, there is no drive-integrated fault reaction when the speed limit is exceeded. The safe feedback can be evaluated in a safety control unit, allowing the user to respond appropriately to the situation.

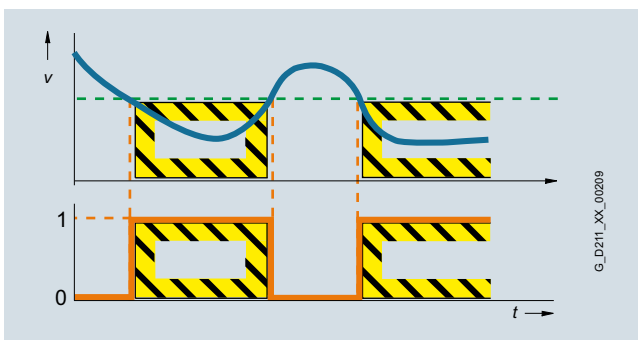
**Safe Direction (SDI)**

The SDI function ensures that the drive can only move in the selected direction.

Effect

Deviation from the direction of motion currently being monitored is detected reliably and the configured drive-integrated fault reaction is initiated. It is possible to select which direction of rotation is to be monitored.

Application

The SDI function is used when the drive may only move in one direction. A typical application is to permit the operator access to a danger zone, as long as the machine is rotating in the safe direction, i.e. away from the operator. In this state, the operator can feed material into the work zone / remove material from the work zone without danger.

Customer benefits

The function saves the use of external components such as speed monitors and the associated wiring. The release of a danger zone while the machine is moving away from the operator increases productivity. Without the SDI function, the machine must be safely stopped during material loading and removal.

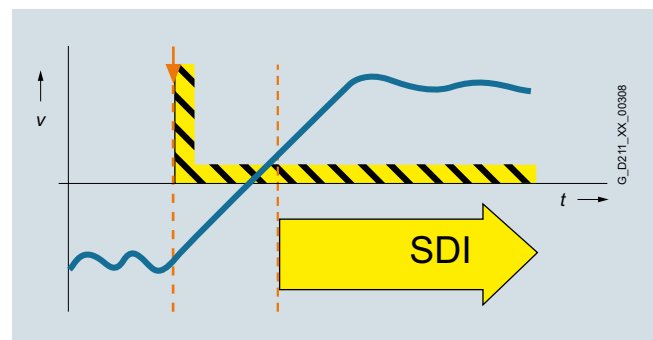



## Highlights

### Safety Integrated

#### Function (continued)

##### *Safely-Limited Position (SLP)*

The SLP function monitors the axis to ensure that it remains within the permissible traversing range.

##### Effect

When SLP is activated, the traversing range limited by the configured software limit switches is safely monitored. If the permitted traversing range is exited, a configurable fault reaction occurs. It is possible to toggle between two traversing ranges, even when the machine is in operation.

##### Application

SLP is used for applications in which machine operators have to enter a protection area, e.g. for feeding in and removing material. Safe monitoring of the axis position ensures that the axis cannot move into the protection area released for operators and so place them in danger, for example, on storage and retrieval machines, gantry cranes or machining centers.

##### Customer benefits

SLP can be used for highly-effective protection area monitoring. The function does away with the use of external components such as hardware limit switches and the associated wiring expense. Due to the short reaction time following a limit overshoot, safety clearances can be reduced.

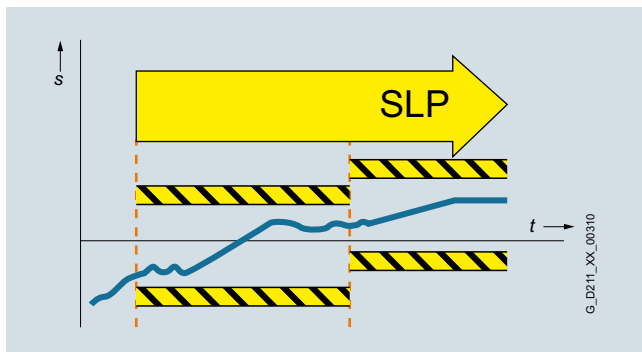

##### *Safe Position (SP)*

The SP function transfers the actual position values determined safely in the drive over safe PROFIsafe communication to a safety control.

##### Effect

In contrast to the SLP function that monitors the current actual position value against a limit and, in the case of an overshoot, activates a drive-integrated fault reaction, SP transfers the current actual position values to the safety control. Position monitoring is implemented in the safety program of the control. Extended PROFIsafe telegrams are available for transferring the position values. The position values can be transferred in 16-bit or 32-bit resolution, as required. A time stamp is also transferred with the position values.

##### Application

Tailor-made safety concepts can be created using the SP function. It is ideal for use on machines that require flexible safety functions. It is extremely versatile and can be used, for example, to implement safe, axis-specific range detection by means of safe cams. The SP function can also be used to implement multi-axis safety concepts, multi-dimensional protection areas and zone concepts.

##### Customer benefits

Position monitoring or speed monitoring is implemented in the safety program of the control, so the user has the flexibility for implementing tailor-made safety functions. The reaction to a limit overshoot must also be specified in the safety program. This means a higher initial programming outlay, but it does offer the opportunity for initiating different fault reactions.

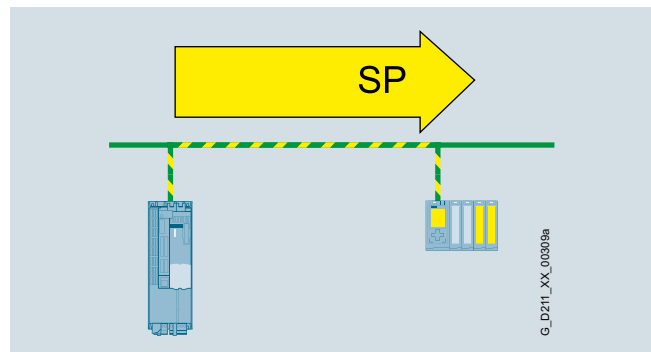

**Function** (continued)**Basic Functions and Extended Functions**

The Safety Integrated functions are grouped into Basic Functions and Extended Functions

- Basic Functions
  - Safe Torque Off (STO)
  - Safe Brake Control (SBC)
  - Safe Stop 1 (SS1)
- Extended Functions
  - Safe Stop 1 (SS1) with SBR or SAM
  - Safe Stop 2 (SS2) with SAM
  - Safe Operating Stop (SOS)
  - Safely-Limited Speed (SLS)
  - Safe Speed Monitor (SSM)
  - Safe Direction (SDI)
  - Safely-Limited Position (SLP)
  - Safe Position (SP)
  - Safe Brake Test (SBT) diagnostic function

For the Extended Functions SS1 and SS2 with SAM, safe acceleration monitoring (SAM) is performed during braking to identify any faults already during the braking phase.

If Safe Stop 1 is used as an encoderless function, a Safe Brake Ramp (SBR) can be configured as an alternative.

The Basic Functions – activated via on-board terminals on the device or via PROFIsafe – do not require an encoder.

**Activation of the integrated safety functions**

The safety functions for SINAMICS drives can be activated via terminals, e.g. for use of a conventional safety circuit.

For standalone safety solutions for small to medium sized applications, it is frequently sufficient that the various sensing components are directly hardwired to the drive.

For integrated safety solutions, the safety-relevant sequences are generally processed and coordinated in the fail-safe SIMATIC controller. Here, the system components communicate via the PROFINET or PROFIBUS fieldbus. The safety functions are controlled via the safe PROFIsafe communication protocol.

SINAMICS drives can be easily integrated into the plant or system topology.

**PROFIsafe**

SINAMICS drives support the PROFIsafe profile based on PROFINET as well as on PROFIBUS.

PROFIsafe is an open communications standard that supports standard and safety-related communication over the same communication path (wired or wireless). A second, separate bus system is therefore not necessary. The telegrams that are sent are continually monitored to ensure safety-relevant communication.

Possible errors such as telegrams that have been lost, repeated or received in the incorrect sequence are avoided. This is done by consecutively numbering the telegrams in a safety-relevant fashion, monitoring their reception within a defined time and transferring an ID for transmitter and receiver of a telegram. A CRC (cyclic redundancy check) data security mechanism is also used.

**The operating principle of Safety Integrated****Two independent switch-off signal paths**

Two independent switch-off signal paths are available. All switch-off signal paths are low active. This ensures that the system is always switched to a safe state if a component fails or in the event of cable breakage. If a fault is discovered in the switch-off signal paths, the STO or SS1 function (depending on parameter settings) is activated and a system restart inhibited.

**Two-channel monitoring structure**

All the main hardware and software functions for Safety Integrated are implemented in two independent monitoring channels (e.g. switch-off signal paths, data management, data comparison). A cyclic crosswise comparison of the safety-relevant data in the two monitoring channels is carried out.

The monitoring functions in each monitoring channel work on the principle that a defined state must prevail before each action is carried out and a specific acknowledgement must be made after each action. If these expectations of a monitoring channel are not fulfilled, the drive coasts to a standstill (two channel) and an appropriate message is output.

**Forced dormant error detection using test stop**

The functions and switch-off signal paths must be tested at least once within a defined time in order to meet requirements as per EN ISO 13849-1 and IEC 61508 in terms of timely fault detection. This must be implemented either in cyclic manual mode or the test stop must be automatically initiated as part of the process. The test stop cycle is monitored, and after a specific time has been exceeded, an alarm is output. A test stop does not require a POWER ON. The acknowledgment is set by canceling the test stop request.

Examples of when forced dormant error detection must be performed:

- When the drives are at a standstill after the system has been switched on
- Before the protective door is opened
- At defined intervals (e.g. every 8 hours)
- In automatic mode, time and event-driven

## Highlights

### Safety Integrated

#### Function (continued)

##### *Safe actual value sensing with or without encoders*

A drive monitor with encoder is necessary for operation of a series of safety functions.

For applications with encoderless mode or with encoders that have no safety capability, the safety functions can also be implemented without encoder. It is not possible to use all safety functions in this case.

The encoderless safety functions can be implemented on request for chassis format units (see the [Function Manuals SINAMICS S120 Safety Integrated and SINAMICS G130, G150, S120 Chassis, S120 Cabinet Modules, S150; Safety Integrated](#)).

In operation without encoder, the actual speed values are calculated from the measured electrical actual values. This means that speed monitoring is also possible during operation without an encoder.

An encoder that is used for the purposes of motor control has no significance for the safety function here.

Safety Integrated Extended Functions "without encoder" must not be used if the motor, after it has been switched off, can still be accelerated by the mechanical elements of the connected machine component.

In the hoisting gear of a crane, for example, the suspended load can accelerate the motor as soon as the motor is switched off. In this case, the safety functions "without encoder" are not permitted.

A horizontal conveyor, on the other hand, is always braked to a standstill due to friction as soon as the motor is switched off. In this case, the safety functions "without encoder" can be used without any restriction.

[Additional information on the encoderless safety functions is available in the Safety Integrated Function Manuals at \[www.siemens.com/sios\]\(http://www.siemens.com/sios\) \(search terms 99668646 and 106254588\).](#)

The safety functions are listed below with criteria for actual value sensing:

	Functions	Abbreviation	With encoder	Without encoder	Description
<b>Basic Functions</b>	Safe Torque Off	STO	Yes	Yes	Safe Torque Off
	Safe Stop 1	SS1	Yes	Yes	Safe stopping process in accordance with stop category 1
	Safe Brake Control	SBC	Yes	Yes	Safe Brake Control
<b>Extended Functions</b>	Safe Torque Off	STO	Yes	Yes	Safe Torque Off
	Safe Stop 1	SS1	Yes	Yes <sup>1)</sup>	Safe stopping process in accordance with stop category 1
	Safe Brake Control	SBC	Yes	Yes	Safe Brake Control
	Safe Operating Stop	SOS	Yes	No	Safe monitoring of the standstill position
	Safe Stop 2	SS2	Yes	No	Safe stopping process in accordance with stop category 2
	Safely-Limited Speed	SLS	Yes	Yes <sup>1)</sup>	Safe monitoring of the maximum speed
	Safe Speed Monitor	SSM	Yes	Yes <sup>1)</sup>	Safe monitoring of the minimum speed
	Safe Direction	SDI	Yes	Yes <sup>1)</sup>	Safe monitoring of the direction of motion
	Safely-Limited Position	SLP	Yes	No	Safely-limited position
	Safe Position	SP	Yes	Yes <sup>2)</sup>	Safe transfer of position values
	Safe Brake Test	SBT	Yes	No	Diagnostic function for safe testing of the required holding torque of a brake

<sup>1)</sup> The use of this safety function without encoder is permitted for asynchronous (induction) motors or synchronous motors of the SIEMOSYN series.

<sup>2)</sup> Only for the transmission of relative position values. An encoder is required to transmit absolute position values.

**Function** (continued)**Safe speed/position sensing with encoder**

Incremental encoders or absolute encoders with photoelectric sampling are permitted for safe sensing of the position values on a drive. HTL/TTL incremental encoders may also be used.

Safe actual value sensing relies on redundant evaluation of the incremental tracks A/B that supply sin/cos signals of  $1 V_{pp}$ . Only encoders of the type whose A/B track signals are created and processed using purely analog techniques can be used. The encoder signals are input via the SMC20 Sensor Module Cabinet-Mounted (option **K48** for cabinets).

HTL/TTL incremental encoders may also be used. In this case, safe actual value sensing is achieved by using two independent encoders. The minimum possible speed resolution must also be taken into account. The encoder signals are input via the SMC30 Sensor Module Cabinet-Mounted (options **K50** and **K52** for cabinets).

As an alternative, motors with an integrated DRIVE-CLiQ interface can be used. The speed or position actual values are generated directly in the motor as safe values and are transferred to the Control Unit over safe communication via DRIVE-CLiQ.

Certified built-on rotary encoders with DRIVE-CLiQ interface may also be used (see <https://support.industry.siemens.com/cs/document/65402168>).

The encoder must be mechanically attached in such a manner that the encoder shaft is unable to unplug or slide off. For notes on this, see IEC 61800-5-2: 2016, Table D.16.

A list of Siemens motors that fulfill the electrical and mechanical requirements is available at: <https://support.industry.siemens.com/cs/document/33512621>

The following can be used for safe speed/position sensing:

- Single-encoder systems or
- Dual-encoder systems

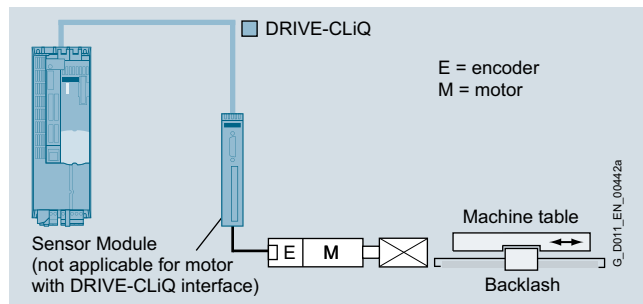

Example: Single-encoder system

In a single-encoder system, the motor encoder is used exclusively for safe actual value sensing. An incremental encoder or absolute encoder with photoelectric sampling must be used in this case.

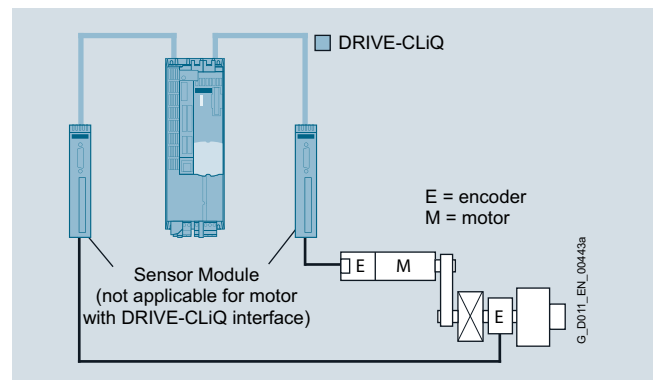

Example: Dual-encoder system

In the case of the dual-encoder system, the safe actual values for a drive are provided by two separate encoders. HTL/TTL incremental encoders can be used as an alternative with a dual-encoder system. Either two HTL/TTL encoders, one dual-HTL/TTL encoder or one HTL/TTL encoder and one sin/cos encoder can be used.

The actual values are transferred to the Control Unit over DRIVE-CLiQ. When motors without a DRIVE-CLiQ connection are used, a Sensor Module (SMC20/30, SME20/25/120/125) must be provided. Each measuring system requires a separate DRIVE-CLiQ connection.

## Highlights

### Safety Integrated for SINAMICS S120 Chassis Format Converter Units and Cabinet Modules, and for SINAMICS S150

#### Overview

The safety functions integrated into the drive can greatly reduce the effort required to implement safety concepts.

The Safety Integrated functions are implemented electronically and therefore offer short response times compared to solutions with externally implemented monitoring functions.

As an alternative to controlling via terminals and/or PROFIsafe, there is also the option to parameterize several safety functions without selection. In this mode, after parameterization and a POWER ON, these functions are permanently selected.

#### Example

"SLS without selection" can be used, for example, to monitor the maximum velocity to prevent the drive from exceeding a mechanical speed limit. For this purpose, use of the "SLS without selection" function means that an F-DI is not needed.

#### Safety Integrated with and without encoder

The Safety Integrated Basic Functions STO, SBC and SS1 can be operated without an encoder. Two safety-capable incremental encoders (HTL or TTL) are required to allow use of the Safety Integrated Extended Functions SLS, SDI, SOS, SS2 and SSM. Each of these is connected to an SMC30 Sensor Module Cabinet (with SINAMICS S120 Cabinet Modules and SINAMICS S150: first SMC30 option **K50**, second SMC30 option **K52**). The minimum possible velocity resolution for an HTL/TTL encoder system must be taken into account.

Further information can be found in the [Safety Integrated Function Manual](#).

#### Licensing

The Safety Integrated Basic Functions do not require a license.

The Safety Integrated Extended Functions require one license for each axis with safety functions. It is of no consequence here which safety functions are used and how many.

The licenses for SINAMICS S120 chassis format units can be ordered as option **F01 to F05** for specific axes at the same time as the memory card. For SINAMICS S120 Cabinet Modules, the licenses can be ordered for specific axes with safety options **K01 to K05** for Motor Modules.

The license for SINAMICS S150 units can be ordered as option **K01**.

#### Safe Brake Adapter

The Safe Brake Control (SBC) function requires a Safe Brake Adapter (option **K88** for SINAMICS S120 Cabinet Modules and SINAMICS S150). The Safe Brake Control is integrated in Motor Modules in booksize format.

The Safe Brake Adapter and the brake control that is integrated in the booksize format allow safe control of electro-mechanical motor brakes.

The Safe Brake Adapter controls 230 V AC brakes. The SBC function monitors the control of the brake, however, not its mechanical functioning.

The converter controls the connected brake using the motor holding brake function.

External surge suppressors are not required. The cable harnesses for connection to the Power Module are included in the scope of supply.

The brake is controlled in accordance with IEC 61508 SIL 2 and EN ISO 13849-1 PL d and Category 3.

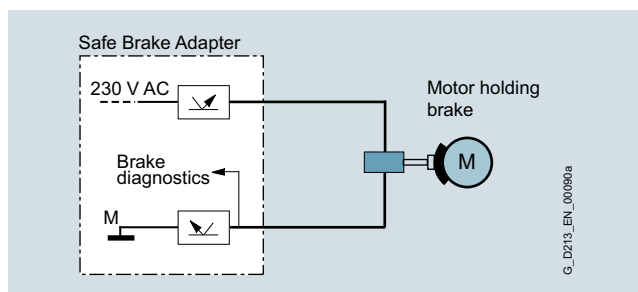

Safe Brake Control (SBC)

Safety Integrated for SINAMICS S120 Chassis Format Converter Units and Cabinet Modules, and for SINAMICS S150

Benefits

Comparison between conventional and integrated safety systems

The Safety Integrated functions are fully integrated in the drive system. They can be activated as follows:

- Via safety-related inputs on the CU310-2 Control Unit or on the power unit (Basic Functions)
- Via safety-related inputs on the TM54F Terminal Module (Extended Functions)
- Via PROFIBUS or PROFINET with the PROFI-safe profile (Basic and Extended Functions)

Safe Torque Off (STO)

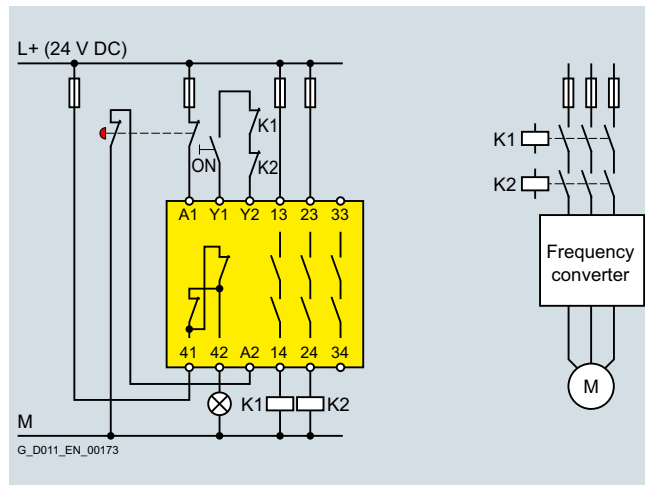

Conventional wiring

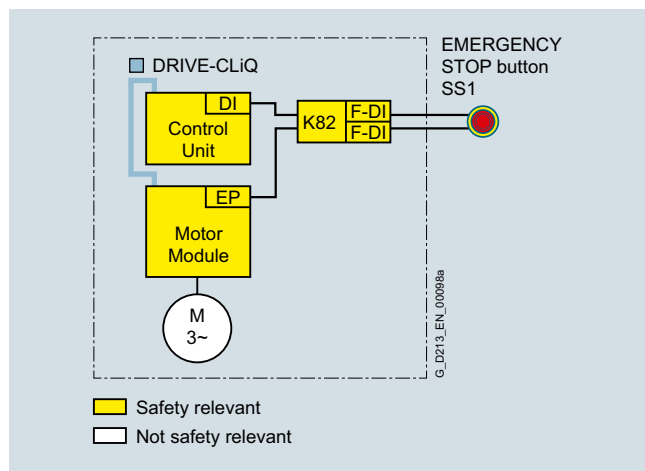

Integrated safety via fail-safe inputs

Safely-Limited Speed (SLS)

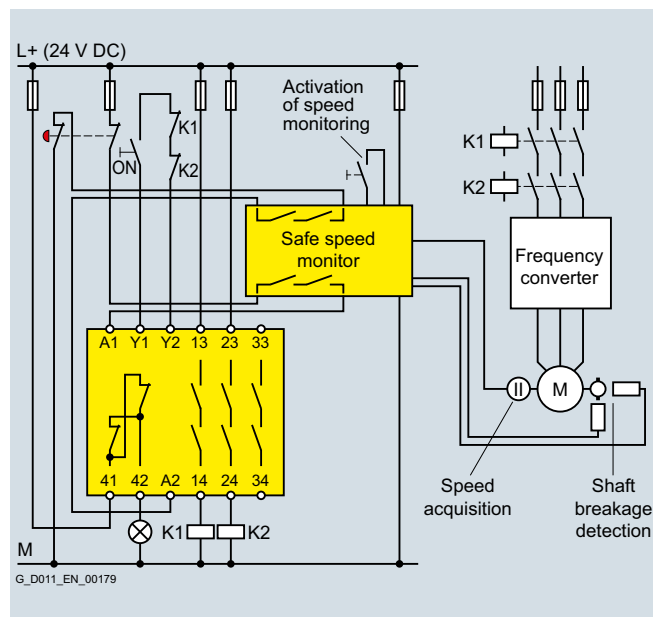

Conventional wiring

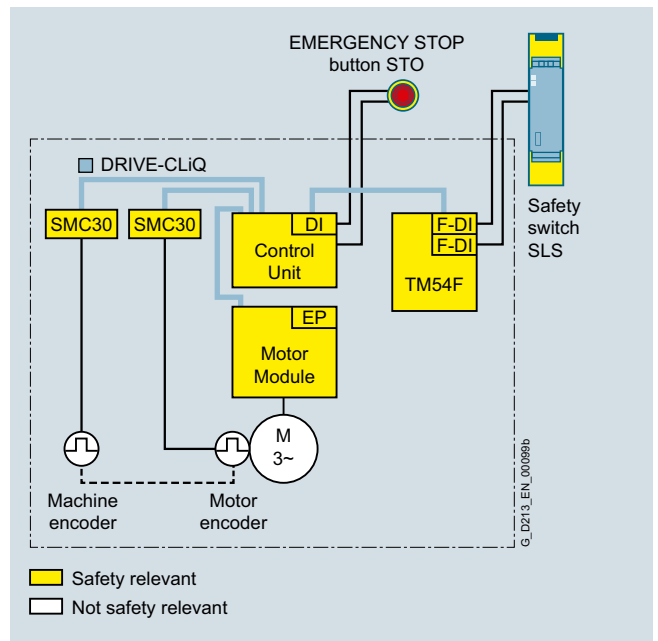

Integrated safety via fail-safe inputs

The TM54F Terminal Module is not required when functions are selected via PROFI-safe.



## Highlights

### Safety Integrated for SINAMICS S120 Chassis Format Converter Units and Cabinet Modules, and for SINAMICS S150

#### Function

##### Overview of Safety Integrated functions

Function	Control	Underlying function	Reaction to limit overshoot	External set-point input effective	Encoder required <sup>1)</sup>	License required
<b>Basic Functions</b>						
<b>STO</b>	<ul style="list-style-type: none"> <li>• EP terminals on power unit and F-DI on CU310-2/D4xx/CX32</li> <li>• Terminal module (option <b>K82</b> <sup>2)</sup>)</li> <li>• PROFIsafe</li> </ul>	SBC (if activated)	–	No	No	No
<b>SBC</b>	<ul style="list-style-type: none"> <li>• With STO (immediately or following expiry of the delay time with SS1)</li> <li>• Via Safe Brake Adapter <sup>2)</sup></li> </ul>	–	–	–	No	No
<b>SS1</b>	<ul style="list-style-type: none"> <li>• EP terminals on power unit and F-DI on CU310-2/D4xx/CX32</li> <li>• Terminal module (option <b>K82</b> <sup>2)</sup>)</li> <li>• PROFIsafe</li> </ul>	STO, following expiry of the parameterized delay time, SBC (if activated)	STO	Can be parameterized	No	No
<b>Extended Functions</b>						
<b>STO</b>	<ul style="list-style-type: none"> <li>• F-DI on TM54F</li> <li>• PROFIsafe</li> </ul>	SBC (if activated)	–	No	Yes	Yes
<b>SS1 with SBR/SAM</b>	<ul style="list-style-type: none"> <li>• F-DI on TM54F</li> <li>• F-DI on CU310-2/D4xx/CX32</li> <li>• PROFIsafe</li> </ul>	Safe Acceleration Monitor (SAM) or Safe Brake Ramp (SBR) during braking. STO and SBC (if activated) following expiry of the parameterized delay time or if the speed falls below the minimum speed limit	STO	Can be parameterized	No	Yes
<b>SS2</b>	<ul style="list-style-type: none"> <li>• F-DI on TM54F</li> <li>• F-DI on CU310-2/D4xx/CX32</li> <li>• PROFIsafe</li> </ul>	Safe Acceleration Monitor (SAM) during braking. Following expiry of the parameterized delay time SOS	SS1 → STO	No	Yes	Yes
<b>SLS encoderless</b>	<ul style="list-style-type: none"> <li>• F-DI on TM54F</li> <li>• F-DI on CU310-2/D4xx/CX32</li> <li>• PROFIsafe</li> <li>• Continuously activated</li> </ul>	–	STO, SS1 (can be parameterized)	Yes	No	Yes
<b>SLS</b>	<ul style="list-style-type: none"> <li>• F-DI on TM54F</li> <li>• F-DI on CU310-2/D4xx/CX32</li> <li>• PROFIsafe</li> <li>• Continuously activated</li> </ul>	–	STO, SS1, SS2 or SOS (can be parameterized)	Yes	Yes	Yes
<b>SOS</b>	<ul style="list-style-type: none"> <li>• F-DI on TM54F</li> <li>• F-DI on CU310-2/D4xx/CX32</li> <li>• PROFIsafe</li> </ul>	–	SS1 → STO	Yes	Yes	Yes
<b>SSM</b>	<ul style="list-style-type: none"> <li>• Always active, if configured</li> </ul>	–	Signals that the speed has fallen below a specified value	Yes	No	Yes
<b>SDI</b>	<ul style="list-style-type: none"> <li>• F-DI on TM54F</li> <li>• F-DI on CU310-2/D4xx/CX32</li> <li>• PROFIsafe</li> <li>• Continuously activated</li> </ul>	–	STO, SS1, SS2 or SOS (can be parameterized)	Yes	No	Yes
<b>SLP</b>	<ul style="list-style-type: none"> <li>• F-DI on TM54F</li> <li>• F-DI on CU310-2/D4xx/CX32</li> <li>• PROFIsafe</li> </ul>	–	STO, SS1, SS2 or SOS (can be parameterized)	Yes	Yes	Yes
<b>SP</b>	<ul style="list-style-type: none"> <li>• Always active, if configured</li> </ul>	–	–	Yes	Yes	Yes
<b>SBT</b>	<ul style="list-style-type: none"> <li>• F-DI on TM54F</li> <li>• F-DI on CU310-2/D4xx/CX32</li> <li>• PROFIsafe</li> </ul>	–	Signals test result. Warning if test fails	Yes	Yes	Yes

<sup>1)</sup> The encoderless Safety Extended Functions can be implemented only on request for SINAMICS S120 chassis format units and cabinet units.

<sup>2)</sup> In addition for SINAMICS S120 Cabinet Modules and SINAMICS S150 converter cabinet units (option **K88**).

## Overview

### Communication overview

Digital bus systems are commonly used in industrial automation today. These handle communication between the control level, the machine control, the sensors and actuators. The SINAMICS product family offers integrated communication interfaces in all product groups – which can be used to connect the most important fieldbus systems in the simplest possible way.

The properties and special application areas of the different bus systems are described briefly below. The following table provides an overview of the protocols available for the CU310-2 and CU320-2 Control Units.

Protocol	CU310-2	CU320-2
<b>PROFINET</b>	✓	✓
• PROFINET RT	✓	✓
• PROFINET IRT isochronous	✓	✓
• PROFINET IRT not isochronous	✓	✓
• PROFINET Shared Device	✓	✓
• PROFINET media redundancy MRP (non-seamless)	✓	✓
• PROFINET media redundancy MRP (seamless)	✓	✓
• System redundancy S2	✓	✓
• PROFI-safe	✓	✓
• PROFInergy	✓	✓
• PROFIdrive application class 1	✓	✓
• PROFIdrive application class 3	✓	✓
• PROFIdrive application class 4	✓	✓
<b>PROFIBUS DP</b>	✓	✓
• PROFIBUS DP equidistance and isochronous mode	✓	✓
• PROFIBUS DP slave-to-slave communication	✓	✓
<b>EtherNet/IP</b>	–	✓
<b>Modbus TCP</b>	–	✓
<b>CANopen</b>	–	✓
<b>USS</b>	✓	✓
<b>Web server</b>	✓	✓

## Highlights

### Communication > PROFINET

#### Overview



G\_D211\_XX\_00050

#### *PROFINET – the Ethernet standard for automation*

PROFINET is the world's leading Industrial Ethernet standard for automation with more than 10 million nodes installed worldwide.

PROFINET makes companies more successful, because it speeds up processes and raises both productivity and plant availability.

#### Your advantages at a glance

##### Flexibility

Tailor-made plant concepts

- ▶ Industrial Wireless LAN
- ▶ Safety
- ▶ Flexible topologies
- ▶ Open standard
- ▶ Web tools
- ▶ Expandability

##### Efficiency

Optimal use of resources

- ▶ One cable for everything
- ▶ Device/network diagnostics
- ▶ Energy efficiency
- ▶ Simple wiring
- ▶ Fast device replacement
- ▶ Ruggedness/stability

##### Performance

Increased productivity

- ▶ Speed
- ▶ High precision
- ▶ Large quantity structures
- ▶ High transmission rate
- ▶ Redundancy
- ▶ Fast start-up

G\_IK10\_XX\_10304

**Overview** (continued)**Flexibility**

Short response times and optimized processes are the basic requirements for competitiveness in global markets because the product lifecycles are becoming shorter and shorter.

PROFINET ensures maximum flexibility in plant structures and production processes, and it enables you to implement innovative machine and plant concepts. For example, mobile devices can also be integrated at locations that are difficult to access.

**Flexible topologies**

In addition to the linear structure characterized by the established fieldbuses, PROFINET also enables the use of star, tree and ring structures. This is made possible by switching technology via active network components, such as Industrial Ethernet switches and media converters, or by integrating switch functionality into the field devices. This results in increased flexibility in the planning of machines and plants, as well as savings in cabling.

The PROFINET network can be installed without any specialist knowledge at all and meets all requirements that are relevant to the industrial environment. The "PROFINET Installations Guidelines" assist manufacturers and users with network planning, installation and commissioning. Symmetrical copper cables or RFI-resistant fiber-optic cables are used, depending on the application. Devices from different manufacturers are easily connected via standardized and rugged plug-in connectors (up to IP65/IP67 degree of protection).

By integrating switch functionality into the devices, linear topologies can be created that are directly oriented toward an existing machine or plant structure. This reduces cabling overhead and cuts down on components such as external switches.

**IWLAN**

PROFINET also supports wireless communication with Industrial Wireless LAN, thus opening up new fields of application. For example, technologies subject to wear, such as trailing cables, can be replaced and automated guided vehicle systems and mobile operator panels can be used.

**Safety**

The PROFIsafe safety profile, which has been tried and tested with PROFIBUS and which permits the transmission of standard and safety-related data on a single bus cable, can also be used with PROFINET. No special network components are necessary for fail-safe communication, which means that standard switches and standard network transitions can continue to be used without any restrictions. In addition, fail-safe communication is equally possible via Industrial Wireless LAN (IWLAN).

**Open standard**

PROFINET, the open multi-vendor standard (IEC 61158/IEC 61784), is supported by PROFIBUS and PROFINET International (PI). It stands for maximum transparency, open IT communication, network security and simultaneous real-time communication.

Thanks to its openness, PROFINET provides the basis for a standardized automation network in the plant, to which all other machines and devices can be connected. Even the integration of existing plant components, for example using PROFIBUS, presents no problems due to the use of network transitions.

**Use of web tools**

Thanks to the unrestricted support of TCP/IP, PROFINET permits the use of standard web services in the device, such as web servers. Irrespective of the tool used, information from the automation level can be accessed from virtually any location using a commercially available Internet browser. This considerably simplifies commissioning and diagnostics. Users can then decide for themselves how much openness to the IT world they want to allow for their machine or plant. This means that PROFINET can be used simply as an isolated plant network or connected via appropriate security modules, such as the SCALANCE S modules, to the office network or the Internet. In this way, new remote maintenance concepts or the high-speed exchange of production data become possible.

**Expandability**

On the one hand, PROFINET facilitates the integration of existing systems and networks without any great effort. In this way, PROFINET safeguards investments in existing plant components that communicate via PROFIBUS and other fieldbuses such as AS-Interface. On the other hand, additional PROFINET nodes can be added at any time. By using additional network components, network infrastructures can be expanded using cabling or wireless methods – even while the plant is operating.

## Highlights

### Communication > PROFINET

#### Overview (continued)

##### Efficiency

Greater global competition means that companies must use their resources economically and efficiently. This applies in particular to production. This is where PROFINET ensures greater efficiency. Simple engineering guarantees fast commissioning, while reliable devices ensure a high level of plant availability. Comprehensive diagnostic and maintenance concepts help to reduce plant downtimes and keep maintenance costs to a minimum.

##### One cable for everything

PROFINET permits simultaneous fieldbus communication with isochronous mode and standard IT communication (TCP/IP) on one cable. This real-time communication for the transmission of user/process data and diagnostic data takes place on a single cable. Specific profile communication (PROFIsafe, PROFIdrive and PROFlenergy) can be integrated without any additional cabling. This solution offers a wide scope of functions at a low level of complexity.

##### Device and network diagnostics

By retaining the tried and tested PROFIBUS device model, the same diagnostics information is available with PROFINET. In addition, module-specific and channel-specific data can also be read out from the devices during device diagnosis, enabling faults to be located quickly and easily. Apart from the availability of device information, the reliability of network operation has top priority in the network management.

In existing networks the Simple Network Management Protocol (SNMP) has established itself as the de facto standard for the maintenance and monitoring of the network components and their functions. PROFINET uses this standard and gives users the opportunity to maintain their networks with tools that are familiar to them, such as the SINEMA Server network management software.

For easier maintenance of PROFINET devices, both on-site and remotely via a secure VPN connection, application-specific web-sites can be set up on the integrated web server of the field devices using the familiar HTML standard.

##### Energy efficiency

Moving toward the green factory: PROFlenergy is a profile that provides functions and mechanisms for PROFINET field devices that support energy-efficient production.

The profile, which is defined by the PNO and is independent of any manufacturers or devices, enables energy demand and costs to be significantly reduced: Using PROFlenergy, any specific loads that are not currently being used can be switched off. This achieves a noticeable reduction in energy costs during breaks in production. PROFlenergy permits the simple, automated activation and deactivation of technologically related plant components. It is coordinated centrally by means of a higher-level controller and is networked via PROFINET. This ensures that as much energy as possible is saved during long breaks. Temporarily switching off plant components contributes to the even distribution and most efficient use of energy.

The use of PROFlenergy is made easy for the machine builder by its integration into familiar series of products. In addition, PROFlenergy is defined in such a way that the necessary function blocks can easily be integrated into existing automation systems at a later stage.

##### Simple wiring

Particularly stringent demands are made on the installation of cables in the industrial environment. In addition, there is a requirement to set up industry-standard networks in the shortest possible time without any special knowledge.

With FastConnect, Siemens offers a high-speed installation system that meets all of these requirements. FastConnect is the standard-compliant, industry-standard cabling system consisting of cables, connectors and assembly tools for PROFINET networks. The time required for connecting terminals is minimized by the simple installation method using just a single tool, while installation errors are prevented by the practical color-coding. Both copper cables and glass fiber optic cables can be easily assembled on site in this way.

##### Fast device replacement

PROFINET devices are identified by means of a name assigned during configuration. When replacing a defective device, a new device can be recognized from its topology information by the IO controller and a new name can be assigned to it automatically. This means that no engineering tool is necessary for the replacement of equipment.

This mechanism can even be used for the initial commissioning of a complete system. This speeds up commissioning, particularly in the case of series machines.

##### Ruggedness

An automation network must be able to withstand most external sources of interference. The use of Switched Ethernet prevents faults in one section of the network from affecting the entire plant network. For areas that are particularly prone to radio frequency interference (RFI), PROFINET allows the use of fiber optic cables.

**Overview** (continued)**Performance**

Productivity and product quality determine the level of success in the market. Precise motion control, dynamic drives, high-speed controllers and the deterministic synchronization of devices are therefore key factors in achieving superior production. They facilitate high production rates and optimum product quality at the same time.

**Speed and precision**

Fast motion control applications demand precise and deterministic exchange of data. This is implemented by means of drive controllers using isochronous real time (IRT).

With IRT and isochronous mode, PROFINET permits fast and deterministic communication. This synchronizes the various cycles of a system (input, network, CPU processing and output), even in the case of parallel TCP/IP traffic. The short cycle times of PROFINET make it possible to raise the productivity of machines and plants and to guarantee the product quality and high level of precision.

The standardized PROFIdrive profile permits vendor-independent communication between CPUs and drives.

**Large quantity structures**

The use of PROFINET makes it possible to overcome the existing restrictions regarding the scope of machines and systems that can be implemented. In one network, several different controllers can interact with their assigned field devices. The number of field devices per PROFINET network is virtually unlimited – the entire range of IP addresses is available.

**High transmission rate**

By using 100 Mbit/s in full duplex mode, PROFINET achieves a significantly higher data rate than previous fieldbuses. This means that other plant data can be transmitted over TCP/IP without any problems, in addition to the process data. PROFINET therefore meets the combined industrial demands for simultaneously transmitting high-speed IO data and large volumes of data for additional sections of the application. Even the transmission of large volumes of data, such as that from cameras, has no adverse effect on the speed and precision of the IO data transmission, thanks to PROFINET mechanisms.

**Media redundancy**

A higher plant availability can be achieved with a redundant installation (ring topology). The media redundancy can be implemented not only with the aid of external switches, but also by means of integrated PROFINET interfaces. Using the media redundancy protocol (MRP), reconfiguration times of 200 ms can be achieved. If the communication is interrupted in just one part of the ring installation this means that a plant standstill is prevented and any necessary maintenance or repair work can be performed without any time pressure.

For motion control applications, PROFINET with IRT in ring topologies offers extended media redundancy for planned duplication (MRPD) which operates in a bumpless mode without any reconfiguration time. If communication is interrupted (e.g. a cable break) the process can continue operating without interruption.

**System redundancy**

SINAMICS S120 supports the PROFINET function "system redundancy": SINAMICS S120 can now be connected to high-availability systems such as SIMATIC S7-400H with two controllers. No additional hardware is required to make the connection. Complex automation tasks in the process industry, in particular, where plant availability and redundancy of the control system are essential, require reliable communication with a high-availability system. Both controllers of the high-availability system always have access to the SINAMICS S120. In the event of a cable break or failure of a CPU, the other controller takes over, thus ensuring uninterrupted communication.

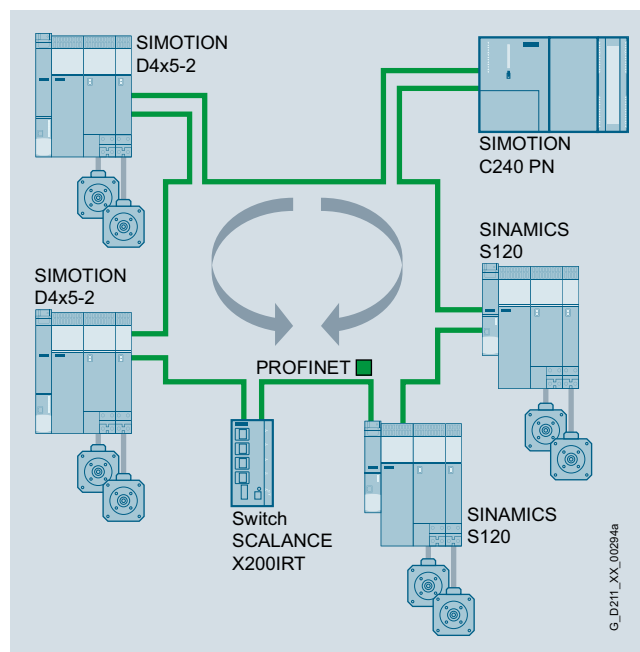

Seamless media redundancy illustrated by example of SINAMICS S120 with SIMOTION and SCALANCE X200IRT



## Highlights

### Communication > PROFINET

#### Benefits

- PROFINET is the open Industrial Ethernet standard for automation
- PROFINET is based on Industrial Ethernet
- PROFINET uses TCP/IP and IT standards
- PROFINET is real-time Ethernet
- PROFINET enables seamless integration of fieldbus systems
- PROFINET supports fail-safe communication via PROFIsafe and also via IWLAN

#### Integration

##### *PROFINET – Functions of the SINAMICS S120/ SINAMICS S150 Control Units*

SINAMICS S120/ SINAMICS S150	CU320-2 PN	CU320-2 DP (CBE20)	CU310-2 PN
PROFINET with IRT (isochronous mode)	✓	✓	✓
Number of ports	2	4	2
Min. send clock in ms	0.25	0.5	0.25
Shared Device	✓	✓	✓
Seamless media redundancy (MRPD)	✓	✓	✓
Non-seamless media redundancy (MRP)	✓	✓	✓
System redundancy S2	✓	–	✓
PROFIsafe	✓	✓	✓
PROFInergy	✓	✓	✓
PROFIdrive	✓	✓	✓

#### More information

More information is available at  
[www.siemens.com/profinet](http://www.siemens.com/profinet)

## Overview



### PROFIdrive – the standardized drive interface for PROFINET and PROFIBUS

PROFIdrive defines the device behavior and technique to access internal device data for electric drives connected to PROFINET and PROFIBUS – from basic frequency converters up to high-performance servo controllers.

It describes in detail the practical use of communication functions – slave-to-slave communication, equidistance and clock cycle synchronization (isochronous mode) in drive applications. In addition, it specifies all device characteristics which influence interfaces connected to a controller over PROFINET or PROFIBUS. This also includes the state machine (sequence control), the encoder interface, scaling of values, definition of standard telegrams, access to drive parameters etc.

The PROFIdrive profile supports both central as well as distributed motion control concepts.

#### What are profiles?

For devices and systems used in automation technology, profiles define properties and modes of behavior. This allows manufacturers and users to define common standards. Devices and systems that comply with such a cross-manufacturer profile, are interoperable on a fieldbus and, to a certain degree, can be interchanged.

#### Are there different types of profiles?

A distinction is made between what are known as application profiles (general or specific) and system profiles:

- Application profiles (also device profiles) predominantly refer to devices (e.g. drives) and include and agreed selection regarding bus communication as well as also specific device applications.
- System profiles describe classes of systems, including master functionality, program interfaces and integration resources.

#### Is PROFIdrive fit for the future?

PROFIdrive has been specified by the PROFIBUS and PROFINET International (PI) user organization, and is specified as a standard that is fit for the future through standard IEC 61800-7.

#### The basic philosophy: Keep it simple

The PROFIdrive profile tries to keep the drive interface as simple as possible and free from technology functions. As a result of this philosophy, referencing models as well as the functionality and performance of the PROFINET/PROFIBUS master have either no influence or only a low influence on the drive interface.

### One drive profile – different application classes

The integration of drives into automation solutions depends very strongly on the particular drive application. In order to be able to address the complete, huge bandwidth of drive applications – from basic frequency converters up to synchronized multi-axis systems with a high dynamic performance – using just one profile, PROFIdrive defines six application classes, to which most drive applications can be assigned:

- Class 1 – standard drives (pumps, fans, agitators, etc.)
- Class 2 – standard drives with technological functions
- Class 3 – positioning drives
- Class 4 - motion control drives with central, higher-level motion control intelligence and the patented "Dynamic Servo Control" positioning concept
- Class 5 - motion control drives with central, higher-level motion control intelligence and position setpoint interface
- Class 6 - motion control drives with distributed motion control intelligence integrated in the drives

## Design

### The device model of PROFIdrive

PROFIdrive defines a device model comprising function modules, which interoperate inside the device and which reflect the intelligence of the drive system. These modules have objects assigned to them which are described in the profile and are defined with respect to their functions. The overall functionality of a drive is therefore described through the sum of its parameters.

In contrast to other drive profiles, PROFIdrive defines only the access mechanisms to the parameters as well as a subset of profile parameters (approx. 30) such as the fault buffer, drive control and device identification.

All other parameters are vendor-specific which gives drive manufacturers great flexibility with respect to implementing control functions. The elements of a parameter are accessed acyclically over data records.

As a communication protocol, PROFIdrive uses DP-V0, DP-V1, and the DP-V2 expansions for PROFIBUS including the functions "Slave-to-Slave Communication" and "Isochronous Operation", or PROFINET IO with real-time classes RT and IRT.

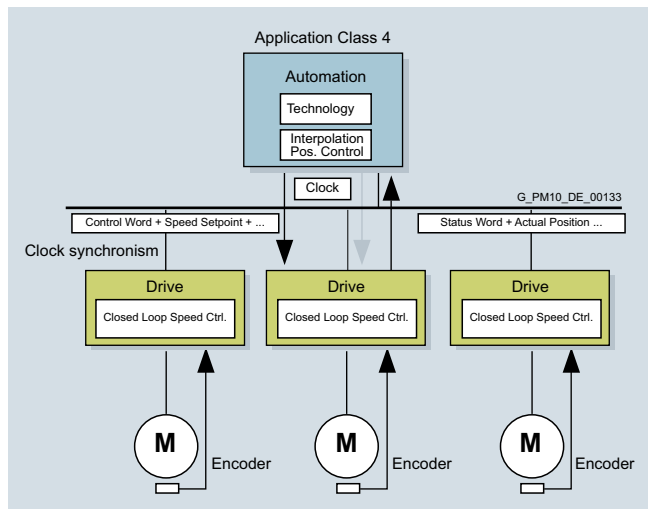

## More information

More information on PROFINET and PROFIBUS is available at [www.profibus.com](http://www.profibus.com)

See under Download / Technical description & books / PROFIdrive – Technology and Application - System Description

## Highlights

### Communication > PROFIBUS

#### Overview



**PROFIBUS – the proven, rugged bus system for automation engineering applications**

The requirements of users for an open, non-proprietary communication system have resulted in the specification and standardization of the PROFIBUS protocol.

PROFIBUS defines the technical and functional features of a serial fieldbus system, with which the distributed field automation devices in the lower area (sensor/actuator level) can be networked up to the mid performance range (cell level).

Standardization according to IEC 61158/EN 50170 secures your investments for the future.

Using the conformity and interoperability test performed by the test laboratories authorized by PROFIBUS & PROFINET International (PI) and the certification of the devices by PI, users have the security of knowing that the quality and functionality is guaranteed, even in multi-vendor installations.

#### PROFIBUS versions

Two different PROFIBUS versions have been defined in order to comply with the widely varying requirements at field level:

- PROFIBUS PA (Process Automation) – the version for applications in process automation. PROFIBUS PA uses the intrinsically safe transmission technology specified in IEC 61158-2.
- PROFIBUS DP (Distributed Periphery) – this version, which is optimized for speed, is specifically tailored to the communication of automation systems with distributed I/O stations and drives. PROFIBUS DP sets itself apart as a result of very short response times and high noise immunity, and replaces cost-intensive, parallel signal transfer with 24 V and measured value transfer utilizing 0/4 ... 20 mA technology.

#### Design

##### Bus participants on PROFIBUS DP

PROFIBUS DP makes a distinction between two different master classes and one slave class:

##### DP master class 1

For PROFIBUS DP, DP master class 1 is the central component. In a defined and continually repeating message cycle the central master station exchanges information with distributed stations (DP slaves).

##### DP master class 2

Devices of this type (programming, configuring or operator control devices) are used during commissioning, for configuring the DP system, for diagnostics or for operating the active plant or system. A DP master class 2 can, for example, read input, output, diagnostic and configuration data of the slaves.

##### DP slave

A DP slave is an I/O device which receives output information or setpoints from the DP master, and as response, returns input information, measured values and actual values to the DP master. A DP slave never sends data automatically, but only when requested by the DP master.

The quantity of input and output information depends on the device, and for each DP slave in each send direction can be a maximum of 244 bytes.

#### Function

##### Functional scope in DP masters and DP slaves

The functional scope can differ between DP masters and DP slaves. The different functional scopes are classified as DP-V0, DP-V1 and DP-V2.

##### DP-V0 communication functions

The DP-V0 master functions consist of "Configuration", "Parameter Assignment" and "Reading Diagnostics Data", as well as cyclic reading of input data/actual values and writing output data/setpoints.

##### DP-V1 communication functions

The DP-V1 function expansions make it possible to perform acyclic read and write functions as well as processing cyclic data communication. This type of slave must be supplied with extensive parameterization data during start-up and during normal operation. These acyclically transferred parameterization data are only rarely changed in comparison to the cyclic setpoints, actual values, and measured values, and are transferred at lower priority in parallel with the cyclic high-speed user data transfer. Detailed diagnostic information can be transferred in the same way.

##### DP-V2 communication functions

The extended DP-V2 master functions mainly comprise functions for isochronous operation and slave-to-slave communication between DP slaves.

- Isochronous mode: Isochronous mode is implemented by means of an equidistant signal in the bus system. This cyclic, equidistant cycle is sent by the DP master to all bus nodes in the form of a Global Control Telegram. Master and slaves can then synchronize their applications with this signal. The signal jitter between cycles is less than 1 µs.
- Slave-to-slave communication: The "publisher/subscriber" model is used to implement slave-to-slave communication. Slaves declared as publishers make their input data/actual values and measured values available to other slaves, the subscribers, for reading. This is performed by sending the response frame to the master as a broadcast. Slave-to-slave communication is therefore a cyclic process.

##### PROFIBUS with SINAMICS

SINAMICS uses the PROFIBUS DP protocol.

SINAMICS drives can only be used as DP slaves.

## Overview



Ethernet is the basic Internet technology for worldwide networking. The many possibilities of intranet and Internet, which have been available for office applications for a long time, are now utilized for production automation with Industrial Ethernet.

Apart from the use of information technology, the deployment of distributed automation systems is also on the increase. This entails breaking up complex control tasks into smaller, manageable and drive-based control systems. This increases the demand for communication and consequently a comprehensive and powerful communication system.

Industrial Ethernet provides a powerful area and cell network for the industrial field, compliant with the IEEE 802.3 (ETHERNET) standard.

## Benefits

Ethernet enables a very fast data transfer (10/100 Mbit/s, 1/10 Gbit/s) and at the same time has full-duplex capability. It therefore provides an ideal basis for communication tasks in the industrial field. With a share of over 90 %, Ethernet is the number one network worldwide and offers important features which have essential advantages:

- Fast commissioning thanks to the simplest connection method
- High availability since existing networks can be extended without any adverse effects
- Almost unlimited communication performance because scalable performance is available through switching technology and high data rates when required
- Networking of different application areas such as office and production areas
- Company-wide communication based on WAN (Wide Area Network) technology or the Internet
- Investment protection due to continuous compatibility with further developments
- Wireless communication using Industrial Wireless LAN

In order to make Ethernet suitable for industrial applications, considerable expansions with respect to functionality and design are required:

- Network components for use in harsh industrial environments
- Fast assembly of the RJ45 connectors
- Fail-safety through redundancy
- Expanded diagnostics and message concept
- Use of future-oriented network components (e.g. switches)

SIMATIC NET offers corresponding network components and products.

## Integration

### *Industrial Ethernet with SINAMICS*

SINAMICS provides Control Units and Communication Boards with PROFINET interface based on 100 Mbit/s Ethernet. This means that process communication in real-time, as well as engineering and HMI via standard TCP/IP are simultaneously possible.

It is also possible to access the web server integrated in SINAMICS at the same time that process communication is in progress.

The CU310-2 and CU320-2 Control Units have an additional Ethernet interface at the front so that service and engineering tasks can be performed very easily.

### *Communication with SINAMICS over Industrial Ethernet*

#### PG/PC/HMI communication

PG/PC/HMI communication is performed using protocols which are based on the basic TCP/IP protocol.

- Engineering and diagnostics with STARTER

#### IT communication

IT communication is performed using protocols which are based on the basic TCP/IP protocol. The most important IT protocols are:

- HTTP/HTTPS: Hypertext Transfer Protocol (Secure)  
Using a standard Internet browser, it is possible to retrieve predefined web pages containing diagnostic information from the device. Furthermore, user-defined web pages containing information defined by the user can be stored in the device.
- SNMP: Simple Network Management Protocol

## Highlights

### Communication > EtherNet/IP

#### Overview



Ethernet Industrial Protocol (EtherNet/IP) is an open standard for industrial networks. EtherNet/IP is used to transmit cyclic I/O data and acyclic parameter data. EtherNet/IP was developed by the ODVA (Open DeviceNet Vendor Association) and belongs to the international standard series IEC 61158.

### Communication > Modbus TCP

#### Overview



The Ethernet protocol Modbus TCP is an open standard for industrial networks. Modbus TCP is used to transmit acyclic register data. Modbus TCP has been standardized in the international series of standards IEC 61158 since 2007.

### Communication > CANopen

#### Overview



CANopen is a communication protocol based on CAN physical characteristics, which is predominantly used in the automation industry and for networking within complex devices. Originally conceived as a fieldbus for networking devices in motion control applications such as handling systems, CANopen has since established itself in the field of medical engineering, vehicle automation, rail and ship networking as well as building automation. Interoperability of CANopen is ensured through the use of application and device profiles, whereby the wide range of options offered by the bus specification enables an appropriate, precise selection to be made for the application or device in question. Furthermore, inverters with CANopen support the "CiA 402 Electrical Drives" device profile.

### Communication > USS

#### Overview

As a simple fieldbus protocol, USS (**U**niversal **S**erial **I**nterface protocol of Siemens AG, 1992) can be used both cyclically and acyclically. Based on RS485 physical bus characteristics, up to 32 nodes can be networked to one bus segment and connected to a higher-level controller. This protocol is generally used when there are limited demands on data throughput.

## SINAMICS S120 Chassis Format Converter Units

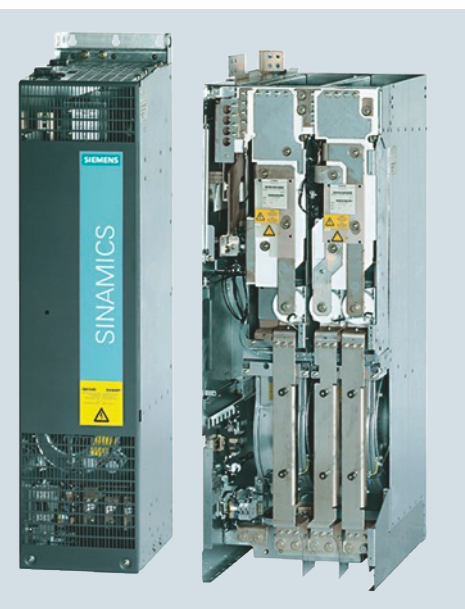

<b>3/2</b>	<b>System overview</b>	<b>3/128</b>	<b>System components</b>
3/2	Overview	3/128	<u>Line-side power components</u>
3/4	Functions	3/129	Line filters
3/5	Technical specifications	3/133	Line reactors
		3/137	Recommended line-side system components
<b>3/6</b>	<b>Air-cooled units</b>	3/143	<u>DC link components</u>
3/6	Technical specifications	3/143	Braking Modules
3/8	Characteristic curves	3/147	Braking resistors
3/11	Power Modules	3/149	DC link fuses
3/15	Basic Line Modules	3/151	<u>Motor-side power components</u>
3/20	Smart Line Modules	3/151	Motor reactors
3/25	Active Line Modules	3/155	dv/dt filter plus VPL
3/30	Active Interface Modules	3/160	dv/dt filter compact plus VPL
3/36	Motor Modules	3/165	Sine-wave filter
3/53	Mounting device for power blocks	3/167	<u>Control Units</u>
		3/170	CU320-2 Control Unit
<b>3/54</b>	<b>Liquid-cooled units</b>	3/174	CompactFlash card for CU320-2
3/54	Overview	3/176	CU310-2 Control Unit
3/55	Technical specifications	3/180	CompactFlash card for CU310-2
3/59	Characteristic curves	3/181	<u>Supplementary system components</u>
3/63	Power Modules	3/181	BOP20 Basic Operator Panel
3/67	Basic Line Modules	3/182	AOP30 Advanced Operator Panel
3/71	Active Line Modules	3/184	CBC10 Communication Board
3/75	Active Interface Modules	3/185	CBE20 Communication Board
3/80	Motor Modules	3/186	DMC20 DRIVE-CLiQ Hub Module
3/90	Mounting device for liquid-cooled power units	3/188	DME20 DRIVE-CLiQ Hub Module
		3/190	TB30 Terminal Board
<b>3/91</b>	<b>Water-cooled units</b>	3/192	TM15 Terminal Module
3/91	Overview	3/194	TM31 Terminal Module
3/92	Technical specifications	3/197	TM41 Terminal Module
3/96	Characteristic curves	3/200	TM54F Terminal Module
3/100	Power Modules	3/203	TM120 Terminal Module
3/104	Active Line Modules	3/205	TM150 Terminal Module
3/108	Active Interface Modules	3/207	VSM10 Voltage Sensing Module
3/114	Motor Modules	3/209	Safe Brake Adapter SBA
3/127	Mounting device for water-cooled power units	3/211	<u>Encoder system connection</u>
		3/212	SMC10 Sensor Module Cabinet-Mounted
		3/213	SMC20 Sensor Module Cabinet-Mounted
		3/214	SMC30 Sensor Module Cabinet-Mounted
		3/215	<u>Connection system</u>
		3/215	Signal cables



# SINAMICS S120 Chassis Format Converter Units

## System overview

### Overview



With its separate power unit and Control Unit, the SINAMICS S120 drive system can be perfectly adapted to a wide variety of different drive tasks.

The Control Unit is selected according to the number of drives to be controlled and the required performance level, while the power unit must be rated to meet the energy requirements of the system. The connection between the Control Unit and power unit is made very simply using the DRIVE-CLiQ digital system interface.

The following drive units are available in chassis format:

- Power Modules
- Basic Line Modules
- Smart Line Modules (only available in the air-cooled version)
- Active Line Modules
- Active Interface Modules
- Motor Modules

### Power Modules

The simplest version of a SINAMICS S120 drive system comprises a CU310-2 Control Unit and a Power Module.

In Power Modules specifically designed for single-motor drives without regenerative feedback into the line supply, the line-side infeed and the motor-side power unit are combined in one unit.

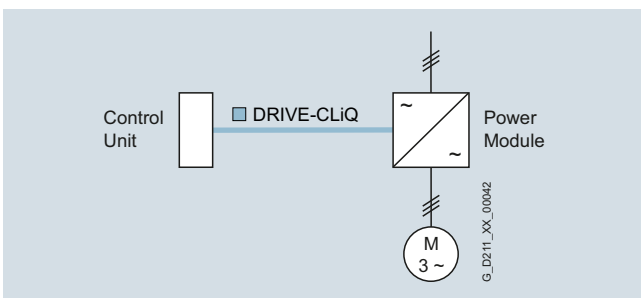

Generated energy produced during braking is converted to heat in braking resistors.

The Control Unit is plugged onto the Power Module; in addition to the complete control intelligence, the Control Unit also has all the drive interfaces for communication with higher-level systems and interfacing of add-on components.

### Line Modules

Line Modules contain the central line infeed for the DC link. Various Line Modules can be selected to address the various application profiles:

- Basic Line Modules
- Smart Line Modules
- Active Line Modules

### Basic Line Modules

Basic Line Modules are designed only for infeed operation, i.e. they are not capable of recovering energy to the line supply. If regenerative energy is produced, e.g. when drives brake, it must be converted into heat using a Braking Module and a braking resistor.

A line filter can be optionally installed in order to ensure compliance with the limits stipulated for Category C2 in EN 61800-3.

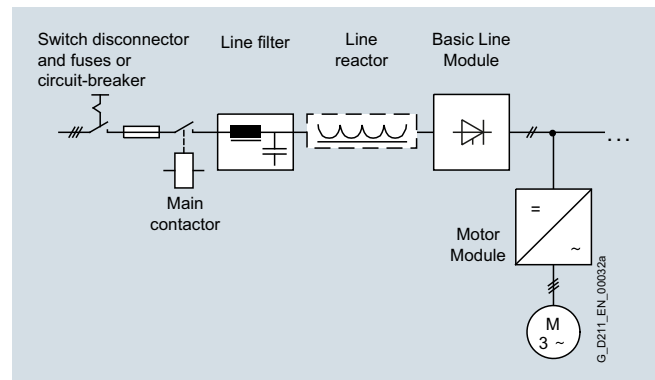

### Smart Line Modules

Smart Line Modules can supply energy and return regenerative energy to the supply system. A Braking Module and braking resistor are required only if the drives need to be decelerated in a controlled manner after a power failure (i.e. when energy cannot be recovered to the supply). For an infeed using a Smart Line Module, the appropriate line reactor is required.

A line filter can be optionally installed in order to ensure compliance with the limits stipulated for Category C2 in EN 61800-3.

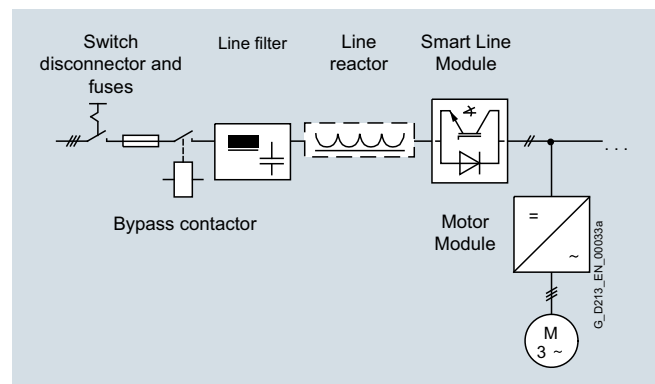



**Overview** (continued)Active Line Modules

Active Line Modules can supply energy and return regenerative energy to the supply system. A Braking Module and braking resistor are required only if the drives need to be decelerated in a controlled manner after a power failure (i.e. when energy cannot be recovered to the supply).

In contrast to Basic Line Modules and Smart Line Modules, Active Line Modules generate a controlled DC voltage that is kept constant despite fluctuations in the line supply voltage if the line supply voltage fluctuates within the permitted tolerance range. Active Line Modules in combination with an Active Interface Module draw a virtually sinusoidal current from the supply system. Almost no harmonics occur.

The total harmonic distortion factors of current THD(I) and voltage THD(U) are typically in the range of approx. 3 %. The stringent limit values of IEEE 519 (2014) are complied with. All of the components necessary to operate an Active Line Module are integrated in the Active Interface Module. A line filter can be optionally installed in order to ensure compliance with the limits stipulated for Category C2 in EN 61800-3.

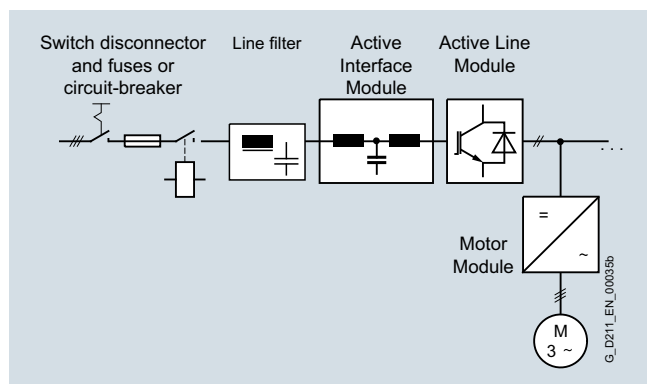
Motor Modules

A voltage DC link and a converter for supplying a motor are integrated in the Motor Module.

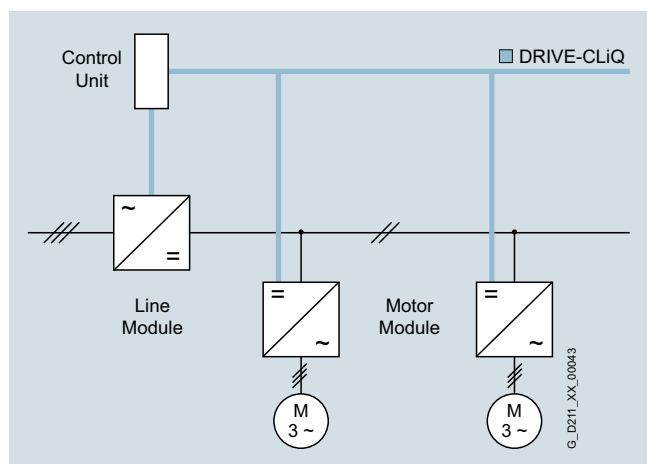

Motor Modules are designed for multi-axis drive systems and are controlled by either a CU320-2 or a SIMOTION D Control Unit. Motor Modules are interconnected through the DC link.

One or several Motor Modules are supplied with energy for the motors via the DC link. Both synchronous and induction motors can be operated.

Since the Motor Modules share the same DC link, they can exchange energy with one another, i.e. if one Motor Module operating in generator mode produces energy, the energy can be used by another Motor Module operating in motor mode. The DC link is supplied with line supply voltage by a Line Module.

Control Units

The control intelligence for all the drive axes integrated in the multi-axis group is combined in the Control Units. They also feature drive-related inputs/outputs and interfaces for communicating with higher-level controllers. Control Units are available with different ranges of functions and with different performance levels.

System components

The structure of the drive system is defined by selecting the Control Unit and Power Module or Line Module and Motor Modules. The additional components provided allow optimum adaptation of the drive system to the application.

These components are subdivided into:

- **Line-side components**, e.g. line reactors and line filters
- **DC link components** e.g. Braking Modules and braking resistors
- **Motor-side components**, e.g. motor reactors and dv/dt filters plus VPL, sine-wave filters
- **Supplementary system components**, e.g. Terminal Modules, Operator Panels, and Communication Boards
- **Encoder system interface** for connecting various encoder types to SINAMICS S120

DRIVE-CLiQ – the digital interface between the components

SINAMICS S120 components, including motors and encoders, are equipped with the high-performance DRIVE-CLiQ system interface.

Line and Motor Modules for example are connected to the Control Unit – and Terminal Modules and Sensor Modules to the drive system via DRIVE-CLiQ – simply and efficiently. Motors that also have this interface can be directly connected to the drive system.

Converter boards (Sensor Modules) for converting standard encoder signals to DRIVE-CLiQ are available for third-party motors or retrofit applications.

The electronic rating plate

An important digital linkage element of the SINAMICS S120 drive system are the electronic rating plates integrated in every component. They allow all drive components to be automatically identified via the DRIVE-CLiQ link.

The electronic rating plate contains all the relevant technical data about that particular component. In addition to the technical data, the rating plate includes logistical data (manufacturer ID, article number and ID). Since this data can be called up electronically on site or remotely, all the components used in a machine can always be individually identified, which helps simplify servicing.

## SINAMICS S120 Chassis Format Converter Units

### System overview

#### Overview (continued)

##### Coated modules

The following devices are equipped as standard with coated modules:

- Blocksize format units
- Booksize format units
- Chassis format units
- Control Units
- Sensor Modules
- Terminal Modules
- Advanced Operator Panel (AOP30)

The coating on the modules protects the sensitive SMD components against corrosive gases, chemically active dust and moisture.

##### Nickel-plated busbars

All of the copper busbars used are nickel-plated in order to achieve the best possible immunity to environmental effects. Furthermore, there is no need to clean the contacts on the customer terminals as otherwise required for bare copper connections.

##### Note:

For some components, parts of the copper busbars cannot be nickel-plated for technical reasons.

#### Function

##### Communication with higher-level controller and customer terminal block

As customer interface to a higher-level control, as standard there is a PROFIBUS or PROFINET communication interface on the Control Unit CU320-2; there are also expansions such as the Terminal Module TM31, the Terminal Board TB30 and modules to communicate via CANopen or EtherNet/IP.

These interfaces can be used to connect the system to the higher-level controller using analog and digital signals, or to connect additional units.

For additional information, please refer to the [SINAMICS Low Voltage Engineering Manual](#).

##### Open-loop and closed-loop control functions

SINAMICS S120 can use a dynamic, high-precision closed-loop vector control (drive object type VECTOR), or a highly dynamic closed-loop servo control (drive object type SERVO).

##### Software and protective functions

The software functions available as standard are described below:

Software and protective functions	Description
<b>Setpoint input</b>	The setpoint can be specified both internally and externally; internally as a fixed setpoint, motorized potentiometer setpoint or jog setpoint, externally via the communications interface or an analog input. The internal fixed setpoint and the motorized potentiometer setpoint can be switched or adjusted via control commands from any interface.
<b>Motor identification</b>	The automatic motor identification function makes commissioning faster and easier and optimizes closed-loop control of the drive.
<b>Ramp-function generator</b>	A user-friendly ramp-function generator with separately adjustable ramp-up and ramp-down times, together with adjustable rounding times in the lower and upper speed ranges, allows the drive to be smoothly accelerated and braked. This results in a good speed control response and contributes to the reduction of stress on the mechanical system. The down ramp can be parameterized separately for a quick stop.
<b>V<sub>dc max</sub> controller</b>	The V <sub>dc max</sub> controller automatically prevents overvoltages in the DC link, if the set down ramp is too short, for example. This may also extend the set ramp-down time. <i>Note:</i> This function only makes sense for single-axis applications.
<b>Kinetic buffering (KIP)</b>	For brief line supply failures, the kinetic energy of the rotating drive is used to buffer the DC link and therefore prevents fault trips. The drive converter remains operational as long as the drive can provide regenerative energy as a result of its motion and the DC link voltage does not drop below the shutdown threshold. When the line supply recovers within this time, the drive is again seamlessly accelerated up to its setpoint speed.
<b>Automatic restart</b>	The automatic restart switches the drive on again when the power is restored after a power failure, and ramps up to the current speed setpoint.
<b>Flying restart</b>	The flying restart function allows the converter to be switched to a motor that is still turning. With the voltage sensing capability provided by the optional VSM10, the flying restart time for large induction motors can be significantly reduced because the motor does not need to be de-magnetized.
<b>Technology controller</b>	Using the technology controller (PID controller) function module, level or flow controls and complex tension controls can be implemented, for example. The existing D component can act both on the system deviation well as on the actual value (factory setting). The P, I, and D components are set separately.
<b>Free function blocks (FFB)</b>	Using the freely programmable function blocks, it is easy to implement logic and arithmetic functions for controlling the SINAMICS drive. The blocks can be programmed at the operator panel or the STARTER commissioning tool.
<b>Drive Control Chart (DCC)</b>	Drive Control Chart (DCC) is an additional tool for the easy configuration of technological functions for SINAMICS. The block library contains a large selection of control, arithmetic and logic blocks as well as extensive open-loop and closed-loop control functions. The user-friendly DCC editor enables easy graphics-based configuration, allows control loop structures to be clearly represented and provides a high degree of reusability of charts that have already been created. DCC is an add-on for the STARTER commissioning tool (→ Tools and Engineering).
<b><math>\hat{P}t</math> sensing for motor protection</b>	A motor model stored in the converter software calculates the motor temperature based on the current speed and load. More exact measurement of the temperature, which also takes into account the influence of the ambient temperature, is possible by means of direct temperature measurement using KTY84 sensors in the motor winding.
<b>Motor temperature evaluation</b>	Motor protection by evaluating a KTY84, Pt1000, PTC or Pt100 temperature sensor. When a KTY84 temperature sensor is connected, the limit values can be set for alarm or shutdown. When a PTC thermistor is connected, the system reaction to triggering of the thermistor (alarm or trip) can be defined.
<b>Motor blocking protection</b>	A blocked motor is detected and protected against thermal overloading by a fault trip.

**Function** (continued)

Software and protective functions	Description
<b>Brake control</b>	"Simple brake control" for control of holding brakes: The holding brake is used to secure drives against unwanted motion when deactivated. "Extended brake control" function module for complex brake control, e.g. for motor holding brakes and operational brakes: When braking with a feedback signal, the brake control reacts to the feedback signal contacts of the brake.
<b>Write protection</b>	Write protection to prevent unintentional changing of the setting parameters (without password function).
<b>Know-how protection</b>	Know-how protection for encrypting stored data, e.g. to protect configuration know-how, and to protect against changes and duplication (with password function).
<b>Web server</b>	The integrated web server provides information about the drive unit via its web pages. The web server is accessed using a web browser via unsecured (http) or secured transfer protocol (https).

**Power unit protection**

Power unit protection	Description
<b>Ground fault monitoring at the output</b>	A ground fault at the output is detected by a total current monitor and results in shutdown in grounded systems.
<b>Electronic short-circuit protection at the output</b>	A short-circuit at the output (e.g. at the converter output terminals, in the motor cable or in the motor terminal box) is detected and the converter shuts down with a "fault".
<b>Thermal overload protection</b>	An alarm is issued first when the overtemperature threshold responds. If the temperature continues to rise, the unit either shuts down or independently adjusts the pulse frequency or output current so that thermal load is reduced. Once the cause of the fault has been eliminated (e.g. cooling has been improved), the original operating values are automatically resumed.

**Technical specifications**

The most important directives and standards are listed below. These are used as the basis for the SINAMICS S120 built-in units in chassis format and they must be carefully observed to achieve an EMC-compliant configuration that is safe both functionally and in operation.

European directives	
<b>2014/35/EU</b>	Low-voltage directive: Directive of the European Parliament and Council of February 26, 2014, for the harmonization of the laws of the member states relating to the provision of electrical equipment designed for use within certain voltage limits on the market (amended version)
<b>2014/30/EU</b>	EMC directive: Directive of the European Parliament and Council of February 26, 2014, for the harmonization of the laws of the member states relating to electromagnetic compatibility (amended version)
<b>2006/42/EC</b>	Machinery Directive: Directive of the European Parliament and Council of May 17, 2006, on machinery and amending Directive 95/16/EC (amended version).
European standards	
<b>EN ISO 3744</b>	Acoustics – Determination of the sound power level and sound energy level for noise sources that result from sound pressure measurements – envelope surface procedure of the accuracy class 2 for a largely free sound field over a reflecting plane
<b>EN ISO 13849-1</b>	Safety of machinery – safety-related parts of control systems; Part 1: General design guidelines (EN ISO 13849-1: 2006) (replaces EN 954-1)
<b>EN 60146-1-1</b>	Semiconductor converters – General requirements and line-commutated converters Part 1-1: Specification of basic requirements
<b>EN 60204-1</b>	Safety of machinery – Electrical equipment of machines; Part 1: General requirements
<b>EN 60529</b>	Degrees of protection provided by enclosures (IP code)
<b>EN 61508-1</b>	Functional safety of electrical/electronic/programmable electronic safety-related systems Part 1: General requirements
<b>EN 61800-2</b>	Adjustable speed electrical power drive systems Part 2: General requirements – Rating specifications for low voltage adjustable frequency AC power drive systems
<b>EN 61800-3</b>	Adjustable speed electrical power drive systems Part 3: EMC requirements and specific test methods
<b>EN 61800-5-1</b>	Adjustable speed electrical power drive systems Part 5: Safety requirements Main section 1: Electrical and thermal requirements
<b>EN 61800-5-2</b>	Adjustable speed electrical power drive systems Part 5-2: Safety requirements – Functional safety (IEC 61800-5-2: 2007)
North American standards	
<b>UL 508A</b>	Industrial Control Panels
<b>UL 508C</b>	Power Conversion Equipment
<b>UL 61800-5-1</b>	Adjustable Speed Electrical Power Drive Systems - Part 5-1: Safety requirements – Electrical, thermal and energy
<b>CSA C22.2 No. 14</b>	Industrial Control Equipment
Certificates of suitability	
<b>cULus, cURus</b>	Testing by UL (Underwriters Laboratories, <a href="http://www.ul.com">www.ul.com</a> ) according to UL and CSA standards

Mark of conformity and UL Files:  
(→ Appendix, Approvals)

## SINAMICS S120 Chassis Format Converter Units

Air-cooled units

### Technical specifications

#### General technical specifications

Unless clearly specified otherwise, the following technical data are valid for all the following components of the air-cooled SINAMICS S120 drive system in chassis format.

Electrical specifications	
<b>Rated voltages</b>	380 ... 480 V 3 AC $\pm 10\%$ (-15% < 1 min) 500 ... 690 V 3 AC $\pm 10\%$ (-15% < 1 min)
<b>Line supply types</b>	Grounded TN/TT systems and non-grounded IT systems
<b>Line frequency</b>	47 ... 63 Hz
<b>Overvoltage category</b>	III to EN 61800-5-1
<b>Electronics power supply</b>	24 V DC, -15% +20% implemented as PELV circuit in accordance with EN 61800-5-1 Ground = negative pole grounded via the electronics
<b>Rated short-circuit current</b> per IEC, in conjunction with the specified fuses or circuit breakers	
• 1.1 ... 447 kW	65 kA
• 448 ... 671 kW	84 kA
• 672 ... 1193 kW	170 kA
• > 1194 kW	200 kA
<b>Rated short-circuit current SCCR (Short Circuit Current Rating)</b> according to UL508C (up to 600 V), in conjunction with the specified fuses or circuit breakers	
• 1.1 ... 447 kW	65 kA
• 448 ... 671 kW	84 kA
• 672 ... 1193 kW	170 kA
• > 1194 kW	200 kA
<b>Control method</b>	Vector/Servo control with and without encoder or V/f control
<b>Fixed speeds</b>	15 fixed speeds plus 1 minimum speed, parameterizable (in the default setting, 3 fixed setpoints plus 1 minimum speed are selectable using terminal block/PROFIBUS/PROFINET)
<b>Skippable speed ranges</b>	4, parameterizable
<b>Setpoint resolution</b>	0.001 rpm digital (14 bits + sign) 12 bits analog
<b>Braking operation</b>	With Active Line Modules and Smart Line Modules, four-quadrant operation as standard (energy recovery). With Basic Line Modules, two-quadrant operation as standard, braking by means of an optional braking chopper, or alternatively by a Motor Module.
Mechanical specifications	
<b>Degree of protection</b>	IP00 or IP20 depending on type
<b>Protection class</b>	I acc. to EN 61800-5-1
<b>Touch protection</b>	EN 50274/DGUV regulation 3 when used as intended
<b>Cooling method</b>	Forced air cooling AF according to EN 60146

# SINAMICS S120 Chassis Format Converter Units

## Air-cooled units

### Technical specifications (continued)

Ambient conditions	Storage <sup>1)</sup>	Transport <sup>1)</sup>	Operation
<b>Ambient temperature</b>	-25 ... +55 °C Class 1K4 acc. to EN 60721-3-1	-25 ... +70 °C Class 2K4 acc. to EN 60721-3-2	Line-side components, Power Modules, Line Modules and Motor Modules: 0 ... 40 °C without derating Up to 55 °C, <a href="#">see derating data</a> Control Units, supplementary system components, and Sensor Modules: 0 ... 55 °C (for operation in a control cabinet) DC link components and motor-side components: 0 ... 55 °C
<b>Relative humidity</b> Condensation, splashwater, and ice formation not permitted (EN 60204, Part 1)	<u>5 ... 95 %</u> Class 1K4 acc. to EN 60721-3-1	5 ... 95 % at 40 °C Class 2K3 acc. to EN 60721-3-2	<u>5 ... 95 %</u> Class 3K3 acc. to EN 60721-3-3
<b>Environmental class/ harmful chemical substances</b>	Class 1C2 acc. to EN 60721-3-1	Class 2C2 acc. to EN 60721-3-2	Class 3C2 acc. to EN 60721-3-3
<b>Organic/ biological influences</b>	Class 1B1 acc. to EN 60721-3-1	Class 2B1 acc. to EN 60721-3-2	Class 3B1 acc. to EN 60721-3-3
<b>Degree of pollution</b>	2 acc. to EN 61800-5-1		
<b>Installation altitude</b>	Up to 2000 m above sea level without derating >2000 m above sea level, <a href="#">see derating data</a>		
Mechanical stability	Storage <sup>1)</sup>	Transport <sup>1)</sup>	Operation
<b>Vibratory load</b>	–	Class 2M2 acc. to EN 60721-3-2	Test values acc. to EN 60068-2-6 test Fc: <ul style="list-style-type: none"> <li>• 10 ... 58 Hz with constant deflection 0.075 mm</li> <li>• 58 ... 150 Hz with constant acceleration 9.81 m/s<sup>2</sup> (1 × g)</li> </ul>
<b>Shock load</b>	–	Class 2M2 acc. to EN 60721-3-2	Test values according to EN 60068-2-27 test Ea: 98 m/s <sup>2</sup> (10 × g)/20 ms
Compliance with standards			
<b>Conformances/ certificates of suitability, according to</b>	CE (EMC Directive No. 2014/30/EU, Low Voltage Directive No. 2014/35/EU, and Machinery Directive 2006/42/EC for functional safety) RCM, RoHS II cULus (only for devices connected to line supply voltages 380 ... 480 V 3 AC and 500 ... 600 V 3 AC)		
<b>Radio interference suppression</b>	SINAMICS S120 chassis format units are not designed for connection to the public grid (first environment). Radio interference suppression is compliant with the EMC product standard for variable-speed drives EN 61800-3, "Second environment" (industrial line supplies). EMC disturbances can occur when connected to the public grid. However, if additional measures are taken (e.g. → line filter), it can also be operated in the "first environment".		

Deviations from the specified class are underlined.

<sup>1)</sup> In transport packaging.

## SINAMICS S120 Chassis Format Converter Units

### Air-cooled units

#### Characteristic curves

##### Derating data, chassis format

Air-cooled SINAMICS G120 chassis format units and the associated system components are rated for an ambient temperature of 40 °C and installation altitudes up to 2000 m above sea level.

At ambient temperatures > 40 °C, the output current must be reduced. Ambient temperatures above 55 °C are not permissible.

At installation altitudes > 2000 m above sea level, it must be taken into account that the air pressure, and therefore air density, decreases as the height increases. As a consequence, the cooling efficiency and the insulation capacity of the air also decrease.

Due to the reduced cooling efficiency, it is necessary, on the one hand, to reduce the ambient temperature and on the other hand, to reduce the heat loss in the built-in unit by reducing the output current, whereby ambient temperatures lower than 40 °C may be offset to compensate.

Current derating factors for SINAMICS S120 chassis units as a function of the ambient/air intake temperature and the installation altitude

Installation altitude above sea level m	Current derating factor (as a percentage of the rated current) for an ambient / air intake temperature of								
	20 °C	25 °C	30 °C	35 °C	40 °C	45 °C	50 °C	55 °C	
0 ... 2000						93.3 %	86.7 %	80 %	
2001 ... 2500					96.3 %				
2501 ... 3000		100 %			98.7 %				
3001 ... 3500									
3501 ... 4000			96.3 %						
4001 ... 4500		97.5 %							
4501 ... 5000	98.2 %								

Current derating for Power Modules and Motor Modules in chassis format as a function of the pulse frequency

To reduce motor noise or to increase output frequency, the pulse frequency can be increased relative to the factory setting (1.25 kHz or 2 kHz). When the pulse frequency is increased, the derating factor of the output current must be taken into account. This derating factor must be applied to the currents specified in the technical specifications.

Derating factor of the output current as a function of the pulse frequency for units with a rated pulse frequency of 2 kHz

Power Module Motor Module	Type rating at 400 V kW	Output current at 2 kHz A	Derating factor at pulse frequency				
			2.5 kHz	4 kHz	5 kHz	7.5 kHz	8 kHz
<b>380 ... 480 V 3 AC</b>							
1TE32-1AA3	110	210	95 %	82 %	74 %	54 %	50 %
1TE32-6AA3	132	260	95 %	83 %	74 %	54 %	50 %
1TE33-1AA3	160	310	97 %	88 %	78 %	54 %	50 %
1TE33-8AA3	200	380	96 %	87 %	77 %	54 %	50 %
1TE35-0AA3	250	490	94 %	78 %	71 %	53 %	50 %

The following table lists the permissible output currents depending on the installation altitude and ambient temperature. The specified values already include a permitted compensation in respect of installation altitude and ambient temperatures < 40 °C (temperature at the air intake of the built-in unit).

The values apply under the precondition that a cooling air flow through the devices is guaranteed as specified in the technical specifications.

As additional measure for installation altitudes from 2000 m up to 5000 m, an isolating transformer is required in order to reduce transient overvoltages according to EN 60664-1.

[For additional information, please refer to the SINAMICS Low Voltage Engineering Manual.](#)

[For additional information, please refer to the SINAMICS Low Voltage Engineering Manual.](#)

The following table lists the rated output currents of the SINAMICS S120 Power Modules and Motor Modules with pulse frequency set in the factory as well as the current derating factors (permissible output currents referred to the rated output current) for higher pulse frequencies.

## SINAMICS S120 Chassis Format Converter Units

### Air-cooled units

#### Characteristic curves (continued)

Derating factor of the output current as a function of the pulse frequency for units with a rated pulse frequency of 1.25 kHz

Motor Module	Type rating at 400 V or 690 V kW	Output current at 1.25 kHz A	Derating factor at pulse frequency					
			2 kHz	2.5 kHz	4 kHz	5 kHz	7.5 kHz	8 kHz
<b>380 ... 480 V 3 AC</b>								
1TE36-1AA3	315	605	83 %	72 %	64 %	60 %	40 %	36%
1TE37-5AA3	400	745	83 %	72 %	64 %	60 %	40 %	36%
1TE38-4AA3	450	840	87 %	79 %	64 %	55 %	40 %	37 %
1TE41-0AA3	560	985	92 %	87 %	70 %	60 %	50 %	47 %
1TE41-2AA3	710	1260	92 %	87 %	70 %	60 %	50 %	47 %
1TE41-4AA3	800	1405	97 %	95 %	74 %	60 %	50 %	47 %
<b>500 ... 690 V 3 AC</b>								
1TG28-5AA3	75	85	93 %	89 %	71 %	60 %	40 %	-
1TG31-0AA3	90	100	92 %	88 %	71 %	60 %	40 %	-
1TG31-2AA3	110	120	92 %	88 %	71 %	60 %	40 %	-
1TG31-5AA3	132	150	90 %	84 %	66 %	55 %	35 %	-
1TG31-8AA3	160	175	92 %	87 %	70 %	60 %	40 %	-
1TG32-2AA3	200	215	92 %	87 %	70 %	60 %	40 %	-
1TG32-6AA3	250	260	92 %	88 %	71 %	60 %	40 %	-
1TG33-3AA3	315	330	89 %	82 %	65 %	55 %	40 %	-
1TG34-1AA3	400	410	89 %	82 %	65 %	55 %	35 %	-
1TG34-7AA3	450	465	92 %	87 %	67 %	55 %	35 %	-
1TG35-8AA3	560	575	91 %	85 %	64 %	50 %	35 %	-
1TG37-4AA3	710	735	87 %	79 %	64 %	55 %	25 %	-
1TG38-1AA3	800	810	97 %	95 %	71 %	55 %	35 %	-
1TG38-8AA3	900	910	92 %	87 %	67 %	55 %	33 %	-
1TG41-0AA3	1000	1025	91 %	86 %	64 %	50 %	30 %	-
1TG41-3AA3	1200	1270	87 %	79 %	55 %	40 %	25 %	-

The following tables list the maximum achievable output frequency as a function of the pulse frequency:

Maximum output frequencies achieved by increasing the pulse frequency in **Vector mode**

Pulse frequency	Max. achievable output frequency
1.25 kHz	100 Hz
2 kHz	160 Hz
2.5 kHz	200 Hz
4 kHz	300 Hz

Maximum output frequencies achieved by increasing the pulse frequency in **Servo mode**

Pulse frequency	Max. achievable output frequency
2 kHz	300 Hz
4 kHz	300/550 Hz <sup>1)</sup>

<sup>1)</sup> Higher frequencies on request. For further information, see <https://support.industry.siemens.com/cs/document/104020669>



# SINAMICS S120 Chassis Format Converter Units

## Air-cooled units

### Characteristic curves (continued)

#### Overload capability

SINAMICS S120 chassis units have an overload reserve, e.g. to handle breakaway torques. If larger surge loads occur, this must be taken into account in the configuration. For drives with overload requirements, the appropriate base-load current must, therefore, be used as a basis for the required load.

The permissible overload levels are valid under the prerequisite that the drive units are operated with their base-load current before and after the overload condition based on a duty cycle duration of 300 s.

Another precondition is that the Power Modules or the Motor Modules are operated at their factory-set pulse frequency at output frequencies > 10 Hz.

For temporary, periodic duty cycles with high variations of load within the duty cycle, the relevant sections of the SINAMICS Low Voltage Engineering Manual must be observed.

#### Power Modules and Motor Modules

The base-load current for a low overload  $I_L$  is based on a duty cycle of 110 % for 60 s or 150 % for 10 s.

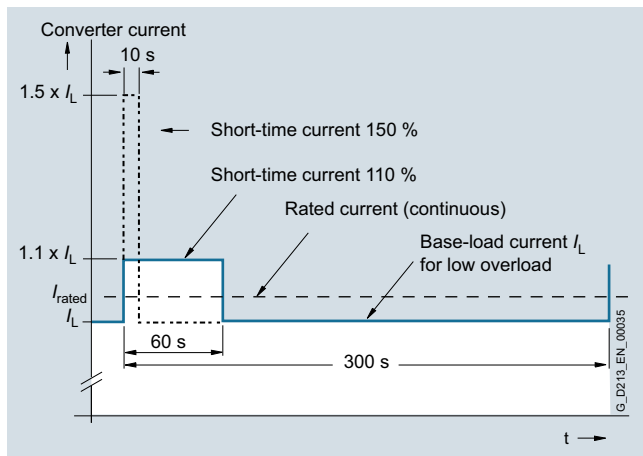

Low overload

The base-load current for a high overload  $I_H$  is based on a duty cycle of 150 % for 60 s or 160 % for 10 s.

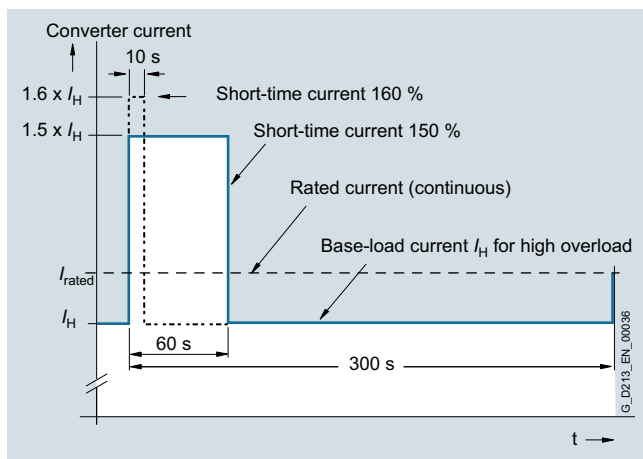

High overload

#### Line Modules

The base-load current for a high overload  $I_{HDC}$  is the basis for a duty cycle of 150 % for 60 s or  $I_{maxDC}$  for 5 s.

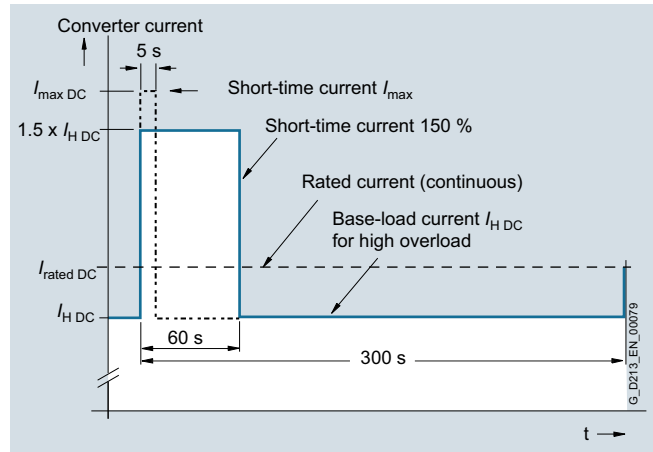

High overload

# SINAMICS S120 Chassis Format Converter Units

## Air-cooled units

### Power Modules

#### Overview



The Power Module comprises a line rectifier, a DC link and a converter to supply the motor.

Power Modules are designed for drives that are not capable of regenerating energy to the mains supply. Regenerative energy produced while braking is converted to heat using braking resistors.

Power Modules in the chassis format can be connected to grounded TN/TT systems and non-grounded IT systems.

#### Design

The Power Modules have the following interfaces as standard:

- 1 line supply connection
- 1 motor connection
- 1 connection for the 24 V DC electronics power supply
- 1 DC link connection (DCPA, DCNA) for connecting a Braking Module
- 1 DC link connection (DCPS, DCNS) for connecting a dv/dt filter
- 3 DRIVE-CLiQ sockets
- 1 temperature sensor input for KTY84-130, Pt1000, PTC or Pt100 (Pt1000 can be used from firmware V4.7 HF17)
- 1 connection for Safe Brake Adapter
- 1 connection for Safety Integrated
- 2 PE connections

The Power Modules are controlled by the CU310-2 Control Unit that can be integrated into the Power Module.

The status of the Power Modules is indicated via three LEDs.

The scope of supply of the Power Modules includes:

- 1 DRIVE-CLiQ cable for connection to the Control Unit
- 1 24 V DC connecting cable for the power supply to the Control Unit
- 1 mounting plate for attaching the Control Unit
- 1 set of warning labels in 30 languages (BG, CN, CZ, DE, DK, EE, ES, FI, FR, GB, GR, HU, IE, IS, IT, JP, KR, LT, LV, MT, NL, NO, PL, PT, RO, RU, SE, SI, SK, TR)

#### Application in multi-axis systems

Power Modules in chassis format can also be connected directly via DRIVE-CLiQ to a separate CU320-2 or SIMOTION D4x5-2 Control Unit or Controller Extension CX32-2. The appropriate DRIVE-CLiQ cable for the required distance must be ordered (see section MOTION-CONNECT connection systems).

#### Selection and ordering data

Type rating at 400 V kW	Rated output current A	Power Module Article No.
<b>Line voltage 380 ... 480 V 3 AC</b>		
110	210	<b>6SL3310-1TE32-1AA3</b>
132	260	<b>6SL3310-1TE32-6AA3</b>
160	310	<b>6SL3310-1TE33-1AA3</b>
200	380	<b>6SL3310-1TE33-8AA3</b>
250	490	<b>6SL3310-1TE35-0AA3</b>

Description	Article No.
-------------	-------------

#### Accessories for re-ordering

<b>Dust protection blanking plugs</b> (50 units) For DRIVE-CLiQ port	<b>6SL3066-4CA00-0AA0</b>
--	---------------------------

For line and motor-side components, Braking Modules as well as recommended line-side system components, see System components.

# SINAMICS S120 Chassis Format Converter Units

Air-cooled units

## Power Modules

### Integration

The Power Modules communicate with the higher-level control module via DRIVE-CLiQ. The Control Unit in this case could be a CU310-2, CU320-2 or a SIMOTION D Control Unit.

3

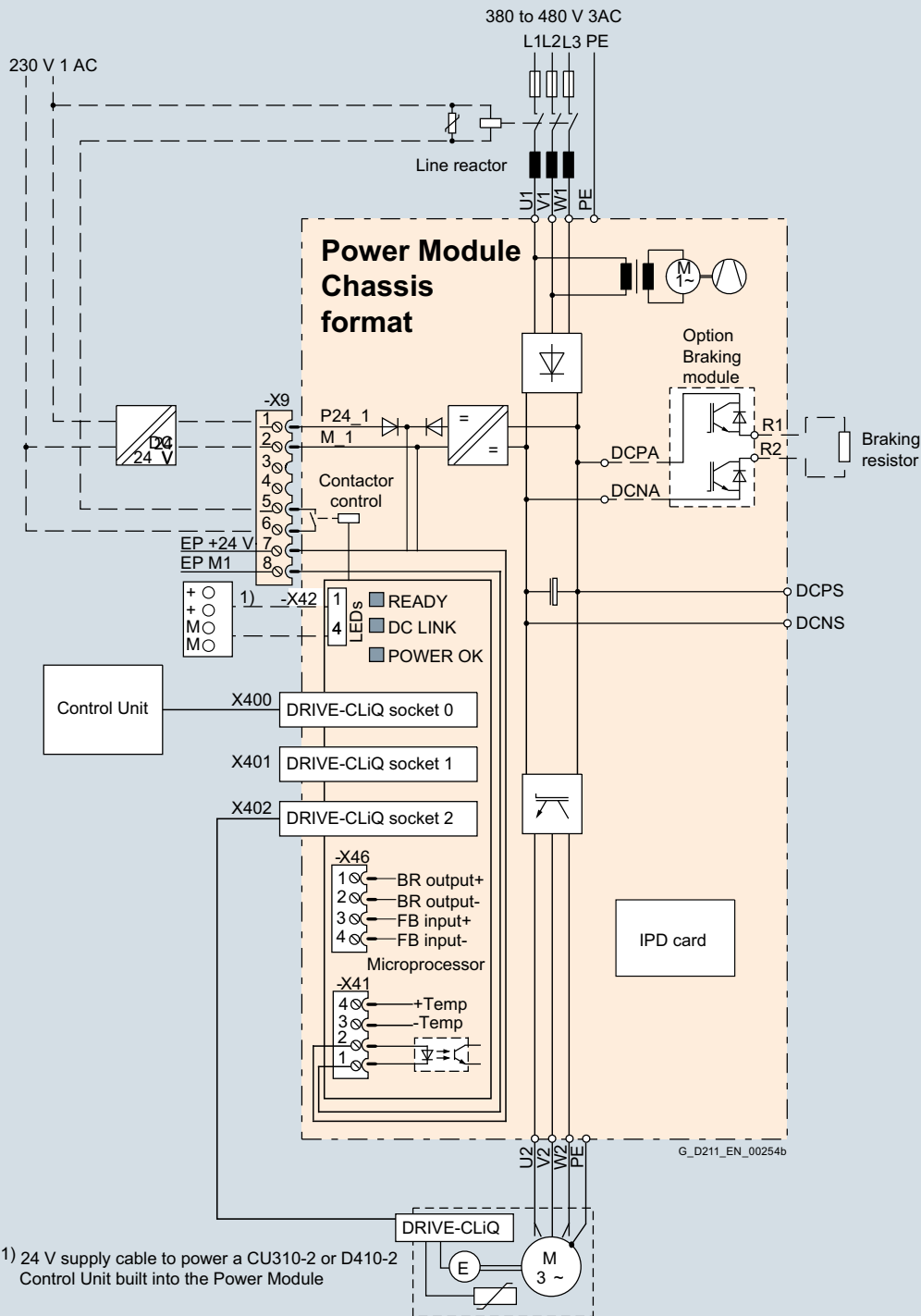

1) 24 V supply cable to power a CU310-2 or D410-2 Control Unit built into the Power Module

Connection example of a Power Module

**Note:**

The integrated 24 V power supply at connector X42 can have a maximum load of 2 A. When the Control Unit is supplied from the integrated power supply, the total load of the digital outputs must be carefully observed to ensure that the 2 A is not exceeded.

## Technical specifications

### General technical specifications

Electrical specifications	
<b>Line connection voltage</b> Up to 2000 m above sea level	380 ... 480 V 3 AC $\pm 10\%$ (-15% < 1 min)
<b>Line power factor</b> for a 3 AC line supply voltage and output power	
• Basic fundamental ( $\cos \varphi_1$ )	>0.96
• Total ( $\lambda$ )	0.75 ... 0.93
<b>DC link voltage, approx. <sup>1)</sup></b>	1.35 × line voltage
<b>Output voltage, approx.</b>	0.97 × $U_{line}$
<b>Output frequency <sup>2)</sup></b>	
• Control mode Servo	0 ... 550 Hz
• Control mode Vector	0 ... 550 Hz
• Control mode V/f	0 ... 550 Hz
<b>Main contactor control</b>	
• Terminal block -X9/5-6	240 V AC, max. 8 A 30 V DC, max. 1 A
<b>Safety Integrated</b>	Safety Integrity Level 2 (SIL2) acc. to IEC 61508, Performance Level d (PLd) acc. to EN ISO 13849-1 and Control Category 3 acc. to EN ISO 13849-1

<sup>1)</sup> The DC link voltage is unregulated and load-dependent.  
For additional information, please refer to the [SINAMICS Low Voltage Engineering Manual](#).

<sup>2)</sup> Please note:

- Note the correlation between max. output frequency, pulse frequency and current derating. Higher output frequencies on request.  
For further information, see <https://support.industry.siemens.com/cs/document/104020669>
- The correlation between the minimum output frequency and permissible output current (current derating).  
Information is provided in the [SINAMICS Low Voltage Engineering Manual](#).

# SINAMICS S120 Chassis Format Converter Units

## Air-cooled units

### Power Modules

#### Technical specifications (continued)

Line voltage 380 ... 480 V 3 AC		Power Modules				
		6SL3310-1TE32-1AA3	6SL3310-1TE32-6AA3	6SL3310-1TE33-1AA3	6SL3310-1TE33-8AA3	6SL3310-1TE35-0AA3
<b>Type rating</b>						
• At $I_L$ (50 Hz 400 V) <sup>1)</sup>	kW	<b>110</b>	<b>132</b>	<b>160</b>	<b>200</b>	<b>250</b>
• At $I_H$ (50 Hz 400 V) <sup>1)</sup>	kW	90	110	132	160	200
• At $I_L$ (60 Hz 460 V) <sup>2)</sup>	hp	150	200	250	300	400
• At $I_H$ (60 Hz 460 V) <sup>2)</sup>	hp	150	200	200	250	350
<b>Output current</b>						
• Rated current $I_{rated O}$	A	210	260	310	380	490
• Base-load current $I_L^{(3)}$	A	205	250	302	370	477
• Base-load current $I_H^{(4)}$	A	178	233	277	340	438
• Maximum current $I_{max O}$	A	307	375	453	555	715
<b>Input current</b>						
• Rated input current $I_{rated I}$	A	229	284	338	395	509
• Maximum input current $I_{max I}$	A	335	410	495	606	781
<b>Current demand</b>						
• 24 V DC auxiliary power supply	A	0.8	0.8	0.9	0.9	0.9
<b>Pulse frequency <sup>5)</sup></b>						
• Rated frequency	kHz	2	2	2	2	2
• Pulse frequency, max.						
- Without current derating	kHz	2	2	2	2	2
- With current derating	kHz	8	8	8	8	8
<b>Power loss, max. <sup>6)</sup></b>						
• At 50 Hz 400 V	kW	2.46	3.27	4	4.54	5.78
• At 60 Hz 460 V	kW	2.54	3.36	4.07	4.67	5.96
<b>Cooling air requirement</b>		m <sup>3</sup> /s	0.17	0.23	0.36	0.36
<b>Sound pressure level <math>L_{pA}</math></b> (1 m) at 50/60 Hz		dB	64/67	71/71	69/73	69/73
<b>Line connection</b> U1, V1, W1			M10 screw	M10 screw	M10 screw	M10 screw
• Conductor cross-section, max. (IEC)	mm <sup>2</sup>	2 × 185	2 × 185	2 × 240	2 × 240	2 × 240
<b>Motor connection</b> U2/T1, V2/T2, W2/T3			M10 screw	M10 screw	M10 screw	M10 screw
• Conductor cross-section, max. (IEC)	mm <sup>2</sup>	2 × 185	2 × 185	2 × 240	2 × 240	2 × 240
<b>Cable length, max. <sup>7)</sup></b>						
• Shielded	m	300	300	300	300	300
• Unshielded	m	450	450	450	450	450
<b>PE1/GND connection</b>			M10 screw	M10 screw	M10 screw	M10 screw
• Conductor cross-section, max. (IEC)	mm <sup>2</sup>	2 × 185	2 × 185	2 × 240	2 × 240	2 × 240
<b>PE2/GND connection</b>			M10 screw	M10 screw	M10 screw	M10 screw
• Conductor cross-section, max. (IEC)	mm <sup>2</sup>	2 × 185	2 × 185	2 × 240	2 × 240	2 × 240
<b>Degree of protection</b>			IP20	IP20	IP20	IP20
<b>Dimensions</b>						
• Width	mm	326	326	326	326	326
• Height	mm	1400	1400	1533	1533	1533
• Depth	mm	356 <sup>8)</sup>	356 <sup>8)</sup>	549	549	549
<b>Weight, approx.</b>		kg	104	104	162	162
<b>Frame size</b>			FX	FX	GX	GX
<b>Minimum short-circuit current <sup>9)</sup></b>		A	3000	3600	4400	4400

<sup>1)</sup> Rated output of a typical 6-pole standard induction motor based on  $I_L$  or  $I_H$  for 400 V 3 AC 50 Hz.

<sup>2)</sup> Rated output of a typical 6-pole standard induction motor based on  $I_L$  or  $I_H$  for 460 V 3 AC 60 Hz.

<sup>3)</sup> The base-load current  $I_L$  is based on a duty cycle of 110 % for 60 s or 150 % for 10 s with a duty cycle duration of 300 s.

<sup>4)</sup> The base-load current  $I_H$  is based on a duty cycle of 150 % for 60 s or 160 % for 10 s with a duty cycle duration of 300 s.

<sup>5)</sup> Information regarding the correlation between the pulse frequency and maximum output current/output frequency is provided in the SINAMICS Low Voltage Engineering Manual.

<sup>6)</sup> The specified power loss represents the maximum value at 100 % utilization. The value is lower under normal operating conditions.

<sup>7)</sup> Longer cable lengths for specific configurations are available on request. For additional information, please refer to the SINAMICS Low Voltage Engineering Manual.

<sup>8)</sup> Depth = 421 mm including front cover when CU310-2 Control Unit is installed.

<sup>9)</sup> Current required for reliably triggering protective devices.

# SINAMICS S120 Chassis Format Converter Units

## Air-cooled units

### Basic Line Modules

#### Overview



Basic Line Modules are available for applications in which no energy is returned to the supply or where the energy exchange between motor and generator axes takes place in the DC link. Basic Line Modules are designed for connection to grounded TN/TT and non-grounded IT supply systems.

The Basic Line Modules are available in different frame sizes. With frame sizes FB and GB, a fully controlled thyristor bridge is used to pre-charge the Basic Line Modules and connected Motor Modules. The thyristors normally operate with a trigger delay angle of 0°.

Basic Line Modules, frame size GD for 900 kW (400 V) or 1500 kW (690 V) include a diode bridge, and the DC link is pre-charged via a separate line-side pre-charging circuit.

A Braking Module of the appropriate frame size can be integrated into a Basic Line Module in order to permit, in conjunction with an external braking resistor, regenerative operation of the drive system (→ DC link components).

#### Design

The Basic Line Modules have the following interfaces as standard:

- 1 line supply connection
- 1 connection for the 24 V DC electronics power supply
- 1 DC link connection (DCP, DCN) for supplying the connected Motor Modules
- 1 DC link connection (DCPA, DCNA) for connecting a Braking Module
- 3 DRIVE-CLiQ sockets
- 1 temperature sensor input for KTY84-130, Pt1000 or PTC (Pt1000 can be used from firmware V4.7 HF17)
- 1 PE connection

The status of the Basic Line Modules is indicated via three LEDs.

The scope of supply of the Basic Line Modules includes:

- DRIVE-CLiQ cable to connect to a Control Unit
- DRIVE-CLiQ cable to connect the Control Unit to the first Motor Module
- 1 set of warning labels in 30 languages (BG, CN, CZ, DE, DK, EE, ES, FI, FR, GB, GR, HU, IE, IS, IT, JP, KR, LT, LV, MT, NL, NO, PL, PT, RO, RU, SE, SI, SK, TR)

#### Pre-charging circuit for the Basic Line Modules, frame size GD

Unlike Basic Line Modules in frame sizes FB and GB, a Basic Line Module in frame size GD requires a separate pre-charging circuit. The pre-charging circuit components must be ordered separately.

During startup, the pre-charging circuit ensures that the DC link capacitors of the Basic Line Module and the connected Motor Modules are pre-charged with current limiting. After pre-charging has been completed, the circuit breaker is closed and the pre-charging circuit bypassed; the Basic Line Module is then directly connected to the line supply.

The pre-charging circuit comprises a pre-charging contactor and pre-charging resistors; the circuit must be protected against overcurrent using suitable protection measures. To increase the permissible DC link capacitance, the pre-charging resistors can also be connected in parallel in each phase.

More information on the pre-charging circuit is to be found in the SINAMICS Low Voltage Engineering Manual.

For components for the pre-charging circuit and for recommended line-side system components, see System components.

#### Selection and ordering data

Rated power at 400 V or 690 V kW	Rated DC link current A	Basic Line Module Article No.
<b>Line voltage 380 ... 480 V 3 AC</b>		
200	420	<b>6SL3330-1TE34-2AA3</b>
250	530	<b>6SL3330-1TE35-3AA3</b>
400	820	<b>6SL3330-1TE38-2AA3</b>
560	1200	<b>6SL3330-1TE41-2AA3</b>
710	1500	<b>6SL3330-1TE41-5AA3</b>
900	1880	<b>6SL3330-1TE41-8AA3</b>
<b>Line voltage 500 ... 690 V 3 AC</b>		
250	300	<b>6SL3330-1TG33-0AA3</b>
355	430	<b>6SL3330-1TG34-3AA3</b>
560	680	<b>6SL3330-1TG36-8AA3</b>
900	1100	<b>6SL3330-1TG41-1AA3</b>
1100	1400	<b>6SL3330-1TG41-4AA3</b>
1500	1880	<b>6SL3330-1TG41-8AA3</b>
Description		Article No.
<b>Accessories for re-ordering</b>		
<b>Dust protection blanking plugs</b> (50 units) For DRIVE-CLiQ port		<b>6SL3066-4CA00-0AA0</b>

For line-side components and recommended line-side system components, see System components.

# SINAMICS S120 Chassis Format Converter Units

Air-cooled units

## Basic Line Modules

### Integration

The Basic Line Modules communicate with the higher-level control module via DRIVE-CLiQ. The control module in this case can be a CU320-2 or a SIMOTION D Control Unit. An external 24 V DC power supply is required to operate Basic Line Modules.

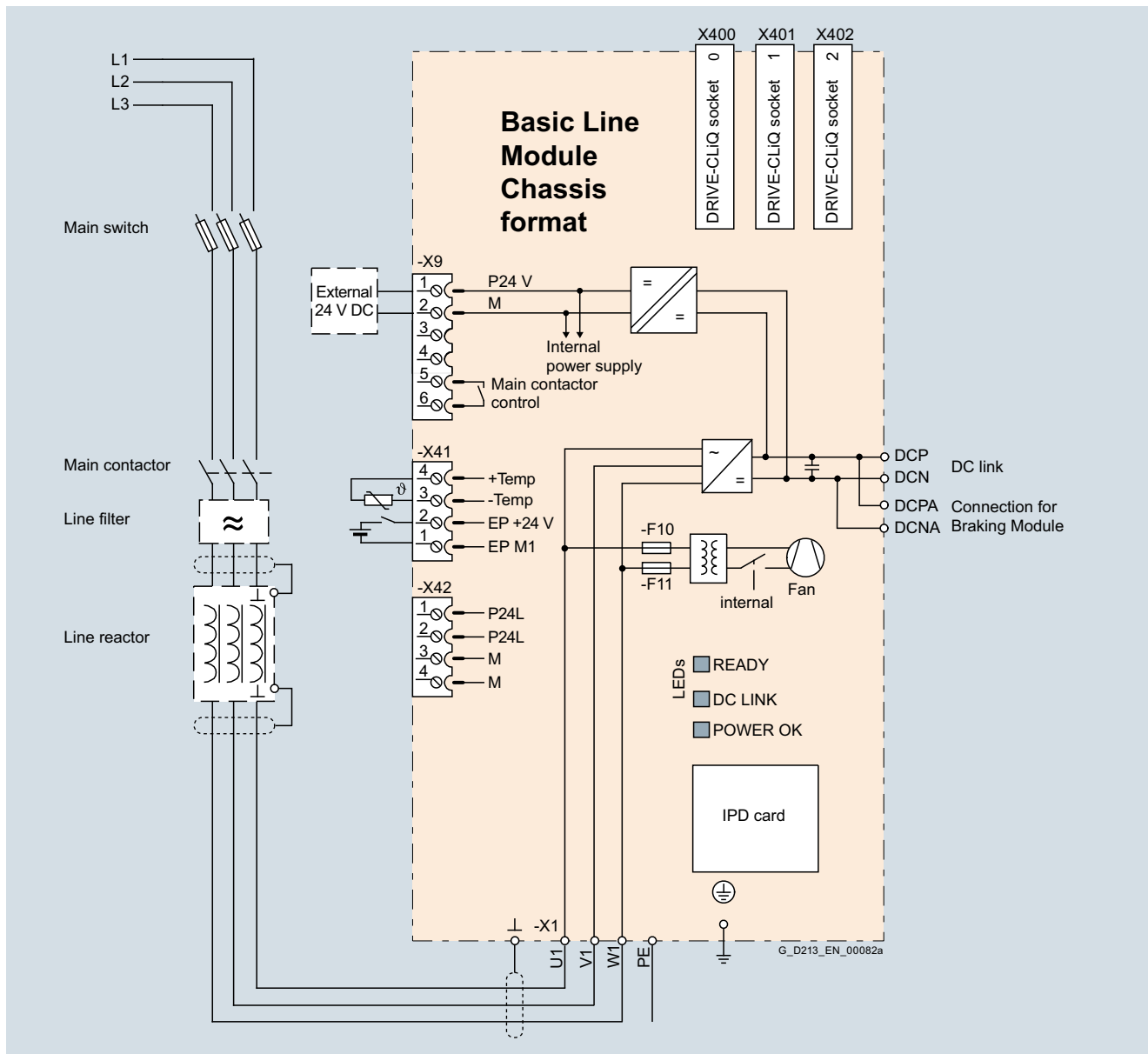

Connection example of a Basic Line Module, frame sizes FB, GB

3



# SINAMICS S120 Chassis Format Converter Units

Air-cooled units

## Basic Line Modules

### Integration (continued)

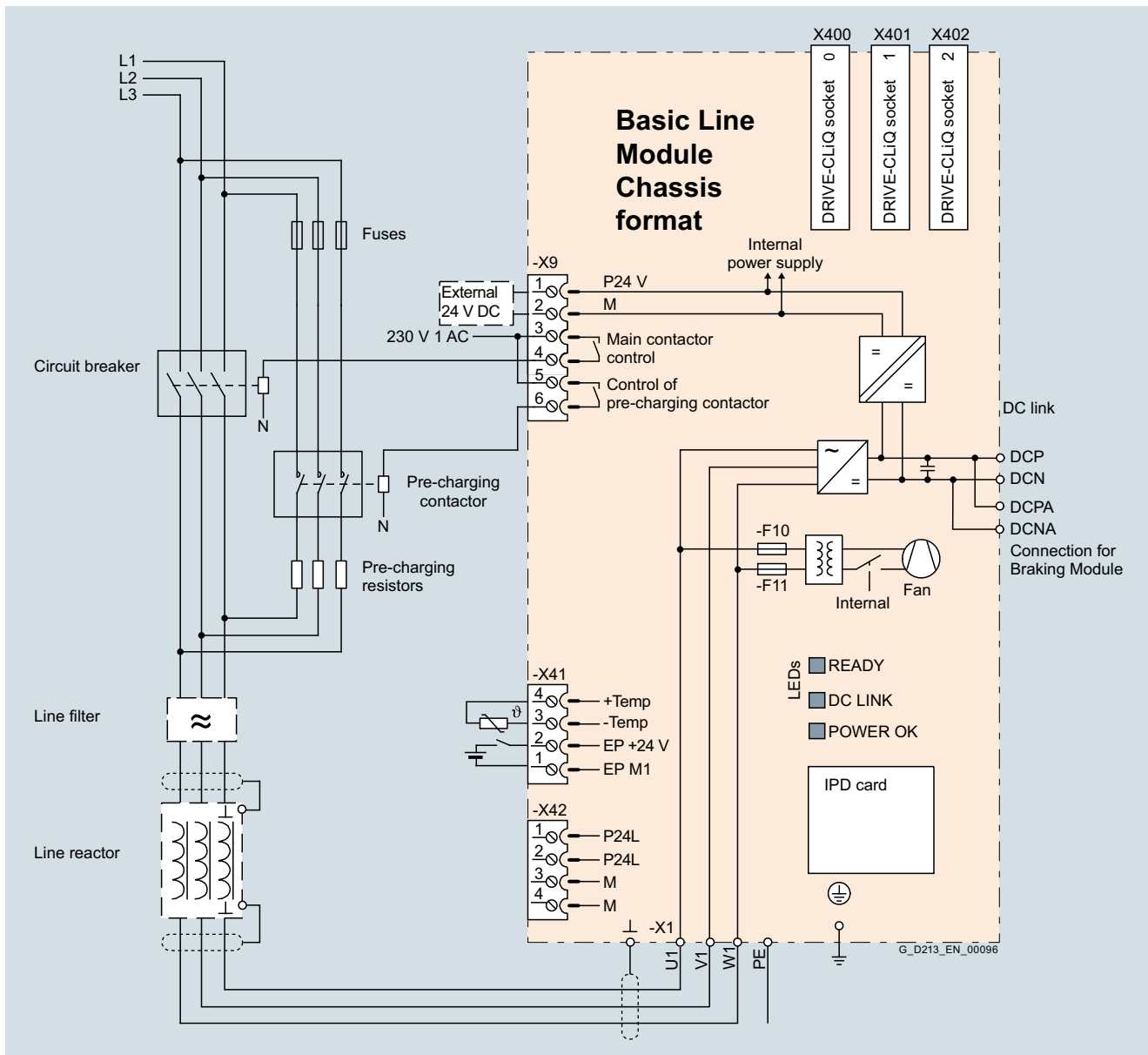

Connection example of a Basic Line Module, frame size GD

3

# SINAMICS S120 Chassis Format Converter Units

## Air-cooled units

### Basic Line Modules

#### Technical specifications

##### General technical specifications

Electrical specifications	
<b>Line power factor</b> at rated power	
• Basic fundamental ( $\cos \varphi_1$ )	>0.96
• Total ( $\lambda$ )	0.75 ... 0.93
<b>Efficiency</b>	>99 %
<b>DC link voltage, approx. <sup>1)</sup></b>	1.35 × line voltage under partial load 1.32 × line voltage under full load
<b>Main contactor control</b>	
• Terminal block -X9/5-6	240 V AC, max. 8 A 30 V DC, max. 1 A

Line voltage 380 ... 480 V 3 AC	Basic Line Modules						
		6SL3330-1TE34-2AA3	6SL3330-1TE35-3AA3	6SL3330-1TE38-2AA3	6SL3330-1TE41-2AA3	6SL3330-1TE41-5AA3	6SL3330-1TE41-8AA3
<b>Rated power</b>							
• At $I_{\text{rated DC}}$ (50 Hz 400 V)	kW	<b>200</b>	<b>250</b>	<b>400</b>	<b>560</b>	<b>710</b>	<b>900</b>
• At $I_{\text{H DC}}$ (50 Hz 400 V)	kW	160	200	315	450	560	705
• At $I_{\text{rated DC}}$ (60 Hz 460 V)	hp	305	385	615	860	1090	1390
• At $I_{\text{H DC}}$ (60 Hz 460 V)	hp	245	305	485	690	860	1090
<b>DC link current</b>							
• Rated current $I_{\text{rated DC}}$	A	420	530	820	1200	1500	1880
• Base-load current $I_{\text{H DC}}^{2)}$	A	328	413	640	936	1170	1467
• Maximum current $I_{\text{max DC}}$	A	630	795	1230	1800	2250	2820
<b>Input current</b>							
• Rated current $I_{\text{rated I}}$	A	365	460	710	1010	1265	1630
• Maximum current $I_{\text{max I}}$	A	547	690	1065	1515	1897	2380
• Max. pre-charging current (max. 3 s)	A	Internal	Internal	Internal	Internal	Internal	308
<b>Current demand</b>							
• 24 V DC auxiliary power supply	A	1.1	1.1	1.1	1.1	1.1	1.1
<b>DC link capacitance</b>							
• Basic Line Module	μF	7200	9600	14600	23200	29000	34800
• Drive line-up, max.	μF	57600	76800	116800	185600	232000	139200/278400 <sup>3)</sup>
<b>Power loss, max. <sup>4)</sup></b>							
• At 50 Hz 400 V	kW	1.9	2.1	3.2	4.6	5.5	6.9
• At 60 Hz 460 V	kW	1.9	2.1	3.2	4.6	5.5	6.9
<b>Cooling air requirement</b>	m <sup>3</sup> /s	0.17	0.17	0.17	0.36	0.36	0.36
<b>Sound pressure level <math>L_{\text{pA}}</math></b> (1 m) at 50/60 Hz	dB	66/68	66/68	66/68	71/73	71/73	71/73
<b>Line connection</b> U1, V1, W1							
• Conductor cross-section, max. (IEC)	mm <sup>2</sup>	Flat connector for M10 screw 2 × 240	Flat connector for M10 screw 2 × 240	Flat connector for M10 screw 2 × 240	Flat connector for M12 screw 6 × 185	Flat connector for M12 screw 6 × 185	Flat connector for M12 screw 6 × 185
<b>DC link connection</b> DCP, DCN							
• Conductor cross-section, max. (IEC)	mm <sup>2</sup>	M10 screw	M10 screw	M10 screw	3 × hole for M12	3 × hole for M12	3 × hole for M12
<b>PE/GND connection</b>							
• Conductor cross-section, max. (IEC)	mm <sup>2</sup>	2 × hole for M10 2 × 240	2 × hole for M10 2 × 240	2 × hole for M10 2 × 240	2 × hole for M12 4 × 240	2 × hole for M12 4 × 240	2 × hole for M12 4 × 240
<b>Cable length, max. <sup>5)</sup></b>							
• Shielded	m	2600	2600	2600	4000	4000	4800
• Unshielded	m	3900	3900	3900	6000	6000	7200
<b>Degree of protection</b>							
<b>Dimensions</b>							
• Width	mm	310	310	310	310	310	310
• Height	mm	1164	1164	1164	1653	1653	1653
• Depth	mm	352	352	352	550	550	550
<b>Weight, approx.</b>	kg	96	96	96	214	214	214
<b>Frame size</b>							
<b>Minimum short-circuit current <sup>6)</sup></b>	A	4400	5200	10000	12400	18400	18600

<sup>1)</sup> The DC link voltage is unregulated and load-dependent.  
For additional information, please refer to the [SINAMICS Low Voltage Engineering Manual](#).

<sup>2)</sup> The base-load current  $I_{\text{H DC}}$  is the basis for a duty cycle of 150 % for 60 s or  $I_{\text{max DC}}$  for 5 s with a duty cycle duration of 300 s.

<sup>3)</sup> The first value applies for one pre-charging resistor for each phase, the second value for two pre-charging resistors connected in parallel for each phase.

<sup>4)</sup> The specified power loss represents the maximum value at 100 % utilization. The value is lower under normal operating conditions.

<sup>5)</sup> Total of all motor cables and DC link. Longer cable lengths for specific configurations are available on request. For additional information, please refer to the [SINAMICS Low Voltage Engineering Manual](#).

<sup>6)</sup> Current required for reliably triggering protective devices.

# SINAMICS S120 Chassis Format Converter Units

## Air-cooled units

### Basic Line Modules

#### Technical specifications (continued)

Line voltage 500 ... 690 V 3 AC		Basic Line Modules					
		6SL3330-1TG33-0AA3	6SL3330-1TG34-3AA3	6SL3330-1TG36-8AA3	6SL3330-1TG41-1AA3	6SL3330-1TG41-4AA3	6SL3330-1TG41-8AA3
<b>Rated power</b>							
• At $I_{\text{rated DC}}$ (50 Hz 690 V)	kW	250	355	560	900	1100	1500
• At $I_{\text{H DC}}$ (50 Hz 690 V)	kW	195	280	440	710	910	1220
• At $I_{\text{rated DC}}$ (50 Hz 500 V)	kW	175	250	390	635	810	1085
• At $I_{\text{H DC}}$ (50 Hz 500 V)	kW	165	235	365	595	755	1015
• At $I_{\text{rated DC}}$ (60 Hz 575 V)	hp	250	350	600	900	1250	1500
• At $I_{\text{H DC}}$ (60 Hz 575 V)	hp	200	300	450	800	1000	1250
<b>DC link current</b>							
• Rated current $I_{\text{rated DC}}$	A	300	430	680	1100	1400	1880
• Base-load current $I_{\text{H DC}}^{1)}$	A	234	335	530	858	1092	1467
• Maximum current $I_{\text{max DC}}$	A	450	645	1020	1650	2100	2820
<b>Input current</b>							
• Rated current $I_{\text{rated I}}$	A	260	375	575	925	1180	1580
• Maximum current $I_{\text{max I}}$	A	390	563	863	1388	1770	2370
• Max. pre-charging current (max. 3 s)	A	Internal	Internal	Internal	Internal	Internal	234
<b>Current demand</b>							
• 24 V DC auxiliary power supply	A	1.1	1.1	1.1	1.1	1.1	1.1
<b>DC link capacitance</b>							
• Basic Line Module	$\mu\text{F}$	3200	4800	7300	11600	15470	19500
• Drive line-up, max.	$\mu\text{F}$	25600	38400	58400	92800	123760	78000/156000 <sup>2)</sup>
<b>Power loss, max.<sup>3)</sup></b>							
• At 50 Hz 690 V	kW	1.5	2.1	3.0	5.4	5.8	7.3
• At 60 Hz 575 V	kW	1.5	2.1	3.0	5.4	5.8	7.3
<b>Cooling air requirement</b>		$\text{m}^3/\text{s}$	0.17	0.17	0.17	0.36	0.36
<b>Sound pressure level <math>L_{\text{pA}}</math></b> (1 m) at 50/60 Hz		dB	66/68	66/68	66/68	71/73	71/73
<b>Line connection</b> U1, V1, W1			Flat connector for M10 screw	Flat connector for M10 screw	Flat connector for M10 screw	Flat connector for M12 screw	Flat connector for M12 screw
• Conductor cross-section, max. (IEC)	$\text{mm}^2$	2 × 240	2 × 240	2 × 240	6 × 185	6 × 185	6 × 185
<b>DC link connection</b> DCP, DCN			M10 screw	M10 screw	M10 screw	3 × hole for M12	3 × hole for M12
• Conductor cross-section, max. (IEC)	$\text{mm}^2$	2 × 240	2 × 240	2 × 240	6 × 185	6 × 185	6 × 185
<b>PE/GND connection</b>			2 × hole for M10	2 × hole for M10	2 × hole for M10	2 × hole for M12	2 × hole for M12
• Conductor cross-section, max. (IEC)	$\text{mm}^2$	2 × 240	2 × 240	2 × 240	4 × 240	4 × 240	4 × 240
<b>Cable length, max.<sup>4)</sup></b>							
• Shielded	m	1500	1500	1500	2250	2250	2750
• Unshielded	m	2250	2250	2250	3375	3375	4125
<b>Degree of protection</b>			IP00	IP00	IP00	IP00	IP00
<b>Dimensions</b>							
• Width	mm	310	310	310	310	310	310
• Height	mm	1164	1164	1164	1653	1653	1653
• Depth	mm	352	352	352	550	550	550
<b>Weight, approx.</b>		kg	96	96	96	214	214
<b>Frame size</b>			FB	FB	FB	GB	GD
<b>Minimum short-circuit current<sup>5)</sup></b>		A	3000	4400	8000	10400	16000

1) The base-load current  $I_{\text{H DC}}$  is the basis for a duty cycle of 150 % for 60 s or  $I_{\text{max DC}}$  for 5 s with a duty cycle duration of 300 s.

2) The first value applies for one pre-charging resistor for each phase, the second value for two pre-charging resistors connected in parallel for each phase.

3) The specified power loss represents the maximum value at 100 % utilization. The value is lower under normal operating conditions.

4) Total of all motor cables and DC link. Longer cable lengths for specific configurations are available on request. For additional information, please refer to the SINAMICS Low Voltage Engineering Manual.

5) Current required for reliably triggering protective devices.

## SINAMICS S120 Chassis Format Converter Units

Air-cooled units

### Smart Line Modules

#### Overview



Smart Line Modules are infeed/regenerative feedback units that supply power to connected Motor Modules. Furthermore, they are capable of feeding regenerative energy back into the grid. The infeed occurs over a diode jumper, while stable, line-commutated regenerative feedback takes place via IGBTs with 100 % continuous energy regeneration. The regenerative capability of the modules can be deactivated by means of parameterization.

Smart Line Modules are designed for connection to grounded TN/TT and non-grounded IT supply systems.

The DC link is pre-charged by means of integrated pre-charging resistors.

To operate the Smart Line Module, the associated line reactor or a suitable transformer is required.

#### Design

The Smart Line Modules have the following interfaces as standard:

- 1 line supply connection
- 1 connection for the 24 V DC electronics power supply
- 1 DC link connection (DCP, DCN) for supplying the connected Motor Modules
- 1 DC link connection (DCPA, DCNA) for connecting a Braking Module
- 3 DRIVE-CLiQ sockets
- 1 temperature sensor input for KTY84-130, Pt1000, PTC or Pt100 (Pt1000 can be used from firmware V4.7 HF17)
- 1 PE/protective conductor connection (2 connections for sizes HX and JX)

The status of the Smart Line Modules is indicated via three LEDs.

The scope of supply of the Smart Line Modules includes:

- DRIVE-CLiQ cable to connect to a Control Unit
- DRIVE-CLiQ cable for connection between the Control Unit and first Motor Module (type dependent)
- 1 set of warning labels in 30 languages (BG, CN, CZ, DE, DK, EE, ES, FI, FR, GB, GR, HU, IE, IS, IT, JP, KR, LT, LV, MT, NL, NO, PL, PT, RO, RU, SE, SI, SK, TR)

#### Selection and ordering data

Rated power at 400 V or 690 V kW	Infeed/regenerative feedback current A	Smart Line Module Article No.
<b>Line voltage 380 ... 480 V 3 AC</b>		
250	463	<b>6SL3330-6TE35-5AA3</b>
355	614	<b>6SL3330-6TE37-3AA3</b>
500	883	<b>6SL3330-6TE41-1AA3</b>
630	1093	<b>6SL3330-6TE41-3AA3</b>
800	1430	<b>6SL3330-6TE41-7AA3</b>
<b>Line voltage 500 ... 690 V 3 AC</b>		
450	463	<b>6SL3330-6TG35-5AA3</b>
710	757	<b>6SL3330-6TG38-8AA3</b>
1000	1009	<b>6SL3330-6TG41-2AA3</b>
1400	1430	<b>6SL3330-6TG41-7AA3</b>
Description		Article No.
<b>Accessories for re-ordering</b>		
<b>Dust protection blanking plugs</b> (50 units) For DRIVE-CLiQ port		<b>6SL3066-4CA00-0AA0</b>

For line-side components, Braking Modules, and recommended system components, see System components.

# SINAMICS S120 Chassis Format Converter Units

Air-cooled units

Smart Line Modules

## Integration

The Smart Line Modules communicate with the higher-level control module via DRIVE-CLiQ. The control module in this case can be a CU320-2 or a SIMOTION D Control Unit. An external 24 V DC power supply is required to operate the Smart Line Modules.

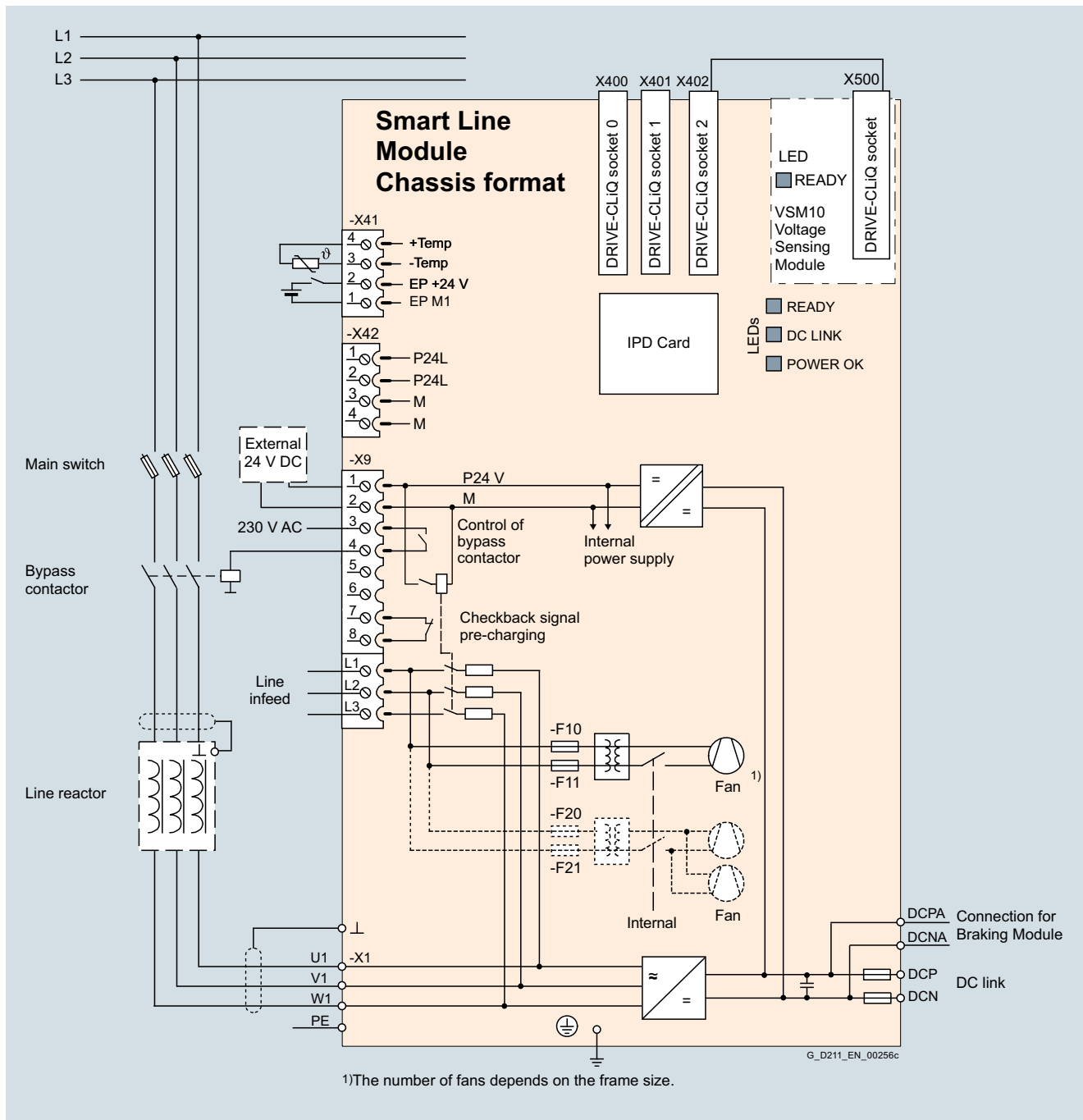

Connection example of a Smart Line Module

## SINAMICS S120 Chassis Format Converter Units

Air-cooled units

### Smart Line Modules

#### Technical specifications

##### General technical specifications

###### Electrical specifications

###### Line power factor at rated power

- |  |               |
|--|---------------|
| • Basic fundamental ( $\cos \varphi_1$ ) | >0.96         |
| • Total ( $\lambda$ )                    | 0.75 ... 0.93 |

###### Efficiency

>98.5 %

###### DC link voltage, approx. <sup>1)</sup>

1.32 × line voltage under partial load  
1.30 × line voltage under full load

###### Main contactor control

- |                          |   |
|--------------------------|---|
| • Terminal block -X9/5-6 | 240 V AC, max. 8 A<br>30 V DC, max. 1 A |
|--------------------------|---|

3

<sup>1)</sup> The DC link voltage is unregulated and load-dependent.  
For additional information, please refer to the SINAMICS Low Voltage Engineering Manual.

# SINAMICS S120 Chassis Format Converter Units

## Air-cooled units

### Smart Line Modules

#### Technical specifications (continued)

Line voltage 380 ... 480 V 3 AC		Smart Line Modules				
		6SL3330-6TE35-5AA3	6SL3330-6TE37-3AA3	6SL3330-6TE41-1AA3	6SL3330-6TE41-3AA3	6SL3330-6TE41-7AA3
<b>Rated power</b>						
• At $I_{\text{rated DC}}$ (50 Hz 400 V)	kW	250	355	500	630	800
• At $I_{\text{H DC}}$ (50 Hz 400 V)	kW	235	315	450	555	730
• At $I_{\text{rated DC}}$ (60 Hz 460 V)	hp	385	545	770	970	1230
• At $I_{\text{H DC}}$ (60 Hz 460 V)	hp	360	485	695	855	1125
<b>DC link current</b>						
• Rated current $I_{\text{rated DC}}$	A	550	730	1050	1300	1700
• Base-load current $I_{\text{H DC}}^{1)}$	A	490	650	934	1157	1513
• Maximum current $I_{\text{max DC}}$	A	825	1095	1575	1950	2550
<b>Infeed/regenerative feedback current</b>						
• Rated current $I_{\text{rated I}}$	A	463	614	883	1093	1430
• Maximum current $I_{\text{max I}}$	A	694	921	1324	1639	2145
<b>Current demand</b>						
• 24 V DC auxiliary power supply	A	1.35	1.35	1.4	1.5	1.7
• 400 V AC	A	1.8	1.8	3.6	5.4	5.4
<b>DC link capacitance</b>						
• Smart Line Module	$\mu\text{F}$	8400	12000	16800	18900	28800
• Drive line-up, max.	$\mu\text{F}$	42000	60000	67200	75600	115200
<b>Power loss, max. <sup>2)</sup></b>						
• At 50 Hz 400 V	kW	3.7	4.7	7.1	11.0	11.5
• At 60 Hz 460 V	kW	3.7	4.7	7.1	11.0	11.5
<b>Cooling air requirement</b>		$\text{m}^3/\text{s}$	0.36	0.36	0.78	1.08
<b>Sound pressure level <math>L_{\text{pA}}</math></b> (1 m) at 50/60 Hz		dB	69/73	69/73	70/73	70/73
<b>Line connection</b> U1, V1, W1			Flat connector for M10 screw	Flat connector for M10 screw	Flat connector for M12 screw	Flat connector for M12 screw
• Conductor cross-section, max. (IEC)	$\text{mm}^2$	2 × 240	2 × 240	4 × 240	6 × 240	6 × 240
<b>DC link connection</b> DCP, DCN			M10 screw	M10 screw	4 × hole for M12	4 × hole for M12
• Conductor cross-section, max. (IEC)	$\text{mm}^2$	2 × 240	2 × 240	Busbar	Busbar	Busbar
<b>PE/GND connection</b>			Hole for M10	Hole for M10	–	–
• Conductor cross-section, max. (IEC)	$\text{mm}^2$	2 × 240	2 × 240	–	–	–
<b>PE1/GND connection</b>			–	–	M12 screw	M12 screw
• Conductor cross-section, max. (IEC)	$\text{mm}^2$	–	–	240	240	240
<b>PE2/GND connection</b>			–	–	2 × M12 screw	2 × M12 screw
• Conductor cross-section, max. (IEC)	$\text{mm}^2$	–	–	2 × 240	2 × 240	2 × 240
<b>Cable length, max. <sup>3)</sup></b>						
• Shielded	m	4000	4000	4800	4800	4800
• Unshielded	m	6000	6000	7200	7200	7200
<b>Degree of protection</b>			IP00	IP00	IP00	IP00
<b>Dimensions</b>						
• Width	mm	310	310	503	704	704
• Height	mm	1413	1413	1475	1480	1480
• Depth	mm	550	550	548	550	550
<b>Weight, approx.</b>		kg	150	150	294	458
<b>Frame size</b>			GX	GX	HX	JX
<b>Minimum short-circuit current <sup>4)</sup></b>		A	6200	9200	10400	16000

<sup>1)</sup> The base-load current  $I_{\text{H DC}}$  is the basis for a duty cycle of 150 % for 60 s or  $I_{\text{max DC}}$  for 5 s with a duty cycle duration of 300 s.

<sup>2)</sup> The specified power loss represents the maximum value at 100 % utilization. The value is lower under normal operating conditions.

<sup>3)</sup> Total of all motor cables and DC link. Longer cable lengths for specific configurations are available on request.  
[For additional information, please refer to the SINAMICS Low Voltage Engineering Manual.](#)

<sup>4)</sup> Current required for reliably triggering protective devices.



# SINAMICS S120 Chassis Format Converter Units

## Air-cooled units

### Smart Line Modules

#### Technical specifications (continued)

Line voltage 500 ... 690 V 3 AC		Smart Line Modules			
		6SL3330-6TG35-5AA3	6SL3330-6TG38-8AA3	6SL3330-6TG41-2AA3	6SL3330-6TG41-7AA3
<b>Rated power</b>					
• At $I_{\text{rated DC}}$ (50 Hz 690 V)	kW	450	710	1000	1400
• At $I_{\text{H DC}}$ (50 Hz 690 V)	kW	405	665	885	1255
• At $I_{\text{rated DC}}$ (50 Hz 500 V)	kW	320	525	705	995
• At $I_{\text{H DC}}$ (50 Hz 500 V)	kW	295	480	640	910
• At $I_{\text{rated DC}}$ (60 Hz 575 V)	hp	500	790	1115	1465
• At $I_{\text{H DC}}$ (60 Hz 575 V)	hp	450	740	990	1400
<b>DC link current</b>					
• Rated current $I_{\text{rated DC}}$	A	550	900	1200	1700
• Base-load current $I_{\text{H DC}}^{1)}$	A	490	800	1068	1513
• Maximum current $I_{\text{max DC}}$	A	825	1350	1800	2550
<b>Infeed/regenerative feedback current</b>					
• Rated current $I_{\text{rated I}}$	A	463	757	1009	1430
• Maximum current $I_{\text{max I}}$	A	694	1135	1513	2145
<b>Current demand</b>					
• 24 V DC auxiliary power supply	A	1.35	1.4	1.5	1.7
• 500 V AC	A	1.3	2.9	4.3	4.3
• 690 V AC	A	0.94	2.1	3.1	3.1
<b>DC link capacitance</b>					
• Smart Line Module	μF	5600	7400	11100	14400
• Drive line-up, max.	μF	28000	29600	44400	57600
<b>Power loss, max. <sup>2)</sup></b>					
• At 50 Hz 690 V	kW	4.3	6.5	12.0	13.8
• At 60 Hz 575 V	kW	4.3	6.5	12.0	13.8
<b>Cooling air requirement</b>					
	m <sup>3</sup> /s	0.36	0.78	1.08	1.08
<b>Sound pressure level <math>L_{\text{pA}}</math> (1 m) at 50/60 Hz</b>					
	dB	69/73	70/73	70/73	70/73
<b>Line connection</b> U1, V1, W1					
• Conductor cross-section, max. (IEC)	mm <sup>2</sup>	Flat connector for M10 screw 2 × 240	Flat connector for M12 screw 4 × 240	Flat connector for M12 screw 6 × 240	Flat connector for M12 screw 6 × 240
<b>DC link connection</b> DCP, DCN					
• Conductor cross-section, max. (IEC)	mm <sup>2</sup>	M10 screw 2 × 240	4 × hole for M12 Busbar	4 × hole for M12 Busbar	4 × hole for M12 Busbar
<b>PE connection</b>					
• Conductor cross-section, max. (IEC)	mm <sup>2</sup>	Hole for M10 2 × 240	–	–	–
<b>PE1/GND connection</b>					
• Conductor cross-section, max. (IEC)	mm <sup>2</sup>	–	M12 screw 240	M12 screw 240	M12 screw 240
<b>PE2/GND connection</b>					
• Conductor cross-section, max. (IEC)	mm <sup>2</sup>	–	2 × M12 screw 2 × 240	2 × M12 screw 2 × 240	2 × M12 screw 2 × 240
<b>Cable length, max. <sup>3)</sup></b>					
• Shielded	m	2250	2750	2750	2750
• Unshielded	m	3375	4125	4125	4125
<b>Degree of protection</b>					
		IP00	IP00	IP00	IP00
<b>Dimensions</b>					
• Width	mm	310	503	704	704
• Height	mm	1413	1475	1480	1480
• Depth	mm	550	548	550	550
<b>Weight, approx.</b>					
	kg	150	294	458	458
<b>Frame size</b>					
		GX	HX	JX	JX
<b>Minimum short-circuit current <sup>4)</sup></b>					
	A	6200	10500	12400	21000

<sup>1)</sup> The base-load current  $I_{\text{H DC}}$  is the basis for a duty cycle of 150 % for 60 s or  $I_{\text{max DC}}$  for 5 s with a duty cycle duration of 300 s.

<sup>2)</sup> The specified power loss represents the maximum value at 100 % utilization. The value is lower under normal operating conditions.

<sup>3)</sup> Total of all motor cables and DC link. Longer cable lengths for specific configurations are available on request.  
For additional information, please refer to the SINAMICS Low Voltage Engineering Manual.

<sup>4)</sup> Current required for reliably triggering protective devices.

# SINAMICS S120 Chassis Format Converter Units

## Air-cooled units

### Active Line Modules

#### Overview

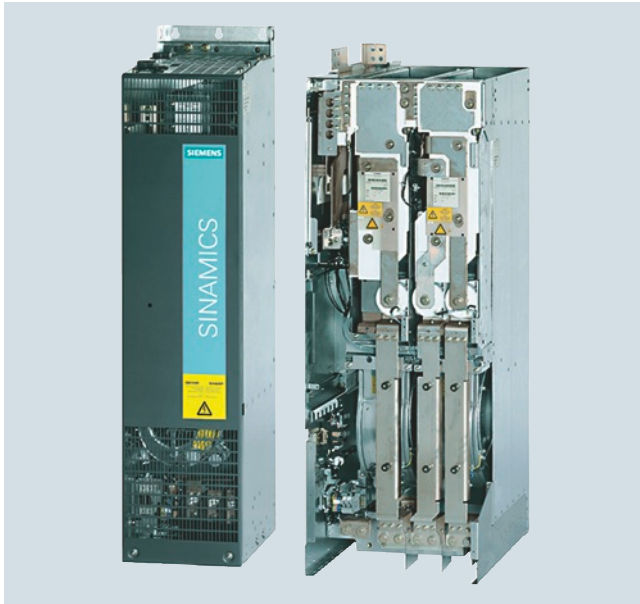

The self-commutated infeed/regenerative feedback units with IGBTs generate a regulated DC link voltage. This means that the connected Motor Modules are decoupled from the line voltage. Line voltage fluctuations within the permissible supply tolerances have no effect on the motor voltage.

If required, the Active Line Modules can also provide reactive power compensation.

Active Line Modules are designed for connection to grounded TN/TT and non-grounded IT supply systems.

Active Line Modules are always operated together with the associated Active Interface Modules. These include the necessary pre-charging circuit as well as a Clean Power Filter.

#### Design

The Active Line Modules have the following interfaces as standard:

- 1 line supply connection
- 1 connection for the 24 V DC electronics power supply
- 1 DC link connection (DCP, DCN) for supplying the connected Motor Modules
- 1 DC link connection (DCPA, DCNA) for connecting a Braking Module
- 3 DRIVE-CLiQ sockets
- 1 temperature sensor input for KTY84-130, Pt1000, PTC or Pt100 (Pt1000 can be used from firmware V4.7 HF17)
- 2 PE connections

The status of the Active Line Modules is indicated via three LEDs.

The scope of supply of the Active Line Modules includes:

- DRIVE-CLiQ cable to connect to a Control Unit
- DRIVE-CLiQ cable to connect the Control Unit to the first Motor Module
- 1 set of warning labels in 30 languages (BG, CN, CZ, DE, DK, EE, ES, FI, FR, GB, GR, HU, IE, IS, IT, JP, KR, LT, LV, MT, NL, NO, PL, PT, RO, RU, SE, SI, SK, TR)

#### Selection and ordering data

Rated power at 400 V or 690 V kW	Rated infeed/ regenerative feedback current A	Active Line Module Article No.
<b>Line voltage 380 ... 480 V 3 AC</b>		
132	210	<b>6SL3330-7TE32-1AA3</b>
160	260	<b>6SL3330-7TE32-6AA3</b>
235	380	<b>6SL3330-7TE33-8AA3</b>
300	490	<b>6SL3330-7TE35-0AA3</b>
380	605	<b>6SL3330-7TE36-1AA3</b>
450	745	<b>6SL3330-7TE37-5AA3</b>
500	840	<b>6SL3330-7TE38-4AA3</b>
630	985	<b>6SL3330-7TE41-0AA3</b>
800	1260	<b>6SL3330-7TE41-2AA3</b>
900	1405	<b>6SL3330-7TE41-4AA3</b>
<b>Line voltage 500 ... 690 V 3 AC</b>		
630	575	<b>6SL3330-7TG35-8AA3</b>
800	735	<b>6SL3330-7TG37-4AA3</b>
1100	1025	<b>6SL3330-7TG41-0AA3</b>
1400	1270	<b>6SL3330-7TG41-3AA3</b>

Description	Article No.
-------------	-------------

#### Accessories for re-ordering

<b>Dust protection blanking plugs</b> (50 units) For DRIVE-CLiQ port	<b>6SL3066-4CA00-0AA0</b>
--	---------------------------

For line-side components, Braking Modules, and recommended system components, see [System components](#).

# SINAMICS S120 Chassis Format Converter Units

Air-cooled units

## Active Line Modules

### Integration

The Smart Line Modules communicate with the higher-level control module via DRIVE-CLiQ. The control module in this case can be a CU320-2 or a SIMOTION D Control Unit. An external 24 V DC power supply is required to operate the Smart Line Modules.

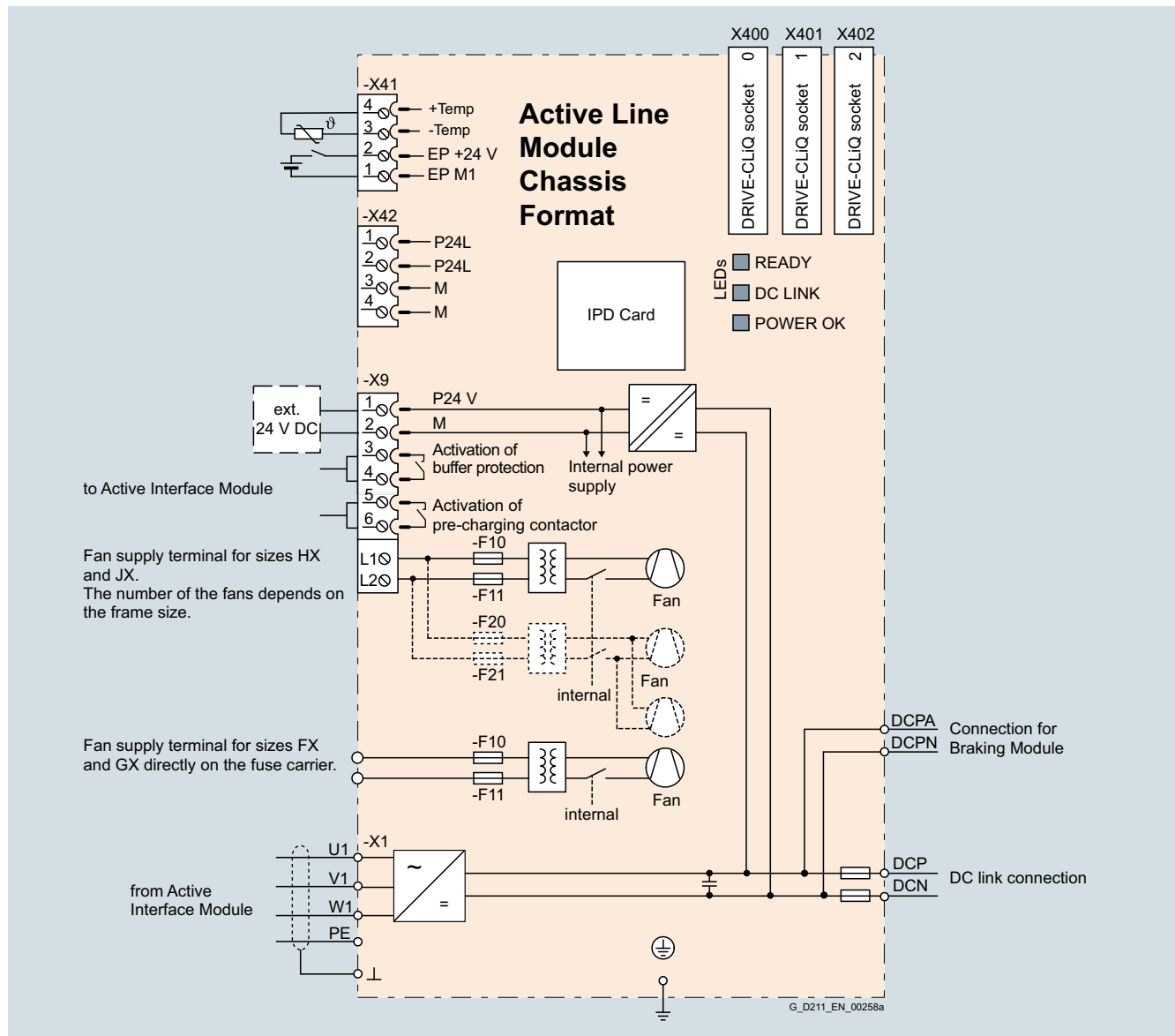

Connection example of an Active Line Module

### Technical specifications

#### General technical specifications

##### Electrical specifications

##### Line power factor

- Basic fundamental ( $\cos \varphi_1$ ) 1 (factory setting), can be altered by inputting a reactive current setpoint
- Total ( $\lambda$ ) 1 (factory setting)

**Efficiency** >97.5 % (including Active Interface Module)

**DC link voltage** The DC link voltage is regulated and can be adjusted as a voltage decoupled from the line voltage. Factory setting of the DC link voltage:  $1.5 \times$  line voltage

##### Radio interference suppression

- Standard (Active Line Module with Active Interface Module) Category C3 to EN 61800-3
- With line filter Category C2 to EN 61800-3

# SINAMICS S120 Chassis Format Converter Units

## Air-cooled units

### Active Line Modules

#### Technical specifications (continued)

Line voltage 380 ... 480 V 3 AC		Active Line Modules				
		6SL3330-7TE32-1AA3	6SL3330-7TE32-6AA3	6SL3330-7TE33-8AA3	6SL3330-7TE35-0AA3	6SL3330-7TE36-1AA3
<b>Rated power</b>						
• At $I_{\text{rated DC}}$ (50 Hz 400 V)	kW	<b>132</b>	<b>160</b>	<b>235</b>	<b>300</b>	<b>380</b>
• At $I_{\text{H DC}}$ (50 Hz 400 V)	kW	115	145	210	270	335
• At $I_{\text{rated DC}}$ (60 Hz 460 V)	hp	200	250	400	500	600
• At $I_{\text{H DC}}$ (60 Hz 460 V)	hp	150	200	300	400	500
<b>DC link current</b>						
• Rated current $I_{\text{rated DC}}$	A	235	291	425	549	678
• Base-load current $I_{\text{H DC}}^{1)}$	A	209	259	378	489	603
• Maximum current $I_{\text{max DC}}$	A	352	436	637	823	1017
<b>Infeed/regenerative feedback current</b>						
• Rated current $I_{\text{rated I}}$	A	210	260	380	490	605
• Maximum current $I_{\text{max I}}$	A	315	390	570	735	907
<b>Current demand</b>						
• 24 V DC auxiliary power supply	A	1.1	1.1	1.35	1.35	1.4
• 400 V AC	A	0.63	1.13	1.8	1.8	3.6
<b>DC link capacitance</b>						
• Active Line Module	μF	4200	5200	7800	9600	12600
• Drive line-up, max.	μF	41600	41600	76800	76800	134400
<b>Power loss, max. <sup>2)</sup></b>						
• At 50 Hz 400 V	kW	2.2	2.7	3.9	4.8	6.2
• At 60 Hz 460 V	kW	2.3	2.9	4.2	5.1	6.6
<b>Cooling air requirement</b>		m <sup>3</sup> /s	0.17	0.23	0.36	0.36
<b>Sound pressure level <math>L_{\text{pA}}^{3)}</math></b> (1 m) at 50/60 Hz		dB	64/67	71/71	69/73	69/73
<b>Line supply connection</b> U1, V1, W1		Flat connector for M10 screw	Flat connector for M10 screw	Flat connector for M10 screw	Flat connector for M10 screw	Flat connector for M12 screw
• Conductor cross-section, max. (IEC)	mm <sup>2</sup>	2 × 185	2 × 185	2 × 240	2 × 240	4 × 240
<b>DC link connection</b> DCP, DCN		M10 screw	M10 screw	M10 screw	M10 screw	4 × hole for M12
• Conductor cross-section, max. (IEC)	mm <sup>2</sup>	2 × 185	2 × 185	2 × 240	2 × 240	Busbar
<b>PE1/GND connection</b>		M10 screw	M10 screw	M10 screw	M10 screw	M12 screw
• Conductor cross-section, max. (IEC)	mm <sup>2</sup>	2 × 185	2 × 185	2 × 240	2 × 240	240
<b>PE2/GND connection</b>		M10 screw	M10 screw	M10 screw	M10 screw	2 × M12 screw
• Conductor cross-section, max. (IEC)	mm <sup>2</sup>	2 × 185	2 × 185	2 × 240	2 × 240	2 × 240
<b>Cable length, max. <sup>4)</sup></b>						
• Shielded	m	2700	2700	2700	2700	3900
• Unshielded	m	4050	4050	4050	4050	5850
<b>Degree of protection</b>		IP20	IP20	IP20	IP20	IP00
<b>Dimensions</b>						
• Width	mm	326	326	326	326	503
• Height	mm	1400	1400	1533	1533	1475
• Depth	mm	356	356	545	545	540
<b>Weight, approx.</b>		kg	95	95	136	136
<b>Frame size</b>			FX	FX	GX	GX
<b>Minimum short-circuit current <sup>5)</sup></b>		A	6200	10500	10500	8000

<sup>1)</sup> The base-load current  $I_{\text{H DC}}$  is the basis for a duty cycle of 150 % for 60 s or  $I_{\text{max DC}}$  for 5 s with a duty cycle duration of 300 s.

<sup>2)</sup> The specified power loss represents the maximum value at 100 % utilization. The value is lower under normal operating conditions.

<sup>3)</sup> Total sound pressure level of Active Interface Module and Active Line Module.

<sup>4)</sup> Total of all motor cables and DC link. Longer cable lengths for specific configurations are available on request. For additional information, please refer to the SINAMICS Low Voltage Engineering Manual.

<sup>5)</sup> Current required for reliably triggering protective devices.

# SINAMICS S120 Chassis Format Converter Units

Air-cooled units

## Active Line Modules

### Technical specifications (continued)

Line voltage 380 ... 480 V 3 AC		Active Line Modules				
		6SL3330-7TE37-5AA3	6SL3330-7TE38-4AA3	6SL3330-7TE41-0AA3	6SL3330-7TE41-2AA3	6SL3330-7TE41-4AA3
<b>Rated power</b>						
• At $I_{\text{rated DC}}$ (50 Hz 400 V)	kW	450	500	630	800	900
• At $I_{\text{H DC}}$ (50 Hz 400 V)	kW	400	465	545	690	780
• At $I_{\text{rated DC}}$ (60 Hz 460 V)	hp	600	700	900	1000	1250
• At $I_{\text{H DC}}$ (60 Hz 460 V)	hp	600	700	800	900	1000
<b>DC link current</b>						
• Rated current $I_{\text{rated DC}}$	A	835	940	1103	1412	1574
• Base-load current $I_{\text{H DC}}^{1)}$	A	700	837	982	1255	1401
• Maximum current $I_{\text{max DC}}$	A	1252	1410	1654	2120	2361
<b>Infeed/regenerative feedback current</b>						
• Rated current $I_{\text{rated I}}$	A	745	840	985	1260	1405
• Maximum current $I_{\text{max I}}$	A	1117	1260	1477	1890	2107
<b>Current demand</b>						
• 24 V DC auxiliary power supply	A	1.4	1.4	1.5	1.7	1.7
• 400 V AC	A	3.6	3.6	5.4	5.4	5.4
<b>DC link capacitance</b>						
• Active Line Module	$\mu\text{F}$	15600	16800	18900	26100	28800
• Drive line-up, max.	$\mu\text{F}$	134400	134400	230400	230400	230400
<b>Power loss, max. <sup>2)</sup></b>						
• At 50 Hz 400 V	kW	7.3	7.7	10.1	12.1	13.3
• At 60 Hz 460 V	kW	7.7	8.2	10.8	13.0	14.2
<b>Cooling air requirement</b>		$\text{m}^3/\text{s}$	0.78	0.78	1.08	1.08
<b>Sound pressure level <math>L_{\text{pA}}^{3)}</math></b> (1 m) at 50/60 Hz		dB	70/73	70/73	71/73	71/73
<b>Line supply connection</b> U1, V1, W1			Flat connector for M12 screw	Flat connector for M12 screw	Flat connector for M12 screw	Flat connector for M12 screw
• Conductor cross-section, max. (IEC)	$\text{mm}^2$	4 × 240	4 × 240	6 × 240	6 × 240	6 × 240
<b>DC link connection</b> DCP, DCN			4 × hole for M12	4 × hole for M12	4 × hole for M12	4 × hole for M12
• Conductor cross-section, max. (IEC)	$\text{mm}^2$	Busbar	Busbar	Busbar	Busbar	Busbar
<b>PE1/GND connection</b>			M12 screw	M12 screw	M12 screw	M12 screw
• Conductor cross-section, max. (IEC)	$\text{mm}^2$	240	240	240	240	240
<b>PE2/GND connection</b>			2 × M12 screw	2 × M12 screw	3 × M12 screw	3 × M12 screw
• Conductor cross-section, max. (IEC)	$\text{mm}^2$	2 × 240	2 × 240	3 × 240	3 × 240	3 × 240
<b>Cable length, max. <sup>4)</sup></b>						
• Shielded	m	3900	3900	3900	3900	3900
• Unshielded	m	5850	5850	5850	5850	5850
<b>Degree of protection</b>			IP00	IP00	IP00	IP00
<b>Dimensions</b>						
• Width	mm	503	503	704	704	704
• Height	mm	1475	1475	1480	1480	1480
• Depth	mm	540	540	550	550	550
<b>Weight, approx.</b>		kg	290	290	450	450
<b>Frame size</b>			HX	HX	JX	JX
<b>Minimum short-circuit current <sup>5)</sup></b>		A	8800	10400	16000	21000

<sup>1)</sup> The base-load current  $I_{\text{H DC}}$  is the basis for a duty cycle of 150 % for 60 s or  $I_{\text{max DC}}$  for 5 s with a duty cycle duration of 300 s.

<sup>2)</sup> The specified power loss represents the maximum value at 100 % utilization. The value is lower under normal operating conditions.

<sup>3)</sup> Total sound pressure level of Active Interface Module and Active Line Module.

<sup>4)</sup> Total of all motor cables and DC link. Longer cable lengths for specific configurations are available on request. For additional information, please refer to the SINAMICS Low Voltage Engineering Manual.

<sup>5)</sup> Current required for reliably triggering protective devices.

# SINAMICS S120 Chassis Format Converter Units

## Air-cooled units

### Active Line Modules

#### Technical specifications (continued)

Line voltage 500 ... 690 V 3 AC		Active Line Modules				
		6SL3330-7TG35-8AA3	6SL3330-7TG37-4AA3	6SL3330-7TG41-0AA3	6SL3330-7TG41-3AA3	
<b>Rated power</b>						
• At $I_{\text{rated DC}}$ (50 Hz 690 V)	kW	<b>630</b>	<b>800</b>	<b>1100</b>	<b>1400</b>	
• At $I_{\text{H DC}}$ (50 Hz 690 V)	kW	620	705	980	1215	
• At $I_{\text{rated DC}}$ (50 Hz 500 V)	kW	447	560	780	965	
• At $I_{\text{H DC}}$ (50 Hz 500 V)	kW	450	510	710	880	
• At $I_{\text{rated DC}}$ (60 Hz 575 V)	hp	675	900	1250	1500	
• At $I_{\text{H DC}}$ (60 Hz 575 V)	hp	506	600	1000	1250	
<b>DC link current</b>						
• Rated current $I_{\text{rated DC}}$	A	644	823	1148	1422	
• Base-load current $I_{\text{H DC}}^{1)}$	A	573	732	1022	1266	
• Maximum current $I_{\text{max DC}}$	A	966	1234	1722	2133	
<b>Infeed/regenerative feedback current</b>						
• Rated current $I_{\text{rated I}}$	A	575	735	1025	1270	
• Maximum current $I_{\text{max I}}$	A	862	1102	1537	1905	
<b>Current demand</b>						
• 24 V DC auxiliary power supply	A	1.4	1.5	1.7	1.7	
• 500 V AC	A	3.0	4.4	4.4	4.4	
• 690 V AC	A	2.1	3.1	3.1	3.1	
<b>DC link capacitance</b>						
• Active Line Module	$\mu\text{F}$	7400	11100	14400	19200	
• Drive line-up, max.	$\mu\text{F}$	59200	153600	153600	153600	
<b>Power loss, max. <sup>2)</sup></b>						
• At 50 Hz 690 V	kW	6.8	10.2	13.6	16.5	
• At 60 Hz 575 V	kW	6.2	9.6	12.9	15.3	
<b>Cooling air requirement</b>		$\text{m}^3/\text{s}$	0.78	1.08	1.08	1.08
<b>Sound pressure level <math>L_{\text{PA}}^{3)}</math></b> (1 m) at 50/60 Hz		dB	70/73	71/73	71/73	71/73
<b>Line supply connection</b> U1, V1, W1			Flat connector for M12 screw	Flat connector for M12 screw	Flat connector for M12 screw	Flat connector for M12 screw
• Conductor cross-section, max. (IEC)	$\text{mm}^2$	4 × 240	6 × 240	6 × 240	6 × 240	
<b>DC link connection</b> DCP, DCN			4 × hole for M12	4 × hole for M12	4 × hole for M12	4 × hole for M12
• Conductor cross-section, max. (IEC)	$\text{mm}^2$	Busbar	Busbar	Busbar	Busbar	
<b>PE1/GND connection</b>			M12 screw	M12 screw	M12 screw	M12 screw
• Conductor cross-section, max. (IEC)	$\text{mm}^2$	240	240	240	240	
<b>PE2/GND connection</b>			2 × M12 screw	3 × M12 screw	3 × M12 screw	3 × M12 screw
• Conductor cross-section, max. (IEC)	$\text{mm}^2$	2 × 240	3 × 240	3 × 240	3 × 240	
<b>Cable length, max. <sup>4)</sup></b>						
• Shielded	m	2250	2250	2250	2250	
• Unshielded	m	3375	3375	3375	3375	
<b>Degree of protection</b>			IP00	IP00	IP00	IP00
<b>Dimensions</b>						
• Width	mm	503	704	704	704	
• Height	mm	1475	1480	1480	1480	
• Depth	mm	540	550	550	550	
<b>Weight, approx.</b>		kg	290	450	450	450
<b>Frame size</b>			HX	JX	JX	JX
<b>Minimum short-circuit current <sup>5)</sup></b>		A	8400	10500	16000	20000

<sup>1)</sup> The base-load current  $I_{\text{H DC}}$  is the basis for a duty cycle of 150 % for 60 s or  $I_{\text{max DC}}$  for 5 s with a duty cycle duration of 300 s.

<sup>2)</sup> The specified power loss represents the maximum value at 100 % utilization. The value is lower under normal operating conditions.

<sup>3)</sup> Total sound pressure level of Active Interface Module and Active Line Module.

<sup>4)</sup> Total of all motor cables and DC link. Longer cable lengths for specific configurations are available on request. For additional information, please refer to the SINAMICS Low Voltage Engineering Manual.

<sup>5)</sup> Current required for reliably triggering protective devices.

## SINAMICS S120 Chassis Format Converter Units

Air-cooled units

### Active Interface Modules

#### Overview



Active Interface Modules are used in conjunction with Active Line Modules. Active Interface Modules contain a Clean Power Filter with basic RI suppression, the pre-charging circuit for the Active Line Module, the line voltage sensing circuit and monitoring sensors. The bypass contactor is an integral component in frame sizes FI and GI. This ensures a highly compact design. The bypass contactor must be provided separately for frame sizes HI and JI.

Line harmonics are largely suppressed by the Clean Power Filter.

#### Design

Active Interface Modules have the following interfaces as standard:

- 1 line supply connection
- 1 load connection
- 1 connection for the 24 V DC electronics power supply
- 1 connection for the external 230 V AC supply (fan power supply)
- 1 DRIVE-CLiQ socket (on VSM10 Voltage Sensing Module)
- 1 connection for pre-charging circuit, frame sizes HI and JI
- 1 PE connection

The scope of supply of the Active Interface Modules includes:

- DRIVE-CLiQ cable for the connection between Active Interface Module and Active Line Module
- 1 set of warning labels in 30 languages (BG, CN, CZ, DE, DK, EE, ES, FI, FR, GB, GR, HU, IE, IS, IT, JP, KR, LT, LV, MT, NL, NO, PL, PT, RO, RU, SE, SI, SK, TR)

#### Selection and ordering data

Suitable for Active Line Module chassis format, air-cooled	Rated power of the Active Line Modules at 400 V or 690 V kW	Active Interface Module
		Article No.
<b>Line voltage 380 ... 480 V 3 AC</b>		
6SL3330-7TE32-1AA3	132	<b>6SL3300-7TE32-6AA1</b>
6SL3330-7TE32-6AA3	160	<b>6SL3300-7TE32-6AA1</b>
6SL3330-7TE33-8AA3	235	<b>6SL3300-7TE33-8AA1</b>
6SL3330-7TE35-0AA3	300	<b>6SL3300-7TE35-0AA1</b>
6SL3330-7TE36-1AA3	380	<b>6SL3300-7TE38-4AA1</b>
6SL3330-7TE37-5AA3	450	<b>6SL3300-7TE38-4AA1</b>
6SL3330-7TE38-4AA3	500	<b>6SL3300-7TE38-4AA1</b>
6SL3330-7TE41-0AA3	630	<b>6SL3300-7TE41-4AA1</b>
6SL3330-7TE41-2AA3	800	<b>6SL3300-7TE41-4AA1</b>
6SL3330-7TE41-4AA3	900	<b>6SL3300-7TE41-4AA1</b>
<b>Line voltage 500 ... 690 V 3 AC</b>		
6SL3330-7TG35-8AA3	630	<b>6SL3300-7TG35-8AA1</b>
6SL3330-7TG37-4AA3	800	<b>6SL3300-7TG37-4AA1</b>
6SL3330-7TG41-0AA3	1100	<b>6SL3300-7TG41-3AA1</b>
6SL3330-7TG41-3AA3	1400	<b>6SL3300-7TG41-3AA1</b>



# SINAMICS S120 Chassis Format Converter Units

Air-cooled units

## Active Interface Modules

### Integration

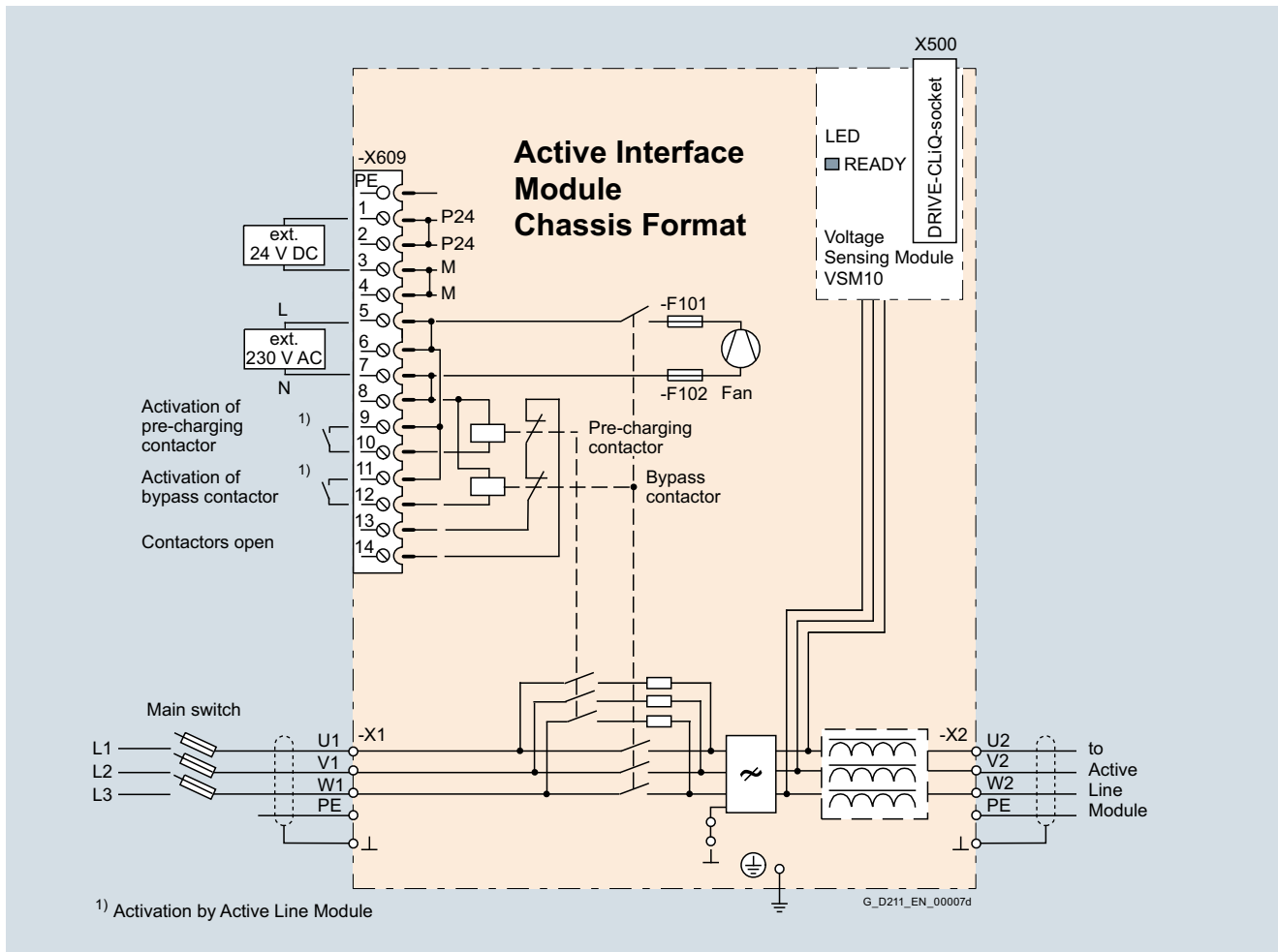

Connection example of an Active Interface Module with integrated bypass contactor (frame sizes F1 and G1)

3

# SINAMICS S120 Chassis Format Converter Units

Air-cooled units

## Active Interface Modules

### Integration (continued)

3

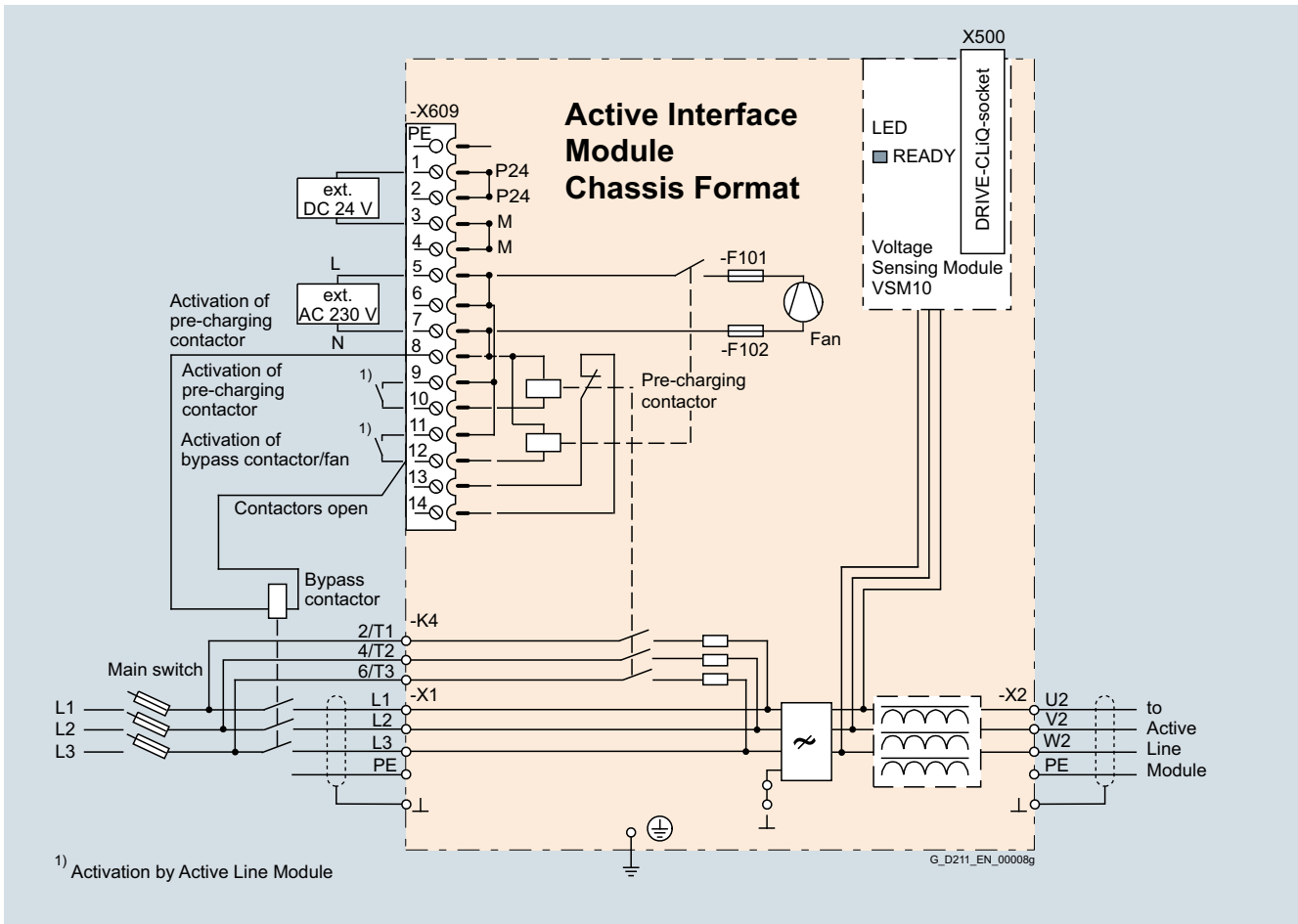

Connection example of an Active Interface Module with externally mounted bypass contactor (frame sizes HI and JI)

# SINAMICS S120 Chassis Format Converter Units

## Air-cooled units

### Active Interface Modules

#### Technical specifications

Line voltage 380 ... 480 V 3 AC		Active Interface Modules			
		6SL3300-7TE32-6AA1	6SL3300-7TE32-6AA3	6SL3300-7TE33-8AA1	6SL3300-7TE35-0AA1
<b>Suitable for Active Line Module</b>					
• Rated power at 400 V	kW	<b>132</b>	<b>160</b>	<b>235</b>	<b>300</b>
- Air-cooled		6SL3330-7TE32-1AA3	6SL3330-7TE32-6AA3	6SL3330-7TE33-8AA3	6SL3330-7TE35-0AA3
- Liquid-cooled		–	–	–	6SL3335-7TE35-0AA3
<b>Rated current</b>	A	210	260	380	490
<b>Bypass contactor</b>		Included	Included	Included	Included
<b>Current demand</b>					
• 24 V DC auxiliary power supply	A	0.17	0.17	0.17	0.17
• 230 V 2 AC					
- Inrush current	A	1.25	1.25	2.5	2.5
- Holding current	A	0.6	0.6	1.2	1.2
<b>DC link capacitance</b> of drive line-up, max. <sup>1)</sup>	µF	41600	41600	76800	76800
<b>Power loss, max. <sup>2)</sup></b>					
• At 50 Hz 400 V	kW	2.1	2.2	3.0	3.9
• At 60 Hz 460 V	kW	2.1	2.2	3.0	3.9
<b>Cooling air requirement</b>	m <sup>3</sup> /s	0.24	0.24	0.47	0.47
<b>Line/load connection</b> L1, L2, L3 / U2, V2, W2		Flat connector for M10 screw	Flat connector for M10 screw	Flat connector for M10 screw	Flat connector for M10 screw
• Conductor cross-section, max. (IEC)	mm <sup>2</sup>	2 × 185	2 × 185	2 × 185	2 × 185
<b>PE/GND connection</b>		2 × M10 nut	2 × M10 nut	2 × M10 nut	2 × M10 nut
• Conductor cross-section, max. (IEC)	mm <sup>2</sup>	2 × 185	2 × 185	2 × 185	2 × 185
<b>Degree of protection</b>		IP20	IP20	IP20	IP20
<b>Dimensions</b>					
• Width	mm	325	325	325	325
• Height	mm	1400	1400	1533	1533
• Depth	mm	355	355	544	544
<b>Weight, approx.</b>	kg	135	135	190	190
<b>Frame size</b>		FI	FI	GI	GI
<b>Minimum short-circuit current <sup>3)</sup></b>	A	6200	10500	10500	8000

<sup>1)</sup> Information on higher capacities is included in the SINAMICS Low Voltage Engineering Manual.

<sup>2)</sup> The specified power loss represents the maximum value at 100 % utilization. The value is lower under normal operating conditions.

<sup>3)</sup> Current required for reliable triggering of the protective devices.

# SINAMICS S120 Chassis Format Converter Units

Air-cooled units

## Active Interface Modules

### Technical specifications (continued)

Line voltage 380 ... 480 V 3 AC		Active Interface Modules			
		6SL3300-7TE38-4AA1		6SL3300-7TE41-4AA1	
Suitable for Active Line Module		380	450/500	630	800/900
• Rated power at 400 V - Air-cooled	kW	6SL3330-7TE36-1AA3	6SL3330-7TE37-5AA3 6SL3330-7TE38-4AA3	6SL3330-7TE41-0AA3	6SL3330-7TE41-2AA3 6SL3330-7TE41-4AA3
<b>Rated current</b>	A	605	745/840	985	1260/1405
<b>Bypass contactor</b>		3RT1476-6AP36	3WL1110-2BB34-4AN2-Z C22 <sup>1)</sup>	3WL1112-2BB34-4AN2-Z C22 <sup>1)</sup>	3WL1116-2BB34-4AN2-Z C22 <sup>1)</sup>
<b>Current demand</b>					
• 24 V DC auxiliary power supply	A	0.17	0.17	0.17	0.17
• 230 V 2 AC					
- Inrush current	A	9.9	9.9	10.5	10.5
- Holding current	A	4.6	4.6	4.9	4.9
<b>DC link capacitance</b> of the drive line-up, max. <sup>2)</sup>	μF	134400	134400	230400	230400
<b>Power loss, max. <sup>3)</sup></b>					
• At 50 Hz 400 V	kW	5.5	6.1	7.5	8.5
• At 60 Hz 460 V	kW	5.5	6.1	7.5	8.5
<b>Cooling air requirement</b>	m <sup>3</sup> /s	0.4	0.4	0.4	0.4
<b>Line/load connection</b> L1, L2, L3 / U2, V2, W2		4 × hole for M12	4 × hole for M12	3 × hole for M12	3 × hole for M12
• Conductor cross-section, max. (IEC)	mm <sup>2</sup>	4 × 240	4 × 240	6 × 240	6 × 240
<b>PE/GND connection</b>		2 × M12 nut	2 × M12 nut	4 × M12 nut	4 × M12 nut
• Conductor cross-section, max. (IEC)	mm <sup>2</sup>	2 × 240	2 × 240	4 × 240	4 × 240
<b>Degree of protection</b>		IP00	IP00	IP00	IP00
<b>Dimensions</b>					
• Width	mm	305	305	505	505
• Height	mm	1750	1750	1750	1750
• Depth	mm	544	544	544	544
<b>Weight, approx.</b>	kg	390	390	480	480
<b>Frame size</b>		HI	HI	JI	JI
<b>Minimum short-circuit current <sup>4)</sup></b>	A	9200	8800/10400	16000	21000

<sup>1)</sup> The breakers must always be switched ON and OFF by the sequence control. An interlocking set 3WL9111-0BA21-0AA0 as described in Catalog LV 10 should be provided for the bypass contactor to exclude the risk of unintentional manual operation. Manual operation bypasses the pre-charging circuit and can therefore destroy the Active Line Module.

<sup>2)</sup> Information on higher capacities is included in the SINAMICS Low Voltage Engineering Manual.

<sup>3)</sup> The specified power loss represents the maximum value at 100 % utilization. The value is lower under normal operating conditions.

<sup>4)</sup> Current required for reliably triggering protective devices.

# SINAMICS S120 Chassis Format Converter Units

## Air-cooled units

### Active Interface Modules

#### Technical specifications (continued)

Line voltage 500 ... 690 V 3 AC		Active Interface Modules			
		6SL3300-7TG35-8AA1	6SL3300-7TG37-4AA1	6SL3300-7TG41-3AA1	
<b>Suitable for Active Line Module</b>					
• Rated power at 690 V	kW	<b>630</b>	<b>800</b>	<b>1100</b>	<b>1400</b>
- Air-cooled		6SL3330-7TG35-8AA3	6SL3330-7TG37-4AA3	6SL3330-7TG41-0AA3	6SL3330-7TG41-3AA3
- Liquid-cooled		6SL3335-7TG35-8AA3	–	–	–
<b>Rated current</b>	A	575	735	1025	1270
<b>Bypass contactor</b>		3RT1476-6AP36	3RT1476-6AP36 (3 units)	3WL <sup>1</sup> 1212-4BB34-4AN2-Z C22 <sup>1)</sup>	3WL <sup>1</sup> 1216-4BB34-4AN2-Z C22 <sup>1)</sup>
<b>Current demand</b>					
• 24 V DC auxiliary power supply	A	0.17	0.17	0.17	0.17
• 230 V 2 AC					
- Inrush current	A	9.9	10.5	10.5	10.5
- Holding current	A	4.6	4.9	4.9	4.9
<b>DC link capacitance</b> of the drive line-up, max. <sup>2)</sup>	µF	59200	153600	153600	153600
<b>Power loss, max. <sup>3)</sup></b>					
• At 50 Hz 690 V	kW	6.8	9.0	9.2	9.6
• At 60 Hz 575 V	kW	6.8	9.0	9.2	9.6
<b>Cooling air requirement</b>	m <sup>3</sup> /s	0.4	0.4	0.4	0.4
<b>Line/load connection</b> L1, L2, L3 / U2, V2, W2		4 × hole for M12	3 × hole for M12	3 × hole for M12	3 × hole for M12
• Conductor cross-section, max. (IEC)	mm <sup>2</sup>	4 × 240	6 × 240	6 × 240	6 × 240
<b>PE/GND connection</b>		2 × M12 nut	4 × M12 nut	4 × M12 nut	4 × M12 nut
• Conductor cross-section, max. (IEC)	mm <sup>2</sup>	2 × 240	4 × 240	4 × 240	4 × 240
<b>Degree of protection</b>		IP00	IP00	IP00	IP00
<b>Dimensions</b>					
• Width	mm	305	505	505	505
• Height	mm	1750	1750	1750	1750
• Depth	mm	544	544	544	544
<b>Weight, approx.</b>	kg	390	430	530	530
<b>Frame size</b>		HI	JI	JI	JI
<b>Minimum short-circuit current <sup>4)</sup></b>	A	8400	10500	16000	20000

<sup>1)</sup> The breakers must always be switched ON and OFF by the sequence control. An interlocking set 3WL9111-0BA21-0AA0 as described in Catalog LV 10 should be provided for the bypass contactor to exclude the risk of unintentional manual operation. Manual operation bypasses the pre-charging circuit and can therefore destroy the Active Line Module.

<sup>2)</sup> Information on higher capacities is included in the SINAMICS Low Voltage Engineering Manual.

<sup>3)</sup> The specified power loss represents the maximum value at 100 % utilization. The value is lower under normal operating conditions.

<sup>4)</sup> Current required for reliably triggering protective devices.

## SINAMICS S120 Chassis Format Converter Units

Air-cooled units

### Motor Modules

#### Overview



A Motor Module comprises a self-commutated converter with IGBTs. It generates a variable voltage with variable frequency from the DC link voltage that feeds the connected motor.

Multiple Motor Modules can be operated on a single DC link. This permits energy to be transferred between the Motor Modules. This means that if one Motor Module operating in generator mode produces energy, the energy can be used by another Motor Module operating in motor mode.

Motor Modules are controlled by a Control Unit.

#### Design

The Motor Modules in the chassis format have the following interfaces as standard:

- 1 motor connection
- 1 connection for the 24 V DC electronics power supply
- 1 DC link connection (DCP, DCN) for connecting to the supply DC link
- 1 DC link connection (DCPA, DCNA) for connecting a Braking Module
- 1 DC link connection (DCPS, DCNS) for connecting a dv/dt filter
- 3 DRIVE-CLiQ sockets
- 1 temperature sensor input for KTY84-130, Pt1000, PTC or Pt100 (Pt1000 can be used from firmware V4.7 HF17)
- 1 connection for Safe Brake Adapter
- 1 connection for Safety Integrated
- 2 PE connections

The status of the Motor Modules is indicated via three LEDs.

The scope of supply of the Motor Modules includes:

- DRIVE-CLiQ cable for connection to the Control Unit
- DRIVE-CLiQ cable for connection to the next Motor Module
- 1 set of warning labels in 30 languages (BG, CN, CZ, DE, DK, EE, ES, FI, FR, GB, GR, HU, IE, IS, IT, JP, KR, LT, LV, MT, NL, NO, PL, PT, RO, RU, SE, SI, SK, TR)

#### Selection and ordering data

Type rating at 400 V or 690 V kW	Rated output current A	Motor Module Article No.
<b>Line voltage 380 ... 480 V 3 AC (DC link voltage 510 ... 720 V DC)</b>		
110	210	<b>6SL3320-1TE32-1AA3</b>
132	260	<b>6SL3320-1TE32-6AA3</b>
160	310	<b>6SL3320-1TE33-1AA3</b>
200	380	<b>6SL3320-1TE33-8AA3</b>
250	490	<b>6SL3320-1TE35-0AA3</b>
315	605	<b>6SL3320-1TE36-1AA3</b>
400	745	<b>6SL3320-1TE37-5AA3</b>
450	840	<b>6SL3320-1TE38-4AA3</b>
560	985	<b>6SL3320-1TE41-0AA3</b>
710	1260	<b>6SL3320-1TE41-2AA3</b>
800	1405	<b>6SL3320-1TE41-4AA3</b>
<b>Line voltage 500 ... 690 V 3 AC (DC link voltage 675 ... 1035 V DC)</b>		
75	85	<b>6SL3320-1TG28-5AA3</b>
90	100	<b>6SL3320-1TG31-0AA3</b>
110	120	<b>6SL3320-1TG31-2AA3</b>
132	150	<b>6SL3320-1TG31-5AA3</b>
160	175	<b>6SL3320-1TG31-8AA3</b>
200	215	<b>6SL3320-1TG32-2AA3</b>
250	260	<b>6SL3320-1TG32-6AA3</b>
315	330	<b>6SL3320-1TG33-3AA3</b>
400	410	<b>6SL3320-1TG34-1AA3</b>
450	465	<b>6SL3320-1TG34-7AA3</b>
560	575	<b>6SL3320-1TG35-8AA3</b>
710	735	<b>6SL3320-1TG37-4AA3</b>
800	810	<b>6SL3320-1TG38-1AA3</b>
900	910	<b>6SL3320-1TG38-8AA3</b>
1000	1025	<b>6SL3320-1TG41-0AA3</b>
1200	1270	<b>6SL3320-1TG41-3AA3</b>

Description	Article No.
<b>Accessories for re-ordering</b>	
<b>Dust protection blanking plugs</b> (50 units) For DRIVE-CLiQ port	<b>6SL3066-4CA00-0AA0</b>

For motor-side components and Braking Modules, see System components.

# SINAMICS S120 Chassis Format Converter Units

Air-cooled units

## Motor Modules

### Integration

The Motor Modules communicate with the higher-level control module via DRIVE-CLiQ. The control module in this case can be a CU320-2 or a SIMOTION D Control Unit.

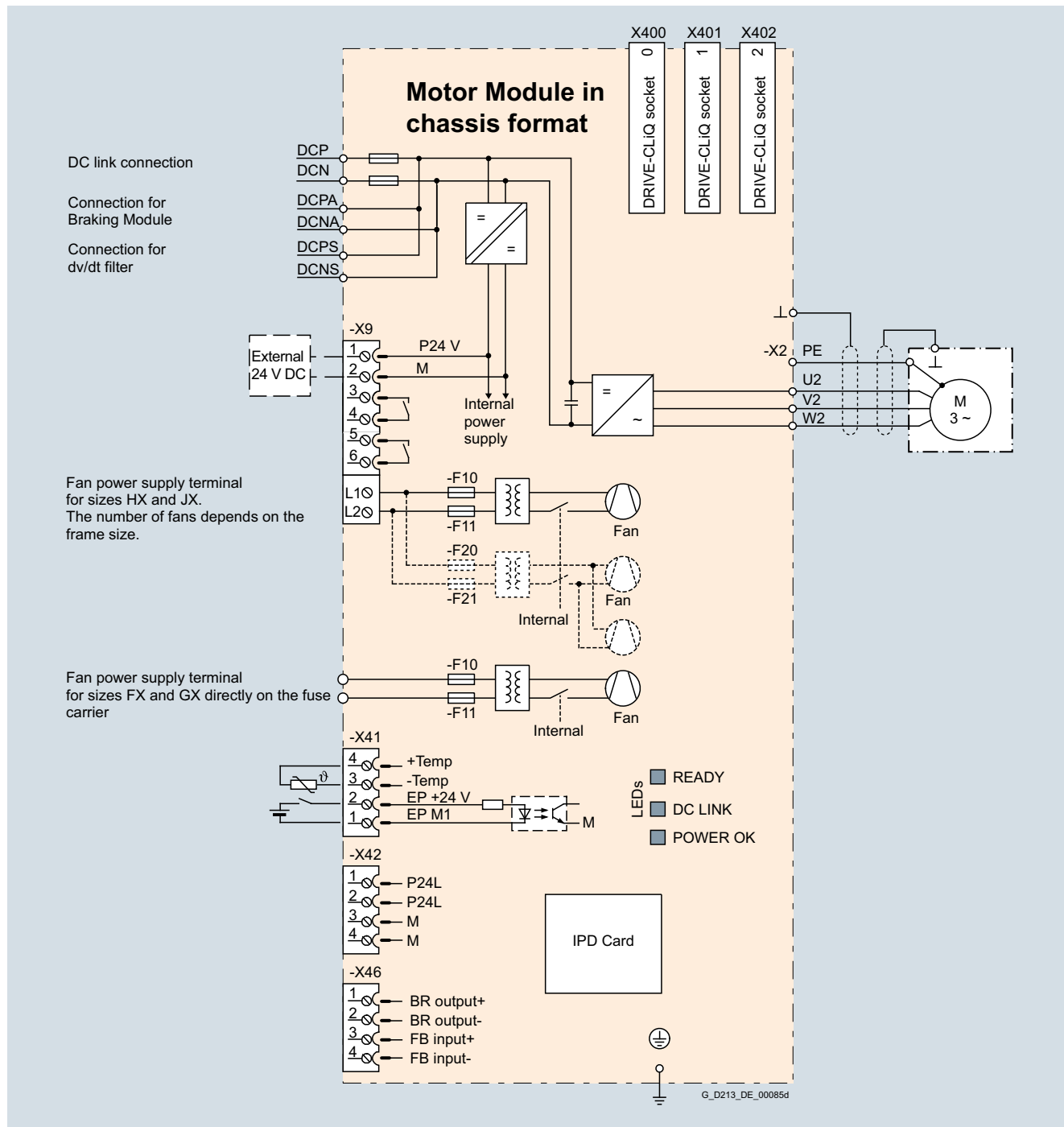

Connection example of a Motor Module

3



## SINAMICS S120 Chassis Format Converter Units

Air-cooled units

### Motor Modules

#### Technical specifications

##### General technical specifications

Electrical specifications	
<b>Efficiency</b>	>98.5 %
<b>DC link voltage</b> (up to 2000 m above sea level)	510 ... 720 V DC (line voltage 380 ... 480 V 3 AC) or 675 ... 1035 V DC (line voltage 500 ... 690 V 3 AC)
<b>Output frequency <sup>1)</sup></b>	
• Control type Servo	0 ... 550 Hz
• Control type Vector	0 ... 550 Hz
• Control mode V/f	0 ... 550 Hz
<b>Safety Integrated</b>	Safety Integrity Level 2 (SIL2) acc. to IEC 61508, Performance Level d (PLd) acc. to EN ISO 13849-1 and Control Category 3 acc. to EN ISO 13849-1

3

<sup>1)</sup> Please note:

- The correlation between the maximum output frequency, pulse frequency and current derating. Higher output frequencies on request. For further information, see <https://support.industry.siemens.com/cs/document/104020669>
- The correlation between the minimum output frequency and permissible output current (current derating).  
Information is provided in the SINAMICS Low Voltage Engineering Manual.

# SINAMICS S120 Chassis Format Converter Units

## Air-cooled units

### Motor Modules

#### Technical specifications (continued)

Line voltage 380 ... 480 V 3 AC DC link voltage 510 ... 720 V DC		Motor Modules				
		6SL3320-1TE32-1AA3	6SL3320-1TE32-6AA3	6SL3320-1TE33-1AA3	6SL3320-1TE33-8AA3	6SL3320-1TE35-0AA3
<b>Type rating</b>						
• At $I_L$ (50 Hz 400 V) <sup>1)</sup>	kW	<b>110</b>	<b>132</b>	<b>160</b>	<b>200</b>	<b>250</b>
• At $I_H$ (50 Hz 400 V) <sup>1)</sup>	kW	90	110	132	160	200
• At $I_L$ (60 Hz 460 V) <sup>2)</sup>	hp	150	200	250	300	400
• At $I_H$ (60 Hz 460 V) <sup>2)</sup>	hp	150	200	200	250	350
<b>Output current</b>						
• Rated current $I_{rated O}$	A	210	260	310	380	490
• Base-load current $I_L$ <sup>3)</sup>	A	205	250	302	370	477
• Base-load current $I_H$ <sup>4)</sup>	A	178	233	277	340	438
• Maximum current $I_{max O}$	A	307	375	453	555	715
<b>DC link current</b>						
• Rated current $I_{rated DC}$ when supplied via						
- Basic/Smart Line Module	A	252	312	372	456	588
- Active Line Module	A	227	281	335	411	529
• Base-load current $I_{L DC}$ <sup>3)</sup> when supplied via						
- Basic/Smart Line Module	A	245	304	362	444	573
- Active Line Module	A	221	273	326	400	515
• Base-load current $I_{H DC}$ <sup>4)</sup> when supplied via						
- Basic/Smart Line Module	A	224	277	331	405	523
- Active Line Module	A	202	250	298	365	470
<b>Current demand</b>						
• 24 V DC auxiliary power supply	A	0.8	0.8	0.9	0.9	0.9
• 400 V AC	A	0.63	1.13	1.8	1.8	1.8
<b>DC link capacitance</b>	μF	4200	5200	6300	7800	9600
<b>Pulse frequency <sup>5)</sup></b>						
• Rated frequency	kHz	2	2	2	2	2
• Pulse frequency, max.						
- Without current derating	kHz	2	2	2	2	2
- With current derating	kHz	8	8	8	8	8
<b>Power loss, max. <sup>6)</sup></b>						
• At 50 Hz 400 V	kW	1.86	2.5	2.96	3.67	4.28
• At 60 Hz 460 V	kW	1.94	2.6	3.1	3.8	4.5
<b>Cooling air requirement</b>	m <sup>3</sup> /s	0.17	0.23	0.36	0.36	0.36
<b>Sound pressure level <math>L_{pA}</math></b> (1 m) at 50/60 Hz	dB	64/67	71/71	69/73	69/73	69/73
<b>DC link connection</b> DCP, DCN		M10 screw	M10 screw	M10 screw	M10 screw	M10 screw
• Conductor cross-section, max. (IEC)	mm <sup>2</sup>	2 × 185	2 × 185	2 × 240	2 × 240	2 × 240
<b>Connection for Braking Module</b> DCPA, DCNA <sup>7)</sup>		M6 threaded bolt	M6 threaded bolt	M6 threaded bolt	M6 threaded bolt	M6 threaded bolt
<b>Connection for dv/dt filter</b> DCPS, DCNS		M8 screw	M8 screw	M8 screw	M8 screw	M8 screw
• Conductor cross-section, max. (IEC)	mm <sup>2</sup>	1 × 35	1 × 35	1 × 70	1 × 70	1 × 70
<b>Motor connection</b> U2, V2, W2		M10 screw	M10 screw	M10 screw	M10 screw	M10 screw
• Conductor cross-section, max. (IEC)	mm <sup>2</sup>	2 × 185	2 × 185	2 × 240	2 × 240	2 × 240
<b>Cable length, max. <sup>8)</sup></b>						
• Shielded	m	300	300	300	300	300
• Unshielded	m	450	450	450	450	450

For footnotes, see next page.

## SINAMICS S120 Chassis Format Converter Units

Air-cooled units

### Motor Modules

#### Technical specifications (continued)

Line voltage 380 ... 480 V 3 AC DC link voltage 510 ... 720 V DC		Motor Modules				
		6SL3320-1TE32-1AA3	6SL3320-1TE32-6AA3	6SL3320-1TE33-1AA3	6SL3320-1TE33-8AA3	6SL3320-1TE35-0AA3
<b>PE1/GND connection</b>		M10 screw				
• Conductor cross-section, max. (IEC)	mm <sup>2</sup>	2 × 185	2 × 185	2 × 240	2 × 240	2 × 240
<b>PE2/GND connection</b>		M10 screw				
• Conductor cross-section, max. (IEC)	mm <sup>2</sup>	2 × 185	2 × 185	2 × 240	2 × 240	2 × 240
<b>Degree of protection</b>		IP20				
<b>Dimensions</b>						
• Width	mm	326	326	326	326	326
• Height	mm	1400	1400	1533	1533	1533
• Depth	mm	356	356	545	545	545
<b>Weight, approx.</b>	kg	95	95	136	136	136
<b>Frame size</b>		FX FX GX GX GX				

1) Rated output of a typical 6-pole standard induction motor based on  $I_L$  or  $I_H$  for 400 V 3 AC 50 Hz.

2) Rated output of a typical 6-pole standard induction motor based on  $I_L$  or  $I_H$  for 460 V 3 AC 60 Hz.

3) The base-load current  $I_L$  is based on a duty cycle of 110 % for 60 s or 150 % for 10 s with a duty cycle duration of 300 s.

4) The base-load current  $I_H$  is based on a duty cycle of 150 % for 60 s or 160 % for 10 s with a duty cycle duration of 300 s.

5) Information regarding the correlation between the pulse frequency and maximum output current/output frequency is provided in the SINAMICS Low Voltage Engineering Manual.

6) The specified power loss represents the maximum value at 100 % utilization. The value is lower under normal operating conditions.

7) The connecting cables are included in the scope of supply of the Braking Module.

8) Total of all motor cables and DC link. Longer cable lengths for specific configurations are available on request. For additional information, please refer to the SINAMICS Low Voltage Engineering Manual.

# SINAMICS S120 Chassis Format Converter Units

## Air-cooled units

### Motor Modules

#### Technical specifications (continued)

Line voltage 380 ... 480 V 3 AC DC link voltage 510 ... 720 V DC		Motor Modules		
		6SL3320-1TE36-1AA3	6SL3320-1TE37-5AA3	6SL3320-1TE38-4AA3
<b>Type rating</b>				
• At $I_L$ (50 Hz 400 V) <sup>1)</sup>	kW	<b>315</b>	<b>400</b>	<b>450</b>
• At $I_H$ (50 Hz 400 V) <sup>1)</sup>	kW	250	315	400
• At $I_L$ (60 Hz 460 V) <sup>2)</sup>	hp	500	600	700
• At $I_H$ (60 Hz 460 V) <sup>2)</sup>	hp	350	450	600
<b>Output current</b>				
• Rated current $I_{rated O}$	A	605	745	840
• Base-load current $I_L$ <sup>3)</sup>	A	590	725	820
• Base-load current $I_H$ <sup>4)</sup>	A	460	570	700
• Maximum current $I_{max O}$	A	885	1087	1230
<b>DC link current</b>				
• Rated current $I_{rated DC}$ when supplied via				
- Basic/Smart Line Module	A	726	894	1008
- Active Line Module	A	653	805	907
• Base-load current $I_L DC$ <sup>3)</sup> when supplied via				
- Basic/Smart Line Module	A	707	871	982
- Active Line Module	A	636	784	884
• Base-load current $I_H DC$ <sup>4)</sup> when supplied via				
- Basic/Smart Line Module	A	646	795	897
- Active Line Module	A	581	716	807
<b>Current demand</b>				
• 24 V DC auxiliary power supply	A	1.0	1.0	1.0
• 400 V AC	A	3.6	3.6	3.6
<b>DC link capacitance</b>				
	μF	12600	15600	16800
<b>Pulse frequency <sup>5)</sup></b>				
• Rated frequency	kHz	1.25	1.25	1.25
• Pulse frequency, max.				
- Without current derating	kHz	1.25	1.25	1.25
- With current derating	kHz	7.5	7.5	7.5
<b>Power loss, max. <sup>6)</sup></b>				
• At 50 Hz 400 V	kW	5.84	6.68	7.15
• At 60 Hz 460 V	kW	6.3	7.3	7.8
<b>Cooling air requirement</b>				
	m <sup>3</sup> /s	0.78	0.78	0.78
<b>Sound pressure level <math>L_{pA}</math> (1 m) at 50/60 Hz</b>				
	dB	70/73	70/73	70/73
<b>DC link connection</b> DCP, DCN				
		4 × hole for M10 Busbar	4 × hole for M10 Busbar	4 × hole for M10 Busbar
<b>Connection for Braking Module</b> DCPA, DCNA <sup>7)</sup>				
		Connection for connection clip	Connection for connection clip	Connection for connection clip
<b>Connection for dv/dt filter</b> DCPS, DCNS				
• Conductor cross-section, max. (IEC)	mm <sup>2</sup>	1 × 185	1 × 185	1 × 185
<b>Motor connection</b> U2, V2, W2				
• Conductor cross-section, max. (IEC)	mm <sup>2</sup>	4 × 240	4 × 240	4 × 240
<b>Cable length, max. <sup>8)</sup></b>				
• Shielded	m	300	300	300
• Unshielded	m	450	450	450

## SINAMICS S120 Chassis Format Converter Units

Air-cooled units

### Motor Modules

#### Technical specifications (continued)

Line voltage 380 ... 480 V 3 AC DC link voltage 510 ... 720 V DC		Motor Modules		
		6SL3320-1TE36-1AA3	6SL3320-1TE37-5AA3	6SL3320-1TE38-4AA3
<b>PE1/GND connection</b>		M12 screw	M12 screw	M12 screw
• Conductor cross-section, max. (IEC)	mm <sup>2</sup>	240	240	240
<b>PE2/GND connection</b>		2 × M12 screw	2 × M12 screw	2 × M12 screw
• Conductor cross-section, max. (IEC)	mm <sup>2</sup>	2 × 240	2 × 240	2 × 240
<b>Degree of protection</b>		IP00	IP00	IP00
<b>Dimensions</b>				
• Width	mm	503	503	503
• Height	mm	1475	1475	1475
• Depth	mm	547	547	547
<b>Weight, approx.</b>	kg	290	290	290
<b>Frame size</b>		HX	HX	HX

1) Rated output of a typical 6-pole standard induction motor based on  $I_L$  or  $I_H$  for 400 V 3 AC 50 Hz.

2) Rated output of a typical 6-pole standard induction motor based on  $I_L$  or  $I_H$  for 460 V 3 AC 60 Hz.

3) The base-load current  $I_L$  is based on a duty cycle of 110 % for 60 s or 150 % for 10 s with a duty cycle duration of 300 s.

4) The base-load current  $I_H$  is based on a duty cycle of 150 % for 60 s or 160 % for 10 s with a duty cycle duration of 300 s.

5) Information regarding the correlation between the pulse frequency and maximum output current/output frequency is provided in the SINAMICS Low Voltage Engineering Manual.

6) The specified power loss represents the maximum value at 100 % utilization. The value is lower under normal operating conditions.

7) The connecting cables are included in the scope of supply of the Braking Module.

8) Total of all motor cables and DC link. Longer cable lengths for specific configurations are available on request. For additional information, please refer to the SINAMICS Low Voltage Engineering Manual.

# SINAMICS S120 Chassis Format Converter Units

## Air-cooled units

### Motor Modules

#### Technical specifications (continued)

Line voltage 380 ... 480 V 3 AC DC link voltage 510 ... 720 V DC		Motor Modules		
		6SL3320-1TE41-0AA3	6SL3320-1TE41-2AA3	6SL3320-1TE41-4AA3
<b>Type rating</b>				
• At $I_L$ (50 Hz 400 V) <sup>1)</sup>	kW	<b>560</b>	<b>710</b>	<b>800</b>
• At $I_H$ (50 Hz 400 V) <sup>1)</sup>	kW	450	560	710
• At $I_L$ (60 Hz 460 V) <sup>2)</sup>	hp	800	1000	1150
• At $I_H$ (60 Hz 460 V) <sup>2)</sup>	hp	700	900	1000
<b>Output current</b>				
• Rated current $I_{rated O}$	A	985	1260	1405
• Base-load current $I_L$ <sup>3)</sup>	A	960	1230	1370
• Base-load current $I_H$ <sup>4)</sup>	A	860	1127	1257
• Maximum current $I_{max O}$	A	1440	1845	2055
<b>DC link current</b>				
• Rated current $I_{rated DC}$ when supplied via				
- Basic/Smart Line Module	A	1182	1512	1686
- Active Line Module	A	1064	1361	1517
• Base-load current $I_L DC$ <sup>3)</sup> when supplied via				
- Basic/Smart Line Module	A	1152	1474	1643
- Active Line Module	A	1037	1326	1479
• Base-load current $I_H DC$ <sup>4)</sup> when supplied via				
- Basic/Smart Line Module	A	1051	1345	1500
- Active Line Module	A	946	1211	1350
<b>Current demand</b>				
• 24 V DC auxiliary power supply	A	1.25	1.4	1.4
• 400 V AC	A	5.4	5.4	5.4
<b>DC link capacitance</b>				
	μF	18900	26100	28800
<b>Pulse frequency <sup>5)</sup></b>				
• Rated frequency	kHz	1.25	1.25	1.25
• Pulse frequency, max.				
- Without current derating	kHz	1.25	1.25	1.25
- With current derating	kHz	7.5	7.5	7.5
<b>Power loss, max. <sup>6)</sup></b>				
• At 50 Hz 400 V	kW	9.5	11.1	12.0
• At 60 Hz 460 V	kW	10.2	12.0	13.0
<b>Cooling air requirement</b>				
	m <sup>3</sup> /s	1.08	1.08	1.08
<b>Sound pressure level <math>L_{pA}</math></b> (1 m) at 50/60 Hz				
	dB	71/73	71/73	71/73
<b>DC link connection</b> DCP, DCN				
		4 × hole for M10 Busbar	4 × hole for M10 Busbar	4 × hole for M10 Busbar
<b>Connection for Braking Module</b> DCPA, DCNA <sup>7)</sup>				
		Connection for connection clip	Connection for connection clip	Connection for connection clip
<b>Connection for dv/dt filter</b> DCPS, DCNS				
• Conductor cross-section, max. (IEC)	mm <sup>2</sup>	2 × M10 screw 2 × 185	2 × M10 screw 2 × 185	2 × M10 screw 2 × 185
<b>Motor connection</b> U2, V2, W2				
• Conductor cross-section, max. (IEC)	mm <sup>2</sup>	3 × M12 screw 6 × 240	3 × M12 screw 6 × 240	3 × M12 screw 6 × 240
<b>Cable length, max. <sup>8)</sup></b>				
• Shielded	m	300	300	300
• Unshielded	m	450	450	450

## SINAMICS S120 Chassis Format Converter Units

Air-cooled units

### Motor Modules

#### Technical specifications (continued)

Line voltage 380 ... 480 V 3 AC DC link voltage 510 ... 720 V DC		Motor Modules		
		6SL3320-1TE41-0AA3	6SL3320-1TE41-2AA3	6SL3320-1TE41-4AA3
<b>PE1/GND connection</b>		M12 screw	M12 screw	M12 screw
• Conductor cross-section, max. (IEC)	mm <sup>2</sup>	240	240	240
<b>PE2/GND connection</b>		3 × M12 screw	3 × M12 screw	3 × M12 screw
• Conductor cross-section, max. (IEC)	mm <sup>2</sup>	3 × 240	3 × 240	3 × 240
<b>Degree of protection</b>		IP00	IP00	IP00
<b>Dimensions</b>				
• Width	mm	704	704	704
• Height	mm	1475	1475	1475
• Depth	mm	549	549	549
<b>Weight, approx.</b>	kg	450	450	450
<b>Frame size</b>		JX	JX	JX

1) Rated output of a typical 6-pole standard induction motor based on  $I_L$  or  $I_H$  for 400 V 3 AC 50 Hz.

2) Rated output of a typical 6-pole standard induction motor based on  $I_L$  or  $I_H$  for 460 V 3 AC 60 Hz.

3) The base-load current  $I_L$  is based on a duty cycle of 110 % for 60 s or 150 % for 10 s with a duty cycle duration of 300 s.

4) The base-load current  $I_H$  is based on a duty cycle of 150 % for 60 s or 160 % for 10 s with a duty cycle duration of 300 s.

5) Information regarding the correlation between the pulse frequency and maximum output current/output frequency is provided in the SINAMICS Low Voltage Engineering Manual.

6) The specified power loss represents the maximum value at 100 % utilization. The value is lower under normal operating conditions.

7) The connecting cables are included in the scope of supply of the Braking Module.

8) Total of all motor cables and DC link. Longer cable lengths for specific configurations are available on request. For additional information, please refer to the SINAMICS Low Voltage Engineering Manual.



# SINAMICS S120 Chassis Format Converter Units

## Air-cooled units

### Motor Modules

#### Technical specifications (continued)

Line voltage 500 ... 690 V 3 AC DC link voltage 675 ... 1035 V DC		Motor Modules			
		6SL3320-1TG28-5AA3	6SL3320-1TG31-0AA3	6SL3320-1TG31-2AA3	6SL3320-1TG31-5AA3
<b>Type rating</b>					
• At $I_L$ (50 Hz 690 V) <sup>1)</sup>	kW	<b>75</b>	<b>90</b>	<b>110</b>	<b>132</b>
• At $I_H$ (50 Hz 690 V) <sup>1)</sup>	kW	55	75	90	110
• At $I_L$ (50 Hz 500 V) <sup>1)</sup>	kW	55	55	75	90
• At $I_H$ (50 Hz 500 V) <sup>1)</sup>	kW	45	55	75	90
• At $I_L$ (60 Hz 575 V) <sup>2)</sup>	hp	75	75	100	150
• At $I_H$ (60 Hz 575 V) <sup>2)</sup>	hp	75	75	100	125
<b>Output current</b>					
• Rated current $I_{rated O}$	A	85	100	120	150
• Base-load current $I_L$ <sup>3)</sup>	A	80	95	115	142
• Base-load current $I_H$ <sup>4)</sup>	A	76	89	107	134
• Maximum current $I_{max O}$	A	120	142	172	213
<b>DC link current</b>					
• Rated current $I_{rated DC}$ when supplied via					
- Basic/Smart Line Module	A	102	120	144	180
- Active Line Module	A	92	108	130	162
• Base-load current $I_{L DC}$ <sup>3)</sup> when supplied via					
- Basic/Smart Line Module	A	99	117	140	175
- Active Line Module	A	89	105	126	157
• Base-load current $I_{H DC}$ <sup>4)</sup> when supplied via					
- Basic/Smart Line Module	A	90	106	128	160
- Active Line Module	A	81	96	115	144
<b>Current demand</b>					
• 24 V DC auxiliary power supply	A	0.8	0.8	0.8	0.8
• 500 V AC	A	0.7	0.7	0.7	0.7
• 690 V AC	A	0.4	0.4	0.4	0.4
<b>DC link capacitance</b>	μF	1200	1200	1600	2800
<b>Pulse frequency <sup>5)</sup></b>					
• Rated frequency	kHz	1.25	1.25	1.25	1.25
• Pulse frequency, max.					
- Without current derating	kHz	1.25	1.25	1.25	1.25
- With current derating	kHz	7.5	7.5	7.5	7.5
<b>Power loss, max. <sup>6)</sup></b>					
• At 50 Hz 690 V	kW	1.17	1.43	1.89	1.8
• At 60 Hz 575 V	kW	1.1	1.3	1.77	1.62
<b>Cooling air requirement</b>	m <sup>3</sup> /s	0.17	0.17	0.17	0.17
<b>Sound pressure level <math>L_{pA}</math></b> (1 m) at 50/60 Hz	dB	64/67	64/67	64/67	64/67
<b>DC link connection</b> DCP, DCN		M10 screw	M10 screw	M10 screw	M10 screw
• Conductor cross-section, max. (IEC)	mm <sup>2</sup>	2 × 185	2 × 185	2 × 185	2 × 185
<b>Connection for Braking Module</b> DCPA, DCNA <sup>7)</sup>		M6 stud	M6 stud	M6 stud	M6 stud
<b>Connection for dv/dt filter</b> DCPS, DCNS		M8 screw	M8 screw	M8 screw	M8 screw
• Conductor cross-section, max. (IEC)	mm <sup>2</sup>	1 × 70	1 × 70	1 × 70	1 × 70
<b>Motor connection</b> U2, V2, W2		M10 screw	M10 screw	M10 screw	M10 screw
• Conductor cross-section, max. (IEC)	mm <sup>2</sup>	2 × 185	2 × 185	2 × 185	2 × 185

For footnotes, see next page.

## SINAMICS S120 Chassis Format Converter Units

Air-cooled units

### Motor Modules

#### Technical specifications (continued)

Line voltage 500 ... 690 V 3 AC DC link voltage 675 ... 1035 V DC		Motor Modules			
		6SL3320-1TG28-5AA3	6SL3320-1TG31-0AA3	6SL3320-1TG31-2AA3	6SL3320-1TG31-5AA3
<b>Cable length, max. <sup>8)</sup></b>					
• Shielded	m	300	300	300	300
• Unshielded	m	450	450	450	450
<b>PE1/GND connection</b>		M10 screw	M10 screw	M10 screw	M10 screw
• Conductor cross-section, max. (IEC)	mm <sup>2</sup>	2 × 185	2 × 185	2 × 185	2 × 185
<b>PE2/GND connection</b>		M10 screw	M10 screw	M10 screw	M10 screw
• Conductor cross-section, max. (IEC)	mm <sup>2</sup>	2 × 185	2 × 185	2 × 185	2 × 185
<b>Degree of protection</b>		IP20	IP20	IP20	IP20
<b>Dimensions</b>					
• Width	mm	326	326	326	326
• Height	mm	1400	1400	1400	1400
• Depth	mm	356	356	356	356
<b>Weight, approx.</b>	kg	95	95	95	95
<b>Frame size</b>		FX	FX	FX	FX

<sup>1)</sup> Rated output of a typical 6-pole standard induction motor based on  $I_L$  or  $I_H$  for 500 V or 690 V 3 AC 50 Hz.

<sup>2)</sup> Rated output of a typical 6-pole standard induction motor based on  $I_L$  or  $I_H$  for 575 V 3 AC 60 Hz.

<sup>3)</sup> The base-load current  $I_L$  is based on a duty cycle of 110 % for 60 s or 150 % for 10 s with a duty cycle duration of 300 s.

<sup>4)</sup> The base-load current  $I_H$  is based on a duty cycle of 150 % for 60 s or 160 % for 10 s with a duty cycle duration of 300 s.

<sup>5)</sup> Information regarding the correlation between the pulse frequency and maximum output current/output frequency is provided in the SINAMICS Low Voltage Engineering Manual.

<sup>6)</sup> The specified power loss represents the maximum value at 100 % utilization. The value is lower under normal operating conditions.

<sup>7)</sup> The connecting cables are included in the scope of supply of the Braking Module.

<sup>8)</sup> Total of all motor cables and DC link. Longer cable lengths for specific configurations are available on request. For additional information, please refer to the SINAMICS Low Voltage Engineering Manual.

# SINAMICS S120 Chassis Format Converter Units

## Air-cooled units

### Motor Modules

#### Technical specifications (continued)

Line voltage 500 ... 690 V 3 AC DC link voltage 675 ... 1035 V DC		Motor Modules			
		6SL3320-1TG31-8AA3	6SL3320-1TG32-2AA3	6SL3320-1TG32-6AA3	6SL3320-1TG33-3AA3
<b>Type rating</b>					
• At $I_L$ (50 Hz 690 V) <sup>1)</sup>	kW	<b>160</b>	<b>200</b>	<b>250</b>	<b>315</b>
• At $I_H$ (50 Hz 690 V) <sup>1)</sup>	kW	132	160	200	250
• At $I_L$ (50 Hz 500 V) <sup>1)</sup>	kW	110	132	160	200
• At $I_H$ (50 Hz 500 V) <sup>1)</sup>	kW	90	110	132	160
• At $I_L$ (60 Hz 575 V) <sup>2)</sup>	hp	150	200	250	300
• At $I_H$ (60 Hz 575 V) <sup>2)</sup>	hp	150	200	200	250
<b>Output current</b>					
• Rated current $I_{rated O}$	A	175	215	260	330
• Base-load current $I_L$ <sup>3)</sup>	A	171	208	250	320
• Base-load current $I_H$ <sup>4)</sup>	A	157	192	233	280
• Maximum current $I_{max O}$	A	255	312	375	480
<b>DC link current</b>					
• Rated current $I_{rated DC}$ when supplied via					
- Basic/Smart Line Module	A	210	258	312	396
- Active Line Module	A	189	232	281	356
• Base-load current $I_{L DC}$ <sup>3)</sup> when supplied via					
- Basic/Smart Line Module	A	204	251	304	386
- Active Line Module	A	184	226	273	347
• Base-load current $I_{H DC}$ <sup>4)</sup> when supplied via					
- Basic/Smart Line Module	A	186	229	277	352
- Active Line Module	A	168	206	250	316
<b>Current demand</b>					
• 24 V DC auxiliary power supply	A	0.9	0.9	0.9	0.9
• 500 V AC	A	1.5	1.5	1.5	1.5
• 690 V AC	A	1.0	1.0	1.0	1.0
<b>DC link capacitance</b>	μF	2800	2800	3900	4200
<b>Pulse frequency <sup>5)</sup></b>					
• Rated frequency	kHz	1.25	1.25	1.25	1.25
• Pulse frequency, max.					
- Without current derating	kHz	1.25	1.25	1.25	1.25
- With current derating	kHz	7.5	7.5	7.5	7.5
<b>Power loss, max. <sup>6)</sup></b>					
• At 50 Hz 690 V	kW	2.67	3.09	3.62	4.34
• At 60 Hz 575 V	kW	2.5	2.91	3.38	3.98
<b>Cooling air requirement</b>	m <sup>3</sup> /s	0.36	0.36	0.36	0.36
<b>Sound pressure level <math>L_{pA}</math></b> (1 m) at 50/60 Hz	dB	69/73	69/73	69/73	69/73
<b>DC link connection</b> DCP, DCN		M10 screw	M10 screw	M10 screw	M10 screw
• Conductor cross-section, max. (IEC)	mm <sup>2</sup>	2 × 240	2 × 240	2 × 240	2 × 240
<b>Connection for Braking Module</b> DCPA, DCNA <sup>7)</sup>		M6 stud	M6 stud	M6 stud	M6 stud
<b>Connection for dv/dt filter</b> DCPS, DCNS		M8 screw	M8 screw	M8 screw	M8 screw
• Conductor cross-section, max. (IEC)	mm <sup>2</sup>	1 × 70	1 × 70	1 × 70	1 × 70
<b>Motor connection</b> U2, V2, W2		M10 screw	M10 screw	M10 screw	M10 screw
• Conductor cross-section, max. (IEC)	mm <sup>2</sup>	2 × 240	2 × 240	2 × 240	2 × 240

For footnotes, see next page.

## SINAMICS S120 Chassis Format Converter Units

Air-cooled units

### Motor Modules

#### Technical specifications (continued)

Line voltage 500 ... 690 V 3 AC DC link voltage 675 ... 1035 V DC		Motor Modules			
		6SL3320-1TG31-8AA3	6SL3320-1TG32-2AA3	6SL3320-1TG32-6AA3	6SL3320-1TG33-3AA3
<b>Cable length, max. <sup>8)</sup></b>					
• Shielded	m	300	300	300	300
• Unshielded	m	450	450	450	450
<b>PE1/GND connection</b>		M10 screw	M10 screw	M10 screw	M10 screw
• Conductor cross-section, max. (IEC)	mm <sup>2</sup>	2 × 240	2 × 240	2 × 240	2 × 240
<b>PE2/GND connection</b>		M10 screw	M10 screw	M10 screw	M10 screw
• Conductor cross-section, max. (IEC)	mm <sup>2</sup>	2 × 240	2 × 240	2 × 240	2 × 240
<b>Degree of protection</b>		IP20	IP20	IP20	IP20
<b>Dimensions</b>					
• Width	mm	326	326	326	326
• Height	mm	1533	1533	1533	1533
• Depth	mm	545	545	545	545
<b>Weight, approx.</b>	kg	136	136	136	136
<b>Frame size</b>		GX	GX	GX	GX

<sup>1)</sup> Rated output of a typical 6-pole standard induction motor based on  $I_L$  or  $I_H$  for 500 V or 690 V 3 AC 50 Hz.

<sup>2)</sup> Rated output of a typical 6-pole standard induction motor based on  $I_L$  or  $I_H$  for 575 V 3 AC 60 Hz.

<sup>3)</sup> The base-load current  $I_L$  is based on a duty cycle of 110 % for 60 s or 150 % for 10 s with a duty cycle duration of 300 s.

<sup>4)</sup> The base-load current  $I_H$  is based on a duty cycle of 150 % for 60 s or 160 % for 10 s with a duty cycle duration of 300 s.

<sup>5)</sup> Information regarding the correlation between the pulse frequency and maximum output current/output frequency is provided in the SINAMICS Low Voltage Engineering Manual.

<sup>6)</sup> The specified power loss represents the maximum value at 100 % utilization. The value is lower under normal operating conditions.

<sup>7)</sup> The connecting cables are included in the scope of supply of the Braking Module.

<sup>8)</sup> Total of all motor cables and DC link. Longer cable lengths for specific configurations are available on request. For additional information, please refer to the SINAMICS Low Voltage Engineering Manual.

# SINAMICS S120 Chassis Format Converter Units

## Air-cooled units

### Motor Modules

#### Technical specifications (continued)

Line voltage 500 ... 690 V 3 AC DC link voltage 675 ... 1035 V DC		Motor Modules			
		6SL3320-1TG34-1AA3	6SL3320-1TG34-7AA3	6SL3320-1TG35-8AA3	6SL3320-1TG37-4AA3
<b>Type rating</b>					
• At $I_L$ (50 Hz 690 V) <sup>1)</sup>	kW	400	450	560	710
• At $I_H$ (50 Hz 690 V) <sup>1)</sup>	kW	315	400	450	630
• At $I_L$ (50 Hz 500 V) <sup>1)</sup>	kW	250	315	400	500
• At $I_H$ (50 Hz 500 V) <sup>1)</sup>	kW	200	250	315	450
• At $I_L$ (60 Hz 575 V) <sup>2)</sup>	hp	400	450	600	700
• At $I_H$ (60 Hz 575 V) <sup>2)</sup>	hp	350	450	500	700
<b>Output current</b>					
• Rated current $I_{rated O}$	A	410	465	575	735
• Base-load current $I_L$ <sup>3)</sup>	A	400	452	560	710
• Base-load current $I_H$ <sup>4)</sup>	A	367	416	514	657
• Maximum current $I_{max O}$	A	600	678	840	1065
<b>DC link current</b>					
• Rated current $I_{rated DC}$ when supplied via					
- Basic/Smart Line Module	A	492	558	690	882
- Active Line Module	A	443	502	621	794
• Base-load current $I_{L DC}$ <sup>3)</sup> when supplied via					
- Basic/Smart Line Module	A	479	544	672	859
- Active Line Module	A	431	489	605	774
• Base-load current $I_{H DC}$ <sup>4)</sup> when supplied via					
- Basic/Smart Line Module	A	437	496	614	784
- Active Line Module	A	394	446	552	706
<b>Current demand</b>					
• 24 V DC auxiliary power supply	A	1.0	1.0	1.0	1.25
• 500 V AC	A	3.0	3.0	3.0	4.4
• 690 V AC	A	2.1	2.1	2.1	3.1
<b>DC link capacitance</b>					
	μF	7400	7400	7400	11100
<b>Pulse frequency <sup>5)</sup></b>					
• Rated frequency	kHz	1.25	1.25	1.25	1.25
• Pulse frequency, max.					
- Without current derating	kHz	1.25	1.25	1.25	1.25
- With current derating	kHz	7.5	7.5	7.5	7.5
<b>Power loss, max. <sup>6)</sup></b>					
• At 50 Hz 690 V	kW	6.13	6.80	10.3	10.9
• At 60 Hz 575 V	kW	5.71	6.32	9.7	10
<b>Cooling air requirement</b>					
	m <sup>3</sup> /s	0.78	0.78	0.78	1.08
<b>Sound pressure level <math>L_{pA}</math> (1 m) at 50/60 Hz</b>					
	dB	70/73	70/73	70/73	71/73
<b>DC link connection</b> DCP, DCN					
		4 × hole for M10 Busbar	4 × hole for M10 Busbar	4 × hole for M10 Busbar	4 × hole for M10 Busbar
<b>Connection for Braking Module</b> DCPA, DCNA <sup>7)</sup>					
		M8 stud	M8 stud	M8 stud	M8 stud
<b>Connection for dv/dt filter</b> DCPS, DCNS					
• Conductor cross-section, max. (IEC)	mm <sup>2</sup>	1 × 185	1 × 185	1 × 185	2 × 185
<b>Motor connection</b> U2, V2, W2					
• Conductor cross-section, max. (IEC)	mm <sup>2</sup>	4 × 240	4 × 240	4 × 240	6 × 240

For footnotes, see next page.

## SINAMICS S120 Chassis Format Converter Units

Air-cooled units

### Motor Modules

#### Technical specifications (continued)

Line voltage 500 ... 690 V 3 AC DC link voltage 675 ... 1035 V DC		Motor Modules			
		6SL3320-1TG34-1AA3	6SL3320-1TG34-7AA3	6SL3320-1TG35-8AA3	6SL3320-1TG37-4AA3
<b>Cable length, max. <sup>8)</sup></b>					
• Shielded	m	300	300	300	300
• Unshielded	m	450	450	450	450
<b>PE1/GND connection</b>		M12 screw	M12 screw	M12 screw	M12 screw
• Conductor cross-section, max. (IEC)	mm <sup>2</sup>	240	240	240	240
<b>PE2/GND connection</b>		2 × M12 screw	2 × M12 screw	2 × M12 screw	3 × M12 screw
• Conductor cross-section, max. (IEC)	mm <sup>2</sup>	2 × 240	2 × 240	2 × 240	3 × 240
<b>Degree of protection</b>		IP00	IP00	IP00	IP00
<b>Dimensions</b>					
• Width	mm	503	503	503	704
• Height	mm	1475	1475	1475	1475
• Depth	mm	547	547	547	550
<b>Weight, approx.</b>	kg	290	290	290	450
<b>Frame size</b>		HX	HX	HX	JX

<sup>1)</sup> Rated output of a typical 6-pole standard induction motor based on  $I_L$  or  $I_H$  for 500 V or 690 V 3 AC 50 Hz.

<sup>2)</sup> Rated output of a typical 6-pole standard induction motor based on  $I_L$  or  $I_H$  for 575 V 3 AC 60 Hz.

<sup>3)</sup> The base-load current  $I_L$  is based on a duty cycle of 110 % for 60 s or 150 % for 10 s with a duty cycle duration of 300 s.

<sup>4)</sup> The base-load current  $I_H$  is based on a duty cycle of 150 % for 60 s or 160 % for 10 s with a duty cycle duration of 300 s.

<sup>5)</sup> Information regarding the correlation between the pulse frequency and maximum output current/output frequency is provided in the SINAMICS Low Voltage Engineering Manual.

<sup>6)</sup> The specified power loss represents the maximum value at 100 % utilization. The value is lower under normal operating conditions.

<sup>7)</sup> The connecting cables are included in the scope of supply of the Braking Module.

<sup>8)</sup> Total of all motor cables and DC link. Longer cable lengths for specific configurations are available on request. For additional information, please refer to the SINAMICS Low Voltage Engineering Manual.

# SINAMICS S120 Chassis Format Converter Units

## Air-cooled units

### Motor Modules

#### Technical specifications (continued)

Line voltage 500 ... 690 V 3 AC DC link voltage 675 ... 1035 V DC		Motor Modules			
		6SL3320-1TG38-1AA3	6SL3320-1TG38-8AA3	6SL3320-1TG41-0AA3	6SL3320-1TG41-3AA3
<b>Type rating</b>					
• At $I_L$ (50 Hz 690 V) <sup>1)</sup>	kW	<b>800</b>	<b>900</b>	<b>1000</b>	<b>1200</b>
• At $I_H$ (50 Hz 690 V) <sup>1)</sup>	kW	710	800	900	1000
• At $I_L$ (50 Hz 500 V) <sup>1)</sup>	kW	560	630	710	900
• At $I_H$ (50 Hz 500 V) <sup>1)</sup>	kW	500	560	630	800
• At $I_L$ (60 Hz 575 V) <sup>2)</sup>	hp	800	900	1000	1250
• At $I_H$ (60 Hz 575 V) <sup>2)</sup>	hp	700	800	900	1000
<b>Output current</b>					
• Rated current $I_{rated O}$	A	810	910	1025	1270
• Base-load current $I_L$ <sup>3)</sup>	A	790	880	1000	1230
• Base-load current $I_H$ <sup>4)</sup>	A	724	814	917	1136
• Maximum current $I_{max O}$	A	1185	1320	1500	1845
<b>DC link current</b>					
• Rated current $I_{rated DC}$ when supplied via					
- Basic/Smart Line Module	A	972	1092	1230	1524
- Active Line Module	A	875	983	1107	1372
• Base-load current $I_{L DC}$ <sup>3)</sup> when supplied via					
- Basic/Smart Line Module	A	947	1064	1199	1485
- Active Line Module	A	853	958	1079	1337
• Base-load current $I_{H DC}$ <sup>4)</sup> when supplied via					
- Basic/Smart Line Module	A	865	971	1094	1356
- Active Line Module	A	778	874	985	1221
<b>Current demand</b>					
• 24 V DC auxiliary power supply	A	1.25	1.4	1.4	1.4
• 500 V AC	A	4.4	4.4	4.4	4.4
• 690 V AC	A	3.1	3.1	3.1	3.1
<b>DC link capacitance</b>	μF	11100	14400	14400	19200
<b>Pulse frequency</b> <sup>5)</sup>					
• Rated frequency	kHz	1.25	1.25	1.25	1.25
• Pulse frequency, max.					
- Without current derating	kHz	1.25	1.25	1.25	1.25
- With current derating	kHz	7.5	7.5	7.5	7.5
<b>Power loss, max.</b> <sup>6)</sup>					
• At 50 Hz 690 V	kW	11.5	11.7	13.2	16.0
• At 60 Hz 575 V	kW	10.5	10.6	12.0	14.2
<b>Cooling air requirement</b>	m <sup>3</sup> /s	1.08	1.08	1.08	1.08
<b>Sound pressure level <math>L_{pA}</math></b> (1 m) at 50/60 Hz	dB	71/73	71/73	71/73	71/73
<b>DC link connection</b> DCP, DCN		4 × hole for M10 Busbar	4 × hole for M10 Busbar	4 × hole for M10 Busbar	4 × hole for M10 Busbar
<b>Connection for Braking Module</b> DCPA, DCNA <sup>7)</sup>		M8 stud	M8 stud	M8 stud	M8 stud
<b>Connection for dv/dt filter</b> DCPS, DCNS		2 × M10 screw	2 × M10 screw	2 × M10 screw	2 × M10 screw
• Conductor cross-section, max. (IEC)	mm <sup>2</sup>	2 × 185	2 × 185	2 × 185	2 × 185
<b>Motor connection</b> U2, V2, W2		3 × M12 screw	3 × M12 screw	3 × M12 screw	3 × M12 screw
• Conductor cross-section, max. (IEC)	mm <sup>2</sup>	6 × 240	6 × 240	6 × 240	6 × 240



## SINAMICS S120 Chassis Format Converter Units

Air-cooled units

### Motor Modules

#### Technical specifications (continued)

Line voltage 500 ... 690 V 3 AC DC link voltage 675 ... 1035 V DC		Motor Modules			
		6SL3320-1TG38-1AA3	6SL3320-1TG38-8AA3	6SL3320-1TG41-0AA3	6SL3320-1TG41-3AA3
<b>Cable length, max. <sup>8)</sup></b>					
• Shielded	m	300	300	300	300
• Unshielded	m	450	450	450	450
<b>PE1/GND connection</b>		M12 screw	M12 screw	M12 screw	M12 screw
• Conductor cross-section, max. (IEC)	mm <sup>2</sup>	240	240	240	240
<b>PE2/GND connection</b>		3 × M12 screw	3 × M12 screw	3 × M12 screw	3 × M12 screw
• Conductor cross-section, max. (IEC)	mm <sup>2</sup>	3 × 240	3 × 240	3 × 240	3 × 240
<b>Degree of protection</b>		IP00	IP00	IP00	IP00
<b>Dimensions</b>					
• Width	mm	704	704	704	704
• Height	mm	1475	1475	1475	1475
• Depth	mm	550	550	550	550
<b>Weight, approx.</b>	kg	450	450	450	450
<b>Frame size</b>		JX	JX	JX	JX

<sup>1)</sup> Rated output of a typical 6-pole standard induction motor based on  $I_L$  or  $I_H$  for 500 V or 690 V 3 AC 50 Hz.

<sup>2)</sup> Rated output of a typical 6-pole standard induction motor based on  $I_L$  or  $I_H$  for 575 V 3 AC 60 Hz.

<sup>3)</sup> The base-load current  $I_L$  is based on a duty cycle of 110 % for 60 s or 150 % for 10 s with a duty cycle duration of 300 s.

<sup>4)</sup> The base-load current  $I_H$  is based on a duty cycle of 150 % for 60 s or 160 % for 10 s with a duty cycle duration of 300 s.

<sup>5)</sup> Information regarding the correlation between the pulse frequency and maximum output current/output frequency is provided in the SINAMICS Low Voltage Engineering Manual.

<sup>6)</sup> The specified power loss represents the maximum value at 100 % utilization. The value is lower under normal operating conditions.

<sup>7)</sup> The connecting cables are included in the scope of supply of the Braking Module.

<sup>8)</sup> Total of all motor cables and DC link. Longer cable lengths for specific configurations are available on request. For additional information, please refer to the SINAMICS Low Voltage Engineering Manual.

### Overview



Power block mounting device for installing and removing the power blocks for the Basic Line Modules, Smart Line Modules, Active Line Modules, Power Modules, and Motor Modules in chassis format.

The mounting device is a mounting aid. It is placed in front of the module and attached to the module. The telescopic rails allow the device to be adjusted to the installation height of the power blocks.

Once the mechanical and electrical connections have been released, the Power block can be removed from the module.

The power block is guided and supported by the guide rails on the handling device.

### Selection and ordering data

Description	Article No.
<b>Mounting device</b> for installing and removing power blocks	<b>6SL3766-1FA00-0AA0</b>

## SINAMICS S120 Chassis Format Converter Units

### Liquid-cooled units

#### Overview



The SINAMICS S120 liquid-cooled drive units are specifically designed to address the requirements relating to liquid cooling; they are characterized by their high power density and optimized footprint. Liquid cooling dissipates heat much more efficiently than air cooling systems. As a result, liquid-cooled units are much more compact than air-cooled units with the same power rating. Since the heat losses generated by the electronic components are almost completely dissipated by the liquid coolant, only very small cooling fans are required. This means that the devices are quiet in operation. Due to their compact dimensions and almost negligible cooling air requirement, liquid-cooled units are the preferred solution wherever installation space is restricted and/or the ambient operating conditions are rough.

Control cabinets with liquid cooling are easy to implement as sealed units with degrees of protection of IP55.

The product portfolio includes the following liquid-cooled SINAMICS S120 built-in units:

- Power Modules
- Basic Line Modules
- Active Line Modules
- Active Interface Modules
- Motor Modules

The associated system components such as line reactors, motor reactors, dv/dt filters plus VPL and sine-wave filters are air-cooled. Active Interface Modules are available in air-cooled and liquid-cooled versions.

#### *Highlights of the liquid-cooled units*

- Up to a 60 % smaller footprint than air-cooled drive converters
- All main components such as power semiconductors, DC link capacitors and balancing resistors are cooled by the cooling circuit
- Only a low flow rate is required
- Uniform pressure drop of 0.7 bar
- Automatic protective functions
- Nickel-plated busbars
- Low noise
- Compatible with all components and functions and tools of the SINAMICS system family
- The power rating can be extended by connecting units in parallel
- No equipment fans

#### Cabinet units in liquid-cooled version

Liquid-cooled SINAMICS S120 drive units are also available as cabinet units, including cooling system (Heat Exchanger Module). [See section SINAMICS S120 Cabinet Modules → Liquid-cooled units.](#)

## Overview (continued)

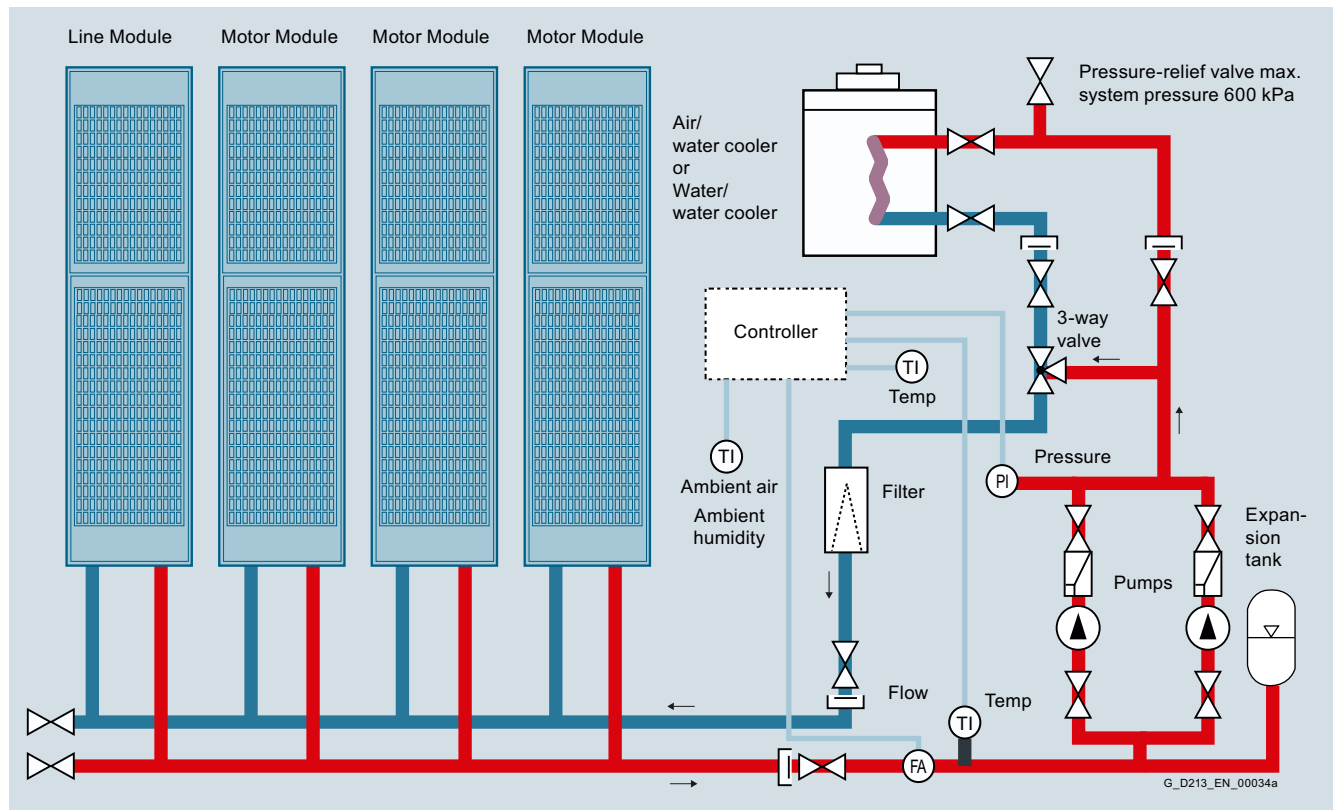

Example of a drive line-up with SINAMICS S120 liquid-cooled units

## Technical specifications

### General technical specifications

Unless clearly specified otherwise, the following technical data are valid for all the following components of the liquid-cooled SINAMICS S120 drive system in chassis format.

Electrical specifications	
<b>Rated voltages</b>	380 ... 480 V 3 AC $\pm 10\%$ (-15% <1 min) 500 ... 690 V 3 AC $\pm 10\%$ (-15% <1 min)
<b>Line supply types</b>	Grounded TN/TT systems and non-grounded IT systems
<b>Line frequency</b>	47 ... 63 Hz
<b>Overvoltage category</b>	III to EN 61800-5-1
<b>Electronics power supply</b>	24 V DC, -15% +20% implemented as PELV circuit in accordance with EN 61800-5-1 Ground = negative pole grounded via the electronics
<b>Rated short-circuit current</b> per IEC, in conjunction with the specified fuses or circuit breakers	
• 1.1 ... 447 kW	65 kA
• 448 ... 671 kW	84 kA
• 672 ... 1193 kW	170 kA
• > 1194 kW	200 kA
<b>Rated short-circuit current SCCR (Short Circuit Current Rating)</b> according to UL508C (up to 600 V), in conjunction with the specified fuses or circuit breakers	
• 1.1 ... 447 kW	65 kA
• 448 ... 671 kW	84 kA
• 672 ... 1193 kW	170 kA
• > 1194 kW	200 kA

# SINAMICS S120 Chassis Format Converter Units

## Liquid-cooled units

### Technical specifications (continued)

Electrical specifications			
<b>Control method</b>	Vector/Servo control with and without encoder or V/f control		
<b>Fixed speeds</b>	15 fixed speeds plus 1 minimum speed, parameterizable (in the default setting, 3 fixed setpoints plus 1 minimum speed are selectable using terminal block/PROFIBUS/PROFINET)		
<b>Skippable speed ranges</b>	4, parameterizable		
<b>Setpoint resolution</b>	0.001 rpm digital (14 bits + sign) 12 bits analog		
<b>Braking operation</b>	With Active Line Modules, four-quadrant operation as standard (energy recovery). With Basic Line Modules, two-quadrant operation as standard, braking by means of a Motor Module.		
Mechanical specifications			
<b>Degree of protection</b>	IP00 (IP20, without taking into account the connecting busbars)		
<b>Protection class</b>	I acc. to EN 61800-5-1		
<b>Touch protection</b>	EN 50274/DGUV regulation 3 when used as intended		
<b>Cooling method</b>	Liquid cooling with integrated heat exchanger in aluminum or stainless steel version		
Ambient conditions	Storage <sup>1)</sup>	Transport <sup>1)</sup>	Operation
<b>Ambient temperature (air)</b>	-25 ... +55 °C Class 1K4 acc. to EN 60721-3-1	-25 ... +70 °C Class 2K4 acc. to EN 60721-3-2	Line-side components, Power Modules, Line Modules and Motor Modules: 0 ... 45 °C without derating >45 ... 50 °C <a href="#">see derating characteristic curves</a> Control Units, supplementary system components, and Sensor Modules: 0 ... 55 °C (for operation in a control cabinet) DC link components and motor-side components: 0 ... 55 °C
<b>Relative humidity</b> Condensation, splashwater, and ice formation not permitted (EN 60204, Part 1)	<u>5 ... 95 %</u> Class 1K4 acc. to EN 60721-3-1	Max. 95 % at 40 °C Class 2K4 acc. to EN 60721-3-2	5 ... <u>95 %</u> Class 3K3 acc. to EN 60721-3-3
<b>Environmental class/harmful chemical substances</b>	Class 1C2 acc. to EN 60721-3-1	Class 2C2 acc. to EN 60721-3-2	Class 3C2 acc. to EN 60721-3-3
<b>Organic/biological influences</b>	Class 1B1 acc. to EN 60721-3-1	Class 2B1 acc. to EN 60721-3-2	Class 3B1 acc. to EN 60721-3-3
<b>Degree of pollution</b>	2 acc. to IEC/EN 61800-5-1		
<b>Installation altitude</b>	Up to 2000 m above sea level without derating, > 2000 m above sea level, <a href="#">refer to the derating data</a>		
Mechanical stability	Storage <sup>1)</sup>	Transport <sup>1)</sup>	Operation
<b>Vibratory load</b>		Class 2M2 acc. to EN 60721-3-2	Test values acc. to EN 60068-2-6 test Fc: • 10 ... 58 Hz with constant deflection 0.075 mm • 58 ... 150 Hz with constant acceleration 9.81 m/s <sup>2</sup> (1 × g)
<b>Shock load</b>		Class 2M2 acc. to EN 60721-3-2	Test values acc. to EN 60068-2-27 test Ea: 98 m/s <sup>2</sup> (10 × g)/20 ms
Compliance with standards			
<b>Conformances/certificates of suitability, according to</b>	CE (EMC Directive 2014/30/EU, Low Voltage Directive 2014/35/EU, and Machinery Directive 2006/42/EC for functional safety) RCM, RoHS II, DNV GL cULus (only for devices connected to line supply voltages 380 ... 480 V 3 AC and 500 ... 600 V 3 AC <a href="#">see appendix</a> )		
<b>Radio interference suppression</b>	SINAMICS S120 chassis format units are not designed for connection to the public grid (first environment). Radio interference suppression is compliant with the EMC product standard for variable-speed drives EN 61800-3, "Second environment" (industrial line supplies). EMC disturbances can occur when connected to the public grid.		

Deviations from the specified class are underlined.

<sup>1)</sup> In transport packaging.

### Technical specifications (continued)

#### Cooling circuit and coolant quality

The following tables and sections describe the quality requirements of the coolant used in the liquid-cooled SINAMICS S120 drive system in chassis format.

Cooling circuit	
• System pressure with reference to atmospheric pressure, max.	600 kPa
• Pressure drop at rated volumetric flow	70 kPa
• Recommended pressure range	80 ... 150 kPa (is applicable for water as coolant)
• Inlet temperature of liquid coolant	Dependent on ambient temperature, no condensation permitted 0 ... 45° C without derating >45 ... 50 °C, <a href="#">see derating data</a> Antifreeze essential for temperature range between 0 °C and 5 °C
Coolant quality	
<u>Coolant basis for aluminum heat sinks</u>	
• Electrical conductivity when filling	<30 µS/cm (3 mS/m)
• pH value	5 ... 8
• Components that can be oxidized as oxygen content	<30 mg/l
• Residue after vaporization and drying at 110 °C	<10 mg/kg
<u>Coolant basis for stainless steel heat sinks</u>	
• Electrical conductivity	Filtered drinking, process, and cooling water <2500 µS/cm (250 mS/m)
• pH value	6.5 ... 9
• Total salt content TDS	<1550 mg/l
• Chloride ions	<250 mg/l
• Sodium	<200 mg/l
• Sulfate ions	<240 mg/l
• Sulfide ions	<1 mg/l
• Nitrate ions	<50 mg/l
• Iron	<1 mg/l
• Silicate	<10 mg/l
• Ammonia (NH <sub>3</sub> ), ammonium (NH <sub>4</sub> <sup>+</sup> )	<1 mg/l
• Total hardness with a maximum of	<1.78 mmol/l (10 °dH)
- Calcium hardness	<1.25 mmol/l (7 °dH), <57 mg/l calcium
- Magnesium hardness	<1.43 mmol/l (8 °dH), <35 mg/l magnesium
- Carbonate hardness	<0.45 mmol/l (2.5 °dH)
• Suspended solids/suspended substances	
- Solids	<340 mg/l
- Size of entrained particles	<100 µm
The coolant definition specified here should only be considered as recommendation. For units that have been shipped, the information and data provided in the equipment manual supplied should be observed!	

## SINAMICS S120 Chassis Format Converter Units

### Liquid-cooled units

#### Technical specifications (continued)

##### Antifreeze and inhibitors

Antifreeze	Antifrogen N	Antifrogen L	DOWCAL 100
Manufacturer	Clariant	Clariant	DOW
Chemical base	Ethylene glycol	Propylene glycol	Ethylene glycol
Minimum concentration	25 %	25 %	25 %
Antifreeze agent with minimum concentration	-10 °C	-10 °C	-10 °C
Maximum concentration	45 %	48 %	45 %
Antifreeze agent with maximum concentration	-30 °C	-30 °C	-30 °C
Inhibitor content	Contains inhibitors with nitrites	Contains inhibitors that are free of nitrates, amines, borates and phosphates	Contains inhibitors that are free of nitrates, amines and phosphates
Biocide action with a concentration of	>25 %	>25 %	>25 %

Biocides prevent corrosion that is caused by slime-forming, corrosive or iron-depositing bacteria. These can occur in closed cooling circuits with low water hardness and in open cooling circuits. Biocides must always be selected according to the relevant bacterial risks. Compatibility with inhibitors or antifreeze used with them must be checked on a case-by-case basis.

Inhibitors	Antifrogen N	ANTICORIT S 2000 A
Manufacturer	Clariant	Fuchs
Chemical base	Ethylene glycol	–
Minimum concentration	25 %	4 %
Maximum concentration	45 %	5 %

##### Recommended service

The manufacturer of the antifreeze/inhibitor should analyze the coolant at least once per annum. The concentration and boundary conditions of the antifreeze/inhibitor should be checked. It may be necessary to correct the concentration on the plant side.

### Technical specifications (continued)

#### Protection against condensation

With liquid-cooled units, warm air can condense on the cold surfaces of heat sinks, pipes and hoses. This condensation depends on the air humidity and the temperature difference between the ambient air and the coolant.

The water which is produced as a result of condensation can cause corrosion as well as electrical damage such as creepage shorts and flashovers. As the SINAMICS units cannot prevent condensation if it is caused by the prevailing climatic conditions, any potential risk of condensation must be prevented by appropriate engineering or by precautionary measures implemented by the customer. These measures include the following:

- a fixed coolant temperature that has been adjusted to the expected air humidity or ambient temperature ensures that critical differences between the coolant and ambient air temperatures do not develop or
- temperature regulation of the coolant as a function of the ambient air temperature

The temperature at which water vapor contained in the air condenses into water is known as the dew point. In order to reliably prevent condensation, the coolant temperature must always be higher than the dew point.

The table below specifies the dew point as a function of room temperature  $T$  and relative air humidity  $\Phi$  for an atmospheric pressure of 100 kPa (1 bar). This corresponds to an installation altitude of 0 up to approximately 500 m above sea level. Since the dew point drops as the air pressure decreases, the dew point values at higher installation altitudes are lower than the specified table values. It is therefore the safest approach to engineer the coolant temperature according to the values in the table for an installation altitude of zero.

A detailed description of the cooling circuits and the recommended coolant is given in the SINAMICS Low Voltage Engineering Manual.

Room temperature T	Relative air humidity $\Phi$										
	20 %	30 %	40 %	50 %	60 %	70 %	80 %	85 %	90 %	95 %	100 %
10 °C	<0 °C	<0 °C	<0 °C	0.2 °C	2.7 °C	4.8 °C	6.7 °C	7.6 °C	8.4 °C	9.2 °C	10 °C
20 °C	<0 °C	2 °C	6 °C	9.3 °C	12 °C	14.3 °C	16.4 °C	17.4 °C	18.3 °C	19.1 °C	20 °C
25 °C	0.6 °C	6.3 °C	10.5 °C	13.8 °C	16.7 °C	19.1 °C	21.2 °C	22.2 °C	23.2 °C	24.1 °C	24.9 °C
30 °C	4.7 °C	10.5 °C	14.9 °C	18.4 °C	21.3 °C	23.8 °C	26.1 °C	27.1 °C	28.1 °C	29 °C	29.9 °C
35 °C	8.7 °C	14.8 °C	19.3 °C	22.9 °C	26 °C	28.6 °C	30.9 °C	32 °C	33 °C	34 °C	34.9 °C
40 °C	12.8 °C	19.1 °C	23.7 °C	27.5 °C	30.6 °C	33.4 °C	35.8 °C	36.9 °C	37.9 °C	38.9 °C	39.9 °C
45 °C	16.8 °C	23.3 °C	28.2 °C	32 °C	35.3 °C	38.1 °C	40.6 °C	41.8 °C	42.9 °C	43.9 °C	44.9 °C
50 °C	20.8 °C	27.5 °C	32.6 °C	36.6 °C	40 °C	42.9 °C	45.5 °C	46.6 °C	47.8 °C	48.9 °C	49.9 °C

### Characteristic curves

#### Pressure drop

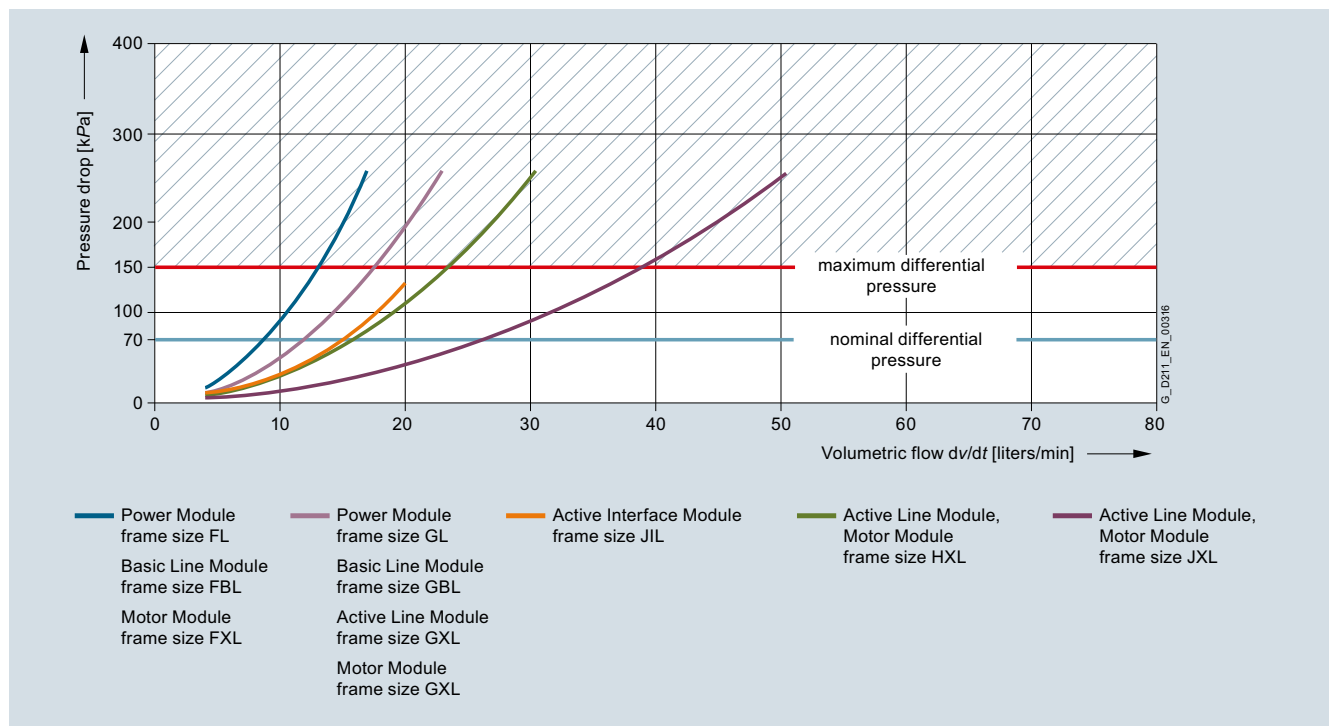

Pressure drop for liquid-cooled built-in units in chassis format

The pressure drop characteristic curves are valid for water. If antifreeze is used, the characteristic curves typically shift to the left.

For further information, please refer to the SINAMICS Low Voltage Engineering Manual.



# SINAMICS S120 Chassis Format Converter Units

## Liquid-cooled units

### Characteristic curves (continued)

#### Derating

Liquid-cooled SINAMICS S120 chassis format units are rated for an ambient temperature of 45 °C and installation altitudes up to 2000 m above sea level. At ambient temperatures > 45 °C, the output current must be reduced. Ambient temperatures above 50 °C are not permissible. At installation altitudes > 2000 m above sea level, it must be taken into account that the air pressure, and therefore air density, decreases as the height increases. As a consequence, the cooling efficiency and the insulation capacity of the air also decrease.

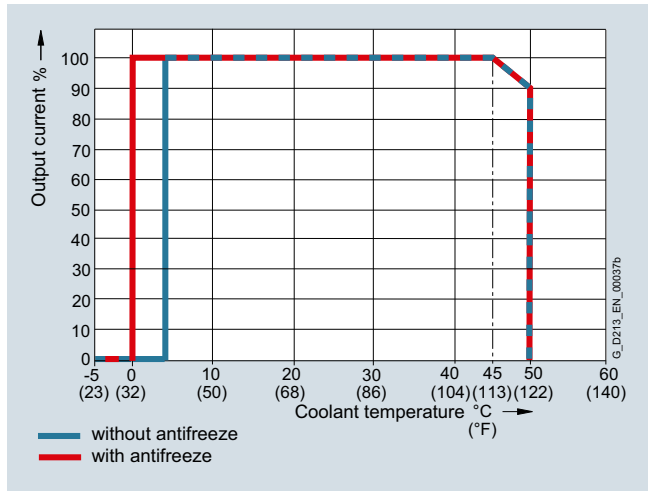

Current derating as a function of the temperature of the cooling liquid <sup>1)</sup>

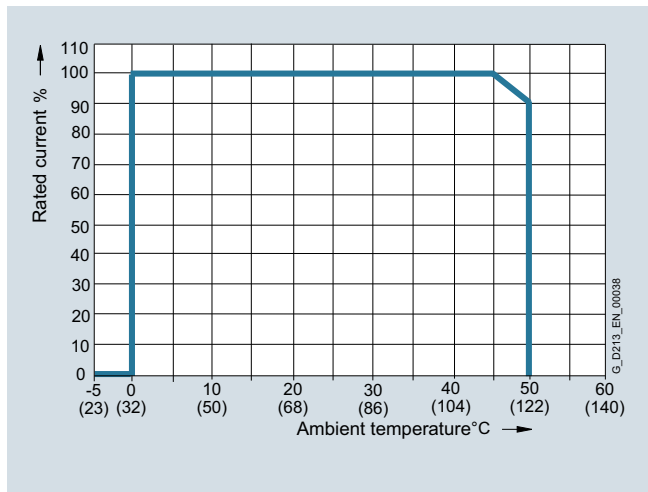

Current derating as a function of ambient temperature <sup>1)</sup>

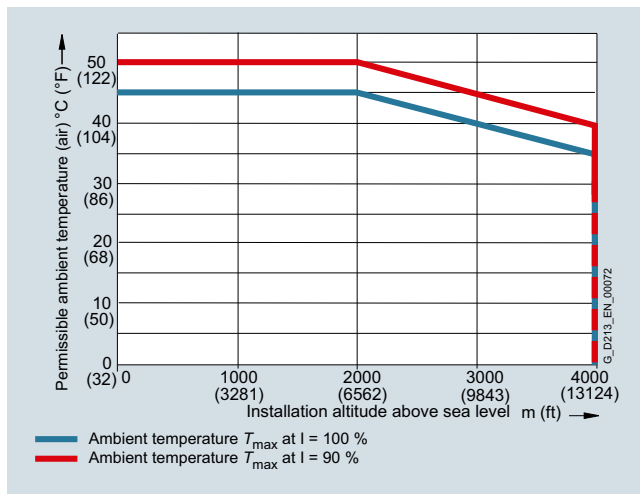

Permissible ambient temperature as a function of installation altitude

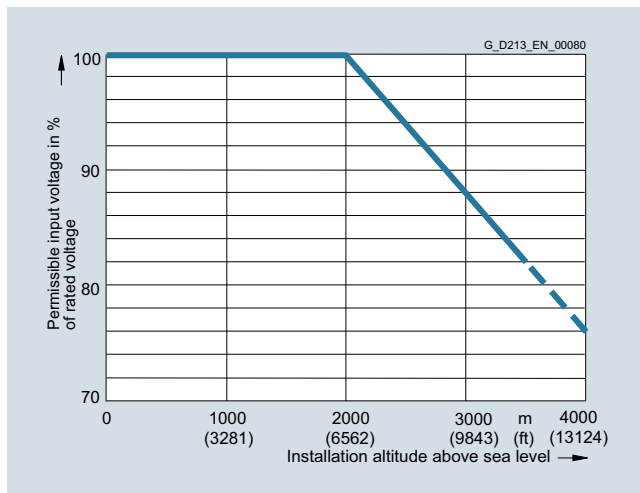

Voltage derating as a function of installation altitude

<sup>1)</sup> The factors of the two curves must not be multiplied. The highest value in each case must be assumed for the purposes of calculation, so that the derating factor in the worst-case scenario is 0.9.

### Characteristic curves (continued)

#### Current derating for Power Modules and Motor Modules in chassis format as a function of the pulse frequency

To reduce motor noise or to increase output frequency, the pulse frequency can be increased relative to the factory setting (1.25 kHz or 2 kHz). When the pulse frequency is increased, the derating factor of the output current must be taken into account. This derating factor must be applied to the currents specified in the technical specifications.

For additional information, please refer to the SINAMICS Low Voltage Engineering Manual.

The following tables list the rated output currents of the SINAMICS S120 Power Modules and Motor Modules with pulse frequency set in the factory as well as the current derating factors (permissible output currents referred to the rated output current) for higher pulse frequencies.

#### Derating factor of the output current as a function of the pulse frequency for units with a rated pulse frequency of 2 kHz

Power Module Motor Module	Type rating at 400 V	Output current at 2 kHz	Derating factor at pulse frequency					
			2.5 kHz	4 kHz	5 kHz	7.5 kHz	8 kHz	
6SL3315-... 6SL3325-...	kW	A						
<b>380 ... 480 V 3 AC</b>								
1TE32-1AA3	110	210	95 %	82 %	74 %	54 %	50 %	
1TE32-6AA3	132	260	95 %	83 %	74 %	54 %	50 %	
1TE33-1AA3	160	310	97 %	88 %	78 %	54 %	50 %	
1TE35-0AA3	250	490	94 %	78 %	71 %	53 %	50 %	
1TE41-4AS3 <sup>1)</sup>	800	1330	88 %	55 %	–	–	–	

#### Derating factor of the output current as a function of the pulse frequency for units with a rated pulse frequency of 1.25 kHz

Motor Module	Type rating at 400 V or 690 V	Output current at 1.25 kHz	Derating factor at pulse frequency						
			2 kHz	2.5 kHz	4 kHz	5 kHz	7.5 kHz	8 kHz	
6SL3325-...	kW	A							
<b>380 ... 480 V 3 AC</b>									
1TE36-1AA3	315	605	83 %	72 %	64 %	60 %	40 %	–	
1TE37-5AA3	400	745	83 %	72 %	64 %	60 %	40 %	–	
1TE38-4AA3	450	840	87 %	79 %	64 %	60 %	40 %	–	
1TE41-0AA3	560	985	92 %	87 %	70 %	60 %	50 %	47 %	
1TE41-2AA3	710	1260	92 %	87 %	70 %	60 %	50 %	47 %	
1TE41-4AA3	800	1405	97 %	95 %	74 %	60 %	50 %	47 %	
<b>500 ... 690 V 3 AC</b>									
1TG31-0AA3	90	100	92 %	88 %	71 %	60 %	40 %	–	
1TG31-5AA3	132	150	90 %	84 %	66 %	55 %	35 %	–	
1TG32-2AA3	200	215	92 %	87 %	70 %	60 %	40 %	–	
1TG33-3AA3	315	330	89 %	82 %	65 %	55 %	40 %	–	
1TG34-7AA3	450	465	92 %	87 %	67 %	55 %	35 %	–	
1TG35-8AA3	560	575	91 %	85 %	64 %	50 %	35 %	–	
1TG37-4AA3	710	735	84 %	74 %	53 %	40 %	25 %	–	
1TG38-0AA3 <sup>2)</sup>	800	810	82 %	71 %	52 %	40 %	25 %	–	
1TG38-1AA3	800	810	97 %	95 %	71 %	55 %	35 %	–	
1TG41-0AA3	1000	1025	91 %	86 %	64 %	50 %	30 %	–	
1TG41-3AA3	1200	1270	87 %	79 %	55 %	40 %	25 %	–	
1TG41-6AP3	1500	1560	87 %	79 %	55 %	40 %	25 %	–	

The following tables list the maximum achievable output frequency as a function of the pulse frequency:

#### Maximum output frequencies achieved by increasing the pulse frequency in Vector mode

Pulse frequency	Max. achievable output frequency
1.25 kHz	100 Hz
2 kHz	160 Hz
2.5 kHz	200 Hz
4 kHz	320 Hz
5 kHz	400 Hz

#### Maximum output frequencies achieved by increasing the pulse frequency in Servo mode

Pulse frequency	Max. achievable output frequency
2 kHz	300 Hz
4 kHz	300/550 Hz <sup>3)</sup>

<sup>1)</sup> This Motor Module has been specifically designed for loads demanding a high dynamic performance. The derating factor  $k_{\text{GBT}}$  and the derating characteristic curves can be ignored (see section "Duty cycles" in the SINAMICS Low Voltage Engineering Manual).

<sup>2)</sup> The Motor Module 6SL3325-1TG38-0AA3 is optimized for low overload; with an increased pulse frequency, the derating factor is higher than for the Motor Module 6SL3325-1TG38-1AA3.

<sup>3)</sup> Higher frequencies on request. For further information see <https://support.industry.siemens.com/cs/document/104020669>

# SINAMICS S120 Chassis Format Converter Units

## Liquid-cooled units

### Characteristic curves (continued)

#### Overload capability

Liquid-cooled SINAMICS S120 units have an overload reserve, e.g. to handle breakaway torques. If larger surge loads occur, this must be taken into account in the configuration. For drives with overload requirements, the appropriate base-load current must, therefore, be used as a basis for the required load.

The permissible overload levels are valid under the prerequisite that the drive units are operated with their base-load current before and after the overload condition based on a duty cycle duration of 300 s.

Another precondition is that the Power Modules or the Motor Modules are operated at their factory-set pulse frequency at output frequencies > 10 Hz.

For temporary, periodic duty cycles with high variations of load within the duty cycle, the relevant sections of the SINAMICS Low Voltage Engineering Manual must be observed.

#### Power Modules and Motor Modules

The base-load current for a low overload  $I_L$  is the basis for a duty cycle of 110 % for 60 s or 150 % for 10 s.

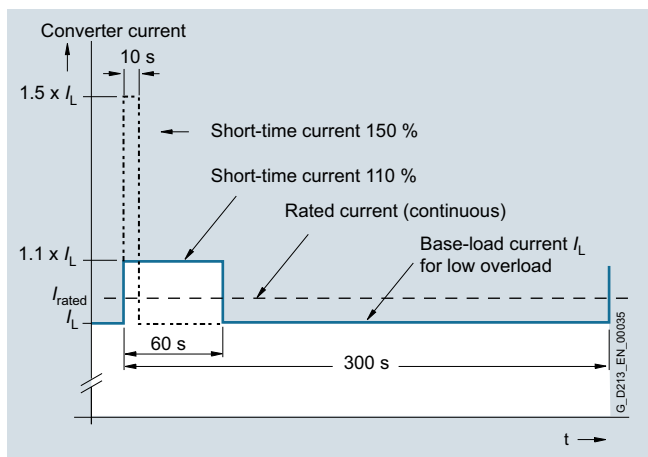

Low overload

The base-load current  $I_H$  for a high overload is based on a duty cycle of 150 % for 60 s or 160 % for 10 s.

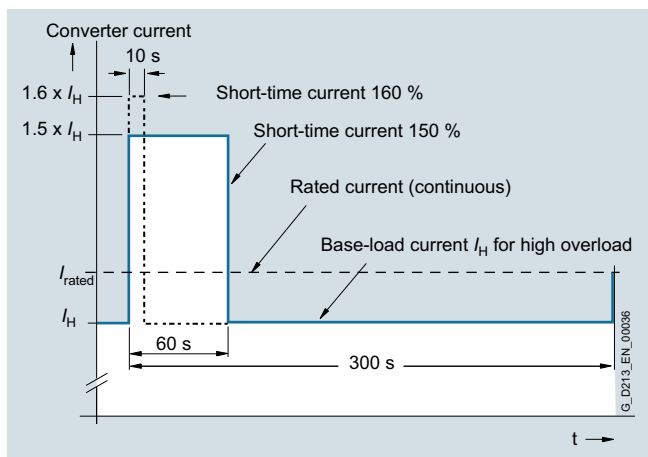

High overload

The following applies to the Motor Module 6SL3325-1TG41-6AP3:

This Motor Module is particularly suited to high breakaway torques with applications such as drilling, mixers, centrifuges, and test bays. An **additional** duty cycle is required at output frequencies of 5 Hz to 10 Hz.

At output frequencies of 1 Hz to 5 Hz, the short-time current is 1900 A for 5 s.

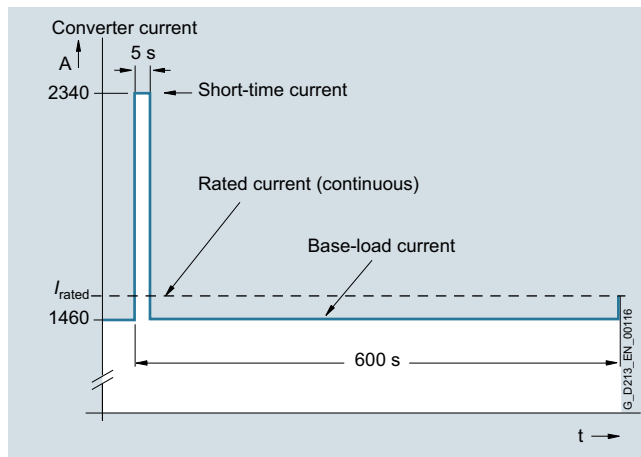

High overload for Motor Module 6SL3325-1TG41-6AP3

#### Line Modules

The base-load current for a high overload  $I_{H DC}$  is the basis for a duty cycle of 150 % for 60 s or  $I_{max DC}$  for 5 s.

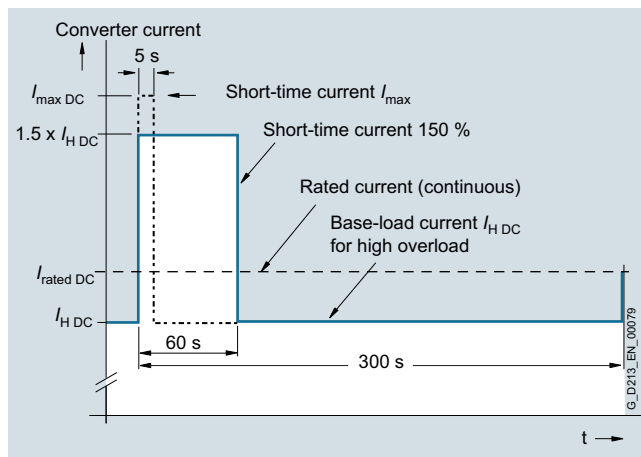

High overload

# SINAMICS S120 Chassis Format Converter Units

## Liquid-cooled units

### Power Modules

#### Overview



The Power Module comprises a line rectifier, a DC link and a converter to supply the motor.

Power Modules are designed for drives that are not capable of regenerating energy to the mains supply. If the motor produces energy during braking, a Braking Module with braking resistors will be required.

Liquid-cooled Power Modules are especially suitable for applications where installation space is restricted and environmental conditions are harsh. Liquid cooling ensures efficient heat dissipation.

Power Modules in the chassis format can be connected to grounded TN/TT systems and non-grounded IT systems.

#### Design

The liquid-cooled Power Modules have the following interfaces as standard:

- 1 line supply connection
- 1 motor connection
- 1 connection for the 24 V DC electronics power supply
- 1 DC link connection
- 3 DRIVE-CLiQ sockets
- 1 temperature sensor input for KTY84-130, Pt1000, PTC or Pt100 (Pt1000 can be used from firmware V4.7 HF17)
- 1 connection for Safe Brake Adapter
- 1 connection for Safety Integrated
- 2 PE connections
- 2 coolant connections

The CU310-2 Control Unit can be integrated into the liquid-cooled Power Modules.

The status of the Power Modules is indicated via three LEDs.

The scope of supply of the Power Modules includes:

- 1 DRIVE-CLiQ cable for connection to the Control Unit
- 2 seals for coolant connections
- 1 set of warning labels in 30 languages (BG, CN, CZ, DE, DK, EE, ES, FI, FR, GB, GR, HU, IE, IS, IT, JP, KR, LT, LV, MT, NL, NO, PL, PT, RO, RU, SE, SI, SK, TR)

<sup>1)</sup> Recommended components for installing a flow control as condensation protection; manufactured by Siemens Building Technologies.

#### Selection and ordering data

Type rating at 400 V kW	Rated output current A	Power Module Article No.
<b>Line voltage 380 ... 480 V 3 AC</b>		
110	210	<b>6SL3315-1TE32-1AA3</b>
132	260	<b>6SL3315-1TE32-6AA3</b>
160	310	<b>6SL3315-1TE33-1AA3</b>
250	490	<b>6SL3315-1TE35-0AA3</b>
Description		Article No.
<b>Accessories</b>		
<b>3-way valve <sup>1)</sup></b>		<b>VXF41.../VXG41...</b>
<b>Actuator for 3-way valve <sup>1)</sup></b>		
• 230 V 1 AC		<b>SAX31...</b>
• 24 V AC/DC		<b>SAX61.../SAX81...</b>
<b>Accessories for re-ordering</b>		
<b>Dust protection blanking plugs</b> (50 units)		<b>6SL3066-4CA00-0AA0</b>
For DRIVE-CLiQ port		

For additional information, refer to the manual.

For line-side and motor-side components, see System components.

# SINAMICS S120 Chassis Format Converter Units

Liquid-cooled units

## Power Modules

### Integration

The Power Modules communicate with the higher-level control module via DRIVE-CLiQ. The Control Unit in this case could be a CU310-2, CU320-2 or a SIMOTION D Control Unit. An external 24 V DC power supply is required to operate liquid-cooled Power Modules.

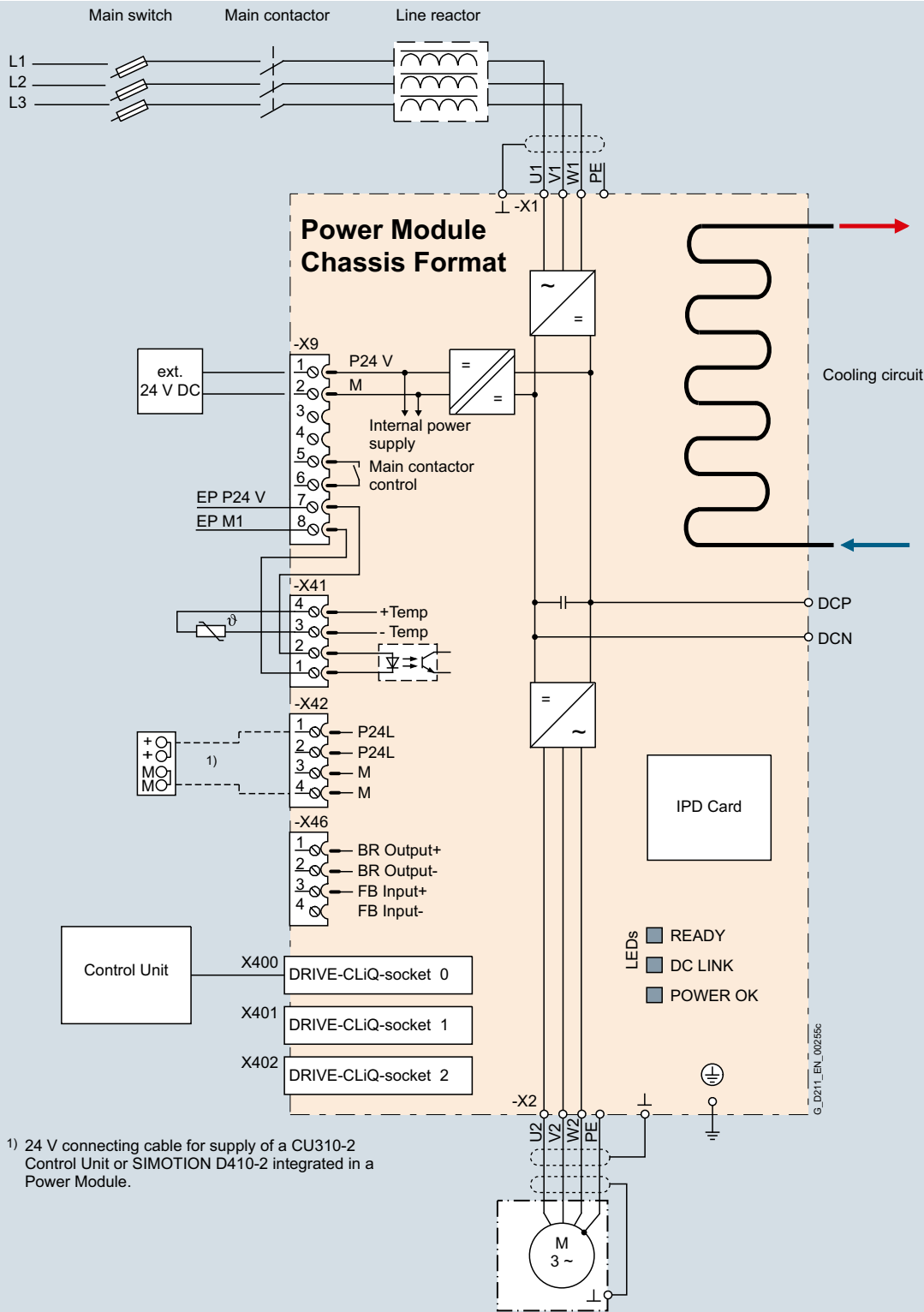

1) 24 V connecting cable for supply of a CU310-2 Control Unit or SIMOTION D410-2 integrated in a Power Module.

Connection example of a liquid-cooled Power Module in the chassis format

**Note:**

The integrated 24 V power supply at connector X42 can have a maximum load of 2 A. When the Control Unit is supplied from the

integrated power supply, the total load of the digital outputs must be carefully observed to ensure that the 2 A is not exceeded.

## Technical specifications

### General technical specifications

Electrical specifications	
<b>Line connection voltage</b> Up to 2000 m above sea level	380 ... 480 V 3 AC $\pm 10\%$ (-15% < 1 min)
<b>Line power factor</b> for a 3 AC line supply voltage and rated output	
• Basic fundamental ( $\cos \varphi_1$ )	>0.96
• Total ( $\lambda$ )	0.75 ... 0.93
<b>Efficiency</b>	> 98 %
<b>DC link voltage, approx.</b>	1.35 × line voltage
<b>Output voltage, approx.</b>	0 ... $0.97 \times U_{\text{line}}$
<b>Output frequency <sup>1)</sup></b>	
• Control type Servo	0 ... 550 Hz
• Control type Vector	0 ... 550 Hz
• Control mode V/f	0 ... 550 Hz
<b>Electronics power supply</b>	24 V DC -15 %/+20 %
<b>Main contactor control</b>	
Terminal block -X9/5-6	240 V AC, max. 8 A 30 V DC, max. 1 A
<b>Safety Integrated</b>	Safety Integrity Level 2 (SIL2) acc. to IEC 61508, Performance Level d (PLd) acc. to EN ISO 13849-1 and Control Category 3 acc. to EN ISO 13849-1.

<sup>1)</sup> Please note:

- The correlation between the maximum output frequency, pulse frequency and current derating. Higher output frequencies on request. For further information see <https://support.industry.siemens.com/cs/document/104020669>
- The correlation between the minimum output frequency and permissible output current (current derating).  
Information is provided in the SINAMICS Low Voltage Engineering Manual.

# SINAMICS S120 Chassis Format Converter Units

## Liquid-cooled units

### Power Modules

#### Technical specifications (continued)

Line voltage 380 V ... 480 V 3 AC		Power Modules			
		6SL3315-1TE32-1AA3	6SL3315-1TE32-6AA3	6SL3315-1TE33-1AA3	6SL3315-1TE35-0AA3
<b>Type rating</b>					
• At $I_L$ (50 Hz 400 V) <sup>1)</sup>	kW	<b>110</b>	<b>132</b>	<b>160</b>	<b>250</b>
• At $I_H$ (50 Hz 400 V) <sup>1)</sup>	kW	90	110	132	200
• At $I_L$ (60 Hz 460 V) <sup>2)</sup>	hp	150	200	250	400
• At $I_H$ (60 Hz 460 V) <sup>2)</sup>	hp	150	200	200	350
<b>Output current</b>					
• Rated current $I_{rated O}$	A	210	260	310	490
• Base-load current $I_L$ <sup>3)</sup>	A	205	250	302	477
• Base-load current $I_H$ <sup>4)</sup>	A	178	233	277	438
• Max. output current $I_{max O}$	A	307	375	453	715
<b>Input current</b>					
• Rated current $I_{rated I}$	A	230	285	340	540
• Maximum current $I_{max I}$	A	336	411	496	788
<b>Current demand</b>					
• 24 V DC auxiliary power supply	A	1.4	1.4	1.5	1.5
<b>Pulse frequency <sup>5)</sup></b>					
• Rated frequency	kHz	2	2	2	2
• Pulse frequency, max.					
- Without current derating	kHz	2	2	2	2
- With current derating	kHz	8	8	8	8
<b>Power loss, at 50 Hz 400 V <sup>6)</sup></b>					
• Dissipated to coolant	kW	2.36	2.97	3.31	5.29
• Dissipated to ambient air	kW	0.06	0.07	0.09	0.14
• Total	kW	2.42	3.04	3.4	5.43
<b>Coolant volume flow <sup>7)</sup></b>		l/min	9	12	12
<b>Liquid volume</b> of the integrated heat exchanger		dm <sup>3</sup>	0.52	0.88	0.88
<b>Pressure drop, typ. <sup>8)</sup></b> for volume flow		Pa	70000	70000	70000
<b>Heat exchanger material</b>			Stainless steel	Stainless steel	Stainless steel
<b>Coolant connections</b> Intake/return			Pipe thread ISO 228 G 3/4 B (external thread 3/4", flat-sealing)		
<b>Sound pressure level <math>L_{pA}</math></b> (1 m) at 50/60 Hz		dB	52	52	52
<b>Line supply connection</b> U1, V1, W1			Hole for M12	Hole for M12	Hole for M12
• Conductor cross-section, max. (IEC)	mm <sup>2</sup>	2 × 95	2 × 95	2 × 240	2 × 240
<b>DC link connection</b> DCP, DCN			Hole for M12	Hole for M12	Hole for M12
• Conductor cross-section, max. (IEC)	mm <sup>2</sup>	2 × 95	2 × 95	2 × 240	2 × 240
<b>Motor connection</b> U2/T1, V2/T2, W2/T3			Hole for M12	Hole for M12	2 × hole for M12
• Conductor cross-section, max. (IEC)	mm <sup>2</sup>	2 × 95	2 × 95	2 × 240	2 × 240
<b>Cable length, max <sup>9)</sup></b>					
• Shielded	m	300	300	300	300
• Unshielded	m	450	450	450	450
<b>PE/GND connection</b>			2 × hole for M12	2 × hole for M12	2 × hole for M12
• Conductor cross-section, max. (IEC)	mm <sup>2</sup>	2 × 95	2 × 95	2 × 240	2 × 240
<b>Dimensions</b>					
• Width	mm	265	265	265	265
• Height	mm	836	836	983	983
• Depth	mm	549	549	549	549
<b>Weight, approx.</b>		kg	77	108	108
<b>Frame size</b>			FL	GL	GL
<b>Minimum short-circuit current <sup>10)</sup></b>		A	3000	3600	4400

<sup>1)</sup> Rated output of a typical 6-pole standard induction motor based on  $I_L$  or  $I_H$  for 400 V 3 AC 50 Hz.

<sup>2)</sup> Rated output of a typical 6-pole standard induction motor based on  $I_L$  or  $I_H$  for 460 V 3 AC 60 Hz.

<sup>3)</sup> The base-load current  $I_L$  is based on a duty cycle of 110 % for 60 s or 150 % for 10 s with a duty cycle duration of 300 s.

<sup>4)</sup> The base-load current  $I_H$  is based on a duty cycle of 150 % for 60 s or 160 % for 10 s with a duty cycle duration of 300 s.

<sup>5)</sup> Information regarding the correlation between the pulse frequency and maximum output current/output frequency is provided in the SINAMICS Low Voltage Engineering Manual.

<sup>6)</sup> The specified power loss represents the maximum value at 100 % utilization. The value is lower under normal operating conditions. To ensure safe dissipation of the minor power loss released to the ambient air, it is important to follow the instructions pertaining to control cabinet installation in the SINAMICS Low Voltage Engineering Manual.

<sup>7)</sup> The value applies to coolants comprising water and a mixture of water and antifreeze agent.

<sup>8)</sup> The value is valid for water as coolant. Additional information and notes on other coolants are provided in the SINAMICS Low Voltage Engineering Manual.

<sup>9)</sup> Longer cable lengths for specific configurations are available on request. For additional information, please refer to the SINAMICS Low Voltage Engineering Manual.

<sup>10)</sup> Current required for reliably triggering protective devices.

# SINAMICS S120 Chassis Format Converter Units

## Liquid-cooled units

### Basic Line Modules

#### Overview



Basic Line Modules are used for applications where energy is not fed back into the line supply or where energy is exchanged in the DC link between axes operating in the motor and generator modes. The connected Motor Modules are pre-charged via the thyristor gate control. Basic Line Modules are designed for connection to grounded TN/TT and non-grounded IT supply systems.

Liquid-cooled Basic Line Modules are especially suitable for applications where installation space is restricted and environmental conditions are harsh. Liquid cooling ensures efficient heat dissipation.

#### Design

The liquid-cooled Basic Line Modules have the following interfaces as standard:

- 1 line supply connection
- 1 connection for the 24 V DC electronics power supply
- 1 DC link connection (DCP, DCN) for supplying the connected Motor Modules
- 3 DRIVE-CLiQ sockets
- 1 temperature sensor input for KTY84-130, Pt1000, PTC or Pt100 (Pt1000 can be used from firmware V4.7 HF17)
- 1 PE connection
- 2 coolant connections

The status of the Basic Line Modules is indicated via three LEDs.

The scope of supply of the Power Modules includes:

- 1 DRIVE-CLiQ cable for connection to the Control Unit
- 2 seals for coolant connections
- 1 set of warning labels in 30 languages (BG, CN, CZ, DE, DK, EE, ES, FI, FR, GB, GR, HU, IE, IS, IT, JP, KR, LT, LV, MT, NL, NO, PL, PT, RO, RU, SE, SI, SK, TR)

#### Selection and ordering data

Rated power at 400 V or 690 V kW	Rated DC link current A	Basic Line Module Article No.
<b>Line voltage 380 ... 480 V 3 AC</b>		
360	740	<b>6SL3335-1TE37-4AA3</b>
600	1220	<b>6SL3335-1TE41-2AA3</b>
830	1730	<b>6SL3335-1TE41-7AA3</b>
<b>Line voltage 500 ... 690 V 3 AC</b>		
355	420	<b>6SL3335-1TG34-2AA3</b>
630	730	<b>6SL3335-1TG37-3AA3</b>
1100	1300	<b>6SL3335-1TG41-3AA3</b>
1370	1650	<b>6SL3335-1TG41-7AA3</b>
Description		Article No.
<i>Accessories</i>		
<b>3-way valve <sup>1)</sup></b>		<b>VXF41.../VXG41...</b>
<b>Actuator for 3-way valve <sup>1)</sup></b>		
• 230 V 1 AC		<b>SAX31...</b>
• 24 V AC/DC		<b>SAX61.../SAX81...</b>
<i>Accessories for re-ordering</i>		
<b>Dust protection blanking plugs</b> (50 units)		<b>6SL3066-4CA00-0AA0</b>
For DRIVE-CLiQ port		

For line-side components, see System components.

<sup>1)</sup> Recommended components for installing a flow control as condensation protection; manufactured by Siemens Building Technologies.



## SINAMICS S120 Chassis Format Converter Units

Liquid-cooled units

### Basic Line Modules

#### Integration

The liquid-cooled Basic Line Modules communicate with the higher-level control module via DRIVE-CLiQ. The control module in this case can be a CU320-2 or a SIMOTION D Control Unit. An external 24 V DC power supply is required to operate liquid-cooled Basic Line Modules.

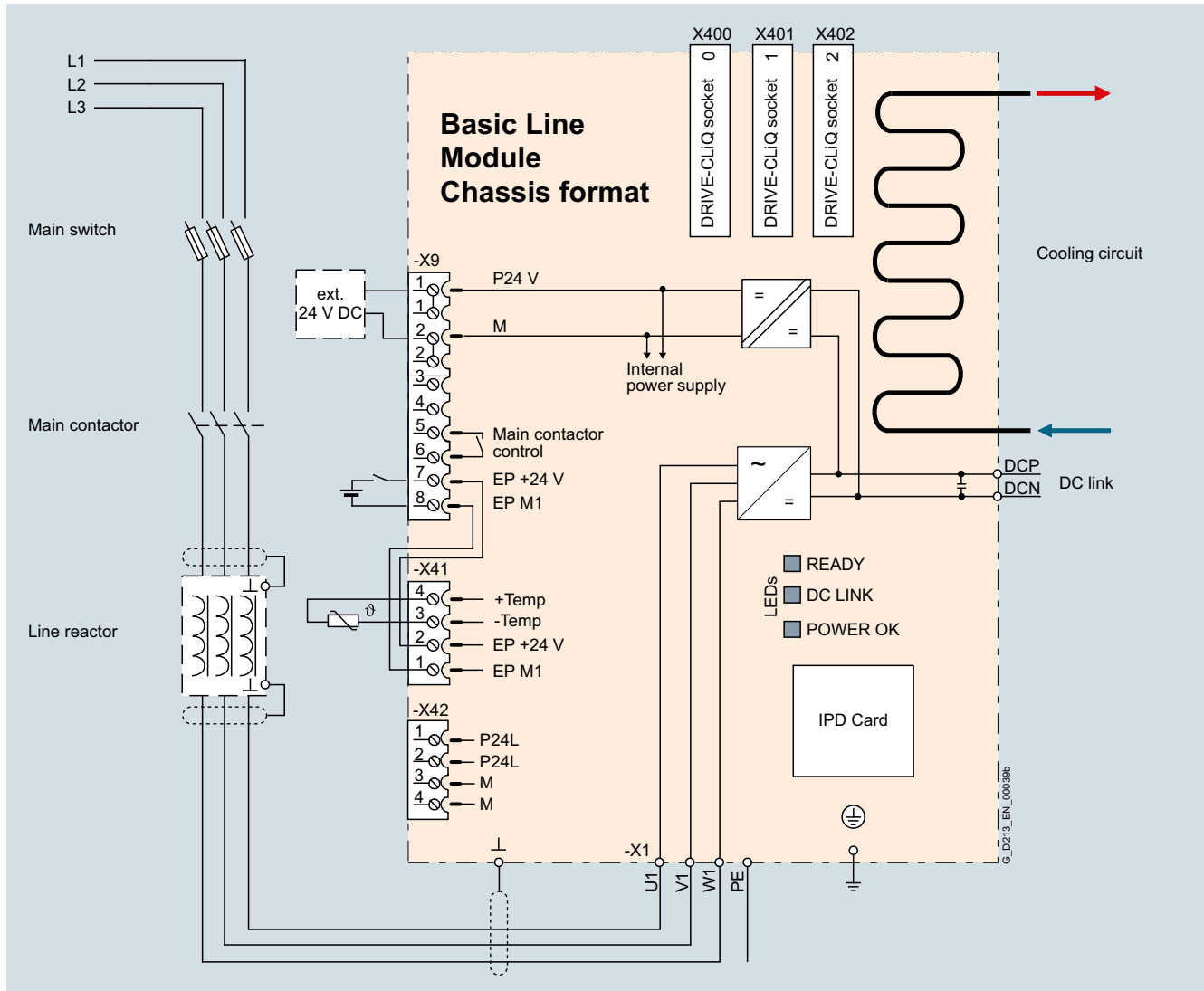

Connection example of a Basic Line Module

#### Technical specifications

##### General technical specifications

##### Electrical specifications

##### Line power factor at rated power

- Basic fundamental ( $\cos \varphi_1$ ) >0.96
- Total ( $\lambda$ ) 0.75 ... 0.93

**Efficiency** >99 %

**DC link voltage, approx. <sup>1)</sup>**  $1.35 \times$  line voltage

##### Main contactor control

Terminal block -X9/5-6  
240 V AC, max. 8 A  
30 V DC, max. 1 A

<sup>1)</sup> The DC link voltage is unregulated and load-dependent.  
For additional information, please refer to the SINAMICS Low Voltage Engineering Manual.

# SINAMICS S120 Chassis Format Converter Units

## Liquid-cooled units

### Basic Line Modules

#### Technical specifications (continued)

Line voltage 380 ... 480 V 3 AC		Basic Line Modules		
		6SL3335-1TE37-4AA3	6SL3335-1TE41-2AA3	6SL3335-1TE41-7AA3
<b>Rated power</b>				
• At $I_{rated\ DC}$ (50 Hz 400 V)	kW	<b>360</b>	<b>600</b>	<b>830</b>
• At $I_H$ (50 Hz 400 V)	kW	280	450	650
• At $I_{rated\ DC}$ (60 Hz 460 V)	hp	555	925	1280
• At $I_H$ (60 Hz 460 V)	hp	430	690	1000
<b>DC link current</b>				
• Rated current $I_{rated\ DC}$	A	740	1220	1730
• Base-load current $I_{H\ DC}^{1)}$	A	578	936	1350
• Maximum current $I_{max\ DC}$	A	1110	1830	2595
<b>Input current</b>				
• Rated current $I_{rated\ I}$	A	610	1000	1420
• Maximum current $I_{max\ I}$	A	915	1500	2130
<b>Current demand</b>				
• 24 V DC auxiliary power supply	A	0.7	0.7	0.7
<b>DC link capacitance</b>				
• Basic Line Module	μF	12000	20300	26100
• Drive line-up, max.	μF	96000	162400	208800
<b>Power loss, at 50 Hz 400 V <sup>2)</sup></b>				
• Dissipated to coolant	kW	2.7	4.36	5.82
• Dissipated to ambient air	kW	0.25	0.41	0.57
• Total	kW	2.95	4.77	6.39
<b>Coolant volume flow <sup>3)</sup></b>	l/min	9	9	12
<b>Liquid volume of the integrated heat exchanger</b>	dm <sup>3</sup>	0.45	0.45	0.79
<b>Pressure drop, typ. <sup>4)</sup> for volume flow</b>	Pa	70000	70000	70000
<b>Heat exchanger material</b>		Aluminum	Aluminum	Aluminum
<b>Coolant connections Intake/return</b>		Pipe thread ISO 228 G 3/4 B (external thread 3/4", flat-sealing)		
<b>Sound pressure level <math>L_{pA}</math> (1 m) at 50/60 Hz</b>	dB	54	56	56
<b>Line supply connection U1, V1, W1</b>		2 × M12 nut	2 × M12 nut	2 × M12 nut
• Conductor cross-section, max. (IEC)	mm <sup>2</sup>	4 × 240	4 × 240	4 × 240
<b>DC link connection DCP, DCN</b>		2 × M12 nut Busbar	2 × M12 nut Busbar	2 × M12 nut Busbar
<b>PE/GND connection</b>		2 × M12 nut	2 × M12 nut	2 × M12 nut
• Conductor cross-section, max. (IEC)	mm <sup>2</sup>	4 × 240	4 × 240	4 × 240
<b>Cable length, max. <sup>5)</sup></b>				
• Shielded	m	2600	4000	4800
• Unshielded	m	3900	6000	7200
<b>Dimensions</b>				
• Width	mm	160	160	160
• Height	mm	1137	1137	1562
• Depth	mm	545	545	545
<b>Weight, approx.</b>	kg	108	108	185
<b>Frame size</b>		FBL	FBL	GBL
<b>Minimum short-circuit current <sup>6)</sup></b>	A	8800	12400	20000

<sup>1)</sup> The base-load current  $I_{H\ DC}$  is the basis for a duty cycle of 150 % for 60 s or  $I_{max\ DC}$  for 5 s with a duty cycle duration of 300 s.

<sup>2)</sup> The specified power loss represents the maximum value at 100 % utilization. The value is lower under normal operating conditions. To ensure safe dissipation of the minor power loss released to the ambient air, it is important to follow the instructions pertaining to control cabinet installation in the SINAMICS Low Voltage Engineering Manual.

<sup>3)</sup> The value applies to coolants comprising water and a mixture of water and antifreeze agent.

<sup>4)</sup> The value is valid for water as coolant. [Additional information and notes on other coolants are provided in the SINAMICS Low Voltage Engineering Manual.](#)

<sup>5)</sup> Total of all motor cables and DC link. Longer cable lengths for specific configurations are available on request. [For additional information, please refer to the SINAMICS Low Voltage Engineering Manual.](#)

<sup>6)</sup> Current required for reliably triggering protective devices.

# SINAMICS S120 Chassis Format Converter Units

## Liquid-cooled units

### Basic Line Modules

#### Technical specifications (continued)

Line voltage 500 ... 690 V 3 AC		Basic Line Modules			
		6SL3335-1TG34-2AA3	6SL3335-1TG37-3AA3	6SL3335-1TG41-3AA3	6SL3335-1TG41-7AA3
<b>Rated power</b>					
• At $I_{rated\ DC}$ (50 Hz 690 V)	kW	<b>355</b>	<b>630</b>	<b>1100</b>	<b>1370</b>
• At $I_H$ (50 Hz 690 V)	kW	275	475	840	1070
• At $I_{rated\ DC}$ (50 Hz 500 V)	kW	245	420	750	950
• At $I_H$ (50 Hz 500 V)	kW	200	345	610	775
• At $I_{rated\ DC}$ (60 Hz 575 V)	hp	395	705	1230	1530
• At $I_H$ (60 Hz 575 V)	hp	305	530	940	1195
<b>DC link current</b>					
• Rated current $I_{rated\ DC}$	A	420	730	1300	1650
• Base-load current $I_{H\ DC}^{1)}$	A	328	570	1014	1287
• Maximum current $I_{max\ DC}$	A	630	1095	1950	2475
<b>Input current</b>					
• Rated current $I_{rated\ I}$	A	340	600	1070	1350
• Maximum current $I_{max\ I}$	A	510	900	1605	2025
<b>Current demand</b>					
• 24 V DC auxiliary power supply	A	0.7	0.7	0.7	0.7
<b>DC link capacitance</b>					
• Basic Line Module	$\mu F$	4800	7700	15500	19300
• Drive line-up, max.	$\mu F$	38400	61600	124000	154400
<b>Power loss, at 50 Hz 690 V <sup>2)</sup></b>					
• Dissipated to coolant	kW	1.55	2.71	4.66	5.7
• Dissipated to ambient air	kW	0.21	0.38	0.43	0.55
• Total	kW	1.76	3.09	5.09	6.25
<b>Coolant volume flow <sup>3)</sup></b>		l/min	9	12	12
<b>Liquid volume</b> of the integrated heat exchanger		dm <sup>3</sup>	0.45	0.79	0.79
<b>Pressure drop, typ. <sup>4)</sup></b> for volume flow		Pa	70000	70000	70000
<b>Heat exchanger material</b>			Aluminum	Aluminum	Aluminum
<b>Coolant connections</b> Intake/return			Pipe thread ISO 228 G 3/4 B (external thread 3/4", flat-sealing)		
<b>Sound pressure level <math>L_{pA}</math></b> (1 m) at 50/60 Hz		dB	54	54	56
<b>Line supply connection</b> U1, V1, W1			2 × M12 nut	2 × M12 nut	2 × M12 nut
• Conductor cross-section, max. (IEC)	mm <sup>2</sup>	4 × 240	4 × 240	4 × 240	4 × 240
<b>DC link connection</b> DCP, DCN			2 × M12 nut Busbar	2 × M12 nut Busbar	2 × M12 nut Busbar
<b>PE/GND connection</b>			2 × M12 nut	2 × M12 nut	2 × M12 nut
• Conductor cross-section, max. (IEC)	mm <sup>2</sup>	4 × 240	4 × 240	4 × 240	4 × 240
<b>Cable length, max. <sup>5)</sup></b>					
• Shielded	m	1500	1500	2250	2250
• Unshielded	m	2250	2250	3375	3375
<b>Dimensions</b>					
• Width	mm	160	160	160	160
• Height	mm	1137	1137	1562	1562
• Depth	mm	545	545	545	545
<b>Weight, approx.</b>		kg	108	108	185
<b>Frame size</b>			FBL	FBL	GBL
<b>Minimum short-circuit current <sup>6)</sup></b>		A	4400	7200	16800

<sup>1)</sup> The base-load current  $I_{H\ DC}$  is the basis for a duty cycle of 150 % for 60 s or  $I_{max\ DC}$  for 5 s with a duty cycle duration of 300 s.

<sup>2)</sup> The specified power loss represents the maximum value at 100 % utilization. The value is lower under normal operating conditions. To ensure safe dissipation of the minor power loss released to the ambient air, it is important to follow the instructions pertaining to control cabinet installation in the SINAMICS Low Voltage Engineering Manual.

<sup>3)</sup> The value applies to coolants comprising water and a mixture of water and antifreeze agent.

<sup>4)</sup> The value is valid for water as coolant. [Additional information and notes on other coolants are provided in the SINAMICS Low Voltage Engineering Manual.](#)

<sup>5)</sup> Total of all motor cables and DC link. Longer cable lengths for specific configurations are available on request. [For additional information, please refer to the SINAMICS Low Voltage Engineering Manual.](#)

<sup>6)</sup> Current required for reliably triggering protective devices.

# SINAMICS S120 Chassis Format Converter Units

## Liquid-cooled units

### Active Line Modules

#### Overview



The self-commutated infeed/regenerative feedback units (with IGBTs in infeed and regenerative feedback directions) generate a regulated DC link voltage. This means that the connected Motor Modules are decoupled from the line voltage. Line voltage fluctuations within the permissible supply tolerances have no effect on the motor voltage.

If required, the Active Line Modules can also provide reactive power compensation.

Active Line Modules are designed for connection to grounded TN/TT and non-grounded IT supply systems.

Liquid-cooled Active Line Modules are especially suitable for applications where installation space is restricted and environmental conditions are harsh. Liquid cooling ensures efficient heat dissipation.

Active Line Modules are always operated together with the associated Active Interface Modules. These include the necessary pre-charging circuit as well as a Clean Power Filter.

#### Design

The liquid-cooled Active Line Modules have the following interfaces as standard:

- 1 line supply connection
- 1 connection for the 24 V DC electronics power supply
- 1 DC link connection (DCP, DCN) for supplying the connected Motor Modules
- 3 DRIVE-CLiQ sockets
- 1 temperature sensor input for KTY84-130, Pt1000, PTC or Pt100 (Pt1000 can be used from firmware V4.7 HF17)
- 1 PE connection
- 2 coolant connections

The status of the Active Line Modules is indicated via three LEDs.

The following are included in the scope of supply of the Active Line Modules:

- 1 DRIVE-CLiQ cable for connection to the Control Unit
- 2 seals for coolant connections
- 1 set of warning labels in 30 languages (BG, CN, CZ, DE, DK, EE, ES, FI, FR, GB, GR, HU, IE, IS, IT, JP, KR, LT, LV, MT, NL, NO, PL, PT, RO, RU, SE, SI, SK, TR)

#### Selection and ordering data

Rated power at 400 V or 690 V kW	Rated infeed/ regenerative feedback current A	Active Line Module Article No.
<b>Line voltage 380 ... 480 V 3 AC</b>		
300	490	<b>6SL3335-7TE35-0AA3</b>
380	605	<b>6SL3335-7TE36-1AA3</b>
500	840	<b>6SL3335-7TE38-4AA3</b>
630	985	<b>6SL3335-7TE41-0AA3</b>
900	1405	<b>6SL3335-7TE41-4AA3</b>
<b>Line voltage 500 ... 690 V 3 AC</b>		
630	575	<b>6SL3335-7TG35-8AA3</b>
800	735	<b>6SL3335-7TG37-4AA3</b>
900	810	<b>6SL3335-7TG38-1AA3</b>
1100	1020	<b>6SL3335-7TG41-0AA3</b>
1400	1270	<b>6SL3335-7TG41-3AA3</b>
1700	1560	<b>6SL3335-7TG41-6AA3</b>
Description		Article No.
<b>Accessories</b>		
<b>3-way valve <sup>1)</sup></b>		<b>VXF41.../VXG41...</b>
<b>Actuator for 3-way valve <sup>1)</sup></b>		
• 230 V 1 AC		<b>SAX31...</b>
• 24 V AC/DC		<b>SAX61.../SAX81</b>
<b>Accessories for re-ordering</b>		
<b>Dust protection blanking plugs</b> (50 units) For DRIVE-CLiQ port		<b>6SL3066-4CA00-0AA0</b>

For line-side components and recommended system components, see system components.

<sup>1)</sup> Recommended components for installing a flow control as condensation protection; manufactured by Siemens Building Technologies.

## SINAMICS S120 Chassis Format Converter Units

### Liquid-cooled units

#### Active Line Modules

#### Integration

Active Line Modules are always operated together with the associated Active Interface Modules. Active Interface Modules contain a Clean Power Filter with basic RI suppression, the pre-charging circuit for the Active Line Module, line supply voltage sensing circuit and monitoring sensors.

The liquid-cooled Active Line Modules communicate with the higher-level control module via DRIVE-CLiQ. The control module in this case can be a CU320-2 or a SIMOTION D Control Unit. An external 24 V DC power supply is required to operate the Active Line Modules.

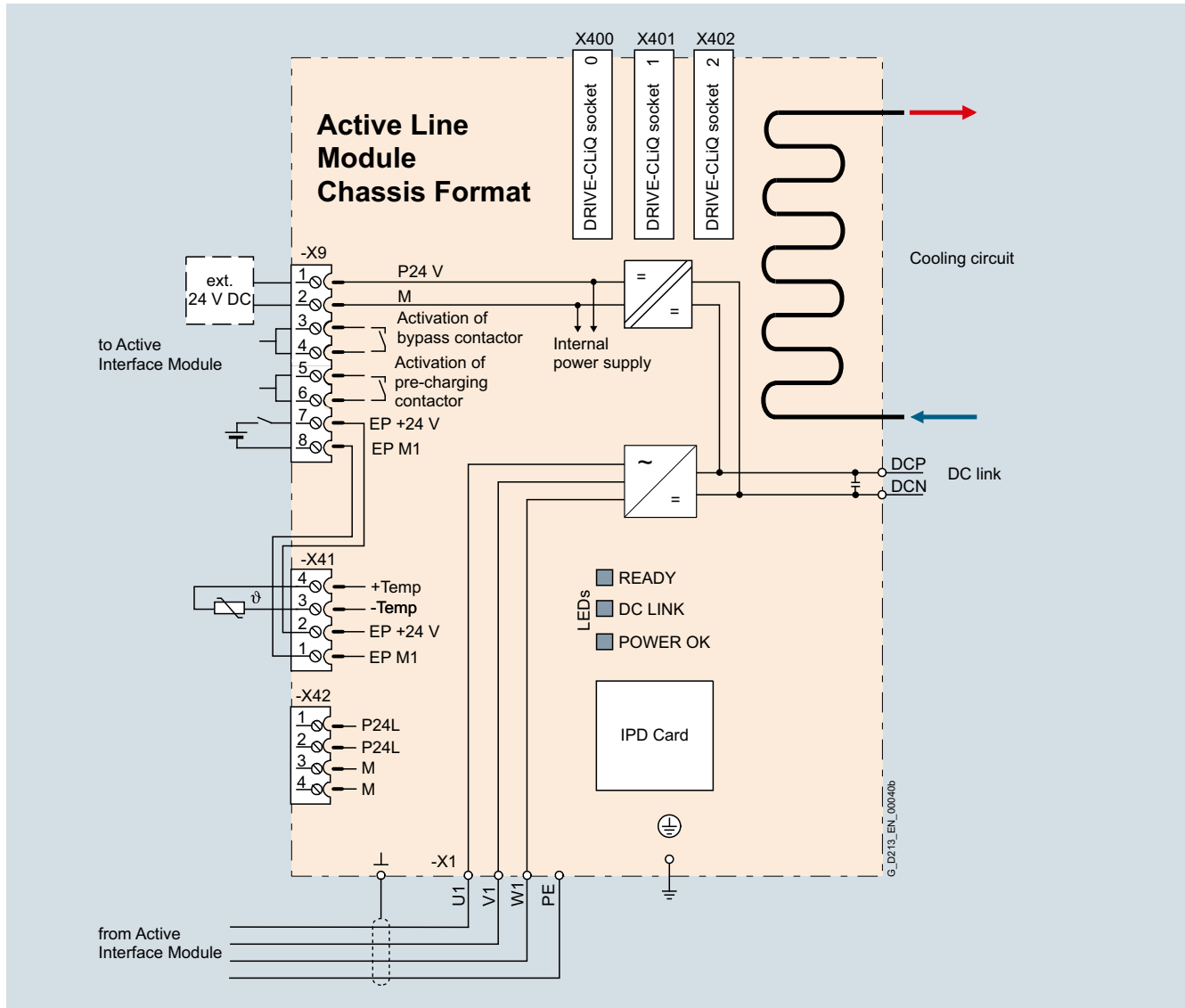

Connection example of an Active Line Module

#### Technical specifications

##### General technical specifications

##### Electrical specifications

##### Line power factor

- Basic fundamental ( $\cos \varphi_1$ ) 1 (factory setting), can be altered by inputting a reactive current setpoint
- Total ( $\lambda$ ) 1 (factory setting)

##### Efficiency

>98.5 % (Active Line Modules)  
>99 % (Active Interface Module)

##### DC link voltage, approx.

The DC link voltage is regulated and can be adjusted as a voltage decoupled from the line voltage. Factory setting of the DC link voltage:  $1.5 \times$  line voltage

# SINAMICS S120 Chassis Format Converter Units

## Liquid-cooled units

### Active Line Modules

#### Technical specifications (continued)

Line voltage 380 V ... 480 V 3 AC		Active Line Modules				
		6SL3335-7TE35-0AA3	6SL3335-7TE36-1AA3	6SL3335-7TE38-4AA3	6SL3335-7TE41-0AA3	6SL3335-7TE41-4AA3
<b>Rated power</b>						
• At $I_{\text{rated DC}}$ (50 Hz 400 V)	kW	300	380	500	630	900
• At $I_{\text{H DC}}$ (50 Hz 400 V)	kW	270	335	465	545	780
• At $I_{\text{rated DC}}$ (60 Hz 460 V)	hp	500	600	700	900	1250
• At $I_{\text{H DC}}$ (60 Hz 460 V)	hp	400	500	700	800	1000
<b>DC link current</b>						
• Rated current $I_{\text{rated DC}}$	A	549	677	941	1100	1573
• Base-load current $I_{\text{H DC}}^{1)}$	A	489	603	837	982	1401
• Maximum current $I_{\text{max DC}}$	A	823	1017	1410	1654	2361
<b>Infeed/regenerative feedback current</b>						
• Rated current $I_{\text{rated I}}$	A	490	605	840	985	1405
• Maximum current $I_{\text{max I}}$	A	735	907	1260	1477	2055
<b>Current demand</b>						
• 24 V DC auxiliary power supply	A	1.5	1.6	1.6	1.6	1.6
<b>DC link capacitance</b>						
• Active Line Module	μF	9600	12600	17400	18900	28800
• Drive line-up, max.	μF	76800	134400	134400	230400	230400
<b>Pulse frequency</b>	kHz	4	2.5	2.5	2.5	2.5
<b>Power loss, at 50 Hz 400 V<sup>2)</sup></b>						
• Dissipated to coolant	kW	3.42	4.65	5.52	7.46	9.58
• Dissipated to ambient air	kW	0.14	0.17	0.23	0.44	0.62
• Total	kW	3.56	4.82	5.75	7.9	10.2
<b>Coolant volume flow<sup>3)</sup></b>	l/min	12	16	16	27	27
<b>Liquid volume of the integrated heat exchanger</b>	dm <sup>3</sup>	0.91	0.74	0.74	1.56	1.56
<b>Pressure drop, typ.<sup>4)</sup> for volume flow</b>	Pa	70000	70000	70000	70000	70000
<b>Heat exchanger material</b>		Stainless steel	Aluminum	Aluminum	Aluminum	Aluminum
<b>Coolant connections Intake/return</b>		Pipe thread ISO 228 G 3/4 B (external thread 3/4", flat-sealing)				
<b>Sound pressure level <math>L_{\text{pA}}^{5)}</math> (1 m) at 50/60 Hz</b>	dB	69/73	70/73	70/73	71/73	71/73
<b>Line supply connection U1, V1, W1</b>		Hole for M12	2 x hole for M12	2 x hole for M12	2 x hole for M12	2 x hole for M12
• Conductor cross-section, max. (IEC)	mm <sup>2</sup>	2 x 240	4 x 185	4 x 185	Busbar	Busbar
<b>DC link connection DCP, DCN</b>		2 x hole for M12 Busbar	2 x hole for M12 Busbar	2 x hole for M12 Busbar	2 x hole for M12 Busbar	2 x hole for M12 Busbar
<b>PE/GND connection</b>		2 x hole for M12	2 x hole for M12	2 x hole for M12	2 x hole for M12	2 x hole for M12
• Conductor cross-section, max. (IEC)	mm <sup>2</sup>	2 x 240	4 x 185	4 x 185	4 x 240	4 x 240
<b>Cable length, max.<sup>6)</sup></b>						
• Shielded	m	2700	3900	3900	3900	3900
• Unshielded	m	4050	5850	5850	5850	5850
<b>Dimensions</b>						
• Width	mm	150	265	265	295	295
• Height	mm	1172	1002	1002	1516	1516
• Depth	mm	545	545	545	545	545
<b>Weight, approx.</b>	kg	80	110	110	220	220
<b>Frame size</b>		GXL	HXL	HXL	JXL	JXL
<b>Minimum short-circuit current<sup>7)</sup></b>	A	8000	9200	10400	16000	21000

1) The base-load current  $I_{\text{H DC}}$  is the basis for a duty cycle of 150 % for 60 s or  $I_{\text{max DC}}$  for 5 s with a duty cycle duration of 300 s.

2) The specified power loss represents the maximum value at 100 % utilization. The value is lower under normal operating conditions. To ensure safe dissipation of the minor power loss released to the ambient air, it is important to follow the instructions pertaining to control cabinet installation in the SINAMICS Low Voltage Engineering Manual.

3) The value applies to coolants comprising water and a mixture of water and antifreeze agent.

4) The value is valid for water as coolant. [Additional information and notes on other coolants are provided in the SINAMICS Low Voltage Engineering Manual.](#)

5) Total sound pressure level of Active Interface Module and Active Line Module.

6) Total of all motor cables and DC link. Longer cable lengths for specific configurations are available on request. [For additional information, please refer to the SINAMICS Low Voltage Engineering Manual.](#)

7) Current required for reliably triggering protective devices.

# SINAMICS S120 Chassis Format Converter Units

## Liquid-cooled units

### Active Line Modules

#### Technical specifications (continued)

Line voltage 500 ... 690 V 3 AC		Active Line Modules					
		6SL3335-7TG35-8AA3	6SL3335-7TG37-4AA3	6SL3335-7TG38-1AA3	6SL3335-7TG41-0AA3	6SL3335-7TG41-3AA3	6SL3335-7TG41-6AA3
<b>Rated power</b>							
• At $I_{\text{rated DC}}$ (50 Hz 690 V)	kW	<b>630</b>	<b>800</b>	<b>900</b>	<b>1100</b>	<b>1400</b>	<b>1700</b>
• At $I_{\text{H DC}}$ (50 Hz 690 V)	kW	620	705	670	1000	1215	1490
• At $I_{\text{rated DC}}$ (50 Hz 500 V)	kW	447	560	620	780	965	1180
• At $I_{\text{H DC}}$ (50 Hz 500 V)	kW	450	510	485	710	880	1080
• At $I_{\text{rated DC}}$ (60 Hz 575 V)	hp	675	900	975	1250	1500	1880
• At $I_{\text{H DC}}$ (60 Hz 575 V)	hp	506	600	765	1000	1250	1530
<b>DC link current</b>							
• Rated current $I_{\text{rated DC}}$	A	644	823	907	1147	1422	1740
• Base-load current $I_{\text{H DC}}^{1)}$	A	573	732	808	936	1266	1550
• Maximum current $I_{\text{max DC}}$	A	966	1235	1360	1722	2133	2620
<b>Infeed/regenerative feedback current</b>							
• Rated current $I_{\text{rated I}}$	A	575	735	810	1025	1270	1560
• Maximum current $I_{\text{max I}}$	A	862	1100	1214	1537	1905	2055
<b>Current demand</b>							
• 24 V DC auxiliary power supply	A	1.6	1.6	1.6	1.6	1.46	1.5
<b>DC link capacitance</b>							
• Active Line Module	$\mu\text{F}$	9670	10500	10500	16000	19330	21000
• Drive line-up, max.	$\mu\text{F}$	59200	153600	153600	153600	153600	210000
<b>Pulse frequency</b>							
	kHz	2.5	2.5	2.5	2.5	2.5	2.5
<b>Power loss, at 50 Hz 690 V <sup>2)</sup></b>							
• Dissipated to coolant	kW	5.45	7.45	8.28	10.37	12.98	17.17
• Dissipated to ambient air	kW	0.16	0.2	0.22	0.53	0.57	0.79
• Total	kW	5.61	7.65	8.5	10.9	13.55	17.96
<b>Coolant volume flow <sup>3)</sup></b>							
	l/min	16	16	16	27	27	27
<b>Liquid volume of the integrated heat exchanger</b>							
	dm <sup>3</sup>	0.74	0.74	0.74	1.56	1.56	1.56
<b>Pressure drop, typ. <sup>4)</sup> for volume flow</b>							
	Pa	70000	70000	70000	70000	70000	70000
<b>Heat exchanger material</b>							
		Aluminum	Aluminum	Aluminum	Aluminum	Aluminum	Aluminum
<b>Coolant connections Intake/return</b>							
		Pipe thread ISO 228 G 3/4 B (external thread 3/4", flat-sealing)					
<b>Sound pressure level <math>L_{\text{pA}}^{5)}</math> (1 m) at 50/60 Hz</b>							
	dB	70/73	71/73	71/73	71/73	71/73	71/73
<b>Line supply connection U1, V1, W1</b>							
• Conductor cross-section, max. (IEC)	mm <sup>2</sup>	2 × hole for M12	2 × hole for M12	2 × hole for M12	2 × hole for M12	2 × hole for M12	2 × hole for M12
		4 × 185	4 × 185	4 × 185	Busbar	Busbar	Busbar
<b>DC link connection DCP, DCN</b>							
		2 × hole for M12	2 × hole for M12	2 × hole for M12	2 × hole for M12	2 × hole for M12	2 × hole for M12
		Busbar	Busbar	Busbar	Busbar	Busbar	Busbar
<b>PE/GND connection</b>							
• Conductor cross-section, max. (IEC)	mm <sup>2</sup>	2 × hole for M12	2 × hole for M12	2 × hole for M12	2 × hole for M12	2 × hole for M12	2 × hole for M12
		4 × 185	4 × 185	4 × 185	Busbar	Busbar	Busbar
<b>Cable length, max. <sup>6)</sup></b>							
• Shielded	m	2250	2250	2250	2250	2250	2250
• Unshielded	m	3375	3375	3375	3375	3375	3375
<b>Dimensions</b>							
• Width	mm	265	265	265	295	295	295
• Height	mm	1002	1002	1002	1516	1516	1516
• Depth	mm	545	545	545	545	545	545
<b>Weight, approx.</b>							
	kg	110	110	110	220	220	230
<b>Frame size</b>							
		HXL	HXL	HXL	JXL	JXL	JXL
<b>Minimum short-circuit current <sup>7)</sup></b>							
	A	8400	10500	12600	16000	20000	24000

<sup>1)</sup> The base-load current  $I_{\text{H DC}}$  is the basis for a duty cycle of 150 % for 60 s or  $I_{\text{max DC}}$  for 5 s with a duty cycle duration of 300 s.

<sup>2)</sup> The specified power loss represents the maximum value at 100 % utilization. The value is lower under normal operating conditions. To ensure safe dissipation of the minor power loss released to the ambient air, it is important to follow the instructions pertaining to control cabinet installation in the SINAMICS Low Voltage Engineering Manual.

<sup>3)</sup> The value applies to coolants comprising water and a mixture of water and antifreeze agent.

<sup>4)</sup> The value is valid for water as coolant. [Additional information and notes on other coolants are provided in the SINAMICS Low Voltage Engineering Manual.](#)

<sup>5)</sup> Total sound pressure level of Active Interface Module and Active Line Module.

<sup>6)</sup> Total of all motor cables and DC link. Longer cable lengths for specific configurations are available on request. [For additional information, please refer to the SINAMICS Low Voltage Engineering Manual.](#)

<sup>7)</sup> Current required for reliably triggering protective devices.



# SINAMICS S120 Chassis Format Converter Units

## Liquid-cooled units

### Active Interface Modules

#### Overview

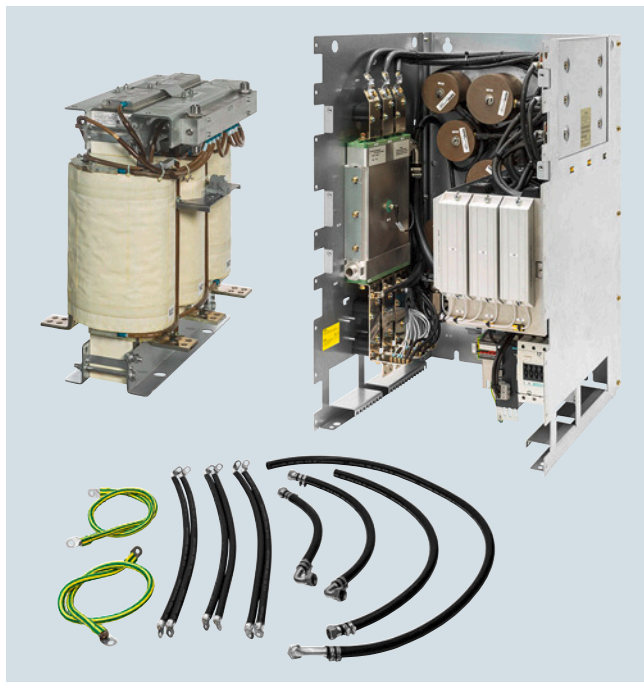

The Active Interface Module essentially comprises a liquid-cooled filter reactor and a liquid-cooled filter module. The filter module contains a Clean Power Filter with basic RI suppression, the pre-charging circuit for the Active Line Module, the line voltage sensing circuit and monitoring sensors.

A bypass contactor is provided separately. Active Interface Modules are used in conjunction with Active Line Modules.

Liquid-cooled Active Interface Modules cannot be supplied for all liquid-cooled Active Line Modules. Where they are not available, air-cooled Active Interface Modules can be ordered instead.

#### Design

Active Interface Modules have the following interfaces as standard:

- 1 line supply connection
- 1 load connection
- 1 connection for the 24 V DC electronics power supply
- 1 connection for the external 230 V AC supply
- 1 DRIVE-CLiQ socket (on VSM10 Voltage Sensing Module)
- 1 connection for pre-charging circuit
- 1 PE connection
- 2 coolant connections

The scope of supply of the Active Interface Modules includes:

- Liquid-cooled filter reactor
- Liquid-cooled filter module
- Connection kit (cables and hoses)
- DRIVE-CLiQ cable for the connection between Active Interface Module and Active Line Module
- 2 seals for coolant connections
- 1 set of warning labels in 30 languages (BG, CN, CZ, DE, DK, EE, ES, FI, FR, GB, GR, HU, IE, IS, IT, JP, KR, LT, LV, MT, NL, NO, PL, PT, RO, RU, SE, SI, SK, TR)

3

#### Selection and ordering data

Suitable for Active Line Module chassis format, liquid-cooled	Rated power of the Active Line Modules at 400 V or 690 V kW	Active Interface Module, liquid-cooled Article No.	Active Interface Module, air-cooled Article No.
<b>Line voltage 380 ... 480 V 3 AC</b>			
6SL3335-7TE35-0AA3	300	– <sup>1)</sup>	<b>6SL3300-7TE35-0AA1</b>
6SL3335-7TE36-1AA3	380	<b>6SL3305-7TE38-4AA5</b>	–
6SL3335-7TE38-4AA3	500	<b>6SL3305-7TE38-4AA5</b>	–
6SL3335-7TE41-0AA3	630	<b>6SL3305-7TE41-4AA5</b>	–
6SL3335-7TE41-4AA3	900	<b>6SL3305-7TE41-4AA5</b>	–
<b>Line voltage 500 ... 690 V 3 AC</b>			
6SL3335-7TG35-8AA3	630	– <sup>1)</sup>	<b>6SL3300-7TG35-8AA1</b>
6SL3335-7TG37-4AA3	800	<b>6SL3305-7TG37-4AA5</b>	–
6SL3335-7TG38-1AA3	900	<b>6SL3305-7TG41-0AA5</b>	–
6SL3335-7TG41-0AA3	1100	<b>6SL3305-7TG41-0AA5</b>	–
6SL3335-7TG41-3AA3	1400	<b>6SL3305-7TG41-3AA5</b>	–
6SL3335-7TG41-6AA3	1700	<b>6SL3305-7TG41-6AA5</b>	–

<sup>1)</sup> For these power ratings, no liquid-cooled Active Interface Modules are available. Air-cooled devices can be alternatively used. See the right-hand column and additional information in section Air-cooled Active Interface Modules from page 3/30.



# SINAMICS S120 Chassis Format Converter Units

Liquid-cooled units

## Active Interface Modules

### Integration

3

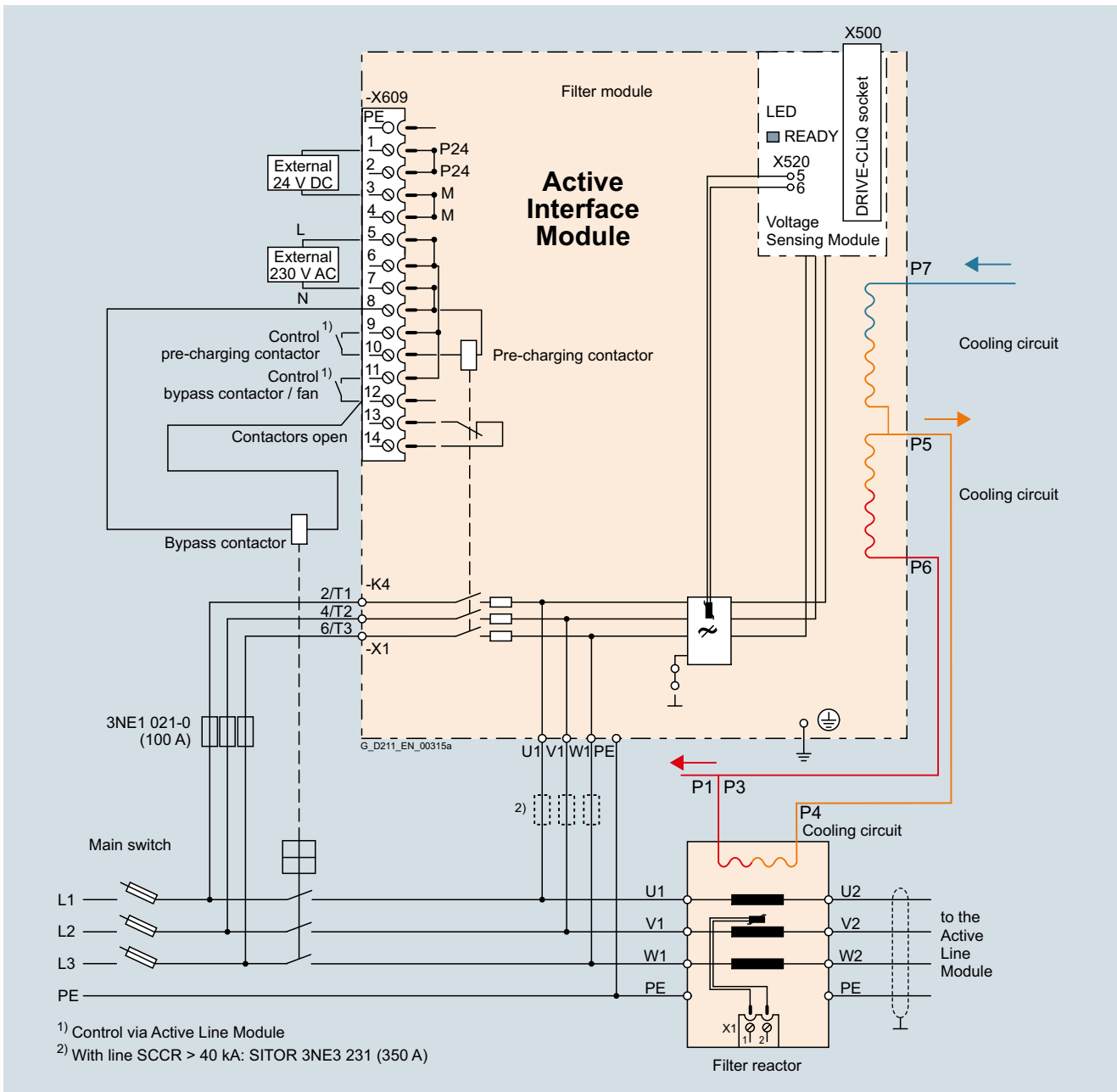

Connection example of liquid-cooled Active Interface Module with external bypass contactor, valid for article numbers 6SL3305-7TE41-4AA5 and 6SL3305-7TG41-6AA5

# SINAMICS S120 Chassis Format Converter Units

Liquid-cooled units

## Active Interface Modules

### Integration (continued)

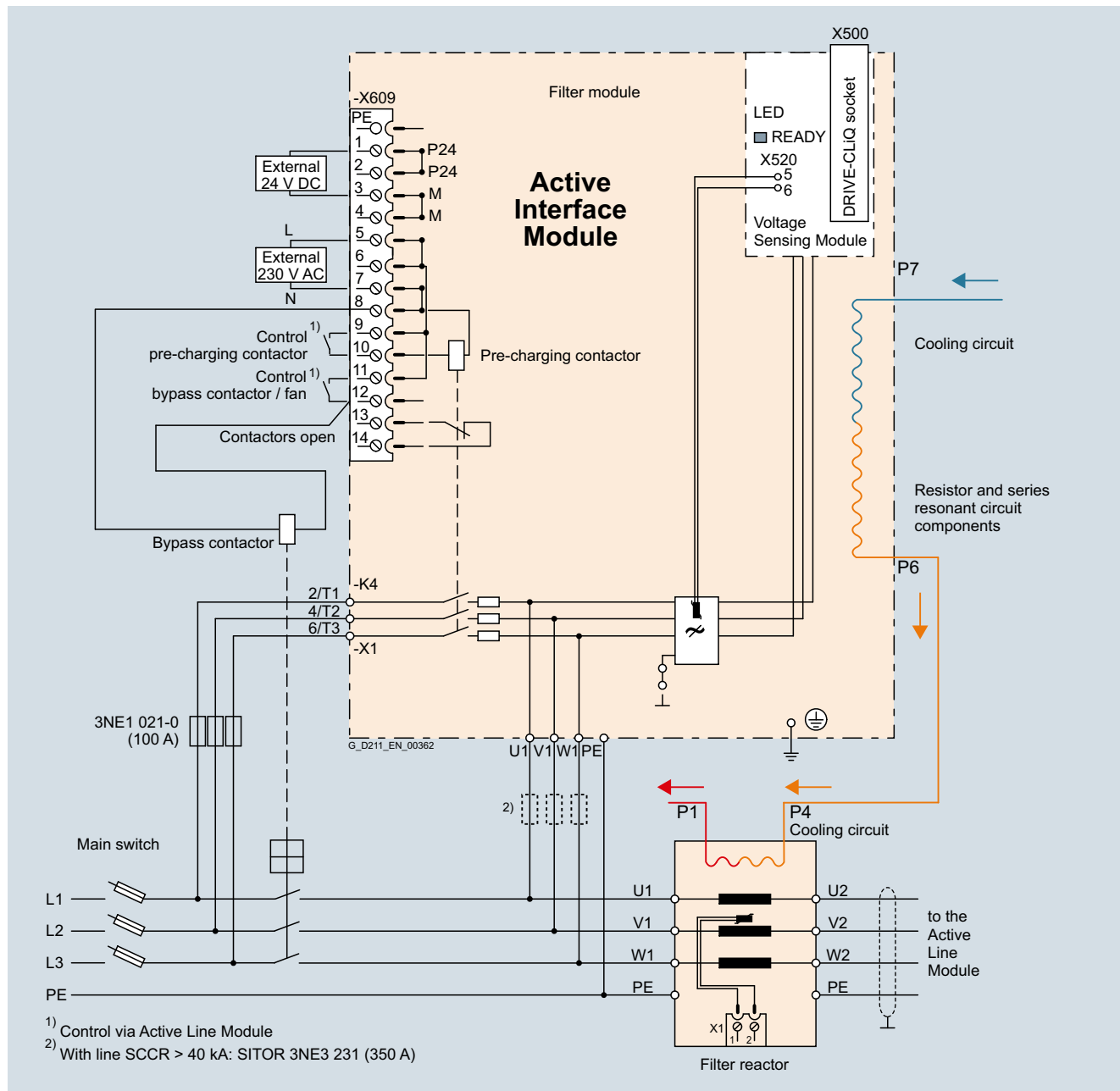

Connection example of liquid-cooled Active Interface Module with external bypass contactor, valid for article numbers 6SL3305-7TE38-4AA5, 6SL3305-7TG37-4AA5, 6SL3305-7TG41-0AA5, and 6SL3305-7TG41-3AA5

# SINAMICS S120 Chassis Format Converter Units

## Liquid-cooled units

### Active Interface Modules

#### Technical specifications

Line voltage 380 ... 480 V 3 AC		Active Interface Module			
		6SL3305-7TE38-4AA5		6SL3305-7TE41-4AA5	
<b>Suitable for Active Line Module</b>					
• Rated power at 400 V - Liquid-cooled	kW	<b>380</b> 6SL3335-7TE36-1AA3	<b>500</b> 6SL3335-7TE38-4AA3	<b>630</b> 6SL3335-7TE41-0AA3	<b>900</b> 6SL3335-7TE41-4AA3
<b>Rated current</b>	A	605	840	985	1405
<b>Bypass contactor <sup>1)</sup></b>		3RT1476-6AP36	3WL1110-2BB34-4AN2-Z C22 <sup>2)</sup>	3WL1112-2BB34-4AN2-Z C22 <sup>2)</sup>	3WL1116-2BB34-4AN2-Z Z = C22 <sup>2)</sup>
<b>Current demand</b>					
• 24 V DC auxiliary power supply	A	0.17	0.17	0.17	0.17
• 230 V 2 AC					
- Inrush current	A	1.0	1.0	1.0	1.0
- Holding current	A	0.1	0.1	0.1	0.1
<b>DC link capacitance</b> of the drive line-up, max. <sup>3)</sup>	µF	134400	134400	230400	230400
<b>Coolant volume flow</b>	l/min	10	10	16	16
<b>Pressure drop, typ. for volume flow</b>	Pa	70000	70000	70000	70000
<b>Sound pressure level <math>L_{pA}</math></b> (1 m) at 50/60 Hz	dB	71/71	71/71	71/71	71/71
<b>Frame size</b>		JIL	JIL	JIL	JIL
<b>Filter reactor</b>					
<b>Power loss <sup>4)</sup></b>					
• At 50 Hz 400 V	kW	3.5	3.5	8.6	8.6
• At 60 Hz 460 V	kW	3.5	3.5	8.6	8.6
• Dissipated to ambient air	kW	1.2	1.2	0.9	0.9
<b>Liquid volume</b>					
• Of integrated reactor cooler	dm <sup>3</sup>	0.6	0.6	0.6	0.6
• Of hoses supplied	dm <sup>3</sup> /m	0.285	0.285	0.285	0.285
<b>Coolant volume flow</b>	l/min	10	10	8	8
<b>Pressure drop, typ. for volume flow</b>	Pa	70000	70000	70000	70000
<b>Heat exchanger material</b>		Aluminum	Aluminum	Aluminum	Aluminum
<b>Coolant connections</b> Return and connection to filter module		Pipe thread ISO 228 G 3/4 B (external thread 3/4", flat-sealing)			
<b>Line/load connection</b> L1, L2, L3 / U2, V2, W2		Flat connector for M12 screws	Flat connector for M12 screws	Flat connector for M12 screws	Flat connector for M12 screws
<b>PE/GND connection</b> • Conductor cross-section, max. (IEC)	mm <sup>2</sup>	M10 stud 1 × 240	M10 stud 1 × 240	M10 stud 1 × 240	M10 stud 1 × 240
<b>Degree of protection</b>		IP00	IP00	IP00	IP00
<b>Dimensions</b>					
• Width	mm	349	349	382	382
• Height	mm	700	700	698	698
• Depth	mm	575	575	575	575
<b>Weight, approx.</b>	kg	230	230	299	299
<b>Filter module</b>					
<b>Power loss <sup>4)</sup></b>					
• At 50 Hz 400 V	kW	2.7	2.7	3.6	3.6
• At 60 Hz 460 V	kW	2.7	2.7	3.6	3.6
• Dissipated to ambient air	kW	0.15	0.15	0.15	0.15
<b>Liquid volume</b>	dm <sup>3</sup>	1	1	1	1
<b>Heat exchanger material</b>		Aluminum	Aluminum	Aluminum	Aluminum
<b>Coolant connections</b> Intake and connection to filter reactor		Pipe thread ISO 228 G 3/4 B (external thread 3/4", flat-sealing)			
<b>PE/GND connection</b> • Conductor cross-section, max. (IEC)	mm <sup>2</sup>	Flat connector for M8 screw 2 × 120	Flat connector for M8 screw 2 × 120	Flat connector for M8 screw 2 × 120	Flat connector for M8 screw 2 × 120
<b>Degree of protection</b>		IP00	IP00	IP00	IP00
<b>Dimensions</b>					
• Width	mm	506	506	506	506
• Height	mm	840	840	840	840
• Depth	mm	574	574	574	574
<b>Weight, approx.</b>	kg	110	110	110	110

<sup>1)</sup> The bypass contactor is not included in the scope of supply.

<sup>2)</sup> The breakers must only be switched ON and OFF by the sequence control. An interlocking set 3WL9111-0BA21-0AA0 as described in Catalog LV 10 should be provided for the bypass contactor to exclude the risk of unintentional manual operation. Manual operation bypasses the pre-charging circuit and can therefore destroy the Active Line Module.

<sup>3)</sup> Information on higher capacitances is included in the SINAMICS Low Voltage Engineering Manual.

<sup>4)</sup> The specified power loss represents the maximum value at 100 % utilization. The value is lower under normal operating conditions. To ensure safe dissipation of the minor power loss released to the ambient air, it is important to follow the instructions pertaining to control cabinet installation in the SINAMICS Low Voltage Engineering Manual.

# SINAMICS S120 Chassis Format Converter Units

## Liquid-cooled units

### Active Interface Modules

#### Technical specifications (continued)

Line voltage 500 ... 690 V 3 AC		Active Interface Modules			
		6SL3305-7TG37-4AA5	6SL3305-7TG41-0AA5	6SL3305-7TG41-3AA5	6SL3305-7TG41-6AA5
<b>Suitable for Active Line Module</b>					
• Rated power at 690 V - Liquid-cooled	kW	<b>800</b> 6SL3335-7TG37-4AA3	<b>900/1100</b> 6SL3335-7TG38-1AA3 6SL3335-7TG41-0AA3	<b>1400</b> 6SL3335-7TG41-3AA3	<b>1700</b> 6SL3335-7TG41-6AA3
<b>Rated current</b>	A	735	1025	1270	1560
<b>Bypass contactor <sup>1)</sup></b>		3RT1476-6AP36 (3 units)	3WL1212-4BB34-4AN2-Z C22 <sup>2)</sup>	3WL1216-4BB34-4AN2-Z C22 <sup>2)</sup>	3WL1216-4BB34-4AN2-Z C22 <sup>2)</sup>
<b>Current demand</b>					
• 24 V DC auxiliary power supply	A	0.17	0.17	0.17	0.17
• 230 V 2 AC	A	1.0	1.0	1.0	1.0
- Inrush current	A	0.1	0.1	0.1	0.1
- Holding current	A	0.1	0.1	0.1	0.1
<b>DC link capacitance</b> of the drive line-up, max. <sup>3)</sup>	µF	153600	153600	153600	210000
<b>Coolant volume flow</b>	l/min	10	16	16	16
<b>Pressure drop, typ. for volume flow</b>	Pa	70000	70000	70000	70000
<b>Sound pressure level <math>L_{pA}</math></b> (1 m) at 50/60 Hz	dB	71/71	71/71	71/71	71/71
<b>Frame size</b>		JIL	JIL	JIL	JIL
<b>Filter reactor</b>					
<b>Power loss <sup>4)</sup></b>					
• At 50 Hz 690 V	kW	5.5	6.2	9.3	11.0
• At 60 Hz 575 V	kW	5.5	6.2	9.3	11.0
• Dissipated to ambient air	kW	0.5	0.6	0.95	1.15
<b>Liquid volume</b>					
• Of integrated reactor cooler	dm <sup>3</sup>	0.6	0.6	0.6	0.6
• Of hoses supplied	dm <sup>3</sup> /m	0.285	0.285	0.285	0.285
<b>Coolant volume flow</b>	l/min	10	10	10	8
<b>Pressure drop, typ. for volume flow</b>	Pa	70000	70000	70000	70000
<b>Heat exchanger material</b>		Aluminum	Aluminum	Aluminum	Aluminum
<b>Coolant connections</b> Return and connection to filter module		Pipe thread ISO 228 G 3/4 B (external thread 3/4", flat-sealing)			
<b>Line/load connection</b> L1, L2, L3 / U2, V2, W2		Flat connector for M12 screws	Flat connector for M12 screws	Flat connector for M12 screws	Flat connector for M12 screws
<b>PE/GND connection</b> • Conductor cross-section, max. (IEC)	mm <sup>2</sup>	M10 stud 1 × 240	M10 stud 1 × 240	M10 stud 1 × 240	M10 stud 1 × 240
<b>Degree of protection</b>		IP00	IP00	IP00	IP00
<b>Dimensions</b>					
• Width	mm	358	440	440	440
• Height	mm	675	705	705	705
• Depth	mm	575	575	575	580
<b>Weight, approx.</b>	kg	234	365	365	365
<b>Filter module</b>					
<b>Power loss <sup>4)</sup></b>					
• At 50 Hz 690 V	kW	4.0	5.0	5.0	7.5
• At 60 Hz 575 V	kW	4.0	5.0	5.0	7.5
• Dissipated to ambient air	kW	0.15	0.15	0.15	0.15
<b>Liquid volume</b>	dm <sup>3</sup>	1	1	1	1
<b>Heat exchanger material</b>		Aluminum	Aluminum	Aluminum	Aluminum
<b>Coolant connections</b> Intake and connection to filter reactor		Pipe thread ISO 228 G 3/4 B (external thread 3/4", flat-sealing)			
<b>PE/GND connection</b> • Conductor cross-section, max. (IEC)	mm <sup>2</sup>	Flat connector for M8 screw 2 × 120	Flat connector for M8 screw 2 × 120	Flat connector for M8 screw 2 × 120	Flat connector for M8 screw 2 × 120
<b>Degree of protection</b>		IP00	IP00	IP00	IP00
<b>Dimensions</b>					
• Width	mm	506	506	506	506
• Height	mm	840	840	840	840
• Depth	mm	574	574	574	574
<b>Weight, approx.</b>	kg	110	110	110	110

<sup>1)</sup> The bypass contactor is not included in the scope of supply.

<sup>2)</sup> The breakers must only be switched ON and OFF by the sequence control. An interlocking set 3WL9111-0BA21-0AA0 as described in Catalog LV 10 should be provided for the bypass contactor to exclude the risk of unintentional manual operation. Manual operation bypasses the pre-charging circuit and can therefore destroy the Active Line Module.

<sup>3)</sup> Information on higher capacitances is included in the SINAMICS Low Voltage Engineering Manual.

<sup>4)</sup> The specified power loss represents the maximum value at 100 % utilization. The value is lower under normal operating conditions. To ensure safe dissipation of the minor power loss released to the ambient air, it is important to follow the instructions pertaining to control cabinet installation in the SINAMICS Low Voltage Engineering Manual.

# SINAMICS S120 Chassis Format Converter Units

Liquid-cooled units

## Motor Modules

### Overview



A Motor Module comprises a self-commutated converter with IGBTs. It generates a variable voltage with variable frequency from the DC link voltage that feeds the connected motor.

Multiple Motor Modules can be operated on a single DC link. This permits energy to be transferred between the Motor Modules. This means that if one Motor Module operating in generator mode produces energy, the energy can be used by another Motor Module operating in motor mode.

Motor Modules are controlled by a Control Unit.

Liquid-cooled Motor Modules are especially suitable for applications where installation space is restricted and environmental conditions are harsh. Liquid cooling ensures efficient heat dissipation.

### Design

The liquid-cooled Motor Modules have the following interfaces as standard:

- 1 motor connection
- 1 connection for the 24 V DC electronics power supply
- 1 DC link connection (DCP, DCN) for connecting to the supply DC link
- 3 DRIVE-CLiQ sockets
- 1 temperature sensor input for KTY84-130, Pt1000, PTC or Pt100 (Pt1000 can be used from firmware V4.7 HF17)
- 1 connection for Safe Brake Adapter
- 1 connection for Safety Integrated
- 2 PE connections
- 2 coolant connections

The status of the Motor Modules is indicated via three LEDs.

The scope of supply of the Motor Modules includes:

- 1 DRIVE-CLiQ cable for connection to the Control Unit
- 2 seals for coolant connections
- 1 set of warning labels in 30 languages (BG, CN, CZ, DE, DK, EE, ES, FI, FR, GB, GR, HU, IE, IS, IT, JP, KR, LT, LV, MT, NL, NO, PL, PT, RO, RU, SE, SI, SK, TR)

### Selection and ordering data

Type rating at 400 V or 690 V kW	Rated output current A	Motor Module Article No.
<b>Line voltage 380 ... 480 V 3 AC (DC link voltage 510 ... 720 V DC)</b>		
110	210	<b>6SL3325-1TE32-1AA3</b>
132	260	<b>6SL3325-1TE32-6AA3</b>
160	310	<b>6SL3325-1TE33-1AA3</b>
250	490	<b>6SL3325-1TE35-0AA3</b>
315	605	<b>6SL3325-1TE36-1AA3</b>
400	745	<b>6SL3325-1TE37-5AA3</b>
450	840	<b>6SL3325-1TE38-4AA3</b>
560	985	<b>6SL3325-1TE41-0AA3</b>
710	1260	<b>6SL3325-1TE41-2AA3</b>
800	1405	<b>6SL3325-1TE41-4AA3</b>
800 <sup>1)</sup>	1330	<b>6SL3325-1TE41-4AS3</b>
<b>Line voltage 500 ... 690 V 3 AC (DC link voltage 675 ... 1035 V DC)</b>		
90	100	<b>6SL3325-1TG31-0AA3</b>
132	150	<b>6SL3325-1TG31-5AA3</b>
200	215	<b>6SL3325-1TG32-2AA3</b>
315	330	<b>6SL3325-1TG33-3AA3</b>
450	465	<b>6SL3325-1TG34-7AA3</b>
560	575	<b>6SL3325-1TG35-8AA3</b>
710	735	<b>6SL3325-1TG37-4AA3</b>
800	810	<b>6SL3325-1TG38-0AA3</b>
800	810	<b>6SL3325-1TG38-1AA3</b>
1000	1025	<b>6SL3325-1TG41-0AA3</b>
1200	1270	<b>6SL3325-1TG41-3AA3</b>
1500	1560	<b>6SL3325-1TG41-6AP3</b>

Description	Article No.
<b>Accessories</b>	
<b>3-way valve <sup>2)</sup></b>	<b>VXF41.../VXG41...</b>
<b>Actuator for 3-way valve <sup>2)</sup></b>	
• 230 V 1 AC	<b>SAX31...</b>
• 24 V AC/DC	<b>SAX61.../SAX81...</b>
<b>Accessories for re-ordering</b>	
<b>Dust protection blanking plugs</b> (50 units) For DRIVE-CLiQ port	<b>6SL3066-4CA00-0AA0</b>

For motor-side components, see [System components](#).

<sup>1)</sup> This Motor Module has been specifically designed for loads demanding a high dynamic performance.

<sup>2)</sup> Recommended components for installing a flow control as condensation protection; manufactured by Siemens Building Technologies.

### Integration

The liquid-cooled Motor Modules communicate with the higher-level control module via DRIVE-CLiQ. The control module in this case can be a CU320-2 or a SIMOTION D Control Unit.

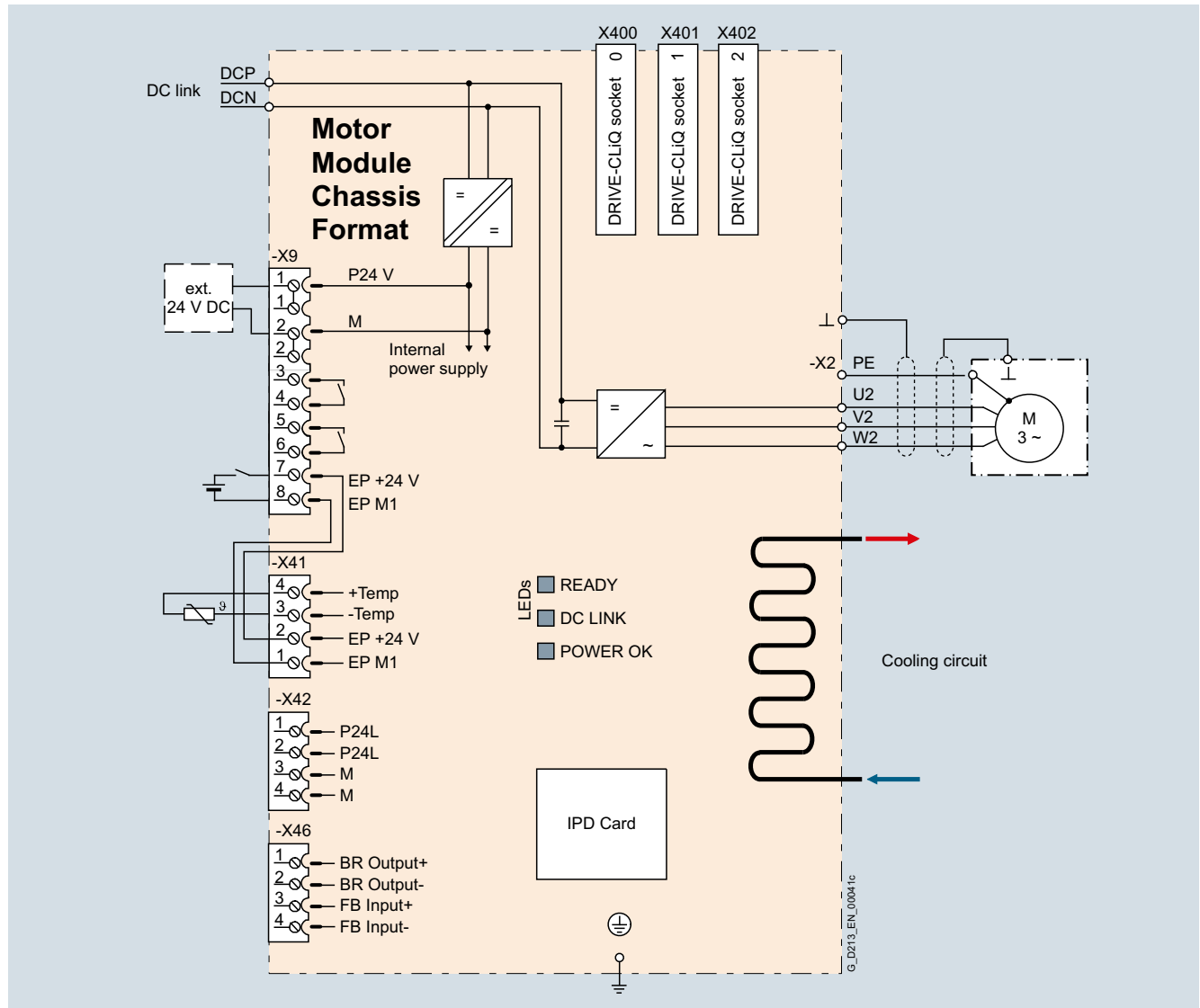

Connection example of a liquid-cooled Motor Module

### Technical specifications

#### General technical specifications

Electrical specifications	
<b>Efficiency</b>	98.5 %
<b>DC link voltage</b> (up to 2000 m above sea level)	510 ... 720 V DC (line voltage 380 ... 480 V 3 AC) or 675 ... 1035 V DC (line voltage 500 ... 690 V 3 AC)
<b>Output frequency</b> <sup>1)</sup>	
• Control type Servo	0 ... 550 Hz
• Control type Vector	0 ... 550 Hz
• Control mode V/f	0 ... 550 Hz
<b>Safety Integrated</b>	Safety Integrity Level 2 (SIL2) acc. to IEC 61508, Performance Level d (PLd) acc. to EN ISO 13849-1 and Control Category 3 acc. to EN ISO 13849-1.

<sup>1)</sup> Please note:

- The correlation between the maximum output frequency, pulse frequency and current derating. Higher output frequencies on request. For further information, see <https://support.industry.siemens.com/cs/document/104020669>
- The correlation between the minimum output frequency and permissible output current (current derating). Information is provided in the SINAMICS Low Voltage Engineering Manual.

# SINAMICS S120 Chassis Format Converter Units

## Liquid-cooled units

### Motor Modules

#### Technical specifications (continued)

Line voltage 380 ... 480 V 3 AC DC link voltage 510 ... 720 V DC		Motor Modules				
		6SL3325-1TE32-1AA3	6SL3325-1TE32-6AA3	6SL3325-1TE33-1AA3	6SL3325-1TE35-0AA3	6SL3325-1TE36-1AA3
<b>Type rating</b>						
• At $I_L$ (50 Hz 400 V) <sup>1)</sup>	kW	<b>110</b>	<b>132</b>	<b>160</b>	<b>250</b>	<b>315</b>
• At $I_H$ (50 Hz 400 V) <sup>1)</sup>	kW	90	110	132	200	250
• At $I_L$ (60 Hz 460 V) <sup>2)</sup>	hp	150	200	250	400	500
• At $I_H$ (60 Hz 460 V) <sup>2)</sup>	hp	150	200	200	350	350
<b>Output current</b>						
• Rated current $I_{rated O}$	A	210	260	310	490	605
• Base-load current $I_L$ <sup>3)</sup>	A	205	250	302	477	590
• Base-load current $I_H$ <sup>4)</sup>	A	178	233	277	438	460
• Maximum current $I_{max O}$	A	307	375	453	715	885
<b>DC link current</b>						
• Rated current $I_{rated DC}$ when supplied via						
- Basic Line Module	A	256	317	380	600	738
- Active Line Module	A	230	287	340	538	664
• Base-load current $I_{L DC}$ <sup>3)</sup> when supplied via						
- Basic Line Module	A	250	305	368	581	719
- Active Line Module	A	225	274	331	522	646
• Base-load current $I_{H DC}$ <sup>4)</sup> when supplied via						
- Basic Line Module	A	227	284	338	534	561
- Active Line Module	A	195	255	303	480	504
<b>Current demand</b>						
• 24 V DC auxiliary power supply	A	1.4	1.4	1.5	1.5	1.6
<b>DC link capacitance</b>		μF	4800	5800	8400	9600
<b>Pulse frequency <sup>5)</sup></b>						
• Rated frequency	kHz	2	2	2	2	1.25
• Pulse frequency, max.						
- Without current derating	kHz	2	2	2	2	1.25
- With current derating	kHz	8	8	8	8	7.5
<b>Power loss, max. <sup>6)</sup></b>						
• At 50 Hz 400 V	kW	1.61	1.95	2.29	3.56	4.81
• At 60 Hz 460 V	kW	1.68	2.06	2.38	3.74	5.25
• Dissipated to ambient air	kW	0.06	0.07	0.09	0.14	0.16
<b>Coolant volume flow <sup>7)</sup></b>		l/min	9	9	12	12
<b>Liquid volume of the integrated heat exchanger</b>		dm <sup>3</sup>	0.31	0.31	0.91	0.91
<b>Pressure drop, typ. <sup>8)</sup> for volume flow</b>		Pa	70000	70000	70000	70000
<b>Heat exchanger material</b>			Stainless steel	Stainless steel	Stainless steel	Stainless steel
<b>Coolant connections Intake/return</b>			Pipe thread ISO 228 G 3/4 B (external thread 3/4", flat-sealing)			
<b>Sound pressure level <math>L_{pA}</math> (1 m) at 50/60 Hz</b>		dB	52	52	52	52
<b>DC link connection DCP, DCN</b>			2 × hole for M12 Busbar	2 × hole for M12 Busbar	2 × hole for M12 Busbar	2 × hole for M12 Busbar
<b>Motor connection U2, V2, W2</b>			Hole for M12	Hole for M12	Hole for M12	Hole for M12
• Conductor cross-section, max. (IEC)	mm <sup>2</sup>	2 × 95	2 × 95	2 × 240	2 × 240	4 × 185
<b>PE/GND connection</b>			2 × hole for M12	2 × hole for M12	2 × hole for M12	2 × hole for M12
• Conductor cross-section, max. (IEC)	mm <sup>2</sup>	2 × 95	2 × 95	2 × 240	2 × 240	4 × 185

For footnotes, see next page.

# SINAMICS S120 Chassis Format Converter Units

## Liquid-cooled units

### Motor Modules

#### Technical specifications (continued)

Line voltage 380 ... 480 V 3 AC DC link voltage 510 ... 720 V DC		Motor Modules				
		6SL3325-1TE32-1AA3	6SL3325-1TE32-6AA3	6SL3325-1TE33-1AA3	6SL3325-1TE35-0AA3	6SL3325-1TE36-1AA3
<b>Cable length, max <sup>9)</sup></b>						
• Shielded	m	300	300	300	300	300
• Unshielded	m	450	450	450	450	450
<b>Dimensions</b>						
• Width	mm	150	150	150	150	265
• Height	mm	746	746	1172	1172	1002
• Depth	mm	545	545	545	545	545
<b>Weight, approx.</b>	kg	41	41	80	80	110
<b>Frame size</b>		FXL	FXL	GXL	GXL	HXL

<sup>1)</sup> Rated output of a typical 6-pole standard induction motor based on  $I_L$  or  $I_H$  for 400 V 3 AC 50 Hz.

<sup>2)</sup> Rated output of a typical 6-pole standard induction motor based on  $I_L$  or  $I_H$  for 460 V 3 AC 60 Hz.

<sup>3)</sup> The base-load current  $I_L$  is based on a duty cycle of 110 % for 60 s or 150 % for 10 s with a duty cycle duration of 300 s.

<sup>4)</sup> The base-load current  $I_H$  is based on a duty cycle of 150 % for 60 s or 160 % for 10 s with a duty cycle duration of 300 s.

<sup>5)</sup> Additional notes regarding the correlation between the pulse frequency and maximum output current/output frequency is provided in the SINAMICS Low Voltage Engineering Manual.

<sup>6)</sup> The specified power loss represents the maximum value at 100 % utilization. The value is lower under normal operating conditions. To ensure safe dissipation of the minor power loss released to the ambient air, it is important to follow the instructions pertaining to control cabinet installation in the SINAMICS Low Voltage Engineering Manual.

<sup>7)</sup> The value applies to coolants comprising water and a mixture of water and antifreeze agent.

<sup>8)</sup> The value is valid for water as coolant. Additional information and notes on other coolants are provided in the SINAMICS Low Voltage Engineering Manual.

<sup>9)</sup> Total of all motor cables. Longer cable lengths for specific configurations are available on request. For additional information, please refer to the SINAMICS Low Voltage Engineering Manual.



# SINAMICS S120 Chassis Format Converter Units

## Liquid-cooled units

### Motor Modules

#### Technical specifications (continued)

Line voltage 380 ... 480 V 3 AC DC link voltage 510 ... 720 V DC		Motor Modules					
		6SL3325-1TE37-5AA3	6SL3325-1TE38-4AA3	6SL3325-1TE41-0AA3	6SL3325-1TE41-2AA3	6SL3325-1TE41-4AA3	6SL3325-1TE41-4AS3 <sup>1)</sup>
<b>Type rating</b>							
• At $I_L$ (50 Hz 400 V) <sup>2)</sup>	kW	400	450	560	710	800	800
• At $I_H$ (50 Hz 400 V) <sup>2)</sup>	kW	315	400	450	630	710	630
• At $I_L$ (60 Hz 460 V) <sup>3)</sup>	hp	600	700	800	1000	1150	1000
• At $I_H$ (60 Hz 460 V) <sup>3)</sup>	hp	450	600	700	900	1000	900
<b>Output current</b>							
• Rated current $I_{rated O}$	A	745	840	985	1260	1405	1330
• Base-load current $I_L$ <sup>4)</sup>	A	725	820	960	1230	1370	1310
• Base-load current $I_H$ <sup>5)</sup>	A	570	700	860	1127	1257	1150
• Maximum current $I_{max O}$	A	1087	1230	1440	1845	2055	2055
<b>DC link current</b>							
• Rated current $I_{rated DC}$ when supplied via							
- Basic Line Module	A	894	1025	1202	1512	1714	1550
- Active Line Module	A	805	922	1080	1361	1544	1403
• Base-load current $I_{L DC}$ <sup>4)</sup> when supplied via							
- Basic Line Module	A	871	1000	1170	1474	1670	1525
- Active Line Module	A	784	898	1051	1326	1500	1405
• Base-load current $I_{H DC}$ <sup>5)</sup> when supplied via							
- Basic Line Module	A	795	853	1048	1345	1532	1676
- Active Line Module	A	716	767	942	1211	1377	1403
<b>Current demand</b>							
• 24 V DC auxiliary power supply	A	1.6	1.6	1.46	1.46	1.46	1.46
<b>DC link capacitance</b>		μF	17400	17400	21000	29000	21000
<b>Pulse frequency<sup>6)</sup></b>							
• Rated frequency	kHz	1.25	1.25	1.25	1.25	1.25	2
• Pulse frequency, max.							
- Without current derating	kHz	1.25	1.25	1.25	1.25	1.25	2
- With current derating	kHz	7.5	7.5	7.5	7.5	7.5	4
<b>Power loss, max.<sup>7)</sup></b>							
• At 50 Hz 400 V	kW	5.1	5.75	7.9	9.15	10.2	10.9
• At 60 Hz 460 V	kW	5.61	6.33	8.55	10.05	11.2	12.3
• Dissipated to ambient air	kW	0.2	0.23	0.44	0.56	0.62	0.65
<b>Coolant volume flow<sup>8)</sup></b>		l/min	16	16	27	27	27
<b>Liquid volume of the integrated heat exchanger</b>		dm <sup>3</sup>	0.74	0.74	1.56	1.56	1.56
<b>Pressure drop, typ.<sup>9)</sup> for volume flow</b>		Pa	70000	70000	70000	70000	70000
<b>Heat exchanger material</b>			Aluminum	Aluminum	Aluminum	Aluminum	Aluminum
<b>Coolant connections Intake/return</b>			Pipe thread ISO 228 G 3/4 B (external thread 3/4", flat-sealing)				
<b>Sound pressure level <math>L_{pA}</math> (1 m) at 50/60 Hz</b>		dB	54	54	56	56	56
<b>DC link connection DCP, DCN</b>			2 × hole for M12 Busbar	2 × hole for M12 Busbar	2 × hole for M12 Busbar	2 × hole for M12 Busbar	2 × hole for M12 Busbar
<b>Motor connection U2, V2, W2</b>			2 × hole for M12	2 × hole for M12	2 × hole for M12	2 × hole for M12	2 × hole for M12
• Conductor cross-section, max. (IEC)	mm <sup>2</sup>	4 × 185	4 × 185	4 × 240	4 × 240	4 × 240	4 × 240
<b>PE/GND connection</b>			2 × hole for M12	2 × hole for M12	2 × hole for M12	2 × hole for M12	2 × hole for M12
• Conductor cross-section, max. (IEC)	mm <sup>2</sup>	4 × 185	4 × 185	Busbar	Busbar	Busbar	Busbar

For footnotes, see next page.

# SINAMICS S120 Chassis Format Converter Units

## Liquid-cooled units

### Motor Modules

#### Technical specifications (continued)

Line voltage 380 ... 480 V 3 AC DC link voltage 510 ... 720 V DC		Motor Modules					
		6SL3325-1TE37-5AA3	6SL3325-1TE38-4AA3	6SL3325-1TE41-0AA3	6SL3325-1TE41-2AA3	6SL3325-1TE41-4AA3	6SL3325-1TE41-4AS3 <sup>1)</sup>
<b>Cable length, max.</b> <sup>10)</sup>							
• Shielded	m	300	300	300	300	300	300
• Unshielded	m	450	450	450	450	450	450
<b>Dimensions</b>							
• Width	mm	265	265	295	295	295	295
• Height	mm	1002	1002	1516	1516	1516	1516
• Depth	mm	545	545	545	545	545	545
<b>Weight, approx.</b>	kg	110	110	220	220	220	230
<b>Frame size</b>		HXL	HXL	JXL	JXL	JXL	JXL

<sup>1)</sup> This Motor Module has been specifically designed for loads demanding a high dynamic performance. The derating factor  $k_{IGBT}$  and the derating characteristic curves can be ignored (see section "Duty cycles" in the SINAMICS Low Voltage Engineering Manual).

<sup>2)</sup> Rated output of a typical 6-pole standard induction motor based on  $I_L$  or  $I_H$  for 400 V 3 AC 50 Hz.

<sup>3)</sup> Rated output of a typical 6-pole standard induction motor based on  $I_L$  or  $I_H$  for 460 V 3 AC 60 Hz.

<sup>4)</sup> The base-load current  $I_L$  is based on a duty cycle of 110 % for 60 s or 150 % for 10 s with a duty cycle duration of 300 s.

<sup>5)</sup> The base-load current  $I_H$  is based on a duty cycle of 150 % for 60 s or 160 % for 10 s with a duty cycle duration of 300 s.

<sup>6)</sup> Additional notes regarding the correlation between the pulse frequency and maximum output current/output frequency is provided in the SINAMICS Low Voltage Engineering Manual.

<sup>7)</sup> The specified power loss represents the maximum value at 100 % utilization. The value is lower under normal operating conditions. To ensure safe dissipation of the minor power loss released to the ambient air, it is important to follow the instructions pertaining to control cabinet installation in the SINAMICS Low Voltage Engineering Manual.

<sup>8)</sup> The value applies to coolants comprising water and a mixture of water and antifreeze agent.

<sup>9)</sup> The value is valid for water as coolant. Additional information and notes on other coolants are provided in the SINAMICS Low Voltage Engineering Manual.

<sup>10)</sup> Sum of all motor cables. Longer cable lengths for specific configurations are available on request. For additional information, please refer to the SINAMICS Low Voltage Engineering Manual.

# SINAMICS S120 Chassis Format Converter Units

## Liquid-cooled units

### Motor Modules

#### Technical specifications (continued)

Line voltage 500 ... 690 V 3 AC DC link voltage 675 ... 1035 V DC		Motor Modules					
		6SL3325-1TG31-0AA3	6SL3325-1TG31-5AA3	6SL3325-1TG32-2AA3	6SL3325-1TG33-3AA3	6SL3325-1TG34-7AA3	6SL3325-1TG35-8AA3
<b>Type rating</b>							
• At $I_L$ (50 Hz 690 V) <sup>1)</sup>	kW	<b>90</b>	<b>132</b>	<b>200</b>	<b>315</b>	<b>450</b>	<b>560</b>
• At $I_H$ (50 Hz 690 V) <sup>1)</sup>	kW	75	110	160	250	400	450
• At $I_L$ (50 Hz 500 V) <sup>1)</sup>	kW	55	90	132	200	315	400
• At $I_H$ (50 Hz 500 V) <sup>1)</sup>	kW	55	90	132	200	250	315
• At $I_L$ (60 Hz 575 V) <sup>2)</sup>	hp	75	150	200	300	450	600
• At $I_H$ (60 Hz 575 V) <sup>2)</sup>	hp	75	125	200	250	450	500
<b>Output current</b>							
• Rated current $I_{rated O}$	A	100	150	215	330	465	575
• Base-load current $I_L$ <sup>3)</sup>	A	95	142	208	320	452	560
• Base-load current $I_H$ <sup>4)</sup>	A	89	134	192	280	416	514
• Maximum current $I_{max O}$	A	142	213	312	480	678	840
<b>DC link current</b>							
• Rated current $I_{rated DC}$ when supplied via							
- Basic Line Module	A	122	183	263	403	558	702
- Active Line Module	A	110	165	237	363	502	632
• Base-load current $I_{L DC}$ <sup>3)</sup> when supplied via							
- Basic Line Module	A	116	173	253	390	544	683
- Active Line Module	A	105	156	229	352	489	616
• Base-load current $I_{H DC}$ <sup>4)</sup> when supplied via							
- Basic Line Module	A	108	163	234	341	496	627
- Active Line Module	A	98	147	211	308	446	565
<b>Current demand</b>							
• 24 V DC auxiliary power supply	A	1.0	1.0	1.5	1.5	1.6	1.6
<b>DC link capacitance</b>	μF	2800	2800	4200	5800	9670	9670
<b>Pulse frequency <sup>5)</sup></b>							
• Rated frequency	kHz	1.25	1.25	1.25	1.25	1.25	1.25
• Pulse frequency, max.							
- Without current derating	kHz	1.25	1.25	1.25	1.25	1.25	1.25
- With current derating	kHz	7.5	7.5	7.5	7.5	7.5	7.5
<b>Power loss, max. <sup>6)</sup></b>							
• At 50 Hz 690 V	kW	1.15	1.64	2.34	3.38	5.44	5.61
• At 60 Hz 575 V	kW	1.02	1.45	2.05	2.96	5.1	5.45
• Dissipated to ambient air	kW	0.06	0.07	0.09	0.12	0.14	0.16
<b>Coolant volume flow <sup>7)</sup></b>	l/min	9	9	12	12	16	16
<b>Liquid volume</b> of the integrated heat exchanger	dm <sup>3</sup>	0.31	0.31	0.91	0.91	0.74	0.74
<b>Pressure drop, typ. <sup>8)</sup></b> for volume flow	Pa	70000	70000	70000	70000	70000	70000
<b>Heat exchanger material</b>		Stainless steel	Stainless steel	Stainless steel	Stainless steel	Aluminum	Aluminum
<b>Coolant connections</b> Intake/return		Pipe thread ISO 228 G 3/4 B (external thread 3/4", flat-sealing)					
<b>Sound pressure level <math>L_{pA}</math></b> (1 m) at 50/60 Hz	dB	52	52	52	52	54	54
<b>DC link connection</b> DCP, DCN		2 × hole for M12 Busbar	2 × hole for M12 Busbar	2 × hole for M12 Busbar	2 × hole for M12 Busbar	2 × hole for M12 Busbar	2 × hole for M12 Busbar
<b>Motor connection</b> U2, V2, W2		Hole for M12	Hole for M12	Hole for M12	Hole for M12	2 × hole for M12	2 × hole for M12
• Conductor cross-section, max. (IEC)	mm <sup>2</sup>	2 × 95	2 × 95	4 × 240	4 × 240	4 × 185	4 × 185

For footnotes, see next page.

# SINAMICS S120 Chassis Format Converter Units

## Liquid-cooled units

### Motor Modules

#### Technical specifications (continued)

Line voltage 500 ... 690 V 3 AC DC link voltage 675 ... 1035 V DC		Motor Modules					
		6SL3325-1TG31-0AA3	6SL3325-1TG31-5AA3	6SL3325-1TG32-2AA3	6SL3325-1TG33-3AA3	6SL3325-1TG34-7AA3	6SL3325-1TG35-8AA3
<b>PE/GND connection</b>		2 × hole for M12					
• Conductor cross-section, max. (IEC)	mm <sup>2</sup>	2 × 95	2 × 95	2 × 240	2 × 240	4 × 185	4 × 185
<b>Cable length, max <sup>9)</sup></b>							
• Shielded	m	300	300	300	300	300	300
• Unshielded	m	450	450	450	450	450	450
<b>Dimensions</b>							
• Width	mm	150	150	150	150	265	265
• Height	mm	728	728	1172	1172	1002	1002
• Depth	mm	545	545	545	545	545	545
<b>Weight, approx.</b>	kg	41	41	80	80	110	110
<b>Frame size</b>		FXL	FXL	GXL	GXL	HXL	HXL

<sup>1)</sup> Rated output of a typical 6-pole standard induction motor based on  $I_L$  or  $I_H$  for 500 V or 690 V 3 AC 50 Hz.

<sup>2)</sup> Rated output of a typical 6-pole standard induction motor based on  $I_L$  or  $I_H$  for 575 V 3 AC 60 Hz.

<sup>3)</sup> The base-load current  $I_L$  is based on a duty cycle of 110 % for 60 s or 150 % for 10 s with a duty cycle duration of 300 s.

<sup>4)</sup> The base-load current  $I_H$  is based on a duty cycle of 150 % for 60 s or 160 % for 10 s with a duty cycle duration of 300 s.

<sup>5)</sup> Additional notes regarding the correlation between the pulse frequency and maximum output current/output frequency is provided in the SINAMICS Low Voltage Engineering Manual.

<sup>6)</sup> The specified power loss represents the maximum value at 100 % utilization. The value is lower under normal operating conditions. To ensure safe dissipation of the minor power loss released to the ambient air, it is important to follow the instructions pertaining to control cabinet installation in the SINAMICS Low Voltage Engineering Manual.

<sup>7)</sup> The value applies to coolants comprising water and a mixture of water and antifreeze agent.

<sup>8)</sup> The value is valid for water as coolant. [Additional information and notes on other coolants are provided in the SINAMICS Low Voltage Engineering Manual.](#)

<sup>9)</sup> Total of all motor cables. Longer cable lengths for specific configurations are available on request. [For additional information, please refer to the SINAMICS Low Voltage Engineering Manual.](#)

# SINAMICS S120 Chassis Format Converter Units

## Liquid-cooled units

### Motor Modules

#### Technical specifications (continued)

Line voltage 500 ... 690 V 3 AC DC link voltage 675 ... 1035 V DC		Motor Modules					
		6SL3325-1TG37-4AA3	6SL3325-1TG38-0AA3 <sup>1)</sup>	6SL3325-1TG38-1AA3	6SL3325-1TG41-0AA3	6SL3325-1TG41-3AA3	6SL3325-1TG41-6AP3 <sup>11)</sup>
<b>Type rating</b>							
• At $I_L$ (50 Hz 690 V) <sup>2)</sup>	kW	710	800	800	1000	1200	1500
• At $I_H$ (50 Hz 690 V) <sup>2)</sup>	kW	630	710	710	900	1000	1260
• At $I_L$ (50 Hz 500 V) <sup>2)</sup>	kW	500	560	560	710	900	1000
• At $I_H$ (50 Hz 500 V) <sup>2)</sup>	kW	450	500	560	630	800	900
• At $I_L$ (60 Hz 575 V) <sup>3)</sup>	hp	700	800	800	1000	1250	1500
• At $I_H$ (60 Hz 575 V) <sup>3)</sup>	hp	700	700	700	900	1000	1250
<b>Output current</b>							
• Rated current $I_{rated O}$	A	735	810	810	1025	1270	1560
• Base-load current $I_L^{4)}$	A	710	790	790	1000	1230	1500
• Base-load current $I_H^{5)}$	A	657	724	724	917	1136	1370
• Maximum current $I_{max O}$	A	1065	1185	1185	1500	1845	2250
<b>DC link current</b>							
• Rated current $I_{rated DC}$ when supplied via							
- Basic Line Module	A	903	990	990	1250	1550	1903
- Active Line Module	A	808	891	891	1125	1395	1714
• Base-load current $I_{L DC}^{4)}$ when supplied via							
- Basic Line Module	A	870	948	963	1219	1500	1800
- Active Line Module	A	781	870	869	1100	1353	1650
• Base-load current $I_{H DC}^{5)}$ when supplied via							
- Basic Line Module	A	795	885	883	1118	1384	1680
- Active Line Module	A	732	808	796	1009	1250	1550
<b>Current demand</b>							
• 24 V DC auxiliary power supply	A	1.6	1.6	1.46	1.46	1.46	1.46
<b>DC link capacitance</b>	μF	10500	10500	14000	16000	19330	21000
<b>Pulse frequency<sup>6)</sup></b>							
• Rated frequency	kHz	1.25	1.25	1.25	1.25	1.25	1.25
• Pulse frequency, max.							
- Without current derating	kHz	1.25	1.25	1.25	1.25	1.25	1.25
- With current derating	kHz	7.5	7.5	7.5	7.5	7.5	7.5
<b>Power loss, max.<sup>7)</sup></b>							
• At 50 Hz 690 V	kW	7.65	8.47	9.56	10.87	13.49	17.9
• At 60 Hz 575 V	kW	6.67	7.39	8.34	9.55	11.84	15.7
• Dissipated to ambient air	kW	0.2	0.22	0.43	0.53	0.57	0.78
<b>Coolant volume flow<sup>8)</sup></b>	l/min	16	16	27	27	27	27
<b>Liquid volume</b> of the integrated heat exchanger	dm <sup>3</sup>	0.74	0.74	1.56	1.56	1.56	1.56
<b>Pressure drop, typ.<sup>9)</sup></b> for volume flow	Pa	70000	70000	70000	70000	70000	70000
<b>Heat exchanger material</b>		Aluminum	Aluminum	Aluminum	Aluminum	Aluminum	Aluminum
<b>Coolant connections</b> Intake/return		Pipe thread ISO 228 G 3/4 B (external thread 3/4", flat-sealing)					
<b>Sound pressure level <math>L_{pA}</math></b> (1 m) at 50/60 Hz	dB	54	54	56	56	56	56
<b>DC link connection</b> DCP, DCN		2 × hole for M12 Busbar	2 × hole for M12 Busbar	2 × hole for M12 Busbar	2 × hole for M12 Busbar	2 × hole for M12 Busbar	2 × hole for M12 Busbar
<b>Motor connection</b> U2, V2, W2		2 × hole for M12	2 × hole for M12	2 × hole for M12	2 × hole for M12	2 × hole for M12	2 × hole for M12
• Conductor cross-section, max. (IEC)	mm <sup>2</sup>	4 × 185	4 × 185	Busbar	Busbar	Busbar	Busbar

For footnotes, see next page.

# SINAMICS S120 Chassis Format Converter Units

## Liquid-cooled units

### Motor Modules

#### Technical specifications (continued)

Line voltage 500 ... 690 V 3 AC DC link voltage 675 ... 1035 V DC		Motor Modules					
		6SL3325-1TG37-4AA3	6SL3325-1TG38-0AA3 <sup>1)</sup>	6SL3325-1TG38-1AA3	6SL3325-1TG41-0AA3	6SL3325-1TG41-3AA3	6SL3325-1TG41-6AP3 <sup>11)</sup>
<b>PE/GND connection</b>		2 × hole for M12					
• Conductor cross-section, max. (IEC) mm <sup>2</sup>		4 × 185	4 × 185	Busbar	Busbar	Busbar	Busbar
<b>Cable length, max.<sup>10)</sup></b>							
• Shielded m		300	300	300	300	300	300
• Unshielded m		450	450	450	450	450	450
<b>Dimensions</b>							
• Width mm		265	265	295	295	295	295
• Height mm		1002	1002	1516	1516	1516	1516
• Depth mm		545	545	545	545	545	545
<b>Weight, approx.</b> kg		110	110	220	220	220	230
<b>Frame size</b>		HXL	HXL	JXL	JXL	JXL	JXL

<sup>1)</sup> The device is optimized for a base pulse frequency of 1.25 kHz, for an increased pulse frequency – or for certain overloads the derating factor is higher than that for the device with article number 6SL3325-1TG38-1AAx.

<sup>2)</sup> Rated output of a typical 6-pole standard induction motor based on  $I_L$  or  $I_H$  for 500 V or 690 V 3 AC 50 Hz.

<sup>3)</sup> Rated output of a typical 6-pole standard induction motor based on  $I_L$  or  $I_H$  for 575 V 3 AC 60 Hz.

<sup>4)</sup> The base-load current  $I_L$  is based on a duty cycle of 110 % for 60 s or 150 % for 10 s with a duty cycle duration of 300 s.

<sup>5)</sup> The base-load current  $I_H$  is based on a duty cycle of 150 % for 60 s or 160 % for 10 s with a duty cycle duration of 300 s.

<sup>6)</sup> Additional notes regarding the correlation between the pulse frequency and maximum output current/output frequency are provided in the SINAMICS Low Voltage Engineering Manual.

<sup>7)</sup> The specified power loss represents the maximum value at 100 % utilization. The value is lower under normal operating conditions. To ensure safe dissipation of the minor power loss released to the ambient air, it is important to follow the instructions pertaining to control cabinet installation in the SINAMICS Low Voltage Engineering Manual.

<sup>8)</sup> The value applies to coolants comprising water and a mixture of water and antifreeze agent.

<sup>9)</sup> The value is valid for water as coolant. [Additional information and notes on other coolants are provided in the SINAMICS Low Voltage Engineering Manual.](#)

<sup>10)</sup> Sum of all motor cables. Longer cable lengths for specific configurations are available on request. [For additional information, please refer to the SINAMICS Low Voltage Engineering Manual.](#)

<sup>11)</sup> Additional duty cycle for output frequencies from 5 Hz to 10 Hz: Base-load current = 1460 A, short-time current = 2340 A for 5 s with a duty cycle duration of 600 s. For output frequencies from 1 Hz to 5 Hz, the short-time current is 1900 A for 5 s.

## SINAMICS S120 Chassis Format Converter Units

### Liquid-cooled units

#### Mounting device for liquid-cooled power units

##### Overview

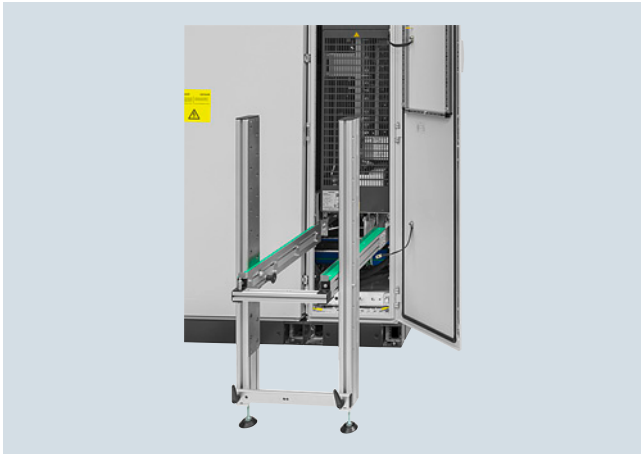

The mounting device is used to install or remove liquid-cooled power units (Power Modules, Line Modules, Motor Modules) into or out of a control cabinet. The mounting device can be used if the power units are mounted on mounting rails, which at the front have two M6 threads at a vertical distance of 20 mm to attach the mounting device.

The mounting device is a mounting aid. It is placed in front of the power unit and attached to the mounting rails below the power unit. The telescopic rails allow the mounting device to be adjusted to the installation height and width of the power unit. The power unit can be removed from the control cabinet after releasing the mechanical and electrical connections and the coolant connections. The power unit is guided and supported by the guide rails on the mounting device. To prevent it toppling over, the power unit must be secured to a crane, tripod, or similar assembly using the lifting lugs or the lifting equipment. The unit can then be lowered down from the mounting device.

##### Selection and ordering data

Description	Article No.
<b>Mounting device</b> for installing and removing power units	<b>6SL3766-1CA00-0AA0</b>

## SINAMICS S120 Chassis Format Converter Units

### Water-cooled units

#### Overview



The water-cooled SINAMICS S120 chassis units are specifically designed for the operation of shared cooling circuits for the plant, motor, and converter.

They are especially suitable for applications where installation space is restricted and environmental conditions are harsh. They ensure efficient heat dissipation.

The main difference to the current liquid-cooled SINAMICS S120 chassis units is the operation with a significantly reduced water quality. The components are resistant to a proportion of oxygen in the cooling water. Generally, the water usually used in industry can also be used for cooling the drive system. Additives such as antifreeze or inhibitors are not required.

The new cooling concept saves space and costs. Water cooling for motor and converter ensures that less space is needed, as the converter cooling unit can be dispensed with due to the shared cooling circuit. This results in low acquisition and operating costs.

The devices with copper-nickel heat sinks are fitted with rail profiles at the bottom and can be stored on the floor in a way that is easy to assemble.

The product portfolio includes the following water-cooled SINAMICS S120 built-in units:

- Power Modules
- Active Line Modules
- Active Interface Modules
- Motor Modules

The associated system components such as motor reactors and dv/dt filters plus VPL are air-cooled.

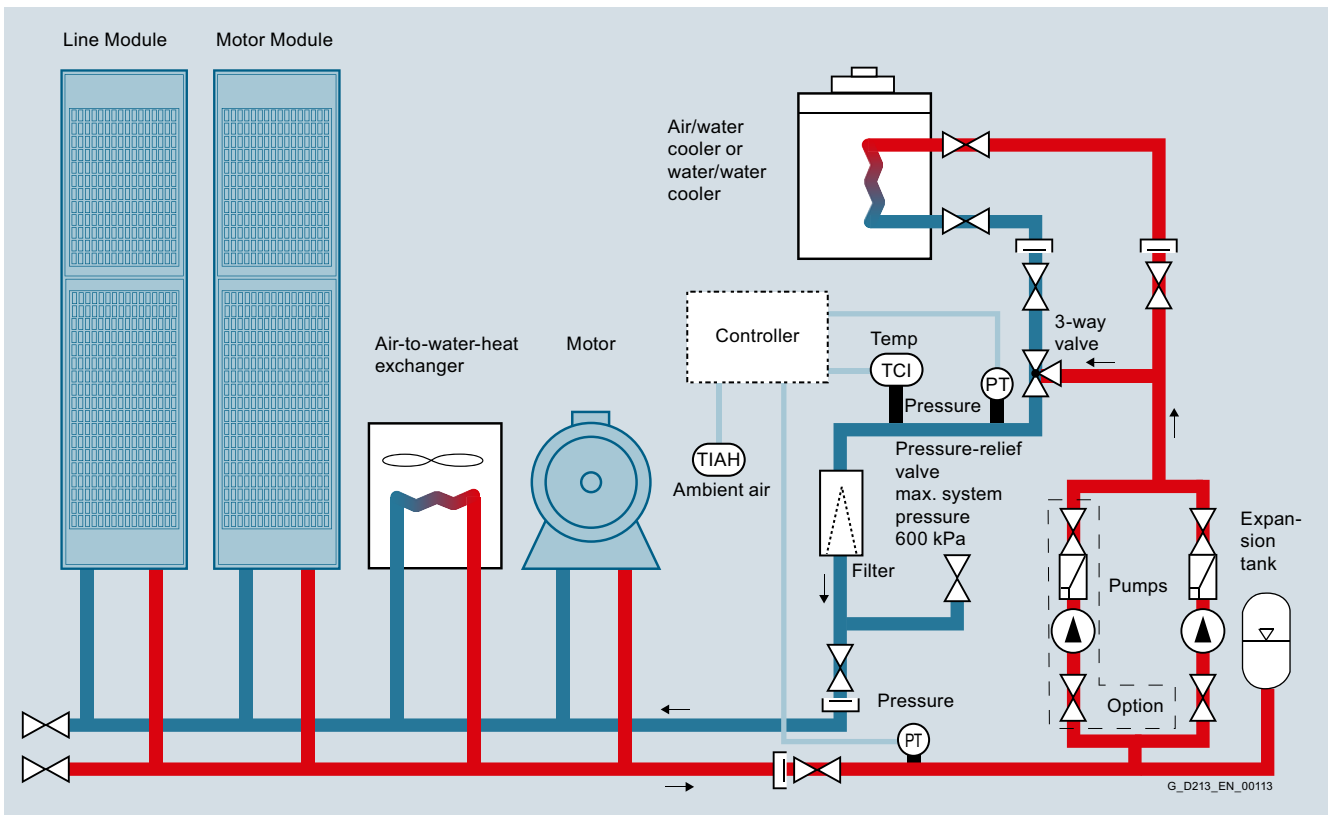

Example of a drive line-up with SINAMICS S120 water-cooled units



# SINAMICS S120 Chassis Format Converter Units

## Water-cooled units

### Technical specifications

#### General technical specifications

Unless clearly specified otherwise, the following technical specifications are valid for all the following components of the water-cooled SINAMICS S120 drive system in chassis format.

Electrical specifications			
<b>Rated voltages</b>	380 ... 480 V 3 AC $\pm 10\%$ (-15 % <1 min) 500 ... 690 V 3 AC $\pm 10\%$ (-15 % <1 min)		
<b>Line supply types</b>	Grounded TN/TT systems and non-grounded IT systems		
<b>Line frequency</b>	47 ... 63 Hz		
<b>Overvoltage category</b>	III to EN 61800-5-1		
<b>Electronics power supply</b>	24 V DC, -15 % +20 % implemented as PELV circuit in accordance with EN 61800-5-1 Ground = negative pole grounded via the electronics		
<b>Rated short-circuit current</b> per IEC, in conjunction with the specified fuses or circuit breakers	<ul style="list-style-type: none"> <li>• 1.1 ... 447 kW 65 kA</li> <li>• 448 ... 671 kW 84 kA</li> <li>• 672 ... 1193 kW 170 kA</li> <li>• &gt; 1194 kW 200 kA</li> </ul>		
<b>Rated short-circuit current SCCR (Short Circuit Current Rating)</b> according to UL508C (up to 600 V), in conjunction with the specified fuses or circuit breakers	<ul style="list-style-type: none"> <li>• 1.1 ... 447 kW 65 kA</li> <li>• 448 ... 671 kW 84 kA</li> <li>• 672 ... 1193 kW 170 kA</li> <li>• &gt; 1194 kW 200 kA</li> </ul>		
<b>Control method</b>	Vector/Servo control with and without encoder or V/f control		
<b>Fixed speeds</b>	15 fixed speeds plus 1 minimum speed, parameterizable (in the default setting, 3 fixed setpoints plus 1 minimum speed are selectable using terminal block/PROFIBUS/PROFINET)		
<b>Skippable speed ranges</b>	4, parameterizable		
<b>Setpoint resolution</b>	0.001 rpm digital (14 bits + sign) 12 bits analog		
<b>Braking operation</b>	With Active Line Modules, four-quadrant operation as standard (energy recovery). Braking with a Motor Module.		
Mechanical specifications			
<b>Degree of protection</b>	IP00 (IP20, without taking into account the connecting busbars)		
<b>Protection class</b>	I acc. to EN 61800-5-1		
<b>Touch protection</b>	EN 50274/DGUV regulation 3 when used as intended		
<b>Cooling method</b>	Water cooling with integrated heat exchanger in copper-nickel version		
Ambient conditions	Storage <sup>1)</sup>	Transport <sup>1)</sup>	Operation
<b>Ambient temperature (air)</b>	-25 ... +55 °C Class 1K4 acc. to EN 60721-3-1	-25 ... +70 °C Class 2K4 acc. to EN 60721-3-2	Line-side components, Line Modules, and Motor Modules: 0 ... 45 °C without derating >45 ... 50 °C <a href="#">see derating characteristic curves</a> Control Units, supplementary system components, and Sensor Modules: 0 ... 55 °C (for operation in a control cabinet) DC link components and motor-side components: 0 ... 55 °C
<b>Relative humidity</b> Condensation, splashwater, and ice formation not permitted (EN 60204, Part 1)	5 ... 95 % Class 1K4 acc. to EN 60721-3-1	Max. 95 % at 40 °C Class 2K4 acc. to EN 60721-3-2	5 ... 95 % Class 3K3 acc. to EN 60721-3-3
<b>Environmental class/harmful chemical substances</b>	Class 1C2 acc. to EN 60721-3-1	Class 2C2 acc. to EN 60721-3-2	Class 3C2 acc. to EN 60721-3-3
<b>Organic/biological influences</b>	Class 1B1 acc. to EN 60721-3-1	Class 2B1 acc. to EN 60721-3-2	Class 3B1 acc. to EN 60721-3-3
<b>Degree of pollution</b>	2 acc. to IEC/EN 61800-5-1		

## SINAMICS S120 Chassis Format Converter Units

### Water-cooled units

#### Technical specifications (continued)

Electrical specifications			
<b>Installation altitude</b>	Up to 2000 m above sea level without derating, > 2000 m above sea level, <a href="#">refer to the derating data</a>		
<b>Mechanical stability</b>	<b>Storage <sup>1)</sup></b>	<b>Transport <sup>1)</sup></b>	<b>Operation</b>
<b>Vibratory load</b>		Class 2M2 acc. to EN 60721-3-2	Test values acc. to EN 60068-2-6 test Fc: <ul style="list-style-type: none"> <li>• 10 ... 58 Hz with constant deflection 0.075 mm</li> <li>• 58 ... 150 Hz with constant acceleration 9.81 m/s<sup>2</sup> (1 × g)</li> </ul>
<b>Shock load</b>		Class 2M2 acc. to EN 60721-3-2	Test values acc. to EN 60068-2-27 test Ea: 98 m/s <sup>2</sup> (10 × g)/20 ms
Compliance with standards			
<b>Conformances/certificates of suitability, according to</b>	CE (EMC Directive 2014/30/EU, Low Voltage Directive 2014/35/EU, and Machinery Directive 2006/42/EC for functional safety) RCM, RoHS II cULus (only for devices connected to line supply voltages 380 ... 480 V 3 AC and 500 ... 600 V 3 AC)		
<b>Radio interference suppression</b>	SINAMICS S120 chassis format units are not designed for connection to the public grid (first environment). Radio interference suppression is compliant with the EMC product standard for variable-speed drives EN 61800-3, "Second environment" (industrial line supplies). EMC disturbances can occur when connected to the public grid. <a href="#">For further information, see section Configuring information.</a>		

Deviations from the specified class are underlined.

<sup>1)</sup> In transport packaging.

## SINAMICS S120 Chassis Format Converter Units

### Water-cooled units

#### Technical specifications (continued)

##### Cooling circuit and coolant quality

The following tables and sections describe the quality requirements of the coolant used in the water-cooled SINAMICS S120 drive system in chassis format.

Cooling circuit	
System pressure with reference to atmospheric pressure, max.	600 kPa
Pressure drop at rated volumetric flow	70 kPa
Recommended pressure range	80 ... 150 kPa (is applicable for water as coolant)
Inlet temperature of liquid coolant	Dependent on ambient temperature, no condensation permitted 0 ... 38 °C without derating >38 ... 43 °C <a href="#">see derating data</a> Antifreeze essential for temperature range between 0 °C and 5 °C <b>Note:</b> Compared to the liquid-cooled chassis format units, the inlet temperatures are 7 K lower, as a heat exchanger is not required.

##### Coolant quality

	Coolant basis for copper-nickel heat sink: Filtered drinking, process, and cooling water	Coolant basis for stainless steel heat sink: Filtered drinking, process, and cooling water
• Electrical conductivity	<2900 µS/cm (>290 mS/m)	<2500 µS/cm (>250 mS/m)
• pH value	6.5 ... 9	6.5 ... 9
• Total salt content TDS	<1800 mg/l	<1550 mg/l
• Chloride ions	<500 mg/l	<250 mg/l
• Sodium	<200 mg/l	<200 mg/l
• Sulfate ions	<300 mg/l	<240 mg/l
• Sulfide ions	<1 mg/l	<1 mg/l
• Nitrate ions	<50 mg/l	<50 mg/l
• Iron	<1 mg/l	<1 mg/l
• Silicate	<10 mg/l	<10 mg/l
• Ammonia (NH <sub>3</sub> ), ammonium (NH <sub>4</sub> <sup>+</sup> )	<1 mg/l	<1 mg/l
• Total hardness with a maximum of	<1.78 mmol/l (10 °dH)	<1.78 mmol/l (10 °dH)
- Calcium hardness	<1.25 mmol/l (7 °dH), <57 mg/l calcium	<1.25 mmol/l (7 °dH), <57 mg/l calcium
- Magnesium hardness	< 1.43 mmol/l (8 °dH), <35 mg/l magnesium	< 1.43 mmol/l (8 °dH), <35 mg/l magnesium
- Carbonate hardness	<0.45 mmol/l (2.5 °dH)	<0.45 mmol/l (2.5 °dH)
• Suspended solids/suspended substances		
- Solids	<340 mg/l	<340 mg/l
- Size of entrained particles	<100 µm	<100 µm
The coolant definition specified here should only be considered as recommendation. For units that have been shipped, the information and data provided in the equipment manual supplied should be observed! <b>Recommendation:</b> With an open pressure equalization tank, initial filling should be conducted using demineralized water (via ion exchanger).		

### Technical specifications (continued)

#### Antifreeze and biocide

The water-cooled built-in units can be operated within a temperature range above 5 °C without antifreeze. At operating temperatures of <5 °C, one of the following antifreeze agents must be used.

Antifreeze	Antifrogen N	Antifrogen L	DOWCAL 100
Manufacturer	Clariant	Clariant	DOW
Chemical base	Ethylene glycol	Propylene glycol	Ethylene glycol
Minimum concentration	25 %	25 %	25 %
Antifreeze agent with minimum concentration	-10 °C	-10 °C	-10 °C
Maximum concentration	45 %	48 %	45 %
Antifreeze agent with maximum concentration	-30 °C	-30 °C	-30 °C
Inhibitor content	Contains inhibitors with nitrites	Contains inhibitors that are free of nitrates, amines, borates and phosphates	Contains inhibitors that are free of nitrates, amines and phosphates
Biocide action with a concentration of	>25 %	>25 %	>25 %

Biocides prevent corrosion that is caused by slime-forming, corrosive or iron-depositing bacteria. These can occur in closed cooling circuits with low water hardness and in shared cooling circuits with open pressure equalization vessel. Biocides must always be selected according to the relevant bacterial risks. Compatibility with inhibitors or antifreeze used with them must be checked on a case-by-case basis.

#### Protection against condensation

With water-cooled units, warm air can condense on the cold surfaces of heat sinks, pipes, and hoses. This condensation depends on the air humidity and the temperature difference between the ambient air and the coolant.

The water which is produced as a result of condensation can cause corrosion as well as electrical damage such as creepage shorts and flashovers. As the SINAMICS units cannot prevent condensation if it is caused by the prevailing climatic conditions, any potential risk of condensation must be prevented by appropriate engineering or by precautionary measures implemented by the customer. These measures include the following:

- a fixed coolant temperature that has been adjusted to the expected air humidity or ambient temperature ensures that critical differences between the coolant and ambient air temperatures do not develop or
- temperature regulation of the coolant as a function of the ambient air temperature

Room temperature T	Relative air humidity $\Phi$										
	20 %	30 %	40 %	50 %	60 %	70 %	80 %	85 %	90 %	95 %	100 %
10 °C	<0 °C	<0 °C	<0 °C	0.2 °C	2.7 °C	4.8 °C	6.7 °C	7.6 °C	8.4 °C	9.2 °C	10 °C
20 °C	<0 °C	2 °C	6 °C	9.3 °C	12 °C	14.3 °C	16.4 °C	17.4 °C	18.3 °C	19.1 °C	20 °C
25 °C	0.6 °C	6.3 °C	10.5 °C	13.8 °C	16.7 °C	19.1 °C	21.2 °C	22.2 °C	23.2 °C	24.1 °C	24.9 °C
30 °C	4.7 °C	10.5 °C	14.9 °C	18.4 °C	21.3 °C	23.8 °C	26.1 °C	27.1 °C	28.1 °C	29 °C	29.9 °C
35 °C	8.7 °C	14.8 °C	19.3 °C	22.9 °C	26 °C	28.6 °C	30.9 °C	32 °C	33 °C	34 °C	34.9 °C
40 °C	12.8 °C	19.1 °C	23.7 °C	27.5 °C	30.6 °C	33.4 °C	35.8 °C	36.9 °C	37.9 °C	38.9 °C	39.9 °C
45 °C	16.8 °C	23.3 °C	28.2 °C	32 °C	35.3 °C	38.1 °C	40.6 °C	41.8 °C	42.9 °C	43.9 °C	44.9 °C
50 °C	20.8 °C	27.5 °C	32.6 °C	36.6 °C	40 °C	42.9 °C	45.5 °C	46.6 °C	47.8 °C	48.9 °C	49.9 °C

A detailed description of the cooling circuits and the recommended coolant is given in the SINAMICS Low Voltage Engineering Manual.

#### Recommended service

The cooling water must be checked 3 months after the cooling circuit is initially filled and once every year thereafter. We recommend contacting a coolant manufacturer for the coolant inspection. If the cooling water becomes cloudy, is colored, or becomes contaminated by mold spores, the cooling circuit must be cleaned and refilled.

The temperature at which water vapor contained in the air condenses into water is known as the dew point. To prevent condensation reliably, the coolant temperature must always be higher than the dew point.

The table below specifies the dew point as a function of room temperature T and relative air humidity  $\Phi$  for an atmospheric pressure of 100 kPa (1 bar). This corresponds to an installation altitude of 0 up to approximately 500 m above sea level. Since the dew point drops as the air pressure decreases, the dew point values at higher installation altitudes are lower than the specified table values. It is therefore the safest approach to engineer the coolant temperature according to the values in the table for an installation altitude of zero.

# SINAMICS S120 Chassis Format Converter Units

## Water-cooled units

### Characteristic curves

#### Derating

Water-cooled SINAMICS S120 chassis format units are rated for an ambient temperature of 45 °C and installation altitudes up to 2000 m above sea level. At ambient temperatures > 45 °C, the output current must be reduced. Ambient temperatures above 50 °C are not permissible. At installation altitudes > 2000 m above sea level, it must be taken into account that the air pressure, and therefore air density, decreases as the height increases. As a consequence, the cooling efficiency and the insulation capacity of the air also decrease.

#### Note:

Compared to the liquid-cooled chassis format units, the inlet temperatures are 7 K lower, as a heat exchanger is not required.

3

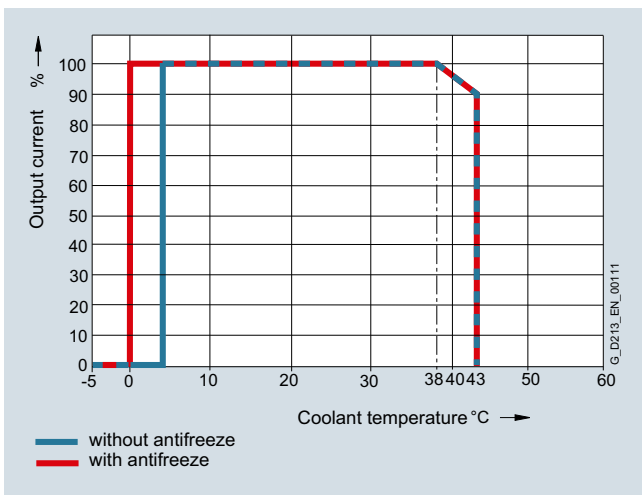

Current derating as a function of the temperature of the cooling liquid <sup>1)</sup>

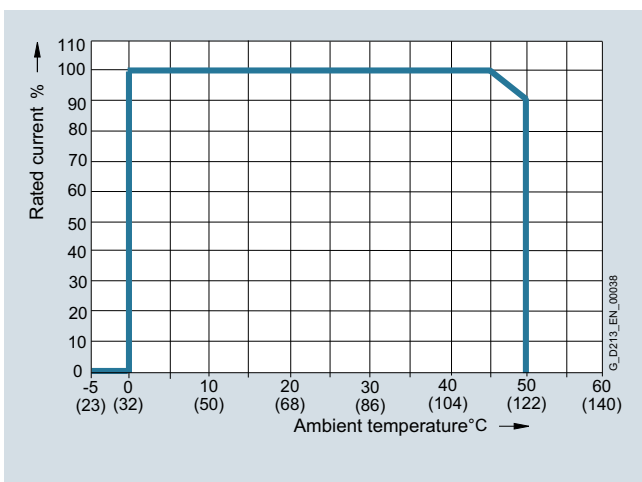

Current derating as a function of ambient temperature <sup>1)</sup>

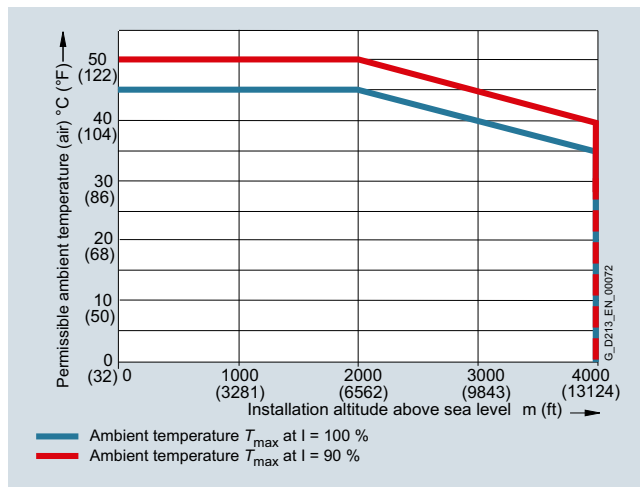

Permissible ambient temperature as a function of installation altitude

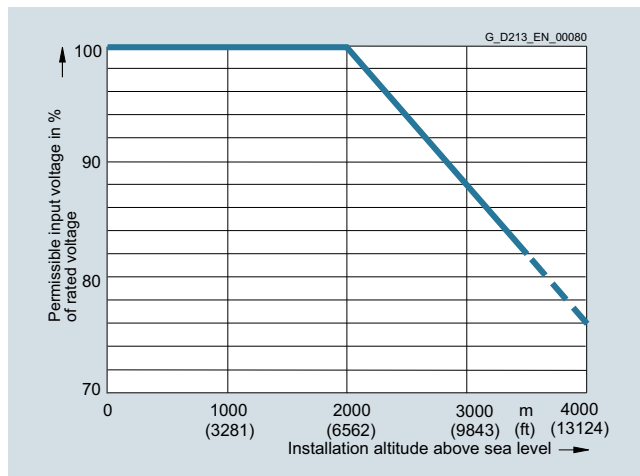

Voltage derating as a function of installation altitude

#### Current derating as a function of the pulse frequency

To reduce motor noise or to increase output frequency, the pulse frequency can be increased relative to the factory setting (1.25 kHz or 2 kHz). When the pulse frequency is increased, the derating factor of the output current must be taken into account. This derating factor must be applied to the currents specified in the technical specifications.

For additional information, please refer to the SINAMICS Low Voltage Engineering Manual.

<sup>1)</sup> The factors of the two curves must not be multiplied. The highest value in each case must be assumed for the purposes of calculation, so that the derating factor in the worst-case scenario is 0.9.

## SINAMICS S120 Chassis Format Converter Units

### Water-cooled units

#### Characteristic curves (continued)

The following tables list the rated output currents of the SINAMICS S120 Motor Modules with pulse frequency set in the factory as well as the current derating factors (permissible output currents referred to the rated output current) for higher pulse frequencies.

Derating factor of the output current as a function of the pulse frequency for units with a rated pulse frequency of 2 kHz

Power Module Motor Module	Type rating at 400 V kW	Output current at 2 kHz A	Derating factor at pulse frequency				
			2.5 kHz	4 kHz	5 kHz	7.5 kHz	8 kHz
<b>380 ... 480 V 3 AC</b>							
1TE32-1AA3	110	210	95 %	82 %	74 %	54 %	50 %
1TE32-6AA3	132	260	95 %	83 %	74 %	54 %	50 %
1TE33-1AA3	160	310	97 %	88 %	78 %	54 %	50 %
1TE35-0AA3	250	490	94 %	78 %	71 %	53 %	50 %

Derating factor of the output current as a function of the pulse frequency for units with a rated pulse frequency of 1.25 kHz

Motor Module	Type rating at 400 V or 690 V kW	Output current at 1.25 kHz A	Derating factor at pulse frequency					
			2 kHz	2.5 kHz	4 kHz	5 kHz	7.5 kHz	8 kHz
<b>380 ... 480 V 3 AC</b>								
1TE37-5AA7	400	745	83 %	72 %	64 %	60 %	40 %	-
1TE41-0AA7	560	985	92 %	87 %	70 %	60 %	50 %	47 %
1TE41-2AA7	710	1260	92 %	87 %	70 %	60 %	50 %	47 %
1TE41-4AA7	800	1405	97 %	95 %	74 %	60 %	50 %	47 %
<b>500 ... 690 V 3 AC</b>								
1TG31-0AA3	90	100	92 %	88 %	71 %	60 %	40 %	-
1TG31-5AA3	132	150	90 %	84 %	66 %	55 %	35 %	-
1TG32-2AA3	200	215	92 %	87 %	70 %	60 %	40 %	-
1TG33-3AA3	315	330	89 %	82 %	65 %	55 %	40 %	-
1TG34-7AA7	450	465	92 %	87 %	67 %	55 %	35 %	-
1TG35-8AA7	560	575	91 %	85 %	64 %	50 %	35 %	-
1TG38-1AA7	800	810	97 %	95 %	71 %	55 %	35 %	-
1TG41-0AA7	1000	1025	91 %	86 %	64 %	50 %	30 %	-
1TG41-3AA7	1200	1270	87 %	79 %	55 %	40 %	25 %	-
1TG41-6AA7	1500	1560	87 %	79 %	55 %	40 %	25 %	-

The following tables list the maximum achievable output frequency as a function of the pulse frequency:

Maximum output frequencies achieved by increasing the pulse frequency in Vector mode

Pulse frequency	Max. achievable output frequency
1.25 kHz	100 Hz
2 kHz	160 Hz
2.5 kHz	200 Hz
4 kHz	320 Hz
5 kHz	400 Hz

Maximum output frequencies achieved by increasing the pulse frequency in Servo mode

Pulse frequency	Max. achievable output frequency
2 kHz	300 Hz
4 kHz	300/550 Hz <sup>1)</sup>

<sup>1)</sup> Higher frequencies on request. For further information see <https://support.industry.siemens.com/cs/document/104020669>

## SINAMICS S120 Chassis Format Converter Units

Water-cooled units

### Characteristic curves (continued)

#### Pressure drop

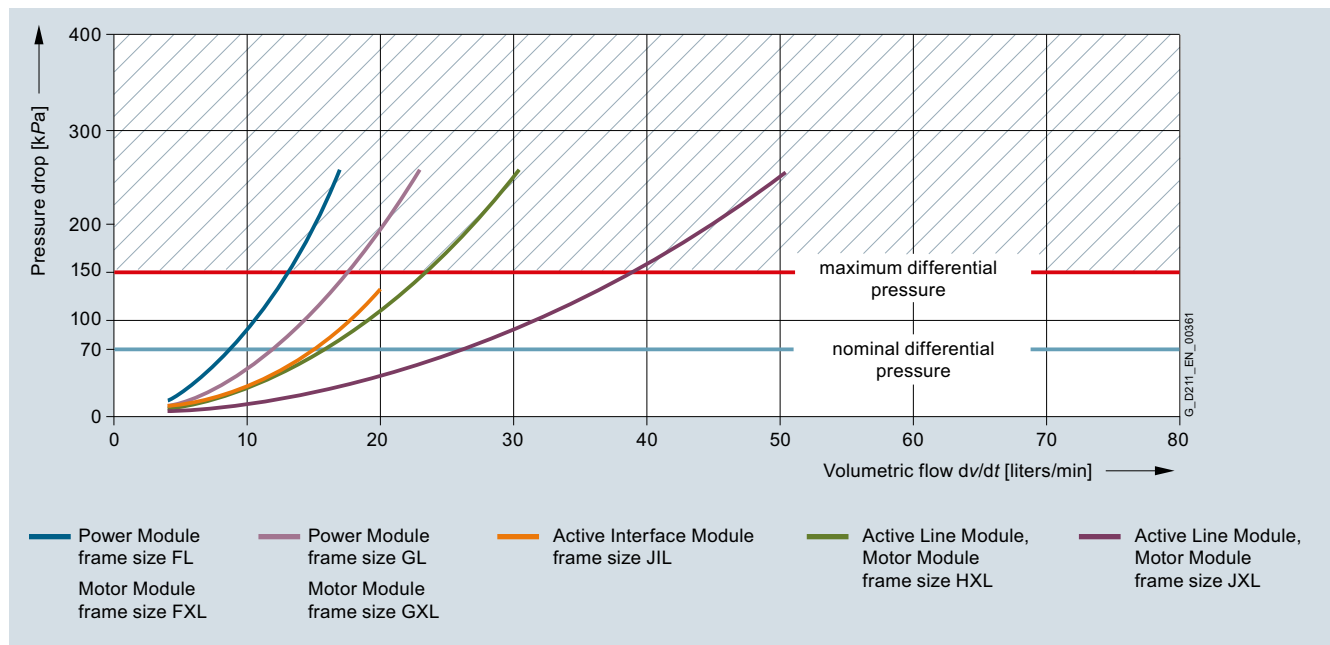

Pressure drop for water-cooled chassis format units

The pressure drop characteristic curves are valid for water. If antifreeze is used, the characteristic curves typically shift to the left.

For further information, please refer to the [SINAMICS Low Voltage Engineering Manual](#).

### Characteristic curves (continued)

#### Overload capability

Water-cooled SINAMICS S120 units have an overload reserve, e.g. to handle breakaway torques. If larger surge loads occur, this must be taken into account in the configuration. For drives with overload requirements, the appropriate base-load current must, therefore, be used as a basis for the required load.

The permissible overload levels are valid under the prerequisite that the drive units are operated with their base-load current before and after the overload condition based on a duty cycle duration of 300 s.

Another precondition is that the Power Modules or the Motor Modules are operated at their factory-set pulse frequency at output frequencies > 10 Hz.

For temporary, periodic duty cycles with high variations of load within the duty cycle, the relevant sections of the SINAMICS Low Voltage Engineering Manual must be observed.

#### Power Modules and Motor Modules

The base-load current for a low overload  $I_L$  is the basis for a duty cycle of 110 % for 60 s or 150 % for 10 s.

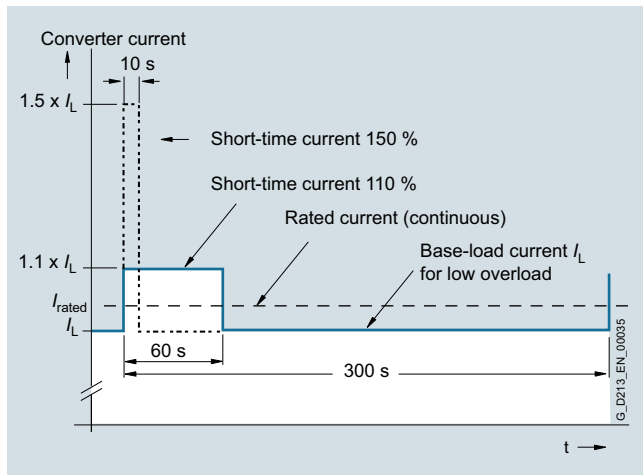

Low overload

The base-load current  $I_H$  for a high overload is based on a duty cycle of 150 % for 60 s or 160 % for 10 s.

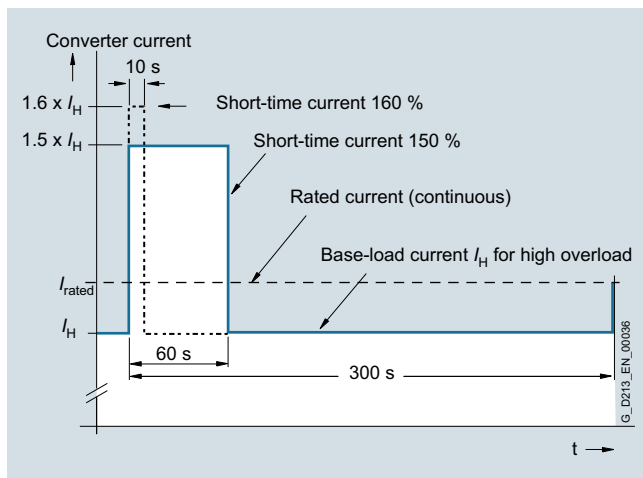

High overload

The following applies to the 6SL3325-1TG41-3AA7 and 6SL3325-1TG41-6AA7 Motor Modules:

The short-time current for low overload must be reduced from 150 % to 130 % for 10 s. At 10 s and 60 s, the short-time current for high overload must be reduced to 130 %. The duty cycle remains unchanged.

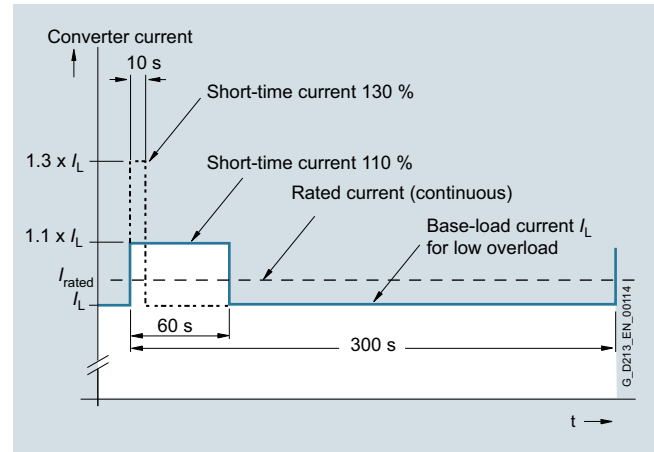

Low overload

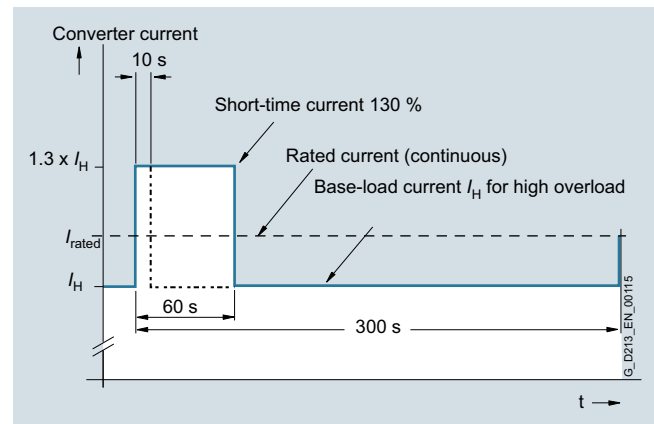

High overload

#### Line Modules

The base-load current for a high overload  $I_{HDC}$  is the basis for a duty cycle of 150 % for 60 s or  $I_{maxDC}$  for 5 s.

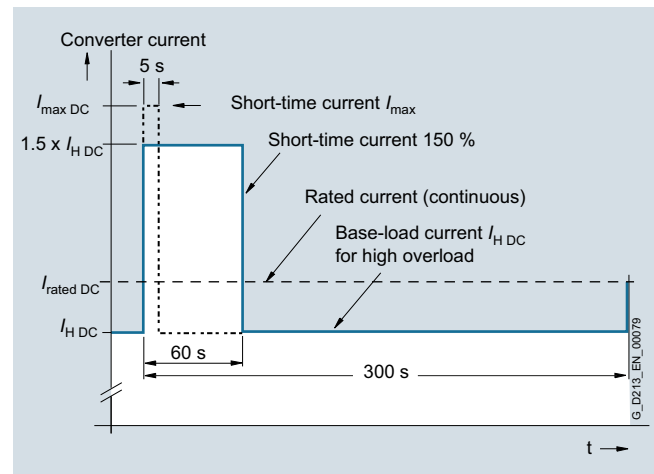

High overload



## SINAMICS S120 Chassis Format Converter Units

Water-cooled units

### Power Modules

#### Overview



The Power Module comprises a line rectifier, a DC link, and a converter to supply the motor.

Power Modules are designed for drives that are not capable of regenerating energy to the line supply system. If the motor produces energy during braking, a Braking Module with braking resistors will be required.

The water-cooled Power Modules are specifically designed for the operation of shared cooling circuits for the plant, motor and converter.

Power Modules in chassis format can be connected to grounded TN/TT systems and non-grounded IT systems.

#### Design

The water-cooled Power Modules have the following interfaces as standard:

- 1 line supply connection
- 1 motor connection
- 1 connection for the 24 V DC electronics power supply
- 1 DC link connection
- 3 DRIVE-CLiQ sockets
- 1 temperature sensor input for KTY84-130, Pt1000, PTC, or Pt100 (Pt1000 can be used from firmware V4.7 HF17)
- 1 connection for Safe Brake Adapter
- 1 connection for Safety Integrated
- 2 PE connections
- 2 cooling water ports

The CU310-2 Control Unit can be integrated into the water-cooled Power Modules.

The status of the Power Modules is indicated via three LEDs.

The scope of supply of the Power Modules includes:

- 1 DRIVE-CLiQ cable for connection to the Control Unit
- 2 seals for cooling water connections
- 1 set of warning labels in 30 languages (BG, CN, CZ, DE, DK, EE, ES, FI, FR, GB, GR, HU, IE, IS, IT, JP, KR, LT, LV, MT, NL, NO, PL, PT, RO, RU, SE, SI, SK, TR)

<sup>1)</sup> Recommended components for installing a flow control as condensation protection; manufactured by Siemens Building Technologies.

#### Selection and ordering data

Type rating at 400 V kW	Rated output current A	Power Module Article No.
<b>Line voltage 380 ... 480 V 3 AC</b>		
110	210	<b>6SL3315-1TE32-1AA3</b>
132	260	<b>6SL3315-1TE32-6AA3</b>
160	310	<b>6SL3315-1TE33-1AA3</b>
250	490	<b>6SL3315-1TE35-0AA3</b>
Description		Article No.
<b>Accessories</b>		
<b>3-way valve <sup>1)</sup></b>		<b>VXF41.../VXG41...</b>
<b>Actuator for 3-way valve <sup>1)</sup></b>		
• 230 V 1 AC		<b>SAX31...</b>
• 24 V AC/DC		<b>SAX61.../SAX81...</b>
<b>Accessories for re-ordering</b>		
<b>Dust protection blanking plugs</b> (50 units) For DRIVE-CLiQ port		<b>6SL3066-4CA00-0AA0</b>

For additional information, refer to the manual.

For line-side and motor-side components, see System components.

# SINAMICS S120 Chassis Format Converter Units

## Water-cooled units

### Power Modules

#### Integration

The Power Modules communicate with the higher-level control module via DRIVE-CLiQ. The control module in this case could be a CU310-2, CU320-2, or a SIMOTION D Control Unit. An external 24 V DC power supply is required to operate water-cooled Power Modules.

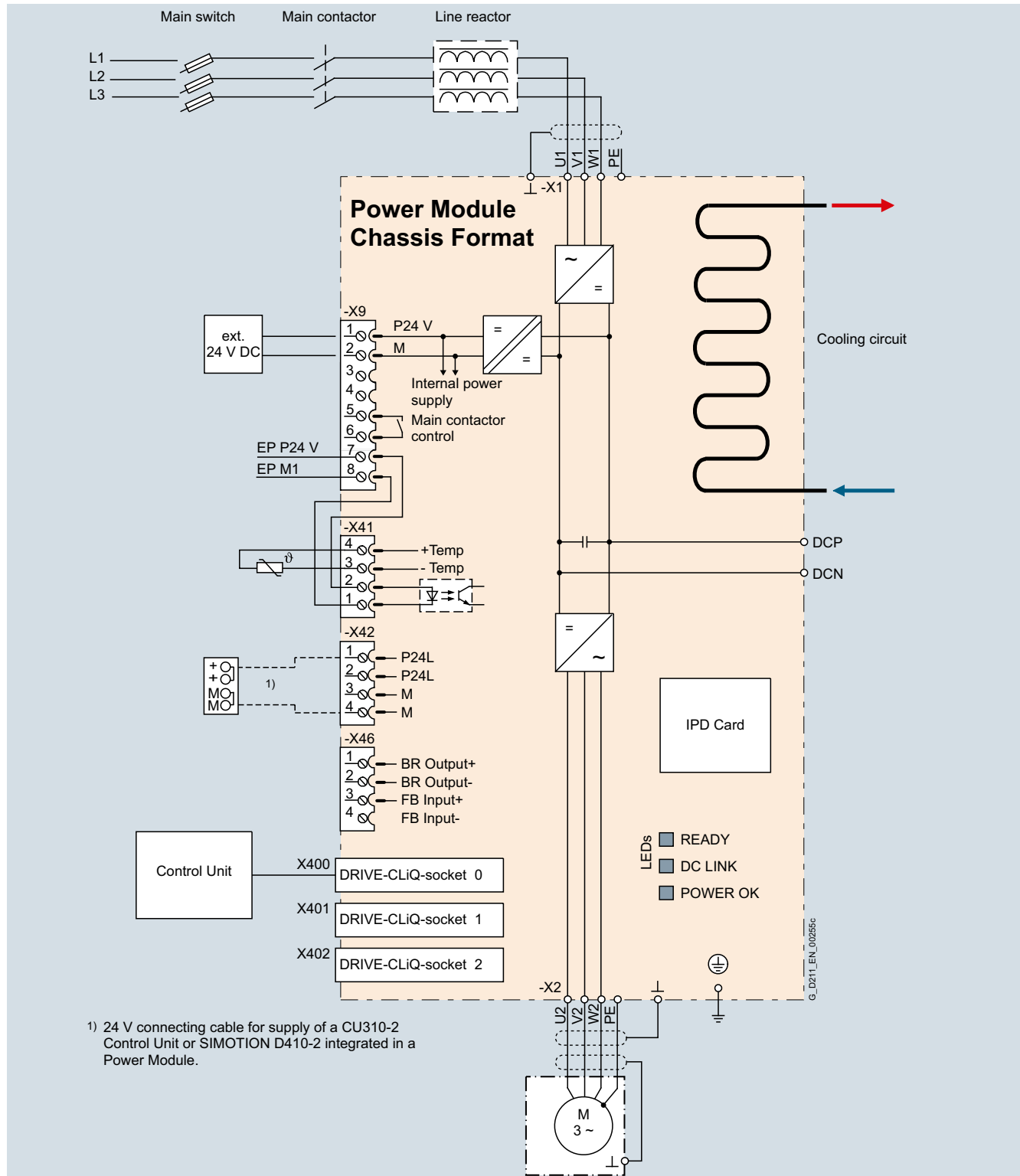

Connection example of a water-cooled Power Module in chassis format

#### Note:

The integrated 24 V power supply at connector X42 can have a maximum load of 2 A. When the Control Unit is supplied from the

integrated power supply, the total load of the digital outputs must be carefully observed to ensure that the 2 A is not exceeded.

## SINAMICS S120 Chassis Format Converter Units

Water-cooled units

### Power Modules

#### Technical specifications

##### General technical specifications

Electrical specifications	
<b>Line connection voltage</b> Up to 2000 m above sea level	380 ... 480 V 3 AC $\pm 10\%$ (-15 % <1 min)
<b>Line power factor</b> for a 3 AC line supply voltage and rated output	
• Basic fundamental ( $\cos \varphi_1$ )	>0.96
• Total ( $\lambda$ )	0.75 ... 0.93
<b>Efficiency</b>	>98 %
<b>DC link voltage, approx.</b>	1.35 $\times$ line voltage
<b>Output voltage, approx.</b>	0 ... $0.97 \times U_{\text{line}}$
<b>Output frequency <sup>1)</sup></b>	
• Control type Servo	0 ... 550 Hz
• Control type Vector	0 ... 550 Hz
• Control mode V/f	0 ... 550 Hz
<b>Electronics power supply</b>	24 V DC -15 %/+20 %
<b>Main contactor control</b>	
• Terminal block -X9/5-6	240 V AC, max. 8 A 30 V DC, max. 1 A
<b>Safety Integrated</b>	Safety Integrity Level 2 (SIL2) acc. to IEC 61508, Performance Level d (PLd) acc. to EN ISO 13849-1 and Control Category 3 acc. to EN ISO 13849-1.

<sup>1)</sup> Please note:

- The correlation between the maximum output frequency, pulse frequency and current derating. Higher output frequencies on request. For further information see <https://support.industry.siemens.com/cs/document/104020669>
- The correlation between the minimum output frequency and permissible output current (current derating). Information is provided in the SINAMICS Low Voltage Engineering Manual.

# SINAMICS S120 Chassis Format Converter Units

## Water-cooled units

### Power Modules

#### Technical specifications (continued)

Line voltage 380 V ... 480 V 3 AC		Power Modules			
		6SL3315-1TE32-1AA3	6SL3315-1TE32-6AA3	6SL3315-1TE33-1AA3	6SL3315-1TE35-0AA3
<b>Type rating</b>					
• At $I_L$ (50 Hz 400 V) <sup>1)</sup>	kW	<b>110</b>	<b>132</b>	<b>160</b>	<b>250</b>
• At $I_H$ (50 Hz 400 V) <sup>1)</sup>	kW	90	110	132	200
• At $I_L$ (60 Hz 460 V) <sup>2)</sup>	hp	150	200	250	400
• At $I_H$ (60 Hz 460 V) <sup>2)</sup>	hp	150	200	200	350
<b>Output current</b>					
• Rated current $I_{rated O_3}$	A	210	260	310	490
• Base-load current $I_L$ <sup>3)</sup>	A	205	250	302	477
• Base-load current $I_H$ <sup>4)</sup>	A	178	233	277	438
• Max. output current $I_{max O}$	A	307	375	453	715
<b>Input current</b>					
• Rated current $I_{rated I}$	A	230	285	340	540
• Maximum current $I_{max I}$	A	336	411	496	788
<b>Current demand</b>					
• 24 V DC auxiliary power supply	A	1.4	1.4	1.5	1.5
<b>Pulse frequency</b> <sup>5)</sup>					
• Rated frequency	kHz	2	2	2	2
• Pulse frequency, max.					
- Without current derating	kHz	2	2	2	2
- With current derating	kHz	8	8	8	8
<b>Power loss, at 50 Hz 400 V</b> <sup>6)</sup>					
• Dissipated to coolant	kW	2.36	2.97	3.31	5.29
• Dissipated to ambient air	kW	0.06	0.07	0.09	0.14
• Total	kW	2.42	3.04	3.4	5.43
<b>Coolant volume flow</b> <sup>7)</sup>		l/min	9	12	12
<b>Liquid volume</b> of the integrated heat exchanger		dm <sup>3</sup>	0.52	0.88	0.88
<b>Pressure drop, typ.</b> <sup>8)</sup> for volume flow		Pa	70000	70000	70000
<b>Heat exchanger material</b>			Stainless steel	Stainless steel	Stainless steel
<b>Coolant connections</b> Intake/return			Pipe thread ISO 228 G 3/4 B (external thread 3/4", flat-sealing)		
<b>Sound pressure level <math>L_{pA}</math></b> (1 m) at 50/60 Hz		dB	52	52	52
<b>Line supply connection</b> U1, V1, W1			Hole for M12	Hole for M12	Hole for M12
• Conductor cross-section, max. (IEC)	mm <sup>2</sup>	2 × 95	2 × 95	2 × 240	2 × 240
<b>DC link connection</b> DCP, DCN			Hole for M12	Hole for M12	Hole for M12
• Conductor cross-section, max. (IEC)	mm <sup>2</sup>	2 × 95	2 × 95	2 × 240	2 × 240
<b>Motor connection</b> U2/T1, V2/T2, W2/T3			Hole for M12	Hole for M12	2 × hole for M12
• Conductor cross-section, max. (IEC)	mm <sup>2</sup>	2 × 95	2 × 95	2 × 240	2 × 240
<b>Cable length, max</b> <sup>9)</sup>					
• Shielded	m	300	300	300	300
• Unshielded	m	450	450	450	450
<b>PE/GND connection</b>					
• Conductor cross-section, max. (IEC)	mm <sup>2</sup>	2 × hole for M12 2 × 95	2 × hole for M12 2 × 95	2 × hole for M12 2 × 240	2 × hole for M12 2 × 240
<b>Dimensions</b>					
• Width	mm	265	265	265	265
• Height	mm	836	836	983	983
• Depth	mm	549	549	549	549
<b>Weight, approx.</b>		kg	77	108	108
<b>Frame size</b>			FL	GL	GL
<b>Minimum short-circuit current</b> <sup>10)</sup>		A	3000	3600	4400
				4400	8000

<sup>1)</sup> Rated output of a typical 6-pole standard induction motor based on  $I_L$  or  $I_H$  for 400 V 3 AC 50 Hz.

<sup>2)</sup> Rated output of a typical 6-pole standard induction motor based on  $I_L$  or  $I_H$  for 460 V 3 AC 60 Hz.

<sup>3)</sup> The base-load current  $I_L$  is based on a duty cycle of 110 % for 60 s or 150 % for 10 s with a duty cycle duration of 300 s.

<sup>4)</sup> The base-load current  $I_H$  is based on a duty cycle of 150 % for 60 s or 160 % for 10 s with a duty cycle duration of 300 s.

<sup>5)</sup> Information regarding the correlation between the pulse frequency and maximum output current/output frequency is provided in the SINAMICS Low Voltage Engineering Manual.

<sup>6)</sup> The specified power loss represents the maximum value at 100 % utilization. The value is lower under normal operating conditions. To ensure safe dissipation of the minor power loss released to the ambient air, it is important to follow the instructions pertaining to control cabinet installation in the SINAMICS Low Voltage Engineering Manual.

<sup>7)</sup> The value applies to coolants comprising water and a mixture of water and antifreeze agent.

<sup>8)</sup> The value is valid for water as coolant. [Additional information and notes on other coolants are provided in the SINAMICS Low Voltage Engineering Manual.](#)

<sup>9)</sup> Longer cable lengths for specific configurations are available on request. [For additional information, please refer to the SINAMICS Low Voltage Engineering Manual.](#)

<sup>10)</sup> Current required for reliably triggering protective devices.

## SINAMICS S120 Chassis Format Converter Units

Water-cooled units

### Active Line Modules

#### Overview



The self-commutated infeed/regenerative feedback units (with IGBTs in infeed and regenerative feedback directions) generate a regulated DC link voltage. This means that the connected Motor Modules are decoupled from the line voltage. Line voltage fluctuations within the permissible supply tolerances have no effect on the motor voltage.

If required, the Active Line Modules can also provide reactive power compensation.

Active Line Modules are designed for connection to grounded TN/TT and non-grounded IT supply systems.

The water-cooled Active Line Modules are specifically designed for the operation of shared cooling circuits for the plant, motor and converter.

Active Line Modules are always operated together with the associated Active Interface Modules. These include the necessary pre-charging circuit as well as a Clean Power Filter.

#### Design

The water-cooled Active Line Modules have the following interfaces as standard:

- 1 line supply connection
- 1 connection for the 24 V DC electronics power supply
- 1 DC link connection (DCP, DCN) for supplying the connected Motor Modules
- 3 DRIVE-CLiQ sockets
- 1 temperature sensor input for KTY84-130, Pt1000, PTC, or Pt100 (Pt1000 can be used from firmware V4.7 HF17)
- 1 PE connection
- 2 cooling water ports

The status of the Active Line Modules is indicated via three LEDs.

The following are included in the scope of supply of the Active Line Modules:

- 1 DRIVE-CLiQ cable for connection to the Control Unit
- 2 seals for cooling water connections
- 1 set of warning labels in 30 languages (BG, CN, CZ, DE, DK, EE, ES, FI, FR, GB, GR, HU, IE, IS, IT, JP, KR, LT, LV, MT, NL, NO, PL, PT, RO, RU, SE, SI, SK, TR)

#### Selection and ordering data

Rated power at 400 V or 690 V kW	Rated infeed/ regenerative feedback current A	Active Line Module Article No.
<b>Line voltage 380 ... 480 V 3 AC</b>		
630	985	<b>6SL3335-7TE41-0AA7</b>
900	1405	<b>6SL3335-7TE41-4AA7</b>
<b>Line voltage 500 ... 690 V 3 AC</b>		
900	810	<b>6SL3335-7TG38-1AA7</b>
1100	1020	<b>6SL3335-7TG41-0AA7</b>
1400	1270	<b>6SL3335-7TG41-3AA7</b>
1700	1560	<b>6SL3335-7TG41-6AA7</b>
Description		Article No.

#### Accessories

<b>3-way valve <sup>1)</sup></b>	<b>VXF41...</b> <b>VXG41...</b>
<b>Actuator for 3-way valve <sup>1)</sup></b>	<b>SAX31...</b> <b>SAX61...</b> <b>SAX81...</b>

#### Accessories for re-ordering

<b>Dust protection blanking plugs</b> (50 units) For DRIVE-CLiQ port	<b>6SL3066-4CA00-0AA0</b>
--	---------------------------

For additional information, refer to the manual.

For line-side components and recommended system components, see system components.

<sup>1)</sup> Recommended components for installing a flow control as condensation protection; manufactured by Siemens Building Technologies.

# SINAMICS S120 Chassis Format Converter Units

## Water-cooled units

### Active Line Modules

#### Integration

Active Line Modules are always operated together with the associated Active Interface Modules. Active Interface Modules contain a Clean Power Filter with basic RI suppression, the pre-charging circuit for the Active Line Module, line voltage sensing circuit, and monitoring sensors.

The water-cooled Active Line Modules communicate with the higher-level control module via DRIVE-CLiQ. The control module in this case can be a CU320-2 or a SIMOTION D Control Unit. An external 24 V DC power supply is required to operate water-cooled Active Line Modules.

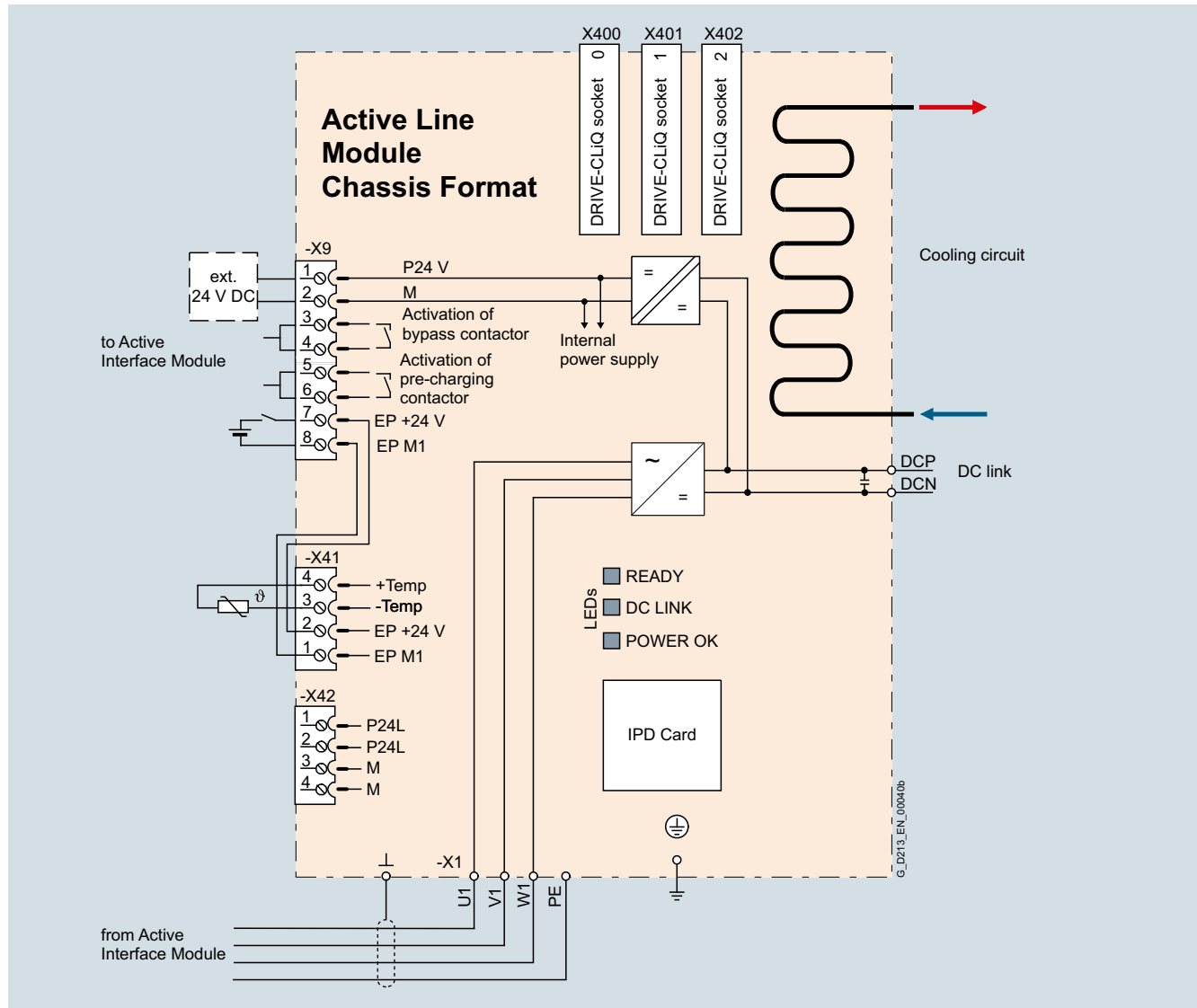

Connection example of an Active Line Module

#### Technical specifications

##### General technical specifications

##### Electrical specifications

##### Line power factor

- Basic fundamental ( $\cos \varphi_1$ ) 1 (factory setting), can be altered by inputting a reactive current setpoint
- Total ( $\lambda$ ) 1 (factory setting)

##### Efficiency

>98.5 % (Active Line Module)  
>99 % (Active Interface Module)

##### DC link voltage, approx.

The DC link voltage is regulated and can be adjusted as a voltage decoupled from the line voltage. Factory setting of the DC link voltage:  $1.5 \times$  line voltage

# SINAMICS S120 Chassis Format Converter Units

## Water-cooled units

### Active Line Modules

#### Technical specifications (continued)

Line voltage 380 V ... 480 V 3 AC		Active Line Modules	
		6SL3335-7TE41-0AA7	6SL3335-7TE41-4AA7
<b>Rated power</b>			
• At $I_{\text{rated DC}}$ (50 Hz 400 V)	kW	<b>630</b>	<b>900</b>
• At $I_{\text{H DC}}$ (50 Hz 400 V)	kW	545	780
• At $I_{\text{rated DC}}$ (60 Hz 460 V)	hp	900	1250
• At $I_{\text{H DC}}$ (60 Hz 460 V)	hp	800	1000
<b>DC link current</b>			
• Rated current $I_{\text{rated DC}}$	A	1100	1573
• Base-load current $I_{\text{H DC}}^{1)}$	A	982	1401
• Maximum current $I_{\text{max DC}}$	A	1654	2361
<b>Infeed/regenerative feedback current</b>			
• Rated current $I_{\text{rated I}}$	A	985	1405
• Maximum current $I_{\text{max I}}$	A	1477	2055
<b>Current demand</b>			
• 24 V DC auxiliary power supply	A	1.6	1.6
<b>DC link capacitance</b>			
• Active Line Module	$\mu\text{F}$	18900	28800
• Drive line-up, max.	$\mu\text{F}$	230400	230400
<b>Pulse frequency</b>			
	kHz	2.5	2.5
<b>Power loss, at 50 Hz 400 V <sup>2)</sup></b>			
• Dissipated to coolant	kW	7.46	9.58
• Dissipated to ambient air	kW	0.44	0.62
• Total	kW	7.9	10.2
<b>Coolant volume flow <sup>3)</sup></b>			
	l/min	27	27
<b>Liquid volume of the integrated heat exchanger</b>			
	$\text{dm}^3$	1.56	1.56
<b>Pressure drop, typ. <sup>4)</sup> for volume flow</b>			
	Pa	70000	70000
<b>Heat exchanger material</b>			
		Copper-nickel alloy	Copper-nickel alloy
<b>Coolant connections Intake/return</b>			
		Pipe thread ISO 228 G 3/4 B (external thread 3/4", flat-sealing)	
<b>Sound pressure level <math>L_{\text{pA}}^{5)}</math> (1 m) at 50/60 Hz</b>			
	dB	71/73	71/73
<b>Line supply connection U1, V1, W1</b>			
• Conductor cross-section, max. (IEC)	$\text{mm}^2$	Busbar	Busbar
<b>DC link connection DCP, DCN</b>			
		2 x hole for M12 Busbar	2 x hole for M12 Busbar
<b>PE/GND connection</b>			
• Conductor cross-section, max. (IEC)	$\text{mm}^2$	2 x hole for M12 4 x 240	2 x hole for M12 4 x 240
<b>Cable length, max. <sup>6)</sup></b>			
• Shielded	m	3900	3900
• Unshielded	m	5850	5850
<b>Dimensions</b>			
• Width	mm	295	295
• Height	mm	1510	1510
• Depth	mm	545	545
<b>Weight, approx.</b>			
	kg	230	230
<b>Frame size</b>			
		JXL	JXL
<b>Minimum short-circuit current <sup>7)</sup></b>			
	A	16000	21000

<sup>1)</sup> The base-load current  $I_{\text{H DC}}$  is the basis for a duty cycle of 150 % for 60 s or  $I_{\text{max DC}}$  for 5 s with a duty cycle duration of 300 s.

<sup>2)</sup> The specified power loss represents the maximum value at 100 % utilization. The value is lower under normal operating conditions. To ensure safe dissipation of the minor power loss released to the ambient air, it is important to follow the instructions pertaining to control cabinet installation in the SINAMICS Low Voltage Engineering Manual.

<sup>3)</sup> The value applies to coolants comprising water and a mixture of water and antifreeze agent.

<sup>4)</sup> The value is valid for water as coolant. [Additional information and notes on other coolants are provided in the SINAMICS Low Voltage Engineering Manual.](#)

<sup>5)</sup> Total sound pressure level of Active Interface Module and Active Line Module.

<sup>6)</sup> Total of all motor cables and DC link. Longer cable lengths for specific configurations are available on request. [For additional information, please refer to the SINAMICS Low Voltage Engineering Manual.](#)

<sup>7)</sup> Current required for reliably triggering protective devices.

# SINAMICS S120 Chassis Format Converter Units

## Water-cooled units

### Active Line Modules

#### Technical specifications (continued)

Line voltage 500 ... 690 V 3 AC		Active Line Modules			
		6SL3335-7TG38-1AA7	6SL3335-7TG41-0AA7	6SL3335-7TG41-3AA7	6SL3335-7TG41-6AA7
<b>Rated power</b>					
• At $I_{\text{rated DC}}$ (50 Hz 690 V)	kW	<b>900</b>	<b>1100</b>	<b>1400</b>	<b>1700</b>
• At $I_{\text{H DC}}$ (50 Hz 690 V)	kW	670	1000	1215	1490
• At $I_{\text{rated DC}}$ (50 Hz 500 V)	kW	620	780	965	1180
• At $I_{\text{H DC}}$ (50 Hz 500 V)	kW	485	710	880	1080
• At $I_{\text{rated DC}}$ (60 Hz 575 V)	hp	975	1250	1500	1880
• At $I_{\text{H DC}}$ (60 Hz 575 V)	hp	765	1000	1250	1530
<b>DC link current</b>					
• Rated current $I_{\text{rated DC}}$	A	907	1147	1422	1740
• Base-load current $I_{\text{H DC}}^{1)}$	A	808	936	1266	1550
• Maximum current $I_{\text{max DC}}$	A	1360	1722	2133	2620
<b>Infeed/regenerative feedback current</b>					
• Rated current $I_{\text{rated I}}$	A	810	1025	1270	1560
• Maximum current $I_{\text{max I}}$	A	1214	1537	1905	2055
<b>Current demand</b>					
• 24 V DC auxiliary power supply	A	1.6	1.6	1.46	1.5
<b>DC link capacitance</b>					
• Active Line Module	μF	10500	16000	19330	21000
• Drive line-up, max.	μF	153600	153600	153600	210000
<b>Pulse frequency</b>		kHz	2.5	2.5	2.5
<b>Power loss, at 50 Hz 690 V <sup>2)</sup></b>					
• Dissipated to coolant	kW	8.28	10.37	12.98	17.17
• Dissipated to ambient air	kW	0.22	0.53	0.57	0.79
• Total	kW	8.5	10.9	13.55	17.96
<b>Coolant volume flow <sup>3)</sup></b>		l/min	16	27	27
<b>Liquid volume</b> of the integrated heat exchanger		dm <sup>3</sup>	0.74	1.56	1.56
<b>Pressure drop, typ. <sup>4)</sup></b> for volume flow		Pa	70000	70000	70000
<b>Heat exchanger material</b>			Copper-nickel alloy	Copper-nickel alloy	Copper-nickel alloy
<b>Coolant connections</b> Intake/return			Pipe thread ISO 228 G 3/4 B (external thread 3/4", flat-sealing)		
<b>Sound pressure level <math>L_{\text{pA}}^{5)}</math></b> (1 m) at 50/60 Hz		dB	71/73	71/73	71/73
<b>Line supply connection</b> U1, V1, W1			2 × hole for M12	2 × hole for M12	2 × hole for M12
• Conductor cross-section, max. (IEC)	mm <sup>2</sup>	4 × 185	Busbar	Busbar	Busbar
<b>DC link connection</b> DCP, DCN			2 × hole for M12 Busbar	2 × hole for M12 Busbar	2 × hole for M12 Busbar
<b>PE/GND connection</b> • Conductor cross-section, max. (IEC)		mm <sup>2</sup>	2 × hole for M12 4 × 185	2 × hole for M12 Busbar	2 × hole for M12 Busbar
<b>Cable length, max. <sup>6)</sup></b>					
• Shielded	m	2250	2250	2250	2250
• Unshielded	m	3375	3375	3375	3375
<b>Dimensions</b>					
• Width	mm	265	295	295	295
• Height	mm	987	1510	1510	1510
• Depth	mm	545	545	545	545
<b>Weight, approx.</b>		kg	125	230	230
<b>Frame size</b>			HXL	JXL	JXL
<b>Minimum short-circuit current <sup>7)</sup></b>		A	12600	16000	20000

<sup>1)</sup> The base-load current  $I_{\text{H DC}}$  is the basis for a duty cycle of 150 % for 60 s or  $I_{\text{max DC}}$  for 5 s with a duty cycle duration of 300 s.

<sup>2)</sup> The specified power loss represents the maximum value at 100 % utilization. The value is lower under normal operating conditions. To ensure safe dissipation of the minor power loss released to the ambient air, it is important to follow the instructions pertaining to control cabinet installation in the SINAMICS Low Voltage Engineering Manual.

<sup>3)</sup> The value applies to coolants comprising water and a mixture of water and antifreeze agent.

<sup>4)</sup> The value is valid for water as coolant. [Additional information and notes on other coolants are provided in the SINAMICS Low Voltage Engineering Manual.](#)

<sup>5)</sup> Total sound pressure level of Active Interface Module and Active Line Module.

<sup>6)</sup> Total of all motor cables and DC link. Longer cable lengths for specific configurations are available on request. [For additional information, please refer to the SINAMICS Low Voltage Engineering Manual.](#)

<sup>7)</sup> Current required for reliably triggering protective devices.



## SINAMICS S120 Chassis Format Converter Units

Water-cooled units

### Active Interface Modules

#### Overview

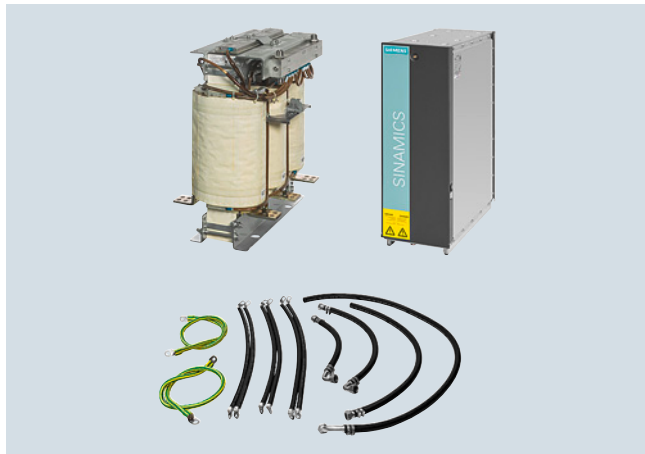

The Active Interface Module essentially comprises a water-cooled filter reactor and a water-cooled filter module. The filter module contains a Clean Power Filter with basic RI suppression, the pre-charging circuit for the Active Line Module, the line voltage sensing circuit and monitoring sensors.

A bypass contactor is provided separately. Active Interface Modules are used in conjunction with Active Line Modules.

The water-cooled Active Interface Modules are specifically designed for the operation of shared cooling circuits for the plant, motor, and converter.

#### Design

Active Interface Modules have the following interfaces as standard:

- 1 line supply connection
- 1 load connection
- 1 connection for the 24 V DC electronics power supply
- 1 connection for the external 230 V AC supply
- 1 DRIVE-CLiQ socket (on VSM10 Voltage Sensing Module)
- 1 connection for pre-charging circuit
- 1 PE connection
- 2 cooling water ports

The scope of supply of the Active Interface Modules includes:

- Water-cooled filter reactor
- Water-cooled filter module
- Connection kit (cables and hoses)
- DRIVE-CLiQ cable for the connection between Active Interface Module and Active Line Module
- 2 seals for cooling water connections
- 1 set of warning labels in 30 languages (BG, CN, CZ, DE, DK, EE, ES, FI, FR, GB, GR, HU, IE, IS, IT, JP, KR, LT, LV, MT, NL, NO, PL, PT, RO, RU, SE, SI, SK, TR)

#### Accessories

##### Installation kit for Active Interface Module

The installation kit includes support plates, holding plates, insulating plates and mats, and mounting materials for installing an Active Interface Module in a 600 mm wide electrical cabinet.

##### Note:

When using the installation kit, the mounting device can also be used for installing and removing the filter module.

#### Selection and ordering data

Suitable for Active Line Module in chassis format, water-cooled	Rated power of the Active Line Modules at 400 V or 690 V kW	Active Interface Module, water-cooled Article No.
<b>Line voltage 380 ... 480 V 3 AC</b>		
6SL3335-7TE41-0AA7	630	<b>6SL3305-7TE41-4AA7</b>
6SL3335-7TE41-4AA7	900	<b>6SL3305-7TE41-4AA7</b>
<b>Line voltage 500 ... 690 V 3 AC</b>		
6SL3335-7TG38-1AA7	900	<b>6SL3305-7TG41-0AA7</b>
6SL3335-7TG41-0AA7	1100	<b>6SL3305-7TG41-0AA7</b>
6SL3335-7TG41-3AA7	1400	<b>6SL3305-7TG41-3AA7</b>
6SL3335-7TG41-6AA7	1700	<b>6SL3305-7TG41-6AA7</b>
Description		Article No.
<b>Accessories</b>		
<b>Installation kit for Active Interface Modules</b> for installation in a Rittal TS8 electrical cabinet		<b>6SL3065-1FJ00-0AA0</b>

# SINAMICS S120 Chassis Format Converter Units

Water-cooled units

## Active Interface Modules

### Integration

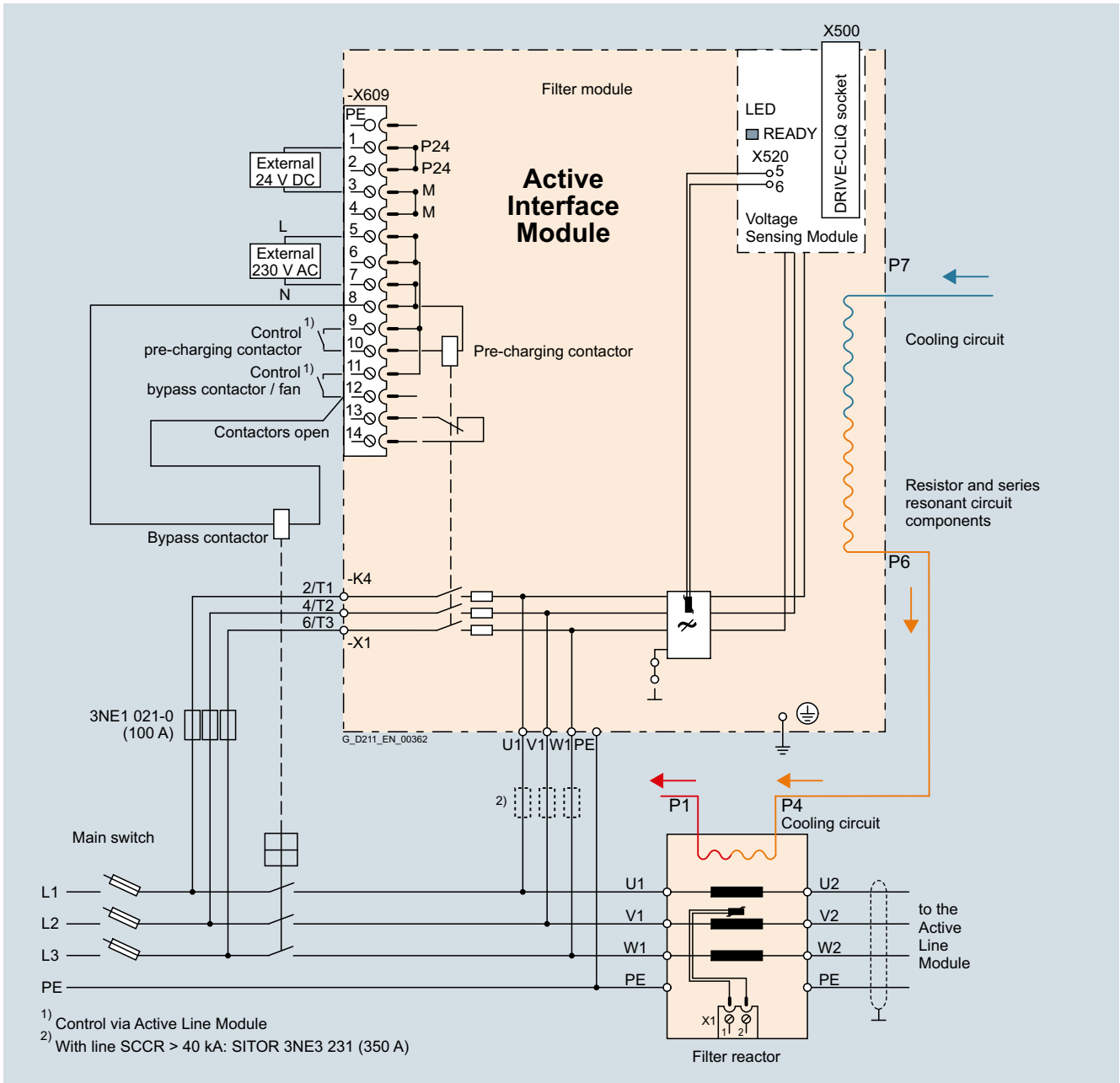

Connection example of water-cooled Active Interface Module with external bypass contactor

1) Control via Active Line Module  
 2) With line SCCR > 40 kA: SITOP 3NE3 231 (350 A)

# SINAMICS S120 Chassis Format Converter Units

Water-cooled units

## Active Interface Modules

### Technical specifications

Line voltage 380 ... 480 V 3 AC		Active Interface Module	
		6SL3305-7TE41-4AA7	
<b>Suitable for Active Line Module</b>			
• Rated power at 400 V - Water-cooled	kW	<b>630</b> 6SL3335-7TE41-0AA7	<b>900</b> 6SL3335-7TE41-4AA7
<b>Rated current</b>	A	985	1405
<b>Bypass contactor <sup>1)</sup></b>		3WL1112-2BB34-4AN2-Z C22 <sup>2)</sup>	3WL1116-2BB34-4AN2-Z C22 <sup>2)</sup>
<b>Current demand</b>			
• 24 V DC auxiliary power supply	A	0.17	0.17
• 230 V 2 AC			
- Inrush current	A	1.0	1.0
- Holding current	A	0.1	0.1
<b>DC link capacitance</b> of the drive line-up, max. <sup>3)</sup>	µF	230400	230400
<b>Coolant volume flow</b>	l/min	10	10
<b>Pressure drop, typ. for volume flow</b>	Pa	70000	70000
<b>Sound pressure level <math>L_{pA}</math></b> (1 m) at 50/60 Hz	dB	71/71	71/71
<b>Frame size</b>		JIL	JIL
<b>Filter reactor</b>			
<b>Power loss <sup>4)</sup></b>			
• At 50 Hz 400 V	kW	6.0	8.6
• At 60 Hz 460 V	kW	6.0	8.6
• Dissipated to ambient air	kW	0.9	0.9
<b>Liquid volume</b>			
• Of integrated reactor cooler	dm <sup>3</sup>	0.6	0.6
• Of hoses supplied	dm <sup>3</sup> /m	0.285	0.285
<b>Coolant volume flow</b>	l/min	10	10
<b>Pressure drop, typ. for volume flow</b>	Pa	70000	70000
<b>Heat exchanger material</b>		Copper-nickel alloy	Copper-nickel alloy
<b>Coolant connections</b> Return and connection to filter module		Pipe thread ISO 228 G 3/4 B (external thread 3/4", flat-sealing)	
<b>Line/load connection</b> L1, L2, L3 / U2, V2, W2		Flat connector for M12 screws	Flat connector for M12 screws
<b>PE/GND connection</b> • Conductor cross-section, max. (IEC)	mm <sup>2</sup>	M10 stud 1 × 240	M10 stud 1 × 240
<b>Degree of protection</b>		IP00	IP00
<b>Dimensions</b>			
• Width	mm	382	382
• Height	mm	698	698
• Depth	mm	575	575
<b>Weight, approx.</b>	kg	299	299
<b>Filter module</b>			
<b>Power loss <sup>4)</sup></b>			
• At 50 Hz 400 V	kW	3.6	3.6
• At 60 Hz 460 V	kW	3.6	3.6
• Dissipated to ambient air	kW	0.15	0.15
<b>Liquid volume</b>	dm <sup>3</sup>	1	1
<b>Heat exchanger material</b>		Copper-nickel alloy	Copper-nickel alloy
<b>Coolant connections</b> Intake and connection to filter reactor		Pipe thread ISO 228 G 3/4 B (external thread 3/4", flat-sealing)	

For footnotes, see next page.

# SINAMICS S120 Chassis Format Converter Units

## Water-cooled units

### Active Interface Modules

#### Technical specifications (continued)

Line voltage 380 ... 480 V 3 AC		Active Interface Module	
		6SL3305-7TE41-4AA7	
<b>PE/GND connection</b>		Flat connector for M8 screw	Flat connector for M8 screw
• Conductor cross-section, max. (IEC)	mm <sup>2</sup>	2 × 120	2 × 120
<b>Degree of protection</b>		IP00	IP00
<b>Dimensions</b>			
• Width	mm	300	300
• Height	mm	864	864
• Depth	mm	540	540
<b>Weight, approx.</b>	kg	160	160

<sup>1)</sup> The bypass contactor is not included in the scope of supply.

<sup>2)</sup> The breakers must only be switched ON and OFF by the sequence control. An interlocking set 3WL9111-0BA21-0AA0 as described in Catalog LV 10 should be provided for the bypass contactor to exclude the risk of unintentional manual operation. Manual operation bypasses the pre-charging circuit and can therefore destroy the Active Line Module.

<sup>3)</sup> Information on higher capacitances is included in the [SINAMICS Low Voltage Engineering Manual](#).

<sup>4)</sup> The specified power loss represents the maximum value at 100 % utilization. The value is lower under normal operating conditions. To ensure safe dissipation of the minor power loss released to the ambient air, it is important to follow the instructions pertaining to control cabinet installation in the [SINAMICS Low Voltage Engineering Manual](#).

# SINAMICS S120 Chassis Format Converter Units

Water-cooled units

## Active Interface Modules

### Technical specifications (continued)

Line voltage 500 ... 690 V 3 AC		Active Interface Modules		
		6SL3305-7TG41-0AA7	6SL3305-7TG41-3AA7	6SL3305-7TG41-6AA7
<b>Suitable for Active Line Module</b>				
<ul style="list-style-type: none"> <li>Rated power at 690 V</li> <li>Water-cooled</li> </ul>	kW	<b>900/1100</b> 6SL3335-7TG38-1AA7 6SL3335-7TG41-0AA7	<b>1400</b> 6SL3335-7TG41-3AA7	<b>1700</b> 6SL3335-7TG41-6AA7
<b>Rated current</b>	A	1025	1270	1560
<b>Bypass contactor <sup>1)</sup></b>		3WL1212-4BB34-4AN2-Z C22 <sup>2)</sup>	3WL1216-4BB34-4AN2-Z C22 <sup>2)</sup>	3WL1216-4BB34-4AN2-Z C22 <sup>2)</sup>
<b>Current demand</b>				
<ul style="list-style-type: none"> <li>24 V DC auxiliary power supply</li> <li>230 V 2 AC</li> <li>Inrush current</li> <li>Holding current</li> </ul>	A	0.17	0.17	0.17
	A	1.0	1.0	1.0
	A	0.1	0.1	0.1
<b>DC link capacitance</b> of the drive line-up, max. <sup>3)</sup>	μF	153600	153600	210000
<b>Coolant volume flow</b>	l/min	16	16	16
<b>Pressure drop, typ. for volume flow</b>	Pa	70000	70000	70000
<b>Sound pressure level <math>L_{pA}</math></b> (1 m) at 50/60 Hz	dB	71/71	71/71	71/71
<b>Frame size</b>		JIL	JIL	JIL
<b>Filter reactor</b>				
<b>Power loss <sup>4)</sup></b>				
<ul style="list-style-type: none"> <li>At 50 Hz 690 V</li> <li>At 60 Hz 575 V</li> <li>Dissipated to ambient air</li> </ul>	kW	6.2	9.3	11.0
	kW	6.2	9.3	11.0
	kW	0.6	0.95	1.15
<b>Liquid volume</b>				
<ul style="list-style-type: none"> <li>Of integrated reactor cooler</li> <li>Of hoses supplied</li> </ul>	dm <sup>3</sup>	0.6	0.6	0.6
	dm <sup>3</sup> /m	0.285	0.285	0.285
<b>Coolant volume flow</b>	l/min	10	10	8
<b>Pressure drop, typ. for volume flow</b>	Pa	70000	70000	70000
<b>Heat exchanger material</b>		Copper-nickel alloy	Copper-nickel alloy	Copper-nickel alloy
<b>Coolant connections</b> Return and connection to filter module		Pipe thread ISO 228 G 3/4 B (external thread 3/4", flat-sealing)		
<b>Line/load connection</b> L1, L2, L3 / U2, V2, W2		Flat connector for M12 screws	Flat connector for M12 screws	Flat connector for M12 screws
<b>PE/GND connection</b>				
<ul style="list-style-type: none"> <li>Conductor cross-section, max. (IEC)</li> </ul>	mm <sup>2</sup>	M10 stud 1 × 240	M10 stud 1 × 240	M10 stud 1 × 240
<b>Degree of protection</b>		IP00	IP00	IP00
<b>Dimensions</b>				
<ul style="list-style-type: none"> <li>Width</li> <li>Height</li> <li>Depth</li> </ul>	mm	440	440	440
	mm	705	705	705
	mm	575	575	580
<b>Weight, approx.</b>	kg	365	365	365
<b>Filter module</b>				
<b>Power loss <sup>4)</sup></b>				
<ul style="list-style-type: none"> <li>At 50 Hz 690 V</li> <li>At 60 Hz 575 V</li> <li>Dissipated to ambient air</li> </ul>	kW	5.0	5.0	7.5
	kW	5.0	5.0	7.5
	kW	0.15	0.15	0.15
<b>Liquid volume</b>	dm <sup>3</sup>	1	1	1
<b>Heat exchanger material</b>		Copper-nickel alloy	Copper-nickel alloy	Copper-nickel alloy
<b>Coolant connections</b> Intake and connection to filter reactor		Pipe thread ISO 228 G 3/4 B (external thread 3/4", flat-sealing)		

For footnotes, see next page.

# SINAMICS S120 Chassis Format Converter Units

## Water-cooled units

### Active Interface Modules

#### Technical specifications (continued)

Line voltage 500 ... 690 V 3 AC		Active Interface Modules		
		6SL3305-7TG41-0AA7	6SL3305-7TG41-3AA7	6SL3305-7TG41-6AA7
<b>PE/GND connection</b>		Flat connector for M8 screw		
• Conductor cross-section, max. (IEC)	mm <sup>2</sup>	2 × 120	2 × 120	2 × 120
<b>Degree of protection</b>		IP00	IP00	IP00
<b>Dimensions</b>				
• Width	mm	300	300	300
• Height	mm	864	864	864
• Depth	mm	540	540	540
<b>Weight, approx.</b>	kg	160	160	160

<sup>1)</sup> The bypass contactor is not included in the scope of supply.

<sup>2)</sup> The breakers must only be switched ON and OFF by the sequence control. An interlocking set 3WL9111-0BA21-0AA0 as described in Catalog LV 10 should be provided for the bypass contactor to exclude the risk of unintentional manual operation. Manual operation bypasses the pre-charging circuit and can therefore destroy the Active Line Module.

<sup>3)</sup> [Information on higher capacitances is included in the SINAMICS Low Voltage Engineering Manual.](#)

<sup>4)</sup> The specified power loss represents the maximum value at 100 % utilization. The value is lower under normal operating conditions. To ensure safe dissipation of the minor power loss released to the ambient air, it is important to follow the instructions pertaining to control cabinet installation in the SINAMICS Low Voltage Engineering Manual.

# SINAMICS S120 Chassis Format Converter Units

Water-cooled units

## Motor Modules

### Overview



A Motor Module comprises a self-commutated converter with IGBTs. It generates a variable voltage with variable frequency from the DC link voltage that feeds the connected motor.

Multiple Motor Modules can be operated on a single DC link. This permits energy to be transferred between the Motor Modules. This means that if one Motor Module operating in generator mode produces energy, the energy can be used by another Motor Module operating in motor mode.

Motor Modules are controlled by a Control Unit.

The water-cooled Motor Modules are specifically designed for the operation of shared cooling circuits for the plant, motor, and converter.

### Design

The water-cooled Motor Modules have the following interfaces as standard:

- 1 motor connection
- 1 connection for the 24 V DC electronics power supply
- 1 DC link connection (DCP, DCN) for connecting to the supply DC link
- 3 DRIVE-CLiQ sockets
- 1 temperature sensor input for KTY84-130, Pt1000, PTC, or Pt100 (Pt1000 can be used from firmware V4.7 HF17)
- 1 connection for Safe Brake Adapter
- 1 connection for Safety Integrated
- 2 PE connections
- 2 cooling water ports

The status of the Motor Modules is indicated via three LEDs.

The scope of supply of the Motor Modules includes:

- 1 DRIVE-CLiQ cable for connection to the Control Unit
- 2 seals for cooling water connections
- 1 set of warning labels in 30 languages (BG, CN, CZ, DE, DK, EE, ES, FI, FR, GB, GR, HU, IE, IS, IT, JP, KR, LT, LV, MT, NL, NO, PL, PT, RO, RU, SE, SI, SK, TR)

### Selection and ordering data

Type rating at 400 V or 690 V kW	Rated output current A	Motor Module Article No.
<b>Line voltage 380 ... 480 V 3 AC (DC link voltage 510 ... 720 V DC)</b>		
110	210	<b>6SL3325-1TE32-1AA3</b>
132	260	<b>6SL3325-1TE32-6AA3</b>
160	310	<b>6SL3325-1TE33-1AA3</b>
250	490	<b>6SL3325-1TE35-0AA3</b>
400	745	<b>6SL3325-1TE37-5AA7</b>
560	985	<b>6SL3325-1TE41-0AA7</b>
710	1260	<b>6SL3325-1TE41-2AA7</b>
800	1405	<b>6SL3325-1TE41-4AA7</b>
<b>Line voltage 500 ... 690 V 3 AC (DC link voltage 675 ... 1035 V DC)</b>		
90	100	<b>6SL3325-1TG31-0AA3</b>
132	150	<b>6SL3325-1TG31-5AA3</b>
200	215	<b>6SL3325-1TG32-2AA3</b>
315	330	<b>6SL3325-1TG33-3AA3</b>
450	465	<b>6SL3325-1TG34-7AA7</b>
560	575	<b>6SL3325-1TG35-8AA7</b>
800	810	<b>6SL3325-1TG38-1AA7</b>
1000	1025	<b>6SL3325-1TG41-0AA7</b>
1200	1270	<b>6SL3325-1TG41-3AA7</b>
1500	1560	<b>6SL3325-1TG41-6AA7</b>

Description	Article No.
<b>Accessories</b>	
<b>3-way valve <sup>1)</sup></b>	<b>VXF41...</b> <b>VXG41...</b>
<b>Actuator for 3-way valve <sup>1)</sup></b>	<b>SAX31...</b> <b>SAX61...</b> <b>SAX81...</b>
<b>Accessories for re-ordering</b>	
<b>Dust protection blanking plugs</b> (50 units) For DRIVE-CLiQ port	<b>6SL3066-4CA00-0AA0</b>

For motor-side components, see System components.

<sup>1)</sup> Recommended components for installing a flow control as condensation protection; manufactured by Siemens Building Technologies.

# SINAMICS S120 Chassis Format Converter Units

## Water-cooled units

### Motor Modules

#### Integration

The water-cooled Motor Modules communicate with the higher-level control module via DRIVE-CLiQ.

The control module in this case can be a CU320-2 or a SIMOTION D Control Unit.

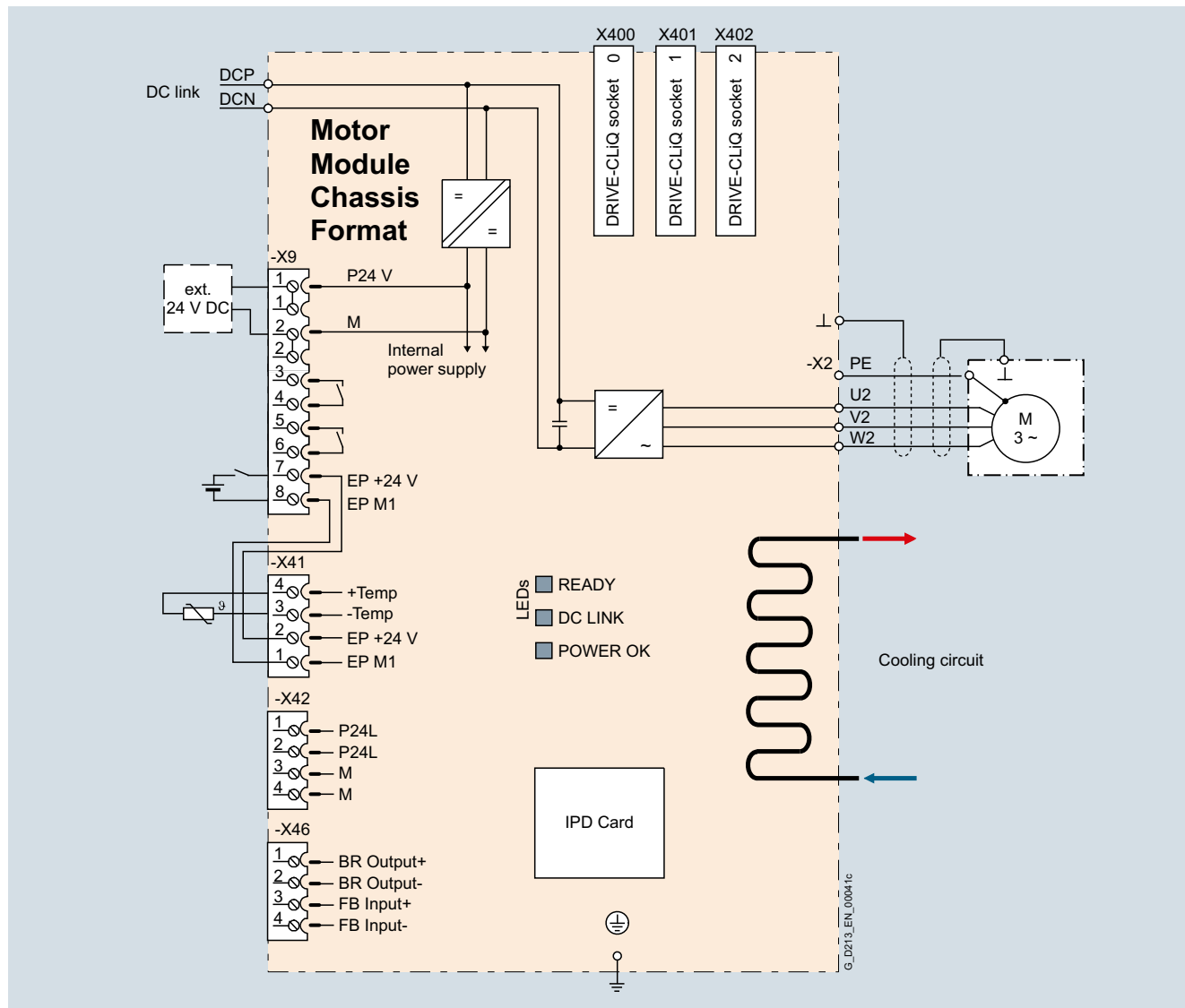

Connection example of a water-cooled Motor Module



## SINAMICS S120 Chassis Format Converter Units

Water-cooled units

### Motor Modules

#### Technical specifications

##### General technical specifications

Electrical specifications	
<b>Efficiency</b>	98.5 %
<b>DC link voltage</b> (up to 2000 m above sea level)	510 ... 720 V DC (line voltage 380 ... 480 V 3 AC) or 675 ... 1035 V DC (line voltage 500 ... 690 V 3 AC)
<b>Output frequency <sup>1)</sup></b>	
• Control type Servo	0 ... 550 Hz
• Control type Vector	0 ... 550 Hz
• Control mode V/f	0 ... 550 Hz
<b>Safety Integrated</b>	Safety Integrity Level 2 (SIL2) acc. to IEC 61508, Performance Level d (PLd) acc. to EN ISO 13849-1 and Control Category 3 acc. to EN ISO 13849-1.

3

<sup>1)</sup> Please note:

- The correlation between the maximum output frequency, pulse frequency and current derating. Higher output frequencies on request. For further information, see <https://support.industry.siemens.com/cs/document/104020669>

- The correlation between the minimum output frequency and permissible output current (current derating). Information is provided in the [SINAMICS Low Voltage Engineering Manual](#).

# SINAMICS S120 Chassis Format Converter Units

## Water-cooled units

### Motor Modules

#### Technical specifications (continued)

Line voltage 380 ... 480 V 3 AC DC link voltage 510 ... 720 V DC		Motor Modules				
		6SL3325-1TE32-1AA3	6SL3325-1TE32-6AA3	6SL3325-1TE33-1AA3	6SL3325-1TE35-0AA3	
<b>Type rating</b>						
• At $I_L$ (50 Hz 400 V) <sup>1)</sup>	kW	<b>110</b>	<b>132</b>	<b>160</b>	<b>250</b>	
• At $I_H$ (50 Hz 400 V) <sup>1)</sup>	kW	90	110	132	200	
• At $I_L$ (60 Hz 460 V) <sup>2)</sup>	hp	150	200	250	400	
• At $I_H$ (60 Hz 460 V) <sup>2)</sup>	hp	150	200	200	350	
<b>Output current</b>						
• Rated current $I_{rated O}$	A	210	260	310	490	
• Base-load current $I_L$ <sup>3)</sup>	A	205	250	302	477	
• Base-load current $I_H$ <sup>4)</sup>	A	178	233	277	438	
• Maximum current $I_{max O}$	A	307	375	453	715	
<b>DC link current</b>						
• Rated current $I_{rated DC}$ when supplied via						
- Basic Line Module	A	256	317	380	600	
- Active Line Module	A	230	287	340	538	
• Base-load current $I_{L DC}$ <sup>3)</sup> when supplied via						
- Basic Line Module	A	250	305	368	581	
- Active Line Module	A	225	274	331	522	
• Base-load current $I_{H DC}$ <sup>4)</sup> when supplied via						
- Basic Line Module	A	227	284	338	534	
- Active Line Module	A	195	255	303	480	
<b>Current demand</b>						
• 24 V DC auxiliary power supply	A	1.4	1.4	1.5	1.5	
<b>DC link capacitance</b>		$\mu F$	4800	5800	8400	9600
<b>Pulse frequency <sup>5)</sup></b>						
• Rated frequency	kHz	2	2	2	2	
• Pulse frequency, max.						
- Without current derating	kHz	2	2	2	2	
- With current derating	kHz	8	8	8	8	
<b>Power loss, max. <sup>6)</sup></b>						
• At 50 Hz 400 V	kW	1.61	1.95	2.29	3.56	
• At 60 Hz 460 V	kW	1.68	2.06	2.38	3.74	
• Dissipated to ambient air	kW	0.06	0.07	0.09	0.14	
<b>Coolant volume flow <sup>7)</sup></b>		l/min	9	9	12	12
<b>Liquid volume</b> of the integrated heat exchanger		dm <sup>3</sup>	0.31	0.31	0.91	0.91
<b>Pressure drop, typ. <sup>8)</sup></b> for volume flow		Pa	70000	70000	70000	70000
<b>Heat exchanger material</b>			Stainless steel	Stainless steel	Stainless steel	Stainless steel
<b>Coolant connections</b> Intake/return			Pipe thread ISO 228 G 3/4 B (external thread 3/4", flat-sealing)			
<b>Sound pressure level <math>L_{pA}</math></b> (1 m) at 50/60 Hz		dB	52	52	52	52
<b>DC link connection</b> DCP, DCN			2 × hole for M12 Busbar	2 × hole for M12 Busbar	2 × hole for M12 Busbar	2 × hole for M12 Busbar
<b>Motor connection</b> U2, V2, W2			Hole for M12	Hole for M12	Hole for M12	Hole for M12
• Conductor cross-section, max. (IEC)	mm <sup>2</sup>	2 × 95	2 × 95	2 × 240	2 × 240	2 × 240

For footnotes, see next page.

## SINAMICS S120 Chassis Format Converter Units

Water-cooled units

### Motor Modules

#### Technical specifications (continued)

Line voltage 380 ... 480 V 3 AC DC link voltage 510 ... 720 V DC		Motor Modules			
		6SL3325-1TE32-1AA3	6SL3325-1TE32-6AA3	6SL3325-1TE33-1AA3	6SL3325-1TE35-0AA3
<b>PE/GND connection</b>		2 × hole for M12	2 × hole for M12	2 × hole for M12	2 × hole for M12
• Conductor cross-section, max. (IEC)	mm <sup>2</sup>	2 × 95	2 × 95	2 × 240	2 × 240
<b>Cable length, max <sup>9)</sup></b>					
• Shielded	m	300	300	300	300
• Unshielded	m	450	450	450	450
<b>Dimensions</b>					
• Width	mm	150	150	150	150
• Height	mm	746	746	1172	1172
• Depth	mm	545	545	545	545
<b>Weight, approx.</b>	kg	41	41	80	80
<b>Frame size</b>		FXL	FXL	GXL	GXL

<sup>1)</sup> Rated output of a typical 6-pole standard induction motor based on  $I_L$  or  $I_H$  for 400 V 3 AC 50 Hz.

<sup>2)</sup> Rated output of a typical 6-pole standard induction motor based on  $I_L$  or  $I_H$  for 460 V 3 AC 60 Hz.

<sup>3)</sup> The base-load current  $I_L$  is based on a duty cycle of 110 % for 60 s or 150 % for 10 s with a duty cycle duration of 300 s.

<sup>4)</sup> The base-load current  $I_H$  is based on a duty cycle of 150 % for 60 s or 160 % for 10 s with a duty cycle duration of 300 s.

<sup>5)</sup> Additional notes regarding the correlation between the pulse frequency and maximum output current/output frequency is provided in the SINAMICS Low Voltage Engineering Manual.

<sup>6)</sup> The specified power loss represents the maximum value at 100 % utilization. The value is lower under normal operating conditions. To ensure safe dissipation of the minor power loss released to the ambient air, it is important to follow the instructions pertaining to control cabinet installation in the SINAMICS Low Voltage Engineering Manual.

<sup>7)</sup> The value applies to coolants comprising water and a mixture of water and antifreeze agent.

<sup>8)</sup> The value is valid for water as coolant. [Additional information and notes on other coolants are provided in the SINAMICS Low Voltage Engineering Manual.](#)

<sup>9)</sup> Total of all motor cables. Longer cable lengths for specific configurations are available on request. [For additional information, please refer to the SINAMICS Low Voltage Engineering Manual.](#)

# SINAMICS S120 Chassis Format Converter Units

## Water-cooled units

### Motor Modules

#### Technical specifications (continued)

Line voltage 380 ... 480 V 3 AC DC link voltage 510 ... 720 V DC		Motor Modules			
		6SL3325-1TE37-5AA7	6SL3325-1TE41-0AA7	6SL3325-1TE41-2AA7	6SL3325-1TE41-4AA7
<b>Type rating</b>					
• At $I_L$ (50 Hz 400 V) <sup>1)</sup>	kW	400	560	710	800
• At $I_H$ (50 Hz 400 V) <sup>1)</sup>	kW	315	450	630	710
• At $I_L$ (60 Hz 460 V) <sup>2)</sup>	hp	600	800	1000	1150
• At $I_H$ (60 Hz 460 V) <sup>2)</sup>	hp	450	700	900	1000
<b>Output current</b>					
• Rated current $I_{rated O}$	A	745	985	1260	1405
• Base-load current $I_L$ <sup>3)</sup>	A	725	960	1230	1370
• Base-load current $I_H$ <sup>4)</sup>	A	570	860	1127	1257
• Maximum current $I_{max O}$	A	1087	1440	1845	2055
<b>DC link current</b>					
• Rated current $I_{rated DC}$ when supplied via					
- Basic Line Module	A	894	1202	1512	1714
- Active Line Module	A	805	1080	1361	1544
• Base-load current $I_{L DC}$ <sup>3)</sup> when supplied via					
- Basic Line Module	A	871	1170	1474	1670
- Active Line Module	A	784	1051	1326	1500
• Base-load current $I_{H DC}$ <sup>4)</sup> when supplied via					
- Basic Line Module	A	795	1048	1345	1532
- Active Line Module	A	716	942	1211	1377
<b>Current demand</b>					
• 24 V DC auxiliary power supply	A	1.6	1.46	1.46	1.46
<b>DC link capacitance</b>					
	μF	17400	21000	29000	29000
<b>Pulse frequency <sup>5)</sup></b>					
• Rated frequency	kHz	1.25	1.25	1.25	1.25
• Pulse frequency, max.					
- Without current derating	kHz	1.25	1.25	1.25	1.25
- With current derating	kHz	7.5	7.5	7.5	7.5
<b>Power loss, max. <sup>6)</sup></b>					
• At 50 Hz 400 V	kW	5.1	7.9	9.15	10.2
• At 60 Hz 460 V	kW	5.61	8.55	10.05	11.2
• Dissipated to ambient air	kW	0.2	0.44	0.56	0.62
<b>Coolant volume flow <sup>7)</sup></b>					
	l/min	16	27	27	27
<b>Liquid volume of the integrated heat exchanger</b>					
	dm <sup>3</sup>	0.74	1.56	1.56	1.56
<b>Pressure drop, typ. <sup>8)</sup> for volume flow</b>					
	Pa	70000	70000	70000	70000
<b>Heat exchanger material</b>					
		Copper-nickel alloy	Copper-nickel alloy	Copper-nickel alloy	Copper-nickel alloy
<b>Coolant connections Intake/return</b>					
		Pipe thread ISO 228 G 3/4 B (external thread 3/4", flat-sealing)			
<b>Sound pressure level <math>L_{pA}</math> (1 m) at 50/60 Hz</b>					
	dB	54	56	56	56
<b>DC link connection DCP, DCN</b>					
		2 × hole for M12 Busbar	2 × hole for M12 Busbar	2 × hole for M12 Busbar	2 × hole for M12 Busbar
<b>Motor connection U2, V2, W2</b>					
		2 × hole for M12	2 × hole for M12	2 × hole for M12	2 × hole for M12
• Conductor cross-section, max. (IEC)	mm <sup>2</sup>	4 × 185	4 × 240	4 × 240	4 × 240

## SINAMICS S120 Chassis Format Converter Units

Water-cooled units

### Motor Modules

#### Technical specifications (continued)

Line voltage 380 ... 480 V 3 AC DC link voltage 510 ... 720 V DC		Motor Modules			
		6SL3325-1TE37-5AA7	6SL3325-1TE41-0AA7	6SL3325-1TE41-2AA7	6SL3325-1TE41-4AA7
<b>PE/GND connection</b>		2 × hole for M12	2 × hole for M12	2 × hole for M12	2 × hole for M12
• Conductor cross-section, max. (IEC)	mm <sup>2</sup>	4 × 185	Busbar	Busbar	Busbar
<b>Cable length, max <sup>9)</sup></b>					
• Shielded	m	300	300	300	300
• Unshielded	m	450	450	450	450
<b>Dimensions</b>					
• Width	mm	265	295	295	295
• Height	mm	987	1510	1510	1510
• Depth	mm	545	545	545	545
<b>Weight, approx.</b>	kg	125	230	230	230
<b>Frame size</b>		HXL	JXL	JXL	JXL

<sup>1)</sup> Rated output of a typical 6-pole standard induction motor based on  $I_L$  or  $I_H$  for 400 V 3 AC 50 Hz.

<sup>2)</sup> Rated output of a typical 6-pole standard induction motor based on  $I_L$  or  $I_H$  for 460 V 3 AC 60 Hz.

<sup>3)</sup> The base-load current  $I_L$  is based on a duty cycle of 110 % for 60 s or 150 % for 10 s with a duty cycle duration of 300 s.

<sup>4)</sup> The base-load current  $I_H$  is based on a duty cycle of 150 % for 60 s or 160 % for 10 s with a duty cycle duration of 300 s.

<sup>5)</sup> Additional notes regarding the correlation between the pulse frequency and maximum output current/output frequency is provided in the SINAMICS Low Voltage Engineering Manual.

<sup>6)</sup> The specified power loss represents the maximum value at 100 % utilization. The value is lower under normal operating conditions. To ensure safe dissipation of the minor power loss released to the ambient air, it is important to follow the instructions pertaining to control cabinet installation in the SINAMICS Low Voltage Engineering Manual.

<sup>7)</sup> The value applies to coolants comprising water and a mixture of water and antifreeze agent.

<sup>8)</sup> The value is valid for water as coolant. [Additional information and notes on other coolants are provided in the SINAMICS Low Voltage Engineering Manual.](#)

<sup>9)</sup> Total of all motor cables. Longer cable lengths for specific configurations are available on request. [For additional information, please refer to the SINAMICS Low Voltage Engineering Manual.](#)

# SINAMICS S120 Chassis Format Converter Units

## Water-cooled units

### Motor Modules

#### Technical specifications (continued)

Line voltage 500 ... 690 V 3 AC DC link voltage 675 ... 1035 V DC		Motor Modules				
		6SL3325-1TG31-0AA3	6SL3325-1TG31-5AA3	6SL3325-1TG32-2AA3	6SL3325-1TG33-3AA3	
<b>Type rating</b>						
• At $I_L$ (50 Hz 690 V) <sup>1)</sup>	kW	<b>90</b>	<b>132</b>	<b>200</b>	<b>315</b>	
• At $I_H$ (50 Hz 690 V) <sup>1)</sup>	kW	75	110	160	250	
• At $I_L$ (50 Hz 500 V) <sup>1)</sup>	kW	55	90	132	200	
• At $I_H$ (50 Hz 500 V) <sup>1)</sup>	kW	55	90	132	200	
• At $I_L$ (60 Hz 575 V) <sup>2)</sup>	hp	75	150	200	300	
• At $I_H$ (60 Hz 575 V) <sup>2)</sup>	hp	75	125	200	250	
<b>Output current</b>						
• Rated current $I_{rated O}$	A	100	150	215	330	
• Base-load current $I_L$ <sup>3)</sup>	A	95	142	208	320	
• Base-load current $I_H$ <sup>4)</sup>	A	89	134	192	280	
• Maximum current $I_{max O}$	A	142	213	312	480	
<b>DC link current</b>						
• Rated current $I_{rated DC}$ when supplied via						
- Basic Line Module	A	122	183	263	403	
- Active Line Module	A	110	165	237	363	
• Base-load current $I_{L DC}$ <sup>3)</sup> when supplied via						
- Basic Line Module	A	116	173	253	390	
- Active Line Module	A	105	156	229	352	
• Base-load current $I_{H DC}$ <sup>4)</sup> when supplied via						
- Basic Line Module	A	108	163	234	341	
- Active Line Module	A	98	147	211	308	
<b>Current demand</b>						
• 24 V DC auxiliary power supply	A	1.0	1.0	1.5	1.5	
<b>DC link capacitance</b>		μF	2800	2800	4200	5800
<b>Pulse frequency <sup>5)</sup></b>						
• Rated frequency	kHz	1.25	1.25	1.25	1.25	
• Pulse frequency, max.						
- Without current derating	kHz	1.25	1.25	1.25	1.25	
- With current derating	kHz	7.5	7.5	7.5	7.5	
<b>Power loss, max. <sup>6)</sup></b>						
• At 50 Hz 690 V	kW	1.15	1.64	2.34	3.38	
• At 60 Hz 575 V	kW	1.02	1.45	2.05	2.96	
• Dissipated to ambient air	kW	0.06	0.07	0.09	0.12	
<b>Coolant volume flow <sup>7)</sup></b>		l/min	9	9	12	12
<b>Liquid volume of the integrated heat exchanger</b>		dm <sup>3</sup>	0.31	0.31	0.91	0.91
<b>Pressure drop, typ. <sup>8)</sup> for volume flow</b>		Pa	70000	70000	70000	70000
<b>Heat exchanger material</b>			Stainless steel	Stainless steel	Stainless steel	Stainless steel
<b>Coolant connections Intake/return</b>			Pipe thread ISO 228 G 3/4 B (external thread 3/4", flat-sealing)			
<b>Sound pressure level <math>L_{pA}</math> (1 m) at 50/60 Hz</b>		dB	52	52	52	52
<b>DC link connection DCP, DCN</b>			2 × hole for M12 Busbar	2 × hole for M12 Busbar	2 × hole for M12 Busbar	2 × hole for M12 Busbar
<b>Motor connection U2, V2, W2</b>			Hole for M12	Hole for M12	Hole for M12	Hole for M12
• Conductor cross-section, max. (IEC)	mm <sup>2</sup>	2 × 95	2 × 95	4 × 240	4 × 240	4 × 240

For footnotes, see next page.

## SINAMICS S120 Chassis Format Converter Units

Water-cooled units

### Motor Modules

#### Technical specifications (continued)

Line voltage 500 ... 690 V 3 AC DC link voltage 675 ... 1035 V DC		Motor Modules			
		6SL3325-1TG31-0AA3	6SL3325-1TG31-5AA3	6SL3325-1TG32-2AA3	6SL3325-1TG33-3AA3
<b>PE/GND connection</b>		2 × hole for M12			
• Conductor cross-section, max. (IEC)	mm <sup>2</sup>	2 × 95	2 × 95	2 × 240	2 × 240
<b>Cable length, max <sup>9)</sup></b>					
• Shielded	m	300	300	300	300
• Unshielded	m	450	450	450	450
<b>Dimensions</b>					
• Width	mm	150	150	150	150
• Height	mm	728	728	1172	1172
• Depth	mm	545	545	545	545
<b>Weight, approx.</b>	kg	41	41	80	80
<b>Frame size</b>		FXL	FXL	GXL	GXL

<sup>1)</sup> Rated output of a typical 6-pole standard induction motor based on  $I_L$  or  $I_H$  for 500 V or 690 V 3 AC 50 Hz.

<sup>2)</sup> Rated output of a typical 6-pole standard induction motor based on  $I_L$  or  $I_H$  for 575 V 3 AC 60 Hz.

<sup>3)</sup> The base-load current  $I_L$  is based on a duty cycle of 110 % for 60 s or 150 % for 10 s with a duty cycle duration of 300 s.

<sup>4)</sup> The base-load current  $I_H$  is based on a duty cycle of 150 % for 60 s or 160 % for 10 s with a duty cycle duration of 300 s.

<sup>5)</sup> Additional notes regarding the correlation between the pulse frequency and maximum output current/output frequency is provided in the SINAMICS Low Voltage Engineering Manual.

<sup>6)</sup> The specified power loss represents the maximum value at 100 % utilization. The value is lower under normal operating conditions. To ensure safe dissipation of the minor power loss released to the ambient air, it is important to follow the instructions pertaining to control cabinet installation in the SINAMICS Low Voltage Engineering Manual.

<sup>7)</sup> The value applies to coolants comprising water and a mixture of water and antifreeze agent.

<sup>8)</sup> The value is valid for water as coolant. [Additional information and notes on other coolants are provided in the SINAMICS Low Voltage Engineering Manual.](#)

<sup>9)</sup> Total of all motor cables. Longer cable lengths for specific configurations are available on request. [For additional information, please refer to the SINAMICS Low Voltage Engineering Manual.](#)

# SINAMICS S120 Chassis Format Converter Units

## Water-cooled units

### Motor Modules

#### Technical specifications (continued)

Line voltage 500 ... 690 V 3 AC DC link voltage 675 ... 1035 V DC		Motor Modules	
		6SL3325-1TG34-7AA7	6SL3325-1TG35-8AA7
<b>Type rating</b>			
• At $I_L$ (50 Hz 690 V) <sup>1)</sup>	kW	450	560
• At $I_H$ (50 Hz 690 V) <sup>1)</sup>	kW	400	450
• At $I_L$ (50 Hz 500 V) <sup>1)</sup>	kW	315	400
• At $I_H$ (50 Hz 500 V) <sup>1)</sup>	kW	250	315
• At $I_L$ (60 Hz 575 V) <sup>2)</sup>	hp	450	600
• At $I_H$ (60 Hz 575 V) <sup>2)</sup>	hp	450	500
<b>Output current</b>			
• Rated current $I_{rated O}$	A	465	575
• Base-load current $I_L$ <sup>3)</sup>	A	452	560
• Base-load current $I_H$ <sup>4)</sup>	A	416	514
• Maximum current $I_{max O}$	A	678	840
<b>DC link current</b>			
• Rated current $I_{rated DC}$ when supplied via			
- Basic Line Module	A	558	702
- Active Line Module	A	502	632
• Base-load current $I_{L DC}$ <sup>3)</sup> when supplied via			
- Basic Line Module	A	544	683
- Active Line Module	A	489	616
• Base-load current $I_{H DC}$ <sup>4)</sup> when supplied via			
- Basic Line Module	A	496	627
- Active Line Module	A	446	565
<b>Current demand</b>			
• 24 V DC auxiliary power supply	A	1.6	1.6
<b>DC link capacitance</b>			
	μF	9670	9670
<b>Pulse frequency <sup>5)</sup></b>			
• Rated frequency	kHz	1.25	1.25
• Pulse frequency, max.			
- Without current derating	kHz	1.25	1.25
- With current derating	kHz	7.5	7.5
<b>Power loss, max. <sup>6)</sup></b>			
• At 50 Hz 690 V	kW	5.44	5.61
• At 60 Hz 575 V	kW	5.1	5.45
• Dissipated to ambient air	kW	0.14	0.16
<b>Coolant volume flow <sup>7)</sup></b>			
	l/min	16	16
<b>Liquid volume of the integrated heat exchanger</b>			
	dm <sup>3</sup>	0.74	0.74
<b>Pressure drop, typ. <sup>8)</sup> for volume flow</b>			
	Pa	70000	70000
<b>Heat exchanger material</b>			
		Copper-nickel alloy	Copper-nickel alloy
<b>Coolant connections Intake/return</b>			
		Pipe thread ISO 228 G 3/4 B (external thread 3/4", flat-sealing)	
<b>Sound pressure level <math>L_{pA}</math> (1 m) at 50/60 Hz</b>			
	dB	54	54
<b>DC link connection DCP, DCN</b>			
		2 × hole for M12 Busbar	2 × hole for M12 Busbar
<b>Motor connection U2, V2, W2</b>			
		2 × hole for M12	2 × hole for M12
• Conductor cross-section, max. (IEC)	mm <sup>2</sup>	4 × 185	4 × 185

For footnotes, see next page.



## SINAMICS S120 Chassis Format Converter Units

Water-cooled units

### Motor Modules

#### Technical specifications (continued)

Line voltage 500 ... 690 V 3 AC DC link voltage 675 ... 1035 V DC		Motor Modules	
		6SL3325-1TG34-7AA7	6SL3325-1TG35-8AA7
<b>PE/GND connection</b>		2 × hole for M12	
• Conductor cross-section, max. (IEC)	mm <sup>2</sup>	4 × 185	4 × 185
<b>Cable length, max <sup>9)</sup></b>			
• Shielded	m	300	300
• Unshielded	m	450	450
<b>Dimensions</b>			
• Width	mm	265	265
• Height	mm	987	987
• Depth	mm	545	545
<b>Weight, approx.</b>	kg	125	125
<b>Frame size</b>		HXL	HXL

<sup>1)</sup> Rated output of a typical 6-pole standard induction motor based on  $I_L$  or  $I_H$  for 500 V or 690 V 3 AC 50 Hz.

<sup>2)</sup> Rated output of a typical 6-pole standard induction motor based on  $I_L$  or  $I_H$  for 575 V 3 AC 60 Hz.

<sup>3)</sup> The base-load current  $I_L$  is based on a duty cycle of 110 % for 60 s or 150 % for 10 s with a duty cycle duration of 300 s.

<sup>4)</sup> The base-load current  $I_H$  is based on a duty cycle of 150 % for 60 s or 160 % for 10 s with a duty cycle duration of 300 s.

<sup>5)</sup> Additional notes regarding the correlation between the pulse frequency and maximum output current/output frequency is provided in the SINAMICS Low Voltage Engineering Manual.

<sup>6)</sup> The specified power loss represents the maximum value at 100 % utilization. The value is lower under normal operating conditions. To ensure safe dissipation of the minor power loss released to the ambient air, it is important to follow the instructions pertaining to control cabinet installation in the SINAMICS Low Voltage Engineering Manual.

<sup>7)</sup> The value applies to coolants comprising water and a mixture of water and antifreeze agent.

<sup>8)</sup> The value is valid for water as coolant. [Additional information and notes on other coolants are provided in the SINAMICS Low Voltage Engineering Manual.](#)

<sup>9)</sup> Total of all motor cables. Longer cable lengths for specific configurations are available on request. [For additional information, please refer to the SINAMICS Low Voltage Engineering Manual.](#)

# SINAMICS S120 Chassis Format Converter Units

## Water-cooled units

### Motor Modules

#### Technical specifications (continued)

Line voltage 500 ... 690 V 3 AC DC link voltage 675 ... 1035 V DC		Motor Modules			
		6SL3325-1TG38-1AA7	6SL3325-1TG41-0AA7	6SL3325-1TG41-3AA7 <sup>1)</sup>	6SL3325-1TG41-6AA7 <sup>1)</sup>
<b>Type rating</b>					
• At $I_L$ (50 Hz 690 V) <sup>2)</sup>	kW	<b>800</b>	<b>1000</b>	<b>1200</b>	<b>1500</b>
• At $I_H$ (50 Hz 690 V) <sup>2)</sup>	kW	710	900	1000	1260
• At $I_L$ (50 Hz 500 V) <sup>2)</sup>	kW	560	710	900	1000
• At $I_H$ (50 Hz 500 V) <sup>2)</sup>	kW	560	630	800	900
• At $I_L$ (60 Hz 575 V) <sup>3)</sup>	hp	800	1000	1250	1500
• At $I_H$ (60 Hz 575 V) <sup>3)</sup>	hp	700	900	1000	1250
<b>Output current</b>					
• Rated current $I_{rated O}$	A	810	1025	1270	1560
• Base-load current $I_L$ <sup>4)</sup>	A	790	1000	1230	1500
• Base-load current $I_H$ <sup>5)</sup>	A	724	917	1136	1284
• Maximum current $I_{max O}$	A	1185	1500	1600	1950
<b>DC link current</b>					
• Rated current $I_{rated DC}$ when supplied via					
- Basic Line Module	A	990	1250	1550	1903
- Active Line Module	A	891	1125	1395	1714
• Base-load current $I_{L DC}$ <sup>4)</sup> when supplied via					
- Basic Line Module	A	963	1219	1500	1800
- Active Line Module	A	869	1100	1353	1650
• Base-load current $I_{H DC}$ <sup>5)</sup> when supplied via					
- Basic Line Module	A	883	1118	1384	1680
- Active Line Module	A	796	1009	1250	1550
<b>Current demand</b>					
• 24 V DC auxiliary power supply	A	1.46	1.46	1.46	1.46
<b>DC link capacitance</b>		μF	14000	16000	19330
<b>Pulse frequency <sup>6)</sup></b>					
• Rated frequency	kHz	1.25	1.25	1.25	1.25
• Pulse frequency, max.					
- Without current derating	kHz	1.25	1.25	1.25	1.25
- With current derating	kHz	7.5	7.5	7.5	7.5
<b>Power loss, max. <sup>7)</sup></b>					
• At 50 Hz 690 V	kW	9.56	10.87	13.49	17.9
• At 60 Hz 575 V	kW	8.34	9.55	11.84	15.7
• Dissipated to ambient air	kW	0.43	0.53	0.57	0.78
<b>Coolant volume flow <sup>8)</sup></b>		l/min	27	27	27
<b>Liquid volume</b> of the integrated heat exchanger		dm <sup>3</sup>	1.56	1.56	1.56
<b>Pressure drop, typ. <sup>9)</sup></b> for volume flow		Pa	70000	70000	70000
<b>Heat exchanger material</b>			Copper-nickel alloy	Copper-nickel alloy	Copper-nickel alloy
<b>Coolant connections</b> Intake/return			Pipe thread ISO 228 G 3/4 B (external thread 3/4", flat-sealing)		
<b>Sound pressure level <math>L_{pA}</math></b> (1 m) at 50/60 Hz		dB	56	56	56
<b>DC link connection</b> DCP, DCN			2 × hole for M12 Busbar	2 × hole for M12 Busbar	2 × hole for M12 Busbar
<b>Motor connection</b> U2, V2, W2			2 × hole for M12	2 × hole for M12	2 × hole for M12
• Conductor cross-section, max. (IEC)	mm <sup>2</sup>	Busbar	Busbar	Busbar	Busbar

For footnotes, see next page.

## SINAMICS S120 Chassis Format Converter Units

Water-cooled units

### Motor Modules

#### Technical specifications (continued)

Line voltage 500 ... 690 V 3 AC DC link voltage 675 ... 1035 V DC		Motor Modules			
		6SL3325-1TG38-1AA7	6SL3325-1TG41-0AA7	6SL3325-1TG41-3AA7 <sup>1)</sup>	6SL3325-1TG41-6AA7 <sup>1)</sup>
<b>PE/GND connection</b>		2 × hole for M12	2 × hole for M12	2 × hole for M12	2 × hole for M12
• Conductor cross-section, max. (IEC)	mm <sup>2</sup>	Busbar	Busbar	Busbar	Busbar
<b>Cable length, max. <sup>10)</sup></b>					
• Shielded	m	300	300	300	300
• Unshielded	m	450	450	450	450
<b>Dimensions</b>					
• Width	mm	295	295	295	295
• Height	mm	1510	1510	1510	1510
• Depth	mm	545	545	545	545
<b>Weight, approx.</b>	kg	230	230	230	240
<b>Frame size</b>		JXL	JXL	JXL	JXL

<sup>1)</sup> The short-time current for 10 s for low overload must be reduced from 150 % to 130 % for this Motor Module. At 10 s and 60 s, the short-time current for high overload must be reduced to 130 % for this Motor Module. The duty cycle remains unchanged.

<sup>2)</sup> Rated output of a typical 6-pole standard induction motor based on  $I_L$  or  $I_H$  for 500 V or 690 V 3 AC 50 Hz.

<sup>3)</sup> Rated output of a typical 6-pole standard induction motor based on  $I_L$  or  $I_H$  for 575 V 3 AC 60 Hz.

<sup>4)</sup> The base-load current  $I_L$  is based on a duty cycle of 110 % for 60 s or 150 % for 10 s with a duty cycle duration of 300 s.

<sup>5)</sup> The base-load current  $I_H$  is based on a duty cycle of 150 % for 60 s or 160 % for 10 s with a duty cycle duration of 300 s.

<sup>6)</sup> Additional notes regarding the correlation between the pulse frequency and maximum output current/output frequency are provided in the SINAMICS Low Voltage Engineering Manual.

<sup>7)</sup> The specified power loss represents the maximum value at 100 % utilization. The value is lower under normal operating conditions. To ensure safe dissipation of the minor power loss released to the ambient air, it is important to follow the instructions pertaining to control cabinet installation in the SINAMICS Low Voltage Engineering Manual.

<sup>8)</sup> The value applies to coolants comprising water and a mixture of water and antifreeze agent.

<sup>9)</sup> The value is valid for water as coolant. Additional information and notes on other coolants are provided in the SINAMICS Low Voltage Engineering Manual.

<sup>10)</sup> Sum of all motor cables. Longer cable lengths for specific configurations are available on request. For additional information, please refer to the SINAMICS Low Voltage Engineering Manual.

# SINAMICS S120 Chassis Format Converter Units

## Water-cooled units

### Mounting device for water-cooled power units

#### Overview

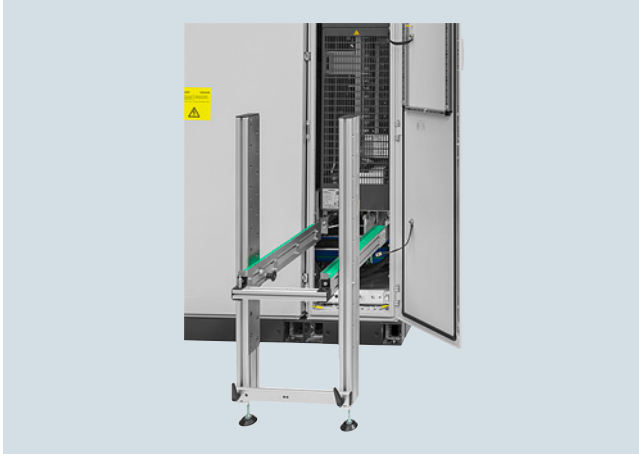

The mounting device is used to install or remove water-cooled power units (Power Modules, Line Modules, Motor Modules, Filter Module on the Active Interface Module) in or out of a control cabinet. The mounting device can be used if the power units are mounted on mounting rails, which at the front have two M6 threads at a vertical distance of 20 mm to attach the mounting device.

The mounting device is a mounting aid. It is placed in front of the power unit and attached to the mounting rails below the power unit. The telescopic rails allow the mounting device to be adjusted to the installation height and width of the power unit. The power unit can be removed from the control cabinet after releasing the mechanical and electrical connections and the coolant connections. The power unit is guided and supported by the guide rails on the mounting device. To prevent it toppling over, the power unit must be secured to a crane, tripod, or similar assembly using the lifting lugs or the lifting equipment. The unit can then be lowered down from the mounting device.

#### Selection and ordering data

Description	Article No.
<b>Mounting device</b> for installing and removing power units	<b>6SL3766-1CA00-0AA0</b>

# SINAMICS S120 Chassis Format Converter Units

## System components

### Line-side power components

#### Technical specifications

##### General technical specifications

Unless clearly specified otherwise, the following technical data are valid for all the following system components of the air-cooled and liquid-cooled SINAMICS S120 drive system in chassis format.

Electrical specifications			
<b>Rated voltages</b>	380 ... 480 V 3 AC ±10 % (-15 % <1 min) 500 ... 690 V 3 AC ±10 % (-15 % <1 min)		
<b>Line supply types</b>	Grounded TN/TT systems and non-grounded IT systems		
<b>Line frequency</b>	47 ... 63 Hz		
<b>Overvoltage category</b>	III to EN 61800-5-1		
<b>Electronics power supply</b>	24 V DC, -15 % +20 % implemented as PELV circuit in accordance with EN 61800-5-1 Ground = negative pole grounded via the electronics		
Mechanical specifications			
<b>Degree of protection</b>	IP00 or IP20 depending on type		
<b>Protection class</b>	I acc. to EN 61800-5-1		
<b>Touch protection</b>	EN 50274/DGUV regulation 3 when used as intended		
Ambient conditions	Storage <sup>1)</sup>	Transport <sup>1)</sup>	Operation
<b>Ambient temperature</b>	-25 ... +55 °C Class 1K4 acc. to EN 60721-3-1	-25 ... +70 °C Class 2K4 acc. to EN 60721-3-2	Line-side components: 0 ... 40 °C without derating Up to 55 °C, <a href="#">see derating data</a> Control Units, supplementary system components, and Sensor Modules: 0 ... 55 °C (for operation in a control cabinet) DC link components and motor-side components: 0 ... 55 °C
<b>Relative humidity</b> Condensation, splashwater, and ice formation not permitted (EN 60204, Part 1)	5 ... 95 % Class 1K4 acc. to EN 60721-3-1	5 ... 95 % at 40 °C Class 2K4 acc. to EN 60721-3-2	5 ... 95 % Class 3K3 acc. to EN 60721-3-3
<b>Environmental class/harmful chemical substances</b>	Class 1C2 acc. to EN 60721-3-1	Class 2C2 acc. to EN 60721-3-2	Class 3C2 acc. to EN 60721-3-3
<b>Organic/biological influences</b>	Class 1B1 acc. to EN 60721-3-1	Class 2B1 acc. to EN 60721-3-2	Class 3B1 acc. to EN 60721-3-3
<b>Degree of pollution</b>	2 acc. to IEC/EN 61800-5-1	2 acc. to IEC/EN 61800-5-1	2 acc. to IEC/EN 61800-5-1
<b>Installation altitude</b>	Up to 2000 m above sea level without derating >2000 m above sea level, <a href="#">see derating data</a>		
Mechanical stability	Storage <sup>1)</sup>	Transport <sup>1)</sup>	Operation
<b>Vibratory load</b>	–	Class 2M2 acc. to EN 60721-3-2	Test values acc. to EN 60068-2-6 test Fc: • 10 ... 58 Hz with constant deflection 0.075 mm • 58 ... 150 Hz with constant acceleration 9.81 m/s <sup>2</sup> (1 × g)
<b>Shock load</b>	–	Class 2M2 acc. to EN 60721-3-2	Test values according to EN 60068-2-27 test Ea: 98 m/s <sup>2</sup> (10 × g)/20 ms
Compliance with standards			
<b>Conformances/certificates of suitability, according to</b>	CE (EMC Directive 2014/30/EU, Low Voltage Directive 2014/35/EU, Machinery Directive 2006/42/EC for functional safety) cURus or cULus (only for devices connected to line supply voltages 380 ... 480 V 3 AC and 500 ... 600 V 3 AC)		
<b>Radio interference suppression</b>	SINAMICS S120 chassis format units are not designed for connection to the public grid (first environment). Radio interference suppression is compliant with the EMC product standard for variable-speed drives EN 61800-3, "Second environment" (industrial line supplies). EMC disturbances can occur when connected to the public grid. However, if additional measures are taken (e.g. → line filter), it can also be operated in the "first environment".		

Deviations from the specified class are underlined.

<sup>1)</sup> In transport packaging.

# SINAMICS S120 Chassis Format Converter Units

## System components

Line-side power components &gt; Line filters

### Overview



In conjunction with line reactors and a logically consistent configuration of the plant or system, line filters limit the interference conducted by the Line Modules and Power Modules to the limit values of Category C2 acc. to EN 61800-3.

The line filters are suitable for TN and TT supply systems grounded at the neutral point.

### Selection and ordering data

#### Line filters for Power Modules

Suitable for Power Module in the chassis format, air-cooled 6SL3310-...	Type rating of the Power Module at 400 V kW	Rated input current of the Power Module A	Line filter Article No.
<b>Line voltage 380 ... 480 V 3 AC</b>			
1TE32-1AA3	110	229	<b>6SL3000-0BE32-5AA0</b>
1TE32-6AA3	132	284	<b>6SL3000-0BE34-4AA0</b>
1TE33-1AA3	160	338	
1TE33-8AA3	200	395	
1TE35-0AA3	250	509	<b>6SL3000-0BE36-0AA0</b>

#### Line filters for Basic Line Modules

Suitable for Basic Line Module chassis format, air-cooled 6SL3330-...	Rated power of the Basic Line Module at 400 V or 690 V kW	Rated input current of the Basic Line Module A	Line filter Article No.
<b>Line voltage 380 ... 480 V 3 AC</b>			
1TE34-2AA3	200	365	<b>6SL3000-0BE34-4AA0</b>
1TE35-3AA3	250	460	<b>6SL3000-0BE36-0AA0</b>
1TE38-2AA3	400	710	<b>6SL3000-0BE41-2AA0</b>
1TE41-2AA3	560	1010	
1TE41-5AA3	710	1265	<b>6SL3000-0BE41-6AA0</b>
1TE41-8AA3	900	1581	
<b>Line voltage 500 ... 690 V 3 AC</b>			
1TG33-0AA3	250	260	<b>6SL3000-0BG34-4AA0</b>
1TG34-3AA3	355	375	
1TG36-8AA3	560	575	<b>6SL3000-0BG36-0AA0</b>
1TG41-1AA3	900	925	<b>6SL3000-0BG41-2AA0</b>
1TG41-4AA3	1100	1180	
7TG41-8AA3	1500	1580	<b>6SL3000-0BG41-6AA0</b>

## SINAMICS S120 Chassis Format Converter Units

### System components

#### Line-side power components > Line filters

#### Selection and ordering data (continued)

##### Line filters for Smart Line Modules

Suitable for Smart Line Module in chassis format, air-cooled 6SL3330-...	Rated power of the Smart Line Module at 400 V or 690 V kW	Rated input current of the Smart Line Module A	Line filter Article No.
<b>Line voltage 380 ... 480 V 3 AC</b>			
6TE35-5AA3	250	463	<b>6SL3000-0BE35-0AA0</b>
6TE37-3AA3	355	614	<b>6SL3760-0MB00-0AA0</b>
6TE41-1AA3	500	883	<b>6SL3760-0MC00-0AA0</b>
6TE41-3AA3	630	1093	
6TE41-7AA3	800	1430	
<b>Line voltage 500 ... 690 V 3 AC</b>			
6TG35-5AA3	450	463	<b>6SL3760-0ME00-0AA0</b>
6TG38-8AA3	710	757	<b>6SL3760-0MN00-0AA0</b>
6TG41-2AA3	1000	1009	
6TG41-7AA3	1400	1430	<b>6SL3760-0MG00-0AA0</b>

##### Line filters for Active Line Modules

Suitable for Active Line Module chassis format, air-cooled 6SL3330-...	Rated power of the Active Line Module at 400 V or 690 V kW	Rated input current of the Active Line Module A	Line filter Article No.
<b>Line voltage 380 ... 480 V 3 AC</b>			
7TE32-1AA3	132	210	<b>6SL3000-0BE33-1AA0</b>
7TE32-6AA3	160	260	
7TE33-8AA3	235	380	<b>6SL3000-0BE35-0AA0</b>
7TE35-0AA3	300	490	
7TE36-1AA3	380	605	<b>6SL3760-0MB00-0AA0</b>
7TE37-5AA3	450	745	
7TE38-4AA3	500	840	<b>6SL3760-0MC00-0AA0</b>
7TE41-0AA3	630	985	
7TE41-2AA3	800	1260	
7TE41-4AA3	900	1405	
<b>Line voltage 500 ... 690 V 3 AC</b>			
7TG35-8AA3	630	575	<b>6SL3760-0ME00-0AA0</b>
7TG37-4AA3	800	735	<b>6SL3760-0MN00-0AA0</b>
7TG41-0AA3	1100	1025	
7TG41-3AA3	1400	1270	<b>6SL3760-0MG00-0AA0</b>

#### Note:

Line filters are not available for liquid-cooled drive units.

# SINAMICS S120 Chassis Format Converter Units

## System components

Line-side power components &gt; Line filters

### Technical specifications

Line voltage 380 ... 480 V 3 AC		Line filter				
		6SL3000-0BE32-5AA0	6SL3000-0BE34-4AA0	6SL3000-0BE36-0AA0	6SL3000-0BE41-2AA0	6SL3000-0BE41-6AA0
<b>Rated current</b>	A	250	440	600	1200	1600
<b>Power loss <sup>1)</sup></b> At 50 Hz	kW	0.015	0.047	0.053	0.119	0.153
<b>Load/line supply connection</b>		1 × hole for M10 Provided for busbar connection	1 × hole for M10 Provided for busbar connection	1 × hole for M10 Provided for busbar connection	1 × hole for M12 Provided for busbar connection	1 × hole for M12 Provided for busbar connection
<b>PE connection</b>		Hole for M8	Hole for M8	Hole for M10	Hole for M10	Hole for M10
<b>Degree of protection</b>		IP00	IP00	IP00	IP00	IP00
<b>Dimensions</b>						
• Width	mm	360	360	400	425	505
• Height	mm	240	240	265	265	265
• Depth	mm	116	116	140	145	145
<b>Weight, approx.</b>	kg	12.3	12.3	19	25.2	28.8
<b>Suitable for Power Module in chassis format</b>						
• Air-cooled	6SL3310-	1TE32-1AA3	1TE32-6AA3 1TE33-1AA3 1TE33-8AA3	1TE35-0AA3	–	–
<b>Suitable for Basic Line Module in chassis format</b>						
• Air-cooled	6SL3330-	–	1TE34-2AA3	1TE35-3AA3	1TE38-2AA3 1TE41-2AA3	1TE41-5AA3 1TE41-8AA3
Line voltage 500 ... 690 V 3 AC		Line filter				
		6SL3000-0BG34-4AA0	6SL3000-0BG36-0AA0	6SL3000-0BG41-2AA0	6SL3000-0BG41-6AA0	
<b>Rated current</b>	A	440	600	1200	1600	
<b>Power loss <sup>1)</sup></b> At 50 Hz	kW	0.047	0.053	0.119	0.153	
<b>Load/line supply connection</b>		1 × hole for M10 Provided for busbar connection	1 × hole for M10 Provided for busbar connection	2 × hole for M12 Provided for busbar connection	2 × hole for M12 Provided for busbar connection	
<b>PE connection</b>		Hole for M8	Hole for M10	Hole for M10	Hole for M10	
<b>Degree of protection</b>		IP00	IP00	IP00	IP00	
<b>Dimensions</b>						
• Width	mm	360	400	425	505	
• Height	mm	240	265	265	265	
• Depth	mm	116	140	145	145	
<b>Weight, approx.</b>	kg	12.3	19	25.2	28.8	
<b>Suitable for Basic Line Module in chassis format</b>						
• Air-cooled	6SL3330-	1TG33-0AA3 1TG34-3AA3	1TG36-8AA3	1TG41-1AA3 1TG41-4AA3	1TG41-8AA3	

<sup>1)</sup> The specified power loss represents the maximum value at 100 % utilization. The value is lower under normal operating conditions.



# SINAMICS S120 Chassis Format Converter Units

## System components

### Line-side power components > Line filters

#### Technical specifications (continued)

Line voltage 380 ... 480 V 3 AC		Line filter			
		6SL3000-0BE33-1AA0	6SL3000-0BE35-0AA0	6SL3760-0MB00-0AA0	6SL3760-0MC00-0AA0
Rated current	A	400	600	840	1405
Power loss <sup>1)</sup> At 50 Hz	kW	0.042	0.06	0.058	0.111
Load/line supply connection		M10 connecting lugs	M10 connecting lugs	M10 connecting lugs	M10 connecting lugs
PE connection		Hole for M8	Hole for M10	Hole for M10	Hole for M10
Degree of protection		IP00	IP00	IP00	IP00
<b>Dimensions</b>					
• Width	mm	360	390	425	505
• Height	mm	240	265	265	265
• Depth	mm	116	140	145	145
Weight, approx.	kg	12.7	19.9	25.9	28.9
<b>Suitable for Smart Line Module in chassis format</b>					
• Air-cooled	6SL3330-	–	6TE35-5AA3	6TE37-3AA3	6TE41-1AA3 6TE41-3AA3 6TE41-7AA3
<b>Suitable for Active Line Module in chassis format</b>					
• Air-cooled	6SL3330-	7TE32-1AA3 7TE32-6AA3	7TE33-8AA3 7TE35-0AA3	7TE36-1AA3 7TE37-5AA3	7TE38-4AA3 7TE41-0AA3 7TE41-2AA3 7TE41-4AA3
Line voltage 500 ... 690 V 3 AC		Line filter			
		6SL3760-0ME00-0AA0	6SL3760-0MN00-0AA0	6SL3760-0MG00-0AA0	
Rated current	A	600	1025	1270	
Power loss <sup>1)</sup> At 50 Hz	kW	0.063	0.063	0.097	
Load/line supply connection		M10 connecting lugs	M12 connecting lugs	M12 connecting lugs	
PE connection		Hole for M10	Hole for M10	Hole for M10	
Degree of protection		IP00	IP00	IP00	
<b>Dimensions</b>					
• Width	mm	400	425	505	
• Height	mm	365	365	365	
• Depth	mm	140	145	145	
Weight, approx.	kg	27	36.7	36.7	
<b>Suitable for Smart Line Module in chassis format</b>					
• Air-cooled	6SL3330-	6TG35-5AA3	6TG38-8AA3 6TG41-2AA3	6TG41-7AA3	
<b>Suitable for Active Line Module in chassis format</b>					
• Air-cooled	6SL3330-	7TG35-8AA3	7TG37-4AA3 7TG41-0AA3	7TG41-3AA3	

<sup>1)</sup> The specified power loss represents the maximum value at 100 % utilization. The value is lower under normal operating conditions.

# SINAMICS S120 Chassis Format Converter Units

## System components

Line-side power components &gt; Line reactors

### Overview

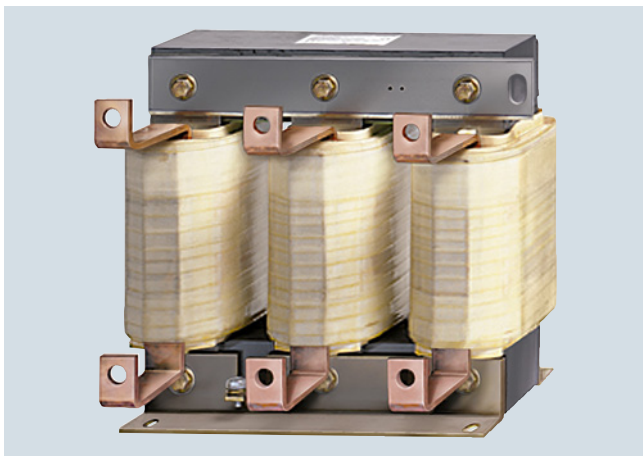

With a high line short-circuit power (i.e. low line supply cable inductance) a line reactor is required in order to

- protect the drive converter itself from excessively high harmonic currents and therefore overload
- limit the harmonics to permissible values. The harmonic currents are limited by the complete inductance comprising the line reactor and line supply cable inductance.

For additional information, please refer to the [SINAMICS Low Voltage Engineering Manual](#).

### Selection and ordering data

#### Line reactors for SINAMICS S120 Power Modules

Suitable for Power Module in chassis format, <u>air-cooled</u>	Suitable for Power Module in chassis format, <u>liquid-cooled</u>	Type rating of the Power Modules at 400 V	Rated input current of the Power Module	Line reactor
6SL3310-...	6SL3315-...	kW	A	Article No.
<b>Line voltage 380 ... 480 V 3 AC</b>				
1TE32-1AA3	1TE32-1AA3	110	229/230	<b>6SL3000-OCE32-3AA0</b>
1TE32-6AA3	1TE32-6AA3	132	284/285	<b>6SL3000-OCE32-8AA0</b>
1TE33-1AA3	1TE33-1AA3	160	338/340	<b>6SL3000-OCE33-3AA0</b>
1TE33-8AA3	–	200	395	<b>6SL3000-OCE35-1AA0</b>
1TE35-0AA3	1TE35-0AA3	250	509/540	

#### Line reactors for SINAMICS S120 Basic Line Modules

Suitable for Basic Line Module chassis format, <u>air-cooled</u>	Suitable for Basic Line Module chassis format, <u>liquid-cooled</u>	Rated power of the Basic Line Module at 400 V or 690 V	Rated input current of the Basic Line Module	Line reactor
6SL3330-...	6SL3335-...	kW	A	Article No.
<b>Line voltage 380 ... 480 V 3 AC</b>				
1TE34-2AA3	–	200	365	<b>6SL3000-OCE35-1AA0</b>
1TE35-3AA3	–	250	460	
–	1TE37-4AA3	360	610	<b>6SL3000-OCE36-3AA0</b>
1TE38-2AA3	–	400	710	<b>6SL3000-OCE37-7AA0</b>
1TE41-2AA3	–	560	1010	<b>6SL3000-OCE41-0AA0</b>
–	1TE41-2AA3	600	1000	
1TE41-5AA3	–	710	1265	<b>6SL3000-OCE41-5AA0</b>
–	1TE41-7AA3	830	1420	
1TE41-8AA3	–	900	1581	<b>6SL3000-OCE41-6AA0</b>
<b>Line voltage 500 ... 690 V 3 AC</b>				
1TG33-0AA3	–	250	260	<b>6SL3000-OCH32-7AA0</b>
–	1TG34-2AA3	355	340	<b>6SL3000-OCH33-4AA0</b>
1TG34-3AA3	–	355	375	<b>6SL3000-OCH34-8AA0</b>
1TG36-8AA3	–	560	575	<b>6SL3000-OCH36-0AA0</b>
–	1TG37-3AA3	630	600	
1TG41-1AA3	–	900	925	<b>6SL3000-OCH41-2AA0</b>
–	1TG41-3AA3	1100	1070	
1TG41-4AA3	–	1100	1180	
–	1TG41-7AA3	1370	1350	<b>6SL3000-OCH41-6AA0</b>
1TG41-8AA3	–	1500	1580	

# SINAMICS S120 Chassis Format Converter Units

## System components

### Line-side power components > Line reactors

#### Selection and ordering data (continued)

##### Line reactors for SINAMICS S120 Smart Line Modules

Suitable for Smart Line Module in chassis format, air-cooled 6SL3330-...	Rated power of the Smart Line Module at 400 V or 690 V kW	Rated input current of the Smart Line Module A	Line reactor Article No.
<b>Line voltage 380 ... 480 V 3 AC</b>			
6TE35-5AA3	250	463	<b>6SL3000-0EE36-2AA0</b>
6TE37-3AA3	355	614	
6TE41-1AA3	500	883	<b>6SL3000-0EE38-8AA0</b>
6TE41-3AA3	630	1093	<b>6SL3000-0EE41-4AA0</b>
6TE41-7AA3	800	1430	
<b>Line voltage 500 ... 690 V 3 AC</b>			
6TG35-5AA3	450	463	<b>6SL3000-0EH34-7AA0</b>
6TG38-8AA3	710	757	<b>6SL3000-0EH37-6AA0</b>
6TG41-2AA3	1000	1009	<b>6SL3000-0EH41-4AA0</b>
6TG41-7AA3	1400	1430	

#### Technical specifications

<b>Line voltage 380 ... 480 V 3 AC</b>		<b>Line reactor</b>					
		6SL3000-0CE32-3AA0	6SL3000-0CE32-8AA0	6SL3000-0CE33-3AA0	6SL3000-0CE35-1AA0	6SL3000-0CE36-3AA0	6SL3000-0CE37-7AA0
<b>Rated current</b>	A	224	278	331	508	628	773
<b>Nominal inductance <math>L_N</math></b>	$\mu\text{H}$	76	62	52	42	27	22
<b>Power loss <sup>1)</sup></b> At 50 Hz	kW	0.274	0.247	0.267	0.365	0.368	0.351
<b>Line/load connection</b>		1 × hole for M10 Provided for bus-bar connection	1 × hole for M10 Provided for bus-bar connection	1 × hole for M10 Provided for bus-bar connection	1 × hole for M12 Provided for bus-bar connection	1 × hole for M12 Provided for bus-bar connection	1 × hole for M12 Provided for bus-bar connection
<b>PE connection</b>		M6 screw	M6 screw	M6 screw	M6 screw	M6 screw	M6 screw
<b>Degree of protection</b>		IP00	IP00	IP00	IP00	IP00	IP00
<b>Dimensions</b>							
• Width	mm	270	270	270	300	300	300
• Height	mm	248	248	248	269	269	269
• Depth	mm	200	200	200	212	212	212
<b>Weight, approx.</b>	kg	24.5	26	27.8	38	41.4	51.3
<b>Suitable for Power Module in chassis format</b>							
• Air-cooled	6SL3310-	1TE32-1AA3	1TE32-6AA3	1TE33-1AA3	1TE33-8AA3 1TE35-0AA3	–	–
• Liquid-cooled	6SL3315-	1TE32-1AA3	1TE32-6AA3	1TE33-1AA3	1TE35-0AA3	–	–
<b>Suitable for Basic Line Module in chassis format</b>							
• Air-cooled	6SL3330-	–	–	–	1TE34-2AA3 1TE35-3AA3	–	1TE38-2AA3
• Liquid-cooled	6SL3335-	–	–	–	–	1TE37-4AA3	–

<sup>1)</sup> The specified power loss represents the maximum value at 100 % utilization. The value is lower under normal operating conditions.

# SINAMICS S120 Chassis Format Converter Units

## System components

### Line-side power components > Line reactors

#### Technical specifications (continued)

Line voltage 380 ... 480 V 3 AC		Line reactor		
		6SL3000-0CE41-0AA0	6SL3000-0CE41-5AA0	6SL3000-0CE41-6AA0
Rated current	A	1060	1485	1600
Nominal inductance $L_N$	$\mu\text{H}$	16	13	13
Power loss <sup>1)</sup> At 50 Hz	kW	0.498	0.776	0.606
Line/load connection		1 × hole for M12 Provided for busbar connection	1 × hole for M12 Provided for busbar connection	1 × hole for M12 Provided for busbar connection
PE connection		M6 screw	M6 screw	M6 screw
Degree of protection		IP00	IP00	IP00
<b>Dimensions</b>				
• Width	mm	350	460	416
• Height	mm	321	435	435
• Depth	mm	211	235	235
Weight, approx.	kg	69.6	118	123
<b>Suitable for Basic Line Module in chassis format</b>				
• Air-cooled	6SL3330-	1TE41-2AA3	1TE41-5AA3	1TE41-8AA3
• Liquid-cooled	6SL3335-	1TE41-2AA3	1TE41-7AA3	–
Line voltage 380 ... 480 V 3 AC		Line reactor		
		6SL3000-0EE36-2AA0	6SL3000-0EE38-8AA0	6SL3000-0EE41-4AA0
Rated current	A	615	885	1430
Nominal inductance $L_N$	$\mu\text{H}$	55	35	25
Power loss <sup>1)</sup> At 50 Hz	kW	0.56	0.81	1.08
Line/load connection		1 × hole for M10 Provided for busbar connection	2 × hole for M10 Provided for busbar connection	2 × hole for M10 Provided for busbar connection
PE connection		M6 thread	M6 thread	M6 thread
Degree of protection		IP00	IP00	IP00
<b>Dimensions</b>				
• Width	mm	300	442	544
• Height	mm	264	376	386
• Depth	mm	203	263	232
Weight, approx.	kg	57	85.5	220
<b>Suitable for Smart Line Module in chassis format</b>				
• Air-cooled	6SL3330-	6TE35-5AA3 6TE37-3AA3	6TE41-1AA3	6TE41-3AA3 6TE41-7AA3

<sup>1)</sup> The specified power loss represents the maximum value at 100 % utilization. The value is lower under normal operating conditions.

# SINAMICS S120 Chassis Format Converter Units

## System components

### Line-side power components > Line reactors

#### Technical specifications (continued)

Line voltage 500 ... 690 V 3 AC		Line reactor					
		6SL3000-0CH32-7AA0	6SL3000-0CH33-4AA0	6SL3000-0CH34-8AA0	6SL3000-0CH36-0AA0	6SL3000-0CH41-2AA0	6SL3000-0EH41-6AA0
<b>Rated current</b>	A	270	342	482	597	1167	1600
<b>Nominal inductance <math>L_N</math></b>	$\mu\text{H}$	100	81	65	46	30	17
<b>Power loss <sup>1)</sup></b> At 50 Hz	kW	0.277	0.27	0.48	0.485	0.783	0.977
<b>Line/load connection</b>		1 × hole for M10 Provided for busbar connection	1 × hole for M10 Provided for busbar connection	1 × hole for M12 Provided for busbar connection	1 × hole for M12 Provided for busbar connection	2 × hole for M12 Provided for busbar connection	2 × hole for M12 Provided for busbar connection
<b>PE connection</b>		M6 screw	M6 screw	M6 screw	M6 screw	M6 screw	M6 screw
<b>Degree of protection</b>		IP00	IP00	IP00	IP00	IP00	IP00
<b>Dimensions</b>							
• Width	mm	270	270	350	350	460	416
• Height	mm	248	248	321	321	435	435
• Depth	mm	200	200	232	232,5	235	250
<b>Weight, approx.</b>	kg	27.9	38.9	55.6	63.8	147	134
<b>Suitable for Basic Line Module in chassis format</b>							
• Air-cooled	6SL3330-	1TG33-0AA3	–	1TG34-3AA3	1TG36-8AA3	1TG41-1AA3 1TG41-4AA3	1TG41-8AA3
• Liquid-cooled	6SL3335-	–	1TG34-2AA3	–	1TG37-3AA3	1TG41-3AA3	1TG41-7AA3
Line voltage 500 ... 690 V 3 AC		Line reactor					
		6SL3000-0EH34-7AA0		6SL3000-0EH37-6AA0		6SL3000-0EH41-4AA0	
<b>Rated current</b>	A	465		760		1430	
<b>Nominal inductance <math>L_N</math></b>	$\mu\text{H}$	115		70		40	
<b>Power loss <sup>1)</sup></b> At 50 Hz	kW	0.82		0.95		1.85	
<b>Line/load connection</b>		1 × hole for M10 Provided for busbar connection		2 × hole for M10 Provided for busbar connection		2 × hole for M10 Provided for busbar connection	
<b>PE connection</b>		M6 nut		M6 nut		M6 nut	
<b>Degree of protection</b>		IP00		IP00		IP00	
<b>Dimensions</b>							
• Width	mm	360		442		655	
• Height	mm	325		370		383	
• Depth	mm	229		303		288	
<b>Weight, approx.</b>	kg	58		145		239	
<b>Suitable for Smart Line Module in chassis format</b>							
• Air-cooled	6SL3330-	6TG35-5AA3		6TG38-8AA3		6TG41-2AA3 6TG41-7AA3	

<sup>1)</sup> The specified power loss represents the maximum value at 100 % utilization. The value is lower under normal operating conditions.

# SINAMICS S120 Chassis Format Converter Units

## System components

### Line-side power components > Recommended line-side system components

#### Selection and ordering data

Appropriate line-side power components are assigned depending on the power rating of the Power Modules, Basic Line Modules, Smart Line Modules or Active Line Modules.

Further information about the main contactors, switch disconnectors, fuses and circuit breakers is provided in the Catalogs IC 10 and LV 10.

#### Assignment of line-side power components to air-cooled and liquid-cooled Power Modules in chassis format

Type rating at 400 V kW	Rated input current		Suitable for Power Module in chassis format 6SL3310-... <sup>1)</sup> 6SL3315-... <sup>2)</sup>	Main contactor		Switch disconnector without handle and shaft		Switch disconnector with handle and shaft	
	Air-cooled A	Liquid-cooled A		Article No.	Article No.	Article No.	Article No.		
<b>Line voltage 380 ... 480 V 3 AC</b>									
110	229	230	1TE32-1AA3	<b>3RT1064-6AP36</b>		<b>3KL5530-1AB01</b>		<b>3KL5530-1GB01</b>	
132	284	285	1TE32-6AA3	<b>3RT1065-6AP36</b>		<b>3KL5730-1AB01</b>		<b>3KL5730-1GB01</b>	
160	338	340	1TE33-1AA3	<b>3RT1066-6AP36</b>		–			
200	395	–	1TE33-8AA3	<b>3RT1075-6AP36</b>		–			
250	509	540	1TE35-0AA3	<b>3RT1076-6AP36</b>		<b>3KL6130-1AB02</b>		<b>3KL6130-1GB02</b>	

Type rating at 400 V kW	Rated input current		Suitable for Power Module in chassis format 6SL3310-... <sup>1)</sup> 6SL3315-... <sup>2)</sup>	Cable protection fuse		Cable protection fuse incl. semiconductor protection	
	Air-cooled A	Liquid-cooled A		Rated current A	Article No.	Rated current A	Article No.
<b>Line voltage 380 ... 480 V 3 AC</b>							
110	229	230	1TE32-1AA3	250	<b>3NA3144</b>	315	<b>3NE1230-2</b>
132	284	285	1TE32-6AA3	300	<b>3NA3250</b>	350	<b>3NE1331-2</b>
160	338	340	1TE33-1AA3	355	<b>3NA3254</b>	450	<b>3NE1333-2</b>
200	395	–	1TE33-8AA3	400	<b>3NA3260</b>		
250	509	540	1TE35-0AA3	630	<b>3NA3372</b>	2 × 315/630	<b>3NE1230-2 or 3NE1436-2</b>

<sup>1)</sup> 6SL3310-... is the air-cooled version.

<sup>2)</sup> 6SL3315-... is the liquid-cooled version.

# SINAMICS S120 Chassis Format Converter Units

## System components

### Line-side power components > Recommended line-side system components

#### Selection and ordering data (continued)

#### Assignment of line-side power components to air-cooled and liquid-cooled Basic Line Modules in chassis format

Rated power at 400 V or 690 V kW	Rated input current A	Suitable for Basic Line Module	Main contactor Type	Fixed-mounted circuit breaker Article No.	Switch disconnector without handle and shaft Article No.	Switch disconnector with handle and shaft Article No.
<b>Line voltage 380 ... 480 V 3 AC</b>						
200	365	6SL3330-1TE34-2AA3 <sup>1)</sup>	<b>3RT1075-...</b>	–	<b>3KL6130-1AB02</b>	<b>3KL6130-1GB02</b>
250	460	6SL3330-1TE35-3AA3 <sup>1)</sup>	<b>3RT1076-...</b>	–	<b>3KL6130-1AB02</b>	<b>3KL6130-1GB02</b>
360	610	6SL3335-1TE37-4AA3 <sup>2)</sup>	<b>3RT1076-...</b>	–	<b>3KL6130-1AB02</b>	<b>3KL6130-1GB02</b>
400	710	6SL3330-1TE38-2AA3 <sup>1)</sup>	<b>3RT1066-...</b> (3 units)	–	<b>3KL6230-1AB02</b>	<b>3KL6230-1GB02 <sup>3)</sup></b>
560	1010	6SL3330-1TE41-2AA3 <sup>1)</sup>	–	<b>3WL1112-2BB34-4AN2-Z C22 <sup>4)</sup></b>	–	–
600	1000	6SL3335-1TE41-2AA3 <sup>2)</sup>	–	<b>3WL1112-2BB34-4AN2-Z C22 <sup>4)</sup></b>	–	–
710	1265	6SL3330-1TE41-5AA3 <sup>1)</sup>	–	<b>3WL1116-2BB34-4AN2-Z C22 <sup>4)</sup></b>	–	–
830	1420	6SL3335-1TE41-7AA3 <sup>2)</sup>	–	<b>3WL1116-2BB34-4AN2-Z C22 <sup>4)</sup></b>	–	–
900	1630	6SL3330-1TE41-8AA3 <sup>1)</sup>	–	<b>3WL1220-2BB34-4AN2-Z C22 <sup>4)</sup></b>	–	–
<b>Line voltage 500 ... 690 V 3 AC</b>						
250	260	6SL3330-1TG33-0AA3 <sup>1)</sup>	<b>3RT1066-...</b>	–	<b>3KL5730-1AB01</b>	<b>3KL5730-1GB01</b>
355	375	6SL3330-1TG34-3AA3 <sup>1)</sup>	<b>3RT1075-...</b>	–	<b>3KL6130-1AB02</b>	<b>3KL6130-1GB02</b>
	340	6SL3335-1TG34-2AA3 <sup>2)</sup>				
560	575	6SL3330-1TG36-8AA3 <sup>1)</sup>	<b>3RT1076-...</b>	–	<b>3KL6130-1AB02</b>	<b>3KL6130-1GB02</b>
630	600	6SL3335-1TG37-3AA3 <sup>2)</sup>	<b>3RT1076-...</b>	–	<b>3KL6130-1AB02</b>	<b>3KL6130-1GB02</b>
900	925	6SL3330-1TG41-1AA3 <sup>1)</sup>	–	<b>3WL1210-4BB34-4AN2-Z C22 <sup>4)</sup></b>	–	–
1100	1180	6SL3330-1TG41-4AA3 <sup>1)</sup>	–	<b>3WL1212-4BB34-4AN2-Z C22 <sup>4)</sup></b>	–	–
	1070	6SL3335-1TG41-3AA3 <sup>2)</sup>				
1370	1350	6SL3335-1TG41-7AA3 <sup>2)</sup>	–	<b>3WL1216-4BB34-4AN2-Z C22 <sup>4)</sup></b>	–	–
1500	1580	6SL3330-1TG41-8AA3 <sup>1)</sup>	–	<b>3WL1220-4BB34-4AN2-Z C22 <sup>4)</sup></b>	–	–

<sup>1)</sup> 6SL3330-... is the air-cooled version.

<sup>2)</sup> 6SL3335-... is the liquid-cooled version.

<sup>3)</sup> Suitable only for 3NE1 fuses up to size 3.

<sup>4)</sup> The breakers must always be switched ON and OFF by the sequence control. An interlocking set 3WL9111-0BA21-0AA0 as described in Catalog LV 10 should be provided for the circuit breakers in order to exclude the risk of unintentional manual operation. Manual operation bypasses the pre-charging circuit and can therefore destroy the Line Module.

# SINAMICS S120 Chassis Format Converter Units

## System components

Line-side power components > Recommended line-side system components

### Selection and ordering data (continued)

Rated power at 400 V or 690 V kW	Rated input current A	Suitable for Basic Line Module	Cable protection fuse		Cable protection fuse incl. semiconductor protection	
			Rated current A	Article No.	Rated current A	Article No.
<b>Line voltage 380 ... 480 V 3 AC</b>						
200	365	6SL3330-1TE34-2AA3 <sup>1)</sup>	500	<b>3NA3365</b>	450	<b>3NE1333-2</b>
250	460	6SL3330-1TE35-3AA3 <sup>1)</sup>	630	<b>3NA3372</b>	500	<b>3NE1334-2</b>
360	610	6SL3335-1TE37-4AA3 <sup>2)</sup>	2 × 315	<b>3NA3352</b> (2 units)	2 × 450	<b>3NE1333-2</b> (2 units)
400	710	6SL3330-1TE38-2AA3 <sup>1)</sup>	800	<b>3NA3475</b>	800	<b>3NE1438-2</b>
560	1010	6SL3330-1TE41-2AA3 <sup>1)</sup>	1250	<b>3NA3482</b>	2 × 560	<b>3NE1435-2</b> (2 units)
600	1000	6SL3335-1TE41-2AA3 <sup>2)</sup>	2 × 500	<b>3NA3365</b> (2 units)	2 × 560	<b>3NE1435-2</b> (2 units)
710	1265	6SL3330-1TE41-5AA3 <sup>1)</sup>	2 × 800	<b>3NA3475</b> (2 units)	2 × 710	<b>3NE1437-2</b> (2 units)
830	1420	6SL3335-1TE41-7AA3 <sup>2)</sup>	3 × 500	<b>3NA3365</b> (3 units)	2 × 800	<b>3NE1438-2</b> (2 units)
900	1630	6SL3330-1TE41-8AA3 <sup>1)</sup>	3 × 630	<b>3NA3372</b> (3 units)	3 × 630	<b>3NE1436-2</b> (3 units)
<b>Line voltage 500 ... 690 V 3 AC</b>						
250	260	6SL3330-1TG33-0AA3 <sup>1)</sup>	315	<b>3NA3252-6</b>	315	<b>3NE1230-2</b>
355	375	6SL3330-1TG34-3AA3 <sup>1)</sup>	500	<b>3NA3365-6</b>	450	<b>3NE1333-2</b>
	340	6SL3335-1TG34-2AA3 <sup>2)</sup>	355	<b>3NA3354-6</b>		
560	575	6SL3330-1TG36-8AA3 <sup>1)</sup>	2 × 315	<b>3NA3252-6</b> (2 units)	630	<b>3NE1436-2</b>
630	600	6SL3335-1TG37-3AA3 <sup>2)</sup>	2 × 300	<b>3NA3250-6</b> (2 units)	2 × 350	<b>3NE1331-2</b> (2 units)
900	925	6SL3330-1TG41-1AA3 <sup>1)</sup>	2 × 500	<b>3NA3365-6</b> (2 units)	2 × 500	<b>3NE1334-2</b> (2 units)
1100	1180	6SL3330-1TG41-4AA3 <sup>1)</sup>	3 × 500	<b>3NA3365-6</b> (3 units)	2 × 630	<b>3NE1436-2</b> (2 units)
	1070	6SL3335-1TG41-3AA3 <sup>2)</sup>	3 × 400	<b>3NA3360-6</b> (3 units)	2 × 670	<b>3NE1447-2</b> (2 units)
1370	1350	6SL3335-1TG41-7AA3 <sup>2)</sup>	3 × 500	<b>3NA3365-6</b> (3 units)	3 × 560	<b>3NE1435-2</b> (3 units)
1500	1580	6SL3330-1TG41-8AA3 <sup>1)</sup>	4 × 500	<b>3NA3365-6</b> (4 units)	3 × 630	<b>3NE1436-2</b> (3 units)

### Power components for the pre-charging circuit of the Basic Line Module in chassis format, frame size GD

Rated power at 400 V or 690 V kW	Rated input current A	Suitable for Basic Line Module 6SL3330-...	Pre-charging resistors		Pre-charging contactor Type	Cable protection fuse for pre-charging arm	
			Pre-charging current <sup>3)</sup> A	Article No.		Rated current A	Article No.
<b>Line voltage 380 ... 480 V 3 AC</b>							
900	1630	1TE41-8AA3	91 <sup>4)</sup>	<b>6SL3000-OKE12-2AA0</b>	<b>3RT1034-...</b> <sup>4)</sup> <b>3RT1044-...</b> <sup>5)</sup>	50	<b>3NE1817-0</b> <sup>4)</sup>
			182 <sup>5)</sup>			100	<b>3NE1021-0</b> <sup>5)</sup>
<b>Line voltage 500 ... 690 V 3 AC</b>							
1500	1580	1TG41-8AA3	86 <sup>4)</sup> 172 <sup>5)</sup>	<b>6SL3000-OKH14-0AA0</b>	<b>3RT1034-...</b> <sup>4)</sup> <b>3RT1044-...</b> <sup>5)</sup>	50 100	<b>3NE1817-0</b> <sup>4)</sup> <b>3NE1021-0</b> <sup>5)</sup>

#### Note:

The dimension drawings of the pre-charging resistors are to be found in the dimension drawing collection for Catalog D 21.3 in the Information and Download Center ([www.siemens.com/industry/infocenter](http://www.siemens.com/industry/infocenter)).

<sup>1)</sup> 6SL3330-... is the air-cooled version.

<sup>2)</sup> 6SL3335-... is the liquid-cooled version.

<sup>3)</sup> Line current present at the start of the pre-charging process (initial rms value).

<sup>4)</sup> With one pre-charging resistor per phase.

<sup>5)</sup> With two pre-charging resistors connected in parallel per phase.



## SINAMICS S120 Chassis Format Converter Units

### System components

#### Line-side power components > Recommended line-side system components

##### Selection and ordering data (continued)

##### Assignment of line-side power components to Smart Line Modules in chassis format

Rated power at 400 V or 690 V kW	Rated input current A	Suitable for Smart Line Module 6SL3330-...	Main contactor		Fixed-mounted circuit breaker		Switch disconnecter without handle and shaft		Switch disconnecter with handle and shaft	
			Article No.	Article No.	Article No.	Article No.	Article No.	Article No.		
<b>Line voltage 380 ... 480 V 3 AC</b>										
250	463	6TE35-5AA3	<b>3RT1476-6AP36</b>	–	–	<b>3KL6130-1AB02</b>	–	<b>3KL6130-1GB02</b>	–	<b>3KL6130-1GB02</b>
355	614	6TE37-3AA3	<b>3RT1476-6AP36</b>	–	–	<b>3KL6230-1AB02</b>	–	<b>3KL6230-1GB02</b>	–	<b>3KL6230-1GB02</b>
500	883	6TE41-1AA3	–	–	<b>3WL1210-4CB34-4AN2-Z C22</b> <sup>1)</sup>	–	–	–	–	–
630	1093	6TE41-3AA3	–	–	<b>3WL1212-4CB34-4AN2-Z C22</b> <sup>1)</sup>	–	–	–	–	–
800	1430	6TE41-7AA3	–	–	<b>3WL1216-4CB34-4AN2-Z C22</b> <sup>1)</sup>	–	–	–	–	–
<b>Line voltage 500 ... 690 V 3 AC</b>										
450	463	6TG35-5AA3	<b>3RT1466-6AP36</b>	–	–	<b>3KL6130-1AB02</b>	–	<b>3KL6130-1GB02</b>	–	<b>3KL6130-1GB02</b>
710	757	6TG38-8AA3	<b>3RT1466-6AP36</b> (3 units)	–	–	<b>3KL6230-1AB02</b>	–	<b>3KL6230-1GB02</b>	–	<b>3KL6230-1GB02</b>
1000	1009	6TG41-2AA3	–	–	<b>3WL1212-4CB34-4AN2-Z C22</b> <sup>1)</sup>	–	–	–	–	–
1400	1430	6TG41-7AA3	–	–	<b>3WL1216-4CB34-4AN2-Z C22</b> <sup>1)</sup>	–	–	–	–	–

Rated power at 400 V or 690 V kW	Rated input current A	Suitable for Smart Line Module 6SL3330-...	Cable protection fuse		Cable protection fuse incl. semiconductor protection	
			Rated current A	Article No.	Rated current A	Article No.
<b>Line voltage 380 ... 480 V 3 AC</b>						
250	463	6TE35-5AA3	500	<b>3NA3365</b>	560	<b>3NE1435-2</b>
355	614	6TE37-3AA3	630	<b>3NA3372</b>	710	<b>3NE1437-2</b>
500	883	6TE41-1AA3	1000	<b>3NA3480</b>	2 × 500	<b>3NE1334-2</b> (2 units)
630	1093	6TE41-3AA3	1250	<b>3NA3482</b>	2 × 630	<b>3NE1436-2</b> (2 units)
800	1430	6TE41-7AA3	2 × 800	<b>3NA3475</b> (2 units)	2 × 850	<b>3NE1448-2</b> (2 units)
<b>Line voltage 500 ... 690 V 3 AC</b>						
450	463	6TG35-5AA3	500	<b>3NA3365-6</b>	560	<b>3NE1435-2</b>
710	757	6TG38-8AA3	2 × 400	<b>3NA3360-6</b> (2 units)	850	<b>3NE1448-2</b>
1000	1009	6TG41-2AA3	3 × 355	<b>3NA3354-6</b> (3 units)	2 × 560	<b>3NE1435-2</b> (2 units)
1400	1430	6TG41-7AA3	3 × 500	<b>3NA3365-6</b> (3 units)	2 × 850	<b>3NE1448-2</b> (2 units)

<sup>1)</sup> The breakers must always be switched ON and OFF by the sequence control. An interlocking set 3WL9111-0BA21-0AA0 as described in Catalog LV 10 should be provided for the circuit breakers in order to exclude the risk of unintentional manual operation. Manual operation bypasses the pre-charging circuit and can therefore destroy the Line Module.

# SINAMICS S120 Chassis Format Converter Units

## System components

Line-side power components > Recommended line-side system components

### Selection and ordering data (continued)

*Assignment of line-side power components to air-cooled and liquid-cooled Active Line Modules or Active Interface Modules in chassis format*

Rated power at 400 V or 690 V kW	Rated input current A	Suitable for Active Interface Module	Suitable for Active Line Module	Bypass contactor Article No.
<b>Line voltage 380 ... 480 V 3 AC</b>				
132	210	6SL3300-7TE32-6AA1	6SL3330-7TE32-1AA3	Included in Active Interface Module
160	260	6SL3300-7TE32-6AA1	6SL3330-7TE32-6AA3	Included in Active Interface Module
235	380	6SL3300-7TE33-8AA1	6SL3330-7TE33-8AA3	Included in Active Interface Module
300	490	6SL3300-7TE35-0AA1	6SL3330-7TE35-0AA3 6SL3335-7TE35-0AA3	Included in Active Interface Module
380	605	6SL3300-7TE38-4AA1 6SL3305-7TE38-4AA5	6SL3330-7TE36-1AA3 6SL3335-7TE36-1AA3	<b>3RT1476-6AP36</b>
450	745	6SL3300-7TE38-4AA1	6SL3330-7TE37-5AA3	<b>3WL1110-2BB34-4AN2-Z C22</b> <sup>1)</sup>
500	840	6SL3300-7TE38-4AA1 6SL3305-7TE38-4AA5	6SL3330-7TE38-4AA3 6SL3335-7TE38-4AA3	<b>3WL1110-2BB34-4AN2-Z C22</b> <sup>1)</sup>
630	985	6SL3300-7TE41-4AA1 6SL3305-7TE41-4AA5 6SL3305-7TE41-4AA7	6SL3330-7TE41-0AA3 6SL3335-7TE41-0AA3 6SL3335-7TE41-0AA7	<b>3WL1112-2BB34-4AN2-Z C22</b> <sup>1)</sup>
800	1260	6SL3300-7TE41-4AA1	6SL3330-7TE41-2AA3	<b>3WL1116-2BB34-4AN2-Z C22</b> <sup>1)</sup>
900	1405	6SL3300-7TE41-4AA1 6SL3305-7TE41-4AA5 6SL3305-7TE41-4AA7	6SL3330-7TE41-4AA3 6SL3335-7TE41-4AA3 6SL3335-7TE41-4AA7	<b>3WL1116-2BB34-4AN2-Z C22</b> <sup>1)</sup>
<b>Line voltage 500 ... 690 V 3 AC</b>				
630	575	6SL3300-7TG35-8AA1	6SL3330-7TG35-8AA3 6SL3335-7TG35-8AA3	<b>3RT1476-6AP36</b>
800	735	6SL3300-7TG37-4AA1 6SL3305-7TG37-4AA5	6SL3330-7TG37-4AA3 6SL3335-7TG37-4AA3	<b>3RT1476-6AP36</b> (3 units)
900	810	6SL3305-7TG41-0AA5 6SL3305-7TG41-0AA7	6SL3335-7TG38-1AA3 6SL3335-7TG38-1AA7	<b>3WL1212-4BB34-4AN2-Z C22</b> <sup>1)</sup>
1100	1025	6SL3300-7TG41-3AA1 6SL3305-7TG41-0AA5 6SL3305-7TG41-0AA7	6SL3330-7TG41-0AA3 6SL3335-7TG41-0AA3 6SL3335-7TG41-0AA7	<b>3WL1212-4BB34-4AN2-Z C22</b> <sup>1)</sup>
1400	1270	6SL3300-7TG41-3AA1 6SL3305-7TG41-3AA5 6SL3305-7TG41-3AA7	6SL3330-7TG41-3AA3 6SL3335-7TG41-3AA3 6SL3335-7TG41-3AA7	<b>3WL1216-4BB34-4AN2-Z C22</b> <sup>1)</sup>
1700	1560	6SL3305-7TG41-6AA5 6SL3305-7TG41-6AA7	6SL3335-7TG41-6AA3 6SL3335-7TG41-6AA7	<b>3WL1216-4BB34-4AN2-Z C22</b> <sup>1)</sup>

<sup>1)</sup> The breakers must always be switched ON and OFF by the sequence control. An interlocking set 3WL9111-0BA21-0AA0 as described in Catalog LV 10 should be provided for the circuit breakers in order to exclude the risk of unintentional manual operation. Manual operation bypasses the pre-charging circuit and can therefore destroy the Line Module.

# SINAMICS S120 Chassis Format Converter Units

## System components

### Line-side power components > Recommended line-side system components

#### Selection and ordering data (continued)

Rated power at 400 V or 690 V kW	Rated input current A	Suitable for Active Interface Module 6SL3300-... 6SL3305-...	Suitable for Active Line Module 6SL3330-... 6SL3335-...	Switch disconnector without handle and shaft Article No.	Switch disconnector with handle and shaft Article No.	Cable protection fuse		Cable protection fuse incl. semiconductor protection	
						Rated current A	Article No.	Rated current A	Article No.
<b>Line voltage 380 ... 480 V 3 AC</b>									
132	210	7TE32-6AA1	7TE32-1AA3	<b>3KL5530-1AB01</b>	<b>3KL5530-1GB01</b>	315	<b>3NA3252</b>	315	<b>3NE1230-2</b>
160	260	7TE32-6AA1	7TE32-6AA3	<b>3KL5730-1AB01</b>	<b>3KL5730-1GB01</b>	355	<b>3NA3254</b>	350	<b>3NE1331-2</b>
235	380	7TE33-8AA1	7TE33-8AA3	<b>3KL5730-1AB01</b>	<b>3KL5730-1GB01</b>	500	<b>3NA3365</b>	500	<b>3NE1334-2</b>
300	490	7TE35-0AA1	7TE35-0AA3 7TE35-0AA3 <sup>1)</sup>	<b>3KL6130-1AB02</b>	<b>3KL6130-1GB02</b>	630	<b>3NA3372</b>	630	<b>3NE1436-2</b>
380	605	7TE38-4AA1 7TE38-4AA5 <sup>1)</sup>	7TE36-1AA3 7TE36-1AA3 <sup>1)</sup>	<b>3KL6230-1AB02</b>	<b>3KL6230-1GB02</b>	800	<b>3NA3475</b>	800	<b>3NE1438-2</b>
500	840	7TE38-4AA1 7TE38-4AA5 <sup>1)</sup>	7TE38-4AA3 7TE38-4AA3 <sup>1)</sup>	–	–	2 × 425	<b>3NA3362</b> (2 units)	2 × 500	<b>3NE1334-2</b> (2 units)
630	985	7TE41-4AA1 7TE41-4AA5 <sup>1)</sup> 7TE41-4AA7 <sup>1)</sup>	7TE41-0AA3 7TE41-0AA3 <sup>1)</sup> 7TE41-0AA7 <sup>1)</sup>	–	–	2 × 500	<b>3NA3365</b> (2 units)	2 × 630	<b>3NE1436-2</b> (2 units)
800	1260	7TE41-4AA1	7TE41-2AA3	–	–	3 × 425	<b>3NA3362</b> (2 units)	2 × 850	<b>3NE1448-2</b> (2 units)
900	1405	7TE41-4AA1 7TE41-4AA5 <sup>1)</sup> 7TE41-4AA7 <sup>1)</sup>	7TE41-4AA3 7TE41-4AA3 <sup>1)</sup> 7TE41-4AA7 <sup>1)</sup>	–	–	3 × 500	<b>3NA3365</b> (3 units)	2 × 850	<b>3NE1448-2</b> (2 units)
<b>Line voltage 500 ... 690 V 3 AC</b>									
560/630	575	7TG35-8AA1	7TG35-8AA3 7TG35-8AA3 <sup>1)</sup>	<b>3KL6130-1AB02</b>	<b>3KL6130-1GB02</b>	2 × 315	<b>3NA3352-6</b> (2 units)	670	<b>3NE1447-2</b>
800	735	7TG37-4AA1 7TG37-4AA5 <sup>1)</sup>	7TG37-4AA3 7TG37-4AA3 <sup>1)</sup>	<b>3KL6230-1AB02</b>	<b>3KL6230-1GB02</b>	2 × 400	<b>3NA3360-6</b> (2 units)	850	<b>3NE1448-2</b>
900	810	7TG41-0AA5 <sup>1)</sup> 7TG41-0AA7 <sup>1)</sup>	7TG38-1AA3 <sup>1)</sup> 7TG38-1AA7 <sup>1)</sup>	–	–	2 × 500	<b>3NA3365-6</b> (2 units)	2 × 560	<b>3NE1435-2</b> (2 units)
1100	1025	7TG41-3AA1 7TG41-0AA5 <sup>1)</sup> 7TG41-0AA7 <sup>1)</sup>	7TG41-0AA3 7TG41-0AA3 <sup>1)</sup> 7TG41-0AA7 <sup>1)</sup>	–	–	3 × 355	<b>3NA3354-6</b> (3 units)	2 × 630	<b>3NE1436-2</b> (2 units)
1400	1270	7TG41-3AA1 7TG41-3AA5 <sup>1)</sup> 7TG41-3AA7 <sup>1)</sup>	7TG41-3AA3 7TG41-3AA3 <sup>1)</sup> 7TG41-3AA7 <sup>1)</sup>	–	–	3 × 500	<b>3NA3365-6</b> (3 units)	2 × 800	<b>3NE1438-2</b> (2 units)
1700	1560	7TG41-6AA5 <sup>1)</sup> 7TG41-6AA7 <sup>1)</sup>	7TG41-6AA3 <sup>1)</sup> 7TG41-6AA7 <sup>1)</sup>	–	–	4 × 500	<b>3NA3365-6</b> (4 units)	3 × 630	<b>3NE1436-2</b> (3 units)

<sup>1)</sup> Liquid-cooled version, 6SL3305-... or 6SL3335-...

# SINAMICS S120 Chassis Format Converter Units

## System components

DC link components &gt; Braking Modules

### Overview

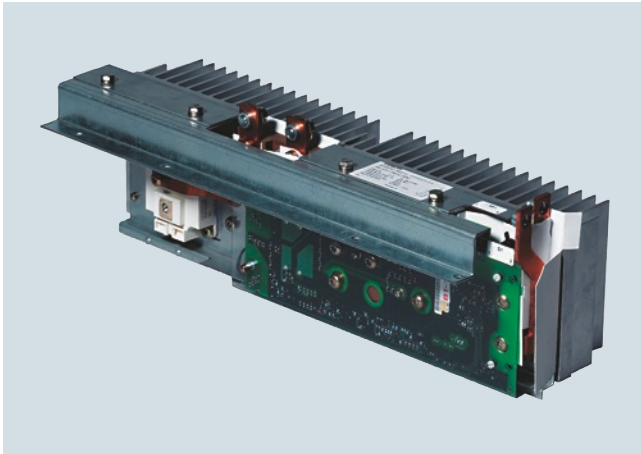

A Braking Module and the matching external braking resistor are required to bring drives to a controlled standstill in the event of a power failure (e.g. with an EMERGENCY STOP) or to limit the DC link voltage for brief periods of regenerative operation, e.g. if the Line Module is not capable of energy recovery.

The Braking Module includes the power electronics and the associated control circuit. During operation, the DC link energy is converted to heat loss in an external braking resistor.

The Braking Module works independently of the converter control.

Several Braking Modules can be operated in parallel, but a separate braking resistor must be connected to each Braking Module.

Braking Modules are designed to be integrated into air-cooled Motor Modules, Line Modules or Power Modules and are cooled by the fans on these modules. The supply voltage for the electronics is taken from the DC link. The Braking Modules are connected to the DC link by means of the busbar sets included in the scope of supply or flexible cables and, in the case of Basic Line Modules of frame size GB or GD, using a separate cable harness set.

The activation threshold of the Braking Module can be adjusted by means of a DIP switch. The braking power values specified in the technical specifications apply to the upper activation threshold.

### Design

The Braking Modules have the following interfaces as standard:

- 1 DC link connection
- 1 braking resistor connection
- 1 digital input (inhibit Braking Module / acknowledge error)
- 1 digital output (Braking Module inhibited)
- 1 DIP switch for adjusting the activation threshold

[Information about Braking Module activation thresholds and other notes](#) are included in the [SINAMICS Low Voltage Engineering Manual](#).

### Selection and ordering data

Rated power $P_{DB}$ kW	Peak power $P_{15}$ kW	Frame size	Braking Module Article No.
<b>Line voltage 380 ... 480 V 3 AC DC link voltage 510 ... 720 V DC</b>			
25	125	FX/FB	<b>6SL3300-1AE31-3AA0</b>
50	250	GX/GB/GD	<b>6SL3300-1AE32-5AA0</b>
50	250	HX/JX	<b>6SL3300-1AE32-5BA0</b>
<b>Line voltage 500 ... 600 V 3 AC DC link voltage 675 ... 900 V DC</b>			
25	125	FX/FB	<b>6SL3300-1AF31-3AA0</b>
50	250	GX/GB/GD	<b>6SL3300-1AF32-5AA0</b>
50	250	HX/JX	<b>6SL3300-1AF32-5BA0</b>
<b>Line voltage 660 ... 690 V 3 AC DC link voltage 890 ... 1035 V DC</b>			
25	125	FX/FB	<b>6SL3300-1AH31-3AA0</b>
50	250	GX/GB/GD	<b>6SL3300-1AH32-5AA0</b>
50	250	HX/JX	<b>6SL3300-1AH32-5BA0</b>
Description			Article No.
<b>Accessories</b>			
<b>Cable harness set</b> for mounting a Braking Module of frame size GX into a Basic Line Module of frame size GB or GD			<b>6SL3366-2NG00-0AA0</b>

3

# SINAMICS S120 Chassis Format Converter Units

## System components

### DC link components > Braking Modules

#### Integration

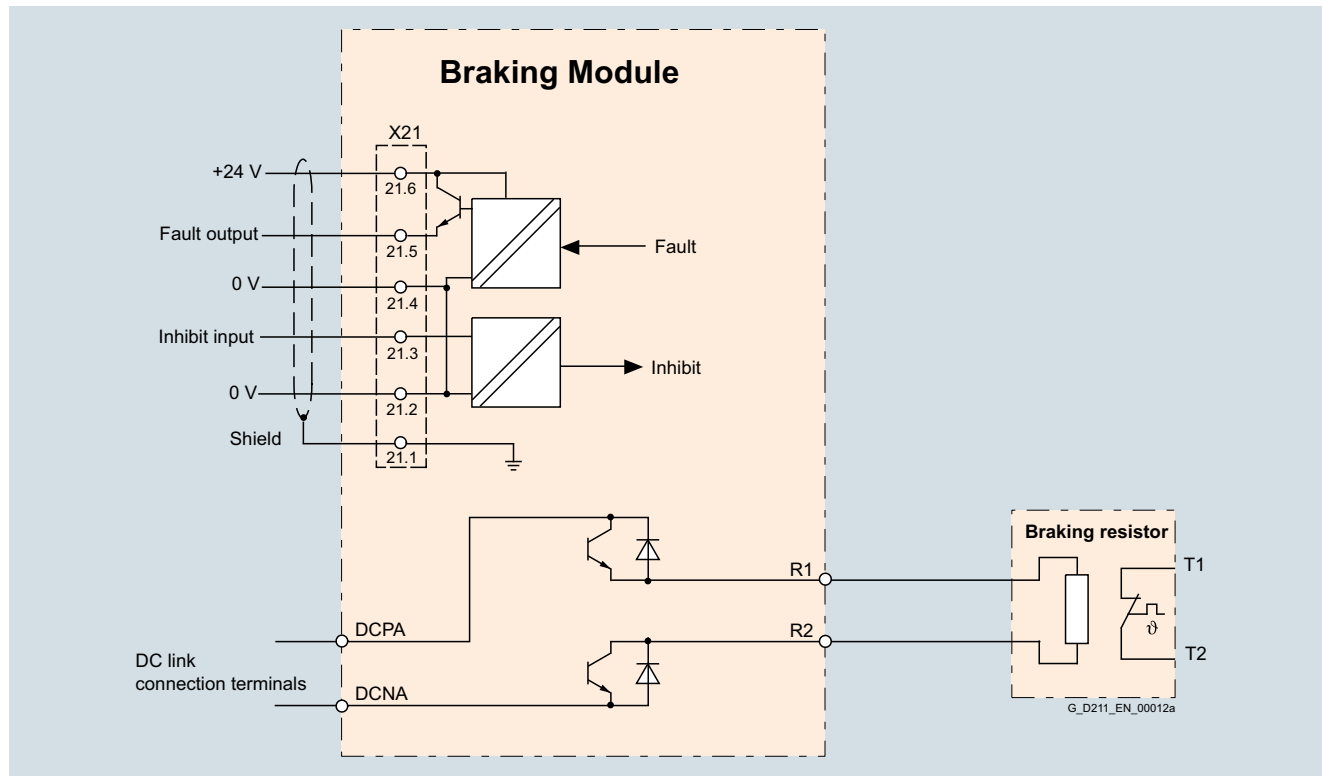

Connection example of a Braking Module

#### Characteristic curves

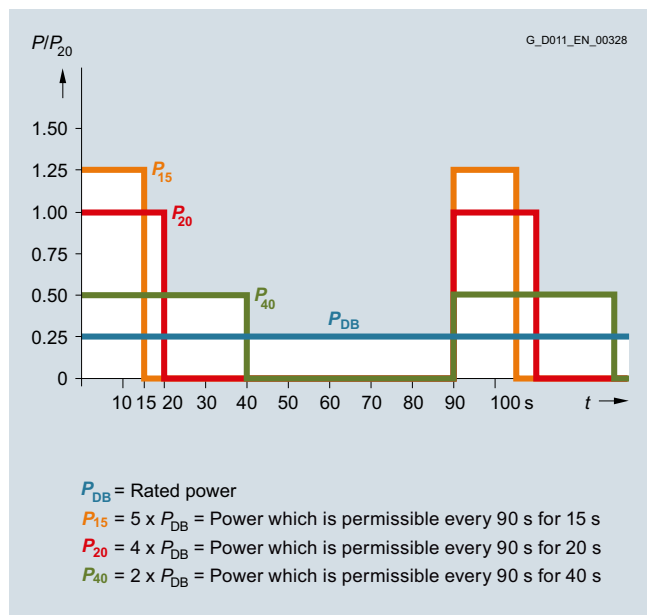

Load diagram for Braking Modules and braking resistor

3

# SINAMICS S120 Chassis Format Converter Units

## System components

### DC link components > Braking Modules

#### Technical specifications

Line voltage 380 ... 480 V 3 AC DC link voltage 510 ... 720 V DC		Braking Module		
		6SL3300-1AE31-3AA0	6SL3300-1AE32-5AA0	6SL3300-1AE32-5BA0
<b>Power</b>				
• Rated power $P_{DB}$	kW	25	50	50
• Peak power $P_{15}$	kW	125	250	250
• Power $P_{20}$	kW	100	200	200
• Power $P_{40}$	kW	50	100	100
<b>Activation thresholds</b> (adjustable via DIP switch)		V	774 (factory setting) or 673	774 (factory setting) or 673
<b>Digital inputs</b> in accordance with IEC 61131-2 Type 1				
• Voltage	V	24 DC	24 DC	24 DC
• Low level (an open digital input is interpreted as "low")	V	-3 ... +5	-3 ... +5	-3 ... +5
• High level	V	15 ... 30	15 ... 30	15 ... 30
• Current consumption at 24 V DC, typ.	mA	10	10	10
• Conductor cross-section, max.	mm <sup>2</sup>	1.5	1.5	1.5
<b>Digital outputs</b> sustained-short-circuit-proof				
• Voltage	V	24 DC	24 DC	24 DC
• Load current per digital output, max.	mA	500	500	500
• Conductor cross-section, max.	mm <sup>2</sup>	1.5	1.5	1.5
<b>R1/R2 connection</b>		M8 nut	M8 nut	M8 nut
• Conductor cross-section, max.	mm <sup>2</sup>	35	50	50
<b>Weight, approx.</b>		kg	3.6	7.3
<b>Suitable for installation in air-cooled Power Modules, Line Modules or Motor Modules</b>				
• Air-cooled	Frame size	FX/FB	GX/GB/GD <sup>1)</sup>	HX/JX

Line voltage 500 ... 600 V 3 AC DC link voltage 675 ... 900 V DC		Braking Module		
		6SL3300-1AF31-3AA0	6SL3300-1AF32-5AA0	6SL3300-1AF32-5BA0
<b>Power</b>				
• Rated power $P_{DB}$	kW	25	50	50
• Peak power $P_{15}$	kW	125	250	250
• Power $P_{20}$	kW	100	200	200
• Power $P_{40}$	kW	50	100	100
<b>Activation thresholds</b> (adjustable via DIP switch)		V	967 (factory setting) or 841	967 (factory setting) or 841
<b>Digital inputs</b> in accordance with IEC 61131-2 Type 1				
• Voltage	V	24 DC	24 DC	24 DC
• Low level (an open digital input is interpreted as "low")	V	-3 ... +5	-3 ... +5	-3 ... +5
• High level	V	15 ... 30	15 ... 30	15 ... 30
• Current consumption at 24 V DC, typ.	mA	10	10	10
• Conductor cross-section, max.	mm <sup>2</sup>	1.5	1.5	1.5
<b>Digital outputs</b> sustained-short-circuit-proof				
• Voltage	V	24 DC	24 DC	24 DC
• Load current per digital output, max.	mA	500	500	500
• Conductor cross-section, max.	mm <sup>2</sup>	1.5	1.5	1.5
<b>R1/R2 connection</b>		M8 nut	M8 nut	M8 nut
• Conductor cross-section, max.	mm <sup>2</sup>	35	50	50
<b>Weight, approx.</b>		kg	3.6	7.3
<b>Suitable for installation in air-cooled Power Modules, Line Modules or Motor Modules</b>				
• Air-cooled	Frame size	FX/FB	GX/GB/GD <sup>1)</sup>	HX/JX

<sup>1)</sup> Cable harness set 6SL3366-2NG00-0AA0 is required to connect the Braking Module to a Basic Line Module of frame size GB or GD.

# SINAMICS S120 Chassis Format Converter Units

## System components

### DC link components > Braking Modules

#### Technical specifications (continued)

Line voltage 660 ... 690 V 3 AC DC link voltage 890 ... 1035 V DC		Braking Module			
		6SL3300-1AH31-3AA0	6SL3300-1AH32-5AA0	6SL3300-1AH32-5BA0	
<b>Power</b>					
• Rated power $P_{DB}$	kW	25	50	50	
• Peak power $P_{15}$	kW	125	250	250	
• Power $P_{20}$	kW	100	200	200	
• Power $P_{40}$	kW	50	100	100	
<b>Activation thresholds</b> (adjustable via DIP switch)		V	1158 (factory setting) or 1070	1158 (factory setting) or 1070	1158 (factory setting) or 1070
<b>Digital inputs</b> in accordance with IEC 61131-2 Type 1					
• Voltage	V	24 DC	24 DC	24 DC	
• Low level (an open digital input is interpreted as "low")	V	-3 ... +5	-3 ... +5	-3 ... +5	
• High level	V	15 ... 30	15 ... 30	15 ... 30	
• Current consumption at 24 V DC, typ.	mA	10	10	10	
• Conductor cross-section, max.	mm <sup>2</sup>	1.5	1.5	1.5	
<b>Digital outputs</b> sustained-short-circuit-proof					
• Voltage	V	24 DC	24 DC	24 DC	
• Load current per digital output, max.	mA	500	500	500	
• Conductor cross-section, max.	mm <sup>2</sup>	1.5	1.5	1.5	
<b>R1/R2 connection</b>		M8 nut	M8 nut	M8 nut	
• Conductor cross-section, max.	mm <sup>2</sup>	35	50	50	
<b>Weight, approx.</b>		kg	3.6	7.3	7.5
<b>Suitable for installation in air-cooled Power Modules, Line Modules or Motor Modules</b>					
• Air-cooled	Frame size	FX/FB	GX/GB/GD <sup>1)</sup>	HX/JX	

<sup>1)</sup> Cable harness set 6SL3366-2NG00-0AA0 is required to connect the Braking Module to a Basic Line Module of frame size GB or GD.

# SINAMICS S120 Chassis Format Converter Units

## System components

### DC link components > Braking resistors

#### Overview

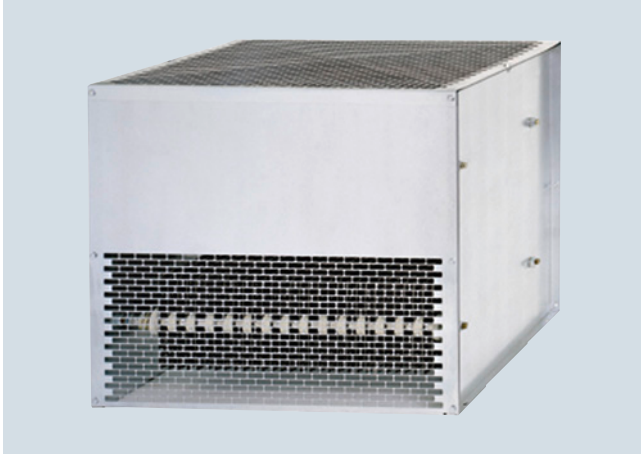

Excess energy in the DC link is dissipated via the braking resistor.

The braking resistor is connected to a Braking Module.

By positioning the braking resistor outside the cabinet or switch-gear room, it is possible to extract the heat losses away from the Line Modules / Motor Modules. This reduces the level of air conditioning required.

The maximum permissible cable length between the Braking Module and braking resistor is 100 m.

Two braking resistors with different rated and peak power values are available for the devices.

The braking resistor is monitored on the basis of the duty cycle. A temperature switch (NC contact) is also fitted. This responds when the maximum permissible temperature is exceeded and can be evaluated by a controller.

Information about possible duty cycles of the braking resistors and other notes are included in the SINAMICS Low Voltage Engineering Manual.

#### Selection and ordering data

Rated power $P_{DB}$ kW	Suitable for Braking Module 6SL3300-...	Braking resistor Article No.
<b>Line voltage 380 ... 480 V 3 AC DC link voltage 510 ... 720 V DC</b>		
25	1AE31-3AA0	<b>6SL3000-1BE31-3AA0</b>
50	1AE32-5 . A0	<b>6SL3000-1BE32-5AA0</b>
<b>Line voltage 500 ... 600 V 3 AC DC link voltage 675 ... 900 V DC</b>		
25	1AF31-3AA0	<b>6SL3000-1BF31-3AA0</b>
50	1AF32-5 . A0	<b>6SL3000-1BF32-5AA0</b>
<b>Line voltage 660 ... 690 V 3 AC DC link voltage 890 ... 1035 V DC</b>		
25	1AH31-3AA0	<b>6SL3000-1BH31-3AA0</b>
50	1AH32-5 . A0	<b>6SL3000-1BH32-5AA0</b>

#### Characteristic curves

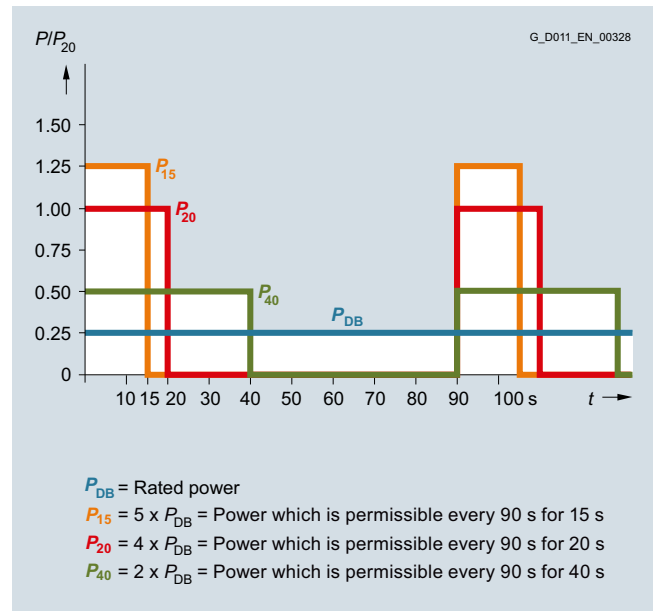

Load diagram for Braking Modules and braking resistors



# SINAMICS S120 Chassis Format Converter Units

## System components

### DC link components > Braking resistors

#### Technical specifications

Line voltage 380 ... 480 V 3 AC DC link voltage 510 ... 720 V DC		Braking resistor	
		6SL3000-1BE31-3AA0	6SL3000-1BE32-5AA0
Resistance	Ω	4.4 (±7.5 %)	2.2 (±7.5 %)
Rated power $P_{DB}$ (continuous braking power)	kW	25	50
Power $P_{15}$	kW	125	250
Power $P_{20}$	kW	100	200
Power $P_{40}$	kW	50	100
Current, max.	A	189	378
Power connection		M10 stud	M10 stud
• Conductor cross-section, max. (IEC)	mm <sup>2</sup>	50	70
Degree of protection		IP20	IP20
Dimensions			
• Width	mm	740	810
• Height	mm	605	1325
• Depth	mm	486	486
Weight, approx.	kg	50	120 (265)
Suitable for Braking Module	Type	6SL3300-1AE31-3AA0	6SL3300-1AE32-5 . A0
Line voltage 500 ... 600 V 3 AC DC link voltage 675 ... 900 V DC		Braking resistor	
		6SL3000-1BF31-3AA0	6SL3000-1BF32-5AA0
Resistance	Ω	6.8 (±7.5 %)	3.4 (±7.5 %)
Rated power $P_{DB}$ (continuous braking power)	kW	25	50
Power $P_{15}$	kW	125	250
Power $P_{20}$	kW	100	200
Power $P_{40}$	kW	50	100
Current, max.	A	189	378
Power connection		M10 stud	M10 stud
• Conductor cross-section, max. (IEC)	mm <sup>2</sup>	50	70
Degree of protection		IP20	IP20
Dimensions			
• Width	mm	740	810
• Height	mm	605	1325
• Depth	mm	486	486
Weight, approx.	kg	50	120
Suitable for Braking Module	Type	6SL3300-1AF31-3AA0	6SL3300-1AF32-5 . A0
Line voltage 660 ... 690 V 3 AC DC link voltage 890 ... 1035 V DC		Braking resistor	
		6SL3000-1BH31-3AA0	6SL3000-1BH32-5AA0
Resistance	Ω	9.8 (±7.5 %)	4.9 (±7.5 %)
Rated power $P_{DB}$ (continuous braking power)	kW	25	50
Power $P_{15}$	kW	125	250
Power $P_{20}$	kW	100	200
Power $P_{40}$	kW	50	100
Current, max.	A	125	255
Power connection		M10 stud	M10 stud
• Conductor cross-section, max. (IEC)	mm <sup>2</sup>	50	70
Degree of protection		IP20	IP20
Dimensions			
• Width	mm	740	810
• Height	mm	605	1325
• Depth	mm	486	486
Weight, approx.	kg	50	120
Suitable for Braking Module	Type	6SL3300-1AH31-3AA0	6SL3300-1AH32-5 . A0

# SINAMICS S120 Chassis Format Converter Units

## System components

DC link components &gt; DC link fuses

### Selection and ordering data

Suitable DC link fuses are assigned depending on the power rating of the Motor Modules. Further information about the fuses listed is provided in the Catalogs IC 10 and LV 10.

#### Assignment of the DC link fuses to the Motor Modules in chassis format, liquid-cooled and water-cooled

Type rating at 400 V	Rated DC link current for power supplied via Basic Line Module / Active Line Module	Suitable for Motor Module chassis format	DC link fuse according to IEC				DC link fuse according to UL <sup>1)</sup>			
			Rated current	Quantity/Phase	Frame size	Article No.	Rated current	Quantity/Phase	Frame size	Article No.
kW	A	6SL3325-...	A				A			
<b>Line voltage 380 ... 480 V 3 AC</b>										
110	256/230	1TE32-1AA3	315	1	1	<b>3NE3230-0B</b>	315	1	1	<b>3NE3230-0B</b>
							315	1	2L	<b>3NB1231-4KK11</b>
132	317/287	1TE32-6AA3	400	1	1	<b>3NE3232-0B</b>	400	1	1	<b>3NE3232-0B</b>
							400	1	2L	<b>3NB1234-4KK11</b>
160	380/340	1TE33-1AA3	450	1	1	<b>3NE3233</b>	450	1	1	<b>3NE3233</b>
							500	1	3L	<b>3NB1337-4KK11</b>
250	600/538	1TE35-0AA3	630	1	2	<b>3NE3236</b>	630	1	2	<b>3NE3236</b>
							800	1	3L	<b>3NB1345-4KK11</b>
315	738/664	1TE36-1AA3	800	1	2	<b>3NE3338-8</b>	800	1	2	<b>3NE3338-8</b>
							800	1	3L	<b>3NB2345-4KK16</b>
400	894/805	1TE37-5AA3 1TE37-5AA7	500	2	2	<b>3NE3334-0B</b>	1000	1	3L	<b>3NB2350-4KK16</b>
450	1025/922	1TE38-4AA3	560	2	2	<b>3NE3335</b>	560	2	2	<b>3NE3335</b>
							1000	1	3L	<b>3NB2350-4KK16</b>
560	1202/1080	1TE41-0AA3 1TE41-0AA7	630	2	2	<b>3NE3336</b>	630	2	2	<b>3NE3336</b>
							1400	1	3L	<b>3NB2355-4KK16</b>
710	1512/1361	1TE41-2AA3 1TE41-2AA7	900	2	2	<b>3NE3340-8</b>	2100	1	3L	<b>3NB2364-4KK17</b>
800	1714/1544	1TE41-4AA3 1TE41-4AA7	900	2	2	<b>3NE3340-8</b>	900	2	2	<b>3NE3340-8</b>
							2100	1	3L	<b>3NB2364-4KK17</b>
800	1550/1403	1TE41-4AS3 <sup>2)</sup>	900	2	2	<b>3NE3340-8</b>	2100	1	3L	<b>3NB2364-4KK17</b>

<sup>1)</sup> To achieve a UL-approved system, it is absolutely essential to use the fuse types specified in the table.

<sup>2)</sup> This Motor Module has been specifically designed for loads demanding a high dynamic performance.

# SINAMICS S120 Chassis Format Converter Units

## System components

### DC link components > DC link fuses

#### Selection and ordering data (continued)

Type rating at 690 V kW	Rated DC link current for power supplied via Basic Line Module / Active Line Module A	Suitable for Motor Module chassis format 6SL3325-...	DC link fuse according to IEC				DC link fuse according to UL <sup>1)</sup>			
			Rated current A	Quantity/Phase	Frame size	Article No.	Rated current A	Quantity/Phase	Frame size	Article No.
<b>Line voltage 500 ... 690 V 3 AC</b>										
90	122/110	1TG31-0AA3	160	1	1	<b>3NE3224</b>	160	1	1	<b>3NE3224</b>
							200	1	1L	<b>3NB1126-4KK11</b>
132	183/165	1TG31-5AA3	200	1	1	<b>3NE3225</b>	200	1	1	<b>3NE3225</b>
							250	1	1L	<b>3NB1128-4KK11</b>
200	263/237	1TG32-2AA3	315	1	1	<b>3NE3230-0B</b>	315	1	1	<b>3NE3230-0B</b>
							315	1	2L	<b>3NB1231-4KK11</b>
315	403/363	1TG33-3AA3	450	1	2	<b>3NE3233</b>	450	1	2	<b>3NE3233</b>
							500	1	3L	<b>3NB1337-4KK11</b>
450	558/502	1TG34-7AA3 1TG34-7AA7	630	1	2	<b>3NE3336</b>	800	1	3L	<b>3NB1345-4KK11</b>
							800	1	3L	<b>3NB1345-4KK11</b>
560	702/632	1TG35-8AA3 1TG35-8AA7	400	2	1	<b>3NE3232-0B</b>	400	2	1	<b>3NE3232-0B</b>
							800	1	3L	<b>3NB2345-4KK16</b>
710	903/759	1TG37-4AA3	560	2	2	<b>3NE3335</b>	1000	1	3L	<b>3NB2350-4KK16</b>
800	990/891	1TG38-0AA3 <sup>2)</sup>	560	2	2	<b>3NE3335</b>	1000	1	3L	<b>3NB2350-4KK16</b>
800	990/891	1TG38-1AA3 1TG38-1AA7	560	2	2	<b>3NE3335</b>	560	2	2	<b>3NE3335</b>
							1000	1	3L	<b>3NB2350-4KK16</b>
1000	1250/1125	1TG41-0AA3 1TG41-0AA7	710	2	2	<b>3NE3337-8</b>	710	2	2	<b>3NE3337-8</b>
							1600	1	3L	<b>3NB2357-4KK16</b>
1200	1550/1395	1TG41-3AA3 1TG41-3AA7	900	2	2	<b>3NE3340-8</b>	900	2	2	<b>3NE3340-8</b>
							2100	1	3L	<b>3NB2364-4KK17</b>
1500	1903/1605	1TG41-6AA3 1TG41-6AA7	710	3	2	<b>3NE3337-8</b>	2400	1	3L	<b>3NB2366-4KK17</b>
							2400	1	3L	<b>3NB2366-4KK17</b>

<sup>1)</sup> To achieve a UL-approved system, it is absolutely essential to use the fuse types specified in the table.

<sup>2)</sup> Device 6SL3325-1TG38-0AA3 is optimized for a base pulse frequency of 1.25 kHz, for an increased pulse frequency or for certain overloads, the derating factor is higher than for the device 6SL3325-1TG38-1AA3.

# SINAMICS S120 Chassis Format Converter Units

## System components

Motor-side power components > Motor reactors

### Overview

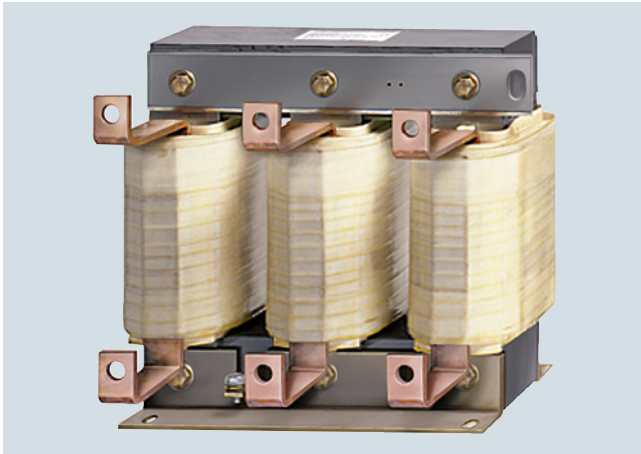

Motor reactors reduce the voltage load on the motor windings by reducing the voltage gradients at the motor terminals that occur during converter operation. At the same time, the capacitive charge/discharge currents that place an additional load on the converter output when long motor cables are used, are reduced. For group drives, output reactors should always be used. The maximum permissible output frequency when a motor reactor is used is 150 Hz.

The motor reactor must be installed as close as possible to the Motor Module or Power Module. Up to two motor reactors can be connected in series.

Motor reactors are approved for use only in conjunction with Vector and V/f control modes.

For additional notes on the use of motor reactors, please refer to the SINAMICS Low Voltage Engineering Manual.

### Selection and ordering data

Suitable for Power Module		Suitable for Motor Module		Type rating at 400 V kW	Rated output current A	Motor reactor Article No.
Air-cooled	Liquid-cooled	Air-cooled	Liquid-cooled			
<b>Line voltage 380 ... 480 V 3 AC</b>						
6SL3310-1TE32-1AA3	6SL3315-1TE32-1AA3	6SL3320-1TE32-1AA3	6SL3325-1TE32-1AA3	110	210	<b>6SL3000-2BE32-1AA0</b>
6SL3310-1TE32-6AA3	6SL3315-1TE32-6AA3	6SL3320-1TE32-6AA3	6SL3325-1TE32-6AA3	132	260	<b>6SL3000-2BE32-6AA0</b>
6SL3310-1TE33-1AA3	6SL3315-1TE33-1AA3	6SL3320-1TE33-1AA3	6SL3325-1TE33-1AA3	160	310	<b>6SL3000-2BE33-2AA0</b>
6SL3310-1TE33-8AA3	–	6SL3320-1TE33-8AA3	–	200	380	<b>6SL3000-2BE33-8AA0</b>
6SL3310-1TE35-0AA3	6SL3315-1TE35-0AA3	6SL3320-1TE35-0AA3	6SL3325-1TE35-0AA3	250	490	<b>6SL3000-2BE35-0AA0</b>
–	–	6SL3320-1TE36-1AA3	6SL3325-1TE36-1AA3	315	605	<b>6SL3000-2AE36-1AA0</b>
–	–	6SL3320-1TE37-5AA3	6SL3325-1TE37-5AA3 6SL3325-1TE37-5AA7	400	745	<b>6SL3000-2AE38-4AA0</b>
–	–	6SL3320-1TE38-4AA3	6SL3325-1TE38-4AA3	450	840	
–	–	6SL3320-1TE41-0AA3	6SL3325-1TE41-0AA3 6SL3325-1TE41-0AA7	560	985	<b>6SL3000-2AE41-0AA0</b>
–	–	6SL3320-1TE41-2AA3	6SL3325-1TE41-2AA3 6SL3325-1TE41-2AA7	710	1260	<b>6SL3000-2AE41-4AA0</b>
–	–	6SL3320-1TE41-4AA3	6SL3325-1TE41-4AA3 6SL3325-1TE41-4AA7	800	1405	
			6SL3325-1TE41-4AS3 <sup>1)</sup>	800	1330	

<sup>1)</sup> This Motor Module has been specifically designed for loads demanding a high dynamic performance.

# SINAMICS S120 Chassis Format Converter Units

## System components

### Motor-side power components > Motor reactors

#### Selection and ordering data (continued)

Suitable for Power Module		Suitable for Motor Module		Type rating at 690 V	Rated output current	Motor reactor
Air-cooled	Liquid-cooled	Air-cooled	Liquid-cooled	kW	A	Article No.
<b>Line voltage 500 ... 690 V 3 AC</b>						
–	–	6SL3320-1TG28-5AA3	–	75	85	<b>6SL3000-2AH31-0AA0</b>
–	–	6SL3320-1TG31-0AA3	6SL3325-1TG31-0AA3	90	100	
–	–	6SL3320-1TG31-2AA3	–	110	120	<b>6SL3000-2AH31-5AA0</b>
–	–	6SL3320-1TG31-5AA3	6SL3325-1TG31-5AA3	132	150	
–	–	6SL3320-1TG31-8AA3	–	160	175	<b>6SL3000-2AH31-8AA0</b>
–	–	6SL3320-1TG32-2AA3	6SL3325-1TG32-2AA3	200	215	<b>6SL3000-2AH32-4AA0</b>
–	–	6SL3320-1TG32-6AA3	–	250	260	<b>6SL3000-2AH32-6AA0</b>
–	–	6SL3320-1TG33-3AA3	6SL3325-1TG33-3AA3	315	330	<b>6SL3000-2AH33-6AA0</b>
–	–	6SL3320-1TG34-1AA3	–	400	410	<b>6SL3000-2AH34-5AA0</b>
–	–	6SL3320-1TG34-7AA3	6SL3325-1TG34-7AA3 6SL3325-1TG34-7AA7	450	465	<b>6SL3000-2AH34-7AA0</b>
–	–	6SL3320-1TG35-8AA3	6SL3325-1TG35-8AA3 6SL3325-1TG35-8AA7	560	575	<b>6SL3000-2AH35-8AA0</b>
–	–	6SL3320-1TG37-4AA3	6SL3325-1TG37-4AA3	710	735	<b>6SL3000-2AH38-1AA0</b>
–	–	6SL3320-1TG38-1AA3	6SL3325-1TG38-0AA3 6SL3325-1TG38-1AA3 6SL3325-1TG38-1AA7	800	810	
–	–	6SL3320-1TG38-8AA3	–	900	910	<b>6SL3000-2AH41-0AA0</b>
–	–	6SL3320-1TG41-0AA3	6SL3325-1TG41-0AA3 6SL3325-1TG41-0AA7	1000	1025	<b>6SL3000-2AH41-1AA0</b>
–	–	6SL3320-1TG41-3AA3	6SL3325-1TG41-3AA3 6SL3325-1TG41-3AA7	1200	1270	<b>6SL3000-2AH41-3AA0</b>

#### Technical specifications

Line voltage 380 ... 480 V 3 AC		Motor reactor (for pulse frequencies of 2 kHz to 4 kHz)									
		6SL3000-2BE32-1AA0		6SL3000-2BE32-6AA0		6SL3000-2BE33-2AA0		6SL3000-2BE33-8AA0		6SL3000-2BE35-0AA0	
<b>Rated current</b>	A	210		260		310		380		490	
<b>Power loss, max. <sup>1)</sup></b>	kW	0.486		0.5		0.47		0.5		0.5	
<b>Load connection</b>		1 × hole for M10		1 × hole for M10		1 × hole for M10		1 × hole for M10		1 × hole for M12	
<b>PE connection</b>		M8 screw		M8 screw		M8 screw		M8 screw		M8 screw	
<b>Cable length, max.</b> between the motor reactor and motor (number of reactors in series)		(1)	(2)	(1)	(2)	(1)	(2)	(1)	(2)	(1)	(2)
• Shielded	m	300	525	300	525	300	525	300	525	300	525
• Unshielded	m	450	787	450	787	450	787	450	787	450	787
<b>Degree of protection</b>		IP00		IP00		IP00		IP00		IP00	
<b>Dimensions</b>											
• Width	mm	300		300		300		300		300	
• Height	mm	285		315		285		285		365	
• Depth	mm	257		277		257		277		277	
<b>Weight, approx.</b>	kg	66		66		66		73		100	
<b>Suitable for Power Module</b>		6SL3310-1TE32-1AA3 6SL3315-1TE32-1AA3		6SL3310-1TE32-6AA3 6SL3315-1TE32-6AA3		6SL3310-1TE33-1AA3 6SL3315-1TE33-1AA3		6SL3310-1TE33-8AA3		6SL3310-1TE35-0AA3 6SL3315-1TE35-0AA3	
<b>Suitable for Motor Module</b>		6SL3320-1TE32-1AA3 6SL3325-1TE32-1AA3		6SL3320-1TE32-6AA3 6SL3325-1TE32-6AA3		6SL3320-1TE33-1AA3 6SL3325-1TE33-1AA3		6SL3320-1TE33-8AA3		6SL3320-1TE35-0AA3 6SL3325-1TE35-0AA3	
• Rated output current of Motor Module	A	210		260		310		380		490	

<sup>1)</sup> The specified power loss represents the maximum value at 100 % utilization. The value is lower under normal operating conditions.

# SINAMICS S120 Chassis Format Converter Units

## System components

### Motor-side power components > Motor reactors

#### Technical specifications (continued)

Line voltage 380 ... 480 V 3 AC		Motor reactor (for pulse frequencies of 1.25 kHz to 2.5 kHz)													
		6SL3000-2AE36-1AA0		6SL3000-2AE38-4AA0				6SL3000-2AE41-0AA0		6SL3000-2AE41-4AA0					
Rated current	A	605		745		840		985		1260		1405			
Power loss, max. <sup>1)</sup>	kW	0.9		0.84		0.943		1.062		0.9		1.054			
Load connection		1 × hole for M12		1 × hole for M12		1 × hole for M12		1 × hole for M12		2 × hole for M12		2 × hole for M12			
PE connection		M10 screw		M10 screw		M10 screw		M10 screw		M10 screw		M10 screw			
Cable length, max. between the motor reactor and motor (number of reactors in series)			(1)	(2)	(1)	(2)	(1)	(2)	(1)	(2)	(1)	(2)	(1)	(2)	
• Shielded	m	300	525	300	525	300	525	300	525	300	525	300	525	300	525
• Unshielded	m	450	787	450	787	450	787	450	787	450	787	450	787	450	787
Degree of protection		IP00		IP00		IP00		IP00		IP00		IP00			
Dimensions															
• Width	mm	410		410		410		410		460		460			
• Height	mm	392		392		392		392		392		392			
• Depth	mm	292		292		292		302		326		326			
Weight, approx.	kg	130		140		140		146		179		179			
Suitable for Motor Module		6SL3320-1TE36-1AA3		6SL3320-1TE37-5AA3		6SL3320-1TE38-4AA3		6SL3320-1TE41-0AA3		6SL3320-1TE41-2AA3		6SL3320-1TE41-4AA3			
		6SL3325-1TE36-1AA3		6SL3325-1TE37-5AA3		6SL3325-1TE38-4AA3		6SL3325-1TE41-0AA3		6SL3325-1TE41-2AA3		6SL3325-1TE41-4AA3			
				6SL3325-1TE37-5AA7				6SL3325-1TE41-0AA7		6SL3325-1TE41-2AA7		6SL3325-1TE41-4AA7			
• Rated output current of Motor Module	A	605		745		840		985		1260		1405			
6SL3325-1TE41-4AS3 <sup>2)</sup>															

Line voltage 500 ... 690 V 3 AC		Motor reactor (for pulse frequencies of 1.25 kHz to 2.5 kHz)													
		6SL3000-2AH31-0AA0				6SL3000-2AH31-5AA0				6SL3000-2AH31-8AA0		6SL3000-2AH32-4AA0			
Rated current	A	85		100		120		150		175		215			
Power loss, max. <sup>1)</sup>	kW	0.257		0.3		0.318		0.335		0.4		0.425			
Load connection		Flat connector for M10 screw		Flat connector for M10 screw		Flat connector for M10 screw		Flat connector for M10 screw		Flat connector for M10 screw		Flat connector for M10 screw			
PE connection		M6 screw		M6 screw		M6 screw		M6 screw		M6 screw		M6 screw			
Cable length, max. between the motor reactor and motor (number of reactors in series)			(1)	(2)	(1)	(2)	(1)	(2)	(1)	(2)	(1)	(2)	(1)	(2)	
• Shielded	m	300	525	300	525	300	525	300	525	300	525	300	525	300	525
• Unshielded	m	450	787	450	787	450	787	450	787	450	787	450	787	450	787
Degree of protection		IP00		IP00		IP00		IP00		IP00		IP00			
Dimensions															
• Width	mm	270		270		270		270		300		300			
• Height	mm	248		248		248		248		285		285			
• Depth	mm	200		200		200		200		212		212			
Weight, approx.	kg	25		25		25.8		25.8		34		34			
Suitable for Motor Module		6SL3320-1TG28-5AA3		6SL3320-1TG31-0AA3		6SL3320-1TG31-2AA3		6SL3320-1TG31-5AA3		6SL3320-1TG31-8AA3		6SL3320-1TG32-2AA3			
				6SL3325-1TG31-0AA3				6SL3325-1TG31-5AA3				6SL3325-1TG32-2AA3			
• Rated output current of Motor Module	A	85		100		120		150		175		215			

<sup>1)</sup> The specified power loss represents the maximum value at 100 % utilization. The value is lower under normal operating conditions.

<sup>2)</sup> This Motor Module has been specifically designed for loads demanding a high dynamic performance.

# SINAMICS S120 Chassis Format Converter Units

## System components

### Motor-side power components > Motor reactors

#### Technical specifications (continued)

Line voltage 500 ... 690 V 3 AC		Motor reactor (for pulse frequencies of 1.25 kHz to 2.5 kHz)											
		6SL3000-2AH32-6AA0		6SL3000-2AH33-6AA0		6SL3000-2AH34-5AA0		6SL3000-2AH34-7AA0		6SL3000-2AH35-8AA0		6SL3000-2AH38-1AA0	
<b>Rated current</b>	A	260		330		410		465		575		735	
<b>Power loss, max. <sup>1)</sup></b>	kW	0.44		0.45		0.545		0.72		0.8		0.96	
<b>Load connection</b>		Flat connector for M10 screw		Flat connector for M10 screw		Flat connector for M12 screw		Flat connector for M12 screw		Flat connector for M12 screw		Flat connector for M12 screw	
<b>PE connection</b>		M6 screw		M6 screw		M8 screw		M8 screw		M8 screw		M8 screw	
<b>Cable length, max.</b> between the motor reactor and motor (number of reactors in series)		(1)	(2)	(1)	(2)	(1)	(2)	(1)	(2)	(1)	(2)	(1)	(2)
• Shielded	m	300	525	300	525	300	525	300	525	300	525	300	525
• Unshielded	m	450	787	450	787	450	787	450	787	450	787	450	787
<b>Degree of protection</b>		IP00		IP00		IP00		IP00		IP00		IP00	
<b>Dimensions</b>													
• Width	mm	300		300		350		410		410		410	
• Height	mm	285		285		330		392		392		392	
• Depth	mm	212		212		215		292		292		279	
<b>Weight, approx.</b>	kg	40		46		68		80		80		146	
<b>Suitable for Motor Module</b>		6SL3320-1TG32-6AA3		6SL3320-1TG33-3AA3 6SL3325-1TG33-3AA3		6SL3320-1TG34-1AA3		6SL3320-1TG34-7AA3 6SL3325-1TG34-7AA3 6SL3325-1TG34-7AA7		6SL3320-1TG35-8AA3 6SL3325-1TG35-8AA3 6SL3325-1TG35-8AA7		6SL3320-1TG37-4AA3 6SL3325-1TG37-4AA3	
• Rated output current of Motor Module	A	260		330		410		465		575		735	

Line voltage 500 ... 690 V 3 AC		Motor reactor (for pulse frequencies of 1.25 kHz to 2.5 kHz)							
		6SL3000-2AH38-1AA0		6SL3000-2AH41-0AA0		6SL3000-2AH41-1AA0		6SL3000-2AH41-3AA0	
<b>Rated current</b>	A	810		910		1025		1270	
<b>Power loss, max. <sup>1)</sup></b>	kW	1.0		0.97		1.05		0.95	
<b>Load connection</b>		Flat connector for M12 screw		Flat connector for M12 screw		Flat connector for M12 screw		Flat connector for M12 screw	
<b>PE connection</b>		M8 screw		M8 screw		M8 screw		M8 screw	
<b>Cable length, max.</b> between the motor reactor and motor (number of reactors in series)		(1)	(2)	(1)	(2)	(1)	(2)	(1)	(2)
• Shielded	m	300	525	300	525	300	525	300	525
• Unshielded	m	450	787	450	787	450	787	450	787
<b>Degree of protection</b>		IP00		IP00		IP00		IP00	
<b>Dimensions</b>									
• Width	mm	410		410		410		460	
• Height	mm	392		392		392		392	
• Depth	mm	279		279		317		296	
<b>Weight, approx.</b>	kg	146		150		163		153	
<b>Suitable for Motor Module</b>		6SL3320-1TG38-1AA3 6SL3325-1TG38-0AA3 6SL3325-1TG38-1AA3 6SL3325-1TG38-1AA7		6SL3320-1TG38-8AA3		6SL3320-1TG41-0AA3 6SL3325-1TG41-0AA3 6SL3325-1TG41-0AA7		6SL3320-1TG41-3AA3 6SL3325-1TG41-3AA3 6SL3325-1TG41-3AA7	
• Rated output current of Motor Module	A	810		910		1025		1270	

<sup>1)</sup> The specified power loss represents the maximum value at 100 % utilization. The value is lower under normal operating conditions.

#### Overview

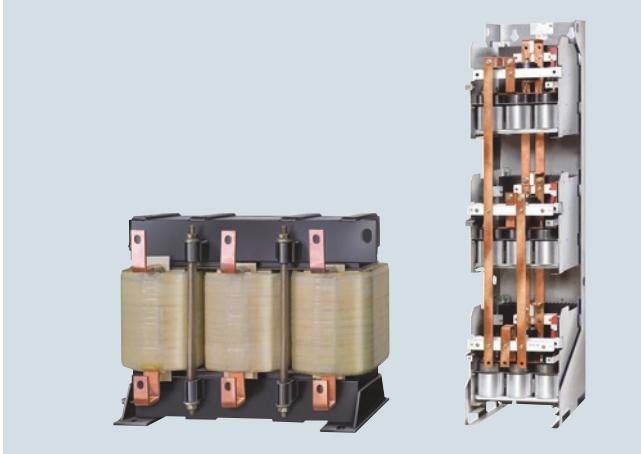

dv/dt filter plus VPL (**V**oltage **P**eak **L**imiter) limit the voltage rate-of-rise  $dv/dt$  to values  $< 500 \text{ V}/\mu\text{s}$  and the typical voltage peaks to the following values in accordance with the limit value curve according to IEC/TS 60034-17: 2006:

$< 1000 \text{ V}$  at  $U_{\text{line}} < 575 \text{ V}$

$< 1250 \text{ V}$  at  $660 \text{ V} < U_{\text{line}} < 690 \text{ V}$

Standard motors with standard insulation and without insulated bearings with a supply voltage of up to 690 V can be used for converter operation if a dv/dt filter plus VPL is used.

dv/dt filters plus VPL are designed for the following maximum motor cable lengths:

- Shielded cables: 300 m (e.g. Protodur NYCWY)
- Unshielded cables: 450 m (e.g. Protodur NYY)

For shorter cable lengths (100 m shielded, 150 m unshielded), see also [dv/dt filter compact plus VPL](#).

#### Notice:

The maximum permissible cable length between the dv/dt filter plus VPL and the Power Module/Motor Module is 5 m.

#### Design

The dv/dt filter plus VPL consists of two components, which are also supplied as separate mechanical units:

- dv/dt reactor
- Voltage limiting network, which cuts off the voltage peaks and feeds the energy back to the DC link.



# SINAMICS S120 Chassis Format Converter Units

## System components

### Motor-side power components > dv/dt filter plus VPL

#### Selection and ordering data

Suitable for Power Module		Suitable for Motor Module		Type rating at 400 V/ 690 V kW	Rated output current A	dv/dt filter plus VPL Article No.
Air-cooled	Liquid-cooled	Air-cooled	Liquid-cooled			
<b>Line voltage 380 ... 480 V 3 AC</b>						
6SL3310-1TE32-1AA3	6SL3315-1TE32-1AA3	6SL3320-1TE32-1AA3	6SL3325-1TE32-1AA3	110	210	<b>6SL3000-2DE32-6AA0</b>
6SL3310-1TE32-6AA3	6SL3315-1TE32-6AA3	6SL3320-1TE32-6AA3	6SL3325-1TE32-6AA3	132	260	
6SL3310-1TE33-1AA3	6SL3315-1TE33-1AA3	6SL3320-1TE33-1AA3	6SL3325-1TE33-1AA3	160	310	<b>6SL3000-2DE35-0AA0</b>
6SL3310-1TE33-8AA3	–	6SL3320-1TE33-8AA3	–	200	380	
6SL3310-1TE35-0AA3	6SL3315-1TE35-0AA3	6SL3320-1TE35-0AA3	6SL3325-1TE35-0AA3	250	490	<b>6SL3000-2DE38-4AA0</b>
–	–	6SL3320-1TE36-1AA3	6SL3325-1TE36-1AA3	315	605	
–	–	6SL3320-1TE37-5AA3	6SL3325-1TE37-5AA3 6SL3325-1TE37-5AA7	400	745	<b>6SL3000-2DE41-4AA0</b>
–	–	6SL3320-1TE38-4AA3	6SL3325-1TE38-4AA3	450	840	
–	–	6SL3320-1TE41-0AA3	6SL3325-1TE41-0AA3 6SL3325-1TE41-0AA7	560	985	<b>6SL3000-2DE41-4AA0</b>
–	–	6SL3320-1TE41-2AA3	6SL3325-1TE41-2AA3 6SL3325-1TE41-2AA7	710	1260	
–	–	6SL3320-1TE41-4AA3	6SL3325-1TE41-4AA3 6SL3325-1TE41-4AA7	800	1405	<b>6SL3000-2DE41-4AA0</b>
–	–	–	6SL3325-1TE41-4AS3 <sup>1)</sup>	800	1330	
<b>Line voltage 500 ... 690 V 3 AC</b>						
–	–	6SL3320-1TG28-5AA3	–	75	85	<b>6SL3000-2DH31-0AA0</b>
–	–	6SL3320-1TG31-0AA3	6SL3325-1TG31-0AA3	90	100	
–	–	6SL3320-1TG31-2AA3	–	110	120	<b>6SL3000-2DH31-5AA0</b>
–	–	6SL3325-1TG31-5AA3	6SL3320-1TG31-5AA3	132	150	
–	–	6SL3320-1TG31-8AA3	–	160	175	<b>6SL3000-2DH32-2AA0</b>
–	–	6SL3320-1TG32-2AA3	6SL3325-1TG32-2AA3	200	215	
–	–	6SL3320-1TG32-6AA3	–	250	260	<b>6SL3000-2DH33-3AA0</b>
–	–	6SL3320-1TG33-3AA3	6SL3325-1TG33-3AA3	315	330	
–	–	6SL3320-1TG34-1AA3	–	400	410	<b>6SL3000-2DH34-1AA0</b>
–	–	6SL3320-1TG34-7AA3	6SL3325-1TG34-7AA3 6SL3325-1TG34-7AA7	450	465	
–	–	6SL3320-1TG35-8AA3	6SL3325-1TG35-8AA3 6SL3325-1TG35-8AA7	560	575	<b>6SL3000-2DH35-8AA0</b>
–	–	6SL3320-1TG37-4AA3	6SL3325-1TG37-4AA3	710	735	
–	–	6SL3320-1TG38-1AA3	6SL3325-1TG38-0AA3 6SL3325-1TG38-1AA3 6SL3325-1TG38-1AA7	800	810	<b>6SL3000-2DH38-1AA0</b>
–	–	6SL3320-1TG38-8AA3	–	900	910	
–	–	6SL3320-1TG41-0AA3	6SL3325-1TG41-0AA3 6SL3325-1TG41-0AA7	1000	1025	<b>6SL3000-2DH41-3AA0</b>
–	–	6SL3320-1TG41-3AA3	6SL3325-1TG41-3AA3 6SL3325-1TG41-3AA7	1200	1270	

<sup>1)</sup> This Motor Module has been specifically designed for loads demanding a high dynamic performance.

# SINAMICS S120 Chassis Format Converter Units

## System components

Motor-side power components > dv/dt filter plus VPL

### Technical specifications

Line voltage 380 ... 480 V 3 AC		dv/dt filter plus VPL			
		6SL3000-2DE32-6AA0	6SL3000-2DE35-0AA0	6SL3000-2DE38-4AA0	6SL3000-2DE41-4AA0 <sup>1)</sup>
<b>I<sub>th max</sub></b>	A	260	490	840	1405
<b>Degree of protection</b>		IP00	IP00	IP00	IP00
<b>Cable length, max.</b> between dv/dt filter and motor <sup>2)</sup>					
• Shielded	m	300	300	300	300
• Unshielded	m	450	450	450	450
<b>Conformity</b>		CE	CE	CE	CE
<b>Certificate of suitability</b>		cURus	cURus	cURus	cURus
<b>dv/dt reactor</b>					
<b>Power loss, max.</b> <sup>3)</sup>					
• At 50 Hz 400 V	kW	0.701	0.874	1.106	1.111
• At 60 Hz 460 V	kW	0.729	0.904	1.115	1.154
• At 150 Hz 400 V	kW	0.78	0.963	1.226	1.23
<b>Connections</b>					
• To the Power Module/ Motor Module		1 × hole for M10	1 × hole for M12	1 × hole for M12	2 × hole for M12
• To load		1 × hole for M10	1 × hole for M12	1 × hole for M12	2 × hole for M12
• PE		M6 screw	M6 screw	M6 screw	M6 screw
<b>Dimensions</b>					
• Width	mm	410	460	460	445
• Height	mm	370	370	385	385
• Depth	mm	229	275	312	312
<b>Weight, approx.</b>	kg	66	122	149	158
<b>Voltage Peak Limiter (VPL)</b>					
<b>Power loss, max.</b>					
• At 50 Hz 400 V	kW	0.029	0.042	0.077	0.134
• At 60 Hz 460 V	kW	0.027	0.039	0.072	0.125
• At 150 Hz 400 V	kW	0.025	0.036	0.066	0.114
<b>Connections</b>					
• To dv/dt reactor		M8 nut	70 mm <sup>2</sup> terminals	1 × hole for M8	1 × hole for M10
• To DC link		M8 nut	70 mm <sup>2</sup> terminals	1 × hole for M8	1 × hole for M10
• PE		M8 stud	35 mm <sup>2</sup> terminals	M8 stud	M8 stud
<b>Dimensions</b>					
• Width	mm	265	392	309	309
• Height	mm	263	285	1313	1313
• Depth	mm	190	210	400	400
<b>Weight, approx.</b>	kg	6	16	48	72
<b>Suitable for Power Module</b>		6SL3310-1TE32-1AA3 6SL3315-1TE32-1AA3 6SL3310-1TE32-6AA3 6SL3315-1TE32-6AA3	6SL3310-1TE33-1AA3 6SL3315-1TE33-1AA3 6SL3310-1TE33-8AA3 6SL3310-1TE35-0AA3 6SL3315-1TE35-0AA3	–	–
<b>Suitable for Motor Module</b>		6SL3320-1TE32-1AA3 6SL3325-1TE32-1AA3 6SL3320-1TE32-6AA3 6SL3325-1TE32-6AA3	6SL3320-1TE33-1AA3 6SL3325-1TE33-1AA3 6SL3320-1TE33-8AA3 6SL3320-1TE35-0AA3 6SL3325-1TE35-0AA3	6SL3320-1TE36-1AA3 6SL3325-1TE36-1AA3 6SL3320-1TE37-5AA3 6SL3325-1TE37-5AA3 6SL3325-1TE37-5AA7 6SL3320-1TE38-4AA3 6SL3325-1TE38-4AA3	6SL3320-1TE41-0AA3 6SL3325-1TE41-0AA3 6SL3325-1TE41-0AA7 6SL3320-1TE41-2AA3 6SL3325-1TE41-2AA3 6SL3325-1TE41-2AA7 6SL3320-1TE41-4AA3 6SL3325-1TE41-4AA3 6SL3325-1TE41-4AA7 6SL3325-1TE41-4AS3 <sup>2)</sup>

<sup>1)</sup> These dv/dt filters include two dv/dt reactors. The technical specifications listed refer to a dv/dt reactor. For additional information on dv/dt filters, please refer to the SINAMICS Low Voltage Engineering Manual.

<sup>2)</sup> Longer cable lengths for specific configurations are available on request.

<sup>3)</sup> This Motor Module has been specifically designed for loads demanding a high dynamic performance.

# SINAMICS S120 Chassis Format Converter Units

## System components

### Motor-side power components > dv/dt filter plus VPL

#### Technical specifications (continued)

Line voltage 500 ... 690 V 3 AC		dv/dt filter plus VPL			
		6SL3000-2DH31-0AA0	6SL3000-2DH31-5AA0	6SL3000-2DH32-2AA0	6SL3000-2DH33-3AA0
<b>I<sub>th max</sub></b>	A	100	150	215	330
<b>Degree of protection</b>		IP00	IP00	IP00	IP00
<b>Cable length, max.</b> between dv/dt filter and motor <sup>1)</sup>					
• Shielded	m	300	300	300	300
• Unshielded	m	450	450	450	450
<b>Conformity</b>		CE	CE	CE	CE
<b>Certificate of suitability <sup>2)</sup></b>		cURus	cURus	cURus	cURus
<b>dv/dt reactor</b>					
<b>Power loss, max.</b>					
• At 50 Hz 500/690 V	kW	0.49	0.389	0.578	0.595
• At 60 Hz 575 V	kW	0.508	0.408	0.604	0.62
• At 150 Hz 500/690 V	kW	0.541	0.436	0.645	0.661
<b>Connections</b>					
• To the Power Module/ Motor Module		1 × hole for M10	1 × hole for M10	1 × hole for M10	1 × hole for M10
• To load		1 × hole for M10	1 × hole for M10	1 × hole for M10	1 × hole for M10
• PE		M6 screw	M6 screw	M6 screw	M6 screw
<b>Dimensions</b>					
• Width	mm	350	350	460	460
• Height	mm	320	320	360	360
• Depth	mm	227	227	275	275
<b>Weight, approx.</b>	kg	48	50	83	135
<b>Voltage Peak Limiter (VPL)</b>					
<b>Power loss, max.</b>					
• At 50 Hz 500/690 V	kW	0.016	0.02	0.032	0.042
• At 60 Hz 575 V	kW	0.015	0.019	0.03	0.039
• At 150 Hz 500/690 V	kW	0.013	0.018	0.027	0.036
<b>Connections</b>					
• To dv/dt reactor		M8 nut	M8 nut	70 mm <sup>2</sup> terminals	70 mm <sup>2</sup> terminals
• To DC link		M8 nut	M8 nut	70 mm <sup>2</sup> terminals	70 mm <sup>2</sup> terminals
• PE		M8 stud	M8 stud	35 mm <sup>2</sup> terminals	35 mm <sup>2</sup> terminals
<b>Dimensions</b>					
• Width	mm	263	263	392	392
• Height	mm	265	265	285	285
• Depth	mm	188	188	210	210
<b>Weight, approx.</b>	kg	6	6	16	16
<b>Suitable for Motor Module</b>		6SL3320-1TG28-5AA3	6SL3320-1TG31-2AA3	6SL3320-1TG31-8AA3	6SL3320-1TG32-6AA3
		6SL3320-1TG31-0AA3	6SL3320-1TG31-5AA3	6SL3320-1TG32-2AA3	6SL3320-1TG33-3AA3
		6SL3325-1TG31-0AA3	6SL3325-1TG31-5AA3	6SL3325-1TG32-2AA3	6SL3325-1TG33-3AA3

<sup>1)</sup> Longer cable lengths for specific configurations are available on request.

<sup>2)</sup> Only for line voltages 500 ... 600 V 3 AC.

# SINAMICS S120 Chassis Format Converter Units

## System components

### Motor-side power components > dv/dt filter plus VPL

#### Technical specifications (continued)

Line voltage 500 ... 690 V 3 AC		dv/dt filter plus VPL			
		6SL3000-2DH34-1AA0	6SL3000-2DH35-8AA0	6SL3000-2DH38-1AA0 <sup>1)</sup>	6SL3000-2DH41-3AA0 <sup>1)</sup>
<b>I<sub>th max</sub></b>	A	410	575	810	1270
<b>Degree of protection</b>		IP00	IP00	IP00	IP00
<b>Cable length, max.</b> between dv/dt filter and motor <sup>2)</sup>					
• Shielded	m	300	300	300	300
• Unshielded	m	450	450	450	450
<b>Conformity</b>		CE	CE	CE	CE
<b>Certificate of suitability<sup>3)</sup></b>		cURus	cURus	cURus	cURus
<b>dv/dt reactor</b>					
<b>Power loss, max.</b>					
• At 50 Hz 500/690 V	kW	0.786	0.862	0.828	0.865
• At 60 Hz 575 V	kW	0.826	0.902	0.867	0.904
• At 150 Hz 500/690 V	kW	0.884	0.964	0.927	0.966
<b>Connections</b>					
• To the Power Module/ Motor Module		1 × hole for M12	1 × hole for M12	2 × hole for M12	2 × hole for M12
• To load		1 × hole for M12	1 × hole for M12	2 × hole for M12	2 × hole for M12
• PE		M6 screw	M6 screw	M6 screw	M6 screw
<b>Dimensions</b>					
• Width	mm	460	460	445	445
• Height	mm	385	385	385	385
• Depth	mm	312	312	312	312
<b>Weight, approx.</b>	kg	147	172	160	164
<b>Voltage Peak Limiter (VPL)</b>					
<b>Power loss, max.</b>					
• At 50 Hz 500/690 V	kW	0.051	0.063	0.106	0.15
• At 60 Hz 575 V	kW	0.048	0.059	0.1	0.14
• At 150 Hz 500/690 V	kW	0.043	0.054	0.091	0.128
<b>Connections</b>					
• To dv/dt reactor		1 × hole for M8	1 × hole for M8	1 × hole for M10	1 × hole for M10
• To DC link		1 × hole for M8	1 × hole for M8	1 × hole for M10	1 × hole for M10
• PE		M8 stud	M8 stud	M8 stud	M8 stud
<b>Dimensions</b>					
• Width	mm	309	309	309	309
• Height	mm	1313	1313	1313	1313
• Depth	mm	400	400	400	400
<b>Weight, approx.</b>	kg	48	48	72	73
<b>Suitable for Motor Module</b>		6SL3320-1TG34-1AA3	6SL3320-1TG34-7AA3 6SL3325-1TG34-7AA3 6SL3325-1TG34-7AA7 6SL3320-1TG35-8AA3 6SL3325-1TG35-8AA3 6SL3325-1TG35-8AA7	6SL3320-1TG37-4AA3 6SL3325-1TG37-4AA3 6SL3320-1TG38-1AA3 6SL3325-1TG38-0AA3 6SL3325-1TG38-1AA3 6SL3325-1TG38-1AA7	6SL3320-1TG38-8AA3 6SL3320-1TG41-0AA3 6SL3325-1TG41-0AA3 6SL3325-1TG41-0AA7 6SL3320-1TG41-3AA3 6SL3325-1TG41-3AA3 6SL3325-1TG41-3AA7

<sup>1)</sup> These dv/dt filters include two dv/dt reactors. The technical specifications listed refer to a dv/dt reactor. For additional information on dv/dt filters, please refer to the SINAMICS Low Voltage Engineering Manual.

<sup>2)</sup> Longer cable lengths for specific configurations are available on request.

<sup>3)</sup> Only for line voltages 500 ... 600 V 3 AC.

## SINAMICS S120 Chassis Format Converter Units

### System components

#### Motor-side power components > dv/dt filter compact plus VPL

##### Overview

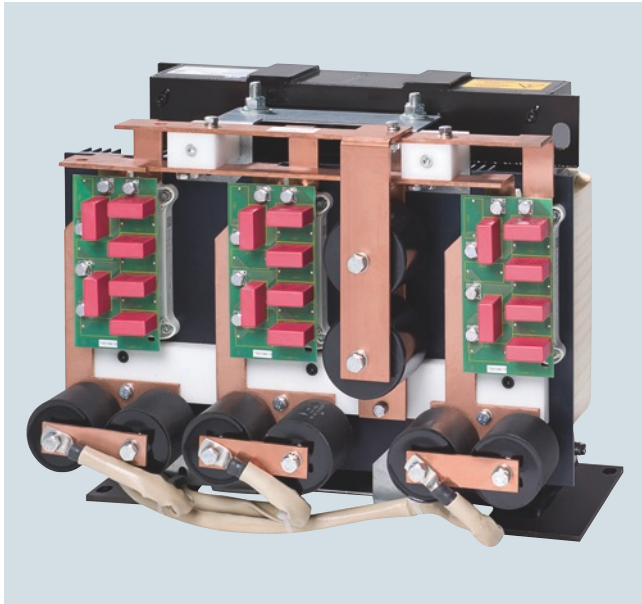

##### Design

The dv/dt filter compact plus VPL consists of two components, which are supplied together as a compact mechanical unit:

- dv/dt reactor
- Voltage limiting network, which cuts off the voltage peaks and feeds the energy back to the DC link.

dv/dt filters compact plus VPL (**V**oltage **P**eak **L**imiter) limit the voltage rate-of-rise  $dv/dt$  to values of  $< 1600 \text{ V}/\mu\text{s}$  and the typical voltage peaks to the following values in accordance with the limit value curve A according to IEC 60034-25: 2007:

$< 1150 \text{ V}$  at  $U_{\text{line}} < 575 \text{ V}$

$< 1400 \text{ V}$  at  $660 \text{ V} < U_{\text{line}} < 690 \text{ V}$

Standard motors with standard insulation and without insulated bearings with a supply voltage of up to 690 V can be used for converter operation if a dv/dt filter compact plus VPL is used.

dv/dt filters compact plus VPL are designed for the following maximum motor cable lengths:

- Shielded cables: 100 m (e.g. Protodur NYCWY)
- Unshielded cables: 150 m (e.g. Protodur NYY)

For longer cable lengths ( $> 100 \text{ m}$  shielded,  $> 150 \text{ m}$  unshielded) refer to [dv/dt filter plus VPL](#).

##### Notice:

- The max. permissible cable length between the dv/dt filter and Motor Module is 5 m
- Operation with output frequencies  $< 10 \text{ Hz}$  is permissible for max. 5 min.

# SINAMICS S120 Chassis Format Converter Units

## System components

Motor-side power components > dv/dt filter compact plus VPL

### Selection and ordering data

Suitable for Power Module		Suitable for Motor Module		Type rating at 400 V/690 V kW	dv/dt filter compact plus VPL Article No.
Air-cooled	Liquid-cooled	Air-cooled	Liquid-cooled		
<b>Line voltage 380 ... 480 V 3 AC</b>					
6SL3310-1TE32-1AA3	6SL3315-1TE32-1AA3	6SL3320-1TE32-1AA3	6SL3325-1TE32-1AA3	110	<b>6SL3000-2DE32-6EA0</b>
6SL3310-1TE32-6AA3	6SL3315-1TE32-6AA3	6SL3320-1TE32-6AA3	6SL3325-1TE32-6AA3	132	
6SL3310-1TE33-1AA3	6SL3315-1TE33-1AA3	6SL3320-1TE33-1AA3	6SL3325-1TE33-1AA3	160	<b>6SL3000-2DE35-0EA0</b>
6SL3310-1TE33-8AA3	–	6SL3320-1TE33-8AA3	–	200	
6SL3310-1TE35-0AA3	6SL3315-1TE35-0AA3	6SL3320-1TE35-0AA3	6SL3325-1TE35-0AA3	250	<b>6SL3000-2DE38-4EA0</b>
–	–	6SL3320-1TE36-1AA3	6SL3325-1TE36-1AA3	315	
–	–	6SL3320-1TE37-5AA3	6SL3325-1TE37-5AA3 6SL3325-1TE37-5AA7	400	<b>6SL3000-2DE41-4EA0</b>
–	–	6SL3320-1TE38-4AA3	6SL3325-1TE38-4AA3	450	
–	–	6SL3320-1TE41-0AA3	6SL3325-1TE41-0AA3 6SL3325-1TE41-0AA7	560	<b>6SL3000-2DE41-4EA0</b>
–	–	6SL3320-1TE41-2AA3	6SL3325-1TE41-2AA3 6SL3325-1TE41-2AA7	710	
–	–	6SL3320-1TE41-4AA3	6SL3325-1TE41-4AA3 6SL3325-1TE41-4AA7	800	<b>6SL3000-2DE41-4EA0</b>
–	–	–	6SL3325-1TE41-4AS3 <sup>1)</sup>	800	
<b>Line voltage 500 ... 690 V 3 AC</b>					
–	–	6SL3320-1TG28-5AA3	–	75	<b>6SL3000-2DG31-0EA0</b>
–	–	6SL3320-1TG31-0AA3	6SL3325-1TG31-0AA3	90	<b>6SL3000-2DG31-5EA0</b>
–	–	6SL3320-1TG31-2AA3	–	110	
–	–	6SL3320-1TG31-5AA3	6SL3325-1TG31-5AA3	132	<b>6SL3000-2DG32-2EA0</b>
–	–	6SL3320-1TG31-8AA3	–	160	
–	–	6SL3320-1TG32-2AA3	6SL3325-1TG32-2AA3	200	<b>6SL3000-2DG33-3EA0</b>
–	–	6SL3320-1TG32-6AA3	–	250	
–	–	6SL3320-1TG33-3AA3	6SL3325-1TG33-3AA3	315	<b>6SL3000-2DG34-1EA0</b>
–	–	6SL3320-1TG34-1AA3	–	400	
–	–	6SL3320-1TG34-7AA3	6SL3325-1TG34-7AA3 6SL3325-1TG34-7AA7	450	<b>6SL3000-2DG35-8EA0</b>
–	–	6SL3320-1TG35-8AA3	6SL3325-1TG35-8AA3 6SL3325-1TG35-8AA7	560	
–	–	6SL3320-1TG37-4AA3	6SL3325-1TG37-4AA3	710	<b>6SL3000-2DG38-1EA0</b>
–	–	6SL3320-1TG38-1AA3	6SL3325-1TG38-0AA3	800	
–	–	–	6SL3325-1TG38-1AA3 6SL3325-1TG38-1AA7	800	<b>6SL3000-2DG41-3EA0</b>
–	–	6SL3320-1TG38-8AA3	–	900	
–	–	6SL3320-1TG41-0AA3	6SL3325-1TG41-0AA3 6SL3325-1TG41-0AA7	1000	<b>6SL3000-2DG41-3EA0</b>
–	–	6SL3320-1TG41-3AA3	6SL3325-1TG41-3AA3 6SL3325-1TG41-3AA7	1200	

For additional information on dv/dt filters, please refer to the SINAMICS Low Voltage Engineering Manual.

<sup>1)</sup> This Motor Module has been specifically designed for loads demanding a high dynamic performance.

# SINAMICS S120 Chassis Format Converter Units

## System components

### Motor-side power components > dv/dt filter compact plus VPL

#### Technical specifications

Line voltage 380 ... 480 V 3 AC		dv/dt filter compact plus VPL			
		6SL3000-2DE32-6EA0	6SL3000-2DE35-0EA0	6SL3000-2DE38-4EA0	6SL3000-2DE41-4EA0
<b>Rated current</b>	A	260	490	840	1405
<b><math>I_{th\ max}</math></b>	A	260	490	840	1405
<b>Power loss, max.</b>					
• At 50 Hz 400 V	kW	0.21	0.29	0.518	Reactor: 1.027 VPL: 0.127 Total: 1.154
• At 60 Hz 460 V	kW	0.215	0.296	0.529	Reactor: 1.077 VPL: 0.12 Total: 1.197
• At 150 Hz 400 V	kW	0.255	0.344	0.609	Reactor: 1.354 VPL: 0.09 Total: 1.444
<b>Power connection</b> input and output side		Hole for M10	Hole for M10	Hole for M12	2 × elongated hole, 14 × 18 mm
• Conductor cross-section, max. (IEC)		Provided for busbar connection	Provided for busbar connection	Provided for busbar connection	Provided for busbar connection
<b>DC link connection</b> DCPS, DCNS		M8 threaded socket	M8 threaded socket	Hole for M8	Hole for M8
• Conductor cross-section, max. (IEC)	mm <sup>2</sup>	16	25	50	95
<b>PE/GND connection</b>		M6 threaded socket	M6 threaded socket	M6 threaded socket	M6 threaded socket (reactor and VPL)
<b>Motor cable length, max.</b>					
• Shielded	m	100	100	100	100
• Unshielded	m	150	150	150	150
<b>Degree of protection</b>		IP00	IP00	IP00	IP00
<b>Dimensions</b>					
• Width	mm	310	350	440	Reactor: 430 VPL: 277
• Height	mm	283	317	369	Reactor: 385 VPL: 360
• Depth	mm	238	260	311	Reactor: 323 VPL: 291
<b>Weight, approx.</b>	kg	41	61	103	Reactor: 168.8 VPL: 19.2 Total: 188
<b>Conformity</b>		CE	CE	CE	CE
<b>Certificates of suitability</b>		cURus	cURus	cURus	cURus
<b>Suitable for Power Module</b>		6SL3310-1TE32-1AA3 6SL3315-1TE32-1AA3 6SL3310-1TE32-6AA3 6SL3315-1TE32-6AA3	6SL3310-1TE33-1AA3 6SL3315-1TE33-1AA3 6SL3310-1TE33-8AA3 6SL3310-1TE35-0AA3 6SL3315-1TE35-0AA3		
<b>Suitable for Motor Module</b>		6SL3320-1TE32-1AA3 6SL3325-1TE32-1AA3 6SL3320-1TE32-6AA3 6SL3325-1TE32-6AA3	6SL3320-1TE33-1AA3 6SL3325-1TE33-1AA3 6SL3320-1TE33-8AA3 6SL3320-1TE35-0AA3 6SL3325-1TE35-0AA3	6SL3320-1TE36-1AA3 6SL3325-1TE36-1AA3 6SL3320-1TE37-5AA3 6SL3325-1TE37-5AA7 6SL3320-1TE38-4AA3 6SL3325-1TE38-4AA3	6SL3320-1TE41-0AA3 6SL3325-1TE41-0AA3 6SL3325-1TE41-0AA7 6SL3320-1TE41-2AA3 6SL3325-1TE41-2AA3 6SL3325-1TE41-2AA7 6SL3320-1TE41-4AA3 6SL3325-1TE41-4AA3 6SL3325-1TE41-4AA7 6SL3325-1TE41-4AS3 <sup>1)</sup>

<sup>1)</sup> This Motor Module has been specifically designed for loads demanding a high dynamic performance.

# SINAMICS S120 Chassis Format Converter Units

## System components

### Motor-side power components > dv/dt filter compact plus VPL

#### Technical specifications (continued)

Line voltage 500 ... 690 V 3 AC		dv/dt filter compact plus VPL			
		6SL3000-2DG31-0EA0	6SL3000-2DG31-5EA0	6SL3000-2DG32-2EA0	6SL3000-2DG33-3EA0
<b>Rated current</b>	A	100	150	215	330
<b><math>I_{th\ max}</math></b>	A	100	150	215	330
<b>Power loss, max.</b>					
• At 50 Hz 500/690 V	kW	0.227	0.27	0.305	0.385
• At 60 Hz 575 V	kW	0.236	0.279	0.316	0.399
• At 150 Hz 500/690 V	kW	0.287	0.335	0.372	0.48
<b>Power connection</b> input and output side		Hole for M10	Hole for M10	Hole for M10	Hole for M10
• Conductor cross-section, max. (IEC)		Provided for busbar connection	Provided for busbar connection	Provided for busbar connection	Provided for busbar connection
<b>DC link connection</b> DCPS, DCNS		M8 threaded socket	M8 threaded socket	Hole for M8	Hole for M8
• Conductor cross-section, max. (IEC)	mm <sup>2</sup>	16	16	25	25
<b>PE/GND connection</b>		M6 threaded socket	M6 threaded socket	M6 threaded socket	M6 threaded socket
<b>Motor cable length, max.</b>					
• Shielded	m	100	100	100	100
• Unshielded	m	150	150	150	150
<b>Degree of protection</b>		IP00	IP00	IP00	IP00
<b>Dimensions</b>					
• Width	mm	310	310	350	350
• Height	mm	283	283	317	317
• Depth	mm	238	238	260	260
<b>Weight, approx.</b>	kg	34	36	51	60
<b>Conformity</b>		CE	CE	CE	CE
<b>Certificate of suitability <sup>1)</sup></b>		cURus	cURus	cURus	cURus
<b>Suitable for Motor Module</b>		6SL3320-1TG28-5AA3 6SL3320-1TG31-0AA3 6SL3325-1TG31-0AA3	6SL3320-1TG31-2AA3 6SL3320-1TG31-5AA3 6SL3325-1TG31-5AA3	6SL3320-1TG31-8AA3 6SL3320-1TG32-2AA3 6SL3325-1TG32-2AA3	6SL3320-1TG32-6AA3 6SL3320-1TG33-3AA3 6SL3325-1TG33-3AA3

<sup>1)</sup> Only for line voltages 500 ... 600 V 3 AC.



# SINAMICS S120 Chassis Format Converter Units

## System components

### Motor-side power components > dv/dt filter compact plus VPL

#### Technical specifications (continued)

Line voltage 500 ... 690 V 3 AC		dv/dt filter compact plus VPL			
		6SL3000-2DG34-1EA0	6SL3000-2DG35-8EA0	6SL3000-2DG38-1EA0	6SL3000-2DG41-3EA0
<b>Rated current</b>	A	410	575	810	1270
<b><math>I_{th\ max}</math></b>	A	410	575	810	1270
<b>Power loss, max.</b>					
• At 50 Hz 500/690 V	kW	0.55	0.571	Reactor: 0.88 VPL: 0.084 Total: 0.964	Reactor: 0.926 VPL: 0.124 Total: 1.05
• At 60 Hz 575 V	kW	0.568	0.586	Reactor: 0.918 VPL: 0.08 Total: 0.998	Reactor: 0.993 VPL: 0.111 Total: 1.104
• At 150 Hz 500/690 V	kW	0.678	0.689	Reactor: 1.137 VPL: 0.059 Total: 1.196	Reactor: 1.23 VPL: 0.089 Total: 1.319
<b>Power connection</b> input and output side		Hole for M12	Hole for M12	2 × elongated hole, 14 × 18 mm	2 × elongated hole, 14 × 18 mm
• Conductor cross-section, max. (IEC)		Provided for busbar connection	Provided for busbar connection	Provided for busbar connection	Provided for busbar connection
<b>DC link connection</b> DCPS, DCNS		Hole for M8	Hole for M8	Hole for M8	Hole for M8
• Conductor cross-section, max. (IEC)	mm <sup>2</sup>	50	50	95	95
<b>PE/GND connection</b>		M6 threaded socket	M6 threaded socket	M6 threaded socket (reactor and VPL)	M6 threaded socket (reactor and VPL)
<b>Motor cable length, max.</b>					
• Shielded	m	100	100	100	100
• Unshielded	m	150	150	150	150
<b>Degree of protection</b>		IP00	IP00	IP00	IP00
<b>Dimensions</b>					
• Width	mm	440	440	Reactor: 430 VPL: 277	Reactor: 430 VPL: 277
• Height	mm	369	369	Reactor: 385 VPL: 360	Reactor: 385 VPL: 360
• Depth	mm	311	311	Reactor: 323 VPL: 291	Reactor: 323 VPL: 291
<b>Weight, approx.</b>	kg	87	100	Reactor: 171.2 VPL: 18.8 Total: 190	Reactor: 175.8 VPL: 19.2 Total: 195
<b>Conformity</b>		CE	CE	CE	CE
<b>Certificate of suitability <sup>1)</sup></b>		cURus	cURus	cURus	cURus
<b>Suitable for Motor Module</b>		6SL3320-1TG34-1AA3	6SL3320-1TG34-7AA3 6SL3325-1TG34-7AA3 6SL3325-1TG34-7AA7 6SL3320-1TG35-8AA3 6SL3325-1TG35-8AA3 6SL3325-1TG35-8AA7	6SL3320-1TG37-4AA3 6SL3325-1TG37-4AA3 6SL3320-1TG38-1AA3 6SL3325-1TG38-0AA3 6SL3325-1TG38-1AA3 6SL3325-1TG38-1AA7	6SL3320-1TG38-8AA3 6SL3320-1TG41-0AA3 6SL3325-1TG41-0AA3 6SL3325-1TG41-0AA7 6SL3320-1TG41-3AA3 6SL3325-1TG41-3AA3 6SL3325-1TG41-3AA7

<sup>1)</sup> Only for line voltages 500 ... 600 V 3 AC.

# SINAMICS S120 Chassis Format Converter Units

## System components

### Motor-side power components > Sine-wave filter

#### Overview

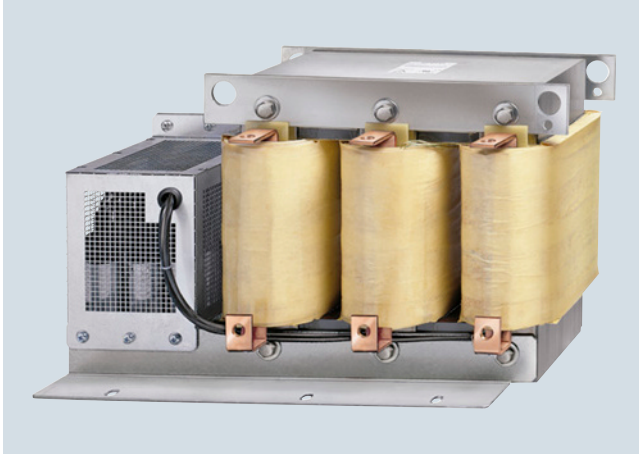

If a sine-wave filter is connected to the output of the Power Module or Motor Module, the voltage between the motor terminals is virtually sinusoidal. This reduces the voltage load on the motor windings and prevents motor noise induced by the pulse frequency.

The pulse frequency of the modules must be set to 4 kHz for the sine-wave filters. The max. output frequency with sine-wave filter is limited to 150 Hz.

As a result, the max. possible output current and the max. achievable output voltage of the units are reduced. The voltage drops across the sine-wave filter, a factor which must also be taken into account in the drive design.

A sine-wave filter must be installed as close as possible to the Motor Module or Power Module.

It is only permissible to operate the sine-wave filter when the motor is connected (sine-wave filters are not no-load proof)!

For additional information on sine-wave filters, please refer to the [SINAMICS Low Voltage Engineering Manual](#).

#### Selection and ordering data

Suitable for Power Module		Suitable for Motor Module		Type rating at 400 V kW	Rated output current A	<b>Sine-wave filter</b> Article No.
Air-cooled	Liquid-cooled	Air-cooled	Liquid-cooled			
<b>Line voltage 380 ... 480 V 3 AC</b>						
6SL3310-1TE32-1AA3	6SL3315-1TE32-1AA3	6SL3320-1TE32-1AA3	6SL3325-1TE32-1AA3	110	210	<b>6SL3000-2CE32-3AA0</b>
6SL3310-1TE32-6AA3	6SL3315-1TE32-6AA3	6SL3320-1TE32-6AA3	6SL3325-1TE32-6AA3	132	260	
6SL3310-1TE33-1AA3	6SL3315-1TE33-1AA3	6SL3320-1TE33-1AA3	6SL3325-1TE33-1AA3	160	310	<b>6SL3000-2CE32-8AA0</b>
6SL3310-1TE33-8AA3	–	6SL3320-1TE33-8AA3	–	200	380	<b>6SL3000-2CE33-3AA0</b>
6SL3310-1TE35-0AA3	6SL3315-1TE35-0AA3	6SL3320-1TE35-0AA3	6SL3325-1TE35-0AA3	250	490	<b>6SL3000-2CE34-1AA0</b>

## SINAMICS S120 Chassis Format Converter Units

### System components

#### Motor-side power components > Sine-wave filter

##### Technical specifications

Line voltage 380 ... 480 V 3 AC		Sine-wave filter				
		6SL3000-2CE32-3AA0	6SL3000-2CE32-8AA0	6SL3000-2CE33-3AA0	6SL3000-2CE34-1AA0	
<b>Rated current</b>	A	225	276	333	408	
<b>Power loss, max.</b>						
• At 50 Hz 400 V	kW	0.221	0.235	0.245	0.34	
• At 60 Hz 460 V	kW	0.265	0.282	0.294	0.408	
• At 150 Hz 400 V	kW	0.48	0.5	0.53	0.75	
<b>Load connection</b>		Flat connector for M10 screw	Flat connector for M10 screw	Flat connector for M10 screw	Flat connector for M10 screw	
<b>PE connection</b>		1 × hole for M10	1 × hole for M10	1 × hole for M10	1 × hole for M10	
<b>Cable length, max.</b> between sine-wave filter and motor						
• Shielded	m	300	300	300	300	
• Unshielded	m	450	450	450	450	
<b>Degree of protection</b>		IP00	IP00	IP00	IP00	
<b>Dimensions</b>						
• Width	mm	620	620	620	620	
• Height	mm	300	300	370	370	
• Depth	mm	320	320	360	360	
<b>Weight, approx.</b>	kg	124	127	136	198	
<b>Conformity</b>		CE	CE	CE	CE	
<b>Certificate of suitability</b>		cURus	cURus	cURus	cURus	
<b>Suitable for Power Module</b>		6SL3310-1TE32-1AA3 6SL3315-1TE32-1AA3	6SL3310-1TE32-6AA3 6SL3315-1TE32-6AA3	6SL3310-1TE33-1AA3 6SL3315-1TE33-1AA3	6SL3310-1TE33-8AA3	6SL3310-1TE35-0AA3 6SL3315-1TE35-0AA3
<b>Suitable for Motor Module</b>		6SL3320-1TE32-1AA3 6SL3325-1TE32-1AA3	6SL3320-1TE32-6AA3 6SL3325-1TE32-6AA3	6SL3320-1TE33-1AA3 6SL3325-1TE33-1AA3	6SL3320-1TE33-8AA3	6SL3320-1TE35-0AA3 6SL3325-1TE35-0AA3
• Rated output current of the Motor Module or Power Module at a pulse frequency of 4 kHz	A	170	215	270	330	380

### Overview



CU310-2 PN Control Unit



CU320-2 PN Control Unit

### System architecture with a central Control Unit

Electronically coordinated single-motor drives work together to perform your drive tasks. In multi-axis drives, the individual drives are controlled from the higher-level control systems in such a way as to achieve the desired coordinated movement. This requires cyclic data exchange between the controller and the drives. A central Control Unit controls the drives for all connected axes and also establishes the technological links between the drives and/or axes. Since all the required data is stored in the central Control Unit, it does not need to be transferred. Inter-axis connections can be established within a Control Unit and easily configured in the STARTER commissioning tool using a mouse.

- The SINAMICS Control Unit can handle simple technological tasks by itself
- The **CU310-2 DP** or **CU310-2 PN** Control Units are used in conjunction with Power Modules and single-motor drives.
- The **CU320-2 DP** or **CU320-2 PN** Control Units are used in conjunction with all Motor Modules or Line Modules for single or multi-motor drives.
- Sophisticated motion control tasks can be implemented with the support of the more powerful **D410-2**, **D425-2**, **D435-2**, and **D445-2** Control Units of **SIMOTION D** (graded according to performance).

[You can obtain further information about SIMOTION in the Industry Mall and Catalog PM 21.](#)

Each of these Control Units is based on an object-oriented SINAMICS standard firmware, which contains all common control modes and can be scaled to meet even the most advanced performance requirements.

The drive controls are supplied as ready-to-configure drive objects:

- Infeed Control for mains infeed
- Vector control
  - Speed-controlled drives with high speed and torque stability in general machine and plant construction
  - Particularly suitable for induction motors
  - Optimized pulse patterns for efficient motor/converter systems
- Servo control
  - Drives with highly dynamic motion control
  - Angular-locked synchronism with isochronous PROFIBUS/PROFINET
  - For use in machine tools and clocked production machines

The most commonly used v/f control modes are stored in the "Vector control" drive object and are ideal for implementing even simple applications such as group drives with SIEMOSYN motors.

### CompactFlash card

The functions of the drives are stored on a CompactFlash card. This card contains the firmware and parameter settings for all drives in the form of a project. The CompactFlash card can also hold additional projects, which means that the correct project can be accessed immediately when series machines of different types are commissioned. When the Control Unit has booted, the data on the CompactFlash card is read and loaded to the RAM.

The firmware is organized in objects. Drive objects are used to implement open-loop and closed-loop control functions for Line Modules, Motor Modules, Power Modules and other system components connected by DRIVE-CLiQ.

# SINAMICS S120 Chassis Format Converter Units

## System components

### Control Units

#### Overview (continued)

#### Overview of key open-loop and closed-loop control functions

	Closed-loop control types S120	Open-loop control types S120	Main functions S120 for booksize/chassis	Comment, note
<b>Infeed Control</b>	<ul style="list-style-type: none"> <li>Chassis</li> <li>Current control with VSM10</li> <li>V<sub>DC</sub> control with VSM10</li> <li>Network functionalities (island grids)</li> </ul>	<ul style="list-style-type: none"> <li>Booksize/chassis</li> <li>Basic Mode Rectification only</li> <li>Smart Mode Rectification and regenerative feedback</li> </ul>	<ul style="list-style-type: none"> <li>Mains identification</li> <li>Controller optimization</li> <li>Harmonics filter</li> <li>Automatic restart</li> </ul>	The VSM10 is the Voltage Sensing Module; "current" is the line current; 3-phase with line frequency
<b>Vector control</b>	<ul style="list-style-type: none"> <li>Induction motor</li> <li>Torque control with/without encoder</li> <li>Speed control with/without encoder</li> <li>Torque motor</li> <li>Torque control with encoder</li> <li>Speed control with/without encoder</li> <li>Induction motor, torque motor</li> <li>Position control with encoder</li> <li>Reluctance motor</li> <li>Torque control with/without encoder</li> <li>Speed control with/without encoder</li> </ul>	<ul style="list-style-type: none"> <li>Linear V/f characteristic</li> <li>Constant-frequency V/f characteristic (textile)</li> <li>Independent voltage setpoint input</li> </ul>	<ul style="list-style-type: none"> <li>Data set changeover</li> <li>Extended setpoint input</li> <li>Motor identification</li> <li>Current/speed controller optimization</li> <li>Technology controller</li> <li>Basic positioner</li> <li>Automatic restart</li> <li>Flying restart with/without encoder</li> <li>Kinetic buffering</li> <li>Synchronization</li> <li>Drift</li> <li>Brake control</li> </ul>	<p>Mixed operation with V/f control modes is possible; it is for this reason that the V/f control modes are stored only once in the "Vector control" drive object</p> <p>Position control can be selected as a function module from both Servo and Vector mode</p> <p>Permanent-magnet 1FW4 synchronous motors can be operated over the complete operating range in <u>Vector control</u>.</p>
<b>Servo control</b>	<ul style="list-style-type: none"> <li>Induction motor</li> <li>Torque control with/without encoder</li> <li>Speed control with/without encoder</li> <li>Synchronous motor, linear motor and torque motor</li> <li>Torque control with encoder</li> <li>Speed control with encoder</li> <li>All motor types</li> <li>Position control with encoder</li> </ul>	<ul style="list-style-type: none"> <li>Linear V/f characteristic</li> <li>Constant-frequency V/f characteristic (textile)</li> <li>Independent voltage setpoint input</li> </ul>	<ul style="list-style-type: none"> <li>Data set changeover</li> <li>Setpoint input</li> <li>Motor identification</li> <li>Damping application</li> <li>Technology controller</li> <li>Basic positioner</li> <li>Brake control</li> </ul>	<p>Mixed operation with V/f control modes is possible; it is for this reason that the V/f control modes are stored only once in the "Vector control" drive object</p> <p>Position control can be selected as a function module from both Servo and Vector mode.</p>

#### Drive objects

A drive object is a self-contained software function with its own parameters and, where appropriate, its own fault messages and alarms.

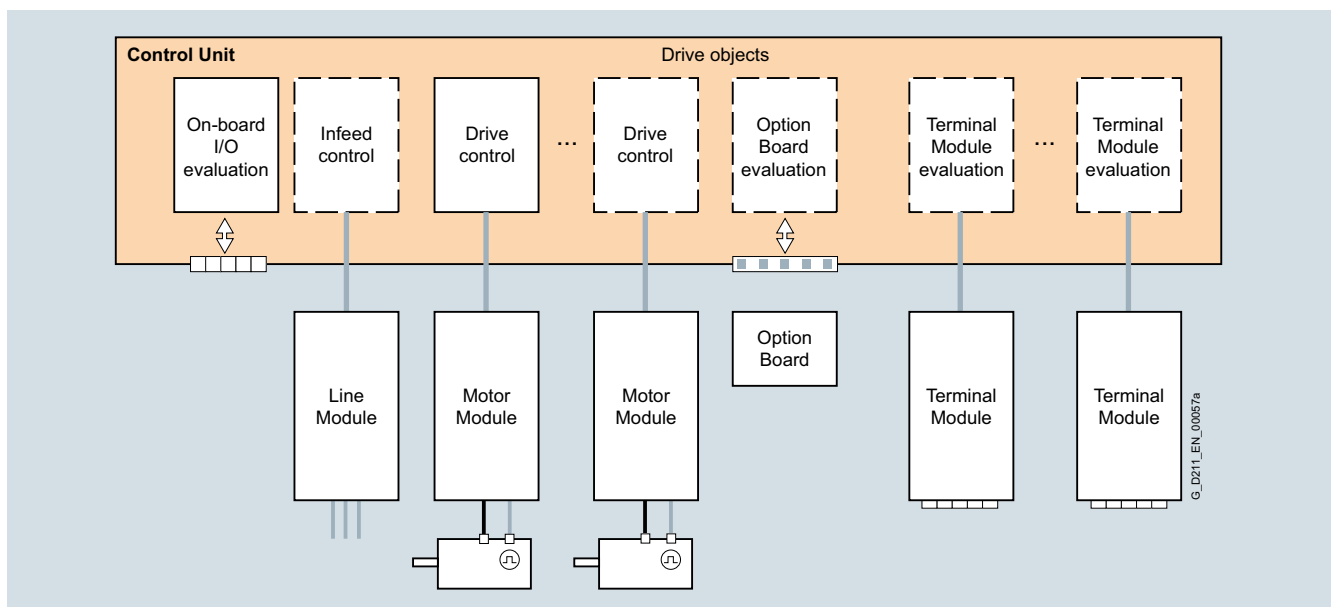

### Overview (continued)

#### Extended technology with SIMOTION

SIMOTION D Control Units support the coordinated motion control of multiple drives. Technology objects are implemented in addition to drive objects on these Control Units. These are grouped to form technology packages and make available extended Motion Control functions (e.g. synchronous operation, cam disk, path interpolation and others) or technological functions (e.g. a cam controller, a temperature or pressure control). The IEC 61131-3-compliant PLC integrated in SIMOTION D Control Units means that they are not just capable of controlling sequences of motions, but the entire machine including HMI and I/Os.

You can obtain further information about SIMOTION in the Industry Mall and Catalog PM 21.

#### Comprehensive package of open-loop and closed-loop control functions

A wide variety of standard functions such as setpoint input, data set changeover, controller optimization, kinetic buffering, etc. ensure a high degree of functional reliability and excellent flexibility when addressing the application.

#### BICO technology

Every drive object contains a large number of input and output variables which can be freely and independently interconnected using Binector Connector Technology (BICO). A binector is a logic signal which can assume the value 0 or 1. A connector is a numerical value, e.g. the actual speed or current setpoint.

#### Drive Control Chart (DCC)

Drive Control Chart (DCC) for SINAMICS S120 is a user-friendly tool with which drive-related closed-loop control, logic and arithmetic functions can be configured in graphical form. It extends the possibility of configuring technological functions for SINAMICS drives in an extremely easy way.

The user-friendly DCC editor enables easy graphics-based configuration, allows control loop structures to be clearly represented and provides a high degree of reusability of charts that have already been created.

The associated block library (DCB library) contains a large selection of closed-loop control, calculation and logic modules (Drive Control Blocks (DCB)) as well as more complex open-loop and closed-loop control functions.

Two types of DCB library are available, i.e. DCB Standard and DCB Extension. The DCB Standard library is supplied as standard with the SINAMICS DCC software.

DCC is an add-on for the STARTER commissioning tool.

#### Integral safety functions (Safety Integrated)

The Control Units support comprehensive safety functions.

The integrated safety functions are the Safety Integrated Basic Functions

- STO = Safe Torque Off
- SBC = Safe Brake Control
- SS1 = Safe Stop 1 (Time controlled)

and the Safety Integrated Extended Functions that require a license

- SS1 = Safe Stop 1 (time and acceleration controlled)
- SS2 = Safe Stop 2
- SOS = Safe Operating Stop
- SLS = Safely-Limited Speed
- SSM = Safe Speed Monitor
- SDI = Safe Direction
- SLP = Safely-Limited Position
- SP = Safe Position transmission
- SBT = Safe Brake Test

(Abbreviations in accordance with IEC 61800-5-2)

If the integrated safety functions are used, licenses, supplementary system components such as TM54F Terminal Modules, or suitable safety controls will be necessary.

Additional information about the integrated safety functions is provided in section Safety Integrated.

#### Diagnostics optimally supported by trace function

The time characteristic curves of input and output variables associated with drive objects can be measured by the integrated trace function and displayed using the STARTER commissioning tool. Several signals can be simultaneously traced. A recording can be triggered dependent on freely selectable boundary conditions, e.g. the value of an input or output variable.



## SINAMICS S120 Chassis Format Converter Units

### System components

#### Control Units > CU320-2 Control Unit

##### Overview



CU320-2 PN and CU320-2 DP Control Units

The communication, open-loop and closed-loop control functions for one or more Line Modules and/or Motor Modules are executed in a CU320-2 Control Unit. The CU320-2 Control Unit is essentially designed for multi-axis operation. Communication with the higher-level control system is performed via PROFIBUS DP or PROFINET.

##### Design

CU320-2 Control Units feature the following interfaces as standard:

- Fieldbus interface:
  - CU320-2 PN: 1 PROFINET interface with 2 ports (RJ45 sockets) with PROFIdrive V4 profile
  - CU320-2 DP: 1 PROFIBUS interface with PROFIdrive V4 profile
- 4 x DRIVE-CLiQ sockets for communication with other DRIVE-CLiQ nodes, e.g. Motor Modules, Active Line Modules, Sensor Modules, Terminal Modules
- 12 parameterizable digital inputs (floating)
- 8 parameterizable bidirectional digital inputs/digital outputs (non-floating)
- 1 serial RS232 interface (e.g. to connect the AOP30 Advanced Operator Panel)
- 1 interface for the BOP20 Basic Operator Panel
- 1 slot for the CompactFlash card on which firmware and parameters are stored
- 1 slot for mounting an option module (e.g. TB30 Terminal Board)
- CU320-2 DP: 2 rotary coding switches for manually setting the PROFIBUS address
- 1 Ethernet interface for commissioning and diagnostics
- 3 measuring sockets and one reference ground for commissioning support
- 1 connection for the electronics power supply via the 24 V DC supply connector
- 1 PE connector
- 1 ground connection

A shield connection for the signal cable shield of the option module is located on the CU320-2 Control Unit.

The available option slot is used to expand the interfaces, for example, to include additional terminals or for communication purposes.

The status of the CU320-2 Control Unit is indicated via multi-color LEDs.

As the firmware and parameter settings are stored on a plug-in CompactFlash card, the Control Unit can be changed without the need for software tools.

The CU320-2 Control Unit can be mounted on the side of the Line Module via brackets integrated in a Line Module. The CU320-2 Control Unit can also be fixed to the wall of the control cabinet using the integrated fixing lugs.



# SINAMICS S120 Chassis Format Converter Units

## System components

Control Units &gt; CU320-2 Control Unit

### Selection and ordering data

Description	Article No.
<b>CU320-2 PN Control Unit</b> Without CompactFlash card	<b>6SL3040-1MA01-0AA0</b>
<b>CU320-2 DP Control Unit</b> Without CompactFlash card	<b>6SL3040-1MA00-0AA0</b>
<b>Accessories</b>	
<b>For CU320-2 PN: Industrial Ethernet FC</b>	
• RJ45 Plug 145 (1 units)	<b>6GK1901-1BB30-0AA0</b>
• RJ45 Plug 145 (10 units)	<b>6GK1901-1BB30-0AB0</b>
• Stripping tool	<b>6GK1901-1GA00</b>
• Standard cable GP 2x2	<b>6XV1840-2AH10</b>
• Flexible cable GP 2x2	<b>6XV1870-2B</b>
• Trailing cable GP 2x2	<b>6XV1870-2D</b>
• Trailing cable 2x2	<b>6XV1840-3AH10</b>
• Marine cable 2x2	<b>6XV1840-4AH10</b>
<b>For CU320-2 DP: PROFIBUS connector</b>	
• <u>Without</u> PG/PC connection	<b>6ES7972-0BA42-0XA0</b>
• <u>With</u> PG/PC connection	<b>6ES7972-0BB42-0XA0</b>
<b>Spacers</b> (2 units) Increases the depth of the CU320-2 DP Control Unit to 270 mm (if the integrated brackets are not to be used, but the depth still has to be 270 mm)	
<b>STARTER commissioning tool <sup>1)</sup></b> On DVD-ROM	<b>6SL3072-0AA00-0AG0</b>
<b>Accessories for re-ordering</b>	
<b>Dust protection blanking plugs</b> (50 units) For DRIVE-CLiQ port	<b>6SL3066-4CA00-0AA0</b>

For more information on connectors and cables, please refer to Catalog IK PI and the Siemens Industry Mall:  
[www.siemens.com/industrymall](http://www.siemens.com/industrymall)

### Integration

DRIVE-CLiQ components, for example, Motor Modules and Active Line Modules, can be connected to a CU320-2 Control Unit. The number of modules depends on the performance required, including duty type and additional functions.

The BOP20 Basic Operator Panel can also be snapped onto the CU320-2 Control Unit during operation for diagnostic purposes.

The CU320-2 Control Unit and other connected components are commissioned and diagnosed with the STARTER commissioning tool and the installed SINAMICS Support Package or the AOP30 Advanced Operator Panel.

To operate the CU320-2 PN Control Unit, a CompactFlash card with firmware V4.4 or higher is required.

To operate the CU320-2 DP Control Unit, a CompactFlash card with firmware V4.3 or higher is required.

3

<sup>1)</sup> For further information, see  
<https://support.industry.siemens.com/cs/document/104020669>



# SINAMICS S120 Chassis Format Converter Units

## System components

### Control Units > CU320-2 Control Unit

#### Integration (continued)

3

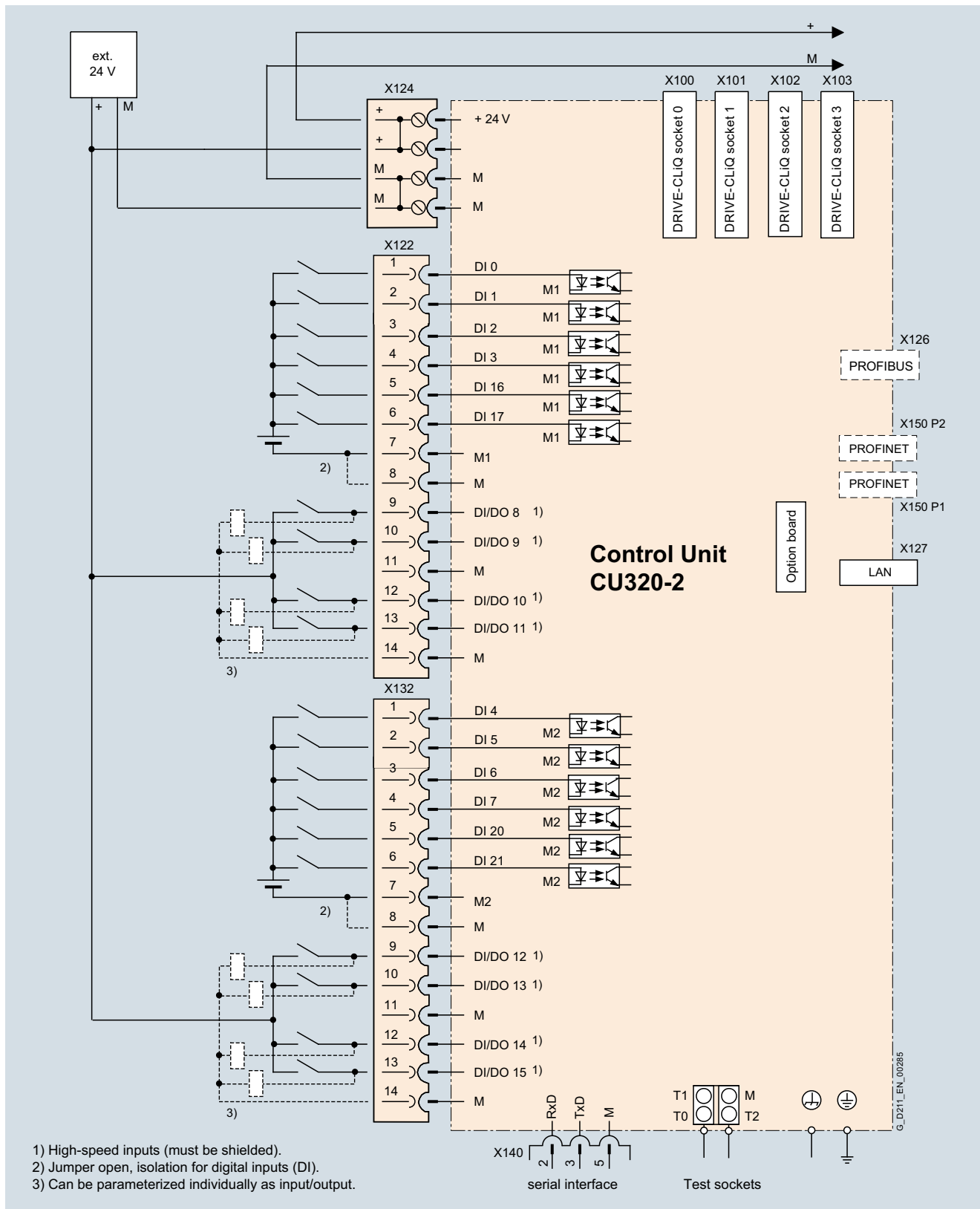

Connection example of a CU320-2 Control Unit

### Technical specifications

	<b>CU320-2 Control Unit</b> 6SL3040-1MA01-0AA0 6SL3040-1MA00-0AA0
<b>PROFINET PROFIBUS</b>	
<b>Power requirement, max.</b> At 24 V DC, without taking account of digital outputs, expansion option slot and DRIVE-CLiQ supply	1.0 A
<b>Conductor cross-section, max.</b>	2.5 mm <sup>2</sup>
<b>Fuse protection, max.</b>	20 A
<b>Digital inputs</b>	In accordance with IEC 61131-2 Type 1 12 floating digital inputs 8 bidirectional non-floating digital inputs/outputs
• Voltage	-3 ... +30 V
• Low level (an open digital input is interpreted as "low")	-3 ... +5 V
• High level	15 ... 30 V
• Current consumption at 24 V DC, typ.	9 mA
• Delay time of digital inputs <sup>1)</sup> , approx.	
- L → H	50 μs
- H → L	100 μs
• Delay time of high-speed digital inputs <sup>1)</sup> , approx.	
- L → H	5 μs
- H → L	50 μs
• Conductor cross-section, max.	1.5 mm <sup>2</sup>
<b>Digital outputs</b> continuously short-circuit proof	8 bidirectional non-floating digital inputs/outputs
• Voltage	24 V DC
• Load current per digital output, max.	500 mA
• Delay time <sup>1)</sup> , typ./max.	
- L → H	150 μs/400 μs
- H → L	75 μs/100 μs
• Conductor cross-section, max.	1.5 mm <sup>2</sup>
<b>Power loss</b>	24 W
<b>PE connection</b>	M5 screw
<b>Ground connection</b>	M5 screw
<b>Dimensions</b>	
• Width	50 mm
• Height	300 mm
• Depth	226 mm
<b>Weight, approx.</b>	2.3 kg

<sup>1)</sup> The specified delay times refer to the hardware. The actual reaction time depends on the time slice in which the digital input or output is processed.

# SINAMICS S120 Chassis Format Converter Units

## System components

### Control Units > CompactFlash card for CU320-2

#### Overview



The CompactFlash card contains the firmware and set parameters. The CompactFlash card is inserted into the appropriate slot of the CU320-2 Control Unit.

#### Design

A CU320-2 Control Unit can perform the communication, open-loop and closed-loop control functions for several power units. The computing capacity requirement increases in proportion to the number of power units and system components and in relation to the dynamic response required. The computing capacity requirement and utilization of the CU320-2 Control Unit can be calculated with the SIZER for Siemens Drives engineering tool. The full computing capacity of the CU320-2 Control Unit is only available on systems with performance extension. For the CU320-2 Control Unit, the performance extension is necessary from the 4th axis.

In addition to the firmware, the CompactFlash card also contains licensing codes which are required to enable firmware options.

In addition to the Article No., the following firmware options can currently be ordered with or without performance extension:

- Safety Integrated Extended Functions, order code per axis **F01** to **F06**
- High output frequency, order code **J01**
- DCB Extension, order code **U01**

Converter cabinets with a Control Unit already contain the CompactFlash card with the current firmware. The firmware options can be added as cabinet options.

The firmware options can also be enabled subsequently. You require the serial number of the CompactFlash card and the article number of the firmware option to be enabled. With this information, you can purchase the associated license code from a license database and enable the firmware option. The license code is only valid for the CompactFlash card declared and cannot be transferred to other CompactFlash cards.

Subsequent licensing is possible in the Internet via the WEB License Manager by generating a license key:  
[www.siemens.com/automation/license](http://www.siemens.com/automation/license)

#### Selection and ordering data

Description	Article No.
<b>CompactFlash card for CU320-2 Control Unit without Safety license</b>	
• Without performance extension	<b>6SL3054-0E□00-1BA0</b>
• With performance extension firmware option	<b>6SL3054-0E□01-1BA0</b>
<b>CompactFlash card for CU320-2 Control Unit with Safety license</b>	
• For 1 axis	<b>6SL3054-0E□0□-1BA0-Z F01</b>
• For 2 axes	<b>6SL3054-0E□0□-1BA0-Z F02</b>
• For 3 axes	<b>6SL3054-0E□0□-1BA0-Z F03</b>
• For 4 axes	<b>6SL3054-0E□01-1BA0-Z F04</b>
• For 5 axes	<b>6SL3054-0E□01-1BA0-Z F05</b>
• For 6 axes	<b>6SL3054-0E□01-1BA0-Z F06</b>
<b>CompactFlash card for CU320-2 Control Unit with/without safety license</b>	
• With high output frequency <sup>1)</sup>	<b>6SL3054-0E□0□-1BA0-Z J01</b>
• With DCB Extension license (firmware V4.6 and higher) (further information about DCB Extension and license upgrades can be found under Drive Control Chart (DCC) in section Tools and Engineering)	<b>6SL3054-0E□0□-1BA0-Z U01</b>
<b>Firmware version</b>	↑
V4.7	<b>H</b>
V4.8	<b>J</b>
	↑
Without performance extension	<b>0</b>
With performance extension firmware option	<b>1</b>
<b>License upgrades</b>	
• <b>Performance Extension</b> including Certificate of License for additional licensing of a CompactFlash card	<b>6SL3074-0AA01-0AA0</b>
• <b>Safety Integrated Extended Functions</b> including Certificate of License License upgrade for one axis on a CompactFlash card. This option must be ordered once for each axis, e.g. a maximum of 6 for one CompactFlash card	<b>6SL3074-0AA10-0AA0</b>
• <b>High output frequency<sup>1)</sup></b> Upgrading license to enable high output frequencies above 550 Hz for all axes on a CompactFlash card	<b>6SL3074-0AA02-0AA0</b>
• <b>SINAMICS DCB Extension</b> including Certificate of License Runtime license as of firmware V 4.6 for upgrading the license on a CompactFlash card (see section Tools and Engineering, SINAMICS Drive Control Chart engineering software)	<b>6SL3077-0AA00-0AB0</b>

A firmware version of  $\geq 4.3$  is required for the CU320-2 Control Unit.

The current firmware version at the time of publication of this catalog is version 4.8.

<sup>1)</sup> For further information, see  
<https://support.industry.siemens.com/cs/document/104020669>

## More information

### Firmware version

The firmware version is encoded as follows in the article number printed on the CompactFlash card:

Article No.:	6SL3054-0□□□-1BA0	
Firmware version		↑
	4	E
	5	F
Version		↑
	.1	B
	.2	C
	.3	D
	.4	E
	.5	F
	.6	G
	.7	H
	.8	J
		↑
Without performance extension		0
With performance extension		1

A firmware version of  $\geq 4.3$  is required for the CU320-2 Control Unit.

The current firmware version at the time of publication of this catalog is version 4.8.

Firmware version 5.1 (6SL3054-1FB00-1BA0) scheduled for the end of 2017.

## SINAMICS S120 Chassis Format Converter Units

### System components

#### Control Units > CU310-2 Control Unit

##### Overview



CU310-2 PN and CU310-2 DP Control Units

The CU310-2 Control Unit for the communication and open-loop/closed-loop control functions of a Power Module is combined with the Power Module to create a powerful single-motor drive. A PROFINET (PN) variant and a PROFIBUS (DP) variant are available for fieldbus communication.

##### Design

CU310-2 Control Units feature the following interfaces as standard:

- Fieldbus interface
  - CU310-2 PN:
    - 1 PROFINET interface with 2 ports (RJ45 sockets) with PROFIdrive V4 profile
  - CU310-2 DP:
    - 1 PROFIBUS interface with PROFIdrive V4 profile
- 1 DRIVE-CLiQ socket to allow communication with other DRIVE-CLiQ nodes
- 1 encoder evaluation for evaluating the following encoder signals
  - Incremental encoder TTL/HTL
  - SSI encoders without incremental signals
- 6 parameterizable digital inputs (isolated) or alternatively 3 parameterizable, fail-safe digital inputs (isolated, can be used with firmware V4.5 and higher).  
The fail-safe digital inputs can be routed, i.e. they can be routed via PROFI-safe to a higher-level controller.
- 5 parameterizable digital inputs (floating)
- 1 digital output (isolated) or alternatively 1 parameterizable, fail-safe digital output (isolated, can be used with firmware V4.5 or higher)
- 8 parameterizable bidirectional digital inputs/digital outputs (non-floating)
- 1 analog input, either  $\pm 10$  V (resolution 12 bits + sign) or  $\pm 20$  mA (11 bits + sign)
- 1 Ethernet interface (RJ45 socket) for commissioning and diagnostics
- 1 serial RS232 interface
- 1 connection for the electronics power supply via the 24 V DC supply connector
- 1 temperature sensor input for KTY84-130, Pt1000 or PTC (Pt1000 can be used from firmware V4.7 HF17)
- 3 measuring sockets and one reference ground for commissioning support
- 1 slot for the CompactFlash card on which firmware and parameters are stored
- 1 PM-IF interface for communication with Power Modules in blocksize format
- 1 interface to the BOP20 Basic Operator Panel
- 1 PE connection

The status of the CU310-2 Control Unit is indicated via multi-color LEDs.

A BOP20 Basic Operator Panel can also be snapped directly onto the CU310-2 Control Unit for diagnostic procedures.

As the firmware and parameter settings are stored on a plug-in CompactFlash card, the Control Unit can be changed without the need for software tools.

# SINAMICS S120 Chassis Format Converter Units

## System components

Control Units &gt; CU310-2 Control Unit

### Selection and ordering data

Description	Article No.
<b>CU310-2 PN Control Unit</b> Without CompactFlash card	<b>6SL3040-1LA01-0AA0</b>
<b>CU310-2 DP Control Unit</b> Without CompactFlash card	<b>6SL3040-1LA00-0AA0</b>
<i>Accessories</i>	
<b>For CU310-2 PN:</b>	
<b>Industrial Ethernet FC</b>	
• RJ45 plug 180 (1 unit)	<b>6GK1901-1BB10-2AA0</b>
• RJ45 plug 180 (10 units)	<b>6GK1901-1BB10-2AB0</b>
• Stripping tool	<b>6GK1901-1GA00</b>
• Standard cable GP 2x2	<b>6XV1840-2AH10</b>
• Flexible cable GP 2x2	<b>6XV1870-2B</b>
• Trailing cable GP 2x2	<b>6XV1870-2D</b>
• Trailing cable 2x2	<b>6XV1840-3AH10</b>
• Marine cable 2x2	<b>6XV1840-4AH10</b>
<b>For CU310-2 DP:</b>	
<b>PROFIBUS connector</b>	
• <u>Without</u> PG/PC connection	<b>6ES7972-0BA42-0XA0</b>
• <u>With</u> PG/PC connection	<b>6ES7972-0BB42-0XA0</b>
<b>STARTER commissioning tool <sup>1)</sup></b> On DVD-ROM	<b>6SL3072-0AA00-0AG0</b>
<i>Accessories for re-ordering</i>	
<b>Dust protection blanking plugs</b> (50 units) For DRIVE-CLiQ port	<b>6SL3066-4CA00-0AA0</b>

For more information on connectors and cables, please refer to Catalog IK PI and the Siemens Industry Mall:  
[www.siemens.com/industrymall](http://www.siemens.com/industrymall)

### Integration

Power Modules in chassis format are controlled from the CU310-2 Control Unit via the DRIVE-CLiQ interface. Sensor Modules and Terminal Modules must be connected to the free DRIVE-CLiQ sockets of the Power Module.

With the BOP20 Basic Operator Panel, parameters can be changed directly on the device. The BOP20 Basic Operator Panel can also be snapped onto the CU310-2 Control Unit during operation to perform diagnostics.

The CU310-2 Control Unit and other connected components are commissioned and diagnosed with the STARTER commissioning tool.

A CU310-2 DP Control Unit communicates with the higher-level control system using PROFIBUS and the PROFIdrive V4 profile.

A CU310-2 PN Control Unit communicates with the higher-level control system using PROFINET IO and the PROFIdrive V4 profile.

The SINAMICS S120 drive system with the CU310-2 PN Control Unit then assumes the function of a PROFINET IO device and can perform the following functions:

- PROFINET IO device
- 100 Mbit/s full duplex
- Supports real-time classes of PROFINET IO:
  - RT (Real-Time)
  - IRT (Isochronous Real-Time), minimum send clock 250 µs
- Connects to controls as PROFINET IO devices using PROFIdrive compliant with Specification V4
- Standard TCP/IP communication for engineering processes using the STARTER commissioning tool
- Integrated 2-port switch with two RJ45 sockets based on the ERTEC ASIC. The optimum topology (line, star, tree) can therefore be configured without additional external switches.

A 24 V power supply must be connected to terminal X124 in order to use the digital outputs. To operate the CU310-2 Control Unit, a CompactFlash card with firmware V4.4 or higher is required.

<sup>1)</sup> For further information, see  
<https://support.industry.siemens.com/cs/document/104020669>

# SINAMICS S120 Chassis Format Converter Units

## System components

### Control Units > CU310-2 Control Unit

#### Integration (continued)

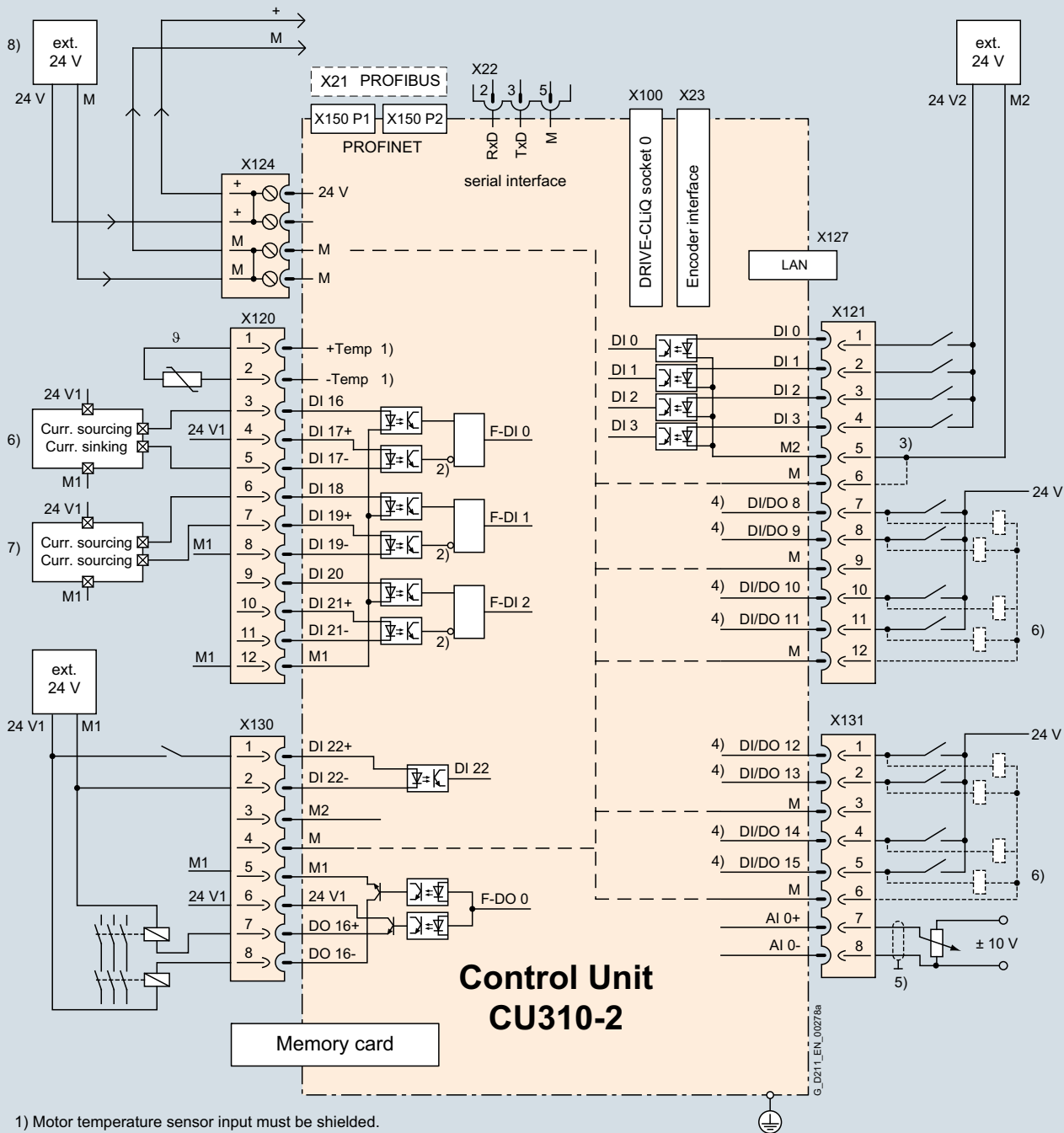

Connection example of CU310-2 Control Unit

3





## SINAMICS S120 Chassis Format Converter Units

### System components

#### Control Units > CompactFlash card for CU310-2

##### Overview



The CompactFlash card contains the firmware and set parameters. The CompactFlash card is plugged into the appropriate slot on the CU310-2 Control Unit.

##### Design

A CU310-2 Control Unit can perform the communication, open-loop and closed-loop control functions for one Power Module. The performance extension is not required in this case.

In addition to the firmware, the CompactFlash card also contains licensing codes which are required to enable firmware options.

In addition to the Article No., the following firmware options can currently be ordered:

- Safety Integrated Extended Functions, order code **F01**
- High output frequency, order code **J01**
- DCB Extension, order code **U01**

The firmware options can also be enabled subsequently. You will need the serial number of the CompactFlash card and the Article No. of the firmware option to be enabled. With this information, you can purchase the associated license code from a license database and enable the firmware option. The license code is only valid for the CompactFlash card declared and cannot be transferred to other CompactFlash cards.

Subsequent licensing is possible in the Internet via the WEB License Manager by generating a license key:  
[www.siemens.com/automation/license](http://www.siemens.com/automation/license)

##### Selection and ordering data

Description	Article No.
<b>CompactFlash card for CU310-2 Control Units without safety license</b>	<b>6SL3054-0E□00-1BA0</b>
<b>CompactFlash card for CU310-2 Control Units with safety license</b> • Including Certificate of License	<b>6SL3054-0E□00-1BA0-Z F01</b>
<b>CompactFlash card for CU310-2 Control Units with/without safety license</b> • With high output frequency <sup>1)</sup>	<b>6SL3054-0E□00-1BA0-Z J01</b>
• With DCB Extension license (firmware V4.6 and higher) (further information about DCB Extension and license upgrades can be found under Drive Control Chart (DCC) in section Tools and Engineering)	<b>6SL3054-0E□00-1BA0-Z U01</b>
<b>Firmware version</b>	↑
V4.7	<b>H</b>
V4.8	<b>J</b>
<b>License upgrades</b>	
• <b>Safety Integrated Extended Functions</b> including Certificate of License Upgrading license for one axis on a CompactFlash card	<b>6SL3074-0AA10-0AA0</b>
• <b>High output frequency</b> <sup>1)</sup> Upgrading license to enable high output frequencies above 550 Hz for all axes on a CompactFlash card	<b>6SL3074-0AA02-0AA0</b>

<sup>1)</sup> For further information, see  
<https://support.industry.siemens.com/cs/document/104020669>

# SINAMICS S120 Chassis Format Converter Units

## Supplementary system components

### BOP20 Basic Operator Panel

#### Overview



BOP20 Basic Operator Panel

Parameters can be set, diagnostics information (e.g. alarm and fault messages) read out and faults acknowledged using the BOP20 Basic Operator Panel.

#### Design

The BOP20 Basic Operator Panel has a backlit two-line display area with six keys.

The integrated plug connector on the rear of the BOP20 Basic Operator Panel provides its power and establishes communication with the Control Unit.

#### Selection and ordering data

Description	Article No.
<b>BOP20 Basic Operator Panel</b>	<b>6SL3055-0AA00-4BA0</b>

#### Integration

The BOP20 Basic Operator Panel can be inserted on the following Control Units:

- SINAMICS S120
  - CU310-2
  - CU320-2



CU310-2 PN Control Unit with inserted BOP20 Basic Operator Panel



CU320-2 PN Control Unit with inserted BOP20 Basic Operator Panel

## SINAMICS S120 Chassis Format Converter Units

### Supplementary system components

#### AOP30 Advanced Operator Panel

##### Overview



The AOP30 Advanced Operator Panel is an input/output device for converters of the SINAMICS series, preferably for cabinet installation.

It has the following characteristic curves:

- Graphical backlit LCD display for plain text display and a bar display of process variables
- LEDs for display of the operating states
- Help function describing causes of and remedies for faults and alarms
- Keypad for operational control of a drive
- Local/remote switchover for selecting the operating location (control priority assigned to operator panel or customer terminal block / communication channel)
- Numeric keypad for input of setpoint or parameter values
- Function keys for guided navigation in the menu
- Two-stage safety concept to protect against accidental or unauthorized changes to settings.
  - Operation of the drive from the operator panel can be disabled by the keyboard lock so that only parameter values and process variables can be displayed on the operator panel.
  - A password can be used to prevent the unauthorized modification of converter parameters.
- Front panel with degree of protection IP55

The AOP30 and SINAMICS drive communicate via the RS232 serial interface with PPI protocol.

The AOP30 may be omitted if the drive is only operated via PROFIBUS, for example, and no local display is required on the cabinet. The AOP30 can then be used simply for commissioning purposes and to obtain diagnostic information, in which case, it is plugged into the RS232 interface on the CU320-2 Control Unit. In this case, an external 24 V power supply (max. current requirement 200 mA) is required.

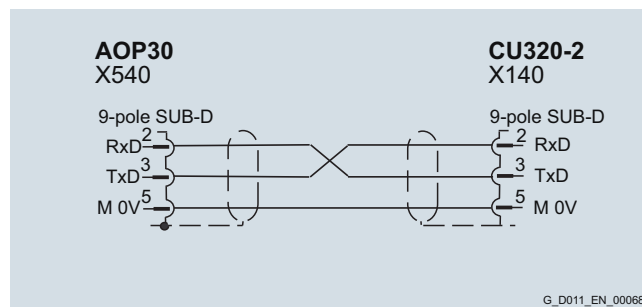

Assignment of the serial plug-in cable

##### Design

The AOP30 is an operator panel with graphical display and membrane keyboard. The device can be installed in a cabinet door which is between 2 mm and 4 mm thick.

Features:

- Display with green backlighting, resolution 240 × 64 pixels
- Membrane keyboard with 26 keys
- Connection for a 24 V power supply
- RS232 interface
- Time and date memory with internal battery backup
- 4 LEDs to indicate the operating state of the drive:
  - RUN green
  - ALARM yellow
  - FAULT red
  - Local/Remote green

##### Selection and ordering data

Description	Article No.
<b>AOP30 Advanced Operator Panel</b>	<b>6SL3055-0AA00-4CA5</b>
<b>Accessories</b>	
<b>RS232 plug-in cable</b> for connecting the AOP30 to the CU320-2	
1 m long	<b>6FX8002-1AA01-1AB0</b>
2 m long	<b>6FX8002-1AA01-1AC0</b>
3 m long	<b>6FX8002-1AA01-1AD0</b>
4 m long	<b>6FX8002-1AA01-1AE0</b>
5 m long	<b>6FX8002-1AA01-1AF0</b>
6 m long	<b>6FX8002-1AA01-1AG0</b>
7 m long	<b>6FX8002-1AA01-1AH0</b>
8 m long	<b>6FX8002-1AA01-1AJ0</b>
9 m long	<b>6FX8002-1AA01-1AK0</b>
10 m long	<b>6FX8002-1AA01-1BA0</b>

For the SINAMICS S120 Cabinet Modules, the AOP30 can be ordered as an option by specifying order code **K08**.

For the SINAMICS S150, the AOP30 Advanced Operator Panel is installed in the cabinet door as standard.

## SINAMICS S120 Chassis Format Converter Units

### Supplementary system components

#### AOP30 Advanced Operator Panel

##### Function

The current operating states, setpoints and actual values, parameters, indices, faults and alarms are displayed on the display panel.

German, English, French, Italian, Spanish and Chinese are stored on the CU320-2 Control Unit CompactFlash card as operator panel languages. The desired language must be downloaded to the AOP30 prior to commissioning.

In addition to these preinstalled languages, Russian and Portuguese (Brazil) are also available for subsequent installation. Further languages are available on request.

##### Integration

If just one CU320-2 Control Unit controls several power units (multi-motor drives) in the SINAMICS S120 drive system, the parameters, alarms and faults of all the connected devices can be simultaneously displayed and processed on the AOP30 Advanced Operator Panel.

##### Technical specifications

<b>AOP30 Advanced Operator Panel</b> 6SL3055-0AA00-4CA5	
<b>Power supply</b>	24 V DC (20.4 ... 28.8 V)
<b>Current requirement</b>	<ul style="list-style-type: none"> <li>• Without backlighting &lt; 100 mA</li> <li>• For max. backlighting &lt; 200 mA</li> </ul>
<b>Data interface</b>	RS232 interface, PPI protocol
<b>Backup battery</b>	3 V lithium CR2032
<b>Operating temperature</b>	0 ... 55 °C
<b>Storage and transport temperature</b>	-25 ... +70 °C
<b>Degree of protection</b>	IP20 for the inside of the cabinet IP55 for the outside of the cabinet
<b>Dimensions</b>	<ul style="list-style-type: none"> <li>• Width 212 mm</li> <li>• Height 156 mm</li> <li>• Depth 31 mm</li> </ul>
<b>Weight, approx.</b>	0.55 kg

## SINAMICS S120 Chassis Format Converter Units

Supplementary system components

### CBC10 Communication Board

#### Overview

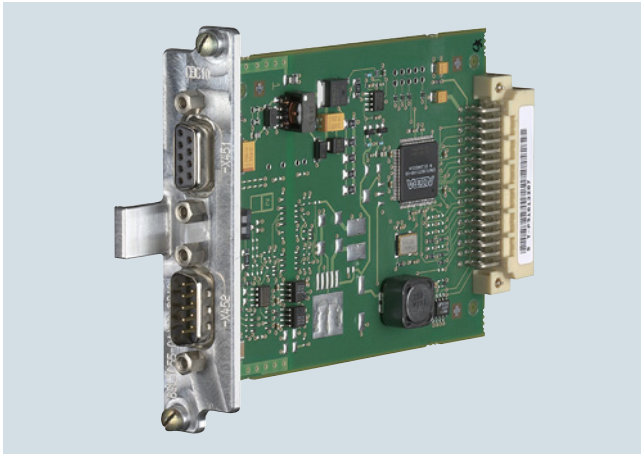

The CBC10 Communication Board is used to interface the CU320-2 Control Unit and therefore the drive system to the CAN (Controller Area Network) protocol. The board's driver software fulfills the standards of the following CANopen specification of the CiA organization (CAN in Automation):

- Communication profiles in accordance with DS 301
- Drive profile in accordance with DSP 402 (in this case Profile Velocity Mode)
- EDS (Electronic Data Sheet) in accordance with DSP 306
- Operational status signaling in accordance with DSP 305

#### Note:

The CAN address is set on the CU320-2 DP Control Unit by means of the two address switches. These address switches are not available on the CU320-2 PN Control Unit. In this case, the address can be set by means of parameters.

#### Integration

The CBC10 Communication Board plugs into the option slot on the CU320-2 Control Unit. Two SUB-D connections for input and output are provided for the CAN interface on the CBC10 Communication Board.

#### Selection and ordering data

Description	Article No.
<b>CBC10 Communication Board</b>	<b>6SL3055-0AA00-2CA0</b>

For the SINAMICS S150 and SINAMICS S120 Cabinet Modules, the CBC10 Communication Board can be ordered as an option by specifying order code **G20**.

#### Technical specifications

<b>CBC10 Communication Board</b> 6SL3055-0AA00-2CA0	
<b>Current requirement, max.</b> at 24 V DC via CU320-2 Control Unit	0.05 A
<b>Power loss, max.</b>	3 W
<b>Weight, approx.</b>	0.1 kg

# SINAMICS S120 Chassis Format Converter Units

## Supplementary system components

### CBE20 Communication Board

#### Overview



The CBE20 Communication Board can be used to connect to a PROFINET IO network via a CU320-2 Control Unit.

With the Communication Board CBE20, SINAMICS S120 and/or SINAMICS S150 is a PROFINET IO device in the sense of PROFINET and can perform the following functions:

- PROFINET IO device
- 100 Mbit/s full duplex
- Supports real-time classes of PROFINET IO:
  - RT (Real-Time)
  - IRT (Isochronous Real-Time), minimum send cycle 500  $\mu$ s
- Connection to control systems as PROFINET IO devices in accordance with PROFIdrive, Specification V4
- Standard TCP/IP communication for engineering processes using the STARTER commissioning tool
- Integrated 4-port switch with four RJ45 sockets based on the PROFINET ASIC ERTEC400. The optimum topology (line, star, tree) can therefore be configured without additional external switches
- Supports the functions "media redundancy" and "shared device"

The CBE20 Communication Board is required if:

- a SINAMICS S120 or SINAMICS S150 converter with a CU320-2 DP Control Unit (PROFIBUS) should be connected to a PROFINET-IO network
- SINAMICS Link is to be used to directly exchange data between several CU320-2 DP (PROFIBUS) or CU320-2 PN (PROFINET) Control Units without using a higher-level control system
- EtherNet/IP connectivity is required.

#### SINAMICS Link

SINAMICS Link can be used to directly exchange data between several CU320-2 DP (PROFIBUS) or CU320-2 PN (PROFINET) Control Units without using a higher-level control system. In this case, the CBE20 Communication Board is required. Possible applications for the SINAMICS Link include:

- Torque distribution for several drives
- Setpoint cascading for several drives
- Load distribution for drives coupled through a material web
- Couplings between SINAMICS G or SINAMICS S with the CU320-2 Control Unit and SINAMICS DC Master with CUD Control Units.

Participants other than CU320-2 Control Units and/or CUD Control Units of the SINAMICS DC Master cannot be integrated into this communication.

SINAMICS Link is activated by appropriately parameterizing the Control Units of the participants.

#### Selection and ordering data

Description	Article No.
<b>CBE20 Communication Board</b>	<b>6SL3055-0AA00-2EB0</b>

#### Accessories

##### Industrial Ethernet FC

• RJ45 Plug 180 (1 unit)	<b>6GK1901-1BB10-2AA0</b>
• RJ45 Plug 180 (10 units)	<b>6GK1901-1BB10-2AB0</b>
• Stripping tool	<b>6GK1901-1GA00</b>
• Standard cable GP 2x2	<b>6XV1840-2AH10</b>
• Flexible cable GP 2x2	<b>6XV1870-2B</b>
• Trailing cable GP 2x2	<b>6XV1870-2D</b>
• Trailing cable 2x2	<b>6XV1840-3AH10</b>
• Marine cable 2x2	<b>6XV1840-4AH10</b>

For more information on connectors and cables, please refer to Catalog IK PI and the Siemens Industry Mall:

[www.siemens.com/industrymall](http://www.siemens.com/industrymall)

For the SINAMICS S150 and SINAMICS S120 Cabinet Modules, the CBE20 Communication Board can be ordered as an option by specifying order code **G33**.

#### Integration

The CBE20 Communication Board plugs into the option slot on the CU320-2 Control Unit.

#### Technical specifications

<b>CBE20 Communication Board</b> 6SL3055-0AA00-2EB0	
<b>Current requirement</b> at 24 V DC	0.16 A
<b>Power loss</b>	2.4 W
<b>Weight, approx.</b>	0.1 kg

## SINAMICS S120 Chassis Format Converter Units

### Supplementary system components

#### DMC20 DRIVE-CLiQ Hub Module

##### Overview



The DMC20 DRIVE-CLiQ Hub Module is used to implement a star-shaped topology of a DRIVE-CLiQ line. Two DMC20 DRIVE-CLiQ Hub Modules can be connected in series (cascaded).

##### Design

The DMC20 DRIVE-CLiQ Hub Module in degree of protection IP20 is designed for mounting in control cabinets.

The following are located on the DMC20 DRIVE-CLiQ Hub Module:

- 6 DRIVE-CLiQ sockets for connecting 5 DRIVE-CLiQ devices
- 1 connection for the electronics power supply via the 24 V DC supply connector

The status of the DMC20 DRIVE-CLiQ Hub Module is indicated via a multi-color LED.

The DMC20 DRIVE-CLiQ Hub Module can be snapped onto a TH 35 standard mounting rail in accordance with EN 60715 (IEC 60715).

##### Selection and ordering data

Description	Article No.
<b>DMC20 DRIVE-CLiQ Hub Module</b> Without DRIVE-CLiQ cable	<b>6SL3055-0AA00-6AA1</b>
<i>Accessories for re-ordering</i>	
<b>Dust protection blanking plugs</b> (50 units) For DRIVE-CLiQ port	<b>6SL3066-4CA00-0AA0</b>

##### Technical specifications

<b>DMC20 DRIVE-CLiQ Hub Module</b> 6SL3055-0AA00-6AA1	
<b>Current requirement, max.</b> at 24 V DC without DRIVE-CLiQ supply	0.15 A
• Conductor cross-section, max.	2.5 mm <sup>2</sup>
<b>Degree of protection</b>	IP20
<b>Dimensions</b>	
• Width	30 mm
• Height	151 mm
• Depth	110 mm
<b>Weight, approx.</b>	0.36 kg
<b>Certificate of suitability</b>	cULus

## SINAMICS S120 Chassis Format Converter Units

### Supplementary system components

#### DMC20 DRIVE-CLiQ Hub Module

#### Integration

Signals from more than one encoder can be collected with one DRIVE-CLiQ Hub Module and forwarded to the Control Unit through a single DRIVE-CLiQ cable.

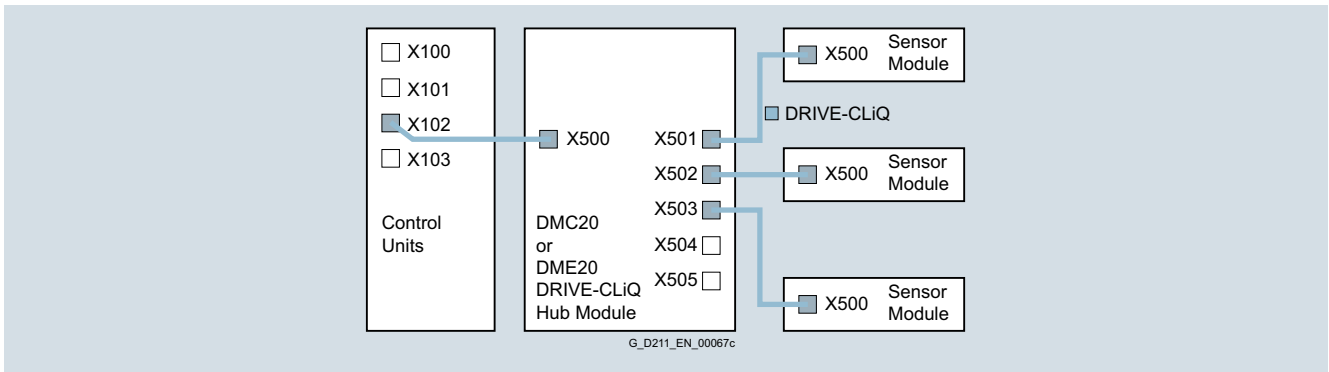

With a DRIVE-CLiQ Hub Module, individual DRIVE-CLiQ nodes can be removed without interrupting the data exchange with the remaining devices in the DRIVE-CLiQ line.

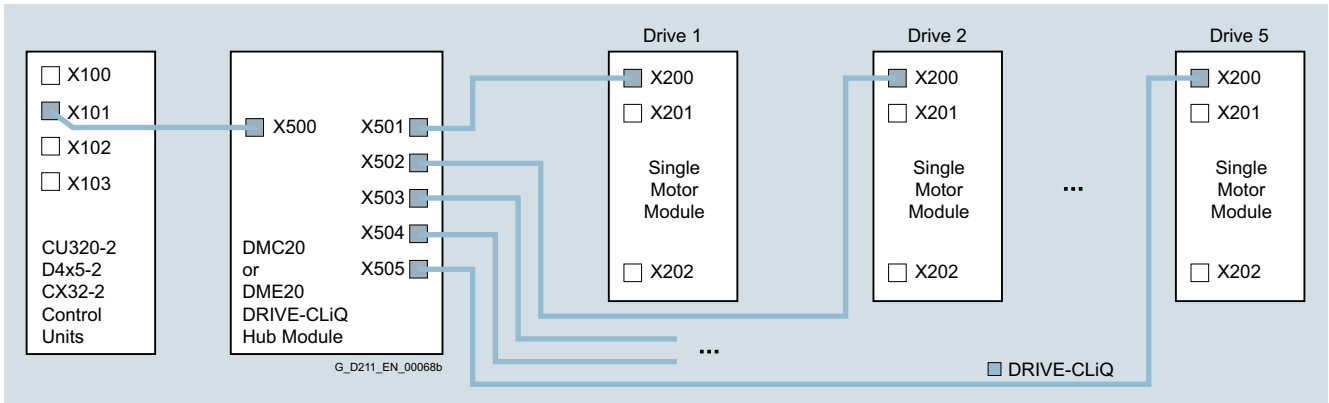



## SINAMICS S120 Chassis Format Converter Units

### Supplementary system components

#### DME20 DRIVE-CLiQ Hub Module

##### Overview



The DME20 DRIVE-CLiQ Hub Module is used to implement a star-shaped topology of a DRIVE-CLiQ line. Two DME20 DRIVE-CLiQ Hub Modules can be connected in series (cascaded).

##### Design

The following are located on the DME20 DRIVE-CLiQ Hub Module:

- 6 DRIVE-CLiQ sockets for connecting 5 DRIVE-CLiQ devices
- 1 connection for the electronics power supply via the 24 V DC circular supply connector with conductor cross-section  $4 \times 0.75 \text{ mm}^2$  (pins 1+2 internally bridged; pins 3+4 internally bridged)

The scope of supply of the DME20 DRIVE-CLiQ Hub Modules includes:

- 6 blanking plugs for sealing unused DRIVE-CLiQ sockets

##### Selection and ordering data

Description	Article No.
<b>DME20 DRIVE-CLiQ Hub Module</b> Without DRIVE-CLiQ cable; without electronics power supply cable and circular connector for 24 V DC	<b>6SL3055-0AA00-6AB0</b>
<b>Accessories</b>	
<b>24 V DC power supply cable</b>	
Ordering and delivery Phoenix Contact <a href="http://www.phoenixcontact.com">www.phoenixcontact.com</a>	
<ul style="list-style-type: none"> <li>• Shielded connector, 5-pole, can be assembled by the user</li> </ul>	Type No. 1508365
<ul style="list-style-type: none"> <li>• Unshielded connector, 4-pole, can be assembled by the user, Speedcon rapid interlock</li> </ul>	Type No. 1521601
<b>Accessories for re-ordering</b>	
<b>SINAMICS dust protection blanking plugs IP67</b> (6 units) For DRIVE-CLiQ port	<b>6SL3066-4CA01-0AA0</b>

##### Technical specifications

<b>DME20 DRIVE-CLiQ Hub Module</b> 6SL3055-0AA00-6AB0	
<b>Current requirement, max.</b> at 24 V DC without DRIVE-CLiQ supply	0.15 A
<ul style="list-style-type: none"> <li>• Conductor cross-section, max.</li> </ul>	$4 \times 0.75 \text{ mm}^2$
<b>Degree of protection</b>	IP67
<b>Dimensions</b>	
<ul style="list-style-type: none"> <li>• Width</li> <li>• Height</li> <li>• Depth</li> </ul>	99 mm 149 mm 55.7 mm (without connector)
<b>Weight, approx.</b>	0.8 kg
<b>Certificate of suitability</b>	cULus

# SINAMICS S120 Chassis Format Converter Units

## Supplementary system components

### DME20 DRIVE-CLiQ Hub Module

#### Integration

Signals from more than one encoder can be collected with one DRIVE-CLiQ Hub Module and forwarded to the Control Unit through a single DRIVE-CLiQ cable.

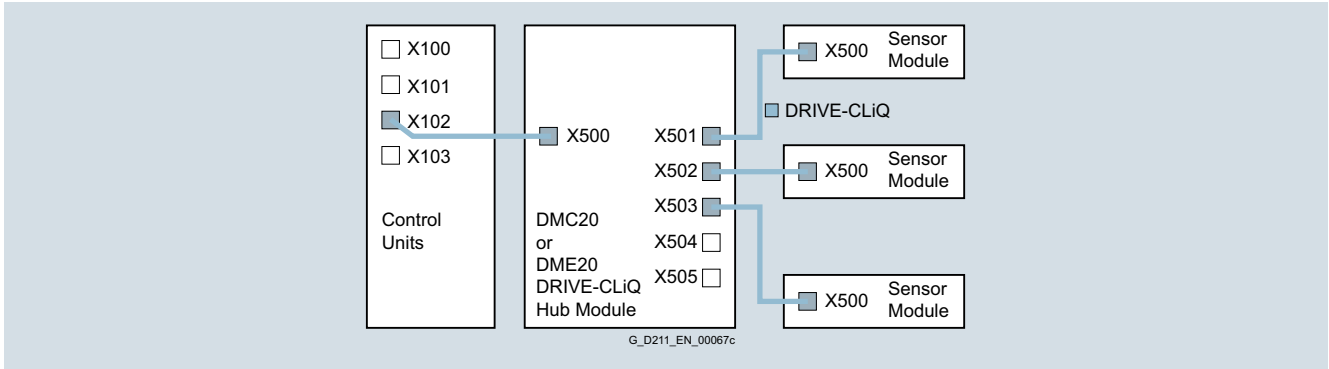

With a DRIVE-CLiQ Hub Module, individual DRIVE-CLiQ nodes can be removed without interrupting the data exchange with the remaining devices in the DRIVE-CLiQ line.

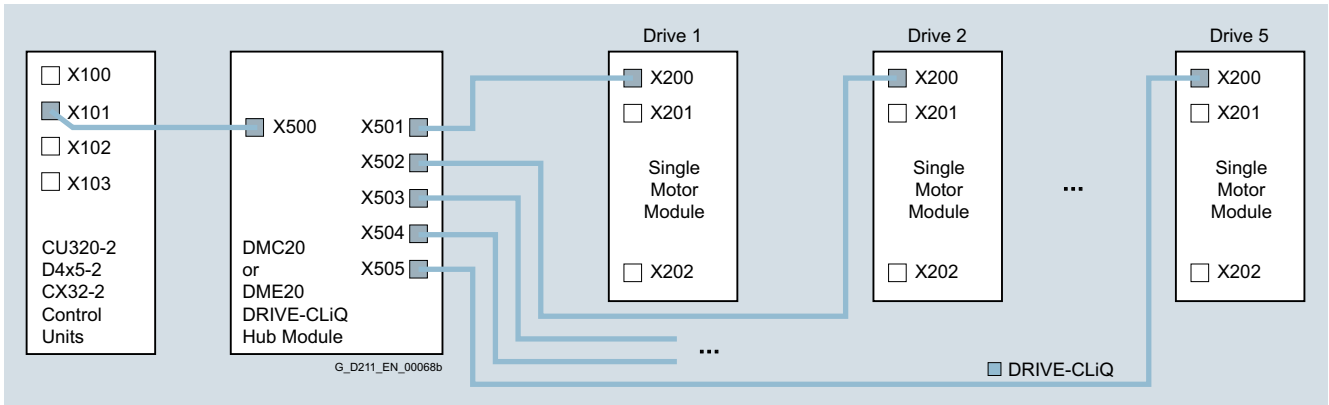

The DME20 DRIVE-CLiQ Hub Module in degree of protection IP67 is suitable for installation outside control cabinets.

## SINAMICS S120 Chassis Format Converter Units

### Supplementary system components

#### TB30 Terminal Board

##### Overview

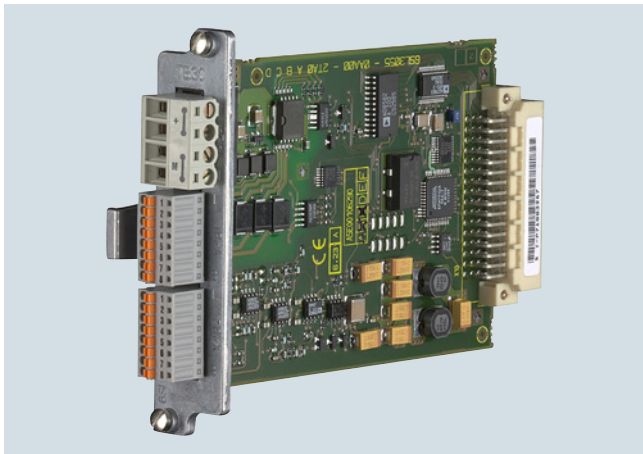

TB30 Terminal Board

The TB30 Terminal Board supports the addition of digital inputs/digital outputs and analog inputs/analog outputs to the CU320-2 Control Unit.

##### Design

The following are located on the TB30 Terminal Board:

- Power supply for digital inputs/digital outputs
- 4 digital inputs
- 4 digital outputs
- 2 analog inputs
- 2 analog outputs

A shield connection for the signal cable shield is located on the Control Unit.

##### Selection and ordering data

Description	Article No.
<b>TB30 Terminal Board</b>	<b>6SL3055-0AA00-2TA0</b>

For SINAMICS S150, the TB30 Terminal Board can be ordered as an option by specifying order code **G62**.

##### Technical specifications

<b>TB30 Terminal Board</b> 6SL3055-0AA00-2TA0	
<b>Current requirement, max.</b> at 24 V DC via CU320-2 Control Unit without taking account of digital outputs	0.05 A
<ul style="list-style-type: none"> <li>• Conductor cross-section, max.</li> <li>• Fuse protection, max.</li> </ul>	2.5 mm <sup>2</sup> 20 A
<b>Digital inputs</b> In accordance with IEC 61131-2 Type 1	
<ul style="list-style-type: none"> <li>• Voltage</li> <li>• Low level (an open digital input is interpreted as "low")</li> <li>• High level</li> <li>• Current consumption at 24 V DC, typ.</li> <li>• Delay time of digital inputs <sup>1)</sup>, approx.</li> <li>- L → H</li> <li>- H → L</li> <li>• Conductor cross-section, max.</li> </ul>	-3 ... +30 V -3 ... +5 V 15 ... 30 V 6 mA 50 μs 100 μs 0.5 mm <sup>2</sup>
<b>Digital outputs</b> (continuously short-circuit proof)	
<ul style="list-style-type: none"> <li>• Voltage</li> <li>• Load current per digital output, max.</li> <li>• Delay time of digital outputs <sup>1)</sup>, approx.</li> <li>• Conductor cross-section, max.</li> </ul>	24 V DC 500 mA 150 μs 0.5 mm <sup>2</sup>
<b>Analog inputs</b> (difference)	
<ul style="list-style-type: none"> <li>• Voltage range (an open analog input is interpreted as 0 V)</li> <li>• Internal resistance <math>R_i</math></li> <li>• Resolution <sup>2)</sup></li> <li>• Conductor cross-section, max.</li> </ul>	-10 ... +10 V 65 kΩ 13 bits + sign 0.5 mm <sup>2</sup>
<b>Analog outputs</b> (continuously short-circuit proof)	
<ul style="list-style-type: none"> <li>• Voltage range</li> <li>• Max. load current</li> <li>• Resolution</li> <li>• Settling time, approx.</li> <li>• Conductor cross-section, max.</li> </ul>	-10 ... +10 V -3 ... +3 mA 11 bits + sign 200 μs 0.5 mm <sup>2</sup>
<b>Power loss, max.</b>	3 W
<b>Weight, approx.</b>	0.1 kg

<sup>1)</sup> The specified delay times refer to the hardware. The actual reaction time depends on the time slot in which the digital input/output is processed.

<sup>2)</sup> If the analog input is to be operated in the signal processing sense with continuously variable input voltage, the sampling frequency  $f_a = 1/t_{\text{time slice}}$  must be at least twice the value of the highest signal frequency  $f_{\text{max}}$ .

# SINAMICS S120 Chassis Format Converter Units

## Supplementary system components

### TB30 Terminal Board

#### Integration

The TB30 Terminal Board is inserted in the slot to optionally expand the CU320-2 Control Unit.

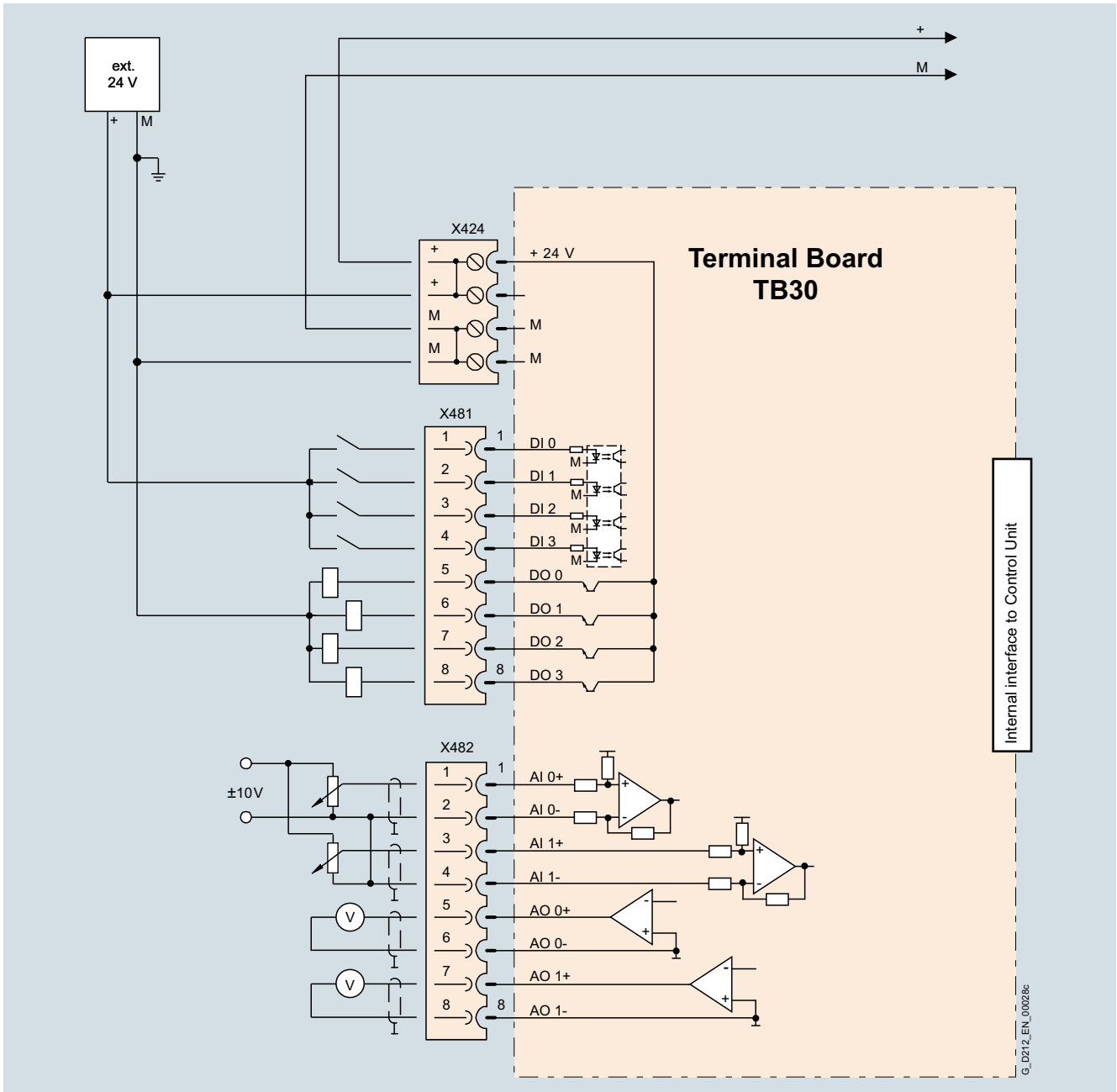

Connection example of a TB30 Terminal Board

## SINAMICS S120 Chassis Format Converter Units

### Supplementary system components

#### TM15 Terminal Module

##### Overview



The number of available digital inputs and outputs within a drive system can be expanded with the TM15 Terminal Module.

##### Design

The TM15 Terminal Module is equipped with the following:

- 24 bidirectional digital inputs/outputs (electrical isolation in 3 groups with 8 channels per group)
- 24 green status LEDs for indicating the logical signal state of the corresponding terminal
- 2 DRIVE-CLiQ sockets
- 1 connection for the electronics power supply via the 24 V DC power supply connector
- 1 PE connection

The status of the TM15 Terminal Module is indicated via a multi-color LED.

The TM15 Terminal Module can be snapped onto a TH 35 standard mounting rail in accordance with EN 60715 (IEC 60715).

The signal cable shield can be connected to the TM15 Terminal Module by means of a shield connection terminal, e.g. Phoenix Contact type SK8 or Weidmüller type KLBÜ CO 1. The shield connection terminal must not be used as a strain relief mechanism.

##### Selection and ordering data

Description	Article No.
<b>TM15 Terminal Module</b>	<b>6SL3055-0AA00-3FA0</b>
Without DRIVE-CLiQ cable	
<i>Accessories for re-ordering</i>	
<b>Dust protection blanking plugs</b> (50 units)	<b>6SL3066-4CA00-0AA0</b>
For DRIVE-CLiQ port	

##### Technical specifications

<b>TM15 Terminal Module</b> 6SL3055-0AA00-3FA0	
<b>Current requirement, max.</b> at 24 V DC without load	0.15 A
• Conductor cross-section, max.	2.5 mm <sup>2</sup>
• Fuse protection, max.	20 A
<b>Number of DRIVE-CLiQ sockets</b>	2
<b>I/O</b>	
• Digital inputs/outputs	Parameterizable channel-by-channel as DI or DO
• Number of digital inputs/outputs	24
• Isolation	Yes, in groups of 8
• Cables and connections	Plug-in screw-type terminals
• Conductor cross-section, max.	1.5 mm <sup>2</sup>
<b>Digital inputs</b>	
• Voltage	-30 ... +30 V
• Low level (an open digital input is interpreted as "low")	-30 ... +5 V
• High level	15 ... 30 V
• Current consumption at 24 V DC	9 mA
• Delay times of digital inputs, typ. <sup>1)</sup>	
- L → H	50 μs
- H → L	100 μs
<b>Digital outputs</b> (continuously short-circuit proof)	
• Voltage	24 V DC
• Load current per digital output, max.	0.5 A
• Delay times (resistive load) <sup>1)</sup>	
- L → H, typ.	50 μs
- L → H, max.	100 μs
- H → L, typ.	150 μs
- H → L, max.	225 μs
• Total current of outputs (per group), max.	
- To 60 °C	2 A
- To 50 °C	3 A
- To 40 °C	4 A
<b>Power loss, max.</b>	3 W
<b>PE connection</b>	M4 screw
<b>Dimensions</b>	
• Width	50 mm
• Height	150 mm
• Depth	111 mm
<b>Weight, approx.</b>	1 kg

<sup>1)</sup> The specified delay times refer to the hardware. The actual reaction time depends on the time slot in which the digital input/output is processed.

# SINAMICS S120 Chassis Format Converter Units

## Supplementary system components

### TM15 Terminal Module

#### Integration

The TM15 Terminal Module communicates with the CU310-2 or CU320-2 Control Unit via DRIVE-CLiQ.

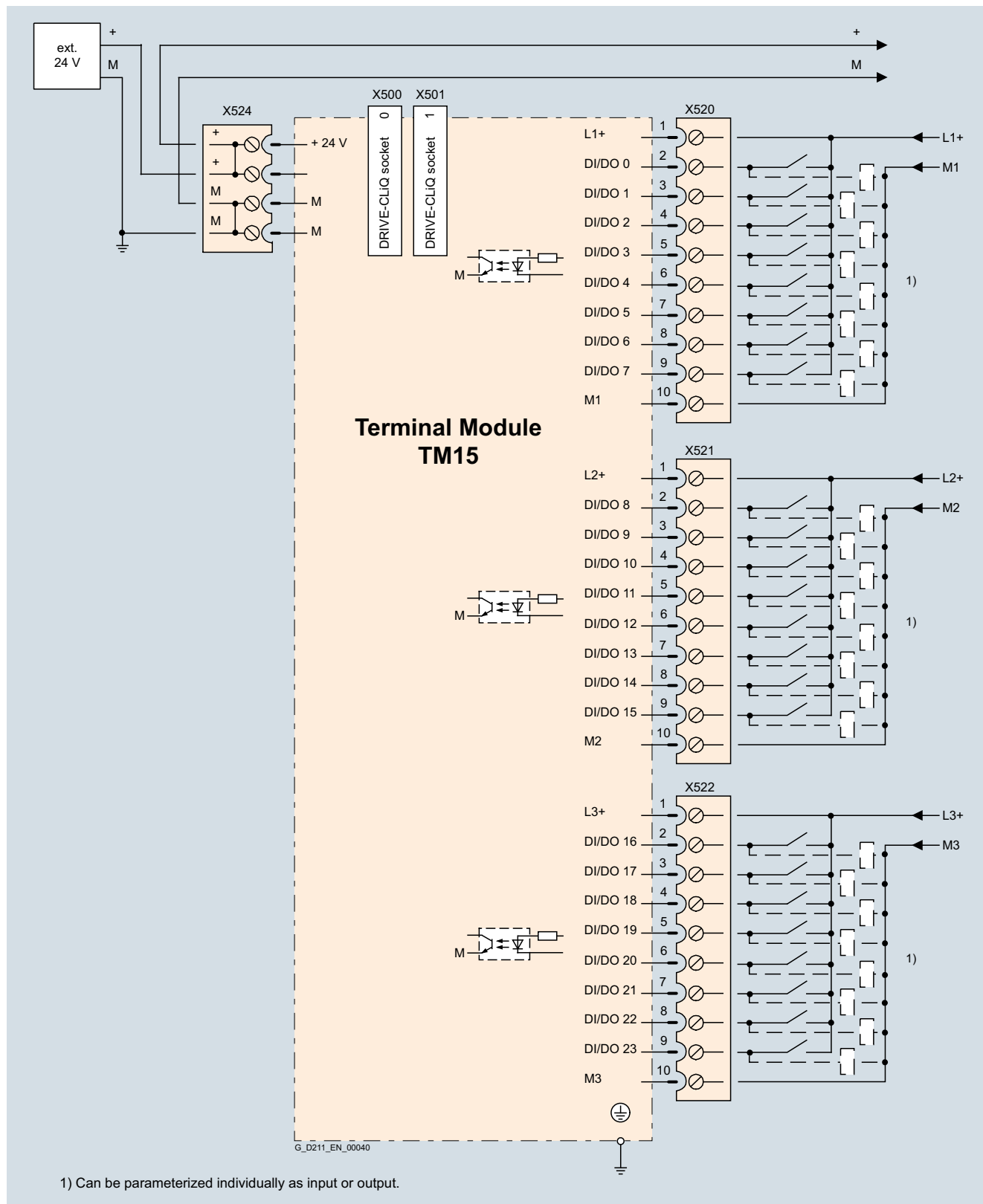

Connection example of TM15 Terminal Module

## SINAMICS S120 Chassis Format Converter Units

### Supplementary system components

#### TM31 Terminal Module

##### Overview



With the TM31 Terminal Module, the number of available digital inputs and outputs and the number of analog input and outputs within a drive can be expanded.

The TM31 Terminal Module also features relay outputs with changeover contact and a temperature sensor input.

##### Design

The following are located on the TM31 Terminal Module:

- 8 digital inputs
- 4 bidirectional digital inputs/outputs
- 2 relay outputs with changeover contact
- 2 analog inputs
- 2 analog outputs
- 1 temperature sensor input for KTY84-130, Pt1000 or PTC (Pt1000 can be used from firmware V4.7 HF17)
- 2 DRIVE-CLiQ sockets
- 1 connection for the electronics power supply via the 24 V DC supply connector
- 1 PE connection

The status of the TM31 Terminal Module is indicated via a multi-color LED.

The TM31 Terminal Module can be snapped onto a TH 35 standard mounting rail in accordance with EN 60715 (IEC 60715).

The signal cable shield can be attached to the TM31 Terminal Module via a shield connection terminal, e.g. type SK8 supplied by Phoenix Contact or type KLBÜ CO 1 supplied by Weidmüller. The shield connection terminal must not be used as a strain relief mechanism.

##### Selection and ordering data

Description	Article No.
<b>TM31 Terminal Module</b> Without DRIVE-CLiQ cable	<b>6SL3055-0AA00-3AA1</b>
<i>Accessories for re-ordering</i>	
<b>Dust protection blanking plugs</b> (50 units) For DRIVE-CLiQ port	<b>6SL3066-4CA00-0AA0</b>

For the SINAMICS S150 and SINAMICS S120 Cabinet Modules, the TM31 Terminal Module can be ordered as an option by specifying order code **G60** or **G61**.

# SINAMICS S120 Chassis Format Converter Units

## Supplementary system components

### TM31 Terminal Module

#### Technical specifications

<b>TM31 Terminal Module</b> 6SL3055-0AA00-3AA1	
<b>Current requirement, max.</b> At 24 V DC without taking account of the digital outputs and DRIVE-CLiQ supply	0.5 A
• Conductor cross-section, max.	2.5 mm <sup>2</sup>
• Fuse protection, max.	20 A
<b>Digital inputs</b> In accordance with IEC 61131-2 Type 1	
• Voltage	-3 ... +30 V
• Low level (an open digital input is interpreted as "low")	-3 ... +5 V
• High level	15 ... 30 V
• Current consumption at 24 V DC, typ.	9 mA
• Delay times of digital inputs <sup>1)</sup> , approx.	
- L → H	50 μs
- H → L	100 μs
• Conductor cross-section, max.	1.5 mm <sup>2</sup>
<b>Digital outputs</b> (continuously short-circuit proof)	
• Voltage	24 V DC
• Load current per digital output, max.	100 mA
• Total current of digital outputs, max.	400 mA
• Delay times of digital outputs <sup>1)</sup>	
- Typ.	150 μs with 0.5 A resistive load
- Max.	500 μs
• Conductor cross-section, max.	1.5 mm <sup>2</sup>
<b>Analog inputs</b> (a switch is used to toggle between voltage and current input)	
• As voltage input	
- Voltage range	-10 ... +10 V
- Internal resistance $R_i$	100 kΩ
- Resolution <sup>2)</sup>	11 bits + sign
• As current input	
- Current ranges	4 ... 20 mA, -20 ... +20 mA, 0 ... 20 mA
- Internal resistance $R_i$	250 Ω
- Resolution <sup>2)</sup>	10 bits + sign
• Conductor cross-section, max.	1.5 mm <sup>2</sup>

<b>TM31 Terminal Module</b> 6SL3055-0AA00-3AA1	
<b>Analog outputs</b> (continuously short-circuit proof)	
• Voltage range	-10 ... +10 V
• Max. load current	-3 ... +3 mA
• Current ranges	4 ... 20 mA, -20 ... +20 mA, 0 ... 20 mA
• Load resistance, max.	500 Ω in the range -20 ... +20 mA
• Resolution	11 bits + sign
• Conductor cross-section, max.	1.5 mm <sup>2</sup>
<b>Relay outputs</b> (CO contacts)	
• Max. load current	8 A
• Operational voltage, max.	250 V AC, 30 V DC
• Switching capacity, max.	
- At 250 V AC	2000 VA (cos φ = 1) 750 VA (cos φ = 0.4)
- At 30 V DC	240 W (resistive load)
• Required minimum current	100 mA
• Conductor cross-section, max.	2.5 mm <sup>2</sup>
<b>Power loss, max.</b>	10 W
<b>PE connection</b>	M4 screw
<b>Dimensions</b>	
• Width	50 mm
• Height	150 mm
• Depth	111 mm
<b>Weight, approx.</b>	0.49 kg

<sup>1)</sup> The specified delay times refer to the hardware. The actual reaction time depends on the time slot in which the digital input/output is processed.

<sup>2)</sup> If the analog input is to be operated in the signal processing sense with continuously variable input voltage, the sampling frequency  $f_a = 1/t_{\text{time slice}}$  must be at least twice the value of the highest signal frequency  $f_{\text{max}}$ .



# SINAMICS S120 Chassis Format Converter Units

## Supplementary system components

### TM31 Terminal Module

#### Integration

The TM31 Terminal Module communicates with the CU310-2 or CU320-2 Control Unit via DRIVE-CLiQ.

3

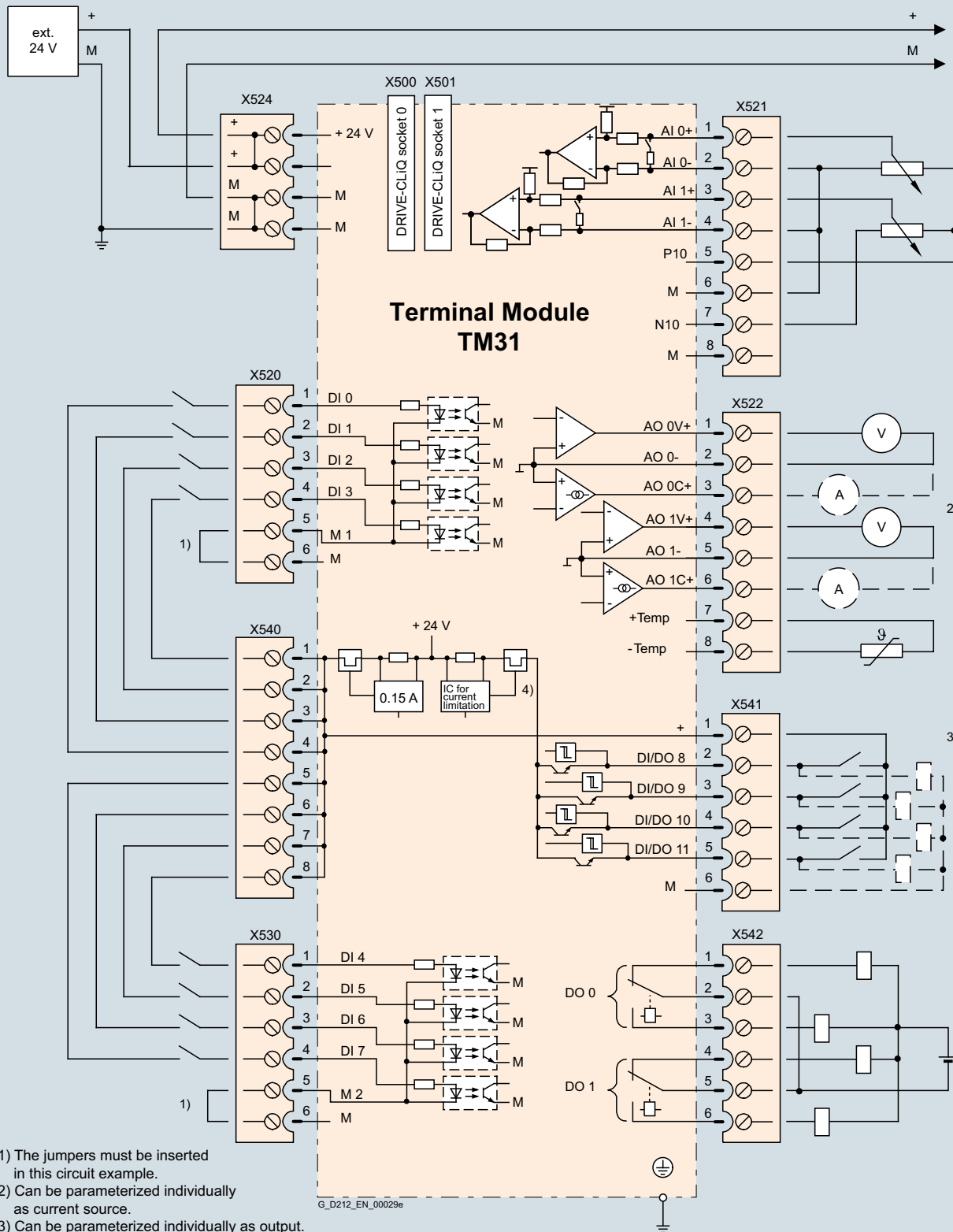

- 1) The jumpers must be inserted in this circuit example.
- 2) Can be parameterized individually as current source.
- 3) Can be parameterized individually as output.
- 4) Current limitation can be parameterized (0.1 A or 1 A)

Connection example of TM31 Terminal Module

# SINAMICS S120 Chassis Format Converter Units

## Supplementary system components

### TM41 Terminal Module

#### Overview

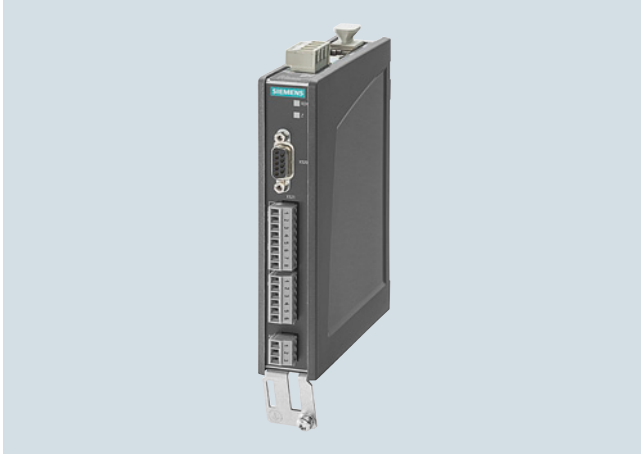

The TM41 Terminal Module supplies TTL signals which emulate an incremental encoder, e.g. to a higher-level control. The encoder interface (incremental encoder emulation) can be linked to an encoder signal from the Control Unit, e.g. incremental encoder sin/cos, by parameter assignment.

The TM41 Terminal Module increases the number of digital inputs/outputs and analog inputs that are available in the drive system.

#### Design

The following are located on the TM41 Terminal Module:

- 4 bidirectional digital inputs/outputs
- 4 digital inputs (with electrical isolation)
- 1 analog input
- 1 interface for emulation of TTL incremental encoder (RS422)
- 1 LED for signaling zero mark detection for encoder interface
- 2 DRIVE-CLiQ sockets
- 1 connection for the electronics power supply and to supply the digital outputs via the 24 V DC power supply connector
- 1 PE connection

The status of the TM41 Terminal Module is indicated via a multi-color LED.

An LED next to the interface for TTL pulse encoder emulation is illuminated as soon as a zero mark is detected.

The TM41 Terminal Module can be snapped onto a TH 35 standard mounting rail in accordance with EN 60715 (IEC 60715).

The signal cable shield can be attached to the TM41 Terminal Module via a shield connection terminal, e.g. type SK8 supplied by Phoenix Contact or type KLBÜ CO 1 supplied by Weidmüller. The shield connection terminal must not be used as a strain relief mechanism.

#### Selection and ordering data

Description	Article No.
<b>TM41 Terminal Module</b>	<b>6SL3055-0AA00-3PA1</b>
Without DRIVE-CLiQ cable	
<i>Accessories for re-ordering</i>	
<b>Dust protection blanking plugs</b> (50 units)	<b>6SL3066-4CA00-0AA0</b>
For DRIVE-CLiQ port	

# SINAMICS S120 Chassis Format Converter Units

## Supplementary system components

### TM41 Terminal Module

#### Technical specifications

<b>TM41 Terminal Module</b> 6SL3055-0AAA00-3PA1	
<b>Current requirement</b> (X524 at 24 V DC) without DRIVE-CLiQ supply or digital outputs (X514)	0.5 A
• Conductor cross-section, max.	2.5 mm <sup>2</sup>
• Fuse protection, max.	20 A
<b>I/O</b>	
• Digital inputs/outputs	Individually parameterizable as DI or DO
• Number of digital inputs/outputs	4
• Number of digital input/outputs (with isolation)	4
• Cables and connections	Plug-in screw-type terminals
• Conductor cross-section, max.	1.5 mm <sup>2</sup>
<b>Digital inputs</b>	
• Voltage	
- Without electrical isolation	-3 ... +30 V
- With electrical isolation	-30 ... +30 V
• Low level (an open digital input is interpreted as "low")	
- Without electrical isolation	-3 ... +5 V
- With electrical isolation	-30 ... +5 V
• High level	15 ... 30 V
• Current consumption at 24 V DC, typ.	<9 mA
• Delay times of digital inputs, max. <sup>1)</sup>	
- L → H	3 ms
- H → L	3 ms
<b>Digital outputs</b> (continuously short-circuit proof)	
• Voltage	24 V DC
• Load current per digital output, max.	0.5 A
• Delay times (resistive load) <sup>1)</sup>	
- L → H, typ.	50 μs
- L → H, max.	100 μs
- H → L, typ.	75 μs
- H → L, max.	150 μs
<b>Analog input</b> (difference)	
• Voltage range	-10 ... +10 V
• Internal resistance	≥100 kΩ
• Resolution <sup>2)</sup>	12 bits + sign

<b>TM41 Terminal Module</b> 6SL3055-0AAA00-3PA1	
<b>Pulse encoder emulation</b>	
• Level	TTL (RS422), A+, A-, B+, B-, zero track N+, N-
• Limit frequency $f_{max}$ .	512 kHz
• Ratio Encoder pulses : Encoder emulation	Any number of ratio/reduction ratio of pulses
<b>Power loss, max.</b>	12 W
<b>PE connection</b>	M4 screw
<b>Dimensions</b>	
• Width	30 mm
• Height	151 mm
• Depth	110 mm
<b>Weight, approx.</b>	0.32 kg

<sup>1)</sup> The specified delay times refer to the hardware. The actual reaction time depends on the time slot in which the digital input/output is processed.

<sup>2)</sup> If the analog input is to be operated in the signal processing sense with continuously variable input voltage, the sampling frequency  $f_a = 1/t_{\text{time slice}}$  must be at least twice the value of the highest signal frequency  $f_{max}$ .

# SINAMICS S120 Chassis Format Converter Units

## Supplementary system components

### TM41 Terminal Module

#### Integration

The TM41 Terminal Module communicates with the CU310-2 or CU320-2 Control Unit via DRIVE-CLiQ.

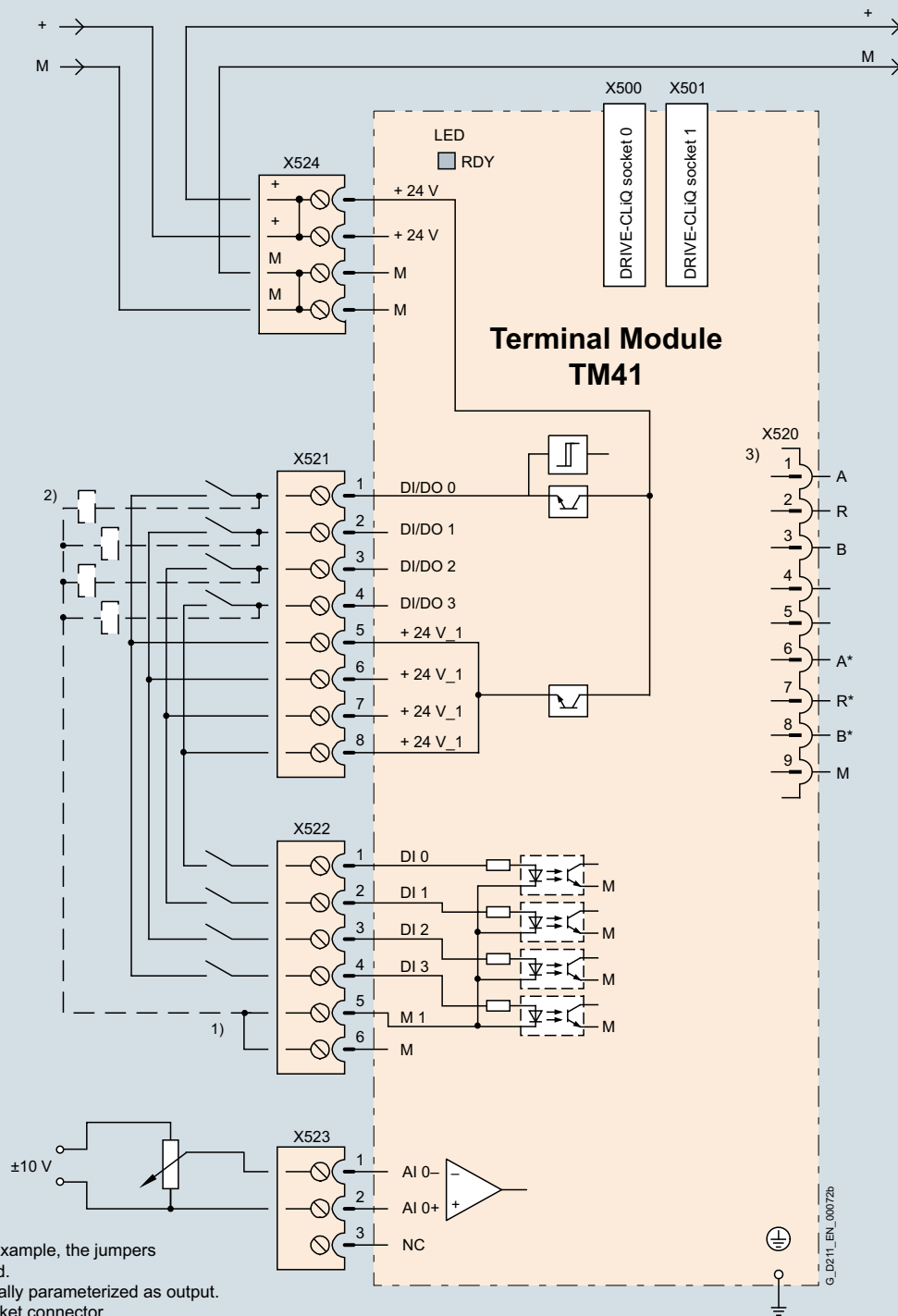

Connection example of TM41 Terminal Module

3

## SINAMICS S120 Chassis Format Converter Units

### Supplementary system components

#### TM54F Terminal Module

##### Overview



The TM54F Terminal Module is a dual-processor I/O interface with four fail-safe digital outputs and ten fail-safe digital inputs for utilization of the Safety Integrated functions of the SINAMICS S120 drive system via external actuators and sensors.

Every available safety function integrated in the drive can be controlled via the fail-safe digital inputs on the TM54F Terminal Module. In the event that the parameterized safety functions of several drives operated together on a Control Unit are to be executed together, then these drives can be grouped in the TM54F Terminal Module. The advantage of this approach is that only one fail-safe digital input needs to be connected for these drives.

The fail-safe digital inputs and outputs have two channels and are redundantly configured with an internal data cross-check using the two processors. A fail-safe digital output consists of one P-switching and one M-switching output as well as one digital input to read back the switching state. A fail-safe digital input consists of two digital inputs.

Safety sensors can be connected over two switchable 24 V sensor supplies and can be evaluated over the fail-safe digital inputs. The switchable 24 V sensor supply ensures that the fail-safe digital inputs can be dynamized to detect dormant errors (this dynamization is used to check the shutdown paths). An unswitchable 24 V sensor supply is additionally provided by the TM54F Terminal Module for connecting undynamizable safety sensors.

The TM54F Terminal Module must be directly connected to a Control Unit via a DRIVE-CLiQ cable. Only one TM54F Terminal Module can be assigned to each Control Unit. It is not permissible to make the TM54F connection via another DRIVE-CLiQ device, e.g. a Motor Module or a Line Module.

##### Design

The following are located on the TM54F Terminal Module:

- 4 fail-safe digital outputs
- 10 fail-safe digital inputs
- 4 LEDs, single color for indicating the status of the read back channel of the fail-safe digital outputs
- 4 LEDs, dual-color for indicating the status of the fail-safe digital outputs
- 20 LEDs, dual-color for indicating the status of the fail-safe digital inputs
- 3 LEDs, single color for indicating the status of the 24 V sensor supplies
- 2 DRIVE-CLiQ sockets
- 2 connections for 24 V sensor supply, switchable
- 1 connection for 24 V sensor supply, not switchable
- 1 connection for the electronics power supply via the 24 V DC power supply connector
- 1 connection for the 24 V power supply to digital outputs and sensors
- 1 PE connection

The status of the TM54F Terminal Module is indicated via a multi-color LED.

The TM54F Terminal Module can be snapped onto a TH 35 standard mounting rail in accordance with EN 60715 (IEC 60715).

The signal cable shield can be attached to the TM54F Terminal Module via a shield connection terminal, e.g. type SK8 supplied by Phoenix Contact or type KLBÜ CO 1 supplied by Weidmüller. The shield connection terminal must not be used as a strain relief mechanism.

Pins for connector coding are included in the TM54F Terminal Module scope of supply.

##### Selection and ordering data

Description	Article No.
<b>TM54F Terminal Module</b> Without DRIVE-CLiQ cable	<b>6SL3055-0AA00-3BA0</b>
<i>Accessories for re-ordering</i>	
<b>Dust protection blanking plugs</b> (50 units) For DRIVE-CLiQ port	<b>6SL3066-4CA00-0AA0</b>

For the SINAMICS S150 and SINAMICS S120 Cabinet Modules, the TM54F Terminal Module can be ordered as an option by specifying order code **K87**.

# SINAMICS S120 Chassis Format Converter Units

## Supplementary system components

### TM54F Terminal Module

#### Technical specifications

<b>TM54F Terminal Module</b> 6SL3055-0AA00-3BA0	
<b>Current requirement</b> (X524 at 24 V DC) without DRIVE-CLiQ supply	0.2 A
• Conductor cross-section, max.	2.5 mm <sup>2</sup>
• Fuse protection, max.	20 A
<b>Max. current requirement ext. 24 V</b> for supplying the digital outputs and 24 V sensor supply (X514 at 24 V DC)	4 A
• Conductor cross-section, max.	2.5 mm <sup>2</sup>
• Fuse protection, max.	20 A
<b>I/O</b>	
• Number of fail-safe digital inputs	10
• Number of fail-safe digital outputs	4
• 24 V sensor supply	3, of which 2 can be temporarily shut down using an internal test routine for dynamizing fail-safe digital inputs, current carrying capacity 0.5 A each
• Cables and connections	Plug-in screw-type terminals
• Conductor cross-section, max.	1.5 mm <sup>2</sup>
<b>Digital inputs</b> in accordance with IEC 61131-2 Type 1, with galvanic isolation	
• Voltage	-3 ... +30 V
• Low level (an open digital input is interpreted as "low")	-3 ... +5 V
• High level	15 ... 30 V
• Current consumption at 24 V DC, typ.	>3.2 mA
• Delay time of digital inputs, approx. <sup>1)</sup>	
- L → H, typ.	30 μs
- H → L, typ.	60 μs
• Safe state	Low level (for inputs that can be inverted: without inversion)
<b>Digital outputs</b> sustained-short-circuit-proof	
• Voltage	24 V DC
• Load current per fail-safe digital output, max. <sup>2)</sup>	0.5 A
• Delay times (resistive load) <sup>1)</sup>	
- L → H, typ.	300 μs
- H → L, typ.	350 μs
• Safe state	Output switched off

<b>TM54F Terminal Module</b> 6SL3055-0AA00-3BA0	
<b>Scanning cycle <math>t_{SI}</math></b> for fail-safe digital inputs or fail-safe digital outputs	4 ... 25 ms (adjustable)
<b>Power loss, max.</b>	4.5 W at 24 V
<b>PE connection</b>	M4 screw
<b>Dimensions</b>	
• Width	50 mm
• Height	151 mm
• Depth	110 mm
<b>Weight, approx.</b>	0.9 kg
<b>Safety Integrated</b>	Safety Integrity Level 2 (SIL2) acc. to IEC 61508, Performance Level d (PLd) acc. to EN ISO 13849-1 and Control Category 3 acc. to EN ISO 13849-1

<sup>1)</sup> The specified delay times refer to the hardware. The actual reaction time depends on the time slot in which the digital input/output is processed.

<sup>2)</sup> The total current of all fail-safe digital outputs must not exceed 5.33 A.

# SINAMICS S120 Chassis Format Converter Units

## Supplementary system components

### TM54F Terminal Module

#### Integration

The TM54F Terminal Module communicates with the CU310-2 or CU320-2 Control Unit via DRIVE-CLiQ.

3

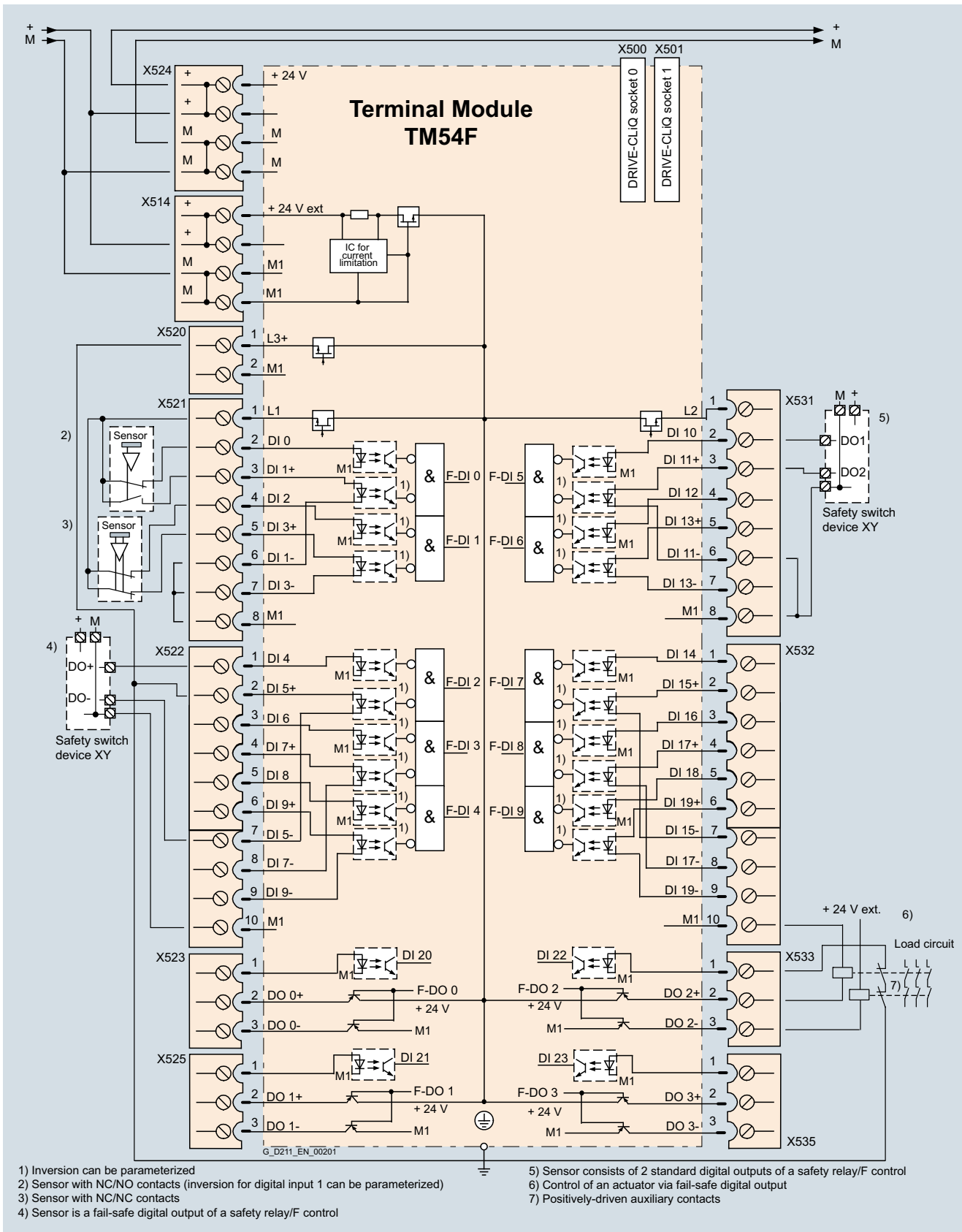

Connection example of TM54F Terminal Module

# SINAMICS S120 Chassis Format Converter Units

## Supplementary system components

### TM120 Terminal Module

#### Overview



Four temperature sensors can be evaluated via the TM120 Terminal Module. The temperature sensor inputs are safely electrically isolated from the evaluation electronics in the TM120 Terminal Module and are suitable for evaluating the temperature of special motors, e.g. SIMOTICS L-1FN linear motors and SIMOTICS T-1FW6 built-in torque motors.

#### Design

The following are located on the TM120 Terminal Module:

- 4 temperature sensor inputs for KTY84-130, Pt1000 or PTC (Pt1000 can be used from firmware V4.7 HF17)
- 2 DRIVE-CLiQ sockets
- 1 connection for the electronics power supply via the 24 V DC supply connector
- 1 PE connection

The status of the TM120 Terminal Module is indicated via a multi-color LED.

The TM120 Terminal Module can be snapped onto a TH 35 standard mounting rail in accordance with EN 60715 (IEC 60715).

#### Selection and ordering data

Description	Article No.
<b>TM120 Terminal Module</b> Without DRIVE-CLiQ cable	<b>6SL3055-0AA00-3KA0</b>
<i>Accessories for re-ordering</i>	
<b>Dust protection blanking plugs</b> (50 units) For DRIVE-CLiQ port	<b>6SL3066-4CA00-0AA0</b>

#### Technical specifications

<b>TM120 Terminal Module</b> 6SL3055-0AA00-3KA0	
<b>Current requirement, max.</b> at 24 V DC	0.5 A
• Conductor cross-section, max.	2.5 mm <sup>2</sup>
• Fuse protection, max.	20 A
<b>Temperature sensor inputs</b>	
The inputs can be individually parameterized to evaluate sensors of type KTY84-130, Pt1000, PTC or temperature switches	
• Conductor cross-section	0.2 ... 6 mm <sup>2</sup>
• Constant current per sensor, approx.	2 mA
• Safe electrical separation up to line voltage, max.	480 V AC
<b>Power loss, typically</b>	2.4 W
<b>PE connection</b>	M4 screw
<b>Dimensions</b>	
• Width	30 mm
• Height	150 mm
• Depth	111 mm
<b>Weight, approx.</b>	0.41 kg



## SINAMICS S120 Chassis Format Converter Units

### Supplementary system components

#### TM120 Terminal Module

#### Integration

The TM120 Terminal Module communicates with the CU310-2 or CU320-2 Control Unit via DRIVE-CLiQ.

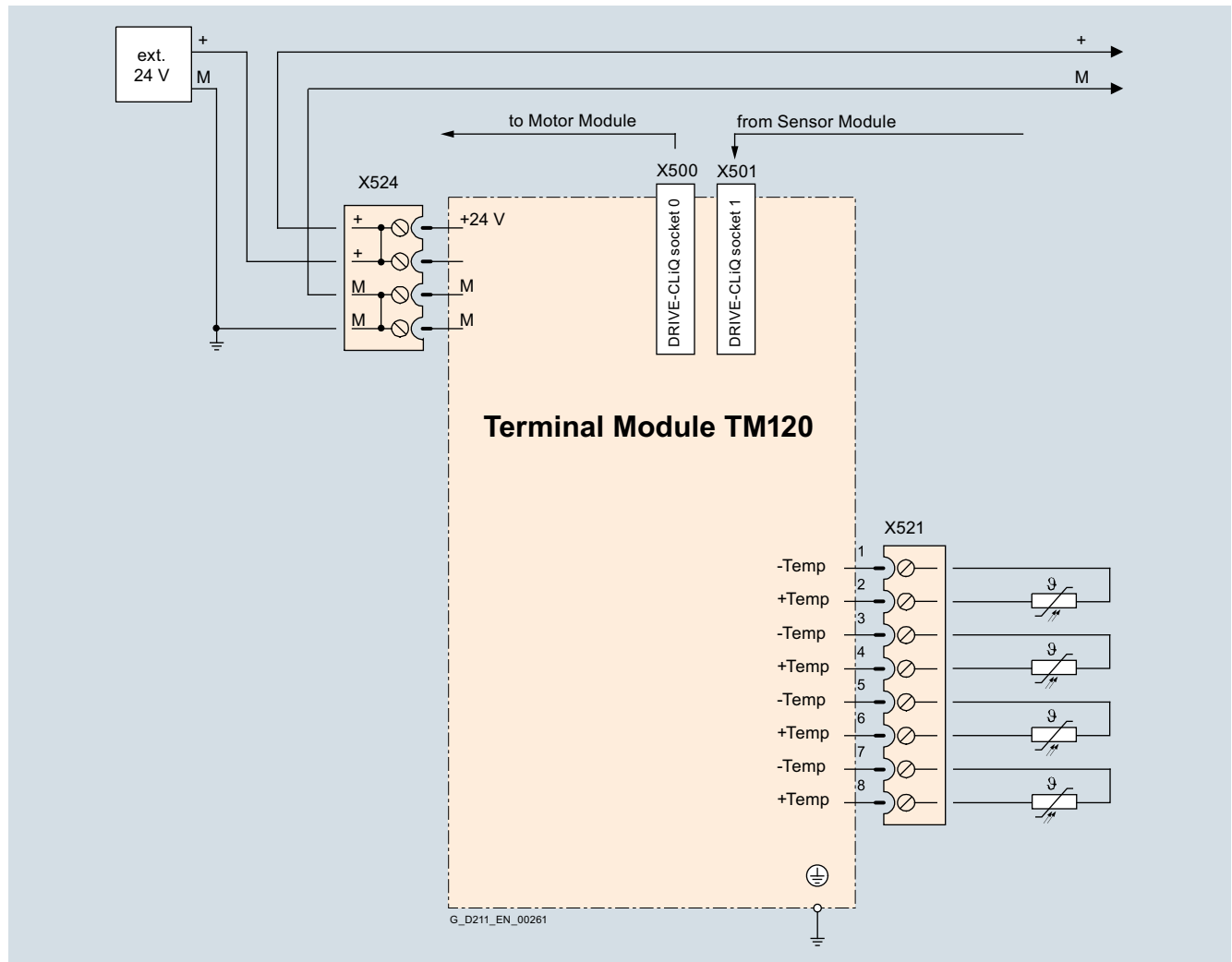

Example connection of TM120 Terminal Module

# SINAMICS S120 Chassis Format Converter Units

## Supplementary system components

### TM150 Terminal Module

#### Overview



The TM150 Terminal Module is a DRIVE-CLiQ component for temperature evaluation. The temperature is measured in a temperature range from -99 °C to +250 °C for the following temperature sensors:

- Pt100 (with monitoring for wire breakage and short-circuit)
- Pt1000 (with monitoring for wire breakage and short-circuit, can be used from firmware V4.7 HF17)
- KTY84 (with monitoring for wire breakage and short-circuit)
- PTC (with short-circuit monitoring)
- Bimetallic NC contact (without monitoring)

For the temperature sensor inputs, for each terminal block the evaluation can be parameterized for 1×2-wire, 2×2-wire, 3-wire or 4-wire. There is no galvanic isolation in the TM150 Terminal Module.

The temperature channels of a TM150 can be subdivided into 3 groups and evaluated together.

#### Design

The following are located on the TM150 Terminal Module:

- 6 ... 12 temperature sensor inputs
- 2 DRIVE-CLiQ sockets
- 1 connection for the electronics power supply via the 24 V DC supply connector
- 1 PE connection

The status of the TM150 Terminal Module is indicated via a multi-color LED.

The TM150 Terminal Module can be snapped onto a TH 35 standard mounting rail in accordance with EN 60715 (IEC 60715).

#### Selection and ordering data

Description	Article No.
<b>TM150 Terminal Module</b> Without DRIVE-CLiQ cable	<b>6SL3055-0AA00-3LA0</b>
<i>Accessories for re-ordering</i>	
<b>Dust protection blanking plugs</b> (50 units) For DRIVE-CLiQ port	<b>6SL3066-4CA00-0AA0</b>

For the SINAMICS S150 and SINAMICS S120 Cabinet Modules, the TM150 Terminal Module can be ordered as an option by specifying order code **G51** or **G51 to G54**.

#### Technical specifications

<b>TM150 Terminal Module</b> 6SL3055-0AA00-3LA0	
<b>Current requirement, max.</b> at 24 V DC	0.5 A
<ul style="list-style-type: none"> <li>• Conductor cross-section, max.</li> <li>• Fuse protection, max.</li> </ul>	2.5 mm <sup>2</sup> 20 A
<b>Temperature sensor inputs</b> The inputs can be parameterized individually for the evaluation of sensors	
<ul style="list-style-type: none"> <li>• Conductor cross-section, max.</li> <li>• Measuring current per sensor, approx.</li> </ul>	1.5 mm <sup>2</sup> 0.8 mA
<b>Power loss</b>	1.6 W
<b>PE connection</b>	M4 screw
<b>Dimensions</b>	
<ul style="list-style-type: none"> <li>• Width</li> <li>• Height</li> <li>• Depth</li> </ul>	30 mm 150 mm 111 mm
<b>Weight, approx.</b>	0.41 kg

# SINAMICS S120 Chassis Format Converter Units

Supplementary system components

## TM150 Terminal Module

### Integration

The TM150 Terminal Module communicates with the CU310-2 or CU320-2 Control Unit via DRIVE-CLiQ.

3

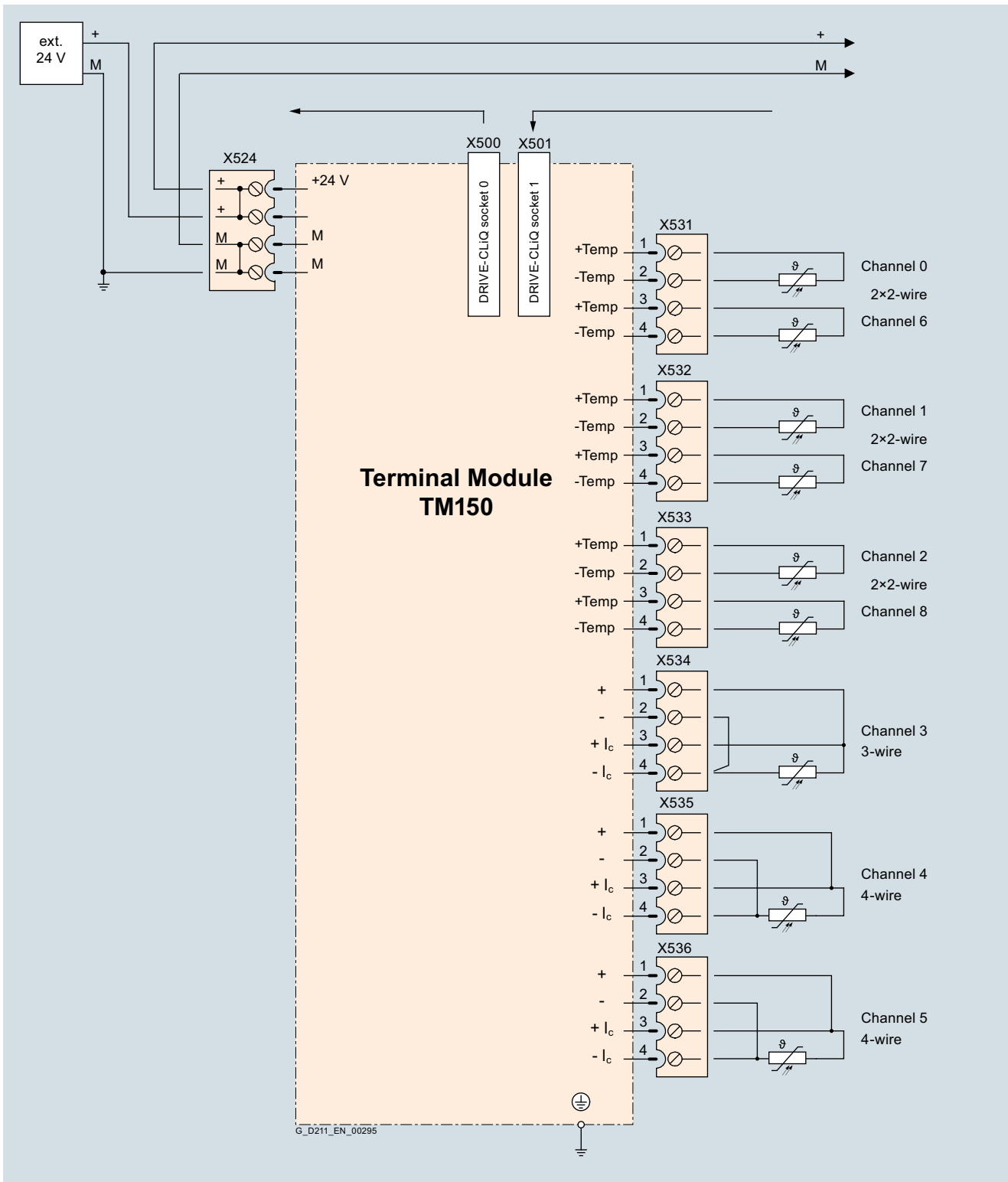

Connection example of TM150 Terminal Module

# SINAMICS S120 Chassis Format Converter Units

## Supplementary system components

### VSM10 Voltage Sensing Module

#### Overview



The VSM10 Voltage Sensing Module enables the line or motor voltage characteristic to be measured precisely. The phase differential voltage can be measured, either grounded (in the delivery state with jumper plugged in) or isolated. The VSM10 Voltage Sensing Module is integrated in Active Interface Modules in chassis format and Smart Line Modules in chassis format.

In addition, the VSM10 is used to connect to rotating synchronous motors – or for a "quick flying restart" of rotating induction motors.

#### Design

The VSM10 Voltage Sensing Module has the following connections and interfaces:

- 1 connection for direct voltage sensing up to 690 V
- 1 connection for voltage sensing using voltage transformers, max. 100 V
- 2 analog inputs (reserved for monitoring of resonance in the Active Interface Module in chassis format)
- 1 temperature sensor input for KTY84-130, Pt1000 or PTC (Pt1000 can be used from firmware V4.7 HF17)
- 1 DRIVE-CLiQ socket
- 1 connection for the electronics power supply via the 24 V DC supply connector
- 1 plug-in jumper for either grounded (delivery state) or isolated measurement
- 1 PE connection

The status of the VSM10 Voltage Sensing Module is indicated via a dual-color LED.

The VSM10 Voltage Sensing Module can be snapped onto a TH 35 DIN rail in accordance with EN 60715 (IEC 60715).

#### Selection and ordering data

Description	Article No.
<b>VSM10 Voltage Sensing Module</b> Without DRIVE-CLiQ cable	<b>6SL3053-0AA00-3AA1</b>
<i>Accessories for re-ordering</i>	
<b>Dust protection blanking plugs</b> (50 units) For DRIVE-CLiQ port	<b>6SL3066-4CA00-0AA0</b>

For SINAMICS S150 and SINAMICS S120 Cabinet Modules, to implement the flying restart function, VSM10 can be ordered as an option with order code **K51**.

#### Technical specifications

<b>VSM10 Voltage Sensing Module</b> 6SL3053-0AA00-3AA1	
<b>Power requirement, max.</b> at 24 V DC	0.2 A
• Conductor cross-section, max.	2.5 mm <sup>2</sup>
<b>Power loss, max.</b>	10 W
<b>Line voltage detection</b>	
• Insulation resistance neutral point – ground when jumper is not inserted	>10 MΩ
• Input resistance	
- Terminal X521	>362 kΩ/phase
- Terminal X522	>2.5 MΩ/phase
<b>Analog inputs</b> (reserved for monitoring an Active Interface Module in chassis format)	
• Internal resistance, approx. (between differential inputs)	100 kΩ
• Resolution	12 bits + sign
<b>PE connection</b>	M4 screw
<b>Dimensions</b>	
• Width	50 mm
• Height	150 mm
• Depth	111 mm
<b>Weight, approx.</b>	1 kg

# SINAMICS S120 Chassis Format Converter Units

## Supplementary system components

### VSM10 Voltage Sensing Module

#### Integration

The VSM10 Voltage Sensing Module communicates with the CU310-2 or CU320-2 Control Unit via DRIVE-CLiQ.

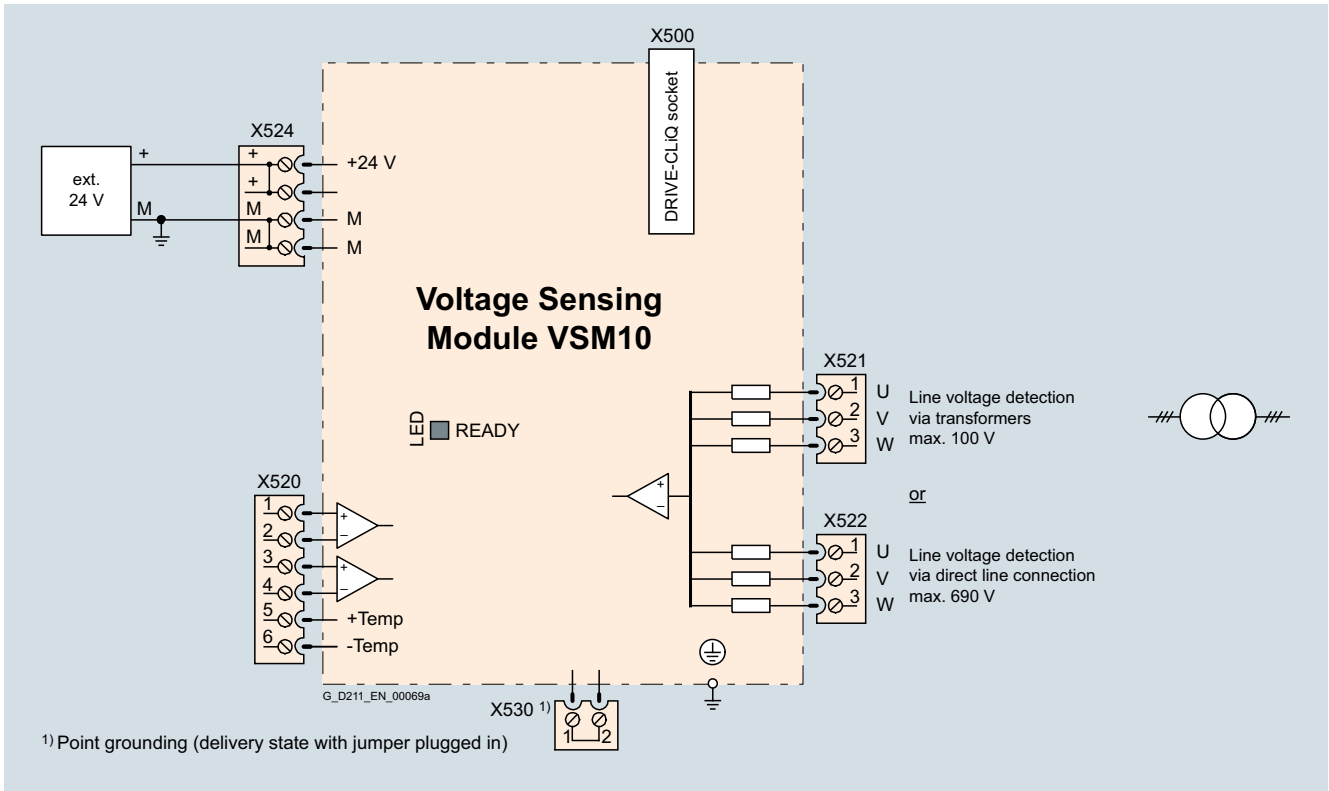

Connection example of a VSM10 Voltage Sensing Module

# SINAMICS S120 Chassis Format Converter Units

## Supplementary system components

### Safe Brake Adapter SBA

#### Overview



For SINAMICS S120, S150, G130 and G150 units, a Safe Brake Adapter SBA is required to safely control a motor holding brake via the Safe Brake Control (SBC) safety function according to IEC 61800-5-2.

The Safe Brake Adapter is available for a 230 V AC brake control voltage.

It can be ordered as supplementary component for SINAMICS S120 chassis format units as well as for SINAMICS G130 built-in units.

It is available as option (**K88**) for SINAMICS S120 Cabinet Modules and SINAMICS S150 or G150 cabinet units.

#### Note:

The SBA is approved for the IEC area. Safe Brake Adapter with UL approval are available on request. The UL approval is valid for a maximum permissible current consumption of 1.5 A (inductive).

#### Design

The Safe Brake Adapter SBA has the following connections and interfaces:

- 1 connection for the connecting cable to the Power Module/ Motor Module
- 1 connection for the external 230 V AC supply
- 1 connection for motor holding brake
- 1 connection for fast de-excitation

#### Selection and ordering data

Description	Article No.
<b>Safe Brake Adapter</b> 230 V AC/2 A	<b>6SL3355-2DX00-1AA0</b>
<b>Accessories</b>	
<b>Pre-assembled interface cable to connect the SBA to the electronics module (4 m)</b>	<b>6SL3060-4DX04-0AA0</b>

#### Technical specifications

<b>Safe Brake Adapter</b> 6SL3355-2DX00-1AA0	
<b>Electronics power supply</b>	
• Supply voltage (via the Control Interface Module)	24 V DC (20.4 ... 28.8 V DC)
<b>Supply voltage of the motor holding brake</b>	230 V AC
<b>Current consumption, max perm. <sup>1)</sup></b>	
• Motor holding brake	2 A
• Fast de-energization	2 A
<b>Cable length, max.</b>	
• To the Control Interface Module	10 m
• To the brake	300 m
<b>Conductor cross-section</b>	2.5 mm <sup>2</sup>
<b>Dimensions</b>	
• Width	75 mm
• Height	111 mm
• Depth	89 mm
<b>Weight, approx.</b>	0.25 kg
<b>Safety Integrated</b>	Safety Integrity Level 2 (SIL2) acc. to IEC 61508, Performance Level d (PLd) acc. to EN ISO 13849-1 and Control Category 3 acc. to EN ISO 13849-1

<sup>1)</sup> The UL approval is valid for a maximum permissible current consumption of 1.5 A (inductive).

## SINAMICS S120 Chassis Format Converter Units

### Supplementary system components

#### Safe Brake Adapter SBA

##### Integration

The control and feedback signal regarding the switching state of the SBA relay is implemented via terminals of the Control Interface Module (CIM) in the Motor Module/Power Module. The excitation coil of the holding brake is connected directly at the SBA.

For SINAMICS S120, the brake supply voltage must be externally supplied at the SBA.

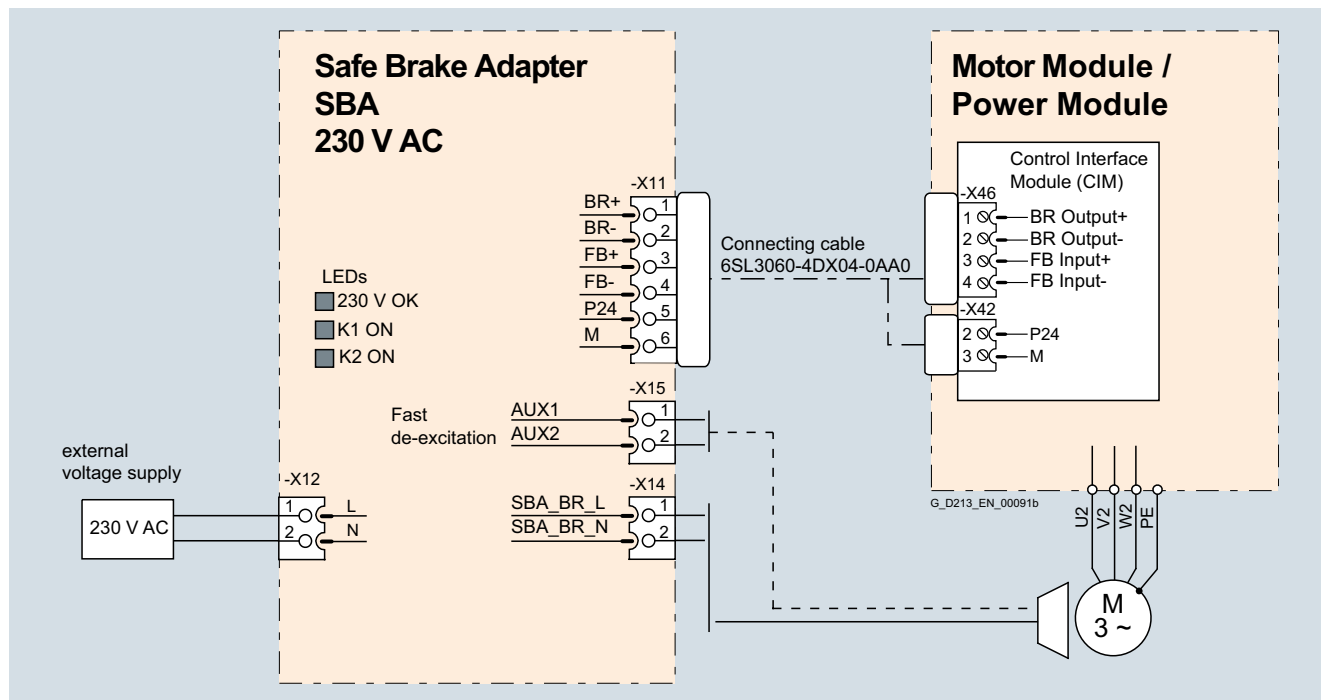

Connection example of a Safe Brake Adapter SBA

**Overview*****Motors without DRIVE-CLiQ interface***

The encoder and temperature signals of motors without DRIVE-CLiQ interfaces, as well as those of external encoders, must be connected via Sensor Modules. Sensor Modules Cabinet-Mounted are available in degree of protection IP20 for control cabinet installation, as well as Sensor Modules External-Mounted in degree of protection IP67.

Only one encoder system can be connected to each Sensor Module.

**More information**

Motor encoder and temperature signals must be connected to the corresponding Motor Module or Power Module and external encoders to the Control Unit. However, the DRIVE-CLiQ connections can also be bundled via DRIVE-CLiQ Hub Modules.

***Safety Integrated***

Suitable encoders are required in order to allow unrestricted use of Safety Integrated Extended Functions.

***Belt-driven motor***

Unfavorable material combinations generate static electricity between the belt pulley and the belt. Electrostatic charging must be prevented, since this can discharge via the motor shaft and the encoder, thereby causing disturbances in the encoder signals. One remedy is to use an anti-static belt.



## SINAMICS S120 Chassis Format Converter Units

### Encoder system connection

#### SMC10 Sensor Module Cabinet-Mounted

##### Overview



The SMC10 Sensor Module Cabinet-Mounted is required to evaluate the encoder signals of motors without a DRIVE-CLiQ interface. External encoders can also be connected via the SMC10.

The following encoder signals can be evaluated:

- 2-pole resolver
- Multi-pole resolver

##### Design

The SMC10 Sensor Module Cabinet-Mounted features the following connections and interfaces as standard:

- 1 encoder connection including motor temperature sensing (KTY84-130, Pt1000 or PTC) via SUB-D connector
- 1 DRIVE-CLiQ interface
- 1 connection for the electronics power supply via the 24 V DC supply connector
- 1 PE connection

The status of the SMC10 Sensor Module Cabinet-Mounted is indicated via a multi-color LED.

The SMC10 Sensor Module Cabinet-Mounted can be snapped onto a TH 35 standard mounting rail according to EN 60715 (IEC 60715).

The signal cable shield is connected via the encoder system connector and can also be connected to the SMC10 Sensor Module Cabinet-Mounted via a shield connection terminal, e.g. Phoenix Contact type SK8 or Weidmüller type KLBÜ CO 1. The shield connection terminal must not be used as a strain relief mechanism.

##### Selection and ordering data

Description	Article No.
<b>SMC10 Sensor Module Cabinet-Mounted</b> Without DRIVE-CLiQ cable	<b>6SL3055-0AA00-5AA3</b>
<i>Accessories for re-ordering</i>	
<b>Dust protection blanking plugs</b> (50 units) For DRIVE-CLiQ port	<b>6SL3066-4CA00-0AA0</b>

For the SINAMICS S150 and SINAMICS S120 Cabinet Modules, the SMC10 Sensor Module Cabinet-Mounted can be ordered as an option by specifying order code **K46**.

##### Integration

SMC10 Sensor Modules Cabinet-Mounted communicate with a Control Unit via DRIVE-CLiQ.

##### Technical specifications

<b>SMC10 Sensor Module Cabinet-Mounted</b> 6SL3055-0AA00-5AA3	
<b>Current requirement, max.</b> at 24 V DC, without taking encoder into account	0.2 A
• Conductor cross-section, max.	2.5 mm <sup>2</sup>
• Fuse protection, max.	20 A
<b>Power loss, max.</b>	10 W
<b>Encoders which can be evaluated</b>	<ul style="list-style-type: none"> <li>• 2-pole resolvers</li> <li>• Multi-pole resolver</li> </ul>
• Excitation voltage, rms	4.1 V
• Excitation frequency	5 ... 16 kHz depending on the current controller clock cycle of the Motor Module or Power Module
• Transformation ratio	0.5
• Encoder frequency, max.	2 kHz (120000 rpm) depending on the number of resolver pole pairs and current controller clock cycle of the Motor Module or Power Module
• Signal subdivision (interpolation), max.	16384 times (14 bits)
• Cable length to encoder, max.	130 m
<b>PE connection</b>	M4 screw
<b>Dimensions</b>	
• Width	30 mm
• Height	150 mm
• Depth	111 mm
<b>Weight, approx.</b>	0.45 kg

# SINAMICS S120 Chassis Format Converter Units

## Encoder system connection

### SMC20 Sensor Module Cabinet-Mounted

#### Overview



The SMC20 Sensor Module Cabinet-Mounted is required to evaluate the encoder signals of motors without a DRIVE-CLiQ interface. External encoders can also be connected via the SMC20.

The following encoder signals can be evaluated:

- Incremental encoder sin/cos 1 V<sub>pp</sub>
- Absolute encoder EnDat 2.1
- SSI encoder with incremental signals sin/cos 1 V<sub>pp</sub> (firmware version 2.4 and later)

The motor temperature can also be sensed using a PTC thermistor KTY84-130, Pt1000 or PTC.

#### Design

The SMC20 Sensor Module Cabinet-Mounted features the following connections and interfaces as standard:

- 1 encoder connection including motor temperature sensing (KTY84-130, Pt1000 or PTC) via SUB-D connector
- 1 DRIVE-CLiQ interface
- 1 connection for the electronics power supply via the 24 V DC supply connector
- 1 PE connection

The status of the SMC20 Sensor Module Cabinet-Mounted is indicated via a multi-color LED.

The SMC20 Sensor Module Cabinet-Mounted can be snapped onto a TH 35 standard mounting rail according to EN 60715 (IEC 60715).

The signal cable shield is connected via the encoder system connector and can also be connected to the SMC20 Sensor Module Cabinet-Mounted via a shield connection terminal, e.g. Phoenix Contact type SK8 or Weidmüller type KLBÜ CO 1. The shield connection terminal must not be used as a strain relief mechanism.

#### Selection and ordering data

Description	Article No.
<b>SMC20 Sensor Module Cabinet-Mounted</b> Without DRIVE-CLiQ cable	<b>6SL3055-0AA00-5BA3</b>

#### Accessories for re-ordering

<b>Dust protection blanking plugs</b> (50 units) For DRIVE-CLiQ port	<b>6SL3066-4CA00-0AA0</b>
--	---------------------------

For the SINAMICS S150 and SINAMICS S120 Cabinet Modules, the SMC20 Sensor Module Cabinet-Mounted can be ordered as an option by specifying order code **K48**.

#### Integration

SMC20 Sensor Modules Cabinet-Mounted communicate with a Control Unit via DRIVE-CLiQ.

#### Technical specifications

<b>SMC20 Sensor Module Cabinet-Mounted</b> 6SL3055-0AA00-5BA3	
<b>Current requirement, max.</b> at 24 V DC, without taking encoder into account	0.2 A
• Conductor cross-section, max.	2.5 mm <sup>2</sup>
• Fuse protection, max.	20 A
<b>Power loss, max.</b>	10 W
<b>Encoders which can be evaluated</b>	<ul style="list-style-type: none"> <li>• Incremental encoder sin/cos 1 V<sub>pp</sub></li> <li>• Absolute encoder EnDat 2.1</li> <li>• SSI encoder with incremental signals sin/cos 1 V<sub>pp</sub> (firmware version 2.4 and later)</li> </ul>
• Encoder supply	5 V DC/0.35 A
• Encoder frequency incremental signals, max.	500 kHz
• Signal subdivision (interpolation), max.	16384 times (14 bits)
• SSI baud rate	100 ... 1000 kBaud
• Cable length to encoder, max.	100 m
<b>PE connection</b>	M4 screw
<b>Dimensions</b>	
• Width	30 mm
• Height	150 mm
• Depth	111 mm
<b>Weight, approx.</b>	0.45 kg

## SINAMICS S120 Chassis Format Converter Units

### Encoder system connection

#### SMC30 Sensor Module Cabinet-Mounted

##### Overview



The SMC30 Sensor Module Cabinet-Mounted is required to evaluate the encoder signals of motors without a DRIVE-CLiQ interface. External encoders can also be connected via the SMC30.

The following encoder signals can be evaluated:

- Incremental encoders TTL/HTL with/without open-circuit detection (open-circuit detection is only available with bipolar signals)
- SSI encoder with TTL/HTL incremental signals
- SSI encoder without incremental signals

The motor temperature can also be sensed using a PTC thermistor KTY84-130, Pt1000 or PTC.

##### Design

The SMC30 Sensor Module Cabinet-Mounted features the following connections and interfaces as standard:

- 1 encoder connection including motor temperature sensing (KTY84-130, Pt1000 or PTC) either via SUB-D connector or via terminals
- 1 DRIVE-CLiQ interface
- 1 connection for the electronics power supply via the 24 V DC supply connector
- 1 PE connection

The status of the SMC30 Sensor Module Cabinet-Mounted is indicated using a multi-color LED.

The SMC30 Sensor Module Cabinet-Mounted can be snapped onto a TH 35 standard mounting rail according to EN 60715 (IEC 60715).

The maximum encoder cable length between SMC30 modules and encoders is 100 m. For HTL encoders, this length can be increased to 300 m if the A+/A- and B+/B- signals are evaluated and the power supply cable has a minimum cross-section of 0.5 mm<sup>2</sup>.

The signal cable shield can be connected to the SMC30 Sensor Module Cabinet-Mounted via a shield connection terminal, e.g., Phoenix Contact type SK8 or Weidmüller type KLBÜ CO 1. The shield connection terminal must not be used as a strain relief mechanism.

##### Selection and ordering data

Description	Article No.
<b>SMC30 Sensor Module Cabinet-Mounted</b> Without DRIVE-CLiQ cable	<b>6SL3055-0AA00-5CA2</b>
<i>Accessories for re-ordering</i>	
<b>Dust protection blanking plugs</b> (50 units) For DRIVE-CLiQ port	<b>6SL3066-4CA00-0AA0</b>

For the SINAMICS S150 and SINAMICS S120 Cabinet Modules, the SMC30 Sensor Module Cabinet-Mounted can be ordered as an option by specifying order code **K50**.

##### Integration

SMC30 Sensor Modules Cabinet-Mounted communicate with a Control Unit via DRIVE-CLiQ.

##### Technical specifications

<b>SMC30 Sensor Module Cabinet-Mounted</b> 6SL3055-0AA00-5CA2	
<b>Current requirement, max.</b> at 24 V DC, without taking encoder into account	0.2 A
• Conductor cross-section, max.	2.5 mm <sup>2</sup>
• Fuse protection, max.	20 A
<b>Power loss, max.</b>	10 W
<b>Encoders which can be evaluated</b>	<ul style="list-style-type: none"> <li>• Incremental encoder TTL/HTL</li> <li>• SSI encoder with TTL/HTL incremental signals</li> <li>• SSI encoder without incremental signals</li> </ul>
• Input current range TTL/HTL	4 ... 20 mA (typ. 10 mA)
• Encoder supply	24 V DC/0.35 A or 5 V DC/0.35 A
• Encoder frequency, max.	300 kHz
• SSI baud rate	100 ... 1000 kBaud
• Limiting frequency	300 kHz
• Resolution absolute position SSI	30 bit
• Cable length, max.	
- TTL encoder	100 m (only bipolar signals permitted) <sup>1)</sup>
- HTL encoder	100 m for unipolar signals 300 m for bipolar signals <sup>1)</sup>
- SSI encoder	100 m
<b>PE connection</b>	M4 screw
<b>Dimensions</b>	
• Width	30 mm
• Height	150 mm
• Depth	111 mm
<b>Weight, approx.</b>	0.45 kg

<sup>1)</sup> Signal cables twisted in pairs and shielded.

### Overview



MOTION-CONNECT DRIVE-CLiQ signal cable with IP20/IP67 connector

Signal cables are required for the DRIVE-CLiQ connection between different components. Signal cables are pre-assembled and are sold by the meter. The following signal cables are available:

- DRIVE-CLiQ signal cables
- MOTION-CONNECT DRIVE-CLiQ signal cables
- MOTION-CONNECT pre-assembled signal cables

#### Type of delivery for pre-assembled signal cables

Pre-assembled signal cables are available in units of 10 cm.

The cables are supplied on reels up to 30 kg or 100 m. Above 30 kg or 100 m, cable drums are used instead of reels.

### Application

#### *DRIVE-CLiQ signal cables without 24 V DC cores*

are used to connect components with DRIVE-CLiQ connections which have a separate or external 24 V DC power supply.

#### *MOTION-CONNECT DRIVE-CLiQ signal cables with 24 V DC cores*

are used whenever components with DRIVE-CLiQ connections must meet high requirements such as mechanical stress and oil resistance, e.g. where a connection is made outside the control cabinet between

- Motor Modules and Sensor Modules
- Power Modules/Motor Modules and motors with DRIVE-CLiQ interface
- Motor Modules and direct measuring systems with DRIVE-CLiQ interface (incl. non-Siemens measuring systems)

#### *MOTION-CONNECT pre-assembled signal cables*

are used whenever motor encoders on motors without DRIVE-CLiQ interface are connected to Sensor Modules.

### Design

If pre-assembled signal cables are to be installed in a cable carrier in such a way that the connector would inhibit assembly, pre-assembled cables without assembled connector can also be supplied. In this case, the contacts of the cables are crimped and the connector housing is supplied separately. After installing the cables, the customer assembles the connector housing.

The 6FX.002-2....-.... signal cables are available with crimped contacts and with the connector housing supplied separately (not in the case of DRIVE-CLiQ signal cables and signal cables with exposed conductor ends).

Signal cables with **module-side** connector housing supplied as a separate accessory: In this case, the 6th position of the Article No. must be changed from **0** to **1**: 6FX.012-2C...-.... (not for signal cables for connecting via terminals or 6FX.002-2AH00-...., 6FX.002-2CA12-....).

Signal cables with **motor-side** connector housing supplied as a separate accessory. In this case, the 6th position of the Article No. must be changed from **0** to **4**: 6FX.042-2C...-.... (not for signal cables for connecting via terminals or 6FX8002-2BA20-...., 6FX8002-2BA21-....).

#### Note:

Once the contacts have latched into the insulator, they can no longer be removed.

# SINAMICS S120 Chassis Format Converter Units

## Connection system

### Signal cables

#### Selection and ordering data

Signal cable	Length	Connector/degree of protection module-side	Connector/degree of protection motor-side	Basic cable Article No.
<b>Pre-assembled DRIVE-CLiQ signal cables (without 24 V DC cores)</b>				
Fixed lengths	0.11 m	RJ45/IP20	RJ45/IP20	<b>6SL3060-4AB00-0AA0</b>
	0.16 m			<b>6SL3060-4AD00-0AA0</b>
	0.21 m			<b>6SL3060-4AF00-0AA0</b>
	0.26 m			<b>6SL3060-4AH00-0AA0</b>
	0.31 m			<b>6SL3060-4AK00-0AA0</b>
	0.36 m			<b>6SL3060-4AM00-0AA0</b>
	0.41 m			<b>6SL3060-4AP00-0AA0</b>
	0.60 m			<b>6SL3060-4AU00-0AA0</b>
	0.95 m			<b>6SL3060-4AA10-0AA0</b>
	1.20 m			<b>6SL3060-4AW00-0AA0</b>
	1.45 m			<b>6SL3060-4AF10-0AA0</b>
	2.10 m			<b>6SL3060-4AB20-0AA0</b>
	2.80 m			<b>6SL3060-4AJ20-0AA0</b>
	5.00 m			<b>6SL3060-4AA50-0AA0</b>
To the decimeter	Max. 70 m	RJ45/IP20	RJ45/IP20	<b>6FX2002-1DC00-....</b>
	Max. 70 m	RJ45/IP67	RJ45/IP67	<b>6FX2002-1DC20-....</b>
<b>DRIVE-CLiQ MOTION-CONNECT 500 signal cables (with 24 V DC cores)</b>				
To the decimeter	Max. 100 m	RJ45/IP20	RJ45/IP20	<b>6FX5002-2DC00-....</b>
	Max. 100 m	RJ45/IP20	RJ45/IP67	<b>6FX5002-2DC10-....</b>
	Max. 100 m	RJ45/IP67	RJ45/IP67	<b>6FX5002-2DC20-....</b>
<b>DRIVE-CLiQ MOTION-CONNECT 800PLUS signal cables (with 24 V DC cores)</b>				
To the decimeter	Max. 75 m	RJ45/IP20	RJ45/IP20	<b>6FX8002-2DC00-....</b>
	Max. 75 m	RJ45/IP20	RJ45/IP67	<b>6FX8002-2DC10-....</b>
	Max. 75 m	RJ45/IP67	RJ45/IP67	<b>6FX8002-2DC20-....</b>

## Selection and ordering data (continued)

### Length codes

Description	Article No. supplement				
<b>Length codes for pre-assembled cables</b>					
	<b>6FX.0.2-.....-</b>	<input type="checkbox"/>	<input type="checkbox"/>	<input type="checkbox"/>	<input type="checkbox"/>
0 m	1				
100 m	2				
200 m	3				
0 m		<b>A</b>			
10 m		<b>B</b>			
20 m		<b>C</b>			
30 m		<b>D</b>			
40 m		<b>E</b>			
50 m		<b>F</b>			
60 m		<b>G</b>			
70 m		<b>H</b>			
80 m		<b>J</b>			
90 m		<b>K</b>			
0 m		<b>A</b>			
1 m		<b>B</b>			
2 m		<b>C</b>			
3 m		<b>D</b>			
4 m		<b>E</b>			
5 m		<b>F</b>			
6 m		<b>G</b>			
7 m		<b>H</b>			
8 m		<b>J</b>			
9 m		<b>K</b>			
0 m				<b>0</b>	
0.1 m				<b>1</b>	
0.2 m				<b>2</b>	
0.3 m				<b>3</b>	
0.4 m				<b>4</b>	
0.5 m				<b>5</b>	
0.6 m				<b>6</b>	
0.7 m				<b>7</b>	
0.8 m				<b>8</b>	
Examples:	1.0 m	1	A	B	0
	2.2 m	1	A	C	2
	8.0 m	1	A	J	0
	299.0 m	3	K	K	0

Description	Article No. supplement				
<b>Length codes for power/signal cables available by the meter <sup>1)</sup></b>					
	<b>6FX.008-.....-</b>	<input type="checkbox"/>	<input type="checkbox"/>	<b>A</b>	<b>0</b>
50 m	1	<b>F</b>			
100 m	2	<b>A</b>			
200 m	3	<b>A</b>			
500 m	6	<b>A</b>			

For further information on DRIVE-CLiQ signal cables, see section MOTION-CONNECT connection system in Catalog D 21.4 as well as in the Industry Mall.

## More information

Further information is available:

- Catalog D21.4 (SINAMICS S120 and SIMOTICS)
- Interactive Catalog CA 01
- Internet
  - [www.siemens.com/motion-connect](http://www.siemens.com/motion-connect)
  - [www.siemens.com/industrymall](http://www.siemens.com/industrymall)

<sup>1)</sup> Note type of delivery. Cables with core cross-section 4 x 4 m<sup>2</sup> or 4 x 4 m<sup>2</sup> with brake cores can be delivered in units of 1 m.

# SINAMICS S120 Chassis Format Converter Units

## Connection system

### Signal cables

#### Integration

##### Connection overview for the CU320-2 Control Unit

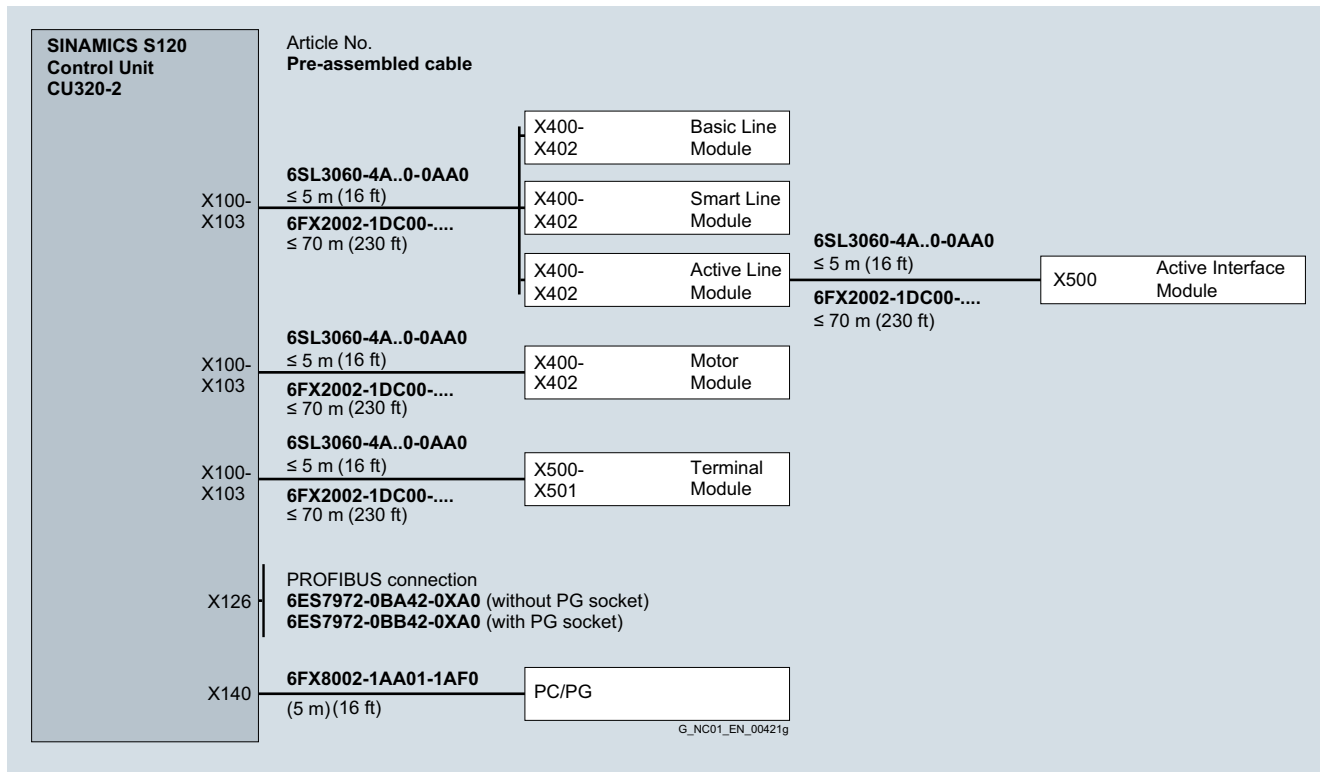

##### SIMOTION D4x5-2 Control Unit connection overview

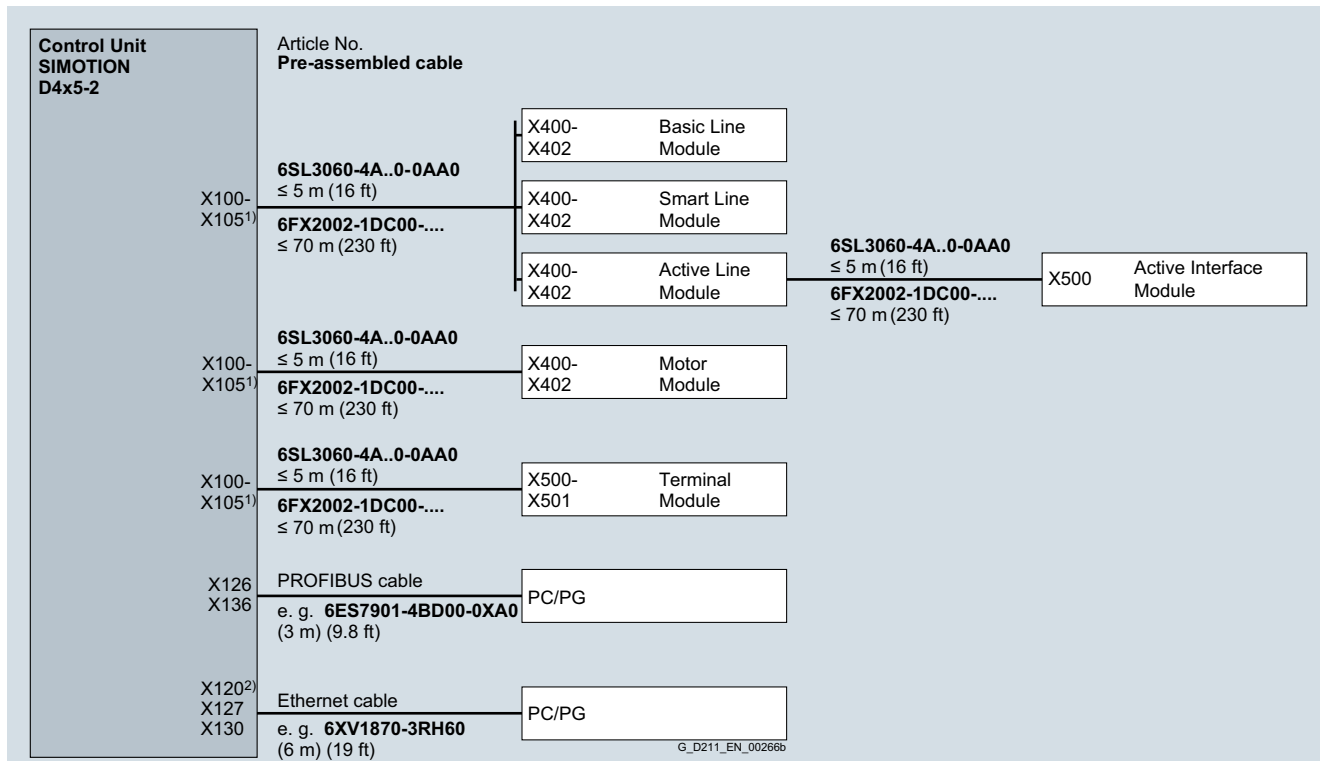

<sup>1)</sup> For SIMOTION D425-2: X100-X103.  
 For SIMOTION D435-2/D445-2/D455-2: X100-X105.

<sup>2)</sup> X120 for D4x5-2 DP only.

**Integration** (continued)

*Connection overview for Line Modules and Motor Modules*

The DRIVE-CLiQ type 6SL3060-4A..0-0AA0 cables for the standard configuration are part of the scope of supply of the Line Modules and Motor Modules. In this case, the modules must be mounted directly adjacent in a line.

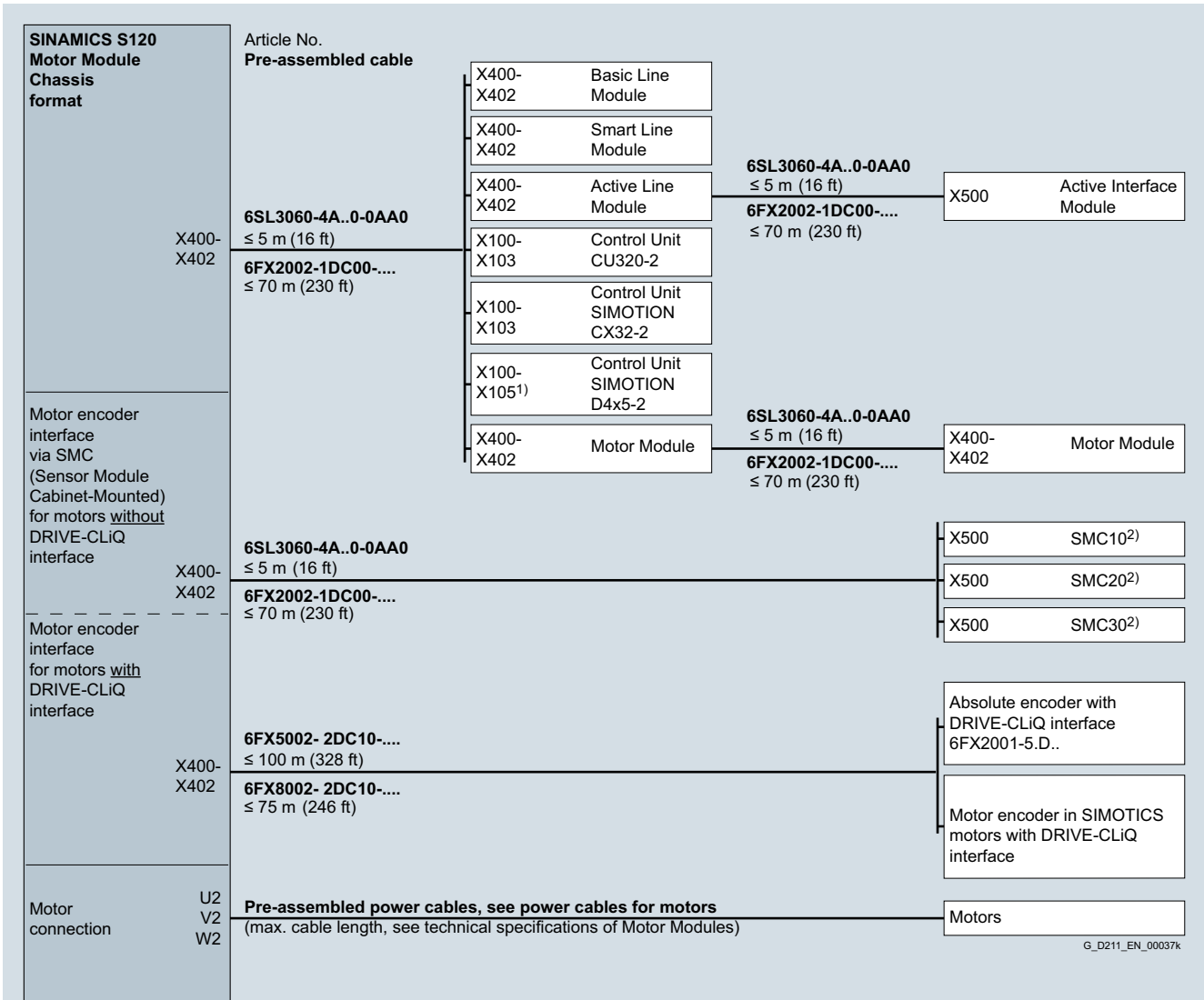

<sup>1)</sup> For SIMOTION D425-2: X100-X103  
 For SIMOTION D435-2/D445-2/D455-2: X100-X105  
<sup>2)</sup> See connection overviews SMC10/SMC20/SMC30

G\_D211\_EN\_00037k



# SINAMICS S120 Chassis Format Converter Units

## Connection system

### Signal cables

#### Integration (continued)

##### Connection overview for Power Modules

A DRIVE-CLiQ cable of type 6SL3060-4A..0-0AA0 for connection to the chassis-mounted CU310-2 Control Unit is already included in the scope of supply.

SINAMICS S120 Power Module		Article No.	
<b>Chassis format</b>		<b>Pre-assembled cable</b>	
Line connection	U1/L1 V1/L2 W1/L3	Power supply cables, see power cables for motors (by the meter)	
Motor encoder interface via SMC (Sensor Module Cabinet-Mounted) for motors <u>without</u> DRIVE-CLiQ interface	X400- X402	<b>6SL3060-4A..0-0AA0</b> ≤ 5 m (16 ft)	X100 SINAMICS S120 Control Unit CU310-2
		<b>6FX2002-1DC00-....</b> ≤ 70 m (230 ft)	X100- X103 SINAMICS S120 Control Unit CU320-2
Motor encoder interface for motors <u>with</u> DRIVE-CLiQ interface	X402	<b>6SL3060-4A..0-0AA0</b> ≤ 5 m (16 ft)	X100 Control Unit SIMOTION D410-2
		<b>6FX2002-1DC00-....</b> ≤ 70 m (230 ft)	X100- X105 <sup>1)</sup> Control Unit SIMOTION D4x5-2
		<b>6FX5002-2DC10-....</b> ≤ 100 m (328 ft)	X100- X103 Control Unit SIMOTION CX32-2
Motor encoder interface for motors <u>with</u> DRIVE-CLiQ interface	X402	<b>6FX8002-2DC10-....</b> ≤ 75 m (246 ft)	X500- X501 Terminal Module
			X400- X402 Power Module
Motor connection	U2 V2 W2	<b>Pre-assembled power cables, see power cables for motors</b> (max. cable length, see technical specifications of Motor Modules)	X500 SMC10 <sup>2)</sup>
			X500 SMC20 <sup>2)</sup>
			X500 SMC30 <sup>2)</sup>
			Absolute encoder with DRIVE-CLiQ interface 6FX2001-5.D..
			Motor encoder for SIMOTICS motors with DRIVE-CLiQ interface
			Motors

G\_D211\_EN\_001391

<sup>1)</sup> For SIMOTION D425-2: X100-X103  
For SIMOTION D435-2/D445-2/D455-2: X100-X105

<sup>2)</sup> See connection overviews SMC10/SMC20/SMC30

**Integration** (continued)

*Connection of a machine encoder (direct measuring system)*

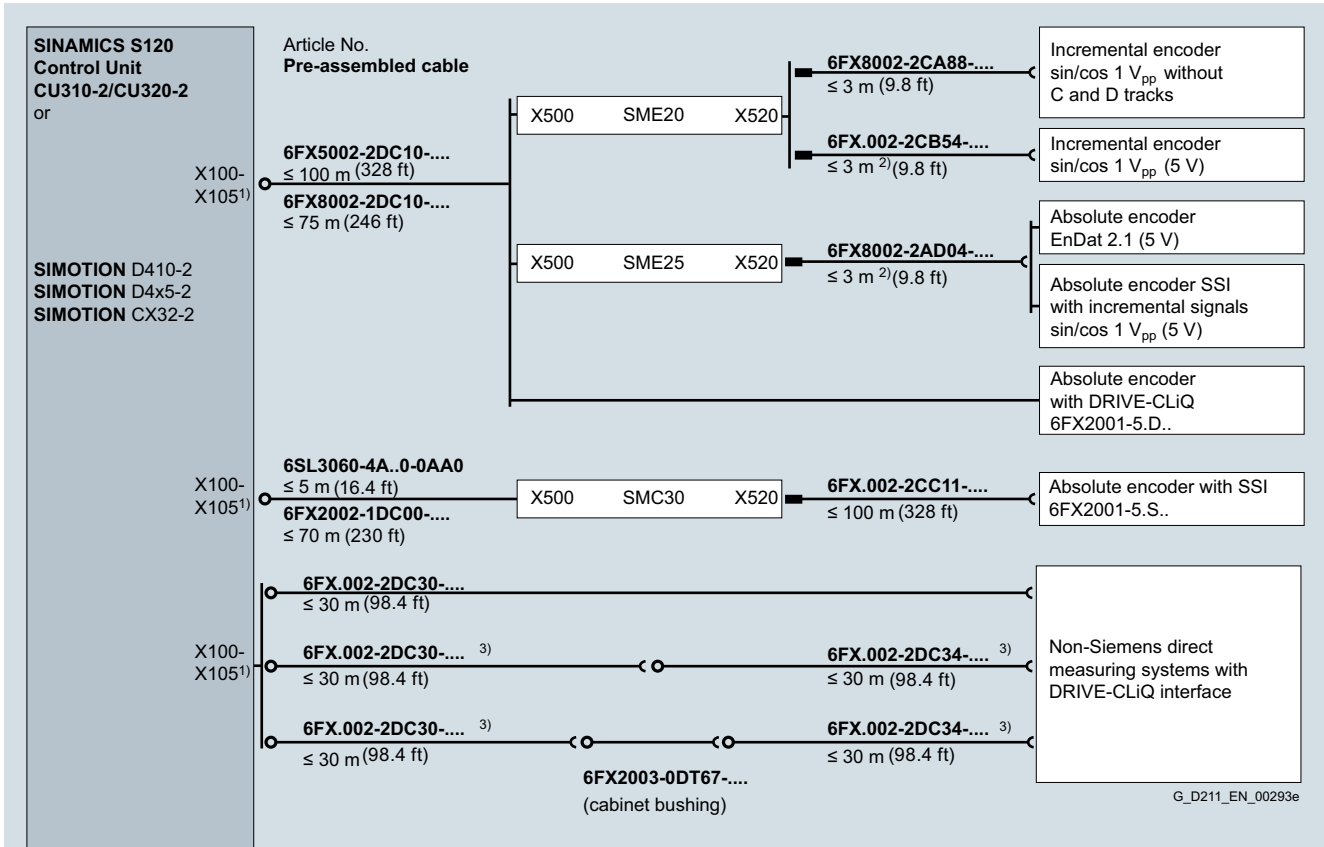

1) For Control Unit CU310-2/SIMOTION D410-2: X100  
 For Control Unit CU320-2/SIMOTION D425-2/SIMOTION CX32-2: X100-X103  
 For SIMOTION D435-2/D445-2/D455-2: X100-X105  
 2) Up to 10 m (32.8 ft) possible, dependent on encoder current consumption.  
 3) The total cable length (basic cable and extension cable) must not exceed 30 m (98.4 ft).

*Connection overview of SINAMICS S120 Sensor Module Cabinet Mounted SMC10*

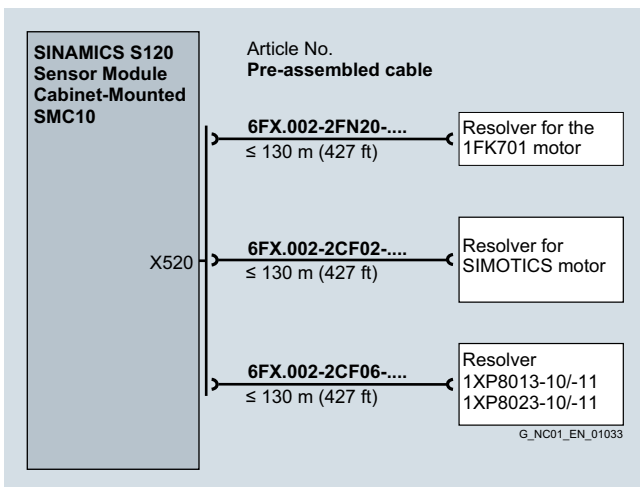

3

# SINAMICS S120 Chassis Format Converter Units

## Connection system

### Signal cables

#### Integration (continued)

Connection overview of SINAMICS S120 Sensor Module Cabinet-Mounted SMC20

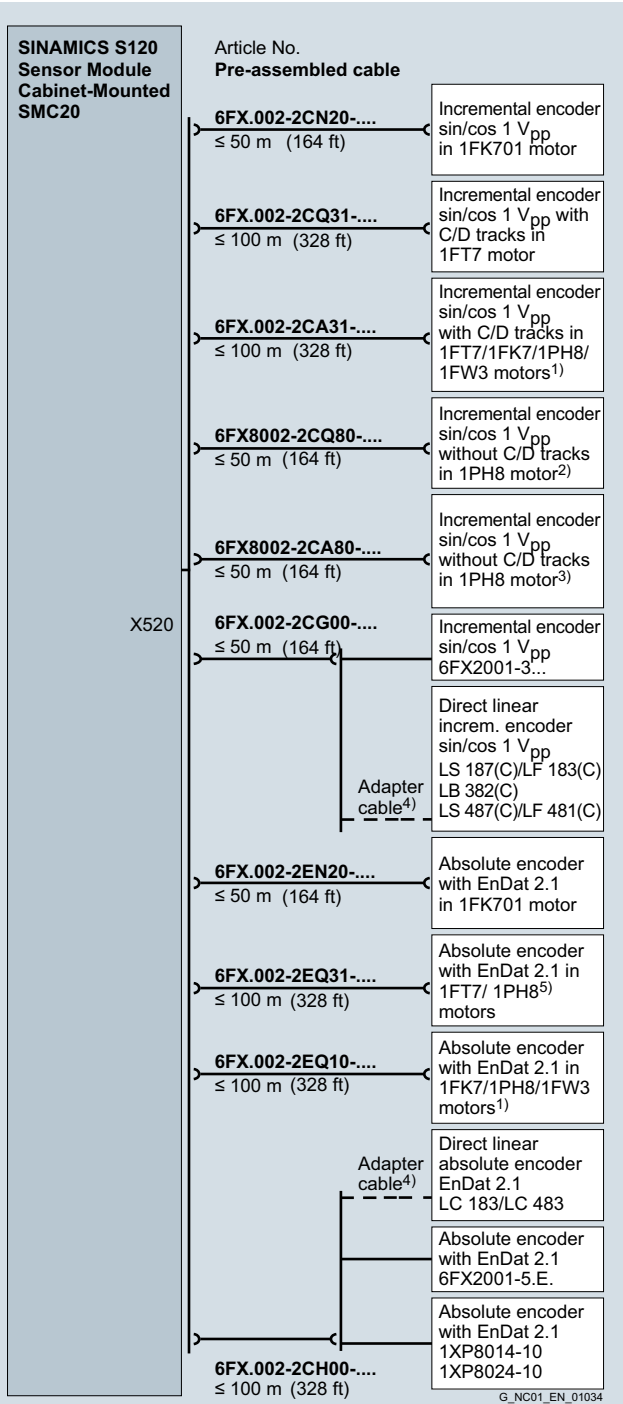

1) 1FW3 motor not suitable for machine tools.  
 2) Possible for 1PH808/1PH810/1PH813/1PH816 motors for encoders with 512 S/R and 256 S/R.  
 3) Possible for 1PH8 motors for encoders with 512 S/R and 256 S/R.  
 4) Adapter cable available from measuring system manufacturer.  
 5) Possible for 1PH808/1PH810/1PH813/1PH816 motors.

Connection overview of SINAMICS S120 Sensor Module Cabinet-Mounted SMC30

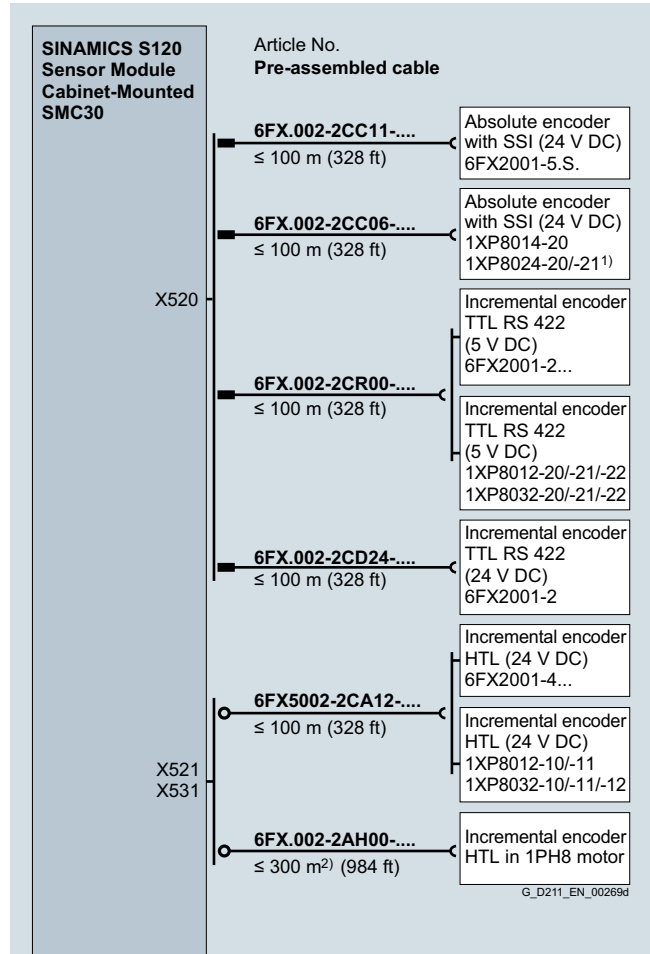

1) For position control only.  
 2) Applies to HTL encoders with bipolar signal evaluation or for evaluation of difference signals A\*, A and B\*, B; for HTL encoders with unipolar signal evaluation the permissible cable length is reduced to 100 m (328 ft).

G\_D211\_EN\_00269d

### Technical specifications

Signal cables	MOTION-CONNECT 500 6FX50...-.....-.....	MOTION-CONNECT 800PLUS 6FX80...-.....-.....
<b>Certificates of suitability, according to</b>		
• cURus or UR/CSA	UL758-CSA-C22.2-N.210.2-M90	UL758-CSA-C22.2-N.210.2-M90
• UR-CSA File No. <sup>1)</sup>	Yes	Yes
• RoHS conformity	Yes	Yes
<b>Rated voltage according to EN 50395</b>	30 V	30 V
<b>Test voltage, rms</b>	500 V	500 V
<b>Operating temperature on the surface</b>		
• Permanently installed	-20 ... +80 °C	-50 ... +80 °C
• Flexible installation	0 ... 60 °C	-20 ... +60 °C
<b>Tensile stress, max.</b>		
• Permanently installed	50 N/mm <sup>2</sup>	50 N/mm <sup>2</sup>
• Flexible installation	20 N/mm <sup>2</sup>	20 N/mm <sup>2</sup>
<b>Smallest bending radius</b>		
• Permanently installed	60 mm	4 × D <sub>max</sub>
• Flexible installation	100 mm	70 mm <sup>2)</sup>
<b>Torsional stress</b>	Absolute 30°/m	Absolute 30°/m
<b>Bending operations</b>	2 million	10 million
<b>Traversing speed</b>	180 m/min	Up to 300 m/min
<b>Acceleration</b>	5 m/s <sup>2</sup>	Up to 50 m/s <sup>2</sup>
<b>Insulation material, incl. jacket</b>	CFC/silicone-free	CFC/halogen/silicone-free IEC 60754-1/DIN VDE 0472-815
<b>Oil resistance</b>	EN 60811-2-1 (mineral oil only)	EN 60811-2-1
<b>Jacket</b>	PVC DESINA color green RAL 6018	PUR, HD22.10 S2 (VDE 0282, Part 10) DESINA color green RAL 6018
<b>Flame-retardant</b>	EN 60332-1-1 to 1-3	EN 60332-1-1 to 1-3

Degree of protection of the pre-assembled signal cables and their extensions when closed and inserted: IP67.

<sup>1)</sup> The File No. is printed on the cable jacket.

<sup>2)</sup> Exception: 6FX8002-2SL...-.....; smallest bending radius (flexible): 85 mm.

# SINAMICS S120 Chassis Format Converter Units

## Connection system

### Signal cables

#### Technical specifications (continued)

DRIVE-CLiQ signal cables	DRIVE-CLiQ 6FX2...-1DC..-....	DRIVE-CLiQ MOTION-CONNECT 500 6FX5...-DC..-....	DRIVE-CLiQ MOTION-CONNECT 800PLUS 6FX8...-DC..-....
<b>Certificates of suitability, according to</b>			
• cURus or UR/CSA	UL STYLE 2502/CSA-N.210.2-M90	UL STYLE 2502/CSA-N.210.2-M90	UL STYLE 2502/CSA-N.210.2-M90
• UR-CSA File No. <sup>1)</sup>	Yes	Yes	Yes
• RoHS conformity	Yes	Yes	Yes
<b>Rated voltage according to EN 50395</b>	30 V	30 V	30 V
<b>Test voltage, rms</b>	500 V	500 V	500 V
<b>Operating temperature on the surface</b>			
• Permanently installed	-20 ... +80 °C	-20 ... +80 °C	-20 ... +80 °C
• Flexible installation	–	0 ... 60 °C	-20 ... +60 °C
<b>Tensile stress, max.</b>			
• Permanently installed	45 N/mm <sup>2</sup>	80 N/mm <sup>2</sup>	50 N/mm <sup>2</sup>
• Flexible installation	–	30 N/mm <sup>2</sup>	20 N/mm <sup>2</sup>
<b>Smallest bending radius</b>			
• Permanently installed	50 mm	35 mm	35 mm
• Flexible installation	–	125 mm	75 mm
<b>Torsional stress</b>	–	Absolute 30°/m	Absolute 30°/m
<b>Bending operations</b>	–	100000	10 million
<b>Traversing speed</b>	–	30 m/min	300 m/min
<b>Acceleration</b>	–	2 m/s <sup>2</sup>	Up to 50 m/s <sup>2</sup>
<b>Insulation material, incl. jacket</b>	CFC/silicone-free	CFC/silicone-free	CFC/halogen/silicone-free IEC 60754-1/DIN VDE 0472-815
<b>Oil resistance</b>	EN 60811-2-1	EN 60811-2-1 (mineral oil only)	EN 60811-2-1
<b>Jacket</b>	PVC	PVC	PUR, HD22.10 S2 (VDE 0282, Part 10)
	Gray RAL 7032	DESINA color green RAL 6018	DESINA color green RAL 6018
<b>Flame-retardant</b>	EN 60332-1-1 to 1-3	EN 60332-1-1 to 1-3	EN 60332-1-1 to 1-3

Degree of protection of the pre-assembled signal cables and their extensions when closed and inserted: IP67.

<sup>1)</sup> The File No. is printed on the cable jacket.

## SINAMICS S120 Cabinet Modules



<b>4/2</b>	<b>System overview</b>
4/2	Overview
4/3	Benefits
4/4	Application
4/4	Design
4/5	Function
4/7	Technical specifications
<b>4/8</b>	<b>Air-cooled units</b>
4/15	Line Connection Modules
4/22	Basic Line Modules
4/27	Smart Line Modules
4/31	Active Line Modules incl. Active Interface Modules
4/37	Motor Modules in booksize format
4/41	Motor Modules in chassis format
4/48	Central Braking Modules
4/52	Auxiliary Power Supply Modules
4/55	Customer terminal strip -X55
<b>4/58</b>	<b>Liquid-cooled units</b>
4/68	Basic Line Connection Modules
4/72	Active Line Connection Modules
4/76	Motor Modules
4/84	Auxiliary Power Supply Modules
4/87	Heat Exchanger Modules
<b>4/92</b>	<b>Options</b>
4/92	Overview
4/98	Option selection matrix
4/100	Description of the options
<b>4/115</b>	<b>Supplementary system components</b>
4/115	Mounting device for air-cooled power blocks
4/115	Mounting device for liquid-cooled power units
<b>4/116</b>	<b>Order-specific integration engineering</b>
4/116	Option selection matrix of the order-specific integration engineering
<b>4/117</b>	<b>Customized solutions</b>

## SINAMICS S120 Cabinet Modules

### System overview

#### Overview



SINAMICS S120 Cabinet Modules, air-cooled and liquid-cooled

SINAMICS S120 Cabinet Modules are the components of a modular cabinet system for multi-motor drives with a central supply infeed and a common DC link busbar, as used, for example, in the process industry, automotive industry, metal processing industry as well as in the crane and mining domains. They are available in air-cooled or liquid-cooled versions. As standard, they are installed side by side in a row. Other installation types (e.g. back to back) are possible on request.

SINAMICS S120 Cabinet Modules include the chassis units from the SINAMICS S120 series in booksize format (Motor Modules) and chassis format, thus making the range an ideal supplement to the SINAMICS G150 and SINAMICS S150 cabinet converter series for single-motor drives.

All drive components, from the supply infeed to the motor-side converters, are configured in a clear, compact layout in the individual Cabinet Modules. They can be flexibly combined and optimally adapted to customer-specific requirements thanks to a comprehensive array of options.

The main components of the air-cooled system are as follows:

- Line Connection Modules with line-side components such as contactors, fuses and circuit breakers, as well as line reactors for Basic Line Modules
- The following types of infeed Line Modules:
  - Basic Line Modules for two-quadrant operation
  - Smart Line Modules for four-quadrant operation
  - Active Line Modules for four-quadrant operation with negligible line harmonics
- Central Braking Modules for braking operation
- The following types of Motor Modules:
  - Booksize Cabinet Kit
  - Chassis
- Control Units
- Auxiliary Power Supply Modules to supply the auxiliary power supply system

The main components of the liquid-cooled system are as follows:

- Active Line Connection Modules as a combination of Line Connection Module and Active Line Module with an Active Interface Module
- Basic Line Connection Modules as a combination of Line Connection Module and Basic Line Module
- Motor Modules
- Control Units
- Auxiliary Power Supply Modules to supply the auxiliary power supply system
- Heat Exchanger Modules with pumps, closed-loop control and a heat exchanger between the deionized water and raw water circuits

Standardized interfaces for both the power and the control connections facilitate engineering and installation. Communication between the power units and the central Control Unit takes place via DRIVE-CLiQ, the internal drive serial interface.

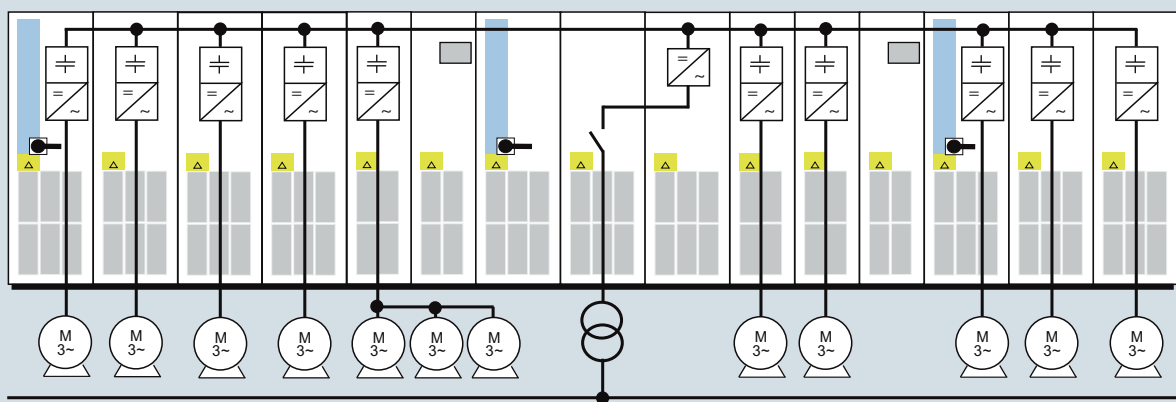

Example of a drive line-up with SINAMICS S120 Cabinet Modules for a multi-motor drive

**Overview** (continued)

The following tables provide an overview of the voltage ranges and power ratings of the available SINAMICS S120 Cabinet Modules.

## Voltage ranges and powers for air-cooled SINAMICS S120 Cabinet Modules

	Line voltage	Input current	DC link voltage	DC link current	Output current	Power range of single modules
<b>Line Connection Modules</b> <sup>1)</sup>	380 ... 480 V 3 AC	250 ... 3200 A	–	–	–	–
	500 ... 690 V 3 AC	280 ... 3200 A	–	–	–	–
<b>Basic Line Modules</b> <sup>1)</sup>	380 ... 480 V 3 AC	365 ... 1630 A	510 ... 650 V	420 ... 1880 A	–	200 ... 900 kW
	500 ... 690 V 3 AC	260 ... 1580 A	675 ... 930 V	300 ... 1880 A	–	250 ... 1500 kW
<b>Smart Line Modules</b> <sup>1)</sup>	380 ... 480 V 3 AC	463 ... 1430 A	510 ... 650 V	550 ... 1700 A	–	250 ... 800 kW
	500 ... 690 V 3 AC	463 ... 1430 A	675 ... 930 V	550 ... 1700 A	–	450 ... 1400 kW
<b>Active Line Modules</b> <sup>1)</sup>	380 ... 480 V 3 AC	210 ... 1405 A	570 ... 720 V	235 ... 1574 A	–	132 ... 900 kW
	500 ... 690 V 3 AC	575 ... 1270 A	750 ... 1035 V	644 ... 1422 A	–	630 ... 1400 kW
<b>Motor Modules booksize</b>	380 ... 480 V 3 AC	–	510 ... 720 V	–	9 ... 132 A	4.8 ... 71 kW
<b>Motor Modules chassis</b> <sup>1)</sup>	380 ... 480 V 3 AC	–	510 ... 720 V	–	210 ... 1405 A	110 ... 800 kW
	500 ... 690 V 3 AC	–	675 ... 1035 V	–	85 ... 1270 A	75 ... 1200 kW
<b>Central Braking Modules</b> <sup>1)</sup>	380 ... 480 V 3 AC	–	510 ... 720 V	–	–	500 ... 1000 kW
	500 ... 600 V 3 AC	–	675 ... 900 V	–	–	550 ... 1100 kW
	660 ... 690 V 3 AC	–	890 ... 1035 V	–	–	630 ... 1200 kW
<b>Auxiliary Power Supply Modules</b>	380 ... 690 V 3 AC	125 ... 250 A	–	–	–	–

## Voltage ranges and power ratings for liquid-cooled SINAMICS S120 Cabinet Modules

	Line voltage	Input current	DC link voltage	DC link current	Output current	Power range of single modules
<b>Basic Line Connection Modules</b> <sup>1)</sup>	380 ... 480 V 3 AC	610 ... 1420 A	510 ... 650 V	740 ... 1730 A	–	360 ... 830 kW
	500 ... 690 V 3 AC	340 ... 1350 A	675 ... 930 V	420 ... 1650 A	–	355 ... 1370 kW
<b>Active Line Connection Modules</b> <sup>1)</sup>	380 ... 480 V 3 AC	605 ... 1405 A	570 ... 720 V	677 ... 1573 A	–	380 ... 900 kW
	500 ... 690 V 3 AC	735 ... 1560 A	750 ... 1035 V	823 ... 1740 A	–	800 ... 1700 kW
<b>Motor Modules</b> <sup>1)</sup>	380 ... 480 V 3 AC	–	510 ... 720 V	–	210 ... 1405 A	110 ... 800 kW
	500 ... 690 V 3 AC	–	675 ... 1035 V	–	100 ... 1560 A	90 ... 1500 kW
<b>Auxiliary Power Supply Modules</b>	380 ... 690 V 3 AC	25 A	–	–	–	–

**Benefits**

The outstanding system features of the SINAMICS S120 Cabinet Modules provide the following advantages:

- Process optimization with minimum outlay
  - A standard PROFIBUS or PROFINET interface and various analog and digital interfaces enable easy integration into automation solutions
  - Vector and servo control ensures that they fulfill the most exacting requirements regarding the accuracy and dynamic response of drives
- High level of reliability and availability
  - Individual modules and power components can be replaced quickly and easily, which ensures a higher level of plant availability
- Energy saving during operation
  - The motor-side converters are coupled via the common DC link and allow energy to be exchanged between motors that are motoring and generating. This means that energy is saved, there is less load on the supply infeed and line harmonics are reduced
- Generally the line infeed is only dimensioned for the maximum energy required when motoring or the maximum current required when motoring – and not the sum of the energy requirements of the Motor Modules connected to the DC link. As a consequence, for example, for conveyor belts or motor test bays with Motor Modules that are simultaneously operated in motoring and generating modes, a significantly smaller line infeed unit can be selected
- Minimal operative, maintenance, and servicing costs
  - Simple commissioning thanks to the menu-driven STARTER commissioning tool
  - Optional, menu-navigated AOP30 advanced operator panel with plain text display and bar-type display of process variables
  - All modules are easily accessible, making them extremely service friendly
- Space-saving design
- Environmentally-friendly operation
  - The converters are exceptionally quiet and compact thanks to state-of-the-art IGBT power semiconductors and an innovative cooling concept

<sup>1)</sup> The power can be increased by connecting up to four identical modules in parallel.



## SINAMICS S120 Cabinet Modules

### System overview

#### Application

SINAMICS S120 Cabinet Modules have been specially developed to allow simple configuration of multi-motor systems. They are used for applications where several motors must be coordinated to realize a drive task as multi-motor drives in a drive line-up. Examples of such applications include:

- Packaging machines
- Plastics processing machines
- Textile machines
- Presses and punches
- Rolling mill drives

- Hoists and cranes
- Printing and paper machines
- Vehicle and gearbox test bays
- Test bay applications
- Machines used in the woodworking, glass and ceramics industries
- Handling and assembly systems
- Machine tools

High-power single-motor drives (parallel connection) can also be implemented with Cabinet Modules.

#### Design

The devices have been designed according to the zone concept principle and therefore offer the highest possible level of operational reliability. EMC measures have been rigorously implemented. With the help of simulated conditions, partitions have been designed to act as air guides and heat dissipation units.

Special measures used in the construction of the cabinets ensure that they remain mechanically durable over their entire life cycle.

Attention has been paid to providing a wide range of cable routing options and special design concepts are applied consistently to broaden the scope of application and simplify service. The units have all the necessary connections and connecting elements. Thanks to their carefully considered configuration concept, cabinets are shipped in a ready-to-connect state or, in the case of multiple transport units, have been prepared for quick assembly. An extensive spectrum of options designed to adapt the units to a variety of different applications facilitates the selection process.

All components, from individual parts to the ready-to-connect cabinet, undergo rigorous testing throughout the entire production process. This guarantees a high level of functional reliability during installation and commissioning, as well as in operation.

Replaceable components have been designed so that they can be quickly and easily replaced. In addition, the "Spares On Web" Internet tool makes it easy to view the spare parts that are available for the particular order at all times <sup>1)</sup>.

#### System design

Line Modules are coupled with the various Motor Modules by means of prefabricated busbar sets with different current carrying capacities.

All standard busbars, as well as electronics components, are protected against environmental influences. This is achieved through the use of nickel-plated copper bars and painted modules throughout.

#### Auxiliary power supply system

A special, standard auxiliary power supply system supplies the individual Cabinet Modules with the required auxiliary voltages for the power components, fans and 24 V loads.

These voltages are preferably generated using an Auxiliary Power Supply Module. Additional supply possibilities are available using the **K76** option (auxiliary power supply generation in the Line Connection Module) or using an external supply in the auxiliary power supply system.

The auxiliary power supply system comprises one Auxiliary Power Supply Module with two terminal blocks (air cooling) and one connecting terminal with two terminal blocks (liquid cooling) and a 24 V DC fuse as well as the required connecting cables. It is supplied completely assembled and ready to operate. Only the cable connections to the adjacent Cabinet Module must be established on-site.

#### DRIVE-CLiQ communication

Communication between the Control Unit, power units and other active SINAMICS components is realized via DRIVE-CLiQ connections.

DRIVE-CLiQ is an internal serial interface of the drive that enables fast and easy configuration of the complete drive line-up with prefabricated cables in varying lengths.

#### Transport units

The Cabinet Modules can be optionally supplied in pre-configured transport units up to a total length of 2400 mm. This option is particularly recommended in air-cooled Cabinet Modules for Line Modules together with Line Connection Modules since, in this case, the Line Connection Module must be equipped with a pre-charging DC link or line reactors (depending on the type of Line Module), in addition to the electrical interface (busbar). For liquid-cooled Cabinet Modules, delivery in transport units has the advantage that the tube system of the cooling system can be implemented completely without couplings. Transport units thus enable the various devices to be quickly and easily assembled on-site.

#### Coated modules

The following devices are equipped as standard with coated modules:

- Booksize format units
- Chassis format units
- Control Units
- Sensor Modules
- Terminal Modules
- Advanced Operator Panel (AOP30)

The coating on the modules protects the sensitive SMD components against corrosive gases, chemically active dust and moisture.

#### Nickel-plated busbars

All of the copper busbars used in the converter cabinets are nickel-plated to achieve the best possible immunity to environmental effects. Furthermore, there is no need to clean the contacts on the customer terminals as otherwise required for bare copper connections.

#### Note:

With some options, parts of the copper busbars cannot be nickel-plated for technical reasons.

<sup>1)</sup> The properties of the SINAMICS S120 Cabinet Modules described in this catalog are not transferable to cabinet units constructed to meet the requirements of specific applications.

**Design** (continued)**PE bars**

The Cabinet Modules are delivered with a PE bar as standard. It is used to connect and fasten PE conductors.

**Degrees of protection of Cabinet Modules**

The EN 60529 standard covers the protection of electrical equipment by means of housings, covers or equivalent, and includes:

- Protection of persons against accidental contact with live or moving parts within the housing and protection of the equipment against the ingress of solid foreign bodies (touch protection and protection against ingress of solid foreign bodies)
- Protection of the equipment against the ingress of water (water protection)
- Abbreviations for the internationally agreed degrees of protection

The degrees of protection are specified by abbreviations comprising the code letters IP and two digits.

Degree of protection	First code number (touch protection and protection against solid foreign bodies)	Second code number (protection of the equipment against the ingress of water)
<b>IP20</b> (Standard for air-cooled version)	Protected against solid foreign bodies Diameter $\geq$ 12.5 mm	No water protection
<b>IP21</b> (Standard for liquid-cooled version, option <b>M21</b> for air-cooled version)	Protected against solid foreign bodies Diameter $\geq$ 12.5 mm	Protected against drip water Vertically falling water drops shall not have a harmful effect.
<b>IP23</b> (Option <b>M23</b> )	Protected against solid foreign bodies Diameter $\geq$ 12.5 mm	Protected against spray water Water sprayed on both sides of the vertical at an angle of up to 60° shall not have a harmful effect.
<b>IP43</b> (Option <b>M43</b> )	Protected against solid foreign bodies Diameter $\geq$ 1 mm	Protected against spray water Water sprayed on both sides of the vertical at an angle of up to 60° shall not have a harmful effect.
<b>IP54</b> <b>(Air-cooled version only)</b> (Option <b>M54</b> )	Dust protected Ingress of dust is not totally prevented, but dust must not be allowed to enter in such quantities that the functioning or safety of the equipment is impaired. Complete touch protection	Protected against splash water Water splashing onto the enclosure from any direction shall not have a harmful effect.
<b>IP55</b> <b>(Liquid-cooled version only)</b> (Option <b>M55</b> )	Dust protected Ingress of dust is not totally prevented, but dust must not be allowed to enter in such quantities that the functioning or safety of the equipment is impaired. Complete touch protection	Protected against water jet (nozzle) Water projected by a nozzle against the enclosure from any direction shall not have a harmful effect.

Air-cooled Cabinet Modules meet degree of protection IP20, liquid-cooled Cabinet Modules degree of protection IP21, as standard. Heat Exchanger Modules have degree of protection IP55 as standard.

**Function****Communication with higher-level controller and customer terminal block**

As the customer interface to the control system, a PROFIBUS interface is available on the CU320-2 DP Control Unit or a PROFINET interface on the CU320-2 PN Control Unit as standard.

In the case of the air-cooled Cabinet Modules, the inputs and outputs available as standard on the customer terminal block - X55, which are easy to access and easy to connect up, can be provided.

In the case of the liquid-cooled Cabinet Modules, the components are directly connected.

For additional information, please refer to the SINAMICS Low Voltage Engineering Manual.

**Open-loop and closed-loop control functions**

SINAMICS S120 can use a dynamic, high-precision closed-loop vector control (drive object type VECTOR), or a highly dynamic closed-loop servo control (drive object type SERVO).

# SINAMICS S120 Cabinet Modules

## System overview

### Function (continued)

#### Software and protective functions

The software functions available as standard are described below:

Software and protective functions	Description
<b>Setpoint input</b>	The setpoint can be specified both internally and externally; internally as a fixed setpoint, motorized potentiometer setpoint or jog setpoint, externally via the communications interface or an analog input. The internal fixed setpoint and the motorized potentiometer setpoint can be switched or adjusted via control commands from any interface.
<b>Motor identification</b>	The automatic motor identification function makes commissioning faster and easier and optimizes closed-loop control of the drive.
<b>Ramp-function generator</b>	A user-friendly ramp-function generator with separately adjustable ramp-up and ramp-down times, together with adjustable rounding times in the lower and upper speed ranges, allows the drive to be smoothly accelerated and braked. This results in a good speed control response and plays its role in reducing the stress on the mechanical system. The down ramp can be parameterized separately for a quick stop.
<b>V<sub>dc max</sub> controller</b>	The V <sub>dc max</sub> controller automatically prevents overvoltages in the DC link, if the set down ramp is too short, for example. This may also extend the set ramp-down time. <u>Note:</u> This function only makes sense for single-axis applications.
<b>Kinetic buffering (KIP)</b>	For brief line supply failures, the kinetic energy of the rotating drive is used to buffer the DC link and therefore prevents fault trips. The drive converter remains operational as long as the drive can provide regenerative energy as a result of its motion and the DC link voltage does not drop below the shutdown threshold. When the line supply recovers within this time, the drive is again seamlessly accelerated up to its setpoint speed.
<b>Automatic restart</b>	The automatic restart switches the drive on again when the power is restored after a power failure, and ramps up to the current speed setpoint.
<b>Flying restart</b>	The flying restart function allows the converter to be switched to a motor that is still turning. With the voltage sensing capability provided by the optional VSM10, the flying restart time for large induction motors can be significantly reduced because the motor does not need to be de-magnetized.
<b>Technology controller</b>	Using the technology controller (PID controller) function module, level or flow controls and complex tension controls can be implemented, for example. The existing D component can act both on the system deviation as well as on the actual value (factory setting). The P, I, and D components are set separately.
<b>Free function blocks</b>	Using the freely programmable function blocks, it is easy to implement logic and arithmetic functions for controlling the SINAMICS drive. The blocks can be programmed via the operator panel or the STARTER commissioning tool.
<b>Drive Control Chart (DCC)</b>	Drive Control Chart (DCC) is an additional tool for the easy configuration of technological functions for SINAMICS. The block library contains a large selection of control, arithmetic and logic blocks as well as extensive open-loop and closed-loop control functions. The user-friendly DCC editor enables easy graphics-based configuration, allows control loop structures to be clearly represented and provides a high degree of reusability of charts that have already been created. DCC is an add-on for the STARTER commissioning tool (→ Tools and Engineering).
<b>R<sup>2</sup>t sensing for motor protection</b>	A motor model stored in the converter software calculates the motor temperature based on the current speed and load. More exact measurement of the temperature, which also takes into account the influence of the ambient temperature, is possible by means of direct temperature measurement using KTY84 sensors in the motor winding.
<b>Motor temperature evaluation</b>	Motor protection by evaluating a KTY84, PTC or Pt100 temperature sensor. When a KTY84 temperature sensor is connected, the limit values can be set for alarm or shutdown. When a PTC thermistor is connected, the system reaction to triggering of the thermistor (alarm or trip) can be defined.
<b>Motor blocking protection</b>	A blocked motor is detected and protected against thermal overloading by a fault trip.
<b>Brake control</b>	"Simple brake control" for controlling holding brakes: The holding brake is used to secure drives against unwanted motion when deactivated. The "extended braking control" function module allows complex braking control, for example, for motor holding brakes and operational brakes. In the case of brakes with feedback signal, the brake control reacts to the feedback contacts of the brake.
<b>Write protection</b>	Write protection to prevent unintentional changing of the setting parameters (without password function).
<b>Know-how protection</b>	Know-how protection for encrypting stored data, e.g. to protect expert configuring knowledge, and to protect against modification and duplication (with password function).
<b>Web server</b>	The integrated web server provides information about the drive unit via its web pages. The web server is accessed using a web browser via unsecured (http) or secured transfer protocol (https).

#### Power unit protection

Power unit protection	Description
<b>Ground fault monitoring at the output</b>	A ground fault at the output is detected by a total current monitor and results in shutdown in grounded systems.
<b>Electronic short-circuit protection at the output</b>	A short-circuit at the output (e.g. at the converter output terminals, in the motor cable or in the motor terminal box) is detected and the converter shuts down with a "fault".
<b>Thermal overload protection</b>	An alarm is issued first when the overtemperature threshold responds. If the temperature continues to rise, the unit either shuts down or independently adjusts the pulse frequency or output current so that thermal load is reduced. Once the cause of the fault has been eliminated (e.g. cooling has been improved), the original operating values are automatically resumed.

## Technical specifications

The most important directives and standards are listed below. These are used as the basis for the SINAMICS S120 Cabinet Modules and they must be carefully observed to achieve an EMC-compliant configuration that is safe both in terms of function and operation.

European directives	
<b>2014/35/EU</b>	Low Voltage Directive: Directive of the European Parliament and Council of February 26, 2014 on the harmonization of the laws of the member states relating to the making available on the market of electrical equipment designed for use within certain voltage limits (recast)
<b>2014/30/EU</b>	EMC Directive: Directive of the European Parliament and Council of February 26, 2014 on the harmonization of the laws of the member states relating to electromagnetic compatibility (recast)
<b>2006/42/EC</b>	Machinery Directive: Directive of the European Parliament and Council of May 17, 2006 on machinery and amending Directive 95/16/EC (recast)
European standards	
<b>EN ISO 3744</b>	Acoustics - Determination of sound power levels and sound energy levels of noise sources using sound pressure – Engineering methods for an essentially free field over a reflecting plane
<b>EN ISO 13849-1</b>	Safety of machinery – safety-related parts of control systems Part 1: General principles for design (EN ISO 13849-1: 2006)
<b>EN 60146-1-1</b>	Semiconductor converters – General requirements and line-commutated converters Part 1-1: Specification of basic requirements
<b>EN 60204-1</b>	Safety of machinery – Electrical equipment of machines Part 1: General requirements
<b>EN 60529</b>	Degrees of protection provided by enclosures (IP Code)
<b>EN 61508-1</b>	Functional safety of electrical/electronic/programmable electronic safety-related systems Part 1: General requirements
<b>EN 61800-2</b>	Adjustable speed electrical power drive systems Part 2: General requirements – Rating specifications for low voltage adjustable frequency AC power drive systems
<b>EN 61800-3</b>	Adjustable speed electrical power drive systems Part 3: EMC requirements and specific test methods
<b>EN 61800-5-1</b>	Adjustable speed electrical power drive systems Part 5: Safety requirements Main section 1: Electrical and thermal requirements
<b>EN 61800-5-2</b>	Adjustable speed electrical power drive systems Part 5-2: Safety requirements – Functional safety (IEC 61800-5-2: 2007)

## SINAMICS S120 Cabinet Modules

Air-cooled units

### Air-cooled units

#### Overview

##### Line Modules

Power is fed to the drive line-up via Line Modules, which generate a DC voltage from the line voltage and, therefore, supply energy to the Motor Modules connected to the DC link. They are suitable for connection to grounded TN/TT and non-grounded IT systems.

The Line Modules are connected to the line supply system via Line Connection Modules and are equipped as standard according to Category C3. Category C3 is part of the "second environment" (in accordance with EN 61800-3). The "second environment" constitutes locations outside residential areas or industrial sites which are supplied from the medium-voltage network via a separate transformer.

The range of Line Modules has power ratings from 132 kW to 900 kW (380 V to 480 V) and from 250 kW to 1500 kW (500 V to 690 V). Furthermore, up to four identical Line Modules can be connected in parallel in order to increase the power rating.

For a compact configuration, Line Connection Modules up to input currents of 3200 A are available. Two Line Modules can be operated in parallel on these Line Connection Modules.

The following types of Line Module are available:

- Basic Line Modules
- Smart Line Modules
- Active Line Modules

##### Basic Line Modules

Basic Line Modules are designed only for infeed operation, i.e. they are not capable of recovering energy to the line supply.

If regenerative energy is produced, e.g. when the drives brake, then it must be converted to heat by means of a Braking Module and a braking resistor.

When a Basic Line Module is used as the infeed, a line reactor appropriate to the supply conditions must be installed. Line reactors are generally required if two or more Basic Line Modules are operated in parallel on a common supply system in order to increase power.

For this reason, line reactors are installed in the appropriate Line Connection Module as standard.

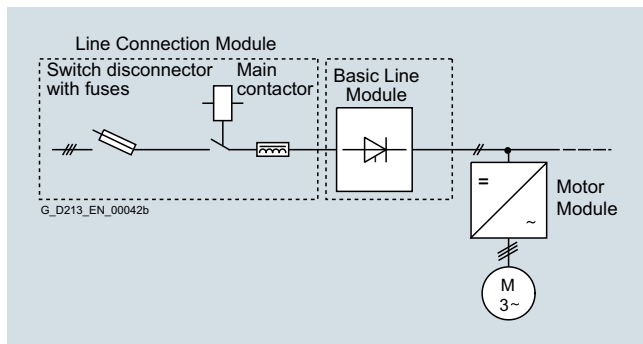

Line Connection Module with Basic Line Module  $\leq 800$  A

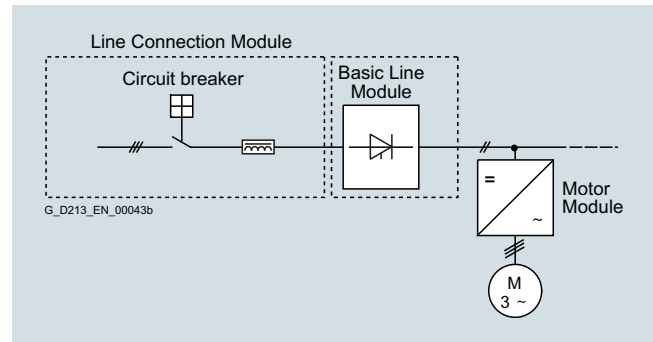

Line Connection Module with Basic Line Module  $> 800$  A

If, for example, a converter transformer is used to connect to the line supply (12-pulse operation), it may be possible to omit line reactors (depending on the supply conditions on site) and they can be optionally deselected (option **L22** for a Line Connection Module combined with a Basic Line Module).

For a compact configuration, Line Connection Modules with input currents of up to 3200 A are available. Two Basic Line Modules can be operated in parallel on these Line Connection Modules. Versions with line-side fuses are available for parallel connections in order to provide selective protection of the individual Basic Line Modules.

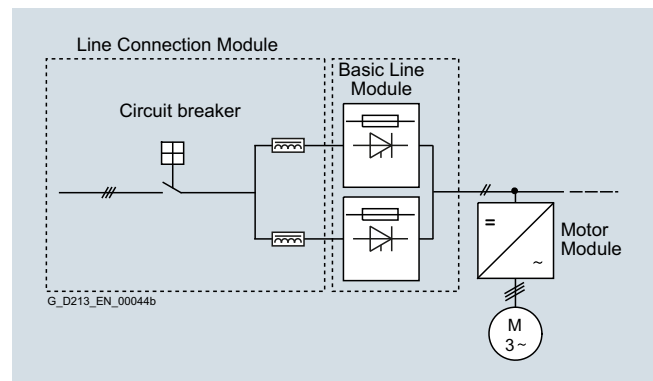

Line Connection Module with Basic Line Modules connected in parallel

**Overview** (continued)

Smart Line Modules

Smart Line Modules can supply energy to the DC link and return regenerative energy to the supply system. A Braking Module and braking resistor are required only if the drives need to be decelerated in a controlled manner after a power failure (i.e. when energy cannot be recovered to the supply). When a Smart Line Module is used as the infeed, the necessary line reactor is included in the device as standard and can be optionally deselected (option **L22**).

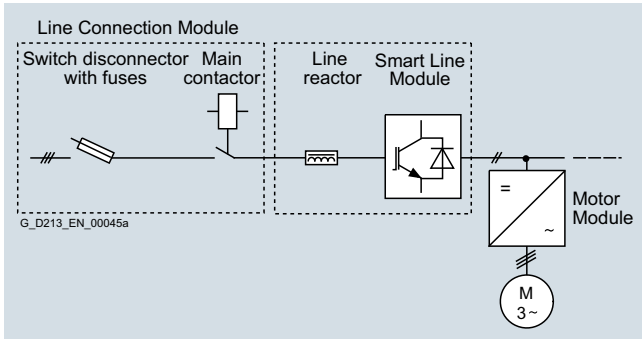

Line Connection Module with Smart Line Module ≤ 800 A

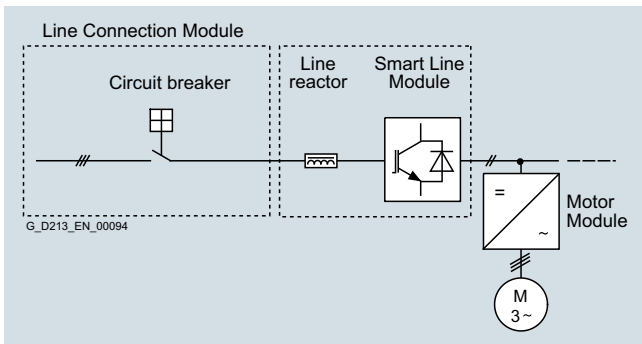

Line Connection Module with Smart Line Module > 800 A

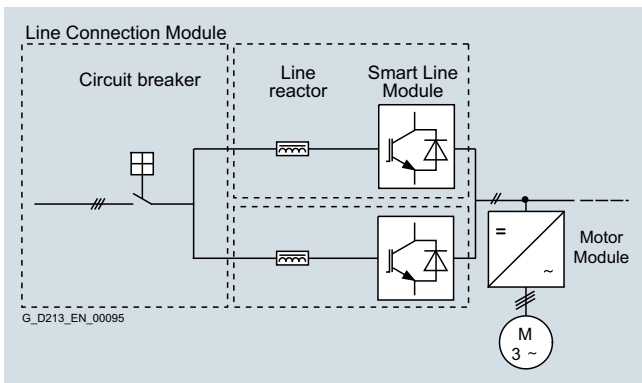

Line Connection Module with Smart Line Modules connected in parallel

Active Line Modules

Active Line Modules can supply energy to the DC link and return regenerative energy to the supply system. A Braking Module and braking resistor are required only if the drives need to be decelerated in a controlled manner after a power failure (i.e. when energy cannot be recovered to the supply).

In contrast to Basic Line Modules and Smart Line Modules, however, Active Line Modules generate a regulated DC voltage which remains constant despite fluctuations in the line voltage. However, in this case, the line voltage must remain within the permissible tolerance range. Active Line Modules in combination with an Active Interface Module draw a virtually sinusoidal current from the supply system. Almost no harmonics occur. The total harmonic distortion factors of current THD(I) and voltage THD(U) are typically in the range of approx. 3%. The stringent limit values of IEEE 519 (2014) are complied with.

Active Line Modules must always be used in conjunction with an Active Interface Module. Active Interface Modules include the required pre-charging circuit for the Active Line Module in addition to a Clean Power Filter. For SINAMICS S120 Cabinet Modules, these two components are always regarded as a single unit.

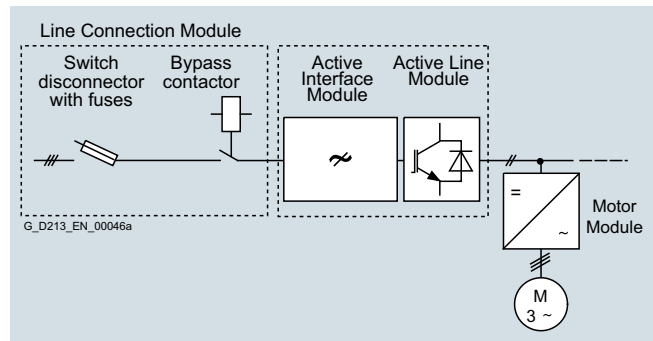

Line Connection Module with Active Interface Module and Active Line Module ≤ 800 A (example frame size HX + HI)

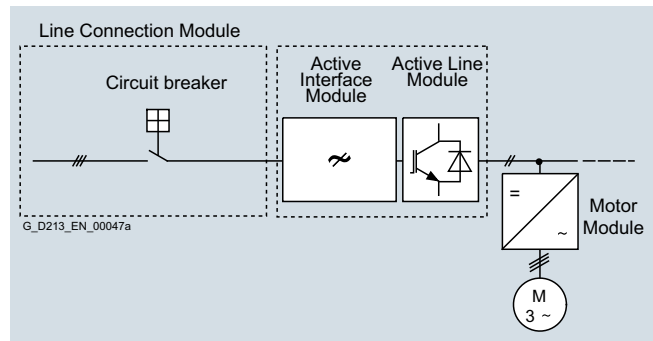

Line Connection Module with Active Interface Module and Active Line Module > 800 A

## SINAMICS S120 Cabinet Modules

### Air-cooled units

#### Air-cooled units

#### Overview (continued)

In the example, two units comprising an Active Interface Module and Active Line Module are connected in parallel to jointly supply the DC link.

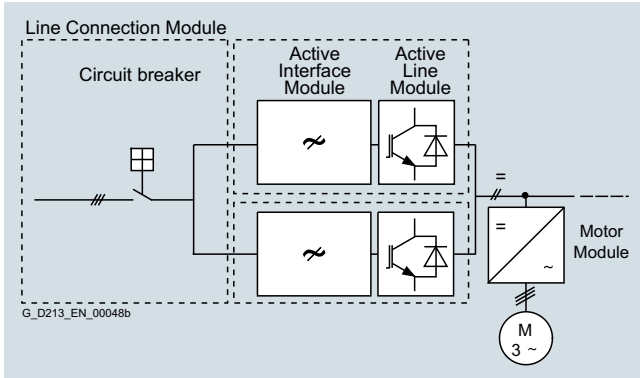

Line Connection Module with Active Interface Modules and Active Line Modules connected in parallel

#### DC link components

Braking Modules enable braking resistors to absorb the regenerative energy produced during drive deceleration, which is then converted into heat. Using a Braking Module and a braking resistor, it is possible to brake motors even when the power fails.

#### Braking Modules as a Line Module or Motor Module option

For lower braking powers, Braking Modules are available with continuous braking powers up to 50 kW. These Braking Modules are ordered as an option for the Line Modules and Motor Modules (order codes **L61/L64** (25 kW) or **L62/L65** (50 kW), refer to the [Description of the options](#)).

#### Central Braking Modules

For higher continuous braking powers, separate Central Braking Modules are available. These modules are used centrally in the drive line-up. To increase the braking power, up to four Central Braking Modules can be connected in parallel.

#### Motor Modules

There are two different types of Motor Module available with the SINAMICS S120 Cabinet Modules drive system.

#### Booksized Base Cabinets with Booksized Cabinet Kits

Motor Modules at the low end of the power range from 4.8 kW to 71 kW (380 V to 480 V) can be implemented as Booksized Cabinet Kits installed in Booksized Base Cabinets.

#### Chassis Cabinets

Each Chassis Cabinet is fitted with one SINAMICS S120 Motor Module in chassis format and covers the power range from 75 kW to 1200 kW (380 V to 480 V or 500 V to 690 V). The power rating can be extended up to approx. 4500 kW by connecting up to four Motor Modules in chassis format in parallel.

SINAMICS S120 Motor Modules in chassis format can also be used as a Braking Module (braking chopper) if a 3-phase braking resistor is connected instead of a motor.

[For more information on this topic, please refer to the SINAMICS Low Voltage Engineering Manual.](#)

#### Auxiliary Power Supply Modules

Auxiliary Power Supply Modules supply power to the auxiliary power supply system of the SINAMICS S120 Cabinet Modules.

Units connected to this auxiliary power supply system include the fans of the SINAMICS S120 devices installed in the Cabinet Modules. In addition, the auxiliary power supply system supplies the electronic modules with an external 24 V DC voltage. This is required when the DC link is not charged, for instance, in order to maintain PROFIBUS or PROFINET communication.



### Technical specifications

#### General technical specifications

Electrical specifications			
<b>Line voltages</b>	380 ... 480 V 3 AC, ±10 % (-15 % <1 min) 500 ... 690 V 3 AC, ±10 % (-15 % <1 min)		
<b>Line supply types</b>	Grounded TN/TT systems and non-grounded IT systems		
<b>Line frequency</b>	47 ... 63 Hz		
<b>Output frequency <sup>1)</sup></b>	0 ... 550 Hz		
• Control type Servo	0 ... 550 Hz		
• Control type Vector	0 ... 550 Hz		
• Control mode V/f	0 ... 550 Hz		
<b>Line power factor</b>	>0.96		
<b>Fundamental</b>	>0.96		
• Basic Line Module	Adjustable (factory-set to $\cos \varphi = 1$ )		
• Smart Line Module			
• Active Line Module			
<b>Efficiency</b>	>99 %		
• Basic Line Module	>98.5 %		
• Smart Line Module	>97.5 % (including Active Interface Module)		
• Active Line Module	>98.5 %		
• Motor Module			
<b>Overvoltage category</b>	III acc. to EN 61800-5-1		
<b>Control method</b>	Vector/Servo control with and without encoder or V/f control		
<b>Fixed speeds</b>	15 fixed speeds plus 1 minimum speed, parameterizable (in the default setting, 3 fixed setpoints plus 1 minimum speed are selectable using terminal block/PROFIBUS/PROFINET)		
<b>Skippable speed ranges</b>	4, parameterizable		
<b>Setpoint resolution</b>	0.001 rpm digital (14 bits + sign) 12 bits analog		
<b>Braking operation</b>	With Active Line Modules and Smart Line Modules, four-quadrant operation as standard (energy recovery) With Basic Line Modules, two-quadrant operation as standard, braking by means of an optional braking chopper, or alternatively by a Motor Module		
Cabinet system			
<b>Cabinet system</b>	Rittal TS 8, doors with double-bit key, three-section base plates for cable entry		
<b>Paint finish</b>	RAL 7035 (indoor requirements)		
Mechanical specifications			
<b>Degree of protection</b>	IP20 (higher degrees of protection up to IP54 optional)		
<b>Protection class</b>	I acc. to EN 61800-5-1		
<b>Touch protection</b>	EN 50274/DGUV regulation 3 when used as intended		
<b>Cooling method</b>	Forced air cooling AF according to EN 60146		
Ambient conditions	Storage <sup>2)</sup>	Transport <sup>2)</sup>	Operation
<b>Ambient temperature</b>	-25 ... +55 °C	-25 ... +70 °C from -40 °C for 24 hours	0 ... +40 °C to +50 °C <a href="#">see derating data</a>
<b>Relative humidity</b> (condensation not permissible)	5 ... 95 % Class 1K4 acc. to IEC 60721-3-1	5 ... 95 % at 40 °C Class 2K3 acc. to IEC 60721-3-2	5 ... 95 % Class 3K3 acc. to IEC 60721-3-3
<b>Environmental class/harmful chemical substances</b>	Class 1C2 acc. to EN 60721-3-1	Class 2C2 acc. to EN 60721-3-2	Class 3C2 acc. to EN 60721-3-3
<b>Organic/biological influences</b>	Class 1B1 acc. to EN 60721-3-1	Class 2B1 acc. to EN 60721-3-2	Class 3B1 acc. to EN 60721-3-3
<b>Degree of pollution</b>	2 acc. to IEC/EN 61800-5-1		
<b>Installation altitude</b>	Cabinet Modules chassis format: ≤ 2000 m above sea level - no derating; >2000 m, see <a href="#">characteristic curves/derating data</a> For Booksize Cabinet Kit format Motor Modules as well as Central Braking Modules: ≤ 1000 m above sea level without derating, > 1000 m, see <a href="#">characteristic curves/derating data</a>		
Mechanical stability	Storage <sup>2)</sup>	Transport <sup>2)</sup>	Operation
<b>Vibratory load</b>	Class 1M2 acc. to EN 60721-3-1 1.5 mm at 5 ... 9 Hz 5 m/s <sup>2</sup> at >9 ... 200 Hz	Class 2M2 acc. to EN 60721-3-2 3.1 mm at 5 ... 9 Hz 10 m/s <sup>2</sup> at >9 ... 200 Hz	-
• Deflection			0.075 mm at 10 ... 58 Hz
• Acceleration			9.8 m/s <sup>2</sup> at >58 ... 200 Hz
<b>Shock load</b>	Class 1M2 acc. to EN 60721-3-1 40 m/s <sup>2</sup> at 22 ms	Class 2M2 acc. to EN 60721-3-2 100 m/s <sup>2</sup> at 11 ms	Class 3M4 acc. to EN 60721-3-3 100 m/s <sup>2</sup> at 11 ms
• Acceleration			
Compliance with standards			
<b>Conformances/certificates of suitability, according to</b>	CE (EMC Directive 2014/30/EU, Low Voltage Directive 2014/35/EU, and Machinery Directive 2006/42/EC for functional safety), RCM		
<b>Radio interference suppression</b>	SINAMICS drive converter systems are not designed for connection to the public grid (first environment). Radio interference suppression is compliant with the EMC product standard for variable-speed drives EN 61800-3, "second environment" (industrial networks). EMC disturbances can occur when connected to the public grid. However, if additional measures are taken (e.g. → line filter), it can also be operated in the "first environment".		

Deviations from the specified class are underlined.

<sup>1)</sup> Higher output frequencies available on request.

<sup>2)</sup> In transport packaging.



## SINAMICS S120 Cabinet Modules

### Air-cooled units

#### Air-cooled units

#### Characteristic curves

##### Derating data for the chassis format

SINAMICS S120 Cabinet Modules and the associated system components are rated for an ambient temperature of 40 °C and installation altitudes up to 2000 m above sea level.

At ambient temperatures > 40 °C, the output current must be reduced. Ambient temperatures above 50 °C are not permissible.

At installation altitudes > 2000 m above sea level, it must be taken into account that the air pressure, and therefore air density, decreases as the height increases. As a consequence, the cooling efficiency and the insulation capacity of the air also decrease.

Due to the reduced cooling efficiency, it is necessary to both reduce the ambient temperature and lower heat loss in the Cabinet Module by reducing the output current, whereby ambient temperatures lower than 40 °C may be offset to compensate.

The following table specifies the permissible output currents as a function of the installation altitude and ambient temperature for the various degrees of protection. (The permissible compensation between installation altitude and ambient temperatures < 40 °C – air intake temperature at the entry to the Cabinet Module – has been taken into account in the specified values.)

The values apply under the precondition that it is guaranteed that the cooling air, as specified in the technical specifications, flows through the units as a result of the cabinet arrangement.

As an additional measure for installation altitudes from 2000 m up to 5000 m, an isolating transformer is required in order to reduce transient overvoltages according to EN 60664-1.

[For additional information, please refer to the SINAMICS Low Voltage Engineering Manual.](#)

Current derating factors for Cabinet Modules as a function of the ambient/air intake temperature, the installation altitude and the degree of protection

Degree of protection	Installation altitude above sea level m	Current derating factor (as a percentage of the rated current) for an ambient / air intake temperature of						
		20 °C	25 °C	30 °C	35 °C	40 °C	45 °C	50 °C
IP20, IP21, IP23, IP43	0 ... 2000						93.3 %	86.7 %
	2001 ... 2500					96.3 %		
	2501 ... 3000		100 %		98.7 %			
	3001 ... 3500				96.3 %			
	3501 ... 4000				97.5 %			
	4001 ... 4500				98.2 %			
IP54	0 ... 2000					93.3 %	86.7 %	80 %
	2001 ... 2500				96.3 %	89.8 %		
	2501 ... 3000		100 %		98.7 %	92.5 %		
	3001 ... 3500				94.7 %			
	3501 ... 4000				96.3 %	90.7 %		
	4001 ... 4500				97.5 %	92.1 %		
	4501 ... 5000				93 %			

### Characteristic curves (continued)

#### Current derating for SINAMICS S120 Motor Modules, chassis format as a function of the pulse frequency

To reduce motor noise or to increase output frequency, the pulse frequency can be increased relative to the factory setting (1.25 kHz or 2 kHz). When the pulse frequency is increased,

the derating factor of the output current must be taken into account. This derating factor must be applied to the currents specified in the technical specifications.

For additional information, please refer to the [SINAMICS Low Voltage Engineering Manual](#).

#### Derating factor of the output current as a function of the pulse frequency for units with a rated pulse frequency of 2 kHz

Motor Module in chassis format 6SL3720-...	Type rating at 400 V kW	Output current at 2 kHz A	Derating factor at pulse frequency				
			2.5 kHz	4 kHz	5 kHz	7.5 kHz	8 kHz
<b>380 ... 480 V 3 AC</b>							
1TE32-1AA3	110	210	95 %	82 %	74 %	54 %	50 %
1TE32-6AA3	132	260	95 %	83 %	74 %	54 %	50 %
1TE33-1AA3	160	310	97 %	88 %	78 %	54 %	50 %
1TE33-8AA3	200	380	96 %	87 %	77 %	54 %	50 %
1TE35-0AA3	250	490	94 %	78 %	71 %	53 %	50 %

#### Derating factor of the output current as a function of the pulse frequency for units with a rated pulse frequency of 1.25 kHz

Motor Module in chassis format 6SL3720-...	Type rating at 400 V or 690 V kW	Output current at 1.25 kHz A	Derating factor at pulse frequency					
			2 kHz	2.5 kHz	4 kHz	5 kHz	7.5 kHz	8 kHz
<b>380 ... 480 V 3 AC</b>								
1TE36-1AA3	315	605	83 %	72 %	64 %	60 %	40 %	36 %
1TE37-5AA3	400	745	83 %	72 %	64 %	60 %	40 %	36 %
1TE38-4AA3	450	840	87 %	79 %	64 %	55 %	40 %	37 %
1TE41-0AA3	560	985	92 %	87 %	70 %	60 %	50 %	47 %
1TE41-2AA3	710	1260	92 %	87 %	70 %	60 %	50 %	47 %
1TE41-4AA3	800	1405	97 %	95 %	74 %	60 %	50 %	47 %
<b>500 ... 690 V 3 AC</b>								
1TG28-5AA3	75	85	93 %	89 %	71 %	60 %	40 %	–
1TG31-0AA3	90	100	92 %	88 %	71 %	60 %	40 %	–
1TG31-2AA3	110	120	92 %	88 %	71 %	60 %	40 %	–
1TG31-5AA3	132	150	90 %	84 %	66 %	55 %	35 %	–
1TG31-8AA3	160	175	92 %	87 %	70 %	60 %	40 %	–
1TG32-2AA3	200	215	92 %	87 %	70 %	60 %	40 %	–
1TG32-6AA3	250	260	92 %	88 %	71 %	60 %	40 %	–
1TG33-3AA3	315	330	89 %	82 %	65 %	55 %	40 %	–
1TG34-1AA3	400	410	89 %	82 %	65 %	55 %	35 %	–
1TG34-7AA3	450	465	92 %	87 %	67 %	55 %	35 %	–
1TG35-8AA3	560	575	91 %	85 %	64 %	50 %	35 %	–
1TG37-4AA3	710	735	87 %	79 %	64 %	55 %	25 %	–
1TG38-1AA3	800	810	97 %	95 %	71 %	55 %	35 %	–
1TG38-8AA3	900	910	92 %	87 %	67 %	55 %	33 %	–
1TG41-0AA3	1000	1025	91 %	86 %	64 %	50 %	30 %	–
1TG41-3AA3	1200	1270	87 %	79 %	55 %	40 %	25 %	–

The following tables list the maximum achievable output frequency as a function of the pulse frequency:

#### Maximum output frequencies achieved by increasing the pulse frequency in Vector mode

Pulse frequency	Max. achievable output frequency
1.25 kHz	100 Hz
2 kHz	160 Hz
2.5 kHz	200 Hz
4 kHz	300 Hz

#### Maximum output frequencies achieved by increasing the pulse frequency in Servo mode

Pulse frequency	Max. achievable output frequency
2 kHz	300 Hz
4 kHz	300/550 Hz <sup>1)</sup>

<sup>1)</sup> Higher frequencies on request.

## SINAMICS S120 Cabinet Modules

### Air-cooled units

#### Air-cooled units

#### Characteristic curves (continued)

##### Derating data for the booksize format

SINAMICS S120 Cabinet Modules with power units in booksize format and the associated system components are rated for an ambient temperature of 40 °C and installation altitudes up to 1000 m above sea level. If SINAMICS S120 Cabinet Modules with power units in booksize format are operated at ambient temperatures higher than 40 °C and/or installation altitudes higher than 1000 m above sea level, then the corresponding derating factors must be taken into account as a function of the ambient temperature and/or the installation altitude. [These derating factors are different from the derating factors for the chassis format power units and are listed in Catalog PM 21.](#)

##### Overload capability

SINAMICS S120 Cabinet Modules have an overload reserve, e.g. to handle breakaway torques. If larger surge loads occur, this must be taken into account in the configuration. For drives with overload requirements, the appropriate base-load current must therefore be used as a basis for the required load.

Permissible overload assumes that the drive converter is operated at its base-load current before and after the overload occurs, based on a duty cycle duration of 300 s.

Another precondition is that the Motor Modules are operated at their factory-set pulse frequency at output frequencies >10 Hz.

For temporary, periodic duty cycles with high variations of load within the duty cycle, the relevant sections of the SINAMICS Low Voltage Engineering Manual must be observed.

##### Motor Modules in chassis format

Motor Modules with power units in chassis format can be configured on the basis of different base-load currents.

The base-load current for a low overload  $I_L$  is based on a duty cycle of 110 % for 60 s or 150 % for 10 s.

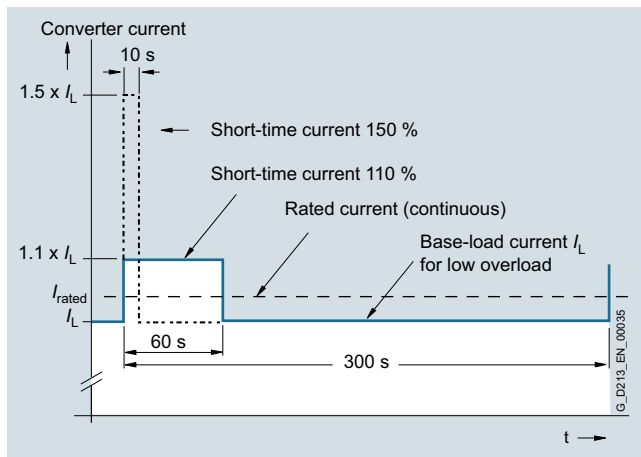

Low overload

The base-load current  $I_H$  for a high overload is based on a duty cycle of 150 % for 60 s or 160 % for 10 s.

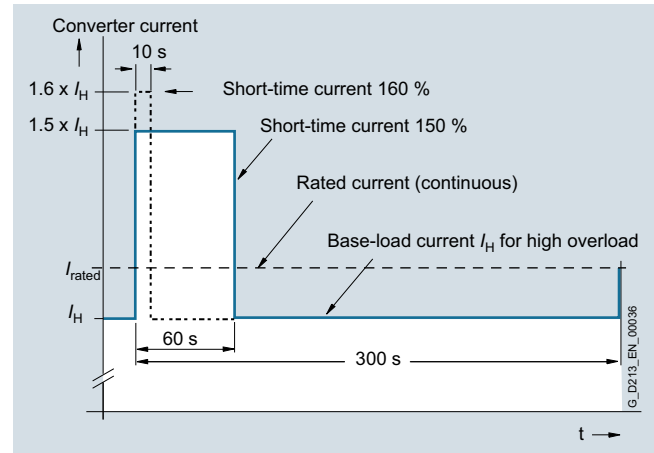

High overload

##### Motor Modules in booksize format

Motor Modules with power units in booksize format have the following overload capabilities:

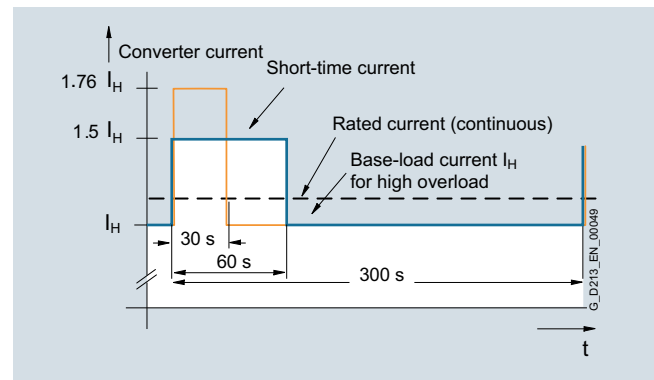

High overload

##### Line Modules in chassis format

The base-load current for a high overload  $I_{HDC}$  is based on a duty cycle of 150 % for 60 s or  $I_{maxDC}$  for 5 s.

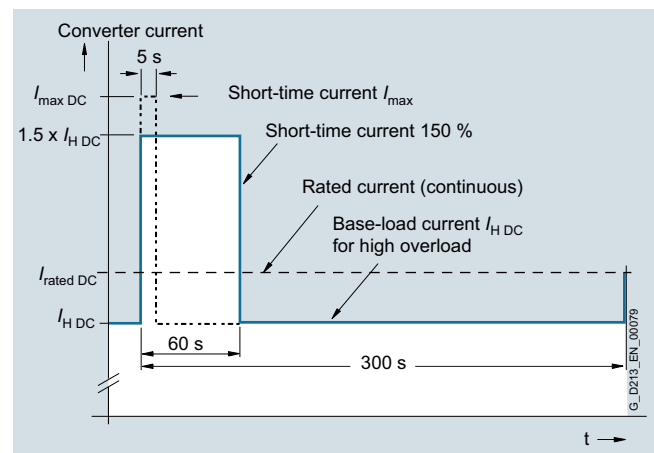

## Overview



Line Connection Modules (LCM) contain the line-side infeed via main circuit breaker with fuse switch disconnecter or circuit breaker and provide the connection between the plant power system and the Line Modules.

Line Connection Modules are available for the following voltages and currents:

Line voltage	Rated infeed/ regenerative feedback current
380 ... 480 V 3 AC	250 ... 3200 A
500 ... 690 V 3 AC	280 ... 3200 A

## Design

Different versions exist depending on the input current:

- Units  $\leq 800$  A are equipped with a main circuit breaker with a fuse switch disconnecter
- Units  $> 800$  A are equipped with a fixed-mounted circuit breaker (draw-out circuit breaker is available as an option)

When Line Connection Modules are ordered, the type of Line Module used must be specified:

- For Basic Line Modules: Option **L43**
- For Smart Line Modules: Option **L44**
- For Active Line Modules: Option **L42**

When using a Basic Line Module, a reactor is included in the scope of delivery of the Line Connection Module, and when required, can be deselected (option **L22**).

For additional information, please refer to the [SINAMICS Low Voltage Engineering Manual](#).

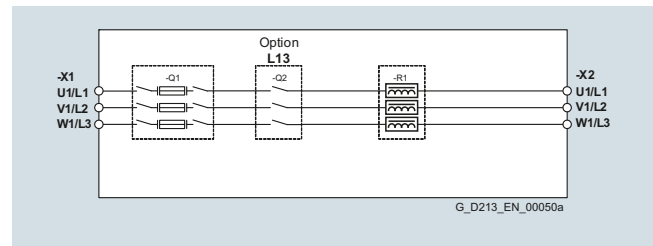

Connection example: Line Connection Module for units  $\leq 800$  A to connect to Basic Line Modules, option **L43**, option main contactor, order code **L13**

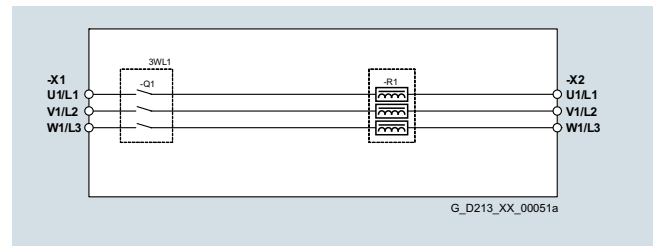

Connection example: Line Connection Module for units  $> 800$  A,  $< 2000$  A to connect to Basic Line Modules, option **L43**

For input currents  $\geq 2000$  A, additional options are available:

- Grounding switch upstream of main circuit breaker: Option **L46**
- Current transformer upstream of main circuit breaker: Option **L41**
- Grounding switch downstream of main circuit breaker: Option **L47**

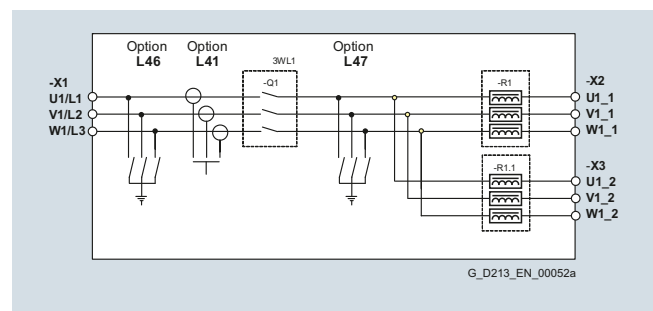

Connection example: Line Connection Module  $\geq 2000$  A

## SINAMICS S120 Cabinet Modules

Air-cooled units

### Line Connection Modules

#### Design (continued)

When Basic Line Modules that are fed via a common Line Connection Module are connected in parallel, line reactors are generally required. These are installed in the Line Connection Module.

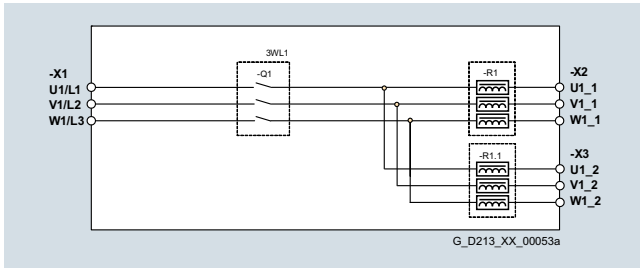

Connection example: Line Connection Module  $\geq 2000$  A for connection to Basic Line Modules, option **L43**

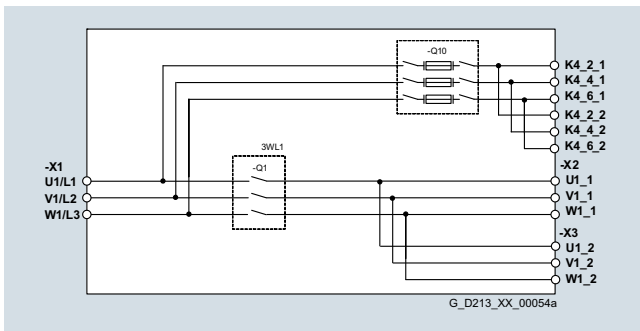

Connection example: Line Connection Module  $\geq 2000$  A for connection to Active Line Modules in parallel connection, option **L42**

#### Selection and ordering data

Rated infeed/ regenerative feedback current <sup>1)</sup> A	Line Connection Module Article No.
<b>Line voltage 380 ... 480 V 3 AC</b>	
250	<b>6SL3700-0LE32-5AA3</b>
380	<b>6SL3700-0LE34-0AA3</b>
600	<b>6SL3700-0LE36-3AA3</b>
770	<b>6SL3700-0LE38-0AA3</b>
1000	<b>6SL3700-0LE41-0AA3</b>
1250	<b>6SL3700-0LE41-3AA3</b>
1600	<b>6SL3700-0LE41-6AA3</b>
2000	<b>6SL3700-0LE42-0AA3</b>
2000	<b>6SL3700-0LE42-0BA3</b>
2500	<b>6SL3700-0LE42-5BA3</b>
3200	<b>6SL3700-0LE43-2BA3</b>
<b>Line voltage 500 ... 690 V 3 AC</b>	
280	<b>6SL3700-0LG32-8AA3</b>
380	<b>6SL3700-0LG34-0AA3</b>
600	<b>6SL3700-0LG36-3AA3</b>
770	<b>6SL3700-0LG38-0AA3</b>
1000	<b>6SL3700-0LG41-0AA3</b>
1250	<b>6SL3700-0LG41-3AA3</b>
1600	<b>6SL3700-0LG41-6AA3</b>
2000	<b>6SL3700-0LG42-0BA3</b>
2500	<b>6SL3700-0LG42-5BA3</b>
3200	<b>6SL3700-0LG43-2BA3</b>

#### Note:

When ordering Line Connection Modules, the option order code must be appended to the article number to indicate whether the Line Connection Module is to be connected to a Basic Line Module (option **L43**), a Smart Line Module (option **L44**) or an Active Line Module (option **L42**).

This information is required to ensure that the Line Connection Module is correctly equipped at the factory. This particularly applies to the busbar connection at the 3-phase end (3 AC), to any pre-charging circuits required and to the specified line reactors for Basic Line Modules.

When Cabinet Modules are selected and combined, the specified equipping and preparation of the Line Connection Modules is performed at the factory in accordance with the assignment table in the Integration section. For all other combinations deviating from this, this is not the case. In such cases, the 3-AC busbar connections will have to be engineered and installed on site.

<sup>1)</sup> The current values stated are based on an ambient temperature (air intake temperature) of 40 °C.

### Integration

Line Connection Module		Basic Line Module		Smart Line Module		Active Line Module	
Rated infeed/ regenerative feed- back current <sup>1)</sup>		Rated input current		Rated infeed/ regenerative feed- back current		Rated infeed/ regenerative feed- back current	
A		A		A		A	
<b>Line voltage 380 ... 480 V 3 AC</b>							
250	6SL3700-0LE32-5AA3	–	–	–	–	210	6SL3730-7TE32-1BA3
380	6SL3700-0LE34-0AA3	–	–	–	–	260	6SL3730-7TE32-6BA3
600	6SL3700-0LE36-3AA3	365	6SL3730-1TE34-2AA3	463	6SL3730-6TE35-5AA3	380	6SL3730-7TE33-8BA3
		460	6SL3730-1TE35-3AA3			490	6SL3730-7TE35-0BA3
770	6SL3700-0LE38-0AA3	710	6SL3730-1TE38-2AA3	614	6SL3730-6TE37-3AA3	605	6SL3730-7TE36-1BA3
1000	6SL3700-0LE41-0AA3	–	–	883	6SL3730-6TE41-1AA3	840	6SL3730-7TE38-4BA3
1250	6SL3700-0LE41-3AA3	1010	6SL3730-1TE41-2AA3	1093	6SL3730-6TE41-3AA3	985	6SL3730-7TE41-0BA3
1600	6SL3700-0LE41-6AA3	1265	6SL3730-1TE41-5AA3	1430	6SL3730-6TE41-7AA3	1405	6SL3730-7TE41-4BA3
2000	6SL3700-0LE42-0AA3	1630	6SL3730-1TE41-8AA3	–	–	–	–
2000	6SL3700-0LE42-0BA3	2 × 935	6SL3730-1TE41-2BA3	2 × 817	6SL3730-6TE41-1BA3	2 × 936	6SL3730-7TE41-0BA3
			6SL3730-1TE41-2BC3		6SL3730-6TE41-1BC3		6SL3730-7TE41-0BC3
2500	6SL3700-0LE42-5BA3	2 × 1170	6SL3730-1TE41-5BA3	2 × 1011	6SL3730-6TE41-3BA3	–	–
			6SL3730-1TE41-5BC3		6SL3730-6TE41-3BC3		–
3200	6SL3700-0LE43-2BA3	2 × 1508	6SL3730-1TE41-8BA3	2 × 1323	6SL3730-6TE41-7BA3	2 × 1335	6SL3730-7TE41-4BA3
			6SL3730-1TE41-8BC3		6SL3730-6TE41-7BC3		6SL3730-7TE41-4BC3
<b>Line voltage 500 ... 690 V 3 AC</b>							
280	6SL3700-0LG32-8AA3	260	6SL3730-1TG33-0AA3	–	–	–	–
380	6SL3700-0LG34-0AA3	375	6SL3730-1TG34-3AA3	–	–	–	–
600	6SL3700-0LG36-3AA3	575	6SL3730-1TG36-8AA3	463	6SL3730-6TG35-5AA3	575	6SL3730-7TG35-8BA3
770	6SL3700-0LG38-0AA3	–	–	757	6SL3730-6TG38-8AA3	735	6SL3730-7TG37-4BA3
1000	6SL3700-0LG41-0AA3	925	6SL3730-1TG41-1AA3	–	–	–	–
1250	6SL3700-0LG41-3AA3	1180	6SL3730-1TG41-4AA3	1009	6SL3730-6TG41-2AA3	1025	6SL3730-7TG41-0BA3
1600	6SL3700-0LG41-6AA3	1580	6SL3730-1TG41-8AA3	1430	6SL3730-6TG41-7AA3	1270	6SL3730-7TG41-3BA3
2000	6SL3700-0LG42-0BA3	2 × 855	6SL3730-1TG41-1BA3	2 × 700	6SL3730-6TG38-8BA3	2 × 698	6SL3730-7TG37-4BA3
			6SL3730-1TG41-1BC3		6SL3730-6TG38-8BC3		6SL3730-7TG37-4BC3
2500	6SL3700-0LG42-5BA3	–	–	2 × 934	6SL3730-6TG41-2BA3	2 × 974	6SL3730-7TG41-0BA3
			–		6SL3730-6TG41-2BC3		6SL3730-7TG41-0BC3
3200	6SL3700-0LG43-2BA3	2 × 1092	6SL3730-1TG41-4BA3	–	–	2 × 1206	6SL3730-7TG41-3BA3
			6SL3730-1TG41-4BC3		–		6SL3730-7TG41-3BC3
3200	6SL3700-0LG43-2BA3	2 × 1462	6SL3730-1TG41-8BA3	2 × 1323	6SL3730-6TG41-7BA3	–	–
			6SL3730-1TG41-8BC3		6SL3730-6TG41-7BC3		–
<p><i>Entries in italics:</i> Parallel circuit of two Line Modules connected to a Line Connection Module.  The required derating factors listed below are already included in the current values given above:</p> <ul style="list-style-type: none"> <li>• 7.5% for Basic Line Modules</li> <li>• 7.5% for Smart Line Modules</li> <li>• 5% for Active Line Modules</li> </ul>							

<sup>1)</sup> The current values stated are based on an ambient temperature (air intake temperature) of 40 °C.

# SINAMICS S120 Cabinet Modules

## Air-cooled units

### Line Connection Modules

#### Technical specifications

Line voltage 380 ... 480 V 3 AC		Line Connection Modules						
		6SL3700-0LE32-5AA3	6SL3700-0LE34-0AA3	6SL3700-0LE36-3AA3	6SL3700-0LE38-0AA3	6SL3700-0LE41-0AA3	6SL3700-0LE41-3AA3	
<b>Infeed/regenerative feedback current</b>								
• Rated current $I_{rated}$	A	<b>250</b>	<b>380</b>	<b>600</b>	<b>770</b>	<b>1000</b>	<b>1250</b>	
<b>Current demand</b>								
• Fan power supply 230 V AC	A	–	–	–	–	1.07	1.07	
• 230 V AC <sup>1)</sup>								
- Inrush current	A	3.6	3.6	3.6	10.8	0.5	0.5	
- Holding current	A	0.04	0.04	0.04	0.12	0.06	0.06	
<b>Power loss, max. <sup>2)</sup></b>								
• At 50 Hz 400 V								
- Option <b>L42/L44</b>	kW	0.115	0.19	0.31	0.39	0.18	0.29	
- Option <b>L43</b>	kW	–	–	0.675	0.74	–	0.787	
• At 60 Hz 460 V								
- Option <b>L42/L44</b>	kW	0.115	0.19	0.31	0.39	0.18	0.29	
- Option <b>L43</b>	kW	–	–	0.675	0.74	–	0.787	
<b>Cooling air requirement <sup>3)</sup></b>		m <sup>3</sup> /s	–	–	–	0.36	0.36	
<b>Sound pressure level <math>L_{pA}</math></b> (1 m) at 50/60 Hz		dB	–	–	–	68/70	68/70	
<b>Line supply connection</b> L1, L2, L3			2/M12	2/M12	2/M12	4/M12	5/M12 + 4/M16	5/M12 + 4/M16
• Conductor cross-section, max. (IEC)	mm <sup>2</sup>	2 × 150	2 × 150	4 × 240	8 × 240	8 × 240	8 × 240	
<b>PE/GND connection</b>			PE bar	PE bar	PE bar	PE bar	PE bar	
• Busbar cross-section	mm <sup>2</sup>	600	600	600	600	600	600	
• Conductor cross-section, max. (IEC)	mm <sup>2</sup>	240	240	240	240	240	240	
<b>Degree of protection</b>			IP20	IP20	IP20	IP20	IP20	
<b>Dimensions</b>								
• Width	mm	400	400	600	600	600	600	
• Height <sup>4)</sup>	mm	2200	2200	2200	2200	2200	2200	
• Depth	mm	600	600	600	600	600	600	
<b>Weight, approx.</b>								
• Option <b>L42/L44</b>	kg	210	230	310	340	450	470	
• Option <b>L43</b>	kg	–	–	360	420	–	570	
<b>Frame size</b>			FL	FL	GL	HL	JL	JL
<b>Short-circuit current rating according to IEC</b>		kA	50	50	50	50	50	
<b>Minimum short-circuit current <sup>5)</sup></b>		A	3000	3000	8000	12000	2000	2500

<sup>1)</sup> Current demand of contactors/circuit breakers and fans with degree of protection IP23, IP43, IP54 (in combination with Basic Line Modules).

<sup>2)</sup> The specified power loss represents the maximum value at 100 % utilization. The value is lower under normal operating conditions.

<sup>3)</sup> For IP23, IP43 or IP54 degree of protection only (in combination with Basic Line Modules).

<sup>4)</sup> The cabinet height increases by 250 mm with degree of protection IP21, and by 400 mm with degrees of protection IP23, IP43 and IP54.

<sup>5)</sup> Current required to ensure reliable tripping of installed protective devices.

**Technical specifications (continued)**

Line voltage 380 ... 480 V 3 AC	Line Connection Modules					
		6SL3700-OLE41-6AA3	6SL3700-OLE42-0AA3	6SL3700-OLE42-0BA3	6SL3700-OLE42-5BA3	6SL3700-OLE43-2BA3
		<i>Prepared for connection to Line Modules connected in parallel</i>				
<b>Infeed/regenerative feedback current</b>						
• Rated current $I_{rated}$	A	<b>1600</b>	<b>2000</b>	<b>2000</b>	<b>2500</b>	<b>3200</b>
<b>Current demand</b>						
• Fan power supply 230 V AC	A	1.07	2.14	2.14	2.14	2.14
• 230 V AC <sup>1)</sup>						
- Inrush current	A	0.5	0.5	0.5	0.5	0.5
- Holding current	A	0.06	0.06	0.06	0.06	0.04
<b>Power loss, max. <sup>2)</sup></b>						
• At 50 Hz 400 V						
- Option <b>L42/L44</b>	kW	0.41	0.6	0.6	0.95	0.95
- Option <b>L43</b>	kW	1.186	1.366	1.594	2.502	2.482
• At 60 Hz 460 V						
- Option <b>L42/L44</b>	kW	0.41	0.6	0.6	0.95	0.95
- Option <b>L43</b>	kW	1.186	1.366	1.594	2.502	2.482
<b>Cooling air requirement <sup>3)</sup></b>	m <sup>3</sup> /s	0.36	0.72	0.72	0.72	0.72
<b>Sound pressure level <math>L_{pA}</math></b> (1 m) at 50/60 Hz	dB	68/70	70/72	70/72	70/72	70/72
<b>Line supply connection</b> L1, L2, L3		5/M12 + 4/M16	5/M12 + 4/M16	5/M12 + 4/M16	5/M12 + 4/M16	5/M12 + 4/M16
• Conductor cross-section, max. (IEC)	mm <sup>2</sup>	8 × 240	10 × 240	10 × 240	10 × 240	10 × 300
<b>PE/GND connection</b>		PE bar	PE bar	PE bar	PE bar	PE bar
• Busbar cross-section	mm <sup>2</sup>	600	600	600	600	600
• Conductor cross-section, max. (IEC)	mm <sup>2</sup>	240	240	240	240	240
<b>Degree of protection</b>		IP20	IP20	IP20	IP20	IP20
<b>Dimensions</b>						
• Width	mm	600	1000	1000	1000	1000
• Height <sup>4)</sup>	mm	2200	2200	2200	2200	2200
• Depth	mm	600	600	600	600	600
<b>Weight, approx.</b>						
• Option <b>L42/L44</b>	kg	490	600	620	620	720
• Option <b>L43</b>	kg	650	760	820	900	1000
<b>Frame size</b>		JL	KL	KL	KL	LL
<b>Short-circuit current rating according to IEC</b>	kA	100	100	100	100	100
<b>Minimum short-circuit current <sup>5)</sup></b>	A	3200	4000	4000	5000	6400

<sup>1)</sup> Current demand of contactors/circuit breakers and fans with degree of protection IP23, IP43, IP54 (in combination with Basic Line Modules).

<sup>2)</sup> The specified power loss represents the maximum value at 100 % utilization. The value is lower under normal operating conditions.

<sup>3)</sup> For IP23, IP43 or IP54 degree of protection only (in combination with Basic Line Modules).

<sup>4)</sup> The cabinet height increases by 250 mm with degree of protection IP21, and by 400 mm with degrees of protection IP23, IP43 and IP54.

<sup>5)</sup> Current required to ensure reliable tripping of installed protective devices.



# SINAMICS S120 Cabinet Modules

## Air-cooled units

### Line Connection Modules

#### Technical specifications (continued)

Line voltage 500 ... 690 V 3 AC	Line Connection Modules					
	6SL3700-OLG32-8AA3	6SL3700-OLG34-0AA3	6SL3700-OLG36-3AA3	6SL3700-OLG38-0AA3	6SL3700-OLG41-0AA3	
<b>Infeed/regenerative feedback current</b>						
• Rated current $I_{rated}$	A	<b>280</b>	<b>380</b>	<b>600</b>	<b>770</b>	<b>1000</b>
<b>Current demand</b>						
• Fan power supply 230 V AC	A	–	–	–	–	1.07
• 230 V AC <sup>1)</sup>						
- Inrush current	A	3.6	3.6	3.6	10.8	0.5
- Holding current	A	0.04	0.04	0.04	0.12	0.06
<b>Power loss, max. <sup>2)</sup></b>						
• At 50 Hz 500/690 V						
- Option <b>L42/L44</b>	kW	0.125	0.19	0.31	0.39	0.18
- Option <b>L43</b>	kW	0.402	0.668	0.794	–	0.963
• At 60 Hz 575 V						
- Option <b>L42/L44</b>	kW	0.125	0.19	0.31	0.39	0.18
- Option <b>L43</b>	kW	0.402	0.668	0.794	–	0.963
<b>Cooling air requirement <sup>3)</sup></b>	m <sup>3</sup> /s	–	–	–	–	0.36
<b>Sound pressure level <math>L_{pA}</math></b> (1 m) at 50/60 Hz	dB	–	–	–	–	68/70
<b>Line supply connection</b> L1, L2, L3		2/M12	2/M12	2/M12	2/M12	5/M12 + 4/M16
• Conductor cross-section, max. (IEC)	mm <sup>2</sup>	2 × 150	2 × 150	4 × 240	8 × 240	8 × 240
<b>PE/GND connection</b>		PE bar	PE bar	PE bar	PE bar	PE bar
• Busbar cross-section	mm <sup>2</sup>	600	600	600	600	600
• Conductor cross-section, max. (IEC)	mm <sup>2</sup>	240	240	240	240	240
<b>Degree of protection</b>		IP20	IP20	IP20	IP20	IP20
<b>Dimensions</b>						
• Width	mm	400	600	600	600	600
• Height <sup>4)</sup>	mm	2200	2200	2200	2200	2200
• Depth	mm	600	600	600	600	600
<b>Weight, approx.</b>						
• Option <b>L42/L44</b>	kg	220	230	310	340	450
• Option <b>L43</b>	kg	260	310	400	–	650
<b>Frame size</b>		FL	FL	GL	HL	JL
<b>Short-circuit current rating according to IEC</b>	kA	50	50	50	50	85
<b>Minimum short-circuit current <sup>5)</sup></b>	A	3200	3500	9000	15000	2000

<sup>1)</sup> Current demand of contactors/circuit breakers and fans with degree of protection IP23, IP43, IP54 (in combination with Basic Line Modules).

<sup>2)</sup> The specified power loss represents the maximum value at 100 % utilization. The value is lower under normal operating conditions.

<sup>3)</sup> For IP23, IP43 or IP54 degree of protection only (in combination with Basic Line Modules).

<sup>4)</sup> The cabinet height increases by 250 mm with degree of protection IP21, and by 400 mm with degrees of protection IP23, IP43 and IP54.

<sup>5)</sup> Current required to ensure reliable tripping of installed protective devices.

**Technical specifications (continued)**

Line voltage 500 ... 690 V 3 AC	Line Connection Modules					
		6SL3700- OLG41-3AA3	6SL3700- OLG41-6AA3	6SL3700- OLG42-0BA3	6SL3700- OLG42-5BA3	6SL3700- OLG43-2BA3
		<i>Prepared for connection to Line Modules connected in parallel</i>				
<b>Infeed/regenerative feedback current</b>						
• Rated current $I_{rated}$	A	<b>1250</b>	<b>1600</b>	<b>2000</b>	<b>2500</b>	<b>3200</b>
<b>Current demand</b>						
• Fan power supply 230 V AC	A	1.07	1.07	2.14	2.14	2.14
• 230 V AC <sup>1)</sup>						
- Inrush current	A	0.5	0.5	0.5	0.5	0.5
- Holding current	A	0.06	0.06	0.06	0.06	0.06
<b>Power loss, max. <sup>2)</sup></b>						
• At 50 Hz 500/690 V						
- Option <b>L42/L44</b>	kW	0.29	0.41	0.6	0.6	0.95
- Option <b>L43</b>	kW	1.073	1.387	2.166	2.166	2.894
• At 60 Hz 575 V						
- Option <b>L42/L44</b>	kW	0.29	0.41	0.6	0.6	0.95
- Option <b>L43</b>	kW	1.073	1.387	2.166	2.166	2.894
<b>Cooling air requirement <sup>3)</sup></b>	m <sup>3</sup> /s	0.36	0.36	0.72	0.72	0.72
<b>Sound pressure level <math>L_{pA}</math></b> (1 m) at 50/60 Hz	dB	68/70	68/70	70/72	70/72	70/72
<b>Line supply connection</b> L1, L2, L3		5/M12 + 4/M16	5/M12 + 4/M16	5/M12 + 4/M16	5/M12 + 4/M16	5/M12 + 4/M16
• Conductor cross-section, max. (IEC)	mm <sup>2</sup>	8 × 240	8 × 240	10 × 240	10 × 240	10 × 300
<b>PE/GND connection</b>		PE bar	PE bar	PE bar	PE bar	PE bar
• Busbar cross-section	mm <sup>2</sup>	600	600	600	600	600
• Conductor cross-section, max. (IEC)	mm <sup>2</sup>	240	240	240	240	240
<b>Degree of protection</b>		IP20	IP20	IP20	IP20	IP20
<b>Dimensions</b>						
• Width	mm	600	600	1000	1000	1000
• Height <sup>4)</sup>	mm	2200	2200	2200	2200	2200
• Depth	mm	600	600	600	600	600
<b>Weight, approx.</b>						
• Option <b>L42/L44</b>	kg	470	490	600	620	720
• Option <b>L43</b>	kg	670	680	980	1000	1080
<b>Frame size</b>		JL	JL	KL	KL	LL
<b>Short-circuit current rating according to IEC</b>	kA	85	85	85	85	85
<b>Minimum short-circuit current <sup>5)</sup></b>	A	2500	3200	4000	5000	6400

<sup>1)</sup> Current demand of contactors/circuit breakers and fans with degree of protection IP23, IP43, IP54 (in combination with Basic Line Modules).

<sup>2)</sup> The specified power loss represents the maximum value at 100 % utilization. The value is lower under normal operating conditions.

<sup>3)</sup> For IP23, IP43 or IP54 degree of protection only (in combination with Basic Line Modules).

<sup>4)</sup> The cabinet height increases by 250 mm with degree of protection IP21, and by 400 mm with degrees of protection IP23, IP43 and IP54.

<sup>5)</sup> Current required to ensure reliable tripping of installed protective devices.

## SINAMICS S120 Cabinet Modules

Air-cooled units

### Basic Line Modules

#### Overview



Basic Line Modules (BLM) are compact line infeeds for two-quadrant operation, i.e. no regenerative feedback.

They are used when energy need not be fed back into the network.

If regenerative conditions occur in the drive line-up, Braking Modules must be used because they convert the excess energy into heat in braking resistors.

Basic Line Modules are suitable for connection to grounded TN/TT and non-grounded IT systems. The following voltages and power ratings are available:

Line voltage	Rated power
380 ... 480 V 3 AC	200 ... 900 kW
500 ... 690 V 3 AC	250 ... 1500 kW

The power ratings can be increased by connecting up to four identical Basic Line Modules in parallel.

For an infeed with the Basic Line Modules, depending on the line short-circuit power, a line reactor should be provided at the connection point. This reactor is available as standard in the Line Connection Module. However, it can be omitted if it is not required (option **L22**).

For additional information, please refer to the SINAMICS Low Voltage Engineering Manual.

4

#### Design

The Basic Line Modules are available in different frame sizes.

With frame sizes FB and GB, a fully controlled thyristor bridge is used to pre-charge the Basic Line Modules and connected Motor Modules. The thyristors normally operate with a trigger delay angle of 0°.

Basic Line Modules, frame size GD for 900 kW (400 V) or 1500 kW (690 V) include a diode bridge, and the DC link is pre-charged via a separate line-side pre-charging device that is located in the Line Connection Module (option **L43**, Line Connection Module for Basic Line Module).

#### Parallel connection of Basic Line Modules to increase power rating

Line Modules can be connected in parallel (relative to the line supply) in two ways for the purpose of creating drive line-ups with a higher power rating.

#### Two Basic Line Modules supplied with power via two separate Line Connection Modules

With this arrangement, each Basic Line Module is supplied via a Line Connection Module and the Basic Line Modules are protected by fuses or circuit breakers (at  $I > 800$  A) in the Line Connection Module. A Basic Line Module is assigned to a Line Connection Module and is mechanically coupled. It is not necessary to mechanically directly couple both "groups" comprising Line Connection Module and Basic Line Module. Other modules can also be inserted in between.

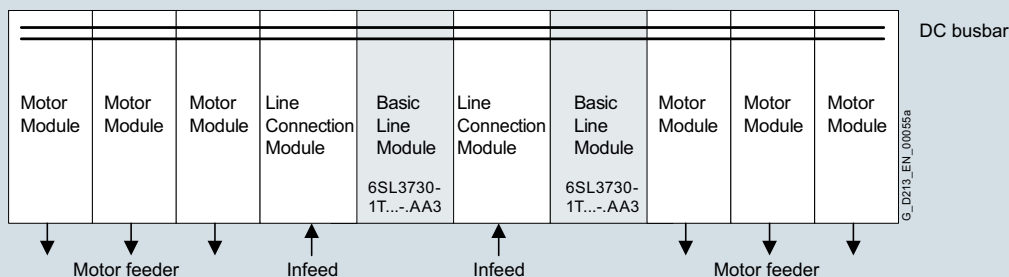

## Design (continued)

### Two Basic Line Modules supplied with power via a single Line Connection Module

Basic Line Modules are available that can be operated on a single Line Connection Module. These can be connected to the left and right of the Line Connection Module. The power connections on the Basic Line Module on the left of the Line Connection Module are a mirror image (article no. with "C" in the next to last position, example: 6SL3730-1T.41-.BC3), which results in a very compact design for the line infeed.

For additional information, please refer to the SINAMICS Low Voltage Engineering Manual.

These module versions feature integrated line-side fuses which are required because the circuit breaker in the Line Connection Module is not capable of providing selective protection for the Basic Line Modules. They are therefore 200 mm wider in each case than version 6SL3730-1T...-AA3.

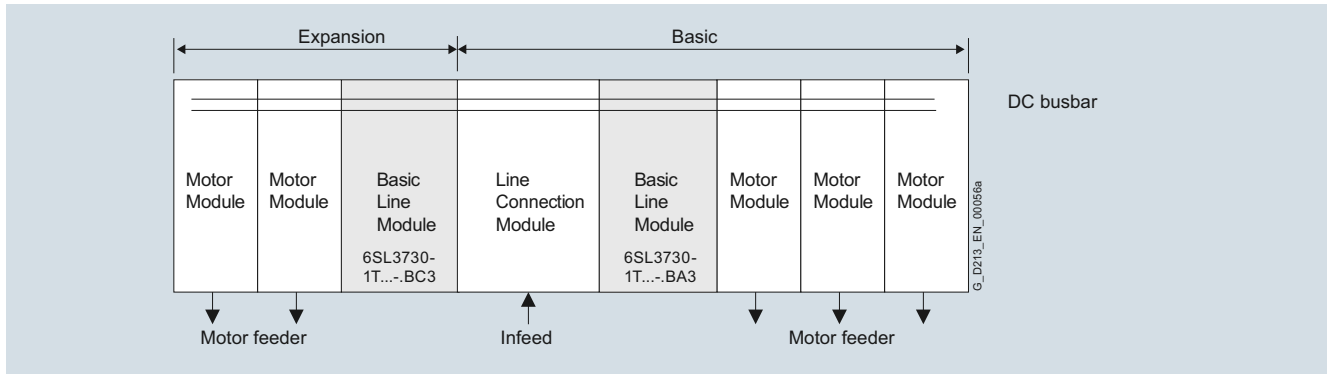

### Note:

If the Basic Line Modules are supplied with power via the same circuit breaker, line-side fuses are provided to ensure selective individual protection of the modules. This arrangement increases the cabinet width by 200 mm (dimension data in selection tables includes extra width).

Please note that only Basic Line Modules with exactly the same output rating may be connected in parallel. The potential for imbalances in current distribution means that current derating of

7.5 % applies and this must be taken into account when the modules are dimensioned.

A connection of the Basic Line Modules connected in parallel using DRIVE-CLiQ must be taken into consideration during the engineering phase.

For additional information, please refer to the SINAMICS Low Voltage Engineering Manual.

## Selection and ordering data

Rated power at 400 V kW	Rated DC link current A	Note for a parallel connection Mounting onto a Line Connection Module	Basic Line Module Article No.
<b>Line voltage 380 ... 480 V 3 AC (DC link voltage 510 ... 650 V DC)</b>			
200	420	–	<b>6SL3730-1TE34-2AA3</b>
250	530	–	<b>6SL3730-1TE35-3AA3</b>
400	820	–	<b>6SL3730-1TE38-2AA3</b>
560	1200	–	<b>6SL3730-1TE41-2AA3</b>
		Right	<b>6SL3730-1TE41-2BA3</b>
		Left	<b>6SL3730-1TE41-2BC3</b>
710	1500	–	<b>6SL3730-1TE41-5AA3</b>
		Right	<b>6SL3730-1TE41-5BA3</b>
		Left	<b>6SL3730-1TE41-5BC3</b>
900	1880	–	<b>6SL3730-1TE41-8AA3</b>
		Right	<b>6SL3730-1TE41-8BA3</b>
		Left	<b>6SL3730-1TE41-8BC3</b>

Rated power at 690 V kW	Rated DC link current A	Note for a parallel connection Mounting onto a Line Connection Module	Basic Line Module Article No.
<b>Line voltage 500 ... 690 V 3 AC (DC link voltage 675 ... 930 V DC)</b>			
250	300	–	<b>6SL3730-1TG33-0AA3</b>
355	430	–	<b>6SL3730-1TG34-3AA3</b>
500	680	–	<b>6SL3730-1TG36-8AA3</b>
900	1100	–	<b>6SL3730-1TG41-1AA3</b>
		Right	<b>6SL3730-1TG41-1BA3</b>
		Left	<b>6SL3730-1TG41-1BC3</b>
1100	1400	–	<b>6SL3730-1TG41-4AA3</b>
		Right	<b>6SL3730-1TG41-4BA3</b>
		Left	<b>6SL3730-1TG41-4BC3</b>
1500	1880	–	<b>6SL3730-1TG41-8AA3</b>
		Right	<b>6SL3730-1TG41-8BA3</b>
		Left	<b>6SL3730-1TG41-8BC3</b>

# SINAMICS S120 Cabinet Modules

Air-cooled units

## Basic Line Modules

### Integration

4

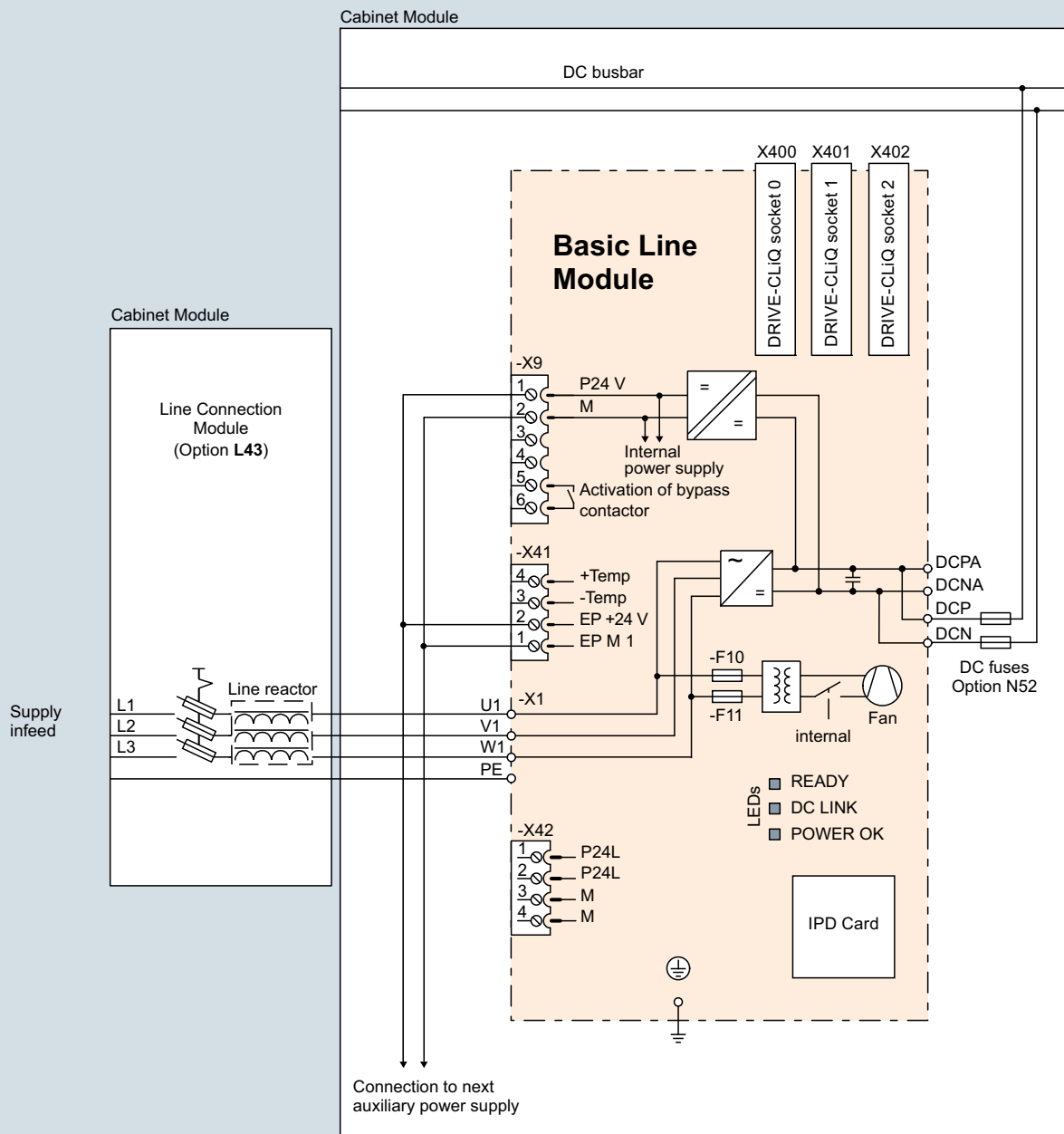

Connection example: Basic Line Module

G\_D213\_EN\_00057c

### Technical specifications

Line voltage 380 ... 480 V 3 AC		Basic Line Modules					
		6SL3730-1TE34-2AA3	6SL3730-1TE35-3AA3	6SL3730-1TE38-2AA3	6SL3730-1TE41-2AA3	6SL3730-1TE41-5AA3	6SL3730-1TE41-8AA3
For a parallel circuit configuration, mounted to the <u>right</u> of the Line Connection Module					6SL3730-1TE41-2BA3	6SL3730-1TE41-5BA3	6SL3730-1TE41-8BA3
For a parallel circuit configuration, mounted to the <u>left</u> of the Line Connection Module					6SL3730-1TE41-2BC3	6SL3730-1TE41-5BC3	6SL3730-1TE41-8BC3
<b>Rated power</b>							
• At $I_{\text{rated DC}}$ (50 Hz 400 V)	kW	<b>200</b>	<b>250</b>	<b>400</b>	<b>560</b>	<b>710</b>	<b>900</b>
• At $I_{\text{H DC}}$ (50 Hz 400 V)	kW	160	200	315	450	560	705
• At $I_{\text{rated DC}}$ (60 Hz 460 V)	hp	305	385	615	860	1090	1390
• At $I_{\text{H DC}}$ (60 Hz 460 V)	hp	245	305	485	690	860	1090
<b>DC link current</b>							
• Rated current $I_{\text{rated DC}}$	A	420	530	820	1200	1500	1880
• Base-load current $I_{\text{H DC}}^{(1)}$	A	328	413	640	936	1170	1467
• Maximum current $I_{\text{max DC}}$	A	630	795	1230	1800	2250	2820
<b>Input current</b>							
• Rated current $I_{\text{rated I}}$	A	365	460	710	1010	1265	1630
• Maximum current $I_{\text{max I}}$	A	547	690	1065	1515	1897	2380
<b>Current demand</b>							
• 24 V DC auxiliary power supply	A	1.1	1.1	1.1	1.1	1.1	1.1
• 400 V AC <sup>2)</sup>	A	Internal	Internal	Internal	Internal	Internal	Internal
<b>DC link capacitance</b>							
• Basic Line Module	μF	7200	9600	14600	23200	29000	34800
• Drive line-up, max.	μF	57600	76800	116800	185600	232000	139200
<b>Power loss, max. <sup>3)</sup></b>							
• At 50 Hz 400 V	kW	1.9	2.1	3.2	4.6	5.5	6.9
• At 60 Hz 460 V	kW	1.9	2.1	3.2	4.6	5.5	6.9
<b>Cooling air requirement</b>		m <sup>3</sup> /s	0.17	0.17	0.17	0.36	0.36
<b>Sound pressure level <math>L_{\text{pA}}</math> (1 m) at 50/60 Hz</b>		dB	66/68	66/68	66/68	71/73	71/73
<b>PE/GND connection</b>		PE bar	PE bar	PE bar	PE bar	PE bar	PE bar
• Busbar cross-section	mm <sup>2</sup>	600	600	600	600	600	600
• Conductor cross-section, max. (IEC)	mm <sup>2</sup>	240	240	240	240	240	240
<b>Cable length, max. <sup>4)</sup></b>							
• Shielded	m	2600	2600	2600	4000	4000	4800
• Unshielded	m	3900	3900	3900	6000	6000	7200
<b>Degree of protection</b>		IP20	IP20	IP20	IP20	IP20	IP20
<b>Dimensions</b>							
• Width	mm	400	400	400	400/600/600	400/600/600	400/600/600
• Height <sup>5)</sup>	mm	2200	2200	2200	2200	2200	2200
• Depth	mm	600	600	600	600	600	600
<b>Weight, approx.</b>		kg	166	166	166	320/440/480	320/440/480
<b>Frame size</b>		FB	FB	FB	GB	GB	GD
<b>Short-circuit current rating according to IEC</b>		kA	65	65	65	84	100
<b>Minimum short-circuit current <sup>6)</sup></b>		A	4400	5200	10000	2500	3200
• For connection in parallel	A	–	–	–	4000	5000	6400

<sup>1)</sup> The base-load current  $I_{\text{H DC}}$  is based on a duty cycle of 150 % for 60 s or  $I_{\text{max DC}}$  for 5 s with a duty cycle duration of 300 s.

<sup>2)</sup> The current demand for the 400 V AC auxiliary power supply is drawn from the line input voltage.

<sup>3)</sup> The specified power loss represents the maximum value at 100% utilization. The value is lower under normal operating conditions.

<sup>4)</sup> Total of all motor cables and DC link. Longer cable lengths for specific configurations are available on request.

<sup>5)</sup> The cabinet height increases by 250 mm with degree of protection IP21, and by 400 mm with degrees of protection IP23, IP43 or IP54.

<sup>6)</sup> Current required to ensure reliable tripping of installed protective devices.

# SINAMICS S120 Cabinet Modules

## Air-cooled units

### Basic Line Modules

#### Technical specifications (continued)

Line voltage 500 ... 690 V 3 AC		Basic Line Modules					
		6SL3730-1TG33-0AA3	6SL3730-1TG34-3AA3	6SL3730-1TG36-8AA3	6SL3730-1TG41-1AA3	6SL3730-1TG41-4AA3	6SL3730-1TG41-8AA3
For a parallel circuit configuration, mounted to the <u>right</u> of the Line Connection Module					6SL3730-1TG41-1BA3	6SL3730-1TG41-4BA3	6SL3730-1TG41-8BA3
For a parallel circuit configuration, mounted to the <u>left</u> of the Line Connection Module					6SL3730-1TG41-1BC3	6SL3730-1TG41-4BC3	6SL3730-1TG41-8BC3
<b>Rated power</b>							
• At $I_{\text{rated DC}}$ (50 Hz 690 V)	kW	<b>250</b>	<b>355</b>	<b>560</b>	<b>900</b>	<b>1100</b>	<b>1500</b>
• At $I_{\text{H DC}}$ (50 Hz 690 V)	kW	195	280	440	710	910	1220
• At $I_{\text{rated DC}}$ (50 Hz 500 V)	kW	175	250	390	635	810	1085
• At $I_{\text{H DC}}$ (50 Hz 500 V)	kW	165	235	365	595	755	1015
• At $I_{\text{rated DC}}$ (60 Hz 575 V)	hp	250	350	600	900	1250	1500
• At $I_{\text{H DC}}$ (60 Hz 575 V)	hp	200	300	450	800	1000	1250
<b>DC link current</b>							
• Rated current $I_{\text{rated DC}}$	A	300	430	680	1100	1400	1880
• Base-load current $I_{\text{H DC}}^{(1)}$	A	234	335	530	858	1092	1467
• Maximum current $I_{\text{max DC}}$	A	450	645	1020	1650	2100	2820
<b>Input current</b>							
• Rated current $I_{\text{rated I}}$	A	260	375	575	925	1180	1580
• Maximum current $I_{\text{max I}}$	A	390	563	863	1388	1770	2370
<b>Current demand</b>							
• 24 V DC auxiliary power supply	A	1.1	1.1	1.1	1.1	1.1	1.1
• 500 V/690 V AC <sup>2)</sup>	A	Internal	Internal	Internal	Internal	Internal	Internal
<b>DC link capacitance</b>							
• Basic Line Module	μF	3200	4800	7300	11600	15470	19500
• Drive line-up, max.	μF	25600	38400	58400	92800	123760	78000
<b>Power loss, max. <sup>3)</sup></b>							
• At 50 Hz 690 V	kW	1.5	2.1	3	5.4	5.8	7.3
• At 60 Hz 575 V	kW	1.5	2.1	3	5.4	5.8	7.3
<b>Cooling air requirement</b>		m <sup>3</sup> /s	0.17	0.17	0.17	0.36	0.36
<b>Sound pressure level <math>L_{\text{pA}}</math></b> (1 m) at 50/60 Hz		dB	66/68	66/68	66/68	71/73	71/73
<b>PE/GND connection</b>		PE bar	PE bar	PE bar	PE bar	PE bar	PE bar
• Busbar cross-section	mm <sup>2</sup>	600	600	600	600	600	600
• Conductor cross-section, max. (IEC)	mm <sup>2</sup>	240	240	240	240	240	240
<b>Cable length, max. <sup>4)</sup></b>							
• Shielded	m	1500	1500	1500	2250	2250	2750
• Unshielded	m	2250	2250	2250	3375	3375	4125
<b>Degree of protection</b>		IP20	IP20	IP20	IP20	IP20	IP20
<b>Dimensions</b>							
• Width	mm	400	400	400	400/600/600	400/600/600	400/600/600
• Height <sup>5)</sup>	mm	2200	2200	2200	2200	2200	2200
• Depth	mm	600	600	600	600	600	600
<b>Weight, approx.</b>		kg	166	166	166	320/440/480	320/440/480
<b>Frame size</b>			FB	FB	FB	GB	GD
<b>Short-circuit current rating according to IEC</b>		kA	65	65	84	100	100
<b>Minimum short-circuit current <sup>6)</sup></b>		A	3000	4400	8000	2000	2500
• For connection in parallel	A	–	–	–	4000	5000	6400

<sup>1)</sup> The base-load current  $I_{\text{H DC}}$  is based on a duty cycle of 150 % for 60 s or  $I_{\text{max DC}}$  for 5 s with a duty cycle duration of 300 s.

<sup>2)</sup> The current demand for the 500 V/690 V AC auxiliary power supply is drawn from the line input voltage.

<sup>3)</sup> The specified power loss represents the maximum value at 100% utilization. The value is lower under normal operating conditions.

<sup>4)</sup> Total of all motor cables and DC link. Longer cable lengths for specific configurations are available on request.

<sup>5)</sup> The cabinet height increases by 250 mm with degree of protection IP21, and by 400 mm with degrees of protection IP23, IP43 or IP54.

<sup>6)</sup> Current required to ensure reliable tripping of installed protective devices.

## Overview



Smart Line Modules are non-regulated rectifier/regenerative units. The infeed occurs over a diode jumper, while stable, line-commutated regenerative feedback takes place via IGBTs with 100 % continuous energy regeneration. An autotransformer is not required for regenerative feedback.

The regenerative capability can be deactivated.

Smart Line Modules are suitable for connection to grounded TN/TT and non-grounded IT systems. The following voltages and power ratings are available:

Line voltage	Rated power
380 ... 480 V 3 AC	250 ... 800 kW
500 ... 690 V 3 AC	450 ... 1400 kW

The power ratings can be increased by connecting up to four identical Smart Line Modules in parallel.

For additional information, please refer to the [SINAMICS Low Voltage Engineering Manual](#).

## Design

IGBTs (fundamental frequency-switched) serve as Smart Line Module power semiconductors. As this reduces switching losses, a high percentage of the power unit current can be utilized.

The current flows in the direction of the infeed via the freewheeling diodes of the IGBTs. This means that the Smart Line Module behaves in a similar way to the Basic Line Module. If the DC link voltage increases due to regenerative operation of the drives, the IGBTs conduct the current, thus feeding the energy back into the supply system.

In contrast to Active Line Modules, Smart Line Modules do not require a line-side filter; all they require is a line reactor (4 %  $u_k$ ). The unit has a built-in pre-charging circuit for the DC link capacitors. For this reason, a main contactor or a motor-driven circuit breaker is absolutely essential. By specifying the option with order code **L44** for the Line Connection Modules, these components are appropriately accommodated in the Line Connection Module.

### Parallel connection of Smart Line Modules to increase power rating

Up to four Smart Line Modules with the same power rating can be connected in parallel in order to increase power. Current derating of 7.5% with respect to the rated current of each Smart Line Module must be taken into account when the system is dimensioned.

A connection of the Smart Line Modules connected in parallel using DRIVE-CLiQ must be taken into consideration during the engineering phase.

For additional information, please refer to the [SINAMICS Low Voltage Engineering Manual](#).

A 4% reactor is always required upstream of each Smart Line Module for the purpose of current symmetrization. This is integrated as standard. Just as with the Basic Line Modules, "mirror-image" power connections are available for Smart Line Modules, which enable parallel circuits to be realized in a compact design. Units that are arranged to the left of the Line Connection Module have the letter "C" in the penultimate position of the article number.

Example: 6SL3730-6TE41-1BC3 (see also the corresponding diagram for the Basic Line Modules).

## Selection and ordering data

Rated power at 400 V	Rated infeed/regenerative feedback current	Note for a parallel connection	Smart Line Module
kW	A	Mounting onto a Line Connection Module	Article No.
<b>Line voltage 380 ... 480 V 3 AC (DC link voltage 510 ... 650 V DC)</b>			
250	463	–	<b>6SL3730-6TE35-5AA3</b>
355	614	–	<b>6SL3730-6TE37-3AA3</b>
500	883	–	<b>6SL3730-6TE41-1AA3</b>
		Right	<b>6SL3730-6TE41-1BA3</b>
		Left	<b>6SL3730-6TE41-1BC3</b>
630	1093	–	<b>6SL3730-6TE41-3AA3</b>
		Right	<b>6SL3730-6TE41-3BA3</b>
		Left	<b>6SL3730-6TE41-3BC3</b>
800	1430	–	<b>6SL3730-6TE41-7AA3</b>
		Right	<b>6SL3730-6TE41-7BA3</b>
		Left	<b>6SL3730-6TE41-7BC3</b>

Rated power at 690 V	Rated infeed/regenerative feedback current	Note for a parallel connection	Smart Line Module		
kW	A	Mounting onto a Line Connection Module	Article No.		
<b>Line voltage 500 ... 690 V 3 AC (DC link voltage 675 ... 930 V DC)</b>					
450	463	–	<b>6SL3730-6TG35-5AA3</b>		
		710	757	–	<b>6SL3730-6TG38-8AA3</b>
		Right	<b>6SL3730-6TG38-8BA3</b>		
		Left	<b>6SL3730-6TG38-8BC3</b>		
1000	1009	–	<b>6SL3730-6TG41-2AA3</b>		
		Right	<b>6SL3730-6TG41-2BA3</b>		
		Left	<b>6SL3730-6TG41-2BC3</b>		
1400	1430	–	<b>6SL3730-6TG41-7AA3</b>		
		Right	<b>6SL3730-6TG41-7BA3</b>		
		Left	<b>6SL3730-6TG41-7BC3</b>		



# SINAMICS S120 Cabinet Modules

Air-cooled units

## Smart Line Modules

### Integration

4

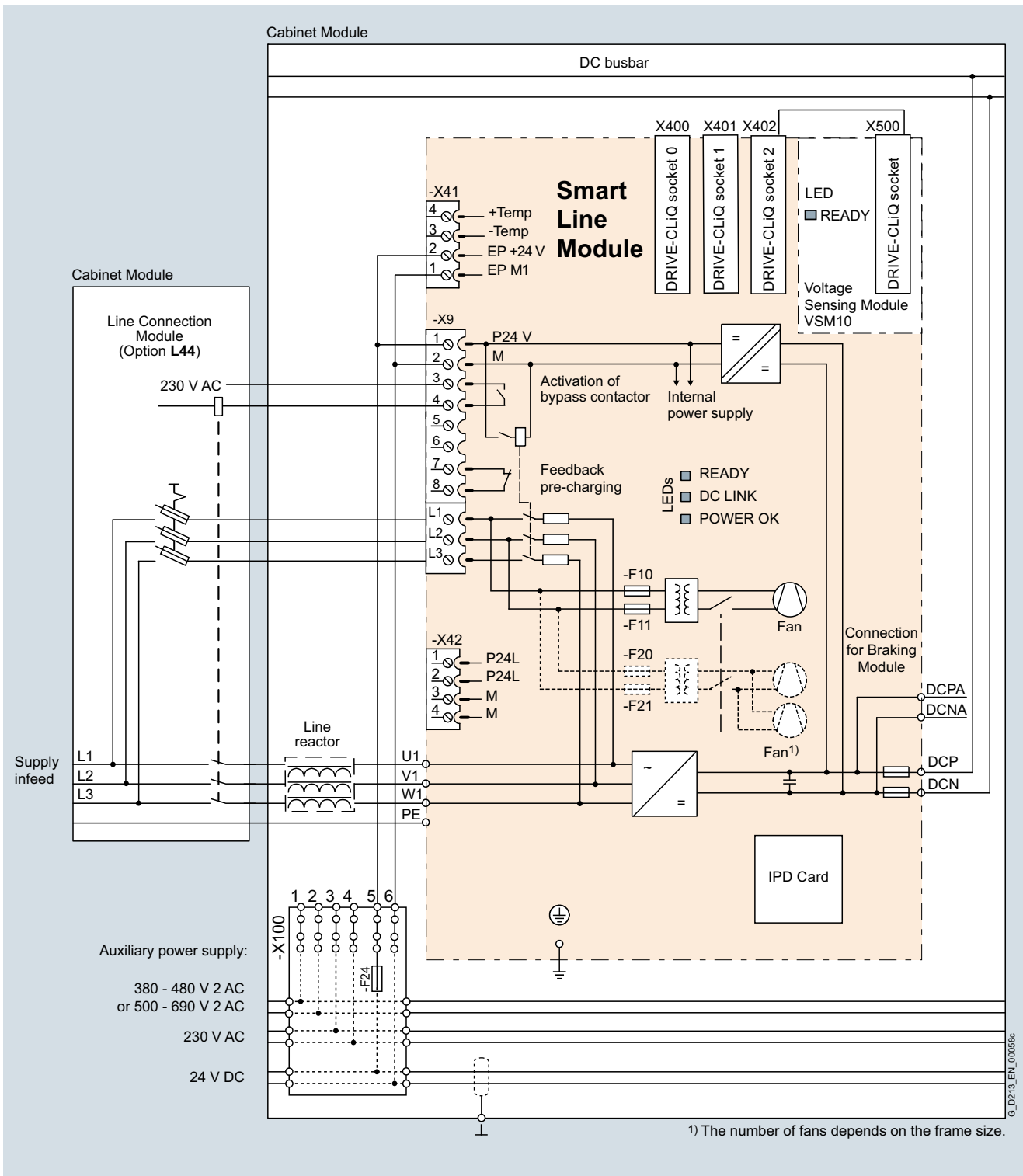

Connection example: Smart Line Module

**Technical specifications**

Line voltage 380 ... 480 V 3 AC		Smart Line Modules				
		6SL3730-6TE35-5AA3	6SL3730-6TE37-3AA3	6SL3730-6TE41-1AA3	6SL3730-6TE41-3AA3	6SL3730-6TE41-7AA3
For a parallel circuit configuration, mounted to the <u>right</u> of the Line Connection Module				6SL3730-6TE41-1BA3	6SL3730-6TE41-3BA3	6SL3730-6TE41-7BA3
For a parallel circuit configuration, mounted to the <u>left</u> of the Line Connection Module				6SL3730-6TE41-1BC3	6SL3730-6TE41-3BC3	6SL3730-6TE41-7BC3
<b>Rated power</b>						
• At $I_{\text{rated DC}}$ (50 Hz 400 V)	kW	<b>250</b>	<b>355</b>	<b>500</b>	<b>630</b>	<b>800</b>
• At $I_{\text{H DC}}$ (50 Hz 400 V)	kW	235	315	450	555	730
• At $I_{\text{rated DC}}$ (60 Hz 460 V)	hp	395	545	770	970	1230
• At $I_{\text{H DC}}$ (60 Hz 460 V)	hp	360	485	695	855	1125
<b>DC link current</b>						
• Rated current $I_{\text{rated DC}}$	A	550	730	1050	1300	1700
• Base-load current $I_{\text{H DC}}^{1)}$	A	490	650	934	1157	1513
• Maximum current $I_{\text{max DC}}$	A	825	1095	1575	1950	2550
<b>Infeed/regenerative feedback current</b>						
• Rated current $I_{\text{rated I}}$	A	463	614	883	1093	1430
• Maximum current $I_{\text{max I}}$	A	694	921	1324	1639	2145
<b>Current demand</b>						
• 24 V DC auxiliary power supply	A	1.35	1.35	1.4	1.5	1.7
• 400 V AC <sup>2)</sup>	A	1.8	1.8	3.6	5.4	5.4
<b>DC link capacitance</b>						
• Smart Line Module	μF	8400	12000	16800	18900	28800
• Drive line-up, max.	μF	42000	60000	67200	75600	115200
<b>Power loss, max. <sup>3)</sup></b>						
• At 50 Hz 400 V	kW	3.7	4.7	7.1	11.0	11.5
• At 60 Hz 460 V	kW	3.7	4.7	7.1	11.0	11.5
<b>Cooling air requirement</b>		m <sup>3</sup> /s	0.36	0.36	0.78	1.08
<b>Sound pressure level <math>L_{\text{pA}}</math> (1 m) at 50/60 Hz</b>		dB	69/73	69/73	70/73	70/73
<b>PE/GND connection</b>		PE bar	PE bar	PE bar	PE bar	PE bar
• Busbar cross-section	mm <sup>2</sup>	600	600	600	600	600
• Conductor cross-section, max. (IEC)	mm <sup>2</sup>	240	240	240	240	240
<b>Cable length, max. <sup>4)</sup></b>						
• Shielded	m	4000	4000	4800	4800	4800
• Unshielded	m	6000	6000	7200	7200	7200
<b>Degree of protection</b>		IP20	IP20	IP20	IP20	IP20
<b>Dimensions</b>						
• Width	mm	400	400	600	800	800
• Height <sup>5)</sup>	mm	2200	2200	2200	2200	2200
• Depth	mm	600	600	600	600	600
<b>Weight, approx.</b>		kg	270	270	490	775
<b>Frame size</b>		GX	GX	HX	JX	JX
<b>Short-circuit current rating according to IEC</b>		kA	65	65	84	100
<b>Minimum short-circuit current <sup>6)</sup></b>		A	6200	9200	2000	2500

<sup>1)</sup> The base-load current  $I_{\text{H DC}}$  is based on a duty cycle of 150 % for 60 s or  $I_{\text{max DC}}$  for 5 s with a duty cycle duration of 300 s.

<sup>2)</sup> The current demand for the 400 V AC auxiliary power supply is drawn from the line input voltage.

<sup>3)</sup> The specified power loss represents the maximum value at 100 % utilization. The value is lower under normal operating conditions.

<sup>4)</sup> Total of all motor cables and DC link. Longer cable lengths for specific configurations are available on request.

<sup>5)</sup> The cabinet height increases by 250 mm with degree of protection IP21, and by 400 mm with degrees of protection IP23, IP43 or IP54.

<sup>6)</sup> Current required to ensure reliable tripping of installed protective devices.

# SINAMICS S120 Cabinet Modules

Air-cooled units

## Smart Line Modules

### Technical specifications (continued)

Line voltage 500 ... 690 V 3 AC		Smart Line Modules			
		6SL3730-6TG35-5AA3	6SL3730-6TG38-8AA3	6SL3730-6TG41-2AA3	6SL3730-6TG41-7AA3
For a parallel circuit configuration, mounted to the <u>right</u> of the Line Connection Module			6SL3730-6TG38-8BA3	6SL3730-6TG41-2BA3	6SL3730-6TG41-7BA3
For a parallel circuit configuration, mounted to the <u>left</u> of the Line Connection Module			6SL3730-6TG38-8BC3	6SL3730-6TG41-2BC3	6SL3730-6TG41-7BC3
<b>Rated power</b>					
• At $I_{\text{rated DC}}$ (50 Hz 690 V)	kW	450	710	1000	1400
• At $I_{\text{H DC}}$ (50 Hz 690 V)	kW	405	665	885	1255
• At $I_{\text{rated DC}}$ (50 Hz 500 V)	kW	320	525	705	995
• At $I_{\text{H DC}}$ (50 Hz 500 V)	kW	295	480	640	910
• At $I_{\text{rated DC}}$ (60 Hz 575 V)	hp	500	790	1115	1465
• At $I_{\text{H DC}}$ (60 Hz 575 V)	hp	450	740	990	1400
<b>DC link current</b>					
• Rated current $I_{\text{rated DC}}$	A	550	900	1200	1700
• Base-load current $I_{\text{H DC}}^{1)}$	A	490	800	1068	1513
• Maximum current $I_{\text{max DC}}$	A	825	1350	1800	2550
<b>Infeed/regenerative feedback current</b>					
• Rated current $I_{\text{rated I}}$	A	463	757	1009	1430
• Maximum current $I_{\text{max I}}$	A	694	1135	1513	2145
<b>Current demand</b>					
• 24 V DC auxiliary power supply	A	1.35	1.4	1.5	1.7
• 500 V AC <sup>2)</sup>	A	1.3	2.9	4.3	4.3
• 690 V AC	A	1	2.1	3.1	3.1
<b>DC link capacitance</b>					
• Smart Line Module	μF	5600	7400	11100	14400
• Drive line-up, max.	μF	28000	29600	44400	57600
<b>Power loss, max. <sup>3)</sup></b>					
• At 50 Hz 690 V	kW	4.3	6.5	12.0	13.8
• At 60 Hz 575 V	kW	4.3	6.5	12.0	13.8
<b>Cooling air requirement</b>					
	m <sup>3</sup> /s	0.36	0.78	1.08	1.08
<b>Sound pressure level <math>L_{\text{pA}}</math></b> (1 m) at 50/60 Hz					
	dB	69/73	70/73	70/73	70/73
<b>PE/GND connection</b>					
• Busbar cross-section	mm <sup>2</sup>	600	600	600	600
• Conductor cross-section, max. (IEC)	mm <sup>2</sup>	240	240	240	240
<b>Cable length, max. <sup>4)</sup></b>					
• Shielded	m	2250	2750	2750	2750
• Unshielded	m	3375	4125	4125	4125
<b>Degree of protection</b>					
		IP20	IP20	IP20	IP20
<b>Dimensions</b>					
• Width	mm	400	600	800	800
• Height <sup>5)</sup>	mm	2200	2200	2200	2200
• Depth	mm	600	600	600	600
<b>Weight, approx.</b>					
	kg	270	550	795	795
<b>Frame size</b>					
		GX	HX	JX	JX
<b>Short-circuit current rating according to IEC</b>					
	kA	65	84	100	100
<b>Minimum short-circuit current <sup>6)</sup></b>					
	A	6200	10500	2500	3200

<sup>1)</sup> The base-load current  $I_{\text{H DC}}$  is based on a duty cycle of 150 % for 60 s or  $I_{\text{max DC}}$  for 5 s with a duty cycle duration of 300 s.

<sup>2)</sup> The current demand for the 500 V / 690 V AC auxiliary power supply is drawn from the line input voltage.

<sup>3)</sup> The specified power loss represents the maximum value at 100 % utilization. The value is lower under normal operating conditions.

<sup>4)</sup> Total of all motor cables and DC link. Longer cable lengths for specific configurations are available on request.

<sup>5)</sup> The cabinet height increases by 250 mm with degree of protection IP21, and by 400 mm with degrees of protection IP23, IP43 or IP54.

<sup>6)</sup> Current required to ensure reliable tripping of installed protective devices.

## Overview



Active Line Modules are regulated rectifier/regenerative units. They can supply energy to the DC link and return regenerative energy to the supply system.

In contrast to Basic Line Modules and Smart Line Modules, Active Line Modules generate a stabilized DC voltage that is kept constant despite fluctuations in the line voltage (the line voltage must remain within the permissible tolerance range). Active Line Modules in combination with an Active Interface Module draw a virtually sinusoidal current from the supply system. Almost no harmonics occur.

A Braking Module and braking resistor are required only if the drives need to be decelerated in a controlled manner after a power failure (i.e. when energy cannot be recovered to the supply).

Active Line Modules are suitable for connection to grounded TN/TT and non-grounded IT systems. The following voltages and power ratings are available:

Line voltage	Rated power
380 ... 480 V 3 AC	132 ... 900 kW
500 ... 690 V 3 AC	630 ... 1400 kW

## Design

Active Line Modules are always operated together with an Active Interface Module that contains the associated Clean Power Filter and pre-charging circuit. The integrated line filter ensures compliance with the EMC requirements for the "second environment".

The Active Line Module and Active Interface Module are supplied as a complete, fully wired unit, i.e. the customer does not need to supply any further cables or carry out any other wiring tasks.

### Parallel connection of Active Line Modules to increase power rating

Active Line Modules are available for creating drive line-ups with more power. These modules can be operated in parallel on a common Line Connection Module and are arranged to the right and left of the Line Connection Module.

The power connections on the Active Line Module on the left of the Line Connection Module are a mirror image (article no. with "C" in the next to last position, example: 6SL3730-7T.41.-BC3), which results in a very compact design for the line infeed.

Please note that only Active Line Modules with exactly the same power rating may be connected in parallel. The potential for imbalances in current distribution means that a current derating of 5 % applies; this must be taken into account when the modules are dimensioned.

A connection of the Active Line Modules connected in parallel using DRIVE-CLiQ must be taken into consideration during the engineering phase.

For additional information, please refer to the [SINAMICS Low Voltage Engineering Manual](#).

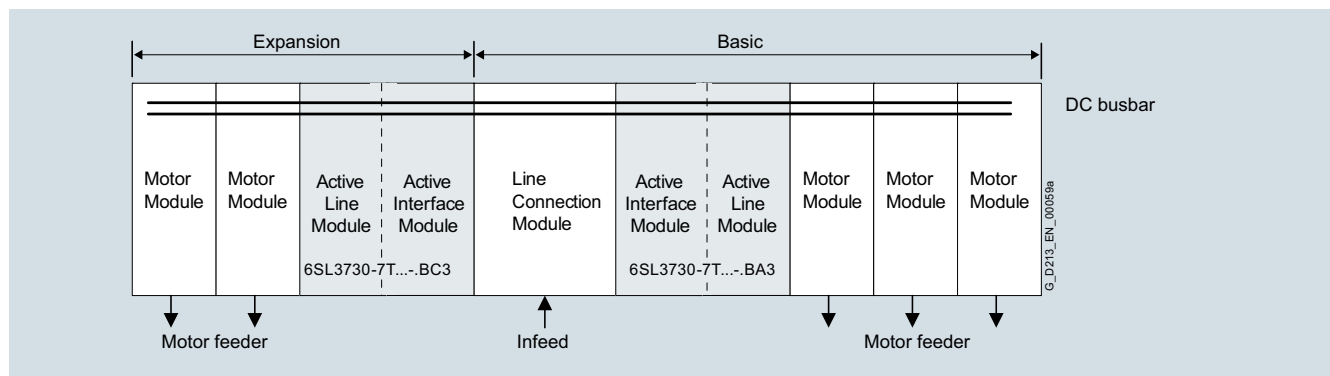

## SINAMICS S120 Cabinet Modules

Air-cooled units

### Active Line Modules incl. Active Interface Modules

#### Selection and ordering data

Rated power at 400 V kW	Rated infeed/ regenerative feedback current A	Note for a parallel connection  <i>Mounting onto a Line Connection Module</i>	Active Line Module (incl. Active Interface Module)  Article No.
<b>Line voltage 380 ... 480 V 3 AC (DC link voltage 570 ... 720 V DC)</b>			
132	210	–	<b>6SL3730-7TE32-1BA3</b>
160	260	–	<b>6SL3730-7TE32-6BA3</b>
235	380	–	<b>6SL3730-7TE33-8BA3</b>
300	490	–	<b>6SL3730-7TE35-0BA3</b>
380	605	–	<b>6SL3730-7TE36-1BA3</b>
500	840	–	<b>6SL3730-7TE38-4BA3</b>
630	985	–	<b>6SL3730-7TE41-0BA3</b>
		<i>Left</i>	<b>6SL3730-7TE41-0BC3</b>
900	1405	–	<b>6SL3730-7TE41-4BA3</b>
		<i>Left</i>	<b>6SL3730-7TE41-4BC3</b>

Rated power at 690 V kW	Rated infeed/ regenerative feedback current A	Note for a parallel connection  <i>Mounting onto a Line Connection Module</i>	Active Line Module (incl. Active Interface Module)  Article No.
<b>Line voltage 500 ... 690 V 3 AC (DC link voltage 750 ... 1035 V DC)</b>			
630	575	–	<b>6SL3730-7TG35-8BA3</b>
800	735	–	<b>6SL3730-7TG37-4BA3</b>
		<i>Left</i>	<b>6SL3730-7TG37-4BC3</b>
1100	1025	–	<b>6SL3730-7TG41-0BA3</b>
		<i>Left</i>	<b>6SL3730-7TG41-0BC3</b>
1400	1270	–	<b>6SL3730-7TG41-3BA3</b>
		<i>Left</i>	<b>6SL3730-7TG41-3BC3</b>

**Integration**

The Active Line Module is controlled by the CU320-2 Control Unit. Communication between the Control Unit and module is established via DRIVE-CLiQ connections. The Active Interface Module is included in the scope of delivery for the Active Line Module.

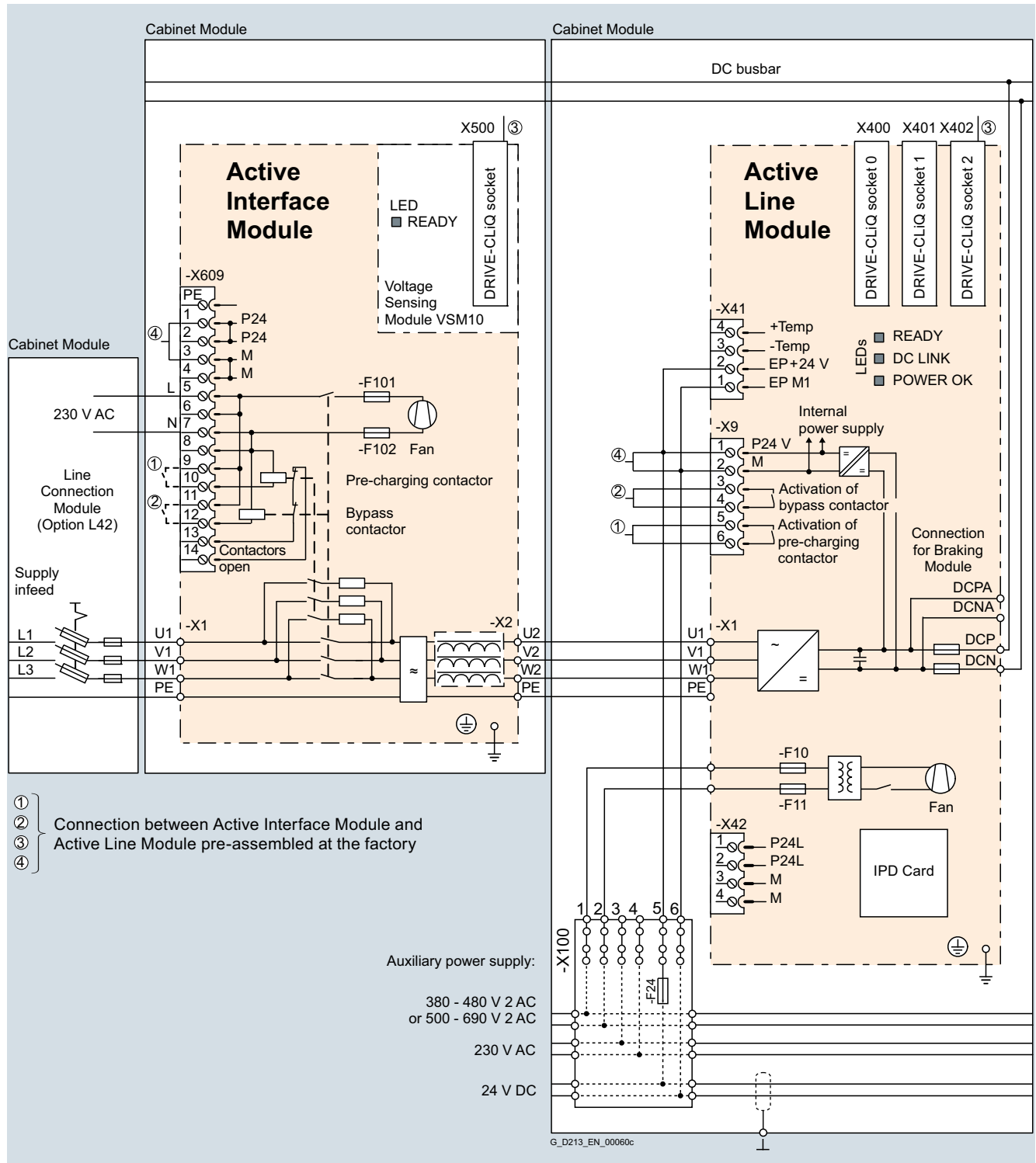

Connection example: Active Line Module (frame size FI/FX and GI/GX)

# SINAMICS S120 Cabinet Modules

Air-cooled units

Active Line Modules incl. Active Interface Modules

Integration (continued)

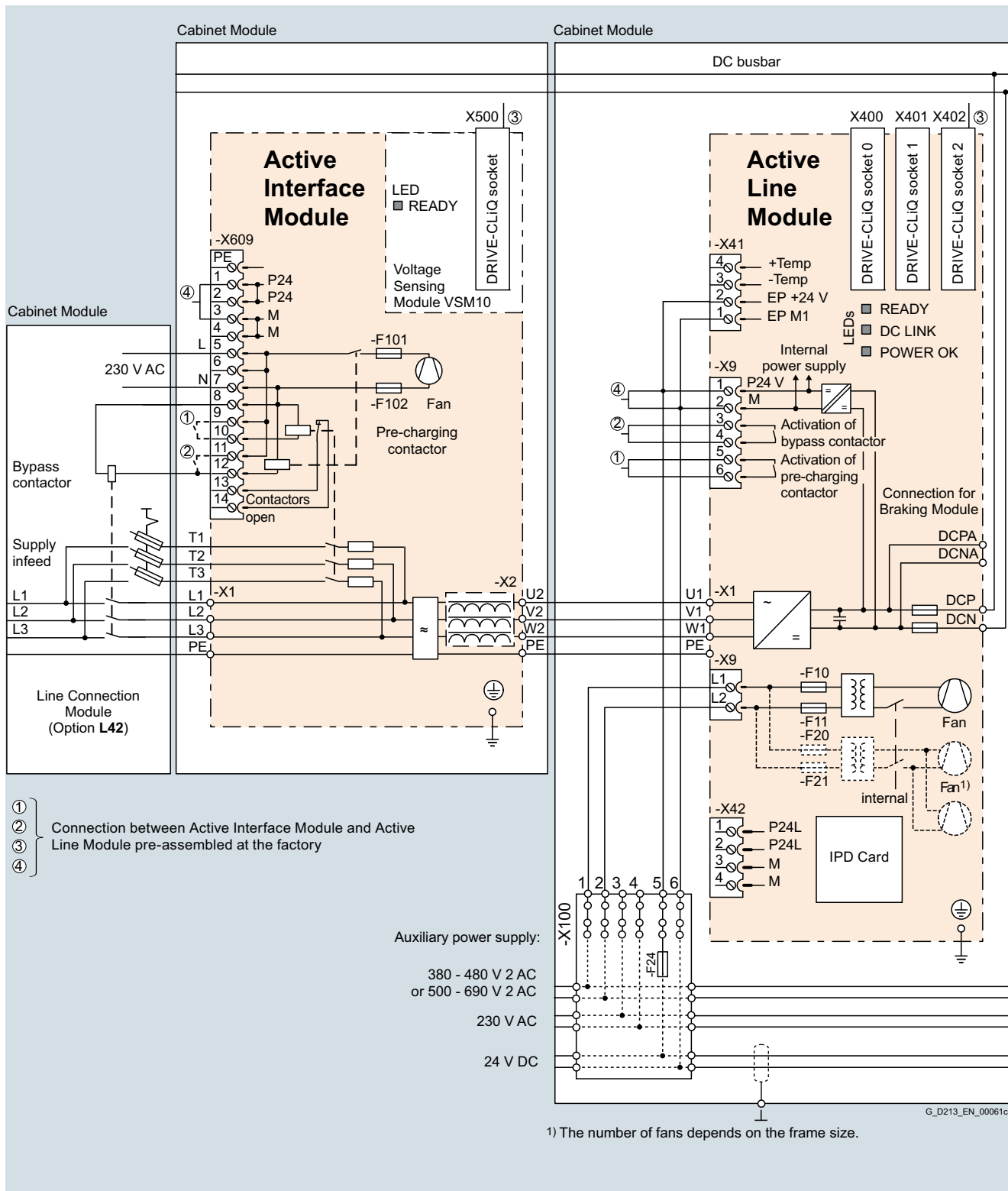

Connection example: Active Line Module (frame size HI/HX and JI/JX)

## Technical specifications

Line voltage 380 ... 480 V 3 AC		Active Line Modules							
		6SL3730-7TE32-1BA3	6SL3730-7TE32-6BA3	6SL3730-7TE33-8BA3	6SL3730-7TE35-0BA3	6SL3730-7TE36-1BA3	6SL3730-7TE38-4BA3	6SL3730-7TE41-0BA3	6SL3730-7TE41-4BA3
<i>For a parallel circuit configuration, mounted to the left of the Line Connection Module</i>								6SL3730-7TE41-0BC3	6SL3730-7TE41-4BC3
<b>Rated power</b>									
• At $I_{\text{rated DC}}$ (50 Hz 400 V)	kW	132	160	235	300	380	500	630	900
• At $I_{\text{H DC}}$ (50 Hz 400 V)	kW	115	145	210	270	335	465	545	780
• At $I_{\text{rated DC}}$ (60 Hz 460 V)	hp	200	250	400	500	600	700	900	1250
• At $I_{\text{H DC}}$ (60 Hz 460 V)	hp	150	200	300	400	500	700	800	1000
<b>DC link current</b>									
• Rated current $I_{\text{rated DC}}$	A	235	291	425	549	678	940	1103	1574
• Base-load current $I_{\text{H DC}}^{1)}$	A	209	259	378	489	603	837	982	1404
• Maximum current $I_{\text{max DC}}$	A	352	436	637	823	1017	1410	1654	2361
<b>Infeed/regenerative feedback current</b>									
• Rated current $I_{\text{rated I}}$	A	210	260	380	490	605	840	985	1405
• Maximum current $I_{\text{max I}}$	A	315	390	570	735	907	1260	1477	2107
<b>Current demand</b>									
• 24 V DC auxiliary power supply	A	1.27	1.27	1.52	1.52	1.57	1.57	1.67	1.67
• 230 V AC auxiliary power supply	A	0.6	0.6	1.2	1.2	4.6	4.6	4.9	4.9
• 400 V AC <sup>2)</sup>	A	0.63	1.13	1.8	1.8	3.6	3.6	5.4	5.4
<b>DC link capacitance</b>									
• Active Line Module	μF	4200	5200	7800	9600	12600	16800	18900	28800
• Drive line-up, max.	μF	41600	41600	76800	76800	134400	134400	230400	230400
<b>Power loss, max. <sup>3)</sup></b>									
• At 50 Hz 400 V	kW	4.3	4.9	6.9	8.7	11.7	13.8	17.6	21.8
• At 60 Hz 460 V	kW	4.4	5.1	7.2	9.0	12.1	14.3	18.3	22.7
<b>Cooling air requirement</b>		m <sup>3</sup> /s	0.47	0.47	0.83	0.83	1.18	1.18	1.48
<b>Sound pressure level <math>L_{\text{pA}}</math> <sup>4)</sup></b> (1 m) at 50/60 Hz		dB	71/73	71/73	72/74	72/74	77/79	77/79	78/80
<b>PE/GND connection</b>		PE bar	PE bar	PE bar	PE bar	PE bar	PE bar	PE bar	PE bar
• Busbar cross-section	mm <sup>2</sup>	600	600	600	600	600	600	600	600
• Conductor cross-section, max. (IEC)	mm <sup>2</sup>	240	240	240	240	240	240	240	240
<b>Cable length, max. <sup>5)</sup></b>									
• Shielded	m	2700	2700	2700	2700	3900	3900	3900	3900
• Unshielded	m	4050	4050	4050	4050	5850	5850	5850	5850
<b>Degree of protection</b>		IP20	IP20	IP20	IP20	IP20	IP20	IP20	IP20
<b>Dimensions</b>									
• Width	mm	800	800	800	800	1000	1000	1400	1400
• Height <sup>6)</sup>	mm	2200	2200	2200	2200	2200	2200	2200	2200
• Depth	mm	600	600	600	600	600	600	600	600
<b>Weight, approx.</b>		kg	380	380	530	530	930	930	1360
<b>Frame size</b>			FX + FI	FX + FI	GX + GI	GX + GI	HX + HI	HX + HI	JX + JI
<b>Short-circuit current rating according to IEC</b>		kA	65	65	65	65	65	84	84
<b>Minimum short-circuit current <sup>7)</sup></b>		A	6200	10500	10500	10500	12000	2000	4000

1) The base-load current  $I_{\text{H DC}}$  is based on a duty cycle of 150 % for 60 s or  $I_{\text{max DC}}$  for 5 s with a duty cycle duration of 300 s.

2) The current demand for the 400 V AC auxiliary power supply is drawn from the line input voltage.

3) The specified power loss represents the maximum value at 100% utilization. The value is lower under normal operating conditions.

4) Total sound pressure level of Active Interface Module and Active Line Module.

5) Total of all motor cables and DC link. Longer cable lengths for specific configurations are available on request.

6) The cabinet height increases by 250 mm with degree of protection IP21, and by 400 mm with degrees of protection IP23, IP43 or IP54.

7) Current required to ensure reliable tripping of installed protective devices.



# SINAMICS S120 Cabinet Modules

Air-cooled units

## Active Line Modules incl. Active Interface Modules

### Technical specifications (continued)

Line voltage 500 ... 690 V 3 AC		Active Line Modules			
		6SL3730-7TG35-8BA3	6SL3730-7TG37-4BA3	6SL3730-7TG41-0BA3	6SL3730-7TG41-3BA3
For a parallel circuit configuration, mounted to the left of the Line Connection Module			6SL3730-7TG37-4BC3	6SL3730-7TG41-0BC3	6SL3730-7TG41-3BC3
<b>Rated power</b>					
• At $I_{rated\ DC}$ (50 Hz 690 V)	kW	<b>630</b>	<b>800</b>	<b>1100</b>	<b>1400</b>
• At $I_{H\ DC}$ (50 Hz 690 V)	kW	620	705	980	1215
• At $I_{rated\ DC}$ (50 Hz 500 V)	kW	447	560	780	965
• At $I_{H\ DC}$ (50 Hz 500 V)	kW	450	510	710	880
• At $I_{rated\ DC}$ (60 Hz 575 V)	hp	675	900	1250	1500
• At $I_{H\ DC}$ (60 Hz 575 V)	hp	506	600	1000	1250
<b>DC link current</b>					
• Rated current $I_{rated\ DC}$	A	644	823	1148	1422
• Base-load current $I_{H\ DC}^{1)}$	A	573	732	1022	1266
• Maximum current $I_{max\ DC}$	A	966	1234	1722	2133
<b>Infeed/regenerative feedback current</b>					
• Rated current $I_{rated\ I}$	A	575	735	1025	1270
• Maximum current $I_{max\ I}$	A	862	1102	1537	1905
<b>Current demand <sup>2)</sup></b>					
• 24 V DC auxiliary power supply	A	1.57	1.67	1.87	1.87
• 230 V AC auxiliary power supply	A	4.6	4.9	4.9	4.9
• 500 V AC	A	3.0	4.4	4.4	4.4
• 690 V AC	A	2.1	3.1	3.1	3.1
<b>DC link capacitance</b>					
• Active Line Module	μF	7400	11100	14400	19200
• Drive line-up, max.	μF	59200	153600	153600	153600
<b>Power loss, max. <sup>3)</sup></b>					
• At 50 Hz 500/690 V	kW	13.6	19.2	22.8	26.1
• At 60 Hz 575 V	kW	13.0	18.6	22.1	24.9
<b>Cooling air requirement</b>					
	m <sup>3</sup> /s	1.18	1.48	1.48	1.48
<b>Sound pressure level <math>L_{pA}</math> <sup>4)</sup></b> (1 m) at 50/60 Hz					
	dB	77/79	77/79	77/79	77/79
<b>PE/GND connection</b>					
• Busbar cross-section	mm <sup>2</sup>	600	600	600	600
• Conductor cross-section, max. (IEC)	mm <sup>2</sup>	240	240	240	240
<b>Cable length, max. <sup>5)</sup></b>					
• Shielded	m	2250	2250	2250	2250
• Unshielded	m	3375	3375	3375	3375
<b>Degree of protection</b>					
		IP20	IP20	IP20	IP20
<b>Dimensions</b>					
• Width	mm	1000	1400	1400	1400
• Height <sup>6)</sup>	mm	2200	2200	2200	2200
• Depth	mm	600	600	600	600
<b>Weight, approx.</b>					
	kg	930	1360	1360	1360
<b>Frame size</b>					
		HX + HI	JX + JI	JX + JI	JX + JI
<b>Short-circuit current rating according to IEC</b>					
	kA	65	84	100	100
<b>Minimum short-circuit current <sup>7)</sup></b>					
• For connection in parallel	A	9000	10500	2500	3200
	A	–	4000	4000	5000

<sup>1)</sup> The base-load current  $I_{H\ DC}$  is based on a duty cycle of 150 % for 60 s or  $I_{max\ DC}$  for 5 s with a duty cycle duration of 300 s.

<sup>2)</sup> The current demand for the 500 V/690 V AC auxiliary power supply is drawn from the line input voltage.

<sup>3)</sup> The specified power loss represents the maximum value at 100% utilization. The value is lower under normal operating conditions.

<sup>4)</sup> Total sound pressure level of Active Interface Module and Active Line Module.

<sup>5)</sup> Total of all motor cables and DC link. Longer cable lengths for specific configurations are available on request.

<sup>6)</sup> The cabinet height increases by 250 mm with degree of protection IP21, and by 400 mm with degrees of protection IP23, IP43 or IP54.

<sup>7)</sup> Current required to ensure reliable tripping of installed protective devices.

## Overview



Motor Modules Booksize format are also available as Booksize Cabinet Kits in voltage class 380 V to 480 V (DC link voltage 510 V to 720 V).

Motor Modules are also available as Single Motor Modules for power ratings of 4.8 kW to 71 kW for connection of a motor.

## Design

Motor Modules Booksize format are installed in the factory as Booksize Cabinet Kits in Booksize Base Cabinets. This complete unit contains all of the components necessary for operation.

Several Booksize Cabinet Kits can be installed in one Booksize Base Cabinet, depending on the installation width requirements, which in turn depend on the power rating. The number of Booksize Cabinet Kits that can be installed in a Booksize Base Cabinet is determined solely on the basis of the available cabinet width. By changing the way in which the cabinet width is used (i.e. the equipment that is installed), it can be adapted to suit system requirements.

Each Motor Module is connected separately to the DC busbar of the SINAMICS S120 Cabinet Module via a separate fuse switch disconnector with integrated fuses. The DC connecting busbar integrated in the units is not used.

The basic version of the Booksize Cabinet Kit comprises the following components:

- Motor Module in booksize format
- Fuse switch disconnector for each Motor Module installed
- Customer interface -X55.1 located in the connection area of the Booksize Base Cabinet
- Shield connection plate
- Complete electrical connection to the Booksize Base Cabinet interfaces

The Booksize Base Cabinets can be operated up to and including IP54 degree of protection without additional temperature derating. However, some values need to be taken into account that differ from those of the chassis format. [For derating data, see System overview → Characteristic curves.](#)

## Selection and ordering data

Type rating at 400 V kW	Rated output current $I_{rated}$ A	Width mm	Single Motor Module Booksize Cabinet Kit Article No.
<b>Line voltage 380 ... 480 V 3 AC (DC link voltage 510 ... 720 V DC)</b>			
4.8	9	100	<b>6SL3720-1TE21-0AB3</b>
9.7	18	100	<b>6SL3720-1TE21-8AB3</b>
16	30	100	<b>6SL3720-1TE23-0AB3</b>
24	45	200	<b>6SL3720-1TE24-5AB3</b>
32	60	200	<b>6SL3720-1TE26-0AB3</b>
46	85	200	<b>6SL3720-1TE28-5AB3</b>
71	132	300	<b>6SL3720-1TE31-3AB3</b>

Booksize Cabinet Kits must always be ordered in combination with at least one Booksize Base Cabinet (cannot be supplied as a single unit).

The required number of Booksize Cabinet Kits installed in a Booksize Base Cabinet must be stated in plain text in the order. The number of possible kits is limited only by the usable installation width of the Booksize Base Cabinet.

Booksize Base Cabinets ready to be installed in the Booksize Cabinet Kits:

Usable installation width mm	Weight, approx. kg	Dimensions with degree of protection IP20 <sup>1)</sup> (W × D × H) mm	Booksize Base Cabinet Article No.
600	170	800 × 600 × 2200	<b>6SL3720-1TX38-0AA3</b>
1000	240	1200 × 600 × 2200	<b>6SL3720-1TX41-2AA3</b>

<sup>1)</sup> The cabinet height increases by 250 mm with degree of protection IP21, 400 mm with degrees of protection IP23, IP43 and IP54.

# SINAMICS S120 Cabinet Modules

Air-cooled units

Motor Modules in booksize format

## Integration

4

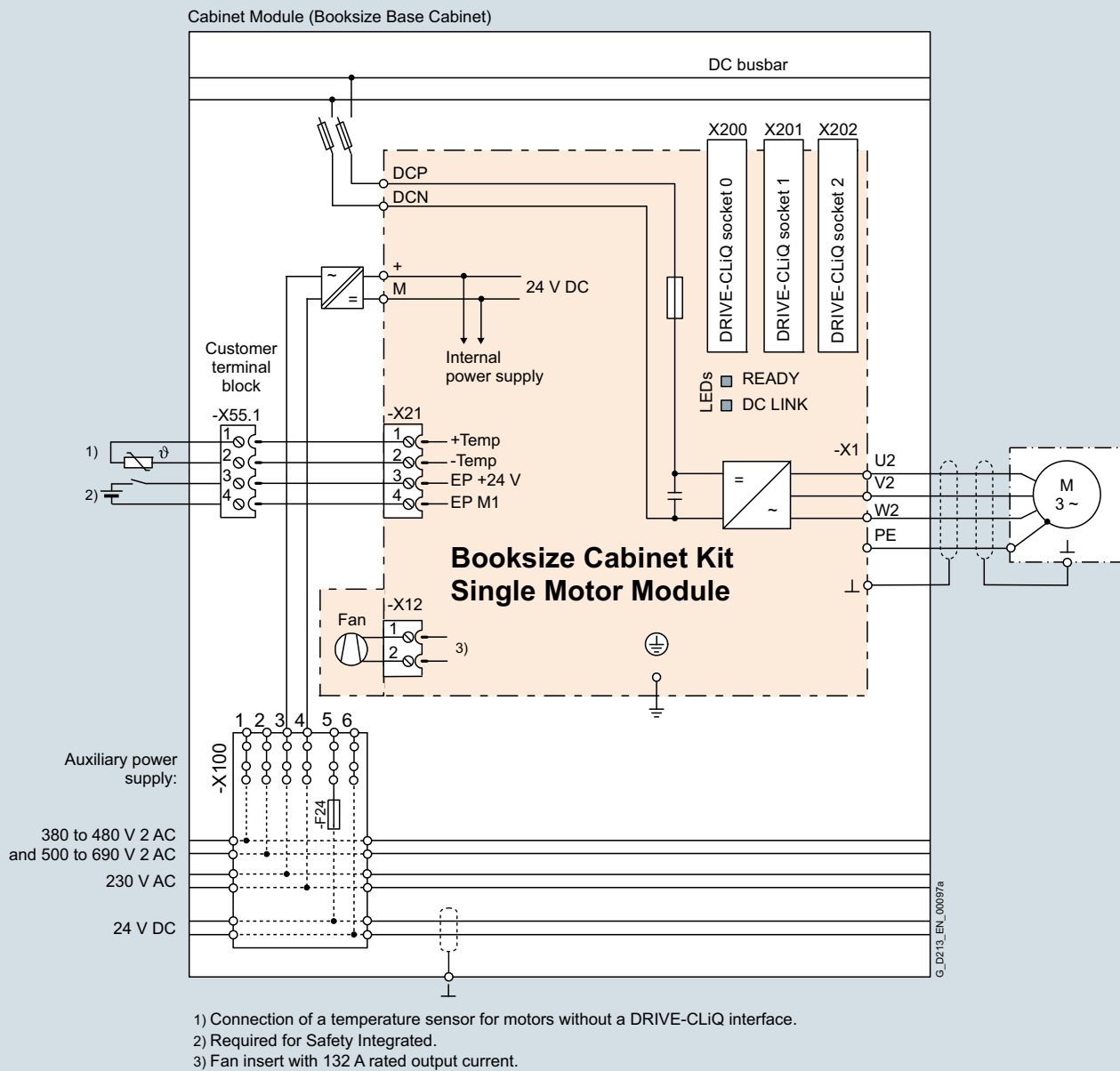

Connection example: Booksize Cabinet Kit (Single Motor Module in booksize format) in Booksize Base Cabinet

**Technical specifications**

Line voltage 380 ... 480 V 3 AC DC link voltage 510 ... 720 V DC		Single Motor Modules Booksize Cabinet Kit			
		6SL3720-1TE21-0AB3	6SL3720-1TE21-8AB3	6SL3720-1TE23-0AB3	6SL3720-1TE24-5AB3
<b>Type rating</b>					
• At $I_L$ (50 Hz 400 V) <sup>1)</sup>	kW	4.8	9.7	16	24
• At $I_H$ (50 Hz 400 V) <sup>1)</sup>	kW	4.1	8.2	13.7	21
• At $I_L$ (60 Hz 460 V) <sup>2)</sup>	hp	5	10	20	30
• At $I_H$ (60 Hz 460 V) <sup>2)</sup>	hp	5	10	15	25
<b>Output current</b>					
• Rated current $I_{rated O}$	A	9	18	30	45
• Base-load current $I_H$ <sup>3)</sup>	A	7.7	15.3	25.5	38
• Maximum current $I_{max O}$	A	18	36	56	85
<b>DC link current <math>I_d</math> <sup>4)</sup></b>	A	11	22	36	54
<b>Current demand</b>					
• 24 V DC, max.	A	0.85	0.85	0.9	1.2
<b>DC link capacitance</b>	μF	110	220	710	1175
<b>Pulse frequency <sup>5)</sup></b>					
• Rated frequency	kHz	4	4	4	4
• Pulse frequency, max. - With current derating	kHz	16	16	16	16
<b>Power loss, max. <sup>6)</sup></b>					
• At 50 Hz 400 V	kW	0.08	0.165	0.29	0.43
• At 60 Hz 460 V	kW	0.08	0.165	0.29	0.43
<b>Cooling air requirement</b>	m <sup>3</sup> /s	0.008	0.008	0.016	0.031
<b>Sound pressure level <math>L_{pA}</math></b> (1 m) at 50/60 Hz	dB	<60	<60	<60	<65
<b>Motor connection</b> U2, V2, W2		Terminal	Terminal	Terminal	Terminal
• Conductor cross-section, max. (IEC)	mm <sup>2</sup>	6	6	6	16
<b>Cable length, max. <sup>7)</sup></b>					
• Shielded	m	50	70	100	100
• Unshielded	m	75	100	150	150
<b>PE/GND connection</b>		PE bar	PE bar	PE bar	PE bar
• Busbar cross-section	mm <sup>2</sup>	600	600	600	600
• Conductor cross-section, max. (IEC)	mm <sup>2</sup>	240	240	240	240
<b>Degree of protection</b>		IP20	IP20	IP20	IP20
<b>Weight, approx.</b>	kg	20	20	21.9	27
<b>Width</b>	mm	100	100	100	200
<b>Short-circuit current rating according to IEC</b>	kA	65	65	65	65

<sup>1)</sup> Rated output of a typical 6-pole standard induction motor based on  $I_L$  or  $I_H$  for 400 V 3 AC 50 Hz.

<sup>2)</sup> Rated output of a typical 6-pole standard induction motor based on  $I_L$  or  $I_H$  for 460 V 3 AC 60 Hz.

<sup>3)</sup> The base-load current  $I_L$  is based on a duty cycle of 110 % for 60 s or 150 % for 10 s with a duty cycle duration of 300 s.

<sup>4)</sup> For a DC link voltage of 600 V DC.

<sup>5)</sup> Information regarding the correlation between the pulse frequency and max. output current/output frequency is provided in the SINAMICS Low Voltage Engineering Manual.

<sup>6)</sup> The specified power loss represents the maximum value at 100% utilization. The value is lower under normal operating conditions.

<sup>7)</sup> Total of all motor cables. Longer cable lengths for specific configurations are available on request.

# SINAMICS S120 Cabinet Modules

Air-cooled units

## Motor Modules in booksize format

### Technical specifications (continued)

Line voltage 380 ... 480 V 3 AC DC link voltage 510 ... 720 V DC		Single Motor Modules Booksize Cabinet Kit		
		6SL3720-1TE26-0AB3	6SL3720-1TE28-5AB3	6SL3720-1TE31-3AB3
<b>Type rating</b>				
• At $I_L$ (50 Hz 400 V) <sup>1)</sup>	kW	<b>32</b>	<b>46</b>	<b>71</b>
• At $I_H$ (50 Hz 400 V) <sup>1)</sup>	kW	28	37	57
• At $I_L$ (60 Hz 460 V) <sup>2)</sup>	hp	40	60	100
• At $I_H$ (60 Hz 460 V) <sup>2)</sup>	hp	40	50	75
<b>Output current</b>				
• Rated current $I_{rated O}$	A	60	85	132
• Base-load current $I_H$ <sup>3)</sup>	A	52	68	105
• Maximum current $I_{max O}$	A	113	141	210
<b>DC link current <math>I_d</math> <sup>4)</sup></b>	A	72	102	158
<b>Current demand</b>				
• 24 V DC, max.	A	1.2	1.5	1.5
<b>DC link capacitance</b>	μF	1410	1880	2820
<b>Pulse frequency <sup>5)</sup></b>				
• Rated frequency	kHz	4	4	4
• Pulse frequency, max. - With current derating	kHz	16	16	16
<b>Power loss, max. <sup>6)</sup></b>				
• At 50 Hz 400 V	kW	0.59	0.75	1.25
• At 60 Hz 460 V	kW	0.59	0.75	1.25
<b>Cooling air requirement</b>	m <sup>3</sup> /s	0.031	0.044	0.144
<b>Sound pressure level <math>L_{pA}</math></b> (1 m) at 50/60 Hz	dB	<65	<60	<73
<b>Motor connection</b> U2, V2, W2		Terminal	Terminal	Terminal
• Conductor cross-section, max. (IEC)	mm <sup>2</sup>	16	35	70
<b>Cable length, max. <sup>7)</sup></b>				
• Shielded	m	100	100	100
• Unshielded	m	150	150	150
<b>PE/GND connection</b>		PE bar	PE bar	PE bar
• Busbar cross-section	mm <sup>2</sup>	600	600	600
• Conductor cross-section, max. (IEC)	mm <sup>2</sup>	240	240	240
<b>Degree of protection</b>		IP20	IP20	IP20
<b>Weight, approx.</b>	kg	27	33	41
<b>Width</b>	mm	200	200	300
<b>Short-circuit current rating according to IEC</b>	kA	65	65	65

<sup>1)</sup> Rated output of a typical 6-pole standard induction motor based on  $I_L$  or  $I_H$  for 400 V 3 AC 50 Hz.

<sup>2)</sup> Rated output of a typical 6-pole standard induction motor based on  $I_L$  or  $I_H$  for 460 V 3 AC 60 Hz.

<sup>3)</sup> The base-load current  $I_L$  is based on a duty cycle of 110 % for 60 s or 150 % for 10 s with a duty cycle duration of 300 s.

<sup>4)</sup> For a DC link voltage of 600 V DC.

<sup>5)</sup> Information regarding the correlation between the pulse frequency and max. output current/output frequency is provided in the SINAMICS Low Voltage Engineering Manual.

<sup>6)</sup> The specified power loss represents the maximum value at 100% utilization. The value is lower under normal operating conditions.

<sup>7)</sup> Total of all motor cables. Longer cable lengths for specific configurations are available on request.

# SINAMICS S120 Cabinet Modules

## Air-cooled units

### Motor Modules in chassis format

#### Overview



Motor Modules in chassis format are available in the power range from 75 kW to 1200 kW.

Line voltage	DC link voltage	Type rating
380 ... 480 V 3 AC	510 ... 720 V DC	110 ... 800 kW
500 ... 690 V 3 AC	675 ... 1035 V DC	75 ... 1200 kW

By connecting in parallel up to four Motor Modules operated on one Control Unit and which supply one motor, it is possible to increase the available shaft power to a maximum of approx. 4500 kW (taking into account the derating factors according to the SINAMICS Low Voltage Engineering Manual).

SINAMICS S120 Motor Modules in chassis format can also be used as a Braking Module if, instead of a motor, a 3-phase braking resistor is connected.

[For additional information, please refer to the SINAMICS Low Voltage Engineering Manual.](#)

#### Design

Motor Modules in chassis format contain the following components as standard:

- Retaining device for the DC busbar, including the connection to the DC connections of the Motor Module
- Nickel-plated connection busbars for motor cables for Motor Modules, frame sizes FX and GX; for Motor Modules, frame sizes HX and JX, the connection is made directly on the unit
- Cable retaining bar for the power cables
- DRIVE-CLiQ interface (3 DRIVE-CLiQ sockets), without Control Unit
- Customer interface -X55
- Auxiliary power supply system (6-pole) for the auxiliary power supply, including cable connections for looping through to the next Cabinet Module
- Nickel-plated PE bar (60 x 10 mm), including jumper for looping through to the next Cabinet Module
- EMC-compliant design thanks to additional shielding measures and appropriately routed cables

#### Selection and ordering data

Type rating at 400 V or 690 V kW	Rated output current $I_{rated}$ A	Motor Module in chassis format Article No.
<b>Line voltage 380 ... 480 V 3 AC (DC link voltage 510 ... 720 V DC)</b>		
110	210	<b>6SL3720-1TE32-1AA3</b>
132	260	<b>6SL3720-1TE32-6AA3</b>
160	310	<b>6SL3720-1TE33-1AA3</b>
200	380	<b>6SL3720-1TE33-8AA3</b>
250	490	<b>6SL3720-1TE35-0AA3</b>
315	605	<b>6SL3720-1TE36-1AA3</b>
400	745	<b>6SL3720-1TE37-5AA3</b>
450	840	<b>6SL3720-1TE38-4AA3</b>
560	985	<b>6SL3720-1TE41-0AA3</b>
710	1260	<b>6SL3720-1TE41-2AA3</b>
800	1405	<b>6SL3720-1TE41-4AA3</b>
<b>Line voltage 500 ... 690 V 3 AC (DC link voltage 675 ... 1035 V DC)</b>		
75	85	<b>6SL3720-1TG28-5AA3</b>
90	100	<b>6SL3720-1TG31-0AA3</b>
110	120	<b>6SL3720-1TG31-2AA3</b>
132	150	<b>6SL3720-1TG31-5AA3</b>
160	175	<b>6SL3720-1TG31-8AA3</b>
200	215	<b>6SL3720-1TG32-2AA3</b>
250	260	<b>6SL3720-1TG32-6AA3</b>
315	330	<b>6SL3720-1TG33-3AA3</b>
400	410	<b>6SL3720-1TG34-1AA3</b>
450	465	<b>6SL3720-1TG34-7AA3</b>
560	575	<b>6SL3720-1TG35-8AA3</b>
710	735	<b>6SL3720-1TG37-4AA3</b>
800	810	<b>6SL3720-1TG38-1AA3</b>
900	910	<b>6SL3720-1TG38-8AA3</b>
1000	1025	<b>6SL3720-1TG41-0AA3</b>
1200	1270	<b>6SL3720-1TG41-3AA3</b>

# SINAMICS S120 Cabinet Modules

Air-cooled units

## Motor Modules in chassis format

### Integration

Motor Modules are controlled by the CU320-2 DP or CU320-2 PN Control Unit. Communication between the Control Unit and Modules is established via a DRIVE-CLiQ connection.

If the Control Unit is integrated in the same cabinet as an option with order code **K90** or **K95**, these communication cables will already be installed. If the Control Unit is to be mounted exter-

nally, the DRIVE-CLiQ cable will not be included in the scope of delivery and must be configured on site.

For additional information, please refer to the [SINAMICS Low Voltage Engineering Manual](#).

For a description of the terminal block, see section [Customer terminal block -X55](#).

4

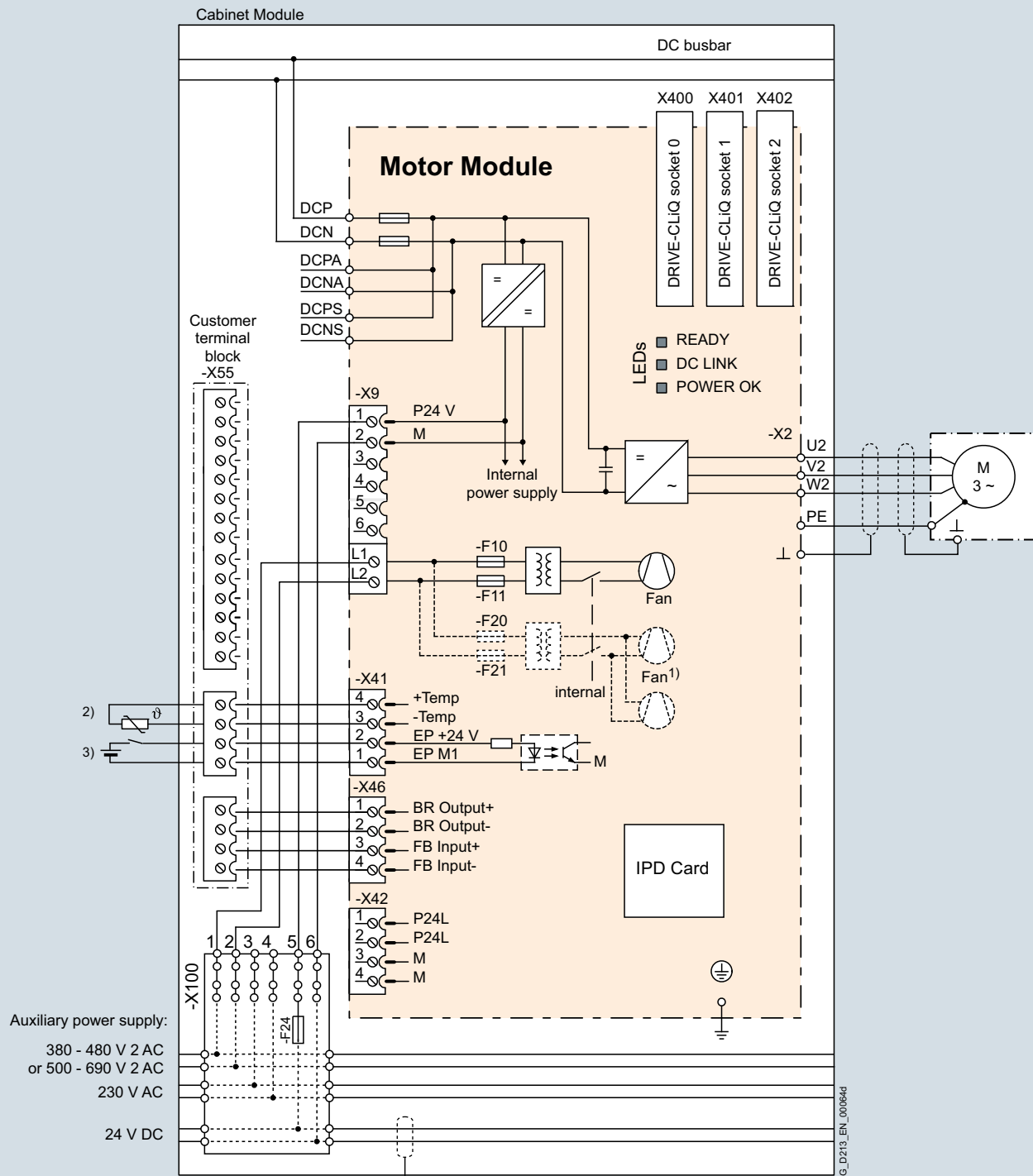

- 1) The number and the terminals of the fans depend on the frame size.
- 2) Connection of temperature sensor for motors without DRIVE-CLiQ interface.
- 3) Required for Safety Integrated.

Connection example: Motor Module in chassis format

#### Technical specifications

Line voltage 380 ... 480 V 3 AC		Motor Modules in chassis format					
DC link voltage 510 ... 720 V DC		6SL3720-1TE32-1AA3	6SL3720-1TE32-6AA3	6SL3720-1TE33-1AA3	6SL3720-1TE33-8AA3	6SL3720-1TE35-0AA3	6SL3720-1TE36-1AA3
<b>Type rating</b>							
• At $I_L$ (50 Hz 400 V) <sup>1)</sup>	kW	<b>110</b>	<b>132</b>	<b>160</b>	<b>200</b>	<b>250</b>	<b>315</b>
• At $I_H$ (50 Hz 400 V) <sup>1)</sup>	kW	90	110	132	160	200	250
• At $I_L$ (60 Hz 460 V) <sup>2)</sup>	hp	150	200	250	300	400	500
• At $I_H$ (60 Hz 460 V) <sup>2)</sup>	hp	150	200	200	250	350	350
<b>Output current</b>							
• Rated current $I_{rated}$ <sup>3)</sup>	A	210	260	310	380	490	605
• Base-load current $I_L$ <sup>3)</sup>	A	205	250	302	370	477	590
• Base-load current $I_H$ <sup>4)</sup>	A	178	233	277	340	438	460
• Maximum current $I_{max}$ <sup>0</sup>	A	307	375	453	555	715	885
<b>DC link current</b>							
• Rated current $I_{rated}$ DC when supplied via							
- Basic/Smart Line Module	A	252	312	372	456	588	726
- Active Line Module	A	227	281	335	411	529	653
• Base-load current $I_L$ DC <sup>3)</sup> when supplied via							
- Basic/Smart Line Module	A	245	304	362	444	573	707
- Active Line Module	A	221	273	326	400	515	636
• Base-load current $I_H$ DC <sup>4)</sup> when supplied via							
- Basic/Smart Line Module	A	224	277	331	405	523	646
- Active Line Module	A	202	250	298	365	470	581
<b>Current demand</b>							
• 24 V DC auxiliary power supply	A	0.8	0.8	0.9	0.9	0.9	1.0
• 400 V AC	A	0.63	1.13	1.8	1.8	1.8	3.6
<b>DC link capacitance</b>		μF	4200	5200	6300	7800	9600
<b>Pulse frequency <sup>5)</sup></b>							
• Rated frequency	kHz	2	2	2	2	2	1.25
• Pulse frequency, max.							
- Without current derating	kHz	2	2	2	2	2	1.25
- With current derating	kHz	8	8	8	8	8	7.5
<b>Power loss, max. <sup>6)</sup></b>							
• At 50 Hz 400 V	kW	1.86	2.5	2.96	3.67	4.28	5.84
• At 60 Hz 460 V	kW	1.94	2.6	3.1	3.8	4.5	6.3
<b>Cooling air requirement</b>		m <sup>3</sup> /s	0.17	0.23	0.36	0.36	0.78
<b>Sound pressure level <math>L_{pA}</math></b> (1 m) at 50/60 Hz		dB	67	69	69	69	72
<b>Motor connection</b>			M12 screws	M12 screws	M12 screws	M12 screws	M12 screws
U2, V2, W2							
• Conductor cross-section, max. (IEC)	mm <sup>2</sup>	2 × 185	2 × 185	2 × 240	2 × 240	2 × 240	4 × 240
<b>Cable length, max. <sup>7)</sup></b>							
• Shielded	m	300	300	300	300	300	300
• Unshielded	m	450	450	450	450	450	450
<b>PE/GND connection</b>			PE bar	PE bar	PE bar	PE bar	PE bar
• Busbar cross-section	mm <sup>2</sup>	600	600	600	600	600	600
• Conductor cross-section, max. (IEC)	mm <sup>2</sup>	240	240	240	240	240	240
<b>Degree of protection</b>			IP20	IP20	IP20	IP20	IP20
<b>Dimensions</b>							
• Width <sup>8)</sup>	mm	400	400	400	400	400	600
• Height <sup>9)</sup>	mm	2200	2200	2200	2200	2200	2200
• Depth	mm	600	600	600	600	600	600
<b>Weight, approx.</b>		kg	145	145	286	286	490
<b>Frame size</b>			FX	FX	GX	GX	HX
<b>Short-circuit current rating according to IEC</b>		kA	65	65	65	65	65

<sup>1)</sup> Rated output of a typical 6-pole standard induction motor based on  $I_L$  or  $I_H$  for 400 V 3 AC 50 Hz.

<sup>2)</sup> Rated output of a typical 6-pole standard induction motor based on  $I_L$  or  $I_H$  for 460 V 3 AC 60 Hz.

<sup>3)</sup> The base-load current  $I_L$  is based on a duty cycle of 110 % for 60 s or 150 % for 10 s with a duty cycle duration of 300 s.

<sup>4)</sup> The base-load current  $I_H$  is based on a duty cycle of 150 % for 60 s or 160 % for 10 s with a duty cycle duration of 300 s.

<sup>5)</sup> Information regarding the correlation between the pulse frequency and max. output current/output frequency is provided in the SINAMICS Low Voltage Engineering Manual.

<sup>6)</sup> The specified power loss represents the maximum value at 100% utilization. The value is lower under normal operating conditions.

<sup>7)</sup> Total of all motor cables. Longer cable lengths for specific configurations are available on request. [For additional information, please refer to the SINAMICS Low Voltage Engineering Manual.](#)

<sup>8)</sup> With option **L10** (dv/dt filter plus VPL):  
 - Frame sizes FX/GX/HX/JX: Additional cabinet 600 mm wide  
 With option **L34** (circuit breaker on the output side):  
 - Frame size FX/GX: Additional cabinet 400 mm wide  
 - Frame size HX/JX: Additional cabinet 600 mm wide.

<sup>9)</sup> The cabinet height increases by 250 mm with degree of protection IP21, and by 400 mm with degrees of protection IP23, IP43 and IP54.



# SINAMICS S120 Cabinet Modules

Air-cooled units

## Motor Modules in chassis format

### Technical specifications (continued)

Line voltage 380 ... 480 V 3 AC DC link voltage 510 ... 720 V DC		Motor Modules in chassis format				
		6SL3720-1TE37-5AA3	6SL3720-1TE38-4AA3	6SL3720-1TE41-0AA3	6SL3720-1TE41-2AA3	6SL3720-1TE41-4AA3
<b>Type rating</b>						
• At $I_L$ (50 Hz 400 V) <sup>1)</sup>	kW	400	450	560	710	800
• At $I_H$ (50 Hz 400 V) <sup>1)</sup>	kW	315	400	450	560	710
• At $I_L$ (60 Hz 460 V) <sup>2)</sup>	hp	600	700	800	1000	1150
• At $I_H$ (60 Hz 460 V) <sup>2)</sup>	hp	450	600	700	900	1000
<b>Output current</b>						
• Rated current $I_{rated O}$	A	745	840	985	1260	1405
• Base-load current $I_L^{(3)}$	A	725	820	960	1230	1370
• Base-load current $I_H^{(4)}$	A	570	700	860	1127	1257
• Maximum current $I_{max O}$	A	1087	1230	1440	1845	2055
<b>DC link current</b>						
• Rated current $I_{rated DC}$ when supplied via						
- Basic/Smart Line Module	A	894	1008	1182	1512	1686
- Active Line Module	A	805	907	1064	1361	1517
• Base-load current $I_L^{DC (3)}$ when supplied via						
- Basic/Smart Line Module	A	871	982	1152	1474	1643
- Active Line Module	A	784	884	1037	1326	1479
• Base-load current $I_H^{DC (4)}$ when supplied via						
- Basic/Smart Line Module	A	795	897	1051	1345	1500
- Active Line Module	A	716	807	946	1211	1350
<b>Current demand</b>						
• 24 V DC auxiliary power supply	A	1.0	1.0	1.25	1.4	1.4
• 400 V AC	A	3.6	3.6	5.4	5.4	5.4
<b>DC link capacitance</b>	μF	15600	16800	18900	26100	28800
<b>Pulse frequency <sup>5)</sup></b>						
• Rated frequency	kHz	1.25	1.25	1.25	1.25	1.25
• Pulse frequency, max.						
- Without current derating	kHz	1.25	1.25	1.25	1.25	1.25
- With current derating	kHz	7.5	7.5	7.5	7.5	7.5
<b>Power loss, max. <sup>6)</sup></b>						
• At 50 Hz 400 V	kW	6.68	7.15	9.5	11.1	12.0
• At 60 Hz 460 V	kW	7.3	7.8	10.2	12.0	13.0
<b>Cooling air requirement</b>	m <sup>3</sup> /s	0.78	0.78	1.08	1.08	1.08
<b>Sound pressure level <math>L_{pA}</math></b> (1 m) at 50/60 Hz	dB	72	72	72	72	72
<b>Motor connection</b>						
U2, V2, W2		M12 screws	M12 screws	M12 screws	M12 screws	M12 screws
• Conductor cross-section, max. (IEC)	mm <sup>2</sup>	4 × 240	4 × 240	6 × 240	6 × 240	6 × 240
<b>Cable length, max. <sup>7)</sup></b>						
• Shielded	m	300	300	300	300	300
• Unshielded	m	450	450	450	450	450
<b>PE/GND connection</b>						
• Busbar cross-section	mm <sup>2</sup>	PE bar 600	PE bar 600	PE bar 600	PE bar 600	PE bar 600
• Conductor cross-section, max. (IEC)	mm <sup>2</sup>	240	240	240	240	240
<b>Degree of protection</b>		IP20	IP20	IP20	IP20	IP20
<b>Dimensions</b>						
• Width <sup>8)</sup>	mm	600	600	800	800	800
• Height <sup>9)</sup>	mm	2200	2200	2200	2200	2200
• Depth	mm	600	600	600	600	600
<b>Weight, approx.</b>	kg	490	490	700	700	700
<b>Frame size</b>		HX	HX	JX	JX	JX
<b>Short-circuit current rating according to IEC</b>	kA	65	84	84	100	100

<sup>1)</sup> Rated output of a typical 6-pole standard induction motor based on  $I_L$  or  $I_H$  for 400 V 3 AC 50 Hz.

<sup>2)</sup> Rated output of a typical 6-pole standard induction motor based on  $I_L$  or  $I_H$  for 460 V 3 AC 60 Hz.

<sup>3)</sup> The base-load current  $I_L$  is based on a duty cycle of 110 % for 60 s or 150 % for 10 s with a duty cycle duration of 300 s.

<sup>4)</sup> The base-load current  $I_H$  is based on a duty cycle of 150 % for 60 s or 160 % for 10 s with a duty cycle duration of 300 s.

<sup>5)</sup> Information regarding the correlation between the pulse frequency and max. output current/output frequency is provided in the SINAMICS Low Voltage Engineering Manual.

<sup>6)</sup> The specified power loss represents the maximum value at 100% utilization. The value is lower under normal operating conditions.

<sup>7)</sup> Total of all motor cables. Longer cable lengths for specific configurations are available on request. For additional information, please refer to the SINAMICS Low Voltage Engineering Manual.

<sup>8)</sup> With option **L10** (dv/dt filter plus VPL):  
- Frame sizes FX/GX/HX/JX: Additional cabinet 600 mm wide  
With option **L34** (circuit breaker on the output side):  
- Frame size FX/GX: Additional cabinet 400 mm wide  
- Frame size HX/JX: Additional cabinet 600 mm wide.

<sup>9)</sup> The cabinet height increases by 250 mm with degree of protection IP21, and by 400 mm with degrees of protection IP23, IP43 and IP54.

#### Technical specifications (continued)

Line voltage 500 ... 690 V 3 AC DC link voltage 675 ... 1035 V DC		Motor Modules in chassis format					
		6SL3720-1TG28-5AA3	6SL3720-1TG31-0AA3	6SL3720-1TG31-2AA3	6SL3720-1TG31-5AA3	6SL3720-1TG31-8AA3	6SL3720-1TG32-2AA3
<b>Type rating</b>							
• At $I_L$ (50 Hz 690 V) <sup>1)</sup>	kW	75	90	110	132	160	200
• At $I_H$ (50 Hz 690 V) <sup>1)</sup>	kW	55	75	90	110	132	160
• At $I_L$ (50 Hz 500 V) <sup>1)</sup>	kW	55	55	75	90	110	132
• At $I_H$ (50 Hz 500 V) <sup>1)</sup>	kW	45	55	75	90	90	110
• At $I_L$ (60 Hz 575 V) <sup>2)</sup>	hp	75	75	100	150	150	200
• At $I_H$ (60 Hz 575 V) <sup>2)</sup>	hp	75	75	100	125	150	200
<b>Output current</b>							
• Rated current $I_{rated}$ <sup>3)</sup>	A	85	100	120	150	175	215
• Base-load current $I_L$ <sup>4)</sup>	A	80	95	115	142	170	208
• Base-load current $I_H$ <sup>4)</sup>	A	76	89	107	134	157	192
• Maximum current $I_{max}$ <sup>4)</sup>	A	120	142	172	213	255	312
<b>DC link current</b>							
• Rated current $I_{rated}$ DC when supplied via							
- Basic/Smart Line Module	A	102	120	144	180	210	258
- Active Line Module	A	92	108	130	162	189	232
• Base-load current $I_L$ DC <sup>3)</sup> when supplied via							
- Basic/Smart Line Module	A	99	117	140	175	204	251
- Active Line Module	A	89	105	126	157	184	226
• Base-load current $I_H$ DC <sup>4)</sup> when supplied via							
- Basic/Smart Line Module	A	90	106	128	160	186	229
- Active Line Module	A	81	96	115	144	168	206
<b>Current demand</b>							
• 24 V DC auxiliary power supply	A	0.8	0.8	0.8	0.8	0.9	0.9
• 690 V AC	A	0.4	0.4	0.4	0.4	1.0	1.0
<b>DC link capacitance</b>	μF	1200	1200	1600	2800	2800	2800
<b>Pulse frequency <sup>5)</sup></b>							
• Rated frequency	kHz	1.25	1.25	1.25	1.25	1.25	1.25
• Pulse frequency, max.							
- Without current derating	kHz	1.25	1.25	1.25	1.25	1.25	1.25
- With current derating	kHz	7.5	7.5	7.5	7.5	7.5	7.5
<b>Power loss, max. <sup>6)</sup></b>							
• At 50 Hz 690 V	kW	1.17	1.43	1.89	1.8	2.67	3.09
• At 60 Hz 575 V	kW	1.1	1.3	1.77	1.62	2.5	2.91
<b>Cooling air requirement</b>	m <sup>3</sup> /s	0.17	0.17	0.17	0.17	0.36	0.36
<b>Sound pressure level <math>L_{pA}</math></b> (1 m) at 50/60 Hz	dB	67	67	67	67	69	69
<b>Motor connection</b>							
U2, V2, W2		M12 screws	M12 screws	M12 screws	M12 screws	M12 screws	M12 screws
• Conductor cross-section, max. (IEC)	mm <sup>2</sup>	2 × 185	2 × 185	2 × 185	2 × 185	2 × 240	2 × 240
<b>Cable length, max. <sup>7)</sup></b>							
• Shielded	m	300	300	300	300	300	300
• Unshielded	m	450	450	450	450	450	450
<b>PE/GND connection</b>							
• Busbar cross-section	mm <sup>2</sup>	PE bar 600	PE bar 600	PE bar 600	PE bar 600	PE bar 600	PE bar 600
• Conductor cross-section, max. (IEC)	mm <sup>2</sup>	240	240	240	240	240	240
<b>Degree of protection</b>							
		IP20	IP20	IP20	IP20	IP20	IP20
<b>Dimensions</b>							
• Width <sup>8)</sup>	mm	400	400	400	400	400	400
• Height <sup>9)</sup>	mm	2200	2200	2200	2200	2200	2200
• Depth	mm	600	600	600	600	600	600
<b>Weight, approx.</b>	kg	145	145	145	145	286	286
<b>Frame size</b>		FX	FX	FX	FX	GX	GX
<b>Short-circuit current rating according to IEC</b>	kA	65	65	65	65	65	65

<sup>1)</sup> Rated output of a typical 6-pole standard induction motor based on  $I_L$  or  $I_H$  for 500 V or 690 V 3 AC 50 Hz.

<sup>2)</sup> Rated output of a typical 6-pole standard induction motor based on  $I_L$  or  $I_H$  for 575 V 3 AC 60 Hz.

<sup>3)</sup> The base-load current  $I_L$  is based on a duty cycle of 110 % for 60 s or 150 % for 10 s with a duty cycle duration of 300 s.

<sup>4)</sup> The base-load current  $I_H$  is based on a duty cycle of 150 % for 60 s or 160 % for 10 s with a duty cycle duration of 300 s.

<sup>5)</sup> Information regarding the correlation between the pulse frequency and max. output current/output frequency is provided in the SINAMICS Low Voltage Engineering Manual.

<sup>6)</sup> The specified power loss represents the maximum value at 100% utilization. The value is lower under normal operating conditions.

<sup>7)</sup> Total of all motor cables. Longer cable lengths for specific configurations are available on request. For additional information, please refer to the SINAMICS Low Voltage Engineering Manual.

<sup>8)</sup> With option **L10** (dv/dt filter plus VPL):  
- Frame sizes FX/GX/HX/JX: Additional cabinet 600 mm wide  
With option **L34** (circuit breaker on the output side):  
- Frame size FX/GX: Additional cabinet 400 mm wide  
- Frame size HX/JX: Additional cabinet 600 mm wide.

<sup>9)</sup> The cabinet height increases by 250 mm with degree of protection IP21, and by 400 mm with degrees of protection IP23, IP43 and IP54.

# SINAMICS S120 Cabinet Modules

## Air-cooled units

### Motor Modules in chassis format

#### Technical specifications (continued)

Line voltage 500 ... 690 V 3 AC DC link voltage 675 ... 1035 V DC		Motor Modules in chassis format					
		6SL3720-1TG32-6AA3	6SL3720-1TG33-3AA3	6SL3720-1TG34-1AA3	6SL3720-1TG34-7AA3	6SL3720-1TG35-8AA3	6SL3720-1TG37-4AA3
<b>Type rating</b>							
• At $I_L$ (50 Hz 690 V) <sup>1)</sup>	kW	250	315	400	450	560	710
• At $I_H$ (50 Hz 690 V) <sup>1)</sup>	kW	200	250	315	400	450	630
• At $I_L$ (50 Hz 500 V) <sup>1)</sup>	kW	160	200	250	315	400	500
• At $I_H$ (50 Hz 500 V) <sup>1)</sup>	kW	132	160	200	250	315	450
• At $I_L$ (60 Hz 575 V) <sup>2)</sup>	hp	250	300	400	450	600	700
• At $I_H$ (60 Hz 575 V) <sup>2)</sup>	hp	200	250	350	450	500	700
<b>Output current</b>							
• Rated current $I_{rated}$ <sup>3)</sup>	A	260	330	410	465	575	735
• Base-load current $I_L$ <sup>4)</sup>	A	250	320	400	452	560	710
• Base-load current $I_H$ <sup>4)</sup>	A	233	280	367	416	514	657
• Maximum current $I_{max}$ <sup>4)</sup>	A	375	480	600	678	840	1065
<b>DC link current</b>							
• Rated current $I_{rated}$ DC when supplied via							
- Basic/Smart Line Module	A	312	396	492	558	690	882
- Active Line Module	A	281	356	443	502	621	794
• Base-load current $I_L$ DC <sup>3)</sup> when supplied via							
- Basic/Smart Line Module	A	304	386	479	544	672	859
- Active Line Module	A	273	347	431	489	605	774
• Base-load current $I_H$ DC <sup>4)</sup> when supplied via							
- Basic/Smart Line Module	A	277	352	437	496	614	784
- Active Line Module	A	250	316	394	446	552	706
<b>Current demand</b>							
• 24 V DC auxiliary power supply	A	0.9	0.9	1.0	1.0	1.0	1.25
• 690 V AC	A	1.0	1.0	2.1	2.1	2.1	3.1
<b>DC link capacitance</b>	μF	3900	4200	7400	7400	7400	11100
<b>Pulse frequency <sup>5)</sup></b>							
• Rated frequency	kHz	1.25	1.25	1.25	1.25	1.25	1.25
• Pulse frequency, max.							
- Without current derating	kHz	1.25	1.25	1.25	1.25	1.25	1.25
- With current derating	kHz	7.5	7.5	7.5	7.5	7.5	7.5
<b>Power loss, max. <sup>6)</sup></b>							
• At 50 Hz 690 V	kW	3.62	4.34	6.13	6.8	10.3	10.9
• At 60 Hz 575 V	kW	3.38	3.98	5.71	6.32	9.7	10.0
<b>Cooling air requirement</b>	m <sup>3</sup> /s	0.36	0.36	0.78	0.78	0.78	1.08
<b>Sound pressure level <math>L_{pA}</math></b> (1 m) at 50/60 Hz	dB	69	69	72	72	72	72
<b>Motor connection</b>							
U2, V2, W2		M12 screws	M12 screws	M12 screws	M12 screws	M12 screws	M12 screws
• Conductor cross-section, max. (IEC)	mm <sup>2</sup>	2 × 240	2 × 240	4 × 240	4 × 240	4 × 240	6 × 240
<b>Cable length, max. <sup>7)</sup></b>							
• Shielded	m	300	300	300	300	300	300
• Unshielded	m	450	450	450	450	450	450
<b>PE/GND connection</b>							
• Busbar cross-section	mm <sup>2</sup>	PE bar 600	PE bar 600	PE bar 600	PE bar 600	PE bar 600	PE bar 600
• Conductor cross-section, max. (IEC)	mm <sup>2</sup>	240	240	240	240	240	240
<b>Degree of protection</b>							
		IP20	IP20	IP20	IP20	IP20	IP20
<b>Dimensions</b>							
• Width <sup>8)</sup>	mm	400	400	600	600	600	800
• Height <sup>9)</sup>	mm	2200	2200	2200	2200	2200	2200
• Depth	mm	600	600	600	600	600	600
<b>Weight, approx.</b>	kg	286	286	490	490	490	700
<b>Frame size</b>		GX	GX	HX	HX	HX	JX
<b>Short-circuit current rating according to IEC</b>	kA	65	65	65	84	84	100

<sup>1)</sup> Rated output of a typical 6-pole standard induction motor based on  $I_L$  or  $I_H$  for 500 V or 690 V 3 AC 50 Hz.

<sup>2)</sup> Rated output of a typical 6-pole standard induction motor based on  $I_L$  or  $I_H$  for 575 V 3 AC 60 Hz.

<sup>3)</sup> The base-load current  $I_L$  is based on a duty cycle of 110 % for 60 s or 150 % for 10 s with a duty cycle duration of 300 s.

<sup>4)</sup> The base-load current  $I_H$  is based on a duty cycle of 150 % for 60 s or 160 % for 10 s with a duty cycle duration of 300 s.

<sup>5)</sup> Information regarding the correlation between the pulse frequency and max. output current/output frequency is provided in the SINAMICS Low Voltage Engineering Manual.

<sup>6)</sup> The specified power loss represents the maximum value at 100% utilization. The value is lower under normal operating conditions.

<sup>7)</sup> Total of all motor cables. Longer cable lengths for specific configurations are available on request. For additional information, please refer to the SINAMICS Low Voltage Engineering Manual.

<sup>8)</sup> With option **L10** (dv/dt filter plus VPL):  
- Frame sizes FX/GX/HX/JX: Additional cabinet 600 mm wide  
With option **L34** (circuit breaker on the output side):  
- Frame size FX/GX: Additional cabinet 400 mm wide  
- Frame size HX/JX: Additional cabinet 600 mm wide.

<sup>9)</sup> The cabinet height increases by 250 mm with degree of protection IP21, and by 400 mm with degrees of protection IP23, IP43 and IP54.

## Technical specifications (continued)

Line voltage 500 ... 690 V 3 AC		Motor Modules in chassis format				
DC link voltage 675 ... 1035 V DC		6SL3720-1TG38-1AA3	6SL3720-1TG38-8AA3	6SL3720-1TG41-0AA3	6SL3720-1TG41-3AA3	
<b>Type rating</b>						
• At $I_L$ (50 Hz 690 V) <sup>1)</sup>	kW	<b>800</b>	<b>900</b>	<b>1000</b>	<b>1200</b>	
• At $I_H$ (50 Hz 690 V) <sup>1)</sup>	kW	710	800	900	1000	
• At $I_L$ (50 Hz 500 V) <sup>1)</sup>	kW	560	630	710	900	
• At $I_H$ (50 Hz 500 V) <sup>1)</sup>	kW	500	560	630	800	
• At $I_L$ (60 Hz 575 V) <sup>2)</sup>	hp	800	900	1000	1250	
• At $I_H$ (60 Hz 575 V) <sup>2)</sup>	hp	700	800	900	1000	
<b>Output current</b>						
• Rated current $I_{rated O}$	A	810	910	1025	1270	
• Base-load current $I_L^{(3)}$	A	790	880	1000	1230	
• Base-load current $I_H^{(4)}$	A	724	814	917	1136	
• Maximum current $I_{max O}$	A	1185	1320	1500	1845	
<b>DC link current</b>						
• Rated current $I_{rated DC}$ when supplied via						
- Basic/Smart Line Module	A	972	1092	1230	1524	
- Active Line Module	A	875	983	1107	1372	
• Base-load current $I_{L DC}^{(3)}$ when supplied via						
- Basic/Smart Line Module	A	947	1064	1199	1485	
- Active Line Module	A	853	958	1079	1337	
• Base-load current $I_{H DC}^{(4)}$ when supplied via						
- Basic/Smart Line Module	A	865	971	1094	1356	
- Active Line Module	A	778	874	985	1221	
<b>Current demand</b>						
• 24 V DC auxiliary power supply	A	1.25	1.4	1.4	1.4	
• 690 V AC	A	3.1	3.1	3.1	3.1	
<b>DC link capacitance</b>		μF	11100	14400	14400	19200
<b>Pulse frequency <sup>5)</sup></b>						
• Rated frequency	kHz	1.25	1.25	1.25	1.25	
• Pulse frequency, max.						
- Without current derating	kHz	1.25	1.25	1.25	1.25	
- With current derating	kHz	7.5	7.5	7.5	7.5	
<b>Power loss, max. <sup>6)</sup></b>						
• At 50 Hz 690 V	kW	11.5	11.7	13.2	16.0	
• At 60 Hz 575 V	kW	10.5	10.6	12.0	14.2	
<b>Cooling air requirement</b>		m <sup>3</sup> /s	1.08	1.08	1.08	1.08
<b>Sound pressure level <math>L_{pA}</math></b> (1 m) at 50/60 Hz		dB	72	72	72	72
<b>Motor connection</b>			M12 screws	M12 screws	M12 screws	M12 screws
U2, V2, W2						
• Conductor cross-section, max. (IEC)	mm <sup>2</sup>	6 x 240	6 x 240	6 x 240	6 x 240	
<b>Cable length, max. <sup>7)</sup></b>						
• Shielded	m	300	300	300	300	
• Unshielded	m	450	450	450	450	
<b>PE/GND connection</b>			PE bar	PE bar	PE bar	PE bar
• Busbar cross-section	mm <sup>2</sup>	600	600	600	600	
• Conductor cross-section, max. (IEC)	mm <sup>2</sup>	240	240	240	240	
<b>Degree of protection</b>			IP20	IP20	IP20	IP20
<b>Dimensions</b>						
• Width <sup>8)</sup>	mm	800	800	800	800	
• Height <sup>9)</sup>	mm	2200	2200	2200	2200	
• Depth	mm	600	600	600	600	
<b>Weight, approx.</b>		kg	700	700	700	700
<b>Frame size</b>			JX	JX	JX	JX
<b>Short-circuit current rating according to IEC</b>		kA	100	100	100	100

<sup>1)</sup> Rated output of a typical 6-pole standard induction motor based on  $I_L$  or  $I_H$  for 500 V or 690 V 3 AC 50 Hz.

<sup>2)</sup> Rated output of a typical 6-pole standard induction motor based on  $I_L$  or  $I_H$  for 575 V 3 AC 60 Hz.

<sup>3)</sup> The base-load current  $I_L$  is based on a duty cycle of 110 % for 60 s or 150 % for 10 s with a duty cycle duration of 300 s.

<sup>4)</sup> The base-load current  $I_H$  is based on a duty cycle of 150 % for 60 s or 160 % for 10 s with a duty cycle duration of 300 s.

<sup>5)</sup> Information regarding the correlation between the pulse frequency and max. output current/output frequency is provided in the SINAMICS Low Voltage Engineering Manual.

<sup>6)</sup> The specified power loss represents the maximum value at 100% utilization. The value is lower under normal operating conditions.

<sup>7)</sup> Total of all motor cables. Longer cable lengths for specific configurations are available on request. For additional information, please refer to the SINAMICS Low Voltage Engineering Manual.

<sup>8)</sup> With option **L10** (dv/dt filter plus VPL):  
 - Frame sizes FX/GX/HX/JX: Additional cabinet 600 mm wide  
 With option **L34** (circuit breaker on the output side):  
 - Frame size FX/GX: Additional cabinet 400 mm wide  
 - Frame size HX/JX: Additional cabinet 600 mm wide.

<sup>9)</sup> The cabinet height increases by 250 mm with degree of protection IP21, and by 400 mm with degrees of protection IP23, IP43 and IP54.

## SINAMICS S120 Cabinet Modules

Air-cooled units

### Central Braking Modules

#### Overview



Central Braking Modules limit the DC link voltage at a central location in the drive line-up when the motors are operating in generator mode and energy recovery to the supply system is not possible. If, in regenerative mode, the voltage of the DC busbar exceeds a limit value, an externally installed braking resistor is switched in, thus restricting the voltage from increasing further. The regenerative energy is converted into heat. The braking resistor is switched in by the Braking Unit integrated in the Cabinet Module, which is equipped with state-of-the-art MOSFET/IGBT semiconductors.

Central Braking Modules are an alternative to the optional Braking Modules (options **L61/L62** or **L64/L65**) and are particularly suitable when high braking powers are required in a drive line-up. The required braking power can also be increased by connecting units in parallel.

Line voltage	DC link voltage	Braking power $P_{150}$
380 ... 480 V 3 AC	510 ... 720 V DC	500 kW/1000 kW
500 ... 600 V 3 AC	675 ... 900 V DC	550 kW/1100 kW
660 ... 690 V 3 AC	890 ... 1035 V DC	630 kW/1200 kW

The built-in fan means that Central Braking Modules are also suitable for high continuous power levels.

#### Design

The Central Braking Module is a cabinet unit with integrated braking chopper. Using state-of-the-art MOSFET/IGBT semiconductors, the power unit controls when the braking resistor is switched in.

Central Braking Modules are designed as a 400 mm wide cabinet module. Its connection to the DC link is protected by fuses.

Central Braking Modules require braking resistors that must be externally mounted and which can be ordered separately. The cables to the resistors can be connected to lugs which are specially prepared for plant application and which are located in the connection area of the cabinet.

The power units have diagnostics LEDs for the display of faults and also a control output for the communication of faults. The Central Braking Module can be disabled externally via a control input.

The arrangement in the DC link system is subject to specific configuring rules.

For additional information, please refer to the [SINAMICS Low Voltage Engineering Manual](#).

#### Selection and ordering data

Braking powers				Central Braking Module
$P_{15}$	$P_{150}$	$P_{270}$	$P_{DB}$	Article No.
kW	kW	kW	kW	
<b>DC link voltage 510 ... 720 V DC</b>				
730	500	300	200	<b>6SL3700-1AE35-0AA3</b>
1380	1000	580	370	<b>6SL3700-1AE41-0AA3</b>
<b>DC link voltage 675 ... 900 V DC</b>				
830	550	340	220	<b>6SL3700-1AF35-5AA3</b>
1580	1100	650	420	<b>6SL3700-1AF41-1AA3</b>
<b>DC link voltage 890 ... 1035 V DC</b>				
920	630	380	240	<b>6SL3700-1AH36-3AA3</b>
1700	1200	720	460	<b>6SL3700-1AH41-2AA3</b>

Note:

In contrast to the optional Braking Modules (options **L61**, **L62** or **L64**, **L65**), the braking resistors for the Central Braking Modules must be ordered separately.

Braking power $P_{150}$	Dimensions (W × D × H)	Braking resistor in degree of protection IP21
kW	mm	Article No.
<b>DC link voltage 510 ... 720 V DC</b>		
500	960 × 620 × 790	<b>6SL3000-1BE35-0AA0</b>
1000	960 × 620 × 1430	<b>6SL3000-1BE41-0AA0</b>
<b>DC link voltage 675 ... 900 V DC</b>		
550	960 × 620 × 1110	<b>6SL3000-1BF35-5AA0</b>
1100	960 × 620 × 1430	<b>6SL3000-1BF41-1AA0</b>
<b>DC link voltage 890 ... 1035 V DC</b>		
630	960 × 620 × 1110	<b>6SL3000-1BH36-3AA0</b>
1200	960 × 620 × 1430	<b>6SL3000-1BH41-2AA0</b>

**Integration**

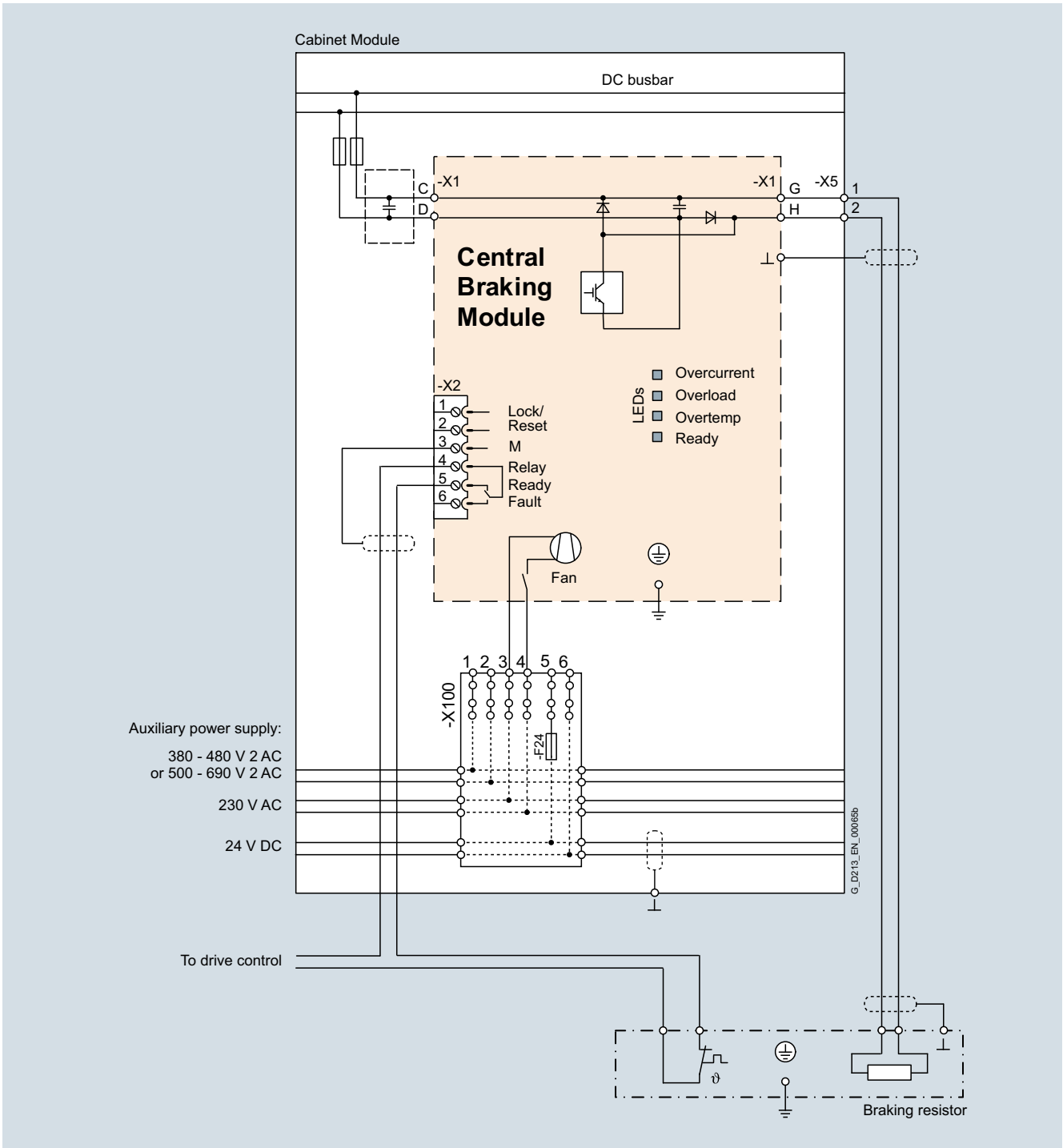

Connection example: Central Braking Module

# SINAMICS S120 Cabinet Modules

Air-cooled units

## Central Braking Modules

### Technical specifications

	Central Braking Modules						
		6SL3700-1AE35-0AA3	6SL3700-1AE41-0AA3	6SL3700-1AF35-5AA3	6SL3700-1AF41-1AA3	6SL3700-1AH36-3AA3	6SL3700-1AH41-2AA3
<b>Line voltage</b>		<b>380 ... 480 V</b>		<b>500 ... 600 V</b>		<b>660 ... 690 V</b>	
<b>Braking power <math>P_{150}</math></b>	kW	500	1000	550	1100	630	1200
<b>Continuous braking power <math>P_{DB}</math></b>	kW	200	370	220	420	240	460
<b>Braking current for <math>P_{150}</math></b>	A	650	1200	580	1100	520	1000
<b>Current demand <sup>1)</sup></b>							
• 230 V 2 AC	A	0.4	0.4	0.4	0.4	0.4	0.4
<b>Power loss, max. <sup>2)</sup></b> At 50 Hz 400/500/690 V	kW	0.8	1.5	0.8	1.5	0.8	1.5
<b>DC link capacitance</b>	μF	8160	9720	7640	8680	7640	8680
<b>Cooling air requirement</b>	m <sup>3</sup> /s	0.14	0.14	0.14	0.14	0.14	0.14
<b>Sound pressure level <math>L_{pA}</math></b> (1 m) at 50/60 Hz	dB	55	55	55	55	55	55
<b>Braking resistor connection</b>		M12 screws	M12 screws	M12 screws	M12 screws	M12 screws	M12 screws
• Conductor cross-section, max. (IEC)	mm <sup>2</sup>	2 × 240	2 × 240	2 × 240	2 × 240	2 × 240	2 × 240
<b>PE/GND connection</b>		PE bar	PE bar	PE bar	PE bar	PE bar	PE bar
• Busbar cross-section	mm <sup>2</sup>	600	600	600	600	600	600
• Conductor cross-section, max. (IEC)	mm <sup>2</sup>	240	240	240	240	240	240
<b>Degree of protection</b>		IP20	IP20	IP20	IP20	IP20	IP20
<b>Dimensions</b>							
• Width	mm	400	400	400	400	400	400
• Height <sup>3)</sup>	mm	2200	2200	2200	2200	2200	2200
• Depth	mm	600	600	600	600	600	600
<b>Weight, approx.</b>	kg	230	230	230	230	230	230
<b>Frame size</b>	mm	400	400	400	400	400	400

	Braking resistors						
		6SL3000-1BE35-0AA0	6SL3000-1BE41-0AA0	6SL3000-1BF35-5AA0	6SL3000-1BF41-1AA0	6SL3000-1BH36-3AA0	6SL3000-1BH41-2AA0
<b>Line voltage</b>		<b>380 ... 480 V</b>		<b>500 ... 600 V</b>		<b>660 ... 690 V</b>	
<b>Braking power <math>P_{BR}</math></b>	kW	500	1000	550	1100	630	1200
<b>Continuous braking power <math>P_{DB}</math></b>	kW	23	58	34	62	42	75
<b>Resistance value</b>	Ω	0.95	0.49	1.35	0.69	1.8	0.95
<b>Degree of protection</b>		IP21	IP21	IP21	IP21	IP21	IP21
<b>Dimensions</b>							
• Width	mm	960	960	960	960	960	960
• Height	mm	620	620	620	620	620	620
• Depth	mm	790	1430	1110	1430	1110	1430
<b>Weight, approx.</b>	kg	82	170	110	180	124	196

<sup>1)</sup> Current demand of the fans.

<sup>2)</sup> The specified power loss represents the maximum value at 100% utilization. The value is lower under normal operating conditions.

<sup>3)</sup> The cabinet height increases by 250 mm with degree of protection IP21, and by 400 mm with degrees of protection IP23, IP43 and IP54.

### Characteristic curves

Central Braking Modules are dimensioned for braking powers with the following duty cycles:

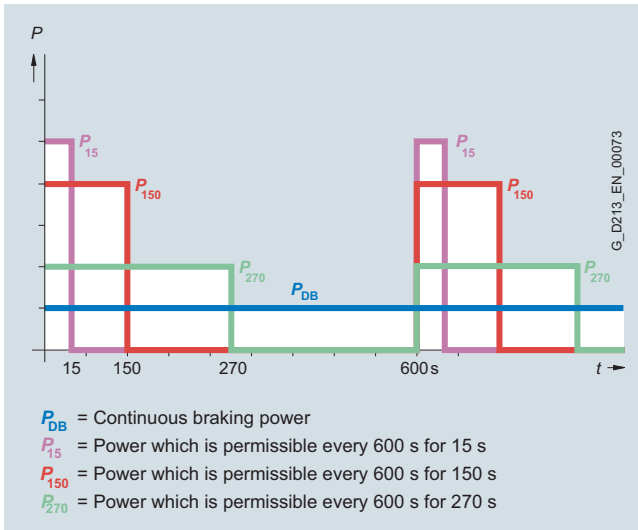

Braking powers of the Central Braking Modules

The braking powers are subject to a cycle time of 600 s.  $P_{150}$  is assumed to be the rated braking power. The braking resistors can be assigned according to these power ratings.

In most applications, Central Braking Modules are only used for occasional braking operations, e.g. stopping a drive in an emergency. Low-cost braking resistors in degree of protection IP21 are specifically offered for these types of applications; these braking resistors are dimensioned for braking powers  $P_{BR}$  with the following duty cycle:

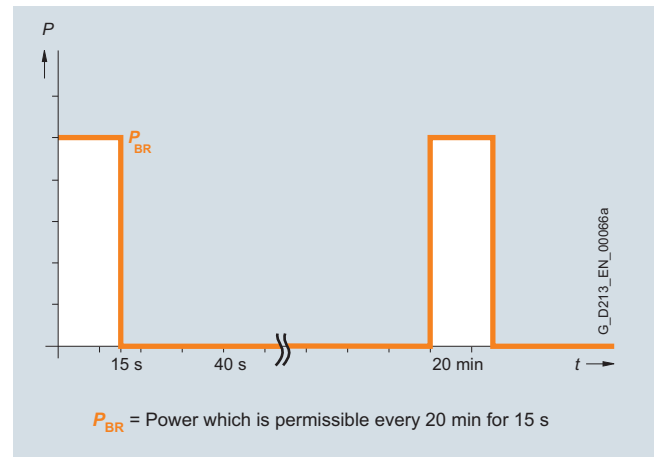

Duty cycle for braking resistors

Braking resistors with a higher braking power and shorter cycle times are available on request.



## SINAMICS S120 Cabinet Modules

Air-cooled units

### Auxiliary Power Supply Modules

#### Overview



Auxiliary Power Supply Modules supply the auxiliary power supply for the SINAMICS S120 Cabinet Modules. Units connected to this auxiliary power supply system include the fans of the SINAMICS S120 devices installed in the Cabinet Modules. In addition, the auxiliary power supply system supplies the electronic modules with an external voltage of 24 V DC. This is required when the DC link is not charged, for instance, in order to maintain PROFIBUS/PROFINET communication.

#### Selection and ordering data

System-side power supply (380 ... 690 V 3 AC)	Auxiliary Power Supply Module
A	Article No.
125	<b>6SL3700-0MX14-0AA3</b>
160	<b>6SL3700-0MX16-3AA3</b>
200	<b>6SL3700-0MX21-0AA3</b>
250	<b>6SL3700-0MX21-4AA3</b>

#### Note:

In smaller systems, there is often no need for an additional Cabinet Module for the auxiliary power supply. In such cases, the infeed for the auxiliary power supply system can also be supplied by the Line Connection Module. This must then be separately ordered (option **K76**).

4

#### Design

The Auxiliary Power Supply Module is connected in the customer's plant to a voltage corresponding to the respective rated unit voltage.

The standard version contains the following components:

- Fuse switch disconnecter with fuse monitoring for external evaluation
- Supply of the auxiliary power supply system with 3 fused auxiliary voltages:
  - 24 V DC for the electronics power supply
  - 230 V 2 AC to supply 230 V loads
  - 380 V to 690 V 2 AC to supply the equipment fans
- Transformer with 230 V output voltage
- SITOP 24 V DC power supply
- 6-pole auxiliary power supply system (ready-wired), including connections for looping through to the next Cabinet Module
- Nickel-plated PE bar (60 mm × 10 mm), including jumper for looping through to the next Cabinet Module

**Integration**

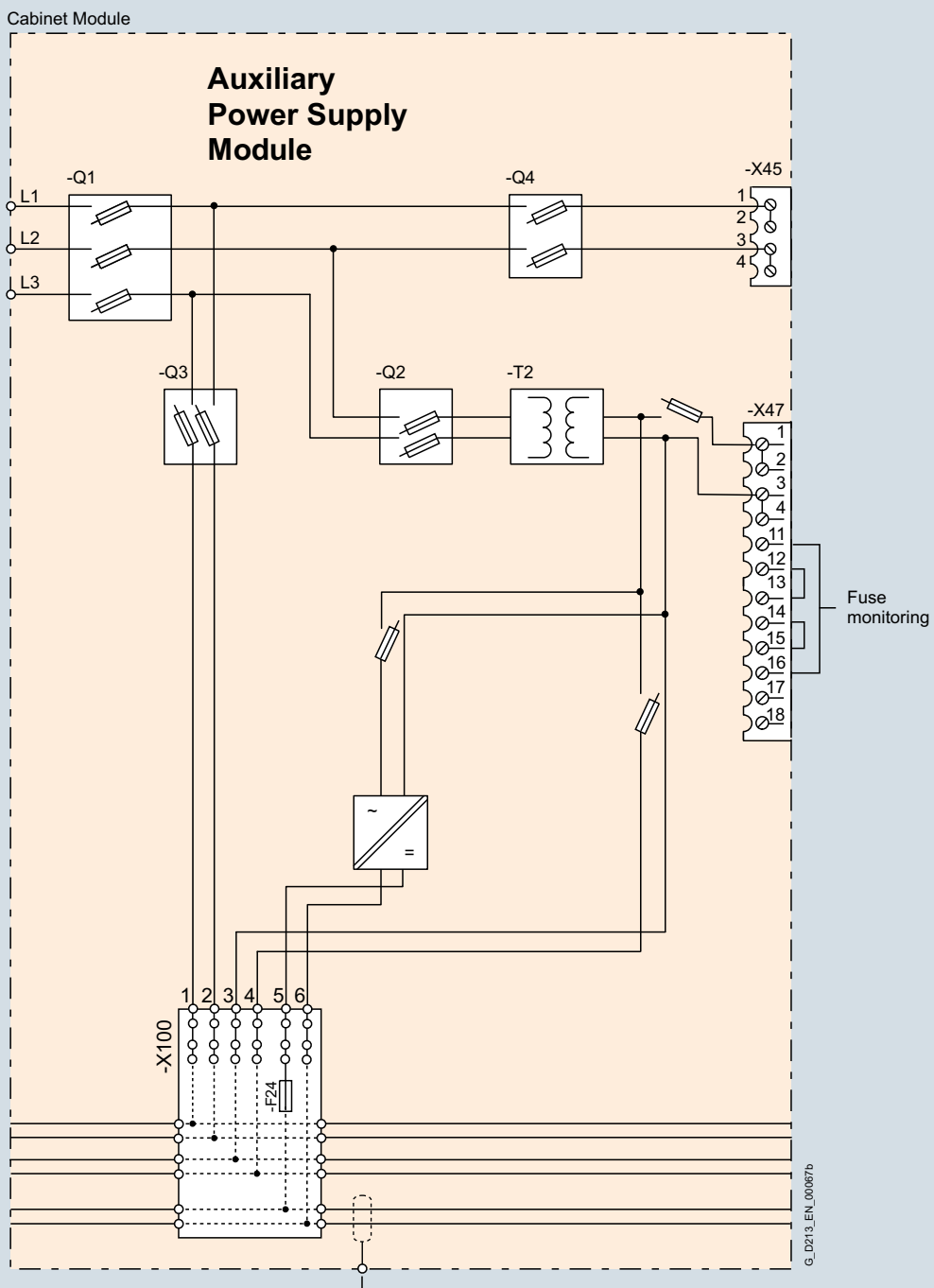

Connection example: Auxiliary Power Supply Module

# SINAMICS S120 Cabinet Modules

Air-cooled units

## Auxiliary Power Supply Modules

### Technical specifications

		Auxiliary Power Supply Modules			
		6SL3700-0MX14-0AA3	6SL3700-0MX16-3AA3	6SL3700-0MX21-0AA3	6SL3700-0MX21-4AA3
<b>Plant-side power supply</b> 380 V ... 690 V 3 AC	A	<b>125</b>	<b>160</b>	<b>200</b>	<b>250</b>
<b>Line supply connection</b>					
• Conductor cross-section, max. (IEC)	mm <sup>2</sup>	150	150	150	150
<b>Current carrying capacity, max.</b>					
• Load connection 380 V ... 690 V AC					
- To auxiliary power supply	A	63	80	100	100
- To customer terminal -X45	A	50	63	80	80
• Load connection 230 V 2 AC					
- To auxiliary power supply	A	6	10	10	20
- To customer terminal -X47	A	8	10	10	20
• Load connection 24 V DC					
- To auxiliary power supply	A	20	40	80	80
<b>Cable cross-section, max.</b>					
• Connection -X45	mm <sup>2</sup>	16	16	16	16
• Connection -X47	mm <sup>2</sup>	2.5	2.5	2.5	2.5
<b>Cooling air requirement</b>	m <sup>3</sup> /s	Natural convection	Natural convection	Natural convection	Natural convection
<b>PE/GND connection</b>		PE bar	PE bar	PE bar	PE bar
• Busbar cross-section	mm <sup>2</sup>	600	600	600	600
• Conductor cross-section, max. (IEC)	mm <sup>2</sup>	240	240	240	240
<b>Degree of protection</b>		IP20	IP20	IP20	IP20
<b>Dimensions</b>					
• Width	mm	600	600	600	600
• Height <sup>1)</sup>	mm	2200	2200	2200	2200
• Depth	mm	600	600	600	600
<b>Weight, approx.</b>	kg	170	180	210	240
<b>Minimum short-circuit current <sup>2)</sup></b>	A	3200	4000	5000	7000

<sup>1)</sup> The cabinet height increases by 250 mm with degree of protection IP21, and by 400 mm with degrees of protection IP23, IP43 and IP54.

<sup>2)</sup> Current required to ensure reliable tripping of installed protective devices.

## Overview

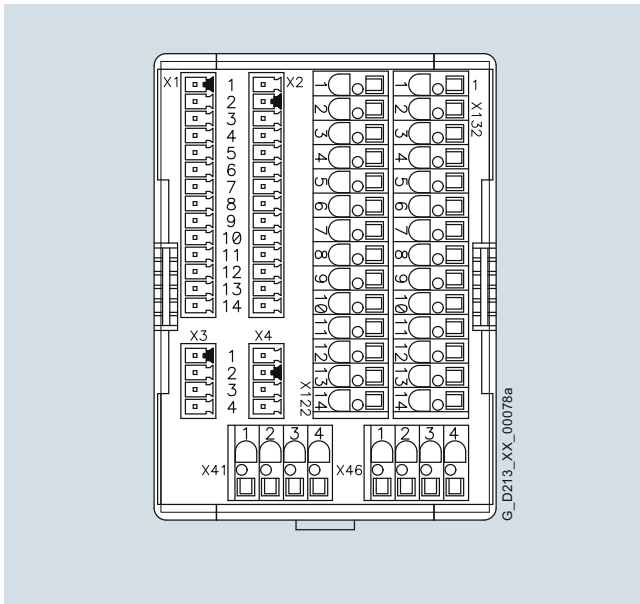

Customer terminal block -X55 is the interface with the I/O devices and marshals a range of cabinet-internal signals to a central terminal block module mounted in the lower part of the cabinet.

It can be used for Motor Modules in the chassis format as well as together with options **K90** (Control Unit CU320-2 DP) or **K95** (Control Unit CU320-2 PN) for Basic Line Modules, Smart Line Modules, Active Line Modules and Booksize Cabinet Kits.

## Design

To connect signal cables on the customer side, terminal block -X55 includes terminals -X122, -X132, -X41 and -X46 (terminals -X1 to -X4 are used inside the cabinet and are not available). As a consequence, depending on the version (with/without option **K90**) the following digital inputs/outputs and/or signals are available:

The customer terminal strip -X55 includes:	Motor Modules in chassis format		Line Modules	
	Without CU320-2 ( <b>K90/K95</b> )	With CU320-2 ( <b>K90/K95</b> )	Without CU320-2 ( <b>K90/K95</b> )	With CU320-2 ( <b>K90/K95</b> )
<b>-X122, -X132</b>				
12 digital inputs DI	–	✓	–	✓
8 bidirectional inputs/outputs (DI/DO)	–	✓	–	✓
<b>-X41</b>				
Connection safety function Safe Torque Off / Safe Stop 1	✓	✓	– <sup>1)</sup>	– <sup>1)</sup>
Connection temperature sensor KTY84/PTC/Pt100	✓	✓	– <sup>1)</sup>	– <sup>1)</sup>
<b>-X46</b>				
Connection, Safe Brake Adapter	✓	✓	–	–

<sup>1)</sup> For Booksize Cabinet Kits, a connection is provided at the separate customer terminal block -X55.1.

# SINAMICS S120 Cabinet Modules

Air-cooled units

## Customer terminal strip -X55

Design (continued)

Pin assignment

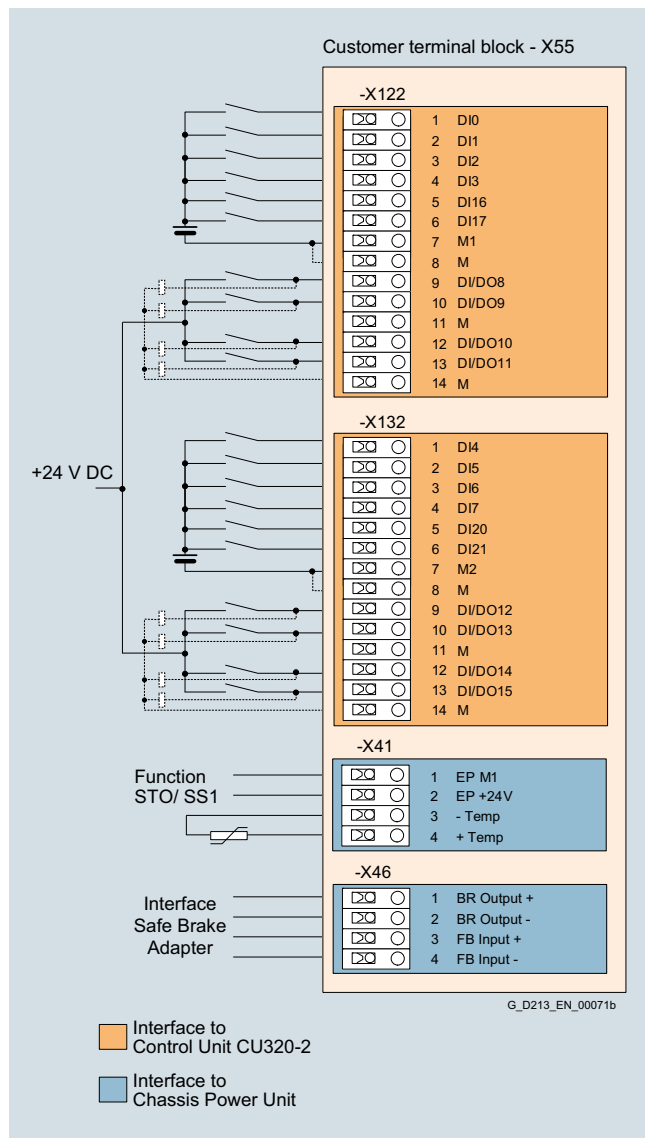

Terminal assignment of customer terminal block -X55

### Terminal block -X55-X122 digital inputs/outputs

Terminal	Designation <sup>1)</sup>	Technical data
1	DI 0	Voltage -30 V to +30 V DC
2	DI 1	Current consumption, typical: 9 mA at 24 V DC
3	DI 2	Electrical isolation: The reference potential is terminal M1
4	DI 3	Level (incl. ripple):
5	DI 16	High level: 15 V ... 30 V
6	DI 17	Low level: -30 V ... +5 V
		Input delay (typ.):
		at 0 → 1: 50 μs
		at 1 → 0: 150 μs
7	M1	Reference potential for terminals 1 to 6
8	M	Ground
9	DI/DO 8	As input:
10	DI/DO 9	Voltage -30 V ... +30 V DC
		Current consumption, typical: 9 mA at 24 V DC
11	M	Level (incl. ripple):
12	DI/DO 10	High level: 15 V ... 30 V
13	DI/DO 11	Low level: -30 V ... +5 V
14	M	Fast inputs: <sup>2)</sup>
		DI/DO 8, 9, 10 and 11
		Input delay (typ.):
		at 0 → 1: 5 μs
		at 1 → 0: 50 μs
		As output:
		Voltage 24 V DC
		Max. load current per output: 500 mA
		Continuously short-circuit proof
		Output delay (typ./max.): <sup>3)</sup>
		at 0 → 1: 150 μs/400 μs
		at 1 → 0: 75 μs/100 μs
		Switching frequency:
		For resistive load: max. 100 Hz
		For inductive load: max. 0.5 Hz
		For lamp load: max. 10 Hz
		Max. lamp load: 5 W

Max. connectable cross-section: 2.5 mm<sup>2</sup>

<sup>1)</sup> DI: Digital input  
DI/DO: Bidirectional digital input/output  
M: Electronics ground  
M1: Reference ground.

<sup>2)</sup> Can be used as measuring probe input or input for the external zero mark.

<sup>3)</sup> Data for:  $U_{CC} = 24 \text{ V}$ ; load  $48 \Omega$ ; High (1) = 90 %  $U_{out}$ ; Low (0) = 10 %  $U_{out}$ .

## Design (continued)

**Terminal block -X55-X132 digital inputs/outputs**

Terminal	Designation <sup>1)</sup>	Technical data
1	DI 4	Voltage -30 V to +30 V DC Current consumption, typical: 9 mA at 24 V DC
2	DI 5	
3	DI 6	Electrical isolation: The reference potential is terminal M2
4	DI 7	
5	DI 20	Level (incl. ripple): High level: 15 V ... 30 V Low level: -30 V ... +5 V
6	DI 21	Input delay (typ.): at 0 → 1: 50 μs at 1 → 0: 150 μs
7	M2	Reference potential for terminals 1 to 6
8	M	Ground
9	DI/DO 12	<u>As input:</u>
10	DI/DO 13	Voltage -30 V ... +30 V DC Current consumption, typical: 9 mA at 24 V DC
11	M	
12	DI/DO 14	Level (incl. ripple): High level: 15 V ... 30 V Low level: -30 V ... +5 V
13	DI/DO 15	Fast inputs: <sup>2)</sup> DI/DO 12, 13, 14 and 15
14	M	Input delay (typ.): at 0 → 1: 5 μs at 1 → 0: 50 μs <u>As output:</u> Voltage 24 V DC Max. load current per output: 500 mA Continuously short-circuit proof Output delay (typ./max.): <sup>3)</sup> at 0 → 1: 150 μs/400 μs at 1 → 0: 75 μs/100 μs Switching frequency: For resistive load: max. 100 Hz For inductive load: max. 0.5 Hz For lamp load: max. 10 Hz Max. lamp load: 5 W

Max. connectable cross-section: 2.5 mm<sup>2</sup>**Terminal block -X55-X41 temperature sensor connection**

Terminal	Function	Technical data
1	EP M1 (enable pulses)	Supply voltage 24 V DC (20.4 ... 28.8 V DC) Current consumption: 10 mA
2	EP +24 V (enable pulses)	Signal propagation times: L → H: 100 μs H → L: 1000 μs  The pulse inhibit function is only available when Safety Integrated Basic Functions are enabled
3	-Temp	Temperature sensor connection for motor temperature sensing: KTY84-1C130, PTC, Pt100
4	+Temp	

Max. connectable cross-section: 2.5 mm<sup>2</sup>**Terminal block -X55-X46 brake control and monitoring**

Terminal	Function	Technical data
1	BR output +	The interface is used to connect the Safe Brake Adapter
2	BR output -	
3	FB input +	
4	FB input -	

Max. connectable cross-section: 2.5 mm<sup>2</sup>

<sup>1)</sup> DI: Digital input  
DI/DO: Bidirectional digital input/output  
M: Electronics ground  
M2: Reference ground.

<sup>2)</sup> Can be used as measuring probe input or input for the external zero mark.

<sup>3)</sup> Data for:  $U_{cc} = 24\text{ V}$ ; load  $48\ \Omega$ ; High (1) = 90 %  $U_{out}$ ; Low (0) = 10 %  $U_{out}$ .

## SINAMICS S120 Cabinet Modules

### Liquid-cooled units

#### Liquid-cooled units

#### Overview

To comply with high requirements regarding installation and ambient conditions, SINAMICS S120 Cabinet Modules are also available in a liquid-cooled version.

The power loss of the units is transferred to the cooling liquid and dissipated, without noticeably increasing the temperature of the surrounding environment. As a consequence it is possible to save the expense of controlling the climate of the electrical room.

The system consists of liquid-cooled Basic Line Connection Modules, Active Line Connection Modules, Motor Modules, an Auxiliary Power Supply Module, and a suitably selected cooling unit (Heat Exchanger Module).

#### Basic Line Connection Modules

Basic Line Connection Modules comprise a Line Connection Module and a liquid-cooled Basic Line Module. Basic Line Connection Modules are only suitable for infeed operation, i.e. they are not capable of feeding regenerative energy back into the supply system.

If regenerative energy is produced, e.g. when the drives brake, it must be converted into heat in external braking resistors using a supplementary Motor Module, which is used as a Braking Module.

When a Basic Line Connection Module is used as the infeed, a line reactor appropriate for the supply conditions must be installed. If the infeed is realized via a transformer with an appropriate rating in 6-pulse operation with a Basic Line Connection Module or in 12-pulse operation with two Basic Line Connection Modules, the line reactor is optional and can be omitted.

If two or more Basic Line Connection Modules are operated in parallel on a common supply system in order to increase power, then line reactors must also be used.

#### Active Line Connection Modules

Active Line Connection Modules comprise a Line Connection Module, a liquid-cooled Active Interface Module and a liquid-cooled Active Line Module. Active Line Connection Modules can supply energy to the DC link and return regenerative energy to the line supply (energy recovery). The use of an additional Motor Module as a Braking Module is only required if the drives need to be decelerated in a controlled manner after a power failure (i.e. when energy cannot be fed back into the line supply).

In contrast to Basic Line Connection Modules, Active Line Connection Modules generate a regulated DC voltage which remains constant irrespective of fluctuations in the line voltage. However, in this case, the line voltage must remain within the permissible tolerance range. Active Line Connection Modules draw a virtually sinusoidal current from the supply system. Almost no harmonics occur.

The total harmonic distortion factors of current THD(I) and voltage THD(U) are typically in the range of approx. 3 %. The stringent limit values of IEEE 519 (2014) are complied with.

Active Line Connection Modules always contain an Active Interface Module which, in addition to a Clean Power Filter, also includes the necessary pre-charging circuit for the Active Line Module.

4

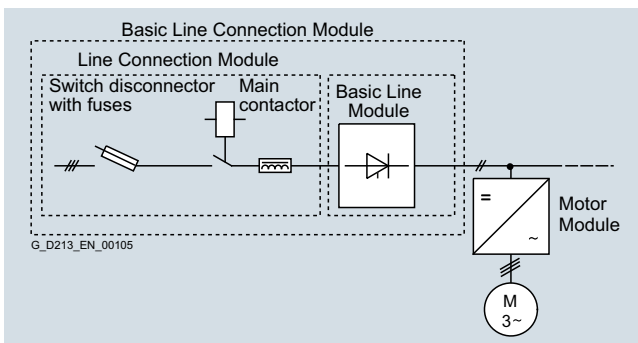

Basic Line Connection Module  $\leq 800$  A

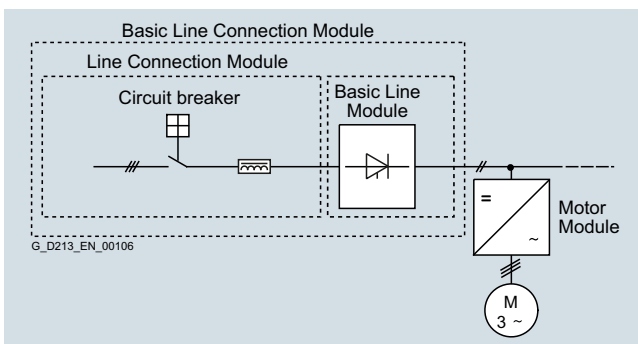

Basic Line Connection Module  $> 800$  A

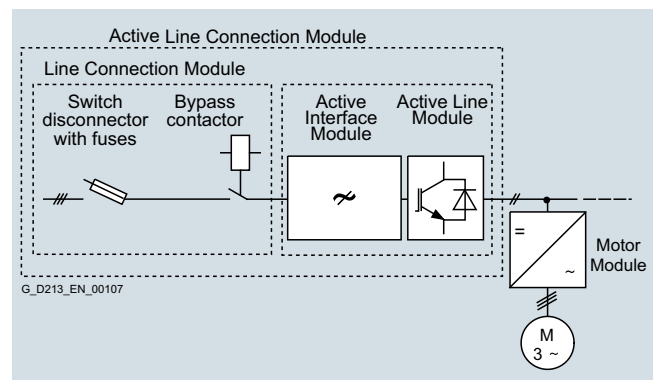

Active Line Connection Module with Active Interface Module and Active Line Module  $\leq 800$  A

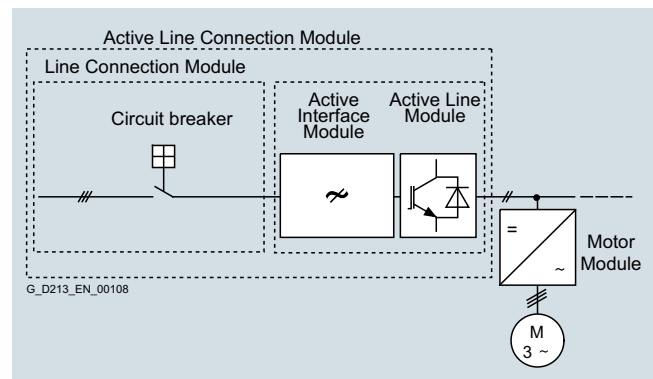

Active Line Connection Module with Active Interface Module and Active Line Module  $> 800$  A

**Overview** (continued)**Motor Modules**

Each Cabinet Module is fitted with one SINAMICS S120 Motor Module in chassis format and covers the power range from 90 kW to 1500 kW (380 V to 480 V or 500 V to 690 V). The power rating can be extended up to approx. 5700 kW by connection in parallel.

The Motor Modules can also be used as Braking Modules (braking chopper) if a 3-phase braking resistor is connected instead of a motor.

[For additional information, please refer to the SINAMICS Low Voltage Engineering Manual.](#)

**Auxiliary Power Supply Modules**

Auxiliary Power Supply Modules supply power to the auxiliary power supply system of the SINAMICS S120 Cabinet Modules.

The heat exchangers, which are installed in the SINAMICS S120 Cabinet Modules with degree of protection IP55, are one of the connections to the auxiliary power supply system. In addition, the auxiliary power supply system supplies the electronic modules with an external 24 V DC voltage. This is required when the DC link is not charged, for instance, in order to maintain PROFIBUS or PROFINET communication.

The installation is analogous to the air-cooled Auxiliary Power Supply Modules with an additional water pipe system.

The Auxiliary Power Supply Modules provide an expansion to the option **K76** (auxiliary voltage generating unit) if higher power ratings are required.



## SINAMICS S120 Cabinet Modules

### Liquid-cooled units

#### Liquid-cooled units

#### Technical specifications

##### General technical specifications

Electrical specifications	
<b>Line voltages</b>	380 ... 480 V 3 AC, ±10 % (-15 % <1 min) 500 ... 690 V 3 AC, ±10 % (-15 % <1 min)
<b>Line supply types</b>	Grounded TN/TT systems and non-grounded IT systems
<b>Line frequency</b>	47 ... 63 Hz
<b>Output frequency <sup>1)</sup></b>	
• Control type Servo	0 ... 550 Hz
• Control type Vector	0 ... 550 Hz
• Control mode V/f	0 ... 550 Hz
<b>Line power factor Fundamental</b>	
• Basic Line Module	>0.96
• Active Line Module	Adjustable (factory-set to $\cos \varphi = 1$ )
<b>Efficiency</b>	
• Basic Line Module	>99 %
• Active Line Module	>97.5 % (including Active Interface Module)
• Motor Module	>98.5 %
<b>Overvoltage category</b>	III acc. to EN 61800-5-1
<b>Control method</b>	Vector/Servo control with and without encoder or V/f control
<b>Fixed speeds</b>	15 fixed speeds plus 1 minimum speed, parameterizable (in the default setting, 3 fixed setpoints plus 1 minimum speed are selectable using terminal block/PROFIBUS/PROFINET)
<b>Skippable speed ranges</b>	4, parameterizable
<b>Setpoint resolution</b>	0.001 rpm digital (14 bits + sign) 12 bits analog
<b>Braking operation</b>	With Active Line Modules, four-quadrant operation as standard (energy recovery). With Basic Line Modules, two-quadrant operation as standard, braking by means of a Motor Module
Cabinet system	
<b>Cabinet system</b>	Rittal TS 8, doors with double-barb lock, base plate with cable entry options
<b>Paint finish</b>	RAL 7035 (indoor requirements)
Mechanical specifications	
<b>Degree of protection</b>	IP21 (higher degrees of protection up to IP55 optional)
<b>Protection class</b>	I acc. to EN 61800-5-1
<b>Touch protection</b>	EN 50274/DGUV regulation 3 when used as intended
<b>Cooling method</b>	Cooling in compliance with EN 60146: Basic Line Connection Modules, Active Line Connection Modules, Motor Modules: WE - W: Liquid cooling - E: Forced air cooling, drive device outside the equipment Line reactors, motor reactors, dv/dt filters with Voltage Peak Limiter: AN - A: Air cooling - N: Natural cooling (convection)

<sup>1)</sup> Higher output frequencies available on request.

### Technical specifications (continued)

Ambient conditions	Storage <sup>1)</sup>	Transport <sup>1)</sup>	Operation
<b>Ambient temperature</b>	-25 ... +55 °C	-25 ... +70 °C from <u>-40 °C</u> for 24 hours	0 ... +45 °C to +50 °C <a href="#">see derating data</a>
<b>Relative humidity</b> (condensation not permissible)	5 ... 95 % Class 1K4 acc. to IEC 60721-3-1	5 ... 95 % at 40 °C Class 2K3 acc. to IEC 60721-3-2	5 ... 95 % Class 3K3 acc. to IEC 60721-3-3
<b>Environmental class/harmful chemical substances</b>	Class 1C2 acc. to EN 60721-3-1	Class 2C2 acc. to EN 60721-3-2	Class 3C2 acc. to EN 60721-3-3
<b>Organic/biological influences</b>	Class 1B1 acc. to EN 60721-3-1	Class 2B1 acc. to EN 60721-3-2	Class 3B1 acc. to EN 60721-3-3
<b>Degree of pollution</b>	2 acc. to IEC/EN 61800-5-1		
<b>Installation altitude</b>	≤ 2000 m above sea level without derating; > 2000 m <a href="#">see derating data</a>		
Mechanical stability	Storage <sup>1)</sup>	Transport <sup>1)</sup>	Operation
<b>Vibratory load</b>	Class 1M2 acc. to EN 60721-3-1	Class 2M2 acc. to EN 60721-3-2	–
• Deflection	1.5 mm at <u>5</u> ... 9 Hz	3.1 mm at <u>5</u> ... 9 Hz	0.075 mm at 10 ... 58 Hz
• Acceleration	5 m/s <sup>2</sup> at >9 ... 200 Hz	10 m/s <sup>2</sup> at >9 ... 200 Hz	9.8 m/s <sup>2</sup> at >58 ... 200 Hz
<b>Shock load</b>	Class 1M2 acc. to EN 60721-3-1	Class 2M2 acc. to EN 60721-3-2	Class 3M4 acc. to EN 60721-3-3
• Acceleration	40 m/s <sup>2</sup> at 22 ms	100 m/s <sup>2</sup> at 11 ms	100 m/s <sup>2</sup> at 11 ms
Compliance with standards			
<b>Conformances/certificates of suitability, according to</b>	CE (EMC Directive 2014/30/EU, Low Voltage Directive 2014/35/EU, and Machinery Directive 2006/42/EC for functional safety), RCM		
<b>Radio interference suppression</b>	SINAMICS drive converter systems are not designed for connection to the public grid (first environment). Radio interference suppression is compliant with the EMC product standard for variable-speed drives EN 61800-3, "second environment" (industrial networks). EMC disturbances can occur when connected to the public grid.		

Deviations from the specified class are underlined.

## SINAMICS S120 Cabinet Modules

### Liquid-cooled units

#### Liquid-cooled units

#### Technical specifications (continued)

##### Cooling circuit and coolant quality

The following tables and sections describe the coolant quality requirements for the raw water circuit on the plant side and the deionized water circuit of the liquid-cooled SINAMICS S120 Cabinet Modules on the converter side.

##### Plant-side raw water circuit (based on VDI 3803)

• System pressure with reference to atmospheric pressure, max.	600 kPa
• Inlet temperature of liquid coolant	Antifreeze essential for temperature range between 0 °C and 5 °C
- Degree of protection < IP55	0 ... 38 °C without derating > 38 ... 43 °C, <a href="#">see derating data</a>
- Degree of protection IP55	0 ... 33 °C without derating > 33 ... 38 °C, <a href="#">see derating data</a>

##### Coolant quality

• Electrical conductivity	< 2200 µS/cm
• pH value	7.5 ... 9
• Chloride ions	< 180 mg/l
• Sulfate ions	< 200 mg/l
• Orthophosphate	< 50 mg/l
• Dissolved iron	< 3 mg/l
• Dissolved copper	< 0.2 mg/l
• Biological load	< 50 CFU/ml
• SiO <sub>2</sub> as silicic acid	< 47 mg/l
• Aluminum	< 2.65 mg/l
• Fluoride	< 4 mg/l
• Total hardness	< 20 (< 40 °C) °dH
• Size of entrained particles	≤ 0.5 mm
• SK 4,3 (upper limit value of polymer phosphates for untreated additional water)	< 10 mmol/l
• Permissible limit values for suspended particles in the coolant	No deposits of solid particles at ≥ 0.5 m/s

##### Converter-side deionized water circuit

• System pressure with reference to atmospheric pressure, max.	600 kPa
• Pressure drop at rated volumetric flow	70 kPa
• Recommended pressure range	80 ... 150 kPa (applicable for water as coolant)
• Inlet temperature of liquid coolant	Depending on ambient temperature; no condensation permitted Antifreeze essential for temperature range between 0 °C and 5 °C
- Degree of protection < IP55	0 ... 45 °C without derating > 45 ... 50 °C, <a href="#">see derating data</a>
- Degree of protection IP55	0 ... 40 °C without derating > 40 ... 45 °C, <a href="#">see derating data</a>

##### Coolant quality

• Coolant basis	Distilled, demineralized, completely desalinated water or deionized water with reduced electrical conductivity in acc. with ISO 3696, quality 3 or based on IEC 60993
• Electrical conductivity when filling	< 30 µS/cm (3 mS/m)
• pH value	5 ... 8
• Components that can be oxidized as oxygen content	< 30 mg/l
• Residue after vaporization and drying at 110 °C	< 10 mg/kg

The coolant definition specified here should only be considered as a recommendation. For units that have been shipped, the information and data provided in the equipment manual supplied should be observed!

<sup>1)</sup> In transport packaging.

**Technical specifications** (continued)

**Antifreeze and inhibitors**

Antifreeze	Antifrogen N	Antifrogen L	DOWCAL 100
<b>Manufacturer</b>	Clariant	Clariant	DOW
<b>Chemical base</b>	Ethylene glycol	Propylene glycol	Ethylene glycol
<b>Minimum concentration</b>	25 %	25 %	25 %
<b>Antifreeze agent with minimum concentration</b>	-10 °C	-10 °C	-10 °C
<b>Maximum concentration</b>	45 %	48 %	45 %
<b>Antifreeze agent with maximum concentration</b>	-30 °C	-30 °C	-30 °C
<b>Inhibitor content</b>	Contains inhibitors with nitrites	Contains inhibitors that are free of nitrates, amines, borates, and phosphate	Contains inhibitors that are free of nitrates, amines, and phosphate
<b>Biocide action with a concentration of</b>	> 25 %	> 25 %	> 25 %

Biocides prevent corrosion that is caused by slime-forming, corrosive or iron-depositing bacteria. These can occur in closed cooling circuits with low water hardness and in open cooling circuits. Biocides must always be selected according to the relevant bacterial risks. Compatibility with inhibitors or antifreeze used with them must be checked on a case-by-case basis.

Inhibitors	Antifrogen N	ANTICORIT S 200 A
<b>Manufacturer</b>	Clariant	Fuchs
<b>Chemical base</b>	Ethylene glycol	-
<b>Minimum concentration</b>	25 %	4 %
<b>Maximum concentration</b>	45 %	5 %

Recommended service

The manufacturer of the antifreeze/inhibitor should analyze the coolant at least once per annum. The concentration and boundary conditions of the antifreeze/inhibitor should be checked. It may be necessary to correct the concentration on the plant side.

## SINAMICS S120 Cabinet Modules

### Liquid-cooled units

#### Liquid-cooled units

#### Technical specifications (continued)

##### Protection against condensation

With liquid-cooled units, warm air can condense on the cold surfaces of heat sinks, pipes and hoses. This condensation depends on the air humidity and the temperature difference between the ambient air and the coolant.

The water which is produced as a result of condensation can cause corrosion as well as electrical damage such as creepage shorts and flashovers. As the SINAMICS units cannot prevent condensation if it is caused by the prevailing climatic conditions, any potential risk of condensation must be prevented by appropriate engineering or by precautionary measures implemented by the customer. These measures include the following:

- a fixed coolant temperature that has been adjusted to the expected air humidity or ambient temperature ensures that critical differences between the coolant and ambient air temperatures do not develop or
- temperature regulation of the coolant as a function of the ambient air temperature

The temperature at which water vapor contained in the air condenses into water is known as the dew point. In order to reliably prevent condensation, the coolant temperature must always be higher than the dew point.

The table below specifies the dew point as a function of room temperature  $T$  and relative air humidity  $\Phi$  for an atmospheric pressure of 100 kPa (1 bar). This corresponds to an installation altitude of 0 to approximately 500 m above sea level. Since the dew point drops as the air pressure decreases, the dew point values at higher installation altitudes are lower than the specified table values. It is therefore the safest approach to engineer the coolant temperature according to the table values for an installation altitude of zero.

Room temperature T	Relative air humidity $\Phi$										
	20 %	30 %	40 %	50 %	60 %	70 %	80 %	85 %	90 %	95 %	100 %
10 °C	< 0 °C	< 0 °C	< 0 °C	0.2 °C	2.7 °C	4.8 °C	6.7 °C	7.6 °C	8.4 °C	9.2 °C	10 °C
20 °C	< 0 °C	2 °C	6 °C	9.3 °C	12 °C	14.3 °C	16.4 °C	17.4 °C	18.3 °C	19.1 °C	20 °C
25 °C	0.6 °C	6.3 °C	10.5 °C	13.8 °C	16.7 °C	19.1 °C	21.2 °C	22.2 °C	23.2 °C	24.1 °C	24.9 °C
30 °C	4.7 °C	10.5 °C	14.9 °C	18.4 °C	21.3 °C	23.8 °C	26.1 °C	27.1 °C	28.1 °C	29 °C	29.9 °C
35 °C	8.7 °C	14.8 °C	19.3 °C	22.9 °C	26 °C	28.6 °C	30.9 °C	32 °C	33 °C	34 °C	34.9 °C
40 °C	12.8 °C	19.1 °C	23.7 °C	27.5 °C	30.6 °C	33.4 °C	35.8 °C	36.9 °C	37.9 °C	38.9 °C	39.9 °C
45 °C	16.8 °C	23.3 °C	28.2 °C	32 °C	35.3 °C	38.1 °C	40.6 °C	41.8 °C	42.9 °C	43.9 °C	44.9 °C
50 °C	20.8 °C	27.5 °C	32.6 °C	36.6 °C	40 °C	42.9 °C	45.5 °C	46.6 °C	47.8 °C	48.9 °C	49.9 °C

A detailed description of the cooling circuits and the recommended coolant is given in the SINAMICS Low Voltage Engineering Manual.

**Characteristic curves**

**Derating**

Liquid-cooled SINAMICS S120 Cabinet Modules are rated for an ambient temperature of 45 °C and installation altitudes up to 2000 m above sea level and a plant-side raw water temperature of 38 °C (< IP55) or 33 °C (IP55). At ambient temperatures > 45 °C and a plant-side raw water temperature > 38 °C (< IP55) or 33 °C (IP55), the output current must be reduced. Ambient temperatures above 50 °C are not permissible. At installation altitudes > 2000 m above sea level, it must be taken into account that the air pressure, and therefore air density, decreases as the height increases. As a consequence, the cooling efficiency and the insulation capacity of the air also decrease.

The intake temperatures in the plant/system-side raw water circuit must always be at least 7 K below the intake temperatures in the converter-side deionized water circuit. This ensures that the cooling power of the Heat Exchanger Module of the deionized water circuit, specified in the technical specifications, can be dissipated to the raw water circuit.

For additional information, please refer to the [SINAMICS Low Voltage Engineering Manual](#).

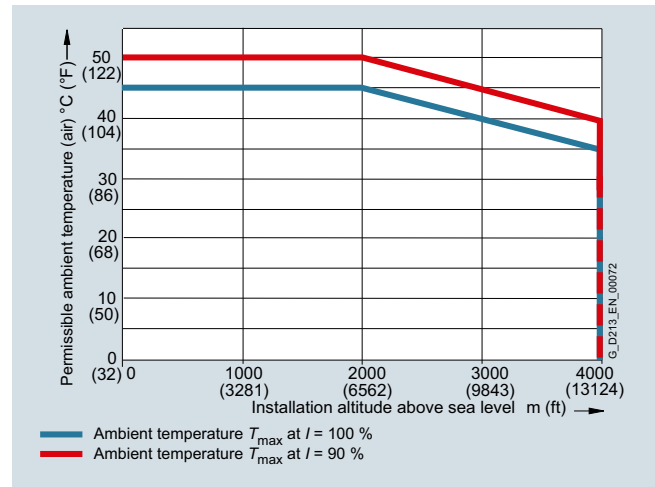

Permissible ambient temperature as a function of installation altitude

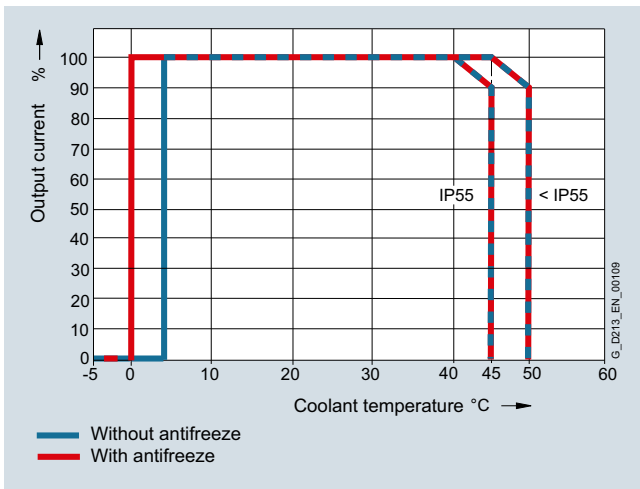

Current derating as a function of the temperature of the cooling liquid in the converter-side deionized water circuit <sup>1)</sup>

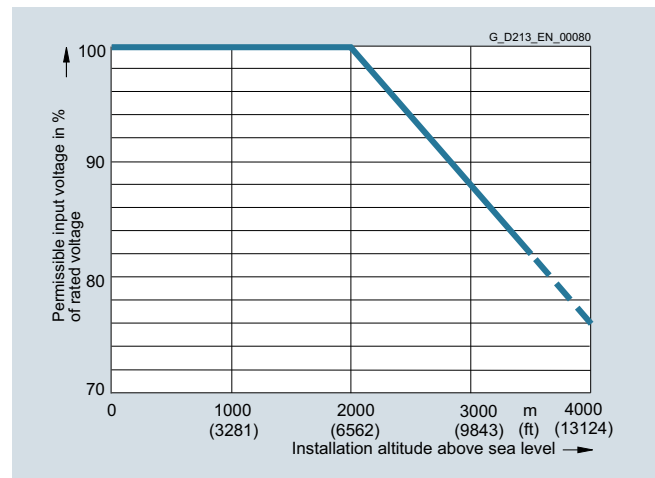

Voltage derating as a function of installation altitude

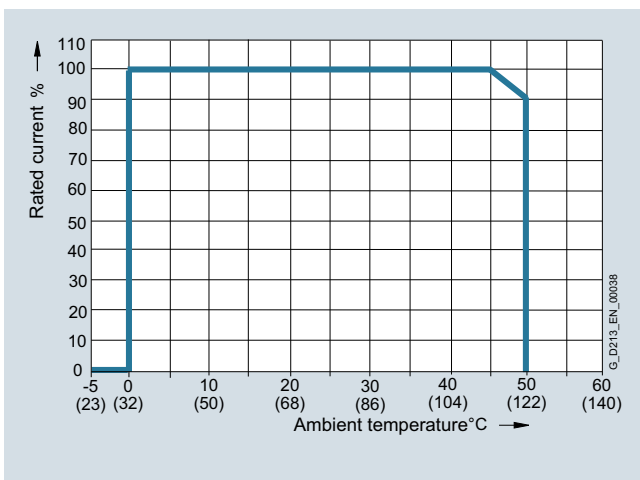

Current derating as a function of ambient temperature <sup>1)</sup>

<sup>1)</sup> The factors of the two derating curves must not be multiplied. The highest value in each case must be assumed for the purposes of calculation, so that the derating factor in the worst-case scenario is 0.9.

## SINAMICS S120 Cabinet Modules

### Liquid-cooled units

#### Liquid-cooled units

#### Characteristic curves (continued)

##### Current derating as a function of the pulse frequency

To reduce motor noise or to increase output frequency, the pulse frequency can be increased relative to the factory setting (1.25 kHz or 2 kHz). When the pulse frequency is increased, the derating factor of the output current must be taken into account. This derating factor must be applied to the currents specified in the technical specifications.

For additional information, please refer to the [SINAMICS Low Voltage Engineering Manual](#).

The following table lists the rated output currents of the Motor Modules with pulse frequency set at the factory, as well as the current derating factors (permissible output currents referred to the rated output current) for higher pulse frequencies.

##### Derating factor of the output current as a function of the pulse frequency for units with a rated pulse frequency of 2 kHz

Motor Module	Type rating at 400 V kW	Output current at 2 kHz A	Derating factor at pulse frequency				
			2.5 kHz	4 kHz	5 kHz	7.5 kHz	8 kHz
<b>380 ... 480 V 3 AC / 510 ... 720 V DC</b>							
1TE32-1AA3	110	210	95 %	82 %	74 %	54 %	50 %
1TE32-6AA3	132	260	95 %	83 %	74 %	54 %	50 %
1TE33-1AA3	160	310	97 %	88 %	78 %	54 %	50 %
1TE35-0AA3	250	490	94 %	78 %	71 %	53 %	50 %
1TE41-4AS3 <sup>1)</sup>	800	1330	88 %	55 %	–	–	–

##### Derating factor of the output current as a function of the pulse frequency for units with a rated pulse frequency of 1.25 kHz

Motor Module	Type rating at 400 V or 690 V kW	Output current at 1.25 kHz A	Derating factor at pulse frequency					
			2 kHz	2.5 kHz	4 kHz	5 kHz	7.5 kHz	8 kHz
<b>380 ... 480 V 3 AC / 510 ... 720 V DC</b>								
1TE36-1AA3	315	605	83 %	72 %	64 %	60 %	40 %	–
1TE37-5AA3	400	745	83 %	72 %	64 %	60 %	40 %	–
1TE38-4AA3	450	840	87 %	79 %	64 %	60 %	40 %	–
1TE41-0AA3	560	985	92 %	87 %	70 %	60 %	50 %	47 %
1TE41-2AA3	710	1260	92 %	87 %	70 %	60 %	50 %	47 %
1TE41-4AA3	800	1405	97 %	95 %	74 %	60 %	50 %	47 %
<b>500 ... 690 V 3 AC / 675 ... 1035 V DC</b>								
1TG31-0AA3	90	100	92 %	88 %	71 %	60 %	40 %	–
1TG31-5AA3	132	150	90 %	84 %	66 %	55 %	35 %	–
1TG32-2AA3	200	215	92 %	87 %	70 %	60 %	40 %	–
1TG33-3AA3	315	330	89 %	82 %	65 %	55 %	40 %	–
1TG34-7AA3	450	465	92 %	87 %	67 %	55 %	35 %	–
1TG35-8AA3	560	575	91 %	85 %	64 %	50 %	35 %	–
1TG37-4AA3	710	735	84 %	74 %	53 %	40 %	25 %	–
1TG38-0AA3	800 <sup>2)</sup>	810	82 %	71 %	52 %	40 %	25 %	–
1TG38-1AA3	800	810	97 %	95 %	71 %	55 %	35 %	–
1TG41-0AA3	1000	1025	91 %	86 %	64 %	50 %	30 %	–
1TG41-3AA3	1200	1270	87 %	79 %	55 %	40 %	25 %	–
1TG41-6AA3	1500	1560	87 %	79 %	55 %	40 %	25 %	–

The following tables list the maximum achievable output frequency as a function of the pulse frequency:

##### Maximum output frequencies achieved by increasing the pulse frequency in Vector mode

Pulse frequency	Max. achievable output frequency
1.25 kHz	100 Hz
2 kHz	160 Hz
2.5 kHz	200 Hz
4 kHz	320 Hz
5 kHz	400 Hz

##### Maximum output frequencies achieved by increasing the pulse frequency in Servo mode

Pulse frequency	Max. achievable output frequency
2 kHz	300 Hz
4 kHz	300/550 Hz <sup>3)</sup>

<sup>1)</sup> This Motor Module has been specifically designed for loads demanding a high dynamic performance. The derating factor  $k_{IGBT}$  and the derating characteristics can be ignored (see section "Duty cycles" in the [SINAMICS Low Voltage Engineering Manual](#)).

<sup>2)</sup> The Motor Module 6SL3725-1TG38-0AA3 is optimized for low overload; with an increased pulse frequency, the derating factor is higher than for the Motor Module 6SL3725-1TG38-1AA3.

<sup>3)</sup> Higher frequencies on request.

**Characteristic curves (continued)**

**Overload capability**

SINAMICS S120 Cabinet Modules have an overload reserve, e.g. to handle breakaway torques. If larger surge loads occur, this must be taken into account in the configuration. For drives with overload requirements, the appropriate base-load current must, therefore, be used as a basis for the required load.

Permissible overload assumes that the drive converter is operated at its base-load current before and after the overload occurs, based on a duty cycle duration of 300 s.

Another precondition is that the Motor Modules are operated at their factory-set pulse frequency at output frequencies > 10 Hz.

For temporary, periodic duty cycles with high variations of load within the duty cycle, the relevant sections of the SINAMICS Low Voltage Engineering Manual must be observed.

**Motor Modules**

Motor Modules can be configured on the basis of different base-load currents.

The base-load current for a low overload  $I_L$  is based on a duty cycle of 110 % for 60 s or 150 % for 10 s.

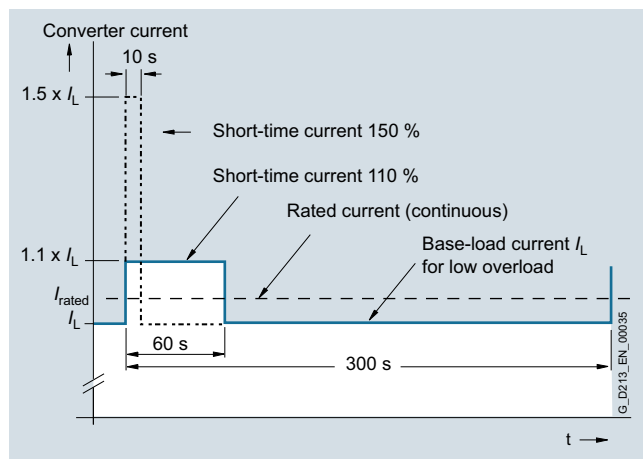

Low overload

The base-load current  $I_H$  for a high overload is based on a duty cycle of 150 % for 60 s or 160 % for 10 s.

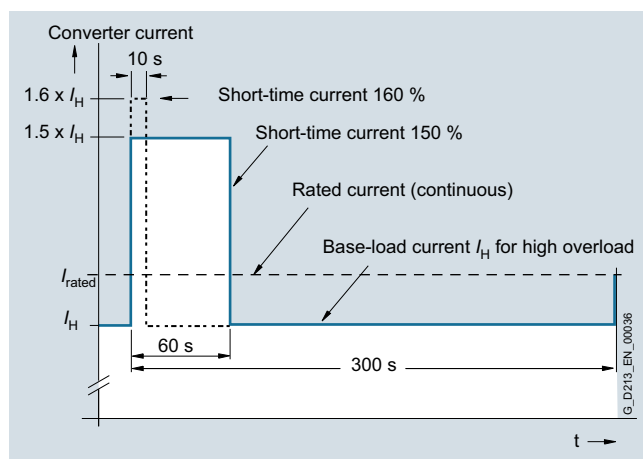

High overload

The following applies to the Motor Module **6SL3725-1TG41-6AP3**:

This Motor Module is particularly suited to high breakaway torques with applications such as drilling, mixers, centrifuges, and test bays. An **additional** duty cycle is required at output frequencies of 5 Hz to 10 Hz.

At output frequencies of 1 Hz to 5 Hz, the short-time current is 1900 A for 5 s.

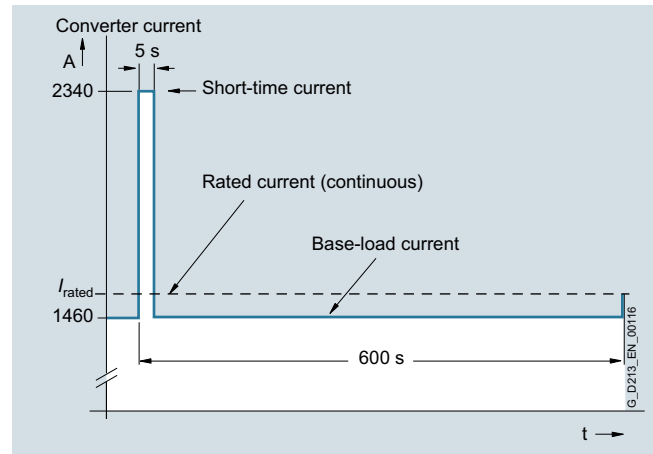

High overload for Motor Module 6SL3725-1TG41-6AP3

**Basic Line Connection Modules and Active Line Connection Modules**

The base-load current for a high overload  $I_{H DC}$  is based on a duty cycle of 150 % for 60 s or  $I_{max DC}$  for 5 s.

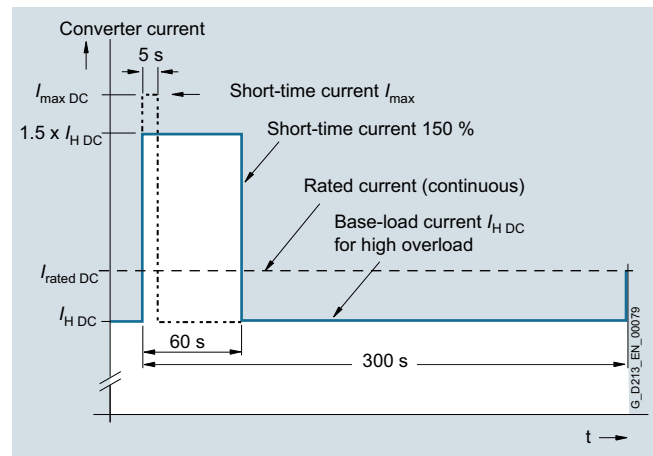

High overload



## SINAMICS S120 Cabinet Modules

Liquid-cooled units

### Basic Line Connection Modules

#### Overview



Basic Line Connection Modules are compact line infeeds for two-quadrant operation, i.e. no regenerative feedback. They are used when energy need not be fed back into the network.

Basic Line Connection Modules comprise a Line Connection Module and a liquid-cooled Basic Line Module.

As standard, the Basic Line Connection Module is positioned in the drive line-up so that the Motor Modules are arranged to the right. If Motor Modules are to be arranged to the left of the Basic Line Connection Module, option **M88** (DC bus system for line-side Cabinet Modules) must be ordered.

Line Connection Modules contain the line-side infeed via main circuit breaker with fuse switch disconnecter or circuit breaker and establish the connection between the plant power system and the Basic Line Modules. They are equipped as standard with a radio interference suppression filter according to EN 61800-3 Category C3.

Under full load, the DC link voltage is higher than the rms value of the rated line voltage by a factor of 1.32, and under partial load by a factor of 1.35.

If regenerative conditions occur in the drive line-up, a Motor Module can be used as a braking chopper, which then converts excess energy to heat in a braking resistor.

Basic Line Connection Modules are suitable for connection to grounded TN/TT and non-grounded IT systems. The following voltages and power ratings are available:

Line voltage	Rated input current	Rated power
380 ... 480 V 3 AC	610 ... 1420 A	360 ... 830 kW
500 ... 690 V 3 AC	340 ... 1350 A	355 ... 1370 kW

For a Basic Line Connection Module a line reactor should be provided at the connection point depending on the line short-circuit power. This reactor is available as standard. However, it can be omitted if it is not required (option **L22**).

For additional information, please refer to the [SINAMICS Low Voltage Engineering Manual](#).

#### Design

Depending on the input current, the following versions are available:

- ≤ 800 A: Main circuit breaker with fuse switch disconnecter
- > 800 A: Circuit breaker, type 3WL, with option **L25** as withdrawable circuit breaker

A fully controlled thyristor bridge is used to pre-charge the Basic Line Connection Module and the connected DC link. The thyristors normally operate with a trigger delay angle of 0°.

The power rating can be increased by connecting Basic Line Connection Modules in parallel. You must observe the following rules:

- Up to four identical Active Line Connection Modules can be connected in parallel.
- A common Control Unit is required whenever the modules are connected in parallel.
- The parallel connection must be supplied from a common infeed point (i.e. the modules cannot be operated on different line supplies). For information on using line reactors, see [section Basic Line Connection Modules → Overview](#).
- A derating factor of 7.5 % must be taken into consideration, regardless of the number of modules connected in parallel.
- The main contactors or circuit breakers of the respective Line Connection Modules must close together and simultaneously. Monitoring is performed via the -X50 terminals of the respective Line Connection Module.
- Option **M88** must be ordered.

For additional information, please refer to the [SINAMICS Low Voltage Engineering Manual](#).

#### Selection and ordering data

Rated power at 400 V or 690 V kW	Rated DC link current A	Basic Line Connection Module Article No.
<b>Line voltage 380 ... 480 V 3 AC (DC link voltage 510 ... 650 V DC)</b>		
360	740	<b>6SL3735-1TE37-4LA3</b>
600	1220	<b>6SL3735-1TE41-2LA3</b>
830	1730	<b>6SL3735-1TE41-7LA3</b>
<b>Line voltage 500 ... 690 V 3 AC (DC link voltage 675 ... 930 V DC)</b>		
355	420	<b>6SL3735-1TG34-2LA3</b>
630	730	<b>6SL3735-1TG37-3LA3</b>
1100	1300	<b>6SL3735-1TG41-3LA3</b>
1370	1650	<b>6SL3735-1TG41-7LA3</b>

**Integration**

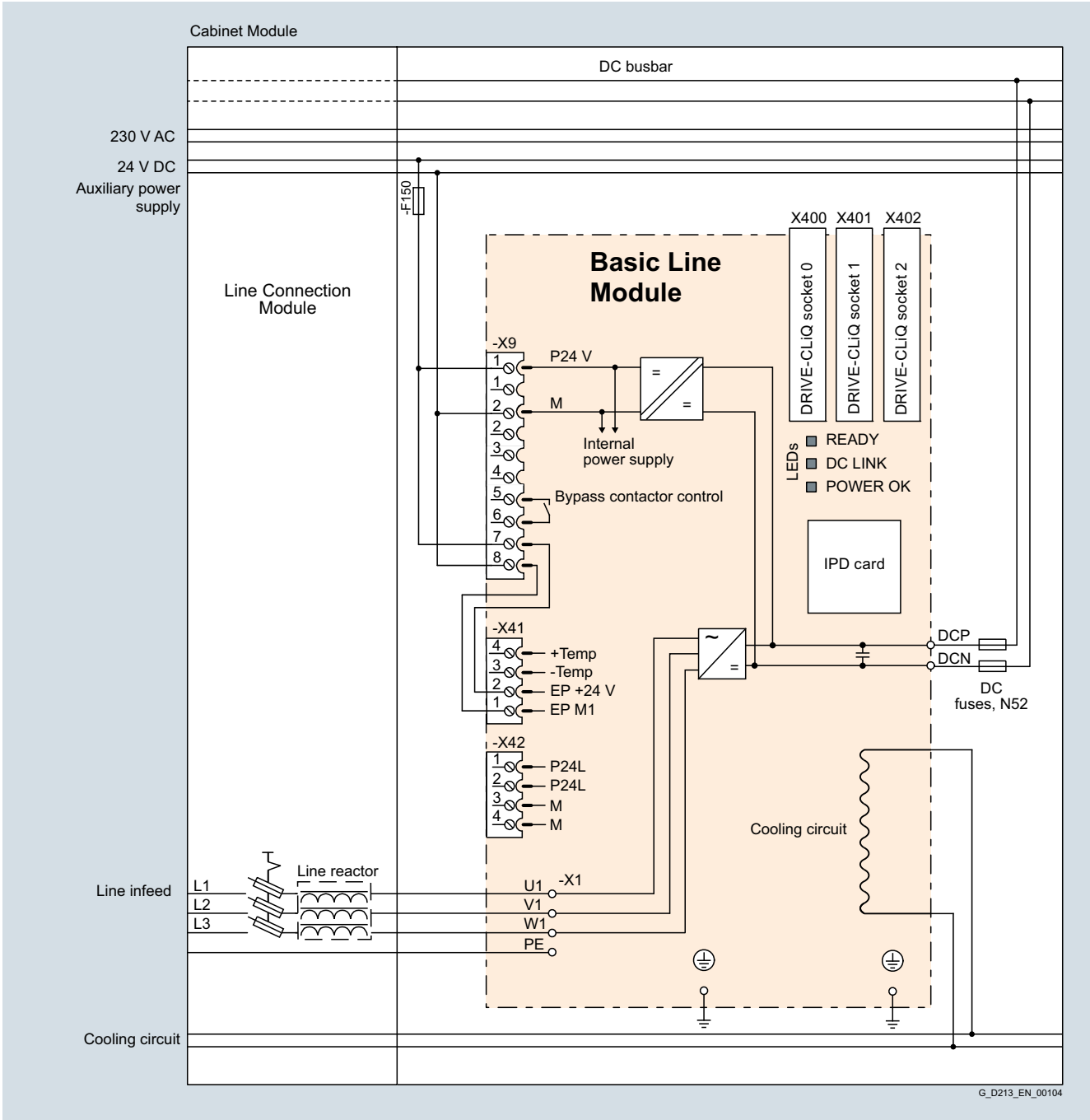

Connection example: Basic Line Connection Module, liquid-cooled

# SINAMICS S120 Cabinet Modules

## Liquid-cooled units

### Basic Line Connection Modules

#### Technical specifications

Line voltage 380 ... 480 V 3 AC		Basic Line Connection Modules			
		6SL3735-1TE37-4LA3	6SL3735-1TE41-2LA3	6SL3735-1TE41-7LA3	
<b>Rated power</b>					
• At $I_{rated DC}$ (50 Hz 400 V)	kW	<b>360</b>	<b>600</b>	<b>830</b>	
• At $I_{H DC}$ (50 Hz 400 V)	kW	280	450	650	
• At $I_{rated DC}$ (60 Hz 460 V)	hp	555	925	1280	
• At $I_{H DC}$ (60 Hz 460 V)	hp	430	690	1000	
<b>DC link current</b>					
• Rated current $I_{rated DC}$	A	740	1220	1730	
• Base-load current $I_{H DC}$ <sup>1)</sup>	A	578	936	1350	
• Maximum current $I_{max DC}$	A	1110	1830	2595	
<b>Input current</b>					
• Rated current $I_{rated I}$	A	610	1000	1420	
• Maximum current $I_{max I}$	A	915	1500	2130	
<b>Current demand</b>					
• 24 V DC auxiliary power supply	A	0.7	0.7	0.7	
• 230 V 1 AC	A	1.2	1.2	1.2	
<b>DC link capacitance</b>					
• Basic Line Module	μF	12000	20300	26100	
• Drive line-up, max.	μF	96000	162400	208800	
<b>Power loss, max. <sup>2)</sup></b>					
At 50 Hz 400 V					
• Degree of protection <IP55					
- Dissipated to coolant	kW	2.7	4.4	5.8	
- Dissipated to ambient air	kW	2.7	3.5	4.2	
• Degree of protection IP55					
- Dissipated to coolant	kW	4.9	7.4	9.5	
- Dissipated to ambient air	kW	0.5	0.5	0.5	
<b>Coolant volume flow <sup>3)</sup></b>					
Degree of protection <IP55/IP55	l/min	9/36	9/36	12/39	
<b>Liquid volume</b>					
Degree of protection <IP55/IP55	dm <sup>3</sup>	6.6/10.2	6.6/10.2	6.9/10.5	
<b>Pressure drop, max. <sup>4)</sup></b>					
For volume flow	Pa	150000	150000	150000	
<b>Heat exchanger material</b>		Aluminum	Aluminum	Aluminum	
<b>Sound pressure level <math>L_{pA}</math></b>					
(1 m) at 50/60 Hz	dB	54	56	56	
<b>Line supply connection</b>					
L1, L2, L3		4/M12	5/M12 + 4/M16	5/M12 + 4/M16	
• Conductor cross-section, max. (IEC)	mm <sup>2</sup>	4 × 240	8 × 240	10 × 240	
<b>PE/GND connection</b>					
• Busbar cross-section	mm <sup>2</sup>	PE bar 600	PE bar 600	PE bar 600	
• Conductor cross-section, max. (IEC)	mm <sup>2</sup>	240	240	240	
<b>Cable length, max. <sup>5)</sup></b>					
Shielded/unshielded	m	2600/3900	4000/6000	4800/7200	
<b>Degree of protection</b>					
(standard version)		IP21	IP21	IP21	
<b>Dimensions</b>					
• Width	mm	1000	1000	1000	
• Height	mm	2200	2200	2200	
• Depth	mm	600	600	600	
<b>Weight, approx.</b>					
(standard version)	kg	688	838	995	
<b>Frame size</b>					
• Line Connection Module		HL	JL	JL	
• Basic Line Module		FBL	FBL	GBL	
<b>Short-circuit current rating according to IEC</b>		kA	65	84	100
<b>Minimum short-circuit current <sup>6)</sup></b>		A	8800	2000	3200

<sup>1)</sup> The base-load current  $I_{H DC}$  is based on a duty cycle of 150 % for 60 s or  $I_{max DC}$  for 5 s with a duty cycle duration of 300 s.

<sup>2)</sup> The specified power loss represents the maximum value at 100 % utilization. The value is lower under normal operating conditions.

<sup>3)</sup> The value applies to coolants comprising water and a mixture of water and antifreeze agent.

<sup>4)</sup> The value is valid for water as coolant. [Additional information and notes on other coolants are provided in the SINAMICS Low Voltage Engineering Manual.](#)

<sup>5)</sup> Total of all motor cables and DC link. Longer cable lengths for specific configurations are available on request.

<sup>6)</sup> Current required for reliably triggering protective devices.

#### Technical specifications (continued)

Line voltage 500 ... 690 V 3 AC		Basic Line Connection Modules			
		6SL3735-1TG34-2LA3	6SL3735-1TG37-3LA3	6SL3735-1TG41-3LA3	6SL3735-1TG41-7LA3
<b>Rated power</b>					
• At $I_{rated\ DC}$ (50 Hz 690 V)	kW	<b>355</b>	<b>630</b>	<b>1100</b>	<b>1370</b>
• At $I_{H\ DC}$ (50 Hz 690 V)	kW	275	475	840	1070
• At $I_{rated\ DC}$ (50 Hz 500 V)	kW	245	420	750	950
• At $I_{H\ DC}$ (50 Hz 500 V)	kW	200	345	610	775
• At $I_{rated\ DC}$ (60 Hz 575 V)	hp	395	705	1230	1530
• At $I_{H\ DC}$ (60 Hz 575 V)	hp	305	530	940	1195
<b>DC link current</b>					
• Rated current $I_{rated\ DC}$	A	420	730	1300	1650
• Base-load current $I_{H\ DC}$ <sup>1)</sup>	A	328	570	1014	1287
• Maximum current $I_{max\ DC}$	A	630	1095	1950	2475
<b>Input current</b>					
• Rated current $I_{rated\ I}$	A	340	600	1070	1350
• Maximum current $I_{max\ I}$	A	510	900	1605	2025
<b>Current demand</b>					
• 24 V DC auxiliary power supply	A	0.7	0.7	0.7	0.7
• 230 V 1 AC	A	1.2	1.2	1.2	1.2
<b>DC link capacitance</b>					
• Basic Line Module	μF	4800	7700	15500	19300
• Drive line-up, max.	μF	38400	61600	124000	154400
<b>Power loss, max. <sup>2)</sup></b> at 50 Hz 690 V					
• Degree of protection <IP55					
- Dissipated to coolant	kW	1.8	2.7	4.7	5.7
- Dissipated to ambient air	kW	2.3	2.7	3.3	5.1
• Degree of protection IP55					
- Dissipated to coolant	kW	3.3	4.9	7.5	10.3
- Dissipated to ambient air	kW	0.5	0.5	0.5	0.5
<b>Coolant volume flow <sup>3)</sup></b>					
Degree of protection <IP55/IP55	l/min	9/36	9/36	12/39	12/39
<b>Liquid volume</b>					
Degree of protection <IP55/IP55	dm <sup>3</sup>	6.6/10.2	6.6/10.2	6.9/10.5	6.9/10.5
<b>Pressure drop, max. <sup>4)</sup></b> For volume flow					
	Pa	150000	150000	150000	150000
<b>Heat exchanger material</b>		Aluminum	Aluminum	Aluminum	Aluminum
<b>Sound pressure level <math>L_{pA}</math></b> (1 m) at 50/60 Hz		dB	54	54	56
<b>Line supply connection</b>					
L1, L2, L3		2/M12	4/M12	5/M12 + 4/M16	5/M12 + 4/M16
• Conductor cross-section, max. (IEC)	mm <sup>2</sup>	2 × 150	4 × 240	8 × 240	8 × 240
<b>PE/GND connection</b>					
• Busbar cross-section	mm <sup>2</sup>	PE bar 600	PE bar 600	PE bar 600	PE bar 600
• Conductor cross-section, max. (IEC)	mm <sup>2</sup>	240	240	240	240
<b>Cable length, max. <sup>5)</sup></b>					
Shielded/unshielded	m	1500/2250	1500/2250	2250/3375	2250/3375
<b>Degree of protection</b> (standard version)		IP21	IP21	IP21	IP21
<b>Dimensions</b>					
• Width	mm	1000	1000	1000	1000
• Height	mm	2200	2200	2200	2200
• Depth	mm	600	600	600	600
<b>Weight, approx.</b> (standard version)		kg	578	668	995
<b>Frame size</b>					
• Line Connection Module		GL	HL	JL	JL
• Basic Line Module		FBL	FBL	GBL	GBL
<b>Short-circuit current rating according to IEC</b>		kA	65	84	100
<b>Minimum short-circuit current <sup>6)</sup></b>		A	4400	7200	2500

<sup>1)</sup> The base-load current  $I_{H\ DC}$  is based on a duty cycle of 150 % for 60 s or  $I_{max\ DC}$  for 5 s with a duty cycle duration of 300 s.

<sup>2)</sup> The specified power loss represents the maximum value at 100 % utilization. The value is lower under normal operating conditions.

<sup>3)</sup> The value applies to coolants comprising water and a mixture of water and antifreeze agent.

<sup>4)</sup> The value is valid for water as coolant. [Additional information and notes on other coolants are provided in the SINAMICS Low Voltage Engineering Manual.](#)

<sup>5)</sup> Total of all motor cables and DC link. Longer cable lengths for specific configurations are available on request.

<sup>6)</sup> Current required for reliably triggering protective devices.

## SINAMICS S120 Cabinet Modules

Liquid-cooled units

### Active Line Connection Modules

#### Overview



Active Line Connection Modules comprise a Line Connection Module, a liquid-cooled Active Interface Module and a liquid-cooled Active Line Module. They can supply motoring energy to the DC link and return regenerative energy to the line supply.

As standard, the Active Line Connection Module is positioned in the drive line-up so that the Motor Modules are arranged to the right. If Motor Modules are to be arranged to the left of the Active Line Connection Module, option **M88** (DC bus system for line-side Cabinet Modules) must be ordered.

Line Connection Modules contain the line-side infeed via main circuit breaker with fuse switch disconnecter or circuit breaker and establish the connection between the plant power system and the Active Line Modules. They are equipped as standard with a radio interference suppression filter according to EN 61800-3 Category C3.

Active Line Connection Modules produce a stabilized DC voltage that remains constant regardless of fluctuations in the line voltage (the line voltage must remain within the permissible tolerances).

In the factory setting, the DC voltage is regulated to 1.5 times the rms value of the rated line voltage.

Active Line Connection Modules draw a virtually sinusoidal current from the supply system and cause virtually no line harmonics.

Active Line Connection Modules are suitable for connection to supply systems grounded at the neutral point (TN, TT) and non-grounded (IT) supply systems. The following voltages and currents are available:

Line voltage	Rated infeed/regenerative feedback current	Rated power
380 ... 480 V 3 AC	605 ... 1405 A	380 ... 900 kW
500 ... 690 V 3 AC	735 ... 1560 A	800 ... 1700 kW

#### Design

Active Line Connection Modules always include an Active Interface Module, which contains the associated Clean Power Filter and pre-charging circuit. The line filter that is included ensures compliance with the EMC requirements for the "second environment".

Depending on the input current, the following versions are available:

- $\leq 800$  A: Main circuit breaker with fuse switch disconnecter
- $> 800$  A: Circuit breaker, type 3WL, with option **L25** as withdrawable circuit breaker

The power rating can be increased by connecting Active Line Connection Modules in parallel. You must observe the following rules:

- Up to four identical Active Line Connection Modules can be connected in parallel.
- A common Control Unit is required whenever the modules are connected in parallel.
- The parallel connection must be supplied from a common infeed point (i.e. the modules cannot be operated on different line supplies).
- A derating factor of 5% must be taken into consideration, regardless of the number of modules connected in parallel.
- The main contactors or circuit breakers of the respective Line Connection Modules must close together and simultaneously. Monitoring is performed via the -X50 terminals of the respective Line Connection Module.
- Option **M88** must be ordered.

For additional information, please refer to the [SINAMICS Low Voltage Engineering Manual](#).

#### Selection and ordering data

Rated power at 400 V or 690 V kW	Rated DC link current A	Active Line Connection Module Article No.
<b>Line voltage 380 ... 480 V 3 AC (DC link voltage 570 ... 720 V DC)</b>		
380	677	<b>6SL3735-7TE36-1LA3</b>
500	941	<b>6SL3735-7TE38-4LA3</b>
630	1100	<b>6SL3735-7TE41-0LA3</b>
900	1573	<b>6SL3735-7TE41-4LA3</b>
<b>Line voltage 500 ... 690 V 3 AC (DC link voltage 750 ... 1035 V DC)</b>		
800	823	<b>6SL3735-7TG37-4LA3</b>
900	907	<b>6SL3735-7TG38-1LA3</b>
1100	1147	<b>6SL3735-7TG41-0LA3</b>
1400	1422	<b>6SL3735-7TG41-3LA3</b>
1700	1740	<b>6SL3735-7TG41-6LA3</b>

**Integration**

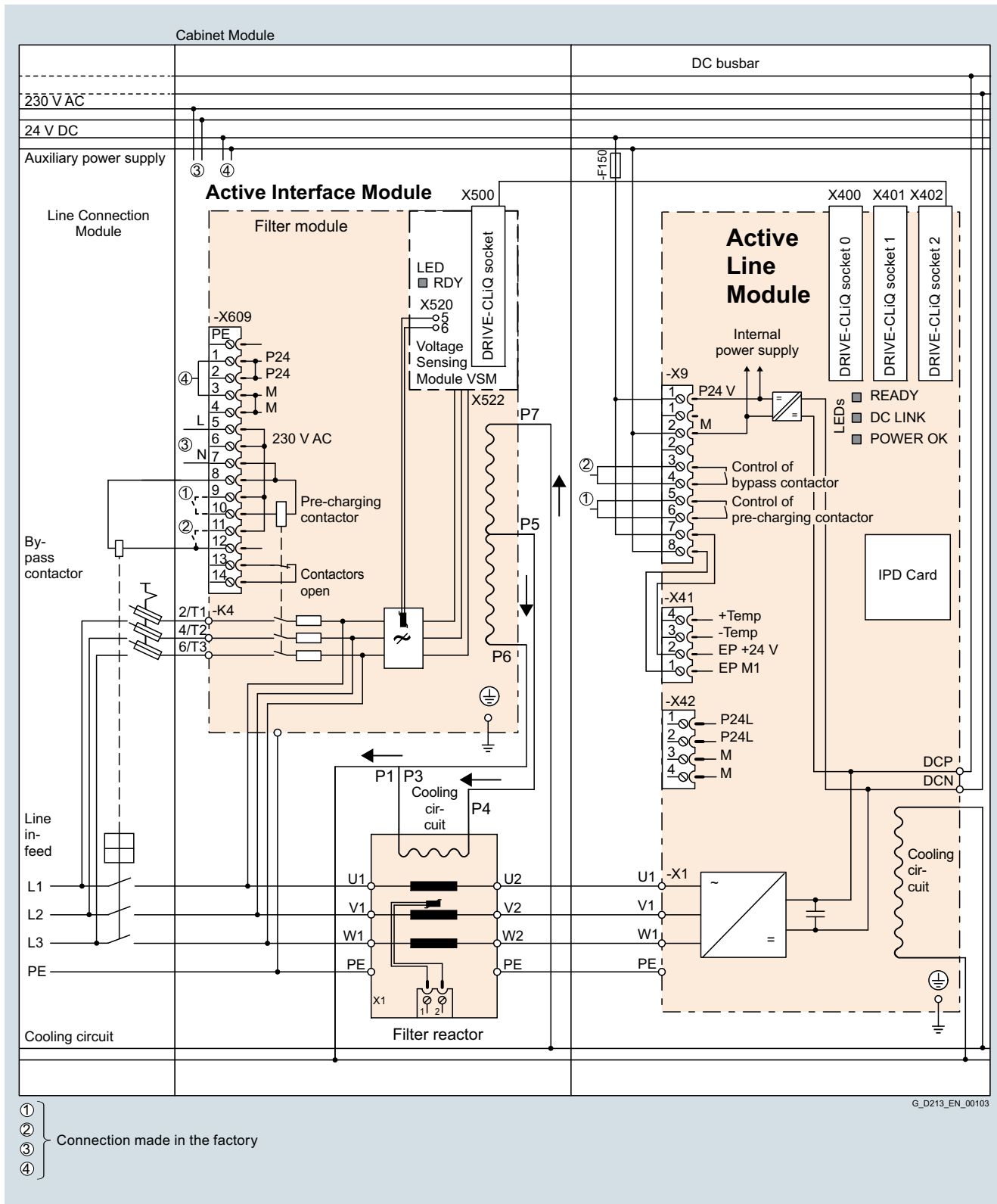

Connection example: Active Line Connection Module, liquid-cooled

# SINAMICS S120 Cabinet Modules

## Liquid-cooled units

### Active Line Connection Modules

#### Technical specifications

Line voltage 380 ... 480 V 3 AC		Active Line Connection Modules			
		6SL3735-7TE36-1LA3	6SL3735-7TE38-4LA3	6SL3735-7TE41-0LA3	6SL3735-7TE41-4LA3
<b>Rated power</b>					
• At $I_{\text{rated DC}}$ (50 Hz 400 V)	kW	<b>380</b>	<b>500</b>	<b>630</b>	<b>900</b>
• At $I_{\text{H DC}}$ (50 Hz 400 V)	kW	335	465	545	780
• At $I_{\text{rated DC}}$ (60 Hz 460 V)	hp	600	700	900	1250
• At $I_{\text{H DC}}$ (60 Hz 460 V)	hp	500	700	800	1000
<b>DC link current</b>					
• Rated current $I_{\text{rated DC}}$	A	677	941	1100	1573
• Base-load current $I_{\text{H DC}}^{1)}$	A	603	837	982	1401
• Maximum current $I_{\text{max DC}}$	A	1017	1410	1654	2361
<b>Infeed/regenerative feedback current</b>					
• Rated current $I_{\text{rated I}}$	A	605	840	985	1405
• Maximum current $I_{\text{max I}}$	A	907	1260	1477	2055
<b>Current demand</b>					
• 24 V DC auxiliary power supply	A	1.77	1.77	1.77	1.77
• 230 V 1 AC	A	1.2	1.2	1.2	1.2
<b>DC link capacitance</b>					
• Active Line Module	μF	12600	17400	18900	28800
• Drive line-up, max.	μF	134400	134400	230400	230400
<b>Power loss, max. <sup>2)</sup></b> at 50 Hz 400 V					
• Degree of protection <IP55					
- Dissipated to coolant	kW	10.9	11.7	19.6	21.8
- Dissipated to ambient air	kW	2.4	2.3	3.1	3.8
• Degree of protection IP55					
- Dissipated to coolant	kW	12.2	13.1	21.8	24.7
- Dissipated to ambient air	kW	0.9	0.9	0.9	0.9
<b>Coolant volume flow <sup>3)</sup></b> Degree of protection <IP55/IP55		l/min	32/59	32/59	43/70
<b>Liquid volume</b> Degree of protection <IP55/IP55		dm <sup>3</sup>	13/16.6	13/16.6	14/17.6
<b>Pressure drop, max. <sup>4)</sup></b> For volume flow		Pa	150000	150000	150000
<b>Heat exchanger material</b>					
• Active Line Module		Aluminum	Aluminum	Aluminum	Aluminum
• Active Interface Module		Aluminum	Aluminum	Aluminum	Aluminum
<b>Sound pressure level <math>L_{\text{pA}}^{5)}</math></b> (1 m) at 50/60 Hz		dB	65/65	65/65	65/65
<b>Line supply connection</b> L1, L2, L3			4 x M12	4 x M12	5 x M12 + 4 x M16
• Conductor cross-section, max. (IEC)	mm <sup>2</sup>	4 x 240	4 x 240	8 x 240	10 x 240
<b>PE/GND connection</b>					
• Busbar cross-section	mm <sup>2</sup>	PE bar 600	PE bar 600	PE bar 600	PE bar 600
• Conductor cross-section, max. (IEC)	mm <sup>2</sup>	240	240	240	240
<b>Cable length, max. <sup>6)</sup></b> Shielded/unshielded		m	3900/5850	3900/5850	3900/5850
<b>Degree of protection</b> (standard version)			IP21	IP21	IP21
<b>Dimensions</b>					
• Width	mm	1600	1600	1600	1600
• Height	mm	2200	2200	2200	2200
• Depth	mm	600	600	600	600
<b>Weight, approx.</b> (standard version)		kg	1134	1244	1430
<b>Frame size</b>					
• Line Connection Module		HL	JL	JL	JL
• Active Interface Module		JIL	JIL	JIL	JIL
• Active Line Module		HXL	HXL	JXL	JXL
<b>Short-circuit current rating according to IEC</b>		kA	65	84	100
<b>Minimum short-circuit current <sup>7)</sup></b>		A	9200	2000	2000

1) The base-load current  $I_{\text{H DC}}$  is based on a duty cycle of 150 % for 60 s or  $I_{\text{max DC}}$  for 5 s with a duty cycle duration of 300 s.

2) The specified power loss represents the maximum value at 100 % utilization. The value is lower under normal operating conditions.

3) The value applies to coolants comprising water and a mixture of water and antifreeze agent.

4) The value is valid for water as coolant. [Additional information and notes on other coolants are provided in the SINAMICS Low Voltage Engineering Manual.](#)

5) Total sound pressure level of Active Interface Module and Active Line Module.

6) Total of all motor cables and DC link. Longer cable lengths for specific configurations are available on request.

7) Current required for reliably triggering protective devices.



### Technical specifications (continued)

Line voltage 500 ... 690 V 3 AC		Active Line Connection Modules				
		6SL3735-7TG37-4LA3	6SL3735-7TG38-1LA3	6SL3735-7TG41-0LA3	6SL3735-7TG41-3LA3	6SL3735-7TG41-6LA3
<b>Rated power</b>						
• At $I_{rated\ DC}$ (50 Hz 690 V)	kW	800	900	1100	1400	1700
• At $I_{H\ DC}$ (50 Hz 690 V)	kW	705	670	1000	1215	1490
• At $I_{rated\ DC}$ (50 Hz 500 V)	kW	560	620	780	965	1180
• At $I_{H\ DC}$ (50 Hz 500 V)	kW	510	485	710	880	1080
• At $I_{rated\ DC}$ (60 Hz 575 V)	hp	900	975	1250	1500	1855
• At $I_{H\ DC}$ (60 Hz 575 V)	hp	600	765	1000	1250	1530
<b>DC link current</b>						
• Rated current $I_{rated\ DC}$	A	823	907	1147	1422	1740
• Base-load current $I_{H\ DC}^{1)}$	A	732	808	936	1266	1550
• Maximum current $I_{max\ DC}$	A	1235	1360	1722	2133	2620
<b>Infeed/regenerative feedback current</b>						
• Rated current $I_{rated\ I}$	A	735	810	1025	1270	1560
• Maximum current $I_{max\ I}$	A	1100	1214	1537	1905	2055
<b>Current demand</b>						
• 24 V DC auxiliary power supply	A	1.77	1.77	1.77	1.63	1.67
• 230 V 1 AC	A	1.2	1.2	1.2	1.2	1.2
<b>DC link capacitance</b>						
• Active Line Module	μF	10500	10500	16000	19330	21000
• Drive line-up, max.	μF	153600	153600	153600	153600	210000
<b>Power loss, max. <sup>2)</sup></b> at 50 Hz 400 V						
• Degree of protection <IP55						
- Dissipated to coolant	kW	17.0	19.5	21.6	27.3	37.7
- Dissipated to ambient air	kW	2.4	2.4	3.1	3.7	4.4
• Degree of protection IP55						
- Dissipated to coolant	kW	18.4	20.9	23.7	30.1	39.2
- Dissipated to ambient air	kW	0.9	0.9	0.9	0.9	0.9
<b>Coolant volume flow <sup>3)</sup></b>		l/min	32/59	43/70	43/70	43/70
Degree of protection <IP55/IP55						
<b>Liquid volume</b>		dm <sup>3</sup>	13/16.6	14/17.6	14/17.6	14/17.6
Degree of protection <IP55/IP55						
<b>Pressure drop, max. <sup>4)</sup></b> For volume flow		Pa	150000	150000	150000	150000
<b>Heat exchanger material</b>						
• Active Line Module		Aluminum	Aluminum	Aluminum	Aluminum	Aluminum
• Active Interface Module		Aluminum	Aluminum	Aluminum	Aluminum	Aluminum
<b>Sound pressure level <math>L_{pA}</math> <sup>5)</sup></b> (1 m) at 50/60 Hz		dB	65/65	65/65	65/65	65/65
<b>Line supply connection</b>						
L1, L2, L3		4 x M12	4 x M12	5 x M12 + 4 x M16	5 x M12 + 4 x M16	5 x M12 + 4 x M16
• Conductor cross-section, max. (IEC)	mm <sup>2</sup>	8 x 240	8 x 240	8 x 240	8 x 240	8 x 240
<b>PE/GND connection</b>						
• Busbar cross-section	mm <sup>2</sup>	PE bar 600	PE bar 600	PE bar 600	PE bar 600	PE bar 600
• Conductor cross-section, max. (IEC)	mm <sup>2</sup>	240	240	240	240	240
<b>Cable length, max. <sup>6)</sup></b> Shielded/unshielded		m	2250/3375	2250/3375	2250/3375	2250/3375
<b>Degree of protection</b> (standard version)			IP21	IP21	IP21	IP21
<b>Dimensions</b>						
• Width	mm	1600	1600	1600	1600	1600
• Height	mm	2200	2200	2200	2200	2200
• Depth	mm	600	600	600	600	600
<b>Weight, approx.</b> (standard version)		kg	1150	1365	1520	1540
<b>Frame size</b>						
• Line Connection Module		HL	JL	JL	JL	JL
• Active Interface Module		JIL	JIL	JIL	JIL	JIL
• Active Line Module		HXL	HXL	JXL	JXL	JXL
<b>Short-circuit current rating according to IEC</b>		kA	84	100	100	100
<b>Minimum short-circuit current <sup>7)</sup></b>		A	10500	2000	2000	3200

1) The base-load current  $I_{H\ DC}$  is based on a duty cycle of 150 % for 60 s or  $I_{max\ DC}$  for 5 s with a duty cycle duration of 300 s.

2) The specified power loss represents the maximum value at 100 % utilization. The value is lower under normal operating conditions.

3) The value applies to coolants comprising water and a mixture of water and antifreeze agent.

4) The value is valid for water as coolant. [Additional information and notes on other coolants are provided in the SINAMICS Low Voltage Engineering Manual.](#)

5) Total sound pressure level of Active Interface Module and Active Line Module.

6) Total of all motor cables and DC link. Longer cable lengths for specific configurations are available on request.

7) Current required for reliably triggering protective devices.



## SINAMICS S120 Cabinet Modules

Liquid-cooled units

### Motor Modules

#### Overview



Motor Modules are available in the power range from 90 kW to 1500 kW.

Line voltage	DC link voltage	Type rating
380 ... 480 V 3 AC	510 ... 720 V DC	110 ... 800 kW
500 ... 690 V 3 AC	675 ... 1035 V DC	90 ... 1500 kW

By connecting in parallel up to four Motor Modules, which are operated on one Control Unit and supply one motor, it is possible to increase the available shaft power to max. approx. 5700 kW (taking into account the derating factors according to the SINAMICS Low Voltage Engineering Manual).

The Motor Modules can also be used as Braking Modules (braking chopper) if a 3-phase braking resistor is connected instead of a motor.

For additional information, please refer to the SINAMICS Low Voltage Engineering Manual.

#### Design

Motor Modules contain the following components as standard:

- Retaining device for the DC busbar, including the connection to the DC connections of the Motor Module
- Connection busbars, nickel-plated
  - on Motor Modules, frame size JXL, the connection for the motor cables is routed to the right of the device
  - on Motor Modules, frame size HXL, the connection is underneath the device
- Cable retaining bar for the power cables
- DRIVE-CLiQ interface (three DRIVE-CLiQ sockets), without Control Unit
- Auxiliary power supply system (4-pole) for the auxiliary power supply, including cable connections for looping through to the next Cabinet Module
- Nickel-plated PE bar (60 x 10 mm), including jumper for looping through to the next Cabinet Module
- EMC-compliant design thanks to additional shielding measures and appropriately routed cables

#### Selection and ordering data

Type rating at 400 V or 690 V kW	Rated output current $I_{rated}$ A	Motor Module Article No.
<b>Line voltage 380 ... 480 V 3 AC (DC link voltage 510 ... 720 V DC)</b>		
110	210	<b>6SL3725-1TE32-1AA3</b>
132	260	<b>6SL3725-1TE32-6AA3</b>
160	310	<b>6SL3725-1TE33-1AA3</b>
250	490	<b>6SL3725-1TE35-0AA3</b>
315	605	<b>6SL3725-1TE36-1AA3</b>
400	745	<b>6SL3725-1TE37-5AA3</b>
450	840	<b>6SL3725-1TE38-4AA3</b>
560	985	<b>6SL3725-1TE41-0AA3</b>
710	1260	<b>6SL3725-1TE41-2AA3</b>
800	1405	<b>6SL3725-1TE41-4AA3</b>
800	1330	<b>6SL3725-1TE41-4AS3</b>
<b>Line voltage 500 ... 690 V 3 AC (DC link voltage 675 ... 1035 V DC)</b>		
90	100	<b>6SL3725-1TG31-0AA3</b>
132	150	<b>6SL3725-1TG31-5AA3</b>
200	215	<b>6SL3725-1TG32-2AA3</b>
315	330	<b>6SL3725-1TG33-3AA3</b>
450	465	<b>6SL3725-1TG34-7AA3</b>
560	575	<b>6SL3725-1TG35-8AA3</b>
710	735	<b>6SL3725-1TG37-4AA3</b>
800	810	<b>6SL3725-1TG38-0AA3</b>
800	810	<b>6SL3725-1TG38-1AA3</b>
1000	1025	<b>6SL3725-1TG41-0AA3</b>
1200	1270	<b>6SL3725-1TG41-3AA3</b>
1500	1560	<b>6SL3725-1TG41-6AP3</b>

**Integration**

Motor Modules are controlled by the CU320-2 DP or CU320-2 PN Control Unit. Communication between the Control Unit and Modules is established via a DRIVE-CLiQ connection.

If the Control Unit is integrated in the same cabinet as an option with order code **K90** or **K95**, these communication cables will

already be installed. If the Control Unit is to be mounted externally, the DRIVE-CLiQ cable will not be included in the scope of delivery and must be configured on site.

For additional information, please refer to the [SINAMICS Low Voltage Engineering Manual](#).

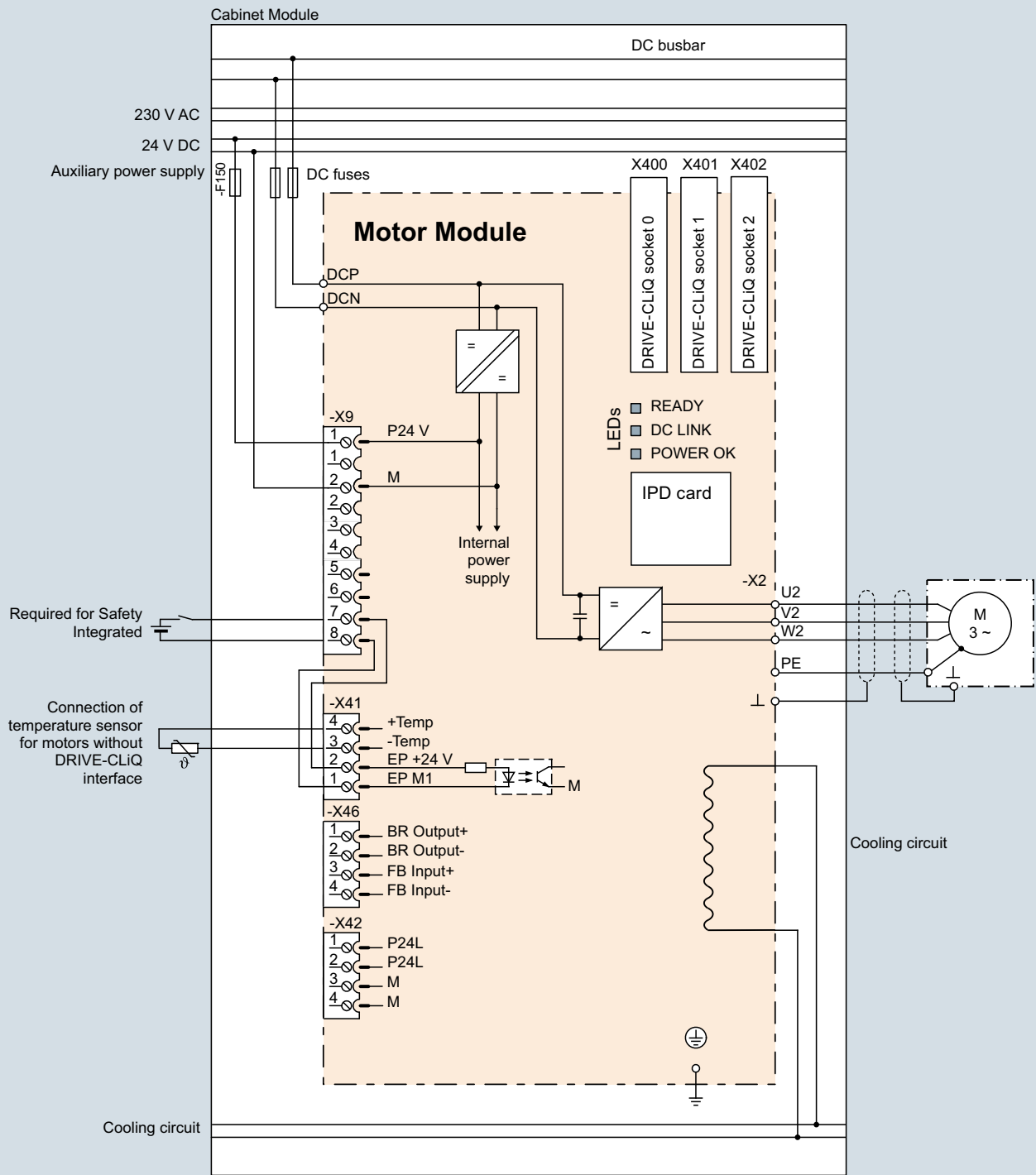

G\_D213\_EN\_00102

Connection example: Motor Module, liquid-cooled

# SINAMICS S120 Cabinet Modules

## Liquid-cooled units

### Motor Modules

#### Technical specifications

Line voltage 380 ... 480 V 3 AC		Motor Modules			
DC link voltage 510 ... 720 V DC		6SL3725-1TE32-1AA3	6SL3725-1TE32-6AA3	6SL3725-1TE33-1AA3	6SL3725-1TE35-0AA3
<b>Type rating</b>					
• At $I_L$ (50 Hz 400 V) <sup>1)</sup>	kW	<b>110</b>	<b>132</b>	<b>160</b>	<b>250</b>
• At $I_H$ (50 Hz 400 V) <sup>1)</sup>	kW	90	110	132	200
• At $I_L$ (60 Hz 460 V) <sup>2)</sup>	hp	150	200	250	400
• At $I_H$ (60 Hz 460 V) <sup>2)</sup>	hp	150	200	200	350
<b>Output current</b>					
• Rated current $I_{rated}$ <sup>3)</sup>	A	210	260	310	490
• Base-load current $I_{L DC}$ <sup>4)</sup>	A	205	250	302	477
• Base-load current $I_{H DC}$ <sup>4)</sup>	A	178	233	277	438
• Maximum current $I_{max O}$	A	307	375	453	715
<b>DC link current</b>					
• Rated current $I_{rated DC}$ when supplied via					
- Basic Line Module	A	256	317	380	600
- Active Line Module	A	230	287	340	538
• Base-load current $I_{L DC}$ <sup>3)</sup> when supplied via					
- Basic Line Module	A	250	305	368	581
- Active Line Module	A	225	274	331	522
• Base-load current $I_{H DC}$ <sup>4)</sup> when supplied via					
- Basic Line Module	A	227	284	338	534
- Active Line Module	A	195	255	303	480
<b>Current demand</b>					
• 24 V DC auxiliary power supply	A	1.3	1.3	1.3	1.3
• 230 V 1 AC	A	0.6	0.6	0.6	0.6
<b>DC link capacitance</b>	µF	4800	5800	8400	9600
<b>Pulse frequency</b> <sup>5)</sup>					
• Rated frequency	kHz	2	2	2	2
• Pulse frequency, max.					
- Without current derating	kHz	2	2	2	2
- With current derating	kHz	8	8	8	8
<b>Power loss, max.</b> <sup>6)</sup> at 50 Hz 400 V					
• Degree of protection <IP55					
- Dissipated to coolant	kW	1.6	1.9	2.2	3.4
- Dissipated to ambient air	kW	0.2	0.2	0.2	0.3
• Degree of protection IP55					
- Dissipated to coolant	kW	1.7	2.1	2.4	3.8
- Dissipated to ambient air	kW	0.2	0.2	0.2	0.2
<b>Coolant volume flow</b> <sup>7)</sup>	l/min	9	9	12	12
All degrees of protection					
<b>Liquid volume</b>	dm <sup>3</sup>	2.9/4.7	2.9/4.7	3.5/5.3	3.5/5.3
Degree of protection <IP55/IP55					
<b>Pressure drop, max.</b> <sup>8)</sup>	Pa	150000	150000	150000	150000
For volume flow					
<b>Heat exchanger material</b>		Stainless steel	Stainless steel	Stainless steel	Stainless steel
<b>Sound pressure level <math>L_{pA}</math></b>	dB	52	52	52	52
(1 m) at 50/60 Hz					
<b>Motor connection</b>		M12	M12	M12	M12
U2, V2, W2					
• Conductor cross-section, max. (IEC)	mm <sup>2</sup>	2 × 95	2 × 95	2 × 240	2 × 240
<b>PE/GND connection</b>		PE bar	PE bar	PE bar	PE bar
• Busbar cross-section	mm <sup>2</sup>	600	600	600	600
• Conductor cross-section, max. (IEC)	mm <sup>2</sup>	240	240	240	240
<b>Cable length, max.</b> <sup>9)</sup>	m	300/450	300/450	300/450	300/450
Shielded/unshielded					
<b>Degree of protection (standard version)</b>		IP21	IP21	IP21	IP21
<b>Dimensions</b>					
• Width	mm	400	400	400	400
• Height	mm	2200	2200	2200	2200
• Depth	mm	600	600	600	600
<b>Weight, approx.</b>	kg	280	280	320	320
<b>Frame size</b>		FXL	FXL	GXL	GXL
<b>Short-circuit current rating acc. to IEC</b>	kA	65	65	65	65

<sup>1)</sup> Rated output of a typical 6-pole standard induction motor based on  $I_L$  or  $I_H$  for 400 V 3 AC 50 Hz.

<sup>2)</sup> Rated output of a typical 6-pole standard induction motor based on  $I_L$  or  $I_H$  for 460 V 3 AC 60 Hz.

<sup>3)</sup> The base-load current  $I_L$  is based on a duty cycle of 110 % for 60 s or 150 % for 10 s with a duty cycle duration of 300 s.

<sup>4)</sup> The base-load current  $I_H$  is based on a duty cycle of 150 % for 60 s or 160 % for 10 s with a duty cycle duration of 300 s.

<sup>5)</sup> Information regarding the correlation between the pulse frequency and max. output current/output frequency is provided in the SINAMICS Low Voltage Engineering Manual.

<sup>6)</sup> The specified power loss represents the maximum value at 100 % utilization. The value is lower under normal operating conditions.

<sup>7)</sup> The value applies to coolants comprising water and a mixture of water and antifreeze agent.

<sup>8)</sup> The value is valid for water as coolant. [Additional information and notes on other coolants are provided in the SINAMICS Low Voltage Engineering Manual.](#)

<sup>9)</sup> Total of all motor cables. Longer cable lengths for specific configurations are available on request. [For additional information, please refer to the SINAMICS Low Voltage Engineering Manual.](#)

### Technical specifications (continued)

Line voltage 380 ... 480 V 3 AC		Motor Modules		
DC link voltage 510 ... 720 V DC		6SL3725-1TE36-1AA3	6SL3725-1TE37-5AA3	6SL3725-1TE38-4AA3
<b>Type rating</b>				
• At $I_L$ (50 Hz 400 V) <sup>1)</sup>	kW	<b>315</b>	<b>400</b>	<b>450</b>
• At $I_H$ (50 Hz 400 V) <sup>1)</sup>	kW	250	315	400
• At $I_L$ (60 Hz 460 V) <sup>2)</sup>	hp	500	600	700
• At $I_H$ (60 Hz 460 V) <sup>2)</sup>	hp	350	450	600
<b>Output current</b>				
• Rated current $I_{rated O}$	A	605	745	840
• Base-load current $I_{L DC}^{3)}$	A	590	725	820
• Base-load current $I_{H DC}^{4)}$	A	460	570	700
• Maximum current $I_{max O}$	A	885	1087	1230
<b>DC link current</b>				
• Rated current $I_{rated DC}$ when supplied via	A			
- Basic Line Module	A	738	894	1025
- Active Line Module	A	664	805	922
• Base-load current $I_{L DC}^{3)}$ when supplied via	A			
- Basic Line Module	A	719	871	1000
- Active Line Module	A	646	784	898
• Base-load current $I_{H DC}^{4)}$ when supplied via	A			
- Basic Line Module	A	561	795	853
- Active Line Module	A	504	716	767
<b>Current demand</b>				
• 24 V DC auxiliary power supply	A	1.6	1.6	1.6
• 230 V 1 AC	A	0.6	0.6	0.6
<b>DC link capacitance</b>				
	μF	12600	17400	17400
<b>Pulse frequency <sup>5)</sup></b>				
• Rated frequency	kHz	1.25	1.25	1.25
• Pulse frequency, max.	kHz			
- Without current derating	kHz	1.25	1.25	1.25
- With current derating	kHz	7.5	7.5	7.5
<b>Power loss, max. <sup>6)</sup></b>				
at 50 Hz 400 V				
• Degree of protection <IP55				
- Dissipated to coolant	kW	4.6	5.2	5.5
- Dissipated to ambient air	kW	0.6	0.7	0.8
• Degree of protection IP55				
- Dissipated to coolant	kW	5.0	5.7	6.2
- Dissipated to ambient air	kW	0.2	0.2	0.2
<b>Coolant volume flow <sup>7)</sup></b>				
All degrees of protection	l/min	16	16	16
<b>Liquid volume</b>				
Degree of protection <IP55/IP55	dm <sup>3</sup>	3.3/5.1	3.3/5.1	3.3/5.1
<b>Pressure drop, max. <sup>8)</sup></b>				
For volume flow	Pa	150000	150000	150000
<b>Heat exchanger material</b>				
		Aluminum	Aluminum	Aluminum
<b>Sound pressure level <math>L_{pA}</math></b>				
(1 m) at 50/60 Hz	dB	54	54	54
<b>Motor connection</b>				
U2, V2, W2		2/M12	2/M12	2/M12
• Conductor cross-section, max. (IEC)	mm <sup>2</sup>	4 × 185	4 × 185	4 × 185
<b>PE/GND connection</b>				
• Busbar cross-section	mm <sup>2</sup>	PE bar 600	PE bar 600	PE bar 600
• Conductor cross-section, max. (IEC)	mm <sup>2</sup>	240	240	240
<b>Cable length, max. <sup>9)</sup></b>				
Shielded/unshielded	m	300/450	300/450	300/450
<b>Degree of protection (standard version)</b>				
		IP21	IP21	IP21
<b>Dimensions</b>				
• Width	mm	400	400	400
• Height	mm	2200	2200	2200
• Depth	mm	600	600	600
<b>Weight, approx.</b>				
	kg	350	350	350
<b>Frame size</b>				
		HXL	HXL	HXL
<b>Short-circuit current rating according to IEC</b>				
	kA	65	65	84

<sup>1)</sup> Rated output of a typical 6-pole standard induction motor based on  $I_L$  or  $I_H$  for 400 V 3 AC 50 Hz.

<sup>2)</sup> Rated output of a typical 6-pole standard induction motor based on  $I_L$  or  $I_H$  for 460 V 3 AC 60 Hz.

<sup>3)</sup> The base-load current  $I_L$  is based on a duty cycle of 110 % for 60 s or 150 % for 10 s with a duty cycle duration of 300 s.

<sup>4)</sup> The base-load current  $I_H$  is based on a duty cycle of 150 % for 60 s or 160 % for 10 s with a duty cycle duration of 300 s.

<sup>5)</sup> Information regarding the correlation between the pulse frequency and max. output current/output frequency is provided in the SINAMICS Low Voltage Engineering Manual.

<sup>6)</sup> The specified power loss represents the maximum value at 100 % utilization. The value is lower under normal operating conditions.

<sup>7)</sup> The value applies to coolants comprising water and a mixture of water and antifreeze agent.

<sup>8)</sup> The value is valid for water as coolant. [Additional information and notes on other coolants are provided in the SINAMICS Low Voltage Engineering Manual.](#)

<sup>9)</sup> Total of all motor cables. Longer cable lengths for specific configurations are available on request. [For additional information, please refer to the SINAMICS Low Voltage Engineering Manual.](#)

# SINAMICS S120 Cabinet Modules

## Liquid-cooled units

### Motor Modules

#### Technical specifications (continued)

Line voltage 380 ... 480 V 3 AC		Motor Modules			
DC link voltage 510 ... 720 V DC		6SL3725-1TE41-0AA3	6SL3725-1TE41-2AA3	6SL3725-1TE41-4AA3	6SL3725-1TE41-4AS3 <sup>10)</sup>
<b>Type rating</b>					
• At $I_L$ (50 Hz 400 V) <sup>1)</sup>	kW	<b>560</b>	<b>710</b>	<b>800</b>	<b>800</b>
• At $I_H$ (50 Hz 400 V) <sup>1)</sup>	kW	450	630	710	630
• At $I_L$ (60 Hz 460 V) <sup>2)</sup>	hp	800	1000	1150	1000
• At $I_H$ (60 Hz 460 V) <sup>2)</sup>	hp	700	900	1000	900
<b>Output current</b>					
• Rated current $I_{rated, G}$	A	985	1260	1405	1330
• Base-load current $I_{L DC}$ <sup>3)</sup>	A	960	1230	1370	1310
• Base-load current $I_{H DC}$ <sup>4)</sup>	A	860	1127	1257	1150
• Maximum current $I_{max O}$	A	1440	1845	2055	2055
<b>DC link current</b>					
• Rated current $I_{rated DC}$ when supplied via					
- Basic Line Module	A	1202	1512	1714	1550
- Active Line Module	A	1080	1361	1544	1403
• Base-load current $I_{L DC}$ <sup>3)</sup> when supplied via					
- Basic Line Module	A	1170	1474	1670	1525
- Active Line Module	A	1051	1326	1500	1405
• Base-load current $I_{H DC}$ <sup>4)</sup> when supplied via					
- Basic Line Module	A	1048	1345	1532	1676
- Active Line Module	A	942	1211	1377	1403
<b>Current demand</b>					
• 24 V DC auxiliary power supply	A	1.46	1.46	1.46	1.46
• 230 V 1 AC	A	0.6	0.6	0.6	0.6
<b>DC link capacitance</b>		μF	21000	29000	29000
<b>Pulse frequency <sup>5)</sup></b>					
• Rated frequency	kHz	1.25	1.25	1.25	2
• Pulse frequency, max.					
- Without current derating	kHz	1.25	1.25	1.25	2
- With current derating	kHz	7.5	7.5	7.5	4
<b>Power loss, max. <sup>6)</sup></b>					
at 50 Hz 400 V					
• Degree of protection <IP55					
- Dissipated to coolant	kW	7.5	8.6	9.5	10.2
- Dissipated to ambient air	kW	1.0	1.3	1.5	1.4
• Degree of protection IP55					
- Dissipated to coolant	kW	8.3	9.6	10.7	11.3
- Dissipated to ambient air	kW	0.2	0.3	0.3	0.3
<b>Coolant volume flow <sup>7)</sup></b>		l/min	27	27	27
All degrees of protection					
<b>Liquid volume</b>		dm <sup>3</sup>	5.2/7	5.2/7	5.2/7
Degree of protection <IP55/IP55					
<b>Pressure drop, max. <sup>8)</sup></b>		Pa	150000	150000	150000
For volume flow					
<b>Heat exchanger material</b>			Aluminum	Aluminum	Aluminum
<b>Sound pressure level <math>L_{pA}</math></b>		dB	56	56	56
(1 m) at 50/60 Hz					
<b>Motor connection</b>			2/M12	2/M12	2/M12
U2, V2, W2					
• Conductor cross-section, max. (IEC)	mm <sup>2</sup>	4 × 240	4 × 240	4 × 240	4 × 240
<b>PE/GND connection</b>					
• Busbar cross-section	mm <sup>2</sup>	PE bar 600	PE bar 600	PE bar 600	PE bar 600
• Conductor cross-section, max. (IEC)	mm <sup>2</sup>	240	240	240	240
<b>Cable length, max. <sup>9)</sup></b>		m	300/450	300/450	300/450
Shielded/unshielded					
<b>Degree of protection (standard version)</b>			IP21	IP21	IP21
<b>Dimensions</b>					
• Width	mm	600	600	600	600
• Height	mm	2200	2200	2200	2200
• Depth	mm	600	600	600	600
<b>Weight, approx.</b>		kg	460	460	470
<b>Frame size</b>			JXL	JXL	JXL
<b>Short-circuit current rating according to IEC</b>		kA	84	100	100

<sup>1)</sup> Rated output of a typical 6-pole standard induction motor based on  $I_L$  or  $I_H$  for 400 V 3 AC 50 Hz.

<sup>2)</sup> Rated output of a typical 6-pole standard induction motor based on  $I_L$  or  $I_H$  for 460 V 3 AC 60 Hz.

<sup>3)</sup> The base-load current  $I_L$  is based on a duty cycle of 110 % for 60 s or 150 % for 10 s with a duty cycle duration of 300 s.

<sup>4)</sup> The base-load current  $I_H$  is based on a duty cycle of 150 % for 60 s or 160 % for 10 s with a duty cycle duration of 300 s.

<sup>5)</sup> Information regarding the correlation between the pulse frequency and max. output current/output frequency is provided in the SINAMICS Low Voltage Engineering Manual.

<sup>6)</sup> The specified power loss represents the maximum value at 100 % utilization. The value is lower under normal operating conditions.

<sup>7)</sup> The value applies to coolants comprising water and a mixture of water and antifreeze agent.

<sup>8)</sup> The value is valid for water as coolant. Additional information and notes on other coolants are provided in the SINAMICS Low Voltage Engineering Manual.

<sup>9)</sup> Total of all motor cables. Longer cable lengths for specific configurations are available on request. For additional information, please refer to the SINAMICS Low Voltage Engineering Manual.

<sup>10)</sup> This Motor Module has been specifically designed for loads demanding a high dynamic performance. The derating factor  $k_{IGBT}$  and the derating characteristics can be ignored (see section "Duty cycles" in the SINAMICS Low Voltage Engineering Manual).

### Technical specifications (continued)

Line voltage 500 ... 690 V 3 AC		Motor Modules			
DC link voltage 675 ... 1035 V DC		6SL3725-1TG31-0AA3	6SL3725-1TG31-5AA3	6SL3725-1TG32-2AA3	6SL3725-1TG33-3AA3
<b>Type rating</b>					
• At $I_L$ (50 Hz 690 V) <sup>1)</sup>	kW	90	132	200	315
• At $I_H$ (50 Hz 690 V) <sup>1)</sup>	kW	75	110	160	250
• At $I_L$ (50 Hz 500 V) <sup>1)</sup>	kW	55	90	132	200
• At $I_H$ (50 Hz 500 V) <sup>1)</sup>	kW	55	90	132	200
• At $I_L$ (60 Hz 575 V) <sup>2)</sup>	hp	75	150	200	300
• At $I_H$ (60 Hz 575 V) <sup>2)</sup>	hp	75	125	200	250
<b>Output current</b>					
• Rated current $I_{rated Q_3}$	A	100	150	215	330
• Base-load current $I_L$ <sup>3)</sup>	A	95	142	208	320
• Base-load current $I_H$ <sup>4)</sup>	A	89	134	192	280
• Maximum current $I_{max O}$	A	142	213	312	480
<b>DC link current</b>					
• Rated current $I_{rated DC}$ when supplied via					
- Basic Line Module	A	122	183	263	403
- Active Line Module	A	110	165	237	363
• Base-load current $I_{L DC}$ <sup>3)</sup> when supplied via					
- Basic Line Module	A	116	173	253	390
- Active Line Module	A	105	156	229	352
• Base-load current $I_{H DC}$ <sup>4)</sup> when supplied via					
- Basic Line Module	A	108	163	234	341
- Active Line Module	A	98	147	211	308
<b>Current demand</b>					
• 24 V DC auxiliary power supply	A	1.0	1.0	1.5	1.5
• 230 V 1 AC	A	0.6	0.6	0.6	0.6
<b>DC link capacitance</b>					
	μF	2800	2800	4200	5800
<b>Pulse frequency <sup>5)</sup></b>					
• Rated frequency	kHz	1.25	1.25	1.25	1.25
• Pulse frequency, max.					
- Without current derating	kHz	1.25	1.25	1.25	1.25
- With current derating	kHz	7.5	7.5	7.5	7.5
<b>Power loss, max. <sup>6)</sup></b>					
at 50 Hz 690 V					
• Degree of protection <IP55					
- Dissipated to coolant	kW	1.1	1.6	2.3	3.3
- Dissipated to ambient air	kW	0.1	0.1	0.2	0.3
• Degree of protection IP55					
- Dissipated to coolant	kW	1.2	1.7	2.4	3.5
- Dissipated to ambient air	kW	0.1	0.1	0.2	0.2
<b>Coolant volume flow <sup>7)</sup></b>					
All degrees of protection	l/min	9	9	12	12
<b>Liquid volume</b>					
Degree of protection <IP55/IP55	dm <sup>3</sup>	2.9/4.7	2.9/4.7	3.5/5.3	3.5/5.3
<b>Pressure drop, max. <sup>8)</sup></b>					
For volume flow	Pa	150000	150000	150000	150000
<b>Heat exchanger material</b>					
		Stainless steel	Stainless steel	Stainless steel	Stainless steel
<b>Sound pressure level <math>L_{pA}</math></b>					
(1 m) at 50/60 Hz	dB	52	52	52	52
<b>Motor connection</b>					
U2, V2, W2		M12	M12	M12	M12
• Conductor cross-section, max. (IEC)	mm <sup>2</sup>	2 × 95	2 × 95	2 × 240	2 × 240
<b>PE/GND connection</b>					
• Busbar cross-section	mm <sup>2</sup>	PE bar 600	PE bar 600	PE bar 600	PE bar 600
• Conductor cross-section, max. (IEC)	mm <sup>2</sup>	240	240	240	240
<b>Cable length, max. <sup>9)</sup></b>					
Shielded/unshielded	m	300/450	300/450	300/450	300/450
<b>Degree of protection (standard version)</b>					
		IP21	IP21	IP21	IP21
<b>Dimensions</b>					
• Width	mm	400	400	400	400
• Height	mm	2200	2200	2200	2200
• Depth	mm	600	600	600	600
<b>Weight, approx.</b>					
	kg	280	280	320	320
<b>Frame size</b>					
		FXL	FXL	GXL	GXL
<b>Short-circuit current rating according to IEC</b>					
	kA	65	65	65	65

<sup>1)</sup> Rated output of a typical 6-pole standard induction motor based on  $I_L$  or  $I_H$  for 500 V or 690 V 3 AC 50 Hz.

<sup>2)</sup> Rated output of a typical 6-pole standard induction motor based on  $I_L$  or  $I_H$  for 575 V 3 AC 60 Hz.

<sup>3)</sup> The base-load current  $I_L$  is based on a duty cycle of 110 % for 60 s or 150 % for 10 s with a duty cycle duration of 300 s.

<sup>4)</sup> The base-load current  $I_H$  is based on a duty cycle of 150 % for 60 s or 160 % for 10 s with a duty cycle duration of 300 s.

<sup>5)</sup> Information regarding the correlation between the pulse frequency and max. output current/output frequency is provided in the SINAMICS Low Voltage Engineering Manual.

<sup>6)</sup> The specified power loss represents the maximum value at 100 % utilization. The value is lower under normal operating conditions.

<sup>7)</sup> The value applies to coolants comprising water and a mixture of water and antifreeze agent.

<sup>8)</sup> The value is valid for water as coolant. [Additional information and notes on other coolants are provided in the SINAMICS Low Voltage Engineering Manual.](#)

<sup>9)</sup> Total of all motor cables. Longer cable lengths for specific configurations are available on request. [For additional information, please refer to the SINAMICS Low Voltage Engineering Manual.](#)

# SINAMICS S120 Cabinet Modules

## Liquid-cooled units

### Motor Modules

#### Technical specifications (continued)

Line voltage 500 ... 690 V 3 AC		Motor Modules			
DC link voltage 675 ... 1035 V DC		6SL3725-1TG34-7AA3	6SL3725-1TG35-8AA3	6SL3725-1TG37-4AA3	6SL3725-1TG38-0AA3 <sup>10)</sup>
<b>Type rating</b>					
• At $I_L$ (50 Hz 690 V) <sup>1)</sup>	kW	450	560	710	800
• At $I_H$ (50 Hz 690 V) <sup>1)</sup>	kW	400	450	630	710
• At $I_L$ (50 Hz 500 V) <sup>1)</sup>	kW	315	400	500	560
• At $I_H$ (50 Hz 500 V) <sup>1)</sup>	kW	250	315	450	500
• At $I_L$ (60 Hz 575 V) <sup>2)</sup>	hp	450	600	700	800
• At $I_H$ (60 Hz 575 V) <sup>2)</sup>	hp	450	500	700	700
<b>Output current</b>					
• Rated current $I_{rated, Q3}$	A	465	575	735	810
• Base-load current $I_{L DC}$ <sup>3)</sup>	A	452	560	710	790
• Base-load current $I_{H DC}$ <sup>4)</sup>	A	416	514	657	724
• Maximum current $I_{max, O}$	A	678	840	1065	1185
<b>DC link current</b>					
• Rated current $I_{rated DC}$ when supplied via					
- Basic Line Module	A	558	702	903	990
- Active Line Module	A	502	632	808	891
• Base-load current $I_{L DC}$ <sup>3)</sup> when supplied via					
- Basic Line Module	A	544	683	870	948
- Active Line Module	A	489	616	781	870
• Base-load current $I_{H DC}$ <sup>4)</sup> when supplied via					
- Basic Line Module	A	496	627	795	885
- Active Line Module	A	446	565	732	808
<b>Current demand</b>					
• 24 V DC auxiliary power supply	A	1.6	1.6	1.6	1.6
• 230 V 1 AC	A	0.6	0.6	0.6	0.6
<b>DC link capacitance</b>					
	μF	9670	9670	10500	10500
<b>Pulse frequency <sup>5)</sup></b>					
• Rated frequency	kHz	1.25	1.25	1.25	1.25
• Pulse frequency, max.					
- Without current derating	kHz	1.25	1.25	1.25	1.25
- With current derating	kHz	7.5	7.5	7.5	7.5
<b>Power loss, max. <sup>6)</sup></b>					
at 50 Hz 690 V					
• Degree of protection <IP55					
- Dissipated to coolant	kW	5.3	5.5	7.5	8.3
- Dissipated to ambient air	kW	0.4	0.5	0.6	0.7
• Degree of protection IP55					
- Dissipated to coolant	kW	5.6	5.8	7.9	8.8
- Dissipated to ambient air	kW	0.2	0.2	0.2	0.2
<b>Coolant volume flow <sup>7)</sup></b>					
All degrees of protection	l/min	16	16	16	16
<b>Liquid volume</b>					
Degree of protection <IP55/IP55	dm <sup>3</sup>	3.3/5.1	3.3/5.1	3.3/5.1	3.3/5.1
<b>Pressure drop, max. <sup>8)</sup></b>					
For volume flow	Pa	150000	150000	150000	150000
<b>Heat exchanger material</b>					
		Aluminum	Aluminum	Aluminum	Aluminum
<b>Sound pressure level <math>L_{pA}</math></b>					
(1 m) at 50/60 Hz	dB	54	54	54	54
<b>Motor connection</b>					
U2, V2, W2		2/M12	2/M12	2/M12	2/M12
• Conductor cross-section, max. (IEC)	mm <sup>2</sup>	4 × 185	4 × 185	4 × 185	4 × 185
<b>PE/GND connection</b>					
• Busbar cross-section	mm <sup>2</sup>	PE bar 600	PE bar 600	PE bar 600	PE bar 600
• Conductor cross-section, max. (IEC)	mm <sup>2</sup>	240	240	240	240
<b>Cable length, max. <sup>9)</sup></b>					
Shielded/unshielded	m	300/450	300/450	300/450	300/450
<b>Degree of protection (standard version)</b>					
		IP21	IP21	IP21	IP21
<b>Dimensions</b>					
• Width	mm	400	400	400	400
• Height	mm	2200	2200	2200	2200
• Depth	mm	600	600	600	600
<b>Weight, approx.</b>					
	kg	350	350	350	350
<b>Frame size</b>					
		HXL	HXL	HXL	HXL
<b>Short-circuit current rating according to IEC</b>					
	kA	84	84	100	100

<sup>1)</sup> Rated output of a typical 6-pole standard induction motor based on  $I_L$  or  $I_H$  for 500 V or 690 V 3 AC 50 Hz.

<sup>2)</sup> Rated output of a typical 6-pole standard induction motor based on  $I_L$  or  $I_H$  for 575 V 3 AC 60 Hz.

<sup>3)</sup> The base-load current  $I_L$  is based on a duty cycle of 110 % for 60 s or 150 % for 10 s with a duty cycle duration of 300 s.

<sup>4)</sup> The base-load current  $I_H$  is based on a duty cycle of 150 % for 60 s or 160 % for 10 s with a duty cycle duration of 300 s.

<sup>5)</sup> Information regarding the correlation between the pulse frequency and max. output current/output frequency is provided in the SINAMICS Low Voltage Engineering Manual.

<sup>6)</sup> The specified power loss represents the maximum value at 100 % utilization. The value is lower under normal operating conditions.

<sup>7)</sup> The value applies to coolants comprising water and a mixture of water and antifreeze agent.

<sup>8)</sup> The value is valid for water as coolant. [Additional information and notes on other coolants are provided in the SINAMICS Low Voltage Engineering Manual.](#)

<sup>9)</sup> Total of all motor cables. Longer cable lengths for specific configurations are available on request. [For additional information, please refer to the SINAMICS Low Voltage Engineering Manual.](#)

<sup>10)</sup> The device is optimized for a base pulse frequency of 1.25 kHz. For an increased pulse frequency or for certain overloads, the derating factor is higher than that for the device with article number 6SL3325-1TG38-1AAx.



### Technical specifications (continued)

Line voltage 500 ... 690 V 3 AC		Motor Modules				
DC link voltage 675 ... 1035 V DC		6SL3725-1TG38-1AA3	6SL3725-1TG41-0AA3	6SL3725-1TG41-3AA3	6SL3725-1TG41-6AP3 <sup>10)</sup>	
<b>Type rating</b>						
• At $I_L$ (50 Hz 690 V) <sup>1)</sup>	kW	800	1000	1200	1500	
• At $I_H$ (50 Hz 690 V) <sup>1)</sup>	kW	710	900	1000	1260	
• At $I_L$ (50 Hz 500 V) <sup>1)</sup>	kW	560	710	900	1000	
• At $I_H$ (50 Hz 500 V) <sup>1)</sup>	kW	560	630	800	900	
• At $I_L$ (60 Hz 575 V) <sup>2)</sup>	hp	800	1000	1250	1500	
• At $I_H$ (60 Hz 575 V) <sup>2)</sup>	hp	700	900	1000	1250	
<b>Output current</b>						
• Rated current $I_{rated}$ <sup>3)</sup>	A	810	1025	1270	1560	
• Base-load current $I_{L DC}$ <sup>4)</sup>	A	790	1000	1230	1500	
• Base-load current $I_{H DC}$	A	724	917	1136	1370	
• Maximum current $I_{max O}$	A	1185	1500	1845	2250	
<b>DC link current</b>						
• Rated current $I_{rated DC}$ when supplied via	A					
- Basic Line Module	A	990	1250	1550	1903	
- Active Line Module	A	891	1125	1395	1714	
• Base-load current $I_{L DC}$ <sup>3)</sup> when supplied via	A					
- Basic Line Module	A	963	1219	1500	1800	
- Active Line Module	A	869	1100	1353	1650	
• Base-load current $I_{H DC}$ <sup>4)</sup> when supplied via	A					
- Basic Line Module	A	883	1118	1384	1680	
- Active Line Module	A	796	1009	1250	1550	
<b>Current demand</b>						
• 24 V DC auxiliary power supply	A	1.46	1.46	1.46	1.46	
• 230 V 1 AC	A	0.6	0.6	0.6	0.6	
<b>DC link capacitance</b>		μF	14000	16000	19330	21000
<b>Pulse frequency <sup>5)</sup></b>						
• Rated frequency	kHz	1.25	1.25	1.25	1.25	
• Pulse frequency, max.	kHz					
- Without current derating	kHz	1.25	1.25	1.25	1.25	
- With current derating	kHz	7.5	7.5	7.5	7.5	
<b>Power loss, max. <sup>6)</sup></b>						
At 50 Hz 690 V						
• Degree of protection <IP55						
- Dissipated to coolant	kW	9.0	10.0	12.9	17.1	
- Dissipated to ambient air	kW	1.1	1.2	1.4	1.6	
• Degree of protection IP55						
- Dissipated to coolant	kW	9.8	11.2	14.0	18.4	
- Dissipated to ambient air	kW	0.3	0.3	0.3	0.3	
<b>Coolant volume flow <sup>7)</sup></b>		l/min	27	27	27	27
All degrees of protection						
<b>Liquid volume</b>		dm <sup>3</sup>	5.2/7	5.2/7	5.2/7	5.2/7
Degree of protection <IP55/IP55						
<b>Pressure drop, max. <sup>8)</sup></b>		Pa	150000	150000	150000	150000
For volume flow						
<b>Heat exchanger material</b>			Aluminum	Aluminum	Aluminum	Aluminum
<b>Sound pressure level <math>L_{pA}</math></b>		dB	56	56	56	56
(1 m) at 50/60 Hz						
<b>Motor connection</b>			2/M12	2/M12	2/M12	2/M12
U2, V2, W2						
• Conductor cross-section, max. (IEC)	mm <sup>2</sup>	4 × 240	4 × 240	4 × 240	4 × 240	
<b>PE/GND connection</b>			PE bar	PE bar	PE bar	PE bar
• Busbar cross-section	mm <sup>2</sup>	600	600	600	600	
• Conductor cross-section, max. (IEC)	mm <sup>2</sup>	240	240	240	240	
<b>Cable length, max. <sup>9)</sup></b>		m	300/450	300/450	300/450	300/450
Shielded/unshielded						
<b>Degree of protection (standard version)</b>			IP21	IP21	IP21	IP21
<b>Dimensions</b>						
• Width	mm	600	600	600	600	
• Height	mm	2200	2200	2200	2200	
• Depth	mm	600	600	600	600	
<b>Weight, approx.</b>		kg	460	460	460	480
<b>Frame size</b>			JXL	JXL	JXL	JXL
<b>Short-circuit current rating according to IEC</b>		kA	100	100	100	100

<sup>1)</sup> Rated output of a typical 6-pole standard induction motor based on  $I_L$  or  $I_H$  for 500 V or 690 V 3 AC 50 Hz.

<sup>2)</sup> Rated output of a typical 6-pole standard induction motor based on  $I_L$  or  $I_H$  for 575 V 3 AC 60 Hz.

<sup>3)</sup> The base-load current  $I_L$  is based on a duty cycle of 110 % for 60 s or 150 % for 10 s with a duty cycle duration of 300 s.

<sup>4)</sup> The base-load current  $I_H$  is based on a duty cycle of 150 % for 60 s or 160 % for 10 s with a duty cycle duration of 300 s.

<sup>5)</sup> Information regarding the correlation between the pulse frequency and max. output current/output frequency is provided in the SINAMICS Low Voltage Engineering Manual.

<sup>6)</sup> The specified power loss represents the maximum value at 100 % utilization. The value is lower under normal operating conditions.

<sup>7)</sup> The value applies to coolants comprising water and a mixture of water and antifreeze agent.

<sup>8)</sup> The value is valid for water as coolant. Additional information and notes on other coolants are provided in the SINAMICS Low Voltage Engineering Manual.

<sup>9)</sup> Total of all motor cables. Longer cable lengths for specific configurations are available on request. For additional information, please refer to the SINAMICS Low Voltage Engineering Manual.

<sup>10)</sup> Additional duty cycle for output frequencies from 5 Hz to 10 Hz: Base-load current = 1460 A, short-time current = 2340 A for 5 s with a duty cycle duration of 600 s. For output frequencies from 1 Hz to 5 Hz, the short-time current is 1900 A for 5 s.



## SINAMICS S120 Cabinet Modules

Liquid-cooled units

### Auxiliary Power Supply Modules

#### Overview



Auxiliary Power Supply Modules supply the auxiliary power supply system for the SINAMICS S120 Cabinet Modules as well as additional external loads. The heat exchangers, which are installed in the Cabinet Modules with degree of protection IP55, are one of the connections to the auxiliary power supply system. In addition, the auxiliary power supply system supplies the electronic modules with an external voltage of 24 V DC. This is required when the DC link is not charged, for instance, in order to maintain PROFIBUS/PROFINET communication.

The Auxiliary Power Supply Module provides an expansion to the option **K76** (auxiliary voltage generating unit in the Line Connection Module) if higher power ratings are required.

#### Design

The Auxiliary Power Supply Module is connected in the customer's plant to a voltage corresponding to the respective rated unit voltage.

The standard version contains the following components:

- Fuse switch disconnecter with fuse monitoring for external evaluation
- Supply of auxiliary power supply system with 2 auxiliary voltages:
  - 24 V DC for the electronics power supply
  - 230 V 2 AC to supply 230 V loads
- Transformer with 230 V output voltage
- SITOP 24 V DC power supply
- Nickel-plated PE bar (60 mm × 10 mm), including jumper for looping through to the next Cabinet Module

#### Selection and ordering data

Plant-side power supply  
(380 ... 690 V 3 AC)

A  
25

**Auxiliary Power Supply  
Module**

Article No.

**6SL3705-0MX22-0AA3**

**Integration**

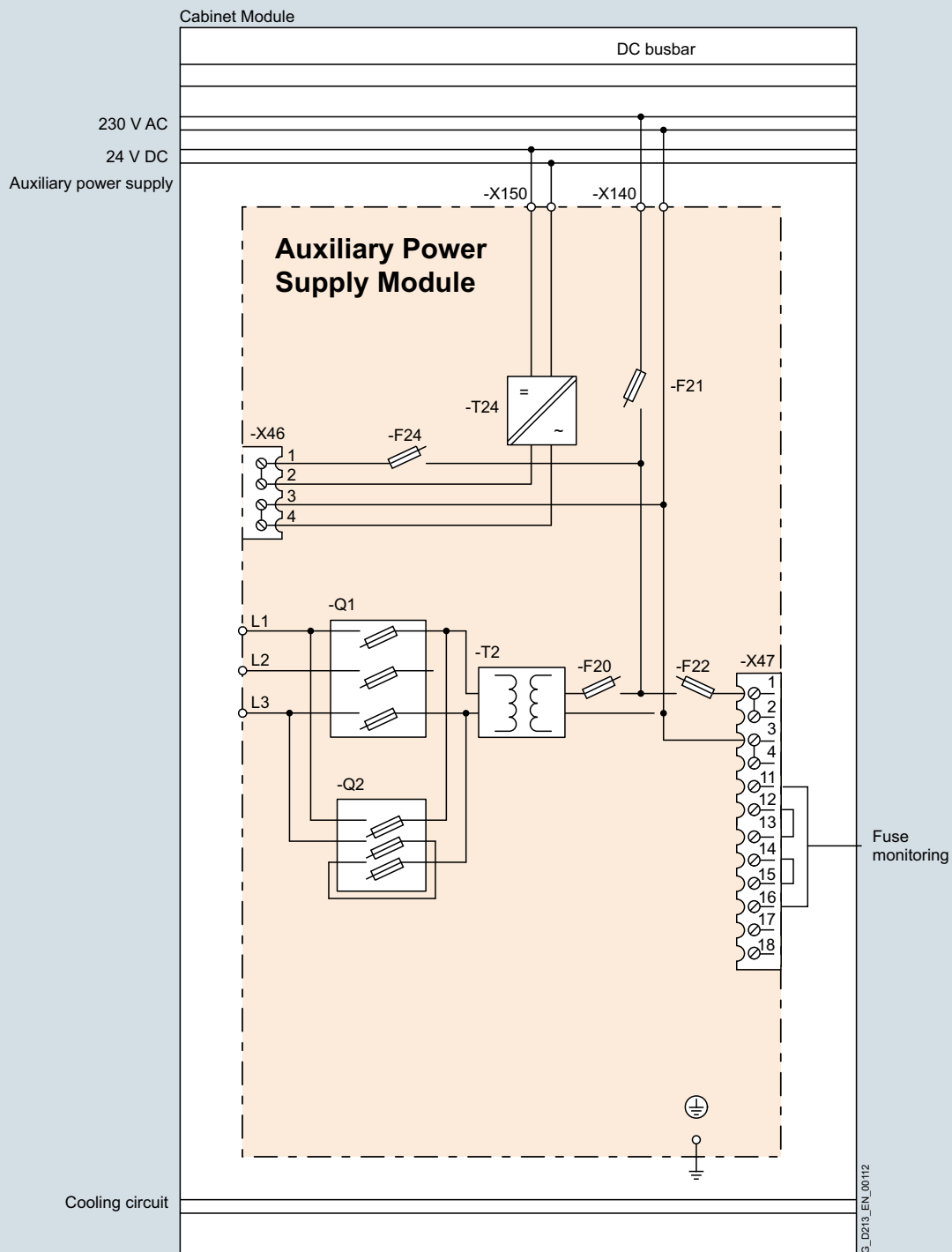

Connection example: Auxiliary Power Supply Module, liquid-cooled

## SINAMICS S120 Cabinet Modules

### Liquid-cooled units

#### Auxiliary Power Supply Modules

##### Technical specifications

		<b>Auxiliary Power Supply Module</b> 6SL3705-0MX22-0AA3	
<b>Plant-side power supply</b> 380 ... 690 V 3 AC	A		<b>25</b>
<b>Line supply connection</b>			
• Conductor cross-section, max. (IEC)	mm <sup>2</sup>	70	
• Recommended conductor cross-section	mm <sup>2</sup>	6	
<b>Current carrying capacity, max.</b>			
• Load connection 230 V 2 AC			
- To auxiliary power supply	A	10	
- To customer terminal -X47	A	10	
• Load connection 24 V DC			
- To auxiliary power supply	A	20	
<b>Cable cross-section, max.</b>			
• Connection -X47	mm <sup>2</sup>	2.5	
<b>Cooling air requirement</b>		Natural convection	
<b>PE/GND connection</b>		PE bar	
• Busbar cross-section	mm <sup>2</sup>	600	
• Conductor cross-section, max. (IEC)	mm <sup>2</sup>	240	
<b>Degree of protection</b>		IP21	
<b>Dimensions</b>			
• Width	mm	600	
• Height	mm	2200	
• Depth	mm	600	
<b>Weight, approx.</b>	kg	160	
<b>Short-circuit current rating acc. to IEC</b>	kA	80	
<b>Minimum short-circuit current <sup>1)</sup></b>	A	400	

<sup>1)</sup> Current required to ensure reliable tripping of installed protective devices.

### Overview



Heat Exchanger Modules are used to dissipate the power loss from the converter. They comprise a deionized water circuit on the converter side and a raw water circuit on the plant side.

The hot deionized water in the circuit on the converter side passes through a low-maintenance circulating pump (2 redundant pumps with option **W01**) into the water/water plate-type heat exchanger. This is made of stainless steel and connected to the raw water circuit on the plant side. The deionized water is cooled there by the raw water of the outer circuit and flows back into the drive.

The closed converter-side deionized water circuit is filled with coolant in accordance with the requirements in section "Cooling circuit and coolant quality" and deaerated before commissioning. The pressure is maintained by means of an expansion chamber. Any residual air that arises in the circuit during operation is removed via automatic vents.

To avoid condensation at excessively low coolant temperatures, a 3-way valve for controlling the coolant temperature is installed.

The Heat Exchanger Modules are controlled and monitored in the external CU320-2 Control Unit as "Technology Extension HEM". This means that the Heat Exchanger Modules are controlled and monitored in a drive-related manner which therefore increases usability. The system parameters of the Heat Exchanger Modules can be accessed using the familiar tools (STARTER). The current LOGO! modules are being replaced by the SINAMICS product range (TM31, TM150 Terminal Modules). New functionalities for avoiding condensation are integrated and can be parameterized together with further settings. Integration into the drive system means that integration into higher-level control systems to visualize signals and messages is considerably easier.

Heat Exchanger Modules are available for the following voltages and cooling power ratings:

Line voltage	Cooling power
380 ... 415 V 3 AC, 50 Hz	32 ... 120 kW
660 ... 690 V 3 AC, 50 Hz	32 ... 120 kW

Heat Exchanger Modules for the line voltages 440 V to 480 V, 60 Hz as well as 660 V to 690 V, 60 Hz are available with options **C95** and **C97**.

### Design

The deionized water is monitored by the drive itself to ensure intrinsic protection. The operating status is signaled to the drive.

Heat Exchanger Modules contain the following components as standard:

- 1 pump
- 1 stainless steel plate-type heat exchanger
- 1 3-way valve
- Filter, expansion chamber, vent, safety valve, pressure sensors, pressure display, temperature sensor, TM31 and TM150 Terminal Modules

#### Scope of delivery:

The pipe connections (couplings) for connection to the deionized water circuit on the converter side are included in the scope of delivery. The pipe connections (couplings) for connection to the raw water circuit on the plant/system side are not components of the scope of delivery. For this connection, a connecting pipe and a pipe coupling with the appropriate diameter must be used. The respective data is given in the [Technical specifications](#).

#### Note:

Heat Exchanger Modules can only be located at the beginning or end of a cabinet row for technical reasons.

### Selection and ordering data

Cooling power kW	Heat Exchanger Module Article No.
<b>Line voltage 380 ... 415 V 3 AC, 50 Hz; 440 ... 480 V 3 AC, 60 Hz</b>	
32	<b>6SL3705-0RE23-2AA4</b>
48	<b>6SL3705-0RE24-8AA4</b>
72	<b>6SL3705-0RE27-2AA4</b>
120	<b>6SL3705-0RE31-1AA4</b>
<b>Line voltage 660 ... 690 V 3 AC, 50/60 Hz</b>	
32	<b>6SL3705-0RG23-2AA4</b>
48	<b>6SL3705-0RG24-8AA4</b>
72	<b>6SL3705-0RG27-2AA4</b>
120	<b>6SL3705-0RG31-1AA4</b>

# SINAMICS S120 Cabinet Modules

Liquid-cooled units

## Heat Exchanger Modules

### Integration

4

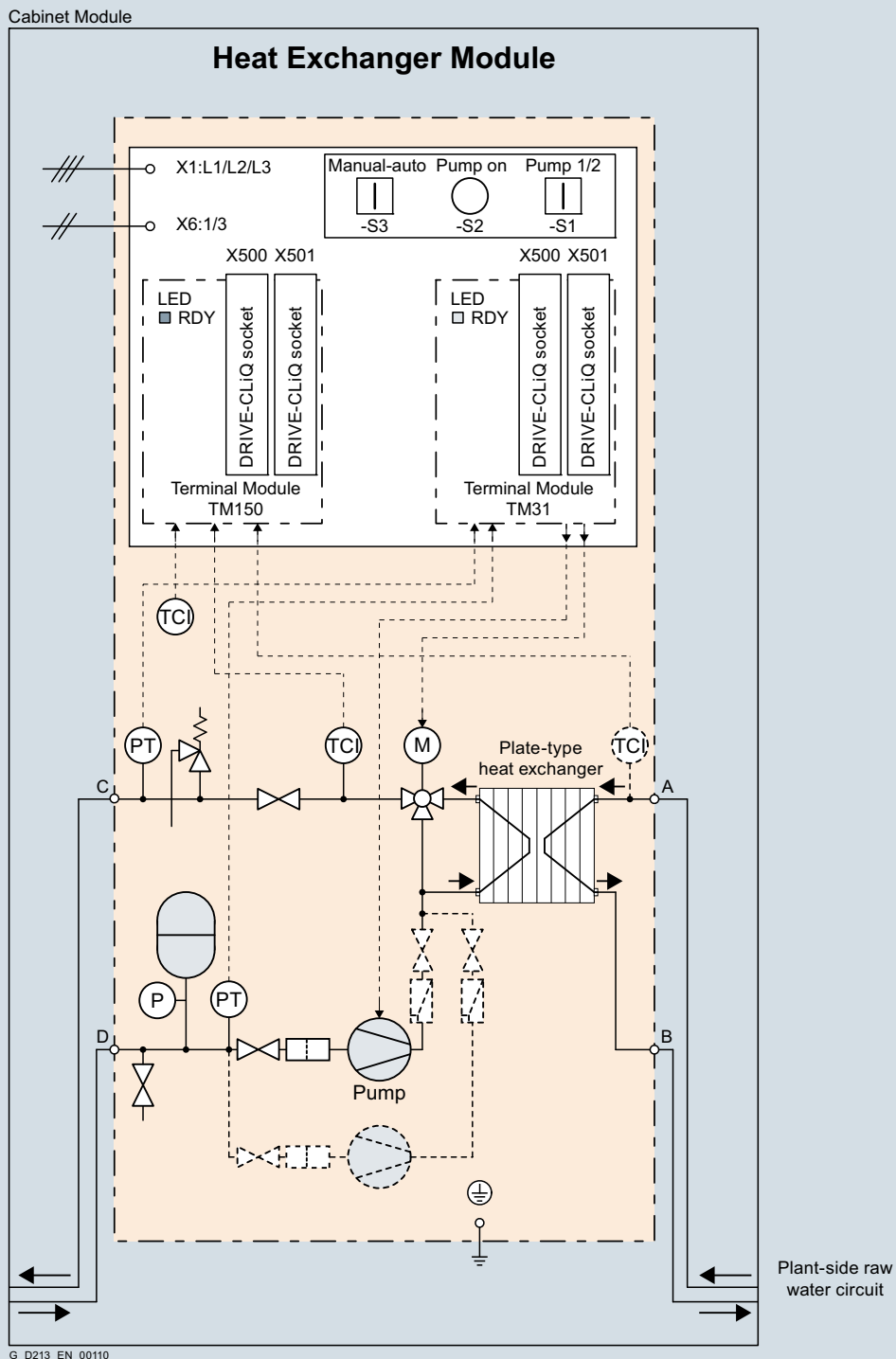

Connection example: Heat Exchanger Module, liquid-cooled

### Technical specifications

The Heat Exchanger Modules must be selected appropriately for the required cooling power and the required volume flow of coolant in the converter-side deionized water circuit. The values stated in the technical specifications of the Cabinet Modules for the heat loss dissipated into the coolant must be summated. The total value is then the required cooling power.

The volume flow of coolant stated in the technical specifications of the Cabinet Modules must also be added.

If either of the two total values exceeds the values defined in the technical specifications of the Heat Exchanger Module (cooling power and volume flow of coolant for converter-side deionized water), the next larger Heat Exchanger Module must be selected.

Line voltage 380 ... 415 V 3 AC 50 Hz		Heat Exchanger Modules			
Line voltage 440 ... 480 V 3 AC 60 Hz <sup>1)</sup>		6SL3705-0RE23-2AA4	6SL3705-0RE24-8AA4	6SL3705-0RE27-2AA4	6SL3705-0RE31-1AA4
<b>Cooling power</b>	kW	<b>32</b>	<b>48</b>	<b>72</b>	<b>120</b>
<b>Deionized water circuit (on the converter side)</b>					
<b>Inlet temperature</b>					
• Min.	°C	Depending on the ambient temperature and humidity of the air (see table for the dew point in section Liquid-cooled Cabinet Modules → Protection against condensation)			
• Max.					
- Drive line-up degree of protection <IP55	°C	45	45	45	45
- Drive line-up degree of protection IP55	°C	40	40	40	40
<b>Intake pressure</b>					
• Min.	bar	1.7	1.7	1.7	1.7
• Max.	bar	6	6	6	6
<b>Coolant volume flow <sup>2)</sup></b>	l/min	88	132	197	267
<b>Liquid volume</b>	l	20.4	21.4	30.5	32.5
<b>Intake/return connection</b>					
• External diameter x wall thickness	mm	76.1 x 2	76.1 x 2	76.1 x 2	76.1 x 2
<b>Raw water circuit (on the plant side)</b>					
<b>Inlet temperature</b>					
• Min.	°C	5 <sup>3)</sup>	5 <sup>3)</sup>	5 <sup>3)</sup>	5 <sup>3)</sup>
• Max.					
- Drive line-up degree of protection <IP55	°C	38	38	38	38
- Drive line-up degree of protection IP55	°C	33	33	33	33
<b>Intake pressure, max.</b>	bar	6	6	6	6
<b>Coolant volume flow <sup>2)</sup></b>	l/min	132	198	263	445
<b>Intake/return connection</b>					
• External diameter x wall thickness	mm	42 x 1.5	42 x 1.5	76.1 x 2	76.1 x 2
<b>General data</b>					
<b>Heat exchanger material</b>		Stainless steel	Stainless steel	Stainless steel	Stainless steel
<b>Current consumption</b>					
• Operating current, total at 50/60 Hz 400 V	A	7.5/7.0	7.5/7.0	11.0/12.0	11.0/12.0
• Electronics current (24 V DC)	A	1.0	1.0	1.0	1.0
<b>Power consumption, max.</b> at 50/60 Hz 400 V	kW	3.5/4.7	3.5/4.7	5.5/6.4	5.5/6.4
<b>Sound pressure level <math>L_{pA}</math></b> (1 m) at 50 Hz	dB	60	60	60	60
<b>Line supply connection</b> L1, L2, L3					
• Conductor cross-section, max. (IEC)	mm <sup>2</sup>	4	4	4	4
<b>PE/GND connection</b>					
• Conductor cross-section, max. (IEC)	mm <sup>2</sup>	4	4	4	4
<b>Degree of protection (standard version)</b>					
		IP55	IP55	IP55	IP55
<b>Dimensions</b>					
• Width <sup>4)</sup>	mm	600	600	600	600
• Height	mm	2200	2200	2200	2200
• Depth	mm	600	600	600	600
<b>Weight, approx. <sup>5)</sup></b> (standard version)	kg	310	310	320	320

<sup>1)</sup> Heat Exchanger Modules 440 V to 480 V, 60 Hz available with option **C95**.

<sup>2)</sup> The value is valid for water as coolant. For other coolants, see section Cooling circuit and coolant properties.

<sup>3)</sup> 0 °C with antifreeze (see derating characteristics).

<sup>4)</sup> With option **W01**, the cabinet width increases to 1000 mm.

<sup>5)</sup> With option **W01**, the cabinet weight increases by approximately 110 kg.

# SINAMICS S120 Cabinet Modules

## Liquid-cooled units

### Heat Exchanger Modules

#### Technical specifications (continued)

With Heat Exchanger Modules for line voltages of 660 ... 690 V 3 AC, the voltage is adapted to the 400 V 3 AC/50 Hz or 460 V/3 AC 60 Hz supply voltage of the pump using a transformer.

Line voltage 660 ... 690 V 3 AC 50 Hz Line voltage 660 ... 690 V 3 AC 60 Hz <sup>1)</sup>		Heat Exchanger Modules			
		6SL3705-0RG23-2AA4	6SL3705-0RG24-8AA4	6SL3705-0RG27-2AA4	6SL3705-0RG31-1AA4
<b>Cooling power</b>	kW	<b>32</b>	<b>48</b>	<b>72</b>	<b>120</b>
<b>Deionized water circuit (on the converter side)</b>					
<b>Inlet temperature</b>					
• Min.	°C	Depending on the ambient temperature and humidity of the air (see table for the dew point in section <a href="#">Liquid-cooled Cabinet Modules → Protection against condensation</a> )			
• Max.					
- Drive line-up degree of protection <IP55	°C	45	45	45	45
- Drive line-up degree of protection IP55	°C	40	40	40	40
<b>Intake pressure</b>					
• Min.	bar	1.7	1.7	1.7	1.7
• Max.	bar	6	6	6	6
<b>Coolant volume flow <sup>2)</sup></b>	l/min	88	132	197	267
<b>Liquid volume</b>	l	20.4	21.4	30.5	32.5
<b>Intake/return connection</b>					
• External diameter x wall thickness	mm	76.1 x 2	76.1 x 2	76.1 x 2	76.1 x 2
<b>Raw water circuit (on the plant side)</b>					
<b>Inlet temperature</b>					
• Min.	°C	5 <sup>3)</sup>	5 <sup>3)</sup>	5 <sup>3)</sup>	5 <sup>3)</sup>
• Max.					
- Drive line-up degree of protection <IP55	°C	38	38	38	38
- Drive line-up degree of protection IP55	°C	33	33	33	33
<b>Intake pressure, max.</b>	bar	6	6	6	6
<b>Coolant volume flow <sup>2)</sup></b>	l/min	132	198	263	445
<b>Intake/return connection</b>					
• External diameter x wall thickness	mm	42 x 1.5	42 x 1.5	76.1 x 2	76.1 x 2
<b>General data</b>					
<b>Heat exchanger material</b>		Stainless steel	Stainless steel	Stainless steel	Stainless steel
<b>Current consumption</b>					
• Operating current, total at 50/60 Hz 690 V	A	4.4/4.1	4.4/4.1	6.4/7.0	6.4/7.0
• Electronics current (24 V DC)	A	1.0	1.0	1.0	1.0
<b>Power consumption, max.</b> at 50/60 Hz 690 V	kW	3.5/4.7	3.5/4.7	5.5/6.4	5.5/6.4
<b>Sound pressure level <math>L_{pA}</math></b> (1 m) at 50/60 Hz	dB	60	60	60	60
<b>Line supply connection</b> L1, L2, L3					
• Conductor cross-section, max. (IEC)	mm <sup>2</sup>	Terminal 4	Terminal 4	Terminal 4	Terminal 4
<b>PE/GND connection</b>					
• Conductor cross-section, max. (IEC)	mm <sup>2</sup>	Terminal 4	Terminal 4	Terminal 4	Terminal 4
<b>Degree of protection (standard version)</b>					
		IP55	IP55	IP55	IP55
<b>Dimensions</b>					
• Width <sup>4)</sup>	mm	600	600	600	600
• Height	mm	2200	2200	2200	2200
• Depth	mm	600	600	600	600
<b>Weight, approx. <sup>5)</sup></b> (standard version)	kg	350	350	360	360

<sup>1)</sup> Heat Exchanger Modules 660 V to 690 V, 60 Hz available with option **C97**.

<sup>2)</sup> The value is valid for water as coolant. For other coolants, see section [Cooling circuit and coolant properties](#).

<sup>3)</sup> 0 °C with antifreeze (see [derating characteristics](#)).

<sup>4)</sup> With option **W01**, the cabinet width increases to 1000 mm.

<sup>5)</sup> With option **W01**, the cabinet weight increases by approximately 110 kg.

## Accessories

### *Components for filling the cooling circuit with liquid-cooled SINAMICS S120 Cabinet Modules*

For commissioning and filling the deionized water circuit on the converter side with the corresponding cooling medium, the following components are needed:

- 1 pump
- 1 vessel with capacity of 100 l
- 1 hose (1/2")
- 1 ball valve

The coolant base must be mixed before filling the cooling circuit with the coolant additive. 100+ liter drums are suitable for this purpose, for example.

We recommend that a drum pump is used that can produce a pressure of 3 bar. The following pumps are recommended for filling:

- Drum and container pumps for emptying the drum, RE-PP, for corrosive and neutral liquids from Lutz Pumpen GmbH, [www.lutz-pumpen.com](http://www.lutz-pumpen.com) or
- Chemical pumps, electrical drum pumps from Sinntec Schmierysteme GmbH, [www.sinntec.de](http://www.sinntec.de)

#### Note:

When placing an order, please state that a hose (1/2"), a ball valve, and a terminal piece are required for a connection with 1/2" on the pump outlet.



# SINAMICS S120 Cabinet Modules

## Options

### Overview

The following table provides an overview of all of the available options and their assignment to the individual Cabinet Modules.

SINAMICS S120 Cabinet Modules		Air-cooled Cabinet Modules								Liquid-cooled Cabinet Modules					
Order code	Options	Line Connection Module	Basic Line Module	Smart Line Module	Active Line Module with Active Interface Module	Motor Module Booksize (Cabinet Kit)	Motor Module Booksize (Base Cabinet)	Motor Module Chassis	Central Braking Module	Auxiliary Power Supply Module	Basic Line Connection Module	Active Line Connection Module	Motor Module	Auxiliary Power Supply Module	Heat Exchanger Module
<b>C95</b>	Supply voltage for the Heat Exchanger Module, 440 ... 480 V/60 Hz	-	-	-	-	-	-	-	-	-	-	-	-	-	✓
<b>C97</b>	Supply voltage for the Heat Exchanger Module, 660 ... 690 V/60 Hz	-	-	-	-	-	-	-	-	-	-	-	-	-	✓
<b>G20</b> <sup>1)</sup>	CBC10 Communication Board	-	✓	✓	✓	✓	-	✓	-	-	✓	✓	✓	-	-
<b>G33</b> <sup>1)</sup>	CBE20 Communication Board	-	✓	✓	✓	✓	-	✓	-	-	✓	✓	✓	-	-
<b>G51</b>	1 x TM150 temperature sensor evaluation unit	✓	-	-	-	-	-	-	-	-	✓	✓	✓	-	-
<b>G52</b>	2 x TM150 temperature sensor evaluation units	✓	-	-	-	-	-	-	-	-	✓	✓	✓	-	-
<b>G53</b>	3 x TM150 temperature sensor evaluation units	✓	-	-	-	-	-	-	-	-	✓	✓	-	-	-
<b>G54</b>	4 x TM150 temperature sensor evaluation units	✓	-	-	-	-	-	-	-	-	✓	✓	-	-	-
<b>G56</b>	Contacting monitoring	-	✓	✓	✓ <sup>2)</sup>	-	-	-	-	-	-	-	-	-	-
<b>G60</b> <sup>1)</sup>	TM31 Terminal Module	-	-	-	-	-	-	-	-	-	✓	✓	✓	-	-
<b>G61</b> <sup>1)</sup>	Additional TM31 Terminal Module	-	-	-	-	-	-	-	-	-	✓	✓	✓	-	-
<b>G62</b> <sup>1)</sup>	TB30 Terminal Board	-	✓	✓	✓	✓	-	✓	-	-	✓	✓	✓	-	-
<b>K01 to K05</b>	Safety license for 1 to 5 axes	-	-	-	-	✓	-	✓	-	-	-	-	✓	-	-
<b>K08</b> <sup>1)</sup>	AOP30 Advanced Operator Panel installed in the cabinet door	-	✓	✓	✓	✓	-	✓	-	-	✓	✓	✓	-	-
<b>K46</b>	SMC10 Sensor Module Cabinet-Mounted	-	-	-	-	✓	-	✓	-	-	-	-	✓	-	-
<b>K48</b>	SMC20 Sensor Module Cabinet-Mounted	-	-	-	-	✓	-	✓	-	-	-	-	✓	-	-
<b>K50</b>	SMC30 Sensor Module Cabinet-Mounted	-	-	-	-	✓	-	✓	-	-	-	-	✓	-	-
<b>K51</b>	VSM10 Voltage Sensing Module	-	-	-	-	✓	-	✓	-	-	-	-	✓	-	-
<b>K52</b>	Second SMC30 Sensor Module Cabinet-Mounted	-	-	-	-	✓	-	✓	-	-	-	-	✓	-	-
<b>K70</b>	Fan power supply	✓	-	-	-	-	-	-	-	-	-	-	-	-	-
<b>K73</b>	SITOP power supply 24 V DC	-	-	-	-	-	✓	-	-	-	-	-	-	-	-
<b>K76</b>	Auxiliary power generation (in the Line Connection Module)	✓	-	-	-	-	-	-	-	-	✓	✓	-	-	-
<b>K82</b>	Terminal module for controlling the Safe Torque Off and Safe Stop 1 safety functions	-	-	-	-	✓	-	✓	-	-	-	-	✓	-	-
<b>K87</b>	TM54F Terminal Module	-	-	-	-	✓	-	✓	-	-	-	-	✓	-	-
<b>K88</b>	Safe Brake Adapter 230 V AC	-	-	-	-	-	-	✓	-	-	-	-	✓	-	-
<b>K90</b>	CU320-2 DP Control Unit	-	✓	✓	✓	✓	-	✓	-	-	✓	✓	✓	-	-
<b>K94</b> <sup>1)</sup>	Performance expansion for CU320-2 Control Unit	-	✓	✓	✓	✓	-	✓	-	-	✓	✓	✓	-	-
<b>K95</b>	CU320-2 PN Control Unit	-	✓	✓	✓	✓	-	✓	-	-	✓	✓	✓	-	-

✓ Option can be ordered for this Cabinet Module

- Option cannot be ordered for this Cabinet Module

## Overview (continued)

SINAMICS S120 Cabinet Modules		Air-cooled Cabinet Modules								Liquid-cooled Cabinet Modules					
Order code	Options	Line Connection Module	Basic Line Module	Smart Line Module	Active Line Module with Active Interface Module	Motor Module Booksize (Cabinet Kit)	Motor Module Booksize (Base Cabinet)	Motor Module Chassis	Central Braking Module	Auxiliary Power Supply Module	Basic Line Connection Module	Active Line Connection Module	Motor Module	Auxiliary Power Supply Module	Heat Exchanger Module
L00 <sup>3)</sup>	Use in the "first environment" according to EN 61800-3, Category C2 (TN/TT supply systems with grounded neutral point)	✓	-	-	-	-	-	-	-	-	-	-	-	-	-
L07	dv/dt filter compact plus Voltage Peak Limiter	-	-	-	-	-	-	✓	-	-	-	-	-	-	-
L08	Motor reactor	-	-	-	-	✓	-	✓	-	-	-	-	-	-	-
L09	2 motor reactors connected in series	-	-	-	-	✓	-	-	-	-	-	-	-	-	-
L10	dv/dt filter plus Voltage Peak Limiter	-	-	-	-	-	-	✓	-	-	-	-	-	-	-
L13	Main contactor (for supply currents of ≤ 800 A)	✓ <sup>4)</sup>	-	-	-	-	-	-	-	-	✓ <sup>4)</sup>	-	-	-	-
L21	Surge suppression	✓	-	-	-	-	-	-	-	-	✓	✓	-	-	-
L22	Scope of delivery without line reactor	✓ <sup>5)</sup>	-	✓	-	-	-	-	-	-	✓	-	-	-	-
L25	Withdrawable circuit breaker in place of a fixed-mounted circuit breaker	✓ <sup>6)</sup>	-	-	-	-	-	-	-	-	✓ <sup>6)</sup>	✓ <sup>6)</sup>	-	-	-
L34	Output-side circuit breaker (motor-driven)	-	-	-	-	-	-	✓	-	-	-	-	-	-	-
L37	DC interface incl. pre-charging circuit of the associated DC link capacitance	-	-	-	-	✓	-	✓	-	-	-	-	-	-	-
L40	Line filter monitoring	-	-	-	✓	-	-	-	-	-	-	✓	-	-	-
L41	Current transformer upstream of main circuit breaker	✓	-	-	-	-	-	-	-	-	✓	✓	-	-	-
L42	Line Connection Module for Active Line Modules	✓	-	-	-	-	-	-	-	-	-	-	-	-	-
L43	Line Connection Module for Basic Line Modules	✓	-	-	-	-	-	-	-	-	-	-	-	-	-
L44	Line Connection Module for Smart Line Modules	✓	-	-	-	-	-	-	-	-	-	-	-	-	-
L45	EMERGENCY OFF pushbutton installed in the cabinet door	✓	-	-	-	-	-	-	-	-	✓	✓	-	-	-
L46	Grounding switch upstream of main circuit breaker	✓ <sup>7)</sup>	-	-	-	-	-	-	-	-	-	-	-	-	-
L47	Grounding switch downstream of main circuit breaker	✓ <sup>7)</sup>	-	-	-	-	-	-	-	-	-	-	-	-	-
L50	Cabinet lighting with service socket	✓	-	-	-	-	-	-	-	-	✓	✓	-	-	-
L55	Cabinet anti-condensation heating	✓	✓	✓	✓	-	✓	✓	✓	✓	✓	✓	✓	✓	✓
L61	25/125 kW braking unit (can be used for frame size FB) for line voltages of 380 ... 480 V and 660 ... 690 V	-	✓	-	✓	-	-	✓	-	-	-	-	-	-	-
L62	50/250 kW braking unit (can be used for frame size GB/GD) for line voltages of 380 ... 480 V and 660 ... 690 V	-	✓ <sup>8)</sup>	✓	✓	-	-	✓	-	-	-	-	-	-	-
L64	25/125 kW braking unit (can be used for frame size FB) for line voltages of 500 ... 600 V	-	✓	-	✓	-	-	✓	-	-	-	-	-	-	-
L65	50/250 kW braking unit (can be used for frame size GB/GD) for line voltages of 500 ... 600 V	-	✓	✓	✓	-	-	✓	-	-	-	-	-	-	-
L87	Insulation monitoring	✓	-	-	-	-	-	-	-	-	✓	✓	-	-	-

✓ Option can be ordered for this Cabinet Module

- Option cannot be ordered for this Cabinet Module

# SINAMICS S120 Cabinet Modules

## Options

### Overview (continued)

SINAMICS S120 Cabinet Modules		Air-cooled Cabinet Modules								Liquid-cooled Cabinet Modules					
Order code	Options	Line Connection Module	Basic Line Module	Smart Line Module	Active Line Module with Active Interface Module	Motor Module Booksize (Cabinet Kit)	Motor Module Booksize (Base Cabinet)	Motor Module Chassis	Central Braking Module	Auxiliary Power Supply Module	Basic Line Connection Module	Active Line Connection Module	Motor Module	Auxiliary Power Supply Module	Heat Exchanger Module
<b>M06</b>	Base 100 mm high, RAL 7022	✓	✓	✓	✓	–	✓	✓	✓	✓	✓	✓	✓	✓	✓
<b>M07</b>	Cable marshaling compartment 200 mm high, RAL 7035	✓	✓	✓	✓	–	✓	✓	✓	✓	✓	✓	✓	✓	✓
<b>M21</b>	Degree of protection IP21	✓	✓	✓	✓	–	✓	✓	✓	✓	–	–	–	–	–
<b>M23</b>	Degree of protection IP23 (includes <b>M60</b> )	✓	✓	✓	✓	–	✓	✓	✓	✓	✓	✓	✓	✓	– <sup>9)</sup>
<b>M26</b>	Side panel mounted to the right	–	✓	✓	✓	–	✓	✓	✓	✓	✓	✓	✓	✓	✓
<b>M27</b>	Side panel mounted to the left	✓	✓	✓	✓	–	✓	✓	✓	✓	✓	✓	✓	✓	✓
<b>M43</b>	Degree of protection IP43 (includes <b>M60</b> )	✓	✓	✓	✓	–	✓	✓	✓	✓	✓	✓	✓	✓	– <sup>9)</sup>
<b>M51</b>	Motor connection wired to customer terminal	–	–	–	–	✓	–	–	–	–	–	–	–	–	–
<b>M54</b>	Degree of protection IP54 (includes <b>M60</b> )	✓	✓	✓	✓	–	✓	✓	✓	✓	–	–	–	–	–
<b>M55</b>	Degree of protection IP55	–	–	–	–	–	–	–	–	–	✓	✓	✓	✓	– <sup>9)</sup>
<b>M56</b>	Reinforced mechanical design	✓	✓	✓	✓	–	✓	✓	✓	✓	–	–	–	–	–
<b>M59</b>	Closed cabinet door, air intake from below through floor opening	✓	✓	✓	✓	–	✓	✓	✓	✓	–	–	–	–	–
<b>M60</b> <sup>10)</sup>	Additional touch protection (included in <b>M23</b> , <b>M43</b> , and <b>M54</b> )	✓	✓	✓	✓	–	–	✓	–	–	–	–	–	–	–
<b>M70</b>	EMC shield bus	✓	–	–	–	–	✓	✓	–	✓	✓	✓	✓	✓	–
<b>M72</b>	Quick-release couplings for water hoses	–	–	–	–	–	–	–	–	–	✓	✓	✓	–	–
<b>M77</b>	Version without component support plates and without additional control components	–	–	–	–	–	✓	–	–	–	–	–	–	–	–
<b>M90</b>	Crane transport assembly (top-mounted)	✓	✓	✓	✓	–	✓	✓	✓	✓	✓	✓	✓	✓	✓
<b>M91</b>	Marking of all control cable wire ends (including customer-specific cables)	✓	✓	✓	✓	–	✓	✓	✓	✓	✓	✓	✓	✓	✓
<b>N52</b>	DC link fuses	–	✓	–	–	–	–	–	–	–	✓	✓	–	–	–
<b>P10</b>	Measuring instrument for line supply values; mounted in cabinet door (includes <b>L41</b> )	✓	–	–	–	–	–	–	–	–	✓	✓	–	–	–
<b>P11</b>	Measuring instrument for line supply values like option <b>P10</b> , with PROFIBUS connection	✓	–	–	–	–	–	–	–	–	✓	✓	–	–	–
<b>W01</b>	Heat Exchanger Module, partially redundant with 2 pumps	–	–	–	–	–	–	–	–	–	–	–	–	–	✓
<b>W10</b>	Pipe insulation in the raw water circuit	–	–	–	–	–	–	–	–	–	–	–	–	–	✓
<b>W20</b>	Raw-water connection from the bottom	–	–	–	–	–	–	–	–	–	–	–	–	–	✓
<b>W34</b>	Heat Exchanger Module for installation on the left	–	–	–	–	–	–	–	–	–	–	–	–	–	✓
<b>W36</b>	Heat Exchanger Module for installation on the right	–	–	–	–	–	–	–	–	–	–	–	–	–	✓
<b>W43</b>	Release valve in the deionized water circuit	–	–	–	–	–	–	–	–	–	–	–	–	–	✓
<b>W49</b>	Leakage sensor in the Heat Exchanger Module	–	–	–	–	–	–	–	–	–	–	–	–	–	✓
<b>W62</b>	Sensors in the raw water circuit on the plant/system side	–	–	–	–	–	–	–	–	–	–	–	–	–	✓
<b>Y09</b>	Special paint finish for cabinet	✓	✓	✓	✓	–	✓	✓	✓	✓	✓	✓	✓	✓	✓
<b>Y11</b>	Factory-assembled transport units	✓	✓	✓	✓	–	✓	✓	✓	✓	✓	✓	✓	✓	–

- ✓ Option can be ordered for this Cabinet Module
- Option cannot be ordered for this Cabinet Module

## Overview (continued)

SINAMICS S120 Cabinet Modules		Air-cooled Cabinet Modules									Liquid-cooled Cabinet Modules				
Order code	Options	Line Connection Module	Basic Line Module	Smart Line Module	Active Line Module with Active Interface Module	Motor Module Booksize (Cabinet Kit)	Motor Module Booksize (Base Cabinet)	Motor Module Chassis	Central Braking Module	Auxiliary Power Supply Module	Basic Line Connection Module	Active Line Connection Module	Motor Module	Auxiliary Power Supply Module	Heat Exchanger Module
<b>Production flowcharts</b>															
<b>B43</b>	Document - Production flowchart: one issue	✓	✓	✓	✓	-	✓	✓	✓	✓	✓	✓	✓	✓	✓
<b>B44</b>	Document - Production flowchart: updated every two weeks	✓	✓	✓	✓	-	✓	✓	✓	✓	✓	✓	✓	✓	✓
<b>B45</b>	Document - Production flowchart: updated every month	✓	✓	✓	✓	-	✓	✓	✓	✓	✓	✓	✓	✓	✓
<b>Packaging options</b>															
<b>B55</b>	Generation of a preliminary and a final packing list (shipping)	✓	✓	✓	✓	-	✓	✓	✓	✓	✓	✓	✓	✓	✓
<b>B56</b>	Packed items labeled with a customized label	✓	✓	✓	✓	-	✓	✓	✓	✓	✓	✓	✓	✓	✓
<b>B57</b>	Photo documentation of the ordered units	✓	✓	✓	✓	-	✓	✓	✓	✓	✓	✓	✓	✓	✓
<b>Mechanical options for DC busbar system</b>															
<b>M80</b>	DC busbar system ( $I_d = 1170$ A, $1 \times 60 \times 10$ mm)	✓	✓	✓	✓	-	✓	✓	✓	✓	✓	✓	✓	✓	-
<b>M81</b>	DC busbar system ( $I_d = 1500$ A, $1 \times 80 \times 10$ mm)	✓	✓	✓	✓	-	✓	✓	✓	✓	✓	✓	✓	✓	-
<b>M82</b>	DC busbar system ( $I_d = 1840$ A, $1 \times 100 \times 10$ mm)	✓	✓	✓	✓	-	✓	✓	✓	✓	✓	✓	✓	✓	-
<b>M83</b>	DC busbar system ( $I_d = 2150$ A, $2 \times 60 \times 10$ mm)	✓	✓	✓	✓	-	✓	✓	✓	✓	✓	✓	✓	✓	-
<b>M84</b>	DC busbar system ( $I_d = 2730$ A, $2 \times 80 \times 10$ mm)	✓	✓	✓	✓	-	✓	✓	✓	✓	✓	✓	✓	✓	-
<b>M85</b>	DC busbar system ( $I_d = 3320$ A, $2 \times 100 \times 10$ mm)	✓	✓	✓	✓	-	✓	✓	✓	✓	✓	✓	✓	✓	-
<b>M86</b>	DC busbar system ( $I_d = 3720$ A, $3 \times 80 \times 10$ mm)	✓	✓	✓	✓	-	✓	✓	✓	✓	✓	✓	✓	✓	-
<b>M87</b>	DC busbar system ( $I_d = 4480$ A, $3 \times 100 \times 10$ mm)	✓	✓	✓	✓	-	✓	✓	✓	✓	✓	✓	✓	✓	-
<b>M88</b>	DC busbar system for line-side Cabinet Modules	-	-	-	-	-	-	-	-	-	✓	✓	-	-	-
✓	Option can be ordered for this Cabinet Module														
-	Option cannot be ordered for this Cabinet Module														

# SINAMICS S120 Cabinet Modules

## Options

### Overview (continued)

SINAMICS S120 Cabinet Modules		Air-cooled Cabinet Modules									Liquid-cooled Cabinet Modules				
Order code	Options	Line Connection Module	Basic Line Module	Smart Line Module	Active Line Module with Active Interface Module	Motor Module Booksize (Cabinet Kit)	Motor Module Booksize (Base Cabinet)	Motor Module Chassis	Central Braking Module	Auxiliary Power Supply Module	Basic Line Connection Module	Active Line Connection Module	Motor Module	Auxiliary Power Supply Module	Heat Exchanger Module
<b>Documentation</b>															
<b>D00</b>	Documentation in German	✓	✓	✓	✓	–	✓	✓	✓	✓	✓	✓	✓	✓	✓
<b>D02</b>	Customer documentation (circuit diagram, terminal diagram, layout diagram) in DXF format	✓	✓	✓	✓	–	✓	✓	✓	✓	✓	✓	✓	✓	✓
<b>D14</b>	Preliminary version of customer documentation in PDF format	✓	✓	✓	✓	–	✓	✓	✓	✓	✓	✓	✓	✓	✓
<b>D56</b>	Documentation in Russian	✓	✓	✓	✓	–	✓	✓	✓	✓	✓	✓	✓	✓	✓
<b>D58</b>	Documentation in English/French	✓	✓	✓	✓	–	✓	✓	✓	✓	✓	✓	✓	✓	✓
<b>D60</b>	Documentation in English/Spanish	✓	✓	✓	✓	–	✓	✓	✓	✓	✓	✓	✓	✓	✓
<b>D72</b>	Documentation in Italian	✓	✓	✓	✓	–	✓	✓	✓	✓	✓	✓	✓	✓	✓
<b>D76</b>	Documentation in English	✓	✓	✓	✓	–	✓	✓	✓	✓	✓	✓	✓	✓	✓
<b>D77</b>	Documentation in French	✓	✓	✓	✓	–	✓	✓	✓	✓	✓	✓	✓	✓	✓
<b>D78</b>	Documentation in Spanish	✓	✓	✓	✓	–	✓	✓	✓	✓	✓	✓	✓	✓	✓
<b>D80</b>	Documentation in English/Italian	✓	✓	✓	✓	–	✓	✓	✓	✓	✓	✓	✓	✓	✓
<b>D84</b>	Documentation in Chinese	✓	✓	✓	✓	–	✓	✓	✓	✓	✓	✓	✓	✓	✓
<b>D91</b>	Documentation in English/Chinese	✓	✓	✓	✓	–	✓	✓	✓	✓	✓	✓	✓	✓	✓
<b>D93</b>	Documentation in English/Portuguese (Brazil)	✓	✓	✓	✓	–	✓	✓	✓	✓	–	–	–	–	–
<b>D94</b>	Documentation in English/Russian	✓	✓	✓	✓	–	✓	✓	✓	✓	✓	✓	✓	✓	✓
<b>D99</b>	Without operating instructions	✓	✓	✓	✓	–	✓	✓	✓	✓	✓	✓	✓	✓	✓
<b>Labeling plates</b>															
<b>T58</b>	Rating plate data in English/French	✓	✓	✓	✓	–	✓	✓	✓	✓	✓	✓	✓	✓	✓
<b>T60</b>	Rating plate data in English/Spanish	✓	✓	✓	✓	–	✓	✓	✓	✓	✓	✓	✓	✓	✓
<b>T80</b>	Rating plate data in English/Italian	✓	✓	✓	✓	–	✓	✓	✓	✓	✓	✓	✓	✓	✓
<b>T83</b>	Rating plate data in English/Portuguese (Brazil)	✓	✓	✓	✓	–	✓	✓	✓	✓	–	–	–	–	–
<b>T85</b>	Rating plate data in English/Russian	✓	✓	✓	✓	–	✓	✓	✓	✓	✓	✓	✓	✓	✓
<b>T91</b>	Rating plate data in English/Chinese	✓	✓	✓	✓	–	✓	✓	✓	✓	✓	✓	✓	✓	✓
<b>Y31</b>	One-line label for system identification, 40 × 80 mm	✓	✓	✓	✓	–	✓	✓	✓	✓	✓	✓	✓	✓	✓
<b>Y32</b>	Two-line label for system identification, 40 × 180 mm	✓	✓	✓	✓	–	✓	✓	✓	✓	✓	✓	✓	✓	✓
<b>Y33</b>	Four-line label for system identification, 40 × 180 mm	✓	✓	✓	✓	–	✓	✓	✓	✓	✓	✓	✓	✓	✓
✓	Option can be ordered for this Cabinet Module														
–	Option cannot be ordered for this Cabinet Module														

## Overview (continued)

SINAMICS S120 Cabinet Modules		Air-cooled Cabinet Modules								Liquid-cooled Cabinet Modules					
Order code	Options	Line Connection Module	Basic Line Module	Smart Line Module	Active Line Module with Active Interface Module	Motor Module Booksize (Cabinet Kit)	Motor Module Booksize (Base Cabinet)	Motor Module Chassis	Central Braking Module	Auxiliary Power Supply Module	Basic Line Connection Module	Active Line Connection Module	Motor Module	Auxiliary Power Supply Module	Heat Exchanger Module
<b>Converter acceptance inspection</b>															
<b>F03</b>	Visual acceptance	✓	✓	✓	✓	–	✓	✓	✓	✓	✓	✓	✓	✓	✓
<b>F71</b>	Function test without motor (witnessed by customer)	✓	✓	✓	✓	–	✓	✓	✓	✓	✓	✓	✓	✓	✓
<b>F72</b>	Function test without motor (not witnessed by customer)	✓	✓	✓	✓	–	✓	✓	✓	✓	✓	✓	✓	✓	✓
<b>F74</b>	Function test with test bay motor in no-load operation (not witnessed by customer) <sup>11)</sup>	✓	✓	✓	✓	–	✓	✓	–	–	✓	✓	✓	–	–
<b>F75</b>	Function test with test bay motor in no-load operation (witnessed by customer) <sup>11)</sup>	✓	✓	✓	✓	–	✓	✓	–	–	✓	✓	✓	–	–
<b>F76</b>	Insulation test (not witnessed by customer)	✓	✓	✓	✓	–	✓	✓	✓	✓	✓	✓	✓	✓	✓
<b>F77</b>	Insulation test (witnessed by customer)	✓	✓	✓	✓	–	✓	✓	✓	✓	✓	✓	✓	✓	✓
<b>F97</b>	Customer-specific acceptance inspections (on request)	✓	✓	✓	✓	–	✓	✓	✓	✓	✓	✓	✓	✓	✓
✓	Option can be ordered for this Cabinet Module														
–	Option cannot be ordered for this Cabinet Module														

1) Only in conjunction with option **K90** or **K95**.

2) Option **G56** cannot be selected for Active Line Modules in frame sizes FX and GX.

3) For Basic Line Modules for cable lengths < 100 m. Not for a parallel connection of Line Modules to a common Line Connection Module.

4) For rated currents ≤ 800 A.

5) Only with option **L43** (for Basic Line Modules) and for rated currents ≤ 2000 A.

6) For rated currents ≥ 800 A.

7) For rated currents ≥ 2000 A.

8) When Basic Line Modules are connected in parallel with a Line Connection Module, there is only space to fit a braking unit in the right-hand Basic Line Module.

9) Heat Exchanger Modules have degree of protection IP55 as standard.

10) Can only be ordered for air-cooled Cabinet Modules. Liquid-cooled Cabinet Modules incorporate additional touch protection as a standard feature.

11) For a function test with test bay motor, the motor is connected to Motor Modules in chassis format and/or Motor Modules in booksize format in the Base Cabinet.

## SINAMICS S120 Cabinet Modules

### Options

#### Overview (continued)

##### Option selection matrix

Certain options are mutually exclusive.  
Options that are not affected are not shown.

✓	Possible combination
–	Combination not possible

##### Electrical options

	G20	G33	G62	K90	K95
G20		–	–	✓	✓
G33	–		–	✓	✓
G62	–	–		✓	✓
K90	✓	✓	✓		–
K95	✓	✓	✓	–	

	L61/64	L62/65
L61/64		–
L62/65	–	

	K46	K48	K50	K51	K52	K88	L07	L08	L09 <sup>1)</sup>	L10	L34	L37
K46		–	–	–	–	✓	✓	✓	✓	✓	✓	✓
K48	–		–	–	–	✓	✓	✓	✓	✓	✓	✓
K50	–	–		–	✓	✓	✓	✓	✓	✓	✓	✓
K51	–	–	–		–	✓	✓	✓	✓	✓	✓	✓
K52	–	–	✓	–		✓	✓	✓	✓	✓	✓	✓
K88	✓	✓	✓	✓	✓		✓	✓	✓	✓	✓	✓
L07	✓	✓	✓	✓	✓	✓		–	–	–	–	✓
L08	✓	✓	✓	✓	✓	✓	–		–	–	✓	✓
L09 <sup>1)</sup>	✓	✓	✓	✓	✓	✓	–	–		–	–	✓
L10	✓	✓	✓	✓	✓	✓	–	–	–		–	✓
L34	✓	✓	✓	✓	✓	✓	–	✓	–	–		✓
L37	✓	✓	✓	✓	✓	✓	✓	✓	✓	✓	✓	

<sup>1)</sup> Option for Booksize Cabinet Kit only.

##### Electrical options (Line Connection Module)

	K76	L13 <sup>1)</sup>	L25 <sup>2)</sup>	L41	L46 <sup>3)</sup>	L47 <sup>3)</sup>	P10	P11
K76		✓	✓	✓	–	✓	✓	✓
L13 <sup>1)</sup>	✓		–	✓	–	–	✓	✓
L25 <sup>2)</sup>	✓	–		✓	✓	✓	✓	✓
L41	✓	✓	✓		✓	✓	–	–
L46 <sup>3)</sup>	–	–	✓	✓		✓	✓	✓
L47 <sup>3)</sup>	✓	–	✓	✓	✓		✓	✓
P10	✓	✓	✓	–	✓	✓		–
P11	✓	✓	✓	–	✓	✓	–	

<sup>1)</sup> Option for rated currents of ≤ 800 A only.

<sup>2)</sup> Option for rated currents of > 800 A only.

<sup>3)</sup> Option for rated currents of ≥ 2000 A only.

## Overview (continued)

## Mechanical/electrical options

	L22	L42	L43	L44	M06	M07	M21	M23	M26	M27	M43	M54	M55	M60	M90	Y11	Y31	Y32	Y33	
L22		-	✓	-	✓	✓	✓	✓	✓	✓	✓	✓	✓	✓	✓	✓	✓	✓	✓	✓
L42	-		-	-	✓	✓	✓	✓	✓	✓	✓	✓	-	✓	✓	✓	✓	✓	✓	✓
L43	✓	-		-	✓	✓	✓	✓	✓	✓	✓	✓	-	✓	✓	✓	✓	✓	✓	✓
L44	-	-	-		✓	✓	✓	✓	✓	✓	✓	✓	-	✓	✓	✓	✓	✓	✓	✓
M06	✓	✓	✓	✓		-	✓	✓	✓	✓	✓	✓	✓	✓	✓	✓	✓	✓	✓	✓
M07	✓	✓	✓	✓	-		✓	✓	✓	✓	✓	✓	✓	✓	✓	✓	✓	✓	✓	✓
M21	✓	✓	✓	✓	✓	✓		-	✓	✓	-	-	-	✓	✓	✓	✓	✓	✓	✓
M23	✓	✓	✓	✓	✓	✓	-		✓	✓	-	-	-	- <sup>1)</sup>	✓	✓	✓	✓	✓	✓
M26	✓	✓	✓	✓	✓	✓	✓	✓		-	✓	✓	✓	✓	✓	✓	✓	✓	✓	✓
M27	✓	✓	✓	✓	✓	✓	✓	✓	-		✓	✓	✓	✓	✓	✓	✓	✓	✓	✓
M43	✓	✓	✓	✓	✓	✓	-	-	✓	✓		-	-	- <sup>1)</sup>	✓	✓	✓	✓	✓	✓
M54	✓	✓	✓	✓	✓	✓	-	-	✓	✓	-		-	- <sup>1)</sup>	✓	✓	✓	✓	✓	✓
M55	✓	-	-	-	✓	✓	-	-	✓	✓	-	-		-	✓	✓	✓	✓	✓	✓
M60	✓	✓	✓	✓	✓	✓	✓	- <sup>1)</sup>	✓	✓	- <sup>1)</sup>	- <sup>1)</sup>	-		✓	✓	✓	✓	✓	✓
M90	✓	✓	✓	✓	✓	✓	✓	✓	✓	✓	✓	✓	✓	✓		-	✓	✓	✓	✓
Y11	✓	✓	✓	✓	✓	✓	✓	✓	✓	✓	✓	✓	✓	✓	-		✓	✓	✓	✓
Y31	✓	✓	✓	✓	✓	✓	✓	✓	✓	✓	✓	✓	✓	✓	✓	✓		-	-	-
Y32	✓	✓	✓	✓	✓	✓	✓	✓	✓	✓	✓	✓	✓	✓	✓	✓	-		-	-
Y33	✓	✓	✓	✓	✓	✓	✓	✓	✓	✓	✓	✓	✓	✓	✓	✓	-	-		-

<sup>1)</sup> Option **M60** is already included in **M23**, **M43**, and **M54** for all Line Modules and Motor Modules in chassis format.

## DC busbar system mechanical options (busbars between individual Cabinet Modules)

	M80	M81	M82	M83	M84	M85	M86	M87
M80		-	-	✓	-	-	-	-
M81	-		-	-	✓	-	✓	-
M82	-	-		-	-	✓	-	✓
M83	✓	-	-		-	-	-	-
M84	-	✓	-	-		-	✓	-
M85	-	-	✓	-	-		-	✓
M86	-	✓	-	-	✓	-		-
M87	-	-	✓	-	-	✓	-	

## Documentation

	D00	D02	D14	D56	D58	D60	D72	D76	D77	D78	D80	D84	D91	D93	D94	D99
D00		✓	✓	✓	✓	✓	✓	✓	✓	✓	✓	✓	✓	✓	✓	-
D02	✓		✓	✓	✓	✓	✓	✓	✓	✓	✓	✓	✓	✓	✓	-
D14	✓	✓		✓	✓	✓	✓	✓	✓	✓	✓	✓	✓	✓	✓	-
D56	✓	✓	✓		✓	✓	✓	✓	✓	✓	✓	✓	✓	✓	-	-
D58	✓	✓	✓	✓		-	✓	-	-	✓	-	✓	-	-	-	-
D60	✓	✓	✓	✓	-		✓	-	✓	-	-	✓	-	-	-	-
D72	✓	✓	✓	✓	✓	✓		✓	✓	✓	-	✓	✓	✓	✓	-
D76	✓	✓	✓	✓	-	-	✓		✓	✓	-	✓	-	-	-	-
D77	✓	✓	✓	✓	-	✓	✓	✓		✓	✓	✓	✓	✓	✓	-
D78	✓	✓	✓	✓	✓	-	✓	✓	✓		✓	✓	✓	✓	✓	-
D80	✓	✓	✓	✓	-	-	-	-	✓	✓		✓	-	-	-	-
D84	✓	✓	✓	✓	✓	✓	✓	✓	✓	✓	✓		-	✓	✓	-
D91	✓	✓	✓	✓	-	-	✓	-	✓	✓	-	-		-	-	-
D93	✓	✓	✓	✓	-	-	✓	-	✓	✓	-	✓	-		-	-
D94	✓	✓	✓	-	-	-	✓	-	✓	✓	-	✓	-	-		-
D99	-	-	-	-	-	-	-	-	-	-	-	-	-	-	-	



## SINAMICS S120 Cabinet Modules

### Options

#### Options

##### **B43, B44, B45**

##### *Production flowcharts*

Production flowcharts are provided with options **B43** to **B45**.

After the order has been clarified, these are emailed as a dual-language (English/German) PDF file.

Option	Description
<b>B43</b>	Documentation - Production flowchart: one issue
<b>B44</b>	Documentation - Production flowchart: updated every two weeks
<b>B45</b>	Documentation - Production flowchart: updated every month

##### **B55**

##### *Generation of a preliminary and a final packing list (shipping)*

This option provides an electronically editable packing list (possibly predefined from the factory) with the following information in Excel format:

- Number of individual packages
- Type of package (pallet, crate, etc.)
- Weight (unpacked and packed)
- Dimensions (unpacked and packed)
- Delivery location
- Label for package item (when option **B56** is ordered)
- Description of what is in the package

An initial packing list is generated after complete technical clarification with preliminary data. When shipped, a final packing list is provided with the actual data.

##### **B56**

##### *Packed items labeled with a customized label*

With this option, customized labels are attached to the unpacked and packed packaged units. Internal customers must provide two labels at least 2 weeks before the shipping date (printout to the factory logistics department, specifying the article number).

##### **B57**

##### *Photographic documentation of the ordered units*

This option provides digital photographic documentation with the following content:

- 1 photo diagonally from the front
- 1 photo diagonally from the rear (opposite)
- 1 photo with the packed item on which the label is legible

The listed photos of the packed items are taken in both an unpacked and a packed state in each position (a total of 6 photos per packed item).

##### **C95, C97**

##### *Power supply voltage for the Heat Exchanger Module with 60 Hz*

With option **C95**, Heat Exchanger Modules are provided for power supply voltages of 440 V to 480 V 3 AC at 60 Hz.

With option **C97** for line voltages of 660 to 690 V 3 AC/60 Hz, the voltage is adapted to the 440 V to 480 V 3 AC/60 Hz supply voltage of the pump using a transformer.

##### **D02**

##### *Customer documentation (circuit diagram, terminal diagram, layout diagram) in DXF format*

Option **D02** can be used to order documents such as circuit diagrams, terminal diagrams, layout diagrams, and dimension drawings in DXF format, e.g. for further processing in CAD systems.

##### **D14**

##### *Preliminary version of customer documentation in PDF format*

If documents such as circuit diagrams, terminal diagrams, layout diagrams and dimension drawings are required in advance for the purpose of system engineering (integration of drive into higher-level systems, interface definition, installation, building planning, etc.), it is possible to order a draft copy of the documentation when ordering the Cabinet Modules. These documents are then supplied electronically a few working days following receipt of the order. If the order includes options that fall outside the scope of standard delivery, these will not be covered by the documentation due to the obvious time constraints.

The client is sent the documentation relating to the order by email. The recipient's email address must be specified with the order for this purpose. In the email, the recipient will also receive a link for downloading order-specific documentation. With option **D02**, the documents are also delivered in DXF format.

##### **D58, D60, D80, D91, D93, D94**

##### *Documentation as language package*

If a documentation option is not selected, the relevant documentation is supplied as standard in English/German. When one of the options specified in the table is selected, the standard documentation language will be changed from English/German to the language combination provided by the option.

Order code	Language
<b>D58</b>	English/French
<b>D60</b>	English/Spanish
<b>D80</b>	English/Italian
<b>D91</b>	English/Chinese
<b>D93</b>	English/Portuguese (Brazil)
<b>D94</b>	English/Russian

##### **D00, D56, D72, D76, D77, D78, D84**

##### *Documentation in a single language*

The documentation is also available in a single language, for example, to be able to order other language combinations.

If a further language is required for standard documentation in English/German, the option **D74** (documentation in English/German) must also be ordered in addition to that language.

Order code	Language
<b>D00</b>	German
<b>D56</b>	Russian
<b>D72</b>	Italian
<b>D76</b>	English
<b>D77</b>	French
<b>D78</b>	Spanish
<b>D84</b>	Chinese

## Options (continued)

**D99****Without operating instructions**

The Cabinet Modules or Booksize Cabinet Kit are shipped without a documentation CD.

**F03, F71, F72, F74, F75, F76, F77, F97**  
**Converter acceptance inspections**

Order code	Description
<b>F03</b>	<p><b>Visual acceptance</b></p> <p>The inspection includes the following:</p> <ul style="list-style-type: none"> <li>• Check of degree of protection</li> <li>• Check of equipment (components)</li> <li>• Check of equipment identifiers</li> <li>• Check of clearance and creepage distances</li> <li>• Check of cables</li> <li>• Check of customer documentation</li> <li>• Submission of the acceptance report</li> </ul> <p>All the above checks are performed with the equipment in a no-voltage condition.</p>
<b>F71</b> (witnessed by customer) <b>F72</b> (not witnessed by customer)	<p><b>Function test without motor</b></p> <p>After the visual acceptance with the converter switched off, the converter is connected to rated voltage. No current at the converter output end.</p> <p>The inspection includes the following:</p> <ul style="list-style-type: none"> <li>• Visual acceptance as described for option <b>F03</b></li> <li>• Check of power supply</li> <li>• Check of protective and monitoring devices (simulation)</li> <li>• Check of fans</li> <li>• Pre-charging test</li> <li>• Function test without connected motor</li> <li>• Submission of the acceptance report</li> </ul>
<b>F74</b> (not witnessed by customer) <b>F75</b> (witnessed by customer)	<p><b>Function test with test bay motor under no-load conditions</b></p> <p>After the visual acceptance with the converter switched off, the converter is connected to rated voltage. A small current flows at the converter output end in order to operate the test bay motor under no-load conditions.</p> <p>The inspection includes the following:</p> <ul style="list-style-type: none"> <li>• Visual acceptance as described for option <b>F03</b></li> <li>• Check of power supply</li> <li>• Check of protective and monitoring devices (simulation)</li> <li>• Check of fans</li> <li>• Function test with test bay motor under no-load conditions</li> <li>• Submission of the acceptance report</li> </ul>
<b>F76</b> (not witnessed by customer) <b>F77</b> (witnessed by customer)	<p><b>Insulation test of the equipment</b></p> <p>The inspection includes the following:</p> <ul style="list-style-type: none"> <li>• High-voltage test</li> <li>• Measurement of the insulation resistance</li> <li>• Submission of the acceptance report</li> </ul>
<b>F97</b>	<p><b>Customer-specific acceptance inspections (on request)</b></p> <p>If acceptance inspections that are not covered by the options <b>F03, F71/F72, F74/F75</b> or <b>F76/F77</b> are required, then customer-specific acceptance inspections/supplementary tests can be ordered using order code <b>F97</b> on request and following technical clarification.</p>

Note:

The options for converter acceptance must be ordered separately for each Cabinet Module and each order position.

**G20****CBC10 Communication Board**

The CBC10 Communication Board is used to interface the CU320-2 Control Unit and thus the SINAMICS S120 Cabinet Modules to the CAN (Controller Area Network) protocol. The associated driver software fulfills the standards of the following CANopen specification of the CiA organization (CAN in Automation):

- Communication profiles in accordance with DS 301
- Drive profile in accordance with DSP 402 (in this case Profile Velocity Mode)
- EDS (Electronic Data Sheet) in accordance with DSP 306
- Operational state signaling in accordance with DSP 305

The CBC10 Communication Board plugs into the option slot on the CU320-2 Control Unit. The CAN interface on the CBC10 has 2 SUB-D connections each for input and output.

The CBC10 Communication Board can only be ordered in conjunction with a CU320-2 Control Unit (option **K90** or **K95**). A combination with options **G33** and **G62** is not possible.

[Description of the CBC10 Communication Board](#) → [Chassis format units](#) → [System components](#) → [Supplementary system components](#).

**G33****CBE20 Communication Board**

The CBE20 Communication Board can be used to connect the SINAMICS S120 Cabinet Modules to a PROFINET-IO or EtherNet/IP network via a CU320-2 Control Unit. The CBE20 Communication Board plugs into the option slot on the CU320-2 Control Unit.

The CBE20 Communication Board can only be ordered as option **G33** in conjunction with a CU320-2 Control Unit (option **K90** or **K95**) and is supplied in an accessories pack for possible configuration. A combination with options **G20** and **G62** is not possible.

Note:

Only one communication interface can be used in isochronous operation when operating the CBE20 Communication Board in a Control Unit CU320-2.

- CU320-2 DP: Either the DP interface of the Control Unit or the PN interfaces of the CBE20
- CU320-2 PN: Either the internal PN interfaces or the external PN interfaces of the CBE20

[Description of the CBE20 Communication Board](#) → [Chassis format units](#) → [System components](#) → [Supplementary system components](#).

## SINAMICS S120 Cabinet Modules

### Options

#### Options (continued)

##### G51 to G54

##### TM150 temperature sensor evaluation unit

Options **G51** to **G54** can be used to order between one and four TM150 Terminal Modules for sensing and evaluating several temperature sensors.

Order code	Option
<b>G51</b>	1 x TM150 temperature sensor evaluation unit
<b>G52</b>	2 x TM150 temperature sensor evaluation units
<b>G53</b>	3 x TM150 temperature sensor evaluation units
<b>G54</b>	4 x TM150 temperature sensor evaluation units

The TM150 Terminal Module is a DRIVE-CLiQ component for temperature evaluation. The temperature is measured in a temperature range from -99 °C to +250 °C for the following temperature sensors:

- Pt100 (with monitoring for wire breakage and short-circuit)
- Pt1000 (with monitoring for wire breakage and short-circuit)
- KTY84 (with monitoring for wire breakage and short-circuits)
- PTC (with monitoring for short-circuit)
- Bimetallic NC contact (without monitoring)

For the temperature sensor inputs, the evaluation can be parameterized for 1x2-wire, 2x2-wire, 3-wire or 4-wire for each terminal block. There is no electrical isolation in the TM150.

A maximum of 12 temperature sensors can be connected to the TM150 Terminal Module.

[Description of the TM150 Terminal Module → SINAMICS S120 chassis format units → System components → Supplementary system components.](#)

##### G56

##### Contactors monitoring

The option is used for monitoring the pre-charging and bypass contactors of the Line Modules, mainly for infeeds connected in parallel.

Note:

Option **G56** cannot be selected for Active Line Modules in frame sizes FX and GX.

##### G60

##### TM31 Terminal Module

The TM31 Terminal Module is used to expand the customer terminal.

The following additional interfaces are available:

- 8 digital inputs
- 4 bidirectional digital inputs/outputs
- 2 relay outputs with changeover contact
- 2 analog inputs
- 2 analog outputs
- 1 temperature sensor input (KTY84-130/PTC)
- 2 DRIVE-CLiQ sockets
- 1 connection for the electronics power supply via the 24 V DC supply connector
- 1 PE connection

To simplify configuration and commissioning of the drive, the optional TM31 Terminal Module can be preset with various factory settings, which can then be selected when commissioning the system.

[Description of the TM31 Terminal Module → SINAMICS S120 chassis format units → System components → Supplementary system components.](#)

[For additional information, please refer to the SINAMICS Low Voltage Engineering Manual.](#)

##### G61

##### Additional TM31 Terminal Module

With option **G61**, the number of digital inputs/outputs, as well as the number of analog inputs/outputs in the drive system can be expanded using a second TM31 Terminal Module (in addition to the TM31 Terminal Module that can be selected using option **G60**).

Note:

Option **G61** requires option **G60**.

##### G62

##### TB30 Terminal Board

The TB30 Terminal Board provides a way of adding digital inputs/digital outputs and analog inputs/analog outputs to the Control Unit. The TB30 Terminal Board plugs into the option slot on the Control Unit.

The following are located on the TB30 Terminal Board:

- Power supply for digital inputs/digital outputs
- 4 digital inputs
- 4 digital outputs
- 2 analog inputs
- 2 analog outputs

The **TB30** Terminal Board can only be ordered in conjunction with a CU320-2 Control Unit (option **K90** or **K95**). A combination with options **G20** and **G33** is not possible.

[Description of the TB30 Terminal Board → SINAMICS S120 chassis format units → System components → Supplementary system components.](#)

**Options** (continued)**K01 to K05****Safety license for 1 to 5 axes**

The Safety Integrated Basic Functions do not require a license. However, the Safety Integrated Extended Functions require a license for each axis equipped with safety functions. It is irrelevant which safety functions are used and how many.

Option **K01** includes the license for 1 axis, **K02** for 2 axes, etc. up to option **K05** for 5 axes.

The required licenses can be optionally ordered with the CompactFlash card.

Subsequent licensing is possible online via the WEB License Manager by generating a license key:

[www.siemens.com/automation/license](http://www.siemens.com/automation/license)

**K08****AOP30 Advanced Operator Panel installed in the cabinet door**

The AOP30 Advanced Operator Panel is an optional input/output device for the Cabinet Modules. If, for the Cabinet Module or the Booksize Cabinet Kit, an autonomous closed-loop control (option **K90** or **K95**) is selected, this module can be assigned to its own operator panel with option **K08**.

The AOP30 Advanced Operator Panel is installed in the cabinet door of each Cabinet Module.

[Description of the AOP30](#) → [Chassis format units](#) → [System components](#) → [Supplementary system components](#).

**K46****SMC10 Sensor Module Cabinet-Mounted**

The SMC10 Sensor Module Cabinet-Mounted can be used to simultaneously sense the speed and the rotor position angle. The signals received from the resolver are converted here and made available to the closed-loop controller via the DRIVE-CLiQ interface for evaluation purposes.

The following encoder signals can be evaluated:

- 2-pole resolver
- Multi-pole resolver

The motor temperature can also be measured using KTY84-130 or PTC thermistors.

[Description of the SMC10 Sensor Module Cabinet-Mounted](#) → [Chassis format units](#) → [System components](#) → [Supplementary system components](#).

**K48****SMC20 Sensor Module Cabinet-Mounted**

The SMC20 Sensor Module Cabinet-Mounted can be used to simultaneously sense the speed and position. The signals received from the incremental encoder are converted here and made available to the closed-loop controller via the DRIVE-CLiQ interface for evaluation purposes.

The following encoder signals can be evaluated:

- Incremental encoder sin/cos  $1 V_{pp}$
- Absolute encoder EnDat 2.1
- SSI encoder with incremental signals sin/cos  $1 V_{pp}$

The motor temperature can also be measured using KTY84-130 or PTC thermistors.

[Description of the SMC20 Sensor Module](#) → [Chassis format units](#) → [System components](#) → [Supplementary system components](#).

**K50****SMC30 Sensor Module Cabinet-Mounted**

The SMC30 Sensor Module Cabinet-Mounted can be used to evaluate the encoders of motors without a DRIVE-CLiQ interface. External encoders can also be connected via the SMC30.

The following encoder signals can be evaluated:

- Incremental encoders TTL/HTL with and without open-circuit detection (open-circuit detection is only available with bipolar signals)
- SSI encoders with TTL/HTL incremental signals
- SSI encoders without incremental signals

The motor temperature can also be measured using KTY84-130 or PTC thermistors.

[Description of the SMC30 Sensor Module](#) → [Chassis format units](#) → [System components](#) → [Supplementary system components](#).

**K51****VSM10 Voltage Sensing Module**

The VSM10 Voltage Sensing Module is used to measure the voltage characteristic on the motor side, so that the following functions can be implemented:

- Operation of a permanent-magnet synchronous motor without encoder with the requirement to be able to connect to a motor that is already running (flying restart function)
- Quick flying restart of large induction motors: The voltage sensing function eliminates the delay incurred by demagnetization of the motor

[Description of the VSM10 Voltage Sensing Module](#) → [Chassis format units](#) → [System components](#) → [Supplementary system components](#).

**K52****Second SMC30 Sensor Module Cabinet-Mounted**

With option **K50**, the cabinet unit contains an SMC30 Sensor Module Cabinet-Mounted. An additional SMC30 (option **K52**) enables reliable actual-value acquisition when Safety Integrated extended functions are used (requires a license: options **K01** to **K05**).

Detailed and comprehensive instructions and information for the Safety Integrated functions can be found in the associated Function Manual.

## SINAMICS S120 Cabinet Modules

### Options

#### Options (continued)

##### K70

##### Fan power supply

With option **K70**, the line voltage supply for the 400 V 3 AC auxiliary power supply system is tapped downstream of the circuit breaker and protected by a motor starter protector.

The voltages 230 V 1 AC and 24 V DC of the auxiliary power supply system are supplied externally on the plant side.

##### K73

##### SITOP power supply 24 V DC

The 24 V DC supply for standard Booksize Cabinet Kits is tapped from the auxiliary power supply.

With option **K73**, the 24 V DC supply is provided by a dedicated SITOP power supply unit.

##### K76

##### Auxiliary voltage generation in the Line Connection Module

Cabinet Modules require an auxiliary energy supply to function properly. This current demand must be included in the configuration and supplied from an external source. If an external supply is not possible, the required auxiliary voltages can be supplied by means of an Auxiliary Power Supply Module.

Alternatively, option **K76** can be selected. This provides for generation of auxiliary voltages in the Line Connection Module. This is particularly advisable for smaller device configurations.

With option **K76**, the following auxiliary voltages are provided:

	Air-cooled Cabinet Modules	Liquid-cooled Cabinet Modules
<b>380 ... 480 V or 500 ... 690 V 2 AC</b>	Possible tap for the following Line Connection Modules: <ul style="list-style-type: none"> <li>Line Connection Module with rated current up to 800 A: 35 A</li> <li>Line Connection Module with rated current of 1000 to 1600 A: 50 A</li> <li>Line Connection Module 6SL3700-0LE42-0AA3: 50 A</li> <li>Line Connection Module with rated current of 2000 to 3200 A: 80 A</li> </ul>	–
<b>230 V 1 AC</b>	Possible tap for the Line Connection Modules: <ul style="list-style-type: none"> <li>&lt; 800 A: approx. 4 A</li> <li>&gt; 800 A: approx. 6 A</li> </ul>	Possible tap for Basic Line Connection Modules / Active Line Connection Modules <ul style="list-style-type: none"> <li>4 ... 10 A</li> </ul>
<b>24 V DC</b>	Possible tap for the Line Connection Modules: <ul style="list-style-type: none"> <li>&lt; 800 A: approx. 20 A</li> <li>&gt; 800 A: approx. 40 A</li> </ul>	Possible tap for Basic Line Connection Modules / Active Line Connection Modules <ul style="list-style-type: none"> <li>5 ... 20 A</li> </ul>

The supply for the auxiliary power supply system is connected at the auxiliary voltage module of the Line Connection Module.

##### K82

##### Terminal Module for controlling the Safe Torque Off and Safe Stop 1 safety functions

The terminal module controls the Safety Integrated Basic Functions Safe Torque Off (STO) and Safe Stop 1 (SS1) (time-controlled) over a wide voltage range from 24 V to 240 V DC/AC (terminology as defined in IEC 61800-5-2).

The integrated safety functions, starting from the Safety Integrated (SI) input terminals of the components (Control Unit and Motor Module), satisfy the requirements of EN 61800-5-2, EN 60204-1, EN ISO 13849-1 Category 3 for Performance Level (PL) d and IEC 61508 SIL 2.

With option **K82**, the requirements specified in EN 61800-5-2, EN 60204-1, EN ISO 13849-1 Category 3 for Performance Level (PL) d and IEC 61508 SIL 2 are fulfilled.

The Safety Integrated functions using option **K82** are only available in conjunction with certified components and software versions.

The Safety Integrated functions of SINAMICS are generally certified by independent institutes. An up-to-date list of certified components is available on request from your local Siemens office.

##### K87

##### TM54F Terminal Module

The TM54F Terminal Module is a terminal expansion module with safe digital inputs and outputs to control the Safety Integrated functions.

The TM54F is directly connected to a Control Unit via DRIVE-CLiQ. Each Control Unit can be assigned to precisely one TM54F.

##### Note:

It is not permissible to connect Motor Modules or Line Modules to a TM54F.

The TM54F provides 4 fail-safe digital outputs and 10 fail-safe digital inputs. A fail-safe digital output consists of one 24 V DC switching output, one output switching to ground and one digital input to check the switching state. A fail-safe digital input consists of two digital inputs.

[Description of the TM54F Terminal Module](#) → [SINAMICS S120 chassis format units](#) → [System components](#) → [Supplementary system components](#).



**Options** (continued)**K88****SBA Safe Brake Adapter, 230 V AC**

The Safe Brake Control (SBC) is a safety function that is used in safety-relevant applications, for example, in presses or rolling mills. In the no-current state, the brake acts on the drive motor using spring force. The brake is released when current flows in it (low active).

The Safe Brake Adapter is already installed in the cabinet unit in the factory. An infeed is connected to terminal -X12 on the Safe Brake Adapter for the power supply. For control, a connection is established between the Safe Brake Adapter and the Control Interface Module in the factory using a cable harness.

On the plant side, to control the brake, a connection must be established between terminal -X14 on the Safe Brake Adapter and the brake.

[Description of the SBA Safe Brake Adapter → SINAMICS S120 chassis format units → System components → Supplementary system components.](#)

**K90****CU320-2 DP Control Unit (PROFIBUS)**

Option **K90** assigns a CU320-2 DP Control Unit incl. CompactFlash card to the Line Modules and Motor Modules. This unit handles the communication and open-loop/closed-loop control functions. DRIVE-CLiQ is used to establish a connection to the various modules and, where required, to additional I/O modules. A PROFIBUS interface is available as standard for higher-level communication.

The computational performance required from the CU320-2 DP Control Unit increases with the number of connected Motor Modules and system components – as well as the dynamic performance demanded.

Without performance expansion, it is generally possible to operate two Motor Modules with one Line Module.

The full computational performance of the CU320-2 DP is only available on systems with performance expansion (option **K94**).

[Description of the CU320-2 Control Unit → SINAMICS S120 chassis format units → System components → Control Units.](#)

**K94****Performance expansion for CU320-2 Control Unit**

With option **K94**, the CU320-2 Control Unit (option **K90** or **K95**) is supplied with a CompactFlash card with performance expansion. This therefore provides the full computational performance of the CU320-2 Control Unit.

In addition to the firmware, the CompactFlash card also contains licensing codes that are required to enable firmware options, for example, the performance expansion and the Safety Integrated Extended Functions.

**K95****CU320-2 PN Control Unit (PROFINET)**

Option **K95** assigns a CU320-2 PN Control Unit, incl. CompactFlash card, to the Line Modules and Motor Modules. This unit handles the communication and open-loop/closed-loop control functions. DRIVE-CLiQ is used to establish a connection to the various modules and, where required, to additional I/O modules. A PROFINET interface is available for higher-level communication.

The computational performance required from the CU320-2 PN Control Unit increases with the number of connected Motor Modules and system components – as well as the dynamic performance demanded.

Without performance expansion, it is generally possible to operate two Motor Modules with one Line Module.

The full computational performance of the CU320-2 PN is only available on systems with performance expansion (option **K94**).

[Description of the CU320-2 Control Unit → SINAMICS S120 chassis format units → System components → Control Units.](#)

**L00****Use in the first environment according to EN 61800-3, Category C2 (TN/TT supply systems with grounded neutral point)**

With option **L00**, the Line Modules have a line filter as well as additional measures installed in the factory; this means that the Cabinet Modules can also comply with the limit values for use in the first environment (Category C2) according to EN 61800-3.

[Notes on the measures to be implemented by the customer are provided in the SINAMICS Low Voltage Engineering Manual.](#)

In order to achieve the full filter effect, the optional line filter must always be used in conjunction with a line reactor.

Note:

Option **L00** is not available for Line Modules in a parallel connection.

## SINAMICS S120 Cabinet Modules

### Options

#### Options (continued)

##### L07

##### *dv/dt filter compact plus Voltage Peak Limiter*

dv/dt filters compact plus VPL (**V**oltage **P**eak **L**imiter) limit the voltage rate-of-rise dv/dt to values of < 1600 V/μs and the typical voltage peaks to the following values in accordance with the limit value curve A according to IEC 60034-25: 2007:

- < 1150 V at  $U_{line} < 575$  V
- < 1400 V at  $660$  V <  $U_{line} < 690$  V

The dv/dt filter compact plus VPL functionally consists of two components that are supplied as a compact mechanical unit, the dv/dt reactor and the voltage limiting network (VPL), which limits voltage peaks and feeds back the energy to the DC link.

It is so compact that it can be completely integrated into the cabinet, even for high power ratings. An additional cabinet is not required.

By using a dv/dt filter compact plus VPL, standard motors with standard insulation and without insulated bearings can be used with supply voltages up to 690 V in converter operation.

The power losses stated in section System components → Motor-side components → dv/dt filters compact plus VPL can be used to determine the total losses for engineering purposes.

dv/dt filters compact plus VPL are designed for the following maximum motor cable lengths:

- Shielded cables 100 m (e.g. Protodur NYCWY)
- Unshielded cables 150 m (e.g. Protodur NYY)

For longer cable lengths (> 100 m shielded, > 150 m unshielded), the dv/dt filter plus VPL (option **L10**) should be used.

##### Note:

- Operation with output frequencies <10 Hz is permissible for max. 5 min.
- The maximum permissible output frequency is 150 Hz.

When using dv/dt filters, restrictions regarding permissible pulse frequencies must be observed.

Please also note the relevant information provided in the [SINAMICS Low Voltage Engineering Manual](#).

##### Note:

Option **L07** cannot be combined with the following options:

- **L08** (motor reactor)
- **L10** (dv/dt filter plus VPL)

## 4

##### L08

##### *Motor reactor*

Motor reactors reduce the voltage load on the motor windings by reducing the voltage gradients at the motor terminals that occur during converter operation. At the same time, the capacitive charge/discharge currents that place an additional load at the Motor Module output when long motor cables are used are reduced.

Suitably dimensioned motor reactors or a series connection of several motor reactors make it possible to connect larger capacitances and thus allow the use of longer motor cables.

In the case of multi-motor drives, the use of motor reactors is recommended as a general principle.

The motor reactor is accommodated in the Cabinet Module. An additional 600-mm-wide cabinet located to the right of the Motor Module is only required for the chassis format in frame sizes HX and JX.

The power losses stated in the section System components → Motor-side components → Motor reactors can be used to determine the total losses for engineering purposes.

##### Note:

The terminal lugs of the reactors are not nickel-plated.

For Motor Modules in chassis format, the maximum cable lengths when using motor reactors are 300 m (shielded) or 450 m (unshielded).

For Motor Modules in Booksize Cabinet Kit format, the maximum motor cables lengths specified in the following table can be reached by using motor reactors (option **L08**).

Booksize Cabinet Kit	Rated output current of Motor Module	Maximum motor cable length when using motor reactors for Booksize Cabinet Kits					
		Shielded cable			Unshielded cable		
		Without reactor	With one reactor (option <b>L08</b> )	With two reactors in series (option <b>L09</b> )	Without reactor	With one reactor (option <b>L08</b> )	With two reactors in series (option <b>L09</b> )
6SL3720-...	A	m	m	m	m	m	m
1TE21-0AB3	9	50	135	–	75	200	–
1TE21-8AB3	18	70	160	320	100	240	480
1TE23-0AB3	30	100	190	375	150	280	560
1TE24-5AB3	45	100	200	400	150	300	600
1TE26-0AB3	60	100	200	400	150	300	600
1TE28-5AB3	85	100	200	400	150	300	600
1TE31-3AB3	132	100	200	400	150	300	600

**Options** (continued)**L09****Two motor reactors in series**

With option **L09** for Booksize Cabinet Kits, two motor reactors are used in series that can be located within the standard width of the Cabinet Kit.

The maximum permissible motor cable lengths when using option L09 are specified in the table under option **L08**.

Note:

The terminal lugs of the reactors are not nickel-plated.

**L10****dv/dt filter plus Voltage Peak Limiter**

A dv/dt filter plus VPL (Voltage **P**eak **L**imiter) limits the voltage rate-of-rise dv/dt to values < 500 V/μs and the typical voltage peaks to the following values in accordance with the limit value curve according to IEC/TS 60034-17: 2006:

- < 1000 V at  $U_{\text{line}} < 575 \text{ V}$
- < 1250 V at  $660 \text{ V} < U_{\text{line}} < 690 \text{ V}$

The dv/dt filter plus VPL functionally consists of two components, the dv/dt reactor and the voltage limiting network (VPL), which limits voltage peaks and feeds the energy back to the DC link.

Option **L10** is installed in an additional cabinet with a width of 600 mm that is located on the right-hand side of the Motor Module.

By using a dv/dt filter plus VPL, standard motors with standard insulation and without insulated bearings can be used with supply voltages up to 690 V in converter operation.

dv/dt filters plus VPL are designed for the following maximum motor cable lengths:

- Shielded cables (e.g. Protodur NYCWY)
  - Motor Modules, frame sizes FX to HX: 300 m
  - Motor Modules, frame size JX: 150 m
- Unshielded cables (e.g. Protodur NYY)
  - Motor Modules, frame sizes FX to HX: 450 m
  - Motor Modules, frame size JX: 225 m

For cable lengths < 100 m shielded or < 150 m unshielded, the dv/dt filter compact plus VPL (option **L07**) can be used advantageously.

The power losses stated in the section System components → Motor-side components → dv/dt filters plus VPL can be used to determine the total losses for engineering purposes.

Notice:

- Operation with output frequencies < 10 Hz is permissible for max. 5 min.
- The maximum permissible output frequency is 150 Hz.

When using dv/dt filters, restrictions regarding permissible pulse frequencies must be observed.

Please also note the relevant information provided in the [SINAMICS Low Voltage Engineering Manual](#).

Note:

Parts of option **L10** do not have nickel-plated copper busbars. Option **L10** cannot be combined with the following options:

- **L07** (dv/dt filter compact plus VPL)
- **L08** (motor reactor)

**L13****Main contactor (for supply currents ≤ 800 A)**

Line Connection Modules for current ratings up to 800 A feature only a manually operated fuse switch disconnector as standard. Option **L13** is needed if a switching element is also required for disconnecting the cabinet from the supply (needed for EMERGENCY OFF). The contactor is controlled by the closed-loop control in this case. Option **L13** can be ordered for Line Connection Modules together with Basic Line Modules (option **L43**). With Smart Line Modules and Active Line Modules, the main contactor is included as standard.

**L21****Surge suppression**

In ungrounded IT systems, the line voltage is not permanently connected to the ground potential because of the missing ground connection of the supply network. Therefore, when a ground fault occurs during operation, a voltage against ground increased by a factor of 2 can occur. For this reason, it is recommended that a surge suppression against ground be installed for operation on IT systems. The surge suppression option includes the installation of line-side surge arresters and upstream fuses for each system phase. The signaling contacts for monitoring the surge arresters are connected in series and connected to a customer interface.

Note:

Option **L21** does not include the components required to install an insulation monitor for the IT system. An insulation monitor should always be ordered separately as option **L87** when the supplying IT system is not monitored at another position (e.g. at the transformer outgoing feeder). Only one insulation monitor should ever be used within the same electrically connected network.

Option **L21** also does not include removal in the factory of the metal bracket that makes the connection to ground of the radio interference suppression filter installed as standard. The metal bracket should therefore be removed during the installation or commissioning of the converter if the device is to be operated on an ungrounded IT system.

**L22****Delivery scope without line reactor**

The air-cooled Basic Line Modules and Smart Line Modules as well as the liquid-cooled Basic Line Connection Modules are supplied with line reactors as standard; the reason for this is that frequently, in practice, the line configuration at the connection point of the drive line-up and/or the line supply short-circuit power is not known.

If the supply is connected through a separate transformer or if the line has a suitably low short-circuit power or if the standard integrated line reactor does not need to be supplied for other reasons, then this can be indicated by selecting option **L22**.

In the case of air-cooled Cabinet Modules, option **L22** can be selected for Line Connection Modules (rated current < 2000 A) in conjunction with Basic Line Modules (option **L43**) and for Smart Line Modules. In the case of liquid-cooled Cabinet Modules, option **L22** can be selected for Basic Line Connection Modules.

For Basic Line Modules and Basic Line Connection Modules connected in parallel, a line reactor should always be used, i.e. option **L22** cannot be selected.

The power losses of each line reactor stated in section System components → Line-side components → Line reactors can be deducted from the total power loss for engineering purposes.

For additional information, please refer to the [SINAMICS Low Voltage Engineering Manual](#).



## SINAMICS S120 Cabinet Modules

### Options

#### Options (continued)

##### L25

##### *Withdrawable circuit breaker*

Line Connection Modules (air-cooled), Active Line Connection Modules and Basic Line Connection Modules (liquid-cooled) with an input current of > 800 A are equipped with fixed-mounted circuit breakers as standard. Where the customer requires a visible isolating distance, a withdrawable circuit breaker can be ordered as an option.

##### L34

##### *Output-side circuit breaker*

Option **L34** can be used to disconnect the motor terminals from the Motor Module Chassis.

A rotating permanent-magnet synchronous motor generates a voltage at its motor terminals proportional to the speed. The motor terminal voltage is also available at the converter output terminals as well as at the DC link and the components connected to it.

Option **L34** is available for disconnection in the case of a fault or if maintenance work is to be carried out.

Option **L34** is completely prewired and is accommodated in an additional cabinet, which is arranged on the right-hand side of the Motor Module (400 mm wide for frame sizes FX/GX, 600 mm wide for frame sizes HX/JX). It is controlled using a TM31 Terminal Module, which is included with this option. This means that the output switch is automatically controlled via the Motor Module.

Option **L34** cannot be combined with the following options:

- **L07** (dv/dt filter compact plus VPL)
- **L10** (dv/dt filter plus VPL)

##### L37

##### *DC interface incl. pre-charging circuit of the relevant DC link capacitance*

If, for reasons relating to the process or availability, the Motor Module needs to be disconnected from the common DC link for an entire drive line-up or connected to it during operation, a manually operated isolating distance can be ordered as an option. With chassis format power units, this takes the form of switch disconnectors, and with Booksize Cabinet Kits, a contactor combination.

Option **L37** is installed on the busbar between the Motor Module and the main DC busbar. To ensure that the module can be connected to a pre-charged DC link, the option also includes a pre-charging circuit for the DC link capacitors of the relevant Motor Module.

The switching operation is performed externally. The operating levers can be locked using a padlock (padlock not included in scope of delivery). The degree of protection of the cabinets is not influenced.

The air guidance contains option **L37** and also option **M60** (additional touch protection).

Options **L61/L62** and **L64/L65** (braking units) cannot be ordered together with option **L37** for space reasons.

##### L40

##### *Line filter monitoring*

With option **L40**, the filter in the Active Interface Module is monitored for effectiveness against harmonic effects on the system. The capacitance of the filter capacitors of the integrated filter is continuously calculated and compared with the installed nominal capacitance by measuring the current and voltage in the Active Interface Module. If the calculated capacity deviates by more than the set tolerance, an alarm is triggered.

##### L41

##### *Current transformer upstream of main circuit breaker*

If additional current transformers are required for measuring or monitoring purposes, these can be ordered for (air-cooled) Line Connection Modules or (liquid-cooled) Active Line Connection Modules and Basic Line Connection Modules with option **L41**. The current transformers are installed upstream of the main circuit breaker in all three infeed phases.

The transformers have an accuracy class of 1.0. The secondary current is maximum 1 A.

The transformer measuring connections are routed to the terminal block in the Line Connection Module.

##### Note:

These current transformers are already included in options **P10** and **P11** (measuring instrument for the display of line values).

##### L42

##### *Line Connection Module for Active Line Modules*

Order code **L42** is specified in the order to indicate that the Line Connection Module will be connected to an Active Line Module. The Line Connection Module is then adapted accordingly (pre-charging circuit, connection busbars, etc.). [See also the information for the Line Connection Modules and the overview of options.](#)

##### L43

##### *Line Connection Module for Basic Line Modules*

Order code **L43** is specified in the order to indicate that the Line Connection Module will be connected to a Basic Line Module. The Line Connection Module is then adapted accordingly (line reactors, pre-charging circuit, connection busbars, etc.). [See also the information for the Line Connection Modules and the overview of options.](#)

##### L44

##### *Line Connection Module for Smart Line Modules*

Order code **L44** is specified in the order to indicate that the Line Connection Module will be connected to a Smart Line Module. The Line Connection Module is then adapted accordingly (pre-charging circuit, connection busbars, etc.). [See also the assignment table for the Line Connection Modules and the overview of options.](#)

##### L45

##### *EMERGENCY OFF pushbutton, installed in the cabinet door*

The EMERGENCY OFF pushbutton with protective collar is installed in the cabinet door of the Line Connection Module and its contacts are connected to a terminal block. From here, the EMERGENCY OFF pushbutton can be integrated into the plant-side EMERGENCY OFF chain.

**Options** (continued)**L46****Grounding switch upstream of main circuit breaker**

The grounding switch is upstream of the circuit breaker in the Line Connection Module and short-circuits the incoming supply system to ground. The grounding switch is manually engaged using a rotary operating mechanism to ensure isolation from the line supply when maintenance is being carried out. Measures must be taken at the plant to ensure that the grounding switch cannot be engaged when voltage is applied.

It is also essential to ensure that the supply system cannot be connected when the grounding switch is engaged.

The signals required for mutual interlocking are available on the terminal block.

**L47****Grounding switch downstream of main circuit breaker**

The grounding switch is installed downstream of the circuit breaker in the Line Connection Module and short-circuits the incoming supply system to ground downstream of the main circuit breaker. The grounding switch is manually engaged using a rotary operating mechanism to ensure isolation from the line supply when maintenance work is being carried out on the converter.

In this case, the grounding switch and the main circuit breaker for the Line Connection Module are interlocked with each other, which ensures that the grounding switch cannot be closed when the main circuit breaker is closed.

If the grounding switch is engaged, it is interconnected to ensure that the main circuit breaker cannot be closed.

**L50****Cabinet lighting with service socket**

With option **L50**, cabinet lighting is included with an additional service socket for a SCHUKO connector (connector type F) according to CEE 7/4. The power supply for the cabinet lighting and the service socket is external and must be fuse-protected for max. 10 A.

The cabinet lighting consists of an LED hand lamp with On/Off switch and with magnetic fasteners an approx. 3 m long connecting cable. The lamp is factory-positioned in the cabinet door at a defined marking, and the connecting cable is wound on the associated mount.

**L55****Cabinet anti-condensation heating**

The anti-condensation heating is recommended at low ambient temperatures and high levels of humidity to prevent condensation. Depending on the cabinet width, a 100 W cabinet heater is installed for each Cabinet Module.

1 heating element for cabinet width up to 600 mm,  
2 heating elements for cabinet width over 800 mm.

The power supply for the anti-condensation heating (110 V to 230 V AC, at terminal block -X240) must be provided externally and fused with max. 16 A.

**L61, L62, L64, L65****Braking units**

Braking units may be required for drives in which motors might operate in generator mode, but have no facility for feeding energy back into the supply system.

The braking unit comprises two components:

- A Braking Module that can be installed in the air discharge of the chassis format power units
- A braking resistor to be mounted externally (degree of protection IP20)

The braking unit functions as an autonomous unit and does not require an external power supply. During the braking process, the kinetic energy is converted into heat in the externally mounted braking resistor.

A max. cable length of 100 m is permissible between the Braking Module and the braking resistor. This allows the braking resistor to be mounted externally so that heat losses can be dissipated outside the converter enclosure. The braking resistor is directly connected to the Braking Module.

For SINAMICS S120 Cabinet Modules the following braking modules are available, depending on the frame size:

Option	Can be used with frame sizes	Braking Module		
		Rated power $P_{DB}$ kW	Braking power $P_{20}$ kW	Peak power $P_{15}$ kW
<b>380 ... 480 V 3 AC, 660 ... 690 V 3 AC</b>				
<b>L61</b>	FX	25	100	125
<b>L62</b>	GX, HX, JX	50	200	250
<b>500 ... 600 V 3 AC</b>				
<b>L64</b>	FX	25	100	125
<b>L65</b>	GX, HX, JX	50	200	250

$P_{DB}$ : Rated power (continuous braking power)

$P_{20}$ : 20 s power referred to a braking interval of 90 s

$P_{15}$ : 15 s power referred to a braking interval of 90 s

If the braking units listed here do not provide adequate braking power, up to four braking units on a DC link busbar may be connected in parallel. Braking power can be shared among several Modules. In this case, a Braking Module is assigned to each braking resistor.

**Note:**

It is only possible to use a Braking Module if a DC interface (option **L37**) has not been selected for the Motor Module.

When engineering the system, it should be ensured that the module in which the Braking Module is installed is switched on during braking so that the Braking Module is properly cooled. Failure to follow this instruction means that the Braking Module could overheat and shut down, and the drive will no longer be able to operate in braking mode. In this case, the Braking Modules should preferably be located in the Line Modules.

## SINAMICS S120 Cabinet Modules

### Options

#### Options (continued)

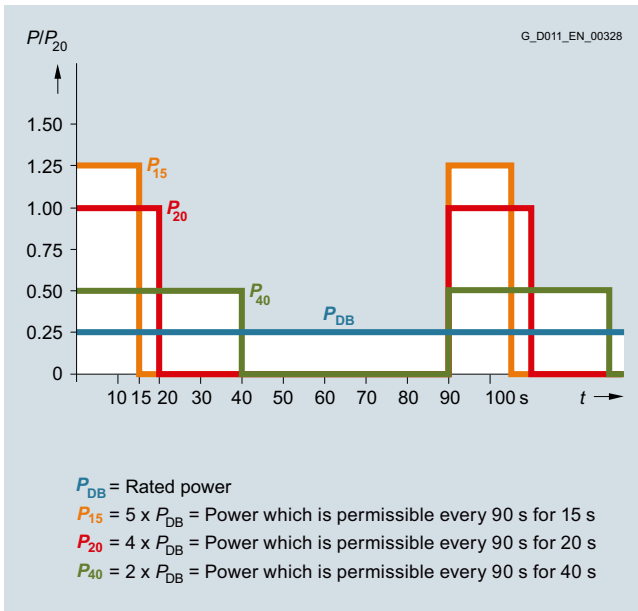

Load diagram for Braking Modules and braking resistors

Additional notes about possible duty cycles of the braking resistors and other engineering notes are included in the SINAMICS Low Voltage Engineering Manual.

#### L87 Insulation monitoring

An insulation monitor must be used if the converter is connected to an ungrounded line supply. The device monitors the entire galvanically coupled circuit for insulation faults.

An alarm is output in the event of a fault.

#### Notice:

Only **one** insulation monitor can be used in each galvanically coupled network.

As there are different response strategies when a ground fault occurs in an ungrounded system, output relays of the insulation monitor are provided for integration in a plant-side control. It is also possible to integrate the outputs into the Cabinet Modules monitoring system on the plant side.

#### M06 Base 100 mm high, RAL 7022

The additional cabinet base allows larger bending radii for cables (cable inlet from below) and enables them to be routed within the cabinet base.

The cabinet base is supplied in RAL 7022 as standard. A special paint finish is not available for the base. It is delivered completely assembled with the cabinet. The height of the operator panel changes accordingly.

#### M07 Cable marshaling compartment 200 mm high, RAL 7035

The cable marshaling compartment is made of strong sheet steel and allows cables to be connected more flexibly (entry from below). It also allows routing of cables within the cable marshaling compartment. It is delivered completely assembled with the cabinet. The height of the operator panel changes accordingly.

#### Notice:

The cable marshaling compartment is painted in RAL 7035 as standard. If a special color is requested for the cabinet (option **Y09**), the cable marshaling compartment is also painted in this color.

#### M21 Degree of protection IP21 (for air cooling only)

Cabinet version in IP20, but with additional top covers or canopies. This increases the cabinet height by 250 mm. For transport reasons, the top covers or canopies are delivered separately and must be fitted on site.

#### Notice:

The top covers or canopies are painted in RAL 7035 as standard. If a special color is requested for the cabinet (option **Y09**), the top covers or canopies are also painted in this color.

Degree of protection IP21 is the standard version for liquid-cooled Cabinet Modules.

#### M23 Degree of protection IP23

Cabinet Modules with degree of protection IP23 are supplied with additional plastic ventilation grilles and a filter medium in the air inlet and outlet. The filter medium must be maintained according to the local environmental conditions. The covers provided with option **M60** are also included in the scope of supply.

The air-cooled Cabinet Modules are additionally supplied with a roof section. This increases the cabinet height by 400 mm. For transport reasons, the roof sections are delivered separately and must be fitted on site.

#### Notice:

The roof sections are painted in RAL 7035 as standard. If a special color is requested for the cabinet (option **Y09**), the roof section is also painted in this color. The molded plastic parts (e.g. ventilation grilles) are in RAL 7035 and cannot be painted.

#### M26 Side panel mounted to the right

For side-by-side installation of Cabinet Modules from left to right, cabinets can be ordered ready-prepared at the factory for assembly on-site. If option **M26** is ordered, the Cabinet Module is shipped with a side panel fitted on the right.

This side panel is essential for ensuring compliance with IP20 and higher degrees of protection.

**Options** (continued)**M27****Side panel mounted to the left**

For side-by-side installation of Cabinet Modules from right to left, cabinets can be ordered ready-prepared at the factory for assembly on-site. If option **M27** is ordered, the Cabinet Module is shipped with a side panel fitted on the left.

This side panel is essential for ensuring compliance with IP20 and higher degrees of protection.

**M43****Degree of protection IP43**

Cabinet Modules with degree of protection IP43 are supplied with additional plastic ventilation grilles and a filter medium in the air inlet and outlet. The filter medium must be maintained according to the local environmental conditions. The covers provided with option **M60** are also included in the scope of supply.

The air-cooled Cabinet Modules are additionally supplied with a roof section. This increases the cabinet height by 400 mm. For transport reasons, the roof sections are delivered separately and must be fitted on site.

Notice:

The roof sections are painted in RAL 7035 as standard. If a special color is requested for the cabinet (option **Y09**), the roof section is also painted in this color. The molded plastic parts (e.g. ventilation grilles) are in RAL 7035 and cannot be painted.

**M51****Motor connection wired to customer terminal**

Option **M51** can only be selected in combination with option **M77** (version without component support plates or additional control components).

With option **M51**, the connection of the motor cable is wired to a customer terminal -X1 and thus makes the process of connecting motor cables easier.

Without option **M51**, the motor cable is connected directly to the Motor Module. In systems with one motor reactor or two series-connected motor reactors (option **L08/L09**), the motor cables are connected directly to the motor reactor.

**M54****Degree of protection IP54 (for air cooling only)**

Cabinet Modules with degree of protection IP54 are supplied with additional roof sections, plastic ventilation grilles, and a filter medium in the air inlet and outlet, which ensures compliance with degree of protection IP54. This increases the cabinet height by 400 mm. For transport reasons, the roof sections are delivered separately and must be fitted on site.

The filters must be maintained according to the local environmental conditions.

Notice:

- The roof sections are painted in RAL 7035 as standard. If a special color is requested for the cabinet (option **Y09**), the roof section is also painted in this color. The molded plastic parts (e.g. ventilation grilles) are in RAL 7035 and cannot be painted.
- For units with degree of protection IP54, it is important to observe the derating factor for output currents in relation to ambient temperature and installation altitude.

**M55****Degree of protection IP55 (for liquid cooling only)**

Cabinet Modules with degree of protection IP55 are supplied with closed doors and roof sheets (without additional roof section). Water jets from any angle are permitted. Because the cabinets are completely enclosed and there is no exchange of air with the environment, it is not necessary to clean a filter medium.

The derating data are provided in the derating characteristics for the liquid-cooled Cabinet Modules.

Almost all heat losses are dissipated into the cooling liquid.

**M56****Reinforced mechanical design**

This option includes a strengthened mechanical version of the cabinet and mechanical locking of the cabinet doors. To secure the converter to the floor, a welding frame (5 mm high) is supplied separately. This option is available for all degrees of protection.

Note:

Option **M56** cannot be combined with option **M70** (EMC shielding busbar).

**M59****Closed cabinet doors, air inlet from below through floor opening**

If the Cabinet Modules are erected on a false floor or duct which forms part of a forced ventilation system, the modules can be ordered with closed cabinet doors. To ensure an adequate air inlet cross-section, the units are shipped without the standard base plates. In this case, the customer must ensure that no dirt/dust or moisture can enter the Cabinet Module. Cables must not be routed in such a way that they impede the flow of air through the cabinet floor opening. If the area beneath the Cabinet Modules can be accessed, the customer must provide touch protection.

**M60****Additional touch protection**

The Cabinet Modules are designed in accordance with DGUV regulation 3 as standard. With option **M60**, additional covers (out of reach) at accessible operator control and switching elements are provided in the area of the AC and DC busbars and in front of the power unit.

Option **M60** is already included in **M23**, **M43**, and **M54** for the following Cabinet Modules.

- Line Connection Modules
- Basic Line Modules
- Smart Line Modules
- Active Line Modules with Active Interface Modules
- Motor Modules chassis
- Central Braking Modules
- Auxiliary Supply Modules

Liquid-cooled Cabinet Modules incorporate additional touch protection as a standard feature - it does not have to be ordered with option **M60**.

**M70****EMC shield bus**

The EMC shield bus is used to connect shielded line and motor supply cables. The shields can be applied over a large surface area with the supplied EMC shield clips.

## SINAMICS S120 Cabinet Modules

### Options

#### Options (continued)

##### M72

##### *Quick-release couplings for water hoses (for liquid cooling only)*

With option **M72**, the ports for connecting the water hoses to the power modules and heat exchangers are fitted with quick-release couplings. The quick-release couplings ensure that no liquid escapes during uncoupling.

The use of quick-release couplings makes disassembly of the power units and heat exchangers considerably easier.

##### M77

##### *Version without component support plates and without additional control components*

If electronic components (Control Unit, Terminal Modules, Sensor Modules) are not used in the Booksize Cabinet Kit, the mechanical component support plates are omitted with option **M77**, including the customer terminal blocks for connecting motor cables.

The motor cables are then connected directly to the Motor Module in booksize format.

When option **L08/L09** is used (motor reactor / 2 motor reactors in series), the motor cables are connected directly to the motor reactor.

The table below provides an overview of possible motor cable connection cross-sections for motor cables connected directly to a Motor Module in booksize format:

Booksize Cabinet Kit	Rated output current of Motor Module	Conductor cross-section
6SL3720-...	A	mm <sup>2</sup>
1TE21-0AB3	9	1.5 ... 6
1TE21-8AB3	18	1.5 ... 6
1TE23-0AB3	30	1.5 ... 6
1TE24-5AB3	45	6 ... 50
1TE26-0AB3	60	6 ... 50
1TE28-5AB3	85	16 ... 120
1TE31-3AB3	132	25 ... 120

#### Note:

When combined with option **M51**, the motor connection is wired to a customer terminal.

##### M80 to M87

##### *DC busbar system*

The correct DC busbar for the Cabinet Module must be ordered. This is fitted in the upper section of the Cabinet Modules and connects the Line Modules to the Motor Modules.

The busbar is dimensioned according to the load requirements and demand factor associated with operation of the individual drives, and according to the specific Cabinet Module layout. For this reason, the DC busbar is not supplied as standard, but must be ordered as an option.

When selecting busbars, it is important to ensure that the systems of adjacent Cabinet Modules are compatible with one another (refer to the table below and option selection matrix for the Cabinet Modules in question).

Where Cabinet Modules are ordered as a factory-assembled transport unit with option **Y11**, all busbars in the transport unit must be identical.

Order code	DC busbar system, rated current $I_{rated}$ A	Number	Dimensions mm	Compatible with
<b>M80</b>	1170	1	60 × 10	<b>M83</b>
<b>M81</b>	1500	1	80 × 10	<b>M84 and M86</b>
<b>M82</b>	1840	1	100 × 10	<b>M85 and M87</b>
<b>M83</b>	2150	2	60 × 10	<b>M80</b>
<b>M84</b>	2730	2	80 × 10	<b>M81 and M86</b>
<b>M85</b>	3320	2	100 × 10	<b>M82 and M87</b>
<b>M86</b>	3720	3	80 × 10	<b>M81 and M84</b>
<b>M87</b>	4480	3	100 × 10	<b>M82 and M85</b>

The DC busbars are nickel-plated as standard and are available in different designs for a variety of current-carrying capacities. The scope of delivery also includes the jumpers required to link the busbar systems of individual Cabinet Modules.

##### M88

##### *DC busbar system for line-side Cabinet Modules (for liquid cooling only)*

Option **M88** is required if Motor Modules are to be installed to the left or if up to four Basic Line Connection Modules or Active Line Connection Modules are to be connected for a parallel connection.

For this purpose, DC busbars are built into the upper part on the left hand side in the line-side Cabinet Module of each Active Line Connection Module and Basic Line Connection Module.

The busbars are nickel-plated as standard and are selected for different current carrying capacities as for the selected options **M80 to M87**.

##### M90

##### *Crane transport assembly (top-mounted)*

A top-mounted crane transport assembly can be ordered as an option for Cabinet Modules.

Depending on the width of the module, it consists of either transport eyebolts (width ≤ 800 mm) or transport rails (width > 800 mm).

When Cabinet Modules are ordered as factory-assembled transport units (option **Y11**), they are shipped with transport rails, i.e. option **M90** is automatically included in the scope of delivery of option **Y11** and does not need to be ordered separately.



**Options** (continued)**M91****Marking of all control cable conductor ends (incl. customer-specific wiring)**

When this option is selected, all control cables or conductor ends (including all customer-specific options) are labeled throughout the cabinet.

**N52****DC link fuses**

The Basic Line Modules (air-cooled), Active Line Connection Modules and Basic Line Connection Modules (liquid-cooled) come without DC link fuses as standard.

If fuses are required, they can be ordered with option **N52**. The fuses are mounted on the connecting rail to the DC busbar in the cabinet rather than in the power unit.

The use of DC link fuses is recommended when Basic Line Modules, Active Line Connection Modules, and Basic Line Connection Modules are connected in parallel.

The Motor Modules contain DC link fuses as standard.

**P10****Measuring instrument for line values, mounted in the cabinet door**

A measuring instrument with display, installed in the cabinet door of the Line Connection Module, for acquiring measured values of the power supply. In addition to these measured values, additional plant values (such as power and power factor, etc.) are calculated from the measured values using powerful, state-of-the-art microprocessors.

Current transformers (option **L41**) are already included in the scope of delivery.

**P11****Measuring instrument for line values with PROFIBUS connection, mounted in the cabinet door**

A measuring instrument with display, installed in the cabinet door of the Line Connection Module, for acquiring measured values of the power supply. In addition to these measured values, additional plant values (such as power and power factor, etc.) are calculated from the measured values using powerful, state-of-the-art microprocessors. The measuring instrument has a PROFIBUS interface that permits a data transfer rate of up to 12 Mbps.

Current transformers (option **L41**) are already included in the scope of delivery.

**T58, T60, T80, T83, T85, T91****Rating plate data**

The rating plate is provided in English/German as standard. A rating plate in another language combination can be selected by specifying the following option order codes.

Option	Rating plate language
<b>T58</b>	English/French
<b>T60</b>	English/Spanish
<b>T80</b>	English/Italian
<b>T83</b>	English/Portuguese (Brazil)
<b>T85</b>	English/Russian
<b>T91</b>	English/Chinese

**W01****Heat Exchanger Module, partially redundant with 2 pumps**

The Heat Exchanger Module is equipped with a pump and a plate-type heat exchanger as standard. With option **W01**, two redundant pumps with two dirt traps and non-return valves are fitted. The pumps, which operate alternately, pump the hot coolant of the deionized water circuit on the converter side into the plate-type heat exchanger and there it is cooled by the raw water of the plant-side circuit.

System reliability is increased as a result of the alternating operation of the redundant pumps. The time in hours can be parameterized. In addition, the dirt traps can be cleaned independently and during operation, as shutoff valves are installed before and after the individual pumps.

**Note:**

Option **W01** increases the cabinet width by 400 mm and its weight by 110 kg.

**W10****Pipe insulation in the raw water circuit**

With this option, the pipes in the raw water circuit are insulated. This means that if the raw water on the plant side is too cold, condensation does not occur on the pipes and liquid does not collect in the Heat Exchanger Module.

**W20****Raw water connection from the bottom**

The raw water from the supply is fed into the Heat Exchanger Module from above as standard. With option **W20**, the plant-side raw water connection in the Heat Exchanger Module is at the bottom.

The piping system is made of W 1.4404 (V4A, AISI 316) stainless steel.

**W34****Heat Exchanger Module for installation on the left**

With this option, a fixed pipe connection is routed downward on the right-hand side. This option is required to install the Heat Exchanger Module at the left-hand end of the drive line-up and to connect it to the deionized water circuit on the converter side. The connecting parts are enclosed.

**W36****Heat Exchanger Module for installation on the right**

With this option, a fixed pipe connection is routed downward on the left-hand side. This option is required to install the Heat Exchanger Module at the right-hand end of the drive line-up and to connect it to the deionized water circuit on the converter side. The connecting parts are enclosed.

**W43****Release valve in the deionized water circuit**

A release valve is installed between the intake and return in the converter-side deionized water circuit. The valve limits the discharge pressure of the circulating pumps. As soon as the discharge pressure exceeds the value set at the valve, the valve opens the bypass.

**W49****Leakage sensor in the Heat Exchanger Module, at the bottom in the cabinet floor**

With this option, a leakage sensor is installed in the cabinet floor of the Heat Exchanger Module. The installed evaluation module is connected to a digital input of the TM31 Terminal Module. When a leak is detected, a corresponding alarm or fault (can be parameterized) is output.

## SINAMICS S120 Cabinet Modules

### Options

#### Options (continued)

##### W62

##### *Sensors in the raw water circuit on the plant/system side*

With this option, a flow monitor and a Pt1000 temperature sensor are installed in the intake of the plant-side raw water circuit. The signals are transferred to the TM31 or TM150 Terminal Module. This means that the flow and temperature can be monitored. The temperature alarm limit can be parameterized in the Control Unit. The flow signal is parameterized at the sensor, and is evaluated by the TM31 Terminal Module.

##### Y09

##### *Special cabinet paint finish*

The Cabinet Modules are delivered in RAL 7035 as standard. The special paint finish must be specified in plain text when ordering. Any RAL colors that are available as powdered coatings can be selected.

##### Notice:

If options such as cable marshaling compartment (option **M07**), top covers or canopies (option **M21**) or roof sections (options **M23/M43/M54**) are ordered for the Cabinet Modules, they will also be supplied in the paint finish specified for the cabinet in the order. The molded plastic parts (e.g. ventilation grilles) are in RAL 7035 and cannot be painted.

##### Y11

##### *Factory assembly into transport units*

With this option, Cabinet Modules can be ordered as factory-assembled transport units with a maximum total width of up to 2400 mm. In this case, the relevant modules are shipped as interconnected units (both electrically and mechanically).

When DC busbars (options **M80** to **M87**) are selected, it must be ensured that identical busbars are installed within the transport unit and are compatible with all adjacent Cabinet Modules.

In the case of a transport unit order, all the Cabinet Modules to be included in the unit and their installation sequence from left to right must be specified in plain text according to the syntax below:

Plain text required to order	TE	1	-	1 ... 6
• Transport unit (TU)				
• Serial number of transport unit				
• Position of Cabinet Module within transport unit from left to right				

In the case of air-cooled Cabinet Modules, option **Y11** is recommended when creating units comprising Line Connection Modules with Line Modules because the required pre-charging circuits and connection busbars, for example, can be incorporated for certain versions. Please refer to the assignment tables for the Line Connection Modules.

With liquid-cooled Cabinet Modules, option **Y11** is especially recommended to reduce the number of connection elements used in the cooling circuit on the converter side. It results in lower resistance to flow and avoids leaks. Option **Y11** is not admissible in combination with Heat Exchanger Modules.

The transport unit is shipped with a crane transport rail, which means that option **M90** is not required.

##### Y31

##### *One-line label for system identification, 40 × 80 mm*

Resopal labeling plates (white with black lettering) for identifying Cabinet Modules are available. The labels are stuck to the cabinet door.

Dimensions H × W: 40 × 80 mm

The text must be specified in plain text when ordering.

Field 1: Max. 9 characters, font size 10 mm

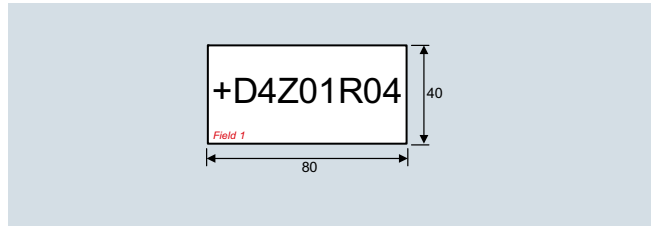

##### Y32

##### *Two-line label for system identification, 40 × 180 mm*

Resopal labeling plates (white with black lettering) for identifying Cabinet Modules are available. The labels are stuck to the cabinet door.

Dimensions H × W: 40 × 180 mm

The text must be specified in plain text when ordering.

Field 1: Max. 9 characters, font size 10 mm

Field 2: Max. 9 characters, font size 10 mm

Field 3: Max. 20 characters, font size 10 mm

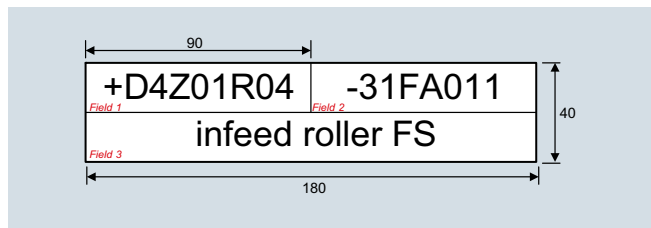

##### Y33

##### *Four-line label for system identification, 40 × 180 mm*

Resopal labeling plates (white with black lettering) for identifying Cabinet Modules are available. The labels are stuck to the cabinet door.

Dimensions H × W: 40 × 180 mm

The text must be specified in plain text when ordering.

Field 1: Max. 9 characters, font size 10 mm

Field 2: Max. 20 characters, font size 6 mm

Field 3: Max. 20 characters, font size 6 mm

Field 4: Max. 20 characters, font size 6 mm

Field 5: Max. 20 characters, font size 6 mm

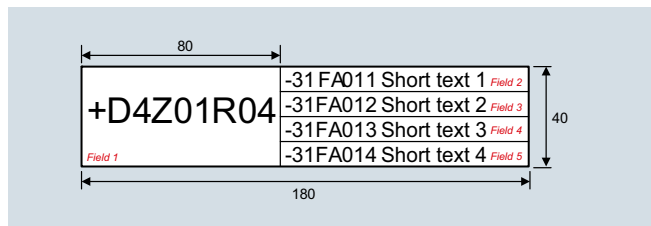

## SINAMICS S120 Cabinet Modules

### Supplementary system components

#### Mounting device for air-cooled power blocks

##### Overview



Power block mounting device for installing and removing the power blocks for the Basic Line Modules, Smart Line Modules, Active Line Modules and Motor Modules in chassis format.

The mounting device is a mounting aid. It is placed in front of the module and attached to the module. The telescopic rails allow the device to be adjusted to the installation height of the power blocks.

Once the mechanical and electrical connections have been released, the power block can be removed from the module.

The power block is guided and supported by the guide rails on the handling device.

##### Selection and ordering data

Description	Article No.
<b>Mounting device</b> For installing and removing power blocks	<b>6SL3766-1FA00-0AA0</b>

4

#### Mounting device for liquid-cooled power units

##### Overview

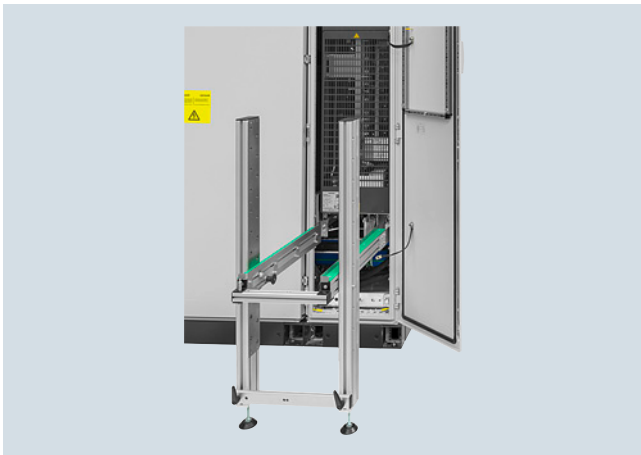

The mounting device is used to install or remove liquid-cooled power units (Line Modules, Motor Modules) in or out of a control cabinet. The mounting device can be used if the power units are mounted on mounting rails, which at the front have two M6 threads at a vertical distance of 20 mm to attach the mounting device.

The mounting device is a mounting aid. It is placed in front of the power unit and attached to the mounting rails below the power unit. The telescopic rails allow the mounting device to be adjusted to the installation height and width of the power unit. The power unit can be removed from the control cabinet after releasing the mechanical and electrical connections and the coolant connections. The power unit is guided and supported by the guide rails on the mounting device. To prevent it toppling over, the power unit must be secured to a crane, tripod, or similar assembly using the lifting lugs or the lifting equipment. The unit can then be lowered down from the mounting device.

##### Selection and ordering data

Description	Article No.
<b>Mounting device</b> For installing and removing power units	<b>6SL3766-1CA00-0AA0</b>



## SINAMICS S120 Cabinet Modules

### Order-specific integration engineering

#### Overview

Just like the SINAMICS S120 chassis units, SINAMICS S120 Cabinet Modules form a modular drive system that consists of various intelligent Drive Objects such as Line Modules, Motor Modules, Control Units, Sensor Modules, etc.

As a consequence, SINAMICS S120 Cabinet Modules are supplied with documentation that only includes and describes the individual Cabinet Modules (circuit diagram, layout diagram, terminal diagram and additional Operating Instructions).

By selecting option **Y11**, individual Cabinet Modules are assembled at the factory as interconnected units for transport and are then supplied as such.

Detailed documentation showing features such as the signal connections between the individual Cabinet Modules that make up the order, is not included in the normal scope of delivery.

In this case, only a collection of the individual documents are shipped with the converter.

If the documentation is to include a complete representation of the equipment supplied, the equipment and documentation must be additionally processed. This can be ordered with the integration engineering.

Integration engineering includes the following:

- Checking the combinations and options ordered, in relation to the device configurations
- Defining how the individual drive objects are to be connected and coordinated, with the customer if required
- Checking the performance of the ordered CompactFlash card
- Installing the required DRIVE-CLiQ cables within the transport units.  
Cables between the transport units are connected at one end
- Higher-level documentation of the scope of delivery (layout diagram, circuit diagram, terminal diagram, dimension drawing, spare parts list)
- Summary of the individual documents included in a shipment, in conjunction with a delivery address separate from the equipment
- Customer-specific system and location designations, coordinated with the customer

#### Note:

The order-specific integration engineering is especially recommended for liquid-cooled Cabinet Modules.

#### Selection and ordering data

The following engineering services can be ordered depending on the number of drives/axes included in an order:

Integration engineering	Article No.
<b>For 1 drive</b> (also parallel connection) including the associated Line Modules, Sensor Modules, Terminal Modules, etc.	<b>6SL3780-0AA00-0AA0</b>
<b>For up to 3 drives</b> (also parallel connection) including the associated Line Modules, Sensor Modules, Terminal Modules, etc.	<b>6SL3780-0AC00-0AA0</b>
<b>For up to 5 drives</b> (also parallel connection) including the associated Line Modules, Sensor Modules, Terminal Modules, etc.	<b>6SL3780-0AE00-0AA0</b>
<b>For up to 10 drives</b> (also parallel connection) including the associated Line Modules, Sensor Modules, Terminal Modules, etc.	<b>6SL3780-0AJ00-0AA0</b>

Engineering services for larger drive systems are also available on request.

#### Options

The table below lists the options available for order-specific integration engineering (for details, see [Description of the options](#)):

Available options	Order code
Customer documentation (circuit diagram, terminal diagram, layout diagram) in DXF format	<b>D02</b>
Preliminary version of customer documentation in PDF format	<b>D14</b>
Documentation in English / French	<b>D58</b>
Documentation in English / Spanish	<b>D60</b>
Documentation in English / Italian	<b>D80</b>
Documentation in English / Chinese	<b>D91</b>
Documentation in English / Russian	<b>D94</b>

When ordering the order-specific integration engineering, the required documentation options must always be ordered together with the order engineering (not to the individual Cabinet Modules).

Ordering the documentation options for the particular Cabinet Modules is only required if equipment is ordered without integration engineering.

#### Option selection matrix of the order-specific integration engineering

Certain options are mutually exclusive.

✓	Possible combination
–	Combination not possible

	D02	D14	D58	D60	D80	D91	D94
D02		✓	✓	✓	✓	✓	✓
D14	✓		✓	✓	✓	✓	✓
D58	✓	✓		–	–	–	–
D60	✓	✓	–		–	–	–
D80	✓	✓	–	–		–	–
D91	✓	✓	–	–	–		–
D94	✓	✓	–	–	–	–	

**More information****Customized solutions**

In addition to the wide range of possibilities of configuring drives with the available modules and options to address specific plant and system requirements, for special applications we also offer customized applications to fully comply with the actual requirement.

These are based on the standard SINAMICS S120 Cabinet Modules and are supplied as completely wired units that are ready to be connected up.

Examples of applications such as these include:

- **SINAMICS S120 Cabinet Modules**

- **Application Marine Drive**

The range of requirements that drive systems have to meet aboard a ship is enormous – and highly varied. In addition to maximum efficiency and reliability, compactness is absolutely essential given the confined spaces. The systems used must also be low-maintenance, service-friendly, and in every way suitable for marine applications. Siemens' answer to these requirements is the SINAMICS S120 Cabinet Modules Application Marine Drive.

The innovative liquid-cooled drive system for all marine applications is based on the SINAMICS platform, which is a proven success worldwide. Its footprint has been optimized for use on board and it impresses with its flexibility and economic efficiency.

- **SINAMICS S120 Switch-Over Modules**

In order to operate different motors at different times on a common converter, SINAMICS S120 Switch-Over Modules are the ideal solution.

A Switch-Over Module switches the output of the Motor Module over to the motor that is required.

If, for example, processes powered by specific motors run subsequently at different times, or if the individual motor is only briefly used during the day, then costs and space can be saved by using just one converter, supplemented with the corresponding Switch-Over Module.

Such applications include, for instance, pump drives on tankers when various ship compartments have to be emptied one after the other, or container cranes, if in addition to the drive for loading and unloading, the drive for operating the boom also has to be fed from the converter.

- **SINAMICS S120 Motor Multi-Connection Modules**

For applications performed in combination with group drives that require a different number of multi-motor outputs, SINAMICS S120 Motor Multi-Connection Modules are a sensible choice.

Motor Modules are supplemented with a corresponding control system, as well as switching and protection devices. This configuration allows the associated motors with small power ratings (motor groups) to be operated from a common converter with a high power rating.

The completely prewired, ready-to-connect cabinet units facilitate and shorten the commissioning procedure. The transparent and flexible design allows changes and additions to be made at any time at low associated costs.

Simply contact us if you are interested or require these or any other applications.

Notes regarding the addresses of contact persons are provided in the appendix under "Contact partners for Industry Automation and Drive Technologies."



Cement mill



Ship docked in port



Oil rig

## SINAMICS S120 Cabinet Modules

### Notes

# SINAMICS S150 Converter Cabinet Units

# 5



## 5/2 **SINAMICS S150 converter cabinet units**

- 5/2 Overview
- 5/2 Benefits
- 5/3 Application
- 5/3 Selection and ordering data
- 5/4 Design
- 5/6 Function
- 5/8 Technical specifications
- 5/15 Characteristic curves
- 5/18 Options

## 5/22 **Description of the options**

## 5/36 **Line-side components – recommended fuses**

## 5/37 **Cable cross-sections and connections**

## 5/39 **Supplementary system components**

- 5/39 Mounting device for power blocks

## SINAMICS S150 Converter Cabinet Units

### SINAMICS S150 converter cabinet units

#### Overview



SINAMICS S150 converter cabinet units are particularly suitable for all variable-speed single-axis drives with high performance requirements, i.e. drives with:

- High dynamic requirements
- Frequent braking cycles and high braking energy levels
- Four-quadrant operation

SINAMICS S150 offers high-performance speed control with excellent accuracy and a high dynamic response.

The following voltages and power ratings are available:

Line voltage	Type rating
380 ... 480 V 3 AC	110 ... 800 kW
500 ... 690 V 3 AC	75 ... 1200 kW

Degrees of protection are IP20 (standard) and optionally IP21, IP23, IP43 and IP54.

Line and motor-side components as well as additional monitoring devices can be installed in the converter cabinet units.

A wide range of electrical and mechanical components enable the drive system to be optimized individually to suit customer requirements.

#### Benefits

The self-commutating, pulsed infeed/regenerative unit uses IGBT technology and is equipped with a Clean Power Filter. This combination guarantees extremely line-friendly behavior which is characterized by the following:

- Negligible line harmonics as a result of the Clean Power Filter ( $\ll 1\%$ )
- The stringent limit values of IEEE 519 (2014) are complied with, without any exceptions. The total harmonic distortion factors of current THD(I) and voltage THD(U) are typically in the range of approx. 3 %.
- Regenerative feedback (four-quadrant operation)
- Tolerant to fluctuations in the line voltage
- Operation on weak line supplies
- Reactive power compensation is possible (inductive or capacitive)
- High drive dynamic performance

In addition, factors have been considered to ensure easy handling of the drive from the planning and design phase through to operation. These factors include:

- Compact, modular design with an optimum degree of service friendliness
- Straightforward configuring and commissioning thanks to assistance provided by the SIZER for Siemens Drives and STARTER tools
- Simple installation, as it is ready to be connected up
- Fast, menu-prompted commissioning with no complex parameterization
- Clear and convenient drive monitoring/diagnostics, commissioning and operation via a user-friendly graphical operator panel with measured values displayed in plain text or in a quasi-analog bar display.
- SINAMICS as an integral part of Totally Integrated Automation (TIA). The TIA concept offers an optimized range of products for automation and drive technology. This concept is characterized by configuration, communication, and data management that are consistent throughout the product range. SINAMICS is fully integrated in the TIA concept. Separate S7/PCS7 blocks and faceplates for WinCC are available.
- Integration in SIMATIC H systems via Y-Link
- SINAMICS Drive Control Chart (SINAMICS DCC) SINAMICS DCC is an additional tool for the easy configuration of process-oriented functions for SINAMICS. The block library encompasses a large selection of closed-loop, arithmetic and logic blocks, as well as a more comprehensive range of open-loop and closed-loop control functions. The user-friendly DCC editor enables easy graphics-based configuration, allows control loop structures to be clearly represented and provides a high degree of reusability of charts that have already been created. SINAMICS DCC is an add-on to the STARTER commissioning tool.

**Application**

SINAMICS S150 is especially suitable for use in all applications that place the highest demands on process operations with dynamic, reproducible processes. These include, for example:

- Test bays
- Centrifuges
- Elevators and cranes
- Cross cutters and shears
- Conveyor belts with a high power demand and energy recovery
- Presses
- Cable winches

**Selection and ordering data**

Type rating at 400 V or 690 V kW	Rated output current $I_{rated}$ A	<b>SINAMICS S150 converter cabinet unit</b> Article No.
<b>Line voltage 380 ... 480 V 3 AC</b>		
110	210	<b>6SL3710-7LE32-1AA3</b>
132	260	<b>6SL3710-7LE32-6AA3</b>
160	310	<b>6SL3710-7LE33-1AA3</b>
200	380	<b>6SL3710-7LE33-8AA3</b>
250	490	<b>6SL3710-7LE35-0AA3</b>
315	605	<b>6SL3710-7LE36-1AA3</b>
400	745	<b>6SL3710-7LE37-5AA3</b>
450	840	<b>6SL3710-7LE38-4AA3</b>
560	985	<b>6SL3710-7LE41-0AA3</b>
710	1260	<b>6SL3710-7LE41-2AA3</b>
800	1405	<b>6SL3710-7LE41-4AA3</b>
<b>Line voltage 500 ... 690 V 3 AC</b>		
75	85	<b>6SL3710-7LG28-5AA3</b>
90	100	<b>6SL3710-7LG31-0AA3</b>
110	120	<b>6SL3710-7LG31-2AA3</b>
132	150	<b>6SL3710-7LG31-5AA3</b>
160	175	<b>6SL3710-7LG31-8AA3</b>
200	215	<b>6SL3710-7LG32-2AA3</b>
250	260	<b>6SL3710-7LG32-6AA3</b>
315	330	<b>6SL3710-7LG33-3AA3</b>
400	410	<b>6SL3710-7LG34-1AA3</b>
450	465	<b>6SL3710-7LG34-7AA3</b>
560	575	<b>6SL3710-7LG35-8AA3</b>
710	735	<b>6SL3710-7LG37-4AA3</b>
800	810	<b>6SL3710-7LG38-1AA3</b>
900	910	<b>6SL3710-7LG38-8AA3</b>
1000	1025	<b>6SL3710-7LG41-0AA3</b>
1200	1270	<b>6SL3710-7LG41-3AA3</b>



# SINAMICS S150 Converter Cabinet Units

## Converter cabinet units

### Design

The SINAMICS S150 converter cabinet units are characterized by their compact, modular and service-friendly design.

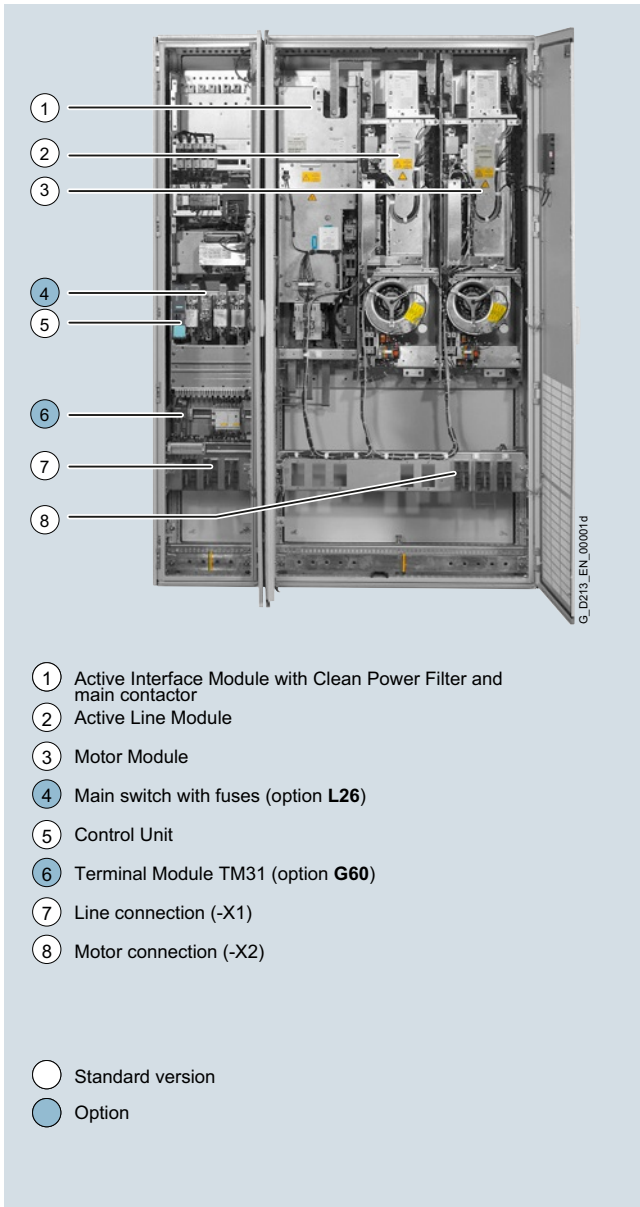

Design example of a SINAMICS S150 converter cabinet unit

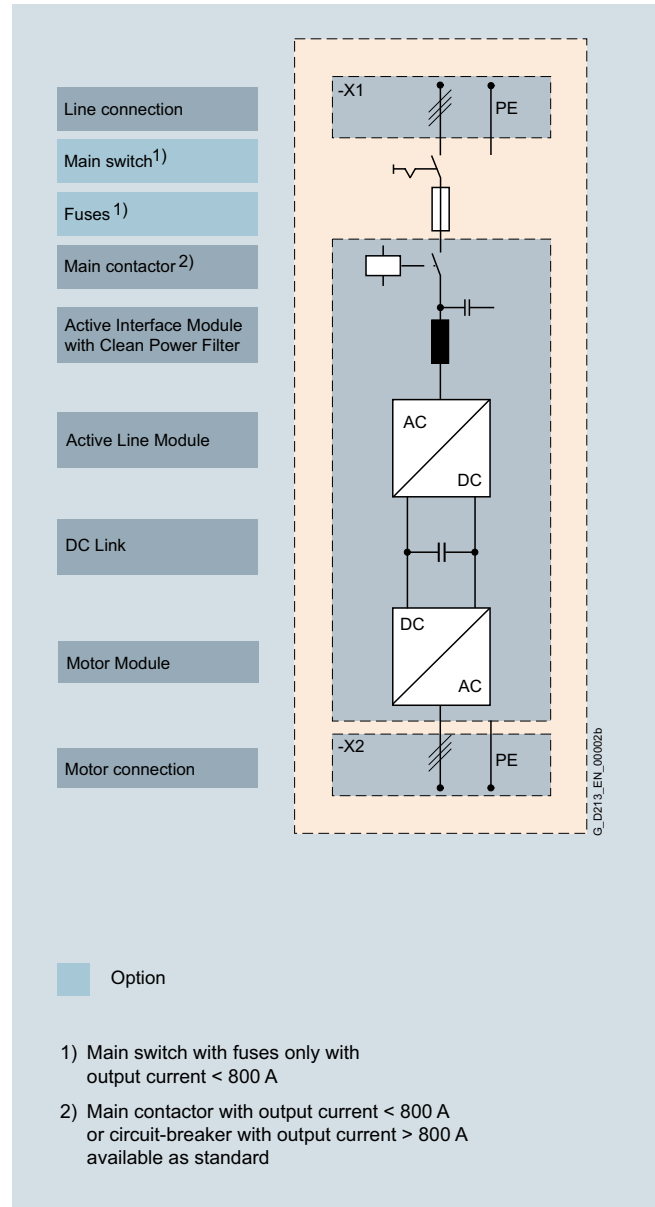

Basic design of a SINAMICS S150 converter cabinet unit with a number of version-specific options

**Design** (continued)**Coated modules**

The following devices are equipped as standard with coated modules:

- Chassis format units
- Control Units
- Sensor Modules
- Terminal Modules
- Advanced Operator Panel (AOP30)

The coating on the modules protects the sensitive SMD components against corrosive gases, chemically active dust and moisture.

**Nickel-plated busbars**

All of the copper busbars used in the converter cabinets are nickel-plated in order to achieve the best possible immunity to environmental effects. Further, it is possible to eliminate having to clean the contacts at the customer connections, which is required for bare copper connections.

**Note:**

With some options, parts of the copper busbars cannot be nickel-plated for technical reasons.

**Degrees of protection**

The EN 60529 standard covers the protection of electrical equipment by means of housings, covers or equivalent, and includes:

- Protection of persons against accidental contact with live or moving parts within the housing and protection of the equipment against the ingress of solid foreign bodies (touch protection and protection against ingress of solid foreign bodies)
- Protection of the equipment against the ingress of water (water protection)
- Abbreviations for the internationally agreed degrees of protection

The degrees of protection are specified by abbreviations comprising the code letters IP and two digits.

Degree of protection	First digit (Touch protection and protection against foreign bodies)	Second digit (Protection of equipment against the ingress of water)
<b>IP20</b> (Standard)	Protected against solid foreign bodies with a diameter $\geq 12.5$ mm	No water protection
<b>IP21</b> (Option <b>M21</b> )	Protected against solid foreign bodies with a diameter $\geq 12.5$ mm	Protected against drip water Vertically falling water drops must not have any harmful effects.
<b>IP23</b> (Option <b>M23</b> )	Protected against solid foreign bodies with a diameter $\geq 12.5$ mm	Protected against spray water Water sprayed on both sides of the vertical at an angle of up to $60^\circ$ shall not have a harmful effect.
<b>IP43</b> (Option <b>M43</b> )	Protected against solid foreign bodies diameter $\geq 1$ mm	Protected against spray water Water sprayed on both sides of the vertical at an angle of up to $60^\circ$ shall not have a harmful effect.
<b>IP54</b> (Option <b>M54</b> )	Dust protected Ingress of dust is not totally prevented, but dust must not be allowed to enter in such quantities that the functioning or safety of the equipment is impaired.	Protected against splash water Water splashing onto the housing from any direction must not have any harmful effects.



# SINAMICS S150 Converter Cabinet Units

## Converter cabinet units

### Function

#### AOP30 Advanced Operator Panel

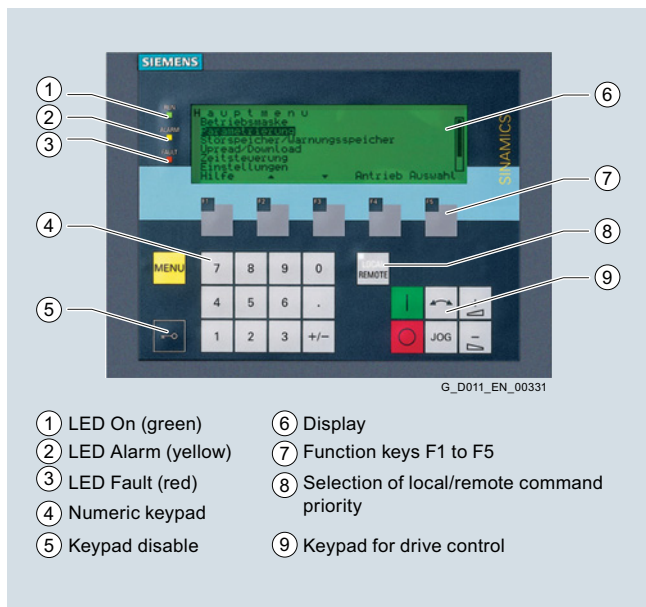

An Advanced Operator Panel (AOP30) is installed in the cabinet door of the converter for operation, monitoring and commissioning tasks.

The user is guided by interactive menus through the drive commissioning screens. When the drive is commissioned for the first time, only 6 motor parameters (which can be found on the motor rating plate) have to be entered on the AOP30. The closed-loop control is then optimized automatically to adapt the converter to the motor.

The AOP30's two-stage safety concept prevents unintentional or unauthorized changes to settings. Operation of the drive from the operator panel can be disabled by the keyboard lock and so that only parameter values and process variables can be displayed on the operator panel. The OFF key is factory-set to "active", but can be deactivated by the customer. A password can be used to prevent the unauthorized changing of converter parameters.

German, English, French, Italian, Spanish and Chinese are stored on the CU320-2 Control Unit CompactFlash card as operator panel languages. The desired language must be downloaded to the AOP30 prior to commissioning. In addition to these standard operator panel languages, Russian can also be retro-installed. Further languages are available on request.

Examples of plain-text displays during various phases of operation are shown below.

The **first commissioning** is performed via the operator panel.

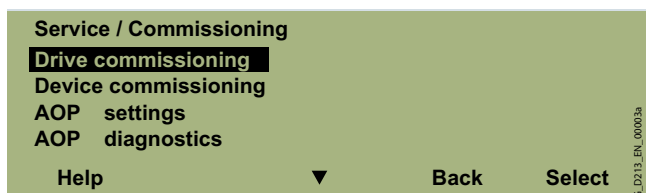

Only 6 motor parameters have to be entered: Power, speed, current, cos φ, voltage and frequency of the motor.

This information can be found on the motor rating plate, and must be entered in the screens on the display by following a short, menu-assisted procedure. The motor cooling method must also be specified.

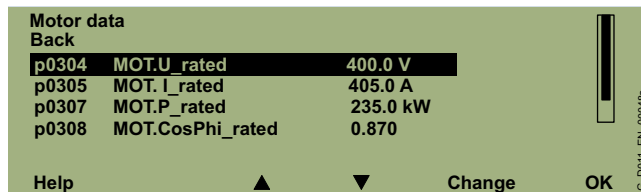

The next screen contains the parameter values that are used to automatically optimize the control.

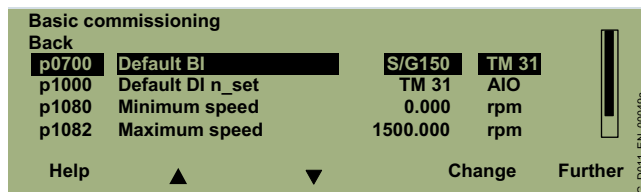

During operation, the display shows current data, such as set-points and actual values as absolute values or it is possible to parameterize up to 3 process variables as a quasi-analog bar display.

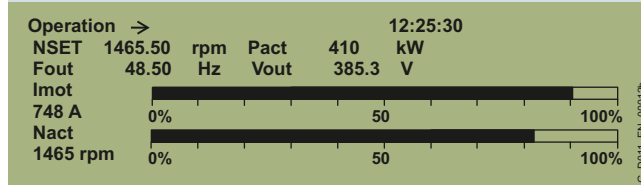
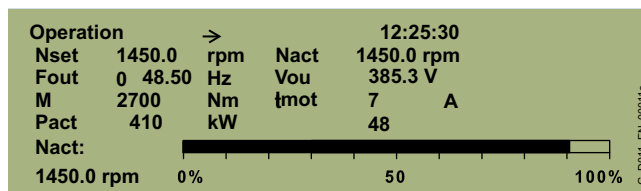

Any **alarms** that occur are signaled by flashing of the yellow ALARM LED, **faults** by the red FAULT LED, which is then lit. There is also an indication of the cause displayed in plain text on the display's status line (with counter/remedial measures).

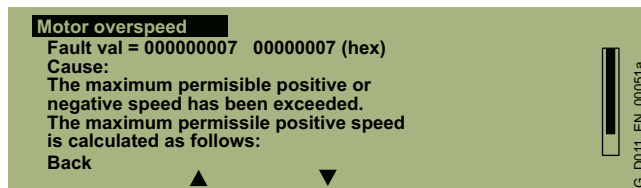
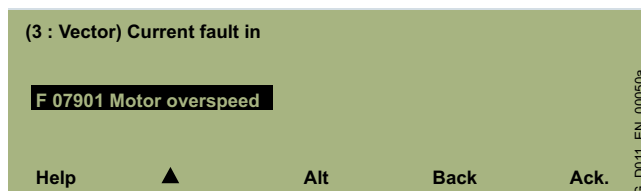

**Function** (continued)**Communication with higher-level controller and customer terminal block**

A PROFIBUS or PROFINET interface on the Control Unit CU320-2 is provided as standard as the customer control interface.

This interface can be used to connect the system to the higher-level controller using analog and digital signals, or to connect additional units.

The inputs and outputs available as standard can be optionally expanded by up to two Terminal Modules TM31 (refer to the [description of options, option G60 or G61](#)). To simplify configuration and commissioning of the drive, the TM31 Terminal Module can be preset to a variety of factory settings.

For additional information, please refer to the [SINAMICS Low Voltage Engineering Manual](#).

**Open-loop and closed-loop control functions**

SINAMICS S150 has a high-dynamic vector control with speed and current control – with and without speed actual value feedback.

**Software and protective functions**

The software functions available as standard are described below.

Software and protective functions	Description
<b>Setpoint input</b>	The setpoint can be specified both internally and externally; internally as a fixed setpoint, motorized potentiometer setpoint or jog setpoint, externally via the communications interface or an analog input. The internal fixed setpoint and the motorized potentiometer setpoint can be switched or adjusted via control commands from any interface.
<b>Motor identification</b>	The automatic motor identification function makes commissioning faster and easier and optimizes closed-loop control of the drive.
<b>Ramp-function generator</b>	A user-friendly ramp-function generator with separately adjustable ramp-up and ramp-down times, together with adjustable rounding times in the lower and upper speed ranges, allows the drive to be smoothly accelerated and braked. This results in a good speed control response and plays its role in reducing the stress on the mechanical system. The down ramps can be parameterized separately for quick stop.
<b>V<sub>dc max</sub> controller</b>	The V <sub>dc max</sub> controller automatically prevents overvoltages in the DC link, if the set down ramp is too short, for example. This may also extend the set ramp-down time.
<b>Kinetic buffering (KIP)</b>	For brief line supply failures, the kinetic energy of the rotating drive is used to buffer the DC link and therefore prevents fault trips. The drive converter remains operational as long as the drive can provide regenerative energy as a result of its motion and the DC link voltage does not drop below the shutdown threshold. When the line supply recovers within this time, the drive is again seamlessly accelerated up to its setpoint speed.
<b>Automatic restart</b>	The automatic restart switches the drive on again when the power is restored after a power failure, and ramps up to the current speed setpoint.
<b>Flying restart</b>	The flying restart function allows the converter to be switched to a motor that is still turning. With the voltage sensing capability provided by the optional VSM10, the flying restart time for large induction motors can be significantly reduced because the motor does not need to be de-magnetized.
<b>Technology controller</b>	The technology controller function module allows simple control functions to be implemented, e.g. level control or volumetric flow control and complex tension controls. The existing D component can act both on the system deviation well as on the actual value (factory setting). The P, I, and D components are set separately.
<b>Free function blocks</b>	Using the freely programmable function blocks, it is easy to implement logic and arithmetic functions for controlling the SINAMICS drive. The blocks can be programmed at the operator panel or the STARTER commissioning tool.
<b>SINAMICS Drive Control Chart (SINAMICS DCC)</b>	SINAMICS DCC is an additional tool for the easy configuration of technological functions for SINAMICS. The block library contains a large selection of control, arithmetic and logic blocks as well as extensive open-loop and closed-loop control functions. The user-friendly DCC editor enables easy graphics-based configuration, allows control loop structures to be clearly represented and provides a high degree of reusability of charts that have already been created. SINAMICS DCC is an add-on to the STARTER commissioning tool (→ Tools and Engineering).
<b><math>\hat{P}t</math> sensing for motor protection</b>	A motor model stored in the converter software calculates the motor temperature based on the current speed and load. More exact measurement of the temperature, which also takes into account the influence of the ambient temperature, is possible by means of direct temperature measurement using KTY84 sensors in the motor winding.
<b>Motor temperature evaluation</b>	Motor protection by evaluating a KTY84, PTC or Pt100 temperature sensor. When a KTY84 temperature sensor is connected, the limit values can be set for alarm or shutdown. When a PTC thermistor is connected, the system reaction to triggering of the thermistor (alarm or trip) can be defined.
<b>Motor blocking protection</b>	A blocked motor is detected and protected against thermal overloading by a fault trip.
<b>Brake control</b>	"Simple brake control" for control of holding brakes: The holding brake is used to secure drives against unwanted motion when deactivated. "Extended brake control" function module for complex brake control, e.g. for motor holding brakes and operational brakes: When braking with a feedback signal, the brake control reacts to the feedback signal contacts of the brake.
<b>Essential service mode</b>	Special converter operating mode that increases the availability of the drive system, e.g. in the event of a fire.
<b>Write protection</b>	Write protection to prevent unintentional changing of the setting parameters (without password function).
<b>Know-how protection</b>	Know-how protection for encrypting stored data, e.g. to protect configuration know-how, and to protect against changes and duplication (with password function).
<b>Web server</b>	The integrated web server provides information about the drive unit via its web pages. The web server is accessed using an Internet browser via unsecured (http) or secured transmission (https).

# SINAMICS S150 Converter Cabinet Units

## Converter cabinet units

### Function (continued)

#### Power unit protection

Power unit protection	Description
<b>Ground fault monitoring at the output</b>	A ground fault at the output is detected by a total current monitor and results in shutdown in grounded systems.
<b>Electronic short-circuit protection at the output</b>	A short-circuit at the output (e.g. at the converter output terminals, in the motor cable or in the motor terminal box) is detected and the converter shuts down with a "fault".
<b>Thermal overload protection</b>	An alarm is issued first when the overtemperature threshold responds. If the temperature continues to rise, the unit either shuts down or independently adjusts the pulse frequency or output current so that thermal load is reduced. Once the cause of the fault has been eliminated (e.g. cooling has been improved), the original operating values are automatically resumed.

### Technical specifications

The most important directives and standards are listed below. These are used as basis for the SINAMICS S150 converter cabinet units and they must be carefully observed to achieve an EMC-compliant configuration that is safe both functionally and in operation.

European directives	
<b>2014/30/EU</b>	EMC Directive: Directive of the European Parliament and Council of February 26, 2014, on the harmonization of the laws of the member states relating to electromagnetic compatibility (recast)
<b>2006/42/EC</b>	Machinery Directive: Directive of the European Parliament and Council of May 17, 2006, on machinery and amending Directive 95/16/EC (recast).
European standards	
<b>EN ISO 3744</b>	Acoustics – Determination of the sound power level and sound energy level for noise sources that result from sound pressure measurements – envelope surface procedure of the accuracy class 2 for a largely free sound field over a reflecting plane
<b>EN ISO 13849-1</b>	Safety of machinery – safety-related parts of control systems; Part 1: General principles for design (EN ISO 13849-1: 2006)
<b>EN 60146-1-1</b>	Semiconductor converters – General requirements and line-commutated converters Part 1-1: Specification of basic requirements
<b>EN 60204-1</b>	Safety of machinery – Electrical equipment of machines; Part 1: General requirements
<b>EN 60529</b>	Degrees of protection provided by enclosures (IP Code)
<b>EN 61508-1</b>	Functional safety of electrical/electronic/programmable electronic safety-related systems Part 1: General requirements
<b>EN 61800-2</b>	Adjustable speed electrical power drive systems Part 2: General requirements; rating specifications for low voltage adjustable frequency AC power drive systems
<b>EN 61800-3</b>	Adjustable speed electrical power drive systems Part 3: EMC requirements and specific test methods
<b>EN 61800-5-1</b>	Adjustable speed electrical power drive systems Part 5: Safety requirements Main section 1: Electrical and thermal requirements
<b>EN 61800-5-2</b>	Adjustable speed electrical power drive systems Part 5-2: Safety requirements – Functional safety (IEC 61800-5-2: 2007)

## Technical specifications (continued)

## General technical specifications

Electrical specifications			
<b>Line voltages</b>	380 ... 480 V 3 AC, ±10 % (-15 % <1 min) 500 ... 690 V 3 AC, ±10 % (-15 % <1 min)		
<b>Line supply types</b>	Grounded TN/TT systems and non-grounded IT systems		
<b>Line frequency</b>	47 ... 63 Hz		
<b>Output frequency <sup>1)</sup></b>	0 ... 550 Hz		
<b>Line power factor</b>	Adjustable (factory-set to $\cos \varphi = 1$ )		
<b>Efficiency</b>	>96 %		
<b>Overvoltage category</b>	III to EN 61800-5-1		
<b>Control method</b>	Vector control with and without encoder or V/f control		
<b>Fixed speeds</b>	15 fixed speeds plus 1 minimum speed, parameterizable (in the default setting, 3 fixed setpoints plus 1 minimum speed are selectable using terminal block/PROFIBUS/PROFINET)		
<b>Skippable speed ranges</b>	4, parameterizable		
<b>Setpoint resolution</b>	0.001 rpm digital (14 bits + sign) 12 bits analog		
<b>Braking operation</b>	Four-quadrant operation is possible as standard (optional via a braking unit if braking is required when power fails)		
Mechanical specifications			
<b>Degree of protection</b>	IP20 (higher degrees of protection up to IP54 optional)		
<b>Protection class</b>	I acc. to EN 61800-5-1		
<b>Touch protection</b>	EN 50274/DGUV regulation 3 when used as intended		
<b>Cabinet system</b>	Rittal TS 8, doors with double-bit key, three-section base plates for cable entry		
<b>Paint finish</b>	RAL 7035 (indoor requirements)		
<b>Cooling method</b>	Forced air cooling AF according to EN 60146		
Ambient conditions	Storage <sup>2)</sup>	Transport <sup>2)</sup>	Operation
<b>Ambient temperature</b>	-25 ... +55 °C	-25 ... +70 °C from <u>-40 °C</u> for 24 hours	<u>0 ... 40 °C</u> to +50 °C, <a href="#">see derating data</a>
<b>Relative humidity</b> (condensation not permissible)	<u>5 ... 95%</u> Class 1K4 acc. to IEC 60721-3-1	5 ... 95 % at 40 °C Class 2K3 acc. to IEC 60721-3-2	<u>5 ... 95 %</u> Class 3K3 acc. to IEC 60721-3-3
<b>Environmental class/harmful chemical substances</b>	Class 1C2 acc. to IEC 60721-3-1	Class 2C2 acc. to IEC 60721-3-2	Class 3C2 acc. to IEC 60721-3-3
<b>Organic/biological influences</b>	Class 1B1 acc. to IEC 60721-3-1	Class 2B1 acc. to IEC 60721-3-2	Class 3B1 acc. to IEC 60721-3-3
<b>Degree of pollution</b>	2 acc. to EN 61800-5-1		
<b>Installation altitude</b>	Up to 2000 m above sea level without derating; > 2000 m <a href="#">see derating data</a>		
Mechanical stability	Storage <sup>2)</sup>	Transport <sup>2)</sup>	Operation
<b>Vibratory load</b>	Class 1M2 acc. to IEC 60721-3-1	Class 2M2 acc. to IEC 60721-3-2	–
• Deflection	1.5 mm at <u>5 ... 9 Hz</u>	3.1 mm at <u>5 ... 9 Hz</u>	0.075 mm at 10 ... 58 Hz
• Acceleration	5 m/s <sup>2</sup> at >9 ... 200 Hz	10 m/s <sup>2</sup> at 9 ... 200 Hz	9.8 m/s <sup>2</sup> at 58 ... 200 Hz
<b>Shock load</b>	Class 1M2 acc. to IEC 60721-3-1	Class 2M2 acc. to IEC 60721-3-2	Class 3M4 acc. to IEC 60721-3-3
• Acceleration	40 m/s <sup>2</sup> at 22 ms	100 m/s <sup>2</sup> at 11 ms	100 m/s <sup>2</sup> at 11 ms
Compliance with standards			
<b>Certificates of suitability</b>	CE (EMC Directive 2014/30/EU and Machinery Directive 2006/42/EC for functional safety) RCM		
<b>Radio interference suppression</b>	SINAMICS drive converter systems are not designed for connection to the public grid (first environment). Radio interference suppression is compliant with the EMC product standard for variable-speed drives EN 61800-3, "Second environment" (industrial networks). EMC disturbances can occur when connected to the public grid. However, if additional measures are taken (e.g. → line filter), it can also be operated in the "first environment".		

Deviations from the specified classes are underlined.

<sup>1)</sup> Please note:

- The correlation between the maximum output frequency, pulse frequency and current derating. Higher output frequencies on request.
- The correlation between the maximum output frequency and permissible output current (current derating).

Information is provided in the SINAMICS Low Voltage Engineering Manual.

<sup>2)</sup> In transport packaging

# SINAMICS S150 Converter Cabinet Units

## Converter cabinet units

### Technical specifications (continued)

Line voltage 380 ... 480 V 3 AC		SINAMICS S150 converter cabinet units					
		6SL3710-7LE32-1AA3	6SL3710-7LE32-6AA3	6SL3710-7LE33-1AA3	6SL3710-7LE33-8AA3	6SL3710-7LE35-0AA3	6SL3710-7LE36-1AA3
<b>Type rating</b>							
• At $I_L$ (50 Hz 400 V) <sup>1)</sup>	kW	110	132	160	200	250	315
• At $I_H$ (50 Hz 400 V) <sup>1)</sup>	kW	90	110	132	160	200	250
• At $I_L$ (60 Hz 460 V) <sup>2)</sup>	hp	150	200	250	300	400	500
• At $I_H$ (60 Hz 460 V) <sup>2)</sup>	hp	150	200	200	250	350	350
<b>Output current</b>							
• Rated current $I_{rated O}$	A	210	260	310	380	490	605
• Base-load current $I_L$ <sup>3)</sup>	A	205	250	302	370	477	590
• Base-load current $I_H$ <sup>4)</sup>	A	178	233	277	340	438	460
• Maximum current $I_{max O}$	A	307	375	453	555	715	885
<b>Infeed/regenerative feedback current</b>							
• Rated input current $I_{rated I}$	A	197	242	286	349	447	549
• Maximum input current $I_{max I}$	A	315	390	570	570	735	907
<b>Current demand, max.</b> <sup>5)</sup>							
• 24 V DC aux. power supply	A	Internal	Internal	Internal	Internal	Internal	Internal
<b>Pulse frequency</b> <sup>6)</sup>							
• Rated frequency	kHz	2	2	2	2	2	1.25
• Pulse frequency, max.							
- Without current derating	kHz	2	2	2	2	2	1.25
- With current derating	kHz	8	8	8	8	8	7.5
<b>Power loss, max.</b> <sup>7)</sup>							
• At 50 Hz 400 V	kW	6.31	7.55	10.01	10.72	13.13	17.69
• At 60 Hz 460 V	kW	6.49	7.85	10.45	11.15	13.65	18.55
<b>Cooling air requirement</b>		m <sup>3</sup> /s	0.58	0.7	1.19	1.19	1.96
<b>Sound pressure level <math>L_{pA}</math></b> (1 m) at 50/60 Hz		dB	71/73	71/73	72/74	72/74	77/79
<b>Cable length, max.</b>							
• Shielded	m	300	300	300	300	300	300
• Unshielded	m	450	450	450	450	450	450
<b>Degree of protection</b>			IP20	IP20	IP20	IP20	IP20
<b>Dimensions</b>							
• Width	mm	1400	1400	1600	1800	1800	2200
• Height	mm	2000	2000	2000	2000	2000	2000
• Depth	mm	600	600	600	600	600	600
<b>Weight (without options), approx.</b>		kg	708	708	892	980	1716
<b>Short-circuit current rating according to IEC</b> <sup>8)</sup>		kA	65	65	65	65	65
<b>Minimum short-circuit current</b> <sup>9)</sup>		A	3000	3000	4500	4500	8000
<b>Frame sizes</b>							
• Active Interface Module		FI	FI	GI	GI	GI	HI
• Active Line Module		FX	FX	GX	GX	GX	HX
• Motor Module		FX	FX	GX	GX	GX	HX

#### Note:

The power data in hp units is based on the NEC/CEC standards for the North American market. Information about line supply connections, motor connections and cabinet grounding can be found under **Cable cross-sections and connections**.

<sup>1)</sup> Rated output of a typical 6-pole standard induction motor based on  $I_L$  or  $I_H$  for 400 V 3 AC 50 Hz.

<sup>2)</sup> Rated output of a typical 6-pole standard induction motor based on  $I_L$  or  $I_H$  for 460 V 3 AC 60 Hz.

<sup>3)</sup> The base-load current  $I_L$  is based on a duty cycle of 110 % for 60 s or 150 % for 10 s with a duty cycle duration of 300 s.

<sup>4)</sup> The base-load current  $I_H$  is based on a duty cycle of 150 % for 60 s or 160 % for 10 s with a duty cycle duration of 300 s.

<sup>5)</sup> If the drive closed-loop control is still to remain active when the line supply fails, the equipment must be provided with an external 24 V DC supply.

<sup>6)</sup> Information regarding the correlation between the pulse frequency and max. output current/output frequency is provided in the SINAMICS Low Voltage Engineering Manual.

<sup>7)</sup> The specified power losses are the maximum values at 100 % utilization. The values are lower under normal operating conditions.

<sup>8)</sup> In conjunction with the specified fuses or circuit breakers.

<sup>9)</sup> Current required for reliably triggering protective devices.

## Technical specifications (continued)

Line voltage 380 ... 480 V 3 AC		SINAMICS S150 converter cabinet units				
		6SL3710-7LE37-5AA3	6SL3710-7LE38-4AA3	6SL3710-7LE41-0AA3	6SL3710-7LE41-2AA3	6SL3710-7LE41-4AA3
<b>Type rating</b>						
• At $I_L$ (50 Hz 400 V) <sup>1)</sup>	kW	400	450	560	710	800
• At $I_H$ (50 Hz 400 V) <sup>1)</sup>	kW	315	400	450	560	710
• At $I_L$ (60 Hz 460 V) <sup>2)</sup>	hp	600	700	800	900	1150
• At $I_H$ (60 Hz 460 V) <sup>2)</sup>	hp	450	600	700	900	1000
<b>Output current</b>						
• Rated current $I_{rated O}$	A	745	840	985	1260	1405
• Base-load current $I_L$ <sup>3)</sup>	A	725	820	960	1230	1370
• Base-load current $I_H$ <sup>4)</sup>	A	570	700	860	1127	1257
• Maximum current $I_{max O}$	A	1087	1230	1440	1845	2055
<b>Infeed/regenerative feedback current</b>						
• Rated input current $I_{rated I}$	A	674	759	888	1133	1262
• Maximum input current $I_{max I}$	A	1118	1260	1477	1891	2107
<b>Current demand, max.</b> <sup>5)</sup>						
• 24 V DC aux. power supply	A	Internal	Internal	Internal	Internal	Internal
<b>Pulse frequency</b> <sup>6)</sup>						
• Rated frequency	kHz	1.25	1.25	1.25	1.25	1.25
• Pulse frequency, max.						
- Without current derating	kHz	1.25	1.25	1.25	1.25	1.25
- With current derating	kHz	7.5	7.5	7.5	7.5	7.5
<b>Power loss, max.</b> <sup>7)</sup>						
• At 50 Hz 400 V	kW	20.63	21.1	27.25	33.05	33.95
• At 60 Hz 460 V	kW	21.75	22.25	28.65	34.85	35.85
<b>Cooling air requirement</b>		m <sup>3</sup> /s	1.96	1.96	2.6	2.6
<b>Sound pressure level <math>L_{pA}</math></b> (1 m) at 50/60 Hz		dB	77/79	77/79	77/79	78/80
<b>Cable length, max.</b>						
• Shielded	m	300	300	300	300	300
• Unshielded	m	450	450	450	450	450
<b>Degree of protection</b>			IP20	IP20	IP20	IP20
<b>Dimensions</b>						
• Width	mm	2200	2200	2800	2800	2800
• Height	mm	2000	2000	2000	2000	2000
• Depth	mm	600	600	600	600	600
<b>Weight (without options), approx.</b>		kg	1731	1778	2408	2408
<b>Short-circuit current rating according to IEC</b> <sup>8)</sup>		kA	65	65	84	100
<b>Minimum short-circuit current</b> <sup>9)</sup>		A	15000	2000	2500	3200
<b>Frame sizes</b>						
• Active Interface Module		HI	HI	J1	J1	J1
• Active Line Module		HX	HX	JX	JX	JX
• Motor Module		HX	HX	JX	JX	JX

## Note:

The power data in hp units is based on the NEC/CEC standards for the North American market. Information about line supply connections, motor connections and cabinet grounding can be found under **Cable cross-sections and connections**.

<sup>1)</sup> Rated output of a typical 6-pole standard induction motor based on  $I_L$  or  $I_H$  for 400 V 3 AC 50 Hz.

<sup>2)</sup> Rated output of a typical 6-pole standard induction motor based on  $I_L$  or  $I_H$  for 460 V 3 AC 60 Hz.

<sup>3)</sup> The base-load current  $I_L$  is based on a duty cycle of 110 % for 60 s or 150 % for 10 s with a duty cycle duration of 300 s.

<sup>4)</sup> The base-load current  $I_H$  is based on a duty cycle of 150 % for 60 s or 160 % for 10 s with a duty cycle duration of 300 s.

<sup>5)</sup> If the drive closed-loop control is still to remain active when the line supply fails, the equipment must be provided with an external 24 V DC supply.

<sup>6)</sup> Information regarding the correlation between the pulse frequency and max. output current/output frequency is provided in the SINAMICS Low Voltage Engineering Manual.

<sup>7)</sup> The specified power losses are the maximum values at 100 % utilization. The values are lower under normal operating conditions.

<sup>8)</sup> In conjunction with the specified fuses or circuit breakers.

<sup>9)</sup> Current required for reliably triggering protective devices.

# SINAMICS S150 Converter Cabinet Units

## Converter cabinet units

### Technical specifications (continued)

Line voltage 500 ... 690 V 3 AC		SINAMICS S150 converter cabinet units					
		6SL3710-7LG28-5AA3	6SL3710-7LG31-0AA3	6SL3710-7LG31-2AA3	6SL3710-7LG31-5AA3	6SL3710-7LG31-8AA3	6SL3710-7LG32-2AA3
<b>Type rating</b>							
• At $I_L$ (50 Hz 690 V) <sup>1)</sup>	kW	75	90	110	132	160	200
• At $I_H$ (50 Hz 690 V) <sup>1)</sup>	kW	55	75	90	110	132	160
• At $I_L$ (50 Hz 500 V) <sup>1)</sup>	kW	55	55	75	90	110	132
• At $I_H$ (50 Hz 500 V) <sup>1)</sup>	kW	45	55	75	90	90	110
• At $I_L$ (60 Hz 575 V) <sup>2)</sup>	hp	75	75	100	150	150	200
• At $I_H$ (60 Hz 575 V) <sup>2)</sup>	hp	75	75	100	125	150	200
<b>Output current</b>							
• Rated current $I_{rated O}$	A	85	100	120	150	175	215
• Base-load current $I_L$ <sup>3)</sup>	A	80	95	115	142	170	208
• Base-load current $I_H$ <sup>4)</sup>	A	76	89	117	134	157	192
• Maximum current $I_{max O}$	A	120	142	172	213	255	312
<b>Infeed/regenerative feedback current</b>							
• Rated current $I_{rated I}$	A	86	99	117	144	166	202
• Maximum current $I_{max I}$	A	125	144	170	210	253	308
<b>Current demand, max.</b> <sup>5)</sup>							
• 24 V DC aux. power supply	A	Internal	Internal	Internal	Internal	Internal	Internal
<b>Pulse frequency</b> <sup>6)</sup>							
• Rated frequency	kHz	1.25	1.25	1.25	1.25	1.25	1.25
• Pulse frequency, max.							
- Without current derating	kHz	1.25	1.25	1.25	1.25	1.25	1.25
- With current derating	kHz	7.5	7.5	7.5	7.5	7.5	7.5
<b>Power loss, max.</b> <sup>7)</sup>							
• At 50 Hz 690 V	kW	5.12	5.38	5.84	5.75	11.02	11.44
• At 60 Hz 575 V	kW	4.45	4.65	5.12	4.97	11.15	11.56
<b>Cooling air requirement</b>		m <sup>3</sup> /s	0.58	0.58	0.58	1.19	1.19
<b>Sound pressure level <math>L_{pA}</math></b> (1 m) at 50/60 Hz		dB	71/73	71/73	71/73	75/77	75/77
<b>Cable length, max.</b>							
• Shielded	m	300	300	300	300	300	300
• Unshielded	m	450	450	450	450	450	450
<b>Degree of protection</b>			IP20	IP20	IP20	IP20	IP20
<b>Dimensions</b>							
• Width	mm	1400	1400	1400	1400	1600	1600
• Height	mm	2000	2000	2000	2000	2000	2000
• Depth	mm	600	600	600	600	600	600
<b>Weight (without options), approx.</b>		kg	708	708	708	892	892
<b>Short-circuit current rating according to IEC</b> <sup>8)</sup>		kA	65	65	65	65	65
<b>Minimum short-circuit current</b> <sup>9)</sup>		A	1000	1000	1300	1800	2500
<b>Frame size</b>							
• Active Interface Module		FI	FI	FI	FI	GI	GI
• Active Line Module		FX	FX	FX	FX	GX	GX
• Motor Module		FX	FX	FX	FX	GX	GX

#### Note:

The power data in hp units is based on the NEC/CEC standards for the North American market. Information about line supply connections, motor connections and cabinet grounding can be found under **Cable cross-sections and connections**.

<sup>1)</sup> Rated output of a typical 6-pole standard induction motor based on  $I_L$  or  $I_H$  for 690 V 3 AC 50 Hz.

<sup>2)</sup> Rated output of a typical 6-pole standard induction motor based on  $I_L$  or  $I_H$  for 575 V 3 AC 60 Hz.

<sup>3)</sup> The base-load current  $I_L$  is based on a duty cycle of 110 % for 60 s or 150 % for 10 s with a duty cycle duration of 300 s.

<sup>4)</sup> The base-load current  $I_H$  is based on a duty cycle of 150 % for 60 s or 160 % for 10 s with a duty cycle duration of 300 s.

<sup>5)</sup> If the drive closed-loop control is still to remain active when the line supply fails, the equipment must be provided with an external 24 V DC supply.

<sup>6)</sup> Information regarding the correlation between the pulse frequency and max. output current/output frequency is provided in the SINAMICS Low Voltage Engineering Manual.

<sup>7)</sup> The specified power losses are the maximum values at 100 % utilization. The values are lower under normal operating conditions.

<sup>8)</sup> In conjunction with the specified fuses or circuit breakers. Current required for reliably triggering protective devices.

<sup>9)</sup> Current required for reliably triggering protective devices.



## Technical specifications (continued)

Line voltage 500 ... 690 V 3 AC		SINAMICS S150 converter cabinet units					
		6SL3710-7LG32-6AA3	6SL3710-7LG33-3AA3	6SL3710-7LG34-1AA3	6SL3710-7LG34-7AA3	6SL3710-7LG35-8AA3	6SL3710-7LG37-4AA3
<b>Type rating</b>							
• At $I_L$ (50 Hz 690 V) <sup>1)</sup>	kW	250	315	400	450	560	710
• At $I_H$ (50 Hz 690 V) <sup>1)</sup>	kW	200	250	315	400	450	630
• At $I_L$ (50 Hz 500 V) <sup>1)</sup>	kW	160	200	250	315	400	500
• At $I_H$ (50 Hz 500 V) <sup>1)</sup>	kW	132	160	200	250	315	450
• At $I_L$ (60 Hz 575 V) <sup>2)</sup>	hp	250	300	400	450	600	700
• At $I_H$ (60 Hz 575 V) <sup>2)</sup>	hp	200	250	350	450	500	700
<b>Output current</b>							
• Rated current $I_{rated O}$	A	260	330	410	465	575	735
• Base-load current $I_L$ <sup>3)</sup>	A	250	320	400	452	560	710
• Base-load current $I_H$ <sup>4)</sup>	A	233	280	367	416	514	657
• Maximum current $I_{max O}$	A	375	480	600	678	840	1065
<b>Infeed/regenerative feedback current</b>							
• Rated current $I_{rated I}$	A	242	304	375	424	522	665
• Maximum current $I_{max I}$	A	370	465	619	700	862	1102
<b>Current demand, max. <sup>5)</sup></b>							
• 24 V DC auxiliary power supply	A	Internal	Internal	Internal	Internal	Internal	Internal
<b>Pulse frequency <sup>6)</sup></b>							
• Rated frequency	kHz	1.25	1.25	1.25	1.25	1.25	1.25
• Pulse frequency, max.							
- Without current derating	kHz	1.25	1.25	1.25	1.25	1.25	1.25
- With current derating	kHz	7.5	7.5	7.5	7.5	7.5	7.5
<b>Power loss, max. <sup>7)</sup></b>							
• At 50 Hz 690 V	kW	11.97	12.69	19.98	20.55	24.05	30.25
• At 60 Hz 575 V	kW	12.03	12.63	18.86	19.47	22.85	28.75
<b>Cooling air requirement</b>		m <sup>3</sup> /s	1.19	1.19	1.96	1.96	2.6
<b>Sound pressure level <math>L_{pA}</math></b> (1 m) at 50/60 Hz		dB	75/77	75/77	77/79	77/79	77/79
<b>Cable length, max.</b>							
• Shielded	m	300	300	300	300	300	300
• Unshielded	m	450	450	450	450	450	450
<b>Degree of protection</b>			IP20	IP20	IP20	IP20	IP20
<b>Dimensions</b>							
• Width	mm	1600	1600	2200	2200	2200	2800
• Height	mm	2000	2000	2000	2000	2000	2000
• Depth	mm	600	600	600	600	600	600
<b>Weight (without options), approx.</b>		kg	892	892	1716	1716	2300
<b>Short-circuit current rating according to IEC <sup>8)</sup></b>		kA	65	65	65	65	85
<b>Minimum short-circuit current <sup>9)</sup></b>		A	3000	4500	4500	7000	9000
<b>Frame size</b>							
• Active Interface Module		GI	GI	HI	HI	HI	JI
• Active Line Module		GX	GX	HX	HX	HX	JX
• Motor Module		GX	GX	HX	HX	HX	JX

## Note:

The power data in hp units is based on the NEC/CEC standards for the North American market. Information about line supply connections, motor connections and cabinet grounding can be found under **Cable cross-sections and connections**.

<sup>1)</sup> Rated output of a typical 6-pole standard induction motor based on  $I_L$  or  $I_H$  for 690 V 3 AC 50 Hz.

<sup>2)</sup> Rated output of a typical 6-pole standard induction motor based on  $I_L$  or  $I_H$  for 575 V 3 AC 60 Hz.

<sup>3)</sup> The base-load current  $I_L$  is based on a duty cycle of 110 % for 60 s or 150 % for 10 s with a duty cycle duration of 300 s.

<sup>4)</sup> The base-load current  $I_H$  is based on a duty cycle of 150 % for 60 s or 160 % for 10 s with a duty cycle duration of 300 s.

<sup>5)</sup> If the drive closed-loop control is still to remain active when the line supply fails, the equipment must be provided with an external 24 V DC supply.

<sup>6)</sup> Information regarding the correlation between the pulse frequency and max. output current/output frequency is provided in the SINAMICS Low Voltage Engineering Manual.

<sup>7)</sup> The specified power losses are the maximum values at 100 % utilization. The values are lower under normal operating conditions.

<sup>8)</sup> In conjunction with the specified fuses or circuit breakers.

<sup>9)</sup> Current required for reliably triggering protective devices.



# SINAMICS S150 Converter Cabinet Units

## Converter cabinet units

### Technical specifications (continued)

Line voltage 500 ... 690 V 3 AC		SINAMICS S150 converter cabinet units			
		6SL3710- 7LG38-1AA3	6SL3710- 7LG38-8AA3	6SL3710- 7LG41-0AA3	6SL3710- 7LG41-3AA3
<b>Type rating</b>					
• At $I_L$ (50 Hz 690 V) <sup>1)</sup>	kW	<b>800</b>	<b>900</b>	<b>1000</b>	<b>1200</b>
• At $I_H$ (50 Hz 690 V) <sup>1)</sup>	kW	710	800	900	1000
• At $I_L$ (50 Hz 500 V) <sup>1)</sup>	kW	560	630	710	900
• At $I_H$ (50 Hz 500 V) <sup>1)</sup>	kW	500	560	630	800
• At $I_L$ (60 Hz 575 V) <sup>2)</sup>	hp	800	900	1000	1250
• At $I_H$ (60 Hz 575 V) <sup>2)</sup>	hp	700	800	900	1000
<b>Output current</b>					
• Rated current $I_{rated O}$	A	810	910	1025	1270
• Base-load current $I_L$ <sup>3)</sup>	A	790	880	1000	1230
• Base-load current $I_H$ <sup>4)</sup>	A	724	814	917	1136
• Maximum current $I_{max O}$	A	1185	1320	1500	1845
<b>Infeed/regenerative feedback current</b>					
• Rated current $I_{rated I}$	A	732	821	923	1142
• Maximum current $I_{max I}$	A	1218	1367	1537	1905
<b>Current demand, max. <sup>5)</sup></b>					
• 24 V DC aux. power supply	A	Internal	Internal	Internal	Internal
<b>Pulse frequency <sup>6)</sup></b>					
• Rated frequency	kHz	1.25	1.25	1.25	1.25
• Pulse frequency, max.					
- Without current derating	kHz	1.25	1.25	1.25	1.25
- With current derating	kHz	7.5	7.5	7.5	7.5
<b>Power loss, max. <sup>7)</sup></b>					
• At 50 Hz 690 V	kW	34.45	34.65	36.15	42.25
• At 60 Hz 575 V	kW	32.75	32.85	34.25	39.25
<b>Cooling air requirement</b>		m <sup>3</sup> /s	2.6	2.6	2.6
<b>Sound pressure level <math>L_{pA}</math></b> (1 m) at 50/60 Hz		dB	77/79	77/79	77/79
<b>Cable length, max.</b>					
• Shielded	m	300	300	300	300
• Unshielded	m	450	450	450	450
<b>Degree of protection</b>			IP20	IP20	IP20
<b>Dimensions</b>					
• Width	mm	2800	2800	2800	2800
• Height	mm	2000	2000	2000	2000
• Depth	mm	600	600	600	600
<b>Weight (without options), approx.</b>		kg	2408	2408	2408
<b>Short-circuit current rating according to IEC <sup>8)</sup></b>		kA	85	85	85
<b>Minimum short-circuit current <sup>9)</sup></b>		A	2000	2000	2500
<b>Frame size</b>					
• Active Interface Module		J1	J1	J1	J1
• Active Line Module		JX	JX	JX	JX
• Motor Module		JX	JX	JX	JX

#### Note:

The power data in hp units is based on the NEC/CEC standards for the North American market. Information about line supply connections, motor connections and cabinet grounding can be found under **Cable cross-sections and connections**.

<sup>1)</sup> Rated output of a typical 6-pole standard induction motor based on  $I_L$  or  $I_H$  for 690 V 3 AC 50 Hz.

<sup>2)</sup> Rated output of a typical 6-pole standard induction motor based on  $I_L$  or  $I_H$  for 575 V 3 AC 60 Hz.

<sup>3)</sup> The base-load current  $I_L$  is based on a duty cycle of 110 % for 60 s or 150 % for 10 s with a duty cycle duration of 300 s.

<sup>4)</sup> The base-load current  $I_H$  is based on a duty cycle of 150 % for 60 s or 160 % for 10 s with a duty cycle duration of 300 s.

<sup>5)</sup> If the drive closed-loop control is still to remain active when the line supply fails, the equipment must be provided with an external 24 V DC supply.

<sup>6)</sup> Information regarding the correlation between the pulse frequency and max. output current/output frequency is provided in the SINAMICS Low Voltage Engineering Manual.

<sup>7)</sup> The specified power losses are the maximum values at 100 % utilization. The values are lower under normal operating conditions.

<sup>8)</sup> In conjunction with the specified fuses or circuit breakers.

<sup>9)</sup> Current required for reliably triggering protective devices.

## Characteristic curves

### Derating data

SINAMICS S150 converter cabinet units and the associated system components are rated for an ambient temperature of 40 °C and installation altitudes up to 2000 m above sea level.

At ambient temperatures > 40 °C, the output current must be reduced. Ambient temperatures above 50 °C are not permissible.

At installation altitudes > 2000 m above sea level, it must be taken into account that the air pressure, and therefore air density, decreases as the height increases. As a consequence, the cooling efficiency and the insulation capacity of the air also decrease.

Due to the reduced cooling efficiency, it is necessary, on the one hand, to reduce the ambient temperature and on the other hand, to lower heat loss in the converter cabinet unit by reducing the output current, whereby ambient temperatures lower than 40 °C may be offset to compensate.

The following table lists the permissible output currents depending on the installation altitude and ambient temperature for the various degrees of protection. The specified values already include a permitted compensation in respect of installation altitude and ambient temperatures < 40 °C (temperature at the air intake of the converter cabinet unit).

The values apply under the precondition that the cooling air flow stated in the technical specifications is ensured by the way the devices are installed in the cabinet.

As additional measure for installation altitudes from 2000 m up to 5000 m, an isolating transformer is required in order to reduce transient overvoltages according to EN 60664-1.

For additional information, please refer to the [SINAMICS Low Voltage Engineering Manual](#).

Degree of protection	Installation altitude above sea level m	Current derating factor (as a percentage of the rated current) for an ambient / air intake temperature of						
		20 °C	25 °C	30 °C	35 °C	40 °C	45 °C	50 °C
IP20, IP21, IP23, IP43	0 ... 2000						93.3 %	86.7 %
	2001 ... 2500					96.3 %		
	2501 ... 3000		100 %		98.7 %			
	3001 ... 3500							
	3501 ... 4000			96.3 %				
	4001 ... 4500		97.5 %					
IP54	4501 ... 5000	98.2 %						
	0 ... 2000					93.3 %	86.7 %	80 %
	2001 ... 2500				96.3 %	89.8 %		
	2501 ... 3000		100 %	98.7 %	92.5 %			
	3001 ... 3500			94.7 %				
	3501 ... 4000		96.3 %	90.7 %				
	4001 ... 4500	97.5 %	92.1 %					
4501 ... 5000	93 %							

## SINAMICS S150 Converter Cabinet Units

### Converter cabinet units

#### Characteristic curves (continued)

##### Current derating as a function of the pulse frequency

To reduce motor noise or to increase output frequency, the pulse frequency can be increased relative to the factory setting (1.25 kHz or 2 kHz). When the pulse frequency is increased, the derating factor of the output current must be taken into account. This derating factor must be applied to the currents specified in the technical specifications.

For additional information, please refer to the SINAMICS Low Voltage Engineering Manual.

Derating factor of the output current depending on the pulse frequency for devices with a rated pulse frequency of 2 kHz

SINAMICS S150 converter cabinet unit	Type rating at 400 V	Output current at 2 kHz	Derating factor at pulse frequency				
			2.5 kHz	4 kHz	5 kHz	7.5 kHz	8 kHz
<b>380 ... 480 V 3 AC</b>							
7LE32-1AA3	110	210	95 %	82 %	74 %	54 %	50 %
7LE32-6AA3	132	260	95 %	83 %	74 %	54 %	50 %
7LE33-1AA3	160	310	97 %	88 %	78 %	54 %	50 %
7LE33-8AA3	200	380	96 %	87 %	77 %	54 %	50 %
7LE35-0AA3	250	490	94 %	78 %	71 %	53 %	50 %

Derating factor of the output current depending on the pulse frequency for devices with a rated pulse frequency of 1.25 kHz

SINAMICS S150 converter cabinet unit	Type rating at 400 V or 690 V	Output current at 1.25 kHz	Derating factor at pulse frequency				
			2 kHz	2.5 kHz	4 kHz	5 kHz	7.5 kHz
<b>380 ... 480 V 3 AC</b>							
7LE36-1AA3	315	605	83 %	72 %	64 %	60 %	40 %
7LE37-5AA3	400	745	83 %	72 %	64 %	60 %	40 %
7LE38-4AA3	450	840	87 %	79 %	64 %	55 %	40 %
7LE41-0AA3	560	985	92 %	87 %	70 %	60 %	50 %
7LE41-2AA3	710	1260	92 %	87 %	70 %	60 %	50 %
7LE41-4AA3	800	1405	97 %	95 %	74 %	60 %	50 %
<b>500 ... 690 V 3 AC</b>							
7LG28-5AA3	75	85	93 %	89 %	71 %	60 %	40 %
7LG31-0AA3	90	100	92 %	88 %	71 %	60 %	40 %
7LG31-2AA3	110	120	92 %	88 %	71 %	60 %	40 %
7LG31-5AA3	132	150	90 %	84 %	66 %	55 %	35 %
7LG31-8AA3	160	175	92 %	87 %	70 %	60 %	40 %
7LG32-2AA3	200	215	92 %	87 %	70 %	60 %	40 %
7LG32-6AA3	250	260	92 %	88 %	71 %	60 %	40 %
7LG33-3AA3	315	330	89 %	82 %	65 %	55 %	40 %
7LG34-1AA3	400	410	89 %	82 %	65 %	55 %	35 %
7LG34-7AA3	450	465	92 %	87 %	67 %	55 %	35 %
7LG35-8AA3	560	575	91 %	85 %	64 %	50 %	35 %
7LG37-4AA3	710	735	87 %	79 %	64 %	55 %	25 %
7LG38-1AA3	800	810	97 %	95 %	71 %	55 %	35 %
7LG38-8AA3	900	910	92 %	87 %	67 %	55 %	33 %
7LG41-0AA3	1000	1025	91 %	86 %	64 %	50 %	30 %
7LG41-3AA3	1200	1270	87 %	79 %	55 %	40 %	25 %

The following table lists the maximum achievable output frequency as a function of the pulse frequency:

Pulse frequency	Max. achievable output frequency
1.25 kHz	100 Hz
2 kHz	160 Hz
2.5 kHz	200 Hz
≥4 kHz	300 Hz

**Characteristic curves** (continued)**Overload capability**

The SINAMICS S150 converter cabinet units are equipped with an overload reserve to deal with breakaway torques, for example. If larger surge loads occur, this must be taken into account in the configuration. For drives with overload requirements, the appropriate base load current must, therefore, be used as a basis for the required load.

The criterion for overload is that the drive is operated with its base load current before and after the overload occurs on the basis of a duty cycle duration of 300 s.

Another precondition is that the frequency converter is operated at its factory-set pulse frequency at output frequencies >10 Hz.

For temporary, periodic duty cycles with high variations of load within the duty cycle, the relevant sections of the SINAMICS Low Voltage Engineering Manual must be observed.

The base-load current for a low overload  $I_L$  is the basis for a duty cycle of 110 % for 60 s or 150 % for 10 s.

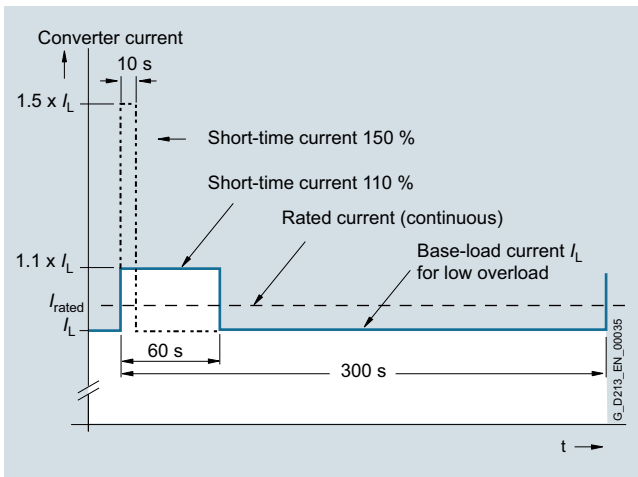

Low overload

The base-load current  $I_H$  for a high overload is based on a duty cycle of 150 % for 60 s or 160 % for 10 s.

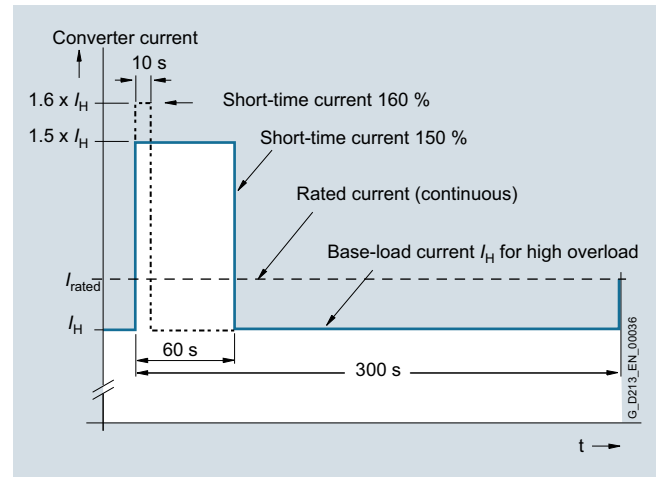

High overload

# SINAMICS S150 Converter Cabinet Units

## Converter cabinet units

### Options

When ordering a converter with options, add the suffix **"-Z"** to the article number and then the order code(s) for the desired option(s).

Example:

**6SL3710-7LE32-1AA3-Z  
M07+D60+...**

See also ordering examples.

Available options	Order code
<b>Input side</b>	
Use in the first environment according to EN 618003, Category C2 (TN-TT line supplies with grounded neutral point)	<b>L00</b>
Infeed module one level lower	<b>L04</b>
Surge suppression	<b>L21</b>
Main switch incl. fuses or circuit breakers	<b>L26</b>
Line filter monitoring	<b>L40</b>
EMC shielding busbar (cable connection from below) <sup>1)</sup>	<b>M70</b>
<b>Output side</b>	
dv/dt filter compact plus Voltage Peak Limiter	<b>L07</b>
Motor reactor	<b>L08</b>
dv/dt filter plus Voltage Peak Limiter	<b>L10</b>
Sine-wave filter (only for the voltage range 380 to 480 V, up to 200 kW)	<b>L15</b>
EMC shield bus (cable connection from below) <sup>1)</sup>	<b>M70</b>
<b>Motor protection and safety functions</b>	
EMERGENCY OFF pushbutton installed in the cabinet door	<b>L45</b>
EMERGENCY OFF Category 0, 230 V AC or 24 V DC	<b>L57</b>
EMERGENCY STOP Category 1, 230 V AC	<b>L59</b>
EMERGENCY STOP Category 1, 24 V DC	<b>L60</b>
Thermistor motor protection device (alarm)	<b>L83</b>
Thermistor motor protection device (trip)	<b>L84</b>
Pt100 evaluation unit	<b>L86</b>
Insulation monitoring	<b>L87</b>
Additional touch protection	<b>M60</b>
<b>Degree of protection increase</b>	
Degree of protection IP21	<b>M21</b>
Degree of protection IP23	<b>M23</b>
Degree of protection IP43	<b>M43</b>
Degree of protection IP54	<b>M54</b>
<b>Mechanical options</b>	
Base 100 mm high, RAL 7022	<b>M06</b>
Cable marshaling compartment 200 mm high, RAL 7035	<b>M07</b>
Line connection from above	<b>M13</b>
Motor connection from above	<b>M78</b>
Crane transport assembly (top-mounted)	<b>M90</b>
<b>Safety Integrated</b>	
Safety license for 1 axis	<b>K01</b>
Second SMC30 Sensor Module Cabinet-Mounted	<b>K52</b>
Terminal module for controlling the Safe Torque Off and Safe Stop 1 safety functions	<b>K82</b>
TM54F Terminal Module	<b>K87</b>
Safe Brake Adapter SBA, 230 V AC	<b>K88</b>

Available options	Order code
<b>Other options</b>	
CBC10 Communication Board	<b>G20</b>
CBE20 Communication Board	<b>G33</b>
TM150 temperature sensor evaluation unit	<b>G51</b>
TM31 Terminal Module	<b>G60</b>
Additional TM31 Terminal Module	<b>G61</b>
TB30 Terminal Board	<b>G62</b>
SMC10 Sensor Module Cabinet-Mounted	<b>K46</b>
SMC20 Sensor Module Cabinet-Mounted	<b>K48</b>
SMC30 Sensor Module Cabinet-Mounted	<b>K50</b>
VSM10 Voltage Sensing Module	<b>K51</b>
CU320-2 PN Control Unit	<b>K95</b>
Connection for external auxiliaries	<b>L19</b>
Cabinet lighting with service socket	<b>L50</b>
Cabinet anti-condensation heating	<b>L55</b>
25/125 kW braking unit for line voltages of 380 ... 480 V (110 ... 132 kW) and 660 ... 690 V (75 ... 132 kW)	<b>L61</b>
50/250 kW braking unit for line voltages of 380 ... 480 V (160 ... 800 kW) and 660 ... 690 V (160 ... 1200 kW)	<b>L62</b>
25/125 kW braking unit for line voltages of 500 ... 600 V (110 ... 132 kW)	<b>L64</b>
50/250 kW braking unit for line voltages of 500 ... 600 V (160 ... 1200 kW)	<b>L65</b>
Marking of all control cable conductor ends	<b>M91</b>
Special cabinet paint finish <sup>2)</sup>	<b>Y09</b>
One-line label for system identification, 40 × 80 mm	<b>Y31</b>
Two-line label for system identification, 40 × 180 mm	<b>Y32</b>
Four-line label for system identification, 40 × 180 mm	<b>Y33</b>
<b>Production flowcharts</b>	
Documentation, production flowchart: one issue	<b>B43</b>
Documentation, production flowchart: updated every two weeks	<b>B44</b>
Documentation, production flowchart: updated every month	<b>B45</b>
<b>Packaging options</b>	
Generation of a preliminary and a final packing list (shipping)	<b>B55</b>
Packed items labeled with a customized label	<b>B56</b>
Photo documentation of the ordered units	<b>B57</b>

<sup>1)</sup> This option is listed for the input- and output-side options, but is only required once.

<sup>2)</sup> The order code **Y..** requires data in plain text.

## Options (continued)

Available options	Order code
<b>Documentation (standard: English/German)</b>	
Documentation in German	<b>D00</b>
Customer documentation (circuit diagram, terminal diagram, layout diagram) in DXF format	<b>D02</b>
Customer documentation as hard copy	<b>D04</b>
Preliminary version of customer documentation	<b>D14</b>
Documentation in Russian	<b>D56</b>
Documentation in English / French	<b>D58</b>
Documentation in English / Spanish	<b>D60</b>
Documentation in Italian	<b>D72</b>
Documentation in English	<b>D76</b>
Documentation in French	<b>D77</b>
Documentation in Spanish	<b>D78</b>
Documentation in English / Italian	<b>D80</b>
Documentation in Chinese	<b>D84</b>
Documentation in English / Chinese	<b>D91</b>
Documentation in English / Portuguese (Brazil)	<b>D93</b>
Documentation in English / Russian	<b>D94</b>
<b>Rating plate data (standard: English/German)</b>	
Rating plate data in English/French	<b>T58</b>
Rating plate data in English/Spanish	<b>T60</b>
Rating plate data in English/Italian	<b>T80</b>
Rating plate data in English/Portuguese (Brazil)	<b>T83</b>
Rating plate data in English/Russian	<b>T85</b>
Rating plate data in English/Chinese	<b>T91</b>

Available options	Order code
<b>Options specific to the chemical industry</b>	
NAMUR terminal block	<b>B00</b>
Protective separation for 24 V supply (PELV)	<b>B02</b>
Outgoing feeder for external auxiliaries (uncontrolled)	<b>B03</b>
<b>Options specific to the shipbuilding industry</b>	
Marine version	<b>M66</b>
Individual certificate from Germanische Lloyd (GL)	<b>E11</b>
Individual certificate from Lloyds Register (LR)	<b>E21</b>
Individual certificate from Bureau Veritas (BV)	<b>E31</b>
Individual certificate from Det Norske Veritas (DNV)	<b>E51</b>
Individual certificate from American Bureau of Shipping (ABS)	<b>E61</b>
Individual certificate from Chinese Classification Society (CCS)	<b>E71</b>
<b>Converter acceptance in presence of customer</b>	
Visual acceptance	<b>F03</b>
Function test without motor	<b>F71</b>
Function test with test bay motor under no-load conditions	<b>F75</b>
Insulation test	<b>F77</b>
Customer-specific acceptance inspections (on request)	<b>F97</b>
<b>Converter acceptance without the customer present</b>	
Function test without motor	<b>F72</b>
Function test with test bay motor under no-load conditions	<b>F74</b>
Insulation test	<b>F76</b>

## Option selection matrix

Certain options can mutually exclude one another (options that are not involved, are also not shown).

✓	Possible combination
–	Combination not possible

## Electrical options

	L07	L08	L10	L15	L57	L59	L60	L61/L64	L62/L65	L87	K82	M78
L07		–	–	–	✓	✓	✓	✓	✓	✓	✓	–
L08	–		–	–	✓	✓	✓	✓	✓	✓	✓	–
L10	–	–		–	✓	✓	✓	✓	✓	✓	✓	–
L15	–	–	–		✓	✓	✓	✓	✓	✓	✓	–
L57	✓	✓	✓	✓		–	–	✓	✓	✓	✓	✓
L59	✓	✓	✓	✓	–		–	✓	✓	✓	✓	✓
L60	✓	✓	✓	✓	–	–		✓	✓	✓	✓	✓
L61/L64	✓	✓	✓	✓	✓	✓	✓		–	✓	✓	✓
L62/L65	✓	✓	✓	✓	✓	✓	✓	–		✓	✓	✓
L87	✓	✓	✓	✓	✓	✓	✓	✓	✓		– 1)	✓
K82	✓	✓	✓	✓	✓	✓	✓	✓	✓	– 1)		✓
M78	–	–	–	–	✓	✓	✓	✓	✓	✓	✓	

1) A combination of **L87** and **K82** is available on request.

# SINAMICS S150 Converter Cabinet Units

## Converter cabinet units

### Options (continued)

#### Mechanical/electrical options

	M06	M07	M13	M21	M23	M43	M54	M60	M66	M70	M78
M06		–	✓	✓	✓	✓	✓	✓	✓	✓	✓
M07	–		✓	✓	✓	✓	✓	✓	✓	✓	✓
M13	✓	✓		✓	✓	✓	✓	✓	✓	– <sup>1)</sup>	✓
M21	✓	✓	✓		–	–	–	– <sup>2)</sup>	–	✓	–
M23	✓	✓	✓	–		–	–	–	–	✓	✓
M43	✓	✓	✓	–	–		–	–	✓	✓	✓
M54	✓	✓	✓	–	–	–		–	✓	✓	✓
M60	✓	✓	–	– <sup>2)</sup>	–	–	–		✓	✓	–
M66	✓	✓	✓	–	–	✓	✓	✓		✓	–
M70	✓	✓	– <sup>1)</sup>	✓	✓	✓	✓	✓	✓		– <sup>1)</sup>
M78	✓	✓	✓	–	✓	✓	✓	–	–	– <sup>1)</sup>	

#### Other options

	G20	G33	G62	K46	K48	K50	K51	K52
G20		–	–	✓	✓	✓	✓	✓
G33	–		–	✓	✓	✓	✓	✓
G62	–	–		✓	✓	✓	✓	✓
K46	✓	✓	✓		–	–	–	–
K48	✓	✓	✓	–		–	–	–
K50	✓	✓	✓	–	–		–	✓
K51	✓	✓	✓	–	–	–		–
K52	✓	✓	✓	–	–	✓	–	

#### Documentation

	D00	D02	D14	D56	D58	D60	D72	D76	D77	D78	D80	D84	D91	D93	D94	D99
D00		✓	✓	✓	✓	✓	✓	✓	✓	✓	✓	✓	✓	✓	✓	–
D02	✓		✓	✓	✓	✓	✓	✓	✓	✓	✓	✓	✓	✓	✓	–
D14	✓	✓		✓	✓	✓	✓	✓	✓	✓	✓	✓	✓	✓	✓	–
D56	✓	✓	✓		✓	✓	✓	✓	✓	✓	✓	✓	✓	✓	–	–
D58	✓	✓	✓	✓		–	✓	–	–	✓	–	✓	–	–	–	–
D60	✓	✓	✓	✓	–		✓	–	✓	–	–	✓	–	–	–	–
D72	✓	✓	✓	✓	✓	✓		✓	✓	✓	–	✓	✓	✓	✓	–
D76	✓	✓	✓	✓	–	–	✓		✓	✓	–	✓	–	–	–	–
D77	✓	✓	✓	✓	–	✓	✓	✓		✓	✓	✓	✓	✓	✓	–
D78	✓	✓	✓	✓	✓	–	✓	✓	✓		✓	✓	✓	✓	✓	–
D80	✓	✓	✓	✓	–	–	–	–	✓	✓		✓	–	–	–	–
D84	✓	✓	✓	✓	✓	✓	✓	✓	✓	✓	✓		–	✓	✓	–
D91	✓	✓	✓	✓	–	–	✓	–	✓	✓	–	–		–	–	–
D93	✓	✓	✓	✓	–	–	✓	–	✓	✓	–	✓	–		–	–
D94	✓	✓	✓	–	–	–	✓	–	✓	✓	–	✓	–	–		–
D99	–	–	–	–	–	–	–	–	–	–	–	–	–	–	–	

#### Rating plate data

	T58	T60	T80	T85	T91
T58		–	–	–	–
T60	–		–	–	–
T80	–	–		–	–
T85	–	–	–		–
T91	–	–	–	–	

<sup>1)</sup> If the line connection (option **M13**) and the motor connection (option **M78**) are from above, the EMC shield bus is not required in the lower cabinet area.

<sup>2)</sup> Can only be selected for converters in the voltage range 400 V to 250 kW and 690 V to 315 kW. The **M60** option is fitted as standard for higher outputs.

**Options** (continued)*Ordering examples*Example 1*Task:*

A drive system is required for a vehicle roller test bench to perform exhaust gas analysis which can simulate driving profiles and cycles as encountered in everyday traffic situations. This means for the drive system that the dynamometer must be operated both in the motoring as well as regenerating modes.

A drive with regenerative feedback into the line supply is required as regenerative operation is the predominant operating mode and dynamic switching operations are required.

The max. regenerative power is 200 kW. The drive converter must have degree of protection IP54 as a result of the environmental conditions. An installation altitude of < 1000 m and 45 °C as the maximum ambient temperature can be assumed. The windings must be equipped with Pt100 resistance thermometers and monitored by the drive converter for alarm and trip. A switch disconnecter must be provided to disconnect the converter from the 400 V power supply. In addition, the cabinet is to have a special paint finish in RAL 3002.

*Solution:*

Taking into account the derating factors for degree of protection IP54 and the increased ambient temperature of 45 °C, a converter with a minimum power rating of 223 kW should be configured.

A converter with a power rating of at least 250 kW and options **M54** (degree of protection IP54), **L26** (main switch including fuses), **L86** (Pt100 evaluation unit) and **Y09** (special paint finish) is selected.

The ordering data are as follows:

**6SL3710-7LE35-0AA3-Z**

**M54+L26+L86+Y09**

Cabinet color RAL 3002

Example 2*Task:*

A drive system is required for a conveyor belt in a brown-coal open-cast mine that is capable of both motor and generator operation. Since the conveyor belt must be capable of starting after a fault when loaded with bulk material, and it is possible for peak loads to occur where 1.5 times the power is required for up to 60 s, the drive system must be designed according to the overload requirements of such a case. The drive converter is installed in a climate-controlled container as a result of the environmental conditions typical of an open-cast mine. The installation altitude is 320 m above sea level and the maximum ambient temperature in the container is 35 °C. The drive is powered through a converter transformer from the medium-voltage system. The drive is connected to an isolated-neutral system and must have insulation monitoring. A motor with separately-driven fan is selected here as the motor is subject to a high load torque when starting and in the lower range. The fan supply voltage is 690 V and must be drawn from the drive converter. The required motor power is 420 kW.

*Solution:*

Since the converter is installed in an air-conditioned container, it can be designed with degree of protection IP20. The ambient temperature of 35 °C does not necessitate any additional derating. However, due to the specified overload conditions, the base load current  $I_H$  (for high overload) must be applied. This results in a power of approx. 520 kW for the drive converter. The converter with article no. 6SL3710-7LG35-8AA3 must be selected.

Option **L87** (insulation monitoring) must be selected for insulation monitoring.

Option **L19** (connection for external auxiliaries) must be selected for the controlled outgoing feeder to power the separately driven fan.

The ordering data are as follows:

**6SL3710-7LG35-8AA3-Z**

**L19+L87**



# SINAMICS S150 Converter Cabinet Units

## Description of options

### Options

#### B00, B02, B03

#### Options compliant with NAMUR requirements

Exclusion list with other options:

The following restrictions and exclusions applicable to the NAMUR terminal block **B00** with regard to other available options must be taken into account.

Not permissible with options	Reason
<b>L45, L57, L59, L60</b>	A Category 0 EMERGENCY OFF is already provided in the NAMUR version. The forced line supply disconnection is connected at terminal -X2: 17, 18.
<b>L83, L84</b>	The <b>B00</b> option already provides a PTC thermistor evaluation unit as standard (trip).
<b>L19</b>	Alternatively, option <b>B03</b> can be selected. This provides a reduced scope for external auxiliaries.
<b>L87</b>	The insulation monitor monitors the complete electrically coupled network. An insulation monitor must therefore be provided on site.
<b>G60</b>	The <b>B00</b> option already provides a Terminal Module TM31 as a standard feature.

With options **L50, L55, L86**, the connection is made as described in the standard. There is no wiring to the NAMUR terminal block.

#### B00

#### NAMUR terminal block

The terminal block is designed according to the requirements and directives of the standards association for measurement and control in the chemical industry (NAMUR recommendation NE37). I.e. terminals are specifically assigned to particular device functions. The inputs and outputs connected to the terminals fulfill PELV requirements (protective extra-low voltage) with protective separation.

The terminal block and associated functions have been reduced to the necessary minimum. Unlike the NAMUR recommendation, optional terminals are not available.

Terminal -X2:	Meaning	Default	Remarks
<b>10</b>	DI	ON (dynamic) / ON/OFF (static)	The effective mode can be encoded using a wire jumper at terminal -400: 9; 10 codable
<b>11</b>	DI	OFF (dynamic)	
<b>12</b>	DI	Faster	
<b>13</b>	DI	Slower	
<b>14</b>	DI	RESET	
<b>15</b>	DI	Interlock	
<b>16</b>	DI	Counter-clockwise	0 signal for CW rotating field 1 signal for CCW rotating field
<b>17, 18</b>		Supply disconnection	EMERGENCY OFF circuit
<b>30, 31</b>		Ready	Relay output (NO contact)
<b>32, 33</b>		Motor is turning	Relay output (NO contact)
<b>34</b>	DO (NO)	Fault	Relay output (changeover contact)
<b>35</b>	DO (COM)		
<b>36</b>	DO (NC)		
<b>50, 51</b>	AI 0/4 ... 20 mA	Speed setpoint	
<b>60, 61</b>	AO 0/4 ... 20 mA	Motor frequency	
<b>62, 63</b>	AO 0/4 ... 20 mA	Motor current	Motor current is default setting; can be reparameterized for other variables

The 24 V supply is provided on the plant side via terminals -X2: 1-3 (fused in the converter with 1 A). It must be ensured that the PELV safety requirements are fulfilled (protective extra-low voltage with protective separation).

Terminal -X2:	Meaning	
<b>1</b>	M	Reference conductor
<b>2</b>	P24	24 V DC supply
<b>3</b>	P24	24 V DC outgoing feeder

For temperature monitoring of explosion-proof motors, option **B00** includes a PTC thermistor. Exceeding the limit value causes a shutdown. The associated PTC sensor is connected to terminal -X3: 90, 91.

Terminal -X3:	Meaning	
<b>90, 91</b>	AI	Connection of PTC sensor

**Options** (continued)**B02****Protective separation for 24 V supply (PELV)**

If no protective separation for 24 V supply (PELV) is available at the customer site, this option is used to provide a second power supply to guarantee compliance with PELV. (Terminal assignments as for option **B00**, 24 V supply at terminals -X1:1, 2, 3 is not required)

**Notice:**

The option **B02** must always be combined with **B00**.

**B03****Outgoing feeder for external auxiliaries (uncontrolled)**

If a motor fan is to be supplied with power from the plant, option **B03** provides an uncontrolled external outgoing feeder with a 10 A fuse. As soon as the supply voltage is present at the converter input, a voltage is also present at these terminals. This corresponds to the converter input voltage ( $U = U_{line}$ ). You must take this into account when configuring an external fan.

Terminal -X1:	Meaning
1, 2, 3, PE	Outgoing feeder for external auxiliaries

**Notice:**

Option **B03** must always be combined with **B00**.

**B43, B44, B45****Production flowcharts**

Production flowcharts are provided with options **B43** to **B45**. After the order has been clarified, these are emailed as a dual language (English/German) PDF file.

Option	Description
<b>B43</b>	Documentation - Production flowchart: one issue
<b>B44</b>	Documentation - Production flowchart: updated every two weeks
<b>B45</b>	Documentation - Production flowchart: updated every month

**B55****Generation of a preliminary and a final packing list (shipping)**

This option provides the electronically editable packing list (possibly predefined from the factory) with the following information in Excel format:

- Number of individual packages
- Type of package (pallet, crate, etc.)
- Weight (unpacked and packed)
- Dimensions (unpacked and packed)
- Delivery location
- Label for package item (when option B56 is ordered)
- Description of what is in the package

A first packing list is generated after complete technical clarification with preliminary data. When shipped, a final packing list is provided with the actual data.

**B56****Packed items labeled with a customized label**

With this option, customized labels are attached to the unpacked and packed packaged units. Internal customers must provide two labels at least 2 weeks before the shipping date (printout to the factory logistics department, specifying the article number).

**B57****Photo documentation of the ordered units**

This option provides digital photographic documentation with the following content:

- 1 photo diagonally from the front
- 1 photo diagonally from the rear (opposite)
- 1 photo with the packed item on which the label is legible

The listed photos of the packed items are taken in both an unpacked and a packed state in each position (a total of 6 photos per packed item).

**D02****Customer documentation (circuit diagram, terminal diagram, layout diagram) in DXF format**

Option **D02** can be used to order documents such as circuit diagrams, terminal diagrams, layout diagrams, and dimension drawings in DXF format, e.g. for further processing in AutoCAD systems.

**D04****Customer documentation as hard copy**

Device documentation is supplied electronically on a CD-ROM as standard. If the customer also requires a hard copy of the documentation and selects option **D04**, the following documents will be supplied in a folder with the converter:

- Operating instructions
- Circuit diagram
- Terminal diagram
- Layout diagram
- Dimension drawing
- Spare parts list
- Test certificate

Regardless of whether option **D04** is selected, hard copies of the safety and transportation guidelines, a check list and a registration form are always supplied.

**D14****Preliminary version of customer documentation**

If documents such as circuit diagrams, terminal diagrams, layout diagrams and dimension drawings are required in advance for the purpose of system engineering (integration of drive into higher-level systems, interface definition, installation, building planning, etc.), it is possible to order a draft copy of the documentation when ordering the converter cabinet units. These documents are then supplied electronically a few working days following receipt of the order. If the order includes options that fall outside the scope of standard delivery, these will not be covered by the documentation due to the obvious time constraints.

The client is sent the documentation relating to the order by email. The recipient's email address must be specified with the order for this purpose. In the email, the recipient will also receive a link for downloading order-specific documentation.

With the option **D02**, the documents are also delivered in DXF format.

## SINAMICS S150 Converter Cabinet Units

### Description of options

#### Options (continued)

##### *D58, D60, D80, D91, D93, D94*

##### *Documentation as language package*

If a documentation option is not selected, the relevant documentation is supplied as standard in English/German. When one of the options specified in the table is selected, the standard documentation language will be changed from English/German to the language combination provided by the option.

Order code	Language
<b>D58</b>	English/French
<b>D60</b>	English/Spanish
<b>D80</b>	English/Italian
<b>D91</b>	English/Chinese
<b>D93</b>	English/Portuguese (Brazil)
<b>D94</b>	English/Russian

##### *D00, D56, D72, D76, D77, D78, D84*

##### *Documentation in a single language*

The documentation is also available in a single language, for example, to be able to order other language combinations.

If a further language is required for standard documentation in English/German, the option **D74** (documentation in English/German) must also be ordered in addition to that language.

Order code	Language
<b>D00</b>	German
<b>D56</b>	Russian
<b>D72</b>	Italian
<b>D76</b>	English
<b>D77</b>	French
<b>D78</b>	Spanish
<b>D84</b>	Chinese

##### *E11 to E71*

##### *Individual certification*

The individual certification of the converter by the relevant certification body contains the expansions described in option **M66**.

- **E11** Individual certificate from Germanische Lloyd (GL)
- **E21** Individual certificate from Lloyds Register (LR)
- **E31** Individual certificate from Bureau Veritas (BV)
- **E51** Individual certificate from Det Norske Veritas (DNV)
- **E61** Individual certificate from American Bureau of Shipping (ABS)
- **E71** Individual certificate from Chinese Classification Society (CCS)

##### Note:

Several individual certificates can be combined.

##### *F03, F71, F72, F74, F75, F76, F77, F97*

##### *Converter acceptance inspections*

Order code	Description
<b>F03</b>	<p><b>Visual acceptance</b></p> <p>The inspection includes the following:</p> <ul style="list-style-type: none"> <li>• Check of degree of protection</li> <li>• Check of equipment (components)</li> <li>• Check of equipment identifiers</li> <li>• Check of clearance and creepage distances</li> <li>• Check of cables</li> <li>• Check of customer documentation</li> <li>• Submission of the acceptance report</li> </ul> <p>The tests are carried out with the converter de-energized.</p>
<b>F71</b> (witnessed by customer) <b>F72</b> (not witnessed by customer)	<p><b>Function test without connected motor</b></p> <p>After the visual acceptance with the converter switched off, the converter is connected to rated voltage. No current at the converter output end.</p> <p>The inspection includes the following:</p> <ul style="list-style-type: none"> <li>• Visual acceptance as described for option <b>F03</b></li> <li>• Check of power supply</li> <li>• Check of protective and monitoring devices (simulation)</li> <li>• Check of fans</li> <li>• Pre-charging test</li> <li>• Function test without connected motor</li> </ul> <p>Submission of the acceptance report</p>
<b>F74</b> (not witnessed by customer) <b>F75</b> (witnessed by customer)	<p><b>Function test with test bay motor under no-load conditions</b></p> <p>After the visual acceptance with the converter switched off, the converter is connected to rated voltage. A small current flows at the converter output end in order to operate the test bay motor under no-load conditions.</p> <p>The inspection includes the following:</p> <ul style="list-style-type: none"> <li>• Visual acceptance as described for option <b>F03</b></li> <li>• Check of power supply</li> <li>• Check of protective and monitoring devices (simulation)</li> <li>• Check of fans</li> <li>• Pre-charging test</li> <li>• Function test with test bay motor under no-load conditions</li> </ul> <p>Submission of the acceptance report</p>
<b>F76</b> (not witnessed by customer) <b>F77</b> (witnessed by customer)	<p><b>Insulation test</b></p> <p>The inspection includes the following:</p> <ul style="list-style-type: none"> <li>• High-voltage test</li> <li>• Measurement of the insulation resistance</li> <li>• Submission of the acceptance report</li> </ul>
<b>F97</b>	<p><b>Customer-specific acceptance inspections (on request)</b></p> <p>If acceptance inspections that are not covered by the options <b>F03</b>, <b>F71</b>, <b>F75</b>, or <b>F77</b> are required, customer-specific acceptance inspections/supplementary tests can be ordered using order code <b>F97</b> on request and following technical clarification.</p>

**Options** (continued)**G20****CBC10 Communication Board**

The CBC10 Communication Board is used to connect the CU320-2 Control Unit and thus the SINAMICS S150 to the CAN (Controller Area Network) protocol. The associated driver software fulfills the standards of the following CANopen specification of the CiA organization (CAN in Automation):

- Communication profiles according to DS 301
- Drive profile in accordance with DSP 402 (in this case Profile Velocity Mode)
- EDS (Electronic Data Sheet) in accordance with DSP 306
- Operational state signaling according to DSP 305

The CBC10 Communication Board plugs into the option slot on the CU320-2 Control Unit. The CAN interface on the CBC10 has two SUB-D connections for input and output.

It cannot be combined with option **G33**.

[Description of the CBC10 Communication Board → SINAMICS S120 chassis format units → System components → Supplementary system components.](#)

**G33****CBE20 Communication Board**

The CBE20 Communication Board can be used to connect the SINAMICS S150 to a PROFINET IO or Ethernet/IP network via a CU320-2 Control Unit. The CBE Communication Board plugs into the option slot on the CU320-2 Control Unit.

It cannot be combined with option **G20**.

**Note:**

Only one communication interface can be used in isochronous operation when the Communication Board CBE20 is used in a Control Unit CU320-2.

- CU320-2 DP: Either the DP interface of the Control Unit or the PN interfaces of the CBE20
- CU320--2 PN: Either the internal PN interfaces or the external PN interfaces of the CBE20

[Description of the CBE20 Communication Board → SINAMICS S120 chassis format units → System components → Supplementary system components.](#)

**G51****TM150 temperature sensor evaluation unit**

The TM150 Terminal Module is a DRIVE-CLiQ component that is used to acquire and evaluate data from several temperature sensors. The temperature is measured in a temperature range from -99 °C to +250 °C for the following temperature sensors:

- Pt100 (with monitoring for wire breakage and short-circuit)
- Pt1000 (with monitoring for wire breakage and short-circuit)
- KTY84 (with monitoring for wire breakage and short-circuit)
- PTC (with monitoring for short-circuit)
- Bimetallic NC contact (without monitoring)

For the temperature sensor inputs, for each terminal block the evaluation can be parameterized for 1×2-wire, 2×2-wire, 3-wire or 4-wire. There is no electrical isolation in the TM150.

A maximum of 12 temperature sensors can be connected to the TM150 Terminal Module.

[Description of the TM150 Terminal Module → SINAMICS S120 chassis format units → System components → Supplementary system components.](#)

**G60****TM31 Terminal Module**

The TM31 Terminal Module is used to expand the customer terminal.

The following additional interfaces are available:

- 8 digital inputs
- 4 bidirectional digital inputs/outputs
- 2 relay outputs with changeover contact
- 2 analog inputs
- 2 analog outputs
- 1 temperature sensor input (KTY84-130/PTC)
- 2 DRIVE-CLiQ sockets
- 1 connection for the electronics power supply via the 24 V DC supply connector
- 1 PE/protective conductor connection

To simplify configuration and commissioning of the drive, the optional TM31 Terminal Module is already preset with various factory settings, which can then be selected when commissioning the system.

[Description of the TM31 Terminal Module → SINAMICS S120 chassis format units → System components → Supplementary system components.](#)

[For additional information, please refer to the SINAMICS Low Voltage Engineering Manual.](#)

**G61****Additional TM31 Terminal Module**

With option **G61**, the number of digital inputs/outputs, as well as the number of analog inputs/outputs in the drive system can be expanded using a second TM31 Terminal Module (in addition to the TM31 Terminal Module that can be selected using option **G60**).

**Note:**

Option **G61** requires option **G60**

**G62****TB30 Terminal Board**

The TB30 Terminal Board supports the addition of digital inputs/digital outputs and analog inputs/analog outputs to the Control Unit. The TB30 Terminal Board plugs into the option slot on the Control Unit.

The following are located on the TB30 Terminal Board:

- Power supply for digital inputs/digital outputs
- 4 digital inputs
- 4 digital outputs
- 2 analog inputs
- 2 analog outputs

[Description of the TB30 Terminal Board → SINAMICS S120 chassis format units → System components → Supplementary system components.](#)

## SINAMICS S150 Converter Cabinet Units

### Description of options

#### Options (continued)

##### K01

##### *Safety license for 1 axis*

The Safety Integrated Basic Functions do not require a license. However, the Safety Integrated Extended Functions require a license for each axis equipped with safety functions. It is irrelevant which safety functions are used and how many. Option **K01** contains the license for one axis.

Subsequent licensing is possible online via the WEB License Manager by generating a license key:

[www.siemens.com/automation/license](http://www.siemens.com/automation/license)

##### K46

##### *SMC10 Sensor Module Cabinet-Mounted*

The SMC10 Sensor Module Cabinet-Mounted can be used to simultaneously sense the speed and the rotor position angle. The signals received from the resolver are converted here and made available to the closed-loop controller via the DRIVE-CLiQ interface for evaluation purposes.

The following encoder signals can be evaluated:

- 2-pole resolver
- Multi-pole resolver

The motor temperature can also be measured using KTY84-130 or PTC thermistors.

[Description of the SMC10 Sensor Module Cabinet-Mounted → SINAMICS S120 chassis format units → System components → Encoder system interface.](#)

##### K48

##### *SMC20 Sensor Module Cabinet-Mounted*

The SMC20 Sensor Module Cabinet-Mounted can be used to simultaneously sense the speed and position. The signals received from the incremental encoder are converted here and made available to the closed-loop controller via the DRIVE-CLiQ interface for evaluation purposes.

The following encoder signals can be evaluated:

- Incremental encoder  $\sin/\cos 1 V_{pp}$
- Absolute encoder EnDat 2.1
- SSI encoder with incremental signals  $\sin/\cos 1 V_{pp}$

The motor temperature can also be detected using KTY84-130 or PTC/Pt100 thermistors.

[Description of the SMC20 Sensor Module Cabinet-Mounted → SINAMICS S120 chassis format units → System components → Encoder system interface.](#)

##### K50

##### *SMC30 Sensor Module Cabinet-Mounted*

The SMC30 Sensor Module Cabinet-Mounted can be used to evaluate the encoders of motors without a DRIVE-CLiQ interface. External encoders can also be connected via the SMC30.

The following encoder signals can be evaluated:

- Incremental encoders TTL/HTL with and without open-circuit detection (open-circuit detection is only available with bipolar signals)
- SSI encoders with TTL/HTL incremental signals
- SSI encoders without incremental signals

The motor temperature can also be measured using KTY84-130 or PTC thermistors.

[Description of the SMC30 Sensor Module Cabinet-Mounted → SINAMICS S120 chassis format units → System components → Encoder system interface.](#)

##### K51

##### *VSM10 Voltage Sensing Module*

The VSM10 Voltage Sensing Module is used to measure the voltage characteristic on the motor side, so that the following function can be implemented:

- Operation of a permanent-magnet synchronous motor without encoder with the requirement to be able to connect to a motor that is already running (flying restart function)
- Quick flying restart of large induction motors: The time for the demagnetization of the motor is eliminated through the measurement of the voltage.

[Description of the VSM10 Voltage Sensing Module → SINAMICS S120 chassis format units → System components → Supplementary system components.](#)

##### K52

##### *Second SMC30 Sensor Module Cabinet-Mounted*

With option **K50**, the cabinet unit contains an SMC30 Sensor Module Cabinet-Mounted. An additional SMC30 (Option **K52**) Sensor Module enables reliable actual-value acquisition when using Safety Integrated Extended Functions (requires a license: Option **K01**).

[Detailed and comprehensive instructions and information for the Safety Integrated functions can be found in the associated Function Manual.](#)

##### K82

##### *Terminal Module for controlling the Safe Torque Off and Safe Stop 1 safety functions*

The terminal module controls the Safety Integrated Basic Functions Safe Torque Off (STO) and Safe Stop 1 (SS1) (time-controlled) over a wide voltage range from 24 V to 240 V DC/AC (terminology as defined in IEC 61800-5-2).

The integrated safety functions, starting from the Safety Integrated (SI) input terminals of the components (Control Unit and Power Module), satisfy the requirements of EN 61800-5-2, EN 60204-1, EN ISO 13849-1 Category 3 for Performance Level (PL) d and IEC 61508 SIL 2.

With option **K82**, the requirements specified in EN 61800-5-2, EN 60204-1, EN ISO 13849-1 Category 3 for Performance Level (PL) d and IEC 61508 SIL 2 are fulfilled.

The Safety Integrated functions using option **K82** are only available in conjunction with certified components and software versions.

The Safety Integrated functions of SINAMICS are generally certified by independent institutes. An up-to-date list of certified components is available on request from your local Siemens office.

##### K87

##### *TM54F Terminal Module*

The Terminal Module TM54F is a terminal expansion module with safe digital inputs and outputs to control the Safety Integrated functions.

The TM54F is directly connected to a Control Unit via DRIVE-CLiQ. Each Control Unit can be assigned precisely to one TM54F.



**Options** (continued)**Note:**

It is not permissible to connect Motor Modules or Line Modules to a TM54F.

The TM54F provides 4 fail-safe digital outputs and 10 fail-safe digital inputs. A fail-safe digital output consists of one 24 V DC switching output, one output switching to ground and one digital input to check the switching state. A fail-safe digital input consists of two digital inputs.

[Description of the TM54F Terminal Module → SINAMICS S120 chassis format units → System components → Supplementary system components.](#)

**K88****Safe Brake Adapter SBA, 230 V AC**

The Safe Brake Control (SBC) is a safety function that is used in safety-relevant applications, for example in presses or rolling mills. In the no-current state, the brake acts on the drive motor using spring force. The brake is released when current flows in it (low active).

The Safe Brake Adapter is already installed in the cabinet unit in the factory. A source of power is connected to terminal -X12 on the Safe Brake Adapter. For control, a connection is established between the Safe Brake Adapter and the Control Interface Module in the factory using a cable harness.

On the plant side, to control the brake, a connection must be established between terminal -X14 on the Safe Brake Adapter and the brake.

[Description of the SBA Safe Brake Adapter → SINAMICS S120 chassis format units → System components → Supplementary system components.](#)

**K95****CU320-2 PN Control Unit (PROFINET)**

Instead of the CU320-2 DP (PROFIBUS) Control Unit provided as standard, the drive is delivered with a CU320-2 PN Control Unit (PROFINET), including a CompactFlash card.

[Description of the CU320-2 Control Unit → SINAMICS S120 chassis format units → System components → Control Units.](#)

**L00****Use in the first environment according to EN 61800-3, Category C2 (TN/TT supply systems with grounded neutral point)**

To limit interference emission, the converter includes as standard a radio interference suppression filter according to the EMC product standard EN 61800-3, Category C3 (use in the industrial environment or in the second environment).

By using the optionally available line filter (option **L00**), up to a motor cable length of 300 m on grounded line supplies, the converters are suitable for use according to Category C2 (residential area or first environment).

However, complying with the limit values in the standard means that all of the relevant installation specifications regarding grounding and shielding must be strictly observed.

[Notes on this are provided in the SINAMICS Low Voltage Engineering Manual as well as in the appropriate operating instructions.](#)

**L04****Infeed module one level lower**

With this option, an infeed (Active Line Module/Active Interface Module) rated one power level lower than the Motor Module (inverter) is used.

For instance, this option is suitable for the following applications:

- When the Motor Module is operated at pulse frequencies greater than the rated pulse frequency, which means that the output power is reduced (current derating as a function of the pulse frequency).
- When the rated power is demanded when generating, and the system losses are covered by the Motor Module.
- When using motors with a higher efficiency and/or a lower power factor when compared to typical standard induction motors.
- The maximum current of the Motor Module is demanded below the maximum power of the unit, e.g. drives with a high breakaway torque.

When using option **L04**, the following restrictions must always be taken into consideration:

- The rated output current of the Motor Module is only available as long as the infeed (Active Line Module) is not loaded with the rated power.
- For line undervoltage conditions, the output power is reduced linearly with the line voltage.
- The unit should be operated with a system power factor  $\cos \varphi = 1$  (this is the factory setting) and should only provide the active power. Additional compensation of reactive power from the power system is not advisable.

Option **L04** is available for the following cabinet units:

SINAMICS S150 converter cabinet unit	Type rating at 400 V	Permissible currents		
		Output	Input Standard	With option L04
6SL3710-...	kW	A	A	A
<b>Line voltage 380 ... 480 V 3 AC</b>				
7LE33-1AA3	160	310	310	260
7LE35-0AA3	250	490	490	380
7LE36-1AA3	315	605	605	490
7LE37-5AA3	400	745	745	605
7LE41-0AA3	560	985	985	840

**L07****dv/dt filter compact plus Voltage Peak Limiter**

dv/dt filters compact plus VPL (**V**oltage **P**eak **L**imiter) limit the voltage rate-of-rise dv/dt to values of < 1600 V/μs and the typical voltage peaks to the following values in accordance with the limit value curve A according to IEC 60034-25: 2007:

- < 1150 V at  $U_{line} < 575$  V
- < 1400 V at  $660$  V <  $U_{line} < 690$  V

The dv/dt filter compact plus VPL functionally consists of two components that are supplied as a compact mechanical unit, the dv/dt reactor and the voltage limiting network (VPL), which limits voltage peaks and feeds back the energy to the DC link.

## SINAMICS S150 Converter Cabinet Units

### Description of options

#### Options (continued)

It is so compact that it can be completely integrated into the cabinet, even for high power ratings. An additional cabinet is not required.

By using a dv/dt filter compact plus VPL, standard motors with standard insulation and without insulated bearings can be used with supply voltages up to 690 V in converter operation.

The power losses stated in section System components → Motor-side components → dv/dt filter compact plus VPL can be used to determine the total losses for engineering purposes.

dv/dt filters compact plus VPL are designed for the following maximum motor cable lengths:

- Shielded cables 100 m (e.g. Protodur NYCWY)
- Unshielded cables 150 m (e.g. Protodur NYY)

For longer cable lengths (>100 m shielded, >150 m unshielded), the dv/dt filter plus VPL (option **L10**) should be used.

#### Notice:

- Operation with output frequencies <10 Hz is permissible for max. 5 min.
- The maximum permissible output frequency is 150 Hz.

When using dv/dt filters, restrictions regarding permissible pulse frequencies must be observed.

For additional information, please refer to the [SINAMICS Low Voltage Engineering Manual](#).

#### Note:

Option **L07** cannot be combined with the following options:

- **L08** (motor reactor)
- **L10** (dv/dt filter plus VPL)
- **L15** (sine-wave filter)
- **M78** (motor connection from above)

#### L08

##### Motor reactor

Motor reactors reduce the voltage load on the motor windings by reducing the voltage gradients at the motor terminals that occur during converter operation. At the same time, the capacitive charge/discharge currents that place an additional load on the converter output when long motor cables are used, are reduced.

The maximum permissible output frequency when a motor reactor is used is 150 Hz.

The power losses stated in section System components → Motor-side components → Motor reactors can be used to determine the total losses for engineering purposes.

#### Note:

Option **L08** cannot be combined with the following options:

- **L07** (dv/dt filter compact plus VPL)
- **L10** (dv/dt filter plus VPL)
- **L15** (sine-wave filter)
- **M78** (motor connection from above)

#### L10

##### dv/dt filter plus Voltage Peak Limiter

A dv/dt filter plus VPL (**V**oltage **P**eak **L**imiter) limits the voltage rate-of-rise dv/dt to values <500 V/μs and the typical voltage peaks to the following values in accordance with the limit value curve according to IEC/TS 60034-17: 2006:

- <1000 V at  $U_{line} < 575$  V
- <1250 V at  $660$  V <  $U_{line} < 690$  V

The dv/dt filter plus VPL functionally consists of two components, the dv/dt reactor and the voltage limiting network (VPL), which limits voltage peaks and feeds the energy back to the DC link.

Depending on the converter power, option **L10** can be accommodated in the converter cabinet unit or an additional cabinet is required with a width of 400 mm or 600 mm.

Voltage range	Installation of the dv/dt filter plus VPL		
	in the converter (without additional cabinet)	in the additional cabinet	
		400 mm wide	600 mm wide
380 ... 480 V	110 ... 250 kW	315 ... 450 kW	560 ... 800 kW
500 ... 690 V	75 ... 315 kW	400 ... 560 kW	710 ... 1200 kW

By using a dv/dt filter plus VPL, standard motors with standard insulation and without insulated bearings can be used with supply voltages up to 690 V in converter operation.

dv/dt filters plus VPL are designed for the following maximum motor cable lengths:

- Shielded cables 300 m (e.g. Protodur NYCWY)
- Unshielded cables: 450 m (e.g. Protodur NYY)

For cable lengths <100 m shielded or <150 m unshielded, the dv/dt filter compact plus VPL (option **L07**) can be used advantageously.

The power losses stated in section System components → Motor-side components → dv/dt filter plus VPL can be used to determine the total losses for engineering purposes.

#### Notice:

The maximum permissible output frequency is 150 Hz.

When using dv/dt filters, restrictions regarding permissible pulse frequencies must be observed.

For additional information, please refer to the [SINAMICS Low Voltage Engineering Manual](#).

#### Note:

Parts of option **L10** do not have nickel-plated copper busbars.

Option **L10** cannot be combined with the following options:

- **L07** (dv/dt filter compact plus VPL)
- **L08** (motor reactor)
- **L15** (sine-wave filter)
- **M78** (motor connection from above)

**Options** (continued)**L15****Sine-wave filter**

Sine-wave filters are available for converters with a power rating of up to 250 kW (380 V to 480 V). The sine-wave filter at the converter output supplies almost perfect sinusoidal voltages at the motor so that standard motors can be used without special cables or power derating. Standard cables can be used to connect the motor. The max. permissible motor cable length is limited to 300 m.

The power losses stated in section System components → Motor-side components → Sine-wave filter can be used to determine the total losses for engineering purposes.

**Note:**

In conjunction with the option **L15**, the pulse frequency of the converter must be increased. This reduces the power available at the drive converter output (derating factor 0.88). The modulation depth of the output voltage decreases to approx. 85 % (380 V to 480 V). The maximum output frequency is 150 Hz. It should be noted that the reduced voltage at the motor terminals compared with the rated motor voltage means that the motor switches to field weakening mode earlier.

**Note:**

Option **L15** cannot be combined with the following options:

- **L07** (dv/dt filter compact plus VPL)
- **L08** (motor reactor)
- **L10** (dv/dt filter plus VPL)
- **M78** (motor connection from above)

**L19****Connection for external auxiliaries**

An outgoing feeder fused with max. 10 A for external auxiliaries (for example, separately driven motor fan).

The voltage is tapped at the converter input upstream of the main contactor / circuit breaker and, therefore, has the same level as the supply voltage.

The outgoing feeder can be switched inside the drive converter or externally.

Terminal -X155:	Meaning	Range
<b>1</b>	L1	380 ... 690 V AC
<b>2</b>	L2	380 ... 690 V AC
<b>3</b>	L3	380 ... 690 V AC
<b>11</b>	Contactor control	230 V AC
<b>12</b>	Contactor control	230 V AC
<b>13</b>	Feedback signal, circuit breaker	230 V AC/0.5 A; 24 V DC/2 A
<b>14</b>	Feedback signal, circuit breaker	230 V AC/0.5 A; 24 V DC/2 A
<b>15</b>	Feedback signal, contactor	230 V AC/6 A
<b>16</b>	Feedback signal, contactor	230 V AC/6 A
<b>PE</b>	PE	–

For more information on engineering, see:  
<https://support.industry.siemens.com/cs/document/104961375>

**L21****Surge suppression**

In ungrounded IT systems, the line voltage is not permanently connected to the ground potential because of the missing ground connection of the supply network. Therefore, when a ground fault occurs during operation, a voltage against ground increased by a factor of 2 can occur. For this reason, it is recommended that a surge suppression against ground be installed for operation on IT systems. The surge suppression option includes the installation of line-side surge arresters and upstream fuses for each system phase. The signaling contacts for monitoring the surge arresters are connected in series and connected to a customer interface.

**Note:**

Option **L21** does not include the components required to install an insulation monitor for the IT system. An insulation monitor should always be ordered separately as option **L87** when the supplying IT system is not monitored at another position (e.g. at the transformer outgoing feeder). Only one insulation monitor can ever be used within the same electrically connected network.

Option **L21** also does not include removal in the factory of the metal bracket that makes the connection to ground of the radio interference suppression filter installed as standard. The metal bracket should therefore be removed during installation or commissioning of the converter if the device is to be operated on an ungrounded IT system.

**L26****Main switch incl. fuses or circuit breakers**

Up to 800 A a switch disconnector with fuses is available as the main switch. For currents greater than 800 A, a circuit breaker provided as standard is used to isolate the drive system from the line supply. The circuit breaker is controlled and supplied within the converter.

Terminal -X50:	Meaning
<b>1</b>	Checkback contact (NO contact) Main switch/circuit breaker closed
<b>2</b>	Checkback contact (NC contact) Main switch/circuit breaker closed
<b>3</b>	Common potential

**L40****Line filter monitoring**

With option **L40**, the filter in the Active Interface Module is monitored for effectiveness against harmonic effects on the system.

The capacitance of the filter capacitors of the integrated filter is continuously calculated and compared with the installed nominal capacitance by measuring the current and voltage in the Active Interface Module. If the calculated capacity deviates by more than the set tolerance, an alarm is triggered.



## SINAMICS S150 Converter Cabinet Units

### Description of options

#### Options (continued)

##### L45

##### **EMERGENCY OFF pushbutton installed in the cabinet door**

The option **L45** only includes the EMERGENCY OFF pushbutton which is fitted with a protective collar in the cabinet door of the converter. The contacts of the pushbutton are brought out and connected to a terminal block.

The EMERGENCY OFF and/or EMERGENCY STOP functions of Category 0 or 1 can be activated in conjunction with options **L57**, **L59**, and **L60**.

Terminal -X120:	Meaning
1	Checkback contact of the EMERGENCY OFF pushbutton in the cabinet door
2	Checkback contact of the EMERGENCY OFF pushbutton in the cabinet door
3	Checkback contact of the EMERGENCY OFF pushbutton in the cabinet door <sup>1)</sup>
4	Checkback contact of the EMERGENCY OFF pushbutton in the cabinet door <sup>1)</sup>

##### Notice:

By pressing the EMERGENCY OFF pushbutton, the motor is stopped either uncontrolled or controlled depending on the selected stop Category 0 or 1, and the main voltage disconnected from the motor, in compliance with IEC 60204-1 (VDE 0113). Auxiliary voltages such as the supply for an external fan or anti-condensation heating may still be present. Certain areas within the converter also remain live (under voltage), such as the control or auxiliary equipment. If complete disconnection of all voltages is required, the EMERGENCY OFF pushbutton must be incorporated into a protective system to be implemented by the customer. For this purpose, an NC contact is provided at terminal -X120.

##### L50

##### **Cabinet lighting with service socket**

With option **L50**, cabinet lighting is included with an additional service socket for a SCHUKO connector (connector type F) according to CEE 7/4. The power supply for the cabinet lighting and the service socket is external and must be fuse-protected for max. 10 A.

The cabinet lighting consists of an LED hand lamp with On/Off switch and with magnetic fasteners with an approx. 3 m long connecting cable. The lamp is factory-positioned in the cabinet door at a defined marking, and the connecting cable is wound on the associated mount.

##### L55

##### **Cabinet anti-condensation heating**

The anti-condensation heating is recommended at low ambient temperatures and high levels of humidity to prevent condensation. A 100 W cabinet heater is installed in each cabinet section (two heaters are installed per cabinet with cabinet section widths of between 800 mm and 1200 mm).

The power supply for the anti-condensation heating (110 V to 230 V AC, at terminal block -X240) must be provided externally and fused with max. 16 A.

Terminal -X240:	Meaning
1	L1 (110 ... 230 V AC)
2	N
3	PE

##### L57

##### **EMERGENCY OFF Category 0, 230 V AC or 24 V DC**

EMERGENCY OFF Category 0 for uncontrolled stopping according to EN 60204-1.

The function includes disconnecting the voltage at the converter by means of the line contactor and bypassing the microprocessor controller using a safety combination according to EN 60204-1. The motor then coasts down. When delivered, the pushbutton circuit is preset to 230 V AC. Jumpers must be appropriately set when using 24 V DC.

Terminal -X120:	Meaning
7	Loop in the EMERGENCY OFF pushbutton from the plant side; remove jumper 7-8!
8	Loop in the EMERGENCY OFF pushbutton from the plant side; remove jumper 7-8!
15	"ON" for monitored start; remove jumper 15-16!
16	"ON" for monitored start; remove jumper 15-16!
17	Checkback signal, "Safety combination has tripped"
18	Checkback signal, "Safety combination has tripped"

##### L59

##### **EMERGENCY STOP Category 1, 230 V AC**

EMERGENCY STOP Category 1 for controlled stopping according to EN 60204-1.

The function stops the drive using a fast stop along a down ramp that is parameterized by the user. The voltage is then disconnected as described for EMERGENCY OFF Category 0 (option **L57**). The pushbutton circuit is operated at 230 V AC.

In order to maintain the specified stopping times, it may be necessary to use a braking unit.

Terminal -X120:	Meaning
7	Loop in the EMERGENCY OFF pushbutton from the plant side; remove jumper 7-8!
8	Loop in the EMERGENCY OFF pushbutton from the plant side; remove jumper 7-8!
15	"ON" for manual start; remove jumper 15-16!
16	"ON" for manual start; remove jumper 15-16!
17	Checkback signal, "Safety combination has tripped"
18	Checkback signal, "Safety combination has tripped"

<sup>1)</sup> For option **L57** to **L60** is preassigned in the converter.

## Options (continued)

**L60****EMERGENCY STOP Category 1, 24 V DC**

EMERGENCY STOP Category 1 for controlled stopping according to EN 60204-1.

The function stops the drive using a fast stop along a down ramp that is parameterized by the user. The voltage is then disconnected as described for EMERGENCY OFF Category 0 (option **L57**). The pushbutton circuit is operated at 24 V DC.

In order to maintain the specified stopping times, it may be necessary to use a braking unit.

Terminal -X120:	Meaning
7	Loop in the EMERGENCY OFF pushbutton from the plant side; remove jumper 7-8!
8	Loop in the EMERGENCY OFF pushbutton from the plant side; remove jumper 7-8!
15	"ON" for manual start; remove jumper 15-16!
16	"ON" for manual start; remove jumper 15-16!
17	Checkback signal, "Safety combination has tripped"
18	Checkback signal, "Safety combination has tripped"

**L61, L62, L64, L65**  
**Braking units**

Braking units may be required for drives in which motors might operate in generator mode, but have no facility for feeding energy back into the supply system.

The braking unit comprises two components:

- A Braking Module that can be installed in the air discharge of the chassis format power units
- A braking resistor to be mounted externally (degree of protection IP20)

The braking unit functions as an autonomous unit, and does not require an external power supply. During the braking process, the kinetic energy is converted into heat in the externally mounted braking resistor.

A max. cable length of 100 m is permissible between the Braking Module and the braking resistor. This allows the braking resistor to be mounted externally so that heat losses can be dissipated outside the converter enclosure. The braking resistor is connected directly to the terminal -X5 of the converter.

The following braking units are available for SINAMICS S150 converter cabinet units:

Option	SINAMICS S150 converter Type rating kW	Braking Module		
		Rated power $P_{DB}$ kW	Braking power $P_{20}$ kW	Peak power $P_{15}$ kW
<b>380 ... 480 V 3 AC</b>				
<b>L61</b>	110 ... 132	25	100	125
<b>L62</b>	160 ... 800	50	200	250
<b>500 ... 600 V 3 AC</b>				
<b>L64</b>	75 ... 132	25	100	125
<b>L65</b>	160 ... 1200	50	200	250
<b>660 ... 690 V 3 AC</b>				
<b>L61</b>	75 ... 132	25	100	125
<b>L62</b>	160 ... 1200	50	200	250

$P_{DB}$  = Rated power (continuous braking power)

$P_{20} = 4 \times P_{DB}$ : 20 s power referred to a braking interval of 90 s

$P_{15} = 5 \times P_{DB}$ : 15 s power referred to a braking interval of 90 s

If more braking power is required than provided by the braking units listed here, then braking units may be connected in parallel for higher converter outputs (on request). In this case, a Braking Module is assigned to each braking resistor.

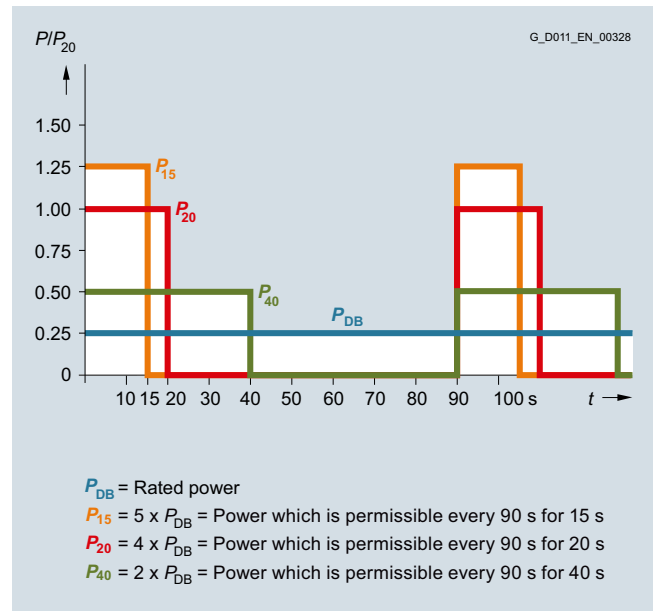

Load diagram for Braking Modules and braking resistors

Additional notes about possible duty cycles of the braking units and other engineering notes are included in the SINAMICS Low Voltage Engineering Manual.

## SINAMICS S150 Converter Cabinet Units

### Description of options

#### Options (continued)

##### L83

##### *Thermistor motor protection device (alarm)*

Thermistor motor protection device for PTC thermistors (PTC resistors, type A) for alarm. The thermistor motor protection device is supplied with power and evaluated internally in the converter.

Terminal -B127:	Meaning
T1	Sensor circuit connection
T2	Sensor circuit connection

##### L84

##### *Thermistor motor protection device (trip)*

Thermistor motor protection device for PTC thermistors (PTC resistors, type A) for trip. The thermistor motor protection device is supplied with power and evaluated internally in the converter.

Terminal -B125:	Meaning
T1	Sensor circuit connection
T2	Sensor circuit connection

##### L86

##### *Pt100 evaluation unit*

The Pt100 evaluation unit can monitor up to six sensors. The sensors can be connected in a two or three-wire system. The limit values can be freely programmed for each channel.

In the factory setting, the measuring channels are subdivided into two groups, each with 3 channels. With motors, for example, this means that three Pt100s in the stator windings and two Pt100s in the motor bearings can be monitored. Unused channels can be hidden via parameters.

The output relays are integrated into the internal fault and shutdown sequence of the converter.

##### L87

##### *Insulation monitoring*

An insulation monitor must be used if the converter is connected to an ungrounded line supply. The device monitors the entire galvanically coupled circuit for insulation faults.

An alarm is output in the event of a fault.

##### Notice:

Only **one** insulation monitor can be used in each galvanically coupled network.

As there are different response strategies when a ground fault occurs in an ungrounded system, output relays of the insulation monitor are provided for integration in a plant-side control. The customer can also choose to integrate the outputs into the converter monitoring system.

##### M06

##### *Base 100 mm high, RAL 7022*

The additional cabinet base allows larger bending radii for cables (cable inlet from below) and enables them to be routed within the cabinet base.

The cabinet base is supplied in RAL 7022 as standard. A special paint finish is not available for the base. It is delivered completely assembled with the cabinet. The height of the operator panel changes accordingly.

##### M07

##### *Cable marshaling compartment 200 mm high, RAL 7035*

The cable marshaling compartment is made of strong sheet steel and allows cables to be connected more flexibly (entry from below). It also allows routing of cables within the marshaling compartment. It is delivered completely assembled with the cabinet. The height of the operator panel changes accordingly.

##### Notice:

The cable marshaling compartment is painted as standard with RAL 7035. If a special color is requested for the cabinet (option **Y09**), the cable marshaling compartment is also painted in this color.

##### M13

##### *Line connection from above*

The control cabinet is provided with an additional roof section to allow a line connection from above. The connection lugs for the power cables, the clamping bar for mechanically securing the cables, an EMC shield bus, and a PE bar are located within this roof section.

This increases the cabinet height by 405 mm. The busbars for the connection from above are delivered completely pre-installed. For transport reasons, the roof sections are delivered separately and must be fitted on site. Crane transport assemblies (option **M90**) can still be used. However, they must be removed on site before the roof sections can be installed. Use of rope spreaders should be considered in the case of small crane hook heights.

An undrilled aluminum mounting plate (5 mm thick) is provided in the roof section for feeding in the cables. Depending on the number of cables and the cross-sections used, holes for attaching cable glands for feeding in the cables must be drilled in this mounting plate on site.

##### Note:

The control cables are still connected from below. Option **M13** eliminates the lugs, provided as standard, to connect the line supply from below.

The degree of protection of the roof sections is IP21. In combination with options **M23**, **M43** and **M54**, additional plastic ventilation grilles and filter elements are provided.

##### Notice:

The roof sections are painted in RAL 7035 as standard. If a special color is requested for the cabinet (option **Y09**), the roof section is also painted in this color. Ventilation grilles used with degrees of protection IP23 and IP54 have color RAL 7035 and cannot be painted.

The covers provided with option **M60** are also included in the scope of supply.

**Options** (continued)**M21****Degree of protection IP21**

Cabinet version in IP20, but with additional top covers or canopies. This increases the cabinet height by 250 mm.

For transport reasons, the top covers or canopies are delivered separately and must be fitted on site.

Notice:

The top covers or canopies are painted in RAL 7035 as standard. If a special color is requested for the cabinet (option **Y09**), the top covers or canopies are also painted in this color.

**M23****Degree of protection IP23**

Converter cabinet units with degree of protection IP23 are supplied with additional roof sections as well as plastic ventilation grilles and a filter medium in the air inlet and outlet. This increases the cabinet height by 400 mm. The covers provided with option **M60** are also included in the scope of supply. The filter medium must be maintained according to the local environmental conditions.

For transport reasons, the roof sections are delivered separately and must be fitted on site.

Notice:

The roof sections are painted in RAL 7035 as standard. If a special color is requested for the cabinet (option **Y09**), the roof section is also painted in this color. The molded plastic parts (e.g. ventilation grilles) are in RAL 7035 and cannot be painted.

**M43****Degree of protection IP43**

Converter cabinet units with IP43 degree of protection are supplied with additional roof sections as well as plastic ventilation grilles and a wire mesh in the air inlet and outlet. This increases the cabinet height by 400 mm. The covers provided with option **M60** are also included in the scope of supply. They are an integral component of the internal cabinet air guidance system and are adapted accordingly.

For transport reasons, the roof sections are delivered separately and must be fitted on site.

Notice:

The roof sections are painted in RAL 7035 as standard. If a special color is requested for the cabinet (option **Y09**), the roof section is also painted in this color. The molded plastic parts (e.g. ventilation grilles) are in RAL 7035 and cannot be painted.

**M54****Degree of protection IP54**

Converter cabinet units with IP54 degree of protection are supplied with additional roof sections as well as plastic ventilation grilles and a filter medium in the air inlet and outlet. This increases the cabinet height by 400 mm. The covers provided with option **M60** are also included in the scope of supply. They are an integral component of the internal cabinet air guidance system and are adapted accordingly. The filters must be maintained according to the local environmental conditions.

For transport reasons, the roof sections are delivered separately and must be fitted on site.

Notice:

- The roof sections are painted in RAL 7035 as standard. If a special color is requested for the cabinet (option **Y09**), the roof section is also painted in this color. The molded plastic parts (e.g. ventilation grilles) are in RAL 7035 and cannot be painted.
- For units with IP54 degree of protection, it is important to observe the derating factor for output currents in relation to ambient temperature and installation altitude.

**M60****Additional touch protection**

The converter cabinet units are designed as standard according to DGUV regulation 3. Option **M60** provides additional covers (outside arm's reach) in the vicinity of the AC busbars and above the power unit (can only be selected as an option with converters up to 250 kW in the 400 V range and with converters up to 315 kW in the 690 V range with degrees of protection IP20 and IP21; otherwise supplied as standard).

**M66****Marine version**

For compliance with the requirements of the classification institutes:

- Lloyds Register
- American Bureau of Shipping
- Germanischer Lloyd
- Bureau Veritas
- Det Norske Veritas
- China Classification Society

This option includes a strengthened mechanical version of the cabinet, handles (handrail) below the operator panel and mechanical locking of the cabinet doors. The cabinet has degree of protection IP23 (option **M23**) and includes a cabinet anti-condensation heater (option **L55**). To secure the converter to the ship's hull, a welding frame (5 mm high) is supplied separately.

Note:

Combination with options **M21**, **M23**, and **L55** is not possible. Individual certification is additionally required if the converter is used for a safety-related drive on the ship (see options **E11** to **E71**).

## SINAMICS S150 Converter Cabinet Units

### Description of options

#### Options (continued)

##### M70

##### *EMC shield bus (cable connection from below)*

The EMC shield bus is used to connect shielded line and motor supply cables. With the options **M13** and **M78**, the EMC shield bus is already included as standard for the connection busbars underneath the roof section.

##### M78

##### *Motor connection from above*

The control cabinet is provided with an additional roof section for a motor connection from above. The connection lugs for the power cables, the clamping bar for mechanically securing the cables, an EMC shield bus, and a PE bar are located within this roof section.

This increases the cabinet height by 405 mm. The busbars for the connection from above are delivered completely pre-installed. For transport reasons, the roof sections are delivered separately and must be fitted on site. Crane transport assemblies (option **M90**) can still be used. However, they must be removed on site before the roof sections can be installed. Use of rope spreaders should be considered in the case of small crane hook heights.

An undrilled aluminum mounting plate (5 mm thick) is provided in the roof section for feeding in the cables. Depending on the number of cables and the cross-sections used, holes for attaching cable glands for feeding in the cables must be drilled in this mounting plate on site.

##### Note:

The control cables are still connected from below. Option **M78** eliminates the lugs, provided as standard, to connect the motor from below.

The degree of protection of the roof sections is IP21. In combination with options **M23**, **M43** and **M54**, additional plastic ventilation grilles and filter elements are provided.

##### Notice:

The roof sections are painted in RAL 7035 as standard. If a special color is requested for the cabinet (option **Y09**), the roof section is also painted in this color. Ventilation grilles used with IP23, IP43 and IP54 degrees of protection are in RAL 7035 and cannot be painted.

The covers provided with option **M60** are also included in the scope of supply.

##### Note:

Option **M78** cannot be combined with the following options:

- **L07** (dv/dt filter compact plus VPL)
- **L08** (motor reactor)
- **L10** (dv/dt filter plus VPL)
- **L15** (sine-wave filter)

##### M90

##### *Crane transport assembly (top-mounted)*

For single cabinets up to a width of 600 mm, the crane transport assembly consists of transport eyebolts. For cabinet widths of 800 mm and wider, transport rails are used.

##### M91

##### *Marking of all control cable conductor ends*

When this option is selected, all control cables or conductor ends (including all customer-specific options) are labeled throughout the cabinet.

##### **T58, T60, T80, T83, T85, T91**

##### *Rating plate data*

The rating plate is provided in English/German as standard. A rating plate in another language combination can be selected by specifying the following option order codes.

Option	Rating plate language
<b>T58</b>	English/French
<b>T60</b>	English/Spanish
<b>T80</b>	English/Italian
<b>T83</b>	English/Portuguese (Brazil)
<b>T85</b>	English/Russian
<b>T91</b>	English/Chinese

##### Y09

##### *Special cabinet paint finish*

The converter cabinet units are delivered in RAL 7035 as standard. The special paint finish must be specified in plain text when ordering. All RAL colors which are available as powder coatings can be selected.

##### Notice:

If options such as cable marshaling compartment (option **M07**), top covers or canopies (option **M21**), roof sections (options **M23/M43/M54**) or cable connection from above (options **M13/M78**) are ordered for the converter cabinet units, they will also be supplied in the paint finish stated in the order. The molded plastic parts (e.g. ventilation grilles) are in RAL 7035 and cannot be painted.

**Options** (continued)**Y31****One-line label for system identification, 40 × 80 mm**

Resopal labels (white with black lettering) for identifying the control cabinets are available. The labels are stuck to the cabinet door.

Dimensions H × W: 40 × 80 mm

The text must be specified in plain text when ordering.

Field 1: Max. 9 characters, font size 10 mm

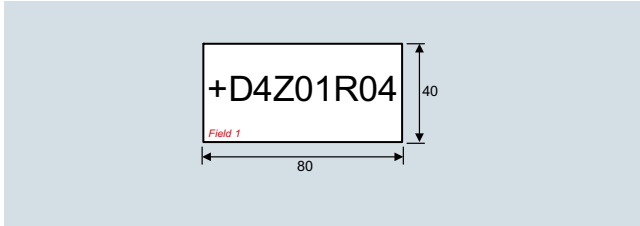
**Y32****Two-line label for system identification, 40 × 180 mm**

Resopal labels (white with black lettering) for identifying the control cabinets are available. The labels are stuck to the cabinet door.

Dimensions H × W: 40 × 180 mm

The text must be specified in plain text when ordering.

Field 1: Max. 9 characters, font size 10 mm

Field 2: Max. 9 characters, font size 10 mm

Field 3: Max. 20 characters, font size 10 mm

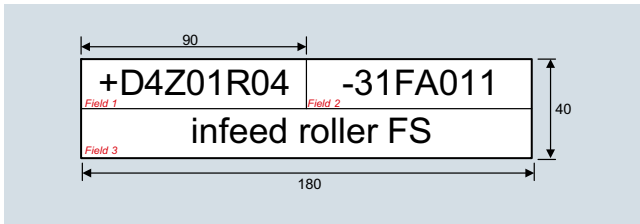
**Y33****Four-line label for system identification, 40 × 180 mm**

Resopal labels (white with black lettering) for identifying the control cabinets are available. The labels are stuck to the cabinet door.

Dimensions H × W: 40 × 180 mm

The text must be specified in plain text when ordering.

Field 1: Max. 9 characters, font size 10 mm

Field 2: Max. 20 characters, font size 6 mm

Field 3: Max. 20 characters, font size 6 mm

Field 4: Max. 20 characters, font size 6 mm

Field 5: Max. 20 characters, font size 6 mm

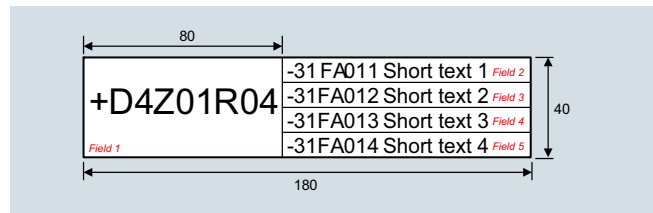

## SINAMICS S150 Converter Cabinet Units

### Line-side components – recommended fuses

#### Overview

The fuses specified below are the recommended types for protecting the unit on the low-voltage distribution panel. If option **L26** was selected for SINAMICS S150 with rated input currents <800 A, then the semiconductor protection is already integrated in the unit. For units of >800 A, this function is performed by the circuit breaker provided as standard.

In this case, a 3NA fuse can be used in the distribution board. If option **L26** has not been selected for units <800 A, we strongly advise that 3NE fuses are used <sup>1)</sup>.

Catalog LV 10 contains additional information on the listed fuses.

Type rating at 400 V or 690 V		SINAMICS S150 converter 6SL3710-...	Cable protection fuse in systems with a fuse switch disconnector			Cable protection fuse (incl. semiconductor protection) in systems without fuse switch disconnector		
At $I_L$ , 50 Hz 400 V, 500 V or 690 V kW	At $I_L$ , 60 Hz 460 V or 575 V hp		Rated current A	Size according to DIN 43620-1	Article No.	Rated current A	Size according to DIN 43620-1	
<b>Line voltage 380 ... 480 V 3 AC</b>								
110	150	7LE32-1AA3	<b>3NA3252</b>	315	2	<b>3NE1230-2</b>	315	1
132	200	7LE32-6AA3	<b>3NA3254</b>	355	2	<b>3NE1331-2</b>	350	2
160	250	7LE33-1AA3	<b>3NA3365</b>	500	3	<b>3NE1334-2</b>	500	2
200	300	7LE33-8AA3	<b>3NA3365</b>	500	3	<b>3NE1334-2</b>	500	2
250	400	7LE35-0AA3	<b>3NA3372</b>	630	3	<b>3NE1436-2</b>	630	3
315	500	7LE36-1AA3	<b>3NA3475</b>	800	4	<b>3NE1438-2</b>	800	3
400	600	7LE37-5AA3	<b>3NA3475</b>	800	4	<b>3NE1448-2</b>	850	3
450	700	7LE38-4AA3	–	–	–	Circuit breaker included as standard		
560	800	7LE41-0AA3	–	–	–	Circuit breaker included as standard		
710	1000	7LE41-2AA3	–	–	–	Circuit breaker included as standard		
800	1000	7LE41-4AA3	–	–	–	Circuit breaker included as standard		
<b>Line voltage 500 ... 690 V 3 AC</b>								
75	75	7LG28-5AA3	<b>3NA3132-6</b>	125	1	<b>3NE1022-2</b>	125	00
90	75	7LG31-0AA3	<b>3NA3132-6</b>	125	1	<b>3NE1022-2</b>	125	00
110	100	7LG31-2AA3	<b>3NA3136-6</b>	160	1	<b>3NE1224-2</b>	160	1
132	150	7LG31-5AA3	<b>3NA3240-6</b>	200	2	<b>3NE1225-2</b>	200	1
160	150	7LG31-8AA3	<b>3NA3244-6</b>	250	2	<b>3NE1227-2</b>	250	1
200	200	7LG32-2AA3	<b>3NA3252-6</b>	315	2	<b>3NE1230-2</b>	315	1
250	250	7LG32-6AA3	<b>3NA3354-6</b>	355	3	<b>3NE1331-2</b>	350	2
315	300	7LG33-3AA3	<b>3NA3365-6</b>	500	3	<b>3NE1334-2</b>	500	2
400	400	7LG34-1AA3	<b>3NA3365-6</b>	500	3	<b>3NE1334-2</b>	500	2
450	450	7LG34-7AA3	<b>3NA3352-6</b>	2 × 315	2	<b>3NE1435-2</b>	560	3
560	600	7LG35-8AA3	<b>3NA3354-6</b>	2 × 355	3	<b>3NE1447-2</b>	670	3
710	700	7LG37-4AA3	<b>3NA3365-6</b>	2 × 500	3	<b>3NE1448-2</b>	850	3
800	800	7LG38-1AA3	–	–	–	Circuit breaker included as standard		
900	900	7LG38-8AA3	–	–	–	Circuit breaker included as standard		
1000	1000	7LG41-0AA3	–	–	–	Circuit breaker included as standard		
1200	1250	7LG41-3AA3	–	–	–	Circuit breaker included as standard		

<sup>1)</sup> The double function fuses (3NE1.) for cable and semiconductor protection are recommended to protect the converter. These fuses are specially adapted to the requirements of the semiconductors in the input rectifier.

- Super fast
- Lower arc voltage
- Improved current limiting (lower let-through values).



## Overview

The following tables list the recommended and maximum connectable line and motor-side cable cross-sections and connections for a single connection.

The recommended cross-sections are based on the specified fuses. They are valid for a 3-conductor copper cable routed horizontally in air with PVC insulation and a permissible conductor temperature of 70 °C (e.g. Protodur NYY or NYCWY) at an ambi-

ent temperature of 40 °C and individual routing. In conditions (cable routing, cable bundling, ambient temperature) that deviate from this the corresponding correction factors according to IEC 60364-5-52 must be considered.

For additional information, please refer to the [SINAMICS Low Voltage Engineering Manual](#).

Type rating at 400 V or 690 V	SINAMICS S150 converter cabinet unit	Line supply connection			Motor connection			Cabinet grounding	
		Recom- mended cross- section <sup>1)</sup>	Maximum conductor cross-section	M12 fixing screw	Recom- mended cross- section <sup>1)</sup>	Maximum conductor cross-section	M12 fixing screw	M12 fixing screw	Remarks
kW	6SL3710-...	IEC	IEC	(Number of holes)	IEC	IEC	(Number of holes)	(Number of holes)	
		mm <sup>2</sup>	mm <sup>2</sup>		mm <sup>2</sup>	mm <sup>2</sup>			
<b>380 ... 480 V 3 AC</b>									
110	7LE32-1AA3	2 × 70	4 × 240	(2)	2 × 50	2 × 150	(2)	(2)	
132	7LE32-6AA3	2 × 95	4 × 240	(2)	2 × 70	2 × 150	(2)	(2)	
160	7LE33-1AA3	2 × 120	4 × 240	(2)	2 × 95	2 × 150	(2)	(2)	
200	7LE33-8AA3	2 × 120	4 × 240	(2)	2 × 95	2 × 150	(2)	(2)	
250	7LE35-0AA3	2 × 185	4 × 240	(2)	2 × 150	2 × 240	(2)	(2)	
315	7LE36-1AA3	2 × 240	4 × 240	(2)	2 × 185	4 × 240	(2)	(2)	
400	7LE37-5AA3	3 × 185	4 × 240	(2)	2 × 240	4 × 240	(2)	(10)	Cu bar
450	7LE38-4AA3	4 × 150	8 × 240	(4)	3 × 185	4 × 240	(2)	(16)	Cu bar
560	7LE41-0AA3	4 × 185	8 × 240	(4)	4 × 185	6 × 240	(3)	(18)	Cu bar
710	7LE41-2AA3	4 × 240	8 × 240	(4)	4 × 240	6 × 240	(3)	(18)	Cu bar
800	7LE41-4AA3	6 × 185	8 × 240	(4)	6 × 185	6 × 240	(3)	(18)	Cu bar
<b>500 ... 690 V 3 AC</b>									
75	7LG28-5AA3	50	4 × 240	(2)	35	2 × 70	(2)	(2)	
90	7LG31-0AA3	50	4 × 240	(2)	50	2 × 150	(2)	(2)	
110	7LG31-2AA3	70	4 × 240	(2)	70	2 × 150	(2)	(2)	
132	7LG31-5AA3	95	4 × 240	(2)	70	2 × 150	(2)	(2)	
160	7LG31-8AA3	120	4 × 240	(2)	95	2 × 150	(2)	(2)	
200	7LG32-2AA3	2 × 70	4 × 240	(2)	120	2 × 150	(2)	(2)	
250	7LG32-6AA3	2 × 95	4 × 240	(2)	2 × 70	2 × 185	(2)	(2)	
315	7LG33-3AA3	2 × 120	4 × 240	(2)	2 × 95	2 × 240	(2)	(2)	
400	7LG34-1AA3	2 × 185	4 × 240	(2)	2 × 120	4 × 240	(2)	(2)	
450	7LG34-7AA3	2 × 185	4 × 240	(2)	2 × 150	4 × 240	(2)	(2)	
560	7LG35-8AA3	2 × 240	4 × 240	(2)	2 × 185	4 × 240	(2)	(2)	
710	7LG37-4AA3	3 × 185	8 × 240	(4)	3 × 150	6 × 240	(3)	(18)	Cu bar
800	7LG38-1AA3	4 × 150	8 × 240	(4)	3 × 185	6 × 240	(3)	(18)	Cu bar
900	7LG38-8AA3	4 × 150	8 × 240	(4)	4 × 150	6 × 240	(3)	(18)	Cu bar
1000	7LG41-0AA3	4 × 185	8 × 240	(4)	4 × 185	6 × 240	(3)	(18)	Cu bar
1200	7LG41-3AA3	4 × 240	8 × 240	(4)	4 × 240	6 × 240	(3)	(18)	Cu bar

<sup>1)</sup> The recommendations for the North American market in AWG or MCM must be taken from the appropriate NEC (National Electrical Code) and CEC (Canadian Electrical Code) standards.



## SINAMICS S150 Converter Cabinet Units

### Cable cross-sections and connections

#### Overview (continued)

##### Cable cross-sections for line and motor connection

It is generally recommended to use shielded 3-wire three-phase cables between the converter and motor – and for higher power ratings, symmetrical cables where possible. If required, several of these cables can be connected in parallel. There are two main reasons for this:

- Only then can the high IP55 degree of protection at the motor terminal box be easily achieved. The reason for this is that cables are routed into the terminal box through glands, and the number of possible glands is restricted by the terminal box geometry. Therefore single cables are less suitable.
- With symmetrical 3-wire three-phase cables, the summed ampere-turns over the cable outer diameter are equal to zero. They can easily be routed in conductive, metal cable ducts or racks without any significant currents (ground current or leakage current) being induced in these conductive, metal connections. The danger of induced leakage currents and thus of increased cable sheath losses is significantly higher with single-conductor cables.

The cable cross-section required depends on the current being conducted in the cable. The permissible current load capability of cables is defined, for example in IEC 60364-5-52. It depends partly on the ambient conditions such as temperature, but also on the routing method. It should be taken into account whether cables are individually routed with relatively good cooling, or whether several cables are routed together; in this case, cable ventilation is significantly poorer, which can therefore result in higher cable temperatures. Regarding this topic, reference is made to the corresponding correction factors for these secondary conditions in IEC 60364-5-52.

For 3-wire copper and aluminum cables with PVC insulation and a permissible conductor temperature of 70 °C (e.g. Protodur NYY or NYCWY), as well as an ambient temperature of 40 °C, the cross-sections can be determined from the following table, which is based on IEC 60364-5-52.

Cross-section of 3-wire cable mm <sup>2</sup>	Copper cable		Aluminum cable	
	Individual routing A	Several cables next to one another <sup>1)</sup> A	Individual routing A	Several cables next to one another <sup>1)</sup> A
3 × 2.5	22	17	17	13
3 × 4.0	30	23	23	18
3 × 6.0	37	29	29	22
3 × 10	52	41	40	31
3 × 16	70	54	53	41
3 × 25	88	69	68	53
3 × 35	110	86	84	65
3 × 50	133	104	102	79
3 × 70	171	133	131	102
3 × 95	207	162	159	124
3 × 120	240	187	184	144
3 × 150	278	216	213	166
3 × 185	317	247	244	190
3 × 240	374	292	287	224

Current-carrying capacity according to IEC 60364-5-52 at 40 °C

<sup>1)</sup> A maximum of 9 cables may be routed directly next to one another horizontally on a cable tray.

Cables must be connected in parallel for higher currents.

##### Note:

The recommendations for the North American market in AWG or MCM must be taken from the appropriate NEC (National Electrical Code) and CEC (Canadian Electrical Code) standards.

##### Grounding and protective conductor cross-section

The protective conductor must be dimensioned taking into account the following data:

- In the case of a ground fault, no impermissibly high contact voltages resulting from voltage drops on the PE conductor caused by the ground fault current may occur (< 50 V AC or < 120 V DC, IEC 61800-5-1, IEC 60364, IEC 60543).
- The protective conductor must not be excessively loaded by any ground fault current it carries.
- If it is possible for continuous currents to flow through the protective conductor when a fault occurs, then the protective conductor cross-section must be dimensioned for this continuous current.
- The protective conductor cross-section must be selected according to EN 60204-1, EN 60439-1, IEC 60364.

Cross-section, line conductor mm <sup>2</sup>	Minimum cross-section, external protective conductor mm <sup>2</sup>
up to 16	Minimum cross-section of line conductor
16 ... 35	16
from 35	Minimum half the cross-section of line conductor

##### Note:

The recommendations for the North American market in AWG or MCM must be taken from the appropriate NEC (National Electrical Code) and CEC (Canadian Electrical Code) standards.

- Switchgear and motors are usually grounded separately via a local grounding electrode. With this constellation, the ground fault current flows via the parallel ground connections and is divided. In spite of the relatively small protective conductor cross-sections used in accordance with the table above, no inadmissible touch voltages occur with this grounding system. However, from experience gained with different grounding constellations, we recommend that the ground cable from the motor return directly to the converter. For EMC reasons and to avoid bearing currents, for large power ratings, it is preferable to use symmetrical 3-wire three-phase cables instead of four-conductor cables. For 3-wire cables, the protective or PE conductor must be routed separately or arranged symmetrically in the motor cable. Symmetry of the PE conductor is achieved using a conductor surrounding all phase conductors or using a cable with a symmetrical arrangement of the three phase conductors and three ground conductors.  
[For additional information, please refer to the SINAMICS Low Voltage Engineering Manual.](#)
- Through their high-speed control, the converters limit the load current (motor and ground fault currents) to an rms value corresponding to the rated current. As a result of this fact, we recommend that the cross-section of the protective conductor to ground the cabinets is the same as for the line conductor.

## SINAMICS S150 Converter Cabinet Units

### Supplementary system components

#### Mounting device for power blocks

#### Overview



The mounting device is used for installing and removing the power blocks.

The mounting device is a mounting aid. It is placed in front of the module and attached to the module. The telescopic rails allow the device to be adjusted to the installation height of the power blocks.

Once the mechanical and electrical connections have been released, the power block can be removed from the module.

The power block is guided and supported by the guide rails on the handling device.

#### Selection and ordering data

Description	Article No.
<b>Mounting device</b> for installing and removing power blocks	<b>6SL3766-1FA00-0AA0</b>

## SINAMICS S150 Converter Cabinet Units

### Notes

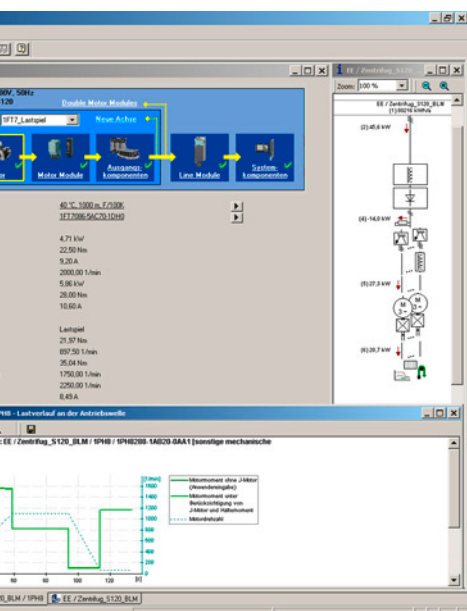

### Security information

Siemens provides products and solutions with industrial security functions that support the secure operation of plants, systems, machines and networks.

In order to protect plants, systems, machines and networks against cyber threats, it is necessary to implement – and continuously maintain – a holistic, state-of-the-art industrial security concept. Siemens' products and solutions constitute one element of such a concept.

Customers are responsible for preventing unauthorized access to their plants, systems, machines and networks. Such systems, machines and components should only be connected to an enterprise network or the internet if and to the extent such a connection is necessary and only when appropriate security measures (e.g. firewalls and/or network segmentation) are in place.

For additional information on industrial security measures that may be implemented, please visit

[www.siemens.com/industrialsecurity](http://www.siemens.com/industrialsecurity).

Siemens' products and solutions undergo continuous development to make them more secure. Siemens strongly recommends that product updates are applied as soon as they are available and that the latest product versions are used. Use of product versions that are no longer supported, and failure to apply the latest updates may increase customer's exposure to cyber threats.

To stay informed about product updates, subscribe to the Siemens Industrial Security RSS Feed under

[www.siemens.com/industrialsecurity](http://www.siemens.com/industrialsecurity).

6/2

6/2

6/3

6/4

6/5

6/6

6/8

6/9

6/11

6/13

6/13

6/14

6/17

### Engineering tools

SinaSave energy efficiency tool  
 Drive Technology Configurator  
 SIZER for Siemens Drives engineering tool  
 SIZER WEB ENGINEERING engineering tool  
 STARTER commissioning tool  
 SINAMICS Drive Control Chart (SINAMICS DCC)  
 Drive ES engineering software  
 Engineering with EPLAN

### Engineering information

Engineering procedure  
 EMC notes for applying product standard EN 61800-3  
 Engineering Manual

## Tools and Engineering

### Engineering tools

#### SinaSave energy efficiency tool

##### Overview

The SinaSave energy efficiency tool calculates potential energy savings and amortization times based on your individual conditions of use and therefore offers practical assistance in making decisions about investments in energy-efficient technologies.

From SinaSave Version 6.0 and higher, the drive systems to be compared and the relevant drive component parameters are displayed graphically. An additional expansion are the numerous comparison possibilities for different control types and comprehensive product combinations for drive solutions for pump and fan applications. In addition to SIMOTICS motors and SINAMICS drives, the product portfolio comprises SIRIUS controls, offering a comprehensive range of comparison possibilities – according to your individual requirements.



SinaSave offers numerous comparison scenarios:

- Comparison of drive systems for pump and fan applications in the output range from 0.55 kW (low voltage) to 5.5 MW (medium voltage) for
  - Reactor control (fixed speed; motor and switching device)
  - Bypass control (fixed speed; motor and switching device)
  - Speed control (variable speed; motor and frequency converter)
- Comparison and evaluation of standard motors (incl. ignition protection motors) in different energy efficiency classes

SinaSave supports the evaluation of the various comparisons of product and system by

- Displaying the potential savings for energy and energy costs, as well as CO<sub>2</sub> emissions
- Estimation of the amortization time
- Estimation of the individual total lifecycle costs
- Representation of the system power losses according to EN 50598-2 for full load and partial load
- Direct comparison of Siemens drives with the reference Power Drive System (PDS) described in EN 50598-2



[Access to the SinaSave energy efficiency tool](#)

SinaSave can be called up without registration and without a login:

[www.automation.siemens.com/sinasave](http://www.automation.siemens.com/sinasave)

##### More information

For more information about the amortization calculator for energy-efficient drive systems, visit [www.siemens.com/sinasave](http://www.siemens.com/sinasave)

More information about services for energy saving is available on the Internet at [www.siemens.com/energysaving](http://www.siemens.com/energysaving)

## Overview

The Drive Technology Configurator (DT Configurator) helps you to configure the optimum drive technology products for your application – starting with gear units, motors, inverters as well as the associated options and components and ending with controllers, software licenses and connection systems. Whether with little or detailed knowledge of products: preselected product groups, deliberate navigation through selection menus and direct product selection through entry of the product number support quick, efficient and convenient configuration.

In addition, comprehensive documentation comprising technical data sheets, 2D dimensional drawings/3D CAD models, operating instructions, certificates, etc. can be selected in the DT Configurator. Immediate ordering is possible by simply transferring a parts list to the shopping cart of the Industry Mall.

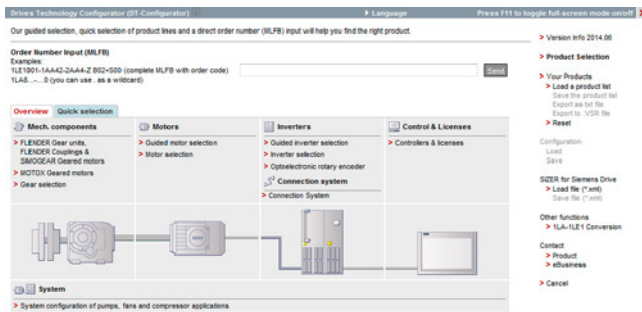

Drive Technology Configurator for efficient drive configuration with the following functions

- Quick and easy configuration of drive products and associated components – gear units, motors, inverters, controllers, connection systems
- Configuration of drive systems for pumps, fans and compressor applications from 1 kW to 2.6 MW
- Retrievable documentation for configured products and components, such as
  - Data sheets in up to 9 languages in PDF or RTF format
  - 2D dimensional drawings/3D CAD models in various formats
  - Terminal box drawing and terminal connection diagram
  - Operating instructions
  - Certificates
  - Start-up calculation for SIMOTICS motors
  - EPLAN macros
- Support with retrofitting in conjunction with Spares On Web ([www.siemens.com/sow](http://www.siemens.com/sow))
- Ability to order products directly through the Siemens Industry Mall

Access to the Drive Technology Configurator

The Drive Technology Configurator can be called up without registration and without a login:

[www.siemens.com/dt-configurator](http://www.siemens.com/dt-configurator)

## Selection and ordering data

Description	Article No.
<b>Interactive catalog CA 01</b> on DVD-ROM including Drive Technology Configurator, English	<b>E86060-D4001-A510-D8-7600</b>

## More information

[Online access to the Drive Technology Configurator](#)

More information about the Drive Technology Configurator is available on the Internet at

[www.siemens.com/dtconfigurator](http://www.siemens.com/dtconfigurator)

[Offline access to the Drive Technology Configurator in the Interactive Catalog CA 01](#)

In addition, the Drive Technology Configurator is also included in the Interactive Catalog CA 01 on DVD-ROM – the offline version of the Siemens Industry Mall.

The Interactive Catalog CA 01 can be ordered from the relevant Siemens sales office or via the Internet:

[www.siemens.com/automation/CA01](http://www.siemens.com/automation/CA01)

## Tools and Engineering

### Engineering tools

#### SIZER for Siemens Drives engineering tool

##### Overview

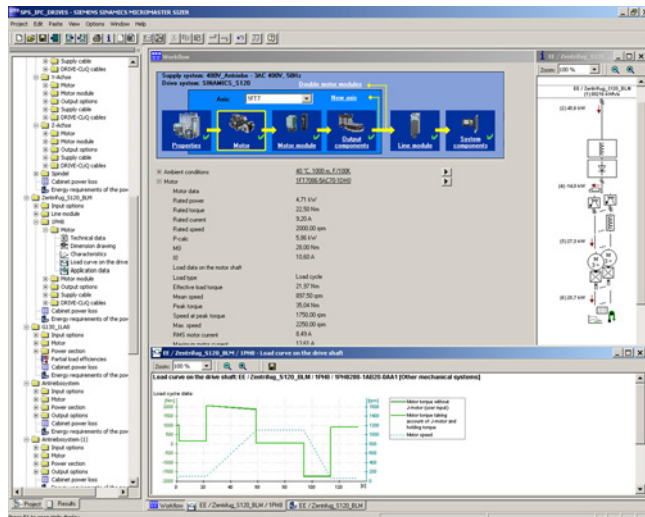

The following drives and controls can be engineered in a user-friendly way using the SIZER for Siemens Drives engineering tool:

- SIMOTICS low-voltage motors, including servo geared motors
- SINAMICS low-voltage drive systems
- Motor starters
- SINUMERIK CNC
- SIMOTION Motion Control controller
- SIMATIC controller

It provides support when selecting the technologies involved in the hardware and firmware components required for a drive task. SIZER for Siemens Drives covers the full range of operations required to configure a complete drive system, from basic single-motor drives to complex multi-axis applications.

SIZER for Siemens Drives supports all of the engineering steps in one workflow:

- Configuring the power supply
- Designing the motor and gearbox, including calculation of mechanical transmission elements
- Configuring the drive components
- Compiling the required accessories
- Selecting the line-side and motor-side power options, e.g. cables, filters, and reactors

When SIZER for Siemens Drives was being designed, particular importance was placed on a high degree of usability and a universal, function-based approach to the drive application. The extensive user guidance makes it easy to use the tool. Status information keeps you continually informed about the progress of the configuration process.

The SIZER for Siemens Drives user interface is available in English, French, German and Italian.

The drive configuration is saved in a project. In the project, the components and functions used are displayed in a hierarchical tree structure.

The project view permits the configuration of drive systems and the copying/inserting/modifying of drives already configured.

The configuration process produces the following results:

- A parts list of the required components (export to Excel, use of the Excel data sheet for import to SAP)
- Technical specifications of the system
- Characteristic curves
- Comments on system reactions
- Mounting arrangement of drive and control components and dimensional drawings of motors
- Energy requirements of the configured application

These results are displayed in a results tree and can be reused for documentation purposes.

Support is provided by the technological online help menu:

- Detailed technical specifications
- Information about the drive systems and their components
- Decision-making criteria for the selection of components
- Online help in English, French, German, Italian, Chinese and Japanese

##### System requirements

- PG or PC with Pentium III min. 800 MHz (recommended > 1 GHz)
- 512 MB RAM (1 GB RAM recommended)
- At least 4.1 GB of free hard disk space
- An additional 100 MB of free hard disk space on Windows system drive
- Screen resolution 1024 × 768 pixels (1280 × 1024 pixels recommended)
- Operating system:
  - Windows 7 Professional (32/64-bit)
  - Windows 7 Enterprise (32/64-bit)
  - Windows 7 Ultimate (32/64-bit)
  - Windows 7 Home (32/64-bit)
  - Windows 8.1 Professional (32/64-bit)
  - Windows 8.1 Enterprise (32/64-bit)
- Microsoft Internet Explorer V5.5 SP2

##### Selection and ordering data

Description	Article No.
<b>SIZER for Siemens Drives engineering tool</b> on DVD-ROM	<b>6SL3070-0AA00-0AG0</b>
German, English, French, Italian	

##### More information

The SIZER for Siemens Drives engineering tool is available free on the Internet at [www.siemens.com/sizer](http://www.siemens.com/sizer)



## Overview



The SIZER WEB ENGINEERING tool is used to engineer motors, converters/inverters and drive systems for a broad spectrum of applications within a wide power range starting below 1 kW up to 30 MW and above. To engineer a solution, you need to enter parameters for the motor, converter/inverter or the system – as well as parameters for your own specific application.

When the process is complete, you will receive comprehensive technical documentation (e.g. 3D models) including price information.

An inquiry function integrated in SIZER WEB ENGINEERING allows you to design special solutions for your drive task.

SIZER WEB ENGINEERING fully supports you from the inquiry stage, through the process of engineering products and drive systems, until your own individual quotation is ready. It supplies pricing information and then transfers the engineered products to your shopping cart in the Industry Mall. Seamless support during the engineering process enables you to save time and increase your productivity because you only need to enter the data once. You can use the entered data and the result as a basis for inquiries and orders.

SIZER WEB ENGINEERING is the platform for flexible engineering of your drive tasks and user-friendly management of your projects in conjunction with the engineering tools Drive Technology Configurator and SIZER for Siemens Drives.

## Function

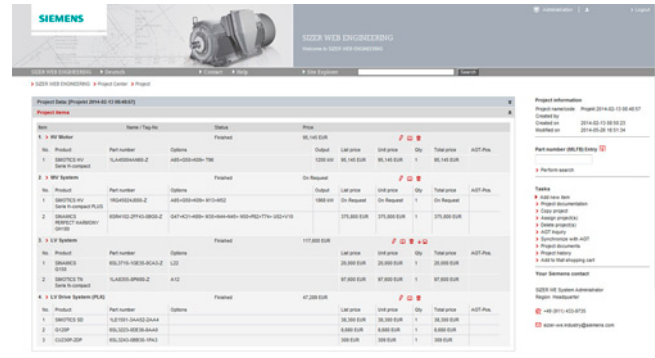

You can quickly find a solution for your drive task with the web-based tool: Menu-prompted workflows navigate you through the technical selection and dimensioning of products and drive systems, including the accessories. Based on an integrated inquiry functionality, SIZER WEB ENGINEERING also offers you special customized solutions for applications which cannot be addressed using "standard products", i.e. the focus is on flexibility and customized solutions.

Furthermore, you can engineer high-voltage motors, medium-voltage systems and rectifiers for your projects in addition to products from the low-voltage range. Integral tool functions also include comprehensive documentation such as data sheets, start-up calculations for low and high-voltage motors, 2D dimensional drawings and 3D CAD models, and offer documentation to name just a few.

**Access to the SIZER WEB ENGINEERING engineering tool**

SIZER WEB ENGINEERING is available after registration and approval:

[www.siemens.com/sizer-we](http://www.siemens.com/sizer-we)

**More information**

- More information on the SIZER WEB ENGINEERING engineering tool is available on the Internet at [www.siemens.com/sizer-we](http://www.siemens.com/sizer-we)
- Selection and Engineering Tools: [www.siemens.com/engineering-tools](http://www.siemens.com/engineering-tools)



## Tools and Engineering

### Engineering tools

#### STARTER commissioning tool

##### Overview

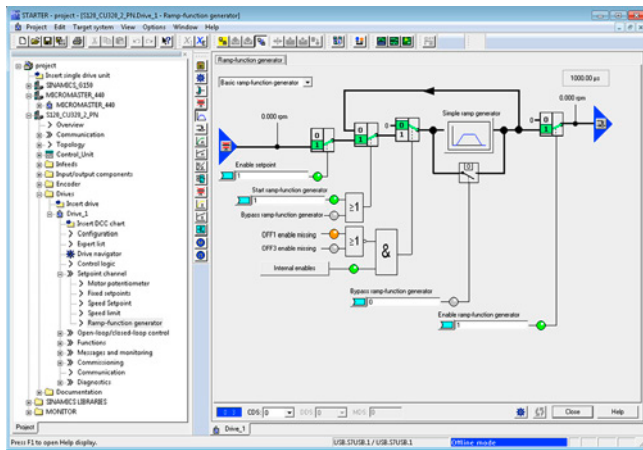

The user-friendly STARTER commissioning tool can be used for:

- Commissioning
- Optimization
- Diagnostics

This software can be operated as a standalone PC application, or integrated as a TIA-compatible program in SIMATIC STEP 7, or highly integrated into the SCOUT Engineering System (for SIMOTION). The basic functions and handling are the same in both cases.

In addition to the SINAMICS drives, STARTER also supports MICROMASTER 4 devices.

The project wizards can be used to create the drives within the structure of the project tree.

Beginners are supported by solution-based dialog guidance, whereby a standard graphics-based display maximizes clarity when setting the drive parameters.

First commissioning is guided by a wizard which makes all the basic settings in the drive. Therefore, getting a motor up and running is merely a question of setting a few of the drive parameters as part of the drive configuration process.

The individual settings required are made using graphics-based parameterization screens, which also precisely visualize the principle of operation of the drive.

Examples of individual settings that can be made include:

- How terminals are used
- Bus interface
- Setpoint channel (e.g., fixed setpoints)
- Closed-loop speed control (e.g., ramp-function generator, limits)
- BICO interconnections
- Diagnostics

For experts, the expert list can be used to specifically and quickly access individual parameters at any time. An individual compilation of frequently used parameters can be saved in dedicated user lists and watch tables.

In addition, the following functions are available for optimization purposes:

- Self-optimization of the controller settings (depending on drive unit)
- Setup and evaluation of trace recordings<sup>1)</sup>  
Tool function for recording 2 × 8 signals with
  - Measuring cursor function
  - Extensive trigger functions
  - Several Y scales
  - Sampling times in the current controller cycle clock

Diagnostics functions provide information about:

- Control/status words
- Parameter status
- Operating conditions
- Communication states

##### Performance features

- User-friendly: Only a small number of settings need to be made for successful first commissioning: The motor starts to rotate
- Solution-oriented dialog-based user guidance simplifies commissioning
- Self-optimization functions reduce manual effort for optimization.

##### Minimum system requirements

The following minimum requirements must be complied with:

- Hardware
  - PG or PC with Pentium III min. 1 GHz (recommended >1 GHz)
  - Work memory 2 GB (4 GB recommended)
  - Screen resolution 1024 × 768 pixels, 16-bit color depth
  - Free hard disk memory: min. 5 GB
- Software
  - Microsoft Internet Explorer V6.0 or higher
  - 32-bit operating systems:
    - Microsoft Windows 7 Professional incl. SP1
    - Microsoft Windows 7 Ultimate incl. SP1
    - Microsoft Windows 7 Enterprise incl. SP1 (standard installation)
  - 64-bit operating systems:
    - Microsoft Windows 7 Professional SP1
    - Microsoft Windows 7 Ultimate SP1
    - Microsoft Windows 7 Enterprise SP1 (standard installation)
    - Microsoft Windows Server 2008 R2 SP1
    - Microsoft Windows 10 Pro
    - Microsoft Windows 10 Enterprise

##### Integration

Data can be exchanged (depending on the version) via PROFIBUS or PROFINET/Ethernet or via a serial interface.

For commissioning and service, a PG/PC can be connected to the CU320-2 Control Unit via PROFIBUS. A PROFIBUS connection must be available with a connecting cable at the PG/PC.

Further, communication between a CU320-2 Control Unit and PG/PC can also be established via Ethernet, either via an (optional) CBE20 Communication Board or the Ethernet interface -X127 on the CU320-2 Control Unit.

##### Note:

The terminal strip -X127 is suitable as a communication link to the PG/PC only for the purposes of servicing and commissioning.

<sup>1)</sup> Depending on the drive unit. Not supported for MICROMASTER 4, SINAMICS G110, SINAMICS G120 <firmware V4.4, SINAMICS G110D and SINAMICS G120D <firmware V4.5.

**Selection and ordering data**

Description	Article No.
<b>STARTER commissioning tool</b> for SINAMICS and MICROMASTER English, French, German, Italian, Spanish	<b>6SL3072-0AA00-0AG0</b>

**Note:**

In addition to the STARTER commissioning tool, SINAMICS Drive Control Chart (SINAMICS DCC) can be installed. This allows the device functionality in the SINAMICS drive system to be expanded with dedicated technology functions as required.

More information about SINAMICS DCC can be found in section "SINAMICS Drive Control Chart (SINAMICS DCC)"

**More information**

The commissioning tool STARTER is also available on the internet at [www.siemens.com/starter](http://www.siemens.com/starter)

**Accessories**

Depending on the version of the Control Unit (CU), the Control Unit of the drive unit can communicate with the programming device (PG) or PC via PROFIBUS or PROFINET/Ethernet or via a serial interface. The following accessories are available for the particular drive system as listed in the following table.

Description	<b>Recommended accessories</b>	
	For communication between the drive unit and the programming device or PC	
	Article No.	
<b>SINAMICS S120</b>		
• RS232	<b>SIMATIC S7 connecting cable</b> Null modem cable, 6 m	<b>6ES7901-1BF00-0XA0</b>
• PROFIBUS	<b>CP 5711 communication module</b> USB adapter for connecting a PG or notebook to PROFIBUS or MPI USB cable (2 m) included in scope of supply	<b>6GK1571-1AA00</b>
	<b>SIMATIC DP plug-in cable</b> 12 MBaud, for PG connection, pre-assembled with 2 × 9-pin SUB D connector, 3 m	<b>6ES7901-4BD00-0XA0</b>
• PROFINET/ Ethernet	Standard CAT5 Ethernet cable or PROFINET cable	–
<b>SINAMICS S150</b>		
• PROFIBUS	<b>CP 5711 communication module</b> USB adapter for connecting a PG or notebook to PROFIBUS or MPI USB cable (2 m) included in scope of supply	<b>6GK1571-1AA00</b>
	<b>SIMATIC DP plug-in cable</b> 12 MBaud, for PG connection, pre-assembled with 2 × 9-pin SUB D connector, 3 m	<b>6ES7901-4BD00-0XA0</b>
• PROFINET/ Ethernet	Standard CAT5 Ethernet cable or PROFINET cable	–

<sup>1)</sup> An overview of all the supplementary products (e.g. cables and connectors) that are available for the distributed drives family can be found at the following link:  
[www.siemens.com/distributeddrives-supplementaryproducts](http://www.siemens.com/distributeddrives-supplementaryproducts)

## Tools and Engineering

### Engineering tools

#### SINAMICS Drive Control Chart (SINAMICS DCC)

##### Overview

SINAMICS Drive Control Chart (SINAMICS DCC) expands the scope of device functions by means of freely available closed-loop control, arithmetic and logic blocks and offers a means by which proprietary technological functions can be graphically configured in the SINAMICS drive system. In addition, local data processing in the drive supports the implementation of modular machine concepts and results in an increase in the overall machine performance. SINAMICS DCC is a part of the Advanced Technology Function, and is installed as an add-on to the STARTER commissioning tool.

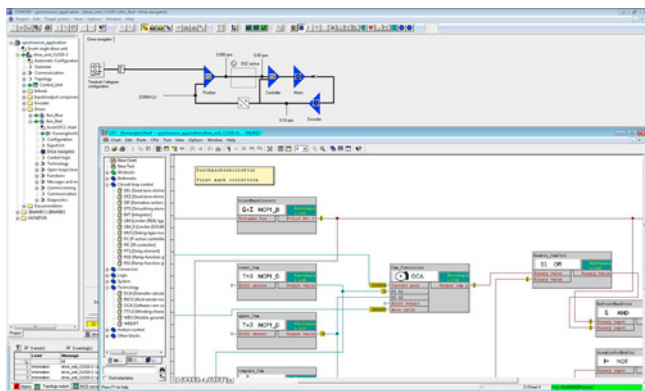

SINAMICS DCC provides users with greater integral scope to adapt systems to the specific functions of their machines. SINAMICS DCC does not limit the number of functions that can be used. The number of functions is limited only by the performance capability of the Control Unit.

SINAMICS DCC is available for the following SINAMICS drive systems:

- SINAMICS G130 and SINAMICS G150
- SINAMICS S120 and SINAMICS S150
- SINAMICS DCM and SINAMICS DCP
- SINAMICS GM150 and SINAMICS SM150
- SINAMICS GL150 and SINAMICS SL150

The user-friendly DCC editor enables easy graphics-based configuration, allows control loop structures to be clearly represented and provides a high degree of reusability of diagrams that have already been created.

The open-loop and closed-loop control functions are defined by using multi-instance-capable blocks (Drive Control Blocks (DCBs)) from a library (DCB library) that are selected and graphically linked with one another by dragging and dropping. Test and diagnostic functions allow the program behavior to be verified and, in the case of a fault, the cause identified.

Two types of DCB library are available, i.e. DCB Standard and DCB Extension. The DCB Standard library supplied with SINAMICS DCC contains a large selection of closed-loop, arithmetic and logic blocks, as well as comprehensive open-loop and closed-loop control functions.

For logically combining, evaluating and acquiring binary signals, all commonly used logic functions are available for selection (AND, XOR, on/off delay, RS flipflop, counter, etc.). A wide range of arithmetic functions, such as absolute value generation, dividers and minimum/maximum evaluation are available to monitor and evaluate numerical quantities.

In addition to the closed-loop drive control, axial winder functions, PI controllers, ramp-function generators or wobble generators are simple to configure.

SINAMICS DCC also offers the DCB Extension library from firmware version V4.6 and higher. This contains an extended range of blocks that is used as an additional, independent library in the DCC Editor. It includes the GMC and Math Extended library.

The GMC contains motion control blocks (GEAR, POSMC, CAMD, etc.).

With Math Extended, supplementary mathematical and logical function blocks (ASIN, ACOS, ATAN, LOG, etc.) are made available.

These libraries are ready for downloading along with application examples from the Siemens Application Support website.

Further information can be found in the [Drive Applications](#) section.

As well as the option of using the libraries made available by DCB Extension, DCB Extension proprietary libraries can also be created with custom-programmed blocks. These blocks and libraries are programmed with the separate SINAMICS DCB Studio development tool in the C/C++ high-level language and can be used as your own DCB Extension library in the DCC editor. Use of the DCB Extension blocks requires a runtime license.

The separate SINAMICS DCB Studio development tool is required for programming the blocks and generating the library as a DCB Extension.

##### Minimum hardware and software requirements

See [STARTER commissioning tool](#).

##### Selection and ordering data

SINAMICS DCC comprises the graphical configuring tool (DCC Editor) and the DCB Standard library. SINAMICS DCC is installed as an add-on to the STARTER commissioning tool.

The necessary engineering license for each PC (floating) for SINAMICS DCC is acquired at the same time the order is placed. No runtime license is required for the DCB Standard library included in the scope of supply.

Existing licenses for SINAMICS DCC V2.1, V2.2 SP1 and V2.3 SPx are also valid for SINAMICS DCC V2.4 SP1.

An upgrade version including an engineering license for applications with STARTER V4.5 SP1 is available for existing SINAMICS DCC V2.0 SPx.

Description	Article No.
<b>SINAMICS DCC V2.4 SP1</b> for STARTER V4.5 SP1 Graphic configuring with SINAMICS DCC Editor + DCB Standard library	
<ul style="list-style-type: none"> <li>• Single-user engineering license, with data carrier</li> </ul>	<b>6AU1810-1HA24-1XA0</b>
<ul style="list-style-type: none"> <li>• Upgrade engineering license, with data carrier</li> </ul>	<b>6AU1810-1HA24-1XE0</b>
<b>DCB Extension license</b> Runtime license for license upgrading with firmware version V4.6 or later (can also be ordered in conjunction with the CompactFlash card, see <a href="#">CompactFlash card for CU310-2 and CU320-2 Control Units</a> )	<b>6SL3077-0AA00-0AB0</b>
<b>SINAMICS DCB Studio V1.2</b> Development tool for programming blocks and DCB Extension libraries with firmware version V4.6 or later	On request

## Overview

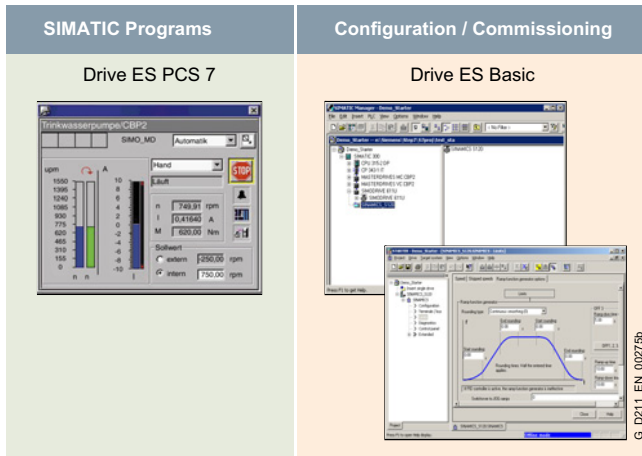

Drive ES is the engineering system used to integrate the communication, configuration and data management functions of Siemens drive technology into the SIMATIC automation world easily, efficiently and cost-effectively.

The following software packages are available for selection:

- Drive ES Basic (discontinued product)
- Drive ES Basic Maintenance (in preparation)
- Drive ES PCS 7

Drive ES (**Drive Engineering Software**) fully integrates drives from Siemens into the world of Totally Integrated Automation.

## Design

The following software packages are available for selection:

- **Drive ES Basic** (discontinued product)
- **Drive ES Basic Maintenance** (in preparation)
- **Drive ES PCS 7** (APL Style or Classic Style)

**Drive ES Basic (discontinued product)**

Drive ES Basic is for first-time users of the world of Totally Integrated Automation and the basic software for setting the parameters of all drives online and offline in this environment. Drive ES Basic enables both the automation system and the drives to be handled using the SIMATIC Manager software. Drive ES Basic is the starting point for common data archiving for complete projects and for extending the use of the SIMATIC teleservice to drives. Drive ES Basic provides the configuration tools for the new motion control functions – slave-to-slave communication, equidistance and isochronous operation with PROFIBUS DP and ensures that drives with PROFINET IO are simply integrated into the SIMATIC environment.

Note:

For SINAMICS and MICROMASTER 4 drives, this TIA functionality is provided with the STARTER commissioning tool (V4.3.2 and higher).

**Drive ES Basic Maintenance (in preparation)**

This software product will ensure TIA functionality for the previous drive systems not supported by STARTER. Drive ES Basic Maintenance will thus replace the current product Drive ES Basic.

**Drive ES PCS 7 (APL Style or Classic Style)**

Drive ES PCS 7 links the drives with a PROFIBUS DP interface into the SIMATIC PCS 7 process control system, and it requires that SIMATIC PCS 7, V6.1 and higher has first been installed. Drive ES PCS 7 provides a block library with blocks for the drives and the corresponding faceplates for the operator station, which enables the drives to be operated from the PCS 7 process control system. From V6.1 and higher, drives will also be able to be represented in the PCS 7 Maintenance Station.

From Drive ES PCS 7 V8.0 and higher, two versions of the library are available: The APL (Advanced Process Library) variant and the previous version in the so-called Classic Style.

Detailed contents of the Drive ES PCS 7 (APL Style or Classic Style)

- **Block library for SIMATIC PCS 7** Faceplates and control blocks for SIMOVERT MASTERDRIVES VC and MC, as well as MICROMASTER/MIDIMASTER of the third and fourth generation and SIMOREG DC MASTER and SINAMICS
- **STEP 7 slave object manager** for convenient configuration of drives and non-cyclic PROFIBUS DP communication with the drives
- **STEP 7 device object manager** for easy configuration of drives with PROFINET-IO interfaces (V8.0 SP1 and higher)
- **SETUP program** for installing the software in the PCS 7 environment

## Tools and Engineering

### Engineering tools

#### Drive ES engineering software

##### Selection and ordering data

Description	Article No.
<b>Drive ES PCS 7 V8.0 SPx <sup>*)</sup></b> Block library for PCS 7 for the integration of drives in Classic Style (as predecessor) Requirement: PCS 7 V8.0 and higher Type of delivery: CD-ROM Languages: de, en, fr, it, es with electronic documentation	
<ul style="list-style-type: none"> <li>• Single-user license incl. 1 runtime license</li> </ul>	<b>6SW1700-8JD00-0AA0</b>
<ul style="list-style-type: none"> <li>• Runtime license (without data carrier)</li> </ul>	<b>6SW1700-5JD00-1AC0</b>
<ul style="list-style-type: none"> <li>• Update service for single-user license</li> </ul>	<b>6SW1700-0JD00-0AB2</b>
<ul style="list-style-type: none"> <li>• Upgrade from V6.x to V8.0 SPx <sup>*)</sup></li> </ul>	<b>6SW1700-8JD00-0AA4</b>
<b>Drive ES PCS 7 APL V8.0 SPx <sup>*)</sup></b> Block library for PCS 7 for the integration of drives in APL Style (Advanced Process Library) Requirement: PCS 7 V8.0 and higher Type of delivery: CD-ROM Languages: de, en, fr, it, es with electronic documentation	
<ul style="list-style-type: none"> <li>• Single-user license incl. 1 runtime license</li> </ul>	<b>6SW1700-8JD01-0AA0</b>
<ul style="list-style-type: none"> <li>• Runtime license (without data carrier)</li> </ul>	<b>6SW1700-5JD00-1AC0</b>
<ul style="list-style-type: none"> <li>• Update service for single-user license</li> </ul>	<b>6SW1700-0JD01-0AB2</b>
<ul style="list-style-type: none"> <li>• Upgrade of APL V8.0 to V8.0 SP1 or Drive ES PCS7 V6.x, V7.x, V8.x classic to Drive ES PCS7 APL V8.0 SPx <sup>*)</sup></li> </ul>	<b>6SW1700-8JD01-0AA4</b>
<b>Drive ES PCS 7 V8.1 SPx <sup>*)</sup></b> Block library for PCS 7 for the integration of drives in Classic Style (as predecessor) Requirement: PCS 7 V8.1 and higher Type of delivery: CD-ROM Languages: de, en, fr, it, es with electronic documentation	
<ul style="list-style-type: none"> <li>• Single-user license incl. 1 runtime license</li> </ul>	<b>6SW1700-8JD00-1AA0</b>
<ul style="list-style-type: none"> <li>• Runtime license (without data carrier)</li> </ul>	<b>6SW1700-5JD00-1AC0</b>
<ul style="list-style-type: none"> <li>• Update service for single-user license</li> </ul>	<b>6SW1700-0JD00-0AB2</b>
<ul style="list-style-type: none"> <li>• Upgrade from V6.x/V7.x/V8.x to V8.1 SPx <sup>*)</sup></li> </ul>	<b>6SW1700-8JD00-1AA4</b>
<b>Drive ES PCS 7 APL V8.1 SPx <sup>*)</sup></b> Block library for PCS 7 for the integration of drives in APL Style (Advanced Process Library) Requirement: PCS 7 V8.1 and higher Type of delivery: CD-ROM Languages: de, en, fr, it, es with electronic documentation	
<ul style="list-style-type: none"> <li>• Single-user license incl. 1 runtime license</li> </ul>	<b>6SW1700-8JD01-1AA0</b>
<ul style="list-style-type: none"> <li>• Runtime license (without data carrier)</li> </ul>	<b>6SW1700-5JD00-1AC0</b>
<ul style="list-style-type: none"> <li>• Update service for single-user license</li> </ul>	<b>6SW1700-0JD01-0AB2</b>
<ul style="list-style-type: none"> <li>• Upgrade of APL V8.x to V8.1 SPx <sup>*)</sup> or Drive ES PCS 7 V6.x, V7.x, V8.x classic to Drive ES PCS 7 APL V8.1 SPx <sup>*)</sup></li> </ul>	<b>6SW1700-8JD01-1AA4</b>

Description	Article No.
<b>Drive ES PCS 7 V8.2 SPx <sup>*)</sup></b> Block library for PCS 7 for the integration of drives in Classic Style (as predecessor) Requirement: PCS 7 V8.2 and higher Type of delivery: CD-ROM Languages: de, en, fr, it, es with electronic documentation	
<ul style="list-style-type: none"> <li>• Single-user license incl. 1 runtime license</li> </ul>	<b>6SW1700-8JD00-2AA0</b>
<ul style="list-style-type: none"> <li>• Runtime license (without data carrier)</li> </ul>	<b>6SW1700-5JD00-1AC0</b>
<ul style="list-style-type: none"> <li>• Update service for single-user license</li> </ul>	<b>6SW1700-0JD00-0AB2</b>
<ul style="list-style-type: none"> <li>• Upgrade from V6.x/V7.x/V8.x to V8.2 SPx <sup>*)</sup></li> </ul>	<b>6SW1700-8JD00-2AA4</b>
<b>Drive ES PCS 7 V8.2 SPx <sup>*)</sup></b> Block library for PCS 7 for the integration of drives in APL Style (Advanced Process Library) Requirement: PCS 7 V8.2 and higher Type of delivery: CD-ROM Languages: de, en, fr, it, es with electronic documentation	
<ul style="list-style-type: none"> <li>• Single-user license incl. 1 runtime license</li> </ul>	<b>6SW1700-8JD01-2AA0</b>
<ul style="list-style-type: none"> <li>• Runtime license (without data carrier)</li> </ul>	<b>6SW1700-5JD00-1AC0</b>
<ul style="list-style-type: none"> <li>• Update service for single-user license</li> </ul>	<b>6SW1700-0JD01-0AB2</b>
<ul style="list-style-type: none"> <li>• Upgrade of APL V8.x to V8.2 SPx or Drive ES PCS 7 V6.x, V7.x, V8.x classic to Drive ES PCS 7 APL V8.2 SPx <sup>*)</sup></li> </ul>	<b>6SW1700-8JD01-2AA4</b>

##### Options

###### Drive ES software update service

A software update service can also be purchased for the Drive ES software. The user will automatically receive the latest software, service packs and full versions for one year after ordering.

The update service can only be ordered in addition to an existing (i.e. previously ordered) full version.

- Period of update service: 1 year

The update service is automatically extended by 1 further year unless canceled up to 6 weeks prior to expiration.

Description	Article No.
<b>Drive ES PCS 7</b>	
<ul style="list-style-type: none"> <li>• Update service for single-user license</li> </ul>	<b>6SW1700-0JD00-0AB2</b>
<b>Drive ES PCS 7 APL</b>	
<ul style="list-style-type: none"> <li>• Update service for single-user license</li> </ul>	<b>6SW1700-0JD01-0AB2</b>

##### More information

More information is available on the Internet at [www.siemens.com/drive-es](http://www.siemens.com/drive-es)

<sup>\*)</sup> Orders are automatically supplied with the latest Service Pack (SP).



**Overview***Configuring with EPLAN*

EPLAN is an engineering software for configuring electrical installations. The EPLAN platform combines expert systems for various disciplines, such as electrical, fluid and EMC engineering (EMC = electrical, measuring and control engineering) as well as control cabinet and plant engineering. It provides the wiring information required to determine the optimal laying routes, connection lengths, bundle diameters, and design of the cable tree.

EPLAN Electric P8 – an EPLAN module – is CAE software specifically for configuring documentation and managing electrical automation projects for machines and systems. EPLAN Electric P8 offers the following functions:

- Creating circuit diagrams for control cabinets
- Managing article master data
- Automatic generation of bills of materials, terminal plans, PLC diagrams and overviews
- Preparation of the documentation for the configured system
- Design of the mechanical control cabinet configuration

*EPLAN macros for SINAMICS components*

EPLAN Electric P8 macros are available as downloads without charge, so that SINAMICS components can be easily and cost-effectively integrated into an EPLAN project. Macros are available for the following components:

- SINAMICS G120P, PM330 Power Modules
- SINAMICS G130 built-in units
- SINAMICS S120 chassis units
- SINAMICS DCM DC converters
- Line and motor-side components
- DC link components
- Control Units
- Supplementary system components

Using EPLAN Electric P8 macros substantially shortens the configuration time. All the necessary information about a component is supplied at the press of a button. This ensures that the data is up-to-date and correct – and mistakes/errors can be avoided.

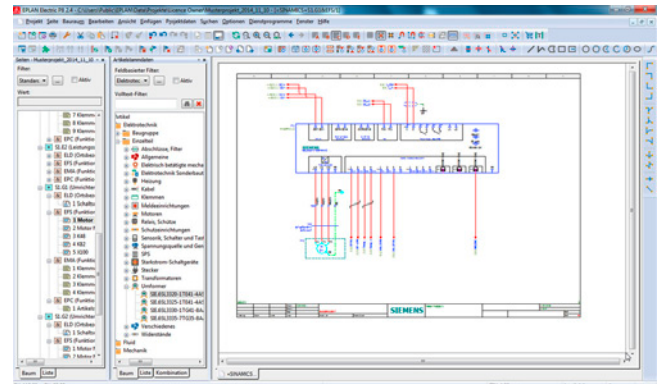

EPLAN user interface

The macros are provided in the file format EDZ (EPLAN Data Archived Zipped). An EDZ file is an archive for article master data, CAX data and macros. A macro in EDZ format contains the following data:

- Internal circuit diagrams
- Wiring diagrams
- Product master data
- Product images
- Data sheets

EPLAN Electric P8 macros for SINAMICS components are available in the following tools:

- Drive Technology Configurator ([www.siemens.com/dt-configurator](http://www.siemens.com/dt-configurator))
- CAX Onlinemanager
- Image database (download)

*EPLAN projects for SINAMICS converter cabinet units*

EPLAN projects are available for SINAMICS converter cabinet units, that simplify the configuration, and save time throughout the entire engineering process. EPLAN projects are available for the following converter cabinet units:

- SINAMICS G120P Cabinet
- SINAMICS G150
- SINAMICS G180
- SINAMICS S120 Cabinet Modules
- SINAMICS S150
- SINAMICS DCM Cabinet

The complete EPLAN project is supplied on a separate DVD-ROM together with the converter. The order is made by stating an additional Article No.

## Tools and Engineering

### Engineering tools

#### Configuration with EPLAN

##### Overview (continued)

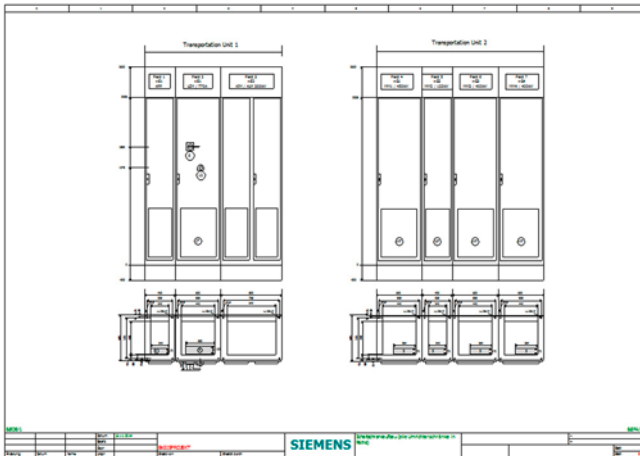

EPLAN project: Control cabinet layout

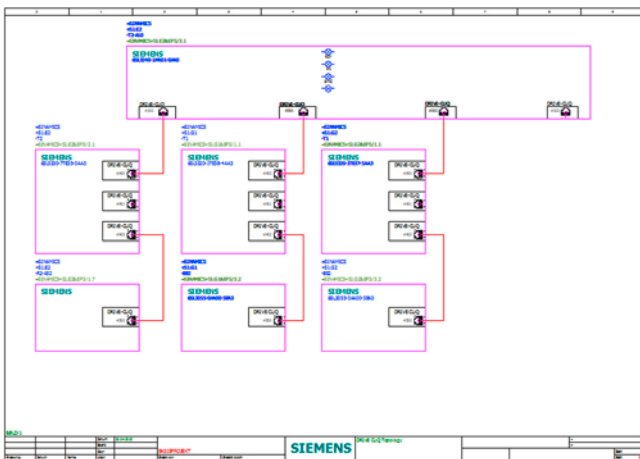

EPLAN project: DRIVE-CLiQ topology

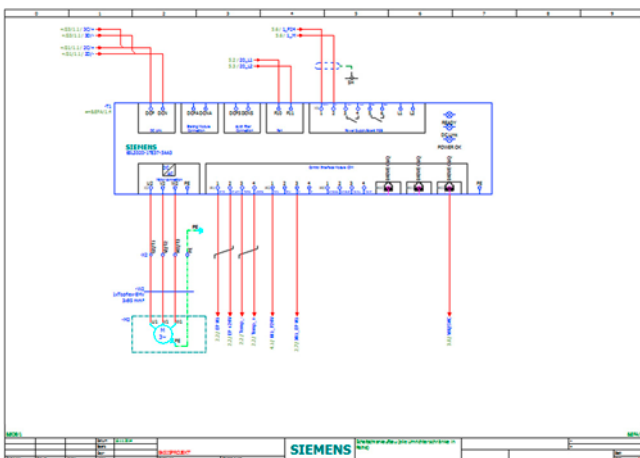

EPLAN project: Circuit diagram

The following data are available when you purchase the DVD-ROM:

- EPLAN project as a ZW1 file
- Updated, customer-specific, project article master database
- List of the Article Nos. created in the project
- A PDF version of the project

The EPLAN project includes the following documentation components:

- Title sheet
- Table of contents
- List of the structure identifiers used
- Single-line diagram
- General layout, external view
- General layout, internal view
- Circuit diagram
- Terminal diagram
- Connector diagram
- Parts list
- Order list/complete parts list

#### Selection and ordering data

Description	Article No.
<b>EPLAN Electric P8</b> Project documentation on DVD-ROM for: <ul style="list-style-type: none"> <li>• SINAMICS G120 P Cabinet</li> <li>• SINAMICS S120 Cabinet Modules</li> <li>• SINAMICS S150</li> <li>• SINAMICS G150</li> </ul>	<b>6SL3780-0AK00-0AA0</b>

**Overview***General procedure when engineering*

The function description of the machine provides the basis for the configuration. The definition of the components is based on physical interdependencies and is usually carried out as follows:

Step	Description of configuration activity
1	Clarification of type of drive
2	Specification of the supplementary conditions and integration in the automation system
3	Definition of the load, calculation of the max. load torque, selection of the motor
4	Definition of the Motor Module
5	Repetition of steps 3 and 4 for additional axes
6	Calculation of the required DC link power and definition of the Line Module
7	Specification of the required control performance and selection of the Control Unit, definition of component cabling
8	Specification of the line-side power options (main switch, fuses, line filters, etc.) and cable cross-sections for system connection and motor connection
9	Definition of additional system components
10	Calculation of the current requirement for the 24 V DC supply for the components and specification of power supplies (SITOP devices, Control Supply Modules)
11	Specification of components for connection system
12	Configuration of drive line-up components
13	Thermal design of the control cabinet

Configuration begins with the mechanical interface to the machine. A suitable motor is selected according to the specified torques and speeds. A matching power unit is then also chosen. Depending on the requirements of the machine, the motor is supplied as a single-motor drive via a Power Module or within a multi-motor drive group via a Motor Module. Once the basic components have been defined, the system components for matching to the electrical and mechanical interfaces are selected.

The SIZER for Siemens Drives engineering tool allows the correct components to be selected quickly and easily. Based on the torque and speed characteristics entered, SIZER for Siemens Drives guides the user through the configuring process, identifying suitable motors and matching SINAMICS power units and other system components.

Important information about SINAMICS S120 components that are needed to create a drive system subject to certain supplementary conditions can be found in the SINAMICS Low Voltage Engineering Manual, and in the online help for the SIZER for Siemens Drives engineering tool.



## Tools and Engineering

### Engineering information

#### EMC notes for applying product standard EN 61800-3

##### Overview

The electromagnetic compatibility describes - according to the definition of the EMC Directive - the "capability of a device to work satisfactorily in the electromagnetic environment without itself causing electromagnetic interference which is unacceptable for other devices present in this environment". To guarantee that the appropriate EMC Directives are observed, the devices must demonstrate a sufficiently high noise immunity, and also the emitted interference must be limited to acceptable values.

The product standard EN 61800-3 describes the EMC requirements placed on "Variable-speed drive systems".

A variable-speed drive system (or Power Drive System PDS) consists of the Control Unit and Power Module or Control Unit, Line Module, and Motor Module plus the relevant electric motors and encoders including connecting cables. The driven machine is not part of the drive system.

##### Environments

EN 61800-3 defines different limit values depending on the site of installation of the drive system, referred to as the first and second environments.

Residential buildings or locations at which the drive system is directly connected to a public low-voltage supply without intermediate transformer are defined as the **first environment**.

A **second environment** refers to all locations outside residential areas, or industrial sites which are supplied from the medium-voltage network via a separate transformer.

##### Categories

Four different categories are defined in EN 61800-3 Ed.2 depending on the installation site and the output power of the drive:

- **Category C1:** Drive systems for rated voltages <1000 V for unlimited use in the first environment.
- **Category C2:** Stationary drive systems for rated voltages <1000 V for use in the second environment. Use in the first environment is possible if the drive system is operated and installed by qualified personnel. The warning information and installation instructions supplied by the manufacturer must be observed.
- **Category C3:** Drive systems for rated voltages <1000 V for exclusive use in the second environment.
- **Category C4:** Drive systems for rated voltages  $\geq 1000$  V or for rated currents  $\geq 400$  A for use in complex systems in the second environment. An EMC plan must be drawn up.

The following diagram shows how the four categories are assigned to the first and second environments:

First environment	C1	Second environment
	C2	
	C3	
	C4	

G\_D213\_EN\_0009a

**Configuration**

The SINAMICS S120 and SINAMICS S150 drive systems are basically suitable for operation in the second environment (Categories C3 and C4). The measures necessary for operation in the first and second environment (Category C2) are listed below.

**Measures for complying with product standard EN 61800-3 second environment**Interference immunity

All SINAMICS S120 drive systems, SINAMICS S120 Cabinet Modules, and SINAMICS S150 are suitable for use in the second environment.

Regarding interference immunity, they can be used in both the **first** and **second environments**.

Interference emission – complying with Category C2 second environment

Regarding interference emission, to comply with the limit values according to EN 61800-3 second environment, Category C2, the following measures must be applied:

- The drive system must be installed in compliance with EMC regulations by appropriately trained professionals.
- The drive system requires a radio interference suppression filter, Category C2 (as optional external line filter with/without line reactor)
- The pulse frequency is less than or equal to the rated pulse frequency
- The maximum motor cable length is complied with (shielded)
- Line supply with grounded neutral point (TN/TT supply system)

Device-specific assignment of the measures to comply with product standard EN 61800-3 second environment, Category C2

SINAMICS S120 chassis			Measures for	Maximum pulse frequency $f_p$	Maximum motor cable length (shielded)
Devices	Line voltage	Frame size	Radio interference suppression filter, Category C2	kHz	m
<b>Active Line Modules</b>	380 ... 480 V 3 AC	FX ... JX GXL ... JXL <sup>1)</sup>	External line filter required	4 <sup>3)</sup>	300
	500 ... 690 V 3 AC	FX ... JX HXL and JXL <sup>1)</sup>	External line filter required	4 <sup>3)</sup>	300
<b>Smart Line Modules</b>	380 ... 480 V 3 AC	GX ... JX	External line filter required	4 <sup>3)</sup>	300
	500 ... 690 V 3 AC	GX ... JX	External line filter required	4 <sup>3)</sup>	300
<b>Basic Line Modules</b>	380 ... 480 V 3 AC	FB ... GD FBL and GBL <sup>1)</sup>	External line filter plus line reactor required <sup>2)</sup>	4 <sup>3)</sup>	100
	500 ... 690 V 3 AC	FB ... GD FBL and GBL <sup>1)</sup>	External line filter plus line reactor required <sup>2)</sup>	4 <sup>3)</sup>	100
<b>Power Modules</b>	380 ... 480 V 3 AC	FX and GX FL and GL <sup>1)</sup>	External line filter plus line reactor required <sup>2)</sup>	2	100

<sup>1)</sup> For liquid-cooled and water-cooled devices on request.

<sup>2)</sup> Selection and ordering data for line filters and line reactors see sections [Line-side power components](#).

<sup>3)</sup> Refers to the pulse frequency of the Motor Modules.

## Tools and Engineering

### Engineering information

#### EMC notes for applying product standard EN 61800-3

#### Configuration (continued)

<b>SINAMICS S120 Cabinet Modules, air-cooled <sup>1)</sup></b>			Measures for		
Cabinet Modules	Line voltage	Frame size	Radio interference suppression filter, Category C2	Maximum pulse frequency $f_p$	Maximum motor cable length (shielded)
				kHz	m
Line Connection Modules for Active Line Modules ( <b>L42</b> )	380 ... 480 V 3 AC	FX ... JX	Option L00	4 <sup>3)</sup>	300
	500 ... 690 V 3 AC	FX ... JX	Option L00	4 <sup>3)</sup>	300
Line Connection Modules for Smart Line Modules ( <b>L44</b> )	380 ... 480 V 3 AC	GX ... JX	Option L00	4 <sup>3)</sup>	300
	500 ... 690 V 3 AC	GX ... JX	Option L00	4 <sup>3)</sup>	300
Line Connection Modules for Basic Line Modules ( <b>L43</b> )	380 ... 480 V 3 AC	FB ... GD	Option L00 <sup>2)</sup>	4 <sup>3)</sup>	100
	500 ... 690 V 3 AC	FB ... GD	Option L00 <sup>2)</sup>	4 <sup>3)</sup>	100

<b>SINAMICS S150</b>			Measures for		
Converter cabinet units	Line voltage	Frame size	Radio interference suppression filter, Category C2	Maximum pulse frequency $f_p$	Maximum motor cable length (shielded)
				kHz	m
S150	380 ... 480 V 3 AC	FI+FX ... JI+JX	Option L00	4 <sup>3)</sup>	300
	500 ... 690 V 3 AC	FI+FX ... JI+JX	Option L00	4 <sup>3)</sup>	300

#### Interference emission – complying with Category C3 second environment

Covered by Active Interface Modules in chassis format in the standard version of all SINAMICS S120 Cabinet Modules, SINAMICS S150 converter cabinet units, and SINAMICS S120 Line Modules. A line reactor is required for Power Modules in chassis format.

The maximum cable lengths and pulse frequencies (see previous tables) must be taken into consideration.

#### **Measures for complying with product standard EN 61800-3 first environment**

The SINAMICS S120 drive systems, SINAMICS S120 Cabinet Modules air-cooled, and SINAMICS S150 are basically suitable for use in the second environment.

Regarding interference immunity, they can be used in both the **first and second environments**.

#### Interference emission – complying with Category C2 first environment

For use in the first environment, **in addition** to the requirements for use in the second environment, device-specific notes to maintain the **harmonic current** limits must be **taken into consideration**.

#### Interference emission – complying with Category C4 second environment

When connected to IT line supplies, only devices without integrated filter are permissible. To limit symmetrical interference emission, suitable external filters without capacitors connected to ground must be used.

Further selected accessories are available from the "Siemens Product Partner for Drives Options"  
[www.siemens.com/drives-options-partner](http://www.siemens.com/drives-options-partner)

Here, EMC product standard EN 61800-3 makes reference to the standards pertaining to harmonic currents: EN 61000-3-2 and EN 61000-3-12.

#### More information

Converters are equipment used on a professional basis, deployed in certain areas of business and industry – and are not operated in the general public domain.

Further information on SINAMICS S120 components, SINAMICS S120 Cabinet Modules, and SINAMICS S150, which are needed to create a drive system subject to certain supplementary conditions can be found in the SINAMICS Low Voltage Engineering Manual:

<https://support.industry.siemens.com/cs/document/83180185>

<sup>1)</sup> For liquid-cooled Cabinet Modules on request.

<sup>2)</sup> Option L22 (scope of supply without line reactor) not permissible for use in Category C2 second environment.

<sup>3)</sup> Refers to the pulse frequency of the Motor Modules.

## Overview



To correctly select and configure the devices listed in this catalog, we would like to refer to the SINAMICS Low Voltage Engineering Manual. This supplements the Catalogs D 11 and D 21.3, and is intended to simplify the handling of SINAMICS series devices.

This manual is only available in electronic form and only in German and English. It is available as a PDF in the Information and Download Center:

<https://support.industry.siemens.com/cs/document/83180185>

The Engineering Manual contains general information on the basics of variable-speed electric AC drives, as well as detailed system descriptions and direct specifications for the following SINAMICS series devices:

- SINAMICS G130 Drive Converter Chassis Units (Catalog D 11)
- SINAMICS G150 Drive Converter Cabinet Units (Catalog D 11)
- SINAMICS S120 Modular Chassis Units (Catalogs D 21.3 and D 21.4)
- SINAMICS S120 Cabinet Modules (Catalog D 21.3)
- SINAMICS S150 Converter Cabinet Units (Catalog D 21.3)

The Engineering Manual is divided into several sections with different layouts.

The first chapter – Basics and system description – essentially explains the physical basics of variable-speed electric AC drives and provides a generally valid system description of the SINAMICS series devices.

The second chapter – EMC design guideline – discusses the topic of **E**lectromagnetic **C**ompatibility (EMC) and provides all the information required to configure and install drives with the specified SINAMICS devices in compliance with EMC guidelines.

The following chapters – Configuration of the SINAMICS G130, G150, S120 chassis units, S120 Cabinet Modules and S150 devices – discuss device-specific topics, which go beyond the contents of the generally valid system descriptions.

The information provided addresses technically qualified and trained personnel. It is the responsibility of the configuration engineer to evaluate the completeness of the information provided for the respective application. This person also has the final system responsibility for the entire drive or the plant.

## Tools and Engineering

### Notes

## Services and Documentation



7/2	<b>Partner at Siemens</b>
7/3	<b>Online Services</b>
7/3	Information and Ordering Options on the Internet and DVD
7/4	Information and Download Center, Social Media, Mobile Media
7/5	<b>Industry Services</b>
7/5	Portfolio
7/8	Online Support
7/9	<b>Service &amp; Support</b>
7/9	Extension of the liability for defects
7/11	<b>Training</b>
7/12	Range of training courses
7/13	<b>SPARES on Web</b>
7/14	<b>mySupport documentation</b>
7/15	<b>Documentation</b>

# Services and Documentation

## Partner at Siemens

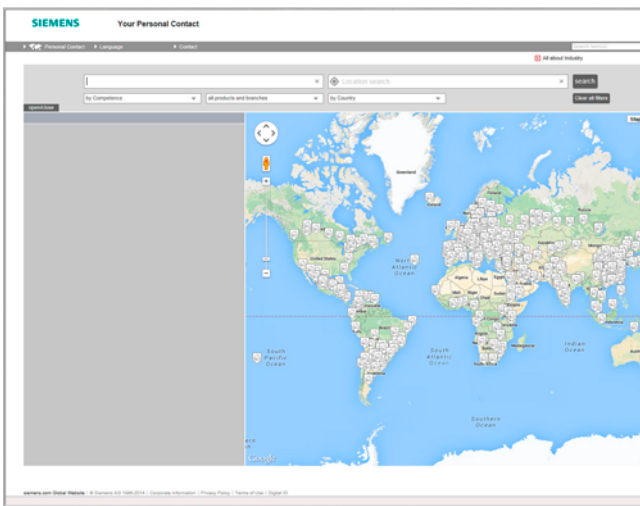

At Siemens we are resolutely pursuing the same goal: long-term improvement of your competitive ability. We are committed to this goal. Thanks to our commitment, we continue to set new standards in automation and drive technology. In all industries – worldwide.

At your service locally, around the globe for consulting, sales, training, service, support, spare parts on the entire portfolio of Digital Factory and Process Industries and Drives.

Your partner can be found in our Personal Contacts Database at: [www.siemens.com/automation-contact](http://www.siemens.com/automation-contact)

You start by selecting

- the required competence,
- products and branches,
- a country,
- a city

or by a

- location search or
- person search.

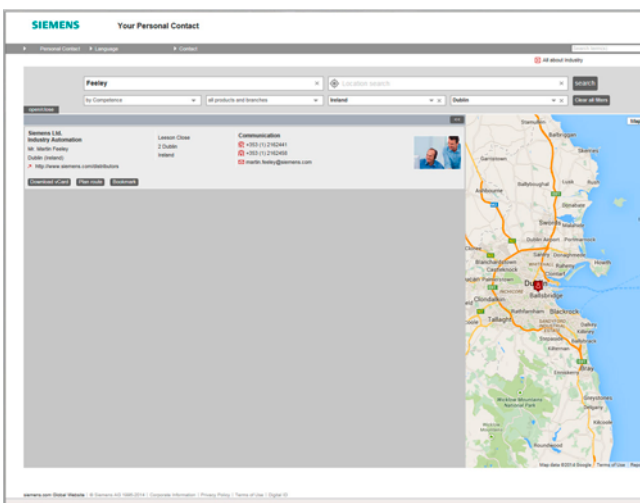
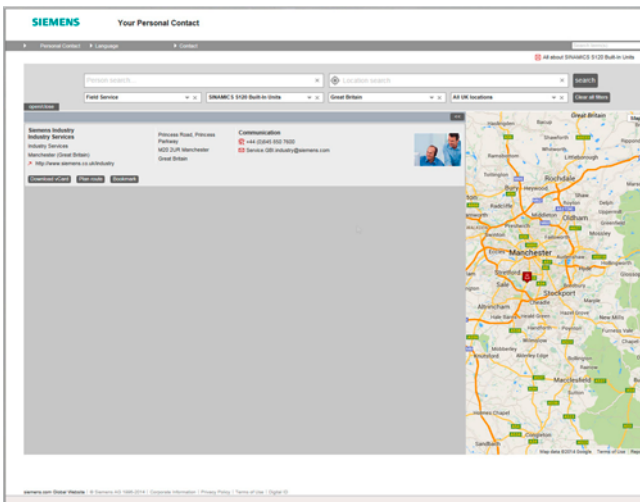



#### The Future of Manufacturing on the Internet

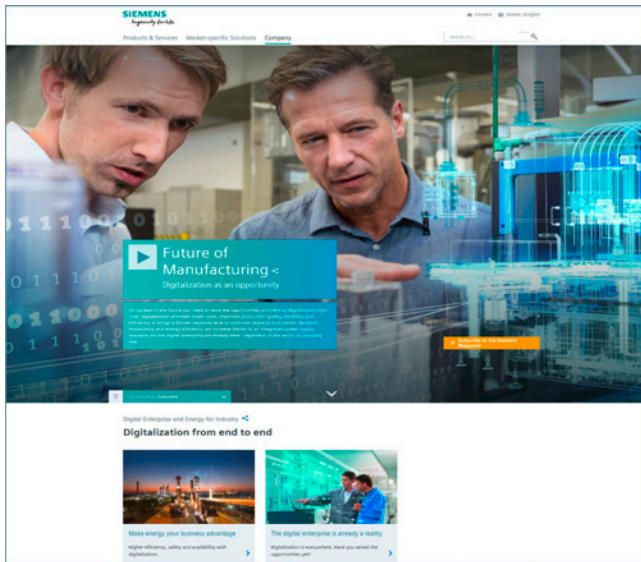

Detailed knowledge of the range of products and services available is essential when planning and engineering automation systems. It goes without saying that this information must always be as up-to-date as possible.

Industry is on the threshold of the fourth industrial revolution as digitization now follows after the automation of production. The goals are to increase productivity and efficiency, speed, and quality. In this way, companies can remain competitive on the path to the future of industry.

You will find everything you need to know about products, systems and services on the internet at:

[www.siemens.com/industry](http://www.siemens.com/industry)

#### Product Selection Using the Interactive CA 01 Automation and Drives Catalog

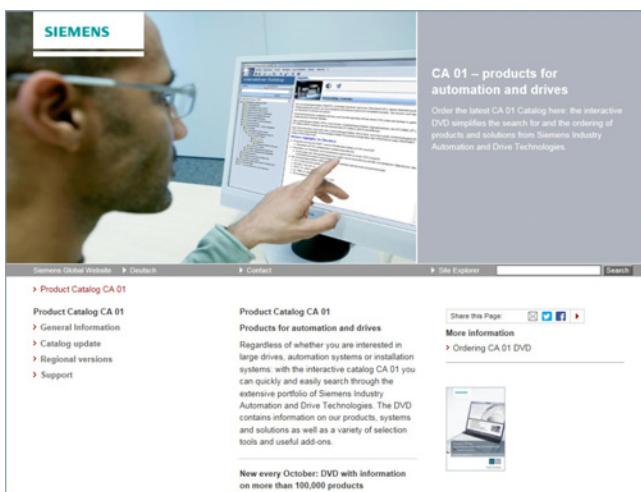

Detailed information together with user-friendly interactive functions:

The CA 01 interactive catalog covers more than 100,000 products, thus providing a comprehensive overview of the product range provided by Siemens.

You will find everything you need here for solving tasks in the fields of automation, switching, installation and drives. All information is provided over a user interface that is both user-friendly and intuitive.

You can order the CA 01 product catalog from your Siemens sales contact or in the Information and Download Center:

[www.siemens.com/industry/infocenter](http://www.siemens.com/industry/infocenter)

Information about the CA 01 interactive catalog can be found on the Internet at:

[www.siemens.com/automation/ca01](http://www.siemens.com/automation/ca01)

or on DVD.

#### Easy Shopping with the Industry Mall

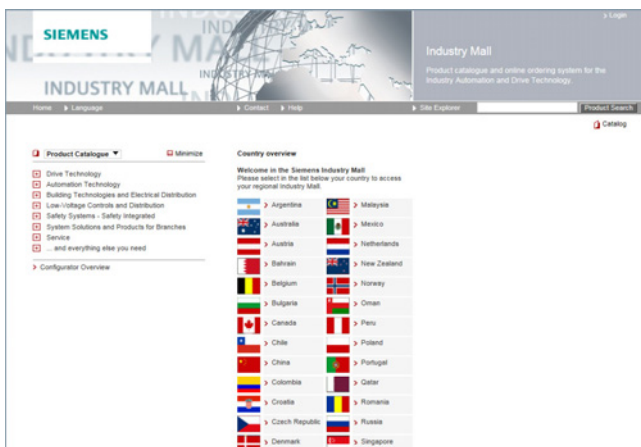

The Industry Mall is the electronic ordering platform of Siemens AG on the Internet. Here you have online access to a huge range of products presented in an informative and attractive way.

Data transfer via EDIFACT allows the whole procedure, from selection through ordering to tracking and tracing, to be carried out online. Availability checks, customer-specific discounts and bid creation are also possible.

Numerous additional functions are provided for your support. For example, powerful search functions make it easy to select the required products. Configurators enable you to configure complex product and system components quickly and easily. CAx data types are also provided here.

You can find the Industry Mall on the Internet at:

[www.siemens.com/industrymall](http://www.siemens.com/industrymall)



## Services and Documentation

### Online Services

#### Information and Download Center, Social Media, Mobile Media

##### Downloading Catalogs

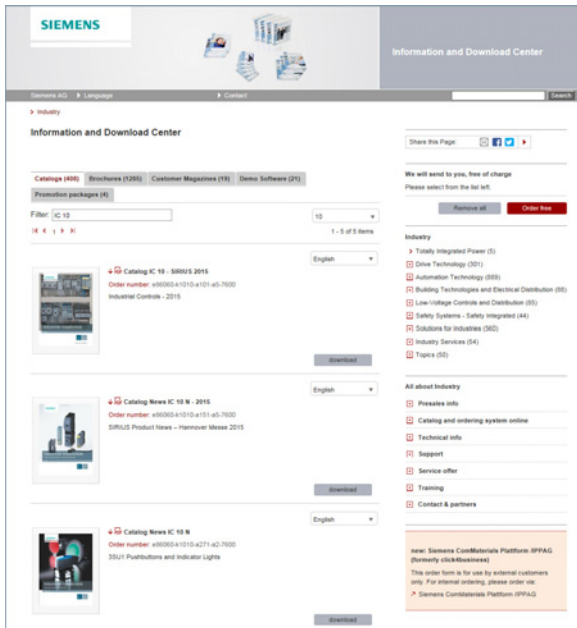

In addition to numerous other useful documents, you can also find the catalogs listed on the back inside cover of this catalog in the Information and Download Center. You can download these catalogs in PDF format without having to register.

The filter dialog above the first catalog displayed makes it possible to carry out targeted searches. If you enter "MD 3" for example, you will find both the MD 30.1 and MD 31.1 catalogs. If you enter "IC 10", both the IC 10 catalog and the associated news or add-ons are displayed.

Visit us at:

[www.siemens.com/industry/infocenter](http://www.siemens.com/industry/infocenter)

##### Social and Mobile Media

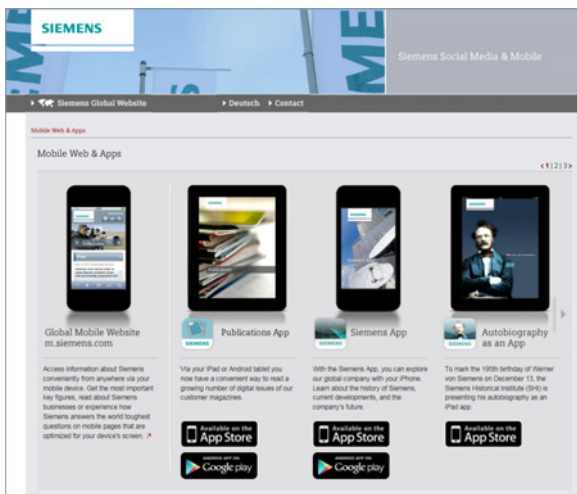

Connect with Siemens through social media: visit our social networking sites for a wealth of useful information, demos on products and services, the opportunity to provide feedback, to exchange information and ideas with customers and other Siemens employees, and much, much more. Stay in the know and follow us on the ever-expanding global network of social media.

To find out more about Siemens' current social media activities, visit us at:

[www.siemens.com/socialmedia](http://www.siemens.com/socialmedia)

Or via our product pages at:

[www.siemens.com/automation](http://www.siemens.com/automation) or [www.siemens.com/drives](http://www.siemens.com/drives)

Here you can read all the news on the future of the industry, watch current videos and obtain information about all the latest industry developments.

[www.siemens.com/future-of-manufacturing](http://www.siemens.com/future-of-manufacturing)

Discover the world of Siemens.

We are also constantly expanding our offering of cross-platform apps for smartphones and tablets. You will find the current Siemens apps at the App Store (iOS) or at Google Play (Android):

<https://itunes.apple.com/en/app/siemens/id452698392?mt=8>

<https://play.google.com/store/search?q=siemens>

The Siemens app, for example, tells you all about the history, latest developments and future plans of the company – with informative pictures, fascinating reports and the most recent press releases.

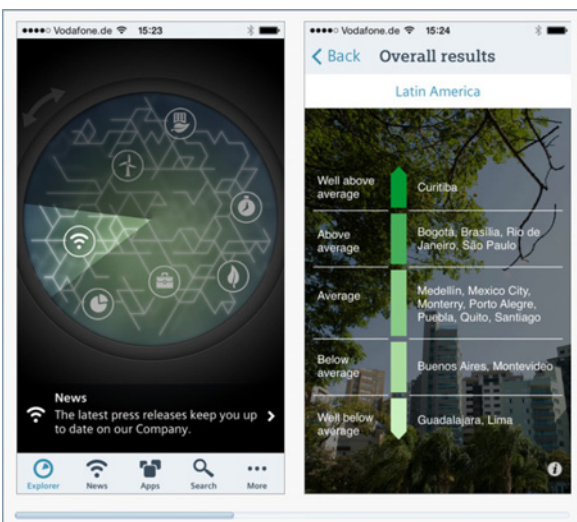

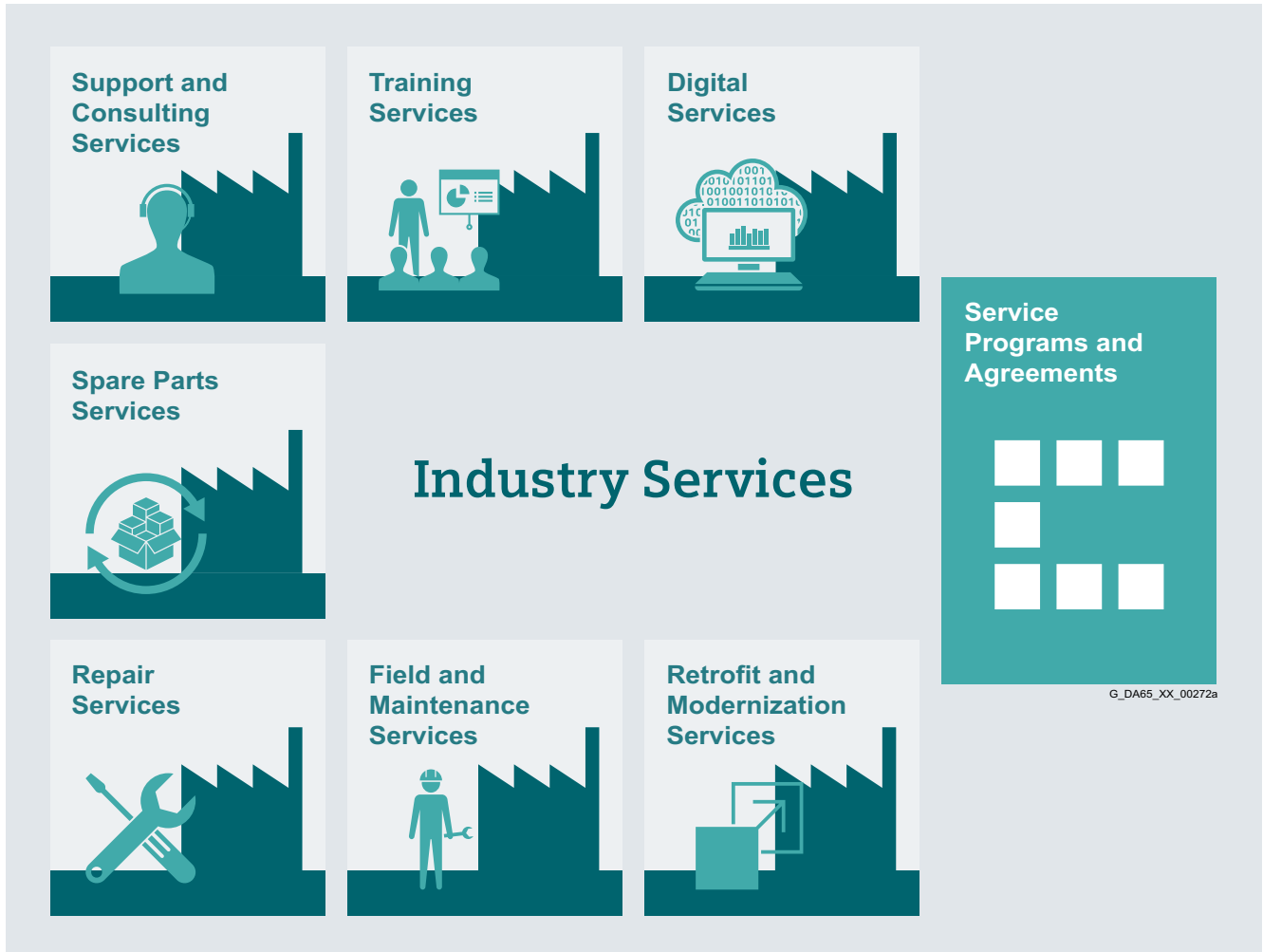
**Overview**

**Keep your business running and shaping your digital future – with Industry Services**

Optimizing the productivity of your equipment and operations can be a challenge, especially with constantly changing market conditions. Working with our service experts makes it easier. We understand your industry's unique processes and provide the services needed so that you can better achieve your business goals.

You can count on us to maximize your uptime and minimize your downtime, increasing your operations' productivity and reliability. When your operations have to be changed quickly to meet a new demand or business opportunity, our services give you the flexibility to adapt. Of course, we take care that your production is protected against cyber threats. We assist in keeping your operations as energy and resource efficient as possible and reducing your total cost of ownership. As a trendsetter, we ensure that you can capitalize on the opportunities of digitalization and by applying data analytics to enhance decision making: You can be sure that your plant reaches its full potential and retains this over the longer lifespan.

You can rely on our highly dedicated team of engineers, technicians and specialists to deliver the services you need – safely, professionally and in compliance with all regulations. We are there for you, where you need us, when you need us.

<https://www.siemens.com/global/en/home/products/services/industry.html>

## Services and Documentation

### Industry Services

#### Industry Services – Portfolio overview

##### Overview

#### Digital Services



Digital Services make your industrial processes transparent to gain improvements in productivity, asset availability, and energy efficiency.

Production data is generated, filtered and translated with intelligent analytics to enhance decision-making.

This is done whilst taking data security into consideration and with continuous protection against cyber-attack threats.

<https://www.siemens.com/global/en/home/products/services/industry/digital-services.html>

#### Support and Consulting Services



**Industry Online Support** site for comprehensive information, application examples, FAQs and support requests.

**Technical and Engineering Support** for advice and answers for all inquiries about functionality, handling, and fault clearance. The Service Card as prepaid support for value added services such as Priority Call Back or Extended Support offers the clear advantage of quick and easy purchasing.

**Information & Consulting Services**, e.g. SIMATIC System Audit; clarity about the state and service capability of your automation system or Lifecycle Information Services; transparency on the lifecycle of the products in your plants.

<https://support.industry.siemens.com/cs/ww/en/sc/2235>

#### Training Services



From the basics and advanced to specialist skills, SITRAIN courses provide expertise right from the manufacturer – and encompass the entire spectrum of Siemens products and systems for the industry.

Worldwide, SITRAIN courses are available wherever you need a training course in more than 170 locations in over 60 countries.

<https://support.industry.siemens.com/cs/ww/en/sc/2226>

#### Spare Parts Services



Spare Parts Services are available worldwide for smooth and fast supply of spare parts – and thus optimal plant availability. Genuine spare parts are available for up to ten years. Logistic experts take care of procurement, transport, custom clearance, storage and order management. Reliable logistics processes ensure that components reach their destination as needed.

Since not all spare parts can be kept in stock at all times, Siemens offers a preventive measure for spare parts provisioning on the customer's premises with optimized **Spare Parts Packages** for individual products, custom-assembled drive components and entire integrated drive trains – including risk consulting.

**Asset Optimization Services** help you design a strategy for parts supply where your investment and carrying costs are reduced and the risk of obsolescence is avoided.

<https://support.industry.siemens.com/cs/ww/en/sc/2110>

### Overview (continued)

#### Repair Services



Repair Services are offered on-site and in regional repair centers for fast restoration of faulty devices' functionality.

Also available are extended repair services, which include additional diagnostic and repair measures, as well as emergency services.

<https://support.industry.siemens.com/cs/ww/en/sc/2154>

#### Retrofit and Modernization Services



Provide a cost-effective solution for the expansion of entire plants, optimization of systems or upgrading existing products to the latest technology and software, e.g. migration services for automation systems.

Service experts support projects from planning through commissioning and, if desired over the entire extended lifespan, e.g. Retrofit for Integrated Drive Systems for an extended lifetime of your machines and plants.

<https://support.industry.siemens.com/cs/ww/de/sc/2286>

#### Field and Maintenance Services

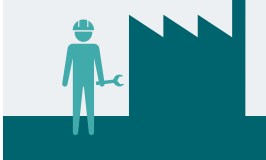

Siemens specialists are available globally to provide expert field and maintenance services, including commissioning, functional testing, preventive maintenance and fault clearance. All services can be included in customized service agreements with defined reaction times or fixed maintenance intervals.

<https://support.industry.siemens.com/cs/ww/en/sc/2265>

#### Service Programs and Agreements



A technical Service Program or Agreement enables you to easily bundle a wide range of services into a single annual or multi-year agreement.

You pick the services you need to match your unique requirements or fill gaps in your organization's maintenance capabilities.

Programs and agreements can be customized as KPI-based and/or performance-based contracts.

<https://support.industry.siemens.com/cs/ww/de/sc/2275>

## Services and Documentation

Industry Services

### Online Support

#### Overview

Online Support – fast, intuitive, whenever you want, wherever you need



**Web**  
support.industry.siemens.com

**App**

Get it on Google Play | Get it on the App Store | Microsoft Store

Scan the QR code for information on our Online Support app.



- FAQ / Application examples**  
Information about industrial products, programming and configuration as well as application examples
- Technical Information**  
Videos, documentation, manuals, updates, product notes, compatibility tool, certificates, planning data such as dimensional drawings, product data, 3D models
- Forum**  
Exchange information and experience with other users and experts

## Online Support for Siemens Products for Industry

7

Siemens Industry and Online Support with some 1.7 million visitors per month is one of the most popular web services provided by Siemens. It is the central access point for comprehensive technical know-how about products, systems and services for automation and drives applications as well as for process industries.

In connection with the challenges and opportunities related to digitalization you can look forward to continued support with innovative offerings.



**Extension of the liability for defects**

We provide the option of extending the liability for defects period beyond the normal period for our SINAMICS S120 Cabinet Modules and SINAMICS S150 cabinet units. The standard liability for defects period, as listed in our standard conditions for the supply of services and products, is 12 months.

**1. Extended liability for defects when ordering new products**

When ordering new products, it is possible to extend the standard liability for defects period for an additional price. Various extension periods can be selected.

Extended liability for defects for converters	
Additional ordering data -Z with order code	Additional text
<b>Q80</b>	Extension of the liability for defects period by 12 months to a total of 24 months (2 years) after being delivered
<b>Q81</b>	Extension of the liability for defects period by 18 months to a total of 30 months (2½ years) after being delivered
<b>Q82</b>	Extension of the liability for defects period by 24 months to a total of 36 months (3 years) after being delivered
<b>Q83</b>	Extension of the liability for defects period by 30 months to a total of 42 months (3½ years) after being delivered
<b>Q84</b>	Extension of the liability for defects period by 36 months to a total of 48 months (4 years) after being delivered
<b>Q85</b>	Extension of the liability for defects period by 48 months to a total of 60 months (5 years) after being delivered

**2. Extended liability for defects period after the product has already been delivered**

If a product has already been delivered, an extended liability for defects period can be ordered if the original liability for defects period has still not expired. In addition to the article number specified on the rating plate, the serial number must also be stated in the order.

The following article numbers are used:

Extended liability for defects for converters	
Article No.	Text
<b>9LD1730-0AA24</b>	Extension of the liability for defects period by 12 months to a total of 24 months (2 years) after being delivered
<b>9LD1730-0AA30</b>	Extension of the liability for defects period by 18 months to a total of 30 months (2½ years) after being delivered
<b>9LD1730-0AA36</b>	Extension of the liability for defects period by 24 months to a total of 36 months (3 years) after being delivered
<b>9LD1730-0AA42</b>	Extension of the liability for defects period by 30 months to a total of 42 months (3½ years) after being delivered
<b>9LD1730-0AA48</b>	Extension of the liability for defects period by 36 months to a total of 48 months (4 years) after being delivered
<b>9LD1730-0AA60</b>	Extension of the liability for defects period by 48 months to a total of 60 months (5 years) after being delivered

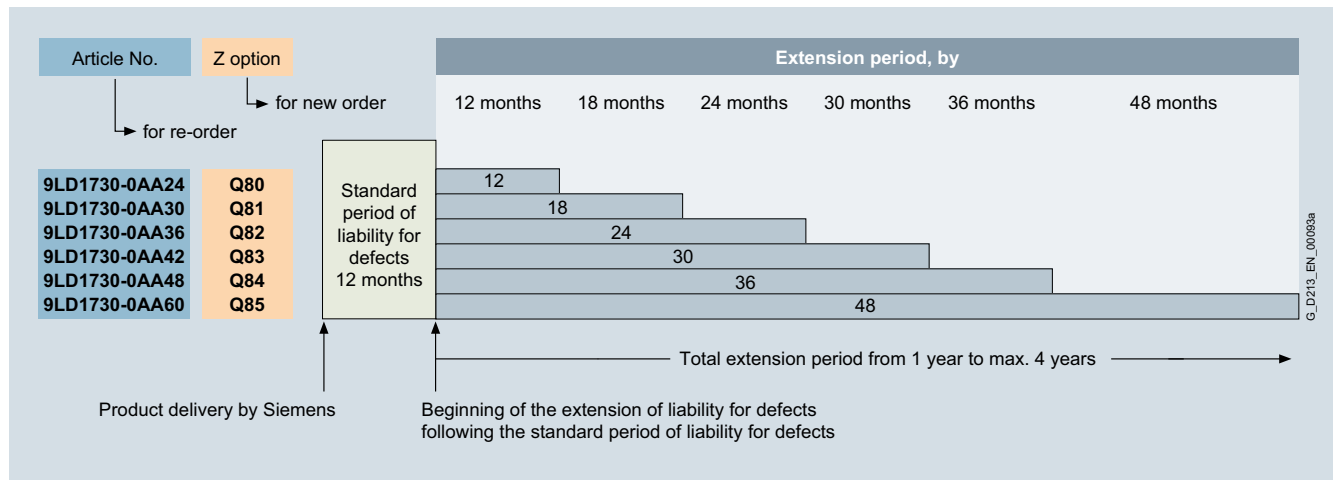
**Overview of the extended liability for defects period**

## Services and Documentation

### Service & Support

#### Extension of the liability for defects

##### *Conditions for an extension of the liability for defects:*

1. The liability for defects period can be extended only once, i.e. it is not possible to extend an extension. If a product has already been delivered, an extended liability for defects period can only be ordered if the original liability for defects period has still not expired.
2. The scope of services provided by an extended liability of defects period includes all material and work expenditure by Siemens for rectification of the damage and, where applicable, all travel costs and expenses.
3. For all extension periods of liability for defects, when ordering a new product and when reordering, the final destination of the product must be known (region in which the equipment will be finally installed). Please contact your Siemens representative for the purpose of providing this information.
4. The general storage conditions described in the operating instructions must be adhered to, especially the specifications for long-term storage. These specifications must be requested separately from Siemens if necessary.
5. Commissioning must be performed by appropriately qualified personnel. When making liability for defect claims, under certain circumstances, it may be necessary to submit the commissioning report to the department making the decision.
6. For all liability of defect extensions, all of the regular maintenance intervals must be complied with according to what is specified in the operating instructions. When ordering the appropriate maintenance, this must be carried out by Siemens or by personnel authorized by Siemens. The corresponding maintenance documentation and history must be submitted when making liability for defect claims.
7. The operating conditions correspond to the specifications and data provided in the operating instructions, in the engineering manual or special conditions specified in the specific contract.
8. The extended liability for defects excludes wearing parts such as fans or filters. This does not apply if it can be clearly proven that the failure is a premature one.
9. Otherwise, the general conditions regarding liability for defects applies as agreed in the delivery contract.



### ***Your benefit from practical training directly from the manufacturer***

SITRAIN – Training for Industry – provides you with comprehensive support in solving your tasks.

Training directly from the manufacturer enables you to make correct decisions with confidence.

### ***Increased profits and lower costs:***

- Shorter times for commissioning, maintenance and servicing
- Optimized production operations
- Reliable configuration and commissioning
- Shortened startup times, reduced downtimes, and faster troubleshooting
- Exclude expensive faulty planning right from the start.
- Flexible plant adaptation to market requirements
- Compliance with quality standards in production
- Increased employee satisfaction and motivation
- Shorter familiarization times following changes in technology and staff

### ***Contact***

Visit our site on the Internet at:  
[www.siemens.com/sitrain](http://www.siemens.com/sitrain)

or let us advise you personally. You can request our latest training catalog from:

***SITRAIN – Training for Industry  
Customer Support Germany:***

Tel.: +49 911 895-7575

Fax: +49 911 895-7576

Email: [info@sitrain.com](mailto:info@sitrain.com)

### ***Your benefits with SITRAIN – Training for Industry***

#### Certified top trainers

Our trainers are skilled specialists with practical experience. Course developers have close contact with product development, and pass on their knowledge to the trainers and then to you.

#### Practical application with practice

Practice, practice, practice! We have designed the trainings with an emphasis on practical exercises. They take up to half of the course time in our trainings. You can therefore implement your new knowledge in practice even faster.

#### 300 courses in more than 60 countries

We offer a total of about 300 classroom-based courses. You can find us at more than 50 locations in Germany, and in 62 countries worldwide. You can find which course is offered at which location at:

[www.siemens.com/sitrain](http://www.siemens.com/sitrain)

#### Skills development

Do you want to develop skills and fill in gaps in your knowledge? Our solution: We will provide a program tailored exactly to your personal requirements. After an individual requirements analysis, we will train you in our training centers near you or directly at your offices. You will practice on the most modern training equipment with special exercise units. The individual training courses are optimally matched to each other and help with the continuous development of knowledge and skills. After finishing a training module, the follow-up measures make success certain, as well as the refreshment and deepening of the knowledge gained.



## Services and Documentation

### Training

#### Range of training courses

##### Overview

##### *Range of training courses for the SINAMICS S120 and SINAMICS S150 drive systems*

Here you will find an overview of the training courses available for SINAMICS S120 and SINAMICS S150.

The courses are modular in design and are directed at a variety of target groups as well as individual customer requirements.

The system overview will acquaint decision-makers and sales personnel with the system very quickly.

The basic and follow-up courses are guaranteed to provide all of the technical knowledge that service personnel will need for commissioning and service.

All courses contain as many practical exercises as possible in order to enable intensive and direct training on the drive system and with the tools in small groups.

You will find further information about course contents and dates in Catalog ITC and on the Internet.

Title (all courses are available in English and/or German)	Target group			Duration	Course code
	Sales personnel, planners, decision makers	Commissioning engineers, programmers	Service personnel, maintenance technicians		
SINAMICS System Overview	✓	–	–	3 days	DR-SYS
Integrated Drive Systems Introduction and Fundamentals	✓	–	–	3 days	DR-IDS
SIMOTICS induction motors Planning and Configuration	✓	–	–	3 days	DR-ASM-PL
SINAMICS S120 Designing and Engineering	✓	–	–	5 days	DR-S12-PL
SINAMICS S120 Parameterizing and Commissioning	–	✓	–	5 days	DR-S12-PM
SINAMICS S120 Parameterizing Advanced	–	✓	–	5 days	DR-S12-PA
SINAMICS S120 Parameterizing Safety Integrated	–	✓	–	4 days	DR-S12-SAF
SINAMICS S120 Parameterizing and Optimization	–	✓	–	3 days	DR-S12-OPT
SINAMICS S120 Diagnostics and Service	–	–	✓	5 days	DR-S12-DG
SINAMICS S120 Diagnostics on Chassis and Cabinet Units	–	✓	✓	3 days	DR-S12-CHA
SINAMICS S120 Diagnostics PROFINET and PROFIBUS	–	✓	✓	3 days	DR-S12-NET

## Overview

### *Spares on Web – online identification of spare parts*

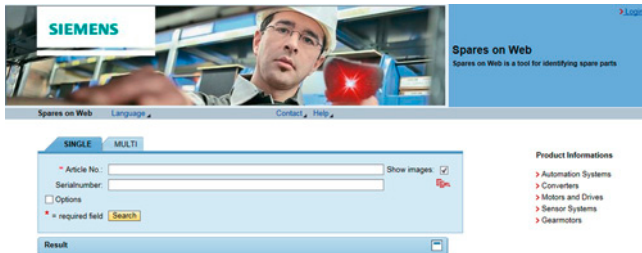

© Siemens AG 2014 | [About Us](#) | [Privacy Policy](#) | [Term of Use](#) | [Digital ID](#) | [GDPR](#)

Spares on Web is a web-based tool for identifying spare parts. After you have entered the Article No. and serial number, the spare parts available for the relevant unit are displayed.

[www.siemens.com/sow](http://www.siemens.com/sow)

## Services and Documentation

### mySupport documentation

#### Overview

#### mySupport documentation – Compiling personal documents

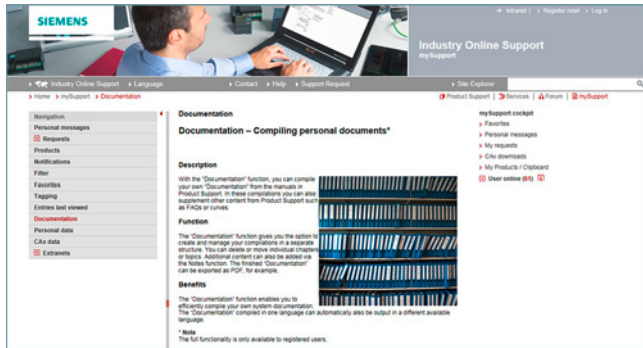

mySupport documentation is a web-based system for generating personalized documentation based on standard documents and is part of the Siemens Industry Online Support portal.

In mySupport, a personal document library can be created in the "Documentation" category. This library can be accessed online in mySupport or also be generated in various formats for offline use.

Previously, this functionality was available in the My Documentation Manager for configurable manuals. Due to the integration in mySupport, all entries of the Industry Online Support can now be imported into the personal document library, including FAQs or product notifications.

If you have already worked with the My Documentation Manager, all of the previously created libraries will continue to be available without restrictions in mySupport.

In addition, the personal library in mySupport can be shared with other mySupport users. In this way, a collection of relevant documents can be created very effectively and used together with other mySupport users all over the world.

You must register/log in for configuring and generating/managing.

#### Benefits

- Display  
View, print or download standard documents or personalized documents
- Configure  
Transfer standard documents or parts of them to personalized documents
- Generate/Manage  
Generate and manage personalized documents in the formats PDF, RTF or XML in all available languages

#### Function

##### Opening mySupport documentation in the Industry Online Support portal

- Via the product support, entry type "Manual":  
<https://support.industry.siemens.com/cs/ww/en/ps/man>  
By clicking on the required version of the manual and then "Show and configure", the manual opens in a modular view, where you can navigate from topic to topic. Here the direct link to a topic can be used and made available to other users. The selected document can be added to the personal library via "mySupport Cockpit" > "Add to mySupport documentation".
- Via the direct link  
<https://support.industry.siemens.com/my/ww/en/documentation/advanced>  
After registration/logon, the online help is displayed as the current document.

#### More information

You can find more information on the Internet at

- <https://support.industry.siemens.com/my/ww/en/documentation>
- [https://support.industry.siemens.com/cs/helpcenter/en/index.htm?#persoenliche\\_bibliothek\\_aufbauen.htm](https://support.industry.siemens.com/cs/helpcenter/en/index.htm?#persoenliche_bibliothek_aufbauen.htm)

**Overview****SINAMICS S120 Cabinet Modules and  
SINAMICS S150 Converter Cabinet Units**

The documentation is provided as standard in PDF format on CD-ROM, and comprises the following sections:

- Description
- Installation instructions
- Commissioning guide
- Function description
- Maintenance information
- Engineering manual
- Lists of spare parts
- Equipment-specific documents such as circuit diagrams, dimensional drawings, layout diagrams, and terminal diagrams

Documentation in English/German is supplied as standard with the device.

The scope of delivery also includes a DVD-ROM with the STARTER commissioning tool.

If one of the languages subsequently listed is required, when ordering this should be specified using the corresponding option order code (see [Description of options](#)):

Language	Order code
English/French	<b>D58</b>
English/Spanish	<b>D60</b>
English/Italian	<b>D80</b>
English/Chinese	<b>D91</b>
English/Portuguese (Brazil)	<b>D93</b>
English/Russian	<b>D94</b>

Configuring documents/documentation available for downloading at:

For SINAMICS S120 Cabinet Modules  
<https://support.industry.siemens.com/cs/ww/en/ps/13233/man>

For SINAMICS S150  
<https://support.industry.siemens.com/cs/ww/en/ps/13234/man>

**SINAMICS S120 Chassis Format Converter Units**

Comprehensive documentation is available for the SINAMICS S120 Chassis Format Converter Units including Operating Instructions, List Manuals and the Engineering Manual.

Information is available in the following formats:

- PDF file
- Configuring documents/documentation available for downloading at:  
<https://support.industry.siemens.com/cs/ww/en/ps/13231/man>

**Application****Explanations for the manuals:**

- **Operating Instructions**  
contain all the information needed to install the device and make electrical connections, information about commissioning and a description of the converter functions.  
Phases of use: Control cabinet construction, commissioning, operation, maintenance and servicing.
- **Manuals**  
contain all the necessary information about the intended use of the components of a system, e.g. technical data, interfaces, dimension drawings, characteristic curves and possible applications.  
Phases of use: Cabinet configuration/setup, circuit diagram configuration/drawing.
- **Engineering Manuals**  
contain all the information needed for EMC-compliant installation and for the configuration of control cabinets and drive systems.  
Phases of use: Control cabinet configuration/construction.
- **List Manuals**  
describe all parameters, function diagrams and faults/alarms for the product/system as well as their meaning and setting options. It contains parameter data and fault/warning descriptions with functional correlations.  
Phases of use: Commissioning of components that have already been connected, configuration of system functions, fault cause/diagnostics.
- **Function Manuals**  
contain all the relevant information about individual drive functions.  
Phases of use: Commissioning of components that have already been connected, configuration of system functions.

## Services and Documentation

### Notes

## Appendix



8/2	<b>Certificates of suitability (approvals)</b>
8/4	<b>Software licenses</b>
8/6	<b>Subject index</b>
8/9	<b>Conversion tables</b>
8/11	<b>Conditions of sale and delivery</b>

## Appendix

### Certificates of suitability (approvals)







#### Overview

Many of the products in this Catalog fulfill requirements, e.g. for UL, CSA or FM and are labeled with the corresponding approval designation.

All of the certificates of suitability, approvals, certificates, declarations of conformity, test certificates, e.g. CE, UL, Safety Integrated etc. have been performed with the associated system components as they are described in the Catalogs and Configuration Manuals.

The certificates are only valid if the products are used with the described system components, are installed according to the Installation Guidelines and used for their intended purpose.

In other cases, the vendor of these products is responsible for arranging for the issue of new certificates.

Test code	Tested by	Device series/ component	Test standard	Product category/ File-No.
<b>UL: Underwriters Laboratories</b> <i>Independent public testing body in North America</i>				
	UL according to UL standard	SINUMERIK	Standard UL 508, CSA C22.2 No. 142	NRAQ/7.E164110 NRAQ/7.E217227
		SIMOTION	Standard UL 508, CSA C22.2 No. 142	NRAQ/7.E164110
	UL according to CSA standard	SINAMICS	Standard UL 508, 508C, 61800-5-1 CSA C22.2 No. 142, 274	NRAQ/7.E164110, NMMS/2/7/8.E192450, NMMS/7.E203250, NMMS/7.E214113, NMMS/7.E253831
	UL according to UL and CSA standards			NMMS/2/7/8.E121068 NMMS/7.E355661 NMMS/7.E323473
	UL according to UL standard	SIMODRIVE	Standard UL 508C, CSA C22.2 No. 274	NMMS/2/7/8.E192450 NMMS/7.E214113
	UL according to CSA standard	Motors	Standard UL 1004-1, 1004-6, 1004-8, CSA C22.2 No. 100	PRGY2/8.E227215 PRHZ2/8.E93429 PRHJ2/8.E342747 PRGY2/8.E253922 PRHZ2/8.E342746
	UL according to UL and CSA standards			
		Line/motor reactors	Standard UL 508, 506, 5085-1, 5085-2, 1561, CSA C22.2 No. 14, 47, 66.1-06, 66.2-06	XQNX2/8.E257859 NMTR2/8.E219022 NMMS2/8.E333628 XPTQ2/8.E257852 XPTQ2/8.E103521 NMMS2/8.E224872 XPTQ2/8.E354316 XPTQ2/8.E198309 XQNX2/8.E475972
		Line filters, dv/dt filters, sine-wave filters	UL 1283, CSA C22.2 No. 8	FOKY2/8.E70122
		Resistors	UL 508, 508C, CSA C22.2 No. 14, 274	NMTR2/8.E224314 NMMS2/8.E192450 NMTR2/8.E221095 NMTR2/8.E226619
<b>TUV: TÜV Rheinland of North America Inc.</b> <i>Independent public testing body in North America, Nationally Recognized Testing Laboratory (NRTL)</i>				
<b>TÜV: TÜV SÜD Product Service</b> <i>Independent public testing body in Germany, Nationally Recognized Testing Laboratory (NRTL) for North America</i>				
	TUV according to UL and CSA standards	SINAMICS	NRTL listing according to standard UL 508C	U7V 12 06 20078 013 U7 11 04 20078 009 U7 11 04 20078 010 U7 11 04 20078 011
		SIMOTION	NRTL listing according to standard UL 508	U7V 13 03 20078 01
		SIMODRIVE	NRTL listing according to standard UL 508C, CSA C22.2. No. 14	CU 72090702
		Motion Control Encoder	NRTL listing according to UL 61010-1 CSA C22.2 No. 61010-1	U8V 10 06 20196 024

## Certificates of suitability (approvals)

## Overview (continued)

Test code	Tested by	Device series/ component	Test standard	Product category/ File-No.
<b>CSA: Canadian Standards Association</b> <i>Independent public testing body in Canada</i>				
	CSA according to CSA standard	SINUMERIK	Standard CSA C22.2 No. 142	2252-01 : LR 102527
<b>FMRC: Factory Mutual Research Corporation</b> <i>Independent public testing body in North America</i>				
	FM according to FM standard	SINUMERIK	Standard FMRC 3600, FMRC 3611, FMRC 3810, ANSI/ISA S82.02.1	–
<b>EAC: Ivanovo-Certificate</b> <i>Independent public testing body in the Russian Federation</i>				
	EAC in accordance with the EAC Directive	SINAMICS SINUMERIK SIMOTION	Standard IEC 61800-5-1/-2, IEC 61800-3	–
<b>RCM: Australian Communications and Media Authority</b> <i>Independent public testing body in Australia</i>				
	RCM according to EMC standard	SINAMICS SINUMERIK SIMOTION	Standard IEC AS 61800-3, EN 61800-3	–
<b>KC: National Radio Research Agency</b> <i>Independent public testing body in South Korea</i>				
	KC according to EMC standard	SINAMICS SINUMERIK SIMOTION	Standard KN 11	–
<b>BIA</b> <i>Federal Institute for Occupational Safety</i>				
–	Functional safety	SINAMICS SINUMERIK SIMOTION	Standard EN 61800-5-2	–
<b>TÜV SÜD Rail</b>				
–	Functional safety	SINAMICS SINUMERIK SIMOTION	Standard EN 61800-5-2	–

More information about certificates can be found online at:  
<https://support.industry.siemens.com/cs/ww/en/ps/cert>



## Appendix

### Software licenses

#### Overview

##### Software types

Software requiring a license is categorized into types. The following software types have been defined:

- Engineering software
- Runtime software

##### Engineering software

This includes all software products for creating (engineering) user software, e.g. for configuring, programming, parameterizing, testing, commissioning or servicing.

Data generated with engineering software and executable programs can be duplicated for your own use or for use by third parties free-of-charge.

##### Runtime software

This includes all software products required for plant/machine operation, e.g. operating system, basic system, system expansions, drivers, etc.

The duplication of the runtime software and executable programs created with the runtime software for your own use or for use by third-parties is subject to a charge.

You can find information about license fees according to use in the ordering data (e.g. in the catalog). Examples of categories of use include per CPU, per installation, per channel, per instance, per axis, per control loop, per variable, etc.

Information about extended rights of use for parameterization/configuration tools supplied as integral components of the scope of delivery can be found in the readme file supplied with the relevant product(s).

##### License types

Siemens Industry Automation & Drive Technologies offers various types of software license:

- Floating license
- Single license
- Rental license
- Rental floating license
- Trial license
- Demo license
- Demo floating license

##### Floating license

The software may be installed for internal use on any number of devices by the licensee. Only the concurrent user is licensed. The concurrent user is the person using the program. Use begins when the software is started. A license is required for each concurrent user.

##### Single license

Unlike the floating license, a single license permits only one installation of the software per license.

The type of use licensed is specified in the ordering data and in the Certificate of License (CoL). Types of use include for example per instance, per axis, per channel, etc.

One single license is required for each type of use defined.

##### Rental license

A rental license supports the "sporadic use" of engineering software. Once the license key has been installed, the software can be used for a specific period of time (the operating hours do not have to be consecutive).

One license is required for each installation of the software.

##### Rental floating license

The rental floating license corresponds to the rental license, except that a license is not required for each installation of the software. Rather, one license is required per object (for example, user or device).

##### Trial license

A trial license supports "short-term use" of the software in a non-productive context, e.g. for testing and evaluation purposes. It can be transferred to another license.

##### Demo license

The demo license support the "sporadic use" of engineering software in a non-productive context, for example, use for testing and evaluation purposes. It can be transferred to another license. After the installation of the license key, the software can be operated for a specific period of time, whereby usage can be interrupted as often as required.

One license is required per installation of the software.

##### Demo floating license

The demo floating license corresponds to the demo license, except that a license is not required for each installation of the software. Rather, one license is required per object (for example, user or device).

##### Certificate of License (CoL)

The CoL is the licensee's proof that the use of the software has been licensed by Siemens. A CoL is required for every type of use and must be kept in a safe place.

##### Downgrading

The licensee is permitted to use the software or an earlier version/release of the software, provided that the licensee owns such a version/release and its use is technically feasible.

##### Delivery versions

Software is constantly being updated. The following delivery versions

- PowerPack
- Upgrade

can be used to access updates.

Existing bug fixes are supplied with the ServicePack version.

##### PowerPack

PowerPacks can be used to upgrade to more powerful software. The licensee receives a new license agreement and CoL (Certificate of License) with the PowerPack. This CoL, together with the CoL for the original product, proves that the new software is licensed.

A separate PowerPack must be purchased for each original license of the software to be replaced.

##### Upgrade

An upgrade permits the use of a new version of the software on the condition that a license for a previous version of the product is already held.

The licensee receives a new license agreement and CoL with the upgrade. This CoL, together with the CoL for the previous product, proves that the new version is licensed.

A separate upgrade must be purchased for each original license of the software to be upgraded.

## Overview

### *ServicePack*

ServicePacks are used to debug existing products. ServicePacks may be duplicated for use as prescribed according to the number of existing original licenses.

### *License key*

Siemens Industry Automation & Drive Technologies supplies software products with and without license keys.

The license key serves as an electronic license stamp and is also the "switch" for activating the software (floating license, rental license, etc.).

The complete installation of software products requiring license keys includes the program to be licensed (the software) and the license key (which represents the license).

### *Software Update Service (SUS)*

As part of the SUS contract, all software updates for the respective product are made available to you free of charge for a period of one year from the invoice date. The contract will automatically be extended for one year if it is not canceled three months before it expires.

The possession of the current version of the respective software is a basic condition for entering into an SUS contract.

You can download explanations concerning license conditions from [www.siemens.com/automation/salesmaterial-as/catalog/en/terms\\_of\\_trade\\_en.pdf](http://www.siemens.com/automation/salesmaterial-as/catalog/en/terms_of_trade_en.pdf)

# Appendix

## Subject index

	Page		Page	
<b>A</b>				
Active Interface Modules .....	4/31	CA 01 .....	6/3	
• Chassis format, air-cooled units .....	3/30	Cable cross-sections and connections .....	5/37	
• Chassis format, liquid-cooled units .....	3/75	CANopen .....	2/24	
• Chassis format, water-cooled units .....	3/103	CBC10 Communication Board .....	3/184, 4/101, 5/25	
Active Line Connection Modules .....	4/72	CBE20 Communication Board .....	3/185, 4/101, 5/25	
Active Line Modules		Central Braking Modules .....	4/48	
• Cabinet Modules, Active Line Modules incl. Active Interface Modules .....	4/31	Certificates of suitability .....	8/2	
• Chassis format, air-cooled units .....	3/25	Communication .....	2/15	
• Chassis format, liquid-cooled units .....	3/71	Communication overview .....	2/15	
• Chassis format, water-cooled units .....	3/104	CompactFlash card		
Advanced Operator Panel AOP30 .....	3/182, 4/103, 5/6	• for CU310-2 .....	3/180	
Air-cooled units		• for CU320-2 .....	3/174	
• SINAMICS S120 Cabinet Modules .....	4/8	Conditions of delivery .....	8/12	
• SINAMICS S120 chassis format converter units .....	3/6	Conditions of sale and delivery .....	8/12	
AOP30 Advanced Operator Panel .....	3/182, 4/103, 5/6	Configuring information .....	6/13	
Applications .....	1/6	Configuring with EPLAN .....	6/11	
Approvals .....	8/2	Connection system .....	3/215	
Auxiliary Power Supply Modules		Consulting Services .....	7/6	
• Cabinet Modules, air-cooled units .....	4/52	Control Units .....	3/158	
• Cabinet Modules, liquid-cooled units .....	4/84	• CU310-2 .....	3/176	
<b>B</b>				
Basic Functions .....	2/9	• CU320-2 .....	3/170	
Basic Line Connection Modules .....	4/68	Converter selection .....	1/7	
Basic Line Modules		Cooling circuit and coolant quality		
• Cabinet Modules, air-cooled units .....	4/52	• Cabinet Modules, liquid-cooled units .....	4/62	
• Chassis format, air-cooled units .....	3/15	• Chassis format, liquid-cooled units .....	3/57	
• Chassis format, liquid-cooled units .....	3/67	• Chassis format, water-cooled units .....	3/94	
BOP20 Basic Operator Panel .....	3/181	Customer terminal block -X55 .....	4/55	
Braking Modules .....	3/143	Customized solutions .....	4/117	
Braking resistors .....	3/147	<b>D</b>		
DC link components .....				3/143
DC link fuses .....				3/149
Derating data .....				3/8, 3/60, 3/96, 4/12, 4/14, 4/65, 5/15
Description of the options .....				4/100, 5/22
Documentation .....				7/15
Download center .....				7/4
Drive Control Chart (SINAMICS DCC) .....				6/8
Drive ES .....				6/9
Drive ES Engineering Software .....				6/9
Drive Technology Configurator .....				6/3
DRIVE-CLiQ Hub Module				
• DMC20 .....				3/186
• DME20 .....				3/188
DRIVE-CLiQ signal cables .....				3/215
dv/dt filters compact plus VPL .....				3/160
dv/dt filters plus VPL .....				3/155

	Page		Page
<b>E</b>			
Encoder system connection .....	3/211		
Energy efficiency .....	1/3		
Engineering Manual .....	6/17		
EPLAN .....	6/11		
EtherNet/IP .....	2/24		
Extended Functions .....	2/9		
Extended liability for defects .....	7/9		
Extension of liability for defects .....	7/9		
<b>F</b>			
Field Services .....	7/7		
Filters			
• dv/dt filters compact plus VPL .....	3/160		
• dv/dt filters plus VPL .....	3/155		
• Line filters .....	3/129		
• Sine-wave filters .....	3/165		
<b>H</b>			
Heat Exchanger Modules .....	4/87		
<b>I</b>			
Identification of spare parts on the Internet .....	7/13		
Industrial Ethernet .....	2/23		
Industry Services .....	7/5		
Information and Download Center, Social Media, Mobile Media .....	7/4		
Information and ordering options on the Internet and on DVD .....	7/3		
Integrated Drive Systems .....	2		
Integration in automation .....	1/2		
Interactive Catalog CA 01 .....	6/3		
<b>L</b>			
Line Connection Modules .....	4/15		
Line filters .....	3/129		
Line reactors .....	3/133		
Line-side components - Recommended fuses .....	5/36		
Line-side power components .....	3/128		
Line-side system components .....	3/137		
Liquid-cooled units			
• SINAMICS S120 Cabinet Modules .....	4/58		
• SINAMICS S120 chassis format converter units .....	3/54		
<b>M</b>			
Maintenance Services .....	7/7		
Metal surcharges .....	8/9		
Mobile Media .....	7/4		
Modbus TCP .....	2/24		
Modernization Services .....	7/7		
MOTION-CONNECT signal cables .....	3/215		
Motor Modules			
• Cabinet Modules, air-cooled units booksize .....	4/37		
• Cabinet Modules, air-cooled units chassis .....	4/41		
• Cabinet Modules, liquid-cooled units .....	4/76		
• Chassis format, air-cooled units .....	3/36		
• Chassis format, liquid-cooled units .....	3/80		
• Chassis format, water-cooled units .....	3/114		
Motor reactors .....	3/151		
Motors, SIMOTICS .....	1/8		
Motor-side components .....	3/151		
Mounting device			
• for liquid-cooled power units .....	3/90, 4/115		
• for power blocks .....	3/53, 4/115, 5/39		
• for water-cooled power units .....	3/127		
mySupport documentation .....	7/14		
<b>O</b>			
Online Services .....	7/3		
Online Support .....	7/8		
Option selection matrix .....	4/98, 5/19		
Options .....	4/92, 5/18		
Ordering options on the Internet and on DVD .....	7/3		
Order-specific integration engineering .....	4/116		
Overload capability .....	3/10, 3/62, 3/99, 4/14, 4/67, 5/17		
Overview of Safety Integrated functions .....	2/14		
<b>P</b>			
Partners at Siemens .....	7/2		
Plant Data Services .....	7/6		
Platform concept .....	1/4		
Power Modules			
• Chassis format, air-cooled units .....	3/11		
• Chassis format, liquid-cooled units .....	3/63		
• Chassis format, water-cooled units .....	3/100		
PROFIBUS .....	2/22		
PROFIdrive .....	2/21		
PROFINET .....	2/16		

# Appendix

## Subject index

	Page		Page
<b>Q</b>			
Quality management according to EN ISO 9001 .....	1/4		
<b>R</b>			
Reactors			
• Line reactors.....	3/133		
• Motor reactors .....	3/151		
Recommended line-side system components .....	3/137		
Repair Services.....	7/7		
Retrofit Services.....	7/7		
<b>S</b>			
Safe actual value sensing with or without encoders.....	2/10		
Safe Brake Adapter SBA .....	3/209		
Safe Brake Control (SBC) .....	2/5		
Safe Brake Test (SBT) .....	2/6		
Safe Direction (SDI) .....	2/7		
Safe Operating Stop (SOS).....	2/5		
Safe Position (SP) .....	2/8		
Safe Speed Monitor (SSM) .....	2/7		
Safe Stop 1 (SS1).....	2/4		
Safe Stop 2 (SS2).....	2/4		
Safe Torque Off (STO).....	2/3		
Safely-Limited Position (SLP).....	2/8		
Safely-Limited Speed (SLS).....	2/6		
Safety Integrated .....	2/2		
Security information .....	6/1		
Selection guide, SINAMICS .....	1/7		
Sensor Module Cabinet-Mounted			
• SMC10.....	3/212		
• SMC20.....	3/213		
• SMC30.....	3/214		
Service & Support.....	7/9		
Service Programs and Agreements.....	7/7		
Signal cables .....	3/215		
SIMOTICS motors .....	1/8		
SINAMICS Drive Control Chart (SINAMICS DCC) .....	6/8		
SINAMICS drive family.....	1/2		
SINAMICS S120 Cabinet Modules			
• Air-cooled units.....	4/8		
• Liquid-cooled units.....	4/58		
SINAMICS S120 chassis format converter units			
• Air-cooled units.....	3/6		
• Liquid-cooled units.....	3/55		
• Water-cooled units.....	3/91		
SINAMICS S150 converter cabinet units .....	5/1		
SINAMICS selection guide .....	1/7		
SinaSave energy efficiency tool.....	6/2		
Sine-wave filters.....	3/165		
SITRAIN .....	7/11		
SIZER for Siemens Drives engineering tool.....	6/4		
SIZER WEB ENGINEERING engineering tool.....	6/5		
Smart Line Modules			
• Cabinet Modules, air-cooled units.....	4/27		
• Chassis format, air-cooled units .....	3/20		
<b>S (continued)</b>			
Social Media.....	7/4		
Software licenses.....	8/4		
Spare Parts Services .....	7/6		
SPARES on Web.....	7/13		
STARTER commissioning tool .....	6/6		
Supplementary system components.....	3/172, 4/115, 5/39		
Support app .....	7/8		
Support Services .....	7/6		
System components.....	3/128		
System overview			
• SINAMICS S120 Cabinet Modules.....	4/2		
• SINAMICS S120 chassis format converter units.....	3/2		
<b>T</b>			
TB30 Terminal Board .....	3/190		
Terminal Module			
• TM120 .....	3/203		
• TM15 .....	3/192		
• TM150 .....	3/205		
• TM31 .....	3/194		
• TM41 .....	3/197		
• TM54F .....	3/200		
The SINAMICS drive family .....	1/2		
Totally Integrated Automation and communication .....	1/2		
Training .....	7/6, 7/11		
Training courses .....	7/12		
<b>U</b>			
USS.....	2/24		
<b>V</b>			
VSM10 Voltage Sensing Module .....	3/207		
<b>W</b>			
Water-cooled units			
SINAMICS S120 chassis format converter units .....	3/91		

## Conversion tables

**Rotary inertia** (to convert from A to B, multiply by entry in table)

A	B	lb-in <sup>2</sup>	lb-ft <sup>2</sup>	lb-in-s <sup>2</sup>	lb-ft-s <sup>2</sup> slug-ft <sup>2</sup>	kg-cm <sup>2</sup>	kg-cm-s <sup>2</sup>	gm-cm <sup>2</sup>	gm-cm-s <sup>2</sup>	oz-in <sup>2</sup>	oz-in-s <sup>2</sup>
lb-in <sup>2</sup>	1		$6.94 \times 10^{-3}$	$2.59 \times 10^{-3}$	$2.15 \times 10^{-4}$	2.926	$2.98 \times 10^{-3}$	$2.92 \times 10^3$	2.984	16	$4.14 \times 10^{-2}$
lb-ft <sup>2</sup>	144	1		0.3729	$3.10 \times 10^{-2}$	421.40	0.4297	$4.21 \times 10^5$	429.71	2304	5.967
lb-in-s <sup>2</sup>	386.08	2.681	1		$8.33 \times 10^{-2}$	$1.129 \times 10^3$	1.152	$1.129 \times 10^6$	$1.152 \times 10^3$	$6.177 \times 10^3$	16
lb-ft-s <sup>2</sup> slug-ft <sup>2</sup>	$4.63 \times 10^3$	32.17	12	1		$1.35 \times 10^4$	13.825	$1.355 \times 10^7$	$1.38 \times 10^4$	$7.41 \times 10^4$	192
kg-cm <sup>2</sup>	0.3417	$2.37 \times 10^{-3}$	$8.85 \times 10^{-4}$	$7.37 \times 10^{-5}$	1		$1.019 \times 10^{-3}$	1000	1.019	5.46	$1.41 \times 10^{-2}$
kg-cm-s <sup>2</sup>	335.1	2.327	0.8679	$7.23 \times 10^{-2}$	980.66	1		$9.8 \times 10^5$	1000	$5.36 \times 10^3$	13.887
gm-cm <sup>2</sup>	$3.417 \times 10^{-4}$	$2.37 \times 10^{-6}$	$8.85 \times 10^{-7}$	$7.37 \times 10^{-8}$	$1 \times 10^{-3}$		$1.01 \times 10^{-6}$	1	$1.01 \times 10^{-3}$	$5.46 \times 10^{-3}$	$1.41 \times 10^{-5}$
gm-cm-s <sup>2</sup>	0.335	$2.32 \times 10^{-3}$	$8.67 \times 10^{-4}$	$7.23 \times 10^{-5}$	0.9806	$1 \times 10^{-3}$		980.6	1	5.36	$1.38 \times 10^{-2}$
oz-in <sup>2</sup>	0.0625	$4.34 \times 10^{-4}$	$1.61 \times 10^{-4}$	$1.34 \times 10^{-5}$	0.182	$1.86 \times 10^{-4}$		182.9	0.186	1	$2.59 \times 10^{-3}$
oz-in-s <sup>2</sup>	24.13	0.1675	$6.25 \times 10^{-2}$	$5.20 \times 10^{-3}$	70.615	$7.20 \times 10^{-2}$		$7.09 \times 10^4$	72.0	386.08	1

**Torque** (to convert from A to B, multiply by entry in table)

A	B	lb-in	lb-ft	oz-in	N-m	kg-cm	kg-m	gm-cm	dyne-cm
lb-in	1		$8.333 \times 10^{-2}$	16	0.113	1.152	$1.152 \times 10^{-2}$	$1.152 \times 10^3$	$1.129 \times 10^6$
lb-ft	12	1		192	1.355	13.825	0.138	$1.382 \times 10^4$	$1.355 \times 10^7$
oz-in	$6.25 \times 10^{-2}$	$5.208 \times 10^{-3}$	1		$7.061 \times 10^{-3}$	$7.200 \times 10^{-2}$	$7.200 \times 10^{-4}$	72.007	$7.061 \times 10^4$
N-m	8.850	0.737	141.612	1		10.197	0.102	$1.019 \times 10^4$	$1 \times 10^7$
kg-cm	0.8679	$7.233 \times 10^{-2}$	13.877	$9.806 \times 10^{-2}$	1		$10^{-2}$	1000	$9.806 \times 10^5$
kg-m	86.796	7.233	$1.388 \times 10^3$	9.806	100	1		$1 \times 10^5$	$9.806 \times 10^7$
gm-cm	$8.679 \times 10^{-4}$	$7.233 \times 10^{-5}$	$1.388 \times 10^{-2}$	$9.806 \times 10^{-5}$	$1 \times 10^{-3}$	$1 \times 10^{-5}$		1	980.665
dyne-cm	$8.850 \times 10^{-7}$	$7.375 \times 10^{-8}$	$1.416 \times 10^{-5}$	$10^{-7}$	$1.0197 \times 10^{-6}$	$1.019 \times 10^{-8}$		$1.019 \times 10^{-3}$	1

**Length** (to convert from A to B, multiply by entry in table)

A	B	inches	feet	cm	yd	mm	m
inches	1		0.0833	2.54	0.028	25.4	0.0254
feet	12	1		30.48	0.333	304.8	0.3048
cm	0.3937	0.03281	1		$1.09 \times 10^{-2}$	10	0.01
yd	36	3	91.44	1		914.4	0.914
mm	0.03937	0.00328	0.1	$1.09 \times 10^{-3}$	1		0.001
m	39.37	3.281	100	1.09	1000	1	

**Force** (to convert from A to B, multiply by entry in table)

A	B	lb	oz	gm	dyne	N
lb	1		16	453.6	$4.448 \times 10^5$	4.4482
oz	0.0625	1		28.35	$2.780 \times 10^4$	0.27801
gm	$2.205 \times 10^{-3}$	0.03527	1		$1.02 \times 10^{-3}$	N.A.
dyne	$2.248 \times 10^{-6}$	$3.59 \times 10^{-5}$	980.7	1		0.00001
N	0.22481	3.5967	N.A.	100000	1	

**Power** (to convert from A to B, multiply by entry in table)

A	B	hp	Watts
hp (English)	1		745.7
(lb-in) (deg./s)	$2.645 \times 10^{-6}$		$1.972 \times 10^{-3}$
(lb-in) (rpm)	$1.587 \times 10^{-5}$		$1.183 \times 10^{-2}$
(lb-ft) (deg./s)	$3.173 \times 10^{-5}$		$2.366 \times 10^{-2}$
(lb-ft) (rpm)	$1.904 \times 10^{-4}$		0.1420
Watts	$1.341 \times 10^{-3}$		1

**Mass** (to convert from A to B, multiply by entry in table)

A	B	lb	oz	gm	kg	slug
lb	1		16	453.6	0.4536	0.0311
oz	$6.25 \times 10^{-2}$	1		28.35	0.02835	$1.93 \times 10^{-3}$
gm	$2.205 \times 10^{-3}$	$3.527 \times 10^{-2}$	1		$10^{-3}$	$6.852 \times 10^{-5}$
kg	2.205	35.27	$10^3$	1		$6.852 \times 10^{-2}$
slug	32.17	514.8	$1.459 \times 10^4$	14.59	1	

**Rotation** (to convert from A to B, multiply by entry in table)

A	B	rpm	rad/s	degrees/s
rpm	1		0.105	6.0
rad/s	9.55	1		57.30
degrees/s	0.167	$1.745 \times 10^{-2}$	1	

## Appendix

### Conversion tables

#### Temperature Conversion

°F	°C	°C	°F
0	-17.8	-10	14
32	0	0	32
50	10	10	50
70	21.1	20	68
90	32.2	30	86
98.4	37	37	98.4
212	100	100	212
subtract 32 and multiply by $\frac{5}{9}$		multiply by $\frac{9}{5}$ and add 32	

#### Mechanism Efficiencies

Acme-screw with brass nut	~0.35–0.65
Acme-screw with plastic nut	~0.50–0.85
Ball-screw	~0.85–0.95
Chain and sprocket	~0.95–0.98
Preloaded ball-screw	~0.75–0.85
Spur or bevel-gears	~0.90
Timing belts	~0.96–0.98
Worm gears	~0.45–0.85
Helical gear (1 reduction)	~0.92

#### Friction Coefficients

Materials	$\mu$
Steel on steel (greased)	~0.15
Plastic on steel	~0.15–0.25
Copper on steel	~0.30
Brass on steel	~0.35
Aluminum on steel	~0.45
Steel on steel	~0.58
Mechanism	$\mu$
Ball bushings	<0.001
Linear bearings	<0.001
Dove-tail slides	~0.2++
Gibb ways	~0.5++

#### Material Densities

Material	lb-in <sup>3</sup>	gm-cm <sup>3</sup>
Aluminum	0.096	2.66
Brass	0.299	8.30
Bronze	0.295	8.17
Copper	0.322	8.91
Hard wood	0.029	0.80
Soft wood	0.018	0.48
Plastic	0.040	1.11
Glass	0.079–0.090	2.2–2.5
Titanium	0.163	4.51
Paper	0.025–0.043	0.7–1.2
Polyvinyl chloride	0.047–0.050	1.3–1.4
Rubber	0.033–0.036	0.92–0.99
Silicone rubber, without filler	0.043	1.2
Cast iron, gray	0.274	7.6
Steel	0.280	7.75

#### Wire Gauges<sup>1)</sup>

Cross-section mm <sup>2</sup>	Standard Wire Gauge (SWG)	American Wire Gauge (AWG)
0.2	25	24
0.3	23	22
0.5	21	20
0.75	20	19
1.0	19	18
1.5	17	16
2.5	15	13
4	13	11
6	12	9
10	9	7
16	7	6
25	5	3
35	3	2
50	0	1/0
70	000	2/0
95	00000	3/0
120	0000000	4/0
150	–	6/0
185	–	7/0

<sup>1)</sup> The table shows approximate SWG/AWG sizes nearest to standard metric sizes; the cross-sections do not match exactly.

## 1. General Provisions

By using this catalog you can acquire hardware and software products described therein from Siemens AG subject to the following Terms and Conditions of Sale and Delivery (hereinafter referred to as "T&C"). Please note that the scope, the quality and the conditions for supplies and services, including software products, by any Siemens entity having a registered office outside Germany, shall be subject exclusively to the General Terms and Conditions of the respective Siemens entity. The following T&C apply exclusively for orders placed with Siemens Aktiengesellschaft, Germany.

### 1.1 For customers with a seat or registered office in Germany

For customers with a seat or registered office in Germany, the following applies subordinate to the T&C:

- the "General Terms of Payment"<sup>1)</sup> and,
- for software products, the "General License Conditions for Software Products for Automation and Drives for Customers with a Seat or Registered Office in Germany"<sup>1)</sup> and,
- for other supplies and services, the "General Conditions for the Supply of Products and Services of the Electrical and Electronics Industry"<sup>1)</sup>.

### 1.2 For customers with a seat or registered office outside Germany

For customers with a seat or registered office outside Germany, the following applies subordinate to the T&C:

- the "General Terms of Payment"<sup>1)</sup> and,
- for software products, the "General License Conditions for Software Products for Automation and Drives for Customers with a Seat or Registered Office outside of Germany"<sup>1)</sup> and
- for other supplies and/or services, the "General Conditions for Supplies of Siemens Industry for Customers with a Seat or Registered Office outside of Germany"<sup>1)</sup>.

## 2. Prices

The prices are in € (Euro) ex point of delivery, exclusive of packaging.

The sales tax (value added tax) is not included in the prices. It shall be charged separately at the respective rate according to the applicable statutory legal regulations.

Prices are subject to change without prior notice. We will charge the prices valid at the time of delivery.

To compensate for variations in the price of raw materials (e.g. silver, copper, aluminum, lead, gold, dysprosium and neodym), surcharges are calculated on a daily basis using the so-called metal factor for products containing these raw materials. A surcharge for the respective raw material is calculated as a supplement to the price of a product if the basic official price of the raw material in question is exceeded.

The metal factor of a product indicates the basic official price (for those raw materials concerned) as of which the surcharges on the price of the product are applied, and with what method of calculation.

You will find a detailed explanation of the metal factor on the page headed "Metal surcharges".

To calculate the surcharge (except in the cases of dysprosium and neodym), the official price from the day prior to that on which the order was received or the release order was effected is used.

To calculate the surcharge applicable to dysprosium and neodym ("rare earths"), the corresponding three-month basic average price in the quarter prior to that in which the order was received or the release order was effected is used with a one-month buffer (details on the calculation can be found in the explanation of the metal factor).

## 3. Additional Terms and Conditions

The dimensions are in mm. In Germany, according to the German law on units in measuring technology, data in inches apply only to devices for export.

Illustrations are not binding.

Insofar as there are no remarks on the individual pages of this catalog - especially with regard to data, dimensions and weights given - these are subject to change without prior notice.

## 4. Export regulations

We shall not be obligated to fulfill any agreement if such fulfillment is prevented by any impediments arising out of national or international foreign trade or customs requirements or any embargoes and/or other sanctions.

Export of goods listed in this catalog may be subject to licensing requirements. We will indicate in the delivery details whether licenses are required under German, European and US export lists. Goods labeled with "AL" not equal to "N" are subject to European or German export authorization when being exported out of the EU. Goods labeled with "ECCN" not equal to "N" are subject to US re-export authorization.

The export indications can be viewed in advance in the description of the respective goods on the Industry Mall, our online catalog system. Only the export labels "AL" and "ECCN" indicated on order confirmations, delivery notes and invoices are authoritative.

Even without a label, or with label "AL:N" or "ECCN:N", authorization may be required i.a. due to the final disposition and intended use of goods.

If you transfer goods (hardware and/or software and/or technology as well as corresponding documentation, regardless of the mode of provision) delivered by us or works and services (including all kinds of technical support) performed by us to a third party worldwide, you must comply with all applicable national and international (re-)export control regulations.

If required for the purpose of conducting export control checks, you (upon request by us) shall promptly provide us with all information pertaining to the particular end customer, final disposition and intended use of goods delivered by us respectively works and services provided by us, as well as to any export control restrictions existing in this relation.

The products listed in this catalog may be subject to European/German and/or US export regulations. Any export requiring approval is therefore subject to authorization by the relevant authorities.

Errors excepted and subject to change without prior notice.

1) The text of the Terms and Conditions of Siemens AG can be downloaded at [www.siemens.com/automation/salesmaterial-as/catalog/en/terms\\_of\\_trade\\_en.pdf](http://www.siemens.com/automation/salesmaterial-as/catalog/en/terms_of_trade_en.pdf)



## Appendix

### Notes

Further information can be obtained from our branch offices listed at [www.siemens.com/automation-contact](http://www.siemens.com/automation-contact)

<b>Interactive Catalog on DVD</b>	<i>Catalog</i>	<b>Process Instrumentation and Analytics</b>	<i>Catalog</i>
Products for Automation and Drives	<b>CA 01</b>	<i>Digital: Field Instruments for Process Automation</i>	FI 01
<b>Building Control</b>		<i>Digital: Display Recorders SIREC D</i>	MP 20
GAMMA Building Control	ET G1	<i>Digital: SIPART Controllers and Software</i>	MP 31
<b>Drive Systems</b>		Products for Weighing Technology	WT 10
SINAMICS G130 Drive Converter Chassis Units	D 11	<i>Digital: Process Analytical Instruments</i>	AP 01
SINAMICS G150 Drive Converter Cabinet Units		<i>Digital: Process Analytics, Components for Continuous Emission Monitoring</i>	AP 11
SINAMICS GM150, SINAMICS SM150 Medium-Voltage Converters	D 12	<b>Low-Voltage Power Distribution and Electrical Installation Technology</b>	
SINAMICS PERFECT HARMONY GH180 Medium-Voltage Air-Cooled Drives (Germany Edition)	D 15.1	SENTRON · SIVACON · ALPHA Protection, Switching, Measuring and Monitoring Devices, Switchboards and Distribution Systems	LV 10
SINAMICS G180 Converters – Compact Units, Cabinet Systems, Cabinet Units Air-Cooled and Liquid-Cooled	D 18.1	Standards-Compliant Components for Photovoltaic Plants	LV 11
SINAMICS S120 Chassis Format Units and Cabinet Modules	D 21.3	Electrical Components for the Railway Industry	LV 12
SINAMICS S150 Converter Cabinet Units		Power Monitoring Made Simple	LV 14
SINAMICS S120 and SIMOTICS	D 21.4	Components for Industrial Control Panels according to UL Standards	LV 16
SINAMICS DCM DC Converter, Control Module	D 23.1	3WT Air Circuit Breakers up to 4000 A	LV 35
SINAMICS Inverters for Single-Axis Drives · Built-In Units	D 31.1	3VT Molded Case Circuit Breakers up to 1600 A	LV 36
SINAMICS Inverters for Single-Axis Drives · Distributed Inverters	D 31.2	<i>Digital: SIVACON System Cubicles, System Lighting and System Air-Conditioning</i>	LV 50
<i>Digital: SINAMICS G120P and SINAMICS G120P Cabinet pump, fan, compressor converters</i>	D 35	<i>Digital: ALPHA Distribution Systems</i>	LV 51
LOHER VARIO High Voltage Motors Flameproof, Type Series 1PS4, 1PS5, 1MV4 and 1MV5 Frame Size 355 to 1000, Power Range 80 to 7100 kW	D 83.2	ALPHA FIX Terminal Blocks	LV 52
Three-Phase Induction Motors SIMOTICS HV, SIMOTICS TN	D 84.1	SIVACON S4 Power Distribution Boards	LV 56
High Voltage Three-phase Induction Motors SIMOTICS HV Series A-compact PLUS	D 84.9	SIVACON 8PS Busbar Trunking Systems	LV 70
<i>Digital: Modular Industrial Generators SIGENTICS M</i>	D 85.1	<i>Digital: DELTA Switches and Socket Outlets</i>	ET D1
Three-Phase Induction Motors SIMOTICS HV, Series H-compact	D 86.1	Vacuum Switching Technology and Components for Medium Voltage	HG 11.01
Synchronous Motors with Permanent-Magnet Technology, HT-direct	D 86.2	<b>Motion Control</b>	
DC Motors	DA 12	SINUMERIK 840 Equipment for Machine Tools	NC 62
SIMOREG DC MASTER 6RA70 Digital Chassis Converters	DA 21.1	SINUMERIK 808 Equipment for Machine Tools	NC 81.1
SIMOREG K 6RA22 Analog Chassis Converters	DA 21.2	SINUMERIK 828 Equipment for Machine Tools	NC 82
<i>Digital: SIMOREG DC MASTER 6RM70 Digital Converter Cabinet Units</i>	DA 22	SIMOTION Equipment for Production Machines	PM 21
SIMOVERT PM Modular Converter Systems	DA 45	<i>Digital: Drive and Control Components for Cranes</i>	CR 1
MICROMASTER 420/430/440 Inverters	DA 51.2	<b>Power Supply</b>	
MICROMASTER 411/COMBIMASTER 411	DA 51.3	SITOP Power supply	KT 10.1
<b>Low-Voltage Three-Phase-Motors</b>		<b>Safety Integrated</b>	
SIMOTOCS S-1FG1 Servo geared motors	D 41	Safety Technology for Factory Automation	SI 10
SIMOTICS Low-Voltage Motors	D 81.1	<b>SIMATIC HMI / PC-based Automation</b>	
SIMOTICS FD Low-Voltage Motors	D 81.8	Human Machine Interface Systems/ PC-based Automation	ST 80/ ST PC
LOHER Low-Voltage Motors	D 83.1	<b>SIMATIC Ident</b>	
<i>Digital: MOTOX Geared Motors</i>	D 87.1	Industrial Identification Systems	ID 10
SIMOGEAR Geared Motors	MD 50.1	<b>SIMATIC Industrial Automation Systems</b>	
SIMOGEAR Electric-monorail geared motors Light-load and heavy-load applications	MD 50.8	Products for Totally Integrated Automation	ST 70
SIMOGEAR Gearboxes with adapter	MD 50.11	SIMATIC PCS 7 Process Control System System components	ST PCS 7
<b>Mechanical Driving Machines</b>		SIMATIC PCS 7 Process Control System Technology components	ST PCS 7 T
FLENDER Standard Couplings	MD 10.1	Add-ons for the SIMATIC PCS 7 Process Control System	ST PCS 7 AO
FLENDER High Performance Couplings	MD 10.2	SIMATIC S7-400 advanced controller	ST 400
FLENDER Backlash-free Couplings	MD 10.3	<b>SIMATIC NET</b>	
FLENDER SIP Standard industrial planetary gear units	MD 31.1	Industrial Communication	IK PI
		<b>SIRIUS Industrial Controls</b>	
		SIRIUS Industrial Controls	IC 10

*Digital: These catalogs are only available as a PDF.***Information and Download Center**

Digital versions of the catalogs are available on the Internet at:

[www.siemens.com/industry/infocenter](http://www.siemens.com/industry/infocenter)

There you'll find additional catalogs in other languages.

Please note the section "Downloading catalogs" on page "Online services" in the appendix of this catalog.

## Get more information

SINAMICS S120  
Chassis Format Converter Units  
and Cabinet Modules  
[www.siemens.com/sinamics-s120](http://www.siemens.com/sinamics-s120)

SINAMICS S150  
Converter Cabinet Units  
[www.siemens.com/sinamics-s150](http://www.siemens.com/sinamics-s150)

The drives family SINAMICS:  
[www.siemens.com/sinamics](http://www.siemens.com/sinamics)

Integrated Drive Systems:  
[www.siemens.com/ids](http://www.siemens.com/ids)

Partners worldwide:  
[www.siemens.com/automation/partner](http://www.siemens.com/automation/partner)

Siemens AG  
Process Industries and Drives  
Large Drives  
Postfach 47 43  
90025 NUERNBERG  
GERMANY

© Siemens AG 2017  
Subject to change without prior notice  
PDF Update 11/2017  
(Article No. E86060-K5521-A131-A6-7600)  
V6.MKKATA.LDT.111 / Dispo 18402  
KG 1017 3. AUM 468 En  
Printed in Germany

The information provided in this catalog contains merely general descriptions or characteristics of performance which in case of actual use do not always apply as described or which may change as a result of further development of the products. An obligation to provide the respective characteristics shall only exist if expressly agreed in the terms of contract. Availability and technical specifications are subject to change without notice.

All product designations may be trademarks or product names of Siemens AG or supplier companies whose use by third parties for their own purposes could violate the rights of the owners.

**Token fee: 5.00 €**

## Security information

Siemens provides products and solutions with industrial security functions that support the secure operation of plants, systems, machines and networks.

In order to protect plants, systems, machines and networks against cyber threats, it is necessary to implement – and continuously maintain – a holistic, state-of-the-art industrial security concept. Siemens' products and solutions constitute one element of such a concept.

Customers are responsible for preventing unauthorized access to their plants, systems, machines and networks. Such systems, machines and components should only be connected to an enterprise network or the internet if and to the extent such a connection is necessary and only when appropriate security measures (e.g. firewalls and/or network segmentation) are in place.

For additional information on industrial security measures that may be implemented, please visit  
<https://www.siemens.com/industrialsecurity>.

Siemens' products and solutions undergo continuous development to make them more secure. Siemens strongly recommends that product updates are applied as soon as they are available and that the latest product versions are used. Use of product versions that are no longer supported, and failure to apply the latest updates may increase customer's exposure to cyber threats.

To stay informed about product updates, subscribe to the Siemens Industrial Security RSS Feed under  
<https://www.siemens.com/industrialsecurity>.

Scan the QR code  
for product  
information

