

Industrial Communication

Catalog IK PI • 2012

















SIMATIC NET

Answers for industry.

SIEMENS

Related Catalogs

<p>SIMATIC Products for Totally Integrated Automation and Micro Automation</p> <p>E86060-K4670-A101-B3-7600</p>	<p>ST 70</p> 	<p>IEC Squirrel-Cage Motors Frame sizes 56 to 450 Power 0.06 to 1250 kW E86060-K5581-A111-A3-7600 D 81.1 E86060-K5581-E111-A1-7600 Suppl. D 81.1 E86060-K5581-A121-A3-7600 (News) D 81.1 N</p>	
<p>SIMATIC HMI / PC-based Automation Human Machine Interface Systems PC-based Automation</p> <p>E86060-K4680-A101-B8-7600</p>	<p>ST 80/ST PC</p> 	<p>SINAMICS G110/SINAMICS G120 D 11.1 Standard Inverters SINAMICS G120D Distributed Inverters</p> <p>E86060-K5511-A111-A6-7600</p>	
<p>SIMATIC SIMATIC PCS 7 Process Control System</p> <p>E86060-K4678-A111-B6-7600</p>	<p>ST PCS 7</p> 	<p>Low-Voltage Power Distribution and Electrical Installation Technology LV 10.1 SENTRON Protection, Switching, Measuring and Monitoring Devices</p> <p>E86060-K8250-A101-A1-7600</p>	
<p>Industrial Controls SIRIUS</p> <p>E86060-K1010-A101-A2-7600</p>	<p>IC 10</p> 	<p>SITOP KT 10.1 Power supply SITOP</p> <p>E86060-K2410-A111-A7-7600</p>	
<p>Motion Control SIMOTION, SINAMICS S120 and Motors for Production Machines</p> <p>E86060-K4921-A101-A2-7600</p>	<p>PM 21</p> 	<p>SITRAIN ITC Training for Automation and Industrial Solutions</p> <p>Only available in German E86060-K6850-A101-C2</p>	
<p>SINUMERIK & SINAMICS Equipment for Machine Tools</p> <p>E86060-K4461-A101-A3-7600</p>	<p>NC 61</p> 	<p>Catalog CA 01 CA 01 Products for Automation and Drives</p> <p>DVD: E86060-D4001-A510-C9-7600</p>	
<p>SIMATIC Ident Industrial Identification Systems</p> <p>E86060-K8310-A101-A7-7600</p>	<p>ID 10</p> 	<p>Industry Mall Information and Ordering Platform in the Internet:</p> <p>www.siemens.com/industrymall</p>	

SIMATIC NET

Industrial Communication

Catalog IK PI · 2012



The products and systems described in this catalog are manufactured/distributed under application of a certified quality management system in accordance with DIN EN ISO 9001 (Certified Registration No. can be found in the Appendix). The certificate is recognized by all IQNet countries.

Supersedes:
Catalog IK PI · 2009
Catalog News IK PI N · January 2010

Refer to the Industry Mall for current updates of this catalog:

www.siemens.com/industrymall

The products contained in this catalog can also be found in the Interactive Catalog CA 01.

Order No.:

E86060-D4001-A510-C9-7600

Please contact your local Siemens branch

© Siemens AG 2011

Introduction	1
PROFINET / Industrial Ethernet	2
PROFIBUS	3
SIMATIC ET 200 Distributed I/O	4
SIMATIC Ident Identification Systems	5
AS-Interface	6
IO-Link	7
Industrial Wireless Communication	8
Industrial Remote Communication	9
ECOFAS	10
Appendix	11

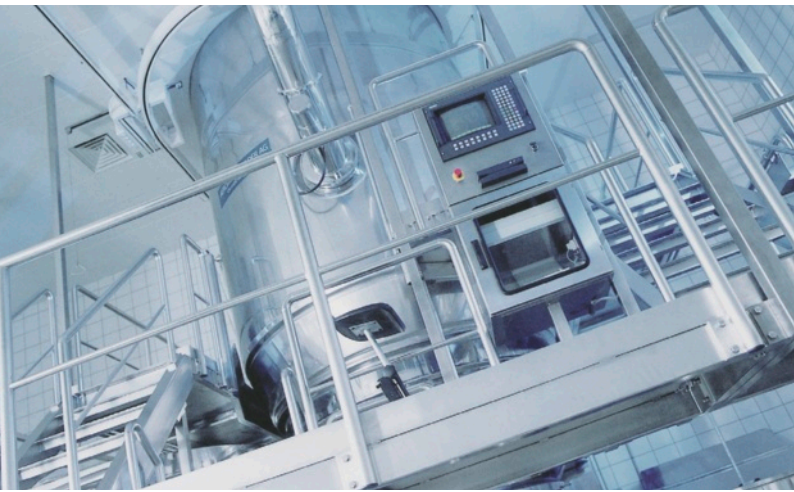

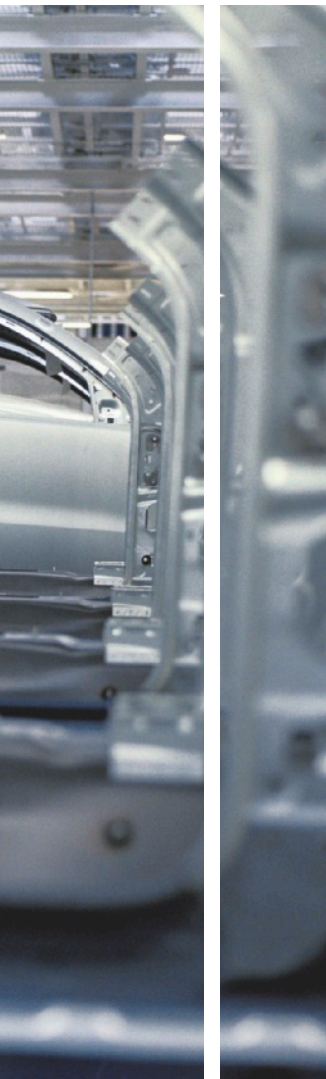

Answers for industry.

Siemens Industry answers the challenges in the manufacturing and the process industry as well as in the building automation business. Our drive and automation solutions based on Totally Integrated Automation (TIA) and Totally Integrated Power (TIP) are employed in all kinds of industry. In the manufacturing and the process industry. In industrial as well as in functional buildings.

Siemens offers automation, drive, and low-voltage switching technology as well as industrial software from standard products up to entire industry solutions. The industry software enables our industry customers to optimize the entire value chain – from product design and development through manufacture and sales up to after-sales service. Our electrical and mechanical components offer integrated technologies for the entire drive train – from couplings to gear units, from motors to control and drive solutions for all engineering industries. Our technology platform TIP offers robust solutions for power distribution.

The high quality of our products sets industry-wide benchmarks. High environmental aims are part of our eco-management, and we implement these aims consistently. Right from product design, possible effects on the environment are examined. Hence many of our products and systems are RoHS compliant (Restriction of Hazardous Substances). As a matter of course, our production sites are certified according to DIN EN ISO 14001, but to us, environmental protection also means most efficient utilization of valuable resources. The best example are our energy-efficient drives with energy savings up to 60 %.

Check out the opportunities our automation and drive solutions provide. And discover how you can sustainably enhance your competitive edge with us.

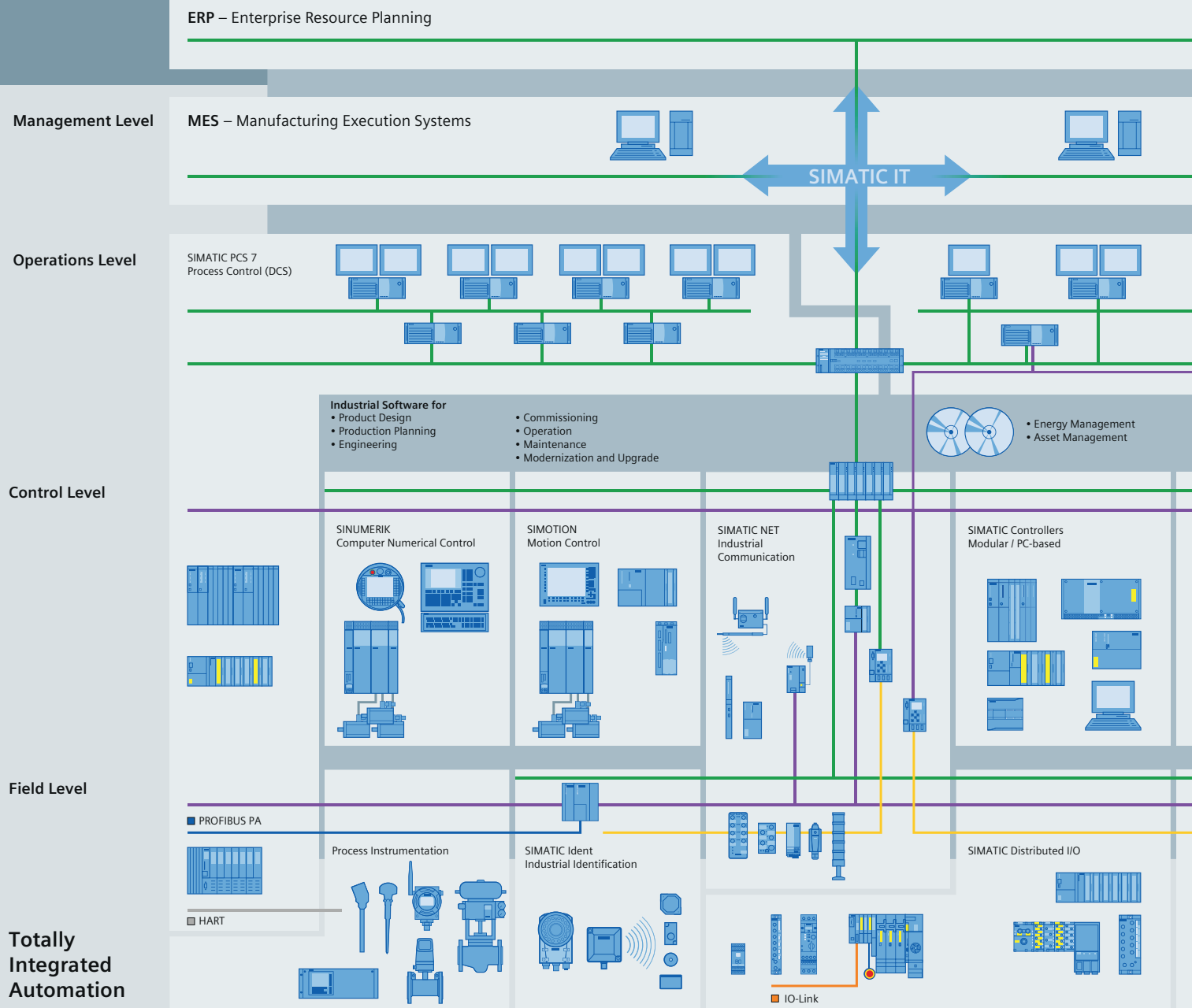

Setting standards in productivity and competitiveness.

Totally Integrated Automation.

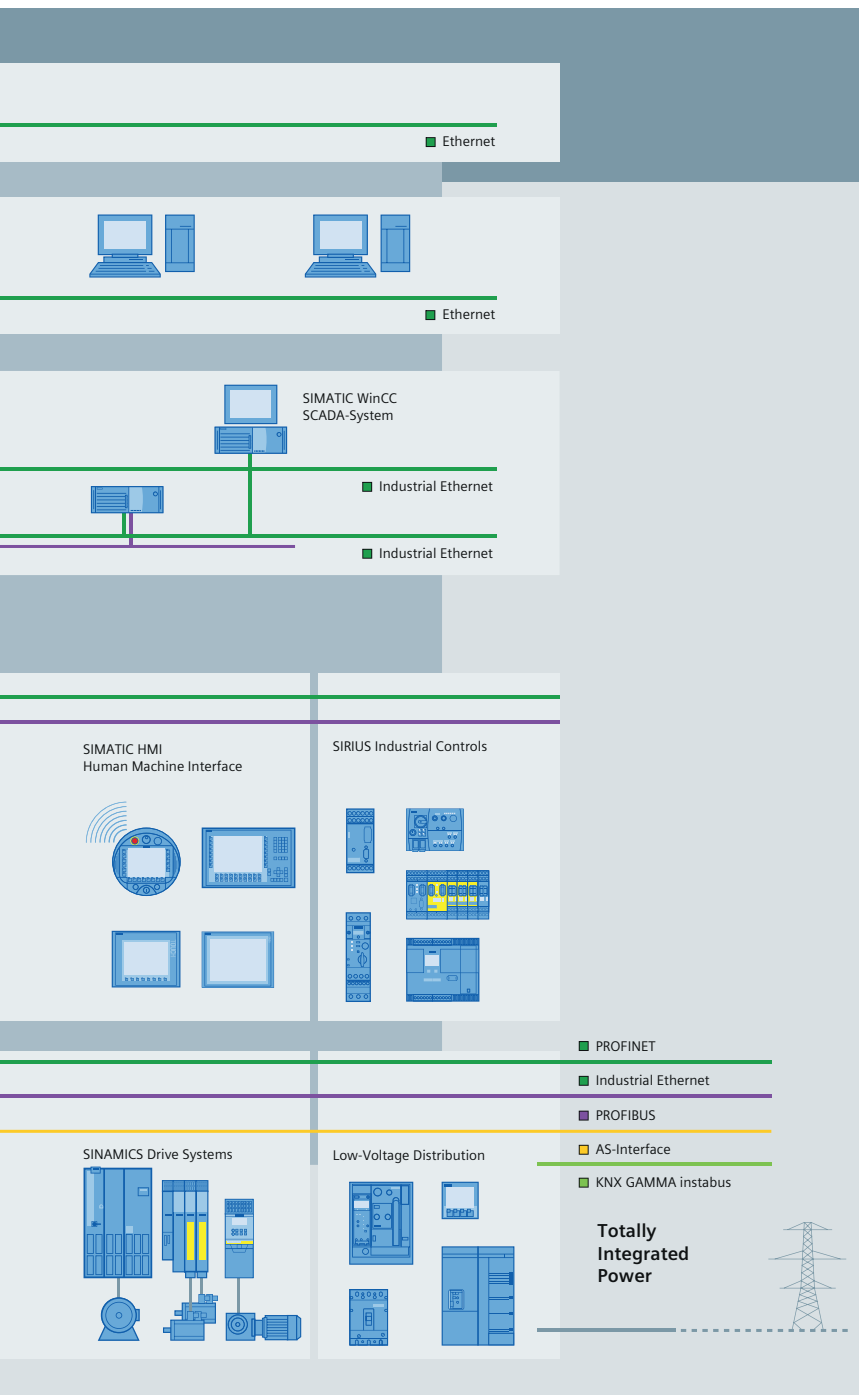

TIA is characterized by its unique continuity.

It provides maximum transparency at all levels with reduced interfacing requirements – covering the field level, production control level, up to the corporate management level. With TIA you also profit throughout the complete life cycle of your plant – starting with the initial planning steps through operation up to modernization, where we offer a high measure of investment security resulting from continuity in the further development of our products and from reducing the number of interfaces to a minimum.

The unique continuity is already a defined characteristic at the development stage of our products and systems.

The result: maximum interoperability – covering the controller, HMI, drives, up to the process control system. This reduces the complexity of the automation solution in your plant. You will experience this, for example, in the engineering phase of the automation solution in the form of reduced time requirements and cost, or during operation using the continuous diagnostics facilities of Totally Integrated Automation for increasing the availability of your plant.

Thanks to Totally Integrated Automation, Siemens provides an integrated basis for the implementation of customized automation solutions – in all industries from inbound to outbound.



Integrated power distribution from one source.

Totally Integrated Power.

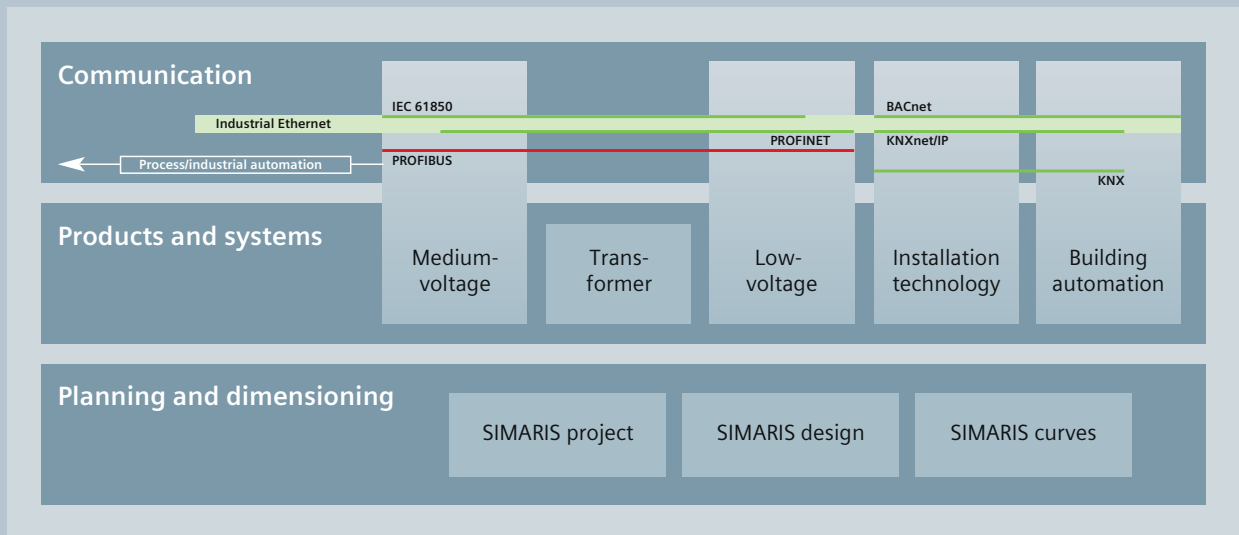

Electrical power distribution requires integrated solutions. Our answer: Totally Integrated Power (TIP). This includes tools and support for planning and configuration and a complete, optimally harmonized product and system portfolio for integrated power distribution from medium-voltage switchgear right to socket outlets.

The power distribution products and systems can be interfaced to building or industrial automation systems (as part of Total Building Solutions or Totally Integrated Automation) via communication capable circuit breakers and modules, allowing the full potential for optimization that an integrated solution offers to be exploited throughout the product cycle – from planning right through to installation and operation.

Thanks to a comprehensive energy management system, power flows can be made transparent and the energy consumption of individual loads can be calculated and allocated. Building operators can thus identify power-intensive loads and implement effective optimization measures. With its products and systems, Totally Integrated Power forms the basis for this functionality and guarantees greater cost-efficiency in industrial applications, infrastructure and buildings.



Much more than a catalog. The Industry Mall.

You have a catalog in your hands that will serve you well for selecting and ordering your products. But have you heard of the electronic online catalog (the Industry Mall) and all its benefits? Take a look around it sometime:

www.siemens.com/industrymall



Selecting

Find your products in the structure tree, in the new "Bread-crum" navigation or with the integral search machine with expert functions. Electronic configurators are also integrated into the Mall. Enter the various characteristic values and the appropriate product will be displayed with the relevant order numbers. You can save configurations, load them and reset them to their initial status.

Ordering

You can load the products that you have selected in this way into the shopping basket at a click of the mouse. You can create your own templates and you will be informed about the availability of the products in your shopping cart. You can load the completed parts lists directly into Excel or Word.

Delivery status

When you have sent the order, you will receive a short e-mail confirmation which you can print out or save. With a click on "Carrier", you will be directly connected to the website of the carrier where you can easily track the delivery status.

Added value due to additional information

So you have found your product and want more information about it? In just a few clicks of the mouse, you will arrive at the image data base, manuals and operating instructions. Create your own user documentation with My Documentation Manager. Also available are FAQs, software downloads, certificates and technical data sheets as well as our training programs. In the image database you will find, depending on the product, 2D/3D graphics, dimension drawings and exploded drawings, characteristic curves or circuit diagrams which you can download.

Convinced? We look forward to your visit!

Your requirements

Do you want to bring new products quickly onto the market? And at the same time be flexible and in a position to change your product range at short notice and shorten your time-to-market? Do you want to be able to manufacture efficiently at low costs? And at the same time optimize the capacity of your plant/machine and minimize possible downtimes?

Then all the machines in your plant should work together perfectly. Therefore, you rely upon open, integrated automation communication not just within the whole company but also for external communication. Avoid isolated automation and information technology solutions by assuring:

- Continuous flow of information from the actuator/sensor level through to the corporate management level
- Availability of information at any location
- High-speed data exchange between the different plant sections
- Easy, plant-wide configuration and efficient diagnostics
- Integrated security functions that block unauthorized access
- Fail-safe and standard communication via the same connection

Our range

Communication networks are of utmost importance for automation solutions. SIMATIC NET – Networking for Industry – stands for a diverse range of modular blocks – Designed for Industry – which contribute to efficiently solving your communications tasks:

- In the different automation areas
- Across the entire workflow
- For the complete plant life cycle
- For all industries

SIMATIC NET offers solutions which both maximize the benefits of Ethernet and simply integrate fieldbus systems. Noticeable examples are:

- The development of the field level for the use of Industrial Ethernet
- Complete integration from the field level to the corporate management level
- The implementation of new solutions by means of mobile communication
- The integration of IT technologies

Worldwide trends

Decentralization has been gaining worldwide importance for a number of years now. A distributed plant structure can reduce installation, maintenance and diagnostics costs. This involves intelligent devices working locally and being connected together across networks. Openness and flexibility are important in order to expand existing setups and to connect up different systems. For this reason, international committees define and standardize the standards for bus systems.

PROFINET/Industrial Ethernet	
Industrial Ethernet (IEEE 802.3)	- the industrial standard based on the international Ethernet standard
PROFINET (IEC 61158/61784)	- the leading Industrial Ethernet standard for automation
Industrial Wireless LAN (IEEE 802.11)	- the industrial standard for wireless communication based on the international standard
PROFIBUS	
PROFIBUS (IEC 61158/61784)	- the international standard for the field level is the global market leader among fieldbus systems
AS-Interface	
AS-Interface (IEC 62026-2/EN 50295)	- the international standard, which, as an economical alternative to the cable harness, links sensors and actuators by means of a two-wire line.
IO-Link	
IO-Link	- the standard for intelligently connecting sensors and actuators from the field level to the MES level

Introduction

Industrial communication with Totally Integrated Automation

With Totally Integrated Automation, Siemens is the only manufacturer to offer an integrated range of products and systems for automation in all sectors – from incoming goods and the production process to outgoing goods, from the field level through the production control level to connection with the corporate management level.

The advantages of Totally Integrated Automation already pay off as regards design and engineering, but also assembly and commissioning and operation and maintenance.

Automation solutions can be implemented at little cost. New scope for development allows a quicker and more flexible response to new market requirements. Systems can be easily expanded or converted without having to interrupt ongoing operations.

Due to the increased use of Industrial Ethernet in automation, two topics within Totally Integrated Automation are becoming more and more important – PROFINET and SCALANCE.

PROFINET ... for increasing the productivity of your plant

You need a seamless information flow for your strategic decisions within your company – from the first manufacturing step through operation up to the corporate management level. In order to achieve this, you rely on efficiency and transparency already during engineering.

PROFINET, the open and innovative Industrial Ethernet standard fulfills all the demands of industrial automation and ensures integrated, company-wide communication.

PROFINET also supports the direct connection of distributed field devices to Industrial Ethernet and the implementation of isochronous motion control applications. PROFINET also allows distributed automation with the support of component technology, as well as vertical integration and the implementation of safety-oriented applications. PROFINET also supports controller-controller communication.

Securely and flexibly networked across all levels with SCALANCE network components

SCALANCE X Industrial Ethernet Switches, SCALANCE S Industrial Security Modules and Industrial Wireless LAN (IWLAN) access points, client modules and SCALANCE M mobile radio routers that ideally meet the demands of industrial applications are available for networking the stations on the PROFINET/Industrial Ethernet.

The use of wireless communication to automation devices and industrial terminal devices helps to achieve greater flexibility. As a result you can simplify maintenance work and reduce service costs and downtimes. With Safety, even fail-safe communication is possible via a wireless network. This increases a company's competitiveness considerably.

Challenging applications with real-time requirements can be implemented in the radio field. The use of wireless features for moving machines saves cable and servicing costs, driverless transport systems can receive data via the wireless system without requiring cables and remain flexible in the choice of route.

An overall solution comprises:

- Bus system with
 - Passive network components, e.g. cables
 - Active network components, e.g. switches
- Interfaces for connecting automation devices to the bus systems
 - Integrated interfaces
 - Own communications processors
- Gateways, e.g. IE/PB Link PN IO
- Software for configuring the networks
- Tools for maintenance and diagnostics



Industrial Ethernet Switch SCALANCE XR552-12M

SIMATIC NET offers all the components necessary for an integrated overall solution and supports the following communication systems:

Industrial Ethernet (IEEE 802.3) – the international standard for area networking is the number one network in the LAN environment. Industrial Ethernet enables powerful communication networks to be constructed over wide areas.

PROFINET (IEC 61158/61784) – the international standard uses Industrial Ethernet and allows real-time communication all the way to the field level, but also integrates the enterprise level. With the full utilization of existing IT standards, PROFINET allows isochronous motion control applications, efficient cross-manufacturer engineering and high availability of machines and systems on the Industrial Ethernet. PROFINET supports distributed automation (and controller-controller communication) and it allows fail-safe applications.

PROFIBUS (IEC 61158/61784) – the international standard for the field level is the global market leader among fieldbus systems. It is the only fieldbus to allow communication both in manufacturing applications and in process-oriented applications.

AS-Interface (EN 50295/IEC 62026) – the international standard which, as an alternative to the cable harness, links especially cost-effective sensors and actuators by means of a two-wire line.

IO-Link – the standard for intelligently connecting sensors and actuators from the field level to the MES level.

Routers are implemented via controllers or links. Configuration and diagnostics can be performed from any point in the plant.

KNX/EIB (EN 50090, ANSI EIA 776) – the basis for building automation is the global standard.

Use of communication systems					
	Industrial Ethernet	PROFINET	PROFIBUS DP	AS-Interface	IO-Link
Enterprise Resource Planning (ERP) (e.g. PC)	●	○			
Control (e.g. SIMATIC S7-300)	●	●	●	○	
Motion Control (e.g. SIMOTION)	○	●	●		
Intelligent field devices (e.g. ET 200S/CPU)		●	●	●	●
Simple field devices (e.g. ET 200)		●	●	●	●
Sensors/actuators		●	●	●	●
Identification systems (z.B. RFID and code reading systems)	●	●	●		
Drives (e.g. SINAMICS)	○	●	●	●	
SIRIUS (e.g. M200D motor starter, compact starters, monitoring and overload relay)		●	●	●	●
CNC system (e.g. SINUMERIK)	●	●	●		
Safety-oriented Communication		●	●	●	

G_IK10_XX_00003

not suitable ○ suitable ● ideally suitable

Industrial bus systems

Industrial bus systems

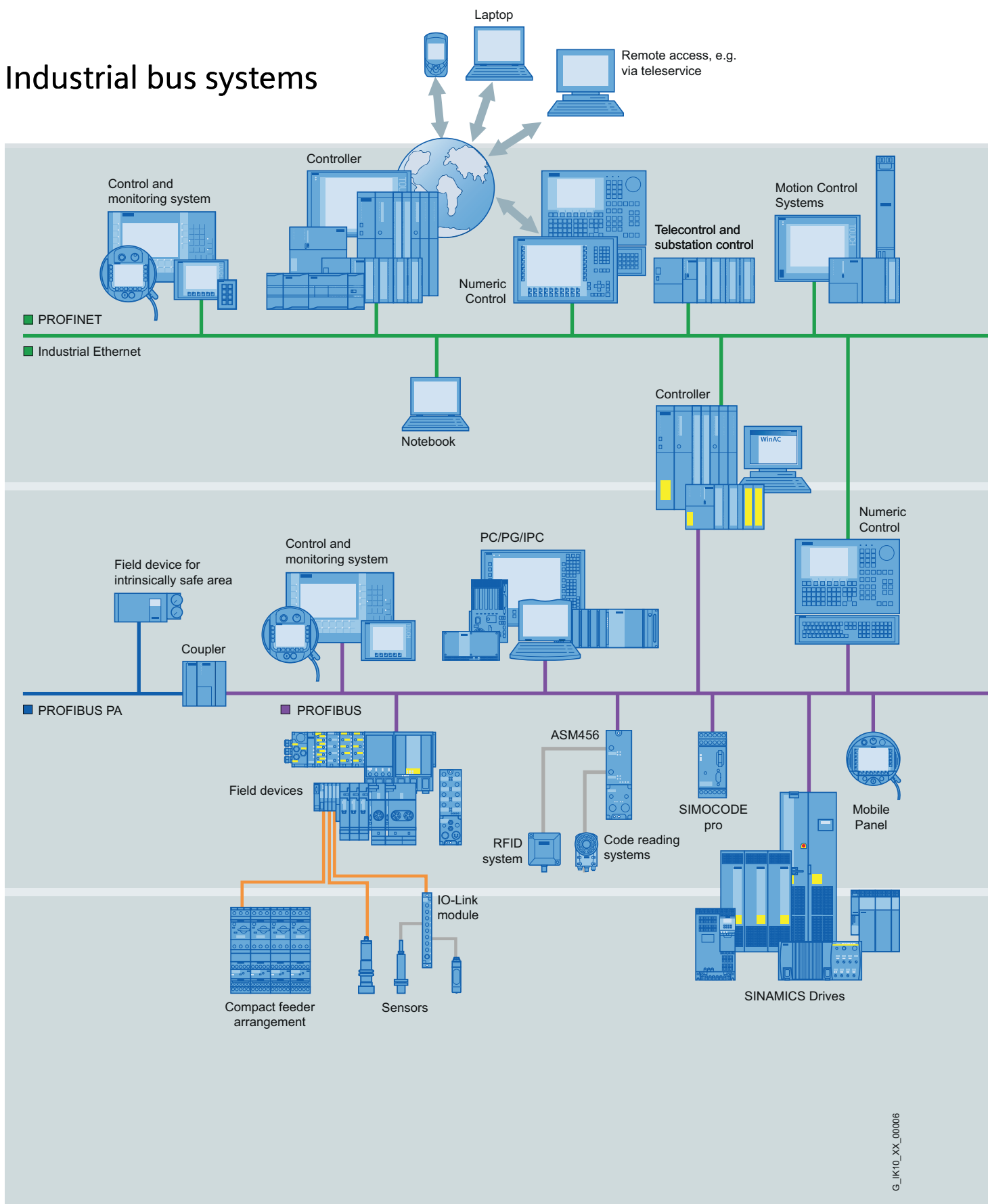

G_IK10_XX_00006

The graphic shows the connection of different automation systems to the standardized networks.

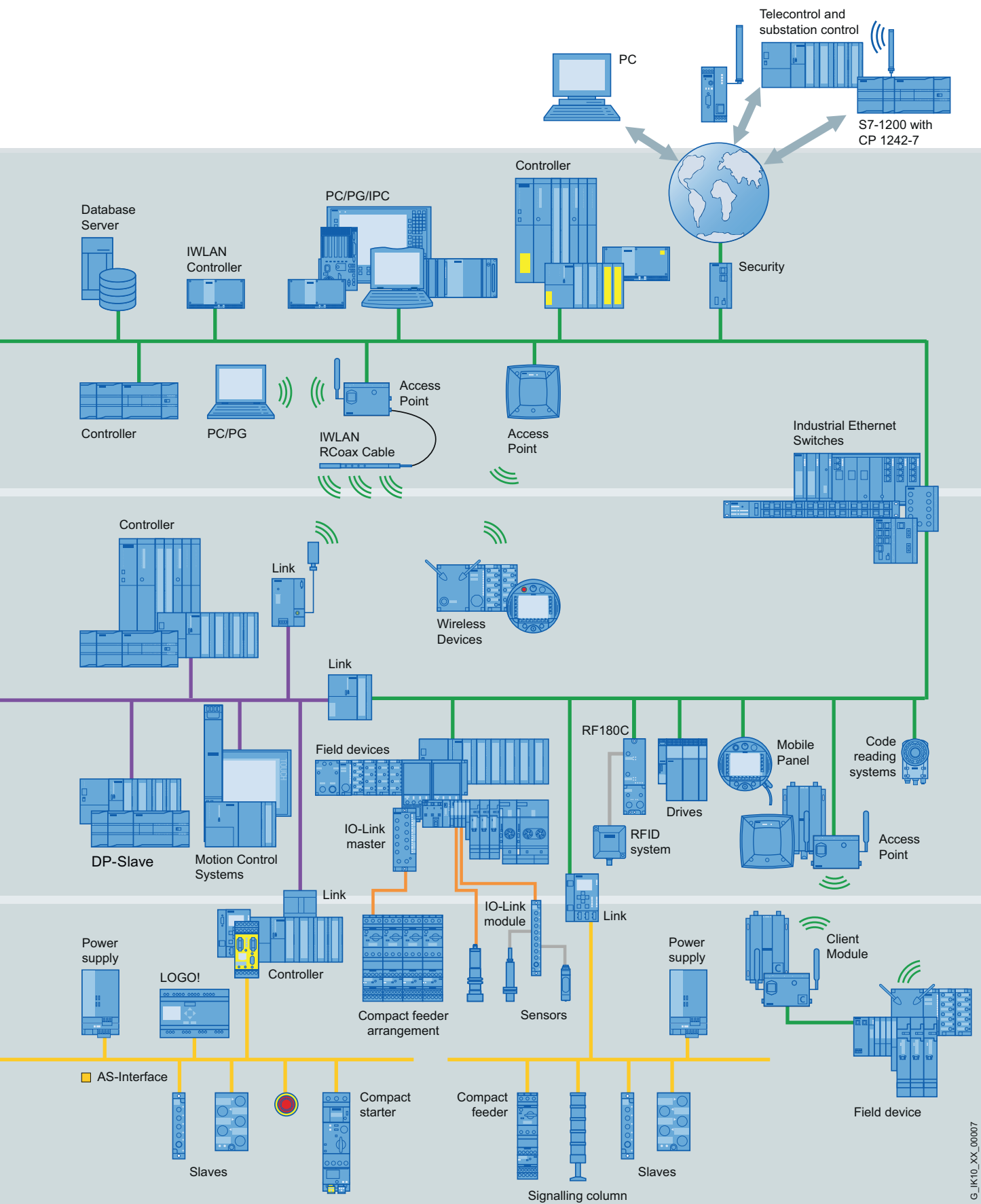

G_IK10_XX_00007

PROFINET/Industrial Ethernet

Industrial Ethernet

Industrial Ethernet provides the industrial area with a powerful network that complies with the IEEE 802.3 (Ethernet) and 802.11 a/b/g/h/n (wireless LAN) standards.

The diverse options of Ethernet and the Internet that are already available today in the office sector can also be used in factory and process automation by means of Industrial Ethernet.

Ethernet technology, which has been used successfully for decades, allows users to precisely match network performance to requirements. The user can choose the data throughput rate to suit particular needs, as integrated compatibility makes it possible to introduce this technology in stages.

Ethernet is the world's current Number 1 in the network environment and offers significant benefits:

- Fast commissioning thanks to the simplest connection method
- High availability since existing networks can be extended without any adverse effects
- Virtually unlimited communication capabilities, since scalable performance using switching technology and high data rates are available
- Networking of the most varied application areas such as the office and production areas
- Company-wide communication thanks to the Internet connection option, with security components providing for data integrity
- Investment protection through continuous compatible further development
- Precise time-based assignment of events in the overall plant by means of plant-wide clock control.

SIMATIC NET, the industrial communication system from Siemens, relies on this proven technology. Siemens has already supplied several million connections worldwide in tough industrial environments subject to electromagnetic interference.

SIMATIC NET provides important supplements to Ethernet technology for industrial environments:

- Network components of the SCALANCE product families for the use of wired and wireless communication in harsh industrial environments
- Fast on-site assembly using the FastConnect cabling system
- Failsafe networks through high-speed redundancy and redundant power supply
- Continuous monitoring of network components through an effective signaling concept, and network monitoring software

The following communication functions/services are offered by Industrial Ethernet:

PG/OP communication

Comprises integrated communication functions which allow data communication via SIMATIC, SIMOTION and SINUMERIK automation systems with every HMI device and SIMATIC PG (STEP 7). PG/OP communication is supported by PROFINET/Industrial Ethernet and PROFIBUS.

S7 communication

S7 communication is the integrated communication function (system function block) for S7-400 or loadable function blocks for S7-300, which have been optimized within SIMOTION, SINUMERIK and SIMATIC S7/WinAC. It also enables PCs/IPCs and workstations to be connected. The maximum volume of user data per task is 64 KB.

S7 communication offers simple, powerful communication services and provides a network-independent software interface.

Open communication

The open communication (SEND/RECEIVE) allows the SIMATIC S7 controllers to communicate with other SIMATIC S7 and SIMATIC S5 controllers, PCs/IPCs and third-party systems. In addition, for the simple connection of HMI stations, FETCH and WRITE are offered.

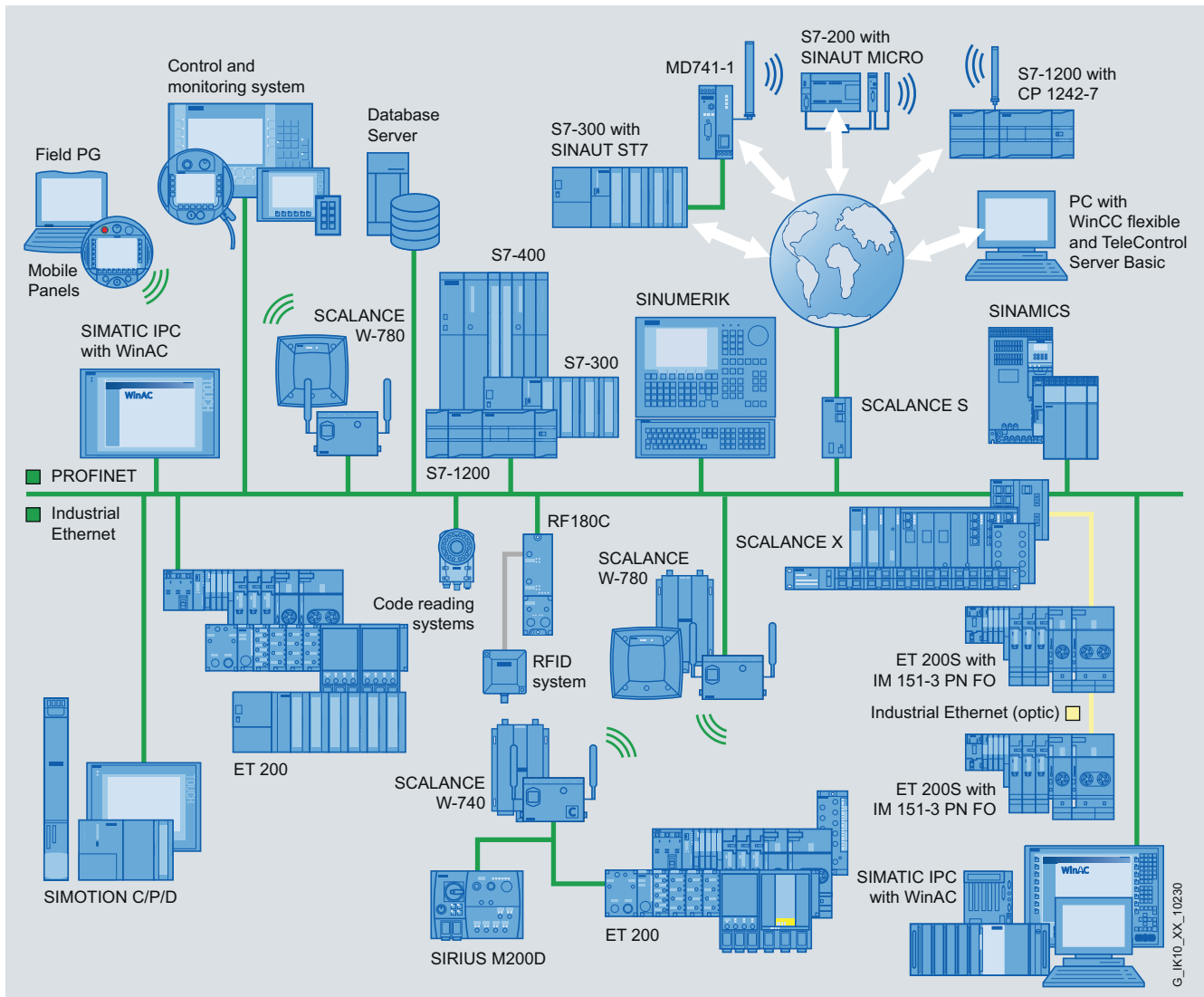

Complete overview of Industrial Ethernet

The socket interface for Industrial Ethernet

allows data communication with computers via TCP/IP. On this interface which is widespread in the PC and UNIX world, users can freely program the data exchange. The SEND/RECEIVE blocks (S/R) are used as access to TCP/IP in SIMATIC S7.

OPC (Openness, Productivity & Collaboration) is a standardized, open and cross-vendor software interface. It permits interfacing of OPC-capable Windows applications to S7-communication, open communication (SEND/RECEIVE) and PROFINET.

IT communication

Information technology (IT) with e-mail, File Transfer (FTP), and web technology integrates SIMATIC, SIMOTION and SINUMERIK into IT via Industrial Ethernet. In the office environment, e-mail, FTP, and web browsers have prevailed as widespread means of communication.

PROFINET communication

This communication is compliant with the IEC 61158/61784 standard. PROFINET, the international standard, uses Industrial Ethernet and enables real-time communication right down to the field level.

PROFINET/Industrial Ethernet

PROFINET – the Ethernet standard for automation

PROFINET is the leading Industrial Ethernet standard with more than 3 million nodes worldwide.

PROFINET increases the companies' success by accelerating processes, boosting productivity, and increasing plant availability.

With PROFINET, Siemens applies the Ethernet standard to automation. PROFINET enables high-speed and secure data exchange at all levels, thus making it possible to implement innovative machine and plant concepts. Thanks to its flexibility and openness, PROFINET offers users maximum freedom when engineering and structuring their plant architectures.

PROFINET's efficiency means optimal use of available user resources and a significant increase in plant availability. Innovative Siemens products and the performance of PROFINET provide a sustained boost to company productivity.

PROFINET innovations

PROFINET has been expanded with several innovative features. These simplify the system configuration, in safety-critical applications for example, and support a leaner and more flexible topology in many different scenarios.

The **I-Device (intelligent IO Device)** function enables simple and fast controller-controller communication through direct access to the IO address image with PROFINET IO protocol. Local controllers such as the ET 200S CPU can be integrated into modular machines more easily, for example.

The **Shared Device** function allows two controllers to access the same PROFINET IO Device, such as a distributed ET 200 or a drive in a safety application. Because fewer devices need to be installed in the field, the engineering, cabling, energy and installation costs are reduced.

Plant availability can be increased using a ring topology and the **Media Redundancy Protocol (MRP)**. This runs directly via the integrated RJ45 ports on PROFINET devices and can be combined in any way with the relevant Industrial Ethernet switches (e.g. SCALANCE X-200).

Advantages at a glance

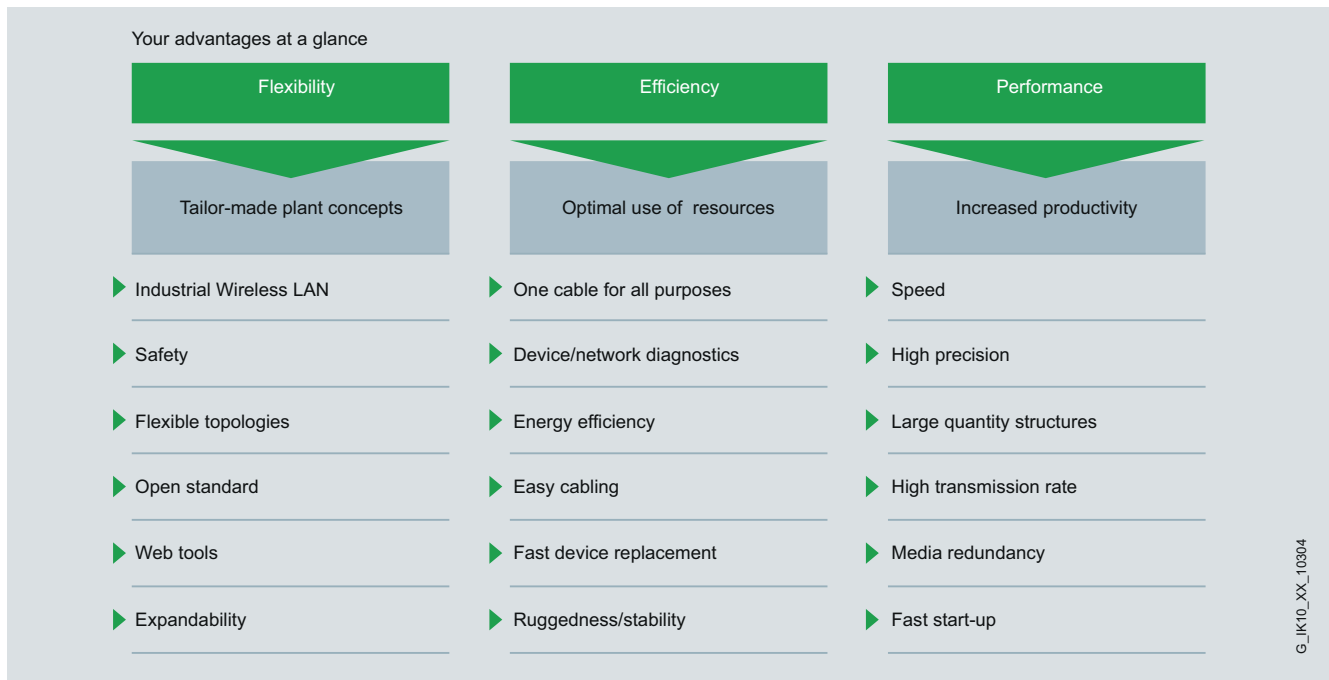

More flexibility with PROFINET

Industrial Wireless LAN (IWLAN)

IWLAN reduces maintenance costs, increases reliability, and convinces with high communication performance. Only PROFINET allows the use of IWLAN with safety.

Safety

Safety-related communication via PROFIsafe reliably protects personnel, the environment, and plants.

Flexible topologies

PROFINET also enables the use of star, tree and ring topologies in addition to the linear topology.

Open standard

Thanks to its openness, PROFINET creates the basis for a uniform machine/plant automation network to which programmable controllers as well as standard Ethernet devices can be connected.

Web tools

PROFINET is 100 percent Ethernet and supports TCP/IP. Among other things, this enables the use of Web technologies, such as access to the integrated Web server of the field devices.

Expandability

With PROFINET, network infrastructures can be expanded as desired, even during operation.

More efficiency with PROFINET

One cable for all purposes

PROFINET offers a host of functions on one cable: Machine data and standard IT data merge. This creates integration and saves costs by reducing the overhead for cabling and training overhead.

Device and network diagnostics

Extensive diagnostic data can be read out from the devices to locate faults quickly. HTML standard Web sites are used for servicing PROFINET devices – locally and remotely.

Increased energy efficiency

PROFenergy switches off individual loads or entire production units during breaks – in a coordinated and centrally controlled way.

Easy cabling

Fault-free establishment of industrial networks in a short time and without specialist knowledge: PROFINET makes this possible with the FastConnect system.

Fast device replacement

When replacing a PROFINET device, the IO Controller detects the new device and automatically assigns its name.

High degree of ruggedness

The use of switches even in field devices prevents faults in one section of the network from influencing the entire plant network. PROFINET enables the use of fiber-optic cables especially for areas that are critically sensitive to EMI.

More performance with PROFINET

Speed

Fast motion control applications need high-speed data exchange. PROFINET's short cycle times increase the productivity of machines and plants.

Precision

Communication via PROFINET is deterministic. A jitter of < 1 μ s results in maximum precision cycles and thus guarantees high product quality.

Large quantity structures

With PROFINET, up to 256 devices can be managed by one SIMATIC controller. The number of nodes per network is more or less unlimited.

High transmission rate

By using Ethernet, PROFINET achieves a significantly higher transmission rate than previous fieldbuses. This enables problem-free transmission of even large volumes of data without affecting I/O data transfer.

Media redundancy

Higher plant availability can be achieved by means of a redundant installation. This can be implemented both with the help of external switches and direct via integral PROFINET interfaces.

Fast start-up

In modular plants, IO Controllers must detect new machines or plant sections quickly. With Fast Startup, PROFINET can detect devices in up to < 500 ms and connect them with the IO Controller.

PROFIBUS

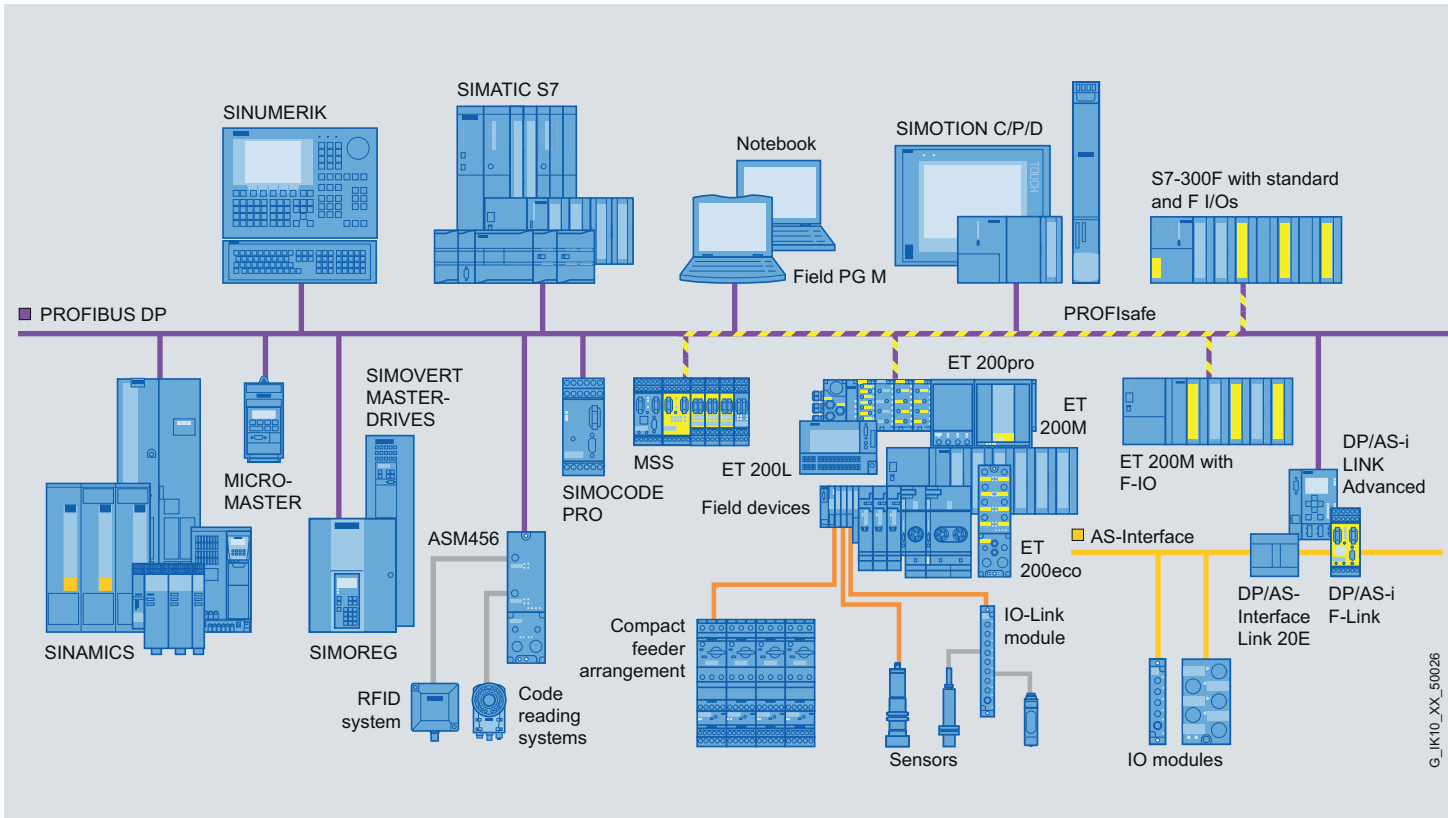

Complete overview of PROFIBUS

PROFIBUS is used to connect field devices, e.g. distributed I/O devices or drives, to automation systems such as SIMATIC S7, SIMOTION, SINUMERIK or PCs. PROFIBUS is standardized in accordance with IEC 61158/61784 and is a powerful, open and rugged fieldbus system with short response times. PROFIBUS is available in different forms for various applications.

PROFIBUS DP (distributed I/O)

is used for connecting distributed field devices, e.g. SIMATIC ET 200, or drives with extremely fast response times. PROFIBUS DP is used when sensors/actuators are distributed at the machine or in the plant (e.g. field level). The actuators and sensors are connected to the field devices. The field devices are supplied with output data in accordance with the master/slave technique and transfer input data to the controller or PC.

Openness all along the line

Thanks to the openness of PROFIBUS DP, standard-compliant components from different manufacturers can also be connected. The IEC 61158/61784 standards provide future protection for your investment. A simple link to other bus systems, e.g. from the AS-Interface, is implemented by means of links and thus permits an integrated solution in the field of failsafety for the protection of both human and machine.

Siemens has a complete range of products of standard and fail-safe controllers, network components, communication software and field devices. And for field device manufacturers, Siemens offers everything to do with the PROFIBUS DP interface, such as ASICs, training, certification, and much more.

PROFIsafe

permits standard and safety-related communication on one and the same bus cable. It is an open solution for safety-related communication over standard buses and uses the PROFIBUS services.

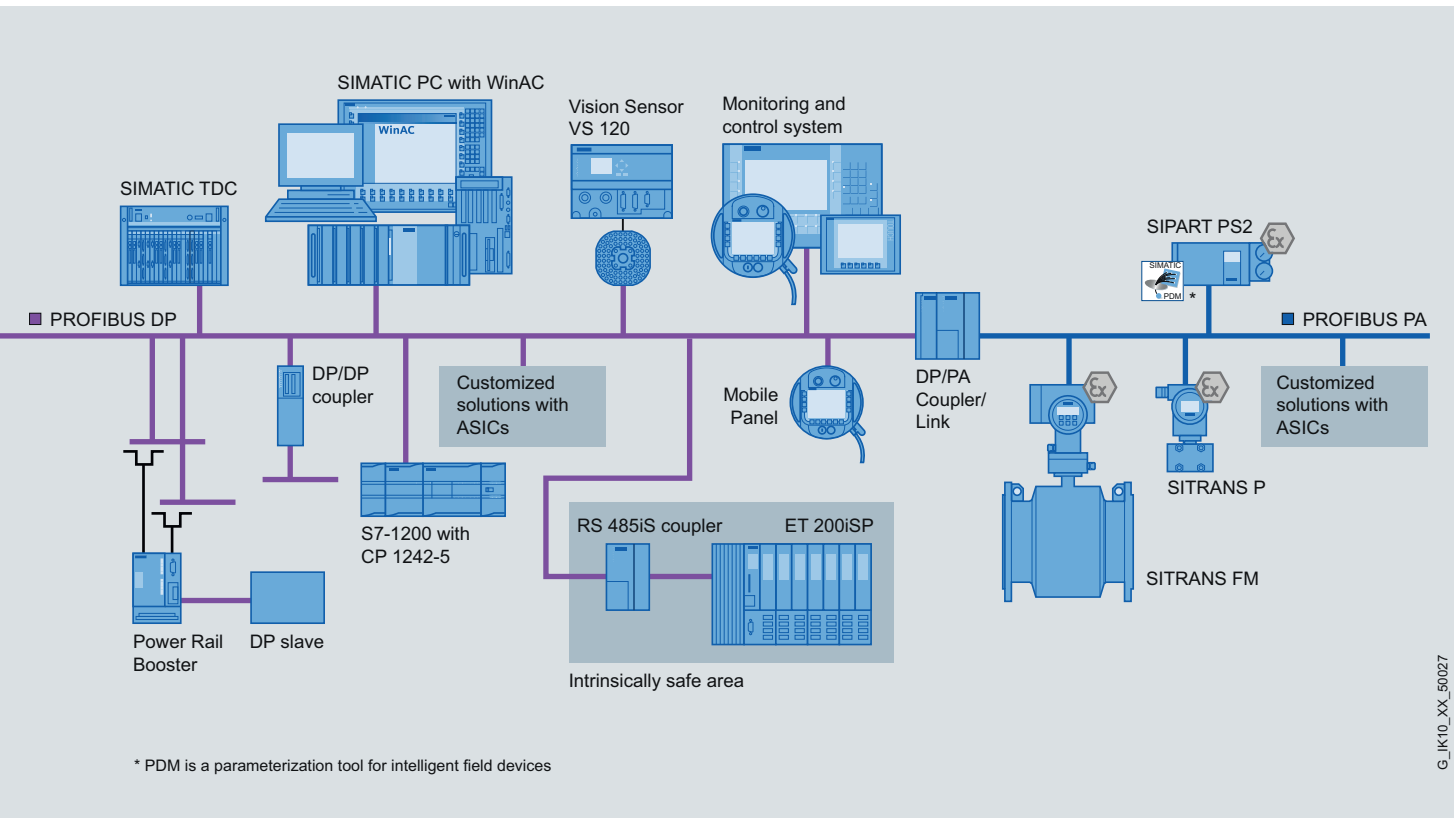

Isochronous mode

The CPU, I/O and user program are synchronized with the PROFIBUS cycle. The "Isochronous mode" function is supported by many CPUs of SIMATIC, SIMOTION, SINUMERIK and servo drives. The drives are controlled using the PROFIdrive profile.

PROFIBUS PA (Process Automation)

expands PROFIBUS DP with intrinsically safe transmission of data and power (e.g. transducers in the food processing industry) in accordance with the international standard IEC 61158-2 (same protocol, different physical properties). PROFIBUS PA is used predominantly in the hazardous areas of refineries (chemical, oil and gas).

AS-Interface

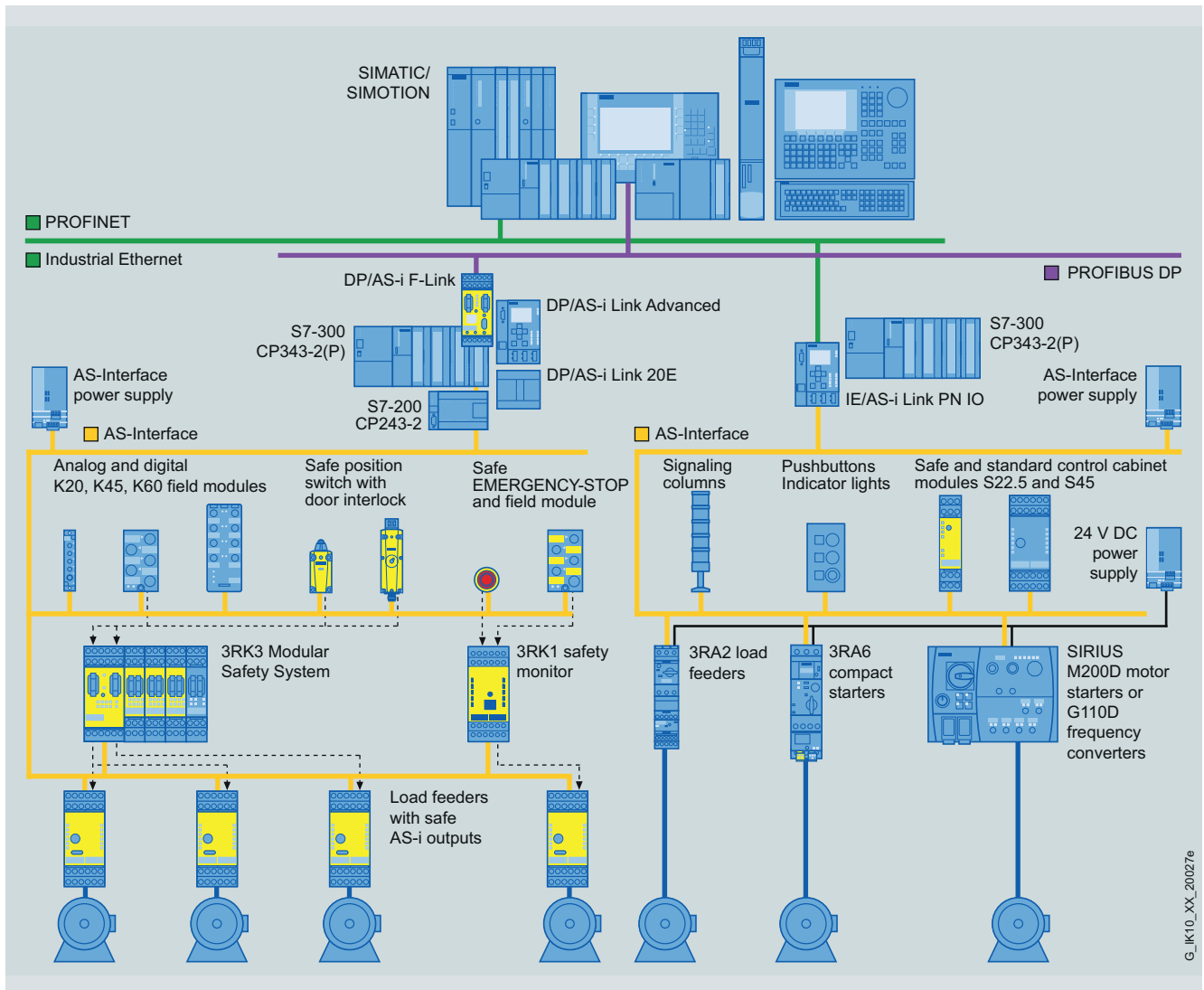

Example of a system configuration

G_IK10_XX_20027e

Sensors, valves, actuators, drives – many different components operate on the field level. All of these actuators/sensors must be connected to an automation system. Distributed I/O devices are used for this; to a certain extent as intelligent outposts directly on-site.

As a cost-effective alternative to the cable harness, AS-Interface links the components of the field level by means of a simple 2-wire cable for data and power. AS-Interface is standardized as an international industrial standard according to EN 50295 and IEC 62026-2 and is supported worldwide by a number of member companies of the AS-International Association, including the leading manufacturers of actuators and sensors. AS-Interface is used where individual actuators/sensors are spatially distributed throughout the machine (e.g. in a bottle filling plant).

AS-Interface is a single master system. There are communications processors (CPs) for SIMATIC and for SIMOTION and links that control field communication as masters. With the AS-Interface specification V2.1 or V3.0, up to 62 slaves can be connected. The AS-Interface specification V3.0 allows a maximum of 1000 digital inputs/outputs to be connected (profile S-7.A.A: 8DI/8DO as A/B slave). New profiles allow extended addressing (A/B) to be used for analog slaves, too. The analog value transmission is accelerated via "fast analog profiles". Thanks to the integrated analog value processing in the masters, the access to analog values is just as easy as the access to digital values.

For connecting the AS-Interface to PROFIBUS DP, the DP/AS-i LINK Advanced, DP/AS-i F-Link or DP/AS-Interface LINK 20E are available with degree of protection IP20. This enables the use of AS-Interface as a subordinate network for PROFIBUS DP. The IE/AS-i LINK PN IO allows AS-Interface to be connected to Industrial Ethernet and thereby a direct embedding in the PROFINET environment.

Cost savings

AS-Interface replaces costly cable harnesses and connects binary actuators and sensors such as proximity switches, valves or indicator lights, as well as analog signals with a controller such as SIMATIC.

In practice this means: Installation runs smoothly because data and power are transported together over **one** single line. Thanks to the specially developed ribbon cable (yellow in color) and insulation displacement technology, the AS-Interface slaves can be connected anywhere.

This concept is extremely flexible and has a great effect on savings. No expert knowledge is required for installation and commissioning. Furthermore, through simple cable laying and the clear cable structure as well as the special design of the cable, you not only significantly reduce the risk of errors, but also service and maintenance costs.



Automation in the beverage industry.

IO-Link

Uninterrupted communication down to the last meter

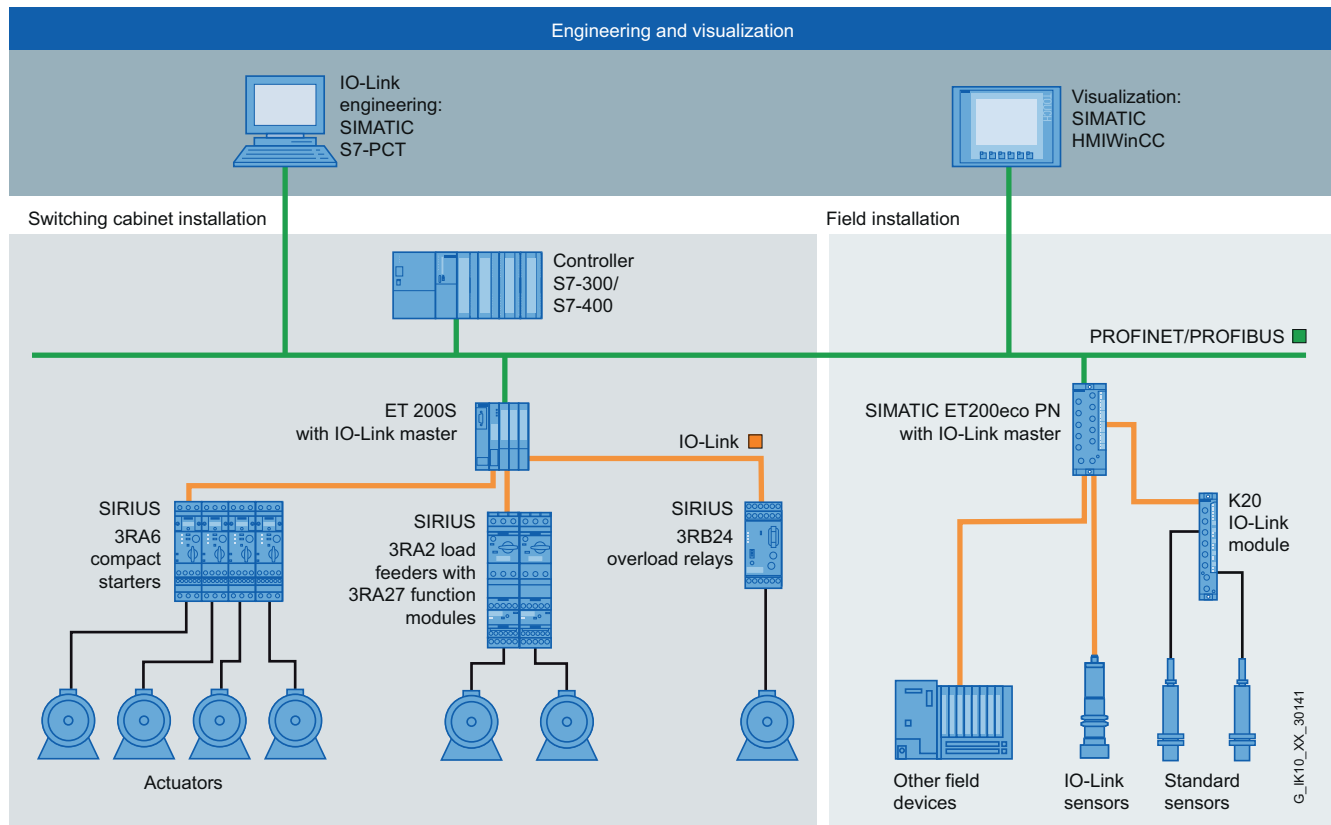

Networking with IO-Link

IO-Link – more than just another interface

IO-Link is the smart concept for the standardized linking of switching devices and sensors to the control level by means of an economical point-to-point connection.

The new communications standard IO-Link below the fieldbus level allows central fault diagnosis and location as far as the actuator/sensor level and simplifies both commissioning and maintenance by allowing the parameter data to be modified dynamically, direct from the application.

Improvements in the intelligence of field devices and their integration in the overall automation support data access down to the lowest field level. The result: greater plant availability and reduced engineering overhead.

As an open interface, the IO-Link can be integrated into all common fieldbus and automation systems. Consistent interoperability ensures maximum protection of investment. This also applies in the context of existing machine concepts for continued use of sensors without an IO-Link interface.

Together for integrated quality

The requirements for integrated communication are increasing. At the same time, the variety of field devices, actuators, and sensors is increasing immensely – with ever greater intelligence.

IO-Link offers the solution for these requirements and is seen by manufacturers as a valuable addition to the communications landscape (including AS-Interface).

As a committed driver of this issue, Siemens is further developing not only its product and system range accordingly, but by integrating IO-Link in Totally Integrated Automation, it is also providing a unique integrated communication solution.

Engineering

Reduced engineering times

- Standardized, open system for more flexibility (third-party IO-Link devices can be integrated in the engineering)
- Uniform and transparent configuration and programming through integrated engineering (SIMATIC STEP 7)
- Freely available function blocks for SIMATIC for user-friendly parameterization and diagnostics, and read-out of measured values
- Efficient engineering thanks to use of off-the-shelf faceplates in SIMATIC HMI
- Low error rate in CAD circuit design thanks to reduction in control circuit wiring



Commissioning

Reduced commissioning times

- Faster installation and minimized error rate thanks to reduction in control circuit wiring
- Space savings in the control cabinet
- Low-cost wiring technology with several branches thanks to unrestricted use of existing Siemens components

Operation and maintenance

Increased plant availability

- High level of transparency in the plant down to the field level
- Reduction of downtime and maintenance times through plant-wide diagnostics and faster error correction
- Support for preventive maintenance
- High transparency through incorporation of energy management systems, readout of current values, and diagnostic messages
- Shorter conversion times thanks to central parameter and recipe management for field devices as well

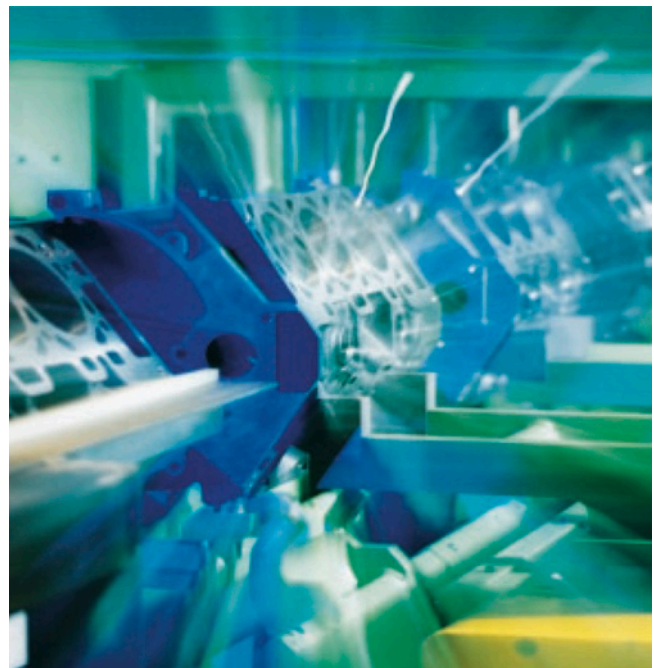

Industrial Wireless Communication

Within the scope of industrial communication, wireless communications opens up new perspectives – from partial modernization of a plant, right up to optimizing complex logistics or production processes.

On the basis of Industrial Wireless Telecontrol, Industrial Wireless LAN and WirelessHART, Siemens offers solutions for reliable automation with Industrial Wireless Communication.

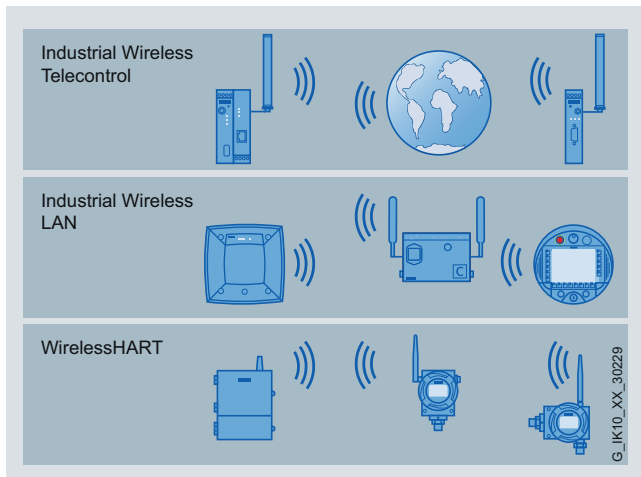

Reliable, wireless communication with IWLAN

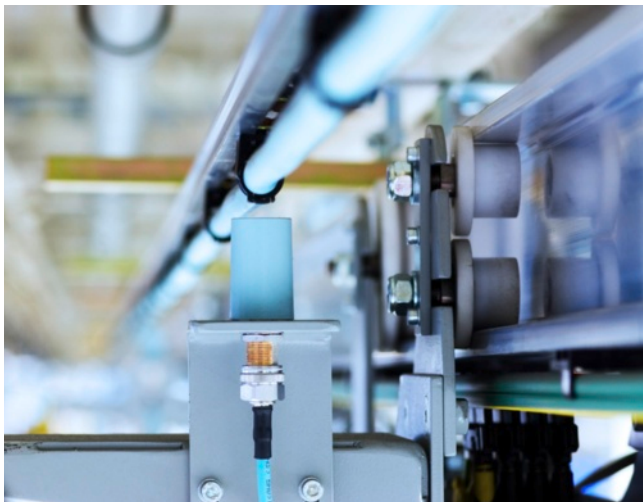

Reliable wireless communication with IWLAN

Industrial Wireless Telecontrol – low-cost and versatile wireless technology for longer distances

Continuous communication between widely separated plant sections in the area of water/wastewater, or high-speed remote maintenance access to machines and plants on the other side of the world - these are just two of countless ways of reaping the benefits of Industrial Wireless Telecontrol (IWT). Thanks to integration in a telecontrol system or an HMI/SCADA system, transferred process data is available at any time via mobile radio.

Industrial Wireless LAN – flexible, plant-wide wireless infrastructure

Wireless solutions are increasingly becoming a matter of course in machines and plants. In the case of high data communication requirements, Industrial Wireless LAN (IWLAN) backs innovations like deterministic radio and the Industrial Ethernet standard PROFINET. Thanks to the use of PROFI-safe via IWLAN, PROFINET opens up completely new perspectives – from efficient engineering, through real-time solutions, all the way to safety-related tasks.

Furthermore, an IWLAN infrastructure can also be used for additional applications such as video monitoring.

WirelessHART – wireless connection of the process instrumentation

WirelessHART is an open industry standard, developed for the particular requirements of wireless communication for field devices in the process industry. It meets all specific requirements for reliability, security, economy and user-friendly operation system-wide. With more than 30 million installed devices worldwide, HART technology is the most frequently used communication protocol for intelligent process instrumentation at the field level. WirelessHART is backwards-compatible with the wired HART technology and thus offers maximum investment security for hardware, software and expertise.

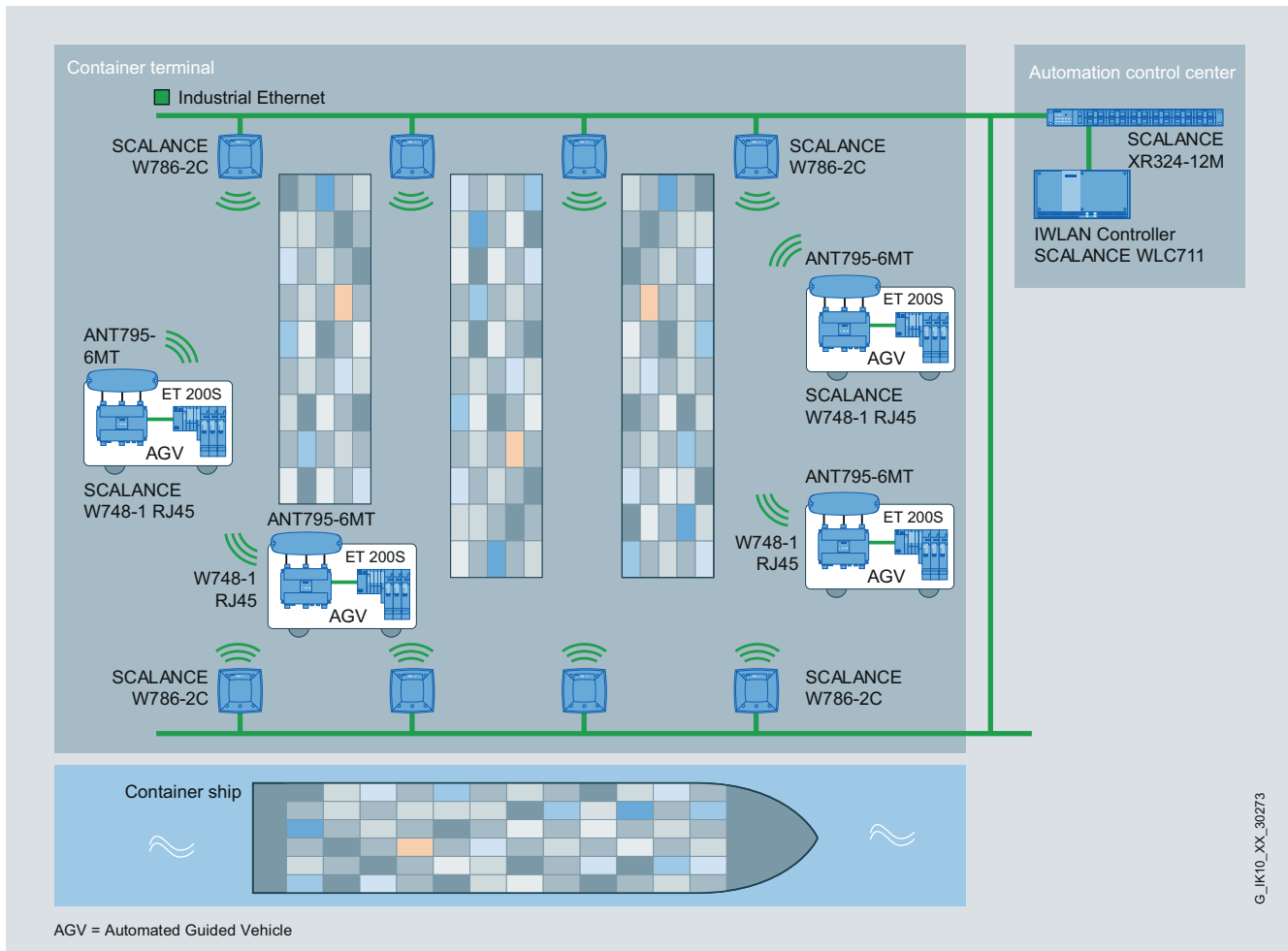

Application example for controller-based IWLAN applications with a large number of access points, e.g. in a container terminal

Advantages of a wireless communication network

- Increased competitiveness, since greater flexibility is achieved through mobility
- Maintenance work is simplified, service costs and downtimes are reduced, and personnel are used optimally
- No wear and tear of rotating and moving equipment or system components
- Integrated wireless network for voice and data across the divisions of the company
- Remote diagnostics for different production machines from a central service location reduces service costs
- Awkwardly located installations can be accessed easily; there is no need for complex wiring

Industrial Remote Communication

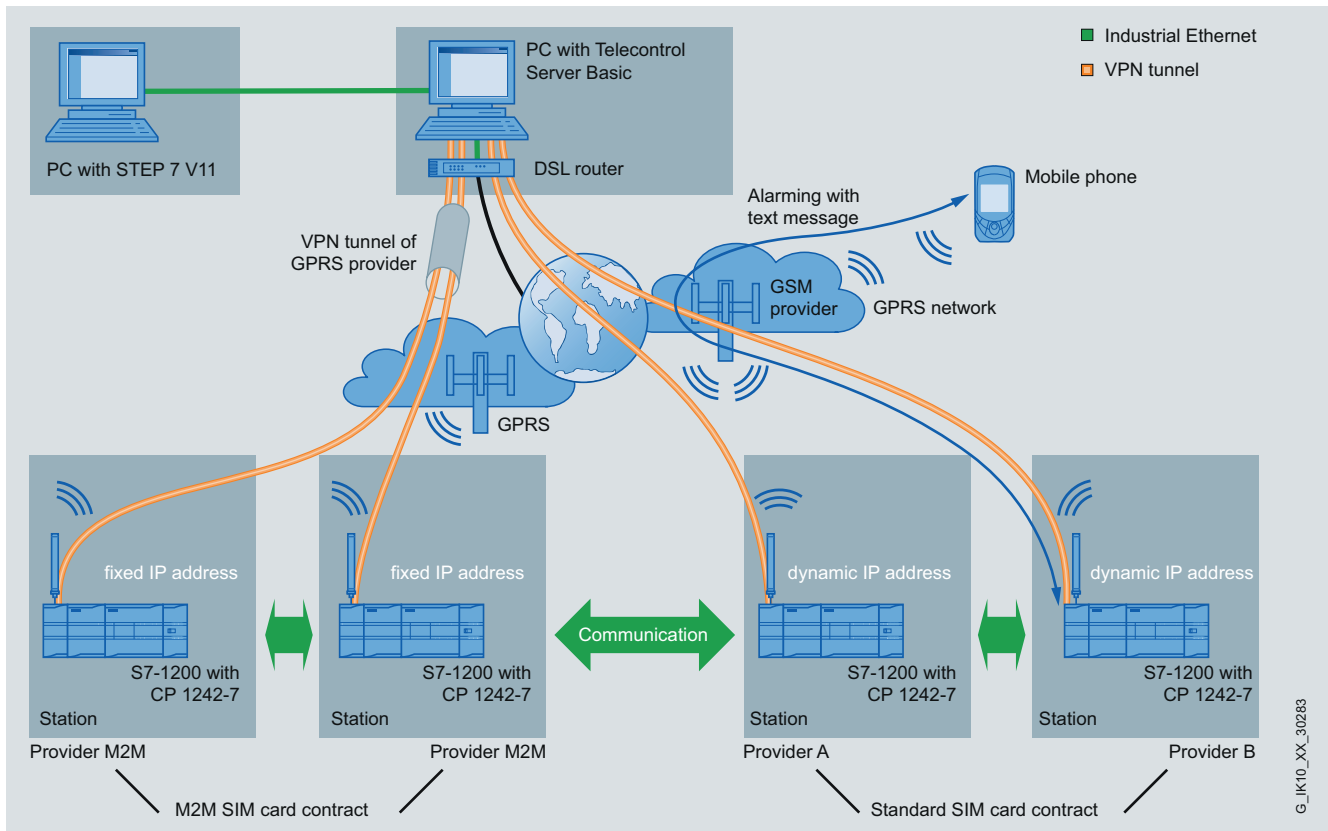

Efficient remote access to plants and machines with SIMATIC via industrial remote access

Efficient industrial remote access

Global remote access to far-flung plants, remote machines and mobile applications is gaining in significance – both in industry and in industry-related areas. With a comprehensive range of solutions for industrial remote access, Siemens offers the ideal basis for efficient and reliable monitoring and control of widely distributed plants of any size.

Secure and flexible access worldwide

Industrial plants are often distributed over large areas – sometimes even across national borders. Siemens offers proven solutions for industrial remote access, such as flexible telecontrol systems and efficient remote maintenance. Whether in public infrastructure, the manufacturing or process industry: With comprehensive solutions for teleservice and telecontrol, Siemens is the right partner every time.

Telecontrol

Telecontrol involves the connection of distant process stations to one or more central control systems. Various different public or private networks can be used for communication for the purposes of monitoring and control. Event-driven or cyclic exchange of process data is performed with special telecontrol protocols and enables the operating personnel to manage the overall process effectively.

The telecontrol systems are based on SIMATIC. They supplement the SIMATIC system with corresponding hardware and software, and thus permit individual process stations to be networked over a WAN (wide area network). The data for this is transmitted via classical WAN, e.g. copper dedicated cable, dial-up networks, wireless, but also via IP-based networks such as mobile wireless networks or the Internet.

Teleservice (remote maintenance/diagnostics)

Teleservice is data exchange with physically remote technical plants (machines, plants, computers, etc.) for the purpose of error detection, diagnostics, maintenance, repair, or optimization.

TeleControl Basic

TeleControl Basic connects the control center via the Telecontrol Server Basic control center software with the substations, consisting of SIMATIC S7-1200 controllers with CP 1242-7 GPRS module. The server also supports the connection of S7-200 stations with MD720-3 modems. Wireless GPRS technology is available as the transmission medium. An S7-1200 substation permit remote communication with a control center (service center) as well as direct slave-slave communication with other S7-1200 substations. Small-scale applications with few outstations can be implemented, as well as large-scale plants comprising up to 5000 outstations. International approvals permit worldwide use.

Extended Telecontrol Server Basic functionalities allow the use of telecontrol server services. The overall solution also includes the teleservice function and thus provides, for example, worldwide access to the S7-1200 stations for international plant and machine manufacturers.

TeleControl Professional

TeleControl Professional comprises the Siemens telecontrol systems for extensive, expanded applications in the process industry. Control systems such as PCS 7, WinCC and third-party control systems with OPC allow reliable control and monitoring of outstations based on the SIMATIC S7-300 and S7-400 controls.

The outstations and substations can communicate with each other as well as with one or more control centers.

Industrial Remote Communication

Transmission networks

Telecontrol supports a wide variety of communication networks. In the classical WAN sector, these are:

- Dedicated lines (private or leased)
- Private radio networks (optionally with time slot procedure)
- Dial-up networks (analog, ISDN, GSM)

SINAUT also offers appropriate modems for conventional WANs. Communication, however, is also possible via Ethernet-based WAN, namely:

- Via Ethernet-based wireless systems, e.g. Industrial Wireless LAN with SCALANCE W
- Via fiber-optic conductors, e.g. through use of SCALANCE X switches with optical ports; distances of up to 120 km can then be covered
- Via public networks and Internet using DSL and/or GPRS and UMTS

All networks can be mixed in any manner in a SINAUT project. Star, line and node topologies can be designed, and also mixed configurations of these. A station can be linked using two transmission paths to permit redundant data transmission. The two paths can be of the same type or also different, e.g. dedicated line combined with telephone network or ISDN with DSL.

Control center systems

A number of different versions can be selected for setting up the control center depending on the process requirements and extent of the information:

- SINAUT ST7cc
This WinCC-based PC control center is the ideal control center system for both SINAUT ST7 and SINAUT ST1. It has been developed specifically for event-driven and time-stamped data transmission on the SINAUT system and can have a single or redundant design.
- PCS 7 with PCS 7 TeleControl
This is the ideal control center system for plants in which larger local automation tasks have to be combined with telecontrol connections. In addition to SINAUT ST7, remote stations with other communication protocols can be connected, e.g. over DNP3 or IEC 870-5-101/-104.
- WinCC TeleControl
This WinCC-based control center system offers the connection of SIMATIC substations to other telecontrol protocols such as DNP3 or IEC 870-5-101/-104.
- SINAUT ST7sc
This OPC server software is ideal for connecting the SINAUT telecontrol system to control centers from other vendors via OPC client function. ST7sc features extensive buffer mechanisms which prevent data from being lost even if the OPC client fails, and it can have a single or redundant design.
- SIMATIC S7 controller as control center
Like the substations, this control center comprises a SIMATIC S7-300 or S7-400 controller and is suitable for simpler applications requiring only one current process image of the telecontrol stations. The station process control can be influenced by entering commands, set-points or parameters. The control center can also be used to extend a PC control center (SINAUT ST7cc or ST7sc), e.g. for data output on a panel, as an emergency operating system, or for implementing cross-station control tasks.

Teleservice (remote diagnostics and remote maintenance)

Remote diagnostics and remote maintenance of production plants are indispensable in modern automation technology. They are more efficient and more cost-effective than an on-site service employee on site. This allows faults to be detected and cleared much faster, downtimes of machines are reduced and their availability is increased.

Machines and plants are increasingly operated in places which are far away from the production site. Plant constructors must nevertheless be able to provide support in the event of a fault. Especially during the warranty period this can result in high costs. Teleservice helps to reduce this risk.

The possible applications for Teleservice are manifold. Plants can be diagnosed, values set and data transmitted from any place on earth via a telephone cable. Teleservice also enables the SIMATIC controllers to send text messages per SMS or e-mail, making a significant contribution to saving travel and personnel costs in service work.

Teleservice via IP-based networks

Optimum remote maintenance is based on reliable, permanently available, secured and economical data connections.

Depending on the application, SIMATIC NET provides the appropriate solution:

- For continuous connections or simultaneous access to several plants, a solution via the Internet using SCALANCE S modules is recommended, both on the service and the plant side.
- For flexible remote maintenance access from any Internet connection – whether in the office, home office or hotel room – SOFTNET Security Client is the right software solution for connecting to the SCALANCE S Security Module installed in the plant.
- For plants without wired network connection, the MD741-1 GPRS router establishes remote maintenance access to the SCALANCE S in the service center.
- The SCALANCE M873 and M875 UMTS routers are available for plants requiring remote maintenance access at an especially high bandwidth.

In all cases, the communication is reliably protected by authentication and encryption via a virtual private network (VPN) tunnel, in order to rule out the possibility of industrial espionage or manipulation.

Siemens Remote Services



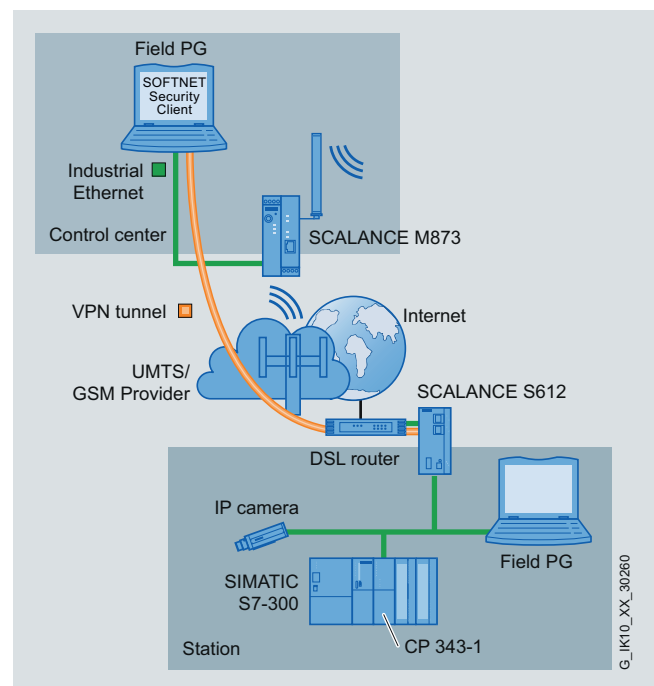

The service concept of "Siemens Remote Services" provides a powerful, secure platform for remote access to machines and plants. The inclusion of "Shared Experts" ensures effective support, not only from Siemens but also from the internal company specialists.



Configuration example for teleservice via UMTS mobile telephone network

Industrial communication

Data for practical applications

Communication Systems Compared in Practice					
	Industrial Ethernet	PROFINET	PROFIBUS DP	AS-Interface	IO-Link
Criteria					
Data rate	10/100 Mbit/s 1/10 Gbit/s (only 100 Mbit/s for PROFINET)	9.6 Kbit/s – 12 Mbit/s adjustable 31.25 Kbit/s ¹⁾	Send cycles 5 ms	4.8/38.4 Kbit/s or SIO (switching operation)	
Number of nodes Maximum	more than 1000	125 125 DP/PA links ¹⁾ 31 field devices per ¹⁾ DP/PA link	62	2	
Length of the network	Between two nodes: ■ electrical up to 100 m ■ optical up to 5 km (multimode) or up to 120 km (singlemode)	For the entire network: ■ electrical up to max. 10 km: - without repeater up to 1 km - with repeater up to 10 km ■ optically with optical link modules (OLM) up to 1875 km	For the entire network: ■ electrical up to max. 600 m: - with extension plug up to 200 m - with repeater or extender up to 300 m - with repeater and extension plug up to 600 m	■ electrical up to 20 m	
Topology	Line Tree Ring Star 	Line Tree Ring Star 	Line Tree Star 	Point-to-point 	
Power supply	- separate 24 V DC - Power-over-Ethernet (PoE)	separate 24 V DC (also via hybrid cable)	Sensors and modules: over bus cable actuators: over U _{AUX} 2 V DC (standard case) or over bus cable (30 V)	integrated	
Fail-safe communication	PROFIsafe SIL3, PL e	PROFIsafe SIL3, PL e	ASIsafe SIL3, PL e	–	

¹⁾ For PROFIBUS PA

The table contains empirical values that can serve as recommendations for selecting the optimum network.

G_1IK10_XX_00004

PROFINET/ Industrial Ethernet

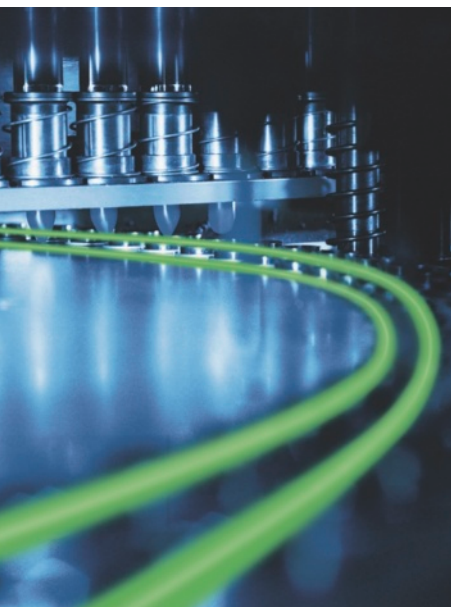

2/4	Industrial Ethernet	2/211	SCALANCE X-200IRT managed
2/4	Introduction	2/212	SCALANCE X-200IRT managed
2/7	Data communication	2/228	SIPLUS SCALANCE X-200IRT managed
2/8	Communication overview	2/229	SCALANCE XF-200IRT managed
2/10	Topologies	2/234	SCALANCE X-300 managed
2/23	Network selection criteria	2/236	SCALANCE X-300 managed
2/24	PROFINET	2/261	SIPLUS SCALANCE X-300 managed
2/24	Introduction	2/263	SCALANCE XR-300 managed
2/28	Cabling technology	2/273	SCALANCE X-300PoE managed
2/28	Passive network components	2/281	SCALANCE XR-300PoE managed
2/31	Overview of Twisted Pair	2/291	SCALANCE X-300EEC managed
2/32	Industrial Ethernet FastConnect	2/314	SCALANCE XR-300EEC managed
2/34	IE FC RJ45 Plug 2 x 2	2/328	Media modules for modular SCALANCE X-300 managed
2/38	IE FC RJ45 Plug 4 x 2	2/344	SCALANCE X-400 managed (Layer 3)
2/41	IE Push Pull Plug PRO	2/345	SCALANCE X-400 managed (Layer 3)
2/46	IE FC M12 Plug PRO	2/365	SCALANCE X-500 managed (Layer 3)
2/50	IE FC TP Cable 2 x 2	2/366	SCALANCE XR-500 managed (Layer 3)
2/60	IE FC TP Cable 4 x 2	2/375	Media modules for modular SCALANCE XR-500 managed
2/65	IE Hybrid Cable	2/389	Power supply for modular SCALANCE XR-500 managed
2/68	Energy cables		
2/73	IE TP Cord	2/392	Industrial Ethernet security
2/79	IE Connecting Cable M12-180/M12-180	2/392	Overview
2/83	IE FC Outlet RJ45	2/393	SCALANCE S
2/88	IE FC RJ45 Modular Outlet	2/402	SOFTNET Security Client
2/94	Industrial Twisted Pair – cables/connectors		
2/100	Overview of FC-FOCs	2/406	Drive systems – SINAMICS G
2/102	FC glass fiber-optic cables	2/406	SINAMICS G120D distributed frequency converters
2/107	FC FO termination kit	2/410	CU240D PN and CU240D PN-F Control Units
2/108	Overview of FOCs		
2/109	Glass fiber-optic cables	2/412	Drive systems / SINAMICS S High Performance Drives
2/124	POF and PCF fiber-optic cables	2/412	SINAMICS S110 servo converters
2/130	POF/PCF FOC Termination Kit	2/414	CU305 Control Unit
2/132	Industrial Ethernet switches / media converters	2/415	SINAMICS S120 drive system
2/132	Overview	2/417	CU310-2 Control Unit for single-axis drives
2/136	Compact switch modules	2/419	CompactFlash Card for CU310-2
2/136	CSM 1277 unmanaged		
2/139	SIPLUS NET CSM 1277		
2/140	CSM 377 unmanaged		
2/144	SCALANCE X-000 unmanaged		
2/145	SCALANCE X005 unmanaged		
2/150	SCALANCE XB-000 unmanaged		
2/158	SCALANCE X-100 unmanaged / media converters		
2/159	SCALANCE X-100 unmanaged		
2/169	SIPLUS SCALANCE X-100 unmanaged		
2/170	SCALANCE X-100 unmanaged media converters		
2/180	SIPLUS SCALANCE X-100 unmanaged media converter		
2/181	SCALANCE X-200 managed		
2/183	SCALANCE X-200 managed		
2/201	SIPLUS SCALANCE X-200 managed		
2/203	SCALANCE XF-200 managed		

PROFINET/ Industrial Ethernet

2/420	Controllers / Modular controllers <u>SIMATIC S7-1200</u>	2/479	System interfaces for SIMATIC S7
2/420	CPU 1211C	2/479	Introduction
2/422	SIPLUS CPU 1211C	2/482	<u>Communication for SIMATIC S7-200</u>
2/424	CPU 1212C	2/482	CP 243-1
2/426	SIPLUS CPU 1212C	2/486	<u>Communication for SIMATIC S7-300</u>
2/428	CPU 1214C	2/486	CP 343-1 Lean
2/430	SIPLUS CPU 1214C	2/491	SIPLUS CP 343-1 Lean
2/432	<u>SIMATIC S7-300</u>	2/492	CP 343-1
2/432	CPU 314C-2 PN/DP	2/498	SIPLUS CP 343-1
2/434	CPU 315-2 PN/DP	2/500	CP 343-1 Advanced
2/436	SIPLUS CPU 315-2 PN/DP	2/509	SIPLUS CP 343-1 Advanced
2/437	CPU 317-2 PN/DP	2/511	CP 343-1 ERPC
2/439	SIPLUS CPU 317-2 PN/DP	2/517	CP 343-1 BACnet
2/440	CPU 319-3 PN/DP	2/522	<u>Communication for SIMATIC S7-400</u>
2/442	CPU 315F-2 PN/DP	2/522	CP 443-1
2/444	SIPLUS CPU 315F-2 PN/DP	2/527	SIPLUS CP 443-1
2/445	CPU 317F-2 PN/DP	2/528	CP 443-1 Advanced
2/447	SIPLUS CPU 317F-2 PN/DP	2/537	SIPLUS CP 443-2 Advanced
2/448	CPU 319F-3 PN/DP		
2/450	<u>SIMATIC S7-400</u>	2/539	System interfaces for PG/PC/IPC
2/450	CPU 412-2 PN	2/539	<u>Communication for PC-based systems</u>
2/452	CPU 414-3 PN/DP		Introduction
2/454	CPU 416-3 PN/DP	2/541	Performance data
2/456	SIPLUS CPU 416-3 PN/DP	2/542	Connection options to SIMATIC IPCs
2/457	CPU 414F-3 PN/DP	2/543	CP 1604
2/459	CPU 416F-3 PN/DP	2/547	CP 1616
2/460	<u>Distributed controllers</u>	2/551	CP 1612 A2
		2/555	CP 1613 A2
2/461	Controllers / PC-based controllers	2/560	CP 1623
2/461	SIMATIC WinAC RTX	2/565	CP 1628
2/462	SIMATIC WinAC RTX F	2/570	HARDNET-IE S7-REDCONNECT
2/463	SIMATIC WinAC ODK	2/573	SOFTNET for Industrial Ethernet
		2/576	SOFTNET PN IO
2/464	Controllers / Embedded controllers	2/578	OPC server for Industrial Ethernet
2/464	SIMATIC S7-modular Embedded Controller EC31	2/581	S7 OPC Redundancy for Industrial Ethernet
2/466	SIMATIC S7-modular Embedded Controller Expansion modules	2/583	SNMP OPC server
		2/585	SOFTNET PN IO Linux
		2/587	SOFTNET-S7/Linux
		2/589	SOFTBUS for Linux
2/467	Controllers / Embedded bundles	2/591	System interfaces for SIMATIC HMI
2/467	SIMATIC IPC227D bundles	2/591	<u>System interfaces with WinCC flexible</u>
2/469	SIMATIC IPC427C bundles	2/592	SIMATIC S7
2/472	SIMATIC HMI IPC277D bundles	2/594	SIMATIC WinCC flexible RT
2/474	SIMATIC HMI IPC477C bundles	2/596	SIMATIC WinCC
2/477	SIMATIC WinAC MP	2/601	<u>System interfaces with WinCC (TIA Portal)</u>
		2/602	SIMATIC S7
		2/604	SIMATIC WinCC (TIA Portal) Runtime
		2/605	WinCC Runtime Communication
		2/609	Accessories
		2/609	C-PLUG
		2/611	Power supply PS791-1PRO
		2/613	SICLOCK time synchronization

2/617	Distributed I/O SIMATIC ET 200S <u>Interface modules</u> 2/617 IM 151-3 PN 2/619 SIPLUS IM 151-3PN 2/620 <u>Interface modules with integrated CPU</u> 2/620 IM 151-8 PN/DP CPU 2/621 Master interface module for IM 151 CPU interface modules 2/622 SIPLUS IM151-8 PN/DP CPU 2/623 SIPLUS master interface module for IM 151 CPU 2/624 IM 151-8F PN/DP CPU 2/626 SIPLUS IM 151-8F PN/DP CPU	2/663	Industrial PC <u>Rack PC</u> 2/669 SIMATIC IPC547D 2/672 SIMATIC IPC547C 2/675 SIMATIC IPC647C 2/679 SIMATIC IPC847C <u>Box PC</u> 2/687 SIMATIC IPC227D 2/689 SIMATIC IPC427C 2/692 SIMATIC IPC627C 2/695 SIMATIC IPC827C <u>SIMATIC Panel PC</u> 2/702 SIMATIC HMI IPC277D 2/704 SIMATIC HMI IPC477C 2/707 SIMATIC HMI IPC577C 2/710 SIMATIC HMI IPC677C
2/627	Distributed I/O SIMATIC ET 200M <u>Interface modules</u> 2/627 IM 153-4 PN 2/629 SIPLUS IM 153-4 PN IO	2/713	Industry monitors and Thin Clients 2/713 SIMATIC Flat Panels 2/715 SCD monitors 1900 2/716 SIMATIC Thin Client
2/630	Distributed I/O SIMATIC ET 200pro <u>Interface modules</u> 2/630 IM 154-4 PN 2/632 IM 154-6 PN IWLAN 2/634 IM 154-8 PN/DP CPU 2/637 IM 154-8 F PN/DP CPU	2/717	SIMATIC Identification systems <u>RFID systems</u> 2/717 SIMATIC RF180C/RF182C <u>Code reading systems</u> 2/719 SIMATIC MV420 2/721 SIMATIC MV440
2/640	SIMATIC ET 200eco 2/640 ET 200eco PN	2/725	Motor starters for operation in the field, high degree of protection Ch. 6 <u>SIRIUS M200D motor starters</u> General data 2/725 M200D motor starters for PROFINET 2/730 Communication modules, motor starter modules 2/731 Accessories for M200D motor starters for PROFINET
2/642	Motion Control System SIMOTION 2/642 The SIMOTION system 2/643 Hardware platforms 2/645 Motion Control architectures with SIMOTION 2/646 PROFINET for SIMOTION 2/647 PROFIdrive for SIMOTION	2/733	Software and tools 2/733 SIMATIC iMap 2/734 BANYnet bus analysis and diagnostics 2/736 BANY PN IO 2/739 SINEMA server
2/649	CNC controls 2/649 SINUMERIK CNC automation system	2/742	PROFINET Technology components 2/742 Enhanced Real-Time Ethernet Controller ERTEC 2/743 Development kit for ERTEC 2/744 Development kit for Standard Ethernet Controllers
2/650	Operator and monitoring devices 2/650 Key Panels SIMATIC HMI KP8/KP8F 2/651 Basic Panels – Standard 2/652 SIPLUS Basic Panels 2/654 Comfort Panels – Standard 2/655 Mobile Panels 2/658 SIMATIC Panels 2/661 SIMATIC Multi Panels	2/745	Network transitions 2/745 IE/PB Link PN IO Ch. 6 IE/AS-i LINK PN IO 2/750 IE/WSN-PA LINK 2/756 PN/PN coupler
		2/758	Partner solutions 2/758 deviceWISE Embedded Edition for SIMATIC S7 Siemens IK PI · 2012

PROFINET/Industrial Ethernet

Industrial Ethernet

Introduction

Overview

- Area and cell network according to the international standards IEEE 802.3 (Ethernet) and IEEE 802.11 a/b/g/h/n (wireless LAN) designed for the industrial environment right down to the field level
- Connection of automation components (controllers and field devices) to each other and to PCs and workstations as well as components for wireless communication
- PROFINET, the Industrial Ethernet standard for automation, is based on Standard Ethernet (IEEE 802.3) and supports the connection of devices from field level up to management level
- Comprehensive open network solutions can be implemented
- High transmission performance at up to 10 Gigabit/s
- Integration of conventional IT functionalities such as Web server and e-mail in the automation sector
- A security solution especially for industrial automation thanks to the industrial security concept with the security products of SIMATIC NET (SIMATIC NET CPs with Security Integrated, SCALANCE S and SCALANCE M)

2

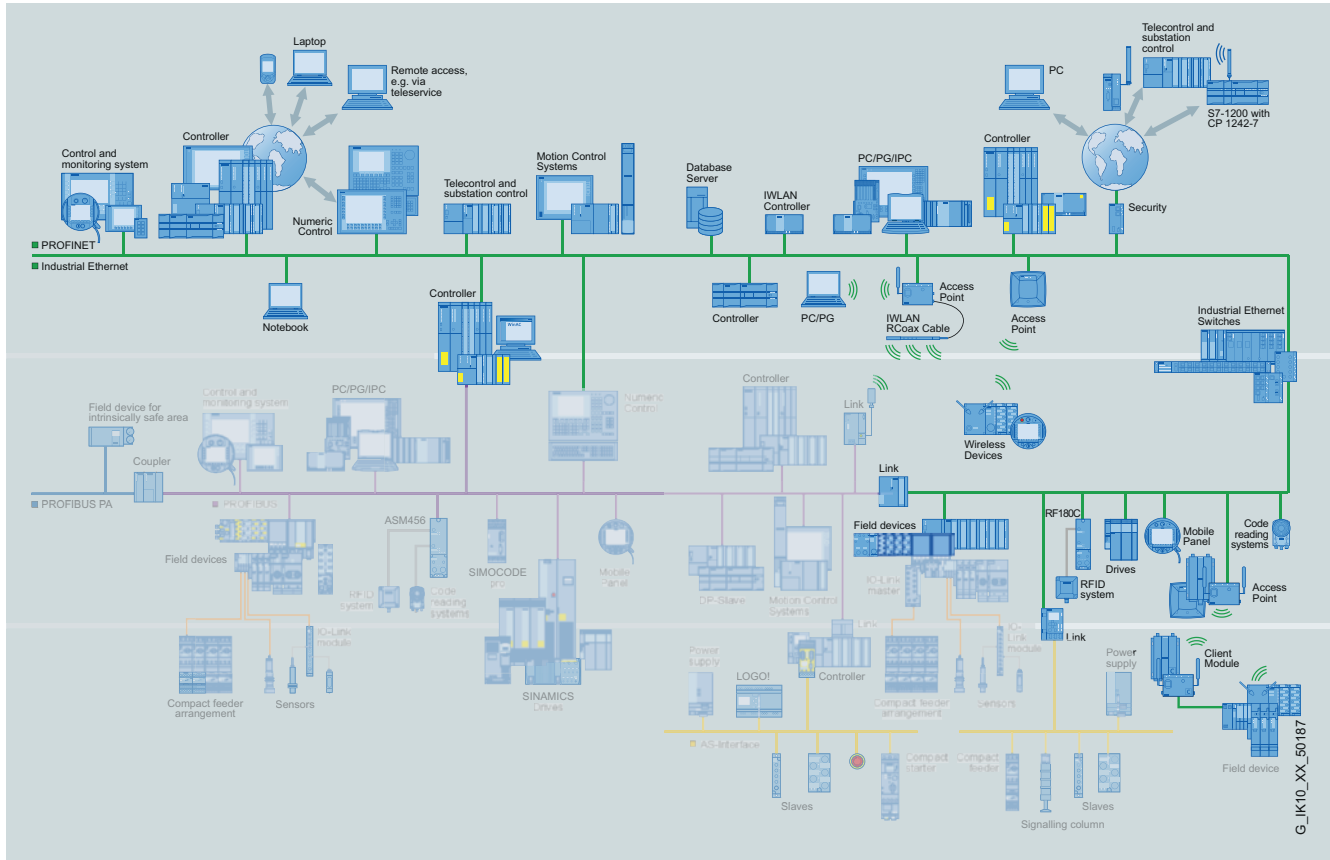

Industrial Ethernet in the communications landscape

Overview (continued)

Ethernet

The LAN standard from the office sector.

Ethernet currently has a market share of over 90% with a rising trend, thus placing it in the pole position in the LAN landscape worldwide. The specification of this baseband LAN was developed in the 1970s and standardized in the international IEEE 802.3 standard. Ethernet has continued to experience rapid development and established itself in all speed ranges and application areas.

Milestones include:

- Virtually unlimited communication capabilities with scalable performance due to
 - switching technology, full duplex, redundancy
 - continuously rising data rates (10/100 Mbit/s, 1/10 Gbit/s)
- High availability of the network, because:
 - existing networks can be expanded without any adverse effects
 - network structures with any form of meshing compensate for the failure of individual network components (e.g. by means of the Rapid Spanning Tree Protocol)
- Compatible protocol expansions, e.g. support of virtual subnetworks and prioritized data traffic through the use of VLANs
- Structured cabling concept
 - Standardized connection technology
 - Simplest connection technology due to use of preassembled twisted pair cables
 - Glass fiber-optic cables for long distances, areas subject to RFI and inter-building cabling

Ethernet forms the basis for overlaid network protocols such as TCP/IP. TCP/IP is responsible for the transport of data between LANs and represents the basis for IT services (e.g. Internet). In addition, this enables different LAN technologies to be easily integrated, e.g. Ethernet with Wireless LAN.

Ethernet components for the office sector are offered by a large number of vendors, but do not always meet the specific requirements of the industrial sector.

For planning, operation and maintenance of Ethernet networks, sufficiently qualified personnel are available worldwide.

Industrial Ethernet

The industry-standard version of Ethernet.

It was not only its performance when exchanging large volumes of data that made Ethernet ideal for use in the industrial environment – high availability, reliability, real-time capability, robust connection technology and ease of operation without special IT knowledge have also made this standard suitable for industrial use.

By means of corresponding additions for tough Industrial use, Siemens has shown that Ethernet can also be used successfully in these applications. This approach has been consistently and successfully applied not only for Industrial Ethernet and PROFINET, but also for Industrial WLAN.

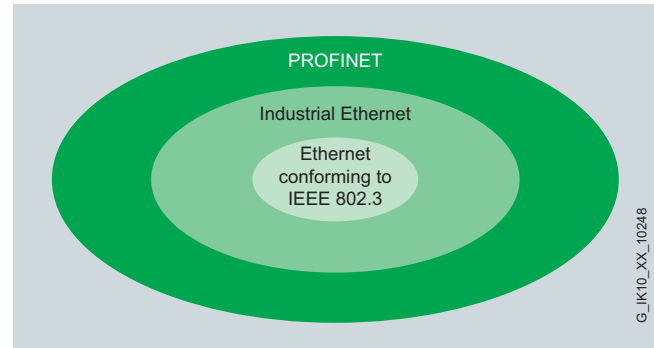

PROFINET/Industrial Ethernet/Ethernet conforming to IEEE 802.3

Industrial Ethernet offers a powerful area and cell network according to IEEE 802.3 (Ethernet) for industrial applications. This ensures that the widest range of application areas, such as office and production, can be networked with one another. The numerous possibilities of the IT standards, familiar from the office world, can thus also be utilized in production and process automation.

Wherever practical, Industrial Ethernet utilizes innovative Ethernet technology and strengthens it for use in the industrial sector.

- Network components for use in tough industrial environments (dust, moisture, extreme temperatures, impact loads, vibrations)
- Rugged and simple connection method on site
 - FastConnect cabling system with RJ45 technology
 - Assembly of POF and PCF fiber-optic cables
- Failsafe networks through high-speed redundancy and redundant power supply
- Connection of automation components (controllers and field devices) to each other and to PCs and workstations
- Optimized communication between automation components and simultaneous, open communication according to TCP/IP standard
- Simple connection to the Wireless LAN and Industrial Wireless LAN (IWLAN) networks in accordance with IEEE 802.11
- A safety solution specially designed for industrial automation with the industrial security concept

Among the Siemens Ethernet components for industrial use, the focus is on compatible successor products and spare parts availability of up to 10 years.

PROFINET/Industrial Ethernet

Industrial Ethernet

Introduction

Overview (continued)

PROFINET

The open Industrial Ethernet standard for automation

With more than three million nodes worldwide, PROFINET is the leading cross-vendor Industrial Ethernet standard (IEC 61158/61784) for automation.

PROFINET increases the companies' success by accelerating processes, boosting productivity, and increasing plant availability.

Advantages at a glance

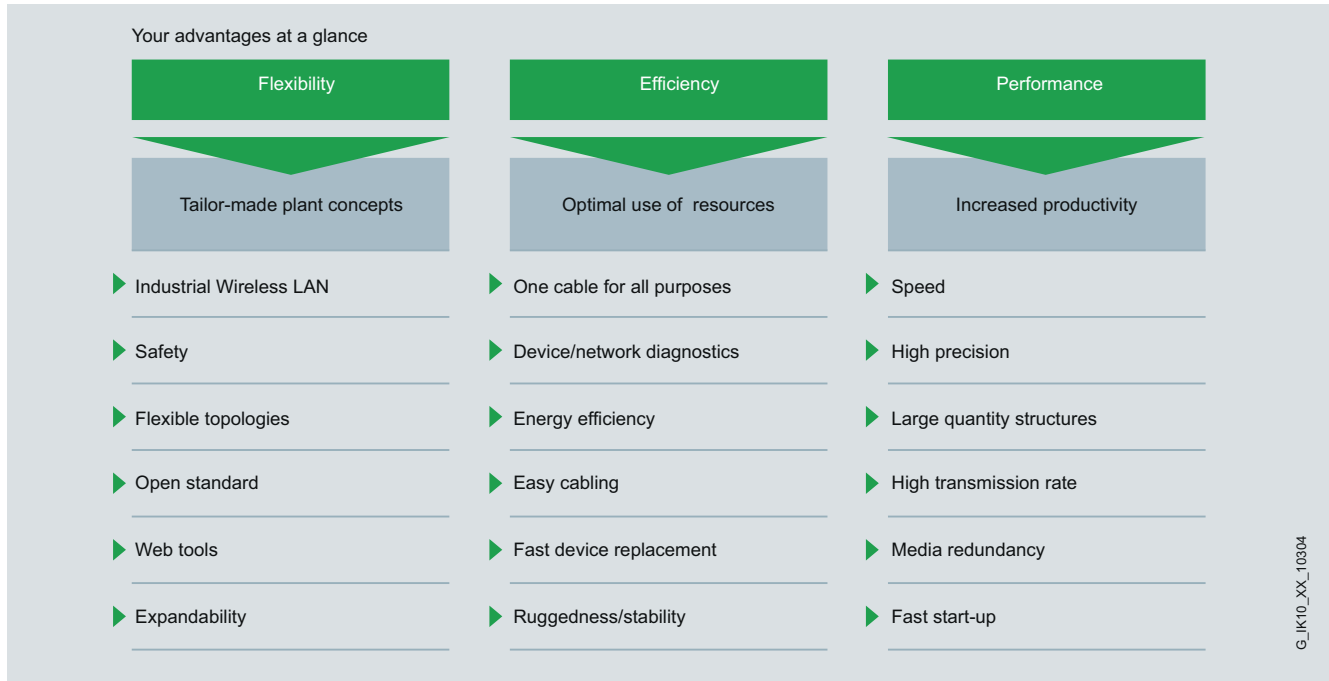

More information

Note:

In many SIMATIC NET components with management function, extensive parameterization and diagnostics functions are provided over open protocols and interfaces (e.g. Web server, network management).

These open interfaces provide access to those components, which can also be used for illicit activities.

When the above-mentioned functions and the open interfaces and protocols are used (e.g. SNMP, HTTP and Telnet), appropriate security precautions must be implemented to suppress unauthorized access to the components or network, especially from the WAN/Internet.

For this reason, automation networks can be isolated from the remaining corporate network using security applications (e.g. SCALANCE S).

For further information, see the section "Industrial Security".

It is important to note the boundary conditions for use of the specified SIMATIC Net products (order numbers 6GK..., 6XV1) which you can view on the Internet.

You will find more information on the Internet at:

www.siemens.com/simatic-net/ik-info

Overview

Standard communication

This comprises standardized protocols for data communication.

ISO, TCP/IP, UDP transport protocols

ISO, TCP/IP and UDP are available as transport protocols.

PROFINET

Based on Industrial Ethernet, PROFINET enables direct communication of field devices (IO Devices) with controllers (IO Controllers) as well the solution of isochronous drive controls for motion control applications.

Media Redundancy Protocol (MRP)

Procedure specified in the IEC 61158 Type 10 standard for increasing the network availability in a ring topology.

Information technology (IT)

IT integrates SIMATIC into the information technology via Industrial Ethernet. These means of communication and communication paths are also available to SIMATIC. Depending on the product and stage of expansion, communications processors support technologies from the IT environment such as:

- **E-mail;**
Via the integral e-mail client, network components, communications processors and routers can send emails to provide information about plant states, e.g. plant standstill or imminent overload, or to automatically request a service call.
- **Freely definable HTML pages;**
Communications processors can perform web diagnostics with the aid of static HTML pages and a user-specific display is supported with the aid of freely definable HTML pages.
- **FTP;**
the File Transfer Protocol (FTP) permits simple, universal coupling, e.g. the PLC can be connected to different computers or embedded systems

IP routing (IP-R)

The system connections for the SIMATIC S7 to Industrial Ethernet, CP 343-1 Advanced, and CP 443-1 Advanced, with two separate interfaces (integrated network separation) and SCALANCE S and SCALANCE X414-3E, support the forwarding of IP messages between Gigabit and PROFINET interfaces. The SCALANCE M mobile wireless routers support routing between the mobile Internet and the connected LAN.

OPC (Openness, Productivity & Collaboration)

OPC is a standardized, open, and vendor-independent interface that is widely used in automation. It permits the connection of OPC-capable Windows applications using many different protocols such as S7-communication, PROFINET, and SNMP.

PG/OP communication

The SIMATIC automation systems can handle data communication with HMI devices (e.g. TP/OP) and programming devices (with STEP 7, STEP 5) via the integral communication functions. PG/OP communication is supported by MPI, PROFIBUS and Industrial Ethernet.

S7 communication

S7 communication is the integral communications function (SFB), which has been optimized within the SIMATIC S7. It enables PCs and workstations to be connected. The maximum volume of user data per task is 64 KB. S7 communication offers simple, powerful communication services and provides a network independent software interface for all networks.

Open communication

The open communication (SEND/RECEIVE) allows the SIMATIC S7 controller to communicate with other SIMATIC S7 and SIMATIC S5 controllers, PCs and third-party systems. In addition, for the simple connection of HMI stations, FETCH and WRITE are offered.

BACnet communication

BACnet (Building Automation and Control Networks) is an ASHRAE (American Society of Heating, Refrigeration and Air Conditioning Engineers Inc.) communication protocol for data networks used for building automation and control. It is equally suitable for the management and automation levels, and is approved as an ANSI, CEN and ISO standard.

MES/ERP communication (ERPConnect)

Communication with ERP or MES systems via database link, e.g. ORACLE, MySQL, MS-SQL, DB2 using a firmware expansion which must be ordered separately

System connections

For many data terminals, communications modules (CPs, CMs, TIMs) are available that already have the communications functions implemented as firmware and which therefore relieve the data terminal of communication tasks (e.g. flow control, blocking, etc.).

Time synchronization

By means of SIMATIC procedures or NTP (Network Time Protocol), plant-wide time synchronization is achieved.



PROFINET/Industrial Ethernet

Industrial Ethernet

Communication overview

Overview

2

	Hardware	Transport protocol			PROFINET			MRP	IT Diagnostics (Web, SNMP) FTP, e-mail, freely definable HTML pages	IP-R	PG/OP	S7 communication			Open communication			Time			Telecontrol			ERP-Connect		
		ISO	TCP	UDP	IO Controller	IO Device	CBA					Standard system	High-availability communication	SEND/RECEIVE	Fetch/Write	TSEND/TRECV	Sending stations	Receiving stations	with NTP	SINAUT S7	DNP3	IEC 9)				
SIMATIC S7-200	CP 243-1		•					• 5)	•		•	•														
	CP 343-1 Lean		•	•		•		• 6)	•		•	• 4)		•	•		• 3)	•	•							
SIMATIC S7-300	CP 343-1	•	•	•	• 2)	• 2)		• 6)	•		•	•		•	•		• 3)	•	•							
	CP 343-1 Advanced	•	•	•	•	•	•	•	•	•	•	•		•	•		• 3)	•	•							
	CP 343-1 ERPC		•	•					•		•	•		•	•		• 3)	•	•					•		
	TIM 3V-IE		•								•								•							
	TIM 3V-IE Advanced		•								•								•							
	TIM 3V-IE DNP3		•								•								•							
	TIM 4R-IE 7)		•								•								•							
	TIM 4V-IE DNP3		•								•								•							
	TIM 4V-IE DNP3		•								•								•							
SIMATIC S7-400	CP 443-1	•	•	•	•		•	•			•	•	• 1)	•	•	•	• 3)	•	•							
	CP 443-1 Advanced	•	•	•	•		•	•	•	•	•	•	• 1)	•	•	•	• 3)	•	•							
	TIM 4R-IE 7)8)		•								•								•							
	TIM 4V-IE DNP3		•								•								•							

1) ISO protocol only
 2) IO Controller or IO Device
 3) if S7-CPU is clock master
 4) S7 server only
 5) only standard page for system diagnosis
 6) Firmware V2.2 or higher
 7) Stand alone can be used
 8) S7-300 module format, connection to S7-400 CPU using MP or Industrial Ethernet
 9) with FB for SIMATIC S7 CPU (SIPLUS RIC Bundle)

• suitable

You can find additional information on block solutions under www.siemens.simatic-net/ik-info

G_IK10_XX_10057

Communications overview for SIMATIC



Overview (continued)

Hardware	Software	Operation system (64 bit)		Operation system (32 bit)				Other operation systems	OPC	Transport protocol			PROFINET		MRP	IT	PG/OP	S7 communication		Open communication		Time	
		Windows 7 Professional / Ultimate ⁷⁾	Windows Server 2008 R2 ⁷⁾	Vista Business / Ultimate + SP1/2 ⁸⁾	Windows XP Pro + SP3 ⁸⁾	Windows Server 2008 + SP1/2 ⁸⁾	Windows Server 2003 R2 / SP2 ⁸⁾			Linux ⁸⁾	ISO	TCP	UDP	IO Controller				IO Device	Diagnostics (Web, SNMP)	Standard system	High-availability communication	SEND/RECV	Fetch/Write
CP 1604 (PCI 104) CP 1616 (PCI 32 Bit)	DK-16xx PN IO	•			•			• ⁴⁾	○ ⁵⁾		•			•	•	•	•						
CP 1613 A2 (PCI 32 Bit)	HARDNET-IE S7 (S7-1613)	•	•	•	•	•	•			•	•	•	○ ³⁾			○ ⁶⁾	•	•		•	•	•	•
	HARDNET-IE S7-REDCONNECT (S7-REDCONNECT)	•	•	•	•	•	•			•	•	○ ³⁾				○ ⁶⁾	•	•	•	•	•	•	•
CP 1623 (PCIe x1)	S7 OPC Redundancy for Industrial Ethernet		•							•							•						
CP 1628 (PCIe x1)	HARDNET-IE S7 (S7-1613)	•	•							•	•	•	○ ³⁾			○ ⁶⁾	•	•		•	•	•	•
	HARDNET-IE S7-REDCONNECT (S7-REDCONNECT)	•	•							•	•	○ ³⁾				○ ⁶⁾	•	•	•	•	•	•	•
	S7 OPC Redundancy for Industrial Ethernet		•							•							•						
CP 1612 A2 (PCI 32 Bit)	SOFTNET-IE S7 (SOFTNET-S7)	•	•	•	•	•	•			•	•	•	○ ³⁾			○ ³⁾	•	•		•	•		
	SOFTNET-IE S7 Lean (SOFTNET-S7 Lean)	•	•	•	•	•	•			•	•	•	○ ³⁾			○ ³⁾	•	•		•	•		
SIMATIC PG/PC with integrated interface ¹⁾	SOFTNET-IE PG (SOFTNET-PG)	•	•	•	•	•	•			•	• ²⁾	• ²⁾				○ ³⁾	•						
	SOFTNET-IE PN IO (SOFTNET PN IO)	•	•	•	•	•	•			•				•		○ ³⁾							
	S7 OPC Redundancy for Industrial Ethernet		•							•							•						
Ethernet Cards ³⁾	SOFTNET-S7/Linux							•		•	•	○ ³⁾				•	•						
	SOFTNET PN IO/Linux							•				○ ³⁾	•										

1) Infos zu weiterer Hardware siehe www.siemens.com/simatic-net/ik-info
 2) PG/OP communication
 3) IT, FTP and UDP functionalities arise in conjunction with the hardware/the CPs and the Windows/Linux software of the PC
 4) Software source of the card driver included; for Suse 12

5) by means of driver porting
 6) CP 1613 A2, CP 1623 and CP 1628 with SNMP
 7) on SIMATIC NET CD V8.1
 8) on SIMATIC NET CD Edition 2008

• suitable
 ○ suitable under certain conditions

G_IK10_XX_10058

Communications overview for PG/PC

PROFINET/Industrial Ethernet

Industrial Ethernet

Topologies

Overview

Network performance and network technologies for Industrial Ethernet

When combined, the current Industrial Ethernet technologies can significantly boost performance on the network in comparison with the original 10 Mbit/s technology. These technologies are:

- **Fast Ethernet** with 100 Mbit/s:
Messages are transported much faster than Ethernet (10 Mbit/s) and therefore only occupy the bus for an extremely short time. For Fast Ethernet, a 4-wire FastConnect cabling system (Cat5e) is available with cable, plug and outlet.
- **Gigabit Ethernet** with 1 Gbit/s:
Gigabit Ethernet is faster than Fast Ethernet by a factor of 10, the bus is occupied for only one tenth of the time. For Gigabit Ethernet, an 8-wire FastConnect cabling system (Cat6) is available with cable, plug and outlet.
- **Gigabit Ethernet** at 10 Gbit/s:
Compared to Ethernet with 1 Gbit/s, Ethernet with 10 Gbit/s is faster again by a factor of 10.
- **Full Duplex** prevents collisions:
The data throughput increases enormously because the usual message repetitions are avoided. Data can be sent and received simultaneously between two stations. The data throughput for a full duplex connection therefore rises to 200 Mbit/s with Fast Ethernet and to 2 Gbit/s with Gigabit Ethernet. With full duplex, a greater length of the network is possible. This means, for example, that when glass fiber-optic cables are used, distances of up to 120 km can be achieved.
- **Switching** supports parallel communication:
When a network is subdivided into several segments using a switch, or individual stations are connected direct to a switch, this results in load separation. Data communication is possible in each individual segment independently of the other segments. In the overall network, several messages can therefore be en-route simultaneously. The increase in performance is therefore due to the sending of several messages simultaneously.
- **Autocrossover** automatically crosses the send and receive cables on Twisted Pair interfaces.
- **Autosensing** describes the characteristic of network nodes (data terminals and network components) that automatically detect the transmission rate of a signal (10 Mbit/s, 100 Mbit/s or 1 Gbit/s) and support autonegotiation.
- **Autonegotiation** is a configuration protocol on Fast Ethernet. Before initiating the actual data transmission, network devices automatically negotiate a transmission mode which is supported by any device (1000 Mbit/s, 100 Mbit/s or 10 Mbit/s, full duplex or half duplex)

Ethernet Switching

The Industrial Ethernet switch has the following functionality:

- Depending on the number of available interfaces, switches are able to simultaneously interconnect several pairs of subnetworks or stations temporarily and dynamically, with each connection possessing the full data throughput.
- By filtering the data traffic on the basis of the Ethernet (MAC) address of the terminals, the data traffic remains local and only data intended for nodes of another subnetwork is forwarded by the switch.
- More data terminals can be connected than in a classic Ethernet network.
- Error propagation is limited to the subnetwork concerned.

The switching technology offers definite advantages:

- Subnetworks and network segments can be created.
- The data throughput is increased and with it the network performance as a result of structuring the data communication.
- Easy rules for network configuration.
- Network topologies with 50 switches and an overall extension of more than 150 km can be implemented without the need to take signal propagation times into account.
- Unlimited extension of the network by connecting individual collision domains/subnetworks.
- Easy, reaction-free extension of existing networks.

Overview (continued)

Full duplex

Full duplex (FDX) is an operating mode in the network that, in contrast to half duplex, allows stations to send and receive data simultaneously. When FDX is used, collision detection is automatically deactivated in the participating stations.

For FDX, transmission media with separate send and receive channels must be used, e.g. FOC and TP, and the participating components must be able to store data packages. With an FDX connection collisions do not occur, so components that support FDX can send and receive simultaneously at the nominal transmission rate. The data throughput therefore increases to twice the nominal transmission rate of the network, to 20 Mbit/s with the classic Ethernet and 200 Mbit/s with Fast Ethernet. With Gigabit Ethernet, up to 2000 Mbit/s are achieved.

A further advantage of FDX is the increase in the network extension.

By deactivating the collision principle, the distance between two components can be increased by the size of a collision domain or more. With full duplex, the maximum distance can extend as far as the performance limit of the send and receive components. This is especially the case in connection with fiber-optic cables. When glass fiber-optic cables are used, distances of up to 120 km can be achieved.

Autosensing/Autonegotiation

Autosensing describes the characteristic of network nodes (data terminals and network components) that automatically detect the transmission rate of a signal (10 Mbit/s, 100 Mbit/s or 1000 Mbit/s) and support autonegotiation.

Autonegotiation is the configuration protocol for Twisted Pair. It enables the participating nodes to negotiate and agree the transmission rate before the first data packages are transferred:

- 10 Mbit/s, 100 Mbit/s, 1 Gbit/s or 10 Gbit/s
- Full duplex or half duplex

Autonegotiation can also be deactivated if a specific transmission rate has to be set.

The advantage with Autosensing lies in the problem-free interoperability of all Ethernet components. Classical Ethernet components that do not support Autosensing work problem-free with Fast Ethernet and new Gigabit Ethernet components that do support Autosensing.

Autocrossover

The Autocrossover function automatically crosses the send and receive cables on Twisted Pair interfaces. This means that crossed connecting lines (e.g. TP XP Cords) are no longer required.

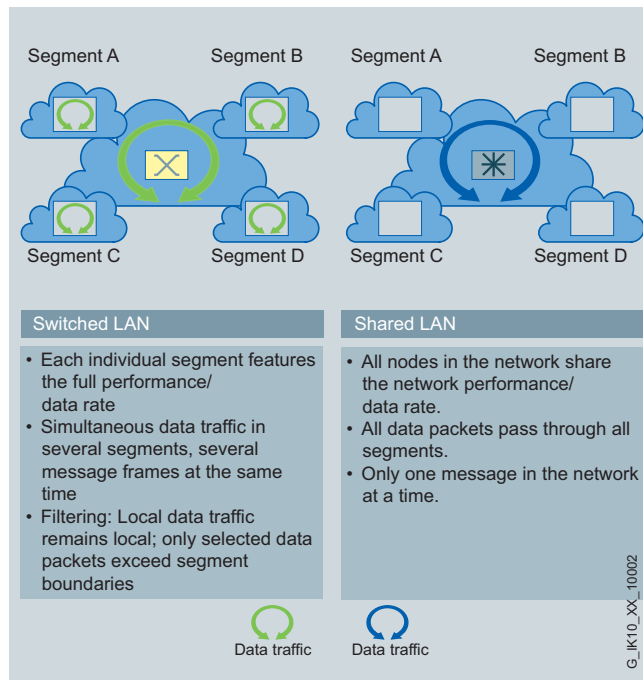

Increased performance through switching, full duplex

PROFINET/Industrial Ethernet

Industrial Ethernet

Topologies

Overview (continued)

Fast redundancy

Extremely fast reconfiguration of the network following an error is indispensable for industrial applications, because the connected data terminals will otherwise disconnect logical communication links. This would result in a process running out of control or emergency shutdown of the plant.

In order to achieve the very fast reaction times required, various standardized procedures are used. A network can then be reconfigured to form a functional network infrastructure in a fraction of a second.

In an optical ring comprising 50 switches, the network will be reconfigured after a fault (cable break or switch failure) in less than 0.2 seconds. The connected data terminals remain unaffected by the changes in the network and logical connections are not disconnected. Control over the process or application is assured at all times.

In addition to implementing high-speed media redundancy in the ring, Industrial Ethernet switches also offer the functions required for high-speed redundant coupling of rings or network segments. Network segments in any topology or rings can be coupled via two switches in each case.

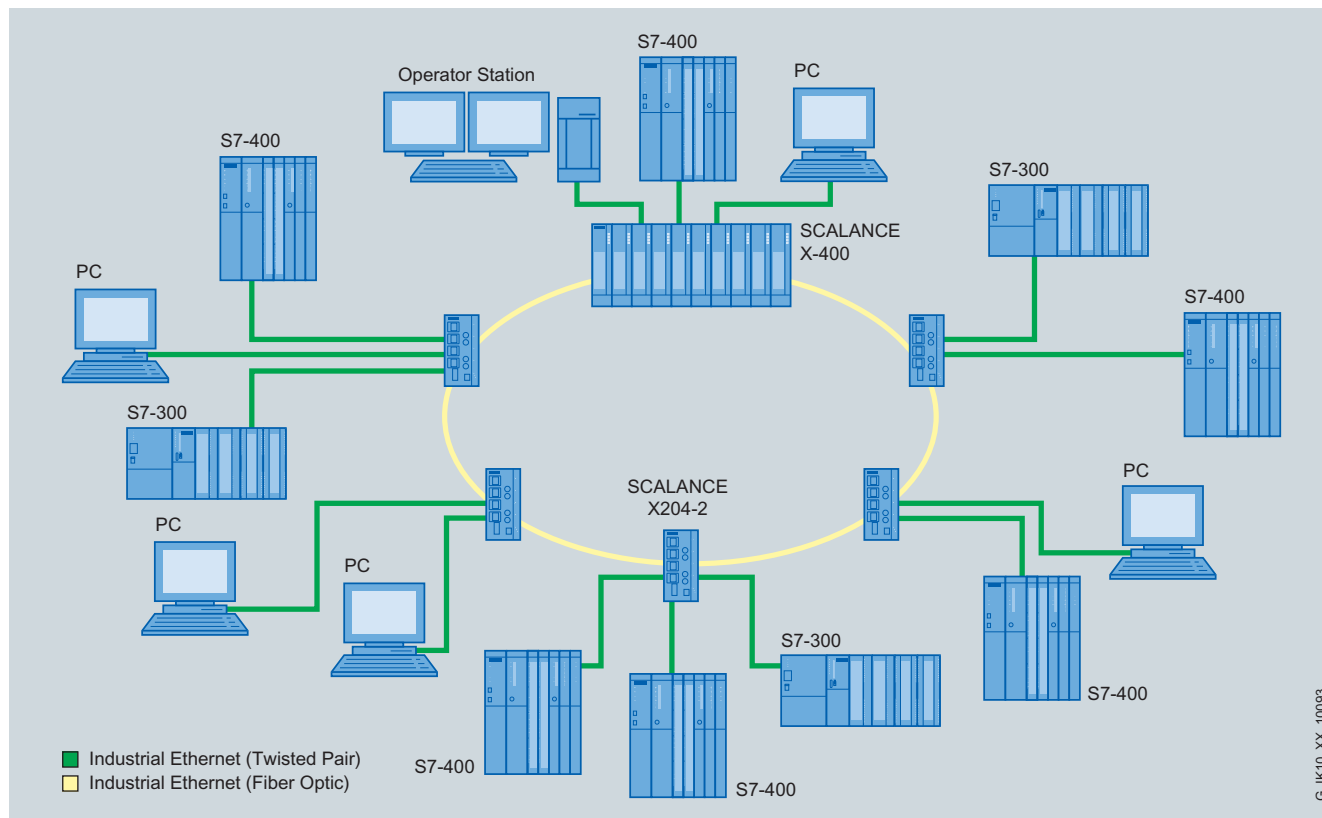

G_IK10_XX_10093

Overview (continued)

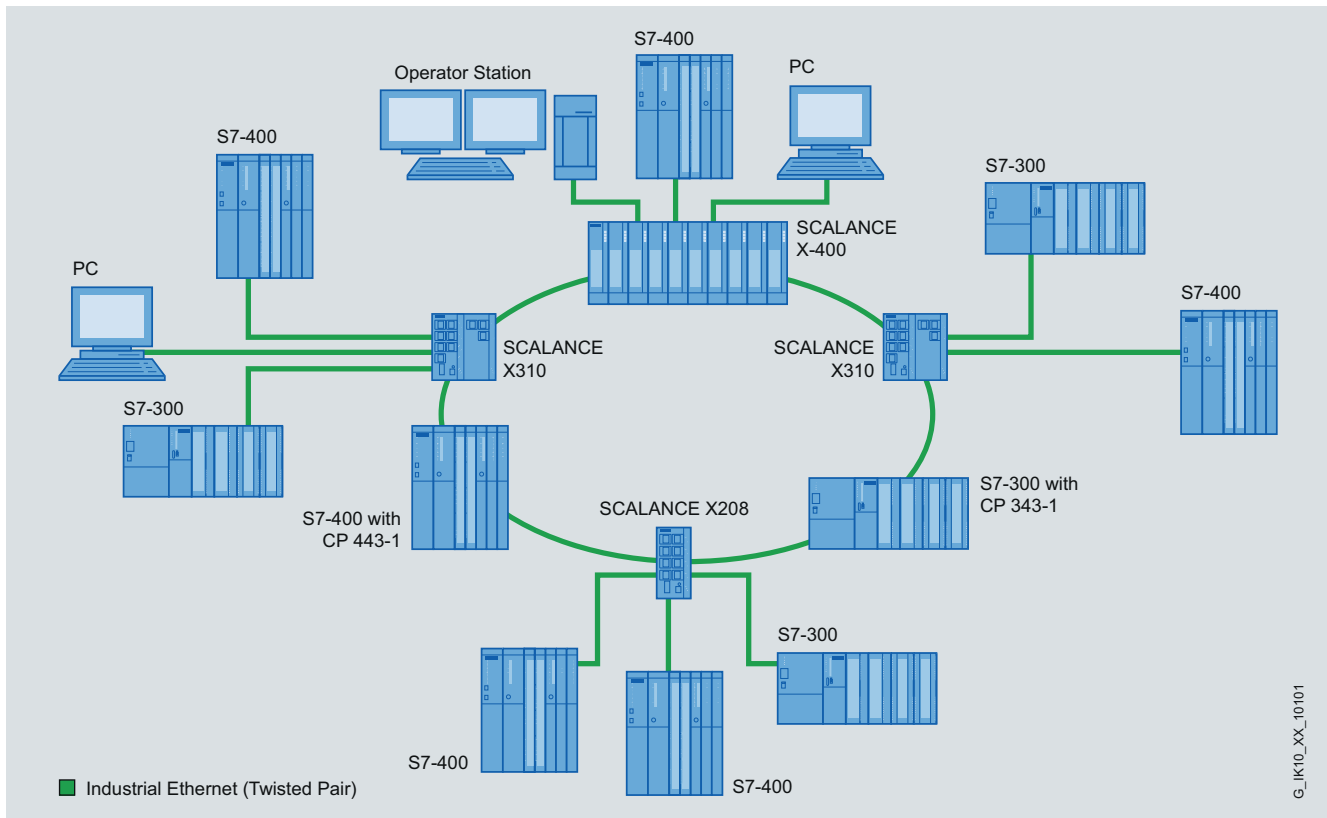

Configuration with high-speed redundancy in the electrical ring

Media Redundancy Protocol (MRP)

Higher plant availability can be achieved by means of a redundant installation (ring topology). The media redundancy can be created on the one hand by means of switches, and on the other hand direct via the PROFINET interfaces on SIMATIC controllers and distributed inputs/outputs. Thanks to the MRP protocol (IEC 61158 Type 10), reconfiguration times of less than 200 ms can be achieved, depending on the number of stations.

If the ring is interrupted at one point, immediate reconfiguration takes place and all communication nodes continue to be accessible.

PROFINET/Industrial Ethernet

Industrial Ethernet

Topologies

Overview (continued)

2

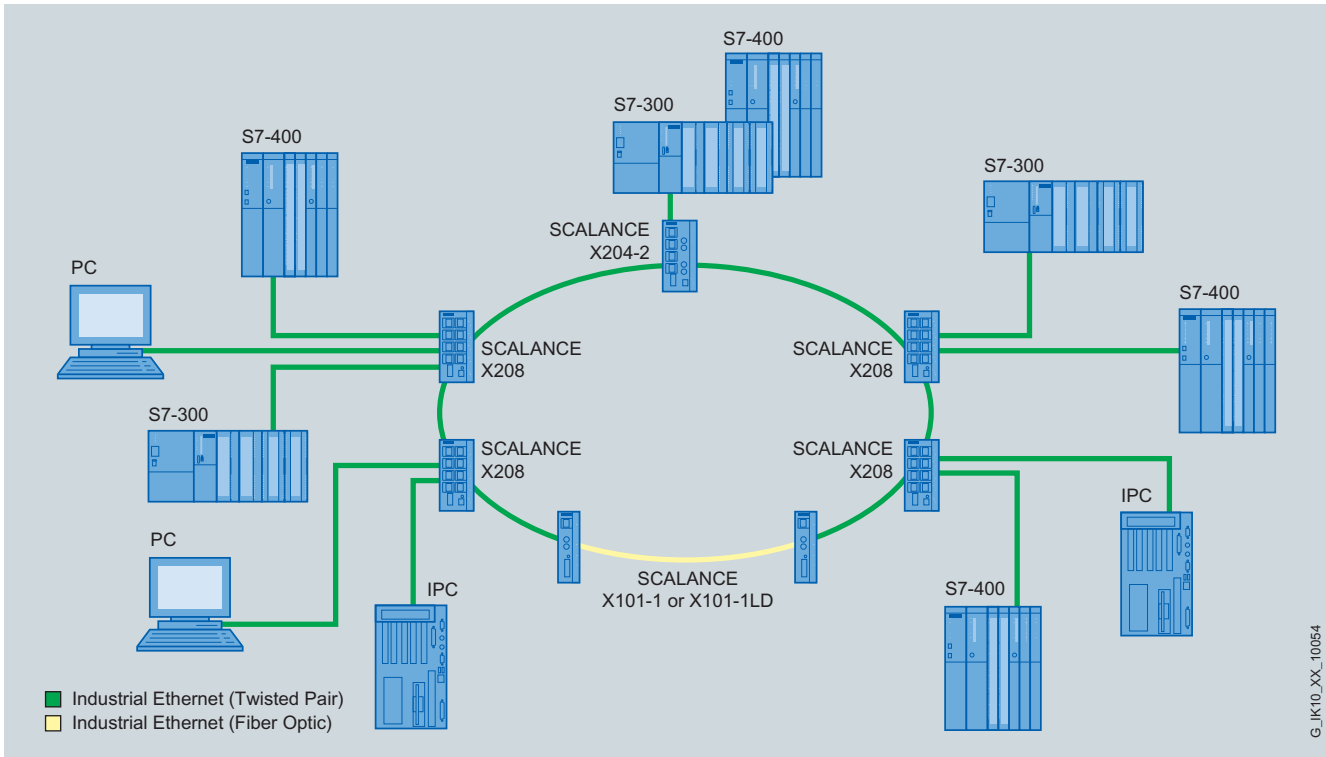

G_IK10_XX_10054

Electrical/optical ring topology with SCALANCE X101-1/X101-1LD

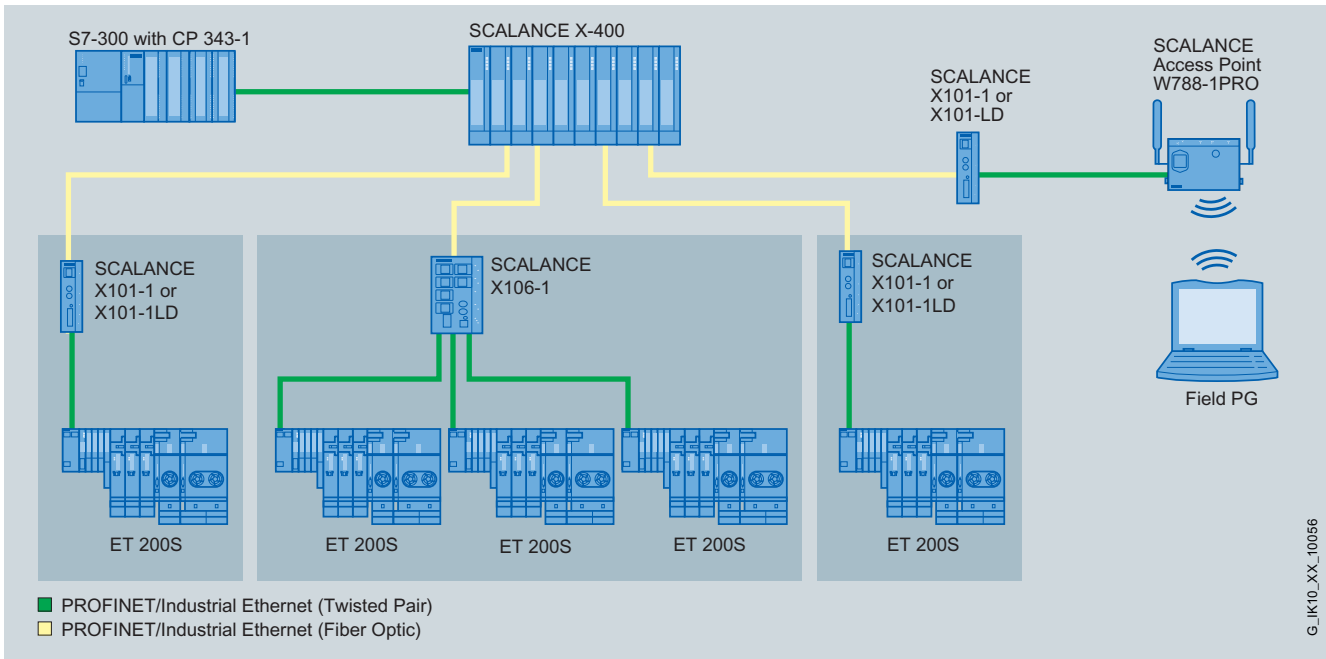

G_IK10_XX_10056

Optical star topology with SCALANCE X101-1/X101-1LD and remote SCALANCE W Access Point

Overview (continued)

Redundancy with the Spanning Tree algorithm

The Spanning Tree algorithm is described in the IEEE 802.1d standard; it organizes any number of meshed Ethernet structures comprising bridges and switches.

To prevent data packages circulating in the network, in the case of closed meshes different connections are switched to standby so that an open tree structure results from the meshed structure.

The bridges/switches communicate for this purpose using the Spanning Tree protocol. This protocol is extremely complex because it has to handle any type of network structure.

The organization of network structures with the Spanning Tree protocol can take from 30 to 60 seconds. During this period, productive communication for reliable visualization or process control in the network is not possible.

In the time-optimized version "Rapid Reconfiguration Spanning Tree" according to IEEE 802.1, the time is shortened to between 1 and 3 seconds for up to 10 series-connected switches. For connecting to office networks, some SIMATIC NET switches support the Rapid Spanning Tree Protocol.

Switched network

Switched industrial networks can be configured electrically or optically with a linear, star or ring structure, or a combination.

They are constructed with SCALANCE X switches and with integral switches, e.g. in communications processors. Fiber-optic conductors or Twisted Pair cables are used as the transmission media between the switches.

Data terminals or network segments are connected over twisted-pair cables or polymer optical fiber (POF). Switched networks can be of any size. The signal propagation times must be taken into account at distances over 150 km.

Optical cabling with POF/PCF or glass fiber optic cable

Fiber-optic cables are always recommended as an alternative to copper cables in environments subject to strong electromagnetic interference (EMI), if reliable equipotential bonding cannot be guaranteed, if the system is in the open air, or if no adverse effects caused by EMI are wanted.

Glass fiber optic cables are used to establish optical network topologies covering long distances, while for shorter distances, plastic fiber optic cable made of light-conducting plastics like polymer optical fiber (POF), or plastic covered glass fibers such as polymer clad fiber (PCF), are used. Simple fiber-optic cabling for machine-level use is implemented with the SC RJ connection system for polymer optical fiber and PCF. The SC RJ connectors can be assembled especially quickly and simply on-site. The plastic fiber optic cables designed for this purpose can be used universally or specifically in festoon cable systems.

For optical cabling, e.g. for a PROFINET system, products with POF or PCF connection are used, e.g. the Industrial Ethernet Switch SCALANCE X200-4P IRT, ET 200S distributed I/O, or the SCALANCE X101-1POF media converter.

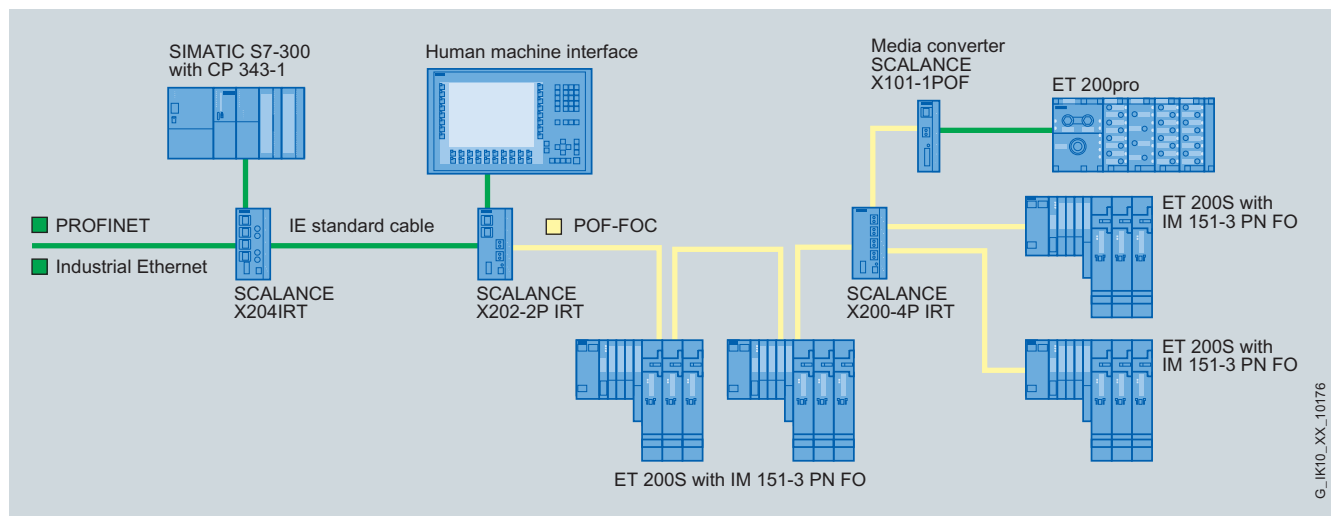

Mixed network with SCALANCE X202-2P IRT and SCALANCE X101-1POF media converter

PROFINET/Industrial Ethernet

Industrial Ethernet

Topologies

Overview (continued)

Fault-tolerant communication

The availability of the communication is increased by means of redundant communication connections, to which the data transmission can be switched quickly in the event of a fault.

Fault-tolerant S7-connections can be set up from S7-400H stations to

- other H stations (one- or two-channel)
- PCs (S7-REDCONNECT software required)

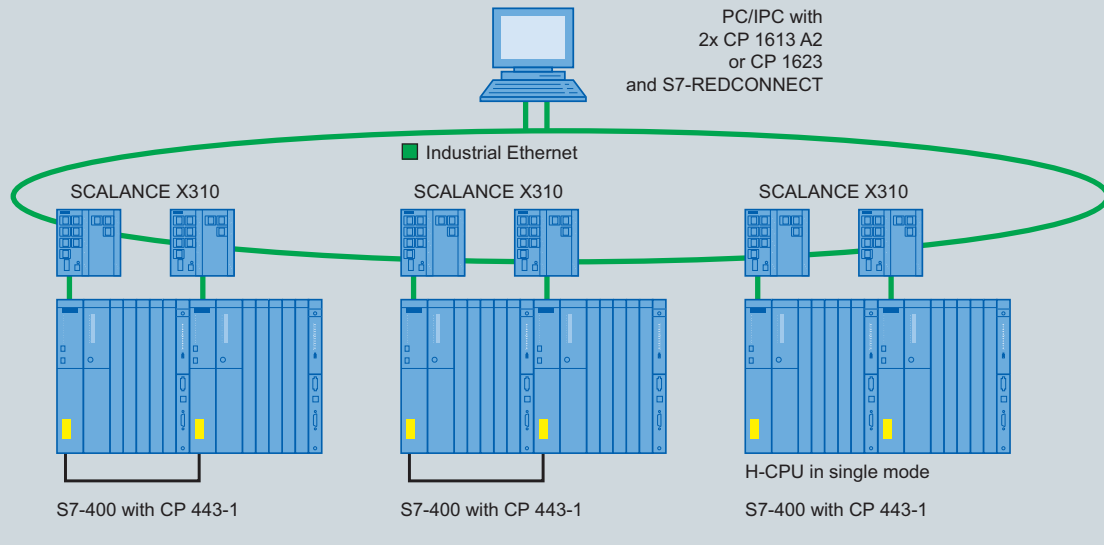

Increased availability by means of redundant communication connections

Overview (continued)

Gigabit at the control level

Whereas in the field level, short response times and small data message frames are in the forefront, the need for high data throughput is constantly increasing in the control level. The reason for this is the rapidly growing number of nodes and data-intensive systems such as HMI, SCADA, code reading systems, web applications or multimedia applications.

In addition to the Gigabit-capable network infrastructure, there are also Gigabit-capable system connections for PCs or SIMATIC S7-300/400. The CP 1623 communications processor for PCI Express supports a high-performance connection of the HMI/SCADA systems and simultaneously increases the reliability of the network by means of an optional external power supply.

The CP 343-1 Advanced and CP 443-1 Advanced communications processors for SIMATIC S7-300/400 implement integral network separation between the control level and field level and provide:

- Separate network connections on a module for the connection of two independent IP-subnetworks, e.g. control level is IP subnetwork 1 (Gigabit Ethernet) and the field level is IP subnetwork 2 (Fast Ethernet)
- Cross-network utilization of IT services through IP routing, such as access to Web servers
- Short response times for the lower-level field device connection with PROFINET
- Firewall for protecting the programmable controllers from unauthorized access regardless of the size of the network to be protected
- Supplementary or alternative VPN (**V**irtual **P**rivate **N**etwork) for secure authentication of the communication partners and encryption of the transmitted data

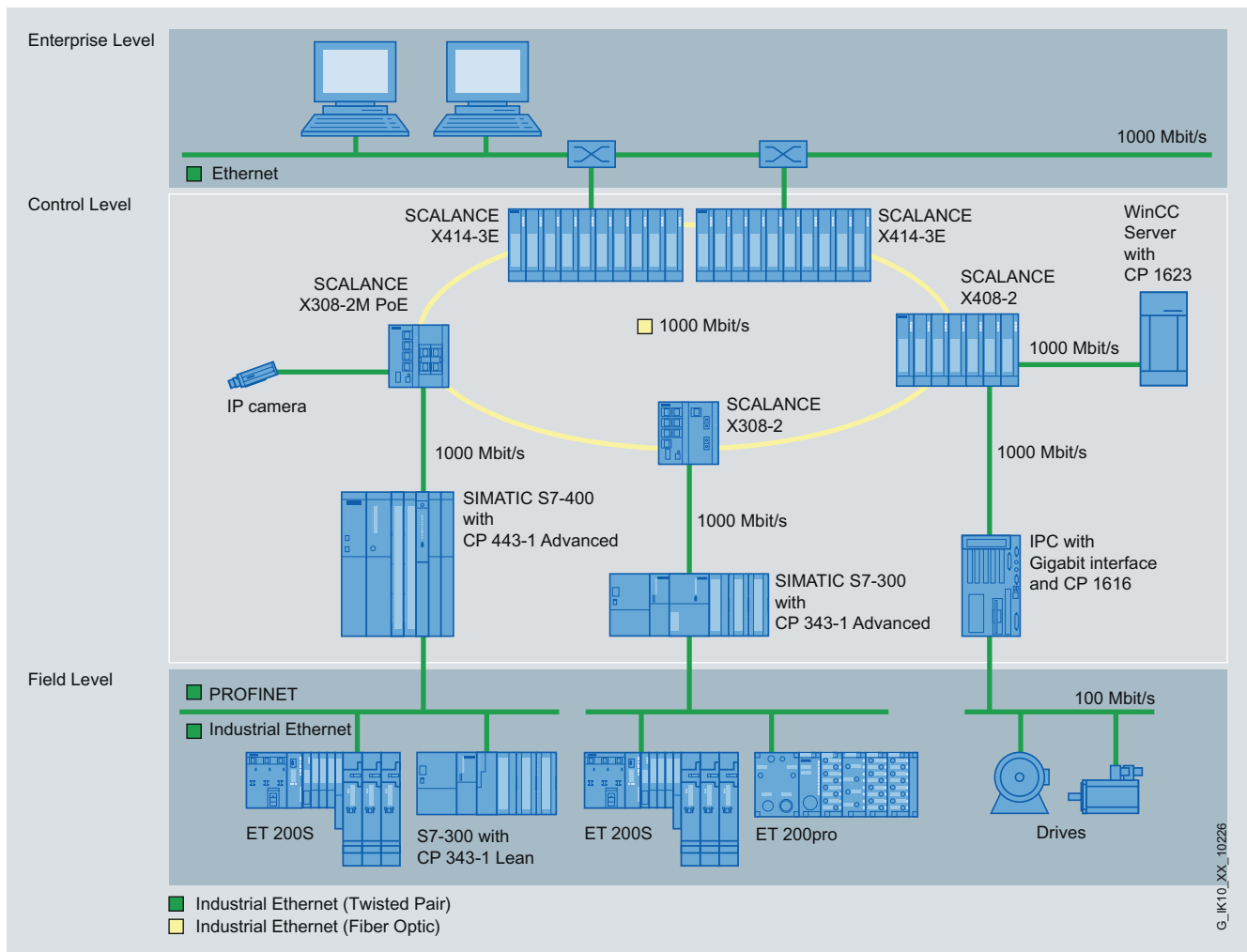

Network separation between field level and control level including Gigabit communication at the control level

PROFINET/Industrial Ethernet

Industrial Ethernet

Topologies

Overview (continued)

Network separation between field level and control level

Networks often have to be separated physically from one another, but nevertheless have to communicate with one another. Reasons for network separation are deliberate load decoupling or different responsibilities within an enterprise (e.g. office and production network).

When using the CP 343-1 Advanced communications processors and CP 443-1 Advanced for S7 controllers this requirement presents no problem. With the introduction of interfaces for separate IP subnetworks in Gigabit Ethernet and Fast Ethernet on one module, the cross-network use of IT services is possible by means of static IP routing. A firewall protects programmable controllers against unauthorized access regardless of the size of the network to be protected. As an alternative or supplement, secure authentication of the communication partners and encryption of the transmitted data can be handled via a VPN (Virtual Private Network).

SIMATIC PCS 7 process control system with Gigabit

In the control room, two SCALANCE X-400 switches are used on the terminal bus. If a high number of nodes are connected to the plant bus, SCALANCE X414-3E switches, for example, can be used with extender modules. These are connected together to create an electrical ring with a transfer rate of 1 Gbit/s.

Several operator panels are provided and divided between the two switches so that the system can still be operated in the event of a failure. The terminal and plant buses are connected using redundant servers, e.g. with SCALANCE X408-2 also via high-performance Gigabit lines.

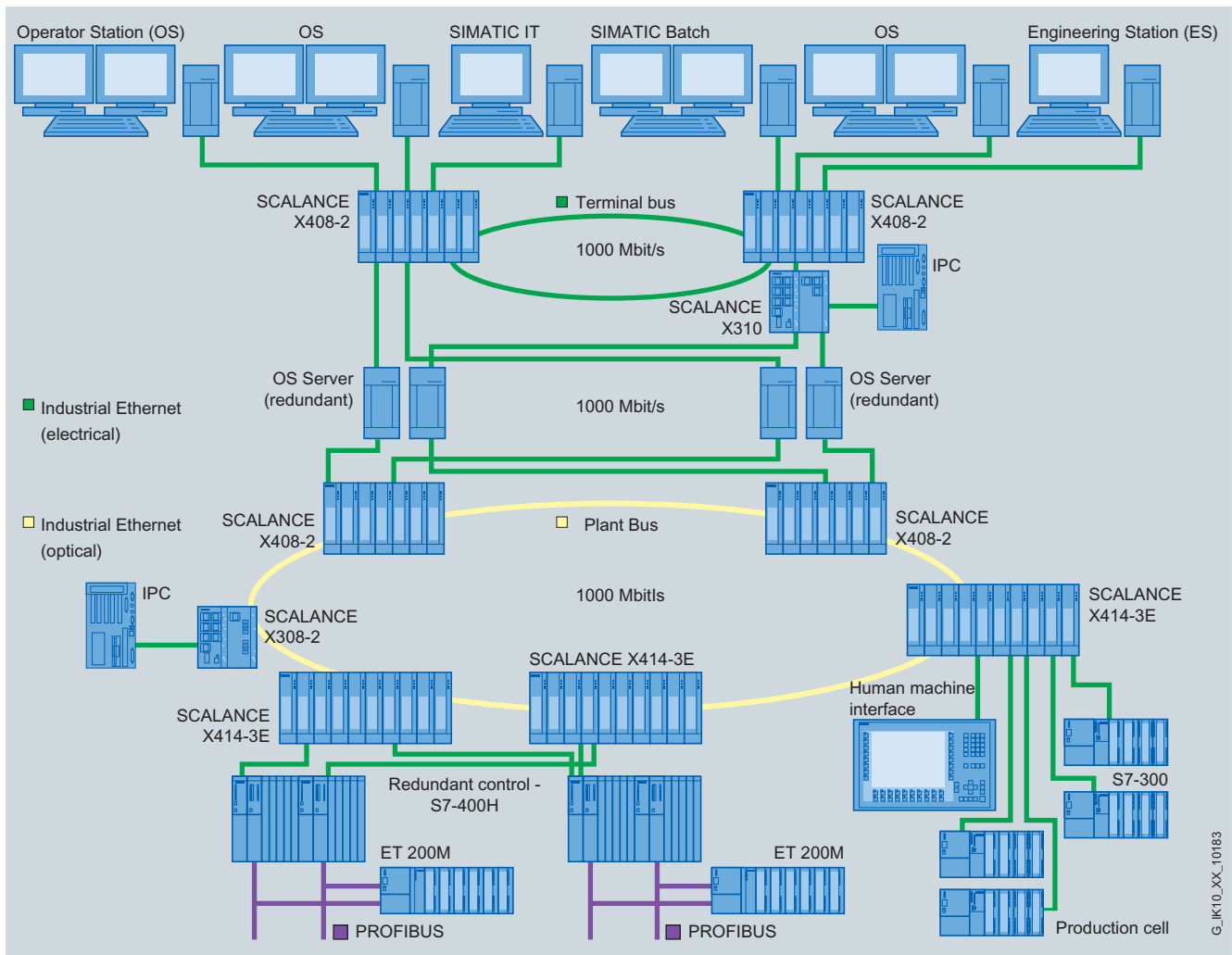

Use of the SCALANCE X switches in a process control system, e.g. PCS 7

Overview (continued)

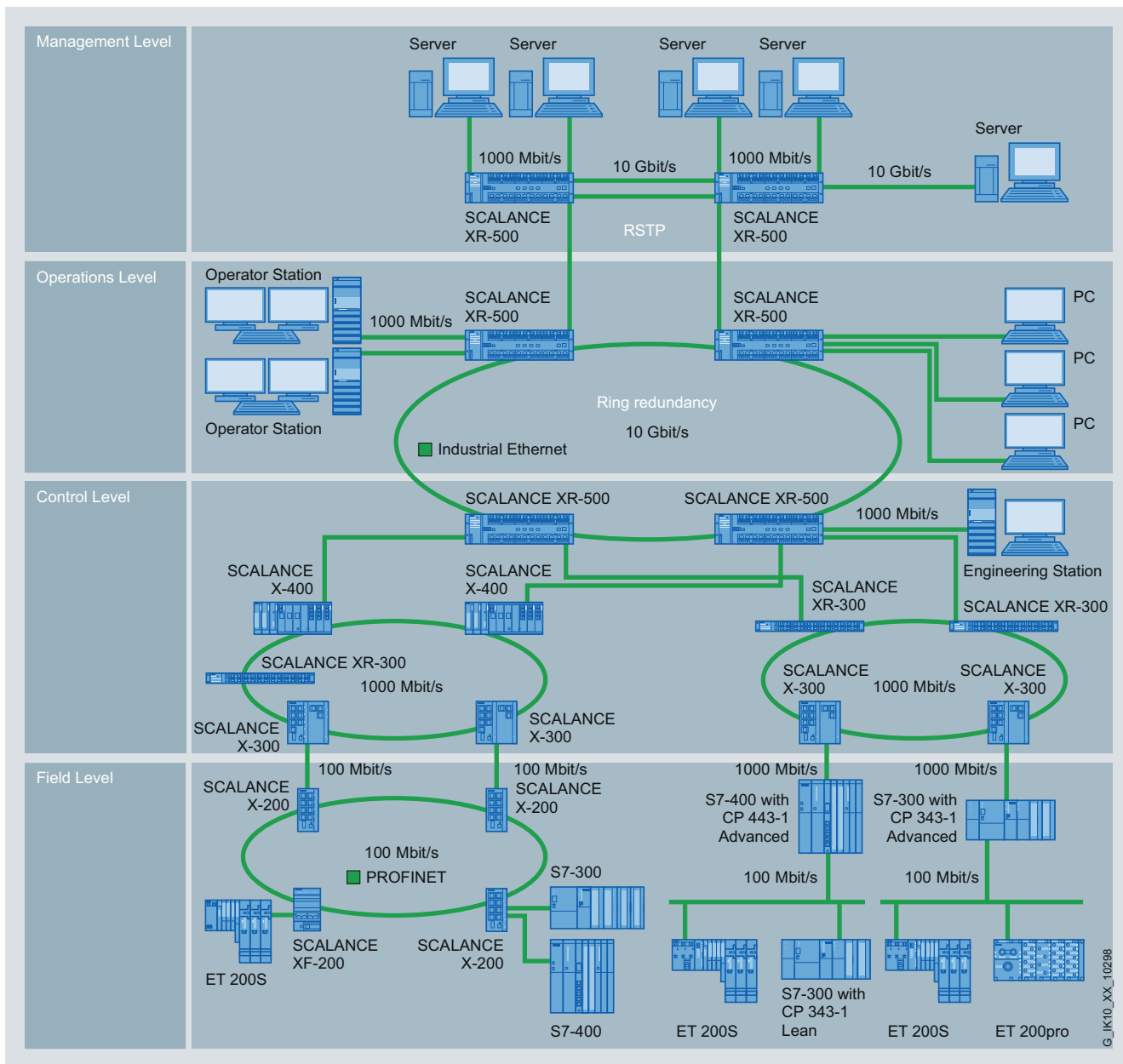

Plant network with connection to the management level or the corporate network with SCALANCE X-500

PROFINET/Industrial Ethernet

Industrial Ethernet

Topologies

Overview (continued)

Fail-safe wireless communication with PROFIsafe

For several years, safety engineering has been integrating into standard automation on the basis of SIMATIC S7 controllers, PROFIBUS and PROFIsafe.

This range has been expanded by PROFINET-enabled components, thus providing a complete product range with failsafe controllers, failsafe I/O and a corresponding engineering environment.

PROFIsafe prevents errors such as address corruption, loss, delay, etc., when transmitting messages through continuous numbering of the PROFIsafe data, time monitoring, and authenticity monitoring using passwords and optimized cyclic redundancy check (CRC).

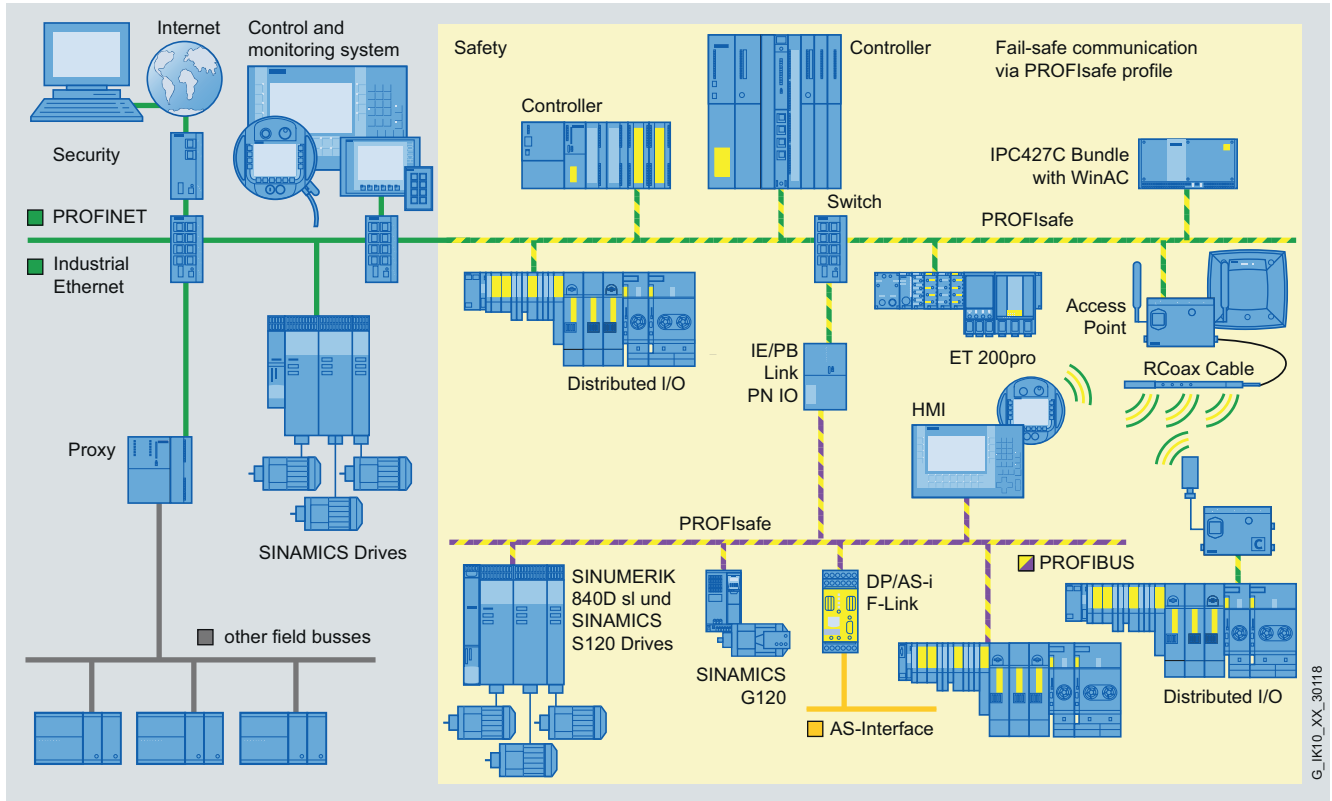

Fail-safe wireless communication with PROFIsafe

G_JK10_XX_30118

2

Overview (continued)

Secure communication with SCALANCE S and Security Integrated

SCALANCE S security modules and modules with Security Integrated offer scalable security functionality for the protection of automation networks. Security Integrated integrates the firewall and VPN security functionalities familiar from SCALANCE S into communications processors (CP 343-1 Advanced, CP 443-1 Advanced, CP 1628) and the SCALANCE M875 mobile wireless router as additional functions. Apart from IP routing, the following are supported:

- Firewall for protecting the programmable controllers from unauthorized access regardless of the size of the network to be protected.
- Supplementary or alternative VPN (Virtual Private Network) for secure authentication of the communication partners and encryption of the transmitted data
- Address translation
 - NAT (Network Address Translation) permits the use of private IP addresses in the internal network in that public IP addresses are converted to private ones
 - NAPT (Network Address and Port Translation) permits the use of private IP addresses in the internal network in that frames are converted to private IP addresses depending on the communications port used

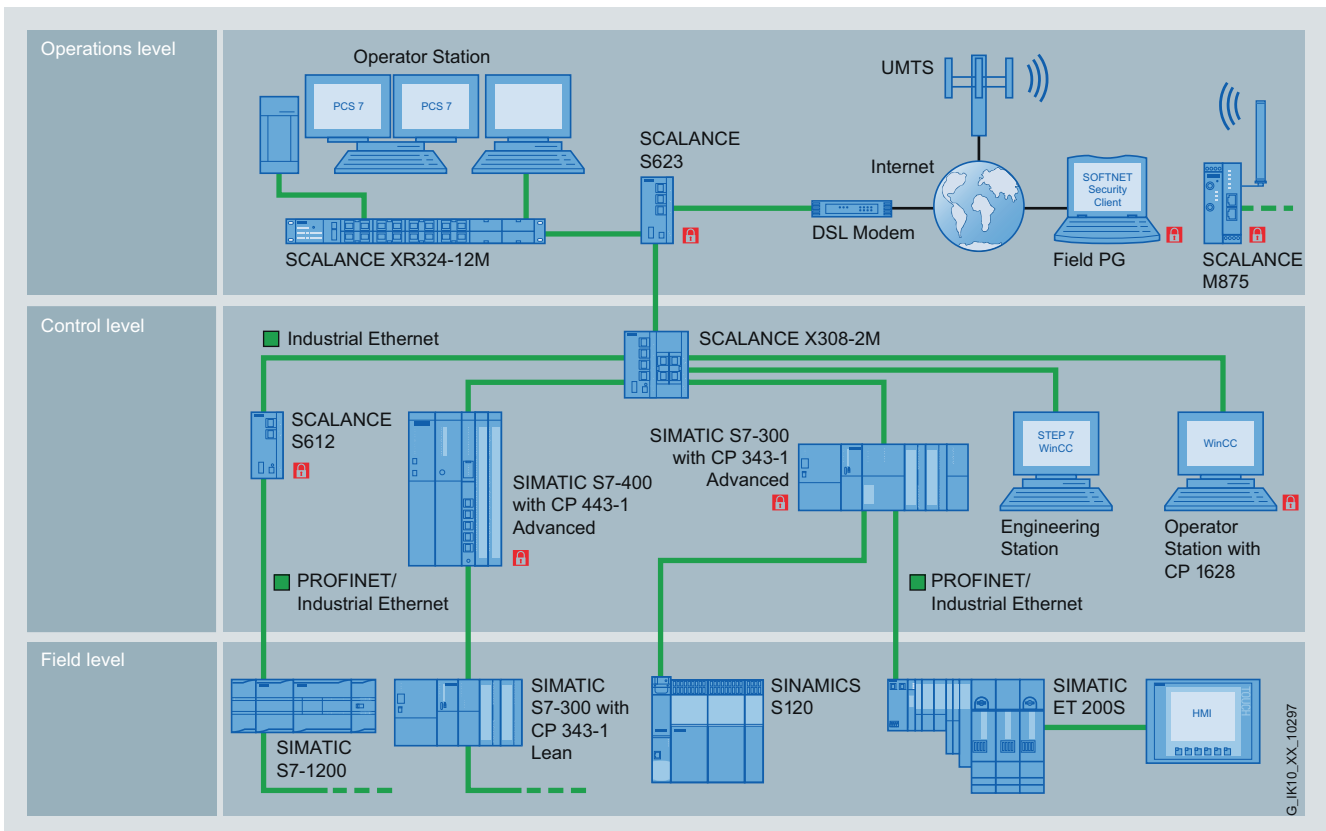

Secure remote maintenance and protection of network segments thanks to SCALANCE S in a Gigabit network infrastructure

PROFINET/Industrial Ethernet

Industrial Ethernet

Topologies

Overview (continued)

For a high-performance coupling of networks, the modular Industrial Ethernet Switch SCALANCE X414-3E is available. In the case of SCALANCE X414-3E, high-speed IP routing permits communication between different IP subnetworks and routers:

- Static routing
- Dynamic routing OSPF (open shortest path first) and
- RIPv1/2 (routing information protocol)
- Redundant routing VRRP (Virtual Router Redundancy Protocol)

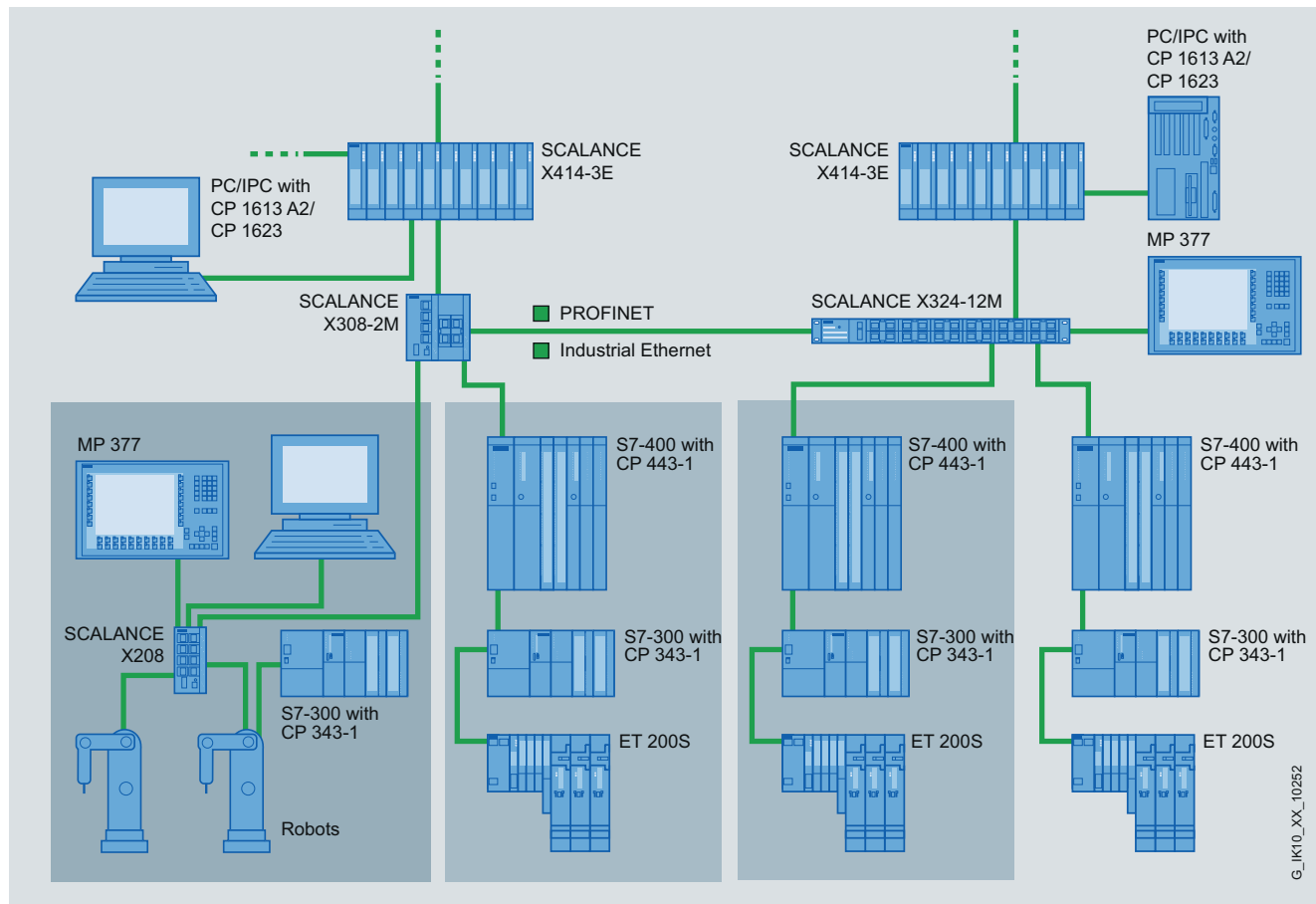

High-performance Layer 3 switching paired with redundant routing (VRRP)

G_IK10_XX_10252

Overview

	Twisted pair network	Fiber optic network	Wireless network
Flexibility of the network topology	● ● ● ●	● ● ●	● ● ●
Suitability for high transmission rates	● ● ● ● ○ ¹⁾	● ● ● ● ● ¹⁾	● ● ○ ○
Inter-building networking	○ ○ ○ ○	● ● ●	● ● ○
EMC	● ● ● ○	● ● ●	● ● ●
Simple cable laying	● ● ● ○	● ● ● ○	—
Performance spectrum for special applications	Cables for indoor area; trailing cable; marine cable; FastConnect cables	Cables for indoor and outdoor area; trailing cable; halogen-free cable	—
Effect of voltage failure	Failure of a subnetwork ²⁾	Failure of a subnetwork ²⁾	Failure of a subnetwork ²⁾
Effect of path failure	Network breaks down into two sub-networks functioning in isolation ³⁾	Network breaks down into two sub-networks functioning in isolation ³⁾	—
Max. network expansion	5000 m ⁴⁾	Up to 150 km ⁴⁾ ; over 150 km, consider signal propagation time	—
Max. distance between two network nodes / Access Points	100 m	50 m POF 100 m PCF 4000-5000 m multimode 120 km single mode	30 m indoors per segment 100 m indoors per segment
Pre-assembled cables	Yes	Yes	—
Assembly on site	without special tool; FastConnect technology	without special tool; FastConnect technology	—
Integrated diagnostics support	LED indicators; signaling contact; SNMP network management; Web-based management, PROFINET diagnostics	LED indicators; signaling contact; SNMP network management; Web-based management, PROFINET diagnostics	LED indicators; SNMP network management; Web-based management, PROFINET diagnostics
Redundant network structures	Electrical ring or doubling of the infrastructure (linear, star, tree)	Optical ring or doubling of the infrastructure (linear, star, tree)	Multiple illumination or use of different frequency bands (2.4 and 5 GHz)
1) suitable for 10 Mbit/s to 10 Gbit/s 2) Safeguard against subnetwork failure by means of redundant voltage supply 3) no effect in the case of ring structure 4) if there are 50 switches in the ring			● ● ● ● suitable ● ● ● ○ partly suitable ● ● ○ ○ ● ○ ○ ○ ○ ○ ○ ○ not applicable

G_IK10_XX_10013

Comparison of networking media

PROFINET/Industrial Ethernet

PROFINET

Introduction

Overview

PROFINET – the Ethernet standard for automation

PROFINET is the leading Industrial Ethernet standard with more than 3 million nodes worldwide.

PROFINET increases the companies' success by accelerating processes, boosting productivity, and increasing plant availability.

Your advantages at a glance

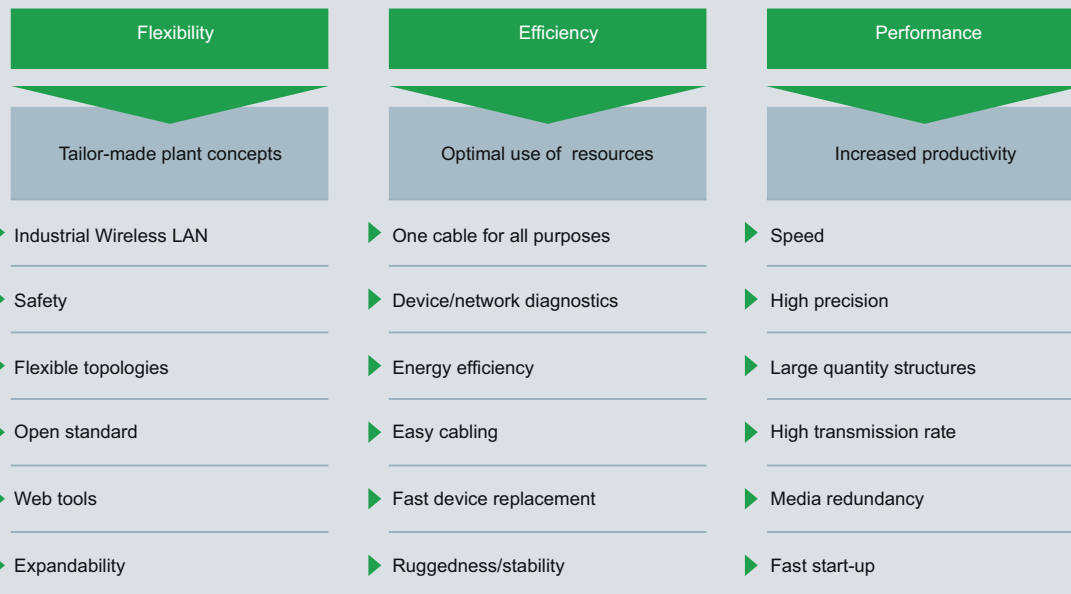

G_IK10_XX_10304

Flexibility

Short response times and optimized processes are prerequisites for competitiveness in global markets, because product lifecycles are becoming shorter and shorter.

PROFINET ensures maximum flexibility in plant structures and production processes, and it enables you to implement innovative machine and plant concepts. Mobile devices, for example, can be integrated into relatively inaccessible locations.

Flexible topologies

PROFINET also enables the use of star, tree, and ring topologies in addition to the linear topology characterized by the established fieldbuses. This is made possible by means of switching technology via active network components, such as Industrial Ethernet switches and media converters, or by integrating switch functionality into field devices. This results in an increased machine and plant planning flexibility, as well as savings in cabling.

The PROFINET network can be installed without any specialist knowledge and meets all requirements relevant to the industrial environment. The PROFINET Guideline "Cabling and Interconnection Technology" provides network installation support for manufacturers and users. Symmetrical copper cables or RFI-resistant fiber-optic cables are used depending on the application. Devices from different manufacturers are easily connected via standardized and rugged plug-in connectors (up to IP65/IP67).

Thanks to the integration of switch functionality into the devices, linear topologies can be formed that are configured based on an existing machine or plant structure. This results in savings in cabling overhead and cuts down on components such as external switches.

IWLAN

PROFINET also supports wireless communication with Industrial Wireless LAN and thus opens up new application fields. For example, technologies subject to wear such as contact wires can be replaced and automated guided vehicle systems and mobile operator panels can be used.

Safety

The PROFIsafe safety profile, which has been tried and tested with PROFIBUS and which permits the transmission of standard and safety-related data on a single bus cable, can also be used with PROFINET. No special network components are required for fail-safe communication, standard switches and standard routers can be used without restrictions. In addition, fail-safe communication is equally possible via Industrial Wireless LAN (IWLAN).

Open standard

PROFINET, the open vendor-independent standard (IEC 61158/61784), is supported by PROFIBUS and PROFINET International (PI). It stands for maximum transparency, open IT communication, network security and simultaneous real-time communication.

Due to its openness, PROFINET creates the basis for a uniform automation network in the plant to which all of the machines and devices can be connected. The integration of existing parts of the plant, using PROFIBUS for example, can also be achieved without any problems through the use of routers.

Overview (continued)

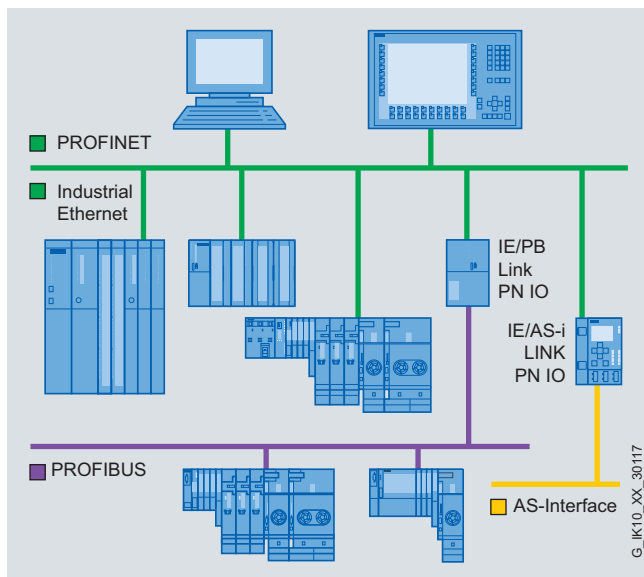

Fieldbus integration via a proxy

Use of web tools

PROFINET's unrestricted support for TCP/IP permits the use of standard web services such as web servers in the device. Independently of the tool used, information from the automation level can be accessed from almost anywhere at any time using a commercially available Internet browser. This considerably simplifies commissioning and diagnostics.

Each user can decide for himself how much openness to the IT world he will permit for his machine or plant. Thus, PROFINET can be easily operated as an isolated plant network or it can be connected to the office network or the Internet via suitable security modules, such as the SCALANCE S modules. This allows new teleservice concepts or even the fast exchange of production data.

Expandability

On the one hand, PROFINET permits the easy integration of existing systems and networks without great effort. Thus, PROFINET protects the investments in existing plant units which communicate via PROFIBUS and other fieldbuses such as AS-Interface, for example.

On the other hand, additional PROFINET stations can be added at any time. Network infrastructures can be expanded using additional network components, both wired and wireless versions, even during operation.

Efficiency

Global competition means that companies must deploy their resources economically and efficiently. This applies in particular to production. PROFINET ensures more efficiency here.

Simple engineering guarantees fast commissioning, and reliable devices enable high plant availability. Comprehensive diagnostics and maintenance concepts help to reduce plant downtimes and maintenance costs to a minimum.

One cable for all purposes

PROFINET permits simultaneous fieldbus communication in isochronous mode and standard IT communication (TCP/IP) via one cable. This real-time communication for the transmission of user/process data and diagnostic data is performed on a single cable. Specific profile communication (PROFIsafe, PROFIdrive and PROFInergy) can be integrated without additional cabling overhead. This solution provides a wide range of functions with a low degree of complexity.

Device and network diagnostics

By retaining the field-proven PROFIBUS device model, the same diagnostic information is available with PROFINET. In addition, device diagnostics also includes read-out of module-specific and channel-specific data from the devices. This enables simple and fast location of faults. In addition to the availability of device information, the top priority in network management is reliability of network operation.

The Simple Network Management Protocol (SNMP) has become established in existing networks as the de-facto standard for the maintenance and monitoring of network components and their functions. PROFINET uses this standard and provides users with the option of servicing networks using familiar tools such as the SINEMA Server network management software.

In order to facilitate the maintenance of PROFINET devices, both locally and also remotely via a secure VPN connection, application-specific Web sites in the familiar HTML standard can be created on the integral Web server of the field devices.

PROFINET/Industrial Ethernet

PROFINET

Introduction

Overview (continued)

Energy efficiency

Moving toward the green factory: PROFlenergy

PROFlenergy is a profile that provides functions and mechanisms for PROFINET field devices that support energy-efficient production.

The vendor and device-independent profile defined by PNO allows the user to significantly reduce the energy consumption and costs: PROFlenergy enables specific loads that are not required to be switched off. This noticeably reduces energy costs during pauses in production. PROFlenergy facilitates automated activation and deactivation of technologically related plant sections. The coordination is performed centrally by means of a higher-level controller, and the networking via PROFINET. This means that during long pauses, as much energy as possible is saved. Plant sections that are switched off for short periods contribute to the even distribution and most efficient use of energy.

The use of PROFlenergy is made easier for the machine builder by its integration into well-known series of products. In addition, PROFlenergy is defined in such a way that the necessary function blocks can be integrated into existing automation systems at a later date.

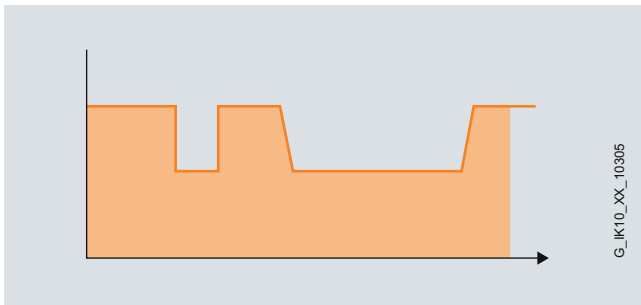

Energy consumption without PROFlenergy

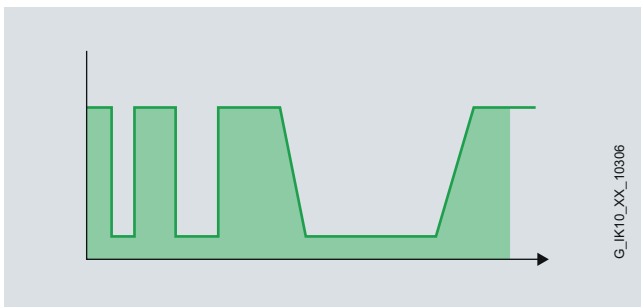

Energy consumption with PROFlenergy

Easy cabling

Stringent demands are placed on the installation of cables in the industrial environment. There is also the requirement to set up error-free industry-standard networks in the shortest possible time without specialist knowledge.

Siemens offers FastConnect, a system that meets all these requirements: FastConnect is the standards-compliant, industry-standard cabling system consisting of cables, connectors, and assembly tools for PROFINET networks.

The time spent for connecting the terminal devices is minimized thanks to the easy installation using only a single tool, and installation errors can be avoided thanks to the practical color-coding. Both copper cables and glass fiber-optic cables can be assembled on-site in this way.

Fast device replacement

PROFINET devices are identified via a name that is assigned in the configuration. When replacing a defective device, a new device can be recognized by the IO Controller by means of topology information and have a name automatically assigned to it. An engineering tool is therefore not required when replacing devices.

This mechanism can also be used during the initial commissioning of a complete plant. Quick commissioning is thus especially possible for series machines.

Ruggedness

An automation network must be able to withstand most external sources of interference. The use of Switched Ethernet prevents faults in one section of the network from influencing the entire plant network. PROFINET enables the use of fiber-optic cables especially for areas that are critically sensitive to EMI.

Overview (continued)

Performance

Productivity and product quality determine market success. Precise motion control, dynamic drives, high-speed controllers, and the deterministic synchronization of devices are therefore key factors in achieving superior production. They allow high production speeds and simultaneously optimized product quality.

Speed and precision

Fast motion control applications need precise and deterministic data exchange. This is implemented thanks to isochronous drive controls using Isochronous Real-Time (IRT).

PROFINET permits high-speed and deterministic communication due to IRT and isochronous mode. The different cycles of a system (input, network, CPU processing and output) are also synchronized in the case of parallel TCP/IP traffic. PROFINET's short cycle times make it possible to increase the productivity of machines and plants, and to ensure product quality through high precision.

The standardized PROFIdrive drive profile enables vendor-independent communication between CPUs and drives.

Large quantity structures

Previous limitations in the scope of the machines and systems to be implemented can be easily overcome through the use of PROFINET. With PROFINET, up to 256 field devices can now be managed by one SIMATIC Controller.

In a network, several controllers can interact with their assigned field devices. The number of field devices per PROFINET network is virtually unlimited – the entire band of IP addresses is available.

High transmission rate

By using 100 Mbit/s in full duplex mode, PROFINET achieves a significantly higher transmission rate than previous fieldbuses. Thanks to this, both the process data and other plant data can be transferred via TCP/IP without any problems. In this way, PROFINET combines the industrial requirements of simultaneously transferring fast IO data and large data quantities for other parts of the application. Even the transfer of large quantities of data such as by cameras does not affect the speed and the precision of the IO data transfer thanks to PROFINET mechanisms.

Media redundancy

Higher plant availability can be achieved by means of a redundant installation (ring topology). The media redundancy can be implemented both with the help of external switches and direct via integral PROFINET interfaces. Reconfiguration times of 200 ms can be achieved. In the case of an interruption to the communication in only one part of the ring installation, this means that a plant standstill is prevented and the necessary servicing and repair work can be carried out without time pressure.

Fast start-up

The Fast Start-Up function allows rapid start-up of PROFINET IO Devices that are connected to SIMATIC Controllers. The communication connection between the controller and the device is established in less than a second. For modular plants, individual plant parts can therefore be connected or disconnected in the shortest time. For example, the tool change can be accelerated significantly in robot applications.

Benefits

- PROFINET is the open Industrial Ethernet standard for automation
- PROFINET is based on Industrial Ethernet
- PROFINET uses TCP/IP and IT standards
- PROFINET is Real-Time Ethernet
- PROFINET permits seamless integration of fieldbus systems
- PROFINET supports fail-safe communication via PROFIsafe over IWLAN as well

PROFINET/Industrial Ethernet

Cabling technology

Passive network components

Overview

Industrial Ethernet		Maximum cable lengths for industrial Ethernet connections									
Type of fiber	0 - 10 m	0 - 50 m	0 - 55 m	0 - 85 m	0 - 100 m	0 - 750 m	0 - 4.000 m	0 - 5.000 m	0 - 26.000 m		
IE FC cables 2x2 at 100 Mbit/s											
FC RJ45 outlet with 2x2 cable (additional 10 m patch cable can be connected in total)				● (0 - 45 m; Torsion Cable)	● (0 - 75 m; Marine/Trailing/ Flexible/ FRNC/Food/ Festoon Cable)	● (0 - 90 m; Standard Cable GP)					
Patch cable	●										
TP FC Standard Cable GP 2x2					●						
TP FC Flexible Cable GP 2x2					●						
TP FC Marine Cable 2x2 GP					●						
TP FC Trailing Cable 2x2					●						
TP FC Trailing Cable GP 2x2					●						
TP Torsion Cable 2x2			●								
TP FC FRNC Cable GP					●						
TP FC Food Cable					●						
TP FC Festoon Cable GP					●						
IE FC cables 4x2 at 1000 Mbit/s											
FC RJ45 outlet with 4x2 cable (AWG 22) (additional 10 m patch cable can be connected in total)						● (0 - 90 m; Standard Cable GP)					
IE FC RJ45 Plug 4x2 with Standard/Flexible Cable 4x2 (AWG 24)			●								
Patch cable	●										
IE Glass FOC											
FO FRNC Cable GP	Multimode (50/125)					● ²⁾		● ¹⁾			
FO Standard Cable GP	Multimode (50/125)					● ²⁾		● ¹⁾			
FO Ground Cable	Multimode (50/125)					● ²⁾		● ¹⁾			
FO Trailing Cable	Multimode (50/125)					● ²⁾		● ¹⁾			
FO Trailing Cable GP	Multimode (50/125)					● ²⁾		● ¹⁾			
FO Robust Cable GP	Multimode (50/125)					● ²⁾		● ¹⁾			
INDOOR FO Cable	Multimode (62,5/125)						● ¹⁾				
FO Standard Cable	Multimode (62,5/125)						● ¹⁾				
Flexible FO Trailing Cable	Multimode (62,5/125)						● ¹⁾				
FO Robust Cable GP	Multimode (4E9/125)									● ¹⁾	
IE POF/PCF Fiber Optic Cable											
POF Standard Cable GP 980/1000	POF (980/1000)		● ¹⁾								
POF Trailing Cable 980/1000	POF (980/1000)		● ¹⁾								
PCF Standard Cable GP	PCF (200/230)					● ¹⁾					
PCF Trailing Cable	PCF (200/230)					● ¹⁾					
PCF Trailing Cable GP	PCF (200/230)					● ¹⁾					
		1) at 100 Mbit/s	2) at 1000 Mbit/s								

G_IK10_XX_10239

Overview (continued)

		Options for connecting Industrial Ethernet cables with plugs, terminals or devices (IE)								
		electrical								
		IE FC Cable 4x2	IE FC Cable 2x2	IE TP Cord 2x2	IE TP Cord 4x2	ITP cables	ITP connector cable	Hybrid cable	Power cable	
		IE FC Standard Cable GP 4x2 (AWG22)	IE FC Standard Cable GP 4x2 (AWG24) IE FC Flexible Cable GP 4x2 (AWG24)	IE TP Standard Cable GP 2x2 IE TP Flexible Cable GP 2x2 IE TP FRNC Cable GP 2x2 IE FC TP Trailing Cable GP 2x2 IE FC TP Trailing Cable 2x2 IE TP Festoon Cable GP 2x2 IE FC TP Festoon Cable GP 2x2 IE TP Marine Cable 2x2 IE FC TP Marine Cable 2x2	IE TP Cord 9/RJ45 IE XP Cord 9/RJ45 IE TP Cord 8/RJ45 IE TP XP Cord 8/RJ45/RJ45 IE TP Cord RJ45/15 IE TP XP Cord RJ45/15 IE TP XP Cord 9/9	IE TP Cord RJ45/RJ45 IE TP XP Cord RJ45/RJ45	ITP Standard Cable ITP FRNC Cable	ITP Standard Cable 9/15 ITP XP Standard Cable 9/9 ITP XP Standard Cable 15/15 ITP FRNC Cable 9/15	Hybrid cable 2x2 + 4x0.34	Energy Cable 2 x 0.75 Energy Cable 5 x 1.5
	IE FC RJ45 Modular Outlet	•						•		
	IE FC Outlet RJ45		•	•	•					
	IE FC RJ45 Plug 2x2		•							
	IE FC RJ45 Plug 4x2	•								
	M12 power connector A-coded								•	
	M12 power connector D-coded		•							
	IP67 hybrid connector							•		
	ITP plug 9-pin/15-pin					•				
	IE devices with Sub-D connection			•			•			
	Devices with RJ45 connection			•	•					
	Power Plug PRO								•	
	7/8" plug-in connector								•	
	IE FC RJ45 Plug PRO		•						•	

G_IK10_XX_10245

PROFINET/Industrial Ethernet

Cabling technology

Passive network components

Overview (continued)

2

		Options for connecting Industrial Ethernet cables with plugs, terminals or devices								
		Optical								
		Fiber-optic cable 50/125/1400 μm	Fiber-optic cable 62.5/125 μm	PCF fiber optic cable 200/230 μm	Fiber-optic cable with BFOC connector	Fiber-optic cable with SC plug	POF-FOC 980/1000 μm	Fiber-optic cable with SC RJ plug	Fiber-optic cable with LC plug	Fiber-optic cable with FC plug
		FO Standard Cable GP FO Trailing Cable GP FO Trailing Cable GP FO Ground Cable	FIBER OPTIC standard cable INDOOR Fiber-Optic indoor cable Flexible Fiber-Optic trailing cable SIENOPYR marine duplex fiber opticcable	PCF Standard Cable GP PCF Trailing Cable GP PCF Trailing Cable	Preassembled FOC with BFOC plug	Preassembled FOC with SC plug	POF Standard Cable GP POF Trailing Cable	Preassembled FOC with SC RJ plug	FO Robust Cable GP (4E9/125/900) FO Robust Cable GP (50/125/900)	FO FC Standard Cable GP (62.5/200/230) FO FC Trailing Cable (62.5/200/230)
	BFOC connector	●	●							
	IE devices with BFOC connection				●					
	SC plug	●								
	IE devices with SC connection				●					
	SC RJ plug			●		●				
	IE devices with SC RJ connection						●			
	IE SC RJ POF Plug PRO					●				
	IE SC RJ PCF Plug PRO			●						
	Multimode FO LC Plug							●		
	Singlemode FO LC Plug							●		
	FO FC BFOC Plug								●	●
	FO FC SC Plug								●	●

G_IK10_XX_10246

Overview

Structured cabling

- Structured cabling to ISO IEC 118011/EN 50173 describes the non-application-specific, tree-like cabling of building complexes for IT purposes. A site is subdivided into the following areas:
 - Primary area (connecting the buildings of a site)
 - Secondary area (connecting the floors of a building)
 - Tertiary area (IT connection of data terminals on a floor)

The structured cabling that can be achieved with the Industrial Ethernet FastConnect System corresponds to the structure of the tertiary cabling in accordance with EN 50173 for Ethernet.

FastConnect Twisted Pair (FC)

- For structured cabling in the production hall, the FastConnect Twisted Pair cabling system is ideal (RJ45 and M12 connections). With the fast installation system for Industrial Ethernet, structured cabling from the office environment not only becomes industry compatible for installation in the production hall.
- FastConnect cables can also be assembled extremely quickly and easily on site. The RJ45 cabling technique, an existing standard, is also available in an industry-standard version that supports structured cabling (patch cables, patch field, installation cables, connection socket, connecting cable).
- With the FastConnect plugs and FastConnect cables as an alternative to structured cabling, up to 100 m cable length can be achieved for a point-to-point link (requires less patch technology).

ITP (Sub D connection method)

- For direct connection between stations and network components with Sub D connections, the ITP Standard Cable continues to be offered preassembled with Sub D plugs as a rugged connection system. This allows cable lengths of up to 100 m to be achieved without the need for patches.

Benefits

- Extensive product range for flexible cabling in industry
- Faster connection of data terminals thanks to safe stripping of the outer sheath and braided shield in one step
- Easy connection method (insulation-piercing contacts) for 4-core (Cat5) and 8-core (Cat6) Industrial Ethernet FC Twisted Pair installation cables
- Easy assembly for all cable types with the preadjusted FC stripping tool
- Reliable shield contacting and strain relief

Application

	10/100 Mbit/s	10/100/1000 Mbit/s
IE FC TP Cable 2x2	•	–
IE FC TP Cable 4x2	–	•
IE FC RJ45 Plug 2x2	•	–
IE FC Plug 4x2	–	•
IE FC Outlet RJ45	•	–
IE FC RJ45 Modular Outlet	–	•
IE TP Cord	• 1)	• 2)

1) All TP Cord types with a Sub D interface

2) IE TP Cord RJ45/RJ45 and IE TP Cord XP

UL approvals

UL listing (safety standard) for network cables is especially necessary for the American and Canadian markets. The requirements for the appropriate approvals depend on where the cable is routed within the building. This applies to all cables which have to be routed from a machine to a remote control cabinet and are positioned on cable racks secured on the building. Cables with UL approval have "GP" (**G**eneral **P**urpose) added to their name.

Design

The FastConnect system comprises:

- Industrial Ethernet FastConnect cables** specially designed for fast connection (UL and CAT5e certified) as FC TP Standard, FC TP Flexible, FC TP Trailing, TP Torsion and FC TP Marine Cable.
- Easy stripping with the **FastConnect Stripping Tool**; the outer sheath and the braided shield are stripped accurately in one step
- The prepared cable is connected in the **FastConnect products** using the insulation displacement method.

Integration

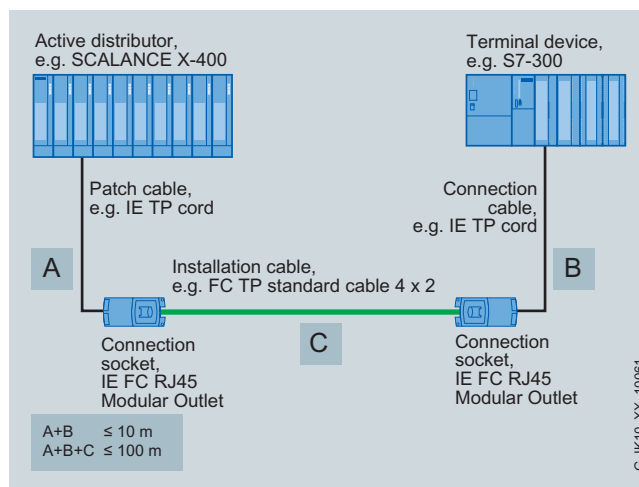

Structured cabling to EN 50173

PROFINET/Industrial Ethernet

Cabling technology

Industrial Ethernet FastConnect

Overview



- With the FastConnect (FC) system for Industrial Ethernet, structured cabling from the office environment becomes industry-compatible for installation in the production hall.
- Time-saving, error-free installation on-site
- RJ45 cabling technology is used as the permanent standard
- The ideal solution for assembly of RJ45 and M12 connectors in the field area with 4-core (2 x 2) Industrial Ethernet FC cables
- The ideal solution for assembly of the IE FC RJ45 Modular Outlet with 8-core (4 x 2) Industrial Ethernet FC cables
- Mistakes are prevented thanks to color coding and the transparent contact cover
- Coordinated system of FC plug-in connectors and an extensive FC cable spectrum with appropriate UL approvals

Benefits

get Designed for Industry

- Compliance with the Industrial Ethernet Standard PROFINET (PROFINET Cabling and Interconnection Technology Guideline¹⁾)
- Faster connection of data terminals thanks to safe stripping of the outer sheath and braided shield in one step
- Reliable shield contact and strain relief thanks to bolt-on cover
- Excellent EMC shielding and deflection (metal housing)
- Mistakes are prevented thanks to color coding and the transparent contact cover

¹⁾ Available as a download at www.profinet.com

Application

Industrial Ethernet FastConnect is a quick-assembly system for easy assembly of 4-core and 8-core Industrial Ethernet FC cables.

After stripping, the IE FC cable can be directly mounted in either the IE FC RJ45 Plug (4-core), the IE FC Outlet RJ45 (4-core) or the IE RJ45 Modular Outlet (8-core).

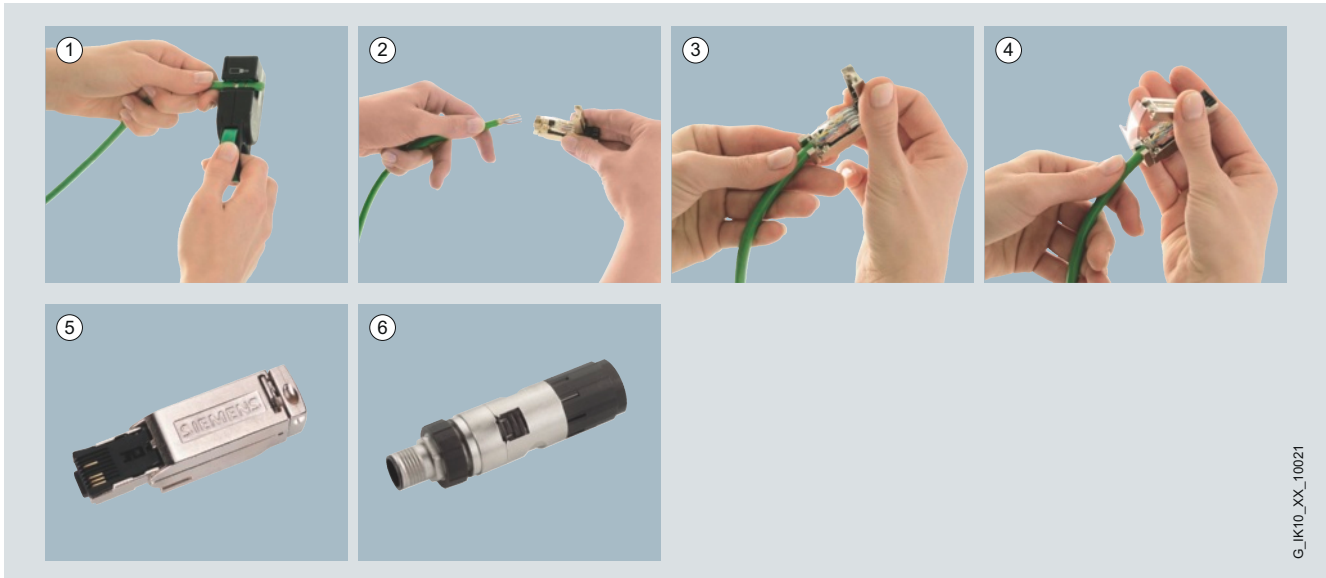

Steps for assembly of Industrial Ethernet copper cables with Industrial Ethernet FastConnect

Design

The complete system:

- Industrial Ethernet FC installation cables designed for fast assembly; 4-core (2x2) Cat5e;
 - IE FC TP Standard Cable GP
 - IE FC TP Flexible Cable GP
 - IE FC TP Trailing Cable GP
 - IE FC TP Trailing Cable
 - IE TP Torsion Cable
 - IE FC TP Marine Cable
 - IE FC TP FRNC Cable GP
 - IE FC TP Food Cable
 - IE FC TP Festoon Cable GP
- 8-core (4 x 2) Cat6 certified, with appropriate UL approval:
 - IE FC TP Standard Cable GP (AWG 22/AWG 24)
 - IE FC TP Flexible Cable (AWG 24)
- User-friendly stripping technique with FC Stripping Tool
- Noise-resistant FC RJ45 and FC M12 Plugs (10/100/1000 Mbit/s), an ideal solution for installation on 4 or 8-core IE FC cables at the field level thanks to the rugged metal enclosure
- The prepared cable is connected in the Industrial Ethernet FC Outlet RJ45 (10/100 Mbits/s; 4-core) or IE FC RJ45 Modular Outlet (10/100/1000 Mbits/s; 8-core) using insulation displacement

Function

The FastConnect stripping technique supports fast and easy connection of the Industrial Ethernet FC cables

- IE FC RJ45 Plug (10/100/1000 Mbit/s)
- IE FC M12 Plug PRO (10/100/1000 Mbit/s)
- IE FC Outlet RJ45 (10/100 Mbit/s)
- IE FC RJ45 Modular Outlet (10/100/1000 Mbit/s)

The data terminals and network components are connected using outlets via TP Cords.

The Industrial Ethernet FastConnect cables are specially designed for use of the Industrial Ethernet FastConnect Stripping Tool, with which the outer insulation and the braided shield can be stripped accurately in one step. The prepared cable is then connected using insulation displacement.

Approvals

UL listing (safety standard) for network cables is especially necessary for the American and Canadian markets. The requirements for the appropriate approvals depend on where the cable is routed within the building. This applies to all cables which have to be routed from a machine to a remote control cabinet and are positioned on cable racks secured on the building. OFN/OFNG cable for routing in bundles (general purpose cable).

The various connectors and cables from the FastConnect cabling system can also be used in hazardous areas (EX-Zone 2). No special approval is necessary.

PROFINET/Industrial Ethernet

Cabling technology

IE FC RJ45 Plug 2 x 2

Overview

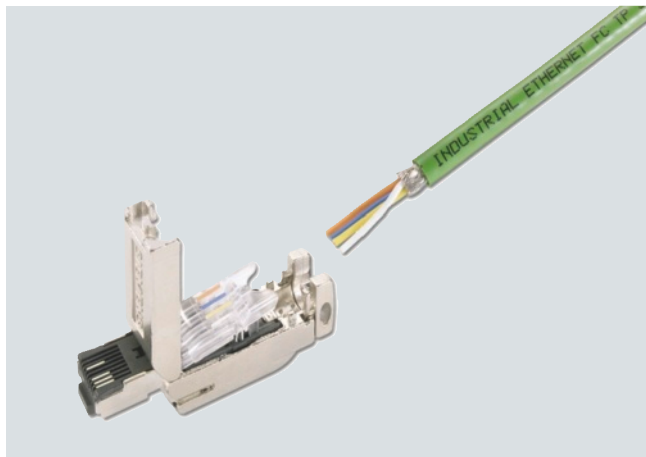

- Implementation of direct device connections over distances of up to 100 m with Industrial Ethernet FC installation cable 2 x 2 without patching
- Easy connection (insulation displacement contacts) for 4-core Twisted Pair installation cables (100 Mbit/s) without the need for special tools
- Error-preventing connection technique thanks to visible connection area as well as colored blade terminals
- Industry-compatible design (rugged metal housing, no easily lost small parts)
- Excellent EMC shielding and deflection (metal housing)
- Integrated strain-relief for installation cables
- Compatible to the EN 50173 (RJ45) / ISO IEC 11801 standard
- Additional strain and bending relief of plug connector possible through latching of plug on device housing, e.g. with SCALANCE X, SCALANCE S, ET 200S.

Benefits

get Designed for Industry

- Ideal solution for installing RJ45 plug-in connectors in the field level
- Time-saving, error-free installation using the FastConnect system
- RJ45 plug-in connector is resistant to interference thanks to the rugged metal housing
- Reliable shield attachment and strain relief are integrated
- Mistakes are prevented thanks to color coding and the transparent contact cover
- A compatible system of Industrial Ethernet FastConnect plug-in connectors and a comprehensive range of FastConnect cables with the appropriate UL approvals and PROFINET compatibility

Application

The compact, rugged design of the connectors makes the FC RJ45 Plug suitable for use in both industrial environments and on office equipment.

The Industrial Ethernet FastConnect RJ45 Plugs 2 x 2 permit quick and easy installation of the Industrial Ethernet FastConnect installation cables 2 x 2 (4-core twisted pair cables) in the field.

The Industrial Ethernet FastConnect Stripping Tool for preparing the end of a cable (stripping the jacket and shield in one step) allows simple handling and fast, reliable fitting of the cable connector to the cable. As all the cable connector parts are captive, it can also be fitted in difficult conditions.

The plug-in connectors enable point-to-point links to be implemented (100 Mbit/s) for Industrial Ethernet between two data terminals/network components up to 100 m without the need for patches.

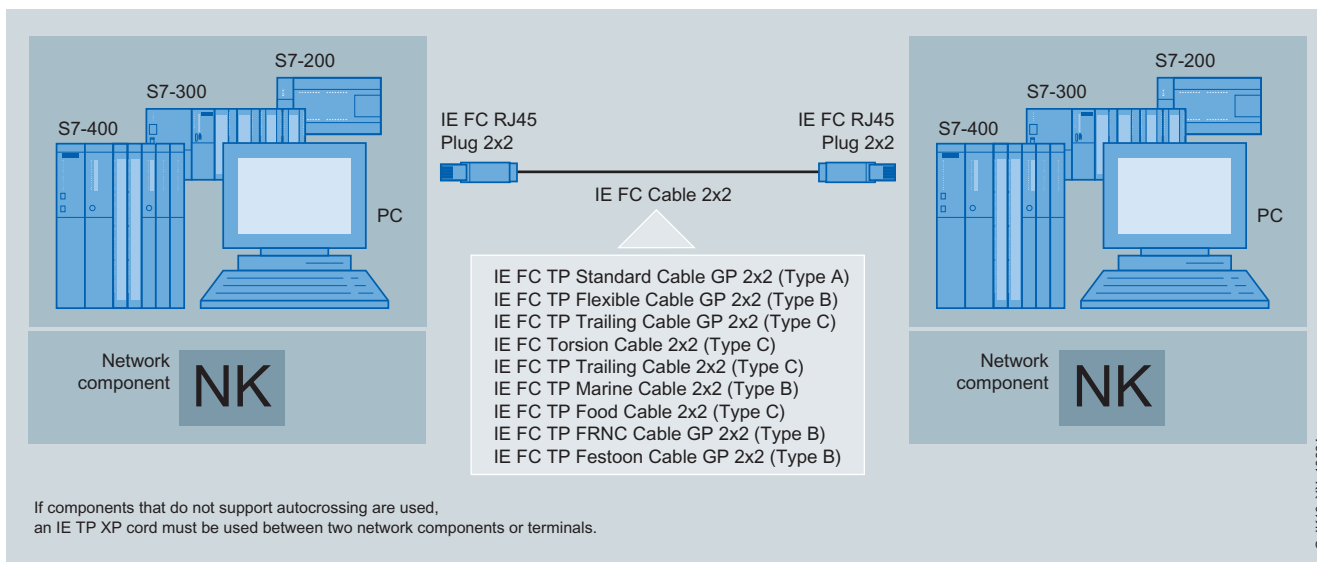

Use of FastConnect cables 2 x 2 with IE FC RJ45 Plug 2 x 2

Design

Industrial Ethernet FC RJ45 Plugs are available in three designs:

- With 180° (straight) cable outlet
- With 145° (angled) cable outlet (SIMOTION and SINAMICS, for example)
- With 90° (angled) cable outlet (for ET 200S, for example)

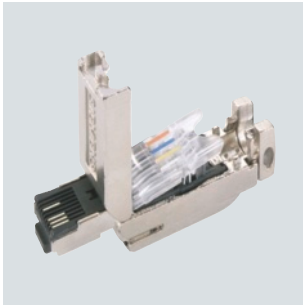

They are used for optimized connection of Industrial Ethernet FastConnect cables to data terminals and network components. The plugs have a rugged, industry-compatible metal housing that provides optimum protection against faults in data communication.

The 4 integrated insulation displacement contacts make contacting of the FC cable versions easy and error-free. After the

stripped cable end has been inserted into the insulation displacement terminations (which have been hinged open), the latter are pressed down for reliable contacting of the conductors.

Thanks to their compactness, the plug-in connectors (IE FC Plug 180°) can be used on devices with individual sockets and on devices with multiple sockets (blocks).

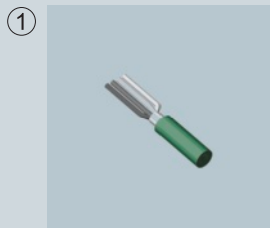

① Strip the IE FC cable 2x2 using stripping tool and fan out the wires according to color coding on the contact cover of the FC RJ45 plug.

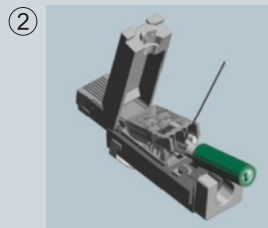

② Open casing of the FC RJ45 plug and insert wires according to color coding as far as the end stop.

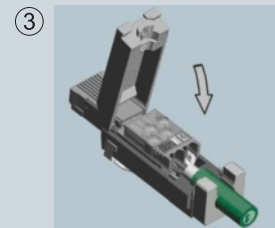

③ Press down contact cover to make contact with the wires.

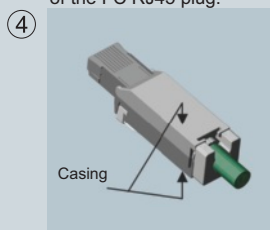

④ Close casing cover and press together with lower connector casing.

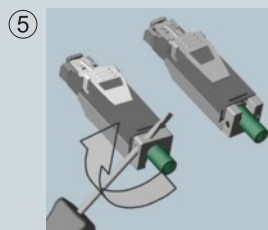

⑤ Using a screwdriver, turn locking ring through 90° to ensure that cable is gripped tightly.

Data terminals with a suitable bracket on the housing provide additional tension and bending relief for the plug-in cable.

Function

The IE FC RJ45 Plugs are used to install uncrossed 100 Mbit/s Ethernet connections up to 100 m without the use of patches. Crossed cables can also be installed by swapping the transmit and receive pair in a plug.

When the housing is open, color markings on the contact cover make it easier to connect the cores to the blade terminals. The user can check that contact has been made correctly through the transparent plastic material of the contact cover.

PROFINET/Industrial Ethernet

Cabling technology

IE FC RJ45 Plug 2 x 2

Technical specifications

Order No.	6GK1 901-1BB20-2AA0	6GK1 901-1BB10-2AA0	6GK1 901-1BB30-0AA0
Product type designation	IE FC RJ45 Plug 90 (2x2)	IE FC RJ45 Plug 180 (2x2)	IE FC RJ45 Plug 145 (2x2)
Product description	RJ45 data connector	RJ45 data connector	RJ45 data connector
Suitability for application	For connection to IE FC TP cables 2x2, suitable for fast mounting with the FastConnect system	For connection to IE FC TP cables 2x2, suitable for fast mounting with the FastConnect system	For connection to IE FC TP cables 2x2, suitable for fast mounting with the FastConnect system
Transmission rate			
Transmission rate			
• 1 with Industrial Ethernet	10 Mbit/s	10 Mbit/s	10 Mbit/s
• 2 with Industrial Ethernet	100 Mbit/s	100 Mbit/s	100 Mbit/s
• 3 with Industrial Ethernet	-	-	-
Interfaces			
Number of electrical/optical connections for Industrial Ethernet FC TP cables	4	4	4
Design of electrical connection			
• for Industrial Ethernet FC TP cables	integrated insulation piercing contacts for 4-core TP FC installation cables	integrated insulation piercing contacts for 4-core TP FC installation cables	integrated insulation piercing contacts for 4-core TP FC installation cables
• for network components or terminal equipment	RJ45 connector	RJ45 connector	RJ45 connector
• FastConnect	Yes	Yes	Yes
Mechanical data			
Enclosure material	Metal	Metal	Metal
Design, dimensions and weights			
Type of cable outlet	90 degree cable outlet	180 degree cable outlet	145 degree cable outlet
Width	13.7 mm	13.7 mm	13.9 mm
Height	16 mm	16 mm	16 mm
Depth	42 mm	55 mm	55.6 mm
Net weight	35 g	35 g	35 g
Permitted ambient conditions			
Ambient temperature			
• During operation	-20 ... +70 °C	-20 ... +70 °C	-20 ... +70 °C
• During storage	-40 ... +80 °C	-40 ... +80 °C	-40 ... +80 °C
• During transport	-40 ... +80 °C	-40 ... +80 °C	-40 ... +80 °C
Relative humidity at 25 °C without condensation during operation, maximum	95 %	95 %	95 %
IP degree of protection	IP20	IP20	IP20
Chemical resistance to water	-	-	-
Product properties, functions, components, general			
Product property silicon-free	Yes	Yes	Yes
Product component strain relief	Yes	Yes	Yes
Standards, specifications, approvals			
Certificate of suitability			
• RoHS compliance	Yes	Yes	Yes
• UL approval	Yes	Yes	Yes
Standard for structured cabling	Cat5	Cat5	Cat5

Ordering data	Order No.	Order No.
<p>IE FC RJ45 plugs</p> <p>RJ45 plug connector for Industrial Ethernet with a rugged metal housing and integrated insulation displacement contacts for connecting Industrial Ethernet FC installation cables</p> <p>IE FC RJ45 Plug 180</p> <p>180° cable outlet; for network components and CPs/CPUs with Industrial Ethernet interface</p> <ul style="list-style-type: none"> • 1 pack = 1 item • 1 pack = 10 items • 1 pack = 50 items <p>IE FC RJ45 Plug 90</p> <p>90° cable outlet; e.g. for ET 200S</p> <ul style="list-style-type: none"> • 1 pack = 1 item • 1 pack = 10 items • 1 pack = 50 items <p>IE FC RJ45 Plug 145</p> <p>145° cable outlet; e.g. for SIMOTION and SINAMICS</p> <ul style="list-style-type: none"> • 1 pack = 1 item • 1 pack = 10 items • 1 pack = 50 items <p>IE FC Stripping Tool</p> <p>Preadjusted stripping tool for fast stripping of Industrial Ethernet FC cables</p> <p>IE FC TP Standard Cable GP 2 x 2 (Type A)</p> <p>4-core, shielded TP installation cable for connection to IE FC Outlet RJ45/ IE FC RJ45 Plug; PROFINET-compatible; with UL approval;</p> <p><u>Sold by the meter</u></p> <p>max. quantity 1,000 m; minimum order 20 m</p> <p><u>Preferred length</u></p> <ul style="list-style-type: none"> • 1000 m <p>IE FC TP Flexible Cable GP 2 x 2 (Type B)</p> <p>4-core, shielded TP installation cable for connection to IE FC Outlet RJ45/ IE FC RJ45 Plug for occasional movement; PROFINET-compatible; with UL approval; <u>Sold by the meter</u>; max. quantity 1000 m, minimum order 20 m</p> <p>IE FC TP Trailing Cable GP 2 x 2 (Type C)</p> <p>4-core, shielded TP installation cable for connection to IE FC Outlet RJ45/ IE FC RJ45 Plug for use in trailing cables; PROFINET-compatible; with UL approval; <u>Sold by the meter</u>; max. quantity 1000 m, minimum order 20 m</p>	<p>6GK1 901-1BB10-2AA0 6GK1 901-1BB10-2AB0 6GK1 901-1BB10-2AE0</p> <p>6GK1 901-1BB20-2AA0 6GK1 901-1BB20-2AB0 6GK1 901-1BB20-2AE0</p> <p>6GK1 901-1BB30-0AA0 6GK1 901-1BB30-0AB0 6GK1 901-1BB30-0AE0</p> <p>6GK1 901-1GA00</p> <p>6XV1 840-2AH10</p> <p>6XV1 840-2AU10</p> <p>6XV1 870-2B</p> <p>6XV1 870-2D</p>	<p>IE FC TP Trailing Cable 2 x 2 (Type C)</p> <p>4-core, shielded TP installation cable for connection to IE FC Outlet RJ45/ IE FC RJ45 Plug 180/90 for use in trailing cables; PROFINET-compatible; without UL approval; <u>Sold by the meter</u>; max. quantity 1000 m, minimum order 20 m</p> <p>IE TP Torsion Cable GP 2 x 2 (Type C)</p> <p>4-core, shielded TP installation cable for connection to IE FC Outlet RJ45/ IE FC RJ45 Plug for use with robots; PROFINET-compatible; with UL approval; <u>Sold by the meter</u>; max. quantity 1000 m, minimum order 20 m</p> <p>IE FC TP Marine Cable 2 x 2 (Type B)</p> <p>4-core, shielded TP installation cable for connection to IE FC Outlet RJ45/ IE FC RJ45 Plug 180/90; marine approval; <u>Sold by the meter</u>; max. quantity 1000 m, minimum order 20 m</p> <p>IE FC TP FRNC Cable GP 2 x 2 (Type B)</p> <p>4-core, shielded, halogen-free TP installation cable for connection to IE FC Outlet RJ45/ IE FC RJ45 Plug for occasional movement; PROFINET-compatible; with UL approval; <u>Sold by the meter</u>; max. quantity 1000 m, minimum order 20 m</p> <p>IE FC TP Festoon Cable GP 2 x 2 (Type B)</p> <p>4-core, shielded TP installation cable for connection to IE FC Outlet RJ45/ IE FC RJ45 Plug 180/90 for use in festoon applications; PROFINET-compatible; with UL approval; <u>Sold by the meter</u>; max. quantity 1000 m, minimum order 20 m</p> <p>IE FC TP Food Cable GP 2 x 2 (Type C)</p> <p>4-core, shielded TP installation cable for connection to IE FC Outlet RJ45/ IE FC RJ45 Plug 180/90 for the food and beverages industry; PROFINET-compliant; <u>Sold by the meter</u>; max. quantity 1000 m, minimum order 20 m</p> <p>IE FC Blade Cassettes (5 mm)</p> <p>Replacement blade cassette for the Industrial Ethernet stripping tool; for use with IE FC RJ45 Plugs and Modular Outlet, 5 items</p>
		<p>6XV1 840-3AH10</p> <p>6XV1 870-2F</p> <p>6XV1 840-4AH10</p> <p>6XV1 871-2F</p> <p>6XV1 871-2S</p> <p>6XV1 871-2L</p> <p>6GK1 901-1GB01</p>

PROFINET/Industrial Ethernet

Cabling technology

IE FC RJ45 Plug 4 x 2

Overview



- Implementation of direct device connections of up to 90 m with Industrial Ethernet FC installation cable 4 x 2 without using patch technology
- Easy connection (insulation displacement contacts) for 8-core twisted pair installation cables (10/100/1000 Mbit/s) without the need for special tools
- Error-minimizing connection technique thanks to visible connection area as well as colored insulation displacement termination
- Industry-compatible design (rugged metal housing, no easily lost small parts)
- Excellent EMC shielding and deflection (metal housing)
- Integrated strain-relief for installation cables
- Compatible with the EN 50173 (RJ45) / ISO IEC 11801 standard
- Additional strain and bending relief of plug connector possible through latching of plug on device housing, e.g. with SCALANCE X, SCALANCE S.

Benefits

get Designed for Industry

- Ideal solution for installation of RJ45 plugs in the field
- Time-saving, error-free installation due to FastConnect system
- Noise-resistant RJ45 plug connector due to rugged metal housing
- Reliable shield attachment and strain relief are integrated
- Mistakes are prevented thanks to color coding and the transparent contact cover
- Coordinated system comprising Industrial Ethernet FastConnect plug-in connectors and an extensive range of FastConnect cables with corresponding UL approvals

Application

The compact, rugged design of the connectors makes the FC RJ45 Plug suitable for use in both industrial environments and on office equipment.

The Industrial Ethernet FastConnect RJ45 Plug 4 x 2 permits quick and easy installation of the Industrial Ethernet FastConnect installation cables 2 x 4 (8-core twisted pair cables) in the field.

The Industrial Ethernet FastConnect Stripping Tool for preparing the end of a cable (stripping the jacket and shield in one step) allows simple handling and fast, reliable fitting of the cable connector to the cable. As all the cable connector parts are captive, it can also be fitted in difficult conditions.

The new plug-in connector enables point-to-point links to be implemented (10/100/1000 Mbit/s) for Industrial Ethernet between two data terminals/network components up to 90 m apart without the need for patches.

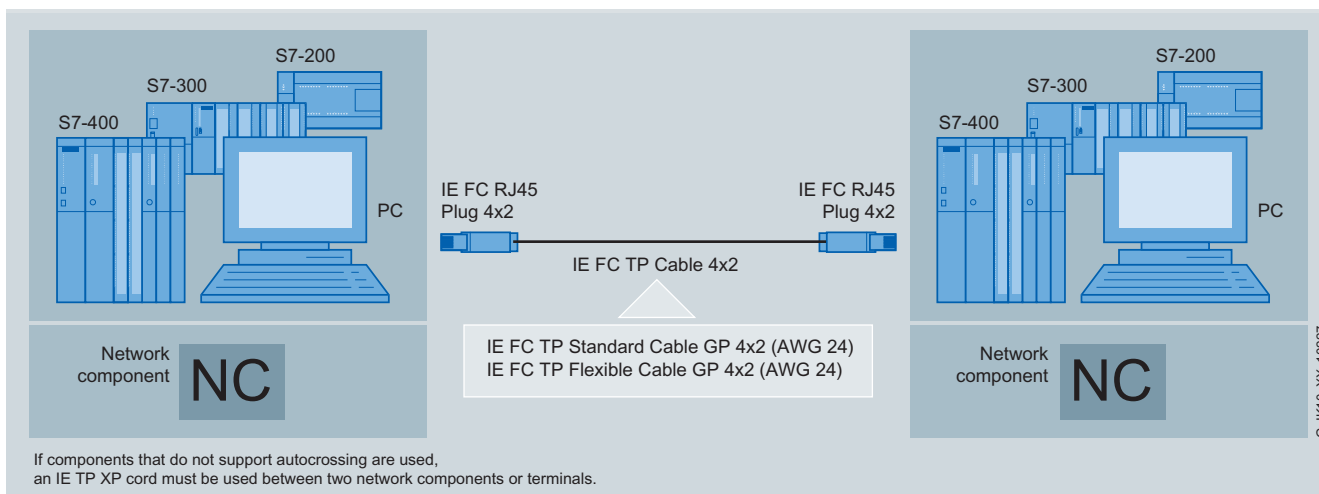

Use of FastConnect cables 4 x 2 with IE FC RJ45 plug 4 x 2

Design

The Industrial Ethernet FC RJ45 Plug 4 x 2 is available with a 180° (straight) cable outlet.

It is the ideal method of connecting an Industrial Ethernet FastConnect cable to data terminals and network components. The plug has a rugged, industry-compatible metal housing that provides optimum protection against faults in data communication.

The eight integrated insulation displacement contacts make contacting of the FC cable versions 4 x 2 and 2 x 2 easy and error-free. After the stripped cable end has been inserted in the insulation displacement terminals, the conductors make contact when the casing is closed.

Owing to their compact size, the plug connectors can be used both on devices with individual jacks and on devices with multiple jacks (blocks).

Data terminals with a suitable bracket on the housing provide additional tension and bending relief for the plug-in cable.

Function

The IE FC RJ45 Plug 4 x 2 is used to install uncrossed 10/100/1000 Mbit/s Ethernet connections up to 90 m without the use of patches. Crossed cables can also be installed by swapping the transmit and receive pair in a plug.

With the casing open, colored markers on the contact element make it simple to connect the cores to the insulation displacement contacts. The transparent synthetic material of the contact element allows users to check the contacts themselves.

Technical specifications

Order No.	6GK1 901-1BB11-2AA0
Product type designation	IE FC RJ45 Plug 180 (4x2)
Product description	RJ45 data connector
Suitability for application	For connection to IE FC TP cables 4x2, suitable for fast mounting with the FastConnect system
Transmission rate	
Transmission rate	
• 1 with Industrial Ethernet	10 Mbit/s
• 2 with Industrial Ethernet	100 Mbit/s
• 3 with Industrial Ethernet	1 000 Mbit/s
Interfaces	
Number of electrical/optical connections for Industrial Ethernet FC TP cables	8
Design of electrical connection	
• for Industrial Ethernet FC TP cables	integrated insulation piercing contacts for 8-core TP FC installation cables
• for network components or terminal equipment	RJ45 connector
• FastConnect	Yes
Mechanical data	
Enclosure material	Metal
Design, dimensions and weights	
Type of cable outlet	180 degree cable outlet
Width	13.7 mm
Height	16 mm
Depth	55 mm
Net weight	35 g
Permitted ambient conditions	
Ambient temperature	
• During operation	-20 ... +70 °C
• During storage	-40 ... +80 °C
• During transport	-40 ... +80 °C
Relative humidity at 25 °C without condensation during operation, maximum	95 %
IP degree of protection	IP20
Product properties, functions, components, general	
Product property silicon-free	Yes
Product component strain relief	Yes
Standards, specifications, approvals	
Certificate of suitability	
• RoHS compliance	Yes
• UL approval	Yes
Standard for structured cabling	Cat6

PROFINET/Industrial Ethernet

Cabling technology

IE FC RJ45 Plug 4 x 2

2

Ordering data	Order No.	Ordering data	Order No.
IE FC RJ45 Plug 4 x 2 RJ45 plug connector for Industrial Ethernet (10/100/1000 Mbit/s) with a rugged metal housing and integrated insulation displacement contacts for connecting Industrial Ethernet FC installation cables; 180° cable outlet; for network components and CPs/CPU's with Industrial Ethernet interface <ul style="list-style-type: none"> • 1 pack = 1 item • 1 pack = 10 items • 1 pack = 50 items 	6GK1 901-1BB11-2AA0 6GK1 901-1BB11-2AB0 6GK1 901-1BB11-2AE0	IE FC TP Standard Cable GP 4 x 2 8-core, shielded TP installation cable for universal applications; with UL approval; <u>sold by the meter</u> ; max. length 1000 m, minimum order 20 m <ul style="list-style-type: none"> • AWG 22, for connection to IE FC RJ45 Modular Outlet • AWG 24, for connection to IE FC RJ45 Plug 4 x 2 	6XV1 870-2E 6XV1 878-2A
IE FC stripping tool Pre-adjusted stripping tool for fast stripping of Industrial Ethernet FC cables	6GK1 901-1GA00	IE FC TP Flexible Cable GP 4 x 2 8-core, shielded TP installation cable for occasional movement; with UL approval; <u>sold by the meter</u> ; max. quantity 1000 m, minimum order 20 m <ul style="list-style-type: none"> • AWG 24, for connection to IE FC RJ45 Plug 4 x 2 	6XV1 878-2B
		IE FC blade cassettes (5 mm) Replacement blade cassette for the Industrial Ethernet stripping tool; for use with IE FC RJ45 Plugs and Modular Outlet, 5 items	6GK1 901-1GB01

Overview



- Data plug-in connectors suitable for on-site assembly for IE FC TP and POF/PCF cables for transmitting data up to 100 Mbit/s
- Power plug-in connector suitable for on-site assembly for transmitting 2 x 24 V between Industrial Ethernet stations
- Degree of protection IP65/67
- The plug-in connectors make contact using a push-pull mechanism.

IE FC RJ45 Plug PRO / IE RJ45 Plug PRO

- FastConnect Industrial Ethernet RJ45 plug-in connector suitable for on-site assembly for SCALANCE X-200IRT PRO switches, ET 200pro and SIMATIC RF systems
- Easy connection (insulation displacement contacts) for 4-core twisted pair installation cables (100 Mbit/s) with or without FastConnect quick-assembly system, without the need for special tools
- Industrial design (rugged plastic housing)
- Good EMC shielding and discharge

IE SC RJ Plug PRO

- Industrial Ethernet SC RJ plug-in connector suitable for on-site assembly of:
 - POF cables for SCALANCE X-200IRT PRO and SIMATIC ET 200pro switches
 - PCF cables for SCALANCE X-200IRT PRO switches
- Industrial design (rugged plastic housing)

Power Plug PRO

- 5-pin power plug-in connector suitable for on-site assembly, for 2 x 24 V voltage supply of the SCALANCE X-200IRT PRO switches, SIMATIC ET 200pro and SIMATIC RF systems

Benefits

get Designed for Industry

- Simple and flexible assembly on site for application-specific plug-in cables through data and power plug-in connectors suitable for on-site assembly in degree of protection IP65/67

Application

IE FC RJ45 Plug PRO and IE SC RJ Plug PRO (POF or PCF) are plug-in connectors with push pull device connection that thanks to their high degree of protection (IP65/67) are used outside cabinets along with suitable end devices and network components with a high degree of protection. Their silicon-free design enables them to also be used in the automobile industry, e.g. in paint shops.

PROFINET/Industrial Ethernet

Cabling technology

IE Push Pull Plug PRO

Technical specifications

Order No.	6GK1 901-1BB20-6AA0	6GK1 901-1BB10-6AA0
Product type designation	IE FC RJ45 Plug PRO (push-pull)	IE RJ45 Plug PRO (push-pull)
Product description	RJ45 data connector	RJ45 data connector
Suitability for use	Field-assembly plug for the push-pull device connection with high degree of protection	Field-assembly plug for the push-pull device connection with high degree of protection
Transmission rate		
Transmission rate		
• 1 with Industrial Ethernet	10 Mbit/s	10 Mbit/s
• 2 with Industrial Ethernet	100 Mbit/s	100 Mbit/s
Interfaces		
Number of electrical connections		
• for Industrial Ethernet FC TP cables	4	4
• for network components or terminals	1	1
Design of electrical connection		
• for Industrial Ethernet FC TP cables	integrated insulation piercing contacts for 4-core TP FC installation cables	integrated insulation piercing contacts for 4-core TP FC installation cables
• for network components or terminal equipment	RJ45 connector (push-pull device connection)	RJ45 connector (push-pull device connection)
Design of electrical connection FastConnect	Yes	No
Mechanical data		
Enclosure material	Plastic	Plastic
Design, dimensions and weights		
Type of cable outlet	180 degree cable outlet	180 degree cable outlet
Width	22 mm	22 mm
Height	29 mm	30 mm
Depth	73 mm	67.7 mm
Net weight	68.8 g	68.8 g
Permissible ambient conditions		
Ambient temperature		
• During operation	-40 ... +70 °C	-40 ... +70 °C
• During storage	-40 ... +70 °C	-40 ... +70 °C
• During transport	-40 ... +70 °C	-40 ... +70 °C
IP degree of protection	IP65/67	IP65/67
Chemical resistance to water	resistant	resistant
Product properties, functions, components		
General		
Product property silicon-free	Yes	Yes
Product component strain relief	Yes	Yes
Standards, specifications, approvals		
Certificate of suitability		
• RoHS compliance	Yes	Yes
• UL approval	No	Yes

Technical specifications (continued)

Order No.	6GK1 900-0MB00-6AA0	6GK1 900-0NB00-6AA0	6GK1 907-0AB10-6AA0
Product type designation	IE SC RJ POF Plug PRO (Push Pull)	IE SC RJ PCF Plug PRO (Push Pull)	Power Plug PRO (Push Pull)
Product description	SC RJ plug for POF fiber-optic cables	SC RJ plug for PCF fiber-optic cables	Power plug, 5-pin
Suitability for application	Field-assembly plug for the push-pull device connection with high degree of protection	Field-assembly plug for the push-pull device connection with high degree of protection	Field-assembly plug for the push-pull device connection with high degree of protection, for voltage supply with 2 x 24 V DC
Transmission rate			
Transmission rate			
• 1 with Industrial Ethernet	100 Mbit/s	100 Mbit/s	-
• 2 with Industrial Ethernet	-	-	-
Interfaces			
Design of electrical connection			
• for Industrial Ethernet FC TP cables	-	-	-
• for network components or terminals	-	-	Power contacts (push-pull casing)
Number of optical connections for fiber-optic cables	1	1	-
Number of optical connections for network components or terminals	SC RJ connector (push-pull device connection)	SC RJ connector (push-pull device connection)	-
Design of electrical connection FastConnect	No	No	No
Mechanical data			
Enclosure material	Plastic	Plastic	Plastic
Design, dimensions and weights			
Type of cable outlet	180 degree cable outlet	180 degree cable outlet	180 degree cable outlet
Width	22 mm	22 mm	36 mm
Height	30 mm	30 mm	30 mm
Depth	62.5 mm	62.5 mm	66.3 mm
Net weight	63.5 g	63.5 g	83.1 g
Permitted ambient conditions			
Ambient temperature			
• During operation	-40 ... +70 °C	-40 ... +70 °C	-40 ... +70 °C
• During storage	-40 ... +70 °C	-40 ... +70 °C	-40 ... +70 °C
• During transport	-40 ... +70 °C	-40 ... +70 °C	-40 ... +70 °C
IP degree of protection	IP65/67	IP65/67	IP65/67
Chemical resistance to water	Resistant	Resistant	Resistant
Product properties, functions, components			
General			
Product property silicon-free	Yes	Yes	Yes
Product component strain relief	Yes	Yes	Yes
Standards, specifications, approvals			
Certificate of suitability			
• RoHS compliance	Yes	Yes	Yes
• UL approval	No	No	Yes

PROFINET/Industrial Ethernet

Cabling technology

IE Push Pull Plug PRO

2

Ordering data	Order No.	Order No.
IE FC RJ45 Plug PRO FastConnect RJ45 plug connector suitable for on-site assembly in degree of protection IP65/67; plastic enclosure, insulation displacement technology, for SCALANCE X-200IRT PRO and SIMATIC ET 200pro switches; 1 package = 1 unit	6GK1 901-1BB20-6AA0	IE FC TP cables IE FC TP Standard Cable GP 2 x 2 (Type A) 4-core, shielded TP installation cable for connection to IE FC Outlet RJ45/ IE FC RJ45 Plug; PROFINET-compliant; with UL approval; sold by the meter; max. length 1000 m, minimum order 20 m
IE RJ45 Plug PRO RJ45 plug connector suitable for on-site assembly in degree of protection IP65/67; plastic enclosure, insulation displacement technology, for SCALANCE X-200IRT PRO and SIMATIC ET 200pro switches; 1 package = 1 unit	6GK1 901-1BB10-6AA0	IE FC TP Flexible Cable GP 2 x 2 (Type B) 4-core, shielded TP installation cable for connection to IE FC Outlet RJ45/ IE FC RJ45 Plug for occasional movement; PROFINET-compliant; with UL approval; sold by the meter; max. length 1000 m, minimum order 20 m
IE SC RJ POF Plug PRO SC RJ plug-in connector suitable for on-site assembly in degree of protection IP65/67 for POF fiber optic cables; plastic housing, for SCALANCE X-200IRT PRO and SIMATIC ET 200pro switches; 1 package = 1 unit	6GK1900-0MB00-6AA0	IE FC TP Trailing Cable GP 2 x 2 (Type C) 4-core, shielded TP installation cable for connection to IE FC Outlet RJ45/ IE FC RJ45 Plug for use as trailing cable; PROFINET-compliant; with UL approval; sold by the meter; max. length 1000 m, minimum order 20 m
IE SC RJ POF Plug PRO SC RJ plug-in connector suitable for on-site assembly in degree of protection IP65/67 for PCF fiber optic cables; plastic housing, for SCALANCE X-200IRT PRO switches; 1 package = 1 unit	6GK1 900-0NB00-6AA0	IE FC TP Trailing Cable 2 x 2 (Type C) 4-core, shielded TP installation cable for connection to IE FC Outlet RJ45/ IE FC RJ45 Plug 180/90 for use as trailing cable; PROFINET-compliant; with UL approval; sold by the meter; max. length 1000 m, minimum order 20 m
Power Plug PRO 5-pole power plug-in connector suitable for on-site assembly in degree of protection IP65/67 for 2 x 24 V voltage supply; plastic housing, for SCALANCE X-200IRT PRO and SIMATIC ET 200pro switches; 1 package = 1 unit	6GK1 907-0AB10-6AA0	IE TP Torsion Cable 2 x 2 (Type C) 4-core, shielded TP installation cable for connection to IE FC Outlet RJ45/ IE FC RJ45 Plug for use with robots; PROFINET-compliant; with UL approval; sold by the meter; max. length 1000 m, minimum order 20 m

Ordering data	Order No.	Order No.
<i>IE FC TP cables (continued)</i>		
IE FC TP Marine Cable 2 x 2 (Type B) 4-core, shielded TP installation cable for connection to IE FC Outlet RJ45/ IE FC RJ45 Plug 180/90; marine approval; sold by the meter, max. length 1000 m, minimum order 20 m	6XV1 840-4AH10	
IE FC TP Food Cable GP 2 x 2 (Type C) 4-core, shielded TP installation cable for connection to IE FC Outlet RJ45/ IE FC RJ45 Plug 180/90 for the food and beverages industry; PROFINET-compliant; sold by the meter; max. length 1000 m, minimum order 20 m	6XV1 871-2L	
IE FC TP Festoon Cable GP 2 x 2 (Type B) 4-core, shielded TP installation cable for connection to IE FC Outlet RJ45/ IE FC RJ45 Plug 180/90 for use in festoon applications; PROFINET-compliant; with UL approval; sold by the meter; max. length 1000 m, minimum order 20 m	6XV1 871-2S	
IE FC TP FRNC Cable GP 2 x 2 (Type B) 4-core, shielded, halogen-free TP installation cable for connection to IE FC Outlet RJ45/ IE FC RJ45 Plug for occasional movement; PROFINET-compliant; with UL approval; sold by the meter; max. length 1000 m, minimum order 20 m	6XV1 871-2F	
<i>FO cables</i>		
POF Standard Cable GP 980/1000 POF standard cable for fixed routing indoors with PVC sheath; sold by the meter; max. length 1000 m; minimum order 20 m		6XV1 874-2A
POF Trailing Cable 980/1000 POF trailing cable for use in cable carriers, with rugged PUR sheath; sold by the meter; Delivery unit max. 1000 m; minimum order 20 m		6XV1 874-2B
PCF Standard Cable GP 200/230 Standard cable, segmentable, sold by the meter; max. length 2000 m; minimum order 20 m		6XV1 861-2A
PCF Trailing Cable 200/230 Trailing cable, segmentable, sold by the meter; max. length 2000 m; minimum order 20 m		6XV1 861-2C
PCF Trailing Cable GP 200/230 Trailing cable, segmentable, sold by the meter; max. length 2000 m; minimum order 20 m		6XV1 861-2D
<i>Energy cables</i>		
Energy Cable 5 x 1.5 Trailable power cable with 5 copper cores (1.5 mm ²) for connecting to 7/8" plug-in connectors; sold by the meter; max. length 1000 m; minimum order 20 m		6XV1 830-8AH10
PROFINET Cabling and Interconnection Technology Guideline		www.profinet.com

More information

Note:

You can order components supplementary to the SIMATIC NET cabling system from your local contact.

Technical advice on this subject is available from:

J. Hertlein

I IA SC IC PRM 4

Phone: +49 (0)911/750 44 65

E-mail: juergen.hertlein@siemens.com

PROFINET/Industrial Ethernet

Cabling technology

IE FC M12 Plug PRO

Overview



FastConnect (FC) plug-in connectors that can be assembled in the field for transmission of data (up to 1000 Mbit/s) between Industrial Ethernet nodes with IP65/IP67 degree of protection

Industrial Ethernet FC M12 Plug PRO (D coded)

- Industrial Ethernet M12 plug-in connector with FastConnect connection system for on-site assembly for SCALANCE X208PRO, IM 154-4 PN and SIMATIC RF systems
- Easy connection (insulation displacement contacts) for 4-core twisted pair FC installation cables (10/100 Mbit/s) without the need for special tools
- Fault-preventing connection method thanks to visible contacting area and color-coded insulation piercing connecting devices
- Industry-compatible design (rugged metal housing)
- Excellent EMC shielding and deflection (metal housing)
- Integrated strain-relief for installation cables

Industrial Ethernet FC M12 Plug PRO 4x2 (X-coded)

- Industrial Ethernet M12 plug connectors, which can be assembled in the field, for on-site installation for SCALANCE W
- Easy connection (insulation displacement contacts) for 8-core twisted pair FC installation cables (10/100/1000 Mbit/s) without the need for special tools
- Fault-preventing connection method thanks to visible contacting area and color-coded insulation piercing connecting devices
- Industry-compatible design (rugged metal housing)
- Excellent EMC shielding and deflection (metal housing)
- Integrated strain-relief for installation cables

Industrial Ethernet panel feedthrough

- Control cabinet feedthrough for conversion from M12 connection method (D coded, IP65/IP67) to RJ45 connection method (IP20)



Control cabinet IE Panel feedthrough

Benefits



- Easy installation on-site for application-specific M12 plug-in cables by means of FastConnect M12 plug-in connectors (IE FC M12 Plug PRO, D-coded, and IE M12 Plug PRO 4x2, X-coded), which can be assembled in the field
- Simple assembly of adapter cables for the transition from IP65/67 degree of protection into the IP20 area within the same control cabinet by connecting the IE FC M12 Plug PRO and IE FC RJ45 Plug 2x2
- Reliable screen contact and strain relief are integrated
- Harmonized system made up of Industrial Ethernet FastConnect plug-in connectors and an extensive range of FastConnect cables with corresponding UL approvals and PROFINET conformity

Technical specifications

Order No.	6GK1 901-0DB20-6AA0	6GK1 901-0DB30-6AA0
Product type designation	IE FC M12 Plug PRO (PROFINET)	IE FC M12 Plug PRO 4 x 2 (PROFINET)
Product description	M12 connector with high degree of protection, 4-pin, D-coded	M12 connector with high degree of protection, 8-pin, X-coded
Suitability for use	For connection of electrical cables to SCALANCE X208PRO, ET 200 PRO PN or ET 200 eco PN, suitable for fast assembly using the FastConnect system	For connection of electrical cables (AWG24) to SCALANCE W (M12 gigabit interface), suitable for fast assembly using the FastConnect system
Transmission rate		
Transmission rate		
• 1 with Industrial Ethernet	10 Mbit/s	-
• 2 with Industrial Ethernet	100 Mbit/s	-
• 3 with Industrial Ethernet	-	1000 Mbit/s
Interfaces		
Number of electrical/optical connections for Industrial Ethernet FC TP cables		
• for Industrial Ethernet FC TP cables	4 (AWG22)	8 (AWG24)
• for network components or terminal equipment	-	1
Design of electrical connection		
• for Industrial Ethernet FC TP cables	integrated insulation piercing contacts for 4-core TP FC installation cables	integrated insulation piercing contacts for 8-core TP FC installation cables (AWG24)
• for network components or terminal equipment	M12 connector (D-coded)	M12 connector (X-coded)
• FastConnect	Yes	Yes
Mechanical data		
Casing material	Metal	Metal
Design, dimensions and weights		
Type of cable outlet	180 degree cable outlet	1180 degree cable outlet
Width	19 mm	16 mm
Height	19 mm	16 mm
Depth	73 mm	53 mm
Net weight	40 g	40 g
Permitted ambient conditions		
Ambient temperature		
• During operation	-40 ... +85 °C	-25 ... +85 °C
• During storage	-40 ... +85 °C	-25 ... +85 °C
• During transport	-40 ... +85 °C	-25 ... +85 °C
Relative humidity at 25 °C without condensation during operation, maximum	95 %	95 %
IP degree of protection	IP65/67	IP65/67
Chemical resistance to water	Resistant	Resistant
Product properties, functions, components General		
Product property silicon-free	Yes	Yes
Product component strain relief	Yes	Yes
Standards, specifications, approvals		
Certificate of suitability		
• RoHS compliance	Yes	Yes
• UL approval	Yes	No
Standard for structured cabling	Cat5	Cat6

PROFINET/Industrial Ethernet

Cabling technology

IE FC M12 Plug PRO

2

Ordering data	Order No.	Order No.
<p>IE FC M12 Plug PRO 2 x 2</p> <p>M12 plug-in connector (D-coded, IP65/IP67) that can be assembled in the field, metal enclosure, FastConnect connection method, for SCALANCE X208PRO and IM 154-4 PN</p> <ul style="list-style-type: none"> • 1 unit • 8 units 	<p>6GK1 901-0DB20-6AA0</p> <p>6GK1 901-0DB20-6AA8</p>	<p>IE TP Torsion Cable GP 2 x 2 (Type C)</p> <p>4-core, shielded TP installation cable for connection to IE FC Outlet RJ45/ IE FC RJ45 Plug for use with robots; PROFINET-compliant; with UL approval; sold by the meter; max. length 1000 m, minimum order 20 m</p> <p>6XV1 870-2F</p>
<p>IE FC M12 Plug PRO 4 x 2</p> <p>M12 plug-in connector suitable for on-site assembly (X-coded, IP65/IP67), metal enclosure, insulation/displacement fast connection method, for SCALANCE W</p> <ul style="list-style-type: none"> • 1 unit • 8 units 	<p>6GK1 901-0DB30-6AA0</p> <p>6GK1 901-0DB30-6AA8</p>	<p>IE FC TP Marine Cable 2 x 2 (Type B)</p> <p>4-core, shielded TP installation cable for connection to IE FC Outlet RJ45/ IE FC RJ45 Plug 180/90; marine approval; sold by the meter; max. length 1000 m, minimum order 20 m</p> <p>6XV1 840-4AH10</p>
<p>IE panel feedthrough</p> <p>Control cabinet feedthrough for conversion from M12 connection method (D coded, IP65/IP67) to RJ45 connection method (IP20)</p> <ul style="list-style-type: none"> • 1 pack = 5 units 	<p>6GK1 901-0DM20-2AA5</p>	<p>IE FC TP Trailing Cable GP 2 x 2 (Type C)</p> <p>4-core, shielded TP installation cable for connection to IE FC Outlet RJ45/ IE FC RJ45 Plug for use as trailing cable; PROFINET-compliant; with UL approval; sold by the meter; max. length 1000 m, minimum order 20 m</p> <p>6XV1 870-2D</p>
<p>IE FC TP Standard Cable GP 2 x 2 (Type A)</p> <p>4-core, shielded TP installation cable for connection to IE FC Outlet RJ45/ IE FC RJ45 Plug; PROFINET-compliant; with UL approval; sold by the meter; max. length 1000 m, minimum order 20 m</p> <p>Preferred length</p> <ul style="list-style-type: none"> • 1000 m 	<p>6XV1 840-2AH10</p> <p>6XV1 840-2AU10</p>	<p>IE FC TP Festoon Cable GP 2 x 2 (Type B)</p> <p>4-core, shielded TP installation cable for connection to IE FC Outlet RJ45/ IE FC RJ45 Plug 180/90 for use in festoon applications; PROFINET-compliant; with UL approval; sold by the meter; max. length 1000 m, minimum order 20 m</p> <p>6XV1 871-2S</p>
<p>IE FC TP Flexible Cable GP 2 x 2 (Type B)</p> <p>4-core, shielded TP installation cable for connection to IE FC Outlet RJ45/ IE FC RJ45 Plug for occasional movement; PROFINET-compliant; with UL approval; sold by the meter; max. length 1000 m, minimum order 20 m</p>	<p>6XV1 870-2B</p>	<p>IE FC TP Food Cable GP 2 x 2 (Type C)</p> <p>4-core, shielded TP installation cable for connection to IE FC Outlet RJ45/ IE FC RJ45 Plug 180/90 for the food and beverages industry; PROFINET-compliant; sold by the meter; max. length 1000 m, minimum order 20 m</p> <p>6XV1 871-2L</p>
<p>IE FC TP Trailing Cable 2 x 2 (Type C)</p> <p>4-core, shielded TP installation cable for connection to IE FC Outlet RJ45/ IE FC RJ45 Plug 180/90 for use as trailing cable; PROFINET-compliant; without UL approval; sold by the meter; max. length 1000 m, minimum order 20 m</p>	<p>6XV1 840-3AH10</p>	<p>IE FC Standard Cable GP 4x2</p> <p>8-core, shielded TP installation cable for connection to IE FC RJ45 Plug 4x2 and IE M12 Plug PRO 4x2; PROFINET-compliant; with UL approval; sold by the meter; max. length 1000 m, minimum order 20 m</p> <p>6XV1 878-2A</p>

Ordering data	Order No.
IE FC Flexible Cable GP 4x2 8-core, shielded TP installation cable for connection to IE FC RJ45 Plug 4x2 and IE M12 Plug PRO 4x2 for occasional movement; PROFINET-compliant; with UL approval; sold by the meter; max. length 1000 m, minimum order 20 m	6XV1 878-2B
IE FC Stripping Tool Preadjusted stripping tool for fast stripping of the Industrial Ethernet FC cables	6GK1 901-1GA00
IE FC blade cassettes (5 mm) Replacement blade cassette for the Industrial Ethernet stripping tool; for use with IE FC RJ45 Plugs and IE FC RJ45 Modular Outlet, 5 units	6GK1 901-1GB01
PROFINET Cabling and Interconnection Technology Guideline	www.profinet.com

More information

Note:

You can order components supplementary to the SIMATIC NET cabling range from your local contact.

Technical advice on this subject is available from:

J. Hertlein
 I IA SC IC PRM 4
 Tel.: +49 (0) 911 911/750 44 65
 E-mail: juergen.hertlein@siemens.com

PROFINET/Industrial Ethernet

Cabling technology

IE FC TP Cable 2 x 2

Overview

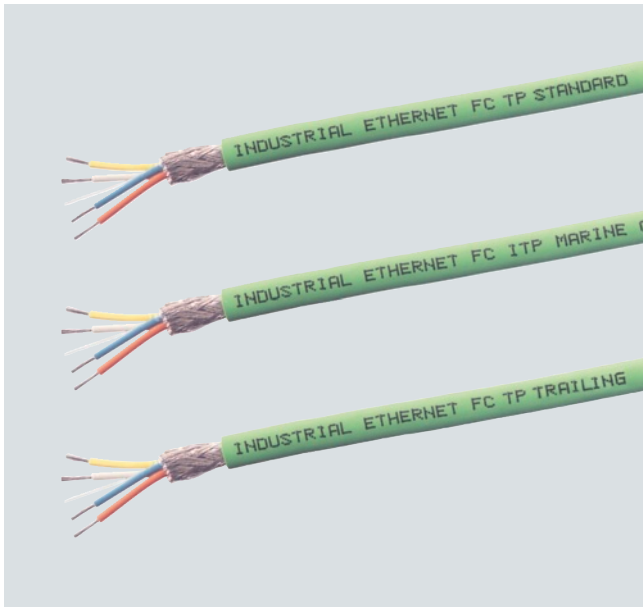

- 4-core FastConnect installation cables for structured Fast Ethernet cabling with special design for fast installation
- Easy stripping with the FastConnect Stripping Tool; the outer sheath and the braided shield are stripped accurately in one step
- Connection to FastConnect products using insulation displacement
- Exceeds Category 5 (Cat5e) of the international cabling standards ISO/IEC 11801 and EN 50173
- PROFINET-compatible
- UL approval
- Different versions for different fields of application (e.g. trailing, food, marine)
- High interference immunity thanks to double shielding
- Easy length measurement thanks to printed meter markings

Benefits

get Designed for Industry

- Time-saving due to simple and quick assembly with FastConnect cables 2 x 2 to Industrial Ethernet FC Outlet RJ45 (10/100 Mbit/s), Industrial Ethernet FC RJ45 Plug 180/90, or IE FC M12 Plug PRO
- Versatile application due to special bus cables
- Network is immune to interference thanks to double shielded cables and a uniform grounding concept
- Silicone-free, therefore suitable for use in the automotive industry (for example on paint lines)

Application

For the construction of Industrial Ethernet networks (4-core), different cable types are offered to suit the different types of application.

In general, the listed Industrial Ethernet FC cables IE FC Cable 2 x 2 must be used.

Note:

You will find other specifications of the network topology in the manual for TP and fiber optic networks.

UL approvals

Different cable versions are offered with appropriate UL approvals for laying in cable bundles and cable racks according to the specifications of NEC (National Electrical Code) Article 800/725. These are identified as GP (General Purpose).

Design

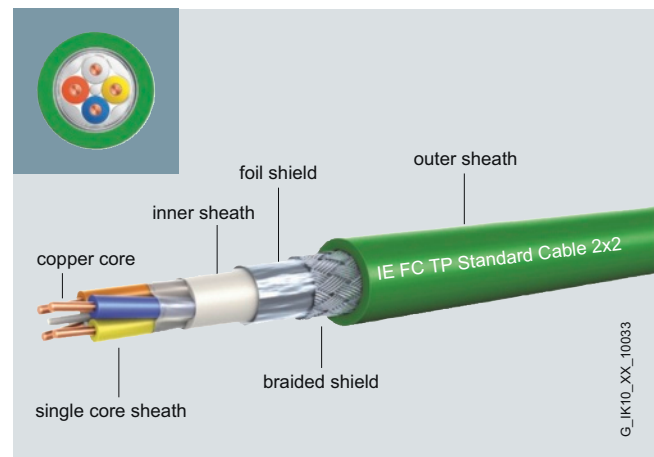

The FastConnect (FC) Industrial Ethernet cables IE FC Cable 2 x 2 are designed with radial symmetry and therefore allow the use of the FC Stripping Tool. The IE FC Outlet RJ45 and the IE FC Plugs can therefore be attached quickly and easily.

- The double shield makes it especially suitable for routing through industrial areas with strong electro-magnetic fields
- Easy connection to the insulation displacement contacts of the IE FC plug without the need for special tools
- System-wide grounding concept can be implemented through the outer shield of the bus cable as well as through the grounding concept of the IE FC Outlet RJ45 and the IE FC Plugs
- Printed meter marks

Design (continued)

Cable types

- **IE FC TP Standard Cable GP 2 x 2:**
Standard bus cable with rigid cores specially designed for fast installation;
four rigid cores connected in a four-branch star
- **IE FC TP Flexible Cable GP 2 x 2:**
Flexible bus cable for the special application of occasional motion control;
four stranded cores connected in a four branch star
- **IE FC TP FRNC Cable GP 2 x 2:**
Flexible, halogen-free cable for use in buildings (FRNC= Flame Retardant Non Corrosive);
four conductors (flexible leads) stranded into star-quad for occasional movement
- **IE FC TP Trailing Cable GP / IE FC TP Trailing Cable 2 x 2:**
Highly flexible bus cable for the special application of constant motion control in a cable carrier, e.g. for continuously moving machine parts;
four stranded cores connected in a four branch star
- **IE FC Festoon Cable GP 2 x 2:**
Flexible cable for special use in constant movement in a cable trail/festoon arrangement, e.g. on crane systems;
four cores (stranded) in twisted quads
- **IE TP Torsion Cable 2 x 2:**
Highly flexible bus cable for the special application of continuous motion control, e.g. for use with robots;
stranded cores
- **IE FC TP Food Cable 2 x 2:**
Flexible cable for special use in the food and beverages industry;
four cores (stranded) in twisted quads
- **IE FC TP Marine Cable 2 x 2:**
Bus cable for marine applications;
four cores (stranded) connected in a four branch star, halogen-free, certified for marine applications

Product overview IE FC TP Cable 2 x 2 (PROFINET-compatible according to "PROFINET Cabling and Interconnection Technology Guideline" ¹⁾)

	PROFINET Type A	PROFINET Type B	PROFINET Type C
	AWG 22/1 rigid laying	AWG 22/7 flexible cable for occasional movement	AWG 22 highly flexible cable for continuous motion, e.g. cable carrier or robots
<u>IE FC TP Standard Cable GP 2 x 2</u> (Type A) 6XV1 840-2AH10	●	–	–
<u>IE FC TP Flexible Cable GP 2 x 2</u> (Type B) 6XV1 870-2B	–	●	–
<u>IE FC TP FRNC Cable GP 2 x 2</u> (Type B) 6XV1 871-2F)	–	●	–
<u>IE FC TP Trailing Cable GP 2 x 2</u> (Type C) 6XV1 870-2D	–	●	●
<u>IE FC TP Trailing Cable 2 x 2</u> (Type C) 6XV1 840-3AH10	–	–	●
<u>IE FC TP Festoon Cable GP 2 x 2</u> (Type B) 6XV1871-2S	–	●	–
<u>IE TP Torsion Cable 2 x 2</u> (Type C) 6XV1 870-2F	–	–	●
<u>IE FC TP Food Cable 2 x 2</u> (Type C) 6XV1871-2L	–	–	●
<u>IE FC TP Marine Cable 2 x 2</u> (Type B) 6XV1 840-4AH10	–	●	–

¹⁾ Available as a download at www.profinet.com

PROFINET/Industrial Ethernet

Cabling technology

IE FC TP Cable 2 x 2

Technical specifications

Order No.	6XV1 840-2AH10	6XV1 870-2B	6XV1 870-2F
Product type designation	IE FC TP Standard Cable GP 2 x 2 (Type A)	IE FC TP Flexible Cable GP 2 x 2 (Type B)	IE TP Torsion Cable 2 x 2 (Type C)
Product description	Standard bus cable (4-core), sold by the meter, in bulk	Flexible bus cable (4-core), sold by the meter, in bulk	Highly flexible bus cable (4-core), sold by the meter, in bulk
Suitability for application	Standard cable with rigid cores for quick installation	For occasionally moved machine components	Continuous movement when using with robots
Cable designation	2YY (ST) CY 2x2x0.64/1.5-100 GN	2YY (ST) CY 2x2x0.75/1.5-100 LI GN	02YS C11Y 1x4x0.75/1.5-100 LI VZN FRNC GN
Cable length	-	-	-
Electrical specifications			
Attenuation factor per length			
• At 10 MHz	52 dB/km	60 dB/km	81 dB/km
• At 100 MHz	195 dB/km	210 dB/km	410 dB/km
Characteristic impedance at 1 MHz to 100 MHz	100 Ω	100 Ω	100 Ω
Relative symmetrical tolerance of characteristic impedance at 1 MHz to 100 MHz	15 %	15 %	15 %
Near-end crosstalk per length at 1 MHz to 100 MHz	500 dB/km	500 dB/km	500 dB/km
Surface transfer resistance at 10 MHz	10 mΩ/m	20 mΩ/m	100 mΩ/m
Loop resistance per length	115 Ω/km	120 Ω/km	120 Ω/km
Operating voltage, maximum	100 V	100 V	100 V
Mechanical data			
Number of electrical cores	4	4	4
Design of shield	Overlapping aluminum-clad foil, sheathed in a braided screen of tinned copper wires	Overlapping aluminum-clad foil, sheathed in a braided screen of tinned copper wires	Overlapping aluminum-clad foil, sheathed in a braided screen of tinned copper wires
Design of electrical connection FastConnect	Yes	Yes	No
AWG number			
Diameter of AWG22 core	0.64 mm	0.75 mm	0.76 mm
Outer diameter			
• of inner conductor	0.64 mm	0.75 mm	0.76 mm
• of core insulation	1.5 mm	1.5 mm	1.5 mm
• of inner sheath of cable	3.9 mm	3.9 mm	-
• of the cable sheath	6.5 mm	6.5 mm	6.5 mm
Symmetrical tolerance of outer diameter of cable sheath	0.2 mm	0.2 mm	0.2 mm
Material			
• of core insulation	PE	PE	PE
• of inner sheath of cable	PVC	PVC	-
• of the cable sheath	PVC	PVC	PUR
- Note	-	-	-
Color			
• of core insulation of data cores	white / yellow / blue / orange	white / yellow / blue / orange	white / yellow / blue / orange
• of the cable sheath	Green	Green	Green
Bending radius			
• With single bending	19.5 mm	32.5 mm	32.5 mm
• With repeated bending	49 mm	52 mm	65 mm
• With continuous bending	-	-	-

Technical specifications (continued)

Order No.	6XV1 840-2AH10	6XV1 870-2B	6XV1 870-2F
Product type designation	IE FC TP Standard Cable GP 2 x 2 (Type A)	IE FC TP Flexible Cable GP 2 x 2 (Type B)	IE TP Torsion Cable 2 x 2 (Type C)
Mechanical data (continued)			
Number of bending cycles	-	-	-
• Note	-	-	Not suitable for festoon mounting
Number of torsion cycles with torsion by $\pm 180^\circ$ on 1 m cable length	-	-	5 000 000
Maximum tensile load	150 N	150 N	130 N
Weight per length	67 kg/km	68 kg/km	54 kg/km
Permitted ambient conditions			
Ambient temperature			
• During operation	-40 ... +75 °C	-25 ... +75 °C	-40 ... +80 °C
• During storage	-40 ... +75 °C	-25 ... +75 °C	-40 ... +80 °C
• During transport	-40 ... +75 °C	-25 ... +75 °C	-40 ... +80 °C
• During mounting	-20 ... +60 °C	-10 ... +60 °C	-20 ... +60 °C
Behavior in fire	Flame-retardant in accordance with UL 1685 (CSA FT 4)	Flame-retardant in accordance with UL 1685 (CSA FT 4)	Flame-retardant in accordance with IEC 60332-1-2
Chemical resistance			
• Mineral oil	Limited resistance	Limited resistance	resistant
• Grease	Limited resistance	Limited resistance	resistant
• Water	Limited resistance	Limited resistance	Limited resistance
Radiological resistance to UV radiation	resistant	resistant	resistant
Product properties, functions, components			
General			
Product property			
• Halogen-free	No	No	Yes
• Silicon-free	Yes	Yes	Yes
Cable length for 100BaseTX with Industrial Ethernet	100 m	85 m	55 m
Standards, specifications, approvals			
UL-Listing at 300 V rating	Yes: CM / CMG / PLTC / Sun Res	Yes: CM / CMG / PLTC / Sun Res	Yes: UL Style 21161
UL-Style at 600 V rating	Yes	No	No
Certificate of suitability			
• RoHS compliance	Yes	Yes	-
Standard for structured cabling	Cat5e	Cat5e	Cat5e
Marine classification association			
• American Bureau of Shipping Europe Ltd. (ABS)	No	No	No
• Bureau Veritas (BV)	No	No	No
• Det Norske Veritas (DNV)	No	No	No
• Germanischer Lloyd (GL)	No	No	No
• Lloyds Register of Shipping (LRS)	No	No	No

PROFINET/Industrial Ethernet

Cabling technology

IE FC TP Cable 2 x 2

Technical specifications (continued)

Order No.	6XV1 870-2D	6XV1 840-3AH10	6XV1 871-2S
Product type designation	IE FC TP Trailing Cable GP 2 x 2 (Type C)	IE FC TP Trailing Cable 2 x 2 (Type C)	IE FC TP Festoon Cable GP 2 x 2 (Type B)
Product description	Highly flexible bus cable (4-core), sold by the meter, in bulk	Highly flexible bus cable (4-core), sold by the meter, in bulk	Flexible bus cable (4-core), sold by the meter, in bulk
Suitability for application	Continuous movement in a trailing cable	Continuous movement in a trailing cable	For continuous movement in a trailing cable, festoon mounting
Cable designation	2YY (ST) CY 2x2x0.75/1.5-100 LI GN	2YH (ST) C11Y 2x2x0.75/1.5-100 LI GN VZN FRNC	2YY (ST) CY 2x2x0.75/1.5 LI GN
Cable length	-	-	-
Electrical specifications			
Attenuation factor per length			
• at 10 MHz	63 dB/km	60 dB/km	63 dB/km
• At 100 MHz	213 dB/km	220 dB/km	213 dB/km
Characteristic impedance at 1 MHz to 100 MHz	100 Ω	100 Ω	100 Ω
Relative symmetrical tolerance of characteristic impedance at 1 MHz to 100 MHz	5 %	15 %	5 %
Near-end crosstalk per length at 1 MHz to 100 MHz	500 dB/km	500 dB/km	500 dB/km
Surface transfer resistance at 10 MHz	20 mΩ/m	10 mΩ/m	0.1 Ω/m
Loop resistance per length	0.12 Ω/m	0.12 Ω/m	0.12 Ω/m
Mechanical data			
Number of electrical cores	4	4	4
Design of shield	Overlapping aluminum-clad foil, sheathed in a braided screen of tin-plated copper wires	Overlapping aluminum-clad foil, sheathed in a braided screen of tin-plated copper wires	Overlapping aluminum-clad foil, sheathed in a braided screen of tin-plated copper wires
Design of electrical connection FastConnect	Yes	Yes	Yes
AWG number			
Diameter of AWG22 core	0.75 mm	0.75 mm	0.75 mm
Outer diameter			
• of inner conductor	0.75 mm	0.75 mm	0.75 mm
• of core insulation	1.5 mm	1.5 mm	1.5 mm
• of inner sheath of cable	3.9 mm	3.9 mm	3.9 mm
• of the cable sheath	6.5 mm	6.5 mm	6.5 mm
Symmetrical tolerance of outer diameter of cable sheath	0.2 mm	0.2 mm	0.2 mm
Material			
• of core insulation	PE	PE	PE
• of inner sheath of cable	PVC	FRNC	PVC
• of the cable sheath	PVC	PUR	PVC
- Note	-	-	-
Color			
• of core insulation of data cores	white / yellow / blue / orange	white / yellow / blue / orange	white / yellow / blue / orange
• of the cable sheath	Green	Green	Green
Bending radius			
• With single bending	32.5 mm	19.5 mm	30 mm
• With repeated bending	49 mm	49 mm	70 mm
• With continuous bending	100 mm	100 mm	70 mm

Technical specifications (continued)

Order No.	6XV1 870-2D	6XV1 840-3AH10	6XV1 871-2S
Product type designation	IE FC TP Trailing Cable GP 2 x 2 (Type C)	IE FC TP Trailing Cable 2 x 2 (Type C)	IE FC TP Festoon Cable GP 2 x 2 (Type B)
Mechanical data (continued)			
Number of bending cycles • Note	3 000 000 Suitable as trailing cable for 3 million bending cycles with a bending radius of 100 mm, a speed of 4 m/s, and an acceleration of 4 m/s ² .	4 000 000 Suitable as trailing cable for 4 million bending cycles with a bending radius of 100 mm, a speed of 4 m/s, and an acceleration of 4 m/s ² .	5 000 000 5 million bending cycles with a bending radius of 70 mm, and an acceleration of 4 m/s ² .
Maximum tensile load	150 N	150 N	150 N
Weight per length	68 kg/km	63 kg/km	68 kg/m
Permitted ambient conditions			
Ambient temperature • During operation • During storage • During transport • During mounting	-25 ... +75 °C -25 ... +75 °C -25 ... +75 °C -10 ... +60 °C	-40 ... +75 °C -50 ... +75 °C -50 ... +75 °C -20 ... +60 °C	-40 ... +75 °C -50 ... +75 °C -50 ... +75 °C -20 ... +60 °C
Behavior in fire	Flame-retardant in accordance with UL 1685 (CSA FT 4)	Flame-retardant in accordance with IEC 60332-1-2	Flame-retardant in accordance with UL 1685 (CSA FT 4)
Chemical resistance • Mineral oil • Grease • Water	Limited resistance Limited resistance Limited resistance	resistant resistant Limited resistance	Limited resistance Limited resistance Limited resistance
Radiological resistance to UV radiation	resistant	resistant	resistant
Product properties, functions, components			
General			
Product property • Halogen-free • Silicon-free	No Yes	Yes Yes	No Yes
Cable length for 100BaseTX with Industrial Ethernet	85 m	85 m	85 m
Standards, specifications, approvals			
UL listing at 300 V rating UL-Style at 600 V rating	Yes: CMG / PLTC / Sun Res Yes	Yes: CMX No	Yes: CMG / PLTC / Sun Res Yes
Certificate of suitability • RoHS compliance	Yes	Yes	Yes
Standard for structured cabling	Cat5e	Cat5e	Cat5e
Marine classification association • American Bureau of Shipping Europe Ltd. (ABS) • Bureau Veritas (BV) • Det Norske Veritas (DNV) • Germanischer Lloyd (GL) • Lloyds Register of Shipping (LRS)	No No No No No	No No No No No	No No No No No

PROFINET/Industrial Ethernet

Cabling technology

IE FC TP Cable 2 x 2

Technical specifications (continued)

Order No.	6XV1 871-2F	6XV1 871-2L	6XV1 840-4AH10
Product type designation	IE FC TP FRNC Cable GP 2 x 2 (Type B)	IE FC TP Food Cable 2 x 2 (Type C)	IE FC TP Marine Cable 2 x 2 (Type B)
Product description	Flexible, halogen-free bus cable (4-core), sold by the meter, in bulk	Flexible bus cable (4-core), sold by the meter, in bulk	Bus cable (4-core), sold by the meter, in bulk
Suitability for application	For occasionally moved machine components	Food, beverages and tobacco industries	For marine and offshore use
Cable designation	L-9YH (ST) CH 2x2x0.34/1.5-100 GN VZN FRNC	2YH (ST) C2Y 2X2X0.75/1.5-100 LI	L-9YH (ST) CH 2 x 2 x 0.34/1.5-100 GN VZN FRNC
Cable length	-	-	-
Electrical specifications			
Attenuation factor per length			
• at 10 MHz	60 dB/km	63 dB/m	60 dB/km
• At 100 MHz	220 dB/km	213 dB/m	220 dB/km
Characteristic impedance at 1 MHz to 100 MHz	100 Ω	100 Ω	100 Ω
Relative symmetrical tolerance of characteristic impedance at 1 MHz to 100 MHz	15 %	5 %	15 %
Near-end crosstalk per length at 1 MHz to 100 MHz	500 dB/km	500 dB/km	500 dB/km
Surface transfer resistance at 10 MHz	10 mΩ/m	10 mΩ/m	10 mΩ/m
Loop resistance per length	120 Ω/km	120 Ω/km	120 Ω/km
Mechanical data			
Number of electrical cores	4	4	4
Design of shield	Overlapping aluminum-clad foil, sheathed in a braided screen of tin-plated copper wires	Overlapping aluminum-clad foil, sheathed in a braided screen of tin-plated copper wires	Overlapping aluminum-clad foil, sheathed in a braided screen of tin-plated copper wires
Design of electrical connection FastConnect	Yes	Yes	Yes
AWG number			
Diameter of AWG22 core	0.75 mm	0.75 mm	0.75 mm
Outer diameter			
• of inner conductor	0.75 mm	0.75 mm	0.75 mm
• of core insulation	1.5 mm	1.5 mm	1.5 mm
• of inner sheath of cable	3.9 mm	3.9 mm	3.9 mm
• of the cable sheath	6.5 mm	6.5 mm	6.5 mm
Symmetrical tolerance of outer diameter of cable sheath	0.2 mm	0.2 mm	0.2 mm
Material			
• of core insulation	PP	PE	PP
• of inner sheath of cable	FRNC	FRNC	FRNC
• of the cable sheath	FRNC	PE	FRNC
- Note	-	-	-
Color			
• of core insulation of data cores	white / yellow / blue / orange	white / yellow / blue / orange	white / yellow / blue / orange
• of the cable sheath	Green	Black	Green

Technical specifications (continued)

Order No.	6XV1 871-2F	6XV1 871-2L	6XV1 840-4AH10
Product type designation	IE FC TP FRNC Cable GP 2 x 2 (Type B)	IE FC TP Food Cable 2 x 2 (Type C)	IE FC TP Marine Cable 2 x 2 (Type B)
Mechanical data (continued)			
Bending radius			
• With single bending	39 mm	20 mm	39 mm
• With repeated bending	97.5 mm	49 mm	97.5 mm
Maximum tensile load	150 N	150 N	150 N
Weight per length	68 kg/km	55 kg/km	68 kg/km
Permitted ambient conditions			
Ambient temperature			
• During operation	-25 ... +70 °C	-40 ... +75 °C	-25 ... +70 °C
• During storage	-40 ... +75 °C	-50 ... +75 °C	-40 ... +70 °C
• During transport	-40 ... +75 °C	-50 ... +75 °C	-40 ... +70 °C
• During mounting	0 ... +50 °C	-20 ... +60 °C	0 ... +50 °C
Behavior in fire	Flame-retardant in accordance with IEC 60332-3-22 (Category A/F)	Flammable	Flame-retardant in accordance with IEC 60332-3-22 (Category A/F)
Chemical resistance			
• Mineral oil	Limited resistance	Limited resistance	Limited resistance
• Grease	Limited resistance	Limited resistance	Limited resistance
• Water	Limited resistance	Limited resistance	Limited resistance
Radiological resistance to UV radiation	resistant	resistant	resistant
Product properties, functions, components			
General			
Product property			
• Halogen-free	Yes	Yes	Yes
• Silicon-free	Yes	Yes	Yes
Cable length for 100BaseTX with Industrial Ethernet	85 m	85 m	85 m
Standards, specifications, approvals			
UL listing at 300 V rating	Yes: CMG / PLTC / Sun Res	No	Yes: CM / CMG / PLTC / Sun Res
UL-Style at 600 V rating	No	No	No
Certificate of suitability			
• RoHS compliance	Yes	Yes	Yes
Standard for structured cabling	Cat5e	Cat5e	Cat5e
Marine classification association			
• American Bureau of Shipping Europe Ltd. (ABS)	No	No	Yes
• Bureau Veritas (BV)	No	No	Yes
• Det Norske Veritas (DNV)	No	No	Yes
• Germanischer Lloyd (GL)	No	No	Yes
• Llyods Register of Shipping (LRS)	No	No	Yes

PROFINET/Industrial Ethernet

Cabling technology

IE FC TP Cable 2 x 2

2

Ordering data	Order No.	Ordering data	Order No.
IE FC TP Standard Cable GP 2 x 2 (Type A) 4-core, shielded TP installation cable for connection to IE FC Outlet RJ45/ IE FC RJ45 Plug; PROFINET-compliant; with UL approval; <u>sold by the meter</u> max. length 1,000 m; minimum order 20 m <u>Preferred length</u> • 1000 m	6XV1 840-2AH10 6XV1 840-2AU10	IE TP Torsion Cable 2 x 2 (Type C) 4-core, shielded TP installation cable for connection to IE FC Outlet RJ45/ IE FC RJ45 Plug for use with robots; PROFINET-compliant; with UL approval; <u>sold by the meter</u> ; max. length 1000 m, minimum order 20 m	6XV1 870-2F
IE FC TP Flexible Cable GP 2 x 2 (Type B) 4-core, shielded TP installation cable for connection to IE FC Outlet RJ45/ IE FC RJ45 Plug for occasional movement; PROFINET-compliant; with UL approval; <u>sold by the meter</u> ; max. length 1000 m, minimum order 20 m	6XV1 870-2B	IE FC TP Food Cable GP 2 x 2 (Type C) 4-core, shielded TP installation cable for connection to IE FC Outlet RJ45/ IE FC RJ45 Plug 180/90 for the food and beverages industry; PROFINET-compliant; <u>sold by the meter</u> ; max. length 1000 m, minimum order 20 m	6XV1 871-2L
IE FC TP FRNC Cable GP 2 x 2 (Type B) 4-core, shielded, halogen-free TP installation cable for connection to IE FC Outlet RJ45/ IE FC RJ45 Plug for occasional movement; PROFINET-compliant; with UL approval; <u>sold by the meter</u> ; max. length 1000 m, minimum order 20 m	6XV1 871-2F	IE FC TP Marine Cable 2 x 2 (Type B) 4-core, shielded TP installation cable for connection to IE FC Outlet RJ45/ IE FC RJ45 Plug 180/90; marine approval; <u>sold by the meter</u> ; max. length 1000 m, minimum order 20 m	6XV1 840-4AH10
IE FC TP Trailing Cable GP 2 x 2 (Type C) 4-core, shielded TP installation cable for connection to IE FC Outlet RJ45/ IE FC RJ45 Plug for use as trailing cable; PROFINET-compliant; with UL approval; <u>sold by the meter</u> ; max. length 1000 m, minimum order 20 m	6XV1 870-2D	IE Hybrid Cable 2x2 + 4x0.34 Flexible cable, 4 x Cu Cat5, shielded (0.75 mm) and 4 x Cu (0.34 mm ²) with IE FC modular outlet and power insert and IP67 hybrid plug connector; <u>sold by the meter</u> ; max. length 1000 m, minimum order 20 m	6XV1870-2J
IE FC TP Trailing Cable 2 x 2 (Type C) 4-core, shielded TP installation cable for connection to IE FC Outlet RJ45/ IE FC RJ45 Plug 180/90 for use as trailing cable; PROFINET-compliant; with UL approval; <u>sold by the meter</u> ; max. length 1000 m, minimum order 20 m	6XV1 840-3AH10	Accessories IE FC Stripping Tool Preadjusted stripping tool for fast stripping of the Industrial Ethernet FC cables	6GK1 901-1GA00
IE FC TP Festoon Cable GP 2 x 2 (Type B) 4-core, shielded TP installation cable for connection to IE FC Outlet RJ45/ IE FC RJ45 Plug 180/90 for use in festoon applications; PROFINET-compliant; with UL approval; <u>sold by the meter</u> ; max. length 1000 m, minimum order 20 m	6XV1 871-2S	IE FC Blade Cassettes (12 mm) Replacement blade cassette for the Industrial Ethernet stripping tool; for use with IE FC Outlet RJ45, ELS TP40, 5 units	6GK1 901-1GB00
		IE FC Blade Cassettes (5 mm) Replacement blade cassette for the Industrial Ethernet stripping tool; for use with IE FC RJ45 Plugs and IE FC RJ45 Modular Outlet, 5 units	6GK1 901-1GB01

Ordering data	Order No.	More information
<p>IE FC RJ45 plugs</p> <p>RJ45 plug connector for Industrial Ethernet with a rugged metal enclosure and integrated insulation displacement contacts for connecting Industrial Ethernet FC installation cables</p> <p>IE FC RJ45 Plug 180</p> <p>180° cable outlet; for network components and CPs/CPU with Industrial Ethernet interface</p> <ul style="list-style-type: none"> • 1 pack = 1 unit • 1 pack = 10 units • 1 pack = 50 units <p>IE FC RJ45 plug 90</p> <p>90° cable outlet; e.g. for ET 200S</p> <ul style="list-style-type: none"> • 1 pack = 1 unit • 1 pack = 10 units • 1 pack = 50 units <p>IE FC RJ45 Plug 145</p> <p>145° cable outlet; e.g. for SIMOTION and SINAMICS</p> <ul style="list-style-type: none"> • 1 pack = 1 unit • 1 pack = 10 units • 1 pack = 50 units 	<p>6GK1 901-1BB10-2AA0 6GK1 901-1BB10-2AB0 6GK1 901-1BB10-2AE0</p> <p>6GK1 901-1BB20-2AA0 6GK1 901-1BB20-2AB0 6GK1 901-1BB20-2AE0</p> <p>6GK1 901-1BB30-0AA0 6GK1 901-1BB30-0AB0 6GK1 901-1BB30-0AE0</p>	<p>Installation instructions</p> <p>The bus cables are supplied by the meter with meter marks printed on them.</p> <p><i>FastConnect</i></p> <p>With the help of Industrial Ethernet FastConnect Stripping Tool, it is possible to strip the outer sheath and shield of Industrial Ethernet FastConnect cables 2 x 2 to the right length in one step. The IE Outlet RJ45 and the PROFINET-compatible plug-in connectors IE FC RJ45 and IE FC M12 can be connected quickly and easily to the Industrial Ethernet FC cable 2 x 2.</p> <p><i>Cable routing</i></p> <p>During storage, transport and cable laying, keep both ends sealed with a shrink-on cap; comply with the permissible bending radii and tensile load.</p>
<p>IE FC M12 Plugs</p> <p>IE FC M12 Plug PRO</p> <p>M12 plug-in connector (D-coded, IP65/IP67) that can be assembled in the field, metal enclosure, FastConnect connection method, for SCALANCE X208PRO and IM 154-4 PN</p> <ul style="list-style-type: none"> • 1 unit • 8 units 	<p>6GK1 901-0DB20-6AA0 6GK1 901-0DB20-6AA8</p>	
<p>SIMATIC NET Manual Collection</p> <p>Electronic manuals for communication systems, communication protocols, and communication products; on DVD; German/English</p>	<p>6GK1 975-1AA00-3AA0</p>	
<p>PROFINET Cabling and Interconnection Technology Guideline</p>	<p>www.profinet.com</p>	

PROFINET/Industrial Ethernet

Cabling technology

IE FC TP Cable 4 x 2

Overview



- 8-core FastConnect installation cables for cabling system with Gigabit capability (AWG22 and AWG24 versions)
- Easy stripping with the FastConnect Stripping Tool; the outer sheath and the braided shield are stripped accurately in one step
- Connection to IE FC RJ45 Modular Outlet (AWG22) or IE FC RJ45 Plug 4 x 2 (AWG24) using insulation displacement
- Satisfies Category 6 (Cat6) of the international cabling standards ISO/IEC 11801 and EN 50173
- UL approval
- Easy length measurement thanks to printed meter markings

Benefits

get Designed for Industry

- Time-saving due to quick and easy assembly using FastConnect cables 4 x 2 on IE FC RJ 45 Modular Outlet or IE FC RJ45 Plug 4 x 2 or IE FC M12 Plug PRO (X-coded)
- Simple and error-free construction of an 8-core cabling system with Gigabit capability
- Due to the 8-core cabling, you can either implement two Industrial Ethernet connections for Fast Ethernet (with IE FC RJ 45 Modular Outlet) or one Gigabit Ethernet
- Noise-immune network due to a consistent grounding concept.

Application

The 8-core cabling system of SIMATIC NET allows transmission rates of 10/100/1000 Mbit/s for Ethernet as with the service-independent cabling from the office environment. This permits the transition from the 4-core Industrial Ethernet cabling system to the 8-core cabling system with Gigabit capability.

The IE FC TP Standard Cable GP 4x2 (AWG22) must be used in conjunction with the IE FC Modular Outlet and the TP Cords for constructing Industrial Ethernet networks (8-core) up to 100 m.

IE FC TP Standard Cable 4x2 (AWG22)

The IE FC TP Standard Cable GP 4x2 (AWG22) must be used in conjunction with the IE FC Modular Outlet and the TP Cords for constructing Industrial Ethernet networks (8-core) up to 100 m.

IE FC TP Cable 4x2 (AWG24)

For direct connection without using patch technology, the IE FC RJ45 Plug 4 x 2 and the IE FC TP Cable 4 x 2 (AWG24) of up to 90 m can be used.

Note:

You will find other specifications of the network topology in the manual for TP and fiberoptic networks.

UL approvals

The IE FC TP Cable GP 4 x 2 (AWG22 and AWG24) has the relevant UL approvals for laying in cable bundles and cable racks according to the specifications of NEC (National Electrical Code) Article 800/725.

Design

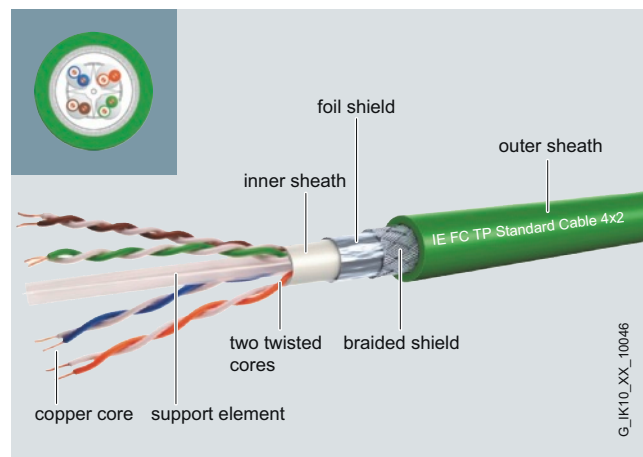

The FastConnect (FC) Industrial Ethernet cables IE FC Cable 4 x 2 (AWG22 and AWG24) are designed with radial symmetry and therefore allow the use of the IE FC Stripping Tool. The IE FC RJ45 Modular Outlet and the IE FC RJ45 Plug 4 x 2 can then be connected quickly and easily by means of insulation displacement contacts without the need for special tools.

Design (continued)

Cable types

- IE FC Standard Cable GP 4 x 2 (AWG22):**
 Standard bus cable with rigid cores specially designed for fast mounting on IE FC RJ45 Modular Outlet; with appropriate UL approval (General Purpose) for laying in cable bundles and on cable racks according to the specifications of the NEC (National Electrical Code) Article 800/725.
- IE FC Standard Cable GP 4 x 2 (AWG24):**
 Standard bus cable with rigid cores specially designed for fast mounting on IE FC RJ45 Plug 4 x 2; with appropriate UL approval (General Purpose) for laying in cable bundles and on cable racks according to the specifications of the NEC (National Electrical Code) Article 800/725.
- IE FC Flexible Cable GP 4 x 2 (AWG24):**
 Bus cable with flexible cores for occasional movement and specially designed for fast mounting on IE FC RJ45 Plug 4 x 2; with appropriate UL approval (General Purpose) for laying in cable bundles and on cable racks according to the specifications of the NEC (National Electrical Code) Article 800/725.

Integration

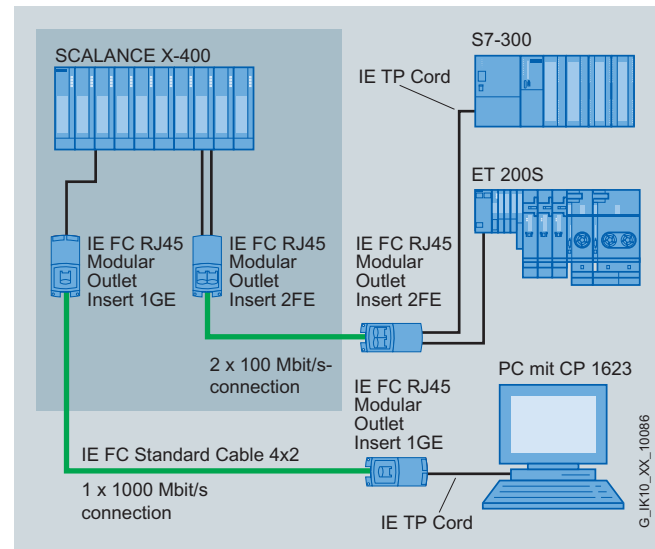

System configuration with IE FC RJ45 Modular Outlet 100 Mbit/s and 1000 Mbit/s

PROFINET/Industrial Ethernet

Cabling technology

IE FC TP Cable 4 x 2

Technical specifications

Order No.	6XV1 870-2E	6XV1 878-2A	6XV1 878-2B
Product type designation	IE FC TP Standard Cable GP 4x2 (AWG 22)	IE FC TP Standard Cable GP 4x2 (AWG 24)	IE FC TP Flexible Cable GP 4x2 (AWG 24)
Product description	Standard bus cable (8-core), sold by the meter, in bulk	Shielded TP installation cable (8-core), sold by the meter, in bulk	Bus cable (8-core) with flexible cores, sold by the meter, in bulk
Suitability for application	Standard cable with rigid cores for fast assembly, for fixed installation	Standard cable with rigid cores for fast assembly, for fixed installation	Flexible cable for fast assembly for occasionally moved machine components
Cable designation	2YH (ST) C 4X2X0.64/1.25-100 GN	2YH (ST) CY 4x2x0.5/1.0- 100 GN	LI02YSH (ST) CY 4x2x0.22/ 1.1- 100 GN
Cable length	-	-	-
Electrical specifications			
Attenuation factor per length			
• At 10 MHz	60 dB/km	63 dB/km	90 dB/km
• At 100 MHz	199 dB/km	207 dB/km	299 dB/km
• At 250 MHz	330 dB/km	350 dB/km	495 dB/km
Characteristic impedance at 1 MHz to 100 MHz	100 Ω	100 Ω	100 Ω
Near-end crosstalk per length at 1 MHz ... 250 MHz	383 dB/km	383 dB/km	383 dB/km
Surface transfer resistance at 10 MHz	10 mΩ/m	20 mΩ/m	20 mΩ/m
Loop resistance per length	118 Ω/km	180 Ω/km	180 Ω/km
Insulation resistance coefficient	5 000 GΩ·m	≥ 5 000 kΩ·m	≥ 5 000 kΩ·m
Operating voltage, maximum	100 V	100 V	100 V
Mechanical data			
Number of electrical cores	8	8	8
Design of shield	Overlapping aluminum-clad foil, sheathed in a braided screen of tin-plated copper wires	Overlapping aluminum-clad foil, sheathed in a braided screen of tin-plated copper wires	Overlapping aluminum-clad foil, sheathed in a braided screen of tin-plated copper wires
Design of electrical connection FastConnect	Yes	Yes	Yes
AWG number			
Core diameter			
• of AWG22 core	0.64 mm	-	-
• of AWG24 core	-	0.51 mm	0.51 mm
Outer diameter			
• of inner conductor	0.64 mm	0.51 mm	0.6 mm
• of core insulation	1.25 mm	1 mm	1.1 mm
• of inner sheath of cable	7.6 mm	5.8 mm	6.1 mm
• of the cable sheath	9.6 mm	8 mm	8 mm
Symmetrical tolerance of outer diameter of cable sheath	0.3 mm	0.2 mm	0.2 mm
Material			
• of core insulation	PE	PE	PE
• of inner sheath of cable	PVC	FRNC	FRNC
• of the cable sheath	PVC	PVC	PVC
- Note	-	-	-

Technical specifications (continued)

Order No.	6XV1 870-2E	6XV1 878-2A	6XV1 878-2B
Product type designation	IE FC TP Standard Cable GP 4x2 (AWG 22)	IE FC TP Standard Cable GP 4x2 (AWG 24)	IE FC TP Flexible Cable GP 4x2 (AWG 24)
Color			
• of core insulation of data cores	White/blue, white/orange, white/green, white/brown	blue and white/blue, orange and white/orange, green and white/green, brown and white/brown	blue and white/blue, orange and white/orange, green and white/green, brown and white/brown
• of the cable sheath	Green	Green	Green
Bending radius			
• With single bending	38 mm	24 mm	24 mm
• With repeated bending	80 mm	40 mm	40 mm
Maximum tensile load	180 N	100 N	100 N
Weight per length	104 kg/km	78 kg/km	72 kg/km
Permitted ambient conditions			
Ambient temperature			
• During operation	-40 ... +80 °C	-40 ... +80 °C	-40 ... +80 °C
• During storage	-40 ... +80 °C	-40 ... +80 °C	-40 ... +80 °C
• During transport	-40 ... +80 °C	-40 ... +80 °C	-40 ... +80 °C
• During mounting	-40 ... +80 °C	-40 ... +80 °C	-40 ... +80 °C
Behavior in fire	Flame-retardant in accordance with IEC 60332-1-2	Flame-retardant in accordance with IEC 60332-3-24 (Category C)	Flame-retardant in accordance with IEC 60332-3-24 (Category C)
Chemical resistance			
• Mineral oil	Limited resistance	Limited resistance	Limited resistance
• Grease	Limited resistance	Limited resistance	Limited resistance
• Water	Limited resistance	Limited resistance	Limited resistance
Radiological resistance to UV radiation	Resistant	Resistant	Resistant
Product properties, functions, components			
General			
Product property			
• Halogen-free	No	No	No
• Silicon-free	Yes	Yes	Yes
Cable length			
• with 100BaseTX and Industrial Ethernet	90 m	90 m	60 m
• with 1000BaseT and Industrial Ethernet	90 m	90 m	60 m
Standards, specifications, approvals			
UL-Listing at 300 V rating	Yes: CMG, Sun Res	Yes: CMG	Yes: CMG
UL-Style at 600 V rating	No	No	No
Certificate of suitability			
• RoHS compliance	Yes	Yes	Yes
Standard for structured cabling	Cat6	Cat6	Cat6

PROFINET/Industrial Ethernet

Cabling technology

IE FC TP Cable 4 x 2

2

Ordering data

IE FC TP Standard Cable GP 4 x 2

8-core, shielded TP installation cable for universal applications; with UL approval; sold by the meter; max. length 1000 m, minimum order 20 m

- AWG22, for connection to IE FC RJ45 Modular Outlet
- AWG24, for connection to IE FC RJ45 Plug 4 x 2

Order No.

6XV1 870-2E

6XV1 878-2A

IE FC TP Flexible Cable GP 4 x 2

8-core, shielded TP installation cable for occasional movement; with UL approval; sold by the meter; max. length 1000 m, minimum order 20 m

- AWG24, for connection to IE FC RJ45 Plug 4 x 2

6XV1 878-2B

IE FC Stripping Tool

Preadjusted stripping tool for fast stripping of Industrial Ethernet FC cables 4 x 2

6GK1 901-1GA00

IE FC Blade Cassettes (5 mm)

Replacement blade cassette for the Industrial Ethernet stripping tool, for use with IE FC RJ45 Plugs and IE FC RJ45 Modular Outlet, 5 units

6GK1 901-1GB01

IE FC RJ45 Modular Outlet

FastConnect RJ45 Outlet for Industrial Ethernet with interface for a replaceable insert;

- **without replaceable insert**
- **With 2FE insert;** replaceable insert for 2 x 100 Mbit/s interfaces
- **With 1GE insert;** replaceable insert for 1 x 1000 Mbit/s interfaces
- **With power insert;** replaceable insert for 1 x 24 V DC and 1 x 100 Mbit/s interface

6GK1 901-1BE00-0AA0
6GK1 901-1BE00-0AA1

6GK1 901-1BE00-0AA2

6GK1 901-1BE00-0AA3

IE FC RJ45 Modular Outlet Insert 2FE

Replaceable insert for FC Modular Outlet Base; 2 x RJ45 for 2 x 100 Mbit/s interfaces; 1 pack = 4 items

Order No.

6GK1 901-1BK00-0AA1

IE FC RJ45 Modular Outlet Insert 1GE

Replaceable insert for FC Modular Outlet Base; 1 x RJ45 for 1 x 1000 Mbit/s interface; 1 pack = 4 items

6GK1 901-1BK00-0AA2

IE FC RJ45 Plug 4 x 2

RJ45 plug connector for Industrial Ethernet with a rugged metal enclosure and integrated insulation displacement contacts for connecting Industrial Ethernet FC installation cables 4 x 2; 180° cable outlet; for network components and CPs/CPUs with Industrial Ethernet interface

- 1 pack = 1 unit
- 1 pack = 10 units
- 1 pack = 50 units

6GK1 901-1BB11-2AA0
6GK1 901-1BB11-2AB0
6GK1 901-1BB11-2AE0

IE FC M12 Plug PRO 4 x 2

M12 plug-in connector suitable for on-site assembly (X-coded, IP65/IP67), metal enclosure, insulation/displacement fast connection method, for SCALANCE W

- 1 unit
- 8 units

6GK1 901-0DB30-6AA0
6GK1 901-0DB30-6AA8

SIMATIC NET Manual Collection

Electronic manuals for communication systems, communication protocols, and communication products; on DVD; German/English

6GK1 975-1AA00-3AA0

More information

Installation instructions

The bus cable is supplied by the meter with meter marks printed on it.

FastConnect

With the help of Industrial Ethernet FastConnect Stripping Tool, it is possible to strip the outer sheath and shield of the Industrial Ethernet FastConnect cable 4 x 2 to the right length in one step. This allows the IE FC RJ45 Modular Outlet to be attached quickly and easily to the Industrial Ethernet FC cable 4 x 2.

Cable routing

During storage, transport and cable laying, keep both ends sealed with a shrink-on cap; comply with the permissible bending radii and tensile load.

PROFINET/Industrial Ethernet

Cabling technology

IE Hybrid Cable

Overview

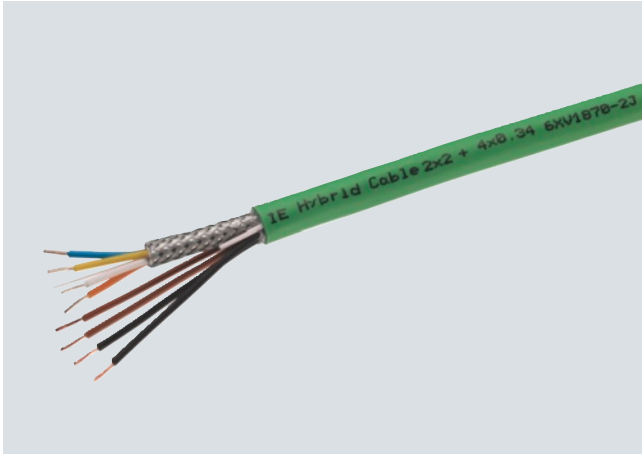

- Industry-standard Industrial Ethernet hybrid cable for transmitting data (10/100 Mbit) and power (24 V/400 mA)
- The IE Hybrid cable 2x2 + 4x0.34 contains:
 - Industrial Ethernet cable 2 x 2 Cat5e, shielded as twisted quad (stranded, 4-core)
 - four power cores 0.34 mm² (stranded)

Benefits

get Designed for Industry

- Simple installation thanks to insulation displacement connection in the IE FC RJ45 Modular Outlet and with hybrid connectors on SCALANCE W788-xPRO/RR and W74x-1PRO/RR
- Reduced installation costs since only one cable has to be installed to supply remote nodes (e.g. SCALANCE W)
- Halogen-free cable design for universal use in the industrial and office areas
- Rugged, UV-resistant industrial cable with UL approval

Application

The IE Hybrid cable 2x2 + 4x0.34 and the IE FC RJ45 Modular Outlet with Power Insert can be used to supply remote nodes (e.g. SCALANCE W) simultaneously with data (10/100 Mbit/s) and power. Having both data and power on one cable leads to a significant reduction of installation costs.

A maximum of 80 m can be covered between the IE FC RJ45 Modular Outlet and SCALANCE W, with an additional 6 m patch cable on the Modular Outlet.

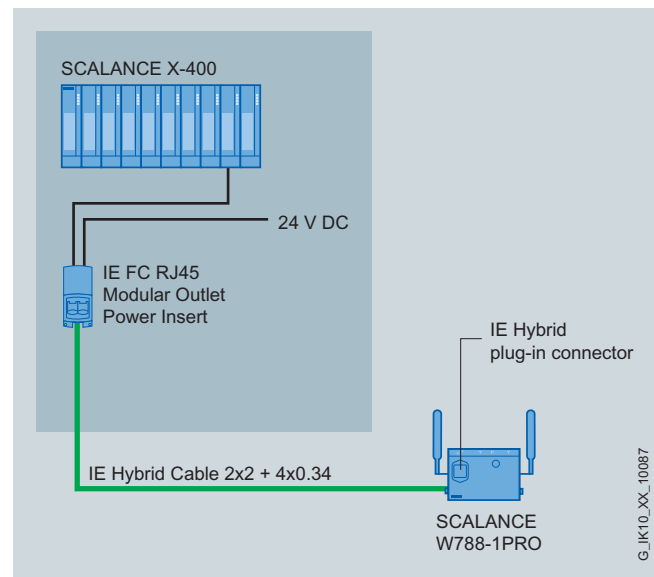

Network structure with IE FC RJ45 Modular Outlet and Power Insert for supplying the SCALANCE W788-xPRO/RR Access Points and the SCALANCE W74x-1PRO/RR client modules

Design

Rugged, halogen-free Ethernet hybrid cable with four shielded, flexible data cores (AWG22, twisted quad) and four power cores (0.34 mm²) for transmitting data and power.

The IE Hybrid cable 2x2 + 4x0.34 is available in customized lengths.

PROFINET/Industrial Ethernet

Cabling technology

IE Hybrid Cable

Technical specifications

Order No.	6XV1 870-2J
Product type designation	IE Hybrid Cable 2x2 + 4x0.34
Product description	Hybrid cable (data and power cores), sold by the meter, in bulk
Suitability for application	Ethernet hybrid cable for transmission of data and power
Cable designation	2YH (ST) C 2x2x0.76/1.5LI LIH H 4x0,34/1.6GN FRNC
Cable length	-
Electrical specifications	
Attenuation factor per length	
• Max. at 10 MHz	0.075 dB/m
• Max. at 100 MHz	0.26 dB/m
Characteristic impedance at 1 MHz to 100 MHz	100 Ω
Relative symmetrical tolerance of characteristic impedance at 1 MHz to 100 MHz	15 %
Near-end crosstalk per length at 1 MHz to 100 MHz	353 dB/km
Surface transfer resistance at 10 MHz	10 mΩ/m
Max. loop resistance per length	0.12 Ω/m
Insulation resistance coefficient	500 GΩ·m
Operating voltage, rms value	100 V
Conductor cross-section of power core	0.34 mm ²
Continuous current of power cores	5 A
Mechanical data	
Design of shield	Overlapping aluminum-clad foil, sheathed in a braided screen of tin-plated copper wires
Number of electrical cores	8
Design of electrical connection FastConnect	No
AWG number	22
Diameter of AWG22 cores	0.76 mm
Outer diameter	
• of inner conductor	
• of core insulation	1.5 mm
• of inner sheath of cable	3.9 mm
• of cable sheath	8.5 mm
Symmetrical tolerance of outer diameter of cable sheath	0.4 mm
Outer diameter of cable sheath - Note	-
Material	
• of core insulation	PE
• of inner sheath of cable	FRNC
• of cable sheath	FRNC
- Note	-

Order No.	6XV1 870-2J
Product type designation	IE Hybrid Cable 2x2 + 4x0.34
Color	
• of core insulation of data cores	white / yellow / blue / orange
• of core insulation of power cores	Black / brown
• of cable sheath	Green
Bending radius	
• Minimum permitted single bending radius	42.5 mm
• Minimum permitted repeated bending radius	85 mm
Maximum tensile load	260 N
Weight per length	105 kg/km
Permitted ambient conditions	
Ambient temperature	
• During operation	-25 ... +70 °C
• During storage	-25 ... +70 °C
• During transport	-25 ... +70 °C
• During mounting	-25 ... +70 °C
Behavior in fire	Flame-retardant in accordance with IEC 60332-3-24 (Category C)
Chemical resistance	
• Mineral oil	Limited resistance
• Grease	Limited resistance
• Water	Limited resistance
Radiological resistance to UV radiation	Resistant
Product properties, functions, componentsGeneral	
Product property	
• Halogen-free	Yes
• Silicon-free	Yes
Cable length for 100BaseTX with Industrial Ethernet	100 m
Standards, specifications, approvals	
UL-Listing at 300 V rating	Yes: CMG / PLTC / SunRes
UL-Style at 600 V rating	Yes
Certificate of suitability	
• RoHS compliance	Yes
Standard for structured cabling	Cat 5e (data cores), AWG 22 (power cores)

Ordering data	Order No.	Order No.
IE Hybrid Cable 2x2 + 4x0.34 Flexible cable, 4 x Cu Cat 5E, shielded (AWG22) and 4 x Cu (0.34 mm ²) with IE FC RJ45 modular outlet and power insert and IP67 hybrid plug connector; <u>sold by the meter</u>	6XV1 870-2J	
<i>Additional components</i>		
IE TP Cord RJ45/RJ45 TP cable 4 x 2 with 2 RJ45 plugs <ul style="list-style-type: none"> • 0.5 m • 1 m • 2 m • 6 m • 10 m 	6XV1 870-3QE50 6XV1 870-3QH10 6XV1 870-3QH20 6XV1 870-3QH60 6XV1 870-3QN10	
IE TP XP Cord RJ45/RJ45 Twisted TP cable 4 x 2 with 2 RJ45 plugs <ul style="list-style-type: none"> • 0.5 m • 1 m • 2 m • 6 m • 10 m 	6XV1 870-3RE50 6XV1 870-3RH10 6XV1 870-3RH20 6XV1 870-3RH60 6XV1 870-3RN10	
		IE FC RJ45 Modular Outlet FastConnect RJ45 Outlet for Industrial Ethernet with interface for a replaceable insert; <ul style="list-style-type: none"> • With 2FE insert; replaceable insert for 2 x 100 Mbit/s interfaces • With 1GE insert; replaceable insert for 1 x 1000 Mbit/s interfaces • With power insert; replaceable insert for 1 x 24 V DC and 1 x 100 Mbit/s interface
		6GK1 901-1BE00-0AA1 6GK1 901-1BE00-0AA2 6GK1 901-1BE00-0AA3
		IP 67 hybrid connector Connector for connecting SCALANCE W-700 to Industrial Ethernet and Power over Ethernet (PoE), with assembly instructions, 1 unit
		09 45 125 1300.00 Order directly from: HARTING Deutschland GmbH & Co. KG Postfach 24-51 D -32381 Minden Tel. +49 571-8896-0 Fax. +49 571-8896-354 Email: de.sales@HARTING.com Internet: www.HARTING.com

PROFINET/Industrial Ethernet

Cabling technology

Energy cables

Overview



- Different versions (5-core, 2-core) for different fields of application
- Pre-assembled M12 plug-in cables for energy transfer
- Rugged cable design for installation in industrial applications
- UL approvals
- Easy length measurement thanks to printed meter markings

Benefits

get Designed for Industry

- Flexible application possibilities thanks to rugged cable design
- Silicon-free, therefore particularly suitable for use in the automotive industry (e.g. on paint shop conveyors)

Application

Different cable types are needed to supply power to Industrial Ethernet/PROFINET or PROFIBUS. The listed power cables should always be used. They are used for devices with IP65/67 degree of protection to connect the signaling contact or 24-V supply of the SCALANCE X and SCALANCE W components (power cable 2x0.75) and for the power supply (power cable 5x1.5 for ET 200).

In addition, preassembled power connecting cables (4 x 0.75) are available in different lengths for the power supply of the ET 200 (M12 Power Connecting Cable).

UL approvals

As a result of appropriate UL styles, the cables can be used worldwide.

Design

Rugged 2-core, 4-core or 5-core cable with circular cross-section for connection of signaling contact and power supply to IP65/67 components in industrial areas.

Cable types

The following cables with industrial capability are available for connection of the power supply and signaling contact:

- Power cable 2 x 0.75; power cable for connection of signaling contact and 24 V supply voltage to SCALANCE X and SCALANCE W components
- Power cable 5 x 1.5; power cable for connection of 24 V power supply of ET 200 using 7/8" plug connectors
- M12 Power Connecting Cable M12-180/M12-180; 4-core M12 power connecting cables (A-coded) with straight cable outlet for 24 V power supply of the ET 200 (pre-assembled)

Technical specifications

Order No.	6XV1 812-8A	6XV1 830-8AH10	6XV1 801-5DH10
Product type designation	Energy Cable 2 x 0.75	Energy Cable 5 x 1.5	POWER CONNECTING CABLE M12-180/M12-180
Product description	Energy cable (2-core), sold by the meter, in bulk	Energy cable (5-core), sold by the meter, in bulk	Flexible connecting cable (4-core), preferred length, preassembled with a 4-pin M12 plug and a 4-pin M12 socket (A-coded)
Suitability for application	Connection of signaling contact and 24 V power supply to SCALANCE X and SCALANCE W	Power supply of ET 200 modules with 7/8" power interface	Cable for connecting the 24 V power supply to ET 200eco PN with IP65/67 protection
Cable designation	L-YY-2x1x0.75 GR	L-Y11Y-Z 5x1x1.5 GR	LI9YH-Y 4x0.75
Cable length	-	-	1 m
Electrical specifications			
Operating voltage, rms value	600 V	600 V	300 V
Conductor cross-section of power core	0.75 mm ²	1.5 mm ²	0.75 mm ²
Continuous current of power cores	6 A	16 A	-
Mechanical data			
Number of electrical cores	2	5	4
Outer diameter			
• of inner conductor	1.3 mm	1.55 mm	1.1 mm
• of core insulation	2.5 mm	2.73 mm	1.7 mm
• of the cable sheath	7.4 mm	10.5 mm	5.7 mm
Symmetrical tolerance of outer diameter of cable sheath	0.3 mm	0.3 mm	-
Outer diameter of cable sheath - Note	-	-	0.2 mm
Material			
• of core insulation	PVC	PVC	PP
• of the cable sheath	PVC	PUR	PVC
- Note	-	-	-
Color			
• of core insulation of power cores	Brown / blue	4x black; 1x green / yellow	Brown / white / blue / black
• of the cable sheath	Gray	Gray	Gray
Bending radius			
• With single bending	19 mm	27 mm	57 mm
• With repeated bending	45 mm	63 mm	57 mm
Maximum tensile load	100 N	500 N	15 N
Weight per length	70 kg/km	149 kg/km	54 kg/km
Permissible ambient conditions			
Ambient temperature			
• During operation	-20 ... +80 °C	-40 ... +80 °C	-25 ... +80 °C
• During storage	-20 ... +80 °C	-40 ... +80 °C	-25 ... +80 °C
• During transport	-20 ... +80 °C	-40 ... +80 °C	-25 ... +80 °C
• During mounting	-20 ... +80 °C	-40 ... +80 °C	-5 ... 80 °C
• Note	-	-	With moving applications, an operating temperature of -5 to +80 °C is permitted
Ambient conditions for operation	-	-	-
IP degree of protection	-	-	IP65/67
Behavior in fire	Flame-retardant in accordance with IEC 60332-1-2	Flame-retardant in accordance with IEC 60332-1-2	Flame-retardant in accordance with UL 758 (CSA FT 1)
Chemical resistance			
• Mineral oil	Limited resistance	Resistant	Limited resistance
• Grease	Limited resistance	Resistant	Limited resistance
• Water	Limited resistance	Limited resistance	Limited resistance
Radiological resistance against UV radiation	Resistant	Resistant	Not resistant

PROFINET/Industrial Ethernet

Cabling technology

Energy cables

Technical specifications (continued)

Order No.	6XV1 812-8A	6XV1 830-8AH10	6XV1 801-5DH10
Product type designation	Energy Cable 2 x 0.75	Energy Cable 5 x 1.5	POWER CONNECTING CABLE M12-180/M12-180
Product properties, functions, components			
General			
Product property			
• Halogen-free	No	No	No
• Silicon-free	Yes	Yes	Yes
Standards, specifications, approvals			
UL-Listing at 300 V rating	Yes: CL3	No	-
UL-Style at 600 V rating	Yes	Yes	-
Certificate of suitability	-	-	UL approval
• RoHS compliance	Yes	Yes	Yes

Order No.	6GK1 905-0FA00	6GK1 905-0FB00	6GK1 905-0FC00
Product type designation	7/8" connector	7/8" connector	7/8" Power T-Tap PRO
Product description	7/8" connector with pin insert, 5-pin	7/8" connector with female contact insert, 5-pin	Energy T-piece with two 7/8" female contact inserts and one 7/8" pin insert, each 5-pin
Suitability for application	For field assembly for ET 200	For field assembly for ET 200	For energy connection and energy distribution to ET 200pro modules
Transmission rate			
Transmission rate with PROFIBUS	-	-	-
Interfaces			
Maximum number of electrical connections for network components or terminal equipment	1	1	3
Number of electrical connections for network components or terminals	7/8" connector (pin insert)	7/8" connector (female contact insert)	7/8" connector (2 x female contact insert, 1 x pin insert)
Mechanical data			
Enclosure material	Metal	Metal	Metal
Design, dimensions and weights			
Type of cable outlet	180 degree cable outlet	180 degree cable outlet	-
Width	27 mm	27 mm	58.5 mm
Height	27 mm	27 mm	73.5 mm
Depth	83 mm	83 mm	26.5 mm
Net weight	50 g	50 g	112 g
Permissible ambient conditions			
Ambient temperature			
• During operation	-40 ... +70 °C	-40 ... +70 °C	-40 ... +70 °C
• During storage	-40 ... +80 °C	-40 ... +80 °C	-40 ... +80 °C
• During transport	-40 ... +80 °C	-40 ... +80 °C	-40 ... +80 °C
Relative humidity at 25 °C without condensation during operation, maximum	-	-	-
IP degree of protection	IP65/67	IP65/67	IP65/67
Chemical resistance to water	Resistant	Resistant	Resistant
Product properties, functions, components			
General			
Product property silicon-free	Yes	Yes	Yes
Product component strain relief	Yes	Yes	Yes
Standards, specifications, approvals			
Certificate of suitability: RoHS conformity	Yes	Yes	Yes

Technical specifications (continued)

Order No.	6GK1 908-0DC10-6AA3	6GK1 907-0DC10-6AA3	6GK1 907-0DB10-6AA3
Product type designation	Signaling Contact M12 Cable Connector	Power M12 Cable Connector PRO	Power M12 Plug PRO
Product description	M12 connecting socket for signal contact, 5-pin, B-coded	M12 Power connecting socket, 4-pin, A-coded	M12 Power connector, 4-pin, A-coded
Suitability for application	For connection to SCALANCE X208PRO for signal contact	For connection to SCALANCE W-700 / X208PRO for 24 V DC power supply	For connection to PS791-1PRO power supply for 24 V DC power supply
Interfaces			
Maximum number of electrical connections for network components or terminal equipment	1	1	1
Number of electrical connections for network components or terminals	M12 connector (B-coded, 5-pin)	M12 connector (female contact insert, A-coded, 4-pin)	M12 connector (pin insert, A-coded, 4-pin)
Mechanical data			
Enclosure material	Plastic	Plastic	Plastic
Design, dimensions and weights			
Type of cable outlet	180 degree cable outlet	180 degree cable outlet	180 degree cable outlet
Width	14 mm	19 mm	19 mm
Height	14 mm	19 mm	19 mm
Depth	59 mm	73 mm	73 mm
Net weight	37 g	40 g	40 g
Permissible ambient conditions			
Ambient temperature			
• During operation	-40 ... +70 °C	-40 ... +70 °C	-40 ... +70 °C
• During storage	-40 ... +80 °C	-40 ... +80 °C	-40 ... +80 °C
• During transport	-40 ... +80 °C	-40 ... +80 °C	-40 ... +80 °C
IP degree of protection	IP65/67	IP65/67	IP65/67
Chemical resistance to water	Resistant	Resistant	Resistant
Product properties, functions, components			
General			
Product property silicon-free	Yes	Yes	Yes
Product component strain relief	Yes	Yes	Yes
Standards, specifications, approvals			
Certificate of suitability: RoHS conformity	Yes	Yes	Yes

PROFINET/Industrial Ethernet

Cabling technology

Energy cables

2

Ordering data	Order No.	Order No.
Energy cable 2 x 0.75 Energy cable with trailing capability with 2 copper cores (0.75 mm ²) for connecting to M12 plug-in connector; <u>sold by the meter</u> ; max. 1000 m; minimum order quantity 20 m	6XV1 812-8A	Additional components 7/8" plug-in connector Plug with axial cable outlet for field assembly for ET 200, 5-core, plastic enclosure, 1 pack = 5 items • Male pins • Socket insert 7/8" Power T-Tap PRO Power T-piece for ET 200 with two 7/8" socket inserts and one 7/8" pin insert 1 pack = 5 items Signaling Contact M12 Cable Connector PRO Socket for connection of SCALANCE X208PRO for signaling contact; 5-pole, B-coded, with assembly instructions; 3 items Power M12 Cable Connector PRO Socket for connection of SCALANCE W-700 for 24 V DC supply voltage; 4-pole, A-coded, with assembly instructions, 3 items Power M12 Plug PRO Plug for connection to PS791-1PRO power supply for 24 V DC supply voltage; 4-pole, A-coded, with assembly instructions, 3 items SIMATIC NET Manual Collection Electronic manuals for communication systems, communication protocols, and communication products; on DVD, German/English
Energy cable 5 x 1.5 Energy cable with trailing capability with 5 copper cores (1.5 mm ²) for connecting to 7/8" plug-in connector; <u>sold by the meter</u> ; max. 1000 m; minimum order quantity 20 m	6XV1 830-8AH10	
M12 Power Connecting Cable M12-180/M12-180 Flexible 4-core power connecting cable, assembled with A-coded 5-pin M12 connector and A-coded, 5-pin M12 socket to supply the ET 200 with 24 V DC; length: • 0.3 m • 0.5 m • 1.0 m • 1.5 m • 2.0 m • 3.0 m • 5.0 m • 10 m • 15 m	6XV1 801-5DE30 6XV1 801-5DE50 6XV1 801-5DH10 6XV1 801-5DH15 6XV1 801-5DH20 6XV1 801-5DH30 6XV1 801-5DH50 6XV1 801-5DN10 6XV1 801-5DN15	
		6GK1 905-0FA00 6GK1 905-0FB00 6GK1 905-0FC00 6GK1908-0DC10-6AA3 6GK1 907-0DC10-6AA3 6GK1 907-0DB10-6AA3 6GK1 975-1AA00-3AA0

More information

Cable routing:

During storage, transport and cable laying, keep both ends sealed with a shrink-on cap.

Comply with the permissible bending radii and tensile load!

Note:

You can order components supplementary to the SIMATIC NET cabling range from your local contact.

Technical advice on this subject is available from:

J. Hertlein
 I IA SC IC PRM 4
 Tel.: +49 (0)911/750 44 65
 E-mail: juergen.hertlein@siemens.com

Overview



- Patch cable, available as preassembled cables (max. length 10 m)
- With 2 x 2 cores for 10/100 Mbit/s and 4 x 2 cores for 10/100/1000 Mbit/s Ethernet
- Small cable diameter
- Category Cat5e (2 x 2) and Cat6 (4 x 2) of the international cabling standards ISO/IEC 11801 and EN 50173

Benefits

get Designed for Industry

- Simple connection of terminals with an RJ45 interface to the interference-proof Industrial Ethernet FC cabling system (10/100/1000 Mbit/s)
- Quick and error-free commissioning thanks to pre-assembled, factory-tested patch cables
- Simple cable laying due to small cable diameter
- Silicone-free, therefore suitable for use in the automotive industry (for example on paint lines)
- Color-coded RJ45 connectors for differentiation between twisted and non-twisted lines
 - Twisted: RJ45 connector red on both sides
 - Non-twisted: RJ45 connector green on both sides

PROFINET/Industrial Ethernet

Cabling technology

IE TP Cord

Application

2

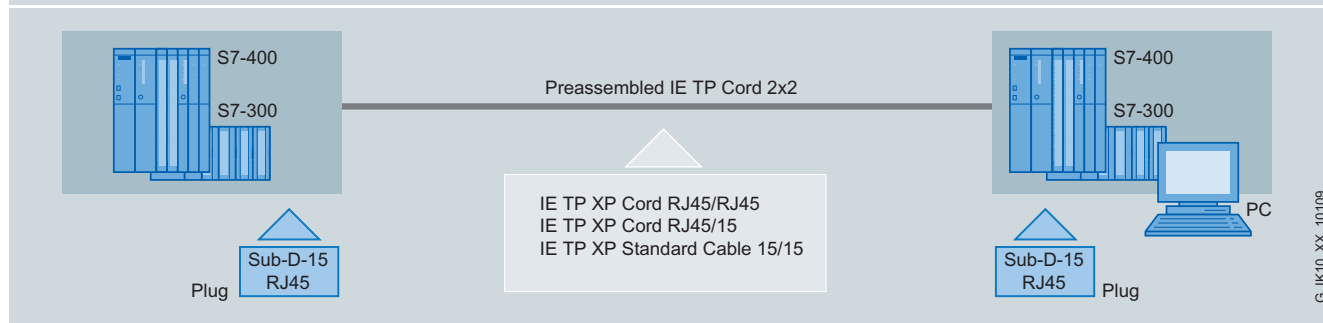
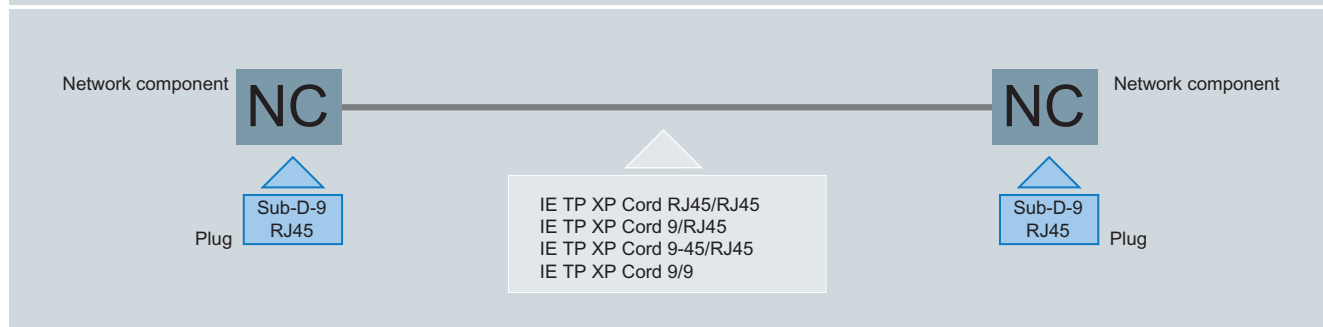
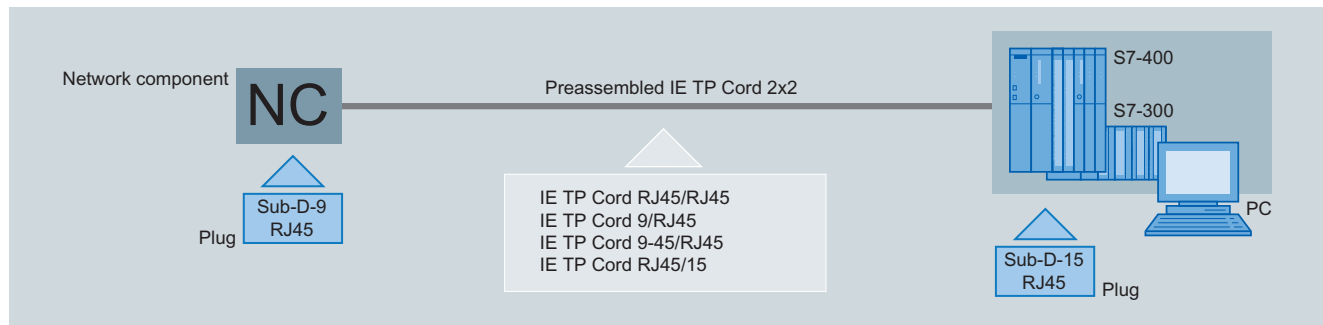

IE TP Cord can be used to directly connect individual components (10/100 Mbit/s)

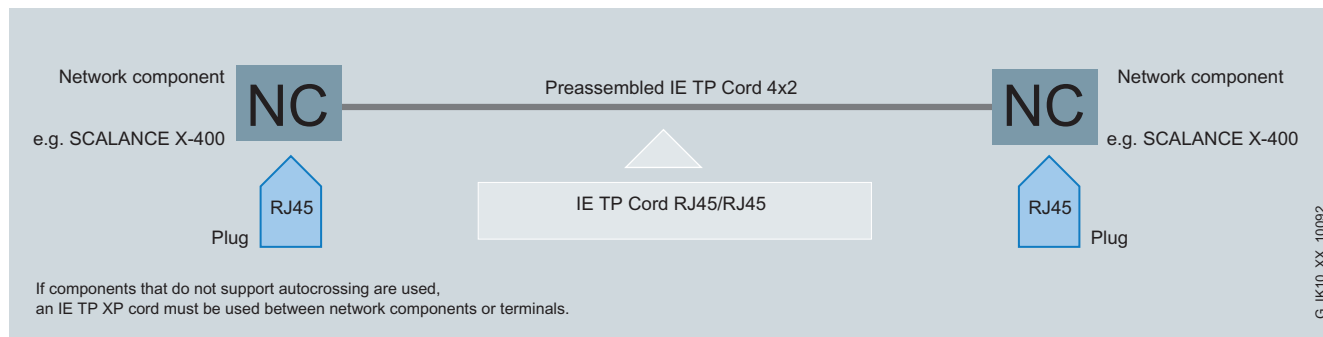

IE TP Cord RJ45/RJ45 can be used to directly connect individual components (10/100/1000 Mbit/s)

Design

- 2 x 2 cores for 10/100 Mbit/s transmission rate;
4 x 2 cores for 10/100/1000 Mbit/s transmission rate
- Two cores with two dummy elements twisted into a pair.
- Each pair is encased in plastic film and shielded with a plastic-clad aluminum foil
- Outer woven shield around all pairs comprising tinned copper wires
- Plastic sheath (PVC)

IE TP Cord is available as TP Cord 4 x 2, pre-assembled cables in the following versions:

- *IE TP Cord RJ45/RJ45*
with 2 x RJ45 plugs
- *IE TP XP Cord RJ45/RJ45*
with 2 x RJ45 plugs, send and receive cables are twisted.

IE TP Cord is available as TP Cord 2 x 2, pre-assembled cables in the following versions:

- *IE TP Cord 9/RJ45*
with one 9-pole Sub-D connector and one RJ45 connector
- *IE TP XP Cord 9/RJ45*
with one RJ45 connector and one 9-pole Sub-D connector, send and receive cable are twisted
- *IE TP Cord 9-45/RJ45*
with one RJ45 connector and one 9-pole Sub-D connector, 45° cable outlet
- *IE TP XP Cord 9-45/RJ45*
with one RJ45 connector and one 9-pole Sub-D connector, 45° cable outlet; send and receive cable are twisted
- *IE TP XP Cord 9/9*
with two 9-pole Sub-D connectors, send and receive cable are twisted.
- *IE TP Cord RJ45/15*
with one RJ45 connector and one 15-pole Sub-D connector; this is used to directly connect data terminals with ITP interfaces to network components with an RJ45 interface.
- *IE TP XP Cord RJ45/15*
with one RJ45 connector and one 15-pole Sub-D connector, twisted send and receive cable; used for direct connection of a data terminal with 15-pole Sub-D connector to a data terminal with RJ45 plug.
- *IE TP Converter Cord 15/RJ45*
with a 15-pole Sub-D socket with slide locking and an RJ45 plug. A retaining clip clamps it in place. IE TP Converter Cord 15/RJ45 2 x 2 is used to connect data terminals with an RJ45 interface to the ITP cabling system, e.g. over the ITP Standard 9/15 cable.

Function

The flexibility of the cable ensures easy installation, for example in a control cabinet, or to connect equipment in a control room. The maximum length of an IE TP Cord is 10 m.

Adapter cables are used to connect devices with a 9-pin ITP interface to devices with an RJ45 interface.

The IE TP Converter Cord 15/RJ45 is used to connect devices with a 15-pin ITP interface to devices with an RJ45 interface.

PROFINET/Industrial Ethernet

Cabling technology

IE TP Cord

Technical specifications

Order No.	6XV1 870-3QH10	6XV1 850-2JH10
Product type designation	IE TP Cord RJ45/RJ45, 4x2	IE TP Cord 9/RJ45, 2x2
Product description	Patch cord, preferred length, preassembled with two RJ45 connectors	Patch cord, preferred length, preassembled with a 9-pin Sub-D connector and an RJ45 connector
Suitability for application	Simple connection of data terminals to the IE FC cabling system	Simple connection of data terminals to the IE FC cabling system
Cable designation	LI 02YSCH 4x2x0.15 PIMF GN FRNC	LI 02YSCY 2x2x0.15/0.98 PIMF ICCS GN
Cable length	1 m	1 m
Electrical specifications		
Attenuation factor per length		
• Max. at 10 MHz	0.086 dB/m	0.085 dB/m
• Max. at 100 MHz	0.28 dB/m	0.278 dB/m
• Max. at 300 MHz	0.501 dB/m	0.500 dB/m
• Max. at 600 MHz	0.735 dB/m	0.733 dB/m
Characteristic impedance		
• At 1 MHz ... 100 MHz	100 Ω	100 Ω
• At 10 MHz ... 600 MHz	100 Ω	100 Ω
Relative symmetrical tolerance		
• of characteristic impedance at 1 MHz ... 100 MHz	15 %	15 %
• of characteristic impedance at 10 MHz ... 600 MHz	10 %	6 %
Surface transfer resistance at 10 MHz	10 mΩ/m	10 mΩ/m
Max. loop resistance per length	290 Ω/km	300 Ω/km
Insulation resistance coefficient	-	150 GΩ·m
Operating voltage, maximum	500 GΩ·m	500 GΩ·m
Mechanical data		
Number of electrical cores	8	4
Design of shield	Overlapped aluminum-clad foil, sheathed in a braided screen of tin-plated copper wires	Overlapped aluminum-clad foil, sheathed in a braided screen of tin-plated copper wires
AWG number		
Core diameter		
• of AWG22 core	-	-
• of AWG26 core	0.5 mm	-
Outer diameter		
• of inner conductor	0.5 mm	0.48 mm
• of core insulation	1 mm	1.05 mm
• of cable sheath	6.2 mm	-
Symmetrical tolerance of outer diameter of cable sheath	0.3 mm	-
Width of cable sheath	-	5.8 mm
Symmetrical tolerance of cable sheath width	-	0.2 mm
Thickness of cable sheath	-	3.7 mm
Symmetrical tolerance of cable sheath thickness	-	0.2 mm

Technical specifications (continued)

Order No.	6XV1 870-3QH10	6XV1 850-2JH10
Product type designation	IE TP Cord RJ45/RJ45, 4x2	IE TP Cord 9/RJ45, 2x2
Material		
• of core insulation	PE	PE
• of cable sheath	FRNC	PVC
Material of cable sheath - Note	-	-
Color		
• of core insulation of data cores	White/blue, white/orange, white/green, white/brown	White/blue, white/orange
• of the cable sheath	Green	Green
Bending radius		
• With single bending	31 mm	24 mm
• With repeated bending	43.5 mm	42 mm
Weight per length	50 kg/km	32 kg/km
Permitted ambient conditions		
Ambient temperature		
• During operation	-25 ... +70 °C	-40 ... +70 °C
• During storage	-25 ... +70 °C	-40 ... +70 °C
• During transport	-25 ... +70 °C	-40 ... +70 °C
• During mounting	-25 ... +70 °C	-40 ... +70 °C
IP degree of protection	IP20	IP20
Behavior in fire	Flame-retardant in accordance with IEC 60332-1	Flame-retardant in accordance with IEC 60332-1-2
Chemical resistance		
• Mineral oil	Limited resistance	Limited resistance
• Grease	Limited resistance	Limited resistance
Product properties, functions, components		
General		
Product property		
• Halogen-free	Yes	No
• Silicon-free	Yes	Yes
Standards, specifications, approvals		
UL-Listing at 300 V rating	No	No
UL-Style at 600 V rating	No	No
Certificate of suitability	UL approval	UL approval

PROFINET/Industrial Ethernet

Cabling technology

IE TP Cord

2

Ordering data	Order No.	Order No.	
IE TP Cord RJ45/RJ45 TP cable 4 x 2 with 2 RJ45 plugs <ul style="list-style-type: none"> • 0.5 m • 1 m • 2 m • 6 m • 10 m 	6XV1 870-3QE50 6XV1 870-3QH10 6XV1 870-3QH20 6XV1 870-3QH60 6XV1 870-3QN10	IE TP Cord RJ45/15 TP cable 2 x 2 with one 15-pole Sub D connector and one RJ45 connector <ul style="list-style-type: none"> • 0.5 m • 1 m • 2 m • 6 m • 10 m 	6XV1 850-2LE50 6XV1 850-2LH10 6XV1 850-2LH20 6XV1 850-2LH60 6XV1 850-2LN10
IE TP XP Cord RJ45/RJ45 Twisted TP cable 4 x 2 with 2 RJ45 plugs <ul style="list-style-type: none"> • 0.5 m • 1 m • 2 m • 6 m • 10 m 	6XV1 870-3RE50 6XV1 870-3RH10 6XV1 870-3RH20 6XV1 870-3RH60 6XV1 870-3RN10	IE TP XP Cord RJ45/15 Crossed TP cable 2 x 2 with one 15-pole sub D connector and one RJ45 connector <ul style="list-style-type: none"> • 0.5 m • 1 m • 2 m • 6 m • 10 m 	6XV1 850-2SE50 6XV1 850-2SH10 6XV1 850-2SH20 6XV1 850-2SH60 6XV1 850-2SN10
IE TP Cord 9/RJ45 TP cable 2 x 2 with one 9-pole sub D connector and one RJ45 connector <ul style="list-style-type: none"> • 0.5 m • 1 m • 2 m • 6 m • 10 m 	6XV1 850-2JE50 6XV1 850-2JH10 6XV1 850-2JH20 6XV1 850-2JH60 6XV1 850-2JN10	IE TP Converter Cord 15/RJ45 TP connecting cable 2 x 2 for connecting data terminals with RJ45 interfaces to the ITP cabling system; with a 15-pole Sub D socket with slide locking and an RJ45 connector. <ul style="list-style-type: none"> • 0.5 m • 2 m 	6XV1 850-2EE50 6XV1 850-2EH20
IE TP XP Cord 9/RJ45 Twisted TP cable 2 x 2 with one 9-pole sub D connector and one RJ45 connector <ul style="list-style-type: none"> • 0.5 m • 1 m • 2 m • 6 m • 10 m 	6XV1 850-2ME50 6XV1 850-2MH10 6XV1 850-2MH20 6XV1 850-2MH60 6XV1 850-2MN10	IE FC Outlet RJ45 For connection Industrial Ethernet FC cables and TP Cords; graded prices from 10 and 50 units	6GK1 901-1FC00-0AA0
IE TP Cord 9-45/RJ45 TP cable 2 x 2 with one RJ45 connector and one Sub D connector with 45° cable outlet (not for OSM/ESM) <ul style="list-style-type: none"> • 1 m 	6XV1 850-2NH10	IE FC RJ45 Modular Outlet FastConnect RJ45 Outlet for Industrial Ethernet with interface for a replaceable insert;	<ul style="list-style-type: none"> • With 2FE insert; replaceable insert for 2 x 100 Mbit/s interfaces • With 1GE insert; replaceable insert for 1 x 1000 Mbit/s interfaces • With power insert; replaceable insert for 1 x 24 V DC and 1 x 100 Mbit/s interface
IE TP XP Cord 9-45/RJ45 Twisted TP cable 2 x 2 with one RJ45 connector and one Sub D connector with 45° cable outlet (not for OSM/ESM) <ul style="list-style-type: none"> • 1 m 	6XV1 850-2PH10	SIMATIC NET Manual Collection Electronic manuals for communication systems, communication protocols, and communication products; on DVD; German/English	6GK1 901-1BE00-0AA1 6GK1 901-1BE00-0AA2 6GK1 901-1BE00-0AA3 6GK1 975-1AA00-3AA0
IE TP XP Cord 9/9 Twisted TP cable 2 x 2 for direct connection of two Industrial Ethernet components with an ITP interface with two 9-pole Sub D connectors <ul style="list-style-type: none"> • 1 m 	6XV1 850-2RH10		

More information

You can order components supplementary to the SIMATIC NET cabling range from your local contact.

Technical advice on this subject is available from:

J. Hertlein
 I IA SC IC PRM 4
 Phone: +49 (0)911/750 44 65
 E-mail: juergen.hertlein@siemens.com

Overview



Flexible connecting cables for the transmission of data (up to 100 Mbit/s) or energy between Industrial Ethernet stations with IP65/IP67 degree of protection

Industrial Ethernet Connecting Cable M12-180/M12-180 (D-coded)

- Pre-assembled connecting cable (IE FC TP Trailing Cable GP) for connecting Industrial Ethernet nodes (such as SIMATIC ET 200, SCALANCE X208PRO and SIMATIC RF systems) with IP65/IP67 degree of protection
- For transmission rates of 10/100 Mbit/s

Industrial Ethernet Connecting Cable M12-180 (D-coded)/IE FC RJ45 Plug-145

- Pre-assembled connecting cable (IE FC TP Trailing Cable GP) for connecting Industrial Ethernet nodes (such as SIMATIC ET 200, SCALANCE X208PRO and SIMOTION) with IP65/IP67 degree of protection
- For transmission rates of 10/100 Mbit/s

Power Connecting Cable M12-180/M12-180 (A-coded)

- Pre-assembled connecting cable (4-core power cable, 4 x 0.75 mm²) for connecting Industrial Ethernet nodes (such as SIMATIC ET 200, SCALANCE X208PRO) with IP65/IP67 degree of protection
- For power transfer (24 V DC, 4-pin)

Benefits

get Designed for Industry

- Time-saving and fault-free connection of terminal stations by means of pre-fabricated connection cables
- Reliable screen contact and strain relief are integrated
- Comprehensive product range with different lengths and corresponding UL approvals and PROFINET conformity

2

PROFINET/Industrial Ethernet

Cabling technology

IE Connecting Cable M12-180/M12-180

Technical specifications

Order No.	6XV1 870-8AH10	6XV1 871-5TN10
Product type designation	IE Connecting Cable M12-180/M12-180	IE Connecting Cable M12-180/IE FC RJ45-145
Product description	Flexible connecting cable (4-core), preferred length, preassembled with two 4-pin M12 plugs (D-coded)	Flexible connecting cable (4-core), preferred length, preassembled with one 4-pin M12 plug (D-coded) and an IE FC RJ45 Plug 145
Suitability for use	For connecting Industrial Ethernet nodes (e.g. SIMATIC ET 200pro and SCALANCE X208PRO) with IP65/67 degree of protection	For connecting Industrial Ethernet nodes (e.g. SIMATIC ET 200pro and SCALANCE X208PRO and SIMOTION)
Cable designation	2YY (ST) CY 2x2x0.75/1.5-100 LI GN	2YY (ST) CY 2x2x0.75/1.5-100 LI GN
Cable length	1 m	10 m
Electrical specifications		
Attenuation factor per length		
• Max. at 10 MHz	0.063 dB/m	0.063 dB/m
• Max. at 100 MHz	0.213 dB/m	0.213 dB/m
Characteristic impedance at 1 MHz to 100 MHz	100 Ω	100 Ω
Relative symmetrical tolerance of characteristic impedance at 1 MHz to 100 MHz	5 %	5 %
Near-end crosstalk per length at 1 MHz to 100 MHz	0.5 dB/m	0.5 dB/m
Surface transfer resistance at 10 MHz	20 mΩ/m	20 mΩ/m
Max. loop resistance per length	120 Ω/km	120 Ω/km
Mechanical data		
Number of electrical cores	4	4
Design of shield	Overlapping aluminum-clad foil, sheathed in a braided screen of tin-plated copper wires	Overlapping aluminum-clad foil, sheathed in a braided screen of tin-plated copper wires
Diameter of AWG22 cores	0.75 mm	0.75 mm
Outer diameter		
• of inner conductor	0.75 mm	0.75 mm
• of core insulation	1.5 mm	1.5 mm
• of inner sheath of cable	3.9 mm	3.9 mm
• of the cable sheath	6.5 mm	6.5 mm
Symmetrical tolerance of outer diameter of cable sheath	0.2 mm	0.2 mm
Outer diameter of cable sheath - Note	-	-
Material		
• of core insulation	PE	PE
• of inner sheath of cable	PVC	PVC
• of the cable sheath	PVC	PVC
- Note	-	-
Color		
• of core insulation of data cores	white / yellow / blue / orange	white / yellow / blue / orange
• of the cable sheath	green	Green

2

Technical specifications (continued)

Order No.	6XV1 870-8AH10	6XV1 871-5TN10
Product type designation	IE Connecting Cable M12-180/M12-180	IE Connecting Cable M12-180/IE FC RJ45-145
Bending radius		
• With single bending	32.5 mm	32.5 mm
• With repeated bending	49 mm	49 mm
• With continuous bending	100 mm	100 mm
Number of bending cycles	3 000 000	3 000 000
• Note	Suitable as trailing cable for 3 million bending cycles with a bending radius of 100 mm, a speed of 4 m/s and an acceleration of 4 m/s ²	Suitable as trailing cable for 3 million bending cycles with a bending radius of 100 mm, a speed of 4 m/s and an acceleration of 4 m/s ²
Maximum tensile load	150 N	150 N
Weight per length	68 kg/km	68 kg/km
Permitted ambient conditions		
Ambient temperature		
• During operation	-25 ... +75 °C	-25 ... +75 °C
• During storage	-25 ... +75 °C	-25 ... +75 °C
• During transport	-25 ... +75 °C	-25 ... +75 °C
• During mounting	-10 ... +60 °C	-10 ... +60 °C
IP degree of protection	IP65/67	-
Behavior in fire	Flame-retardant in accordance with UL 1685 (CSA FT 4)	Flame-retardant in accordance with UL 1685 (CSA FT 4)
Chemical resistance		
• Mineral oil	Limited resistance	Limited resistance
• Grease	Limited resistance	Limited resistance
Radiological resistance to UV radiation	Resistant	Resistant
Product properties, functions, components		
General		
Product property		
• Halogen-free	No	No
• Silicon-free	Yes	Yes
Standards, specifications, approvals		
UL listing at 300 V rating	Yes: CMG / PLTC / Sun Res	Yes: CMG / PLTC / Sun Res
UL style at 600 V rating	Yes	Yes
Certificate of suitability		
• RoHS compliance	Yes	Yes
Standard for structured cabling	Cat5e	Cat5e
Marine classification corporation		
• American Bureau of Shipping Europe Ltd. (ABS)	No	No
• Bureau Veritas (BV)	No	No
• Det Norske Veritas (DNV)	No	No
• Germanischer Lloyd (GL)	No	No
• Lloyds Register of Shipping (LRS)	No	No

PROFINET/Industrial Ethernet

Cabling technology

IE Connecting Cable M12-180/M12-180

Ordering data

Order No.

IE Connecting Cable M12-180/M12-180

Pre-assembled IE FC TP
Trailing Cable GP 2 x 2
(PROFINET Type C) with two
4-pin M12 plugs (D-coded)
up to 85 m,
IP65/IP67 degree of protection
Length:

- 0.3 m
- 0.5 m
- 1.0 m
- 1.5 m
- 2.0 m
- 3.0 m
- 5.0 m
- 10 m
- 15 m

6XV1 870-8AE30
6XV1 870-8AE50
6XV1 870-8AH10
6XV1 870-8AH15
6XV1 870-8AH20
6XV1 870-8AH30
6XV1 870-8AH50
6XV1 870-8AN10
6XV1 870-8AN15

IE Connecting Cable M12-180/IE FC RJ45 Plug-145

Pre-assembled IE FC TP
trailing cable GP 2 x 2
(PROFINET type C)
with M12 plug (D-coded) and
IE FC RJ45 plug, IP65/
IP67 degree of protection
Length:

- 2.0 m
- 3.0 m
- 5.0 m
- 10 m
- 15 m

6XV1 871-5TH20
6XV1 871-5TH30
6XV1 871-5TH50
6XV1 871-5TN10
6XV1 871-5TN15

M12 Power Connecting Cable M12-180/M12-180

Flexible 4-core power connecting
cable, assembled with A-coded
5-pin M12 connector and
A-coded, 5-pin M12 socket to
supply the ET 200 with 24 V DC;
length:

- 0.3 m
- 0.5 m
- 1.0 m
- 1.5 m
- 2.0 m
- 3.0 m
- 5.0 m
- 10 m
- 15 m

Additional special lengths with
90° or 180° cable outlet

6XV1 801-5DE30
6XV1 801-5DE50
6XV1 801-5DH10
6XV1 801-5DH15
6XV1 801-5DH20
6XV1 801-5DH30
6XV1 801-5DH50
6XV1 801-5DN10
6XV1 801-5DN15

See
[http://
support.automation.siemens.com/
WWW/view/en/26999294](http://support.automation.siemens.com/WWW/view/en/26999294)

PROFINET Cabling and Interconnection Technology Guideline

www.profinet.com

More information

Note:

You can order components supplementary to the SIMATIC NET
cabling range from your local contact.

Technical advice on this subject is available from:

J. Hertlein
I IA SC IC PRM 4
Phone: +49 (0)911/750 44 65
E-mail: juergen.hertlein@siemens.com

Overview



- Simple design of structured twisted-pair cabling
- Extremely short installation times thanks to insulation displacement method
- Rugged full-metal module certified according to Category 5
- Reliable shield contact and strain relief thanks to bolt-on cover
- Color marking prevents errors

Benefits

get Designed for Industry

- Simple connection of network components or terminals to the interference-proof Industrial Ethernet FC cabling system
- Time-saving and error-free installation thanks to FC cables and pre-assembled TP Cords (10/100 Mbit/s)
- Interference-proof thanks to rugged metal enclosure and flexible mounting options (DIN rail, direct mounting)
- Reliable shield contact and strain relief thanks to bolt-on cover
- Color marking prevents errors

Application

The IE FC Outlet RJ45 is used as a transition from the rugged Industrial Ethernet FC cables used in the industrial environment to prefabricated TP Cord cables (10/100 Mbit/s) using an RJ45 socket.

By connecting several IE FC Outlet RJ45 devices in series, a patch field can be constructed with the required connection density (e.g. 16 outlets over 19" width).

PROFINET/Industrial Ethernet

Cabling technology

IE FC Outlet RJ45

Application (continued)

2

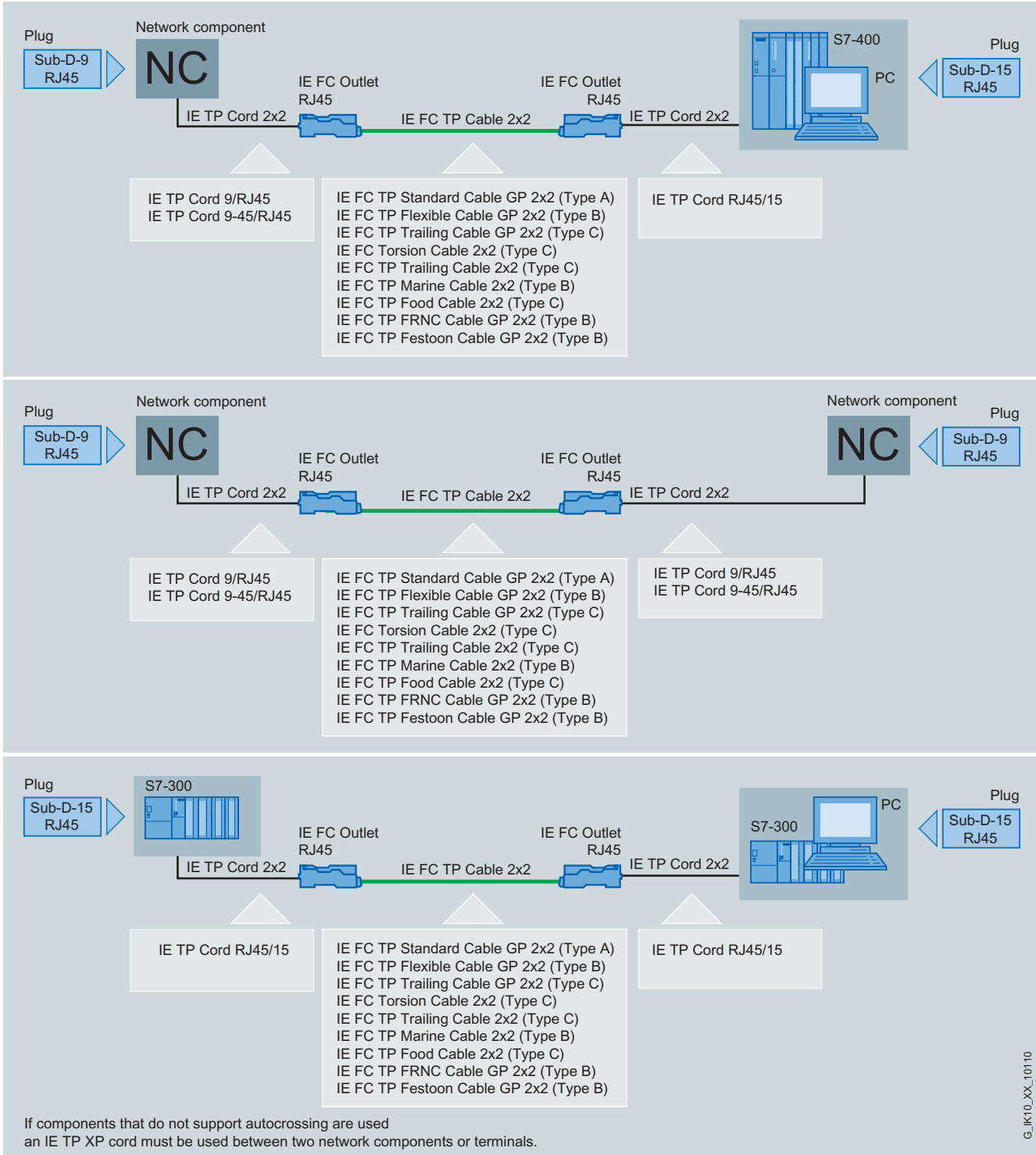

IE TP Cord can be used for patch technology with IE FC Outlet RJ45 (10/100 Mbit/s)

Design

The IE FC Outlet RJ45 has a rugged metal housing and satisfies Category 5 of the international cable standard ISO/IEC 11801 and EN 50173. It is suitable both for mounting on rails and wall mounting by means of four through holes.

The Outlet RJ45 can also be mounted behind a metal plate with a cutout (e.g. in a control cabinet).

The Outlet RJ45 has the following connections

- 4 insulation-piercing contacts for connecting the Industrial Ethernet FC cable 2 x 2 (contacts are color coded)
- RJ45 socket with dust protection cap for connecting different TP Cord cables (10/100 Mbit/s).

Function

The Industrial Ethernet FC Outlet RJ45 is attached directly to the Industrial Ethernet FC cable 2 x 2.

For connection between IE Outlet RJ45 and network components or a terminal device, various preassembled RJ45 patch cables (10/100 Mbit/s) are available.

2

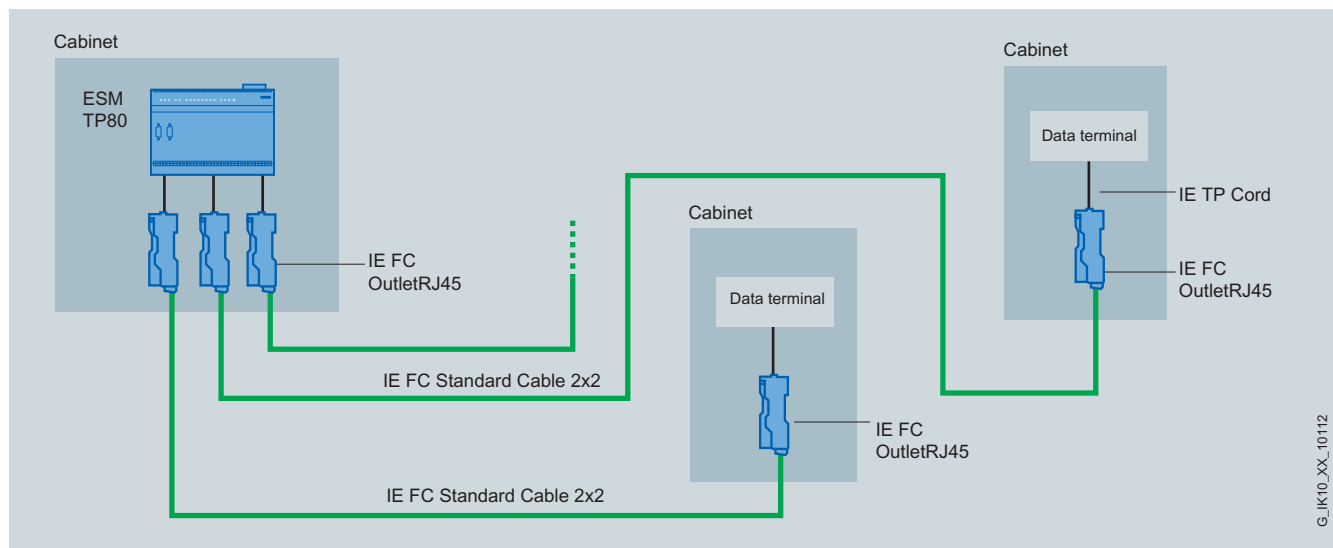

System configuration with IE FC Outlet RJ45

G_IK10_XX_10112

PROFINET/Industrial Ethernet

Cabling technology

IE FC Outlet RJ45

Integration

2

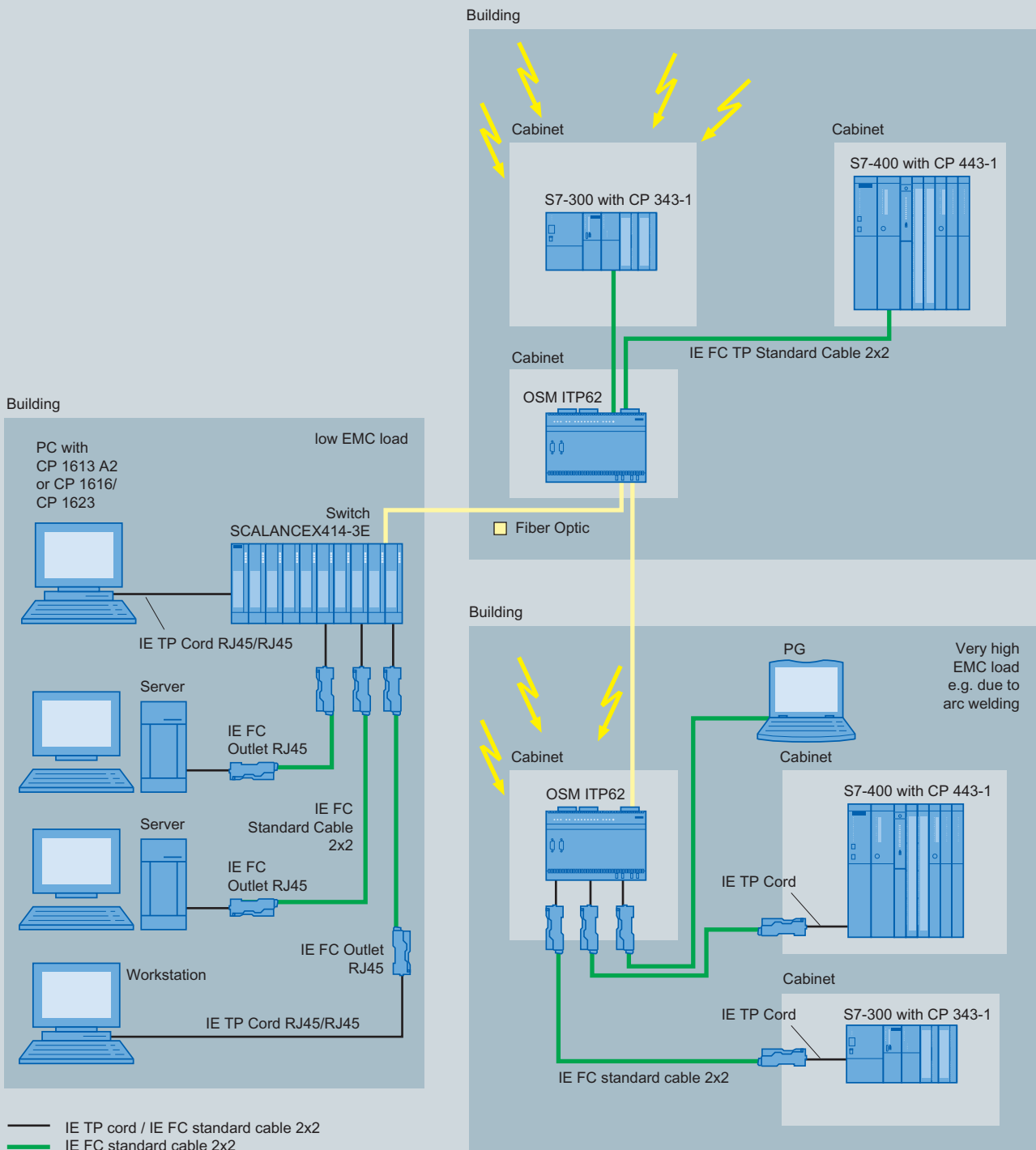

G_IK10_XX_10111

Configuration example with TP and FO cabling technology

Technical specifications

Order No.	6GK1 901-1FC00-0AA0
Product type designation	IE FC Outlet RJ45
Design	CAT 5
Number of electrical connections • for Industrial Ethernet FC TP cables	4
Design of electrical connection • for Industrial Ethernet FC TP cables	Insulation displacement terminals for all IE cables 2 x 2
for network components or terminal equipment	RJ45 socket
Ambient temperature • During operating phase • During storage • During transport	-25 ... +70 °C -40 ... +70 °C -40 ... +70 °C

Order No.	6GK1 901-1FC00-0AA0
Product type designation	IE FC Outlet RJ45
Design, dimensions and weights	
Width	31.7 mm
Height	107 mm
Depth	30 mm
Net weight	300 g
Type of mounting	DIN rail or wall mounting
IP degree of protection	IP20
Certificate of suitability: UL approval	Yes
Standard for structured cabling acc. to ISO/IEC 11801	Yes

Ordering data

Ordering data	Order No.
IE FC Outlet RJ45 For connection of Industrial Ethernet FC cables and TP Cords; graded prices from 10 and 50 items upwards	6GK1 901-1FC00-0AA0
IE TP Cord 9/RJ45 TP cable 2 x 2 with one 9-pole Sub-D connector and one RJ45 connector • 0.5 m • 1 m • 2 m • 6 m • 10 m	6XV1 850-2JE50 6XV1 850-2JH10 6XV1 850-2JH20 6XV1 850-2JH60 6XV1 850-2JN10
IE TP XP Cord 9/RJ45 Twisted TP cable 2 x 2 with one 9-pole Sub-D connector and one RJ45 connector • 0.5 m • 1 m • 2 m • 6 m • 10 m	6XV1 850-2ME50 6XV1 850-2MH10 6XV1 850-2MH20 6XV1 850-2MH60 6XV1 850-2MN10
IE TP Cord 9-45/RJ45 TP cable 2 x 2 with one RJ45 connector and one Sub-D connector with 45° cable outlet (for OSM/ESM only) • 1 m	6XV1 850-2NH10
IE TP XP Cord 9-45/RJ45 Twisted TP cable with one RJ45 connector and one Sub-D connector with 45° cable outlet (for OSM/ESM only) • 1 m	6XV1 850-2PH10
IE TP XP Cord 9/9 Twisted TP cable 2 x 2 for direct connection of two Industrial Ethernet components with an ITP interface with two 9-pole Sub-D connectors • 1 m	6XV1 850-2RH10

Ordering data	Order No.
IE TP Cord RJ45/15 TP cable 2 x 2 with one 15-pole Sub-D connector and one RJ45 connector • 0.5 m • 1 m • 2 m • 6 m • 10 m	6XV1 850-2LE50 6XV1 850-2LH10 6XV1 850-2LH20 6XV1 850-2LH60 6XV1 850-2LN10
IE TP XP Cord RJ45/15 Twisted TP cable 2 x 2 with one 15-pole Sub-D connector and one RJ45 connector • 0.5 m • 1 m • 2 m • 6 m • 10 m	6XV1 850-2SE50 6XV1 850-2SH10 6XV1 850-2SH20 6XV1 850-2SH60 6XV1 850-2SN10
IE TP Converter Cord 15/RJ45 TP connecting cable 2 x 2 for connecting data terminals with RJ45 interfaces to the ITP cabling technology; with a 15-pole Sub-D socket with slide locking and an RJ45 connector. • 0.5 m • 1 m	6XV1 850-2EE50 6XV1 850-2EH20
SIMATIC NET Manual Collection Electronic manuals for communication systems, communication protocols, and communication products; on DVD; German/English	6GK1 975-1AA00-3AA0

PROFINET/Industrial Ethernet

Cabling technology

IE FC RJ45 Modular Outlet

Overview



- Simple connection technology (insulation displacement contacts) for 8-core Industrial Ethernet FastConnect twisted pair installation cables (Cat6)
- Safe connection technology thanks to visible connection area
- Industry-standard design
 - Rugged metal housing
 - Dust caps
- Wall and DIN rail mounting inside or outside control cubicles thanks to IP40 protection
- Good electromagnetic shielding and conduction due to metal housing
- Integral strain relief for 8-core installation cables
- Replaceable inserts for
 - 2 x Fast Ethernet connection
IE FC RJ45 Modular Outlet insert 2FE
 - 1 x Gigabit Ethernet connection
IE FC RJ45 Modular Outlet insert 1GE
 - 1 x Fast Ethernet connection, 1 x 24 V DC connection
IE FC RJ45 Modular Outlet Power Insert

Benefits



- Easy and problem-free assembly due to integrated color-coded insulation displacement contacts
- Time-saving and trouble-free installation with 8-core Industrial Ethernet FC TP installation cables
- Universal use due to replaceable inserts (insert for two 10/100 Mbit/s ports, one 1000 Mbit/s port or one 24 V DC power supply and 100 Mbit/s port)
- Wide operating temperature range (-20 °C to +70 °C)
- Reliable shield contact and strain relief thanks to bolt-on cover
- Protection of investment, as a 100 Mbit/s network can be upgraded without difficulty to a 1000 Mbit/s network by replacing the insert without having to release the cable contacts

Application

The 8-core cabling system of SIMATIC NET allows transfer rates of 10/100/1000 Mbit/s for Ethernet and for the service-independent cabling from this office environment. Thanks to the 8-core cabling it is now possible to implement two Industrial Ethernet connections for Fast Ethernet, but in future it will also be possible to upgrade to a Gigabit Ethernet connection. This implements the transition from 4-core Industrial Ethernet FastConnect TP cabling system to the 8-core Gigabit cabling system.

The FC RJ45 Modular Outlet base module can optionally be equipped with three different replaceable inserts, as follows:

- IE FC RJ45 Modular Outlet Insert 2FE with 2 x RJ45 sockets for 100 Mbit/s systems
- IE FC RJ45 Modular Outlet Insert 1GE with 1 x RJ45 socket for 1000 Mbit/s systems
- IE FC RJ45 Modular Outlet Power Insert for SCALANCE W WLAN system with 1 x 24 V, 1 x RJ45 socket

Thus it is possible not only to implement individual device connections, but also 100 Mbit/s dual connections.

By replacing the insert, it is possible to switch from network structures that are operated at transfer rates of 100 Mbit/s to structures with rates of 1000 Mbit/s. Replacement of the cabling is not necessary (permanent cabling).

Like the 4-wire cabling system, the Gigabit cabling system with the IE FC RJ45 Modular Outlet also takes the conditions in the field of industrial automation into account. No special tools are required for the assembly; the same FC stripping tool is used as for the 4-wire system.

8-wire FC installations cables are used for the cabling (AWG 22):

- IE FC Standard Cable 4 x 2; for fixed routing as standard type for the IE FC RJ45 Modular Outlet Inserts 2FE and 1GE
- IE Hybrid Cable 2x2 + 4x0.34 for the IE FC RJ45 Modular Outlet with Power Insert

Max. distance which can be covered between two IE FC Modular Outlets using IE FC Standard Cable is 90 m; the total length of the patch cords to the terminal units at each end must not exceed 10 m.

Application (continued)

Application examples

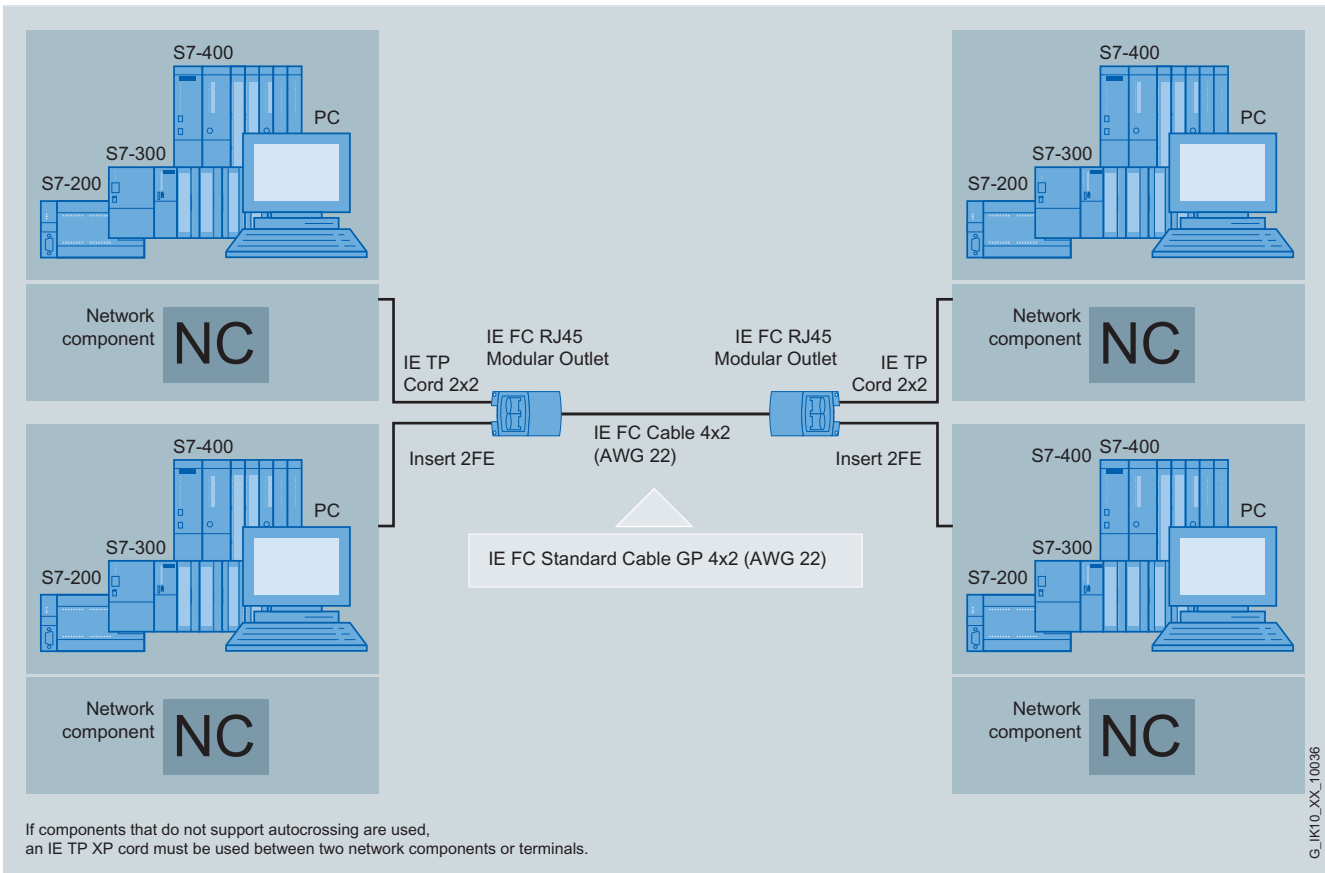

IE TP Cord can be used with IE FC RJ45 Modular Outlet with Insert 2FE (10/100 Mbit/s)

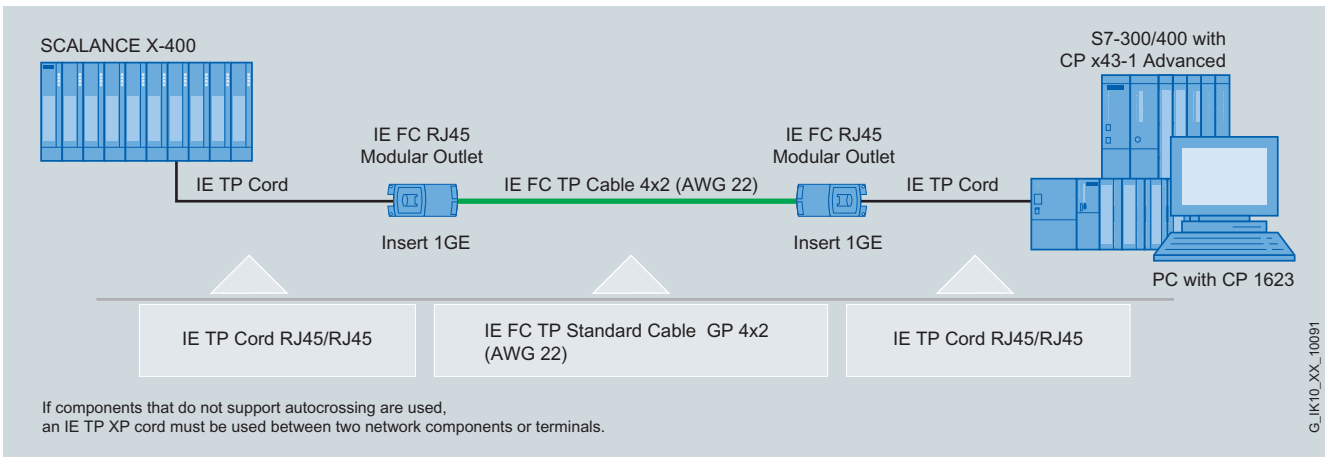

IE TP Cord RJ45/RJ45 can be used for patch technology with IE FC RJ45 Modular Outlet with Insert 1GE (10/100/1000 Mbit/s)

PROFINET/Industrial Ethernet

Cabling technology

IE FC RJ45 Modular Outlet

Application (continued)

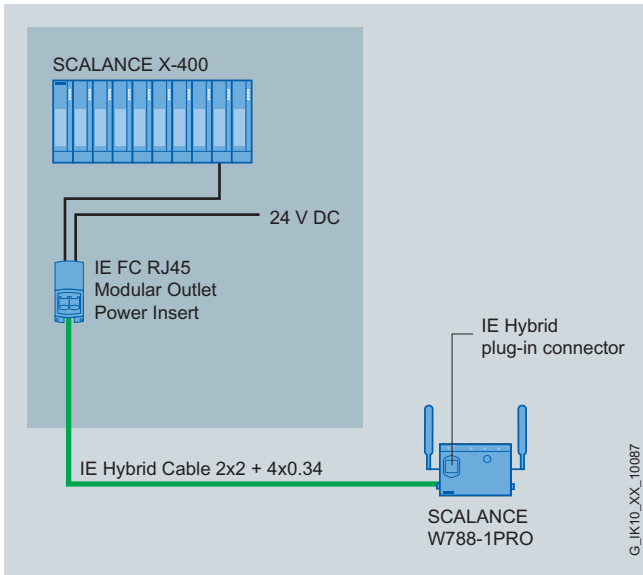

IE TP Cord can be used with IE FC RJ45 Modular Outlet with Power Insert (10/100 Mbit/s)

Design

IE FC RJ45 Modular Outlet (base modules)

- Robust metal housing, complies with Category 6 of the international cabling standards ISO/IEC 11801 and EN 50173
- Suitable both for DIN rail and wall mounting
- Thanks to its high degree of protection IP40, it can be mounted directly on site

Ports:

- 8 insulation displacement contacts for connection of the 8-core Industrial Ethernet FC installation cables
- Interface for insertion of a replaceable insert with one or two RJ45 sockets or one RJ45 socket and one terminal for 24 V DC voltage supply (outlet insert, outlet power insert).



As delivered

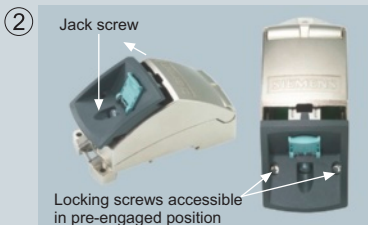

Release insert with jack screw and pull into pre-engaged position

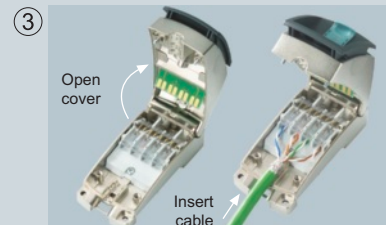

Connect cable

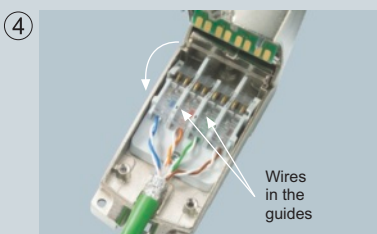

Connect cable: Press down insulation displacement contacts



Close cover



Push insert into end position. Tighten the interlocking screws of the strain-relief, push insert in, tighten jack screw



Outlet assembly complete



Outlet ready for use

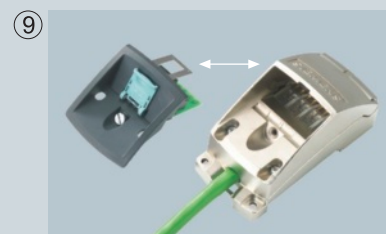

Exchanging the insert: Insert can be replaced while basic housing is closed by pulling it past the pre-engaged position.

G_IK10_XX_30029

IE FC RJ45 Modular Outlet

2

Function

The IE FC RJ45 Modular Outlet is connected direct to the 8-core Industrial Ethernet FC cables 4 x 2. Pre-assembled RJ45 patch cables (TP cord) are available for the connection between outlet and network component or data terminal. These conform with Cat6 of the international cabling standards.

When housing is opened, colored markings on the contact element simplify connection of the individual wires to the insulation displacement contacts.

In order to supply remote stations with power and data, the IE FC RJ45 Modular Outlet with Power Insert is connected to the IE Hybrid Cable 2x2 + 4x0.34. A maximum of 80 m can be covered between the Outlet and the IP67 hybrid connector. The connection between Outlet and data terminal can be established using a patch cable with a maximum length of 6 m.

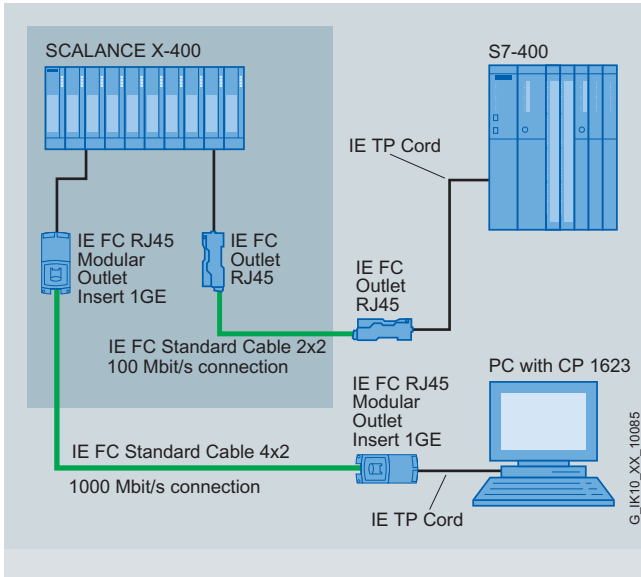

System configuration with IE FC RJ45 Modular Outlet and IE FC Outlet RJ45

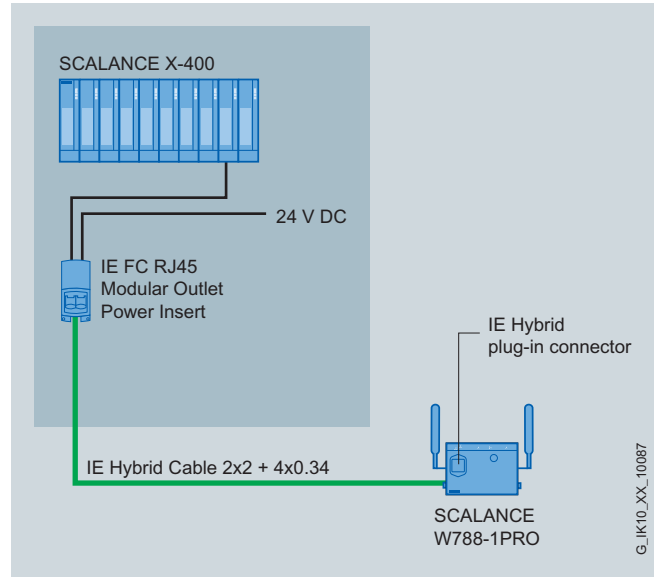

Network structure with IE FC RJ45 Modular Outlet with Power Insert

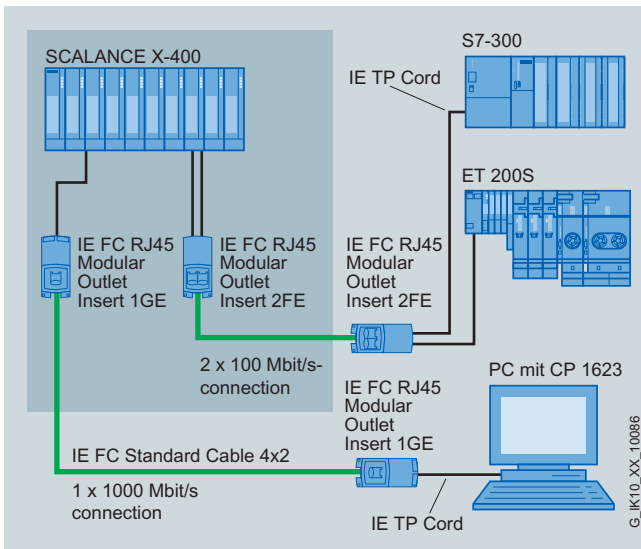

System configuration with IE FC RJ45 Modular Outlet 100 Mbit/s and 1000 Mbit/s

PROFINET/Industrial Ethernet

Cabling technology

IE FC RJ45 Modular Outlet

Technical specifications

Order No.	6GK1 901-1BE00-0AA0	6GK1 901-1BE00-0AA1	6GK1 901-1BE00-0AA2
Product type designation	IE FC RJ45 Modular Outlet	IE FC RJ45 Modular Outlet (Insert 2FE)	IE FC RJ45 Modular Outlet (Insert 1GE)
Electrical specifications			
Transmission rate 1	-	10/100 Mbit/s	10/100/1000 Mbit/s
Transmission rate 2	-	-	-
Transmission rate 3	-	-	-
Interfaces			
Number of electrical connections			
• for Industrial Ethernet FC TP cables	8	8	8
• for network components or terminal equipment	-	-	-
Design of electrical connection			
• for Industrial Ethernet FC TP cables	Integrated insulation displacement contacts	Integrated insulation displacement contacts	Integrated insulation displacement contacts
• for FC RJ45 Modular Outlet Insert 2FE	-	2 x RJ45 socket (10/100 Mbit/s)	-
• for FC RJ45 Modular Outlet Insert 1GE	-	-	1 x RJ45 socket (10/100/1000 Mbit/s)
• FastConnect	Yes	Yes	Yes
Mechanical data			
Enclosure material	Metal	Metal	Metal
Design, dimensions and weights			
Width	50 mm	50 mm	50 mm
Height	115.25 mm	115.25 mm	115.25 mm
Depth	58.95 mm	58.95 mm	58.95 mm
Net weight	450 g	450 g	450 g
Type of mounting			
• 35 mm DIN rail mounting	Yes	Yes	Yes
• Wall mounting	Yes	Yes	Yes
Permitted ambient conditions			
Ambient temperature			
• During operating phase	-20 ... +70 °C	-20 ... +70 °C	-20 ... +70 °C
• During storage	-40 ... +80 °C	-40 ... +80 °C	-40 ... +80 °C
• During transport	-40 ... +80 °C	-40 ... +80 °C	-40 ... +80 °C
Relative humidity at 25 °C without condensation during operating phase, maximum	95%	95%	95%
IP degree of protection	IP40	IP40	IP40
Standards, specifications, approvals			
Certificate of suitability: RoHS conformity	Yes	Yes	Yes
Certificate of suitability: UL approval	Yes	Yes	Yes
Standard for structured cabling	Cat 6	Cat 6	Cat 6

Technical specifications (continued)		Ordering data	Order No.
Order No.	6GK1 901-1BE00-0AA3	IE FC RJ45 Modular Outlet	
Product type designation	IE FC RJ45 Modular Outlet (Power Insert)	FastConnect RJ45 Outlet for Industrial Ethernet with interface for a replaceable insert;	
Electrical specifications		• without replaceable insert	6GK1 901-1BE00-0AA0 6GK1 901-1BE00-0AA1
Transmission rate 1	10/100 Mbit/s	• with 2FE insert; replaceable insert for 2 x 100 Mbit/s interfaces	6GK1 901-1BE00-0AA2
Transmission rate 2	-	• with 1GE insert; replaceable insert for 1 x 1000 Mbit/s interfaces	6GK1 901-1BE00-0AA3
Interfaces		• with power insert; replaceable insert for 1 x 24 V DC and 1 x 100 Mbit/s interface	
Number of electrical connections	8	IE FC RJ45 Modular Outlet Insert 2FE	6GK1 901-1BK00-0AA1
• for Industrial Ethernet FC TP cables	-	Replaceable insert for FC Modular Outlet Base; 2 x RJ45 for 2 x 100 Mbit/s interfaces; 1 pack = 4 items	
• for network components or terminal equipment	-	IE FC RJ45 Modular Outlet Insert 1GE	6GK1 901-1BK00-0AA2
Design of electrical connection	Integrated insulation displacement contacts	Replaceable insert for FC Modular Outlet Base; 1 x RJ45 for 1 x 1000 Mbit/s interface; 1 pack = 4 items	
• for Industrial Ethernet FC TP cables	1 x RJ45 socket (10/100 Mbit/s), 1 x 24 V DC terminal	IE FC TP Standard Cable 4 x 2	6XV1 870-2E
• for FC RJ45 Modular Outlet Power Insert	Yes	8-core FastConnect cable (Cat6) for permanent wiring; sold by the meter	
• FastConnect	Yes	IE Hybrid Cable 2x2 + 4x0.34	6XV1870-2J
Mechanical data		Flexible cable, 4 x Cu Cat5, shielded (0.75 mm) and 4 x Cu (0.34 mm ²) with IE FC modular outlet and power insert and IP67 hybrid plug connector; <u>sold by the meter</u> ; up to 1000 m; minimum order 20 m	
Enclosure material	Metal	Energy Cable	6XV1812-8A
Design, dimensions and weights		2-wire energy cable; stranded wire, 2 x 0.75 mm ² , can be trailed, <u>sold by the meter</u> ; up to 1000 m; minimum order 20 m	
Width	50 mm	IE TP Cord	see TP Cord
Height	115.25 mm	8-core patch cable for connection between FC Modular Outlet base modules and data terminal; available in different lengths	
Depth	58.95 mm	IE FC stripping tool	6GK1 901-1GA00
Net weight	450 g	Preadjusted stripping tool for fast stripping of Industrial Ethernet FC cables	
Type of mounting			
• 35 mm DIN rail mounting	Yes		
• Wall mounting	Yes		
Permitted ambient conditions			
Ambient temperature			
• During operating phase	-20 ... +70 °C		
• During storage	-40 ... +80 °C		
• During transport	-40 ... +80 °C		
Relative humidity at 25 °C without condensation during operating phase, maximum	95%		
IP degree of protection	IP40		
Standards, specifications, approvals			
Certificate of suitability: RoHS conformity	Yes		
Certificate of suitability: UL approval	Yes		
Standard for structured cabling	-		

PROFINET/Industrial Ethernet

Cabling technology

Industrial Twisted Pair – cables/connectors

Overview

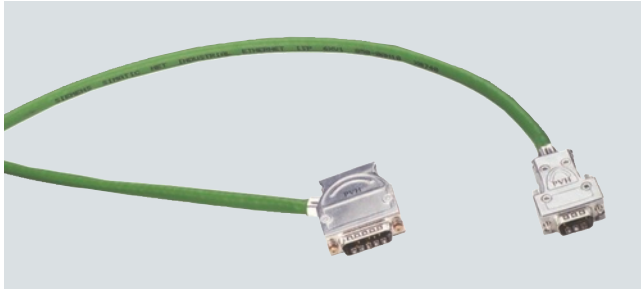

Industrial Twisted Pair cable

- For constructing Industrial Twisted Pair (ITP) networks
- Double cable shield for industrial use
- Easy to lay
- Low-cost connection of data terminals
- Exceeds Category 5 of the international cabling standards ISO/IEC 11801 and EN 50173
- Available as standard type and as halogen-free version (FRNC)

Industrial Twisted Pair connector

- Connector is assembled on site with screw terminals without the need for special tools
- Data transfer is noise resistant thanks to
 - Rugged metal connector
 - System-wide grounding concept
- Fast, error-free installation using factory-tested preassembled cables

Benefits



Noise-resistant data transmission through

- Double shielding with foil and braided shield
- Consistent grounding concept
- Silicone-free and therefore suitable for use in the automotive industry (for example in paint shops)
- Available as standard and as halogen-free version

Function

- With their double, particularly dense shield, the industrial twisted pair cables are especially suitable for installation in industrial environments subject to electromagnetic interference, e.g. for linking control cabinets.
- An integrated grounding concept can be implemented through the outer shield.
- The ITP cable is flame retardant and has a copolymer outer casing FRNC (Flame Retardant Non Corrosive)
- The cables considerably exceed Category 5 of the international cabling standard. They can be implemented for up to 300 MHz and are suitable for Fast Ethernet with 100 Mbit/s.

Design

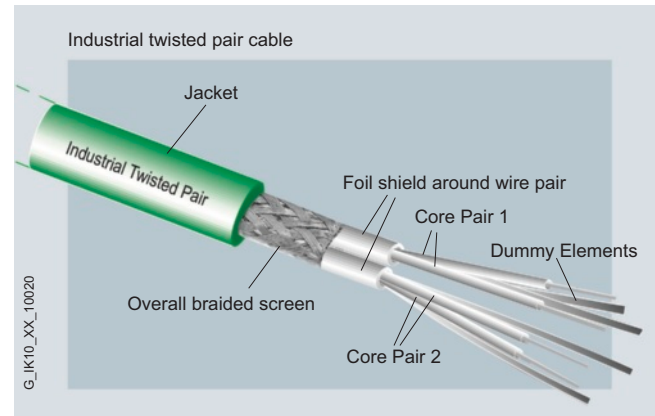

Industrial Twisted Pair cable

- 2 x 2 cores
- Two cores with two dummy elements twisted into a pair.
- Each pair is enclosed by a plastic film and shielded with two aluminum-clad plastic films
- Outer woven shield around all pairs comprising tinned copper wires
- Plastic sheath (PVC)

The ITP Cable is available as a pre-assembled cable in the following versions:

- *ITP cable 9/15*
with one 9-pin and one 15-pin connector;
for direct connection of data terminals with an ITP interface to Industrial Ethernet network components with ITP interface
- *ITP XP Standard Cable 9/9*
with two 9-pin connectors;
crossed, for direct connection of two Industrial Ethernet network components with ITP interface
- *ITP XP Standard Cable 15/15*
with two 15-pin connectors;
crossed, for direct connection of two terminal devices with ITP interface

	Network component	Terminal device
Network component	ITP XP 9/9	ITP 9/15
Terminal device	ITP 9/15	ITP XP 15/15

Possible applications of the preassembled ITP cables

Industrial Twisted Pair connector (9-pin)

- Sub-D connectors made of metal
- Straight cable outlet
- For connection of the 2 x 2-core installation cable to the OSM or ESM
- Easy mounting with screwdriver

Industrial Twisted Pair connector (15-pin)

- Sub-D connectors made of metal
- Variable cable outlet
- For connection of the 2 x 2-core installation cable connected to a terminal device
- Internal jumper for automatic switchover from AU1 to twisted pair operation in SIMATIC NET CPs with integrated twisted pair transceiver
- Easy mounting with screwdriver

Technical specifications

Order No.	6XV1 850-0AH10	6XV1 851-0AH10
Product type designation	ITP Standard Cable GP for Industrial Ethernet	ITP FRNC Cable GP for Industrial Ethernet
Product description	Industrial Twisted Pair cable (4-core), sold by the meter, in bulk	Halogen-free Industrial Twisted Pair cable (4-core), sold by the meter, in bulk
Suitability for application	Used for Industrial Twisted Pair (ITP) networks	Used for Industrial Twisted Pair (ITP) networks
Cable designation	J-02YSCY 2x2x0.64/1.5 PIMF F GN	J-02YSCH 2x2x0.64/1.5 PIMF F GN FRNC
Cable length	-	-
Electrical specifications		
Attenuation factor per length		
• Max. at 10 MHz	57 dB/km	57 dB/km
• Max. at 100 MHz	180 dB/km	180 dB/km
• Max. at 300 MHz	310 dB/km	310 dB/km
Characteristic impedance		
• At 1 MHz to 100 MHz	100 Ω	100 Ω
• At 100 MHz to 300 MHz	100 Ω	100 Ω
Relative symmetrical tolerance		
• of characteristic impedance at 1 MHz to 100 MHz	15 %	15 %
• of characteristic impedance at 100 MHz to 300 MHz	45 %	45 %
Surface transfer resistance at 10 MHz	2 mΩ/m	2 mΩ/m
Max. loop resistance per length	124 Ω/km	124 Ω/km
Insulation resistance coefficient	5 000 GΩ·m	5 000 GΩ·m
Operating voltage, maximum	225 V	-
Mechanical data		
Number of electrical cores	4	4
Design of shield	Overlapping aluminum-clad foil (per core), surrounded by a complete braided screen of tin-plated copper wires	Overlapping aluminum-clad foil (per core), surrounded by a complete braided screen of tin-plated copper wires
AWG number	-	-
Diameter of AWG22 cores	0.64 mm	0.64 mm
Outer diameter		
• of inner conductor	0.64 mm	0.64 mm
• of core insulation	1.5 mm	1.5 mm
Width of cable sheath	9.2 mm	9.4 mm
Symmetrical tolerance of cable sheath width	0.5 mm	0.5 mm
Thickness of cable sheath	6 mm	6 mm
Symmetrical tolerance of cable sheath thickness	0.5 mm	0.5 mm
Material		
• of core insulation	PE	PE
• of cable sheath	PVC	FRNC
Color		
• of core insulation of data cores	White/blue, white/orange	White/blue, white/orange
• of cable sheath	Green	Green
Bending radius		
• With single bending	30 mm	60 mm
• With repeated bending	45 mm	90 mm
Maximum tensile load	80 N	80 N
Weight per length	96 kg/km	98 kg/km

PROFINET/Industrial Ethernet

Cabling technology

Industrial Twisted Pair – cables/connectors

Technical specifications (continued)

Order No.	6XV1 850-0AH10	6XV1 851-0AH10
Product type designation	ITP Standard Cable GP for Industrial Ethernet	ITP FRNC Cable GP for Industrial Ethernet
Permitted ambient conditions		
Ambient temperature		
• During operation	-40 ... +70 °C	-40 ... +80 °C
• During storage	-40 ... +70 °C	-40 ... +80 °C
• During transport	-40 ... +70 °C	-40 ... +80 °C
• During mounting	-40 ... +70 °C	-25 ... +80 °C
Behavior in fire	Flame-retardant in accordance with IEC 60332-1	Flame-retardant in accordance with IEC 60332-3-23 (Category B) and IEC 60332-3-24 (Category C)
Chemical resistance		
• Mineral oil	Limited resistance	Limited resistance
• Grease	Limited resistance	Limited resistance
Radiological resistance to UV radiation	-	Limited resistance
Product properties, functions, components		
General		
Product property		
• Halogen-free	No	Yes
• Silicon-free	Yes	Yes
Cable length for 100BaseTX with Industrial Ethernet	-	-
Standards, specifications, approvals		
UL-Listing at 300 V rating	No	Yes: CMG / CL3 / Sun Res
UL-Style at 600 V rating	No	No

2

Technical specifications (continued)

Order No.	6GK1 901-0CA00-0AA0	6GK1 901-0CA01-0AA0
Product type designation	ITP plug (9-pin)	ITP plug (15-pin)
Product description	9-pin SUB-D connector	15-pin SUB-D connector
Suitability for application	For assembling 2x2-core ITP installation cables	For assembling 2x2-core ITP installation cables
Transmission rate		
Transmission rate		
• 1 with Industrial Ethernet	10 Mbit/s	10 Mbit/s
• 2 with Industrial Ethernet	100 Mbit/s	100 Mbit/s
• 3 with Industrial Ethernet	-	-
Interfaces		
Number of electrical/optical connections for Industrial Ethernet FC TP cables	-	-
Design of electrical connection		
• for Industrial Ethernet FC TP cables	-	-
• for network components or terminal equipment	SUB-D connector (9-pin)	SUB-D connector (15-pin)
• FastConnect	No	No
Mechanical data		
Enclosure material	Metal	Metal
Design, dimensions and weights		
Type of cable outlet	180 degree cable outlet	Variable cable outlet
Width	42.5 mm	39 mm
Height	31 mm	15 mm
Depth	15 mm	42 mm
Net weight	63 g	50 g
Permitted ambient conditions		
IP degree of protection	IP20	IP20
Product properties, functions, components General		
Product property silicon-free	Yes	Yes
Product component strain relief	Yes	Yes
Standards, specifications, approvals		
Certificate of suitability		
• RoHS compliance	Yes	Yes
• UL approval	No	No

PROFINET/Industrial Ethernet

Cabling technology

Industrial Twisted Pair – cables/connectors

2

Ordering data

ITP Standard Cable for Industrial Ethernet

Not pre-assembled, sold by the meter, 2 x 2-core, without plug

For connecting a data terminal, for self-assembly of plug, or for connecting the patch field to the outlet

Order No.
6XV1 850-0AH10

ITP Standard Cable 9/15

ITP installation cable for the direct connection of data terminals with an ITP interface to Industrial Ethernet network components with an ITP interface; with one 9-pin and one 15-pin Sub-D connector

2 m

6XV1 850-0BH20

5 m

6XV1 850-0BH50

8 m

6XV1 850-0BH80

12 m

6XV1 850-0BN12

15 m

6XV1 850-0BN15

20 m

6XV1 850-0BN20

30 m

6XV1 850-0BN30

40 m

6XV1 850-0BN40

50 m

6XV1 850-0BN50

60 m

6XV1 850-0BN60

70 m

6XV1 850-0BN70

80 m

6XV1 850-0BN80

90 m

6XV1 850-0BN88

100 m

6XV1 850-0BT10

ITP XP Standard Cable 9/9

Twisted ITP installation cable for direct connection of two Industrial Ethernet network components with an ITP interface; with two 9-pin Sub-D connectors

2 m

6XV1 850-0CH20

5 m

6XV1 850-0CH50

8 m

6XV1 850-0CH80

12 m

6XV1 850-0CN12

15 m

6XV1 850-0CN15

20 m

6XV1 850-0CN20

30 m

6XV1 850-0CN30

40 m

6XV1 850-0CN40

50 m

6XV1 850-0CN50

60 m

6XV1 850-0CN60

70 m

6XV1 850-0CN70

80 m

6XV1 850-0CN80

90 m

6XV1 850-0CN88

100 m

6XV1 850-0CT10

ITP XP Standard Cable 15/15

Twisted ITP installation cable for direct connection of two data terminals with an ITP interface; with two 15-pin Sub-D connectors

• 2 m

• 6 m

• 10 m

6XV1 850-0DH20

6XV1 850-0DH60

6XV1 850-0DN10

ITP FRNC Cable for Industrial Ethernet

Not pre-assembled, halogen-free, sold by the meter, 2 x 2-core, without plug

For connecting a data terminal, for self-assembly of plug, or for connecting the patch field to the outlet

6XV1 851-0AH10

ITP FRNC Cable 9/15

ITP installation cable for the direct connection of data terminals with an ITP interface to Industrial Ethernet network components with an ITP interface; with one 9-pin and one 15-pin Sub-D connector

2 m

6XV1 851-1AH20

5 m

6XV1 851-1AH50

8 m

6XV1 851-1AH80

12 m

6XV1 851-1AN12

15 m

6XV1 851-1AN15

20 m

6XV1 851-1AN20

30 m

6XV1 851-1AN30

ITP plug

ITP Plug for Industrial Ethernet 9-pin

For connecting to OLM/ELM and OSM/ESM

6GK1 901-0CA00-0AA0

ITP Plug for Industrial Ethernet 15-pin

For connecting to a data terminal with an ITP interface

6GK1 901-0CA01-0AA0

SIMATIC NET Manual Collection

Electronic manuals for communication systems, communication protocols, and communication products; on DVD; German/English

6GK1 975-1AA00-3AA0

More information

Installation instructions

The installation cable is either supplied by the meter or with preassembled connectors. It can be used to connect a single data terminal or two active network components (OSM/ESM).

On the network component side, 9-pole metal Sub-D connectors are used, and on the device side, 15-pole connectors are used. The 15-pole connectors contain a special plug-in jumper which can be used by modules with integrated twisted pair transceiver to switch from AUI to twisted pair operation.

Preassembled cables are used to connect data terminals directly to an active network component or for cascading active network components.

The ITP cables can also be ordered by the meter for on site assembly. 9-pole and 15-pole ITP connectors for assembly without special tools are available for this purpose.

The maximum cable length of a laid ITP Standard Cable is 100 m if connected directly.

ITP cables are intended only for use inside buildings.

Notes:

You can order components supplementary to the SIMATIC NET cabling range from your local contact.

Technical advice on this subject is available from:

J. Hertlein
I IA SC IC PRM 4
Phone: +49 (0)91 1/750 44 65
E-mail: juergen.hertlein@siemens.com

Additional installation instructions can be found in the manual for TP and fiber-optic networks.

PROFINET/Industrial Ethernet

Cabling technology

Overview of FC-FOCs

Overview

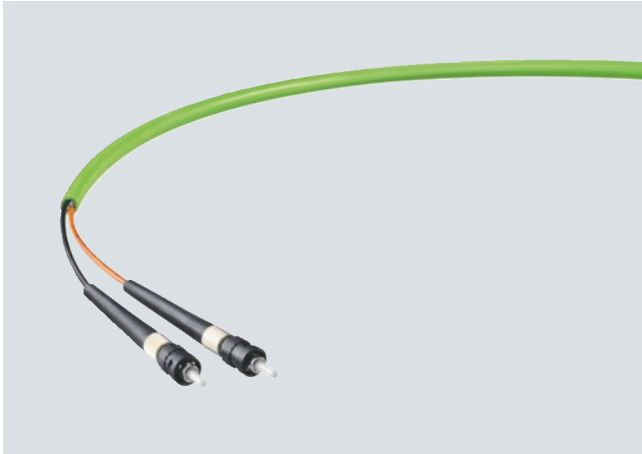

- Simple on-site assembly of glass FOC in the field
- Optical signal transmission
- No radiation emission from the cable
- Unaffected by external noise fields
- No grounding problems
- Electrical isolation
- Low weight
- Simple laying of cables

Design

Fiber-optic cables with glass core (62.5/200/230) are offered for the FastConnect fiber-optic cable system:

- FC glass fiber-optic cable; duplex cable for indoor and outdoor fiber-optic networks

The fiber structure corresponds to that of the PCF. This allows simple assembly on site.

Sheath material	Application
PVC	Standard use in indoor and outdoor areas of industrial applications
PUR	Highly mobile applications (tow chains) for high mechanical or chemical stress in harsh industrial environments
PE	Routing of cables in moist areas indoors and outdoors, and for direct burying in earth
FRNC	Standard applications with high fire protection requirements

Approvals

UL listing (safety standard) for network lines is especially necessary for the American and Canadian markets. The requirements for the appropriate approvals depend on where the cable is routed within the building. This applies to all cables which have to be routed from a machine to a remote control cabinet and are positioned on cable racks secured in the building. These cables are identified by the suffix "GP" (general purpose) in the product name and have the corresponding UL approvals.

Application

The fiber-optic cable (FOC) is used for the transmission of signals in very extensive plants and where there are significant potential differences within a plant. The light beam is guided by total reflection at the transition from core to cladding which has a lower refractive index than the core.

The FastConnect fiber-optic (FC FO) system enables fast on-site assembly of glass fiber-optic cables with the right lengths to suit the respective application.

Assembly with FastConnect for glass fiber-optic cables

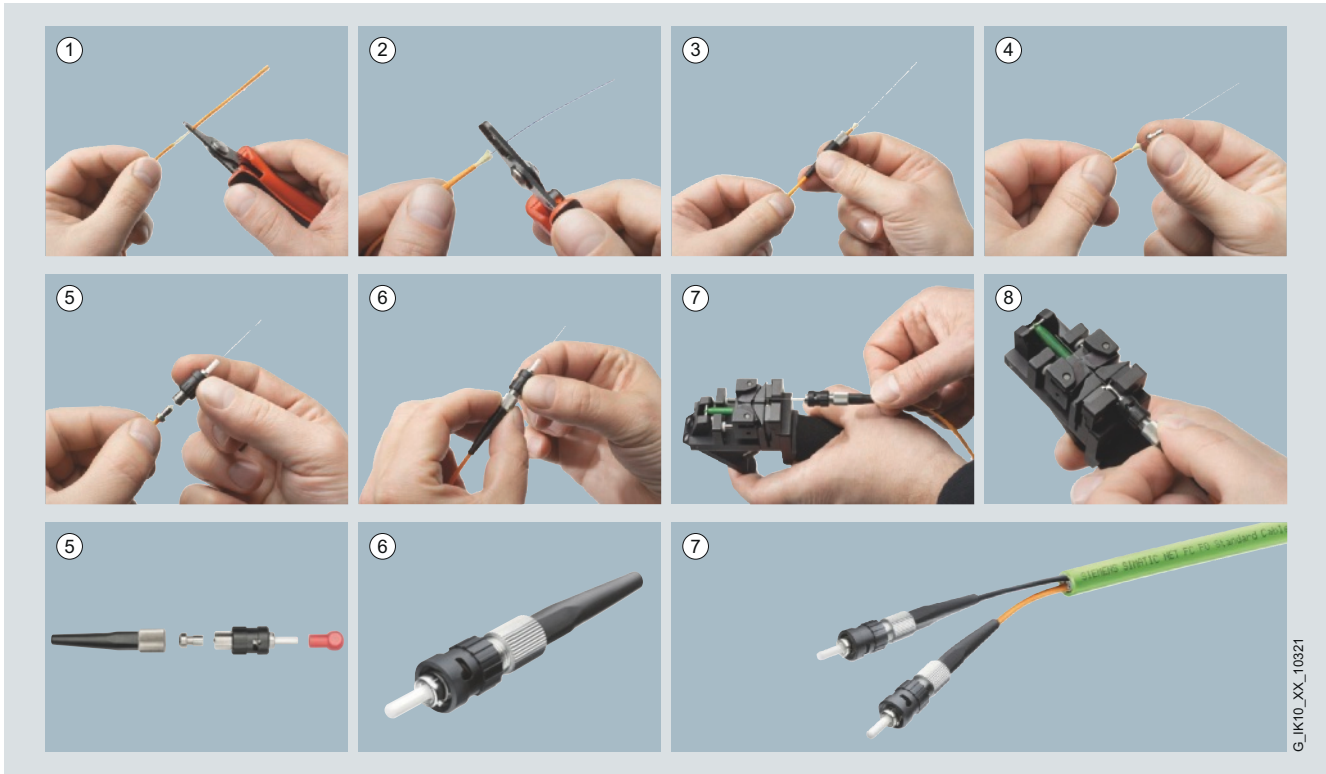

Steps for assembly of Industrial Ethernet fiber-optic cables with Industrial Ethernet FastConnect

PROFINET/Industrial Ethernet

Cabling technology

FC glass fiber-optic cables

Overview

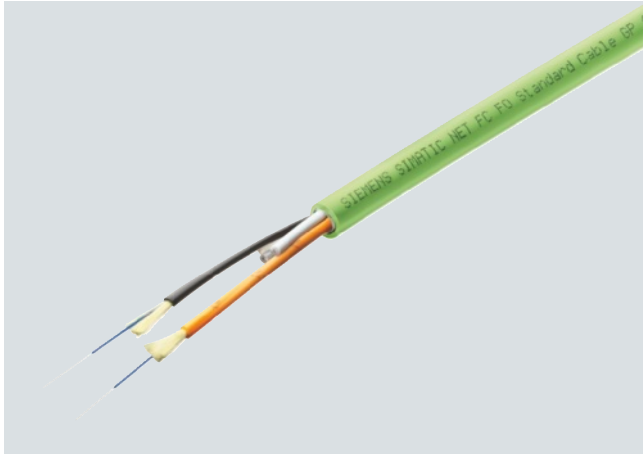

- FastConnect standard fiber-optic cable for use in optical Industrial Ethernet and PROFIBUS networks
- For all users who want to install and assemble the glass fiber-optic cables themselves over longer distances on site for office or industrial applications.
- Simple FastConnect SC/BFOC connector assembly on site
- Rugged construction for industrial applications both indoors and outdoors
- High interference immunity, as they are not sensitive to electromagnetic interference
- Extensive range of approvals (UL approvals)

Benefits

get Designed for Industry

- Avoidance of excessive cable lengths in the control cabinet, as the fiber-optic cables can be assembled to the right length on site
- Easy installation of cables in buildings, as cables can be pulled in without connectors attached
- Simple extension of installed glass fiber-optic cables via SC and BFOC couplers
- Devices with different connection method (SC or BFOC) can easily be connected to one another using self-assembled adapter cables
- Electrical isolation of Industrial Ethernet/PROFINET/PROFIBUS devices
- Unaffected by electromagnetic interference
- Tap-proof: no radiation from cable

Application

SIMATIC NET FastConnect glass fiber-optic cables are used to construct optical indoor and outdoor Industrial Ethernet/PROFINET and PROFIBUS networks. Devices with integral optical interface (SC or BFOC connection technology) are, for example, optical link modules (OLM) and SCALANCE X Industrial Ethernet switches.

FastConnect glass fiber-optic cables are to be assembled on site using FastConnect SC or FastConnect BFOC connectors. A corresponding assembly kit (FC FO Termination Kit) is available for this purpose. The Termination Kit permits the stripping and the "cleaving" of the fiber in the assembled connector, as is familiar from PCF fiber-optic cables. To extend existing lines, a BFOC or SC coupler may be used depending on the connection technology.

Design

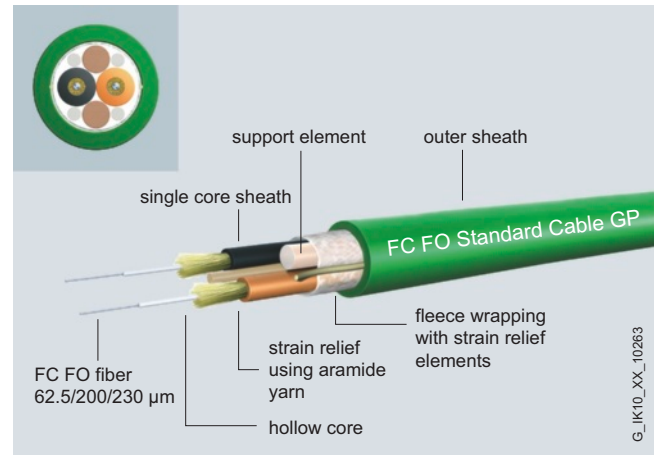

FC FO Standard Cable GP (General Purpose); rugged round cable with green outer sheath, Kevlar strain relief elements, and 62.5/200/230 FC FO fibers for indoor/outdoor applications

FC FO Trailing Cable;

rugged round cable with green outer sheath, Kevlar strain relief elements and 62.5/200/230 FC FO fibers for use in tow chains and moving applications

Maximum cable length between two devices:

- 3000 m for 100 Mbit/s Ethernet or for PROFIBUS
- 350 m for 1000 Mbit/s Ethernet (1000Base-SX)
- 550 m for 1000 Mbit/s Ethernet (1000Base-LX)

The maximum cable lengths can be assembled from partial lengths using FastConnect couplings (SC or BFOC; maximum two couplings, approx. 2.5 dB attenuation per coupling). It is also possible to combine existing installed, conventional 62.5/125 μm multimode glass fiber-optic cable sections with the FastConnect fiber-optic cables.

G_IK10_XX_10263

Technical specifications

Order No.	6XV1 847-2A	6XV1 847-2C
Product type designation	FC FO Standard Cable GP	FC FO Trailing Cable
Product description	Glass fiber-optic cable for field assembly, cut-to-length, non-assembled	Flexible glass fiber-optic cable for field assembly, cut-to-length, non-assembled
Suitability for application	Cable for fixed routing in cable ducts and conduits, UL approval	Cable for high mechanical loading for use in trailing cables indoors and outdoors
Design of preassembled FO cable	Can be fitted with four BFOC or SC connectors	Can be fitted with four BFOC or SC connectors
Cable designation	AT-V(ZN)YY 2GK 62.5/200/230	AT-V(ZN)Y(ZN)11Y 2GK 62.5/200/230
Cable length	-	-
Optical data		
Attenuation factor per length		
• Max. at 850 nm	3.2 dB/km	3.2 dB/km
• Max. at 1300 nm	0.9 dB/km	0.9 dB/km
Bandwidth length product		
• At 850 nm	200 000 MHz·m	200 000 MHz·m
• At 1300 nm	500 000 MHz·m	500 000 MHz·m
Mechanical data		
Number of fibers per FO core	1	1
Number of FO cores per FO cable	2	2
Design of FO fiber	Multi-mode gradient fiber 62.5/200/230 µm	Multi-mode gradient fiber 62.5/200/230 µm
Design of FO core	Fixed core	Fixed core
Design of FO cable	Splittable cable	Splittable cable
Outer diameter		
• of optical fiber	62.5 µm	62.5 µm
• of optical fiber sheath	230 µm	230 µm
• of FO core sheath	2.2 mm	2.2 mm
• of cable	7.2 mm	8.8 mm
Symmetrical deviation		
• of outer diameter of FO core sheath	0.1 mm	0.1 mm
• of outer diameter of cable	0.5 mm	0.5 mm
Material		
• of optical fiber core	Quartz glass	Quartz glass
• of optical fiber sheath	ETFE	ETFE
• of FO core sheath	PVC	PVC
• of FO cable sheath	PVC	PUR
• of the strain relief	Aramide fibers	Aramide fibers (double-ply)
Color		
• of FO core sheath	Orange/black	Orange/black
• of cable sheath	Green	Green
Bending radius		
• Minimum permitted single bending radius	70 mm	130 mm
• Minimum permitted repeated bending radius	105 mm	175 mm
• With continuous bending	-	-
Number of bending cycles	-	5 000 000
Maximum tensile load	100 N	800 N
Short-term lateral force per length	500 N/cm	500 N/cm
Continuous lateral force per length	300 N/cm	300 N/cm
Weight per length	49 kg/km	65 kg/km

PROFINET/Industrial Ethernet

Cabling technology

FC glass fiber-optic cables

Technical specifications (continued)

Order No.	6XV1 847-2A	6XV1 847-2C
Product type designation	FC FO Standard Cable GP	FC FO Trailing Cable
Permitted ambient conditions		
Ambient temperature		
• During operation	-40 ... +85 °C	-25 ... +75 °C
• During storage	-40 ... +85 °C	-30 ... +75 °C
• During transport	-40 ... +85 °C	-30 ... +75 °C
• During mounting	-5 ... +50 °C	-5 ... +50 °C
Behavior in fire	Flame-retardant in accordance with IEC 60332-1-2 and IEC 60332-3-22 (Cat. A)	Flame-retardant in accordance with IEC 60332-1-2
Chemical resistance		
• to mineral oil	Limited resistance	Resistant
• to grease	Limited resistance	Resistant
• to water	Limited resistance	Limited resistance
Radiological resistance to UV radiation	Resistant	Resistant
Product properties, functions, components		
General		
Product property		
• Halogen-free	No	No
• Silicon-free	Yes	Yes
Product component: protection against rodents	No	No
Cable length with glass FOC		
• Maximum with 100BaseFX and Industrial Ethernet	3 000 m	3 000 m
• Maximum with 1000BaseSX and Industrial Ethernet	350 m	350 m
• Maximum with 1000BaseFX and Industrial Ethernet	550 m	550 m
• Maximum with PROFIBUS	3 000 m	3 000 m
Standards, specifications, approvals		
Certificate of suitability	UL approval: OFN (NEC Article 770, UL 1651) / CSA approval: OFN 90 Cel, FT1, FT4 (CSA Standard C22.2 No232-M1988)	-
• RoHS compliance	Yes	Yes
Marine classification corporation		
• Bureau Veritas (BV)	-	-
• Germanischer Lloyd (GL)	-	-
• Lloyds Register of Shipping (LRS)	-	-

Technical specifications (continued)

Order No.	6GK1 900-1LB00-0AC0	6GK1 900-1GB00-0AC0	6GK1 900-1LP00-0AB0	6GK1 900-1GP00-0AB0
Product type designation	FC FO SC Plug	FC FO BFOC Plug	FC FO SC Coupler	FC FO BFOC Coupler
Product description	SC plug for FastConnect assembly	BFOC plug for FastConnect assembly	SC duplex coupler for FastConnect assembly	BFOC coupler for FastConnect assembly
Suitability for application	For connection of glass fiber-optic cables, suitable for fast mounting with the FastConnect FO system	For connection of glass fiber-optic cables, suitable for fast mounting with the FastConnect FO system	-	-
Transmission rate				
Transmission rate				
• 1 with Industrial Ethernet	10 Mbit/s	10 Mbit/s	10 Mbit/s	10 Mbit/s
• 2 with Industrial Ethernet	100 Mbit/s	100 Mbit/s	100 Mbit/s	100 Mbit/s
• 3 with Industrial Ethernet	1 000 Mbit/s	1 000 Mbit/s	1 000 Mbit/s	1 000 Mbit/s
• with PROFIBUS	9.6 kbit/s ... 12 Mbit/s	9.6 kbit/s ... 12 Mbit/s	9.6 kbit/s ... 12 Mbit/s	9.6 kbit/s ... 12 Mbit/s
Interfaces				
Number of optical connections for fiber-optic cables	1	1	1	1
Number of optical connections for network components or terminals	SC connector	BFOC connector	SC duplex coupling	BFOC coupling
Design of electrical connection FastConnect	Yes	Yes	Yes	Yes
Mechanical data				
Enclosure material	Metal and plastic	Metal and plastic	Metal and plastic	Metal and plastic
Design, dimensions and weights				
Type of cable outlet	180 degree cable outlet	180 degree cable outlet	180 degree cable outlet	180 degree cable outlet
Width	8 mm	10 mm	9 mm	11 mm
Height	8 mm	10 mm	35 mm	11 mm
Depth	49 mm	22 mm	28 mm	29.5 mm
Net weight	11 g	9 g	18 g	9 g
Permitted ambient conditions				
Ambient temperature				
• During operation	-40 ... +85 °C	-40 ... +85 °C	-40 ... +85 °C	-40 ... +85 °C
• During storage	-40 ... +85 °C	-40 ... +85 °C	-40 ... +85 °C	-40 ... +85 °C
• During transport	-40 ... +85 °C	-40 ... +85 °C	-40 ... +85 °C	-40 ... +85 °C
Relative humidity at 25 °C without condensation during operation, maximum	95 %	95 %	95 %	95 %
IP degree of protection	IP20	IP20	IP20	IP20
Product properties, functions, components				
General				
Product property silicon-free	Yes	Yes	Yes	Yes
Product component strain relief	Yes	Yes	Yes	Yes
Standards, specifications, approvals				
Certificate of suitability: RoHS conformity	Yes	Yes	Yes	Yes

PROFINET/Industrial Ethernet

Cabling technology

FC glass fiber-optic cables

Ordering data	Order No.
FC FO standard cable GP 62.5/200/230 FC FO standard cable for fixed routing indoors with PVC sheath; <u>sold by the meter</u> max. length 1000 m; minimum order 20 m	6XV1 847-2A
FC FO trailing cable FC FO trailing cable for use in tow chains and moving applications; <u>sold by the meter</u>	6XV1 847-2C
FC FO termination kit Assembly case for local assembly of FC SC and FC BFOC connectors to FC FO standard cable, comprising a stripping tool, Kevlar cutters, fiber breaking tool and microscope	6GK1 900-1GL00-0AA0
FC SC plug Screw connector for on-site assembly on FC fiber-optic cable; (1 pack = 10 duplex plugs + cleaning cloths)	6GK1 900-1LB00-0AC0
FC BFOC plug Screw connector for on-site assembly on FC fiber-optic cable; (1 pack = 20 units + cleaning cloths)	6GK1 900-1GB00-0AC0
FC SC coupler FC SC duplex coupling; (1 pack = 5 units)	6GK1 900-1LP00-0AB0
FC BFOC coupler FC BFOC coupling; (1 pack = 10 units)	6GK1 900-1GP00-0AB0
SIMATIC NET Manual Collection Electronic manuals for communication systems, communication protocols, and communication products; on DVD; German/English	6GK1 975-1AA00-3AA0

More information

You can order components supplementary to the SIMATIC NET cabling range from your local contact.

Technical advice on this subject is available from:

J. Hertlein
 I IA SC IC PRM 4
 Phone: +49 (0)911/750 44 65
 E-mail: juergen.hertlein@siemens.com

Overview



- Compact, rugged assembly case for FastConnect glass fiber-optic cables
- Simple fitting of SC and BFOC connectors to FastConnect glass fiber-optic cables
- The quality of the assembly can be checked using the enclosed microscope

Benefits

get Designed for Industry

- Simple installation of the unassembled cable
- Flexible connector assembly possible on site (SC/BFOC connectors)
- Prevention of faults by simply checking the assembled connectors using a microscope
- Simple repair of FC glass fiber-optic cables in the field

Application

SIMATIC NET FC glass fiber-optic cables are used to construct optical indoor and outdoor Industrial Ethernet/PROFINET and PROFIBUS networks. They are easy to assemble on-site using the termination kit with SC or BFOC connectors. The maximum cable length between two Industrial Ethernet/PROFINET or PROFIBUS devices is 3000 m in the case of 100 Mbit/s Ethernet or PROFIBUS.

Design

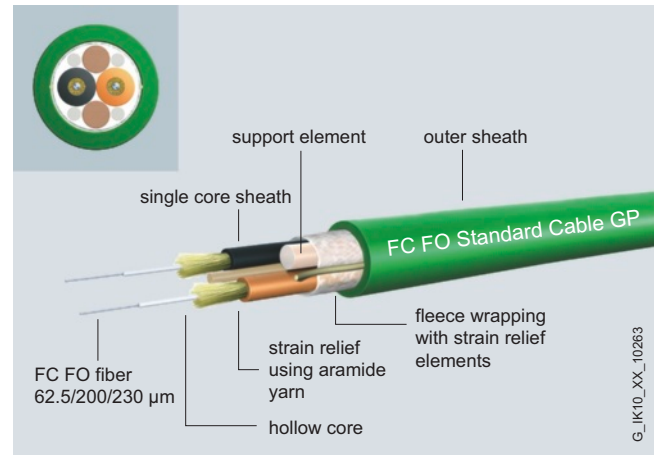

Cable construction FC glass optical fiber

The kit is available in an assembly case for on-site installation of FC SC and FC BFOC connectors on FC glass fiber-optic cables. It consists of a stripping tool, buffer stripping tool, Kevlar scissors, fiber breaking tool and microscope.

Ordering data

Order No.

FC FO Termination Kit

Assembly case for on-site installation of FC SC and FC BFOC connectors on FC glass fiber-optic standard cables; consists of stripping tool, Kevlar scissors, fiber breaking tool and microscope

6GK1 900-1GL00-0AA0

More information

You can order components supplementary to the SIMATIC NET cabling range from your local contact.

Technical advice on this subject is available from:

J. Hertlein
 I IA SC IC PRM 4
 Phone: +49 (0)911/750 44 65
 E-mail: juergen.hertlein@siemens.com

PROFINET/Industrial Ethernet

Cabling technology

Overview of FOCs

Overview

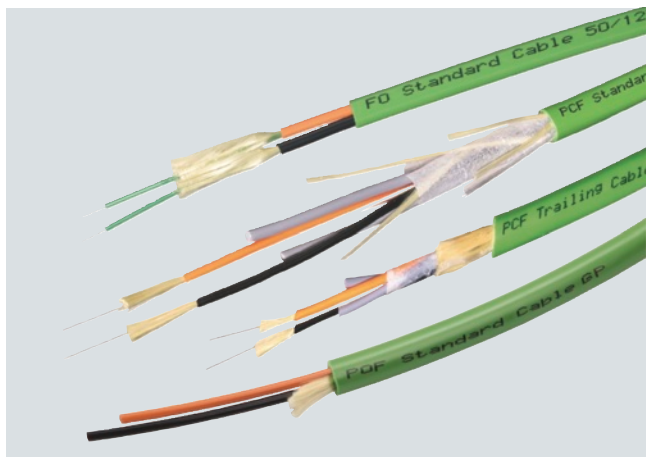

- Optical signal transmission
- No radiation along the cable
- Unaffected by external noise fields
- No grounding problems
- Electrical isolation
- Low weight
- Easy routing

Application

The fiber optic (FO) cable is used for transmitting signals with the help of waves in the optical frequency range. The light beam is guided by total reflection at the transition from core to cladding which has a lower refractive index than the core.

The fiber optic cable is provided with a protective coating. The term "fiber" is often also used for fiber-optic cables (FOC).

Design

Fiber-optic cables with glass fibers, PCF fibers (Polymer Cladded Fiber) and POF fibers (Polymer Optical Fiber) are offered for Industrial Ethernet:

- Glass fiber-optic cable; duplex cable for fiber-optic networks indoors and outdoors
- POF fiber-optic cable; Duplex cable for POF networks in the indoor area
- PCF fiber-optic cable; duplex cable for PCF networks indoors and outdoors

Sheath material	Application
PVC	Standard use in indoor and outdoor areas of industrial applications
PUR	Highly mobile applications (tow chains) for high mechanical or chemical stress in harsh industrial environments
PE	Routing of cables in moist areas indoors and outdoors, and for direct burying in earth
FRNC	Standard applications with high fire protection requirements

Approvals

UL listing (safety standard) for network lines is especially necessary for the American and Canadian markets. The requirements for the appropriate approvals depend on where the cable is routed within the building. This applies to all cables which have to be routed from a machine to a remote control cabinet and are positioned on cable racks secured in the building. These cables are identified by the suffix "GP" (general purpose) in the product name and have the corresponding UL approvals.

Product overview PROFINET fiber optic, PCF and POF cable

	PROFINET Type B	PROFINET Type C
	fixed or flexible cable depending on cable design	extremely flexible, continuous movement, vibrations or torsion loading, also for special applications
Fibre Optic Cable	2x 50/125µ	
<u>FO Standard Cable GP</u> 6XV1 873-2A	–	●
<u>FO FRNC Cable</u> 6XV1 873-2B	●	–
<u>FO Trailing Cable</u> 6XV1 873-2C	–	●
<u>FO TP Trailing Cable GP</u> 6XV1 873-2D	–	●
<u>FO Ground Cable</u> 6XV1873-2G	–	●
<u>FO Robust Cable GP</u>	–	–
<u>FO Robust Cable GP</u>	4x 9/125/900µ	–
PCF Cable	2x 200/230µ	
<u>PCF Standard Cable GP</u> 6XV1 861-2A	●	–
<u>PCF Tailing Cable</u> 6XV1 861-2C	●	–
<u>PCF Tailing Cable GP</u> 6XV1 861-2C	●	–
POF Cable	2x 980/1000µ	
<u>POF Standard Cable GP</u> 6XV1 874-2A	●	–
<u>POF Trailing Cable</u> 6XV1 874-2B	–	●

Overview



- Used for the optical Industrial Ethernet and PROFIBUS networks
- Rugged design for industrial applications indoors and outdoors
- Halogen-free design for installation inside buildings
- Trailing cable for the special application of forced motion control
- High immunity to noise thanks to insensitivity to electromagnetic fields
- Available preassembled
- Extensive approvals (UL)

Benefits

get Designed for Industry

- Easy routing with
 - Pre-assembled cables
 - No grounding problems
 - Very light fiber-optic cable
- Tap-proof due to lack of radiation from the cable
- Silicon-free; therefore suitable for use in the automotive industry (e.g. on paint shop conveyors)

Application

Marine duplex FOC SIENOPYR

Halogen-free, non-crush, flame-retardant, marine-approved fiber-optic cable for permanent installation on ships and offshore platforms indoors and on open deck. Sold by the meter

Fiber-optic indoor cable

Halogen-free fiber-optic cable, non-crush, flame-retardant, for installation inside buildings (e.g. in production halls and in building automation). Supplied in fixed lengths, pre-assembled with four BFOC connectors.

Standard FOC/FRNC cable

Fiber-optic cables for the following application areas indoors and outdoors

- For routing above ground
- For installation inside buildings.

Sold by the meter and in fixed lengths, pre-assembled with four BFOC connectors or four SC connectors.

Fiber-optic trailing cable

Fiber-optic cables for the special application of forced motion control, such as in continuously moving machine parts (in trailing cables) indoors and outdoors. Two cable versions are available for this application:

- FO Trailing Cable; Cable for high mechanical stress, PUR outer sheath, no UL approval
- FO Trailing Cable GP (general purpose); Cable for low mechanical stress, PVC outer sheath, with UL approval

Sold by the meter and in fixed lengths, pre-assembled with four BFOC connectors or four SC connectors.

Fiber-optic outdoor cable

Waterproof cable (lengthwise and sideways) for use outdoors with non-metallic protection against rodents for laying into the ground.

Sold by the meter and in fixed lengths, pre-assembled with four BFOC connectors or four SC connectors.

Note:

Special tools and specially trained personnel are required for pre-assembling glass fiber-optic cables

PROFINET/Industrial Ethernet

Cabling technology

Glass fiber-optic cables

Application (continued)

Application examples

2

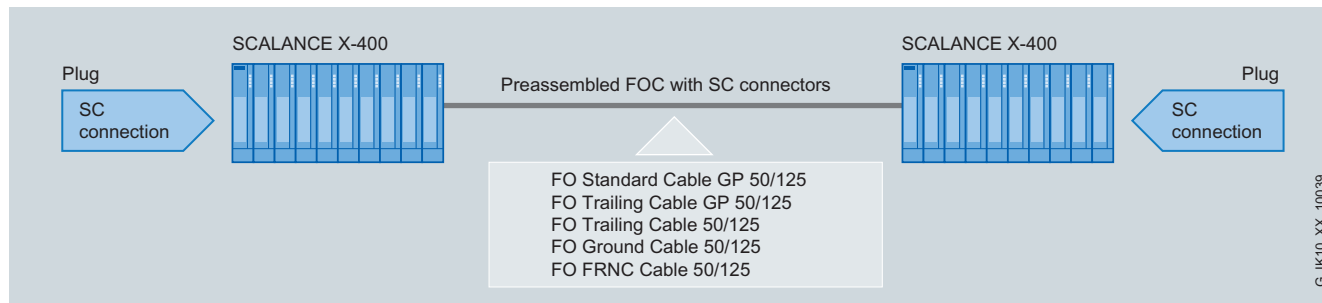

Use of pre-assembled fiber-optic cables with SC connectors (1000 Mbit/s)

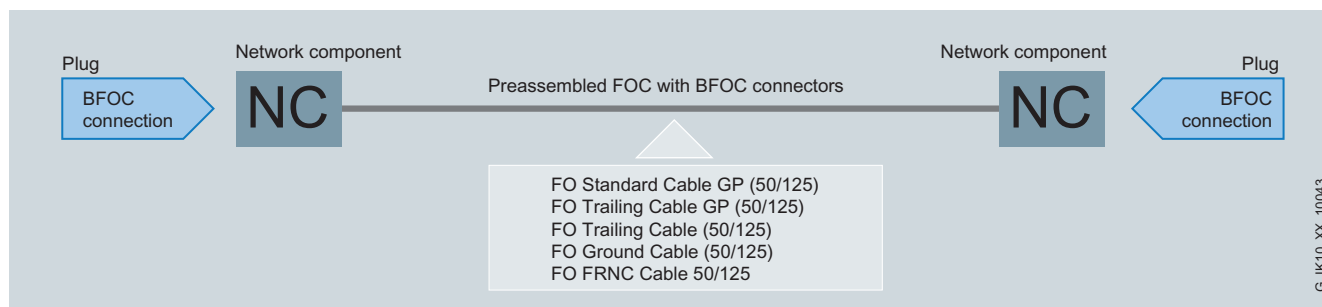

Use of pre-assembled fiber-optic cables with BFOC connectors (100 Mbit/s)

Design

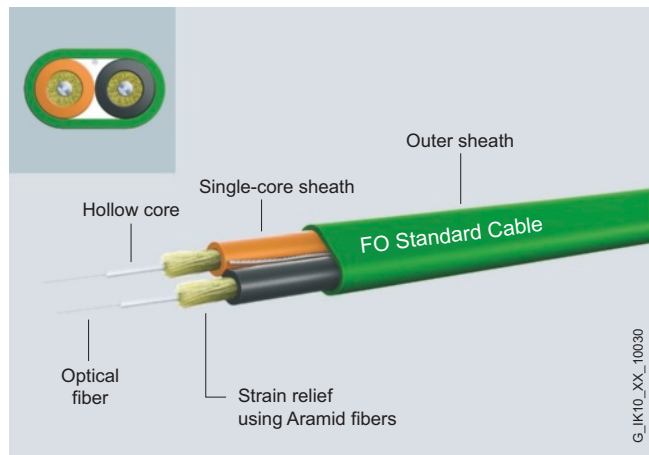

The following types of cable are available:

- 100Base FX; 62.5/125 μm fiber, 4000 m
- 100Base FX; 50/125 μm fiber, 5000 m
- 100Base FX; 9/125 μm fiber, 26000 m
- 1000Base SX; 50/125 μm fiber, 750 m
- 1000Base LX; 50/125 μm fiber, 2000 m
- 1000Base LX; 9/125 μm fiber, 10000 m; the distances that can be spanned by cables depend on the device-specific wavelength.

In the respective applications, the maximum cable lengths must be taken into account. Passive connection of different fiber types is not permissible. The use of 50 μm fiber is recommended for future installations due to the greater range of gigabit Ethernet. Use of the 62.5 μm fiber is only recommended for existing network installations. In order to span very long distances, the use of singlemode cables with a 9 μm fiber is recommended.

Cable types	50/125 μm	62.5/125 μm	9/125 μm
FO standard cable GP (50/125/1400)	●	—	—
FO FRNC cable (50/125/1400)	●	—	—
FO trailing cable (50/125/1400)	●	—	—
FO trailing cable GP (50/125/1400)	●	—	—
FO ground cable (50/125/1400)	●	—	—
FO robust cable GP (50/125/900)	●	—	—
Fiber-optic standard cable (62.5/125/900)	—	●	—
INDOOR fiber-optic cable (62.5/125/900)	—	●	—
Flexible fiber-optic trailing cable (62.5/125/1400)	—	●	—
SIENOPYR marine duplex fiber-optic cable (62.5/125/900)	—	●	—
FO robust cable GP (4E9/125/900)	—	—	●

Technical specifications

Order No.	6XV1 873-2A	6XV1 873-2B	6XV1 873-2G
Product type designation	FO Standard Cable GP	FO FRNC Cable GP	FO Ground Cable
Product description	Glass fiber-optic cable, sold by the meter, in bulk	Glass fiber-optic cable, sold by the meter, in bulk	Glass fiber-optic cable, sold by the meter, in bulk
Suitability for application	Cable for indoor and outdoor use, UL approval	Halogen-free cable for indoor and outdoor use, for fixed installation, UL approval	Cable with longitudinal and lateral water tightness with non-metallic protection against rodents for outdoor use and for direct laying in soil
Design of preassembled FO cable	Can be fitted with four BFOC or SC connectors	Can be fitted with four BFOC or SC connectors	Can be fitted with four BFOC or SC connectors
Cable designation	AT-W(ZN)YY 2x1 G 50/125	AT-W(ZN)HH 2G 50/125 UV	AT-WQ(ZN)Y(ZN)B2Y 2G 50/125
Cable length	-	-	-
Optical data			
Attenuation factor per length			
• Max. at 850 nm	2.7 dB/km	2.7 dB/km	2.7 dB/km
• Max. at 1300 nm	0.7 dB/km	0.7 dB/km	0.7 dB/km
Bandwidth length product			
• At 850 nm	600 GHz·m	600 GHz·m	600 GHz·m
• At 1300 nm	1 200 GHz·m	1 200 GHz·m	1 200 GHz·m
Mechanical data			
Number of fibers per FO core	1	1	1
Number of FO cores per FO cable	2	2	2
Design of FO fiber	Multimode graded-index fiber 50/125 µm, OM 2	Multimode graded-index fiber 50/125 µm, OM 2	Multimode graded-index fiber 50/125 µm, OM 2
Design of FO core	Hollow core, filled, diameter 1400 µm	Hollow core, filled, diameter 1400 µm	Hollow core, filled, diameter 1400 µm
Design of FO cable	Splittable	Splittable	Splittable
Outer diameter			
• of optical fiber	50 µm	50 µm	50 µm
• of optical fiber sheath	125 µm	125 µm	125 µm
• of FO core sheath	2.9 mm	2.9 mm	2.9 mm
• of cable	-	9.2 mm	10.5 mm
Symmetrical deviation			
• of outer diameter of FO core sheath	0.1 mm	0.1 mm	0.1 mm
• of outer diameter of cable	-	0.3 mm	0.5 mm
Material			
• of optical fiber core	Quartz glass	Quartz glass	Quartz glass
• of optical fiber sheath	Quartz glass	Quartz glass	Quartz glass
• of FO core sheath	PVC	FRNC	PVC
• of FO cable sheath	PVC	FRNC	PE
• of the strain relief	Aramide fibers	Aramide fibers	Aramide fibers
Color			
• of FO core sheath	Orange/black	Orange/black	Orange/black
• of the cable sheath	Green	Green	Black
Bending radius			
• Minimum permitted single bending radius	45 mm	90 mm	105 mm
• Minimum permitted repeated bending radius	65 mm	135 mm	155 mm
Number of bending cycles			
Maximum tensile load	500 N	500 N	800 N
Short-term lateral force per length	600 N/cm	500 N/cm	500 N/cm
Continuous lateral force per length	400 N/cm	-	300 N/cm
Weight per length	40 kg/km	85 kg/km	90 kg/km

PROFINET/Industrial Ethernet

Cabling technology

Glass fiber-optic cables

Technical specifications (continued)

Order No.	6XV1 873-2A	6XV1 873-2B	6XV1 873-2G
Product type designation	FO Standard Cable GP	FO FRNC Cable GP	FO Ground Cable
Permitted ambient conditions			
Ambient temperature			
• During operation	-25 ... +80 °C	-40 ... +70 °C	-40 ... +75 °C
• During storage	-25 ... +80 °C	-40 ... +70 °C	-40 ... +75 °C
• During transport	-25 ... +80 °C	-40 ... +70 °C	-40 ... +75 °C
• During mounting	-5 ... +50 °C	-5 ... +50 °C	-5 ... +50 °C
Behavior in fire	Flame-retardant in accordance with IEC 60332-1-2 and IEC 60332-3-22 (Cat. A)	Flame-retardant in accordance with IEC 60332-1-2 and IEC 60332-3-22 (Cat. A)	Flammable
Chemical resistance			
• against mineral oil	Limited resistance	Limited resistance	Resistant
• against grease	Limited resistance	Limited resistance	Resistant
• against water	Limited resistance	Limited resistance	Resistant
Radiological resistance to UV radiation	Resistant	Resistant	Resistant
Product properties, functions, components			
General			
Product property			
• Halogen-free	No	Yes	No
• Silicon-free	Yes	Yes	Yes
Product component: protection against rodents	No	No	Yes
Cable length with glass FOC			
• Maximum with 100BaseFX and Industrial Ethernet	5 000 m	5 000 m	5 000 m
• Maximum with 1000BaseSX and Industrial Ethernet	750 m	750 m	750 m
• Maximum with 1000BaseLX and Industrial Ethernet	2 000 m	2 000 m	2 000 m
• Maximum with PROFIBUS	3 000 m	3 000 m	3 000 m
Standards, specifications, approvals			
Certificate of suitability	UL approval: OFN (NEC Article 770, UL 1651) / CSA approval: OFN 90 Cel, FT1, FT4 (CSA Standard C22.2 No232-M1988)	UL approval: OFN (NEC Article 770, UL 1651) / CSA approval: OFN (CSA standard C22.2 No232-M1988)	-
• RoHS compliance	Yes	Yes	Yes
Marine classification corporation			
• Bureau Veritas (BV)	-	-	-
• Germanischer Lloyd (GL)	-	-	-
• Llyods Register of Shipping (LRS)	-	-	-

Technical specifications (continued)

Order No.	6XV1 873-2C	6XV1 873-2D
Product type designation	FO Trailing Cable	FO Trailing Cable GP
Product description	Glass fiber-optic cable, sold by the meter, in bulk	Glass fiber-optic cable, sold by the meter, in bulk
Suitability for application	Flexible cable for use in trailing cables with high mechanical stress, without UL approval	Flexible cable for use in trailing cables with high mechanical stress, UL approval
Design of preassembled FO cable	Can be fitted with four BFOC or SC connectors	Can be fitted with four BFOC or SC connectors
Cable designation	AT-W(ZN)Y(ZN)11Y 2G 50/125	AT-W(ZN)Y(ZN)Y 2G 50/125
Cable length	-	-
Optical data		
Attenuation factor per length		
• Max. at 850 nm	2.7 dB/km	2.7 dB/km
• Max. at 1300 nm	0.7 dB/km	0.7 dB/km
• Max. at 1550 nm	-	-
Bandwidth length product		
• At 850 nm	600 GHz·m	600 GHz·m
• At 1300 nm	1 200 GHz·m	1 200 GHz·m
Mechanical data		
Number of fibers per FO core	1	1
Number of FO cores per FO cable	2	2
Design of FO fiber	Multimode graded-index fiber 50/125 µm, OM 2	Multimode graded-index fiber 50/125 µm, OM 2
Design of FO core	Hollow core, filled, diameter 1400 µm	Hollow core, filled, diameter 1400 µm
Design of FO cable	Splittable	Splittable
Outer diameter		
• of optical fiber	50 µm	50 µm
• of optical fiber sheath	125 µm	125 µm
• of FO core sheath	2.9 mm	2.9 mm
• of cable	10.5 mm	10.5 mm
Symmetrical deviation		
• of outer diameter of FO core sheath	0.1 mm	0.1 mm
• of outer diameter of cable	0.5 mm	0.5 mm
Material		
• of optical fiber core	Quartz glass	Quartz glass
• of optical fiber sheath	Quartz glass	Quartz glass
• of FO core sheath	PVC	PVC
• of FO cable sheath	PUR	PVC
• of the strain relief	Aramide fibers	Aramide fibers
Color		
• of FO core sheath	Orange/black	Orange/black
• of the cable sheath	Green	Green
Bending radius		
• Minimum permitted single bending radius	150 mm	150 mm
• Minimum permitted repeated bending radius	200 mm	200 mm
Number of bending cycles	5 000 000	3 500 000
Maximum tensile load	800 N	800 N
Short-term lateral force per length	700 N/cm	700 N/cm
Continuous lateral force per length	400 N/cm	400 N/cm
Weight per length	90 kg/km	90 kg/km

PROFINET/Industrial Ethernet

Cabling technology

Glass fiber-optic cables

Technical specifications (continued)

Order No.	6XV1 873-2C	6XV1 873-2D
Product type designation	FO Trailing Cable	FO Trailing Cable GP
Permitted ambient conditions		
Ambient temperature		
• During operation	-40 ... +80 °C	-25 ... +80 °C
• During storage	-40 ... +80 °C	-25 ... +80 °C
• During transport	-40 ... +80 °C	-25 ... +80 °C
• During mounting	-5 ... +50 °C	-5 ... +50 °C
Ambient conditions for operation	-	-
IP degree of protection	-	-
Behavior in fire	Flammable	Flame-retardant in accordance with IEC 60332-1-2 and IEC 60332-3-22 (Cat. A)
Chemical resistance		
• against mineral oil	Resistant	Limited resistance
• against grease	Resistant	Limited resistance
• against water	Limited resistance	Limited resistance
Radiological resistance to UV radiation	Resistant	Resistant
Product properties, functions, components		
General		
Product property		
• Halogen-free	No	No
• Silicon-free	Yes	Yes
Product component: protection against rodents	No	No
Cable length with glass FOC		
• Maximum with 100BaseFX and Industrial Ethernet	5 000 m	5 000 m
• Maximum with 1000BaseSX and Industrial Ethernet	750 m	750 m
• Maximum with 1000BaseLX and Industrial Ethernet	2 000 m	2 000 m
• Maximum with PROFIBUS	3 000 m	3 000 m
Standards, specifications, approvals		
Certificate of suitability	-	UL approval: OFN (NEC Article 770, UL 1651) / CSA approval: OFN 90 Cel, FT1, FT4 (CSA Standard C22.2 No232-M1988)
• RoHS compliance	Yes	Yes
Marine classification corporation		
• Bureau Veritas (BV)	-	-
• Germanischer Lloyd (GL)	-	-
• Llyods Register of Shipping (LRS)	-	-

Technical specifications (continued)

Order No.	6XV1 820-5AH10	6XV1 820-7AH10
Product type designation	Fiber Optic Standard Cable	INDOOR Fiber Optic Cable
Product description	Flexible glass fiber-optic cable, sold by the meter, in bulk	Glass fiber-optic cable, sold by the meter, in bulk
Suitability for application	Cable for indoor and outdoor use	Crush-resistant, halogen-free and flame-retardant cable for indoor use
Design of preassembled FO cable	can be fitted with four BFOC connectors	can be fitted with four BFOC connectors
Cable designation	AT-V(ZN)YY 2X1 G 62.5/125	I-V(ZN)HH 2x1 G 62.5/125
Cable length	-	-
Optical data		
Attenuation factor per length		
• Max. at 850 nm	3.1 dB/km	3.1 dB/km
• Max. at 1300 nm	0.8 dB/km	0.8 dB/km
• Max. at 1550 nm	-	-
Bandwidth length product		
• At 850 nm	200 GHz·m	200 GHz·m
• At 1300 nm	600 GHz·m	600 GHz·m
Mechanical data		
Number of fibers per FO core	1	1
Number of FO cores per FO cable	2	2
Design of FO fiber	Multimode graded-index fiber 62.5/125 µm, OM 2	Multimode graded-index fiber 62.5/125 µm, OM 2
Design of FO core	Compact core, diameter 900 µm	Solid core, diameter 900 µm
Design of FO cable	Splittable outer cable	Splittable inner cable
Outer diameter		
• of optical fiber	62.5 µm	62.5 µm
• of optical fiber sheath	125 µm	125 µm
• of FO core sheath	3.5 mm	2.9 mm
Symmetrical deviation		
• of outer diameter of FO core sheath	-	0.1 mm
• of outer diameter of cable	-	-
Width of cable sheath	9.8 mm	6.8 mm
Thickness of cable sheath	6.3 mm	3.9 mm
Symmetrical tolerance of cable sheath thickness	-	-
Material		
• of optical fiber core	Quartz glass	Quartz glass
• of optical fiber sheath	Quartz glass	Quartz glass
• of FO core sheath	PVC	FRNC
• of FO cable sheath	PVC	FRNC
• of the strain relief	Aramide fibers with additionally integrated compression protection elements	Aramide fibers
Color		
• of FO core sheath	Gray	Gray
• of the cable sheath	Black	Orange
Bending radius		
• Minimum permitted single bending radius	80 mm	30 mm
• Minimum permitted repeated bending radius	80 mm	50 mm

PROFINET/Industrial Ethernet

Cabling technology

Glass fiber-optic cables

Technical specifications (continued)

Order No.	6XV1 820-5AH10	6XV1 820-7AH10
Product type designation	Fiber Optic Standard Cable	INDOOR Fiber Optic Cable
Number of bending cycles	-	-
Maximum tensile load	1 500 N	200 N
Short-term lateral force per length	-	300 N/cm
Continuous lateral force per length	200 N/cm	100 N/cm
Weight per length	70 kg/km	30 kg/km
Permitted ambient conditions		
Ambient temperature		
• During operation	-20 ... +60 °C	-20 ... +60 °C
• During storage	-25 ... +70 °C	-25 ... +70 °C
• During transport	-25 ... +70 °C	-25 ... +70 °C
• During mounting	-5 ... +50 °C	-5 ... +50 °C
Behavior in fire	Flame-retardant in accordance with IEC 60332-1-2 and IEC 60332-3-22 (Cat. A)	Flame-retardant in accordance with IEC 60332-1-2 and IEC 60332-3-22 (Cat. A)
Chemical resistance		
• against mineral oil	Not resistant	Not resistant
• against grease	Not resistant	Not resistant
• against water	Limited resistance	Limited resistance
Radiological resistance to UV radiation	Resistant	Not resistant
Product properties, functions, components		
General		
Product property		
• Halogen-free	No	Yes
• Silicon-free	Yes	Yes
Product component: protection against rodents	No	No
Cable length with glass FOC		
• Maximum with 100BaseFX and Industrial Ethernet	4 000 m	4 000 m
• Maximum with 1000BaseSX and Industrial Ethernet	350 m	350 m
• Maximum with 1000BaseLX and Industrial Ethernet	550 m	550 m
• Maximum with PROFIBUS	3 000 m	3 000 m
Standards, specifications, approvals		
Certificate of suitability	-	-
• RoHS compliance	Yes	Yes
Marine classification corporation		
• Bureau Veritas (BV)	-	-
• Germanischer Lloyd (GL)	-	-
• Llyods Register of Shipping (LRS)	-	-

Technical specifications (continued)

Order No.	6XV1 820-6AH10	6XV1 830-0NH10
Product type designation	Flexible Fiber Optic Trailing Cable	SIENOPYR Marine Duplex FO Cable
Product description	Flexible glass fiber-optic cable, sold by the meter, in bulk	Glass fiber-optic cable, SIENOPYR marine cable, sold by the meter, non-assembled
Suitability for application	Flexible cable for indoor and outdoor use in trailing cables	For fixed installation on ships and offshore units, in all rooms and exposed decks, marine approval assigned
Design of preassembled FO cable	can be fitted with four BFOC connectors	can be fitted with four BFOC connectors
Cable designation	AT-W11Y(ZN)11Y 2 G 62.5/125	MI-VHH 2G 62.5/125 3.1B200 + 0.8F600 + 2x1Cu 300V
Cable length	-	-
Optical data		
Attenuation factor per length		
• Max. at 850 nm	3.1 dB/km	3.1 dB/km
• Max. at 1300 nm	0.8 dB/km	0.8 dB/km
• Max. at 1550 nm	-	-
Bandwidth length product		
• At 850 nm	200 GHz·m	200 GHz·m
• At 1300 nm	600 GHz·m	600 GHz·m
Mechanical data		
Number of fibers per FO core	1	1
Number of FO cores per FO cable	2	2
Design of FO fiber	Multimode graded-index fiber 62.5/125 µm, OM 2	Multimode graded-index fiber 62.5/125 µm, OM 2
Design of FO core	Hollow core, filled, diameter 1400 µm	Solid core
Design of FO cable	Splittable outer cable	Splittable outer cable
Outer diameter		
• of optical fiber	62.5 µm	62.5 µm
• of optical fiber sheath	125 µm	125 µm
• of FO core sheath	3.5 mm	2.9 mm
• of cable	12.9 mm	13.3 mm
Material		
• of optical fiber core	Quartz glass	Mineral glass
• of optical fiber sheath	Quartz glass	-
• of FO core sheath	PUR	Polyolefin
• of FO cable sheath	PUR	SHF1 mixture
• of the strain relief	Aramide fibers, plus central element made of glass-reinforced plastic	Aramide fibers
Color		
• of FO core sheath	Black	-
• of the cable sheath	Black	Black
Bending radius		
• Minimum permitted single bending radius	150 mm	133 mm
• Minimum permitted repeated bending radius	150 mm	266 mm
Number of bending cycles	100 000	-
Maximum tensile load	1 000 N	250 N
Weight per length	130 kg/km	220 kg/km

PROFINET/Industrial Ethernet

Cabling technology

Glass fiber-optic cables

Technical specifications (continued)

Order No.	6XV1 820-6AH10	6XV1 830-0NH10
Product type designation	Flexible Fiber Optic Trailing Cable	SIENOPYR Marine Duplex FO Cable
Permitted ambient conditions		
Ambient temperature		
• During operation	-30 ... +60 °C	-40 ... +80 °C
• During storage	-30 ... +70 °C	-40 ... +80 °C
• During transport	-30 ... +70 °C	-40 ... +80 °C
• During mounting	-30 ... +60 °C	-10 ... +50 °C
Ambient conditions for operation	-	At temperatures below -10 °C, the cables must not be exposed to any movements in excess of the vibrations and oscillations which are normal on ships
IP degree of protection	-	-
Behavior in fire	Flammable	Flame-retardant in accordance with IEC 60332-3 (Cat. A)
Chemical resistance		
• against mineral oil	Resistant	-
• against grease	Resistant	-
• against water	Limited resistance	Limited resistance
Radiological resistance to UV radiation	Resistant	Resistant
Product properties, functions, components General		
Product property		
• Halogen-free	Yes	Yes
• Silicon-free	Yes	Yes
Product component: protection against rodents	No	No
Cable length with glass FOC		
• Maximum with 100BaseFX and Industrial Ethernet	4 000 m	-
• Maximum with 1000BaseSX and Industrial Ethernet	350 m	-
• Maximum with 1000BaseLX and Industrial Ethernet	550 m	-
• Maximum with PROFIBUS	3 000 m	3 000 m
Standards, specifications, approvals		
Certificate of suitability	-	-
• RoHS compliance	Yes	Yes
Marine classification corporation		
• Bureau Veritas (BV)	-	Yes
• Germanischer Lloyd (GL)	-	Yes
• Llyods Register of Shipping (LRS)	-	Yes

2

Technical specifications (continued)

Order No.	6XV1 873-2R	6XV1 843-2R
Product type designation	MM FO robust cable GP	SM FO robust cable GP
Product description	Glass fiber-optic cable, sold by the meter, in bulk	Glass fiber-optic cable, sold by the meter, in bulk
Suitability for application	Cable with longitudinal and lateral water tightness with non-metallic protection against rodents for outdoor and indoor use and for direct laying in soil	Cable with longitudinal and lateral water tightness with non-metallic protection against rodents for outdoor and indoor use and for direct laying in soil
Design of preassembled FO cable	Can be fitted with two BFOC, SC and LC duplex plugs	Can be fitted with two BFOC, SC and LC duplex plugs
Cable designation	AT-V(ZN)H(ZN)BH 2G50/125	AT-V(ZN)H(ZN)BH 4E9/125
Cable length	-	-
Optical data		
Attenuation factor per length		
• Max. at 850 nm	2.7 dB/km	-
• Max. at 1300 nm	1 dB/km	0.5 dB/km
• Max. at 1550 nm	-	0.5 dB/km
Bandwidth length product		
• At 850 nm	600 GHz·m	-
• At 1300 nm	1 200 GHz·m	-
Mechanical data		
Number of fibers per FO core	1	1
Number of FO cores per FO cable	2	4
Design of FO fiber	Multimode graded-index fiber 50/125/245 µm, OM2	Single-mode fiber 4E9/125/900, OS1 and OS2
Design of FO core	Solid core, diameter 900 µm	Solid core, diameter 900 µm
Design of FO cable	Splittable	Splittable
Outer diameter		
• of optical fiber	50 µm	9 µm
• of optical fiber sheath	125 µm	125 µm
• of FO core sheath	2.2 mm	2.2 mm
• of cable	7.5 mm	9 mm
Material		
• of optical fiber core	Quartz glass	Quartz glass
• of optical fiber sheath	Quartz glass	Quartz glass
• of FO core sheath	PE flame-retardant	PE flame retardant
• of FO cable sheath	PE flame retardant	PE flame retardant
• of the strain relief	Aramide fibers and glass roving	Aramide fibers, plus central support element and glass roving
Color		
• of FO core sheath	orange / black, with directional arrow	orange / black, with directional arrow (numbering of the core pairs with 1 and 2)
• of the cable sheath	Black	Black
Bending radius		
• Minimum permitted single bending radius	25 mm	90 mm
• Minimum permitted repeated bending radius	40 mm	135 mm
Number of bending cycles		
Maximum tensile load	1 000 N	1 000 N
Short-term lateral force per length	600 N/cm	600 N/cm
Continuous lateral force per length	200 N/cm	200 N/cm
Weight per length	67 kg/km	87 kg/km

PROFINET/Industrial Ethernet

Cabling technology

Glass fiber-optic cables

Technical specifications (continued)

Order No.	6XV1 873-2R	6XV1 843-2R
Product type designation	MM FO robust cable GP	SM FO robust cable GP
Permitted ambient conditions		
Ambient temperature		
• During operation	-40 ... +70 °C	-40 ... +70 °C
• During storage	-40 ... +70 °C	-40 ... +70 °C
• During transport	-40 ... +70 °C	-40 ... +70 °C
• During mounting	-20 ... +60 °C	-20 ... +60 °C
Ambient conditions for operation	-	-
IP degree of protection	-	-
Behavior in fire	Flame-retardant in accordance with IEC 60332-3-24	Flame-retardant in accordance with IEC 60332-3-24
Chemical resistance		
• against mineral oil	Limited resistance	Limited resistance
• against grease	Limited resistance	Limited resistance
• against water	Resistant	Resistant
Radiological resistance to UV radiation	Resistant	Resistant
Product properties, functions, components		
General		
Product property		
• Halogen-free	Yes	Yes
• Silicon-free	Yes	Yes
Product component: protection against rodents	Yes	Yes
Cable length with glass FOC		
• Maximum with 100BaseFX and Industrial Ethernet	5 000 m	26 000 m
• Maximum with 1000BaseSX and Industrial Ethernet	750 m	-
• Maximum with 1000BaseLX and Industrial Ethernet	2 000 m	5 000 m
• Maximum with PROFIBUS	3 000 m	15 000 m
Standards, specifications, approvals		
Certificate of suitability	-	-
• RoHS compliance	Yes	Yes
Marine classification corporation		
• Bureau Veritas (BV)	-	-
• Germanischer Lloyd (GL)	-	-
• Llyods Register of Shipping (LRS)	-	-

2

Technical specifications (continued)

Order No.	6GK1 901-0DA20-0AA0
Product type designation	BFOC connector set
Product description	BFOC connector set
Suitability for application	for the connection of glass fiber-optic cables
Transmission rate	
Transmission rate	
• 1 with Industrial Ethernet	10 Mbit/s
• 2 with Industrial Ethernet	100 Mbit/s
• 3 with Industrial Ethernet	1 000 Mbit/s
• with PROFIBUS	9.6 kbit/s ... 12 Mbit/s
Interfaces	
Number of optical connections for fiber-optic cables	1
Number of optical connections for network components or terminals	BFOC connector
Design of electrical connection FastConnect	No
Mechanical data	
Enclosure material	Metal and plastic
Design, dimensions and weights	
Type of cable outlet	180 degree cable outlet
Width	10 mm
Height	10 mm
Depth	10 mm
Net weight	8 g
Permitted ambient conditions	
IP degree of protection	IP20
Product properties, functions, components	
General	
Product property silicon-free	Yes
Product component strain relief	Yes
Standards, specifications, approvals	
Certificate of suitability: RoHS conformity	Yes

Ordering data

Order No.

FO standard cable GP 50/125/1400 ²⁾

Multimode cable,
sold by the meter;
max. length 1000 m;
minimum order 20 m;

Preferred lengths ¹⁾
pre-assembled
with 4 BFOC connectors

- 0.5 m
- 1 m
- 2 m
- 3 m
- 5 m
- 10 m
- 15 m
- 20 m
- 30 m
- 40 m
- 50 m
- 80 m
- 100 m
- 150 m
- 200 m
- 300 m

Preferred lengths ¹⁾
pre-assembled
with 4 SC connectors

- 0.5 m
- 1 m
- 2 m
- 3 m
- 5 m
- 10 m
- 15 m
- 20 m
- 30 m
- 40 m
- 50 m
- 80 m
- 100 m
- 150 m
- 200 m
- 300 m

FO FRNC cable 50/125/1400 ²⁾

Multimode cable,
sold by the meter;
max. length 1000 m;
minimum order 20 m;

6XV1 873-2A

6XV1 873-3AH05
6XV1 873-3AH10
6XV1 873-3AH20
6XV1 873-3AH30
6XV1 873-3AH50
6XV1 873-3AN10
6XV1 873-3AN15
6XV1 873-3AN20
6XV1 873-3AN30
6XV1 873-3AN40
6XV1 873-3AN50
6XV1 873-3AN80
6XV1 873-3AT10
6XV1 873-3AT15
6XV1 873-3AT20
6XV1 873-3AT30

6XV1 873-6AH05
6XV1 873-6AH10
6XV1 873-6AH20
6XV1 873-6AH30
6XV1 873-6AH50
6XV1 873-6AN10
6XV1 873-6AN15
6XV1 873-6AN20
6XV1 873-6AN30
6XV1 873-6AN40
6XV1 873-6AN50
6XV1 873-6AN80
6XV1 873-6AT10
6XV1 873-6AT15
6XV1 873-6AT20
6XV1 873-6AT30

6XV1 873-2B

PROFINET/Industrial Ethernet

Cabling technology

Glass fiber-optic cables

2

Ordering data	Order No.	Order No.	
FO trailing cable 50/125/1400²⁾ Multimode cable, <u>sold by the meter;</u> max. length 1000 m; minimum order 20 m; <u>Preferred lengths¹⁾</u> pre-assembled with 4 BFOC connectors <ul style="list-style-type: none"> • 3 m • 5 m • 10 m • 20 m • 50 m • 100 m 	6XV1 873-2C	FO robust cable GP 50/125/900²⁾ Multimode cable, <u>sold by the meter;</u> max. length 2000 m; minimum order 20 m;	6XV1 873-2R
FO trailing cable GP 50/125/1400²⁾ Multimode cable, <u>sold by the meter;</u> max. length 1000 m; minimum order 20 m; <u>Preferred lengths¹⁾</u> pre-assembled with 4 SC connectors <ul style="list-style-type: none"> • 3 m • 5 m • 10 m • 20 m • 50 m • 100 m 	6XV1 873-3CH30 6XV1 873-3CH50 6XV1 873-3CN10 6XV1 873-3CN20 6XV1 873-3CN50 6XV1 873-3CT10	Standard FIBER OPTIC CABLE (62.5/125/900), segmentable²⁾ Multimode cable, <u>sold by the meter;</u> max. length 2000 m minimum order 20 m <u>Preferred lengths¹⁾</u> pre-assembled with 4 BFOC plugs <ul style="list-style-type: none"> • 1 m • 2 m • 3 m • 4 m • 5 m • 10 m • 15 m • 20 m • 30 m • 40 m • 50 m • 55 m • 60 m • 65 m • 70 m • 75 m • 80 m • 100 m • 120 m • 130 m • 150 m • 200 m • 250 m • 300 m 	6XV1 820-5AH10
FO trailing cable GP 50/125/1400²⁾ Multimode cable, <u>sold by the meter;</u> max. length 1000 m; minimum order 20 m; <u>Preferred lengths¹⁾</u> pre-assembled with 4 BFOC connectors <ul style="list-style-type: none"> • 3 m • 5 m • 10 m • 20 m • 50 m • 100 m 	6XV1 873-3DH30 6XV1 873-3DH50 6XV1 873-3DN10 6XV1 873-3DN20 6XV1 873-3DN50 6XV1 873-3DT10	INDOOR FIBER OPTIC CABLE (62.5/125/900), segmentable²⁾ Multimode cable, <u>sold by the meter;</u> max. length 2000 m minimum order 20 m <u>Preferred lengths;</u> pre-assembled with 4 BFOC connectors <ul style="list-style-type: none"> • 0.5 m • 1 m • 2 m • 3 m • 5 m • 10 m • 15 m • 20 m • 25 m • 50 m • 75 m • 100 m 	6XV1 820-5BH10 6XV1 820-5BH20 6XV1 820-5BH30 6XV1 820-5BH40 6XV1 820-5BH50 6XV1 820-5BN10 6XV1 820-5BN15 6XV1 820-5BN20 6XV1 820-5BN30 6XV1 820-5BN40 6XV1 820-5BN50 6XV1 820-5BN55 6XV1 820-5BN60 6XV1 820-5BN65 6XV1 820-5BN70 6XV1 820-5BN75 6XV1 820-5BN80 6XV1 820-5BT10 6XV1 820-5BT12 6XV1 820-5BT13 6XV1 820-5BT15 6XV1 820-5BT20 6XV1 820-5BT25 6XV1 820-5BT30
FO ground cable 50/125/1400²⁾ Multimode cable, <u>sold by the meter;</u> max. length 2000 m; minimum order 20 m; <u>Preferred lengths¹⁾</u> pre-assembled with 4 BFOC connectors <ul style="list-style-type: none"> • 100 m • 200 m • 300 m 	6XV1 873-2G		
FO ground cable 50/125/1400²⁾ Multimode cable, <u>sold by the meter;</u> max. length 2000 m; minimum order 20 m; <u>Preferred lengths¹⁾</u> pre-assembled with 4 SC connectors <ul style="list-style-type: none"> • 100 m • 200 m • 300 m 	6XV1 873-3GT10 6XV1 873-3GT20 6XV1 873-3GT30		
FO ground cable 50/125/1400²⁾ Multimode cable, <u>sold by the meter;</u> max. length 2000 m; minimum order 20 m; <u>Preferred lengths¹⁾</u> pre-assembled with 4 SC connectors <ul style="list-style-type: none"> • 100 m • 200 m • 300 m 	6XV1 873-6GT10 6XV1 873-6GT20 6XV1 873-6GT30		

Ordering data	Order No.
FLEXIBLE FIBER OPTIC CABLE trailing cable (62.5/125/1400), segmentable ²⁾ Multimode cable, sold by the meter; max. length 2000 m minimum order 20 m <u>Preferred lengths:</u> pre-assembled with 4 BFOC connectors <ul style="list-style-type: none"> • 1 m • 2 m • 3 m • 5 m • 10 m • 15 m • 20 m • 30 m • 50 m 	6XV1 820-6AH10 6XV1 820-6BH10 6XV1 820-6BH20 6XV1 820-6BH30 6XV1 820-6BH50 6XV1 820-6BN10 6XV1 820-6BN15 6XV1 820-6BN20 6XV1 820-6BN30 6XV1 820-6BN50
SIENOPYR marine duplex fiber-optic cable; (62.5/125/900) Fiber-optic cable for routing on ships and offshore platforms Multimode cable, sold by the meter; max. length 1000 m minimum order 20 m	6XV1 830-0NH10
FO robust cable GP 4E9/125/900 ²⁾ Singlemode cable, sold by the meter; max. length 2000 m; minimum order 20 m;	6XV1 843-2R
Accessories	
Multimode FO BFOC connector set for FO standard cable (50/125/1400), FO ground cable (50/125/1400), flexible FO trailing cable, INDOOR FO cable (62.5/125/900), 20 units	6GK1 901-0DA20-0AA0
Multimode FO LC duplex plug LC duplex plug (10 units) for INDOOR FO cable (62.5/125/900), FO robust cable GP (50/125/900), FO standard cable (62.5/125/900)	6GK1 901-0RB10-2AB0
Singlemode FO LC duplex plug LC duplex plug (10 units) for FO robust cable GP (4E9/125/900)	6GK1 901-0SB10-2AB0
SIMATIC NET Manual Collection Electronic manuals for communication systems, communication protocols, and communication products; on DVD; German/English	6GK1 975-1AA00-3AA0

More information

You can order components supplementary to the SIMATIC NET cabling range from your local contact.

Technical advice on this subject is available from:

J. Hertlein

I IA SC IC PRM 4

Phone: +49 (0)911/750 44 65

E-mail: juergen.hertlein@siemens.com

¹⁾ Special fiber-optic cables, lengths and accessories available on request

²⁾ Special tools and specially trained personnel are required for pre-assembling glass fiber-optic cables

³⁾ Further language versions and manuals can be found for the respective products at www.siemens.com/automation/csi/net

PROFINET/Industrial Ethernet

Cabling technology

POF and PCF fiber-optic cables

Overview

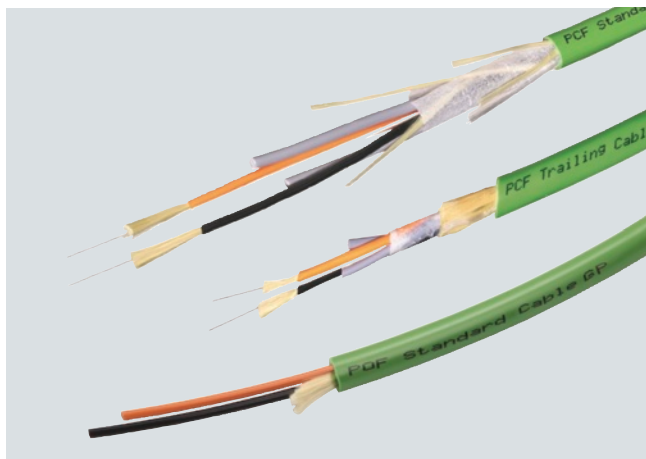

- Electrical isolation of PROFINET/Ethernet devices
- Protection of the transmission path against electromagnetic interference
- Up to 50 m cable length with plastic fiber optic cables and up to 100 m with PCF fiber optic cables
- Rugged fiber-optic standard cables, designed for industrial applications
- Extensive approvals (UL)

Benefits

get Designed for Industry

- Plastic and PCF fiber optic cables can be pre-assembled on site
- Easy connector assembly on site
- Time savings on start-up thanks to pre-assembled cables
- Protection of the transmission path against electromagnetic interference
- Tap-proof, because the cable does not radiate

Application

SIMATIC NET POF and PCF fiber optic conductors are used to construct optical indoor PROFINET and Industrial Ethernet networks. Devices with integral optical interface (SC RJ connection system) are, for example, SCALANCE X200-4P IRT, SCALANCE X201-3P IRT, SCALANCE X202-2P IRT, SCALANCE X101-1POF and ET 200S.

POF and PCF fiber optic cables can be assembled easily on site with SC RJ plugs. The maximum cable length between two devices is 50 m for POF and 100 m for PCF fiber-optic cables. PCF cables are also available preassembled with 2 SC RJ plugs.

Design

Different types of POF and PCF fiber optic cables are offered:

POF fiber optic cables

Rugged round cables with green outer sheath and Kevlar strain relief elements as well as two plastic fibers with rugged Polyamid inner sheath for applications indoors/outdoors with cable lengths **up to 50 m**. The cables are suitable for assembly in the field.

- *POF Standard Cable GP* (General Purpose); for applications indoor/outdoors
- *POF Trailing Cable*; for trailing cable applications

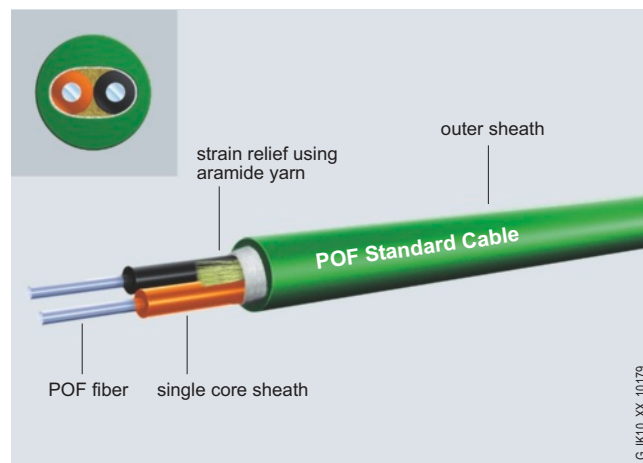

PCF fiber optic cables

Rugged round cables with green outer sheath and Kevlar strain relief elements for applications indoor/outdoors with cable lengths **up to 100 m**. The cables are suitable for assembly in the field.

- *PCF Standard Cable GP* (General Purpose); for applications indoor/outdoors with cable lengths up to 100 m.
- *PCF fiber-optic trailing cable*; for trailing cable applications with cable lengths of up to 100 m. The cable is suitable for assembly in the field. The following cable versions are available:
 - *PCF Trailing Cable*; cable for high mechanical stress, PUR outer sheath, no UL approval
 - *PCF Trailing Cable GP* (general purpose); cable for low mechanical stress, PVC outer sheath, with UL approval

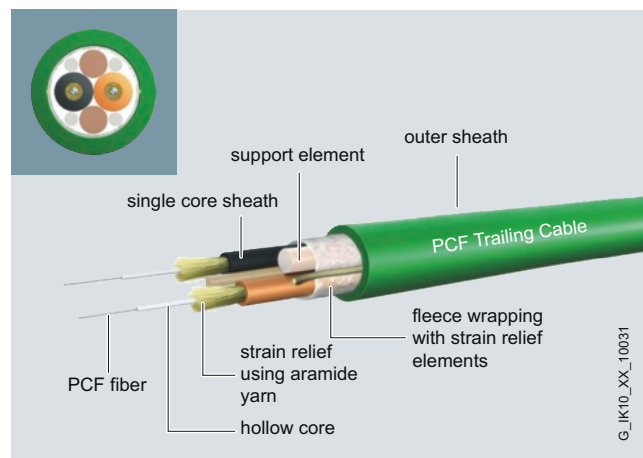

Technical specifications

Order No.	6XV1 874-2A	6XV1 874-2B
Product type designation	POF Standard Cable GP	POF Trailing Cable
Product description	Fiber-optic cable with poly-optical fiber, sold by the meter, non-assembled	Fiber-optic cable with poly-optical fiber, sold by the meter, non-assembled
Suitability for application	Cable for fixed installation indoors, UL approval	Cable for moving applications (e.g. trailing cables)
Design of preassembled FO cable	Can be fitted with SC RJ or SC RJ Plug PRO connectors	Can be fitted with SC RJ or SC RJ Plug PRO connectors
Cable designation	I-V4Y(ZN)Y 2P 980/1000	I-V4Y(ZN)11Y 2P 980/1000 FLEX UL
Cable length	-	-
Optical data		
Maximum damping factor per length at 650 nm	0.16 dB/m	0.18 dB/m
Bandwidth length product at 650 nm	1 GHz·m	1 GHz·m
Mechanical data		
Number of fibers per FO core	1	1
Number of FO cores per FO cable	2	2
Design of FO fiber	Plastic optical fiber 980/1000 µm	Plastic optical fiber 980/1000 µm
Outer diameter		
• of optical fiber	980 µm	980 µm
• of optical fiber sheath	1 000 µm	1 000 µm
• of FO core sheath	2.2 mm	2.2 mm
• of cable	7.8 mm	8 mm
Symmetrical deviation		
• of outer diameter of FO core sheath	0.1 mm	0.1 mm
Material		
• of optical fiber core	Polymethylmethacrylate (PMMA)	Polymethylmethacrylate (PMMA)
• of optical fiber sheath	Fluoridated special polymer	Fluoridated special polymer
• of FO core sheath	PA	PA
• of FO cable sheath	PVC	PUR
• of the strain relief	Kevlar fibers	Kevlar fibers
Color		
• of FO core sheath	Orange/black	Orange/black
• of cable sheath	Green	Green
Bending radius		
• Minimum permitted single bending radius	100 mm	60 mm
• Minimum permitted repeated bending radius	150 mm	60 mm
• With continuous bending	-	0.04 m
Number of bending cycles	-	5 000 000
Maximum tensile load	100 N	100 N
Short-term lateral force per length	100 N/cm	200 N/cm
Continuous lateral force per length	-	20 N/cm
Weight per length	65 kg/km	55 kg/km

PROFINET/Industrial Ethernet

Cabling technology

POF and PCF fiber-optic cables

Technical specifications (continued)

Order No.	6XV1 874-2A	6XV1 874-2B
Product type designation	POF Standard Cable GP	POF Trailing Cable
Permitted ambient conditions		
Ambient temperature		
• During operation	-30 ... +70 °C	-20 ... +70 °C
• During storage	-30 ... +70 °C	-40 ... +80 °C
• During transport	-30 ... +70 °C	-40 ... +80 °C
• During mounting	+0 ... +50 °C	+5 ... +50 °C
Ambient conditions for operation	-	-
IP degree of protection	-	-
Behavior in fire	Flame-retardant in accordance with IEC 60332-1-2	Flame-retardant in accordance with IEC 60332-1-2
Chemical resistance		
• Mineral oil	Limited resistance	Resistant
• Grease	Limited resistance	Resistant
Radiological resistance against UV radiation	Not resistant	Resistant
Product properties, functions, components		
General		
Product property		
• Halogen-free	No	No
• Silicon-free	Yes	Yes
Product component: protection against rodents	No	No
Cable length with plastic optical fiber		
• Maximum with Industrial Ethernet	50 m	50 m
• Maximum with PROFIBUS	-	-
Standards, specifications, approvals		
Certificate of suitability	UL approval: OFN (NEC Article 770, UL 1651) / CSA approval: OFN (CSA standard C22.2 No232-M1988)	UL-758 AWM Style 5422
• RoHS compliance	Yes	Yes

2

Technical specifications (continued)

Order No.	6XV1 861-2A	6XV1 861-2C	6XV1 861-2D
Product type designation	PCF Standard Cable GP	PCF Trailing Cable	PCF Trailing Cable GP
Product description	Polymer clad fiber cable, sold by the meter, non-assembled	Polymer clad fiber cable, sold by the meter, non-assembled	Polymer clad fiber cable, sold by the meter, non-assembled
Suitability for application	Cable for fixed installation for indoor and outdoor use, UL approval	Cable for use with high mechanical stress and moving applications (e.g. trailing cables), without UL approval	Cable for use with high mechanical stress and moving applications (e.g. trailing cables), UL approval
Design of preassembled FO cable	Can be fitted with SC RJ, SC RJ Plug PRO, BFOC and Simplex connectors	Can be fitted with SC RJ, SC RJ Plug PRO, BFOC and Simplex connectors	Can be fitted with SC RJ, SC RJ Plug PRO, BFOC and Simplex connectors
Cable designation	AT-V(ZN)YY 2K 200/230	AT-V(ZN)Y(ZN)11Y 2K 200/230	AT-V(ZN)Y(ZN)Y 2K 200/230
Cable length	-	-	-
Optical data			
Maximum damping factor per length at 660 nm	10 dB/km	10 dB/km	10 dB/km
Bandwidth length product at 650 nm	17 GHz·m	17 GHz·m	17 GHz·m
Mechanical data			
Number of fibers per FO core	1	1	1
Number of FO cores per FO cable	2	2	2
Design of FO fiber	Step index fiber 200/230 µm	Step index fiber 200/230 µm	Step index fiber 200/230 µm
Outer diameter			
• of optical fiber	200 µm	200 µm	200 µm
• of optical fiber sheath	230 µm	230 µm	230 µm
• of FO core sheath	2.2 mm	2.2 mm	2.2 mm
• of cable	7.2 mm	8.8 mm	8.8 mm
Symmetrical deviation			
• of outer diameter of FO core sheath	0.1 mm	0.1 mm	0.1 mm
• of outer diameter of cable	0.5 mm	0.5 mm	0.5 mm
Material			
• of optical fiber core	Quartz glass	Quartz glass	Quartz glass
• of optical fiber sheath	Special polymer	Special polymer	Special polymer
• of FO core sheath	PVC	PVC	PVC
• of FO cable sheath	PVC	PUR	PVC
• of the strain relief	Aramide fibers	Aramide fibers	Aramide fibers
Color			
• of FO core sheath	Orange/black	Orange/black	Orange/black
• of cable sheath	Green	Green	Green
Bending radius			
• Minimum permitted single bending radius	70 mm	130 mm	130 mm
• Minimum permitted repeated bending radius	105 mm	175 mm	175 mm
Number of bending cycles	-	5 000 000	5 000 000
Maximum tensile load	100 N	800 N	800 N
Short-term lateral force per length	500 N/cm	500 N/cm	500 N/cm
Continuous lateral force per length	300 N/cm	300 N/cm	300 N/cm
Weight per length	45 kg/km	85 kg/km	85 kg/km

PROFINET/Industrial Ethernet

Cabling technology

POF and PCF fiber-optic cables

Technical specifications (continued)

Order No.	6XV1 861-2A	6XV1 861-2C	6XV1 861-2D
Product type designation	PCF Standard Cable GP	PCF Trailing Cable	PCF Trailing Cable GP
Permitted ambient conditions			
Ambient temperature			
• During operation	-40 ... +90 °C	-25 ... +75 °C	-25 ... +75 °C
• During storage	-40 ... +90 °C	-30 ... +75 °C	-30 ... +75 °C
• During transport	-40 ... +90 °C	-30 ... +75 °C	-30 ... +75 °C
• During mounting	-5 ... +50 °C	-5 ... +50 °C	-5 ... +50 °C
Behavior in fire	Flame-retardant in accordance with IEC 60332-1-2 and IEC 60332-3-22 (Cat. A)	Flame-retardant	Flame-retardant in accordance with IEC 60332-1-2 and IEC 60332-3-22 (Cat. A)
Chemical resistance			
• Mineral oil	Limited resistance	Resistant	Limited resistance
• Grease	Limited resistance	Resistant	Limited resistance
• Water	Limited resistance	Limited resistance	Limited resistance
Radiological resistance against UV radiation	Resistant	Resistant	Resistant
Product properties, functions, components			
General			
Product property			
• Halogen-free	No	No	No
• Silicon-free	Yes	Yes	Yes
Product component: protection against rodents	No	No	No
Cable length with polymer clad fiber			
• Maximum with Industrial Ethernet	100 m	100 m	100 m
• Maximum with PROFIBUS	400 m	400 m	400 m
Standards, specifications, approvals			
Certificate of suitability	UL approval: OFN (NEC Article 770, UL 1651) / CSA approval: OFN 90 Cel, FT1, FT4 (CSA standard C22.2 No232-M1988)	-	UL approval: OFN (NEC Article 770, UL 1651) / CSA approval: OFN 90 Cel, FT1, FT4 (CSA standard C22.2 No232-M1988)
• RoHS compliance	Yes	Yes	Yes

2

Ordering data	Order No.
POF Standard Cable GP 980/1000 POF standard cable for fixed routing indoors with PVC sheath; <u>sold by the meter</u> max. length 1000 m, minimum order 20 m	6XV1 874-2A
PCF Trailing Cable 980/1000 POF trailing cable for use in cable carriers, with rugged PUR sheath; <u>sold by the meter</u> Delivery unit max. 1000 m, minimum order 20 m	6XV1 874-2B
PCF Standard Cable GP 200/230 Standard cable, segmentable, <u>sold by the meter</u> ; max. length 2000 m; minimum order 20 m;	6XV1 861-2A
PCF Trailing Cable 200/230 Trailing cable, segmentable, <u>sold by the meter</u> ; max. length 2000 m; minimum order 20 m;	6XV1 861-2C
PCF Trailing Cable GP 200/230 Trailing cable, segmentable, <u>sold by the meter</u> ; max. length 2000 m; minimum order 20 m;	6XV1 861-2D
Termination Kit SC RJ POF Plug Assembly case for local assembly of SC RJ connectors, comprising a stripping tool, Kevlar scissors, microscope, grinding paper and grinding base	6GK1 900-0ML00-0AA0
IE SC RJ POF Plug Screw connector for local assembly on POF FOC (1 pack = 20 items)	6GK1 900-0MB00-0AC0
IE SC RJ POF refill set Refill set for Termination Kit SC RJ POF Plug consisting of grinding paper and grinding base (set of 5)	6GK1 900-0MN00-0AA0
Termination Kit SC RJ PCF Plug Assembly case for local assembly of SC RJ connectors, comprising a stripping tool, buffer stripping tool, Kevlar scissors, fiber breaking tool, microscope	6GK1 900-0NL00-0AA0
Industrial Ethernet SC RJ PCF Plug Screw connector for local assembly on POF FOC (1 pack = 10 items)	6GK1 900-0NB00-0AC0
SIMATIC NET Manual Collection Electronic manuals for communication systems, communication protocols, and communication products; on DVD; German/English	6GK1 975-1AA00-3AA0

More information

You can order components supplementary to the SIMATIC NET cabling range from your local contact.

Technical advice on this subject is available from:

J. Hertlein
 I IA SC IC PRM 4
 Phone: +49 (0)911/750 44 65
 E-mail: juergen.hertlein@siemens.com

PROFINET/Industrial Ethernet

Cabling technology

POF/PCF FOC Termination Kit

Overview



- Compact, rugged assembly case for POF and PCF fiber-optic cables
- Special versions for easy assembly of SC RJ plugs on POF and PCF fiber-optic cables
- The quality of the assembly can be checked using the enclosed microscope

Benefits

get Designed for Industry

- Easy installation of the unassembled cables in industrial plants
- Flexible assembly of connectors on POF and PCF fiber optic cables on site (SC RJ connectors)
- Mistakes are prevented with easy visual inspection of the assembled connector on site using a microscope
- Simple repair of POF and PCF fiber optic cables in the field

Application

SIMATIC NET POF and PCF fiber-optic cables are used to construct optical indoor and outdoor Industrial Ethernet/PROFINET networks. They are easy to assemble on-site with the Termination Kits and 2 x 2 RJ connectors. The maximum cable length between two Industrial Ethernet/PROFINET devices is 100 m for PCF and 50 m for POF fiber-optic cables.

Industrial Ethernet/PROFINET devices with integral optical interface (SC RJ connection system) are, for example, SCALANCE X-200P IRT and ET 200S.

Design

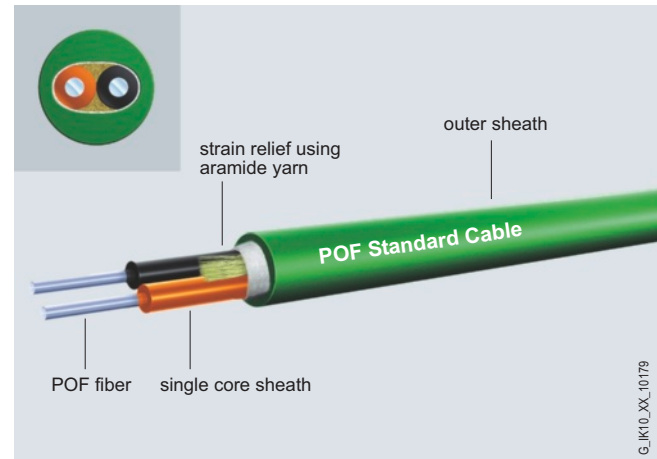

Cable construction POF plastic optical fiber

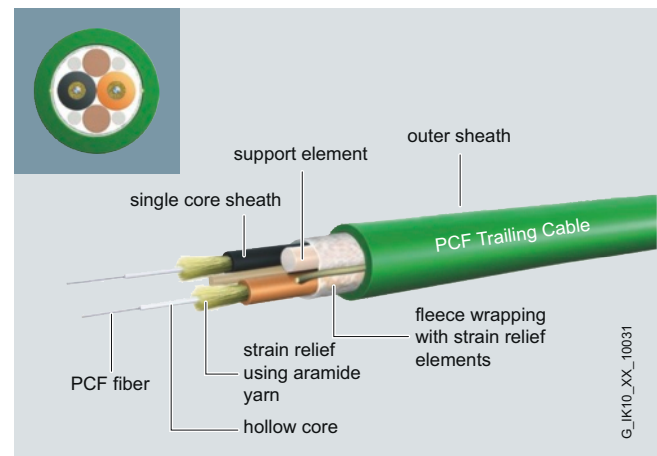

Cable construction PCF plastic optical fiber

The kit is available in assembly cases for on-site installation of SC RJ connectors on PCF fiber-optic cables.

It consists of a stripping tool, buffer stripping tool, Kevlar scissors, fiber breaking tool and microscope.

Ordering data	Order No.
Termination Kit SC RJ POF Plug Assembly case for on-site installation of SC RJ POF connectors; consisting of stripping tool, Kevlar cutters, SC RJ grinding plate, grinding paper, grinding base and microscope	6GK1 900-0ML00-0AA0
Termination Kit SC RJ PCF Plug Assembly case for on-site assembly of SC RJ PCF connectors, comprising a stripping tool, buffer stripping tool, Kevlar cutters, fiber breaking tool and microscope	6GK1 900-0NL00-0AA0
<i>Accessories</i>	
IE SC RJ POF Plug 20 plugs for on-site assembly	6GK1 900-0MB00-0AC0
IE SC RJ PCF Plug 10 plugs for on-site assembly	6GK1 900-0NB00-0AC0
IE SC RJ POF refill set Refill set for Termination Kit SC RJ POF Plug consisting of grinding paper and grinding plate (set of 5)	6GK1 900-0MN00-0AA0

More information

You can order components supplementary to the SIMATIC NET cabling range from your local contact.

Technical advice on this subject is available from:

J. Hertlein
 I IA SC IC PRM 4
 Phone: +49 (0)911/750 44 65
 E-mail: juergen.hertlein@siemens.com

PROFINET/Industrial Ethernet

Industrial Ethernet switches / media converters

Overview

Overview

Industrial Ethernet switching components comprise

- Compact switch modules (CSM)
- SCALANCE X Industrial Ethernet switches
- Communications processors (CP) with integral switch

Compact switch modules (CSM)

Unmanaged switches for use directly on the SIMATIC for interface expansion and integration of machines into existing plant networks

SCALANCE X-000/XB-000 unmanaged

Unmanaged switches with electrical and/or optical ports for designing small networks for machine or plant islands with 10/100/1000 Mbit/s

SCALANCE X-100 unmanaged

Switches with electrical and/or optical ports, redundant power supply, and signaling contact for use in machine-level applications (also available as media converter with two ports for conversion between two different media).

SCALANCE X-200 managed

For universal use, from machine-level applications to networked subsystems. Configuration and remote diagnosis are integrated into the STEP 7 engineering tool. This increases the plant availability. Devices with a high degree of protection permit cabinetless installation.

Corresponding switches (SCALANCE X-200IRT) are also available for use in subsystem networks with hard real-time requirements and maximum availability.

SCALANCE XF-200 managed

The functions of the SCALANCE XF-200 Industrial Ethernet switches correspond to those of the SCALANCE X-200 switches. The flat design in ET 200S format (IP20 protection) mean they are optimally suitable for space-saving use in small control boxes.

SCALANCE X-300 managed

Networking of subsystem/plant areas, as well as linking to the enterprise network. The SCALANCE X-300 managed product line combines the firmware functionality of the SCALANCE X-400 line with the compact design of the SCALANCE X-200 line. This means the SCALANCE X-300 switches have extended management functions and an extended firmware functionality compared to the SCALANCE X-200 switches.

Electrical and optical Gigabit Ethernet ports are available in addition.

SCALANCE XR-300 managed

The functions of the SCALANCE XR-300 Industrial Ethernet switches correspond to those of the SCALANCE X-300 switches. Designed as rack switches, they are particularly suitable for use in 19" control cabinets. They are also fully modular, and can be adapted to the respective task using 2-port media modules (electrical and optical).

EEC versions (Enhanced Environmental Conditions) in compact and rack design can be used in power engineering systems and under difficult environmental conditions.

SCALANCE X-400 managed (layer 3)

For use in high-performance plant networks (e.g. with high-speed redundancy). Thanks to the modular design, the switches can be adapted to the respective task. Due to the support of IT standards (e.g. VLAN, IGMP, RSTP), the seamless integration of automation networks into existing office networks is possible.

Routing functions on layer 3 permit communication between different IP subnetworks.

SCALANCE X-500 managed (layer 3)

For networking and structuring high-performance industrial networks and for connecting office networks to automation networks. As a Layer 3 switch, SCALANCE X-500 is extremely well suited to use as a central component in backbone networks, e.g. when a high number of ports is required, at extremely high transmission rates (10 Gigabit Ethernet), or for redundant connection to an office infrastructure. The rack switch (19" design) can be used flexibly to suit requirements thanks to its modular design and the plug-in 4-port media modules (electrical and optical).

Routing functions on layer 3 permit communication between different IP subnetworks.

Communications processors for SIMATIC with integral switch

Managed switches for expanding SIMATIC by Industrial Ethernet/PROFINET interfaces, and for integrating the PLCs into existing line or ring topologies.

Use as a router between IP subnets is also possible with the advanced CPs as a result of the integral layer 3 functionality.

Communications processors for PC with integral switch

Managed switches for expanding industrial PCs by Industrial Ethernet/PROFINET interfaces, and for integrating the PCs into existing line topologies.

PROFINET/Industrial Ethernet

Industrial Ethernet switches / media converters

Overview (continued)

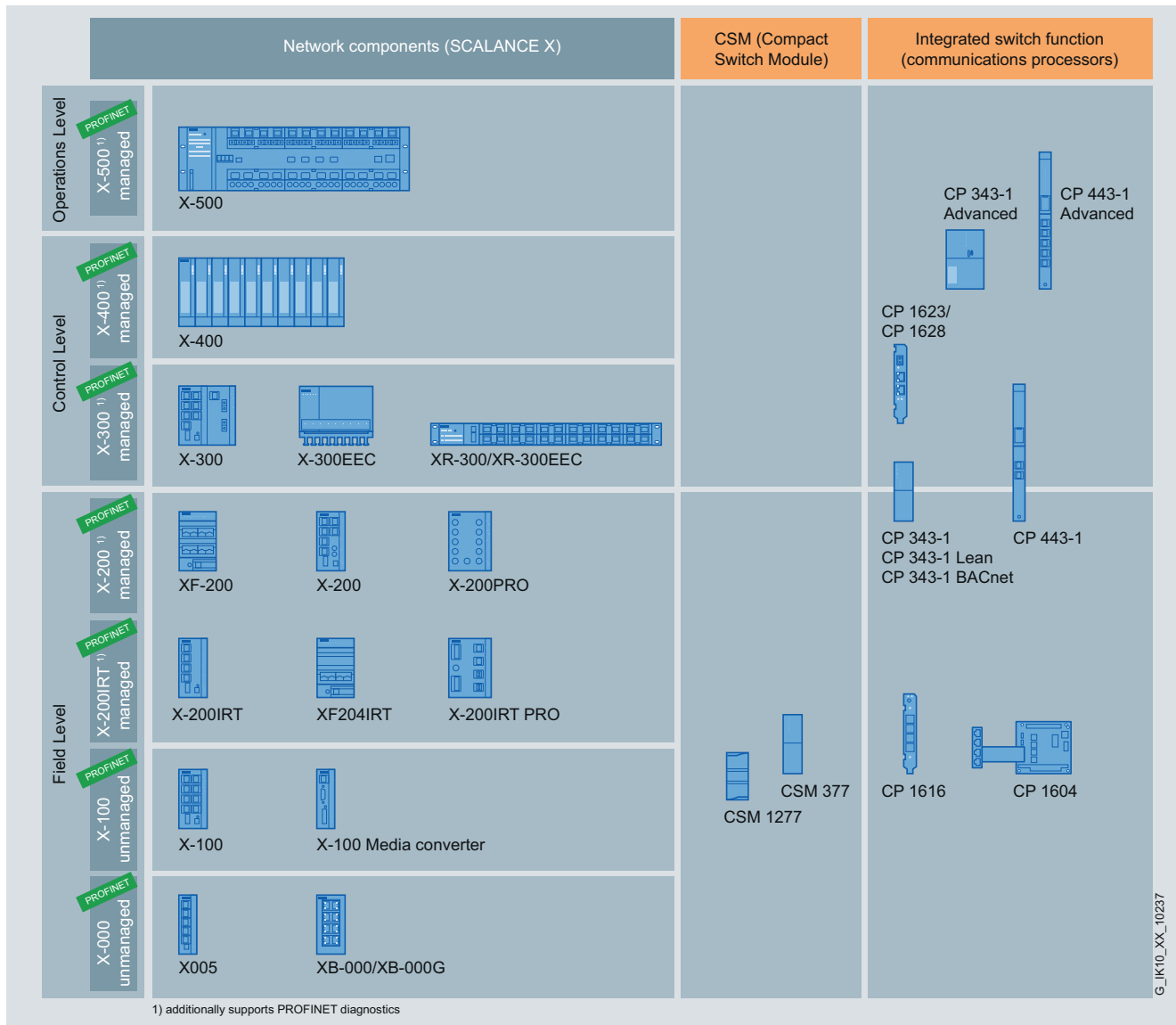

Overview of SCALANCE X Industrial Ethernet switches and components with switch functionality



PROFINET/Industrial Ethernet

Industrial Ethernet switches / media converters

Overview

Overview (continued)

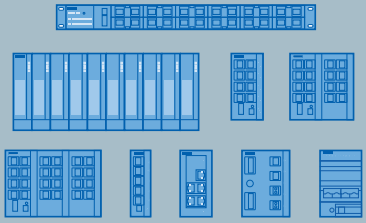
2

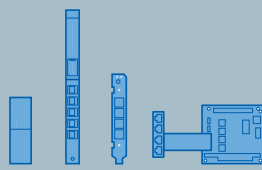
Network component	CSM	Integral switch function
		
<ul style="list-style-type: none"> • Basis for integrated networking in industrial automation - from the field to the management level • Network components optimized for various applications: <ul style="list-style-type: none"> - Small and large-scale networks - Management functions for network structuring - Configuring of redundant networks - Use with PROFINET and Industrial Ethernet • Robust housing for harsh environments • Graded diagnostics concept 	<ul style="list-style-type: none"> • Configuration of small networks • Easy expansion of the number of ports for: <ul style="list-style-type: none"> - Connection of local HMI systems - Connection to higher-level networks - Service/maintenance • Space-saving design of SIMATIC • Unmanaged Switch with local diagnostics 	<ul style="list-style-type: none"> • Communications processor for interfacing with PROFINET/Industrial Ethernet including integral switch for: <ul style="list-style-type: none"> - For interfacing with distributed I/O. - Connection to higher-level networks - IP routing - Service/maintenance • SIMATIC or PC module design • Functions for network diagnostics

G_IK10_XX_10238

Application areas / type of network / requirements		Office incorporation	Plant networking	Industry-related applications	Energy generation and distribution	Wind energy plants	Machine building and plant engineering	Plant subnetworking	High-volume machine building	Internal machine networking	Network setup using SIMATIC S7	PC-based applications
X-500	High-performance backbone networks with very high emphasis on functionality / port density / availability and interface to IT network	•	•	•								
X-400	High-performance plant network with high emphasis on functionality and availability	•	•	•								
X-300	Large networks with high emphasis on functionality and availability		•		•	•						
X-200	Networks with higher emphasis on functionality and availability						•	•				
X-100	Networks with low emphasis on functionality						•		•			
X-000	Networks with low emphasis on functionality and robustness								•	•		
CSM	Very small networks or interface expansion for SIMATIC S7										•	
CPs	Very small networks through integrated switch in CP										•	•

• applies

G_IK10_XX_10301

SCALANCE X Industrial Ethernet switches: Applications

Overview (continued)

Features		Modular through media modules	19" design	Support of Gigabit Ethernet	Additional interface for SIMATIC S7	Power-over-Ethernet	Can be used under Enhanced Environmental Conditions (EEC)	Isosynchronous Real-Time (IRT)	Layer 3	Office features (VLAN)	Diagnosis	PROFINET IO Device	Time synchronization according to IEEE 1588
X-500		•	•	•		•			•	•	•	•	
X-400		•		•					•	•	•	•	
X-300		•	•	•		•				•	•	•	
	X-300EEC/ XR-300EEC	•	•	•			•				•	•	•
X-200		•						• ²⁾			•	•	
X-100						•							
X-000				• ¹⁾									
CSM					•								
CPs					•				•		•	•	

• applies

1) with Gigabit version

2) with IRT version

G_IK10_XX_10302

SCALANCE X Industrial Ethernet switches: Function overview

More information

To assist in selecting the right Industrial Ethernet switches as well as configuration of modular versions, the SIMATIC NET Selection Tool is available:

Online version:

www.siemens.com/snst

Offline version:

www.siemens.com/snst-download

PROFINET/Industrial Ethernet

Industrial Ethernet switches / media converters

Compact switch modules CSM 1277 unmanaged

Overview



- Unmanaged switch for connecting a SIMATIC S7-1200 to an Industrial Ethernet network with a line, tree or star topology
- Multiplication of Ethernet interfaces on a SIMATIC S7-1200 for additional connection of up to three programming devices, operator controls, and further Ethernet nodes
- Simple, space-saving mounting on the SIMATIC S7-1200 mounting rail
- Low-cost solution for implementing small, local Ethernet networks
- Connection without any problems using RJ45 standard connectors
- Simple and fast status display via LEDs on the device
- Integral autocrossover function permits use of uncrossed connecting cables

Benefits

get Designed for Industry

- Reduction in assembly costs and mounting space compared to use of external network components
- Fast commissioning, as no configuration is necessary
- Flexible expansion of the network by simply inserting the CSM

Application

The CSM 1277 is an Industrial Ethernet switch of compact design for use in the SIMATIC S7-1200. The CSM 1277 can be used to multiply the Ethernet interface of the SIMATIC S7-1200 for simultaneous communication with operator panels, programming devices, other controllers, or the office world.

The CSM 1277 and the SIMATIC S7-1200 controller can be used to implement simple automation networks at low cost.

Design

The CSM 1277 compact switch module offers all advantages of the SIMATIC S7-1200 design:

- Compact design; the rugged plastic enclosure contains:
 - 4 x RJ45 ports for connecting to Industrial Ethernet
 - 3-pole plug-in terminal strip for connection of the external 24 V DC supply on the top
 - LEDs for diagnostics and for status display of the Industrial Ethernet ports
- Simple mounting on the mounting rail of the S7-1200
- Fanless and consequently low-maintenance design
- The module can be replaced without using a programming device

Function

- Multiplication of Ethernet interfaces of the SIMATIC S7-1200
- Design of a small, local Industrial Ethernet network with three further nodes
- Automatic detection of data transfer rate by means of autosensing and autocrossover functions
- LEDs for diagnostics and for status display

Network topology and network configuration

Various network topologies can be implemented using the CSM 1277 compact switch module:

- Connection of SIMATIC S7-1200 in linear topology: at least one RJ45 connection of the SIMATIC S7-1200 remains vacant, e.g. for connecting a programming device (PG)
- Connection of SIMATIC S7-1200 to a higher-level network in a tree/star topology: at least two RJ45 connections of the SIMATIC S7-1200 remain vacant, e.g. for connecting a programming device/operator panel (PG/OP)
- Design of a small, local network with a SIMATIC S7-1200 and three further Ethernet nodes

Configuration

The CSM 1277 compact switch module is an unmanaged switch and need not be configured.

Diagnostics

The following information is displayed on LEDs on the device:

- Power
- Port status
- Data traffic

PROFINET/Industrial Ethernet

Industrial Ethernet switches / media converters

Compact switch modules
CSM 1277 unmanaged

Technical specifications

Order No.	6GK7 277-1AA10-0AA0
Product type designation	CSM 1277
Transmission rate	
Transmission rate 1	10 Mbit/s
Transmission rate 2	100 Mbit/s
Interfaces	
Maximum number of electrical/optical connections for network components or terminal equipment	4
Number of electrical connections	4
• For network components or terminal equipment	-
• For signal contact	-
• For power supply	1
Design of electrical connection	RJ45 port
• For network components or terminal equipment	-
• For signal contact	-
• For power supply	3-pin terminal block
Supply voltage, current consumption, power loss	
Type of power supply	DC
Supply voltage, external	24 V
• Minimum	19.2 V
• Maximum	28.8 V
Product component: fusing of power supply input	Yes
Type of fusing of power supply input	0.5 A / 60 V
Current consumption, maximum	0.07 A
Effective power loss at 24 V with DC	1.6 W
Permitted ambient conditions	
Ambient temperature	0 ... 60 °C
• During operation	-40 ... +70 °C
• During storage	-40 ... +70 °C
• During transport	-40 ... +70 °C
Relative humidity at 25 °C without condensation during operation, maximum	95 %
IP degree of protection	IP20

Order No.	6GK7 277-1AA10-0AA0
Product type designation	CSM 1277
Design, dimensions and weights	
Type of construction	SIMATIC S7-1200 device design
Width	45 mm
Height	100 mm
Depth	75 mm
Net weight	0.15 kg
Type of mounting	
• 35 mm DIN rail mounting	Yes
• Wall mounting	Yes
• S7-300 rail mounting	No
Product functions Management, configuration, programming	
Product function: switch-managed	No
Standards, specifications, approvals	
Standard	
• For EMC of FM	FM3611: Class 1, Division 2, Group A, B, C, D / T., CL.1, Zone 2, GP. IIC, T., Ta
• for hazardous zone	EN 600079-15:2005, EN 600079-0:2006, II 3 G Ex nA II T4, KEMA 08 ATEX 0003 X
• For CSA and UL safety	UL 508, CSA C22.2 No. 142
• for hazardous zone of CSA and UL	-
• For emitted interference	EN 61000-6-4 (Class A)
• For noise immunity	EN 61000-6-2
Certificate of suitability	EN 61000-6-2, EN 61000-6-4
• CE mark	Yes
• C-Tick	Yes

2

PROFINET/Industrial Ethernet

Industrial Ethernet switches / media converters

Compact switch modules CSM 1277 unmanaged

2

Ordering data

Order No.

CSM 1277 compact switch module

Unmanaged switch for connecting a SIMATIC S7-1200 and up to three further nodes to Industrial Ethernet with 10/100 Mbit/s; 4 x RJ45 ports; external 24 V DC power supply, diagnostics on LEDs, S7-1200 module including electronic manual on CD-ROM

6GK7 277-1AA10-0AA0

Accessories

IE TP Cord RJ45/RJ45

TP cable 4 x 2 with 2 RJ45 connectors

- 0.5 m
- 1 m
- 2 m
- 6 m
- 10 m

6XV1 870-3QE50
6XV1 870-3QH10
6XV1 870-3QH20
6XV1 870-3QH60
6XV1 870-3QN10

IE FC Outlet RJ45

For connecting Industrial Ethernet FC cables and TP cords; graduated prices for 10 and 50 units or more

6GK1 901-1FC00 0AA0

More information

To assist in selecting the right Industrial Ethernet switches as well as configuration of modular versions, the SIMATIC NET Selection Tool is available at:

Online version:

www.siemens.com/snst

Offline version:

www.siemens.com/snst-download

PROFINET/Industrial Ethernet

Industrial Ethernet switches / media converters

Compact switch modules SIPLUS NET CSM 1277

Overview



- Unmanaged switch for connection of SIPLUS S7-1200 to an Industrial Ethernet network with a line, tree or star topology
- Multiplication of Ethernet interfaces on a SIPLUS S7-1200 for additional connection of up to three programming devices, operator controls, and further Ethernet nodes
- Simple, space-saving mounting on the SIPLUS S7-1200 rail
- Low-cost solution for implementing small, local Ethernet networks
- Problem-free connection using RJ45 standard connectors
- Simple and fast status display via LEDs on the device
- Integral autocrossover function permits use of uncrossed connecting cables

Note:

SIPLUS extreme products are based on Siemens Industry standard products. The contents listed here were taken from the respective standard products. SIPLUS extreme-specific information was added.

SIPLUS NET CSM 1277

Order number	6AG1 277-1AA00-4AA0
Order number based on	6GK7 277-1AA00-0AA0
Ambient temperature range	0 ... +55 °C
Ambient conditions	Suitable for exceptional medial exposure (e.g. in sulfur chloride atmosphere).
Technical data	The technical data of the standard product applies except for the ambient conditions.

Ambient conditions

Relative humidity	5 ... 100 % Condensation permissible
Biologically active substances	Conformity with EN 60721-3-3, Class 3B2 mold and fungal spores (except fauna)
Chemically active substances	Conformity with EN 60721-3-3, Class 3C4 incl. salt mist and ISA-S71.04 severity level G1; G2; G3; GX ^{1) 2)}
Mechanically active substances	Conformity with EN 60721-3-3, Class 3S4 including sand, dust ²⁾
Air pressure (depending on the highest positive temperature range specified)	1080 ... 795 hPa (-1000 ... +2000 m) see ambient temperature range 795 ... 658 hPa (+2000 ... +3500 m) derating 10 K 658 ... 540 hPa (+3500 ... +5000 m) derating 20 K

- 1) ISA-S71.04 severity level GX: Long-term load: SO₂ < 4.8 ppm; H₂S < 9.9 ppm; Cl < 0.2 ppm; HCl < 0.66 ppm; HF < 0.12 ppm; NH < 49 ppm; O₃ < 0.1 ppm; NOX < 5.2 ppm
Limit value (max. 30 min/d): SO₂ < 14.8 ppm; H₂S < 49.7 ppm; Cl < 1.0 ppm; HCl < 3.3 ppm; HF < 2.4 ppm; NH < 247 ppm; O₃ < 1.0 ppm; NOX < 10.4 ppm

- 2) The supplied plug covers must remain in place over the unused interface when operated in atmospheres containing corrosive gases!

For further technical documentation on SIPLUS, see:
www.siemens.com/siplus-extreme

Ordering data

Order No.

SIPLUS NET CSM 1277 compact switch module

(extended temperature range and medial exposure)

Unmanaged switch for connection of SIPLUS S7-1200 and up to three further nodes to Industrial Ethernet with 10/100 Mbit/s; 4 x RJ45 ports; external 24 V DC power supply, LED diagnostics, S7-1200 module including electronic Manual on CD-ROM

6AG1 277-1AA00-4AA0

Accessories

See ordering data for CSM 1277 unmanaged

PROFINET/Industrial Ethernet

Industrial Ethernet switches / media converters

Compact switch modules CSM 377 unmanaged

Overview



- Unmanaged switch for the connection of a SIMATIC S7-300 with integral PROFINET interface or with an Industrial Ethernet CP or ET 200M to an Industrial Ethernet in an electrical linear, tree or star structure
- As many as three additional nodes can be connected
- As an unmanaged switch, the CSM 377 is used for integrating small machines into existing automation networks or for the standalone operation of the machines
- Simple, space-saving attachment to S7-300 mounting rail due to design as single-width module in S7-300 format
- Low-cost solution for implementing small, local Ethernet networks
- Rugged, industry-standard node connections with PROFINET-compliant RJ45 connectors that latch onto the enclosure to offer additional strain and bending relief

Benefits

get Designed for Industry

- Quick and easy connection of a SIMATIC S7-300 or ET 200M to electrical Industrial Ethernets in linear, tree or star structures by means of three additional RJ45 ports
- Ideal solution for the implementation of small local Ethernets with a SIMATIC S7-300 station
- Secure data communication by means of industry standard device connection with PROFINET-compliant connector IE FC RJ45 Plug 180 and latching of the connector to the enclosure to provide additional strain relief
- Low-maintenance operation thanks to fanless construction
- Quick and easy diagnosis by means of LEDs on the device
- Use of uncrossed connection cables possible by means of integrated autocrossover function

Application

- For the economical construction of small, electrical Industrial Ethernets with star, tree and linear structures using a SIMATIC S7-300 or ET 200M

Design

The compact switch module CSM 377 features all the advantages of the SIMATIC S7-300 design:

- Compact construction; the rugged plastic enclosure features the following on the front panel:
 - 4 x RJ45 ports for the connection to Industrial Ethernet (retaining collar)
 - 1 x 2-pin pluggable terminal strip for the connection of the external 24 VDC power supply
 - LEDs for diagnostics and for status display of the Industrial Ethernet ports
- 10/100BaseTX; automatic detection of the data rate with autosensing and autocrossover function for the connection of IE FC cables by means of IE FC RJ45 Plug 180 up to 100 m
- Simple mounting; the CSM 377 switch module is mounted on the mounting rail of the S7-300. As it has no connection to the backplane bus of the S7-300 or ET 200M, it must either be inserted at the beginning (first module to the left of the CPU) or at the end (last module on far right) of the S7-300 station. The connection to the CPU of the S7-300 is either by means of an Industrial Ethernet cable or an Industrial Ethernet twisted pair cord.
- Three further Industrial Ethernet interfaces (TP ports) are available for the connection of additional Ethernet nodes such as HMI panels or ET 200
- The CSM 377 can be operated without a fan and no backup battery is necessary
- The module can be replaced without a programming device

PROFINET/Industrial Ethernet

Industrial Ethernet switches / media converters

Compact switch modules
CSM 377 unmanaged

2

Function

- Connection of a SIMATIC S7-300 to a higher-level electrical network in a linear, tree or point-to-point structure
- Construction of a small local network with one SIMATIC S7-300 and three other Ethernet nodes

Thanks to the switching technology used, the CSM 377 is suitable for use in PROFINET networks, but offers no additional PROFINET functions, i.e. no integration into the PROFINET diagnostics.

Network topology and network configuration

When configuring the network, it is necessary to observe the following boundary conditions:

- Length of the TP cable between two nodes:
 - max. 100 m with Industrial Ethernet FastConnect cable and IE FC RJ45 Plug 180;
 - of which no more than 10 m by means of patching with TP cord

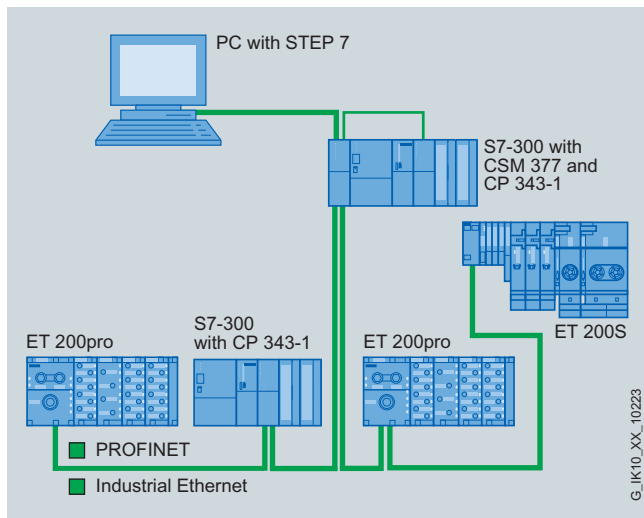

Connection of SIMATIC S7-300 with CSM 377 to Industrial Ethernet with linear structure

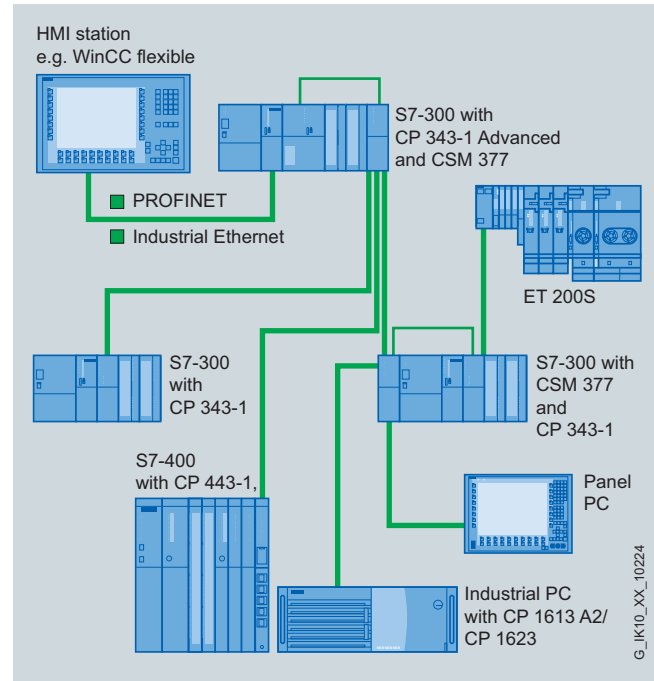

Construction of a local Industrial Ethernet with SIMATIC S7-300 and CSM 377 in a point-to-point structure

Configuration

The Compact Switch Module CSM 377 is an unmanaged switch and requires no configuration.

Diagnostics

The following information is indicated on the device by means of LEDs:

- Power
- Port status
- Data traffic

PROFINET/Industrial Ethernet

Industrial Ethernet switches / media converters

Compact switch modules CSM 377 unmanaged

Technical specifications

Order No.	6GK7 377-1AA00-0AA0
Product type designation	CSM 377
Transmission rate	
Transmission rate 1	10 Mbit/s
Transmission rate 2	100 Mbit/s
Interfaces	
Maximum number of electrical/optical connections for network components or terminal equipment	4
Number of electrical connections	4
• for network components or terminal equipment	-
• for signaling contact	1
• for power supply	1
Design of electrical connection	RJ45 port
• for network components or terminal equipment	-
• for signaling contact	-
• for power supply	2-pin terminal block
Supply voltage, current consumption, power loss	
Type of power supply	DC
External power supply	24 V
• Minimum	19.2 V
• Maximum	28.8 V
Product component: fusing at power supply input	Yes
Type of fusing of power supply input	0.5 A / 60 V
Current consumed, maximum	0.07 A
Effective power loss at 24 V with DC	1.6 W
Permitted ambient conditions	
Ambient temperature	0 ... 60 °C
• During operation	0 ... 60 °C
• During storage	-40 ... +70 °C
• During transport	-40 ... +70 °C
Relative humidity at 25 °C without condensation during operation, maximum	95 %
IP degree of protection	IP20

Order No.	6GK7 377-1AA00-0AA0
Product type designation	CSM 377
Design, dimensions and weights	
Design	SIMATIC S7-300 design
Width	40 mm
Height	125 mm
Depth	118 mm
Net weight	0.2 kg
Type of mounting	
• 35 mm DIN rail mounting	No
• Wall mounting	No
• S7-300 rail mounting	Yes
Product functions Management, configuration, programming	
Product function: Switch-managed	No
Standards, specifications, approvals	
Standard	
• for EMC of FM	FM3611: Class 1, Division 2, Group A, B, C, D / T., CL.1, Zone 2, GP. IIC, T., Ta
• For hazardous zone	EN 60079-15, II 3 G Ex nA II T., KEMA 06 ATEX 0021 X
• For CSA and UL safety	UL 508, CSA C22.2 No. 142
• for hazardous zone of CSA and UL	UL 1604 and UL 2279-15 (Hazardous Location)
• For emitted interference	EN 61000-6-4:2001
• For noise immunity	EN 61000-6-2:2001
Certificate of suitability	EN 61000-6-2:2001, EN 61000-6-4:2001
• CE mark	Yes
• C-Tick	Yes

2

PROFINET/Industrial Ethernet

Industrial Ethernet switches / media converters

Compact switch modules
CSM 377 unmanaged

Ordering data	Order No.	More information
<p>Compact switch module CSM 377</p> <p>Unmanaged switch for connecting a SIMATIC S7-300, ET 200 M and up to three further nodes to Industrial Ethernet with 10/100 Mbit/s; 4 x RJ45 ports; external 24 V DC power supply, diagnostics on LEDs, S7-300 module including electronic manual on CD-ROM</p>	6GK7 377-1AA00-0AA0	<p>To assist in selecting the right Industrial Ethernet switches as well as configuration of modular versions, the SIMATIC NET Selection Tool is available:</p> <p>Online version: www.siemens.com/snst</p> <p>Offline version: www.siemens.com/snst-download</p>
<i>Accessories</i>		
<p>IE FC TP standard cable GP 2 x 2 (Type A)</p> <p>4-core, shielded TP installation cable for connection to IE FC outlet RJ45/ IE FC RJ45 plug; PROFINET-compliant; with UL approval; sold by the meter; max. quantity 1000 m, minimum order 20 m</p>	6XV1 840-2AH10	
<p>IE FC RJ45 Plug 180 2 x 2</p> <p>RJ45 plug connector for Industrial Ethernet with a rugged metal housing and integrated insulation displacement contacts for connecting Industrial Ethernet FC installation cables; 180° cable outlet; for network components and CPs/CPU with Industrial Ethernet interface</p> <ul style="list-style-type: none"> • 1 pack = 1 unit • 1 pack = 10 units • 1 pack = 50 units 	<p>6GK1 901-1BB10-2AA0</p> <p>6GK1 901-1BB10-2AB0</p> <p>6GK1 901-1BB10-2AE0</p>	
<p>IE FC stripping tool</p> <p>Preadjusted stripping tool for fast stripping of the Industrial Ethernet FC cables</p>	6GK1 901-1GA00	

PROFINET/Industrial Ethernet

Industrial Ethernet switches / media converters

SCALANCE X-000 unmanaged

2

Overview

SCALANCE X-000	Type of device	Hardware																	
		Connection to S7 backplane bus	Format module S7	PC module	Fiat type of construction	Box type of construction	19" type of construction	Rugged, compact housing	Modular design	10 Gigabit Ethernet	Gigabit Ethernet	PoE (Power over Ethernet)	LED diagnosis	SIMATIC environment	Redundant power supply (2 x 24 V DC)	External supply for integrated switch	Signal contact	Local display (SET pushbutton)	C-PLUG slot
	X005 / X005TS							•				•	•						
	XB004-1					•						•							
	XB004-1G					•						•							
	XB004-1LD					•						•							
	XB004-1LDG					•						•							
	XB005					•						•							
	XB005G					•						•							
	XB008					•						•							
	XB008G					•						•							

• applies

G_JK10_XX_10317

Function overview SCALANCE X-000 unmanaged

PROFINET/Industrial Ethernet

Industrial Ethernet switches / media converters

SCALANCE X005 unmanaged

Overview



The unmanaged Industrial Ethernet Switch SCALANCE X005 is optimized for low-cost installation of small Industrial Ethernet networks with data transfer rates of 10/100 Mbit/s in a line and star topology.

- Five electrical nodes or network connections
- Rugged metal enclosure for space-saving cubicle mounting on standard rails, S7-300 DIN rail or for wall mounting
- Rugged, industry-standard station connections with PROFINET-compatible RJ45 connectors that offer additional strain relief and bending strain relief thanks to latching on the housing
- Diagnostics on the device by means of LEDs (power, link status, data communication)

Benefits

get **Designed for Industry**

- Ideal solution for configuring small Industrial Ethernet line and star topologies
- Space-saving installation in the cabinet thanks to the compact design in S7-300 format
- Reliable plug-in connection thanks to rugged, industry-standard device connection in conjunction with PROFINET-compliant FastConnect connectors
- Installation is possible without a patch field by means of IE FC RJ45 Plug 180 and IE FC Standard Cable
- Use of uncrossed connection cables possible by means of integrated autocrossover function

Application

- For low-cost configuration of small, electrical Industrial Ethernet star and line topologies with switching functionality, e.g. machine or plant islands
- For use in the control cabinet
- The SCALANCE X005TS (**T**ransportation **S**ystems) is suitable for use in rail and road transport due to its specification according to EN 50155 and e1/E1

Product versions

- **SCALANCE X005**
for setting up electrical star and linear topologies with five electrical ports
- **SCALANCE X005TS**
for setting up electrical star and linear topologies with five electrical ports for use in rail and road transport with extended temperature range

Design

The SCALANCE Industrial Ethernet switches with a rugged metal housing (IP30) are optimized for mounting on a standard rail and an S7-300 DIN rail. Direct wall mounting in different positions is also possible. Due to the housing dimensions that correspond to those of the SIMATIC S7-300, the devices are very well suited for integration into an automation solution using S7-300 components.

The SCALANCE X005 switch is equipped with:

- Supply voltage 1 x 24 V DC
- A row of LEDs for displaying status information (power, link status, data communication)
- 5 x 10/100BaseTX, RJ45 ports:
automatic detection of the data rate (10 or 100 Mbit/s), with autosensing and autocrossover function for connecting IE FC cables via IE FC RJ45 Plug 180 over distances up to 100 m

2

PROFINET/Industrial Ethernet

Industrial Ethernet switches / media converters

SCALANCE X005 unmanaged

Function

- Uncrossed connecting cables can be used due to Autocrossover function integrated in the ports
- Network load disconnection through integral switch functionality

Network topology and network configuration

The SCALANCE X005 is typically accommodated in one control cubicle together with the nodes to be connected. It can be operated in small electrical star and line topologies. Network configuration and expansion are easy to implement; there are no limitations with the cascading of SCALANCE X005.

When configuring the network, it is necessary to observe the following boundary conditions:

- Length of the TP cable between two SCALANCE X switches:
- Max. 100 m with Industrial Ethernet FastConnect products

Diagnostics

The following information is displayed on site by LEDs:

- Port status
- Data traffic

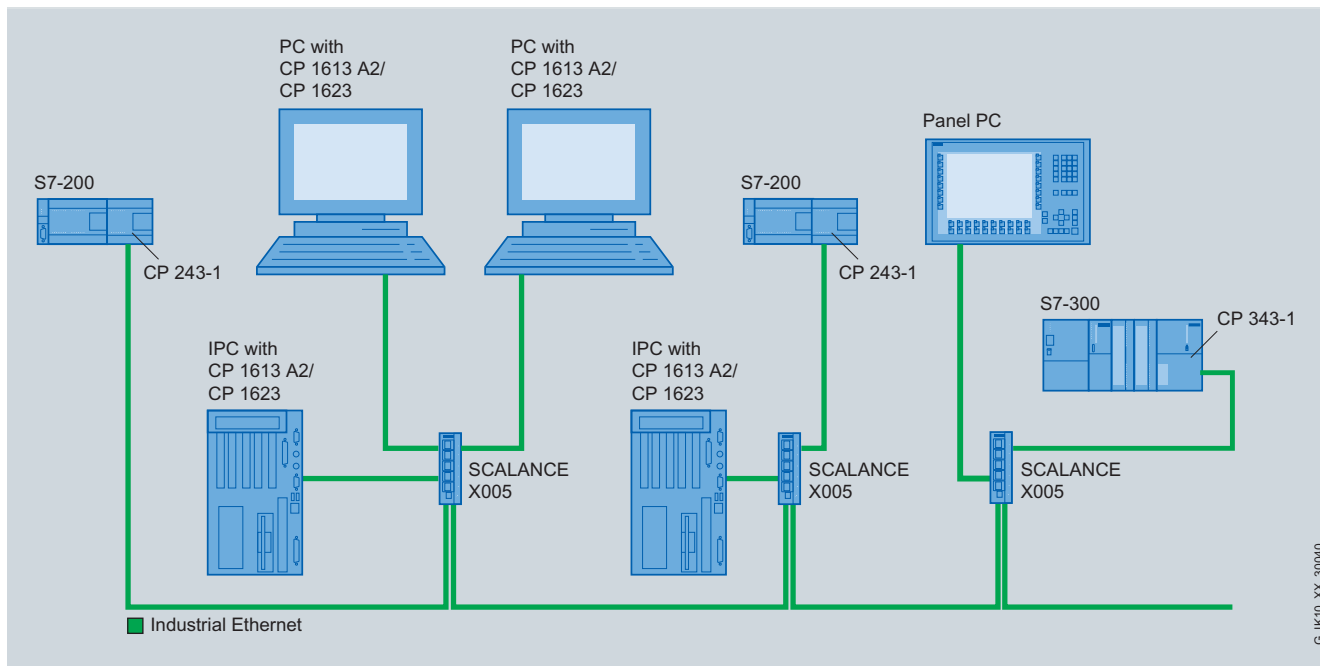
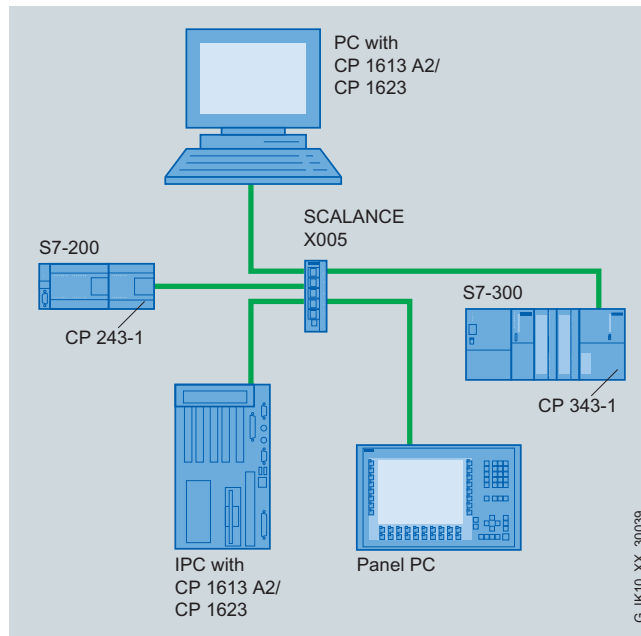

Technical specifications

Order No.	6GK5 005-0BA00-1AA3	6GK5 005-0BA00-1CA3
Product type designation	SCALANCE X005	SCALANCE X005TS
Transmission rate		
Transmission rate 1	10 Mbit/s	10 Mbit/s
Transmission rate 2	100 Mbit/s	100 Mbit/s
Interfaces		
Maximum number of electrical/optical connections for network components or terminal equipment	5	5
Number of electrical connections		
• for network components or terminal equipment	5	5
• for signaling contact	-	-
• for power supply	1	1
Design of electrical connection		
• for network components or terminal equipment	RJ45 port	RJ45 port
• for signaling contact	-	-
• for power supply	2-pin terminal block	2-pin terminal block
Supply voltage, current consumption, power loss		
Type of power supply	DC	DC
External power supply	24 V	24 V
• Minimum	18 V	18 V
• Maximum	32 V	32 V
Product component: fusing at power supply input	Yes	Yes
Type of fusing of power supply input	0.5 A / 60 V	0.5 A / 60 V
Current consumed, maximum	0.08 A	0.08 A
Effective power loss at 24 V with DC	2 W	2 W
Permitted ambient conditions		
Ambient temperature		
• During operation	0 ... 65 °C	-40 ... +75 °C
• During storage	-40 ... +80 °C	-40 ... +80 °C
• During transport	-40 ... +80 °C	-40 ... +80 °C
Relative humidity at 25 °C without condensation during operation, maximum	95 %	95 %
IP degree of protection	IP20	IP30

PROFINET/Industrial Ethernet

Industrial Ethernet switches / media converters

SCALANCE X005 unmanaged

Technical specifications (continued)

Order No.	6GK5 005-0BA00-1AA3	6GK5 005-0BA00-1CA3
Product type designation	SCALANCE X005	SCALANCE X005TS
Design, dimensions and weights		
Design	Compact	Compact
Width	40 mm	40 mm
Height	125 mm	125 mm
Depth	124 mm	124 mm
Net weight	0.55 kg	0.55 kg
Type of mounting		
• 35 mm DIN rail mounting	Yes	Yes
• Wall mounting	Yes	Yes
• S7-300 rail mounting	Yes	Yes
Standards, specifications, approvals		
Standard		
• for EMC of FM	-	-
• For hazardous zone	-	-
• For CSA and UL safety	UL 60950-1, CSA C22.2 No. 60950-1	-
• for hazardous zone of CSA and UL	-	-
• For emitted interference	EN 61000-6-4 (Class A)	-
• For noise immunity	EN 61000-6-2	-
Certificate of suitability	EN 61000-6-2, EN 61000-6-4	EN 61000-6-2, EN 61000-6-4
• CE mark	Yes	Yes
• C-Tick	Yes	Yes
• Bahnanwendung nach EN 50155	No	Yes
• E1 approval	No	Yes
• e1 approval	No	Yes
Marine classification corporation		
• American Bureau of Shipping Europe Ltd. (ABS)	Yes	Yes
• Bureau Veritas (BV)	Yes	Yes
• Det Norske Veritas (DNV)	No	No
• Germanischer Lloyd (GL)	No	No
• Lloyds Register of Shipping (LRS)	Yes	Yes
• Nippon Kaiji Kyokai (NK)	Yes	Yes

2

PROFINET/Industrial Ethernet

Industrial Ethernet switches / media converters

SCALANCE X005 unmanaged

Ordering data	Order No.
SCALANCE X005 Industrial Ethernet Switch for 10/100 Mbit/s; with five 10/100 Mbit/s RJ45 ports for configuring small star and line structures	6GK5 005-0BA00-1AA3
SCALANCE X005TS Industrial Ethernet Switch for 10/100 Mbit/s; with five 10/100 Mbit/s RJ45 ports for configuring small star and line structures with extended temperature range and approvals for use in rail and road transport	6GK5 005-0BA00-1CA3
Accessories	
IE FC TP Standard Cable GP 2 x 2 (Type A) 4-core, shielded TP installation cable for connection to IE FC Outlet RJ45/ IE FC RJ45 Plug; PROFINET-compliant; with UL approval; <u>sold by the meter</u> ; max. length 1000 m, minimum order 20 m	6XV1 840-2AH10
IE FC RJ45 Plug 180 2 x 2 180° cable outlet; for network components and CPs/CPUs with Industrial Ethernet interface <ul style="list-style-type: none"> • 1 pack = 1 unit • 1 pack = 10 units • 1 pack = 50 units 	6GK1 901-1BB10-2AA0 6GK1 901-1BB10-2AB0 6GK1 901-1BB10-2AE0
IE FC Stripping Tool Preadjusted stripping tool for fast stripping of the Industrial Ethernet FC cables	6GK1 901-1GA00
SITOP compact 24 V/ 0.6 A 1-phase power supply with wide-range input 85 - 264 V AC/110 - 300 V DC, stabilized output voltage 24 V, rated output current value 0.6 A, slim design	6EP1 331-5BA00

More information

To assist in selecting the right Industrial Ethernet switches as well as configuration of modular versions, the SIMATIC NET Selection Tool is available at:

Online version:
www.siemens.com/snst

Offline version:
www.siemens.com/snst-download

PROFINET/Industrial Ethernet

Industrial Ethernet switches / media converters

SCALANCE XB-000 unmanaged

Overview

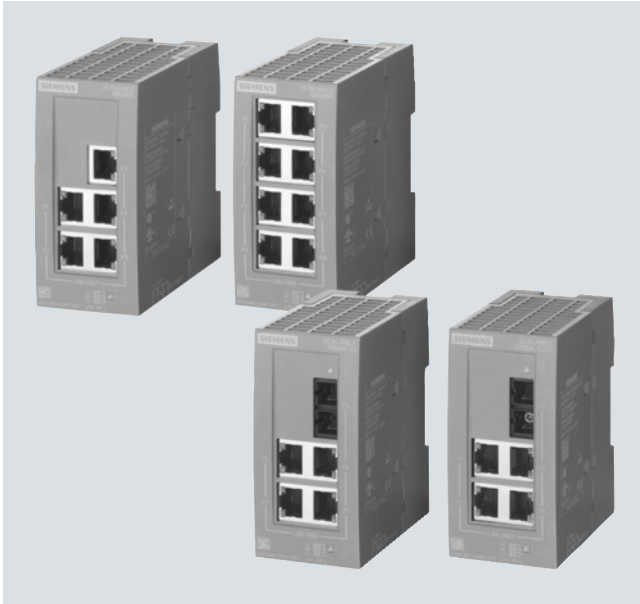

The unmanaged Industrial Ethernet switches of the SCALANCE XB-000 line are optimized for installing Industrial Ethernet networks in a line and star topology.

- Electrical or optical station or network connection
- *SCALANCE XB-000*; for Fast Ethernet (10/100 Mbit/s)
- *SCALANCE XB-000G*; for Gigabit Ethernet (10/100/1000 Mbit/s)
- *SCALANCE XB-000LD* (Long Distance); for connecting especially remote nodes
- Enclosure for space-saving installation in control cabinets or boxes on a standard mounting rail

Benefits

get Designed for Industry

- Implementation of simple and very economical machine networking
- Space-saving installation thanks to small, compact design
- Can be used in industrial environments
- Quick commissioning without configuration
- Easy on-site diagnostics via LEDs
- Uncomplicated use of uncrossed connecting cables possible thanks to the integrated Autocrossover function
- Low-cost connection of especially remote nodes possible

Application

The unmanaged Industrial Ethernet switches of the SCALANCE XB-000 line allow cost-effective solutions for setting up small, electrical/optical star or line topologies with switching functionality in machines or plant units.

The enclosure is designed for space-saving installation in a control cabinet on a standard rail.

Product versions

SCALANCE XB005 and SCALANCE XB008

- 5 or 8 x 10/100 Mbit/s electrical RJ45 ports

SCALANCE XB005G and SCALANCE XB008G

- 5 or 8 x 10/100/1000 Mbit/s electrical RJ45 ports

SCALANCE XB004-1

- 4 x 10/100 Mbit/s electrical RJ45 ports
- 1 x 100 Mbit/s optical SC port (multimode, glass), up to 5 km

SCALANCE XB004-1LD

- 4 x 10/100 Mbit/s electrical RJ45 ports
- 1 x 100 Mbit/s optical SC port (singlemode, glass), up to 26 km

SCALANCE XB004-1G

- 4 x 10/100/1000 Mbit/s electrical RJ45 ports
- 1 x 1000 Mbit/s optical SC port (multimode, glass), up to 750 m

SCALANCE XB004-1LDG

- 4 x 10/100/1000 Mbit/s electrical RJ45 ports
- 1 x 1000 Mbit/s optical SC port (singlemode, glass), up to 10 km

Design

The SCALANCE XB-000 Industrial Ethernet switches are optimized for installation on a standard rail. Wall mounting is possible.

The SCALANCE XB-000 switches have:

- A 3-pole terminal block for connecting the power supply (1 x 24 V DC) and functional ground
- An LED for indicating the status information (power)
- LEDs for indicating the status information (link status and data exchange) per port

The following port types are available:

- 10/100 BaseTX electrical RJ45 ports or 10/100/1000 BaseTX electrical RJ45 ports: automatic data transmission rate detection (10 or 100 Mbit/s), with Autosensing and Autocrossing function for connecting IE TP cables up to 100 m.
- 100 BaseFX, optical SC port for direct connection to Industrial Ethernet FO cables. Multimode fiber-optic cable up to 5 km
- 100 BaseFX, optical SC port for direct connection to Industrial Ethernet FO cables. Single mode fiber-optic cable up to 26 km
- 1000 BaseSX, optical SC port for direct connection to Industrial Ethernet FO cables. Multimode fiber-optic cable up to 750 m
- 1000 BaseLX, optical SC port for direct connection to Industrial Ethernet FO cables. Single mode fiber-optic cable up to 10 km

All connections for data cables are located at the front, and the connection for the power supply is at the bottom.

PROFINET/Industrial Ethernet

Industrial Ethernet switches / media converters

SCALANCE XB-000 unmanaged

Function

- Construction of electrical Industrial Ethernet line or star topologies
- Automatic data transmission rate detection (10/100/1000 Mbit/s), with autosensing and autocrossover function
- Easy network configuration and network expansion; no limitation on network expansion with cascading of the switches

Network topology and network configuration

The SCALANCE XB-000 switches are typically installed with the stations to be connected in a control cabinet or control box.

When configuring the network, it is necessary to observe the following boundary conditions:

- Length of the TP cable between two SCALANCE XB-000 switches:
 - max. 100 m
 - max. 10 m via patch cables with TP Cord
 - max. 100 m via Industrial Ethernet FC Outlet RJ45, IE FC Standard Cable and TP Cord
- Length of the fiber-optic cables:
 - max. 5 km with Industrial Ethernet FO cables Multimode
 - max. 26 km with Industrial Ethernet FO cables Single mode

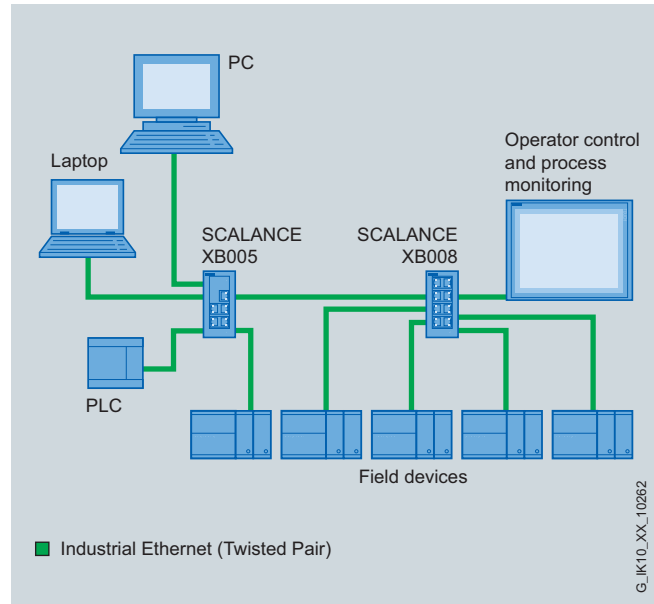

Electrical line topology with SCALANCE XB005 and XB008, or SCALANCE XB005G and XB008G

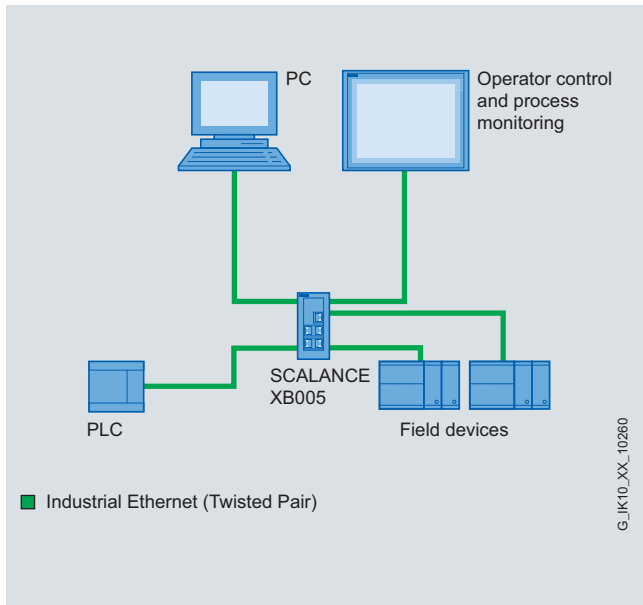

Electrical star topology with SCALANCE XB005 or SCALANCE XB005G

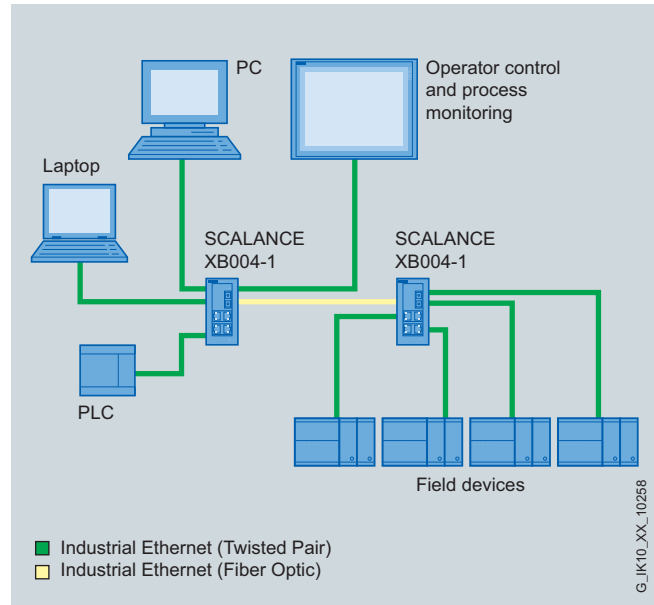

Mixed star topology with SCALANCE XB004-1 or SCALANCE XB004-1G

PROFINET/Industrial Ethernet

Industrial Ethernet switches / media converters

SCALANCE XB-000 unmanaged

Function (continued)

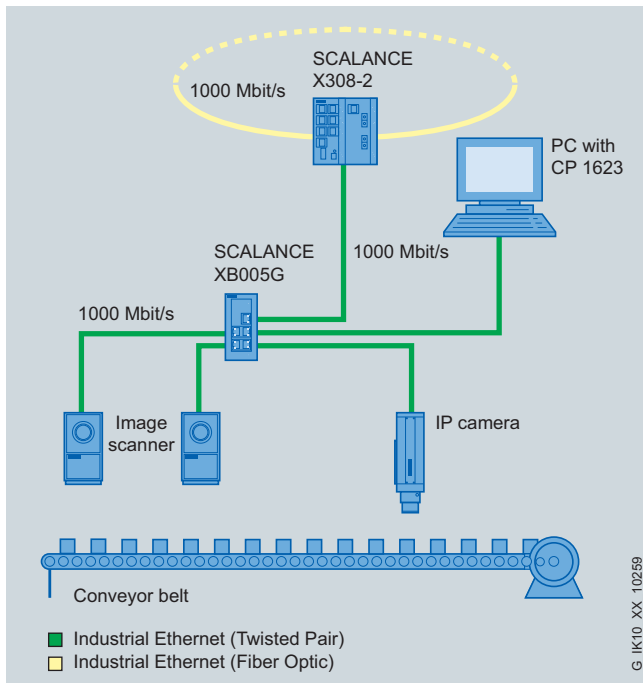

Electrical star topology with SCALANCE XB005G and connection to a Gigabit Ethernet ring

Diagnostics

The following information is displayed by LEDs on site:

- Power
- Port status
- Data traffic

Technical specifications

Order No.	6GK5 004-1BD00-1AB2	6GK5 004-1BF00-1AB2	6GK5 005-0BA00-1AB2	6GK5 008-0BA00-1AB2
Product type designation	SCALANCE XB004-1	SCALANCE XB004-1LD	SCALANCE XB005	SCALANCE XB008
Transmission rate				
Transmission rate 1	10 Mbit/s	10 Mbit/s	10 Mbit/s	10 Mbit/s
Transmission rate 2	100 Mbit/s	100 Mbit/s	100 Mbit/s	100 Mbit/s
Transmission rate 3	-	-	-	-
Interfaces				
Maximum number of electrical/optical connections for network components or terminal equipment	5	5	5	8
Number of electrical connections				
• For network components or terminal equipment	4	4	5	8
• For signal contact	-	-	-	-
• for power supply	1	1	1	1
Design of electrical connection				
• for network components or terminal equipment	RJ45 port	RJ45 port	RJ45 port	RJ45 port
• for signaling contact	-	-	-	-
• for power supply	3-pin terminal block	3-pin terminal block	3-pin terminal block	3-pin terminal block
Number of optical connections for fiber-optic cables				
• at 100 Mbit/s	1	1	-	-
• at 1000 Mbit/s	-	-	-	-
Design of optical connection for fiber-optic cables				
• At 100 Mbit/s	SC port (multimode up to 5 km)	SC port (singlemode up to 26 km)	-	-
• at 1000 Mbit/s	-	-	-	-
Injectable optical power referred to 1 mW				
• of the transmitter output	-19 ... -14 dB	-5 ... +0 dB	-	-
• of the receiver input, maximum	-14 dB	0 dB	-	-
Minimum optical sensitivity referred to 1 mW of the receiver input	-32 dB	-34 dB	-	-
Minimum required attenuation factor of the FO transmission link	0 dB	0 dB	-	-
The range at the optical interface depends on the type of optical fiber used	0 ... 5 km	0 ... 26 km	-	-
Supply voltage, current consumption, power loss				
Type of power supply	DC	DC	DC	DC
Supply voltage, external	24 V	24 V	24 V	24 V
• Minimum	19.2 V	19.2 V	19.2 V	19.2 V
• Maximum	28.8 V	28.8 V	28.8 V	28.8 V
Product component: fusing of power supply input	Yes	Yes	Yes	Yes
Type of fusing of power supply input	0.6 A / 60 V	0.6 A / 60 V	0.6 A / 60 V	0.6 A / 60 V
Current consumption, maximum	0.11 A	0.1 A	0.07 A	0.12 A
Effective power loss at 24 V with DC	2.64 W	2.4 W	1.68 W	2.88 W

PROFINET/Industrial Ethernet

Industrial Ethernet switches / media converters

SCALANCE XB-000 unmanaged

Technical specifications (continued)

Order No.	6GK5 004-1BD00-1AB2	6GK5 004-1BF00-1AB2	6GK5 005-0BA00-1AB2	6GK5 008-0BA00-1AB2
Product type designation	SCALANCE XB004-1	SCALANCE XB004-1LD	SCALANCE XB005	SCALANCE XB008
Permitted ambient conditions				
Ambient temperature				
• During operation	-10 ... +60 °C	-10 ... +60 °C	-10 ... +60 °C	-10 ... +60 °C
• During storage	-40 ... +80 °C	-40 ... +80 °C	-40 ... +80 °C	-40 ... +80 °C
• During transport	-40 ... +80 °C	-40 ... +80 °C	-40 ... +80 °C	-40 ... +80 °C
Relative humidity at 25 °C without condensation during operation, maximum	95 %	95 %	95 %	95 %
IP degree of protection	IP20	IP20	IP20	IP20
Design, dimensions and weights				
Type of construction	Box	Box	Box	Box
Width	45 mm	45 mm	45 mm	45 mm
Height	100 mm	100 mm	100 mm	100 mm
Depth	87 mm	87 mm	87 mm	87 mm
Net weight	0.165 kg	0.165 kg	0.165 kg	0.18 kg
Type of mounting				
• 35 mm DIN rail mounting	Yes	Yes	Yes	Yes
• Wall mounting	Yes	Yes	Yes	Yes
Type of mounting	-	-	-	-
Standards, specifications, approvals				
Standard				
• for EMC of FM	-	-	-	-
• for hazardous zone	-	-	-	-
• for CSA and UL safety	UL 60950-1, CSA C22.2 No. 60950-1	UL 60950-1, CSA C22.2 No. 60950-1	UL 60950-1, CSA C22.2 No. 60950-1	UL 60950-1, CSA C22.2 No. 60950-1
• for hazardous zone of CSA and UL	-	-	-	-
• For emitted interference	EN 61000-6-4 (Class A)	EN 61000-6-4 (Class A)	EN 61000-6-4 (Class A)	EN 61000-6-4 (Class A)
• For noise immunity	EN 61000-6-2	EN 61000-6-2	EN 61000-6-2	EN 61000-6-2
Certificate of suitability	EN 61000-6-2, EN 61000-6-4	EN 61000-6-2, EN 61000-6-4	EN 61000-6-2, EN 61000-6-4	EN 61000-6-2, EN 61000-6-4
• CE mark	Yes	Yes	Yes	Yes
• C-Tick	Yes	Yes	Yes	Yes

Technical specifications (continued)

Order No.	6GK5 004-1GL00-1AB2	6GK5 004-1GM00-1AB2	6GK5 005-0GA00-1AB2	6GK5 008-0GA00-1AB2
Product type designation	SCALANCE XB004-1G	SCALANCE XB004-1LDG	SCALANCE XB005G	SCALANCE XB008G
Transmission rate				
Transmission rate 1	10 Mbit/s	10 Mbit/s	10 Mbit/s	10 Mbit/s
Transmission rate 2	100 Mbit/s	100 Mbit/s	100 Mbit/s	100 Mbit/s
Transmission rate 3	1 000 Mbit/s	1 000 Mbit/s	1 000 Mbit/s	1 000 Mbit/s
Interfaces				
Maximum number of electrical/optical connections for network components or terminal equipment	5	5	5	8
Number of electrical connections				
• For network components or terminal equipment	4	4	5	8
• For signal contact	-	-	-	-
• for power supply	1	1	1	1
Design of electrical connection				
• for network components or terminal equipment	RJ45 port	RJ45 port	RJ45 port	RJ45 port
• for signaling contact	-	-	-	-
• for power supply	3-pin terminal block	3-pin terminal block	3-pin terminal block	3-pin terminal block
Number of optical connections for fiber-optic cables				
• at 100 Mbit/s	-	-	-	-
• at 1000 Mbit/s	1	1	-	-
Design of optical connection for fiber-optic cables				
• At 100 Mbit/s	-	-	-	-
• At 1000 Mbit/s	SC port (multimode up to 0.75 km)	SC port (singlemode up to 10 km)	-	-
Injectable optical power referred to 1 mW				
• of the transmitter output	-9.5 ... -4 dB	-9.5 ... -3 dB	-	-
• of the receiver input, maximum	-3 dB	-3 dB	-	-
Minimum optical sensitivity referred to 1 mW of the receiver input	-17 dB	-21 dB	-	-
Minimum required attenuation factor of the FO transmission link	0 dB	0 dB	-	-
The range at the optical interface depends on the type of optical fiber used	0 ... 0.75 km	0 ... 10 km	-	-
Supply voltage, current consumption, power loss				
Type of supply voltage	DC	DC	DC	DC
External supply voltage	24 V	24 V	24 V	24 V
• Minimum	19.2 V	19.2 V	19.2 V	19.2 V
• Maximum	28.8 V	28.8 V	28.8 V	28.8 V
Product component: fusing at power supply input	Yes	Yes	Yes	Yes
Design of fusing at input for supply voltage	0.6 A / 60 V	0.6 A / 60 V	0.6 A / 60 V	0.6 A / 60 V
Current consumption, maximum	0.52 A	0.52 A	0.44 A	0.52 A
Effective power loss at 24 V with DC	12.5 W	12.5 W	10.5 W	12.5 W

PROFINET/Industrial Ethernet

Industrial Ethernet switches / media converters

SCALANCE XB-000 unmanaged

Technical specifications (continued)

Order No.	6GK5 004-1GL00-1AB2	6GK5 004-1GM00-1AB2	6GK5 005-0GA00-1AB2	6GK5 008-0GA00-1AB2
Product type designation	SCALANCE XB004-1G	SCALANCE XB004-1LDG	SCALANCE XB005G	SCALANCE XB008G
Permitted ambient conditions				
Ambient temperature				
• During operation	-10 ... +60 °C	-10 ... +60 °C	-10 ... +60 °C	-10 ... +60 °C
• During storage	-40 ... +80 °C	-40 ... +80 °C	-40 ... +80 °C	-40 ... +80 °C
• During transport	-40 ... +80 °C	-40 ... +80 °C	-40 ... +80 °C	-40 ... +80 °C
Relative humidity at 25 °C without condensation during operation, maximum	95 %	95 %	95 %	95 %
IP degree of protection	IP20	IP20	IP20	IP20
Design, dimensions and weights				
Type of construction	Box	Box	Box	Box
Width	45 mm	45 mm	45 mm	45 mm
Height	100 mm	100 mm	100 mm	100 mm
Depth	87 mm	87 mm	87 mm	87 mm
Net weight	0.21 kg	0.21 kg	0.22 kg	0.26 kg
Type of mounting				
• 35 mm DIN rail mounting	Yes	Yes	Yes	Yes
• Wall mounting	Yes	Yes	Yes	Yes
Type of mounting	-	-	-	-
Standards, specifications, approvals				
Standard				
• for EMC of FM	-	-	-	-
• for hazardous zone	-	-	-	-
• for CSA and UL safety	UL 60950-1, CSA C22.2 No. 60950-1	UL 60950-1, CSA C22.2 No. 60950-1	UL 60950-1, CSA C22.2 No. 60950-1	UL 60950-1, CSA C22.2 No. 60950-1
• for hazardous zone of CSA and UL	-	-	-	-
• For emitted interference	EN 61000-6-4 (Class A)	EN 61000-6-4 (Class A)	EN 61000-6-4 (Class B)	EN 61000-6-4 (Class B)
• For noise immunity	EN 61000-6-2	EN 61000-6-2	EN 61000-6-2	EN 61000-6-2
Certificate of suitability	EN 61000-6-2, EN 61000-6-4	EN 61000-6-2, EN 61000-6-4	EN 61000-6-2, EN 61000-6-4	EN 61000-6-2, EN 61000-6-4
• CE mark	Yes	Yes	Yes	Yes
• C-Tick	Yes	Yes	Yes	Yes

Ordering data	Order No.
SCALANCE XB-000 Industrial Ethernet switches	
Unmanaged Industrial Ethernet switches for 10/100/1000 Mbit/s, degree of protection IP20, incl. operating instructions, Industrial Ethernet network manual on CD-ROM	
<ul style="list-style-type: none"> • SCALANCE XB005 5 x 10/100 Mbit/s RJ45 ports electrical • SCALANCE XB008 8 x 10/100 Mbit/s RJ45 ports electrical • SCALANCE XB004-1 4 x 10/100 Mbit/s RJ45 ports electrical 1 x 100 Mbit/s SC port optical (multimode, glass), up to 5 km • SCALANCE XB004-1LD 4 x 10/100 Mbit/s RJ45 ports electrical 1 x 100 Mbit/s SC port optical (single-mode, glass), up to 26 km • SCALANCE XB005G 5 x 10/100/1000 Mbit/s electrical RJ45 ports • SCALANCE XB008G 8 x 10/100/1000 Mbit/s electrical RJ45 ports • SCALANCE XB004-1G 4 x 10/100/1000 Mbit/s electrical RJ45 ports 1 x 1000 Mbit/s optical SC port (multimode, glass), up to 0.75 km • SCALANCE XB004-1LDG 4 x 10/100/1000 Mbit/s electrical RJ45 ports 1 x 1000 Mbit/s optical SC port (single mode, glass), up to 10 km 	<p>6GK5 005-0BA00-1AB2</p> <p>6GK5 008-0BA00-1AB2</p> <p>6GK5 004-1BD00-1AB2</p> <p>6GK5 004-1BF00-1AB2</p> <p>6GK5 005-0GA00-1AB2</p> <p>6GK5 008-0GA00-1AB2</p> <p>6GK5 004-1GL00-1AB2</p> <p>6GK5 004-1GM00-1AB2</p>
Accessories	
IE TP Cord RJ45/RJ45 TP cable 4 x 2 with 2 RJ45 connectors <ul style="list-style-type: none"> • 0.5 m • 1 m • 2 m • 6 m • 10 m 	<p>6XV1 870-3QE50</p> <p>6XV1 870-3QH10</p> <p>6XV1 870-3QH20</p> <p>6XV1 870-3QH60</p> <p>6XV1 870-3QN10</p>
FO Standard Cable GP 50/125/1400^{1) 2)} Multimode cable, sold by the meter; max. length 1000 m; minimum order 20 m;	6XV1 873-2A
SITOP compact 24 V/ 0.6 A 1-phase power supply with wide-range input 85 – 264 V AC/110 – 300 V DC, stabilized output voltage 24 V, rated output current value 0.6 A, slim design	6EP1 331-5BA00

1) Special fiber-optic cables, lengths and accessories available on request

2) Special tools and trained personnel are required for pre-assembling glass fiber-optic cables

More information

To assist in selecting the right Industrial Ethernet switches as well as configuration of modular versions, the SIMATIC NET Selection Tool is available:

Online version:
www.siemens.com/snst

Offline version:
www.siemens.com/snst-download

PROFINET/Industrial Ethernet

Industrial Ethernet switches / media converters

SCALANCE X-100 unmanaged / media converters

Overview

SCALANCE X-100	Type of device	Hardware																
		Connection to S7 backplane bus	Format module S7	PC module	Fiat type of construction	Box type of construction	19" type of construction	Rugged, compact housing	Modular design	10 Gigabit Ethernet	Gigabit Ethernet	PoE (Power over Ethernet)	LED diagnosis	SIMATIC environment	Redundant power supply (2 x 24 V DC)	External supply for integrated switch	Signal contact	Local display (SET pushbutton)
	X104-2						•					•	•	•		•	•	
	X106-1						•					•	•	•		•	•	
	X108						•					•	•	•		•	•	
	X108PoE						•			•		•	•	•		•	•	
	X112-2						•					•	•	•		•	•	
	X116						•					•	•	•		•	•	
	X124						•					•	•	•		•	•	

• applies

G_IK10_XX_10316

Function overview SCALANCE X-100 unmanaged

PROFINET/Industrial Ethernet

Industrial Ethernet switches / media converters

SCALANCE X-100 unmanaged
Overview

The unmanaged Industrial Ethernet switches of the SCALANCE X-100 product line are optimized for installing Industrial Ethernet networks at transmission rates of 10/100 Mbit/s in a line and star topology.

- Depending on the port type of the devices, the connection to a station or network is electrical or optical with Power-over-Ethernet (PoE) functionality according to IEEE 802.3at Type 1 (corresponds to IEEE 802.3af)
- Rugged metal enclosure for space-saving cubicle mounting on standard rails, S7-300 DIN rail or for wall mounting
- Rugged, industry-standard station connections with PROFINET-compatible RJ45 connectors that offer additional strain relief and bending strain relief thanks to latching on the housing
- Redundant power supply
- Diagnostics on the device by means of LEDs (power, link status, data communication)
- Error signaling contact with easy adjustment using the SET button

Benefits

Designed for Industry

- Ideal solution for configuring Industrial Ethernet line and star topologies
- Reduction of network installation costs by transmitting data and energy (Power-over-Ethernet) via the conventional 4-core Industrial Ethernet cable (only SCALANCE X108PoE)
- Additional power supply units can be omitted thanks to generating the Power-over-Ethernet voltage (48 V DC) direct at the switch (SCALANCE X108PoE only)
- Space-saving installation in the cabinet thanks to the compact design in S7-300 format
- Reliable plug-in connection thanks to industry-standard device connection in conjunction with PROFINET-compliant FastConnect connectors
- Installation is possible without a patch field by means of IE FC RJ45 Plug 180 and IE FC Standard Cable
- Use of uncrossed connection cables possible by means of integrated autocrossover function

Application

The switches of the SCALANCE X-100 product line support the inexpensive construction of Industrial Ethernet line or star topologies with switching functions. They are designed for installation in the control cabinet.

Product versions
SCALANCE X104-2 / SCALANCE X106-1 / SCALANCE X112-2

- Construction of optical Industrial Ethernet line or star topologies:
 - SCALANCE X104-2; with 4 electrical ports and 2 optical ports
 - SCALANCE X106-1; with 6 electrical ports and 1 optical port
 - SCALANCE X112-2; with 12 electrical ports and 2 optical ports
- Diagnostics on the device using LEDs (power, link status, data traffic) and signaling contact (alarm screen form can be set using a button on the device)
- The RJ45 ports are suitable for industrial use and have additional retaining collars: optimal for connecting the IE FC RJ45 Plug 180

SCALANCE X108 / SCALANCE X108PoE / SCALANCE X116 / SCALANCE X124

- Construction of electrical Industrial Ethernet star and line topologies
 - SCALANCE X108 with eight electrical ports
 - SCALANCE X108PoE with eight electrical ports, two of which have Power-over-Ethernet functionality
 - SCALANCE X116 with 16 electrical ports
 - SCALANCE X124 with 24 electrical ports
- Diagnostics on the device using LEDs (power, link status, data traffic) and signaling contact (alarm screen form can be set using a button on the device)
- The RJ45 ports are suitable for industrial use and have additional retaining collars: optimal for connecting the IE FC RJ45 Plug 180

2

PROFINET/Industrial Ethernet

Industrial Ethernet switches / media converters

SCALANCE X-100 unmanaged

Design

The SCALANCE Industrial Ethernet switches with a rugged metal housing are optimized for mounting on a standard rail and an S7-300 rail. Direct wall mounting in various positions is also possible. Due to the dimensions of the housing that conform to those of SIMATIC S7-300, the devices are optimized for integration in an automation solution with S7-300 components.

The SCALANCE X-100 switches have:

- A 4-pole terminal block for connecting the redundant supply voltage (2 x 24 V DC)
- A row of LEDs for displaying status information (power, link status, data communication, signaling contact)
- A 2-pole terminal block for connecting the floating signaling contact
- A SET button for on-site configuration of the signaling contact

The following port types are available:

- *10/100BaseTX, RJ45 port;*
automatic detection of the transmission rate (10 or 100 Mbit/s), with autosensing and autocrossover functions for connecting IE FC cables using IE FC RJ45 Plug 180 up to 100 m
- *10/100BaseTX, RJ45 ports and Power-over-Ethernet functionality;*
automatic detection of the transmission rate (10 or 100 Mbit/s), with autosensing and autocrossover functions for connecting IE FC cables using IE FC RJ45 Plug 180 up to 100 m and integrated Power-over-Ethernet functionality according to IEEE 802.3at Type 1
- *100BaseFX, BFOC port;*
for direct connection to the Industrial Ethernet glass FOC up to 5 km

Function

- Construction of electrical and optical Industrial Ethernet line or star topologies
- Use of uncrossed connecting leads is possible due to integrated auto-crossover function of the ports
- Power supply of Power-over-Ethernet-capable terminal equipment via the data line for SCALANCE X108PoE
- Isolation of the load due to integrated switch functions
- Easy network configuration and network expansion; no limitation of the expansion of the network when switches of the SCALANCE X-100 product line are cascaded

Network topology and network configuration

The SCALANCE X-100 switches are typically installed with the stations to be connected in a control cabinet. They can be mixed electrically and optically in star and line topologies.

When configuring the network, it is necessary to observe the following boundary conditions:

- Length of the TP cable between SCALANCE X switches:
 - Max. 100 m with Industrial Ethernet FastConnect products
- Length of the TP cable between SCALANCE X switch and Power-over-Ethernet terminal equipment:
 - Max. 100 m with Industrial Ethernet FastConnect products
- Length of the fiber-optic cables:
 - Max. 5 km with Industrial Ethernet glass fiber-optic cables

PROFINET/Industrial Ethernet

Industrial Ethernet switches / media converters

SCALANCE X-100 unmanaged

Function (continued)

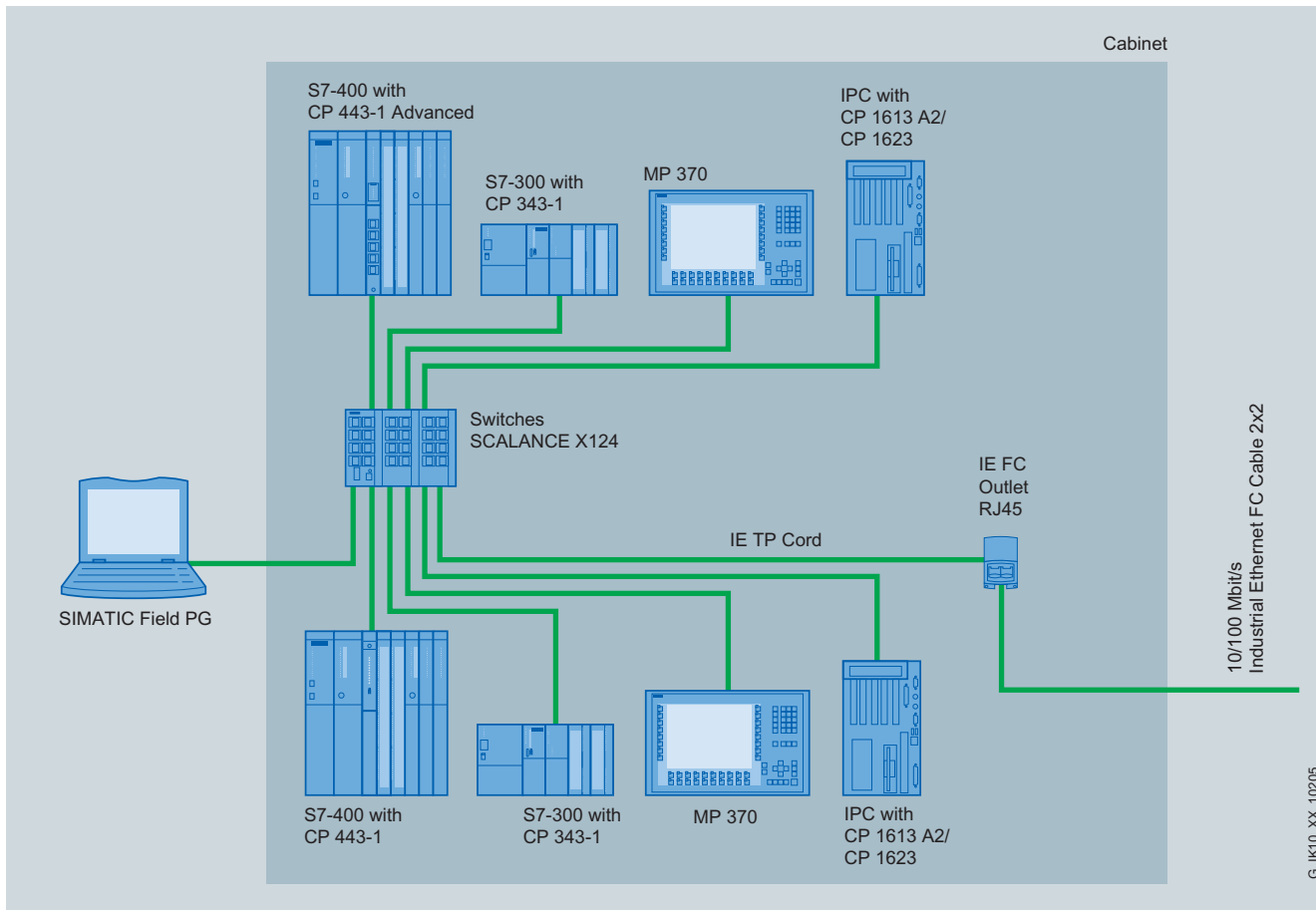

2

Star-shaped network topology with SCALANCE X124

PROFINET/Industrial Ethernet

Industrial Ethernet switches / media converters

SCALANCE X-100 unmanaged

Function (continued)

2

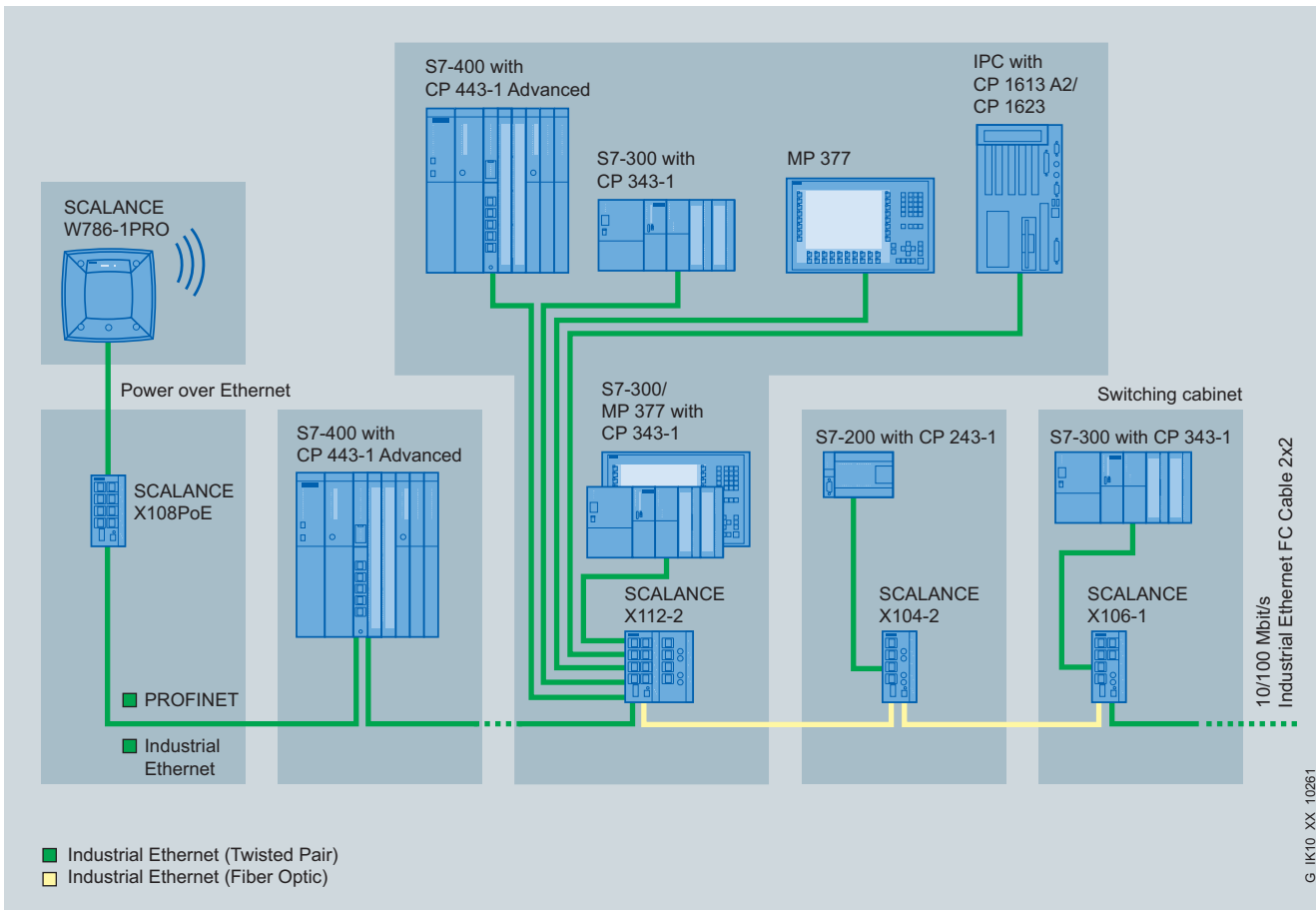

Electrical and optical line topology with SCALANCE X112-2, X104-2 and X106-1 as well as connection and supply of data terminals with Power-over-Ethernet (PoE) by SCALANCE X108PoE

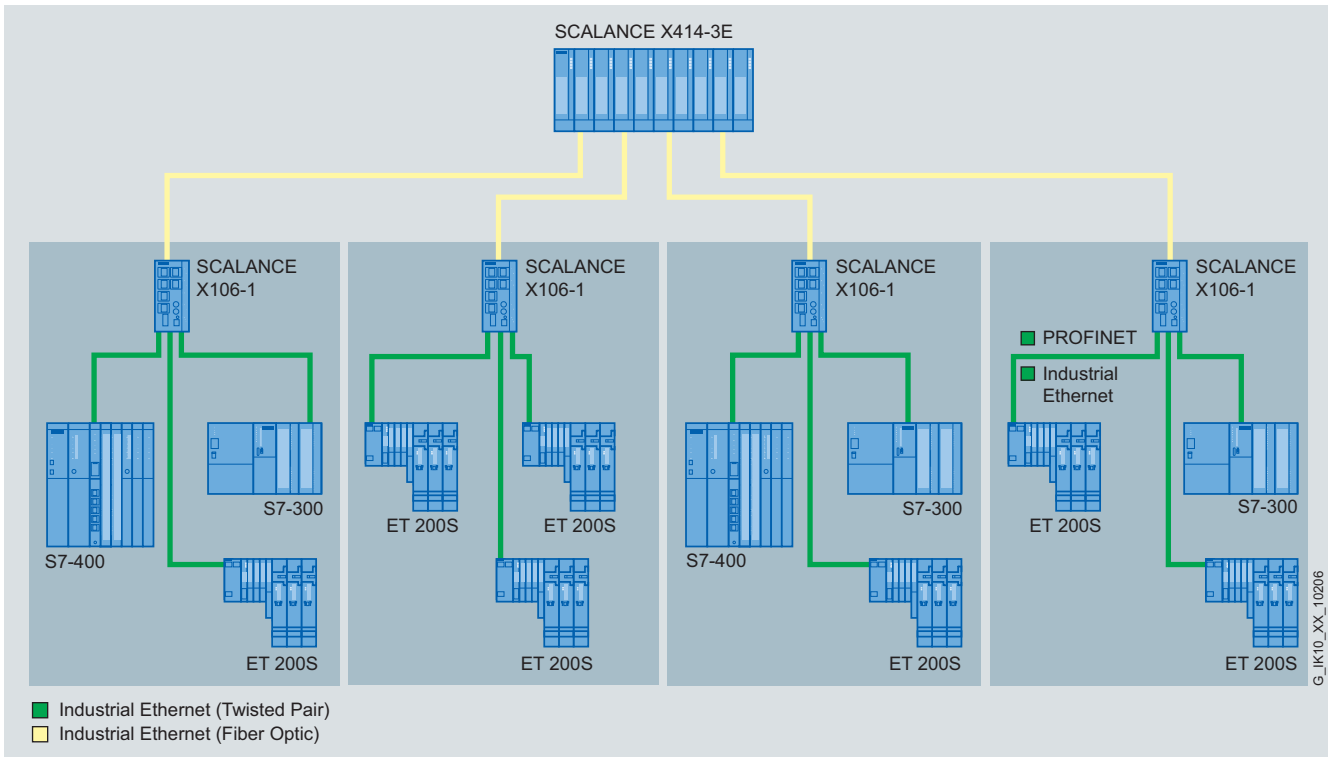
Function (continued)

Optical star topology with SCALANCE X106-1

Diagnostics

The following information is displayed by LEDs on site:

- Power
- Port status
- Data traffic

The Industrial Ethernet switches of the SCALANCE X-100 line can also be monitored over the floating signaling contact.

PROFINET/Industrial Ethernet

Industrial Ethernet switches / media converters

SCALANCE X-100 unmanaged

Technical specifications

Order No.	6GK5 104-2BB00-2AA3	6GK5 106-1BB00-2AA3	6GK5 108-0BA00-2AA3	6GK5 108-0PA00-2AA3
Product type designation	SCALANCE X104-2	SCALANCE X106-1	SCALANCE X108	SCALANCE X108PoE
Transmission rate				
Transmission rate 1	10 Mbit/s	10 Mbit/s	10 Mbit/s	10 Mbit/s
Transmission rate 2	100 Mbit/s	100 Mbit/s	100 Mbit/s	100 Mbit/s
Interfaces				
Maximum number of electrical/optical connections for network components or terminal equipment	6	7	8	8
Number of electrical connections				
• For network components or terminal equipment	4	6	8	6
• With Power-over-Ethernet for network components or terminal equipment	-	-	-	2
• For signal contact	1	1	1	1
• For power supply	1	1	1	1
• For redundant power supply	1	1	1	1
Design of electrical connection				
• For network components or terminal equipment	RJ45 port	RJ45 port	RJ45 port	RJ45 port
• With Power-over-Ethernet for network components or terminal equipment	-	-	-	RJ45 port
• For signal contact	2-pin terminal block	2-pin terminal block	2-pin terminal block	2-pin terminal block
• For power supply	4-pin terminal block	4-pin terminal block	4-pin terminal block	4-pin terminal block
Number of optical connections for fiber-optic cables				
• At 10 Mbit/s	-	-	-	-
• at 100 Mbit/s	2	1	-	-
Design of optical connection for fiber-optic cables				
• At 10 Mbit/s	-	-	-	-
• at 100 Mbit/s	BFOC port (multimode up to 5 km)	BFOC port (multimode up to 5 km)	-	-
Injectable optical power referred to 1 mW				
• of the transmitter output	-19 ... -14 dB	-19 ... -14 dB	-	-
• of the receiver input, maximum	-14 dB	-14 dB	-	-
Minimum optical sensitivity referred to 1 mW of the receiver input	-32 dB	-32 dB	-	-
Minimum required attenuation factor of the FO transmission link	0 dB	0 dB	-	-
The range at the optical interface depends on the type of optical fiber used	0 ... 5 km	0 ... 5 km	-	-
Inputs/outputs				
Operating voltage of signaling contacts with DC rated value	24 V	24 V	24 V	24 V
Maximum operating current of signal contacts with DC	0.1 A	0.1 A	0.1 A	0.1 A
Supply voltage, current consumption, power loss				
Type of power supply	DC	DC	DC	DC
Supply voltage, external	24 V	24 V	24 V	24 V
• Minimum	18 V	18 V	18 V	18 V
• Maximum	32 V	32 V	32 V	32 V
Product component: fusing of power supply input	Yes	Yes	Yes	Yes
Type of fusing of power supply input	0.6 A / 60 V	0.6 A / 60 V	0.6 A / 60 V	4 A / 125 V
Current consumption, maximum	0.16 A	0.15 A	0.14 A	1.7 A
Effective power loss at 24 V with DC	3.8 W	3.6 W	3.36 W	10 W

Technical specifications (continued)

Order No.	6GK5 104-2BB00-2AA3	6GK5 106-1BB00-2AA3	6GK5 108-0BA00-2AA3	6GK5 108-0PA00-2AA3
Product type designation	SCALANCE X104-2	SCALANCE X106-1	SCALANCE X108	SCALANCE X108PoE
Permitted ambient conditions				
Ambient temperature				
• During operation	-10 ... +60 °C	-10 ... +60 °C	-20 ... +70 °C	-20 ... +60 °C
• During storage	-40 ... +80 °C	-40 ... +80 °C	-40 ... +80 °C	-40 ... +80 °C
• During transport	-40 ... +80 °C	-40 ... +80 °C	-40 ... +80 °C	-40 ... +80 °C
Relative humidity at 25 °C without condensation during operation, maximum	95 %	95 %	95 %	95 %
IP degree of protection	IP30	IP30	IP30	IP30
Design, dimensions and weights				
Type of construction	Compact	Compact	Compact	Compact
Width	60 mm	60 mm	60 mm	60 mm
Height	125 mm	125 mm	125 mm	125 mm
Depth	124 mm	124 mm	124 mm	124 mm
Net weight	0.78 kg	0.78 kg	0.78 kg	0.9 kg
Type of mounting				
• 35 mm DIN rail mounting	Yes	Yes	Yes	Yes
• Wall mounting	Yes	Yes	Yes	Yes
• S7-300 rail mounting	Yes	Yes	Yes	Yes
Type of mounting	-	-	-	-
Standards, specifications, approvals				
Standard				
• For EMC of FM	FM3611: Class 1, Division 2, Group A, B, C, D / T.., Class 1, Zone 2, Group IIC, T..	FM3611: Class 1, Division 2, Group A, B, C, D / T.., Class 1, Zone 2, Group IIC, T..	FM3611: Class 1, Division 2, Group A, B, C, D / T.., Class 1, Zone 2, Group IIC, T..	FM3611: Class 1, Division 2, Group A, B, C, D / T.., Class 1, Zone 2, Group IIC, T..
• for hazardous zone	EN 60079-0: 2006, EN60079-15: 2005, II 3 G Ex nA IIT.., KEMA 07 ATEX 0145 X	EN 60079-0: 2006, EN60079-15: 2005, II 3 G Ex nA IIT.., KEMA 07 ATEX 0145 X	EN 60079-0: 2006, EN60079-15: 2005, II 3 G Ex nA IIT.., KEMA 07 ATEX 0145 X	EN 60079-0: 2006, EN60079-15: 2005, II 3 G Ex nA IIT.., KEMA 07 ATEX 0145 X
• For CSA and UL safety	UL 60950-1, CSA C22.2 No. 60950-1	UL 60950-1, CSA C22.2 No. 60950-1	UL 60950-1, CSA C22.2 No. 60950-1	UL 60950-1, CSA C22.2 No. 60950-1
• for hazardous zone of CSA and UL	UL 1604 and UL 2279-15 (Hazardous Location), Class 1 / Division 2 / Group A, B, C, D / T.., Class 1 / Zone 2 / Group IIC / T..	UL 1604 and UL 2279-15 (Hazardous Location), Class 1 / Division 2 / Group A, B, C, D / T.., Class 1 / Zone 2 / Group IIC / T..	UL 1604 and UL 2279-15 (Hazardous Location), Class 1 / Division 2 / Group A, B, C, D / T.., Class 1 / Zone 2 / Group IIC / T..	UL 1604 and UL 2279-15 (Hazardous Location), Class 1 / Division 2 / Group A, B, C, D / T.., Class 1 / Zone 2 / Group IIC / T..
• For emitted interference	EN 61000-6-4 (Class A)	EN 61000-6-4 (Class A)	EN 61000-6-4 (Class A)	EN 61000-6-4:2001
• For noise immunity	EN 61000-6-2	EN 61000-6-2	EN 61000-6-2	EN 61000-6-2:2001
Certificate of suitability	EN 61000-6-2, EN 61000-6-4	EN 61000-6-2, EN 61000-6-4	EN 61000-6-2, EN 61000-6-4	EN 61000-6-2:2001, EN 61000-6-4:2001
• CE mark	Yes	Yes	Yes	Yes
• C-Tick	Yes	Yes	Yes	Yes
• Railroad application according to EN 50155	-	-	-	-
• Railroad application according to EN 50124-1	-	-	-	-
Marine classification association				
• American Bureau of Shipping Europe Ltd. (ABS)	Yes	Yes	Yes	No
• Bureau Veritas (BV)	Yes	Yes	Yes	No
• Det Norske Veritas (DNV)	Yes	Yes	Yes	No
• Germanischer Lloyd (GL)	Yes	Yes	Yes	No
• Lloyds Register of Shipping (LRS)	Yes	Yes	Yes	No
• Nippon Kaiji Kyokai (NK)	Yes	Yes	Yes	No
• Polski Rejestr Statkow (PRS)	Yes	Yes	Yes	No

PROFINET/Industrial Ethernet

Industrial Ethernet switches / media converters

SCALANCE X-100 unmanaged

Technical specifications (continued)

Order No.	6GK5 112-2BB00-2AA3	6GK5 116-0BA00-2AA3	6GK5 124-0BA00-2AA3
Product type designation	SCALANCE X112-2	SCALANCE X116	SCALANCE X124
Transmission rate			
Transmission rate 1	10 Mbit/s	10 Mbit/s	10 Mbit/s
Transmission rate 2	100 Mbit/s	100 Mbit/s	100 Mbit/s
Interfaces			
Maximum number of electrical/ optical connections for network components or terminal equipment	14	16	24
Number of electrical connections			
• For network components or terminal equipment	12	16	24
• With Power-over-Ethernet for network components or terminal equipment	-	-	-
• For signal contact	1	1	1
• For power supply	1	1	1
• For redundant power supply	1	1	1
Design of electrical connection			
• For network components or terminal equipment	RJ45 port	RJ45 port	RJ45 port
• With Power-over-Ethernet for network components or terminal equipment	-	-	-
• For signal contact	2-pin terminal block	2-pin terminal block	2-pin terminal block
• For power supply	4-pin terminal block	4-pin terminal block	4-pin terminal block
Number of optical connections for fiber-optic cables			
• At 10 Mbit/s	-	-	-
• at 100 Mbit/s	2	-	-
Design of optical connection for fiber-optic cables			
• At 10 Mbit/s	-	-	-
• at 100 Mbit/s	BFOC port (multimode up to 5 km)	-	-
Injectable optical power referred to 1 mW			
• of the transmitter output	-19 ... -14 dB	-	-
• of the receiver input, maximum	-14 dB	-	-
Minimum optical sensitivity referred to 1 mW of the receiver input	-32 dB	-	-
Minimum required attenuation factor of the FO transmission link	0 dB	-	-
The range at the optical interface depends on the type of optical fiber used	0 ... 5 km	-	-
Inputs/outputs			
Operating voltage of signaling contacts with DC rated value	24 V	24 V	24 V
Maximum operating current of signal contacts with DC	0.1 A	0.1 A	0.1 A
Supply voltage, current consumption, power loss			
Type of power supply	DC	DC	DC
Supply voltage, external	24 V	24 V	24 V
• Minimum	18 V	18 V	18 V
• Maximum	32 V	32 V	32 V
Product component: fusing of power supply input	No	No	No
Type of fusing of power supply input	-	-	-
Current consumption, maximum	0.45 A	0.3 A	0.45 A
Effective power loss at 24 V with DC	5.16 W	4.4 W	4.8 W

Technical specifications (continued)

Order No.	6GK5 112-2BB00-2AA3	6GK5 116-0BA00-2AA3	6GK5 124-0BA00-2AA3
Product type designation	SCALANCE X112-2	SCALANCE X116	SCALANCE X124
Permitted ambient conditions			
Ambient temperature			
• During operation	-10 ... +70 °C	-20 ... +70 °C	-20 ... +70 °C
• During storage	-40 ... +80 °C	-40 ... +80 °C	-40 ... +80 °C
• During transport	-40 ... +80 °C	-40 ... +80 °C	-40 ... +80 °C
Relative humidity at 25 °C without condensation during operation, maximum	95 %	95 %	95 %
IP degree of protection	IP30	IP30	IP30
Design, dimensions and weights			
Type of construction	Compact	Compact	Compact
Width	120 mm	120 mm	180 mm
Height	125 mm	125 mm	125 mm
Depth	124 mm	124 mm	124 mm
Net weight	1.1 kg	1.1 kg	1.5 kg
Type of mounting			
• 35 mm DIN rail mounting	Yes	Yes	Yes
• Wall mounting	Yes	Yes	Yes
• S7-300 rail mounting	Yes	Yes	Yes
Type of mounting	-	-	-
Standards, specifications, approvals			
Standard			
• For EMC of FM	FM3611: Class 1, Division 2, Group A, B, C, D / T., Class 1, Zone 2, Group IIC, T.	FM3611: Class 1, Division 2, Group A, B, C, D / T., Class 1, Zone 2, Group IIC, T.	FM3611: Class 1, Division 2, Group A, B, C, D / T., Class 1, Zone 2, Group IIC, T.
• for hazardous zone	EN 60079-0:2006, EN60079-15:2005, II 3 G Ex nA II T.. KEMA 08 ATEX 0003 X	EN 60079-0:2006, EN60079-15:2005, II 3 G Ex nA II T.. KEMA 08 ATEX 0003 X	EN 60079-0:2006, EN60079-15:2005, II 3 G Ex nA II T.. KEMA 08 ATEX 0003 X
• For CSA and UL safety	UL 60950-1, CSA C22.2 No. 60950-1	UL 60950-1, CSA C22.2 No. 60950-1	UL 60950-1, CSA C22.2 No. 60950-1
• for hazardous zone of CSA and UL	UL 1604 and UL 2279-15 (Hazardous Location), Class 1 / Division 2 / Group A, B, C, D / T., Class 1 / Zone 2 / Group IIC / T..	UL 1604 and UL 2279-15 (Hazardous Location), Class 1 / Division 2 / Group A, B, C, D / T., Class 1 / Zone 2 / Group IIC / T..	UL 1604 and UL 2279-15 (Hazardous Location), Class 1 / Division 2 / Group A, B, C, D / T., Class 1 / Zone 2 / Group IIC / T..
• For emitted interference	EN 61000-6-4:2001	EN 61000-6-4:2001	EN 61000-6-4:2001
• For noise immunity	EN 61000-6-2:2001	EN 61000-6-2:2001	EN 61000-6-2:2001
Certificate of suitability	EN 61000-6-2:2001, EN 61000-6-4:2001	EN 61000-6-2:2001, EN 61000-6-4:2001	EN 61000-6-2:2001, EN 61000-6-4:2001
• CE mark	Yes	Yes	Yes
• C-Tick	Yes	Yes	Yes
• Railroad application according to EN 50155	-	-	-
• Railroad application according to EN 50124-1	-	-	-
Marine classification association			
• American Bureau of Shipping Europe Ltd. (ABS)	Yes	Yes	Yes
• Bureau Veritas (BV)	Yes	Yes	Yes
• Det Norske Veritas (DNV)	No	No	No
• Germanischer Lloyd (GL)	No	No	No
• Lloyds Register of Shipping (LRS)	Yes	Yes	Yes
• Nippon Kaiji Kyokai (NK)	Yes	Yes	Yes
• Polski Rejestr Statkow (PRS)	No	No	No

PROFINET/Industrial Ethernet

Industrial Ethernet switches / media converters

SCALANCE X-100 unmanaged

2

Ordering data

Order No.

Order No.

SCALANCE X-100 Industrial Ethernet switches

Industrial Ethernet switches for 10/100 Mbit/s, incl. operating instructions, Industrial Ethernet network manual and configuration software on CD-ROM

- **SCALANCE X104-2**
4 x 10/100 Mbit/s RJ45 ports, electrical
2 x BFOC ports, optical (multimode, glass) up to 5 km
- **SCALANCE X106-1**
6 x 10/100 Mbit/s RJ45 ports, electrical
1 x BFOC port, optical (multi-mode, glass) up to 5 km
- **SCALANCE X112-2**
12 x 10/100 Mbit/s RJ45 ports, electrical
2 x BFOC ports, optical (multi-mode, glass) up to 5 km
- **SCALANCE X108**
8 x 10/100 Mbit/s RJ45 ports, electrical
- **SCALANCE X108PoE**
6 x 10/100 Mbit/s RJ45 ports, electrical
2 x 10/100 Mbit/s RJ45 PoE ports, electrical
- **SCALANCE X116**
16 x 10/100 Mbit/s RJ45 ports, electrical
- **SCALANCE X124**
24 x 10/100 Mbit/s RJ45 ports, electrical

6GK5 104-2BB00-2AA3

6GK5106-1BB00-2AA3

6GK5 112-2BB00-2AA3

6GK5 108-0BA00-2AA3

6GK5 108-0PA00-2AA3

6GK5 116-0BA00-2AA3

6GK5 124-0BA00-2AA3

Accessories

IE FC TP Standard Cable GP 2 x 2 (Type A)

4-core, shielded TP installation cable for connection to IE FC Outlet RJ45/IE FC RJ45 Plug; PROFINET-compliant; with UL approval; sold by the meter; max. length 1000 m, minimum order 20 m

6XV1 840-2AH10

FO Standard Cable GP 50/125/1400^{1) 2)}

Multimode cable, sold by the meter; max. length 1000 m; minimum order 20 m

6XV1 873-2A

FC FO Standard Cable GP 62.5/200/230

FC FO standard cable for fixed routing indoors with PVC sheath; sold by the meter max. length 1000 m, minimum order 20 m

6XV1 847-2A

IE FC RJ45 Plug 180 2 x 2

RJ45 plug connector for Industrial Ethernet with a rugged metal enclosure and integrated insulation displacement contacts for connecting Industrial Ethernet FC installation cables; with 180° cable outlet; for network components and CPs/CPUs with Industrial Ethernet interface

- 1 pack = 1 unit
- 1 pack = 10 units
- 1 pack = 50 units

6GK1 901-1BB10-2AA0

6GK1 901-1BB10-2AB0

6GK1 901-1BB10-2AE0

FC BFOC Plug

Screw connector for on-site assembly on FC fiber-optic cable; (1 pack = 20 units + cleaning cloths)

6GK1 900-1GB00-0AC0

IE FC Stripping Tool

Preadjusted stripping tool for fast stripping of the Industrial Ethernet FC cables

6GK1 901-1GA00

FC FO termination kit

Assembly case for local assembly of FC SC and FC BFOC connectors to FC FO standard cable, comprising a stripping tool, Kevlar cutters, fiber breaking tool and microscope

6GK1 900-1GL00-0AA0

SITOP compact 24 V/ 0.6 A

1-phase power supply with wide-range input 85 – 264 V AC/110 – 300 V DC, stabilized output voltage 24 V, rated output current value 0.6 A, slim design

6EP1 331-5BA00

¹⁾ Special fiber-optic cables, lengths and accessories available on request

²⁾ Special tools and trained personnel are required for pre-assembling glass fiber-optic cables

More information

To assist in selecting the right Industrial Ethernet switches as well as configuration of modular versions, the SIMATIC NET Selection Tool is available:

Online version:

www.siemens.com/snst

Offline version:

www.siemens.com/snst-download

PROFINET/Industrial Ethernet

Industrial Ethernet switches / media converters

SIPLUS SCALANCE X-100 unmanaged

Overview



- The unmanaged Industrial Ethernet switches of the SCALANCE X-100 product line are optimized for installing Industrial Ethernet networks with 10/100 Mbit/s in a line and star topology
- Nodes or networks connected electrically, optically or electrically with Power-over-Ethernet functionality (PoE) in accordance with IEEE 802.3af
- Rugged metal housing for space-saving cubicle mounting on standard rails, S7-300 DIN rail or for wall mounting
- Rugged, industry-standard station connections with PROFINET-compatible RJ45 connectors that offer additional strain relief and bending strain relief thanks to latching on the housing
- Redundant power supply
- Diagnostics on the device by means of LEDs (power, link status, data communication)
- Error signaling contact with easy adjustment using the SET button

Note:

SIPLUS extreme products are based on Siemens Industry standard products. The contents listed here were taken from the respective standard products. SIPLUS extreme-specific information was added.

Order number	SIPLUS SCALANCE X-100 unmanaged
Order No. based on	6AG1 104-2BB00-2AA3
Ambient temperature range	-25 ... +60 °C
Conformal coating	Coating of the printed circuit boards and the electronic components
Technical data	The technical data of the standard product applies except for the ambient conditions.

Ambient conditions	
Relative humidity	5 ... 100 % Condensation permissible
Biologically active substances	Conformity with EN 60721-3-3, Class 3B2 mold and fungal spores (except fauna)
Chemically active substances	Conformity with EN 60721-3-3, Class 3C4 incl. salt mist and ISA-S71.04 severity level G1; G2; G3; GX ^{1) 2)}
Mechanically active substances	Conformity with EN 60721-3-3, Class 3S4 including conductive sand, dust ²⁾
Air pressure (depending on the highest positive temperature range specified)	1080 ... 795 hPa (-1000 ... +2000 m) see ambient temperature range 795 ... 658 hPa (+2000 ... +3500 m) derating 10 K 658 ... 540 hPa (+3500 ... +5000 m) derating 20 K

- 1) ISA-S71.04 severity level GX: Long-term load: SO₂ < 4.8 ppm; H₂S < 9.9 ppm; Cl < 0.2 ppm; HCl < 0.66 ppm; HF < 0.12 ppm; NH < 49 ppm; O₃ < 0.1 ppm; NOX < 5.2 ppm
Limit value (max. 30 min/d): SO₂ < 17.8 ppm; H₂S < 49.7 ppm; Cl < 1.0 ppm; HCl < 3.3 ppm; HF < 2.4 ppm; NH < 247 ppm; O₃ < 1.0 ppm; NOX < 10.4 ppm
- 2) The supplied plug covers must remain in place over the unused interface when operated in atmospheres containing corrosive gases!

The technical documentation on SIPLUS can be found here:
www.siemens.com/siplus-extreme

Ordering data	Order No.
Industrial Ethernet Switches (extended temperature range and medial exposure) Industrial Ethernet switches for 10/100 Mbit/s, incl. operating instructions, Industrial Ethernet network manual and configuration software on CD-ROM • SIPLUS SCALANCE X104-2 4 x 10/100 Mbit/s RJ45 ports, electrical 2 x BFOC ports, optical (multimode, glass) up to 5 km	6AG1 104-2BB00-2AA3
Accessories	See ordering data for SCALANCE X-100 unmanaged

PROFINET/Industrial Ethernet

Industrial Ethernet switches / media converters

SCALANCE X-100 unmanaged media converters

Overview



The unmanaged Industrial Ethernet media converters of the SCALANCE X-100 product line are ideally suited to the conversion of different transmission media in Industrial Ethernet networks at data transfer rates of 10/100 Mbit/s in line, star and ring topologies.

- Electrical or optical connection to stations or network in accordance with the port type of the devices
- Rugged metal enclosure for space-saving cubicle mounting on standard rails, S7-300 DIN rail or for wall mounting
- Rugged, industry-standard station connections with PROFINET-compatible RJ45 connectors that offer additional strain relief and bending strain relief thanks to latching on the housing
- Redundant power supply
- Diagnostics on the device by means of LEDs (power, link status, data communication)
- Error signaling contact with easy adjustment using the SET button
- Connection of existing 10 Mbit/s fiber-optic networks
- Connection of existing 10Base5 networks (e.g. SINEC H1)

Benefits

get Designed for Industry

- Ideal solution for converting various transmission media in Industrial Ethernet line, star and ring topologies
- Space-saving installation in the cabinet thanks to the compact design in S7-300 format
- Reliable plug-in connection thanks to industry-standard device connection with PROFINET-compliant FastConnect connectors
- Integration of existing 10Base FL and/or 10Base5 networks
- Cost savings, since installation is possible without a patch field by means of IE FC RJ45 Plug and IE FC Standard Cable
- Uncrossed connecting cables can be used due to the integrated Autocrossover function

Application

The unmanaged media converters of the SCALANCE X-100 product line permit low-cost conversion of various transmission media within Industrial Ethernet line, star and ring topologies. They are designed for installation in the control cabinet.

Single, remote terminal units on network segments can be linked via the optical path of the SCALANCE X-100 media converters. Integration of an optical path into a redundant ring is also possible, as well as installation of the SCALANCE X-100 media converters into a standby link.

Product versions

SCALANCE X101-1, SCALANCE X101-1LD, SCALANCE X101-1POF, SCALANCE X101-1FL and SCALANCE X101-1AUI

- For converting electrical signals into optical signals in Industrial Ethernet line, star and ring topologies
- The Industrial Ethernet media converters have an electrical 10/100 Mbit/s RJ45 port and:
 - **SCALANCE X101-1**
1x 100 Mbit/s BFOC port, optical (multimode, glass)
 - **SCALANCE X101-1LD**
1x 100 Mbit/s BFOC port, optical (singlemode, glass)
 - **SCALANCE X101-1POF**
1x 100 Mbit/s SC-RJ port, optical (plastic optical fiber, POF)
 - **SCALANCE X101-1AUI**
1x 10 Mbit/s AUI interface with Sub-D connections
 - **SCALANCE X101-1FL**
1x 10 Mbit/s BFOC port, optical (multimode, glass)
- Redundant power supply with 2 x 24 V DC
- Diagnostics on the device using LEDs (power, link status, data traffic) and signaling contact (alarm screen form can be set using a button on the device)
- The electric RJ45 port is industry-standard and features an additional retaining collar for connection of the IE FC RJ45 Plugs

Design

The SCALANCE Industrial Ethernet media converters with a rugged metal enclosure are optimized for mounting on a standard rail and an S7-300 DIN rail. Direct wall mounting in various positions is also possible. Due to the housing dimensions that correspond to those of the S7-300, the devices are ideally suited for integration into an automation solution using S7-300 components.

The SCALANCE X-100 media converters feature:

- A 4-pole terminal block for connecting the redundant supply voltage (2 x 24 V DC)
- A row of LEDs for displaying status information (power, link status, data communication, signaling contact)
- A 2-pole terminal block for connecting the floating signaling contact
- A SET button for local configuration of the signaling contact and of cascading mode

The following port types are available:

- *10/100BaseTX, RJ45 port*: automatic detection of the data rate (10 or 100 Mbit/s), with autosensing and autocrossover function for connecting IE FC cables via IE FC RJ45 connectors over distances up to 100 m
- *100BaseFX, BFOC port* with glass fiber-optic cable: for direct connection to Industrial Ethernet glass fiber-optic cables up to 3000 m or 26000 m for configuring line, star or ring topologies
- *100BaseFX, SC RJ port* with POF fiber-optic cable: for direct connection to Industrial Ethernet POF fiber-optic cables up to 50 m or to Industrial Ethernet PCF fiber-optic cables up to 100 m for configuring line, star or ring topologies
- *10BaseFL, BFOC port* with glass fiber-optic cable: for direct connection to Industrial Ethernet glass fiber-optic cables up to 3000 m for configuring line, star or ring topologies
- *AUI, 15-pin Sub-D port*: for connecting an Industrial Ethernet AUI cable (connecting cable 727-1/drop cable) of up to 50 m to AUI transceiver (no terminal equipment)

Function

- Configuring electrical and optical Industrial Ethernet line, star or ring topologies
- Uncrossed connecting cables can be used due to Autocrossover function integrated in the TP ports
- Easy configuration and extension of the network; no limits to network extension when switches or media converters of the SCALANCE X-100 family are cascaded.
- Integration of existing 10Base FL and/or 10Base5 networks

	Type and number of ports						Characteristics							
	Twisted Pair	Fiber Optic					Compact enclosure	LED diagnostics	SIMATIC environment	2 x 24 V DC	Signaling contact	On-site display (SET button)	Ring redundancy without RM	
	10 / 100 Mbit/s	Fast Ethernet				10 Mbit/s								
		RJ45	POF / PCF	Multimode BFOC	Singlemode BFOC	AUI								Multimode BFOC
1					1									
SCALANCE X101-1	1		1				•	•	•	•	•	•	•	
SCALANCE X101-1LD	1			1			•	•	•	•	•	•	•	
SCALANCE X101-1POF	1	1					•	•	•	•	•	•	•	
SCALANCE X101-1AUI	1				1		•	•	•	•	•	•	•	
SCALANCE X101-1FL	1					1	•	•	•	•	•	•	•	

Function overview of Industrial Ethernet media converters

PROFINET/Industrial Ethernet

Industrial Ethernet switches / media converters

SCALANCE X-100 unmanaged media converters

Function (continued)

Network topology and network configuration

The SCALANCE X-100 media converters are typically accommodated in one control cabinet together with the nodes to be connected. They can be installed in line, star and ring topologies.

When configuring the network, it is necessary to observe the following boundary conditions:

- Length of the TP cable between two SCALANCE X media converters:
 - Max. 100 m with Industrial Ethernet FastConnect products

- Length of the optical cables:
 - Max. 5 km with Industrial Ethernet multimode fiber-optic cables
 - Max. 26 km with Industrial Ethernet singlemode fiber-optic cables
 - Max. 100 m with Industrial Ethernet PCF fiber-optic cables
 - Max. 50 m with Industrial Ethernet POF fiber-optic cables
- Length of the AUI cable:
 - max. 50 m with Industrial Ethernet connecting cable 727-1 (AUI drop cable)

2

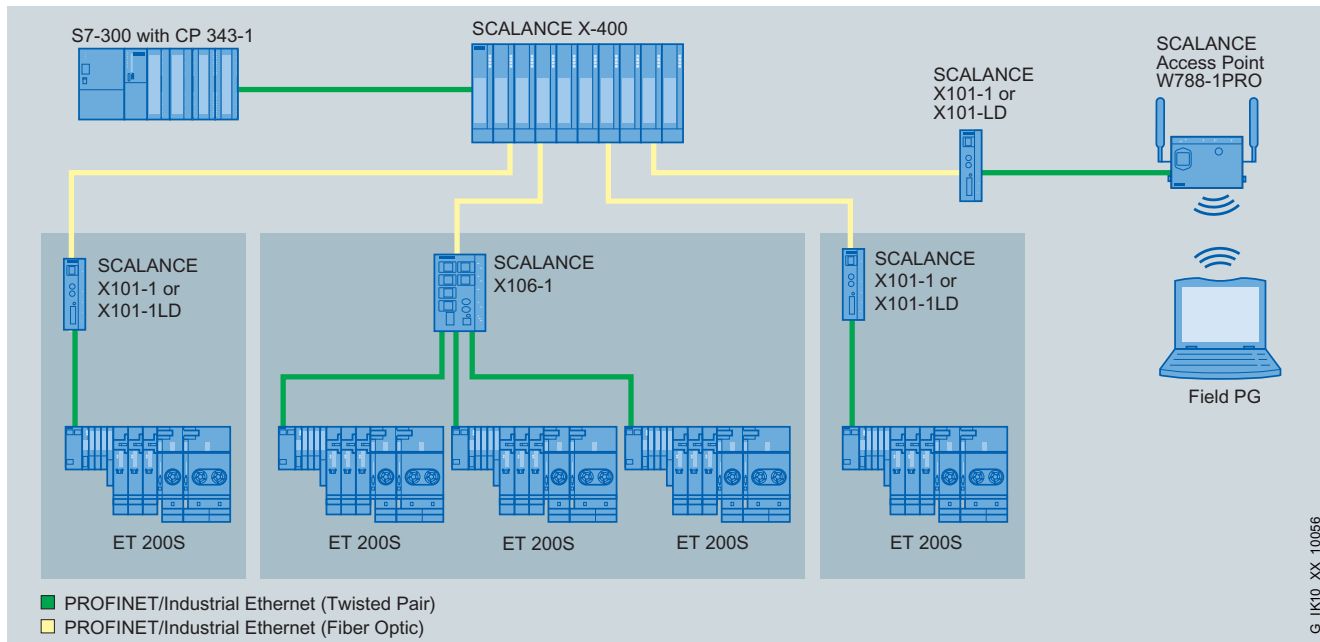

Optical star topology with SCALANCE X101-1/X101-1LD and remote SCALANCE W Access Point

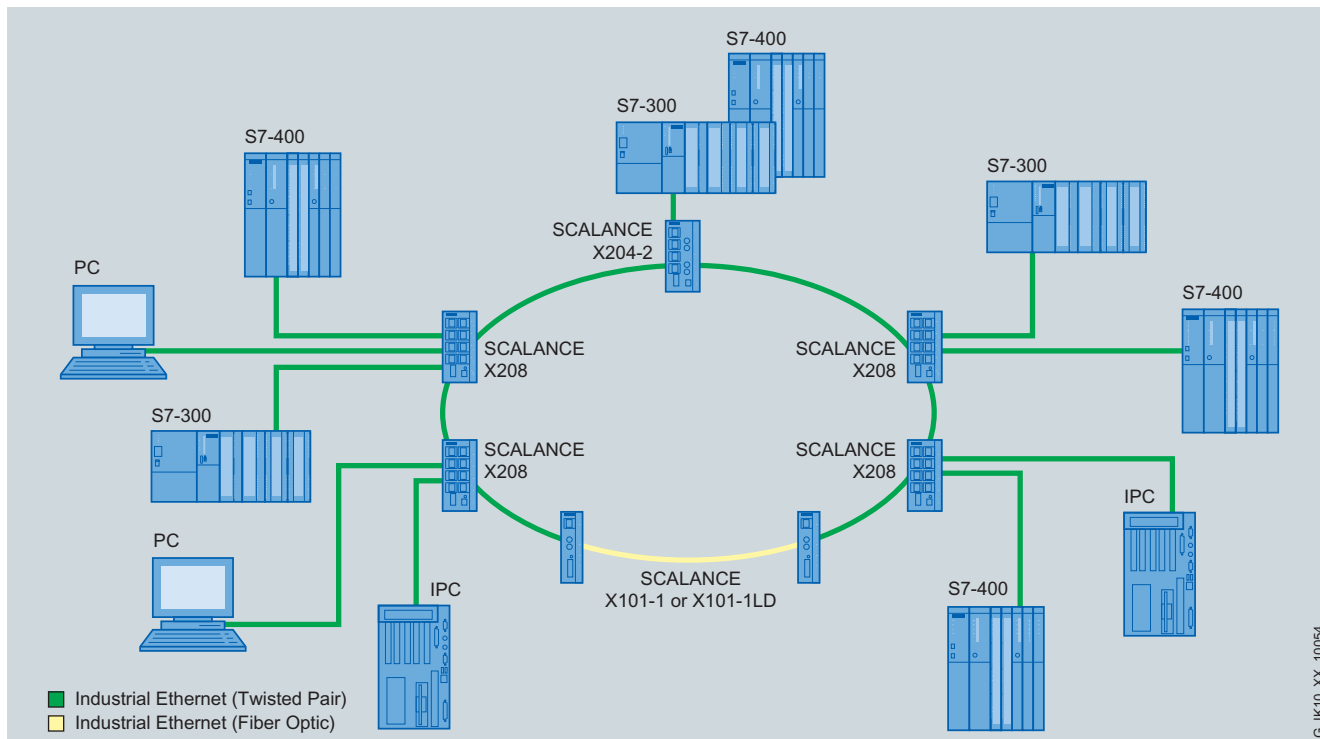

Mixed ring topology with twisted-pair and fiber optic cables

G_IK10_XX_10056

G_IK10_XX_10054

PROFINET/Industrial Ethernet

Industrial Ethernet switches / media converters

SCALANCE X-100 unmanaged media converters

2

Function (continued)

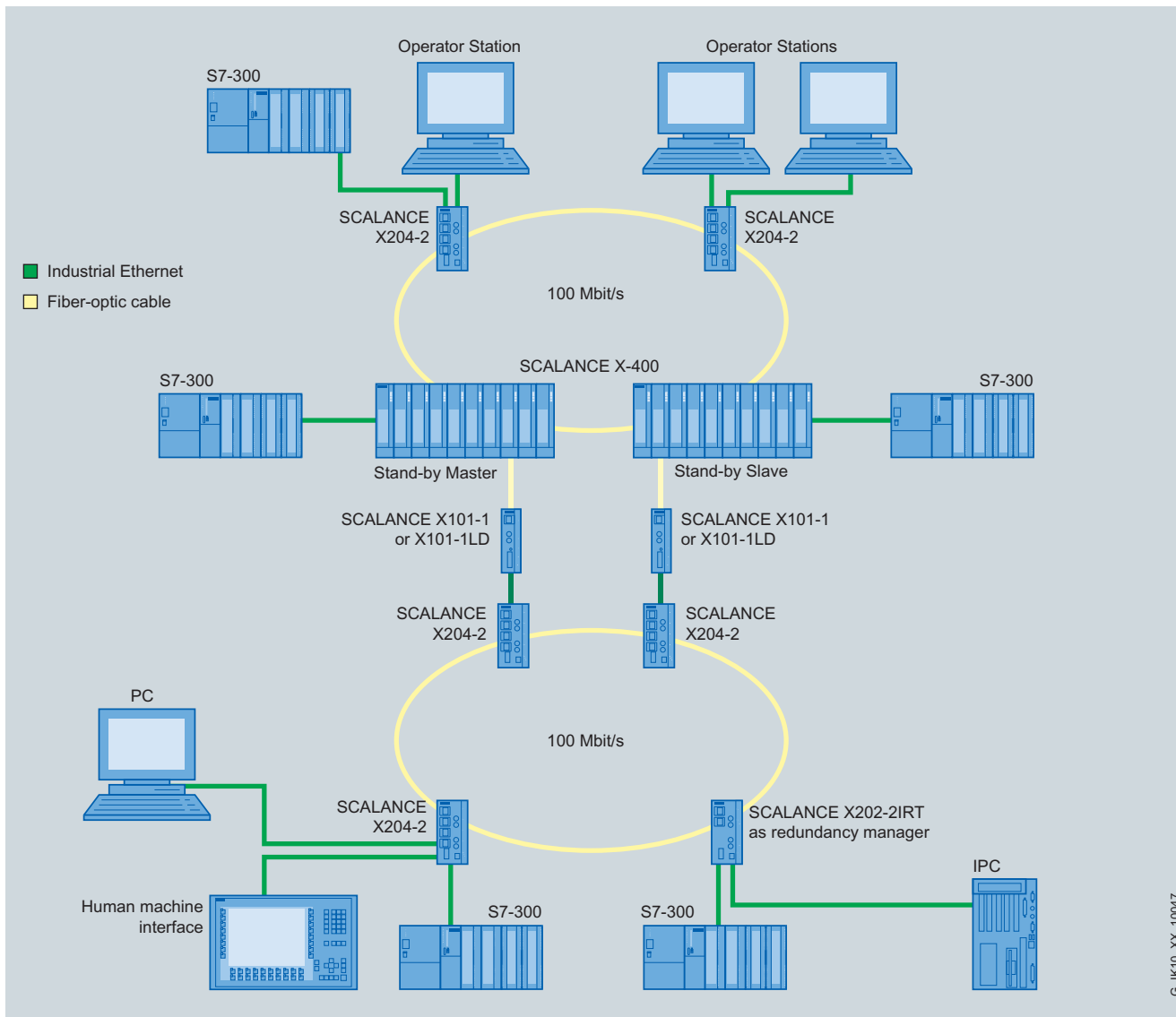

Optical redundant connection of two optical rings with SCALANCE X101-1 or SCALANCE X101-1LD

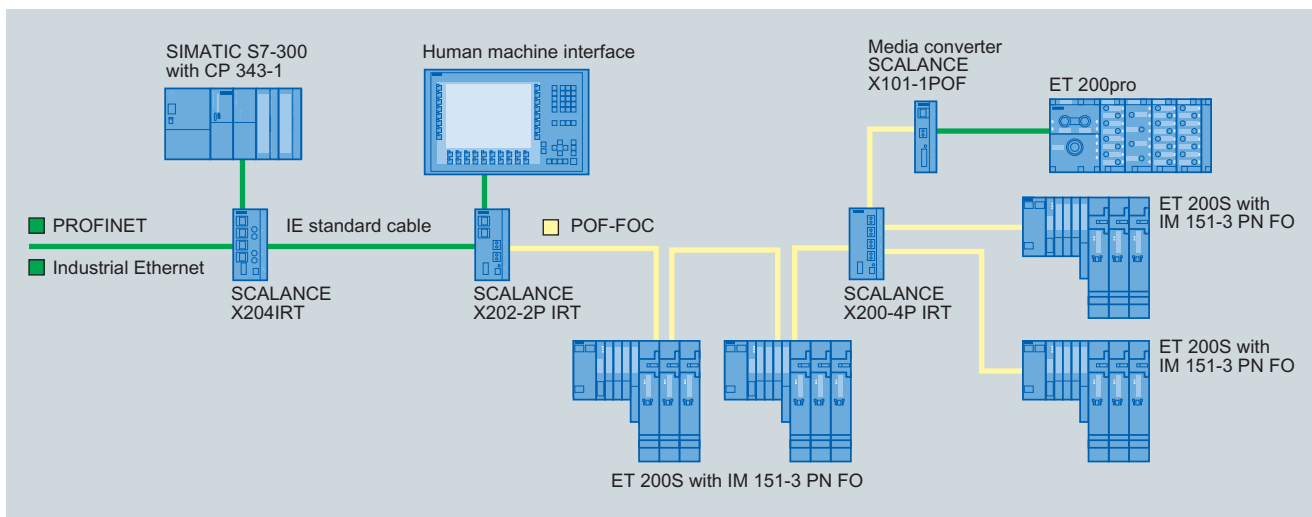

Network structure with plastic fiber optic cabling

PROFINET/Industrial Ethernet

Industrial Ethernet switches / media converters

SCALANCE X-100 unmanaged media converters

Function (continued)

2

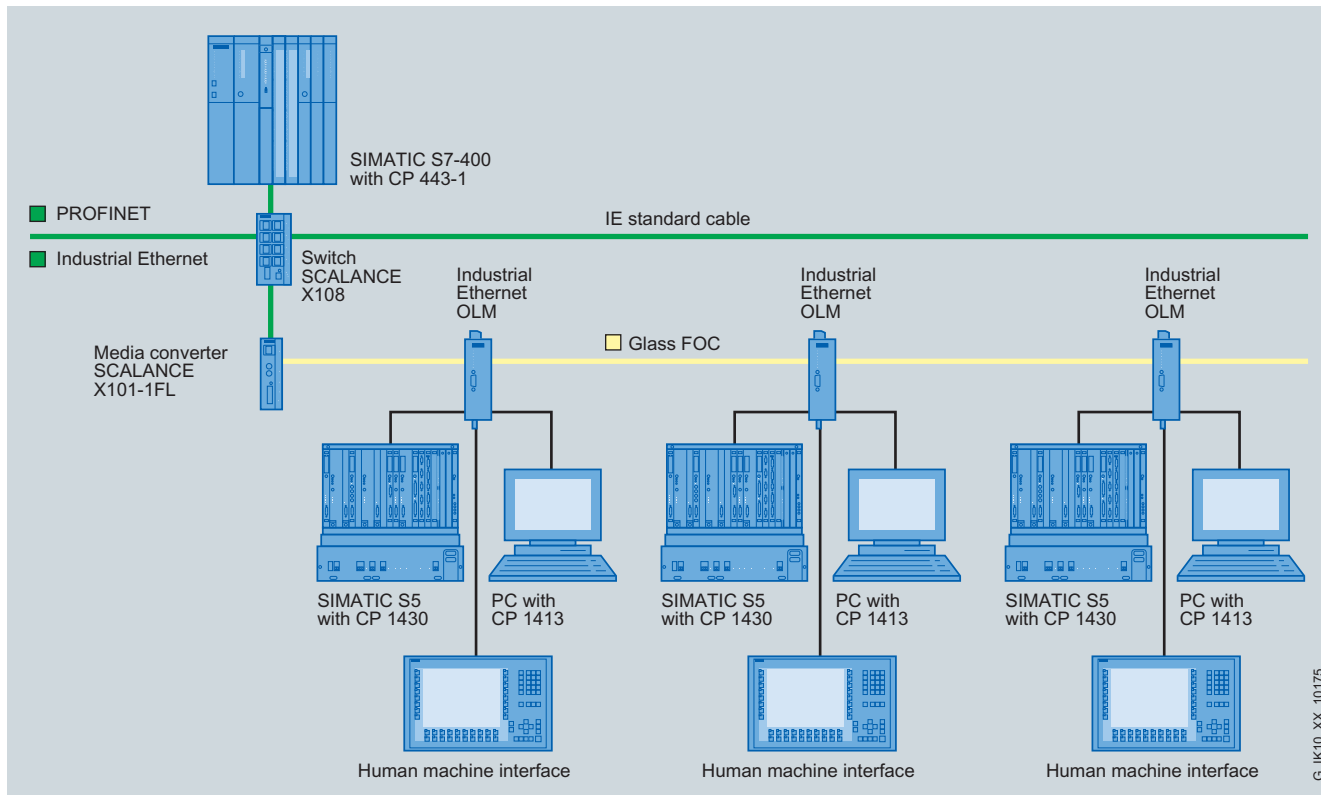

Connection of a 10BaseFL segment to Industrial Ethernet (10/100 Mbit/s) with SCALANCE X101-1FL

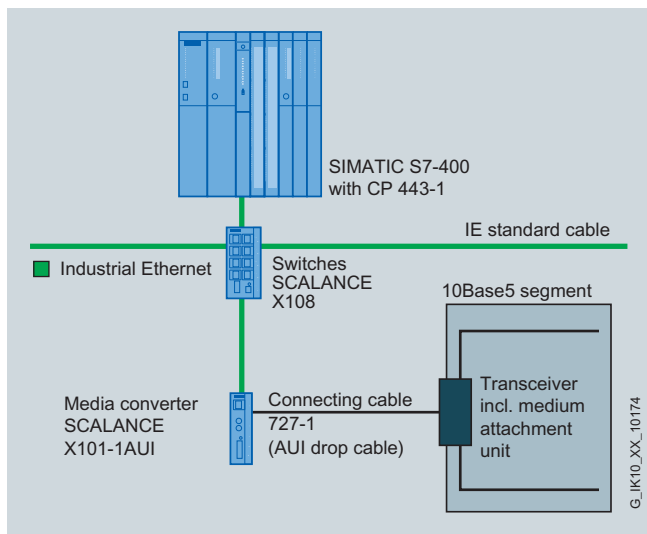

Connection of a 10Base5 segment (e.g. SINEC H1) to Industrial Ethernet (10/100 Mbit/s) with SCALANCE X101-1AU1

Diagnostics

The following information is displayed on site by LEDs:

- Power
- Port status
- Data traffic

The Industrial Ethernet media converters of the SCALANCE X-100 product line can also be monitored using the floating signaling contact. Two media converters of the same type can be connected in cascading mode.

Technical specifications

Order No.	6GK5 101-1BB00-2AA3	6GK5 101-1BC00-2AA3
Product type designation	SCALANCE X101-1	SCALANCE X101-1LD
Transmission rate		
Transmission rate 1	-	-
Transmission rate 2	100 Mbit/s	100 Mbit/s
Interfaces		
Maximum number of electrical/optical connections for network components or terminal equipment	2	2
Number of electrical connections		
• for network components or terminal equipment	1	1
• with power-over-Ethernet for network components or terminal equipment	-	-
• for signaling contact	1	1
• for power supply	1	1
• For redundant power supply	1	1
Design of electrical connection		
• for network components or terminal equipment	RJ45 port	RJ45 port
• with power-over-Ethernet for network components or terminal equipment	-	-
• for signaling contact	2-pin terminal block	2-pin terminal block
• for power supply	4-pin terminal block	4-pin terminal block
Number of optical connections for fiber-optic cables		
• At 10 Mbit/s	-	-
• At 100 Mbit/s	1	1
Design of optical connection for fiber-optic cables		
• At 10 Mbit/s	-	-
• At 100 Mbit/s	BFOC port (multimode up to 5 km)	BFOC port (singlemode up to 26 km)
Injectable optical power relative to 1 mW		
• of transmitter output	-19 ... -14 dB	-5 ... +0 dB
• of the receiver input, maximum	-14 dB	0 dB
Minimum optical sensitivity referred to 1 mW of the receiver input	-31 dB	-35 dB
Minimum required attenuation factor of the FO transmission link	0 dB	0 dB
The range at the optical interface depends on the type of optical fiber used	0 ... 5 km	0 ... 26 km
Inputs/outputs		
Operating voltage of signaling contacts with DC rated value	24 V	24 V
Maximum operating current of signaling contacts with DC	0.1 A	0.1 A
Supply voltage, current consumption, power loss		
Type of power supply	DC	DC
External power supply	24 V	24 V
• Minimum	18 V	18 V
• Maximum	32 V	32 V

PROFINET/Industrial Ethernet

Industrial Ethernet switches / media converters

SCALANCE X-100 unmanaged media converters

Technical specifications (continued)

Order No.	6GK5 101-1BB00-2AA3	6GK5 101-1BC00-2AA3
Product type designation	SCALANCE X101-1	SCALANCE X101-1LD
Product component: fusing at power supply input	Yes	Yes
Type of fusing of power supply input	0.5 A / 60 V	0.5 A / 60 V
Current consumed, maximum	0.12 A	0.12 A
Effective power loss at 24 V with DC	3 W	3 W
Permitted ambient conditions		
Ambient temperature		
• During operation	-10 ... +60 °C	-10 ... +60 °C
• During storage	-40 ... +80 °C	-40 ... +80 °C
• During transport	-40 ... +80 °C	-40 ... +80 °C
Relative humidity at 25 °C without condensation during operation, maximum	95 %	95 %
IP degree of protection	IP30	IP30
Design, dimensions and weights		
Design	Compact	Compact
Width	40 mm	40 mm
Height	125 mm	125 mm
Depth	124 mm	124 mm
Net weight	0.55 kg	0.55 kg
Type of mounting		
• 35 mm DIN rail mounting	Yes	Yes
• Wall mounting	Yes	Yes
• S7-300 rail mounting	Yes	Yes
Type of mounting	-	-
Standards, specifications, approvals		
Standard		
• For EMC of FM	FM3611: Class 1, Division 2, Group A, B, C, D / T., Class 1, Zone 2, Group IIC, T..	FM3611: Class 1, Division 2, Group A, B, C, D / T., Class 1, Zone 2, Group IIC, T..
• for hazardous zone	EN 600079-15 II 3 G EEx nA II T.. KEMA 06 ATEX 0021 X	EN 600079-15 II 3 G EEx nA II T.. KEMA 06 ATEX 0021 X
• For CSA and UL safety	UL 60950-1, CSA C22.2 No. 60950-1	UL 60950-1, CSA C22.2 No. 60950-1
• for hazardous zone of CSA and UL	UL 1604 and UL 2279-15 (Hazardous Location), 1 / Division 2 / Group A, B, C, D / T., Class 1 / Zone 2 / Group IIC / T..	UL 1604 and UL 2279-15 (Hazardous Location), Class 1 / Division 2 / Group A, B, C, D / T., Class 1 / Zone 2 / Group IIC / T..
• For emitted interference	EN 61000-6-3	EN 61000-6-4:2001
• For noise immunity	EN 61000-6-2:2001	EN 61000-6-2:2001
Certificate of suitability	EN 61000-6-2:2001, EN 61000-6-4:2001	EN 61000-6-2:2001, EN 61000-6-4:2001
• CE mark	Yes	Yes
• C-Tick	Yes	Yes
• Railroad application according to EN 50155	-	-
• Railroad application according to EN 50124-1	-	-
Marine classification corporation		
• American Bureau of Shipping Europe Ltd. (ABS)	Yes	Yes
• Bureau Veritas (BV)	Yes	Yes
• Det Norske Veritas (DNV)	Yes	Yes
• Germanischer Lloyd (GL)	Yes	Yes
• Lloyds Register of Shipping (LRS)	Yes	Yes
• Nippon Kaiji Kyokai (NK)	Yes	Yes
• Polski Rejestr Statkow (PRS)	No	No

Technical specifications (continued)

Order No.	6GK5 101-1BH00-2AA3	6GK5 101-1BY00-2AA3	6GK5 101-1BX00-2AA3
Product type designation	SCALANCE X101-1POF	SCALANCE X101-1FL	SCALANCE X101-1AUI
Transmission rate			
Transmission rate 1	-	10 Mbit/s	10 Mbit/s
Transmission rate 2	100 Mbit/s	-	-
Interfaces			
Maximum number of electrical/optical connections for network components or terminal equipment	2	2	2
Number of electrical connections			
• for network components or terminal equipment	1	1	2
• with power-over-Ethernet for network components or terminal equipment	-	-	-
• for signaling contact	1	1	1
• for power supply	1	1	1
• For redundant power supply	1	1	1
Design of electrical connection			
• for network components or terminal equipment	RJ45 port	RJ45 port	RJ45 port, 15-pin D-sub socket
• with power-over-Ethernet for network components or terminal equipment	-	-	-
• for signaling contact	2-pin terminal block	2-pin terminal block	2-pin terminal block
• for power supply	4-pin terminal block	4-pin terminal block	4-pin terminal block
Number of optical connections for fiber-optic cables			
• At 10 Mbit/s	-	1	-
• At 100 Mbit/s	1	-	-
Design of optical connection for fiber-optic cables			
• At 10 Mbit/s	-	BFOC port (multimode up to 5 km)	-
• At 100 Mbit/s	SC-RJ/POF port	-	-
Injectable optical power relative to 1 mW			
• of transmitter output	-6 ... -0.5 dB	-16 ... -9 dB	-
• of the receiver input, maximum	1 dB	-8.2 dB	-
Minimum optical sensitivity referred to 1 mW of the receiver input	-23 dB	-30.6 dB	-
Minimum required attenuation factor of the FO transmission link	0 dB	0 dB	-
The range at the optical interface depends on the type of optical fiber used	0 ... 0.05 km	0 ... 5 km	-
Inputs/outputs			
Operating voltage of signaling contacts with DC rated value	24 V	24 V	24 V
Maximum operating current of signal contacts with DC	0.1 A	0.1 A	0.1 A
Supply voltage, current consumption, power loss			
Type of power supply	DC	DC	DC
External power supply	24 V	24 V	24 V
• Minimum	18 V	18 V	18 V
• Maximum	32 V	32 V	32 V
Product component: fusing at power supply input	Yes	Yes	Yes
Type of fusing of power supply input	0.5 A / 60 V	0.5 A / 60 V	1 A / 33 V
Current consumed, maximum	0.12 A	0.12 A	0.16 A
Effective power loss at 24 V with DC	3 W	3 W	3 W

PROFINET/Industrial Ethernet

Industrial Ethernet switches / media converters

SCALANCE X-100 unmanaged media converters

Technical specifications (continued)

Order No.	6GK5 101-1BH00-2AA3	6GK5 101-1BY00-2AA3	6GK5 101-1BX00-2AA3
Product type designation	SCALANCE X101-1POF	SCALANCE X101-1FL	SCALANCE X101-1AUI
Permitted ambient conditions			
Ambient temperature			
• During operation	-10 ... +60 °C	-10 ... +60 °C	-10 ... +60 °C
• During storage	-40 ... +80 °C	-40 ... +80 °C	-40 ... +80 °C
• During transport	-40 ... +80 °C	-40 ... +80 °C	-40 ... +80 °C
Relative humidity at 25 °C without condensation during operation, maximum	95 %	95 %	95 %
IP degree of protection	IP30	IP30	IP30
Design, dimensions and weights			
Design	Compact	Compact	Compact
Width	40 mm	40 mm	40 mm
Height	125 mm	125 mm	125 mm
Depth	124 mm	124 mm	124 mm
Net weight	0.55 kg	0.55 kg	0.56 kg
Type of mounting			
• 35 mm DIN rail mounting	Yes	Yes	Yes
• Wall mounting	Yes	Yes	Yes
• S7-300 rail mounting	Yes	Yes	Yes
Type of mounting	-	-	-
Product properties, functions, components General			
Cascading with star topology	-	-	-
Standards, specifications, approvals			
Standard			
• For EMC of FM	FM3611: Class 1, Division 2, Group A, B, C, D / T., Class 1, Zone 2, Group IIC, T.	FM3611: Class 1, Division 2, Group A, B, C, D / T., Class 1, Zone 2, Group IIC, T.	FM3611: Class 1, Division 2, Group A, B, C, D / T., Class 1, Zone 2, Group IIC, T.
• for hazardous zone	EN 60079-15 II 3 G EEx nA II T., KEMA 06 ATEX 0021 X	EN 60079-15 II 3 G EEx nA II T., KEMA 06 ATEX 0021 X	EN 60079-15 II 3 G EEx nA II T., KEMA 06 ATEX 0021 X
• For CSA and UL safety	UL 60950-1, CSA C22.2 No. 60950-1	UL 60950-1, CSA C22.2 No. 60950-1	UL 60950-1, CSA C22.2 No. 60950-1
• for hazardous zone of CSA and UL	UL 1604 and UL 2279-15 (Hazardous Location), Class 1 / Division 2 / Group A, B, C, D / T., Class 1 / Zone 2 / Group IIC / T.	UL 1604 and UL 2279-15 (Hazardous Location), Class 1 / Division 2 / Group A, B, C, D / T., Class 1 / Zone 2 / Group IIC / T.	UL 1604 and UL 2279-15 (Hazardous Location), Class 1 / Division 2 / Group A, B, C, D / T., Class 1 / Zone 2 / Group IIC / T.
• For emitted interference	EN 61000-6-3 (Class B)	EN 61000-6-3	EN 61000-6-4:2001
• For noise immunity	EN 61000-6-4:2001	EN 61000-6-2:2001	EN 61000-6-2:2001
Certificate of suitability	EN 61000-6-2:2001, EN 61000-6-4:2001	EN 61000-6-2:2001, EN 61000-6-4:2001	EN 61000-6-2:2001, EN 61000-6-4:2001
• CE mark	Yes	Yes	Yes
• C-Tick	Yes	Yes	Yes
• Railroad application according to EN 50155	-	-	-
• Railroad application according to EN 50124-1	-	-	-
Marine classification corporation			
• American Bureau of Shipping Europe Ltd. (ABS)	Yes	Yes	Yes
• Bureau Veritas (BV)	Yes	Yes	Yes
• Det Norske Veritas (DNV)	Yes	Yes	Yes
• Germanischer Lloyd (GL)	Yes	Yes	Yes
• Lloyds Register of Shipping (LRS)	Yes	Yes	Yes
• Nippon Kaiji Kyokai (NK)	Yes	Yes	Yes
• Polski Rejestr Statkow (PRS)	No	No	No

PROFINET/Industrial Ethernet

Industrial Ethernet switches / media converters

SCALANCE X-100 unmanaged media converters

Ordering data	Order No.
SCALANCE X-100 unmanaged media converter	
<p>Industrial Ethernet media converters, LED diagnostics, fault signaling contact with SET key, redundant power supply, PROFINET-compatible retaining collar; incl. Operating Instructions, Industrial Ethernet network manual and configuration software on CD-ROM</p> <ul style="list-style-type: none"> • SCALANCE X101-1 1 x 10/100 Mbit/s RJ45 Port 1 x 100 Mbit/s multimode BFOC • SCALANCE X101-1LD 1 x 10/100 Mbit/s RJ45 Port 1 x 100 Mbit/s singlemode BFOC • SCALANCE X101-1POF 1 x 10/100 Mbit/s RJ45 Port 1 x 100 Mbit/s POF SC RJ • SCALANCE X101-1AUI 1 x 10/100 Mbit/s RJ45 Port 1 x 10 Mbit/s AUI segment port • SCALANCE X101-1FL 1 x 10/100 Mbit/s RJ45 Port 1 x 10 Mbit/s multimode BFOC 	<p>6GK5 101-1BB00-2AA3</p> <p>6GK5 101-1BC00-2AA3</p> <p>6GK5 101-1BH00-2AA3</p> <p>6GK5 101-1BX00-2AA3</p> <p>6GK5 101-1BY00-2AA3</p>
Accessories	
<p>IE FC TP standard cable GP 2 x 2 (Type A)</p> <p>4-core, shielded TP installation cable for connection to IE FC Outlet RJ45/IE FC RJ45 Plug; PROFINET-compatible; with UL approval; sold by the meter; max. length 1000 m, minimum order quantity 20 m</p>	6XV1 840-2AH10
<p>IE FC RJ45 Plug 180 2 x 2</p> <p>RJ45 plug connector for Industrial Ethernet with a rugged metal housing and integrated insulation displacement contacts for connecting Industrial Ethernet FC installation cables; 180° cable outlet; for network components and CPs/CPUs with Industrial Ethernet interface</p> <ul style="list-style-type: none"> • 1 pack = 1 unit • 1 pack = 10 units • 1 pack = 50 units 	<p>6GK1 901-1BB10-2AA0</p> <p>6GK1 901-1BB10-2AB0</p> <p>6GK1 901-1BB10-2AE0</p>
<p>IE FC stripping tool</p> <p>Preadjusted stripping tool for fast stripping of the Industrial Ethernet FC cables</p>	6GK1 901-1GA00
<p>SITOP compact 24 V/ 0.6 A</p> <p>1-phase power supply with wide-range input 85 – 264 V AC/110 – 300 V DC, stabilized output voltage 24 V, rated output current value 0.6 A, slim design</p>	6EP1 331-5BA00

More information

To assist in selecting the right Industrial Ethernet switches as well as configuration of modular versions, the SIMATIC NET Selection Tool is available:

Online version:
www.siemens.com/snst

Offline version:
www.siemens.com/snst-download

PROFINET/Industrial Ethernet

Industrial Ethernet switches / media converters

SIPLUS SCALANCE X-100 unmanaged / media converter

Overview



- The unmanaged Industrial Ethernet media converters of the SCALANCE X-100 product line are ideally suited for implementing various transmission media in Industrial Ethernet networks operating at 10/100 Mbit/s in a line, star and ring topology
- Electrical or optical connection to stations or network according to the device port type
- Rugged metal housing for space-saving cubicle mounting on standard rails, S7-300 DIN rail or for wall mounting
- Rugged, industry-standard station connections with PROFINET-compatible RJ45 connectors that offer additional strain relief and bending strain relief thanks to latching on the housing
- Redundant power supply
- Diagnostics on the device by means of LEDs (power, link status, data communication)
- Error signaling contact with easy adjustment using the SET button
- Connection of existing 10 Mbit/s fiber-optic networks
- Connection of existing 10Base5 networks (e.g. SINEC H1)

Note:

SIPLUS extreme products are based on Siemens Industry standard products. The contents listed here were taken from the respective standard products. SIPLUS extreme-specific information was added.

SIPLUS SCALANCE X101-1	
Order number	6AG1 101-1BB00-4AA3
Order No. based on	6GK5 101-1BB00-2AA3
Ambient temperature range	-10 ... +60 °C
Conformal coating	Coating of the printed circuit boards and the electronic components
Technical data	The technical data of the standard product applies except for the ambient conditions.

Ambient conditions

Relative humidity	5 ... 100 % Condensation permissible
Biologically active substances	Conformity with EN 60721-3-3, Class 3B2 mold and fungal spores (except fauna)
Chemically active substances	Conformity with EN 60721-3-3, Class 3C4 incl. salt mist and ISA-S71.04 severity level G1; G2; G3; GX ^{1) 2)}
Mechanically active substances	Conformity with EN 60721-3-3, Class 3S4 including conductive sand, dust ²⁾
Air pressure (depending on the highest positive temperature range specified)	1080 ... 795 hPa (-1000 ... +2000 m) see ambient temperature range 795 ... 658 hPa (+2000 ... +3500 m) derating 10 K 658 ... 540 hPa (+3500 ... +5000 m) derating 20 K

¹⁾ ISA-S71.04 severity level GX: Long-term load: SO₂ < 4.8 ppm; H₂S < 9.9 ppm; Cl < 0.2 ppm; HCl < 0.66 ppm; HF < 0.12 ppm; NH₃ < 49 ppm; O₃ < 0.1 ppm; NO_x < 5.2 ppm

Limit value (max. 30 min/d): SO₂ < 17.8 ppm; H₂S < 49.7 ppm; Cl < 1.0 ppm; HCl < 3.3 ppm; HF < 2.4 ppm; O₃ < 1.0 ppm; NO_x < 10.4 ppm

²⁾ The supplied plug covers must remain in place over the unused interface when operated in atmospheres containing corrosive gases!

The technical documentation on SIPLUS can be found here:
www.siemens.com/siplus-extreme

Ordering data	Order No.
SIPLUS SCALANCE X-100 unmanaged media converter	
SIPLUS SCALANCE X101-1	6AG1 101-1BB00-4AA3
1 x 10/100 Mbit/s RJ45 port 1 x 100 Mbit/s multi-mode BFOC	
Accessories	See ordering data for SCALANCE X-100 unmanaged



Overview

SCALANCE X-200	Type of device	Hardware																
		Connection to S7 backplane bus	Format module S7	PC module	Fiat type of construction	Box type of construction	19" type of construction	Rugged, compact housing	Modular design	10 Gigabit Ethernet	Gigabit Ethernet	PoE (Power over Ethernet)	LED diagnosis	SIMATIC environment	Redundant power supply (2 x 24 V DC)	External supply for integrated switch	Signal contact	Local display (SET pushbutton)
X204-2							•					•	•	•		•	•	•
X204-2TS							•					•	•	•		•	•	•
X204-2LD							•					•	•	•		•	•	•
X206-1							•					•	•	•		•	•	•
X206-1LD							•					•	•	•		•	•	•
X208							•					•	•	•		•	•	•
X208PRO							•					•	•	•		•	•	•
X212-2							•					•	•	•		•	•	•
X212-2LD							•					•	•	•		•	•	•
X216							•					•	•	•		•	•	•
X224							•					•	•	•		•	•	•
XF204				•								•	•	•		•	•	•
XF204-2				•								•	•	•		•	•	•
XF206-1				•								•	•	•		•	•	•
XF208				•								•	•	•		•	•	•

• applies

G_IK10_XX_10312

Function overview SCALANCE X-200 managed: Hardware

PROFINET/Industrial Ethernet

Industrial Ethernet switches / media converters

SCALANCE X-200 managed

Overview (continued)

2

SCALANCE X-200	Type of device	Software																										
		Security Integrated (Firewall/VPN)	PROFINET diagnosis	Topology support (LLDP)	Command Line Interface / Telnet	Web based Management	Configuration with STEP 7	SNMP	Ring redundancy incl. RM-functionality	Standby redundancy	IRT capability	VLAN (Virtual Local Area Network)	GVRP (Generic VLAN Registration Protocol)	STP/ RSTP (Spanning Tree Protocol/ Rapid Spanning Tree Protocol)	Passive Listening	IGMP Snooping/Querier (Internet Group Management Protocol)	GMRP (Generic Multicast Protocol)	Broadcast/ Multicast/ Unicast Limiter	Broadcast blocking	DHCP Option 82 (Dynamic Host Configuration Protocol)	IP Access List	Access Control List (MAC)	IEEE 802.1x (Radius)	Link Aggregation	Static Routing	RIPv2 (Dynamic Routing)	OSPFv2 (Dynamic Routing)	VRRP, Router Redundancy (Virtual Router Redundancy Protocol)
X204-2		•	•	•	•	•	•	•						•														
X204-2TS		•	•	•	•	•	•	•						•														
X204-2LD		•	•	•	•	•	•	•						•														
X206-1		•	•	•	•	•	•	•						•														
X206-1LD		•	•	•	•	•	•	•						•														
X208		•	•	•	•	•	•	•						•														
X208PRO						•	•	•																				
X212-2		•	•	•	•	•	•	•						•														
X212-2LD		•	•	•	•	•	•	•						•														
X216		•	•	•	•	•	•	•						•														
X224		•	•	•	•	•	•	•						•														
XF204		•	•	•	•	•	•	•						•														
XF204-2		•	•	•	•	•	•	•						•														
XF206-1		•	•	•	•	•	•	•						•														
XF208		•	•	•	•	•	•	•						•														

• applies

G_IK10_XX_10313

Function overview SCALANCE X-200 managed: Software

PROFINET/Industrial Ethernet

Industrial Ethernet switches / media converters

SCALANCE X-200 managed

Overview



The managed Industrial Ethernet switches of the SCALANCE X-200 line are optimized for setting up Industrial Ethernet networks at data transfer rates of 10/100 Mbit/s in a line, star or ring topology.

- Integrated redundancy manager for constructing Fast Ethernet ring topologies with high-speed media redundancy (excluding SCALANCE X208PRO)
- Electrical or optical connection to stations or network in accordance with the port type of the devices
- Rugged metal enclosure in S7-300 format for mounting on standard rail, S7-300 standard mounting rail or for direct wall mounting in various positions
- Rugged, industry-standard node connections with PROFINET-compliant RJ45 connectors that are latched onto the housing to provide additional strain and bending relief
- Redundant power supply
- Diagnostics on the device by means of LEDs (power, link status, data communication)
- Error signaling contact with easy adjustment using the SET button
- PROFINET diagnostics, SNMP access, integrated web server and automatic e-mail transmission function for remote diagnostics and signaling via the network

Benefits

get Designed for Industry

- Ideal solution for configuring Industrial Ethernet line, star and ring topologies
- Reliable plug-in connection thanks to rugged, industry-standard device connection in conjunction with PROFINET-compliant FastConnect connectors
- High network availability through design of redundant ring structures (Redundancy Manager integrated, except for SCALANCE X208PRO)
- Integration of the SCALANCE X-200 switches in the existing network management infrastructure through SNMP access point
- Easy integration in the process diagnosis and system diagnosis with PROFINET
- Configuration and diagnostics integrated into STEP 7 provide significant benefits during engineering, commissioning, and the operating phase of a plant
- Module replacement without the need for a programming device, using the C-PLUG swap media for backing up the configuration data

Application

The SCALANCE X-200 Industrial Ethernet switches permit cost-effective configuration of Industrial Ethernet line, star or ring topologies with switching functionality for networks in which high availability or remote diagnostics options are required. The devices with IP30 degree of protection have been designed for use in the control cabinet. The SCALANCE X208PRO, is designed to the IP65 degree of protection for installation outside the control cabinet. The SCALANCE X204-2TS (TS = Transportation Systems) is suitable for use in railway applications due to its specification according to EN 50155.

2

PROFINET/Industrial Ethernet

Industrial Ethernet switches / media converters

SCALANCE X-200 managed

Application (continued)

Product versions

- Switches with electrical and optical ports for glass multimode FOC up to 5 km:
 - *SCALANCE X204-2*;
for constructing optical line or ring topologies with four electrical ports and two optical ports
 - *SCALANCE X204-2TS* (*degree of protection IP20*);
for setting up optical line or ring topologies with four electrical ports and two optical ports especially for railway applications (EN 50155) with extended temperature range
 - *SCALANCE X206-1*;
for setting up star topologies with 6 electrical ports and 1 optical port,
line or ring topologies with electrical and optical transmission paths
 - *SCALANCE X212-2*;
for constructing optical line or ring topologies with 12 electrical ports and two optical ports
- Switches with electrical and optical ports for glass single mode FOC up to 26 km:
 - *SCALANCE X204-2LD*;
for constructing optical line or ring topologies with 4 electrical ports and 2 optical ports
 - *SCALANCE X206-1LD*;
for constructing star topologies with 6 electrical ports and 1 optical port,
line or ring topologies with electrical and optical transmission paths
 - *SCALANCE X212-2LD*;
for constructing optical line or ring topologies with 12 electrical ports and 2 optical ports

- Switches with electrical ports for configuring electrical Industrial Ethernet line, star or ring topologies:
 - *SCALANCE X208*;
with 8 electrical ports for mounting in the control cabinet
 - *SCALANCE X208PRO* (*IP65 degree of protection*);
with 8 electrical ports especially for use outside the control cabinet (M12 connection system)
 - *SCALANCE X216*;
with 16 electrical ports for mounting in the control cabinet
 - *SCALANCE X224*;
with 24 electrical ports for mounting in the control cabinet

Features:

- The RJ45 ports are industry-standard and feature additional retaining collars (except for SCALANCE X208PRO), for connection to the IE FC RJ45 Plug 180
- The eight PROFINET-compliant M12 ports of the SCALANCE X208PRO are designed with IP65 degree of protection for connection to the IE M12 Plug PRO or the pre-assembled IE M12 connecting cable
- The SCALANCE X208PRO can be mounted on a DIN rail or S7-300 rail or direct on the equipment or machine; the status information can be read off regardless of the mounting position thanks to the angled LED strip.
- Power can also be supplied to the SCALANCE X208PRO from outside the control cabinet from the PS791-1PRO power supply module at 230 V AC.

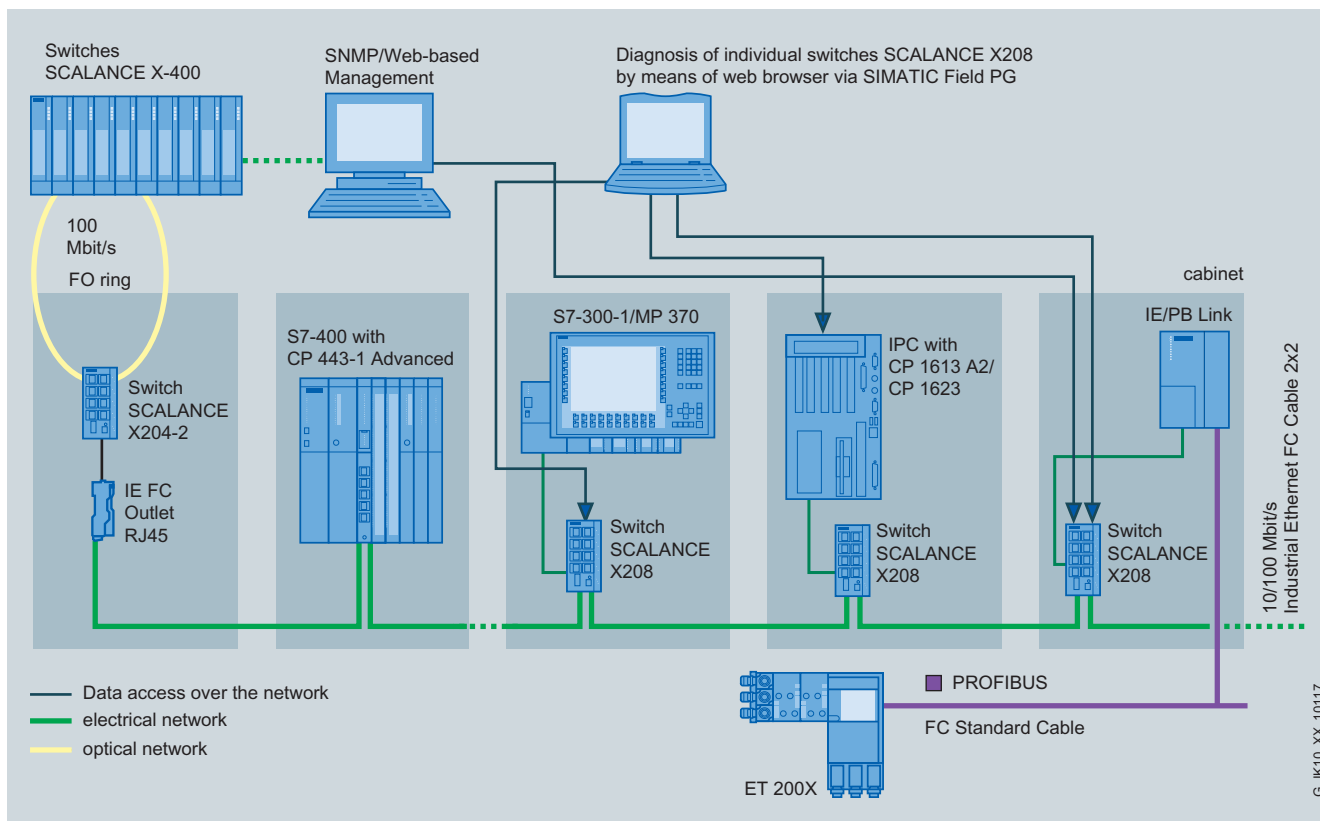

Diagnostics access over SNMP and Web browser with SCALANCE X208

Design

The SCALANCE X-200 Industrial Ethernet switches with a rugged metal housing are optimized for mounting on a standard rail and an S7-300 rail. Direct wall mounting in various positions is also possible. Thanks to the S7-300 housing dimensions, the devices are suitable for integration into an automation solution with S7-300 components.

The switches with IP20/IP30 degree of protection feature:

- A 4-pole terminal block for connecting the redundant supply voltage (2 x 24 V DC)
- A row of LEDs to indicate the status information (power, link status, data exchange, power supply, signaling contact)
- A 2-pole terminal block for connecting the floating signaling contact
- A SET button for on-site configuration of the signaling contact

The SCALANCE X208PRO with IP65 degree of protection features:

- 2 x M12 interfaces for connecting the redundant supply voltage (2 x 24 V DC)
- A row of LEDs to indicate the status information (power, link status, data exchange, power supply, signaling contact)
- An M12 interface for connecting the isolated signaling contact

The SCALANCE X-200 switches are available with the following port types:

- *10/100BaseTX, RJ45 or M12 connection;*
RJ45 or M12 port, automatic detection of the data rate (10 or 100 Mbit/s), with Autosensing and Autocrossover functions for connecting IE FC cables using IE FC RJ45 Plug 180 or IE M12 Plug PRO up to 100 m.
- *100BaseFX, BFOC connection technique;*
BFOC ports for direct connection to Industrial Ethernet glass fiber-optic cables up to 5 km (multimode FOC) or up to 26 km (singlemode FOC) for configuring line, ring and star topologies.

Function

- Configuring electrical and optical Industrial Ethernet line, star and ring topologies
- Fast redundancy in the ring with High Speed Redundancy (HSR); up to 0.3 seconds for reconfiguration of the ring with 50 switches in the ring
- The functioning of the ring is continuously monitored by the integrated redundancy manager (with the exception of SCALANCE X208 PRO). It recognizes failure of a transmission path in the ring or failure of a SCALANCE X-200 and activates the substitute path within 0.3 seconds
- Use in ring topologies (100 Mbit/s) together with SCALANCE X-300, SCALANCE X-400 and SCALANCE X-500
- Uncrossed connecting cables can be used due to Autocrossover function integrated in the ports
- Easy diagnostics using signaling contact, SNMP and Web browser
- Easy copper cable diagnostics with Web browser for localizing cable breaks
- Integration into the diagnostics of a PROFINET I/O controller with expanded diagnostics functions for a consistent diagnostics concept, including network infrastructure
- Diagnosis of data traffic by means of a parameterizable mirror port with a standard commercial network analyzer
- Optimized support of PROFINET real-time communication (RT) through prioritizing
- Fast device replacement in the event of a fault by using the optional C-PLUG swap medium (not included in scope of supply)

Network topology and network configuration

The Industrial Ethernet SCALANCE X-200 switches with IP30 degree of protection are usually installed in a control cabinet together with the stations to be connected. Electrical and optical versions can be installed together in star, line and ring topologies. The SCALANCE X208PRO is designed for installation outside the control cabinet.

When configuring the network, it is necessary to observe the following boundary conditions:

- Length of the TP cable between two SCALANCE X switches:
 - Max. 100 m with IE FC cable and IE FC RJ45 Plug 180 or IE FC M12 Plug PRO
 - Max. 10 m using patches with TP cord
- Length of the optical cables
 - Max. 5000 m with Industrial Ethernet glass fiber optic cables (multimode)
 - Max. 26000 m with Industrial Ethernet glass fiber optic cables (singlemode)
- IP Address:
The IP address is assigned by means of the DHCP (Dynamic Host Configuration Protocol). If there is no corresponding server in the network, the IP address can be assigned using the supplied software tool PST (Primary Setup Tool) or STEP 7.

PROFINET/Industrial Ethernet

Industrial Ethernet switches / media converters

SCALANCE X-200 managed

Function (continued)

2

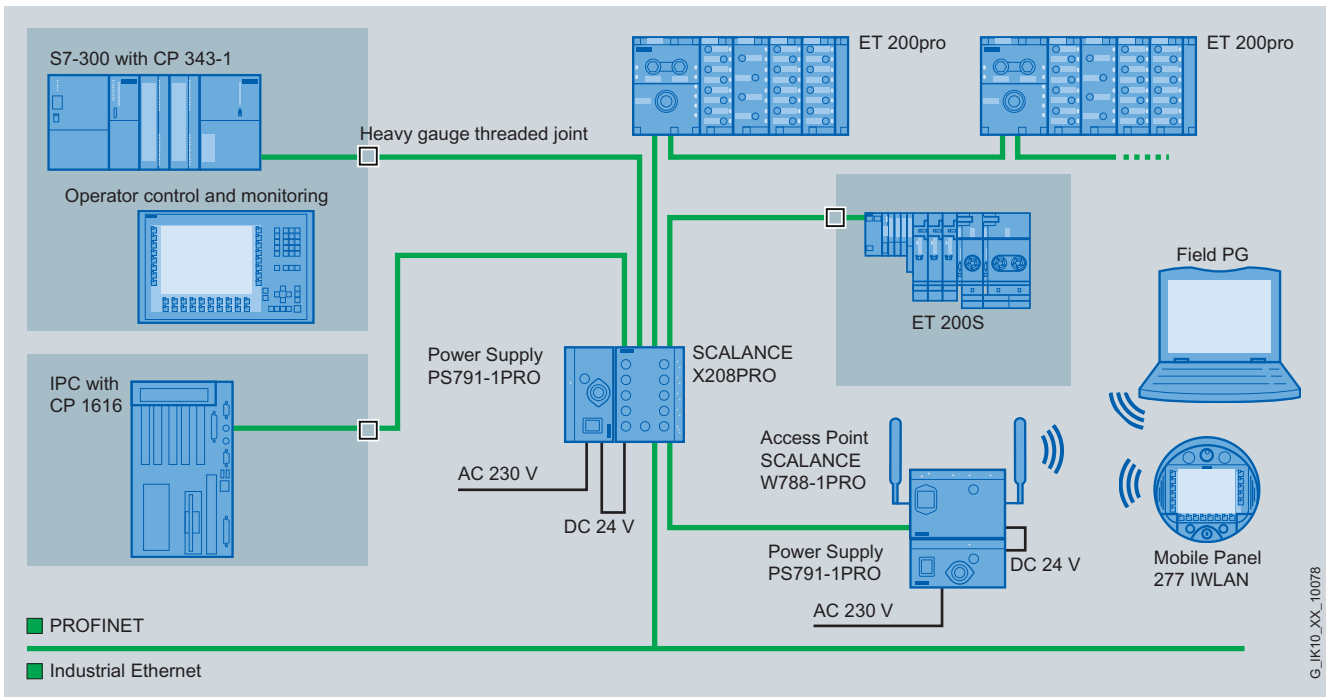

G_IK10_XX_10078

Star network topology with SCALANCE X208PRO outside the control cabinet and 230 V AC power supply

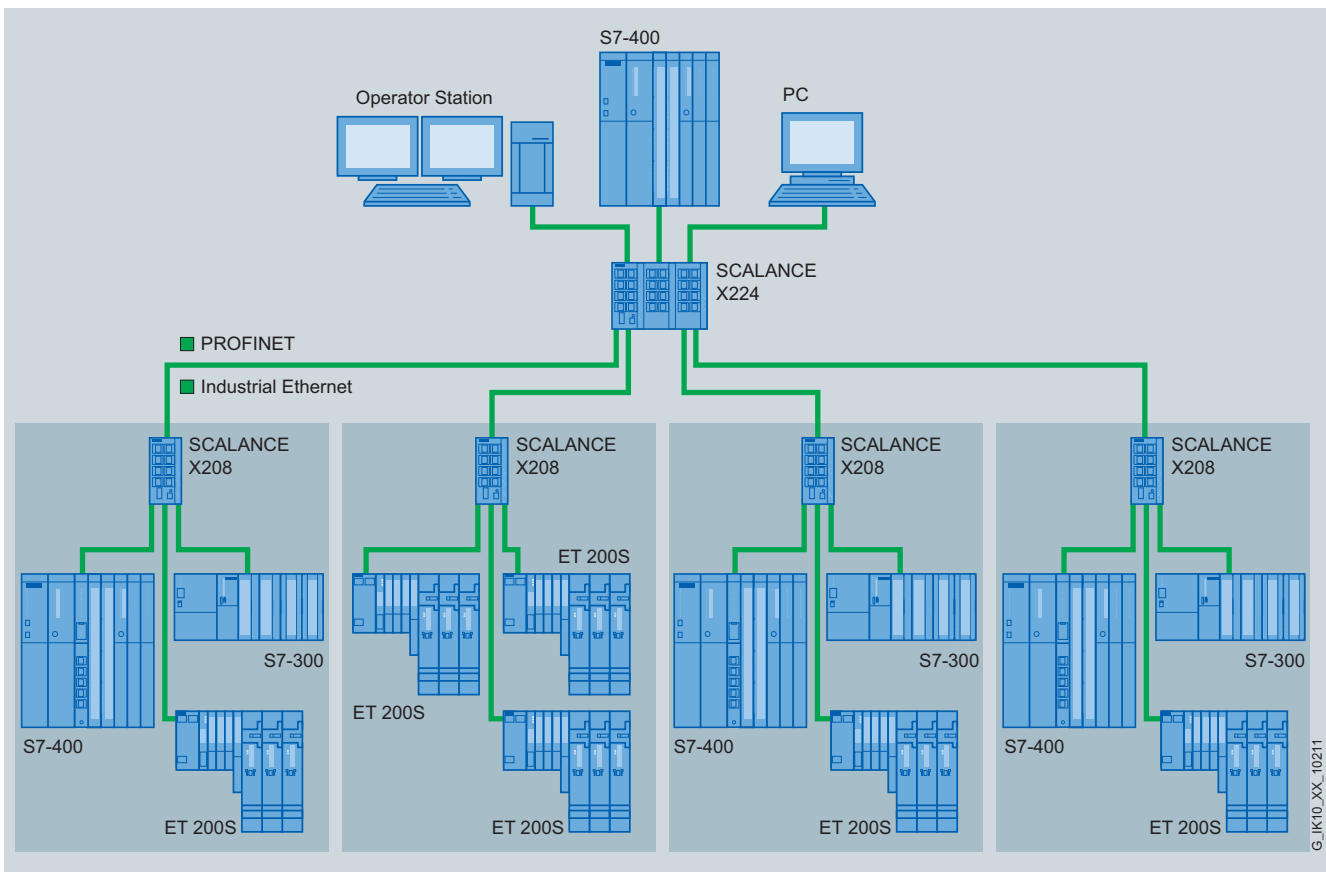

G_IK10_XX_10211

Star topology with SCALANCE X224

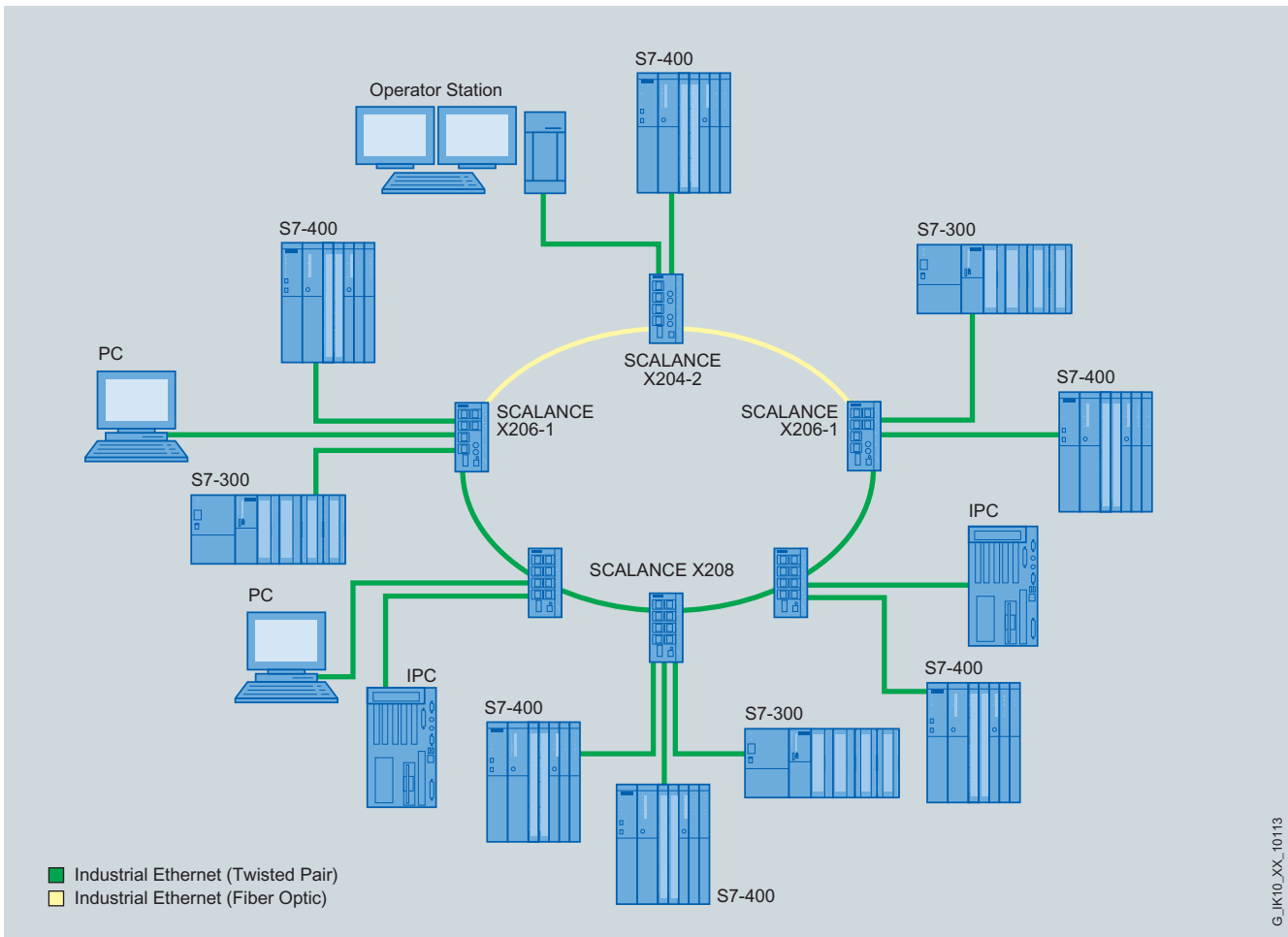
Function (continued)

High-speed redundancy in mixed ring with fiber-optic and twisted-pair cables

Commissioning and diagnosis

PROFINET diagnostic interrupts from SCALANCE X 200 Switches can be displayed with the appropriate SIMATIC Engineering Tools and processed in the controller with expanded diagnostics function. The engineering outlay for the PLC and HMI have been drastically reduced due to the complete integration in the SIMATIC concept for system error messages.

The SCALANCE X-200 Industrial Ethernet switches can also be integrated into a network management system such as SINEMA Server through the standardized Simple Network Management Protocol (SNMP). If faults occur on the device, error messages (SNMP traps) can be sent to a network management system or as e-mail to a specified network administrator.

The integral Web server enables configuration and diagnostics settings to be made using a standard browser (e.g. port configuration). Statistical information can also be read out over the Web server (e.g. port capacity utilization).

The following information is displayed on site by LEDs:

- Power
- Port status
- Data traffic
- Signaling contact
- Redundancy manager function (excluding SCALANCE X208 PRO)

The Industrial Ethernet switches of the SCALANCE X-200 line can also be monitored using the floating signaling contact.

PROFINET/Industrial Ethernet

Industrial Ethernet switches / media converters

SCALANCE X-200 managed

Technical specifications

Order No.	6GK5 204-2BB10-2AA3	6GK5 204-2BC10-2AA3	6GK5 204-2BB10-2CA2
Product type designation	SCALANCE X204-2	SCALANCE X204-2LD	SCALANCE X204-2TS
Transmission rate			
Transmission rate 1	10 Mbit/s	10 Mbit/s	10 Mbit/s
Transmission rate 2	100 Mbit/s	100 Mbit/s	100 Mbit/s
Interfaces			
Number of electrical/optical connections			
• for network components or terminal equipment, maximum	6	6	6
• as combo port for network components or terminal equipment	-	-	-
Number of electrical connections			
• for network components or terminal equipment	4	4	4
• for signaling contact	1	1	1
• for power supply	1	1	1
• For redundant power supply	1	1	1
Design of electrical/optical connections for network components or terminal equipment			
Design of electrical connection			
• for network components or terminal equipment	RJ45 port	RJ45 port	RJ45 port
• for signaling contact	2-pin terminal block	2-pin terminal block	2-pin terminal block
• for power supply	4-pin terminal block	4-pin terminal block	4-pin terminal block
Number of optical connections for fiber-optic cables at 100 Mbit/s	2	2	2
Design of optical connection for fiber-optic cables at 100 Mbit/s	BFOC port (multimode up to 5 km)	BFOC port (singlemode up to 26 km)	BFOC port (multimode up to 5 km)
Coupled-in optical power referred to 1 mW			
• of transmitter output	-19 ... -14 dB	-15 ... -7 dB	-19 ... -14 dB
• of the receiver input, maximum	-	-	-
Minimum optical sensitivity relative to 1 mW of the receiver input	-34 dB	-34 dB	-34 dB
Minimum required damping factor of FO transmission link	0 dB	0 dB	0 dB
The range at the optical interface depends on the type of optical fiber used	0 ... 5 km	0 ... 26 km	0 ... 5 km
Design of swap medium C-Plug	Yes	Yes	Yes
Inputs/outputs			
Operating voltage of signaling contacts with DC rated value	24 V	24 V	24 V
Maximum operating current of signal contacts with DC	0.1 A	0.1 A	0.05 A

2

Technical specifications (continued)

Order No.	6GK5 204-2BB10-2AA3	6GK5 204-2BC10-2AA3	6GK5 204-2BB10-2CA2
Product type designation	SCALANCE X204-2	SCALANCE X204-2LD	SCALANCE X204-2TS
Supply voltage, current consumption, power loss			
Type of supply voltage	DC	DC	DC
External supply voltage	24 V	24 V	12 V ... 24 V
• Minimum	18 V	18 V	10 V
• Maximum	32 V	32 V	30 V
Product component: fusing at power supply input	Yes	Yes	Yes
Design of fusing at input for supply voltage	0.6 A / 60 V	0.6 A / 60 V	3 A / 32 V
Current consumption, maximum	0.265 A	0.265 A	0.6 A
Effective power loss at 24 V with DC	6.36 W	6.36 W	6.6 W (with 12 V DC)
Permissible ambient conditions			
Ambient temperature			
• During operation	-40 ... +60 °C	-40 ... +60 °C	-40 ... +70 °C
• During storage	-40 ... +70 °C	-40 ... +70 °C	-40 ... +70 °C
• During transport	-40 ... +70 °C	-40 ... +70 °C	-40 ... +70 °C
• Note	-	-	If the IE switch X204-2TS is installed horizontally, a maximum ambient temperature of +40 °C is permitted
Relative humidity at 25 °C without condensation during operation, maximum	95 %	95 %	95 %
IP degree of protection	IP30	IP30	IP20
Design, dimensions and weights			
Design	Compact	Compact	Compact
Width	60 mm	60 mm	60 mm
Height	125 mm	125 mm	125 mm
Depth	124 mm	124 mm	124 mm
Net weight	0.78 kg	0.78 kg	0.78 kg
Type of mounting			
• 35 mm DIN rail mounting	Yes	Yes	Yes
• Wall mounting	Yes	Yes	Yes
• S7-300 rail mounting	Yes	Yes	Yes
Product properties, functions, components			
General			
Cascading with redundant ring at reconfiguration time < 0.3 s	50	50	50
Cascading with star topology	Any (only dependent on signal propagation time)	Any (only dependent on signal propagation time)	Any (only dependent on signal propagation time)

PROFINET/Industrial Ethernet

Industrial Ethernet switches / media converters

SCALANCE X-200 managed

Technical specifications (continued)

Order No.	6GK5 204-2BB10-2AA3	6GK5 204-2BC10-2AA3	6GK5 204-2BB10-2CA2
Product type designation	SCALANCE X204-2	SCALANCE X204-2LD	SCALANCE X204-2TS
Product functions Management, configuration, programming			
Product function			
• CLI	Yes	Yes	Yes
• Web-based management	Yes	Yes	Yes
• MIB support	Yes	Yes	Yes
• TRAPs via e-mail	Yes	Yes	Yes
• Configuration with STEP 7	Yes	Yes	Yes
• SMTP server	Yes	Yes	Yes
• Port mirroring	Yes	Yes	Yes
• with IRT PROFINET IO Switch	No	No	No
• PROFINET IO diagnostics	Yes	Yes	Yes
• Switch-managed	Yes	Yes	Yes
Protocol is supported			
• Telnet	Yes	Yes	Yes
• HTTP	Yes	Yes	Yes
• HTTPS	Yes	Yes	Yes
• TFTP	Yes	Yes	Yes
• FTP	Yes	Yes	Yes
• BOOTP	No	No	No
• SNMP v1	Yes	Yes	Yes
• SNMP v2	Yes	Yes	Yes
• SNMP v3	Yes	Yes	Yes
• DCP	Yes	Yes	Yes
• LLDP	Yes	Yes	Yes
Identification & maintenance			
• I&MO - device-specific information	Yes	Yes	Yes
• I&M1 - higher-level designation/ location designation	Yes	Yes	Yes
Product functions Diagnostics			
Product function			
• Port diagnostics	Yes	Yes	Yes
• Packet Size Statistics	Yes	Yes	Yes
• Packet Type Statistics	Yes	Yes	Yes
• Error Statistics	Yes	Yes	Yes
Product functions DHCP			
Product function DHCP client	Yes	Yes	Yes
Product functions Redundancy			
Product function			
• Ring redundancy	Yes	Yes	Yes
• Redundancy manager	Yes	Yes	Yes
• Standby redundancy	No	No	No
• Redundancy procedure HSR	Yes	Yes	Yes
• Redundancy procedure MRP	Yes	Yes	Yes
• Redundancy procedure PRP	No	No	No
• Passive listening	Yes	Yes	Yes
Product functions Security			
Protocol is supported SSH	Yes	Yes	Yes
Product functions Time			
Product function			
• SICLOCK support	Yes	Yes	Yes
Protocol is supported			
• NTP	No	No	No
• SNTP	Yes	Yes	Yes

PROFINET/Industrial Ethernet

Industrial Ethernet switches / media converters

SCALANCE X-200 managed

Technical specifications (continued)

Order No.	6GK5 204-2BB10-2AA3	6GK5 204-2BC10-2AA3	6GK5 204-2BB10-2CA2
Product type designation	SCALANCE X204-2	SCALANCE X204-2LD	SCALANCE X204-2TS
Standards, specifications, approvals			
Standard			
• for EMC of FM	FM3611: Class 1, Division 2, Group A, B, C, D / T4, CL.1, Zone 2, GP. IIC, T4	FM3611: Class 1, Division 2, Group A, B, C, D / T4, CL.1, Zone 2, GP. IIC, T4	FM3611: Class 1, Division 2, Group A, B, C, D / T4, CL.1, Zone 2, GP. IIC, T4
• For hazardous zone	EN 60079-0: 2006, EN 60079-15: 2005, II 3 G Ex nA II T4 KEMA 07 ATEX 0145X	EN 60079-0: 2006, EN 60079-15: 2005, II 3 G Ex nA II T4 KEMA 07 ATEX 0145X	EN 60079-0: 2006, EN 60079-15: 2005, II 3 G Ex nA II T4 KEMA 07 ATEX 0145X
• For CSA and UL safety	UL 60950-1, CSA C22.2 No. 60950-1	UL 60950-1, CSA C22.2 No. 60950-1	UL 60950-1, CSA C22.2 No. 60950-1
• For CSA and UL hazardous zone	ANSI / ISA 12.12.01, CSA C22.2 No. 213-M1987, CL. 1 / Div. 2 / GP. A, B, C, D T4, CL. 1 / Zone 2 / GP. IIC, T4	ANSI / ISA 12.12.01, CSA C22.2 No. 213-M1987, CL. 1 / Div. 2 / GP. A, B, C, D T4, CL. 1 / Zone 2 / GP. IIC, T4	ANSI / ISA 12.12.01, CSA C22.2 No. 213-M1987, CL. 1 / Div. 2 / GP. A, B, C, D T4, CL. 1 / Zone 2 / GP. IIC, T4
• For emitted interference	EN 61000-6-4:2001 (Class A)	EN 61000-6-4 (Class A)	EN 61000-6-4 (Class A)
• For noise immunity	EN 61000-6-4:2001	EN 61000-6-2	EN 61000-6-2
Certificate of suitability	EN 61000-6-4:2001	EN 61000-6-2, EN 61000-6-4	EN 61000-6-2, EN 61000-6-4
• CE marking	Yes	Yes	Yes
• C-Tick	Yes	Yes	Yes
• Railroad application according to EN 50155	No	No	Yes
• Railroad application according to EN 50124-1	No	No	No
Marine classification association			
• American Bureau of Shipping Europe Ltd. (ABS)	Yes	Yes	No
• Bureau Veritas (BV)	Yes	Yes	No
• Det Norske Veritas (DNV)	Yes	Yes	No
• Germanischer Lloyd (GL)	Yes	Yes	No
• Lloyds Register of Shipping (LRS)	Yes	Yes	No
• Nippon Kaiji Kyokai (NK)	Yes	Yes	No
• Polski Rejestr Statkow (PRS)	Yes	Yes	No

Order No.	6GK5 206-1BB10-2AA3	6GK5 206-1BC10-2AA6	6GK5 208-0BA10-2AA3	6GK5 208-0HA00-2AA6
Product type designation	SCALANCE X206-1	SCALANCE X206-1LD	SCALANCE X208	SCALANCE X208PRO
Transmission rate				
Transmission rate 1	10 Mbit/s	10 Mbit/s	10 Mbit/s	10 Mbit/s
Transmission rate 2	100 Mbit/s	100 Mbit/s	100 Mbit/s	100 Mbit/s
Interfaces				
Number of electrical/optical connections				
• for network components or terminal equipment, maximum	7	7	8	8
• as combo port for network components or terminal equipment	-	-	-	-
Number of electrical connections				
• for network components or terminal equipment	6	6	8	8
• for signaling contact	1	1	1	1
• for power supply	1	1	1	1
• For redundant power supply	1	1	1	1

PROFINET/Industrial Ethernet

Industrial Ethernet switches / media converters

SCALANCE X-200 managed

Technical specifications (continued)

Order No.	6GK5 206-1BB10-2AA3	6GK5 206-1BC10-2AA6	6GK5 208-0BA10-2AA3	6GK5 208-0HA00-2AA6
Product type designation	SCALANCE X206-1	SCALANCE X206-1LD	SCALANCE X208	SCALANCE X208PRO
Design of electrical/optical connections for network components or terminal equipment				
Design of electrical connection				
• for network components or terminal equipment	RJ45 port	RJ45 port	RJ45 port	M12 port, 4-pin, d-coded
• for signaling contact	2-pin terminal block	2-pin terminal block	2-pin terminal block	5-pin M12 socket (b-coded)
• for power supply	4-pin terminal block	4-pin terminal block	4-pin terminal block	4-pin M12 interface (a-coded)
Number of optical connections for fiber-optic cables at 100 Mbit/s	1	1	-	-
Design of optical connection for fiber-optic cables at 100 Mbit/s	BFOC port (multimode up to 5 km)	BFOC port (singlemode up to 26 km)	-	-
Coupled-in optical power referred to 1 mW				
• of transmitter output	-19 ... -14 dB	-15 ... -7 dB	-	-
• of the receiver input, maximum	-	-	-	-
Minimum optical sensitivity relative to 1 mW of the receiver input	-	-34 dB	-	-
Minimum required damping factor of FO transmission link	0 dB	0 dB	-	-
The range at the optical interface depends on the type of optical fiber used	0 ... 5 km	0 ... 26 km	-	-
Design of swap medium C-Plug	Yes	Yes	Yes	Yes
Inputs/outputs				
Operating voltage of signaling contacts with DC rated value	24 V	24 V	24 V	24 V
Maximum operating current of signal contacts with DC	0.1 A	0.1 A	0.1 A	0.1 A
Supply voltage, current consumption, power loss				
Type of supply voltage	DC	DC	DC	DC
External supply voltage	24 V	24 V	24 V	24 V
• Minimum	18 V	18 V	18 V	18 V
• Maximum	32 V	32 V	32 V	32 V
Product component: fusing at power supply input	Yes	Yes	Yes	Yes
Design of fusing at input for supply voltage	0.6 A / 60 V	0.6 A / 60 V	0.6 A / 60 V	0.6 A / 60 V
Current consumption, maximum	0.22 A	0.2 A	0.185 A	0.185 A
Effective power loss at 24 V with DC	5.28 W	5.28 W	3.84 W	4.4 W
Permissible ambient conditions				
Ambient temperature				
• During operation	-40 °C ... +60 °C	-40 °C ... +60 °C	-40 °C ... +60 °C	-20 ... +70 °C
• During storage	-40 ... +70 °C	-40 ... +70 °C	-40 ... +70 °C	-40 ... +70 °C
• During transport	-40 ... +70 °C	-40 ... +70 °C	-40 ... +70 °C	-40 ... +70 °C
• Note	-	-	-	-
Relative humidity at 25 °C without condensation during operation, maximum	95 %	95 %	95 %	95 %
IP degree of protection	IP30	IP30	IP30	IP 65/67

Technical specifications (continued)

Order No.	6GK5 206-1BB10-2AA3	6GK5 206-1BC10-2AA6	6GK5 208-0BA10-2AA3	6GK5 208-0HA00-2AA6
Product type designation	SCALANCE X206-1	SCALANCE X206-1LD	SCALANCE X208	SCALANCE X208PRO
Design, dimensions and weights				
Design	Compact	Compact	Compact	Compact
Width	60 mm	60 mm	60 mm	90 mm
Height	125 mm	125 mm	125 mm	125 mm
Depth	124 mm	124 mm	124 mm	124 mm
Net weight	0.78 kg	0.78 kg	0.78 kg	1 kg
Type of mounting				
• 35 mm DIN rail mounting	Yes	Yes	Yes	Yes
• Wall mounting	Yes	Yes	Yes	Yes
• S7-300 rail mounting	Yes	Yes	Yes	Yes
Product properties, functions, components General				
Cascading with redundant ring at reconfiguration time < 0.3 s	50	50	50	50
Cascading with star topology	Any (only dependent on signal propagation time)	Any (only dependent on signal propagation time)	Any (only dependent on signal propagation time)	Any (only dependent on signal propagation time)
Product functions Management, configuration, programming				
Product function				
• CLI	Yes	Yes	Yes	No
• Web-based management	Yes	Yes	Yes	Yes
• MIB support	Yes	Yes	Yes	Yes
• TRAPs via e-mail	Yes	Yes	Yes	Yes
• Configuration with STEP 7	Yes	Yes	Yes	Yes
• SMTP server	Yes	Yes	Yes	Yes
• Port mirroring	Yes	Yes	Yes	Yes
• with IRT PROFINET IO Switch	No	No	No	No
• PROFINET IO diagnostics	Yes	Yes	Yes	No
• Switch-managed	Yes	Yes	Yes	Yes
Protocol is supported				
• Telnet	Yes	Yes	Yes	Yes
• HTTP	Yes	Yes	Yes	Yes
• HTTPS	Yes	Yes	Yes	Yes
• TFTP	Yes	Yes	Yes	Yes
• FTP	Yes	Yes	Yes	Yes
• BOOTP	No	No	No	No
• SNMP v1	Yes	Yes	Yes	Yes
• SNMP v2	Yes	Yes	Yes	Yes
• SNMP v3	Yes	Yes	Yes	Yes
• DCP	Yes	Yes	Yes	No
• LLDP	Yes	Yes	Yes	No
Identification & maintenance				
• I&M0 - device-specific information	Yes	Yes	Yes	-
• I&M1 - higher-level designation/ location designation	Yes	Yes	Yes	-
Product functions Diagnostics				
Product function				
• Port diagnostics	Yes	Yes	Yes	Yes
• Packet size statistics	Yes	Yes	Yes	Yes
• Packet type statistics	Yes	Yes	Yes	Yes
• Error statistics	Yes	Yes	Yes	Yes

PROFINET/Industrial Ethernet

Industrial Ethernet switches / media converters

SCALANCE X-200 managed

Technical specifications (continued)

Order No.	6GK5 206-1BB10-2AA3	6GK5 206-1BC10-2AA6	6GK5 208-0BA10-2AA3	6GK5 208-0HA00-2AA6
Product type designation	SCALANCE X206-1	SCALANCE X206-1LD	SCALANCE X208	SCALANCE X208PRO
Product functions DHCP				
Product function DHCP client	Yes	Yes	Yes	Yes
Product functions Redundancy				
Product function				
• Ring redundancy	Yes	Yes	Yes	Yes
• Redundancy manager	Yes	Yes	Yes	No
• Standby redundancy	No	No	No	No
• Redundancy procedure HSR	Yes	Yes	Yes	Yes
• Redundancy procedure MRP	Yes	Yes	Yes	No
• Passive listening	Yes	Yes	Yes	Yes
Product functions Security				
Protocol is supported SSH	Yes	Yes	Yes	Yes
Product functions Time				
Product function				
• SICLOCK support	Yes	Yes	Yes	No
Protocol is supported				
• NTP	No	No	No	No
• SNTP	Yes	Yes	Yes	No
Standards, specifications, approvals				
Standard				
• for EMC of FM	FM3611: Class 1, Division 2, Group A, B, C, D / T4, CL.1, Zone 2, GP. IIC, T4	FM3611: Class 1, Division 2, Group A, B, C, D / T4, CL.1, Zone 2, GP. IIC, T4	FM3611: Class 1, Division 2, Group A, B, C, D / T4, CL.1, Zone 2, GP. IIC, T4	FM3611: Class 1, Division 2, Group A, B, C, D / T4, CL.1, Zone 2, GP. IIC, T4
• for hazardous zone	EN 60079-0: 2006, EN 60079-15: 2005, II 3 G Ex nA II T4 KEMA 07 ATEX 0145X	EN 60079-0: 2006, EN 60079-15: 2005, II 3 G Ex nA II T4 KEMA 07 ATEX 0145X	EN 60079-0: 2006, EN 60079-15: 2005, II 3 G Ex nA II T4 KEMA 07 ATEX 0145X	EN 60079-0: 2006, EN 60079-15: 2005, II 3 G Ex nA II T4 KEMA 07 ATEX 0145X
• for CSA and UL safety	UL 60950-1, CSA C22.2 No. 60950-1	UL 60950-1, CSA C22.2 No. 60950-1	UL 60950-1, CSA C22.2 No. 60950-1	UL 60950-1, CSA C22.2 No. 60950-1
• for hazardous zone of CSA and UL	ANSI / ISA 12.12.01, CSA C22.2 No. 213-M1987, CL. 1 / Div. 2 / GP. A, B, C, D T4, CL. 1 / Zone 2 / GP. IIC, T4	ANSI / ISA 12.12.01, CSA C22.2 No. 213-M1987, CL. 1 / Div. 2 / GP. A, B, C, D T4, CL. 1 / Zone 2 / GP. IIC, T4	ANSI / ISA 12.12.01, CSA C22.2 No. 213-M1987, CL. 1 / Div. 2 / GP. A, B, C, D T4, CL. 1 / Zone 2 / GP. IIC, T4	ANSI / ISA 12.12.01, CSA C22.2 No. 213-M1987, CL. 1 / Div. 2 / GP. A, B, C, D T4, CL. 1 / Zone 2 / GP. IIC, T4
• For emitted interference	EN 61000-6-4:2001 (Class A)	EN 61000-6-4 (Class A)	EN 61000-6-4 (Class A)	EN 61000-6-4:2001 (Class A)
• For noise immunity	EN 61000-6-2:2001	EN 61000-6-2	EN 61000-6-2	EN 61000-6-2:2001
Certificate of suitability	EN 61000-6-2:2001, EN 61000-6-4:2001	EN 61000-6-2, EN 61000-6-4	EN 61000-6-2, EN 61000-6-4	EN 61000-6-2:2001, EN 61000-6-4:2001
• CE marking	Yes	Yes	Yes	Yes
• C-Tick	Yes	Yes	Yes	Yes
• Railroad application according to EN 50155	No	No	No	No
• Railroad application according to EN 50124-1	No	No	No	No
Marine classification association				
• American Bureau of Shipping Europe Ltd. (ABS)	Yes	Yes	Yes	Yes
• Bureau Veritas (BV)	Yes	Yes	Yes	Yes
• Det Norske Veritas (DNV)	Yes	Yes	Yes	Yes
• Germanischer Lloyd (GL)	Yes	Yes	Yes	Yes
• Lloyds Register of Shipping (LRS)	Yes	Yes	Yes	Yes
• Nippon Kaiji Kyokai (NK)	Yes	Yes	Yes	Yes
• Polski Rejestr Statkow (PRS)	Yes	Yes	Yes	Yes

Technical specifications (continued)

Order No.	6GK5 212-2BB00-2AA3	6GK5 212-2BC00-2AA3	6GK5 216-0BA00-2AA3	6GK5 224-0BA00-2AA3
Product type designation	SCALANCE X212-2	SCALANCE X212-2LD	SCALANCE X216	SCALANCE X224
Transmission rate				
Transmission rate 1	10 Mbit/s	10 Mbit/s	10 Mbit/s	10 Mbit/s
Transmission rate 2	100 Mbit/s	100 Mbit/s	100 Mbit/s	100 Mbit/s
Interfaces				
Number of electrical/optical connections				
• for network components or terminal equipment, maximum	14	14	16	24
• as combo port for network components or terminal equipment	-	-	-	-
Number of electrical connections				
• for network components or terminal equipment	12	12	16	24
• for signaling contact	1	1	1	1
• for power supply	1	1	1	1
• For redundant power supply	1	1	1	1
Design of electrical/optical connections for network components or terminal equipment	-	-	-	-
Design of electrical connection				
• for network components or terminal equipment	RJ45 port	RJ45 port	RJ45 port	RJ45 port
• for signaling contact	2-pin terminal block	2-pin terminal block	2-pin terminal block	2-pin terminal block
• for power supply	4-pin terminal block	4-pin terminal block	4-pin terminal block	4-pin terminal block
Number of optical connections for fiber-optic cables at 100 Mbit/s	2	2	-	-
Design of optical connection for fiber-optic cables at 100 Mbit/s	BFOC port (multimode up to 5 km)	BFOC port (singlemode up to 26 km)	-	-
Coupled-in optical power referred to 1 mW				
• of transmitter output	-19 ... -14 dB	-15 ... -7 dB	-	-
• of the receiver input, maximum	-	-	-	-
Minimum optical sensitivity relative to 1 mW of the receiver input	-34 dB	-34 dB	-	-
Minimum required damping factor of FO transmission link	0 dB	0 dB	-	-
The range at the optical interface depends on the type of optical fiber used	0 ... 5 km	0 ... 26 km	-	-
Design of swap medium C-Plug	Yes	Yes	Yes	Yes
Inputs/outputs				
Operating voltage of signaling contacts with DC rated value	24 V	24 V	24 V	24 V
Maximum operating current of signal contacts with DC	0.1 A	0.1 A	0.1 A	0.1 A

PROFINET/Industrial Ethernet

Industrial Ethernet switches / media converters

SCALANCE X-200 managed

Technical specifications (continued)

Order No.	6GK5 212-2BB00-2AA3	6GK5 212-2BC00-2AA3	6GK5 216-0BA00-2AA3	6GK5 224-0BA00-2AA3
Product type designation	SCALANCE X212-2	SCALANCE X212-2LD	SCALANCE X216	SCALANCE X224
Supply voltage, current consumption, power loss				
Type of supply voltage	DC	DC	DC	DC
External supply voltage	24 V	24 V	24 V	24 V
• Minimum	18 V	18 V	18 V	18 V
• Maximum	32 V	32 V	32 V	32 V
Product component: fusing at power supply input	Yes	Yes	Yes	Yes
Design of fusing at input for supply voltage	1.1 A / 33 V	1.1 A / 33 V	1.1 A / 33 V	1.1 A / 33 V
Current consumption, maximum	0.33 A	0.33 A	0.24 A	0.35 A
Effective power loss at 24 V with DC	7.92 W	7.92 W	5.76 W	8.4 W
Permissible ambient conditions				
Ambient temperature				
• During operation	-40 ... +60 °C	-40 ... +60 °C	-40 ... +60 °C	-40 ... +60 °C
• During storage	-40 ... +70 °C	-40 ... +70 °C	-40 ... +70 °C	-40 ... +70 °C
• During transport	-40 ... +70 °C	-40 ... +70 °C	-40 ... +70 °C	-40 ... +70 °C
• Note	-	-	-	-
Relative humidity at 25 °C without condensation during operation, maximum	95 %	95 %	95 %	95 %
IP degree of protection	IP30	IP30	IP30	IP30
Design, dimensions and weights				
Design	Compact	Compact	Compact	Compact
Width	120 mm	120 mm	120 mm	180 mm
Height	125 mm	125 mm	125 mm	125 mm
Depth	124 mm	124 mm	124 mm	124 mm
Net weight	1.2 kg	1.2 kg	1.2 kg	1.6 kg
Type of mounting				
• 35 mm DIN rail mounting	Yes	Yes	Yes	Yes
• Wall mounting	Yes	Yes	Yes	Yes
• S7-300 rail mounting	Yes	Yes	Yes	Yes
Product properties, functions, components				
General				
Cascading with redundant ring with reconfiguration time < 0.3 s	50	50	50	50
Cascading with star topology	Any (only dependent on signal propagation time)	Any (only dependent on signal propagation time)	Any (only dependent on signal propagation time)	Any (only dependent on signal propagation time)

Technical specifications (continued)

Order No.	6GK5 212-2BB00-2AA3	6GK5 212-2BC00-2AA3	6GK5 216-0BA00-2AA3	6GK5 224-0BA00-2AA3
Product type designation	SCALANCE X212-2	SCALANCE X212-2LD	SCALANCE X216	SCALANCE X224
Product functions Management, configuration, programming				
Product function				
• CLI	Yes	Yes	Yes	Yes
• Web-based management	Yes	Yes	Yes	Yes
• MIB support	Yes	Yes	Yes	Yes
• TRAPs via e-mail	Yes	Yes	Yes	Yes
• Configuration with STEP 7	Yes	Yes	Yes	Yes
• SMTP server	Yes	Yes	Yes	Yes
• Port mirroring	Yes	Yes	Yes	Yes
• with IRT PROFINET IO Switch	No	No	No	No
• PROFINET IO diagnostics	Yes	Yes	Yes	Yes
• Switch-managed	Yes	Yes	Yes	Yes
Protocol is supported				
• Telnet	Yes	Yes	Yes	Yes
• HTTP	Yes	Yes	Yes	Yes
• HTTPS	Yes	Yes	Yes	Yes
• TFTP	Yes	Yes	Yes	Yes
• FTP	Yes	Yes	Yes	Yes
• BOOTP	No	No	No	No
• SNMP v1	Yes	Yes	Yes	Yes
• SNMP v2	Yes	Yes	Yes	Yes
• SNMP v3	Yes	Yes	Yes	Yes
• DCP	Yes	Yes	Yes	Yes
• LLDP	Yes	Yes	Yes	Yes
Identification & maintenance				
• I&M0 - device-specific information	Yes	Yes	Yes	Yes
• I&M1 - higher-level designation/ location designation	Yes	Yes	Yes	Yes
Product functions Diagnostics				
Product function				
• Port diagnostics	Yes	Yes	Yes	Yes
• Packet size statistics	Yes	Yes	Yes	Yes
• Packet type statistics	Yes	Yes	Yes	Yes
• Error statistics	Yes	Yes	Yes	Yes
Product functions DHCP				
Product function DHCP client	Yes	Yes	Yes	Yes
Product functions Redundancy				
Product function				
• Ring redundancy	Yes	Yes	Yes	Yes
• Redundancy manager	Yes	Yes	Yes	Yes
• Standby redundancy	No	No	No	No
• Redundancy procedure HSR	Yes	Yes	Yes	Yes
• Passive listening	Yes	Yes	Yes	Yes

PROFINET/Industrial Ethernet

Industrial Ethernet switches / media converters

SCALANCE X-200 managed

Technical specifications (continued)

Order No.	6GK5 212-2BB00-2AA3	6GK5 212-2BC00-2AA3	6GK5 216-0BA00-2AA3	6GK5 224-0BA00-2AA3
Product type designation	SCALANCE X212-2	SCALANCE X212-2LD	SCALANCE X216	SCALANCE X224
Product functions Security				
Protocol is supported SSH	Yes	Yes	Yes	Yes
Product functions Time				
Product function: SICLOCK support	Yes	Yes	Yes	Yes
Protocol is supported				
• NTP	No	No	No	No
• SNTP	Yes	Yes	Yes	Yes
Standards, specifications, approvals				
Standard				
• for EMC of FM	FM3611: Class 1, Division 2, Group A, B, C, D / T4, CL.1, Zone 2, GP. IIC, T4	FM3611: Class 1, Division 2, Group A, B, C, D / T4, CL.1, Zone 2, GP. IIC, T4	FM3611: Class 1, Division 2, Group A, B, C, D / T4, CL.1, Zone 2, GP. IIC, T4	FM3611: Class 1, Division 2, Group A, B, C, D / T4, CL.1, Zone 2, GP. IIC, T4
• for hazardous zone	EN 60079-0: 2006, EN 60079-15: 2005, II 3 G Ex nA II T4 KEMA 07 ATEX 0145X	EN 60079-0: 2006, EN 60079-15: 2005, II 3 G Ex nA II T4 KEMA 07 ATEX 0145X	EN 60079-0: 2006, EN 60079-15: 2005, II 3 G Ex nA II T4 KEMA 07 ATEX 0145X	EN 60079-0: 2006, EN 60079-15: 2005, II 3 G Ex nA II T4 KEMA 07 ATEX 0145X
• for CSA and UL safety	UL 60950-1, CSA C22.2 No. 60950-1	UL 60950-1, CSA C22.2 No. 60950-1	UL 60950-1, CSA C22.2 No. 60950-1	UL 60950-1, CSA C22.2 No. 60950-1
• for hazardous zone of CSA and UL	ANSI / ISA 12.12.01, CSA C22.2 No. 213-M1987, CL. 1 / Div. 2 / GP. A, B, C, D T4, CL. 1 / Zone 2 / GP. IIC, T4	ANSI / ISA 12.12.01, CSA C22.2 No. 213-M1987, CL. 1 / Div. 2 / GP. A, B, C, D T4, CL. 1 / Zone 2 / GP. IIC, T4	ANSI / ISA 12.12.01, CSA C22.2 No. 213-M1987, CL. 1 / Div. 2 / GP. A, B, C, D T4, CL. 1 / Zone 2 / GP. IIC, T4	ANSI / ISA 12.12.01, CSA C22.2 No. 213-M1987, CL. 1 / Div. 2 / GP. A, B, C, D T4, CL. 1 / Zone 2 / GP. IIC, T4
• For emitted interference	EN 61000-6-4:2001 (Class A)	EN 61000-6-4:2001 (Class A)	EN 61000-6-4:2001 (Class A)	EN 61000-6-4:2001 (Class A)
• For noise immunity	EN 61000-6-2:2001	EN 61000-6-2:2001	EN 61000-6-2:2001	EN 61000-6-2:2001
Certificate of suitability	EN 61000-6-2:2001, EN 61000-6-4:2001	EN 61000-6-2:2001, EN 61000-6-4:2001	EN 61000-6-2:2001, EN 61000-6-4:2001	EN 61000-6-2:2001, EN 61000-6-4:2001
• CE marking	Yes	Yes	Yes	Yes
• C-Tick	Yes	Yes	Yes	Yes
• Railroad application according to EN 50155	No	No	No	No
• Railroad application according to EN 50124-1	No	No	No	No
Marine classification association				
• American Bureau of Shipping Europe Ltd. (ABS)	Yes	Yes	Yes	Yes
• Bureau Veritas (BV)	Yes	Yes	Yes	Yes
• Det Norske Veritas (DNV)	Yes	Yes	Yes	Yes
• Germanischer Lloyd (GL)	Yes	Yes	Yes	Yes
• Lloyds Register of Shipping (LRS)	Yes	Yes	Yes	Yes
• Nippon Kaiji Kyokai (NK)	Yes	Yes	Yes	Yes
• Polski Rejestr Statkow (PRS)	No	No	No	No

PROFINET/Industrial Ethernet

Industrial Ethernet switches / media converters

SCALANCE X-200 managed

Ordering data	Order No.	Order No.
Industrial Ethernet Switches SCALANCE X-200		Accessories
<p>Industrial Ethernet switches with integral SNMP access, online diagnostics, copper cable diagnostics and PROFINET diagnostics for configuring line, star and ring topologies; with integrated redundancy manager (exception: SCALANCE X208PRO); incl. operating instructions, Industrial Ethernet network manual and configuration software on CD-ROM</p> <ul style="list-style-type: none"> With electrical and optical ports for glass multimode FOC up to max. 5 km <ul style="list-style-type: none"> SCALANCE X204-2 with four 10/100 Mbit/s RJ45 ports and two fiber-optic ports SCALANCE X204-2TS with four 10/100 Mbit/s RJ45 ports and two fiber-optic ports with extended temperature range and EN 50155 approval for railway applications SCALANCE X206-1; with six 10/100 Mbit/s RJ45 ports and one fiber-optic port SCALANCE X212-2 with 12 10/100 Mbit/s RJ45 ports and two fiber-optic ports With electrical and optical ports for glass single mode FOC up to max. 26 km <ul style="list-style-type: none"> SCALANCE X204-2LD with four 10/100 Mbit/s RJ45 ports and two long-distance fiber-optic ports SCALANCE X206-1LD; with six 10/100 Mbit/s RJ45 ports and one long-distance fiber-optic port SCALANCE X212-2LD with twelve 10/100 Mbit/s RJ45 ports and two long-distance fiber-optic ports With electrical ports <ul style="list-style-type: none"> SCALANCE X208; with eight 10/100 Mbit/s RJ45 ports SCALANCE X208PRO with eight 10/100 Mbit/s M12 ports, incl. eleven M12 dust protection caps, IP65 degree of protection SCALANCE X216 with sixteen 10/100 Mbit/s RJ45 ports SCALANCE X224 with twenty-four 10/100 Mbit/s RJ45 ports 	<p>6GK5 204-2BB10-2AA3</p> <p>6GK5 204-2BB10-2CA2</p> <p>6GK5 206-1BB10-2AA3</p> <p>6GK5 212-2BB00-2AA3</p> <p>6GK5 204-2BC10-2AA3</p> <p>6GK5 206-1BC10-2AA3</p> <p>6GK5 212-2BC00-2AA3</p> <p>6GK5 208-0BA10-2AA3</p> <p>6GK5 208-0HA00-2AA6</p> <p>6GK5 216-0BA00-2AA3</p> <p>6GK5 224-0BA00-2AA3</p>	<p>IE FC TP Standard Cable GP 2 x 2 (Type A)</p> <p>4-core, shielded TP installation cable for connection to IE FC Outlet RJ45 / IE FC RJ45 Plug; PROFINET-compliant; with UL approval; sold by the meter; max. length 1000 m, minimum order 20 m</p> <p>6XV1 840-2AH10</p> <hr/> <p>FO Standard Cable GP 50/125/1400 ^{1) 2)}</p> <p>Multimode cable, sold by the meter; max. length 1000 m; minimum order 20 m;</p> <p>6XV1 873-2A</p> <hr/> <p>FO Robust Cable GP 4E9/125/90</p> <p>Singlemode cable, sold by the meter; max. length 1000 m; minimum order 20 m</p> <p>6XV1 843-2R</p> <hr/> <p>FC FO Standard Cable GP 62.5/200/230</p> <p>FC FO standard cable for fixed routing indoors with PVC sheath; sold by the meter; max. length 1000 m; minimum order 20 m</p> <p>6XV1 847-2A</p> <hr/> <p>IE FC RJ45 Plug 180 2 x 2</p> <p>RJ45 plug connector for Industrial Ethernet with a rugged metal enclosure and integrated insulation displacement contacts for connecting Industrial Ethernet FC installation cables; with 180° cable outlet; for network components and CPs/CPUs with Industrial Ethernet interface</p> <ul style="list-style-type: none"> 1 pack = 1 unit 1 pack = 10 units 1 pack = 50 units <p>6GK1 901-1BB10-2AA0 6GK1 901-1BB10-2AB0 6GK1 901-1BB10-2AE0</p> <hr/> <p>FC BFOC Plug</p> <p>Screw connector for on-site assembly on FC fiber-optic cable; (1 pack = 20 units + cleaning cloths)</p> <p>6GK1 900-1GB00-0AC0</p> <hr/> <p>IE FC M12 Plug PRO</p> <p>M12 plug connector for connection of Industrial Ethernet FC installation cables; 4-pole, D-coded, metal enclosure, IP65 degree of protection, pin insert; 180° cable outlet; for network components and Industrial Ethernet stations with IP65/IP67 degree of protection</p> <ul style="list-style-type: none"> 1 pack = 1 unit 1 pack = 8 units <p>6GK1 901-0DB20-6AA0 6GK1 901-0DB20-6AA8</p>

¹⁾ Special fiber-optic cables, lengths and accessories available on request

²⁾ Special tools and trained personnel are required for pre-assembling glass fiber-optic cables

PROFINET/Industrial Ethernet

Industrial Ethernet switches / media converters

SCALANCE X-200 managed

Ordering data

Order No.

IE Connecting Cable M12-180/M12-180

Pre-assembled IE FC TP trailing cable GP 2 x 2 (PROFINET type C) with two 4-pole M12 plugs, 4-pole, D-coded, IP65/IP67 degree of protection;
Length:

- 0.3 m
- 0.5 m
- 1.0 m
- 1.5 m
- 2.0 m
- 3.0 m
- 5.0 m
- 10 m
- 15 m

6XV1 870-8AE30
6XV1 870-8AE50
6XV1 870-8AH10
6XV1 870-8AH15
6XV1 870-8AH20
6XV1 870-8AH30
6XV1 870-8AH50
6XV1 870-8AN10
6XV1 870-8AN15

IE M12 Panel Feedthrough

Control cabinet feedthrough for transition from 4-pole, D-coded M12 interface (IP65/IP67) to RJ45 socket (IP20)

- 1 pack = 5 units

6GK1 901-0DM20-2AA5

IE Power M12 Cable Connector PRO

Socket for connecting SCALANCE W-700/SCALANCE X208PRO for 24 V DC supply; 4-pole, A-coded, with installation instructions

6GK1 907-0DC10-6AA3

Signaling Contact M12 Cable Connector PRO

Socket for connecting SCALANCE X208PRO for signaling contact; 5-pole, B-coded, with installation instructions

6GK1 908-0DC10-6AA3

SITOP compact 24 V/ 0.6 A

1-phase power supply with wide-range input 85 – 264 V AC/110 – 300 V DC, stabilized output voltage 24 V, rated output current value 0.6 A, slim design

6EP1 331-5BA00

PS791-1PRO Power Supply

AC/DC power supply, 10 W, IP65 (-20 to +60 °C) for SCALANCE X208PRO, input: AC 85 V – 265 V, output: 24 V DC, metal housing, Scope of supply: AC power 3+PE cable connector, DC power cord M12, installation materials, manuals German/English

6GK5 791-1PS00-0AA6

C-PLUG

Swap medium for simple replacement of devices in the event of a fault; for storing configuration or engineering and application data; can be used for SIMATIC NET products with C-PLUG slot

6GK1 900-0AB00

More information

To assist in selecting the right Industrial Ethernet switches as well as configuration of modular versions, the SIMATIC NET Selection Tool is available:

Online version:

www.siemens.com/snst

Offline version:

www.siemens.com/snst-download

PROFINET/Industrial Ethernet

Industrial Ethernet switches / media converters

SIPLUS SCALANCE X-200 managed
Overview

- The managed Industrial Ethernet switches of the SCALANCE X-200 product line are optimized for installing Industrial Ethernet networks with 10/100 Mbit/s in a line, star and ring topology
- Integrated redundancy manager for constructing Fast Ethernet ring topologies with high-speed media redundancy (excluding SCALANCE X208 PRO)
- Electrical or optical connection to stations or network according to the device port type
- Fast media redundancy due to the integrated redundancy manager for Fast Ethernet
- Rugged metal housing in S7-300 format for mounting on standard rail, S7-300 standard mounting rail or for direct wall mounting in various positions
- Rugged, industry-standard station connections with PROFINET-compatible RJ45 connectors that offer additional strain relief and bending strain relief thanks to latching on the housing
- Redundant power supply
- Diagnostics on the device by means of LEDs (power, link status, data communication)
- Error signaling contact with easy adjustment using the SET button
- The devices feature PROFINET diagnostics, SNMP access, integral web server and automatic e-mail sending function for remote diagnosis and signaling over the network.

Note:

SIPLUS extreme products are based on Siemens Industry standard products. The contents listed here were taken from the respective standard products. SIPLUS extreme-specific information was added.

SIPLUS SCALANCE	X204-2	X204-2LD	X208	X212-2
Order number	6AG1 204-2BB10-4AA3	6AG1 204-2BC10-2AA3	6AG1 208-0BA10-2AA0	6AG1 212-2BB00-4AA3
Order No. based on	6GK5 204-2BB10-2AA3	6GK5 204-2BC10-2AA3	6GK5 208-0BA10-2AA3	6GK5 212-2BB00-2AA3
Ambient temperature range	-40 ... +60 °C	-25 ... +60 °C	-40 ... +60 °C	-40 ... +60 °C
Conformal coating	Coating of the printed circuit boards and the electronic components			
Technical data	The technical data of the standard product applies except for the ambient conditions.			

Ambient conditions

Relative humidity	5 ... 100 % Condensation permissible
Biologically active substances	Conformity with EN 60721-3-3, Class 3B2 mold and fungal spores (except fauna)
Chemically active substances	Conformity with EN 60721-3-3, Class 3C4 incl. salt mist and ISA-S71.04 severity level G1; G2; G3; GX ^{1) 2)}
Mechanically active substances	Conformity with EN 60721-3-3, Class 3S4 including conductive sand, dust ²⁾
Air pressure (depending on the highest positive temperature range specified)	1080 ... 795 hPa (-1000 ... +2000 m) see ambient temperature range 795 ... 658 hPa (+2000 ... +3500 m) derating 10 K 658 ... 540 hPa (+3500 ... +5000 m) derating 20 K

¹⁾ ISA-S71.04 severity level GX: Long-term load:
SO₂ < 4.8 ppm; H₂S < 9.9 ppm; Cl < 0.2 ppm; HCl < 0.66 ppm; HF < 0.12 ppm; NH < 49 ppm; O₃ < 0.1 ppm; NOX < 5.2 ppm
Limit value (max. 30 min/d):
SO₂ < 17.8 ppm; H₂S < 49.7 ppm; Cl < 1.0 ppm; HCl < 3.3 ppm; HF < 2.4 ppm; NH < 247 ppm; O₃ < 1.0 ppm; NOX < 10.4 ppm

²⁾ The supplied plug covers must remain in place over the unused interface when operated in atmospheres containing corrosive gases!

The technical documentation on SIPLUS can be found here:
www.siemens.com/siplus-extreme

PROFINET/Industrial Ethernet

Industrial Ethernet switches / media converters

SIPLUS SCALANCE X-200 managed

Ordering data

Order No.

Order No.

SIPLUS SCALANCE X-200 Industrial Ethernet switches

Industrial Ethernet switches with integral SNMP access, online diagnostics, copper cable diagnostics and PROFINET diagnostics for configuring line, star and ring topologies; with integrated redundancy manager (exception: SCALANCE X208PRO); incl. operating instructions, Industrial Ethernet network manual and configuration software on CD-ROM

- With electrical and optical ports for glass multimode FOC up to max. 5 km
- Extended temperature range and medial exposure
 - **SIPLUS SCALANCE X204-2** with four 10/100 Mbit/s RJ45 ports and two fiber-optic ports
 - **SIPLUS SCALANCE X212-2** with 12 10/100 Mbit/s RJ45 ports and two fiber-optic ports
- With electrical and optical ports for glass single mode FOC up to max. 26 km
 - **SIPLUS SCALANCE X204-2LD** with four 10/100 Mbit/s RJ45 ports and two long-distance fiber-optic ports

6AG1 204-2BB10-7AA3

6AG1 212-2BB00-4AA3

6AG1 204-2BC10-2AA3

Accessories

See ordering data for SCALANCE X-200 managed

PROFINET/Industrial Ethernet

Industrial Ethernet switches / media converters

SCALANCE XF-200 managed

Overview

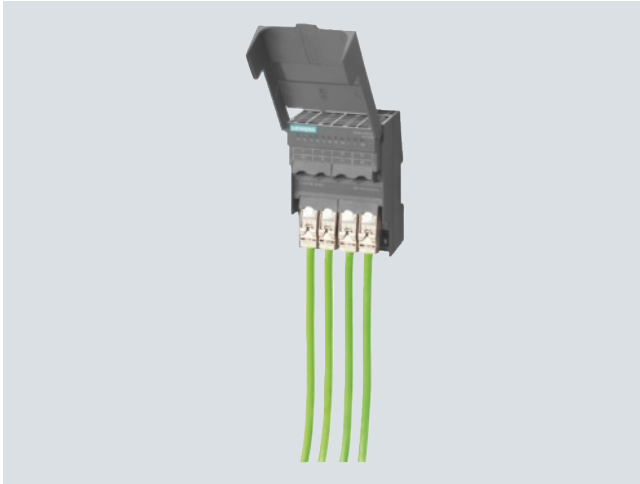

The managed Industrial Ethernet switches of the SCALANCE XF-200 line are optimized for setting up Industrial Ethernet networks at data transfer rates of 10/100 Mbit/s in a line, star or ring topology.

- Integrated redundancy manager for constructing Fast Ethernet ring topologies with fast media redundancy
- Electrical or optical connection to stations or network in accordance with the port type of the devices
- Enclosure in ET 200S format (slim design) for use in small control boxes
- Rugged, industry-standard node connections with PROFINET-compliant RJ45 connectors that latch onto the enclosure to offer additional strain and bending relief
- PROFINET diagnostics, SNMP access, integrated web server and automatic e-mail transmission function for remote diagnostics and signaling via the network

Benefits

get Designed for Industry

- Saves space in the control cabinet and uses smaller control boxes due to slim design in the format of the ET 200S distributed I/O
- Simple connection and disconnection of the RJ45 plug by means of easily accessible RJ45 sockets angled downward on the device
- High availability of the network thanks to:
 - Redundant power supply
 - Redundant network structures based on fiber-optic or twisted pair cables (redundancy manager integrated)
 - Easy device replacement by means of plug-in C-PLUG swap medium
- Lower susceptibility to failure and higher availability of the plant networking due to latching of the RJ45 FastConnect connectors in the sleeve of the RJ45 ports
- Protection of investment due to integration into existing network management systems by means of standardized SNMP access
- Time savings during engineering, commissioning and in the operating phase of a plant by using the configuration and diagnostics integrated in STEP 7

2

PROFINET/Industrial Ethernet

Industrial Ethernet switches / media converters

SCALANCE XF-200 managed

Application

The SCALANCE XF-200 Industrial Ethernet switches permit cost-effective configuration of Industrial Ethernet line, star or ring topologies with switching functionality for networks in which high availability or remote diagnostics options are required. The devices with degree of protection IP20 are designed for operation in the control cabinet.

Product versions

- Switches with electrical and optical ports for glass multimode FOC up to 5 km:
 - *SCALANCE XF204-2*;
4 x 10/100 Mbit/s RJ45 port, electrical
2 x 100 Mbit/s BFOC port, optical
 - *SCALANCE XF206-1*;
6 x 10/100 Mbit/s RJ45 port, electrical
1 x 100 Mbit/s BFOC port, optical
- Switches with electrical ports:
 - *SCALANCE XF204*;
4 x 10/100 Mbit/s RJ45 port, electrical
 - *SCALANCE XF208*;
8 x 10/100 Mbit/s RJ45 port, electrical

Characteristics:

- Diagnostics on the device by means of LEDs (power, link status, data traffic)
- Remote diagnostics by means of signaling contact, PROFINET, SNMP, and Web browser
- The RJ45 sockets are designed to be industry-compatible with additional sleeves, for connection of the IE FC RJ45 Plug 180

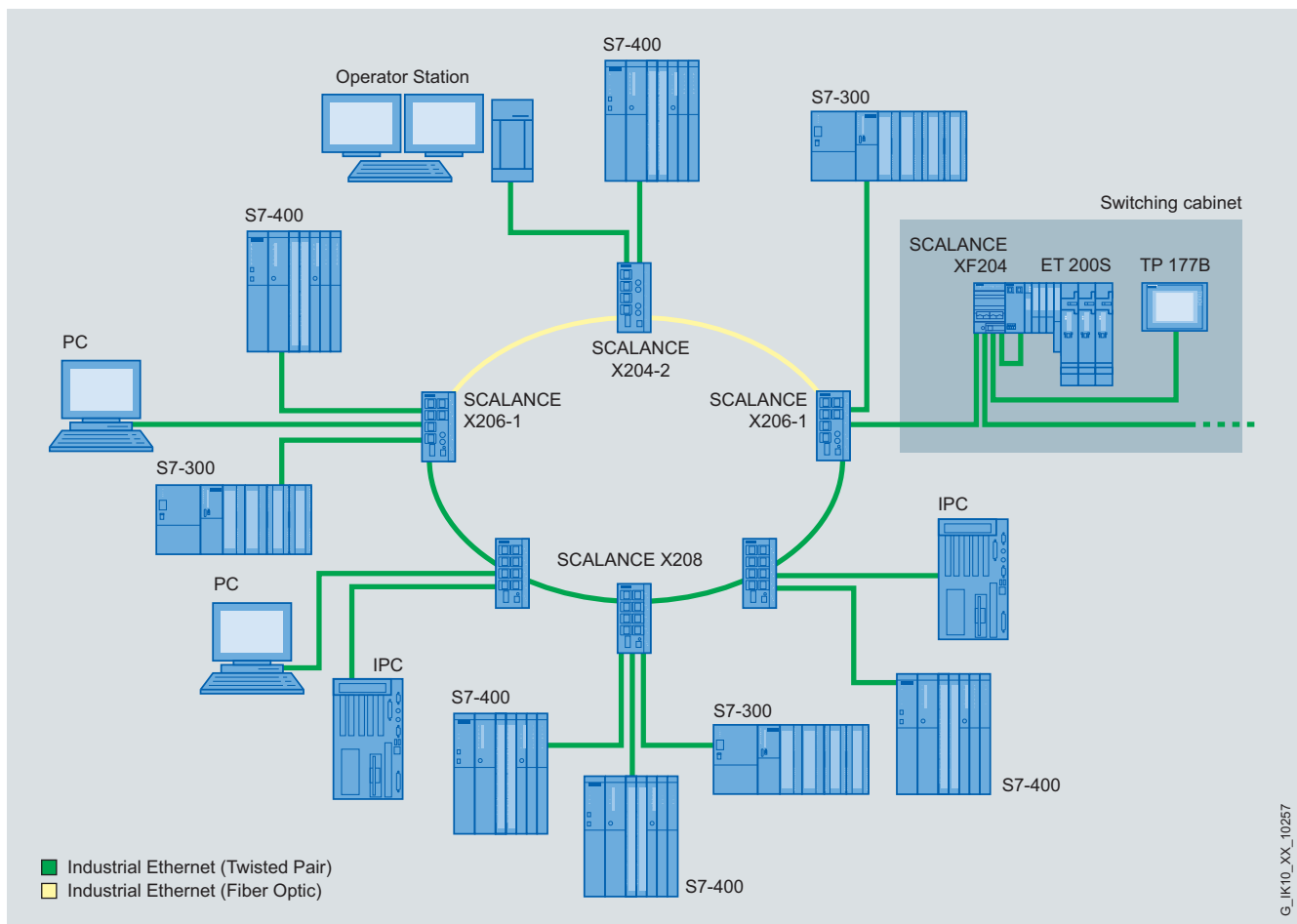

Ring topology with SCALANCE X-200 and XF-200

PROFINET/Industrial Ethernet

Industrial Ethernet switches / media converters

SCALANCE XF-200 managed

Design

The SCALANCE XF-200 managed Industrial Ethernet switches are designed for installation on a standard DIN rail. With their enclosure in ET 200S format (slim design), the devices are optimally suited for integration in automation solutions in small control boxes together with the ET 200S.

The switches with IP20 degree of protection feature:

- A 4-pole terminal block for connecting the redundant supply voltage (2 x 24 V DC)
- A row of LEDs to indicate the status information (power, link status, data traffic, power supply, signaling contact)
- A 2-pole terminal block for connecting the isolated signaling contact
- A SET button for on-site configuration of the signaling contact

The SCALANCE XF-200 switches are available with the following port types:

- *10/100BaseTX, RJ45 connection;*
RJ45 socket, automatic detection of the data rate (10 or 100 Mbit/s), with Autosensing and Autocrossover functions for connecting IE FC cables using the IE FC RJ45 Plug 180.
- *100BaseFX, BFOC connection technique;*
BFOC sockets for direct connection to Industrial Ethernet glass fiber-optic cables up to 5 km (multimode fiber-optic cable) for configuring line, ring, and star topologies.

Function

- Setup of electrical and optical Industrial Ethernet line, star and ring topologies
- Fast redundancy in the ring with High Speed Redundancy (HSR); up to 0.3 seconds for reconfiguration of the ring with 50 switches in the ring
- Fast redundancy in the ring with PROFINET-compliant Media Redundancy Protocol (MRP); max. 0.2 seconds required for reconfiguration of the ring with 50 switches in the ring
- The functioning of the ring is continuously monitored by the integrated redundancy manager. It recognizes failure of a transmission path in the ring or failure of a SCALANCE XF-200 and activates the substitute path within 0.3 or 0.2 seconds
- Use in ring topologies (100 Mbit/s) together with SCALANCE X-400, SCALANCE X-300, SCALANCE X-200, SCALANCE X-200IRT
- Uncrossed connecting cables can be used due to Autocrossover function integrated in the ports
- Load disconnection through integral switch functionality
- Easy diagnostics using signaling contact, SNMP and Web browser
- Easy copper cable diagnostics with Web browser for localizing cable breaks
- Integration into the diagnostics of a PROFINET I/O controller with expanded diagnostics functions for a consistent diagnostics concept, including network infrastructure
- Diagnosis of data traffic by means of a parameterizable mirror port with a standard commercial network analyzer
- Fast device replacement in the event of a fault by using the optional C-PLUG swap medium (not included in scope of supply)

Network topology and network configuration

The SCALANCE XF-200 Industrial Ethernet switches with IP20 degree of protection are usually installed in a control cabinet together with the stations to be connected. Electrical and optical versions can be installed together in star, line and ring topologies.

When configuring the network, it is necessary to observe the following boundary conditions:

- Length of the TP cable between two SCALANCE XF switches:
 - Max. 100 m with IE FC cable and IE FC RJ45 Plug 180
 - Max. 10 m using patches with TP cord
- Length of the optical cables
 - Max. 5000 m with Industrial Ethernet glass fiber-optic cables (multimode)
- IP address:
 - The IP address is assigned using the DHCP (Dynamic Host Configuration Protocol) mechanism. If there is no corresponding server in the network, the IP address can be assigned using the supplied software tool PST (Primary Setup Tool) or STEP 7. The SCALANCE XF-200 switches are configured with STEP 7.

Commissioning and diagnostics

PROFINET diagnostic interrupts from SCALANCE XF-200 switches can be displayed with the appropriate SIMATIC Engineering Tools and processed in the controller with expanded diagnostics function. The engineering outlay for the PLC and HMI have been drastically reduced due to the complete integration in the SIMATIC concept for system error messages.

The SCALANCE XF-200 Industrial Ethernet switches can also be integrated into a network management system through the standardized protocol SNMP (Simple Network Management Protocol). In the event of a fault in the device, error messages (SNMP traps) can be sent to a network system or as e-mail to a specified network administrator.

The integral Web server enables configuration and diagnostics settings to be made using a standard browser (e.g. port configuration). Statistical information can also be read out over the Web server (e.g. port capacity utilization).

The following information is displayed by LEDs on site:

- Power
- Port status
- Data traffic
- Signaling contact
- Redundancy manager function

The Industrial Ethernet switches of the SCALANCE XF-200 line can also be monitored using the floating signaling contact.

PROFINET/Industrial Ethernet

Industrial Ethernet switches / media converters

SCALANCE XF-200 managed

Technical specifications

Order No.	6GK5 204-0BA00-2AF2	6GK5 204-2BC00-2AF2	6GK5 206-1BC00-2AF2	6GK5 208-0BA00-2AF2
Product type designation	SCALANCE XF204	SCALANCE XF204-2	SCALANCE XF206-1	SCALANCE XF208
Transmission rate				
Transmission rate 1	10 Mbit/s	10 Mbit/s	10 Mbit/s	10 Mbit/s
Transmission rate 2	100 Mbit/s	100 Mbit/s	100 Mbit/s	100 Mbit/s
Interfaces				
Number of electrical/optical connections				
• for network components or terminal equipment, maximum	4	6	7	8
• as combo port for network components or terminal equipment	-	-	-	-
Number of electrical connections				
• For network components or terminal equipment	4	4	6	8
• For signal contact	1	1	1	1
• For power supply	1	1	1	1
• For redundant power supply	1	1	1	1
Design of electrical/optical connections for network components or terminal equipment				
Design of electrical connection				
• For network components or terminal equipment	RJ45 port	RJ45 port	RJ45 port	RJ45 port
• For signal contact	2-pin terminal block	2-pin terminal block	2-pin terminal block	2-pin terminal block
• For power supply	4-pin terminal block	4-pin terminal block	4-pin terminal block	4-pin terminal block
Number of optical connections for fiber-optic cables at 100 Mbit/s	-	2	1	-
Design of optical connection for fiber-optic cables at 100 Mbit/s	-	BFOC port (multimode up to 5 km)	BFOC port (multimode up to 5 km)	-
Injectable optical power referred to 1 mW				
• of the transmitter output	-	-19 ... -14 dB	-19 ... -14 dB	-
• of the receiver input, maximum	-	-	-	-
Minimum optical sensitivity referred to 1 mW of the receiver input	-	-34 dB	-	-
Minimum required attenuation factor of the FO transmission link	-	0 dB	0 dB	-
The range at the optical interface depends on the type of optical fiber used	-	0 ... 5 km	0 ... 5 km	-
Design of the swap medium C-Plug	Yes	Yes	Yes	Yes
Inputs/outputs				
Operating voltage of signaling contacts with DC rated value	24 V	24 V	24 V	24 V
Maximum operating current of signal contacts with DC	0.1 A	0.1 A	0.1 A	0.1 A

Technical specifications (continued)

Order No.	6GK5 204-0BA00-2AF2	6GK5 204-2BC00-2AF2	6GK5 206-1BC00-2AF2	6GK5 208-0BA00-2AF2
Product type designation	SCALANCE XF204	SCALANCE XF204-2	SCALANCE XF206-1	SCALANCE XF208
Supply voltage, current consumption, power loss				
Type of power supply	DC	DC	DC	DC
Supply voltage, external	24 V	24 V	24 V	24 V
• Minimum	18 V	18 V	18 V	18 V
• Maximum	32 V	32 V	32 V	32 V
Product component: fusing of power supply input	Yes	Yes	Yes	Yes
Type of fusing of power supply input	1.1 A / 33 V	1.1 A / 33 V	1.1 A / 33 V	1.1 A / 33 V
Current consumption, maximum	0.11 A	0.22 A	0.17 A	0.13 A
Effective power loss at 24 V with DC	2.64 W	5.28 W	4.08 W	3.12 W
Permitted ambient conditions				
Ambient temperature				
• During operation	-40 ... +60 °C	-40 ... +60 °C	-40 ... +60 °C	-40 ... +60 °C
• During storage	-40 ... +70 °C	-40 ... +70 °C	-40 ... +70 °C	-40 ... +70 °C
• During transport	-40 ... +70 °C	-40 ... +70 °C	-40 ... +70 °C	-40 ... +70 °C
• Note	If the IE switch XF200 is installed horizontally, a maximum ambient temperature of +40 °C is permitted	If the IE switch XF200 is installed horizontally, a maximum ambient temperature of +40 °C is permitted	If the IE switch XF200 is installed horizontally, a maximum ambient temperature of +40 °C is permitted	If the IE switch XF200 is installed horizontally, a maximum ambient temperature of +40 °C is permitted
Relative humidity at 25 °C without condensation during operation, maximum	95 %	95 %	95 %	95 %
IP degree of protection	IP20	IP20	IP20	IP20
Design, dimensions and weights				
Type of construction	Flat	Flat	Flat	Flat
Width	75 mm	75 mm	75 mm	75 mm
Height	125 mm	125 mm	125 mm	125 mm
Depth	73 mm	73 mm	73 mm	73 mm
Net weight	250 g	250 g	250 g	250 g
Type of mounting				
• 35 mm DIN rail mounting	Yes	Yes	Yes	Yes
• Wall mounting	No	No	No	No
• S7-300 rail mounting	No	No	No	No
Type of mounting	-	-	-	-
Product properties, functions, components				
General				
Cascading with redundant ring at reconfiguration time < 0.3 s	50	50	50	50
Cascading with star topology	Any (only dependent on signal propagation time)	Any (only dependent on signal propagation time)	Any (only dependent on signal propagation time)	Any (only dependent on signal propagation time)

PROFINET/Industrial Ethernet

Industrial Ethernet switches / media converters

SCALANCE XF-200 managed

Technical specifications (continued)

Order No.	6GK5 204-0BA00-2AF2	6GK5 204-2BC00-2AF2	6GK5 206-1BC00-2AF2	6GK5 208-0BA00-2AF2
Product type designation	SCALANCE XF204	SCALANCE XF204-2	SCALANCE XF206-1	SCALANCE XF208
Product functions Management, configuration, programming				
Product function				
• CLI	Yes	Yes	Yes	Yes
• Web-based management	Yes	Yes	Yes	Yes
• MIB support	Yes	Yes	Yes	Yes
• Traps via e-mail	Yes	Yes	Yes	Yes
• Configuration with STEP 7	Yes	Yes	Yes	Yes
• SMTP server	Yes	Yes	Yes	Yes
• Port mirroring	Yes	Yes	Yes	Yes
• with IRT PROFINET IO Switch	No	No	No	No
• PROFINET IO-Diagnostics	Yes	Yes	Yes	Yes
• Switch-managed	Yes	Yes	Yes	Yes
Protocol is supported				
• Telnet	Yes	Yes	Yes	Yes
• HTTP	Yes	Yes	Yes	Yes
• HTTPS	Yes	Yes	Yes	Yes
• TFTP	Yes	Yes	Yes	Yes
• FTP	Yes	Yes	Yes	Yes
• BOOTP	No	No	No	No
• SNMP v1	Yes	Yes	Yes	Yes
• SNMP v2	Yes	Yes	Yes	Yes
• SNMP v3	Yes	Yes	Yes	Yes
• DCP	Yes	Yes	Yes	Yes
• LLDP	Yes	Yes	Yes	Yes
Identification & Maintenance				
• I&M0 - device-specific information	Yes	Yes	Yes	Yes
• I&M1 - higher-level designation/ location designation	Yes	Yes	Yes	Yes
Product functions Diagnostics				
Product function				
• Port diagnostics	Yes	Yes	Yes	Yes
• Packet size statistics	Yes	Yes	Yes	Yes
• Packet type statistics	Yes	Yes	Yes	Yes
• Error statistics	Yes	Yes	Yes	Yes
Product functions DHCP				
Product function DHCP client	Yes	Yes	Yes	Yes
Product functions Redundancy				
Product function				
• Ring redundancy	Yes	Yes	Yes	Yes
• Redundancy manager	Yes	Yes	Yes	Yes
• Standby redundancy	No	No	No	No
• Redundancy procedure HSR	Yes	Yes	Yes	Yes
• Redundancy procedure MRP	Yes	Yes	Yes	Yes
• Redundancy procedure PRP	No	No	No	No
• Passive listening	Yes	Yes	Yes	Yes

2

Technical specifications (continued)

Order No.	6GK5 204-0BA00-2AF2	6GK5 204-2BC00-2AF2	6GK5 206-1BC00-2AF2	6GK5 208-0BA00-2AF2
Product type designation	SCALANCE XF204	SCALANCE XF204-2	SCALANCE XF206-1	SCALANCE XF208
Product functions Security				
SSH protocol is supported	Yes	Yes	Yes	Yes
Product functions Time				
Product function: SICLOCK support	Yes	Yes	Yes	Yes
Protocol is supported				
• NTP	No	No	No	No
• SNTP	Yes	Yes	Yes	Yes
Standards, specifications, approvals				
Standard				
• For EMC of FM	FM3611: Class 1, Division 2, Group A, B, C, D / T4, CL.1, Zone 2, GP. IIC, T4	FM3611: Class 1, Division 2, Group A, B, C, D / T4, CL.1, Zone 2, GP. IIC, T4	FM3611: Class 1, Division 2, Group A, B, C, D / T4, CL.1, Zone 2, GP. IIC, T4	FM3611: Class 1, Division 2, Group A, B, C, D / T4, CL.1, Zone 2, GP. IIC, T4
• for hazardous zone	EN 60079-0: 2006, EN 60079-15: 2005, II 3 G Ex nA II T4, KEMA 07 ATEX 0145 X	EN 60079-0: 2006, EN 60079-15: 2005, II 3 G Ex nA II T4, KEMA 07 ATEX 0145 X	EN 60079-0: 2006, EN 60079-15: 2005, II 3 G Ex nA II T4, KEMA 07 ATEX 0145 X	EN 60079-0: 2006, EN 60079-15: 2005, II 3 G Ex nA II T4, KEMA 07 ATEX 0145 X
• For CSA and UL safety	UL 60950-1, CSA C22.2 No. 60950-1	UL 60950-1, CSA C22.2 No. 60950-1	UL 60950-1, CSA C22.2 No. 60950-1	UL 60950-1, CSA C22.2 No. 60950-1
• for hazardous zone of CSA and UL	ANSI / ISA 12.12.01, CSA C22.2 No. 213-M1987, CL. 1 / Div. 2 / GP. A, B, C, D T4, CL. 1 / Zone 2 / GP. IIC, T4	ANSI / ISA 12.12.01, CSA C22.2 No. 213-M1987, CL. 1 / Div. 2 / GP. A, B, C, D T4, CL. 1 / Zone 2 / GP. IIC, T4	ANSI / ISA 12.12.01, CSA C22.2 No. 213-M1987, CL. 1 / Div. 2 / GP. A, B, C, D T4, CL. 1 / Zone 2 / GP. IIC, T4	ANSI / ISA 12.12.01, CSA C22.2 No. 213-M1987, CL. 1 / Div. 2 / GP. A, B, C, D T4, CL. 1 / Zone 2 / GP. IIC, T4
• For emitted interference	EN 61000-6-4:2001 (Class A)	EN 61000-6-4:2001 (Class A)	EN 61000-6-4:2001 (Class A)	EN 61000-6-4:2001 (Class A)
• For noise immunity	EN 61000-6-4:2001	EN 61000-6-2:2001	EN 61000-6-2:2001	EN 61000-6-2:2001
Certificate of suitability	EN 61000-6-4:2001	EN 61000-6-2:2001, EN 61000-6-4:2001	EN 61000-6-2:2001, EN 61000-6-4:2001	EN 61000-6-2:2001, EN 61000-6-4:2001
• CE mark	Yes	Yes	Yes	Yes
• C-Tick	Yes	Yes	Yes	Yes
• Railroad application according to EN 50155	No	No	No	No
• Railroad application according to EN 50124-1	No	No	No	No
Marine classification association				
• American Bureau of Shipping Europe Ltd. (ABS)	No	No	No	No
• Bureau Veritas (BV)	Yes	No	No	No
• Det Norske Veritas (DNV)	No	No	No	No
• Germanischer Lloyd (GL)	No	No	No	No
• Lloyds Register of Shipping (LRS)	No	No	No	No
• Nippon Kaiji Kyokai (NK)	No	No	No	No
• Polski Rejestr Statkow (PRS)	No	No	No	No

PROFINET/Industrial Ethernet

Industrial Ethernet switches / media converters

SCALANCE XF-200 managed

2

Ordering data

Order No.

Order No.

SCALANCE XF-200 Industrial Ethernet switches

Industrial Ethernet switches with integrated SNMP access, online diagnostics, copper cable diagnostics and PROFINET diagnostics for configuring line, star and ring topologies; with integrated redundancy manager; incl. operating instructions, Industrial Ethernet network manual and configuration software on CD-ROM

• SCALANCE XF204-2

4 x 10/100 Mbit/s RJ45 ports, electrical;
2 x 100 Mbit/s BFOC ports, optical (multimode, glass), up to 5 km

6GK5 204-2BC00-2AF2

• SCALANCE XF206-1

6 x 10/100 Mbit/s RJ45 ports, electrical;
1 x 100 Mbit/s BFOC optical port (multimode, glass), up to 5 km

6GK5 206-1BC00-2AF2

• SCALANCE XF204

4 x 10/100 Mbit/s RJ45 ports, electrical

6GK5 204-0BA00-2AF2

• SCALANCE XF208

8 x 10/100 Mbit/s RJ45 ports, electrical

6GK5 208-0BA00-2AF2

Accessories

IE FC TP Standard Cable GP 2 x 2 (Type A)

4-core, shielded TP installation cable for connection to IE FC Outlet RJ45 / IE FC RJ45 Plug; PROFINET-compliant; with UL approval; sold by the meter; max. length 1000 m, minimum order 20 m

6XV1 840-2AH10

FO Standard Cable GP 50/125/1400 ^{1) 2)}

Multimode cable, sold by the meter; max. length 1000 m; minimum order 20 m;

6XV1 873-2A

FO Robust Cable GP 4E9/125/90

Singlemode cable, sold by the meter; max. length 1000 m; minimum order 20 m

6XV1 843-2R

FC FO Standard Cable GP 62.5/200/230

FC FO standard cable for fixed routing indoors with PVC sheath; sold by the meter; max. length 1000 m; minimum order 20 m

6XV1 847-2A

¹⁾ Special fiber-optic cables, lengths and accessories available on request

²⁾ Special tools and trained personnel are required for pre-assembling glass fiber-optic cables

IE FC RJ45 Plug 180 2 x 2

RJ45 plug connector for Industrial Ethernet with a rugged metal enclosure and integrated insulation displacement contacts for connecting Industrial Ethernet FC installation cables; with 180° cable outlet; for network components and CPs/CPU with Industrial Ethernet interface

- 1 pack = 1 unit
- 1 pack = 10 units
- 1 pack = 50 units

6GK1 901-1BB10-2AA0
6GK1 901-1BB10-2AB0
6GK1 901-1BB10-2AE0

FC BFOC plug

Screw connector for on-site assembly on FC fiber-optic cable; (1 pack = 20 units + cleaning cloths)

6GK1 900-1GB00-0AC0

IE FC Stripping Tool

Preadjusted stripping tool for fast stripping of the Industrial Ethernet FC cables

6GK1 901-1GA00

FC FO Termination Kit

Assembly case for local assembly of FC SC and FC BFOC connectors to FC FO standard cable, comprising a stripping tool, Kevlar cutters, fiber breaking tool and microscope

6GK1 900-1GL00-0AA0

SITOP compact 24 V/ 0.6 A

1-phase power supply with wide-range input 85 – 264 V AC/110 – 300 V DC, stabilized output voltage 24 V, rated output current value 0.6 A, slim design

6EP1 331-5BA00

C-PLUG

Swap medium for simple replacement of devices in the event of a fault; for storing configuration or engineering and application data; can be used for SIMATIC NET products with C-PLUG slot

6GK1 900-0AB00

More information

To assist in selecting the right Industrial Ethernet switches as well as configuration of modular versions, the SIMATIC NET Selection Tool is available.

Online version:
www.siemens.com/snst

Offline version:
www.siemens.com/snst-download

PROFINET/Industrial Ethernet

Industrial Ethernet switches / media converters

SCALANCE X-200IRT managed



Overview

SCALANCE X-200IRT	Type of device	Hardware																
		Connection to S7 backplane bus	Format module S7	PC module	Flat type of construction	Box type of construction	19" type of construction	Rugged, compact housing	Modular design	10 Gigabit Ethernet	Gigabit Ethernet	PoE (Power over Ethernet)	LED diagnosis	SIMATIC environment	Redundant power supply (2 x 24 V DC)	External supply for integrated switch	Signal contact	Local display (SET pushbutton)
	X200-4P IRT											•	•	•		•	•	•
	X201-3P IRT											•	•	•		•	•	•
	X201-3P IRT PRO											•	•	•		•	•	•
	X202-2IRT											•	•	•		•	•	•
	X202-2P IRT											•	•	•		•	•	•
	X202-2P IRT PRO											•	•	•		•	•	•
	X204IRT											•	•	•		•	•	•
	X204IRT PRO											•	•	•		•	•	•
	XF204IRT			•								•	•	•		•	•	•

• applies

G_IK10_XX_10314

Function overview SCALANCE X-200IRT managed: Hardware

SCALANCE X-200IRT	Type of device	Software																										
		Security Integrated (Firewall/VPN)	PROFINET diagnosis	Topology support (LLDP)	Command Line Interface / Telnet	Web based Management	Configuration with STEP 7	SNMP	Ring redundancy incl. RM-functionality	Standby redundancy	IRT capability	VLAN (Virtual Local Area Network)	GVRP (Generic VLAN Registration Protocol)	STP/ RSTP (Spanning Tree Protocol/ Rapid Spanning Tree Protocol)	Passive Listening	IGMP Snooping/Querier (Internet Group Management Protocol)	GMRP (Generic Multicast Protocol)	Broadcast/ Multicast/ Unicast Limiter	Broadcast blocking	DHCP Option 82 (Dynamic Host Configuration Protocol)	IP Access List	Access Control List (MAC)	IEEE 802.1x (Radius)	Link Aggregation	Static Routing	RIPV2 (Dynamic Routing)	OSPFv2 (Dynamic Routing)	VRRP, Router Redundancy (Virtual Router Redundancy Protocol)
	X200-4P IRT	•	•	•	•	•	•	•	•	•				•														
	X201-3P IRT	•	•	•	•	•	•	•	•	•				•														
	X201-3P IRT PRO	•	•	•	•	•	•	•	•	•				•														
	X202-2IRT	•	•	•	•	•	•	•	•	•				•														
	X202-2P IRT	•	•	•	•	•	•	•	•	•				•														
	X202-2P IRT PRO	•	•	•	•	•	•	•	•	•				•														
	X204IRT	•	•	•	•	•	•	•	•	•				•														
	X204IRT PRO	•	•	•	•	•	•	•	•	•				•														
	XF204IRT	•	•	•	•	•	•	•	•	•				•														

• applies

G_IK10_XX_10315

Function overview SCALANCE X-200IRT managed: Software

PROFINET/Industrial Ethernet

Industrial Ethernet switches / media converters

SCALANCE X-200IRT managed

Overview



SCALANCE X-200IRT switches are especially designed for constructing isochronous real-time (IRT) Industrial Ethernet networks in line, star and ring topologies at transmission rates of 10/100 Mbit/s (Redundancy Manager integrated); construction of redundant ring connections possible.

- Optimized performance due to combination of the switching mechanisms "Cut Through" and "Store and Forward"
- Fast media redundancy due to the integrated redundancy manager for Fast Ethernet
- Rugged, industry-standard station connections with PROFINET-compatible plug-in connectors that offer additional strain relief and bending strain relief thanks to latching on the enclosure
- PROFINET diagnostics, SNMP access, integrated web server and automatic e-mail transmission function for remote diagnostics and signaling via the network
- Different device versions with copper and fiber-optic interfaces (BFOC, SC RJ)
- Implementation of cabinet-free plant concepts with PROFINET-compliant push pull connection systems with device versions with IP65/67 protection

Benefits

g e t **Designed for Industry**

- The ideal solution for constructing isochronous real-time (IRT) Industrial Ethernet segments especially in line, star and ring topologies with copper and fiber-optic cabling (glass FOC, PCF FOC, POF FOC)
- Reliable data communication thanks to rugged, industry-standard device connection using PROFINET-compatible connectors (IE FC RJ45 Plug) that offer additional strain relief and bending strain relief thanks to latching on the enclosure
- High network availability in ring topologies, without reconfiguration times, when using the PROFINET-compliant MRPD process (**M**edia **R**edundancy for **P**lanned **D**uplication according to IEC 61158)
- Fast and easy diagnosis with LEDs on the device, through the integral Web server and through signaling contacts
- Easy integration in the process diagnosis and system diagnosis with PROFINET
- Configuration and diagnostics integrated into STEP 7 provide significant benefits during the engineering, start-up and operating phases of a plant
- Module replacement without the need for a programming device, using the C-PLUG swap media for backing up the configuration data

Application

The SCALANCE X-200IRT Industrial Ethernet switches permit the construction of isochronous real-time (IRT) Industrial Ethernet line and star topologies. Ring structures can also be designed using the integral redundancy manager (RM). Redundant ring connections are also possible. Thanks to innovative switching technology, the special requirements of automation with regard to line topology, isochronous mode for motion control applications and unlimited IT openness have been satisfied for the first time within a single technology based on the PROFINET standard.

The switches with IP30 degree of protection have been designed for use in the control cabinet. The switches with IP65/67 protection are designed for cabinet-free mounting (PROFINET-compliant push pull connection technology).

PROFINET/Industrial Ethernet

Industrial Ethernet switches / media converters

SCALANCE X-200IRT managed

Application (continued)

Product versions

SCALANCE X204IRT

- For configuring electrical Industrial Ethernet linear bus, star or ring topologies with 4 electrical ports

SCALANCE X202-2IRT

- For configuring electrical/optical Industrial Ethernet linear bus, star or ring topologies with two electrical ports and two glass fiber optic ports

SCALANCE X202-2P IRT

- For configuring electrical/optical Industrial Ethernet linear bus, star or ring topologies with two electrical ports and two optical POF fiber optic ports

SCALANCE X201-3P IRT

- For configuring electrical/optical Industrial Ethernet linear bus, star or ring topologies with one electrical port and three optical POF fiber optic ports

SCALANCE X200-4P IRT

- For configuring optical Industrial Ethernet linear bus, star or ring topologies with 4 optical POF fiber-optic ports

SCALANCE X204 IRT PRO

- For the construction of electrical Industrial Ethernet linear, star or ring topologies with four electrical ports in degree of protection IP65/67 with PROFINET-compliant push-pull connection technology

SCALANCE X202-2P IRT PRO

- For the construction of electrical/optical Industrial Ethernet linear bus, star or ring structures with two electrical and two optical POF/PCF fiber optic ports in degree of protection IP65/67 with PROFINET-compliant push-pull connection technology

SCALANCE X201-3P IRT PRO

- For the construction of electrical/optical Industrial Ethernet linear bus, star or ring topologies with one electrical and three optical POF/PCF fiber optic ports in degree of protection IP65/67 with PROFINET-compliant push-pull connection technology

Applicable to all versions:

- Integral redundancy manager (RM)
- Device diagnostics with LEDs (power, link status, data communication)
- Remote diagnostics possible by means of signaling contact (signaling dialog box can be set on-site using pushbutton), PROFINET, SNMP and web browser
- Automatic e-mail send function
- Rugged, industry-standard station connections with PROFINET-compliant RJ45 connectors that offer additional strain relief and bending strain relief thanks to latching on the housing

The SCALANCE X-200IRT switches, based on PROFINET, satisfy the real-time requirements of the field level up to high-performance motion control applications.

Real-time Ethernet

- Interfacing of the PROFINET IO-Devices to the PROFINET IO-Controller through high-performance, optimized data transmission
- Coexistence of isochronous mode for motion control applications and IT openness:
Reaction-free transmission of real-time and non-real-time communication on the same line

Additionally through isochronous real-time (IRT) Ethernet

- Isochronous real-time communication based on the transmission procedure of the IEEE 802 standard by combining the switching mechanisms "Cut Through" and "Store and Forward"
- For drive controls, PROFINET with isochronous real-time is the best performing system worldwide with regard to its isochronous and deterministic response.
With a cycle time of 1 ms, for example, axes can be controlled in isochronous mode whereby 50% of the bandwidth is available solely for IT communication.

Design

- The SCALANCE X-200IRT switches in a rugged metal housing with IP30 and IP65/67 degree of protection are optimized for mounting on a standard rail and an S7-300 rail. Direct wall mounting in various positions is also possible. Thanks to the S7-300 housing dimensions, the devices are suitable for integration into an automation solution with S7-300 components.
- The switches have a 4-pin terminal block for connecting the redundant supply voltage (2 x 24 V DC). The versions with IP65/67 protection have two 5-pin push-pull connectors via which the supply voltage is fed and forwarded. In addition, the load voltage circuit is also looped through for the ET 200pro devices further along the line. The devices with IP65/67 protection thus have no redundant voltage feed, but permit optimal integration into cabinet-free plant concepts with ET 200pro modules.
The status information (power, link status, data traffic, voltage supply, signaling contact) is indicated by means of a row of LEDs.

The SCALANCE X-200IRT modules are available with the following port types:

- *10/100BaseTX, RJ45 connection*
RJ45 port, automatic detection of the data rate (10 or 100 Mbit/s), with Autosensing and Autocrossover function for connecting IE FC cables over IE FC RJ45 Plug 180 over distances up to 100 m.
- *10/100BaseTX, push-pull RJ45 connection*
RJ45 port, automatic detection of the data rate (10 or 100 Mbit/s), with Autosensing and Autocrossover function for connecting IE FC cables via IE FC RJ45 Plug PRO over distances up to 100 m
- *100BaseFX, BFOC connection technique*
BFOC ports for direct connection to Industrial Ethernet glass fiber-optic cables up to 5000 m for configuring line and star topologies.
- *100BaseFX, SC RJ connections*
SC RJ ports for connection to Industrial Ethernet POF (50 m) and PCF FOC (100 m) using SC RJ plug connectors
- *100BaseFX, push-pull SC RJ connections*
SC RJ ports for connection to Industrial Ethernet POF (50 m) and PCF FOC (100 m) using SC RJ plug PRO connectors

PROFINET/Industrial Ethernet

Industrial Ethernet switches / media converters

SCALANCE X-200IRT managed

Function

- 4-port switch for configuring electrical and optical Industrial Ethernet line, star and ring topologies
- Integral redundancy manager for design of ring topologies
- Integral standby function for redundant coupling of two rings
- Extremely short cycle times with highly accurate clock-pulse rates thanks to integrated real-time functions
- Bumpless ring redundancy by sending message frames twice in the ring, by means of PROFINET-compliant MRPD procedure (**M**edia **R**edundancy for **P**lanned **D**uplication according to IEC 61158)
- System-wide clock accuracy (less than 1 ms)
- Uncrossed connecting cables can be used due to Autocrossover function integrated in the ports
- Load disconnection through integral switch functionality
- Easy diagnostics using signaling contact, SNMP and Web browser
- Automatic e-mail function
- Integration into the diagnostics of a PROFINET IO-Controllers for a consistent diagnostics concept, including network infrastructure
- Fast device replacement in the event of a fault by using the optional C-PLUG swap medium (not included in scope of supply)

Network topology and network configuration

The SCALANCE X-200IRT Industrial Ethernet Switches are usually installed in the control cabinet together with the stations to be connected (e.g. ET 200S) or, in the case of cabinet-free designs, mounted directly onto the machine. When configuring the network, it is necessary to observe the following boundary conditions:

- Length of the TP cable between two SCALANCE X switches:
 - Max. 100 m with IE FC cable and IE FC RJ45 Plug 180 or IE FC RJ45 Plug PRO
 - Max. 10 m with TP Cord
- Length of the optical cables
 - Max. 4000 m with Industrial Ethernet glass fiber-optic cables (62.5/125 μm)
 - Max. 5000 m with Industrial Ethernet glass fiber-optic cables (50/125 μm)
 - Max. 100 m with Industrial Ethernet PCF fiber-optic cables.
 - Max. 50 m with Industrial Ethernet POF fiber-optic cables.
- IP Address:

The IP address is assigned by means of the DHCP (Dynamic Host Configuration Protocol). If there is no corresponding server in the network, the IP address can be assigned using the supplied software tool PST (Primary Setup Tool) or STEP 7. The SCALANCE X-200IRT switches and their real-time functions are configured with STEP 7.

Commissioning and diagnosis

PROFINET diagnostic alarms from SCALANCE X-200IRT Switches can be displayed with the appropriate SIMATIC Engineering Tools and processed in the control unit. The engineering outlay for the PLC and HMI have been drastically reduced due to the complete integration in the SIMATIC concept for system error messages.

The SCALANCE X-200IRT Industrial Ethernet switches can also be integrated into a network management system through the standardized protocol SNMP (Simple Network Management Protocol). In the event of a device fault, error messages (SNMP traps) can be sent to a network system or as e-mail to a specified network manager.

The integral Web server enables configuration and diagnosis settings to be made using a standard browser. Statistical information can also be read out over the Web server. Warning thresholds, and alarms generated by them, permit early recognition of critical fiber states (only with POF). Cable failures (fiber breakage) can thus be avoided, and plant downtimes reduced, since maintenance work can be carried out at an early point in time and outside production periods.

The following information is displayed on site by LEDs:

- Power
- Port status
- Data traffic
- RM activated
- POF cable diagnostics

The Industrial Ethernet switches of the SCALANCE X-200IRT line can also be monitored using the floating signaling contact.

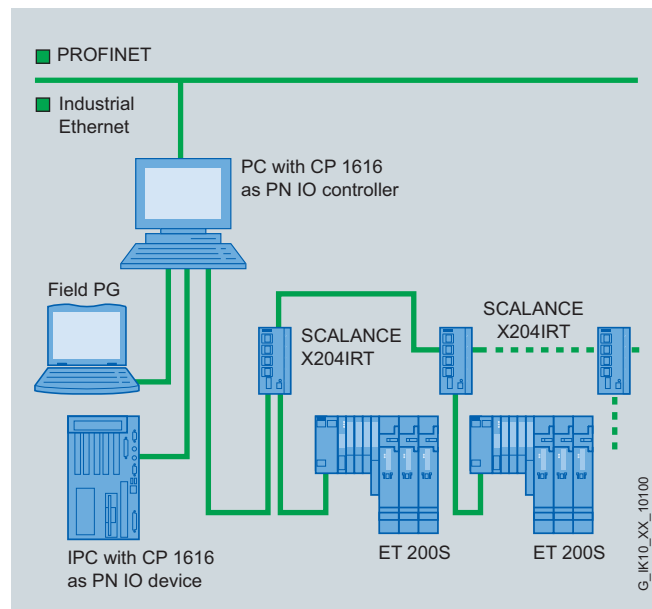

Configuration example for SCALANCE X204IRT

Function (continued)

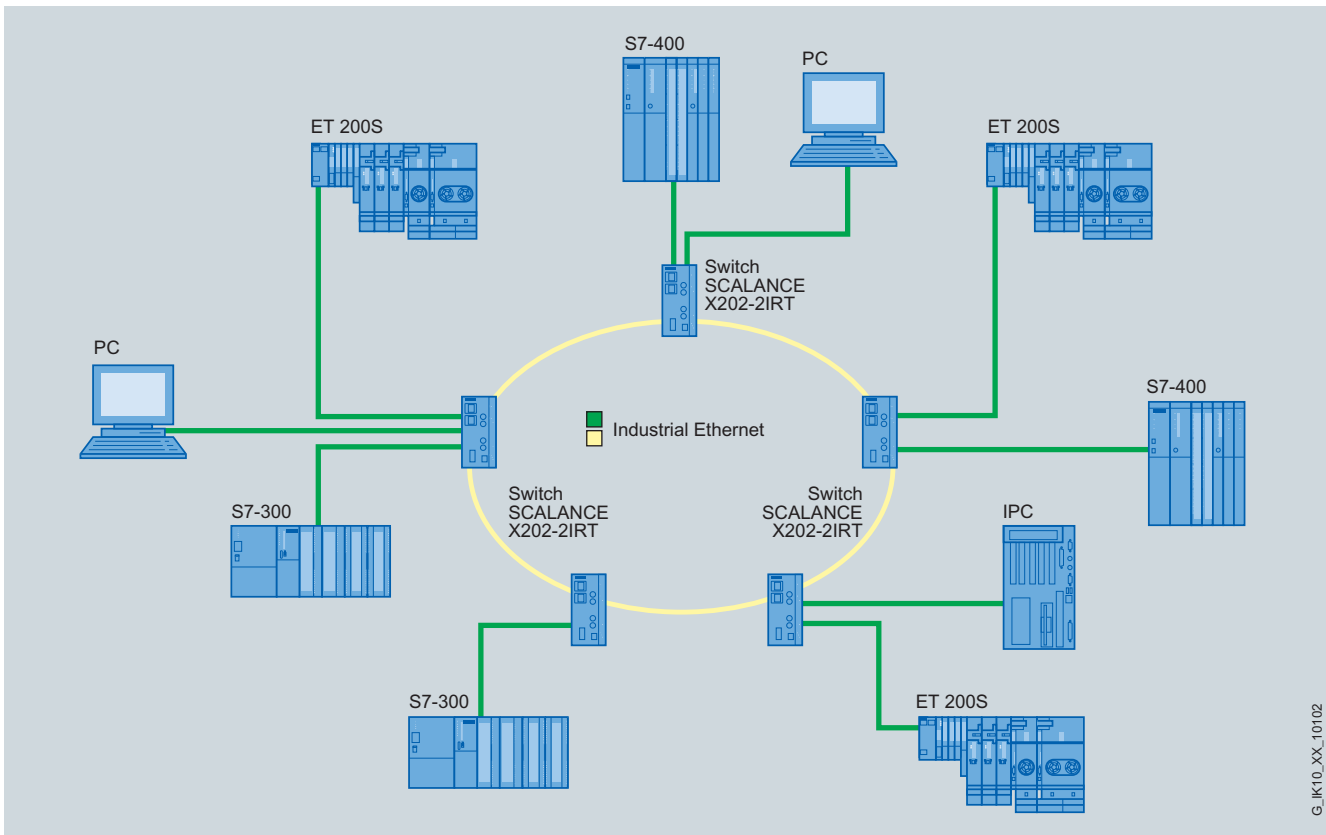

2

Configuration with high-speed redundancy in the optical ring

PROFINET/Industrial Ethernet

Industrial Ethernet switches / media converters

SCALANCE X-200IRT managed

Function (continued)

2

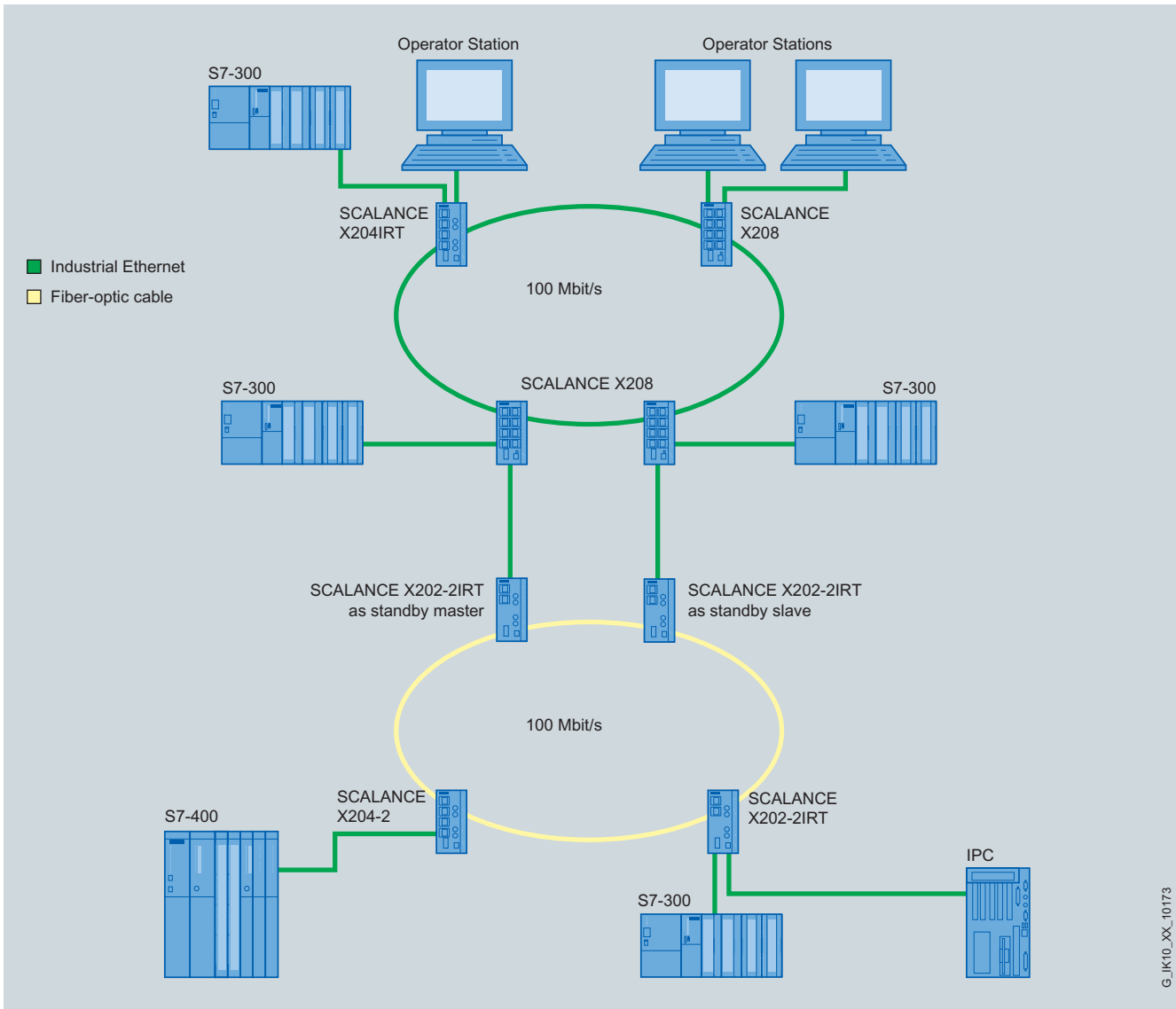

Redundant coupling of two subnetworks with SCALANCE X-200IRT

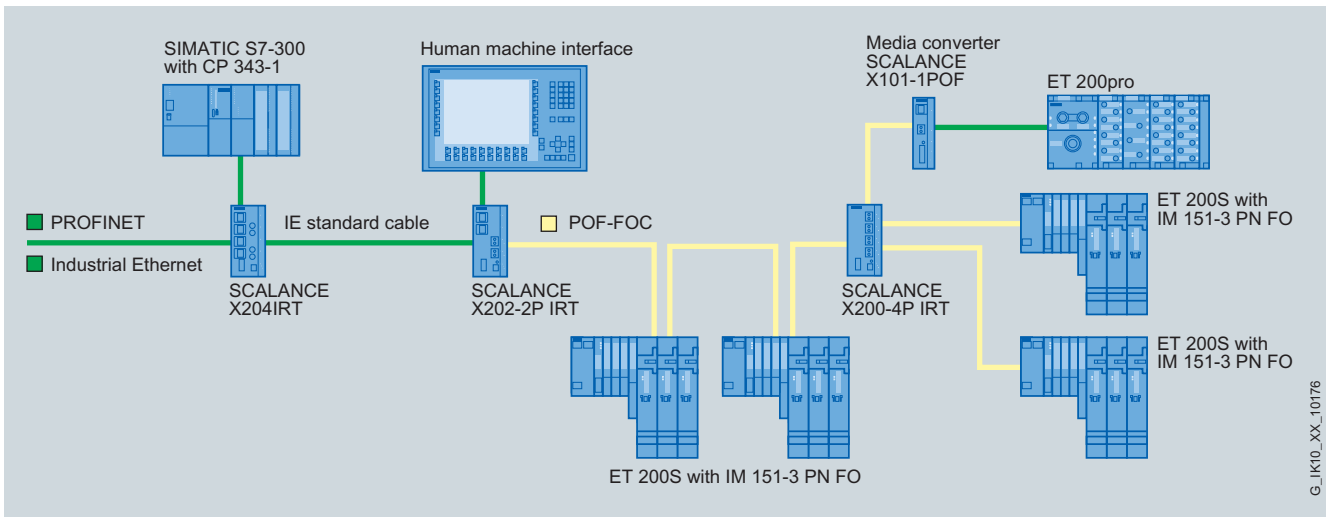

Mixed network topology with plastic fiber-optic cables and twisted-pair cables

Technical specifications

Order No.	6GK5 200-4AH00-2BA3	6GK5 201-3BH00-2BA3	6GK5 202-2BH00-2BA3
Product type designation	SCALANCE X200-4P IRT	SCALANCE X201-3P IRT	SCALANCE X202-2P IRT
Transmission rate			
Transmission rate 1	10 Mbit/s	10 Mbit/s	10 Mbit/s
Transmission rate 2	100 Mbit/s	100 Mbit/s	100 Mbit/s
Interfaces			
Number of electrical/optical connections			
• for network components or terminal equipment, maximum	4	4	4
• as combo port for network components or terminal equipment	-	-	-
Number of electrical connections			
• for network components or terminal equipment	-	1	2
• for signaling contact	1	1	1
• for power supply	1	1	1
• For redundant power supply	1	1	1
Design of electrical/optical connections for network components or terminal equipment			
Design of electrical connection			
• for network components or terminal equipment	-	RJ45 port	RJ45 port
• for signaling contact	2-pin terminal block	2-pin terminal block	2-pin terminal block
• for power supply	4-pin terminal block	4-pin terminal block	4-pin terminal block
Number of optical connections for fiber-optic cables at 100 Mbit/s	4	3	2
Design of optical connection for fiber-optic cables at 100 Mbit/s	SC-RJ/POF port	SC-RJ/POF port	SC-RJ/POF port
Injectable optical power relative to 1 mW			
• of the transmitter output	-8 ... -2 dB	-8 ... -2 dB	-8 ... -2 dB
• of the receiver input, maximum	-	-	-
Optical sensitivity referred to 1 mW of receiver input, minimum	-25 dB	-25 dB	-25 dB
Minimum required attenuation factor of the FO transmission link	0 dB	0 dB	0 dB
The range at the optical interface depends on the type of optical fiber used	0 ... 0.05 km	0 ... 0.05 km	0 ... 0.05 km
Design of swap medium C-Plug	Yes	Yes	Yes
Inputs/outputs			
Operating voltage of signaling contacts with DC rated value	24 V	24 V	24 V
Maximum operating current of signaling contacts with DC	0.1 A	0.1 A	0.1 A
Supply voltage, current consumption, power loss			
Type of power supply	DC	DC	DC
External power supply	24 V	24 V	24 V
• Minimum	18 V	18 V	18 V
• Maximum	32 V	32 V	32 V
Product component: fusing at power supply input	Yes	Yes	Yes
Type of fusing of power supply input	1.1 A / 33 V	1.1 A / 33 V	1.1 A / 33 V
Current consumed, maximum	0.4 A	0.35 A	0.3 A
Effective power loss at 24 V with DC	9.6 W	8.4 W	7.2 W

PROFINET/Industrial Ethernet

Industrial Ethernet switches / media converters

SCALANCE X-200IRT managed

Technical specifications (continued)

Order No.	6GK5 200-4AH00-2BA3	6GK5 201-3BH00-2BA3	6GK5 202-2BH00-2BA3
Product type designation	SCALANCE X200-4P IRT	SCALANCE X201-3P IRT	SCALANCE X202-2P IRT
Permissible ambient conditions			
Ambient temperature			
• During operation	-25 ... +40 °C	-25 ... +50 °C	-25 ... +60 °C
• During storage	-40 ... +70 °C	-40 ... +70 °C	-40 ... +70 °C
• During transport	-40 ... +70 °C	-40 ... +70 °C	-40 ... +70 °C
• Note	-	-	-
Relative humidity at 25 °C without condensation during operation, maximum	95 %	95 %	95 %
IP degree of protection	IP30	IP30	IP30
Design, dimensions and weights			
Design	Compact	Compact	Compact
Width	60 mm	60 mm	60 mm
Height	125 mm	125 mm	125 mm
Depth	124 mm	124 mm	124 mm
Net weight	0.78 kg	0.78 kg	0.78 kg
Type of mounting			
• 35 mm DIN rail mounting	Yes	Yes	Yes
• Wall mounting	Yes	Yes	Yes
• S7-300 rail mounting	Yes	Yes	Yes
Product properties, functions, components			
General			
Cascading with redundant ring at reconfiguration time < 0.3 s	50	50	50
Cascading with star topology	Any (only dependent on signal propagation time)	Any (only dependent on signal propagation time)	Any (only dependent on signal propagation time)
Product functions			
Management, configuration, programming			
Product function			
• CLI	Yes	Yes	Yes
• Web-based management	Yes	Yes	Yes
• MIB support	Yes	Yes	Yes
• TRAPs via e-mail	Yes	Yes	Yes
• Configuration with STEP 7	Yes	Yes	Yes
• SMTP server	Yes	Yes	Yes
• Port mirroring	No	No	No
• with IRT PROFINET IO Switch	Yes	Yes	Yes
• PROFINET IO Diagnostics	Yes	Yes	Yes
• Switch-managed	Yes	Yes	Yes
Protocol is supported			
• Telnet	Yes	Yes	Yes
• HTTP	Yes	Yes	Yes
• HTTPS	Yes	Yes	Yes
• TFTP	Yes	Yes	Yes
• FTP	Yes	Yes	Yes
• BOOTP	No	No	No
• SNMP v1	Yes	Yes	Yes
• SNMP v2	Yes	Yes	Yes
• SNMP v3	Yes	Yes	Yes
• DCP	Yes	Yes	Yes
• LLDP	Yes	Yes	Yes
Identification & Maintenance			
• I&M0 - device-specific information	Yes	Yes	Yes
• I&M1 - higher-level designation/ location designation	Yes	Yes	Yes

Technical specifications (continued)

Order No.	6GK5 200-4AH00-2BA3	6GK5 201-3BH00-2BA3	6GK5 202-2BH00-2BA3
Product type designation	SCALANCE X200-4P IRT	SCALANCE X201-3P IRT	SCALANCE X202-2P IRT
Product functions Diagnostics			
Product function			
• Port diagnostics	Yes	Yes	Yes
• Packet Size Statistics	Yes	Yes	Yes
• Packet Type Statistics	Yes	Yes	Yes
• Error Statistics	Yes	Yes	Yes
Product functions DHCP			
Product function: DHCP client	Yes	Yes	Yes
Product functions Redundancy			
Product function			
• Ring redundancy	Yes	Yes	Yes
• Redundancy manager	Yes	Yes	Yes
• Standby redundancy	Yes	Yes	Yes
• Redundancy procedure HSR	Yes	Yes	Yes
• Redundancy procedure MRP	Yes	Yes	Yes
• Redundancy procedure PRP	No	No	No
• Passive listening	Yes	Yes	Yes
Product functions Security			
SSH protocol is supported	Yes	Yes	Yes
Product functions Time			
Product function: support	Yes	Yes	Yes
Protocol is supported			
• NTP	No	No	No
• SNTP	Yes	Yes	Yes
Standards, specifications, approvals			
Standard			
• for EMC of FM	FM3611: Class 1, Division 2, Group A, B, C, D / T4, CL.1, Zone 2, GP. IIC, T4	FM3611: Class 1, Division 2, Group A, B, C, D / T4, CL.1, Zone 2, GP. IIC, T4	FM3611: Class 1, Division 2, Group A, B, C, D / T4, CL.1, Zone 2, GP. IIC, T4
• for hazardous zone	EN 60079-0: 2006, EN 60079-15: 2005, II 3 G Ex nA II T4 KEMA 07 ATEX 0145X	EN 60079-0: 2006, EN 60079-15: 2005, II 3 G Ex nA II T4 KEMA 07 ATEX 0145X	EN 60079-0: 2006, EN 60079-15: 2005, II 3 G Ex nA II T4 KEMA 07 ATEX 0145X
• for CSA and UL safety	UL 60950-1, CSA C22.2 No. 60950-1	UL 60950-1, CSA C22.2 No. 60950-1	UL 60950-1, CSA C22.2 No. 60950-1
• for hazardous zone of CSA and UL	ANSI / ISA 12.12.01, CSA C22.2 No. 213-M1987, CL. 1 / Div. 2 / GP. A, B, C, D T4, CL. 1 / Zone 2 / GP. IIC, T4	ANSI / ISA 12.12.01, CSA C22.2 No. 213-M1987, CL. 1 / Div. 2 / GP. A, B, C, D T4, CL. 1 / Zone 2 / GP. IIC, T4	ANSI / ISA 12.12.01, CSA C22.2 No. 213-M1987, CL. 1 / Div. 2 / GP. A, B, C, D T4, CL. 1 / Zone 2 / GP. IIC, T4
• for emitted interference	EN 61000-6-4:2001	EN 61000-6-4 (Class A)	EN 61000-6-4:2001 (Class A)
• for noise immunity	EN 61000-6-2:2001	EN 61000-6-2	EN 61000-6-4:2001
Certificate of suitability	EN 61000-6-2:2001, EN 61000-6-4:2001	EN 61000-6-2, EN 61000-6-4	EN 61000-6-4:2001
• CE mark	Yes	Yes	Yes
• C-Tick	Yes	Yes	Yes
• Railroad application according to EN 50155	No	No	No
• Railroad application according to EN 50124-1	No	No	No
Marine classification corporation			
• American Bureau of Shipping Europe Ltd. (ABS)	No	No	No
• Bureau Veritas (BV)	No	No	No
• Det Norske Veritas (DNV)	Yes	Yes	Yes
• Germanischer Lloyd (GL)	Yes	Yes	Yes
• Lloyds Register of Shipping (LRS)	Yes	Yes	Yes
• Nippon Kaiji Kyokai (NK)	No	No	Yes
• Polski Rejestr Statkow (PRS)	No	No	No

PROFINET/Industrial Ethernet

Industrial Ethernet switches / media converters

SCALANCE X-200IRT managed

Technical specifications (continued)

Order No.	6GK5 202-2BB00-2BA3	6GK5 204-0BA00-2BA3
Product type designation	SCALANCE X202-2IRT	SCALANCE X204IRT
Transmission rate		
Transmission rate 1	10 Mbit/s	10 Mbit/s
Transmission rate 2	100 Mbit/s	100 Mbit/s
Interfaces		
Number of electrical/optical connections		
• for network components or terminal equipment, maximum	4	4
• as combo port for network components or terminal equipment	-	-
Number of electrical connections		
• for network components or terminal equipment	2	4
• for signaling contact	1	1
• for power supply	1	1
• For redundant power supply	1	1
Design of electrical/optical connections for network components or terminal equipment		
Design of electrical connection		
• for network components or terminal equipment	RJ45 port	RJ45 port
• for signaling contact	2-pin terminal block	2-pin terminal block
• for power supply	4-pin terminal block	4-pin terminal block
Number of optical connections for fiber-optic cables at 100 Mbit/s	2	-
Design of optical connection for fiber-optic cables at 100 Mbit/s	BFOC port (multimode up to 5 km)	-
Injectable optical power relative to 1 mW		
• of the transmitter output	-19 ... -14 dB	-
• of the receiver input, maximum	-	-
Optical sensitivity referred to 1 mW of receiver input, minimum	-34 dB	-
Minimum required damping factor of FO transmission link	0 dB	-
The range at the optical interface depends on the type of optical fiber used	0 ... 0.05 km	-
Design of swap medium C-Plug	Yes	Yes
Inputs/outputs		
Operating voltage of signaling contacts with DC rated value	24 V	24 V
Operating current of signaling contacts with DC, maximum	0.1 A	0.1 A
Supply voltage, current consumption, power loss		
Type of power supply	DC	DC
External power supply	24 V	24 V
• Minimum	18 V	18 V
• Maximum	32 V	32 V
Product component: fusing at power supply input	Yes	Yes
Type of fusing of power supply input	0.6 A / 60 V	0.6 A / 60 V
Current consumed, maximum	0.3 A	0.2 A
Effective power loss at 24 V with DC	6 W	4.8 W

Technical specifications (continued)

Order No.	6GK5 202-2BB00-2BA3	6GK5 204-0BA00-2BA3
Product type designation	SCALANCE X202-2IRT	SCALANCE X204IRT
Permissible ambient conditions		
Ambient temperature		
• During operation	-40 ... +60 °C	-40 ... +70 °C
• During storage	-40 ... +70 °C	-40 ... +70 °C
• During transport	-40 ... +70 °C	-40 ... +70 °C
• Note	-	-
Relative humidity at 25 °C without condensation during operation, maximum	95 %	95 %
IP degree of protection	IP30	IP30
Design, dimensions and weights		
Design	Compact	Compact
Width	60 mm	60 mm
Height	125 mm	125 mm
Depth	124 mm	124 mm
Net weight	0.78 kg	0.78 kg
Type of mounting		
• 35 mm DIN rail mounting	Yes	Yes
• Wall mounting	Yes	Yes
• S7-300 rail mounting	Yes	Yes
Product properties, functions, components		
General		
Cascading with redundant ring at reconfiguration time < 0.3 s	50	50
Cascading with star topology	Any (only dependent on signal propagation time)	Any (only dependent on signal propagation time)
Product functions		
Management, configuration, programming		
Product function		
• CLI	Yes	Yes
• Web-based management	Yes	Yes
• MIB support	Yes	Yes
• TRAPS via e-mail	Yes	Yes
• Configuration with STEP 7	Yes	Yes
• SMTP server	Yes	Yes
• Port mirroring	No	No
• with IRT PROFINET IO Switch	Yes	Yes
• PROFINET IO diagnostics	Yes	Yes
• Switch-managed	Yes	Yes
Protocol is supported		
• Telnet	Yes	Yes
• HTTP	Yes	Yes
• HTTPS	Yes	Yes
• TFTP	Yes	Yes
• FTP	Yes	Yes
• BOOTP	No	No
• SNMP v1	Yes	Yes
• SNMP v2	Yes	Yes
• SNMP v3	Yes	Yes
• DCP	Yes	Yes
• LLDP	Yes	Yes
Identification & Maintenance		
• I&M0 - device-specific information	Yes	Yes
• I&M1 - higher-level designation/ location designation	Yes	Yes

PROFINET/Industrial Ethernet

Industrial Ethernet switches / media converters

SCALANCE X-200IRT managed

Technical specifications (continued)

Order No.	6GK5 202-2BB00-2BA3	6GK5 204-0BA00-2BA3
Product type designation	SCALANCE X202-2IRT	SCALANCE X204IRT
Product functions Diagnostics		
Product function		
• Port diagnostics	Yes	Yes
• Packet Size Statistics	Yes	Yes
• Packet Type Statistics	Yes	Yes
• Error Statistics	Yes	Yes
Product functions DHCP		
Product function: DHCP client	Yes	Yes
Product functions Redundancy		
Product function		
• Ring redundancy	Yes	Yes
• Redundancy manager	Yes	Yes
• Standby redundancy	Yes	Yes
• Redundancy procedure HSR	Yes	Yes
• Redundancy procedure MRP	Yes	Yes
• Redundancy procedure PRP	No	No
• Passive listening	Yes	Yes
Product functions Security		
Protocol is supported SSH	Yes	Yes
Product functions Time		
Product function: SICLOCK support	Yes	Yes
Protocol is supported		
• NTP	No	No
• SNTP	Yes	Yes
Standards, specifications, approvals		
Standard		
• for EMC of FM	FM3611: Class 1, Division 2, Group A, B, C, D / T4, CL.1, Zone 2, GP. IIC, T4	FM3611: Class 1, Division 2, Group A, B, C, D / T4, CL.1, Zone 2, GP. IIC, T4
• For hazardous zone	EN 60079-0: 2006, EN 60079-15: 2005, II 3 G Ex nA II T4 KEMA 07 ATEX 0145X	EN 60079-0: 2006, EN 60079-15: 2005, II 3 G Ex nA II T4 KEMA 07 ATEX 0145X
• For CSA and UL safety	UL 60950-1, CSA C22.2 No. 60950-1	UL 60950-1, CSA C22.2 No. 60950-1
• For CSA and UL hazardous zone	ANSI / ISA 12.12.01, CSA C22.2 No. 213-M1987, CL. 1 / Div. 2 / GP. A, B, C, D T4, CL. 1 / Zone 2 / GP. IIC, T4	ANSI / ISA 12.12.01, CSA C22.2 No. 213-M1987, CL. 1 / Div. 2 / GP. A, B, C, D T4, CL. 1 / Zone 2 / GP. IIC, T4
• For emitted interference	EN 61000-6-4:2001 (Class A)	EN 61000-6-4:2001 (Class A)
• for noise immunity	EN 61000-6-4:2001	EN 61000-6-4:2001
Certificate of suitability	EN 61000-6-4:2001	EN 61000-6-4:2001
• CE mark	Yes	Yes
• C-Tick	Yes	Yes
• Railroad application according to EN 50155	No	No
• Railroad application according to EN 50124-1	No	No
Marine classification corporation		
• American Bureau of Shipping Europe Ltd. (ABS)	Yes	Yes
• Bureau Veritas (BV)	No	Yes
• Det Norske Veritas (DNV)	Yes	Yes
• Germanischer Lloyd (GL)	Yes	Yes
• Lloyds Register of Shipping (LRS)	Yes	Yes
• Nippon Kaiji Kyokai (NK)	Yes	Yes
• Polski Rejestr Statkow (PRS)	No	No

Technical specifications (continued)

Order No.	6GK5 204-0JA00-2BA6	6GK5 202-2JR00-2BA6	6GK5 201-3JR00-2BA6
Product type designation	SCALANCE X204 IRT PRO	SCALANCE X202-2P IRT PRO	SCALANCE X201-3P IRT PRO
Transmission rate			
Transmission rate 1	10 Mbit/s	10 Mbit/s	10 Mbit/s
Transmission rate 2	100 Mbit/s	100 Mbit/s	100 Mbit/s
Interfaces			
Number of electrical/optical connections			
• for network components or terminal equipment, maximum	4	4	4
• as combo port for network components or terminal equipment	-	-	-
Number of electrical connections			
• for network components or terminal equipment	4	2	1
• for signaling contact	1	1	1
• for power supply	1	1	1
• For redundant power supply	-	-	-
Design of electrical/optical connections for network components or terminal equipment	-	-	-
Design of electrical connection			
• for network components or terminal equipment	RJ45 Push Pull Plug PRO	RJ45 Push Pull Plug PRO	RJ45 Push Pull Plug PRO
• for signaling contact	5-pin M12 socket	5-pin M12 socket	5-pin M12 socket
• for power supply	5-pin Push Pull Plug PRO socket	5-pin Push Pull Plug PRO socket	5-pin Push Pull Plug PRO socket
Number of optical connections for fiber-optic cables at 100 Mbit/s	-	2	3
Design of optical connection for fiber-optic cables at 100 Mbit/s	-	SC-RJ/POF Push Pull Plug PRO port	SC-RJ/POF Push Pull Plug PRO port
Injectable optical power relative to 1 mW			
• of the transmitter output	-	-8 ... -2 dB	-8 ... -2 dB
• of the receiver input, maximum	-	-	-
Minimum optical sensitivity relative to 1 mW of the receiver input	-	-25 dB	-25 dB
Minimum required damping factor of FO transmission link	-	0 dB	0 dB
The range at the optical interface depends on the type of optical fiber used	-	0 ... 0.05 km	0 ... 0.05 km
Design of swap medium C-Plug	Yes	Yes	Yes
Inputs/outputs			
Operating voltage of signaling contacts with DC rated value	24 V	24 V	24 V
Operating current of signaling contacts with DC maximum	0.1 A	0.1 A	0.1 A

PROFINET/Industrial Ethernet

Industrial Ethernet switches / media converters

SCALANCE X-200IRT managed

Technical specifications (continued)

Order No.	6GK5 204-0JA00-2BA6	6GK5 202-2JR00-2BA6	6GK5 201-3JR00-2BA6
Product type designation	SCALANCE X204 IRT PRO	SCALANCE X202-2P IRT PRO	SCALANCE X201-3P IRT PRO
Supply voltage, current consumption, power loss			
Type of power supply	DC	DC	DC
External power supply	24 V	24 V	24 V
• Minimum	18 V	18 V	18 V
• Maximum	32 V	32 V	32 V
Product component: fusing at power supply input	Yes	Yes	Yes
Type of fusing of power supply input	0.6 A / 60 V	1.1 A / 33 V	1.1 A / 33 V
Current consumed, maximum	0.2 A	0.3 A	0.33 A
Effective power loss at 24 V with DC	4.8 W	7.2 W	7.92 W
Permissible ambient conditions			
Ambient temperature			
• During operation	-25 ... +70 °C	-25 ... +60 °C	-25 ... +60 °C
• During storage	-40 ... +70 °C	-40 ... +70 °C	-40 ... +70 °C
• During transport	-40 ... +70 °C	-40 ... +70 °C	-40 ... +70 °C
• Note	-	-	-
Relative humidity at 25 °C without condensation during operation, maximum	95 %	95 %	95 %
IP degree of protection	IP67	IP67	IP67
Design, dimensions and weights			
Design	Compact	Compact	Compact
Width	90 mm	90 mm	90 mm
Height	125 mm	125 mm	125 mm
Depth	124 mm	124 mm	124 mm
Net weight	1 kg	1 kg	1 kg
Type of mounting			
• 35 mm DIN rail mounting	Yes	Yes	Yes
• Wall mounting	Yes	Yes	Yes
• S7-300 rail mounting	Yes	Yes	Yes
Product properties, functions, components			
General			
Cascading with redundant ring at reconfiguration time < 0.3 s	50	50	50
Cascading with star topology	Any (only dependent on signal propagation time)	Any (only dependent on signal propagation time)	Any (only dependent on signal propagation time)
Product functions			
Management, configuration, programming			
Product function			
• CLI	Yes	Yes	Yes
• Web-based management	Yes	Yes	Yes
• MIB support	Yes	Yes	Yes
• TRAPS via e-mail	Yes	Yes	Yes
• Configuration with STEP 7	Yes	Yes	Yes
• SMTP server	Yes	Yes	Yes
• Port mirroring	No	No	No
• with IRT PROFINET IO Switch	Yes	Yes	Yes
• PROFINET IO diagnostics	Yes	Yes	Yes
• Switch-managed	Yes	Yes	Yes

Technical specifications (continued)

Order No.	6GK5 204-0JA00-2BA6	6GK5 202-2JR00-2BA6	6GK5 201-3JR00-2BA6
Product type designation	SCALANCE X204 IRT PRO	SCALANCE X202-2P IRT PRO	SCALANCE X201-3P IRT PRO
Protocol is supported			
• Telnet	Yes	Yes	Yes
• HTTP	Yes	Yes	Yes
• HTTPS	Yes	Yes	Yes
• TFTP	Yes	Yes	Yes
• FTP	Yes	Yes	Yes
• BOOTP	No	No	No
• SNMP v1	Yes	Yes	Yes
• SNMP v2	Yes	Yes	Yes
• SNMP v3	Yes	Yes	Yes
• DCP	Yes	Yes	Yes
• LLDP	Yes	Yes	Yes
Identification & Maintenance			
• I&M0 - device-specific information	Yes	Yes	Yes
• I&M1 - higher-level designation/ location designation	Yes	Yes	Yes
Product functions Diagnostics			
Product function			
• Port diagnostics	Yes	Yes	Yes
• Packet Size Statistics	Yes	Yes	Yes
• Packet Type Statistics	Yes	Yes	Yes
• Error Statistics	Yes	Yes	Yes
Product functions DHCP			
Product function: DHCP client	Yes	Yes	Yes
Product functions Redundancy			
Product function			
• Ring redundancy	Yes	Yes	Yes
• Redundancy manager	Yes	Yes	Yes
• Standby redundancy	Yes	Yes	Yes
• Redundancy procedure HSR	Yes	Yes	Yes
• Redundancy procedure MRP	Yes	Yes	Yes
• Redundancy procedure PRP	No	No	No
• Passive listening	Yes	Yes	Yes
PRP protocol is supported	-	-	-
Product functions Security			
Protocol is supported SSH	Yes	Yes	Yes
Product functions Time			
Product function: SICLOCK support	Yes	Yes	Yes
Protocol is supported			
• NTP	No	No	No
• SNTP	Yes	Yes	Yes
Standards, specifications, approvals			
Standard			
• for EMC of FM	FM3611: Class 1, Division 2, Group A, B, C, D / T4, CL.1, Zone 2, GP. IIC, T4	FM3611: Class 1, Division 2, Group A, B, C, D / T4, CL.1, Zone 2, GP. IIC, T4	FM3611: Class 1, Division 2, Group A, B, C, D / T4, CL.1, Zone 2, GP. IIC, T4
• for hazardous zone	EN 60079-0: 2006, EN 60079-15: 2005, II 3 G Ex nA II T4 KEMA 07 ATEX 0145X	EN 60079-0: 2006, EN 60079-15: 2005, II 3 G Ex nA II T4 KEMA 07 ATEX 0145X	EN 60079-0: 2006, EN 60079-15: 2005, II 3 G Ex nA II T4 KEMA 07 ATEX 0145X
• for CSA and UL safety	UL 60950-1, CSA C22.2 No. 60950-1	UL 60950-1, CSA C22.2 No. 60950-1	UL 60950-1, CSA C22.2 No. 60950-1
• for hazardous zone of CSA and UL	ANSI / ISA 12.12.01, CSA C22.2 No. 213-M1987, CL. 1 / Div. 2 / GP. A, B, C, D T4, CL. 1 / Zone 2 / GP. IIC, T4	ANSI / ISA 12.12.01, CSA C22.2 No. 213-M1987, CL. 1 / Div. 2 / GP. A, B, C, D T4, CL. 1 / Zone 2 / GP. IIC, T4	ANSI / ISA 12.12.01, CSA C22.2 No. 213-M1987, CL. 1 / Div. 2 / GP. A, B, C, D T4, CL. 1 / Zone 2 / GP. IIC, T4
• For emitted interference	EN 61000-6-4:2001 (Class A)	EN 61000-6-4:2001 (Class A)	EN 61000-6-4:2001 (Class A)
• for noise immunity	EN 61000-6-4:2001	EN 61000-6-4:2001	EN 61000-6-4:2001

PROFINET/Industrial Ethernet

Industrial Ethernet switches / media converters

SCALANCE X-200IRT managed

Technical specifications (continued)

Order No.	6GK5 204-0JA00-2BA6	6GK5 202-2JR00-2BA6	6GK5 201-3JR00-2BA6
Product type designation	SCALANCE X204 IRT PRO	SCALANCE X202-2P IRT PRO	SCALANCE X201-3P IRT PRO
Certificate of suitability	EN 61000-6-4:2001	EN 61000-6-4:2001	EN 61000-6-4:2001
• CE marking	Yes	Yes	Yes
• C-Tick	Yes	Yes	Yes
• Railroad application according to EN 50155	No	No	No
• Railroad application according to EN 50124-1	No	No	No
Marine classification corporation			
• American Bureau of Shipping Europe Ltd. (ABS)	No	No	No
• Bureau Veritas (BV)	Yes	No	No
• Det Norske Veritas (DNV)	Yes	Yes	No
• Germanischer Lloyd (GL)	Yes	Yes	No
• Lloyds Register of Shipping (LRS)	Yes	Yes	No
• Nippon Kaiji Kyokai (NK)	Yes	Yes	No
• Polski Rejestr Statkow (PRS)	No	No	No

Ordering data

Industrial Ethernet Switches SCALANCE X-200IRT

Managed Industrial Ethernet switches; Isochronous Real-Time, LED diagnostics, fault signaling contact with SET button, redundant power supply; incl. operating instructions, Industrial Ethernet network manual and configuration software on CD-ROM

- **SCALANCE X204IRT;**
4 x 10/100 Mbit/s RJ45 ports
- **SCALANCE X204IRT PRO;**
4 x 10/100 Mbit/s RJ45 push-pull ports
- **SCALANCE X202-2IRT;**
2 x 10/100 Mbit/s RJ45 ports, 2 x 100 Mbit/s Multimode BFOC ports
- **SCALANCE X202-2P IRT;**
2 x 10/100 Mbit/s RJ45 ports, 2 x 100 Mbit/s POF/PCF SC RJ ports
- **SCALANCE X202-2P IRT PRO;**
2 x 10/100 Mbit/s RJ45 push-pull ports, 2 x 100 Mbit/s POF/PCF SC RJ push-pull ports
- **SCALANCE X201-3P IRT;**
1 x 10/100 Mbit/s RJ45 port, 3 x 100 Mbit/s POF/PCF SC RJ ports
- **SCALANCE X201-3P IRT;**
1 x 10/100 Mbit/s RJ45 port, 3 x 100 Mbit/s POF/PCF SC RJ ports
- **SCALANCE X200-4P IRT;**
4 x 100 Mbit/s POF/PCF SC RJ

Order No.

- 6GK5 204-0BA00-2BA3**
- 6GK5 204-0JA00-2BA6**
- 6GK5 202-2BB00-2BA3**
- 6GK5 202-2BH00-2BA3**
- 6GK5 202-2JR00-2BA6**
- 6GK5 201-3BH00-2BA3**
- 6GK5 201-3JR00-2BA6**
- 6GK5 200-4AH00-2BA3**

Order No.

Accessories

Industrial Ethernet media converter SCALANCE X-100

Industrial Ethernet media converters, LED diagnostics, fault signaling contact with SET key, redundant power supply, PROFINET-compliant securing collars

- **SCALANCE X101-1POF;**
1 X 10/100 Mbit/s RJ45 port, 1 X 100 Mbit/s POF SC RJ port

6GK5 101-1BH00-2AA3

IE FC TP Standard Cable GP 2 x 2 (Type A)

4-core, shielded TP installation cable for connection to IE FC Outlet RJ45 / IE FC RJ45 Plug; PROFINET-compliant; with UL approval; sold by the meter; max. length 1000 m, minimum order 20 m

6XV1 840-2AH10

FO Standard Cable GP 50/125/1400 ^{1) 2)}

Multimode cable, sold by the meter; max. length 1000 m; minimum order 20 m;

6XV1 873-2A

POF Standard Cable GP 980/1000

POF standard cable for fixed routing indoors with PVC sheath; sold by the meter; max. length 1000 m; minimum order 20 m

6XV1 874-2A

PCF Standard Cable GP 200/230

Standard cable, segmentable, sold by the meter; max. length 2000 m; minimum order 20 m;

6XV1 861-2A

¹⁾ Special fiber-optic cables, lengths and accessories available on request

²⁾ Special tools and trained personnel are required for pre-assembling glass fiber-optic cables

PROFINET/Industrial Ethernet

Industrial Ethernet switches / media converters

SCALANCE X-200IRT managed

Ordering data	Order No.
<i>Accessories (continued)</i>	
IE FC RJ45 Plug 180 2 x 2 RJ45 plug connector for Industrial Ethernet with a rugged metal enclosure and integrated insulation displacement contacts for connecting Industrial Ethernet FC installation cables; with 180° cable outlet; for network components and CPs/CPU's with Industrial Ethernet interface <ul style="list-style-type: none"> • 1 pack = 1 unit • 1 pack = 10 units • 1 pack = 50 units 	6GK1 901-1BB10-2AA0 6GK1 901-1BB10-2AB0 6GK1 901-1BB10-2AE0
IE FC RJ45 Plug PRO FastConnect RJ45 plug connector; plastic housing, insulation displacement technology, for SCALANCE X-200IRT PRO switches and SIMATIC ET 200pro; 1 connector (IP65/67) suitable for on-site assembly	6GK1 901-1BB20-6AA0
SC RJ POF Plug 20 plugs for on-site assembly	6GK1 900-0MB00-0AC0
SC RJ POF Plug PRO 1 plug (IP65/67) for on-site assembly	6GK1 900-0MB00-6AA0
SC RJ PCF Plug 10 plugs for on-site assembly	6GK1 900-0NB00-0AC0
SC RJ PCF Plug PRO 1 plug (IP65/67) for on-site assembly	6GK1 900-0NB00-6AA0
Termination Kit SC RJ POF Plug Assembly case for on-site installation of SC RJ POF connectors; consisting of stripping tool, Kevlar cutters, SC RJ grinding plate, grinding paper, grinding base and microscope	6GK1 900-0ML00-0AA0
Termination Kit SC RJ PCF Plug Assembly case for local assembly of SC RJ PCF connectors, comprising a stripping tool, buffer stripping tool, Kevlar cutters, fiber breaking tool and microscope	6GK1 900-0NL00-0AA0
Power Plug PRO 1 plug (IP65/67) for on-site assembly (5-core)	6GK1 907-0AB10-6AA0
SITOP compact 24 V/ 0.6 A 1-phase power supply with wide-range input 85 – 264 V AC/110 – 300 V DC, stabilized output voltage 24 V, rated output current value 0.6 A, slim design	6EP1 331-5BA00
C-PLUG Swap medium for simple replacement of devices in the event of a fault; for storing configuration or engineering and application data; can be used for SIMATIC NET products with C-PLUG slot	6GK1 900-0AB00

More information

To assist in selecting the right Industrial Ethernet switches as well as configuration of modular versions, the SIMATIC NET Selection Tool is available:

Online version:
www.siemens.com/snst

Offline version:
www.siemens.com/snst-download

PROFINET/Industrial Ethernet

Industrial Ethernet switches / media converters

SIPLUS SCALANCE X-200IRT managed

Overview



- Especially designed for constructing real-time (RT) and isochronous real-time (IRT) Industrial Ethernet networks in line, star and ring topologies with 10/100 Mbit/s (integrated redundancy manager); construction of redundant ring connections possible
- Combination of the switching mechanisms "Cut Through" and "Store and Forward" for optimized performance
- Electrical or optical connection to stations or network according to the device port type
- Rugged metal enclosure for space-saving cubicle mounting on standard rails, S7-300 mounting rails, or for wall mounting
- Rugged, industry-standard station connections with PROFINET-compatible plug-in connectors that offer additional strain relief and bending strain relief thanks to latching on the housing
- Redundant power supply
- Can be used for fault-tolerant applications and can be replaced during normal operation thanks to redundant transmission characteristics
- Diagnostics on the device by means of LEDs (power, link status, data communication)
- Error signaling contact with easy adjustment using the SET button
- The devices feature PROFINET diagnostics, SNMP access, integral web server and automatic e-mail sending function for remote diagnostics and signaling over the network
- Different device versions with copper and fiber-optic interfaces (BFOC, SC RJ)
- Device versions with IP65/67 protection for cabinet-free plant concepts with PROFINET-compliant push pull connection systems

Note:

SIPLUS extreme products are based on Siemens Industry standard products. The contents listed here were taken from the respective standard products. SIPLUS extreme-specific information was added.

SIPLUS SCALANCE X202-2P IRT	
Order number	6AG1 202-2BH00-2BA3
Order No. based on	6GK5 202-2BH00-2BA3
Ambient temperature range	-25 ... +60 °C
Conformal coating	Coating of the printed circuit boards and the electronic components
Technical data	The technical data of the standard product applies except for the ambient conditions.

Ambient conditions	
Relative humidity	5 ... 100 % Condensation permissible
Biologically active substances	Conformity with EN 60721-3-3, Class 3B2 mold and fungal spores (except fauna)
Chemically active substances	Conformity with EN 60721-3-3, Class 3C4 incl. salt mist and ISA-S71.04 severity level G1; G2; G3; GX ^{1) 2)}
Mechanically active substances	Conformity with EN 60721-3-3, Class 3S4 including conductive sand, dust ²⁾
Air pressure (depending on the highest positive temperature range specified)	1080 ... 795 hPa (-1000 ... +2000 m) see ambient temperature range 795 ... 658 hPa (+2000 ... +3500 m) derating 10 K 658 ... 540 hPa (+3500 ... +5000 m) derating 20 K

- ¹⁾ ISA-S71.04 severity level GX: Long-term load: SO₂ < 4.8 ppm; H₂S < 9.9 ppm; Cl < 0.2 ppm; HCl < 0.66 ppm; HF < 0.12 ppm; NH < 49 ppm; O₃ < 0.1 ppm; NO_x < 5.2 ppm
Limit value (max. 30 min/d): SO₂ < 17.8 ppm; H₂S < 49.7 ppm; Cl < 1.0 ppm; HCl < 3.3 ppm; HF < 2.4 ppm; NH < 247 ppm; O₃ < 1.0 ppm; NO_x < 10.4 ppm

- ²⁾ The supplied plug covers must remain in place over the unused interface when operated in atmospheres containing corrosive gases!

The technical documentation on SIPLUS can be found here:
www.siemens.com/siplus-extreme

Ordering data	Order No.
SIPLUS SCALANCE X202-2 IRT; (extended temperature range) 2 x 10/100 Mbit/s RJ45 ports, 2 x 100 Mbit/s POF/PCF SC RJ ports	6AG1 202-2BH00-2BA3
Accessories	See ordering data for SCALANCE X-200IRT managed

Overview

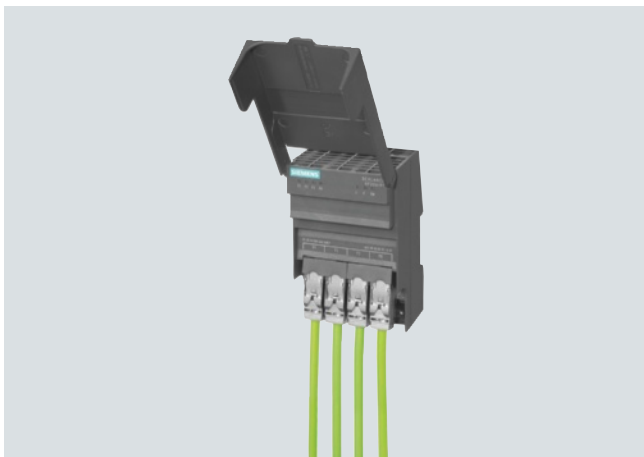

The SCALANCE XF204IRT Industrial Ethernet switch is suitable for the construction of deterministic and isochronous real-time Industrial Ethernet networks, at data transfer rates of 10/100 Mbit/s, in line, star, and ring topologies.

- Connection of up to four terminal units possible
- Enclosure in ET 200S format (slim design, 75 mm width) for space-saving use in small control boxes
- Integrated redundancy manager for constructing Fast Ethernet ring topologies with fast media redundancy
- PROFINET diagnostics, SNMP access, integrated web server and automatic e-mail transmission function for remote diagnostics and signaling via the network

Benefits

get Designed for Industry

- Optimized startup behavior (link setup, data forwarding) of PROFINET network components and IO Devices through fast start-up functionality
- Lower susceptibility to failure and higher availability of the plant networking due to latching of the RJ45 FastConnect connectors in the sleeve of the RJ45 ports
- Simple connection and disconnection of the RJ45 plug by means of easily accessible RJ45 sockets angled downward on the device
- High network availability in ring topologies, without reconfiguration times, when using the PROFINET-compliant MRPD process (**M**edia **R**edundancy for **P**lanned **D**uplication according to IEC 61158)
- Protection of investment through integration into existing network management systems, such as SINEMA Server, by means of standardized SNMP access
- Time savings during engineering, commissioning and in the operating phase of a plant by using the configuration and diagnostics integrated in STEP 7

Application

The SCALANCE XF204IRT Industrial Ethernet switch permits the construction of isochronous real-time (IRT) Industrial Ethernet line and star topologies. Thanks to innovative switching technology, the special requirements of automation with regard to line topology, isochronous mode for motion control applications, and unlimited IT openness are satisfied within a single technology based on the PROFINET standard.

Product versions

SCALANCE XF204IRT

- For setting up electrical Industrial Ethernet line, star or ring topologies with four electrical ports (ET 200S design)

Characteristics:

- Diagnostics on the device by means of LEDs (power, link status, data traffic)
- Remote diagnostics is possible through signaling contact (signal mask can be set locally using buttons), PROFINET, SNMP, and web browser
- Automatic e-mail sending function
- The RJ45 sockets are designed to be industry-compatible with additional sleeves, for connection of the IE FC RJ45 Plug 180

Real-Time Ethernet

- Interfacing of the PROFINET IO Devices to the PROFINET IO Controller through high-performance, optimized data transmission
- Coexistence of isochronous mode for motion control applications and IT openness:
Reaction-free transmission of real-time and non-real-time communication on the same line

Additionally through isochronous real-time (IRT) Ethernet

- Isochronous real-time communication based on the transmission procedure of the IEEE 802 standard by combining the switching mechanisms "Cut Through" and "Store and Forward"
- For drive controls, PROFINET with isochronous real-time is the most powerful system worldwide with regard to determinism and isochronous mode.
For example, with a cycle time of 1 ms, axes can be controlled in isochronous mode while 50% of the bandwidth is available at the same time for IT communication without restriction.

PROFINET/Industrial Ethernet

Industrial Ethernet switches / media converters

SCALANCE XF-200IRT managed

Design

The SCALANCE XF-204IRT managed Industrial Ethernet switch is designed for mounting on a standard mounting rail. With its enclosure in ET 200S format (slim design), the device is optimally suited for integration in automation solutions in small control boxes together with the ET 200S.

The switch with degree of protection IP30 features:

- 2 x 2-pole terminal block for connecting the redundant supply voltage (2 x 24 V DC)
- A row of LEDs to indicate the status information (power, link status, data traffic, power supply, signaling contact)
- A 2-pole terminal block for connecting the isolated signaling contact
- A SET button for on-site configuration of the signaling contact

The SCALANCE XF204IRT switch is available with the following port types:

- *10/100BaseTX, RJ45 connection;*
RJ45 socket, automatic detection of the data rate (10 or 100 Mbit/s), with Autosensing and Autocrossover functions for connecting IE FC cables using the IE FC RJ45 Plug 180.

Function

- Configuration of electrical Industrial Ethernet line, star and ring topologies
- Integral redundancy manager for setting up ring topologies
- Integral standby function for redundant coupling of two rings
- Extremely short cycle times with highly accurate clock-pulse rates thanks to integrated real-time functions
- Bumpless ring redundancy by sending message frames twice in the ring, by means of PROFINET-compliant MRPD procedure (**M**edia **R**edundancy for **P**lanned **D**uplication according to IEC 61158)
- System-wide clock accuracy (deviation less than 1 ms)
- Uncrossed connecting cables can be used due to Autocrossover function integrated in the ports
- Easy diagnostics using signaling contact, SNMP and Web browser
- Integration into the diagnostics of a PROFINET IO Controller by means of real-time communication (RT) according to the PROFINET standard
- Fast device replacement in the event of a fault by using the optional C-PLUG swap medium (not included in scope of supply)

Network topology and network configuration

The SCALANCE XF204IRT Industrial Ethernet switch with IP30 degree of protection is installed in a control cabinet together with the stations to be connected. It can be combined electrically in star, line and ring topologies.

When configuring the network, it is necessary to observe the following boundary conditions:

- Length of the TP cable between two SCALANCE XF switches:
 - Max. 100 m with IE FC cable and IE FC RJ45 Plug 180
- IP Address:
 - The IP address is assigned using the DHCP (Dynamic Host Configuration Protocol) mechanism. If there is no corresponding server in the network, the IP address can be assigned using the supplied software tool PST (Primary Setup Tool) or STEP 7. The device and real-time configuration of the SCALANCE XF204IRT switch is performed via STEP 7.

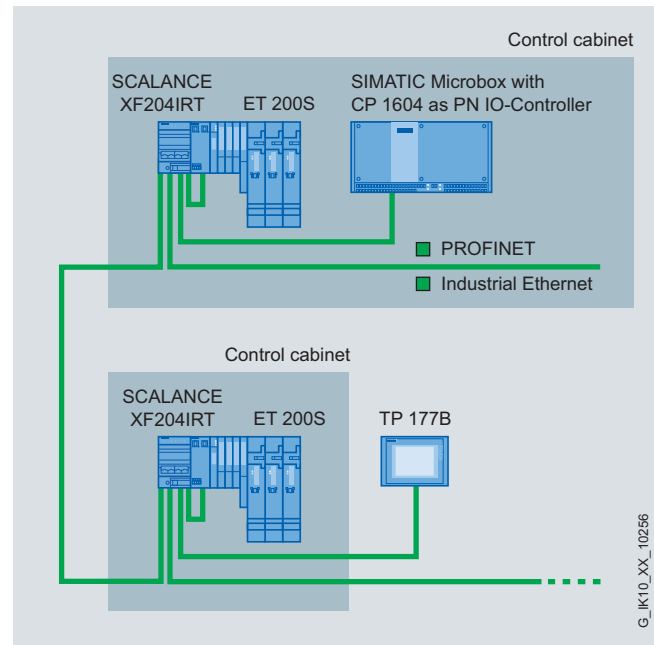

SCALANCE XF204IRT with ET 200S and SIMATIC Microbox in compact control cabinets or boxes

Commissioning and diagnosis

PROFINET diagnostic interrupts from SCALANCE XF204IRT can be displayed with the appropriate SIMATIC Engineering Tools and processed in the controller with expanded diagnostics function. The engineering outlay for the PLC and HMI have been drastically reduced due to the complete integration in the SIMATIC concept for system error messages.

The SCALANCE XF204IRT Industrial Ethernet switch can also be integrated into a network management system, e.g. SINEMA Server, through the standardized Simple Network Management Protocol (SNMP). In the event of a fault in the device, error messages (SNMP traps) can be sent to a network system or as e-mail to a specified network administrator.

The integral Web server enables configuration and diagnostics settings to be made using a standard browser (e.g. port configuration). Statistical information can also be read out over the Web server (e.g. port capacity utilization).

The following information is displayed by LEDs on site:

- Power
- Port status
- Data traffic
- Signaling contact
- Redundancy manager function

Technical specifications

Order No.	6GK5 204-0BA00-2BF2
Product type designation	SCALANCE XF204IRT
Data transmission rate	
Transmission rate 1	10 Mbit/s
Transmission rate 2	100 Mbit/s
Interfaces	
Number of electrical/optical connections	
• for network components or terminal equipment, maximum	4
• as combo port for network components or terminal equipment	-
Number of electrical connections	
• For network components or terminal equipment	4
• For signal contact	1
• For power supply	1
• For redundant power supply	1
Design of electrical/optical connections for network components or terminal equipment	
Design of electrical connection	
• For network components or terminal equipment	RJ45 port
• For signal contact	2-pin terminal block
• For power supply	4-pin terminal block
Number of optical connections for fiber-optic cables at 100 Mbit/s	-
Design of optical connection for fiber-optic cables at 100 Mbit/s	-
Injectable optical power referred to 1 mW	
• of the transmitter output	-
• of the receiver input, maximum	-
Minimum optical sensitivity referred to 1 mW of the receiver input	-
Minimum required attenuation factor of the FO transmission link	-
The range at the optical interface depends on the type of optical fiber used	-
Design of the swap medium C-Plug	Yes
Inputs/outputs	
Nominal value of operating voltage of signal contacts with DC	24 V
Maximum operating current of signal contacts with DC	0.1 A

Order No.	6GK5 204-0BA00-2BF2
Product type designation	SCALANCE XF204IRT
Supply voltage, current consumption, power loss	
Type of power supply	DC
Supply voltage, external	24 V
• Minimum	18 V
• Maximum	32 V
Product component: fusing of power supply input	Yes
Type of fusing of power supply input	0.6 A / 60 V
Current consumption, maximum	0.2 A
Effective power loss at 24 V with DC	4.8 W
Permitted ambient conditions	
Ambient temperature	
• During operation	-40 ... +60 °C
• During storage	-40 ... +60 °C
• During transport	-40 ... +60 °C
• Note	If the IE switch XF200 is installed horizontally, a maximum ambient temperature of +40 °C is permitted
Relative humidity at 25 °C without condensation during operation, maximum	95 %
IP degree of protection	IP20
Design, dimensions and weights	
Type of construction	Flat
Width	75 mm
Height	125 mm
Depth	73 mm
Net weight	0.25 kg
Type of mounting	
• 35 mm DIN rail mounting	Yes
• Wall mounting	No
• S7-300 rail mounting	No
Product properties, functions, components	
General	
Cascading with redundant ring at reconfiguration time < 0.3 s	50
Cascading with star topology	Any (only dependent on signal propagation time)

PROFINET/Industrial Ethernet

Industrial Ethernet switches / media converters

SCALANCE XF-200IRT managed

Technical specifications (continued)

Order No.	6GK5 204-0BA00-2BF2
Product type designation	SCALANCE XF204IRT
Product functions Management, configuration, programming	
Product function	
• CLI	Yes
• Web-based management	Yes
• MIB support	Yes
• Traps via e-mail	Yes
• Configuration with STEP 7	Yes
• SMTP server	Yes
• Port mirroring	No
• with IRT PROFINET IO Switch	Yes
• PROFINET IO-Diagnostics	Yes
• Switch-managed	Yes
Protocol is supported	
• Telnet	Yes
• HTTP	Yes
• HTTPS	Yes
• TFTP	Yes
• FTP	Yes
• BOOTP	No
• SNMP v1	Yes
• SNMP v2	Yes
• SNMP v3	Yes
• DCP	Yes
• LLDP	Yes
Identification & maintenance	
• I&M0 - device-specific information	Yes
• I&M1 - higher-level designation/ location designation	Yes
Product functions Diagnostics	
Product function	
• Port diagnostics	Yes
• Packet size statistics	Yes
• Packet type statistics	Yes
• Error statistics	Yes
Product functions DHCP	
Product function DHCP client	Yes
Product functions Redundancy	
Product function	
• Ring redundancy	Yes
• Redundancy manager	Yes
• Standby redundancy	Yes
• Redundancy procedure HSR	Yes
• Redundancy procedure MRP	Yes
• Redundancy procedure PRP	No
• Passive listening	Yes

Order No.	6GK5 204-0BA00-2BF2
Product type designation	SCALANCE XF204IRT
Product functions Security	
SSH protocol is supported	Yes
Product functions Time	
Product function: SICLOCK support	Yes
Protocol is supported	
• NTP	No
• SNTP	Yes
Standards, specifications, approvals	
Standard	
• For EMC from FM	FM3611: Class 1, Division 2, Group A, B, C, D / T4, CL.1, Zone 2, GP. IIC, T4
• For Ex zone	EN 60079-0: 2006, EN 60079-15: 2005, II 3 G Ex nA II T4, KEMA 07 ATEX 0145 X
• For CSA and UL safety	UL 60950-1, CSA C22.2 No. 60950-1
• For Ex zone of CSA and UL	ANSI / ISA 12.12.01, CSA C22.2 No. 213-M1987, CL. 1 / Div. 2 / GP. A, B, C, D T4, CL. 1 / Zone 2 / GP. IIC, T4
• For emitted interference	EN 61000-6-4:2001 (Class A)
• For noise immunity	EN 61000-6-4:2001
Certificate of suitability	EN 61000-6-4:2001
• CE mark	Yes
• C-Tick	Yes
• Railroad application according to EN 50155	No
• Railroad application according to EN 50124-1	No
Marine classification association	
• American Bureau of Shipping Europe Ltd. (ABS)	No
• Bureau Veritas (BV)	No
• Det Norske Veritas (DNV)	No
• Germanischer Lloyd (GL)	No
• Lloyds Register of Shipping (LRS)	No
• Nippon Kaiji Kyokai (NK)	No
• Polski Rejestr Statkow (PRS)	No

PROFINET/Industrial Ethernet

Industrial Ethernet switches / media converters

SCALANCE XF-200IRT managed

Ordering data	Order No.
Industrial Ethernet Switches SCALANCE XF-200IRT	
Managed Industrial Ethernet Switches for setting up line, star and ring topologies; Isochronous Real Time, LED diagnostics, fault signaling contact with SET button, redundant power supply; incl. operating instructions, Industrial Ethernet network manual and configuration software on CD-ROM • SCALANCE XF204IRT 4 x 10/100 Mbit/s RJ45 electrical port;	6GK5 204-2BA00-2BF2
Accessories	
IE FC TP Standard Cable GP 2 x 2 (Type A) 4-core, shielded TP installation cable for connection to IE FC RJ45 outlet / IE FC RJ45 plug; PROFINET-compliant; with UL approval; <u>sold by the meter</u> ; max. quantity 1000 m, minimum order 20 m	6XV1 840-2AH10
IE FC RJ45 Plug 180 2 x 2 RJ45 plug-in connector for Industrial Ethernet with a rugged metal enclosure and integrated insulation displacement contacts for connecting Industrial Ethernet FC installation cables; with 180° cable outlet; for network components and CPs/CPUs with Industrial Ethernet interface <ul style="list-style-type: none"> • 1 pack = 1 unit • 1 pack = 10 units • 1 pack = 50 units 	6GK1 901-1BB10-2AA0 6GK1 901-1BB10-2AB0 6GK1 901-1BB10-2AE0
IE FC Stripping Tool Preadjusted stripping tool for fast stripping of the Industrial Ethernet FC cables	6GK1 901-1GA00
SITOP compact 24 V/ 0.6 A 1-phase power supply with wide-range input 85 – 264 V AC/110 – 300 V DC, stabilized output voltage 24 V, rated output current value 0.6 A, slim design	6EP1 331-5BA00
C-PLUG Swap medium for simple replacement of devices in the event of a fault; for storing configuration or engineering and application data; can be used for SIMATIC NET products with C-PLUG slot	6GK1 900-0AB00

More information

To assist in selecting the right Industrial Ethernet switches as well as configuration of modular versions, the SIMATIC NET Selection Tool is available:

Online version:
www.siemens.com/snst

Offline version:
www.siemens.com/snst-download

2

PROFINET/Industrial Ethernet

Industrial Ethernet switches / media converters

SCALANCE X-300 managed

2

Overview

SCALANCE X-300	Type of device	Hardware																
		Connection to S7 backplane bus	Format module S7	PC module	Flat type of construction	Box type of construction	19" type of construction	Rugged, compact housing	Modular design	10 Gigabit Ethernet	Gigabit Ethernet	PoE (Power over Ethernet)	LED diagnosis	SIMATIC environment	Redundant power supply (2 x 24 V DC)	External supply for integrated switch	Signal contact	Local display (SET pushbutton)
X302-7EEC							•			•		•	•	•		•	•	•
X304-2FE							•					•	•	•		•	•	•
X306-1LD FE							•					•	•	•		•	•	•
X307-2EEC							•			•		•	•	•		•	•	•
X307-3							•			•		•	•	•		•	•	•
X307-3LD							•			•		•	•	•		•	•	•
X308-2							•			•		•	•	•		•	•	•
X308-2LD							•			•		•	•	•		•	•	•
X308-2LH							•			•		•	•	•		•	•	•
X308-2LH+							•			•		•	•	•		•	•	•
X308-2M							•	•		•		•	•	•		•	•	•
X308-2M PoE							•	•		•	•	•	•	•		•	•	•
X308-2M TS							•	•		•		•	•	•		•	•	•
X310							•			•		•	•	•		•	•	•
X310FE							•					•	•	•		•	•	•
X320-1FE							•					•	•	•		•	•	•
X320-3LD FE							•					•	•	•		•	•	•
XR324-12M					•			•		•		•	•	•		•	•	•
XR324-4M PoE					•			•		•	•	•	•	•		•	•	•
XR324-4M EEC					•			•		•		•	•	•		•	•	•

• applies

G_IK10_XX_10310

Function overview SCALANCE X-300 managed: Hardware

PROFINET/Industrial Ethernet

Industrial Ethernet switches / media converters

SCALANCE X-300 managed



Overview (continued)

SCALANCE X-300	Type of device	Software																												
		Security Integrated (Firewall/VPN)	PROFINET diagnosis	Topology support (LLDP)	Command Line Interface / Telnet	Web based Management	Configuration with STEP 7	SNMP	Ring redundancy incl. RM-functionality	Standby redundancy	IRT capability	VLAN (Virtual Local Area Network)	GVRP (Generic VLAN Registration Protocol)	STP/ RSTP (Spanning Tree Protocol/ Rapid Spanning Tree Protocol)	Passive Listening	IGMP Snooping/Querier (Internet Group Management Protocol)	GMRP (Generic Multicast Protocol)	Broadcast/ Multicast/ Unicast Limiter	Broadcast blocking	DHCP Option 82 (Dynamic Host Configuration Protocol)	IP Access List	Access Control List (MAC)	IEEE 802.1x (Radius)	Link Aggregation	Static Routing	RIPv2 (Dynamic Routing)	OSPFv2 (Dynamic Routing)	VRRP Router Redundancy (Virtual Router Redundancy Protocol)		
X302-7EEC		•	•	•	•	•	•	•	•		•	•	•	•	•	•	•	•	•	•		•	•	•	•					
X304-2FE		•	•	•	•	•	•	•	•		•	•	•	•	•	•	•	•	•	•	•		•	•	•	•				
X306-1LD FE		•	•	•	•	•	•	•	•		•	•	•	•	•	•	•	•	•	•	•		•	•	•	•				
X307-2EEC		•	•	•	•	•	•	•	•		•	•	•	•	•	•	•	•	•	•	•		•	•	•	•				
X307-3		•	•	•	•	•	•	•	•		•	•	•	•	•	•	•	•	•	•	•		•	•	•	•				
X307-3LD		•	•	•	•	•	•	•	•		•	•	•	•	•	•	•	•	•	•	•		•	•	•	•				
X308-2		•	•	•	•	•	•	•	•		•	•	•	•	•	•	•	•	•	•	•		•	•	•	•				
X308-2LD		•	•	•	•	•	•	•	•		•	•	•	•	•	•	•	•	•	•	•		•	•	•	•				
X308-2LH		•	•	•	•	•	•	•	•		•	•	•	•	•	•	•	•	•	•	•		•	•	•	•				
X308-2LH+		•	•	•	•	•	•	•	•		•	•	•	•	•	•	•	•	•	•	•		•	•	•	•				
X308-2M		•	•	•	•	•	•	•	•		•	•	•	•	•	•	•	•	•	•	•		•	•	•	•				
X308-2M PoE		•	•	•	•	•	•	•	•		•	•	•	•	•	•	•	•	•	•	•		•	•	•	•				
X308-2M TS		•	•	•	•	•	•	•	•		•	•	•	•	•	•	•	•	•	•	•		•	•	•	•				
X310		•	•	•	•	•	•	•	•		•	•	•	•	•	•	•	•	•	•	•		•	•	•	•				
X310FE		•	•	•	•	•	•	•	•		•	•	•	•	•	•	•	•	•	•	•		•	•	•	•				
X320-1FE		•	•	•	•	•	•	•	•		•	•	•	•	•	•	•	•	•	•	•		•	•	•	•				
X320-3LD FE		•	•	•	•	•	•	•	•		•	•	•	•	•	•	•	•	•	•	•		•	•	•	•				
XR324-12M		•	•	•	•	•	•	•	•		•	•	•	•	•	•	•	•	•	•	•		•	•	•	•				
XR324-4M PoE		•	•	•	•	•	•	•	•		•	•	•	•	•	•	•	•	•	•	•		•	•	•	•				
XR324-4M EEC		•	•	•	•	•	•	•	•		•	•	•	•	•	•	•	•	•	•	•		•	•	•	•				

• applies

G_IK10_XX_10311

Function overview SCALANCE X-300 managed: Software

PROFINET/Industrial Ethernet

Industrial Ethernet switches / media converters

SCALANCE X-300 managed

Overview



The SCALANCE X-300 product line comprises compact Industrial Ethernet switches for constructing electrical and/or optical line, star and ring topologies operating at data transfer rates of 10/100/1000 Mbit/s.

- SCALANCE X-300 is available
 - with integrated electrical and optical Ethernet ports
 - as a partially modular version with four integrated electrical Ethernet ports and two modular slots for 2-port media modules
- High-speed media redundancy through integral redundancy manager both for Gigabit Ethernet (SCALANCE X-300, X-400) and Fast Ethernet (e.g. in combination with SCALANCE X-200 switches)
- Seamless integration of automation networks into existing corporate networks thanks to support for a host of IT standards: Establishment of virtual networks (VLANs)
- Redundant integration into higher-level networks thanks to support for standardized redundancy procedures (Rapid Spanning Tree Protocol)
- PROFINET diagnostics, SNMP access, integrated web server and automatic e-mail transmission function for remote diagnostics and signaling via the network

Benefits

get Designed for Industry

- High availability of the network thanks to:
 - Redundant power supply
 - Redundant network structures based on fiber-optic or twisted pair cables (redundancy manager, standby function, and RSTP are integrated)
 - Easy device replacement by means of plug-in C-PLUG swap medium
 - Very fast reconfiguration of the network in the event of a fault
- Lower susceptibility to failure and higher availability of the plant networking due to latching of the RJ45 FastConnect connectors in the sleeve of the RJ45 ports
- Protection of investment due to integration into existing network management systems by means of standardized SNMP access
- Time savings during engineering, commissioning and in the operating phase of a plant by using the configuration and diagnostics integrated in STEP 7
- Simple adaptation to different network topologies, and reduction in stock keeping costs through flexibility of the partially modular versions

Application

SCALANCE X-300 products enable the establishment of switched networks both at the field level and at the control level where high data transfer rates are required in addition to high network availability and extensive diagnostics facilities. The switches are designed in degree of protection IP30 for installation in control cabinets.

The main area of application is found in high-performance plant networks with interfaces to the corporate network.

The X308-2M TS is suitable for use in railway applications due to its specification according to EN 50155.

Product versions

Switches with Fast Ethernet and Gigabit Ethernet ports

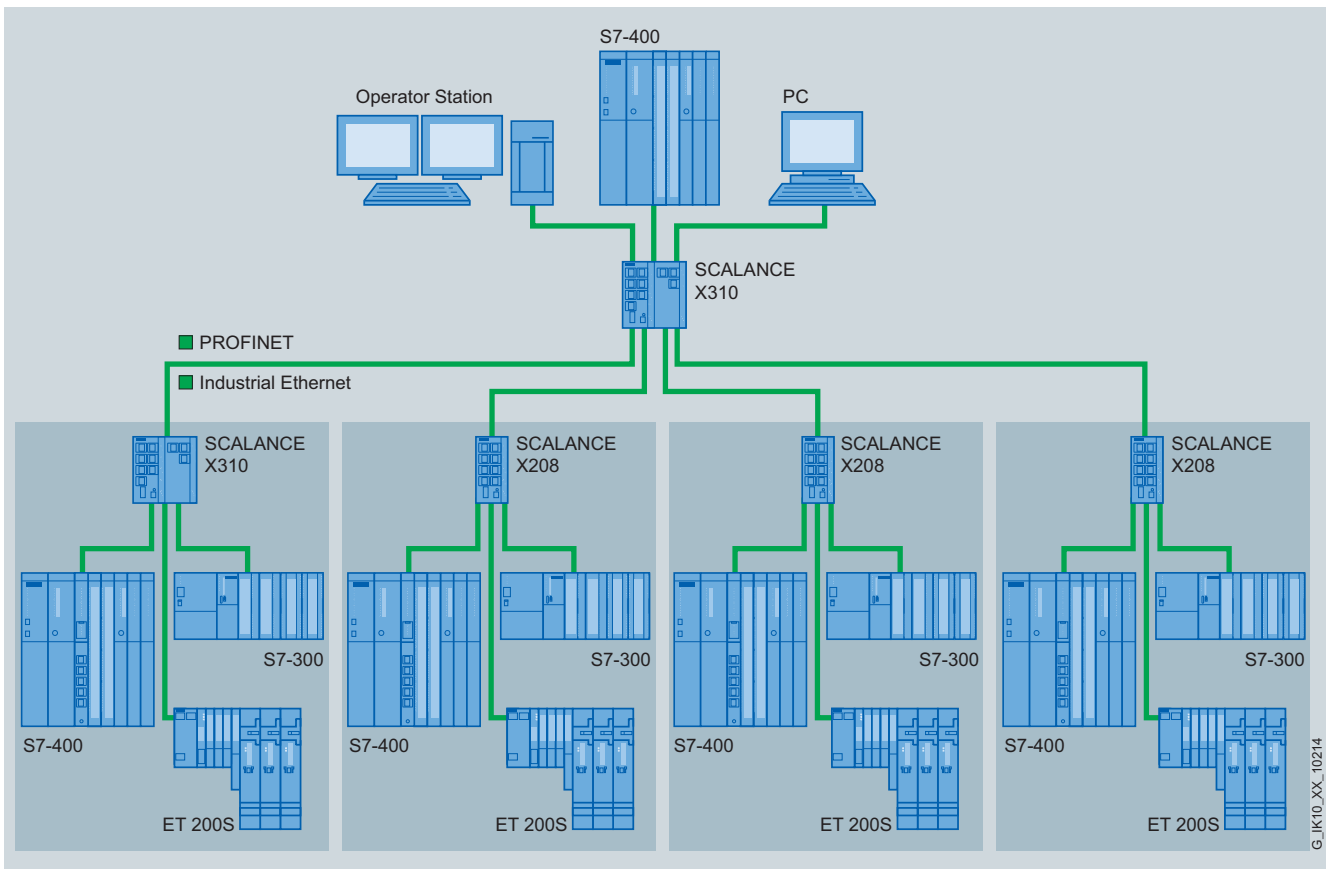

Electrical star topology with SCALANCE X310

SCALANCE X310, SCALANCE X308-2, SCALANCE X308-2LD, SCALANCE X308-2LH, SCALANCE X308-2LH+, SCALANCE X307-3, SCALANCE X307-3LD

- For configuring electrical Industrial Ethernet line, star or ring structures
 - **SCALANCE X310;**
3 x 10/100/1000 Mbit/s RJ45 ports, electrical
7 x 10/100 Mbit/s RJ45 ports, electrical
 - **SCALANCE X308-2;**
1 x 10/100/1000 Mbit/s RJ45 ports, electrical
7 x 10/100 Mbit/s RJ45 ports, electrical
2 x 1000 Mbit/s SC ports, optical, for glass FOC (multimode) up to 750 m
 - **SCALANCE X307-3;**
7 x 10/100 Mbit/s RJ45 ports, electrical
3 x 1000 Mbit/s SC ports, optical, for glass FOC (multimode) up to 750 m
 - **SCALANCE X308-2LD;**
1 x 10/100/1000 Mbit/s RJ45 ports, electrical
7 x 10/100 Mbit/s RJ45 ports, electrical
2 x 1000 Mbit/s SC ports, optical, for glass FOC (singlemode) up to 10 km

- **SCALANCE X307-3LD;**
7 x 10/100 Mbit/s RJ45 ports, electrical
3 x 1000 Mbit/s SC ports, optical, for glass FOC (singlemode) up to 10 km
- **SCALANCE X308-2LH;**
1 x 10/100/1000 Mbit/s RJ45 ports, electrical
7 x 10/100 Mbit/s RJ45 ports, electrical
2 x 1000 Mbit/s SC ports, optical, for glass FOC (singlemode) up to 40 km
- **SCALANCE X308-2LH+;**
1 x 10/100/1000 Mbit/s RJ45 ports, electrical
7 x 10/100 Mbit/s RJ45 ports, electrical
2 x 1000 Mbit/s SC ports, optical, for glass FOC (singlemode) up to 70 km

- The RJ45 ports are designed to be industry-standard with additional holding collars for connection of the IE FC RJ45 Plug 180

PROFINET/Industrial Ethernet

Industrial Ethernet switches / media converters

SCALANCE X-300 managed

Application (continued)

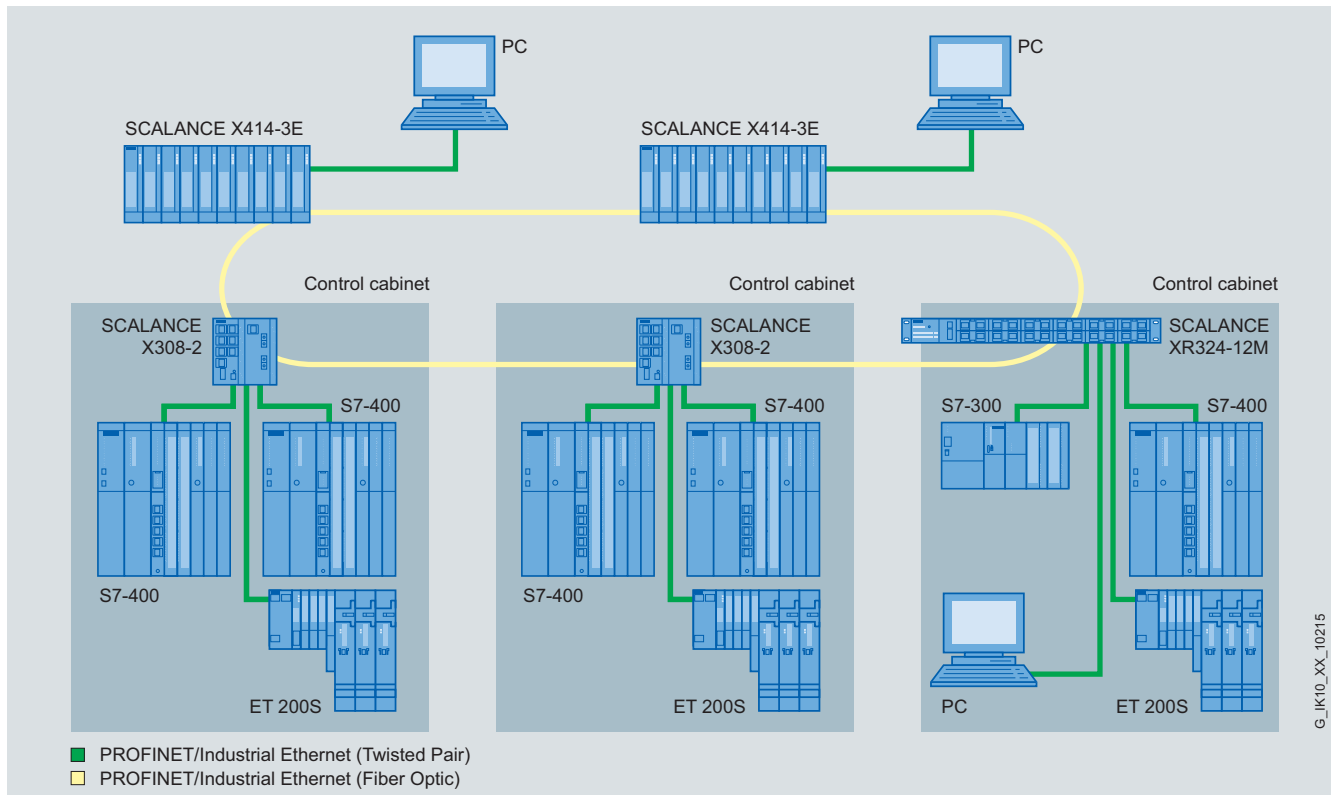

Connection of control cabinets with SCALANCE X308-2 in an optical gigabit ring

Fast Ethernet switches

SCALANCE X310FE
SCALANCE X304-2FE
SCALANCE X306-1LD FE
SCALANCE X320-1FE
SCALANCE X320-3 LD FE

- For configuring electrical and/or optical Industrial Ethernet line, star or ring structures
 - **SCALANCE X310FE**;
10 x 10/100 Mbit/s RJ45 ports, electrical
 - **SCALANCE X304-2FE**;
4 x 10/100 Mbit/s RJ45 ports, electrical
2 x 100 Mbit/s SC ports, optical, for glass FOC (multimode) up to 5 km
 - **SCALANCE X306-1LD FE**;
6 x 10/100 Mbit/s RJ45 ports, electrical
1 x 100 Mbit/s SC port, optical, for glass FOC (singlemode) up to 26 km
 - **SCALANCE X320-1FE**;
20 x 10/100 Mbit/s RJ45 ports, electrical
1 x 100 Mbit/s SC port, optical, for glass FOC (multimode) up to 5 km
 - **SCALANCE X320-3LD FE**;
20 x 10/100 Mbit/s RJ45 ports, electrical
1 x 100 Mbit/s SC port, optical, for glass FOC (multimode) up to 5 km
2 x 100 Mbit/s SC ports, optical, for glass FOC (singlemode), up to 26 km
- The RJ45 ports are designed to be industry-standard with additional holding collars for connection of the IE FC RJ45 Plug 180

Application (continued)

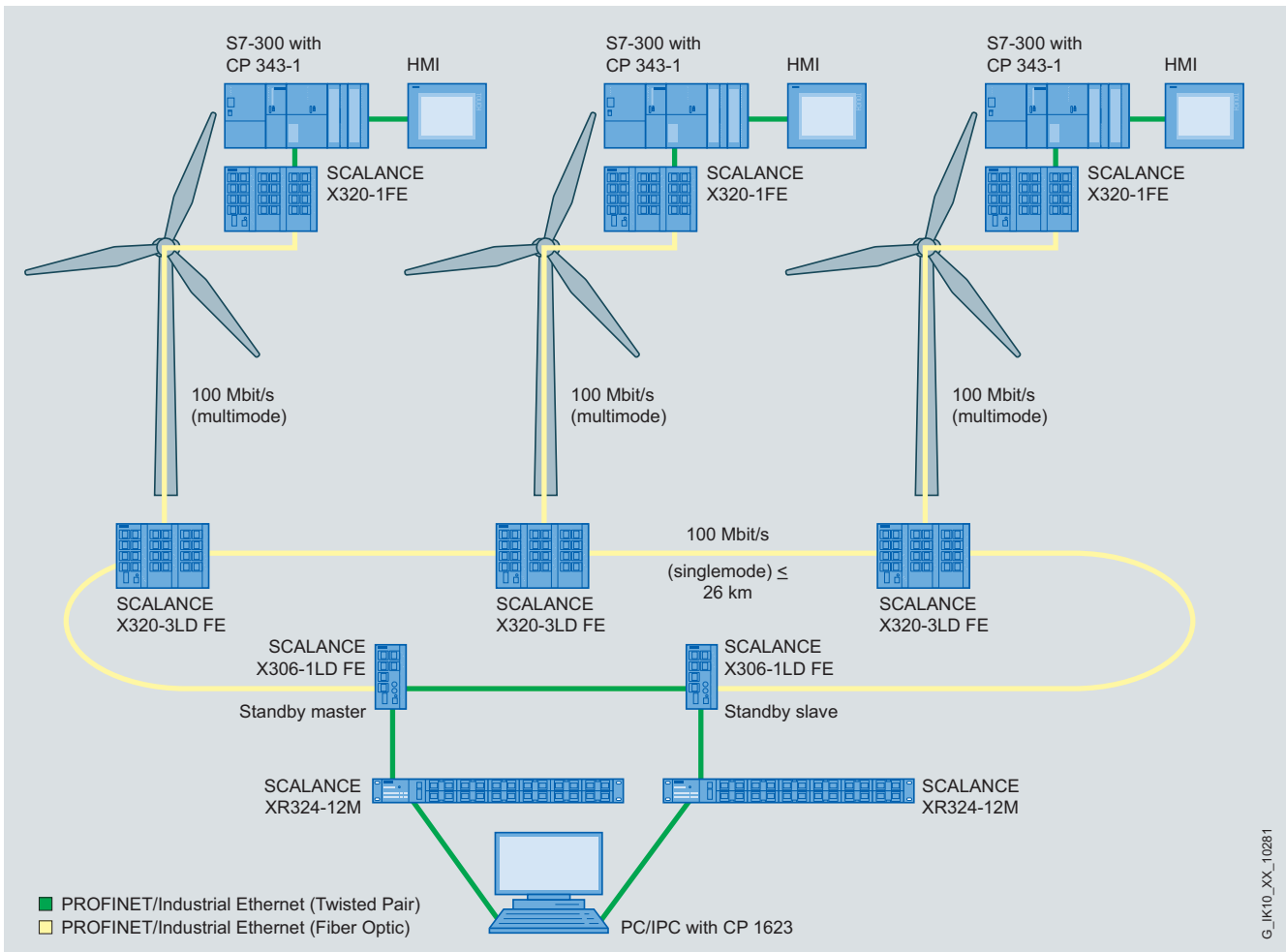

Redundant ring topology with SCALANCE X for wind farms

Full Gigabit switches

SCALANCE X308-2M

SCALANCE X308-2M TS

- For setting up optical line, ring or star network structures with
 - Four integrated electrical Gigabit Ethernet ports and
 - Four modular slots for equipping with any 2-port media modules (see "Media modules for SCALANCE X-300")
- Star hubs in the plant bus (redundant connection possible)
- SCALANCE X308-2M;
 - 4 x 10/100/1000 Mbit/s RJ45 ports, electrical
 - 2 x free module slots for 4 x 10/100/1000 Mbit/s media modules (electrical or optical)
- SCALANCE X308-2M TS (TS = Transportation Systems);
 - 4 x 10/100/1000 Mbit/s RJ45 ports, electrical
 - 2 x free module slots for 4 x 10/100/1000 Mbit/s media modules (electrical or optical)
 is suitable for use in railway applications due to its specification according to EN 50155

PROFINET/Industrial Ethernet

Industrial Ethernet switches / media converters

SCALANCE X-300 managed

Design

The SCALANCE X-300 Industrial Ethernet switches with rugged metal housing are optimized for mounting on a standard DIN rail and the S7-300 rail. Direct wall mounting in various positions is also possible. Thanks to the S7-300 housing dimensions, the devices are suitable for integration into an automation solution with S7-300 components.

The switches have:

- a 4-pin terminal block for connecting the redundant power supply (2 x 24 V DC)
- Row of LEDs for indicating the status information (power, link status, data traffic, fault, redundancy manager, standby manager)
- A 2-pin terminal block for connecting the isolated signaling contact
- SELECT/SET key for on-site configuration of the signaling contact
- Slot for optional C-PLUG swap medium on the rear of the device for easy replacement in the event of a fault

The SCALANCE X-300 switches are available with the following port types:

- *10/100BaseTX, RJ45 connection;*
RJ45 socket, automatic detection of the data rate (10 or 100 Mbit/s), with Autosensing and Autocrossover function for the connection of IE FC cables via IE FC RJ45 Plug 180 to 100 m.
- *10/100/1000BaseTX, RJ45 connection;*
RJ45 socket, automatic detection of the data rate (10 or 100 or 1000 Mbit/s), with Autosensing and Autocrossover function for the connection of
 - IE FC cables 2x2 for 100 Mbit/s via IE FC RJ45 Plug 180 up to 100 m
 - IE FC cables 4x2 for 1000 Mbit/s via TP Cord and IE FC RJ45 Modular Outlet up to 100 m
 - IE FC cables 4x2 for 1000 Mbit/s via IE FC RJ45 Plug 4x2 up to 100 m
- *1000BaseSX, SC connections;*
SC ports for direct connection to the Industrial Ethernet glass fiber-optic cable up to 750 m (multimode)
- *1000BaseFX, SC connections;*
SC ports for direct connection to the Industrial Ethernet glass fiber-optic cable up to 10 km (singlemode)
- *1000BaseLX, SC connections;*
SC ports for direct connection to the Industrial Ethernet glass fiber-optic cable up to 40 km (singlemode)
- *1000BaseLX, SC connections;*
SC ports for direct connection to the Industrial Ethernet glass fiber-optic cable up to 70 km (singlemode)

Function

- Increase of the network performance; by filtering the data traffic on the basis of the Ethernet (MAC) address of the data terminals, data traffic remains local; only data intended for users of another subnetwork are forwarded by the switch.
- Simple network configuration and expansion; the switch saves the data received at the ports and forwards them independently to the destination address. Collision detection (CSMA/CD method) does not restrict the expansion of the network beyond the port.
- Limiting of error spreading to the associated subnetwork; the SCALANCE X-300 switches only pass on data with a valid checksum (CRC).
- Integration of existing subnetworks with 10 Mbit/s into Fast Ethernet networks with 100 Mbit/s; at the twisted-pair ports, the SCALANCE X-300 switch automatically recognizes the conductor pairs for transmission and reception (Autocrossover), the data transfer rate of 10 or 100 or 1000 Mbit/s, as well as full-duplex and half-duplex mode (Autonegotiation).
- High-performance connection of SCALANCE X-300 switches with 1 Gbit/s; SCALANCE X-300 switches have Gigabit Ethernet ports for connecting the switches to each other or with other Gigabit-Ethernet-enabled components (e.g. SCALANCE X-400, X-500)
- Integrated redundancy manager for constructing Fast Ethernet and Gigabit Ethernet ring topologies with high-speed media redundancy.
- High-speed standby redundancy; several network segments such as rings can be interconnected redundantly with SCALANCE X-300 over the integrated standby function. Two X-300 switches are configured in a ring as a master and slave over two links to the other ring. The redundant connection can be made at 1000 Mbit/s.
- Redundant interfacing to higher-level networks; SCALANCE X-300 switches support the standardized redundancy procedures Spanning Tree Protocol (STP) and Rapid Spanning Tree Protocol (RSTP). This enables a subnetwork to be connected redundantly to a higher-level network with reduced requirements for the reconfiguration time (in the order of seconds).
- Support of virtual networks (VLAN); for structuring Industrial Ethernet networks with a fast growing number of users, a physically existing network can be divided into several virtual networks.
- Load limiting when multicast protocols (e.g. video transmission) are used; through learning the multicast sources and targets (IGMP Snooping, IGMP Querier), SCALANCE X-300 switches can also filter multicast data traffic and therefore limit the load in the network.
- Configuration of the ports for terminals that support authentication in accordance to IEEE 802.1x. Authentication is done via a RADIUS server which has to be configured accordingly and must be able to be reached via the network.
- Support of the DHCP Option 82, 66, 67 (Dynamic Host Configuration Protocol); this facilitates the IP address assignment of a terminal depending on the connected switch port. The IP address is assigned via a DHCP Server, which has to be configured accordingly and must be able to be reached via the network.

Function (continued)

- Support from the Access Control List (ACL); if this function is activated for one port, the switch forwards the message frames received to this port if its source address is present in the address table. All connected nodes can be automatically entered in the ACL.
- Syslog; Syslog according to RFC 3164 is used in the IP network for transmitting short, unencrypted text messages via UDP. This requires the use of a Syslog server that must be configured appropriately and must be accessible via the network.
- Time synchronization; diagnostic messages (log table entries, e-mails) are time-stamped. The local time is standardized throughout the network by means of synchronization with a SICLOCK or SNTP time transmitter, thereby simplifying the assignment of diagnostic messages to several devices.
- Fast replacement of devices in event of failure, by means of the C-PLUG switching medium

Network topology and network configuration

The SCALANCE X-300 Industrial Ethernet switches with degree of protection IP30 are typically accommodated in a control cabinet along with the nodes to be connected. They can be mixed electrically and optically in star, line and ring topologies.

The following network structures and combinations of structures can be implemented:

- Fast Ethernet and Gigabit Ethernet rings with fast media redundancy; to increase network availability, as many as 50 X-200, X-300, X-400 or X-500 switches can be cascaded in line and connected into a ring
- Several rings can be redundantly linked through the standby function
- In addition, SCALANCE X-300 supports redundant connection of the ring structure to the corporate network with a rapid spanning tree.
- Star topology with SCALANCE X-300 switches: The SCALANCE X-300 switch represents a star point which can interconnect several nodes or subnets electrically or optically.

When configuring the network, it is necessary to observe the following boundary conditions:

- Maximum line length between two modules for multi-mode fiber-optic conductors:
 - 750 m at 1 Gbit/s
 - 5 km at 100 Mbit/s
- Maximum line length between two modules for single-mode fiber-optic conductors:
 - 10 to 70 km at 1 Gbit/s
 - 26 km at 100 Mbit/s
- Maximum cable length of the TP cable between two SCALANCE X switches:
 - Max. 100 m with IE FC cable 2x2 and IE FC RJ45 Plug 180
 - Max. 100 m at 1 Gbit/s with IE FC Standard Cable 4x2 (90 m), IE FC RJ45 Modular Outlet and patch cable (10 m)
 - Max. 10 m using patches with TP cord

Commissioning and diagnosis

Setting options on the device itself:

- Redundancy manager RM; to establish a ring, a SCALANCE X-300 is switched to RM mode. The Gigabit ports (electrical or optical) are preferably used as ring ports.
- Signal mask; the signal mask is set to the current status of the SCALANCE X-300 (setpoint) by pushbutton operation. The signal mask defines which ports and which power supplies are to be monitored. The signaling contact only reports an error when a monitored port or a monitored feeder fails (deviation of setpoint/actual status).
- IP address; the IP address is assigned via DHCP (Dynamic Host Configuration Protocol). If there is no corresponding server in the network, the IP address can be assigned using an enclosed software tool.

Diagnostic options on site:

- The following status information is displayed by LEDs on site:
 - Port status
 - Port mode (10/100/1000 Mbit/s, full/half-duplex)
 - Status of the two power supplies
 - Signaling contact status
 - Signal mask (setpoint status)
 - RM mode
 - Standby mode
- The status of the signaling contact is routed externally by means of floating relay contacts. This enables, for example, the module to be monitored via an input module from a controller.
- Monitoring via the Industrial Ethernet network; the following possibilities are available:
 - Remote via standard browser (Web-based management): Selection of SCALANCE X-300 switches via the network from a PC with browser
 - Remote via SNMP V1, V2c, V3: Secure integration of SCALANCE X-300 switches via the network into a network management system, e.g. SINEMA Server
 - Remote via PROFINET IO diagnostics: PROFINET diagnostic alarms from SCALANCE X-300 switches can be displayed using the relevant SIMATIC engineering tools and they can also be processed in the controller. The engineering outlay for the PLC and HMI have been drastically reduced due to the complete integration in the SIMATIC concept for system error messages.

PROFINET/Industrial Ethernet

Industrial Ethernet switches / media converters

SCALANCE X-300 managed

Function (continued)

Network management

The network management provides the following functions:

- Password-protected dial-up for "Administrator" (read and write authorization) and "User" (read only)
- Read-out of version and status information
- Setting the signal and standby mask and address information
- Fixed parameterization of the ports (data rates, half/full duplex)
- Setting parameters of the VLANs and multicast services
- Parameterization of the standby connections for a redundant ring link
- Setting of Rapid Spanning Tree parameters
- Parameterization of the web management services
- Security
 - Ports can be connected or disconnected
 - Authentication in accordance with IEEE 802.1x
 - Support from Access Control List (ACL)
- Parameterization of user administration of SNMP V1, V2c, V3
- Output of statistics information
- Diagnosis of data traffic by means of a parameterizable mirror port with a standard commercial network analyzer
- Loading of new firmware versions or of the configuration data via the network by a TFTP server or directly via HTTP/HTTPS using a Web browser
- Saving the configuration data or log table via the network on a TFTP server

If faults occur in the network, the SCALANCE X-300 switch can independently send error messages (traps) to a network management system or also e-mails to a predefined network administrator.

Remote monitoring (RMON) provides the following functions: The SCALANCE X-300 switch can collect statistics information according to the RMON groups 1 through 4. These include, for example, fault statistics that are kept for each port. This information can be read out through web-based management in the statistics sub-area.

Technical specifications

Order No.	6GK5 304-2BD00-2AA3	6GK5 306-1BF00-2AA3	6GK5 307-3BL00-2AA3	6GK5 307-3BM00-2AA3
Product type designation	SCALANCE X304-2FE	SCALANCE X306-1LD FE	SCALANCE X307-3	SCALANCE X307-3LD
Transmission rate				
Transmission rate 1	10 Mbit/s	10 Mbit/s	10 Mbit/s	10 Mbit/s
Transmission rate 2	100 Mbit/s	100 Mbit/s	100 Mbit/s	100 Mbit/s
Transmission rate 3	-	-	1 000 Mbit/s	1 000 Mbit/s
Interfaces				
Maximum number of electrical/optical connections for network components or terminal equipment	6	7	10	10
Number of electrical connections				
• For network components or terminal equipment	4	6	7	7
• For operation panel	-	-	-	-
• For signaling contact	1	1	1	1
• For media module	-	-	-	-
• For power supply	1	1	1	1
• For redundant power supply	2	2	2	2
Design of electrical connection				
• for network components or terminal equipment	RJ45 port	RJ45 port	RJ45 port	RJ45 port
• For operation panel	-	-	-	-
• for signaling contact	2-pin terminal block	2-pin terminal block	2-pin terminal block	2-pin terminal block
• for power supply	4-pin terminal block	4-pin terminal block	4-pin terminal block	4-pin terminal block

Technical specifications (continued)

Order No.	6GK5 304-2BD00-2AA3	6GK5 306-1BF00-2AA3	6GK5 307-3BL00-2AA3	6GK5 307-3BM00-2AA3
Product type designation	SCALANCE X304-2FE	SCALANCE X306-1LD FE	SCALANCE X307-3	SCALANCE X307-3LD
Number of optical connections for fiber-optic cables				
• at 100 Mbit/s	2	1	-	-
• at 1000 Mbit/s	-	-	3	3
Design of optical connection for fiber-optic cables				
• At 100 Mbit/s	SC port (multimode up to 5 km)	SC port (singlemode up to 26 km)	-	-
• At 1000 Mbit/s	-	-	SC port (multimode up to 0.75 km)	SC port (singlemode up to 10 km)
Injectable optical power referred to 1 mW				
• of the transmitter output	-19 ... -14 dB	-15 ... -8 dB	-9.5 ... -4 dB	-9.5 ... -3 dB
• of the receiver input, maximum	-3 dB	-3 dB	-3 dB	-3 dB
Minimum optical sensitivity referred to 1 mW of the receiver input	-32 dB	-34 dB	-17 dB	-21 dB
Minimum required attenuation factor of the FO transmission link	0 dB	0 dB	0 dB	0 dB
The range at the optical interface depends on the type of optical fiber used	0 ... 5 km	0 ... 26 km	0 ... 0.75 km	0 ... 10 km
Design of the swap medium C-Plug	Yes	Yes	Yes	Yes
Inputs/outputs				
Operating voltage of signaling contacts with DC rated value	24 V	24 V	24 V	24 V
Maximum operating current of signaling contacts with DC	0.1 A	0.1 A	0.1 A	0.1 A
Supply voltage, current consumption, power loss				
Redundant type of power supply	No	No	No	No
Type of power supply	DC	DC	DC	DC
Supply voltage, external	24 V	24 V	24 V	24 V
• Minimum	18 V	18 V	18 V	18 V
• Maximum	32 V	32 V	32 V	32 V
Product component: fusing of power supply input	Yes	Yes	Yes	Yes
Type of fusing of power supply input	F 3 A / 32V	F 3 A / 32 V	F 3 A / 32 V	F 3 A / 32 V
Current consumption, maximum	0.26 A	0.2 A	0.4 A	0.4 A
Effective power loss				
• At 24 V DC	6.2 W	4.8 W	9.6 W	9.6 W
• At 230 V AC	-	-	-	-

PROFINET/Industrial Ethernet

Industrial Ethernet switches / media converters

SCALANCE X-300 managed

Technical specifications (continued)

Order No.	6GK5 304-2BD00-2AA3	6GK5 306-1BF00-2AA3	6GK5 307-3BL00-2AA3	6GK5 307-3BM00-2AA3
Product type designation	SCALANCE X304-2FE	SCALANCE X306-1LD FE	SCALANCE X307-3	SCALANCE X307-3LD
Permitted ambient conditions				
Ambient temperature				
• During operation	-40 ... +60 °C	-40 ... +60 °C	-10 ... +60 °C	-40 ... +60 °C
• During storage	-40 ... +70 °C	-40 ... +70 °C	-40 ... +70 °C	-40 ... +70 °C
• During transport	-40 ... +70 °C	-40 ... +70 °C	-40 ... +70 °C	-40 ... +70 °C
• Note	-	-	-	-
Relative humidity at 25 °C without condensation during operation, maximum	95 %	95 %	95 %	95 %
IP degree of protection	IP30	IP30	IP30	IP30
Design, dimensions and weights				
Type of construction	Compact	Compact	Compact	Compact
Width	60 mm	60 mm	120 mm	120 mm
Height	125 mm	125 mm	125 mm	125 mm
Depth	123 mm	123 mm	123 mm	123 mm
Net weight	0.7 kg	0.7 kg	1.4 kg	1.4 kg
Type of mounting				
• 19-inch installation	No	No	No	No
• 35 mm DIN rail mounting	Yes	Yes	Yes	Yes
• Wall mounting	Yes	Yes	Yes	Yes
• S7-300 rail mounting	Yes	Yes	Yes	Yes
Type of mounting	In marine applications, mounting on the 35 mm DIN rail is not permissible	In marine applications, mounting on the 35 mm DIN rail is not permissible	In marine applications, mounting on the 35 mm DIN rail is not permissible	In marine applications, mounting on the 5 mm DIN rail is not permissible
Product properties, functions, components				
General				
Cascading with redundant ring with reconfiguration time < 0.3 s	50	50	50	50
Cascading with star topology	Any (only dependent on signal propagation time)	Any (only dependent on signal propagation time)	Any (only dependent on signal propagation time)	Any (only dependent on signal propagation time)
Product functions				
Management, configuration, programming				
Product function				
• CLI	Yes	Yes	Yes	Yes
• Web-based management	Yes	Yes	Yes	Yes
• MIB support	Yes	Yes	Yes	Yes
• TRAPS via e-mail	Yes	Yes	Yes	Yes
• Configuration with STEP 7	Yes	Yes	Yes	Yes
• RMON	Yes	Yes	Yes	Yes
• SMTP server	Yes	Yes	Yes	Yes
• Port mirroring	Yes	Yes	Yes	Yes
• CoS	Yes	Yes	Yes	Yes
• with IRT PROFINET IO Switch	-	-	-	-
• PROFINET IO-Diagnostics	Yes	Yes	Yes	Yes
• Switch-managed	Yes	Yes	Yes	Yes

Technical specifications (continued)

Order No.	6GK5 304-2BD00-2AA3	6GK5 306-1BF00-2AA3	6GK5 307-3BL00-2AA3	6GK5 307-3BM00-2AA3
Product type designation	SCALANCE X304-2FE	SCALANCE X306-1LD FE	SCALANCE X307-3	SCALANCE X307-3LD
Protocol is supported				
• Telnet	Yes	Yes	Yes	Yes
• HTTP	Yes	Yes	Yes	Yes
• HTTPS	Yes	Yes	Yes	Yes
• TFTP	Yes	Yes	Yes	Yes
• FTP	Yes	Yes	Yes	Yes
• BOOTP	Yes	Yes	Yes	Yes
• SNMP v1	Yes	Yes	Yes	Yes
• SNMP v2	Yes	Yes	Yes	Yes
• SNMP v3	Yes	Yes	Yes	Yes
• IGMP (snooping/querier)	Yes	Yes	Yes	Yes
• GMRP	Yes	Yes	Yes	Yes
• DCP	Yes	Yes	Yes	Yes
• LLDP	Yes	Yes	Yes	Yes
Identification & Maintenance				
• I&M0 - device-specific information	Yes	Yes	Yes	Yes
• I&M1 - higher-level designation/location designation	Yes	Yes	Yes	Yes
Product functions Diagnostics				
Product function				
• Port diagnostics	Yes	Yes	Yes	Yes
• Packet size statistics	Yes	Yes	Yes	Yes
• Packet type statistics	Yes	Yes	Yes	Yes
• Error statistics	Yes	Yes	Yes	Yes
• SysLog	Yes	Yes	Yes	Yes
Product functions VLAN				
Product function				
• VLAN - port-based	Yes	Yes	Yes	Yes
• VLAN - dynamic	Yes	Yes	Yes	Yes
Maximum number of VLANs	255	255	255	255
Maximum number of dynamic VLANs	255	255	255	255
GVRP protocol is supported	Yes	Yes	Yes	Yes
Product functions DHCP				
Product function				
• DHCP client	Yes	Yes	Yes	Yes
• DHCP option 82	Yes	Yes	Yes	Yes
• DHCP option 66	Yes	Yes	Yes	Yes
• DHCP option 67	Yes	Yes	Yes	Yes
Product functions Redundancy				
Product function				
• Ring redundancy	Yes	Yes	Yes	Yes
• Redundancy manager	Yes	Yes	Yes	Yes
• Standby redundancy	Yes	Yes	Yes	Yes
• Redundancy procedure HSR	Yes	Yes	Yes	Yes
• Redundancy procedure MRP	Yes	Yes	Yes	Yes
• Redundancy procedure STP	Yes	Yes	Yes	Yes
• Redundancy procedure RSTP	Yes	Yes	Yes	Yes
• Passive listening	Yes	Yes	Yes	Yes
Protocol is supported				
• STP/RSTP	Yes	Yes	Yes	Yes
• STP	Yes	Yes	Yes	Yes
• RSTP	Yes	Yes	Yes	Yes
• RSTP Big Network Support	Yes	Yes	Yes	Yes
• LACP	Yes	Yes	Yes	Yes

PROFINET/Industrial Ethernet

Industrial Ethernet switches / media converters

SCALANCE X-300 managed

Technical specifications (continued)

Order No.	6GK5 304-2BD00-2AA3	6GK5 306-1BF00-2AA3	6GK5 307-3BL00-2AA3	6GK5 307-3BM00-2AA3
Product type designation	SCALANCE X304-2FE	SCALANCE X306-1LD FE	SCALANCE X307-3	SCALANCE X307-3LD
Product functions Security				
Product function				
• ACL - Port/MAC-based	Yes	Yes	Yes	Yes
• IEEE 802.1x (Radius)	Yes	Yes	Yes	Yes
• Broadcast/Multicast/Unicast Limiter	Yes	Yes	Yes	Yes
• Broadcast blocking	Yes	Yes	Yes	Yes
SSH protocol is supported	Yes	Yes	Yes	Yes
Product functions Time				
Product function: SICLOCK support	Yes	Yes	Yes	Yes
Protocol is supported				
• NTP	No	No	No	No
• SNTP	Yes	Yes	Yes	Yes
• IEEE 1588 profile default	No	No	No	No
• IEEE 1588 profile gPTP	-	-	-	-
• IEEE 1588 profile PSRC	-	-	-	-
Type of time synchronization	-	-	-	-
Standards, specifications, approvals				
Standard				
• for EMC of FM	FM3611: Class 1, Division 2, Group A, B, C, D / T4, Class 1, Zone 2, Group IIC, T4	FM3611: Class 1, Division 2, Group A, B, C, D / T4, Class 1, Zone 2, Group IIC, T4	FM3611: Class 1, Division 2, Group A, B, C, D / T4, Class 1, Zone 2, Group IIC, T4	FM3611: Class 1, Division 2, Group A, B, C, D / T4, Class 1, Zone 2, Group IIC, T4
• for hazardous zone	EN 60079-0: 2006, EN 60079-15: 2005, II 3 G Ex nA II T4 KEMA 07 ATEX 0145X	EN 60079-0: 2006, EN 60079-15: 2005, II 3 G Ex nA II T4 KEMA 07 ATEX 0145X	EN 60079-0: 2006, EN 60079-15: 2005, II 3 G Ex nA II T4 KEMA 07 ATEX 0145X	EN 60079-0: 2006, EN 60079-15: 2005, II 3 G Ex nA II T4 KEMA 07 ATEX 0145X
• for CSA and UL safety	UL 60950-1, CSA C22.2 No. 60950-1	UL 60950-1, CSA C22.2 No. 60950-1	UL 60950-1, CSA C22.2 No. 60950-1	UL 60950-1, CSA C22.2 No. 60950-1
• for hazardous zone of CSA and UL	UL 1604 and UL 2279-15 (Hazardous Location), CSA C22.2 No. 213-M1987, Class 1 / Division 2 / Group A, B, C, D / T4, Class 1 / Zone 2 / Group IIC / T4	UL 1604 and UL 2279-15 (Hazardous Location), CSA C22.2 No. 213-M1987, Class 1 / Division 2 / Group A, B, C, D / T4, Class 1 / Zone 2 / Group IIC / T4	UL 1604 and UL 2279-15 (Hazardous Location), CSA C22.2 No. 213-M1987, Class 1 / Division 2 / Group A, B, C, D / T4, Class 1 / Zone 2 / Group IIC / T4	UL 1604 and UL 2279-15 (Hazardous Location), CSA C22.2 No. 213-M1987, Class 1 / Division 2 / Group A, B, C, D / T4, Class 1 / Zone 2 / Group IIC / T4
• for emitted interference	EN 61000-6-4:2007 (Class A)	EN 61000-6-4:2007 (Class A)	EN 61000-6-4:2007 (Class A)	EN 61000-6-4:2007 (Class A)
• For noise immunity	EN 61000-6-2:2005	EN 61000-6-2:2005	EN 61000-6-2:2005	EN 61000-6-2:2005
Certificate of suitability	EN 61000-6-2:2005, EN 61000-6-4:2007	EN 61000-6-2:2005, EN 61000-6-4:2007	EN 61000-6-2:2005, EN 61000-6-4:2007	EN 61000-6-2:2005, EN 61000-6-4:2007
• CE mark	Yes	Yes	Yes	Yes
• C-Tick	Yes	Yes	Yes	Yes
• Railroad application according to EN 50155	-	-	-	-
• Railroad application according to EN 50124-1	-	-	-	-
Marine classification society				
• American Bureau of Shipping Europe Ltd. (ABS)	-	-	Yes	Yes
• Bureau Veritas (BV)	-	-	Yes	Yes
• Det Norske Veritas (DNV)	-	-	Yes	Yes
• Germanischer Lloyd (GL)	-	-	Yes	Yes
• Lloyds Register of Shipping (LRS)	-	-	Yes	Yes
• Nippon Kaiji Kyokai (NK)	-	-	Yes	Yes

Technical specifications (continued)

Order No.	6GK5 308-2FL00-2AA3	6GK5 308-2FM00-2AA3	6GK5 308-2FN00-2AA3	6GK5 308-2FP00-2AA3
Product type designation	SCALANCE X308-2	SCALANCE X308-2LD	SCALANCE X308-2LH	SCALANCE X308-2LH+
Transmission rate				
Transmission rate 1	10 Mbit/s	10 Mbit/s	10 Mbit/s	10 Mbit/s
Transmission rate 2	100 Mbit/s	100 Mbit/s	100 Mbit/s	100 Mbit/s
Transmission rate 3	1 000 Mbit/s	1 000 Mbit/s	1 000 Mbit/s	1 000 Mbit/s
Interfaces				
Maximum number of electrical/optical connections for network components or terminal equipment	10	10	10	10
Number of electrical connections				
• for network components or terminal equipment	8	8	8	8
• For operation panel	-	-	-	-
• for signaling contact	1	1	1	1
• for media module	-	-	-	-
• for power supply	1	1	1	1
• for redundant power supply	2	2	2	2
Design of electrical connection				
• for network components or terminal equipment	RJ45 port (1 x 1GE, 7 x FE)	RJ45 port (1 x 1GE, 7 x FE)	RJ45 port (1 x 1GE, 7 x FE)	RJ45 port (1 x 1GE, 7 x FE)
• For operation panel	-	-	-	-
• For signaling contact	2-pin terminal block	2-pin terminal block	2-pin terminal block	2-pin terminal block
• for power supply	4-pin terminal block	4-pin terminal block	4-pin terminal block	4-pin terminal block
Number of optical connections for fiber-optic cables				
• at 100 Mbit/s	-	-	-	-
• at 1000 Mbit/s	2	2	2	2
Design of optical connection for fiber-optic cables				
• at 100 Mbit/s	-	-	-	-
• at 1000 Mbit/s	SC port (multimode up to 0.75 km)	SC port (singlemode up to 10 km)	SC port (singlemode up to 40 km)	SC port (singlemode up to 70 km)
Injectable optical power referred to 1 mW				
• of the transmitter output	-9.5 ... -4 dB	-9.5 ... -3 dB	-6 ... +0 dB	0 ... 5 dB
• of the receiver input, maximum	-3 dB	-3 dB	-3 dB	-3 dB
Minimum optical sensitivity referred to 1 mW of the receiver input	-17 dB	-21 dB	-23 dB	-23 dB
Minimum required attenuation factor of the FO transmission link	0 dB	0 dB	3 dB	8 dB
The range at the optical interface depends on the type of optical fiber used	0 ... 0.75 km	0 ... 10 km	8 ... 40 km	30 ... 70 km
Design of swap medium C-Plug	Yes	Yes	Yes	Yes
Inputs/outputs				
Operating voltage of signaling contacts with DC rated value	24 V	24 V	24 V	24 V
Operating current of signaling contacts with DC maximum	0.1 A	0.1 A	0.1 A	0.1 A

PROFINET/Industrial Ethernet

Industrial Ethernet switches / media converters

SCALANCE X-300 managed

Technical specifications (continued)

Order No.	6GK5 308-2FL00-2AA3	6GK5 308-2FM00-2AA3	6GK5 308-2FN00-2AA3	6GK5 308-2FP00-2AA3
Product type designation	SCALANCE X308-2	SCALANCE X308-2LD	SCALANCE X308-2LH	SCALANCE X308-2LH+
Supply voltage, current consumption, power loss				
Redundant type of power supply	No	No	No	No
Type of power supply	DC	DC	DC	DC
Supply voltage, external	24 V	24 V	24 V	24 V
• Minimum	18 V	18 V	18 V	18 V
• Maximum	32 V	32 V	32 V	32 V
Product component: fusing of power supply input	Yes	Yes	Yes	Yes
Type of fusing of power supply input	F 3 A / 32 V	F 3 A / 32 V	F 3 A / 32 V	F 3 A / 32 V
Current consumption, maximum	0.4 A	0.4 A	0.4 A	0.4 A
Effective power loss				
• at 24 V DC	9.6 W	9.6 W	9.6 W	9.6 W
• at 230 V AC	-	-	-	-
Permissible ambient conditions				
Ambient temperature				
• During operation	-10 ... +60 °C	-40 ... +60 °C	-40 ... +60 °C	-40 ... +60 °C
• During storage	-40 ... +70 °C	-40 ... +70 °C	-40 ... +70 °C	-40 ... +70 °C
• During transport	-40 ... +70 °C	-40 ... +70 °C	-40 ... +70 °C	-40 ... +70 °C
• Note	-	-	-	-
Relative humidity at 25 °C without condensation during operation, maximum	95 %	95 %	95 %	95 %
Ambient condition for operation	-	-	-	-
IP degree of protection	IP30	IP30	IP30	IP30
Design, dimensions and weights				
Type of construction	Compact	Compact	Compact	Compact
Width	120 mm	120 mm	120 mm	120 mm
Height	125 mm	125 mm	125 mm	125 mm
Depth	123 mm	123 mm	123 mm	123 mm
Net weight	1.4 kg	1.4 kg	1.4 kg	1.4 kg
Type of mounting				
• 19-inch installation	No	No	No	No
• 35 mm DIN rail mounting	Yes	Yes	Yes	Yes
• Wall mounting	Yes	Yes	Yes	Yes
• S7-300 rail mounting	Yes	Yes	Yes	Yes
Type of mounting	In marine applications, mounting on the 35 mm DIN rail is not permissible	In marine applications, mounting on the 35 mm DIN rail is not permissible	In marine applications, mounting on the 35 mm DIN rail is not permissible	In marine applications, mounting on the 35 mm DIN rail is not permissible
Product properties, functions, components				
General				
Cascading with redundant ring with reconfiguration time < 0.3 s	50	50	50	50
Cascading with star topology	Any (only dependent on signal propagation time)	Any (only dependent on signal propagation time)	Any (only dependent on signal propagation time)	Any (only dependent on signal propagation time)

Technical specifications (continued)

Order No.	6GK5 308-2FL00-2AA3	6GK5 308-2FM00-2AA3	6GK5 308-2FN00-2AA3	6GK5 308-2FP00-2AA3
Product type designation	SCALANCE X308-2	SCALANCE X308-2LD	SCALANCE X308-2LH	SCALANCE X308-2LH+
Product functions Management, configuration, programming				
Product function				
• CLI	Yes	Yes	Yes	Yes
• Web-based management	Yes	Yes	Yes	Yes
• MIB support	Yes	Yes	Yes	Yes
• TRAPS via e-mail	Yes	Yes	Yes	Yes
• Configuration with STEP 7	Yes	Yes	Yes	Yes
• RMON	Yes	Yes	Yes	Yes
• SMTP server	Yes	Yes	Yes	Yes
• Port mirroring	Yes	Yes	Yes	Yes
• CoS	Yes	Yes	Yes	Yes
• with IRT PROFINET IO Switch	-	-	-	-
• PROFINET IO diagnostics	Yes	Yes	Yes	Yes
• Switch-managed	Yes	Yes	Yes	Yes
Protocol is supported				
• Telnet	Yes	Yes	Yes	Yes
• HTTP	Yes	Yes	Yes	Yes
• HTTPS	Yes	Yes	Yes	Yes
• TFTP	Yes	Yes	Yes	Yes
• FTP	Yes	Yes	Yes	Yes
• BOOTP	Yes	Yes	Yes	Yes
• SNMP v1	Yes	Yes	Yes	Yes
• SNMP v2	Yes	Yes	Yes	Yes
• SNMP v3	Yes	Yes	Yes	Yes
• IGMP (snooping/querier)	Yes	Yes	Yes	Yes
• GMRP	Yes	Yes	Yes	Yes
• DCP	Yes	Yes	Yes	Yes
• LLDP	Yes	Yes	Yes	Yes
Identification & Maintenance				
• I&M0 - device-specific information	Yes	Yes	Yes	Yes
• I&M1 - higher-level designation/location designation	Yes	Yes	Yes	Yes
Product functions Diagnostics				
Product function				
• Port diagnostics	Yes	Yes	Yes	Yes
• Packet size statistics	Yes	Yes	Yes	Yes
• Packet type statistics	Yes	Yes	Yes	Yes
• Error statistics	Yes	Yes	Yes	Yes
• SysLog	Yes	Yes	Yes	Yes
Product functions VLAN				
Product function				
• VLAN - port-based	Yes	Yes	Yes	Yes
• VLAN - dynamic	Yes	Yes	Yes	Yes
Maximum number of VLANs	255	255	255	255
Maximum number of dynamic VLANs	255	255	255	255
GVRP protocol is supported	Yes	Yes	Yes	Yes
Product functions DHCP				
Product function				
• DHCP client	Yes	Yes	Yes	Yes
• DHCP option 82	Yes	Yes	Yes	Yes
• DHCP option 66	Yes	Yes	Yes	Yes
• DHCP option 67	Yes	Yes	Yes	Yes

PROFINET/Industrial Ethernet

Industrial Ethernet switches / media converters

SCALANCE X-300 managed

Technical specifications (continued)

Order No.	6GK5 308-2FL00-2AA3	6GK5 308-2FM00-2AA3	6GK5 308-2FN00-2AA3	6GK5 308-2FP00-2AA3
Product type designation	SCALANCE X308-2	SCALANCE X308-2LD	SCALANCE X308-2LH	SCALANCE X308-2LH+
Product functions Redundancy				
Product function				
• Ring redundancy	Yes	Yes	Yes	Yes
• Redundancy manager	Yes	Yes	Yes	Yes
• Standby redundancy	Yes	Yes	Yes	Yes
• Redundancy procedure HSR	Yes	Yes	Yes	Yes
• Redundancy procedure MRP	Yes	Yes	Yes	Yes
• Redundancy procedure STP	Yes	Yes	Yes	Yes
• Redundancy procedure RSTP	Yes	Yes	Yes	Yes
• Passive listening	Yes	Yes	Yes	Yes
Protocol is supported				
• STP/RSTP	Yes	Yes	Yes	Yes
• STP	Yes	Yes	Yes	Yes
• RSTP	Yes	Yes	Yes	Yes
• RSTP Big Network Support	Yes	Yes	Yes	Yes
• LACP	Yes	Yes	Yes	Yes
Product functions Security				
Product function				
• ACL - Port/MAC-based	Yes	Yes	Yes	Yes
• IEEE 802.1x (Radius)	Yes	Yes	Yes	Yes
• Broadcast/Multicast/Unicast Limiter	Yes	Yes	Yes	Yes
• Broadcast blocking	Yes	Yes	Yes	Yes
SSH protocol is supported	Yes	Yes	Yes	Yes
Product functions Time				
Product function: SICLOCK support	Yes	Yes	Yes	Yes
Protocol is supported				
• NTP	No	No	No	No
• SNTP	Yes	Yes	Yes	Yes
• IEEE 1588 profile default	No	No	No	No
• IEEE 1588 profile gPTP	-	-	-	-
• IEEE 1588 profile PSRC	-	-	-	-
Standards, specifications, approvals				
Standard				
• for EMC of FM	FM3611: Class 1, Division 2, Group A, B, C, D / T4, Class 1, Zone 2, Group IIC, T4	FM3611: Class 1, Division 2, Group A, B, C, D / T4, Class 1, Zone 2, Group IIC, T4	FM3611: Class 1, Division 2, Group A, B, C, D / T4, Class 1, Zone 2, Group IIC, T4	FM3611: Class 1, Division 2, Group A, B, C, D / T4, Class 1, Zone 2, Group IIC, T4
• for hazardous zone	EN 60079-0: 2006, EN 60079-15: 2005, II 3 G Ex nA II T4 KEMA 07 ATEX 0145X	EN 60079-0: 2006, EN 60079-15: 2005, II 3 G Ex nA II T4 KEMA 07 ATEX 0145X	EN 60079-0: 2006, EN 60079-15: 2005, II 3 G Ex nA II T4 KEMA 07 ATEX 0145X	EN 60079-0: 2006, EN 60079-15: 2005, II 3 G Ex nA II T4 KEMA 07 ATEX 0145X
• for CSA and UL safety	UL 60950-1, CSA C22.2 No. 60950-1	UL 60950-1, CSA C22.2 No. 60950-1	UL 60950-1, CSA C22.2 No. 60950-1	UL 60950-1, CSA C22.2 No. 60950-1
• for hazardous zone of CSA and UL	UL 1604 and UL 2279-15 (Hazardous Location), CSA C22.2 No. 213-M1987, Class 1 / Division 2 / Group A, B, C, D / T4, Class 1 / Zone 2 / Group IIC / T4	UL 1604 and UL 2279-15 (Hazardous Location), CSA C22.2 No. 213-M1987, Class 1 / Division 2 / Group A, B, C, D / T4, Class 1 / Zone 2 / Group IIC / T4	UL 1604 and UL 2279-15 (Hazardous Location), CSA C22.2 No. 213-M1987, Class 1 / Division 2 / Group A, B, C, D / T4, Class 1 / Zone 2 / Group IIC / T4	UL 1604 and UL 2279-15 (Hazardous Location), CSA C22.2 No. 213-M1987, Class 1 / Division 2 / Group A, B, C, D / T4, Class 1 / Zone 2 / Group IIC / T4
• for emitted interference	EN 61000-6-4:2007 (Class A)	EN 61000-6-4:2007 (Class A)	EN 61000-6-4:2007 (Class A)	EN 61000-6-4:2007 (Class A)
• for noise immunity	EN 61000-6-2:2005	EN 61000-6-2:2005	EN 61000-6-2:2005	EN 61000-6-2:2005
Certificate of suitability	EN 61000-6-2:2005, EN 61000-6-4:2007	EN 61000-6-2:2005, EN 61000-6-4:2007	EN 61000-6-2:2005, EN 61000-6-4:2007	EN 61000-6-2:2005, EN 61000-6-4:2007

PROFINET/Industrial Ethernet

Industrial Ethernet switches / media converters

SCALANCE X-300 managed

Technical specifications (continued)

Order No.	6GK5 308-2FL00-2AA3	6GK5 308-2FM00-2AA3	6GK5 308-2FN00-2AA3	6GK5 308-2FP00-2AA3
Product type designation	SCALANCE X308-2	SCALANCE X308-2LD	SCALANCE X308-2LH	SCALANCE X308-2LH+
Certificate of suitability				
• CE mark	Yes	Yes	Yes	Yes
• C-Tick	Yes	Yes	Yes	Yes
• Railroad application according to EN 50155	-	-	-	-
• Railroad application according to EN 50124-1	-	-	-	-
Marine classification society				
• American Bureau of Shipping Europe Ltd. (ABS)	Yes	Yes	Yes	Yes
• Bureau Veritas (BV)	Yes	Yes	Yes	Yes
• Det Norske Veritas (DNV)	Yes	Yes	Yes	Yes
• Germanischer Lloyd (GL)	Yes	Yes	Yes	Yes
• Lloyds Register of Shipping (LRS)	Yes	Yes	Yes	Yes
• Nippon Kaiji Kyokai (NK)	Yes	Yes	Yes	Yes

Order No.	6GK5 310-0BA00-2AA3	6GK5 310-0FA00-2AA3	6GK5 320-1BD00-2AA3	6GK5 320-3BF00-2AA3
Product type designation	SCALANCE X310FE	SCALANCE X310	SCALANCE X320-1FE	SCALANCE X320-3LD FE
Transmission rate				
Transmission rate 1	10 Mbit/s	10 Mbit/s	10 Mbit/s	10 Mbit/s
Transmission rate 2	100 Mbit/s	100 Mbit/s	100 Mbit/s	100 Mbit/s
Transmission rate 3	-	1 000 Mbit/s	-	-
Interfaces				
Maximum number of electrical/optical connections for network components or terminal equipment	10	10	21	23
Number of electrical connections				
• for network components or terminal equipment	10	10	20	20
• For operation panel	-	-	-	-
• for signaling contact	1	1	1	1
• for media module	-	-	-	-
• for power supply	1	1	1	1
• for redundant power supply	2	2	2	2
Design of electrical connection				
• for network components or terminal equipment	RJ45 port	RJ45 port (3 x 1GE, 7 x FE)	RJ45 port	RJ45 port
• For operation panel	-	-	-	-
• for signaling contact	2-pin terminal block	2-pin terminal block	2-pin terminal block	2-pin terminal block
• for power supply	4-pin terminal block	4-pin terminal block	4-pin terminal block	4-pin terminal block
Number of optical connections for fiber-optic cables				
• at 100 Mbit/s	-	-	1	3
• At 1000 Mbit/s	-	-	-	-
Design of optical connection for fiber-optic cables				
• at 100 Mbit/s	-	-	SC port (multimode up to 5 km)	SC port (1 x multimode up to 5 km, 2 x singlemode up to 26 km)
• at 1000 Mbit/s	-	-	-	-
Injectable optical power referred to 1 mW				
• of the transmitter output	-	-	-19 ... -14 dB	-15 ... -8 dB
• of the receiver input, maximum	-	-	-3 dB	-3 dB
Minimum optical sensitivity referred to 1 mW of the receiver input	-	-	-32 dB	-34 dB

2

PROFINET/Industrial Ethernet

Industrial Ethernet switches / media converters

SCALANCE X-300 managed

Technical specifications (continued)

Order No.	6GK5 310-0BA00-2AA3	6GK5 310-0FA00-2AA3	6GK5 320-1BD00-2AA3	6GK5 320-3BF00-2AA3
Product type designation	SCALANCE X310FE	SCALANCE X310	SCALANCE X320-1FE	SCALANCE X320-3LD FE
Minimum required attenuation factor of the FO transmission link	-	-	0 dB	0 dB
The range at the optical interface depends on the type of optical fiber used	-	-	0 ... 5 km	0 ... 26 km
Design of swap medium C-Plug	Yes	Yes	Yes	Yes
Inputs/outputs				
Operating voltage of signaling contacts with DC rated value	24 V	24 V	24 V	24 V
Operating current of signaling contacts with DC maximum	0.1 A	0.1 A	0.1 A	0.1 A
Supply voltage, current consumption, power loss				
Redundant type of power supply	No	No	No	No
Type of power supply	DC	DC	DC	DC
External power supply	24 V	24 V	24 V	24 V
• Minimum	18 V	18 V	18 V	18 V
• Maximum	32 V	32 V	32 V	32 V
Product component: fusing of power supply input	Yes	Yes	Yes	Yes
Type of fusing of power supply input	F 3A / 32V	F 3A / 32V	F 3A / 32V	F 3A / 32V
Current consumption, maximum	0.4 A	0.4 A	0.4 A	0.5 A
Effective power loss				
• at 24 V DC	9.6 W	9.6 W	9.6 W	12 W
• At 230 V AC	-	-	-	-
Permissible ambient conditions				
Ambient temperature				
• During operation	-40 ... +60 °C	-40 ... +60 °C	-40 ... +60 °C	-40 ... +60 °C
• During storage	-40 ... +70 °C	-40 ... +70 °C	-40 ... +70 °C	-40 ... +70 °C
• During transport	-40 ... +70 °C	-40 ... +70 °C	-40 ... +70 °C	-40 ... +70 °C
• Note	-	-	-	-
Relative humidity at 25 °C without condensation during operation, maximum	95 %	95 %	95 %	95 %
Ambient condition for operation	-	-	-	-
IP degree of protection	IP30	IP30	IP30	IP30
Design, dimensions and weights				
Type of construction	Compact	Compact	Compact	Compact
Width	120 mm	120 mm	180 mm	180 mm
Height	125 mm	125 mm	125 mm	125 mm
Depth	123 mm	123 mm	123 mm	123 mm
Net weight	1.4 kg	1.4 kg	1.65 kg	1.65 kg
Type of mounting				
• 19-inch installation	No	No	No	No
• 35 mm DIN rail mounting	Yes	Yes	Yes	Yes
• Wall mounting	Yes	Yes	Yes	Yes
• S7-300 rail mounting	Yes	Yes	Yes	Yes
Type of mounting	In marine applications, mounting on the 35 mm DIN rail is not permissible	In marine applications, mounting on the 35 mm DIN rail is not permissible	In marine applications, mounting on the 35 mm DIN rail is not permissible	In marine applications, mounting on the 35 mm DIN rail is not permissible

Technical specifications (continued)

Order No.	6GK5 310-0BA00-2AA3	6GK5 310-0FA00-2AA3	6GK5 320-1BD00-2AA3	6GK5 320-3BF00-2AA3
Product type designation	SCALANCE X310FE	SCALANCE X310	SCALANCE X320-1FE	SCALANCE X320-3LD FE
Product properties, functions, components				
General				
Cascading with redundant ring with reconfiguration time < 0.3 s	50	50	50	50
Cascading with star topology	Any (only dependent on signal propagation time)	Any (only dependent on signal propagation time)	Any (only dependent on signal propagation time)	Any (only dependent on signal propagation time)
Product functions				
Management, configuration, programming				
Product function				
• CLI	Yes	Yes	Yes	Yes
• Web-based management	Yes	Yes	Yes	Yes
• MIB support	Yes	Yes	Yes	Yes
• TRAPS via e-mail	Yes	Yes	Yes	Yes
• Configuration with STEP 7	Yes	Yes	Yes	Yes
• RMON	Yes	Yes	Yes	Yes
• SMTP server	Yes	Yes	Yes	Yes
• Port mirroring	Yes	Yes	Yes	Yes
• CoS	Yes	Yes	Yes	Yes
• with IRT PROFINET IO Switch	-	-	-	-
• PROFINET IO diagnostics	Yes	Yes	Yes	Yes
• Switch-managed	Yes	Yes	Yes	Yes
Protocol is supported				
• Telnet	Yes	Yes	Yes	Yes
• HTTP	Yes	Yes	Yes	Yes
• HTTPS	Yes	Yes	Yes	Yes
• TFTP	Yes	Yes	Yes	Yes
• FTP	Yes	Yes	Yes	Yes
• BOOTP	Yes	Yes	Yes	Yes
• SNMP v1	Yes	Yes	Yes	Yes
• SNMP v2	Yes	Yes	Yes	Yes
• SNMP v3	Yes	Yes	Yes	Yes
• IGMP (snooping/querier)	Yes	Yes	Yes	Yes
• GMRP	Yes	Yes	Yes	Yes
• DCP	Yes	Yes	Yes	Yes
• LLDP	Yes	Yes	Yes	Yes
Identification & Maintenance				
• I&MO - device-specific information	Yes	Yes	Yes	Yes
• I&M1 - higher-level designation/ location designation	Yes	Yes	Yes	Yes
Product functions Diagnostics				
Product function				
• Port diagnostics	Yes	Yes	Yes	Yes
• Packet size statistics	Yes	Yes	Yes	Yes
• Packet type statistics	Yes	Yes	Yes	Yes
• Error statistics	Yes	Yes	Yes	Yes
• SysLog	Yes	Yes	Yes	Yes
Product functions VLAN				
Product function				
• VLAN - port-based	Yes	Yes	Yes	Yes
• VLAN - dynamic	Yes	Yes	Yes	Yes
Maximum number of VLANs	255	255	255	255
Maximum number of dynamic VLANs	255	255	255	255
GVRP protocol is supported	Yes	Yes	Yes	Yes

PROFINET/Industrial Ethernet

Industrial Ethernet switches / media converters

SCALANCE X-300 managed

Technical specifications (continued)

Order No.	6GK5 310-0BA00-2AA3	6GK5 310-0FA00-2AA3	6GK5 320-1BD00-2AA3	6GK5 320-3BF00-2AA3
Product type designation	SCALANCE X310FE	SCALANCE X310	SCALANCE X320-1FE	SCALANCE X320-3LD FE
Product functions DHCP				
Product function				
• DHCP client	Yes	Yes	Yes	Yes
• DHCP option 82	Yes	Yes	Yes	Yes
• DHCP option 66	Yes	Yes	Yes	Yes
• DHCP option 67	Yes	Yes	Yes	Yes
Product functions Redundancy				
Product function				
• Ring redundancy	Yes	Yes	Yes	Yes
• Redundancy manager	Yes	Yes	Yes	Yes
• Standby redundancy	Yes	Yes	Yes	Yes
• Redundancy procedure HSR	Yes	Yes	Yes	Yes
• Redundancy procedure MRP	Yes	Yes	Yes	Yes
• Redundancy procedure STP	Yes	Yes	Yes	Yes
• Redundancy procedure RSTP	Yes	Yes	Yes	Yes
• Passive listening	Yes	Yes	Yes	Yes
Protocol is supported				
• STP/RSTP	Yes	Yes	Yes	Yes
• STP	Yes	Yes	Yes	Yes
• RSTP	Yes	Yes	Yes	Yes
• RSTP Big Network Support	Yes	Yes	Yes	Yes
• LACP	Yes	Yes	Yes	Yes
Product functions Security				
Product function				
• ACL - Port/MAC-based	Yes	Yes	Yes	Yes
• IEEE 802.1x (radius)	Yes	Yes	Yes	Yes
• Broadcast/Multicast/Unicast Limiter	Yes	Yes	Yes	Yes
• Broadcast blocking	Yes	Yes	Yes	Yes
SSH protocol is supported	Yes	Yes	Yes	Yes
Product functions Time				
Product function:	Yes	Yes	Yes	Yes
SICLOCK support				
Protocol is supported				
• NTP	No	No	No	No
• SNTP	Yes	Yes	Yes	Yes
• IEEE 1588 profile default	No	No	No	No
• IEEE 1588 profile gPTP	-	-	-	-
• IEEE 1588 profile PSRC	-	-	-	-
Type of time synchronization	-	-	-	-
Standards, specifications, approvals				
Standard				
• for EMC of FM	FM3611: Class 1, Division 2, Group A, B, C, D / T4, Class 1, Zone 2, Group IIC, T4	FM3611: Class 1, Division 2, Group A, B, C, D / T4, Class 1, Zone 2, Group IIC, T4	FM3611: Class 1, Division 2, Group A, B, C, D / T4, Class 1, Zone 2, Group IIC, T4	FM3611: Class 1, Division 2, Group A, B, C, D / T4, Class 1, Zone 2, Group IIC, T4
• for hazardous zone	EN 60079-0: 2006, EN 60079-15: 2005, II 3 G Ex nA II T4 KEMA 07 ATEX 0145X	EN 60079-0: 2006, EN 60079-15: 2005, II 3 G Ex nA II T4 KEMA 07 ATEX 0145X	EN 60079-0: 2006, EN 60079-15: 2005, II 3 G Ex nA II T4 KEMA 07 ATEX 0145X	EN 60079-0: 2006, EN 60079-15: 2005, II 3 G Ex nA II T4 KEMA 07 ATEX 0145X
• for CSA and UL safety	UL 60950-1, CSA C22.2 No. 60950-1	UL 60950-1, CSA C22.2 No. 60950-1	UL 60950-1, CSA C22.2 No. 60950-1	UL 60950-1, CSA C22.2 No. 60950-1
• for hazardous zone of CSA and UL	UL 1604 and UL 2279-15 (Hazardous Location), CSA C22.2 No. 213-M1987, Class 1 / Division 2 / Group A, B, C, D / T4, Class 1 / Zone 2 / Group IIC / T4	UL 1604 and UL 2279-15 (Hazardous Location), CSA C22.2 No. 213-M1987, Class 1 / Division 2 / Group A, B, C, D / T4, Class 1 / Zone 2 / Group IIC / T4	UL 1604 and UL 2279-15 (Hazardous Location), CSA C22.2 No. 213-M1987, Class 1 / Division 2 / Group A, B, C, D / T4, Class 1 / Zone 2 / Group IIC / T4	UL 1604 and UL 2279-15 (Hazardous Location), CSA C22.2 No. 213-M1987, Class 1 / Division 2 / Group A, B, C, D / T4, Class 1 / Zone 2 / Group IIC / T4
• for emitted interference	EN 61000-6-4:2007 (Class A)	EN 61000-6-4:2007 (Class A)	EN 61000-6-4:2007 (Class A)	EN 61000-6-4:2007 (Class A)
• for noise immunity	EN 61000-6-2:2005	EN 61000-6-2:2005	EN 61000-6-2:2005	EN 61000-6-2:2005

PROFINET/Industrial Ethernet

Industrial Ethernet switches / media converters

SCALANCE X-300 managed

Technical specifications (continued)

Order No.	6GK5 310-0BA00-2AA3	6GK5 310-0FA00-2AA3	6GK5 320-1BD00-2AA3	6GK5 320-3BF00-2AA3
Product type designation	SCALANCE X310FE	SCALANCE X310	SCALANCE X320-1FE	SCALANCE X320-3LD FE
Certificate of suitability	EN 61000-6-2:2005, EN 61000-6-4:2007	EN 61000-6-2:2005, EN 61000-6-4:2007	EN 61000-6-2:2005, EN 61000-6-4:2007	EN 61000-6-2:2005, EN 61000-6-4:2007
• CE mark	Yes	Yes	Yes	Yes
• C-Tick	Yes	Yes	Yes	Yes
• Railroad application according to EN 50155	-	-	-	-
• Railroad application according to EN 50124-1	-	-	-	-
Marine classification society				
• American Bureau of Shipping Europe Ltd. (ABS)	Yes	Yes	-	-
• Bureau Veritas (BV)	Yes	Yes	-	-
• Det Norske Veritas (DNV)	Yes	Yes	-	-
• Germanischer Lloyd (GL)	Yes	Yes	-	-
• Lloyds Register of Shipping (LRS)	Yes	Yes	-	-
• Nippon Kaiji Kyokai (NK)	Yes	Yes	-	-

Order No.	6GK5 308-2GG00-2AA2	6GK5 308-2GG00-2CA2
Product type designation	SCALANCE X308-2M	SCALANCE X308-2M TS
Transmission rate		
Transmission rate 1	10 Mbit/s	10 Mbit/s
Transmission rate 2	100 Mbit/s	100 Mbit/s
Transmission rate 3	1 000 Mbit/s	1 000 Mbit/s
Interfaces		
Maximum number of electrical/optical connections for network components or terminal equipment	8	8
Number of electrical connections		
• For network components or terminal equipment	4	4
• For operation panel	-	-
• For signaling contact	1	1
• For media module	2	2
• For power supply	1	1
• For redundant power supply	1	1
Design of electrical connection		
• For network components or terminal equipment	RJ45 port	RJ45 port
• For operation panel	-	-
• For signaling contact	2-pin terminal block	2-pin terminal block
• For power supply	4-pin terminal block	4-pin terminal block
Number of optical connections for fiber-optic cables		
• At 100 Mbit/s	-	-
• at 1000 Mbit/s	-	-
Design of optical connection for fiber-optic cables		
• At 100 Mbit/s	Depends on selected media modules	Depends on selected media modules
• At 1000 Mbit/s	Depends on selected media modules	Depends on selected media modules
Injectable optical power referred to 1 mW		
• of the transmitter output	-	-
• of the receiver input, maximum	-	-
Minimum optical sensitivity referred to 1 mW of the receiver input	-	-
Minimum required attenuation factor of the FO transmission link	-	-
The range at the optical interface depends on the type of optical fiber used	-	-
Design of the swap medium C-Plug	Yes	Yes

2

PROFINET/Industrial Ethernet

Industrial Ethernet switches / media converters

SCALANCE X-300 managed

Technical specifications (continued)

Order No.	6GK5 308-2GG00-2AA2	6GK5 308-2GG00-2CA2
Product type designation	SCALANCE X308-2M	SCALANCE X308-2M TS
Inputs/outputs		
Operating voltage of signaling contacts with DC rated value	24 V	24 V
Maximum operating current of signaling contacts with DC	0.1 A	0.1 A
Supply voltage, current consumption, power loss		
Redundant type of power supply	No	No
Type of power supply	DC	DC
Supply voltage, external	24 V	12 V ... 24 V
• Minimum	18 V	20 V
• Maximum	32 V	30 V
Product component: fusing of power supply input	Yes	Yes
Type of fusing of power supply input	F 3 A / 32 V	F 3 A / 32 V
Current consumption, maximum	0.7 A	0.7 A
Effective power loss		
• At 24 V DC	16.6 W	16.6 W (at DC 12 V)
• At 230 V AC	-	-
Permitted ambient conditions		
Ambient temperature		
• During operation	-40 ... +70 °C	-40 ... +70 °C
• During storage	-40 ... +70 °C	-40 ... +70 °C
• During transport	-40 ... +70 °C	-40 ... +70 °C
• Note	Reduced operating temperature as result of use of media modules (-40 to +70 °C) or SFP plug-in transceivers (-40 to +60 °C). With vertical installation, the maximum operating temperature is reduced to +50 °C	Reduced operating temperature as result of use of media modules (-40 to +70 °C) or SFP plug-in transceivers (-40 to +60 °C). With vertical installation, the maximum operating temperature is reduced to +50 °C
Relative humidity at 25 °C without condensation during operation, maximum	95 %	95 %
Ambient condition for operation	-	-
IP degree of protection	IP20	IP20
Design, dimensions and weights		
Type of construction	Compact	Compact
Width	120 mm	120 mm
Height	125 mm	125 mm
Depth	124 mm	124 mm
Net weight	1.4 kg	1.4 kg
Type of mounting		
• 19-inch installation	No	No
• 35 mm DIN rail mounting	Yes	Yes
• Wall mounting	Yes	Yes
• S7-300 rail mounting	Yes	Yes
Type of mounting	In marine applications, mounting on the 35 mm DIN rail is not permissible.	In marine applications, mounting on the 35 mm DIN rail is not permissible.

Technical specifications (continued)

Order No.	6GK5 308-2GG00-2AA2	6GK5 308-2GG00-2CA2
Product type designation	SCALANCE X308-2M	SCALANCE X308-2M TS
Product properties, functions, components		
General		
Cascading with redundant ring with reconfiguration time < 0.3 s	50	50
Cascading with star topology	Any (only dependent on signal propagation time)	Any (only dependent on signal propagation time)
Product functions		
Management, configuration, programming		
Product function		
• CLI	Yes	Yes
• Web-based management	Yes	Yes
• MIB support	Yes	Yes
• Traps via e-mail	Yes	Yes
• Configuration with STEP 7	Yes	Yes
• RMON	Yes	Yes
• SMTP server	Yes	Yes
• Port mirroring	Yes	Yes
• CoS	Yes	Yes
• with IRT PROFINET IO Switch	-	-
• PROFINET IO-Diagnostics	Yes	Yes
• Switch-managed	Yes	Yes
Protocol is supported		
• Telnet	Yes	Yes
• HTTP	Yes	Yes
• HTTPS	Yes	Yes
• TFTP	Yes	Yes
• FTP	Yes	Yes
• BOOTP	Yes	Yes
• SNMP v1	Yes	Yes
• SNMP v2	Yes	Yes
• SNMP v3	Yes	Yes
• IGMP (snooping/querier)	Yes	Yes
• GMRP	Yes	Yes
• DCP	Yes	Yes
• LLDP	Yes	Yes
Identification & Maintenance		
• I&M0 - device-specific information	Yes	Yes
• I&M1 - higher-level designation/location designation	Yes	Yes
Product functions Diagnostics		
Product function		
• Port diagnostics	Yes	Yes
• Packet size statistics	Yes	Yes
• Packet type statistics	Yes	Yes
• Error statistics	Yes	Yes
• SysLog	Yes	Yes
Product functions VLAN		
Product function		
• VLAN - port-based	Yes	Yes
• VLAN - dynamic	Yes	Yes
Maximum number of VLANs	255	255
Maximum number of dynamic VLANs	255	255
GVRP protocol is supported	Yes	Yes
Product functions DHCP		
Product function		
• DHCP client	Yes	Yes
• DHCP option 82	Yes	Yes
• DHCP option 66	Yes	Yes
• DHCP option 67	Yes	Yes

PROFINET/Industrial Ethernet

Industrial Ethernet switches / media converters

SCALANCE X-300 managed

Technical specifications (continued)

Order No.	6GK5 308-2GG00-2AA2	6GK5 308-2GG00-2CA2
Product type designation	SCALANCE X308-2M	SCALANCE X308-2M TS
Product functions Redundancy		
Product function		
• Ring redundancy	Yes	Yes
• Redundancy manager	Yes	Yes
• Standby redundancy	Yes	Yes
• Redundancy procedure HSR	Yes	Yes
• Redundancy procedure MRP	Yes	Yes
• Redundancy procedure STP	Yes	Yes
• Redundancy procedure RSTP	Yes	Yes
• Passive listening	Yes	Yes
Protocol is supported		
• STP/RSTP	Yes	Yes
• STP	Yes	Yes
• RSTP	Yes	Yes
• RSTP Big Network Support	Yes	Yes
• LACP	Yes	Yes
Product functions Security		
Product function		
• ACL - Port/MAC-based	Yes	Yes
• IEEE 802.1x (Radius)	Yes	Yes
• Broadcast/Multicast/Unicast Limiter	Yes	Yes
• Broadcast blocking	Yes	Yes
SSH protocol is supported	Yes	Yes
Product functions Time		
Product function: SICLOCK support	Yes	Yes
Protocol is supported		
• NTP	No	No
• SNTP	Yes	Yes
• IEEE 1588 profile default	Yes	Yes
• IEEE 1588 profile gPTP	-	-
• IEEE 1588 profile PSRC	-	-
Type of time synchronization	-	-
Standards, specifications, approvals		
Standard		
• for EMC of FM	FM3611: Class 1, Division 2, Group A, B, C, D / T4, Class 1, Zone 2, Group IIC, T4	FM3611: Class 1, Division 2, Group A, B, C, D / T4, Class 1, Zone 2, Group IIC, T4
• for hazardous zone	EN 60079-0: 2006, EN 60079-15: 2005, II 3 G Ex nA II T4 KEMA 07 ATEX 0145X	EN 60079-0: 2006, EN 60079-15: 2005, II 3 G Ex nA II T4 KEMA 07 ATEX 0145X
• For CSA and UL safety	UL 60950-1, CSA C22.2 No. 60950-1	UL 60950-1, CSA C22.2 No. 60950-1
• for hazardous zone of CSA and UL	UL 1604 and UL 2279-15 (Hazardous Location), CSA C22.2 No. 213-M1987, Class 1 / Division 2 / Group A, B, C, D / T4, Class 1 / Zone 2 / Group IIC / T4	UL 1604 and UL 2279-15 (Hazardous Location), CSA C22.2 No. 213-M1987, Class 1 / Division 2 / Group A, B, C, D / T4, Class 1 / Zone 2 / Group IIC / T4
• For emitted interference	EN 61000-6-4:2007 (Class A)	EN 61000-6-4:2007 (Class A)
• for noise immunity	EN 61000-6-2:2005	EN 61000-6-2:2005
Certificate of suitability	EN 61000-6-2:2005, EN 61000-6-4:2007	EN 61000-6-2:2005, EN 61000-6-4:2007
• CE mark	Yes	Yes
• C-Tick	Yes	Yes
• Railroad application according to EN 50155	-	Yes
• Railroad application according to EN 50124-1	-	-
Marine classification society		
• American Bureau of Shipping Europe Ltd. (ABS)	-	-
• Bureau Veritas (BV)	-	-
• Det Norske Veritas (DNV)	-	-
• Germanischer Lloyd (GL)	-	-
• Lloyds Register of Shipping (LRS)	-	-
• Nippon Kaiji Kyokai (NK)	-	-

PROFINET/Industrial Ethernet

Industrial Ethernet switches / media converters

SCALANCE X-300 managed

2

Ordering data	Order No.	Order No.	
SCALANCE X-300 Industrial Ethernet switches			
<p>Industrial Ethernet switches for setting up electrical and/or optical Industrial Ethernet networks; integrated redundancy manager, IT functions (RSTP, VLAN, etc.), network management via SNMP and web server; incl. operating instructions, Industrial Ethernet network manual and configuration software on CD-ROM; C-PLUG included in the scope of supply</p> <ul style="list-style-type: none"> • SCALANCE X310; 3 x 10/100/1000 Mbit/s RJ45 ports, electrical 7 x 10/100 Mbit/s RJ45 ports, electrical • SCALANCE X308-2; 2 x 1000 Mbit/s SC ports, optical (multimode, glass), up to 750 m 1 x 10/100/1000 Mbit/s RJ45 port, electrical 7 x 10/100 Mbit/s RJ45 ports, electrical; • SCALANCE X308-2LD; 2 x 1000 Mbit/s SC ports, optical (single-mode, glass), up to 10 km 1 x 10/100/1000 Mbit/s RJ45 port, electrical, 7 x 10/100 Mbit/s RJ45 ports, electrical; • SCALANCE X308-2LH; 2 x 1000 Mbit/s SC ports, optical (single-mode, glass), up to 40 km 1 x 10/100/1000 Mbit/s RJ45 port, electrical, 7 x 10/100 Mbit/s RJ45 ports, electrical • SCALANCE X308-2LH+; 2 x 1000 Mbit/s SC ports, optical (single-mode, glass), up to 70 km 1 x 10/100/1000 Mbit/s RJ45 port, electrical, 7 x 10/100 Mbit/s RJ45 ports, electrical • SCALANCE X307-3; 3 x 1000 Mbit/s SC ports, optical (multi-mode, glass), up to 750 m 7 x 10/100 Mbit/s RJ45 ports, electrical • SCALANCE X307-3LD; 3 x 1000 Mbit/s SC ports, optical (single-mode, glass), up to 10 km 7 x 10/100 Mbit/s RJ45 ports, electrical 	<p>6GK5 310-0FA00-2AA3</p> <p>6GK5 308-2FL00-2AA3</p> <p>6GK5 308-2FM00-2AA3</p> <p>6GK5 308-2FN00-2AA3</p> <p>6GK5 308-2FP00-2AA3</p> <p>6GK5 307-3BL00-2AA3</p> <p>6GK5 307-3BM00-2AA3</p>	<p><u>Fast Ethernet switches</u></p> <ul style="list-style-type: none"> • SCALANCE X310FE; 10 x 10/100 Mbit/s RJ45 ports, electrical • SCALANCE X304-2FE; 2 x 100 Mbit/s SC port, optical (singlemode, glass), up to 26 km 4 x 10/100 Mbit/s RJ45 ports, electrical • SCALANCE X306-1LD FE; 1 x 100 Mbit/s SC port, optical (single-mode, glass), up to 26 km 6 x 10/100 Mbit/s RJ45 ports, electrical • SCALANCE X320-1FE; 1 x 100 Mbit/s SC port, optical (multi-mode, glass), up to 5 km 20 x 10/100 Mbit/s RJ45 ports, electrical • SCALANCE X320-3LD FE; 1 x 100 Mbit/s SC port, optical (multi-mode, glass), up to 5 km 2 x 100 Mbit/s SC port, optical (single-mode, glass), up to 26 km 20 x 10/100 Mbit/s RJ45 ports, electrical <p><u>Full Gigabit Ethernet switches</u></p> <ul style="list-style-type: none"> • SCALANCE X308-2M; 4 x 10/100//1000 Mbit/s RJ45 ports, electrical 2 x 10/100/1000 Mbit/s slots for 2-port media modules, electrical or optical • SCALANCE X308-2M TS; 4 x 10/100//1000 Mbit/s RJ45 ports, electrical 2 x 10/100/1000 Mbit/s slots for 2-port media modules, electrical or optical, with extended temperature range and EN 50155 approval for railway applications <p><u>Media modules</u></p> <p>See "Media modules for modular SCALANCE X-300 managed"</p>	<p>6GK5 310-0BA00-2AA3</p> <p>6GK5 304-2BD00-2AA3</p> <p>6GK5 306-1BF00-2AA3</p> <p>6GK5 320-1BD00-2AA3</p> <p>6GK5 320-3BF00-2AA3</p> <p>6GK5 308-2GG00-2AA2</p> <p>6GK5 308-2GG00-2CA2</p>

PROFINET/Industrial Ethernet

Industrial Ethernet switches / media converters

SCALANCE X-300 managed

2

Ordering data	Order No.	Order No.
Accessories		
IE FC TP Standard Cable GP 2 x 2 (Type A) 4-core, shielded TP installation cable for connection to IE FC Outlet RJ45 / IE FC RJ45 Plug; PROFINET-compliant; with UL approval; sold by the meter; max. length 1000 m, minimum order 20 m	6XV1 840-2AH10	IE FC RJ45 Plug 4 x 2 RJ45 plug connector for Industrial Ethernet (10/100/1000 Mbit/s) with a rugged metal enclosure and integrated insulation displacement contacts for connecting Industrial Ethernet FC installation cables; 180° cable outlet; for network components and CPs/CPU's with Industrial Ethernet interface • 1 pack = 1 unit • 1 pack = 10 units • 1 pack = 50 units
IE FC TP Standard Cable GP 4 x 2 8-core, shielded TP installation cable for connection to IE FC RJ45 Modular Outlet for universal application; with UL approval; sold by the meter; max quantity 1000 m, minimum order 20 m	6XV1 870-2E	
IE TP Cord RJ45/RJ45 TP cable 4 x 2 with two RJ45 connectors • 0.5 m • 1 m • 2 m • 6 m • 10 m	6XV1 870-3QE50 6XV1 870-3QH10 6XV1 870-3QH20 6XV1 870-3QH60 6XV1 870-3QN10	FC SC Plug Screw connector for on-site assembly on FC fiber-optic cable; (1 pack = 10 Duplex Plugs + cleaning cloths)
FO Standard Cable GP 50/125/1400 ²⁾ Multimode cable, sold by the meter; max. length 1000 m; minimum order 20 m	6XV1 873-2A	
FO Robust Cable GP 4E9/125/90 Singlemode cable, sold by the meter; max. length 1000 m; minimum order 20 m	6XV1 843-2R	IE FC Stripping Tool Preadjusted stripping tool for fast stripping of the Industrial Ethernet FC cables
Glass fiber-optic cable, pre-assembled with 4 SC connectors ¹⁾ • 80 m • 100 m • 150 m • 200 m • 300 m	6XV1 873-6AN80 6XV1 873-6AT10 6XV1 873-6AT15 6XV1 873-6AT20 6XV1 873-6AT30	FC FO Termination Kit Assembly case for local assembly of FC SC and FC BFOC connectors to FC FO standard cable, comprising a stripping tool, Kevlar cutters, fiber breaking tool and microscope
FC FO Standard Cable GP 62.5/200/230 FC FO standard cable for fixed routing indoors with PVC sheath; sold by the meter; max. length 1000 m; minimum order 20 m	6XV1 847-2A	SITOP compact 24 V/ 0.6 A 1-phase power supply with wide-range input 85 – 264 V AC/110 – 300 V DC, stabilized output voltage 24 V, rated output current value 0.6 A, slim design
IE FC RJ45 Plug 180 2 x 2 RJ45 plug connector for Industrial Ethernet with a rugged metal enclosure and integrated insulation displacement contacts for connecting Industrial Ethernet FC installation cables; with 180° cable outlet; for network components and CPs/CPU's with Industrial Ethernet interface • 1 pack = 1 unit • 1 pack = 10 units • 1 pack = 50 units	6GK1 901-1BB10-2AA0 6GK1 901-1BB10-2AB0 6GK1 901-1BB10-2AE0	IE FC RJ45 Modular Outlet FastConnect RJ45 Outlet for Industrial Ethernet with interface for a replaceable insert; • With insert 2FE; replaceable insert for 2 x 100 Mbit/s interfaces • With insert 1GE; replaceable insert for 1 x 1000 Mbit/s interfaces

¹⁾ Special fiber-optic cables, lengths and accessories available on request

²⁾ Special tools and trained personnel are required for pre-assembling glass fiber-optic cables

More information

To assist in selecting the right Industrial Ethernet switches as well as configuration of modular versions, the SIMATIC NET Selection Tool is available:

Online version:
www.siemens.com/snst

Offline version:
www.siemens.com/snst-download

PROFINET/Industrial Ethernet

Industrial Ethernet switches / media converters

SIPLUS SCALANCE X-300 managed

Overview



- The SCALANCE X-300 product line consists of compact Industrial Ethernet switches for establishing electrical and/or optical line, ring and star topologies at 10/100/1000 Mbit/s
 - Three integral electrical and/or optical Gigabit Ethernet interfaces (10/100/1000 Mbit/s) and seven electrical Fast Ethernet interfaces (10/100 Mbit/s) for interconnecting several switches to establish Gigabit or Fast Ethernet rings or to connect Industrial Ethernet nodes
 - High-speed media redundancy through integral redundancy manager both for Gigabit Ethernet (SCALANCE X-300, SCALANCE X-400, SCALANCE X-500) and Fast Ethernet, e.g. combination with SCALANCE X-200 switches)
 - Switches from the SCALANCE X-300 product line support numerous IT standard and thus permit seamless integration of automation networks into existing corporate networks. Virtual local area networks (VLANs) can be constructed
- The support of standardized redundancy procedures (Rapid Spanning Tree Protocol) permits redundant integration into higher-level enterprise networks
 - By learning the multicast sources and destinations (IGMP Snooping and IGMP Querier (Internet Group Management Protocol)), SCALANCE X-300 switches can also filter multicast data traffic and thus limit the load on the network.
 - The ports can be configured for terminal devices that support authentication in accordance with IEEE 802.1x. Authentication is done via a RADIUS server which has to be configured accordingly and must be able to be reached via the network.
 - Rugged metal enclosure in S7-300 format for mounting on standard rail, S7-300 standard mounting rail or for direct wall mounting in various positions
 - Compact, space-saving design for installation in control cabinet
 - Rugged, industry-standard station connections with PROFINET-compatible RJ45 connectors that offer additional strain relief and bending strain relief thanks to latching on the housing
 - Redundant power supply for protection against power failure
 - Diagnostics on the device by means of LEDs (power, link status, data traffic, fault, redundancy manager)
 - Fault signaling contact, can be easily set by means of the SELECT/SET pushbutton for simple display of faults
 - The devices feature PROFINET diagnostics, SNMP access, integrated web server and automatic e-mail sending function for remote diagnosis and signaling via the network.
- Note:
SIPLUS extreme products are based on Siemens Industry standard products. The contents listed here were taken from the respective standard products. SIPLUS extreme-specific information was added.

2

PROFINET/Industrial Ethernet

Industrial Ethernet switches / media converters

SIPLUS SCALANCE X-300 managed

Overview (continued)

	SIPLUS SCALANCE X308-2
Order number	6AG1 308-2FL00-4AA3
Order No. based on	6GK5 308-2FL00-2AA3
Ambient temperature range	-10 ... +60 °C
Conformal coating	Coating of the printed circuit boards and the electronic components
Technical data	The technical data of the standard product applies except for the ambient conditions.

Ambient conditions

Relative humidity	5 ... 100 % Condensation permissible
Biologically active substances	Conformity with EN 60721-3-3, Class 3B2 mold and fungal spores (except fauna)
Chemically active substances	Conformity with EN 60721-3-3, Class 3C4 incl. salt mist and ISA-S71.04 severity level G1; G2; G3; GX ^{1) 2)}
Mechanically active substances	Conformity with EN 60721-3-3, Class 3S4 including conductive sand, dust ²⁾
Air pressure (depending on the highest positive temperature range specified)	1080 ... 795 hPa (-1000 ... +2000 m) see ambient temperature range 795 ... 658 hPa (+2000 ... +3500 m) derating 10 K 658 ... 540 hPa (+3500 ... +5000 m) derating 20 K

¹⁾ ISA-S71.04 severity level GX: Long-term load:
SO₂ < 4.8 ppm; H₂S < 9.9 ppm; Cl < 0.2 ppm; HCl < 0.66 ppm;
HF < 0.12 ppm; NH < 49 ppm; O₃ < 0.1 ppm; NOX < 5.2 ppm
Limit value (max. 30 min/d):
SO₂ < 17.8 ppm; H₂S < 49.7 ppm; Cl < 1.0 ppm; HCl < 3.3 ppm;
HF < 2.4 ppm; NH < 247 ppm; O₃ < 1.0 ppm; NOX < 10.4 ppm

²⁾ The supplied plug covers must remain in place over the unused interface when operated in atmospheres containing corrosive gases!

The technical documentation on SIPLUS can be found here:
www.siemens.com/siplus-extreme

Ordering data

SIPLUS SCALANCE X308-2;
(medial load)
2 x 1000 Mbit/s multi-mode fiber-optic ports (SC sockets),
1 x 10/100/1000 Mbit/s RJ45 port,
7 x 10/100 Mbit/s RJ45 ports;
for glass fiber-optic cables (multi-mode) up to max. 750 m

Accessories

Order No.

6AG1 308-2FL00-4AA3

See ordering data from SCALANCE X-300 managed

PROFINET/Industrial Ethernet

Industrial Ethernet switches / media converters

SCALANCE XR-300 managed

Overview



The SCALANCE XR-300 Industrial Ethernet switches are fully modular, high-performance, industry-standard switches for the construction of electrical and optical line, ring and star topologies with data transfer rates of 10/100/1000 Mbit/s, designed for installation in 19" control cabinets.

- As many as 24 electrical and/or optical interfaces (10/100/1000 Mbit/s); up to 12 electrical and/or optical 2-port media modules can be inserted at any position in the basic unit
- High-speed media redundancy through integral redundancy manager both for Gigabit Ethernet (with SCALANCE X-300, X-400) and Fast Ethernet (e.g. in combination with SCALANCE X-200 switches)
- Seamless integration of automation networks into existing corporate networks thanks to support for a host of IT standard functions (VLANs, IGMP-Snooping/Querier, STP/RSTP, Link Aggregation, Quality of Service)
- Redundant integration into higher-level networks thanks to support for standardized redundancy procedures (Spanning Tree Protocol/Rapid Reconfiguration Spanning Tree Protocol/ MRP)
- Remote diagnostics by means of PROFINET diagnostics, Web browser, CLI, or SNMP

Benefits

get Designed for Industry

- Unlimited flexibility during network expansions (e.g. more terminals) or conversion (e.g. switching from copper to fiber-optic cable) and reduction of the storage costs due to the modular construction using port modules
- High availability of the network thanks to:
 - Redundant power supply
 - Redundant network structures based on fiber-optic or twisted pair cables (redundancy manager, standby function, and STP/RSTP are integrated)
 - Easy device replacement by means of plug-in C-PLUG swap medium
 - Very fast reconfiguration of the network in the event of a fault
- Lower susceptibility to failure and higher availability of the plant networking due to latching of the RJ45 FastConnect connectors in the sleeve of the RJ45 port modules
- Protection of investment due to integration into existing network management systems by means of standardized SNMP access
- Time saving during engineering, commissioning and in the operating phase of a plant by using the integrated configuration and diagnostics in STEP 7, without additional software
- Space savings in control cabinet due to flexible cable outlet on the front or rear of the device

Application

The SCALANCE XR-300 is ideal for use in plant networks and for integrating the industrial network into an existing corporate network. Both at the field level and the control level, the switch performs the network with the distributed field devices and ensures high plant availability with extensive diagnostics options and high transmission speeds. The modularity permits perfect adaptation to the respective application through the use of electrical and also optical media modules

The SCALANCE XR-300 switch is suitable for establishing electrical and optical Industrial Ethernet line, star or ring topologies with 24 ports that can be optionally equipped with electrical and/or optical 2-port media modules. It can also be used as a hub in the plant bus (redundant connection is possible).

2

PROFINET/Industrial Ethernet

Industrial Ethernet switches / media converters

SCALANCE XR-300 managed

Application (continued)

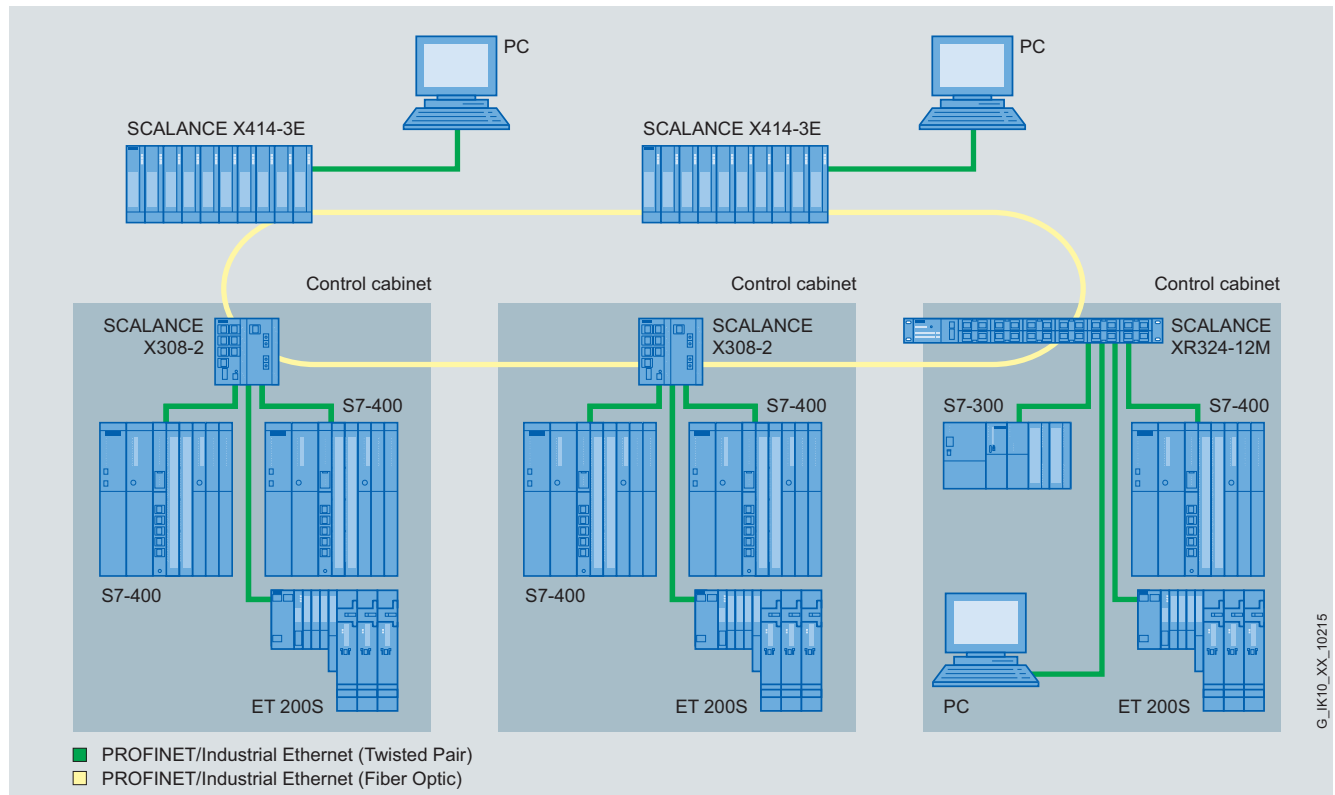

Integration of control cabinets with SCALANCE X-300 in an optical Gigabit ring

The use of media modules in partly and fully modular versions of the SCALANCE X-300 switches supports:

- The extension of networks by subsequent insertion of additional media modules in unused media module slots
- The changing of cabling technology, e.g. conversion from copper to fiber-optic cables, or from multimode to single-mode FOC

Design

The SCALANCE XR-300 Industrial Ethernet switches with rugged metal enclosure with IP30 degree of protection are optimized for installation in the 19" control cabinet. Versions are available with 24 V DC or 230 V AC connection. The connection of the power supply and the data cable outlet are located optionally either at the front or rear of the device.

The switches have:

- 4-pin terminal block for redundant voltage feed to protected against power failure at 24 V DC
- 3-pin terminal block for voltage feed in 230 V AC version
- 2-pin terminal block for connecting the isolated signaling contact for simple display of faults
- Row of LEDs for indicating status information (power, link status, data transfer, power supply, signal contact)
- SELECT/SET pushbutton for easy setting of the fault signaling contact on the device
- Slot for optional C-PLUG swap medium on the side of the device for easy replacement in the event of a fault
- Console port (serial interface) for on-site parameterization/diagnostics (RJ11 cable to RS232 (9-pin) included in scope of delivery)

The SCALANCE XR-300 switches are available with the following port types:

- 12 slots for electrical or optical 2-port media modules for multi-mode or single-mode connections; the optical media modules are available in various connection technologies
- The RJ45 sockets are designed to industry standards with additional sleeves, for connection of the Industrial Ethernet FC RJ45 Plug 180
- All electrical Ethernet interfaces support 10/100/1000 Mbit/s, all optical Ethernet interfaces support 100 or 1000 Mbit/s
- The SCALANCE XR-300 switches support Gigabit Ethernet (1000 Mbit/s) at all ports. The 24 ports are divided into three groups of eight ports each (Gigabit Ethernet Blocking). Gigabit Ethernet is supported with full wire speed within each group, but not between the groups.

Product versions

SCALANCE XR324-12M (12 media module slots)

Versions are available with

- LEDs, power supply connection and data cable outlet on the front
- LEDs on the front, power supply connection and data cable outlet at the rear

All versions have twelve media module slots and

- 1 x 24 V DC power supply
- 1 x 230 V AC power supply

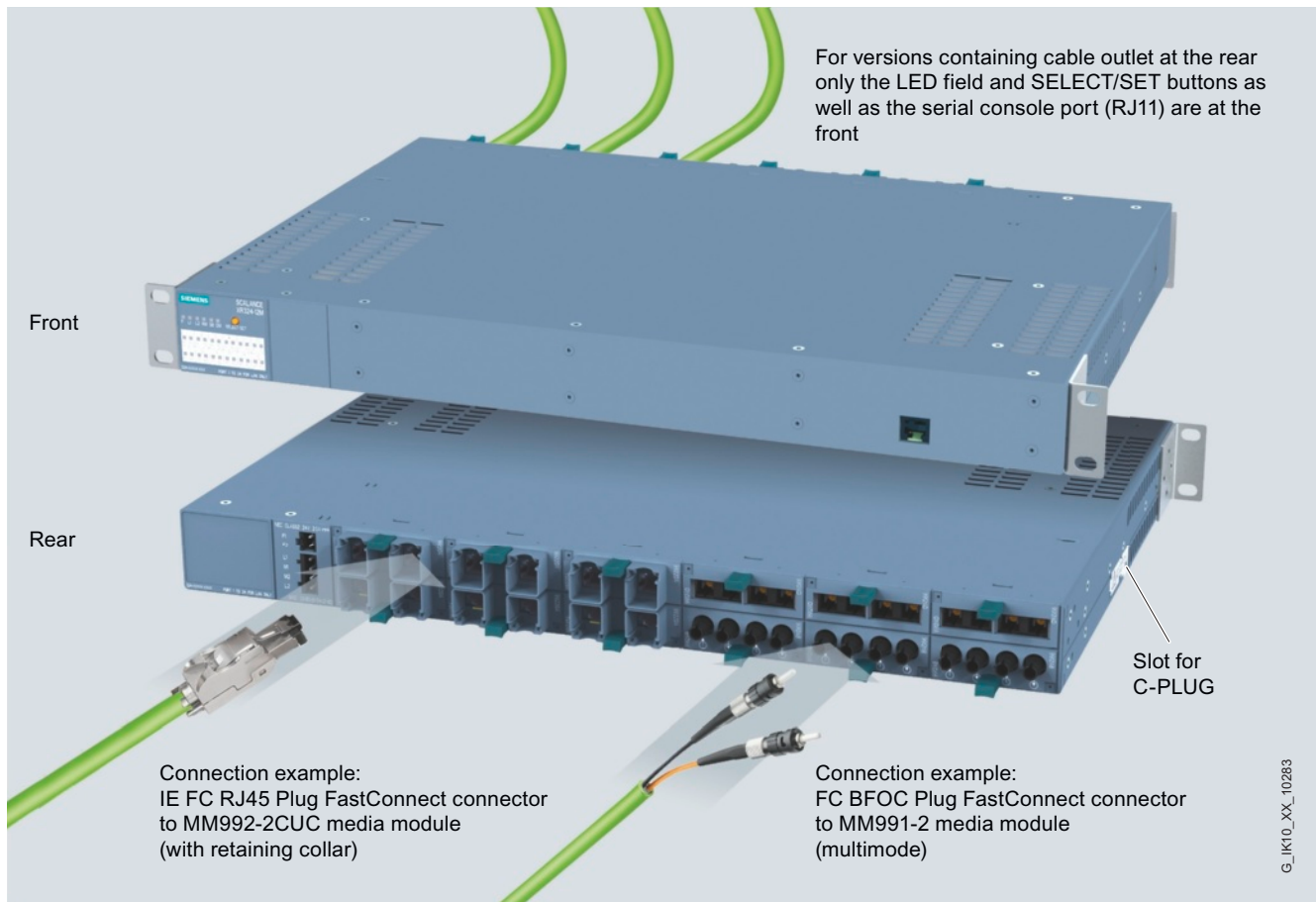

SCALANCE XR-300 with cable outlet at rear

PROFINET/Industrial Ethernet

Industrial Ethernet switches / media converters

SCALANCE XR-300 managed

Function

- Integrated redundancy manager for constructing Fast Ethernet and Gigabit Ethernet ring topologies with high-speed media redundancy. Reliable communication is achieved by closing an optical or electrical line with SCALANCE X-400, X-300 or X-200 switches to form a ring. The redundancy manager (RM) integrated in the SCALANCE XR-300 switch monitors the function of the network. It recognizes the failure of a transmission link or a SCALANCE X switch in the ring and activates the substitute path within a maximum of 0.2 seconds.
- Redundant interfacing to company networks; SCALANCE XR-300 switches support the standardized redundancy procedures Spanning Tree Protocol (STP) and Rapid Spanning Tree Protocol (RSTP). This enables a subnetwork to be connected redundantly to a higher level corporate network with reduced requirements for the reconfiguration time (in the order of seconds).
- Support of virtual networks (VLAN); for structuring Industrial Ethernet networks with a fast growing number of users, a physically existing network can be divided into several virtual networks.
- Load limiting when multicast protocols (e.g. video transmission) are used; through learning the multicast sources and targets (IGMP Snooping, IGMP Querier), SCALANCE XR-300 switches can also filter multicast data traffic and therefore limit the load in the network. Multicast and broadcast traffic can be limited.
- Time synchronization; diagnostic messages (log table entries, e-mails) are time-stamped. The local time is standardized throughout the network by means of synchronization with a SICLOCK time transmitter, thereby simplifying the assignment of diagnostic messages to several devices.
- Fast replacement of devices in event of failure, by means of the C-PLUG switching medium
- Link aggregation (IEEE 802.3ad) for bundling data streams
- Quality of Service (IEEE 802.1p) for prioritization of network traffic

Network topology and network configuration

The network topology can easily be adapted to the structure of the plant using SCALANCE XR-300 Industrial Ethernet switches.

The following network structures and combinations of structures can be implemented:

- Fast Ethernet with fast media redundancy; to increase network availability, as many as 50 X-200, X-300, X-400 or X-500 switches cascaded in line can be connected into a ring.
- Several rings can be redundantly linked through the standby function
- In addition, SCALANCE XR-300 supports redundant connection of the ring structure to the corporate network with a rapid spanning tree.
- Star topology with SCALANCE XR-300 switches: Each SCALANCE XR-300 switch represents a neutral point that can connect up to 24 nodes or subnets with each other electrically.

When configuring the network, it is necessary to observe the following boundary conditions:

- Maximum line length between two modules for multi-mode fiber-optic conductors:
 - 5 km at 100 Mbit/s
 - 750 m at 1 Gbit/s
- Maximum line length between two modules for single-mode fiber-optic conductors:
 - 26 km to 70 km at 100 Mbit/s
 - 10 to 120 km at 1 Gbit/s
- Maximum cable length of the TP cable between two SCALANCE X switches:
 - Max. 100 m with IE FC cable 2x2 and IE FC RJ45 Plug 180
 - Max. 100 m at 1 Gbit/s with IE FC Standard Cable 4x2 (90 m), IE FC RJ45 Modular Outlet and patch cable (10 m)
 - Max. 10 m using patches with TP Cord

Function (continued)

Commissioning and diagnosis

Setting options on the device itself:

- Redundancy manager RM; to establish a ring, a SCALANCE XR-300 is switched to RM mode. The Gigabit ports (electrical or optical) are preferably used as ring ports. The non-ring ports of the RM can be used freely for the connection of data terminals and networks. If the redundancy procedure MRP standardized by PROFINET is used, the RM is adjusted automatically.
- Signal mask; the signal mask is set to the current status of the SCALANCE XR-300 (setpoint) by pushbutton operation. The signal mask defines which ports and which power supplies are to be monitored. The signaling contact only reports an error when a monitored port or a monitored feeder fails (deviation of setpoint/actual status).
- IP address; the IP address is assigned via DHCP (Dynamic Host Configuration Protocol). If there is no corresponding server in the network, the IP address can be assigned using an enclosed software tool.

Diagnostic options on site:

- The following status information is displayed by LEDs on site:
 - Port status
 - Port mode (10/100/1000 Mbit/s, full/half-duplex)
 - Status of the two power supplies
 - Signaling contact status
 - Signal mask (setpoint status)
 - RM mode
 - Standby mode
- The status of the signaling contact is routed externally by means of floating relay contacts. This enables, for example, the module to be monitored via an input module from a controller.
- Monitoring via the Industrial Ethernet network; the following possibilities are available:
 - Remote via standard browser (Web-based management): Selection of SCALANCE XR-300 switches via the network from a PC with browser
 - Remote via SNMP V1, V2c, V3: Secure integration of SCALANCE XR-300 switches via the network into a network management system, e.g. SINEMA Server
 - Remote via PROFINET IO diagnostics: PROFINET diagnostic alarms from SCALANCE X-300 switches can be displayed using the relevant SIMATIC engineering tools and they can also be processed in the controller. The engineering outlay for the PLC and HMI have been drastically reduced due to the complete integration in the SIMATIC concept for system error messages.

Network management

The network management provides the following functions:

- Password-protected dial-up for "Administrator" (read and write authorization) and "User" (read only)
- Read-out of version and status information
- Setting the signal and standby mask and address information
- Fixed parameterization of the ports (data rates, half/full duplex)
- Setting of Spanning/Rapid Spanning Tree parameters
- Parameterization of the web management services
- Security
 - Ports can be connected or disconnected
 - Port-based network access control according to IEEE 802.1x
 - Authentication in accordance with IEEE 802.1x (available soon)
 - Support of Access Control List (ACL) (available soon)
- Output of statistics information
- Diagnosis of data traffic by means of a parameterizable mirror port with a standard commercial network analyzer
- Loading of new firmware versions or of the configuration data via the network by a TFTP server or directly via HTTP/HTTPS using a Web browser
- Saving the configuration data or log table via the network on a TFTP server

If faults occur in the network, the SCALANCE XR-300 switch can independently send error messages (traps) to a network management system or also e-mails to a predefined network administrator.

Remote monitoring (RMON) provides the following functions: The SCALANCE XR-300 switch can collect statistics information according to the RMON groups 1 through 4. These include, for example, fault statistics that are kept for each port. This information can be read out through web-based management in the statistics sub-area.

PROFINET/Industrial Ethernet

Industrial Ethernet switches / media converters

SCALANCE XR-300 managed

Technical specifications

Order No.	6GK5 324-0GG00-1AR2	6GK5 324-0GG00-1HR2	6GK5 324-0GG00-3AR2	6GK5 324-0GG00-3HR2
Product type designation	SCALANCE XR324-12M	SCALANCE XR324-12M	SCALANCE XR324-12M	SCALANCE XR324-12M
Transmission rate				
Transmission rate 1	10 Mbit/s	10 Mbit/s	10 Mbit/s	10 Mbit/s
Transmission rate 2	100 Mbit/s	100 Mbit/s	100 Mbit/s	100 Mbit/s
Transmission rate 3	1 000 Mbit/s	1 000 Mbit/s	1 000 Mbit/s	1 000 Mbit/s
Interfaces				
Maximum number of electrical/optical connections for network components or terminal equipment	24	24	24	24
Number of electrical connections				
• For network components or terminal equipment	-	-	-	-
• For operation panel	1	1	1	1
• For signal contact	1	1	1	1
• For media module	12	12	12	12
• For power supply	1	1	1	1
• For redundant power supply	1	1	0	0
Design of electrical connection				
• For network components or terminal equipment	Depends on selected media modules	Depends on selected media modules	Depends on selected media modules	Depends on selected media modules
• For operation panel	RJ11 port	RJ11 port	RJ11 port	RJ11 port
• For signal contact	2-pin terminal block	2-pin terminal block	2-pin terminal block	2-pin terminal block
• For power supply	4-pin terminal block	4-pin terminal block	2-pin terminal block	2-pin terminal block
Number of optical connections for fiber-optic cables				
• At 100 Mbit/s	-	-	-	-
• At 1000 Mbit/s	-	-	-	-
Design of optical connection for fiber-optic cables				
• At 100 Mbit/s	Depends on selected media modules	Depends on selected media modules	Depends on selected media modules	Depends on selected media modules
• At 1000 Mbit/s	Depends on selected media modules	Depends on selected media modules	Depends on selected media modules	Depends on selected media modules
Design of the swap medium C-Plug	Yes	Yes	Yes	Yes
Inputs/outputs				
Operating voltage of signaling contacts with DC rated value	24 V	24 V	24 V	24 V
Maximum operating current of signal contacts with DC	0.1 A	0.1 A	0.1 A	0.1 A
Supply voltage, current consumption, power loss				
Redundant type of power supply	No	No	No	No
Type of power supply	DC	DC	AC	AC
Supply voltage, external	24 V	24 V	230 V	230 V
• Minimum	19.2 V	19.2 V	85 V	85 V
• Maximum	28.8 V	28.8 V	264 V	264 V
Product component: fusing of power supply input	Yes	Yes	Yes	Yes
Type of fusing of power supply input	F 5 A / 125 V	F 5 A / 125 V	3.15 A / 250 V	3.15 A / 250 V
Current consumption, maximum	1.8 A	1.8 A	0.8 A	0.8 A
Effective power loss				
• At 24 V DC	44 W	44 W	-	-
• At 230 V AC	-	-	50 W	50 W

PROFINET/Industrial Ethernet

Industrial Ethernet switches / media converters

SCALANCE XR-300 managed

Technical specifications (continued)

Order No.	6GK5 324-0GG00-1AR2	6GK5 324-0GG00-1HR2	6GK5 324-0GG00-3AR2	6GK5 324-0GG00-3HR2
Product type designation	SCALANCE XR324-12M	SCALANCE XR324-12M	SCALANCE XR324-12M	SCALANCE XR324-12M
Permitted ambient conditions				
Ambient temperature				
• During operation	-40 ... +70 °C	-40 ... +70 °C	-40 ... +70 °C	-40 ... +70 °C
• During storage	-40 ... +70 °C	-40 ... +70 °C	-40 ... +70 °C	-40 ... +70 °C
• During transport	-40 ... +70 °C	-40 ... +70 °C	-40 ... +70 °C	-40 ... +70 °C
• Note	Reduced operating temperature as result of use of media modules (-40 to +70 °C) or SFP plug-in transceivers (-40 to +60 °C). With vertical installation, the maximum operating temperature is reduced to +50 °C	Reduced operating temperature as result of use of media modules (-40 to +70 °C) or SFP plug-in transceivers (-40 to +60 °C). With vertical installation, the maximum operating temperature is reduced to +50 °C	Reduced operating temperature as result of use of media modules (-40 to +70 °C) or SFP plug-in transceivers (-40 to +60 °C). With vertical installation, the maximum operating temperature is reduced to +50 °C	Reduced operating temperature as result of use of media modules (-40 to +70 °C) or SFP plug-in transceivers (-40 to +60 °C). With vertical installation, the maximum operating temperature is reduced to +50 °C
Relative humidity at 25 °C without condensation during operation, maximum	95 %	95 %	95 %	95 %
Ambient condition for operation	-	-	-	-
IP degree of protection	IP20	IP20	IP20	IP20
Design, dimensions and weights				
Type of construction	19-inch rack	19-inch rack	19-inch rack	19-inch rack
Width	483 mm	483 mm	483 mm	483 mm
Height	44 mm	44 mm	44 mm	44 mm
Depth	305 mm	305 mm	305 mm	305 mm
Net weight	5.5 kg	5.5 kg	5.9 kg	5.9 kg
Type of mounting				
• 19-inch installation	Yes	Yes	Yes	Yes
• 35 mm DIN rail mounting	No	No	No	No
• Wall mounting	No	No	No	No
• S7-300 rail mounting	No	No	No	No
Type of mounting	For 19-inch rack mounting, 4-point mounting is required for marine engineering applications	For 19-inch rack mounting, 4-point mounting is required for marine engineering applications	For 19-inch rack mounting, 4-point mounting is required for marine engineering applications	For 19-inch rack mounting, 4-point mounting is required for marine engineering applications
Product properties, functions, components				
General				
Cascading with redundant ring at reconfiguration time < 0.3 s	50	50	50	50
Cascading with star topology	Any (only dependent on signal propagation time)	Any (only dependent on signal propagation time)	Any (only dependent on signal propagation time)	Any (only dependent on signal propagation time)
Product functions				
Management, configuration, programming				
Product function				
• CLI	Yes	Yes	Yes	Yes
• Web-based management	Yes	Yes	Yes	Yes
• MIB support	Yes	Yes	Yes	Yes
• Traps via e-mail	Yes	Yes	Yes	Yes
• Configuration with STEP 7	Yes	Yes	Yes	Yes
• RMON	Yes	Yes	Yes	Yes
• SMTP server	Yes	Yes	Yes	Yes
• Port mirroring	Yes	Yes	Yes	Yes
• CoS	Yes	Yes	Yes	Yes
• with IRT PROFINET IO Switch	-	-	-	-
• PROFINET IO-Diagnostics	Yes	Yes	Yes	Yes
• Switch-managed	Yes	Yes	Yes	Yes

2

PROFINET/Industrial Ethernet

Industrial Ethernet switches / media converters

SCALANCE XR-300 managed

Technical specifications (continued)

Order No.	6GK5 324-0GG00-1AR2	6GK5 324-0GG00-1HR2	6GK5 324-0GG00-3AR2	6GK5 324-0GG00-3HR2
Product type designation	SCALANCE XR324-12M	SCALANCE XR324-12M	SCALANCE XR324-12M	SCALANCE XR324-12M
Protocol is supported				
• Telnet	Yes	Yes	Yes	Yes
• HTTP	Yes	Yes	Yes	Yes
• HTTPS	Yes	Yes	Yes	Yes
• TFTP	Yes	Yes	Yes	Yes
• FTP	Yes	Yes	Yes	Yes
• BOOTP	Yes	Yes	Yes	Yes
• SNMP v1	Yes	Yes	Yes	Yes
• SNMP v2	Yes	Yes	Yes	Yes
• SNMP v3	Yes	Yes	Yes	Yes
• IGMP (snooping/querier)	Yes	Yes	Yes	Yes
• GMRP	Yes	Yes	Yes	Yes
• DCP	Yes	Yes	Yes	Yes
• LLDP	Yes	Yes	Yes	Yes
Identification & Maintenance				
• I&M0 - device-specific information	Yes	Yes	Yes	Yes
• I&M1 - higher-level designation/location designation	Yes	Yes	Yes	Yes
Product functions Diagnostics				
Product function				
• Port diagnostics	Yes	Yes	Yes	Yes
• Packet size statistics	Yes	Yes	Yes	Yes
• Packet type statistics	Yes	Yes	Yes	Yes
• Error statistics	Yes	Yes	Yes	Yes
• SysLog	Yes	Yes	Yes	Yes
Product functions VLAN				
Product function				
• VLAN - port-based	Yes	Yes	Yes	Yes
• VLAN - dynamic	Yes	Yes	Yes	Yes
Maximum number of VLANs	255	255	255	255
Maximum number of dynamic VLANs	255	255	255	255
GVRP protocol is supported	Yes	Yes	Yes	Yes
Product functions DHCP				
Product function				
• DHCP client	Yes	Yes	Yes	Yes
• DHCP option 82	Yes	Yes	Yes	Yes
• DHCP option 66	Yes	Yes	Yes	Yes
• DHCP option 67	Yes	Yes	Yes	Yes
Product functions Redundancy				
Product function				
• Ring redundancy	Yes	Yes	Yes	Yes
• Redundancy manager	Yes	Yes	Yes	Yes
• Standby redundancy	Yes	Yes	Yes	Yes
• Redundancy procedure HSR	Yes	Yes	Yes	Yes
• Redundancy procedure MRP	Yes	Yes	Yes	Yes
• Redundancy procedure STP	Yes	Yes	Yes	Yes
• Redundancy procedure RSTP	Yes	Yes	Yes	Yes
• Passive listening	Yes	Yes	Yes	Yes
Protocol is supported				
• STP/RSTP	Yes	Yes	Yes	Yes
• STP	Yes	Yes	Yes	Yes
• RSTP	Yes	Yes	Yes	Yes
• RSTP Big Network Support	Yes	Yes	Yes	Yes
• LACP	Yes	Yes	Yes	Yes

Technical specifications (continued)

Order No.	6GK5 324-0GG00-1AR2	6GK5 324-0GG00-1HR2	6GK5 324-0GG00-3AR2	6GK5 324-0GG00-3HR2
Product type designation	SCALANCE XR324-12M	SCALANCE XR324-12M	SCALANCE XR324-12M	SCALANCE XR324-12M
Product functions Security				
Product function				
• ACL - Port/MAC-based	Yes	Yes	Yes	Yes
• IEEE 802.1x (Radius)	Yes	Yes	Yes	Yes
• Broadcast/Multicast/Unicast Limiter	Yes	Yes	Yes	Yes
• Broadcast blocking	Yes	Yes	Yes	Yes
SSH protocol is supported	Yes	Yes	Yes	Yes
Product functions Time				
Product function: SICLOCK support	Yes	Yes	Yes	Yes
Protocol is supported				
• NTP	No	No	No	No
• SNTP	Yes	Yes	Yes	Yes
• IEEE 1588 profile default	Yes	Yes	Yes	Yes
• IEEE 1588 profile gPTP	-	-	-	-
• IEEE 1588 profile PSRC	-	-	-	-
Type of time synchronization	-	-	-	-
Standards, specifications, approvals				
Standard				
• For EMC of FM	FM3611: Class 1, Division 2, Group A, B, C, D / T4, Class 1, Zone 2, Group IIC, T4	FM3611: Class 1, Division 2, Group A, B, C, D / T4, Class 1, Zone 2, Group IIC, T4	No	No
• for hazardous zone	EN 60079-0: 2006, EN 60079-15: 2005, II 3 G Ex nA II T4 KEMA 07 ATEX 0145X	EN 60079-0: 2006, EN 60079-15: 2005, II 3 G Ex nA II T4 KEMA 07 ATEX 0145X	No	No
• For CSA and UL safety	UL 60950-1, CSA C22.2 No. 60950-1-03	UL 60950-1, CSA C22.2 No. 60950-1-03	UL 508, CSA C22.2 No. 142-M1987	UL 508, CSA C22.2 No. 142-M1987
• for hazardous zone of CSA and UL	UL 1604 and UL 2279-15 (Hazardous Location), CSA C22.2 No. 213-M1987, Class 1 / Division 2 / Group A, B, C, D / T4, Class 1 / Zone 2 / Group IIC / T4	UL 1604 and UL 2279-15 (Hazardous Location), CSA C22.2 No. 213-M1987, Class 1 / Division 2 / Group A, B, C, D / T4, Class 1 / Zone 2 / Group IIC / T4	No	No
• For emitted interference	EN 61000-6-4:2007 (Class A)	EN 61000-6-4:2007 (Class A)	EN 61000-6-4:2007 (Class A)	EN 61000-6-4:2007 (Class A)
• For noise immunity	EN 61000-6-2:2005	EN 61000-6-2:2005	EN 61000-6-2:2005	EN 61000-6-2:2005
Certificate of suitability	EN 61000-6-2:2005, EN 61000-6-4:2007	EN 61000-6-2:2005, EN 61000-6-4:2007	EN 61000-6-2:2005, EN 61000-6-4:2007	EN 61000-6-2:2005, EN 61000-6-4:2007
• CE mark	Yes	Yes	Yes	Yes
• C-Tick	Yes	Yes	Yes	Yes
• Railroad application according to EN 50155	-	-	-	-
• Railroad application according to EN 50124-1	-	-	-	-
Marine classification association				
• American Bureau of Shipping Europe Ltd. (ABS)	-	-	-	-
• Bureau Veritas (BV)	-	-	-	-
• Det Norske Veritas (DNV)	-	-	-	-
• Germanischer Lloyd (GL)	-	-	-	-
• Lloyds Register of Shipping (LRS)	-	-	-	-
• Nippon Kaiji Kyokai (NK)	-	-	-	-

PROFINET/Industrial Ethernet

Industrial Ethernet switches / media converters

SCALANCE XR-300 managed

Ordering data

Order No.

SCALANCE XR324-12M Industrial Ethernet switches

Fully modular 19" Industrial Ethernet switches for setting up electrical and/or optical Industrial Ethernet networks; all ports can optionally be equipped with optical or electrical 2-port media modules; all ports support Gigabit Ethernet (blocking), integrated redundancy manager, RSTP, RMON, IGMP-Snooping/Querier, network management via SNMP, PROFINET, and web server
12 x 10/100/1000 Mbit/s slots for 2-port media modules, electrical or optical

24 V DC power supply

- Data cable outlet at front
- Data cable outlet at rear

6GK5 324-0GG00-1AR2
6GK5 324-0GG00-1HR2

110-230 V AC power supply

- Data cable outlet at front
- Data cable outlet at rear

6GK5 324-0GG00-3AR2
6GK5 324-0GG00-3HR2

Media modules for SCALANCE X-300

See "Media modules for modular SCALANCE X-300 managed"

SITOP compact, 2.5 A

6EP1 332-5BA00

Single-phase power supply with wide-range input 85 ... 264 V AC, regulated output voltage 24 V, output current rated value 2.5 A

More information

To assist in selecting the right Industrial Ethernet switches as well as configuration of modular versions, the SIMATIC NET Selection Tool is available:

Online version:

www.siemens.com/snst

Offline version:

www.siemens.com/snst-download

PROFINET/Industrial Ethernet

Industrial Ethernet switches / media converters

SCALANCE X-300PoE managed

Overview



The SCALANCE X-300PoE product line comprises compact Industrial Ethernet switches for constructing electrical and/or optical line, star and ring topologies operating at data transfer rates of 10/100/1000 Mbit/s.

- Partially modular version with four integrated electrical, PoE-enabled Ethernet ports and two slots for 2-port media modules
- High-speed media redundancy through integral redundancy manager both for Gigabit Ethernet (SCALANCE X-300, X-400, X-500) and Fast Ethernet (e.g. in combination with SCALANCE X-200 switches)
- Seamless integration of automation networks into existing corporate networks thanks to support for a host of IT standards: Establishment of virtual networks (VLANs)
- Redundant integration into higher-level networks thanks to support for standardized redundancy procedures (Rapid Spanning Tree Protocol)
- PROFINET diagnostics, SNMP access, integrated web server and automatic e-mail transmission function for remote diagnostics and signaling via the network

Benefits

get Designed for Industry

- Unlimited flexibility during network expansions (e.g. more terminals) or conversion (e.g. switching from copper to fiber-optic cable) and reduction of the storage costs due to the modular construction using port modules
- Saving of additional power supply units and cabling for terminals by means of PoE voltage supply
- High availability of the network due to
 - redundant voltage feed
 - Redundant network structures based on fiber-optic or twisted pair cables (redundancy manager, standby function, and RSTP are integrated)
 - easy device replacement by means of plug-in C-PLUG swap medium
 - very fast reconfiguration of the network in event of a fault
- Lower susceptibility to failure and higher availability of the plant networking due to latching of the RJ45 FastConnect connectors in the sleeve of the RJ45 ports
- Protection of investment through integration into existing network management systems by means of standardized SNMP access
- Time saving during engineering, commissioning and in the operating phase of a plant due to the use of configuration and diagnostics integrated in STEP 7

2

PROFINET/Industrial Ethernet

Industrial Ethernet switches / media converters

SCALANCE X-300PoE managed

Application

SCALANCE X-300 products enable the establishment of switched networks both at the field level and at the control level where high data transfer rates are required in addition to high network availability and extensive diagnostics facilities. The SCALANCE X308-2M PoE switch supplies PoE-compatible devices, such as WLAN access points SCALANCE W, IP cameras and IP telephones, with energy over the data cable. The switch is designed with IP20 degree of protection for installation in control cabinets.

The main area of application is found in high-performance plant networks with interfaces to the corporate network.

Product version

Full Gigabit switches

SCALANCE X308-2M PoE (Power over Ethernet)

- For the construction of electrical and/or optical line, ring and star topologies with
 - four integrated electrical, PoE-compatible Gigabit Ethernet Ports and two slots for any 2-port media modules (see "Media modules for SCALANCE X-300")
- Star coupler in the plant bus (redundant connection is possible)

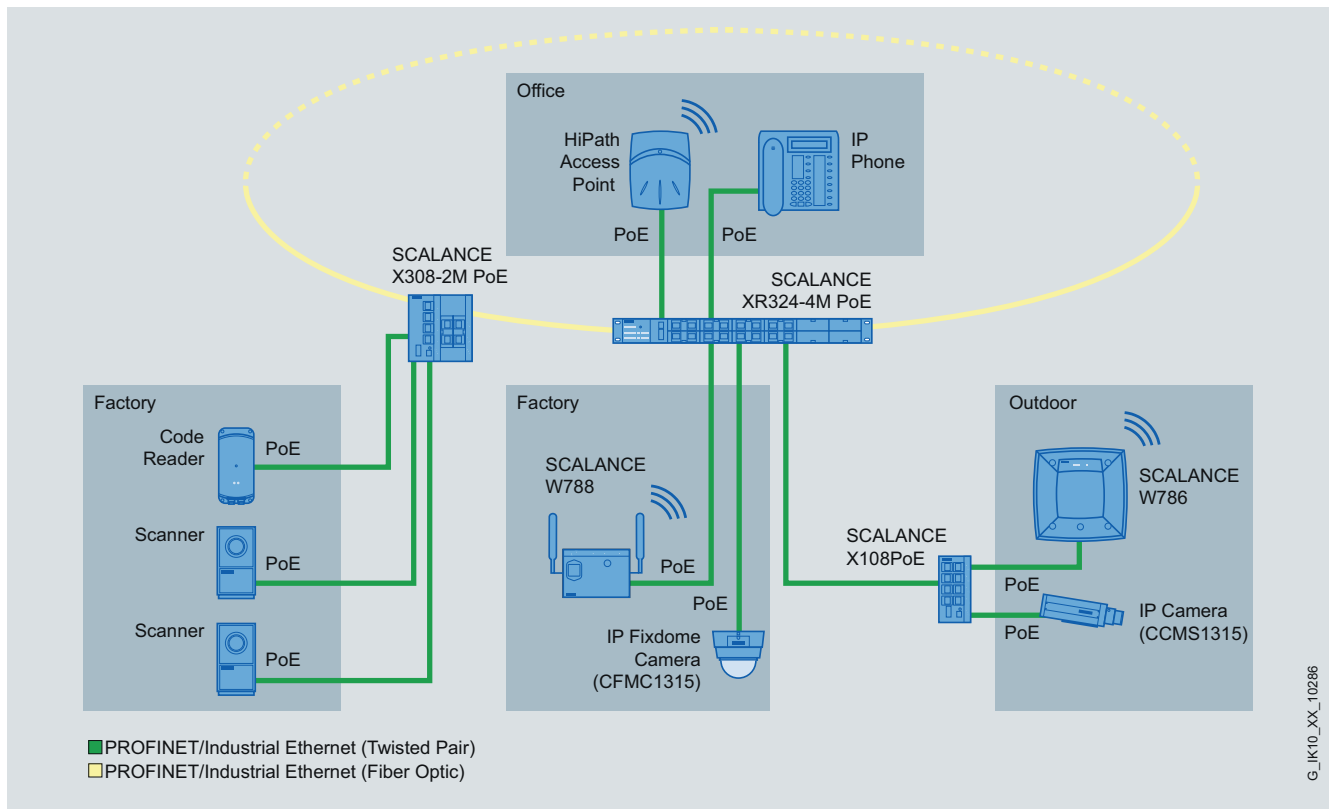

Supply of terminal devices with PoE by means of PoE-compatible switches

Design

The SCALANCE X-300 Industrial Ethernet switches with their robust metal enclosure are optimized for mounting on a standard DIN rail and the S7-300 mounting rail. Direct wall mounting in different positions is also possible. Due to the S7-300 enclosure dimensions, the devices are ideally suited for integration in an automation system using S7-300 components.

The switches have:

- 4-pin terminal block for connection of the redundant power supply (2 x 24 V DC)
- Row of LEDs for indicating status information (power, link status, data transfer, error indication, redundancy manager, standby manager)
- 2-pin terminal block for connecting the isolated signaling contact
- SELECT/SET pushbutton for on-site configuration of the signaling contact
- Slot for optional C-PLUG swap medium on the rear of the device for the easy replacement of the device in the event of a fault
- SCALANCE X308-2M PoE has four integrated electrical, PoE-compatible Ethernet ports and two slots for accommodating 2-port media modules

Function

- Support of Power over Ethernet (PoE) according to IEEE 802.3at Type 1 (corresponds to IEEE 802.3af)
- Increase of the network performance; by filtering the data traffic on the basis of the Ethernet (MAC) address of the data terminals, data traffic remains local; only data intended for users of another subnetwork are forwarded by the switch.
- Simple network configuration and network expansion; the switch saves the data received at the ports and forwards it automatically to the destination address. The limitation of the network expansion by collision detection (CSMA/CD procedure) terminates at the port.
- Limitation of the error propagation to the affected subnetwork; the SCALANCE X-300 switches only forward data with a valid checksum (CRC).
- Integration of existing subnetworks with 10 Mbit/s into Fast Ethernet networks with 100 Mbit/s; at the twisted-pair ports, the SCALANCE X-300 switches automatically recognize the conductor pairs for transmission and reception (autocrossover), the data transfer rate of 10 or 100 or 1000 Mbit/s, as well as full-duplex and half-duplex mode (autonegotiation).
- High-performance connection of SCALANCE X-300 switches with 1 Gbit/s; SCALANCE X-300 PoE switches have up to eight Gigabit Ethernet ports for connecting the switches to each other or with other Gigabit-Ethernet-enabled components (e.g. SCALANCE X-400, X-500)
- Integrated redundancy manager for constructing Fast Ethernet and Gigabit Ethernet ring topologies with high-speed media redundancy.
- High-speed standby redundancy; several network segments such as rings can be interconnected redundantly with SCALANCE X-300 over the integrated standby function. Two X-300 switches are configured in a ring as a master and slave and are connected via two links to the other ring. The redundant link can be implemented at 1000 Mbit/s.
- Redundant interfacing to higher-level networks; SCALANCE X-300 switches support the standardized redundancy procedures Spanning Tree Protocol (STP) and Rapid Spanning Tree Protocol (RSTP). This enables a subnetwork to be connected redundantly to a higher-level network with reduced requirements for the reconfiguration time (in the order of seconds).
- Support of virtual networks (VLAN); for structuring Industrial Ethernet networks with a fast growing number of users, a physically existing network can be divided into several virtual networks.
- Load limiting when multicast protocols (e.g. video transmission) are used; through learning the multicast sources and targets (IGMP Snooping, IGMP Querier), SCALANCE X-300 switches can also filter multicast data traffic and therefore limit the load in the network.
- Configuration of the ports for terminals that support authentication in accordance with IEEE 802.1x. Authentication is by means of a RADIUS server that must be configured appropriately and must be accessible via the network.

- Support of the DHCP Option 82, 66, 67 (Dynamic Host Configuration Protocol); this facilitates the IP address assignment of a terminal depending on the connected switch port. The IP address is assigned via a DHCP Server, which has to be configured accordingly and must be able to be reached via the network.
- Support of Access Control List (ACL); if this function is activated for a port, the switch only forwards message frames received at this port if their source address is listed in the address table. All connected stations can be entered automatically in the ACL.
- Syslog; Syslog compliant with RFC 3164 is used in the IP network for transmitting short, unencrypted text messages via UDP. This requires the use of a Syslog server that must be configured appropriately and must be accessible via the network.
- Time synchronization; diagnostic messages (log table entries, e-mails) are time-stamped. The local time is standardized throughout the network by means of synchronization with a SINCLOCK or SNTP time transmitter, thereby simplifying the assignment of diagnostic messages to several devices.

Network topology and network configuration

The SCALANCE X-300 Industrial Ethernet switches are typically accommodated together with the nodes to be connected in one control cabinet. Electrical and optical versions can be installed together in star, line and ring topologies.

The following network structures and combinations of structures can be implemented:

- Fast Ethernet and Gigabit Ethernet rings with fast media redundancy; to increase network availability, as many as 50 X-200, X-300, X-400 or X-500 switches can be cascaded in line can be connected into a ring.
- Several rings can be redundantly linked through the standby function.
- At the same time, SCALANCE X-300 supports redundant connection of the ring structure to the corporate network with Rapid Spanning Tree.
- Star topology with SCALANCE X300PoE switches: The SCALANCE X-308-2M PoE switch represents a neutral point that can connect up to eight nodes or subnets with each other electrically or optically.

When configuring the network, it is necessary to observe the following boundary conditions:

- Maximum line length between two modules for multi-mode fiber-optic conductors:
 - 750 m at 1 Gbit/s
 - 5 km at 100 Mbit/s
- Maximum line length between two modules for single-mode fiber-optic conductors:
 - 10 to 120 km at 1 Gbit/s
 - 26 to 70 km at 100 Mbit/s
- Maximum cable length of the TP cable between two SCALANCE X switches:
 - Max. 100 m at 10/100 Mbit/s with IE FC Cable 2x2 and IE FC RJ45 Plug 180
 - Max. 100 m at 1 Gbit/s with IE FC Standard Cable 4x2 (90 m), IE FC RJ45 Modular Outlet and patch cable (10 m)
 - Max. 10 m using patches with TP Cord

PROFINET/Industrial Ethernet

Industrial Ethernet switches / media converters

SCALANCE X-300PoE managed

Function (continued)

Commissioning and diagnosis

Setting options on the device itself:

- Redundancy manager RM; to establish a ring, a SCALANCE X-300 is switched to RM mode. The Gigabit ports (electrical or optical) are preferably used as ring ports.
- Signal mask; the signal mask is set to the current status of the SCALANCE X-300 (setpoint) by pushbutton operation. The signal mask defines which ports and which power supplies are to be monitored. The signaling contact only reports an error when a monitored port or a monitored feeder fails (deviation of setpoint/actual status).
- IP address; the IP address is assigned via DHCP (Dynamic Host Configuration Protocol). If there is no corresponding server in the network, the IP address can be assigned using an enclosed software tool.

Diagnostic options on site:

- The following status information is displayed by LEDs on site:
 - Port status
 - Port mode (10/100/1000 Mbit/s, full/half-duplex)
 - Status of the two power supplies
 - Signaling contact status
 - Signal mask (setpoint status)
 - RM mode
 - Standby mode
- The status of the signaling contact is routed externally by means of floating relay contacts. This enables, for example, the module to be monitored via an input module from a controller.
- Monitoring via the Industrial Ethernet network; the following possibilities are available:
 - Remote via standard browser (Web-based management): Selection of SCALANCE X-300 switches via the network from a PC with browser
 - Remote via SNMP V1, V2c, V3: Secure integration of SCALANCE X-300 switches via the network into a network management system, e.g. SINEMA Server
 - Remote via PROFINET IO diagnostics: PROFINET diagnostic alarms from SCALANCE X-300 switches can be displayed using the relevant SIMATIC engineering tools and they can also be processed in the controller. The engineering outlay for the PLC and HMI have been drastically reduced due to the complete integration in the SIMATIC concept for system error messages.

Network management

The network management provides the following functions:

- Password-protected dial-up for "Administrator" (read and write authorization) and "User" (read only)
- Read-out of version and status information
- Setting the signal and standby mask and address information
- Fixed parameterization of the ports (data rates, half/full duplex)
- Parameterization of the VLANs and multicast services
- Parameterization of the standby connections for a redundant ring link
- Setting of Rapid Spanning Tree parameters
- Parameterization of the web management services
- Security
 - Ports can be connected or disconnected
 - Authentication in accordance with IEEE 802.1x
 - Support of Access Control List (ACL)
- Parameterization of the user administration of SNMP V1, V2c, V3:
- Output of statistics information
- Diagnosis of data traffic by means of a parameterizable mirror port with a standard commercial network analyzer
- Loading of new firmware versions or of the configuration data via the network by a TFTP server or directly via HTTP/HTTPS using a Web browser
- Saving the configuration data or log table via the network on a TFTP server

If faults occur in the network, the SCALANCE X-300 switch can independently send error messages (traps) to a network management system or also e-mails to a predefined network administrator.

Remote monitoring (RMON) provides the following functions: The SCALANCE X-300 switches can collect statistics information according to the RMON groups 1 through 4. These include, for example, fault statistics that are kept for each port. This information can be read out through web-based management in the statistics sub-area.

PROFINET/Industrial Ethernet

Industrial Ethernet switches / media converters

SCALANCE X-300PoE managed

Technical specifications

Order No.	6GK5 308-2QG00-2AA2
Product type designation	SCALANCE X308-2M POE
Transmission rate	
Transmission rate 1	10 Mbit/s
Transmission rate 2	100 Mbit/s
Transmission rate 3	1 000 Mbit/s
Interfaces	
Maximum number of electrical/ optical connections for network components or terminal equipment	8
Number of electrical connections	
• for network components or terminal equipment	4
• with power-over-Ethernet for network components or terminal equipment	4
• For operation panel	-
• for signaling contact	1
• for media module	2
• for power supply	1
• for redundant power supply	1
Design of electrical connection	
• for network components or terminal equipment	RJ45 port
• with Power-over-Ethernet for network components or terminal equipment	RJ45 port
• For operation panel	-
• for signaling contact	2-pin terminal block
• for power supply	4-pin terminal block
Number of optical connections for fiber-optic cables	
• at 100 Mbit/s	-
• at 1000 Mbit/s	-
Design of optical connection for fiber-optic cables	
• at 100 Mbit/s	Depends on selected media modules
• at 1000 Mbit/s	Depends on selected media modules
Design of the swap medium C-Plug	Yes
Inputs/outputs	
Operating voltage of signaling contacts with AC rated value	-
Operating current of signaling contacts with AC maximum	-
Operating voltage of signaling contacts with DC rated value	24 V
Maximum operating current of signal contacts with DC	0.1 A

Order No.	6GK5 308-2QG00-2AA2
Product type designation	SCALANCE X308-2M POE
Supply voltage, current consumption, power loss	
Redundant type of power supply	No
Type of power supply	DC
Supply voltage, external	24 V
• Minimum	19.2 V
• Maximum	28.8 V
Product component: fusing of power supply input	Yes
Type of fusing of power supply input	F 3 A / 32 V
Current consumption, maximum	2 A
Effective power loss	
• at 24 V DC	17 W
• at 230 V AC	-
Permitted ambient conditions	
Ambient temperature	
• During operation	-40 ... +60 °C
• During storage	-40 ... +70 °C
• During transport	-40 ... +70 °C
• Note	With vertical installation, the maximum operating temperature is reduced to 60 °C
Relative humidity at 25 °C without condensation during operation, maximum	95 %
Ambient conditions for operation	-
IP degree of protection	IP20
Design, dimensions and weights	
Type of construction	Compact
Width	120 mm
Height	125 mm
Depth	124 mm
Net weight	1.15 kg
Type of mounting	
• 19-inch installation	No
• 35 mm DIN rail mounting	Yes
• Wall mounting	Yes
• S7-300 rail mounting	Yes
Type of mounting	When using SFP plug-in trans- ceivers, only horizontal installation is permitted, when used in marine applications, mounting on the 35 mm DIN rail is not permitted
Product properties, functions, components	
General	
Cascading with redundant ring with reconfiguration time < 0.3 s	50
Cascading with star topology	Any (only dependent on signal propagation time)

2

PROFINET/Industrial Ethernet

Industrial Ethernet switches / media converters

SCALANCE X-300PoE managed

Technical specifications (continued)

Order No.	6GK5 308-2QG00-2AA2
Product type designation	SCALANCE X308-2M POE
Product functions Management, configuration, programming	
Product function	
• CLI	Yes
• Web-based management	Yes
• MIB support	Yes
• TRAPS via e-mail	Yes
• Configuration with STEP 7	Yes
• RMON	Yes
• SMTP server	Yes
• Port mirroring	Yes
• CoS	Yes
• with IRT PROFINET IO Switch	-
• PROFINET IO diagnostics	Yes
• Switch-managed	Yes
Protocol is supported	
• Telnet	Yes
• HTTP	Yes
• HTTPS	Yes
• TFTP	Yes
• FTP	Yes
• BOOTP	Yes
• SNMP v1	Yes
• SNMP v2	Yes
• SNMP v3	Yes
• IGMP (snooping/querier)	Yes
• GMRP	Yes
• DCP	Yes
• LLDP	Yes
Identification & Maintenance	
• I&M0 - device-specific information	Yes
• I&M1 - higher-level designation/location designation	Yes
Product functions Diagnostics	
Product function	
• Port diagnostics	Yes
• Packet size statistics	Yes
• Packet type statistics	Yes
• Error statistics	Yes
• SysLog	Yes
Product functions VLAN	
Product function	
• VLAN - port-based	Yes
• VLAN - dynamic	Yes
Maximum number of VLANs	255
Maximum number of dynamic VLANs	255
GVRP protocol is supported	Yes

Order No.	6GK5 308-2QG00-2AA2
Product type designation	SCALANCE X308-2M POE
Product functions DHCP	
Product function	
• DHCP client	Yes
• DHCP option 82	Yes
• DHCP option 66	Yes
• DHCP option 67	Yes
Product functions Redundancy	
Product function	
• Ring redundancy	Yes
• Redundancy manager	Yes
• Standby redundancy	Yes
• Redundancy procedure HSR	Yes
• Redundancy procedure MRP	Yes
• Redundancy procedure STP	Yes
• Redundancy procedure RSTP	Yes
• Passive listening	Yes
Protocol is supported	
• STP/RSTP	Yes
• STP	Yes
• RSTP	Yes
• RSTP Big Network Support	Yes
• LACP	Yes
Product functions Security	
Product function	
• ACL - Port/MAC-based	Yes
• IEEE 802.1x (Radius)	Yes
• Broadcast/Multicast/Unicast Limiter	Yes
• Broadcast blocking	Yes
SSH protocol is supported	Yes
Product functions Time	
Product function: SICLOCK support	Yes
Protocol is supported	
• NTP	No
• SNTP	Yes
• IEEE 1588 profile default	Yes
• IEEE 1588 profile gPTP	-
• IEEE 1588 profile PSRC	-
Type of time synchronization	-

2

PROFINET/Industrial Ethernet

Industrial Ethernet switches / media converters

SCALANCE X-300PoE managed

Technical specifications (continued)

Order No.	6GK5 308-2QG00-2AA2
Product type designation	SCALANCE X308-2M POE
Standards, specifications, approvals	
Standard	FM3611: Class 1, Division 2, Group A, B, C, D / T4, Class 1, Zone 2, Group IIC, T4
• for EMC of FM	EN 60079-0: 2006, EN 60079-15: 2005, II 3 G Ex nA II T4 KEMA 07 ATEX 0145X
• for hazardous zone	UL 60950-1, CSA C22.2 No. 60950-1
• for CSA and UL safety	UL 1604 and UL 2279-15 (Hazardous Location), CSA C22.2 No. 213-M1987, Class 1 / Division 2 / Group A, B, C, D / T4, Class 1 / Zone 2 / Group IIC / T4
• for hazardous zone of CSA and UL	EN 61000-6-4:2007 (Class A)
• for emitted interference	EN 61000-6-2:2005
• for noise immunity	EN 61000-6-4:2007
Certificate of suitability	EN 61000-6-2:2005, EN 61000-6-4:2007
• CE mark	Yes
• C-Tick	Yes
• Railroad application according to EN 50155	-
• Railroad application according to EN 50124-1	-
Marine classification corporation	
• American Bureau of Shipping Europe Ltd. (ABS)	-
• Bureau Veritas (BV)	-
• Det Norske Veritas (DNV)	-
• Germanischer Lloyd (GL)	-
• Lloyds Register of Shipping (LRS)	-
• Nippon Kaiji Kyokai (NK)	-

Ordering data**Order No.***SCALANCE X-300PoE Industrial Ethernet switches*

PoE-compatible Industrial Ethernet Switches for setting up electrical and/or optical Industrial Ethernet networks; integrated redundancy manager, IT functions (RSTP, VLAN, ...), network management via SNMP and web server; incl. operating instructions, Industrial Ethernet manual and configuration software on CD-ROM; C-PLUG included in scope of supply

Full Gigabit Ethernet switches

- **SCALANCE X308-2M PoE;** 4 x 10/100//1000 Mbit/s RJ45 ports with PoE, electrical; 2 x 10/100/1000 Mbit/s slots for 2-port media modules, electrical or optical

6GK5 308-2QG00-2AA2Media modules

See "Media modules for modular SCALANCE X-300 managed"

Accessories**IE FC TP Standard Cable GP 2 x 2 (Type A)****6XV1 840-2AH10**

4-core, shielded TP installation cable for connection to IE FC outlet RJ45/IE FC RJ45 plug; PROFINET-compatible; with UL approval; sold by the meter; max. quantity 1000 m, minimum order 20 m

IE FC TP Standard Cable GP 4 x 2**6XV1 870-2E**

8-core, shielded TP installation cable for connection to IE FC RJ45 modular outlet for universal use; with UL approval; sold by the meter; max. quantity 1000 m, minimum order 20 m

IE TP Cord RJ45/RJ45

TP cable 4 x 2 with two RJ45 plugs

- 0.5 m
- 1 m
- 2 m
- 6 m
- 10 m

6XV1 870-3QE50
6XV1 870-3QH10
6XV1 870-3QH20
6XV1 870-3QH60
6XV1 870-3QN10

PROFINET/Industrial Ethernet

Industrial Ethernet switches / media converters

SCALANCE X-300PoE managed

Ordering data

Order No.

Accessories (continued)

IE FC RJ45 Plug 180 2 x 2

RJ45 plug-in connector for Industrial Ethernet with a rugged metal enclosure and integrated insulation displacement contacts for connecting Industrial Ethernet FC installation cables; with 180° cable outlet; for network components and CPs/CPUs with Industrial Ethernet interface

- 1 package = 1 unit
- 1 package = 10 units
- 1 package = 50 units

6GK1 901-1BB10-2AA0
6GK1 901-1BB10-2AB0
6GK1 901-1BB10-2AE0

IE FC RJ45 Plug 4 x 2

RJ45 plug-in connector for Industrial Ethernet (10/100/1000 Mbit/s) with a rugged metal enclosure and integrated insulation displacement contacts for connecting Industrial Ethernet FC installation cables; 180° cable outlet; for network components and CPs/CPUs with Industrial Ethernet interface

- 1 pack = 1 unit
- 1 pack = 10 units
- 1 pack = 50 units

6GK1 901-1BB11-2AA0
6GK1 901-1BB11-2AB0
6GK1 901-1BB11-2AE0

FC SC Plug

Screw connector for on-site assembly on FC fiber-optic cable; (1 pack = 10 Duplex Plugs + cleaning cloths)

6GK1 900-1LB00-0AC0

IE FC Stripping Tool

Preadjusted stripping tool for fast stripping of the Industrial Ethernet FC cables

6GK1 901-1GA00

FC FO Termination Kit

Assembly case for local assembly of FC SC and FC BFOC connectors to FC FO standard cable, comprising a stripping tool, Kevlar cutters, fiber breaking tool and microscope

6GK1 900-1GL00-0AA0

IE FC RJ45 Modular Outlet

FastConnect RJ45 outlet for Industrial Ethernet with interface for insertion of a replacement insert;

- **with insert 2FE** ; replacement insert for 2 x 100 Mbit/s interface
- **with insert 1GE** ; replacement insert for 1 x 1000 Mbit/s interface

6GK1 901-1BE00-0AA1

6GK1 901-1BE00-0AA2

SITOP compact PSU100C 24 V/1.3 A

1-phase power supply with wide-range input 85 ... 264 V AC/110 ... 300 V DC, stabilized output voltage 24 V, rated output current value 1.3 A, slim design

6EP1 331-5BA10

More information

To assist in selecting the right Industrial Ethernet switches as well as configuration of modular versions, the SIMATIC NET Selection Tool is available:

Online version:
www.siemens.com/snst

Offline version:
www.siemens.com/snst-download

PROFINET/Industrial Ethernet

Industrial Ethernet switches / media converters

SCALANCE XR-300PoE managed

Overview



The SCALANCE XR-300PoE Industrial Ethernet switches are partly modular, high-performance, industry-standard switches for the construction of electrical and/or optical line, ring and star topologies at data transfer rates of 10/100/1000 Mbit/s, designed for installation in 19" control cabinets

- As many as 24 electrical and/or optical interfaces (10/100/1000 Mbit/s), of which 16 are integrated RJ45 ports, eight of which are PoE-compatible; up to four electrical and/or optical 2-port media modules can additionally be inserted in the media module slots of the basic unit
- High-speed media redundancy through integral redundancy manager both for Gigabit Ethernet (with SCALANCE X-300, X-400, X-500) and Fast Ethernet (e.g. in combination with SCALANCE X-200 switches)
- Seamless integration of automation networks into existing corporate networks thanks to support for a host of IT standard functions (VLANs, IGMP-Snooping/Querier, STP/RSTP, Link Aggregation, Quality of Service)
- Redundant integration into higher-level networks thanks to support for standardized redundancy procedures (Spanning Tree Protocol/Rapid Reconfiguration Spanning Tree Protocol/MRP)
- Remote diagnostics by means of PROFINET diagnostics, Web browser, CLI, or SNMP

Benefits

get Designed for Industry

- Unlimited flexibility during network expansions (e.g. more terminals) or conversion (e.g. switching from copper to fiber-optic cable) and reduction of the storage costs due to the modular construction using port modules
- Saving of additional power supply units and cabling for terminals by means of PoE voltage supply
- High availability of the network due to
 - redundant voltage feed
 - redundant network structures based on FOC or Twisted Pair (redundancy manager, standby function and STP/RSTP integrated)
 - easy device replacement by means of plug-in C-PLUG swap medium
 - very fast reconfiguration of the network in event of a fault
- lower susceptibility to faults and higher availability of the plant networking by latching the RJ45 FastConnect plug in the retaining collar of the RJ45 port modules
- Protection of investment through integration into existing network management systems by means of standardized SNMP access
- Time saving during engineering, commissioning and in the operating phase of a plant due to integrated configuration and diagnostics in STEP 7, without additional software
- Space savings in control cabinet due to flexible cable outlet on the front or rear of the device

Application

The SCALANCE XR-300PoE is ideal for use in plant networks and for integrating the industrial network into an existing corporate network. Both at the field level and the control level, the switch performs the network with the distributed field devices and ensures high plant availability with extensive diagnostics options and high transmission speeds. The modularity permits perfect adaptation to the respective application through the use of electrical and also optical media modules.

The SCALANCE XR-300PoE supplies PoE-compatible devices, such as IWLAN Access Points SCALANCE W, IP cameras and IP telephones, with energy over the data cable and is suitable for constructing electrical and/or optical Industrial Ethernet linear, star or ring structures with up to 24 ports, of which 16 RJ45 ports are pre-assigned. Eight of these support PoE. The switch can be optionally equipped with four electrical and/or optical 2-port media modules. It can also be used as a hub in the plant bus (redundant connection is possible).

2

PROFINET/Industrial Ethernet

Industrial Ethernet switches / media converters

SCALANCE XR-300PoE managed

Application (continued)

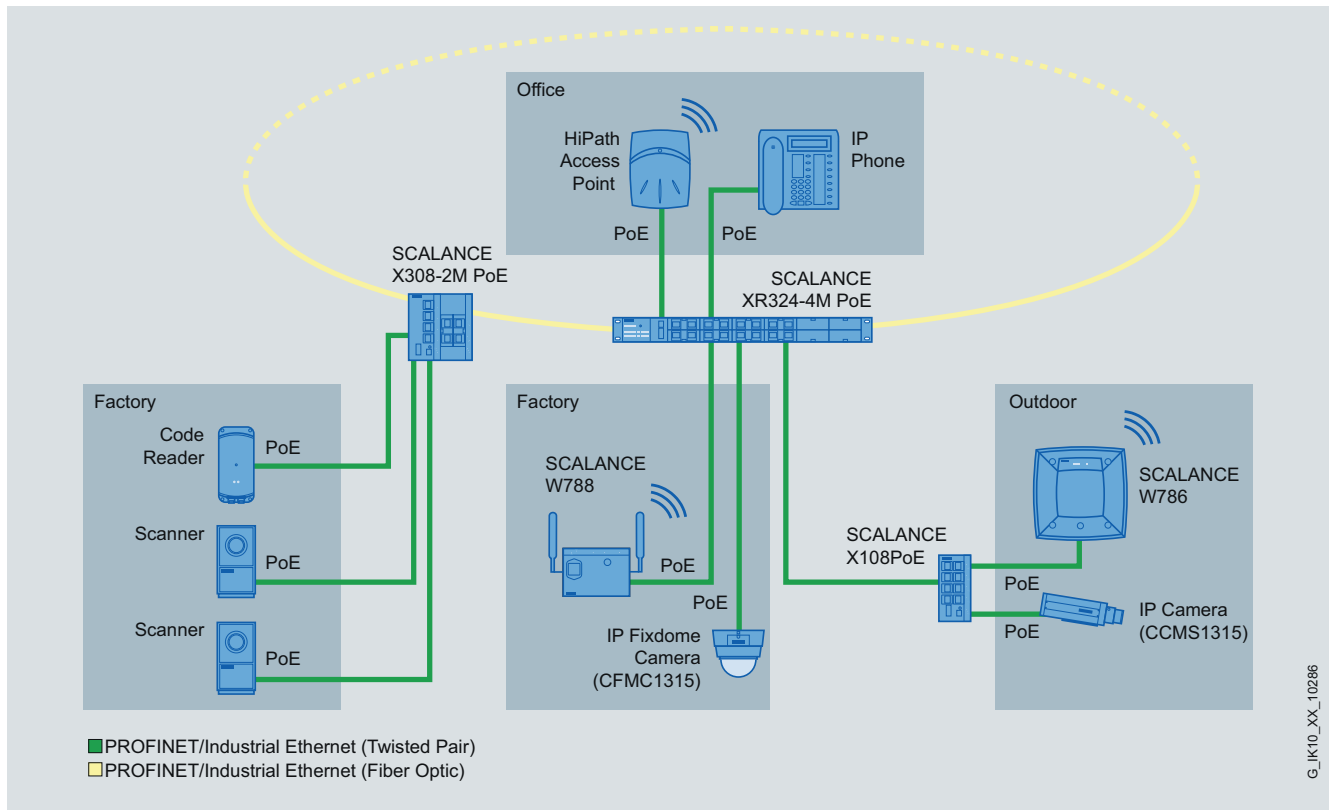

Supply of terminal devices with PoE by means of PoE-compatible switches

The use of media modules in partly and fully modular versions of the SCALANCE X-300 switches supports:

- The extension of networks by subsequent insertion of additional media modules in unused media module slots
- The changing of cabling technology, e.g. conversion from copper to fiber-optic cables, or from multimode to single-mode FOC

Design

The SCALANCE XR-300PoE Industrial Ethernet switches with rugged metal enclosure with IP20 degree of protection are optimized for installation in the 19" control cabinet. Versions are available with either 24 V DC or 100 - 240 V AC connections. The connection of the power supply and the data cable outlet are located optionally either at the front or rear of the device.

The switches have:

- 4-pin terminal block for redundant voltage feed to protected against power failure at 24 V DC
- 2-pin terminal block for voltage feed at 100 - 240 V AC
- 2-pin terminal block for connecting the isolated signaling contact for simple display of faults
- Row of LEDs for indicating status information (power, link status, data transfer, power supply, signal contact)
- SELECT/SET pushbutton for easy setting of the fault signaling contact on the device
- Slot for optional C-PLUG swap medium on the side of the device for easy replacement in the event of a fault
- Console port (serial interface) for on-site parameterization/ diagnostics (RJ11 cable to RS232 (9-pin) included in scope of delivery)

The SCALANCE XR-300PoE switches are available with the following types of port:

- 16 integrated RJ45 ports, eight RJ45 ports supporting PoE;
- The RJ45 sockets are designed to industry standards with additional sleeves, for connection of the Industrial Ethernet FC RJ45 Plug 180
- All electrical Ethernet interfaces support 10/100/1000 Mbit/s, all optical Ethernet interfaces support 100 or 1000 Mbit/s
- The SCALANCE XR-300 switches support Gigabit Ethernet (1000 Mbit/s) at all ports. The 24 ports are divided into three groups of eight ports each (Gigabit Ethernet Blocking). Gigabit Ethernet is supported with full wire speed within each group, but not between the groups.

Product versions

SCALANCE XR324-4M PoE (4 media module slots)

Versions are available with

- LEDs, power supply connection and data cable outlet on the front
- LEDs on the front, power supply connection and data cable outlet at the rear

All versions have twelve media module slots and

- 1 x 24 V DC power supply
- 1 x 100 - 240 V AC power supply unit

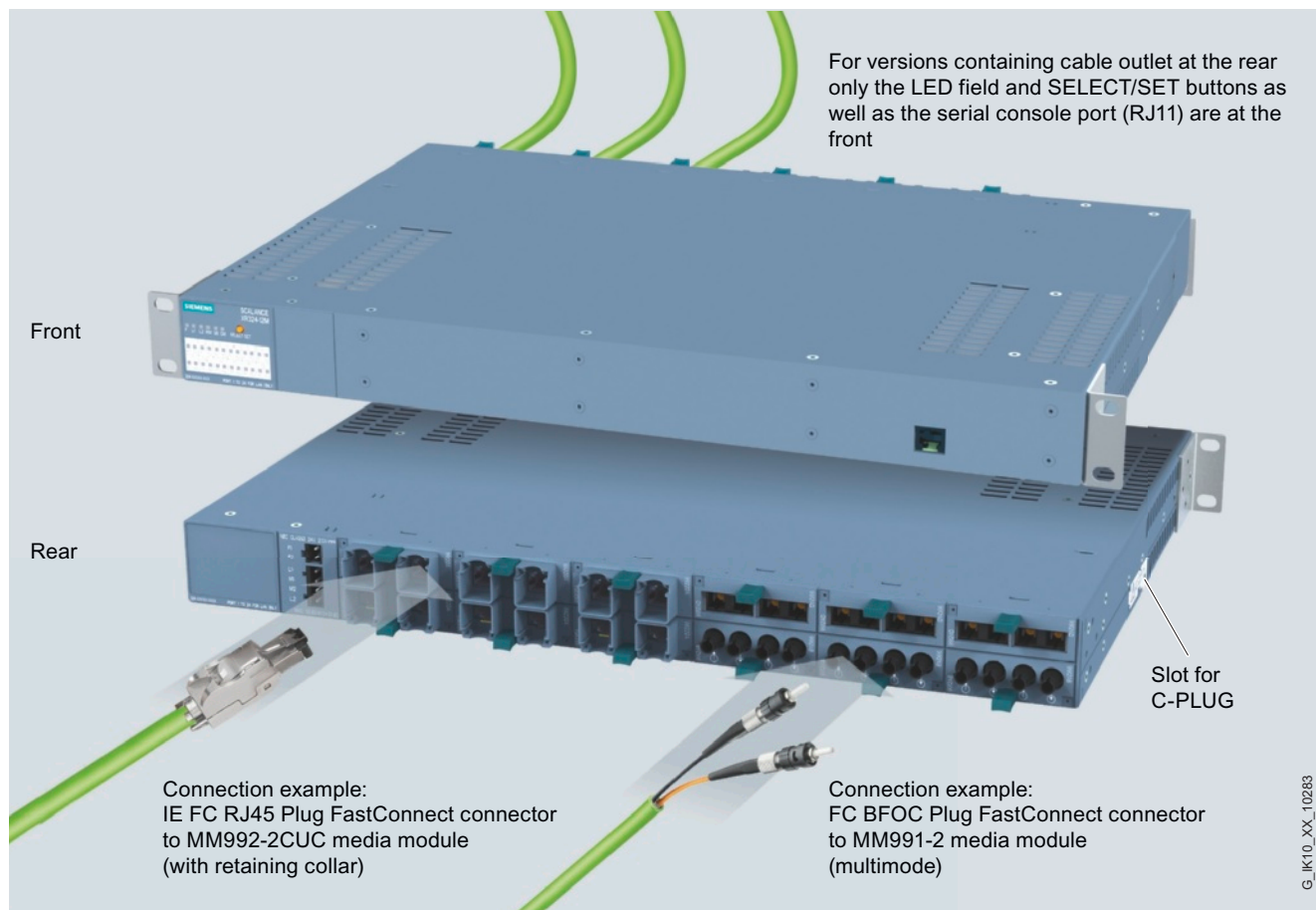

SCALANCE XR-300 with cable outlet at rear

PROFINET/Industrial Ethernet

Industrial Ethernet switches / media converters

SCALANCE XR-300PoE managed

Function

- Support of Power over Ethernet (PoE) to IEEE 802.3at Type1 (corresponds to IEEE 802.3af)
- Integrated redundancy manager for constructing Fast Ethernet and Gigabit Ethernet ring topologies with high-speed media redundancy. Reliable communication is achieved by closing an optical or electrical line with SCALANCE X-400, X-300 or X-200 switches to form a ring. The redundancy manager (RM) integrated in the SCALANCE XR-300 switch monitors the function of the network. It recognizes the failure of a transmission link or a SCALANCE X switch in the ring and activates the substitute path within a maximum of 0.2 seconds.
- Redundant interfacing to company networks; SCALANCE XR-300 switches support the standardized redundancy procedures Spanning Tree Protocol (STP) and Rapid Spanning Tree Protocol (RSTP). This enables a subnetwork to be connected redundantly to a higher level corporate network with reduced requirements for the reconfiguration time (in the order of seconds).
- Support of virtual networks (VLAN); for structuring Industrial Ethernet networks with a fast growing number of users, a physically existing network can be divided into several virtual networks.
- Load limiting when multicast protocols (e.g. video transmission) are used; through learning the multicast sources and targets (IGMP Snooping, IGMP Querier), SCALANCE XR-300 switches can also filter multicast data traffic and therefore limit the load in the network. Multicast and broadcast traffic can be limited.
- Time synchronization; diagnostic messages (log table entries, e-mails) are time-stamped. The local time is standardized throughout the network by means of synchronization with a SICLOCK time transmitter, thereby simplifying the assignment of diagnostic messages to several devices.
- Link aggregation (IEEE 802.3ad) for bundling data streams
- Quality of Service (IEEE 802.1p) for prioritization of network traffic

Network topology and network configuration

The network topology can easily be adapted to the structure of the plant using SCALANCE XR-300 Industrial Ethernet switches .

The following network structures and combinations of structures can be implemented:

- Fast Ethernet with fast media redundancy; to increase network availability, as many as 50 X-200, X-300, X-400 or X-500 switches cascaded in line can be connected into a ring.
- Several rings can be redundantly linked through the standby function
- In addition, SCALANCE XR-300 supports redundant connection of the ring structure to the corporate network with a rapid spanning tree.
- Star topology with SCALANCE XR-300 switches: Each SCALANCE XR-300 switch represents a neutral point that can connect up to 24 nodes or subnets with each other electrically.

When configuring the network, it is necessary to observe the following boundary conditions:

- Maximum line length between two modules for multi-mode fiber-optic conductors:
 - 5 km at 100 Mbit/s
 - 750 m at 1 Gbit/s
- Maximum line length between two modules for single-mode fiber-optic conductors:
 - 26 to 70 km at 100 Mbit/s
 - 10 to 120 km at 1 Gbit/s
- Maximum cable length of the TP cable between two SCALANCE X switches:
 - Max. 100 m at 10/100 Mbit/s with IE FC Cable 2x2 and IE FC RJ45 Plug 180
 - Max. 100 m at 1 Gbit/s with IE FC Standard Cable 4x2 (90 m), IE FC RJ45 Modular Outlet and patch cable (10 m)
 - Max. 10 m using patches with TP Cord

Function (continued)

Commissioning and diagnosis

Setting options on the device itself:

- Redundancy manager RM; to establish a ring, a SCALANCE XR-300 is switched to RM mode. The Gigabit ports (electrical or optical) are preferably used as ring ports. The non-ring ports of the RM can be used freely for the connection of data terminals and networks. If the redundancy procedure MRP standardized by PROFINET is used, the RM is adjusted automatically.
- Signal mask; the signal mask is set to the current status of the SCALANCE XR-300 (setpoint) by pushbutton operation. The signal mask defines which ports and which power supplies are to be monitored. The signaling contact only reports an error when a monitored port or a monitored feeder fails (deviation of setpoint/actual status).
- IP address; the IP address is assigned via DHCP (Dynamic Host Configuration Protocol). If there is no corresponding server in the network, the IP address can be assigned using an enclosed software tool.

Diagnostic options on site:

- The following status information is displayed by LEDs on site:
 - Port status
 - Port mode (10/100/1000 Mbit/s, full/half-duplex)
 - Status of the two power supplies
 - Signaling contact status
 - Signal mask (setpoint status)
 - RM mode
 - Standby mode
- The status of the signaling contact is routed externally by means of floating relay contacts. This enables, for example, the module to be monitored via an input module from a controller.
- Monitoring via the Industrial Ethernet network; the following possibilities are available:
 - Remote via standard browser (Web-based management): Selection of SCALANCE XR-300 switches via the network from a PC with browser
 - Remote via SNMP V1, V2c, V3: Secure integration of SCALANCE XR-300 switches via the network into a network management system, e.g. SINEMA Server
 - Remote via PROFINET IO diagnostics: PROFINET diagnostic alarms from SCALANCE X-300 switches can be displayed using the relevant SIMATIC engineering tools and they can also be processed in the controller. The engineering outlay for the PLC and HMI have been drastically reduced due to the complete integration in the SIMATIC concept for system error messages.

Network management

The network management provides the following functions:

- Password-protected dial-up for "Administrator" (read and write authorization) and "User" (read only)
- Read-out of version and status information
- Setting the signal and standby mask and address information
- Fixed parameterization of the ports (data rates, half/full duplex)
- Setting of Spanning/Rapid Spanning Tree parameters
- Parameterization of the web management services
- Security
 - Ports can be connected or disconnected
 - Port-based network access control according to IEEE 802.1x
 - Authentication in accordance with IEEE 802.1x (available soon)
 - Support of Access Control List (ACL) (available soon)
- Output of statistics information
- Diagnosis of data traffic by means of a parameterizable mirror port with a standard commercial network analyzer
- Loading of new firmware versions or of the configuration data via the network by a TFTP server or directly via HTTP/HTTPS using a Web browser
- Saving the configuration data or log table via the network on a TFTP server

If faults occur in the network, the SCALANCE XR-300 switch can independently send error messages (traps) to a network management system or also e-mails to a predefined network administrator.

Remote monitoring (RMON) provides the following functions: The SCALANCE XR-300 switch can collect statistics information according to the RMON groups 1 through 4. These include, for example, fault statistics that are kept for each port. This information can be read out through web-based management in the statistics sub-area.

PROFINET/Industrial Ethernet

Industrial Ethernet switches / media converters

SCALANCE XR-300PoE managed

Technical specifications

Order No.	6GK5 324-4QG00-1AR2	6GK5 324-4QG00-1HR2	6GK5 324-4QG00-3AR2	6GK5 324-4QG00-3HR2
Product type designation	SCALANCE XR324-4M POE	SCALANCE XR324-4M POE	SCALANCE XR324-4M POE	SCALANCE XR324-4M POE
Transmission rate				
Transmission rate 1	10 Mbit/s	10 Mbit/s	10 Mbit/s	10 Mbit/s
Transmission rate 2	100 Mbit/s	100 Mbit/s	100 Mbit/s	100 Mbit/s
Transmission rate 3	1 000 Mbit/s	1 000 Mbit/s	1 000 Mbit/s	1 000 Mbit/s
Interfaces				
Maximum number of electrical/optical connections for network components or terminal equipment	24	24	24	24
Number of electrical connections				
• for network components or terminal equipment	16	16	16	16
• with power-over-Ethernet for network components or terminal equipment	8	8	8	8
• For operation panel	1	1	1	1
• for signaling contact	1	1	1	1
• for media module	4	4	4	4
• for power supply	1	1	1	1
• for redundant power supply	1	1	0	0
Design of electrical connection				
• for network components or terminal equipment	RJ45 port	RJ45 port	RJ45 port	RJ45 port
• with power-over-Ethernet for network components or terminal equipment	RJ45 port	RJ45 port	RJ45 port	RJ45 port
• For operation panel	RJ11 port	RJ11 port	RJ11 port	RJ11 port
• for signaling contact	2-pin terminal block	2-pin terminal block	2-pin terminal block	2-pin terminal block
• for power supply	4-pin terminal block	4-pin terminal block	2-pin terminal block	2-pin terminal block
Number of optical connections for fiber-optic cables				
• at 100 Mbit/s	-	-	-	-
• at 1000 Mbit/s	-	-	-	-
Design of optical connection for fiber-optic cables				
• at 100 Mbit/s	Depends on selected media modules	Depends on selected media modules	Depends on selected media modules	Depends on selected media modules
• at 1000 Mbit/s	Depends on selected media modules	Depends on selected media modules	Depends on selected media modules	Depends on selected media modules
Design of the swap medium C-Plug	Yes	Yes	Yes	Yes
Inputs/outputs				
Operating voltage of signaling contacts with AC rated value	-	-	-	-
Operating current of signaling contacts with AC maximum	-	-	-	-
Operating voltage of signaling contacts with DC rated value	24 V	24 V	24 V	24 V
Maximum operating current of signal contacts with DC	0.1 A	0.1 A	0.1 A	0.1 A

PROFINET/Industrial Ethernet

Industrial Ethernet switches / media converters

SCALANCE XR-300PoE managed

Technical specifications (continued)

Order No.	6GK5 324-4QG00-1AR2	6GK5 324-4QG00-1HR2	6GK5 324-4QG00-3AR2	6GK5 324-4QG00-3HR2
Product type designation	SCALANCE XR324-4M POE	SCALANCE XR324-4M POE	SCALANCE XR324-4M POE	SCALANCE XR324-4M POE
Supply voltage, current consumption, power loss				
Redundant type of power supply	No	No	No	No
Type of power supply	DC	DC	AC	AC
Supply voltage, external	24 V	24 V	230 V	230 V
• Minimum	19.2 V	19.2 V	85 V	85 V
• Maximum	28.8 V	28.8 V	264 V	264 V
Product component: fusing of power supply input	Yes	Yes	Yes	Yes
Type of fusing of power supply input	F 5 A / 250 V	F 5 A / 250 V	-	-
Current consumption, maximum	4.2 A	4.2 A	1 A	1 A
Effective power loss				
• at 24 V DC	46 W	46 W	-	-
• at 230 V AC	-	-	46 W	46 W
Permitted ambient conditions				
Ambient temperature				
• During operation	-40 ... +60 °C	-40 ... +60 °C	-40 ... +70 °C	-40 ... +70 °C
• During storage	-40 ... +70 °C	-40 ... +70 °C	-40 ... +70 °C	-40 ... +70 °C
• During transport	-40 ... +70 °C	-40 ... +70 °C	-40 ... +70 °C	-40 ... +70 °C
• Note	With vertical installation, the maximum operating temperature is reduced to 60 °C	With vertical installation, the maximum operating temperature is reduced to 60 °C	With vertical installation, the maximum operating temperature is reduced to 60 °C	With vertical installation, the maximum operating temperature is reduced to 60 °C
Relative humidity at 25 °C without condensation during operation, maximum	95 %	95 %	95 %	95 %
Ambient conditions for operation	-	-	-	-
IP degree of protection	IP20	IP20	IP20	IP20
Design, dimensions and weights				
Type of construction	19-inch rack	19-inch rack	19-inch rack	19-inch rack
Width	449 mm	449 mm	449 mm	449 mm
Height	43.6 mm	43.6 mm	43.6 mm	43.6 mm
Depth	305 mm	305 mm	305 mm	305 mm
Net weight	6.8 kg	6.8 kg	6.8 kg	6.8 kg
Type of mounting				
• 19-inch installation	Yes	Yes	Yes	Yes
• 35 mm DIN rail mounting	No	No	No	No
• Wall mounting	No	No	No	No
• S7-300 rail mounting	No	No	No	No
Type of mounting	For 19-inch rack mounting, 4-point fixing is required for marine engineering applications	For 19-inch rack mounting, 4-point fixing is required for marine engineering applications	For 19-inch rack mounting, 4-point fixing is required for marine engineering applications	For 19-inch rack mounting, 4-point fixing is required for marine engineering applications
Product properties, functions, components				
General				
Cascading with redundant ring with reconfiguration time < 0.3 s	50	50	50	50
Cascading with star topology	Any (only dependent on signal propagation time)	Any (only dependent on signal propagation time)	Any (only dependent on signal propagation time)	Any (only dependent on signal propagation time)

PROFINET/Industrial Ethernet

Industrial Ethernet switches / media converters

SCALANCE XR-300PoE managed

Technical specifications (continued)

Order No.	6GK5 324-4QG00-1AR2	6GK5 324-4QG00-1HR2	6GK5 324-4QG00-3AR2	6GK5 324-4QG00-3HR2
Product type designation	SCALANCE XR324-4M POE	SCALANCE XR324-4M POE	SCALANCE XR324-4M POE	SCALANCE XR324-4M POE
Product functions				
Management, configuration, programming				
Product function				
• CLI	Yes	Yes	Yes	Yes
• Web-based management	Yes	Yes	Yes	Yes
• MIB support	Yes	Yes	Yes	Yes
• TRAPS via e-mail	Yes	Yes	Yes	Yes
• Configuration with STEP 7	Yes	Yes	Yes	Yes
• RMON	Yes	Yes	Yes	Yes
• SMTP server	Yes	Yes	Yes	Yes
• Port mirroring	Yes	Yes	Yes	Yes
• CoS	Yes	Yes	Yes	Yes
• with IRT PROFINET IO Switch	-	-	-	-
• PROFINET IO diagnostics	Yes	Yes	Yes	Yes
• Switch-managed	Yes	Yes	Yes	Yes
Protocol is supported				
• Telnet	Yes	Yes	Yes	Yes
• HTTP	Yes	Yes	Yes	Yes
• HTTPS	Yes	Yes	Yes	Yes
• TFTP	Yes	Yes	Yes	Yes
• FTP	Yes	Yes	Yes	Yes
• BOOTP	Yes	Yes	Yes	Yes
• SNMP v1	Yes	Yes	Yes	Yes
• SNMP v2	Yes	Yes	Yes	Yes
• SNMP v3	Yes	Yes	Yes	Yes
• IGMP (snooping/querier)	Yes	Yes	Yes	Yes
• GMRP	Yes	Yes	Yes	Yes
• DCP	Yes	Yes	Yes	Yes
• LLDP	Yes	Yes	Yes	Yes
Identification & Maintenance				
• I&M0 - device-specific information	Yes	Yes	Yes	Yes
• I&M1 - higher-level designation/location designation	Yes	Yes	Yes	Yes
Product functions Diagnostics				
Product function				
• Port diagnostics	Yes	Yes	Yes	Yes
• Packet size statistics	Yes	Yes	Yes	Yes
• Packet type statistics	Yes	Yes	Yes	Yes
• Error statistics	Yes	Yes	Yes	Yes
• SysLog	Yes	Yes	Yes	Yes
Product functions VLAN				
Product function				
• VLAN - port-based	Yes	Yes	Yes	Yes
• VLAN - dynamic	Yes	Yes	Yes	Yes
Maximum number of VLANs	255	255	255	255
Maximum number of dynamic VLANs	255	255	255	255
GVRP protocol is supported	Yes	Yes	Yes	Yes
Product functions DHCP				
Product function				
• DHCP client	Yes	Yes	Yes	Yes
• DHCP option 82	Yes	Yes	Yes	Yes
• DHCP option 66	Yes	Yes	Yes	Yes
• DHCP option 67	Yes	Yes	Yes	Yes

Technical specifications (continued)

Order No.	6GK5 324-4QG00-1AR2	6GK5 324-4QG00-1HR2	6GK5 324-4QG00-3AR2	6GK5 324-4QG00-3HR2
Product type designation	SCALANCE XR324-4M POE	SCALANCE XR324-4M POE	SCALANCE XR324-4M POE	SCALANCE XR324-4M POE
Product functions Redundancy				
Product function				
• Ring redundancy	Yes	Yes	Yes	Yes
• Redundancy manager	Yes	Yes	Yes	Yes
• Standby redundancy	Yes	Yes	Yes	Yes
• Redundancy procedure HSR	Yes	Yes	Yes	Yes
• Redundancy procedure MRP	Yes	Yes	Yes	Yes
• Redundancy procedure STP	Yes	Yes	Yes	Yes
• Redundancy procedure RSTP	Yes	Yes	Yes	Yes
• Passive listening	Yes	Yes	Yes	Yes
Protocol is supported				
• STP/RSTP	Yes	Yes	Yes	Yes
• STP	Yes	Yes	Yes	Yes
• RSTP	Yes	Yes	Yes	Yes
• RSTP Big Network Support	Yes	Yes	Yes	Yes
• LACP	Yes	Yes	Yes	Yes
Product functions Security				
Product function				
• ACL - Port/MAC-based	Yes	Yes	Yes	Yes
• IEEE 802.1x (Radius)	Yes	Yes	Yes	Yes
• Broadcast/Multicast/Unicast Limiter	Yes	Yes	Yes	Yes
• Broadcast blocking	Yes	Yes	Yes	Yes
SSH protocol is supported	Yes	Yes	Yes	Yes
Product functions Time				
Product function:	Yes	Yes	Yes	Yes
SICLOCK support				
Protocol is supported				
• NTP	No	No	No	No
• SNTP	Yes	Yes	Yes	Yes
• IEEE 1588 profile default	Yes	Yes	Yes	Yes
• IEEE 1588 profile gPTP	-	-	-	-
• IEEE 1588 profile PSRC	-	-	-	-
Type of time synchronization	-	-	-	-
Standards, specifications, approvals				
Standard				
• for EMC of FM	FM3611: Class 1, Division 2, Group A, B, C, D / T4, Class 1, Zone 2, Group IIC, T4	FM3611: Class 1, Division 2, Group A, B, C, D / T4, Class 1, Zone 2, Group IIC, T4	No	No
• for hazardous zone	EN 60079-0: 2006, EN 60079-15: 2005, II 3 G Ex nA II T4 KEMA 07 ATEX 0145X	EN 60079-0: 2006, EN 60079-15: 2005, II 3 G Ex nA II T4 KEMA 07 ATEX 0145X	No	No
• for CSA and UL safety	UL 60950-1, CSA C22.2 No. 60950-1	UL 60950-1, CSA C22.2 No. 60950-1	UL 508, CSA C22.2 No. 142-M1987	UL 508, CSA C22.2 No. 142-M1987
• for hazardous zone of CSA and UL	UL 1604 and UL 2279-15 (Hazardous Location), CSA C22.2 No. 213-M1987, Class 1 / Division 2 / Group A, B, C, D / T4, Class 1 / Zone 2 / Group IIC / T4	UL 1604 and UL 2279-15 (Hazardous Location), CSA C22.2 No. 213-M1987, Class 1 / Division 2 / Group A, B, C, D / T4, Class 1 / Zone 2 / Group IIC / T4	No	No
• for emitted interference	EN 61000-6-4:2007 (Class A)	EN 61000-6-4:2007 (Class A)	EN 61000-6-4:2007 (Class A)	EN 61000-6-4:2007 (Class A)
• for noise immunity	EN 61000-6-2:2006	EN 61000-6-2:2006	EN 61000-6-2:2006	EN 61000-6-2:2006

PROFINET/Industrial Ethernet

Industrial Ethernet switches / media converters

SCALANCE XR-300PoE managed

Ordering data Order No. (continued)

Order No.	6GK5 324-4QG00-1AR2	6GK5 324-4QG00-1HR2	6GK5 324-4QG00-3AR2	6GK5 324-4QG00-3HR2
Product type designation	SCALANCE XR324-4M POE	SCALANCE XR324-4M POE	SCALANCE XR324-4M POE	SCALANCE XR324-4M POE
Certificate of suitability	EN 61000-6-2:2006, EN 61000-6-4:2007	EN 61000-6-2:2006, EN 61000-6-4:2007	EN 61000-6-2:2006, EN 61000-6-4:2007	EN 61000-6-2:2006, EN 61000-6-4:2007
• CE mark	Yes	Yes	Yes	Yes
• C-Tick	Yes	Yes	Yes	Yes
• Railroad application according to EN 50155	-	-	-	-
• Railroad application according to EN 50124-1	-	-	-	-
Marine classification corporation				
• American Bureau of Shipping Europe Ltd. (ABS)	-	-	-	-
• Bureau Veritas (BV)	-	-	-	-
• Det Norske Veritas (DNV)	-	-	-	-
• Germanischer Lloyd (GL)	-	-	-	-
• Lloyds Register of Shipping (LRS)	-	-	-	-
• Nippon Kaiji Kyokai (NK)	-	-	-	-

Ordering data

Order No.

SCALANCE XR324-4M PoE Industrial Ethernet switches

Partly modular 19" Industrial Ethernet switches for setting up electrical and optical Industrial Ethernet networks; eight PoE-compatible ports can optionally be equipped with optical or electrical 2-port media modules; all ports support Gigabit Ethernet (blocking), integrated redundancy manager, RSTP, RMON, IGMP-Snooping/Querier, network management via SNMP, PROFINET, and web server
16 x 10/100/1000 Mbit/s RJ45 ports, eight of which support PoE; 4 x 10/100/1000 Mbit/s slots for 2-port media modules, electrical or optical

24 V DC power supply

- Data cable outlet at front
- Data cable outlet at rear

6GK5 324-4QG00-1AR2
6GK5 324-4QG00-1HR2

100-240 V AC power supply

- Data cable outlet at front
- Data cable outlet at rear

6GK5 324-4QG00-3AR2
6GK5 324-4QG00-3HR2

Media modules

See "Media modules for modular SCALANCE X-300 managed"

SITOP modular, 5 A

6EP1 333-3BA00

Single-phase and 2-phase power supply with wide-range input 85 ... 264 V / 176 V ... 550 V AC, regulated output voltage 24 V, output current rated value 5 A

More information

To assist in selecting the right Industrial Ethernet switches as well as configuration of modular versions, the SIMATIC NET Selection Tool is available:

Online version:
www.siemens.com/snst

Offline version:
www.siemens.com/snst-download

PROFINET/Industrial Ethernet

Industrial Ethernet switches / media converters

SCALANCE X-300EEC managed

Overview

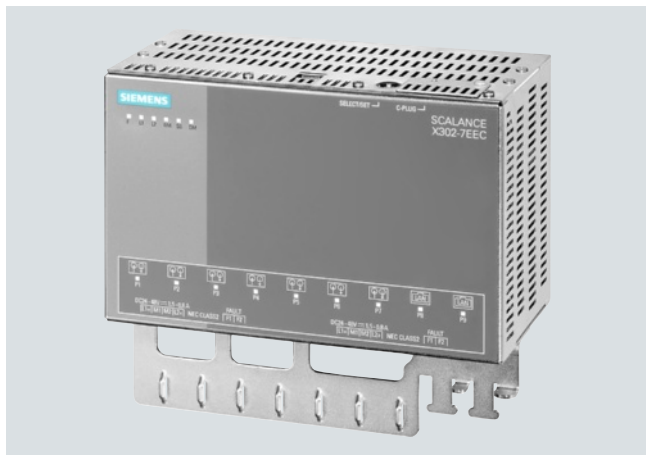

The SCALANCE X-300EEC (**E**nhanced **E**nvironmental **C**onditions) product line comprises compact Industrial Ethernet switches with IT functions for constructing electrical and/or optical line, star and ring topologies at data transfer rates of 10/100/1000 Mbit/s.

- Suitable for use in extremely harsh industrial environments and in low-voltage and high-voltage switchgear thanks to:
 - Extended temperature range (-40 to +70 °C, briefly to +85 °C)
 - Special coating on PCBs (conformal coating)
 - Support for special protocols and standards (IEEE 1613 and IEC 61850-3)
 - Wide-range power supplies (60 to 250 V AC/DC)
- As many as nine integrated electrical and/or optical Ethernet interfaces (10/100/1000 Mbit/s) support the interconnection of a number of switches, the construction of optical/electrical rings, or the connection of several Industrial Ethernet nodes
- High-speed media redundancy through integral redundancy manager both for Gigabit Ethernet and Fast Ethernet
- Seamless integration of automation networks into existing corporate networks thanks to support for a host of IT standard functions (VLANs, IGMP-Snooping/Querier, STP/RSTP)
- PROFINET diagnostics, SNMP access, integrated web server and CLI for remote diagnostics and signaling via the network

Benefits

get Designed for Industry

- Increased reliability of the network due to hardware and software functions specially geared to the particular requirements of power system plants and extreme environmental conditions
- High availability of the network thanks to:
 - Redundant power supply
 - Redundant network components (optional)
 - Redundant network structures based on fiber-optic or twisted pair cables (redundancy manager, standby function, MRP and RSTP are integrated)
 - Easy device replacement by means of plug-in C-PLUG swap medium
 - Very fast reconfiguration of the network in the event of a fault
- Lower susceptibility to failure and higher availability of the plant networking due to latching of the RJ45 FastConnect connectors in the sleeve of the RJ45 ports
- Protection of investment due to integration into existing network management systems by means of standardized SNMP access
- Time saving during engineering, commissioning and in the operating phase of a plant by using the integrated configuration and diagnostics in STEP 7, without additional software

Application

SCALANCE X-300EEC products enable the establishment of switched networks both at the field level and at the control level where high data transfer speeds are required in addition to high network availability and extensive diagnostics facilities. The switches are designed in degree of protection IP30 for installation in control cabinets.

The main area of application is found in high-performance plant networks with interfaces to the corporate network. Thanks to the immunity to electromagnetic interference of the SCALANCE X-300EEC switches, the devices can also be used in medium/high voltage substations.

In addition, SCALANCE X-300EEC switches are suitable for use in railway applications thanks to their specification in accordance with EN 50155.

Their compact, space-saving design (19"/2) also makes them ideal for installation in control cabinets. In addition, specially selected components permit the use of the devices over a wide temperature range (-40 °C to +70 °C, temporarily up to +85 °C). All versions are also available with specially protected printed-circuit boards (conformal coating) for use in environments subject to contamination.

2

PROFINET/Industrial Ethernet

Industrial Ethernet switches / media converters

SCALANCE X-300EEC managed

Application (continued)

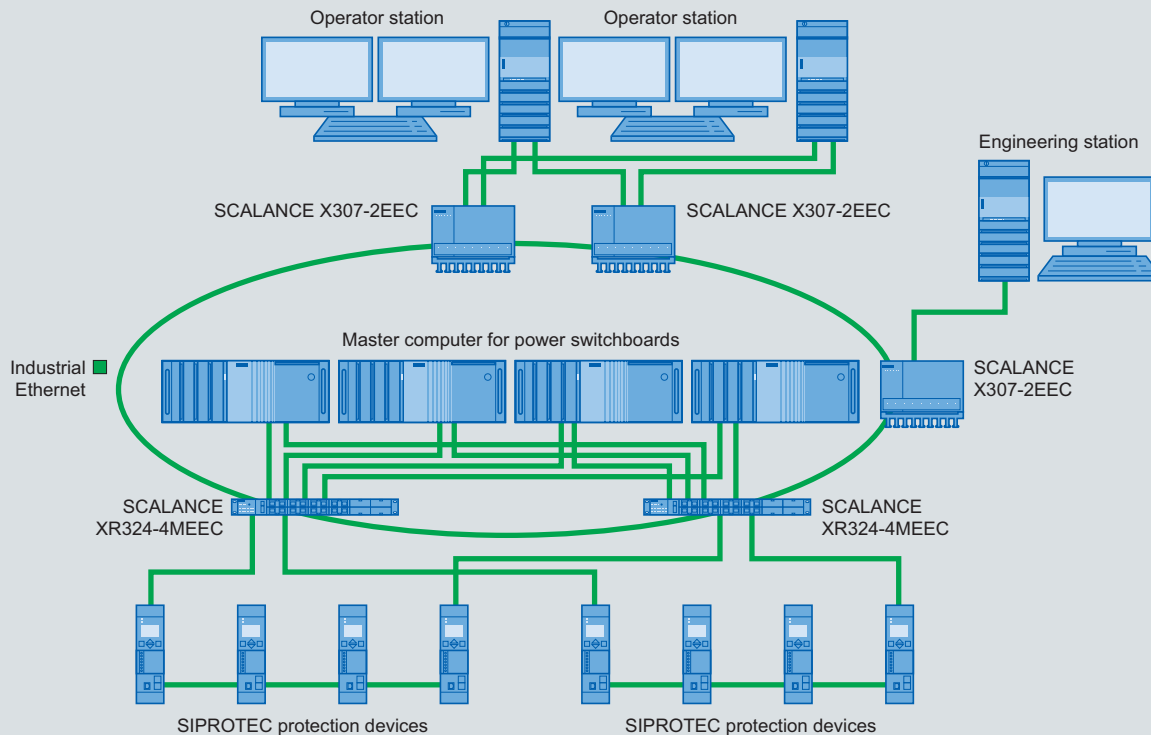

Electrical network structure in power switchgear with SCALANCE X-300EEC and XR324-4M EEC

Design

The SCALANCE X-300EEC Industrial Ethernet switches with rugged metal enclosure are optimized for mounting on a standard DIN rail. Thanks to the enclosure dimension 19¹/₂ (internal dimension), two devices can be mounted side by side in a 19" cabinet.

The switches have:

- a 4-pin terminal block for connecting the redundant power supply (2 x 24 V DC)
- A 2-pin terminal block for connecting the isolated signaling contact
- A row of LEDs to indicate the status information (power, link status, data traffic, power supply, signaling contact)
- SELECT/SET key for on-site configuration of the signaling contact
- Slot for optional C-PLUG swap medium on the top of the device for easy replacement in the event of a fault
- Guide rails for strain-relief attachment of the RJ45 and LC connection to the switch

The SCALANCE X-300EEC switches are available with the following port types:

- As many as seven integrated fiber-optic ports for connecting the SCALANCE X switches with one another (multimode). The Fast Ethernet fiber optic ports are designed using LC connection technology.
- Up to seven integrated twisted pair ports; the RJ45 sockets are designed to be industry-compatible with additional retaining mechanisms, for connection of the Industrial Ethernet FC RJ45 Plug 180.

Product versions

SCALANCE X307-2EEC

- 5 x 10/100 Mbit/s RJ45 port, electrical
- 2 x 10/100/1000 Mbit/s RJ45 port, electrical
- 2 x 100 Mbit/s LC Port optical (multimode, glass), up to 5 km

SCALANCE X302-7EEC

- 2 x 10/100/1000 Mbit/s RJ45 port, electrical
- 7 x 100 Mbit/s LC Port optical (multimode, glass), up to 5 km

SCALANCE X307-2EEC and X302-7EEC are available in versions for

- 24 V DC (single or redundant) and
- with wide-range power supplies for 60 to 250 V DC / 100-240 V AC (single or redundant) as well as
- with or without PCB coating (conformal coating)

Function

- Integrated redundancy manager for constructing ring topologies with fast media redundancy Rings consisting of SCALANCE X-300 and X-400 switches can be operated at 1000 Mbit/s. In rings with SCALANCE X-200 or OSM/ESM it is possible to integrate SCALANCE X-300EEC switches at 100 Mbit/s.
- Redundant interfacing to corporate networks; SCALANCE X-300EEC switches support the standardized redundancy procedures Spanning Tree Protocol (STP) and Rapid Spanning Tree Protocol (RSTP). This enables a subnetwork to be connected redundantly to a higher level corporate network with reduced requirements for the reconfiguration time (in the order of seconds).
- Support of virtual networks (VLAN); for structuring Industrial Ethernet networks with a fast growing number of users, a physically existing network can be divided into several virtual networks.
- Load limiting when multicast protocols (e.g. Querier, video transmission) are used; through learning the multicast sources and targets (IGMP Snooping, IGMP Querier), SCALANCE X-300EEC switches can also filter multicast data traffic and therefore limit the load in the network.
- Time synchronization; diagnostic messages (log table entries, e-mails) are time-stamped. The local time is standardized throughout the network by means of synchronization with a SICLOCK or SNTP time transmitter, thereby simplifying the assignment of diagnostic messages to several devices.
- Fast replacement of devices in event of failure, by means of the C-PLUG switching medium

Network topology and network configuration

The SCALANCE X-300EEC Industrial Ethernet switches with degree of protection IP30 can be adapted to the structure of the plant in star, line and ring topologies.

The following network structures and combinations of structures can be implemented:

- Fast Ethernet rings with fast media redundancy; to increase network availability, as many as 50 X-200, X-300, or X-400 switches cascaded in line can be connected into a ring with a total length of up to 150 km. On the failure of a transmission link or of a SCALANCE X switch in the ring, the transmission path is reconfigured within 0.3 seconds (0.2 seconds for MRP).
- Several rings can be redundantly linked through the standby function
- Construction of interconnected network structures by means of rapid spanning tree protocol (RSTP)
- At the same time, SCALANCE X-300EEC supports redundant connection of the ring structure to the corporate network with a rapid spanning tree.
- Star topology with SCALANCE X-300EEC switches: The SCALANCE X-300EEC switch represents a neutral point that can connect up to nine nodes or subnets with each other.

When configuring the network, it is necessary to observe the following constraints:

- Maximum line length between two modules for multi-mode fiber-optic conductors:
 - 5000 m at 100 Mbit/s
- Maximum cable length of the TP cable between two SCALANCE X switches:
 - max. 100 m

PROFINET/Industrial Ethernet

Industrial Ethernet switches / media converters

SCALANCE X-300EEC managed

Function (continued)

Commissioning and diagnosis

Setting options on the device itself:

- Redundancy manager RM;
to establish a ring, a SCALANCE X-300EEC is switched to RM mode. The non-ring ports of the RM can be used freely for the connection of data terminals and networks. If the redundancy procedure MRP standardized by PROFINET is used, the RM is adjusted automatically.
- Signal mask;
the signal mask is set to the current status of the SCALANCE X-300EEC (setpoint) by pushbutton operation. The signal mask defines which ports and which power supplies are to be monitored. The signaling contact only reports an error when a monitored port or a monitored feeder fails (deviation of setpoint/actual status).

Diagnostic options on site:

- The following status information is displayed by LEDs on site:
 - Port status
 - Port mode (10/100 Mbit/s, full/half-duplex)
 - Status of the two power supplies
 - Signaling contact status
 - Signal mask (setpoint status)
 - RM mode
 - Standby mode
- The status of the signaling contact is routed externally by means of floating relay contacts. This enables, for example, the module to be monitored via an input module from a controller.
- Monitoring via the Industrial Ethernet network; the following possibilities are available:
 - Remote via standard browser (Web-based management):
Selection of SCALANCE X-300 switches via the network from a PC with browser
 - Remote via SNMP V1, V2c, V3:
Secure connection of SCALANCE X-300EEC switches via the network to a network management station
 - Remote via PROFINET IO diagnostics:
PROFINET diagnostic alarms from SCALANCE X-300EEC switches can be displayed using the relevant SIMATIC engineering tools and they can also be processed in the controller. The engineering outlay for the PLC and HMI have been drastically reduced due to the complete integration in the SIMATIC concept for system error messages.

Network management

The network management provides the following functions:

- Password-protected dial-up for "Administrator" (read and write authorization) and "User" (read only)
- Read-out of version and status information
- Setting the signal and standby mask and address information
- Parameterization of the web management services
- Setting of Rapid Spanning Tree parameters
- Fixed parameterization of the ports (data rates, half/full duplex)
- Security
 - Ports can be connected or disconnected
 - Authentication in accordance with IEEE 802.1x (available soon)
 - Support of Access Control List (ACL) (available soon)
- Parameterization of user administration of SNMP V1, V2c, V3
- Output of statistics information
- Diagnosis of data traffic by means of a parameterizable mirror port with a standard commercial network analyzer
- Loading new firmware updates or configuration data via the network from one TFTP server or directly via HTTP/HTTPS with an Internet or Web browser.
- Saving the configuration data or log table via the network on a TFTP server

If faults occur in the network, the SCALANCE X-300EEC switch can independently send error messages (traps) to a network management system or also e-mails to a predefined network administrator.

Remote monitoring (RMON) provides the following functions: The SCALANCE X-300EEC switch can collect statistics information according to the RMON groups 1 through 4. These include, for example, fault statistics that are kept for each port. This information can be read out through web-based management in the statistics sub-area.

Technical specifications

Order No.	6GK5 302-7GD00-1EA3	6GK5 302-7GD00-1GA3	6GK5 302-7GD00-2EA3	6GK5 302-7GD00-2GA3
Product type designation	SCALANCE X302-7 EEC	SCALANCE X302-7 EEC	SCALANCE X302-7 EEC	SCALANCE X302-7 EEC
Transmission rate				
Transmission rate 1	10 Mbit/s	10 Mbit/s	10 Mbit/s	10 Mbit/s
Transmission rate 2	100 Mbit/s	100 Mbit/s	100 Mbit/s	100 Mbit/s
Transmission rate 3	1 000 Mbit/s	1 000 Mbit/s	1 000 Mbit/s	1 000 Mbit/s
Interfaces				
Maximum number of electrical/optical connections for network components or terminal equipment	9	9	9	9
Number of electrical connections				
• For network components or terminal equipment	2	2	2	2
• For operation panel	-	-	-	-
• For signal contact	1	1	2	2
• For media module	-	-	-	-
• for power supply	1	1	2	2
• for redundant power supply	1	1	2	2
Design of electrical connection				
• for network components or terminal equipment	RJ45 port	RJ45 port	RJ45 port	RJ45 port
• For operation panel	-	-	-	-
• For signal contact	2-pin terminal block	2-pin terminal block	2-pin terminal block	2-pin terminal block
• for power supply	4-pin terminal block	4-pin terminal block	2 x 4-pin terminal block	2 x 4-pin terminal block
Number of optical connections for fiber-optic cables				
• At 100 Mbit/s	7	7	7	7
• At 1000 Mbit/s	-	-	-	-
Design of optical connection for fiber-optic cables				
• at 100 Mbit/s	LC port (multimode up to 5 km)	LC port (multimode up to 5 km)	LC port (multimode up to 5 km)	LC port (multimode up to 5 km)
• at 1000 Mbit/s	-	-	-	-
Injectable optical power referred to 1 mW				
• of the transmitter output	-19 ... -14 dB	-19 ... -14 dB	-19 ... -14 dB	-19 ... -14 dB
• of the receiver input, maximum	-14 dB	-14 dB	-14 dB	-14 dB
Minimum optical sensitivity referred to 1 mW of the receiver input	-32 dB	-32 dB	-32 dB	-32 dB
Minimum required attenuation factor of the FO transmission link	0 dB	0 dB	0 dB	0 dB
The range at the optical interface depends on the type of optical fiber used	0 ... 5 km	0 ... 5 km	0 ... 5 km	0 ... 5 km
Design of the swap medium C-Plug	Yes	Yes	Yes	Yes
Inputs/outputs				
Operating voltage of signaling contacts with DC rated value	24 V	24 V	24 V	24 V
Maximum operating current of signal contacts with DC	0.1 A	0.1 A	0.1 A	0.1 A

PROFINET/Industrial Ethernet

Industrial Ethernet switches / media converters

SCALANCE X-300EEC managed

Technical specifications (continued)

Order No.	6GK5 302-7GD00-1EA3	6GK5 302-7GD00-1GA3	6GK5 302-7GD00-2EA3	6GK5 302-7GD00-2GA3
Product type designation	SCALANCE X302-7 EEC	SCALANCE X302-7 EEC	SCALANCE X302-7 EEC	SCALANCE X302-7 EEC
Supply voltage, current consumption, power loss				
Redundant type of power supply	No	No	Yes	Yes
Type of power supply	DC	DC	DC	DC
Supply voltage with AC	-	-	-	-
• Rated value	-	-	-	-
Type of power supply 2	DC	DC	DC	DC
DC power supply	24 V	24 V	24 V	24 V
• Rated value	19.2 ... 57.6 V	19.2 ... 57.6 V	19.2 ... 57.6 V	19.2 ... 57.6 V
Product component: fusing at power supply input	Yes	Yes	Yes	Yes
Design of fusing at input for supply voltage	T 4A / 125V	T 4A / 125V	T 4A / 125V	T 4A / 125V
Current consumption, maximum	0.75 A	0.75 A	0.75 A	0.75 A
Effective power loss				
• at 24 V DC	17 W	17 W	17 W	17 W
• at 230 V AC	-	-	-	-
• at 250 V DC	-	-	-	-
Permissible ambient conditions				
Ambient temperature				
• During operation	-40 ... +70 °C	-40 ... +70 °C	-40 ... +70 °C	-40 ... +70 °C
• During storage	-40 ... +70 °C	-40 ... +70 °C	-40 ... +70 °C	-40 ... +70 °C
• During transport	-40 ... +70 °C	-40 ... +70 °C	-40 ... +70 °C	-40 ... +70 °C
• Note	For a duration of 16 hours, a maximum operating temperature of +85 °C is permitted	For a duration of 16 hours, a maximum operating temperature of +85 °C is permitted	For a duration of 16 hours, a maximum operating temperature of +85 °C is permitted	For a duration of 16 hours, a maximum operating temperature of +85 °C is permitted
Relative humidity at 25 °C without condensation during operation, maximum	95 %	95 %	95 %	95 %
Ambient conditions for operation	-	Conformal coating	-	Conformal coating
IP degree of protection	IP30	IP30	IP30	IP30
Design, dimensions and weights				
Design	Compact	Compact	Compact	Compact
Width	60 mm	60 mm	60 mm	60 mm
Height	125 mm	125 mm	125 mm	125 mm
Depth	123 mm	123 mm	123 mm	123 mm
Net weight	1.8 kg	1.8 kg	2.03 kg	2.03 kg
Type of mounting				
• 19-inch installation	Yes	Yes	Yes	Yes
• 35 mm DIN rail mounting	Yes	Yes	Yes	Yes
• Wall mounting	Yes	Yes	Yes	Yes
• S7-300 rail mounting	Yes	Yes	Yes	Yes
Type of mounting	Wall mounting only possible with additional wall support, 19" mounting only with pairs of X-300EEC switches and a mounting plate	Wall mounting only possible with additional wall support, 19" mounting only with pairs of X-300EEC switches and a mounting plate	Wall mounting only possible with additional wall support, 19" mounting only with pairs of X-300EEC switches and a mounting plate	Wall mounting only possible with additional wall support, 19" mounting only with pairs of X-300EEC switches and a mounting plate

Technical specifications (continued)

Order No.	6GK5 302-7GD00-1EA3	6GK5 302-7GD00-1GA3	6GK5 302-7GD00-2EA3	6GK5 302-7GD00-2GA3
Product type designation	SCALANCE X302-7 EEC	SCALANCE X302-7 EEC	SCALANCE X302-7 EEC	SCALANCE X302-7 EEC
Product properties, functions, components				
General				
Cascading with redundant ring at reconfiguration time < 0.3 s	50	50	50	50
Cascading with star topology	Any (only dependent on signal propagation time)	Any (only dependent on signal propagation time)	Any (only dependent on signal propagation time)	Any (only dependent on signal propagation time)
Product functions				
Management, configuration, programming				
Product function				
• CLI	Yes	Yes	Yes	Yes
• Web-based management	Yes	Yes	Yes	Yes
• MIB support	Yes	Yes	Yes	Yes
• Traps via e-mail	Yes	Yes	Yes	Yes
• Configuration with STEP 7	Yes	Yes	Yes	Yes
• RMON	Yes	Yes	Yes	Yes
• SMTP server	Yes	Yes	Yes	Yes
• Port mirroring	Yes	Yes	Yes	Yes
• CoS	Yes	Yes	Yes	Yes
• with IRT PROFINET IO Switch	No	No	No	No
• PROFINET IO diagnostics	Yes	Yes	Yes	Yes
• Switch-managed	Yes	Yes	Yes	Yes
Protocol is supported				
• Telnet	Yes	Yes	Yes	Yes
• HTTP	Yes	Yes	Yes	Yes
• HTTPS	Yes	Yes	Yes	Yes
• TFTP	Yes	Yes	Yes	Yes
• FTP	Yes	Yes	Yes	Yes
• BOOTP	Yes	Yes	Yes	Yes
• SNMP v1	Yes	Yes	Yes	Yes
• SNMP v2	Yes	Yes	Yes	Yes
• SNMP v3	Yes	Yes	Yes	Yes
• IGMP (snooping/querier)	Yes	Yes	Yes	Yes
• GMRP	Yes	Yes	Yes	Yes
• DCP	Yes	Yes	Yes	Yes
• LLDP	Yes	Yes	Yes	Yes
Identification & maintenance				
• I&M0 - device-specific information	Yes	Yes	Yes	Yes
• I&M1 - higher-level designation/location designation	Yes	Yes	Yes	Yes
Product functions Diagnostics				
Product function				
• Port diagnostics	Yes	Yes	Yes	Yes
• Packet size statistics	Yes	Yes	Yes	Yes
• Packet type statistics	Yes	Yes	Yes	Yes
• Error statistics	Yes	Yes	Yes	Yes
• SysLog	Yes	Yes	Yes	Yes
Product functions VLAN				
Product function				
• VLAN - port-based	Yes	Yes	Yes	Yes
• VLAN - dynamic	Yes	Yes	Yes	Yes
Maximum number of VLANs	255	255	255	255
Maximum number of dynamic VLANs	255	255	255	255
GVRP protocol is supported	Yes	Yes	Yes	Yes

PROFINET/Industrial Ethernet

Industrial Ethernet switches / media converters

SCALANCE X-300EEC managed

Technical specifications (continued)

Order No.	6GK5 302-7GD00-1EA3	6GK5 302-7GD00-1GA3	6GK5 302-7GD00-2EA3	6GK5 302-7GD00-2GA3
Product type designation	SCALANCE X302-7 EEC	SCALANCE X302-7 EEC	SCALANCE X302-7 EEC	SCALANCE X302-7 EEC
Product functions DHCP				
Product function				
• DHCP client	Yes	Yes	Yes	Yes
• DHCP option 82	Yes	Yes	Yes	Yes
• DHCP option 66	Yes	Yes	Yes	Yes
• DHCP option 67	Yes	Yes	Yes	Yes
Product functions Redundancy				
Product function				
• Ring redundancy	Yes	Yes	Yes	Yes
• Redundancy manager	Yes	Yes	Yes	Yes
• Standby redundancy	Yes	Yes	Yes	Yes
• Redundancy procedure HSR	Yes	Yes	Yes	Yes
• Redundancy procedure MRP	Yes	Yes	Yes	Yes
• Redundancy procedure STP	Yes	Yes	Yes	Yes
• Redundancy procedure RSTP	Yes	Yes	Yes	Yes
• Passive listening	Yes	Yes	Yes	Yes
Protocol is supported				
• STP/RSTP	Yes	Yes	Yes	Yes
• STP	Yes	Yes	Yes	Yes
• RSTP	Yes	Yes	Yes	Yes
• RSTP Big Network Support	Yes	Yes	Yes	Yes
• LACP	Yes	Yes	Yes	Yes
Product functions Security				
Product function				
• ACL - Port/MAC-based	Yes	Yes	Yes	Yes
• IEEE 802.1x (radius)	Yes	Yes	Yes	Yes
• Broadcast/Multicast/Unicast Limiter	Yes	Yes	Yes	Yes
• Broadcast blocking	Yes	Yes	Yes	Yes
Protocol is supported SSH	Yes	Yes	Yes	Yes
Product functions Time				
Product function:	Yes	Yes	Yes	Yes
SICLOCK support				
Protocol is supported				
• NTP	No	No	No	No
• SNTP	Yes	Yes	Yes	Yes
• IEEE 1588 profile default	Yes	Yes	Yes	Yes
• IEEE 1588 profile gPTP	-	-	-	-
• IEEE 1588 profile PSRC	-	-	-	-
Type of time synchronization	-	-	-	-
Standards, specifications, approvals				
Standard				
• for EMC	IEC 61850, IEEE 1613	IEC 61850, IEEE 1613	IEC 61850, IEEE 1613	IEC 61850, IEEE 1613
• for EMC of FM	FM3611: Class 1, Division 2, Group A, B, C, D / T4, Class 1, Zone 2, Group IIC, T4	FM3611: Class 1, Division 2, Group A, B, C, D / T4, Class 1, Zone 2, Group IIC, T4	FM3611: Class 1, Division 2, Group A, B, C, D / T4, Class 1, Zone 2, Group IIC, T4	FM3611: Class 1, Division 2, Group A, B, C, D / T4, Class 1, Zone 2, Group IIC, T4
• for hazardous zone	EN 60079-0: 2006, EN 60079-15: 2005, II 3 G Ex nA II T4	EN 60079-0: 2006, EN 60079-15: 2005, II 3 G Ex nA II T4	EN 60079-0: 2006, EN 60079-15: 2005, II 3 G Ex nA II T4	EN 60079-0: 2006, EN 60079-15: 2005, II 3 G Ex nA II T4
• for CSA and UL safety	UL 508	UL 508	UL 508	UL 508
• for hazardous zone of CSA and UL	ANSI / ISA 12.12.01, CSA C22.2 No. 213-M1987, UL 1604 and 2279-15, CL. 1 / Div. 2 / GP. A, B, C, D T4, CL. 1 / Zone 2 / GP. IIC, T4	ANSI / ISA 12.12.01, CSA C22.2 No. 213-M1987, UL 1604 and 2279-15, CL. 1 / Div. 2 / GP. A, B, C, D T4, CL. 1 / Zone 2 / GP. IIC, T4	ANSI / ISA 12.12.01, CSA C22.2 No. 213-M1987, UL 1604 and 2279-15, CL. 1 / Div. 2 / GP. A, B, C, D T4, CL. 1 / Zone 2 / GP. IIC, T4	ANSI / ISA 12.12.01, CSA C22.2 No. 213-M1987, UL 1604 and 2279-15, CL. 1 / Div. 2 / GP. A, B, C, D T4, CL. 1 / Zone 2 / GP. IIC, T4
• For emitted interference	EN 61000-6-4:2007 (Class A)	EN 61000-6-4:2007 (Class A)	EN 61000-6-4:2007 (Class A)	EN 61000-6-4:2007 (Class A)
• for noise immunity	EN 61000-6-2:2005	EN 61000-6-2:2005	EN 61000-6-2:2005	EN 61000-6-2:2005

Technical specifications (continued)

Order No.	6GK5 302-7GD00-1EA3	6GK5 302-7GD00-1GA3	6GK5 302-7GD00-2EA3	6GK5 302-7GD00-2GA3
Product type designation	SCALANCE X302-7 EEC	SCALANCE X302-7 EEC	SCALANCE X302-7 EEC	SCALANCE X302-7 EEC
Certificate of suitability	EN 61000-6-2:2005, EN 61000-6-4:2007	EN 61000-6-2:2005, EN 61000-6-4:2007	EN 61000-6-2:2005, EN 61000-6-4:2007	EN 61000-6-2:2005, EN 61000-6-4:2007
• CE marking	Yes	Yes	Yes	Yes
• C-Tick	Yes	Yes	Yes	Yes
• Railroad application according to EN 50155	Yes	Yes	Yes	Yes
• Railroad application according to EN 50124-1	No	No	No	No
• IEC 61850-3	Yes	Yes	Yes	Yes
Marine classification corporation				
• American Bureau of Shipping Europe Ltd. (ABS)	-	-	-	-
• Bureau Veritas (BV)	-	-	-	-
• Det Norske Veritas (DNV)	-	-	-	-
• Germanischer Lloyd (GL)	-	-	-	-
• Lloyds Register of Shipping (LRS)	-	-	-	-
• Nippon Kaiji Kyokai (NK)	-	-	-	-

Order No.	6GK5 302-7GD00-3EA3	6GK5 302-7GD00-3GA3	6GK5 302-7GD00-4EA3	6GK5 302-7GD00-4GA3
Product type designation	SCALANCE X302-7 EEC	SCALANCE X302-7 EEC	SCALANCE X302-7 EEC	SCALANCE X302-7 EEC
Transmission rate				
Transmission rate 1	10 Mbit/s	10 Mbit/s	10 Mbit/s	10 Mbit/s
Transmission rate 2	100 Mbit/s	100 Mbit/s	100 Mbit/s	100 Mbit/s
Transmission rate 3	1 000 Mbit/s	1 000 Mbit/s	1 000 Mbit/s	1 000 Mbit/s
Interfaces				
Maximum number of electrical/optical connections for network components or terminal equipment	9	9	9	9
Number of electrical connections				
• for network components or terminal equipment	2	2	2	2
• For operation panel	-	-	-	-
• for signaling contact	1	1	2	2
• for media module	-	-	-	-
• for power supply	1	1	1	1
• for redundant power supply	-	-	1	1
Design of electrical connection				
• for network components or terminal equipment	RJ45 port	RJ45 port	RJ45 port	RJ45 port
• For operation panel	-	-	-	-
• For signal contact	3-pin terminal block	3-pin terminal block	3-pin terminal block	3-pin terminal block
• for power supply	3-pin terminal block	3-pin terminal block	2 x 3-pin terminal block	2 x 3-pin terminal block
Number of optical connections for fiber-optic cables				
• At 100 Mbit/s	7	7	7	7
• At 1000 Mbit/s	-	-	-	-
Design of optical connection for fiber-optic cables				
• at 100 Mbit/s	LC port (multimode up to 5 km)	LC port (multimode up to 5 km)	LC port (multimode up to 5 km)	LC port (multimode up to 5 km)
• at 1000 Mbit/s	-	-	-	-
Injectable optical power referred to 1 mW				
• of the transmitter output	-19 ... -14 dB	-19 ... -14 dB	-19 ... -14 dB	-19 ... -14 dB
• of the receiver input, maximum	-14 dB	-14 dB	-14 dB	-14 dB
Minimum optical sensitivity referred to 1 mW of the receiver input	-32 dB	-32 dB	-32 dB	-32 dB

PROFINET/Industrial Ethernet

Industrial Ethernet switches / media converters

SCALANCE X-300EEC managed

Technical specifications (continued)

Order No.	6GK5 302-7GD00-3EA3	6GK5 302-7GD00-3GA3	6GK5 302-7GD00-4EA3	6GK5 302-7GD00-4GA3
Product type designation	SCALANCE X302-7 EEC	SCALANCE X302-7 EEC	SCALANCE X302-7 EEC	SCALANCE X302-7 EEC
Minimum required attenuation factor of the FO transmission link	0 dB	0 dB	0 dB	0 dB
The range at the optical interface depends on the type of optical fiber used	0 ... 5 km	0 ... 5 km	0 ... 5 km	0 ... 5 km
Design of swap medium C-Plug	Yes	Yes	Yes	Yes
Inputs/outputs				
Operating voltage of signaling contacts with AC rated value	276 V	276 V	276 V	276 V
Operating current of signaling contacts with AC maximum	5 A	5 A	5 A	5 A
Operating voltage of signaling contacts with DC rated value	230 V	230 V	230 V	230 V
Operating current of signaling contacts with DC maximum	0.1 A	0.1 A	0.1 A	0.1 A
Supply voltage, current consumption, power loss				
Redundant type of power supply	No	No	Yes	Yes
Type of power supply	AC	AC	AC	AC
Supply voltage with AC • Rated value	230 V 80 ... 276 V	230 V 80 ... 276 V	230 V 80 ... 276 V	230 V 80 ... 276 V
Type of power supply 2	DC	DC	DC	DC
Supply voltage with DC • Rated value	220 V 46.25 ... 300 V	220 V 46.25 ... 300 V	220 V 46.25 ... 300 V	220 V 46.25 ... 300 V
Product component: fusing of power supply input	Yes	Yes	Yes	Yes
Type of fusing of power supply input	T 2 A / 250 V	T 2 A / 250 V	T 2 A / 250 V	T 2 A / 250 V
Current consumption, maximum	0.08 A	0.08 A	0.08 A	0.08 A
Effective power loss • at 24 V DC • at 230 V AC • at 250 V DC	- 18 W 18 W	- 18 W 18 W	- 18 W 18 W	- 18 W 18 W
Permissible ambient conditions				
Ambient temperature • During operation • During storage • During transport • Note	-40 ... +70 °C -40 ... +70 °C -40 ... +70 °C For a duration of 16 hours, a maximum operating temperature of +85 °C is permitted	-40 ... +70 °C -40 ... +70 °C -40 ... +70 °C For a duration of 16 hours, a maximum operating temperature of +85 °C is permitted	-40 ... +70 °C -40 ... +70 °C -40 ... +70 °C For a duration of 16 hours, a maximum operating temperature of +85 °C is permitted	-40 ... +70 °C -40 ... +70 °C -40 ... +70 °C For a duration of 16 hours, a maximum operating temperature of +85 °C is permitted
Relative humidity at 25 °C without condensation during operation, maximum	95 %	95 %	95 %	95 %
Ambient condition for operation	-	Conformal coating	-	Conformal coating
IP degree of protection	IP30	IP30	IP30	IP30

Technical specifications (continued)

Order No.	6GK5 302-7GD00-3EA3	6GK5 302-7GD00-3GA3	6GK5 302-7GD00-4EA3	6GK5 302-7GD00-4GA3
Product type designation	SCALANCE X302-7 EEC	SCALANCE X302-7 EEC	SCALANCE X302-7 EEC	SCALANCE X302-7 EEC
Design, dimensions and weights				
Design	Compact	Compact	Compact	Compact
Width	60 mm	60 mm	60 mm	60 mm
Height	125 mm	125 mm	125 mm	125 mm
Depth	123 mm	123 mm	123 mm	123 mm
Net weight	1.85 kg	1.85 kg	2.12 kg	2.12 kg
Type of mounting				
• 19-inch installation	Yes	Yes	Yes	Yes
• 35 mm DIN rail mounting	Yes	Yes	Yes	Yes
• Wall mounting	Yes	Yes	Yes	Yes
• S7-300 rail mounting	Yes	Yes	Yes	Yes
Type of mounting	Wall mounting only possible with additional wall bracket, 19" installation only when two X-300EEC switches are installed as a pair using a mounting plate	Wall mounting only possible with additional wall bracket, 19" installation only when two X-300EEC switches are installed as a pair using a mounting plate	Wall mounting only possible with additional wall bracket, 19" installation only when two X-300EEC switches are installed as a pair using a mounting plate	Wall mounting only possible with additional wall bracket, 19" installation only when two X-300EEC switches are installed as a pair using a mounting plate
Product properties, functions, components				
General				
Cascading with redundant ring with reconfiguration time < 0.3 s	50	50	50	50
Cascading with star topology	Any (only dependent on signal propagation time)	Any (only dependent on signal propagation time)	Any (only dependent on signal propagation time)	Any (only dependent on signal propagation time)
Product functions				
Management, configuration, programming				
Product function				
• CLI	Yes	Yes	Yes	Yes
• Web-based management	Yes	Yes	Yes	Yes
• MIB support	Yes	Yes	Yes	Yes
• TRAPs via e-mail	Yes	Yes	Yes	Yes
• Configuration with STEP 7	Yes	Yes	Yes	Yes
• RMON	Yes	Yes	Yes	Yes
• SMTP server	Yes	Yes	Yes	Yes
• Port mirroring	Yes	Yes	Yes	Yes
• CoS	Yes	Yes	Yes	Yes
• with IRT PROFINET IO Switch	No	No	No	No
• PROFINET IO diagnostics	Yes	Yes	Yes	Yes
• Switch-managed	Yes	Yes	Yes	Yes
Protocol is supported				
• Telnet	Yes	Yes	Yes	Yes
• HTTP	Yes	Yes	Yes	Yes
• HTTPS	Yes	Yes	Yes	Yes
• TFTP	Yes	Yes	Yes	Yes
• FTP	Yes	Yes	Yes	Yes
• BOOTP	Yes	Yes	Yes	Yes
• SNMP v1	Yes	Yes	Yes	Yes
• SNMP v2	Yes	Yes	Yes	Yes
• SNMP v3	Yes	Yes	Yes	Yes
• IGMP (snooping/querier)	Yes	Yes	Yes	Yes
• GMRP	Yes	Yes	Yes	Yes
• DCP	Yes	Yes	Yes	Yes
• LLDP	Yes	Yes	Yes	Yes
Identification & Maintenance				
• I&M0 - device-specific information	Yes	Yes	Yes	Yes
• I&M1 - higher-level designation/location designation	Yes	Yes	Yes	Yes

PROFINET/Industrial Ethernet

Industrial Ethernet switches / media converters

SCALANCE X-300EEC managed

Technical specifications (continued)

Order No.	6GK5 302-7GD00-3EA3	6GK5 302-7GD00-3GA3	6GK5 302-7GD00-4EA3	6GK5 302-7GD00-4GA3
Product type designation	SCALANCE X302-7 EEC	SCALANCE X302-7 EEC	SCALANCE X302-7 EEC	SCALANCE X302-7 EEC
Product functions Diagnostics				
Product function				
• Port diagnostics	Yes	Yes	Yes	Yes
• Packet size statistics	Yes	Yes	Yes	Yes
• Packet type statistics	Yes	Yes	Yes	Yes
• Error statistics	Yes	Yes	Yes	Yes
• SysLog	Yes	Yes	Yes	Yes
Product functions VLAN				
Product function				
• VLAN - port-based	Yes	Yes	Yes	Yes
• VLAN - dynamic	Yes	Yes	Yes	Yes
Maximum number of VLANs	255	255	255	255
Maximum number of dynamic VLANs	255	255	255	255
Protocol is supported				
• GVRP	Yes	Yes	Yes	Yes
Product functions DHCP				
Product function				
• DHCP client	Yes	Yes	Yes	Yes
• DHCP option 82	Yes	Yes	Yes	Yes
• DHCP option 66	Yes	Yes	Yes	Yes
• DHCP option 67	Yes	Yes	Yes	Yes
Product functions Redundancy				
Product function				
• Ring redundancy	Yes	Yes	Yes	Yes
• Redundancy manager	Yes	Yes	Yes	Yes
• Standby redundancy	Yes	Yes	Yes	Yes
• Redundancy procedure HSR	Yes	Yes	Yes	Yes
• Redundancy procedure MRP	Yes	Yes	Yes	Yes
• Redundancy procedure STP	Yes	Yes	Yes	Yes
• Redundancy procedure RSTP	Yes	Yes	Yes	Yes
• Passive listening	Yes	Yes	Yes	Yes
Protocol is supported				
• STP/RSTP	Yes	Yes	Yes	Yes
• STP	Yes	Yes	Yes	Yes
• RSTP	Yes	Yes	Yes	Yes
• RSTP Big Network Support	Yes	Yes	Yes	Yes
• LACP	Yes	Yes	Yes	Yes
Product functions Security				
Product function				
• ACL - Port/MAC-based	Yes	Yes	Yes	Yes
• IEEE 802.1x (radius)	Yes	Yes	Yes	Yes
• Broadcast/Multicast/Unicast Limiter	Yes	Yes	Yes	Yes
• Broadcast blocking	Yes	Yes	Yes	Yes
SSH protocol is supported	Yes	Yes	Yes	Yes
Product functions Time				
Product function:				
SICLOCK support	Yes	Yes	Yes	Yes
Protocol is supported				
• NTP	No	No	No	No
• SNTP	Yes	Yes	Yes	Yes
• IEEE 1588 profile default	Yes	Yes	Yes	Yes
• IEEE 1588 profile gPTP	-	-	-	-
• IEEE 1588 profile PSRC	-	-	-	-
Type of time synchronization	-	-	-	-

PROFINET/Industrial Ethernet

Industrial Ethernet switches / media converters

SCALANCE X-300EEC managed

Technical specifications (continued)

Order No.	6GK5 302-7GD00-3EA3	6GK5 302-7GD00-3GA3	6GK5 302-7GD00-4EA3	6GK5 302-7GD00-4GA3
Product type designation	SCALANCE X302-7 EEC	SCALANCE X302-7 EEC	SCALANCE X302-7 EEC	SCALANCE X302-7 EEC
Standards, specifications, approvals				
Standard	IEC 61850, IEEE 1613	IEC 61850, IEEE 1613	IEC 61850, IEEE 1613	IEC 61850, IEEE 1613
• For EMC	-	-	-	-
• For EMC of FM	-	-	-	-
• for hazardous zone	-	-	-	-
• For CSA and UL safety	UL 508, CSA C22.2 No. 142-M1987	UL 508, CSA C22.2 No. 142-M1987	UL 508, CSA C22.2 No. 142-M1987	UL 508, CSA C22.2 No. 142-M1987
• for hazardous zone of CSA and UL	-	-	-	-
• For emitted interference	EN 61000-6-4:2007 (Class A)	EN 61000-6-4:2007 (Class A)	EN 61000-6-4:2007 (Class A)	EN 61000-6-4:2007 (Class A)
• for noise immunity	EN 61000-6-2:2005	EN 61000-6-2:2005	EN 61000-6-2:2005	EN 61000-6-2:2005
Certificate of suitability	EN 61000-6-2:2005, EN 61000-6-4:2007	EN 61000-6-2:2005, EN 61000-6-4:2007	EN 61000-6-2:2005, EN 61000-6-4:2007	EN 61000-6-2:2005, EN 61000-6-4:2007
• CE marking	Yes	Yes	Yes	Yes
• C-Tick	Yes	Yes	Yes	Yes
• Railroad application according to EN 50155	Yes	Yes	Yes	Yes
• Railroad application according to EN 50124-1	No	No	No	No
• IEC 61850-3	Yes	Yes	Yes	Yes
Marine classification corporation				
• American Bureau of Shipping Europe Ltd. (ABS)	-	-	-	-
• Bureau Veritas (BV)	-	-	-	-
• Det Norske Veritas (DNV)	-	-	-	-
• Germanischer Lloyd (GL)	-	-	-	-
• Lloyds Register of Shipping (LRS)	-	-	-	-
• Nippon Kaiji Kyokai (NK)	-	-	-	-

Order No.	6GK5 307-2FD00-1EA3	6GK5 307-2FD00-1GA3	6GK5 307-2FD00-2EA3	6GK5 307-2FD00-2GA3
Product type designation	SCALANCE X307-2 EEC	SCALANCE X307-2 EEC	SCALANCE X307-2 EEC	SCALANCE X307-2 EEC
Transmission rate				
Transmission rate 1	10 Mbit/s	10 Mbit/s	10 Mbit/s	10 Mbit/s
Transmission rate 2	100 Mbit/s	100 Mbit/s	100 Mbit/s	100 Mbit/s
Transmission rate 3	1 000 Mbit/s	1 000 Mbit/s	1 000 Mbit/s	1 000 Mbit/s
Interfaces				
Maximum number of electrical/optical connections for network components or terminal equipment	9	9	9	9
Number of electrical connections				
• for network components or terminal equipment	7	7	7	7
• For operation panel	-	-	-	-
• for signaling contact	1	1	2	2
• for media module	-	-	-	-
• for power supply	1	1	2	2
• for redundant power supply	1	1	2	2
Design of electrical connection				
• for network components or terminal equipment	RJ45 port	RJ45 port	RJ45 port	RJ45 port
• For operation panel	-	-	-	-
• For signal contact	2-pin terminal block	2-pin terminal block	2-pin terminal block	2-pin terminal block
• for power supply	4-pin terminal block	4-pin terminal block	2 x 4-pin terminal block	2 x 4-pin terminal block
Number of optical connections for fiber-optic cables				
• At 100 Mbit/s	2	2	2	2
• At 1000 Mbit/s#	-	-	-	-

2

PROFINET/Industrial Ethernet

Industrial Ethernet switches / media converters

SCALANCE X-300EEC managed

Technical specifications (continued)

Order No.	6GK5 307-2FD00-1EA3	6GK5 307-2FD00-1GA3	6GK5 307-2FD00-2EA3	6GK5 307-2FD00-2GA3
Product type designation	SCALANCE X307-2 EEC	SCALANCE X307-2 EEC	SCALANCE X307-2 EEC	SCALANCE X307-2 EEC
Design of optical connection for fiber-optic cables				
• at 100 Mbit/s	LC port (multimode up to 5 km)	LC port (multimode up to 5 km)	LC port (multimode up to 5 km)	LC port (multimode up to 5 km)
• at 1000 Mbit/s	-	-	-	-
Injectable optical power referred to 1 mW				
• of the transmitter output	-19 ... -14 dB	-19 ... -14 dB	-19 ... -14 dB	-19 ... -14 dB
• of the receiver input, maximum	-14 dB	-14 dB	-14 dB	-14 dB
Minimum optical sensitivity referred to 1 mW of the receiver input	-32 dB	-32 dB	-32 dB	-32 dB
Minimum required attenuation factor of the FO transmission link	0 dB	0 dB	0 dB	0 dB
The range at the optical interface depends on the type of optical fiber used	0 ... 5 km	0 ... 5 km	0 ... 5 km	0 ... 5 km
Design of swap medium C-Plug	Yes	Yes	Yes	Yes
Inputs/outputs				
Operating voltage of signaling contacts with DC rated value	24 V	24 V	24 V	24 V
Operating current of signaling contacts with DC maximum	0.1 A	0.1 A	0.1 A	0.1 A
Supply voltage, current consumption, power loss				
Redundant type of power supply	No	No	Yes	Yes
Type of power supply	DC	DC	DC	DC
Supply voltage with AC	-	-	-	-
• Rated value	-	-	-	-
Type of power supply 2	DC	DC	DC	DC
DC power supply	24 V	24 V	24 V	24 V
• Rated value	19.2 ... 57.6 V	19.2 ... 57.6 V	19.2 ... 57.6 V	19.2 ... 57.6 V
Product component: fusing at power supply input	Yes	Yes	Yes	Yes
Design of fusing at input for supply voltage	T 4A / 125V	T 4A / 125V	T 4A / 125V	T 4A / 125V
Current consumption, maximum	0.75 A	0.75 A	0.75 A	0.75 A
Effective power loss				
• at 24 V DC	12 W	12 W	12 W	12 W
• at 230 V AC	-	-	-	-
• at 250 V DC	-	-	-	-
Permissible ambient conditions				
Ambient temperature				
• During operation	-40 ... +70 °C	-40 ... +70 °C	-40 ... +70 °C	-40 ... +70 °C
• During storage	-40 ... +70 °C	-40 ... +70 °C	-40 ... +70 °C	-40 ... +70 °C
• During transport	-40 ... +70 °C	-40 ... +70 °C	-40 ... +70 °C	-40 ... +70 °C
• Note	For a duration of 16 hours, a maximum operating temperature of +85 °C is permitted	For a duration of 16 hours, a maximum operating temperature of +85 °C is permitted	For a duration of 16 hours, a maximum operating temperature of +85 °C is permitted	For a duration of 16 hours, a maximum operating temperature of +85 °C is permitted
Relative humidity at 25 °C without condensation during operation, maximum	95 %	95 %	95 %	95 %
Ambient conditions for operation	-	Conformal coating	-	Conformal coating
IP degree of protection	IP30	IP30	IP30	IP30

PROFINET/Industrial Ethernet

Industrial Ethernet switches / media converters

SCALANCE X-300EEC managed

Technical specifications (continued)

Order No.	6GK5 307-2FD00-1EA3	6GK5 307-2FD00-1GA3	6GK5 307-2FD00-2EA3	6GK5 307-2FD00-2GA3
Product type designation	SCALANCE X307-2 EEC	SCALANCE X307-2 EEC	SCALANCE X307-2 EEC	SCALANCE X307-2 EEC
Design, dimensions and weights				
Design	Compact	Compact	Compact	Compact
Width	60 mm	60 mm	60 mm	60 mm
Height	125 mm	125 mm	125 mm	125 mm
Depth	123 mm	123 mm	123 mm	123 mm
Net weight	1.8 kg	1.8 kg	2.03 kg	2.03 kg
Type of mounting				
• 19-inch installation	Yes	Yes	Yes	Yes
• 35 mm DIN rail mounting	Yes	Yes	Yes	Yes
• Wall mounting	Yes	Yes	Yes	Yes
• S7-300 rail mounting	Yes	Yes	Yes	Yes
Type of mounting	Wall mounting only possible with additional wall bracket, 19" installation only when two X-300EEC switches are installed as a pair using a mounting plate	Wall mounting only possible with additional wall bracket, 19" installation only when two X-300EEC switches are installed as a pair using a mounting plate	Wall mounting only possible with additional wall bracket, 19" installation only when two X-300EEC switches are installed as a pair using a mounting plate	Wall mounting only possible with additional wall bracket, 19" installation only when two X-300EEC switches are installed as a pair using a mounting plate
Product properties, functions, components				
General				
Cascading with redundant ring with reconfiguration time < 0.3 s	50	50	50	50
Cascading with star topology	Any (only dependent on signal propagation time)	Any (only dependent on signal propagation time)	Any (only dependent on signal propagation time)	Any (only dependent on signal propagation time)
Product functions				
Management, configuration, programming				
Product function				
• CLI	Yes	Yes	Yes	Yes
• Web-based management	Yes	Yes	Yes	Yes
• MIB support	Yes	Yes	Yes	Yes
• TRAPs via e-mail	Yes	Yes	Yes	Yes
• Configuration with STEP 7	Yes	Yes	Yes	Yes
• RMON	Yes	Yes	Yes	Yes
• SMTP server	Yes	Yes	Yes	Yes
• Port mirroring	Yes	Yes	Yes	Yes
• CoS	Yes	Yes	Yes	Yes
• with IRT PROFINET IO Switch	No	No	No	No
• PROFINET IO diagnostics	Yes	Yes	Yes	Yes
• Switch-managed	Yes	Yes	Yes	Yes
Protocol is supported				
• Telnet	Yes	Yes	Yes	Yes
• HTTP	Yes	Yes	Yes	Yes
• HTTPS	Yes	Yes	Yes	Yes
• TFTP	Yes	Yes	Yes	Yes
• FTP	Yes	Yes	Yes	Yes
• BOOTP	Yes	Yes	Yes	Yes
• SNMP v1	Yes	Yes	Yes	Yes
• SNMP v2	Yes	Yes	Yes	Yes
• SNMP v3	Yes	Yes	Yes	Yes
• IGMP (snooping/querier)	Yes	Yes	Yes	Yes
• GMRP	Yes	Yes	Yes	Yes
• DCP	Yes	Yes	Yes	Yes
• LLDP	Yes	Yes	Yes	Yes
Identification & maintenance				
• I&M0 - device-specific information	Yes	Yes	Yes	Yes
• I&M1 - higher-level designation/location designation	Yes	Yes	Yes	Yes

2

PROFINET/Industrial Ethernet

Industrial Ethernet switches / media converters

SCALANCE X-300EEC managed

Technical specifications (continued)

Order No.	6GK5 307-2FD00-1EA3	6GK5 307-2FD00-1GA3	6GK5 307-2FD00-2EA3	6GK5 307-2FD00-2GA3
Product type designation	SCALANCE X307-2 EEC	SCALANCE X307-2 EEC	SCALANCE X307-2 EEC	SCALANCE X307-2 EEC
Product functions Diagnostics				
Product function				
• Port diagnostics	Yes	Yes	Yes	Yes
• Packet size statistics	Yes	Yes	Yes	Yes
• Packet type statistics	Yes	Yes	Yes	Yes
• Error statistics	Yes	Yes	Yes	Yes
• SysLog	Yes	Yes	Yes	Yes
Product functions VLAN				
Product function				
• VLAN - port-based	Yes	Yes	Yes	Yes
• VLAN - dynamic	Yes	Yes	Yes	Yes
Maximum number of VLANs	255	255	255	255
Maximum number of dynamic VLANs	255	255	255	255
GVRP protocol is supported	Yes	Yes	Yes	Yes
Product functions DHCP				
Product function				
• DHCP client	Yes	Yes	Yes	Yes
• DHCP option 82	Yes	Yes	Yes	Yes
• DHCP option 66	Yes	Yes	Yes	Yes
• DHCP option 67	Yes	Yes	Yes	Yes
Product functions Redundancy				
Product function				
• Ring redundancy	Yes	Yes	Yes	Yes
• Redundancy manager	Yes	Yes	Yes	Yes
• Standby redundancy	Yes	Yes	Yes	Yes
• Redundancy procedure HSR	Yes	Yes	Yes	Yes
• Redundancy procedure MRP	Yes	Yes	Yes	Yes
• Redundancy procedure STP	Yes	Yes	Yes	Yes
• Redundancy procedure RSTP	Yes	Yes	Yes	Yes
• Passive listening	Yes	Yes	Yes	Yes
Protocol is supported				
• STP/RSTP	Yes	Yes	Yes	Yes
• STP	Yes	Yes	Yes	Yes
• RSTP	Yes	Yes	Yes	Yes
• RSTP Big Network Support	Yes	Yes	Yes	Yes
• LACP	Yes	Yes	Yes	Yes
Product functions Security				
Product function				
• ACL - Port/MAC-based	Yes	Yes	Yes	Yes
• IEEE 802.1x (radius)	Yes	Yes	Yes	Yes
• Broadcast/Multicast/Unicast Limiter	Yes	Yes	Yes	Yes
• Broadcast blocking	Yes	Yes	Yes	Yes
Protocol is supported SSH	Yes	Yes	Yes	Yes
Product functions Time				
Product function:				
SICLOCK support	Yes	Yes	Yes	Yes
Protocol is supported				
• NTP	No	No	No	No
• SNTP	Yes	Yes	Yes	Yes
• IEEE 1588 profile default	Yes	Yes	Yes	Yes
• IEEE 1588 profile gPTP	-	-	-	-
• IEEE 1588 profile PSRC	-	-	-	-
Type of time synchronization	-	-	-	-

PROFINET/Industrial Ethernet

Industrial Ethernet switches / media converters

SCALANCE X-300EEC managed

Technical specifications (continued)

Order No.	6GK5 307-2FD00-1EA3	6GK5 307-2FD00-1GA3	6GK5 307-2FD00-2EA3	6GK5 307-2FD00-2GA3
Product type designation	SCALANCE X307-2 EEC	SCALANCE X307-2 EEC	SCALANCE X307-2 EEC	SCALANCE X307-2 EEC
Standards, specifications, approvals				
Standard	IEC 61850, IEEE 1613	IEC 61850, IEEE 1613	IEC 61850, IEEE 1613	IEC 61850, IEEE 1613
• for EMC	FM3611: Class 1, Division 2, Group A, B, C, D / T4, Class 1, Zone 2, Group IIC, T4	FM3611: Class 1, Division 2, Group A, B, C, D / T4, Class 1, Zone 2, Group IIC, T4	FM3611: Class 1, Division 2, Group A, B, C, D / T4, Class 1, Zone 2, Group IIC, T4	FM3611: Class 1, Division 2, Group A, B, C, D / T4, Class 1, Zone 2, Group IIC, T4
• for EMC of FM	EN 60079-0: 2006, EN 60079-15: 2005, II 3 G Ex nA II T4	EN 60079-0: 2006, EN 60079-15: 2005, II 3 G Ex nA II T4	EN 60079-0: 2006, EN 60079-15: 2005, II 3 G Ex nA II T4	EN 60079-0: 2006, EN 60079-15: 2005, II 3 G Ex nA II T4
• for hazardous zone	UL 508	UL 508	UL 508	UL 508
• for CSA and UL safety	ANSI / ISA 12.12.01, CSA C22.2 No. 213- M1987, UL 1604 and 2279-15, CL. 1 / Div. 2 / GP. A, B, C, D T4, CL. 1 / Zone 2 / GP. IIC, T4	ANSI / ISA 12.12.01, CSA C22.2 No. 213- M1987, UL 1604 and 2279-15, CL. 1 / Div. 2 / GP. A, B, C, D T4, CL. 1 / Zone 2 / GP. IIC, T4	ANSI / ISA 12.12.01, CSA C22.2 No. 213- M1987, UL 1604 and 2279-15, CL. 1 / Div. 2 / GP. A, B, C, D T4, CL. 1 / Zone 2 / GP. IIC, T4	ANSI / ISA 12.12.01, CSA C22.2 No. 213- M1987, UL 1604 and 2279-15, CL. 1 / Div. 2 / GP. A, B, C, D T4, CL. 1 / Zone 2 / GP. IIC, T4
• for hazardous zone of CSA and UL	EN 61000-6-4:2007 (Class A)	EN 61000-6-4:2007 (Class A)	EN 61000-6-4:2007 (Class A)	EN 61000-6-4:2007 (Class A)
• For emitted interference	EN 61000-6-2:2005	EN 61000-6-2:2005	EN 61000-6-2:2005	EN 61000-6-2:2005
• for noise immunity	EN 61000-6-2:2005, EN 61000-6-4:2007	EN 61000-6-2:2005, EN 61000-6-4:2007	EN 61000-6-2:2005, EN 61000-6-4:2007	EN 61000-6-2:2005, EN 61000-6-4:2007
Certificate of suitability	Yes	Yes	Yes	Yes
• CE marking	Yes	Yes	Yes	Yes
• C-Tick	Yes	Yes	Yes	Yes
• Railroad application according to EN 50155	Yes	Yes	Yes	Yes
• Railroad application according to EN 50124-1	No	No	No	No
• IEC 61850-3	Yes	Yes	Yes	Yes
Marine classification corporation				
• American Bureau of Shipping Europe Ltd. (ABS)	-	-	-	-
• Bureau Veritas (BV)	-	-	-	-
• Det Norske Veritas (DNV)	-	-	-	-
• Germanischer Lloyd (GL)	-	-	-	-
• Lloyds Register of Shipping (LRS)	-	-	-	-
• Nippon Kaiji Kyokai (NK)	-	-	-	-

Order No.	6GK5 307-2FD00-3EA3	6GK5 307-2FD00-3GA3	6GK5 307-2FD00-4EA3	6GK5 307-2FD00-4GA3
Product type designation	SCALANCE X307-2 EEC	SCALANCE X307-2 EEC	SCALANCE X307-2 EEC	SCALANCE X307-2 EEC
Transmission rate				
Transmission rate 1	10 Mbit/s	10 Mbit/s	10 Mbit/s	10 Mbit/s
Transmission rate 2	100 Mbit/s	100 Mbit/s	100 Mbit/s	100 Mbit/s
Transmission rate 3	1 000 Mbit/s	1 000 Mbit/s	1 000 Mbit/s	1 000 Mbit/s
Interfaces				
Maximum number of electrical/ optical connections for network components or terminal equipment	9	9	9	9
Number of electrical connections				
• for network components or terminal equipment	7	7	7	7
• For operation panel	-	-	-	-
• for signaling contact	1	1	2	2
• for media module	-	-	-	-
• for power supply	1	1	1	1
• for redundant power supply	-	-	1	1

2

PROFINET/Industrial Ethernet

Industrial Ethernet switches / media converters

SCALANCE X-300EEC managed

Technical specifications (continued)

Order No.	6GK5 307-2FD00-3EA3	6GK5 307-2FD00-3GA3	6GK5 307-2FD00-4EA3	6GK5 307-2FD00-4GA3
Product type designation	SCALANCE X307-2 EEC	SCALANCE X307-2 EEC	SCALANCE X307-2 EEC	SCALANCE X307-2 EEC
Design of electrical connection	RJ45 port	RJ45 port	RJ45 port	RJ45 port
• for network components or terminal equipment				
• For operation panel	-	-	-	-
• For signal contact	3-pin terminal block	3-pin terminal block	3-pin terminal block	3-pin terminal block
• for power supply	3-pin terminal block	3-pin terminal block	2 x 3-pin terminal block	2 x 3-pin terminal block
Number of optical connections for fiber-optic cables				
• At 100 Mbit/s	2	2	2	2
• At 1000 Mbit/s	-	-	-	-
Design of optical connection for fiber-optic cables				
• At 100 Mbit/s	LC port (multimode up to 5 km)	LC port (multimode up to 5 km)	LC port (multimode up to 5 km)	LC port (multimode up to 5 km)
• at 1000 Mbit/s	-	-	-	-
Injectable optical power referred to 1 mW				
• of the transmitter output	-19 ... -14 dB	-19 ... -14 dB	-19 ... -14 dB	-19 ... -14 dB
• of the receiver input, maximum	-14 dB	-14 dB	-14 dB	-14 dB
Minimum optical sensitivity referred to 1 mW of the receiver input	-32 dB	-32 dB	-32 dB	-32 dB
Minimum required attenuation factor of the FO transmission link	0 dB	0 dB	0 dB	0 dB
The range at the optical interface depends on the type of optical fiber used	0 ... 5 km	0 ... 5 km	0 ... 5 km	0 ... 5 km
Design of swap medium C-Plug	Yes	Yes	Yes	Yes
Inputs/outputs				
Operating voltage of signaling contacts with AC rated value	276 V	276 V	276 V	276 V
Operating current of signaling contacts with AC maximum	5 A	5 A	5 A	5 A
Operating voltage of signaling contacts with DC rated value	230 V	230 V	230 V	230 V
Operating current of signaling contacts with DC maximum	0.1 A	0.1 A	0.1 A	0.1 A
Supply voltage, current consumption, power loss				
Redundant type of power supply	No	No	Yes	Yes
Type of power supply	AC	AC	AC	AC
Supply voltage with AC	230 V	230 V	230 V	230 V
• Rated value	80 ... 276 V	80 ... 276 V	80 ... 276 V	80 ... 276 V
Type of power supply 2	DC	DC	DC	DC
Supply voltage with DC	220 V	220 V	220 V	220 V
• Rated value	46.25 ... 300 V	46.25 ... 300 V	46.25 ... 300 V	46.25 ... 300 V
Product component: fusing of power supply input	Yes	Yes	Yes	Yes
Type of fusing of power supply input	T 2 A / 250 V	T 2 A / 250 V	T 2 A / 250 V	T 2 A / 250 V
Current consumption, maximum	0.08 A	0.08 A	0.08 A	0.08 A
Effective power loss				
• at 24 V DC	-	-	-	-
• at 230 V AC	18 W	18 W	18 W	18 W
• at 250 V DC	18 W	18 W	18 W	18 W

PROFINET/Industrial Ethernet

Industrial Ethernet switches / media converters

SCALANCE X-300EEC managed

Technical specifications (continued)

Order No.	6GK5 307-2FD00-3EA3	6GK5 307-2FD00-3GA3	6GK5 307-2FD00-4EA3	6GK5 307-2FD00-4GA3
Product type designation	SCALANCE X307-2 EEC	SCALANCE X307-2 EEC	SCALANCE X307-2 EEC	SCALANCE X307-2 EEC
Permissible ambient conditions				
Ambient temperature				
• During operation	-40 ... +70 °C	-40 ... +70 °C	-40 ... +70 °C	-40 ... +70 °C
• During storage	-40 ... +70 °C	-40 ... +70 °C	-40 ... +70 °C	-40 ... +70 °C
• During transport	-40 ... +70 °C	-40 ... +70 °C	-40 ... +70 °C	-40 ... +70 °C
• Note	For a duration of 16 hours, a maximum operating temperature of +85 °C is permitted	For a duration of 16 hours, a maximum operating temperature of +85 °C is permitted	For a duration of 16 hours, a maximum operating temperature of +85 °C is permitted	For a duration of 16 hours, a maximum operating temperature of +85 °C is permitted
Relative humidity at 25 °C without condensation during operation, maximum	95 %	95 %	95 %	95 %
Ambient conditions for operation	-	Conformal coating	-	Conformal coating
IP degree of protection	IP30	IP30	IP30	IP30
Design, dimensions and weights				
Design	Compact	Compact	Compact	Compact
Width	60 mm	60 mm	60 mm	60 mm
Height	125 mm	125 mm	125 mm	125 mm
Depth	123 mm	123 mm	123 mm	123 mm
Net weight	1.85 kg	1.85 kg	2.12 kg	2.12 kg
Type of mounting				
• 19-inch installation	Yes	Yes	Yes	Yes
• 35 mm DIN rail mounting	Yes	Yes	Yes	Yes
• Wall mounting	Yes	Yes	Yes	Yes
• S7-300 rail mounting	Yes	Yes	Yes	Yes
Type of mounting	Wall mounting only possible with additional wall support, 19" mounting only with pairs of X-300EEC switches and a mounting plate	Wall mounting only possible with additional wall support, 19" mounting only with pairs of X-300EEC switches and a mounting plate	Wall mounting only possible with additional wall support, 19" mounting only with pairs of X-300EEC switches and a mounting plate	Wall mounting only possible with additional wall support, 19" mounting only with pairs of X-300EEC switches and a mounting plate
Product properties, functions, components				
General				
Cascading with redundant ring at reconfiguration time < 0.3 s	50	50	50	50
Cascading with star topology	Any (only dependent on signal propagation time)	Any (only dependent on signal propagation time)	Any (only dependent on signal propagation time)	Any (only dependent on signal propagation time)
Product functions				
Management, configuration, programming				
Product function				
• CLI	Yes	Yes	Yes	Yes
• Web-based management	Yes	Yes	Yes	Yes
• MIB support	Yes	Yes	Yes	Yes
• Traps via e-mail	Yes	Yes	Yes	Yes
• Configuration with STEP 7	Yes	Yes	Yes	Yes
• RMON	Yes	Yes	Yes	Yes
• SMTP server	Yes	Yes	Yes	Yes
• Port mirroring	Yes	Yes	Yes	Yes
• CoS	Yes	Yes	Yes	Yes
• with IRT PROFINET IO Switch	No	No	No	No
• PROFINET IO-Diagnostics	Yes	Yes	Yes	Yes
• Switch-managed	Yes	Yes	Yes	Yes

PROFINET/Industrial Ethernet

Industrial Ethernet switches / media converters

SCALANCE X-300EEC managed

Technical specifications (continued)

Order No.	6GK5 307-2FD00-3EA3	6GK5 307-2FD00-3GA3	6GK5 307-2FD00-4EA3	6GK5 307-2FD00-4GA3
Product type designation	SCALANCE X307-2 EEC	SCALANCE X307-2 EEC	SCALANCE X307-2 EEC	SCALANCE X307-2 EEC
Protocol is supported				
• Telnet	Yes	Yes	Yes	Yes
• HTTP	Yes	Yes	Yes	Yes
• HTTPS	Yes	Yes	Yes	Yes
• TFTP	Yes	Yes	Yes	Yes
• FTP	Yes	Yes	Yes	Yes
• BOOTP	Yes	Yes	Yes	Yes
• SNMP v1	Yes	Yes	Yes	Yes
• SNMP v2	Yes	Yes	Yes	Yes
• SNMP v3	Yes	Yes	Yes	Yes
• IGMP (snooping/querier)	Yes	Yes	Yes	Yes
• GMRP	Yes	Yes	Yes	Yes
• DCP	Yes	Yes	Yes	Yes
• LLDP	Yes	Yes	Yes	Yes
Identification & Maintenance				
• I&M0 - device-specific information	Yes	Yes	Yes	Yes
• I&M1 - higher-level designation/location designation	Yes	Yes	Yes	Yes
Product functions Diagnostics				
Product function				
• Port diagnostics	Yes	Yes	Yes	Yes
• Packet size statistics	Yes	Yes	Yes	Yes
• Packet type statistics	Yes	Yes	Yes	Yes
• Error statistics	Yes	Yes	Yes	Yes
• SysLog	Yes	Yes	Yes	Yes
Product functions VLAN				
Product function				
• VLAN - port-based	Yes	Yes	Yes	Yes
• VLAN - dynamic	Yes	Yes	Yes	Yes
Maximum number of VLANs	255	255	255	255
Maximum number of dynamic VLANs	255	255	255	255
GVRP protocol is supported	Yes	Yes	Yes	Yes
Product functions DHCP				
Product function				
• DHCP client	Yes	Yes	Yes	Yes
• DHCP option 82	Yes	Yes	Yes	Yes
• DHCP option 66	Yes	Yes	Yes	Yes
• DHCP option 67	Yes	Yes	Yes	Yes
Product functions Redundancy				
Product function				
• Ring redundancy	Yes	Yes	Yes	Yes
• Redundancy manager	Yes	Yes	Yes	Yes
• Standby redundancy	Yes	Yes	Yes	Yes
• Redundancy procedure HSR	Yes	Yes	Yes	Yes
• Redundancy procedure MRP	Yes	Yes	Yes	Yes
• Redundancy procedure STP	Yes	Yes	Yes	Yes
• Redundancy procedure RSTP	Yes	Yes	Yes	Yes
• Passive listening	Yes	Yes	Yes	Yes
Protocol is supported				
• STP/RSTP	Yes	Yes	Yes	Yes
• STP	Yes	Yes	Yes	Yes
• RSTP	Yes	Yes	Yes	Yes
• RSTP Big Network Support	Yes	Yes	Yes	Yes
• LACP	Yes	Yes	Yes	Yes

Technical specifications (continued)

Order No.	6GK5 307-2FD00-3EA3	6GK5 307-2FD00-3GA3	6GK5 307-2FD00-4EA3	6GK5 307-2FD00-4GA3
Product type designation	SCALANCE X307-2 EEC	SCALANCE X307-2 EEC	SCALANCE X307-2 EEC	SCALANCE X307-2 EEC
Product functions Security				
Product function				
• ACL - Port/MAC-based	Yes	Yes	Yes	Yes
• IEEE 802.1x (Radius)	Yes	Yes	Yes	Yes
• Broadcast/Multicast/Unicast Limiter	Yes	Yes	Yes	Yes
• Broadcast blocking	Yes	Yes	Yes	Yes
SSH protocol is supported	Yes	Yes	Yes	Yes
Product functions Time				
Product function: SICLOCK support	Yes	Yes	Yes	Yes
Protocol is supported				
• NTP	No	No	No	No
• SNTP	Yes	Yes	Yes	Yes
• IEEE 1588 profile default	Yes	Yes	Yes	Yes
• IEEE 1588 profile gPTP	-	-	-	-
• IEEE 1588 profile PSRC	-	-	-	-
Type of time synchronization	-	-	-	-
Standards, specifications, approvals				
Standard				
• For EMC	IEC 61850, IEEE 1613	IEC 61850, IEEE 1613	IEC 61850, IEEE 1613	IEC 61850, IEEE 1613
• For EMC of FM	-	-	-	-
• for hazardous zone	-	-	-	-
• For CSA and UL safety	UL 508, CSA C22.2 No. 142-M1987	UL 508, CSA C22.2 No. 142-M1987	UL 508, CSA C22.2 No. 142-M1987	UL 508, CSA C22.2 No. 142-M1987
• for hazardous zone of CSA and UL	-	-	-	-
• For emitted interference	EN 61000-6-4:2007 (Class A)	EN 61000-6-4:2007 (Class A)	EN 61000-6-4:2007 (Class A)	EN 61000-6-4:2007 (Class A)
• for noise immunity	EN 61000-6-2:2005	EN 61000-6-2:2005	EN 61000-6-2:2005	EN 61000-6-2:2005
Certificate of suitability	EN 61000-6-2:2005, EN 61000-6-4:2007	EN 61000-6-2:2005, EN 61000-6-4:2007	EN 61000-6-2:2005, EN 61000-6-4:2007	EN 61000-6-2:2005, EN 61000-6-4:2007
• CE mark	Yes	Yes	Yes	Yes
• C-Tick	Yes	Yes	Yes	Yes
• Railroad application according to EN 50155	Yes	Yes	Yes	Yes
• Railroad application according to EN 50124-1	No	No	No	No
• IEC 61850-3	Yes	Yes	Yes	Yes
Marine classification corporation				
• American Bureau of Shipping Europe Ltd. (ABS)	-	-	-	-
• Bureau Veritas (BV)	-	-	-	-
• Det Norske Veritas (DNV)	-	-	-	-
• Germanischer Lloyd (GL)	-	-	-	-
• Lloyds Register of Shipping (LRS)	-	-	-	-
• Nippon Kaiji Kyokai (NK)	-	-	-	-

PROFINET/Industrial Ethernet

Industrial Ethernet switches / media converters

SCALANCE X-300EEC managed

2

Ordering data

Order No.

Order No.

SCALANCE X-300EEC Industrial Ethernet switches

Compact Industrial Ethernet switches for setting up electrical and/or optical Industrial Ethernet networks; RSTP, RMON, IGMP Snooping/Querier, management functionality via SNMP, PROFINET and web server, 24 V power supply; EN 50155 approval for railway applications

SCALANCE X302-7EEC;
2 x 10/100/1000 Mbit/s RJ45 ports, electrical;
7 x 100 Mbit/s LC ports, optical (multimode, glass) up to 5 km

24 V DC power supply

- 1 power supply
- 2 power supplies
- 1 power supply with conformal coating
- 2 power supplies with conformal coating

100-240 AC / 60-250 V DC power supply

- 1 power supply
- 2 power supplies
- 1 power supply with conformal coating
- 2 power supplies with conformal coating

SCALANCE X307-2EEC;
5 x 10/100 Mbit/s RJ45 ports, electrical;
2 x 10/100/1000 Mbit/s RJ45 ports, electrical
2 x 100 Mbit/s LC ports, optical (multimode, glass) up to 5 km

24 V DC power supply

- 1 power supply
- 2 power supplies
- 1 power supply with conformal coating
- 2 power supplies with conformal coating

100-240 AC / 60-250 V DC power supply

- 1 power supply
- 2 power supplies
- 1 power supply with conformal coating
- 2 power supplies with conformal coating

6GK5 302-7GD00-1EA3
6GK5 302-7GD00-2EA3
6GK5 302-7GD00-1GA3

6GK5 302-7GD00-2GA3

6GK5 302-7GD00-3EA3
6GK5 302-7GD00-4EA3
6GK5 302-7GD00-3GA3

6GK5 302-7GD00-4GA3

6GK5 307-2FD00-1EA3
6GK5 307-2FD00-2EA3
6GK5 307-2FD00-1GA3

6GK5 307-2FD00-2GA3

6GK5 307-2FD00-3EA3
6GK5 307-2FD00-4EA3
6GK5 307-2FD00-3GA3

6GK5 307-2FD00-4GA3

Accessories

IE FC TP Standard Cable GP 2 x 2 (Type A)

4-core, shielded TP installation cable for connection to IE FC Outlet RJ45/IE FC RJ45 Plug; PROFINET-compliant; with UL approval; sold by the meter; max. length 1000 m, minimum order 20 m

6XV1 840-2AH10

IE FC TP standard cable GP 4 x 2

8-core, shielded TP installation cable for connection to IE FC RJ45 Modular Outlet for universal application; with UL approval; sold by the meter; max quantity 1000 m, minimum order 20 m

- AWG 22, for connection to IE FC RJ45 Modular Outlet
- AWG 24, for connection to IE FC RJ45 Plug 4 x 2

6XV1 870-2E

6XV1 878-2A

IE FC TP Flexible Cable GP 4 x 2

8-core, shielded TP installation cable for occasional moving; with UL approval; sold by the meter; max. length 1000 m, minimum order 20 m

- AWG 24, for connection to IE FC RJ45 Plug 4 x 2

6XV1 878-2B

IE TP Cord RJ45/RJ45

TP cable 4 x 2 with two RJ45 connectors

- 0.5 m
- 1 m
- 2 m
- 6 m
- 10 m

6XV1 870-3QE50

6XV1 870-3QH10

6XV1 870-3QH20

6XV1 870-3QH60

6XV1 870-3QN10

PROFINET/Industrial Ethernet

Industrial Ethernet switches / media converters

SCALANCE X-300EEC managed

Ordering data	Order No.	More information
<i>Accessories (continued)</i>		
<p>IE FC RJ45 Plug 180</p> <p>RJ45 plug connector for Industrial Ethernet with a rugged metal enclosure and integrated insulation displacement contacts for connecting Industrial Ethernet FC installation cables; with 180° cable outlet; for network components and CPs/CPU with Industrial Ethernet interface</p> <ul style="list-style-type: none"> • 1 pack = 1 unit • 1 pack = 10 units • 1 pack = 50 units 	<p>6GK1 901-1BB10-2AA0 6GK1 901-1BB10-2AB0 6GK1 901-1BB10-2AE0</p>	<p>To assist in selecting the right Industrial Ethernet switches as well as configuration of modular versions, the SIMATIC NET Selection Tool is available:</p> <p>Online version: www.siemens.com/snst</p> <p>Offline version: www.siemens.com/snst-download</p>
<p>IE FC RJ45 Plug 4 x 2</p> <p>RJ45 plug connector for Industrial Ethernet (10/100/1000 Mbit/s) with a rugged metal enclosure and integrated insulation displacement contacts for connecting Industrial Ethernet FC installation cables; 180° cable outlet; for network components and CPs/CPU with Industrial Ethernet interface</p> <ul style="list-style-type: none"> • 1 pack = 1 unit • 1 pack = 10 units • 1 pack = 50 units 	<p>6GK1 901-1BB11-2AA0 6GK1 901-1BB11-2AB0 6GK1 901-1BB11-2AE0</p>	
<p>IE FC Stripping Tool</p> <p>Preadjusted stripping tool for fast stripping of the Industrial Ethernet FC cables</p>	<p>6GK1 901-1GA00</p>	
<p>SIPLUS PS modular 5 A</p> <p>Single-phase and 2-phase power supply with wide-range input 85 ... 264 V / 176 V ... 550 V AC, regulated output voltage 24 V, output current rated value 5 A, coating of the PCB and electronic components (conformal coating)</p>	<p>6EP1 933-3BA00</p>	
<p>IE FC RJ45 Modular Outlet</p> <p>FastConnect Outlet RJ45 for Industrial Ethernet with interface for a replaceable insert</p> <ul style="list-style-type: none"> • with insert 2FE ; replaceable insert for 2 x 100 Mbit/s interfaces • with insert 1GE; replaceable insert for 1 x 1000 Mbit/s interfaces 	<p>6GK1 901-1BE00-0AA1</p> <p>6GK1 901-1BE00-0AA2</p>	

PROFINET/Industrial Ethernet

Industrial Ethernet switches / media converters

SCALANCE XR-300EEC managed

Overview

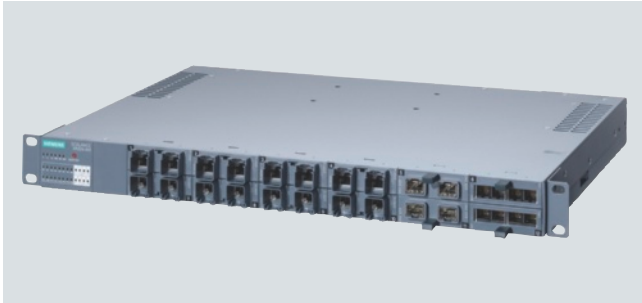

The SCALANCE XR-300EEC (**E**nhanced **E**nvironmental **C**onditions) industrial Ethernet switches are partly modular, high-performance, industry-standard switches for the construction of electrical and/or optical line, ring and star topologies at data transfer rates of 10/100/1000 Mbit/s, designed for installation in 19" control cabinets.

- As many as 24 electrical and/or optical interfaces (10/100/1000 Mbit/s), of which 16 are integral RJ45 ports; up to four electrical and/or optical 2-port media modules can also be inserted in the media module slots of the basic device
- Suitable for use in extremely harsh industrial environments and in low-voltage and high-voltage switchgear thanks to:
 - Extended temperature range (-40 to +70 °C, briefly to +85 °C)
 - Support for special protocols and standards (IEEE 1613 and IEC 61850-3)
 - Wide-range power supplies (60 to 250 V AC/DC)
- High-speed media redundancy through integral redundancy manager both for Gigabit Ethernet and Fast Ethernet
- Seamless integration of automation networks into existing corporate networks thanks to support for a host of IT standards (VLANs, IGMP-Snooping/Querier, STP/RSTP, Link Aggregation, Quality of Service)
- Remote diagnostics by means of PROFINET diagnostics, Web browser, CLI, or SNMP

Benefits

get Designed for Industry

- Increased availability of the network due to hardware and software functions specially geared to the particular requirements of energy technology plants and extreme environmental conditions
- Unlimited flexibility during network expansions (e.g. more terminals) or conversion (e.g. switching from copper to fiber-optic cable) and reduction of the storage costs due to the modular construction using port modules
- High availability of the network thanks to:
 - Redundant power supply
 - Redundant network structures based on fiber-optic or twisted pair cables (redundancy manager, standby function, and STP/RSTP are integrated)
 - Easy device replacement by means of plug-in C-PLUG swap medium
 - Very fast reconfiguration of the network in the event of a fault
- Lower susceptibility to failure and higher availability of the plant networking due to latching of the RJ45 FastConnect connectors in the sleeve of the RJ45 port modules
- Protection of investment due to integration into existing network management systems by means of standardized SNMP access
- Time saving during engineering, commissioning and in the operating phase of a plant by using the integrated configuration and diagnostics in STEP 7, without additional software

Application

The SCALANCE XR-300EEC is ideal for use in plant networks and for integrating the industrial network into an existing corporate network. Both at the field level and the control level, the switch performs the network with the distributed field devices and ensures high plant availability with extensive diagnostics options and high transmission speeds. The modularity permits perfect adaptation to the respective application through the use of electrical and/or optical media modules.

The main area of application is found in high-performance plant networks with interfaces to the corporate network. Thanks to the immunity to electromagnetic interference of the SCALANCE XR-300EEC switches, the devices can also be used in medium/high voltage substations.

The SCALANCE XR-300EEC switch is suitable for establishing optical Industrial Ethernet line, star or ring topologies with 24 ports, 16 of which are integrated RJ45 ports. Up to four electrical and/or optical 2-port media modules can also be inserted in the media module slots of the basic device. The switch can also be used as a hub in the plant bus (redundant connection is possible).

The use of media modules in partly and fully modular versions of the SCALANCE X-300 switches supports:

- Extension of networks by subsequent insertion of additional media modules in unused media module slots
- Changing of cabling technology, such as conversion from copper to fiber-optic cables, or from multimode to single-mode FOC

Application (continued)

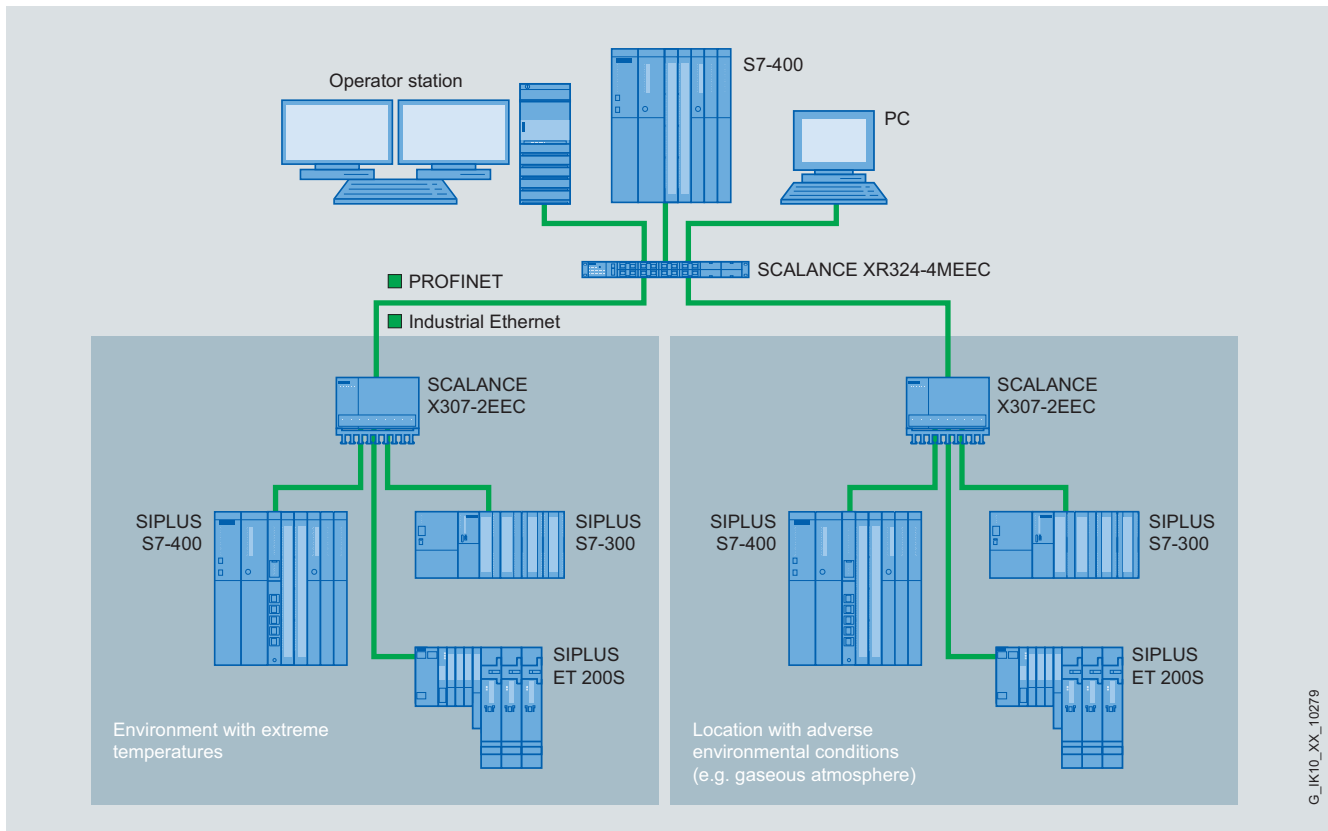

Star structure in switchgear under extreme ambient conditions with SCALANCE XR324-4M EEC and X-300EEC

Design

The SCALANCE XR-300EEC Industrial Ethernet switches with rugged metal enclosure with degree of protection IP20 are optimized for installation in the 19" cabinet.

The switches have:

- 4-pin terminal block for redundant voltage feed for protection against voltage failure in 24 V DC version
- 3-pin terminal block for voltage feed in 230 V AC version
- 2-pin terminal block for connecting the isolated signaling contact for simple display of faults
- A row of LEDs to indicate the status information (power, link status, data traffic, power supply, signaling contact)
- SELECT/SET pushbutton for simple adjustment of the fault signaling contact on the device
- Slot for optional C-PLUG swap medium on the side of the device for easy replacement in the event of a fault
- Console port (serial interface) for on-site parameterization/diagnostics (RJ11 cable to RS232 (9-pin) included in scope of delivery)

The SCALANCE XR-300EEC switches are available with the following port types:

- 16 integrated RJ45 ports;
The RJ45 sockets are designed to be industry-compatible with additional sleeves, for connection of the Industrial Ethernet FC RJ45 Plug 180

- Four slots for electrical or optical 2-port media modules for multimode or single-mode connections; the optical media modules are available in various connection technologies
- All electrical Ethernet interfaces support 10/100/1000 Mbit/s, all optical Ethernet interfaces support 100 or 1000 Mbit/s
- The SCALANCE XR-300EEC switches support Gigabit Ethernet (1000 Mbit/s) at all ports.
The 24 ports are divided into three groups of eight ports each (Gigabit Ethernet Blocking). Gigabit Ethernet is supported with full wire speed within each group, but not between the groups.

Product versions

SCALANCE XR324-4M EEC (4 media module slots)

Versions are available with

- LEDs, data cable outlet on the front and power supply connection at the rear
- LEDs, power supply connection on the front, data cable outlet at the rear

All versions have four media module slots and

- 1 x 24 V DC power supply
- 2 x 24 V DC power supplies
- 1 x 230 V AC power supply
- 2 x 230 V AC power supplies

PROFINET/Industrial Ethernet

Industrial Ethernet switches / media converters

SCALANCE XR-300EEC managed

Function

- Integrated redundancy manager for constructing Fast Ethernet and Gigabit Ethernet ring topologies with high-speed media redundancy. Reliable communication is achieved by closing an optical or electrical line with SCALANCE X-400, X-300 or X-200 switches to form a ring. The redundancy manager (RM) integrated in the SCALANCE XR-300 switch monitors the function of the network. It recognizes the failure of a transmission link or a SCALANCE X switch in the ring and activates the substitute path within a maximum of 0.2 seconds.
- Redundant interfacing to corporate networks; SCALANCE XR-300EEC switches support the standardized redundancy procedures Spanning Tree Protocol (STP) and Rapid Spanning Tree Protocol (RSTP). This enables a subnetwork to be connected redundantly to a higher level corporate network with reduced requirements for the reconfiguration time (in the order of seconds).
- Support of virtual networks (VLAN); for structuring Industrial Ethernet networks with a fast growing number of users, a physically existing network can be divided into several virtual networks.
- Load limiting when multicast protocols (e.g. video transmission) are used; through learning the multicast sources and targets (IGMP Snooping, IGMP Querier), SCALANCE XR-300EEC switches can also filter multicast data traffic and therefore limit the load in the network. Multicast and broadcast traffic can be limited.
- Time synchronization; diagnostic messages (log table entries, e-mails) are time-stamped. The local time is standardized throughout the network by means of synchronization with a SICLOCK time transmitter, thereby simplifying the assignment of diagnostic messages to several devices.
- Fast replacement of devices in event of failure, by means of the C-PLUG switching medium
- Link aggregation (IEEE 802.3ad) for bundling data streams
- Quality of Service (IEEE 802.1p) for prioritization of network traffic

Network topology and network configuration

The network topology can easily be adapted to the structure of the plant using SCALANCE XR-300 Industrial Ethernet switches.

The following network structures and combinations of structures can be implemented:

- Fast Ethernet rings with fast media redundancy; to increase network availability, as many as 50 X-200, X-300, X-400 or X-500 switches cascaded in line can be connected into a ring.
- Several rings can be redundantly linked through the standby function
- At the same time, SCALANCE XR-300EEC supports redundant connection of the ring structure to the corporate network with a rapid spanning tree.
- Star topology with SCALANCE XR-300EEC switches: The SCALANCE XR-300EEC switch represents a neutral point that can interconnect up to 24 nodes or subnets electrically.

When configuring the network, it is necessary to observe the following boundary conditions:

- Maximum line length between two modules for multi-mode fiber-optic conductors:
 - 5 km at 100 Mbit/s
 - 750 m at 1000 Mbit/s
- Maximum line length between two modules for single-mode fiber-optic conductors:
 - 26 to 70 km at 100 Mbit/s
 - 10 to 120 km at 1000 Mbit/s
- Maximum cable length of the TP cable between two SCALANCE X switches:
 - Max. 100 m with IE FC cable 2x2 and IE FC RJ45 Plug 180
 - Max. 100 m at 1000 Mbit/s with IE FC Standard Cable 4x2 (90 m), IE FC RJ45 Modular Outlet and patch cable (10 m)
 - Max. 10 m using patches with TP cord

Function (continued)

Commissioning and diagnosis

Setting options on the device itself:

- Redundancy manager RM; to establish a ring, a SCALANCE XR-300EEC is switched to RM mode. The Gigabit ports (electrical or optical) are preferably used as ring ports. The non-ring ports of the RM can be used freely for the connection of data terminals and networks. If the redundancy procedure MRP standardized by PROFINET is used, the RM is adjusted automatically.
- Signal mask; the signal mask is set to the current status of the SCALANCE XR-300EEC (setpoint) by pushbutton operation. The signal mask defines which ports and which power supplies are to be monitored. The signaling contact only reports an error when a monitored port or a monitored feeder fails (deviation of setpoint/actual status).
- IP address; the IP address is assigned via DHCP (Dynamic Host Configuration Protocol). If there is no corresponding server in the network, the IP address can be assigned using an enclosed software tool.

Diagnostic options on site:

- The following status information is displayed by LEDs on site:
 - Port status
 - Port mode (10/100/1000 Mbit/s, full/half-duplex)
 - Status of the two power supplies
 - Signaling contact status
 - Signal mask (setpoint status)
 - RM mode
 - Standby mode
- The status of the signaling contact is routed externally by means of floating relay contacts. This enables the module to be monitored via an input module from a controller.
- Monitoring via the Industrial Ethernet network; the following possibilities are available:
 - Remote via standard browser (Web-based management): Selection of SCALANCE XR-300EEC switches via the network from a PC with browser
 - Remote via SNMP V1, V2c, V3: Secure integration of SCALANCE XR-300EEC switches via the network to a network management system, e.g. SINEMA Server
 - Remote via PROFINET IO diagnostics: PROFINET diagnostic alarms from SCALANCE XR-300EEC switches can be displayed using the relevant SIMATIC engineering tools and they can also be processed in the controller. The engineering outlay for the PLC and HMI have been drastically reduced due to the complete integration in the SIMATIC concept for system error messages.

Network management

The network management provides the following functions:

- Password-protected dial-up for "Administrator" (read and write authorization) and "User" (read only)
- Read-out of version and status information
- Setting the signal and standby mask and address information
- Parameterization of the web management services
- Setting of Rapid Spanning Tree parameters
- Fixed parameterization of the ports (data rates, half/full duplex)
- Security
 - Ports can be connected or disconnected
 - Port-based network access control according to IEEE 802.1x (available soon)
 - Support of Access Control List (ACL) (available soon)
- Output of statistics information
- Diagnosis of data traffic by means of a parameterizable mirror port with a standard commercial network analyzer
- Loading of new firmware versions or of the configuration data via the network by a TFTP server or directly via HTTP/HTTPS using a Web browser
- Saving the configuration data or log table via the network on a TFTP server

If faults occur in the network, the SCALANCE XR-300EEC switch can independently send error messages (traps) to a network management system or also e-mails to a predefined network administrator.

Remote monitoring (RMON) provides the following functions: The SCALANCE X-300EEC switch can collect statistics information according to the RMON groups 1 through 4. These include, for example, fault statistics that are kept for each port. This information can be read out through web-based management in the statistics sub-area.

PROFINET/Industrial Ethernet

Industrial Ethernet switches / media converters

SCALANCE XR-300EEC managed

Technical specifications

Order No.	6GK5 324-4GG00-1ER2	6GK5 324-4GG00-1JR2	6GK5 324-4GG00-2ER2	6GK5 324-4GG00-2JR2
Product type designation	SCALANCE XR324-4M EEC	SCALANCE XR324-4M EEC	SCALANCE XR324-4M EEC	SCALANCE XR324-4M EEC
Transmission rate				
Transmission rate 1	10 Mbit/s	10 Mbit/s	10 Mbit/s	10 Mbit/s
Transmission rate 2	100 Mbit/s	100 Mbit/s	100 Mbit/s	100 Mbit/s
Transmission rate 3	1 000 Mbit/s	1 000 Mbit/s	1 000 Mbit/s	1 000 Mbit/s
Interfaces				
Maximum number of electrical/optical connections for network components or terminal equipment	24	24	24	24
Number of electrical connections				
• for network components or terminal equipment	16	16	16	16
• For operation panel	1	1	1	1
• for signaling contact	1	1	1	1
• for media module	4	4	4	4
• for power supply	1	1	2	2
• for redundant power supply	1	1	1	1
Design of electrical connection				
• for network components or terminal equipment	RJ45 port	RJ45 port	RJ45 port	RJ45 port
• For operation panel	RJ11 port	RJ11 port	RJ11 port	RJ11 port
• for signal contact	2-pin terminal block	2-pin terminal block	2 x 2-pin terminal block	2 x 2-pin terminal block
• for power supply	4-pin terminal block	4-pin terminal block	2 x 4-pin terminal block	2 x 4-pin terminal block
Number of optical connections for fiber-optic cables				
• At 100 Mbit/s	-	-	-	-
• at 1000 Mbit/s	-	-	-	-
Design of optical connection for fiber-optic cables				
• at 100 Mbit/s	Depends on selected media modules	Depends on selected media modules	Depends on selected media modules	Depends on selected media modules
• at 1000 Mbit/s	Depends on selected media modules	Depends on selected media modules	Depends on selected media modules	Depends on selected media modules
Design of swap medium C-Plug	Yes	Yes	Yes	Yes
Inputs/outputs				
Operating voltage of signaling contacts with DC rated value	24 V	24 V	24 V	24 V
Maximum operating current of signal contacts with DC	0.1 A	0.1 A	0.1 A	0.1 A

Technical specifications (continued)

Order No.	6GK5 324-4GG00-1ER2	6GK5 324-4GG00-1JR2	6GK5 324-4GG00-2ER2	6GK5 324-4GG00-2JR2
Product type designation	SCALANCE XR324-4M EEC	SCALANCE XR324-4M EEC	SCALANCE XR324-4M EEC	SCALANCE XR324-4M EEC
Supply voltage, current consumption, power loss				
Redundant type of power supply	No	No	Yes	Yes
Type of power supply	DC	DC	DC	DC
Supply voltage with AC	-	-	-	-
• Rated value	-	-	-	-
Type of power supply 2	DC	DC	DC	DC
Power supply with DC	24 V	24 V	24 V	24 V
• Rated value	19.2 ... 57.6 V	19.2 ... 57.6 V	19.2 ... 57.6 V	19.2 ... 57.6 V
Product component: fusing of power supply input	Yes	Yes	Yes	Yes
Type of fusing of power supply input	T2H / 250 V	T2H / 250 V	T2H / 250 V	T2H / 250 V
Current consumption, maximum	1.6 A	1.6 A	1.6 A	1.6 A
Effective power loss				
• At 24 V DC	40 W	40 W	40 W	40 W
• At 230 V AC	-	-	-	-
• at 250 V DC	-	-	-	-
Permissible ambient conditions				
Ambient temperature				
• During operation	-40 ... +70 °C	-40 ... +70 °C	-40 ... +70 °C	-40 ... +70 °C
• During storage	-40 ... +70 °C	-40 ... +70 °C	-40 ... +70 °C	-40 ... +70 °C
• During transport	-40 ... +70 °C	-40 ... +70 °C	-40 ... +70 °C	-40 ... +70 °C
• Note	Upper temperature limit extended to +85 °C permissible for 16 hours. Reduced operating temperature when using media modules (-40 °C to +70 °C) or SFP plug-in transceivers (-40 °C to +60 °C)	Upper temperature limit extended to +85 °C permissible for 16 hours. Reduced operating temperature when using media modules (-40 °C to +70 °C) or SFP plug-in transceivers (-40 °C to +60 °C)	Upper temperature limit extended to +85 °C permissible for 16 hours. Reduced operating temperature when using media modules (-40 °C to +70 °C) or SFP plug-in transceivers (-40 °C to +60 °C)	Upper temperature limit extended to +85 °C permissible for 16 hours. Reduced operating temperature when using media modules (-40 °C to +70 °C) or SFP plug-in transceivers (-40 °C to +60 °C)
Relative humidity at 25 °C without condensation during operation, maximum	95 %	95 %	95 %	95 %
Ambient conditions for operation	-	-	-	-
IP degree of protection	IP20	IP20	IP20	IP20
Design, dimensions and weights				
Type of construction	19-inch rack	19-inch rack	19-inch rack	19-inch rack
Width	483 mm	483 mm	483 mm	483 mm
Height	44 mm	44 mm	44 mm	44 mm
Depth	305 mm	305 mm	305 mm	305 mm
Net weight	6.5 kg	6.5 kg	6.8 kg	6.8 kg
Type of mounting				
• 19-inch installation	Yes	Yes	Yes	Yes
• 35 mm DIN rail mounting	No	No	No	No
• Wall mounting	No	No	No	No
• S7-300 rail mounting	No	No	No	No
Type of mounting	For 19-inch rack mounting, 4-point mounting is required for marine engineering applications	For 19-inch rack mounting, 4-point fixing is required for marine engineering applications	For 19-inch rack mounting, 4-point fixing is required for marine engineering applications	For 19-inch rack mounting, 4-point fixing is required for marine engineering applications

PROFINET/Industrial Ethernet

Industrial Ethernet switches / media converters

SCALANCE XR-300EEC managed

Technical specifications (continued)

Order No.	6GK5 324-4GG00-1ER2	6GK5 324-4GG00-1JR2	6GK5 324-4GG00-2ER2	6GK5 324-4GG00-2JR2
Product type designation	SCALANCE XR324-4M EEC	SCALANCE XR324-4M EEC	SCALANCE XR324-4M EEC	SCALANCE XR324-4M EEC
Product properties, functions, components				
General				
Cascading with redundant ring at reconfiguration time < 0.3 s	50	50	50	50
Cascading with star topology	Any (only dependent on signal propagation time)	Any (only dependent on signal propagation time)	Any (only dependent on signal propagation time)	Any (only dependent on signal propagation time)
Product functions				
Management, configuration, programming				
Product function				
• CLI	Yes	Yes	Yes	Yes
• Web-based management	Yes	Yes	Yes	Yes
• MIB support	Yes	Yes	Yes	Yes
• TRAPS via e-mail	Yes	Yes	Yes	Yes
• Configuration with STEP 7	Yes	Yes	Yes	Yes
• RMON	Yes	Yes	Yes	Yes
• SMTP server	Yes	Yes	Yes	Yes
• Port mirroring	Yes	Yes	Yes	Yes
• CoS	Yes	Yes	Yes	Yes
• with IRT PROFINET IO Switch	-	-	-	-
• PROFINET IO diagnostics	Yes	Yes	Yes	Yes
• Switch-managed	Yes	Yes	Yes	Yes
Protocol is supported				
• Telnet	Yes	Yes	Yes	Yes
• HTTP	Yes	Yes	Yes	Yes
• HTTPS	Yes	Yes	Yes	Yes
• TFTP	Yes	Yes	Yes	Yes
• FTP	Yes	Yes	Yes	Yes
• BOOTP	Yes	Yes	Yes	Yes
• SNMP v1	Yes	Yes	Yes	Yes
• SNMP v2	Yes	Yes	Yes	Yes
• SNMP v3	Yes	Yes	Yes	Yes
• IGMP (snooping/querier)	Yes	Yes	Yes	Yes
• GMRP	Yes	Yes	Yes	Yes
• DCP	Yes	Yes	Yes	Yes
• LLDP	Yes	Yes	Yes	Yes
Identification & Maintenance				
• I&M0 - device-specific information	Yes	Yes	Yes	Yes
• I&M1 - higher-level designation/ location designation	Yes	Yes	Yes	Yes
Product functions Diagnostics				
Product function				
• Port diagnostics	Yes	Yes	Yes	Yes
• Packet size statistics	Yes	Yes	Yes	Yes
• Packet type statistics	Yes	Yes	Yes	Yes
• Error statistics	Yes	Yes	Yes	Yes
• SysLog	Yes	Yes	Yes	Yes
Product functions VLAN				
Product function				
• VLAN - port-based	Yes	Yes	Yes	Yes
• VLAN - dynamic	Yes	Yes	Yes	Yes
Maximum number of VLANs	255	255	255	255
Maximum number of dynamic VLANs	255	255	255	255
GVRP protocol is supported	Yes	Yes	Yes	Yes

PROFINET/Industrial Ethernet

Industrial Ethernet switches / media converters

SCALANCE XR-300EEC managed
Technical specifications (continued)

Order No.	6GK5 324-4GG00-1ER2	6GK5 324-4GG00-1JR2	6GK5 324-4GG00-2ER2	6GK5 324-4GG00-2JR2
Product type designation	SCALANCE XR324-4M EEC	SCALANCE XR324-4M EEC	SCALANCE XR324-4M EEC	SCALANCE XR324-4M EEC
Product functions DHCP				
Product function				
• DHCP client	Yes	Yes	Yes	Yes
• DHCP option 82	Yes	Yes	Yes	Yes
• DHCP option 66	Yes	Yes	Yes	Yes
• DHCP option 67	Yes	Yes	Yes	Yes
Product functions Redundancy				
Product function				
• Ring redundancy	Yes	Yes	Yes	Yes
• Redundancy manager	Yes	Yes	Yes	Yes
• Standby redundancy	Yes	Yes	Yes	Yes
• Redundancy procedure HSR	Yes	Yes	Yes	Yes
• Redundancy procedure MRP	Yes	Yes	Yes	Yes
• Redundancy procedure STP	Yes	Yes	Yes	Yes
• Redundancy procedure RSTP	Yes	Yes	Yes	Yes
• Passive listening	Yes	Yes	Yes	Yes
Protocol is supported				
• STP/RSTP	Yes	Yes	Yes	Yes
• STP	Yes	Yes	Yes	Yes
• RSTP	Yes	Yes	Yes	Yes
• RSTP Big Network Support	Yes	Yes	Yes	Yes
• LACP	Yes	Yes	Yes	Yes
Product functions Security				
Product function				
• ACL - Port/MAC-based	Yes	Yes	Yes	Yes
• IEEE 802.1x (radius)	Yes	Yes	Yes	Yes
• Broadcast/Multicast/Unicast Limiter	Yes	Yes	Yes	Yes
• Broadcast blocking	Yes	Yes	Yes	Yes
SSH protocol is supported	Yes	Yes	Yes	Yes
Product functions Time				
Product function:				
SICLOCK support	Yes	Yes	Yes	Yes
Protocol is supported				
• NTP	No	No	No	No
• SNTP	Yes	Yes	Yes	Yes
• IEEE 1588 profile default	Yes	Yes	Yes	Yes
• IEEE 1588 profile gPTP	-	-	-	-
• IEEE 1588 profile PSRC	-	-	-	-
Type of time synchronization	-	-	-	-
Standards, specifications, approvals				
Standard				
• For EMC	IEC 61850, IEEE 1613 FM3611: Class 1, Division 2, Group A, B, C, D / T4, Class 1, Zone 2, Group IIC, T4	IEC 61850, IEEE 1613 FM3611: Class 1, Division 2, Group A, B, C, D / T4, Class 1, Zone 2, Group IIC, T4	IEC 61850, IEEE 1613 FM3611: Class 1, Division 2, Group A, B, C, D / T4, Class 1, Zone 2, Group IIC, T4	IEC 61850, IEEE 1613 FM3611: Class 1, Division 2, Group A, B, C, D / T4, Class 1, Zone 2, Group IIC, T4
• for EMC of FM				
• for hazardous zone	EN 60079-0: 2006, EN 60079-15: 2005, II 3 G Ex nA II T4 KEMA 07 ATEX 0145X	EN 60079-0: 2006, EN 60079-15: 2005, II 3 G Ex nA II T4 KEMA 07 ATEX 0145X	EN 60079-0: 2006, EN 60079-15: 2005, II 3 G Ex nA II T4 KEMA 07 ATEX 0145X	EN 60079-0: 2006, EN 60079-15: 2005, II 3 G Ex nA II T4 KEMA 07 ATEX 0145X
• For CSA and UL safety	UL 60950-1, CSA C22.2 No. 60950-1-03	UL 60950-1, CSA C22.2 No. 60950-1-03	UL 60950-1, CSA C22.2 No. 60950-1-03	UL 60950-1, CSA C22.2 No. 60950-1-03
• for hazardous zone of CSA and UL	ANSI / ISA 12.12.01, CSA C22.2 No. 142-M1987, CL. 1 / Div. 2 / GP. A, B, C, D T4, CL. 1 / Zone 2 / GP. IIC, T4	ANSI / ISA 12.12.01, CSA C22.2 No. 142-M1987, CL. 1 / Div. 2 / GP. A, B, C, D T4, CL. 1 / Zone 2 / GP. IIC, T4	ANSI / ISA 12.12.01, CSA C22.2 No. 142-M1987, CL. 1 / Div. 2 / GP. A, B, C, D T4, CL. 1 / Zone 2 / GP. IIC, T4	ANSI / ISA 12.12.01, CSA C22.2 No. 142-M1987, CL. 1 / Div. 2 / GP. A, B, C, D T4, CL. 1 / Zone 2 / GP. IIC, T4
• For emitted interference	EN 61000-6-4:2007 (Class A)	EN 61000-6-4:2007 (Class A)	EN 61000-6-4:2007 (Class A)	EN 61000-6-4:2007 (Class A)
• for noise immunity	EN 61000-6-2:2005	EN 61000-6-2:2005	EN 61000-6-2:2005	EN 61000-6-2:2005

2

PROFINET/Industrial Ethernet

Industrial Ethernet switches / media converters

SCALANCE XR-300EEC managed

Technical specifications (continued)

Order No.	6GK5 324-4GG00-1ER2	6GK5 324-4GG00-1JR2	6GK5 324-4GG00-2ER2	6GK5 324-4GG00-2JR2
Product type designation	SCALANCE XR324-4M EEC	SCALANCE XR324-4M EEC	SCALANCE XR324-4M EEC	SCALANCE XR324-4M EEC
Certificate of suitability	EN 61000-6-2:2005, EN 61000-6-4:2007	EN 61000-6-2:2005, EN 61000-6-4:2007	EN 61000-6-2:2005, EN 61000-6-4:2007	EN 61000-6-2:2005, EN 61000-6-4:2007
• CE mark	Yes	Yes	Yes	Yes
• C-Tick	Yes	Yes	Yes	Yes
• Railroad application according to EN 50155	-	-	-	-
• Railroad application according to EN 50124-1	-	-	-	-
• IEC 61850-3	Yes	Yes	Yes	Yes
Marine classification corporation				
• American Bureau of Shipping Europe Ltd. (ABS)	-	-	-	-
• Bureau Veritas (BV)	-	-	-	-
• Det Norske Veritas (DNV)	-	-	-	-
• Germanischer Lloyd (GL)	-	-	-	-
• Lloyds Register of Shipping (LRS)	-	-	-	-
• Nippon Kaiji Kyokai (NK)	-	-	-	-

Order No.	6GK5 324-4GG00-3ER2	6GK5 324-4GG00-3JR2	6GK5 324-4GG00-4ER2	6GK5 324-4GG00-4JR2
Product type designation	SCALANCE XR324-4M EEC	SCALANCE XR324-4M EEC	SCALANCE XR324-4M EEC	SCALANCE XR324-4M EEC
Transmission rate				
Transmission rate 1	10 Mbit/s	10 Mbit/s	10 Mbit/s	10 Mbit/s
Transmission rate 2	100 Mbit/s	100 Mbit/s	100 Mbit/s	100 Mbit/s
Transmission rate 3	1 000 Mbit/s	1 000 Mbit/s	1 000 Mbit/s	1 000 Mbit/s
Interfaces				
Maximum number of electrical/optical connections for network components or terminal equipment	24	24	24	24
Number of electrical connections				
• for network components or terminal equipment	16	16	16	16
• For operation panel	1	1	1	1
• for signaling contact	1	1	1	1
• for media module	4	4	4	4
• for power supply	1	1	2	2
• for redundant power supply	0	0	0	0
Design of electrical connection				
• for network components or terminal equipment	RJ45 port	RJ45 port	RJ45 port	RJ45 port
• For operation panel	RJ11 port	RJ11 port	RJ11 port	RJ11 port
• for signal contact	3-pin terminal block	3-pin terminal block	2 x 3-pin terminal block	2 x 3-pin terminal block
• for power supply	3-pin terminal block	3-pin terminal block	2 x 3-pin terminal block	2 x 3-pin terminal block
Number of optical connections for fiber-optic cables				
• at 100 Mbit/s	-	-	-	-
• at 1000 Mbit/s	-	-	-	-
Design of optical connection for fiber-optic cables				
• at 100 Mbit/s	Depends on selected media modules	Depends on selected media modules	Depends on selected media modules	Depends on selected media modules
• at 1000 Mbit/s	Depends on selected media modules	Depends on selected media modules	Depends on selected media modules	Depends on selected media modules
Design of swap medium C-Plug	Yes	Yes	Yes	Yes

PROFINET/Industrial Ethernet

Industrial Ethernet switches / media converters

SCALANCE XR-300EEC managed

Technical specifications (continued)

Order No.	6GK5 324-4GG00-3ER2	6GK5 324-4GG00-3JR2	6GK5 324-4GG00-4ER2	6GK5 324-4GG00-4JR2
Product type designation	SCALANCE XR324-4M EEC	SCALANCE XR324-4M EEC	SCALANCE XR324-4M EEC	SCALANCE XR324-4M EEC
Inputs/outputs				
Operating voltage of signaling contacts with AC rated value	276 V	276 V	276 V	276 V
Operating current of signaling contacts with AC maximum	5 A	5 A	5 A	5 A
Operating voltage of signaling contacts with DC rated value	230 V	230 V	230 V	230 V
Maximum operating current of signal contacts with DC	0.1 A	0.1 A	0.1 A	0.1 A
Supply voltage, current consumption, power loss				
Redundant type of power supply	No	No	Yes	Yes
Type of power supply	AC	AC	AC	AC
Supply voltage with AC	230 V	230 V	230 V	230 V
• Rated value	80 ... 276 V	80 ... 276 V	80 ... 276 V	80 ... 276 V
Type of power supply 2	DC	DC	DC	DC
Power supply with DC	220 V	220 V	220 V	220 V
• Rated value	48 ... 300 V	48 ... 300 V	48 ... 300 V	48 ... 300 V
Product component: fusing of power supply input	Yes	Yes	Yes	Yes
Type of fusing of power supply input	3.15 A / 250 V	3.15 A / 250 V	3.15 A / 250 V	3.15 A / 250 V
Current consumption, maximum	0.7 A	0.7 A	0.7 A	0.7 A
Effective power loss				
• at 24 V DC	-	-	-	-
• at 230 V AC	42 W	42 W	42 W	42 W
• at 250 V DC	42 W	42 W	42 W	42 W
Permissible ambient conditions				
Ambient temperature				
• During operation	-40 ... +70 °C	-40 ... +70 °C	-40 ... +70 °C	-40 ... +70 °C
• During storage	-40 ... +70 °C	-40 ... +70 °C	-40 ... +70 °C	-40 ... +70 °C
• During transport	-40 ... +70 °C	-40 ... +70 °C	-40 ... +70 °C	-40 ... +70 °C
• Note	Upper temperature limit extended to +85 °C permissible for 16 hours. Reduced operating temperature when using media modules (-40 °C to +70 °C) or SFP plug-in transceivers (-40 °C to +60 °C)	Upper temperature limit extended to +85 °C permissible for 16 hours. Reduced operating temperature when using media modules (-40 °C to +70 °C) or SFP plug-in transceivers (-40 °C to +60 °C)	Upper temperature limit extended to +85 °C permissible for 16 hours. Reduced operating temperature when using media modules (-40 °C to +70 °C) or SFP plug-in transceivers (-40 °C to +60 °C)	Upper temperature limit extended to +85 °C permissible for 16 hours. Reduced operating temperature when using media modules (-40 °C to +70 °C) or SFP plug-in transceivers (-40 °C to +60 °C)
Relative humidity at 25 °C without condensation during operation, maximum	95 %	95 %	95 %	95 %
Ambient conditions for operation	-	-	-	-
IP degree of protection	IP20	IP20	IP20	IP20

2

PROFINET/Industrial Ethernet

Industrial Ethernet switches / media converters

SCALANCE XR-300EEC managed

Technical specifications (continued)

Order No.	6GK5 324-4GG00-3ER2	6GK5 324-4GG00-3JR2	6GK5 324-4GG00-4ER2	6GK5 324-4GG00-4JR2
Product type designation	SCALANCE XR324-4M EEC	SCALANCE XR324-4M EEC	SCALANCE XR324-4M EEC	SCALANCE XR324-4M EEC
Design, dimensions and weights				
Design	19-inch rack	19-inch rack	19-inch rack	19-inch rack
Width	483 mm	483 mm	483 mm	483 mm
Height	44 mm	44 mm	44 mm	44 mm
Depth	305 mm	305 mm	305 mm	305 mm
Net weight	6.6 kg	6.6 kg	7 kg	7 kg
Type of mounting				
• 19-inch installation	Yes	Yes	Yes	Yes
• 35 mm DIN rail mounting	No	No	No	No
• Wall mounting	No	No	No	No
• S7-300 rail mounting	No	No	No	No
Type of mounting	For 19-inch rack mounting, 4-point fixing is required for marine engineering applications	For 19-inch rack mounting, 4-point fixing is required for marine engineering applications	For 19-inch rack mounting, 4-point fixing is required for marine engineering applications	For 19-inch rack mounting, 4-point fixing is required for marine engineering applications
Product properties, functions, components				
General				
Cascading with redundant ring with reconfiguration time < 0.3 s	50	50	50	50
Cascading with star topology	Any (only dependent on signal propagation time)	Any (only dependent on signal propagation time)	Any (only dependent on signal propagation time)	Any (only dependent on signal propagation time)
Product functions				
Management, configuration, programming				
Product function				
• CLI	Yes	Yes	Yes	Yes
• Web-based management	Yes	Yes	Yes	Yes
• MIB support	Yes	Yes	Yes	Yes
• TRAPS via e-mail	Yes	Yes	Yes	Yes
• Configuration with STEP 7	Yes	Yes	Yes	Yes
• RMON	Yes	Yes	Yes	Yes
• SMTP server	Yes	Yes	Yes	Yes
• Port mirroring	Yes	Yes	Yes	Yes
• CoS	Yes	Yes	Yes	Yes
• with IRT PROFINET IO Switch	-	-	-	-
• PROFINET IO diagnostics	Yes	Yes	Yes	Yes
• Switch-managed	Yes	Yes	Yes	Yes
Protocol is supported				
• Telnet	Yes	Yes	Yes	Yes
• HTTP	Yes	Yes	Yes	Yes
• HTTPS	Yes	Yes	Yes	Yes
• TFTP	Yes	Yes	Yes	Yes
• FTP	Yes	Yes	Yes	Yes
• BOOTP	Yes	Yes	Yes	Yes
• SNMP v1	Yes	Yes	Yes	Yes
• SNMP v2	Yes	Yes	Yes	Yes
• SNMP v3	Yes	Yes	Yes	Yes
• IGMP (snooping/querier)	Yes	Yes	Yes	Yes
• GMRP	Yes	Yes	Yes	Yes
• DCP	Yes	Yes	Yes	Yes
• LLDP	Yes	Yes	Yes	Yes
Identification & Maintenance				
• I&M0 - device-specific information	Yes	Yes	Yes	Yes
• I&M1 - higher-level designation/location designation	Yes	Yes	Yes	Yes

Technical specifications (continued)

Order No.	6GK5 324-4GG00-3ER2	6GK5 324-4GG00-3JR2	6GK5 324-4GG00-4ER2	6GK5 324-4GG00-4JR2
Product type designation	SCALANCE XR324-4M EEC	SCALANCE XR324-4M EEC	SCALANCE XR324-4M EEC	SCALANCE XR324-4M EEC
Product functions Diagnostics				
Product function				
• Port diagnostics	Yes	Yes	Yes	Yes
• Packet size statistics	Yes	Yes	Yes	Yes
• Packet type statistics	Yes	Yes	Yes	Yes
• Error statistics	Yes	Yes	Yes	Yes
• SysLog	Yes	Yes	Yes	Yes
Product functions VLAN				
Product function				
• VLAN - port-based	Yes	Yes	Yes	Yes
• VLAN - dynamic	Yes	Yes	Yes	Yes
Maximum number of VLANs	255	255	255	255
Maximum number of dynamic VLANs	255	255	255	255
GVRP protocol is supported	Yes	Yes	Yes	Yes
Product functions DHCP				
Product function				
• DHCP client	Yes	Yes	Yes	Yes
• DHCP option 82	Yes	Yes	Yes	Yes
• DHCP option 66	Yes	Yes	Yes	Yes
• DHCP option 67	Yes	Yes	Yes	Yes
Product functions Redundancy				
Product function				
• Ring redundancy	Yes	Yes	Yes	Yes
• Redundancy manager	Yes	Yes	Yes	Yes
• Standby redundancy	Yes	Yes	Yes	Yes
• Redundancy procedure HSR	Yes	Yes	Yes	Yes
• Redundancy procedure MRP	Yes	Yes	Yes	Yes
• Redundancy procedure STP	Yes	Yes	Yes	Yes
• Redundancy procedure RSTP	Yes	Yes	Yes	Yes
• Passive listening	Yes	Yes	Yes	Yes
Protocol is supported				
• STP/RSTP	Yes	Yes	Yes	Yes
• STP	Yes	Yes	Yes	Yes
• RSTP	Yes	Yes	Yes	Yes
• RSTP Big Network Support	Yes	Yes	Yes	Yes
• LACP	Yes	Yes	Yes	Yes
Product functions Security				
Product function				
• ACL - Port/MAC-based	Yes	Yes	Yes	Yes
• IEEE 802.1x (radius)	Yes	Yes	Yes	Yes
• Broadcast/Multicast/Unicast Limiter	Yes	Yes	Yes	Yes
• Broadcast blocking	Yes	Yes	Yes	Yes
SSH protocol is supported	Yes	Yes	Yes	Yes
Product functions Time				
Product function:				
SICLOCK support	Yes	Yes	Yes	Yes
Protocol is supported				
• NTP	No	No	No	No
• SNTP	Yes	Yes	Yes	Yes
• IEEE 1588 profile default	Yes	Yes	Yes	Yes
• IEEE 1588 profile gPTP	-	-	-	-
• IEEE 1588 profile PSRC	-	-	-	-
Type of time synchronization	-	-	-	-

PROFINET/Industrial Ethernet

Industrial Ethernet switches / media converters

SCALANCE XR-300EEC managed

Technical specifications (continued)

Order No.	6GK5 324-4GG00-3ER2	6GK5 324-4GG00-3JR2	6GK5 324-4GG00-4ER2	6GK5 324-4GG00-4JR2
Product type designation	SCALANCE XR324-4M EEC	SCALANCE XR324-4M EEC	SCALANCE XR324-4M EEC	SCALANCE XR324-4M EEC
Standards, specifications, approvals				
Standard				
• for EMC	IEC 61850, IEEE 1613	IEC 61850, IEEE 1613	IEC 61850, IEEE 1613	IEC 61850, IEEE 1613
• for EMC of FM	No	No	No	No
• for hazardous zone	No	No	No	No
• for CSA and UL safety	UL 508, CSA C22.2 No. 142-M1987	UL 508, CSA C22.2 No. 142-M1987	UL 508, CSA C22.2 No. 142-M1987	UL 508, CSA C22.2 No. 142-M1987
• for hazardous zone of CSA and UL	No	No	No	No
• for emitted interference	EN 61000-6-4:2007 (Class A)	EN 61000-6-4:2007 (Class A)	EN 61000-6-4:2007 (Class A)	EN 61000-6-4:2007 (Class A)
• for noise immunity	EN 61000-6-2:2005	EN 61000-6-2:2005	EN 61000-6-2:2005	EN 61000-6-2:2005
Certificate of suitability	EN 61000-6-2:2005, EN 61000-6-4:2007	EN 61000-6-2:2005, EN 61000-6-4:2007	EN 61000-6-2:2005, EN 61000-6-4:2007	EN 61000-6-2:2005, EN 61000-6-4:2007
• CE mark	Yes	Yes	Yes	Yes
• C-Tick	Yes	Yes	Yes	Yes
• Railroad application according to EN 50155	-	-	-	-
• Railroad application according to EN 50124-1	-	-	-	-
• IEC 61850-3	Yes	Yes	Yes	Yes
Marine classification corporation				
• American Bureau of Shipping Europe Ltd. (ABS)	-	-	-	-
• Bureau Veritas (BV)	-	-	-	-
• Det Norske Veritas (DNV)	-	-	-	-
• Germanischer Lloyd (GL)	-	-	-	-
• Lloyds Register of Shipping (LRS)	-	-	-	-
• Nippon Kaiji Kyokai (NK)	-	-	-	-

PROFINET/Industrial Ethernet

Industrial Ethernet switches / media converters

SCALANCE XR-300EEC managed

Ordering data	Order No.	More information
<p><i>Industrial Ethernet Switches SCALANCE XR324-4M EEC</i></p> <p>Partially modular 19" Industrial Ethernet switches for establishing electrical and optical Industrial Ethernet networks; all ports can be optionally equipped with optical or electrical 2-port media modules); All ports support Gigabit Ethernet (blocking), integrated redundancy manager, RSTP, RMON, IGMP snooping querier, network management via SNMP, PROFINET and Web server 16 x 10/100/1000 Mbit/s RJ45 ports, electrical 4 x 10/100/1000 Mbit/s slots for 2-port media modules, electrical or optical</p> <p>SCALANCE XR324-4M EEC</p> <p><u>Power supply 1 x 24 V DC</u></p> <ul style="list-style-type: none"> • Data cable outlet at front • Data cable outlet at rear <p><u>Power supply 1 x 100-240 AC / 60-250 V DC</u></p> <ul style="list-style-type: none"> • Data cable outlet at front • Data cable outlet at rear <p><u>Power supply 2 x 24 V DC</u></p> <ul style="list-style-type: none"> • Data cable outlet at front • Data cable outlet at rear <p><u>Power supply 2 x 100-240 AC / 60-250 V DC</u></p> <ul style="list-style-type: none"> • Data cable outlet at front • Data cable outlet at rear 	<p>6GK5 324-4GG00-1ER2 6GK5 324-4GG00-1JR2</p> <p>6GK5 324-4GG00-3ER2 6GK5 324-4GG00-3JR2</p> <p>6GK5 324-4GG00-2ER2 6GK5 324-4GG00-2JR2</p> <p>6GK5 324-4GG00-4ER2 6GK5 324-4GG00-4JR2</p>	<p>To assist in selecting the right Industrial Ethernet switches as well as configuration of modular versions, the SIMATIC NET Selection Tool is available:</p> <p>Online version: www.siemens.com/snst</p> <p>Offline version: www.siemens.com/snst-download</p>
<p><i>Media modules</i></p>	<p>See "Media modules for modular SCALANCE X-300 managed"</p>	
<p>SIPLUS PS modular 5 A</p> <p>Single-phase and 2-phase power supply with wide-range input 85 ... 264 V / 176 V ... 550 V AC, regulated output voltage 24 V, output current rated value 5 A, coating of the PCB and electronic components (conformal coating)</p>	<p>6EP1 933-3BA00</p>	

2

PROFINET/Industrial Ethernet

Industrial Ethernet switches / media converters

Media modules for modular SCALANCE X-300 managed

Overview

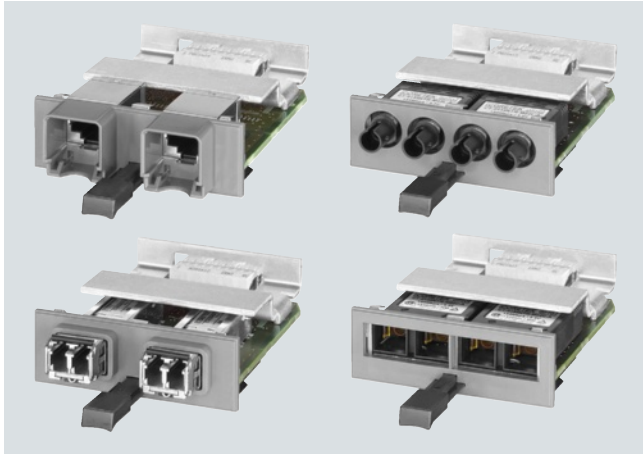

- 2-port media modules for flexible, 2-port-granular equipping of partly and fully modular versions of the SCALANCE X-300 switches (e.g. SCALANCE X308-2M, SCALANCE XR324-12M)
- Electrical versions with RJ45 ports are available as well as optical versions with BFOC and SC ports for the use of multimode and singlemode fiber-optic cables
- A 2-port SFP media module permits the the optional use of fiber-optic SFP plug-in transceivers (**S**mall **F**orm-**F**actor **P**luggable) with LC connection technology

Benefits

g e t Designed for Industry

- Unlimited flexibility in the case of network expansions (e.g. more terminals) or conversion (e.g. from copper to fiber-optic cables) due to modular design with media modules
- Reduction of storage costs and maintenance overhead by focusing on a few basic device versions

Application

The use of media modules in partly and fully modular versions of the SCALANCE X-300 switches supports:

- Extension of networks by subsequent insertion of additional media modules in unused media module slots
- Change of cabling technology (e.g. conversion from copper to fiber-optic cables, or from multi-mode to single-mode FOC)

Design

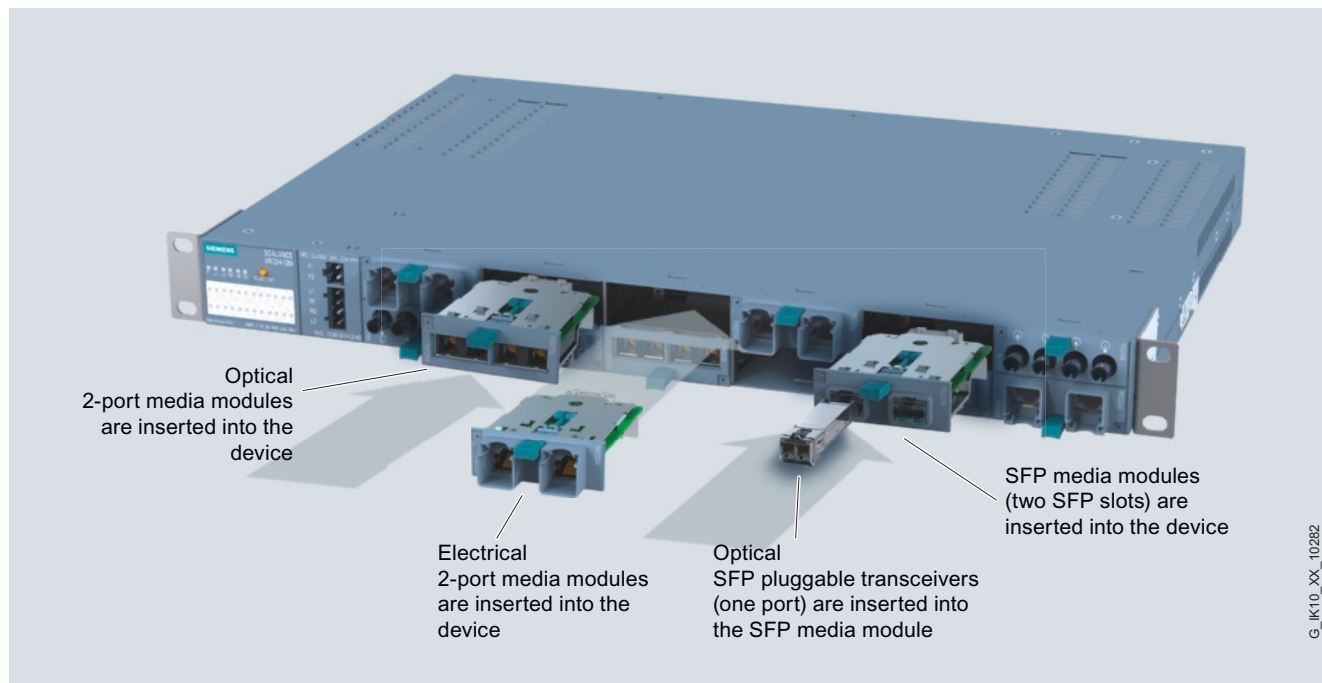

Insertion of 2-port media modules in media module slot

Product versions of media modules

Electrical media modules with 2 x 10/100/1000 Mbit/s RJ45 ports

- MM992-2CUC with retaining sleeve
- MM992-2CU without retaining sleeve

Optical media modules with 2 x 100 Mbit/s BFOC ports

- MM991-2
multimode, glass, up to 5 km
- MM991-2LD
single-mode, glass, up to 26 km

Optical media modules with 2 x 100 Mbit/s SC ports

- MM991-2
multimode, glass, up to 5 km
- MM991-2LD
single-mode, glass, up to 26 km
- MM991-2LH+
single-mode, glass, up to 70 km

Optical media modules with 2 x 1000 Mbit/s SC ports

- MM992-2
multimode, glass, up to 750 m
- MM992-2LD
single-mode, glass, up to 10 km
- MM992-2LH
single-mode, glass, up to 40 km
- MM992-2LH+
single-mode, glass, up to 70 km
- MM992-2ELH
single-mode, glass, up to 120 km

Optical media modules with 2 x 100/1000 Mbit/s for SFP pluggable transceiver

- MM992-2SFP
for SFP plug-in transceivers with 1 x 100 Mbit/s or
1 x 1000 Mbit/s multi-mode or single-mode, glass

Product versions of SFP pluggable transceivers

The SFP plug-in transceivers (**S**mall **F**orm-factor **P**luggable) can only be used together with the SFP media module MM992-2SFP.

Optical SFP pluggable transceivers with 1 x 100 Mbit/s LC port

- SFP991-1
multimode, glass, up to 5 km
- SFP991-1LD
single-mode, glass, up to 26 km
- SFP991-1LH+
single-mode, glass, up to 70 km

Optical SFP pluggable transceivers with 1 x 1000 Mbit/s LC port

- SFP992-1
multimode, glass, up to 750 m
- SFP992-1LD
single-mode, glass, up to 10 km
- SFP992-1LH
single-mode, glass, up to 40 km
- SFP992-1LH+
single-mode, glass, up to 70 km
- SFP992-1ELH
single-mode, glass, up to 120 km

PROFINET/Industrial Ethernet

Industrial Ethernet switches / media converters

Media modules for modular SCALANCE X-300 managed

Design (continued)

Type of module	Type and quantity of ports						Max. distance
	Gigabit Ethernet			Fast Ethernet			
	10 / 100 / 1000 Mbit/s		1000 Mbit/s	100 Mbit/s			
	Electrical		Optical	Optical			
	Twisted Pair	Multimode	Singlemode	Multimode	Singlemode		
Media modules							
MM992-2CUC	2x RJ45 ¹⁾						100 m
MM992-2CU	2x RJ45						100 m
MM991-2				2x BFOC			5 km
MM991-2LD					2x BFOC		26 km
MM991-2				2x SC			5 km
MM991-2LD					2x SC		26 km
MM991-2LH+					2x SC		70 km
MM992-2		2x SC					750 m
MM992-2LD			2x SC				10 km
MM992-2LH			2x SC				40 km
MM992-2LH+			2x SC				70 km
MM992-2ELH			2x SC				120 km
MM992-2SFP		2x LC ²⁾	2x LC ²⁾	2x LC ²⁾	2x LC ²⁾		
SFP modules ³⁾							
SFP991-1				1x LC			5 km
SFP991-1LD					1x LC		26 km
SFP991-1LH+					1x LC		70 km
SFP992-1		1x LC					750 m
SFP992-1LD			1x LC				10 km
SFP992-1LH			1x LC				40 km
SFP992-1LH+			1x LC				70 km
SFP992-1ELH			1x LC				120 km
¹⁾ with retaining collars ²⁾ The MM392-2SFP SFP slot module can accommodate up to two 1-port SFP modules ³⁾ Can only be plugged into an MM392-2SFP slot module							

G_IK10_XX_10277

Overview of media modules for SCALANCE X-300

PROFINET/Industrial Ethernet

Industrial Ethernet switches / media converters

Media modules
for modular SCALANCE X-300 managed

Technical specifications

Order No.	6GK5 992-2SA00-8AA0	6GK5 992-2GA00-8AA0	6GK5 991-2AB00-8AA0	6GK5 991-2AC00-8AA0
Product type designation	MM992-2CU	MM992-2CUC	MM991-2	MM991-2LD
Transmission rate				
Transmission rate 1	10 Mbit/s	10 Mbit/s	100 Mbit/s	100 Mbit/s
Transmission rate 2	100 Mbit/s	100 Mbit/s	-	-
Transmission rate 3	1000 Mbit/s	1000 Mbit/s	-	-
Interfaces				
Maximum number of electrical/optical connections for network components or terminal equipment	2	2	2	2
Number of electrical connections				
• For network components or terminal equipment	2	2	-	-
• with power-over-Ethernet for network components or terminal equipment	-	-	-	-
Design of electrical connection				
• For network components or terminal equipment	RJ45 port	RJ45 port	-	-
• with power-over-Ethernet for network components or terminal equipment	-	-	-	-
Number of optical connections for fiber-optic cables				
• At 100 Mbit/s	-	-	2	2
• At 1000 Mbit/s	-	-	-	-
Design of optical connection for fiber-optic cables				
• At 100 Mbit/s	-	-	ST port (multimode up to 5 km)	ST port (singlemode up to 26 km)
• at 1000 Mbit/s	-	-	-	-
• at 10 Gbit/s	-	-	-	-
Injectable optical power referred to 1 mW				
• of the transmitter output	-	-	-19 ... -14 dB	-15 ... -8 dB
• of the receiver input, maximum	-	-	-3 dB	-3 dB
Minimum optical sensitivity referred to 1 mW of the receiver input	-	-	-32 dB	-34 dB
Minimum required attenuation factor of the FO transmission link	-	-	0 dB	0 dB
The range at the optical interface depends on the type of optical fiber used	-	-	0 ... 5 km	0 ... 26 km
Permitted ambient conditions				
Ambient temperature				
• During operation	0 ... 70 °C	0 ... 70 °C	0 ... 70 °C	0 ... 70 °C
• During storage	0 ... 70 °C	0 ... 70 °C	0 ... 70 °C	0 ... 70 °C
• During transport	0 ... 70 °C	0 ... 70 °C	0 ... 70 °C	0 ... 70 °C
Relative humidity at 25 °C without condensation during operation, maximum	95 %	95 %	95 %	95 %
IP degree of protection	IP20	IP20	IP20	IP20

2

PROFINET/Industrial Ethernet

Industrial Ethernet switches / media converters

Media modules for modular SCALANCE X-300 managed

Technical specifications (continued)

Order No.	6GK5 992-2SA00-8AA0	6GK5 992-2GA00-8AA0	6GK5 991-2AB00-8AA0	6GK5 991-2AC00-8AA0
Product type designation	MM992-2CU	MM992-2CUC	MM991-2	MM991-2LD
Design, dimensions and weights				
Type of construction	Media module	Media module with retaining collar	Media module	Media module
Width	60 mm	60 mm	60 mm	60 mm
Height	22 mm	22 mm	22 mm	22 mm
Depth	100 mm	100 mm	100 mm	100 mm
Net weight	0.08 kg	0.08 kg	0.08 kg	0.08 kg
Type of mounting for installation at media module slot	Yes	Yes	Yes	Yes
Standards, specifications, approvals				
Standard	-	-	-	-
• for EMC	-	-	-	-
• for EMC of FM	FM3611: Class 1, Division 2, Group A, B, C, D / T4, Class 1, Zone 2, Group IIC, T4	FM3611: Class 1, Division 2, Group A, B, C, D / T4, Class 1, Zone 2, Group IIC, T4	FM3611: Class 1, Division 2, Group A, B, C, D / T4, Class 1, Zone 2, Group IIC, T4	FM3611: Class 1, Division 2, Group A, B, C, D / T4, Class 1, Zone 2, Group IIC, T4
• for hazardous zone	EN 60079-0: 2006, EN 60079-15: 2005, II 3 G Ex nA II T4 KEMA 07 ATEX 0145X	EN 60079-0: 2006, EN 60079-15: 2005, II 3 G Ex nA II T4 KEMA 07 ATEX 0145X	EN 60079-0: 2006, EN 60079-15: 2005, II 3 G Ex nA II T4 KEMA 07 ATEX 0145X	EN 60079-0: 2006, EN 60079-15: 2005, II 3 G Ex nA II T4 KEMA 07 ATEX 0145X
• for CSA and UL safety	UL 60950-1, CSA C22.2 No. 60950-1	UL 60950-1, CSA C22.2 No. 60950-1	UL 60950-1, CSA C22.2 No. 60950-1	UL 60950-1, CSA C22.2 No. 60950-1
• for hazardous zone of CSA and UL	UL 1604 and UL 2279-15 (Hazardous Location), CSA C22.2 No. 213-M1987, Class 1 / Division 2 / Group A, B, C, D / T4, Class 1 / Zone 2 / Group IIC / T4	UL 1604 and UL 2279-15 (Hazardous Location), CSA C22.2 No. 213-M1987, Class 1 / Division 2 / Group A, B, C, D / T4, Class 1 / Zone 2 / Group IIC / T4	UL 1604 and UL 2279-15 (Hazardous Location), CSA C22.2 No. 213-M1987, Class 1 / Division 2 / Group A, B, C, D / T4, Class 1 / Zone 2 / Group IIC / T4	UL 1604 and UL 2279-15 (Hazardous Location), CSA C22.2 No. 213-M1987, Class 1 / Division 2 / Group A, B, C, D / T4, Class 1 / Zone 2 / Group IIC / T4
• For emitted interference	EN 61000-6-4:2007 (Class A)	EN 61000-6-4:2007 (Class A)	EN 61000-6-4:2007 (Class A)	EN 61000-6-4:2007 (Class A)
• for noise immunity	EN 61000-6-2:2005	EN 61000-6-2:2005	EN 61000-6-2:2005	EN 61000-6-2:2005
Certificate of suitability	EN 61000-6-2:2005, EN 61000-6-4:2007	EN 61000-6-2:2005, EN 61000-6-4:2007	EN 61000-6-2:2005, EN 61000-6-4:2007	EN 61000-6-2:2005, EN 61000-6-4:2007
• CE mark	Yes	Yes	Yes	Yes
• C-Tick	Yes	Yes	Yes	Yes
• IEC 61850-3	-	-	-	-
Marine classification association	-	-	-	-
• American Bureau of Shipping Europe Ltd. (ABS)	-	-	-	-
• Bureau Veritas (BV)	-	-	-	-
• Det Norske Veritas (DNV)	-	-	-	-
• Germanischer Lloyd (GL)	-	-	-	-
• Lloyds Register of Shipping (LRS)	-	-	-	-
• Nippon Kaiji Kyokai (NK)	-	-	-	-

Technical specifications (continued)

Order No.	6GK5 991-2AD00-8AA0	6GK5 991-2AF00-8AA0	6GK5 991-2AE00-8AA0
Product type designation	MM991-2 (SC)	MM991-2LD	MM991-2LH+
Transmission rate			
Transmission rate 1	100 Mbit/s	100 Mbit/s	100 Mbit/s
Transmission rate 2	-	-	-
Transmission rate 3	-	-	-
Interfaces			
Maximum number of electrical/ optical connections for network components or terminal equipment	2	2	2
Number of electrical connections			
• for network components or terminal equipment	-	-	-
• with power-over-Ethernet for network components or terminal equipment	-	-	-
Design of electrical connection			
• for network components or terminal equipment	-	-	-
• with power-over-Ethernet for network components or terminal equipment	-	-	-
Number of optical connections for fiber-optic cables			
• At 100 Mbit/s	2	2	2
• at 1000 Mbit/s	-	-	-
Design of optical connection for fiber-optic cables			
• At 100 Mbit/s	SC port (multimode up to 5 km)	SC port (singlemode up to 26 km)	SC port (singlemode up to 70 km)
• At 1000 Mbit/s	-	-	-
• at 10 Gbit/s	-	-	-
Injectable optical power referred to 1 mW			
• of the transmitter output	-19 ... -14 dB	-15 ... -8 dB	-5 ... +0 dB
• of the receiver input, maximum	-3 dB	-3 dB	-3 dB
Minimum optical sensitivity referred to 1 mW of the receiver input	-34 dB	-32 dB	-34 dB
Minimum required attenuation factor of the FO transmission link	0 dB	0 dB	3 dB
The range at the optical interface depends on the type of optical fiber used	0 ... 5 km	0 ... 26 km	12 ... 70 km
Permissible ambient conditions			
Ambient temperature			
• During operation	0 ... 70 °C	0 ... 70 °C	0 ... 70 °C
• During storage	0 ... 70 °C	0 ... 70 °C	0 ... 70 °C
• During transport	0 ... 70 °C	0 ... 70 °C	0 ... 70 °C
Relative humidity at 25 °C without condensation during operation, maximum	95 %	95 %	95 %
IP degree of protection	IP20	IP20	IP20
Design, dimensions and weights			
Design	Media module	Media module	Media module
Width	60 mm	60 mm	60 mm
Height	22 mm	22 mm	22 mm
Depth	100 mm	100 mm	100 mm
Net weight	0.08 kg	0.08 kg	0.08 kg
Type of mounting for installation at media module slot	Yes	Yes	Yes

PROFINET/Industrial Ethernet

Industrial Ethernet switches / media converters

Media modules for modular SCALANCE X-300 managed

Technical specifications (continued)

Order No.	6GK5 991-2AD00-8AA0	6GK5 991-2AF00-8AA0	6GK5 991-2AE00-8AA0
Product type designation	MM991-2 (SC)	MM991-2LD	MM991-2LH+
Standards, specifications, approvals			
Standard			
• for EMC	-	-	-
• for EMC of FM	FM3611: Class 1, Division 2, Group A, B, C, D / T4, Class 1, Zone 2, Group IIC, T4	FM3611: Class 1, Division 2, Group A, B, C, D / T4, Class 1, Zone 2, Group IIC, T4	FM3611: Class 1, Division 2, Group A, B, C, D / T4, Class 1, Zone 2, Group IIC, T4
• for hazardous zone	EN 60079-0: 2006, EN 60079-15: 2005, II 3 G Ex nA II T4 KEMA 07 ATEX 0145X	EN 60079-0: 2006, EN 60079-15: 2005, II 3 G Ex nA II T4 KEMA 07 ATEX 0145X	EN 60079-0: 2006, EN 60079-15: 2005, II 3 G Ex nA II T4 KEMA 07 ATEX 0145X
• for CSA and UL safety	UL 60950-1, CSA C22.2 No. 60950-1	UL 60950-1, CSA C22.2 No. 60950-1	UL 60950-1, CSA C22.2 No. 60950-1
• for hazardous zone of CSA and UL	UL 1604 and UL 2279-15 (Hazardous Location), CSA C22.2 No. 213-M1987, Class 1 / Division 2 / Group A, B, C, D / T4, Class 1 / Zone 2 / Group IIC / T4	UL 1604 and UL 2279-15 (Hazardous Location), CSA C22.2 No. 213-M1987, Class 1 / Division 2 / Group A, B, C, D / T4, Class 1 / Zone 2 / Group IIC / T4	UL 1604 and UL 2279-15 (Hazardous Location), CSA C22.2 No. 213-M1987, Class 1 / Division 2 / Group A, B, C, D / T4, Class 1 / Zone 2 / Group IIC / T4
• For emitted interference	EN 61000-6-4:2007 (Class A)	EN 61000-6-4:2007 (Class A)	EN 61000-6-4:2007 (Class A)
• for noise immunity	EN 61000-6-2:2005	EN 61000-6-2:2005	EN 61000-6-2:2005
Certificate of suitability	EN 61000-6-2:2005, EN 61000-6-4:2007	EN 61000-6-2:2005, EN 61000-6-4:2007	EN 61000-6-2:2005, EN 61000-6-4:2007
• CE mark	Yes	Yes	Yes
• C-Tick	Yes	Yes	Yes
• IEC 61850-3	-	-	-
Marine classification society			
• American Bureau of Shipping Europe Ltd. (ABS)	-	-	-
• Bureau Veritas (BV)	-	-	-
• Det Norske Veritas (DNV)	-	-	-
• Germanischer Lloyd (GL)	-	-	-
• Lloyds Register of Shipping (LRS)	-	-	-
• Nippon Kaiji Kyokai (NK)	-	-	-

Order No.	6GK5 992-2AL00-8AA0	6GK5 992-2AM00-8AA0	6GK5 992-2AN00-8AA0
Product type designation	MM992-2	MM992-2LD	MM992-2LH
Transmission rate			
Transmission rate 1	1000 Mbit/s	1000 Mbit/s	1000 Mbit/s
Transmission rate 2	-	-	-
Transmission rate 3	-	-	-
Interfaces			
Maximum number of electrical/optical connections for network components or terminal equipment	2	2	2
Number of electrical connections			
• for network components or terminal equipment	-	-	-
• with power-over-Ethernet for network components or terminal equipment	-	-	-
Design of electrical connection			
• for network components or terminal equipment	-	-	-
• with power-over-Ethernet for network components or terminal equipment	-	-	-
Number of optical connections for fiber-optic cables			
• at 100 Mbit/s	-	-	-
• At 1000 Mbit/s	2	2	2
Design of optical connection for fiber-optic cables			
• At 100 Mbit/s	-	-	-
• At 1000 Mbit/s	SC port (multimode up to 0.75 km)	SC port (singlemode up to 10 km)	SC port (singlemode up to 40 km)

PROFINET/Industrial Ethernet

Industrial Ethernet switches / media converters

Media modules
for modular SCALANCE X-300 managed

Technical specifications (continued)

Order No.	6GK5 992-2AL00-8AA0	6GK5 992-2AM00-8AA0	6GK5 992-2AN00-8AA0
Product type designation	MM992-2	MM992-2LD	MM992-2LH
Injectable optical power referred to 1 mW			
• of the transmitter output	-9.5 ... -4 dB	-9.5 ... -3 dB	-6 ... +0 dB
• of the receiver input, maximum	-3 dB	-3 dB	-3 dB
Minimum optical sensitivity relative to 1 mW of the receiver input	-17 dB	-21 dB	-23 dB
Minimum required attenuation factor of the FO transmission link	0 dB	0 dB	3 dB
The range at the optical interface depends on the type of optical fiber used	0 ... 0.75 km	0 ... 10 km	8 ... 40 km
Permissible ambient conditions			
Ambient temperature			
• During operation	0 ... 70 °C	0 ... 70 °C	0 ... 70 °C
• During storage	0 ... 70 °C	0 ... 70 °C	0 ... 70 °C
• During transport	0 ... 70 °C	0 ... 70 °C	0 ... 70 °C
Relative humidity at 25 °C without condensation during operation, maximum	95 %	95 %	95 %
IP degree of protection	IP20	IP20	IP20
Design, dimensions and weights			
Design	Media module	Media module	Media module
Width	60 mm	60 mm	60 mm
Height	22 mm	22 mm	22 mm
Depth	100 mm	100 mm	100 mm
Net weight	0.08 kg	0.08 kg	0.08 kg
Type of mounting for installation at media module slot	Yes	Yes	Yes
Standards, specifications, approvals			
Standard			
• for EMC	-	-	-
• for EMC of FM	FM3611: Class 1, Division 2, Group A, B, C, D / T4, Class 1, Zone 2, Group IIC, T4	FM3611: Class 1, Division 2, Group A, B, C, D / T4, Class 1, Zone 2, Group IIC, T4	FM3611: Class 1, Division 2, Group A, B, C, D / T4, Class 1, Zone 2, Group IIC, T4
• for hazardous zone	EN 60079-0: 2006, EN 60079-15: 2005, II 3 G Ex nA II T4 KEMA 07 ATEX 0145X	EN 60079-0: 2006, EN 60079-15: 2005, II 3 G Ex nA II T4 KEMA 07 ATEX 0145X	EN 60079-0: 2006, EN 60079-15: 2005, II 3 G Ex nA II T4 KEMA 07 ATEX 0145X
• for CSA and UL safety	UL 60950-1, CSA C22.2 No. 60950-1	UL 60950-1, CSA C22.2 No. 60950-1	UL 60950-1, CSA C22.2 No. 60950-1
• for hazardous zone of CSA and UL	UL 1604 and UL 2279-15 (Hazardous Location), CSA C22.2 No. 213-M1987, Class 1 / Division 2 / Group A, B, C, D / T4, Class 1 / Zone 2 / Group IIC / T4	UL 1604 and UL 2279-15 (Hazardous Location), CSA C22.2 No. 213-M1987, Class 1 / Division 2 / Group A, B, C, D / T4, Class 1 / Zone 2 / Group IIC / T4	UL 1604 and UL 2279-15 (Hazardous Location), CSA C22.2 No. 213-M1987, Class 1 / Division 2 / Group A, B, C, D / T4, Class 1 / Zone 2 / Group IIC / T4
• For emitted interference	EN 61000-6-4:2007 (Class A)	EN 61000-6-4:2007 (Class A)	EN 61000-6-4:2007 (Class A)
• for noise immunity	EN 61000-6-2:2005	EN 61000-6-2:2005	EN 61000-6-2:2005
Certificate of suitability	EN 61000-6-2:2005, EN 61000-6-4:2007	EN 61000-6-2:2005, EN 61000-6-4:2007	EN 61000-6-2:2005, EN 61000-6-4:2007
• CE mark	Yes	Yes	Yes
• C-Tick	Yes	Yes	Yes
• IEC 61850-3	-	-	-
Marine classification corporation			
• American Bureau of Shipping Europe Ltd. (ABS)	-	-	-
• Bureau Veritas (BV)	-	-	-
• Det Norske Veritas (DNV)	-	-	-
• Germanischer Lloyd (GL)	-	-	-
• Lloyds Register of Shipping (LRS)	-	-	-
• Nippon Kaiji Kyokai (NK)	-	-	-

PROFINET/Industrial Ethernet

Industrial Ethernet switches / media converters

Media modules for modular SCALANCE X-300 managed

Technical specifications (continued)

Order No.	6GK5 992-2AP00-8AA0	6GK5 992-2AQ00-8AA0	6GK5 992-2AS00-8AA0
Product type designation	MM992-2LH+	MM992-2ELH	MM992-2SFP
Transmission rate			
Transmission rate 1	1000 Mbit/s	1000 Mbit/s	100 Mbit/s
Transmission rate 2	-	-	1000 Mbit/s
Transmission rate 3	-	-	-
Interfaces			
Maximum number of electrical/ optical connections for network components or terminal equipment	2	2	2
Number of electrical connections			
• for network components or terminal equipment	-	-	-
• with power-over-Ethernet for network components or terminal equipment	-	-	-
Design of electrical connection			
• for network components or terminal equipment	-	-	-
• with power-over-Ethernet for network components or terminal equipment	-	-	-
Number of optical connections for fiber-optic cables			
• at 100 Mbit/s	-	-	-
• At 1000 Mbit/s	2	2	2
Design of optical connection for fiber-optic cables			
• At 100 Mbit/s	-	-	-
• At 1000 Mbit/s	SC port (singlemode up to 70 km)	SC port (singlemode up to 120 km)	SFP slot
• at 10 Gbit/s	-	-	-
Injectable optical power referred to 1 mW			
• of the transmitter output	0 ... 5 dB	0 ... 5 dB	-
• of the receiver input, maximum	-3 dB	-3 dB	-
Minimum optical sensitivity referred to 1 mW of the receiver input	-23 dB	-30 dB	-
Minimum required attenuation factor of the FO transmission link	8 dB	8 dB	-
The range at the optical interface depends on the type of optical fiber used	30 ... 70 km	37 ... 120 km	-
Permissible ambient conditions			
Ambient temperature			
• During operation	0 ... 70 °C	0 ... 70 °C	0 ... 70 °C
• During storage	0 ... 70 °C	0 ... 70 °C	0 ... 70 °C
• During transport	0 ... 70 °C	0 ... 70 °C	0 ... 70 °C
Relative humidity at 25 °C without condensation during operation, maximum	95 %	95 %	95 %
IP degree of protection	IP20	IP20	IP20
Design, dimensions and weights			
Design	Media module	Media module	Media module
Width	60 mm	60 mm	60 mm
Height	22 mm	22 mm	22 mm
Depth	100 mm	100 mm	100 mm
Net weight	0.08 kg	0.08 kg	0.08 kg
Type of mounting for installation at media module slot	Yes	Yes	Yes

PROFINET/Industrial Ethernet

Industrial Ethernet switches / media converters

Media modules
for modular SCALANCE X-300 managed

2

Technical specifications (continued)

Order No.	6GK5 992-2AP00-8AA0	6GK5 992-2AQ00-8AA0	6GK5 992-2AS00-8AA0
Product type designation	MM992-2LH+	MM992-2ELH	MM992-2SFP
Standards, specifications, approvals			
Standard	-	-	-
• for EMC	-	-	-
• for EMC of FM	FM3611: Class 1, Division 2, Group A, B, C, D / T4, Class 1, Zone 2, Group IIC, T4	FM3611: Class 1, Division 2, Group A, B, C, D / T4, Class 1, Zone 2, Group IIC, T4	FM3611: Class 1, Division 2, Group A, B, C, D / T4, Class 1, Zone 2, Group IIC, T4
• for hazardous zone	EN 60079-0: 2006, EN 60079-15: 2005, II 3 G Ex nA II T4 KEMA 07 ATEX 0145X	EN 60079-0: 2006, EN 60079-15: 2005, II 3 G Ex nA II T4 KEMA 07 ATEX 0145X	EN 60079-0: 2006, EN 60079-15: 2005, II 3 G Ex nA II T4 KEMA 07 ATEX 0145X
• for CSA and UL safety	UL 60950-1, CSA C22.2 No. 60950-1	UL 60950-1, CSA C22.2 No. 60950-1	UL 60950-1, CSA C22.2 No. 60950-1
• for hazardous zone of CSA and UL	UL 1604 and UL 2279-15 (Hazardous Location), CSA C22.2 No. 213-M1987, Class 1 / Division 2 / Group A, B, C, D / T4, Class 1 / Zone 2 / Group IIC / T4	UL 1604 and UL 2279-15 (Hazardous Location), CSA C22.2 No. 213-M1987, Class 1 / Division 2 / Group A, B, C, D / T4, Class 1 / Zone 2 / Group IIC / T4	UL 1604 and UL 2279-15 (Hazardous Location), CSA C22.2 No. 213-M1987, Class 1 / Division 2 / Group A, B, C, D / T4, Class 1 / Zone 2 / Group IIC / T4
• For emitted interference	EN 61000-6-4:2007 (Class A)	EN 61000-6-4:2007 (Class A)	EN 61000-6-4:2007 (Class A)
• for noise immunity	EN 61000-6-2:2005	EN 61000-6-2:2005	EN 61000-6-2:2005
Certificate of suitability	EN 61000-6-2:2005, EN 61000-6-4:2007	EN 61000-6-2:2005, EN 61000-6-4:2007	EN 61000-6-2:2005, EN 61000-6-4:2007
• CE mark	Yes	Yes	Yes
• C-Tick	Yes	Yes	Yes
• IEC 61850-3	-	-	-
Marine classification society	-	-	-
• American Bureau of Shipping Europe Ltd. (ABS)	-	-	-
• Bureau Veritas (BV)	-	-	-
• Det Norske Veritas (DNV)	-	-	-
• Germanischer Lloyd (GL)	-	-	-
• Lloyds Register of Shipping (LRS)	-	-	-
• Nippon Kaiji Kyokai (NK)	-	-	-

Order No.	6GK5 991-1AD00-8AA0	6GK5 991-1AF00-8AA0	6GK5 991-1AE00-8AA0
Product type designation	SFP991-1	SFP991-1LD	SFP991-1LH+
Transmission rate			
Transmission rate 1	100 Mbit/s	100 Mbit/s	100 Mbit/s
Transmission rate 2	-	-	-
Transmission rate 3	-	-	-
Interfaces			
Maximum number of electrical/optical connections for network components or terminal equipment	1	1	1
Number of electrical connections	-	-	-
• for network components or terminal equipment	-	-	-
• with power-over-Ethernet for network components or terminal equipment	-	-	-
Design of electrical connection	-	-	-
• for network components or terminal equipment	-	-	-
• with power-over-Ethernet for network components or terminal equipment	-	-	-
Number of optical connections for fiber-optic cables	-	-	-
• At 100 Mbit/s	1	1	1
• at 1000 Mbit/s	-	-	-
Design of optical connection for fiber-optic cables	-	-	-
• at 100 Mbit/s	SC port (multimode up to 5 km)	LC port (singlemode up to 26 km)	LC port (singlemode up to 70 km)
• At 1000 Mbit/s	-	-	-

PROFINET/Industrial Ethernet

Industrial Ethernet switches / media converters

Media modules for modular SCALANCE X-300 managed

Technical specifications (continued)

Order No.	6GK5 991-1AD00-8AA0	6GK5 991-1AF00-8AA0	6GK5 991-1AE00-8AA0
Product type designation	SFP991-1	SFP991-1LD	SFP991-1LH+
Injectable optical power referred to 1 mW			
• of the transmitter output	-19 ... -14 dB	-15 ... -8 dB	-5 ... +0 dB
• of the receiver input, maximum	-3 dB	-3 dB	-3 dB
Minimum optical sensitivity referred to 1 mW of the receiver input	-32 dB	-34 dB	-34 dB
Minimum required attenuation factor of the FO transmission link	0 dB	0 dB	3 dB
The range at the optical interface depends on the type of optical fiber used	0 ... 5 km	0 ... 26 km	12 ... 70 km
Permissible ambient conditions			
Ambient temperature			
• During operation	-40 ... +85 °C	-40 ... +85 °C	-40 ... +85 °C
• During storage	-40 ... +85 °C	-40 ... +85 °C	-40 ... +85 °C
• During transport	-40 ... +85 °C	-40 ... +85 °C	-40 ... +85 °C
Relative humidity at 25 °C without condensation during operation, maximum	95 %	95 %	95 %
IP degree of protection	IP20	IP20	IP20
Design, dimensions and weights			
Design	SFP module	SFP module	SFP module
Width	13.7 mm	13.7 mm	13.7 mm
Height	11.9 mm	11.9 mm	11.9 mm
Depth	56.5 mm	56.5 mm	56.5 mm
Net weight	0.01 kg	0.01 kg	0.01 kg
Type of mounting for installation at media module slot	No	No	No
Standards, specifications, approvals			
Standard			
• for EMC	-	-	-
• for EMC of FM	FM3611: Class 1, Division 2, Group A, B, C, D / T4, Class 1, Zone 2, Group IIC, T4	FM3611: Class 1, Division 2, Group A, B, C, D / T4, Class 1, Zone 2, Group IIC, T4	FM3611: Class 1, Division 2, Group A, B, C, D / T4, Class 1, Zone 2, Group IIC, T4
• for hazardous zone	EN 60079-0: 2006, EN 60079-15: 2005, II 3 G Ex nA II T4 KEMA 07 ATEX 0145X	EN 60079-0: 2006, EN 60079-15: 2005, II 3 G Ex nA II T4 KEMA 07 ATEX 0145X	EN 60079-0: 2006, EN 60079-15: 2005, II 3 G Ex nA II T4 KEMA 07 ATEX 0145X
• for CSA and UL safety	UL 60950-1, CSA C22.2 No. 60950-1-03	UL 60950-1, CSA C22.2 No. 60950-1-03	UL 60950-1, CSA C22.2 No. 60950-1-03
• for hazardous zone of CSA and UL	-	-	-
• For emitted interference	EN 61000-6-4:2007 (Class A)	EN 61000-6-4:2007 (Class A)	EN 61000-6-4:2007 (Class A)
• for noise immunity	EN 61000-6-2:2005	EN 61000-6-2:2005	EN 61000-6-2:2005
Certificate of suitability	EN 61000-6-2:2005, EN 61000-6-4:2007	EN 61000-6-2:2005, EN 61000-6-4:2007	EN 61000-6-2:2005, EN 61000-6-4:2007
• CE marking	Yes	Yes	Yes
• C-Tick	Yes	Yes	Yes
• IEC 61850-3	-	-	-
Marine classification society			
• American Bureau of Shipping Europe Ltd. (ABS)	-	-	-
• Bureau Veritas (BV)	-	-	-
• Det Norske Veritas (DNV)	-	-	-
• Germanischer Lloyd (GL)	-	-	-
• Lloyds Register of Shipping (LRS)	-	-	-
• Nippon Kaiji Kyokai (NK)	-	-	-

PROFINET/Industrial Ethernet

Industrial Ethernet switches / media converters

Media modules
for modular SCALANCE X-300 managed

2

Technical specifications (continued)

Order No.	6GK5 992-1AL00-8AA0	6GK5 992-1AM00-8AA0	6GK5 992-1AN00-8AA0
Product type designation	SFP992-1	SFP992-1LD	SFP992-1LH
Transmission rate			
Transmission rate 1	1000 Mbit/s	1000 Mbit/s	1000 Mbit/s
Transmission rate 2	-	-	-
Transmission rate 3	-	-	-
Interfaces			
Maximum number of electrical/ optical connections for network components or terminal equipment	1	1	1
Number of electrical connections			
• for network components or terminal equipment	-	-	-
• with power-over-Ethernet for network components or terminal equipment	-	-	-
Design of electrical connection			
• for network components or terminal equipment	-	-	-
• with power-over-Ethernet for network components or terminal equipment	-	-	-
Number of optical connections for fiber-optic cables			
• at 100 Mbit/s	-	-	-
• At 1000 Mbit/s	1	1	1
Design of optical connection for fiber-optic cables			
• At 100 Mbit/s	-	-	-
• At 1000 Mbit/s	LC port (multimode up to 0.75 km)	LC port (singlemode up to 10 km)	LC port (singlemode up to 40 km)
• at 10 Gbit/s	-	-	-
Injectable optical power relative to 1 mW			
• of the transmitter output	-9.5 ... -4 dB	-9.5 ... -3 dB	-6 ... +0 dB
• of the receiver input, maximum	-3 dB	-3 dB	-3 dB
Minimum optical sensitivity relative to 1 mW of the receiver input	-17 dB	-21 dB	-23 dB
Minimum required attenuation factor of the FO transmission link	0 dB	0 dB	3 dB
The range at the optical interface depends on the type of optical fiber used	0 ... 0.75 km	0 ... 10 km	8 ... 40 km
Permissible ambient conditions			
Ambient temperature			
• During operation	-40 ... +85 °C	-40 ... +85 °C	-40 ... +85 °C
• During storage	-40 ... +85 °C	-40 ... +85 °C	-40 ... +85 °C
• During transport	-40 ... +85 °C	-40 ... +85 °C	-40 ... +85 °C
Relative humidity at 25 °C without condensation during operation, maximum	95 %	95 %	95 %
IP degree of protection	IP20	IP20	IP20
Design, dimensions and weights			
Design	SFP module	SFP module	SFP module
Width	13.7 mm	13.7 mm	13.7 mm
Height	11.9 mm	11.9 mm	11.9 mm
Depth	56.5 mm	56.5 mm	56.5 mm
Net weight	0.01 kg	0.01 kg	0.01 kg
Type of mounting for installation at media module slot	No	No	No

PROFINET/Industrial Ethernet

Industrial Ethernet switches / media converters

Media modules for modular SCALANCE X-300 managed

Technical specifications (continued)

Order No.	6GK5 992-1AL00-8AA0	6GK5 992-1AM00-8AA0	6GK5 992-1AN00-8AA0
Product type designation	SFP992-1	SFP992-1LD	SFP992-1LH
Standards, specifications, approvals			
Standard	-	-	-
• for EMC	-	-	-
• for EMC of FM	FM3611: Class 1, Division 2, Group A, B, C, D / T4, Class 1, Zone 2, Group IIC, T4	FM3611: Class 1, Division 2, Group A, B, C, D / T4, Class 1, Zone 2, Group IIC, T4	FM3611: Class 1, Division 2, Group A, B, C, D / T4, Class 1, Zone 2, Group IIC, T4
• for hazardous zone	EN 60079-0: 2006, EN 60079-15: 2005, II 3 G Ex nA II T4 KEMA 07 ATEX 0145X	EN 60079-0: 2006, EN 60079-15: 2005, II 3 G Ex nA II T4 KEMA 07 ATEX 0145X	EN 60079-0: 2006, EN 60079-15: 2005, II 3 G Ex nA II T4 KEMA 07 ATEX 0145X
• for CSA and UL safety	UL 60950-1, CSA C22.2 No. 60950-1-03	UL 60950-1, CSA C22.2 No. 60950-1-03	UL 60950-1, CSA C22.2 No. 60950-1-03
• for hazardous zone of CSA and UL	-	-	-
• For emitted interference	EN 61000-6-4:2007 (Class A)	EN 61000-6-4:2007 (Class A)	EN 61000-6-4:2007 (Class A)
• for noise immunity	EN 61000-6-2:2005	EN 61000-6-2:2005	EN 61000-6-2:2005
Certificate of suitability	EN 61000-6-2:2005, EN 61000-6-4:2007	EN 61000-6-2:2005, EN 61000-6-4:2007	EN 61000-6-2:2005, EN 61000-6-4:2007
• CE mark	Yes	Yes	Yes
• C-Tick	Yes	Yes	Yes
• IEC 61850-3	-	-	-
Marine classification society	-	-	-
• American Bureau of Shipping Europe Ltd. (ABS)	-	-	-
• Bureau Veritas (BV)	-	-	-
• Det Norske Veritas (DNV)	-	-	-
• Germanischer Lloyd (GL)	-	-	-
• Lloyds Register of Shipping (LRS)	-	-	-
• Nippon Kaiji Kyokai (NK)	-	-	-

Order No.	6GK5 992-1AP00-8AA0	6GK5 992-1AQ00-8AA0
Product type designation	SFP992-1LH+	SFP992-1ELH
Transmission rate		
Transmission rate 1	1000 Mbit/s	1000 Mbit/s
Transmission rate 2	-	-
Transmission rate 3	-	-
Interfaces		
Maximum number of electrical/optical connections for network components or terminal equipment	1	1
Number of electrical connections	-	-
• For network components or terminal equipment	-	-
• with power-over-Ethernet for network components or terminal equipment	-	-
Design of electrical connection	-	-
• for network components or terminal equipment	-	-
• with power-over-Ethernet for network components or terminal equipment	-	-
Number of optical connections for fiber-optic cables	-	-
• At 100 Mbit/s	-	-
• At 1000 Mbit/s	1	1
Design of optical connection for fiber-optic cables	-	-
• At 100 Mbit/s	-	-
• At 1000 Mbit/s	LC port (singlemode up to 70 km)	LC port (singlemode up to 120 km)
• at 10 Gbit/s	-	-

Technical specifications (continued)

Order No.	6GK5 992-1AP00-8AA0	6GK5 992-1AQ00-8AA0
Product type designation	SFP992-1LH+	SFP992-1ELH
Injectable optical power referred to 1 mW		
• of the transmitter output	0 ... 5 dB	0 ... 5 dB
• of the receiver input, maximum	-3 dB	-8 dB
Minimum optical sensitivity referred to 1 mW of the receiver input	-23 dB	-32 dB
Minimum required attenuation factor of the FO transmission link	8 dB	8 dB
The range at the optical interface depends on the type of optical fiber used	30 ... 70 km	37 ... 120 km
Permissible ambient conditions		
Ambient temperature		
• During operation	-40 ... +85 °C	-40 ... +85 °C
• During storage	-40 ... +85 °C	-40 ... +85 °C
• During transport	-40 ... +85 °C	-40 ... +85 °C
Relative humidity at 25 °C without condensation during operation, maximum	95 %	95 %
IP degree of protection	IP20	IP20
Design, dimensions and weights		
Type of construction	SFP module	SFP module
Width	13.7 mm	13.7 mm
Height	11.9 mm	11.9 mm
Depth	56.5 mm	56.5 mm
Net weight	0.01 kg	0.01 kg
Type of mounting for installation at media module slot	No	No
Standards, specifications, approvals		
Standard		
• for EMC	-	-
• for EMC of FM	FM3611: Class 1, Division 2, Group A, B, C, D / T4, Class 1, Zone 2, Group IIC, T4	FM3611: Class 1, Division 2, Group A, B, C, D / T4, Class 1, Zone 2, Group IIC, T4
• for hazardous zone	EN 60079-0: 2006, EN 60079-15: 2005, II 3 G Ex nA II T4 KEMA 07 ATEX 0145X	EN 60079-0: 2006, EN 60079-15: 2005, II 3 G Ex nA II T4 KEMA 07 ATEX 0145X
• for CSA and UL safety	UL 60950-1, CSA C22.2 No. 60950-1-03	UL 60950-1, CSA C22.2 No. 60950-1-03
• for hazardous zone of CSA and UL	-	-
• for emitted interference	EN 61000-6-4:2007 (Class A)	EN 61000-6-4:2007 (Class A)
• for noise immunity	EN 61000-6-2:2005	EN 61000-6-2:2005
Certificate of suitability	EN 61000-6-2:2005, EN 61000-6-4:2007	EN 61000-6-2:2005, EN 61000-6-4:2007
• CE marking	Yes	Yes
• C-Tick	Yes	Yes
• IEC 61850-3	-	-
Marine classification society		
• American Bureau of Shipping Europe Ltd. (ABS)	-	-
• Bureau Veritas (BV)	-	-
• Det Norske Veritas (DNV)	-	-
• Germanischer Lloyd (GL)	-	-
• Lloyds Register of Shipping (LRS)	-	-
• Nippon Kaiji Kyokai (NK)	-	-

PROFINET/Industrial Ethernet

Industrial Ethernet switches / media converters

Media modules for modular SCALANCE X-300 managed

2

Ordering data	Order No.	Order No.
<i>Electrical media modules</i>		
with 2 x 10/100/1000 Mbit/s RJ45 ports, electrical		
<ul style="list-style-type: none"> MM992-2CUC with retaining sleeve MM992-2CU without retaining sleeve 	6GK5 992-2GA00-8AA0 6GK5 992-2SA00-8AA0	
<i>Fiber optic modules</i>		
with 2 x 100 Mbit/s BFOC ports, optical		
<ul style="list-style-type: none"> MM991-2 multimode, glass, up to 5 km MM991-2LD single-mode, glass, up to 26 km 	6GK5 991-2AB00-8AA0 6GK5 991-2AC00-8AA0	
with 2 x 100 Mbit/s SC ports, optical		
<ul style="list-style-type: none"> MM991-2 multimode, glass, up to 5 km MM991-2LD single-mode, glass, up to 26 km MM991-2LH+ single-mode, glass, up to 70 km 	6GK5 991-2AD00-8AA0 6GK5 991-2AF00-8AA0 6GK5 991-2AE00-8AA0	
with 2 x 1000 Mbit/s SC ports, optical		
<ul style="list-style-type: none"> MM992-2 multimode, glass, up to 750 m MM992-2LD single-mode, glass, up to 10 km MM992-2LH single-mode, glass, up to 40 km MM992-2LH+ single-mode, glass, up to 70 km MM992-2ELH single-mode, glass, up to 120 km 	6GK5 992-2AL00-8AA0 6GK5 992-2AM00-8AA0 6GK5 992-2AN00-8AA0 6GK5 992-2AP00-8AA0 6GK5 992-2AQ00-8AA0	
with 2 x 100/1000 Mbit/s for SFP pluggable transceiver, optical		
<ul style="list-style-type: none"> MM992-2SFP for SFP pluggable transceivers with 1 x 100 or 1 x 1000 Mbit/s multi-mode or single-mode, glass 	6GK5 992-2AS00-8AA0	
<i>SFP pluggable transceiver, optical</i>		
with 1 x 100 Mbit/s LC port, optical		
<ul style="list-style-type: none"> SFP991-1 multimode, glass, up to 5 km SFP991-1LD single-mode, glass, up to 26 km SFP991-1LH+ single-mode, glass, up to 70 km 		6GK5 991-1AD00-8AA0 6GK5 991-1AF00-8AA0 6GK5 991-1AE00-8AA0
with 1 x 1000 Mbit/s LC port, optical		
<ul style="list-style-type: none"> SFP992-1 multimode, glass, up to 750 m SFP992-1LD single-mode, glass, up to 10 km SFP992-1LH single-mode, glass, up to 40 km SFP992-1LH+ single-mode, glass, up to 70 km SFP992-1ELH single-mode, glass, up to 120 km 		6GK5 992-1AL00-8AA0 6GK5 992-1AM00-8AA0 6GK5 992-1AN00-8AA0 6GK5 992-1AP00-8AA0 6GK5 992-1AQ00-8AA0
<i>Accessories</i>		
IE FC RJ45 Modular Outlet		
FastConnect Outlet RJ45 for Industrial Ethernet with interface for a replaceable insert		
<ul style="list-style-type: none"> with insert 2FE; replaceable insert for 2 x 100 Mbit/s interfaces with insert 1GE; replaceable insert for 1 x 1000 Mbit/s interfaces 		6GK1 901-1BE00-0AA1 6GK1 901-1BE00-0AA2
IE FC TP Standard Cable GP 2 x 2 (Type A)		
4-core, shielded TP installation cable for connection to IE FC Outlet RJ45/IE FC RJ45 Plug; PROFINET-compliant; with UL approval; sold by the meter; max. length 1000 m, minimum order 20 m		6XV1 840-2AH10

PROFINET/Industrial Ethernet

Industrial Ethernet switches / media converters

Media modules
for modular SCALANCE X-300 managed

Ordering data	Order No.
<i>Accessories (continued)</i>	
IE FC TP standard cable GP 4 x 2 8-core, shielded TP installation cable for connection to IE FC RJ45 Modular Outlet for universal application; with UL approval; sold by the meter; max quantity 1000 m, minimum order 20 m	6XV1 870-2E
IE TP Cord RJ45/RJ45 TP cable 4 x 2 with two RJ45 connectors <ul style="list-style-type: none"> • 0.5 m • 1 m • 2 m • 6 m • 10 m 	6XV1 870-3QE50 6XV1 870-3QH10 6XV1 870-3QH20 6XV1 870-3QH60 6XV1 870-3QN10
IE FC RJ45 Plug 180 RJ45 plug connector for Industrial Ethernet with a rugged metal enclosure and integrated insulation displacement contacts for connecting Industrial Ethernet FC installation cables; with 180° cable outlet; for network components and CPs/CPUs with Industrial Ethernet interface <ul style="list-style-type: none"> • 1 pack = 1 unit • 1 pack = 10 units • 1 pack = 50 units 	6GK1 901-1BB10-2AA0 6GK1 901-1BB10-2AB0 6GK1 901-1BB10-2AE0
IE FC RJ45 Plug 4 x 2 RJ45 plug connector for Industrial Ethernet (10/100/1000 Mbit/s) with a rugged metal enclosure and integrated insulation displacement contacts for connecting Industrial Ethernet FC installation cables; 180° cable outlet; for network components and CPs/CPUs with Industrial Ethernet interface <ul style="list-style-type: none"> • 1 pack = 1 unit • 1 pack = 10 units • 1 pack = 50 units 	6GK1 901-1BB11-2AA0 6GK1 901-1BB11-2AB0 6GK1 901-1BB11-2AE0

More information

To assist in selecting the right Industrial Ethernet switches as well as configuration of modular versions, the SIMATIC NET Selection Tool is available:

Online version:
www.siemens.com/snst

Offline version:
www.siemens.com/snst-download

PROFINET/Industrial Ethernet

Industrial Ethernet switches / media converters

SCALANCE X-400 managed (Layer 3)

Overview

2

SCALANCE X-400		Hardware																										
		Type of device	Connection to S7 backplane bus	Format module S7	PC module	Flat type of construction	Box type of construction	19" type of construction	Rugged, compact housing	Modular design	10 Gigabit Ethernet	Gigabit Ethernet	PoE (Power over Ethernet)	LED diagnosis	SIMATIC environment	Redundant power supply (2 x 24 V DC)	External supply for integrated switch	Signal contact	Local display (SET pushbutton)	C-PLUG slot								
X408-2									•		•		•	•	•		•	•	•									
X414-3E									•		•		•	•	•		•	•	•									
SCALANCE X-400		Software																										
		Security integrated (Firewall/VPN)	PROFINET diagnosis	Topology support (LLDP)	Command Line Interface / Telnet	Web based Management	Configuration with STEP 7	SNMP	Ring redundancy incl. RM-functionality	Standby redundancy	IRT capability	VLAN (Virtual Local Area Network)	GVRP (Generic VLAN Registration Protocol)	STP/RSTP (Spanning Tree Protocol/ Rapid Spanning Tree Protocol)	Passive Listening	IGMP Snooping/Querier (Internet Group Management Protocol)	GMRP (Generic Multicast Protocol)	Broadcast/ Multicast/ Unicast Limiter	Broadcast blocking	DHCP Option 82 (Dynamic Host Configuration Protocol)	IP Access List	Access Control List (MAC)	IEEE 802.1x (Radius)	Link Aggregation	Static Routing	RIPv2 (Dynamic Routing)	OSPFv2 (Dynamic Routing)	VRRP, Router Redundancy (Virtual Router Redundancy Protocol)
X408-2		•	•	•	•	•	•	•			•	•	•	•	•	•	•	•	•		•	•	•	•	•	•	•	
X414-3E		•	•	•	•	•	•	•			•	•	•	•	•	•	•	•	•	•	•	•	•	•	•	•	•	•

• applies

G...IK10...XX_10309

Function overview SCALANCE X-400 managed

PROFINET/Industrial Ethernet

Industrial Ethernet switches / media converters

SCALANCE X-400 managed (Layer 3)

Overview



The SCALANCE X-400 product range comprises modular Industrial Ethernet switches expandable by various media modules and partially by extenders. It supports 10/100/1000-Mbit technology for various transmission media (twisted pair, fiber optic) and increased port requirements. The main applications are high-performance plant networks (control level). Thanks to its partly modular design, the X-400 product line is also designed for future requirements and can be adapted to the relevant task.

- Two to four integral Gigabit Ethernet twisted pair interfaces (10/100/1000 Mbit/s) for connecting several switches to each other; node connection via the Fast Ethernet twisted pair ports (10/100 Mbit/s) integrated into the basic unit
- *SCALANCE X414-3E*: another eight nodes can be connected to the basic unit via extender modules; the following extender modules are available:
 - Extenders with eight Fast Ethernet twisted-pair ports
 - Extenders with four media module slots for up to eight Fast Ethernet fiber optic ports
- High-speed media redundancy through integral redundancy manager even for large networks, for both Gigabit Ethernet and Fast Ethernet
- For the construction of optical Gigabit Ethernet rings, the integrated Gigabit Ethernet ports can be converted to fiber optic via a 2-port Gigabit Ethernet media module (MM).
- By means of plug-in 2-port Fast Ethernet media modules for multimode or alternatively single-mode fiber-optic cable, SCALANCE X-400 switches can also be integrated into 100-Mbit/s rings, e.g. with SCALANCE X204-2. It is then possible to also provide an optical link to remote stations.
- Remote diagnostics by means of PROFINET diagnostics, CLI, Web browser or SNMP
- Seamless integration of automation networks into existing corporate networks thanks to support for a host of IT standards: Establishment of virtual networks (VLANs)
- Integration into higher-level enterprise networks thanks to support for standardized redundancy procedures (Rapid Spanning Tree Protocol)
- Through learning the Multicast sources and targets (IGMP (**I**nternet **G**roup **M**anagement **P**rotocol snooping), SCALANCE X-400 switches can also filter Multicast data traffic and therefore limit the load in the network.
- Creation of IP subnets and IP router communication by means of Layer 3 switching (IP routing) on SCALANCE X414-3E
 - Static routing
 - Dynamic routing OSPF (Open Shortest Path First) and RIPv1/2 (Routing Information Protocol)
 - Redundant routing VRRP (Virtual Router Redundancy Protocol)

PROFINET/Industrial Ethernet

Industrial Ethernet switches / media converters

SCALANCE X-400 managed (Layer 3)

Benefits

get Designed for Industry

- Flexible configuration of electrical or optical Industrial Ethernet networks; the network topology, type and number of ports can be adapted easily to the structure of the plant.
- High availability of the network thanks to:
 - Redundant power supply
 - Redundant network structures based on fiber-optic or twisted pair cables (redundancy manager, standby function, RSTP and VRRP are integrated)
 - Replacement and extension of media and expansion modules during operation
 - Easy device replacement by means of plug-in C-PLUG swap medium
- Reliable communication thanks to very fast reconfiguration of the network in the event of a fault
- Simple fiber optic connection technology by means of SC sockets (Gigabit Ethernet), BFOC sockets (Fast Ethernet) and prefabricated fiber optic cables
- Twisted pair ports are readily accessible from the front, 10/100/1000 Mbit/s; ports with sleeve for rugged, industry-compatible station connection for direct connections up to 100 m in conjunction with the PROFINET-compatible IE FC RJ45 Plug 180 or IE FC RJ45 Plug 145 connector
- Easy network configuration without runtime calculation also for extremely large networks
- Simple monitoring and diagnosis by means of signaling contact, digital inputs, SNMP, Syslog and e-mail; PROFINET IO diagnostics
- Reduced engineering expenditure for PLC/HMI due to integration into the SIMATIC system fault message concept SFM
- Thanks to the integrated Layer 3 function (IP routing) – static, dynamic and redundant – of SCALANCE X414-3E, networks can be divided into different subnets
- Investment protection for existing networks due to
 - Effortless connection of existing 10 Mbit/s data terminals or network segments to Fast Ethernet networks with 100 Mbit/s
 - Increase in performance through load decoupling and data transfer rates of 100 Mbit/s and 1000 Mbit/s
 - Easy integration into existing network management infrastructures by means of SNMP
- Support of VLAN permits integration into Enterprise Security Policies
- Limiting of load on application of Multicast-based protocols (e.g. video transmission) through IGMP (Internet Group Management Protocol) snooping or GMRP (GARP Multicast Registration Protocol)
- Protection of network against overload by setting of port thresholds
- Operating temperature range
 - SCALANCE X414-3E: -40 °C to + 70 °C
 - SCALANCE X408-2: 0 °C to + 60 °C
- Low-maintenance operation thanks to fanless construction

Application

SCALANCE X-400 products permit the configuration of switched networks at the control level, which not only demands high availability of the network and extensive diagnostic options, but also a high number of ports, high transfer rate and the support of fiber optic and twisted-pair transmission media. SCALANCE X-400 products are designed with degree of protection IP20 for installation in control cabinets.

SCALANCE X408-2

- Control stations with a low concentration of devices
- Star hub in plant bus for applications with low concentration of devices
- High-speed backbone including high-speed media redundancy for process control systems
- In the high-speed backbone for coupling Gigabit network topologies

SCALANCE X414-3E

- Control stations with a high concentration of devices
- Star hub in plant bus for applications with high concentration of devices
- High-speed backbone including high-speed media redundancy for process control systems
- SCALANCE X414-3E equipped with Layer 3 for IP routing (static, dynamic, redundant)

Design

SCALANCE X408-2/SCALANCE X414-3

Communication connections:

- Integral Gigabit Ethernet twisted pair ports (10/100/1000 Mbit/s, RJ45 sockets) for connecting SCALANCE X-400 switches together:
 - SCALANCE X408-2:
 - 4 Gigabit Ethernet twisted pair ports
 - SCALANCE X414-3E:
 - 2 Gigabit Ethernet twisted pair ports
- Integral Fast Ethernet twisted pair ports (10/100 Mbit/s, RJ45 sockets with securing collar) for node connection
 - SCALANCE X408-2:
 - 4 Fast Ethernet twisted pair ports
 - SCALANCE X414-3E:
 - 12 Fast Ethernet twisted pair ports
- The Gigabit Ethernet ports can be converted to fiber-optic connections with optical Gigabit Ethernet media modules

Only for SCALANCE X408-2:

- Two universal slots either for optical Fast Ethernet or Gigabit Ethernet media modules with two ports

Only for SCALANCE X414-3E:

- Two slots for optical Fast Ethernet media modules with two ports
- One extender interface for expansion by 8 Fast Ethernet ports (twisted pair or fiber optic, depending on extender version). In this way, a maximum configuration of two Gigabit Ethernet Ports (electrical or optical) and up to 24 Fast Ethernet Ports (of which between 2 and 12 can be optical) is possible. The installation width including extender is max. 19".

Interfaces

- Console port (serial interface) for on-site parameterization/diagnostics, for firmware update;
- Slot for C-PLUG swap media for easy device replacement (included in scope of supply)
- Redundant 24 V DC supply; two feeds are available for protection against voltage failure
- One floating message output for simple display of faults

Only for SCALANCE X414-3E:

- Additional out-band Ethernet port for on-site parameterization/diagnostics
- Eight floating inputs for recording digital status information such as signal contacts of PROFIBUS OLM or door contacts and forwarding via SCALANCE X-400 diagnostic paths (LED indicator, log table, trap or Email)

Extensive operating mode and status information is displayed via LEDs and selection pushbuttons.

SCALANCE X-400 media modules (MM)

SCALANCE X-400 switches can be equipped with 2-port media modules. Media modules are available for both multimode and single-mode optical fibers. They can be added or replaced during network operation. The operating temperature range is -40 to +70 °C. The SCALANCE X414-3E basic unit supports two optical Gigabit Ethernet ports and up to four additional optical Fast Ethernet ports.

On two media-module slots, SCALANCE X408-2 supports as many as four optical ports which can optionally be equipped with optical Gigabit Ethernet or Fast Ethernet media modules.

The following media modules are available:

- MM491-2;
 - 2 fiber optic ports (BFOC sockets) 100 Mbit/s for distances up to 5 km with multimode fiber-optic conductors
- MM491-2LD;
 - two fiber optic ports (BFOC sockets) 100 Mbit/s for distances up to 26 km with single-mode fiber-optic conductors
- MM491-2LH+;
 - two fiber optic ports (SC sockets) 100 Mbit/s for distances up to 70 km with single-mode fiber-optic conductors
- MM492-2;
 - two fiber optic ports (SC sockets) 1 Gbit/s for distances up to 750 m with multimode fiber-optic conductors (when using SIMATIC NET FO cable 50/125µm)
- MM492-2LD;
 - two fiber optic ports (SC sockets) 1 Gbit/s for distances up to 10 km with single-mode fiber-optic conductors
- MM492-2LH;
 - two fiber optic ports (SC sockets) 1 Gbit/s for distances up to 40 km with single-mode fiber-optic conductors
- MM492-2LH+;
 - two fiber optic ports (SC sockets) 1 Gbit/s for distances up to 70 km with single-mode fiber-optic conductors
- MM492-2ELH;
 - two fiber-optic ports (SC sockets) 1 Gbit/s for distances up to 120 km with single-mode fiber-optic conductors

Plug-in media modules for Gigabit Ethernet convert the two Gigabit Ethernet twisted pair-ports included in the switch to optical mode. The Gigabit ports can then be used as either twisted-pair or fiber-optic ports. In the case of the SCALANCE X414-3E basic device, optical media modules for Fast Ethernet each generate two additional ports per slot.

PROFINET/Industrial Ethernet

Industrial Ethernet switches / media converters

SCALANCE X-400 managed (Layer 3)

Design (continued)

SCALANCE X-400 extender module (EM), only for SCALANCE X414-3E

An optional extender module with up to eight further Fast Ethernet ports can be mounted next to the expansion interface of the SCALANCE X414-3E. The operating temperature range is -40 to +70 °C.

Versions:

- EM495-8; with 8 twisted pair ports (RJ45 sockets with sleeves) 10/100 Mbit/s; this enables the 12 onboard Fast Ethernet twisted pair ports of the SCALANCE X414-3E to be expanded to a total of 20 ports.
- EM496-4; with a further four media module slots for Fast Ethernet media modules for up to 8 optical Fast Ethernet ports

The structure of the SCALANCE X-400 product line offers the following advantages:

- Simple user connection via twisted pair
- Gigabit Ethernet transfer rate between SCALANCE X-400 switches
- Fiber optic connection via fiber-optic media modules
- Reduced costs for spare parts inventories; Electrical and optical versions are covered by a basic unit and fiber-optic media modules

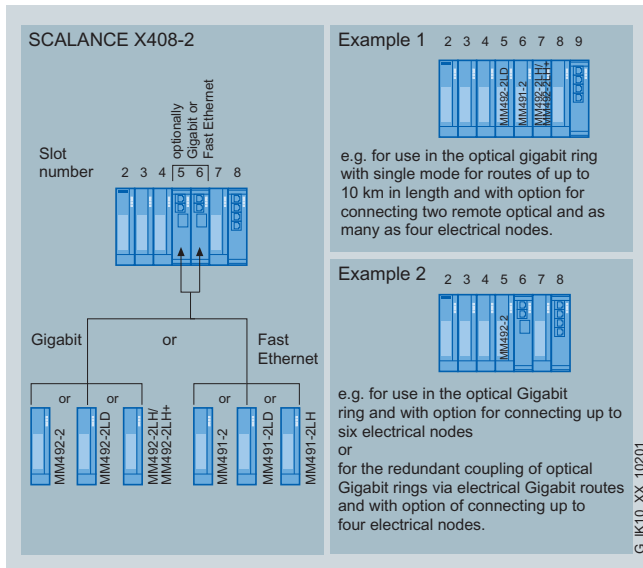

Possible applications of the media modules with SCALANCE X408-2

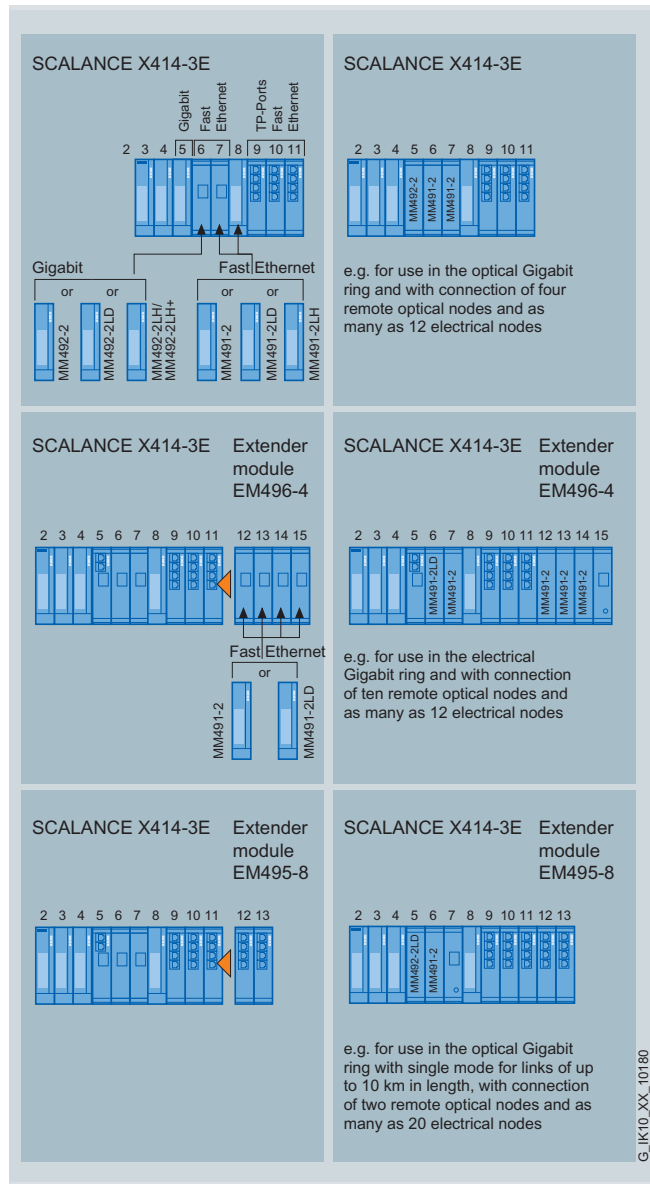

Possible applications of the media and extender modules with SCALANCE X 414-3



Function

- Increasing the network performance; by filtering the data traffic on the basis of the Ethernet (MAC) address of the data terminals, the local data traffic remains local; only data intended for users of another subnetwork are forwarded by the switch.
- Simple network configuration and network expansion; the switch saves the data received at the ports and forwards it automatically to the destination address. The limitation of the network expansion by collision detection (CSMA/CD procedure) terminates at the port.
- Limitation of the error propagation to the affected subnetwork; the SCALANCE X-400 switches only forward data with a valid checksum (CRC).
- Integration of existing subnetworks with 10 Mbit/s into Fast Ethernet networks with 100 Mbit/s; at the twisted-pair ports, the SCALANCE X-400 switch automatically recognizes the conductor pairs for transmission and reception (autocrossover), the data transfer rate of 10 or 100 Mbit/s, as well as full-duplex and half-duplex operation (autonegotiation).
- High-performance connection of SCALANCE X-400 switches with 1 Gbit/s; SCALANCE X-400 switches have two (X414-3E) or four (X408-2) Gigabit Ethernet ports for connecting the switches to each other.
- Integrated redundancy manager for constructing Fast Ethernet and Gigabit Ethernet ring topologies with high-speed media redundancy.
- High-speed standby redundancy; several network segments such as rings can be connected together redundantly with SCALANCE X-400 over the integrated standby function. Two X-400 switches are configured in a ring as a master and slave and are connected via two links to the other ring. In the case of SCALANCE X408-2 or SCALANCE X-300, a high-performance redundant coupling at 1000 Mbit/s is possible.
- Redundant interfacing to company networks; SCALANCE X-400 switches support the standardized redundancy procedures Spanning Tree Protocol (STP) and Rapid Spanning Tree Protocol (RSTP). This enables a subnetwork to be connected redundantly to a higher level corporate network with reduced requirements for the reconfiguration time (in the order of seconds).
- Support of virtual networks (VLAN); for structuring Industrial Ethernet networks with a fast growing number of users, a physically existing network can be divided into several virtual networks.
- Integrated hardware Layer 3 Switching function (IP routing, only SCALANCE X414-3E); IP subnetworks can be created and interconnected, e.g. automation network with office network, enabling a structuring of the networks
- Load limiting with use of Multicast protocols (e.g. video transmission); through learning the Multicast sources and targets (IGMP snooping), SCALANCE X-400 switches can also filter Multicast data traffic and therefore limit the load in the network.
- Time synchronization; diagnostic messages (log table entries, e-mails) are time-stamped. The local time is standardized throughout the network by means of synchronization with a SICLOCK or SNTP time transmitter, thereby simplifying the assignment of diagnostic messages to several devices.
- Fast replacement of devices in event of failure, by means of the C-PLUG switching medium

PROFINET/Industrial Ethernet

Industrial Ethernet switches / media converters

SCALANCE X-400 managed (Layer 3)

2

Function (continued)

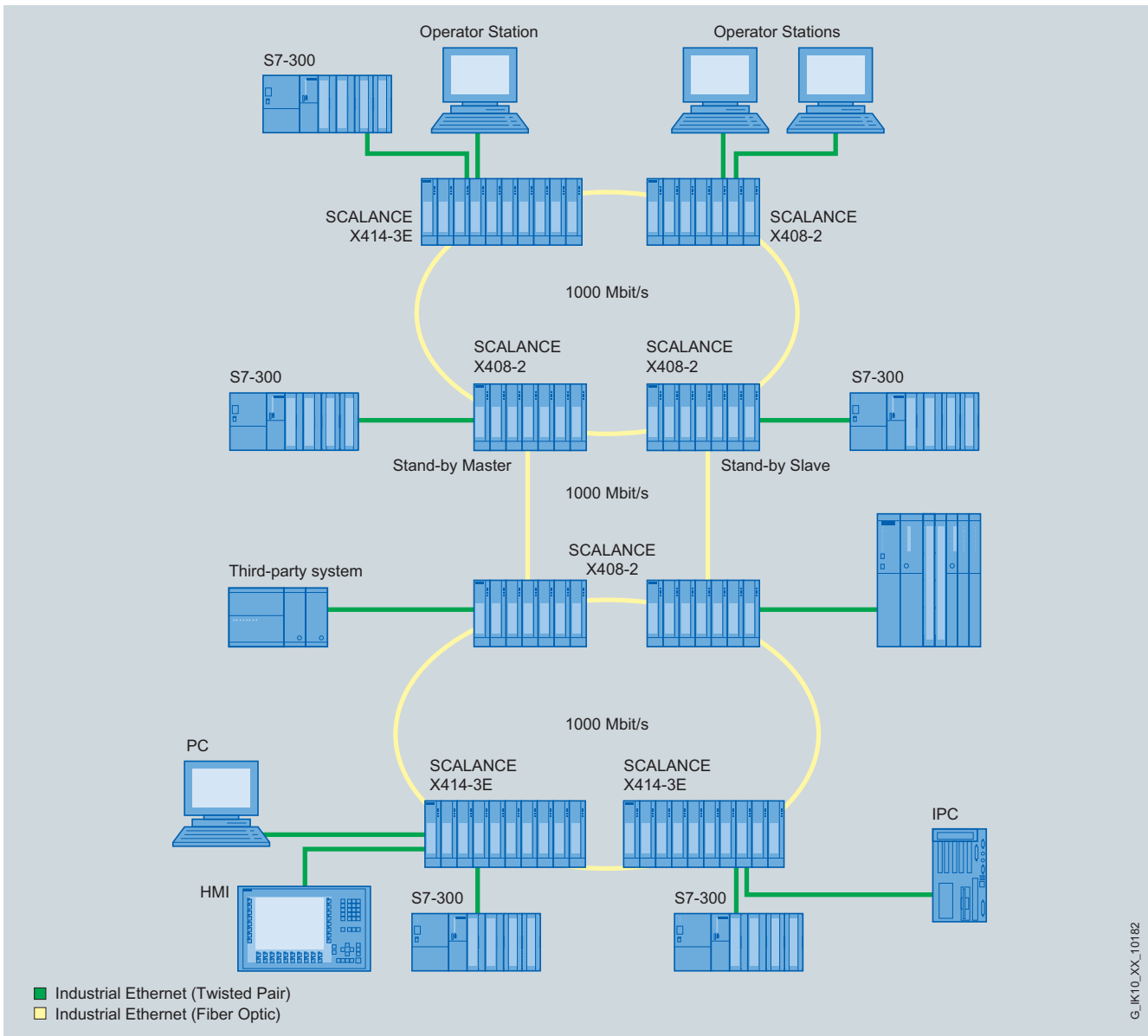

G_IK10_XX_10182

Optical redundant connection of two optical Gigabit subnets with SCALANCE X-400 on Layer 2 and Layer 3

Function (continued)

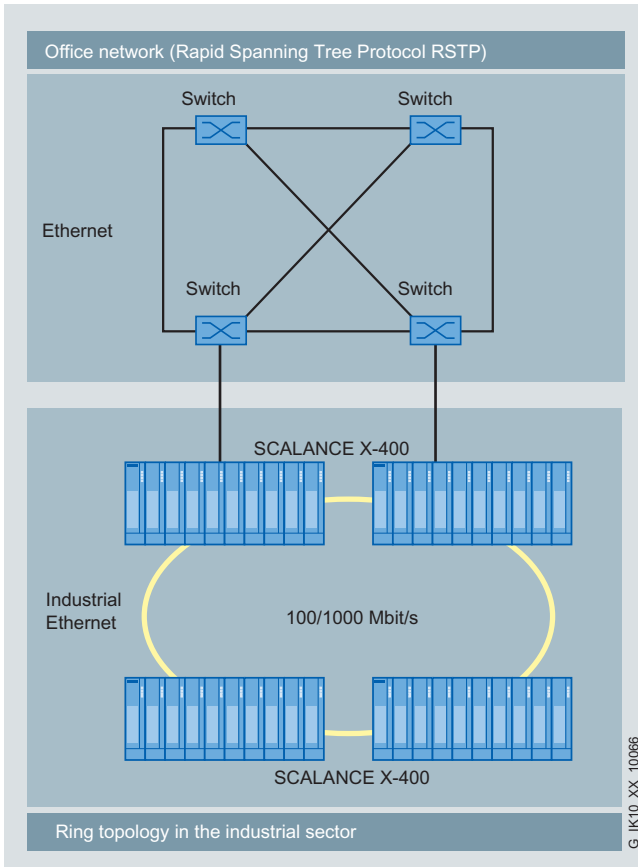

Redundant coupling with an Office network and industrial network on Layer 2 and Layer 3

Network topology and network configuration

The network topology can easily be adapted to the structure of the plant with SCALANCE X-400 Industrial Ethernet switches. The following network structures and combinations of structures can be implemented:

- Fast Ethernet and Gigabit rings with fast media redundancy; to protect against failure of a transmission link or a switch, as many as 50 X-400 switches cascaded in line can be connected into a ring with a total length of up to 150 km using multi-mode or 6,000 km using single mode. On the failure of a transmission link or a SCALANCE X-400 switch in the ring, the transmission path is quickly reconfigured due to the media redundancy.
- Several rings can be redundantly linked through the standby function
- At the same time, SCALANCE X-400 supports redundant connection of the ring structure to the corporate network with Rapid Spanning Tree.
- Star topology with SCALANCE X-400 switches: The SCALANCE X-414-3E switch represents a star point which can interconnect as many as 26 nodes or subnetworks electrically or optically; SCALANCE X408-2 can connect up to 8 nodes or subnetworks

When configuring the network, it is necessary to observe the following boundary conditions:

- Maximum line length between two modules for multi-mode fiber-optic conductors:
 - 3000 m at 100 Mbit/s
 - 750 m at 1 Gbit/s
- Maximum line length between two modules for single-mode fiber-optic conductors:
 - 70 km at 100 Mbit/s
 - 12 km at 1 Gbit/s
- Maximum length of installation cable:
 - 100 m at 100 Mbit/s with IE FC TP Cable 2 x 2 and IE FC Plug 180
 - Max. 90 m at 1 Gbit/s with IE FC TP Cable 4 x 2, IE FC RJ45 Modular Outlet and patch cable (10 m)
 - 100 m at 1000 Mbit/s with IE FC TP Cable 4 x 2 and IE FC Plug 4 x 2

Commissioning and diagnosis

Setting options on the device itself:

- Redundancy manager RM; to establish a ring, a SCALANCE X-400 is switched to RM mode. The Gigabit ports (electrical or – with media module – optical) are preferably used as ring ports. When using in optical rings with 100 Mbit/s, the ring ports can be configured on one media module or on two media modules.
- Signal mask; the signal mask is set to the current status of the SCALANCE X-400 (setpoint) by pushbutton operation. The signal mask defines which ports and which power supplies are to be monitored. The signaling contact only reports an error when a monitored port or a monitored feeder fails (deviation of setpoint/actual status).

Diagnostic options on site:

- The following status information is displayed by LEDs on site:
 - Port status
 - Port mode (10/100/1000 Mbit/s, full/half-duplex)
 - Status of the two power supplies
 - Signaling contact status
 - Signal mask (setpoint status)
 - RM mode
 - Standby mode
- The status of the signaling contact is routed externally by means of floating relay contacts. This enables, for example, the module to be monitored via an input module from a controller.
- A PC or a programming device can be directly connected via a serial interface or, with the X414-3E, also via an Ethernet interface (out-band port). Operation is carried out using commands (**C**ommand **L**ine **I**nterface (CLI)).
- Monitoring via the Industrial Ethernet network; the following possibilities are available:
 - Remote via standard browser (Web-based management): Selection of SCALANCE X-400 switches via the network from a PC with browser
 - Remote via SNMP V1, V2c, V3: Secure integration of SCALANCE X-400 switches via the network into a network management station
 - Remote via PROFINET IO diagnostics
 - Standard diagnostic alarms can be configured in an easy, familiar manner in STEP 7 and processed in SIMATIC. The engineering outlay is drastically reduced for the PLC and HMI through complete integration in the SIMATIC system error message concept SFM.

PROFINET/Industrial Ethernet

Industrial Ethernet switches / media converters

SCALANCE X-400 managed (Layer 3)

Function (continued)

Network management

The network management provides the following functions:

- Password-protected dial-up for "Administrator" (read and write authorization) and "User" (read only)
- Read-out of version and status information
- Setting the signal and standby mask and address information
- Fixed parameterization of the ports (data rates, half/full duplex)
- Parameterization of the VLANs and multicast services
- Parameterization of the standby connections for a redundant ring link
- Setting of Rapid Spanning Tree parameters
- Parameterization of the user administration of SNMP V1, V2c, V3:
- Output of statistics information
- Diagnosis of data traffic by means of a parameterizable mirror port with a standard commercial network analyzer
- Loading of new firmware or the configuration data via the network by a TFTP server
- Saving the configuration data or log table via the network on a TFTP server
- Only for SCALANCE X414-3E: Configuration of the IP routing function (static routing, dynamic routing, (OSPF, RIP v1/2) and redundant routing (VRRP))

If faults occur in the network, the SCALANCE X-400 switch can send error messages (traps) to a network management system or also e-mails to a predefined network administrator.

Remote monitoring (RMON) provides the following functions: The SCALANCE X-400 switch can collect statistics information according to the RMON groups 1 through 4. These include, for example, fault statistics that are kept for each port. This information can be read out through web-based management in the statistics sub-area.

Integration

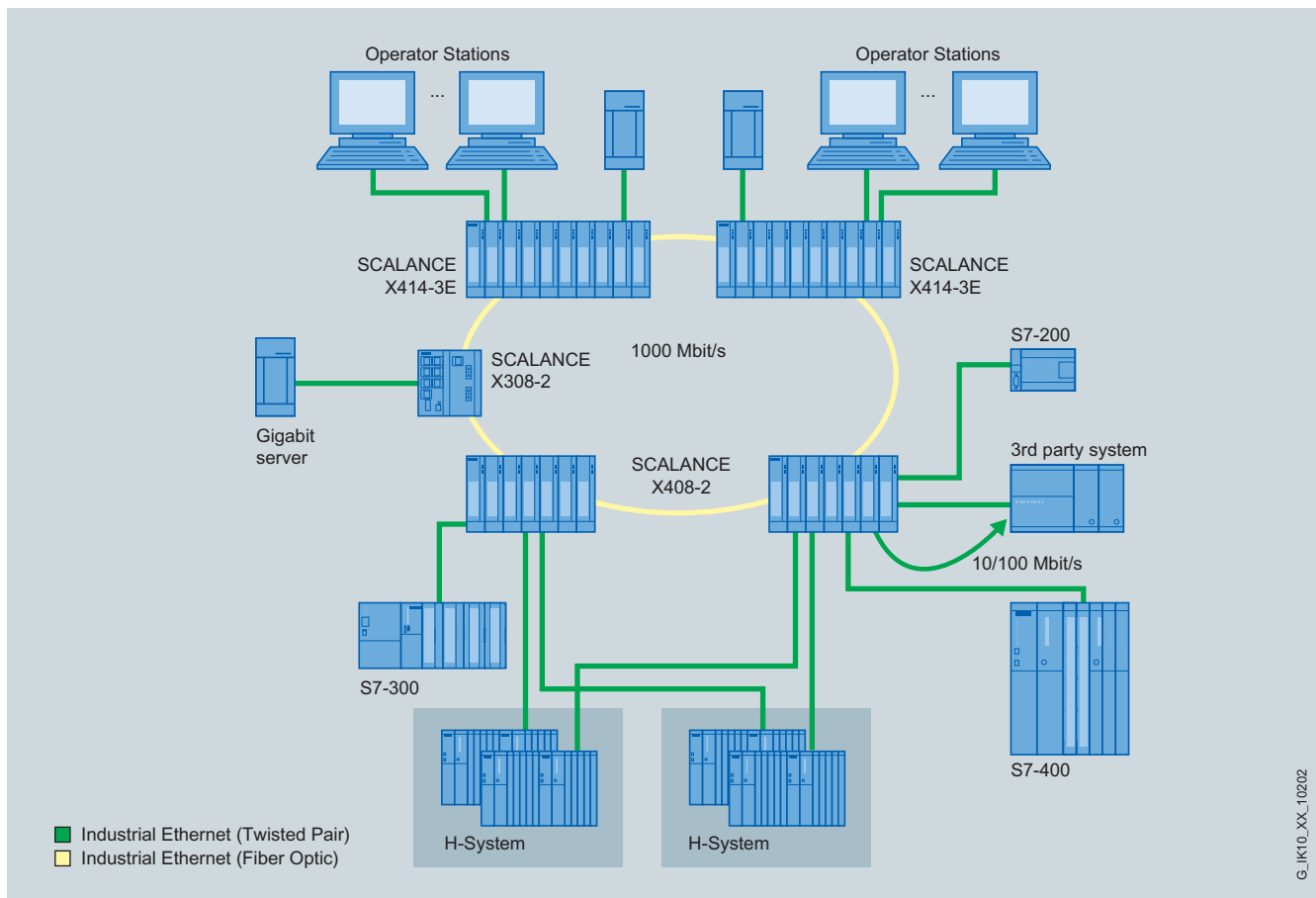

Fault-tolerant system with SCALANCE X-400

Integration (continued)

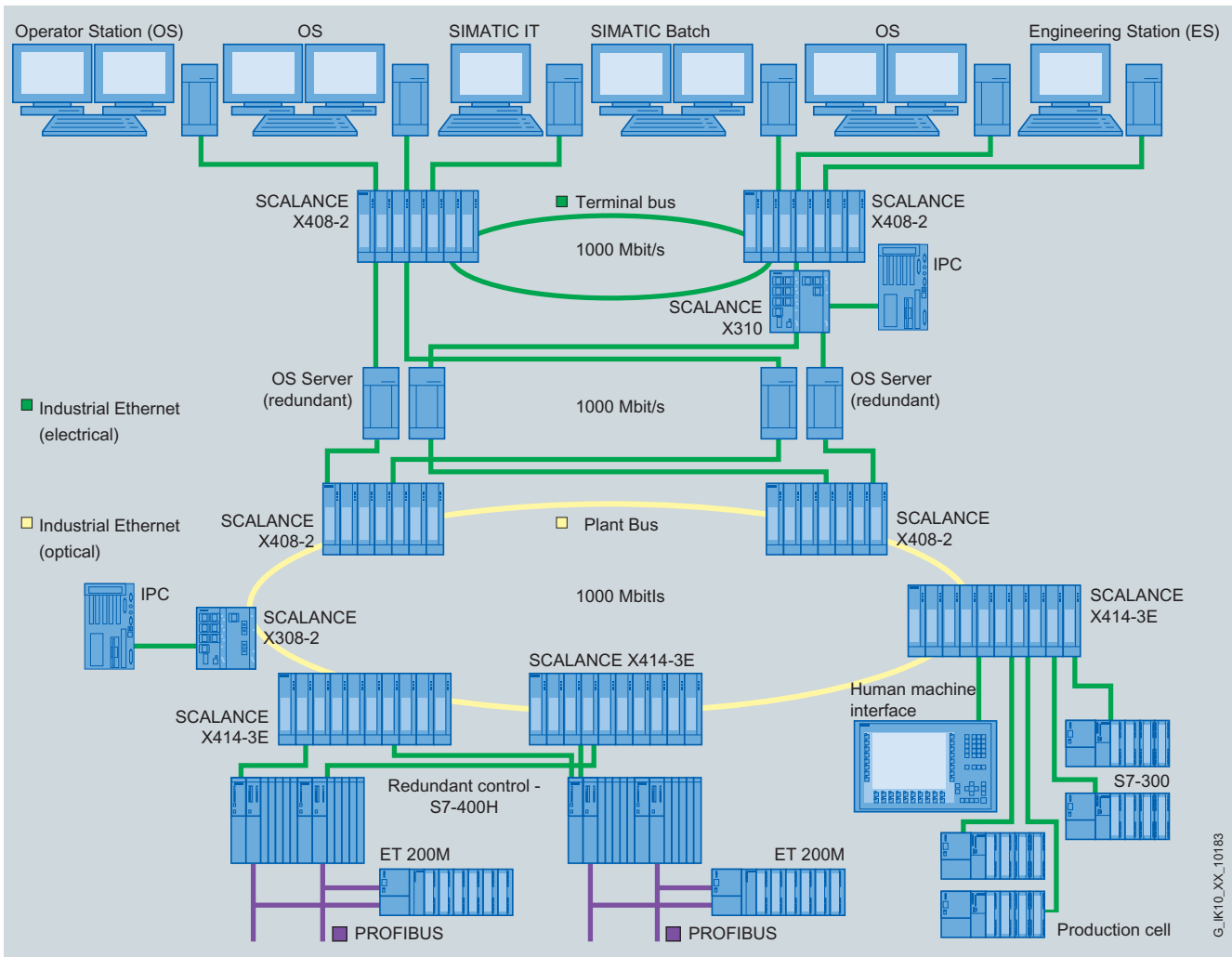

Use of the SCALANCE X-400 switches in a process control system, e.g. PCS 7

In the control room, two SCALANCE X-400 switches are used on the terminal bus. With a higher number of stations, SCALANCE X414-3E switches can be used with extender modules. These are connected together to create an electrical ring with a transfer rate of 1000 Mbit/s. Several operator panels are provided and divided between the two switches, so that the system can still be operated if one switch fails. The terminal and plant buses are connected using redundant servers, and also using high-performance Gigabit plugs in the case of SCALANCE X408-2.

The plant bus is designed as an optical ring. It connects three plant sections with the servers:

- SCALANCE X-400 switches without extenders are used for connecting high-availability SIMATIC controllers (H-systems). On failure of an individual controller or switch, the plant section remains functional.
- One SCALANCE X414-3E with extender (high number of ports) is used for the star-format connection of controllers.

PROFINET/Industrial Ethernet

Industrial Ethernet switches / media converters

SCALANCE X-400 managed (Layer 3)

Technical specifications

Order No.	6GK5 408-2FD00-2AA2	6GK5 414-3FC00-2AA2
Product type designation	SCALANCE X408-2	SCALANCE X414-3E
Transmission rate		
Transmission rate 1	10 Mbit/s	10 Mbit/s
Transmission rate 2	100 Mbit/s	100 Mbit/s
Transmission rate 3	1 000 Mbit/s	1 000 Mbit/s
Interfaces		
Maximum number of electrical/optical connections for network components or terminal equipment	12	24
Number of electrical connections for operation panel	1	1
Design of electrical connection for operation panel	RS232 port	RS232 port
Number of electrical connections		
• for network components or terminal equipment	8	14
• for network components or terminal equipment with extender modules	-	8
• for signaling contact	1	1
• For media module	2	3
• for power supply	1	1
• For redundant power supply	1	1
Design of electrical connection		
• for network components or terminal equipment	RJ45 port (4 x 1GE, 4 x FE)	RJ45 port (2 x 1GE, 12 x FE)
• for network components or terminal equipment with extender modules	-	RJ45 port via EM495-8
• for signaling contact	4-pin terminal block	4-pin terminal block
• for power supply	4-pin terminal block	4-pin terminal block
Number of optical connections for fiber-optic cables		
• At 100 Mbit/s	4	4
• At 1000 Mbit/s	4	2
• With extender modules	-	8
Design of optical connection for fiber-optic cables		
• At 100 Mbit/s	BFOC or SC ports via MM491-2, MM491-2LD, MM491-2LH+ media modules	BFOC or SC ports via MM491-2, MM491-2LD, MM491-2LH+ media modules
• At 1000 Mbit/s	SC ports via MM492-2, MM492-2LD, MM492-2LH, MM492-2LH+ media modules	SC ports via MM492-2, MM492-2LD, MM492-2LH, MM492-2LH+ media modules
• With extender modules	-	BFOC or SC ports via MM491-2, MM491-2LD, MM491-2LH+, MM492-2, MM492-2LD, MM492-2LH, MM492-2LH+ media modules
Number of expansion interfaces for extenders	-	1
Design of expansion interface for extender	-	EM495-8 or EM496-4
Design of swap medium C-Plug	Yes	Yes

Technical specifications (continued)

Order No.	6GK5 408-2FD00-2AA2	6GK5 414-3FC00-2AA2
Product type designation	SCALANCE X408-2	SCALANCE X414-3E
Inputs/outputs		
Operating current of signaling contacts with AC maximum	-	-
Operating voltage of signaling contacts with DC rated value	24 V	24 V
Operating current of signal contacts with DC, maximum	0.1 A	0.1 A
Number of digital inputs	-	2
Number of electrical connections for digital input signals	-	2
Design of electrical connection for digital input signals	-	5-pin terminal block
Supply voltage, current consumption, power loss		
Type of power supply	DC	DC
External power supply	24 V	24 V
• Minimum	20.4 V	20.4 V
• Maximum	28.8 V	28.8 V
Product component: fusing at power supply input	Yes	Yes
Type of fusing of power supply input	F 3 A / 32 V	F 3.15 A / 250 V
Current consumed, maximum	0.7 A	2 A
Effective power loss		
• At 24 V DC	8 W	15 W
• Maximum	48 W	48 W
Permitted ambient conditions		
Ambient temperature		
• During operation	0 ... 60 °C	-40 ... +70 °C
• During storage	-40 ... +80 °C	-40 ... +80 °C
• During transport	-40 ... +80 °C	-40 ... +80 °C
Relative humidity at 25 °C without condensation during operation, maximum	95 %	95 %
IP degree of protection	IP20	IP20
Design, dimensions and weights		
Design	Modular	Modular
Width	242 mm	344 mm
Height	145 mm	145 mm
Depth	117 mm	117 mm
Net weight	1.9 kg	3.07 kg
Type of mounting		
• 35 mm DIN rail mounting	Yes	Yes
• Wall mounting	No	No
• S7-300 rail mounting	Yes	Yes
Product properties, functions, components		
General		
Cascading with redundant ring at reconfiguration time < 0.3 s	50	50
Cascading with star topology	Any (only dependent on signal propagation time)	Any (only dependent on signal propagation time)

PROFINET/Industrial Ethernet

Industrial Ethernet switches / media converters

SCALANCE X-400 managed (Layer 3)

Technical specifications (continued)

Order No.	6GK5 408-2FD00-2AA2	6GK5 414-3FC00-2AA2
Product type designation	SCALANCE X408-2	SCALANCE X414-3E
Product functions Management, configuration, programming		
Product function		
• CLI	Yes	Yes
• Web-based management	Yes	Yes
• MIB support	Yes	Yes
• TRAPs via e-mail	Yes	Yes
• Configuration with STEP 7	Yes	Yes
• RMON	Yes	Yes
• SMTP server	Yes	Yes
• Port mirroring	Yes	Yes
• CoS	Yes	Yes
• with IRT PROFINET IO Switch	-	-
• PROFINET IO Diagnostics	Yes	Yes
• Switch-managed	Yes	Yes
Protocol is supported		
• Telnet	Yes	Yes
• HTTP	Yes	Yes
• HTTPS	Yes	Yes
• TFTP	Yes	Yes
• FTP	Yes	Yes
• BOOTP	Yes	Yes
• SNMP v1	Yes	Yes
• SNMP v2	Yes	Yes
• SNMP v3	Yes	Yes
• IGMP (snooping/querier)	Yes	Yes
• GMRP	Yes	Yes
• DCP	Yes	Yes
• LLDP	Yes	Yes
Identification & Maintenance		
• I&M0 - device-specific information	Yes	Yes
• I&M1 - higher-level designation/location designation	Yes	Yes
Product functions Diagnostics		
Product function		
• Port diagnostics	Yes	Yes
• Packet Size Statistics	Yes	Yes
• Packet Type Statistics	Yes	Yes
• Error Statistics	Yes	Yes
• SysLog	Yes	Yes
Product functions VLAN		
Product function		
• VLAN - port based	Yes	Yes
• VLAN - dynamic	Yes	Yes
Maximum number of VLANs	64	64
Maximum number of dynamic VLANs	64	64
GVRP protocol is supported	Yes	Yes
Product functions DHCP		
Product function		
• DHCP client	Yes	Yes
• DHCP option 82	Yes	Yes
• DHCP option 66	Yes	Yes
• DHCP option 67	Yes	Yes
Product functions Routing		
Product function		
• Static IP routing	No	Yes
• Dynamic IP routing	No	Yes

2

Technical specifications (continued)

Order No.	6GK5 408-2FD00-2AA2	6GK5 414-3FC00-2AA2
Product type designation	SCALANCE X408-2	SCALANCE X414-3E
Protocol is supported		
• RIPv2	No	Yes
• OSPFv2	No	Yes
• VRRP	No	Yes
Product functions Redundancy		
Product function		
• Ring redundancy	Yes	Yes
• Redundancy manager	Yes	Yes
• Standby redundancy	Yes	Yes
• Redundancy procedure HSR	Yes	Yes
• Redundancy procedure MRP	Yes	Yes
• Redundancy procedure STP	Yes	Yes
• Redundancy procedure RSTP	Yes	Yes
• Passive listening	Yes	Yes
Protocol is supported		
• STP/RSTP	Yes	Yes
• STP	Yes	Yes
• RSTP	Yes	Yes
• RSTP Big Network Support	Yes	Yes
• LACP	Yes	Yes
Product functions Security		
Product function		
• ACL - MAC based	Yes	Yes
• ACL - Port/MAC based	Yes	Yes
• IEEE 802.1x (Radius)	Yes	Yes
• Broadcast/Multicast/Unicast Limiter	Yes	Yes
• Broadcast blocking	Yes	Yes
Protocol is supported SSH	Yes	Yes
Product functions Time		
Product function:		
SICLOCK support	Yes	Yes
Protocol is supported		
• NTP	No	No
• SNTP	Yes	Yes
Standards, specifications, approvals		
Standard		
• for EMC of FM	FM3611: Class 1, Division 2, Group A, B, C, D / T4 A, Class 1, Zone 2, Group IIC, T4	FM3611: Class 1, Division 2, Group A, B, C, D / T4 A, Class 1, Zone 2, Group IIC, T4
• For hazardous zone	EN 60079-0: 2006, EN 60079-15: 2005, II 3 G Ex nA IIT4, KEMA 07 ATEX 0145 X	EN 60079-0: 2006, EN 60079-15: 2005, II 3 G Ex nA IIT4, KEMA 07 ATEX 0145 X
• For CSA and UL safety	UL 60950-1, CSA C22.2 No. 60950-1-03	UL 60950-1, CSA C22.2 No. 60950-1-03
• for hazardous zone of CSA and UL	UL 1604 and UL 2279-15 (Hazardous Location), Class 1 / Division 2 / Group A, B, C, D / T4, Class 1 / Zone 2 / Group IIC / T4	UL 1604 and UL 2279-15 (Hazardous Location), Class 1 / Division 2 / Group A, B, C, D / T4, Class 1 / Zone 2 / Group IIC / T4
• For emitted interference	EN 61000-6-4:2001 (Class A)	EN 61000-6-4:2001 (Class A)
• For noise immunity	EN 61000-6-2:2001	EN 61000-6-2:2001
Certificate of suitability	EN 61000-6-2:2001, EN 61000-6-4:2001	EN 61000-6-2:2001, EN 61000-6-4:2001
• CE mark	Yes	Yes
• C-Tick	Yes	Yes
Marine classification corporation		
• American Bureau of Shipping Europe Ltd. (ABS)	Yes	Yes
• Bureau Veritas (BV)	Yes	Yes
• Det Norske Veritas (DNV)	Yes	Yes
• Germanischer Lloyd (GL)	Yes	Yes
• Lloyds Register of Shipping (LRS)	Yes	Yes
• Nippon Kaiji Kyokai (NK)	Yes	Yes

PROFINET/Industrial Ethernet

Industrial Ethernet switches / media converters

SCALANCE X-400 managed (Layer 3)

Technical specifications (continued)

Order No.	6GK5 492-2AL00-8AA2	6GK5 492-2AM00-8AA2	6GK5 492-2AN00-8AA2	6GK5 492-2AP00-8AA2	6GK5 492-2AQ00-8AA2
Product type designation	MM492-2	MM492-2LD	MM492-2LH	MM492-2LH+	MM492-2ELH
Transmission rate					
Transmission rate 1	1 000 Mbit/s	1 000 Mbit/s	1 000 Mbit/s	1 000 Mbit/s	1 000 Mbit/s
Transmission rate 2	-	-	-	-	-
Transmission rate 3	-	-	-	-	-
Interfaces					
Maximum number of electrical/optical connections for network components or terminal equipment	2	2	2	2	2
Number of electrical connections					
• for network components or terminal equipment	-	-	-	-	-
• with power-over-Ethernet for network components or terminal equipment	-	-	-	-	-
Design of electrical connection					
• for network components or terminal equipment	-	-	-	-	-
• with power-over-Ethernet for network components or terminal equipment	-	-	-	-	-
Number of optical connections for fiber-optic cables					
• at 100 Mbit/s	-	-	-	-	-
• At 1000 Mbit/s	2	2	2	2	2
Design of optical connection for fiber-optic cables					
• at 100 Mbit/s	-	-	-	-	-
• at 1000 Mbit/s	SC port (multimode up to 0.75 km)	SC port (singlemode up to 10 km)	SC port (singlemode up to 40 km)	SC port (singlemode up to 70 km)	SC port (singlemode up to 120 km)
• at 10 Gbit/s	-	-	-	-	-
Injectable optical power relative to 1 mW					
• of the transmitter output	-9.5 ... -4 dB	-9.5 ... -3 dB	-6 ... +0 dB	0 ... 5 dB	0 ... 5 dB
• of the receiver input, maximum	-3 dB	-3 dB	-3 dB	-3 dB	-3 dB
Minimum optical sensitivity relative to 1 mW of the receiver input	-17 dB	-21 dB	-23 dB	-23 dB	-30 dB
Minimum required attenuation factor of the FO transmission link	0 dB	0 dB	3 dB	8 dB	8 dB
The range at the optical interface depends on the type of optical fiber used	0 ... 0.75 km	0 ... 10 km	8 ... 40 km	30 ... 70 km	37 ... 120 km
Permitted ambient conditions					
Ambient temperature					
• During operation	-40 ... +70 °C	-40 ... +70 °C	-40 ... +70 °C	-40 ... +70 °C	-40 ... +70 °C
• During storage	-40 ... +80 °C	-40 ... +80 °C	-40 ... +80 °C	-40 ... +80 °C	-40 ... +80 °C
• During transport	-40 ... +80 °C	-40 ... +80 °C	-40 ... +80 °C	-40 ... +80 °C	-40 ... +80 °C
Relative humidity at 25 °C without condensation during operation, maximum	95 %	95 %	95 %	95 %	95 %
IP degree of protection	IP20	IP20	IP20	IP20	IP20

PROFINET/Industrial Ethernet

Industrial Ethernet switches / media converters

SCALANCE X-400 managed (Layer 3)

Technical specifications (continued)

Order No.	6GK5 492-2AL00-8AA2	6GK5 492-2AM00-8AA2	6GK5 492-2AN00-8AA2	6GK5 492-2AP00-8AA2	6GK5 492-2AQ00-8AA2
Product type designation	MM492-2	MM492-2LD	MM492-2LH	MM492-2LH+	MM492-2ELH
Design, dimensions and weights					
Design	Media module	Media module	Media module	Media module	Media module
Width	35 mm	35 mm	35 mm	35 mm	35 mm
Height	145 mm	145 mm	145 mm	145 mm	145 mm
Depth	90 mm	90 mm	90 mm	90 mm	90 mm
Net weight	0.25 kg	0.25 kg	0.25 kg	0.25 kg	0.25 kg
Type of mounting for installation at media module slot	Yes	Yes	Yes	Yes	Yes
Standards, specifications, approvals					
Standard	-	-	-	-	-
• for EMC	-	-	-	-	-
• for EMC of FM	FM3611: Class 1, Division 2, Group A, B, C, D / T4, Class 1, Zone 2, Group IIC, T4	FM3611: Class 1, Division 2, Group A, B, C, D / T4, Class 1, Zone 2, Group IIC, T4	FM3611: Class 1, Division 2, Group A, B, C, D / T4, Class 1, Zone 2, Group IIC, T4	FM3611: Class 1, Division 2, Group A, B, C, D / T4, Class 1, Zone 2, Group IIC, T4	FM3611: Class 1, Division 2, Group A, B, C, D / T4, Class 1, Zone 2, Group IIC, T4
• for hazardous zone	EN 60079-0: 2006, EN 60079-15: 2005, II 3 G Ex nA IIT4, KEMA 07 ATEX 0145 X	EN 60079-0: 2006, EN 60079-15: 2005, II 3 G Ex nA IIT4, KEMA 07 ATEX 0145 X	EN 60079-0: 2006, EN 60079-15: 2005, II 3 G Ex nA IIT4, KEMA 07 ATEX 0145 X	EN 60079-0: 2006, EN 60079-15: 2005, II 3 G Ex nA IIT4, KEMA 07 ATEX 0145 X	EN 60079-0: 2006, EN 60079-15: 2005, II 3 G Ex nA IIT4, KEMA 07 ATEX 0145 X
• for CSA and UL safety	UL 60950-1, CSA C22.2 No. 60950-1-03	UL 60950-1, CSA C22.2 No. 60950-1-03	UL 60950-1, CSA C22.2 No. 60950-1-03	UL 60950-1, CSA C22.2 No. 60950-1-03	UL 60950-1, CSA C22.2 No. 60950-1-03
• for hazardous zone of CSA and UL	UL 1604 and UL 2279-15 (Hazardous Location), Class 1 / Division 2 / Group A, B, C, D / T4, Class 1 / Zone 2 / Group IIC / T4	UL 1604 and UL 2279-15 (Hazardous Location), Class 1 / Division 2 / Group A, B, C, D / T4, Class 1 / Zone 2 / Group IIC / T4	UL 1604 and UL 2279-15 (Hazardous Location), Class 1 / Division 2 / Group A, B, C, D / T4, Class 1 / Zone 2 / Group IIC / T4	UL 1604 and UL 2279-15 (Hazardous Location), Class 1 / Division 2 / Group A, B, C, D / T4, Class 1 / Zone 2 / Group IIC / T4	UL 1604 and UL 2279-15 (Hazardous Location), Class 1 / Division 2 / Group A, B, C, D / T4, Class 1 / Zone 2 / Group IIC / T4
• for emitted interference	EN 61000-6-4:2001 (Class A)	EN 61000-6-4:2001 (Class A)	EN 61000-6-4:2001 (Class A)	EN 61000-6-4:2001 (Class A)	EN 61000-6-4:2001 (Class A)
• For noise immunity	EN 61000-6-2:2001	EN 61000-6-2:2001	EN 61000-6-2:2001	EN 61000-6-2:2001	EN 61000-6-2:2001
Certificate of suitability	EN 61000-6-2:2001, EN 61000-6-4:2001	EN 61000-6-2:2001, EN 61000-6-4:2001	EN 61000-6-2:2001, EN 61000-6-4:2001	EN 61000-6-2:2001, EN 61000-6-4:2001	EN 61000-6-2:2001, EN 61000-6-4:2001
• CE mark	Yes	Yes	Yes	Yes	-
• C-Tick	Yes	Yes	Yes	Yes	-
• IEC 61850-3	-	-	-	-	-
Marine classification corporation					
• American Bureau of Shipping Europe Ltd. (ABS)	Yes	Yes	Yes	Yes	Yes
• Bureau Veritas (BV)	Yes	Yes	Yes	Yes	Yes
• Det Norske Veritas (DNV)	Yes	Yes	Yes	Yes	Yes
• Germanischer Lloyd (GL)	Yes	Yes	Yes	Yes	Yes
• Lloyds Register of Shipping (LRS)	Yes	Yes	Yes	Yes	Yes
• Nippon Kaiji Kyokai (NK)	Yes	Yes	Yes	Yes	Yes

PROFINET/Industrial Ethernet

Industrial Ethernet switches / media converters

SCALANCE X-400 managed (Layer 3)

Technical specifications (continued)

Order No.	6GK5 491-2AB00-8AA2	6GK5 491-2AC00-8AA2	6GK5 491-2AE00-8AA2
Product type designation	MM491-2	MM491-2LD	MM491-2LH+
Transmission rate			
Transmission rate 1	100 Mbit/s	100 Mbit/s	100 Mbit/s
Transmission rate 2	-	-	-
Transmission rate 3	-	-	-
Interfaces			
Maximum number of electrical/optical connections for network components or terminal equipment	2	2	2
Number of electrical connections			
• for network components or terminal equipment	-	-	-
• with power-over-Ethernet for network components or terminal equipment	-	-	-
Design of electrical connection			
• for network components or terminal equipment	-	-	-
• with power-over-Ethernet for network components or terminal equipment	-	-	-
Number of optical connections for fiber-optic cables			
• at 100 Mbit/s	2	2	2
• at 1000 Mbit/s	-	-	-
Design of optical connection for fiber-optic cables			
• at 100 Mbit/s	BFOC port (multimode up to 5 km)	BFOC port (singlemode up to 26 km)	SC port (singlemode up to 70 km)
• At 1000 Mbit/s	-	-	-
• at 10 Gbit/s	-	-	-
Injectable optical power relative to 1 mW			
• of the transmitter output	-19 ... -14 dB	-15 ... -8 dB	-5 ... +0 dB
• of the receiver input, maximum	-3 dB	-3 dB	-3 dB
Minimum optical sensitivity relative to 1 mW of the receiver input	-32 dB	-34 dB	-34 dB
Minimum required attenuation factor of the FO transmission link	0 dB	0 dB	3 dB
The range at the optical interface depends on the type of optical fiber used	0 ... 5 km	0 ... 26 km	12 ... 70 km
Permitted ambient conditions			
Ambient temperature			
• During operation	-40 ... +70 °C	-40 ... +70 °C	-40 ... +70 °C
• During storage	-40 ... +80 °C	-40 ... +80 °C	-40 ... +80 °C
• During transport	-40 ... +80 °C	-40 ... +80 °C	-40 ... +80 °C
Relative humidity at 25 °C without condensation during operation, maximum	95 %	95 %	95 %
IP degree of protection	IP20	IP20	IP20
Design, dimensions and weights			
Type of construction	Media module	Media module	Media module
Width	35 mm	35 mm	35 mm
Height	145 mm	145 mm	145 mm
Depth	90 mm	90 mm	90 mm
Net weight	0.26 kg	0.26 kg	0.26 kg
Type of mounting for installation at media module slot	Yes	Yes	Yes

PROFINET/Industrial Ethernet

Industrial Ethernet switches / media converters

SCALANCE X-400 managed (Layer 3)

Technical specifications (continued)

Order No.	6GK5 491-2AB00-8AA2	6GK5 491-2AC00-8AA2	6GK5 491-2AE00-8AA2
Product type designation	MM491-2	MM491-2LD	MM491-2LH+
Standards, specifications, approvals			
Standard	-	-	-
• for EMC	-	-	-
• for EMC of FM	FM3611: Class 1, Division 2, Group A, B, C, D / T4, Class 1, Zone 2, Group IIC, T4	FM3611: Class 1, Division 2, Group A, B, C, D / T4, Class 1, Zone 2, Group IIC, T4	FM3611: Class 1, Division 2, Group A, B, C, D / T4, Class 1, Zone 2, Group IIC, T4
• for hazardous zone	EN 60079-0: 2006, EN 60079-15: 2005, II 3 G Ex nA IIT4, KEMA 07 ATEX 0145 X	EN 60079-0: 2006, EN 60079-15: 2005, II 3 G Ex nA IIT4, KEMA 07 ATEX 0145 X	EN 60079-0: 2006, EN 60079-15: 2005, II 3 G Ex nA IIT4, KEMA 07 ATEX 0145 X
• for CSA and UL safety	UL 60950-1, CSA C22.2 No. 60950-1-03	UL 60950-1, CSA C22.2 No. 60950-1-03	UL 60950-1, CSA C22.2 No. 60950-1-03
• for hazardous zone of CSA and UL	UL 1604 and UL 2279-15 (Hazardous Location), Class 1 / Division 2 / Group A, B, C, D / T4, Class 1 / Zone 2 / Group IIC / T4	UL 1604 and UL 2279-15 (Hazardous Location), Class 1 / Division 2 / Group A, B, C, D / T4, Class 1 / Zone 2 / Group IIC / T4	UL 1604 and UL 2279-15 (Hazardous Location), Class 1 / Division 2 / Group A, B, C, D / T4, Class 1 / Zone 2 / Group IIC / T4
• for emitted interference	EN 61000-6-4:2001 (Class A)	EN 61000-6-4:2001 (Class A)	EN 61000-6-4:2001 (Class A)
• For noise immunity	EN 61000-6-2:2001	EN 61000-6-2:2001	EN 61000-6-2:2001
Certificate of suitability	EN 61000-6-2:2001, EN 61000-6-4:2001	EN 61000-6-2:2001, EN 61000-6-4:2001	EN 61000-6-2:2001, EN 61000-6-4:2001
• CE mark	Yes	Yes	Yes
• C-Tick	Yes	Yes	Yes
• IEC 61850-3	-	-	-
Marine classification corporation			
• American Bureau of Shipping Europe Ltd. (ABS)	Yes	Yes	Yes
• Bureau Veritas (BV)	Yes	Yes	Yes
• Det Norske Veritas (DNV)	Yes	Yes	Yes
• Germanischer Lloyd (GL)	Yes	Yes	Yes
• Lloyds Register of Shipping (LRS)	Yes	Yes	Yes
• Nippon Kaiji Kyokai (NK)	Yes	Yes	Yes

Order No.	6GK5 495-8BA00-8AA2	6GK5 496-4MA00-8AA2
Product type designation	EM495-8	EM496-4
Transmission rate		
Transmission rate 1	10 Mbit/s	100 Mbit/s
Transmission rate 2	100 Mbit/s	-
Transmission rate 3	-	-
Interfaces		
Maximum number of electrical/optical connections for network components or terminal equipment	8	8
Number of electrical connections		
• for network components or terminal equipment	8	-
• For media module	-	4
Design of electrical connection		
• for network components or terminal equipment	RJ45 port	-
Number of optical connections for fiber-optic cables		
• At 100 Mbit/s	-	-
• At 1000 Mbit/s	-	-
Design of optical connection for fiber-optic cables		
• At 100 Mbit/s	-	Depends on selected media modules
• At 1000 Mbit/s	-	Depends on selected media modules

2

PROFINET/Industrial Ethernet

Industrial Ethernet switches / media converters

SCALANCE X-400 managed (Layer 3)

Technical specifications (continued)

Order No.	6GK5 495-8BA00-8AA2	6GK5 496-4MA00-8AA2
Product type designation	EM495-8	EM496-4
Permitted ambient conditions		
Ambient temperature		
• During operation	-40 ... +70 °C	-40 ... +70 °C
• During storage	-40 ... +80 °C	-40 ... +80 °C
• During transport	-40 ... +80 °C	-40 ... +80 °C
Relative humidity at 25 °C without condensation during operation, maximum	95 %	95 %
IP degree of protection	IP20	IP20
Design, dimensions and weights		
Design	Extender module	Extender module
Width	112.4 mm	112.4 mm
Height	86 mm	154 mm
Depth	145 mm	145 mm
Net weight	0.56 kg	0.98 kg
Standards, specifications, approvals		
Standard		
• For EMC	-	-
• for EMC of FM	FM3611: Class 1, Division 2, Group A, B, C, D / T4, Class 1, Zone 2, Group IIC, T4	FM3611: Class 1, Division 2, Group A, B, C, D / T4, Class 1, Zone 2, Group IIC, T4
• for hazardous zone	EN 60079-0: 2006, EN60079-15: 2005, II 3 G Ex nA IIT4, KEMA 07 ATEX 0145 X	EN 60079-0: 2006, EN60079-15: 2005, II 3 G Ex nA IIT4, KEMA 07 ATEX 0145 X
• For CSA and UL safety	UL 60950-1, CSA C22.2 No. 60950-1-03	UL 60950-1, CSA C22.2 No. 60950-1-03
• for hazardous zone of CSA and UL	UL 1604 and UL 2279-15 (Hazardous Location), Class 1 / Division 2 / Group A, B, C, D / T4, Class 1 / Zone 2 / Group IIC / T4	UL 1604 and UL 2279-15 (Hazardous Location), Class 1 / Division 2 / Group A, B, C, D / T4, Class 1 / Zone 2 / Group IIC / T4
• For emitted interference	EN 61000-6-4:2001 (Class A)	EN 61000-6-4:2001 (Class A)
• For noise immunity	EN 61000-6-2:2001	EN 61000-6-2:2001
Certificate of suitability	EN 61000-6-2:2001, EN 61000-6-4:2001	EN 61000-6-2:2001, EN 61000-6-4:2001
• CE mark	Yes	Yes
• C-Tick	Yes	Yes
Marine classification corporation		
• American Bureau of Shipping Europe Ltd. (ABS)	Yes	Yes
• Bureau Veritas (BV)	Yes	Yes
• Det Norske Veritas (DNV)	Yes	Yes
• Germanischer Lloyd (GL)	Yes	Yes
• Lloyds Register of Shipping (LRS)	Yes	Yes
• Nippon Kaiji Kyokai (NK)	Yes	Yes

PROFINET/Industrial Ethernet

Industrial Ethernet switches / media converters

SCALANCE X-400 managed (Layer 3)

2

Ordering data	Order No.	Order No.
Industrial Ethernet Switches SCALANCE X-400		
<p>Modular Industrial Ethernet switches with integrated RJ45 ports for setting up electrical and/or optical Industrial Ethernet networks;</p> <p>integrated redundancy manager, IT functions (RSTP, VLAN, etc.), PROFINET IO Device, network management via SNMP and web server;</p> <p>incl. operating instructions, Industrial Ethernet network manual and configuration software on CD-ROM;</p> <p>C-PLUG included in the scope of delivery</p> <ul style="list-style-type: none"> • SCALANCE X408-2; 4 x 10/100/1000 Mbit/s and 4 x 10/100 Mbit/s RJ45 ports; 2 x Gigabit/Fast Ethernet media module slots • SCALANCE X414-3E; 2 x 10/100/1000 Mbit/s and 12 x 10/100 Mbit/s RJ45 ports; 1 x Gigabit-Ethernet and 2 x Fast Ethernet media module slots; 1 x extender interface 	<p>6GK5 408-2FD00-2AA2</p> <p>6GK5 414-3FC00-2AA2</p>	<p>Accessories</p> <p>IE FC TP Standard Cable GP 2 x 2 (Type A)</p> <p>4-core, shielded TP installation cable for connection to IE FC Outlet RJ45 / IE FC RJ45 Plug; PROFINET-compliant; with UL approval; <u>sold by the meter</u>; max. length 1000 m, minimum order 20 m</p> <p>IE FC TP Standard Cable GP 4 x 2</p> <p>8-core, shielded TP installation cable for connection to IE FC RJ45 Modular Outlet for universal application; with UL approval; <u>sold by the meter</u>; max quantity 1000 m, minimum order 20 m</p> <p>IE TP Cord RJ45/RJ45</p> <p>TP cable 4 x 2 with two RJ45 connectors</p> <ul style="list-style-type: none"> • 0.5 m • 1 m • 2 m • 6 m • 10 m <p>FO Standard Cable GP 50/125/1400^{1) 2)}</p> <p>Multimode cable, <u>sold by the meter</u>; max. length 1000 m; minimum order 20 m;</p> <p>FO Robust Cable GP 4E9/125/90</p> <p>Singlemode cable, <u>sold by the meter</u>; max. length 1000 m; minimum order 20 m</p> <p>FC FO Standard Cable GP 62.5/200/230</p> <p>FC FO standard cable for fixed routing indoors with PVC sheath; <u>sold by the meter</u>; max. length 1000 m; minimum order 20 m</p> <p>IE FC RJ45 Plug 180 2 x 2</p> <p>RJ45 plug connector for Industrial Ethernet with a rugged metal enclosure and integrated insulation displacement contacts for connecting Industrial Ethernet FC installation cables; with 180° cable outlet; for network components and CPs/CPU's with Industrial Ethernet interface</p> <ul style="list-style-type: none"> • 1 pack = 1 unit • 1 pack = 10 units • 1 pack = 50 units
MM491/MM492 media modules		
<p>Media modules with 2 ports; 1 Gbit/s</p> <p>MM492-2; 1000BaseSX, SC connection, multimode FOC up to 750 m</p> <p>MM492-2LD; 1000BaseLX, SC connection, single-mode FOC up to 10 km</p> <p>MM492-2LH; 1000BaseLX, SC connection, single-mode FOC up to 40 km</p> <p>MM492-2LH+; 1000BaseLX, SC connection, single-mode FOC up to 70 km</p> <p>MM492-2ELH; 1000BaseLX, SC connection, single-mode FOC up to 120 km</p> <p>Media modules with 2 ports; 100 Mbit/s</p> <p>MM491-2; 100BaseLX, BFOC interface, multimode FOC up to 5 km</p> <p>MM491-2LD; 100BaseFX, BFOC interface, singlemode FOC up to 26 km</p> <p>MM491-2LH+; 100BaseFX, SC connection, single-mode FOC up to 70 km</p>	<p>6GK5 492-2AL00-8AA2</p> <p>6GK5 492-2AM00-8AA2</p> <p>6GK5 492-2AN00-8AA2</p> <p>6GK5 492-2AP00-8AA2</p> <p>6GK5 492-2AQ00-8AA2</p> <p>6GK5 491-2AB00-8AA2</p> <p>6GK5 491-2AC00-8AA2</p> <p>6GK5 491-2AE00-8AA2</p>	<p>6XV1 840-2AH10</p> <p>6XV1 870-2E</p> <p>6XV1 870-3QE50</p> <p>6XV1 870-3QH10</p> <p>6XV1 870-3QH20</p> <p>6XV1 870-3QH60</p> <p>6XV1 870-3QN10</p> <p>6XV1 873-2A</p> <p>6XV1843-2R</p> <p>6XV1 847-2A</p> <p>6GK1 901-1BB10-2AA0</p> <p>6GK1 901-1BB10-2AB0</p> <p>6GK1 901-1BB10-2AE0</p>
EM495/EM496 extender modules		
<p>Extender modules for SCALANCE X414-3E</p> <ul style="list-style-type: none"> • EM495-8; with 8 x 10/100 Mbit/s TP ports • EM496-4; with 4 slots for 100 Mbit/s media modules 	<p>6GK5 495-8BA00-8AA2</p> <p>6GK5 496-4MA00-8AA2</p>	

1) Special fiber-optic cables, lengths and accessories available on request

2) Special tools and trained personnel are required for pre-assembling glass fiber-optic cables

PROFINET/Industrial Ethernet

Industrial Ethernet switches / media converters

SCALANCE X-400 managed (Layer 3)

Ordering data

Order No.

Accessories (continued)

IE FC RJ45 Plug 4 x 2

RJ45 plug connector for Industrial Ethernet (10/100/1000 Mbit/s) with a rugged metal enclosure and integrated insulation displacement contacts for connecting Industrial Ethernet FC installation cables; 180° cable outlet; for network components and CPs/CPUs with Industrial Ethernet interface

- 1 pack = 1 unit
- 1 pack = 10 units
- 1 pack = 50 units

6GK1 901-1BB11-2AA0
6GK1 901-1BB11-2AB0
6GK1 901-1BB11-2AE0

FC BFOC Plug

6GK1 900-1GB00-0AC0

Screw connector for on-site assembly on FC fiber-optic cable; (1 pack = 20 units + cleaning cloths)

FC SC plug

6GK1 900-1LB00-0AC0

Screw connector for on-site assembly on FC fiber-optic cable; (1 pack = 10 duplex plugs + cleaning cloths)

IE FC Stripping Tool

6GK1 901-1GA00

Preadjusted stripping tool for fast stripping of the Industrial Ethernet FC cables

FC FO termination kit

6GK1 900-1GL00-0AA0

Assembly case for local assembly of FC SC and FC BFOC connectors to FC FO standard cable, comprising a stripping tool, Kevlar cutters, fiber breaking tool and microscope

Order No.

Accessories (continued)

IE FC RJ45 Modular Outlet

FastConnect RJ45 Outlet for Industrial Ethernet with interface for a replaceable insert;

- **With insert 2FE;**
replaceable insert for 2 x 100 Mbit/s interfaces
- **With insert 1GE;**
replaceable insert for 1 x 1000 Mbit/s interfaces

6GK1 901-1BE00-0AA1

6GK1 901-1BE00-0AA2

SITOP compact, 2.5 A

6EP1 332-5BA00

Single-phase power supply with wide-range input 85 ... 264 V AC, regulated output voltage 24 V, output current rated value 2.5 A

Spare parts

CV490 cover set

6GK5 490-0AA00-0AA2

consisting of covers for:
1 x Gbit submodule slot,
1 x 100 Mbit/s submodule slot,
3 x 10/100 Mbit/s TP slot

Label sheet

6GK5 498-0AA00-0AA0

10 sheets DIN A4, color: petrol,
10 strips/sheet, pre-perforated
for printing with laser printer
10 sheets per pack

4-pole and 5-pole terminal set

6GK5 498-1AA00-0AA0

Straight, with locking lug

More information

To assist in selecting the right Industrial Ethernet switches as well as configuration of modular versions, the SIMATIC NET Selection Tool is available at:

Online version:

www.siemens.com/snst

Offline version:

www.siemens.com/snst-download

PROFINET/Industrial Ethernet

Industrial Ethernet switches / media converters

SCALANCE X-500 managed (Layer 3)



Overview

SCALANCE X-500		Hardware																											
		Type of device	Connection to S7 backplane bus	Format module S7	PC module	Flat type of construction	Box type of construction	19" type of construction	Rugged, compact housing	Modular design	10 Gigabit Ethernet	Gigabit Ethernet	PoE (Power over Ethernet)	LED diagnosis	SIMATIC environment	Redundant power supply (2 x 24 V DC)	External supply for integrated switch	Signal contact	Local display (SET pushbutton)	PLUG slot									
XR552-12M/ XR528-6M						•		•	•	•	•	•	•	•	•		•	•	•										
SCALANCE X-500		Software																											
		XR552-12M/ XR528-6M	Security Integrated (Firewall/VPN)	PROFINET diagnosis	Topology support (LLDP)	Command Line Interface / Teinet	Web based Management	Configuration with STEP 7	SNMP	Ring redundancy incl. RM-functionality	Standby redundancy	IRT capability	VLAN (Virtual Local Area Network)	GVRP (Generic VLAN Registration Protocol)	STP/ RSTP (Spanning Tree Protocol/ Rapid Spanning Tree Protocol)	Passive Listening	IGMP Snooping/Querier (Internet Group Management Protocol)	GMRP (Generic Multicast Protocol)	Broadcast/ Multicast/ Unicast Limiter	Broadcast blocking	DHCP Option 82 (Dynamic Host Configuration Protocol)	IP Access List	Access Control List (MAC)	IEEE 802.1x (Radius)	Link Aggregation	Static Routing	RIPv2 (Dynamic Routing)	OSPFv2 (Dynamic Routing)	RRRP Router Redundancy (Virtual Router Redundancy Protocol)
		•	•	•	•	•	•	•	•		•	•	•	•	•	•	•	•	•	•		•	•	•	i.p.	i.p.	i.p.	i.p.	
		• applies																											
		G_IK10_XX_10308																											

Function overview SCALANCE X-500 managed

PROFINET/Industrial Ethernet

Industrial Ethernet switches / media converters

SCALANCE XR-500 managed (Layer 3)

Overview



The Layer 3-enabled SCALANCE XR-500 Industrial Ethernet switches are fully modular, high-performance, industry-standard switches for the construction of electrical and optical line, ring and star topologies with data transfer rates of up to 10 Gbit/s, designed for installation in 19" control cabinets.

- Four optical interfaces (10 Gbit/s) and up to 48 electrical and/or optical interfaces (10/100/1000 Mbit/s), of which up to 12 electrical PoE interfaces; up to twelve electrical and/or optical 4-port media modules can be plugged into the basic unit at any point.
- Fast media redundancy due to the integrated redundancy manager:
Redundant connection of rings by means of high-speed media redundancy is also possible with SCALANCE XR-500.
- Seamless integration of automation networks into existing corporate networks thanks to support for a host of IT standard functions (VLANs, IGMP-Snooping/Querier, STP/RSTP/MSTP, Link Aggregation, Quality of Service, 802.1x and optional static routing, RIP, OSPF, VRRP for IPv4 and IPv6)
- Redundant integration into higher-level networks through support for standardized redundancy procedures (Multiple Spanning Tree Protocol, Spanning Tree Protocol, Rapid Reconfiguration Spanning Tree Protocol, Media Redundancy Protocol) and standardized IP routing protocols or procedures (Routing Information Protocol, Open Shortest Path First, Virtual Router Redundancy Protocol)
- PROFINET diagnostics, Web browser, CLI and SNMP

Benefits

get Designed for Industry

- Unlimited flexibility during network expansions (e.g. more terminals, higher data transfer rates, PoE ports) or conversion (e.g. switching from copper to fiber-optic cable) and reduction of the storage costs due to the fully modular construction using SFPplus/SFP and media modules
- Retrofitting the Layer 3 switching functions (IP routing) by means of a license on KEY-PLUG (available soon) without replacing the existing hardware
- Changing the media modules during operation
- High availability of the network due to
 - redundant voltage feed
 - redundant network structures based on FOC or Twisted Pair (redundancy manager, standby function and STP/RSTP/MSTP integrated)
 - Easy device replacement by means of plug-in C-PLUG/KEY-PLUG swap medium
 - very fast reconfiguration of the network in event of a fault
- Thanks to support for the Dual Stack Routing function, both IPv4 addressing and IPv6 addressing can be operated in one network
- High flexibility thanks to variable mounting options of the power supply unit, and choice between front or rear cable outlet on the device (depending on the device version)

Application

The SCALANCE XR-500 switches are ideal for use in industrial networks and for integrating the industrial network into an existing corporate network. From the control level to the management level, the switch handles the networking of plant sections as well as distributed field devices and ensures high plant availability with extensive diagnostics options and high transmission speeds. Thanks to the scalability of the basic unit and the optionally available Layer 3 switching function, the network can be established specially for the relevant application, or adapted and expanded at any time.

The SCALANCE XR-500 switches are suitable for establishing electrical and optical Industrial Ethernet line, star or ring topologies with four integral SFP+ slots that can be optionally equipped with SFP+ plug-in transceivers (10 Gbit/s) or SFP plug-in transceivers (1000 Mbit/s), and up to 12 media module slots that can be optionally equipped with electrical and/or optical 4-port media modules. Thanks to data transfer rates of up to 10 Gbit/s, the switches can be used as an Industrial Ethernet backbone switch and as a hub in the plant bus (redundant connection possible).

The use of media modules or SFP+/SFP enables the following:

- Extension of networks by subsequent insertion of additional media modules in unused media module slots
- Changing of cabling technology, e.g. conversion from copper to fiber-optic cables, or from multimode to singlemode FOC
- Changing of the data transfer rate, e.g. from 1000 Mbit/s to 10 Gbit/s

Design

The SCALANCE XR-500 Industrial Ethernet switches with rugged metal enclosure with IP20 degree of protection are optimized for installation in the 19" control cabinet. The power supply optimized for the 19" cabinet (85 to 264 V AC) for power supply to the SCALANCE XR-500 can either be installed directly at the rear of the SCALANCE XR-500 assembled or connected using connecting cables (installation of the power supply unit in a 19" rack). The data cable outlet of the SCALANCE XR-500 is located optionally either at the front or rear of the device (depending on the device version).

The switches have:

- 4-pole terminal block on the front for connecting the optionally available power supply unit (85 V to 264 V AC)
- 6-pin connector for assembly of the optionally available power supply unit (85 V to 264 V AC) on the rear
- 2-pole terminal block for connecting the isolated signaling contact for simple display of faults
- Row of LEDs for indicating status information (power, link status, data transfer, power supply, signal contact)
- SELECT/SET pushbutton for easy setting of the fault signaling contact on the device
- Slot on the side of the device for the C-PLUG swap medium for simple device replacement in the event of a fault, or the KEY-PLUG (available soon) for adding IP routing to the device functionality
- Console port (serial interface, RJ11 cable to RS232 (9-pin) included in scope of delivery) and management port (Ethernet interface) for on-site parameterization/diagnostics

The SCALANCE XR-500 switches are available with the following port types:

- Four SFP+ slots for optical SFP+ or SFP plug-in transceivers (multimode and singlemode connections)
 - The SFP+ plug-in transceivers support 10 Gbit/s
 - The SFP plug-in transceivers support 1000 Mbit/s
- Up to 12 slots for electrical 4-port media modules and electrical PoE 4-port media modules or optical 4-port media modules for multimode or singlemode connections; the optical media modules are available in various connection technologies
 - The RJ45 sockets are also available in industry-standard design with additional retaining collars for connection of the Industrial Ethernet FC RJ45 Plug 180
 - All electrical Ethernet interfaces support 10/100/1000 Mbit/s, all optical Ethernet interfaces support 100 or 1000 Mbit/s

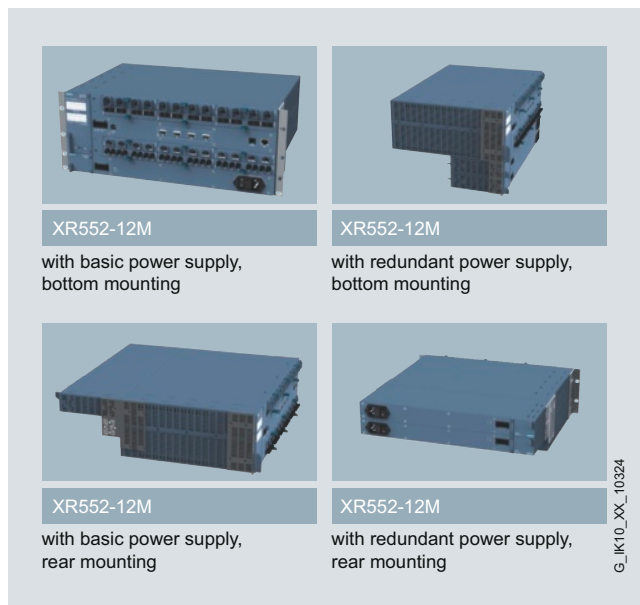

Options for mounting a single/redundant power supply unit to SCALANCE XR552-12M

Product versions

SCALANCE XR552-12M

- LEDs and data cable outlet on the front
- Alternatively, LEDs on the front and data cable outlet at the rear (available soon)
- Connection of power supply unit at rear or above/below the switch
- Four SFP+ slots for equipping with 10 Gigabit Ethernet SFP+ plug-in transceivers or Gigabit SFP plug-in transceivers
- 12x 4-port media module slots

SCALANCE XR528-6M (available soon)

- LEDs and data cable outlet on the front
- Alternatively, LEDs on the front and data cable outlet at the rear (available soon)
- Connection of power supply unit at rear or above/below the switch
- Four SFP+ slots for equipping with 10 Gigabit Ethernet SFP+ plug-in transceivers or Gigabit SFP plug-in transceivers
- 6x 4-port media module slots

PROFINET/Industrial Ethernet

Industrial Ethernet switches / media converters

SCALANCE XR-500 managed (Layer 3)

Function

- Integrated redundancy manager for constructing ring topologies with up to 10 Gbit/s and high-speed media redundancy. By interconnecting the ends of an optical or electrical line to form a ring, reliable communication can be achieved. The redundancy manager (RM) integrated in the SCALANCE XR-500 switch monitors the function of the network. It recognizes the failure of a transmission link or of SCALANCE X switch in the ring and activates the substitute path within a maximum of 0.2 seconds.
- Redundant Layer 2 interfacing to company networks; SCALANCE XR-500 switches support the standardized redundancy procedures Multiple Spanning Tree Protocol (MSTP), Rapid Spanning Tree Protocol (RSTP), and Spanning Tree Protocol (STP). This enables a subnetwork to be connected redundantly to a higher-level corporate network with reduced requirements for the reconfiguration time (in the order of seconds).
- The Layer 3 switching functions¹⁾ (optional) enable simple subdivision of large networks into smaller subnetworks with their own address space. Reasons for subdivision into subnetworks include separation of the Ethernet network to reduce the volume of traffic, separation of sensitive areas from the main network, and subdivision of the network into logical working groups.
- Redundant Layer 3 connection to corporate networks¹⁾; SCALANCE XR-500 switches support the standardized routing protocols Open Shortest Path First (OSPF) and Routing Information Protocol (RIP), and the standardized routing procedure Virtual Router Redundancy Protocol (VRRP). This means industrial, routed subnetworks can also be connected redundantly to a higher-level corporate network.
- Thanks to support for the Dual Stack Routing function, both IPv4 addressing and IPv6 addressing can be operated in one network.
- Support of virtual networks (VLAN); for structuring Industrial Ethernet networks with a fast growing number of users, a physically existing network can be divided into several virtual networks. Port-based, protocol-based and IP-based VLANs are available for selection.
- Load limiting when multicast protocols (e.g. video transmission) are used; through learning the multicast sources and targets (IGMP Snooping, IGMP Querier), SCALANCE XR-500 switches can also filter multicast data traffic and therefore limit the load in the network. Multicast and broadcast traffic can be limited.
- Time synchronization; diagnostic messages (log table entries, e-mails) are time-stamped. The local time is standardized throughout the network by means of synchronization with a SICLOCK time transmitter or SNTP/NTP server, thereby simplifying the assignment of diagnostic messages to several devices.
- Link aggregation (IEEE 802.3ad) for bundling data streams
- Quality of Service (IEEE 802.1p) for prioritization of network traffic

1) Available soon

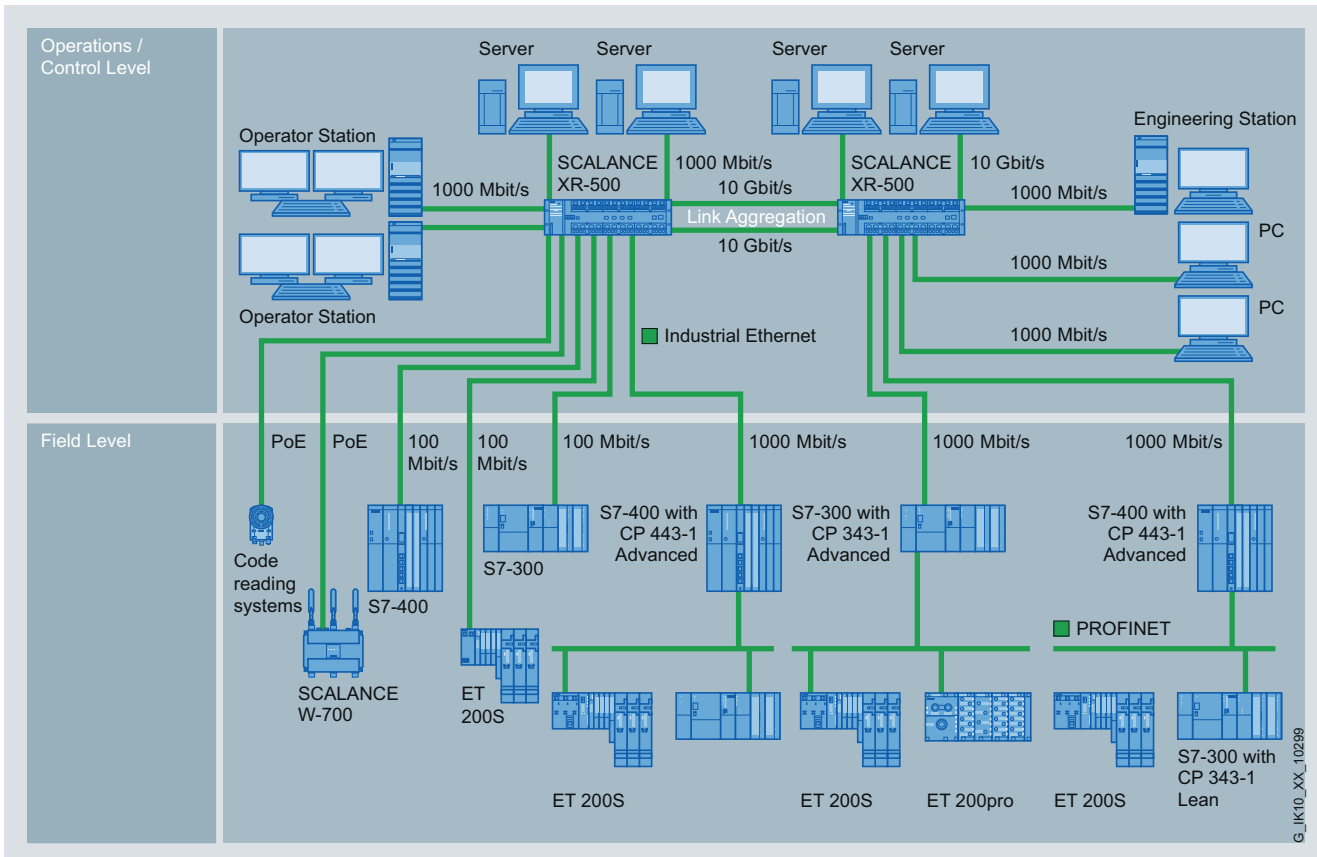

Increasing the transmission bandwidth by means of link aggregation

PROFINET/Industrial Ethernet

Industrial Ethernet switches / media converters

SCALANCE XR-500 managed (Layer 3)



Function (continued)

Network topology and network configuration

The network topology can easily be adapted to the structure of the plant using SCALANCE XR-500 Industrial Ethernet switches.

The following network structures and combinations of structures can be implemented:

- Ethernet with fast media redundancy; to increase network availability, as many as 50 X-200, X-300, X-400 or X-500 switches cascaded in line can be connected into a ring.
- Several rings can be redundantly linked through the standby function
- Star topology with SCALANCE XR-500 switches: Each SCALANCE XR-500 switch represents a neutral point that can connect up to 52 nodes or subnets with each other electrically.

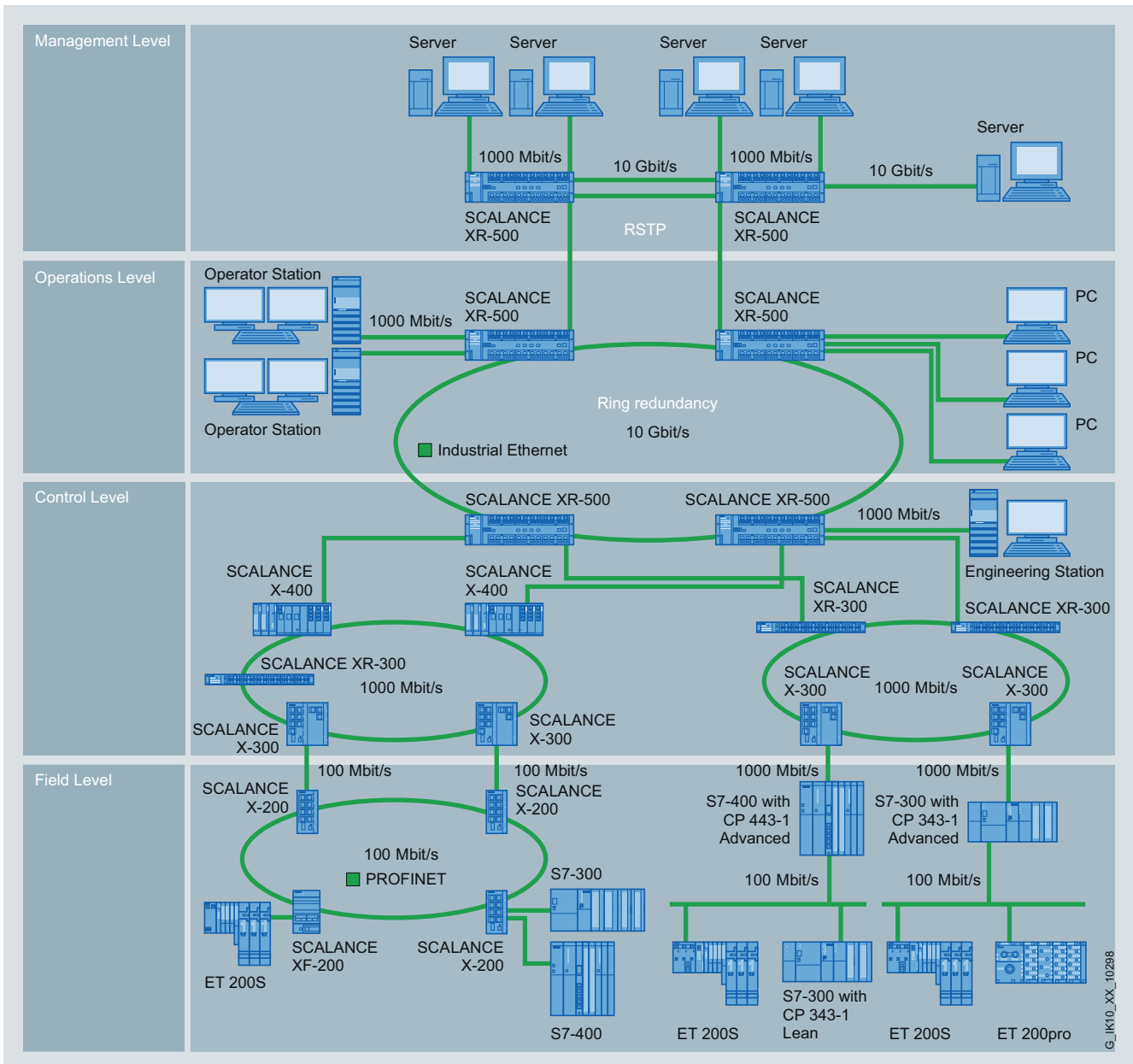

Use of SCALANCE XR-500 in redundant network topologies, e.g. with Rapid Spanning Tree Protocol (RSTP) and ring redundancy

PROFINET/Industrial Ethernet

Industrial Ethernet switches / media converters

SCALANCE XR-500 managed (Layer 3)

Function (continued)

When configuring the network, it is necessary to observe the following boundary conditions:

- Maximum line length between two modules for multi-mode fiber-optic conductors:
 - 5 km at 100 Mbit/s
 - 750 m at 1000 Mbit/s
 - 300 m at 10 Gbit/s
- Maximum line length between two modules for single-mode fiber-optic conductors:
 - 26 to 70 km at 100 Mbit/s
 - 10 to 120 km at 1000 Mbit/s
 - 10 to 40 km at 10 Gbit/s
- Maximum cable length of the TP cable between two SCALANCE X switches:
 - Max. 100 m with IE FC Cable 2 x 2 and IE FC RJ45 Plug 180
 - Max. 100 m at 1 Gbit/s with IE FC Standard Cable 4 x 2 (90 m), IE FC RJ45 Modular Outlet and patch cable (10 m)
 - Max. 10 m using patches with TP Cord

Commissioning and diagnosis

Setting options on the device itself:

- Redundancy manager RM; to establish a ring, a SCALANCE XR-500 is switched to RM mode. The non-ring ports of the RM can be used freely for the connection of data terminals and networks. If the redundancy procedure MRP standardized by PROFINET is used, the RM is adjusted automatically.
- Signal mask; the signal mask is set to the current status of the SCALANCE XR-500 (setpoint) by pushbutton operation. The signal mask defines which ports and which power supplies are to be monitored. The signaling contact only reports an error when a monitored port or a monitored feeder fails (deviation of setpoint/actual status).
- IP address; the IP address is assigned via DHCP (**D**ynamic **H**ost **C**onfiguration **P**rotocol). If there is no corresponding server in the network, the IP address can be assigned using an enclosed software tool.

Diagnostic options on site:

- The following status information is displayed by LEDs on site:
 - Port status
 - Port mode (Mbit/s, full/half-duplex)
 - Status of the two power supplies
 - Signaling contact status
 - Signal mask (setpoint status)
 - RM mode
 - Standby mode
- The status of the signaling contact is routed externally by means of floating relay contacts. This enables, for example, the module to be monitored via an input module from a controller.
- Monitoring via the Industrial Ethernet network; the following possibilities are available:
 - Via standard browser (Web-based management): Selection of SCALANCE XR-500 switches via the network from a PC with browser
 - Via SNMP V1, V2c, V3: Secure integration of SCALANCE XR-500 switches via the network into a network management system, e.g. SINEMA Server
 - Via PROFINET IO diagnostics: PROFINET diagnostic alarms from SCALANCE XR-500 switches can be displayed using the relevant SIMATIC engineering tools and they can also be processed in the controller. The engineering outlay for the PLC and HMI have been drastically reduced due to the complete integration in the SIMATIC concept for system error messages.

Network management

The network management provides the following functions:

- Password-protected dial-up for "Administrator" (read and write authorization) and "User" (read only)
- Read-out of version and status information
- Setting the signal and standby mask and address information
- Fixed parameterization of the ports (data rates, half/full duplex)
- Setting of Spanning/Rapid/Multiple Spanning Tree parameters
- Parameterization of the web management services
- Security
 - Ports can be connected or disconnected
 - Port-based network access control according to IEEE 802.1x
 - Authentication in accordance with IEEE 802.1x
 - Support of Access Control List (ACL)
- Output of statistics information
- Diagnosis of data traffic by means of a parameterizable mirror port with a standard commercial network analyzer
- Loading of new firmware versions or of the configuration data via the network by a TFTP server or directly via HTTP/HTTPS using a Web browser
- Saving the configuration data or log table via the network on a TFTP server

If faults occur in the network, the SCALANCE XR-500 switch can independently send error messages (traps) to a network management system, such as SINEMA Server, or also e-mails to a predefined network administrator.

Remote monitoring (RMON) provides the following functions: The SCALANCE XR-500 switch can collect statistics information according to the RMON groups 1 through 4. These include, for example, fault statistics that are kept for each port. This information can be read out through web-based management in the statistics sub-area.

Technical specifications

Order No.	6GK5 552-0AA00-2AR2 6GK5 552-0AA00-2HR2	6GK5 528-0AA00-2AR2 6GK5 528-0AA00-2HR2
Product type designation	SCALANCE XR552-12M	SCALANCE XR558-6M
Transmission rate		
Transmission rate 1	10 Mbit/s	10 Mbit/s
Transmission rate 2	100 Mbit/s	100 Mbit/s
Transmission rate 3	1 000 Mbit/s	1 000 Mbit/s
Transmission rate 4	10 000 Mbit/s	10 000 Mbit/s
Interfaces		
Maximum number of electrical/optical connections for network components or terminal equipment	52	28
Number of electrical connections		
• for SFP+/SFP	4	4
• for operation panel	1	1
• for management purposes	1	1
• for signaling contact	1	1
• for media module	12	6
• for power supply	1	1
• for redundant power supply	1	1
Design of electrical connection		
• for network components or terminal equipment	Depends on selected media modules	Depends on selected media modules
• with power-over-Ethernet for network components or terminal equipment	-	-
• for operation panel	RJ11 port	RJ11 port
• for management purposes	RJ45 port	RJ45 port
• for signaling contact	2-pin terminal block	2-pin terminal block
• for power supply	4-pin terminal block	4-pin terminal block
Design of optical connection for fiber-optic cables		
• at 100 Mbit/s	Depends on selected media modules	Depends on selected media modules
• at 1000 Mbit/s	Depends on selected media modules	Depends on selected media modules
• at 10 Gbit/s	Depends on selected SFPplus plug-in transceivers	Depends on selected SFPplus plug-in transceivers
The range at the optical interface depends on the type of optical fiber used	-	-
Design of swap medium C-Plug/KEY-PLUG	Yes	Yes
Inputs/outputs		
Operating voltage of signaling contacts with DC rated value	24 V	24 V
Operating current of signaling contacts with DC maximum	0.1 A	0.1 A
Supply voltage, current consumption, power loss		
Type of power supply	DC	DC
External supply voltage	24 V	24 V
• Minimum	19.2 V	19.2 V
• Maximum	28.8 V	28.8 V
Product component: fusing at power supply input	Yes	Yes
Design of fusing at input for supply voltage	F 15 A / 125 V	F 15 A / 125 V
Permissible ambient conditions		
Ambient temperature		
• During operation	0 ... 60 °C	0 ... 60 °C
• During storage	-40 ... +70 °C	-40 ... +70 °C
• During transport	-40 ... +70 °C	-40 ... +70 °C
Relative humidity at 25 °C without condensation during operation, maximum	95 %	95 %
IP degree of protection	IP20	IP20

PROFINET/Industrial Ethernet

Industrial Ethernet switches / media converters

SCALANCE XR-500 managed (Layer 3)

Technical specifications (continued)

Order No.	6GK5 552-0AA00-2AR2 6GK5 552-0AA00-2HR2	6GK5 528-0AA00-2AR2 6GK5 528-0AA00-2HR2
Product type designation	SCALANCE XR552-12M	SCALANCE XR558-6M
Design, dimensions and weights		
Design	19-inch rack	19-inch rack
Width	449 mm	449 mm
Height	130.8 mm	87.2 mm
Depth	305 mm	305 mm
Net weight	10 kg	10 kg
Type of mounting: 19" installation	Yes	Yes
Type of cable outlet	Cable outlet at front	Cable outlet at front
Product properties, functions, components		
General		
Cascading with redundant ring with reconfiguration time < 0.3 s	50	50
Cascading with star topology	Any (only dependent on signal propagation time)	Any (only dependent on signal propagation time)
Product functions		
Management, configuration, programming		
Product function		
• CLI	Yes	Yes
• Web-based management	Yes	Yes
• MIB support	Yes	Yes
• SNMP traps	Yes	Yes
• Configuration with STEP 7	Yes	Yes
• RMON	Yes	Yes
• Send email	Yes	Yes
• Port mirroring	Yes	Yes
• CoS	Yes	Yes
• PROFINET IO diagnostics	Yes	Yes
• Switch-managed	Yes	Yes
Protocol is supported		
• Telnet	Yes	Yes
• HTTP	Yes	Yes
• HTTPS	Yes	Yes
• TFTP	Yes	Yes
• SNMP v1	Yes	Yes
• SNMP v2	Yes	Yes
• SNMP v3	Yes	Yes
• IGMP (snooping/querier)	Yes	Yes
• GMRP	Yes	Yes
• DCP	Yes	Yes
• LLDP	Yes	Yes
Identification & maintenance		
• I&M0 - device-specific information	Yes	Yes
• I&M1 - higher-level designation/location designation	Yes	Yes
Product functionsDiagnostics		
Product function		
• Port diagnostics	Yes	Yes
• Packet size statistics	Yes	Yes
• Packet type statistics	Yes	Yes
• Error statistics	Yes	Yes
• SysLog	Yes	Yes
Product functionsVLAN		
Product function		
• VLAN - port-based	Yes	Yes
• VLAN - dynamic	Yes	Yes
Maximum number of VLANs	255	255
GVRP protocol is supported	Yes	Yes

Technical specifications (continued)

Order No.	6GK5 552-0AA00-2AR2 6GK5 552-0AA00-2HR2	6GK5 528-0AA00-2AR2 6GK5 528-0AA00-2HR2
Product type designation	SCALANCE XR552-12M	SCALANCE XR558-6M
Product functions DHCP		
Product function		
• DHCP client	Yes	Yes
• DHCP option 66	Yes	Yes
• DHCP option 67	Yes	Yes
Product functions Routing		
Routing service - note	IP routing in connection with KEY-PLUG available soon	IP routing in connection with KEY-PLUG available soon
Product function		
• Static IP routing	-	-
• Static IP routing IPv6	-	-
• Dynamic IP routing	-	-
• Dynamic IP routing IPv6	-	-
Protocol is supported		
• RIPv2	-	-
• RIPng for IPv6	-	-
• OSPFv2	-	-
• OSPFv3 for IPv6	-	-
• VRRP	-	-
• VRRP for IPv6	-	-
Product functions Redundancy		
Product function		
• Ring redundancy	Yes	Yes
• Redundancy manager	Yes	Yes
• Standby redundancy	Yes	Yes
• Redundancy procedure HSR	Yes	Yes
• Redundancy procedure MRP	Yes	Yes
• Redundancy procedure STP	Yes	Yes
• Redundancy procedure RSTP	Yes	Yes
• Redundancy procedure MSTP	Yes	Yes
• Passive listening	Yes	Yes
Protocol is supported		
• STP	Yes	Yes
• RSTP	Yes	Yes
• MSTP	Yes	Yes
• RSTP Big Network Support	Yes	Yes
• LACP	Yes	Yes
Product functions Security		
Product function		
• ACL - MAC based	Yes	Yes
• ACL - Port/MAC-based	Yes	Yes
• IEEE 802.1x (radius)	Yes	Yes
• Broadcast/Multicast/Unicast Limiter	Yes	Yes
• Broadcast blocking	Yes	Yes
Protocol is supported SSH	Yes	Yes
Product functions Time		
Product function: SICLOCK support	Yes	Yes
Protocol is supported		
• NTP	Yes	Yes
• SNTP	Yes	Yes
• IEEE 1588 profile default	-	-
• IEEE 1588 profile gPTP	-	-
• IEEE 1588 profile PSRC	-	-
Type of time synchronization	IEEE 1588 available soon	IEEE 1588 available soon

PROFINET/Industrial Ethernet

Industrial Ethernet switches / media converters

SCALANCE XR-500 managed (Layer 3)

Technical specifications (continued)

Order No.	6GK5 552-0AA00-2AR2 6GK5 552-0AA00-2HR2	6GK5 528-0AA00-2AR2 6GK5 528-0AA00-2HR2
Product type designation	SCALANCE XR552-12M	SCALANCE XR558-6M
Standards, specifications, approvals		
Standard		
• for EMC of FM	-	-
• for hazardous zone	-	-
• for CSA and UL safety	UL 60950-1, CSA C22.2 No. 60950-1	UL 60950-1, CSA C22.2 No. 60950-1
• for hazardous zone of CSA and UL	-	-
• For emitted interference	EN 61000-6-4 (Class A)	EN 61000-6-4 (Class A)
• for noise immunity	EN 61000-6-2	EN 61000-6-2
Certificate of suitability	EN 61000-6-2, EN 61000-6-4	EN 61000-6-2, EN 61000-6-4
• CE marking	Yes	Yes
• C-Tick	Yes	Yes
Marine classification association		
• American Bureau of Shipping Europe Ltd. (ABS)	-	-
• Bureau Veritas (BV)	-	-
• Det Norske Veritas (DNV)	-	-
• Germanischer Lloyd (GL)	-	-
• Lloyds Register of Shipping (LRS)	-	-
• Nippon Kaiji Kyokai (NK)	-	-

Ordering data

SCALANCE XR-500 Industrial Ethernet switches

Fully modular Layer 3-enabled Industrial Ethernet switches for establishing electrical and/or optical Industrial Ethernet networks; with data transfer rates up to 10 Gbit/s, designed for installation in 19" control cabinets

SCALANCE XR552-12M

4 x integral 1/10 Gbit/s SFP+ slots for SFP or SFP+ plug-in transceivers
12 x 10/100/1000 Mbit/s slots for 4-port media modules, electrical or optical

- Data cable outlet at front
- Data cable outlet at rear ¹⁾

SCALANCE XR528-6M ¹⁾

4 x integral 1/10 Gbit/s SFP+ slots for SFP or SFP+ plug-in transceivers
6 x 10/100/1000 Mbit/s slots for 4-port media modules, electrical or optical

- Data cable outlet at front
- Data cable outlet at rear

¹⁾ Available soon

Order No.

6GK5 552-0AA00-2AR2
6GK5 552-0AA00-2HR2

6GK5 528-0AA00-2AR2
6GK5 528-0AA00-2HR2

Order No.

Accessories

FAN597-1

Replacement fan slide-in unit for SCALANCE XR552-12M

FAN597-2 ¹⁾

Replacement fan slide-in unit for SCALANCE XR528-6M

KEY-PLUG X500 Layer 3 ¹⁾

Swap medium for expansion of the device functions with IP routing (Layer 3), for integration of configuration data and for easy replacement of SCALANCE X-500 in the event of a fault

Media modules

6GK5 597-1AA00-8AA0

6GK5 597-2AA00-8AA0

6GK5 905-0PA00

See "Media modules for modular SCALANCE XR-500 managed"

Power supply

See "Power supply for modular SCALANCE XR-500 managed"

More information

To assist in selecting the right Industrial Ethernet switches as well as configuration of modular versions, the SIMATIC NET Selection Tool is available:

Online version:
www.siemens.com/snst

Offline version:
www.siemens.com/snst-download

PROFINET/Industrial Ethernet

Industrial Ethernet switches / media converters

Media modules
for modular SCALANCE XR-500 managed

Overview

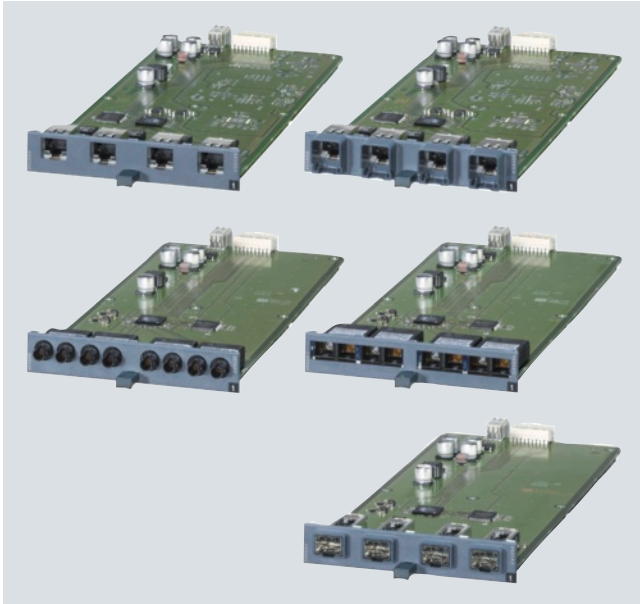

- 4-port media modules for flexible, 4-port-granular equipping of SCALANCE X-500 Industrial Ethernet switches
- Electrical versions with RJ45 ports are available as well as optical versions with BFOC and SC ports for the use of multimode and singlemode fiber-optic cables
- A 4-port SFP media module permits the optional use of fiber-optic SFP plug-in transceivers (**S**mall **F**orm-**F**actor **P**luggable) with LC connection technology
- SFP+ and SFP plug-in transceivers for flexible equipping of the four integral SFP+ slots in SCALANCE X-500

Benefits

get Designed for Industry

- Unlimited flexibility during network expansions (e.g. more terminal devices), conversion (e.g. switching from copper to fiber-optic cables), or performance enhancement (e.g. from Gigabit to 10 Gigabit) through modular construction using media modules and SFP+ or SFP plug-in transceivers
- Reduction of storage costs and maintenance overhead by focusing on a few basic device versions

Application

Use of media modules in the SCALANCE X-500 switches enables:

- Extension of networks by subsequent insertion of additional media modules in unused media module slots (possible during operation)
- Extension of networks by subsequent insertion of additional SFP+ or SFP plug-in transceivers in unused SFP+ slots (possible during operation)
- Changing of cabling technology (e.g. conversion from copper to fiber-optic cables, or from multimode to singlemode FOC)
- Change of the data transfer rate (e.g. conversion from SFP plug-in transceivers (1000 Mbit/s) to SFP+ plug-in transceivers (10 Gbit/s))

2

PROFINET/Industrial Ethernet

Industrial Ethernet switches / media converters

Media modules
for modular SCALANCE XR-500 managed

Design

2

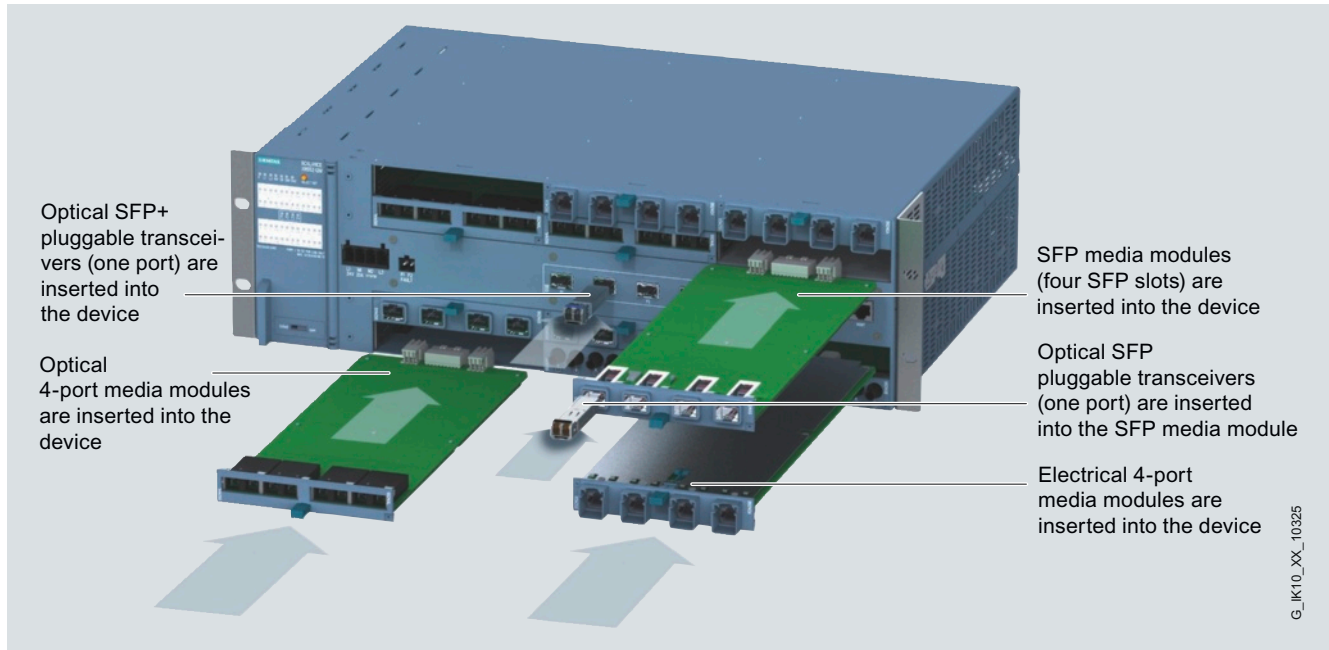

G_IK10_XX_10325

4-port media modules plugged into media module slot and SFP/SFP+ plug-in transceivers in SFP+ slots

Product versions of media modules

Electrical media modules with 4 x 10/100/1000 Mbit/s RJ45 ports

- MM992-4CUC with retaining collar
- MM992-4CU without retaining collar

Electrical media modules with 4 x 10/100/1000 Mbit/s RJ45 ports and PoE

- MM992-4PoEC with retaining collar (available soon)
- MM992-4PoE without retaining collar (available soon)

Optical media modules with 4 x 100 Mbit/s BFOC ports

- MM991-4
multimode, glass, up to 5 km
- MM991-4LD
singlemode, glass, up to 26 km

Optical media modules with 4 x 1000 Mbit/s SC ports

- MM992-4
multimode, glass, up to 750 m
- MM992-4LD
singlemode, glass, up to 10 km

Optical media modules with 4 x 100/1000 Mbit/s for SFP pluggable transceiver

- MM992-4SFP
for SFP plug-in transceivers with 1 x 100 Mbit/s or
1 x 1000 Mbit/s multimode or singlemode, glass

Product versions of SFP pluggable transceivers

The SFP plug-in transceivers (**S**mall **F**orm-factor **P**luggable) can be used together with the SFP media module MM992-4SFP, and in the integral SFP+ slots of the SCALANCE X-500.

Optical SFP pluggable transceivers with 1 x 100 Mbit/s LC port

- SFP991-1
multimode, glass, up to 5 km
- SFP991-1LD
singlemode, glass, up to 26 km
- SFP991-1LH+
singlemode, glass, up to 70 km

Optical SFP pluggable transceivers with 1 x 1000 Mbit/s LC port

- SFP992-1
multimode, glass, up to 750 m
- SFP992-1LD
singlemode, glass, up to 10 km
- SFP992-1LH
singlemode, glass, up to 40 km
- SFP992-1LH+
singlemode, glass, up to 70 km
- SFP992-1ELH
singlemode, glass, up to 120 km

Product versions of SFP+ plug-in transceivers

The SFP+ plug-in transceivers (**S**mall **F**orm-factor **P**lug-in) can only be used in the integral SFP+ slots of the SCALANCE X-500.

Optical SFP+ plug-in transceivers with 1 x 10 Gbit/s LC ports

- SFP993-1
multimode, glass, up to 300 m
- SFP993-1LD
singlemode, glass, up to 10 km
- SFP993-1LH
singlemode, glass, up to 40 km

PROFINET/Industrial Ethernet

Industrial Ethernet switches / media converters

Media modules
for modular SCALANCE XR-500 managed

Design (continued)

Type of module	Type and quantity of ports								Max. distance
	10 Gigabit Ethernet		Gigabit Ethernet			Fast Ethernet			
	10000 Mbit/s		10 / 100 / 1000 Mbit/s	1000 Mbit/s		100 Mbit/s			
	Optical		Electrical	Optical		Optical			
	Multimode	Singlemode	Twisted Pair	Multimode	Singlemode	Multimode	Singlemode		
Media modules									
MM992-4CUC			4x RJ45 ¹⁾						100 m
MM992-4CU			4x RJ45						100 m
MM992-4PoEC			4x RJ45 ¹⁾						100 km
MM992-4PoE			4x RJ45						100 km
MM991-4						4x BFOC			5 km
MM991-4LD							4x BFOC		26 km
MM992-4				4x SC					5 km
MM992-4LD					4x SC				10 km
MM992-4SFP				4x LC ²⁾	4x LC ²⁾	4x LC ²⁾	4x LC ²⁾		
SFP-Module									
SFP991-1 ³⁾						1x LC			5 km
SFP991-1LD ³⁾							1x LC		26 km
SFP991-1LH ³⁾							1x LC		70 km
SFP992-1 ^{3) 4)}				1x LC					750 m
SFP992-1LD ^{3) 4)}					1x LC				10 km
SFP992-1LH ^{3) 4)}					1x LC				40 km
SFP992-1LH ^{3) 4)}					1x LC				70 km
SFP992-1ELH ^{3) 4)}					1x LC				120 km
SFPplus-Module⁴⁾									
SFP993-1	1x LC								300 m
SFP993-1LD		1x LC							10 km
SFP993-1LH		1x LC							40 km

¹⁾ With retaining collars

²⁾ The MM992-4SFP SFP slot module can accommodate up to four 1-port SFP modules

³⁾ Can only be plugged into an MM992-4SFP slot module

⁴⁾ Puggable in XR-500 SFPplus slots only

Overview of media modules for SCALANCE X-500

2

PROFINET/Industrial Ethernet

Industrial Ethernet switches / media converters

Media modules for modular SCALANCE XR-500 managed

Technical specifications

Order No.	6GK5 992-4GA00-8AA0	6GK5 992-4SA00-8AA0	6GK5 991-4AB00-8AA0	6GK5 991-4AC00-8AA0
Product type designation	MM992-4CUC	MM992-4CU	MM991-4	MM991-4LD
Transmission rate				
Transmission rate 1	10 Mbit/s	10 Mbit/s	100 Mbit/s	100 Mbit/s
Transmission rate 2	100 Mbit/s	100 Mbit/s	-	-
Transmission rate 3	1 000 Mbit/s	1 000 Mbit/s	-	-
Interfaces				
Maximum number of electrical/ optical connections for network components or terminal equipment	4	4	4	4
Number of electrical connections				
• for network components or terminal equipment	4	4	-	-
• with power-over-Ethernet for network components or terminal equipment	-	-	-	-
Design of electrical connection				
• for network components or terminal equipment	RJ45 port	RJ45 port	-	-
• with power-over-Ethernet for network components or terminal equipment	-	-	-	-
Number of optical connections for fiber-optic cables				
• at 100 Mbit/s	-	-	4	4
• at 1000 Mbit/s	-	-	-	-
Design of optical connection for fiber-optic cables				
• at 100 Mbit/s	-	-	BFOC port	BFOC port
• at 1000 Mbit/s	-	-	-	-
• at 10 Gbit/s	-	-	-	-
Coupled-in optical power referred to 1 mW				
• of transmitter output	-	-	-19 ... -14 dB	-15 ... -8 dB
• of the receiver input, maximum	-	-	-3 dB	-3 dB
Minimum optical sensitivity relative to 1 mW of the receiver input	-	-	-32 dB	-34 dB
Minimum required damping factor of FO transmission link	-	-	0 dB	0 dB
The range at the optical interface depends on the type of optical fiber used	-	-	0 ... 5 km	0 ... 26 km
Permissible ambient conditions				
Ambient temperature				
• During operation	0 ... 60 °C	0 ... 60 °C	0 ... 60 °C	0 ... 60 °C
• During storage	-40 ... +70 °C	-40 ... +70 °C	-40 ... +70 °C	-40 ... +70 °C
• During transport	-40 ... +70 °C	-40 ... +70 °C	-40 ... +70 °C	-40 ... +70 °C
Relative humidity at 25 °C without condensation during operation, maximum	95 %	95 %	95 %	95 %
IP degree of protection	IP20	IP20	IP20	IP20
Design, dimensions and weights				
Design	Media module	Media module	Media module	Media module
Width	120.3 mm	120.3 mm	120.3 mm	120.3 mm
Height	22.3 mm	22.3 mm	22.3 mm	22.3 mm
Depth	275.5 mm	275.5 mm	275.5 mm	275.5 mm
Net weight	0.3 kg	0.3 kg	0.3 kg	0.3 kg
Type of mounting for installation at media module slot	Yes	Yes	Yes	Yes

PROFINET/Industrial Ethernet

Industrial Ethernet switches / media converters

Media modules
for modular SCALANCE XR-500 managed

2

Technical specifications (continued)

Order No.	6GK5 992-4GA00-8AA0	6GK5 992-4SA00-8AA0	6GK5 991-4AB00-8AA0	6GK5 991-4AC00-8AA0
Product type designation	MM992-4CUC	MM992-4CU	MM991-4	MM991-4LD
Standards, specifications, approvals				
Standard				
• for EMC	-	-	-	-
• for EMC of FM	-	-	-	-
• for hazardous zone	-	-	-	-
• for CSA and UL safety	UL 60950-1, CSA C22.2 No. 60950-4	UL 60950-1, CSA C22.2 No. 60950-7	UL 60950-1, CSA C22.2 No. 60950-1	UL 60950-1, CSA C22.2 No. 60950-1
• for hazardous zone of CSA and UL	-	-	-	-
• For emitted interference	EN 61000-6-4 (Class A)	EN 61000-6-4 (Class A)	EN 61000-6-4 (Class A)	EN 61000-6-4 (Class A)
• for noise immunity	EN 61000-6-2	EN 61000-6-2	EN 61000-6-2	EN 61000-6-2
Certificate of suitability	EN 61000-6-2, EN 61000-6-7	EN 61000-6-2, EN 61000-6-10	EN 61000-6-2, EN 61000-6-4	EN 61000-6-2, EN 61000-6-4
• CE marking	Yes	Yes	Yes	Yes
• C-Tick	Yes	Yes	Yes	Yes
• IEC 61850-3	-	-	-	-
Marine classification association				
• American Bureau of Shipping Europe Ltd. (ABS)	-	-	-	-
• Bureau Veritas (BV)	-	-	-	-
• Det Norske Veritas (DNV)	-	-	-	-
• Germanischer Lloyd (GL)	-	-	-	-
• Lloyds Register of Shipping (LRS)	-	-	-	-
• Nippon Kaiji Kyokai (NK)	-	-	-	-

Order No.	6GK5 992-4AL00-8AA0	6GK5 992-4AM00-8AA0	6GK5 992-4AS00-8AA0
Product type designation	MM992-4	MM992-4LD	MM992-4SFP
Transmission rate			
Transmission rate 1	1 000 Mbit/s	1 000 Mbit/s	100 Mbit/s
Transmission rate 2	-	-	1 000 Mbit/s
Transmission rate 3	-	-	-
Interfaces			
Maximum number of electrical/optical connections for network components or terminal equipment	4	4	4
Number of electrical connections			
• for network components or terminal equipment	-	-	-
• with power-over-Ethernet for network components or terminal equipment	-	-	-
Design of electrical connection			
• for network components or terminal equipment	-	-	-
• with power-over-Ethernet for network components or terminal equipment	-	-	-
Number of optical connections for fiber-optic cables			
• at 100 Mbit/s	-	-	-
• at 1000 Mbit/s	4	4	4
Design of optical connection for fiber-optic cables			
• at 100 Mbit/s	-	-	SFP slot
• at 1000 Mbit/s	LC port	LC port	SFP slot
• at 10 Gbit/s	-	-	-
Coupled-in optical power referred to 1 mW			
• of transmitter output	-9.5 ... -4 dB	-9.5 ... -3 dB	-
• of the receiver input, maximum	-3 dB	-3 dB	-

PROFINET/Industrial Ethernet

Industrial Ethernet switches / media converters

Media modules for modular SCALANCE XR-500 managed

Technical specifications (continued)

Order No.	6GK5 992-4AL00-8AA0	6GK5 992-4AM00-8AA0	6GK5 992-4AS00-8AA0
Product type designation	MM992-4	MM992-4LD	MM992-4SFP
Minimum optical sensitivity relative to 1 mW of the receiver input	-17 dB	-21 dB	-
Minimum required damping factor of FO transmission link	0 dB	0 dB	-
The range at the optical interface depends on the type of optical fiber used	0 ... 0.75 km	0 ... 10 km	-
Permissible ambient conditions			
Ambient temperature			
• During operation	0 ... 60 °C	0 ... 60 °C	0 ... 60 °C
• During storage	-40 °C 70 °C	-40 °C 70 °C	-40 °C 70 °C
• During transport	-40 °C 70 °C	-40 °C 70 °C	-40 °C 70 °C
Relative humidity at 25 °C without condensation during operation, maximum	95 %	95 %	95 %
IP degree of protection	IP20	IP20	IP20
Design, dimensions and weights			
Design	Media module	Media module	Media module
Width	120.3 mm	120.3 mm	120.3 mm
Height	22.3 mm	22.3 mm	22.3 mm
Depth	275.5 mm	275.5 mm	275.5 mm
Net weight	0.3 kg	0.3 kg	0.3 kg
Type of mounting for installation at media module slot	Yes	Yes	Yes
Type of mounting	-	-	-
Standards, specifications, approvals			
Standard			
• for EMC	-	-	-
• for EMC of FM	-	-	-
• for hazardous zone	-	-	-
• for CSA and UL safety	UL 60950-1, CSA C22.2 No. 60950-1	UL 60950-1, CSA C22.2 No. 60950-2	UL 60950-1, CSA C22.2 No. 60950-3
• for hazardous zone of CSA and UL	-	-	-
• For emitted interference	EN 61000-6-4 (Class A)	EN 61000-6-4 (Class A)	EN 61000-6-4 (Class A)
• for noise immunity	EN 61000-6-2	EN 61000-6-2	EN 61000-6-2
Certificate of suitability	EN 61000-6-2, EN 61000-6-4	EN 61000-6-2, EN 61000-6-5	EN 61000-6-2, EN 61000-6-6
• CE marking	Yes	Yes	Yes
• C-Tick	Yes	Yes	Yes
• IEC 61850-3	-	-	-
Marine classification association			
• American Bureau of Shipping Europe Ltd. (ABS)	-	-	-
• Bureau Veritas (BV)	-	-	-
• Det Norske Veritas (DNV)	-	-	-
• Germanischer Lloyd (GL)	-	-	-
• Lloyds Register of Shipping (LRS)	-	-	-
• Nippon Kaiji Kyokai (NK)	-	-	-

Technical specifications (continued)

Order No.	6GK5 991-1AD00-8AA0	6GK5 991-1AF00-8AA0	6GK5 991-1AE00-8AA0
Product type designation	SFP991-1	SFP991-1LD	SFP991-1LH+
Transmission rate			
Transmission rate 1	100 Mbit/s	100 Mbit/s	100 Mbit/s
Transmission rate 2	-	-	-
Transmission rate 3	-	-	-
Interfaces			
Maximum number of electrical/optical connections for network components or terminal equipment	1	1	1
Number of electrical connections			
• for network components or terminal equipment	-	-	-
• with power-over-Ethernet for network components or terminal equipment	-	-	-
Design of electrical connection			
• for network components or terminal equipment	-	-	-
• with power-over-Ethernet for network components or terminal equipment	-	-	-
Number of optical connections for fiber-optic cables			
• at 100 Mbit/s	1	1	1
• at 1000 Mbit/s	-	-	-
Design of optical connection for fiber-optic cables			
• at 100 Mbit/s	SC port	LC port	LC port
• at 1000 Mbit/s	-	-	-
• at 10 Gbit/s	-	-	-
Coupled-in optical power referred to 1 mW			
• of transmitter output	-19 ... -14 dB	-15 ... -8 dB	-5 ... +0 dB
• of the receiver input, maximum	-3 dB	-3 dB	-3 dB
Minimum optical sensitivity relative to 1 mW of the receiver input	-32 dB	-34 dB	-34 dB
Minimum required damping factor of FO transmission link	0 dB	0 dB	3 dB
The range at the optical interface depends on the type of optical fiber used	0 ... 5 km	0 ... 26 km	12 ... 70 km
Permissible ambient conditions			
Ambient temperature			
• During operation	-40 ... +85 °C	-40 ... +85 °C	-40 ... +85 °C
• During storage	-40 ... +85 °C	-40 ... +85 °C	-40 ... +85 °C
• During transport	-40 ... +85 °C	-40 ... +85 °C	-40 ... +85 °C
Relative humidity at 25 °C without condensation during operation, maximum	95 %	95 %	95 %
IP degree of protection	IP20	IP20	IP20
Design, dimensions and weights			
Design	SFP module	SFP module	SFP module
Width	13.7 mm	13.7 mm	13.7 mm
Height	11.9 mm	11.9 mm	11.9 mm
Depth	56.5 mm	56.5 mm	56.5 mm
Net weight	0.01 kg	0.01 kg	0.01 kg
Type of mounting for installation at media module slot	No	No	No

PROFINET/Industrial Ethernet

Industrial Ethernet switches / media converters

Media modules for modular SCALANCE XR-500 managed

Technical specifications (continued)

Order No.	6GK5 991-1AD00-8AA0	6GK5 991-1AF00-8AA0	6GK5 991-1AE00-8AA0
Product type designation	SFP991-1	SFP991-1LD	SFP991-1LH+
Standards, specifications, approvals			
Standard			
• for EMC	-	-	-
• for EMC of FM	FM3611: Class 1, Division 2, Group A, B, C, D / T4, Class 1, Zone 2, Group IIC, T4	FM3611: Class 1, Division 2, Group A, B, C, D / T4, Class 1, Zone 2, Group IIC, T4	FM3611: Class 1, Division 2, Group A, B, C, D / T4, Class 1, Zone 2, Group IIC, T4
• for hazardous zone	EN 60079-0: 2006, EN 60079-15: 2005, II 3 G Ex nA II T4 KEMA 07 ATEX 0145X	EN 60079-0: 2006, EN 60079-15: 2005, II 3 G Ex nA II T4 KEMA 07 ATEX 0145X	EN 60079-0: 2006, EN 60079-15: 2005, II 3 G Ex nA II T4 KEMA 07 ATEX 0145X
• for CSA and UL safety	UL 60950-1, CSA C22.2 No. 60950-1-03	UL 60950-1, CSA C22.2 No. 60950-1-03	UL 60950-1, CSA C22.2 No. 60950-1-03
• for hazardous zone of CSA and UL	-	-	-
• For emitted interference	EN 61000-6-4:2007 (Class A)	EN 61000-6-4:2007 (Class A)	EN 61000-6-4:2007 (Class A)
• for noise immunity	EN 61000-6-2:2005	EN 61000-6-2:2005	EN 61000-6-2:2005
Certificate of suitability	EN 61000-6-2:2005, EN 61000-6-4:2007	EN 61000-6-2:2005, EN 61000-6-4:2007	EN 61000-6-2:2005, EN 61000-6-4:2007
• CE marking	Yes	Yes	Yes
• C-Tick	Yes	Yes	Yes
• IEC 61850-3	-	-	-
Marine classification association			
• American Bureau of Shipping Europe Ltd. (ABS)	-	-	-
• Bureau Veritas (BV)	-	-	-
• Det Norske Veritas (DNV)	-	-	-
• Germanischer Lloyd (GL)	-	-	-
• Lloyds Register of Shipping (LRS)	-	-	-
• Nippon Kaiji Kyokai (NK)	-	-	-
Order No.	6GK5 992-1AL00-8AA0	6GK5 992-1AM00-8AA0	6GK5 992-1AN00-8AA0
Product type designation	SFP992-1	SFP992-1LD	SFP992-1LH
Transmission rate			
Transmission rate 1	1 000 Mbit/s	1 000 Mbit/s	1 000 Mbit/s
Transmission rate 2	-	-	-
Transmission rate 3	-	-	-
Interfaces			
Maximum number of electrical/optical connections for network components or terminal equipment	1	1	1
Number of electrical connections			
• for network components or terminal equipment	-	-	-
• with power-over-Ethernet for network components or terminal equipment	-	-	-
Design of electrical connection			
• for network components or terminal equipment	-	-	-
• with power-over-Ethernet for network components or terminal equipment	-	-	-
Number of optical connections for fiber-optic cables			
• at 100 Mbit/s	-	-	-
• at 1000 Mbit/s	1	1	1
Design of optical connection for fiber-optic cables			
• at 100 Mbit/s	-	-	-
• at 1000 Mbit/s	LC port	LC port	LC port
• at 10 Gbit/s	-	-	-

Technical specifications (continued)

Order No.	6GK5 992-1AL00-8AA0	6GK5 992-1AM00-8AA0	6GK5 992-1AN00-8AA0
Product type designation	SFP992-1	SFP992-1LD	SFP992-1LH
Coupled-in optical power referred to 1 mW			
• of transmitter output	-9.5 ... -4 dB	-9.5 ... -3 dB	-6 ... +0 dB
• of the receiver input, maximum	-3 dB	-3 dB	-3 dB
Minimum optical sensitivity relative to 1 mW of the receiver input	-17 dB	-21 dB	-23 dB
Minimum required damping factor of FO transmission link	0 dB	0 dB	3 dB
The range at the optical interface depends on the type of optical fiber used	0 ... 0.75 km	0 ... 10 km	8 ... 40 km
Permissible ambient conditions			
Ambient temperature			
• During operation	-40 ... +85 °C	-40 ... +85 °C	-40 ... +85 °C
• During storage	-40 ... +85 °C	-40 ... +85 °C	-40 ... +85 °C
• During transport	-40 ... +85 °C	-40 ... +85 °C	-40 ... +85 °C
Relative humidity at 25 °C without condensation during operation, maximum	95 %	95 %	95 %
IP degree of protection	IP20	IP20	IP20
Design, dimensions and weights			
Design	SFP module	SFP module	SFP module
Width	13.7 mm	13.7 mm	13.7 mm
Height	11.9 mm	11.9 mm	11.9 mm
Depth	56.5 mm	56.5 mm	56.5 mm
Net weight	0.01 kg	0.01 kg	0.01 kg
Type of mounting for installation at media module slot	No	No	No
Standards, specifications, approvals			
Standard			
• for EMC	-	-	-
• for EMC of FM	FM3611: Class 1, Division 2, Group A, B, C, D / T4, Class 1, Zone 2, Group IIC, T4	FM3611: Class 1, Division 2, Group A, B, C, D / T4, Class 1, Zone 2, Group IIC, T4	FM3611: Class 1, Division 2, Group A, B, C, D / T4, Class 1, Zone 2, Group IIC, T4
• for hazardous zone	EN 60079-0: 2006, EN 60079-15: 2005, II 3 G Ex nA II T4 KEMA 07 ATEX 0145X	EN 60079-0: 2006, EN 60079-15: 2005, II 3 G Ex nA II T4 KEMA 07 ATEX 0145X	EN 60079-0: 2006, EN 60079-15: 2005, II 3 G Ex nA II T4 KEMA 07 ATEX 0145X
• for CSA and UL safety	UL 60950-1, CSA C22.2 No. 60950-1-03	UL 60950-1, CSA C22.2 No. 60950-1-03	UL 60950-1, CSA C22.2 No. 60950-1-03
• for hazardous zone of CSA and UL	-	-	-
• For emitted interference	EN 61000-6-4:2007 (Class A)	EN 61000-6-4:2007 (Class A)	EN 61000-6-4:2007 (Class A)
• for noise immunity	EN 61000-6-2:2005	EN 61000-6-2:2005	EN 61000-6-2:2005
Certificate of suitability	EN 61000-6-2:2005, EN 61000-6-4:2007	EN 61000-6-2:2005, EN 61000-6-4:2007	EN 61000-6-2:2005, EN 61000-6-4:2007
• CE marking	Yes	Yes	Yes
• C-Tick	Yes	Yes	Yes
• IEC 61850-3	-	-	-
Marine classification association			
• American Bureau of Shipping Europe Ltd. (ABS)	-	-	-
• Bureau Veritas (BV)	-	-	-
• Det Norske Veritas (DNV)	-	-	-
• Germanischer Lloyd (GL)	-	-	-
• Lloyds Register of Shipping (LRS)	-	-	-
• Nippon Kaiji Kyokai (NK)	-	-	-

PROFINET/Industrial Ethernet

Industrial Ethernet switches / media converters

Media modules for modular SCALANCE XR-500 managed

Technical specifications (continued)

Order No.	6GK5 992-1AP00-8AA0	6GK5 992-1AQ00-8AA0
Product type designation	SFP992-1LH+	SFP992-1ELH
Transmission rate		
Transmission rate 1	1 000 Mbit/s	1 000 Mbit/s
Transmission rate 2	-	-
Transmission rate 3	-	-
Interfaces		
Maximum number of electrical/ optical connections for network components or terminal equipment	1	1
Number of electrical connections		
• for network components or terminal equipment	-	-
• with power-over-Ethernet for network components or terminal equipment	-	-
Design of electrical connection		
• for network components or terminal equipment	-	-
• with power-over-Ethernet for network components or terminal equipment	-	-
Number of optical connections for fiber-optic cables		
• at 100 Mbit/s	-	-
• at 1000 Mbit/s	1	1
Design of optical connection for fiber-optic cables		
• at 100 Mbit/s	-	-
• at 1000 Mbit/s	LC port	LC port
• at 10 Gbit/s	-	-
Coupled-in optical power referred to 1 mW		
• of transmitter output	0 ... 5 dB	0 ... 5 dB
• of the receiver input, maximum	-3 dB	-8 dB
Minimum optical sensitivity relative to 1 mW of the receiver input	-23 dB	-32 dB
Minimum required damping factor of FO transmission link	8 dB	8 dB
The range at the optical interface depends on the type of optical fiber used	30 ... 70 km	37 ... 120 km
Permissible ambient conditions		
Ambient temperature		
• During operation	-40 ... +85 °C	-40 ... +85 °C
• During storage	-40 ... +85 °C	-40 ... +85 °C
• During transport	-40 ... +85 °C	-40 ... +85 °C
Relative humidity at 25 °C without condensation during operation, maximum	95 %	95 %
IP degree of protection	IP20	IP20
Design, dimensions and weights		
Design	SFP module	SFP module
Width	13.7 mm	13.7 mm
Height	11.9 mm	11.9 mm
Depth	56.5 mm	56.5 mm
Net weight	0.01 kg	0.01 kg
Type of mounting for installation at media module slot	No	No

PROFINET/Industrial Ethernet

Industrial Ethernet switches / media converters

Media modules
for modular SCALANCE XR-500 managed

2

Technical specifications (continued)

Order No.	6GK5 992-1AP00-8AA0	6GK5 992-1AQ00-8AA0
Product type designation	SFP992-1LH+	SFP992-1ELH
Standards, specifications, approvals		
Standard	-	-
• for EMC	-	-
• for EMC of FM	FM3611: Class 1, Division 2, Group A, B, C, D / T4, Class 1, Zone 2, Group IIC, T4	FM3611: Class 1, Division 2, Group A, B, C, D / T4, Class 1, Zone 2, Group IIC, T4
• for hazardous zone	EN 60079-0: 2006, EN 60079-15: 2005, II 3 G Ex nA II T4 KEMA 07 ATEX 0145X	EN 60079-0: 2006, EN 60079-15: 2005, II 3 G Ex nA II T4 KEMA 07 ATEX 0145X
• for CSA and UL safety	UL 60950-1, CSA C22.2 No. 60950-1-03	UL 60950-1, CSA C22.2 No. 60950-1-03
• for hazardous zone of CSA and UL	-	-
• For emitted interference	EN 61000-6-4:2007 (Class A)	EN 61000-6-4:2007 (Class A)
• for noise immunity	EN 61000-6-2:2005	EN 61000-6-2:2005
Certificate of suitability	EN 61000-6-2:2005, EN 61000-6-4:2007	EN 61000-6-2:2005, EN 61000-6-4:2007
• CE marking	Yes	Yes
• C-Tick	Yes	Yes
• IEC 61850-3	-	-
Marine classification association		
• American Bureau of Shipping Europe Ltd. (ABS)	-	-
• Bureau Veritas (BV)	-	-
• Det Norske Veritas (DNV)	-	-
• Germanischer Lloyd (GL)	-	-
• Lloyds Register of Shipping (LRS)	-	-
• Nippon Kaiji Kyokai (NK)	-	-

Order No.	6GK5 993-1AT00-8AA0	6GK5 993-1AU00-8AA0	6GK5 993-1AV00-8AA0
Product type designation	SFP993-1	SFP993-1LD	SFP993-1LH
Transmission rate			
Transmission rate 1	-	-	-
Transmission rate 2	-	-	-
Transmission rate 3	-	-	-
Transmission rate 4	10 Gbit/s	10 Gbit/s	10 Gbit/s
Interfaces			
Maximum number of electrical/optical connections for network components or terminal equipment	1	1	1
Number of electrical connections			
• for network components or terminal equipment	-	-	-
• with power-over-Ethernet for network components or terminal equipment	-	-	-
Design of electrical connection			
• for network components or terminal equipment	-	-	-
• with power-over-Ethernet for network components or terminal equipment	-	-	-
Number of optical connections for fiber-optic cables			
• at 100 Mbit/s	-	-	-
• at 1000 Mbit/s	-	-	-
• at 10 Gbit/s	1	1	1
Design of optical connection for fiber-optic cables			
• at 100 Mbit/s	-	-	-
• at 1000 Mbit/s	-	-	-
• at 10 Gbit/s	LC port	LC port	LC port
Coupled-in optical power referred to 1 mW			
• of transmitter output	-5 ... -1 dB	-8.2 ... +0.5 dB	0 ... 5 dB
• of the receiver input, maximum	-1 dB	0.5 dB	0.5 dB

PROFINET/Industrial Ethernet

Industrial Ethernet switches / media converters

Media modules for modular SCALANCE XR-500 managed

Technical specifications (continued)

Order No.	6GK5 993-1AT00-8AA0	6GK5 993-1AU00-8AA0	6GK5 993-1AV00-8AA0
Product type designation	SFP993-1	SFP993-1LD	SFP993-1LH
Minimum optical sensitivity relative to 1 mW of the receiver input	-11.1 dB	-12.6 dB	-15 dB
Minimum required damping factor of FO transmission link	0 dB	0 dB	4.5 dB
The range at the optical interface depends on the type of optical fiber used	0 ... 0.3 km	0 ... 10 km	0 ... 40 km
Permissible ambient conditions			
Ambient temperature			
• During operation	0 ... 60 °C	0 ... 60 °C	0 ... 60 °C
• During storage	-40 ... +70 °C	-40 ... +70 °C	-40 ... +70 °C
• During transport	-40 ... +70 °C	-40 ... +70 °C	-40 ... +70 °C
Relative humidity at 25 °C without condensation during operation, maximum	95 %	95 %	95 %
IP degree of protection	IP20	IP20	IP20
Design, dimensions and weights			
Design	SFP+ module	SFP+ module	SFP+ module
Width	13 mm	13 mm	13 mm
Height	12 mm	12 mm	12 mm
Depth	57 mm	57 mm	57 mm
Net weight	0.01 kg	0.01 kg	0.01 kg
Type of mounting for installation at media module slot	Yes	Yes	Yes
Standards, specifications, approvals			
Standard			
• for EMC	-	-	-
• for EMC of FM	-	-	-
• for hazardous zone	-	-	-
• for CSA and UL safety	UL 60950-1, CSA C22.2 No. 60950-8	UL 60950-1, CSA C22.2 No. 60950-9	UL 60950-1, CSA C22.2 No. 60950-10
• for hazardous zone of CSA and UL	-	-	-
• For emitted interference	EN 61000-6-4 (Class A)	EN 61000-6-4 (Class A)	EN 61000-6-4 (Class A)
• for noise immunity	EN 61000-6-2	EN 61000-6-2	EN 61000-6-2
Certificate of suitability	EN 61000-6-2, EN 61000-6-11	EN 61000-6-2, EN 61000-6-12	EN 61000-6-2, EN 61000-6-13
• CE marking	Yes	Yes	Yes
• C-Tick	Yes	Yes	Yes
• IEC 61850-3	-	-	-
Marine classification association			
• American Bureau of Shipping Europe Ltd. (ABS)	-	-	-
• Bureau Veritas (BV)	-	-	-
• Det Norske Veritas (DNV)	-	-	-
• Germanischer Lloyd (GL)	-	-	-
• Lloyds Register of Shipping (LRS)	-	-	-
• Nippon Kaiji Kyokai (NK)	-	-	-

PROFINET/Industrial Ethernet

Industrial Ethernet switches / media converters

Media modules
for modular SCALANCE XR-500 managed

Ordering data	Order No.	Order No.
<i>Media modules for SCALANCE X-500</i>		
Electrical media modules with 4 x 10/100/1000 Mbit/s RJ45 ports, electrical <ul style="list-style-type: none"> MM992-4CuC MM992-4CU with Power over Ethernet <ul style="list-style-type: none"> MM992-4PoEC MM992-4PoE 	6GK5 992-4GA00-8AA0 6GK5 992-4SA00-8AA0 6GK5 992-4RA00-8AA0 ¹⁾ 6GK5 992-4QA00-8AA0 ¹⁾	SFP pluggable transceiver, optical with 1 x 100 Mbit/s LC port, optical <ul style="list-style-type: none"> SFP991-1 multimode, glass, up to 5 km SFP991-1LD single-mode, glass, up to 26 km SFP991-1LH+ single-mode, glass, up to 70 km
Fiber optic modules with 4 x 100 Mbit/s BFOC ports, optical <ul style="list-style-type: none"> MM991-4 multimode, glass, up to 5 km MM991-4LD singlemode, glass, up to 26 km with 4 x 1000 Mbit/s SC ports, optical <ul style="list-style-type: none"> MM992-4 multimode, glass, up to 750 m MM992-4LD singlemode, glass, up to 10 km with 4 x 100/1000 Mbit/s for SFP pluggable transceiver, optical <ul style="list-style-type: none"> MM992-4SFP for SFP plug-in transceivers with 1 x 100 or 1 x 1000 Mbit/s multimode or singlemode, glass 	6GK5 991-4AB00-8AA0 6GK5 991-4AC00-8AA0 6GK5 992-4AL00-8AA0 6GK5 992-4AM00-8AA0 6GK5 992-4AS00-8AA0	with 1 x 1000 Mbit/s LC port, optical <ul style="list-style-type: none"> SFP992-1 multimode, glass, up to 750 m SFP992-1LD single-mode, glass, up to 10 km SFP992-1LH single-mode, glass, up to 40 km SFP992-1LH+ single-mode, glass, up to 70 km SFP992-1ELH single-mode, glass, up to 120 km with 1 x 10 Gbit/s LC port, optical <ul style="list-style-type: none"> SFP993-1 multimode, glass, up to 300 m SFP993-1LD singlemode, glass, up to 10 km SFP993-1LH singlemode, glass, up to 40 km
		6GK5 991-1AD00-8AA0 6GK5 991-1AF00-8AA0 6GK5 991-1AE00-8AA0 6GK5 992-1AL00-8AA0 6GK5 992-1AM00-8AA0 6GK5 992-1AN00-8AA0 6GK5 992-1AP00-8AA0 6GK5 992-1AQ00-8AA0 6GK5 993-1AT00-8AA0 6GK5 993-1AU00-8AA0 6GK5 993-1AV00-8AA0

¹⁾ Available soon

PROFINET/Industrial Ethernet

Industrial Ethernet switches / media converters

Media modules for modular SCALANCE XR-500 managed

Ordering data

Order No.

Accessories

IE FC RJ45 Modular Outlet

FastConnect Outlet RJ45 for Industrial Ethernet with interface for a replaceable insert

- with insert 2FE ; replaceable insert for 2 x 100 Mbit/s interfaces
- with insert 1GE; replaceable insert for 1 x 1000 Mbit/s interfaces

6GK1 901-1BE00-0AA1

6GK1 901-1BE00-0AA2

IE FC TP Standard Cable GP 2 x 2 (Type A)

4-core, shielded TP installation cable for connection to IE FC Outlet RJ45/IE FC RJ45 Plug; PROFINET-compliant; with UL approval; sold by the meter; max. length 1000 m, minimum order 20 m

6XV1 840-2AH10

IE FC TP Standard Cable GP 4 x 2

8-core, shielded TP installation cable for connection to IE FC RJ45 Modular Outlet for universal application; with UL approval; sold by the meter; max quantity 1000 m, minimum order 20 m

6XV1 870-2E

IE TP Cord RJ45/RJ45

TP cable 4 x 2 with two RJ45 connectors

- 0.5 m
- 1 m
- 2 m
- 6 m
- 10 m

6XV1 870-3QE50

6XV1 870-3QH10

6XV1 870-3QH20

6XV1 870-3QH60

6XV1 870-3QN10

IE FC RJ45 Plug 180

RJ45 plug connector for Industrial Ethernet with a rugged metal enclosure and integrated insulation displacement contacts for connecting Industrial Ethernet FC installation cables; with 180° cable outlet; for network components and CPs/CPUs with Industrial Ethernet interface

- 1 pack = 1 unit
- 1 pack = 10 units
- 1 pack = 50 units

6GK1 901-1BB10-2AA0

6GK1 901-1BB10-2AB0

6GK1 901-1BB10-2AE0

IE FC RJ45 Plug 4 x 2

RJ45 plug connector for Industrial Ethernet (10/100/1000 Mbit/s) with a rugged metal enclosure and integrated insulation displacement contacts for connecting Industrial Ethernet FC installation cables; 180° cable outlet; for network components and CPs/CPUs with Industrial Ethernet interface

- 1 pack = 1 unit
- 1 pack = 10 units
- 1 pack = 50 units

6GK1 901-1BB11-2AA0

6GK1 901-1BB11-2AB0

6GK1 901-1BB11-2AE0

More information

To assist in selecting the right Industrial Ethernet switches as well as configuration of modular versions, the SIMATIC NET Selection Tool is available.

Online version:

www.siemens.com/snst

Offline version:

www.siemens.com/snst-download

PROFINET/Industrial Ethernet

Industrial Ethernet switches / media converters

Power supply
for modular SCALANCE X-500 managed

Overview



- The 24 V PS598 power supply is designed for installation in 19" control cabinets or for direct mounting on SCALANCE XR-500 Industrial Ethernet switches; it has degree of protection IP20.
- 300 W output power at an input voltage range of 85 V to 264 V AC and an operating temperature of 0 °C to +60 °C

Benefits

get Designed for Industry

- Global use thanks to wide-range input (85 to 264 V AC)
- High reliability since it is short-circuit proof, secure against no-load operation, and able to bridge short breaks in the mains power

Design

- Non-heating apparatus socket for connecting to the AC network of 85 to 264 V AC (non-heating apparatus cable not included in the scope of delivery; can be ordered optionally on country-specific basis)
- Terminal block for universal supply of products with 24 V DC input
- Plug-in contact for direct connection on the rear of the SCALANCE XR-500 Industrial Ethernet switches (mounting kit included in scope of delivery of SCALANCE XR-500)
- Operating temperatures from 0 °C to +60 °C
- IP20 degree of protection
- Optimized for installation in 19" control cabinet or for direct mounting on SCALANCE XR-500 (SCALANCE XR-500 and power supply unit are mounted in the 19" control cabinet as a single unit)
- LEDs for indicating the status information (power, operating state)

Product versions

PS598-1 24 V power supply

- 300 W output power
- Input voltage range from 85 V to 264 V AC
- Output voltage 24 V DC
- Operating temperature from 0 °C to +60 °C
- IP20 degree of protection

Integration



XR552-12M

with basic power supply,
bottom mounting



XR552-12M

with redundant power supply,
bottom mounting



XR552-12M

with basic power supply,
rear mounting

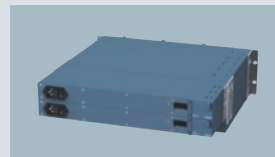

XR552-12M

with redundant power supply,
rear mounting

G_IK10_XX_10324

Options for mounting a single/redundant power supply unit to SCALANCE XR552-12M

PROFINET/Industrial Ethernet

Industrial Ethernet switches / media converters

Power supply for modular SCALANCE X-500 managed

Technical specifications

Order No.	6GK5 598-1AA00-3AA0
Product type designation	POWER SUPPLY PS598-1
Type of power supply	300 W, input: 85-264 V AC, output: 24 DC
Electrical data	
<u>Electrical data input</u>	
Curve shape of the voltage at the input	1-phase AC
Supply voltage	
• With AC	85 ... 264 V
• 1 for AC rated value	230 V
Design of the wide-range input	Yes
Overvoltage category	Category II (20 A rated branch circuit)
Minimum stored energy time at rated value of the output current on power failure	16 ms
Power frequency	
• 1 rated value	50 Hz
• 2 rated value	60 Hz
• Start value	47 Hz
• End value	63 Hz
Input current at rated value of the input voltage 230 V rated value	1.8 A
Maximum limitation of the inrush current at 25 °C	40 A
Design of the fuse at the input	replaceable
<u>Electrical data output</u>	
Curve shape of the voltage at the output	Controlled, isolated DC voltage
Output voltage at DC rated value	24 V
Relative total tolerance of the voltage	2 %
Relative control accuracy of the output voltage	
• with slow fluctuation of the input voltage	0.2%
• with slow fluctuation of the resistive load	0.4%
Maximum residual ripple	0.36 V
Maximum voltage peak	0.24 V
Design of indicators for normal mode	Green LED for 24 V OK and error LED
Behavior of the output voltage on switching on	Overshoot of $U_{out} < 5\%$
Maximum startup delay	1.5 s
Maximum voltage rise time of the output voltage	15 ms
Output current	
• Rated value	12.5 A
• Rated range	0 ... 12.5 A
Active power output, typical	300 W
Product property: parallel switching of channels	Yes
Number of resources switched in parallel to increase output	2
Percentage efficiency	87%
Effective power loss	39 W

Order No.	6GK5 598-1AA00-3AA0
Product type designation	POWER SUPPLY PS598-1
Type of power supply	300 W, input: 85-264 V AC, output: 24 DC
<u>Electrical data</u>	
<u>Closed-loop control</u>	
Relative control accuracy of the output voltage	
• with fast fluctuation of the input voltage by typically +/- 15%	0.8%
• with step change of the resistive load 50/100/50%, typically	3.25%
Settling time	
• with step change of load 50 to 100%, typically	2 ms
• with step change of load 100 to 50%, typically	2 ms
<u>Electrical data</u>	
<u>Protection and monitoring</u>	
Design of the overvoltage protection at the output	< 37 V
Typical current limitation threshold	1.15 A
Property of the output, short-circuit-proof	Yes
Design of the short-circuit protection	Electronic shutdown, automatic restart
Steady short-circuit current rms value, maximum	-
<u>Electrical data</u>	
<u>Safety</u>	
Galvanic isolation between the input and output	Yes
Galvanic isolation	Safety extra low output voltage U_{out} according to EN 60950-1 and EN 50178
Equipment protection class	Class I
Leakage current	
• Maximum	3 mA
• Typical	0.858 mA
Mechanical data	
<u>Design of electrical connection</u>	
• at the input	Non-heating apparatus plug
• at the output	Can be plugged into basic unit or screw terminal in accordance with specification
Width	446 mm
Height	44 mm
Depth	140 mm
Net weight	1.7 kg
Product property of the enclosure: side-by-side enclosure	No
Type of mounting	
• 19-inch installation	Yes
• Wall mounting	No
• DIN rail mounting	No
• S7-300 rail mounting	No
Type of mounting	Plugged into basic unit or rack-mounted

PROFINET/Industrial Ethernet

Industrial Ethernet switches / media converters

Power supply
for modular SCALANCE X-500 managed

2

Technical specifications (continued)		Ordering data	Order No.
Order No.	6GK5 598-1AA00-3AA0	<i>Power supplies for SCALANCE XR-500</i>	
Product type designation	POWER SUPPLY PS598-1	24 V power supplies are designed for installation in 19" control cabinets or for direct mounting on SCALANCE XR-500 Industrial Ethernet switches; degree of protection IP20	
Type of power supply	300 W, input: 85-264 V AC, output: 24 DC	PS598-1	6GK5 598-1AA00-3AA0
Permissible ambient conditions		300 W output power, input voltage range of 85 V to 264 V AC, operating temperature of 0 °C to +60 °C	
Ambient temperature	0 ... 60 °C	<i>Accessories</i>	
• During operation	-25 ... +70 °C	Non-heating apparatus cable (grounded continental European plug)	6ES7 900-0AA00-0XA0
• During storage	-25 ... +70 °C	Region: D/F/NL/ESP/B/A/S/FIN	
• During transport	Operation with integral fan, not replaceable	Non-heating apparatus cable (grounded British plug)	6ES7 900-0BA00-0XA0
• Note	Climate class 3K3, no condensation	Region: UK	
Climate class in accordance with EN 60721	IP20	Non-heating apparatus cable (grounded Swiss plug)	6ES7 900-0CA00-0XA0
IP degree of protection		Region: CH	
Standards, specifications, approvals		Non-heating apparatus cable (grounded North American and Japanese plug)	6ES7 900-0DA00-0XA0
Standard		Region: USA	
• for EMC	-	Non-heating apparatus cable (grounded Italian plug)	6ES7 900-0EA00-0XA0
• for EMC of FM	-	Region: Italy	
• for hazardous zone	-	Non-heating apparatus cable (grounded Chinese plug)	6ES7 900-0FA00-0XA0
• for CSA and UL safety	UL 60950-1, CSA C22.2 No. 60950-1	Region: China	
• for hazardous zone of CSA and UL	-		
• For emitted interference	EN 55022 (Class B)		
• for noise immunity	EN 61000-6-2		
Certificate of suitability	EN 55022, EN 61000-6-4		
• CE marking	Yes		
• C-Tick	Yes		

PROFINET/Industrial Ethernet

Industrial Ethernet security

Overview

Overview

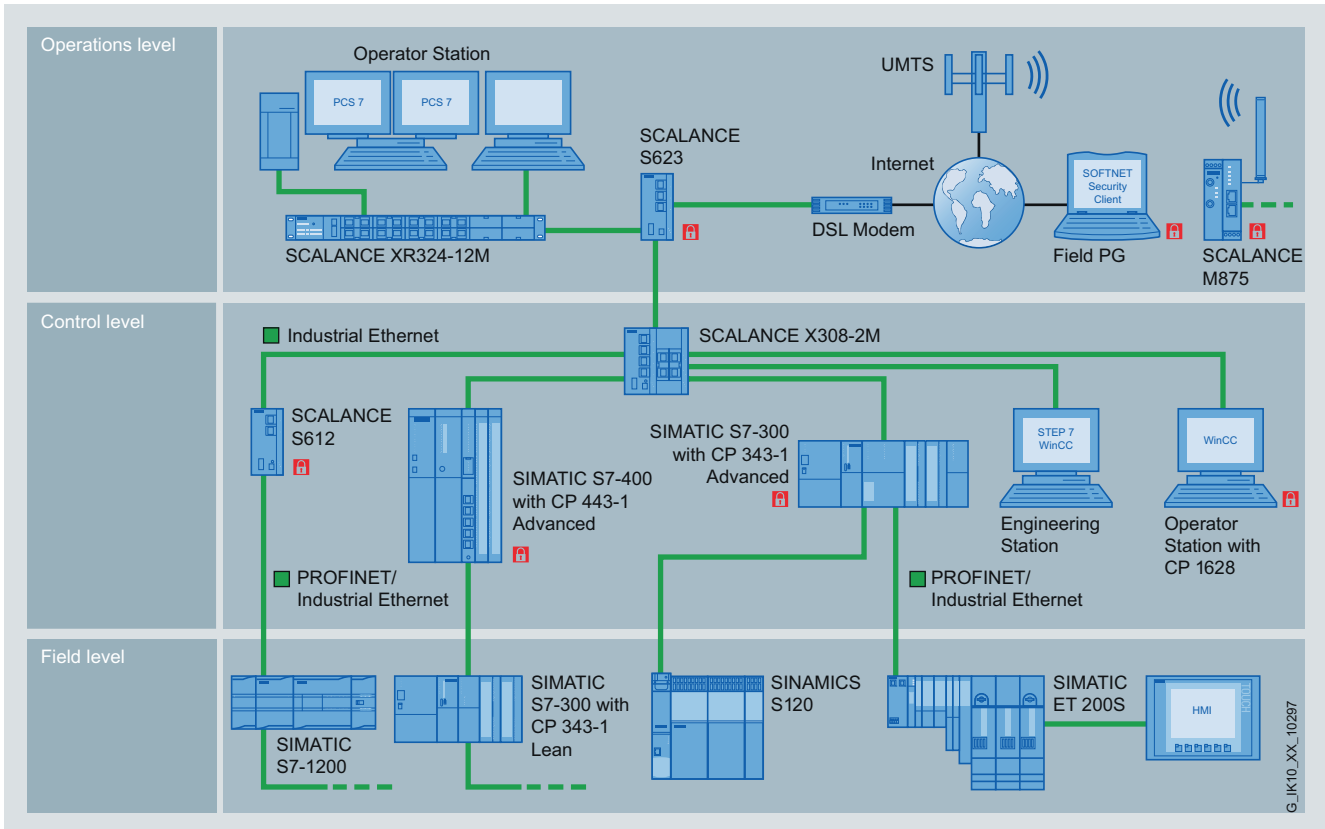

Protection of industrial networks with Industrial Security

Modern automation technology is based on communication and the trend toward increased networking of individual manufacturing islands. It is becoming more and more important to integrate all the manufacturing components into a uniform network that merges with the office network/corporate intranet and provides remote access options for service purposes. In this way, industrial communication interacts more and more with the IT environment and is now subjected to the same dangers that are well-known from the office and IT environment, such as hackers, viruses, worms and Trojans.

Different measures have to be taken to increase the security of industrial automation systems to specific levels. These range from the company organization and its guidelines regarding protective measures for PC and control systems through to protection of automation cells by segmenting the network. Siemens follows the cell protection concept and offers, with the SCALANCE S security modules as well as the communications processors (CPs) with integrated security functions (Security Integrated), components for setting up protected cells. With the cell protection concept, a plant network is subdivided into protected automation cells within which all devices are able to communicate with each other securely. The individual cells are connected to the overall network protected by a VPN and firewall.

Advantages of the cell protection concept:

- Protection from espionage and data manipulation
- Protection against overloading of the communication system
- Protection against mutual interference
- Protection against addressing mistakes
- Secure remote access also over the Internet
- No changes or modification of the existing network structure are necessary
- No changes or modification of the existing applications or network stations are necessary

Siemens offers technical solutions for industrial security in three different forms:

- *Standard security mechanisms*, e.g. encryption, password protection, and the option of deactivating interfaces and services: These functions are included as standard in the most diverse devices such as SIMATIC S7, SIMATIC HMI, SIMATIC NET communications processors and SCALANCE network components.
- *Specific security products* that handle security tasks exclusively: These are the SCALANCE S security modules and the SOFTNET Security Client VPN software.
- *Security Integrated*,¹⁾ hardware components whose tasks are primarily in the area of communication, but which also provide the full security functionality from the area of firewall protection and VPN: this concerns communications processors for SIMATIC S7 (CP 343-1 Advanced and CP 443-1 Advanced) and PC (CP 1628) as well as UMTS router SCALANCE M875.

¹⁾ Available soon

Overview



- Security modules for the protection of automation networks and security during data exchange between automation systems.
- Communication is only possible between authenticated and authorized devices
 - Protection against operator mistakes
 - Prevention of unauthorized access
 - Prevention of faults and communications overload
- Rugged, industry-standard station connections with PROFINET-compatible RJ45 connectors that offer additional strain relief and bending strain relief thanks to latching on the housing
- Easier handling thanks to minimal configuration and no special knowledge of IT security is required
- No modification or adaptation of the existing network structure, applications or stations is required
- Safeguarding of communication is independent of the protocol (e.g. PROFINET or other Ethernet-based fieldbus solutions)
- Remote access via the Internet possible without restrictions and with any providers

Benefits

get Designed for Industry

- High level of IT security for machines and plants thanks to implementation of the cell protection concept
- System-wide network diagnostics thanks to integration into IT infrastructures and network management systems by means of SNMP
- Simple remote maintenance via the Internet by means of PPPoE and DynDNS using dynamic IP addresses
- Problem-free integration into existing networks without reconfiguring terminal nodes or setting up new IP subnetworks
- Module replacement without the need for a programming device, using the C-PLUG swap media for backing up the configuration data

PROFINET/Industrial Ethernet

Industrial Ethernet security

SCALANCE S

Application

The security modules of the SCALANCE S range can be used to protect all devices of an Ethernet network against unauthorized access. In addition, SCALANCE S612 or SCALANCE S623 also protect the data transmission between devices or network segments (e.g. automation cells) against data manipulation and espionage; they can also be used for secure remote access over the Internet.

The security modules can be operated not only in bridge mode but also in router mode, and can thus also be used direct at IP subnetwork borders.

Secure remote access over the Internet or GPRS/UMTS is possible with the MD741-1 GPRS router and the SCALANCE M875 UMTS router.

SCALANCE S is optimized for use in automation and industrial environments, and meets the specific requirements of automation systems, such as easy upgrades of existing systems, simple installation and minimal downtimes in the event of a fault.

Product versions:

SCALANCE S602

- Uses the stateful inspection firewall to protect network segments against unauthorized access
- Connection via 10/100 Mbit/s ports

SCALANCE S612

- Uses the stateful inspection firewall to protect network segments against unauthorized access
- Protects up to 32 devices (128 available soon) using VPN tunnels (up to 64 VPN tunnels simultaneously, 128 available soon); this restriction applies only in bridge mode, not in routing mode
- Connection via 10/100 Mbit/s ports
- Connection via 10/100/1000 Mbit/s ports ¹⁾

SCALANCE S623 ¹⁾

- Uses the stateful inspection firewall to protect network segments against unauthorized access
- Protects up to 128 devices using VPN tunnels, (up to 128 VPN tunnels simultaneously); this restriction applies only in bridge mode, not in routing mode
- Connection via 10/100/1000 Mbit/s ports
- Additional RJ45 DMZ port (DMZ: "demilitarized zone") for secure connection from, for example, remote maintenance modems, laptops, or an additional network. This yellow port protected by firewalls from the red and green ports and can also terminate VPNs.

¹⁾ Available soon

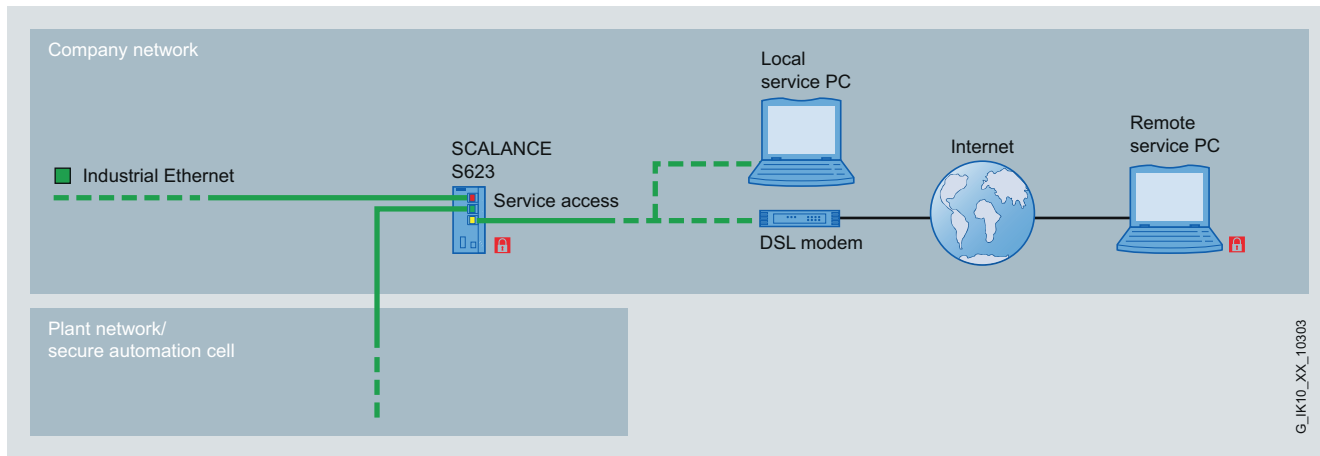

Connection of a local service PC/Internet access via the DMZ port of the SCALANCE S623

G_IK10_XX_10303

Design

SCALANCE S602

- 10/100/1000 Mbit/s ports for the connection and operation of SCALANCE S in Gigabit networks as well
- In addition to bridge mode, it can also be operated in router mode and can therefore also be used directly at IP subnet borders
- Address conversion
 - NAT (Network Address Translation) permits the use of private IP addresses in the internal network by converting public IP addresses into private ones
 - NAT (Network Address and Port Translation) permits the use of private IP addresses in the internal network by converting frames to private IP addresses depending on the communications port used
- Internal network stations can receive their IP addresses from the integral DHCP server
- Log files can also be evaluated by the Syslog server
- Simple and fast configuration of the firewall through global firewall rules and symbolic names for IP addresses
- Enhanced integration in IT infrastructures and network management systems by means of SNMP

SCALANCE S612 and SCALANCE S623

As SCALANCE S602; additionally:

- Encryption of data transmission with VPN (IPSec)
 - Protection against espionage
 - Protection against unauthorized manipulation
- Secure remote access over the Internet, e.g. in conjunction with the SOFTNET Security Client and the MD741-1 GPRS router or the SCALANCE M875 UMTS router

Function

Security functions

VPN (Virtual Private Network)

(only for SCALANCE S612 and SCALANCE S623); for reliable authentication (identification) of the network stations, for encrypting the data and checking data integrity.

- Authentication;

All incoming data traffic is monitored and checked. As IP addresses can be falsified (IP spoofing), checking the IP address (of the client access) is not sufficient. In addition, Client PCs may have changing IP addresses. For this reason the authentication is performed by means of tried and tested VPN mechanisms.
- Data encryption;

Secure encryption is necessary in order to protect data communication from espionage and unauthorized manipulation. This means that the data traffic remains incomprehensible to any eavesdropper in the network. The SCALANCE Security Module establishes VPN tunnels to other Security Modules for this purpose.

Firewall

Can be used as an alternative or to supplement VPN with flexible access control.

The firewall filters data packets and disables or enables communications links in accordance with the filter list (packet filter firewall). Both incoming and outgoing communication can be filtered, IP and MAC addresses, as well as communication protocols (ports).

- Logging;

access data are saved by the Security Module in a log file. Detection of how, when and by whom it has been accessed is as important as detecting access attempts, to ensure that appropriate preventative measures can be taken.

Configuration

Configuring is simple to carry out even without special IT knowledge. Only the Security Modules or SOFTNET Security Clients that have to communicate with each other securely have to be created and configured. All the configuration data can be saved on the optional C-PLUG swap media (not included in scope of supply) so that the Security Module can be replaced quickly in the event of a fault and without the need of a programming device.

PROFINET/Industrial Ethernet

Industrial Ethernet security

SCALANCE S

Function (continued)

Configuration

2

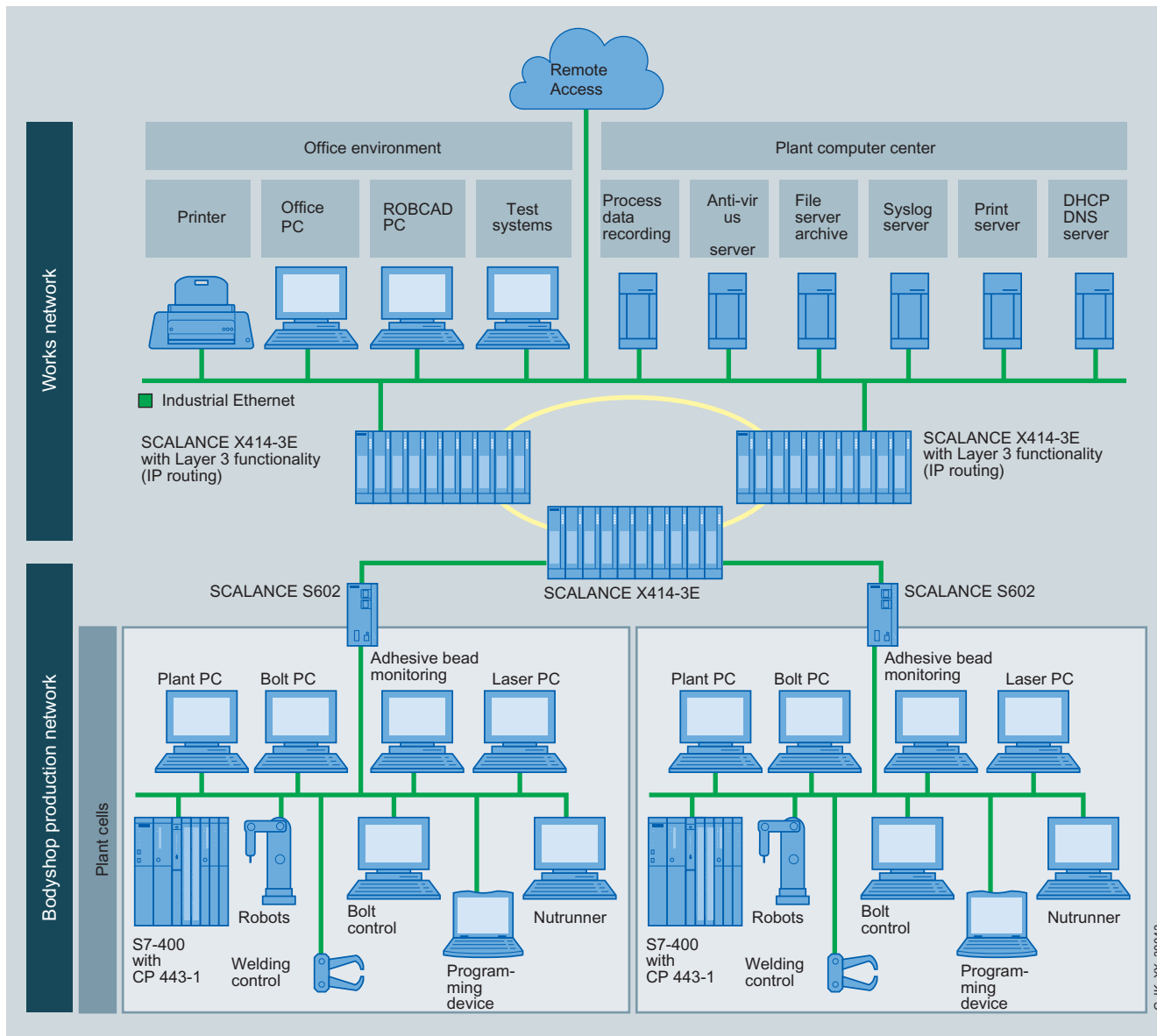

Automation cells protected with SCALANCE S

G_IK_XX_30043

Function (continued)

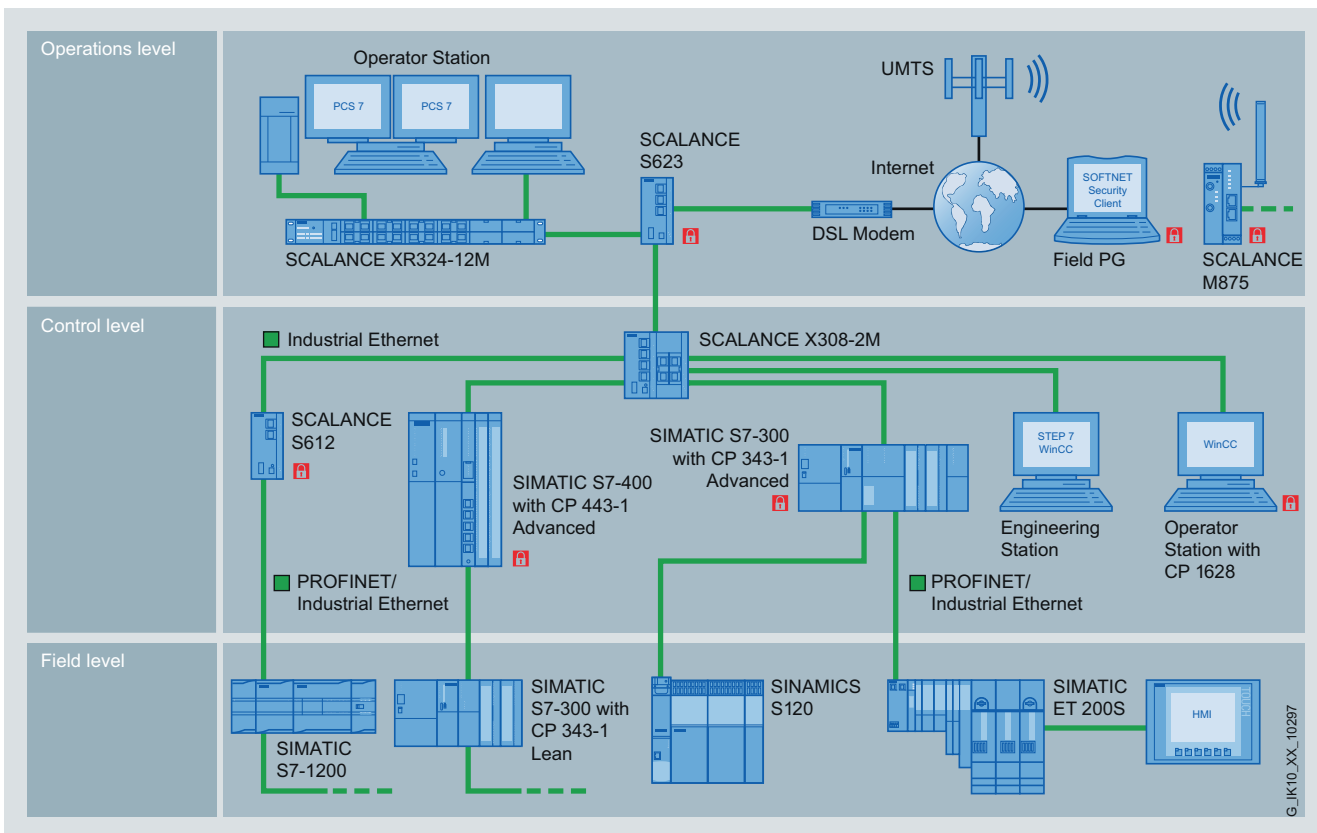

Secure VPN communication between SCALANCE S, SOFTNET Security Client and components with Security Integrated

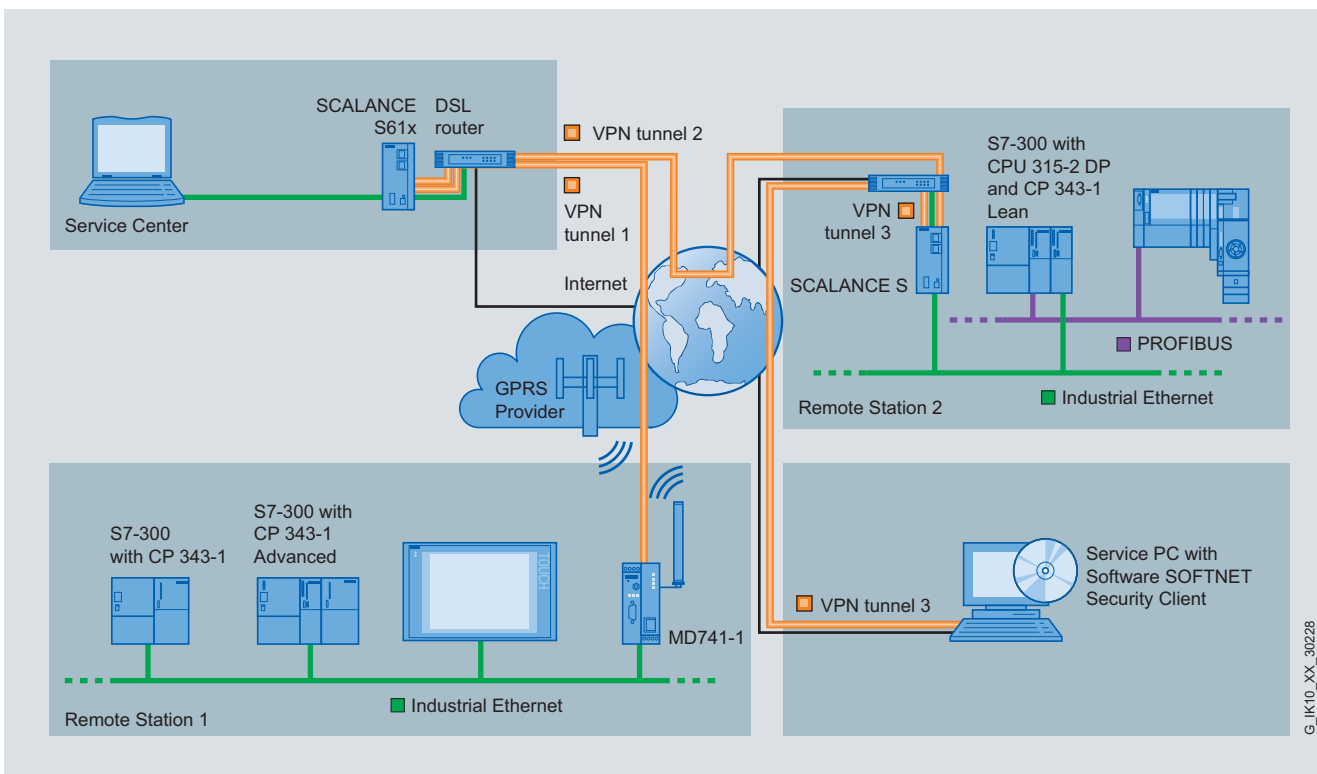

Secure remote access over Internet with SCALANCE S and MD741-1 EGPRS router

PROFINET/Industrial Ethernet

Industrial Ethernet security

SCALANCE S

Technical specifications

Order No.	6GK5 602-0BA10-2AA3	6GK5 612-0BA10-2AA3	6GK5 623-0BA10-2AA3
Product type designation	SCALANCE S602	SCALANCE S612	SCALANCE S623
Transmission rate			
Transmission rate 1	10 Mbit/s	10 Mbit/s	10 Mbit/s
Transmission rate 2	100 Mbit/s	100 Mbit/s	100 Mbit/s
Transmission rate 3	1 000 Mbit/s	1 000 Mbit/s	1 000 Mbit/s
Interfaces			
Number of electrical/optical connections for network components or terminal equipment, maximum	2	2	3
Number of electrical connections			
• for internal network	1	1	1
• for external network	1	1	1
• for DMZ	0	0	1
• for signaling contact	1	1	1
• for power supply	1	1	1
• for redundant power supply	1	1	1
Design of electrical connection			
• for internal network	RJ45 port	RJ45 port	RJ45 port
• for external network	RJ45 port	RJ45 port	RJ45 port
• for DMZ	-	-	RJ45 port
• for signaling contact	2-pin terminal block	2-pin terminal block	2-pin terminal block
• for power supply	4-pin terminal block	4-pin terminal block	4-pin terminal block
Design of swap medium C-Plug	Yes	Yes	Yes
Inputs/outputs			
Operating voltage of signaling contacts with DC, rated value	24 V	24 V	24 V
Operating current of signaling contacts with DC, maximum	0.1 A	0.1 A	0.1 A
Supply voltage, current consumption, power loss			
Type of power supply	DC	DC	DC
External power supply	24 V	24 V	24 V
• Minimum	20.4 V	20.4 V	20.4 V
• Maximum	28.8 V	28.8 V	28.8 V
Current consumed, maximum	0.38 A	0.38 A	0.4 A
Product component: fusing at power supply input	Yes	Yes	Yes
Design of fusing at input for power supply	Non-replaceable safety fuse (F 3 A / 32 V)	Non-replaceable safety fuse (F 3 A / 32 V)	Non-replaceable safety fuse (F 3 A / 32 V)
Effective power loss at 24 V DC, typically	6.72 W	6.72 W	6.96 W
Permitted ambient conditions			
Ambient temperature			
• During operation	-40 ... 70 °C	-40 ... +70 °C	-40 ... +60 °C
• During storage	-40 ... 85 °C	-40 ... +85 °C	-40 ... +85 °C
• During transport	-40 ... 85 °C	-40 ... +85 °C	-40 ... +85 °C
Relative humidity at 25 °C without condensation during operation, maximum	95 %	95 %	95 %
IP degree of protection	IP30	IP30	IP30

Technical specifications (continued)

Order No.	6GK5 602-0BA10-2AA3	6GK5 612-0BA10-2AA3	6GK5 623-0BA10-2AA3
Product type designation	SCALANCE S602	SCALANCE S612	SCALANCE S623
Design, dimensions and weights			
Design	Compact	Compact	Compact
Width	60 mm	60 mm	60 mm
Height	125 mm	125 mm	125 mm
Depth	124 mm	124 mm	124 mm
Net weight	0.8 kg	0.8 kg	0.81 kg
Type of mounting			
• 35 mm DIN rail mounting	Yes	Yes	Yes
• S7-300 rail mounting	Yes	Yes	Yes
• Wall mounting	Yes	Yes	Yes
Type of mounting	Screw mounting on horizontal and vertical surfaces	Screw mounting on horizontal and vertical surfaces	Screw mounting on horizontal and vertical surfaces
Product properties, functions, components			
General			
Product function DynDNS client	Yes	Yes	Yes
PPPoE protocol is supported	Yes	Yes	Yes
Product functions Management, configuration, programming			
Product function: Symbolic names for IP addresses Protocol is supported	Yes	Yes	Yes
• SNMP v1	Yes	Yes	Yes
• SNMP v3	Yes	Yes	Yes
Type of configuring	SCT: Security Configuration Tool (included in scope of delivery)	SCT: Security Configuration Tool (included in scope of delivery)	SCT: Security Configuration Tool (included in scope of delivery)
Product functions Diagnostics			
Product function			
• SysLog	Yes	Yes	Yes
• Packet Filter Log	Yes	Yes	Yes
• Audit Log	Yes	Yes	Yes
• System Log	Yes	Yes	Yes
Product functions DHCP			
Product function: DHCP server - internal network	Yes	Yes	Yes
Product functions Routing			
Product function: Static IP routing	Yes	Yes	Yes

PROFINET/Industrial Ethernet

Industrial Ethernet security

SCALANCE S

Technical specifications (continued)

Order No.	6GK5 602-0BA10-2AA3	6GK5 612-0BA10-2AA3	6GK5 623-0BA10-2AA3
Product type designation	SCALANCE S602	SCALANCE S612	SCALANCE S623
Product functions Security			
Configuration of firewall	Stateful inspection	Stateful inspection	Stateful inspection
Product function with VPN connection	-	IPSec	IPSec
Type of encryption algorithms with VPN connection	-	AES-256, AES-192, AES-128, 3DES-168, DES-56	AES-256, AES-192, AES-128, 3DES-168, DES-56
Type of authentication procedures with VPN connection	-	Preshared Key (PSK), X.509v3 certificates	Preshared Key (PSK), X.509v3 certificates
Type of hashing algorithms with VPN connection	-	MD5, SHA-1	MD5, SHA-1
Number of possible connections with VPN connection	0	128	128
Number of network nodes for internal network with VPN connection			
• Maximum	0	128	128
• Note	-	Limiting only in bridge mode. No limiting in routing mode	Limiting only in bridge mode. No limiting in routing mode
Product function			
• Password protection	Yes	Yes	Yes
• Restricted bandwidth	Yes	Yes	Yes
• NAT/NAPT	Yes	Yes	Yes
Product functions Time			
Product function: Passing-on of time synchronization	Yes	Yes	Yes
Protocol is supported NTP	Yes	Yes	Yes
Product component: hardware real-time clock	Yes	Yes	Yes
Product property: buffered hardware real-time clock	Yes	Yes	Yes
Standards, specifications, approvals			
Standard			
• For EMC from FM	FM3612	FM3614	FM3616
• For hazardous zone	EN 50022	EN 50024	EN 50026
• For CSA and UL safety	UL 60950, CSA C22.2 No. 60951	UL 60950, CSA C22.2 No. 60953	UL 60950, CSA C22.2 No. 60955
• For emitted interference	EN 61000-6-5	EN 61000-6-7	EN 61000-6-9
• For noise immunity	EN 61000-6-3	EN 61000-6-5	EN 61000-6-7
Certificate of suitability	AS/NZS 2064 (Class A), EN 61000-6-2, EN 61000-6-5	AS/NZS 2064 (Class A), EN 61000-6-2, EN 61000-6-7	AS/NZS 2064 (Class A), EN 61000-6-2, EN 61000-6-9
• CE mark	Yes	Yes	Yes
• C-Tick	Yes	Yes	Yes
Marine classification corporation			
• American Bureau of Shipping Europe Ltd. (ABS)	Yes	Yes	Yes
• Bureau Veritas (BV)	Yes	Yes	Yes
• Det Norske Veritas (DNV)	Yes	Yes	Yes
• Germanischer Lloyd (GL)	Yes	Yes	Yes
• Lloyds Register of Shipping (LRS)	Yes	Yes	Yes
• Nippon Kaiji Kyokai (NK)	Yes	Yes	Yes
• Polski Rejestr Statkow (PRS)	Yes	Yes	Yes
Accessories			
Product expansion: optional C-Plug	Yes	Yes	Yes

Ordering data	Order No.	Order No.
SCALANCE S industrial security modules		Accessories (continued)
For protection of programmable controllers and automation networks, and for safeguarding of industrial communication; configuring tool and electronic manual on CD-ROM German, English, French, Italian; Spanish		IE FC Stripping Tool 6GK1 901-1GA00
SCALANCE S602 uses Stateful Inspection Firewall to protect network segments against unauthorized access • With 10/100 Mbit/s • With 10/100/1000 Mbit/s	6GK5 602-0BA00-2AA3 6GK5 602-0BA10-2AA3 ¹⁾	SITOP compact 24 V/ 0.6 A 6EP1 331-5BA00 1-phase power supply with wide-range input 85 – 264 V AC/110 – 300 V DC, stabilized output voltage 24 V, rated output current value 0.6 A, slim design
SCALANCE S612 uses Stateful Inspection Firewall to protect network segments against unauthorized access • With 10/100 Mbit/s protects up to 32 devices, up to 64 VPN tunnels simultaneously • With 10/100/1000 Mbit/s protects up to 128 devices, up to 128 VPN tunnels simultaneously	6GK5 612-0BA00-2AA3 6GK5 612-0BA10-2AA3 ¹⁾	C-PLUG 6GK1 900-0AB00 Swap medium for simple replacement of devices in the event of a fault; for storing configuration or application data; can be used for SIMATIC NET products with C-PLUG slot
SCALANCE S623 ¹⁾ uses Stateful Inspection Firewall to protect network segments against unauthorized access; protects up to 128 devices, up to 128 VPN tunnels simultaneously; enhanced temperature range (-20 to +70 °C)	6GK5 623-0BA10-2AA3	SOFTNET Security Client Software for designing secure IP-based VPN connections from a programming device/PC to network segments which are secured by SCALANCE S; single license for 1 installation, runtime software (German/English), configuring tool (German/English) and electronic manual on CD-ROM (German/English/French/Spanish/Italian)
Accessories		SOFTNET Security Client Edition 2008 6GK1 704-1VW02-0AA0 For 32-bit Windows, XP Professional + SP1, SP2, SP3
IE FC TP Standard Cable GP 2 x 2 (Type A) 4-core, shielded TP installation cable for connection to IE FC Outlet RJ45 / IE FC RJ45 Plug; PROFINET-compliant; with UL approval; sold by the meter; max. length 1000 m, minimum order 20 m	6XV1 840-2AH10	SOFTNET Security Client V3 6GK1 704-1VW03-0AA0 For 32-bit Windows 7 Professional, Ultimate, Windows XP Professional + SP3
IE FC RJ45 Plug 180 RJ45 plug connector for Industrial Ethernet with a rugged metal enclosure and integrated insulation displacement contacts for connecting Industrial Ethernet FC installation cables; with 180° cable outlet; for network components and CPs/CPU with Industrial Ethernet interface • 1 pack = 1 unit • 1 pack = 10 units • 1 pack = 50 units	6GK1 901-1BB10-2AA0 6GK1 901-1BB10-2AB0 6GK1 901-1BB10-2AE0	SOFTNET Security Client V4 6GK1 704-1VW04-0AA0 For 32/64-bit Windows 7 Professional/Ultimate

¹⁾ Available soon**More information**

You can find more information on the topic of Industrial Security on the Internet at:

www.siemens.com/industrialsecurity

PROFINET/Industrial Ethernet

Industrial Ethernet security

SOFTNET Security Client

Overview

- The SOFTNET Security Client is a component of the industrial security concept for protecting automation devices and for security during data exchange between automation systems.
- It is a VPN Client for programming devices, PCs and notebooks in industrial environments and it supports secure client access via LAN or even WAN (e.g. for remote maintenance via the Internet) to automation systems protected by devices with SCALANCE S functionality
- Data transmission is protected against operator error, eavesdropping/espionage and manipulation; communication can only take place between authenticated and authorized devices
- Use of field-proven IPsec mechanisms for setting up and operating VPNs.

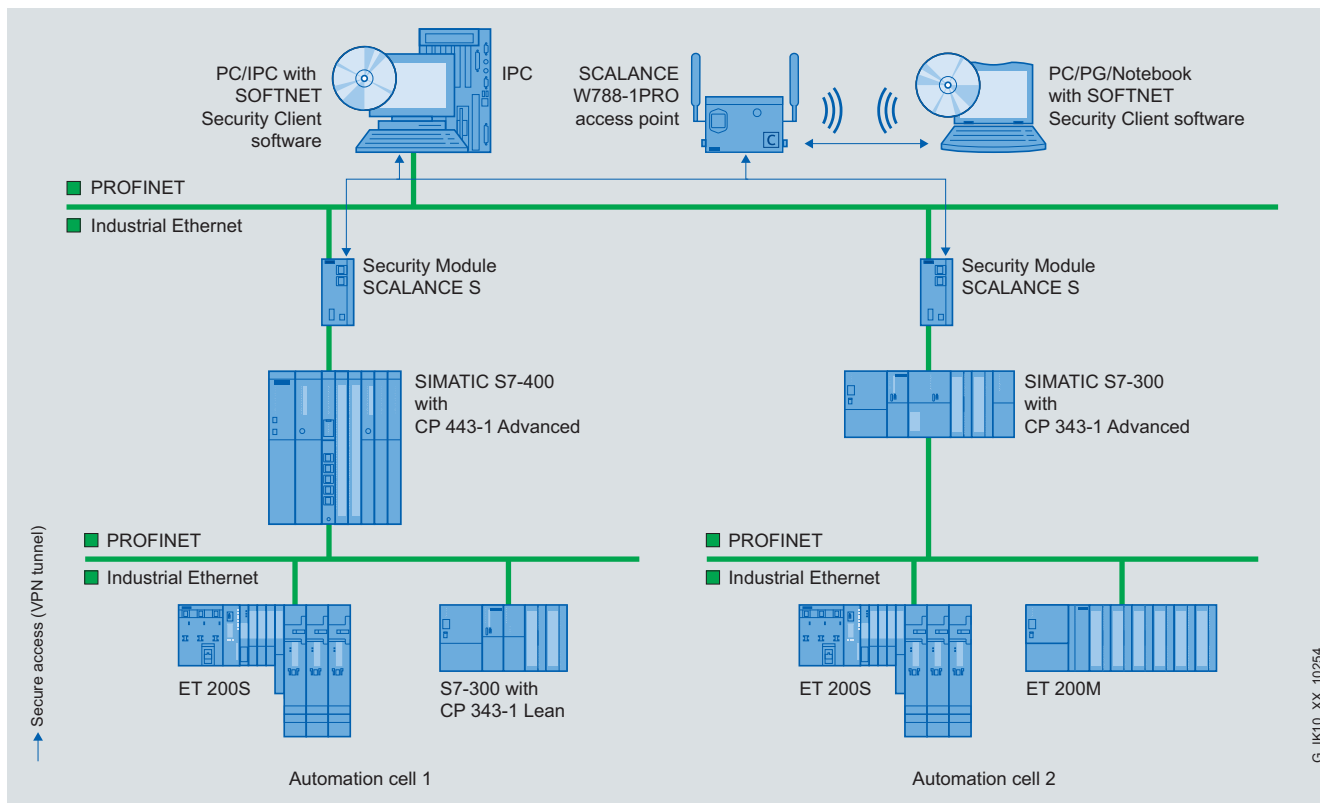

Secure access to automation cells protected by devices with SCALANCE S functionality with the SOFTNET Security Client

Benefits

get Designed for Industry

- Avoidance of system failures through exclusive access using approved programming devices or notebooks to automation devices or complete automation cells
- High flexibility when used on mobile PCs as no hardware is required for safeguarding the communication
- Standardized configuration and integrated security concept for the automation system using SCALANCE S and the SOFTNET Security Client without the need for specialized IT knowledge
- Protection of data transmission against spying and spoofing by means of certified standards.
- Considerable savings when used as remote control solution together with SCALANCE S compared to expensive service calls

Application

The security modules of the SCALANCE S family are provided specially for use in automation, yet connect seamlessly with the security structures of the office and IT world. They offer security and meet the specific requirements of automation systems, such as easy upgrades of existing systems, simple installation and minimal downtimes in the event of a fault.

Depending on the respective security needs, various different security measures can be combined with one another. The SOFTNET Security Client allows programming devices, PCs and notebook computers access to protected network nodes or automation systems thanks to devices with SCALANCE S functionality (e.g. SCALANCE S, CP 1628 ¹⁾, CP 343-1 Advanced ¹⁾).

¹⁾ Available soon

2

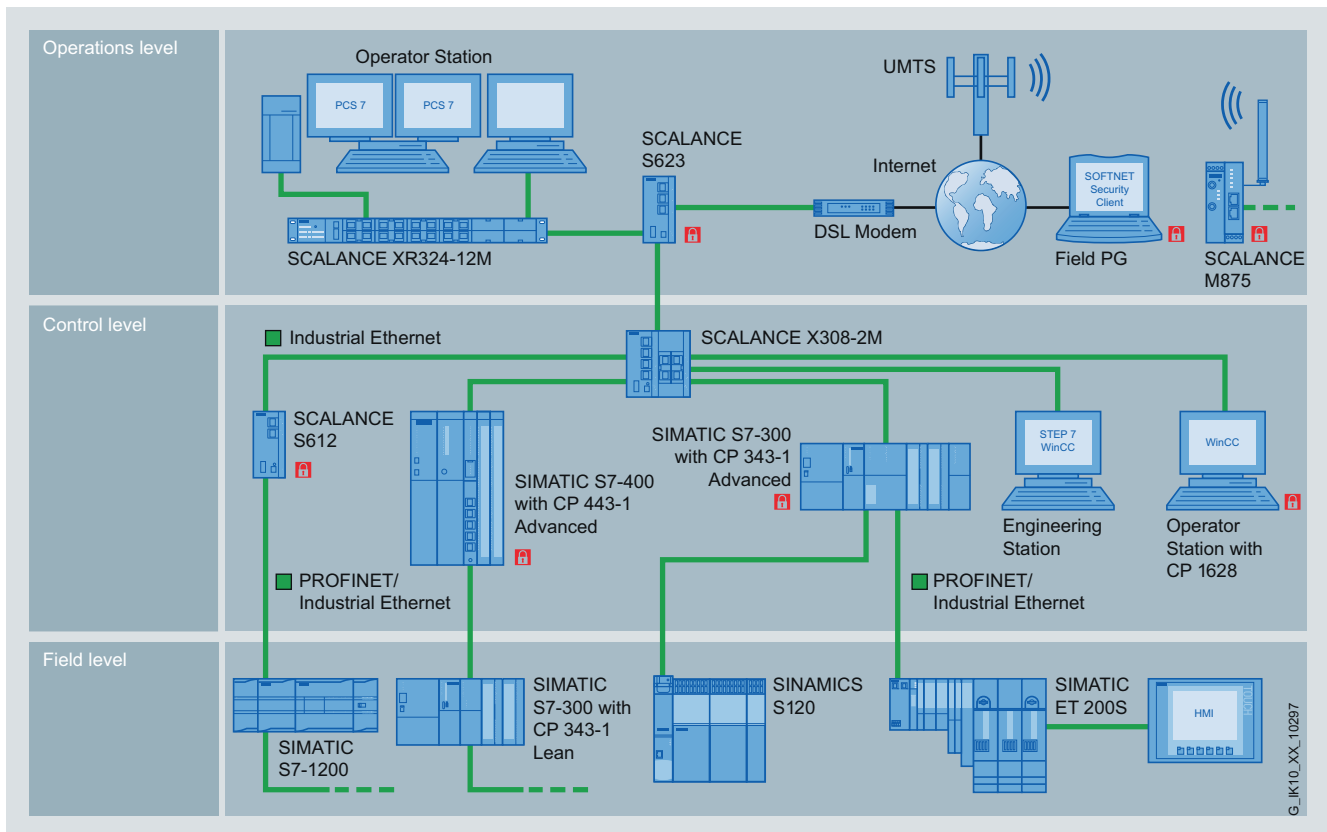

Safe VPN communication between SCALANCE S, SOFTNET Security Client and components with Security Integrated

Function

Authentication

All incoming data traffic is monitored and checked. As IP addresses can be falsified (IP spoofing), checking the IP address (of the client access) is not sufficient. In addition, Client PCs may have changing IP addresses. For this reason the authentication is performed by means of tried and tested VPN mechanisms.

Data encryption

Secure encryption is necessary to protect data communication from espionage and manipulation. This means that the data traffic remains incomprehensible to any eavesdropper in the network. To this end, the SOFTNET Security Client sets up VPN tunnels based on IPsec to other SCALANCE S security modules.

Performance data

System requirements (please note the descriptions under "Ordering data"):
Windows 7 Professional or Ultimate 32/64-bit
Windows XP Professional (32-bit) + SP3

Configuration

Using the associated configuration tool it is possible to handle setup and administration of security rules even without special IT knowledge. In the simplest case, only the SCALANCE S modules or SOFTNET security clients that are to communicate with one another are set up and configured. As soon as the SOFTNET Security Client knows the programmable controllers to be accessed, communication can be established.

PROFINET/Industrial Ethernet

Industrial Ethernet security

SOFTNET Security Client

2

Ordering data	Order No.	Order No.
SOFTNET Security Client V4 Software for designing secure IP-based VPN connections from a programming device/PC to network segments which are secured by SCALANCE S; single license for 1 installation, runtime software (German/English), configuring tool (German/English) and electronic manual on CD-ROM (German/English/French/Spanish/Italian) for 32/64 bit Windows 7 Professional, Ultimate	6GK1 704-1VW04-0AA0	Accessories SCALANCE S industrial security modules For protection of programmable controllers and automation networks, and for safeguarding of industrial communication; configuring tool and electronic manual on CD-ROM German, English, French, Italian; Spanish SCALANCE S612 Uses Stateful Inspection Firewall to protect network segments against unauthorized access; <ul style="list-style-type: none"> • With 10/100 Mbit/s protects up to 32 devices, up to 64 VPN tunnels simultaneously • With 10/100/1000 Mbit/s protects up to 128 devices, up to 128 VPN tunnels simultaneously SCALANCE S623 ¹⁾ Uses stateful inspection firewall to protect network segments against unauthorized access; protects up to 64 devices, up to 128 VPN tunnels simultaneously extended temperature range (-20 °C to +70 °C)
SOFTNET Security Client V3 Software for designing secure IP-based VPN connections from a programming device/PC to network segments which are secured by SCALANCE S; single license for 1 installation, runtime software (German/English), configuring tool (German/English) and electronic manual on CD-ROM (German/English/French/Spanish/Italian), for 32 bit Windows 7 Professional, Ultimate, Windows XP Professional + SP3	6GK1 704-1VW03-0AA0	
SOFTNET Security Client Edition 2008 Software for designing secure IP-based VPN connections from a programming device/PC to network segments which are secured by SCALANCE S; single license for 1 installation, runtime software (German/English), configuring tool (German/English) and electronic manual on CD-ROM (German/English/French/Spanish/Italian) for 32-bit Windows, XP Professional + SP1, SP2, SP3	6GK1 704-1VW02-0AA0	
		CP 1628 ¹⁾ PCI Express x1 card for connection to Industrial Ethernet (10/100/1000 Mbps), with 2-port switch (RJ45) and integrated security (firewall, VPN) via S7-1613 and S7-REDCONNECT. For operating system support, see SIMATIC NET Software

6GK5 612-0BA00-2AA3**6GK5 612-0BA10-2AA3**¹⁾**6GK5 623-0BA10-2AA3****6GK1 162-8AA00**

1) Available soon

Ordering data	Order No.	Ordering data	Order No.
<p><i>Accessories (continued)</i></p> <p>Communication processor CP 343-1 Advanced</p> <p>For connecting the SIMATIC S7-300 CPU to Industrial Ethernet; 1 x 10/100/1000 Mbit/s; 2 x 10/100 Mbit/s (IE switch); RJ45 ports; TCP; UDP; ISO; PROFINET IO-Controller and Device, S7 communication (client + server); open communication (SEND/RECEIVE); S7 routing; IP configuration via DHCP/block; extended Web diagnostics; time synchronization; IP Access Control List; IP routing; FTP; e-mail; PROFINET CBA; C-Plug</p> <ul style="list-style-type: none"> • Without security function • With Security (Firewall + VPN) and PROFlenergy (Controller + Device) 	<p>6GK7 343-1GX30-0XE0 6GK7 343-1GX31-0XE0¹⁾</p>	<p><i>Accessories (continued)</i></p> <p>EGPRS-Router MD741-1</p> <p>For wireless IP communication from Ethernet-based programmable controllers via GSM mobile radio networks; integrated firewall and VPN router (IPsec); quad band GSM; EGPRS Multislot Class 12</p> <p>UMTS router SCALANCE M 875</p> <p>UMTS router for wireless IP communication from Industrial Ethernet-based programmable controllers via UMTS/GSM mobile radio networks; EGPRS Multislot Class 12 with integrated firewall and VPN with IPsec; 2 x RJ45 ports, 2 x antenna connections</p>	<p>6NH9 741-1AA00</p> <p>6GK5 875-0AA10-1AA2</p>
<p>Communication processor CP 443-1 Advanced</p> <p>For connecting the SIMATIC S7-400 CPU to Industrial Ethernet; 1 x 10/100/1000 Mbit/s; 4 x 10/100 Mbit/s (IE SWITCH); RJ45 ports; ISO; TCP; UDP; PROFINET IO controller, S7 communication; open communication (SEND/RECEIVE); S7 routing; IP configuration via DHCP/block; IP Access Control List; time synchronization; expanded web diagnostics; Fast Startup; PROFlenergy support; IP routing; FTP; web server; e-mail; PROFINET CBA</p> <ul style="list-style-type: none"> • Without security function • With security (firewall/VPN) 	<p>6GK7 443-1GX30-0XE0 6GK7 443-1GX31-0XE0¹⁾</p>	<p>ANT794-4MR antenna</p> <p>Quad band antenna for MD720-3 and MD741-1, omnidirectional with 5 m cable</p>	<p>6NH9 860-1AA00</p>

¹⁾ Available soon

PROFINET/Industrial Ethernet

Drive Systems – SINAMICS G

SINAMICS G120D distributed frequency converters

Overview



Example: SINAMICS G120D, size FSA, comprising power module PM250D and fail-safe control unit CU240D PN-F

The new distributed frequency converter series SINAMICS G120D is the solution for demanding drive applications, particularly in the field of conveyor applications. SINAMICS G120D permits continuous speed control of three-phase asynchronous motors and meets all requirements of conveyor applications from simple frequency control to demanding vector control. With its sophisticated modular design and IP65 degree of protection it slots into the system seamlessly, thereby permitting high system availability and low stock levels. The innovative regenerative power section concept helps to save energy. Globally unique safety functions permit improved system concepts and higher productivity. This drive can be optimally linked into the Siemens TIA automation world using PROFIBUS or PROFINET.

With its various device designs (sizes FSA to FSC) in the performance range from 0.75 kW to 7.5 kW, it is suitable for numerous drive solutions.

Reasons for distributed drive technology

- Modular drive solutions – and thus standardized mechatronic elements that can be tested individually
- Control cabinets are dispensed with, meaning that less space and cooling are required
- Long motor cables are dispensed with between converter and motor (less power loss, lower interference emissions and lower costs for shielded cables and additional filters)
- For conveyor applications with their large spatial range (e.g. in the automotive and logistics industries), the distributed installation methods bring great benefits

Modular design

SINAMICS G120D is a modular converter system with IP65 degree of protection and made up of various functional units. The main ones are:

- Control unit (CU)
- Power module (PM)

The control unit controls and monitors the power module and the connected motor in several selectable control types. The digital inputs and digital outputs on the device permit the simple wiring of sensors and actuators directly to the drive. The input signals can either be connected directly within the control unit and trigger autonomous local reactions, or they are passed to a central control system via PROFIBUS or PROFINET where they are processed in the context of the system as a whole.

The power module supplies the motor in a performance range from 0.75 kW to 7.5 kW. The power module is controlled by microprocessor from the control unit. For extremely reliable and flexible motor operation, the latest IGBT technology with pulse width modulation is used. Comprehensive protection functions provide a high degree of protection for the power module and motor. The unusually flat mechanical design is optimized for use direct in the system. Furthermore, the power module has the same hole dimensions for all powers (constant "footprint").

Safety Integrated

Versions of the distributed SINAMICS G120D frequency converters are available for safety-related applications. All power modules are already prepared for Safety Integrated. If a power module is combined with a corresponding fail-safe control unit, this drive becomes a Safety Integrated drive.

The fail-safe frequency converter SINAMICS G120D offers three safety functions, certified according to EN 954-1, Category 3 and IEC 61508 SIL 2:

- Safe torque off (STO) to guard against any active movement of the operating mechanism
- Safe stop 1 (SS1) for continuous monitoring of a safe brake ramp
- Safely limited speed (SLS) to guard against danger from movements caused when a limit speed is exceeded

Both the "Safe Stop 1" function and the "Safely Limited Speed" function operate without motor sensor or encoder; the implementation cost is minimal. Existing systems in particular can be retrofitted with safety technology without the motor or mechanics having to be modified.

The "Safely Limited Speed" and "Safe Stop 1" safety functions are certified for asynchronous motors without sensors – these safety functions are not approved for drawing loads such as lifting devices and unwinders.

Further information can be found in Chapter Highlights, Section Safety Integrated in Catalog D 31.

Efficient Infeed Technology

The innovative Efficient Infeed Technology is used in the PM250D power modules. It is thus possible to feed the generated energy back into the supply network using standard converters with the motor in generator mode. Energy is saved and, at the same time, ongoing operating costs are noticeably reduced.

Further information can be found in Chapter Highlights, Section Efficient Infeed Technology in Catalog D 31.

STARTER commissioning tool

The STARTER commissioning tool (from STARTER Version 4.1, SP1) makes the commissioning and maintenance of SINAMICS G120D easier. It offers operator prompting for quick and easy commissioning, combined with user-friendly and comprehensive functions for the drive solution.

Benefits

- Compact, space-saving design with very flat shape and uniform hole dimensions for all types of power rating
- Wide performance range from 0.75 kW to 7.5 kW
- The safety functionalities mean less cost in the integration of drives in safety-related machines or systems
- Thanks to the innovative switching concept (bidirectional input rectifier with "slim" link), the kinetic energy of a load can be fed back into the network. This regenerative capability means that enormous energy savings are possible, since regenerated energy no longer needs to be converted into heat in a braking resistor. Braking resistors and reactors are superfluous – this is particularly beneficial with regard to the space required and the installation cost at the high degree of protection IP65
- Increased robustness and longer service life due to painting of the electronics assemblies
- Flexibility thanks to modularity for a future-proof distributed drive concept with a high degree of protection IP65
 - Hot swapping possible
 - Easy replacement means excellent ease of maintenance
- Communication is possible via PROFINET or PROFIBUS with PROFIdrive Profile 4.0
 - Reduction of interfaces
 - System-wide engineering
 - Simple handling
- Thanks to the option of the direct connection of up to six sensors and up to two actuators to the control unit, almost all drive-related information can be managed directly; a local pre-processing of the signals relieves the field bus whilst ensuring a rapid and reproducible response time
- Integrated EMC filters of Class A (according to EN 55011), integrated brake control (1 AC 400 V rectified, corresponds to 180 V DC) and integrated motor protection thanks to thermal motor model and evaluation of temperature sensors PTC or KTY 84
- Software parameters for simple adaptation to 50 Hz or 60 Hz motors (IEC or NEMA motors)
- Simple device replacement and time-saving copying of parameters thanks to the optional MMC memory card
- Engineering and commissioning with uniform engineering tools such as SIZER (from Version 2.9), STARTER (from Version 4.1, SP1) and Drive ES: ensure quick configuration and simple commissioning – STARTER is integrated into STEP 7 with Drive ES Basic, with the benefit of central data storage and consistent communication
- Certified worldwide according to CE, UL, cUL, c-tick and Safety Integrated according to EN 954-1, Category 3 and IEC 61508 SIL 2

Application

SINAMICS G120D is perfectly suited for demanding conveyor applications in an industrial environment in which a distributed communication-capable drive is required. This applies in particular for the automotive industry, e.g. assembly lines.

Furthermore, SINAMICS G120D is suitable for many other high-performance applications, e.g. in the airports sector, in the food/luxury food industry (without surfactants) and in distribution logistics (e.g. electrical monorail systems).

Design

The SINAMICS G120D distributed frequency converter is a modular frequency converter for standard drives. Every SINAMICS G120D consists of two operational units: a power module and a control unit.

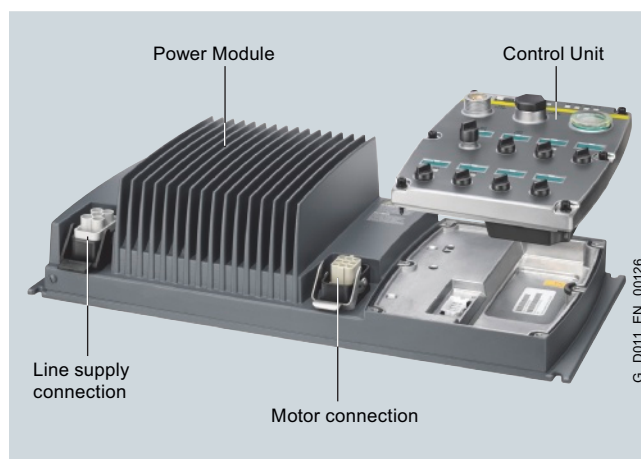

Power module PM250D with mains and motor connection and control unit CU240D

PROFINET/Industrial Ethernet

Drive Systems – SINAMICS G

SINAMICS G120D distributed frequency converters

Design (continued)

Power modules

The following power modules are available for the distributed SINAMICS G120D frequency converters:

PM250D 0.75 kW to 7.5 kW power modules

The PM250D power modules have an innovative switching concept which permits line-commutated power recovery. This innovation allows regenerated energy to be fed back into the electricity network, thus saving energy.

Accessories

Connector sets for the mains supply and motor feeder, as well as preassembled motor cables for the connection to the motor can be ordered as accessories.

Control units

The following control units are available for the distributed SINAMICS G120D frequency converters:

CU240D control units

The converter is controlled by the control unit. In addition to control, other functions are available which can be adapted to the application in question by suitable parameterization. The following control units are available for the PROFINET connection:

- CU240D PN
- CU240D PN-F
- CU240D PN-F PP

Accessories

- MMC memory card

The parameterization of a converter can be saved on the MMC memory card. For service purposes, e.g. after replacement of a converter and retrieval of data from the memory card, the system is ready for use again immediately. The slot in question can be found on the back of the control unit to the side.

- RS232 interface cable for communication with a PC

For the control and commissioning of a converter direct from a PC if the relevant software is installed (commissioning tool STARTER, from Version 4.1, SP1).

- Spare parts kit

For replacement purposes, a spare parts kit is available, consisting of small parts such as seals, covers, PROFIBUS address windows and screws.

- Connection cable

Flexible connecting cables for data transmission between Industrial Ethernet participants or PROFIBUS participants, and for power supply to the control unit.

Technical specifications

The following technical specifications apply, if not expressly stated, for all components of the distributed SINAMICS G120D frequency converter listed here.

Product designation	SINAMICS G120D
Mechanical specifications	
Vibratory load	
• Transport ¹⁾	EN 60068-2-6 5 ... 9 Hz: constant deflection 3.1 mm 9 ... 200 Hz: constant acceleration = 9.81 m/s ² (1 g)
• Operation	EN 60068-2-6 10 ... 58 Hz: constant deflection 0.15 mm 58 ... 200 Hz: constant acceleration = 19.62 m/s ² (2 g)
Shock load	
• Transport ¹⁾	EN 60068-2-27 147.15 m/s ² (15 g)/11 ms; 3 shock loads in each axis and direction
• Operation	EN 60068-2-27 147.15 m/s ² (15 g)/11 ms; 3 shock loads in each axis and direction
Ambient conditions	
Protection class	Class III (PELV) according to EN 61800-5-1
Touch protection	Class I (with protective conductor system) according to EN 61800-5-1
Permitted ambient and coolant temperature (air) for power modules during operation	-10 ... +40 °C without derating, > 40 ... 55 °C see derating characteristic curves
Permitted ambient and coolant temperature (air) for control units during operation	-10 ... +55 °C with CU240D DP-F or CU240D PN-F: 0 ... 40 °C up to 2000 m above sea level

¹⁾ In transport packaging.

²⁾ For further general information see also SINAMICS G110,
Section Technical Specifications, Conformity with Standards.

³⁾ With shielded motor cable up to 15 m.

Product designation	SINAMICS G120D
Climatic ambient conditions	
• Storage ¹⁾	EN 60068-2-1 temperature -40 ... +70 °C
• Transport ¹⁾	EN 60068-2-1 temperature -40 ... +70 °C max. air humidity 95 % at 40 °C
• Operation	EN 60068-2-2 temperature -10 ... +40 °C without derating
Environment class/chemical pollutants	
• Operation	Class 3C2 according to EN 60721-3-3
Pollution degree	
	2 according to EN 61800-5-1
Standards	
Conformity with standards	UL, cUL, CE, c-tick
CE marking	According to Low-Voltage Directive 73/23/EEC and Machinery Directive 98/37/EU
EMC Directive ²⁾	
• Sizes FSA to FSC with integrated Class A line filter	Category C2 ³⁾ according to EN 61800-3 (corresponds with Class A according to EN 55011)

Note:

The EMC product standard EN 61800-3 does not relate directly to a frequency converter, but to a PDS (power drive system) which, in addition to the converter, includes the entire circuitry as well as motor and cables. The frequency converters alone are not generally subject to mandatory labelling according to the EMC Directive.

More information

Further information on the technical specifications and ordering data can be found in the Catalog D 31 "Standard Converter SINAMICS G110/G120 and Distributed Converter SINAMICS G120D" and in the interactive catalog under "Drive Technology/AC Converter/Low-Voltage Converter" for standard converter SINAMICS G110/G120 or "Drive Technology/Distributed Drive Technology" for Distributed Converter SINAMICS G120D.

PROFINET/Industrial Ethernet

Drive systems – SINAMICS G120D distributed frequency converters

CU240D PN and CU240D PN-F Control Units

Overview



Example CU240D PN-F control unit

The converter is controlled by the control unit. In addition to control, other functions are available which can be adapted to the application in question by suitable parameterization. The following control units are available for the PROFINET connection:

- CU240D PN
- CU240D PN-F
- CU240D PN-F PP

Safety Integrated functions

The fail-safe frequency converter SINAMICS G120D offers three safety functions, certified according to EN 954-1, Category 3 and IEC 61508 SIL 2:

- Safe torque off (STO) to guard against any active movement of the operating mechanism
- Safe stop 1 (SS1) for continuous monitoring of a safe brake ramp
- Safely limited speed (SLS) to guard against danger from movements caused when a limit speed is exceeded

Both the "Safe Stop 1" function and the "Safely Limited Speed" function operate without motor sensor or encoder; the implementation cost is minimal. Existing systems in particular can be retrofitted with safety technology without the motor or mechanics having to be modified.

The "Safely Limited Speed" and "Safe Stop 1" safety functions are certified for asynchronous motors without sensors – these safety functions are not approved for drawing loads such as lifting devices and unwinders.

Note:

Further information can be found in Chapter Highlights, Section Safety Integrated in Catalog D 31.

Selection and ordering data

Communication	Digital inputs	Digital outputs	Sensor interfaces	Designation	Control unit Order No.
<i>Standard</i>					
PROFINET	6	2	1	CU240D PN	6SL3544-0FA20-1FA0
<i>Fail-safe for Safety Integrated</i>					
PROFINET	6	2	1	CU240D PN-F	6SL3544-0FA21-1FA0
PROFINET	6	2	1	CU240D PN-F PP	6SL3544-0FA21-1FB0

Accessories

MMC memory card



The parameterization of a converter can be saved on the MMC memory card. For service purposes, e.g. after replacement of a converter and retrieval of data from the memory card, the system is ready for use again immediately. The slot in question can be found on the back of the control unit to the side.

	Order No.
MMC memory card	6SL3 254-0AM00-0AA0

RS232 interface cable for communication with a PC

For the control and commissioning of a converter direct via a point-to-point connection from a PC, if the relevant software is installed on this (commissioning tool STARTER¹⁾, from Version 4.1, SP1).

	Order No.
RS232 interface cable for communication with a PC	3RK1 922-2BP00

STARTER commissioning tool

The STARTER commissioning tool (from STARTER Version 4.1, SP1) makes the commissioning and maintenance of SINAMICS G120D easier. It offers operator prompting for quick and easy commissioning, combined with user-friendly and comprehensive functions for the drive solution.

	Order No.
STARTER commissioning tool ¹⁾ on DVD	6SL3 072-0AA00-0AG0

¹⁾ The STARTER commissioning tool is also available on the Internet at: <http://support.automation.siemens.com/WW/view/en/10804985/133100>

Spare parts kit

For replacement purposes a spare parts kit is available, consisting of small parts such as seals, covers, PROFIBUS address windows and screws.

	Order No.
Spare parts kit for SINAMICS G120D control units comprising replacement seals, caps, PROFIBUS address windows and screws	6SL3 500-0SK01-0AA0

PROFINET connection cable

Flexible connecting cables and plug-in connector for field assembly for the transmission of data (up to 100 Mbit/s) between Industrial Ethernet participants in IP65 degree of protection.

	Order No.
IE connecting cables M12-180/M12-180 factory-fitted IE FC TP trailing cables GP 2 × 2 (PROFINET type C) with two 4-pole M12 plugs (4-pole, D-coded), degree of protection IP65/IP67; length:	
• 0.3 m	6XV1 870-8AE30
• 0.5 m	6XV1 870-8AE50
• 1.0 m	6XV1 870-8AH10
• 1.5 m	6XV1 870-8AH15
• 2.0 m	6XV1 870-8AH20
• 3.0 m	6XV1 870-8AH30
• 5.0 m	6XV1 870-8AH50
• 10 m	6XV1 870-8AN10
• 15 m	6XV1 870-8AN15

IE M12 Plug PRO M12 plug-in connector (D-coded) for field assembly, metal enclosure, fast connection method, for SCALANCE X208PRO and IM 154-4 PN	
• 1 unit	6GK1 901-0DB10-6AA0
• 8 units	6GK1 901-0DB10-6AA8

Connection cable/plug-in connector for power supply to the control unit

	Order No.
7/8" connecting cable for power supply, preassembled with two 5-pole 7/8" connectors/sockets length:	
• 0.3 m	6XV1 822-5BE30
• 0.5 m	6XV1 822-5BE50
• 1.0 m	6XV1 822-5BH10
• 1.5 m	6XV1 822-5BH15
• 2.0 m	6XV1 822-5BH20
• 3.0 m	6XV1 822-5BH30
• 5.0 m	6XV1 822-5BH50
• 10 m	6XV1 822-5BN10
• 15 m	6XV1 822-5BN15
7/8" plug-in connector 5-pole, B-coded, plastic enclosure, 1 pack = 5 units	
• Pin insert	6GK1 905-0FA00
• Female inserts	6GK1 905-0FB00

Further selected supplementary products can be obtained from Siemens Solution Partners. At "Solution Partner Finder" www.siemens.com/automation/partnerfinder select "Distributed Field Installation System" as the technology.

PROFINET/Industrial Ethernet

Drive systems / SINAMICS S High Performance Drives

SINAMICS S110 servo converters

Overview

SINAMICS S110 – the basic positioning drive for single-axis applications



SINAMICS S110: PM340 Power Module in blocksize format with CU305 Control Unit and BOP20

SINAMICS S110 can be used in numerous applications. Typical examples are:

- Handling devices
- Feed and withdrawal devices
- Stacking units
- Automatic assembly machines
- Laboratory automation
- Metalworking
- Woodworking, glass and ceramic industries
- Printing machines
- Plastics processing machines

The SINAMICS S110 servo converter is designed for connection to both synchronous servomotors and induction motors. It supports all the most popular types of encoder.

A variety of fieldbus interfaces are provided for linking the unit to a higher-level control system. Alternatively, it can be controlled via ± 10 V and a pulse direction interface.

The so-called basic positioner (EPos) is an integral component of SINAMICS S110. It provides a simple method of solving positioning tasks.

Flexible in application

SINAMICS S110 is a flexible, versatile system.

Synchronous servomotors and induction motors with outputs up to 90 kW can be used to implement rotary or linear axes. DRIVE-CLiQ motors can be connected simply by means of the integrated DRIVE-CLiQ interface. This means that the electronic rating plate of the motor is easy to read out, reducing the engineering time and cost involved in commissioning the drive.

Furthermore, SINAMICS S110 features an integrated encoder interface for optional use. It can be used to evaluate HTL/TTL and SSI encoders.

In addition to pure point-to-point positioning, SINAMICS S110 naturally also offers on-the-fly changeover from continuous operation to positioning mode in order, for example, to precisely position objects transported randomly on a conveyor belt. Even simple traversing profiles with different motion cycles and wait times can be executed automatically by SINAMICS S110.

The CU305 Control Unit of the SINAMICS S110 is equipped with an integrated communication interface for linking the converter to an automation system. A PROFINET, PROFIBUS or CANopen interface can be ordered. Standardized protocols for linking to a higher-level control are supported – the PROFIdrive profile for positioning mode and the PROFIsafe profile for safety-related communication.

The converter is thus perfectly coordinated with the SIMATIC S7 automation system. The devices are linked by means of PROFIBUS and the SIMATIC S7 uses standard function blocks to communicate with the drive. In addition, the STARTER commissioning tool can be seamlessly integrated into STEP 7, the SIMATIC's programming software.

BICO technology

Every drive contains a large number of input and output variables which can be freely and independently interconnected using Binector Connector technology (BICO). A binector is a logic signal which can assume the value 0 or 1. A connector is a numerical value, e.g. the actual speed or current setpoint.

Free function blocks

The "free function blocks" integrated in the CU305 Control Unit can be adapted easily but precisely to a very broad range of customized requirements. The available range of blocks includes simple logic blocks such as AND/OR elements, as well as more complex devices such as ramp-function generators, smoothing elements or limit-value monitors. All blocks can be flexibly interconnected using BICO (Binector-Connector) technology, ensuring that signals are processed quickly and close to the drive which helps reduce the load on the higher-level control.

Diagnostics optimally supported by trace function

The time characteristics of input and output variables associated with drives can be measured by the integrated trace function and displayed using the STARTER commissioning tool. Up to 4 signals can be recorded simultaneously. Recording can be triggered as a function of freely selectable boundary conditions, e.g. the value of an input or output variable.

Overview (continued)

Safety Integrated

The integrated safety functions of SINAMICS S110 provide highly effective application-oriented protection for personnel and machinery (terms as defined in IEC 61800-5-2).

The following Safety Integrated Basic functions are included as standard:

- Safe Torque Off (STO)
- Safe Brake Control (SBC)
- Safe Stop 1 (SS1)

The following are optionally available Safety Integrated Extended functions

- Safe Stop 2 (SS2)
- Safe Operating Stop (SOS)
- Safely Limited Speed (SLS)
- Safe Speed Monitor (SSM)
- Safe Direction (SDI)

The Safety Integrated functions are fully integrated into the drive system. They can be activated via fail-safe digital inputs on the CU305 Control Unit or over PROFINET or PROFIBUS with PROFIsafe.

The Safety Integrated functions are implemented electronically and therefore offer short response times in comparison to solutions with externally implemented monitoring functions.

Accessories

Memory cards

The SINAMICS Micro Memory Card (MMC) can be optionally used for SINAMICS S110. The relevant slot is located underneath the CU305 Control Unit. On the memory card, the complete functionality of SINAMICS S110 can be saved: the parameter settings and the firmware. When service is required, e.g. after the converter has been replaced and the data have been downloaded from the memory card, the drive system is immediately ready for use again.

A SINAMICS Micro Memory Card (MMC) is essential when the optional Safety Integrated Extended functions are used. The necessary license is saved on the MMC.

Intelligent Operator Panel (IOP)

The IOP supports both entry-level personnel and drive experts. Thanks to the large plain text display, the menu prompting and the application wizards, it is easy to commission, diagnose and locally control standard drives.

The IOP can be connected to the RS232 of the CU305 Control Unit using the appropriate connecting cable. Mounting the IOP directly on the CU305 Control Unit is not possible.

Coated modules

The following units are equipped as standard with coated or partially coated modules:

- Blocksize format units
- Control Units
- Sensor Modules

The coating on the modules protects the sensitive SMD components against corrosive gases, chemically active dust and moisture.

PROFINET/Industrial Ethernet

Drive systems / SINAMICS S High Performance Drives

SINAMICS S110 servo converters CU305 Control Unit

Overview



CU305 PN Control Unit

The CU305 Control Unit for the communication and open-loop/closed-loop control functions of a SINAMICS S110 is combined with the PM340 Power Module to create a powerful single drive.

Design

The CU305 Control Unit features the following connections and interfaces as standard:

- Fieldbus interface
 - CU305 PN: 1 PROFINET interface with 2 ports (RJ45 sockets) with PROFIdrive V4 profile
 - CU305 DP: 1 PROFIBUS interface with PROFIdrive V4 profile
 - CU305 CAN: 1 CANopen interface with DS301 V4.0, DSP402 V2.0, DR303-3 V1.0 profile
- 1 DRIVE-CLiQ socket, used solely to connect a DRIVE-CLiQ motor or a Sensor Module
- 1 onboard encoder evaluation for evaluating the following encoder signals
 - Incremental encoder TTL/HTL
 - SSI encoder without incremental signals
- 1 PE/protective conductor connection
- 1 connection for the electronics power supply via the 24 V DC power supply connector
- 1 temperature sensor input (KTY84-130 or PTC)
- 3 parameterizable, fail-safe digital inputs (floating) or alternatively 6 parameterizable digital inputs (floating)
- 5 parameterizable digital inputs (floating)
- 1 parameterizable, fail-safe digital output (floating) or alternatively 1 digital output (floating)
- 4 parameterizable bidirectional digital inputs/outputs (floating)
- 1 analog input: ± 10 V, ± 12 bit resolution
- 1 serial RS232 interface
- 1 slot for the memory card on which the firmware, parameters and licenses can be stored
- 1 PM-IF interface for communication with the PM340 Power Modules in blocksize format
- 2 test sockets and one reference ground for commissioning support
- 1 interface to the BOP20 Basic Operator Panel

Integration

The CU305 Control Unit controls the PM340 Power Module via the PM-IF interface.

A BOP20 Basic Operator Panel can also be snapped directly onto the CU305 for diagnostic purposes. For comprehensive diagnostics and commissioning functions, an Intelligent Operator Panel (IOP) can be connected to the RS232 interface.

DRIVE-CLiQ motors or Sensor Modules (SMC) can also be connected to the integrated DRIVE-CLiQ socket to permit the operation of motors without a DRIVE-CLiQ interface.

The status of the CU305 is indicated via multi-color LEDs.

The CU305 can be operated optionally with a memory card. The firmware and project data are stored on the plug-in card underneath, so that the CU305 can be replaced without the support of software tools. This memory card can also be used to perform standard commissioning on multiple drives of identical type. The card is available as an empty memory card or containing the latest drive firmware version. The card also contains the safety license for the extended safety functions. To use these extended safety functions, a memory card containing the safety license must be permanently inserted.

The CU305 and other connected components are commissioned and diagnosed with the STARTER commissioning tool.

Ordering data

Order No.

CU305 PN Control Unit Without a memory card	6SL3040-0JA01-0AA0
CU305 DP Control Unit Without a memory card	6SL3040-0JA00-0AA0
CU305 CAN Control Unit Without a memory card	6SL3040-0JA02-0AA0

Accessories

Memory card for Control Units CU305 PN / CU305 DP / CU305 CAN

- Empty
- With firmware version V4.1
- With firmware version V4.3
- With firmware version V4.4
- With firmware version V4.4 and safety license (Extended functions)

6SL3054-4AG00-0AA0
6SL3054-4EB00-0AA0
6SL3054-4ED00-0AA0
6SL3054-4EE00-0AA0
6SL3054-4EE00-0AA0-Z F01

Safety license (Extended functions) **6SL3074-0AA10-0AA0**

STARTER commissioning tool **6SL3072-0AA00-0AG0**

Overview

The SINAMICS S120 drive system can be perfectly adapted to a wide range of different drive tasks thanks to its modular design. The drives and the line supply/regenerative feedback are computed on the Control Unit. Power units (Power Modules, Line Modules and Motor Modules) ensure an optimum conversion of energy between the supply system and motor. SINAMICS S120 is available in blocksize, booksize, booksize compact and chassis format and offers optimum solutions both for simple single-axis drives as well as for complex multi-axis drives.

SINAMICS S120 can be used in a wide range of applications, such as:

- Turning, milling and grinding machines
- Packaging machines
- Machines for producing food and beverages
- Printing and paper machines
- Textile machines
- Plastics processing machines
- Presses and punches
- Machines used in the timber, glass, and ceramics industry
- Assembly and testing equipment
- Handling devices
- Rolling mill drives
- Vehicle and gearbox test stands
- Hoisting gear, cranes
- Plants and processing lines
- Test bays
- Renewable energy

SINAMICS S120 single-axis drives (AC/AC)

The simplest version of a SINAMICS S120 is a single-axis drive. It consists of a CU310-2 Control Unit and a Power Module. A mains rectifier, a voltage-source DC link and an inverter for supplying the motor are integrated in the Power Module.



PM340 Power Module in blocksize format with CU310-2 PN Control Unit

SINAMICS S120 Power Modules are single drives without regenerative feedback into the mains supply. Generated energy produced during braking is converted to heat via braking resistors. Power Modules for SINAMICS S120 are available in the following formats and power ranges:

Format	Rated current (type rating)
Blocksize	0.9 ... 178 A (0.12 ... 90 kW)
Chassis	210 ... 490 A (110 ... 250 kW)

PROFINET/Industrial Ethernet

Drive systems / SINAMICS S High Performance Drives

SINAMICS S120 drive system

Overview (continued)

SINAMICS S120 multi-axis drives:

A multi-axis drive consists of a Line Module, several Motor Modules and a Control Unit. The Line Module generates a DC voltage from the line voltage and supplies the Motor Modules with energy via the DC link. In the Motor Modules, the DC link voltage is converted by an inverter into an AC voltage for feeding the motor. On the shared Control Unit, both the line supply/regenerative feedback and the closed-loop control of the motors are computed. The connection between the Control Unit and the power units is made very simply using the digital system interface DRIVE-CLiQ.

SINAMICS S120 multi-axis drives are available in various cooling methods (internal air cooling, external air cooling, cold plate cooling and liquid cooling) and in the following formats and output ranges:

Format	Rated power or rated current (type rating)
Line Modules	
Booksize Compact	16 kW
Booksize	5 ... 120 kW
Chassis	132 ... 1400 kW
Motor Modules	
Booksize Compact	3 ... 18 A (1.6 ... 9.7 kW)
Booksize	3 ... 200 A (1.6 ... 107 kW)
Chassis	210 ... 1405 A (110 ... 1200 kW)

The SINAMICS S120 multi-axis drives are often used together with a higher-level controller for motion control (SIMOTION, SINUMERIK). For this reason, the following catalogs contain a detailed description of SINAMICS S120 multi-axis drives together with the perfectly matched servo, torque and linear motors including the associated cables and connections and the higher-level controllers for motion control:

- Catalog PM 21 SIMOTION, SINAMICS S120 and Motors for Production Machines
- Catalog NC 61 SINUMERIK & SINAMICS, Equipment for Machine Tools



CU320-2 Control Unit, Line Module and 3 Motor Modules in booksize format

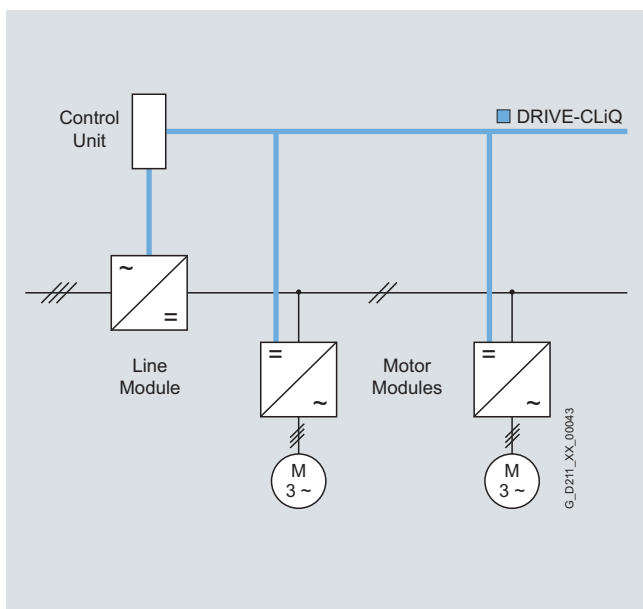

Block diagram with CU320-2 Control Unit, Line Module and 2 Motor Modules

PROFINET/Industrial Ethernet

Drive systems / SINAMICS S High Performance Drives

SINAMICS S120 drive system
CU310-2 Control Unit for single-axis drives

Overview



CU310-2 PN Control Unit

The CU310-2 Control Unit for the communication and open-loop/closed-loop control functions of a SINAMICS S120 AC drive is combined with the PM340 Power Module to create a high-performance single drive. For fieldbus communication, PROFINET (PN) and PROFIBUS (DP) versions are available.

Design

The CU310-2 Control Unit features the following connections and interfaces as standard:

- Fieldbus interface
 - CU310-2 PN: 1 PROFINET interface with 2 ports (RJ45 sockets) with PROFIdrive V4 profile
 - CU310-2 DP: 1 PROFIBUS interface with PROFIdrive V4 profile
- 1 DRIVE-CLiQ socket for communication to the DRIVE-CLiQ motor or other DRIVE-CLiQ stations (e.g. Sensor Modules or Terminal Modules)
- 1 encoder evaluation for evaluating the following encoder signals
 - Incremental encoder TTL/HTL
 - SSI encoder without incremental signals
- 1 PE/protective conductor connection
- 1 connection for the electronics power supply via the 24 V DC power supply connector
- 1 temperature sensor input (KTY84-130 or PTC)
- 3 parameterizable, fail-safe (available soon) digital inputs (isolated), or alternatively 6 parameterizable digital inputs (isolated)
- 5 parameterizable digital inputs (isolated)
- 1 parameterizable, fail-safe (available soon) digital output (isolated), or alternatively 1 digital output (isolated)
- 8 parameterizable bidirectional digital inputs/outputs (non-isolated)
- 1 analog input: ± 10 V, 13 bit resolution
- 1 Ethernet interface (female RJ45) for commissioning and diagnostics
- 1 slot for the CompactFlash card on which firmware and parameters are stored
- 1 PM-IF interface for communication with the Power Modules in blocksize format
- 3 test sockets and one reference ground for commissioning support
- 1 interface to the BOP20 Basic Operator Panel

The status of the CU310-2 Control Unit is indicated via multi-color LEDs.

A BOP20 Basic Operator Panel can also be snapped directly onto the CU310-2 Control Unit for diagnostic purposes.

As the firmware and parameter settings are stored on a plug-in CompactFlash card, the Control Unit can be changed without the need for software tools.

PROFINET/Industrial Ethernet

Drive systems / SINAMICS S High Performance Drives

SINAMICS S120 drive system CU310-2 Control Unit for single-axis drives

Integration

The CU310-2 Control Unit controls Power Modules in blocksize format via the PM-IF interface. DRIVE-CLiQ motors or Sensor Modules (SMC) can also be connected to the integrated DRIVE-CLiQ socket to permit the operation of motors without a DRIVE-CLiQ interface.

With the BOP20 Basic Operator Panel, parameters can be changed directly on the device. The BOP20 Basic Operator Panel can also be snapped onto the CU310-2 Control Unit during operation to perform troubleshooting procedures.

The CU310-2 Control Unit and other connected components are commissioned and diagnosed with the STARTER commissioning tool. The Control Unit CU310-2 requires a CompactFlash card with firmware version V4.2 or higher.

A CU310-2 PN Control Unit communicates with the higher-level control system using PROFINET IO and the PROFIdrive V4 profile.

The SINAMICS S120 drive system with the CU310-2 PN Control Unit then assumes the function of a PROFINET IO Device and can perform the following functions:

- PROFINET IO Device
- 100 Mbit/s full duplex
- Supports real-time classes of PROFINET IO:
 - RT (Real-Time)
 - IRT (Isochronous Real-Time), minimum send cycle 500 µs
- Connects to controls as PROFINET IO Devices in accordance with PROFIdrive according to Specification V4
- Standard TCP/IP communication for engineering processes using the STARTER commissioning tool
- Integrated 2-port switch with two RJ45 sockets based on the ERTEC ASIC. The optimum topology (line, star, tree) can therefore be configured without additional external switches.

Ordering data

Order No.

CU310-2 PN Control Unit
Without CompactFlash card

6SL3040-1LA01-0AA0

CU310-2 DP Control Unit
Without CompactFlash card

6SL3040-1LA00-0AA0

Accessories

STARTER commissioning tool

6SL3072-0AA00-0AG0

Accessories for re-ordering

Dust-proof blanking plugs
(50 units)

6SL3066-4CA00-0AA0

For DRIVE-CLiQ port

For information about connectors and cables, refer to the Siemens Industry Mall: www.siemens.com/industrymall

PROFINET/Industrial Ethernet

Drive systems / SINAMICS S High Performance Drives

Drive system SINAMICS S120
CompactFlash Card for CU310-2

Overview



The CompactFlash card contains the firmware and parameter settings. The CompactFlash card is plugged into the correct slot on the CU310-2 Control Unit.

Design

A CU310-2 Control Unit can perform the communication, open-loop and closed-loop control functions for one Power Module. The performance expansion is not required in this case.

In addition to the firmware, the CompactFlash card also contains licensing codes which are required to enable firmware options (Safety Integrated Extended functions in the current version). The Safety Integrated Extended functions must be ordered via the order code **F01** in addition to the order number.

The firmware option can also be enabled on-site, for example, if the Safety Integrated Extended functions should be enabled later. You will need the serial number of the CompactFlash card and the order number of the firmware option to be enabled. With this information, you can purchase the associated license code from a license database and enable the firmware option. The license code is only valid for the CompactFlash card declared and cannot be transferred to other CompactFlash cards.

Ordering data

Order No.

CompactFlash card for CU310-2 DP, CU310-2 PN Control Units
With firmware version V4.4 including Certificate of License

6SL3054-0EE00-1AA0

CompactFlash Card for CU310-2 DP, CU310-2 PN Control Units
With firmware version V4.4 including Certificate of License and with Safety license

6SL3054-0EE00-1AA0-Z F01

Firmware license
Safety Integrated Extended Functions option including Certificate of License for one axis for upgrading the license of a CompactFlash card.

6SL3074-0AA10-0AA0

More information

Firmware version

The firmware version is encoded as follows in the order number printed on the CompactFlash card:

Order No.	6SL3054-0		00-1AA0
Firmware version	1		B
	2		C
Version	.1		B
	.2		C
	.3		D
	.4		E
	.5		F
	.6		G

Example:

A CompactFlash card with firmware version 2.5 and a Safety license for a CU310-2 PN Control Unit are required:

Order No. 6SL3054-0CF00-1AA0-Z
F01

PROFINET/Industrial Ethernet

Controllers / Modular controllers / SIMATIC S7-1200

CPU 1211C

Overview



- The clever compact solution
- With 10 integral input/outputs
- Expandable by:
 - 1 signal board (SB) or communication board (CB)
 - Max. 3 communication modules (CM)

Ordering data

CPU 1211C

Compact CPU, AC/DC/relay;
integral program/data memory
25 KB, load memory 1 MB;
wide-range power supply
85 ... 264 V AC;
Boolean execution times 0.1 µs
per operation;
6 digital inputs, 4 digital outputs
(relays), 2 analog inputs;
expandable by up to
3 communication modules
and 1 signal board/
communication board;
digital inputs can be used as HSC
at 100 kHz

Order No.

6ES7 211-1BD30-0XB0

Compact CPU, DC/DC/DC;
integrated program/data memory
25 KB, load memory 1 MB;
power supply 24 V DC;
Boolean execution times 0.1 µs
per operation;
6 digital inputs,
4 digital outputs,
2 analog inputs;
expandable by up to
3 communication modules
and 1 signal board/
communication board;
digital inputs can be used as HSC
at 100 kHz,
24 V DC digital outputs can be
used as pulse outputs (PTO) or
pulse-width modulated outputs
(PWM) at 100 kHz

6ES7 211-1AD30-0XB0

Compact CPU, DC/DC/relay;
integrated program/data memory
25 KB, load memory 1 MB;
power supply 24 V DC;
Boolean execution times 0.1 µs
per operation;
6 digital inputs, 4 digital outputs
(relays), 2 analog inputs;
expandable by up to
3 communication modules and
1 signal board/communication
board;
digital inputs can be used as HSC
at 100 kHz

6ES7 211-1HD30-0XB0

Order No.

SB 1221 signal board

4 inputs, 5 V DC, 200 kHz
4 inputs, 24 V DC, 200 kHz

6ES7 221-3AD30-0XB0

6ES7 221-3BD30-0XB0

SB 1222 signal board

4 outputs, 5 V DC, 0.1 A, 200 kHz
4 outputs, 24 V DC, 0.1 A, 200 kHz

6ES7 222-1AD30-0XB0

6ES7 222-1BD30-0XB0

SB 1223 signal board

2 inputs, 24 V DC,
IEC type 1 active high;
2 24 V DC transistor outputs,
0.5 A, 5 W;
can be used as HSC at
up to 30 kHz

6ES7 223-0BD30-0XB0

2 inputs, 5 V DC, 200 kHz
2 outputs 5 V DC, 0.1 A, 200 kHz
2 inputs, 24 V DC, 200 kHz
2 outputs 24 V DC, 0.1 A, 200 kHz

6ES7 223-3AD30-0XB0

6ES7 223-3BD30-0XB0

SB 1231 signal board

1 analog input, ±10 V with 12 bits
or 0 ... 20 mA with 11 bits

6ES7 231-4HA30-0XB0

Thermocouple signal board SB 1231

1 input +/- 80 mV,
resolution 15 bits + sign,
thermocouples type J, K

6ES7 231-5QA30-0XB0

RTD signal board SB 1231

1 input for resistance temperature
sensors Pt 100, Pt 200, Pt 500,
Pt 1000, resolution 15 bits + sign

6ES7 231-5PA30-0XB0

SB 1232 signal board

1 analog output,
±10 V with 12 bits or
0 to 20 mA with 11 bits

6ES7 232-4HA30-0XB0

Communication board CB 1241 RS485

for point-to-point connection,
with 1 RS485 interface

6ES7 241-1CH30-1XB0

Simulator (optional)

8 input switches,
for CPU 1211C / CPU 1212C

6ES7 274-1XF30-0XA0

PROFINET/Industrial Ethernet

Controllers / Modular controllers / SIMATIC S7-1200

CPU 1211C

2

Ordering data	Order No.	Order No.
SIMATIC Memory Card (optional)		
2 MB	6ES7 954 -8LB01-0AA0	
24 MB	6ES7 954 -8LF01-0AA0	
Terminal block (spare part)		
for CPU 1211C/1212C		
For DI, with 14 screws, tin-plated; 4 units	6ES7 292-1AH30-0XA0	
For DO, with 8 screws, tin-plated; 4 units	6ES7 292-1AP30-0XA0	
For AI, with 3 screws, tin-plated; 4 units	6ES7 292-1BC30-0XA0	
Front flap set (spare part)		
for CPU 1211C/1212C	6ES7 291-1AA30-0XA0	
S7-1200 automation system, System Manual		
For SIMATIC S7-1200 and STEP 7 Basic		
German	6ES7 298-8FA30-8AH0	6ES7 822-0AA01-0YA0
English	6ES7 298-8FA30-8BH0	6ES7 822-0AA01-0YE0
French	6ES7 298-8FA30-8CH0	6ES7 822-1AA01-0YC5
Spanish	6ES7 298-8FA30-8DH0	6ES7 822-0AA01-0YA7
Italian	6ES7 298-8FA30-8EH0	6ES7 822-0AA00-0YL0
Chinese	6ES7 298-8FA30-8KH0	6ES7 822-0AA00-0YM0
S7-1200 automation system, Easy Book		
Brief instructions		
German	6ES7 298-8FA30-8AQ0	6GK7 277-1AA10-0AA0
English	6ES7 298-8FA30-8BQ0	
French	6ES7 298-8FA30-8CQ0	
Spanish	6ES7 298-8FA30-8DQ0	
Italian	6ES7 298-8FA30-8EQ0	
Chinese	6ES7 298-8FA30-8KQ0	
		STEP 7 Basic engineering software V11
		<i>Target system:</i> SIMATIC S7-1200 controllers and the associated I/O.
		<i>Requirement:</i> Windows XP Home SP3, Windows XP Professional SP3 (32 bit), Windows 7 Home Premium, Windows 7 Professional (32 bit), Windows 7 Enterprise (32 bit), Windows 7 Ultimate (32 bit), Microsoft Server 2003 R2 Std. SP2 (32 bit), Microsoft Server 2008 Std. SP2 (32 bit)
		<i>Form of delivery:</i> German, English, Chinese, Italian, French, Spanish
		Single license
		Upgrade STEP 7 Basic V10.5 to STEP 7 Basic V11, single license
		Powerpack STEP 7 Basic V11 to STEP 7 Prof. V11, floating license
		STEP 7 Basic V11, trial license
		STEP 7 Basic Software Update Service, 1 year
		STEP 7 Basic Software Update Service Compact, 1 year
		Accessories
		CSM 1277 compact switch module
		Unmanaged switch for connecting a SIMATIC S7-1200 and up to three further nodes to Industrial Ethernet with 10/100 Mbit/s; 4 x RJ45 ports; external 24 V DC power supply, diagnostics on LEDs, S7-1200 module including electronic manual on CD-ROM
		IE TP Cord RJ45/RJ45
		TP cable 4 x 2 with 2 RJ45 plugs
		• 0.5 m
		• 1 m
		• 2 m
		• 6 m
		• 10 m
		IE FC Outlet RJ45
		For connection of Industrial Ethernet FC cables and TP Cords; graded prices from 10 and 50 items upwards

Note:

You can find more information in Catalog ST 70 and in the Industry Mall at www.siemens.com/industrymall

PROFINET/Industrial Ethernet

Controllers / Modular controllers / SIMATIC S7-1200

SIPLUS CPU 1211C

Overview



- The clever compact solution
- With 10 integrated I/Os
- Expandable with:
 - 1 signal board (SB)
 - Max. 3 communication modules (CM)

Note:

SIPLUS extreme products are based on Siemens Industry standard products. The contents listed here were taken from the respective standard products. SIPLUS extreme-specific information was added.

SIPLUS CPU 1211C DC/DC/DC			
Order number	6AG1 211-1AD30-2XB0	6AG1 211-1AD30-4XB0	6AG1 211-1AD30-5XB0
Order No. based on	6ES7 211-1AD30-0XB0		
Ambient temperature range	-25 ... +70 °C ³⁾	0 ... +55 °C	-25 ... +55 °C
Conformal coating	Coating of the printed circuit boards and the electronic components		
Technical data	The technical data of the standard product applies except for the ambient conditions.		

SIPLUS CPU 1211C AC/DC/RLY			
Order number	6AG1 211-1BD30-2XB0	6AG1 211-1BD30-4XB0	6AG1 211-1BD30-5XB0
Order No. based on	6ES7 211-1BD30-0XB0		
Ambient temperature range	-25 ... +70 °C ³⁾	0 ... +55 °C	-25 ... +55 °C
Conformal coating	Coating of the printed circuit boards and the electronic components		
Technical data	The technical data of the standard product applies except for the ambient conditions.		

SIPLUS CPU 1211C DC/DC/RLY			
Order number	6AG1 211-1HD30-2XB0	6AG1 211-1HD30-4XB0	6AG1 211-1HD30-5XB0
Order No. based on	6ES7 211-1HD30-0XB0		
Ambient temperature range	-25 ... +70 °C ³⁾	0 ... +55 °C	-25 ... +55 °C
Conformal coating	Coating of the printed circuit boards and the electronic components		
Technical data	The technical data of the standard product applies except for the ambient conditions.		

Ambient conditions

Relative humidity	5 ... 100 % Condensation permissible
Biologically active substances	Conformity with EN 60721-3-3, Class 3B2 mold and fungal spores (except fauna)
Chemically active substances	Conformity with EN 60721-3-3, Class 3C4 incl. salt mist and ISA-S71.04 severity level G1; G2; G3; GX ^{1) 2)}
Mechanically active substances	Conformity with EN 60721-3-3, Class 3S4 including conductive sand, dust ²⁾
Air pressure (depending on the highest positive temperature range specified)	1080 ... 795 hPa (-1000 ... +2000 m) see ambient temperature range 795 ... 658 hPa (+2000 ... +3500 m) derating 10 K 658 ... 540 hPa (+3500 ... +5000 m) derating 20 K

- 1) ISA-S71.04 severity level GX: Long-term load:
SO₂ < 4.8 ppm; H₂S < 9.9 ppm; Cl < 0.2 ppm; HCl < 0.66 ppm;
HF < 0.12 ppm; NH < 49 ppm; O₃ < 0.1 ppm; NOX < 5.2 ppm
Limit value (max. 30 min/d):
SO₂ < 17.8 ppm; H₂S < 49.7 ppm; Cl < 1.0 ppm; HCl < 3.3 ppm;
HF < 2.4 ppm; NH < 247 ppm; O₃ < 1.0 ppm; NOX < 10.4 ppm
- 2) The supplied plug covers must remain in place over the unused interface when operated in atmospheres containing corrosive gases!
- 3) From +60 °C to +70 °C, the number of simultaneously enabled inputs and outputs is max. 50%; no SB module permitted

The technical documentation on SIPLUS can be found here:
www.siemens.com/siplus-extreme

Ordering data	Order No.	Order No.	Order No.
<p>SIPLUS CPU 1211C compact CPU, AC/DC/relay (extended temperature range and medial exposure)</p> <p>Integrated program and data memory of 25 KB, load memory of 1 MB; wide-range alternating voltage supply 85 ... 264 V AC; Boolean execution times of 0.1 µs per operation; 6 digital inputs, 4 digital outputs (relay), 2 analog inputs; expandable with up to 3 communication modules and 1 signal board; digital inputs usable as HSC with 100 kHz</p> <ul style="list-style-type: none"> • Suitable for areas with extraordinary medial exposure (conformal coating) • Suitable for areas with extraordinary medial exposure (conformal coating); ambient temperature -25 ... +55 °C; without restrictions; SB module can be used • Suitable for areas with extraordinary medial exposure (conformal coating); ambient temperature -25 ... +70 °C; from +60 ... +70 °C number of simultaneously controllable inputs and outputs max. 50%; no SB module possible 	<p>6AG1 211-1BD30-4XB0</p> <p>6AG1 211-1BD30-5XB0</p> <p>6AG1 211-1BD30-2XB0</p>	<p>SIPLUS CPU 1211C compact CPU, DC/DC/relay (extended temperature range and medial exposure)</p> <p>Integrated program and data memory of 25 KB, load memory of 1 MB; power supply 24 V DC; Boolean execution times of 0.1 µs per operation; 6 digital inputs, 4 digital outputs (relay), 2 analog inputs; expandable with up to 3 communication modules and 1 signal board; digital inputs usable as HSC with 100 kHz</p> <ul style="list-style-type: none"> • Suitable for areas with extraordinary medial exposure (conformal coating) • Suitable for areas with extraordinary medial exposure (conformal coating); ambient temperature -25 ... +55 °C; without restrictions; SB module can be used • Suitable for areas with extraordinary medial exposure (conformal coating); ambient temperature -25 ... +70 °C; from +60 ... +70 °C number of simultaneously controllable inputs and outputs max. 50%; no SB module possible 	<p>6AG1 211-1HD30-4XB0</p> <p>6AG1 211-1HD30-5XB0</p> <p>6AG1 212-1HD30-2XB0</p>
<p>SIPLUS CPU 1211C compact CPU, DC/DC/DC (extended temperature range and medial exposure)</p> <p>Integrated program and data memory of 25 KB, load memory of 1 MB; power supply 24 V DC; boolean execution times of 0.1 µs per operation; 6 digital inputs, 4 digital outputs, 2 analog inputs; expandable with up to 3 communication modules and 1 signal board; digital inputs usable as HSC with 100 kHz, 24 V DC digital outputs usable as pulse outputs (PTO) or pulse-width-modulated outputs (PWM) with 100 kHz</p> <ul style="list-style-type: none"> • Suitable for areas with extraordinary medial exposure (conformal coating) • Suitable for areas with extraordinary medial exposure (conformal coating); ambient temperature -25 ... +55 °C; without restrictions; SB module can be used • Suitable for areas with extraordinary medial exposure (conformal coating); ambient temperature -25 ... +70 °C; from +60 ... +70 °C number of simultaneously controllable inputs and outputs max. 50%; no SB module possible 	<p>6AG1 211-1AD30-4XB0</p> <p>6AG1 211-1AD30-5XB0</p> <p>6AG1 211-1AD30-2XB0</p>	<p>Accessories</p>	<p>See SIMATIC S7-1200 CPU 1211C</p>

PROFINET/Industrial Ethernet

Controllers / Modular controllers / SIMATIC S7-1200

CPU 1212C

Overview



- The superior compact solution
- With 14 integral input/outputs
- Expandable by:
 - 1 signal board (SB) or communication board (CB)
 - 2 signal modules (SM)
 - Max. 3 communication modules (CM)

Ordering data

CPU 1212C

Compact CPU, AC/DC/relay;
integral program/data memory
25 KB, load memory 1 MB;
wide-range power supply
85 ... 264 V AC;
Boolean execution times 0.1 µs
per operation;
8 digital inputs,
6 digital outputs (relays),
2 analog inputs;
expandable by up to
3 communication modules,
2 signal modules and 1 signal
board/communication board;
digital inputs can be used as HSC
at 100 kHz

Order No.

6ES7 212-1BD30-0XB0

Compact CPU, DC/DC/DC;
integrated program/data memory
25 KB, load memory 1 MB;
power supply 24 V DC;
Boolean execution times 0.1 µs
per operation;
8 digital inputs,
6 digital outputs,
2 analog inputs;
expandable by up to
3 communication modules,
2 signal modules, and 1 signal
board/communication board;
digital inputs can be used as HSC
at 100 kHz,
24 V DC digital outputs can be
used as pulse outputs (PTO)
or pulse-width modulated outputs
(PWM) at 100 kHz

6ES7 212-1AD30-0XB0

Compact CPU, DC/DC/relay;
integrated program/data memory
25 KB, load memory 1 MB;
power supply 24 V DC;
Boolean execution times 0.1 µs
per operation;
8 digital inputs,
6 digital outputs (relays),
1 analog inputs;
expandable by up to
3 communication modules,
2 signal modules, and 1 signal
board/communication board;
digital inputs can be used as HSC
at 100 kHz

6ES7 212-1HD30-0XB0

Order No.

SB 1221 signal board

4 inputs, 5 V DC, 200 kHz
4 inputs, 24 V DC, 200 kHz

6ES7 221-3AD30-0XB0

6ES7 221-3BD30-0XB0

SB 1222 signal board

4 outputs, 5 V DC, 0.1 A, 200 kHz
4 outputs, 24 V DC, 0.1 A, 200 kHz

6ES7 222-1AD30-0XB0

6ES7 222-1BD30-0XB0

SB 1223 signal board

2 inputs, 24 V DC,
IEC type 1 active high;
2 24 V DC transistor outputs,
0.5 A, 5 W;
can be used as HSC at
up to 30 kHz

6ES7 223-0BD30-0XB0

2 inputs, 5 V DC, 200 kHz
2 outputs 5 V DC, 0.1 A, 200 kHz
2 inputs, 24 V DC, 200 kHz
2 outputs 24 V DC, 0.1 A, 200 kHz

6ES7 223-3AD30-0XB0

6ES7 223-3BD30-0XB0

SB 1231 signal board

1 analog input,
±10 V with 12 bits
or 0 ... 20 mA with 11 bits

6ES7 231-4HA30-0XB0

Thermocouple signal board SB 1231

1 input +/- 80 mV,
resolution 15 bits + sign,
thermocouples type J, K

6ES7 231-5QA30-0XB0

RTD signal board SB 1231

1 input for resistance temperature
sensors Pt 100, Pt 200, Pt 500,
Pt 1000, resolution 15 bits + sign

6ES7 231-5PA30-0XB0

SB 1232 signal board

1 analog output,
±10 V with 12 bits or 0 to 20 mA
with 11 bits

6ES7 232-4HA30-0XB0

Communication board CB 1241 RS485

for point-to-point connection,
with 1 RS485 interface

6ES7 241-1CH30-1XB0

Simulator (optional)

8 input switches,
for CPU 1211C / CPU 1212C

6ES7 274-1XF30-0XA0

Ordering data	Order No.	Order No.
SIMATIC Memory Card (optional) 2 MB 24 MB	6ES7 954 -8LB01-0AA0 6ES7 954 -8LF01-0AA0	
Extension cable for two-tier configuration for connecting digital/analog signal modules; length 2 m	6ES7 290-6AA30-0XA0	
Starter box CPU 1212C AC/DC/relay Complete offer SIMATIC S7-1200, starter box, comprising: CPU 1212C AC/DC/relay, simulator, STEP 7 BASIC CD, manual CD, info material, in Systainer	6ES7 212-1BD30-4YB0	
Terminal block (spare part) for CPU 1211C/1212C For DI, with 14 screws, tin-plated; 4 units For DO, with 8 screws, tin-plated; 4 units For AI, with 3 screws, tin-plated; 4 units	6ES7 292-1AH30-0XA0 6ES7 292-1AP30-0XA0 6ES7 292-1BC30-0XA0	
Front flap set (spare part) for CPU 1211C/1212C	6ES7 291-1AA30-0XA0	
S7-1200 automation system, System Manual For SIMATIC S7-1200 and STEP 7 Basic German English French Spanish Italian Chinese	6ES7 298-8FA30-8AH0 6ES7 298-8FA30-8BH0 6ES7 298-8FA30-8CH0 6ES7 298-8FA30-8DH0 6ES7 298-8FA30-8EH0 6ES7 298-8FA30-8KH0	
S7-1200 automation system, Easy Book Brief instructions German English French Spanish Italian Chinese	6ES7 298-8FA30-8AQ0 6ES7 298-8FA30-8BQ0 6ES7 298-8FA30-8CQ0 6ES7 298-8FA30-8DQ0 6ES7 298-8FA30-8EQ0 6ES7 298-8FA30-8KQ0	
		STEP 7 Basic engineering software V11 <i>Target system:</i> SIMATIC S7-1200 controllers and the associated I/O. <i>Requirement:</i> Windows XP Home SP3, Windows XP Professional SP3 (32 bit), Windows 7 Home Premium, Windows 7 Professional (32 bit), Windows 7 Enterprise (32 bit), Windows 7 Ultimate (32 bit), Microsoft Server 2003 R2 Std. SP2 (32 bit), Microsoft Server 2008 Std. SP2 (32 bit) <i>Form of delivery:</i> German, English, Chinese, Italian, French, Spanish Single license Upgrade STEP 7 Basic V10.5 to STEP 7 Basic V11, single license Powerpack STEP 7 Basic V11 to STEP 7 Prof. V11, floating license STEP 7 Basic V11, trial license STEP 7 Basic Software Update Service, 1 year STEP 7 Basic Software Update Service Compact, 1 year
		6ES7 822-0AA01-0YA0 6ES7 822-0AA01-0YE0 6ES7 822-1AA01-0YC5 6ES7 822-0AA01-0YA7 6ES7 822-0AA00-0YLO 6ES7 822-0AA00-0YM0
		Accessories CSM 1277 compact switch module Unmanaged switch for connecting a SIMATIC S7-1200 and up to three further nodes to Industrial Ethernet with 10/100 Mbit/s; 4 x RJ45 ports; external 24 V DC power supply, diagnostics on LEDs, S7-1200 module including electronic manual on CD-ROM
		6GK7 277-1AA10-0AA0
		IE TP Cord RJ45/RJ45 TP cable 4 x 2 with 2 RJ45 plugs • 0.5 m • 1 m • 2 m • 6 m • 10 m
		6XV1 870-3QE50 6XV1 870-3QH10 6XV1 870-3QH20 6XV1 870-3QH60 6XV1 870-3QN10
		IE FC Outlet RJ45 For connection of Industrial Ethernet FC cables and TP Cords; graded prices from 10 and 50 items upwards
		6GK1 901-1FC00 0AA0

Note:

You can find more information in Catalog ST 70 and in the Industry Mall at www.siemens.com/industrymall

PROFINET/Industrial Ethernet

Controllers / Modular controllers / SIMATIC S7-1200

SIPLUS CPU 1212C

Overview



- The superior compact solution
- With 14 integrated I/Os
- Expandable with:
 - 1 signal board (SB)
 - 2 signal modules (SM)
 - Max. 3 communication modules (CM)

Note:

SIPLUS extreme products are based on Siemens Industry standard products. The contents listed here were taken from the respective standard products. SIPLUS extreme-specific information was added.

SIPLUS CPU 1212C DC/DC/DC			
Order number	6AG1 212-1AD30-2XB0	6AG1 212-1AD30-4XB0	6AG1 212-1AD30-5XB0
Order number based on	6ES7 212-1AD30-0XB0		
Ambient temperature range	-25 ... +70 °C ³⁾	0 ... +55 °C	-25 ... +55 °C
Conformal coating	Coating of the printed circuit boards and the electronic components		
Technical data	The technical data of the standard product applies except for the ambient conditions.		

SIPLUS CPU 1212C AC/DC/RLY			
Order number	6AG1 212-1BD30-2XB0	6AG1 212-1BD30-4XB0	6AG1 212-1BD30-5XB0
Order number based on	6ES7 212-1BD30-0XB0		
Ambient temperature range	-25 ... +70 °C ³⁾	0 ... +55 °C	-25 ... +55 °C
Conformal coating	Coating of the printed circuit boards and the electronic components		
Technical data	The technical data of the standard product applies except for the ambient conditions.		

SIPLUS CPU 1212C DC/DC/RLY			
Order number	6AG1 212-1HD30-2XB0	6AG1 212-1HD30-4XB0	6AG1 212-1HD30-5XB0
Order number based on	6ES7 212-1HD30-0XB0		
Ambient temperature range	-25 ... +70 °C ³⁾	0 ... +55 °C	-25 ... +55 °C
Conformal coating	Coating of the printed circuit boards and the electronic components		
Technical data	The technical data of the standard product applies except for the ambient conditions.		

Ambient conditions

Relative humidity	5 ... 100 % Condensation permissible
Biologically active substances	Conformity with EN 60721-3-3, Class 3B2 mold and fungal spores (except fauna)
Chemically active substances	Conformity with EN 60721-3-3, Class 3C4 incl. salt mist and ISA-S71.04 severity level G1; G2; G3; GX ^{1) 2)}
Mechanically active substances	Conformity with EN 60721-3-3, Class 3S4 including conductive sand, dust ²⁾
Air pressure (depending on the highest positive temperature range specified)	1080 ... 795 hPa (-1000 ... +2000 m) see ambient temperature range 795 ... 658 hPa (+2000 ... +3500 m) derating 10 K 658 ... 540 hPa (+3500 ... +5000 m) derating 20 K

- ISA-S71.04 severity level GX: Long-term load:
SO₂ < 4.8 ppm; H₂S < 9.9 ppm; Cl < 0.2 ppm; HCl < 0.66 ppm; HF < 0.12 ppm; NH < 49 ppm; O₃ < 0.1 ppm; NOX < 5.2 ppm
Limit value (max. 30 min/d):
SO₂ < 17.8 ppm; H₂S < 49.7 ppm; Cl < 1.0 ppm; HCl < 3.3 ppm; HF < 2.4 ppm; NH < 247 ppm; O₃ < 1.0 ppm; NOX < 10.4 ppm
- The supplied plug covers must remain in place over the unused interface when operated in atmospheres containing corrosive gases!
- From +60 °C to +70 °C, the number of simultaneously enabled inputs and outputs is max. 50%; no SB module permitted

Technical documentation on SIPLUS is available under:
www.siemens.com/siplus-extreme

Ordering data	Order No.	Order No.	Order No.
<p>SIPLUS CPU 1212C compact CPU, AC/DC/relay (extended temperature range and medial exposure)</p> <p>Integrated program and data memory of 25 KB, load memory of 1 MB; wide-range alternating voltage supply 85 ... 264 V AC; Boolean execution times of 0.1 µs per operation; 8 digital inputs, 6 digital outputs (relay), 2 analog inputs; expandable with up to 3 communication modules, 2 signal modules, and 1 signal board; digital inputs usable as HSC with 100 kHz</p> <ul style="list-style-type: none"> • Suitable for areas with extraordinary medial exposure (conformal coating) • Suitable for areas with extraordinary medial exposure (conformal coating); ambient temperature -25 ... +55 °C; without restrictions; SB module can be used • Suitable for areas with extraordinary medial exposure (conformal coating); ambient temperature -25 ... +70 °C; from +60 ... +70 °C number of simultaneously controllable inputs and outputs max. 50%; no SB module possible 	<p>6AG1 212-1BD30-4XB0</p> <p>6AG1 212-1BD30-5XB0</p> <p>6AG1 212-1BD30-2XB0</p>	<p>SIPLUS CPU 1212C compact CPU, DC/DC/relay (extended temperature range and medial exposure)</p> <p>Integrated program and data memory of 25 KB, load memory of 1 MB; power supply 24 V DC; Boolean execution times of 0.1 µs per operation; 8 digital inputs, 6 digital outputs (relay), 2 analog inputs; expandable with up to 3 communication modules, 2 signal modules and 1 signal board; digital inputs usable as HSC with 100 kHz</p> <ul style="list-style-type: none"> • Suitable for areas with extraordinary medial exposure (conformal coating) • Suitable for areas with extraordinary medial exposure (conformal coating); ambient temperature -25 ... +55 °C; without restrictions; SB module can be used • Suitable for areas with extraordinary medial exposure (conformal coating); ambient temperature -25 ... +70 °C; from +60 ... +70 °C number of simultaneously controllable inputs and outputs max. 50%; no SB module possible 	<p>6AG1 212-1HD30-4XB0</p> <p>6AG1 212-1HD30-5XB0</p> <p>6AG1 212-1HD30-2XB0</p>
<p>SIPLUS CPU 1212C compact CPU, DC/DC/DC (extended temperature range and medial exposure)</p> <p>Integrated program and data memory of 25 KB, load memory of 1 MB; power supply DC 24 V; Boolean execution times of 0.1 µs per operation; 8 digital inputs, 6 digital outputs, 2 analog inputs; expandable with up to 3 communication modules, 2 signal modules and 1 signal board; digital inputs usable as HSC with 100 kHz; 24 V DC digital outputs usable as pulse outputs (PTO) or pulse-width-modulated outputs (PWM) with 100 kHz</p> <ul style="list-style-type: none"> • Suitable for areas with extraordinary medial exposure (conformal coating) • Suitable for areas with extraordinary medial exposure (conformal coating); ambient temperature -25 ... +55 °C; without restrictions; SB module can be used • Suitable for areas with extraordinary medial exposure (conformal coating); ambient temperature -25 ... +70 °C; from +60 ... +70 °C number of simultaneously controllable inputs and outputs max. 50%; no SB module possible 	<p>6AG1 212-1AD30-4XB0</p> <p>6AG1 212-1AD30-5XB0</p> <p>6AG1 212-1AD30-2XB0</p>	<p>Accessories</p>	<p>See SIMATIC S7-1200 CPU 1212C</p>

PROFINET/Industrial Ethernet

Controllers / Modular controllers / SIMATIC S7-1200

CPU 1214C

Overview



- The compact high-performance CPU
- With 24 integral input/outputs
- Expandable by:
 - 1 signal board (SB) or communication board (CB)
 - 8 signal modules (SM)
 - Max. 3 communication modules (CM)

Ordering data

CPU 1214C

Compact CPU, AC/DC/relay;
integral program/data memory
50 KB, load memory 2 MB;
wide-range power supply
85 ... 264 V AC;
Boolean execution times 0.1 µs
per operation;
14 digital inputs,
10 digital outputs (relays),
2 analog inputs;
expandable by up to
3 communication modules,
8 signal modules and 1 signal
board/communication board;
digital inputs can be used as HSC
at 100 kHz

Order No.

6ES7 214-1BE30-0XB0

Compact CPU, DC/DC/DC;
integrated program/data memory
50 KB, load memory 2 MB;
power supply 24 V DC;
Boolean execution times 0.1 µs
per operation;
14 digital inputs,
10 digital outputs,
2 analog inputs;
expandable by up to
3 communication modules,
8 signal modules, and 1 signal
board/communication board;
digital inputs can be used as HSC
at 100 kHz,
24 V DC digital outputs can be
used as pulse outputs (PTO)
or pulse-width modulated outputs
(PWM) at 100 kHz

6ES7 214-1AE30-0XB0

Compact CPU, DC/DC/relay;
integrated program/data memory
50 KB, load memory 2 MB;
power supply 24 V DC;
Boolean execution times 0.1 µs
per operation;
14 digital inputs,
10 digital outputs (relays),
2 analog inputs;
expandable by up to
3 communication modules,
8 signal modules, and 1 signal
board/communication board;
digital inputs can be used as HSC
at 100 kHz

6ES7 214-1HE30-0XB0

Order No.

SB 1221 signal board

4 inputs, 5 V DC, 200 kHz
4 inputs, 24 V DC, 200 kHz

6ES7 221-3AD30-0XB0

6ES7 221-3BD30-0XB0

SB 1222 signal board

4 outputs, 5 V DC, 0.1 A, 200 kHz
4 outputs, 24 V DC, 0.1 A, 200 kHz

6ES7 222-1AD30-0XB0

6ES7 222-1BD30-0XB0

SB 1223 signal board

2 inputs, 24 V DC,
IEC type 1 active high;
2 24 V DC transistor outputs,
0.5 A, 5 W;
can be used as HSC at
up to 30 kHz

6ES7 223-0BD30-0XB0

2 inputs, 5 V DC, 200 kHz
2 outputs 5 V DC, 0.1 A, 200 kHz
2 inputs, 24 V DC, 200 kHz
2 outputs 24 V DC, 0.1 A, 200 kHz

6ES7 223-3AD30-0XB0

6ES7 223-3BD30-0XB0

SB 1231 signal board

1 analog input,
±10 V with 12 bits or 0 ... 20 mA
with 11 bits

6ES7 231-4HA30-0XB0

Thermocouple signal board SB 1231

1 input +/- 80 mV,
resolution 15 bits + sign,
thermocouples type J, K

6ES7 231-5QA30-0XB0

RTD signal board SB 1231

1 input for resistance temperature
sensors Pt 100, Pt 200, Pt 500,
Pt 1000, resolution 15 bits + sign

6ES7 231-5PA30-0XB0

SB 1232 signal board

1 analog output,
±10 V with 12 bits or 0 to 20 mA
with 11 bits

6ES7 232-4HA30-0XB0

Communication board CB 1241 RS485

for point-to-point connection,
with 1 RS485 interface

6ES7 241-1CH30-1XB0

Simulator (optional)

14 input switches, for CPU 1214C

6ES7 274-1XH30-0XA0

PROFINET/Industrial Ethernet

Controllers / Modular controllers / SIMATIC S7-1200

CPU 1214C

2

Ordering data	Order No.	Order No.
SIMATIC Memory Card (optional) 2 MB 24 MB	6ES7 954 -8LB01-0AA0 6ES7 954 -8LF01-0AA0	
Extension cable for two-tier configuration for connecting digital/analog signal modules; length 2 m	6ES7 290-6AA30-0XA0	
Terminal block (spare part) for CPU 1214C For DI, with 20 screws, tin-plated; 4 units For DO, with 12 screws, tin-plated; 4 units For AI, with 3 screws, tin-plated; 4 units	6ES7 292-1AV30-0XA0 6ES7 292-1AM30-0XA0 6ES7 292-1BC30-0XA0	
Front flap set (spare part) for CPU 1214C	6ES7 291-1AB30-0XA0	
S7-1200 automation system, System Manual For SIMATIC S7-1200 and STEP 7 Basic German English French Spanish Italian Chinese	6ES7 298-8FA30-8AH0 6ES7 298-8FA30-8BH0 6ES7 298-8FA30-8CH0 6ES7 298-8FA30-8DH0 6ES7 298-8FA30-8EH0 6ES7 298-8FA30-8KH0	
S7-1200 automation system, Easy Book Brief instructions German English French Spanish Italian Chinese	6ES7 298-8FA30-8AQ0 6ES7 298-8FA30-8BQ0 6ES7 298-8FA30-8CQ0 6ES7 298-8FA30-8DQ0 6ES7 298-8FA30-8EQ0 6ES7 298-8FA30-8KQ0	
		STEP 7 Basic engineering software V11 <i>Target system:</i> SIMATIC S7-1200 controllers and the associated I/O. <i>Requirement:</i> Windows XP Home SP3, Windows XP Professional SP3 (32 bit), Windows 7 Home Premium, Windows 7 Professional (32 bit), Windows 7 Enterprise (32 bit), Windows 7 Ultimate (32 bit), Microsoft Server 2003 R2 Std. SP2 (32 bit), Microsoft Server 2008 Std. SP2 (32 bit) <i>Form of delivery:</i> German, English, Chinese, Italian, French, Spanish Single license Upgrade STEP 7 Basic V10.5 to STEP 7 Basic V11, single license Powerpack STEP 7 Basic V11 to STEP 7 Prof. V11, floating license STEP 7 Basic V11, trial license STEP 7 Basic Software Update Service, 1 year STEP 7 Basic Software Update Service Compact, 1 year
		6ES7 822-0AA01-0YA0 6ES7 822-0AA01-0YE0 6ES7 822-1AA01-0YC5 6ES7 822-0AA01-0YA7 6ES7 822-0AA00-0YLO 6ES7 822-0AA00-0YM0
		Accessories CSM 1277 compact switch module Unmanaged switch for connecting a SIMATIC S7-1200 and up to three further nodes to Industrial Ethernet with 10/100 Mbit/s; 4 x RJ45 ports; external 24 V DC power supply, diagnostics on LEDs, S7-1200 module including electronic manual on CD-ROM
		6GK7 277-1AA10-0AA0
		IE TP Cord RJ45/RJ45 TP cable 4 x 2 with 2 RJ45 plugs • 0.5 m • 1 m • 2 m • 6 m • 10 m
		6XV1 870-3QE50 6XV1 870-3QH10 6XV1 870-3QH20 6XV1 870-3QH60 6XV1 870-3QN10
		IE FC Outlet RJ45 For connection of Industrial Ethernet FC cables and TP Cords; graded prices from 10 and 50 items upwards
		6GK1 901-1FC00 0AA0

Note:

You can find more information in Catalog ST 70 and in the Industry Mall at www.siemens.com/industrymall

PROFINET/Industrial Ethernet

Controllers / Modular controllers / SIMATIC S7-1200

SIPLUS CPU 1214C

Overview



- The compact high-performance CPU
- With 24 integrated I/Os
- Expandable with:
 - 1 signal board (SB)
 - 8 signal modules (SM)
 - Max. 3 communication modules (CM)

Note:

SIPLUS extreme products are based on Siemens Industry standard products. The contents listed here were taken from the respective standard products. SIPLUS extreme-specific information was added.

SIPLUS CPU 1214C DC/DC/DC

Order No.	6AG1 214-1AE30-2XB0	6AG1 214-1AE30-4XB0	6AG1 214-1AE30-5XB0
Order No. based on	6ES7 214-1AE30-0XB0		
Ambient temperature range	-25 ... +70 °C ³⁾	0 ... +55 °C	-25 ... +55 °C
Conformal coating	Coating of the printed circuit boards and the electronic components		
Technical data	The technical data of the standard product applies except for the ambient conditions.		

SIPLUS CPU 1214C AC/DC/RLY

Order No.	6AG1 214-1BE30-2XB0	6AG1 214-1BE30-4XB0	6AG1 214-1BE30-5XB0
Order No. based on	6ES7 214-1BE30-0XB0		
Ambient temperature range	-25 ... +70 °C ³⁾	0 ... +55 °C	-25 ... +55 °C
Conformal coating	Coating of the printed circuit boards and the electronic components		
Technical data	The technical data of the standard product applies except for the ambient conditions.		

SIPLUS CPU 1214C DC/DC/RLY

Order No.	6AG1 214-1HE30-2XB0	6AG1 214-1HE30-4XB0	6AG1 214-1HE30-5XB0
Order No. based on	6ES7 214-1HE30-0XB0		
Ambient temperature range	-25 ... +70 °C ³⁾	0 ... +55 °C	-25 ... +55 °C
Conformal coating	Coating of the printed circuit boards and the electronic components		
Technical data	The technical data of the standard product applies except for the ambient conditions.		

Ambient conditions

Relative humidity	5 ... 100 % Condensation permissible
Biologically active substances	Conformity with EN 60721-3-3, Class 3B2 mold and fungal spores (except fauna)
Chemically active substances	Conformity with EN 60721-3-3, Class 3C4 incl. salt mist and ISA-S71.04 severity level G1; G2; G3; GX ^{1) 2)}
Mechanically active substances	Conformity with EN 60721-3-3, Class 3S4 including conductive sand, dust ²⁾
Air pressure (depending on the highest positive temperature range specified)	1080 ... 795 hPa (-1000 ... +2000 m) see ambient temperature range 795 ... 658 hPa (+2000 ... +3500 m) derating 10 K 658 ... 540 hPa (+3500 ... +5000 m) derating 20 K

1) ISA-S71.04 severity level GX: Long-term load:
SO₂ < 4.8 ppm; H₂S < 9.9 ppm; Cl < 0.2 ppm; HCl < 0.66 ppm;
HF < 0.12 ppm; NH < 49 ppm; O₃ < 0.1 ppm; NOX < 5.2 ppm
Limit value (max. 30 min/d):

SO₂ < 17.8 ppm; H₂S < 49.7 ppm; Cl < 1.0 ppm; HCl < 3.3 ppm;
HF < 2.4 ppm; NH < 247 ppm; O₃ < 1.0 ppm; NOX < 10.4 ppm

2) The supplied plug covers must remain in place over the unused interface when operated in atmospheres containing corrosive gases!
3) From +60 °C to +70 °C, the number of simultaneously enabled inputs and outputs is max. 50%; no SB module permitted

The technical documentation on SIPLUS can be found here:
www.siemens.com/siplus-extreme

Ordering data	Order No.	Order No.	Order No.
<p>SIPLUS CPU 1214C compact CPU, AC/DC/relay (extended temperature range and medial exposure)</p> <p>Integrated program and data memory of 50 KB, load memory of 2 MB; wide-range alternating voltage supply 85 ... 264 V AC; Boolean execution times of 0.1 µs per operation; 14 digital inputs, 10 digital outputs (relay), 2 analog inputs; expandable with up to 3 communication modules, 8 signal modules, and 1 signal board; digital inputs usable as HSC with 100 kHz</p> <ul style="list-style-type: none"> • Suitable for areas with extraordinary medial exposure (conformal coating) • Suitable for areas with extraordinary medial exposure (conformal coating); ambient temperature -25 ... +55 °C; without restrictions; SB module can be used • Suitable for areas with extraordinary medial exposure (conformal coating); ambient temperature -25 ... +70 °C; from +60 ... +70 °C number of simultaneously controllable inputs and outputs max. 50%; no SB module possible 	<p>6AG1 214-1BE30-4XB0</p> <p>6AG1 214-1BE30-5XB0</p> <p>6AG1 214-1BE30-2XB0</p>	<p>SIPLUS CPU 1214C compact CPU, DC/DC/relay (extended temperature range and medial exposure)</p> <p>Integrated program and data memory of 50 KB, load memory of 2 MB; power supply 24 V DC; Boolean execution times of 0.1 µs per operation; 14 digital inputs, 10 digital outputs (relay), 2 analog inputs; expandable with up to 3 communication modules, 8 signal modules and 1 signal board; digital inputs usable as HSC with 100 kHz</p> <ul style="list-style-type: none"> • Suitable for areas with extraordinary medial exposure (conformal coating) • Suitable for areas with extraordinary medial exposure (conformal coating); ambient temperature -25 ... +55 °C; without restrictions; SB module can be used • Suitable for areas with extraordinary medial exposure (conformal coating); ambient temperature -25 ... +70 °C; from +60 ... +70 °C number of simultaneously controllable inputs and outputs max. 50%; no SB module possible 	<p>6AG1 214-1HE30-4XB0</p> <p>6AG1 214-1HE30-5XB0</p> <p>6AG1 214-1HE30-2XB0</p>
<p>SIPLUS CPU 1214C compact CPU, DC/DC/DC (extended temperature range and medial exposure)</p> <p>Integrated program and data memory of 50 KB, load memory of 2 MB; voltage supply 24 V DC; Boolean execution times of 0.1 µs per operation; 14 digital inputs, 10 digital outputs, 2 analog inputs; expandable with up to 3 communication modules, 8 signal modules and 1 signal board; digital inputs usable as HSC with 100 kHz; 24 V DC digital outputs usable as pulse outputs (PTO) or pulse-width-modulated outputs (PWM) with 100 kHz</p> <ul style="list-style-type: none"> • Suitable for areas with extraordinary medial exposure (conformal coating) • Suitable for areas with extraordinary medial exposure (conformal coating); ambient temperature -25 ... +55 °C; without restrictions; SB module can be used • Suitable for areas with extraordinary medial exposure (conformal coating); ambient temperature -25 ... +70 °C; from +60 ... +70 °C number of simultaneously controllable inputs and outputs max. 50%; no SB module possible 	<p>6AG1 214-1AE30-4XB0</p> <p>6AG1 214-1AE30-5XB0</p> <p>6AG1 214-1AE30-2XB0</p>	<p>Accessories</p>	<p>See SIMATIC S7-1200 CPU 1214C</p>

PROFINET/Industrial Ethernet

Controllers / Modular controllers / SIMATIC S7-300

CPU 314C-2 PN/DP

Overview



- The compact CPU with integral digital and analog inputs/ outputs and technological functions
- High processing performance in binary and floating-point arithmetic
- For connecting distributed I/O via PROFIBUS and PROFINET
- Combined MPI/PROFIBUS DP master/slave interface
- PROFINET interface with 2-port switch
- PROFINET IO Controller for operating distributed I/O on PROFINET
- PROFINET I-Device for connecting the CPU as intelligent PROFINET device under a SIMATIC or third-party PROFINET I/O controller
- Component based Automation (CBA) on PROFINET
- PROFINET proxy for intelligent devices on PROFIBUS DP in Component based Automation (CBA)
- Integrated Web server with the option of creating user-defined web pages
- Isochronous mode on PROFINET

SIMATIC Micro Memory Card required for operation of CPU.

Ordering data

CPU 314C-2 PN/DP

Compact CPU, 192 KB RAM, power supply 24 V DC, 24DI/16DO/4AI/2AO integrated, integrated functions, MPI, PROFIBUS DP master/slave interface; PROFINET IO Controller/I-Device interface, MMC required

Order No.

6ES7 314-6EH04-0AB0

SIMATIC Micro Memory Card

64 KB

6ES7 953-8LF20-0AA0

128 KB

6ES7 953-8LG20-0AA0

512 KB

6ES7 953-8LJ30-0AA0

2 MB

6ES7 953-8LL20-0AA0

4 MB

6ES7 953-8LM20-0AA0

8 MB

6ES7 953-8LP20-0AA0

MPI cable

For connecting SIMATIC S7 and the PG via MPI; 5 m in length

6ES7 901-0BF00-0AA0

Front connector (1 unit)

For compact CPUs

40-pin, with screw connections

- 1 unit
- 100 units

6ES7 392-1AM00-0AA0
6ES7 392-1AM00-1AB0

40-pin, with spring-loaded contacts

- 1 unit
- 100 units

6ES7 392-1BM01-0AA0
6ES7 392-1BM01-1AB0

40-pin, with FastConnect

- 1 unit

6ES7 392-1CM00-0AA0

SIMATIC TOP connect

See Catalog KT 10.2 and Industry Mall at www.siemens.com/industrymall

Slot number labels

6ES7 912-0AA00-0AA0

Order No.

S7-300 manual

Design, CPU data, module data, operations list

German

6ES7 398-8FA10-8AA0

English

6ES7 398-8FA10-8BA0

SIMATIC Manual Collection

Electronic manuals on DVD, multi-language: LOGO!, SIMADYN, SIMATIC bus components, SIMATIC C7, SIMATIC distributed I/O, SIMATIC HMI, SIMATIC Sensors, SIMATIC NET, SIMATIC PC Based Automation, SIMATIC PCS 7, SIMATIC PG/PC, SIMATIC S7, SIMATIC software, SIMATIC TDC

6ES7 998-8XC01-8YE0

SIMATIC Manual Collection update service for 1 year

Current "Manual Collection" DVD and the three subsequent updates

6ES7 998-8XC01-8YE2

Power supply connector

for compact CPUs, innovated standard CPUs and CPU 315F-2 DP (10 units, spare part)

6ES7 391-1AA00-0AA0

Labeling strips

for compact CPUs, standard CPUs and CPU 315F-2 DP (10 units, spare part)

6ES7 392-2XX00-0AA0

Label cover

for compact CPUs, standard CPUs and CPU 315F-2 DP (10 units, spare part)

6ES7 392-2XY00-0AA0

S7-SmartLabel V3.0

Software for automatic labeling of modules direct from the STEP 7 project

Single license

2XV9 450-1SL03-0YX0

Upgrade of single license

2XV9 450-1SL03-0YX4

PROFINET/Industrial Ethernet

Controllers / Modular controllers / SIMATIC S7-300

CPU 314C-2 PN/DP

Ordering data	Order No.	Order No.
Labeling sheets for automatic printing For 16-channel signal modules, DIN A4, for printing with laser printer; 10 units Petrol Light-beige Yellow Red For 32-channel signal modules, DIN A4, for printing with laser printer; 10 units Petrol Light-beige Yellow Red	6ES7 392-2AX00-0AA0 6ES7 392-2BX00-0AA0 6ES7 392-2CX00-0AA0 6ES7 392-2DX00-0AA0 6ES7 392-2AX10-0AA0 6ES7 392-2BX10-0AA0 6ES7 392-2CX10-0AA0 6ES7 392-2DX10-0AA0	PROFINET bus components IE FC TP standard cable GP 2x2 6XV1 840-2AH10 4-core, shielded TP installation cable for connection to IE FC Outlet RJ45/IE FC RJ45 Plug; PROFINET-compliant; with UL approval; sold by the meter, max. delivery unit 1000 m, minimum order quantity 20 m FO standard cable GP (50/125) 6XV1 873-2A Standard cable, splittable, UL approval, sold by the meter SCALANCE X204-2 Industrial Ethernet switch 6GK5 204-2BB10-2AA3 Industrial Ethernet switches with integral SNMP access, Web diagnostics, copper cable diagnostics and PROFINET diagnostics, for configuring linear bus, star and ring topologies; four 10/100 Mbit/s RJ45 ports and two FO ports Compact Switch Module CSM 377 6GK7 377-1AA00-0AA0 Unmanaged switch for the connection of a SIMATIC S7-300, ET 200M and up to three other nodes to Industrial Ethernet operating at 10/100 Mbit/s; 4 x RJ45 ports; external 24 V DC power supply, LED diagnostics, S7-300 module incl. electronic manual on CD-ROM
PC adapter USB for connecting a PC to SIMATIC S7-200/300/400 via USB; with USB cable (5 m)	6ES7 972-0CB20-0XA0	
PROFIBUS DP bus connector RS 485 <ul style="list-style-type: none"> with 90° cable outlet, max. data transfer rate 12 Mbit/s <ul style="list-style-type: none"> - without PG interface - with PG interface with 90° cable outlet for FastConnect connection system, max. data transfer rate 12 Mbit/s <ul style="list-style-type: none"> - without PG interface, 1 unit - without PG interface, 100 units - with PG interface, 1 unit - with PG interface, 100 units with axial cable outlet for SIMATIC OP, for connecting to PPI, MPI, PROFIBUS 	6ES7 972-0BA12-0XA0 6ES7 972-0BB12-0XA0 6ES7 972-0BA52-0XA0 6ES7 972-0BA52-0XB0 6ES7 972-0BB52-0XA0 6ES7 972-0BB52-0XB0 6GK1 500-0EA02	
PROFIBUS FastConnect bus cable Standard type with special design for quick mounting, 2-core, shielded, sold by the meter, max. delivery unit 1000 m, minimum order quantity 20 m	6XV1 830-0EH10	
Repeater RS 485 for PROFIBUS Data transfer rate up to 12 Mbit/s; 24 V DC; IP20 housing	6ES7 972-0AA02-0XA0	
		IE FC RJ45 Plugs RJ45 plug-in connector for Industrial Ethernet with a rugged metal enclosure and integrated insulation displacement contacts for connecting Industrial Ethernet FC installation cables IE FC RJ45 Plug 145 145° cable outlet <ul style="list-style-type: none"> 1 unit 6GK1 901-1BB30-0AA0 10 units 6GK1 901-1BB30-0AB0 50 units 6GK1 901-1BB30-0AE0 IE FC RJ45 Plug 180 180° cable outlet <ul style="list-style-type: none"> 1 unit 6GK1 901-1BB10-2AA0 10 units 6GK1 901-1BB10-2AB0 50 units 6GK1 901-1BB10-2AE0 PROFIBUS/PROFINET bus components See chapter 3, CA 01 catalog For establishing MPI/PROFIBUS/PROFINET communication

Note:

You can find more information in Catalog ST 70 and in the Industry Mall at www.siemens.com/industrymall

PROFINET/Industrial Ethernet

Controllers / Modular controllers / SIMATIC S7-300

CPU 315-2 PN/DP

Overview



- The CPU with mid-range program memory and quantity frameworks
- High processing power in binary and floating-point arithmetic
- Used as central controller in production lines with central and distributed I/O
- PROFINET interface with 2-port switch
- PROFINET IO Controller for operating distributed I/O on PROFINET
- PROFINET I-Device for connecting the CPU as intelligent PROFINET device under a SIMATIC or third-party PROFINET I/O Controller
- Component Based Automation (CBA) on PROFINET
- PROFINET proxy for intelligent devices on PROFIBUS DP in Component Based Automation (CBA)
- Integrated web server with the option of creating user-defined web pages
- Combined MPI/PROFIBUS DP master/slave interface
- Isochronous mode on PROFIBUS and PROFINET

SIMATIC Micro Memory Card required for operation of CPU.

Ordering data

CPU 315-2 PN/DP

Work memory 384 KB, power supply 24 V DC, combined MPI/PROFIBUS DP master/slave interface, Ethernet/PROFINET interface with 2-port switch; MMC required

Order No.

6ES7 315-2EH14-0AB0

SIMATIC Micro Memory Card

64 KB

6ES7 953-8LF20-0AA0

128 KB

6ES7 953-8LG20-0AA0

512 KB

6ES7 953-8LJ30-0AA0

2 MB

6ES7 953-8LL20-0AA0

4 MB

6ES7 953-8LM20-0AA0

8 MB

6ES7 953-8LP20-0AA0

MPI cable

for connection of SIMATIC S7 and PG via MPI; 5 m in length

6ES7 901-0BF00-0AA0

Slot number plates

6ES7 912-0AA00-0AA0

S7-300 manual

Design, CPU data, module data, instruction list

German

6ES7 398-8FA10-8AA0

English

6ES7 398-8FA10-8BA0

Order No.

SIMATIC Manual Collection

Electronic manuals on DVD, multilingual: LOGO!, SIMADYN, SIMATIC bus components, SIMATIC C7, SIMATIC distributed I/O, SIMATIC HMI, SIMATIC Sensors, SIMATIC NET, SIMATIC PC Based Automation, SIMATIC PCS 7, SIMATIC PG/PC, SIMATIC S7, SIMATIC Software, SIMATIC TDC

6ES7 998-8XC01-8YE0

SIMATIC Manual Collection update service for 1 year

Current "Manual Collection" DVD and the three subsequent updates

6ES7 998-8XC01-8YE2

Power supply connector

10 units, spare part

6ES7 391-1AA00-0AA0

Manual "Communication for SIMATIC S7-300/-400"

German

6ES7 398-8EA00-8AA0

English

6ES7 398-8EA00-8BA0

SIMATIC S7 training case

With mounting components for mounting S7-200 and S7-300

6ES7 910-3AA00-0XA0

PC adapter USB

for connecting a PC to SIMATIC S7-200/300/400 via USB; with USB cable (5 m)

6ES7 972-0CB20-0XA0

PROFINET/Industrial Ethernet

Controllers / Modular controllers / SIMATIC S7-300

CPU 315-2 PN/DP

2

Ordering data	Order No.	Order No.	
PROFIBUS bus components		PROFINET bus components	
PROFIBUS DP bus connector RS 485 <ul style="list-style-type: none"> with 90° cable outlet, max. transfer rate 12 Mbit/s <ul style="list-style-type: none"> without PG interface with PG interface with 90° cable outlet for FastConnect connection system, max. transfer rate 12 Mbit/s <ul style="list-style-type: none"> without PG interface, 1 unit without PG interface, 100 units with PG interface, 1 unit with PG interface, 100 units with axial cable outlet for SIMATIC OP, for connecting to PPI, MPI, PROFIBUS 	6ES7 972-0BA12-0XA0 6ES7 972-0BB12-0XA0 6ES7 972-0BA52-0XA0 6ES7 972-0BA52-0XB0 6ES7 972-0BB52-0XA0 6ES7 972-0BB52-0XB0 6GK1 500-0EA02	IE FC TP standard cable GP 2x2 4-core, shielded TP installation cable for connection to IE FC Outlet RJ45/ IE FC RJ45 Plug; PROFINET-compatible; with UL approval; sold by the meter, max. delivery unit 1000 m, minimum ordering quantity 20 m	6XV1 840-2AH10
PROFIBUS FastConnect bus cable Standard type with special design for quick mounting, 2-core, shielded, sold by the meter, max. delivery unit 1000 m, minimum ordering quantity 20 m	6XV1 830-0EH10	FO Standard Cable GP (50/125) Standard cable, splittable, UL approval, sold by the meter	6XV1 873-2A
RS 485 repeater for PROFIBUS Transfer rate up to 12 Mbit/s; 24 V DC; IP20 enclosure	6ES7 972-0AA02-0XA0	SCALANCE X204-2 Industrial Ethernet Switch Industrial Ethernet Switches with integral SNMP access, Web diagnostics, copper cable diagnostics and PROFINET diagnostics for configuring line, star and ring topologies; four 10/100 Mbit/s RJ45 ports and two FO ports	6GK5 204-2BB10-2AA3
		Compact Switch Module CSM 377 Unmanaged switch for connecting a SIMATIC S7-300, ET 200M and up to three other participants to Industrial Ethernet with 10/100 Mbit/s; 4 x RJ45 ports; external 24 V DC power supply, LED diagnostics, S7-300 module incl. electronic manual on CD-ROM	6GK7 377-1AA00-0AA0
		IE FC RJ45 plugs RJ45 plug connector for Industrial Ethernet with a rugged metal enclosure and integrated insulation displacement contacts for connecting Industrial Ethernet FC installation cables	
		IE FC RJ45 plug 145 145° cable outlet <ul style="list-style-type: none"> 1 unit 10 units 50 units 	6GK1 901-1BB30-0AA0 6GK1 901-1BB30-0AB0 6GK1 901-1BB30-0AE0
		IE FC RJ45 plug 180 180° cable outlet <ul style="list-style-type: none"> 1 unit 10 units 50 units 	6GK1 901-1BB10-2AA0 6GK1 901-1BB10-2AB0 6GK1 901-1BB10-2AE0
		PROFIBUS/PROFINET bus components For establishing MPI/PROFIBUS/PROFINET communication	See chapter 3, CA 01 catalog

Note:

You can find more information in Catalog ST 70 and in the Industry Mall at www.siemens.com/industrymall

PROFINET/Industrial Ethernet

Controllers / Modular controllers / SIMATIC S7-300

SIPLUS CPU 315-2 PN/DP

Overview



- The CPU with medium-sized program memory and quantity frameworks
- High processing performance in binary and floating-point arithmetic
- Used as central controller in production lines with central and distributed I/O
- Component Based Automation (CBA) on PROFINET
- PROFINET proxy for intelligent devices on PROFIBUS DP in Component Based Automation (CBA)
- PROFINET IO Controller for operating distributed I/O on PROFINET
- PROFINET interface with 2-port switch
- Combined MPI/PROFIBUS DP master/slave interface
- Isochronous mode on PROFIBUS

SIMATIC Micro Memory Card required for operation of the CPU.

Note:

SIPLUS extreme products are based on Siemens Industry standard products. The contents listed here were taken from the respective standard products. SIPLUS extreme-specific information was added.

SIPLUS CPU 315-2 PN/DP		
Order number	6AG1 315-2EH14-2AY0	6AG1 315-2EH14-7AB0
Order No. based on	6ES7 315-2EH14-0AB0	6ES7 315-2EH14-0AB0
Ambient temperature range	-25 ... +60 °C	-25 ... +70 °C
Conformal coating	Coating of the printed circuit boards and the electronic components	
Technical data	The technical data of the standard product applies except for the ambient conditions	
Compliant with the standards for electronic equipment used on railway rolling stock (EN 50155, temperature T1, category 1).	Yes	No

Ambient conditions

Relative humidity	5 ... 100 % Condensation permissible
Biologically active substances	Conformity with EN 60721-3-3, Class 3B2 mold and fungal spores (except fauna)
Chemically active substances	Conformity with EN 60721-3-3, Class 3C4 incl. salt mist and ISA-S71.04 severity level G1; G2; G3; GX ^{1) 2)}
Mechanically active substances	Conformity with EN 60721-3-3, Class 3S4 including conductive sand, dust ²⁾
Air pressure (depending on the highest positive temperature range specified)	1080 ... 795 hPa (-1000 ... +2000 m) see ambient temperature range 795 ... 658 hPa (+2000 ... +3500 m) derating 10 K 658 ... 540 hPa (+3500 ... +5000 m) derating 20 K

- 1) ISA-S71.04 severity level GX: Long-term load:
SO₂ < 4.8 ppm; H₂S < 9.9 ppm; Cl < 0.2 ppm; HCl < 0.66 ppm;
HF < 0.12 ppm; NH < 49 ppm; O₃ < 0.1 ppm; NOX < 5.2 ppm
Limit value (max. 30 min/d):
SO₂ < 17.8 ppm; H₂S < 49.7 ppm; Cl < 1.0 ppm; HCl < 3.3 ppm;
HF < 2.4 ppm; NH < 247 ppm; O₃ < 1.0 ppm; NOX < 10.4 ppm
- 2) The supplied plug covers must remain in place over the unused interface when operated in atmospheres containing corrosive gases!

The technical documentation on SIPLUS can be found here:
www.siemens.com/siplus-extreme

Ordering data	Order No.
SIPLUS CPU 315-2 PN/DP (extended temperature range and medial exposure)	
Work memory 384 KB, power supply 24 V DC, combined MPI/PROFIBUS DP master/slave interface, Ethernet/PROFINET interface with 2-port switch; MMC required	6AG1 315-2EH14-7AB0
Additional conformance with EN 50155	6AG1 315-2EH14-2AY0
Accessories	See SIMATIC CPU 315-2 PN/DP

PROFINET/Industrial Ethernet

Controllers / Modular controllers / SIMATIC S7-300

CPU 317-2 PN/DP

Overview



- The CPU with a large program memory and quantity framework for demanding applications
- For cross-industry automation tasks in series machine, special machine and plant construction
- Used as central controller in production lines with central and distributed I/O
- High processing power in binary and floating-point arithmetic
- PROFINET interface with 2-port switch
- PROFINET I/O Controller for operating distributed I/O on PROFINET
- PROFINET I-Device for connecting the CPU as intelligent PROFINET device under a SIMATIC or third-party PROFINET I/O Controller
- Distributed intelligence in Component Based Automation (CBA) on PROFINET
- PROFINET proxy for intelligent devices on PROFIBUS DP in Component Based Automation (CBA)
- Integrated web server with the option of creating user-defined web pages
- Combined MPI/PROFIBUS DP master/slave interface
- Isochronous mode on PROFIBUS and PROFINET
- Optionally supports the use of SIMATIC engineering tools

SIMATIC Micro Memory Card required for operation of CPU.

Ordering data

Order No.

CPU 317-2 PN/DP

6ES7 317-2EK14-0AB0

Main memory 1 Mbyte, power supply 24 V DC, combined MPI/PROFIBUS DP master/slave interface, Ethernet/PROFINET interface with 2-port switch; MMC required

SIMATIC Micro Memory Card

64 KB

6ES7 953-8LF20-0AA0

128 KB

6ES7 953-8LG20-0AA0

512 KB

6ES7 953-8LJ30-0AA0

2 MB

6ES7 953-8LL20-0AA0

4 MB

6ES7 953-8LM20-0AA0

8 MB

6ES7 953-8LP20-0AA0

MPI cable

6ES7 901-0BF00-0AA0

for connection of SIMATIC S7 and PG via MPI; 5 m in length

Slot number plates

6ES7 912-0AA00-0AA0

S7-300 manual

Design, CPU data, module data, instruction list

German

6ES7 398-8FA10-8AA0

English

6ES7 398-8FA10-8BA0

SIMATIC Manual Collection

6ES7 998-8XC01-8YE0

Electronic manuals on DVD, multilingual: LOGO!, SIMADYN, SIMATIC bus components, SIMATIC C7, SIMATIC distributed I/O, SIMATIC HMI, SIMATIC Sensors, SIMATIC NET, SIMATIC PC Based Automation, SIMATIC PCS 7, SIMATIC PG/PC, SIMATIC S7, SIMATIC Software, SIMATIC TDC

SIMATIC Manual Collection update service for 1 year

6ES7 998-8XC01-8YE2

Current "Manual Collection" DVD and the three subsequent updates

Power supply connector

6ES7 391-1AA00-0AA0

10 units, spare part

Manual "Communication for SIMATIC S7-300/-400"

German

6ES7 398-8EA00-8AA0

English

6ES7 398-8EA00-8BA0

SIMATIC S7 training case

6ES7 910-3AA00-0XA0

With mounting components for mounting S7-200 and S7-300

PC adapter USB

6ES7 972-0CB20-0XA0

for connecting a PC to SIMATIC S7-200/300/400 via USB; with USB cable (5 m)

2

PROFINET/Industrial Ethernet

Controllers / Modular controllers / SIMATIC S7-300

CPU 317-2 PN/DP

2

Ordering data

Order No.

PROFIBUS bus components

PROFIBUS DP bus connector RS 485

- with 90° cable outlet, max. transfer rate 12 Mbit/s
 - without PG interface
 - with PG interface
- with 90° cable outlet for FastConnect connection system, max. transfer rate 12 Mbit/s
 - without PG interface, 1 unit
 - without PG interface, 100 units
 - with PG interface, 1 unit
 - with PG interface, 100 units
- with axial cable outlet for SIMATIC OP, for connecting to PPI, MPI, PROFIBUS

6ES7 972-0BA12-0XA0
6ES7 972-0BB12-0XA0

6ES7 972-0BA52-0XA0
6ES7 972-0BA52-0XB0
6ES7 972-0BB52-0XA0
6ES7 972-0BB52-0XB0
6GK1 500-0EA02

PROFIBUS FastConnect bus cable

Standard type with special design for quick mounting, 2-core, shielded, sold by the meter, max. delivery unit 1000 m, minimum ordering quantity 20 m

6XV1 830-0EH10

RS 485 repeater for PROFIBUS

Transfer rate up to 12 Mbit/s; 24 V DC; IP20 enclosure

6ES7 972-0AA02-0XA0

Order No.

PROFINET bus components

IE FC TP standard cable GP 2x2

4-core, shielded TP installation cable for connection to IE FC Outlet RJ45/ IE FC RJ45 Plug; PROFINET-compatible; with UL approval; sold by the meter, max. delivery unit 1000 m, minimum ordering quantity 20 m

6XV1 840-2AH10

FO Standard Cable GP (50/125)

Standard cable, splittable, UL approval, sold by the meter

6XV1 873-2A

SCALANCE X204-2 Industrial Ethernet Switch

Industrial Ethernet Switches with integral SNMP access, web diagnostics, copper cable diagnostics and PROFINET diagnostics for configuring line, star and ring topologies; four 10/100 Mbit/s RJ45 ports and two FO ports

6GK5 204-2BB10-2AA3

Compact Switch Module CSM 377

Unmanaged switch for connecting a SIMATIC S7-300, ET 200M and up to three other participants to Industrial Ethernet with 10/100 Mbit/s; 4 x RJ45 ports; external 24 V DC power supply, LED diagnostics, S7-300 module incl. electronic manual on CD-ROM

6GK7 377-1AA00-0AA0

IE FC RJ45 plugs

RJ45 plug connector for Industrial Ethernet with a rugged metal enclosure and integrated insulation displacement contacts for connecting Industrial Ethernet FC installation cables

IE FC RJ45 plug 145

145° cable outlet

- 1 unit
- 10 units
- 50 units

6GK1 901-1BB30-0AA0

6GK1 901-1BB30-0AB0

6GK1 901-1BB30-0AE0

IE FC RJ45 plug 180

180° cable outlet

- 1 unit
- 10 units
- 50 units

6GK1 901-1BB10-2AA0

6GK1 901-1BB10-2AB0

6GK1 901-1BB10-2AE0

PROFIBUS/PROFINET bus components

For establishing MPI/PROFIBUS/PROFINET communication

See chapter 3, CA 01 catalog

Note:

You can find more information in Catalog ST 70 and in the Industry Mall at www.siemens.com/industrymall

PROFINET/Industrial Ethernet

Controllers / Modular controllers / SIMATIC S7-300

SIPLUS CPU 317-2 PN/DP

Overview



- The CPU with a large program memory and quantity structure for demanding applications
- Distributed intelligence in Component Based Automation (CBA) on PROFINET
- PROFINET proxy for intelligent devices on PROFIBUS DP in Component Based Automation (CBA)
- PROFINET IO Controller for operating distributed I/Os on PROFINET
- For cross-sector automation tasks in series machine, special machine and plant construction
- Used as central controller in production lines with central and distributed I/O
- For comprehensive I/O configuration
- For setting up distributed I/O structures
- High processing performance in binary and floating-point arithmetic
- Combined MPI/PROFIBUS DP master/slave interface
- Optionally supports the use of SIMATIC engineering tools

Micro Memory Card required for operation of CPU.

Note:

SIPLUS extreme products are based on Siemens Industry standard products. The contents listed here were taken from the respective standard products. SIPLUS extreme-specific information was added.

	SIPLUS CPU 317-2 PN/DP	
Order No.	6AG1 317-2EK13-2AB0	6AG1 317-2EK13-2AY0
Order No. based on	6ES7 317-2EK13-0AB0	6ES7 317-2EK13-0AB0
Ambient temperature range	-25 ... +70 °C	
Conforms with standard for electronic equipment used on rolling stock (EN 50155)	No	Yes
Conformal coating	Coating of the printed circuit boards and the electronic components	
Technical specifications	The technical data of the standard product applies except for the ambient conditions.	

Ambient conditions

Relative humidity	5 ... 100 % Condensation permissible
Biologically active substances	Conformity with EN 60721-3-3, Class 3B2 mold and fungal spores (except fauna)
Chemically active substances	Conformity with EN 60721-3-3, Class 3C4 incl. salt mist and ISA-S71.04 severity level G1; G2; G3; GX ^{1) 2)}
Mechanically active substances	Conformity with EN 60721-3-3, Class 3S4 including conductive sand, dust ²⁾
Air pressure (depending on the highest positive temperature range specified)	1080 ... 795 hPa (-1000 ... +2000 m) see ambient temperature range 795 ... 658 hPa (+2000 ... +3500 m) derating 10 K 658 ... 540 hPa (+3500 ... +5000 m) derating 20 K

- 1) ISA-S71.04 severity level GX: Long-term load:
SO₂ < 4.8 ppm; H₂S < 9.9 ppm; Cl < 0.2 ppm; HCl < 0.66 ppm;
HF < 0.12 ppm; NH < 49 ppm; O₃ < 0.1 ppm; NOX < 5.2 ppm
Limit value (max. 30 min/d):
SO₂ < 17.8 ppm; H₂S < 49.7 ppm; Cl < 1.0 ppm; HCl < 3.3 ppm;
HF < 2.4 ppm; NH < 247 ppm; O₃ < 1.0 ppm; NOX < 10.4 ppm

- 2) The supplied plug covers must remain in place over the unused interface when operated in atmospheres containing corrosive gases!

Technical documentation on SIPLUS can be found here:
www.siemens.com/siplus-extreme

Ordering data	Order No.
SIPLUS CPU 317-2 PN/DP (extended temperature range and medial exposure)	
Work memory 512 KB, power supply 24 V DC, combined MPI/PROFIBUS DP master/slave interface, Ethernet/PROFINET interface; MMC required	6AG1 317-2EK13-2AB0
Additional conformance with EN 50155	6AG1 317-2EK13-2AY0
Accessories	See SIMATIC CPU 317-2 PN/DP

PROFINET/Industrial Ethernet

Controllers / Modular controllers / SIMATIC S7-300

CPU 319-3 PN/DP

Overview



- The CPU with high command processing performance, large program memory and quantity framework for demanding applications
- For cross-industry automation tasks in series machine, special machine and plant construction
- Used as central controller in production lines with central and distributed I/O on PROFIBUS and PROFINET
- PROFINET I/O controller for operating distributed I/O on PROFINET
- PROFINET I-Device for connecting the CPU as an intelligent PROFINET device under a SIMATIC or non-Siemens PROFINET I/O controller
- PROFINET interface with 2-port switch
- Isochronous mode on PROFIBUS or PROFINET
- Integral Web server with the option of creating user-defined Web sites
- Distributed intelligence in Component Based Automation (CBA) on PROFINET
- PROFINET proxy for intelligent devices on PROFIBUS DP in Component Based Automation (CBA)
- Optionally supports the use of SIMATIC engineering tools

SIMATIC Micro Memory Card required for operation of the CPU.

Ordering data

Order No.

CPU 319-3 PN/DP

Main memory 2 Mbyte, power supply 24 V DC, combined MPI/PROFIBUS DP master/slave interface, PROFIBUS DP master/slave interface, Ethernet/PROFINET interface with 2-port switch; MMC required

6ES7 318-3EL01-0AB0

SIMATIC Micro Memory Card

64 KB

6ES7 953-8LF20-0AA0

128 KB

6ES7 953-8LG20-0AA0

512 KB

6ES7 953-8LJ30-0AA0

2 MB

6ES7 953-8LL20-0AA0

4 MB

6ES7 953-8LM20-0AA0

8 MB

6ES7 953-8LP20-0AA0

MPI cable

for connection of SIMATIC S7 and PG via MPI; 5 m in length

6ES7 901-0BF00-0AA0

Slot number plates

6ES7 912-0AA00-0AA0

S7-300 manual

Design, CPU data, module data, instruction list

German

6ES7 398-8FA10-8AA0

English

6ES7 398-8FA10-8BA0

SIMATIC Manual Collection

Electronic manuals on DVD, multilingual: LOGO!, SIMADYN, SIMATIC bus components, SIMATIC C7, SIMATIC distributed I/O, SIMATIC HMI, SIMATIC Sensors, SIMATIC NET, SIMATIC PC Based Automation, SIMATIC PCS 7, SIMATIC PG/PC, SIMATIC S7, SIMATIC Software, SIMATIC TDC

6ES7 998-8XC01-8YE0

SIMATIC Manual Collection update service for 1 year

Current "Manual Collection" DVD and the three subsequent updates

6ES7 998-8XC01-8YE2

Power supply connector

10 units, spare part

6ES7 391-1AA00-0AA0

Manual "Communication for SIMATIC S7-300/-400"

German

6ES7 398-8EA00-8AA0

English

6ES7 398-8EA00-8BA0

SIMATIC S7 training case

With mounting components for mounting S7-200 and S7-300

6ES7 910-3AA00-0XA0

PC adapter USB

for connecting a PC to SIMATIC S7-200/300/400 via USB; with USB cable (5 m)

6ES7 972-0CB20-0XA0

PROFINET/Industrial Ethernet

Controllers / Modular controllers / SIMATIC S7-300

CPU 319-3 PN/DP

Ordering data	Order No.	Order No.	
PROFIBUS bus components		PROFINET bus components	
PROFIBUS DP bus connector RS 485 <ul style="list-style-type: none"> with 90° cable outlet, max. transfer rate 12 Mbit/s <ul style="list-style-type: none"> without PG interface with PG interface with 90° cable outlet for FastConnect connection system, max. transfer rate 12 Mbit/s <ul style="list-style-type: none"> without PG interface, 1 unit without PG interface, 100 units with PG interface, 1 unit with PG interface, 100 units with axial cable outlet for SIMATIC OP, for connecting to PPI, MPI, PROFIBUS 	6ES7 972-0BA12-0XA0 6ES7 972-0BB12-0XA0	IE FC TP standard cable GP 2x2 4-core, shielded TP installation cable for connection to IE FC Outlet RJ45/ IE FC RJ45 Plug; PROFINET-compatible; with UL approval; sold by the meter, max. delivery unit 1000 m, minimum ordering quantity 20 m	6XV1 840-2AH10
PROFIBUS FastConnect bus cable Standard type with special design for quick mounting, 2-core, shielded, sold by the meter, max. delivery unit 1000 m, minimum ordering quantity 20 m	6XV1 830-0EH10	FO Standard Cable GP (50/125) Standard cable, splittable, UL approval, sold by the meter	6XV1 873-2A
RS 485 repeater for PROFIBUS Transfer rate up to 12 Mbit/s; 24 V DC; IP20 enclosure	6ES7 972-0AA02-0XA0	SCALANCE X204-2 Industrial Ethernet Switch Industrial Ethernet Switches with integral SNMP access, Web diagnostics, copper cable diagnostics and PROFINET diagnostics for configuring line, star and ring topologies; four 10/100 Mbit/s RJ45 ports and two FO ports	6GK5 204-2BB10-2AA3
		Compact Switch Module CSM 377 Unmanaged switch for connecting a SIMATIC S7-300, ET 200M and up to three other participants to Industrial Ethernet with 10/100 Mbit/s; 4 x RJ45 ports; external 24 V DC power supply, LED diagnostics, S7-300 module incl. electronic manual on CD-ROM	6GK7 377-1AA00-0AA0
		IE FC RJ45 plugs RJ45 plug connector for Industrial Ethernet with a rugged metal enclosure and integrated insulation displacement contacts for connecting Industrial Ethernet FC installation cables	
		IE FC RJ45 plug 145 145° cable outlet <ul style="list-style-type: none"> 1 unit 10 units 50 units 	6GK1 901-1BB30-0AA0 6GK1 901-1BB30-0AB0 6GK1 901-1BB30-0AE0
		IE FC RJ45 plug 180 180° cable outlet <ul style="list-style-type: none"> 1 unit 10 units 50 units 	6GK1 901-1BB10-2AA0 6GK1 901-1BB10-2AB0 6GK1 901-1BB10-2AE0
		PROFIBUS/PROFINET bus components For establishing MPI/PROFIBUS/PROFINET communication	see chapter 3, CA 01 catalog

Note:

You can find more information in Catalog ST 70 and in the Industry Mall at www.siemens.com/industrymall

PROFINET/Industrial Ethernet

Controllers / Modular controllers / SIMATIC S7-300

CPU 315F-2 PN/DP

Overview



- Based on CPU 315-2 PN/DP
- The CPU with medium-sized program memory and quantity structures for setting up a fail-safe automation system in plants with increased safety requirements
- Complies with safety requirements up to SIL 3 according to IEC 61508, PL e according to ISO 13849, and up to Cat. 4 according to EN 954-1
- Fail-safe I/O modules in distributed stations can be connected through the integrated PROFINET interface (PROFIsafe) and/or through the integrated PROFIBUS DP interface (PROFIsafe);
- Fail-safe I/O modules of the ET 200M range can also be centrally connected
- Central and distributed use of standard modules for non safety-relevant applications
- Component Based Automation (CBA) on PROFINET
- PROFINET IO Controller for operating distributed I/O on PROFINET
- PROFINET interface with 2-port switch
- PROFINET proxy for intelligent devices on PROFIBUS DP in Component Based Automation (CBA)

SIMATIC Micro Memory Card required for operation of CPU.

Ordering data

Order No.

CPU 315F-2 PN/DP

CPU for SIMATIC S7-300F;
512 KB main memory,
24 V DC power supply,
MPI/PROFIBUS DP master/slave
interface, Industrial Ethernet/
PROFINET interface;
incl. slot number labels

6ES7 315-2FJ14-0AB0

Distributed Safety V5.4 programming tool

Task: Software for configuring
fail-safe user programs for
SIMATIC S7-300F, S7-400F,
ET 200S
Requirement:
STEP 7 V5.3 SP3 and higher

Floating license

6ES7 833-1FC02-0YA5

Software Update Service

6ES7 833-1FC00-0YX2

Distributed Safety Upgrade

From V5.x to V5.4;
Floating license for 1 user

6ES7 833-1FC02-0YE5

SIMATIC Micro Memory Card

64 KB

6ES7 953-8LF20-0AA0

128 KB

6ES7 953-8LG20-0AA0

512 KB

6ES7 953-8LJ30-0AA0

2 MB

6ES7 953-8LL20-0AA0

4 MB

6ES7 953-8LM20-0AA0

8 MB

6ES7 953-8LP20-0AA0

MPI cable

For connection of SIMATIC S7
and PG via MPI; 5 m in length

6ES7 901-0BF00-0AA0

Slot number plates

6ES7 912-0AA00-0AA0

S7-300 manual

Design, CPU data, module data,
instruction list

German

6ES7 398-8FA10-8AA0

English

6ES7 398-8FA10-8BA0

SIMATIC Manual Collection

Electronic manuals on DVD,
multilingual: LOGO!, SIMADYN,
SIMATIC bus components,
SIMATIC C7,
SIMATIC distributed I/O,
SIMATIC HMI, SIMATIC Sensors,
SIMATIC NET, SIMATIC PC Based
Automation, SIMATIC PCS 7,
SIMATIC PG/PC, SIMATIC S7,
SIMATIC Software, SIMATIC TDC

6ES7 998-8XC01-8YE0

SIMATIC Manual Collection update service for 1 year

Current "Manual Collection" DVD
and the three subsequent
updates

6ES7 998-8XC01-8YE2

PROFINET/Industrial Ethernet

Controllers / Modular controllers / SIMATIC S7-300

CPU 315F-2 PN/DP

Ordering data	Order No.	Order No.
Power supply connector 10 units, spare part	6ES7 391-1AA00-0AA0	
Manual "Communication for SIMATIC S7-300/-400" German English	6ES7 398-8EA00-8AA0 6ES7 398-8EA00-8BA0	
PC adapter USB For connecting a PC to SIMATIC S7-200/300/400 via USB; with USB cable (5 m)	6ES7 972-0CB20-0XA0	
PROFIBUS DP bus connector RS 485 <ul style="list-style-type: none"> With 90° cable outlet, max. transmission rate 12 Mbit/s <ul style="list-style-type: none"> Without PG interface With PG interface With 90° cable outlet for FastConnect connection system, max. transmission rate 12 Mbit/s <ul style="list-style-type: none"> Without PG interface, 1 unit Without PG interface, 100 units With PG interface, 1 unit With PG interface, 100 units With axial cable outlet for SIMATIC OP, for connecting to PPI, MPI, PROFIBUS 	6ES7 972-0BA12-0XA0 6ES7 972-0BB12-0XA0 6ES7 972-0BA52-0XA0 6ES7 972-0BA52-0XB0 6ES7 972-0BB52-0XA0 6ES7 972-0BB52-0XB0 6GK1 500-0EA02	
PROFIBUS FastConnect bus cable Standard type with special design for quick mounting, 2-core, shielded, sold by the meter, max. delivery unit 1000 m, minimum ordering quantity 20 m	6XV1 830-0EH10	
RS 485 repeater for PROFIBUS Transmission rate up to 12 Mbit/s; 24 V DC; IP20 enclosure	6ES7 972-0AA02-0XA0	
		PROFINET bus components IE FC TP Standard Cable GP 2x2 4-core, shielded TP installation cable for connection to IE FC Outlet RJ45/ IE FC RJ45 Plug; PROFINET-compatible; with UL approval; sold by the meter, max. delivery unit 1000 m, minimum ordering quantity 20 m FO Standard Cable GP (50/125) Standard cable, splittable, UL approval, sold by the meter SCALANCE X204-2 Industrial Ethernet Switch Industrial Ethernet Switches with integral SNMP access, Web diagnostics, copper cable diagnostics and PROFINET diagnostics for configuring line, star and ring topologies; four 10/100 Mbit/s RJ45 ports and two FO ports CSM 377 Compact Switch Module Unmanaged switch for connecting a SIMATIC S7-300, ET 200M and up to three other participants to Industrial Ethernet with 10/100 Mbit/s; 4 x RJ45 ports; external 24 V DC power supply, LED diagnostics, S7-300 module incl. electronic manual on CD-ROM
		6XV1 840-2AH10 6XV1 873-2A 6GK5 204-2BB10-2AA3 6GK7 377-1AA00-0AA0
		IE FC RJ45 Plugs RJ45 plug connector for Industrial Ethernet with a rugged metal enclosure and integrated insulation displacement contacts for connecting Industrial Ethernet FC installation cables IE FC RJ45 Plug 145 145° cable outlet <ul style="list-style-type: none"> 1 unit 10 units 50 units IE FC RJ45 Plug 180 180° cable outlet <ul style="list-style-type: none"> 1 unit 10 units 50 units
		6GK1 901-1BB30-0AA0 6GK1 901-1BB30-0AB0 6GK1 901-1BB30-0AE0 6GK1 901-1BB10-2AA0 6GK1 901-1BB10-2AB0 6GK1 901-1BB10-2AE0
		PROFIBUS/PROFINET bus components For establishing MPI/PROFIBUS/PROFINET communication See chapter 3, CA 01 catalog

Note:

You can find more information in Catalog ST 70 and in the Industry Mall at www.siemens.com/industrymall

PROFINET/Industrial Ethernet

Controllers / Modular controllers / SIMATIC S7-300

SIPLUS CPU 315F-2 PN/DP

Overview



- The CPU with a medium sized program memory and quantity structures to build a fail-safe automation system for plants with increased safety requirements
- Complies with safety requirements up to SIL 3 according to IEC 61508, PL e in accordance with ISO 13849 and up to category 4 of EN 954-1
- The fail-safe I/O modules can be locally connected to the integrated PROFINET interface (PROFIsafe) and/or to the integrated PROFIBUS DP interface (PROFIsafe)
- The fail-safe I/O modules of ET 200M can be also centrally connected
- The standard modules for non-safety applications can be operated both centrally and locally
- Component based Automation (CBA) on PROFINET
- PROFINET IO Controller for operating distributed I/O on PROFINET
- PROFINET interface with 2-port switch
- PROFINET proxy for intelligent devices on PROFIBUS DP in Component based Automation (CBA)

Micro Memory Card required for CPU operation.

Note:

SIPLUS extreme products are based on Siemens Industry standard products. The contents listed here were taken from the respective standard products. SIPLUS extreme-specific information was added.

SIPLUS CPU 315F-2 PN/DP	
Order No.	6AG1 315-2FJ14-2AB0 6AG1 315-2FJ14-2AY0
Order No. based on	6ES7 315-2FJ14-0AB0 6ES7 315-2FJ14-0AB0
Ambient temperature range	-25 ... +60 °C
Conformal coating	Coating of the printed circuit boards and the electronic components
Technical data	The technical data of the standard product applies except for the ambient conditions.
Compliant with the standards for electronic equipment used on railway rolling stock (EN 50155, temperature T1, category 1).	No Yes
Ambient conditions:	
Relative humidity	5 ... 100%, condensation allowed

Technical documentation on SIPLUS can be found here:
www.siemens.com/siplus-extreme

Ordering data	Order No.
CPU 315F-2 PN/DP	
CPU for SIPLUS S7-300F; work memory 512 KB, power supply 24 V DC, MPI/PROFIBUS DP master/slave interface, Industrial Ethernet/PROFINET interface; incl. slot number labels	6AG1 315-2FJ14-2AB0
Additional conformance with EN 50155	6AG1 315-2FJ14-2AY0
Accessories	See SIMATIC CPU 315F-2 PN/DP

PROFINET/Industrial Ethernet Controllers / Modular controllers / SIMATIC S7-300

CPU 317F-2 PN/DP

Overview



- Based on CPU 317-2 PN/DP
- The fail-safe CPU with a large program memory and quantity framework for demanding applications; for setting up a fail-safe automation system in plants with increased safety requirements.
- Complies with safety requirements up to SIL 3 according to IEC 61508, PL e according to ISO 13849-1, and up to Cat. 4 according to EN 954-1
- Fail-safe I/O modules in distributed stations can be connected through the integrated PROFINET interface (PROFIsafe) and/or through the integrated PROFIBUS DP interface (PROFIsafe)
- Fail-safe I/O modules of the ET 200M range can also be centrally connected
- Central and distributed use of standard modules for non safety-relevant applications
- Component Based Automation (CBA) on PROFINET
- PROFINET IO Controller for operating distributed I/O on PROFINET
- PROFINET interface with 2-port switch
- PROFINET proxy for intelligent devices on PROFIBUS DP in Component Based Automation (CBA)

SIMATIC Micro Memory Card required for operation of CPU.

Ordering data

Order No.

CPU 317F-2 PN/DP

6ES7 317-2FK14-0AB0

Main memory 1.5 MB, power supply 24 V DC, MPI/PROFIBUS DP master/slave interface; Industrial Ethernet/PROFINET interface; MMC required

Distributed Safety V5.4 programming tool

Task: Software for configuring fail-safe user programs for SIMATIC S7-300F, S7-400F, ET 200S

Requirement: STEP 7 V5.3 SP3 and higher

Floating license

6ES7 833-1FC02-0YA5

Software Update Service

6ES7 833-1FC00-0YX2

Distributed Safety Upgrade

From V5.x to V5.4; Floating license for 1 user

6ES7 833-1FC02-0YE5

SIMATIC Micro Memory Card

64 KB

6ES7 953-8LF20-0AA0

128 KB

6ES7 953-8LG20-0AA0

512 KB

6ES7 953-8LJ30-0AA0

2 MB

6ES7 953-8LL20-0AA0

4 MB

6ES7 953-8LM20-0AA0

8 MB

6ES7 953-8LP20-0AA0

MPI cable

6ES7 901-0BF00-0AA0

for connection of SIMATIC S7 and PG via MPI; 5 m in length

Slot number plates

6ES7 912-0AA00-0AA0

S7-300 manual

Design, CPU data, module data, instruction list

German

6ES7 398-8FA10-8AA0

English

6ES7 398-8FA10-8BA0

SIMATIC Manual Collection

6ES7 998-8XC01-8YE0

Electronic manuals on DVD, multilingual: LOGO!, SIMADYN, SIMATIC bus components, SIMATIC C7, SIMATIC distributed I/O, SIMATIC HMI, SIMATIC Sensors, SIMATIC NET, SIMATIC PC Based Automation, SIMATIC PCS 7, SIMATIC PG/PC, SIMATIC S7, SIMATIC Software, SIMATIC TDC

SIMATIC Manual Collection update service for 1 year

6ES7 998-8XC01-8YE2

Current "Manual Collection" DVD and the three subsequent updates

PROFINET/Industrial Ethernet

Controllers / Modular controllers / SIMATIC S7-300

CPU 317F-2 PN/DP

2

Ordering data	Order No.	Order No.
Power supply connector 10 units, spare part	6ES7 391-1AA00-0AA0	
Manual "Communication for SIMATIC S7-300/-400" German English	6ES7 398-8EA00-8AA0 6ES7 398-8EA00-8BA0	
PC adapter USB for connecting a PC to SIMATIC S7-200/300/400 via USB; with USB cable (5 m)	6ES7 972-0CB20-0XA0	
PROFIBUS DP bus connector RS 485 <ul style="list-style-type: none"> with 90° cable outlet, max. transfer rate 12 Mbit/s <ul style="list-style-type: none"> without PG interface with PG interface with 90° cable outlet for FastConnect connection system, max. transfer rate 12 Mbit/s <ul style="list-style-type: none"> without PG interface, 1 unit without PG interface, 100 units with PG interface, 1 unit with PG interface, 100 units with axial cable outlet for SIMATIC OP, for connecting to PPI, MPI, PROFIBUS 	6ES7 972-0BA12-0XA0 6ES7 972-0BB12-0XA0 6ES7 972-0BA52-0XA0 6ES7 972-0BA52-0XB0 6ES7 972-0BB52-0XA0 6ES7 972-0BB52-0XB0 6GK1 500-0EA02	
PROFIBUS FastConnect bus cable Standard type with special design for quick mounting, 2-core, shielded, sold by the meter, max. delivery unit 1000 m, minimum ordering quantity 20 m	6XV1 830-0EH10	
RS 485 repeater for PROFIBUS Transfer rate up to 12 Mbit/s; 24 V DC; IP20 enclosure	6ES7 972-0AA02-0XA0	
		PROFINET bus components IE FC TP standard cable GP 2x2 4-core, shielded TP installation cable for connection to IE FC Outlet RJ45/IE FC RJ45 Plug; PROFINET-compatible; with UL approval; sold by the meter, max. delivery unit 1000 m, minimum ordering quantity 20 m
		6XV1 840-2AH10
		FO Standard Cable GP (50/125) Standard cable, splittable, UL approval, sold by the meter
		6XV1 873-2A
		SCALANCE X204-2 Industrial Ethernet Switch Industrial Ethernet Switches with integral SNMP access, Web diagnostics, copper cable diagnostics and PROFINET diagnostics for configuring line, star and ring topologies; four 10/100 Mbit/s RJ45 ports and two FO ports
		6GK5 204-2BB10-2AA3
		Compact Switch Module CSM 377 Unmanaged switch for connecting a SIMATIC S7-300, ET 200M and up to three other participants to Industrial Ethernet with 10/100 Mbit/s; 4 x RJ45 ports; external 24 V DC power supply, LED diagnostics, S7-300 module incl. electronic manual on CD-ROM
		6GK7 377-1AA00-0AA0
		IE FC RJ45 plugs RJ45 plug connector for Industrial Ethernet with a rugged metal enclosure and integrated insulation displacement contacts for connecting Industrial Ethernet FC installation cables
		IE FC RJ45 plug 145 145° cable outlet <ul style="list-style-type: none"> 1 unit 10 units 50 units
		6GK1 901-1BB30-0AA0 6GK1 901-1BB30-0AB0 6GK1 901-1BB30-0AE0
		IE FC RJ45 plug 180 180° cable outlet <ul style="list-style-type: none"> 1 unit 10 units 50 units
		6GK1 901-1BB10-2AA0 6GK1 901-1BB10-2AB0 6GK1 901-1BB10-2AE0
		PROFIBUS/PROFINET bus components For establishing MPI/PROFIBUS/PROFINET communication
		See chapter 3, CA 01 catalog

Note:

You can find more information in Catalog ST 70 and in the Industry Mall at www.siemens.com/industrymall

PROFINET/Industrial Ethernet Controllers / Modular controllers / SIMATIC S7-300

SIPLUS CPU 317F-2 PN/DP

Overview



- The failsafe CPU with a large program memory and quantity structures for demanding applications to build a fail-safe automation system for plants with increased safety requirements
- Complies with safety requirements up to SIL 3 according to IEC 61508, PL e in accordance with ISO 13849-1 and up to category 4 of EN 954-1
- The fail-safe I/O modules can be locally connected via the integrated PROFINET interface (PROFIsafe) and/or via the integrated PROFIBUS DP interface (PROFIsafe)
- The fail-safe I/O modules of ET 200M can be also centrally connected
- The standard modules for non-safety applications can be operated both centrally and locally
- Component Based Automation (CBA) on PROFINET
- PROFINET IO Controller for operating distributed I/O on PROFINET
- PROFINET interface with 2-port switch
- PROFINET proxy for intelligent devices on PROFIBUS DP in Component Based Automation (CBA)

SIMATIC Micro Memory Card required for operation of the CPU.

Note:

SIPLUS extreme products are based on Siemens Industry standard products. The contents listed here were taken from the respective standard products. SIPLUS extreme-specific information was added.

SIPLUS CPU 317F-2 PN/DP	
Order number	6AG1 317-2FK14-2AB0 6AG1 317-2FK14-2AY0
Order No. based on	6ES7 317-2FK14-0AB0 6ES7 317-2FK14-0AB0
Ambient temperature range	-25 ... +60 °C
Conformal coating	Coating of the printed circuit boards and the electronic components
Technical data	The technical data of the standard product applies except for the ambient conditions.
Compliant with the standards for electronic equipment used on railway rolling stock (EN 50155, temperature T1, category 1).	No Yes
Ambient conditions	
Relative humidity	5 ... 100%, condensation allowed

Technical documentation on SIPLUS can be found here:
www.siemens.com/siplus-extreme

Ordering data	Order No.
SIPLUS CPU 317F-2 PN/DP (extended temperature range and medial exposure)	
Main memory 1.5 MB, power supply 24 V DC, MPI/PROFIBUS DP master/slave interface; Industrial Ethernet/PROFINET interface; MMC required	6AG1 317-2FK14-2AB0
Additional conformance with EN 50155	6AG1 317-2FK14-2AY0
Accessories	See SIMATIC CPU 317F-2 PN/DP

PROFINET/Industrial Ethernet

Controllers / Modular controllers / SIMATIC S7-300

CPU 319F-3 PN/DP

Overview



- The fail-safe CPU with high-performance command processing, large program memory and large quantity structure for demanding applications
- For constructing a fail-safe automation system for plants with increased safety requirements
- Complies with safety requirements up to SIL 3 according to IEC 61508, PL e according to 13849-1, and up to Cat. 4 according to EN 954-1
- Fail-safe I/O modules can be connected decentralized over the integrated PROFINET interface (PROFIsafe) and/or over the integrated PROFIBUS DP interface (PROFIsafe);
- Fail-safe I/O modules of ET200M can also be connected centrally
- Standard modules for non-safety-related applications can be operated centrally and decentralized
- Distributed intelligence in Component Based Automation (CBA) on PROFINET
- Isochronous mode on PROFIBUS
- PROFINET proxy for intelligent devices on PROFIBUS DP in Component based Automation (CBA)

SIMATIC Micro Memory Card required for operation of CPU.

Ordering data

Order No.

CPU 319F-3 PN/DP

6ES7 318-3FL01-0AB0

Main memory 2.5 MB, power supply 24 V DC, combined MPI/PROFIBUS DP master/slave interface, PROFIBUS DP master/slave interface, Ethernet/PROFINET interface; MMC required

Distributed Safety V5.4 programming tool

Task:
Software for configuring fail-safe user programs for SIMATIC S7-300F, S7-400F, ET 200S

Requirement:
STEP 7 V5.3 SP3 and higher

Floating license

6ES7 833-1FC02-0YA5

Software Update Service

6ES7 833-1FC00-0YX2

Distributed Safety Upgrade

6ES7 833-1FC02-0YE5

From V5.x to V5.4; floating license for 1 user

SIMATIC Micro Memory Card

64 KB

6ES7 953-8LF20-0AA0

128 KB

6ES7 953-8LG20-0AA0

512 KB

6ES7 953-8LJ30-0AA0

2 MB

6ES7 953-8LL20-0AA0

4 MB

6ES7 953-8LM20-0AA0

8 MB

6ES7 953-8LP20-0AA0

MPI cable

6ES7 901-0BF00-0AA0

for connection of SIMATIC S7 and PG via MPI; 5 m in length

Slot number plates

6ES7 912-0AA00-0AA0

S7-300 manual

Design, CPU data, module data, instruction list

German

6ES7 398-8FA10-8AA0

English

6ES7 398-8FA10-8BA0

SIMATIC Manual Collection

6ES7 998-8XC01-8YE0

Electronic manuals on DVD, multilingual: LOGO!, SIMADYN, SIMATIC bus components, SIMATIC C7, S IMATIC distributed I/O, SIMATIC HMI, SIMATIC Sensors, SIMATIC NET, SIMATIC PC Based Automation, SIMATIC PCS 7, SIMATIC PG/PC, SIMATIC S7, SIMATIC Software, SIMATIC TDC

SIMATIC Manual Collection update service for 1 year

6ES7 998-8XC01-8YE2

Current "Manual Collection" DVD and the three subsequent updates

PROFINET/Industrial Ethernet

Controllers / Modular controllers / SIMATIC S7-300

CPU 319F-3 PN/DP

Ordering data	Order No.	Order No.
Power supply connector 10 units, spare part	6ES7 391-1AA00-0AA0	
Manual "Communication for SIMATIC S7-300/-400" German English	6ES7 398-8EA00-8AA0 6ES7 398-8EA00-8BA0	
PC adapter USB for connecting a PC to SIMATIC S7-200/300/400 via USB; with USB cable (5 m)	6ES7 972-0CB20-0XA0	
PROFIBUS bus components		
PROFIBUS DP bus connector RS 485 <ul style="list-style-type: none"> with 90° cable outlet, max. transfer rate 12 Mbit/s <ul style="list-style-type: none"> without PG interface with PG interface with 90° cable outlet for FastConnect connection system, max. transfer rate 12 Mbit/s <ul style="list-style-type: none"> without PG interface, 1 unit without PG interface, 100 units with PG interface, 1 unit with PG interface, 100 units with axial cable outlet for SIMATIC OP, for connecting to PPI, MPI, PROFIBUS 	6ES7 972-0BA12-0XA0 6ES7 972-0BB12-0XA0 6ES7 972-0BA52-0XA0 6ES7 972-0BA52-0XB0 6ES7 972-0BB52-0XA0 6ES7 972-0BB52-0XB0 6GK1 500-0EA02	
PROFIBUS FastConnect bus cable Standard type with special design for quick mounting, 2-core, shielded, sold by the meter, max. delivery unit 1000 m, minimum ordering quantity 20 m	6XV1 830-0EH10	
RS 485 repeater for PROFIBUS Transfer rate up to 12 Mbit/s; 24 V DC; IP20 enclosure	6ES7 972-0AA02-0XA0	
PROFINET bus components		
	IE FC TP standard cable GP 2x2 4-core, shielded TP installation cable for connection to IE FC Outlet RJ45/ IE FC RJ45 Plug; PROFINET-compatible; with UL approval; sold by the meter, max. delivery unit 1000 m, minimum ordering quantity 20 m	6XV1 840-2AH10
	FO Standard Cable GP (50/125) Standard cable, splittable, UL approval, sold by the meter	6XV1 873-2A
	SCALANCE X204-2 Industrial Ethernet Switch Industrial Ethernet Switches with integral SNMP access, Web diagnostics, copper cable diagnostics and PROFINET diagnostics for configuring line, star and ring topologies; four 10/100 Mbit/s RJ45 ports and two FO ports	6GK5 204-2BB10-2AA3
	Compact Switch Module CSM 377 Unmanaged switch for connecting a SIMATIC S7-300, ET 200M and up to three other participants to Industrial Ethernet with 10/100 Mbit/s; 4 x RJ45 ports; external 24 V DC power supply, LED diagnostics, S7-300 module incl. electronic manual on CD-ROM	6GK7 377-1AA00-0AA0
	IE FC RJ45 plugs RJ45 plug connector for Industrial Ethernet with a rugged metal enclosure and integrated insulation displacement contacts for connecting Industrial Ethernet FC installation cables	
	IE FC RJ45 plug 145 145° cable outlet <ul style="list-style-type: none"> 1 unit 10 units 50 units 	6GK1 901-1BB30-0AA0 6GK1 901-1BB30-0AB0 6GK1 901-1BB30-0AE0
	IE FC RJ45 plug 180 180° cable outlet <ul style="list-style-type: none"> 1 unit 10 units 50 units 	6GK1 901-1BB10-2AA0 6GK1 901-1BB10-2AB0 6GK1 901-1BB10-2AE0
	PROFIBUS/PROFINET bus components For establishing MPI/PROFIBUS/PROFINET communication	See chapter 3, CA 01 catalog

Note:

You can find more information in Catalog ST 70 and in the Industry Mall at www.siemens.com/industrymall

PROFINET/Industrial Ethernet

Controllers / Modular controllers / SIMATIC S7-400

CPU 412-2 PN

Overview



- The low-cost starter solution for the medium performance range
- Can be used in small and medium-sized systems with requirements of the medium performance range

Ordering data

Order No.

CPU 412-2 PN

Main memory 1 MB, power supply 24 V DC, MPI/PROFIBUS DP master interface, PROFINET interface, slot for memory card, incl. slot number labels

6ES7 412-2EK06-0AB0

Memory card RAM

64 KB

6ES7 952-0AF00-0AA0

256 KB

6ES7 952-1AH00-0AA0

1 MB

6ES7 952-1AK00-0AA0

2 MB

6ES7 952-1AL00-0AA0

4 MB

6ES7 952-1AM00-0AA0

8 MB

6ES7 952-1AP00-0AA0

16 MB

6ES7 952-1AS00-0AA0

64 MB

6ES7 952-1AY00-0AA0

FEPROM memory card

64 KB

6ES7 952-0KF00-0AA0

256 KB

6ES7 952-0KH00-0AA0

1 MB

6ES7 952-1KK00-0AA0

2 MB

6ES7 952-1KL00-0AA0

4 MB

6ES7 952-1KM00-0AA0

8 MB

6ES7 952-1KP00-0AA0

16 MB

6ES7 952-1KS00-0AA0

32 MB

6ES7 952-1KT00-0AA0

64 MB

6ES7 952-1KY00-0AA0

MPI cable

for connection of SIMATIC S7 and PG via MPI; 5 m in length

6ES7 901-0BF00-0AA0

Slot number plates

1 set (spare part)

6ES7 912-0AA00-0AA0

Manual "SIMATIC S7-400 programmable controller"

incl. instruction list

German

6ES7 498-8AA05-8AA0

English

6ES7 498-8AA05-8BA0

S7-400 operation list

German

6ES7 498-8AA05-8AN0

English

6ES7 498-8AA05-8BN0

Manual "Communication for SIMATIC S7-300/-400"

German

6ES7 398-8EA00-8AA0

English

6ES7 398-8EA00-8BA0

PROFINET/Industrial Ethernet

Controllers / Modular controllers / SIMATIC S7-400

CPU 412-2 PN

Ordering data	Order No.	Order No.
SIMATIC Manual Collection Electronic manuals on DVD, multilingual: LOGO!, SIMADYN, SIMATIC bus components, SIMATIC C7, SIMATIC distributed I/O, SIMATIC HMI, SIMATIC Sensors, SIMATIC NET, SIMATIC PC Based Automation, SIMATIC PCS 7, SIMATIC PG/PC, SIMATIC S7, SIMATIC Software, SIMATIC TDC	6ES7 998-8XC01-8YE0	
SIMATIC Manual Collection update service for 1 year Current "Manual Collection" DVD and the three subsequent updates	6ES7 998-8XC01-8YE2	
Brochure "SIMATIC S7-400 programmable controller – Design and application" German English	6ES7 498-8AA00-8AB0 6ES7 498-8AA00-8BB0	
PROFIBUS bus components		
RS 485 bus connector with 90° cable outlet Max. transfer rate 12 Mbit/s without PG interface With PG interface	6ES7 972-0BA12-0XA0 6ES7 972-0BB12-0XA0	
RS 485 bus connector with angled cable outlet Max. transfer rate 12 Mbit/s without PG interface With PG interface	6ES7 972-0BA42-0XA0 6ES7 972-0BB42-0XA0	
RS 485 bus connector with 90° cable outlet for FastConnect system Max. transfer rate 12 Mbit/s without PG interface • 1 unit • 100 units with PG interface • 1 unit • 100 units	6ES7 972-0BA52-0XA0 6ES7 972-0BA52-0XB0 6ES7 972-0BB52-0XA0 6ES7 972-0BB52-0XB0	
RS 485 bus connector with axial cable outlet For SIMATIC OP, for connection to PPI, MPI, PROFIBUS	6GK1 500-0EA02	
PROFIBUS FastConnect bus cable Standard type with special design for quick mounting, 2-core, shielded, <u>sold by the meter</u> , max. delivery unit 1000 m, minimum ordering quantity 20 m	6XV1 830-0EH10	
PROFINET bus components		
IE FC TP standard cable GP 2x2 4-core, shielded TP installation cable for connection to IE FC Outlet RJ45/ IE FC RJ45 Plug; PROFINET-compatible; with UL approval; <u>sold by the meter</u> , max. delivery unit 1000 m, minimum ordering quantity 20 m	6XV1 840-2AH10	
FO Standard Cable GP (50/125) Standard cable, splittable, UL approval, sold by the meter	6XV1 873-2A	
SCALANCE X204-2 Industrial Ethernet switch Industrial Ethernet Switches with integral SNMP access, web diagnostics, copper cable diagnostics and PROFINET diagnostics for configuring line, star and ring topologies; four 10/100 Mbit/s RJ45 ports and two FO ports	6GK5 204-2BB10-2AA3	
IE FC RJ45 Plugs		
RJ45 plug connector for Industrial Ethernet with a rugged metal enclosure and integrated insulation displacement contacts for connecting Industrial Ethernet FC installation cables		
IE FC RJ45 plug 180 180° cable outlet • 1 item • 10 items • 50 items	6GK1 901-1BB10-2AA0 6GK1 901-1BB10-2AB0 6GK1 901-1BB10-2AE0	

Note:

You can find more information in Catalog ST 70 and in the Industry Mall at www.siemens.com/industrymall

2

PROFINET/Industrial Ethernet

Controllers / Modular controllers / SIMATIC S7-400

CPU 414-3 PN/DP

Overview



- CPUs for high demands in the mid-level performance range
- Applicable for plants with additional demands on programming scope and processing speed
- Integrated PROFINET functions in CPU 414-3 PN/DP

Ordering data

Order No.

CPU 414-3 PN/DP

Main memory 4 MB, power supply 24 V DC, MPI/PROFIBUS DP master interface, PROFINET interface, slot for memory card, module slot for 1 IF module, incl. slot number labels

6ES7 414-3EM06-0AB0

Memory card RAM

64 KB

6ES7 952-0AF00-0AA0

256 KB

6ES7 952-1AH00-0AA0

1 MB

6ES7 952-1AK00-0AA0

2 MB

6ES7 952-1AL00-0AA0

4 MB

6ES7 952-1AM00-0AA0

8 MB

6ES7 952-1AP00-0AA0

16 MB

6ES7 952-1AS00-0AA0

64 MB

6ES7 952-1AY00-0AA0

EEPROM memory card

64 KB

6ES7 952-0KF00-0AA0

256 KB

6ES7 952-0KH00-0AA0

1 MB

6ES7 952-1KK00-0AA0

2 MB

6ES7 952-1KL00-0AA0

4 MB

6ES7 952-1KM00-0AA0

8 MB

6ES7 952-1KP00-0AA0

16 MB

6ES7 952-1KS00-0AA0

32 MB

6ES7 952-1KT00-0AA0

64 MB

6ES7 952-1KY00-0AA0

MPI cable

for connection of SIMATIC S7 and PG via MPI; 5 m in length

6ES7 901-0BF00-0AA0

IF 964-DP interface module

To connect an additional DP line; for CPU 414-3, CPU 414-3 PN/DP, CPU 416-3, CPU 416-3 PN/DP, CPU 417-4

6ES7 964-2AA04-0AB0

Slot number plates

1 set (spare part)

6ES7 912-0AA00-0AA0

Manual "SIMATIC S7-400 programmable controller"

incl. instruction list

German

6ES7 498-8AA05-8AA0

English

6ES7 498-8AA05-8BA0

S7-400 operation list

German

6ES7 498-8AA05-8AN0

English

6ES7 498-8AA05-8BN0

Manual "Communication for SIMATIC S7-300/-400"

German

6ES7 398-8EA00-8AA0

English

6ES7 398-8EA00-8BA0

PROFINET/Industrial Ethernet

Controllers / Modular controllers / SIMATIC S7-400

CPU 414-3 PN/DP

Ordering data	Order No.	Order No.
SIMATIC Manual Collection Electronic manuals on DVD, multilingual: LOGO!, SIMADYN, SIMATIC bus components, SIMATIC C7, SIMATIC distributed I/O, SIMATIC HMI, SIMATIC Sensors, SIMATIC NET, SIMATIC PC Based Automation, SIMATIC PCS 7, SIMATIC PG/PC, SIMATIC S7, SIMATIC Software, SIMATIC TDC	6ES7 998-8XC01-8YE0	
SIMATIC Manual Collection update service for 1 year Current "Manual Collection" DVD and the three subsequent updates	6ES7 998-8XC01-8YE2	
Brochure "SIMATIC S7-400 programmable controller – Design and application" German English	6ES7 498-8AA00-8AB0 6ES7 498-8AA00-8BB0	
PROFIBUS bus components		
RS 485 bus connector with 90° cable outlet Max. transfer rate 12 Mbit/s without PG interface With PG interface	6ES7 972-0BA12-0XA0 6ES7 972-0BB12-0XA0	
RS 485 bus connector with angled cable outlet Max. transfer rate 12 Mbit/s without PG interface With PG interface	6ES7 972-0BA42-0XA0 6ES7 972-0BB42-0XA0	
RS 485 bus connector with 90° cable outlet for FastConnect system Max. transfer rate 12 Mbit/s without PG interface • 1 unit • 100 units with PG interface • 1 unit • 100 units	6ES7 972-0BA52-0XA0 6ES7 972-0BA52-0XB0 6ES7 972-0BB52-0XA0 6ES7 972-0BB52-0XB0	
RS 485 bus connector with axial cable outlet For SIMATIC OP, for connection to PPI, MPI, PROFIBUS	6GK1 500-0EA02	
PROFIBUS FastConnect bus cable Standard type with special design for quick mounting, 2-core, shielded, <u>sold by the meter</u> , max. delivery unit 1000 m, minimum ordering quantity 20 m	6XV1 830-0EH10	
RS 485 repeater for PROFIBUS Transfer rate up to 12 Mbit/s; 24 V DC; IP20 enclosure	6ES7 972-0AA02-0XA0	
PROFINET bus components		
IE FC TP standard cable GP 2x2 4-core, shielded TP installation cable for connection to IE FC Outlet RJ45/ IE FC RJ45 Plug; PROFINET-compatible; with UL approval; <u>sold by the meter</u> , max. delivery unit 1000 m, minimum ordering quantity 20 m	6XV1 840-2AH10	
FO Standard Cable GP (50/125) Standard cable, splittable, UL approval, sold by the meter	6XV1 873-2A	
SCALANCE X204-2 Industrial Ethernet switch Industrial Ethernet Switches with integral SNMP access, web diagnostics, copper cable diagnostics and PROFINET diagnostics for configuring line, star and ring topologies; four 10/100 Mbit/s RJ45 ports and two FO ports	6GK5 204-2BB10-2AA3	
IE FC RJ45 plugs		
RJ45 plug connector for Industrial Ethernet with a rugged metal enclosure and integrated insulation displacement contacts for connecting Industrial Ethernet FC installation cables		
IE FC RJ45 plug 180 180° cable outlet • 1 unit • 10 units • 50 units	6GK1 901-1BB10-2AA0 6GK1 901-1BB10-2AB0 6GK1 901-1BB10-2AE0	
PROFIBUS/PROFINET bus components For establishing MPI/PROFIBUS/PROFINET communication	See chapter 3, CA 01 catalog	

Note:

You can find more information in Catalog ST 70 and in the Industry Mall at www.siemens.com/industrymall

2

PROFINET/Industrial Ethernet

Controllers / Modular controllers / SIMATIC S7-400

CPU 416-3 PN/DP

Overview



- High-performance CPUs in the high-end performance range
- Applicable for plants with high requirements in the high-end performance range
- Integrated PROFINET functions in CPU 416-3 PN/DP

Ordering data

Order No.

CPU 416-3 PN/DP

Main memory 16 MB, power supply 24 V DC, MPI/PROFIBUS DP master interface, PROFINET interface, module slot for 1 IF submodule, slot for memory card, incl. slot number labels

6ES7 416-3ES06-0AB0

Memory card RAM

64 KB
256 KB
1 MB
2 MB
4 MB
8 MB
16 MB
64 MB

6ES7 952-0AF00-0AA0
6ES7 952-1AH00-0AA0
6ES7 952-1AK00-0AA0
6ES7 952-1AL00-0AA0
6ES7 952-1AM00-0AA0
6ES7 952-1AP00-0AA0
6ES7 952-1AS00-0AA0
6ES7 952-1AY00-0AA0

EEPROM memory card

64 KB
256 KB
1 MB
2 MB
4 MB
8 MB
16 MB
32 MB
64 MB

6ES7 952-0KF00-0AA0
6ES7 952-0KH00-0AA0
6ES7 952-1KK00-0AA0
6ES7 952-1KL00-0AA0
6ES7 952-1KM00-0AA0
6ES7 952-1KP00-0AA0
6ES7 952-1KS00-0AA0
6ES7 952-1KT00-0AA0
6ES7 952-1KY00-0AA0

MPI cable

for connection of SIMATIC S7 and PG via MPI; 5 m in length

6ES7 901-0BF00-0AA0

IF 964-DP interface module

To connect an additional DP line; for CPU 414-3, CPU 414-3 PN/DP, CPU 416-3, CPU 416-3 PN/DP, CPU 417-4

6ES7 964-2AA04-0AB0

Slot number plates

1 set (spare part)

6ES7 912-0AA00-0AA0

Manual "SIMATIC S7-400 programmable controller"

incl. instruction list

German

6ES7 498-8AA05-8AA0

English

6ES7 498-8AA05-8BA0

S7-400 operation list

German

6ES7 498-8AA05-8AN0

English

6ES7 498-8AA05-8BN0

Manual "Communication for SIMATIC S7-300/-400"

German

6ES7 398-8EA00-8AA0

English

6ES7 398-8EA00-8BA0

PROFINET/Industrial Ethernet

Controllers / Modular controllers / SIMATIC S7-400

CPU 416-3 PN/DP

Ordering data	Order No.	Order No.
SIMATIC Manual Collection Electronic manuals on DVD, multilingual: LOGO!, SIMADYN, SIMATIC bus components, SIMATIC C7, SIMATIC distributed I/O, SIMATIC HMI, SIMATIC Sensors, SIMATIC NET, SIMATIC PC Based Automation, SIMATIC PCS 7, SIMATIC PG/PC, SIMATIC S7, SIMATIC Software, SIMATIC TDC	6ES7 998-8XC01-8YE0	
SIMATIC Manual Collection update service for 1 year Current "Manual Collection" DVD and the three subsequent updates	6ES7 998-8XC01-8YE2	
Brochure "SIMATIC S7-400 programmable controller – Design and application" German English	6ES7 498-8AA00-8AB0 6ES7 498-8AA00-8BB0	
PROFIBUS bus components		
RS 485 bus connector with 90° cable outlet Max. transfer rate 12 Mbit/s without PG interface With PG interface	6ES7 972-0BA12-0XA0 6ES7 972-0BB12-0XA0	
RS 485 bus connector with angled cable outlet Max. transfer rate 12 Mbit/s without PG interface With PG interface	6ES7 972-0BA42-0XA0 6ES7 972-0BB42-0XA0	
RS 485 bus connector with 90° cable outlet for FastConnect system Max. transfer rate 12 Mbit/s without PG interface • 1 unit • 100 units with PG interface • 1 unit • 100 units	6ES7 972-0BA52-0XA0 6ES7 972-0BA52-0XB0 6ES7 972-0BB52-0XA0 6ES7 972-0BB52-0XB0	
RS 485 bus connector with axial cable outlet For SIMATIC OP, for connection to PPI, MPI, PROFIBUS	6GK1 500-0EA02	
PROFIBUS FastConnect bus cable Standard type with special design for quick mounting, 2-core, shielded, <u>sold by the meter,</u> max. delivery unit 1000 m, minimum ordering quantity 20 m	6XV1 830-0EH10	
RS 485 repeater for PROFIBUS Transfer rate up to 12 Mbit/s; 24 V DC; IP20 enclosure	6ES7 972-0AA02-0XA0	
PROFINET bus components		
IE FC TP standard cable GP 2x2 4-core, shielded TP installation cable for connection to IE FC Outlet RJ45/ IE FC RJ45 Plug; PROFINET-compatible; with UL approval; <u>sold by the meter,</u> max. delivery unit 1000 m, minimum ordering quantity 20 m	6XV1 840-2AH10	
FO Standard Cable GP (50/125) Standard cable, splittable, UL approval, sold by the meter	6XV1 873-2A	
SCALANCE X204-2 Industrial Ethernet switch Industrial Ethernet Switches with integral SNMP access, web diagnostics, copper cable diagnostics and PROFINET diagnostics for configuring line, star and ring topologies; four 10/100 Mbit/s RJ45 ports and two FO ports	6GK5 204-2BB10-2AA3	
IE FC RJ45 plugs		
RJ45 plug connector for Industrial Ethernet with a rugged metal enclosure and integrated insulation displacement contacts for connecting Industrial Ethernet FC installation cables		
IE FC RJ45 plug 180 180° cable outlet • 1 unit • 10 units • 50 units	6GK1 901-1BB10-2AA0 6GK1 901-1BB10-2AB0 6GK1 901-1BB10-2AE0	
PROFIBUS/PROFINET bus components For establishing MPI/PROFIBUS/PROFINET communication		See chapter 3, CA 01 catalog

Note:

You can find more information in Catalog ST 70 and in the Industry Mall at www.siemens.com/industrymall

2

PROFINET/Industrial Ethernet

Controllers / Modular controllers / SIMATIC S7-400

SIPLUS CPU 416-3 PN/DP

Overview



High-performance CPUs in the high-end performance range

- Applicable for plants with high requirements in the high-end performance range
- Integrated PROFINET functions in CPU 416-3 PN/DP

Note:

SIPLUS extreme products are based on Siemens Industry standard products. The contents listed here were taken from the respective standard products. SIPLUS extreme-specific information was added.

SIPLUS CPU 416-3 PN/DP	
Order number	6AG1 416-3ER05-4AB0
Order No. based on	6ES7 416-3ER05-0AB0
Range of ambient temperature	0 ... +60 °C
Conformal coating	Coating of the printed circuit boards and the electronic components
Technical data	The technical data of the standard product applies except for the ambient conditions

Ambient conditions

Relative humidity	5 ... 100 % Condensation permissible
Biologically active substances	Conformity with EN 60721-3-3, Class 3B2 mold and fungal spores (except fauna)
Chemically active substances	Conformity with EN 60721-3-3, Class 3C4 incl. salt mist and ISA-S71.04 severity level G1; G2; G3; GX ^{1) 2)}
Mechanically active substances	Conformity with EN 60721-3-3, Class 3S4 including conductive sand, dust ²⁾
Air pressure (depending on the highest positive temperature range specified)	1080 ... 795 hPa (-1000 ... +2000 m) see ambient temperature range 795 ... 658 hPa (+2000 ... +3500 m) derating 10 K 658 ... 540 hPa (+3500 ... +5000 m) derating 20 K

- 1) ISA-S71.04 severity level GX: Long-term load: SO₂ < 4.8 ppm; H₂S < 9.9 ppm; Cl < 0.2 ppm; HCl < 0.66 ppm; HF < 0.12 ppm; NH₃ < 49 ppm; O₃ < 0.1 ppm; NO_x < 5.2 ppm
Limit value (max. 30 min/d): SO₂ < 17.8 ppm; H₂S < 49.7 ppm; Cl < 1.0 ppm; HCl < 3.3 ppm; HF < 2.4 ppm; NH₃ < 247 ppm; O₃ < 1.0 ppm; NO_x < 10.4 ppm

- 2) The supplied plug covers must remain in place over the unused interface when operated in atmospheres containing corrosive gases!

The technical documentation on SIPLUS can be found here:
www.siemens.com/siplus-extreme

Ordering data	Order No.
SIPLUS CPU 416-3 PN/DP (medial exposure) Power supply 24 V DC, MPI/PROFIBUS DP master interface, PROFINET interface, module slot for 1 IF module, slot for memory card, including mounting position labels 11.2 MB work memory	6AG1 416-3ER05-4AB0
Accessories	See SIMATIC CPU 416-3 PN/DP

PROFINET/Industrial Ethernet

Controllers / Modular controllers / SIMATIC S7-400

CPU 414F-3 PN/DP

Overview



- For constructing a fail-safe automation system for plants with increased safety requirements
- CPUs for high demands in the mid-level performance range
- Applicable for plants with additional demands on programming scope and processing speed
- Satisfies safety requirements up to SIL 3 acc. to IEC 61508 and Cat. 4 acc. to EN 954-1
- Standard and safety-related tasks can be performed with a single CPU
- Integrated PROFINET functions in CPU 414F-3 PN/DP
- Multi-processor mode is possible
- Safety-related communication with distributed I/O devices over PROFIBUS DP or PROFINET IO with PROFIsafe profile
- Fail-safe I/O modules can be connected in a distributed manner via the integrated interfaces (DP and PN with CPU 414F-3 PN/DP) and/or through communication modules (CP 443-5 Extended and CP 443-1 Adv.)
- Central and distributed use of standard modules for non-safety-oriented applications

Ordering data

Order No.

CPU 414F-3 PN/DP

For setting up safety-related automation system;
main memory 4 MB,
power supply 24 V DC,
MPI/PROFIBUS DP master interface, PROFINET interface,
slot for memory card,
module slot for 1 IF module,
incl. slot number labels

6ES7 414-3FM06-0AB0

Option package S7 F Distributed Safety V5.4

for generating fail-safe programs for the S7-300F/400F

Floating license

6ES7 833-1FC02-0YA5

Upgrade from V5.x to V5.4

6ES7 833-1FC02-0YE5

Software Update Service

6ES7 833-1FC00-0YX2

Memory Card RAM

64 KB

6ES7 952-0AF00-0AA0

256 KB

6ES7 952-1AH00-0AA0

1 MB

6ES7 952-1AK00-0AA0

2 MB

6ES7 952-1AL00-0AA0

4 MB

6ES7 952-1AM00-0AA0

8 MB

6ES7 952-1AP00-0AA0

16 MB

6ES7 952-1AS00-0AA0

64 MB

6ES7 952-1AY00-0AA0

FEPRAM memory card

64 KB

6ES7952-0KF00-0AA0

256 KB

6ES7952-0KH00-0AA0

1 MB

6ES7 952-1KK00-0AA0

2 MB

6ES7 952-1KL00-0AA0

4 MB

6ES7 952-1KM00-0AA0

8 MB

6ES7 952-1KP00-0AA0

16 MB

6ES7 952-1KS00-0AA0

32 MB

6ES7 952-1KT00-0AA0

64 MB

6ES7 952-1KY00-0AA0

MPI cable

for connection of SIMATIC S7 and PG via MPI; 5 m in length

6ES7 901-0BF00-0AA0

IF 964-DP interface module

For connecting an additional DP line

6ES7 964-2AA04-0AB0

Slot number plates

1 set (spare part)

6ES7 912-0AA00-0AA0

Manual "SIMATIC S7-400 programmable controller"

incl. instruction list

German

6ES7 498-8AA05-8AA0

English

6ES7 498-8AA05-8BA0

S7-400 operation list

German

6ES7 498-8AA05-8AN0

English

6ES7 498-8AA05-8BN0

PROFINET/Industrial Ethernet

Controllers / Modular controllers / SIMATIC S7-400

CPU 414F-3 PN/DP

2

Ordering data	Order No.	Order No.
Manual "Communication for SIMATIC S7-300/-400" German English	6ES7 398-8EA00-8AA0 6ES7 398-8EA00-8BA0	
SIMATIC Manual Collection Electronic manuals on DVD, multilingual: LOGO!, SIMADYN, SIMATIC bus components, SIMATIC C7, SIMATIC distributed I/O, SIMATIC HMI, SIMATIC Sensors, SIMATIC NET, SIMATIC PC Based Automation, SIMATIC PCS 7, SIMATIC PG/PC, SIMATIC S7, SIMATIC Software, SIMATIC TDC	6ES7 998-8XC01-8YE0	
SIMATIC Manual Collection update service for 1 year Current "Manual Collection" DVD and the three subsequent updates	6ES7 998-8XC01-8YE2	
Brochure "SIMATIC S7-400 programmable controller – Design and application" German English	6ES7 498-8AA00-8AB0 6ES7 498-8AA00-8BB0	
PROFIBUS bus components		
RS 485 bus connector with 90° cable outlet Max. transfer rate 12 Mbit/s without PG interface With PG interface	6ES7 972-0BA12-0XA0 6ES7 972-0BB12-0XA0	
RS 485 bus connector with angled cable outlet Max. transfer rate 12 Mbit/s without PG interface With PG interface	6ES7 972-0BA42-0XA0 6ES7 972-0BB42-0XA0	
RS 485 bus connector with 90° cable outlet for FastConnect system Max. transfer rate 12 Mbit/s without PG interface • 1 unit • 100 units with PG interface • 1 unit • 100 units	6ES7 972-0BA52-0XA0 6ES7 972-0BA52-0XB0 6ES7 972-0BB52-0XA0 6ES7 972-0BB52-0XB0	
RS 485 bus connector with axial cable outlet For SIMATIC OP, for connection to PPI, MPI, PROFIBUS	6GK1 500-0EA02	
PROFIBUS FastConnect bus cable Standard type with special design for quick mounting, 2-core, shielded, <u>sold by the meter</u> , max. delivery unit 1000 m, minimum ordering quantity 20 m	6XV1 830-0EH10	
RS 485 repeater for PROFIBUS Transfer rate up to 12 Mbit/s; 24 V DC; IP20 enclosure	6ES7 972-0AA02-0XA0	
PROFINET bus components		
IE FC TP standard cable GP 2x2 4-core, shielded TP installation cable for connection to IE FC Outlet RJ45/IE FC RJ45 Plug; PROFINET-compatible; with UL approval; <u>sold by the meter</u> , max. delivery unit 1000 m, minimum ordering quantity 20 m	6XV1 840-2AH10	
FO Standard Cable GP (50/125) Standard cable, splittable, UL approval, sold by the meter	6XV1 873-2A	
SCALANCE X204-2 Industrial Ethernet Switch Industrial Ethernet Switches with integral SNMP access, Web diagnostics, copper cable diagnostics and PROFINET diagnostics for configuring line, star and ring topologies; four 10/100 Mbit/s RJ45 ports and two FO ports	6GK5 204-2BB10-2AA3	
IE FC RJ45 plugs		
RJ45 plug connector for Industrial Ethernet with a rugged metal enclosure and integrated insulation displacement contacts for connecting Industrial Ethernet FC installation cables		
IE FC RJ45 plug 180 180° cable outlet • 1 unit • 10 units • 50 units		6GK1 901-1BB10-2AA0 6GK1 901-1BB10-2AB0 6GK1 901-1BB10-2AE0
PROFIBUS/PROFINET bus components For establishing MPI/PROFIBUS/PROFINET communication		See chapter 3, CA 01 catalog

Note:

You can find more information in Catalog ST 70 and in the Industry Mall at www.siemens.com/industrymall

PROFINET/Industrial Ethernet Controllers / Modular controllers / SIMATIC S7-400

CPU416F-3 PN/DP

Overview



- For constructing a fail-safe automation system for plants with increased safety requirements
- High-performance CPU in the top-end performance range
- Satisfies safety requirements up to SIL 3 acc. to IEC 61508 and Cat. 4 acc. to EN 954-1
- Standard and safety-related tasks can be performed with a single CPU
- Multi-processor mode is possible
- Safety-related communication with distributed I/O devices over PROFIBUS DP with the *PROFIsafe* profile
- Fail-safe I/O modules can be connected decentralized over the integrated interfaces (DP and PN with CPU 416F-3 PN/DP) and/or through communication modules (CP 443-5 Ext. and CP 443-1 Adv.)
- Standard modules for non-safety-related applications can be operated centrally and decentralized

Ordering data

Order No.

CPU 416F-3 PN/DP

For configuring safety-related automation systems;
24 V DC power supply,
MPI/PROFIBUS DP master interface, PROFINET interface,
PROFIBUS DP master interface, receptacle for 1 IF submodule,
slot for memory card,
incl. slot number labels

16 MB RAM

6ES7 416-3FS06-0AB0

Option package S7 F Distributed Safety V5.4

for generating fail-safe programs for the S7-300F

Floating license

6ES7 833-1FC02-0YA5

Upgrade from V5.x to V5.4

6ES7 833-1FC02-0YE5

Software Update Service

6ES7 833-1FC00-0YX2

Memory card RAM

64 KB

6ES7 952-0AF00-0AA0

256 KB

6ES7 952-1AH00-0AA0

1 MB

6ES7 952-1AK00-0AA0

2 MB

6ES7 952-1AL00-0AA0

4 MB

6ES7 952-1AM00-0AA0

8 MB

6ES7 952-1AP00-0AA0

16 MB

6ES7 952-1AS00-0AA0

64 MB

6ES7 952-1AY00-0AA0

EEPROM memory card

64 KB

6ES7952-0KF00-0AA0

256 KB

6ES7952-0KH00-0AA0

1 MB

6ES7 952-1KK00-0AA0

2 MB

6ES7 952-1KL00-0AA0

4 MB

6ES7 952-1KM00-0AA0

8 MB

6ES7 952-1KP00-0AA0

16 MB

6ES7 952-1KS00-0AA0

32 MB

6ES7 952-1KT00-0AA0

64 MB

6ES7 952-1KY00-0AA0

MPI cable

for connection of SIMATIC S7 and PG via MPI; 5 m in length

6ES7 901-0BF00-0AA0

IF 964-DP interface module

For connecting an additional DP line

6ES7 964-2AA04-0AB0

Slot number plates

1 set (spare part)

6ES7 912-0AA00-0AA0

Manual "SIMATIC S7-400 programmable controller"

incl. instruction list

German

6ES7 498-8AA05-8AA0

English

6ES7 498-8AA05-8BA0

S7-400 operation list

German

6ES7 498-8AA05-8AN0

English

6ES7 498-8AA05-8BN0

PROFINET/Industrial Ethernet

Controllers / Modular controllers / SIMATIC S7-400

CPU416F-3 PN/DP

2

Ordering data	Order No.	Order No.
Manual "Communication for SIMATIC S7-300/-400" German English	6ES7 398-8EA00-8AA0 6ES7 398-8EA00-8BA0	
SIMATIC Manual Collection Electronic manuals on DVD, multilingual: LOGO!, SIMADYN, SIMATIC bus components, SIMATIC C7, SIMATIC distributed I/O, SIMATIC HMI, SIMATIC Sensors, SIMATIC NET, SIMATIC PC Based Automation, SIMATIC PCS 7, SIMATIC PG/PC, SIMATIC S7, SIMATIC Software, SIMATIC TDC	6ES7 998-8XC01-8YE0	
SIMATIC Manual Collection update service for 1 year Current "Manual Collection" DVD and the three subsequent updates	6ES7 998-8XC01-8YE2	
Brochure "SIMATIC S7-400 programmable controller – Design and application" German English	6ES7 498-8AA00-8AB0 6ES7 498-8AA00-8BB0	
PROFIBUS bus components		
RS 485 bus connector with 90° cable outlet Max. transfer rate 12 Mbit/s without PG interface With PG interface	6ES7 972-0BA12-0XA0 6ES7 972-0BB12-0XA0	
RS 485 bus connector with angled cable outlet Max. transfer rate 12 Mbit/s without PG interface With PG interface	6ES7 972-0BA42-0XA0 6ES7 972-0BB42-0XA0	
RS 485 bus connector with 90° cable outlet for FastConnect system Max. transfer rate 12 Mbit/s without PG interface • 1 unit • 100 units with PG interface • 1 unit • 100 units	6ES7 972-0BA52-0XA0 6ES7 972-0BA52-0XB0 6ES7 972-0BB52-0XA0 6ES7 972-0BB52-0XB0	
RS 485 bus connector with axial cable outlet For SIMATIC OP, for connection to PPI, MPI, PROFIBUS	6GK1 500-0EA02	
PROFIBUS FastConnect bus cable Standard type with special design for quick mounting, 2-core, shielded, sold by the meter, max. delivery unit 1000 m, minimum ordering quantity 20 m	6XV1 830-0EH10	
RS 485 repeater for PROFIBUS Transfer rate up to 12 Mbit/s; 24 V DC; IP20 enclosure	6ES7 972-0AA02-0XA0	
PROFINET bus components		
IE FC TP standard cable GP 2x2 4-core, shielded TP installation cable for connection to IE FC Outlet RJ45/IE FC RJ45 Plug; PROFINET-compatible; with UL approval; sold by the meter, max. delivery unit 1000 m, minimum ordering quantity 20 m		6XV1 840-2AH10
FO Standard Cable GP (50/125) Standard cable, splittable, UL approval, sold by the meter		6XV1 873-2A
SCALANCE X204-2 Industrial Ethernet Switch Industrial Ethernet Switches with integral SNMP access, web diagnostics, copper cable diagnostics and PROFINET diagnostics for configuring line, star and ring topologies; four 10/100 Mbit/s RJ45 ports and two FO ports		6GK5 204-2BB10-2AA3
IE FC RJ45 plugs		
RJ45 plug connector for Industrial Ethernet with a rugged metal enclosure and integrated insulation displacement contacts for connecting Industrial Ethernet FC installation cables		
IE FC RJ45 plug 180 180° cable outlet • 1 unit • 10 units • 50 units		6GK1 901-1BB10-2AA0 6GK1 901-1BB10-2AB0 6GK1 901-1BB10-2AE0
PROFIBUS/PROFINET bus components For establishing MPI/PROFIBUS/PROFINET communication		See chapter 3, CA 01 catalog
Note: You can find more information in Catalog ST 70 and in the Industry Mall at www.siemens.com/industrymall		

Controllers / Modular controllers / Distributed controllers

see page 2/620 and the following

Overview



- SIMATIC WinAC RTX:
Optimized for applications that require a high degree of flexibility and integration capability.
- The software solution for tasks that require hard deterministic behavior and high performance.
- With real-time expansion for assuring deterministic behavior for the control section.

New with WinAC RTX 2010:

- Operation under Windows 7
- Web server
- New PROFINET functions:
 - Isochronous mode
 - Shared Device
 - Media redundancy
 - IP configuration

2

Ordering data

SIMATIC WinAC RTX 2010

Software PLC for PC-based automation tasks with stringent deterministic requirements; PROFIBUS and PROFINET; CD-ROM with electronic documentation d, e, f; single license, executable under Windows XP SP2 and SP3 as well as Windows 7 (32 bit)

Order No.

6ES7 671-0RC08-0YA0

SIMATIC WinAC RTX 2010 Upgrade

For upgrading from basic/RTX V3.x, V4.0, V4.1 2005, 2008 and 2009; single license, executable under Windows XP SP2 and SP3 and Windows 7 (32 bits)

6ES7 671-0RC08-0YE0

CP 5611 A2 communication processor

PCI card (32 bit) for connection of a programming device or PC to PROFIBUS

6GK1 561-1AA01

CP 5621 communication processor

- PCI Express x1 card (32 bit) for connection of a programming device or PC to PROFIBUS
- PCI Express x1 card (32 bit) CP 5621 and MPI cable, 5 m

6GK1 562-1AA00

6GK1 562-1AM00

CP 5603 Microbox Package

Comprising CP 5603 module and Microbox expansion rack

6GK1 560-3AU00

CP 5613 A2 communication processor

PCI card (32 bit; 3.3 V/5 V) for connection to PROFIBUS incl. DP-Base software with NCM PC; DP-RAM interface for DP master, incl. PG and FDL protocol; single license for 1 installation, runtime software, software and electronic manual on CD-ROM, Class A, for 32 bit Windows 2000 Professional/Server, Windows XP Professional, German/English

6GK1 561-3AA01

CP 5623

communication processor

PCI Express x1 card (32 bit) for connection to PROFIBUS incl. DP-Base software with NCM PC; DP-RAM interface for DP master or DP slave, incl. PG and FDL protocols; single license for 1 installation, runtime software, software and electronic manual on CD-ROM, Class A, for operating system support see SIMATIC NET software; German/English

Order No.

6GK1 562-3AA00

CP 1616

communication processor

PCI Card (32 bit; 3.3/5 V universal key) with ASIC ERTEC 400 for connecting PCs to PROFINET IO with 4-port real-time switch (RJ45); incl. IO-Base software for PROFINET IO controller (RT operation) and NCM PC; single license for one installation, runtime software, software and electronic manual on CD-ROM, Class A, for 32 bit Windows XP Professional; German/English

6GK1 161-6AA01

CP 1604 Microbox Package

Package for implementing the CP 1604 in the SIMATIC Microbox PC; comprising the CP 1604, connection board, power supply and expansion rack for Microbox PC; for use with Development Kit DK-16xx PN IO; NCM PC

6GK1 160-4AU00

Note:

You can find more information in Catalog ST 70 and in the Industry Mall at www.siemens.com/industrymall

PROFINET/Industrial Ethernet

Controllers / PC-based controllers

SIMATIC WinAC RTX F

Overview



- SIMATIC WinAC RTX F:
Optimized for applications that demand a high degree of flexibility and integration capability and that must also satisfy safety requirements up to SIL 3 (IEC 61508).
- The software solution for tasks that require hard deterministic behavior and high performance.
- With real-time expansion for assuring deterministic behavior for the control section.
- Distributed I/O can be connected over PROFIBUS and/or PROFINET, also safety-related over PROFIsafe.

Ordering data

SIMATIC WinAC RTX F 2010

Order No.

6ES7 671-1RC08-0YA0

SIMATIC WinAC RTX F 2010 upgrade

6ES7 671-1RC08-0YE0

CP 5611 A2 communication processor

6GK1 561-1AA01

PCI card (32 bit) for connection of a programming device or PC to PROFIBUS

CP 5621 communication processor

6GK1 562-1AA00

PCI Express x1 card (32 bit) for connection of a programming device or PC to PROFIBUS

PCI Express x1 card (32 bit)
CP 5621 and MPI cable, 5 m

6GK1 562-1AM00

CP 5603 Microbox Package

6GK1 560-3AU00

Comprising CP 5603 module and Microbox expansion rack

CP 5613 A2 communication processor

6GK1 561-3AA01

PCI card (32 bit; 3.3 V/5 V) for connection to PROFIBUS incl. DP-Base software with NCM PC; DP-RAM interface for DP master, incl. PG and FDL protocol; single license for 1 installation, runtime software, software and electronic manual on CD-ROM, Class A, for 32 bit Windows 2000 Professional/Server, Windows XP Professional, German/English

Order No.

CP 5623 communication processor

6GK1 562-3AA00

PCI Express x1 card (32 bit) for connection to PROFIBUS incl. DP-Base software with NCM PC; DP-RAM interface for DP master or DP slave, incl. PG and FDL protocols; single license for 1 installation, runtime software, software and electronic manual on CD-ROM, Class A, for operating system support see SIMATIC NET software; German/English

CP 1616 communication processor

6GK1 161-6AA01

PCI Card (32 bit; 3.3/5 V universal key) with ASIC ERTEC 400 for connecting PCs to PROFINET IO with 4-port real-time switch (RJ45); incl. IO-Base software for PROFINET IO controller (RT operation) and NCM PC; single license for one installation, runtime software, software and electronic manual on CD-ROM, Class A, for 32 bit Windows XP Professional; German/English

CP 1604 Microbox Package

6GK1 160-4AU00

Package for implementing the CP 1604 in the SIMATIC Microbox PC; comprising the CP 1604, connection board, power supply and expansion rack for Microbox PC; for use with Development Kit DK-16xx PN IO; NCM PC

Note:

You can find more information in Catalog ST 70 and in the Industry Mall at www.siemens.com/industrymall

Overview



- SIMATIC WinAC software PLCs support powerful interfaces which permit close meshing of the control task with PC-based applications.
- WinAC ODK allows the user to develop applications or to integrate already existing applications into the control task.

New with WinAC ODK V4.2:

- CCX interface:
 - New SFB 65003 for asynchronous execution of ODK applications
 - Expansion of data access functions
 - Creation of Windows DLL with C# and VB
- SMX interface:
 - Access to the Shared Memory interface under IntervalZero RTX
 - Expansion of data access functions
 - Creation of Windows applications with C# and VB
- Supports MS Visual Studio 2005 and 2008 (under Windows)

Ordering data

Order No.

SIMATIC WinAC ODK V4.2

for integration of C/C++ code in WinAC PLCs, executable under Windows XP SP2 or SP3; CD-ROM with electronic documentation

Single license

6ES7 806-1CC03-0BA0

Note:

You can find more information in Catalog ST 70 and in the Industry Mall at www.siemens.com/industrymall

PROFINET/Industrial Ethernet

Controllers / Embedded controllers

SIMATIC S7-modular Embedded Controller EC31

Overview



- Get off to a fast start in automation solutions with embedded PC platforms.
 - Ready-to-use SIMATIC WinAC RTX or WinAC RTX F pre-installed on EC31
 - Prepared for use in a SIMATIC environment with PROFINET and Industrial Ethernet
 - Commissioning by specialist automation personnel as with the S7-300
 - Configuring and programming with SIMATIC STEP 7 over Industrial Ethernet
 - Optional visualization
- Modular expansion capability:
 - Central expansion with
 - S7-300 I/O (SM modules of S7-300)
 - Expansion modules for additional PC interfaces, e.g. DVI-I, USB, Gigabit Ethernet networks and memory card slots, as well as PCI-104
- Rugged operation
 - Hard-disk-free operation based on flash disk and Windows Embedded Standard
 - Fan-free operation
- Flexibility of a PC-based automation environment
 - Free memory space on flash disk can be used for other PC applications
 - Use of WinAC ODK with SIMATIC WinAC RTX and WinAC RTX F (read-only in safety-related program part)
 - Connection option for USB devices
 - Memory capacity expandable using multimedia card
- Data retentivity for WinAC RTX and RTX F without uninterruptible power supply (UPS)

PROFINET/Industrial Ethernet Controllers / Embedded controllers

SIMATIC S7-modular Embedded Controller EC31

Ordering data	Order No.	Order No.
SIMATIC S7-modular Embedded Controller		Accessories
EC31 Intel CoreDuo 1.2 GHz processor Memory configuration: 1 GB RAM, 4 GB Flash Disk; interfaces: 1 Industrial Ethernet port, 2 PROFINET ports, 2 USB ports, 1 slot for multimedia card; Software: Windows Embedded Standard preinstalled, Software Development Kit (SDK) for creating C/C++ applications with accesses to central I/O modules	6ES7 677-1DD10-0BA0	CP 5603 mEC Package for use of the CP 5603 in SIMATIC S7-MEC; consists of • CP 5603: PCI104 card for connection to PROFIBUS incl. DP-Base software with NCM PC; DP-RAM interface for DP master or DP slave, incl. PG and FDL protocols; single license for one installation, runtime software, software and electronic manual on CD-ROM, Class A, for operating system support see SIMATIC NET software; German/English • Insert plate for CP 5603 for mounting into the EM PCI-104 expansion module of the SIMATIC S7-MEC
EC31-RTX Intel CoreDuo 1.2 GHz processor Memory configuration: 1 GB RAM, 4 GB Flash Disk; interfaces: 1 Industrial Ethernet port, 2 PROFINET ports, 2 USB ports, 1 slot for multimedia card; Software: Windows Embedded Standard and WinAC RTX 2010 preinstalled	6ES7 677-1DD10-0BB0	EM PCI-104 expansion module For fitting up to 3 additional PCI-104 cards
EC31-RTX F Intel CoreDuo 1.2 GHz processor Memory configuration: 1 GB RAM, 4 GB Flash Disk; interfaces: 1 Industrial Ethernet port, 2 PROFINET ports, 2 USB ports, 1 slot for multimedia card; Software: Windows Embedded Standard and WinAC RTX F 2010 preinstalled	6ES7 677-1FD10-0FB0	EM PC expansion module Additional connection options: 2 USB interfaces, 1 Gigabit Ethernet interface, 1 serial interface, 1 slot for CF card, 1 slot for SD card/Micro Memory Card
EC31-HMI/RTX Intel CoreDuo 1.2 GHz processor Memory configuration: 1 GB RAM, 4 GB Flash Disk; interfaces: 1 Industrial Ethernet port, 2 PROFINET ports, 2 USB ports, 1 slot for multimedia card; Software: Windows Embedded Standard, WinAC RTX 2010, SIMATIC SOFTNET-S7/V7.0 Lean preinstalled • With WinCC flexible 2008 RT 128 PT • With WinCC flexible 2008 RT 512 PT • With WinCC flexible 2008 RT 2048 PT	6ES7 677-1DD10-0BF0 6ES7 677-1DD10-0BG0 6ES7 677-1DD10-0BH0	

Note:

You can find more information in Catalog ST 70 and in the Industry Mall at www.siemens.com/industrymall

PROFINET/Industrial Ethernet

Controllers / Embedded controllers

SIMATIC S7-modular Embedded Controller Expansion modules

Overview



- Expansion modules for SIMATIC S7-modular Embedded Controller EC31
 - EM PCI-104 for additionally accommodating up to 3 PCI-104 cards
 - EM PC with additional PC interfaces and slots for memory media

Ordering data

Order No.

EM PCI-104 expansion module

6ES7 677-1DD40-1AA0

For fitting up to 3 additional PCI-104 cards

EM PC expansion module

6ES7 677-1DD50-2AA0

Additional connection options:
2 USB interfaces,
1 Gigabit Ethernet interface,
1 serial interface,
1 slot for CF card,
1 slot for SD card/Micro Memory Card

CP 5603 mEC Package

6GK1 560-3AE00

for use of the CP 5603 in SIMATIC S7-MEC; consists of

- CP 5603:
 - PCI104 card for connection to PROFIBUS incl. DP-Base software with NCM PC; DP-RAM interface for DP master or DP slave, incl. PG and FDL protocols; single license for one installation, runtime software, software and electronic manual on CD-ROM, Class A, for operating system support see SIMATIC NET software; German/English
- Insert plate for CP 5603 for mounting into the EM PCI-104 expansion module of the SIMATIC S7-MEC

Note:

You can find more information in Catalog ST 70 and in the Industry Mall at www.siemens.com/industrymall

Overview



- A quick start in automation solutions with embedded PC platforms
 - SIMATIC WinAC RTX or SIMATIC WinAC RTX F preinstalled on SIMATIC IPC227D and ready for use
 - PROFINET RT and Industrial Ethernet pre-configured for use in a SIMATIC environment
 - Optional WinCC RT Advanced for visualization tasks in parallel with SIMATIC WinAC RTX
 - Configuration and programming with SIMATIC STEP 7 via Industrial Ethernet or PROFINET
- Safety requirements up to SIL 3 in accordance with IEC 61508/62061 or EN ISO 13849-1 up to PL e can be implemented with WinAC RTX F.
- Rugged operation
 - Operation without a hard disk, based on CompactFlash Card (CF Card) or Solid-State Drive and Windows Embedded Standard 2009
 - Fan-free operation
 - 128 KB of retentive data for WinAC RTX, also without uninterruptible power supply (UPS)
- Flexibility of a PC-based automation environment
 - Use of WinAC ODK with SIMATIC WinAC RTX or SIMATIC WinAC RTX F (read-only for fail-safe program section)
 - Connection option for USB devices, flat panel monitor or screen
 - PCIe cards can be plugged in

PROFINET/Industrial Ethernet

Controllers / Embedded bundles

SIMATIC IPC227D bundles

Ordering data

Order No.

Order No.

Configuration

SIMATIC IPC227D

Interfaces: 2 x Gbit LAN (RJ45),
1 x serial (COM1), 4 x USB

Processors/memory configuration/retentivity

- Atom E660 (1.3 GHz),
2 GByte RAM
- Atom E660 (1.3 GHz),
2 GByte RAM, retentivity
- Atom E640 (1.0 GHz),
1 GByte RAM
- Atom E640 (1.0 GHz),
1 GByte RAM, retentivity
- Atom E620 (600 MHz),
512 MByte RAM
- Atom E620 (600 MHz),
512 MByte RAM, retentivity

Drives

- Without drive, with CF slot
- 250 GByte HDD SATA
- 50 GByte Solid-State Drive SATA
(SLC)
- 2 GByte SIMATIC PC
CompactFlash
- 4 GByte SIMATIC PC
CompactFlash
- 8 GByte SIMATIC PC
CompactFlash

COM interface

- COM1: RS232
- COM1: RS485
- COM1: CAN

On request

Configuration

SIMATIC IPC227D

Operating system

- Without operating system
- WES 2009 preinstalled
(CF ab 2 GB/SSD/HD)
- XP-Prof. MUI preinstalled on
SSD / HD
- WES 7 vorinstalliert
(CF from 4 GB/SSD/HD)
- Windows 7 MUI preinstalled on
SSD / HD

Software bundles

- Without RTX/HMI software
- RTX: WinAC RTX 2010
- RTX-F: WinAC RTX F 2010
- HMI: WinCC RT Advanced
128 PT
- HMI: WinCC RT Advanced
512 PT
- HMI: WinCC RT Advanced
2048 PT
- HMI: WinCC RT Advanced
4096 PT
- HMI/RTX: RT 128 PT
- HMI/RTX: RT 512 PT
- HMI/RTX: RT 2048 PT
- HMI/RTX: RT 4096 PT

Device versions

- Basis
- PCIe (1 slot)
- COM (COM2-4: RS232)
- IO (4 x dig. inputs/outputs each)

Mounting accessories

- Standard mounting rail
- Wall mounting
- Portrait mounting
- Side mounting

On request

Software Packages with SIMATIC WinCC flexible,
SIMATIC WinCC and SIMATIC Win AC RTX (F) can be ordered
together with the SIMATIC IPC, resulting in a price advantage.

Note:

You can find more information in Catalog ST 80/ST PC and in the
Industry Mall at www.siemens.com/industrymall

Overview



- Get off to a fast start in automation solutions with embedded PC platforms.
 - SIMATIC WinAC RTX or SIMATIC WinAC RTX F preinstalled on SIMATIC IPC427C and ready for use
 - PROFINET, PROFIBUS and Industrial Ethernet prepared for use in a SIMATIC environment
 - Optional WinCC flexible for visualization tasks in parallel with SIMATIC WinAC RTX.
 - Configuration and programming with SIMATIC STEP 7 via Industrial Ethernet, PROFINET, or PROFIBUS
- Safety requirements up to SIL 3 in accordance with IEC 61508/62061 or EN ISO 13849-1 up to PL e can be implemented with WinAC RTX F.
- Rugged operation
 - Operation without a hard disk, based on CompactFlash Card (CF Card) or Solid State Drive and Windows Embedded Standard
 - Fan-free operation
 - 128 KB of retentive data for WinAC RTX, also without uninterruptible power supply (UPS)
- Flexibility of a PC-based automation environment
 - Free memory space on CF Card can be used for other PC applications
 - Use of WinAC ODK with SIMATIC WinAC RTX or SIMATIC WinAC RTX F (read-only for fail-safe program section)
 - Connection option for USB devices, flat panel monitor or screen
 - PCI 104 cards can be plugged in
- High-performance service concept
 - Replacement parts for preferred types available ex stock
- New hardware basis SIMATIC IPC427C
- Cost-effective versions with PROFINET, based on the standard Ethernet interface
- Current product versions of the pre-installed software:
 - SIMATIC WinAC RTX 2010 or SIMATIC WinAC RTX F 2010
 - SIMATIC WinCC flexible 2008 SP2
 - SIMATIC NET Edition 2008

PROFINET/Industrial Ethernet Controllers / Embedded bundles

SIMATIC IPC427C bundles

2

Ordering data	Order No.	Ordering data	Order No.
SIMATIC IPC427C bundles <i>Bundles with SIMATIC WinAC RTX 2010 (F) and WinCC flexible 2008</i> (Windows Embedded Standard 2009 operating system) SIMATIC IPC427C with pre-installed software	6ES7 675 - 1 D ■ ■ 0 - ■ ■ ■ 0	SIMATIC IPC427C with pre-installed software Externally accessible mass storage <ul style="list-style-type: none"> Without (can only be ordered with internal mass storage) ¹⁾ 4 GB CompactFlash, Windows Embedded 2009 and software pre-installed ¹⁾ 8 GB CompactFlash, Windows Embedded 2009 and software pre-installed ¹⁾ Software configurations ¹⁾ <ul style="list-style-type: none"> WinAC RTX WinCC flexible RT 128 PT WinCC flexible RT 512 PT WinCC flexible RT 2048 PT WinCC flexible RT 4096 PT WinAC RTX, WinCC flexible RT 128 PT WinAC RTX, WinCC flexible RT 512 PT WinAC RTX, WinCC flexible RT 2048 PT WinAC RTX F WinAC RTX F, WinCC flexible RT 128 PT WinAC RTX F, WinCC flexible RT 512 PT WinAC RTX F, WinCC flexible RT 2048 PT WinAC RTX F, WinCC flexible RT 4096 PT 	6ES7 675 - 1 D ■ ■ 0 - ■ ■ ■ 0 A D E B C D E F K L M N P R S T U
Processor <ul style="list-style-type: none"> Celeron M, 1.2 GHz, 2x PROFINET (IE) ¹⁾ Celeron M, 1.2 GHz, 2x PROFINET (IE), 1x PROFIBUS ¹⁾ Core2 Solo, 1.2 GHz, 2x PROFINET (IE) ¹⁾ Core2 Solo, 1.2 GHz, 2x PROFINET (IE), 1x PROFIBUS ¹⁾ Core2 Solo, 1.2 GHz, 1x PROFINET (IE), PROFINET (RT/IRT) 3 ports Core2 Duo, 1.2 GHz, 2x PROFINET (IE) ¹⁾ Core2 Duo, 1.2 GHz, 2x PROFINET (IE), 1x PROFIBUS ¹⁾ Core2 Duo, 1.2 GHz, 1x PROFINET (IE), PROFINET (RT/IRT) 3 ports 	A B E F G J K L		
Work memory <ul style="list-style-type: none"> 1 GB RAM 2 GB RAM ¹⁾ 4 GB RAM 	2 3 4		
Mass storage, internal <ul style="list-style-type: none"> Without (can only be ordered with externally accessible mass storage) ¹⁾ 80 GB HDD SATA, additionally with externally accessible CF 32 GB Solid State Disk SATA, Windows Embedded 2009 and software pre-installed 4 GB internal CompactFlash, Windows Embedded 2009 and software pre-installed ¹⁾ 8 GB internal CompactFlash, Windows Embedded 2009 and software pre-installed ¹⁾ 	0 1 2 6 7		

¹⁾ Replacement hardware devices available in exchange

Ordering data	Order No.	Order No.
Delivery versions (from stock)		Accessories
Replacement hardware units available in exchange		CP 5603 Microbox Package 6GK1 560-3AU00
SIMATIC IPC427C bundle with WinAC RTX 2010		Package for using the PROFIBUS CP 5603 in Microbox PCs; comprising a CP 5603 module and a Microbox expansion rack
Core2 Solo processor, 1.2 GHz, 2x PROFINET (IE), 1x PROFIBUS, 2 GB RAM, 4 GB CompactFlash	6ES7 675-1DF30-0DB0	CP 1604 Microbox Package 6GK1 160-4AU00
Core2 Solo processor, 1.2 GHz, 2x PROFINET (IE), 1x PROFIBUS, 2 GB RAM, 4 GB CompactFlash	6ES7 675-1DK30-0DB0	Package for using the PROFINET CP 1604 in Microbox PCs; comprising CP 1604, connection board, power supply and expansion rack for Microbox PC; implemented with Development Kit DK-16xx PN IO; NCM P
Core2 Solo processor, 1.2 GHz, 2x PROFINET (IE), 1x PROFIBUS, 2 GB RAM, 8 GB CompactFlash	6ES7 675-1DK30-0EP0	Expansion kit PC/104 6AG4 070-0BA00-0XA0
SIMATIC IPC427C bundle with WinAC RTX 2010 and WinCC flexible 2008 512 PT		Expansion rack incl. mounting hardware; 6 items
Core2 Solo processor, 1.2 GHz, 2x PROFINET (IE), 1x PROFIBUS, 2 GB RAM, 4 GB CompactFlash	6ES7 675-1DK30-0DL0	CompactFlash Cards
		4 GB 6ES7 648-2BF02-0XG0
		8 GB 6ES7 648-2BF02-0XH0
Bundles with WinCC		SIMATIC PC keyboard
("Built to order" with delivery time of max. 14 business days, for hardware only repairs are possible)		German/international, USB connection 6ES7 648-0CB00-0YA0
IPC427C with WinCC RT, V7.0 SP2, incl. Update 1	6ES7 675-1D..0-B.0	German/international, USB connection, with 4-way USB HUB 6ES7 648-0CD00-0YA0
Fan-free, 4 x USB 2.0 (500 mA), 1 x COM (RS 232), 24 V DC power supply with On/Off switch, 2 x PROFINET (IE), Windows Embedded 2009 pre-installed, SIMATIC WinCC V7.0 SP2 incl. Update 1 Runtime pre-installed		SIMATIC PC USB mouse 6ES7 790-0AA01-0XA0
Client configurations	6ES7 675-1DA20-6AX0	Optical, 3 buttons, with PS/2 adapter
Processor Celeron M 1.2 GHz, 1 GB SDRAM-DDR3, 4 GB CF Card, runtime license 128 PT		SIMATIC IPC USB FlashDrive 6ES7 648-0DC50-0AA0
Client and single-user station configurations		8 GB (SLC), USB 2.0, incl. SIMATIC IPC BIOS manager, bootable, metal housing
Processor Core2 Solo 1.2 GHz, 2 GB SDRAM-DDR3, 8 GB CF Card, runtime license 128 PT	6ES7 675-1DE30-7AX0	SIMATIC IPC Service USB FlashDrive 6AV7 672-8JD01-0AA0
Processor Core2 Solo 1.2 GHz, PROFIBUS DP, 2 GB SDRAM-DDR3, 8 GB CF Card, runtime license 128 PT	6ES7 675-1DF30-7AX0	8 GB (SLC), USB 2.0, incl. SIMATIC IPC Image & Partition Creator and SIMATIC IPC BIOS manager (pre-installed), bootable, metal enclosure
Single-user station configurations	6ES7 675-1DK40-A.0	Portrait assembly kit 6ES7 648-1AA20-0YB0
Core2 Duo processor 1.2 GHz, PROFIBUS DP, 4 GB SDRAM-DDR3		Interfaces to the front
• 8 GB CF Card	6ES7 675-1DK40-7A.0	
• 32 GB SSD	6ES7 675-1DK40-2A.0	
• Runtime license 128 PT	6ES7 675-1DK40-AX0	
• Runtime license 2048 PT	6ES7 675-1DK40-AW0	

Note:

You can find more information in Catalog ST 80/ST PC and in the Industry Mall at www.siemens.com/industrymall

PROFINET/Industrial Ethernet

Controllers / Embedded bundles

SIMATIC HMI IPC277D bundles

Overview

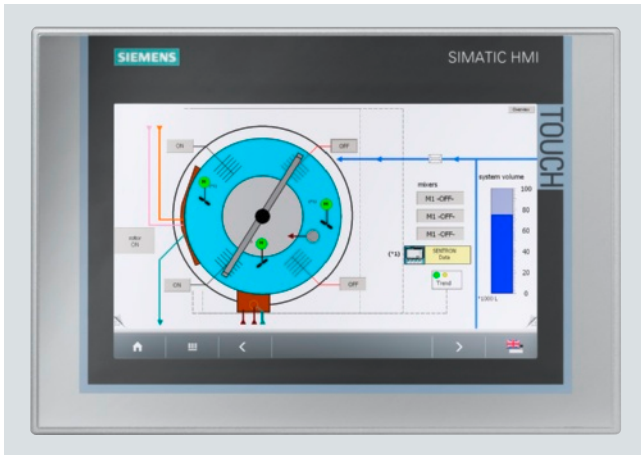

SIMATIC HMI IPC277D for implementing simple visualization and control tasks

- High degree of flexibility when selecting rugged widescreen fronts from 7" to 12" for more freely configurable display area
- High resolution, large viewing angle and up to 100% dimmable backlighting for brilliant display with optimized power consumption
- Absolutely maintenance-free due to the use of CompactFlash and SSD as mass storage and fanless operation up to 50 °C ambient temperature
- Maximum industrial functionality due to non-volatile retentive memory for battery-free operation
- Ready-to-run embedded bundles with visualization or/and control software

The following front installation versions are available:

- 7" Touch
- 9" Touch
- 12" Touch
- All fronts in widescreen design

PROFINET/Industrial Ethernet

Controllers / Embedded bundles

SIMATIC HMI IPC277D bundles

2

Ordering data	Order No.	Order No.
<p>Configuration</p> <p>SIMATIC HMI IPC277D</p> <p>Interfaces: 2 x Gbit LAN (RJ45), 1 x serial (COM1), 3 x USB</p> <p><u>Operating unit</u></p> <ul style="list-style-type: none"> • Touch 7" TFT • Touch 9" TFT • Touch 12" TFT • Touch 15" TFT, front USB interface • Touch 19" TFT, front USB interface <p><u>Processors/memory configuration/retentivity</u></p> <ul style="list-style-type: none"> • Atom E660 (1.3 GHz), 2 GByte RAM • Atom E660 (1.3 GHz), 2 GByte RAM, retentivity • Atom E640 (1.0 GHz), 1 GByte RAM • Atom E640 (1.0 GHz), 1 GByte RAM, retentivity <p><u>Drives</u></p> <ul style="list-style-type: none"> • Without drive, with CF slot • 2 GByte SIMATIC PC CompactFlash • 4 GByte SIMATIC PC CompactFlash • 8 GByte SIMATIC PC CompactFlash • 50 GByte Solid-State Drive SATA (SLC) <p><u>Operating system</u></p> <ul style="list-style-type: none"> • Without operating system • WES 2009 preinstalled (CF ab 2 GByte/SSD) • XP-Prof. MUI preinstalled on SSD • WES 7 vorinstalliert (CF from 4 GByte /SSD) • Windows 7 MUI preinstalled on SSD <p><u>Software bundles</u></p> <ul style="list-style-type: none"> • Without RTX/HMI software • RTX: WinAC RTX 2010 • RTX-F: WinAC RTX F 2010 • HMI: WinCC RT Advanced 128 PT • HMI: WinCC RT Advanced 512 PT • HMI: WinCC RT Advanced 2048 PT • HMI: WinCC RT Advanced 4096 PT • HMI/RTX: RT 128 PT • HMI/RTX: RT 512 PT • HMI/RTX: RT 2048 PT • HMI/RTX: RT 4096 PT 	<p>On request</p>	<p>Accessories</p> <p>Touch pen</p> <p>Captive pen for operation of the touch devices, mounting of the support on the control cabinet or direct on the PRO unit</p> <p>6AV7 672-1JB00-0AA0</p> <p>Software Packages with SIMATIC WinCC flexible, SIMATIC WinCC and SIMATIC WinAC RTX (F) can be ordered together with the SIMATIC IPC, resulting in a price advantage.</p> <p>Please be sure to note:</p> <p>The HMI IPC277D with bundle SW is delivered as standard with an inserted CF card. The licenses are located on the supplied USB flash drive.</p> <p><u>Note:</u></p> <p>You can find more information in Catalog ST 80/ST PC and in the Industry Mall at www.siemens.com/industrymall</p>

PROFINET/Industrial Ethernet

Controllers / Embedded bundles

SIMATIC HMI IPC477C bundles

Overview

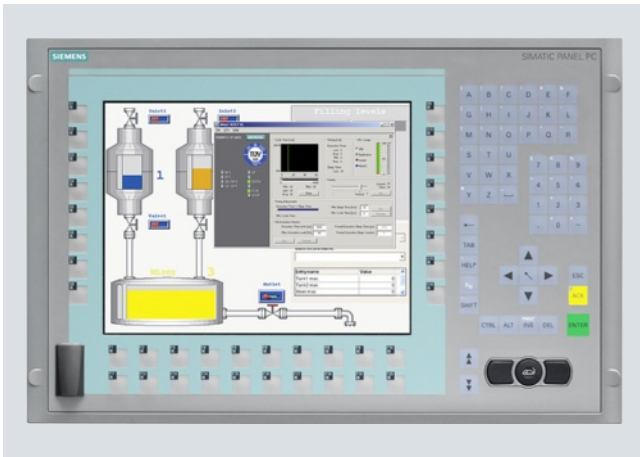

Embedded PC platform with extremely high industrial compatibility for demanding tasks in the field of PC-based automation

- Maintenance-free (no rotating components such as fan and hard disk)
- Rugged construction: The PC is resistant to even the harshest mechanical stress and is extremely reliable in operation
- Battery-backed retentive memory onboard
- Compact design (only 61-69 mm installation depth for 12"-19")
- High investment protection
- Fast integration capability

The following versions are available:

- Built-in versions
 - 12" and 15" TFT Touch
 - 12" and 15" TFT Key
 - 19" Touch
- Support arm versions
 - PRO 15" and 19" Touch
 Fully-enclosed device to IP65 degree of protection for mounting on a support arm/stand.

2

PROFINET/Industrial Ethernet Controllers / Embedded bundles

SIMATIC HMI IPC477C bundles



Ordering data	Order No.	Order No.	
<p>Bundles with WinAC RTX 2010 and WinCC flexible 2008 SP2</p> <p>(Built-to-order version, delivery time max. 15 business days and with identified repair, if not preferred type)</p>			
<p>Configuration</p> <p>SIMATIC HMI IPC477C PRO</p> <p>Embedded and fan-free with fully enclosed IP65 enclosure 4 x USB (500 mA), 24 V DC power supply with On/Off switch</p> <p>SIMATIC HMI IPC477C</p> <p>Fan-free 5 x USB 2.0 (500 mA), one of which on the front 1 x COM (RS232) 24 V DC power supply with On/Off switch</p> <p><u>Front Panels</u></p> <ul style="list-style-type: none"> • 12" TFT Touch ¹⁾ • 12" TFT Key • 15" TFT Touch ¹⁾ • 15" TFT Key • 19" TFT Touch ¹⁾ • 15" TFT Touch (IP65 enclosure; PRO) • 19" TFT Touch (IP65 enclosure; PRO) <p><u>Processors and fieldbus</u></p> <ul style="list-style-type: none"> • Celeron M 1.2 GHz, 2 x PROFINET (IE) ¹⁾ • Celeron M1 1.2 GHz, 2 x PROFINET (IE), 1 x PROFIBUS DP 12 ¹⁾ • Core2 Solo 1.2 GHz, 2 x PROFINET (IE) ¹⁾ • Core2 Solo 1.2 GHz, 2 x PROFINET (IE), 1 x PROFIBUS DP 12 ¹⁾ • Core2 Solo 1.2 GHz, 1 x PROFINET (IE), 1 x PROFINET (3 ports) ¹⁾ • Core2 Duo 1.2 GHz, 2 x PROFINET (IE) ¹⁾ • Core2 Duo 1.2 GHz, 2 x PROFINET (IE), 1 x PROFIBUS DP 12 ¹⁾ • Core2 Duo 1.2 GHz, 1 x PROFINET (IE), 1 x PROFINET (3 ports) ¹⁾ <p><u>Main memory (DDR3 RAM), 1 bank</u></p> <ul style="list-style-type: none"> • 1 GB • 2 GB ¹⁾ • 4 GB 	<p>6AV7 883 - A - - - - 0</p> <p>6AV7 884 - A - - - - 0</p> <p>A</p> <p>B</p> <p>D</p> <p>E</p> <p>F</p> <p>G</p> <p>H</p> <p>J</p> <p>1</p> <p>2</p> <p>3</p>	<p>Configuration (continued)</p> <p>SIMATIC HMI IPC477C</p> <p><u>Second mass storage (installed and formatted)</u></p> <ul style="list-style-type: none"> • Without ¹⁾ • CompactFlash 2 GB (only with Windows Embedded Standard 2009) ¹⁾ • CompactFlash 4 GB ¹⁾ • CompactFlash 8 GB ¹⁾ • SSD (Solid State Drive) min. 32 GB <p><u>Mass storage (installed, Windows Embedded Standard 2009 (En/Ge) preinstalled, optionally with SIMATIC software)</u></p> <ul style="list-style-type: none"> • CompactFlash 2 GB ¹⁾ • CompactFlash 4 GB ¹⁾ • CompactFlash 8 GB ¹⁾ • SSD (Solid State Drive) min. 32 GB <p><u>Operating system</u></p> <ul style="list-style-type: none"> • Windows Embedded 2009, pre-installed ¹⁾ • Windows XP Professional Multi Language, only with SSD; without SIMATIC software <p><u>Software packages, only with CF 4 GB or higher ¹⁾</u></p> <ul style="list-style-type: none"> • with operating system and RTX WinAC RTX 2010 pre-installed and configured • with operating system and HMI WinCC flexible 2008 SP2 RT (incl. archives/recipes) pre-installed and configured <ul style="list-style-type: none"> - Number of tags 128 PT - Number of tags 512 PT - Number of tags 2048 PT - Number of tags 4096 PT • with operating system and HMI/RTX WinCC flexible 2008 SP2 RT (incl. archives/recipes) and WinAC RTX 2010 pre-installed and configured <ul style="list-style-type: none"> - Number of tags 128 PT - Number of tags 512 PT - Number of tags 2048 PT - Number of tags 4096 PT • with operating system and RTX F WinAC RTX 2010 pre-installed and configured • with operating system and HMI/RTX F WinCC flexible 2008 SP2 RT (incl. archives/recipes) and WinAC RTX F 2010 pre-installed and configured <ul style="list-style-type: none"> - Number of tags 128 PT - Number of tags 512 PT - Number of tags 2048 PT - Number of tags 4096 PT 	<p>6AV7 884 - A - - - - 0</p> <p>0</p> <p>2</p> <p>3</p> <p>4</p> <p>6</p> <p>2</p> <p>3</p> <p>4</p> <p>6</p> <p>B A</p> <p>D A</p> <p>B B</p> <p>B C</p> <p>B D</p> <p>B E</p> <p>B F</p> <p>B K</p> <p>B L</p> <p>B M</p> <p>B N</p> <p>B P</p> <p>B R</p> <p>B S</p> <p>B T</p> <p>B U</p>

¹⁾ Preferred versions with repaired replacement device from warehouse

PROFINET/Industrial Ethernet

Controllers / Embedded bundles

SIMATIC HMI IPC477C bundles

Ordering data

Order No.

Bundles with WinCC V7.0 SP2, incl. Update 1

("Built to order" with delivery time of max. 14 business days, for hardware only repairs are possible)

Configuration

SIMATIC HMI IPC477C

6AV7 88 4 - A 0 - B 0

Fan-free
4 x USB 2.0 on rear,
1 x USB 2.0 on front,
1 x COM (RS232),
2 x 10/100/1000 Mbit/s Ethernet (RJ45);
software pre-installed on CF/SSD:
Windows Embedded Standard,
SIMATIC WinCC V7.0 SP1

SIMATIC HMI IPC477C PRO

6AV7 88 3 - A 0 - B 0

Fan-free,
4 x USB 2.0 (500 mA),
1 x USB 2.0 on front (not on PRO),
1 x COM (RS 232), 24 V DC power supply with On/Off switch,
2 x PROFINET (IE), Windows Embedded 2009 pre-installed
SIMATIC WinCC V7.0 SP2 incl. Update 1 Runtime pre-installed

Front Panel

- 15" TFT Touch
- 19" TFT Touch
- 15" TFT Touch PRO
- 19" TFT Touch PRO

6AV7 88 4 2
6AV7 88 4 5
6AV7 88 3 6
6AV7 88 3 7

Client configurations

Processor Celeron M 1.2 GHz,
1 GB DDR3 RAM, 4 GB CF Card,
runtime license 128 PT

6AV7 88 - A A 1 0 - 3 B X 0

Client and single-user station configurations

Processor Core2 Solo 1.2 GHz,
2 GB SDRAM-DDR3,
8 GB CF Card,
runtime license 128 PT

6AV7 88 - A D 2 0 - 4 B X 0

Processor Core2 Solo 1.2 GHz,
PROFIBUS DP,
2 GB SDRAM-DDR3,
8 GB CF Card,
runtime license 128 PT

6AV7 88 - A E 2 0 - 4 B X 0

Single-user station configurations

Core2 Duo processor 1.2 GHz,
PROFIBUS DP,
4 GB SDRAM-DDR3

6AV7 88 - A H 3 0 - B 0

- 8 GB CF Card
- 32 GB SSD
- Runtime license 128 PT
- Runtime license 2048 PT

6AV7 88 - A H 3 0 - 4 B 0
6AV7 88 - A H 3 0 - 6 B 0
6AV7 88 - A H 3 0 - B X 0
6AV7 88 - A H 3 0 - B W 0

1) Preferred versions with repaired replacement device from warehouse

Order No.

Accessories

Protective film for Panel PCs 477/577/677

For protecting the touch screen against dirt/scratches

- for 12" Touch
- for 15" Touch (not for PRO)
- for 19" Touch

6AV7 671-2BA00-0AA0

6AV7 671-4BA00-0AA0

6AV7 672-1CE00-0AA0

Labeling membranes for Panel PCs 477/577/677

For labeling soft keys and function keys, blank, supplied in sets of 10

6AV7 672-0DA00-0AA0

Touch pen

Captive pen for operation of the touch devices, mounting of the support on the control cabinet or direct on the PRO unit

6AV7 672-1JB00-0AA0

Expansion components

SIMATIC IPC DiagMonitor V4.2

Software tool for monitoring SIMATIC PCs, incl. manual, on CD-ROM (German/English)

6ES7 648-6CA04-2YX0

SIMATIC IPC Image & Partition Creator V3.1

Software tool for preventive data backup and hard disk partitioning for SIMATIC PCs, incl. manual on CD-ROM (German, English)

6ES7 648-6AA03-1YA0

SIMATIC IPC USB FlashDrive

8 GB, USB 2.0, metal enclosure, bootable

6ES7 648-0DC50-0AA0

SIMATIC IPC Service USB FlashDrive

8 GB, USB 2.0, metal enclosure, bootable

With: BIOS Manager, Image & Partition Creator pre-installed, incl. CD

6AV7 672-8JD01-0AA0

USB disk drive 3.5"

with 1 m connecting cable

6FC5 235-0AA05-1AA2

Industrial USB Hub 4

4 x USB 2.0, IP65 for control cabinet door or DIN rail

6AV6 671-3AH00-0AX0

CompactFlash Card

- 2 GB
- 4 GB
- 8 GB

6ES7 648-2BF02-0XF0

6ES7 648-2BF02-0XG0

6ES7 648-2BF02-0XH0

Please be sure to note:

The HMI IPC477C is delivered as standard with an inserted CF card. The licenses are located on the supplied USB flash drive.

Note:

You can find more information in Catalog ST 80/ST PC and in the Industry Mall at www.siemens.com/industrymall

Overview

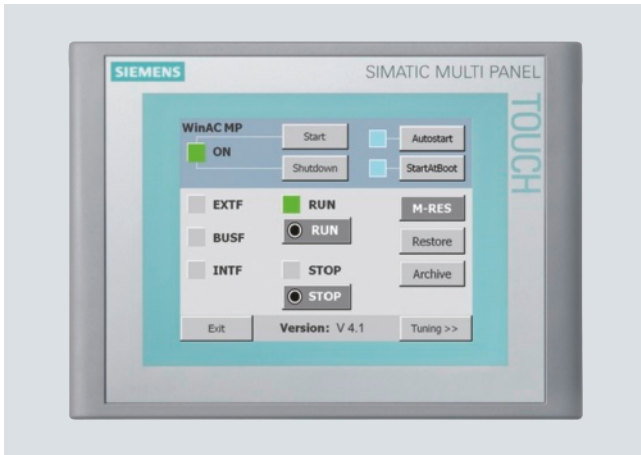

- WinAC MP, the software PLC based on Windows CE
- An optimized version is available for all current MP platforms
- The economical solution for all applications in combination with a rugged hardware platform
- Ideal for tasks on the machine level, saves space and costs
- Best service concept, backup/restore of all data on a standard SD card, standard Multi Media Card or standard USB stick

Ordering data

Order No.

WinAC MP, version WinAC MP 177²⁾

6ES7 671-4EE00-0YA0

incl. a Single License for MP 177 on USB stick¹⁾ and electronic documentation

WinAC MP, version WinAC MP 277²⁾

6ES7 671-5EF01-0YA0

incl. a Single License for MP 277 on USB stick¹⁾ and electronic documentation

WinAC MP, version WinAC MP 377²⁾

6ES7 671-7EG01-0YA0

incl. a Single License for MP 377 on USB stick¹⁾ and electronic documentation

Complete pre-assembled packages

Package MP 177 6" Touch

6AV6 652-2JC01-2AA0

- MP 177 6" Touch
- WinAC MP Version 177
- Electronic documentation
- Single License for MP 177 on USB flash drive¹⁾
- Standard SD card 256 MB (empty)

Package MP 277 8" Touch

6AV6 652-3MC01-1AA0

- MP 277 8" Touch
- WinAC MP Version 277
- Electronic documentation
- Single License for MP 277 on USB stick¹⁾
- Standard SD card 256 MB (empty)

Package MP 277 8" Key

6AV6 652-3LC01-1AA0

- MP 277 8" Key
- WinAC MP Version 277
- Electronic documentation
- Single License for MP 277 on USB stick¹⁾
- Standard SD card 256 MB (empty)

Package MP 277 10" Touch

6AV6 652-3PC01-1AA0

- MP 277 10" Touch
- WinAC MP Version 277
- Electronic documentation
- Single License for MP 277 on USB stick¹⁾
- Standard SD card 256 MB (empty)

Package MP 277 10" Key

6AV6 652-3NC01-1AA0

- MP 277 10" Key
- WinAC MP Version 277
- Electronic documentation
- Single License for MP 277 on USB stick¹⁾
- Standard SD card 256 MB (empty)

¹⁾ Can only be used for license handling

²⁾ UCL version on request

PROFINET/Industrial Ethernet

Controllers / Embedded bundles

SIMATIC WinAC MP

2

Ordering data

Order No.

Complete pre-assembled packages (continued)

Package MP 377 12" Touch <ul style="list-style-type: none"> • MP 377 12" Touch • WinAC MP Version 377 • Electronic documentation • Single License for MP 377 on USB stick ¹⁾ • Standard SD card 256 MB (empty) 	6AV6 652-4FC01-2AA0
Package MP 377 12" Key <ul style="list-style-type: none"> • MP 377 12" Key • WinAC MP Version 377 • Electronic documentation • Single License for MP 377 on USB stick ¹⁾ • Standard SD card 256 MB (empty) 	6AV6 652-4EC01-2AA0
Package MP 377 15" Touch <ul style="list-style-type: none"> • MP 377 15" Touch • WinAC MP Version 377 • Electronic documentation • Single License for MP 377 on USB stick ¹⁾ • Standard SD card 256 MB (empty) 	6AV6 652-4GC01-2AA0
Package MP 377 19" Touch <ul style="list-style-type: none"> • MP 377 19" Touch • WinAC MP Version 377 • Electronic documentation • Single License for MP 377 on USB stick ¹⁾ • Standard SD card 256 MB (empty) 	6AV6 652-4HC01-2AA0

¹⁾ Can only be used for license handling

²⁾ UCL version on request

Order No.

Starter packages

Starter package 613 WinAC MP <ul style="list-style-type: none"> • SIMATIC MP 177 6" Touch with installation accessories, mounting seal, power supply connector • SIMATIC WinAC MP incl. Single License on USB flash drive and electronic documentation • SD card 256 KB (empty) • ET 200M incl. • 16 DI, 16 DO, 8 AI, 2 AO • FM 350-2 8-channel counter • Front connector, bus connector, and mounting rail 	6AV6 652-2JD01-2AA0
Starter package 635T WinAC MP <ul style="list-style-type: none"> • SIMATIC MP 177 6" Touch with installation accessories, mounting seal, power supply connector • SIMATIC WinAC MP incl. Single License on USB flash drive and electronic documentation • SD card 256 KB (empty) • ET 200M incl. • 32 DI, 16 DO, 8 AI, 2 AO • FM 350-2 8-channel counter • Front connector, bus connector, and mounting rail 	6AV6 652-2JD01-2AA1
Starter package 635K WinAC MP <ul style="list-style-type: none"> • SIMATIC MP 277 8" Key with installation accessories, mounting seal, power supply connector • SIMATIC WinAC MP incl. Single License on USB flash drive and electronic documentation • SD card 256 KB (empty) • ET 200M incl. • 32 DI, 16 DO, 8 AI, 2 AO • FM 350-2 8-channel counter • Front connector, bus connector, and mounting rail 	6AV6 652-3LD01-1AA1
Starter package 636K WinAC MP <ul style="list-style-type: none"> • SIMATIC MP 277 8" Key with installation accessories, mounting seal, power supply connector • SIMATIC WinAC MP incl. Single License on USB flash drive and electronic documentation • SD card 256 KB (empty) • ET 200M incl. • 32 DI, 16 DO, 8 AI, 2 AO • Front connector, bus connector, and mounting rail 	6AV6 652-3LD01-1AA0
Starter package 636T WinAC MP <ul style="list-style-type: none"> • SIMATIC MP 277 10" Touch with installation accessories, mounting seal, power supply connector • SIMATIC WinAC MP incl. Single License on USB flash drive and electronic documentation • SD card 256 KB (empty) • ET 200M incl. • 32 DI, 16 DO, 8 AI, 2 AO • Front connector, bus connector, and mounting rail 	6AV6 652-3PD01-1AA0

Note:

You can find more information in Catalog ST 80/ST PC and in the Industry Mall at www.siemens.com/industrymall

Overview

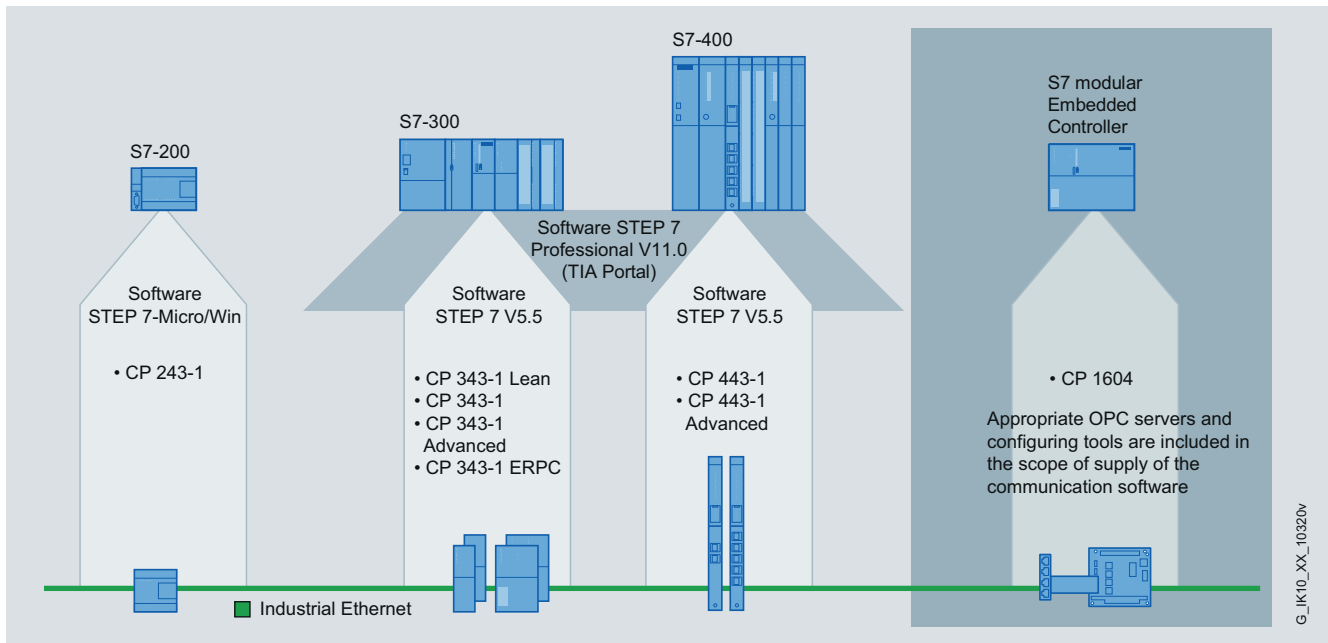

System connections for SIMATIC

CPs with standard functions

- CP 243-1 for SIMATIC S7-200, CP 343-1 Lean and CP 343-1 for SIMATIC S7-300, CP 443-1 for SIMATIC S7-400
- Designed for use in harsh industrial environments
- Shipbuilding certification for use on ships and offshore units
- Additional integrated 2-port switch for setting up small local networks with CP 343-1 Lean, CP 343-1 and CP 443-1
- Can be used via RJ45 interface for the industrial-standard SIMATIC NET FastConnect cabling system
- High-speed data transfer even with large volumes of data (10/100 Mbit/s)

CPs with function expansions

- CP 343-1 Advanced for SIMATIC S7-300
 - With security functionality (firewall and VPN)
 - With IT functionality
 - Can be used as a PROFINET IO Controller and IO Device with real-time characteristics
 - PROFINET CBA
 - With Gigabit connection, incl. routing functionality (10/100/1000 Mbit/s)
 - Network separation with IP-routing functionality
 - Additional integrated 2-port switch for setting up small local networks
 - Access protection via IP access list
- CP 443-1 Advanced for SIMATIC S7-400
 - With security functionality (firewall and VPN)
 - With IT functionality
 - Can be used as a PROFINET IO Controller with real-time characteristics
 - With Gigabit connection, incl. routing functionality (10/100/1000 Mbit/s)
 - Network separation with IP-routing functionality
 - Additional integrated 4-port switch for setting up small local networks
 - Access protection via IP access list
 - Operation in the SIMATIC H system for redundant S7-communication
 - Operation in fail-safe applications (PROFIsafe) together with SIMATIC S7-400 CPU 416F

PROFINET/Industrial Ethernet

System interfaces for SIMATIC S7

Introduction

Overview (continued)

CSMs and CPs with integral switch

2

Modules / CPs for SIMATIC S7		Hardware																																									
		Connection to S7 backplane bus	Format module S7	PC module	Flat type of construction	Box type of construction	19" type of construction	Rugged, compact housing	Modular design	10 Gigabit Ethernet	Gigabit Ethernet	PoE (Power over Ethernet)	LED diagnosis	SIMATIC environment	Redundant power supply (2 x 24 V DC)	External supply for integrated switch	Signal contact	Local display (SET pushbutton)	C-PLUG slot																								
Type of device																																											
CSM 1277			•									•	•																														
CSM 377			•									•	•																														
CP 343-1 Lean		•	•									•	•																														
CP 343-1		•	•									•	•																														
CP 343-1 Advanced		•	•							•		•	•					•																									
CP 343-1 BACnet		•	•									•	•																														
CP 443-1		•	•									•	•																														
CP 443-1 Advanced		•	•							•		•	•					•																									
Modules / CPs for SIMATIC S7		Software																																									
		Security Integrated (Firewall/VPN)	PROFINET diagnosis	Topology support (LLDP)	Command Line Interface / Telnet	Web based Management	Configuration with STEP 7	SNMP	Ring redundancy incl. RM-functionality	Standby redundancy	IRT capability	VLAN (Virtual Local Area Network)	GVRP (Generic VLAN Registration Protocol)	STP/ RSTP (Spanning Tree Protocol/ Rapid Spanning Tree Protocol)	Passive Listening	IGMP Snooping/Querier (Internet Group Management Protocol)	GMRP (Generic Multicast Protocol)	Broadcast/ Multicast/ Unicast Limiter	Broadcast blocking	DHCP Option 82 (Dynamic Host Configuration Protocol)	IP Access List	Access Control List (MAC)	IEEE 802.1x (Radius)	Link Aggregation	Static Routing	RIPv2 (Dynamic Routing)	OSPFv2 (Dynamic Routing)	VRRP, Router Redundancy (Virtual Router Redundancy Protocol)															
CSM 1277																																											
CSM 377																																											
CP 343-1 Lean			•	•		• ¹⁾	•	•	• ²⁾												•																						
CP 343-1			•	•		• ¹⁾	•	•	• ²⁾												•																						
CP 343-1 Advanced		•	•	•		• ¹⁾	•	•	•		•										•				•																		
CP 343-1 BACnet				•			•	•																																			
CP 443-1			•	•		• ¹⁾	•	•	•		•										•																						
CP 443-1 Advanced		•	•	•		• ¹⁾	•	•	•		•										•				•																		
		• applies														1) Port diagnosis possible by means of integrated web server														2) MRP-Client													

G_IK10_XX_10318

Function overview of the communication modules with integral switch for SIMATIC S7



Overview (continued)

CPs for special fields of application "Value Added CP"

Special "Value Added" CPs are available to relieve the SIMATIC CPU of special communication tasks.

There are two such CP versions for the S7-300 system:

- CP 343-1 ERPC optimized for linking to MES or ERP systems by means of additional partner software
- CP 343-1 BACnet (Building Automation and Control Networks) for building automation.

	Hardware	Transport protocol			PROFINET			MRP	IT		IP-R	PG/OP	S7 communication		Open communication			Time			Telecontrol			ERP-Connect	
		ISO	TCP	UDP	IO Controller	IO Device	CBA		Diagnostics (Web, SNMP)	FTP, e-mail, freely definable HTML pages			Standard system	High-availability communication	SEND/RECEIVE	Fetch/Write	TSEND/TRECV	Sending stations	Receiving stations	with NTP	SINAUT S7	DNP3	IEC 9)		
SIMATIC S7-200	CP 243-1		•						• 5)	•		•	•												
SIMATIC S7-300	CP 343-1 Lean		•	•		•		• 6)	•			•	• 4)		•	•			• 3)	•	•				
	CP 343-1	•	•	•	• 2)	• 2)		• 6)	•			•	•		•	•			• 3)	•	•				
	CP 343-1 Advanced	•	•	•	•	•	•	•	•	•	•	•	•		•	•			• 3)	•	•				
	CP 343-1 ERPC		•	•					•			•	•		•	•			• 3)	•	•			•	
	TIM 3V-IE		•									•									•				
	TIM 3V-IE Advanced		•									•									•				
	TIM 3V-IE DNP3		•									•									•				
	TIM 4R-IE 7)		•									•									•				
TIM 4V-IE DNP3		•									•									•					
SIMATIC S7-400	CP 443-1	•	•	•	•			•	•			•	•	• 1)	•	•	•		• 3)	•	•				
	CP 443-1 Advanced	•	•	•	•		•	•	•	•	•	•	•	• 1)	•	•	•		• 3)	•	•				
	TIM 4R-IE 7)8)		•									•								•		•			
	TIM 4V-IE DNP3		•									•								•	•		•		

1) ISO protocol only
 2) IO Controller or IO Device
 3) if S7-CPU is clock master
 4) S7 server only
 5) only standard page for system diagnosis
 6) Firmware V2.2 or higher
 7) Stand alone can be used
 8) S7-300 module format, connection to S7-400 CPU using MP or Industrial Ethernet
 9) with FB for SIMATIC S7 CPU (SIPLUS RIC Bundle)

• suitable
 You can find additional information on block solutions under www.siemens.simatic-net/ik-info

Communication overview for SIMATIC S7 and telecontrol

PROFINET/Industrial Ethernet

Communication for SIMATIC S7-200

CP 243-1

Overview



ISO	TCP	PN	MRP	IT	IP-R	PG/OP	S7
	●			●		●	●

Communication processor for connecting a SIMATIC S7-200 to Industrial Ethernet networks

The CP supports:

- PG/OP communication
- S7 communication
- IT communication

In addition, the CP 243-1 offers e-mail functions and user-created web pages and thus optimally supports maintenance and quality assurance. The Internet functions such as FTP allow connection to the most diverse PC-based systems.

Benefits

get Designed for Industry

- Process information can be accessed simultaneously (password protected) with standard Web browsers; software costs are reduced on the client side
- Low-cost bulk storage for data, statistics and HTML-based machine or plant documentation
- Simple universal linking of PLCs to different computers by means of FTP
- Local and worldwide transmission of event-driven messages by e-mail
- Time and cost savings due to fast and easy configuration, programming and monitoring from a central location via LAN
- Reduction of complexity and savings for networking all automation levels and devices since only Ethernet is required
- Simple startup and easy diagnostics options due to configuration support by STEP 7 Micro/WIN

Application

- The CP 243-1 communication processor is used to connect S7-200 to Industrial Ethernet.
- Distributed plants can be reached over telephone lines or the Internet by using a router and simple diagnostics, signal or user functions can be performed with the help of a web browser. The CP 243-1 is especially suited for plant sections where using PCs for permanent monitoring functions would not be cost-effective.
- PC applications can access the data of an S7-200 via an S7 OPC server. In this way, process data can be easily archived or further processed.
- SIMATIC S7-300 and S7-400 programmable controllers can communicate with a SIMATIC S7-200 with CP 243-1 over Industrial Ethernet which means that the S7-200 can also be used for more complex applications.

Design

The CP 243-1 offers all the advantages of the S7-200 design:

- Compact design in a rugged plastic enclosure
- Terminal strip for connecting the 24 V DC external supply voltage
- LED status display
- Optional DIN rail mounting or direct wall mounting
- RJ45 socket for connection to Industrial Ethernet with automatic data rate detection

2

Function

The CP 243-1 is connected to Industrial Ethernet via an RJ45 interface for 10/100 Mbit/s full/half duplex with autosensing/autonegotiation and autocrossover function.

The CP 243-1 enables communication between an S7-200 module and another S7-200 or S7-300/S7-400 controller via Industrial Ethernet, and access of the S7-200 programming software STEP 7-Micro/WIN to the S7-200 via Industrial Ethernet.

Integration into PC applications is possible by means of the S7-OPC server of the PC software.

IT functions

Simple visualization using Web technology, sending e-mails, and file processing (FTP).

The file system of the CP 243-1 can also be managed through the CPU. It is used as a bulk storage device, a cross-system computer link and a storage location for HTML pages and Java applets. The CP 243-1 has a large file system in which, apart from HTML pages, machine documentation or user guides can also be stored.

Web server

HTML pages can be downloaded and viewed with standard browsers

Web pages

- For observation of the S7-200 controller: standard pages for system diagnostics and a simple variable editor are supplied.
- Other customer-specific pages can be generated with any HTML tools

E-mails

sending of pre-defined e-mails directly from the user program
Variables can be integrated into the text

FTP communication

The CPU can send data blocks as files to other computers or can read or delete the files of other computers (client function).
Communication through FTP is possible with most operating systems

Configuration

- STEP 7 Micro/WIN V4.0 SP8 or higher is required for configuring the full functional scope of the CP 243-1.
- The CP 243-1 is supplied with a globally unique MAC address that cannot be changed.

Integration

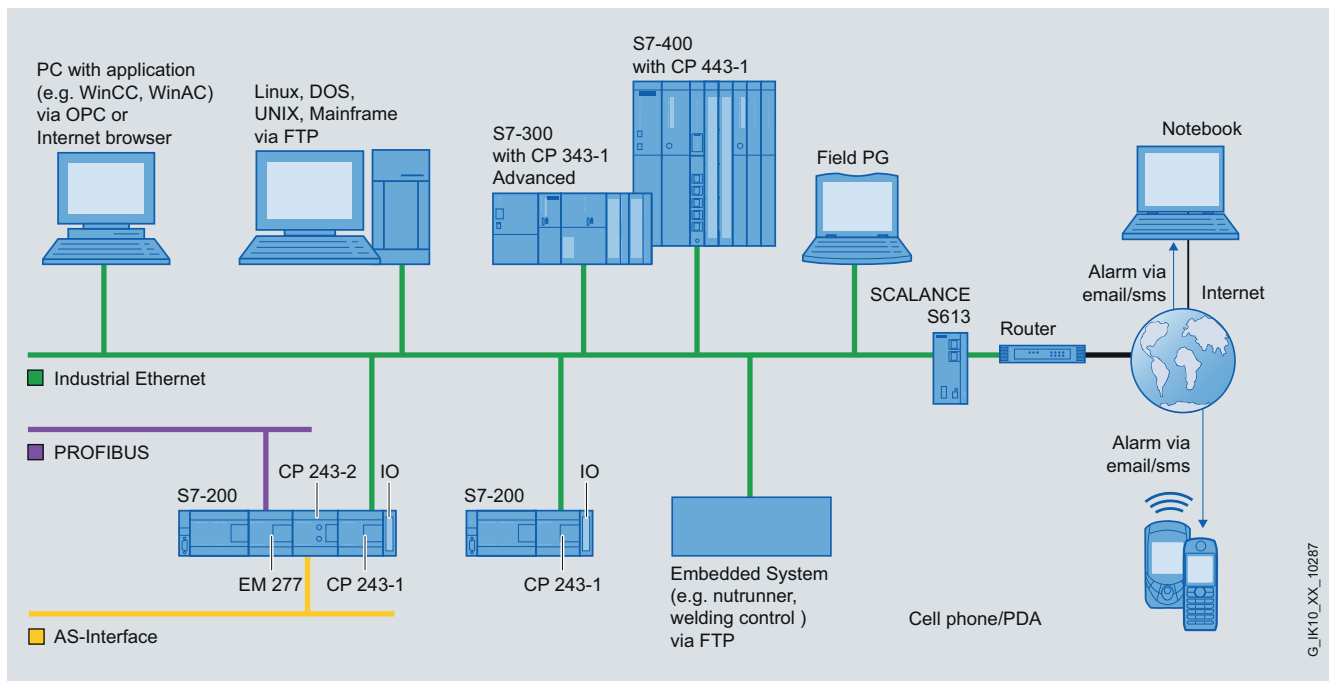

S7-200 communication options with CP 243-1

PROFINET/Industrial Ethernet

Communication for SIMATIC S7-200

CP 243-1

Technical specifications

Order No.	6GK7 243-1EX01-0XE0
Product type designation	CP 243-1
Transmission rate	
Transmission rate at interface 1	10 ... 100 Mbit/s
Interfaces	
Number of electrical connections	
• at interface 1 in accordance with Industrial Ethernet	1
• for power supply	1
Design of electrical connection	
• at interface 1 in accordance with Industrial Ethernet	RJ45 port
• for power supply	3-pin terminal strip
Supply voltage, current consumption, power loss	
Type of power supply	DC
Power supply	
• 1 from backplane bus	5 V
• External	24 V
Relative symmetrical tolerance at 24 V DC	-
Current input from external power supply at 24 V DC	
• Typical	0.053 A
• Maximum	0.06 A
Effective power loss	1.5 W
Permitted ambient conditions	
Ambient temperature	
• with vertical installation during operation	0 ... +45 °C
• with horizontal installation during operation	0 ... +55 °C
• During storage	-40 ... +70 °C
• During transport	-40 ... +70 °C
• Note	-
Relative humidity at 25 °C without condensation during operation, maximum	95 %
IP degree of protection	IP20
Design, dimensions and weights	
Module format	S7-200 compact module, double-width
Width	71.2 mm
Height	80 mm
Depth	62 mm
Net weight	0.15 kg

Order No.	6GK7 243-1EX01-0XE0
Product type designation	CP 243-1
Product properties, functions, components	
General	
Number of modules	
• Per CPU, maximum	1
• Note	-
Performance data	
<u>Performance data S7 communication</u>	
Number of possible connections for S7 communication	
• Maximum	8
• For PG connections, maximum	1
• For PG/OP connections, maximum	8
• Note	-
<u>Performance data IT functions</u>	
Number of possible connections	
• as client with FTP, maximum	1
• as server with HTTP, maximum	4
• as e-mail client, maximum	1
Number of e-mails with 1024 characters of e-mail client, maximum	32
Number of access privileges of access protection function	8
Storage capacity of user memory as FLASH memory file system	8 Mibyte
Number of possible write cycles of flash memory cells	100000
Product functions	
Management, configuration, programming	
Product function: MIB support	No
Protocol is supported SNMP v1	No
Configuration software required	STEP 7-Micro/WIN V4.0 SP8 and higher
Identification & maintenance	
• I&M0 - device-specific information	-
• I&M1 - higher-level designation/ location designation	-
Product functions Diagnostics	
Product function: Web-based diagnostics	Yes

2

Ordering data	Order No.	Order No.
CP 243-1 communication processor for connection of SIMATIC S7-200 to Industrial Ethernet; for S7 communication, PG communication, E-mail and WWW server; with electronic manual on CD-ROM German, English, French, Italian, Spanish	6GK7 243-1EX01-0XE0	SOFTNET-S7 Lean Edition 2008 (V7.1) for Industrial Ethernet Up to eight connections • Single license for one installation
SOFTNET S7 for Industrial Ethernet Software for S7 and open communication, including OPC server, PG/OP communication and NCM PC, runtime software, software and electronic manual on CD-ROM, license key on a USB stick, Class A		Software Update Service For 1 year with automatic extension; requirement: current software version
SOFTNET-IE S7 V8.1 For 32/64-bit Windows 7 Professional/Ultimate; for 64-bit: Windows 2008 Server R2; English/German up to 64 connections • Single license for one installation	6GK1 704-1CW08-1AA0	Upgrade • From Edition 2006 to Edition 2008 or V8.1 • From V6.0, V6.1, V6.2 or V6.3 to Edition 2008 or V8.1
SOFTNET-S7 Edition 2008 (V7.1) for Industrial Ethernet for 32-bit Windows XP Professional SP2/3; Windows 2003 Server R2, SP2; Windows Vista Business/Ultimate SP1; Windows 2008 Server; German/English up to 64 connections • Single license for one installation	6GK1 704-1CW71-3AA0	STEP 7-Micro/WIN V4 programming software <i>Target system:</i> All CPUs of the SIMATIC S7-200 <i>Requirement:</i> Windows 2000/XP on PG or PC, <i>available in:</i> German, English, French, Spanish, Italian, Chinese; with online documentation • Single license • Upgrade Single license ¹⁾
Software Update Service For 1 year with automatic extension; requirement: current software version	6GK1 704-1CW00-3AL0	IE TP Cord RJ45/RJ45 TP cable 4 x 2 with 2 RJ45 connectors • 0.5 m • 1 m • 2 m • 6 m
Upgrade • From Edition 2006 to Edition 2008 or V8.1 • From V6.0, V6.1, V6.2 or V6.3 to Edition 2008 or V8.1	6GK1 704-1CW00-3AE0 6GK1 704-1CW00-3AE1	SCALANCE X005 Industrial Ethernet Switch for 10/100 Mbit/s; with five 10/100 Mbit/s RJ45 ports for configuring small star and line structures
SOFTNET-IE S7 Lean Edition V8.1 Up to eight connections • Single license for one installation	6GK1 704-1LW08-1AA0	6ES7 810-2CC03-0YX0 6ES7 810-2CC03-0YX3
		6XV1 870-3QE50 6XV1 870-3QH10 6XV1 870-3QH20 6XV1 870-3QH60
		6GK5 005-0BA00-1AA3

¹⁾ Upgrade for all previous STEP 7-Micro/WIN and STEP 7-Micro/DOS versions

PROFINET/Industrial Ethernet

Communication for SIMATIC S7-300

CP 343-1 Lean

Overview



ISO	TCP/UDP	PN	MRP	IT	IP-R	PG/OP	S7/S5
	●	●	●			●	●

Communication processor for connecting a SIMATIC S7-300 to Industrial Ethernet networks, also as PROFINET IO Device.

The CP supports:

- PG/OP communication
- S7 communication
- Open communication (SEND/RECEIVE)
- PROFINET communication

Benefits

get Designed for Industry

- High level of plant availability due to support of media redundancy (MRP)
- Optimum support of maintenance through
 - Web-based diagnostics
 - Remote programming via WAN or a telephone network (ISDN)
 - Monitoring by means of IT network management tools (SNMP)
 - Module replacement without programming device thanks to saving of the configuration data on the CPU
- The capability of later connecting existing SIMATIC S7 systems to Industrial Ethernet using the CP 343-1 Lean ensures investment protection

Application

The CP 343-1 Lean is used to connect the SIMATIC S7-300 to Industrial Ethernet networks. With its own processor, it relieves the CPU of communication tasks and facilitates additional connections.

The CP 343-1 Lean offers the communication options of the S7-300 with

- PGs/PCs
- Master computers
- HMI devices
- Other SIMATIC S5/S7 systems
- PROFINET I/O Controllers

Design

The CP 343-1 Lean offers all the advantages of SIMATIC S7-300 system design:

- Compact design; the rugged plastic casing features on the front:
 - Two RJ45 sockets for connecting to Industrial Ethernet with automatic detection of transmission rate by means of autosensing; RJ45 sockets have an industry-compatible design with additional retaining collars for connection of IE FC RJ45 Plug 145/180
 - Diagnostic LEDs for each switch port
 - 2-pin plug-in terminal strip for connection of the 24 V DC external supply voltage
- Easy installation; The CP 343-1 Lean is snap-mounted on the S7-300 DIN rail and connected to adjacent modules through the bus connectors. There are no slot rules.
- The CP 343-1 Lean can be operated without a fan. A standby battery is not required.
- In combination with IM 360/361, CP 343-1 Lean can also be used in an expansion rack (ER).

Function

- PROFINET interface with two RJ45 ports, 10/100 Mbit/s full/half duplex with autosensing and autocrossover functionality via 2-port switch
- Communication services via interface:
 - Open communication (TCP/IP, UDP); Multicast for UDP
 - PG/OP communication: across networks by means of S7 routing
 - S7 communication (server only)
 - PROFINET IO device
- Media redundancy (MRP):
 - Within an Ethernet network with ring topology, the CP supports the media redundancy procedure MRP
- Diagnostics and network management:
 - Extensive diagnostic functions for all modules in the rack
 - Integration into network management systems through the support of SNMP V1
- Configuration of all functions with STEP 7 V5.4 and higher, or STEP 7 Professional V11
- Module replacement without programming device thanks to saving of the configuration data on the CPU

Integration

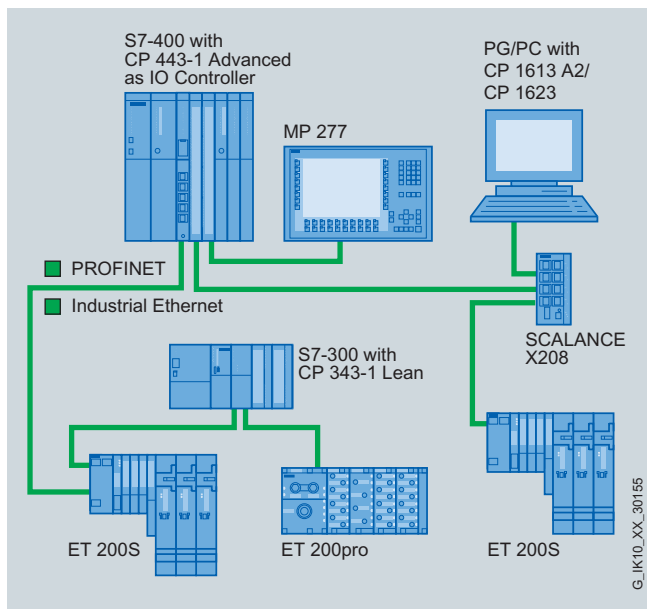

Line structure with CP 343-1 Lean with integrated real-time switch as a PROFINET IO device

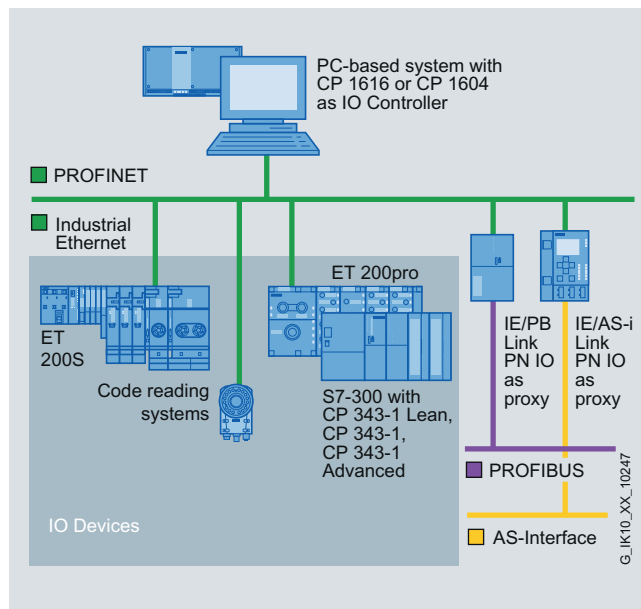

Connection to higher-level network and PC-based system

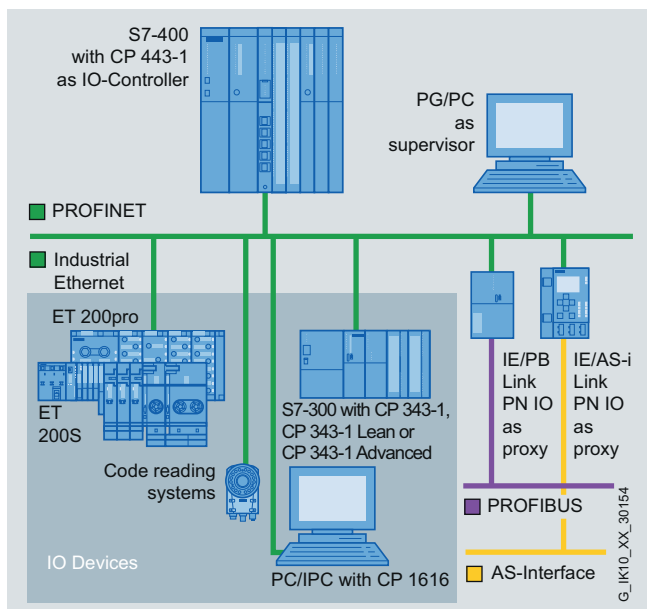

Example configuration of CP 343-1 Lean as PROFINET I/O Device

PROFINET/Industrial Ethernet

Communication for SIMATIC S7-300

CP 343-1 Lean

Technical specifications

Order No.	6GK7 343-1CX10-0XE0
Product type designation	CP 343-1 Lean
Transmission rate	
Transmission rate at interface 1	10 ... 100 Mbit/s
Interfaces	
Number of electrical connections	
• at interface 1 in accordance with Industrial Ethernet	2
• for power supply	1
Design of electrical connection	
• at interface 1 in accordance with Industrial Ethernet	RJ45 port
• for power supply	2-pin plug-in terminal strip
Supply voltage, current consumption, power loss	
Type of power supply	DC
Power supply	
• 1 from backplane bus	5 V
• External	24 V
Relative positive tolerance at 24 V DC	20 %
Relative negative tolerance at 24 V DC	15 %
Current consumed	
• from backplane bus at 5 V DC, typical	0.2 A
• from external power supply with 24 V DC	
- Typical	0.16 A
- Maximum	0.2 A
Effective power loss	5.8 W
Permitted ambient conditions	
Ambient temperature	
• with vertical installation during operation	0 ... +40 °C
• with horizontal installation during operation	0 ... +60 °C
• During storage	-40 ... +70 °C
• During transport	-40 ... +70 °C
Relative humidity at 25 °C without condensation during operation, maximum	95 %
IP degree of protection	IP20
Design, dimensions and weights	
Module format	S7-300 compact module, single-width
Width	40 mm
Height	125 mm
Depth	120 mm
Net weight	0.22 kg

Order No.	6GK7 343-1CX10-0XE0
Product type designation	CP 343-1 Lean
Performance data	
<u>Performance data</u>	
<u>Open communication</u>	
Number of possible connections for open communication by means of SEND/RECEIVE blocks, maximum	8
Data volume	
• as user data per ISO on TCP connection for open communication by means of SEND/RECEIVE blocks, maximum	8 KB
• as user data per TCP connection for open communication by means of SEND/RECEIVE blocks, maximum	8 KB
• as user data per UDP connection for open IE communication by means of SEND/RECEIVE blocks, maximum	2 KB
Number of multicast stations	8
<u>Performance data</u>	
<u>S7 communication</u>	
Number of possible connections for S7 communication	
• Maximum	4
<u>Performance data</u>	
<u>Multiprotocol operation</u>	
Number of active connections in multiprotocol mode	12
<u>Performance data</u>	
<u>PROFINET communication as PN IO Device</u>	
Product function: PROFINET IO Device	Yes
Data volume	
• As user data for input variables as PROFINET IO Device, maximum	512 byte
• As user data for output variables as PROFINET IO Device, maximum	512 byte
• As user data for input variables per submodule as PROFINET IO Device	240 byte
• As user data for output variables per submodule as PROFINET IO Device	240 byte
• As user data for the consistency area per submodule	240 byte
Number of submodules per PROFINET IO Device	32

2

Technical specifications (continued)		Ordering data	Order No.
Order No.	6GK7 343-1CX10-0XE0	Communication processor CP 343-1 Lean	6GK7 343-1CX10-0XE0
Product type designation	CP 343-1 Lean	For connecting SIMATIC S7-300 to Industrial Ethernet through TCP/IP and UDP, Multicast, S7 communication, open communication (SEND/RECEIVE), FETCH/WRITE, PROFINET IO Device, MRP, integrated 2-port switch ERTEC, comprehensive diagnostics facilities, module replacement without PG, SNMP, initial commissioning over LAN; with electronic manual on CD-ROM	
Product functions Management, configuration, programming		IE FC TP Standard Cable GP 2x2	6XV1 840-2AH10
Product function: MIB support	Yes	4-core, shielded TP installation cable for connection to IE FC Outlet RJ45/ IE FC RJ45 Plug; PROFINET-compliant; with UL approval; <u>sold by the meter</u> max. length 1000 m, minimum order 20 m	
Protocol is supported		Compact Switch Module CSM 377	6GK7 377-1AA00-0AA0
• SNMP v1	Yes	Unmanaged switch for connection of a SIMATIC S7-300-CPU, ET 200M and as many as three further nodes to Industrial Ethernet operating at 10/100 Mbit/s; 4 x RJ45 ports; external 24 V DC power supply, LED diagnostics, S7-300 module including electronic Manual on CD-ROM	
• DCP	Yes	IE FC RJ45 Plug 145	
• LLDP	Yes	RJ45 plug connector for Industrial Ethernet with a rugged metal enclosure and integrated insulation displacement contacts for connecting Industrial Ethernet FC installation cables; with 145° cable outlet;	6GK1 901-1BB30-0AA0 6GK1 901-1BB30-0AB0 6GK1 901-1BB30-0AE0
Configuration software required	STEP 7 V5.4 and higher or STEP 7 V11 and higher	• 1 pack = 1 unit • 1 pack = 10 units • 1 pack = 50 units	
Identification & maintenance		IE FC Stripping Tool	6GK1 901-1GA00
• I&M0 - device-specific information	Yes	Preadjusted stripping tool for fast stripping of the Industrial Ethernet FC cables	
• I&M1 - higher-level designation/location designation	Yes		
Product functions Diagnostics			
Product function: Web-based diagnostics	Yes		
Product functions Switch			
Product feature: Switch	Yes		
Product function			
• Switch-managed	No		
• Configuration with STEP 7	Yes		
Product functions Redundancy			
Product function			
• Ring redundancy	Yes		
• Redundancy procedure MRP	Yes		
Product functions Security			
Product function			
• Switching-off non-required services	Yes		
• Blocking of communication via physical ports	Yes		
Product functions Time			
Product function			
• SICLOCK support	Yes		
• Passing-on of time synchronization	Yes		
NTP Protocol is supported	Yes		

PROFINET/Industrial Ethernet

Communication for SIMATIC S7-300

CP 343-1 Lean

2

Ordering data**Order No.****Order No.****SOFTNET S7 for Industrial Ethernet**

Software for S7 and open communication, including OPC server, PG/OP communication and NCM PC, runtime software, software and electronic manual on CD-ROM, license key on USB stick, Class A

SOFTNET-IE S7 V8.1

For 32/64-bit
Windows 7 Professional/Ultimate;
for 64-bit:
Windows 2008 Server R2;
German/English

up to 64 connections
• Single License
for one installation

6GK1 704-1CW08-1AA0**SOFTNET-S7 Edition 2008 (V7.1) for Industrial Ethernet**

for 32-bit
Windows XP Professional SP2/3;
Windows 2003 Server R2, SP2;
Windows Vista Business/Ultimate
SP1; Windows 2008 Server;
German/English

up to 64 connections
• Single License
for one installation

6GK1 704-1CW71-3AA0**Software Update Service**

For 1 year
with automatic extension;
requirement:
Current software version

6GK1 704-1CW00-3AL0**Upgrade**

- From Edition 2006 to Edition 2008 or V8.1
- From V6.0, V6.1, V6.2 or V6.3 to Edition 2008 or V8.1

6GK1 704-1CW00-3AE0**6GK1 704-1CW00-3AE1****SOFTNET-IE S7 Lean Edition V8.1**

Up to eight connections
• Single License
for one installation

6GK1 704-1LW08-1AA0**SOFTNET-S7 Lean Edition 2008 (V7.1) for Industrial Ethernet**

Up to eight connections
• Single License
for one installation

6GK1 704-1LW71-3AA0**Software Update Service**

For 1 year
with automatic extension;
requirement:
Current software version

6GK1 704-1LW00-3AL0**Upgrade**

- From Edition 2006 to Edition 2008 or V8.1
- From V6.0, V6.1, V6.2 or V6.3 to Edition 2008 or V8.1

6GK1 704-1LW00-3AE0**6GK1 704-1LW00-3AE1****STEP 7 Version 5.5**

Target system:
SIMATIC S7-300/400,
SIMATIC C7, SIMATIC WinAC

Requirements:
Windows XP Prof.,
Windows 7 Professional/Ultimate

Type of delivery:
German, English, French,
Spanish, Italian;
including license key
on USB stick, with electronic
documentation

- Floating license on DVD
- Rental license for 50 hours
- Software Update Service on DVD (requires current software version)
- Upgrade Floating License 3.x/4.x/5.x to V5.5; on DVD
- Trial License STEP 7 V5.5; on DVD, 14 day trial

6ES7 810-4CC10-0YA5**6ES7 810-4CC10-0YA6****6ES7 810-4BC01-0YX2****6ES7 810-4CC10-0YE5****6ES7 810-4CC10-0YA7****STEP 7 Professional Engineering Software V11**

Target system:
SIMATIC S7-300/400,
SIMATIC C7, SIMATIC WinAC

Requirements:
Windows XP Professional SP3
(32 bit),
Windows 7 Professional (32 bit),
Windows 7 Enterprise (32 bit),
Windows 7 Ultimate (32 bit),
Microsoft Server 2003 R2 Std.
SP2 (32 bit),
Microsoft Server 2008 Std. SP2
(32 bit)

Type of delivery:
German, English, Chinese, Italian;
French, Spanish

- STEP 7 Professional V11, floating license
- STEP 7 Prof. V11, trial license
- Upgrade STEP 7 Professional 2006/2010 to STEP 7 Professional V11, floating license
- PowerPack & Upgrade STEP 7 V5.4/V5.5 to STEP 7 Prof. V11, floating license
- Powerpack STEP 7 Basic V11 to STEP 7 Prof. V11, floating license
- STEP 7 Professional V11, Software Update Service, 1 year; current software version required
- STEP 7 Professional V11, Software Update Service Compact, 1 year; current software version required
- STEP 7 Professional Software Update Service; 1 year; for STEP 7 Professional and STEP 7 Professional in the TIA Portal, requires current software version
- STEP 7 Professional Software Update Service Compact; 1 year; for STEP 7 Professional and STEP 7 Professional in the TIA Portal, requires current software version

6ES7 822-1AA01-0YA5**6ES7 822-1AA01-0YA7****6ES7 822-1AA01-0XE5****6ES7 822-1AA01-0XC5****6ES7 822-1AA01-0YC5****6ES7 822-1AA00-0YL5****6ES7 822-1AA00-0YM5****6ES7 810-5CC04-0YE2****6ES7 810-5CC00-0YM2**

PROFINET/Industrial Ethernet

Communication for SIMATIC S7-300

SIPLUS CP 343-1 Lean

Overview



ISO	TCP/UDP	PN	MRP	IT	IP-R	PG/OP	S7/S5
	●	●	●			●	●

- Interface for the SIMATIC S7-300 to Industrial Ethernet (not for SINUMERIK)
 - 2 x RJ45 interface for 10/100 Mbit/s full/half duplex connection (with autosensing for automatic switchover and autocrossover function)
 - Integral 2-port real-time switch ERTEC
 - Multi-protocol operation with TCP and UDP transport protocol and PROFINET I/O
 - Keep Alive function
- Communication services:
 - Open communication (TCP/IP and UDP):
 - PG/OP communication
 - S7 communication (server)
 - PROFINET IO device
- Multicast by UDP
- Remote programming and initial commissioning is possible over Industrial Ethernet
- IT communication
 - Web function
- Integration into network management through SNMP
- Configuration with STEP 7
- Cross-network programming device/operator panel communication through S7 routing
- Diagnostics possibilities in STEP 7 and Web browser

Note:

SIPLUS extreme products are based on Siemens Industry standard products. The contents listed here were taken from the respective standard products. SIPLUS extreme-specific information was added.

SIPLUS CP 343-1 Lean

Order number	6AG1 343-1CX10-2XE0	6AG1 343-1CX10-4XE0
Order No. based on	6GK7 343-1CX10-0XE0	
Ambient temperature range	-25 ... +60 °C	0 ... +60 °C
Conformal coating	Coating of the printed circuit boards and the electronic components	
Technical data	The technical data of the standard product applies except for the ambient conditions.	

Ambient conditions

Relative humidity	5 ... 100 % Condensation permissible
Biologically active substances	Conformity with EN 60721-3-3, Class 3B2 mold and fungal spores (except fauna)
Chemically active substances	Conformity with EN 60721-3-3, Class 3C4 incl. salt mist and ISA-S71.04 severity level G1; G2; G3; GX ¹⁾²⁾
Mechanically active substances	Conformity with EN 60721-3-3, Class 3S4 including conductive sand, dust ²⁾
Air pressure (depending on the highest positive temperature range specified)	1080 ... 795 hPa (-1000 ... +2000 m) see ambient temperature range 795 ... 658 hPa (+2000 ... +3500 m) derating 10 K 658 ... 540 hPa (+3500 ... +5000 m) derating 20 K

- 1) ISA-S71.04 severity level GX: Long-term load:
SO₂ < 4.8 ppm; H₂S < 9.9 ppm; Cl < 0.2 ppm; HCl < 0.66 ppm; HF < 0.12 ppm; NH < 49 ppm; O₃ < 0.1 ppm; NO_x < 5.2 ppm
Limit value (max. 30 min/d):
SO₂ < 17.8 ppm; H₂S < 49.7 ppm; Cl < 1.0 ppm; HCl < 3.3 ppm; HF < 2.4 ppm; NH < 247 ppm; O₃ < 1.0 ppm; NO_x < 10.4 ppm
- 2) The supplied plug covers must remain in place over the unused interface when operated in atmospheres containing corrosive gases!

The technical documentation on SIPLUS can be found here:
www.siemens.com/siplus-extreme

Ordering data

Order No.

SIPLUS CP 343-1 Lean communication processor

(extended temperature range and medial exposure)

For connecting SIMATIC S7-300 to Industrial Ethernet through TCP/IP and UDP, Multicast, S7 communication, open communication (SEND/RECEIVE), FETCH/WRITE, PROFINET IO device, integral 2-port switch ERTEC, comprehensive diagnostics facilities, module replacement without PG, SNMP, initial commissioning over LAN; with electronic manual on CD-ROM

Ambient temperature
0 ... +60 °C

6AG1 343-1CX10-4XE0

Ambient temperature
-25 ... +60 °C

6AG1 343-1CX10-2XE0

Accessories

See SIMATIC CP 343-1 Lean communication processor

2

PROFINET/Industrial Ethernet

Communication for SIMATIC S7-300

CP 343-1

Overview



ISO	TCP/UDP	PN	MRP	IT	IP-R	PG/OP	S7/S5
●	●	●	●			●	●

Communication processor for connecting a SIMATIC S7-300/SINUMERIK 840D powerline to Industrial Ethernet networks, also as PROFINET IO Controller or IO Device.

The CP supports:

- PG/OP communication
- S7 communication
- Open communication (SEND/RECEIVE)
- PROFINET communication

Benefits

get Designed for Industry

- High level of plant availability due to support of media redundancy (MRP)
- Optimum support of maintenance through
 - Web-based diagnostics
 - Remote programming via WAN or a telephone network (ISDN)
 - Monitoring by means of IT network management tools (SNMP)
 - Module replacement without programming device thanks to saving of the configuration data on the CPU
- Securing the system against unauthorized access by means of device-related IP address lists
- The capability of later connecting existing SIMATIC S7 systems to Industrial Ethernet using the CP 343-1 ensures investment protection

Application

The CP 343-1 is used for connecting the SIMATIC S7-300/SINUMERIK 840D powerline to Industrial Ethernet networks. With its own processor, it relieves the CPU of communication tasks and facilitates additional connections.

The CP 343-1 permits communication of the S7-300 with:

- PGs/PCs
- Master computers
- HMI devices
- SIMATIC S7/C7 systems
- PROFINET IO devices

Design

The CP 343-1 has all the advantages of the SIMATIC S7-300 design:

- Compact design; on the front, the rugged plastic housing features:
 - Two RJ45 sockets for connection to Industrial Ethernet with automatic sensing of the data transmission rate by means of Autosensing/Autonegotiation; the RJ45 sockets are industrially compatible and designed with additional holding collars for connecting to the IE FC RJ45 Plug 145/180
 - 2-pole plug-in terminal strip for connection of the 24 V DC external supply voltage
 - 8 LEDs for indication of the operating and communication status (diagnostics for each switch port)
- Easy installation; the CP 343-1 is mounted on the S7-300 rail and connected through the bus connector with the neighboring modules. No slot rules apply.
- Fan-free operation; A back-up battery is not required.
- Using the IM 360/361, the CP 343-1 can also be operated in the expansion rack (ER)
- Modules can be replaced without the need for a programming device

Function

- PROFINET interface with two RJ45 ports with 10/100 Mbit/s full/half duplex with autosensing and auto-crossover functionality via 2-port switch
- Communication services via interface:
 - Open communication (TCP/IP, UDP, ISO): Multicast for UDP
 - PG/OP communication: across networks by means of S7 routing
 - S7 communication (client, server, multiplexing)
 - PROFINET IO Controller or IO Device
- Media redundancy (MRP):
 - Within an Ethernet network with ring topology, the CP supports the media redundancy procedure MRP
- Diagnostics and network management:
 - Extensive diagnostic functions for all modules in the rack
 - Integration into network management systems through the support of SNMP V1
- Security mechanisms:
 - Access protection by means of configurable IP access list
- Configuration of all functions with STEP 7 V5.4 and higher, or STEP 7 Professional V11
- Module replacement without programming device thanks to saving of the configuration data on the CPU

Integration

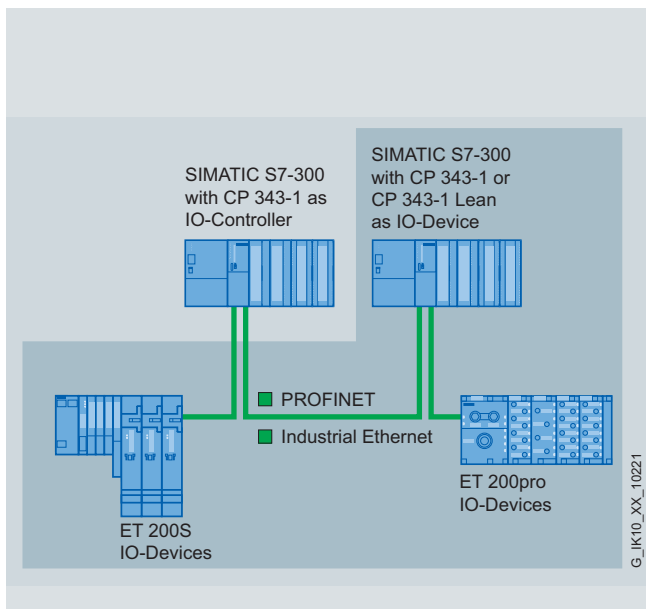

Line structure with CP 343-1 with integrated real-time switch as a PROFINET IO controller or IO device

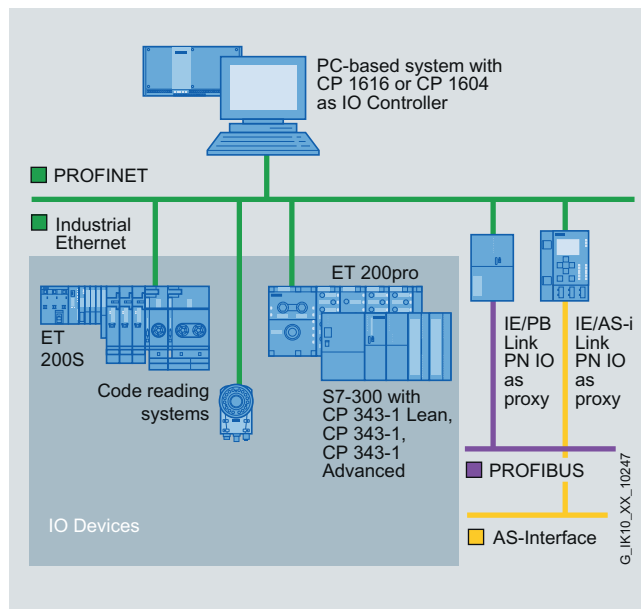

Connection to higher-level network and PC-based system

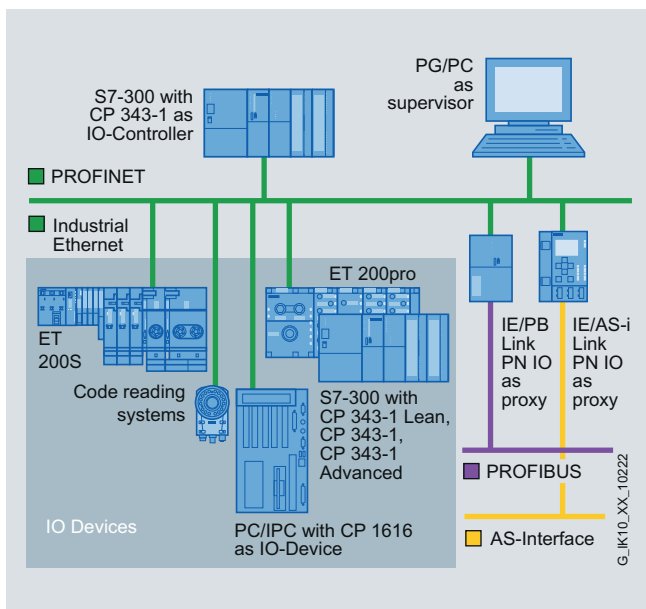

Interfacing to higher-level network with CP 343-1 as PROFINET IO controller

PROFINET/Industrial Ethernet

Communication for SIMATIC S7-300

CP 343-1

Technical specifications

Order No.	6GK7 343-1EX30-0XE0
Product type designation	CP 343-1
Transmission rate	
Transmission rate at interface 1	10 ... 100 Mbit/s
Interfaces	
Number of electrical connections	
• at interface 1 in accordance with Industrial Ethernet	2
• for power supply	1
Design of electrical connection	
• at interface 1 in accordance with Industrial Ethernet	RJ45 port
• for power supply	2-pin plug-in terminal strip
Supply voltage, current consumption, power loss	
Type of power supply	DC
Power supply	
• 1 from backplane bus	5 V
• External	24 V
Relative positive tolerance at 24 V DC	20 %
Relative negative tolerance at 24 V DC	15 %
Current consumed	
• from backplane bus at 5 V DC, typical	0.2 A
• from external power supply with 24 V DC	
- Typical	0.16 A
- Maximum	0.2 A
Effective power loss	5.8 W
Permitted ambient conditions	
Ambient temperature	
• with vertical installation during operation	0 ... +40 °C
• with horizontal installation during operation	0 ... +60 °C
• During storage	-40 ... +70 °C
• During transport	-40 ... +70 °C
• Note	-
Relative humidity at 25 °C without condensation during operation, maximum	95 %
IP degree of protection	IP20
Design, dimensions and weights	
Module format	S7-300 compact module, single-width
Width	40 mm
Height	125 mm
Depth	120 mm
Net weight	0.22 kg

Order No.	6GK7 343-1EX30-0XE0
Product type designation	CP 343-1
Performance data	
<u>Performance data</u>	
<u>Open communication</u>	
Number of possible connections for open communication by means of SEND/RECEIVE blocks, maximum	16
Data volume	
• as user data per ISO connection for open communication by means of SEND/RECEIVE blocks, maximum	8 KB
• as user data per ISO on TCP connection for open communication by means of SEND/RECEIVE blocks, maximum	8 KB
• as user data per TCP connection for open communication by means of SEND/RECEIVE blocks, maximum	8 KB
• as user data per UDP connection for open IE communication by means of SEND/RECEIVE blocks, maximum	2 KB
Number of multicast stations	16
<u>Performance data</u>	
<u>S7 communication</u>	
Number of possible connections for S7 communication	
• Maximum	16
<u>Performance data</u>	
<u>Multiprotocol operation</u>	
Number of active connections in multiprotocol mode	32
<u>Performance data</u>	
<u>PROFINET communication as PN IO Controller</u>	
Total number of PN IO Devices which can be operated on the PROFINET IO Controller	32
Number of external PN IO lines with PROFINET, per rack	1
Data volume	
• As user data for input variables as PROFINET IO Controller, maximum	1 KB
• As user data for output variables as PROFINET IO Controller, maximum	1 KB
• As user data for input variables per PN IO Device as PROFINET IO Controller, maximum	240 bytes
• As user data for output variables per PN IO Device as PROFINET IO Controller, maximum	240 bytes
• As user data for input variables per PN IO Device as PROFINET IO Controller, maximum	240 bytes
• As user data for output variables per PN IO Device as PROFINET IO Controller, maximum	240 bytes

Technical specifications (continued)

Order No.	6GK7 343-1EX30-0XE0
Product type designation	CP 343-1
Performance data <u>PROFINET communication as PN IO Device</u>	
Product function: PROFINET IO Device	Yes
Data volume	
• As user data for input variables as PROFINET IO Device, maximum	512 bytes
• As user data for output variables as PROFINET IO Device, maximum	512 bytes
• As user data for input variables per submodule as PROFINET IO Device	240 bytes
• As user data for output variables per submodule as PROFINET IO Device	240 bytes
• As user data for the consistency area per submodule	240 bytes
Number of submodules per PROFINET IO Device	32
Product functions Management, configuration, programming	
Product function: MIB support	Yes
Protocol is supported	
• SNMP v1	Yes
• DCP	Yes
• LLDP	Yes
Configuration software required	STEP 7 version V5.4 SP2 and higher or STEP 7 V11 and higher
Identification & maintenance	
• I&M0 - device-specific information	Yes
• I&M1 - higher-level designation/location designation	Yes

Order No.	6GK7 343-1EX30-0XE0
Product type designation	CP 343-1
Product functions Diagnostics	
Product function: Web-based diagnostics	Yes
Product functions Switch	
Product feature: Switch	Yes
Product function	
• Switch-managed	No
• Configuration with STEP 7	Yes
Product functions Redundancy	
Product function	
• Ring redundancy	Yes
• Redundancy manager	No
• Redundancy procedure MRP	Yes
Product functions Security	
Product function	
• ACL - IP based	Yes
• Switching-off non-required services	Yes
• Blocking of communication via physical ports	Yes
• Log file for unauthorized access	No
Product functions Time	
Product function	
• SICLOCK support	Yes
• Passing-on of time synchronization	Yes
NTP Protocol is supported	Yes

PROFINET/Industrial Ethernet

Communication for SIMATIC S7-300

CP 343-1

2

Ordering data**Order No.****Order No.****CP 343-1
communication processor****6GK7 343-1EX30-0XE0**

For connection of SIMATIC S7-300 to Industrial Ethernet over ISO and TCP/IP; PROFINET IO Controller or PROFINET IO Device, MRP, integrated 2-port switch ERTEC; S7 communication, open communication (SEND/RECEIVE), FETCH/WRITE, with and without RFC 1006, multicast, DHCP, CPU clock synchronization via SIMATIC procedure and NTP, diagnostics, SNMP, access protection through IP access list, initialization over LAN 10/100 Mbit/s; with electronic manual on DVD

**IE FC TP Standard Cable GP
2x2****6XV1 840-2AH10**

4-core, shielded TP installation cable for connection to IE FC Outlet RJ45/ IE FC RJ45 Plug; PROFINET-compliant; with UL approval; sold by the meter max. length 1000 m, minimum order 20 m

C-PLUG**6GK1 900-0AB00**

Removable media for easy device replacement upon failure, for receiving configuration or projects and application data, may be used in SIMATIC NET products with C-PLUG slot

**Industrial Ethernet Switch
SCALANCE X204-2****6GK5 204-2BB10-2AA3**

Industrial Ethernet switches with integral SNMP access, online diagnostics, copper cable diagnostics and PROFINET diagnostics for configuring line, star and ring topologies; four 10/100 Mbit/s RJ45 ports and two fiber-optic cable ports

**Compact Switch Module
CSM 377****6GK7 377-1AA00-0AA0**

Unmanaged switch for connection of a SIMATIC S7-300-CPU, ET 200M and as many as three further nodes to Industrial Ethernet operating at 10/100 Mbit/s; 4 x RJ45 ports; external 24 V DC power supply, LED diagnostics, S7-300 module including electronic Manual on CD-ROM

IE FC RJ45 Plug 145

RJ45 plug connector for Industrial Ethernet with a rugged metal enclosure and integrated insulation displacement contacts for connecting Industrial Ethernet FC installation cables; 145° cable outlet

- 1 pack = 1 unit
- 1 pack = 10 units
- 1 pack = 50 units

6GK1 901-1BB30-0AA0
6GK1 901-1BB30-0AB0
6GK1 901-1BB30-0AE0

IE FC Stripping Tool**6GK1 901-1GA00**

Preadjusted stripping tool for fast stripping of the Industrial Ethernet FC cables

SOFTNET S7 for Industrial Ethernet

Software for S7 and open communication, including OPC server, PG/OP communication and NCM PC, runtime software, software and electronic manual on CD-ROM, license key on USB stick, Class A

SOFTNET-IE S7 V8.1

For 32/64-bit Windows 7 Professional/Ultimate; for 64-bit: Windows 2008 Server R2; German/English

up to 64 connections

- Single License for one installation

6GK1 704-1CW08-1AA0**SOFTNET-S7 Edition 2008
(V7.1) for Industrial Ethernet**

for 32-bit Windows XP Professional SP2/3; Windows 2003 Server R2, SP2; Windows Vista Business/Ultimate SP1; Windows 2008 Server; German/English

up to 64 connections

- Single License for one installation

6GK1 704-1CW71-3AA0**Software Update Service****6GK1 704-1CW00-3AL0**

For 1 year with automatic extension; requirement: Current software version

Upgrade

- From Edition 2006 to Edition 2008 or V8.1

6GK1 704-1CW00-3AE0

- From V6.0, V6.1, V6.2 or V6.3 to Edition 2008 or V8.1

6GK1 704-1CW00-3AE1**SOFTNET-IE S7 Lean Edition
V8.1**

Up to eight connections

- Single License for one installation

6GK1 704-1LW08-1AA0**SOFTNET-S7 Lean Edition 2008
(V7.1) for Industrial Ethernet**

Up to eight connections

- Single License for one installation

6GK1 704-1LW71-3AA0**Software Update Service****6GK1 704-1LW00-3AL0**

For 1 year with automatic extension; requirement: Current software version

Upgrade

- From Edition 2006 to Edition 2008 or V8.1

6GK1 704-1LW00-3AE0

- From V6.0, V6.1, V6.2 or V6.3 to Edition 2008 or V8.1

6GK1 704-1LW00-3AE1

Ordering data	Order No.		Order No.
<p>STEP 7 Version 5.5</p> <p><i>Target system:</i> SIMATIC S7-300/400, SIMATIC C7, SIMATIC WinAC</p> <p><i>Requirements:</i> Windows XP Prof., Windows 7 Professional/Ultimate</p> <p><i>Type of delivery:</i> German, English, French, Spanish, Italian; including license key on USB stick, with electronic documenta- tion</p> <ul style="list-style-type: none"> Floating license on DVD Rental license for 50 hours Software Update Service on DVD (requires current software version) Upgrade Floating License 3.x/4.x/5.x to V5.5; on DVD Trial License STEP 7 V5.5; on DVD, 14 day trial 	<p>6ES7 810-4CC10-0YA5</p> <p>6ES7 810-4CC10-0YA6</p> <p>6ES7 810-4BC01-0YX2</p> <p>6ES7 810-4CC10-0YE5</p> <p>6ES7 810-4CC10-0YA7</p>	<p>STEP 7 Professional Engineering Software V11</p> <p><i>Target system:</i> SIMATIC S7-300/400, SIMATIC C7, SIMATIC WinAC</p> <p><i>Requirements:</i> Windows XP Professional SP3 (32 bit), Windows 7 Professional (32 bit), Windows 7 Enterprise (32 bit), Windows 7 Ultimate (32 bit), Microsoft Server 2003 R2 Std. SP2 (32 bit), Microsoft Server 2008 Std. SP2 (32 bit)</p> <p><i>Type of delivery:</i> German, English, Chinese, Italian; French, Spanish</p> <ul style="list-style-type: none"> STEP 7 Professional V11, floating license STEP 7 Professional V11, trial license Upgrade STEP 7 Professional 2006/2010 to STEP 7 Professional V11, floating license PowerPack & Upgrade STEP 7 V5.4/V5.5 to STEP 7 Professional V11, floating license Powerpack STEP 7 Basic V11 to STEP 7 Professional V11, floating license STEP 7 Professional V11, Software Update Service, 1 year; current software version required STEP 7 Professional V11, Software Update Service Compact, 1 year; current software version required STEP 7 Professional Software Update Service; 1 year; for STEP 7 Professional and STEP 7 Professional in the TIA Portal, requires current software version STEP 7 Professional Software Update Service Compact; 1 year; for STEP 7 Professional and STEP 7 Professional in the TIA Portal, requires current software version 	<p>6ES7 822-1AA01-0YA5</p> <p>6ES7 822-1AA01-0YA7</p> <p>6ES7 822-1AA01-0XE5</p> <p>6ES7 822-1AA01-0XC5</p> <p>6ES7 822-1AA01-0YC5</p> <p>6ES7 822-1AA00-0YL5</p> <p>6ES7 822-1AA00-0YM5</p> <p>6ES7 810-5CC04-0YE2</p> <p>6ES7 810-5CC00-0YM2</p>

PROFINET/Industrial Ethernet

Communication for SIMATIC S7-300

SIPLUS CP 343-1

Overview



ISO	TCP/UDP	PN	MRP	IT	IP-R	PG/OP	S7/S5
●	●	●	●			●	●

- Connection of SIMATIC S7-300/SINUMERIK 840D powerline to Industrial Ethernet
 - 2 x RJ-45 interface for 10/100 Mbit/s full/half-duplex connection with auto-sensing/auto-negotiation and auto-crossover function
 - Integrated 2-port real-time switch ERTEC
 - Multi-protocol operation with ISO, TCP, UDP transport protocol and PROFINET IO
 - Adjustable keep alive function
- Communication services:
 - Open communication (ISO, TCP/IP, and UDP)
 - PROFINET IO-Controller or PROFINET IO-Device
 - PG/OP communication: Cross-network by means of S7 routing
 - S7 communication (client, server, multiplexing)
- Media redundancy (MRP); within an Ethernet network with ring topology, the CP supports the media redundancy procedure MRP (V2.2 or higher).
- Multicast by UDP
- IP address assignment via DHCP, simple PC tool or via the user program (e.g. HMI)
- Access protection via configurable access list
- Remote programming and commissioning via Industrial Ethernet
- Configuration with STEP 7
- Automatic setting of CPU clock setting over Ethernet with NTP or SIMATIC procedure
- Web diagnostics
- Integration in network management systems via SNMP (MIB2 diagnostics information)
- Diagnostics possibilities in STEP 7 and Web browser

Note:

SIPLUS extreme products are based on Siemens Industry standard products. The contents listed here were taken from the respective standard products. SIPLUS extreme-specific information was added.

SIPLUS CP 343-1

Order No.	6AG1 343-1EX30-4XE0	6AG1 343-1EX30-7XE0
Order No. based on	6GK7 343-1EX30-0XE0	6GK7 343-1EX30-0XE0
Ambient temperature range	0 ... +60 °C	-25 ... +70 °C
Conformal coating	Coating of the printed circuit boards and the electronic components	
Technical data	The technical data of the standard product applies except for the ambient conditions.	

Ambient conditions

Relative humidity	5 ... 100 % Condensation permissible
Biologically active substances	Conformity with EN 60721-3-3, Class 3B2 mold and fungal spores (except fauna)
Chemically active substances	Conformity with EN 60721-3-3, Class 3C4 incl. salt mist and ISA-S71.04 severity level G1; G2; G3; GX ¹⁾²⁾
Mechanically active substances	Conformity with EN 60721-3-3, Class 3S4 including conductive sand, dust ²⁾
Air pressure (depending on the highest positive temperature range specified)	1080 ... 795 hPa (-1000 ... +2000 m) see ambient temperature range 795 ... 658 hPa (+2000 ... +3500 m) derating 10 K 658 ... 540 hPa (+3500 ... +5000 m) derating 20 K

¹⁾ ISA-S71.04 severity level GX: Long-term load:
SO₂ < 4.8 ppm; H₂S < 9.9 ppm; Cl < 0.2 ppm; HCl < 0.66 ppm;
HF < 0.12 ppm; NH < 49 ppm; O₃ < 0.1 ppm; NO_x < 5.2 ppm
Limit value (max. 30 min/d):
SO₂ < 17.8 ppm; H₂S < 49.7 ppm; Cl < 1.0 ppm; HCl < 3.3 ppm;
HF < 2.4 ppm; NH < 247 ppm; O₃ < 1.0 ppm; NO_x < 10.4 ppm

²⁾ The supplied plug covers must remain in place over the unused interface when operated in atmospheres containing corrosive gases!

The technical documentation on SIPLUS can be found here:
www.siemens.com/siplus-extreme

Ordering data	Order No.
<p>SIPLUS CP 343-1 communication processor (extended temperature range and medial exposure)</p> <p>for connecting SIMATIC S7-300 to Industrial Ethernet via ISO and TCP/IP; PROFINET IO-Controller or PROFINET IO-Device, MRP, integrated 2-port switch ERTEC; S7 communication, open communication (SEND/RECEIVE), FETCH/WRITE with or without RFC 1006, multicast, DHCP, CPU clock set via SIMATIC procedure and NTP, diagnostics, SNMP, access control via IP access list, initialization over LAN 10 /100 Mbit/s; with electronic manual on DVD</p> <p>Ambient temperature 0 ... +60 °C</p> <p>Ambient temperature -25 ... +70 °C</p>	<p>6AG1 343-1EX30-4XE0</p> <p>6AG1 343-1EX30-7XE0</p>
<p><i>Accessories</i></p>	<p>See SIMATIC CP 343-1 communication processor</p>

PROFINET/Industrial Ethernet

Communication for SIMATIC S7-300

CP 343-1 Advanced

Overview



ISO	TCP/UDP	PN	MRP	IT	IP-R	PG/OP	S7/S5
●	●	●	●	●	●	●	●

Communication processor for connecting the SIMATIC S7-300/SINUMERIK 840D powerline to Industrial Ethernet networks, also as PROFINET IO Controller and IO Device.

The CP supports:

- PG/OP communication
- S7 communication
- Open communication (SEND/RECEIVE)
- PROFINET communication
- IT communication

In addition, the CP 343-1 Advanced offers e-mail functions and user-created web pages and thus optimally supports maintenance and quality assurance. The Internet functions such as FTP even allow connection to the most diverse PC-based systems. Therefore, for the S7-300, this CP is the bridge between the field level and the MES level. The CP 343-1 Advanced connects seamlessly to the security structures of the office and IT world.

Benefits

get Designed for Industry

- Cost advantage due to connection to two separate Ethernet segments with network separation
- High level of plant availability due to support of media redundancy (MRP)
- Optimum support of maintenance through
 - Web-based diagnostics
 - Remote programming via WAN or a telephone network (ISDN)
 - Monitoring by means of IT network management tools (SNMP)
 - Module replacement without programming device using the C-Plug swap medium
- Securing the system against unauthorized access¹⁾ by means of
 - Central access protection for any devices within an automation cell, e.g. by means of authentication of the network stations
 - Secure remote access via the Internet by means of data encryption (VPN) and data integrity checking
 - Traceability by means of data logging on the basis of standard IT mechanisms (Syslog)
- The capability of later connecting existing SIMATIC S7 systems to Industrial Ethernet using the CP 343-1 Advanced ensures investment protection

Application

The CP 343-1 Advanced is used for connecting the SIMATIC S7-300/SINUMERIK 840D powerline to Industrial Ethernet networks. With its own processor, it relieves the CPU of communication tasks and facilitates additional connections.

The CP 343-1 Advanced provides the following communication options:

- PGs/PCs
- Master computers
- HMI systems
- SIMATIC S5/S7/C7 systems
- PROFINET IO Devices/IO Controllers
- PROFINET CBA components

With it, all of the devices of an Ethernet network can be protected from unauthorized access. The CP 343-1 Advanced allows safe remote access over the Internet and allows data transfer between devices or network segments to be protected from data manipulation/espionage¹⁾.

PROFINET CBA components and security functionalities can only be used alternatively.

¹⁾ Available soon

Application (continued)

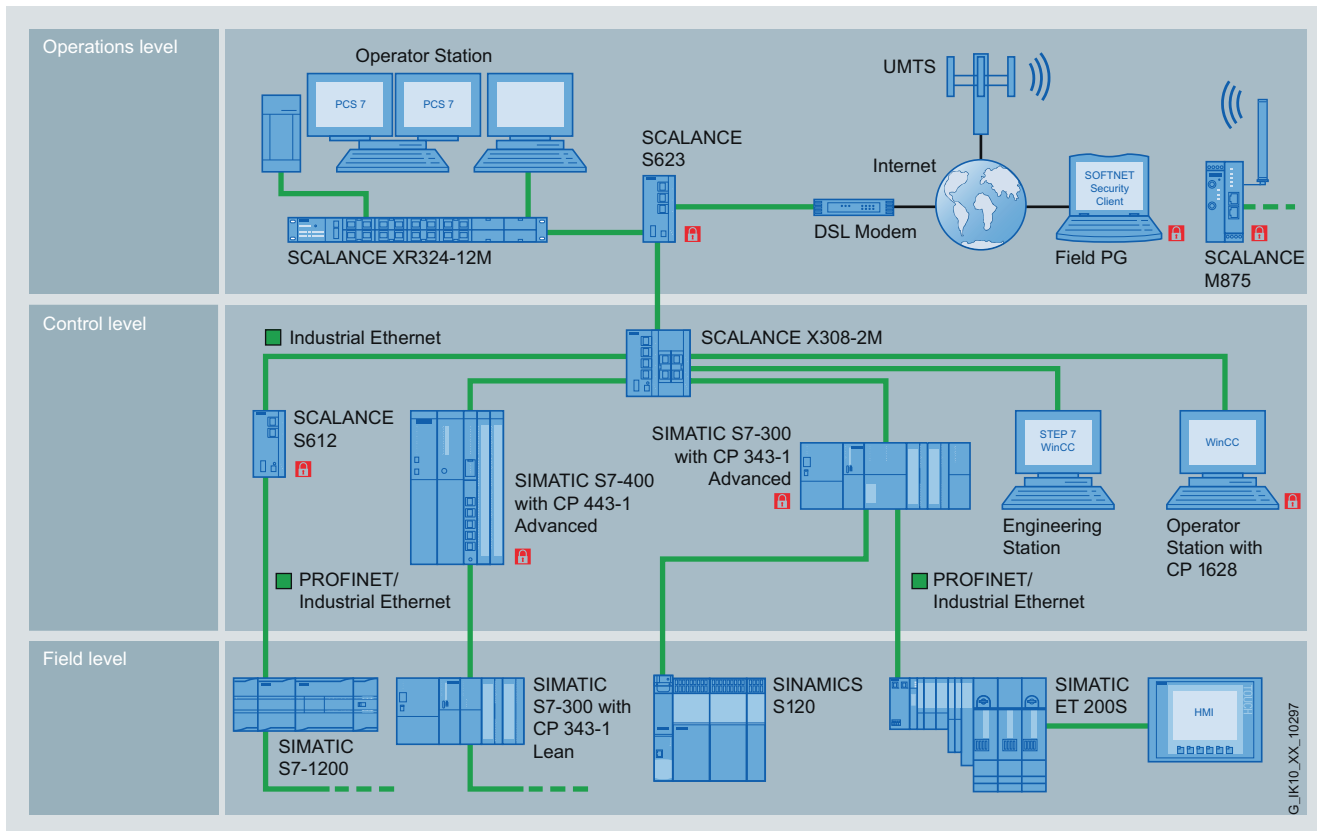

Secure VPN communication between SCALANCE S, SOFTNET Security Client and components with Security Integrated

Design

The CP 343-1 Advanced offers all the advantages of SIMATIC S7-300 system design:

- Compact design:
 - Three RJ45 jacks for connecting to Industrial Ethernet via two independent interfaces; one of which is a security jack for externally safeguarding the network cell;
 - automatic data rate detection by means of the autosensing and autocross function;
 - the connection is made via the IE FC RJ45 Plug 180 with 180° cable outlet or via a standard patch cable
 - 2-pin plug-in terminal strip for connection of the 24 V DC external supply voltage
 - Diagnostics LEDs for indicating the operational and communication status
- Simple installation; the CP 343-1 Advanced is mounted on the S7-300 rack and connected to adjacent modules by means of the bus connector. There are no slot rules.
- The CP 343-1 Advanced can be operated without a fan; no backup battery is required.
- In combination with IM 360/361, the CP 343-1 Advanced can also be used in an expansion rack (ER).
- The module can be replaced without the need for a programming device
- C-PLUG (configuration plug) is included in scope of delivery as a swap medium (cannot be operated without C-PLUG)

PROFINET/Industrial Ethernet

Communication for SIMATIC S7-300

CP 343-1 Advanced

Function

- Two separate interfaces (integrated network separation):
 - Gigabit interface with an RJ45 port with 10/100/1000 Mbit/s full/half duplex with autosensing functionality
 - PROFINET interface with two RJ45 ports with 10/100 Mbit/s full/half duplex with autosensing and auto-crossover functionality via 2-port switch
- Communication services via both interfaces:
 - Open communication (TCP/IP, UDP, ISO): Multicast with UDP, including routing between both interfaces
 - PG/OP communication: across networks by means of S7 routing
 - S7 communication (client, server, multiplexing) including routing between both interfaces
 - IT communication: HTTP communication permits access to process data via own web pages. E-mail client function enables sending of e-mails direct from the user program.. FTP communication allows program-controlled FTP-client communication. Access to data blocks via FTP server.
- Communication services via PROFINET interfaces:
 - PROFINET IO Controller and IO Device with real-time properties (RT and IRT)
 - PROFINET CBA
 - IP address assignment via DHCP, simple PC tool or via program block (e.g. for HMI)
- Media redundancy (MRP):
 - Within an Ethernet network with ring topology, the CP supports the media redundancy procedure MRP
- Diagnostics and network management:
 - Extensive diagnostic functions for all modules in the rack
 - Integration into network management systems through the support of SNMP V1/V3
- Security mechanisms¹⁾:
 - Access protection by means of configurable IP access list
 - Firewall for filtering connections on the basis of their IP/port addresses
 - Limiting bandwidth to avoid communication overload
 - VPN server and VPN client for tap-proof access to controllers
 - Encrypted HTML pages via SSL (HTTPs)
 - Secure file transfer (FTPs)
 - Tap-proof transmission of network analysis information to the network management system (SNMP)
 - Conversion between private and public IP addresses (NAT/NAPT)
 - Secure transfer of the time (NTP V3)
- Configuration of all functions with STEP 7. The security functions¹⁾ are configured using the Security Configuration Tool (SCT), that is included in the scope of delivery of STEP 7 V5.5 SP2 .
- Configuration with STEP 7 Professional V11 except configuration of security functions and CBA. The use of security functions and CBA is not possible with STEP 7 V11 (security functions are planned for later Version).
- Module replacement without programming device: all information is stored on the C-PLUG (also file system for IT functions)

¹⁾ Available soon

Integration

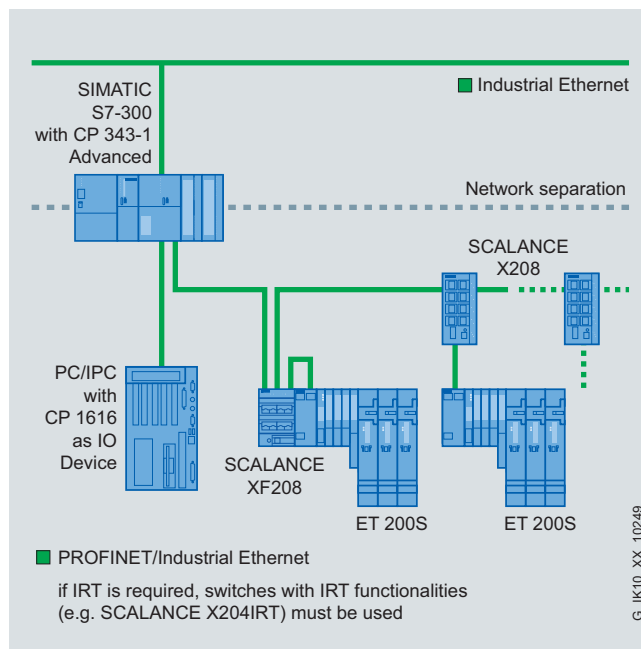

Connection to a higher-level network with network separation and access protection (security functions)

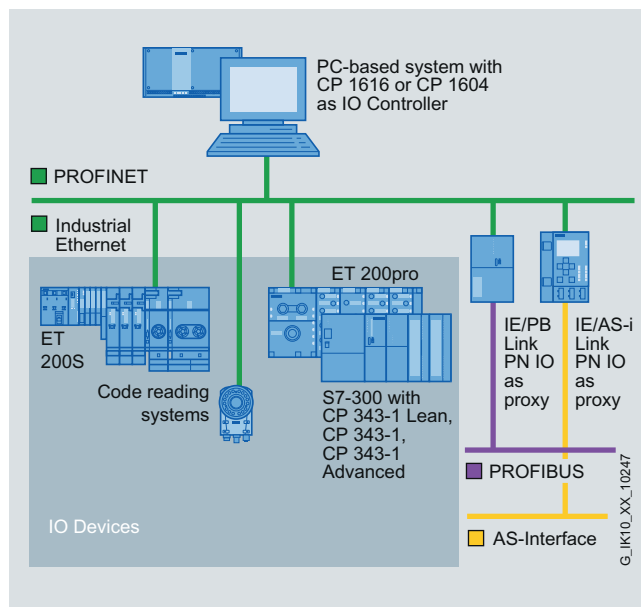

Connection to higher-level network and PC-based system

Integration (continued)

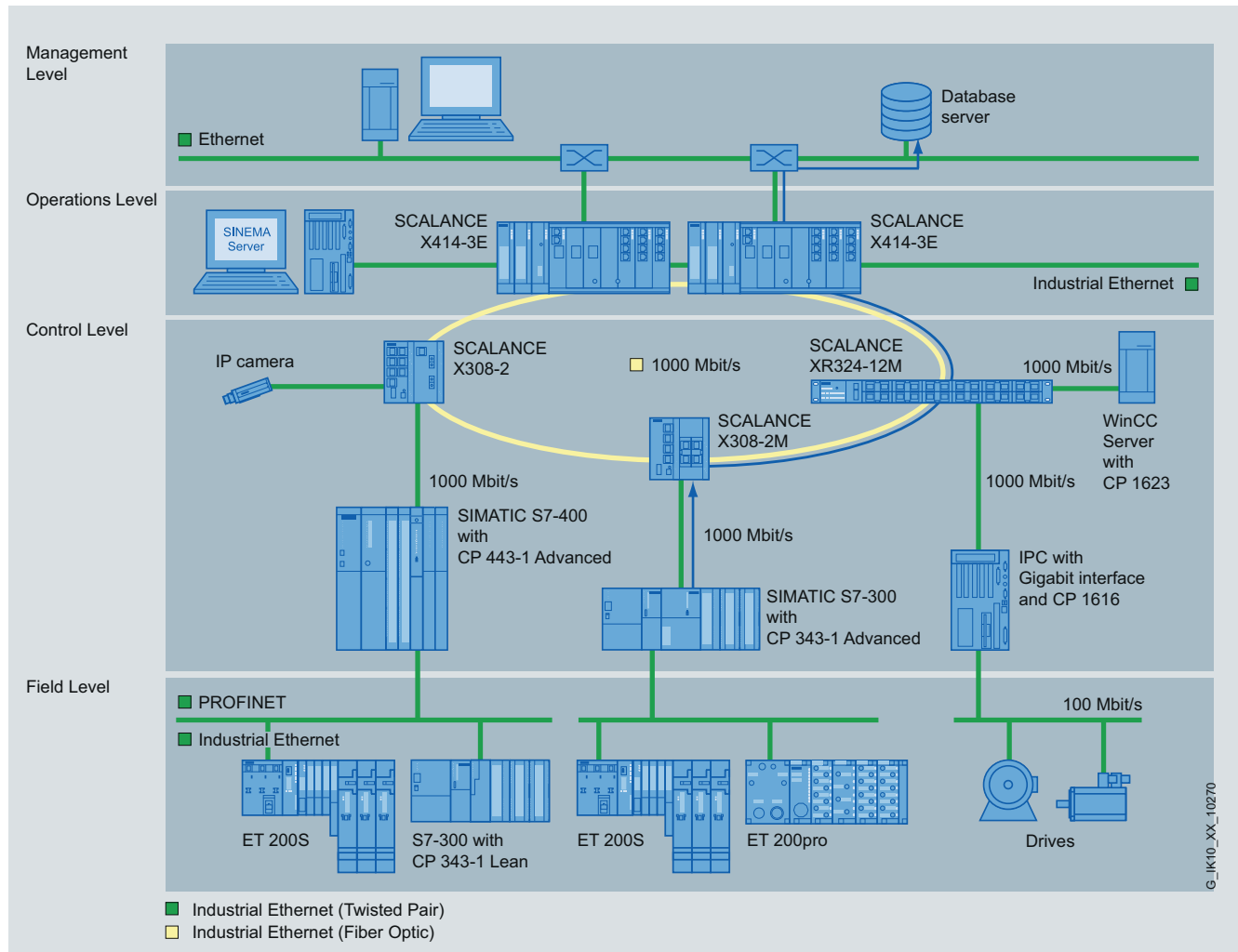

Gigabit communication at the control level

PROFINET/Industrial Ethernet

Communication for SIMATIC S7-300

CP 343-1 Advanced

Technical specifications

Order No.	6GK7 343-1GX31-0XE0
Product type designation	CP 343-1 Advanced
Transmission rate	
Transmission rate	
• at interface 1	10 ... 1 000 Mbit/s
• at interface 2	10 ... 100 Mbit/s
Interfaces	
Number of electrical connections	
• at interface 1 in accordance with Industrial Ethernet	1
• at interface 2 in accordance with Industrial Ethernet	2
• for power supply	
Design of electrical connection	
• at interface 1 in accordance with Industrial Ethernet	RJ45 port
• at interface 2 in accordance with Industrial Ethernet	RJ45 port
• for power supply	2-pin plug-in terminal strip
Design of swap medium C-Plug	Yes
Supply voltage, current consumption, power loss	
Type of power supply	DC
Power supply	
• 1 from backplane bus	5 V
• External	24 V
Relative positive tolerance at 24 V DC	20 %
Relative negative tolerance at 24 V DC	15 %
Current consumed	
• from backplane bus at 5 V DC, typical	0.14 A
• from external power supply with 24 V DC	
- Typical	0.48 A
- Maximum	0.62 A
Effective power loss	14.7 W
Permitted ambient conditions	
Ambient temperature	
• with vertical installation during operating phase	0 ... +40 °C
• with horizontal installation during operating phase	0 ... +60 °C
• During storage	-40 ... +70 °C
• During transport	-40 ... +70 °C
Relative humidity at 25 °C without condensation during operation, maximum	95 %
IP degree of protection	IP20
Design, dimensions and weights	
Module format	Compact module
Width	80 mm
Height	125 mm
Depth	120 mm
Net weight	0.8 kg

Order No.	6GK7 343-1GX31-0XE0
Product type designation	CP 343-1 Advanced
Performance data	
<u>Performance data</u>	
<u>Open communication</u>	
Number of possible connections for open communication by means of SEND/RECEIVE blocks, maximum	16
Data volume	
• as user data per ISO connection for open communication by means of SEND/RECEIVE blocks, maximum	8 KB
• as user data per ISO on TCP connection for open communication by means of SEND/RECEIVE blocks, maximum	8 KB
• as user data per TCP connection for open communication by means of SEND/RECEIVE blocks, maximum	8 KB
• as user data per UDP connection for open IE communication by means of SEND/RECEIVE blocks, maximum	2 KB
Number of multicast stations	16
<u>Performance data</u>	
<u>S7 communication</u>	
Number of possible connections for S7 communication	
• Maximum	16
<u>Performance data</u>	
<u>Multiprotocol operation</u>	
Number of active connections in multiprotocol mode	48
<u>Performance data</u>	
<u>IT functions</u>	
Number of possible connections	
• as client with FTP, maximum	10
• as server	
- with FTP, maximum	2
- with HTTP, maximum	4
• as e-mail client, maximum	1
Data volume as user data for e-mail, maximum	8 KB
Storage capacity of user memory	
• as flash memory file system	28 Mibyte
• as RAM	30 Mibyte
Number of possible write cycles of flash memory cells	100 000

2

Technical specifications (continued)

Order No.	6GK7 343-1GX31-0XE0
Product type designation	CP 343-1 Advanced
<u>Performance data</u> <u>PROFINET communication</u> <u>as PN IO Controller</u>	
Total number of PN IO Devices which can be operated on the PROFINET IO Controller	128
Number of PN IO IRT Devices which can be operated on the PROFINET IO Controller	32
Number of external PN IO lines with PROFINET, per rack	1
<u>Data volume</u>	
• As user data for input variables as PROFINET IO Controller, maximum	4 KB
• As user data for output variables as PROFINET IO Controller, maximum	4 KB
• As user data for input variables per PN IO Device as PROFINET IO Controller, maximum	240 bytes
• As user data for output variables per PN IO Device as PROFINET IO Controller, maximum	240 bytes
• As user data for input variables per PN IO Device as PROFINET IO Controller, maximum	240 bytes
• As user data for output variables per PN IO Device as PROFINET IO Controller, maximum	240 bytes
<u>Performance data</u> <u>PROFINET communication</u> <u>as PN IO Device</u>	
Product function: PROFINET IO Device	Yes
<u>Data volume</u>	
• As user data for input variables as PROFINET IO Device, maximum	1 024 bytes
• As user data for output variables as PROFINET IO Device, maximum	1 024 bytes
• As user data for input variables per submodule as PROFINET IO Device	240 bytes
• As user data for output variables per submodule as PROFINET IO Device	240 bytes
• As user data for the consistency area per submodule	240 bytes
Number of submodules per PROFINET IO Device	32

Order No.	6GK7 343-1GX31-0XE0
Product type designation	CP 343-1 Advanced
<u>Performance data</u> <u>PROFINET CBA</u>	
Number of remote connection partners with PROFINET CBA	64
Total number of connections with PROFINET CBA	1 000
<u>Data volume</u>	
• As user data for digital inputs with PROFINET CBA, maximum	8 192 bytes
• As user data for digital outputs with PROFINET CBA, maximum	8 192 bytes
• As user data for arrays and data types	
- with acyclic transmission with PROFINET CBA, maximum	8 192 bytes
- with cyclic transmission with PROFINET CBA, maximum	250 bytes
- with local connection with PROFINET CBA, maximum	2 400 bytes
<u>Performance data</u> <u>remote connection</u> <u>with acyclic transmission</u>	
Send cycle of remote connections with acyclic transmission with PROFINET CBA	0.1 s
Number of remote connections with input variables with acyclic transmission with PROFINET CBA, maximum	128
Number of remote connections with output variables with acyclic transmission with PROFINET CBA, maximum	128
<u>Data volume</u>	
• as user data for remote connections with input variables with acyclic transmission with PROFINET CBA	8 KB
• as user data for remote connections with output variables with acyclic transmission with PROFINET CBA	8 KB

PROFINET/Industrial Ethernet

Communication for SIMATIC S7-300

CP 343-1 Advanced

Technical specifications (continued)

Order No.	6GK7 343-1GX31-0XE0
Product type designation	CP 343-1 Advanced
<u>Performance data</u> <u>PROFINET CBA</u> <u>remote connection</u> <u>with cyclic transmission</u>	
Send cycle of remote connections with cyclic transmission with PROFINET CBA	8 ms
Number of remote connections with input variables with cyclic transmission with PROFINET CBA, maximum	200
Number of remote connections with output variables with cyclic transmission with PROFINET CBA, maximum	200
Data volume	
• as user data for remote connections with input variables with cyclic transmission with PROFINET CBA, maximum	2 000 bytes
• as user data for remote connections with output variables with cyclic transmission with PROFINET CBA, maximum	2 000 bytes
<u>Performance data</u> <u>PROFINET CBA</u> <u>HMI variables via PROFINET,</u> <u>acyclic</u>	
Number of HMI stations for logging-on for HMI variables with acyclic transmission with PROFINET CBA	3
Send cycle of HMI variables with acyclic transmission with PROFINET CBA	500 ms
Number of HMI variables with acyclic transmission with PROFINET CBA, maximum	200
Data volume as user data for HMI variables with acyclic transmission with PROFINET CBA, maximum	8 KB
<u>Performance data</u> <u>PROFINET CBA</u> <u>device-internal connections</u>	
Maximum number of internal connections with PROFINET CBA	256
Data volume of internal connections with PROFINET CBA, maximum	2 400 bytes
Performance data PROFINET CBA connections with constants	
Maximum number of connections with constants with PROFINET CBA	200
Data volume as user data for connections with constants with PROFINET CBA, maximum	4 096 bytes
<u>Performance data</u> <u>PROFINET CBA</u> <u>PROFIBUS proxy functionality</u>	
Performance data with PROFINET CBA PROFIBUS proxy functionality	No

Order No.	6GK7 343-1GX31-0XE0
Product type designation	CP 343-1 Advanced
Product functions Management, configuration, programming	
Product function: MIB support	Yes
Protocol is supported	
• SNMP v1	Yes
• DCP	Yes
• LLDP	Yes
Configuration software	
• Required	STEP 7 V5.5 SP2
• Required for PROFINET CBA	SIMATIC IMAP V3.0 SP4 and higher
Identification & maintenance	
• I&M0 - device-specific information	Yes
• I&M1 - higher-level designation/ location designation	Yes
Product functions Diagnostics	
Product function: Web-based diagnostics	Yes
Product functions Switch	
Product feature: Switch	Yes
Product function	
• Switch-managed	No
• with IRT PROFINET IO Switch	Yes
• Configuration with STEP 7	Yes
Product functions Redundancy	
Product function	
• Ring redundancy	Yes
• Redundancy manager	Yes
• Redundancy procedure MRP	Yes
Product functions Security ¹⁾	
Configuration of firewall	Stateful inspection
Product function with VPN connection	IPSec
Type of encryption algorithms with VPN connection	AES-256, AES-192, AES-128, 3DES-168, DES-56
Type of authentication procedures with VPN connection	Preshared Key (PSK), X.509v3 certificates
Type of hashing algorithms with VPN connection	MD5, SHA-1
Number of possible connections with VPN connection	32
Product function	
• Password protection for Web applications	Yes
• ACL - IP based	Yes
• ACL - IP based for PLC/routing	Yes
• Switching-off non-required services	Yes
• Blocking of communication via physical ports	Yes
• Log file for unauthorized access	No
Product functions Time	
Product function	
• SICLOCK support	Yes
• Passing-on of time synchronization	Yes
NTP Protocol is supported	Yes

¹⁾ Available soon

Ordering data	Order No.	Order No.
Communication processor CP 343-1 Advanced For connecting the SIMATIC S7-300 CPU to Industrial Ethernet; 1 x 10/100/1000 Mbit/s; 2 x 10/100 Mbit/s (IE switch); RJ45 ports; TCP; UDP; ISO; PROFINET IO-Controller and Device, S7 communication (client + server); open communication (SEND/RECEIVE); S7 routing; IP configuration via DHCP/block; extended Web diagnostics; time synchronization; IP Access Control List; IP routing; FTP; e-mail; PROFINET CBA; C-Plug <ul style="list-style-type: none"> • Without security functions • With Security (Firewall + VPN) and PROFlenergy (Controller + Device) 	6GK7 343-1GX30-0XE0 6GK7 343-1GX31-0XE0 ¹⁾	Software Update Service For 1 year with automatic extension; requirement: Current software version Upgrade <ul style="list-style-type: none"> • From Edition 2006 to Edition 2008 or V8.1 • From V6.0, V6.1, V6.2 or V6.3 to Edition 2008 or V8.1
SOFTNET S7 for Industrial Ethernet Software for S7 and open communication, including OPC server, PG/OP communication and NCM PC, runtime software, software and electronic manual on CD-ROM, license key on USB stick, Class A SOFTNET-IE S7 V8.1 For 32/64-bit Windows 7 Professional/Ultimate; for 64-bit: Windows 2008 Server R2; German/English up to 64 connections <ul style="list-style-type: none"> • Single License for one installation 	6GK1 704-1CW08-1AA0	IE FC TP Standard Cable GP 2 x 2 (Type A) 4-core, shielded TP installation cable for connection to IE FC Outlet RJ45 / IE FC RJ45 Plug; PROFINET-compliant; with UL approval; sold by the meter; max. length 1000 m, minimum order 20 m IE FC TP Standard Cable GP 4 x 2 8-core, shielded TP installation cable for connection to IE FC RJ45 Modular Outlet for universal application; with UL approval; sold by the meter; max quantity 1000 m, minimum order 20 m <ul style="list-style-type: none"> • AWG22, for connection to IE FC RJ45 Modular Outlet • AWG24, for connection to IE FC RJ45 Plug 4 x 2
SOFTNET-S7 Edition 2008 (V7.1) for Industrial Ethernet for 32-bit Windows XP Professional SP2/3; Windows 2003 Server R2, SP2; Windows Vista Business/Ultimate SP1; Windows 2008 Server; German/English up to 64 connections <ul style="list-style-type: none"> • Single License for one installation 	6GK1 704-1CW71-3AA0	IE FC RJ45 Plug 180 RJ45 plug connector for Industrial Ethernet with a rugged metal enclosure and integrated insulation displacement contacts for connecting Industrial Ethernet FC installation cables; with a 180° cable outlet; for network components and CPs/CPU's with Industrial Ethernet interface <ul style="list-style-type: none"> • 1 pack = 1 unit • 1 pack = 10 units • 1 pack = 50 units
Software Update Service For 1 year with automatic extension; requirement: Current software version Upgrade <ul style="list-style-type: none"> • From Edition 2006 to Edition 2008 or V8.1 • From V6.0, V6.1, V6.2 or V6.3 to Edition 2008 or V8.1 	6GK1 704-1CW00-3AL0 6GK1 704-1CW00-3AE0 6GK1 704-1CW00-3AE1	IE FC RJ45 Plug 4 x 2 RJ45 plug connector for Industrial Ethernet (10/100/1000 Mbit/s) with a rugged metal enclosure and integrated insulation displacement contacts for connecting Industrial Ethernet FC installation cables; 180° cable outlet; for network components and CPs/CPU's with Industrial Ethernet interface <ul style="list-style-type: none"> • 1 pack = 1 unit • 1 pack = 10 units • 1 pack = 50 units
SOFTNET-IE S7 Lean Edition V8.1 Up to eight connections <ul style="list-style-type: none"> • Single License for one installation 	6GK1 704-1LW08-1AA0	IE FC Stripping Tool Preadjusted stripping tool for fast stripping of the Industrial Ethernet FC cables
SOFTNET-S7 Lean Edition 2008 (V7.1) for Industrial Ethernet Up to eight connections <ul style="list-style-type: none"> • Single License for one installation 	6GK1 704-1LW71-3AA0	6GK1 901-1BB10-2AA0 6GK1 901-1BB10-2AB0 6GK1 901-1BB10-2AE0 6GK1 901-1BB11-2AA0 6GK1 901-1BB11-2AB0 6GK1 901-1BB11-2AE0 6GK1 901-1GA00

¹⁾ Available soon

PROFINET/Industrial Ethernet

Communication for SIMATIC S7-300

CP 343-1 Advanced

2

Ordering data**Order No.****Order No.****Compact Switch Module
CSM 377****6GK7 377-1AA00-0AA0**

Unmanaged switch for connection of a SIMATIC S7-300-CPU, ET 200M and as many as three further nodes to Industrial Ethernet operating at 10/100 Mbit/s; 4 x RJ45 ports; external 24 V DC power supply, LED diagnostics, S7-300 module including electronic Manual on CD-ROM

**Industrial Ethernet Switch
SCALANCE X308-2****6GK5 308-2FL00-2AA3**

2 x 1000 Mbit/s multimode fiber-optic cable ports (SC sockets), 1 x 10/100/1000 Mbit/s RJ45 port, 7 x 10/100 Mbit/s RJ45 ports; for glass fiber-optic cable (multimode) up to max. 750 m

STEP 7 Version 5.5*Target system:*

SIMATIC S7-300/400, SIMATIC C7, SIMATIC WinAC

Requirements:

Windows XP Prof., Windows 7 Professional/Ultimate

Type of delivery:

German, English, French, Spanish, Italian; including license key on USB stick, with electronic documentation

- Floating license on DVD
- Rental license for 50 hours
- Software Update Service on DVD (requires current software version)
- Upgrade Floating License 3.x/4.x/5.x to V5.5; on DVD
- Trial License STEP 7 V5.5; on DVD, 14 day trial

6ES7 810-4CC10-0YA5
6ES7 810-4CC10-0YA6
6ES7 810-4BC01-0YX2

6ES7 810-4CC10-0YE5**6ES7 810-4CC10-0YA7****SIMATIC iMap V3.0**

for configuring PROFINET CBA,

Requirement:

Windows 2000 Prof. with Service Pack 4 or later or Windows XP Prof. with Service Pack 1 or later or Windows 2003 Server with Service Pack 1 or later; on PG or PC with Pentium processor, min. 1 GHz; STEP 7 V5.3 or later with Service Pack 3, PN OPC Server V6.3 or later

Available in:

German, English, with electronic documentation

- Single license
- Software Update Service
- Upgrade to V3.0, Single license

6ES7 820-0CC04-0YA5
6ES7 820-0CC01-0YX2
6ES7 820-0CC04-0YE5

**STEP 7 Professional
Engineering Software V11***Target system:*

SIMATIC S7-300/400, SIMATIC C7, SIMATIC WinAC

Requirements:

Windows XP Professional SP3 (32 bit), Windows 7 Professional (32 bit), Windows 7 Enterprise (32 bit), Windows 7 Ultimate (32 bit), Microsoft Server 2003 R2 Std. SP2 (32 bit), Microsoft Server 2008 Std. SP2 (32 bit)

Type of delivery:

German, English, Chinese, Italian; French, Spanish

- STEP 7 Professional V11, floating license
- STEP 7 Professional V11, trial license
- Upgrade STEP 7 Professional 2006/2010 to STEP 7 Professional V11, floating license
- PowerPack & Upgrade STEP 7 V5.4/V5.5 to STEP 7 Professional V11, floating license
- Powerpack STEP 7 Basic V11 to STEP 7 Professional V11, floating license
- STEP 7 Professional V11, Software Update Service, 1 year; current software version required
- STEP 7 Professional V11, Software Update Service Compact, 1 year; current software version required
- STEP 7 Professional Software Update Service; 1 year; for STEP 7 Professional and STEP 7 Professional in the TIA Portal, requires current software version
- STEP 7 Professional Software Update Service Compact; 1 year; for STEP 7 Professional and STEP 7 Professional in the TIA Portal, requires current software version

6ES7 822-1AA01-0YA5**6ES7 822-1AA01-0YA7****6ES7 822-1AA01-0XE5****6ES7 822-1AA01-0XC5****6ES7 822-1AA01-0YC5****6ES7 822-1AA00-0YL5****6ES7 822-1AA00-0YM5****6ES7 810-5CC04-0YE2****6ES7 810-5CC00-0YM2****More information**

You will find more information on the topic of Industrial Security on the Internet at:

www.siemens.com/industrialsecurity

Overview



ISO	TCP/UDP	PN	MRP	IT	IP-R	PG/OP	S7/S5
●	●	●	●	●	●	●	●

- Connection of SIMATIC S7-300/SINUMERIK 840D powerline to Industrial Ethernet
 - Multi-protocol operation with TCP and UDP transport protocol
 - Adjustable keep alive function
- Two separate interfaces (integrated network separation):
 - Gigabit interface with one RJ45 port with 10/100/1000 Mbit/s full/half-duplex with auto-sensing capability
 - PROFINET interface with two RJ45 ports with 10/100 Mbit/s full/half-duplex with auto-sensing and auto-crossover functionality via integrated 2-port switch

- Communication services via both interfaces:
 - Open communication (TCP/IP and UDP): Multicast with UDP, including routing between both interfaces
 - PG/OP communication:
 - Cross-network by means of S7 routing
 - S7 communication (client, server, multiplexing) including routing between both interfaces
 - IT communication:
 - HTTP communication supports access to process data via own Web pages;
 - e-mail client function, sending of e-mails directly from user program;
 - FTP communication supports program-controlled FTP client communication;
 - access to data blocks through FTP server
 - Communication services via PROFINET interfaces:
 - PROFINET IO-Controller and IO-Device with real-time properties (RT and IRT) ¹⁾
 - PROFINET CBA
 - IP address assignment via DHCP, simple PC tool or via program block (e.g. for HMI)
 - Configuration with STEP 7
 - Media redundancy (MRP); within an Ethernet network with ring topology, the CP supports the media redundancy procedure MRP (V2.2 or higher).
 - Access protection by means of configurable IP access list
 - Module replacement without programming device; all information is stored on the C-PLUG (also file system for IT functions)
 - Extensive diagnostics functions for all modules in the rack
 - IT communication
 - Web function
 - E-mail function
 - FTP
 - Integration into network management systems through the support of SNMP V1 MIB-II
- ¹⁾ Possible combinations in parallel mode:
- IO-Controller with IRT and IO-Device with RT
 - IO-Controller with RT and IO-Device using IRT

Note:

SIPLUS extreme products are based on Siemens Industry standard products. The contents listed here were taken from the respective standard products. SIPLUS extreme-specific information was added.

PROFINET/Industrial Ethernet

Communication for SIMATIC S7-300

SIPLUS CP 343-1 Advanced

Overview (continued)

SIPLUS CP 343-1 Advanced	
Order No.	6AG1 343-1GX30-4XE0
Order No. based on	6GK7 343-1GX30-0XE0
Ambient temperature range	0 ... +60 °C
Conformal coating	Coating of the printed circuit boards and the electronic components
Technical data	The technical data of the standard product applies except for the ambient conditions.

Ambient conditions

Relative humidity	5 ... 100 % Condensation permissible
Biologically active substances	Conformity with EN 60721-3-3, Class 3B2 mold and fungal spores (except fauna)
Chemically active substances	Conformity with EN 60721-3-3, Class 3C4 incl. salt mist and ISA-S71.04 severity level G1; G2; G3; GX ¹⁾²⁾
Mechanically active substances	Conformity with EN 60721-3-3, Class 3S4 including conductive sand, dust ²⁾
Air pressure (depending on the highest positive temperature range specified)	1080 ... 795 hPa (-1000 ... +2000 m) see ambient temperature range 795 ... 658 hPa (+2000 ... +3500 m) derating 10 K 658 ... 540 hPa (+3500 ... +5000 m) derating 20 K

- ¹⁾ ISA-S71.04 severity level GX: Long-term load:
SO₂ < 4.8 ppm; H₂S < 9.9 ppm; Cl < 0.2 ppm; HCl < 0.66 ppm;
HF < 0.12 ppm; NH < 49 ppm; O₃ < 0.1 ppm; NOX < 5.2 ppm
Limit value (max. 30 min/d):
SO₂ < 17.8 ppm; H₂S < 49.7 ppm; Cl < 1.0 ppm; HCl < 3.3 ppm;
HF < 2.4 ppm; NH < 247 ppm; O₃ < 1.0 ppm; NOX < 10.4 ppm
- ²⁾ ²⁾ The supplied plug covers must remain in place over the unused interface when operated in atmospheres containing corrosive gases!

The technical documentation on SIPLUS can be found here:
www.siemens.com/siplus-extreme

Ordering data

SIPLUS CP 343-1 Advanced communication processor	6AG1 343-1GX30-4XE0
(medial exposure)	
for connecting the SIMATIC S7-300 to Industrial Ethernet, PROFINET IO-Controller and IO-Device with RT and IRT, MRP, PROFINET CBA, TCP/IP and UDP, S7 communication, open communication (SEND/RECEIVE), FETCH/WRITE with or without RFC 1006, diagnostics extensions, multicast, Web server, HTML diagnostics, FTP server, FTP client, e-mail client, CPU clock set via SIMATIC procedure and NTP, access control via IP access List, SNMP, DHCP, initialization over LAN 10/100 Mbit/s; with electronic manual on DVD; C-PLUG included	
Accessories	See SIMATIC CP 343-1 Advanced communication processor

Overview



ERPC	TCP/UDP	PN	MRP	IT	IP-R	PG/OP	S7/S5
●	●					●	●

The CP 343-1 ERPC (Enterprise Connect) communication processor for connecting a SIMATIC S7-300 to Industrial Ethernet networks.

The CP supports:

- PG/OP communication
- S7 communication
- Open communication (SEND/RECEIVE)
- ERPC communication

Connection of the SIMATIC S7-300 to various database systems for vertical integration is supported by means of a firmware expansion from ILS-Technology to be ordered separately.

Benefits

get Designed for Industry

- Cost reductions through simply configured database connection by means of a firmware extension from the company ILS-Technology, to be ordered separately; no costly programming and no additional gateway PCs
- Optimum support of maintenance through
 - Web-based diagnostics
 - Remote programming via LAN/WAN (e.g. Internet)
 - Monitoring by network management tools (SNMP)
 - Module exchange without programming device using the C-PLUG swap medium
- Safeguarding of the system (security) against unauthorized access by means of device-related IP access list (IP-ACL); the capability of later connecting existing SIMATIC S7 systems to Industrial Ethernet using the CP 343-1 Advanced ensures investment protection
- The capability of later connecting existing SIMATIC S7 systems to Industrial Ethernet using the CP 343-1 ERPC ensures investment protection

Application

The CP 343-1 ERPC (Enterprise Connect) is used for connecting the SIMATIC S7-300 to Industrial Ethernet networks and to different ERP or MES systems for vertical integration by means of a firmware extension from the company ILS-Technology, to be ordered separately. With its own processor, the module relieves the CPU of communication tasks and facilitates additional connections.

The CP 343-1 ERPC permits communication of the S7-300 with:

- PGs/PCs
- Master computers
- HMI devices
- SIMATIC S5/S7/C7 systems
- ERP or MES systems by means of database interface, e.g. ORACLE, MySQL, MS-SQL, DB2 by means of a firmware extension from the company ILS-Technology, to be ordered separately

PROFINET/Industrial Ethernet

Communication for SIMATIC S7-300

CP 343-1 ERPC

Design

The CP 343-1 ERPC offers all the advantages of the SIMATIC S7-300 design:

- Compact design; the rugged plastic enclosure features the following on the front panel:
 - RJ45 socket for connection to Industrial Ethernet; Automatic detection of data transfer rate by means of autosensing function; The RJ45 socket is designed to be industry-compatible with an additional sleeve for connection of the IE FC RJ45 Plug 145/180; Integral autocrossover function permits use of uncrossed connecting cables
 - 2-pin plug-in terminal strip for connection of the 24 V DC external supply voltage
 - Diagnostics LEDs for indicating the operational and communication status
- Easy installation; the CP 343-1 ERPC is mounted on the rail of the S7-300 and connected to the adjacent modules by means of the bus connectors. No slot rules apply.
- Fanless operation; no backup battery required.
- The CP 343-1 ERPC can also be used in the expansion rack (ER) in conjunction with the IM 360/361
- The C-PLUG (configuration plug) is included in the scope of delivery as replacement medium (operation without C-PLUG is not possible)

Function

- Gigabit interface with an RJ45 port with 10/100/1000 Mbit/s full/half duplex with autosensing and autocrossover functionality
- Communication services:
 - Communication services: Open communication (TCP/IP, UDP)
 - PG/OP communication: across networks by means of S7 routing
 - S7 communication (client, server)
 - ERPC communication by means of a firmware expansion from the company ILS-Technology, to be ordered separately. Connection to databases such as ORACLE, MySQL, MS-SQL, DB2 and Message Queue systems. For further information on firmware expansion, refer to "deviceWISE Embedded Edition for SIMATIC S7".
- Diagnostics and network management:
 - Extensive diagnostic functions for all modules in the rack
 - Integration in network management systems through the support of SNMP V1
- Security mechanisms:
 - Access protection by means of configurable IP access list
- Configuration
 - For the configuration of the database connection, see "deviceWISE Embedded Edition for SIMATIC S7".
 - Configuration of the automation functionality with STEP 7 or STEP 7 Professional V11
- Module replacement without programming device: All information is stored on the C-PLUG

Integration

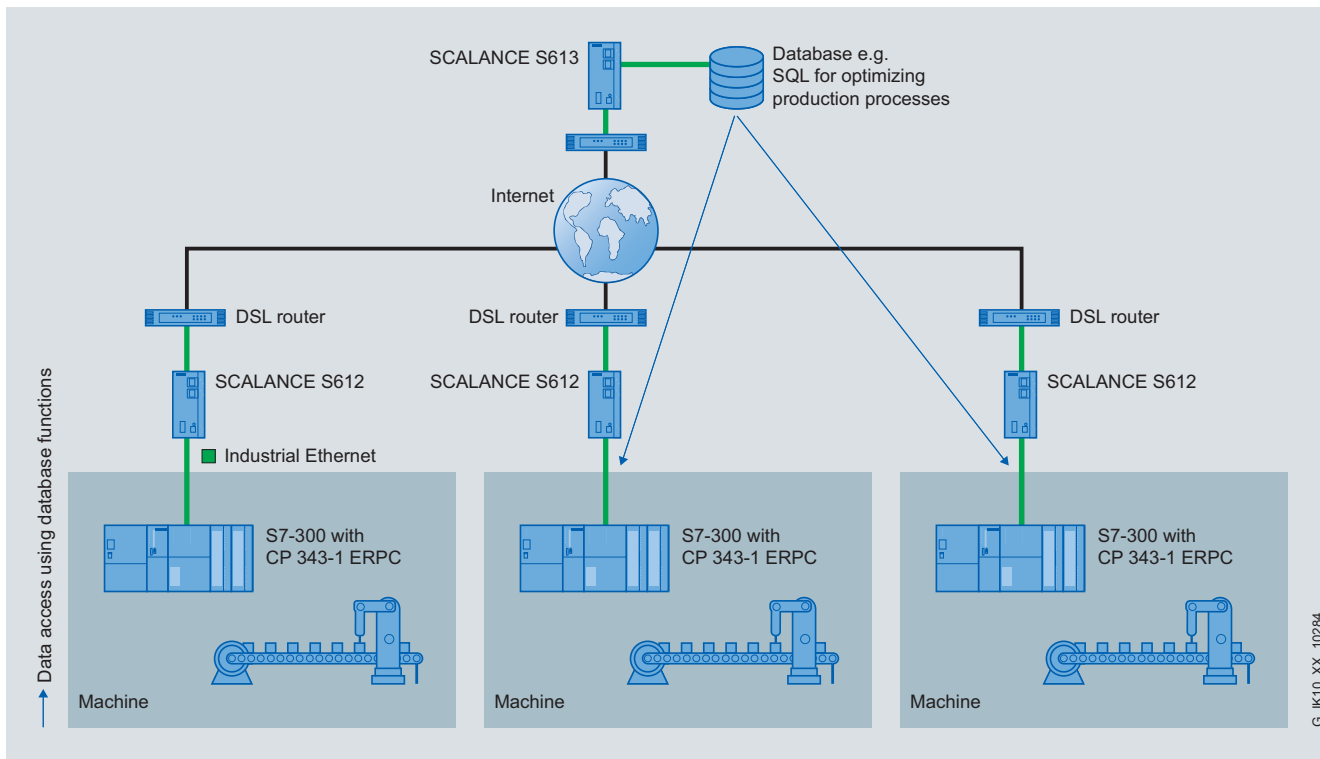

G_IK10_XX_10284

Example configuration of optimization of production process with CP 343-1 ERPC

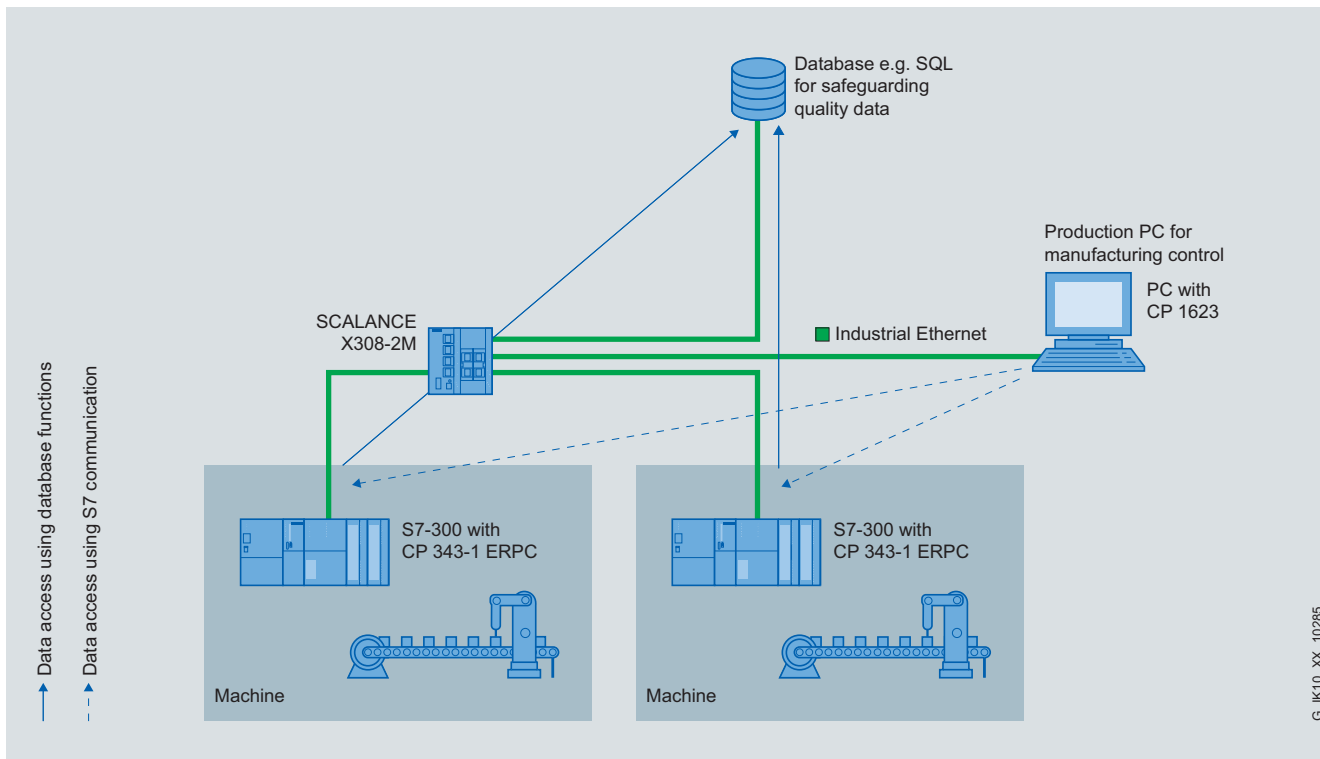

G_IK10_XX_10285

Example configuration of archiving of quality data with CP 343-1 ERPC

PROFINET/Industrial Ethernet

Communication for SIMATIC S7-300

CP 343-1 ERPC

Technical specifications

Order No.	6GK7 343-1FX00-0XE0
Product type designation	CP 343-1 ERPC
Data transmission rate	
Transmission rate at interface 1	10 ... 1 000 Mbit/s
Interfaces	
Number of electrical connections	
• at interface 1 in accordance with Industrial Ethernet	1
• For power supply	1
Design of electrical connection	
• at interface 1 in accordance with Industrial Ethernet	RJ45 port
• For power supply	2-pin plug-in terminal strip
Design of the swap medium C-Plug	Yes
Supply voltage, current consumption, power loss	
Type of power supply	DC
Power supply	
• 1 from backplane bus	5 V
• External	24 V
Relative positive tolerance at 24 V DC	20 %
Relative negative tolerance at 24 V DC	15 %
Current consumed	
• from backplane bus at 5 V DC, typical	0.3 A
• from external power supply at 24 V DC	
- Typical	0.16 A
- Maximum	0.6 A
Effective power loss	14.7 W
Permitted ambient conditions	
Ambient temperature	
• with vertical installation during operating phase	0 ... +40 °C
• with horizontal installation during operating phase	0 ... +60 °C
• During storage	-40 ... +70 °C
• During transport	-40 ... +70 °C
Relative humidity at 25 °C without condensation during operation, maximum	95 %
IP degree of protection	IP20
Design, dimensions and weights	
Module format	Compact module S7-300 double width
Width	80 mm
Height	125 mm
Depth	120 mm
Net weight	0.8 kg

Order No.	6GK7 343-1FX00-0XE0
Product type designation	CP 343-1 ERPC
Performance data	
<u>Performance data</u>	
<u>Open communication</u>	
Number of possible connections for open communication by means of SEND/RECEIVE blocks, maximum	8
Data volume	
• As user data per ISO on TCP connection for open communication by means of SEND/RECEIVE blocks, maximum	8 KB
• As user data per TCP connection for open communication by means of SEND/RECEIVE blocks, maximum	8 KB
• As user data per UDP connection for open IE communication by means of SEND/RECEIVE blocks, maximum	2 KB
Number of multicast stations	8
<u>Performance data</u>	
<u>S7 communication</u>	
Number of possible connections for S7 communication	
• Maximum	8
• Note	plus 2 PG/OP connections and 1 diagnostics connection
<u>Performance data</u>	
<u>Multiprotocol operation</u>	
Number of active connections in multiprotocol mode	32
<u>Performance data</u>	
<u>ERPC functions</u>	
Number of possible connections for communication with ERP or MES stations, maximum	8
Maximum number of possible logical triggers per CP	8
Number of configurable ERPC symbols for database access	
• Per CPU, maximum	2 000
• Per logical trigger, maximum	255
Data quantity as user data and header information per logical trigger	8 KB
Product functions	
Management, configuration, programming	
Product function: MIB support	Yes
Protocol is supported	
• SNMP v1	Yes
• DCP	Yes
• LLDP	Yes
Configuration software required	STEP 7 version V5.4 SP5 and higher plus HSP
Identification & maintenance	
• I&M0 - device-specific information	Yes
• I&M1 - higher-level designation/location designation	Yes

Technical specifications (continued)

Order No.	6GK7 343-1FX00-0XE0
Product type designation	CP 343-1 ERPC
Product functions Diagnostics	
Product function: Web-based diagnostics	Yes
Product functions Redundancy	
Product function • Ring redundancy • Redundancy procedure MRP	No -

Order No.	6GK7 343-1FX00-0XE0
Product type designation	CP 343-1 ERPC
Product functions Security	
Product function • ACL - IP-based • Switching-off non-required services • Blocking of communication via physical ports • Log file for unauthorized access	Yes Yes Yes No
Product functions Time	
Product function • SICLOCK support • Passing-on of time synchronization NTP protocol is supported	Yes Yes Yes

Ordering data

Ordering data	Order No.
Communication processor CP 343-1 ERPC (Enterprise Connect) For the connection of SIMATIC S7-300 to Industrial Ethernet and for the support of the database connection of the SIMATIC S7-300 to various databases; TCP/UDP, S7 communication, open communication (SEND/RECEIVE), with and without RFC 1006, multicast, web server, setting of CPU's clock using SIMATIC procedures and NTP, access protection via IP access list, SNMP, DHCP, initialization over LAN 10/100/1000 Mbit/s; with electronic manual on DVD, C-PLUG included in scope of delivery	6GK7 343-1FX00-0XE0
SOFTNET S7 for Industrial Ethernet Software for S7 and open communication, including OPC server, PG/OP communication and NCM PC, runtime software, software and electronic manual on CD-ROM, license key on USB stick, Class A	
SOFTNET-IE S7 V8.1 For 32/64 bit Windows 7 Professional/Ultimate; for 64 bit: Windows 2008 Server R2; German/English up to 64 connections • Single License for one installation	6GK1 704-1CW08-1AA0
SOFTNET-S7 Edition 2008 (V7.1) for Industrial Ethernet for 32 bit Windows XP Professional SP2/3; Windows 2003 Server R2, SP2; Windows Vista Business/Ultimate SP1; Windows 2008 Server; German/English up to 64 connections • Single License for one installation	6GK1 704-1CW71-3AA0

Ordering data	Order No.
Software Update Service For 1 year with automatic extension; requirement: Current software version	6GK1 704-1CW00-3AL0
Upgrade • From Edition 2006 to Edition 2008 or V8.1 • From V6.0, V6.1, V6.2 or V6.3 to Edition 2008 or V8.1	6GK1 704-1CW00-3AE0 6GK1 704-1CW00-3AE1
SOFTNET-IE S7 Lean Edition V8.1 Up to eight connections • Single License for one installation	6GK1 704-1LW08-1AA0
SOFTNET-S7 Lean Edition 2008 (V7.1) for Industrial Ethernet Up to eight connections • Single License for one installation	6GK1 704-1LW71-3AA0
Software Update Service For 1 year with automatic extension; requirement: Current software version	6GK1 704-1LW00-3AL0
Upgrade • From Edition 2006 to Edition 2008 or V8.1 • From V6.0, V6.1, V6.2 or V6.3 to Edition 2008 or V8.1	6GK1 704-1LW00-3AE0 6GK1 704-1LW00-3AE1
Industrial Ethernet Switch SCALANCE X308-2 2 x 1000 Mbit/s multimode fiber-optic cable ports (SC sockets), 1 x 10/100/1000 Mbit/s RJ45 port, 7 x 10/100 Mbit/s RJ45 ports; for glass fiber-optic cable (multimode) up to max. 750 m	6GK5 308-2FL00-2AA3

PROFINET/Industrial Ethernet

Communication for SIMATIC S7-300

CP 343-1 ERPC

2

Ordering data	Order No.	Order No.
IE FC TP Standard Cable GP 4 x 2 8-core, shielded TP installation cable for universal use; with UL approval; sold by the meter; max. length 1000 m; minimum order 20 m <ul style="list-style-type: none"> • AWG 22, for connection to IE FC RJ45 Modular Outlet • AWG 24, for connection to IE FC RJ45 Plug 4 x 2 	6XV1 870-2E 6XV1 878-2A	
IE FC RJ45 Plug 4 x 2 RJ45 plug connector for Industrial Ethernet (10/100/1000 Mbit/s) with a rugged metal enclosure and integrated insulation displacement contacts for connecting Industrial Ethernet FC installation cables; 180° cable outlet; for network components and CPs/CPU's with Industrial Ethernet interface <ul style="list-style-type: none"> • 1 pack = 1 unit • 1 pack = 10 units • 1 pack = 50 units 	6GK1 901-1BB11-2AA0 6GK1 901-1BB11-2AB0 6GK1 901-1BB11-2AE0	
IE FC Stripping Tool Preadjusted stripping tool for fast stripping of the Industrial Ethernet FC cables	6GK1 901-1GA00	
STEP 7 Version 5.5 <i>Target system:</i> SIMATIC S7-300/400, SIMATIC C7, SIMATIC WinAC <i>Requirements:</i> Windows XP Prof., Windows 7 Professional/Ultimate <i>Type of delivery:</i> German, English, French, Spanish, Italian; including license key on USB stick, with electronic documentation <ul style="list-style-type: none"> • Floating license on DVD • Rental license for 50 hours • Software Update Service on DVD (requires current software version) • Upgrade Floating License 3.x/4.x/5.x to V5.5; on DVD • Trial License STEP 7 V5.5; on DVD, 14 day trial 	6ES7 810-4CC10-0YA5 6ES7 810-4CC10-0YA6 6ES7 810-4BC01-0YX2 6ES7 810-4CC10-0YE5 6ES7 810-4CC10-0YA7	6ES7 822-1AA01-0YA5 6ES7 822-1AA01-0YA7 6ES7 822-1AA01-0XE5 6ES7 822-1AA01-0XC5 6ES7 822-1AA01-0YC5 6ES7 822-1AA00-0YL5 6ES7 822-1AA00-0YM5 6ES7 810-5CC04-0YE2 6ES7 810-5CC00-0YM2
STEP 7 Professional Engineering Software V11 <i>Target system:</i> SIMATIC S7-300/400, SIMATIC C7, SIMATIC WinAC <i>Requirements:</i> Windows XP Professional SP3 (32 bit), Windows 7 Professional (32 bit), Windows 7 Enterprise (32 bit), Windows 7 Ultimate (32 bit), Microsoft Server 2003 R2 Std. SP2 (32 bit), Microsoft Server 2008 Std. SP2 (32 bit) <i>Type of delivery:</i> German, English, Chinese, Italian; French, Spanish <ul style="list-style-type: none"> • STEP 7 Professional V11, floating license • STEP 7 Professional V11, trial license • Upgrade STEP 7 Professional 2006/2010 to STEP 7 Professional V11, floating license • PowerPack & Upgrade STEP 7 V5.4/V5.5 to STEP 7 Professional V11, floating license • Powerpack STEP 7 Basic V11 to STEP 7 Professional V11, floating license • STEP 7 Professional V11, Software Update Service, 1 year; current software version required • STEP 7 Professional V11, Software Update Service Compact, 1 year; current software version required • STEP 7 Professional Software Update Service; 1 year; for STEP 7 Professional and STEP 7 Professional in the TIA Portal, requires current software version • STEP 7 Professional Software Update Service Compact; 1 year; for STEP 7 Professional and STEP 7 Professional in the TIA Portal, requires current software version 		DeviceWISE Embedded Edition for SIMATIC S7 Firmware expansion for database connection of the SIMATIC S7-300 complete with CP 343-1 ERPC to various ERP or MES systems See Partner products / deviceWISE Embedded Edition for SIMATIC S7

More information

You can obtain further information on the software "deviceWISE embedded Edition for SIMATIC S7" from
 ILS Technology LLC;
 5300 Broken Sound Blvd.
 Suite 150
 Boca Raton, FL, USA, 33487
 Phone: +1-561-982-9898 x124
 Fax: +1-561-982-8638
 E-mail: devicewise@ilstechnology.com
 Internet: www.ilstechnology.com/erpc

Overview



BACnet	TCP/UDP	PN	MRP	IT	IP-R	PG/OP	S7/S5
●	●					●	●

BACnet (**B**uilding **A**utomation and **C**ontrol **N**etworks) is a communication protocol for data networks in building automation and control developed by ASHRAE (American Society of Heating, Refrigeration and Air Conditioning Engineers Inc.). It is equally suitable for both the management and automation level and is recognized as an ANSI, CEN and ISO standard.

The CP 343-1 BACnet is a communication processor for the connection of a SIMATIC S7-300 to the Industrial Ethernet and via the BACnet protocol it also permits the integration in systems that support the BACnet protocol

- 2 x RJ45 interfaces for 10/100 Mbit/s full/half duplex connection with autosensing/autonegotiation/autocrossover functionality
- Integrated 2-port switch
- The CP supports:
 - Open communication (SEND/RECEIVE)
 - PG/OP communication
 - S7 communication (server)
 - BACnet communication based on TCP/IP, BACnet server according to EN 16484, Part 5
- Extensive diagnostics functions via STEP 7
- Integration into network management systems through the support of SNMP V1 MIB-II

Benefits

get Designed for Industry

- Direct integration of SIMATIC S7-300 into industrial plants or building systems by means of Industrial Ethernet/BACnet at up to 100 Mbit/s
- Protection of investment for existing systems through the integration of the SIMATIC S7-300 by means of open communication
- Flexible use thanks to absence of slot rules
- Optimum support of maintenance through
 - Remote programming via LAN/WAN (e.g. Internet)
 - Monitoring by network management tools (SNMP)
- Easy module replacement
- Reliable network connection through industry-standard device connection with IE FC RJ45 plug 145/180 and additional strain relief by latching the connector onto housing

Application

The CP 343-1 BACnet is the communication module for the connection of SIMATIC S7-300 to Industrial Ethernet and is used for the integration of the SIMATIC S7 into BACnet systems. Via BACnet communication, the CP can also communicate with a third-party system such as heating or ventilation controllers.

With its own processor, the module relieves the CPU of communication tasks and facilitates additional connections.

The CP 343-1 BACnet permits the S7-300 to communicate with:

- PG/PC
- HMI devices
- SIMATIC S5/S7/C7 systems

Possible fields of application:

- Industrial building automation
- HVAC (heating, ventilation and air conditioning) solutions using PLCs at the automation level
- Infrastructure markets
- Airports
- Tunnels
- Totally Integrated Automation (TIA)
- Totally Integrated Power (TIP)

PROFINET/Industrial Ethernet

Communication for SIMATIC S7-300

CP 343-1 BACnet

Design

The CP 343-1 BACnet offers all the advantages of the SIMATIC S7-300 design:

- Compact design; the rugged plastic enclosure features the following on the front panel:
 - Two RJ45 sockets for connection to Industrial Ethernet/BACnet; the RJ45 sockets are industrially compatible and designed with additional holding collars, for connecting the IE FC RJ45 Plug 145/180; automatic sensing of the data transmission rate by means of the Autosensing function;
 - 2-pin plug-in terminal strip for connection of the 24 V DC external supply voltage
 - Diagnostics LEDs for each port for indicating the operational and communication status
- Easy installation; the CP 343-1 BACnet is installed on the mounting rail of the S7-300 and is connected to adjacent modules via the bus connector. No slot rules apply.
- The CP 343-1 BACnet can be operated without a fan; no back-up battery is required.
- The CP 343-1 BACnet can also be used in the expansion rack (ER) in conjunction with the IM 360/361
- The module can be replaced without using a programming device

Function

The CP 343-1 BACnet independently handles data traffic via Industrial Ethernet and BACnet protocol. The module has its own processor and can be put into service directly using the unique preset Ethernet address (MAC) via the network.

Due to the support of the dynamic host configuration protocol (DHCP), the IP address can be assigned from a central DHCP server.

The CP 343-1 BACnet works in multi-protocol mode for the following communication services:

- PG/OP communication
PG/OP communication allows all S7 stations connected to the network to be remotely programmed.
 - S7 routing; using S7 routing it is possible to use PG communication across networks.
- S7 communication
- Open communication (SEND/RECEIVE)
- A large number of stations can be accessed thanks to the multicast function
- Use of the socket interface in the partner system possible without RFC 1006
- Integral autocrossover function permits use of uncrossed connecting cables
- BACnet communication based on TCP/IP, BACnet server according to EN 16484, Part 5

Siemens completes its building control system DESIGO with the SIMATIC S7. DESIGO S7 introduces two new performance packages to building automation:

- Building Solution
- Building Integration

These enable projects to be implemented for "Industrial Building Automation" where programmable logic controllers (PLCs) are required at the automation level.

The DESIGO S7 Building Solution performance package permits the use SIMATIC S7 within a DESIGO system (control system for building automation) with an S7-HVAC library (**H**eating, **V**entilation and **A**ir Conditioning), that is based on the library of DESIGO PX. Communication with the DESIGO system is by means of BACnet. This permits efficient engineering of HVAC applications.

With DESIGO S7 Building Integration, existing SIMATIC S7 (software without HVAC library) components are efficiently integrated into a DESIGO system by means of BACnet communication.

BACnet communication

Based on TCP/IP, a BACnet server compliant with EN 16484, Part 5 is made available. The CP processes the protocol autonomously as far as possible so that the CPU is not burdened with the BACnet protocol. The CP 343-1 BACnet optionally supports:

- BACnet communication for any SIMATIC software by mapping SIMATIC data onto BACnet
- HVAC functions with BACnet communication by using corresponding function blocks; these HVAC function blocks are a component of the block library and are to be incorporated in the S7 user program.

Function (continued)

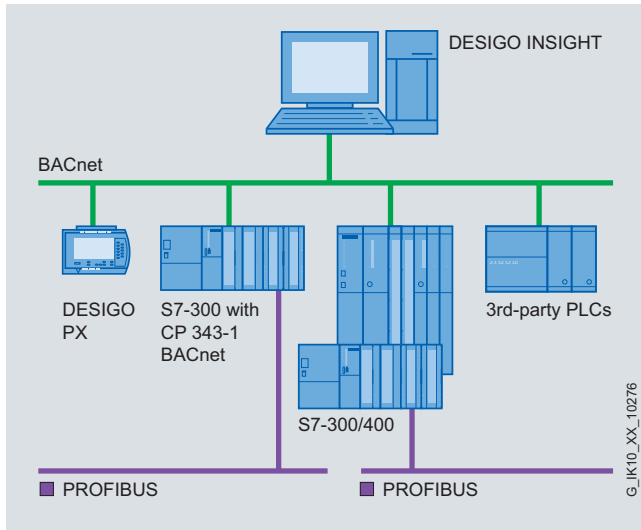

Linear structure with CP 343-1 BACnet with integral switch

BACnet consists of:

- Standardized services that are processed autonomously by the CP
- Standardized objects that present a user view of the automation

The actual configuration of the BACnet objects and their mapping to S7 data is performed by a BACnet mapping tool.

The configuration data of the BACnet objects generated by the mapping tool can be downloaded to the SIMATIC S7 using the general download function or using Delta download. The mapping tool can be obtained free of charge from your local Siemens I BT office.

The standardized transport protocol UDP is used for BACnet, as it already has sufficient transport checking mechanisms available. Like TCP, UDP is a transport protocol, but unlike TCP it operates on a connectionless basis. BACnet devices may only work with the UDP port number permanently assigned to them. The UDP port number 47808 = 0xBAC0 is registered for BACnet.

The Ethernet IP addressing consists of the IP address, the subnet mask and the default gateway. BACnet devices within one subnet have the same subnet address. In the case of devices with integral BBMD functionality (**B**ACnet **B**roadcast **M**anagement **D**evice), e.g. DESIGO automation stations, DHCP – the automatic assignment of IP addresses in networks – is generally not permitted.

BACnet uses broadcast messages for the communication, i.e. all devices are addressed directly. As a rule, Ethernet IP routers block these broadcast messages so that a direct connection of Ethernet subnets is not possible. By using BBMD, broadcast messages can still be distributed.

Diagnostics

Extensive diagnostics options are available via NCM, including:

- Operating status of the CP
- General diagnostics and statistics functions
- Connection diagnostics
- LAN controller statistics
- Diagnostic buffer

Diagnostic options during operation

- Integration into network management systems through the support of SNMP V1 MIB-2 objects; this allows the current status of the Ethernet interface to be called up, e.g. for network management.

Configuration

STEP 7 V5.4 SP5 or higher and NCM S7 for Industrial Ethernet (supplied with STEP 7 V5.x) plus a hardware support package (HSP) are required for configuring the CP 343-1 BACnet. The configuration data of the CP is stored on the CPU. This means a module can be replaced without a PG. An additional "Building Integration" runtime license (reference number S55372-C107) is required in order to use the BACnet protocol on the module. Please contact your regional Siemens representative for ordering the license.

PROFINET/Industrial Ethernet

Communication for SIMATIC S7-300

CP 343-1 BACnet

Technical specifications

Order No.	6FL4 343-1CX10-0XE0
Product type designation	CP 343-1 BACnet
Transmission rate	
Transmission rate at interface 1	10 ... 100 Mbit/s
Interfaces	2
Number of electrical connections	
• at interface 1 in accordance with Industrial Ethernet	1
• for power supply	1
Design of electrical connection	
• at interface 1 in accordance with Industrial Ethernet	RJ45 port
• for power supply	2-pin plug-in terminal strip
Supply voltage, current consumption, power loss	
Type of power supply	DC
Supply voltage	
• 1 from backplane bus	5 V
• External	24 V
Relative positive tolerance at 24 V DC	20 %
Relative negative tolerance at 24 V DC	15 %
Current consumed	
• from backplane bus at 5 V DC, typical	0.2 A
• from external power supply at 24 V DC	
- Maximum	0.2 A
Effective power loss	5.8 W
Permitted ambient conditions	
Ambient temperature	
• During operation	0 ... 60 °C
• During storage	-40 ... +70 °C
• During transport	-40 ... +70 °C
• Note	-
Relative humidity at 25 °C without condensation during operation, maximum	95 %
IP degree of protection	IP20
Design, dimensions and weights	
Module format	Compact module S7-300, single-width
Width	40 mm
Height	125 mm
Depth	120 mm
Net weight	0.22 kg
Product properties, functions, components	
General	
Number of modules	
• Per CPU, maximum	1
• Note	Without BACnet protocol: Max. 8 per station

Order No.	6FL4 343-1CX10-0XE0
Product type designation	CP 343-1 BACnet
Performance data	
<u>Performance data</u>	
<u>Open communication</u>	
Number of possible connections for open communication by means of SEND/RECEIVE blocks, maximum	8
Data volume	
• As user data per TCP connection for open communication by means of SEND/RECEIVE blocks, maximum	8 KB
• As user data per UDP connection for open IE communication by means of SEND/RECEIVE blocks, maximum	2 KB
Number of multicast stations	8
<u>Performance data</u>	
<u>S7 communication</u>	
Number of possible connections for S7 communication	
• Maximum	4
• For PG connections, maximum	2
• For PG/OP connections, maximum	2
<u>Performance data</u>	
<u>Multiprotocol operation</u>	
Number of active connections in multiprotocol mode	12
<u>Performance data</u>	
<u>BACnet</u>	
BACnet/IP protocol is supported	Yes
Product function	
• BACnet device type AAC (Advanced Application Controller)	Yes
• Peer-to-peer between BACnet automation stations	Yes
• BBMD (BACnet Broadcast Management Device)	Yes
Maximum number of BACnet I/O objects	800
Maximum number of BACnet objects, total	1 500
Influence on the cycle time of the automation system	No effect
Required storage capacity of S7 CPU's main memory	4 KB
Standard for BACnet	Communication based on TCP/IP, BACnet server in accordance with EN 16484, Part 5
Product functions	
Management, configuration, programming	
Product function: MIB support	Yes
Protocol is supported	
• SNMP v1	Yes
• DCP	Yes
• LLDP	Yes

Technical specifications (continued)

Order No.	6FL4 343-1CX10-0XE0
Product type designation	CP 343-1 BACnet
Configuration software required	STEP 7 version V5.4 SP5 and higher plus HSP. An additional runtime license "Building Integration" (reference number S55372-C107) is required to use the BACnet protocol on the module. To order the license, please contact your regional Siemens partner.

Order No.	6FL4 343-1CX10-0XE0
Product type designation	CP 343-1 BACnet
Product functions Diagnostics	
Product function: Web-based diagnostics	No
Product functions Switch	
Product feature: Switch	Yes
Product function	
• Switch-managed	No
• Configuration with STEP 7	Yes
Product functions Time	
Product function	
• SICLOCK support	Yes
• Passing-on of time synchronization	Yes
Protocol is supported NTP	Yes

Ordering data

Ordering data	Order No.	Ordering data	Order No.
CP 343-1 BACnet communication processor	6FL4 343-1CX10-0XE0	Compact Switch Module CSM 377	6GK7 377-1AA00-0AA0
for the connection of SIMATIC S7-300 to Industrial Ethernet and for the integration of the SIMATIC S7 into BACnet systems; BACnet protocol, S7 communication, open communication (SEND/RECEIVE), with/without RFC 1006; UDP, PG/OP communication		Unmanaged switch for connection of a SIMATIC S7-300-CPU, ET 200M and as many as three further nodes to Industrial Ethernet operating at 10/100 Mbit/s; 4 x RJ45 ports; external 24 V DC power supply, LED diagnostics, S7-300 module including electronic Manual on CD-ROM	
IE FC TP Standard Cable GP 2 x 2 (Type A)	6XV1 840-2AH10	STEP 7 Version 5.5	
4-core, shielded TP installation cable for connection to IE FC Outlet RJ45/IE FC RJ45 Plug; PROFINET-compliant; with UL approval; sold by the meter; max. length 1000 m, minimum order 20 m		<i>Target system:</i> SIMATIC S7-300/400, SIMATIC C7, SIMATIC WinAC <i>Requirements:</i> Windows XP Prof., Windows 7 Professional/Ultimate <i>Type of delivery:</i> German, English, French, Spanish, Italian; including license key on USB stick, with electronic documentation	
IE FC RJ45 Plug 145	6GK1 901-1BB30-0AA0 6GK1 901-1BB30-0AB0 6GK1 901-1BB30-0AE0	<ul style="list-style-type: none"> • Floating License on DVD • Rental License for 50 hours • Software Update Service on DVD (requires current software version) • Upgrade Floating License 3.x/4.x/5.x to V5.5; on DVD • Trial License STEP 7 V5.5; on DVD, 14 day trial 	6ES7 810-4CC10-0YA5 6ES7 810-4CC10-0YA6 6ES7 810-4BC01-0YX2
RJ45 Plug connector 2 x 2 for Industrial Ethernet with a rugged metal enclosure and integrated insulation displacement contacts for connecting Industrial Ethernet FC installation cables; with 145° cable outlet			6ES7 810-4CC10-0YE5
• 1 pack = 1 unit • 1 pack = 10 units • 1 pack = 50 units			6ES7 810-4CC10-0YA7
IE FC Stripping Tool	6GK1 901-1GA00		
Preadjusted stripping tool for fast stripping of the Industrial Ethernet FC cables			

More information

For technical questions on the CP 343-1 BACnet see www.siemens.com/simatic-net/ik-info

To order the performance packages, please contact your local Siemens I BT office.

PROFINET/Industrial Ethernet

Communication for SIMATIC S7-400

CP 443-1

Overview



ISO	TCP/ UDP	PN	MRP	IT	IP-R	PG/OP	S7/S5
●	●	●	●	●		●	●

Communication processor for connecting a SIMATIC S7-400 to Industrial Ethernet networks, also as PROFINET IO controller or in SIMATIC H systems.

The CP supports:

- PG/OP communication
- S7 communication
- Open communication (SEND/RECEIVE)
- PROFINET communication
- IT communication

The communication processor can also be used for redundant S7 communication in SIMATIC H systems and for fail-safe applications (PROFIsafe) in connection with an S7-400 F-CPU.

Benefits

get Designed for Industry

- High plant availability through the support of media redundancy (MRP) and use in the SIMATIC S7-400 H system
- Optimum support of maintenance through
 - Web-based diagnostics
 - Remote programming via WAN or a telephone network (ISDN)
 - Monitoring by means of IT network management tools (SNMP)
 - Module exchange without programming device using the C-PLUG swap medium
- Securing the system against unauthorized access by means of
 - Central access protection for any devices within an automation cell, e.g. by means of authentication of the network stations
- The capability of later connecting existing SIMATIC S7 systems to Industrial Ethernet using the CP 443-1 ensures investment protection

Application

- The CP 443-1 is used to connect the SIMATIC S7-400 to Industrial Ethernet networks. With its own processor, it relieves the CPU of communication tasks and facilitates additional connections.

The CP 443-1 offers communication options with

- PGs/PCs
- Host computers
- HMI systems
- SIMATIC S5/S7/C7 systems
- PROFINET IO devices

Design

The CP 443-1 features all the advantages of the SIMATIC S7-400 design:

- Compact design:
 - Two RJ45 sockets for connecting to Industrial Ethernet; automatic data rate detection by means of the autosensing/autocrossover function; the connection is made via the IE FC RJ45 Plug 180 with 180° cable outlet or via a standard patch cable
 - Diagnostics LEDs for indicating the operational and communication status
- Easy installation:
 - The CP 443-1 is mounted on the S7-400 rack and connected to the other modules via the backplane bus. No slot rules apply.
- The CP 443-1 can be operated without a fan
- The CP 443-1 can also be operated in the expansion rack (ER) in conjunction with the IM 460/461
- The module can be replaced without the need for a programming device

Function

- Two RJ45 ports with 10/100 Mbit/s full/half duplex with autosensing and autocrossover functionality via integral 2-port switch
- Communication services of the interface:
 - Open IE communication (TCP/IP and UDP): Multicast with UDP, including routing between both interfaces
 - PG/OP communication: across networks by means of S7 routing
 - S7 communication (client, server, multiplexing) including routing between both interfaces
 - S7-H communication for S7-400-H systems
 - PROFINET IO controller with real-time properties (RT and IRT)
 - IP address assignment via DHCP, simple PC tool or via program block (e.g. for HMI)
- Media redundancy (MRP):
 - Within an Ethernet network with ring topology, the CP supports the media redundancy procedure MRP
- Diagnostics and network management:
 - Extensive diagnostic functions for all modules in the rack
 - Integration into network management systems through the support of SNMP V1/V3
- Security mechanisms:
 - Access protection by means of configurable IP access list
- Configuration of all functions with STEP 7 V5.4
- Configuration with STEP 7 Professional V11
- Module replacement without programming device: All information can be stored on the CPU

Integration

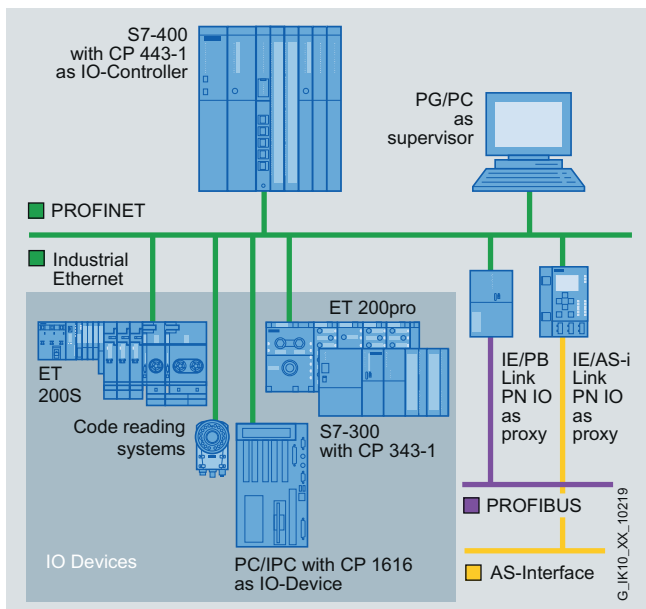

Interfacing to higher-level network with CP 443-1 as PROFINET IO controller

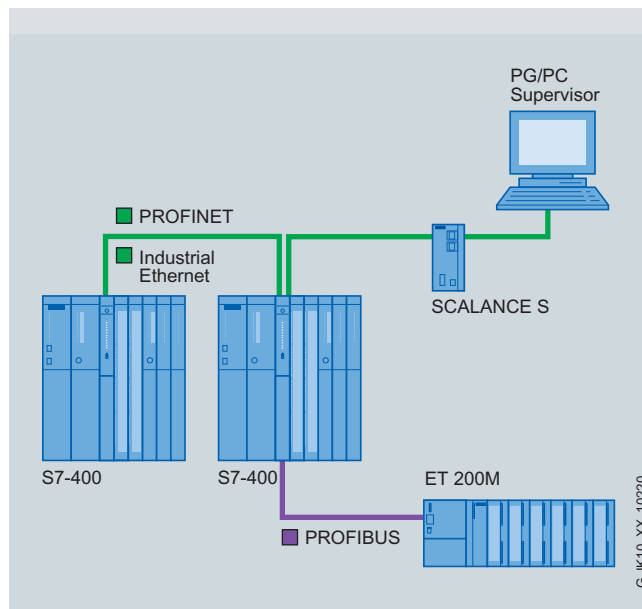

Line structure at the superordinated control level through integrated 2-port switch

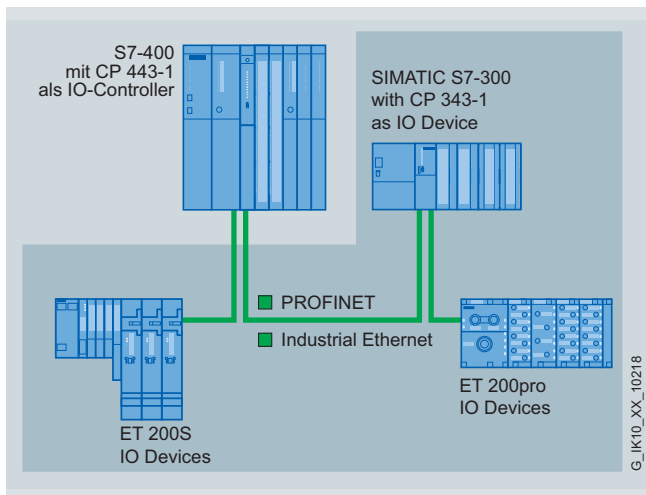

Line structure as PROFINET IO controller with integrated real-time switch

PROFINET/Industrial Ethernet

Communication for SIMATIC S7-400

CP 443-1

Technical specifications

Order No.	6GK7 443-1EX30-0XE0
Product type designation	CP 443-1
Transmission rate	
Transmission rate at interface 1	10 ... 100 Mbit/s
Interfaces	
Number of electrical connections at interface 1 in accordance with Industrial Ethernet	2
Design of electrical connection at interface 1 in accordance with Industrial Ethernet	RJ45 port
Supply voltage, current consumption, power loss	
Type of power supply	DC
Power supply 1 from backplane bus	5 V
Relative symmetrical tolerance at 5 V DC	5 %
Current input from backplane bus with 5 V DC, typical	1.4 A
Effective power loss	8.6 W
Permitted ambient conditions	
Ambient temperature	
• During operation	0 ... 60 °C
• During storage	-40 ... +70 °C
• During transport	-40 ... +70 °C
Relative humidity at 25 °C without condensation during operation, maximum	95 %
IP degree of protection	IP20
Design, dimensions and weights	
Module format	S7-400 compact module, single-width
Width	25 mm
Height	290 mm
Depth	210 mm
Net weight	0.7 kg
Product properties, functions, components	
General	
Number of modules	14
• Per CPU, maximum	Max. 4 as PN IO Ctrl.
• Note	

Order No.	6GK7 443-1EX30-0XE0
Product type designation	CP 443-1
Performance data	
<u>Performance data</u>	
<u>Open communication</u>	
Number of possible connections for open communication by means of SEND/RECEIVE blocks, maximum	64
Data volume	
• as user data per ISO connection for open communication by means of SEND/RECEIVE blocks, maximum	8 KB
• as user data per ISO on TCP connection for open communication by means of SEND/RECEIVE blocks, maximum	8 KB
• as user data per TCP connection for open communication by means of SEND/RECEIVE blocks, maximum	8 KB
• as user data per UDP connection for open IE communication by means of SEND/RECEIVE blocks, maximum	2 KB
Number of possible connections for open communication by means of T blocks, maximum	64
Data volume as user data per ISO on TCP connection for open communication by means of T blocks, maximum	1 452 byte
Number of multicast stations	-
<u>Performance data</u>	
<u>S7 communication</u>	
Number of possible connections for S7 communication	
• Maximum	128
• Maximum with PG connections	2
• For PG/OP connections, maximum	-
• Note	When using several CPUs
<u>Performance data</u>	
<u>Multiprotocol operation</u>	
Number of active connections in multiprotocol mode	128
<u>Performance data</u>	
<u>PROFINET communication as PN IO Controller</u>	
Product function: PROFINET IO Controller	Yes
Total number of PN IO Devices which can be operated on the PROFINET IO Controller	128
Number of PN IO IRT Devices which can be operated on the PROFINET IO Controller	32
Number of external PN IO lines with PROFINET, per rack	4

Technical specifications (continued)		Ordering data	Order No.
Order No.	6GK7 443-1EX30-0XE0	Communication processor CP 443-1	6GK7 443-1EX30-0XE0
Product type designation	CP 443-1	For connecting SIMATIC S7-400 to Industrial Ethernet through TCP/IP, ISO and UDP; PROFINET IO Controller, MRP; integrated real-time switch ERTEC with two ports; 2 x RJ45 interface; S7 communication, open communication (SEND/RECEIVE) with FETCH/WRITE, with and without RFC 1006, DHCP, SNMP V2, diagnostics, multicast, access protection over IP access list, initialization over LAN 10/100 Mbit/s with electronic manual on DVD	
Data volume		SOFTNET S7 for Industrial Ethernet	
• As user data for input variables as PROFINET IO Controller, maximum	4 KB	Software for S7 and open communication, including OPC server, PG/OP communication and NCM PC, runtime software, software and electronic manual on CD-ROM, license key on USB stick, Class A	
• As user data for output variables as PROFINET IO Controller, maximum	4 KB	SOFTNET-IE S7 V8.1	
• As user data for input variables per PN IO Device as PROFINET IO Controller, maximum	240 byte	For 32/64 bit Windows 7 Professional/Ultimate; for 64 bit: Windows 2008 Server R2; German/English	
• As user data for output variables per PN IO Device as PROFINET IO Controller, maximum	240 byte	up to 64 connections	
• As user data for input variables per PN IO Device as PROFINET IO Controller, maximum	-	• Single License for one installation	6GK1 704-1CW08-1AA0
• As user data for output variables per PN IO Device as PROFINET IO Controller, maximum	-	SOFTNET-S7 Edition 2008 (V7.1) for Industrial Ethernet	
Product functions Management, configuration, programming		for 32 bit Windows XP Professional SP2/3; Windows 2003 Server R2, SP2; Windows Vista Business/Ultimate SP1; Windows 2008 Server; German/English	
Product function: MIB support	Yes	up to 64 connections	
Protocol is supported		• Single License for one installation	6GK1 704-1CW71-3AA0
• SNMP v1	Yes	Software Update Service	
• DCP	Yes	For 1 year with automatic extension; requirement: Current software version	6GK1 704-1CW00-3AL0
• LLDP	Yes	Upgrade	
Configuration software required	STEP 7 V5.5 SP1 or STEP 7 V11	• From Edition 2006 to Edition 2008 or V8.1	6GK1 704-1CW00-3AE0
Product functions Diagnostics		• From V6.0, V6.1, V6.2 or V6.3 to Edition 2008 or V8.1	6GK1 704-1CW00-3AE1
Product function: Web-based diagnostics	Yes	SOFTNET-IE S7 Lean Edition V8.1	
Product functions Switch		Up to eight connections	
Product feature: Switch	Yes	• Single License for one installation	6GK1 704-1LW08-1AA0
Product function		SOFTNET-S7 Lean Edition 2008 (V7.1) for Industrial Ethernet	
• Switch-managed	No	Up to eight connections	
• with IRT PROFINET IO Switch	Yes	• Single License for one installation	6GK1 704-1LW71-3AA0
• Configuration with STEP 7	Yes		
Product functions Redundancy			
Product function			
• Ring redundancy	Yes		
• Redundancy manager	Yes		
• Redundancy procedure MRP	Yes		
Product functions Security			
Product function			
• ACL - IP based	Yes		
• Switching-off non-required services	Yes		
• Blocking of communication via physical ports	Yes		
• Log file for unauthorized access	No		
Product functions Time			
Product function			
• SICLOCK support	Yes		
• Passing-on of time synchronization	Yes		
Protocol is supported NTP	Yes		

PROFINET/Industrial Ethernet

Communication for SIMATIC S7-400

CP 443-1

2

Ordering data	Order No.	Order No.
Software Update Service For 1 year with automatic extension; requirement: Current software version	6GK1 704-1LW00-3AL0	STEP 7 Version 5.5 <i>Target system:</i> SIMATIC S7-300/400, SIMATIC C7, SIMATIC WinAC <i>Requirements:</i> Windows XP Prof., Windows 7 Professional/Ultimate <i>Type of delivery:</i> German, English, French, Spanish, Italian; including license key on USB stick, with electronic documentation <ul style="list-style-type: none"> Floating license on DVD Rental license for 50 hours Software Update Service on DVD (requires current software version) Upgrade Floating License 3.x/4.x/5.x to V5.5; on DVD Trial License STEP 7 V5.5; on DVD, 14 day trial
Upgrade <ul style="list-style-type: none"> From Edition 2006 to Edition 2008 or V8.1 From V6.0, V6.1, V6.2 or V6.3 to Edition 2008 or V8.1 	6GK1 704-1LW00-3AE0 6GK1 704-1LW00-3AE1	
IE FC TP Standard Cable GP 2x2 4-core, shielded TP installation cable for connection to IE FC Outlet RJ45/ IE FC RJ45 Plug; PROFINET-compliant; with UL approval; sold by the meter max. length 1000 m, minimum order 20 m	6XV1 840-2AH10	6ES7 810-4CC10-0YA5 6ES7 810-4CC10-0YA6 6ES7 810-4BC01-0YX2 6ES7 810-4CC10-0YE5 6ES7 810-4CC10-0YA7
Industrial Ethernet Switch SCALANCE X204-2 Industrial Ethernet switches with integral SNMP access, online diagnostics, copper cable diagnostics and PROFINET diagnostics for configuring line, star and ring topologies; four 10/100 Mbit/s RJ45 ports and two fiber-optic cable ports	6GK5 204-2BB10-2AA3	STEP 7 Professional Engineering Software V11 <i>Target system:</i> SIMATIC S7-300/400, SIMATIC C7, SIMATIC WinAC <i>Requirements:</i> Windows XP Professional SP3 (32 bit), Windows 7 Professional (32 bit), Windows 7 Enterprise (32 bit), Windows 7 Ultimate (32 bit), Microsoft Server 2003 R2 Std. SP2 (32 bit), Microsoft Server 2008 Std. SP2 (32 bit) <i>Type of delivery:</i> German, English, Chinese, Italian; French, Spanish <ul style="list-style-type: none"> STEP 7 Professional V11, floating license STEP 7 Professional V11, trial license Upgrade STEP 7 Professional 2006/2010 to STEP 7 Professional V11, floating license PowerPack & Upgrade STEP 7 V5.4/V5.5 to STEP 7 Professional V11, floating license Powerpack STEP 7 Basic V11 to STEP 7 Professional V11, floating license STEP 7 Professional V11, Software Update Service, 1 year; current software version required STEP 7 Professional V11, Software Update Service Compact, 1 year; current software version required STEP 7 Professional Software Update Service; 1 year; for STEP 7 Professional and STEP 7 Professional in the TIA Portal, requires current software version STEP 7 Professional Software Update Service Compact; 1 year; for STEP 7 Professional and STEP 7 Professional in the TIA Portal, requires current software version
IE FC RJ45 Plug 180 2x2 RJ45 plug connector for Industrial Ethernet with a rugged metal enclosure and integrated insulation displacement contacts for connecting Industrial Ethernet FC installation cables; with a 180° cable outlet; for network components and CPs/CPUs with Industrial Ethernet interface <ul style="list-style-type: none"> 1 pack = 1 unit 1 pack = 10 units 1 pack = 50 units 	6GK1 901-1BB10-2AA0 6GK1 901-1BB10-2AB0 6GK1 901-1BB10-2AE0	
IE FC Stripping Tool Preadjusted stripping tool for fast stripping of the Industrial Ethernet FC cables	6GK1 901-1GA00	

PROFINET/Industrial Ethernet

Communication for SIMATIC S7-400

SIPLUS CP 443-1

Overview



ISO	TCP/UDP	PN	MRP	IT	IP-R	PG/OP	S7/S5
●	●	●	●	●		●	●

- The connection for the SIMATIC S7-400 to Industrial Ethernet
 - 2 x RJ-45 interface for 10/100 Mbit/s full/half-duplex connection with auto-sensing/auto-negotiation and auto-crossover function
 - Integrated real-time switch ERTEC with two ports
 - Multi-protocol operation for ISO, TCP/IP, UDP and PROFINET IO protocols
 - Adjustable keep alive function
- Communication services:
 - Open communication (ISO, TCP/IP, and UDP)
 - PROFINET IO Controller with real-time properties RT and IRT
 - PG/OP communication: Cross-network by means of S7 routing
 - S7 communication
- Media redundancy (MRP); within an Ethernet network with ring topology, the CP supports the media redundancy procedure MRP.
- Multicast by UDP
- Access protection via configurable access list
- Support for fail-safe programmable controllers together with SIMATIC S7-400 CPU 416F-3PN/DP
- Module replacement without PG
- SIMATIC H system operation for redundant S7 communication
- Configuration with STEP 7
- Diagnostics possibilities in STEP 7 and Web browser
- Automatic CPU-clock setting via Industrial Ethernet with NTP or SIMATIC procedure
- Integration of network management systems via SNMP (MIB II diagnostic information)

Note:

SIPLUS extreme products are based on Siemens Industry standard products. The contents listed here were taken from the respective standard products. SIPLUS extreme-specific information was added.

SIPLUS CP 443-1

Order No.	6AG1 443-1EX20-4XE0
Order No. based on	6GK7 443-1EX20-0XE0
Ambient temperature range	0 ... +60 °C
Conformal coating	Coating of the printed circuit boards and the electronic components
Technical data	The technical data of the standard product applies except for the ambient conditions

Ambient conditions

Relative humidity	5 ... 100 % Condensation permissible
Biologically active substances	Conformity with EN 60721-3-3, Class 3B2 mold and fungal spores (except fauna)
Chemically active substances	Conformity with EN 60721-3-3, Class 3C4 incl. salt mist and ISA-S71.04 severity level G1; G2; G3; GX ^{1) 2)}
Mechanically active substances	Conformity with EN 60721-3-3, Class 3S4 including conductive sand, dust ²⁾
Air pressure (depending on the highest positive temperature range specified)	1080 ... 795 hPa (-1000 ... +2000 m) see ambient temperature range 795 ... 658 hPa (+2000 ... +3500 m) derating 10 K 658 ... 540 hPa (+3500 ... +5000 m) derating 20 K

- ISA-S71.04 severity level GX: Long-term load:
SO₂ < 4.8 ppm; H₂S < 9.9 ppm; Cl < 0.2 ppm; HCl < 0.66 ppm;
HF < 0.12 ppm; NH < 49 ppm; O₃ < 0.1 ppm; NOX < 5.2 ppm
Limit value (max. 30 min/d):
SO₂ < 17.8 ppm; H₂S < 49.7 ppm; Cl < 1.0 ppm; HCl < 3.3 ppm;
HF < 2.4 ppm; NH < 247 ppm; O₃ < 1.0 ppm; NOX < 10.4 ppm
- The supplied plug covers must remain in place over the unused interface when operated in atmospheres containing corrosive gases!

The technical documentation on SIPLUS can be found here:
www.siemens.com/siplus-extreme

Ordering data

SIPLUS CP 443-1 communication processor (media exposure)

For connecting SIMATIC S7-400 to Industrial Ethernet through TCP/IP, ISO and UDP; PROFINET IO Controller, MRP; integrated real-time switch ERTEC with two ports; 2 x RJ-45 interface; S7 communication, open communication (SEND/RECEIVE) with FETCH/WRITE, with and without RFC 1006, DHCP, SNMP V2, diagnostics, multicast, access protection over IP access list, initialization over LAN 10/100 Mbit/s with electronic manual on DVD

Accessories

Order No.

6AG1 443-1EX20-4XE0

See CP 443-1

PROFINET/Industrial Ethernet

Communication for SIMATIC S7-400

CP 443-1 Advanced

Overview



ISO	TCP/UDP	PN	MRP	IT	IP-R	PG/OP	S7/S5
●	●	●	●	●	●	●	●

Communication processor for connecting a SIMATIC S7-400 to Industrial Ethernet networks, also as PROFINET IO controller or in SIMATIC H systems.

The CP supports:

- PG/OP communication
- S7 communication
- Open communication (SEND/RECEIVE)
- PROFINET communication
- IT communication

The communication processor can also be used for redundant S7 communication in SIMATIC H systems and for fail-safe applications (PROFIsafe) in connection with an S7-400 F-CPU. In addition, the CP 443-1 Advanced offers e-mail functions and user-created web pages and thus optimally supports maintenance and quality assurance. The Internet functions such as FTP even allow connection to the most diverse PC-based systems. Therefore, for the S7-400, this CP is the bridge between the field level and the MES level. The CP 443-1 Advanced connects seamlessly to the security structures of the office and IT world.

Benefits

get Designed for Industry

- Cost advantage due to connection to two separate Ethernet segments with integrated network separation
- High plant availability through the support of media redundancy (MRP) and use in the SIMATIC S7-400 H system
- Optimum support of maintenance through
 - Web-based diagnostics
 - Remote programming via WAN or a telephone network (ISDN)
 - Monitoring by means of IT network management tools (SNMP)
 - Module replacement without programming device using the C-PLUG swap medium
- Securing the system against unauthorized access ¹⁾ by means of
 - Central access protection for any devices within an automation cell, e.g. by means of authentication of the network stations
 - Secure remote access via the Internet by means of data encryption (VPN) and data integrity checking
 - Traceability by means of data logging on the basis of standard IT mechanisms (Syslog)
- The capability of later connecting existing SIMATIC S7 systems to Industrial Ethernet using the CP 443-1 Advanced ensures investment protection

¹⁾ Available soon

Application

The CP 443-1 Advanced is used to connect the SIMATIC S7-400 to Industrial Ethernet networks. With its own processor, it relieves the CPU of communication tasks and facilitates additional connections.

The CP 443-1 Advanced provides the following communication options:

- PGs/PCs
- Master computers
- HMI systems
- SIMATIC S5/S7/C7 systems
- PROFINET I/O devices
- PROFINET CBA components

With it, all of the devices of an Ethernet network can be protected from unauthorized access. The CP 443-1 Advanced allows safe remote access over the Internet and allows data transfer between devices or network segments to be protected from data manipulation/espionage¹⁾.

PROFINET CBA components and security functionalities can be used as an alternative.

¹⁾ Available soon

2

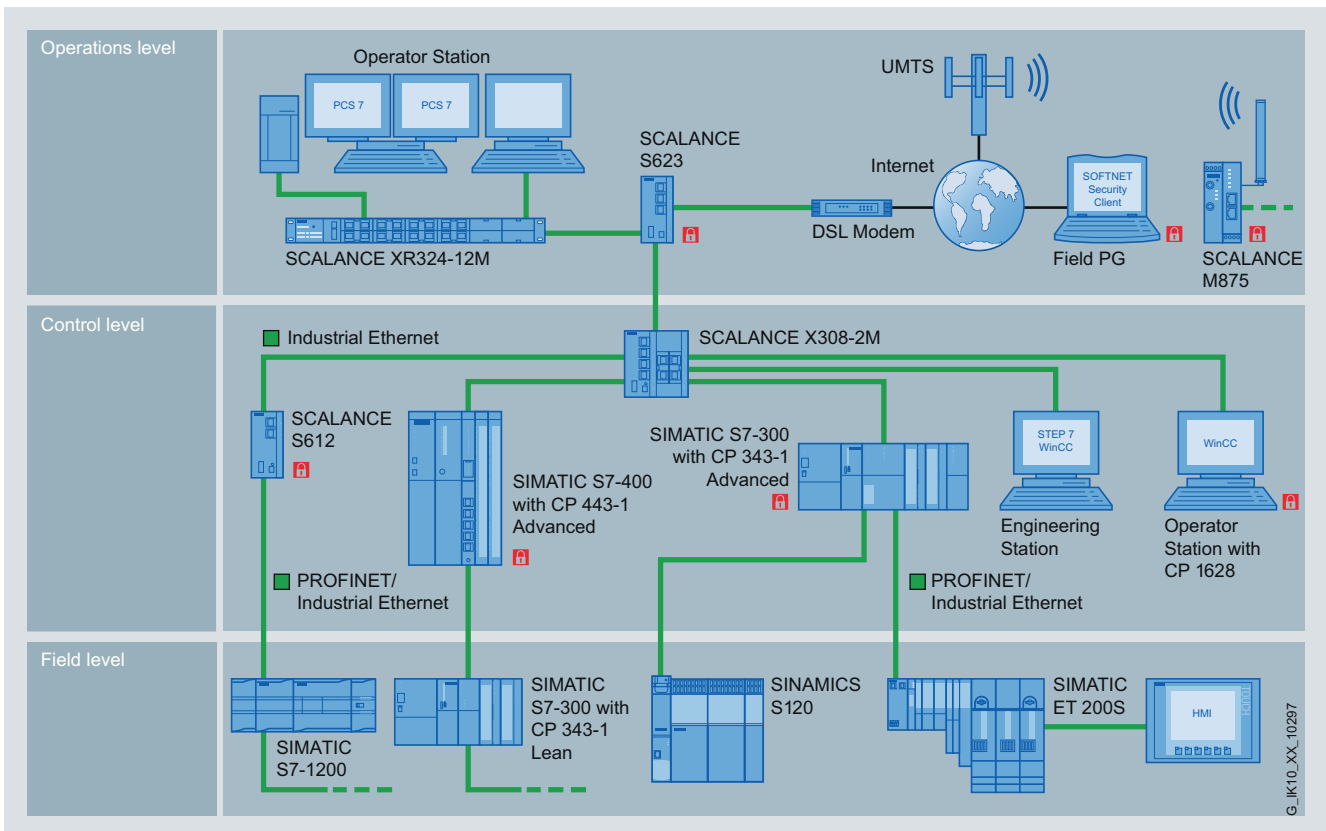

Secure VPN communication between SCALANCE S, SOFTNET Security Client and components with Security Integrated

PROFINET/Industrial Ethernet

Communication for SIMATIC S7-400

CP 443-1 Advanced

Design

The CP 443-1 Advanced offers all the advantages of SIMATIC S7-400 system design:

- Compact design:
 - Five RJ45 jacks for connecting to Industrial Ethernet via two independent interfaces; one of which is a security socket for externally safeguarding the network cell; automatic data rate detection by means of the autosensing and autocross function; the connection is made via the IE FC RJ45 Plug 180 with 180° cable outlet or via a standard patch cable
 - Diagnostics LEDs for indicating the operational and communication status
- Simple installation; the CP 443-1 Advanced is mounted on the S7-400 rack and connected to other modules by means of the backplane bus. There are no slot rules.
- The CP 443-1 Advanced can be operated without a fan.
- In combination with IM 460/461, the CP 443-1 Advanced can also be used in an expansion rack (ER).
- The module can be replaced without the need for a programming device
- C-PLUG (configuration plug) is included in scope of delivery as a swap medium (cannot be operated without C-PLUG).

Function

- Two separate interfaces (integrated network separation):
 - Gigabit interface with an RJ45 port with 10/100/1000 Mbit/s full/half duplex with autosensing functionality
 - PROFINET interface with four RJ45 ports with 10/100 Mbit/s full/half duplex with autosensing and autocrossover functionality via integrated 4-port switch
- Communication services via both interfaces:
 - Open IE communication (TCP/IP and UDP): Multicast with UDP, including routing between both interfaces
 - PG/OP communication: across networks by means of S7 routing
 - S7 communication (client, server, multiplexing) including routing between both interfaces
 - S7-H communication for S7-400-H systems
 - IT communication: HTTP communication permits access to process data via own web pages. E-mail client function enables sending of e-mails direct from the user program. FTP communication allows program-controlled FTP-client communication. Access to data blocks via FTP server.
- Communication services via PROFINET interfaces:
 - PROFINET IO controller with real-time properties (RT and IRT)
 - PROFINET CBA
 - IP address assignment via DHCP, simple PC tool or via program block (e.g. for HMI)
- Media redundancy (MRP):
 - Within an Ethernet network with ring topology, the CP supports the media redundancy procedure MRP
- Diagnostics and network management:
 - Extensive diagnostic functions for all modules in the rack
 - Integration into network management systems through the support of SNMP V1/V3
- Security mechanisms ¹⁾:
 - Access protection by means of configurable IP access list
 - Firewall for filtering connections on the basis of their IP/port addresses
 - Limiting bandwidth to avoid communication overload
 - VPN server and VPN client for tap-proof access to controllers
 - Encrypted HTML pages via SSL (HTTPS)
 - Secure file transfer (FTPs)
 - Tap-proof transmission of network analysis information to the network management system (SNMP)
 - Conversion between private and public IP addresses (NAT/NAPT)
 - Secure transfer of the time (NTP V3)
- Configuration of all functions with STEP 7. The security functions ¹⁾ are configured using the Security Configuration Tool (SCT), that is included in the scope of delivery of STEP 7 V5.5 SP2.
- Configuration with STEP 7 Professional V11. The use of security functions and CBA is not possible with STEP 7 V11 (security functions are planned for later version).
- Module replacement without programming device: all information is stored on the C-PLUG (also file system for IT functions)

¹⁾ Available soon

Integration

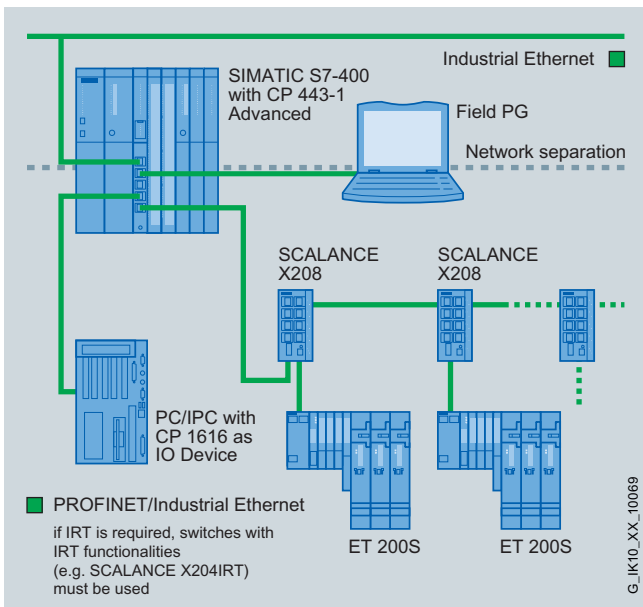

Connection to higher-level network

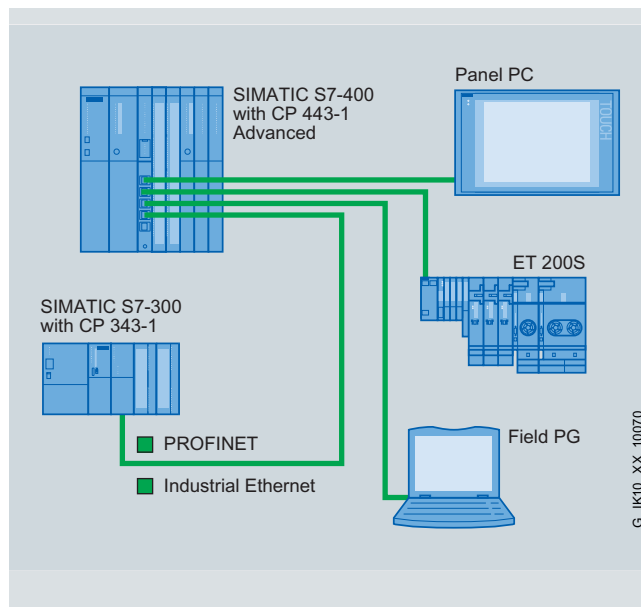

Small independent local networks (e.g. within a machine or cell)

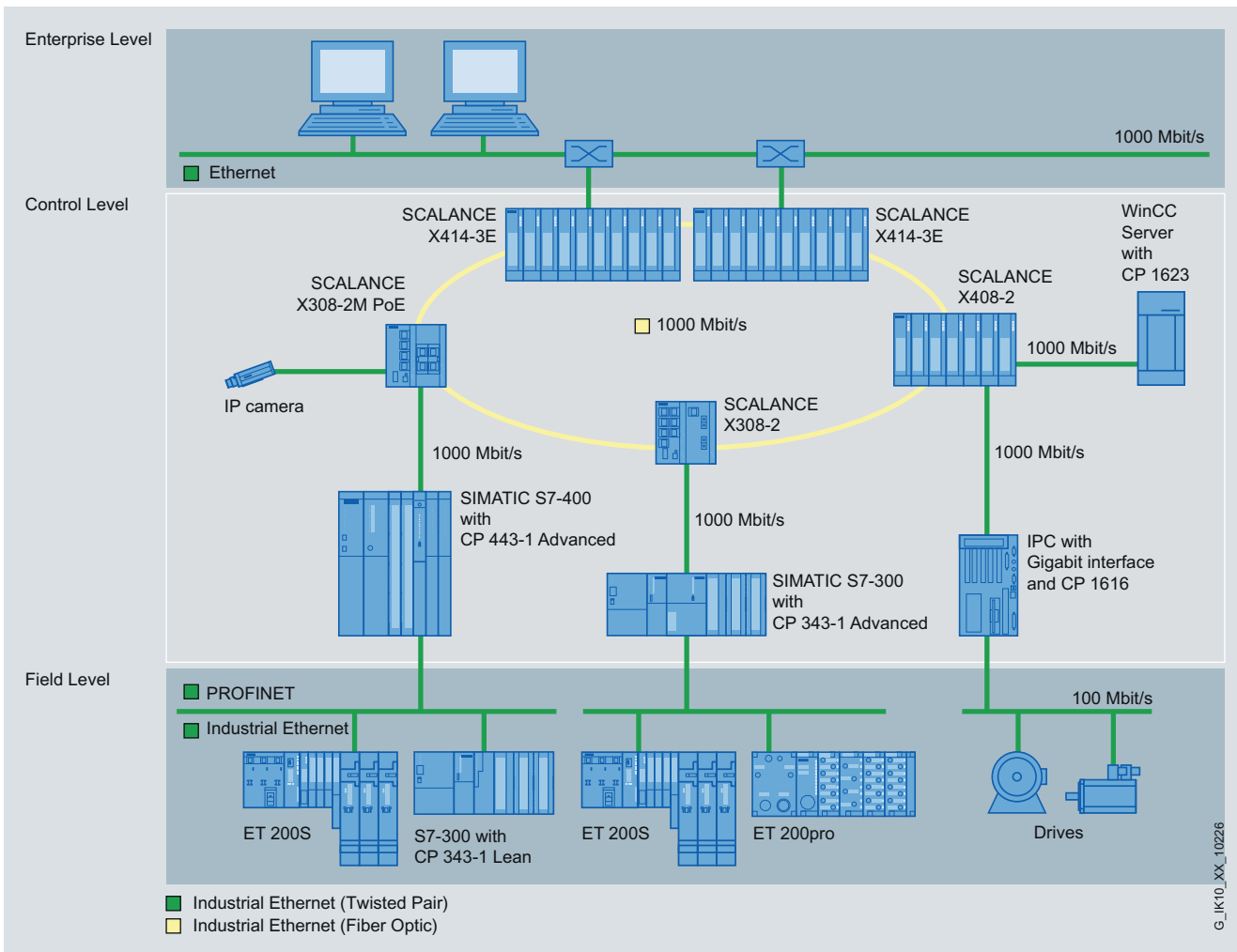

Gigabit communication at the control level

PROFINET/Industrial Ethernet

Communication for SIMATIC S7-400

CP 443-1 Advanced

Technical specifications

Order No.	6GK7 443-1GX30-0XE0
Product type designation	CP 443-1 Advanced
Transmission rate	
Transmission rate	
• at interface 1	10 ... 1 000 Mbit/s
• at interface 2	10 ... 100 Mbit/s
Interfaces	
Number of electrical connections	
• at interface 1 in accordance with Industrial Ethernet	1
• at interface 2 in accordance with Industrial Ethernet	4
Design of electrical connection	
• at interface 1 in accordance with Industrial Ethernet	RJ45 port
• at interface 2 in accordance with Industrial Ethernet	RJ45 port
Design of swap medium C-Plug	Yes
Supply voltage, current consumption, power loss	
Type of power supply	DC
Power supply 1 from backplane bus	5 V
Relative symmetrical tolerance at 5 V DC	5 %
Current input from backplane bus with 5 V DC, typical	1.8 A
Effective power loss	7.25 W
Permitted ambient conditions	
Ambient temperature	
• During operation	0 ... 60 °C
• During storage	-40 ... +70 °C
• During transport	-40 ... +70 °C
• Note	-
Relative humidity at 25 °C without condensation during operation, maximum	95 %
IP degree of protection	IP20
Design, dimensions and weights	
Module format	S7-400 compact module, single-width
Width	25 mm
Height	290 mm
Depth	210 mm
Net weight	0.7 kg
Product properties, functions, components	
General	
Number of modules	
• Per CPU, maximum	14
• Note	Max. 4 as PN IO Ctrl.

Order No.	6GK7 443-1GX30-0XE0
Product type designation	CP 443-1 Advanced
Performance data	
<u>Performance data</u>	
<u>Open communication</u>	
Number of possible connections for open communication by means of SEND/RECEIVE blocks, maximum	64
Data volume	
• as user data per ISO connection for open communication by means of SEND/RECEIVE blocks, maximum	8 KB
• as user data per ISO on TCP connection for open communication by means of SEND/RECEIVE blocks, maximum	8 KB
• as user data per TCP connection for open communication by means of SEND/RECEIVE blocks, maximum	8 KB
• as user data per UDP connection for open IE communication by means of SEND/RECEIVE blocks, maximum	2 KB
Number of possible connections for open communication by means of T blocks, maximum	64
Data volume as user data per ISO on TCP connection for open communication by means of T blocks, maximum	1 452 bytes
Number of multicast stations	-
<u>Performance data</u>	
<u>S7 communication</u>	
Number of possible connections for S7 communication	
• Maximum	128
• Maximum with PG connections	2
• For PG/OP connections, maximum	-
• Note	When using several CPUs
<u>Performance data</u>	
<u>Multiprotocol operation</u>	
Number of active connections in multiprotocol mode	128
<u>Performance data</u>	
<u>IT functions</u>	
Number of possible connections	
• as client with FTP, maximum	20
• as server	
- with FTP, maximum	10
- with HTTP, maximum	4
• as e-mail client, maximum	1
Data volume as user data for e-mail, maximum	8 KB
Storage capacity of user memory	
• as flash memory file system	30 Mibyte
• as RAM	16 Mibyte
• as RAM additionally buffered by central backup battery	512 KB
Number of possible write cycles of flash memory cells	100 000

Technical specifications (continued)

Order No.	6GK7 443-1GX30-0XE0
Product type designation	CP 443-1 Advanced
<u>Performance data</u> <u>PROFINET communication</u> <u>as PN IO Controller</u>	
Product function: PROFINET IO Controller	Yes
Total number of PN IO Devices which can be operated on the PROFINET IO Controller	128
Number of PN IO IRT Devices which can be operated on the PROFINET IO Controller	32
Number of external PN IO lines with PROFINET, per rack	4
<u>Data volume</u>	
• As user data for input variables as PROFINET IO Controller, maximum	4 KB
• As user data for output variables as PROFINET IO Controller, maximum	4 KB
• As user data for input variables per PN IO Device as PROFINET IO Controller, maximum	240 bytes
• As user data for output variables per PN IO Device as PROFINET IO Controller, maximum	240 bytes
• As user data for input variables per PN IO Device as PROFINET IO Controller, maximum	-
• As user data for output variables per PN IO Device as PROFINET IO Controller, maximum	-
<u>Performance data</u> <u>PROFINET CBA</u>	
Number of remote connection partners with PROFINET CBA	64
Total number of connections with PROFINET CBA	600
<u>Data volume</u>	
• As user data for digital inputs with PROFINET CBA, maximum	8 KB
• As user data for digital outputs with PROFINET CBA, maximum	8 KB
• As user data for arrays and data types	
- with acyclic transmission with PROFINET CBA, maximum	8 KB
- with cyclic transmission with PROFINET CBA, maximum	250 bytes
- with local connection with PROFINET CBA, maximum	2 400 bytes
<u>Performance data</u> <u>PROFINET CBA remote connection</u> <u>with acyclic transmission</u>	
Send cycle of remote connections with acyclic transmission with PROFINET CBA	0.1 s
Number of remote connections with input variables with acyclic transmission with PROFINET CBA, maximum	150
Number of remote connections with output variables with acyclic trans- mission with PROFINET CBA, maximum	150

Order No.	6GK7 443-1GX30-0XE0
Product type designation	CP 443-1 Advanced
<u>Data volume</u>	
• as user data for remote connections with input variables with acyclic transmission with PROFINET CBA	8 KB
• as user data for remote connections with output variables with acyclic transmission with PROFINET CBA	8 KB
<u>Performance data</u> <u>PROFINET CBA remote connection</u> <u>with cyclic transmission</u>	
Send cycle of remote connections with cyclic transmission with PROFINET CBA	10 ms
Number of remote connections with input variables with cyclic transmission with PROFINET CBA, maximum	250
Number of remote connections with output variables with cyclic transmission with PROFINET CBA, maximum	250
<u>Data volume</u>	
• as user data for remote connections with input variables with cyclic transmission with PROFINET CBA, maximum	2 000 bytes
• as user data for remote connections with output variables with cyclic transmission with PROFINET CBA, maximum	2 000 bytes
<u>Performance data</u> <u>PROFINET CBA</u> <u>HMI variables via PROFINET,</u> <u>acyclic</u>	
Number of HMI stations for logging-on for HMI variables with acyclic transmission with PROFINET CBA	3
Send cycle of HMI variables with acyclic transmission with PROFINET CBA	500 ms
Number of HMI variables with acyclic transmission with PROFINET CBA, maximum	200
Data volume as user data for HMI variables with acyclic transmission with PROFINET CBA, maximum	8 KB
<u>Performance data</u> <u>PROFINET CBA</u> <u>device-internal connections</u>	
Maximum number of internal connections with PROFINET CBA	300
Data volume of internal connections with PROFINET CBA, maximum	2 400 bytes
<u>Performance data</u> <u>PROFINET CBA</u> <u>connections with constants</u>	
Maximum number of connections with constants with PROFINET CBA	500
Data volume as user data for connections with constants with PROFINET CBA, maximum	4 000 bytes
<u>Performance data</u> <u>PROFINET CBA</u> <u>PROFIBUS proxy functionality</u>	
Performance data with PROFINET CBA PROFIBUS proxy functionality	No

PROFINET/Industrial Ethernet

Communication for SIMATIC S7-400

CP 443-1 Advanced

2

Technical specifications (continued)

Order No.	6GK7 443-1GX30-0XE0
Product type designation	CP 443-1 Advanced
Product functions Management, configuration, programming	
Product function: MIB support	Yes
Protocol is supported	
• SNMP v1	Yes
• DCP	Yes
• LLDP	Yes
Configuration software	
• Required	STEP 7 V5.5 SP2
• Required for PROFINET CBA	SIMATIC IMAP V3.0 SP1 and higher
Product functions Diagnostics	
Product function: Web-based diagnostics	Yes
Product functions Switch	
Product feature: Switch	Yes
Product function	
• Switch-managed	No
• with IRT PROFINET IO Switch	Yes
• Configuration with STEP 7	Yes
Product functions Redundancy	
Product function	
• Ring redundancy	Yes
• Redundancy manager	Yes
• Redundancy procedure MRP	Yes
Product functions Security ¹⁾	
Configuration of firewall	Stateful inspection
Product function with VPN connection	IPSec
Type of encryption algorithms with VPN connection	AES-256, AES-192, AES-128, 3DES-168, DES-56
Type of authentication procedures with VPN connection	Preshared Key (PSK), X.509v3 certificates
Type of hashing algorithms with VPN connection	MD5, SHA-1
Number of possible connections with VPN connection	32
Product function	
• Password protection for Web applications	Yes
• ACL - IP based	Yes
• ACL - IP based for PLC/routing	Yes
• Switching-off non-required services	Yes
• Blocking of communication via physical ports	Yes
• Log file for unauthorized access	No
Product functions Time	
Product function	
• SICLOCK support	Yes
• Passing-on of time synchronization	Yes
Protocol is supported NTP	Yes

¹⁾ Available soon

Ordering data

Order No.

CP 443-1 Advanced communication processor

for connecting the SIMATIC S7-400 CPU to Industrial Ethernet:
 1 x 10/100/1000 Mbit/s;
 4 x 10/100 Mbit/s (IE SWITCH);
 RJ45 ports; ISO; TCP; UDP;
 PROFINET IO controller,
 S7 communication; open communication (SEND/RECEIVE);
 S7 routing;
 IP configuration via DHCP/block;
 IP Access Control List;
 time synchronization;
 expanded web diagnostics;
 Fast Startup; PROFlenergy support; IP routing; FTP;
 web server; e-mail;
 PROFINET CBA

- without security function
- with security (firewall + VPN)

6GK7 443-1GX30-0XE0
6GK7 443-1GX31-0XE0 ¹⁾

SOFTNET S7 for Industrial Ethernet

Software for S7 and open communication, including OPC server, PG/OP communication and NCM PC, runtime software, software and electronic manual on CD-ROM, license key on USB stick, Class A

SOFTNET-IE S7 V8.1

For 32/64 bit
 Windows 7 Professional/Ultimate;
 for 64 bit:
 Windows 2008 Server R2;
 German/English

up to 64 connections
 • Single License
 for one installation

6GK1 704-1CW08-1AA0

SOFTNET-S7 Edition 2008 (V7.1) for Industrial Ethernet

for 32 bit
 Windows XP Professional SP2/3;
 Windows 2003 Server R2, SP2;
 Windows Vista Business/Ultimate
 SP1; Windows 2008 Server;
 German/English

up to 64 connections
 • Single License
 for one installation

6GK1 704-1CW71-3AA0

Software Update Service

For 1 year
 with automatic extension;
 requirement:
 Current software version

6GK1 704-1CW00-3AL0

Upgrade

- From Edition 2006 to Edition 2008 or V8.1
- From V6.0, V6.1, V6.2 or V6.3 to Edition 2008 or V8.1

6GK1 704-1CW00-3AE0

6GK1 704-1CW00-3AE1

Ordering data	Order No.	Order No.
<i>SOFTNET S7 for Industrial Ethernet (continued)</i>		
SOFTNET-IE S7 Lean Edition V8.1 Up to eight connections • Single License for one installation	6GK1 704-1LW08-1AA0	
SOFTNET-S7 Lean Edition 2008 (V7.1) for Industrial Ethernet Up to eight connections • Single License for one installation	6GK1 704-1LW71-3AA0	
Software Update Service For 1 year with automatic extension; requirement: Current software version	6GK1 704-1LW00-3AL0	
Upgrade • From Edition 2006 to Edition 2008 or V8.1 • From V6.0, V6.1, V6.2 or V6.3 to Edition 2008 or V8.1	6GK1 704-1LW00-3AE0 6GK1 704-1LW00-3AE1	
<i>Accessories</i>		
IE FC TP Standard Cable GP 2x2 (type A) 4-core, shielded TP installation cable for connection to IE FC outlet RJ45/IE FC RJ45 Plug; PROFINET-compliant; with UL approval; sold in meters, max. length 1000 m, minimum order 20 m	6XV1 840-2AH10	
IE FC TP standard cable GP 4x2 8-core, shielded TP installation cable for connection to IE FC RJ45 Modular Outlet for universal application; with UL approval; sold in meters, max. length 1000 m, minimum order 20 m • AWG22, for connection to IE FC RJ45 Modular Outlet • AWG24, for connection to IE FC RJ45 Plug 4 x 2	6XV1 870-2E 6XV1 878-2A	
		IE FC RJ45 Plug 180 2x2 RJ45 plug connector for Industrial Ethernet with a rugged metal enclosure and integrated insulation displacement contacts for connecting Industrial Ethernet FC installation cables; with a 180° cable outlet; for network components and CPs/CPUs with Industrial Ethernet interface • 1 pack = 1 unit • 1 pack = 10 units • 1 pack = 50 units
		IE FC RJ45 Plug 4 x 2 RJ45 plug connector for Industrial Ethernet (10/100/1000 Mbit/s) with a rugged metal enclosure and integrated insulation displacement contacts for connecting Industrial Ethernet FC installation cables; 180° cable outlet; for network components and CPs/CPUs with Industrial Ethernet interface • 1 pack = 1 unit • 1 pack = 10 units • 1 pack = 50 units
		IE FC Stripping Tool Preadjusted stripping tool for fast stripping of the Industrial Ethernet FC cables
		Industrial Ethernet Switch SCALANCE X204-2 with four 10/100 Mbit/s RJ45 ports and two fiber-optic cable ports
		Industrial Ethernet Switch SCALANCE X308-2 2 x 1000 Mbit/s multimode fiber-optic cable ports (SC sockets), 1 x 10/100/1000 Mbit/s RJ45 port, 7 x 10/100 Mbit/s RJ45 ports; for glass fiber-optic cable (multimode) up to max. 750 m
		6GK1 901-1BB10-2AA0 6GK1 901-1BB10-2AB0 6GK1 901-1BB10-2AE0 6GK1 901-1BB11-2AA0 6GK1 901-1BB11-2AB0 6GK1 901-1BB11-2AE0 6GK1 901-1GA00 6GK5 204-2BB10-2AA3 6GK5 308-2FL00-2AA3

PROFINET/Industrial Ethernet

Communication for SIMATIC S7-400

CP 443-1 Advanced

2

Ordering data	Order No.	Ordering data	Order No.
STEP 7 Version 5.5 <i>Target system:</i> SIMATIC S7-300/400, SIMATIC C7, SIMATIC WinAC <i>Requirements:</i> Windows XP Prof., Windows 7 Professional/Ultimate <i>Type of delivery:</i> German, English, French, Spanish, Italian; including license key on USB stick, with electronic documentation <ul style="list-style-type: none"> Floating license on DVD Rental license for 50 hours Software Update Service on DVD (requires current software version) Upgrade Floating License 3.x/4.x/5.x to V5.5; on DVD Trial License STEP 7 V5.5; on DVD, 14 day trial 	6ES7 810-4CC10-0YA5 6ES7 810-4CC10-0YA6 6ES7 810-4BC01-0YX2 6ES7 810-4CC10-0YE5 6ES7 810-4CC10-0YA7	STEP 7 Professional Engineering Software V11 <i>Target system:</i> SIMATIC S7-300/400, SIMATIC C7, SIMATIC WinAC <i>Requirements:</i> Windows XP Professional SP3 (32 bit), Windows 7 Professional (32 bit), Windows 7 Enterprise (32 bit), Windows 7 Ultimate (32 bit), Microsoft Server 2003 R2 Std. SP2 (32 bit), Microsoft Server 2008 Std. SP2 (32 bit) <i>Type of delivery:</i> German, English, Chinese, Italian; French, Spanish <ul style="list-style-type: none"> STEP 7 Professional V11, floating license STEP 7 Professional V11, trial license Upgrade STEP 7 Professional 2006/2010 to STEP 7 Professional V11, floating license PowerPack & Upgrade STEP 7 V5.4/V5.5 to STEP 7 Professional V11, floating license Powerpack STEP 7 Basic V11 to STEP 7 Professional V11, floating license STEP 7 Professional V11, Software Update Service, 1 year; current software version required STEP 7 Professional V11, Software Update Service Compact, 1 year; current software version required STEP 7 Professional Software Update Service; 1 year; for STEP 7 Professional and STEP 7 Professional in the TIA Portal, requires current software version STEP 7 Professional Software Update Service Compact; 1 year; for STEP 7 Professional and STEP 7 Professional in the TIA Portal, requires current software version 	6ES7 822-1AA01-0YA5 6ES7 822-1AA01-0YA7 6ES7 822-1AA01-0XE5 6ES7 822-1AA01-0XC5 6ES7 822-1AA01-0YC5 6ES7 822-1AA00-0YL5 6ES7 822-1AA00-0YM5 6ES7 810-5CC04-0YE2 6ES7 810-5CC00-0YM2
SIMATIC iMap V3.0 for configuring PROFINET CBA, <i>Requirement:</i> Windows 2000 Prof. with Service Pack 4 or later or Windows XP Prof. with Service Pack 1 or later or Windows 2003 Server with Service Pack 1 or later; on PG or PC with Pentium processor, min. 1 GHz; STEP 7 V5.3 or later with Service Pack 3, PN OPC Server V6.3 or later <i>Available in:</i> German, English, with electronic documentation <ul style="list-style-type: none"> Single license Software Update Service Upgrade to V3.0, Single license 	6ES7 820-0CC04-0YA5 6ES7 820-0CC01-0YX2 6ES7 820-0CC04-0YE5		

More information

You will find more information on the topic of Industrial Security on the Internet at:

www.siemens.com/industrialsecurity

Overview



ISO	TCP/UDP	PN	MRP	IT	IP-R	PG/OP	S7/S5
●	●	●	●	●	●	●	●

- The connection for the SIMATIC S7-400 to Industrial Ethernet
 - Multi-protocol operation for ISO, TCP/IP, UDP and PROFINET IO protocols
 - Adjustable keep alive function
- Two separate interfaces (integrated network separation):
 - Gigabit interface with one RJ45 port with 10/100/1000 Mbit/s full/half-duplex with auto-sensing capability
 - PROFINET interface with four RJ45 ports with 10/100 Mbit/s full/half duplex with autosensing and auto-crossover functionality via 4-port switch

- Communication services via both interfaces
 - Open communication (ISO, TCP/IP and UDP), multicast with UDP, including routing between both interfaces
 - PG/OP communication:
 - Cross-network by means of S7 routing
 - S7 communication (client, server, multiplexing) including routing between both interfaces
 - IT communication:
 - HTTP communication supports access to process data via own web pages;
 - e-mail client function, sending of e-mails with authentication directly from user program;
 - FTP communication supports program-controlled FTP client communication;
 - access to data blocks through FTP server
- Communication services via PROFINET interface
 - PROFINET IO controller with real-time properties (RT and IRT)
 - PROFINET CBA
 - IP address assignment via DHCP, simple PC tool or via the user program (e.g. HMI)
 - Support of the prioritized startup of PROFINET IO Devices
 - Configuration with STEP 7
- Media redundancy (MRP);
 - within an Ethernet network with ring topology, the CP supports the media redundancy procedure MRP.
- Access protection by means of configurable IP access list
- Module replacement without programming device;
 - all information is stored on the C-PLUG (also file system for IT functions)
- Extensive diagnostics functions for all modules in the rack
- Integration into network management systems through the support of SNMP V1 MIB-II
- SIMATIC H system operation for redundant S7 communication
- Operation in fail-safe applications (PROFIsafe) in combination with SIMATIC S7-400 CPU 416F

Note:

SIPLUS extreme products are based on Siemens Industry standard products. The contents listed here were taken from the respective standard products. SIPLUS extreme-specific information was added.

PROFINET/Industrial Ethernet

Communication for SIMATIC S7-400

SIPLUS CP 443-2 Advanced

Overview (continued)

SIPLUS CP 443-1 Advanced	
Order No.	6AG1 443-1GX20-4XE0
Order No. based on	6GK7 443-1GX20-0XE0
Ambient temperature range	0 ... +60 °C
Conformal coating	Coating of the printed circuit boards and the electronic components
Technical data	The technical data of the standard product applies except for the ambient conditions
Ambient conditions	
Relative humidity	5 ... 100 % Condensation permissible
Biologically active substances	Conformity with EN 60721-3-3, Class 3B2 mold and fungal spores (except fauna)
Chemically active substances	Conformity with EN 60721-3-3, Class 3C4 incl. salt mist and ISA-S71.04 severity level G1; G2; G3; GX ^{1) 2)}
Mechanically active substances	Conformity with EN 60721-3-3, Class 3S4 including conductive sand, dust ²⁾
Air pressure (depending on the highest positive temperature range specified)	1080 ... 795 hPa (-1000 ... +2000 m) see ambient temperature range 795 ... 658 hPa (+2000 ... +3500 m) derating 10 K 658 ... 540 hPa (+3500 ... +5000 m) derating 20 K

¹⁾ ISA-S71.04 severity level GX: Long-term load:
SO₂ < 4.8 ppm; H₂S < 9.9 ppm; Cl < 0.2 ppm; HCl < 0.66 ppm;
HF < 0.12 ppm; NH < 49 ppm; O₃ < 0.1 ppm; NOX < 5.2 ppm
Limit value (max. 30 min/d):
SO₂ < 17.8 ppm; H₂S < 49.7 ppm; Cl < 1.0 ppm; HCl < 3.3 ppm;
HF < 2.4 ppm; NH < 247 ppm; O₃ < 1.0 ppm; NOX < 10.4 ppm

²⁾ The supplied plug covers must remain in place over the unused interface when operated in atmospheres containing corrosive gases!

The technical documentation on SIPLUS can be found here:
www.siemens.com/siplus-extreme

Ordering data

Order No.

SIPLUS CP 443-1 Advanced communication processor

(medial exposure)

For the connection of SIMATIC S7-400 to Industrial Ethernet; PROFINET IO Controller with RT and IRT, MRP, PROFINET CBA, TCP/IP, ISO and UDP; S7 communication, open communication (SEND/RECEIVE) with FETCH/WRITE, with and without RFC 1006, diagnostic expansions, multicast, clock synchronization via SIMATIC procedure or NTP, access protection via IP access list, FTP client/server, HTTP server, HTML diagnostics, SNMP, DHCP, e-mail, data storage on C-PLUG; PROFINET interface: 4 x RJ-45 (10/100 Mbit/s) over switch; Gigabit interface: 1 x RJ-45 (10/100/1000 Mbit/s); with electronic manual on DVD

- For use with SIMATIC S7-400 CPU, V5.2 and higher







Accessories

6AG1 443-1GX20-4XE0

See CP 443-1 Advanced

Overview

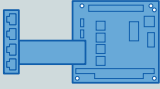

Software	Hardware
<ul style="list-style-type: none"> ▶ You will find software products on the SIMATIC NET/Windows CD. ▶ Development Kits are available for use in various operating system environments (e.g. for CP 1616 or CP 1604). ▶ As a rule, the necessary configuration tools are included in the software packages. ▶ Manuals in PDF format and extensive supplementary information on SIMATIC NET products and communication can be found in the SIMATIC NET Manual Collection which is enclosed with the software products. <div style="text-align: center; margin-top: 20px;">  <p>SIMATIC NET Manual Collection</p> </div>	<p>CPs with an internal microprocessor</p> <div style="border: 1px solid gray; padding: 5px; margin-bottom: 5px;"> <p>CP 1613 A2 (PCI)</p>  </div> <div style="border: 1px solid gray; padding: 5px; margin-bottom: 5px;"> <p>CP 1623/ CP 1628 (PCIe)</p>  </div> <div style="border: 1px solid gray; padding: 5px; margin-bottom: 5px;"> <p>CP 1616 (PCI)</p>  </div> <div style="border: 1px solid gray; padding: 5px; margin-bottom: 5px;"> <p>CP 1604 (PC/104-Plus)</p>  </div> <p>CP without an internal microprocessor</p> <div style="border: 1px solid gray; padding: 5px;"> <p>CP 1612 A2 (PCI 32 Bit)</p>  </div> <p style="font-size: small; margin-top: 5px;">G_IK10_XX_50183</p>

CPs with an internal microprocessor

- Protocol software executes on the CP
- Free PC resources for applications
- Suitable for comprehensive applications
- Recommended for applications with HMI systems which have high performance requirements, e.g. WinCC
- Recommended for large systems (eight stations or more, e.g. SIMATIC)
- Constant communication throughput
- Can be used for redundant communication
- Use for PROFINET IO real-time applications (RT, IRT with CP 1616/CP 1604)
- Time synchronization

CPs without an internal microprocessor

- Protocol software executes on the PG/PC
- PC resources are divided between communications and applications
- Suitable for less comprehensive applications
- Recommended for smaller applications (up to eight stations, e.g. SIMATIC)
- Communications performance depends on PC resources and PC loading

PROFINET/Industrial Ethernet

System interfaces for PG/PC/IPC

Communication for PC-based systems Introduction

Overview (continued)

CPs with integral switch

2

CPs for PG/PC/IPC		Hardware																											
		Type of device	Connection to S7 backplane bus	Format module S7	PC module	Flat type of construction	Box type of construction	19" type of construction	Rugged, compact housing	Modular design	10 Gigabit Ethernet	Gigabit Ethernet	PoE (Power over Ethernet)	LED diagnosis	SIMATIC environment	Redundant power supply (2 x 24 V DC)	External supply for integrated switch	Signal contact	Local display (SET pushbutton)	C-PLUG slot									
CP 1604				•									•	•		•													
CP 1616				•									•	•		•													
CP 1623				•							•		•	•		•													
CP 1628				•							•		•	•		•													
		Software																											
		Security Integrated (Firewall/VPN)	PROFINET diagnosis	Topology support (LLDP)	Command Line Interface / Teinet	Web based Management	Configuration with STEP 7	SNMP	Ring redundancy incl. RM-functionality	Standby redundancy	IRT capability	VLAN (Virtual Local Area Network)	GVRP (Generic VLAN Registration Protocol)	STP/ RSTP (Spanning Tree Protocol/ Rapid Spanning Tree Protocol)	Passive Listening	IGMP Snooping/Querier (Internet Group Management Protocol)	GMRP (Generic Multicast Protocol)	Broadcast/ Multicast/ Unicast Limiter	Broadcast blocking	DHCP Option 82 (Dynamic Host Configuration Protocol)	IP Access List	Access Control List (MAC)	IEEE 802.1x (Radius)	Link Aggregation	Static Routing	RIPv2 (Dynamic Routing)	OSPFv2 (Dynamic Routing)	VRRP, Router Redundancy (Virtual Router Redundancy Protocol)	
CP 1604		•	•	•		• ¹⁾	•	•			•																		
CP 1616			•	•		• ¹⁾	•	•			•																		
CP 1623							•	•																					
CP 1628		•					•	•																					

• applies 1) Port diagnosis possible by means of integrated web server 2) MRP-Client

Function overview of the communication modules with integral switch for SIMATIC PG/PC/IPC

G_IK10_XX_10319

Overview

The following communication processors are available for connecting to the programming device or PC:

- CPs with an internal microprocessor:
 - CP 1616 (PCI)
 - CP 1604 (PC/104-Plus)
 - CP 1613 A2 (PCI)
 - CP 1623 (PCIe)
 - CP 1628 (PCIe)

Data throughput of Industrial Ethernet

Comparisons between Layer-2 Ethernet cards and CP 1613 A2/CP 1623/CP 1628 show the respective communications throughput.

This throughput varies between 0 and the maximum throughput for Layer-2 Ethernet cards with the corresponding software packages.

When the CP 1613 A2/CP 1623/CP 1628 is used with software packages, the communications performance remains constantly at a high level and ensures fast response times without any variations.

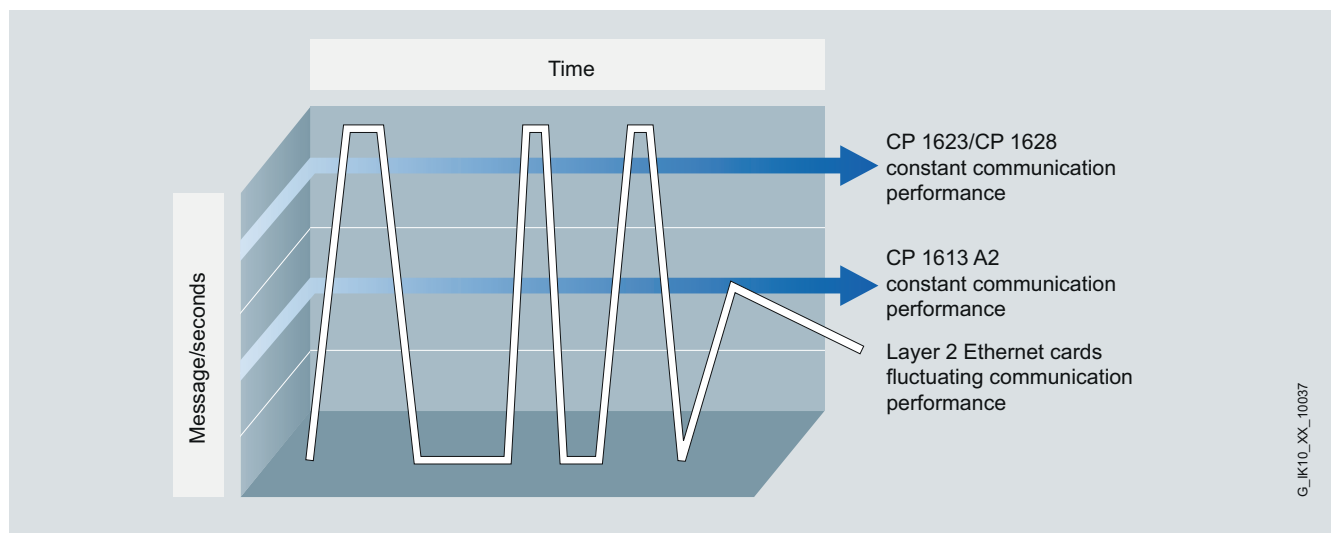

Communication performance comparisons

Advanced PC Configuration

- Enables simple configuration of an OPC server
- Easy to handle thanks to automatic software installation (plug & play)
- Advanced PC configuration is included in the scope of supply of the communications software for the PC from Version 6.0 upwards; the configuration tool NCM PC as well as the configuration console are also supplied with it.

NCM PC

The PC can be configured either in STEP 7 or in NCM PC Version V5.1+SP2 and higher. Both tools offer the same look and feel and create the same database. This enables integrated configuring for the communication functions open communication and S7 communication. Data only has to be entered once and data consistency is assured.

- A configuration wizard integrated into NCM PC also supports user-driven configuration of the PC station.
- With NCM PC and STEP 7 from Version V5.1+SP2 upwards, a PC similar to a SIMATIC S7 station can be configured and loaded over a network. This applies both to the local station on which NCM PC or STEP 7 is installed and to the remote station that is addressed over the network.

Note:

NCM PC does not contain a conversion function for LDBs that were created using COML S7. Reconfiguration is necessary.

More information

You can find more information on the Internet at:
www.siemens.com/simatic-net/ik-info

PROFINET/Industrial Ethernet Communication for PC-based systems

Connection options to SIMATIC IPCs

Overview

The operating systems listed in the table refer exclusively to the communication products specified!

Please refer to the description of the relevant IPC for the operating system that is available and has been released for that IPC.



															Embedded Systems				
Communication hardware	Communication software	Operating system environment of the communication software								SIMATIC Industrial PC/ Field PG					Op. sys.	SIMATIC Industrial PC			
		Windows 7 Professional / Ultimate	Windows Server 2008 R2	Windows Server 2008 + SP1/2	Vista Business / Ultimate + SP1/2	Windows XP Pro + SP3	Windows Server 2003 R2 / SP2	other operating systems	Field PG M3	SIMATIC IPC847C	SIMATIC IPC547C/D	SIMATIC IPC627C	SIMATIC IPC827C	SIMATIC IPC427C		Windows XP Embedded + SP1/SP2/FP 2007	SIMATIC IPC427C, SIMATIC HMI IPC477C	SIMATIC HMI IPC677C	SIMATIC IPC627C
CPs and software for Industrial Ethernet																			
CP 1613 A2 (PCI 32 Bit)	HARDNET-IE S7 (S7-1613)	●	●	●	●	●	●	-	-	●	●	●	●	-	●	-	●	-	
	HARDNET-IE S7 REDCONNECT ³⁾	●	●	●	●	●	●	-	-	●	●	○ ⁴⁾⁵⁾	●	-	●	-	○ ⁴⁾⁵⁾	○ ⁴⁾⁵⁾	
	S7 OPC Redundancy for Industrial Ethernet	-	●	-	-	-	-	-	-	●	●	●	●	-	●	-	●	●	
CP 1623 (PCIe x1)	HARDNET-IE S7 (S7-1613)	●	●	●	●	●	●	-	-	●	●	○ ⁵⁾	●	-	●	-	○ ⁵⁾	○ ⁵⁾	
	HARDNET-IE S7 REDCONNECT ³⁾	●	●	●	●	●	●	-	-	○ ⁵⁾	○ ⁵⁾	○ ⁴⁾⁵⁾	●	-	●	-	○ ⁴⁾⁵⁾	○ ⁴⁾⁵⁾	
	S7 OPC Redundancy for Industrial Ethernet	-	●	-	-	-	-	-	-	●	●	●	●	-	●	-	○ ⁵⁾	●	
CP 1628 (PCIe x1)	HARDNET-IE S7 (S7-1613)	●	●	-	-	-	-	-	-	●	●	○ ⁵⁾	●	-	●	-	○ ⁵⁾	○ ⁵⁾	
	HARDNET-IE S7 REDCONNECT ³⁾	●	●	-	-	-	-	-	-	○ ⁵⁾	○ ⁵⁾	○ ⁴⁾⁵⁾	●	-	●	-	○ ⁴⁾⁵⁾	○ ⁴⁾⁵⁾	
	S7 OPC Redundancy for Industrial Ethernet	-	●	-	-	-	-	-	-	●	●	●	●	-	●	-	○ ⁵⁾	●	
CP 1612 A2 (PCI 32 Bit)	SOFTNET-IE S7	●	●	●	●	●	●	-	-	●	●	●	●	-	●	-	●	●	
	SOFTNET-IE S7 Lean	●	●	●	●	●	●	-	-	●	●	●	●	-	●	-	●	●	
	SOFTNET-IE PG	●	●	●	●	●	●	-	-	●	●	●	●	-	●	-	●	●	
	S7 OPC Redundancy for Industrial Ethernet	-	●	-	-	-	-	-	-	●	●	●	●	-	●	-	●	●	
SIMATIC PG/PC with integral Ethernet interface	SOFTNET-IE S7	●	●	●	●	●	●	-	-	●	●	●	●	-	●	-	●	●	
	SOFTNET-IE S7 Lean	●	●	●	●	●	●	-	-	●	●	●	●	-	●	-	●	●	
	SOFTNET-IE PG	●	●	●	●	●	●	-	-	●	●	●	●	-	●	-	●	●	
	S7 OPC Redundancy for Industrial Ethernet	-	●	-	-	-	-	-	-	●	●	●	●	-	●	-	●	●	
CPs and software for PROFINET																			
CP 1616 ¹⁾ (PCI 32 Bit)	HARDNET PN IO DK (DK-16xx PN IO) ¹⁾	●	-	-	-	●	-	○	-	○	○	○	○	-	○	-	○	○	
CP 1604 ¹⁾ (PCI-104)	HARDNET PN IO DK (DK-16xx PN IO) ¹⁾	●	-	-	-	●	-	○	-	-	-	-	○ ²⁾	○	○ ²⁾	-	-	-	
SIMATIC PG/PC with integral Ethernet interface	SOFTNET PN IO	●	●	●	●	●	●	-	-	●	●	●	●	●	●	●	●	●	
<p>1) Use of these CPs requires porting of the Development Kit DK-16xx PN IO to the relevant operating system environment. You can order the DK-16xx PN IO at www.siemens.com/simatic-net/dk16xx on the Internet. It contains sample software for Linux Suse 12 and Windows XP Professional. For IRT operation an exclusive interrupt is necessary; this is not available in all slots. The additional use of CP 1616/CP 1604 is not approved for SIMATIC Industrial PC versions and integrated PROFINET interface.</p> <p>2) possible with restrictions, if necessary, depending on memory expansion and processor capacity</p> <p>3) requires at least 2 PCI or 2 PCIe slots (4-way redundancy requires 4 free PCI or 4 PCIe slots!); hybrid configurations with CP 1613 A2 (PCI) and CP 1623 (PCIe) are possible, depending on PC expansion</p> <p>4) without 4-way redundancy as there are only 2 slots</p> <p>5) depending on the slots of the selected PC version</p> <p>Notes</p> <ul style="list-style-type: none"> - Please always note the supplementary conditions for the specified SIMATIC NET products that you can view on the Internet pages shown below. - for further details on XP embedded, see http://support.automation.siemens.com/WWW/view/de/21661049 - further details on system requirements and operating environments can be found in the Readme file of the communication products on the SIMATIC NET PC Software V8.1 CD - Updates and supplements to the catalog entries, as well as the above tables can be viewed at http://www.siemens.com/simatic-net/ik-info <p>● suitable - not suitable ○ suitable under certain conditions</p>																			

Connection options of Industrial Ethernet CPs to PG/PC/IPC

Overview

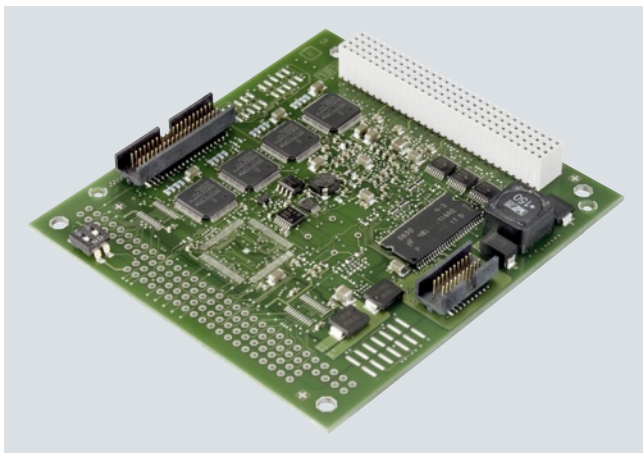

ISO	TCP/UDP	PN	MRP	OPC	PG/OP	S7/S5	IT
	●	●	●				

- PCI-104 module for connecting PCI-104 systems to PROFINET IO
- Full/half duplex with autonegotiation
- With Ethernet real-time ASIC ERTEC 400
- Integral 4-port real-time switch
- Communication services:
 - PROFINET IO controller and/or PROFINET IO device
 - Support of IRT in motion control applications
- High performance through direct memory access
- Integration in network management systems through the support of SNMP
- Comprehensive diagnostics possibilities for installation, start-up and operation of the module
- Powerful configuration tools are included in delivery of module

Benefits

get Designed for Industry

- Connection of field devices to Industrial Ethernet with PROFINET
- Ideally suited for design of small local networks through integral 4-port real-time switch
- Direct memory access to process data by linking as PROFINET IO-Controller via IO-Base interface
- High computing power is available in the PC by taking the load off the host CPU by means of a real-time ASIC ERTEC 400 with support of the PROFINET real-time features RT and IRT
- Implementation in Motion Control applications thanks to support of IRT
- Simple transfer to various operating system environments using HARDNET-PN IO Development Kit
- Switch mode also with the PC switched off, via optional external power supply (in RT mode only)
- Uncrossed connecting cables can be used due to the integrated Autocrossover function

Application

The CP 1604 is used to connect PCI-104 systems to PROFINET IO.

The CP 1604 provides high-performance support for control tasks on the PC (PC based Control, Numeric Control, Robot Control).

With IRT (Isochronous Real-Time), the CP is ideally suited to time-critical applications that are in the range of strictly isochronous closed-loop control in the motion control sector.

The integrated 4-port switch supports low-cost system solutions and the configuration of different topologies.

The CP 1604 offers PCI-104 systems communications facilities with:

- PROFINET IO controller and/or PROFINET IO device

The HARDNET-PN IO Development Kit enables integration of the module into any operating systems.

Design

- Industrial Ethernet (via "Connection Board for CP 1604")
 - Ethernet real-time ASIC ERTEC 400
 - 4 x RJ45 connection
 - Integral 4-port real-time switch for 10/100 Mbit/s Ethernet
 - Half/full duplex
 - Autosensing/Autocrossover/Autonegotiation
- PC/104 Plus port:
 - PCI 2.2
 - 32 bits
 - 33 MHz or 66 MHz
 - Installation through PCI standard mechanisms (Plug & Play)
- Host interface/processor:
 - Dual-port RAM onboard
 - Flash for program memory onboard
 - ARM 946 RISK processor (32-bit) onboard for pre-processing
- Power supply:
 - Operating voltage: 5 V through PC/104 Plus
 - Optional external 24 V DC supply for switch operation when PC is switched off (through "Power Supply for CP 1604")
- Size:
 - PCI-104 format

Function

The CP 1604 can be operated as a PROFINET IO controller and/or PROFINET IO device that stores the process image (input and output data) in the memory area on the CP. With simultaneous controller and device mode, only the controller or the device can be operated in IRT mode. High-performance data transfer to and from the IO devices is performed autonomously by the CP 1604.

Real-time

Support of real-time properties of PROFINET for RT and IRT. The real-time properties of the CP 1604 ensure extremely short cycle times with highly accurate clock-pulse rates.

Switching

According to the industry requirements, the 4-port real-time switch additionally permits the configuration of line topologies with spur lines and makes external switch components unnecessary.

The switch function in RT mode is also available when the PC is turned off thanks to the possibility of independently supplying an external voltage (via "Power Supply for CP 1604").

PROFINET/Industrial Ethernet

Communication for PC-based systems

CP 1604

Function (continued)

Software packages

DK-16xx PN IO development kit

Driver and IO-Base software for CP 1604 as PROFINET IO-Controller and IO-Device under Linux in source code for transfer to any PC-based operating systems with IO-Base interface for:

- PROFINET communication:
 - PROFINET IO controller: Connection of field devices to Industrial Ethernet with PROFINET
 - PROFINET IO device: Link-up with a PROFINET IO controller through real-time communication according to the PROFINET standard
- Access in isochronous mode to real-time data for PROFINET over IRT; extremely short cycle times with highly accurate clock-pulse rates; jitter accuracy, isochronous mode, and cycle time enable high-performance motion control applications.
- Direct memory access to the process data; the process data of the IO-Devices are always consistent. The IO programming interface provides the PC programmer with function calls for data transfer.
- The design of the interface not only permits fast access as PROFINET IO controller, but also easy porting to other operating system environments (e.g. VXWorks, QNX, RMOS, RTX).
- The IO-Base interface for the PROFINET IO controller of the CP 1604 is compatible with the interface for SOFTNET PN IO
- The CP 1604 is functionally compatible to the CP 1616

Using the Development Kit DK-16xx PN IO, the CP 1604 communication processor can be integrated into any PC-based operating system environment. The Development Kit contains the driver and IO-Base source code required for this including the transfer instructions and also the example code which executes with SUSE Linux 10.

User interfaces

Programming interface through C library

- For applications that want to use the PROFINET IO-Controller or IO-Device functionality directly over C/C++, the IO-Base interface can be used. This interface is of a similar design to the DP Base interface of PROFIBUS modules CP 5613 and CP 5614. It is therefore possible to port existing PROFIBUS DP master applications to PROFINET IO-Controller applications.

Diagnostics data

Extensive diagnostic options are available via STEP 7 or SNMP, including:

- General diagnostics functions
- Connection diagnostics
- Diagnostics of the assigned PROFINET field devices
- Integration in network management systems through the support of SNMP

Configuration

Configuration of the CP 1604 is performed with STEP 7/NCM PC, V5.3 SP2 and higher. NCM PC is included with the module.

Integration

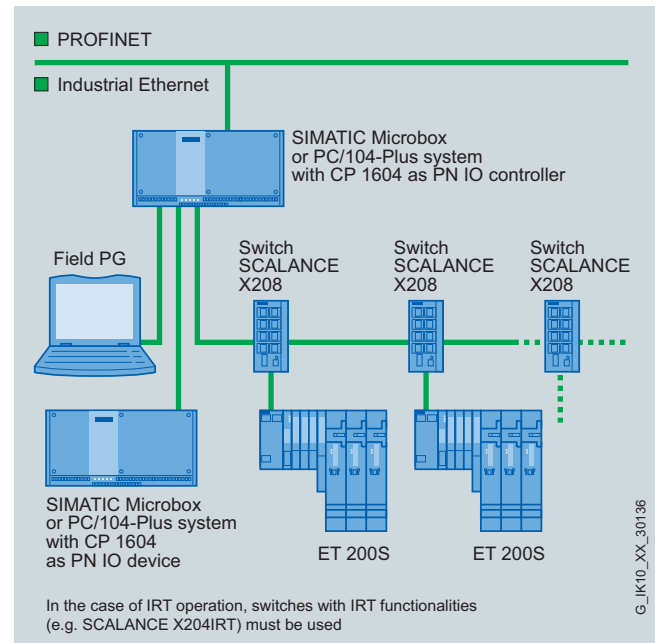

CP 1604 as PROFINET IO-Controller and PROFINET IO-Device

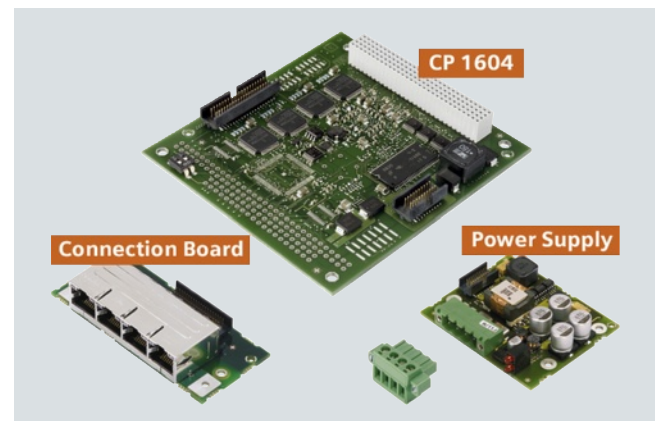

CP 1604 with accessories



CP 1604 Microbox Package

Technical specifications

Order No.	6GK1 160-4AA00
Product type designation	CP 1604
Transmission rate	
Transmission rate at interface 1	10 ... 100 Mbit/s
Interfaces	
Number of electrical connections	
• at interface 1 in accordance with Industrial Ethernet	4
• for power supply	1
Design of electrical connection	
• at interface 1 in accordance with Industrial Ethernet	RJ45 port via connection board PCI-104 (32 bit)
• of backplane bus	4-pin terminal block via power supply board
• for power supply	
Supply voltage, current consumption, power loss	
Type of power supply	DC
Type of power supply: optional external supply	Yes
Power supply	
• 1 from backplane bus	5 V
• External	24 V
• Note	Optional external supply and external supply voltage alternatively via power supply board (optional accessory)
Relative symmetrical tolerance	
• At 5 V with DC	5 %
• At 24 V with DC	20 %
Current consumed	
• Max. 1 from backplane bus with DC	0.8 A
• Maximum from external power supply with 24 V DC	0.3 A
Effective power loss	4 W
• Maximum with switch mode	4.1 W
Permitted ambient conditions	
Ambient temperature	
• During operation	5 ... 55 °C
• During storage	-20 ... +60 °C
• During transport	-20 ... +60 °C
Relative humidity at 25 °C without condensation during operation, maximum	95 %
IP degree of protection	IP00
Design, dimensions and weights	
Module format	PC/104-Plus
Width	90 mm
Height	24 mm
Depth	95 mm
Net weight	110 g

Order No.	6GK1 160-4AA00
Product type designation	CP 1604
Product properties, functions, components	
General	
Number of plug-in cards of same design which can be inserted per PC station	1
Number of modules - Note	-
Performance data	
<u>Performance data</u> <u>PROFINET communication</u> <u>as PN IO Controller</u>	
Software required for PROFINET IO communication	No
Total number of PN IO Devices which can be operated on the PROFINET IO Controller	128
Number of PN IO IRT Devices which can be operated on the PROFINET IO Controller	64
Data volume	
• As user data for input variables as PROFINET IO Controller, maximum	8 192 bytes
• As user data for output variables as PROFINET IO Controller, maximum	8 192 bytes
• As user data for input variables per PN IO Device as PROFINET IO Controller, maximum	1 433 bytes
• As user data for output variables per PN IO Device as PROFINET IO Controller, maximum	1 433 bytes
<u>Performance data</u> <u>PROFINET communication</u> <u>as PN IO Device</u>	
Data volume	
• As user data for input variables as PROFINET IO Device, maximum	1 433 bytes
• As user data for output variables as PROFINET IO Device, maximum	1 433 bytes
• As user data for input variables per submodule as PROFINET IO Device	254 bytes
• As user data for output variables per submodule as PROFINET IO Device	254 bytes
• As user data for the consistency area per submodule	254 bytes
Number of submodules per PROFINET IO Device	64

PROFINET/Industrial Ethernet

Communication for PC-based systems

CP 1604

2

Technical specifications (continued)

Order No.	6GK1 160-4AA00
Product type designation	CP 1604
Product functions Management, configuration, programming	
Product function: MIB support	Yes
Protocol is supported	
• SNMP v1	Yes
• DCP	Yes
• LLDP	Yes
Configuration software required	NCM PC included in scope of delivery
Identification & maintenance	
• I&M0 - device-specific information	Yes
• I&M1 - higher-level designation/location designation	Yes
• I&M2 - installation date	Yes
• I&M3 - comment	Yes
• I&M4 - signature	Yes
Product functions Diagnostics	
Product function	
• Web-based diagnostics	Yes
• Port diagnostics	Yes
Product functions Switch	
Product feature: Switch	Yes
Product function	
• Switch-managed	No
• with IRT PROFINET IO Switch	Yes
Product functions Redundancy	
Product function	
• Ring redundancy	Yes
• Redundancy manager	Yes
• Redundancy procedure MRP	Yes
Standards, specifications, approvals	
Standard	
• For EMC	2004/108/EC
• For CSA and UL safety	CAN/CSA C22.2 & UL 60950-1
• For emitted interference	EN 61000-6-3, EN 61000-6-4
• For noise immunity	EN 61000-6-1, EN 61000-6-2
Certificate of suitability	
• CE mark	Yes
• C-Tick	Yes
Accessories	
Accessories	Optional: Connection Board for CP 1604, Power Supply Board for CP 1604, HARDNET-IE DK (Development Kit)

Ordering data

Order No.

CP 1604 communication processor	6GK1 160-4AA00
PCI-104 card (32-bit) with ASIC ERTEC 400 for connecting PCI-104 systems to PROFINET IO with 4-port real-time switch (RJ45); incl. IO-Base software for PROFINET IO-Controller and NCM PC; single license for one installation, runtime software, software and electronic manual on CD-ROM, Class A, for 32-bit Windows XP Professional and Windows 7; other operating systems by means of DK-16xx PN IO Development Kit German/English	
CP 1604 Microbox Package	6GK1 160-4AU00
Package for implementing the CP 1604 in the SIMATIC Microbox PC; comprising the CP 1604, connection board, power supply and expansion racks for Microbox PC; for use with Development Kit DK-16xx PN IO; NCM PC	
Accessories	
Connection board for CP 1604	6GK1 160-4AC00
Connection board for CP 1604 with four RJ45 sockets incl. connecting cable	
Power supply for CP 1604	6GK1 160-4AP00
Redundant power supply for CP 1604 for operating the integral 4-port switch of the CP 1604 with the PC-104 system switched off; includes connecting cable	
Development Kit DK-16xx PN IO	See www.siemens.com/simatic-net/dk16xx
Software development kit for CP 1616/CP 1604; driver and IO-Base software for CP 1616/CP 1604 as PN IO controller and IO device in source code for transfer to other PC-based operating systems; including executable example code for SUSE Linux 10, Windows XP Professional and Windows 7	
IE TP Cord RJ45/RJ45	
TP cable 4 x 2 with 2 RJ45 connectors	
• 0.5 m	6XV1 870-3QE50
• 1 m	6XV1 870-3QH10
• 2 m	6XV1 870-3QH20
• 6 m	6XV1 870-3QH60
• 10 m	6XV1 870-3QN10
SCALANCE X204IRT	6GK5 204-0BA00-2BA3
Managed Industrial Ethernet switches; isochronous real time, LED diagnostics, error signaling contact with SET button, redundant power supply 4 x 10/100 Mbit/s RJ45 ports	

More information

The DK-16xx PN IO development kit can be found on the Internet at: www.siemens.com/simatic-net/dk16xx

Overview



ISO	TCP/ UDP	PN	MRP	OPC	PG/OP	S7/S5	IT
	●	●	●				

- PCI module for connecting PCs and SIMATIC PGs/PCs to PROFINET IO (Universal Keyed 3.3 V and 5 V; 33 MHz/66 MHz; 32-bit, runs in 64-bit PCI-X systems)
- Full/half duplex with autonegotiation
- With Ethernet real-time ASIC ERTEC 400
- Integral 4-port real-time switch
- Communication services:
 - PROFINET IO controller and/or PROFINET IO device
 - Support of IRT in motion control applications
- High performance through direct memory access
- Integration in network management systems through the support of SNMP
- Comprehensive diagnostics possibilities for installation, start-up and operation of the module
- Powerful configuration tools are part of the scope of delivery of the module

Benefits

get Designed for Industry

- Connection of field devices to Industrial Ethernet with PROFINET
- Ideally suited for design of small local networks through integral 4-port real-time switch
- Direct memory access to process data by linking as PROFINET IO-Controller via IO-Base interface
- High computing power is available in the PC by taking the load off the host CPU by means of a real-time ASIC ERTEC 400 with support of the PROFINET real-time features RT and IRT
- Implementation in Motion Control applications thanks to support of IRT
- Simple transfer to various operating system environments using HARDNET-PN IO Development Kit
- Switch mode also with the PC switched off, via optional external power supply (in RT mode only)
- Uncrossed connecting cables can be used due to the integrated Autocrossover function

Application

The CP 1616 enables SIMATIC PGs/PCs and PCs equipped with a PCI slot to be connected to PROFINET IO.

The CP 1616 provides high-performance support for control tasks on the PC (PC-based control, numeric control, robot control).

With IRT (isochronous real-time), the CP is ideally suited to time-critical applications that are in the range of isochronous closed-loop control in the motion control sector.

The integrated 4-port switch supports low-cost system solutions and the configuration of different topologies.

The CP 1616 provides SIMATIC programming devices/PCs and industrial PCs with communication functions as:

- PROFINET IO controller and/or PROFINET IO device

The HARDNET-PN IO Development Kit enables integration of the module into any operating systems.

Design

- Industrial Ethernet
 - Ethernet real-time ASIC ERTEC 400
 - 4 x RJ45 connection
 - Integral 4-port real-time switch for 10/100 Mbit/s Ethernet
 - Half/full duplex
 - Autosensing/Autocrossover/Autonegotiation
- PCI interface:
 - PCI 2.2
 - 32-bit, for execution in 64-bit PCI X systems
 - 33 MHz or 66 MHz
 - Universal Keyed 3.3 V and 5 V
 - Installation through PCI standard mechanisms (Plug & Play)
- Host interface/processor:
 - Dual-port RAM on board
 - Flash for program memory onboard
 - ARM 946 RISK processor (32-bit) onboard for pre-processing
- Power supply:
 - Operating voltage: 5 V through PCI
 - Optional external 6 to 9 V DC supply for switch operation with PC switched off
- Size:
 - Short PCI format

PROFINET/Industrial Ethernet

Communication for PC-based systems

CP 1616

Function

The CP 1616 can be operated as a PROFINET IO controller and/or PROFINET IO device that stores the process image (input and output data) in the memory area on the CP. With simultaneous controller and device mode, only the controller or the device can be operated in IRT mode. High-performance data transfer to and from the IO devices is performed autonomously by the CP 1616.

Real-time

Support of real-time properties of PROFINET for RT and IRT. The real-time properties of the CP 1616 ensure extremely short cycle times with highly accurate clock-pulse rates.

Switching

According to the industry requirements, the 4-port real-time switch additionally permits the configuration of line topologies with spur lines and makes external switch components unnecessary.

The switch function is also available in RT mode when the PC is turned off thanks to the possibility of independently supplying an external voltage.

Software packages

DK-16xx PN IO development kit

Driver and IO-Base software for CP 1616 as PROFINET IO-Controller and IO-Device under Linux in source code for transfer to any PC-based operating systems with IO-Base interface for:

- PROFINET communication:
 - PROFINET IO controller: Connection of field devices to Industrial Ethernet with PROFINET
 - PROFINET IO device: Link-up with a PROFINET IO controller through real-time communication according to the PROFINET standard
- Access in isochronous mode to real-time data for PROFINET over IRT; extremely short cycle times with highly accurate clock-pulse rates; jitter accuracy, isochronous mode, and cycle time enable high-performance motion control applications.
- Direct memory access to the process data; the process data of the IO-Devices are always consistent. The IO programming interface provides the PC programmer with function calls for data transfer.
- The design of the interface not only permits fast access as PROFINET IO controller, but also easy porting to other operating system environments (e.g. VXWorks, QNX, RMOS, RTX).
- The IO-Base interface for the PROFINET IO controller of the CP 1616 is compatible with the interface for SOFTNET PN IO
- The CP 1616 is functionally compatible with the CP 1604

Using the Development Kit DK-16xx PN IO, the CP 1616 communication processor can be integrated into any PC-based operating system environment. The development kit contains the driver and IO-Base source code required for this including the transfer instructions, and also the example code which executes with SUSE Linux 10.

User interfaces

Programming interface through C library

For applications that want to use the PROFINET IO-Controller or IO-Device functionality directly over C/C++, the IO-Base interface can be used. This interface is of a similar design to the DP Base interface of PROFIBUS modules CP 5613 and CP 5614. It is therefore possible to port existing PROFIBUS DP master applications to PROFINET IO-Controller applications.

Diagnostics

Extensive diagnostic options are available via STEP 7 or SNMP, including:

- General diagnostics functions
- Connection diagnostics
- Diagnostics of the assigned PROFINET field devices
- Integration in network management systems through the support of SNMP

Configuration

Configuration of the CP 1616 is performed with STEP 7/NCM PC, V5.3 SP2 and higher. NCM PC is included with the module.

Integration

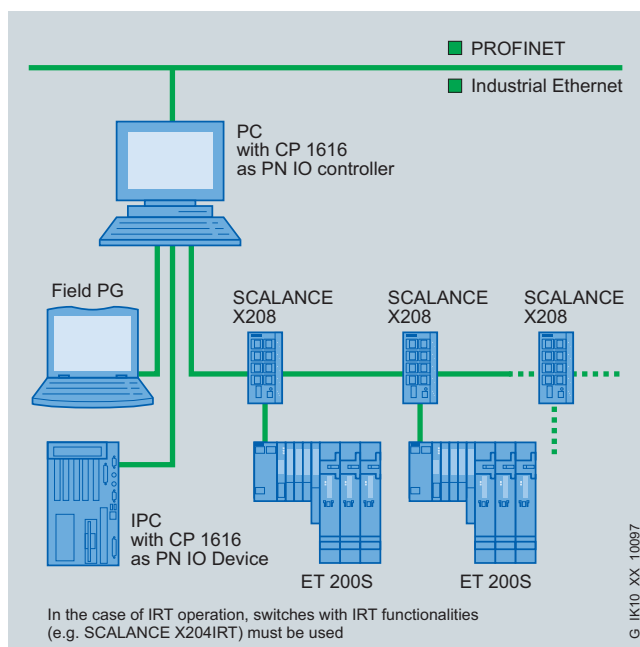

CP 1616 as PROFINET IO-Controller and PROFINET IO-Device

Technical specifications

Order No.	6GK1 161-6AA01
Product type designation	CP 1616
Transmission rate	
Transmission rate at interface 1	10 ... 100 Mbit/s
Interfaces	
Number of electrical connections	
• at interface 1 in accordance with Industrial Ethernet	4
• for power supply	1
Design of electrical connection	
• at interface 1 in accordance with Industrial Ethernet	RJ45 port
• of backplane bus	PCI (32 bit 3.3 V/5 V Universal Key 33/66 MHz)
• for power supply	Low-voltage socket for hollow plug 3.5 mm (-) / 1.3 mm (+)
Supply voltage, current consumption, power loss	
Type of power supply	DC
Type of power supply: optional external supply	Yes
Power supply	
• 1 from backplane bus	5 V
• External	6 ... 9 V
Relative symmetrical tolerance at 5 V DC	5 %
Current consumed	
• Max. 1 from backplane bus with DC	0.8 A
• From external power supply	
- Maximum at 6 V with DC	0.65 A
- Maximum at 9 V with DC	0.45 A
Effective power loss	4 W
• Maximum with switch mode	4.1 W
Permitted ambient conditions	
Ambient temperature	
• During operation	5 ... 60 °C
• During storage	-40 ... +70 °C
• During transport	-20 ... +60 °C
Relative humidity at 25 °C without condensation during operation, maximum	95 %
IP degree of protection	IP00
Design, dimensions and weights	
Module format	PCI
Width	18 mm
Height	107 mm
Depth	167 mm
Net weight	110 g

Order No.	6GK1 161-6AA01
Product type designation	CP 1616
Product properties, functions, components General	
Number of plug-in cards of same design which can be inserted per PC station	1
Number of modules - Note	-
Performance data	
<u>Performance data</u> <u>PROFINET communication</u> <u>as PN IO Controller</u>	
Software required for PROFINET IO communication	No
Total number of PN IO Devices which can be operated on the PROFINET IO Controller	128
Number of PN IO IRT Devices which can be operated on the PROFINET IO Controller	64
Data volume	
• As user data for input variables as PROFINET IO Controller, maximum	8 192 bytes
• As user data for output variables as PROFINET IO Controller, maximum	8 192 bytes
• As user data for input variables per PN IO Device as PROFINET IO Controller, maximum	1 433 bytes
• As user data for output variables per PN IO Device as PROFINET IO Controller, maximum	1 433 bytes
<u>Performance data</u> <u>PROFINET communication</u> <u>as PN IO Device</u>	
Data volume	
• As user data for input variables as PROFINET IO Device, maximum	1 433 bytes
• As user data for output variables as PROFINET IO Device, maximum	1 433 bytes
• As user data for input variables per submodule as PROFINET IO Device	254 bytes
• As user data for output variables per submodule as PROFINET IO Device	254 bytes
• As user data for the consistency area per submodule	254 bytes
Number of submodules per PROFINET IO Device	64

PROFINET/Industrial Ethernet

Communication for PC-based systems

CP 1616

Technical specifications (continued)

Order No.	6GK1 161-6AA01
Product type designation	CP 1616
Product functions Management, configuration, programming	
Product function: MIB support	Yes
Protocol is supported	
• SNMP v1	Yes
• DCP	Yes
• LLDP	Yes
Configuration software required	NCM PC included in scope of delivery
Identification & maintenance	
• I&M0 - device-specific information	Yes
• I&M1 - higher-level designation/ location designation	Yes
• I&M2 - installation date	Yes
• I&M3 - comment	Yes
• I&M4 - signature	Yes
Product functions Diagnostics	
Product function	
• Web-based diagnostics	Yes
• Port diagnostics	Yes
Product functions Switch	
Product feature: Switch	Yes
Product function: Switch-managed	No
Product function with IRT PROFINET IO Switch	Yes
Product functions Redundancy	
Product function	
• Ring redundancy	Yes
• Redundancy manager	Yes
• Redundancy procedure MRP	Yes
Standards, specifications, approvals	
Standard	
• For EMC	89/336/EEC
• For CSA and UL safety	CAN/CSA C22.2 & UL 60950-1
• For emitted interference	EN 61000-6-3, EN 61000-6-4
• For noise immunity	EN 61000-6-1, EN 61000-6-2
Certificate of suitability	
• CE mark	Yes
• C-Tick	Yes

Ordering data

Order No.

CP 1616 communication processor	6GK1 161-6AA01
PCI Card (32 bit; 3.3/5 V universal keyed) with ASIC ERTEC 400 for connecting PCs to PROFINET IO with 4-Port-Real-Time-Switch (RJ45); incl. IO Base Software for PROFINET IO Controller and NCM PC; single license for one installation, runtime software, software and electronic manual on CD-ROM, Class A, for 32-bit Windows XP Professional and Windows 7; other operating systems via Development Kit DK-16xx PN IO; German/English	
Accessories	
Development Kit DK-16xx PN IO	See www.siemens.com/simatic-net/dk16xx
Software development kit for CP 1616/CP 1604; driver and IO-Base software for CP 1616/CP 1604 as PN IO controller and IO device in source code for transfer to other PC-based operating systems; including executable example code for SUSE Linux 10, Windows XP Professional and Windows 7	
IE TP Cord RJ45/RJ45	
TP cable 4 x 2 with 2 RJ45 connectors	
• 0.5 m	6XV1 870-3QE50
• 1 m	6XV1 870-3QH10
• 2 m	6XV1 870-3QH20
• 6 m	6XV1 870-3QH60
• 10 m	6XV1 870-3QN10
SCALANCE X204IRT	6GK5 204-0BA00-2BA3
Managed Industrial Ethernet switches; isochronous real time, LED diagnostics, error signaling contact with SET button, redundant power supply 4 x 10/100 Mbit/s RJ45 ports	

More information

The DK-16xx PN IO development kit can be found on the Internet at: www.siemens.com/simatic-net/dk16xx

Overview



ISO	TCP/UDP	PN	MRP	OPC	PG/OP	S7/S5	IT
●	●	●		●	●	●	●

- PCI card (32 bit; 33 MHz/66 MHz; 3.3 V/5 V Universal Key) for the connection of PG/PC to Industrial Ethernet
- 1 x 10/100/1000 Mbit/s RJ45 port, electrical
- Automatic data transmission rate detection (10/100/1000 Mbit/s), with autosensing and autocrossover function
- Communication services via
 - PROFINET
 - ISO or TCP/IP transport protocol
 - PG/OP communication
 - S7 communication
 - Open communication (SEND/RECEIVE)
- Designed for use in industrial environments
- The appropriate OPC servers and configuration tools are included in the scope of supply of the respective communication software.

Benefits

get Designed for Industry

- Low commissioning overhead due to plug & play and autosensing/autocrossover/autonegotiation (10/100/1000 Mbit/s)
- Particularly suitable for industrial use in PCs that require a smaller quantity structure and no integrated switching functionality
- Ideally suited to SOFTNET for Industrial Ethernet and SOFTNET PN IO
- Simple access to automation data via OPC as standard interface
- Uniform procedure and configuration functionality with NCM PC and STEP 7

Application

The CP 1612 A2 supports the connection to Industrial Ethernet (10/100/1000 Mbit/s) for SIMATIC PG/PC and PCs with a PCI slot. It is designed for use in an industrial environment and can be operated with all SOFTNET for Industrial Ethernet and SOFTNET PN IO packages.

Design

The CP 1612 A2 module (PCI card 32-bit; 33 MHz/66 MHz; 3.3 V/5 V Universal Key) is inserted directly into a SIMATIC PG/PC or in a PC and requires a PCI slot.

- 1 x RJ45 connection with 10/100/1000 Mbit/s (half/full duplex)
- Installation through PCI standard mechanisms (Plug & Play)

Function

The CP 1612 A2 offers the following accesses:

- Level 2: interface for PC networks in the industrial environment
- Level 4 and Level 7: economical access to Industrial Ethernet, e.g. to SIMATIC S5/S7 in connection with SOFTNET packages for Industrial Ethernet.

In addition, the protocols for Industrial Ethernet provided by the operating system are supported.

The IT functionality emerges in connection with the PC's Windows software.

User interfaces

OPC interface

The OPC server included in the respective software package can be used as the standard programming interface for the protocols S7 communication and open communication, in order to connect automation technology applications to OPC-compatible Windows applications (Office, HMI systems, etc.)

Diagnostics

- Integration into network management systems through the support of SNMP

Configuration

- The S7 communication and open communication protocols are configured in STEP 7 V5.1 SP3 or higher or NCM PC V5.1 SP2 or higher.
- The NCM PC configuration tool is included in the scope of delivery of the CP 1612 A2 software packages.
- NCM PC is an integral component of Advanced PC Configuration.

PROFINET/Industrial Ethernet

Communication for PC-based systems

CP 1612 A2

Technical specifications

Order No.	6GK1 161-2AA01
Product type designation	CP 1612 A2
Data transmission rate	
Transmission rate at interface 1	10 ... 1 000 Mbit/s
Interfaces	
Number of electrical connections at interface 1 in accordance with Industrial Ethernet	1
Design of electrical connection	
• at interface 1 in accordance with Industrial Ethernet	RJ45 port
• of the backplane bus	PCI (32 bits, 3.3 V / 5 V universal key 33/66 MHz)
Supply voltage, current consumption, power loss	
Type of power supply	DC
Power supply	
• 1 from backplane bus	5 V
• 2 from backplane bus	12 V
Relative symmetrical tolerance	
• At 5 V with DC	5 %
• At 12 V with DC	5 %
Current consumed	
• Maximum 1 from backplane bus with DC	0.45 A
• Maximum 2 from backplane bus with DC	0.5 A
Effective power loss	3.65 W
Permitted ambient conditions	
Ambient temperature	
• During operation	0 ... 55 °C
• During storage	-10 ... +70 °C
• During transport	-10 ... +70 °C
Relative humidity at 25 °C without condensation during operation, maximum	90 %
IP degree of protection	IP00
Design, dimensions and weights	
Module format	PCI
Width	18 mm
Height	59 mm
Depth	140 mm
Net weight	60 g
Product properties, functions, components	
General	
Number of plug-in cards of same design which can be inserted per PC station	2
Number of modules - Note	-
Performance data	
<u>Performance data</u> <u>Open communication</u>	
Software required for open communication by means of SEND/RECEIVE	Yes, SOFTNET-IE S7 (64 conn.)/SOFTNET-IE S7 Lean (8 conn.)
Number of possible connections for open communication by means of SEND/RECEIVE, maximum	64

Order No.	6GK1 161-2AA01
Product type designation	CP 1612 A2
<u>Performance data</u> <u>S7 communication</u>	
Software required for S7 communication	Yes, SOFTNET-IE S7 (64 conn.)/SOFTNET-IE S7 Lean (8 conn.)
Number of possible connections for S7/PG communication, maximum	64
<u>Performance data</u> <u>Multiprotocol operation</u>	
Number of active connections in multiprotocol mode	64
Number of configurable connections per PC station	207
<u>Performance data</u> <u>PROFINET communication</u> <u>as PN IO-Controller</u>	
Software required for PROFINET IO communication	Yes, SOFTNET-IE PN IO
Total number of PN IO-Devices which can be operated on the PROFINET IO-Controller	64
Number of PN IO IRT-Devices which can be operated on the PROFINET IO-Controller	0
Data volume	
• As user data for input variables as PROFINET IO-Controller, maximum	4 096 bytes
• As user data for output variables as PROFINET IO-Controller, maximum	4 096 bytes
• As user data for input variables per PN IO-Device as PROFINET IO-Controller, maximum	1 472 bytes
• As user data for output variables per PN IO-Device as PROFINET IO-Controller, maximum	1 472 bytes
Product functions Management, configuration, programming	
Product function: MIB support	Yes
Protocol is supported	
• SNMP v1	Yes
• SNMP v3	No
• DCP	No
Configuration software	
• Required	NCM PC included in scope of delivery Yes, SIMATIC iMAP
• Required for PROFINET CBA	
Standards, specifications, approvals	
Standard	
• For EMC	2004/108/EC
• For CSA and UL safety	CAN/CSA C22.2 & UL 60950-1, UL 1950
• For emitted interference	EN 61000-6-3, EN 61000-6-4
• For noise immunity	EN 61000-6-1, EN 61000-6-2
Certificate of suitability	
• CE mark	Yes
• C-Tick	Yes

Ordering data	Order No.	Order No.
CP 1612 A2 communication processor PCI card (32 bit, 33 MHz/66 MHz; 3.3 V/5 V universal keyed) for connection to Industrial Ethernet (10/100/1000 Mbit/s) with RJ45 interface, incl. driver for 32-bit Windows XP Professional SP2/3, 2003 R2 Server SP2, Vista Business/Ultimate SP1, Windows 2008 Server; German/English	6GK1 161-2AA01	
SOFTNET Security Client V4 Software for designing secure IP-based VPN connections from a programming device/PC to network segments which are secured by SCALANCE S in bridge mode; Single license for 1 installation, runtime software (German/English), configuring tool (German/English) and electronic manual on CD-ROM (German/English/French/Italian/Spanish) for 32-bit Windows, XP Professional + SP1, SP2, SP3; for 32/64-bit Windows 7 Ultimate/Business	6GK1 704-1VW04-0AA0	
SOFTNET PN IO Software for PROFINET IO Controller with OPC server and NCM PC, runtime software, software and electronic manual on CD-ROM, license key on USB stick, Class A,		
SOFTNET-IE PN IO V8.1 For 32/64 bit: Windows 7 Professional/Ultimate; for 64 bit: Windows 2008 Server R2 German/English • Single License for one installation	6GK1 704-1HW08-1AA0	
SOFTNET PN IO Edition 2008 (V7.1) for 32 bit Windows XP Professional SP 2/3; Windows 2003 Server R2, SP2; Windows Vista Business/Ultimate SP1; Windows 2008 Server; German/English • Single License for one installation	6GK1 704-1HW71-3AA0	
Software Update Service For 1 year with automatic extension; requirement: Current software version	6GK1 704-1HW00-3AL0	
Upgrade • From Edition 2006 to SOFTNET PN IO Edition 2008 or V8.1 • From V6.0, V6.1, V6.2 or V6.3 to SOFTNET PN IO Edition 2008 or V8.1	6GK1 704-1HW00-3AE0 6GK1 704-1HW00-3AE1	
SOFTNET S7 for Industrial Ethernet Software for S7 and open communication, including OPC server, PG/OP communication and NCM PC, runtime software, software and electronic manual on CD-ROM, license key on USB stick, Class A SOFTNET-IE S7 V8.1 For 32/64 bit: Windows 7 Professional/Ultimate; for 64 bit: Windows 2008 Server R2; German/English up to 64 connections • Single License for one installation		6GK1 704-1CW08-1AA0
SOFTNET S7 Edition 2008 (V7.1) for Industrial Ethernet for 32 bit Windows XP Professional SP2/3; Windows 2003 Server R2, SP2; Windows Vista Business/Ultimate SP1; Windows 2008 Server; German/English up to 64 connections • Single License for one installation		6GK1 704-1CW71-3AA0
Software Update Service For 1 year with automatic extension; requirement: Current software version		6GK1 704-1CW00-3AL0
Upgrade • From Edition 2006 to Edition 2008 or V8.1 • From V6.0, V6.1, V6.2 or V6.3 to Edition 2008 or V8.1		6GK1 704-1CW00-3AE0 6GK1 704-1CW00-3AE1
SOFTNET-IE S7 Lean Edition V8.1 Up to eight connections • Single License for one installation		6GK1 704-1LW08-1AA0
SOFTNET-S7 Lean Edition 2008 (V7.1) for Industrial Ethernet Up to eight connections • Single License for one installation		6GK1 704-1LW71-3AA0
Software Update Service For 1 year with automatic extension; requirement: Current software version		6GK1 704-1LW00-3AL0
Upgrade • From Edition 2006 to Edition 2008 or V8.1 • From V6.0, V6.1, V6.2 or V6.3 to Edition 2008 or V8.1		6GK1 704-1LW00-3AE0 6GK1 704-1LW00-3AE1

PROFINET/Industrial Ethernet

Communication for PC-based systems

CP 1612 A2

2

Ordering data	Order No.	Order No.
SOFTNET-IE PG for Industrial Ethernet		
Software for PG/OP communication, runtime software, software and electronic manual on CD-ROM, license key on USB stick, Class A SOFTNET-IE PG V8.1 For 32/64 bit: Windows 7 Professional/Ultimate; for 64 bit: Windows 2008 Server R2; German/English • Single License for one installation	6GK1 704-1PW08-1AA0	IE TP Cord RJ45/RJ45 TP cable 4 x 2 with 2 RJ45 connectors • 0.5 m • 1 m • 2 m • 6 m • 10 m
SOFTNET-PG Edition 2008 (V7.1) for Industrial Ethernet for 32 bit Windows XP Professional SP2/3; Windows 2003 Server R2, SP2; Windows Vista Business/Ultimate SP1; Windows 2008 Server; German/English • Single License for one installation	6GK1 704-1PW71-3AA0	Software Update Service For 1 year with automatic extension; requirement: Current software version
Software update For 1 year with automatic extension; requirement: Current software version	6GK1 704-1PW00-3AL0	Upgrade • From Edition 2006 and higher to Edition 2008, single license • From V6.0 to Edition 2008, single license
Upgrade • From Edition 2006 to Edition 2008 or V8.1 • From V6.0, V6.1, V6.2 or V6.3 to Edition 2008 or V8.1	6GK1 704-1PW00-3AE0 6GK1 704-1PW00-3AE1	6XV1 870-3QE50 6XV1 870-3QH10 6XV1 870-3QH20 6XV1 870-3QH60 6XV1 870-3QN10 6GK1 706-0HB00-3AL0 6GK1 706-0HB00-3AE0 6GK1 706-0HB00-3AE1

Overview



ISO	TCP/ UDP	PN	MRP	OPC	PG/OP	S7/S5	IT
●	●			●	●	●	●

- PCI card (32 bit; 33 MHz/66 MHz; 3.3 V/5 V universal key) with microprocessor for connection of PG/PC to Industrial Ethernet with 10/100 Mbit/s Autosensing/Autonegotiation
- Communication services using
 - Open IE communication via TCP/IP and UDP)
 - ISO transport protocol
 - PG/OP communication
 - S7 communication
 - Open communication (SEND/RECEIVE)
- 15-pole ITP connection
- RJ45 connection
- Time synchronization
- ISO and TCP/IP transport protocol onboard
- SNMP-supported diagnostics
- The appropriate OPC server and configuration tools are included in the respective scope of supply of the communication software

Benefits

get Designed for Industry

- Constant data throughput through protocol processing on the CP
- Can be connected to many devices through ITP or RJ45 connections on the module
- Free computing capacity for other applications on the PC e.g. HMI (ISO and TCP/IP transport onboard)
- Simple handling through Plug&Play and Autosensing (10/100 Mbit/s)
- Operation of large network configurations with a single card through high number of connections
- Can be used for redundant communication
- OPC as standard interface
- Uniform procedure and configuration functions for NCM PC and STEP 7

PROFINET/Industrial Ethernet

Communication for PC-based systems

CP 1613 A2

Application

The CP 1613 A2 is used to connect SIMATIC PGs/PCs and PCs with a PCI slot to Industrial Ethernet (10/100 Mbit/s).

2

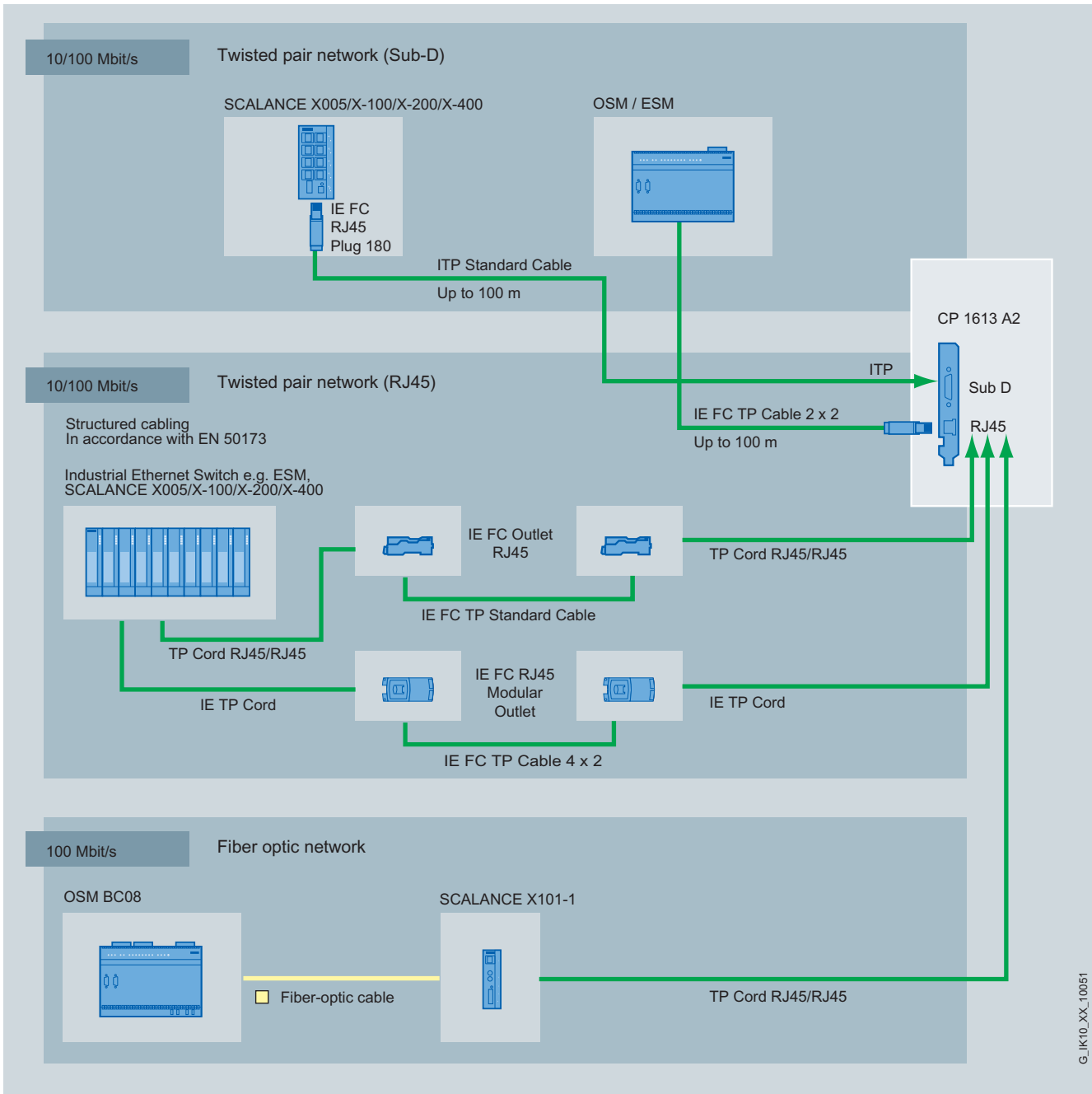

G_IK10_XX_10051

Network connection facilities for CP 1613 A2

Design

The module CP 1613 A2 (PCI card with 32-bit microprocessor; 33 MHz/66 MHz; 3.3 V/5 V Universal Key) is inserted directly into a SIMATIC PG/PC or into a PC and requires a short PCI slot. It is capable of running in 64-bit PCI-X slots (PCI 2.2 and PCI-X-compatible).

Ports:

- 15-pin Sub-D socket for ITP
- RJ45 jack for twisted pair
- Automatic recognition and selection of the interface during booting (ITP or RJ45)

The module is connected, for example,

- in the case of ITP via the ITP standard cable 9/15 to OSM/ESM
- in the case of TP via TP cord up to 10 m or via FastConnect system up to 100 m (IE FC RJ45 Plug and FC cables) to SCALANCE X or SCALANCE S

Function

User interfaces

OPC interface

As a standard programming interface for the S7 communication and open communication protocols, the OPC server contained in the respective software package can be used to connect the automation technology to OPC-compatible Windows applications (Office, HMI systems, etc.).

Programming interface through C library

The programming interfaces for the S7 communication, PG/OP communication, and open communication protocols for existing applications are implemented as Dynamic Link Library (DLL) interfaces.

You can find the released compilers in the Readme file of the SIMATIC NET CD products at www.siemens.com/automation/csi/net.

Software for PG/OP communication

This software supports the programming of SIMATIC S5 and S7 controllers over Industrial Ethernet in combination with STEP 5 / STEP 7 programmable controllers.

It is included in all CP 1613 A2 software packages.

Software for S7 communication (HARDNET-IE S7 or S7-REDCONNECT)

The S7 interface allows PG/PC applications (e.g. WinCC) and user programs to access the SIMATIC S7 system components. This provides easy, flexible access to the data of the SIMATIC S7 controller.

S7 communication offers:

Administrative services

- Connection management
- Mini database
- Trace

Data transfer services

- Read/write variables
- BSEND/BRECEIVE

H-communication

For redundant S7-communication with a fault-tolerant S7-400 H system, the CP 1613/CP1623 can be used in connection with the S7-REDCONNECT software.

Software for open communication (SEND/RECEIVE)

This interface is used for communication between

- PG/PC and SIMATIC S5
- PG/PC and SIMATIC S7
- PG/PC and PG/PC

Open communication (SEND/RECEIVE) offers the following services:

- Management services
- Connection establishment services
- Data transfer services

These functionalities are a component part of the HARDNET-IE S7 software product.

Mode of operation

Protocols up to Level 4 (Transport) are processed autonomously on the module.

16 MB of memory is available for this to support a large quantitative framework and reliable communication.

Data is exchanged between the module and the host in master mode. This means that the CP 1613 A2 accesses the physical RAM of the host.

A Windows driver is responsible for transferring data between the host system and the CP 1613 A2. The transmission rate to Industrial Ethernet is detected and automatically switched over (autosensing).

The IT functionality is provided in combination with the Windows software of the PC.

Diagnostics data

Via SNMP all MIB-2 objects can be read out. This enables the current status of the Ethernet interfaces to be retrieved.

Configuration

- The S7 communication and open communication protocols are configured in STEP 7 or NCM PC.
- The configuration tool NCM PC is included in the CP 1613 A2 software packages.
- NCM PC is a component part of Advanced PC Configuration.

PROFINET/Industrial Ethernet

Communication for PC-based systems

CP 1613 A2

Integration

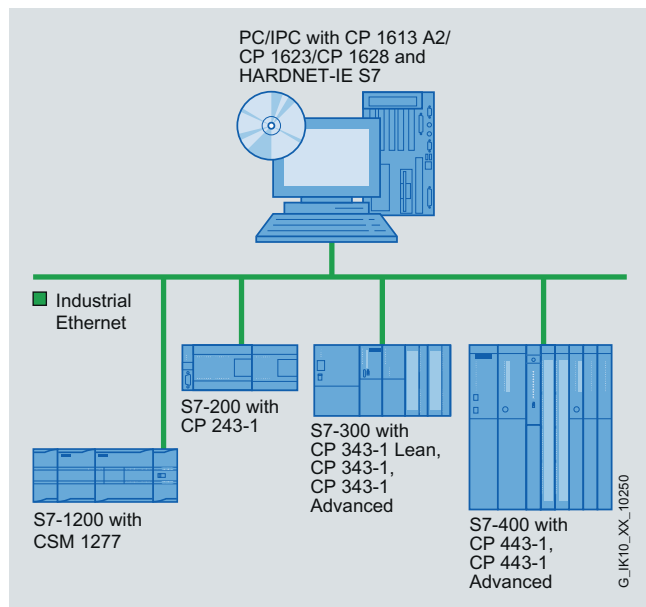

System configuration with CP 1613 A2/CP 1623 and S7-1613

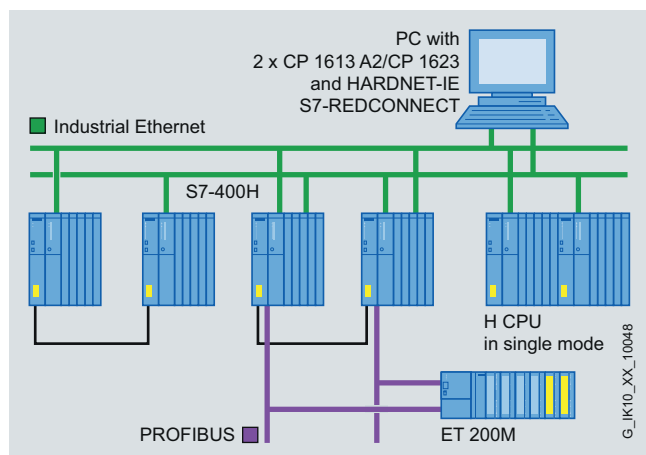

Example of redundant network structure with CP 1613 A2/CP 1623 and S7-REDCONNECT

Technical specifications

Order No.	6GK1 161-3AA01
Product type designation	CP 1613 A2
Transmission rate	
Transmission rate at interface 1	10 ... 100 Mbit/s
Interfaces	
Number of electrical connections at interface 1 in accordance with Industrial Ethernet	2
Design of electrical connection	
• at interface 1 in accordance with Industrial Ethernet	RJ45 port / 15-pin ITP connection
• of backplane bus	PCI (32 bit 3.3 V/5 V Universal Key 33/66 MHz)
Supply voltage, current consumption, power loss	
Type of power supply	DC
Power supply	
• 1 from backplane bus	5 V
• 2 from backplane bus	12 V
Relative symmetrical tolerance	
• At 5 V with DC	5 %
• At 12 V with DC	5 %
Current consumed	
• Max. 1 from backplane bus with DC	0.45 A
• Max. 2 from backplane bus with DC	0.5 A
Effective power loss	4 W
Permitted ambient conditions	
Ambient temperature	
• During operation	5 ... 55 °C
• During storage	-20 ... +60 °C
• During transport	-20 ... +60 °C
Relative humidity at 25 °C without condensation during operation, maximum	95 %
IP degree of protection	IP00
Design, dimensions and weights	
Module format	PCI
Width	21.6 mm
Height	107 mm
Depth	167 mm
Net weight	140 g
Product properties, functions, components	
General	
Number of plug-in cards of same design which can be inserted per PC station	4
Number of modules - Note	-

Technical specifications (continued)		Ordering data	Order No.
Order No.	6GK1 161-3AA01	CP 1613 A2 communication processor	6GK1 161-3AA01
Product type designation	CP 1613 A2	PCI card (32-bit, 33 MHz/66 MHz; 3.3 V/5 V universal keyed) for connection to Industrial Ethernet (10/100 Mbit/s) with ITP and RJ45 connection over HARDNET-IE S7/ S7-1613 and S7-REDCONNECT, for operating system support see SIMATIC NET Software	
Performance data		HARDNET-IE S7 for Industrial Ethernet	
<u>Performance data</u> <u>Open communication</u>		Software for S7 and open communication, incl. PG/OP communication, OPC server and NCM PC; up to 120 connections, runtime software, software and electronic manual on CD-ROM, license key on USB stick, Class A, for CP 1613/CP 1613 A2/ CP 1623/CP 1628;	
Software required for open communication by means of SEND/RECEIVE	Yes, HARDNET-IE S7 (S7-1613)	HARDNET-IE S7 V8.1	
Number of possible connections for open communication by means of SEND/RECEIVE, maximum	120	For 32/64-bit: Windows 7 Professional/Ultimate; for 64-bit: Windows 2008 Server R2 German/English	
<u>Performance data</u> <u>S7 communication</u>		• Single License for one installation	6GK1 716-1CB08-1AA0
Software required for S7 communication	Yes, HARDNET-IE S7 (S7-1613)	S7-1613 Edition 2008 (V7.1)	
Number of possible connections for S7/PG communication, maximum	120	for 32-bit Windows XP Professional SP2/3; Windows 2003 Server R2, SP2; Windows Vista Business/Ultimate SP1; Windows 2008 Server; German/English	
<u>Performance data</u> <u>Multiprotocol operation</u>		• Single License for one installation	6GK1 716-1CB71-3AA0
Number of active connections in multiprotocol mode	120	Software Update Service	
Number of configurable connections per PC station	207	For 1 year with automatic extension; requirement: Current software version	6GK1 716-1CB00-3AL0
Product functions		Upgrade	
Management, configuration, programming		• S7-1613, Edition 2006 or higher, to S7-1613 Edition 2008 or HARDNET-IE S7 V8.1	6GK1 716-1CB00-3AE0
Product function: MIB support	Yes	• from S7-1613 V6.0, V6.1, V6.2 or V6.3 to S7-1613 Edition 2008 or HARDNET-IE S7 V8.1	6GK1 716-1CB00-3AE1
Protocol is supported		IE TP Cord RJ45/RJ45	
• SNMP v1	Yes	TP cable 4 x 2 with 2 RJ45 connectors	
• SNMP v3	No	• 0.5 m	6XV1 870-3QE50
• DCP	Yes	• 1 m	6XV1 870-3QH10
Configuration software		• 2 m	6XV1 870-3QH20
• Required	NCM PC included in scope of delivery	• 6 m	6XV1 870-3QH60
• Required for PROFINET CBA Identification & maintenance	Yes, SIMATIC iMAP	• 10 m	6XV1 870-3QN10
• I&M0 - device-specific information	Yes		
• I&M1 - higher-level designation/ location designation	Yes		
Product functions Redundancy			
Software required for redundancy function	Yes, HARDNET-IE S7-REDCONNECT for communication with SIMATIC S7 H systems		
Product functions Time			
Product function: SICLOCK support	Yes		
NTP protocol is supported	No		
Standards, specifications, approvals			
Standard			
• For EMC	2004/108/EC		
• For CSA and UL safety	CAN/CSA C22.2 & UL 60950-1, UL 1950		
• For emitted interference	EN 61000-6-3, EN 61000-6-4		
• For noise immunity	EN 61000-6-1, EN 61000-6-2		
Certificate of suitability			
• CE mark	Yes		
• C-Tick	Yes		

PROFINET/Industrial Ethernet

Communication for PC-based systems

CP 1623

Overview



ISO	TCP/UDP	PN	MRP	OPC	PG/OP	S7/S5	IT
●	●			●	●	●	●

- PCI Express Card (PCIe x1) with an internal microprocessor for connection of PG/PC to Industrial Ethernet
- 10/100/1000 Mbit/s (Autosensing/Autocrossover/Autonegotiation)
- Integrated 2-port switch (2 x RJ45 connection)
- Communications services via
 - Open IE communication (TCP/IP and UDP)
 - ISO transport protocol
 - PG/OP communication
 - S7 communication
 - Open communication (SEND/RECEIVE)
- Time synchronization
- ISO and TCP/IP transport protocol on board
- Integration into network management systems through the support of SNMP (V1)
- The appropriate OPC server and configuration tools are included in the scope of supply of the respective communication software.

Benefits

g e t **Designed for Industry**

- High plant availability thanks to
 - stable and constant data communication by means of protocol processing on the CP
 - Optional: redundant communication via intelligent CPs combined with fault-tolerant software package (S7-REDCONNECT)
- IT cost savings (e.g. no additional computer) and use of free computer capacity for further applications since high quantity structures and offloading of the host CPU can be implemented with the intelligent CPs
- Simple access to automation/diagnostic data via SNMP and OPC as standard interface
- Simple and low-cost commissioning thanks to plug & play and uniform procedure and configuration functionality with NCM PC and STEP 7
- Connection of additional field devices to the Industrial Ethernet by means of an additional switch port
- Switch operation possible via external power supply even with PC turned off

2

Application

The CP 1623 makes it possible to connect to the Industrial Ethernet (10/100/1000 Mbit/s) for SIMATIC PG/PC and PCs with PCI Express slot. Additional field devices can be flexibly connected to the Industrial Ethernet via the integrated switch.

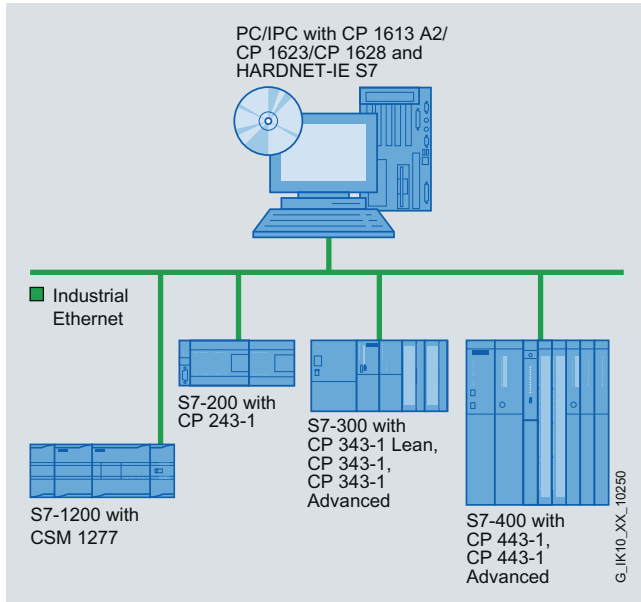

System configuration with CP 1613 A2/CP 1623/CP 1628 and HARDNET-IE S7

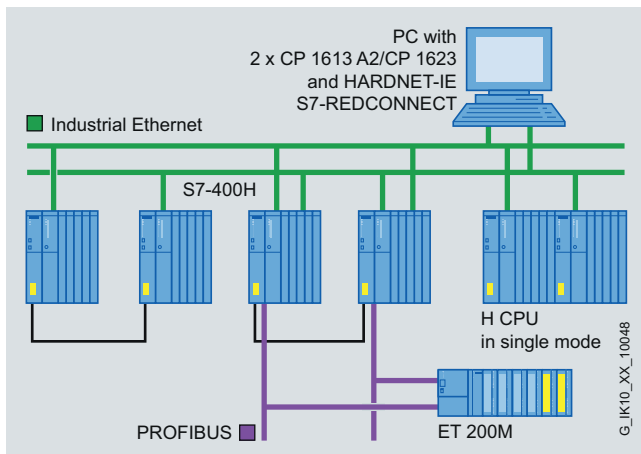

Example of redundant network structure with CP 1613 A2/CP 1623 and HARDNET-IE S7-REDCONNECT

Design

Industrial Ethernet:

- 2 x RJ45 connection
- Integrated 2-port switch for 10/100/1000 Mbit/s (half/full/duplex)
- Autosensing/Autocrossover/Autonegotiation

PG/PC slot:

- PCI Express x1 card
- Can also be operated in PCIe x4-, x8- or x16 slots
- Installation via PCIe standard mechanisms (Plug & Play)

Power supply:

- Operating voltage 3.3 V/12 V via PCIe interface
- Optional external 12 - 24 V DC power supply for switch operation with PG/PC turned off

Size:

- Short PCIe format

PROFINET/Industrial Ethernet

Communication for PC-based systems

CP 1623

Function

User interfaces

OPC interface

As a standard programming interface for the S7 communication and open communication protocols, the OPC server contained in the respective software package can be used to connect the automation technology to OPC-compatible Windows applications (Office, HMI systems, etc.).

Programming interface via C-library

The programming interfaces for the S7 communication, PG/OP communication, and open communication protocols for existing applications are implemented as Dynamic Link Library (DLL) interfaces.

The released compilers can be found in the readme file of the SIMATIC NET CD products at www.siemens.com/automation/csi/net

Software for PG/OP communication

This software makes it possible to program the SIMATIC S5 and S7 controllers via the Industrial Ethernet in conjunction with STEP 5/STEP 7 automation systems.

It is contained in all CP 1623 software packages.

Software for S7 communication (HARDNET-IE S7 or S7-REDCONNECT)

The S7 interface allows PG/PC applications (e.g. WinCC) and user programs to access the SIMATIC S7 system components. This makes for easy and flexible access to SIMATIC S7 data.

S7 communication offers:

Administrative services

- Connection management
- Mini database
- Trace

Data transfer services

- Read/write variables
- BSEND/BRECEIVE

H-communication

For redundant S7 communication with a fault-tolerant S7-400H system, the CP 1613/CP 1623/CP 1628 can be used in connection with the S7-REDCONNECT software.

Software for open communication (SEND/RECEIVE)

This interface is used for communication between

- PG/PC and SIMATIC S5
- PG/PC and SIMATIC S7
- PG/PC and PG/PC

Open communication (SEND/RECEIVE) offers the following services:

- Management services
- Dial-up services
- Data transfer services

These functionalities are a component part of the HARDNET-IE S7 software product.

Mode of operation

The protocols up to and including Level 4 (transport) are independently processed on the module.

The internal memory is available for this purpose and it also provides for a large quantity structure and high communication reliability.

The data exchange between the module and host is done in Master-Mode operation. This means the CP 1623 accesses the physical RAM of the host.

A Windows driver transfers the data between the host system and the CP 1623. The transfer rate to the Industrial Ethernet is detected and automatically switched (Autosensing).

The IT functionality emerges in connection with the PC's Windows software.

Diagnostics

All MIB-2 objects, for example, can be read out via SNMP. As a result, the current status of the Ethernet Interface can be called up.

Configuration

- The S7 communication and open communication protocols are configured in STEP 7 or NCM PC.
- The configuration tool NCM PC is included in the scope of supply of the CP 1623 software package.
- NCM PC is an integral component of advanced PC configuration.

2

Technical specifications

Order No.	6GK1 162-3AA00
Product type designation	CP 1623
Transmission rate	
Transmission rate at interface 1	10 ... 1 000 Mbit/s
Interfaces	
Number of electrical connections	
• at interface 1 in accordance with Industrial Ethernet	2
• for power supply	1
Design of electrical connection	
• at interface 1 in accordance with Industrial Ethernet	RJ45 port
• of backplane bus	PCI Express x1
• for power supply	2-pin terminal block
Supply voltage, current consumption, power loss	
Type of power supply	DC
Type of power supply: optional external supply	Yes
Power supply	
• 1 from backplane bus	3.3 V
• 2 from backplane bus	12 V
• External	24 V
- Minimum	10.5 V
- Maximum	32 V
Relative symmetrical tolerance	
• At 3.3 V with DC	9 %
• At 12 V with DC	8 %
• At 24 V with DC	33 %
Current consumed	
• Max. 1 from backplane bus with DC	0.85 A
• Max. 2 from backplane bus with DC	0.4 A
• From external power supply	
- Maximum at 12 V with DC	0.55 A
- Maximum at 24 V with DC	0.3 A
Effective power loss	7.6 W
• Maximum with switch mode	7.2 W
Permitted ambient conditions	
Ambient temperature	
• During operation	5 ... 55 °C
• During storage	-20 ... +60 °C
• During transport	-20 ... +60 °C
Relative humidity at 25 °C without condensation during operation, maximum	95 %
IP degree of protection	IP00

Order No.	6GK1 162-3AA00
Product type designation	CP 1623
Design, dimensions and weights	
Module format	PCI Express x1 (half length)
Width	18 mm
Height	111 mm
Depth	167 mm
Net weight	124 g
Product properties, functions, components	
General	
Number of plug-in cards of same design which can be inserted per PC station	4
Number of modules - Note	-
Performance data	
<u>Performance data</u>	
<u>Open communication</u>	
Software required for open communication by means of SEND/RECEIVE	Yes, HARDNET-IE S7 (S7-1613)
Number of possible connections for open communication by means of SEND/RECEIVE, maximum	120
<u>Performance data</u>	
<u>S7 communication</u>	
Software required for S7 communication	Yes, HARDNET-IE S7 (S7-1613)
Number of possible connections for S7/PG communication, maximum	120
<u>Performance data</u>	
<u>Multiprotocol operation</u>	
Number of active connections in multiprotocol mode	120
Number of configurable connections per PC station	207
Product functions	
Management, configuration, programming	
Product function: MIB support	Yes
Protocol is supported	
• SNMP v1	Yes
• SNMP v3	No
• DCP	Yes
Configuration software	
• Required	NCM PC included in scope of delivery
• Required for PROFINET CBA	Yes, SIMATIC iMAP
Identification & maintenance	
• I&M0 - device-specific information	Yes
• I&M1 - higher-level designation/location designation	Yes

PROFINET/Industrial Ethernet

Communication for PC-based systems

CP 1623

Technical specifications (continued)

Order No.	6GK1 162-3AA00
Product type designation	CP 1623
Product functions Switch	
Product feature: Switch	Yes
Product function: Switch-managed	No
Product function with IRT PROFINET IO Switch	No
Product functions Redundancy	
Software required for redundancy function	Yes, HARDNET-IE S7-REDCONNECT for communication with SIMATIC S7 H systems
Product functions Time	
Product function: SICLOCK support	Yes
NTP protocol is supported	No
Standards, specifications, approvals	
Standard	
• For EMC	2004/108/EC
• For CSA and UL safety	CAN/CSA C22.2 & UL 60950-1, UL 1950
• For emitted interference	EN 61000-6-3, EN 61000-6-4
• For noise immunity	EN 61000-6-1, EN 61000-6-2
Certificate of suitability	
• CE mark	Yes
• C-Tick	Yes

Ordering data

Order No.

CP 1623 communication processor	6GK1 162-3AA00
PCI Express x1 card for connection to Industrial Ethernet (10/100/1000 Mbit/s), with 2-port switch (RJ45) via HARDNET-IE S7/S7-1613 and S7-REDCONNECT. For operating system support, see SIMATIC NET Software	
HARDNET-IE S7 for Industrial Ethernet	
Software for S7 and open communication, incl. PG/OP communication, OPC server and NCM PC; up to 120 connections, runtime software, software and electronic manual on CD-ROM, license key on USB stick, Class A, for CP 1613/CP 1613 A2/CP 1623/CP 1628;	
HARDNET-IE S7 V8.1	
For 32/64-bit: Windows 7 Professional/Ultimate; for 64-bit: Windows 2008 Server R2 German/English	
• Single License for one installation	6GK1 716-1CB08-1AA0
S7-1613 Edition 2008 (V7.1)	
for 32-bit: Windows XP Professional SP2/3; Windows 2003 Server R2, SP2; Windows Vista Business/Ultimate SP1; Windows 2008 Server; German/English	
• Single License for one installation	6GK1 716-1CB71-3AA0
Software Update Service	6GK1 716-1CB00-3AL0
For 1 year with automatic extension; requirement: Current software version	
Upgrade	
• S7-1613, Edition 2006 or higher, to S7-1613 Edition 2008 or HARDNET-IE S7 V8.1	6GK1 716-1CB00-3AE0
• from S7-1613 V6.0, V6.1, V6.2 or V6.3 to S7-1613 Edition 2008 or HARDNET-IE S7 V8.1	6GK1 716-1CB00-3AE1
IE TP Cord RJ45/RJ45	
TP cable 4 x 2 with 2 RJ45 connectors	
• 0.5 m	6XV1 870-3QE50
• 1 m	6XV1 870-3QH10
• 2 m	6XV1 870-3QH20
• 6 m	6XV1 870-3QH60
• 10 m	6XV1 870-3QN10

2

Overview

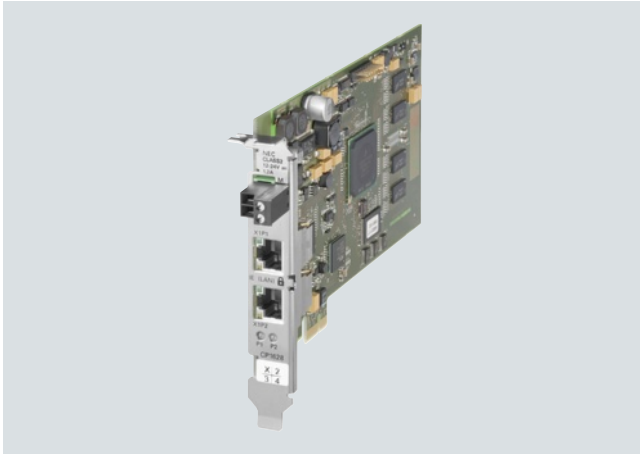

ISO	TCP/ UDP	PN	MRP	OPC	PG/OP	S7/S5	IT
●	●			●	●	●	●

- PCI Express card (PCIe x1) with its own microprocessor and integrated 2-port switch (2 x RJ45 connection, 10/100/1000 Mbit/s) for the connection of a PG/PC to Industrial Ethernet
- Integrated security mechanisms (e.g. Firewall, VPN)
- ISO and TCP/IP transport protocol on board
- Communications services via
 - Open IE communication (TCP/IP and UDP)
 - ISO transport protocol
 - PG/OP communication
 - S7 communication
 - Open communication (SEND/RECEIVE)
- Integration into network management systems through the support of SNMP (V1/V3)

Benefits

get Designed for Industry

- High plant availability thanks to
 - stable and constant data communication by means of protocol processing on the CP
 - Optional: redundant communication via intelligent CPs combined with fault-tolerant software package (HARDNET-IE S7-REDCONNECT)
- Safeguarding important computer systems and their associated data communication by means of integrated security mechanisms on the CP, such as firewall and VPN
- IT cost savings (e.g. no additional computer) and use of free computer capacity for further applications since high quantity structures and offloading of the host CPU can be implemented with the intelligent CPs
- Simple access to automation/diagnostic data via SNMP and OPC as standard interface
- Simple and low-cost commissioning thanks to uniform procedure and configuration functionality with NCM PC and STEP 7

PROFINET/Industrial Ethernet Communication for PC-based systems

CP 1628

2

Application

The CP 1628 makes it possible to connect SIMATIC PG/PC and PCs with PCI Express slot to the Industrial Ethernet (10/100/1000 Mbit/s). Additional field devices can be flexibly connected to the Industrial Ethernet via the integrated switch.

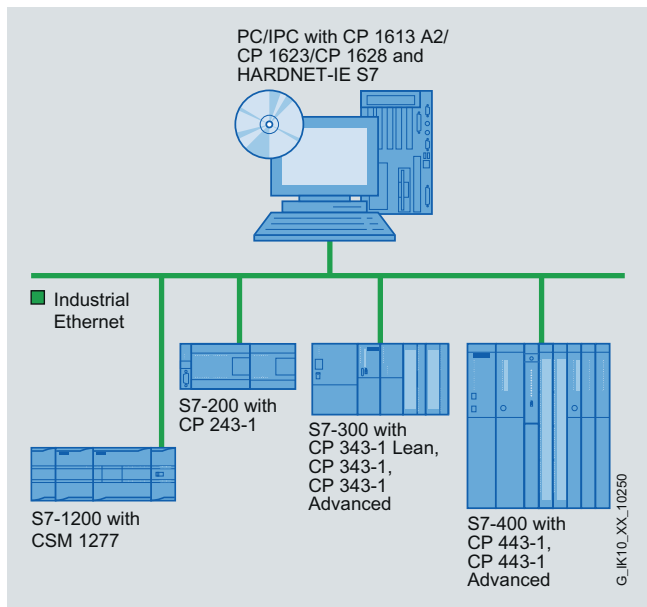

System configuration with CP 1613 A2/CP 1623/CP 1628 and HARDNET-IE S7

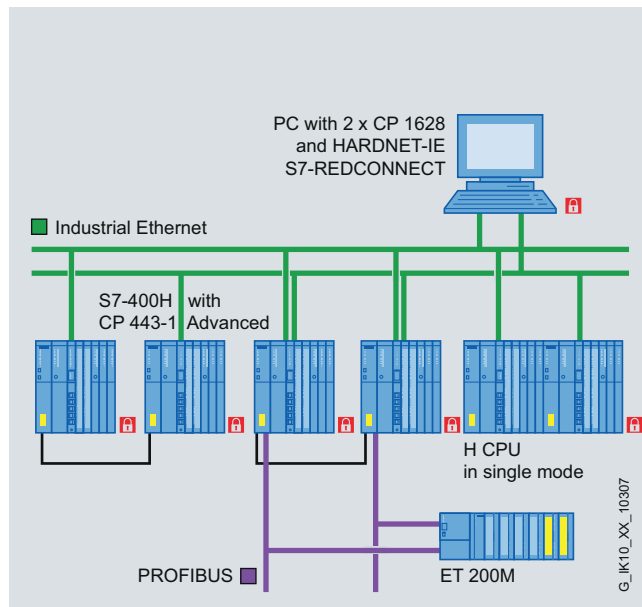

Example of redundant and secure network structure with CP 1628 and HARDNET-IE S7-REDCONNECT

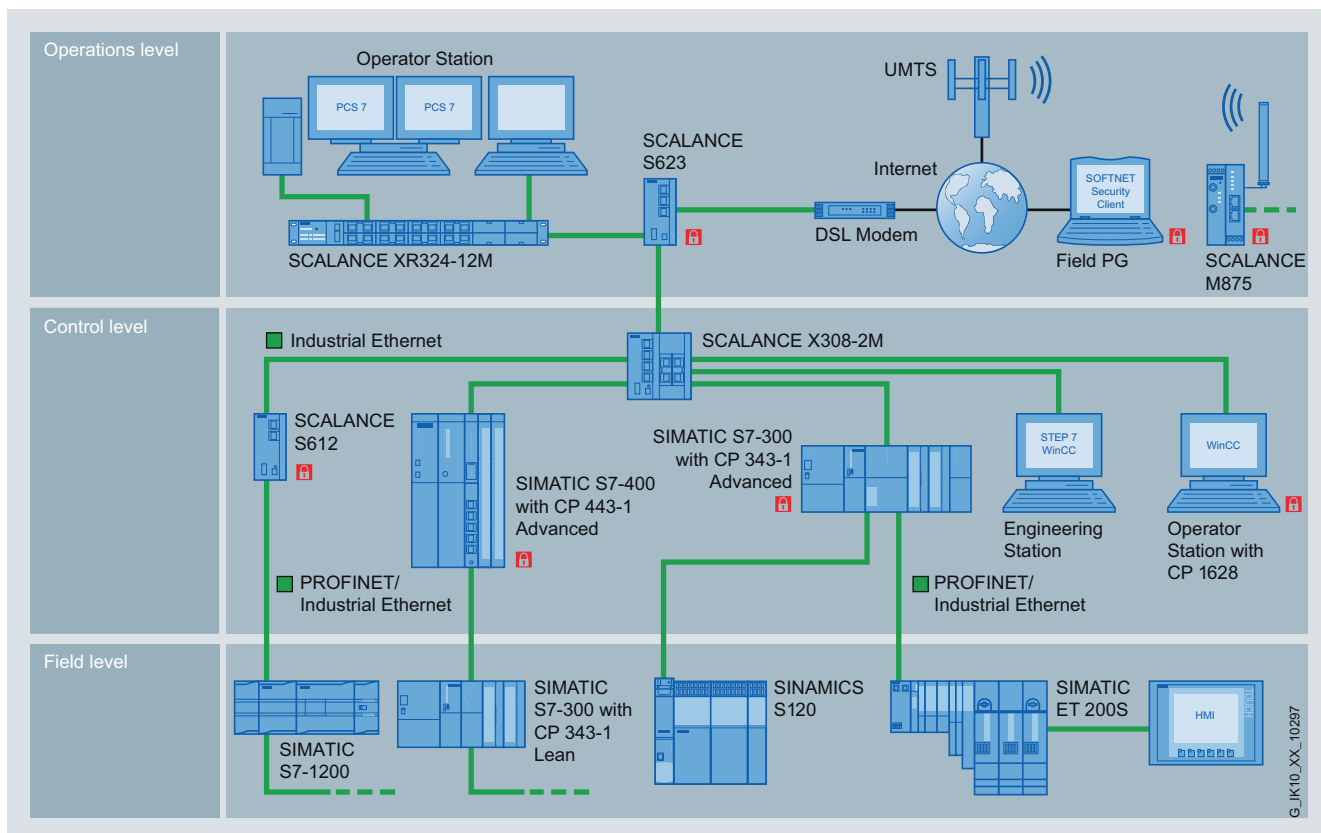

Secure VPN communication between SCALANCE S, SOFTNET Security Client and components with Security Integrated

Design

Industrial Ethernet:

- 2 x RJ45 connection
- Integrated 2-port switch for 10/100/1000 Mbps (half/full duplex)
- Autosensing/Autocrossover/Autonegotiation

PG/PC slot:

- PCI Express x1 card
- Can also be operated in PCIe x4, x8 or x16 slots
- Installation via PCIe standard mechanisms (Plug & Play)

Power supply:

- Operating voltage 3.3 V/12 V via PCIe interface
- Optional external 12 - 24 V DC power supply for switch operation with PG/PC turned off

Size:

- Short PCIe format

Function

User interfaces

OPC interface

As a standard programming interface for the S7 communication and open communication protocols, the OPC server contained in the respective software package can be used to connect the automation technology to OPC-compatible Windows applications (Office, HMI systems, etc.).

Programming interface via C Library

The programming interfaces for the S7 communication, PG/OP communication, and open communication protocols for existing applications are implemented as Dynamic Link Library (DLL) interfaces.

The released compilers can be found in the readme file of the SIMATIC NET CD products at www.siemens.com/automation/csi/net

Software for PG/OP communication

This software makes it possible to program the SIMATIC S5 and S7 controllers via the Industrial Ethernet in conjunction with STEP 5/STEP 7 automation systems.

It is contained in all CP 1628 software packages.

Software for S7 communication (HARDNET-IE S7 or HARDNET-IE S7-REDCONNECT)

The S7 interface allows PG/PC applications (e.g. WinCC) and user programs to access the SIMATIC S7 system components. This makes for easy and flexible access to SIMATIC S7 data.

S7 communication offers:

Administrative services

- Connection management
- Mini database
- Trace

Data transfer services

- Read/write variables
- BSEND/BRECEIVE

H-communication

For redundant S7 communication with a fault-tolerant S7-400H system, the CP 1613/CP1623/CP 1628 can be used in connection with the HARDNET-IE S7-REDCONNECT software.

Software for open communication (SEND/RECEIVE)

This interface is used for communication between

- PG/PC and SIMATIC S5
- PG/PC and SIMATIC S7
- PG/PC and PG/PC

Open communication (SEND/RECEIVE) offers the following services:

- Management services
- Dial-up services
- Data transfer services

These functionalities are a component part of the HARDNET-IE S7 software product.

Security mechanisms

Integrated security mechanisms enable safeguarding of important computer systems, including their associated data communication systems:

- Stateful Inspection Firewall for filtering connections on the basis of their IP/port addresses
- Limiting bandwidth to avoid communication overload
- Secure and encrypted access to controllers or remote access over the Internet by means of VPN Server and VPN Client and checking of data integrity
- Tap-proof transmission of network analysis information to the network management system (SNMP V3)
- Secure transfer of the time (NTP V3)
- Traceability by means of data logging on the basis of standard IT mechanisms (Syslog)

Mode of operation

The protocols up to and including Level 4 (transport) are independently processed on the module.

The internal memory is available for this purpose and it also provides for a large quantity structure and high communication reliability.

The data exchange between the module and host is done in Master-Mode operation. This means that the CP 1628 accesses the physical RAM of the host.

A Windows driver transfers the data between the host system and the CP 1628. The transfer rate to the Industrial Ethernet is detected and automatically switched (Autosensing).

The IT functionality emerges in connection with the PC's Windows software.

Diagnostics

All MIB-2 objects, for example, can be read out via SNMP. This enables the current status of the Ethernet interfaces to be retrieved.

Configuration

- The S7 communication and open communication protocols are configured in STEP 7 or NCM PC.
- The configuration tool NCM PC is included in the scope of supply of the CP 1628 software package.
- NCM PC is an integral component of advanced PC configuration.

PROFINET/Industrial Ethernet

Communication for PC-based systems

CP 1628

Technical specifications

Order no.	6GK1 162-8AA00
Product type designation	CP 1628 ¹⁾
Transmission rate	
Transmission rate at interface 1	10 to 1000 Mbps
Interfaces	
Number of electrical connections	2
• at interface 1 in accordance with Industrial Ethernet	
• for power supply	1
Design of electrical connection	
• at interface 1 in accordance with Industrial Ethernet	RJ45 port
• of the backplane bus	PCI Express x1
• for power supply	2-pin terminal block
Supply voltage, current consumption, power loss	
Type of power supply	DC
Type of power supply optional external supply	Yes
Supply voltage	
• 1 from backplane bus	3.3 V
• 2 from backplane bus	12 V
• External	24 V
- Minimum	10.5 V
- Maximum	32 V
Remark on supply voltage	-
Relative symmetrical tolerance	
• at 3.3 V in the case of DC	9 %
• at 12 V in the case of DC	8 %
• at 24 V in the case of DC	33 %
Current consumed	
• 1 from backplane bus with DC max.	0.85 A
• 2 from backplane bus with DC max.	0.4 A
• from external supply voltage	
- at 12 V with DC max.	0.55 A
- at 24 V with DC max.	0.3 A
Effective power loss	7.6 W
Effective power loss with switch mode max.	7.2 W
Permissible ambient conditions	
Ambient temperature	
• During operation	5 to 55 °C
• During storage	-20 to +60 °C
• During transport	-20 to +60 °C
Relative humidity at 25 °C without condensation during operation, maximum	95 %
IP degree of protection	IP00

¹⁾ Available soon

Order no.	6GK1 162-8AA00
Product type designation	CP 1628 ¹⁾
Design, dimensions and weights	
Module format	PCI Express x1 (half length)
Width	18 mm
Height	111 mm
Depth	167 mm
Net weight	0.124 kg
Product properties, functions, components	
General	
Number of plug-in cards of same design which can be inserted per PC station	4
Remark on number of modules	-
Performance data	
<u>Performance data open communication</u>	
Software required for open communication by means of SEND/RECEIVE	Yes, HARDNET-IE S7
Number of possible connections for open communication by means of SEND/RECEIVE, maximum	120
<u>Performance data S7 communication</u>	
Software required for S7 communication	Yes, HARDNET-IE S7
Maximum number of possible connections for S7/PG communication	120
<u>Performance data multiprotocol operation</u>	
Number of active connections in multiprotocol mode	120
Number of configurable connections per PC station	207
Product functions	
Management, configuration, programming	
Product function: MIB support	Yes
Protocol is supported	
• SNMP v1	Yes
• SNMP v3	Yes
• DCP	Yes
Configuration software	
• Required	NCM PC included in the scope of scope of delivery
Identification & maintenance	
• I&M0 - device-specific information	Yes
• I&M1 - plant designation/location designation	Yes

Technical specifications (continued)		Ordering data	Order No.
Order no.	6GK1 162-8AA00	CP 1628 communication processor ¹⁾ PCI Express x1 card for connection to Industrial Ethernet (10/100/1000 Mbit/s), with 2-port switch (RJ45) and integral security (firewall, VPN) via HARDNET-IE S7 and S7-REDCONNECT. For operating system support, see SIMATIC NET Software	6GK1 162-8AA00
Product type designation	CP 1628 ¹⁾		
Product functions Switch		HARDNET S7 for Industrial Ethernet Software for S7 and open communication, incl. PG/OP communication, OPC server and NCM PC; up to 120 connections, runtime software, software and electronic manual on CD-ROM, license key on USB stick, Class A, for CP 1613/CP 1613 A2/CP 1623/CP 1628; HARDNET-IE S7 V8.1 For 32/64-bit: Windows 7 Professional/Ultimate; for 64-bit: Windows 2008 Server R2 German/English • Single License for one installation	6GK1 716-1CB08-1AA0
Product feature: Switch	Yes		
Product function		Software Update Service For 1 year with automatic extension; requirement: Current software version	6GK1 716-1CB00-3AL0
• Switch-managed	No		
• with IRT PROFINET IO Switch	No	Upgrade • S7-1613, Edition 2006 or higher, to S7-1613 Edition 2008 or HARDNET-IE S7 V8.1 • from S7-1613 V6.0, V6.1, V6.2 or V6.3 to S7-1613 Edition 2008 or HARDNET-IE S7 V8.1	6GK1 716-1CB00-3AE0 6GK1 716-1CB00-3AE1
Product functions Redundancy			
Software required for redundancy function	Yes, HARDNET-IE S7-REDCONNECT for communication with SIMATIC S7 H systems	IE TP Cord RJ45/RJ45 TP cable 4 x 2 with 2 RJ45 connectors • 0.5 m • 1 m • 2 m • 6 m • 10 m	6XV1 870-3QE50 6XV1 870-3QH10 6XV1 870-3QH20 6XV1 870-3QH60 6XV1 870-3QN10
Product functions			
Configuration of firewall	Stateful inspection	Standards, specifications, approvals Standard • for EMC • for CSA and UL security • for emitted interference • for noise immunity Certificate of suitability • CE marking • C-Tick	
Product function with VPN connection	IPSec		
Type of encryption algorithms with VPN connection	AES-256, AES-192, AES-128, 3DES-168, DES-56		
Type of authentication procedures with VPN connection	Preshared Key (PSK), X.509v3 certificates		
Type of hashing algorithms with VPN connection	MD5, SHA-1		
Number of possible connections with VPN connection	64		
Number of usable IP addresses with VPN connection, maximum	16		
Product functions Time			
Product function: SICLOCK support	Yes		
NTP protocol is supported	Yes		

1) Available soon

More information

You will find more information on the topic of Industrial Security on the Internet at:

www.siemens.com/industrialsecurity

PROFINET/Industrial Ethernet

Communication for PC-based systems

HARDNET-IE S7-REDCONNECT

Overview

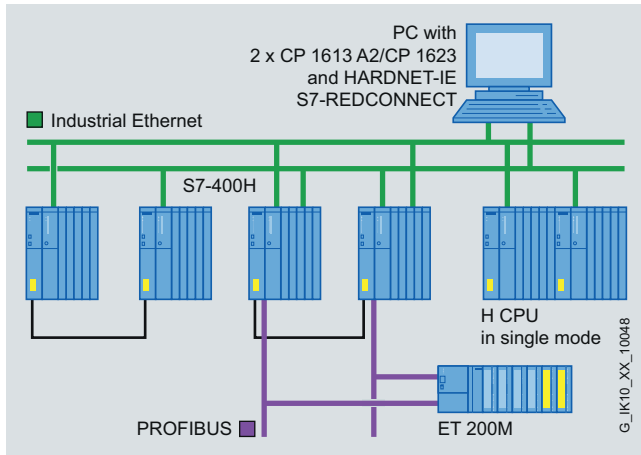

System configuration for S7-REDCONNECT

ISO	TCP/UDP	PN	MRP	OPC	PG/OP	S7/S5	IT
●				●	●	●	

- For connecting PCs over redundant Industrial Ethernet to the SIMATIC S7-400H
- Protected from communication failures arising from a fault in the double bus or in redundant rings
- For redundant Layer 2 or Layer 3 Industrial Ethernet
- Can also be implemented in non-redundant networks
- No additional programming overhead for the PC and in H systems
- The appropriate OPC server and configuration tools are included in the scope of supply of the respective communication software
- Enhanced redundancy over 4-way communication (STEP 7 V5.1 + SP4 and higher)

Benefits

get Designed for Industry

- Protects against communication failures arising from a fault in the double bus or in redundant rings
- Simplifies communication between a PC application and the SIMATIC S7-400H system
- Secures the investment thanks to the use of existing applications and flexible application options
- No additional programming overhead for the PC and in H systems
- Increases the availability of the PC application (e.g. PCS 7) thanks to redundant Layer 2 or Layer 3 communication

Application

The HARDNET-IE S7-REDCONNECT software package connects the SIMATIC S7-400H with applications on the PC such as WinCC.

A redundant Industrial Ethernet is typically used. The software package can also be used if SIMATIC H systems are operated on non-redundant networks.

Combined operation of redundant and single systems is also possible.

Design

The following components are required to design a SIMATIC H system with PC connection

PC with:

- up to four CP 1613 A2/CP 1623/CP 1628 and HARDNET-IE S7-REDCONNECT to connect the PC to Industrial Ethernet with ISO or ISO on TCP protocol

S7-400H with:

- CP 443-1 to connect the S7-400H to Industrial Ethernet with ISO or ISO on TCP protocol
- STEP 7 V5.0 or higher for programming

Function

- HARDNET-IE S7-REDCONNECT contains the functional scope of the HARDNET-IE S7 software package (S7-communication, open communication and PG/OP communication) as well as additional redundant communication over S7 connections. No additional license is required for HARDNET-IE S7.
- Open communication
- Time synchronization
- Existing Windows applications can be used
- Services for monitoring the redundant communication
- Diagnostic tool for visualizing the communication status
- Simple redundancy over 2-way communication (STEP 7 V5.0 SP2 and higher)
- Enhanced redundancy over 4-way communication (STEP 7 V5.1 + SP4 and higher)

Fault-tolerant S7 communication is carried out via a standard connection and a standby connection. These are monitored during operation and switched in the event of a fault. With HARDNET-IE S7-REDCONNECT, these remain hidden from the PC application.

Fault detection, changeover (if required), communication monitoring, and synchronization are all invisible to the application.

The application, e.g. WinCC, communicates with both subunits of the S7-400H as with an S7-CPU.

User interfaces

OPC interface

As a standard programming interface for the S7 communication and open communication protocols, the OPC server contained in the respective software package can be used to connect the automation technology to OPC-compatible Windows applications (Office, HMI systems, etc.).

Configuration

- The S7 communication and open communication protocols are configured in STEP 7 NCM PC V5.1 SP2 or higher.
- The NCM PC configuration tool is included in the scope of supply of the HARDNET-IE S7-REDCONNECT software for Industrial Ethernet.
- NCM PC is a component part of Advanced PC Configuration.

Integration

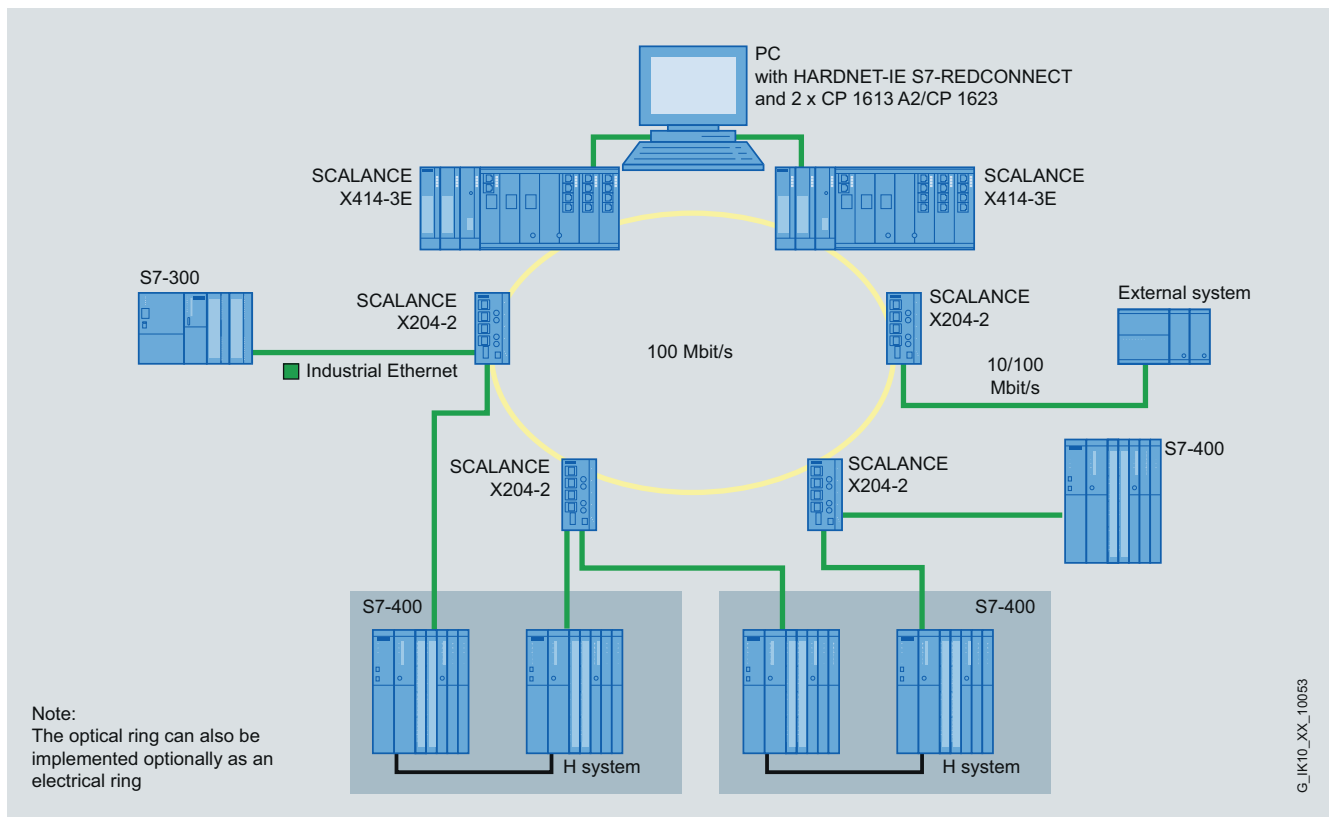

Redundant optical ring for connection of high-availability systems

PROFINET/Industrial Ethernet

Communication for PC-based systems

HARDNET-IE S7-REDCONNECT

2

Ordering data

Order No.

Order No.

HARDNET-IE S7-REDCONNECT

Software for fail-safe S7 communication via redundant networks, incl. S7 OPC server, HARDNET-IE S7, runtime software, software and electronic manual on CD-ROM, license key on USB stick, Class A;

HARDNET-IE S7-REDCONNECT V8.1

For 32/64-bit:
Windows 7 Professional/Ultimate;
for 64-bit:
Windows 2008 Server R2
German/English

- Single License for one installation

6GK1 716-0HB08-1AA0

S7-REDCONNECT Edition 2008 (V7.1)

for 32-bit
Windows XP Professional SP 2/3;
Windows 2003 Server R2, SP2;
Windows Vista Business/Ultimate SP1; Windows 2008 Server;
German/English

- Single License for one installation

6GK1 716-0HB71-3AA0

Software Update Service

For 1 year
with automatic extension;
requirement:
Current software version

6GK1 716-0HB00-3AL0

Upgrade

- From Edition 2006 to S7-REDCONNECT Edition 2008 or V8.1
- From V6.0, V6.1, V6.2 or V6.3 to S7-REDCONNECT Edition 2008 or V8.1

6GK1 716-0HB00-3AE0

6GK1 716-0HB00-3AE1

HARDNET-IE S7-REDCONNECT Power Pack

For expansion from HARDNET-IE S7 to S7-REDCONNECT, single license for one installation, runtime software, software and electronic manual on CD-ROM, license key on USB stick, Class A;

HARDNET-IE S7-REDCONNECT Power Pack V8.1

6GK1 716-0HB08-1AC0

For 32/64-bit:
Windows 7 Professional/Ultimate;
for 64-bit:
Windows 2008 Server R2;
German/English;

S7-REDCONNECT Power Pack Edition 2008 (V7.1)

6GK1 716-0HB71-3AC0

for 32-bit
Windows XP Professional SP 2/3;
Windows 2003 Server R2, SP2;
Windows Vista Business/Ultimate SP1; Windows 2008 Server;
German/English

CP 1613 A2 communication processor

6GK1 161-3AA01

PCI card (32-bit, 33 MHz/66 MHz; 3.3 V/5 V universal keyed) for connection to Industrial Ethernet (10/100 Mbit/s) with ITP and RJ45 connection over HARDNET-IE S7 and S7-REDCONNECT, for operating system support see SIMATIC NET Software

CP 1623 communication processor

6GK1 162-3AA00

PCI Express x1 card for connection to Industrial Ethernet (10/100/1000 Mbit/s), with 2-port switch (RJ45) via HARDNET-IE S7 and S7-REDCONNECT. For operating system support, see SIMATIC NET Software

CP 1628 communication processor ¹⁾

6GK1 162-8AA00

PCI Express x1 card for connection to Industrial Ethernet (10/100/1000 Mbit/s), with 2-port switch (RJ45) and integral security (firewall, VPN) via HARDNET-IE S7 and S7-REDCONNECT. For operating system support, see SIMATIC NET Software

¹⁾ Available soon

Overview

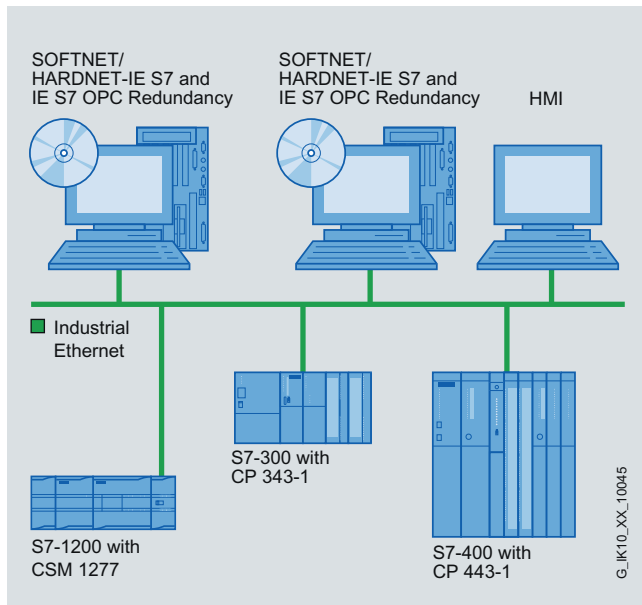

System configuration SOFTNET for Industrial Ethernet

ISO	TCP/UDP	PN	MRP	OPC	PG/OP	S7/S5	IT
●	●			●	●	●	

- Software for coupling programming devices/workstations to automation systems
- Communication services:
 - PG/OP communication
 - S7 communication
 - Open communication (SEND/RECEIVE)
- Can be used with
 - Layer 2 Ethernet card (PCI/PCIe)
 - Integrated Industrial Ethernet interface, e.g. CP 1612 A2
 - Modem (Remote Access Service RAS)
- Complete protocol stack as a software package
- Increased availability thanks to additional option packages such as OPC Server Redundancy

Benefits

get Designed for Industry

- Maximum transparency due to integrated communication with SIMATIC via Industrial Ethernet and OPC as the standard interface
- Low-cost solution for industrial use in PCs that require smaller quantity structures
- Simple and low-cost commissioning thanks to uniform procedure and configuration functionality with NCM PC and STEP 7
- Increased availability of the plant information by means of redundant SIMATIC NET OPC server

Application

With SOFTNET for Industrial Ethernet, PC/PG and workstations can be connected to programmable controllers, such as SIMATIC S7, over Industrial Ethernet.

The following user interfaces are available:

- PG/OP communication for SIMATIC S7
- Open communication (SEND/RECEIVE) for communication with SIMATIC S5 and S7
- S7 communication

SOFTNET is available for the following interfaces:

- Layer 2 Ethernet card (PCI/PCIe)
- integrated Industrial Ethernet interface
- Modem/ISDN (Remote Access Service RAS)

Function

With SOFTNET, the complete protocol stack is processed in the PC.

This architecture means that in contrast to the CP 1613 A2/CP 1623/CP 1628 communication processors, the performance of the SOFTNET packages is dependent on the configuration or capacity utilization of the PC used.

The IT functionality is established in connection with the interfaces and the PC's Windows software.

User interfaces

OPC interface

As a standard programming interface for the S7 communication and open communication protocols, the OPC server contained in the respective software package can be used to connect the automation technology to OPC-compatible Windows applications (Office, HMI systems, etc.).

Software for PG/OP communication

This software makes it possible to program the SIMATIC S5 and S7 controllers via the Industrial Ethernet in conjunction with STEP 5/STEP 7.

Software for S7 communication

SIMATIC S7 system components communicate with each other using S7 communication functions.

The S7 communication can be based optionally on the ISO protocol or the TCP/IP protocol.

S7 communication offers the following services:

- Administrative services
- S7 connection management services
- Variable services
- VFD (Virtual Field Device) services
- Trace and mini database

PROFINET/Industrial Ethernet

Communication for PC-based systems

SOFTNET for Industrial Ethernet

Function (continued)

Open communication (SEND/RECEIVE)

This interface based on Layer 4 (ISO Transport or TCP/IP with RFC 1006) is used for communication between

- PG/PC and SIMATIC S5
- PG/PC and SIMATIC S7
- PG/PC and PG/PC

Open communication (SEND/RECEIVE) offers the following services:

- Management services
- Dial-up services
- Data transfer services

Configuration

- The complete configuration of the S7 communication and open communication protocols takes place in STEP 7 or SIMATIC NCM PC V5.1 SP2 or higher.
- The NCM PC configuration tool is included in the scope of delivery of the corresponding packages.

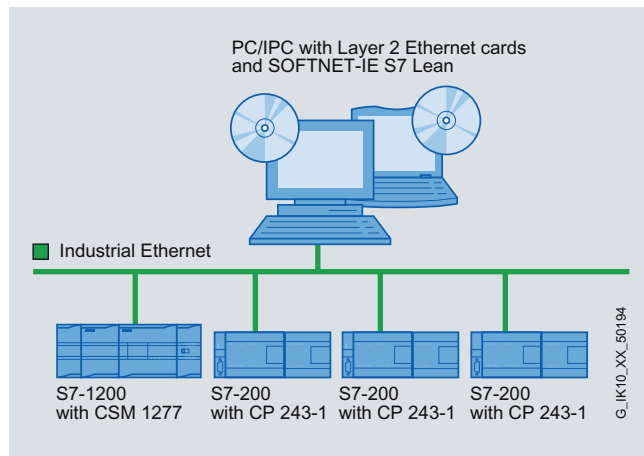

System configuration with SOFTNET-IE S7 Lean for Industrial Ethernet and SIMATIC S7-1200/S7-200

Technical specifications

Product type designation	SOFTNET for Industrial Ethernet
<i>Performance data</i>	
S7 and PG/OP communication (number of operable connections)	
• SOFTNET-IE S7	max. 64
• SOFTNET-IE S7 Lean	max. 8

Ordering data	Order No.	Order No.	
SOFTNET S7 for Industrial Ethernet		SOFTNET-PG for Industrial Ethernet	
Software for S7 and open communication, incl. OPC server, PG/OP communication, and NCM PC, runtime software, software and electronic manual on CD-ROM, license key on USB flash drive, Class A		Software for PG/OP communication, runtime software, software and electronic manual on CD-ROM, license key on USB flash drive, Class A	
SOFTNET-IE S7 V8.1		SOFTNET-IE PG V8.1	
For 32/64-bit Windows 7 Professional/Ultimate; for 64-bit: Windows 2008 Server R2; English/German		For 32/64-bit: Windows 7 Professional/Ultimate; for 64-bit: Windows 2008 Server R2; English/German	
up to 64 connections • Single license for one installation	6GK1 704-1CW08-1AA0	• Single license for one installation	6GK1 704-1PW08-1AA0
SOFTNET-S7 Edition 2008 (V7.1) for Industrial Ethernet		SOFTNET-PG Edition 2008 (V7.1) for Industrial Ethernet	
for 32 bit Windows XP Professional SP2/3; Windows 2003 Server R2, SP2; Windows Vista Business/Ultimate SP1; Windows 2008 Server; English/German		for 32 bit Windows XP Professional SP2/3; Windows 2003 Server R2, SP2; Windows Vista Business/Ultimate SP1; Windows 2008 Server; English/German	
up to 64 connections • Single license for one installation	6GK1 704-1CW71-3AA0	• Single license for one installation	6GK1 704-1PW71-3AA0
Software Update Service	6GK1 704-1CW00-3AL0	Software update	6GK1 704-1PW00-3AL0
For 1 year with automatic extension; requirement: current software version		For 1 year with automatic extension; requirement: current software version	
Upgrade		Upgrade	
• From Edition 2006 to Edition 2008 or V8.1	6GK1 704-1CW00-3AE0	• From Edition 2006 to Edition 2008 or V8.1	6GK1 704-1PW00-3AE0
• From V6.0, V6.1, V6.2 or V6.3 to Edition 2008 or V8.1	6GK1 704-1CW00-3AE1	• From V6.0, V6.1, V6.2 or V6.3 to Edition 2008 or V8.1	6GK1 704-1PW00-3AE1
SOFTNET-IE S7 Lean Edition V8.1		IE S7 OPC Redundancy	
Up to eight connections • Single license for one installation	6GK1 704-1LW08-1AA0	Software for redundant OPC servers in the environment of Industrial Ethernet software, S7 products, Runtime software, software and electronic manual on CD-ROM, license key on USB flash drive, Class A	
SOFTNET-S7 Lean Edition 2008 (V7.1) for Industrial Ethernet		IE S7 OPC Redundancy V8.1	
Up to eight connections • Single license for one installation	6GK1 704-1LW71-3AA0	for 64-bit: Windows 2008 Server R2; English/German	
Software Update Service	6GK1 704-1LW00-3AL0	• Single license for one installation	6GK17 06-1CW08-1AA0
For 1 year with automatic extension; requirement: current software version		• Software Update Service for one year, with automatic extension; requirement: current software version	6GK17 06-1CW00-3AL0
Upgrade			
• From Edition 2006 to Edition 2008 or V8.1	6GK1 704-1LW00-3AE0		
• From V6.0, V6.1, V6.2 or V6.3 to Edition 2008 or V8.1	6GK1 704-1LW00-3AE1		

PROFINET/Industrial Ethernet Communication for PC-based systems

SOFTNET PN IO

Overview

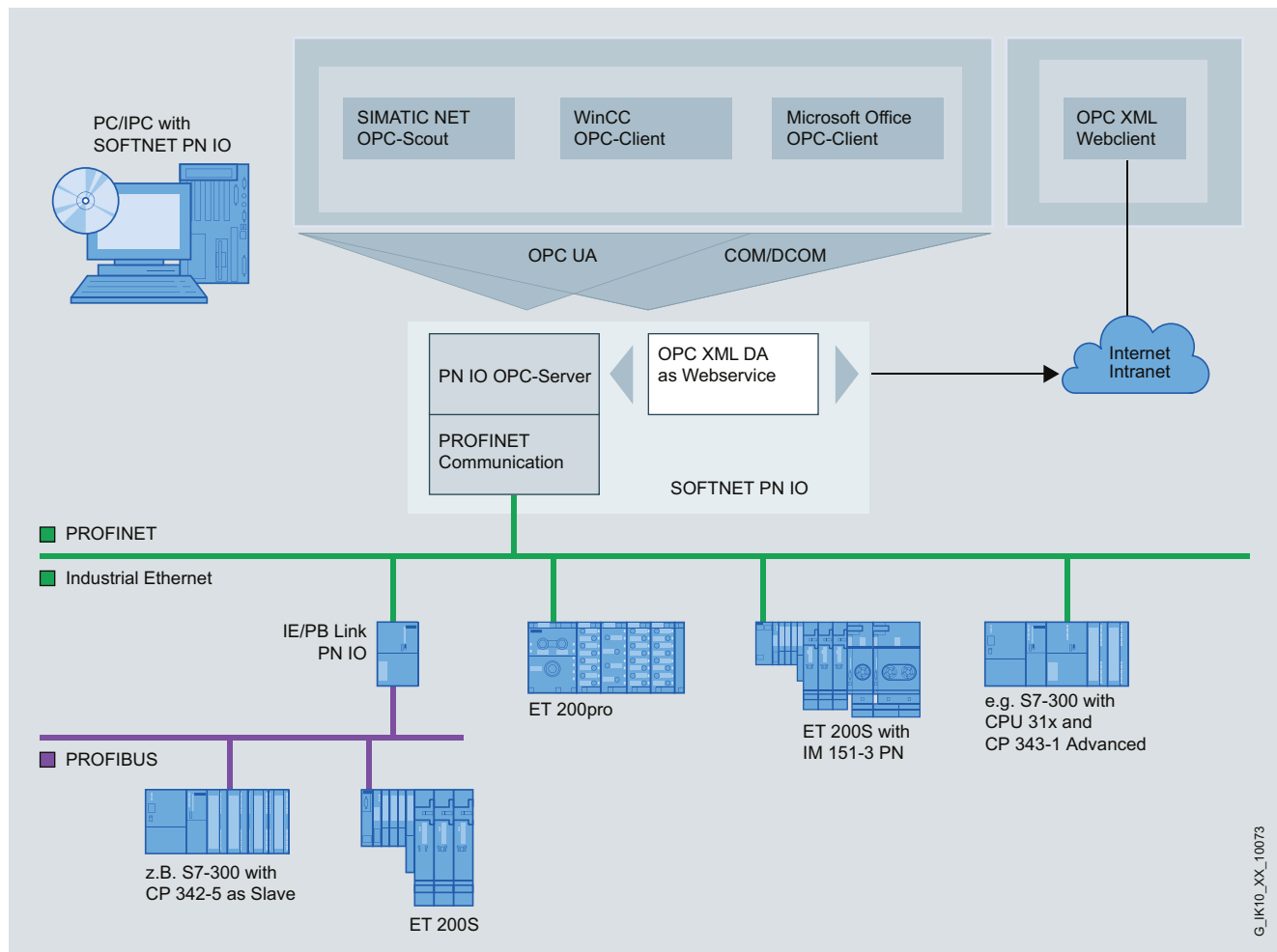

PC with SOFTNET PN IO as PROFINET IO Controller

ISO	TCP/UDP	PN	MRP	OPC	PG/OP	S7/S5	IT
	●	●		●			

Benefits



- Software with PROFINET IO Controller function for coupling PG/PC and IPC with PROFINET IO Devices
- Possible applications:
 - PC-based control systems
 - HMI systems
 - Test applications
- Communication services:
 - PROFINET IO Controller
- Can be used with
 - Integrated interfaces of SIMATIC PG/PC
 - You can find more information about the environment of use at www.siemens.com/simatic-net/ik-info
- Cost-effective solution for the low-end performance range
- OPC server for I/O interfacing over PROFINET included in scope of supply

- Cost-effective interfacing of field devices to Industrial Ethernet with PROFINET
- Simple porting of the application with OPC as a standard interface
- High-performance IO data access through RT Base interface for linking into C/C++ applications
- Simple changeover from PROFIBUS modules CP 5613 A2/ CP 5614 A2 with DP-Base interface to PROFINET through IO-Base interface
- Uniform procedure and configuration functions for NCM PC and STEP 7

G_IK10_XX_10073

Application



Using SOFTNET PN IO, PCs can be linked with PROFINET field devices including PC-based PN IO devices (e.g. with CP 1616 or CP 1604) via Industrial Ethernet.

SOFTNET PN IO is available for the following interfaces:

- CP 1612 A2
- Integrated interfaces of SIMATIC PG/PC

Function

PROFINET communication

PROFINET IO controller

Connection of field devices to Industrial Ethernet with PROFINET

User interfaces

OPC interface

The supplied OPC server can be used as a standard programming interface for PROFINET IO Controller to link automation applications to OPC-capable Windows applications (Office, HMI systems, etc.).

Programming interface via C Library

For applications that want to use the PROFINET IO Controller functionality directly over C/C++, the IO-Base interface can be used. In terms of design, this interface is based on the DP base interface of the PROFIBUS modules CP 5613 A2 and CP 5614 A2. Therefore, the porting of existing PROFIBUS DP master applications to PN IO Controller applications is also possible and easy.

The released compilers can be found in the readme file of the SIMATIC NET CD products at www.siemens.com/automation/csi/net.

SOFTNET PN IO and CP 1616 use compatible functions of the IO-Base interface.

Mode of operation

For SOFTNET, the entire protocol stack is handled in the PC. This architecture means that the performance depends on the configuration of the PC used or the loading on the PC.

Configuration

The configuration is done in STEP 7/NCM PC as of V5.3 SP1

Technical specifications

Product type designation	SOFTNET PN IO
Performance data	
• Number of operable IO devices	Max. 64
• Number of external IO-lines in one central rack	Max. 1
• Size of IO data areas overall	
- I/O input area	Max. 2 KB
- I/O output area	Max. 2 KB
• Size of I/O data area per connected I/O device	
- I/O input range	Max. 1433 byte
- I/O output range	Max. 1433 byte

Ordering data

Order No.

SOFTNET PN IO

Software for PROFINET IO Controller with OPC server and NCM PC, runtime software, software and electronic manual on CD-ROM, license key on USB flash drive, Class A,

SOFTNET-IE PN IO V8.1

For 32/64-bit:
Windows 7 Professional/Ultimate;
for 64-bit:
Windows 2008 Server R2
English/German

- Single license for one installation

6GK1 704-1HW08-1AA0

SOFTNET PN IO Edition 2008 (V7.1)

for 32 Bit
Windows XP Professional SP 2/3;
Windows 2003 Server R2, SP2;
Windows Vista Business/Ultimate SP1; Windows 2008 Server;
English/German

- Single license for one installation

6GK1 704-1HW71-3AA0

Software Update Service

For 1 year
with automatic extension;
requirement:
Current software version

6GK1 704-1HW00-3AL0

Upgrade

- From Edition 2006 to SOFTNET PN IO Edition 2008 or V8.1
- From V6.0, V6.1, V6.2 or V6.3 to SOFTNET PN IO Edition 2008 or V8.1

6GK1 704-1HW00-3AE0

6GK1 704-1HW00-3AE1

PROFINET/Industrial Ethernet

Communication for PC-based systems

OPC server for Industrial Ethernet

Overview

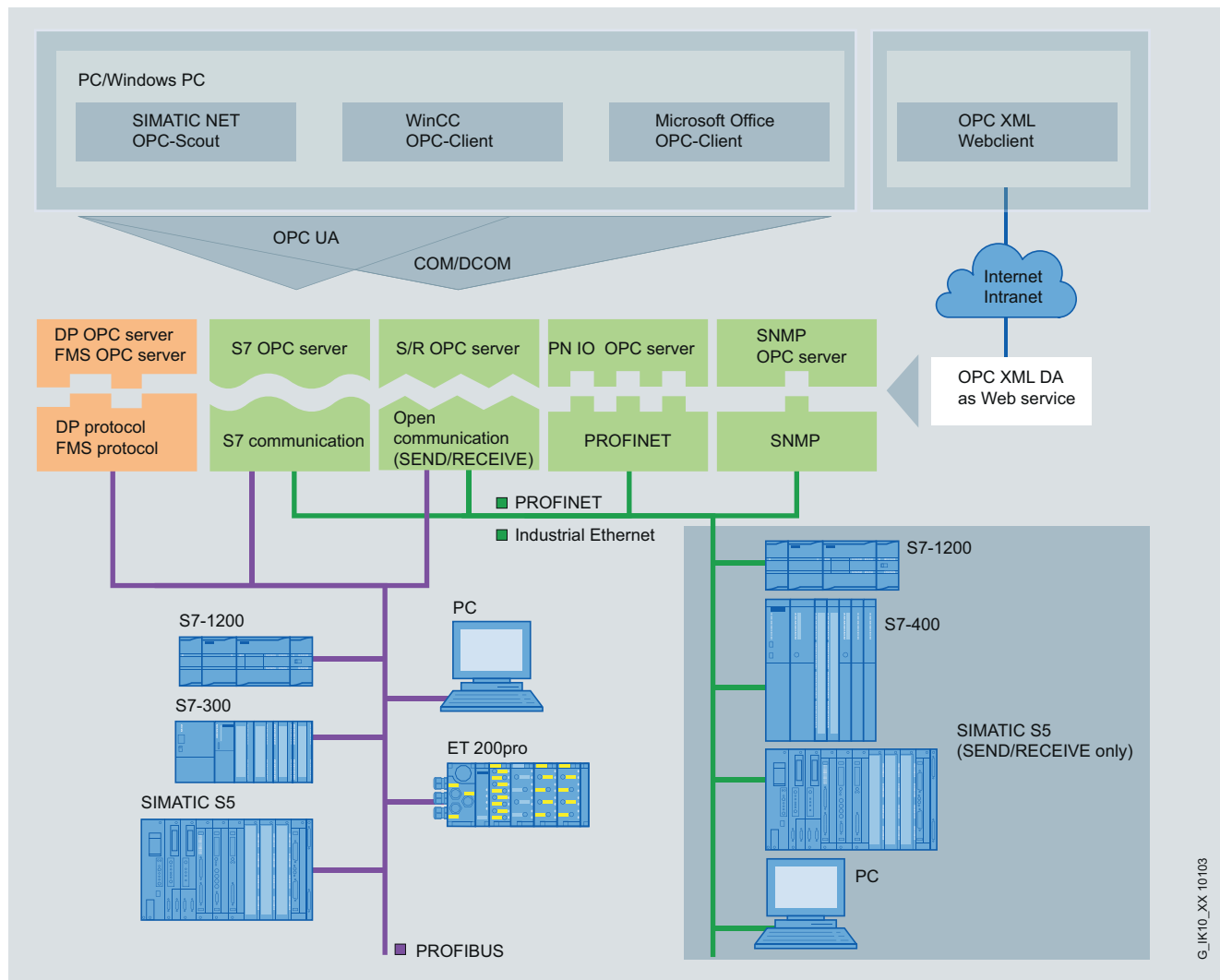

System integration with OPC server

OPC (**O**penness, **P**roductivity & **C**ollaboration) is a standardized, open, and vendor-independent interface that is widely used in automation.

A fundamental distinction is made between the classic OPC and its consistent further development OPC UA (**U**nified **A**rchitecture). Smooth migration to the new OPC UA standard is easily possible; this offers further value added, such as security. The SIMATIC NET OPC servers offer the two interfaces OPC UA and classic OPC for SIMATIC S7 and PROFINET.

- The appropriate OPC servers are included in the scope of supply of the respective communication software
- Standardized, open multi-vendor interface
- It permits interfacing of OPC-capable Windows applications to S7-communication, open communication (SEND/RECEIVE), PROFINET and SNMP.
- Increased availability thanks to additional option packages such as OPC server redundancy
- OPC Scout with browser functionality as an OPC client and OCX Data Control/.NET Data Control for simple OPC client creation

Benefits

get Designed for Industry

- Simple use of different networks and protocols through uniform interface
- Reduced training and familiarization overhead
- Increased availability of the plant information by means of redundant SIMATIC NET OPC server
- Simple integration into the system environment and office applications via C++, Visual Basic- and .NET interfaces
- Short setup times for applications
- Simple handling and cost effective since the appropriate OPC servers are included in the scope of supply of the respective communication software

Application

The basic principle of OPC is that OPC client applications communicate with the OPC server over a standardized, open and manufacturer-independent interface.

It is also possible to connect to OPC-capable Windows applications (Microsoft Office or HMI systems) that are already available on the market.

The following communication possibilities are available for Industrial Ethernet with OPC server:

- S7 communication
- Open communication (SEND/RECEIVE)
- PROFINET
- SNMP (Simple Network Management Protocol)

The OPC server offers, for example:

- Data Access interfaces 2.0, 2.05a and 3.0
- Alarm and event interface 1.1
- OPC XML DA interface 1.0
- Integration of automation products of different manufacturers
- Uniform, easy user interface for different components
- Can be accessed from every computer in the LAN
- High-performance data access over the Custom Interface (C++, NET)
- Easy to use with the "Automation Interface" (VB, NET) or the supplied OCX Data Control or .NET Data Control
- Grouping of variables (Items); which allows a large quantity of data to be pre-processed in a short time.
- Optional redundancy expansion for S7 communication

Function

- Open standardization of the addressing using logical names for objects from an automation component or an automation system
 - Supports STEP 7 symbols
 - Efficient data transfer from a process component to an application for further processing
 - One client application can use several servers simultaneously
 - Simultaneous execution of more than one client is possible on one OPC server
 - Communication protocols can be used in parallel by means of the multiplexer function
- Interfaces
 - "Custom Interface" for high-performance C++/NET applications
 - "Automation Interface" for easily created Visual Basic applications (or similar)
 - XML DA interface; Data access to S7 CPUs is therefore possible over the Internet.
 - OCX Data Control or .NET Data Control for direct integration in Windows applications that support COM/DCOM

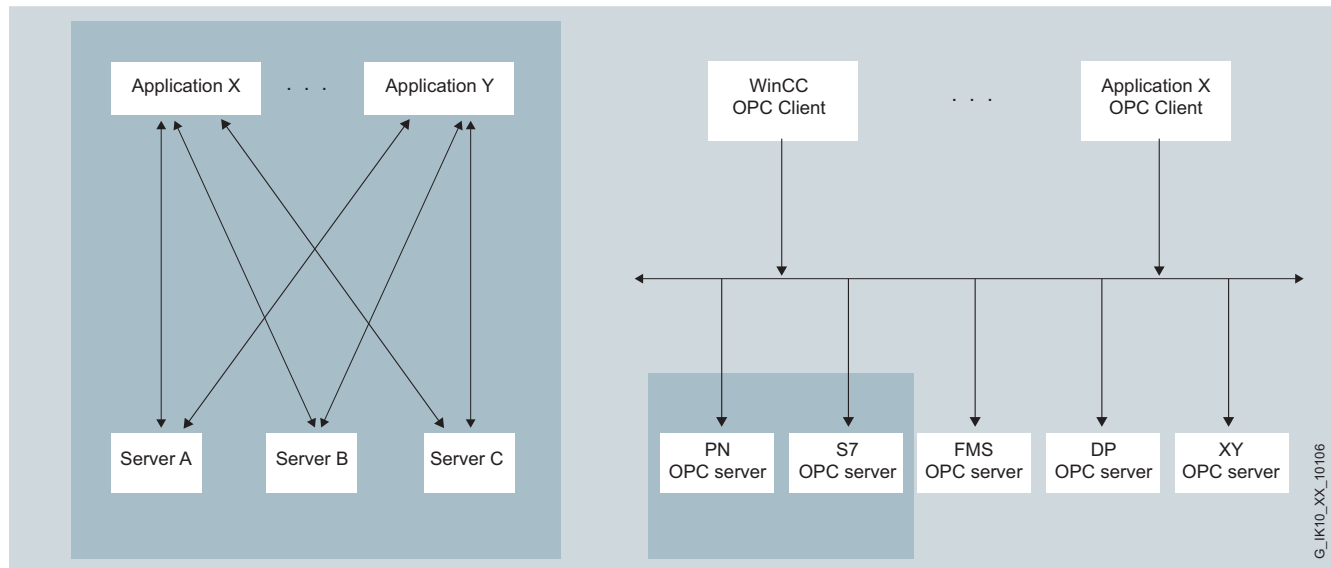

Comparison of conventional client/server architecture with an OPC architecture

Configuration

The communication parameters are configured using only the tools of the installed software Advanced PC Configuration (configuration console, SIMATIC NCM PC or from STEP 7 V5.1 + SP2); SIMATIC iMAP is used for PROFINET CBA.

PROFINET/Industrial Ethernet

Communication for PC-based systems

OPC server for Industrial Ethernet

Technical specifications

Product type designation	OPC server for Industrial Ethernet
Programming	<ul style="list-style-type: none"> • Synchronous and asynchronous reading and writing of variables • Monitoring of variables using the OPC server with a signal to the client when a change occurs • Use of quantity operations; so a large amount of data can be processed in a short time.
Interfaces	<ul style="list-style-type: none"> • Custom Interface (C++, NET) for high OPC performance • Automation Interface (VB, Excel, Access, Delphi, ...) for ease-of-use • Graphics with OCX or .NET Data Control; for configuring instead of programming • OPC XML-Interface for Data Access
Products	include OPC servers for:
Industrial Ethernet	
<ul style="list-style-type: none"> • HARDNET-IE S7, SOFTNET-IE S7, SOFTNET-IE S7 Lean 	S7-OPC server for S7 communication, XML-DA S5-OPC server for open communication ¹⁾ communication, XML-DA
<ul style="list-style-type: none"> • SNMP OPC server 	SNMP OPC server for SNMP protocol access; XML-DA
<ul style="list-style-type: none"> • S7 OPC Redundancy 	Redundant S7-OPC server for S7 communication
PROFINET	
<ul style="list-style-type: none"> • SOFTNET-IE PN IO 	PN IO OPC server for PROFINET IO communication; XML-DA
PROFIBUS	
<ul style="list-style-type: none"> • HARDNET-PB DP, SOFTNET-PB DP, SOFTNET-PB DP slave 	DP-OPC server for PROFIBUS DP communication; XML-DA
<ul style="list-style-type: none"> • FMS-5613 	FMS-OPC server for PROFIBUS FMS communication; XML-DA
<ul style="list-style-type: none"> • HARDNET-PB S7, SOFTNET-PB S7 	S7-OPC server for S7 communication, XML-DA
<ul style="list-style-type: none"> • S7 OPC Redundancy 	Redundant S7-OPC server for S7 communication

¹⁾ also S5-compatible communication

Ordering data

Order No.

SNMP OPC server

Status monitoring of SNMP-capable devices in any OPC client systems; e.g. SIMATIC WinCC/PCS 7

See SNMP OPC server

S7 OPC Redundancy

Software for redundant OPC servers in the environment of Industrial Ethernet software, S7 products, Runtime software, software and electronic manual on CD-ROM, license key on USB stick, Class A

S7 OPC Redundancy V8.1

for 64-bit:
Windows 2008 Server R2;
German/English

- Single License for one installation

6GK1 706-1CW08-1AA0

Software Update Service

For 1 year with automatic extension; requirement: Current software version

6GK1 706-1CW00-3AL0

Overview

OPC (**O**penness, **P**roductivity & **C**ollaboration) is a standardized, open, and vendor-independent interface that is widely used in automation. OPC UA (**U**nified **A**rchitecture) is the result of consistent further development of this standard, offering additional functions such as security or redundancy.

S7 OPC Redundancy is a software product compliant with the OPC UA standard that enables the redundant configuration of OPC UA servers to SIMATIC S7. The availability of automation data to operator control and monitoring systems is guaranteed thanks to the redundant use of OPC UA servers. This requires neither additional cabling for synchronizing the redundant OPC UA servers, nor additional programming overhead in the PC. The OPC UA servers are synchronized via high-performance Industrial Ethernet network access points at 10/100 and 1000 Mbps. S7 OPC Redundancy represents an integrated customer solution for all SIMATIC NET S7 SOFTNET and HARDNET software products in the automation world.

Benefits

- Enhanced plant availability thanks to redundant OPC UA servers that guarantee plant access for operator control and monitoring systems
- Secures investments thanks to the use of existing applications (OPC clients) and flexible application options, regardless of the SIMATIC S7 controller used
- Improved utilization of IT resources thanks to even distribution of the OPC clients among the redundant OPC servers
- Easy and low-cost commissioning thanks to uniform procedure and configuration functionality with NCM PC and STEP 7

Application

The redundant OPC UA server software enables redundant configuration of SIMATIC NET OPC UA servers. Failure of one OPC UA server, as a result of power outage or system failure, for example, results in immediate use of the other OPC UA server, and continuation of the existing OPC UA client connection. This ensures increased availability of automation data to operator control and monitoring systems.

Design

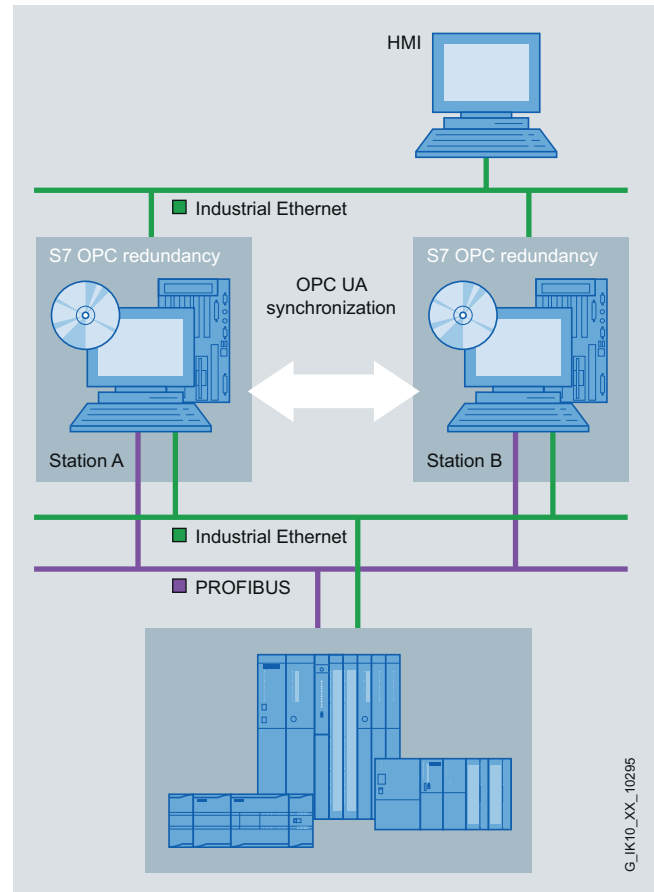

Redundant use of OPC servers

A redundant OPC UA server system comprises the following:

Server PC with

- Operating system for Windows server
- SOFTNET-IE S7 or HARDNET-IE S7 software based on OPC UA server
- S7 OPC Redundancy software

The redundant operation of up to two OPC UA servers is possible.

Client PC (HMI)

- Software for OPC clients that supports OPC UA (incl. reconnect functionalities in accordance with OPC UA specification)

The communication parameters are configured using STEP 7 or SIMATIC NET NCM PC. The NCM PC configuration tool is included in the scope of delivery of the SIMATIC NET PC products.

PROFINET/Industrial Ethernet

Communication for PC-based systems

S7 OPC Redundancy for Industrial Ethernet

Function

S7 OPC Redundancy enables the setup of redundant OPC UA servers, thus ensuring plant access for the operator control and monitoring systems.

This means, for example, that the information synchronization between two SIMATIC NET S7 OPC servers via the S7 OPC Redundancy software package is guaranteed. This is handled transparently for the OPC Client application so that in the event of a fault, the redundant OPC server takes over the tasks from the failed OPC server system.

Data exchange between the OPC clients and the OPC servers takes place via the standardized OPC UA communication. Communication with the SIMATIC S7 controller takes place using the S7 protocol. This is ensured by the software products SIMATIC NET SOFTNET or HARDNET-S7 for Industrial Ethernet that are necessary as the basis for SIMATIC NET IE S7 OPC Redundancy.

The S7 OPC Redundancy software package supports:

- High availability;
Failure of one OPC UA server results in immediate use of the other OPC UA server, and continuation of the existing OPC UA client connection. The basis for this is the OPC UA synchronization that ensures synchronization of the necessary client information.
- Load compensation;
Even distribution of OPC clients among the available OPC servers

Configuration

All configuration is performed with STEP 7 or SIMATIC NCM PC, V5.5 SP1 or higher. The NCM PC configuration tool is included in the scope of delivery of the corresponding packages.

Ordering data

Order No.

S7 OPC Redundancy

Software for redundant OPC servers in the environment of Industrial Ethernet software, S7 products, Runtime software, software and electronic manual on CD-ROM, license key on USB stick, Class A

S7 OPC Redundancy V8.1 for Industrial Ethernet

for 64-bit:
Windows 2008 Server R2;
English/German

- Single license for one installation

Software Update Service

for 1 year
with automatic extension;
requirement:
Current software version

6GK1 706-1CW08-1AA0

6GK1 706-1CW00-3AL0

Overview

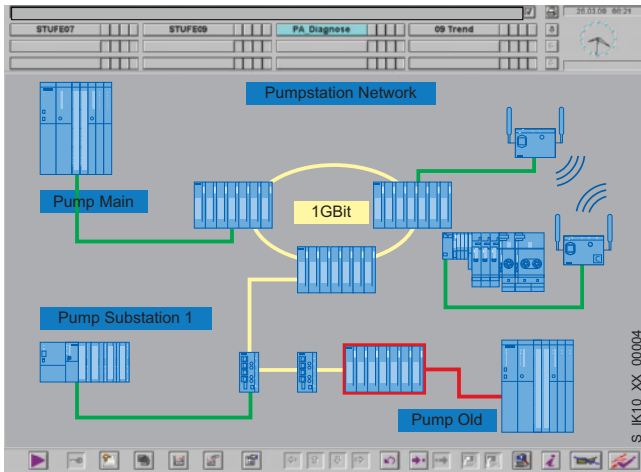

- Status monitoring of SNMP-capable devices in any OPC client systems; e.g. SIMATIC WinCC/PCS 7
- Easy access to SNMP-capable devices over the OPC interface
- Devices without SNMP agents can be monitored using the ping mechanism
- Configuring with STEP 7 or NCM PC
- Ready-to-use SNMP diagnostics profiles for Siemens devices, e.g. SCALANCE X/W
- Generation of any SNMP diagnostics profiles by means of the integral MIB compiler
- Easy setup of the monitored devices with the help of an autodiscovery function

Benefits



- Network view and process view in a single system
- Easy network diagnostics in SIMATIC HMI/SCADA systems and office applications
- Easy configuration and engineering without the need for detailed knowledge of SNMP: embedded in the SIMATIC tool landscape
- It can operate in parallel with other communication protocols

Application

The SNMP OPC server makes data available for the administration of TCP/IP networks for any OPC client systems.

SNMP (Simple Network Management Protocol) is a protocol that has been specifically designed for administration of TCP/IP networks. The individual nodes in the network (network components or data terminals) are equipped with a so-called SNMP agent that provides information in structured form.

OPC (Openness, Productivity & Collaboration) provides a standardized, open, multi-vendor interface for automation engineering.

The SNMP OPC server supports access to device information over the OPC interface. This means that network visualization, system diagnostics and plant status monitoring can be implemented in any OPC client systems (with OPC clients such as WinCC, WinCC flexible, PCS 7). In addition to simple device diagnostics, detailed information such as redundant network structures or network load distribution can be displayed. This increases the operational safety and improves the availability of the plant.

The device information can be visualized according to individual requirements and can be adapted to the special requirements of the respective customer installation. The information that is made available can also be integrated into the signaling system and alarm log of an HMI/SCADA system for example.

Using the SNMP information, it is possible to expand an existing HMI/SCADA system as far as a customer-specific network management station.

The SNMP OPC server can be operated over the following interfaces:

- CP 1613 A2 (PCI)
- CP 1623 (PCIe)
- CP 1628 (PCIe)¹⁾
- Integral Industrial Ethernet interface of SIMATIC programming devices/PCs or CP 1612 A2

¹⁾ Available soon

PROFINET/Industrial Ethernet

Communication for PC-based systems

SNMP OPC server

Function

The SNMP OPC server supports access to SNMP-capable devices in the OPC client systems. For all configured TCP/IP devices that are not SNMP-capable, one OPC variable for -of-life monitoring (ICMP-PING) is offered.

Read access and in part write access to the respective device information is possible. Thus the diagnosis of individual devices is possible as well as diagnosis of the complete plant and device characteristics can be actively controlled.

STEP 7/NCM PC contains an MIB compiler (Management Information Base) for integrating SNMP-enabled devices. This allows device profiles to be created on the basis of an MIB file

Devices with SNMP agents

SIMATIC NET devices that feature special SNMP agents such as switches, WLAN Access Points and Industrial Ethernet PC and S7 communication processors are already included complete with their device profiles.

Thanks to MIB compilers (Management Information Base), other SNMP-enabled devices can be integrated into the OPC configuration through loading of MIBs in accordance with the SMI V1 and SMI V2 standard from STEP 7 V5.4.

Devices with IP addresses without SNMP agents

Devices without SNMP agents can be monitored using the ping mechanism. The user can edit and save device-specific information such as the contact person, site and device description for this purpose.

- Any SNMP-capable devices such as printers or PCs can be depicted using a predefined library.
- The devices are integrated into the desktop of a client application using preconfigured ActiveX Controls.

The predefined device profiles and the associated ActiveX controls allow easy administration of the devices in OPC client applications. Individual expansions can also be implemented.

The SNMP OPC server is integrated in the SIMATIC NET OPC server. The OPC Scout is also included in the functional scope for browsing the displayed SNMP information. The SNMP OPC server can use, for example, PROFINET or S7 communication at the same time as PROFIBUS and Industrial Ethernet communication. This means that existing installations can also be expanded with SNMP functionality. The SNMP OPC server also enables several clients to execute simultaneously on one server.

User interfaces

- "Custom Interface" for high-performance C++ applications
- "Automation Interface" for easily created Visual Basic applications (or similar).
- OPC Data Control for easy creation of client applications by configuring ActiveX controls
- OPC Alarms & Events (Subset)
- Preconfigured ActiveX controls for the device profile used

Configuration

The NCM PC configuration tool is included in the scope of supply of the CP 1612 A2/CP 1613/1623/1628 ¹⁾ software packages and SOFTNET for Industrial Ethernet.

¹⁾ Available soon

Ordering data

Order No.

SNMP OPC server

Including MIB compiler; single license for one installation of runtime software; software and electronic manual on CD-ROM; license key on USB stick, Class A;

SNMP OPC Server Basic

Administration of up to 20 IP addresses

- **Basic V8.1**
for 32/64-bit:
Windows 7 Professional/Ultimate;
for 64-bit:
Windows 2008 Server R2;
Single license for one installation
- **Basic 2008 (V7.1)**
for 32-bit
Windows XP Professional SP2/3;
Windows 2003 Server R2, SP2;
Windows Vista Business/
Ultimate SP1;
Windows 2008 Server;
Single license for one installation

6GK1 706-1NW08-1AA0

6GK1 706-1NW71-3AA0

Software Update Service SNMP OPC Server Basic

For 1 year
with automatic extension;
requirement:
current software version

6GK1 706-1NW00-3AL0

Upgrade SNMP OPC Server Basic

- From Edition 2006 to Edition 2008 or V8.1
- From V6.0, V6.1, V6.2 or V6.3 to Edition 2008 or V8.1

6GK1 706-1NW00-3AE0

6GK1 706-1NW00-3AE1

SNMP OPC Server Extended

Administration of up to 200 IP addresses

- **Extended V8.1**
for 32/64-bit:
Windows 7 Professional/Ultimate;
for 64-bit:
Windows 2008 Server R2;
Single license for one installation
- **Extended 2008 (V7.1)**
for 32-bit
Windows XP Professional SP2/3;
Windows 2003 Server R2, SP2;
Windows Vista Business/
Ultimate SP1;
Windows 2008 Server;
Single license for one installation

6GK1 706-1NX08-1AA0

6GK1 706-1NX71-3AA0

Software Update Service SNMP OPC Server Extended

For 1 year
with automatic extension;
requirement:
Current software version

6GK1 706-1NX00-3AL0

Upgrade SNMP OPC Server Extended

- From Edition 2006 to Edition 2008 or V8.1
- From V6.0, V6.1, V6.2 or V6.3 to Edition 2008 or V8.1

6GK1 706-1NX00-3AE0

6GK1 706-1NX00-3AE1

SNMP OPC Server Power Pack

For upgrade from SNM OPC Server Basic to SNM OPC Server Extended

Power Pack V8.1

6GK1 706-1NX08-1AC0

Power Pack Edition 2008 (V7.1)

6GK1 706-1NX71-3AC0

Overview

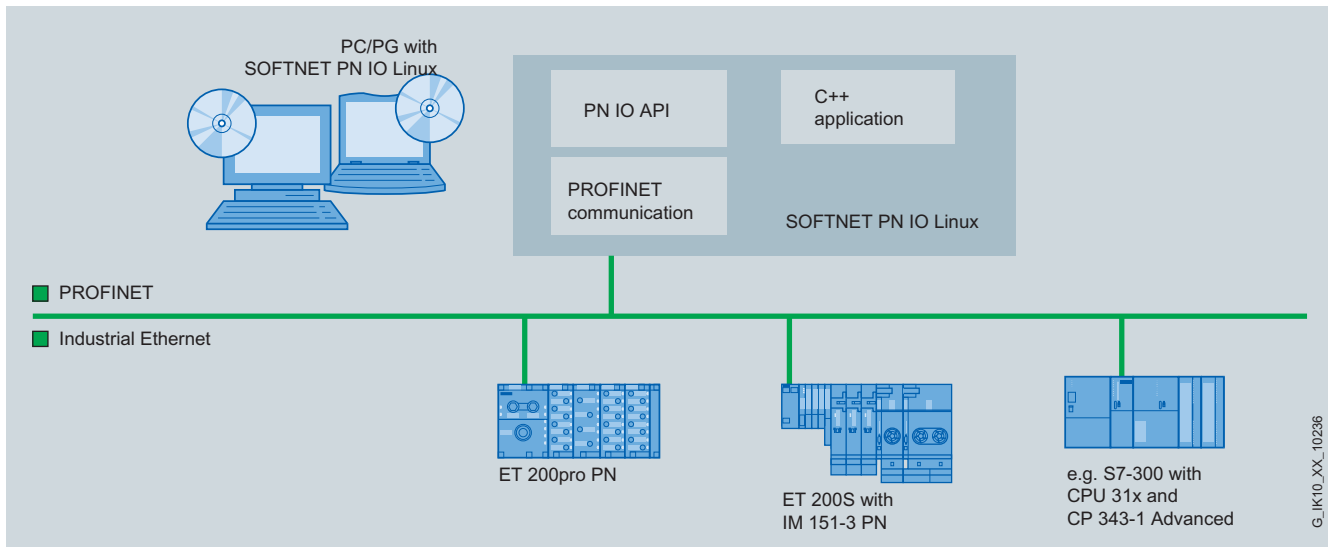

PC with SOFTNET PN IO Linux as PROFINET IO Controller

- Software with PROFINET IO Controller function for coupling PCs and IPCs with PROFINET IO Devices
- Possible applications:
 - PC-based control systems
 - HMI systems
 - Test applications
- Communication services:
 - PROFINET IO Controller
- Can be used in combination with integrated Ethernet interface
- Cost-effective solution for the low-end performance range

Benefits



- Cost-effective interfacing of field devices to Industrial Ethernet with PROFINET
- High-performance access to IO data through IO-Base interface for integration into C/C++ applications
- Simple changeover from CP 5613 A2/CP 5614 A2 PROFIBUS modules with DP-Base interface to PROFINET through IO-Base interface
- Uniform approach and configuration functionality with NCM PC and STEP 7

PROFINET/Industrial Ethernet

Communication for PC-based systems

SOFTNET PN IO Linux

Application

Using SOFTNET PN IO Linux, PCs can be linked with PN field devices including PC-based PN IO Devices (e.g. with CP 1616 or CP 1604) via Industrial Ethernet.

SOFTNET PN IO Linux is available for the following interfaces:

- Integrated Ethernet interfaces

Function

PROFINET communication

PROFINET IO controller

Connection of field devices to Industrial Ethernet with PROFINET

User interfaces

Programming interface via C Library

For the integration of the PROFINET IO controller functionality, the IO-Base interface can be used. In terms of design, this interface is based on the DP base interface of the PROFIBUS modules CP 5613 A2 and CP 5614 A2. Therefore, the porting of existing PROFIBUS DP master applications to PN IO Controller applications is also possible and easy.

SOFTNET PN IO Linux and CP 1616 use compatible functions of the IO Base interface.

Mode of operation

For SOFTNET, the entire protocol stack is handled in the PC. This architecture means that the performance depends on the configuration of the PC used or the loading on the PC.

Configuration

The configuration is done in STEP 7/NCM PC as of V5.3 SP1

Technical specifications

Product type designation	SOFTNET PN IO Linux
<i>Performance data</i>	
• Number of operable IO Devices	max. 64
• Number of external IO lines in one central rack	max. 1
• Size of IO data areas overall	
- I/O input range	Max. 2 KB
- I/O output range	Max. 2 KB
• Size of I/O data area per connected IO Device	
- I/O input range	Max. 1433 bytes
- I/O output range	Max. 1433 bytes

Ordering data

Order No.

SOFTNET PN IO Linux

Software for PROFINET IO Controller; runtime software, software and electronic manual on CD-ROM, for Linux Kernel 2.6.x and glibc 2.3.x; German/English

- Single License for one installation

2XV9 450-1PN00

Overview

- Software for connecting SIMATIC S7
- Provision of S7 communication via SAPI-S7 interface
- Support of ISO and TCP/IP (RFC 1006) protocol
- Available on Linux operating systems
- Simultaneous operation of several cards

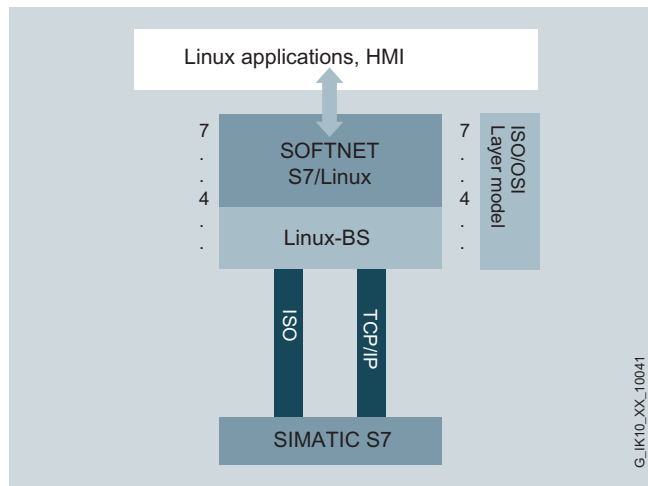

SOFTNET-S7/Linux system configuration

Benefits



- High-speed communication with the S7 based on the S7 protocol
- Cost-saving programming thanks to user-friendly and simple interface
- Flexible in use thanks to hardware-independent software

Application

For Linux systems, Siemens offers high-speed communication with the SIMATIC S7 for Industrial Ethernet based on the S7 protocol.

SAPI-S7 (Simple Application Programmer Interface) provides you with a user-friendly call interface for communication between HMI systems or other Linux applications and the SIMATIC S7.

Function

SOFTNET uses internal standard interfaces of the operating system for accessing the Ethernet connections. This supports the interface cards enabled by the operating system. Simultaneous operation of several cards is possible.

During communication, you can choose between the protocols ISO and TCP/IP with RFC1006 for each connection.

The SOFTNET products offer the user diagnostics and trace functions.

SOFTNET-S7/Linux functions

SIMATIC S7 system components communicate with each other using S7 communication functions. The programming interface SAPI-S7 (Simple Application Programmer Interface) is available for Linux operating systems as well as for the Windows operating systems.

S7 communication offers the following services:

- Administrative services
- Variable services
- BSEND/BRECV

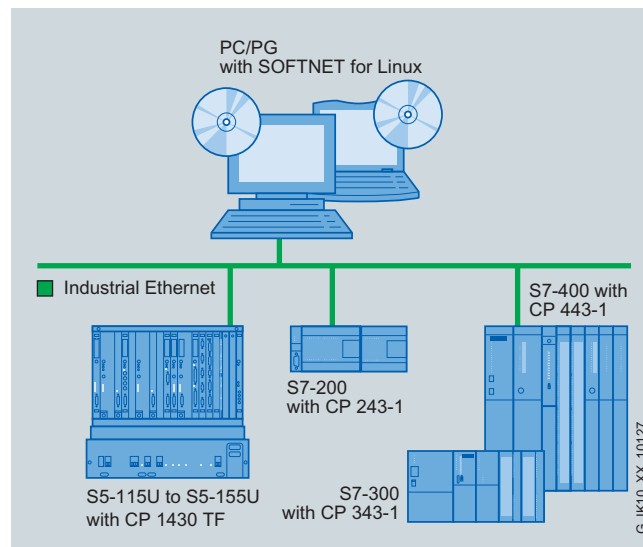

SOFTNET-S7/Linux system configuration

PROFINET/Industrial Ethernet

Communication for PC-based systems

SOFTNET-S7/Linux

Ordering data

SOFTNET-S7/Linux for Industrial Ethernet

Software for S7 communication for SIMATIC S7 including Level 4 interface over ISO or TCP/IP, single license for 1 installation, runtime software, software and electronic manual on CD-ROM, license key by fax, Class A, German/English

Version 2.0

The original distributions of SUSE and RedHat Linux are supported. Please contact your Siemens contacts for information about the latest versions and their variants (32-bit and 64-bit).

Order No.

2XV9 450-1CG00

More information

Support for Linux distributors:
Contact for sales, service and training can be found at:
www.siemens.com/simatic-net/ik-info

2

Overview

- Integrated communication
- Cross-computer communication
- Uniform interface
 - To databases
 - Link to ERP and DB systems
 - To SIMATIC S7

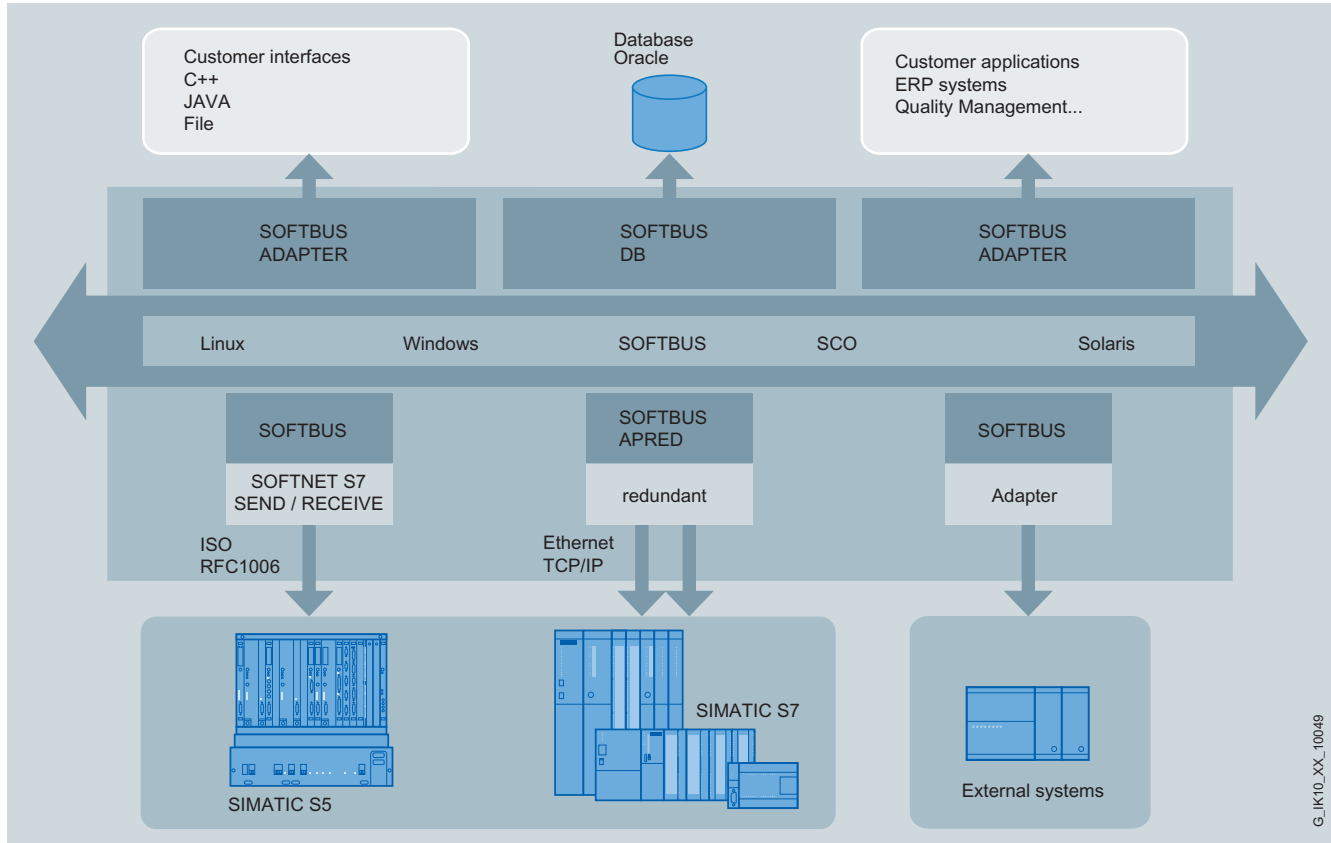

System configuration for SOFTBUS-SOFTNET

Benefits



- Communication across the system with standardized interface.
- Incorporation of ERP and DB systems.
- Interfacing of SIMATIC control systems
- Fast and automatic data flow

Application

The process landscape in industrial companies is frequently a product of historical developments. Thus there are many isolated solutions that function optimally within their own terms of reference but operate in a vacuum.

Integrating these requires a smooth, loss-free and integrated communication system. Only this guarantees that the right information arrives at the right place and at the right time.

SOFTBUS together with SOFTNET-S7 consists of matched modules that are available on the commonly used system platforms (Linux, Windows) and thus ensure smooth communication between the system platforms.

PROFINET/Industrial Ethernet

Communication for PC-based systems

SOFTBUS for Linux

Function

SOFTBUS functions

SOFTBUS comprises software modules that can be used on all commonly available computer systems (Windows, Linux).

The modules are compatible and have been adapted to standards such as SIMATIC NET and thus secure vertical integration with short start-up times.

SOFTBUS DB functions

SOFTBUS-DB merges databases and communication and therefore offers possibilities for transaction protection and uniform data storage.

Interfaces

Thanks to the combination of different modules, all commonly used platforms can be supported and linked together heterogeneously or homogeneously.

The programming interface of SOFTBUS is identical to the WVS-KOM interface of the SIPAX package.

This means that SIPAX applications can migrate to SOFTBUS without any problems.

Ordering data

Order No.

SOFTBUS

Version 2.3

SOFTBUS Linux

- SOFTBUS/Linux redundant (TCP) (32 bit)
- SOFTBUS/Linux redundant (ISO) (32 bit)
- SOFTBUS/Linux (TCP) (32 bit)
- SOFTBUS/Linux (ISO) (32 bit)

Please contact your Siemens contacts for information about the latest versions and their variants (32-bit and 64-bit).

2XV9 450-1CG02

2XV9 450-1CG04

2XV9 450-1CG08

2XV9 450-1CG10

More information

Support for Linux distributors can be found at:
www.siemens.com/simatic-net/ik-info

Overview

SIMATIC Basic Panel, Touch Panels (TP), Operator Panels (OP), Mobile Panel, Multifunctional Platforms (MP) ¹⁾ and the SIMATIC HMI software package for PC WinCC flexible Runtime support HMI functionality in conjunction with:

- SIMATIC S7
- SIMATIC S5
- SIMATIC 505
- SIMOTION
- SINUMERIK ²⁾
- Non-Siemens controllers:
 - Allen Bradley – DF1, DH485 and Ethernet IP protocols
 - GE Fanuc – SNP/SNPX protocol
 - LG GLOFA GM – dedicated protocol
 - Mitsubishi – FX and MP 4 protocols
 - Modicon – Modbus RTU and TCP/IP protocols
 - Omron I – Link/MultiLink protocol
 - Telemecanique – UNI-TELWAY protocol

For more detailed information, refer to the WinCC flexible user manual, the "Windows-based systems communication" manual, and the WinCC flexible online help.

- 1) For the sake of simplicity, SIMATIC TP/OP/MP is always used in the text below. This is not restrictive, as the information is valid for all systems referred to above. If there are constraints, direct reference is made to them in the text.
- 2) Required under WinCC flexible: "SINUMERIK HMI copy license WinCC flexible CE" and "SINUMERIK HMI copy license OA". For configuring, a "SINUMERIK HMI engineering package WinCC flexible" is also necessary.

Note:

Interface options for HMI devices: See the individual device descriptions.

Extended functionality with WinCC flexible

WinCC flexible supports OPC communication for Multi Panel and WinCC flexible Runtime and HTTP communication for all panels with integrated Ethernet interface. Both OPC and HTTP communication can be used in parallel with the process links to SIMATIC S7/S5/505 or non-Siemens PLCs.

OPC Data Access (MP 277, MP 377, WinCC flexible Runtime only)

OPC Data Access is an open standard for exchanging both local and remote variables between various applications via Industrial Ethernet. The original version of OPC is based on Microsoft COM/DCOM and, therefore, requires a Microsoft Windows-based PC operating system (not Windows CE) on both clients and servers. As OPC XML, communication is based on the Internet standard SOAP/XML and is, therefore, suitable for embedded systems with Windows CE.

Options that are required: WinCC flexible /OPC server

HTTP communication for the variable exchange between SIMATIC HMI systems

(only TP 177B DP/PN, OP 177B DP/PN, Mobile Panel 177 PN, TP 277, OP 277, Mobile Panel 277, Mobile Panel 277 IWLAN, MP 277, MP 377, WinCC flexible Runtime)

Communication based on HTTP message frames enables variables to be exchanged between SIMATIC HMI systems.

Options that are required: WinCC flexible/Sm@rt Access

Communication standard Version	SIMATIC HMI			WinCC flexible Runtime	Connection via
	TP 177B DP/PN OP 177B DP/PN Mobile Panel 177 PN MP 177	TP 277 OP 277	Mobile Panel 277 ⁶⁾ Mobile Panel 277 IWLAN MP277 MP 377		
OPC client (COM/DCOM)	–	–	–	•	Industrial Ethernet
OPC server (COM/DCOM)	–	–	–	• ¹⁾	Industrial Ethernet
OPC XML client (SOAP/XML)	–	–	–	• ²⁾	Industrial Ethernet
OPC XML server (SOAP/XML)	–	–	• ³⁾	–	Industrial Ethernet

OPC Data Access V2.05a + OPC Data Access XML V1.00

Communication standard Version	SIMATIC HMI			WinCC flexible Runtime	Connection via
	TP 177B DP/PN OP 177B DP/PN Mobile Panel 177 PN MP 177	TP 277 OP 277	Mobile Panel 277 ⁶⁾ Mobile Panel 277 IWLAN MP277 MP 377		
OPC client (COM/DCOM)	–	–	–	•	Industrial Ethernet
OPC server (COM/DCOM)	–	–	–	• ¹⁾	Industrial Ethernet
OPC XML client (SOAP/XML)	–	–	–	• ²⁾	Industrial Ethernet
OPC XML server (SOAP/XML)	–	–	• ³⁾	–	Industrial Ethernet

HTTP communication for variable exchange between SIMATIC HMI systems

Communication standard Version	SIMATIC HMI			WinCC flexible Runtime	Connection via
	TP 177B DP/PN OP 177B DP/PN Mobile Panel 177 PN MP 177	TP 277 OP 277	Mobile Panel 277 ⁶⁾ Mobile Panel 277 IWLAN MP277 MP 377		
HTTP client	• ⁴⁾	• ⁴⁾	• ⁴⁾	• ⁵⁾	Industrial Ethernet
HTTP server	• ⁴⁾	• ⁴⁾	• ⁴⁾	• ⁵⁾	Industrial Ethernet

- System interface possible
- System interface not possible

- 1) Option WinCC flexible /OPC Server for WinCC flexible Runtime required
- 2) Only with DCOM/XML gateway included in the scope of delivery of WinCC flexible for access to MP 277, MP 377 and MP 370 OPC XML servers
- 3) Option WinCC flexible /OPC Server for SIMATIC Multi Panel required
- 4) Option WinCC flexible /Sm@rtAccess for SIMATIC Panel required
- 5) Option WinCC flexible /Sm@rtAccess for WinCC flexible Runtime required
- 6) Depending on the terminal box used

PROFINET/Industrial Ethernet

System interfaces for SIMATIC HMI

SIMATIC S7

Overview

The following types of interface are supported in respect of the link between SIMATIC HMI Panels and SIMATIC WinCC flexible Runtime with SIMATIC S7:

- **PPI interface:**
Interface between SIMATIC HMI Panels and SIMATIC S7-200 via PPI. Communication runs on the PPI protocol, a standard FB as with SIMATIC S5 is not required.
- **MPI interface:**
Interface between SIMATIC HMI Panels and SIMATIC S7 via the integrated PPI interface with S7-200 or MPI interface with S7-300/-400 or alternatively via the MPI interface of a separate interface module and the backplane bus to the SIMATIC S7-CPU. Communication runs on the MPI protocol (PG/OP communication), a standard FB as with SIMATIC S5 is not required.
- **PROFIBUS interface:**
Interface between SIMATIC HMI Panels and SIMATIC S7 via the integrated PROFIBUS interface on the CPU or alternatively via the PROFIBUS interface on a separate interface module and the backplane bus to the SIMATIC S7-CPU. Communication runs on the MPI protocol (PG/OP communication), a standard FB as with SIMATIC S5 is not required.
- **PROFINET interface:**
Interface between SIMATIC HMI Panels and SIMATIC S7 via the integrated PROFINET interface on the CPU or alternatively via the Industrial Ethernet interface on a separate interface module and the backplane bus to the SIMATIC S7-CPU. Communication runs on the MPI protocol (PG/OP communication), a standard FB as with SIMATIC S5 is not required.

The maximum possible number of S7 connections of a CPU is determined by its power (see Catalog ST 70); from the point of view of SIMATIC HMI Panels the following restrictions apply:

- OP 73micro, TP 177micro: 1 connection
- OP 73: max. 2 connections
- OP 77A, TP 177A, Basic Panel, OP 77B, TP177B, OP 177B, Mobile Panel 177: max. 4 connections
- TP 277, OP 277; Mobile Panel 277, MP 177, MP 277, MP 377: max. 6 connections
- PC with WinCC flexible Runtime: max. 8 connections

PPI interface

From the point of view of the concept, the PPI interface is a point-to-point connection between a SIMATIC HMI Panel (PPI master) or alternatively a PG (PPI master), and an S7-200 (PPI slave).

MPI interface/PROFIBUS interface/Industrial Ethernet interface

The multipoint-enabled communication interfaces of SIMATIC HMI Panels and SIMATIC S7 are used. Options are:

- Interface between one or a number of SIMATIC HMI Panels (MPI master) and one or a number of S7-1200/300/400s or WinAC (MPI master).
(possible network topology: *MPI/PROFIBUS/Industrial Ethernet*)
- Interface between one or a number of SIMATIC HMI Panels (MPI master) and one or a number of S7-200s (MPI slave) ¹⁾
(possible network topology: *PPI/MPI/PROFIBUS*)

Unlike PPI connections, MPI connections are static connections that are set up during booting and then monitored.

The original format of a master/master link has in the meantime been joined by a master/slave link, which has enabled integration of the S7-200 (except CPU 212). ¹⁾

In principle this type of information exchange between SIMATIC HMI Panels and SIMATIC S7 is independent of the network used, PPI, MPI, PROFIBUS or Industrial Ethernet: SIMATIC HMI Panels are S7 clients and SIMATIC S7 CPUs are S7 servers.

¹⁾ Constraints with regard to baud rate for S7-200; see Catalog ST 70.

Overview (continued)

Controller Target hardware (PROTOCOL) (physics)	SIMATIC HMI				Connection via
	TD 100C TD 200 TD 200C TD 400C	OP 73 micro TP 177micro	OP 73	OP 77A TP 177A	
via <i>Industrial Ethernet (TCP/IP)</i> (PG/OP communication) with max. 4 x S7-200, -300, -400, WinAC	–	–	–	–	Industrial Ethernet

- System interface possible
- System interface not possible

Controller Target hardware (PROTOCOL) (physics)	SIMATIC HMI			WinCC flexible Runtime	Connection via
	Basic Panels	OP 77B TP 177B DP OP 177B DP TP 177B DP/PN OP 177B DP/PN Mobile Panel 177 DP Mobile Panel 177 PN	TP 277 OP 277 Mobile Panel 277 Mobile Panel 277 IWLAN MP 177 MP 277 MP 377		
via <i>Industrial Ethernet (TCP/IP)</i> (PG/OP communication) with max. 4 x S7-200, -300, -400, WinAC	– ¹⁾	• ^{1) 2)}	• ^{2) 3)}	• ⁴⁾	Industrial Ethernet (see catalog IK PI)

- System interface possible
- System interface not possible

- 1) Only Basic Panel PN, TP 177B DP/PN, OP 177B DP/PN, Mobile Panel 177 PN
- 2) Mobile Panel 177 PN, Mobile Panel 277 connection via special connecting cable and junction box (see Mobile Panel);
Please refer to the manual for cable assignment
- 3) Mobile Panel 277 IWLAN (wireless interface, see Mobile Panel)
- 4) Connection via integrated Industrial Ethernet interface; use the CP 1612 with a standard PC

PROFINET/Industrial Ethernet

System interfaces for SIMATIC HMI

SIMATIC WinCC flexible RT

Overview

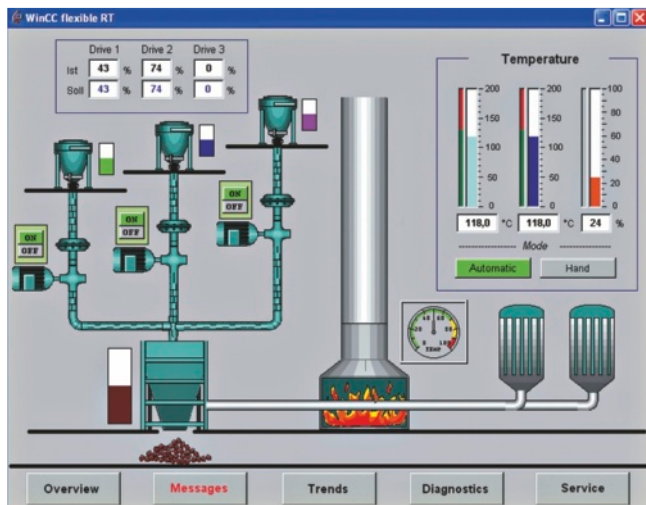

PC-based visualization software for single-user systems directly at the machine.

- Runs under Windows XP Professional and Windows 7 Professional, Ultimate, Enterprise
- Current version: SIMATIC WinCC flexible 2008 Runtime with Service Pack 2

SIMATIC WinCC flexible Runtime is configured with the SIMATIC WinCC flexible Advanced configuration software.

Benefits

- Optimum price/performance ratio thanks to individually scalable system functionality
- Functions for all visualization tasks: Operator functions, graphical and trend displays, signaling system, log system, archiving (option), recipe management (option), Audit Trail (option), process fault diagnostics (option)
- Flexible runtime functionality thanks to Visual Basic scripts
- Innovative service concepts with remote operation, diagnostics and administration via intranet and Internet as well as e-mail communication to increase availability (option)
- Support for simple distributed automation solutions based on TCP/IP networks at the machine level (option)

Integration

SIMATIC WinCC flexible Runtime supports linking to:

Protocol	PC interfaces
SIMATIC S7 via Ethernet (TCP/IP)	
S7-200 with CP 243-1	CP 1612 ¹⁾ CP 1613 A2 CP 1623
S7-300 CPUs with integral Ethernet interface	
S7-300 with CP 343-1	
S7-400 CPUs with integral Ethernet interface	
S7-400 with CP 443-1	
WinAC Basis (V3.0 and higher)	
WinAC RTX	
SIMATIC S7 via integrated interface	
WinAC Basis (V2.0 and higher)	Internal system interface
WinAC RTX	
SIMOTION²⁾	
SINUMERIK³⁾	
Third-party controllers	
Allen Bradley (DF1/DH485)	COM1/COM2
Allen Bradley (Ethernet)	CP 1612 ¹⁾
GE Fanuc (SNP/SNPX)	COM1/COM2
LG GLOFA GM	COM1/COM2
Mitsubishi (FX/MP4)	COM1/COM2
Modicon (Modbus)	COM1/COM2
Modicon (Modbus TCP/IP)	CP 1612 ¹⁾
OMRON (Link/Multilink)	COM1/COM2
OPC^{4) 6)}	
Data Access V2.05a (client + server)	CP 1612 ¹⁾
Data Access XML V1.00 (client)	
HTTP communication for data exchange between SIMATIC HMI (client + server)^{5) 6)}	CP 1612 ¹⁾

¹⁾ For Microbox 427 and Panel PC 477/577/677/877 via internal Ethernet interface

²⁾ For further information, see Catalog PM 10

³⁾ "SINUMERIK HMI copy license OA" option required; for further information, see Catalog NC 60

⁴⁾ OPC Client is included in scope of delivery, the "WinCC flexible /OPC Server for WinCC flexible Runtime" license is required for the OPC Server option

⁵⁾ "WinCC flexible /Sm@rtAccess for WinCC flexible Runtime" license required

⁶⁾ OPC and HTTP communication are additive, i.e. can be used in conjunction with the PLC links listed above

For information about SIMATIC Panels that support OPC/ http communication, see the overview under "System interfaces".

Application note

In parallel with each and every PLC link, WinCC flexible Runtime supports the use of the OPC Client channel; this enables, for example, connection to an SNMP OPC Server for the purpose of visualizing the data stored there. The SNMP OPC Server provides a means of monitoring network components of any type (e.g. switches) which support the SNMP protocol.

Note:

You can find more information in Catalog ST 80 / ST PC and in the Industry Mall at www.siemens.com/industrymall

Integration (continued)

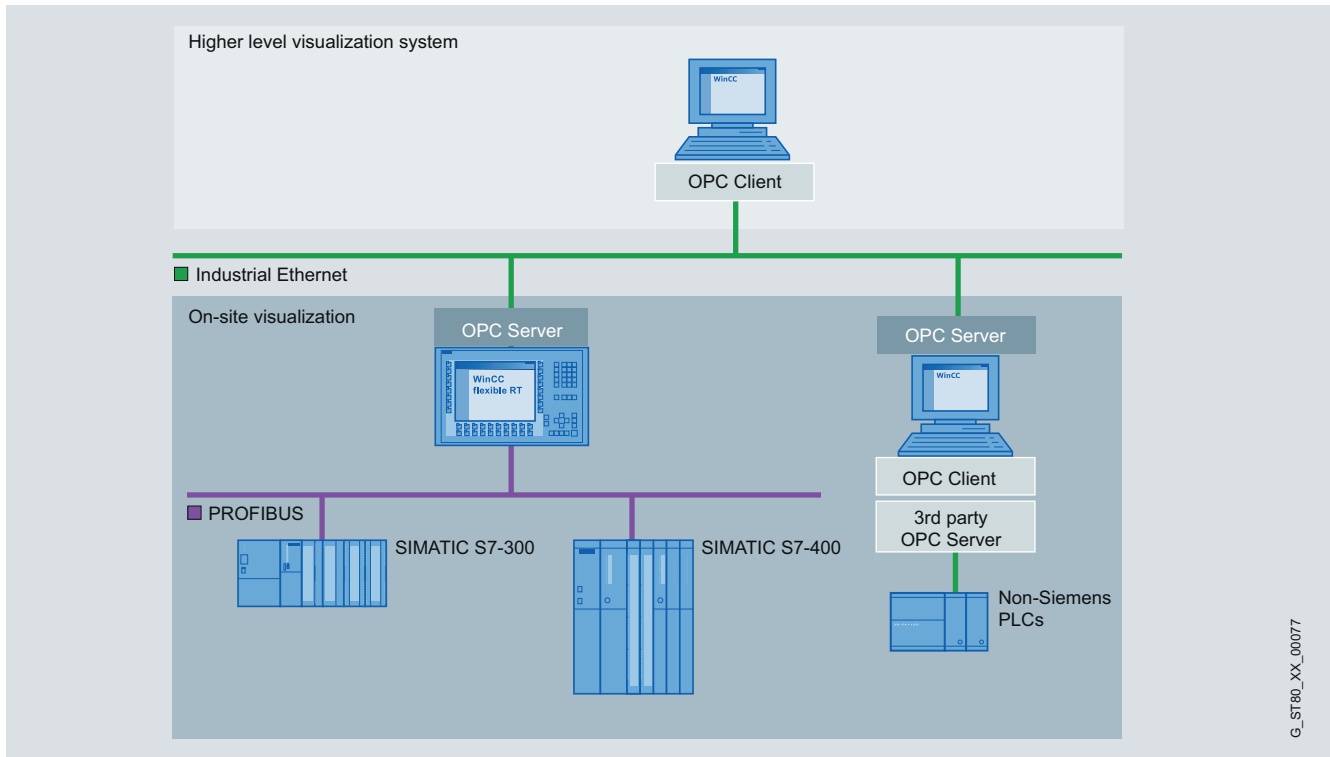

SIMATIC WinCC flexible Runtime application example

More information

Additional information is available on the Internet at:
www.siemens.com/wincc-flexible

PROFINET/Industrial Ethernet

System interfaces for SIMATIC HMI

SIMATIC WinCC

Overview

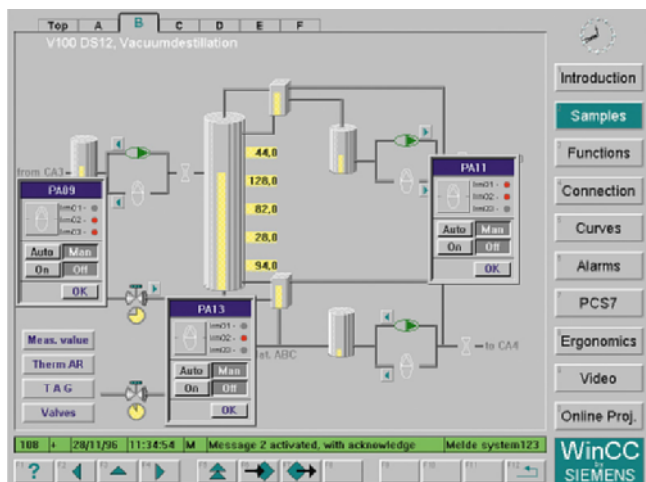

- PC-based operator control and monitoring system for visualizing and operating processes, production flows, machines and plants in all sectors – from the simple single-user station through to distributed multi-user systems with redundant servers and cross-location solutions with Web clients. WinCC is the information hub for corporation-wide vertical integration.
- The basic system configuration (WinCC basic software) includes industry-standard functions for signaling and acknowledging events, archiving of messages and measured values, logging of all process and configuration data, user administration and visualization.
- The WinCC basic software forms the core of a wide range of different applications. Based on the open programming interfaces, a wide range of WinCC options (from Siemens Industry Automation) and WinCC add-ons have been developed (by Siemens-internal and external partners).
- WinCC can be operated with every PC that meets the given HW requirements. Particularly the SIMATIC Panel PC and SIMATIC Rack PC product range is available for the industrial use of WinCC systems. SIMATIC PCs impress with their powerful PC technology, are designed for round-the-clock operation, and can be operated in both office areas and harsh industrial environments.
- Together with the Panel PC 477B, there are turnkey solutions as WinCC Standard Client and with the SIMATIC HMI IPC477C as WinCC Standard Client or Single Station. (See also Packages and HMI IPC477C)

Current versions:

- **SIMATIC WinCC V7.0 SP2:**
Executable with
 - Windows 7 (32-bit) Professional, Enterprise, Ultimate
 - Windows XP Professional SP3
 - Windows 2003 Server SP2 and Windows 2003 Server R2 SP2
 - Windows 2008 Server SP2 (32-bit)
contains the Microsoft SQL Server 2005 SP2
 - Use in virtual environments – for further information, see <http://support.automation.siemens.com/WW/view/en/49370459>
- **SIMATIC WinCC V6.2 SP3:**
Executable with
 - Windows XP Professional
 - Windows 2000 Professional
 - Windows Server 2003 and Windows Server 2003 R2
Contains the Microsoft SQL Server 2005 SP2

Integration

Integration in company-wide solutions (IT and business integration)

WinCC is strictly based on Microsoft technology, which provides for the greatest possible compatibility and integration ability. ActiveX and .net¹⁾ controls support technology and sector-specific expansions. Cross-manufacturer communication is also a simply exercise. The reason: WinCC can be used as an OPC client and server, and in addition to access to current process values, it also supports standards such as OPC HDA (Historical Data Access), OPC Alarm & Events, and OPC XML Data Access. Just as important: Visual Basic for Applications (VBA) for user-specific expansions of the WinCC Graphics Designer and Visual Basic Scripting (VBS) as an easy-to-learn, open runtime language. If desired, professional application developers can also use ANSI-C. And the access to the API programming interfaces is really simple with the Open-Development-Kit ODK.

WinCC integrates a powerful and scalable Historian function based on the Microsoft SQL Server 2005 in the basic system. Thus the user is given all possibilities: from high-performance archiving of current process data, to long-term archiving with high data compression, through to a central information turntable in form of a company-wide Process Historian. With the help of the option Central Archive Server, this can be created within the framework of a WinCC solution. Versatile clients and tools for evaluation, the open interfaces, special options (Connectivity Pack, Connectivity Station, IndustrialDataBridge) provide the basis for an effective IT and business integration.

¹⁾ Only supported by WinCC V7.0

Integration in automation solutions

WinCC is an open process visualization system and offers the option of connecting the most diverse control systems.

Released communication software

Only communication software with the listed (or higher) product versions should be used. Corresponding SIMATIC NET upgrades are available for the upgrading of older versions.

Number of connectable controls

For the number of the connectable controls via Industrial Ethernet CP 1613/CP 1623, the following applies for a message frame length of 512 bytes:

Type of coupling	Number of nodes
SIMATIC S5 Ethernet Layer 4 + TCP/IP	up to 60
SIMATIC S7 Protocol Suite	up to 64
SIMATIC 505 Ethernet Layer 4 + TCP/IP	up to 60

Via PROFIBUS, a maximum of 8 controls with CP 5611 and a maximum of 44 controls with CP 5613 can be connected. With approx. 10 or more controls, the usage of Industrial Ethernet is recommended.

Integration (continued)

Mixed mode with different controls

With their multi-protocol stack, the communication processors CP 1613/CP 1623 and CP 5613 allow for the parallel operation of two protocols, e.g. for the mixed operation of different controls via a bus cable. WinCC supports the operation of two similar interface boards only in connection with the channels SIMATIC S5 Ethernet Layer 4 (2 x CP 1613/CP 1623), SIMATIC S7 Protocol Suite (2 x CP 1613/CP 1623, 2 x CP 5613) as well as PROFIBUS DP (4 x CP 5613; each CP 5613 max. 122 slaves). In addition to communication over industrial Ethernet CP 1613 or PROFIBUS CP 5613, one CP 5611 for communication with SIMATIC S7 via MPI can be used in each case.

Client-server communication

The communication between the clients and the server is achieved using the TCP/IP protocol. The construction of a separate PC-LAN is recommended. For small projects with correspondingly small message frame advert, a SIMATIC NET Industrial Ethernet can be used for both process communication (WinCC/Server ↔ PLC) and for the PC-PC communication (WinCC/client ↔ WinCC/server)

Channel-DLL PROFIBUS DP

In accordance with the PROFIBUS standard, DP/slaves are always permanently assigned to a DP master; i.e. a second WinCC station (DP/master) cannot access the same controls (DP/slave) This means that a redundant operation of two WinCC stations is not possible with the use of the PROFIBUS DP coupling.

Connection to controls from other manufacturers:

For the connection of controls from other manufacturers, OPC (OLE for Process Control) is recommended.

Current notes and information about OPC servers from various suppliers can be found at:

www.opcfoundation.org

WinCC supports the standards:

- OPC Data Access 2.05a
- OPC Data Access 3.00
- OPC XML Data Access 1.00 (Connectivity Pack/Connectivity Station)
- OPC HDA 1.20 (Connectivity Pack/Connectivity Station)
- OPC A&E 1.10 (Connectivity Pack/Connectivity Station)

Coupling overview

Protocol	Description
SIMATIC S7	
SIMATIC S7 Protocol Suite	Channel DLL for S7 functions via MPI, PROFIBUS or Ethernet Layer 4 + TCP/IP
Non-Siemens controllers (from WinCC V7.0)	
Allen Bradley - Ethernet IP	Channel DLL and drivers for communication with Allen Bradley controllers via Ethernet TCP/IP with Ethernet IP protocol
Modbus TCP/IP	Channel DLL and drivers for communication with Modicon controllers via Ethernet TCP/IP using Modbus TCP/IP protocol
Mitsubishi MC TCP/IP	Channel DLL and drivers for communication with Mitsubishi controllers via Ethernet TCP/IP using Mitsubishi MC TCP/IP protocol
Cross-manufacturer	
OPC client ¹⁾ for DA, XML DA	Channel DLL for OPC communication, WinCC can acquire data from OPC server applications.
OPC server for DA, XML DA, A&E, HDA	Server applications for OPC communication; WinCC provides process data for OPC client
PROFIBUS FMS	Channel DLL for PROFIBUS FMS
PROFIBUS DP	Channel DLL for PROFIBUS DP

¹⁾ Application note:

The parallel usage of the OPC client channel allows, for example, the connection to an SNMP-OPC server for visualization of the data contained there. The SNMP-OPC server enables monitoring of any network components (e.g. switch) that support the protocol SNMP. You can find more information under SIMATIC NET Communications Systems/SNMP OPC Server.

PROFINET/Industrial Ethernet

System interfaces for SIMATIC HMI

SIMATIC WinCC

Integration (continued)

Communications components for PG/PC for SIMATIC (for WinCC V7.0)

Industrial Ethernet	SIMATIC S5 Ethernet Layer 4	SIMATIC S5 TCP/IP	SIMATIC S7 Protocol Suite	SIMATIC 505 Ethernet Layer 4	SIMATIC 505 TCP/IP ¹⁾	Order No.
<i>WinCC – channel DLL</i>						
SIMATIC S5 Ethernet Layer 4 Channel DLL for S5 Layer 4 communication + TCP/IP	•	•				Included in the basic package
SIMATIC S7 Protocol Suite Channel DLL for S7 functions			•			Included in the basic package
SIMATIC 505 Ethernet Layer 4 Channel DLL for 505 Layer 4 communication				•		Included in the basic package
SIMATIC 505 TCP/IP ¹⁾ Channel DLL for 505 TCP/IP communication					•	Included in the basic package
<i>Communication components for extension of the OS/OP</i>						
CP 1612 PCI card for connecting a PG/PC to Industrial Ethernet (SOFTNET-S7 or SOFTNET-S7 Lean communications software must be ordered separately)		•	•		•	6GK1 161-2AA00
SOFTNET-S7 communications software for S7 functions (max. 64 connections) • Version 8.0 SP1 ²⁾³⁾ for (32-bit) Windows 7 • Edition 2008 SP2 (V7.1) ²⁾ for Windows XP/2003 Server / (32-bit) 2008 Server		•	•			6GK1 704-1CW80-3AA0 6GK1 704-1CW71-3AA0
SOFTNET-S7 Lean communications software for S7 functions (max. 8 connections) • Version 8.0 SP1 ²⁾³⁾⁴⁾ for (32-bit) Windows 7 • Edition 2008 SP2 (V7.1) ²⁾⁴⁾ for Windows XP/2003 Server / (32-bit) 2008 Server		•	•			6GK1 704-1LW80-3AA0 6GK1 704-1LW71-3AA0
CP 1613 A2 PCI card (32-bit) for connecting a PG/PC to Industrial Ethernet (S7-1613 communications software required)	•	•	•	•	•	6GK1 161-3AA01
CP 1623 PCI Express X1 card (32-bit) for connecting a PG/PC to Industrial Ethernet (S7-1613 communications software required)	•	•	•	•	•	6GK1 162-3AA00
S7-1613 communications software for S7 functions and S5/505 Layer 4 communication with TCP/IP • Version 8.0 SP1 ²⁾³⁾ for (32-bit) Windows 7 • Edition 2008 SP2 (V7.1) ²⁾ for Windows XP/2003 Server / (32-bit) 2008 Server	•	•	•	•		6GK1 716-1CB80-3AA0 6GK1 716-1CB71-3AA0

• System interface possible

¹⁾ Via any Interface Board with NDIS 3.0 interface; no separate communications software required

²⁾ See ordering data for SIMATIC NET upgrade packages

³⁾ SIMATIC NET Version 8.0 SP1 scope of supply includes SIMATIC NET Edition 2008 SP2 (V7.1)

⁴⁾ SOFTNET-S7 Lean included in scope of supply of WinCC V7.0

Integration (continued)

Communications examples

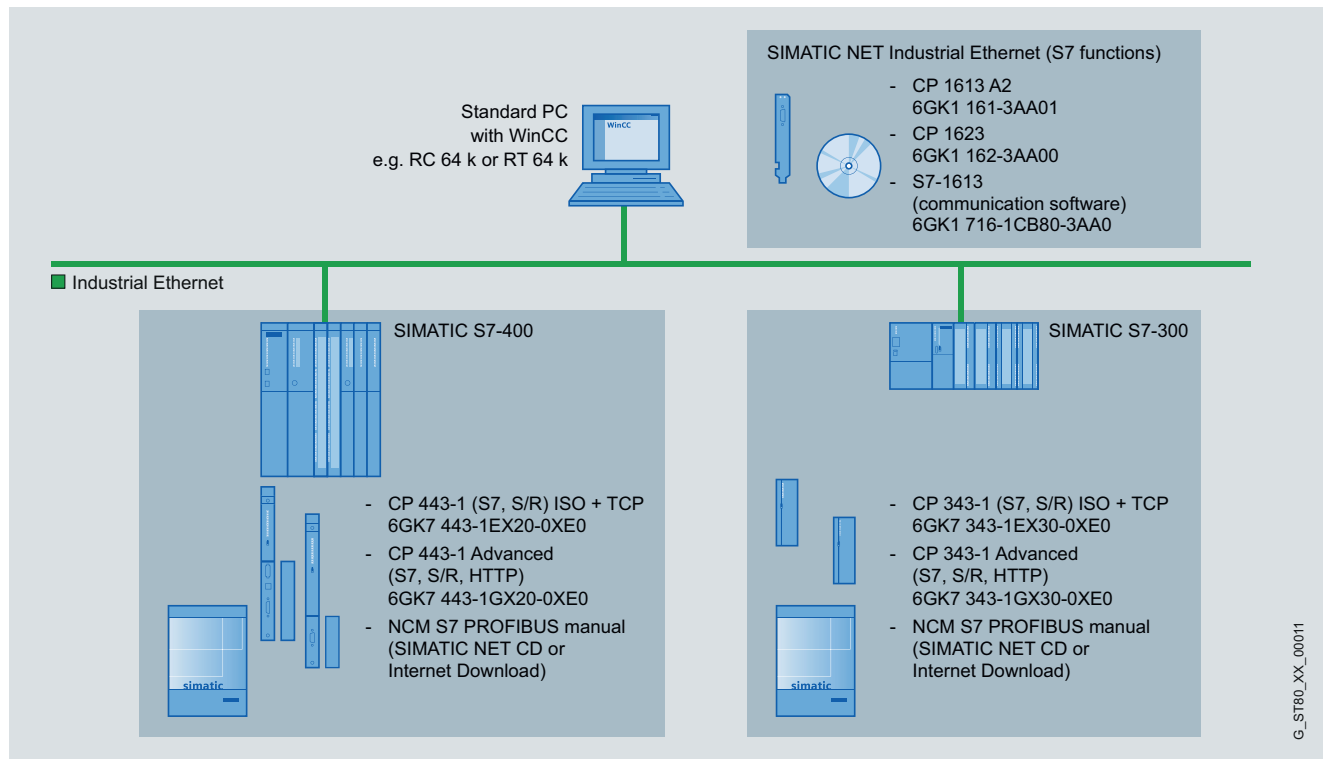

WinCC single-user system: Industrial Ethernet with S7 communication

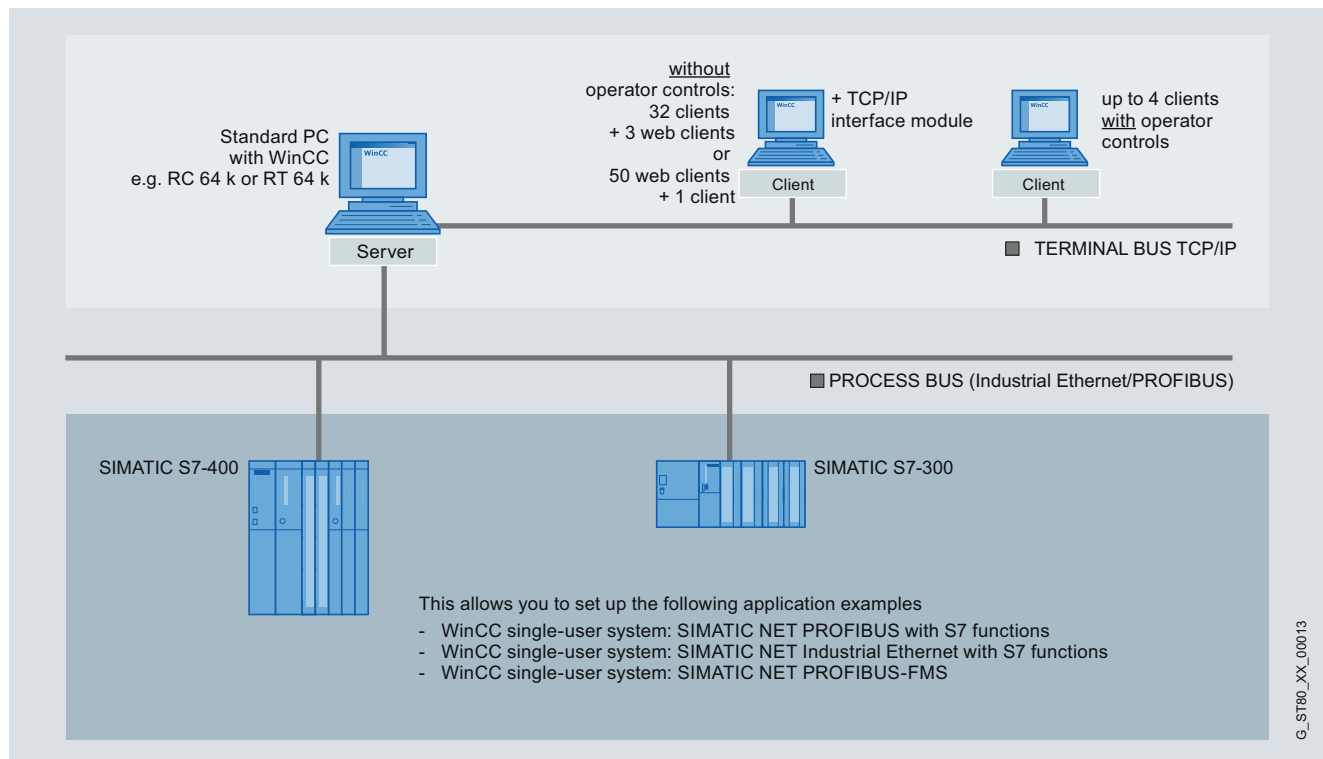

WinCC multi-user system with operable server

PROFINET/Industrial Ethernet System interfaces for SIMATIC HMI

SIMATIC WinCC

Integration (continued)

2

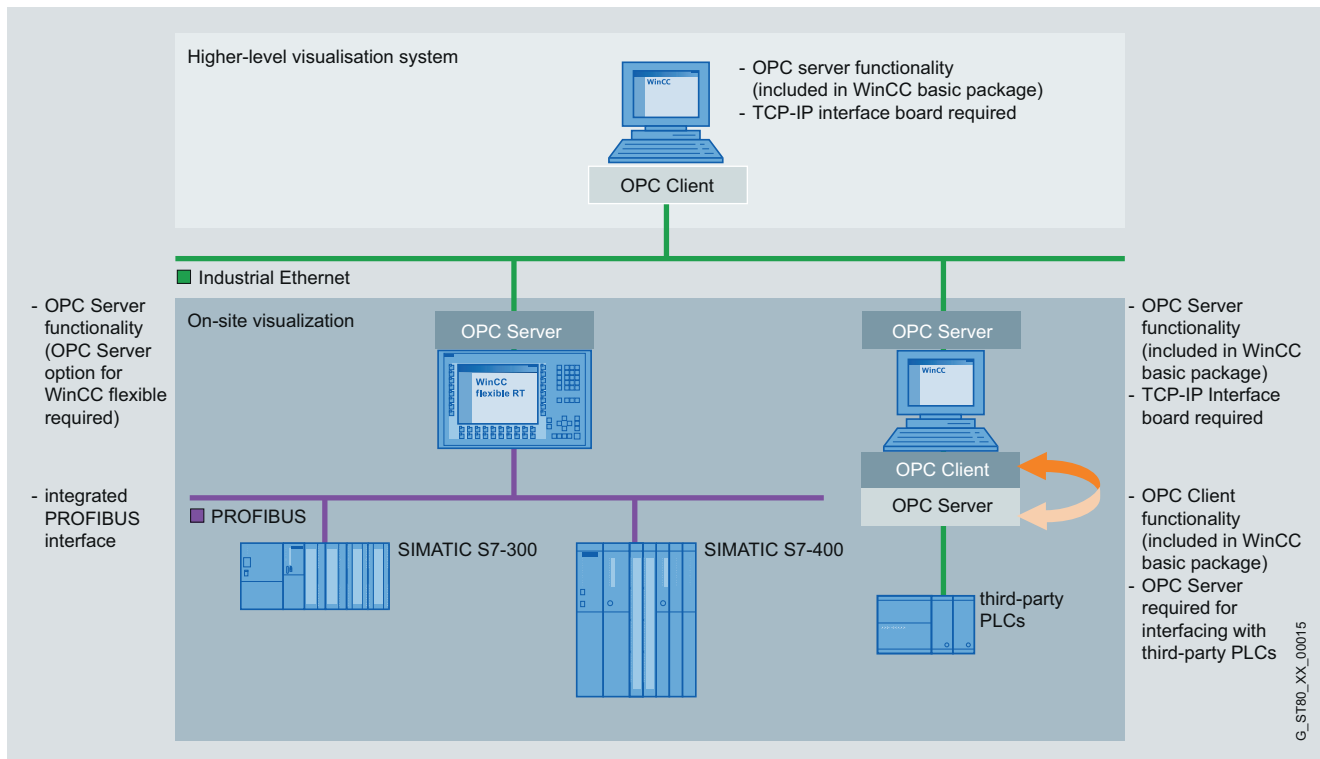

OPC coupling

Note:

You can find more information in Catalog ST 80 / ST PC and in the Industry Mall at www.siemens.com/industrymall

Overview

The SIMATIC Touch Panel (TP), Operator Panel (OP), Basic Panel, Comfort Panel, Mobile Panel, multifunctional platforms (MP) ¹⁾ offer HMI functionality for the control systems:

- SIMATIC S7
- SINUMERIK ²⁾
- Non-Siemens controllers:
 - Allen Bradley
 - Mitsubishi
 - Modicon
 - Omron

For more detailed information, refer to the WinCC flexible user manual, the "Windows-based systems communication" manual, and the WinCC flexible online help.

- 1) For the sake of simplicity, SIMATIC Panel is always used in the text below. This is not restrictive, as the information is valid for all systems referred to above. If there are constraints, direct reference is made to them in the text.
- 2) Required under WinCC flexible: "SINUMERIK HMI copy license WinCC flexible CE" and "SINUMERIK HMI copy license OA". For configuring, a "SINUMERIK HMI engineering package WinCC flexible" is also necessary.

OPC communication and HTTP communication are offered for all Panels with an integrated Ethernet interface. Both OPC and HTTP communication can be used in parallel with the process links to SIMATIC S7 or non-Siemens PLCs.

OPC communication

OPC Data Access is an open standard for exchanging both local and remote variables between various applications via Industrial Ethernet. The original version of OPC is based on Microsoft COM/DCOM and, therefore, requires a Microsoft Windows-based PC operating system (not Windows CE) on both clients and servers. As OPC XML, communication is based on the Internet standard SOAP/XML and is, therefore, suitable for embedded systems with Windows CE.

HTTP communication for variable exchange between SIMATIC HMI systems

Communication based on HTTP message frames enables variables to be exchanged between SIMATIC HMI systems.

Communication standard Version	SIMATIC HMI					WinCC Advanced Runtime WinCC Professional Runtime
	Comfort Panel	TP 177B DP/PN OP 177B DP/PN Mobile Panel 177 PN MP 177	TP 277 OP 277 Mobile Panel 277	MP 277 MP 377		
<i>OPC Data Access V2.05a + OPC Data Access XML V1.00</i>						
OPC DA Client (COM/DCOM)	–	–	–	–	•	
OPC DA server (COM/DCOM)	–	–	–	–	•	
OPC XML DA client (SOAP/XML)	–	–	–	–	• 1)	
OPC XML DA server (SOAP/XML)	•	–	–	•	–	
<i>HTTP communication for variable exchange between SIMATIC HMI systems</i>						
HTTP client	•	•	•	•	•	
HTTP server	•	•	•	•	•	

- System interface possible
- System interface not possible

¹⁾ Only through DCOM/XML gateway in scope of delivery of WinCC Advanced for access to OPC XML server of the SIMATIC Panel

Note:

You can find more information in Catalog ST 80/ST PC and in the Industry Mall at www.siemens.com/industrymall

PROFINET/Industrial Ethernet

System interfaces for SIMATIC HMI

SIMATIC S7

Overview

The following types of interface are differentiated in respect of the link between the SIMATIC Panels and SIMATIC S7 controllers:

- **PROFINET interface:**
Coupling of SIMATIC Panel to SIMATIC S7 controllers via Industrial Ethernet TCP/IP using the integrated PROFINET interface of the CPU or, alternatively, a PROFINET interface module.
- **MPI/PROFIBUS interface:**
Coupling of SIMATIC Panel to SIMATIC S7 controllers via MPI/PROFIBUS using the integrated MPI/PROFIBUS interface of the CPU for S7-300, S7-400 or the integrated PPI interface of the CPU in the case of S7-200 or, alternatively, a PROFIBUS interface module in the case of S7-1200, S7-300 and S7-400.
- **PPI interface:**
Coupling of SIMATIC Panel to SIMATIC S7-200 via PPI network using the integrated PPI interface of the CPU

The maximum possible number of S7 connections of one CPU is determined by its performance capacity (see Catalog ST 70); from the point of view of SIMATIC Panel, the following restrictions apply:

- OP 73: max. 2 connections
- OP 77A, TP 177A, Basic Panel, OP 77B, TP177B, OP 177B, Mobile Panel 177: max. 4 connections
- Comfort Panel, TP 277, OP 277; Mobile Panel 277, MP 177, MP 277, MP 377: max. 6 connections
- PC with PC WinCC Runtime Advanced: max. 8 connections

PPI interface

The PPI interface is a point-to-point connection between a SIMATIC Panel (PPI master) or alternatively a PG (PPI master) and an S7-200 (PPI slave).

MPI/PROFIBUS interface or PROFINET interface

The corresponding multipoint-enabled communication interfaces of SIMATIC Panels and SIMATIC S7 are used. The following are possible:

- Interface between one or a number of SIMATIC Panels (MPI master) and one or a number of S7-1200/300/400s or WinAC (MPI master). (possible network topology: MPI/PROFIBUS or Industrial Ethernet, TCP/IP)
- Interface between one or a number of SIMATIC Panels (MPI master) and one or a number of S7-200s (MPI slave) ¹⁾ (possible network topology: PPI, MPI/PROFIBUS)

Unlike PPI connections, MPI connections are static connections that are set up during booting and then monitored.

The original format of a master/master link has been joined by a master/slave link, which has enabled integration of the S7-200 (except CPU 212). ¹⁾

In principle this type of information exchange between SIMATIC Panels and SIMATIC S7 is independent of the network used, PPI, MPI/PROFIBUS or Industrial Ethernet: SIMATIC Panels are S7 clients and SIMATIC S7 CPUs are S7 servers.

¹⁾ Constraints with regard to baud rate for S7-200; see Catalog ST 70.

Overview (continued)

Controller Target hardware (PROTOCOL) (physics)	SIMATIC HMI					
	OP 73 OP 77A TP 177A	Basic Panel	Comfort Panel	OP 77B TP 177B DP OP 177B DP TP 177B DP/PN Mobile Panel OP 177B DP/PN Mobile Panel 177 DP ¹⁾ Mobile Panel 177 PN ¹⁾	TP 277 OP 277 Mobile Panel 277 ¹⁾ MP 177 MP 277 MP 377	WinCC Runtime Advanced
SIMATIC S7-1200 ²⁾						
Via Ethernet (TCP/IP) to max. 4 x <i>S7-1200</i>	–	• ³⁾	•	• ³⁾	•	•
SIMATIC S7-300, -400, Win AC ²⁾						
Via Ethernet (TCP/IP) to max. 4 x <i>S7-300, -400, WinAC</i>	–	• ³⁾	•	• ³⁾	•	•
SIMATIC S7-200 ²⁾						
Via Ethernet (TCP/IP) (MPI protocol) to max. 4 x <i>S7-200</i>	–	• ³⁾	•	• ³⁾	•	•

- System interface possible
- System interface not possible

¹⁾ Mobile Panel connection via special connecting cable and junction box (see Mobile Panel), see Manual for cable layout.

²⁾ Controllers can be combined as desired

³⁾ Only Basic Panel PN, TP 177B DP/PN, OP 177B DP/PN, Mobile Panel 177 PN

Note:

You can find more information in Catalog ST 80/ST PC and in the Industry Mall at www.siemens.com/industrymall

PROFINET/Industrial Ethernet

System interfaces for SIMATIC HMI

SIMATIC WinCC (TIA Portal) Runtime

Overview

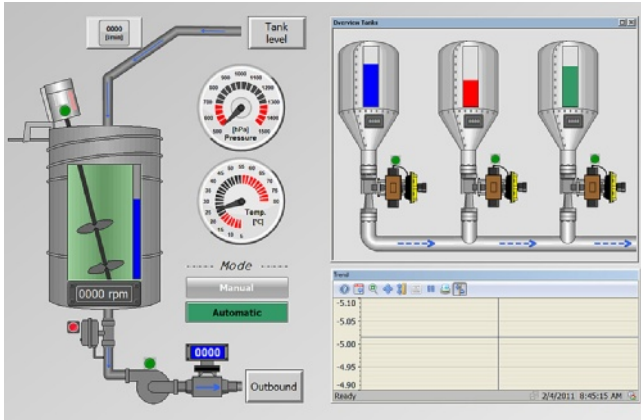

SIMATIC WinCC Runtime Professional visualization software

- PC-based operator control and monitoring system for visualization and operator control of processes, production flows, machines and plants in all sectors – from the simple single-user station through to distributed multi-user systems and cross-location solutions with web clients. WinCC Runtime Professional is the information hub for corporation-wide vertical integration.
- Industry-standard functions for signaling and acknowledging events, archiving of messages and measured values, logging of all process and configuration data, user administration, can be expanded flexibly with VB and C scripts
- Basic package expandable by means of option packages
- Also included are APIs for the Runtime to utilize the open programming interfaces

Note:

You can find more information in Catalog ST 80/ST PC and in the Industry Mall at www.siemens.com/industrymall

SIMATIC WinCC Runtime Advanced visualization software

- PC-based HMI solution for single-user systems directly at the machine
- Basic package for visualization, reporting and logging, user administration, can be expanded flexibly with VB scripts
- Basic package expandable by means of option packages
- Can be integrated into automation solutions based on TCP/IP networks
- Expanded service concepts with remote operation, diagnostics and administration over the intranet and Internet in combination with email communication

Overview

SIMATIC WinCC Runtime Advanced

WinCC Advanced is an open visualization system and offers the option of connecting the most diverse control systems.

Number of connectable controllers

WinCC Advanced permits the parallel coupling of up to 8 controllers.

Connection to third-party controllers

The following "Coupling overview" table lists third-party protocols and controllers which are directly supported by WinCC Advanced. Generally it is also possible to connect third-party controllers via OPC (OLE for Process Control).

Current notes and information about OPC servers from many different suppliers can be found at:

www.opcfoundation.org/

WinCC Advanced supports the standards:

- OPC Data Access 2.05a
- OPC XML Data Access 1.00 (client via DCOM/XML gateway)

Coupling overview for WinCC Runtime Advanced

Protocol	Description	PC interface
<i>SIMATIC HMI</i>		
Ethernet TCP/IP (HTTP communication)	HTTP communication for data exchange between SIMATIC HMI (client + server) ¹⁾	CP 1612 A2
<i>SIMATIC S7</i>		
Ethernet TCP/IP (S7 communication)	Channel for communication via Ethernet TCP/IP with max. 8 x SIMATIC S7 controllers S7-1200, S7-300, S7-400, S7-200 with CP 243-1	CP 1612 A2 CP 1613 A2 CP 1623
<i>SINUMERIK ²⁾</i>		
Ethernet TCP/IP (S7 communication)	Channel for communication via Ethernet TCP/IP with SINUMERIK 840D sl	CP 1612 A2 CP 1613 A2 CP 1623
<i>Third-party controllers (from WinCC V11.0) ³⁾</i>		
Allen Bradley Ethernet IP	Channel for communication with max. 4 x Allen Bradley controllers via Ethernet TCP/IP with Allen Bradley Ethernet IP protocol The controllers ControlLogix / CompactLogix, SLC500 / MicroLogix and PLC5 are supported	CP 1612 A2
Mitsubishi MC TCP/IP	Channel for communication with max. 4 x Mitsubishi controllers via Ethernet TCP/IP with Mitsubishi MC TCP/IP protocol The FX3, Q, and iQ/QnUD controller series are supported	CP 1612 A2
Modbus TCP/IP	Channel for communication with max. 4 x Modicon controllers via Ethernet TCP/IP using the Modbus TCP/IP protocol The Quantum, Momentum, Premium, TSX Micro, Compact and M340 controllers are supported	CP 1612 A2
<i>Cross-manufacturer</i>		
OPC client ^{1) 4)} for DA, XML DA	Channel for OPC communication, WinCC can acquire data from OPC server applications	CP 1612 A2
OPC server for DA	Server applications for OPC communication; WinCC provides process data to OPC clients	CP 1612 A2

¹⁾ HTTP and OPC communication can be used in combination with the other couplings; regarding SIMATIC Panels that support HTTP or OPC communication, see the overview under "System interfaces (WinCC V11)".

²⁾ "SINUMERIK Operate WinCC RT Advanced" license required; for further information, see NC 60 Catalog.

³⁾ For detailed information regarding supported controllers, see "System interfaces (WinCC V11)"

⁴⁾ Application note:

The parallel use of the OPC client channel allows, for example, the connection to an SNMP OPC Server for visualization of the data present there. The SNMP OPC Server enables monitoring of any network components (e.g. switch) that support the SNMP protocol. Further information can be found under SIMATIC NET communications systems/SNMP OPC Server.

PROFINET/Industrial Ethernet

System interfaces for SIMATIC HMI

WinCC Runtime Communication

Overview (continued)

SIMATIC WinCC Runtime Professional

WinCC Professional is an open process visualization system and offers the option of connecting the most diverse control systems.

Released communication software

Only communication software with the listed (or higher) product versions should be used. Corresponding SIMATIC NET upgrades are available for the upgrading of older versions.

Number of connectable controllers

With CP 1613/CP 1623, a maximum of 64 S7 controllers can be connected via Industrial Ethernet; with CP 5611 a maximum of 8 and with CP 5613 a maximum of 44 S7 controllers can be connected via PROFIBUS. With approx. 10 or more controllers, the use of Industrial Ethernet is recommended.

Client-server communication

Communication between the clients and the server is implemented using the TCP/IP protocol. The construction of a separate PC-LAN is recommended. For small projects with correspondingly small message frame advent, a SIMATIC NET Industrial Ethernet can be used for both process communication (WinCC/server ↔ PLC) and for PC-PC communication (WinCC/client ↔ WinCC/server)

Connection to third-party controllers

The following "Coupling overview" table lists third-party protocols and controllers which are directly supported by WinCC Professional. Generally it is also possible to connect third-party controllers via OPC (OLE for Process Control).

Current notes and information about OPC servers from many different suppliers can be found at:
www.opcfoundation.org/

WinCC Professional supports the standards:

- OPC Data Access 2.05a
- OPC Data Access 3.00
- OPC XML Data Access 1.00 (Connectivity Pack/Connectivity Station)
- OPC HDA 1.20 (Connectivity Pack/Connectivity Station)
- OPC A&E 1.10 (Connectivity Pack/Connectivity Station)

Coupling overview for WinCC Runtime Professional

Protocol	Description	PC interface
<i>SIMATIC S7</i>		
SIMATIC S7 Protocol Suite	Protocol Suite with channel units for communication with SIMATIC S7 via <ul style="list-style-type: none"> • Ethernet TCP/IP (S7 communication) to S7-1200, S7-300, S7-400 • Software interface (S7 communication) to WinAC 	CP 1612 A2 CP 1613 A2 CP 1623
<i>Third-party controllers (from WinCC V11.0)</i>		
Allen Bradley Ethernet IP	Channel for communication with Allen Bradley controllers via Ethernet TCP/IP with Ethernet IP protocol The controllers ControlLogix / CompactLogix, SLC500 / MicroLogix, and PLC5 are supported	CP 1612 A2
Mitsubishi MC TCP/IP	Channel for communication with Mitsubishi controllers via Ethernet TCP/IP with Mitsubishi MC TCP/IP protocol The FX3, Q, and iQ/QnUD controller series are supported	CP 1612 A2
Modbus TCP/IP	Channel for communication with Modicon controllers via Ethernet TCP/IP using the Modbus TCP/IP protocol The Quantum, Momentum, Premium, TSX Micro, Compact and M340 controllers are supported	CP 1612 A2
<i>Cross-manufacturer</i>		
OPC client ¹⁾ for DA, XML DA	Channel for OPC communication, WinCC can acquire data from OPC server applications	CP 1612 A2
OPC Server for DA, XML DA, A&E, HDA	Server applications for OPC communication; WinCC provides process data to OPC clients	CP 1612 A2

¹⁾ Application note:

The parallel use of the OPC client channel allows, for example, the connection to an SNMP OPC Server for visualization of the data present there. The SNMP OPC Server enables monitoring of any network components (e.g. switch) that support the SNMP protocol. Further information can be found under SIMATIC NET communications systems/SNMP OPC Server.

Overview (continued)

Communications examples

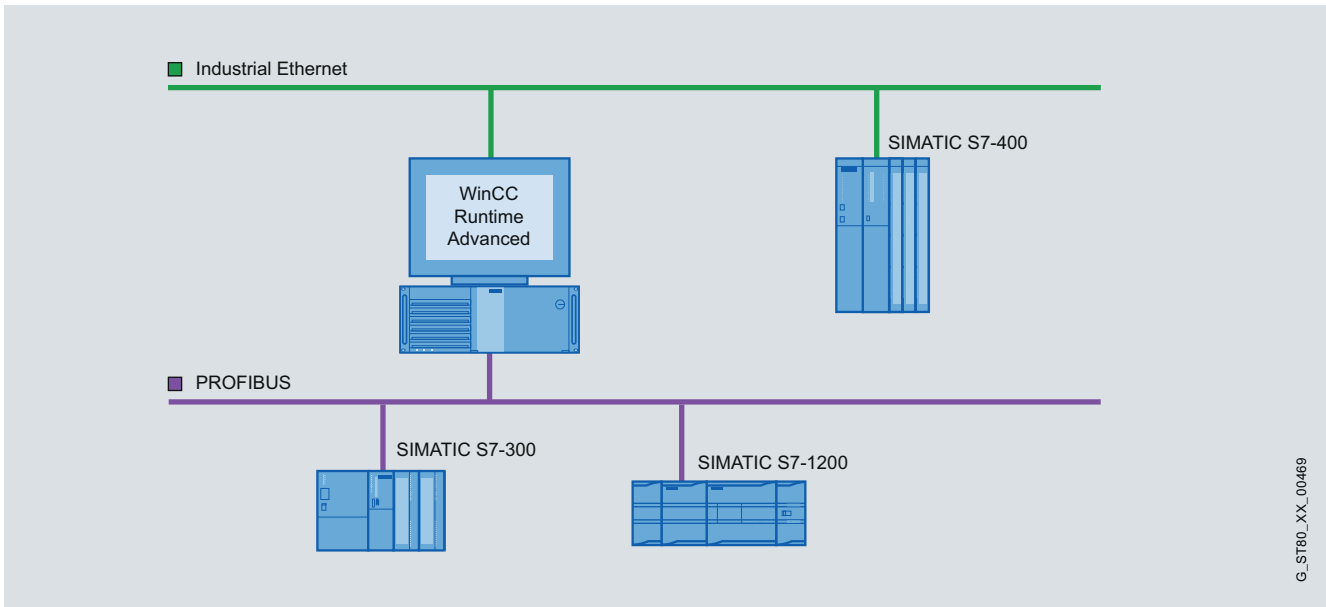

WinCC Runtime Advanced single-user system

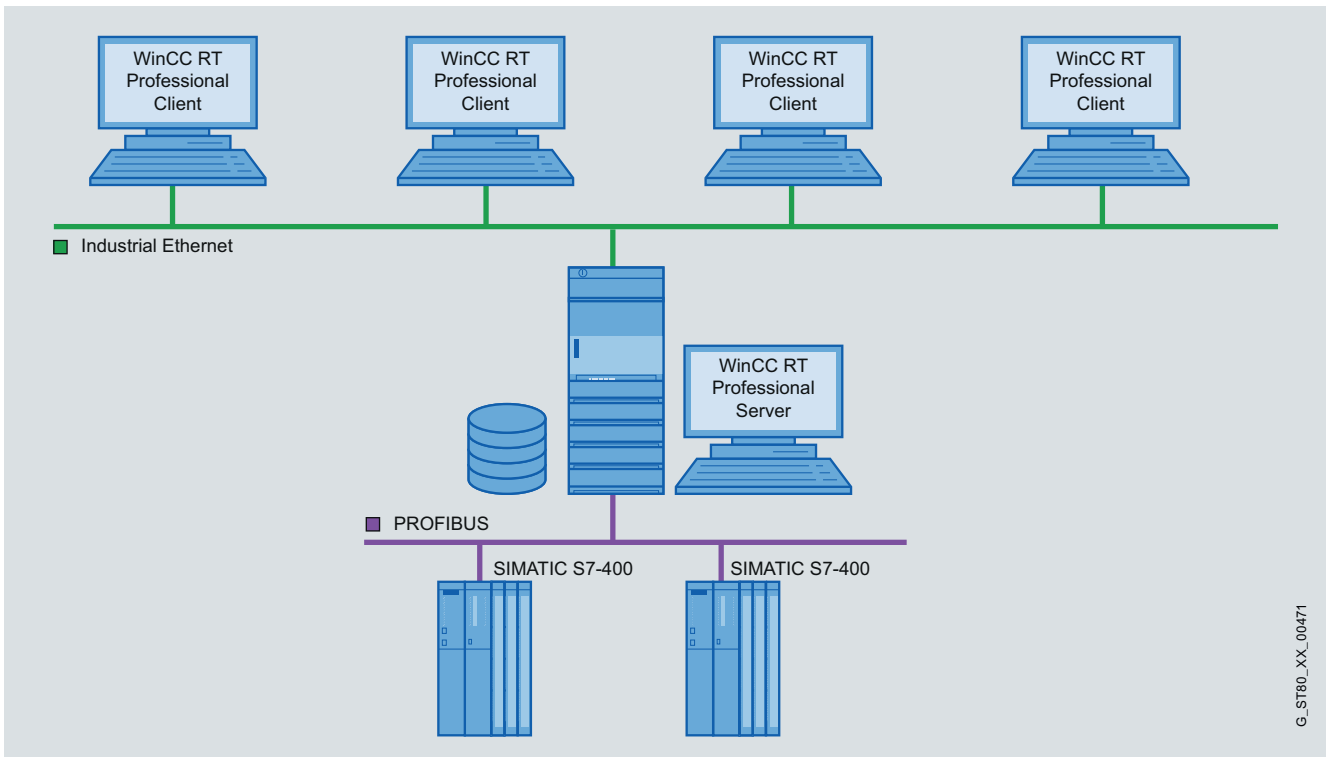

WinCC Runtime Professional multi-user system with operable Server

PROFINET/Industrial Ethernet System interfaces for SIMATIC HMI

WinCC Runtime Communication

2

Overview (continued)

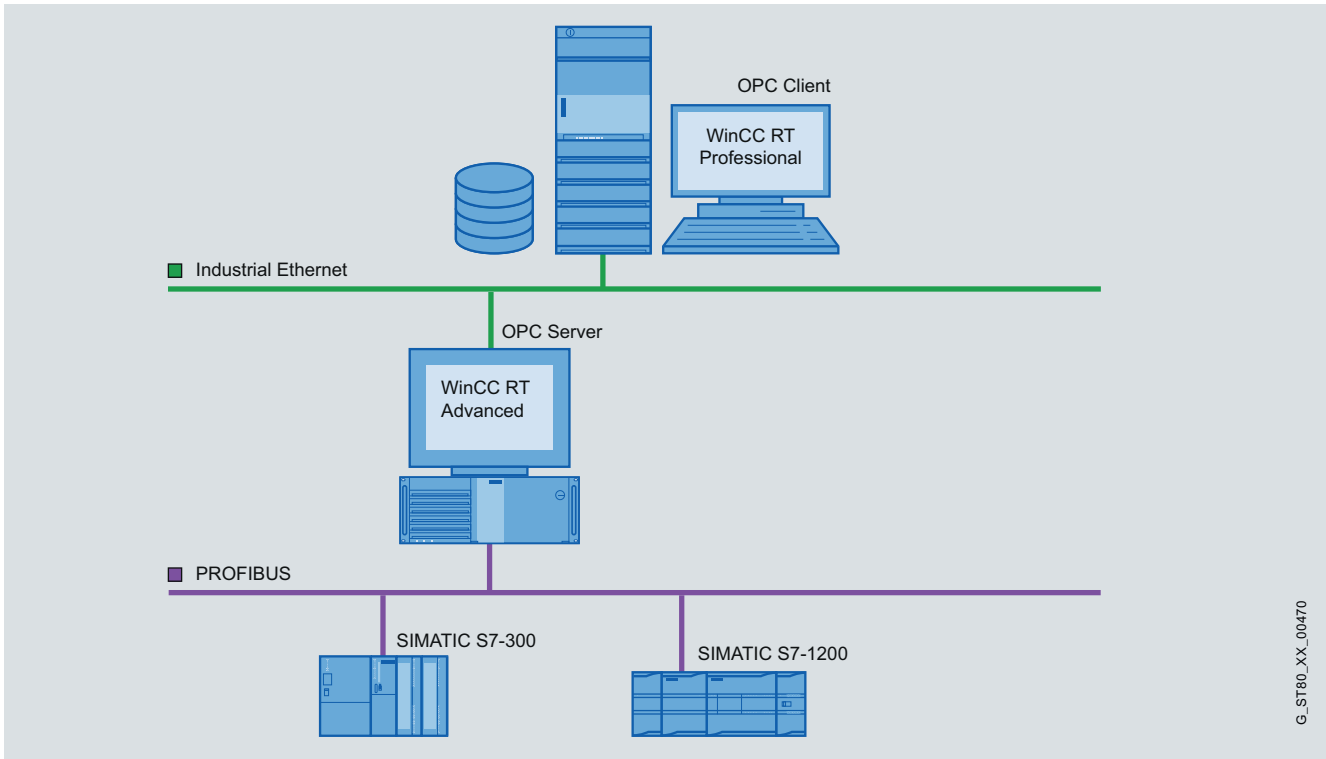

OPC coupling

Note:

You can find more information in Catalog ST 80/ST PC and in the Industry Mall at www.siemens.com/industrymall

Overview



- Swap media that supports the fast and easy replacement of SIMATIC NET components without a programming device in the event of a fault
- For implementation in all SIMATIC NET products with C-PLUG slot
- For automatic backing up of configuration or engineering data from the SIMATIC NET components
- The C-PLUG can also be used to store application data such as documents or Web pages
- In some SIMATIC S7 CP modules, such as the CP 443-1 Advanced, the C-PLUG is a standard component of the scope of supply and is required to guarantee the complete functional scope of the respective component.

Benefits

get Designed for Industry

- Quick and easy replacement of SIMATIC NET components without the need to reconfigure the replacement part
- The device can be replaced without the need for specially trained personnel or a programming device or PC
- The downtime of network segments and connected Industrial Ethernet stations in the event of a fault is minimized.

Application

The C-PLUG is used when it is necessary for network components or communication modules to be replaced quickly and easily in the event of a fault without the need for reconfiguring the replacement part and without the need for special training.

Design

The C-PLUG is designed to the degree of protection IP20. For IP65 components, the degree of protection is ensured by the construction of the target device. The power supply is also provided by the data terminal.

The C-PLUG is plugged into the appropriate slot in the SIMATIC NET component. During start-up of the device and reconfiguring, the configuration data of the device is backed up automatically.

In the event of component failure, the C-PLUG is simply removed from the failed component and plugged into the replacement part. The replacement unit installed in the network or in the automation system then starts up automatically with the same device configuration as the failed device.

To protect against inadvertent removal (falling out), the slot for the C-PLUG is usually mounted on the rear of the data terminal.

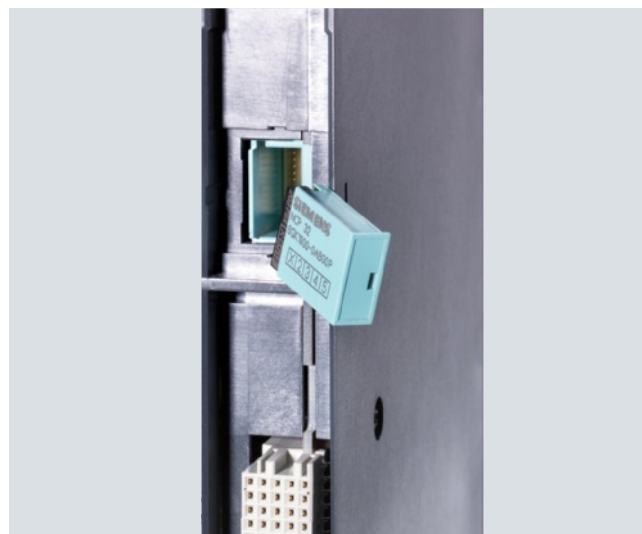

The C-PLUG is plugged into the rear of the CP 443-1 Advanced



The C-PLUG is plugged into the IWLAN Access Point SCALANCE W 788-1PRO on the rear of the device

PROFINET/Industrial Ethernet

Accessories

C-PLUG

Function

During start-up, the device automatically backs up the configuration data on an unwritten C-PLUG (delivery condition) that has been plugged into a SIMATIC NET component. Changes to the configuration during normal operation are also backed up on the C-PLUG without any additional operator intervention.

During start-up an unconfigured device automatically loads the configuration data from an inserted, written C-PLUG provided the data were written by a compatible device type.

Diagnostics

Incorrect C-PLUG handling, such as inserting a C-PLUG that contains the configuration of another device group or general malfunctions of the C-PLUG are signaled over the diagnostic mechanisms for the respective data terminal (LEDs, PROFINET, SNMP, Web-based Management, etc.).

Integration

Supported products

SCALANCE X Industrial Ethernet switches

- SCALANCE X-200
- SCALANCE X-300 (included in scope of supply)
- SCALANCE X-400 (included in scope of supply)
- SCALANCE X-500 (included in scope of supply)

SCALANCE S security modules

- SCALANCE S-600

Industrial Wireless LAN SCALANCE W

- SCALANCE W74x IWLAN Client Modules
- SCALANCE W78x IWLAN Access Points

System connections for SIMATIC S7

- CP 443-1 Advanced (included in delivery)
- CP 343-1 Advanced (included in delivery)
- CP 343-1 ERPC (included in delivery)

Network transitions

- IWLAN/PB Link PN IO
- IE/PB Link PN IO
- IE/AS-i LINK PN IO
- DP/AS-i LINK Advanced

Technical specifications

Product type designation	C-PLUG
Power supply	via terminal equipment
Power dissipation	0.015 mW
Assembly	Can be plugged into C-PLUG slot
Permissible ambient conditions	
• Operating temperature	-40 °C to +85 °C
• Transport/storage temperature	-40 °C to +80 °C
• Relative humidity	max. 95%
Constructional design	
• Dimensions (W x H x D) in mm	24.3 x 17 x 8.1
• Weight	approx. 5 g
Memory capacity	32 MB
Degree of protection	IP20

Ordering data

C-PLUG

Swap medium for simple replacement of devices in the event of a fault; for storing configuration or engineering and application data; can be used for SIMATIC NET products with C-PLUG slot

Order No.

6GK1 900-0AB00

Overview



- The PS791-1 PRO power supply is an AC/DC power supply for input voltages of 90 to 265 V AC for numerous SCALANCE products with IP65 degree of protection.
- Mounting:
 - Wall mounting or on S7-300 rail, immediately under/next to the SCALANCE W788-xPRO and SCALANCE W788-xRR Access Points, SCALANCE W74x-1PRO and SCALANCE W74x-1RR Client Modules, or SCALANCE X-200PRO switches
- Robust metal housing with IP65 protection against water and dust
- Operating temperature -20 °C to +60 °C

Benefits

get Designed for Industry

- Reduced storage of replacement parts, as only one power supply unit is required for several SCALANCE products with IP65 degree of protection
- Global application due to wide input voltage range
- High reliability as power supply is short-circuit proof, secure against no-load operation and is able to bridge short breaks in the mains power
- Variety of possible applications thanks to:
 - wide range of input voltages
 - high degree of efficiency
 - low heat dissipation

Design

- Fanless design and rugged metal casing; High protection against dust and splashwater with IP65 degree of protection
- Operating temperatures from -20 °C to +60 °C
- Resistant to condensation
- Connection to AC network via AC Power 3+PE cable connector (included)
- Direct mounting is possible on the SCALANCE products with IP65 degree of protection using supplied installation material; also suitable for wall-mounting or mounting on standard mounting rail (S7-300)

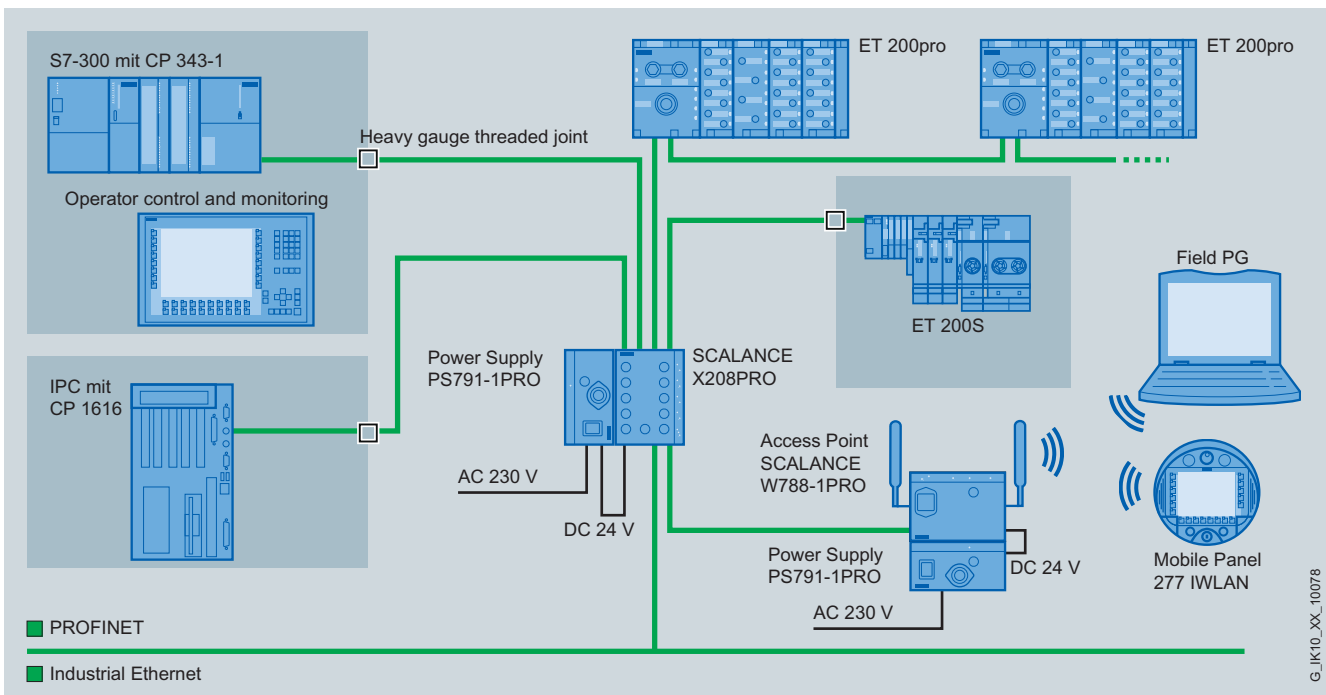

Example for the use of power supply PS791-1PRO with SCALANCE X and SCALANCE W

Note:

When SCALANCE W is connected to SCALANCE X208PRO, the power supply in the hybrid connector is not available; power must be supplied via the M12 plug connector.

PROFINET/Industrial Ethernet

Accessories

Power supply PS791-1PRO

Technical specifications

Order No.	6GK5 791-1PS00-0AA6
Product type designation	Power supply PS791-1PRO
Interfaces	<ul style="list-style-type: none"> • AC Power 3+PE cable connector for 100 ... 240 V AC feed • M12 Plug PRO or Power Cord M12 for 24 V DC output voltage • On/Off switch
Input voltage	90 ... 265 V AC at 47 ... 63 Hz
Output voltage	24 V DC, +-7 %, 0.42 A
Output power	10 W
System disturbances	Stored energy time at least 20 ms at 230 V AC
Permissible ambient conditions	
• Operating temperature	-20°C ... 60°C
• Transport/storage temperature	-40°C ... +85°C
• Relative humidity	100 %
Approvals	EMC: EN 55022 Class B, EN 61000-4; UL 1950, EN 60950;
Device failure	MTBF 600,000 h at full load, 25 °C
Switching frequency	typ. 100 kHz
Degree of protection	IP65
Dimensions (W x H x D) in mm	125 x 60 x 130
Assembly	Wall/DIN rail mounting (S7-300) directly on SCALANCE devices
Weight	700 g

Ordering data

Ordering data	Order No.
PS791-1PRO power supply AC/DC power supply, 10 W, IP65 (-20 ... +60 °C), input: 90 ... 265 V AC , output: 24 V DC, metal housing; scope of supply: AC power 3+PE cable connector, DC power cord M12, installation materials, instruction manual German/English	6GK5 791-1PS00-0AA6
Power M12 Plug PRO Plug for connection to PS791-1PRO power supply for 24 V DC supply voltage; 4-pole, A-coded, with assembly instructions, 3 items	6GK1 907-0DB10-6AA3
AC Power 3+PE cable connector Connection socket for connection of Power Supply PS791-1PRO to AC voltage supply, with assembly instructions, 5 items	6GK1 907-0FC10-0AA5
Power cable 2 x 0.75 Connecting cable for power supply PS791-1PRO, sold by the meter	6XV1 812-8A

More information

You can order components supplementary to the SIMATIC NET cabling range from your local contact. Technical advice on this subject is available from:

J. Hertlein
I IA SC IC PRM 4
Phone +49 (0)911/750 44 65
E-mail: juergen.hertlein@siemens.com

Overview



- SICLOCK TC 400 and TC 100 central plant clock as the central component for time synchronization of a plant over Ethernet
- *SICLOCK TC 400*
 - Four independent Ethernet interfaces for supporting several Ethernet subnets
 - Redundancy options
 - Designed for PROFINET
- *SICLOCK TC 100*
 - An Ethernet interface
 - Designed for mini and small plants
 - Designed for PROFINET
- GPS or DCF77 radio clocks for direct connection to PCs, SIMATIC S7 controllers, and to the SICLOCK TC 400 or TC 100 central plant clocks
- Pulse converter for electrical and optical distribution and interface conversion
- Complete packages for common applications

Application

Time synchronization of all components plays an important part in the automation of production plants. The SICLOCK system is a parameterizable, modular system with perfectly matched components for the time synchronization of plants. GPS (worldwide) as well as DCF77 (Germany) can be used for external radio synchronization

The modular SICLOCK system supports the time synchronization of an individual PLC through to the large plant with multiple redundancy.

Time synchronization concepts

The automation systems and operator stations of a SIMATIC PCS 7 plant or WinCC stations can be synchronized as follows with DCF77 or GPS time signals:

- **Large plants:**
for larger plants with many network stations and stringent requirements for timekeeping, the time synchronization is performed using a SICLOCK TC 400 central plant clock on the plant bus.
- **Small plants:**
For small to medium-sized plants, the PCS 7 Operator Station or the WinCC Station are used as the time master, connecting the corresponding DCF or GPS radio clock directly to the COM interface of the PC.
An alternative to the PC solution is the option of synchronizing the plant over the NTP via the SICLOCK central plant clocks. The SICLOCK TC 100 is recommended for use with these small plants.
- **Stand-alone systems:**
For SIMATIC S7 controllers or small systems, e.g. for laboratory automation, SICLOCK DCFS7 is a low-cost alternative to DCF77 synchronization directly over an S7 digital input.

Design

SICLOCK TC 400 and TC 100 are designed for mounting on a SIMATIC rail. Sets of materials for installation in 19-inch racks are also available.

PROFINET/Industrial Ethernet

Accessories

SICLOCK time synchronization

Function

Central plant clocks

The SICLOCK TC 400 and SICLOCK TC 100 central plant clocks support the synchronization of CPs and PCs with the SIMATIC procedure as well as the NTP procedure over Industrial Ethernet.

SICLOCK TC 400

SICLOCK TC 400 is used as a central plant clock for highly accurate timekeeping and distributes the time to all synchronized systems over Industrial Ethernet, as well as over three additional point-to-point connections with TTY/24 V and RS422/5 V.

The devices are equipped with four independent Ethernet interfaces. This enables separate or redundant automation networks and I&C networks to be synchronized in parallel with just one device. Apart from the well-proven standard networks such as SIMATIC NET or NTP, TC 400 is also prepared for use in PROFINET.

Interfaces, signal types, redundancy, etc. are parameterized over the Internet/HMI. The display of statuses on the device provides fast access to the operating status and any faults.

SICLOCK TC 400 has interrupt capability and can be integrated into the I&C.

SICLOCK TC 100

SICLOCK TC 100 is the "little sister" of the TC 400 and is used as a central plant clock for highly accurate time synchronization. It distributes the time to all systems to be synchronized over an Industrial Ethernet interface.

Like the TC 400, the interfaces, signal types, redundancy, etc. are parameterized over the Internet/HMI. The display of statuses on the device provides fast access to the operating status and any faults.

SICLOCK TC 100 has interrupt capability and can be integrated into the I&C.

On failure of the antennas of radio clocks, the central plant clocks **SICLOCK TC 400** and **SICLOCK TC 100** continue to provide reliable clock control thanks to automatic changeover to highly accurate quartz operation. When the radio clock is returned to service, they accept the time signal without a time step.

Ordering data

Order No.

SICLOCK TC 400 central plant clock

SICLOCK TC 400 with GPS1000 antenna, complete package

2XV9 450-2AR10

Package comprises

- SICLOCK TC 400
- SICLOCK GPS1000 system with antenna rack and approx. 2 m connecting cable; extendable to max. 1000 m
- Lightning protection for GPS

Complete solution, e.g. for use in PCS 7

SICLOCK TC 400 with DCF77 antenna, complete package

2XV9 450-2AR20

SICLOCK TC 400 central plant clock with Ethernet interface + DCFRS radio clock, industrial version; package comprises

- SICLOCK TC 400
- Active DCF77 antenna with TTY output (20 mA line current), antenna rack, and approx. 2 m connecting cable; extendable to max. 1000 m
- Junction box

SICLOCK TC 400 single device

2XV9 450-2AR01

Order No.

SICLOCK TC 100 central plant clock

SICLOCK TC 100 with GPS1000 antenna, complete package

2XV9 450-2AR50

Package comprises

- SICLOCK TC 100
- SICLOCK GPS1000 system with antenna rack and approx. 2 m connecting cable; extendable to max. 1000 m.
- Lightning protection for GPS

Complete solution, e.g. for use in PCS 7

SICLOCK TC 100 with DCF77 antenna, complete package

2XV9 450-2AR26

SICLOCK TC 100 central plant clock with Ethernet interface and DCFRS radio clock, industrial version; package comprises

- SICLOCK TC 100
- Active DCF77 antenna with TTY output (20 mA line current), antenna frame, and approx. 2 m connecting cable. Extendable to max. 1000 m
- Junction box

SICLOCK TC 100 single device

2XV9 450-2AR22

Ordering data	Order No.	Order No.	
<i>DCF radio clocks</i>		<i>GPS radio clocks</i>	
SICLOCK DCFRS, radio clock, industrial version DCF radio clock for time synchronization of individual PCs or servers in industrial environments with high levels of interference; distances of up to 1000 m are possible between the DCF radio clock and the PC, package comprises <ul style="list-style-type: none"> • Active DCF77 antenna with TTY output (20 mA line current) and antenna frame • TTY/RS232 converter • Plug-in power supply • Two junction boxes • 1 m connecting cable mounted, extendable to 1000 m • DCF77 receiving service for Windows 	2XV9 450-1AR21	GPS1000 + power supply, radio clock for Windows GPS radio clock for time synchronization of PCs, programmable controllers as well as SICLOCK TC 400/TC 100 central plant clocks in industrial environments with high levels of interference with distances up to 1000 m between the antenna and device, package comprises <ul style="list-style-type: none"> • GPS1000 antenna head with antenna frame • GPS1000 power supply • Junction box • 5 m RS232 connecting cable • DCF77 receiving service for Windows 	2XV9 450-1AR82
SICLOCK DCFRS, radio clock for Windows DCF radio clock for the time synchronization of individual PCs over short distances, package comprises <ul style="list-style-type: none"> • Active DCF77 antennas with RS232 interface and mounting bracket • 20 m connecting cable, mounted • DCF77 receiving service for Windows 	2XV9 450-1AR14		
SICLOCK DCFS7 Low-cost solution for time synchronization of SIMATIC S7-300/400 over DCF77 over one digital input, package comprises <ul style="list-style-type: none"> • SICLOCK DCFRS, radio clock with RS232 output, 20 m connecting cable and mounting bracket • SICLOCK DCFS7 interface • SICLOCK DCFS7 receiving service (STEP 7 function block for integration in S7 software) 	2XV9 450-1AR36		
<i>Accessories for SICLOCK DCFS7</i>			
SICLOCK DCFS7 interface + receiving service (STEP 7 function block for integration in S7 software)	2XV9 450-1AR30		
SICLOCK DCFS7 interface	2XV9 450-1AR35		
SICLOCK DCFS7 receiving service (STEP 7 function block for integration in S7 software)	2XV9 450-1AR32		

PROFINET/Industrial Ethernet

Accessories

SICLOCK time synchronization

Ordering data

Order No.

Accessories

Kit for SICLOCK TC400 and TC100

- For 19" mounting frame

2XV9 450-2AR81

Lightning protection for antenna cable

- Lightning protection for TTY connecting cable (SICLOCK GPS1000/DCFRS industrial version)

2XV9 450-1AR83

Software

SICLOCK DCF77 receiving service for Windows

2XV9 450-1AR28

Pulse converter

SICLOCK EOPC

Electrical/optical pulse converter for industrial applications with 32 fiber-optic cable outlets for transparent operation and pulse mode

- SICLOCK EOPC 24 to 110 V DC
- SICLOCK EOPC 90 to 230 V AC/DC

2XV9 450-1AR72

2XV9 450-1AR73

SICLOCK PCON

Single-channel electrical/optical pulse converter for industrial applications

- SICLOCK PCON 24 to 230 V AC/DC, with multi-mode fiberglass connection, 820 nm

2XV9 450-1AR63-1SA3

SICLOCK DCFHF

HF modulator for DCF77 signals for industrial applications

2XV9 450-1AR64

More information

Support can be found at:

www.siemens.com/simatic-net/ik-info

You will find more information on the Internet at:

www.siemens.com/siclock

www.siclock.com

Overview



- Interface module for linking the ET 200S to PROFINET
- Handles all data exchange with the PROFINET I/O Controller
- 3 versions:
 - IM151-3 PN STANDARD
 - IM151-3 PN HIGH FEATURE and IM 151-3 PN FO: supports, in contrast to the STANDARD version, the operation of PROFIsafe F modules
- with integrated 2-port switch for line topology
- Delivery including connecting module

Note:

Micro Memory Card required for operation depending on the configuration.

Ordering data

Order No.

IM 151-3 PN interface module

For ET 200S;
transfer rates up to 100 Mbit/s;
data volume depends on the
number of modules inserted,
up to 63 modules can be
connected, bus connection
through RJ45

6ES7 151-3AA23-0AB0

IM 151-3 PN PROFINET High Feature interface module

for ET 200S;
transfer rate up to 100 Mbit/s;
max. 63 modules up to 2 m wide
can be connected;
bus connection via RJ45,
incl. termination module

6ES7 151-3BA23-0AB0

IM 151-3 FO interface module

for ET 200S;
with 2 PROFINET FO-interfaces
and integrated 2-port switch,
max. 63 modules up to 2 m wide
can be connected,
incl. termination module

6ES7 151-3BB23-0AB0

Accessories

Industrial Ethernet FC RJ45 Plug 90

RJ45 plug connector for Industrial
Ethernet with a rugged metal
enclosure and integrated
insulation displacement contacts
for connecting Industrial Ethernet
FC installation cables;
with 90° cable outlet

1 unit

6GK1 901-1BB20-2AA0

10 units

6GK1 901-1BB20-2AB0

50 units

6GK1 901-1BB20-2AE0

Industrial Ethernet FastConnect installation cables

FastConnect standard cable

6XV1 840-2AH10

FastConnect trailing cable

6XV1 840-3AH10

FastConnect marine cable

6XV1 840-4AH10

Industrial Ethernet FastConnect Stripping Tool

6GK1 901-1GA00

Termination Kits

SC RJ POF Plug

Assembly case for on-site
assembly of SC RJ plugs
consisting of stripping tool,
kevlar cutter, microscope,
abrasive paper, grinding support

6GK1 900-0ML00-0AA0

IE SC RJ POF Plug

Screw-in plug for on-site
assembly to POF fiber optic cable
(1 pack = 20 units)

6GK1 900-0MB00-0AC0

IE SC RJ Refill Set POF

Refill set for Termination Kit SC RJ
POF Plug, consisting of abrasive
paper and grinding plate
(set of 5)

6GK1 900-0MN00-0AA0

SC RJ POF Plug

Assembly case for on-site
assembly of SC RJ plugs
consisting of stripping tool,
buffer stripping tool, kevlar cutter,
fiber breaking tool, microscope

6GK1 900-0NL00-0AA0

Industrial Ethernet SC RJ PCF Plug

Screw-in plug for on-site
assembly to PCF fiber optic cable
(1 pack = 10 units)

6GK1 900-0NB00-0AC0

PROFINET/Industrial Ethernet

SIMATIC ET 200S – Interface modules

IM 151-3 PN

2

Ordering data	Order No.	Order No.
Industrial Ethernet FastConnect stripping tool	6GK1 901-1GA00	
MMC 64 KB ¹⁾ For storing the device name	6ES7 953-8LF20-0AA0	
MMC 128 KB ¹⁾ For storing the device name	6ES7 953-8LG20-0AA0	
MMC 512 KB ¹⁾ For storing the device name	6ES7 953-8LJ30-0AA0	
MMC 2 MB ¹⁾ For storing the device name and/or firmware update	6ES7 953-8LL20-0AA0	
MMC 4 MB ¹⁾ For storing the device name and/or firmware update	6ES7 953-8LM20-0AA0	
MMC 8 MB ¹⁾ For storing the device name and/or firmware update	6ES7 953-8LP20-0AA0	
ET 200S distributed I/O system manuals are available on the Internet as PDF files:	www.siemens.com/simatic-docu	
SIMATIC Manual Collection Electronic manuals on DVD, multi-language: S7-200, TD 200, S7-300, M7-300, C7, S7-400, M7-400, STEP 7, Engineering Tools, Runtime Software, SIMATIC DP (Distributed I/O), SIMATIC HMI (Human Machine Interface), SIMATIC NET (Industrial Communication)	6ES7 998-8XC01-8YE0	
SIMATIC Manual Collection – Update service for 1 year Scope of delivery: Current DVD "S7 Manual Collection" and the three subsequent updates	6ES7 998-8XC01-8YE2	
		Label sheets DIN A4 (10 units) Each sheet contains 60 labeling strips for peripheral modules and 20 labeling strips for interface modules • petrol • red • yellow • light beige 6ES7 193-4BH00-0AA0 6ES7 193-4BD00-0AA0 6ES7 193-4BB00-0AA0 6ES7 193-4BA00-0AA0
		Termination module as spare part for ET 200S 6ES7 193-4JA00-0AA0
		Power supply connector Spare part; for connecting the 24 V DC supply voltage • with push-in terminals • with screw-type terminals 6ES7 193-4JB00-0AA0 6ES7 193-4JB50-0AA0
		DIN rail 35 mm • Length: 483 mm for 19" cabinets 6ES5 710-8MA11 • Length: 530 mm for 600 mm cabinets 6ES5 710-8MA21 • Length: 830 mm for 900 mm cabinets 6ES5 710-8MA31 • 2 m long 6ES5 710-8MA41
		Industrial Ethernet Switches Managed Industrial Ethernet Switches; Isochronous real time, LED diagnostics, fault signaling contact with SET button, redundant power supply • SCALANCE X202-2P IRT; 2 x 10/100 Mbit/s RJ45 ports, 2 x 100 Mbit/s POF/PCF SC RJ 6GK5 202-2BH00-2BA3 • SCALANCE X201-3P IRT; 1 x 10/100 Mbit/s RJ45 ports, 3 x 100 Mbit/s POF/PCF SC RJ 6GK5 201-3BH00-2BA3 • SCALANCE X200-4P IRT; 4 x 100 Mbit/s POF/PCF SC RJ 6GK5 200-4AH00-2BA3

¹⁾ For operating the IM 151-3, an MMC is essential

Note:

You can find more information in Catalog ST 70 and in the Industry Mall at www.siemens.com/industrymall

PROFINET/Industrial Ethernet

SIMATIC ET 200S – Interface modules

SIPLUS IM 151-3PN
Overview

- Interface module for interface to ET 200S PROFINET
- Handles all data exchange with the PROFINET I/O Controller
- IM 151-3 PN STANDARD
- With integrated 2-port switch for line topology

Micro Memory Card required for CPU operation.

Note:

SIPLUS extreme products are based on Siemens Industry standard products. The contents listed here were taken from the respective standard products. SIPLUS extreme-specific information was added.

SIPLUS IM 151-3 PN	
Order number	6AG1 151-3AA23-2AB0
Order number based on	6ES7 151-3AA23-0AB0
Ambient temperature range	-25 ... +60 °C
Conformal coating	Coating of the printed circuit boards and the electronic components
Technical data	The technical data of the standard product applies except for the ambient conditions.

Ambient conditions

Relative humidity	5 ... 100 % Condensation permissible
Biologically active substances	Conformity with EN 60721-3-3, Class 3B2 mold and fungal spores (except fauna)
Chemically active substances	Conformity with EN 60721-3-3, Class 3C4 incl. salt mist and ISA-S71.04 severity level G1; G2; G3; GX ^{1) 2)}
Mechanically active substances	Conformity with EN 60721-3-3, Class 3S4 including conductive sand, dust ²⁾
Air pressure (depending on the highest positive temperature range specified)	1080 ... 795 hPa (-1000 ... +2000 m) see ambient temperature range 795 ... 658 hPa (+2000 ... +3500 m) derating 10 K 658 ... 540 hPa (+3500 ... +5000 m) derating 20 K

¹⁾ ISA-S71.04 severity level GX: Long-term load:
SO₂ < 4.8 ppm; H₂S < 9.9 ppm; Cl < 0.2 ppm; HCl < 0.66 ppm;
HF < 0.12 ppm; NH < 49 ppm; O₃ < 0.1 ppm; NOX < 5.2 ppm
Limit value (max. 30 min/d):

SO₂ < 17.8 ppm; H₂S < 49.7 ppm; Cl < 1.0 ppm; HCl < 3.3 ppm;
HF < 2.4 ppm; NH < 247 ppm; O₃ < 1.0 ppm; NOX < 10.4 ppm

²⁾ The supplied plug covers must remain in place over the unused interface when operated in atmospheres containing corrosive gases!

Technical documentation on SIPLUS is available at:

www.siemens.com/siplus-extreme

Ordering data	Order No.
SIPLUS IM 151-3 PN interface module (extended temperature range and medial exposure) For ET 200S; transfer rates up to 100 Mbit/s; data volume depends on the number of modules inserted, up to 63 modules can be connected, bus connection through RJ45	6AG1 151-3AA23-2AB0
Accessories	See SIMATIC IM 151-3 PN interface module

PROFINET/Industrial Ethernet

SIMATIC ET 200S – Interface modules with integrated CPU

IM 151-8 PN/DP CPU

Overview



- Interface module for SIMATIC ET 200S with integrated CPU S7-314
- For high-performance control solutions in ET 200S

- Increase of the availability of systems and machines
- PROFINET IO Controller for up to 128 IO Devices
- PROFINET I-Device for connecting the CPU as an intelligent PROFINET device under a SIMATIC or non-Siemens PROFINET IO controller
- PROFINET interface with integrated 3-port switch
- Isochronous mode on PROFINET
- With many communication options: PG/OP communication, PROFINET IO, PROFINET CBA, open IE communication (TCP, ISO-on-TCP and UDP), web server and S7-communication (with loadable FBs)
- Fast, simple and end-to-end programming of a system with modular programs via STEP 7
- Compact SIMATIC Micro Memory Card (MMC)
- Optional PROFIBUS master for 32 PROFIBUS DP slaves (with master interface 6ES7138-4HA00-0A0)
- Fail-safe IM 151-8F PN/DP CPU PROFIsafe available

Note:

SIMATIC Micro Memory Card required for operation of CPU.

Ordering data

Order No.

IM 151-8 PN/DP CPU interface module (192 K)

6ES7 151-8AB01-0AB0

Including termination module

Accessories

MMC 64 KB ¹⁾

6ES7 953-8LF20-0AA0

for program backup

MMC 128 KB ¹⁾

6ES7 953-8LG11-0AA0

for program backup

MMC 512 KB ¹⁾

6ES7 953-8LJ20-0AA0

for program backup

MMC 2 MB ¹⁾

6ES7 953-8LL20-0AA0

for program backup and/or firmware update

MMC 4 MB ¹⁾

6ES7 953-8LM20-0AA0

for program backup

MMC 8 MB ¹⁾

6ES7 953-8LP20-0AA0

for program backup

External prommer

6ES7 792-0AA00-0XA0

for MMC, among others, with USB interface

PG

On request

with integrated MMC interface

Label sheets DIN A4 (10 units)

Each sheet contains 60 label strips for peripheral modules and 20 label strips for interface modules

- petrol
- red
- yellow
- light beige

6ES7 193-4BH00-0AA0

6ES7 193-4BD00-0AA0

6ES7 193-4BB00-0AA0

6ES7 193-4BA00-0AA0

¹⁾ An MMC is essential to operate the CPU

Order No.

ET 200S distributed I/O system manuals

are available on the Internet as PDF files:

www.siemens.com/simatic-docu

Terminating module

6ES7 193-4JA00-0AA0

as spare part for ET 200S

SIMATIC S5, 35 mm DIN rail

- Length: 483 mm for 19" cabinets
- Length: 530 mm for 600 mm cabinets
- Length: 830 mm for 900 mm cabinets
- 2 m long

6ES5 710-8MA11

6ES5 710-8MA21

6ES5 710-8MA31

6ES5 710-8MA41

Industrial Ethernet Switch SCALANCE XF204-2

4 x 10/100 Mbit/s RJ45 ports electrical; 2 x 100 Mbit/s BFOC ports optical (multimode, glass), up to 5 km

6GK5 204-2BC00-2AF2

Industrial Ethernet FC RJ45 Plug 90

RJ45 plug connector for Industrial Ethernet with a rugged metal housing and integrated insulation displacement contacts for connecting Industrial Ethernet FC installation cables; 90° cable outlet; e.g. for ET 200S

- 1 item
- 10 items
- 50 items

6GK1 901-1BB20-2AA0

6GK1 901-1BB20-2AB0

6GK1 901-1BB20-2AE0

Industrial Ethernet FastConnect installation cable

- FastConnect Standard Cable
- FastConnect Trailing Cable
- FastConnect Marine Cable

6XV1 840-2AH10

6XV1 840-3AH10

6XV1 840-4AH10

Industrial Ethernet FastConnect Stripping Tool

6GK1 901-1GA00

Note:

You can find more information in Catalog ST 70 and in the Industry Mall at www.siemens.com/industrymall

PROFINET/Industrial Ethernet

SIMATIC ET 200S – Interface modules with integrated CPU

Master interface module
for IM 151 CPU interface modules

Overview



PROFIBUS DP master interface module for IM 151-7(F) CPU / IM 151-8(F) PN/DP CPU interface modules

- Integrated 12 Mbit/s PROFIBUS DP master interface in copper design
- Facilitates parallel operation of two PROFIBUS DP interfaces on one IM 151-7 CPU
- Enables operation of a PROFIBUS DP interface on an IM 151-8(F) PN/DP CPU
- Increases the availability of plants and machinery
- Functionality corresponds to the interface of an S7-300 CPU 314-2 DP configured as DP master

Programming is with STEP 7 from Version V5.2 with Service Pack 1.

Ordering data

Order No.

Master interface module for IM 151-7 CPU / IM 151-7 F-CPU / IM 151-8 PN/DP CPU / IM 151-8 F PN/DP CPU interface modules

6ES7 138-4HA00-0AB0

Accessories

Label sheets DIN A4 (10 pieces)

Each sheet contains 60 label strips for peripheral modules and 20 label strips for interface modules

- petrol
- red
- yellow
- light beige

6ES7 193-4BH00-0AA0

6ES7 193-4BD00-0AA0

6ES7 193-4BB00-0AA0

6ES7 193-4BA00-0AA0

ET 200S distributed I/O system manuals

are available on the Internet as PDF files:

www.siemens.com/simatic-docu

Note:

You can find more information in Catalog ST 70 and in the Industry Mall at www.siemens.com/industrymall

PROFINET/Industrial Ethernet

SIMATIC ET 200S – Interface modules with integrated CPU

SIPLUS IM151-8 PN/DP CPU

Overview



- Interface module for SIMATIC ET 200S with integrated CPU S7-314
- For high-performance control solutions in ET 200S
- Increase in the availability of systems and machines
- PROFINET IO-Controller for up to 128 IO-Devices
- PROFINET I-Device for connecting the CPU as an intelligent PROFINET device with a SIMATIC or third-party PROFINET I/O-Controller
- PROFINET interface with integrated 3-port switch
- Isochronous mode on PROFINET
- With many communication options: PG/OP communication, PROFINET IO, PROFINET CBA, open IE communication (TCP, ISO-on-TCP and UDP), Web server and S7 communication (with loadable FBs)
- Fast, simple and uniform programming of a system with modular programs via STEP 7
- Compact SIMATIC micro memory card (MMC)
- Optional PROFIBUS master for 32 PROFIBUS DP slaves (with master interface 6ES7 138-4HA00-0AB0)
- Fail-safe IM 151-8F PN/DP CPU PROFIsafe available

Micro Memory Card required for CPU operation.

Note:

SIPLUS extreme products are based on Siemens Industry standard products. The contents listed here were taken from the respective standard products. SIPLUS extreme-specific information was added.

	SIPLUS IM 151-8 PN/DP CPU	
Order No.	6AG1 151-8AB00-4AB0	6AG1 151-8AB00-7AB0
Order No. based on	6ES7 151-8AB00-0AB0	6ES7 151-8AB00-0AB0
Ambient temperature range	0 ... +60 °C	-25 ... +70 °C
Conformal coating	Coating of the printed circuit boards and the electronic components	
Technical data	The technical data of the standard product applies except for the ambient conditions.	

Ambient conditions:

- Relative humidity: 5 ... 100%, condensation allowed
- Biologically active substances: Conformity with EN 60721-3-3, Class 3B2 mold and fungal spores fauna)

Chemically active substances

- Mechanically active substances: Conformity with EN 60721-3-3, Class 3C4 incl. salt mist and ISA-S71.04 severity level G1; G2; G3; GX ^{1) 2)}
- Air pressure (depending on the highest positive temperature range specified):
 - 1,080...795 hPa (-1,000 ... +2,000 m) See ambient temperature range
 - 795...658 hPa (+2,000 ... +3,500 m) Derating 10 K
 - 658...540 hPa (+3500 ... +5000m) Derating 20K

- 1) ISA-S71.04 severity level GX: Long-term load: SO₂ <4.8 ppm; H₂S <9.9 ppm; Cl <0.2 ppm; HCl <0.66 ppm; HF <0.12 ppm; NH <49 ppm; O₃ <0.1 ppm; NO_x <5.2 ppm
Threshold / limit value (max. 30 min/d): SO₂ <17.8 ppm; H₂S <49.7 ppm; Cl <1.0 ppm; HCl <3.3 ppm; HF <2.4 ppm; NH <247 ppm; O₃ <1.0 ppm; NO_x <10.4 ppm
- 2) The supplied plug covers must remain in place over the unused interface when operated in atmospheres containing corrosive gases!

The technical documentation on SIPLUS can be found here:

www.siemens.com/siplus-extreme

Ordering data	Order No.
SIPLUS IM 151-8 PN/DP CPU interface module (extended temperature range and medial exposure) Including termination module	
• For areas with extreme medial stress (conformal coating)	6AG1 151-8AB00-4AB0
• For areas with extreme medial stress (conformal coating); ambient temperature -25 ... +70 °C	6AG1 151-8AB00-7AB0
Accessories	See SIMATIC IM 151-8 PN/DP CPU interface module

PROFINET/Industrial Ethernet

SIMATIC ET 200S – Interface modules with integrated CPU

SIPLUS master interface module for IM 151 CPU

Overview



PROFIBUS DP master interface module for interface module IM 151-7 (R) CPU / IM 151-8 (F) PN/DP CPU

- Integrated 12 Mbit/s PROFIBUS DP master interface in Cu version
- Allows parallel operation of two PROFIBUS DP interfaces on one IM 151-7 CPU
- Allows operation of one PROFIBUS DP interface with an IM 151-8 (F) PN/DP CPU
- Increase in availability of systems and machines
- Functionality in accordance with a DP master configured interface of an S7-314 CPU

Programming is performed with STEP 7 from version V5.2 with Service Pack 1.

Note:

SIPLUS extreme products are based on Siemens Industry standard products. The contents listed here were taken from the respective standard products. SIPLUS extreme-specific information was added.

Product type designation	SIPLUS master interface module for IM 151 CPU
Order number	6AG1 138-4HA00-7AB0
Order No. based on	6ES7 138-4HA00-0AB0
Ambient temperature range	-25 °C to +70 °C
Conformal coating	Coating of the printed circuit boards and the electronic components
Technical data	The technical data of the standard product applies except for the ambient conditions.

Ambient conditions

Relative humidity	5 ... 100 % Condensation permissible
Biologically active substances	Conformity with EN 60721-3-3, Class 3B2 mold and fungal spores (except fauna)
Chemically active substances	Conformity with EN 60721-3-3, Class 3C4 incl. salt mist and ISA-S71.04 severity level G1; G2; G3; GX ^{1) 2)}
Mechanically active substances	Conformity with EN 60721-3-3, Class 3S4 including conductive sand, dust ²⁾
Air pressure (depending on the highest positive temperature range specified)	1080 ... 795 hPa (-1000 ... +2000 m) See ambient temperature range 795 ... 658 hPa (+2000 ... +3500 m) derating 10 K 658 ... 540 hPa (+3500 ... +5000 m) derating 20 K

- ¹⁾ SA-S71.04 severity level GX: Long-term load: SO₂ < 4.8 ppm; H₂S < 9.9 ppm; Cl < 0.2 ppm; HCl < 0.66 ppm; HF < 0.12 ppm; NH < 49 ppm; O₃ < 0.1 ppm; NOX < 5.2 ppm
Limit value (max. 30 min/d): SO₂ < 17.8 ppm; H₂S < 49.7 ppm; Cl < 1.0 ppm; HCl < 3.3 ppm; HF < 2.4 ppm; NH < 247 ppm; O₃ < 1.0 ppm; NOX < 10.4 ppm

- ²⁾ The supplied plug covers must remain in place over the unused interface when operated in atmospheres containing corrosive gases!

The technical documentation on SIPLUS can be found here:

www.siemens.com/siplus-extreme

Ordering data	Order No.
Master interface module for SIPLUS M 151-7 CPU / IM 151-7 F-CPU / IM 151-8 PN/DP CPU / IM 151-8 F PN/DP CPU interface modules (extended temperature range and medial exposure)	6AG1 138-4HA00-7AB0
Accessories	See SIMATIC master interface module for IM 151 CPU

PROFINET/Industrial Ethernet

SIMATIC ET 200S – Interface modules with integrated CPU

IM 151-8 F PN/DP CPU

Overview



- Interface module for SIMATIC ET 200S with integrated fail-safe CPU
- For constructing a fail-safe automation system for plants with increased safety requirements
- Complies with safety requirements up to SIL 3 according to IEC 61508, IEC 62061, up to PLe according to ISO 13849-1:2006 and Cat. 4 according to EN 954-1
- For high-performance control solutions in ET 200S
- Increase of the availability of systems and machines
- PROFINET IO-Controller for up to 128 IO-Devices
- PROFINET interface with integrated 3-port switch
- With many communication options:
PG/OP communication, PROFINET IO, PROFINET CBA, open IE communication (TCP, ISO-on-TCP and UDP), web server and S7-communication (with loadable FBs)
- Fast, simple and end-to-end programming of a system with modular programs via STEP 7
- Compact SIMATIC Micro Memory Card (MMC)
- Optional PROFIBUS master for 32 PROFIBUS DP slaves (with master interface 6ES7138-4HA00-0AB0)

Note:

SIMATIC Micro Memory Card required for operation of CPU.

Ordering data

Order No.

IM 151-8F PN/DP CPU interface module (256 K)

6ES7 151-8FB01-0AB0

Including termination module

Distributed Safety V5.4 programming tool

Task:

Software for configuring fail-safe application programs for SIMATIC S7-300F, S7-400F, ET 200S

Requirement:

STEP 7 V5.3 SP3 and higher

Floating license

6ES7 833-1FC02-0YA5

Software Update Service

6ES7 833-1FC00-0YX2

Distributed Safety Upgrade

6ES7 833-1FC02-0YE5

From V5.3 to V5.4;
Floating license for 1 user

Accessories

MMC 64 KB ¹⁾

6ES7 953-8LF20-0AA0

for program backup

MMC 128 KB ¹⁾

6ES7 953-8LG20-0AA0

for program backup

MMC 512 KB ¹⁾

6ES7 953-8LJ30-0AA0

for program backup

MMC 2 MB ¹⁾

6ES7 953-8LL20-0AA0

for program backup and/or
firmware update

MMC 4 MB ¹⁾

6ES7 953-8LM20-0AA0

for program backup

MMC 8 MB ¹⁾

6ES7 953-8LP20-0AA0

for program backup

External prommer

6ES7 792-0AA00-0XA0

e.g. for MMC with USB interface

PG

On request

with integrated MMC interface

¹⁾ An MMC is essential for operating the CPU

PROFINET/Industrial Ethernet

SIMATIC ET 200S – Interface modules with integrated CPU

IM 151-8 F PN/DP CPU

Ordering data	Order No.	Ordering data	Order No.
<i>Accessories (continued)</i>		<i>Accessories (continued)</i>	
Label sheets DIN A4 (10 units) Each sheet contains 60 labeling strips for peripheral modules and 20 labeling strips for interface modules <ul style="list-style-type: none"> • petrol • red • yellow • light beige 	6ES7 193-4BH00-0AA0 6ES7 193-4BD00-0AA0 6ES7 193-4BB00-0AA0 6ES7 193-4BA00-0AA0	Industrial Ethernet Switch SCALANCE XF204-2 4 x 10/100 Mbit/s RJ45 ports electrical; 2 x 100 Mbit/s BFOC ports optical (multimode, glass), up to 5 km	6GK5 204-2BC00-2AF2
ET 200S distributed I/O system manuals are available on the Internet as PDF files:	www.siemens.com/simatic-docu	Industrial Ethernet FC RJ45 Plug 180 RJ45 plug connector for Industrial Ethernet with a rugged metal enclosure and integrated insulation displacement contacts for connecting Industrial Ethernet FC installation cables; with 180° cable outlet <ul style="list-style-type: none"> • 1 unit • 10 units • 50 units 	6GK1 901-1BB10-2AA0 6GK1 901-1BB10-2AB0 6GK1 901-1BB10-2AE0
Termination module as spare part for ET 200S	6ES7 193-4JA00-0AA0	Industrial Ethernet FastConnect installation cables <ul style="list-style-type: none"> • FastConnect standard cable • FastConnect trailing cable • FastConnect marine cable 	6XV1 840-2AH10 6XV1 840-3AH10 6XV1 840-4AH10
SIMATIC S5, 35 mm DIN rail <ul style="list-style-type: none"> • Length: 483 mm for 19" cabinets • Length: 530 mm for 600 mm cabinets • Length: 830 mm for 900 mm cabinets • 2 m long 	6ES5 710-8MA11 6ES5 710-8MA21 6ES5 710-8MA31 6ES5 710-8MA41	Industrial Ethernet FastConnect stripping tool	6GK1 901-1GA00

Note:

You can find more information in Catalog ST 70 and in the Industry Mall at www.siemens.com/industrymall

PROFINET/Industrial Ethernet

SIMATIC ET 200S – Interface modules with integrated CPU

SIPLUS IM 151-8 F PN/DP CPU

Overview



- Interface module for SIPLUS ET 200S with integrated CPU S7-314
- For high-performance control solutions in ET 200S
- Increase in the availability of systems and machines
- PROFINET IO-Controller for up to 128 IO-Devices
- PROFINET I-Device for connecting the CPU as an intelligent PROFINET device with a SIMATIC or third-party PROFINET I/O-Controller
- PROFINET interface with integrated 3-port switch
- Isochronous mode on PROFINET
- With many communication options: PG/OP communication, PROFINET IO, PROFINET CBA, open IE communication (TCP, ISO-on-TCP and UDP), Web server and S7 communication (with loadable FBs)
- Fast, simple and uniform programming of a system with modular programs via STEP 7
- Compact SIMATIC micro memory card (MMC)
- Optional PROFIBUS master for 32 PROFIBUS DP slaves (with master interface 6ES7138-4HA00-0AB0)
- Fail-safe IM 151-8F PN/DP CPU PROFIsafe available

SIMATIC Micro Memory Card required for operation of CPU.

Note:

SIPLUS extreme products are based on Siemens Industry standard products. The contents listed here were taken from the respective standard products. SIPLUS extreme-specific information was added.

Product type designation	SIPLUS IM 151-8 F PN/DP CPU
Order No.	6AG1 151-8FB01-2AB0
Order No. based on	6ES7 151-8FB01-0AB0
Ambient temperature range	-25 ... +60 °C
Conformal coating	Coating of the printed circuit boards and the electronic components
Technical data	The technical data of the standard product applies except for the ambient conditions.

Ambient conditions:

Relative humidity	5 ... 100 % Condensation permissible
-------------------	-----------------------------------------

For further technical documentation on SIPLUS, see:

www.siemens.com/siplus-extreme

Ordering data	Order No.
SIPLUS IM 151-8F PN/DP CPU interface module (extended temperature range and medial exposure) Including termination module	6AG1 151-8FB01-2AB0
Accessories	See SIMATIC IM 151-8F PN/DP CPU interface module

Overview



- To connect ET 200M to PROFINET IO (via copper line, RJ45) as an IO device
- 2 versions:
 - IM 153-4 PN STANDARD
 - IM 153-4 PN HIGH FEATURE:
 - supports, in contrast to the STANDARD version, the operation of PROFIsafe F and HART modules
- Integrated 2-port switch
- 12 modules per station
- Usable I/O capacity: 192 bytes each
- Active bus backplane to hot-swap modules available as an option
- Baud rate 10 Mbit/s / 100 Mbit/s (autonegotiation / full duplex)
- I&M functions in accordance with PROFIBUS International guideline order no. 3.502, Version V1.1

Note:

Micro Memory Card with at least 64 KB required if not all the stations in the network support LLDP (Link Layer Discovery Protocol; proximity detection).

PROFINET/Industrial Ethernet

SIMATIC ET 200M – Interface modules

IM 153-4 PN

2

Ordering data	Order No.	Order No.
IM 153-4 PN interface module I/O device to connect an ET 200M to PROFINET <ul style="list-style-type: none"> • Standard • High Feature 	6ES7 153-4AA01-0XB0 6ES7 153-4BA00-0XB0	6ES7 998-8XC01-8YE0
Accessories Bus modules for ET 200M <ul style="list-style-type: none"> • To accommodate a power supply and an IM 153 for the hot-swapping function during RUN, incl. bus module cover • To accommodate two 40-mm wide I/O modules for the hot-swapping function • To accommodate one 80-mm wide I/O module for th hot-swapping function 	6ES7 195-7HA00-0XA0 6ES7 195-7HB00-0XA0 6ES7 195-7HC00-0XA0	6ES7 998-8XC01-8YE2
SIMATIC Micro Memory Card 64 KB ¹⁾	6ES7 953-8LF20-0AA0	6GK7 377-1AA00-0AA0
SIMATIC DP DIN rail for ET 200M Accommodates up to 5 bus modules; for hot-swapping function <ul style="list-style-type: none"> • Length: 483 mm (19") • Length: 530 mm • Length: 620 mm • Length: 2000 mm 	6ES7 195-1GA00-0XA0 6ES7 195-1GF30-0XA0 6ES7 195-1GG30-0XA0 6ES7 195-1GC00-0XA0	6ES7 998-8XC01-8YE2
SIMATIC S7-300 DIN rail <ul style="list-style-type: none"> • Length: 160 mm • Length: 480 mm (19") • Length: 530 mm • Length: 830 mm • Length: 2,000 mm 	6ES7 390-1AB60-0AA0 6ES7 390-1AE80-0AA0 6ES7 390-1AF30-0AA0 6ES7 390-1AJ30-0AA0 6ES7 390-1BC00-0AA0	6GK7 377-1AA00-0AA0
		S7 Manual Collection Electronic manuals on DVD, multi-language: S7-200, TD 200, S7-300, M7-300, C7, S7-400, M7-400, STEP 7, Engineering Tools, Runtime Software, SIMATIC DP (Distributed I/O), SIMATIC HMI (Human Machine Interface), SIMATIC NET (Industrial Communication)
		S7 Manual Collection – Update service for 1 year Scope of delivery: Current DVD "S7 Manual Collection" and the three subsequent updates
		Compact Switch Module CSM 377 Unmanaged switch for connecting a SIMATIC S7-300, ET 200M and up to three further nodes to Industrial Ethernet with 10/100 Mbit/s; 4 x RJ45 ports; external 24 V DC power supply, diagnostics on LEDs, S7-300 module including electronic manual on CD-ROM
		Industrial Ethernet FC RJ45 Plug 180 RJ45 plug connector for Industrial Ethernet with a rugged metal housing and integrated insulation displacement contacts for connecting Industrial Ethernet FC installation cables; with 180° cable outlet <ul style="list-style-type: none"> • 1 unit • 10 units • 50 units
		Industrial Ethernet FastConnect installation cables <ul style="list-style-type: none"> • FastConnect standard cable • FastConnect trailing cable • FastConnect marine cable
		Industrial Ethernet FastConnect Stripping Tool

¹⁾ To operate the IM153-4, an MMC is required with at least 64 KB memory. Cards with higher memory capacity may also be used.

Note:

You can find more information in Catalog ST 70 and in the Industry Mall at www.siemens.com/industrymall

PROFINET/Industrial Ethernet

SIMATIC ET 200M – Interface modules

SIPLUS IM 153-4 PN IO

Overview



- For connection of ET 200M as IO Device to PROFINET IO (copper, RJ45)
- 2 versions:
 - IM 153-4 PN STANDARD
 - IM 153-4 PN HIGH FEATURE: additionally to the STANDARD version, operation of PROFIsafe F and HART modules
- Integrated 2-port switch
- 12 modules per station
- Usable I/O quantity structure: 192 bytes each
- Active backplane bus for hot swapping of modules optionally available
- Baud rate 10 Mbit/s / 100 Mbit/s (Autonegotiation/Full Duplex)
- I&M functions according to PNO-Guideline Order-No. 3.502, Version V1.1

Notes:

Micro Memory Card with min. 4 KB required if not all participants in the network support LLDP (Link Layer Discovery Protocol; neighbor detection).

SIPLUS extreme products are based on Siemens Industry standard products. The contents listed here were taken from the respective standard products. SIPLUS extreme-specific information was added.

Product type designation	SIPLUS ET 200 M IM 153-4 PN
Order number	6AG1 153-4AA01-7XB0
Order No. based on	6ES7 153-4AA01-0XB0
Ambient temperature range	-25 °C ... + 70 °C
Conformal coating	Coating of the printed circuit boards and the electronic components
Technical data	The technical data of the standard product applies except for the ambient conditions.

Ambient conditions

Relative humidity	5 ... 100 % Condensation permissible
Biologically active substances	Conformity with EN 60721-3-3, Class 3B2 mold and fungal spores (except fauna)
Chemically active substances	Conformity with EN 60721-3-3, Class 3C4 incl. salt mist and ISA-S71.04 severity level G1; G2; G3; GX ^{1) 2)}
Mechanically active substances	Conformity with EN 60721-3-3, Class 3S4 including conductive sand, dust ²⁾
Air pressure (depending on the highest positive temperature range specified)	1080 ... 795 hPa (-1000 ... +2000 m) See ambient temperature range 795 ... 658 hPa (+2000 ... +3500 m) derating 10 K 658 ... 540 hPa (+3500 ... +5000 m) derating 20 K

- ¹⁾ ISA-S71.04 severity level GX: Long-term load: SO₂ < 4.8 ppm; H₂S < 9.9 ppm; Cl < 0.2 ppm; HCl < 0.66 ppm; HF < 0.12 ppm; NH < 49 ppm; O₃ < 0.1 ppm; NOX < 5.2 ppm
Limit value (max. 30 min/d): SO₂ < 17.8 ppm; H₂S < 49.7 ppm; Cl < 1.0 ppm; HCl < 3.3 ppm; HF < 2.4 ppm; NH < 247 ppm; O₃ < 1.0 ppm; NOX < 10.4 ppm

- ²⁾ The supplied plug covers must remain in place over the unused interface when operated in atmospheres containing corrosive gases!

The technical documentation on SIPLUS can be found here: www.siemens.com/siplus-extreme

Ordering data	Order No.
SIPLUS ET 200M interface connection IM 153-4 PN (extended temperature range and medial exposure) IO Device to connect an ET 200M to PROFINET ¹⁾	6AG1 153-4AA01-7XB0
Accessories	See SIMATIC ET 200M interface module IM 153-4 PN

- ¹⁾ To operate the IM153-4, an MMC is required with at least 64 KB memory. Cards with higher memory capacity may also be used.

PROFINET/Industrial Ethernet

SIMATIC ET 200pro – Interface modules

IM 154-4 PN

Overview



Interface module for processing the communication between ET 200pro and a higher-level controller over PROFINET IO.

Ordering data

IM 154-4 PN High Feature interface module

For communication between ET 200pro and higher-level controllers over PROFINET IO; support of PROFI-safe

Accessories

CM IM PN connection module M12, 7/8"

For connecting PROFINET PN and 24 V power supply to PROFINET interface modules, 2 x M12 and 2 x 7/8"

CM IM PN connection module 2xRJ45

For connecting PROFINET PN and 24 V power supply to PROFINET interface modules, 2 x RJ45 and 2 x push-pull power connector

CM IM PN 2xSCRJ FO connection module

For connecting PROFINET PN and 24 V power supply to PROFINET interface modules, 2 x SCRJ FO and 2 x push-pull power connector

M12 sealing cap

For protection of unused M12 connections with ET 200pro

Industrial Ethernet Switches SCALANCE X208PRO

with integral SNMP access, online diagnostics, copper cable diagnostics and PROFINET diagnostics for configuring line, star and ring topologies, IP65 degree of protection; with eight 10/100 Mbit/s M12 ports, incl. eleven M12 dust protection caps

Order No.

6ES7 154-4AB10-0AB0

6ES7 194-4AJ00-0AA0

6ES7 194-4AF00-0AA0

6ES7 194-4AG00-0AA0

3RX9 802-0AA00

6GK5 208-0HA00-2AA6

Order No.

Accessories (continued)

IE M12 connecting cables

Preassembled, with two M12 connectors, up to 85 m

- 0.3 m long
- 0.5 m long
- 1.0 m long
- 1.5 m long
- 2.0 m long
- 3.0 m long
- 5.0 m long
- 10 m long
- 15 m long
- Other special lengths with 90° or 180° cable outlet

6XV1 870-8AE30
6XV1 870-8AE50
6XV1 870-8AH10
6XV1 870-8AH15
6XV1 870-8AH20
6XV1 870-8AH30
6XV1 870-8AH50
6XV1 870-8AN10
6XV1 870-8AN15

see <http://support.automation.siemens.com/WWW/view/en/26999294>

7/8" sealing caps

1 pack = 10 units

6ES7 194-3JA00-0AA0

7/8" connecting cable to power supply

5-core, 5 x 1.5 mm², trailing type, preassembled with two 7/8" connectors, 5-pin, up to 50 m

- 1.5 m long
- 2.0 m long
- 3.0 m long
- 5.0 m long
- 10 m long
- 15 m long
- Other special lengths with 90° or 180° cable outlet

6XV1 822-5BH15
6XV1 822-5BH20
6XV1 822-5BH30
6XV1 822-5BH50
6XV1 822-5BN10
6XV1 822-5BN15

see <http://support.automation.siemens.com/WWW/view/en/26999294>

Power cable

5-core, 5 x 1.5 mm², trailing type, sold by the meter, minimum order quantity 20 m, maximum order quantity 1,000 m

6XV1 830-8AH10

7/8" cable connector

For ET 200eco, with axial cable outlet

- with male insert, 5 per pack
- with female insert, 5 per pack

6GK1 905-0FA00
6GK1 905-0FB00

Ordering data	Order No.	Order No.
Accessories (continued)		General accessories
Industrial Ethernet FastConnect installation cables <ul style="list-style-type: none"> • IE FC TP Standard Cable GP 2 x 2; Sold by the meter, max. order quantity 1000 m; Minimum order quantity 20 m • IE FC TP Trailing Cable 2 x 2; Sold by the meter, max. order quantity 1000 m; Minimum order quantity 20 m • IE FC TP Trailing Cable GP 2 x 2; Sold by the meter, max. order quantity 1000 m; Minimum order quantity 20 m • IE TP Torsion Cable GP 2 x 2; Sold by the meter, max. order quantity 1000 m; Minimum order quantity 20 m • IE FC TP Marine Cable 2 x 2; Sold by the meter, max. order quantity 1000 m; Minimum order quantity 20 m 	6XV1 840-2AH10 6XV1 840-3AH10 6XV1 870-2D 6XV1 870-2F 6XV1 840-4AH10	ET 200pro rack <ul style="list-style-type: none"> • Narrow, for interface, electronics and power modules <ul style="list-style-type: none"> - 500 mm - 1000 mm - 2000 mm, can be cut to length • Compact, for interface, electronics and power modules <ul style="list-style-type: none"> - 500 mm - 1000 mm - 2000 mm, can be cut to length • Wide, for interface, electronics, power modules and motor starters <ul style="list-style-type: none"> - 500 mm - 1000 mm - 2000 mm, can be cut to length • Wide, for I/O modules and motor starters <ul style="list-style-type: none"> - 500 mm - 1000 mm - 2000 mm
Power Plug PRO 5-pole power plug for 2 x 24 V power supply in IP65/67-rated design, for on-site assembly, plastic housing, for SCALANCE X-200IRT and ET 200pro 1 pack = 1 unit	6GK1907-0AB10-6AA0	6ES7 194-4GA00-0AA0 6ES7 194-4GA60-0AA0 6ES7 194-4GA20-0AA0 6ES7 194-4GC70-0AA0 6ES7 194-4GC60-0AA0 6ES7 194-4GC20-0AA0 6ES7 194-4GB00-0AA0 6ES7 194-4GB60-0AA0 6ES7 194-4GB20-0AA0 6ES7 194-4GD00-0AA0 6ES7 194-4GD10-0AA0 6ES7 194-4GD20-0AA0
IE panel feedthrough Control cabinet feedthrough for converting M12 D-coded connection system (IP65) to RJ45 connection system (IP20) <ul style="list-style-type: none"> • 1 pack = 5 units 	6GK1 901-0DM20-2AA5	Spare fuse 12.5 A quick-response, for interface and power modules, 10 items per package unit
Push-Pull cable connector For 1L+/ 2L+, unassembled	6GK1 907-0AB10-6AA0	SIMATIC Manual Collection Electronic manuals on DVD, multi-language: S7-200, TD 200, S7-300, M7-300, C7, S7-400, M7-400, STEP 7, Engineering Tools, Runtime Software, SIMATIC DP (Distributed I/O), SIMATIC HMI (Human Machine Interface), SIMATIC NET (Industrial Communication)
Cover caps for Push-Pull RJ45 female connectors 5 items per pack	6ES7 194-4JD50-0AA0	SIMATIC Manual Collection – Update service for 1 year Scope of delivery: Current DVD "S7 Manual Collection" and the three subsequent updates
Industrial Ethernet FastConnect Stripping Tool	6GK1 901-1GA00	6ES7 194-4HB00-0AA0

Note:

You can find more information in Catalog ST 70 and in the Industry Mall at www.siemens.com/industrymall

PROFINET/Industrial Ethernet

SIMATIC ET 200pro – Interface modules

IM 154-6 PN IWLAN

Overview



Interface module for handling communication between ET 200pro and host PROFINET IO controllers over Industrial Wireless LAN (IWLAN) radio networks for 2.4 GHz or 5 GHz with data transfer rates up to 54 Mbit/s.

- Protection against illegal access, espionage, tapping and falsification through use of effective encryption mechanisms
- Fast exchange of devices through use of interchangeable medium MICRO MEMORY CARD

Ordering data

Order No.

IM 154-6 PN HF IWLAN interface module

For communication between ET 200pro and host controllers over Industrial Wireless LAN (IWLAN) radio networks; support of PROFIsafe

With various national approvals; refer to the current list of approvals

With approval for USA

6ES7 154-6AB00-0AB0

6ES7 154-6AB50-0AB0

Antennas with omnidirectional characteristic

Mounting directly on IM154-6 PN HF IWLAN

- ANT IM 154-6 IWLAN; 2 units

6ES7 194-4MA00-0AA0

For wall or pipe mounting

- ANT 792-6MN; rod antenna N-Connect female 2.4 GHz; 1 unit
- ANT793-6MN; rod antenna N-Connect female 5 GHz; 1 unit

6GK5 792-6MN00-0AA6

6GK5 793-6MN00-0AA6

For use with the RCoax antenna system

- ANT 792-4DN; RCoax N-Connect female 2.4 GHz; 1 unit
- ANT793-4MN; RCoax N-Connect female 5 GHz; 1 unit

6GK5 792-4DN00-0AA6

6GK5 793-4MN00-0AA6

Access Points SCALANCE W and Power Supplies PS791

See chapter 8

Ordering data	Order No.	Order No.
Accessories		General accessories
7/8" connecting cable to power supply 5-core, 5 x 1.5 mm ² , trailing type, pre-assembled with two 7/8" connectors <ul style="list-style-type: none"> • 1.5 m long • 2.0 m long • 3.0 m long • 5.0 m long • 10 m long • 15 m long • Other special lengths with 90° or 180° cable outlet 	6XV1 822-5BH15 6XV1 822-5BH20 6XV1 822-5BH30 6XV1 822-5BH50 6XV1 822-5BN10 6XV1 822-5BN15 See http://support.automation.siemens.com/WW/view/en/26999294	ET 200pro rack <ul style="list-style-type: none"> • Narrow, for interface, electronics and power modules <ul style="list-style-type: none"> - 500 mm - 1000 mm - 2000 mm, can be cut to length • Compact, for interface, electronics and power modules <ul style="list-style-type: none"> - 500 mm - 1000 mm - 2000 mm, can be cut to length • Wide, for interface, electronics, power modules and motor starters <ul style="list-style-type: none"> - 500 mm - 1000 mm - 2000 mm, can be cut to length • Wide, for I/O modules and motor starters <ul style="list-style-type: none"> - 500 mm - 1000 mm - 2000 mm
Power cable 5-core, 5 x 1.5 mm ² , trailing type, sold by the meter, minimum order quantity 20 m, maximum order quantity 1,000 m	6XV1 830-8AH10	6ES7 194-4GA00-0AA0 6ES7 194-4GA60-0AA0 6ES7 194-4GA20-0AA0 6ES7 194-4GC70-0AA0 6ES7 194-4GC60-0AA0 6ES7 194-4GC20-0AA0 6ES7 194-4GB00-0AA0 6ES7 194-4GB60-0AA0 6ES7 194-4GB20-0AA0 6ES7 194-4GD00-0AA0 6ES7 194-4GD10-0AA0 6ES7 194-4GD20-0AA0
7/8" cable connector For ET 200eco, with axial cable outlet; with socket insert, pack of 5	6GK1 905-0FB00	Spare fuse 12.5 A quick-response, for interface and power modules, 10 items per package unit 6ES7 194-4HB00-0AA0
Twisted Pair cables 4x2 with RJ45 connectors <ul style="list-style-type: none"> • 0.5 m long • 1 m long • 2 m long • 6 m long • 10 m long 	6XV1 870-3QE50 6XV1 870-3QH10 6XV1 870-3QH20 6XV1 870-3QH60 6XV1 870-3QN10	Labels 20 x 7 mm, pale turquoise, 340 units per pack 3RT1 900-1SB20
Crossed Twisted Pair cables 4x2 with RJ45 connectors <ul style="list-style-type: none"> • 0.5 m long • 1 m long • 2 m long • 6 m long • 10 m long 	6XV1 870-3RE50 6XV1 870-3RH10 6XV1 870-3RH20 6XV1 870-3RH60 6XV1 870-3RN10	SIMATIC Micro Memory Card <ul style="list-style-type: none"> • 64 KB • 128 KB • 512 KB 6ES7 953-8LF20-0AA0 6ES7 953-8LG20-0AA0 6ES7 953-8LJ30-0AA0
		SIMATIC Manual Collection Electronic manuals on DVD, multi-language: S7-200, TD 200, S7-300, M7-300, C7, S7-400, M7-400, STEP 7, Engineering Tools, Runtime Software, SIMATIC DP (Distributed I/O), SIMATIC HMI (Human Machine Interface), SIMATIC NET (Industrial Communication)
		SIMATIC Manual Collection – Update service for 1 year Scope of delivery: Current DVD "S7 Manual Collection" and the three subsequent updates 6ES7 998-8XC01-8YE0 6ES7 998-8XC01-8YE2

More information

Wireless approvals

Current approvals can be found on the Internet.

Further information can be found on the Internet at:

www.siemens.com/wireless-approvals

Note:

You can find more information in Catalog ST 70 and in the Industry Mall at www.siemens.com/industrymall

PROFINET/Industrial Ethernet

SIMATIC ET 200pro – Interface modules

IM 154-8 PN/DP CPU

Overview



- CPU with PLC functionality equivalent to S7-315-2 PN/DP provides distributed intelligence for preprocessing
- Interface module for exchanging pre-processed I/O data between the ET 200pro and a higher-level master/IO Controller via PROFIBUS DP/PROFINET IO
- PROFINET IO Controller to operate distributed I/Os on PROFINET
- Component based Automation (CBA) on PROFINET
- PROFINET proxy for intelligent devices on PROFIBUS DP in Component Based Automation (CBA)
- PROFINET interface with 3-port switch
- Isochronous mode on PROFIBUS or PROFINET
- Integral Web server with the option of creating user-defined Web sites
- Fast, simple and end-to-end programming of a system with modular programs via STEP 7
- Fail-safe IM 154-8F PN/DP CPU PROFIsafe available

Micro Memory Card required for operation of CPU.

Ordering data

Order No.

IM 154-8 PN/DP CPU interface module, V3.2

6ES7 154-8AB01-0AB0

PROFINET IO Controller to operate distributed I/Os on PROFINET, with integrated PLC functionality

Accessories

MMC 64 KB ¹⁾

6ES7 953-8LF20-0AA0

For program backup

MMC 128 KB ¹⁾

6ES7 953-8LG20-0AA0

For program backup

MMC 512 KB ¹⁾

6ES7 953-8LJ30-0AA0

For program backup

MMC 2 MB ¹⁾

6ES7 953-8LL20-0AA0

for program backup and/or firmware updates

MMC 4 MB ¹⁾

6ES7 953-8LM20-0AA0

For program backup

MMC 8 MB ¹⁾

6ES7 953-8LP20-0AA0

For program backup

Connection module

6ES7 194-4AN00-0AA0

For CPU IM154-8 PN/DP, with 4 x M12 and 2 x 7/8", to connect PROFINET and PROFIBUS DP

SCALANCE X-200 Industrial Ethernet Switches

6GK5 208-0HA00-2AA6

With integral SNMP access, Web diagnostics, copper cable diagnostics and PROFINET diagnostics, for setting up linear, star and ring structures SCALANCE X208PRO, in degree of protection IP65, with eight 10/100 Mbit/s M12 ports, incl. eleven M12 dust caps

¹⁾ An MMC is essential for operating the CPU

Ordering data	Order No.	Ordering data	Order No.
<i>Accessories (continued)</i>		<i>Accessories (continued)</i>	
Industrial Ethernet FastConnect installation cables		IE FC M12 Plug PRO	
• FastConnect standard cable	6XV1 840-2AH10	PROFINET M12 plug connector, D-coded with fast connection system, axial cable outlet	
• FastConnect trailing cable	6XV1 840-3AH10	• 1 unit	6GK1 901-0DB20-6AA0
• FastConnect marine cable	6XV1 840-4AH10	• 8 units	6GK1 901-0DB20-6AA8
Industrial Ethernet FastConnect installation cables		PROFINET M12 plug connector, D-coded, angled	3RK1 902-2DA00
• IE FC TP Trailing Cable GP 2 x 2; Sold by the meter, max. order quantity 1000 m; Minimum order quantity 20 m	6XV1 870-2D	IE panel feedthrough	6GK1 901-0DM20-2AA5
• IE TP Torsion Cable GP 2 x 2; Sold by the meter, max. order quantity 1000 m; Minimum order quantity 20 m	6XV1 870-2F	Cabinet feedthrough for converting from the M12 connection system (D-coded, IP65/IP67) to the RJ45 connection system (IP20), 1 pack = 5 units	
Industrial Ethernet FastConnect Stripping Tool	6GK1 901-1GA00	7/8" connecting cable to power supply	
IE Connecting Cable M12-180/M12-180		5-core, 5 x 1.5 mm ² , trailing type, preassembled with two 7/8" connectors (axial cable outlet), 5-pin, up to 50 m Length:	
Preassembled IE FC TP Trailing Cable GP 2 x 2 (PROFINET Type C) with two 4-pin M12 plugs (4-pin, D-coded), degree of protection IP65/IP67, length:		• 1.5 m	6XV1 822-5BH15
• 0.3 m	6XV1 870-8AE30	• 2.0 m	6XV1 822-5BH20
• 0.5 m	6XV1 870-8AE50	• 3.0 m	6XV1 822-5BH30
• 1.0 m	6XV1 870-8AH10	• 5.0 m	6XV1 822-5BH50
• 1.5 m	6XV1 870-8AH15	• 10 m	6XV1 822-5BN10
• 2.0 m	6XV1 870-8AH20	• 15 m	6XV1 822-5BN15
• 3.0 m	6XV1 870-8AH30	• Other special lengths with 90° or 180° cable outlet	See http://support.automation.siemens.com/WWW/view/en/26999294
• 5.0 m	6XV1 870-8AH50	power cable, can be trailed, 5 x 1.5 mm ² , preassembled at both ends with 7/8" angled connectors (female insert at one end, male insert at the other end) Length:	3RK1 902-3NB30
• 10 m	6XV1 870-8AN10	• 3.0 m	3RK1 902-3NB50
• 15 m	6XV1 870-8AN15	• 5.0 m	3RK1 902-3NC10
PROFINET M12 connecting cable, trailing cable preassembled at both ends with angled M12 connectors (male insert)		• 10 m	
• 3.0 m	3RK1 902-2NB30	Power cable, can be trailed, 5 x 1.5 mm ² , preassembled at one end with 7/8" angled connector with female insert (female insert at one end, other end unconnected) Length:	3RK1 902-3GB30
• 5.0 m	3RK1 902-2NB50	• 3.0 m	3RK1 902-3GB50
• 10 m	3RK1 902-2NC10	• 5.0 m	3RK1 902-3GC10
PROFINET M12 connecting cable, trailing cable preassembled at one end with angled M12 connector (male insert at one end, other end unconnected)		• 10 m	
• 3.0 m	3RK1 902-2HB30	Power cable	6XV1 830-8AH10
• 5.0 m	3RK1 902-2HB50	5-core, 5 x 1.5 mm ² , trailing type, sold by the meter, minimum order quantity 20 m, maximum order quantity 1,000 m	
• 10 m	3RK1 902-2HC10		

PROFINET/Industrial Ethernet

SIMATIC ET 200pro – Interface modules

IM 154-8 PN/DP CPU

2

Ordering data

Order No.

Accessories (continued)

7/8" cable connector

For ET 200eco,
with axial cable outlet

- with male insert, 5 per pack
- with female insert, 5 per pack
- angled, with female insert, 1 unit
- angled, with male insert, 1 unit

7/8" cover cap, 10 per pack

6GK1 905-0FA00

6GK1 905-0FB00

3RK1 902-3DA00

3RK1 902-3BA00

6ES7 194-3JA00-0AA0

Twisted Pair cables 4x2 with RJ45 connectors

Length:

- 0.5 m
- 1 m
- 2 m
- 6 m
- 10 m

6XV1 870-3QE50

6XV1 870-3QH10

6XV1 870-3QH20

6XV1 870-3QH60

6XV1 870-3QN10

Crossed Twisted Pair cables 4x2 with RJ45 connectors

Length:

- 0.5 m
- 1 m
- 2 m
- 6 m
- 10 m

6XV1 870-3RE50

6XV1 870-3RH10

6XV1 870-3RH20

6XV1 870-3RH60

6XV1 870-3RN10

M12 sealing cap

For protection of unused M12
connections with ET 200pro

3RX9 802-0AA00

M12 sealing caps with female thread

5 units

6ES7 194-4JD60-0AA0

Order No.

Accessories (continued)

PROFIBUS M12 connecting cable

Preassembled, with two 5-pole
M12 connectors/sockets,
up to 100 m;
length:

- 1.5 m
- 2.0 m
- 3.0 m
- 5.0 m
- 10 m
- 15 m

Other special lengths
with 90° or 180° cable outlet

M12 bus termination connector
for PROFIBUS, female insert

M12 bus termination connector
for PROFIBUS, male insert

M12 plug connector, axial outlet,
with male insert

PROFIBUS FC Standard Cable GP

Standard type specially designed
for fast assembly, 2-core,
shielded,

Sold by the meter;
Max. delivery unit 1000 m,
Minimum order quantity 20 m

PROFIBUS FC Trailing Cable

2-core, shielded

PROFIBUS FC Food Cable

2-core, shielded

Sold by the meter;
Max. delivery unit 1000 m,
Minimum order quantity 20 m

PROFIBUS FC Robust Cable

2-core, shielded

Sold by the meter;
Max. delivery unit 1000 m,
Minimum order quantity 20 m

PROFIBUS M12 cable connector

5-pole, B-coded, metal casing,
1 pack = 5 units

- Female insert

6XV1 830-3DH15

6XV1 830-3DH20

6XV1 830-3DH30

6XV1 830-3DH50

6XV1 830-3DN10

6XV1 830-3DN15

See <http://support.automation.siemens.com/WW/view/en/26999294>

6GK1 905-0ED00

6GK1 905-0EC00

6GK1 905-0EA00

6XV1 830-0EH10

6XV1 830-3EH10

6XV1 830-0GH10

6XV1 830-0JH10

6GK1 905-0EB00

Note:

You can find more information in Catalog ST 70 and
in the Industry Mall at www.siemens.com/industrymall

PROFINET/Industrial Ethernet

SIMATIC ET 200pro – Interface modules

IM 154-8 F PN/DP CPU

Overview



- Interface module for SIMATIC ET 200pro with integrated fail-safe CPU
- CPU with PLC functionality equivalent to CPU S7-315F PN/DP; with distributed intelligence for preprocessing
- For constructing a fail-safe automation system for plants with increased safety requirements
- Complies with safety requirements up to SIL 3 according to IEC 61508, IEC 62061, up to PLe according to ISO 13849-1:2006 and Cat. 4 according to EN 954-1
- For high-performance control solutions in ET 200pro
- Increase of the availability of systems and machines
- Integral Web server with the option of creating user-defined Web sites
- Isochronous mode on PROFIBUS or PROFINET
- PROFINET IO Controller for up to 128 IO Devices
- PROFINET interface with integrated 3-port switch
- With many communication options: PG/OP communication, PROFINET IO, PROFINET CBA, open IE communication (TCP, ISO-on-TCP and UDP), web server and S7-communication (with loadable FBs)
- Fast, simple and end-to-end programming of a system with modular programs via STEP 7
- Compact SIMATIC Micro Memory Card (MMC)

Note:

SIMATIC Micro Memory Card required for operation of CPU.

Ordering data

Order No.

IM 154-8 F PN/DP CPU interface module, V3.2

6ES7 154-8FB01-0AB0

Fail-safe PROFINET IO Controller to operate distributed I/Os on PROFINET, with integrated PLC functionality

Distributed Safety V5.4 programming tool

Task:
Software for configuring fail-safe application programs for SIMATIC S7-300F, S7-400F, ET 200S

Requirement:
STEP 7 V5.3 SP3 and higher

Floating license

6ES7 833-1FC02-0YA5

Software Update Service

6ES7 833-1FC00-0YX2

Distributed Safety Upgrade

6ES7 833-1FC02-0YE5

From V5.3 to V5.4;
Floating license for 1 user

Accessories

MMC 64 KB ¹⁾

6ES7 953-8LF20-0AA0

for program backup

MMC 128 KB ¹⁾

6ES7 953-8LG20-0AA0

for program backup

MMC 512 KB ¹⁾

6ES7 953-8LJ30-0AA0

for program backup

MMC 2 MB ¹⁾

6ES7 953-8LL20-0AA0

for program backup and/or
firmware updates

MMC 4 MB ¹⁾

6ES7 953-8LM20-0AA0

for program backup

MMC 8 MB ¹⁾

6ES7 953-8LP20-0AA0

for program backup

Connection module

6ES7 194-4AN00-0AA0

For CPU IM154-8 PN/DP, with 4 x M12 and 2 x 7/8", to connect PROFINET and PROFIBUS DP

¹⁾ An MMC is essential for operating the CPU

PROFINET/Industrial Ethernet

SIMATIC ET 200pro – Interface modules

IM 154-8 F PN/DP CPU

2

Ordering data**Order No.***Accessories (continued)***SCALANCE X-200
Industrial Ethernet Switches**

With integral SNMP access, Web diagnostics, copper cable diagnostics and PROFINET diagnostics, for setting up linear, star and ring structures SCALANCE X208PRO, in degree of protection IP65, with eight 10/100 Mbit/s M12 ports, incl. eleven M12 dust caps

6GK5 208-0HA00-2AA6**Industrial Ethernet FastConnect
installation cables**

- FastConnect standard cable
- FastConnect trailing cable
- FastConnect marine cable

6XV1 840-2AH10**6XV1 840-3AH10****6XV1 840-4AH10****Industrial Ethernet FastConnect
installation cables**

- **IE FC TP Trailing Cable GP 2 x 2;**
Sold by the meter,
max. order quantity 1000 m;
Minimum order quantity 20 m
- **IE TP Torsion Cable GP 2 x 2;**
Sold by the meter,
max. order quantity 1000 m;
Minimum order quantity 20 m

6XV1 870-2D**6XV1 870-2F****Industrial Ethernet FastConnect**

Stripping Tool

6GK1 901-1GA00**IE Connecting Cable
M12-180/M12-180**

Preassembled IE FC TP Trailing Cable GP 2 x 2 (PROFINET Type C) with two 4-pin M12 plugs (4-pin, D-coded), degree of protection IP65/IP67, length:

- 0.3 m
- 0.5 m
- 1.0 m
- 1.5 m
- 2.0 m
- 3.0 m
- 5.0 m
- 10 m
- 15 m

6XV1 870-8AE30**6XV1 870-8AE50****6XV1 870-8AH10****6XV1 870-8AH15****6XV1 870-8AH20****6XV1 870-8AH30****6XV1 870-8AH50****6XV1 870-8AN10****6XV1 870-8AN15****Order No.***Accessories (continued)***PROFINET M12 connecting
cable**

Trailing cable preassembled at both ends with angled M12 connectors (male insert)

- 3.0 m
- 5.0 m
- 10 m

3RK1 902-2NB30**3RK1 902-2NB50****3RK1 902-2NC10****PROFINET M12 connecting
cable**

Trailing cable preassembled at one end with angled M12 connector (male insert at one end, other end unconnected)

- 3.0 m
- 5.0 m
- 10 m

3RK1 902-2HB30**3RK1 902-2HB50****3RK1 902-2HC10****IE FC M12 Plug PRO**

PROFINET M12 plug connector, D-coded with fast connection system, axial cable outlet

- 1 unit
- 8 units

6GK1 901-0DB20-6AA0**6GK1 901-0DB20-6AA8****3RK1 902-2DA00**

PROFINET M12 plug connector, D-coded, angled

IE panel feedthrough

Cabinet feedthrough for converting from the M12 connection system (D-coded, IP65/IP67) to the RJ45 connection system (IP20), 1 pack = 5 units

6GK1 901-0DM20-2AA5**7/8" connecting cable
to power supply**

5-core, 5 x 1.5 mm², trailing type, preassembled with two 7/8" connectors (axial cable outlet), 5-pin, up to 50 m

Length:

- 1.5 m
- 2.0 m
- 3.0 m
- 5.0 m
- 10 m
- 15 m

6XV1 822-5BH15**6XV1 822-5BH20****6XV1 822-5BH30****6XV1 822-5BH50****6XV1 822-5BN10****6XV1 822-5BN15**

- Other special lengths with 90° or 180° cable outlet

See <http://support.automation.siemens.com/WW/view/en/26999294>

Ordering data	Order No.	Ordering data	Order No.
<i>Accessories (continued)</i>		<i>Accessories (continued)</i>	
7/8" energy cable , can be trailed, 5 x 1.5 mm ² , preassembled at both ends with 7/8" angled connectors (female insert at one end, male insert at the other end) Length: <ul style="list-style-type: none"> • 3.0 m • 5.0 m • 10 m can be trailed, 5 x 1.5 mm ² , preassembled at one end with 7/8" angled connector with female insert (female insert at one end, other end unconnected) Length: <ul style="list-style-type: none"> • 3.0 m • 5.0 m • 10 m 	3RK1 902-3NB30 3RK1 902-3NB50 3RK1 902-3NC10	M12 sealing cap For protection of unused M12 connections with ET 200pro	3RX9 802-0AA00
Energy cable 5-core, 5 x 1.5 mm ² , trailing type, sold by the meter, minimum order quantity 20 m, maximum order quantity 1,000 m	6XV1 830-8AH10	M12 sealing caps with female thread 5 units	6ES7 194-4JD60-0AA0
7/8" cable connector For ET 200eco, with axial cable outlet <ul style="list-style-type: none"> • with male insert, 5 per pack • with female insert, 5 per pack • angled, with female insert, 1 unit • angled, with male insert, 1 unit 7/8" cover cap, 10 per pack	6GK1 905-0FA00 6GK1 905-0FB00 3RK1 902-3DA00 3RK1 902-3BA00 6ES7 194-3JA00-0AA0	PROFIBUS M12 connecting cable Preassembled, with two 5-pole M12 connectors/sockets, up to 100 m; length: <ul style="list-style-type: none"> • 1.5 m • 2.0 m • 3.0 m • 5.0 m • 10 m • 15 m Other special lengths with 90° or 180° cable outlet	6XV1 830-3DH15 6XV1 830-3DH20 6XV1 830-3DH30 6XV1 830-3DH50 6XV1 830-3DN10 6XV1 830-3DN15 See http://support.automation.siemens.com/WW/view/en/26999294
Twisted Pair cables 4x2 with RJ45 connectors Length: <ul style="list-style-type: none"> • 0.5 m • 1 m • 2 m • 6 m • 10 m 	6XV1 870-3QE50 6XV1 870-3QH10 6XV1 870-3QH20 6XV1 870-3QH60 6XV1 870-3QN10	M12 bus termination connector for PROFIBUS, female insert	6GK1 905-0ED00
Crossed Twisted Pair cables 4x2 with RJ45 connectors Length: <ul style="list-style-type: none"> • 0.5 m • 1 m • 2 m • 6 m • 10 m 	6XV1 870-3RE50 6XV1 870-3RH10 6XV1 870-3RH20 6XV1 870-3RH60 6XV1 870-3RN10	M12 bus termination connector for PROFIBUS, male insert	6GK1 905-0EC00
		M12 plug connector axial outlet, with male insert	6GK1 905-0EA00
		PROFIBUS FC Standard Cable GP Standard type specially designed for fast assembly, 2-core, shielded, Sold by the meter; Max. delivery unit 1000 m, Minimum order quantity 20 m	6XV1 830-0EH10
		PROFIBUS FC Trailing Cable 2-core, shielded	6XV1 830-3EH10
		PROFIBUS FC Food Cable 2-core, shielded Sold by the meter; Max. delivery unit 1000 m, Minimum order quantity 20 m	6XV1 830-0GH10
		PROFIBUS FC Robust Cable 2-core, shielded Sold by the meter; Max. delivery unit 1000 m, Minimum order quantity 20 m	6XV1 830-0JH10
		PROFIBUS M12 cable connector 5-pole, B-coded, metal casing, 1 pack = 5 units <ul style="list-style-type: none"> • Female insert 	6GK1 905-0EB00

Note:

You can find more information in Catalog ST 70 and in the Industry Mall at www.siemens.com/industrymall

PROFINET/Industrial Ethernet

SIMATIC ET 200eco

ET 200eco PN

Overview



- Compact block I/O for processing digital, analog and IO-Link signals for connecting to the PROFINET bus system
- Cabinet-free design with degree of protection IP65/66/67 with M12 connections
- Very rugged and resistant metal enclosure and encapsulated
- Compact module in two types of enclosures:
 - 30 mm x 200 mm x 37 mm (W x H x D, long and narrow enclosure), with 4 x M12 for digital signals
 - 60 mm x 175 mm x 37 mm (W x H x D, short and wide enclosure), with 8 x M12 for digital signals and IO-Link
 - 60 mm x 175 mm x 37 mm (W x H x D, short and wide enclosure) with 4 x M12 or 8 x M12 for analog signals
- PROFINET connection: 2 x M12 and automatic PROFINET address assignment
- Data transmission rate 100 Mbit/s
- LLDP proximity detection without PG and Fast Startup (boot up within approx 0.5 seconds)
- Supply and load voltage connection: 2 x M12
- Module variance:
 - 8 DI
 - 16 DI
 - 8 DO (2 A)
 - 8 DO (1.3 A)
 - 8 DO (0.5 A)
 - 16 DO (1.3 A)
 - 8 DI/DO (1.3 A),
 - 8 AI (U, I, TC, RTD)
 - 4 AO (U, I)
 - 4 IO-Link + 8 DI + 4 DO (1.3 A)
- Channel-specific diagnostics

Ordering data

Order No.

ET 200eco PN digital input module

- 8 DI 24 V DC; 4 x M12, dual assignment, degree of protection IP67
- 8 DI 24 V DC; 8 x M12, degree of protection IP67
- 16 DI 24 V DC; 8 x M12, dual assignment, degree of protection IP67

6ES7 141-6BF00-0AB0

6ES7 141-6BG00-0AB0

6ES7 141-6BH00-0AB0

ET 200eco PN digital output module

- 8 DO 24 V DC/0.5 A; 4 x M12, dual assignment, 1 load voltage supply DO; degree of protection IP67
- 8 DO 24 V DC/1.3 A; 4 x M12, dual assignment, degree of protection IP67
- 8 DO 24 V DC/1.3 A; 8 x M12, degree of protection IP67
- 8 DO 24 V DC/2 A; 8 x M12, degree of protection IP67
- 16 DO 24 V DC/1.3 A; 8 x M12, dual assignment, degree of protection IP67

6ES7 142-6BF50-0AB0

6ES7 142-6BF00-0AB0

6ES7 142-6BG00-0AB0

6ES7 142-6BR00-0AB0

6ES7 142-6BH00-0AB0

ET 200eco PN digital input/output modules

- 8 DI/DO 24 V DC/1.3 A; 8 x M12, degree of protection IP67

6ES7 147-6BG00-0AB0

ET 200eco PN analog input modules

- 8 AI 4 U/I + 4 RTD/TC; 8 x M12, degree of protection IP67

6ES7 144-6KD00-0AB0

ET 200eco PN analog output modules

- 4 AO U/I; 4 x M12, degree of protection IP67

6ES7 145-6HD00-0AB0

ET 200eco PN IO-Link master module

- 4 IO-L + 8 DI + 4 DO 24 V DC/1.3 A; 8 x M12, degree of protection IP67

6ES7 148-6JA00-0AB0

Ordering data	Order No.	Order No.
Accessories		Accessories (continued)
<ul style="list-style-type: none"> • PD voltage distributor, 24 V DC; 1 X 7/8", 4 X M12 	6ES7 148-6CB00-0AA0	M12 connector for load supply 24 V DC Connection socket for infeed of 24 V DC; 4-pin, A-coded, 3 units Connector for passing on the 24 V DC; 4-pin, A-coded, 3 units
<ul style="list-style-type: none"> • Terminal block for ET 200eco PN, 10 A insulation piercing connecting devices 	6ES7 194-6CA00-0AA0	
<ul style="list-style-type: none"> • Spare fuses for terminal block, 10 units 	6ES7 194-6HB00-0AA0	M12 power connection cables Pre-assembled power connection cables on both sides with M12 socket and connector 4 x 0.75 mm ² , in various lengths:
<ul style="list-style-type: none"> • Mounting rail 0.5 m 	6ES7 194-6GA00-0AA0	
<ul style="list-style-type: none"> • Profile screw for mounting rail, 50 units 	6ES7 194-6MA00-0AA0	<ul style="list-style-type: none"> • 0.3 m • 0.5 m • 1.0 m • 1.5 m • 2.0 m • 3.0 m • 5.0 m • 10.0 m • 15.0 m
<ul style="list-style-type: none"> • Cap M12 for modules IP67, 10 units 	3RX9 802-0AA00	
<ul style="list-style-type: none"> • Labels 10 x 7 mm, pastel turquoise, 816 units 	3RT1 900-1SB10	6XV1 801-5DE30 6XV1 801-5DE50 6XV1 801-5DH10 6XV1 801-5DH15 6XV1 801-5DH20 6XV1 801-5DH30 6XV1 801-5DH50 6XV1 801-5DN10 6XV1 801-5DN15
PROFINET M12 connector, can be assembled IE FC M12 connector PRO, can be assembled		M12 coupler plug Can be assembled, for connecting actuators or sensors, 5-pin
<ul style="list-style-type: none"> • 1 unit 	6GK1 901-0DB20-6AA0	
<ul style="list-style-type: none"> • 8 units 	6GK1 901-0DB20-6AA8	Y cable M12 For double connection of I/O by means of single cable to ET 200, 5-pin
PROFINET M12 connecting cables Pre-assembled connecting cable with 2 M12 connectors (D-coded) in various lengths:		
<ul style="list-style-type: none"> • 0.3 m • 0.5 m • 1.0 m • 1.5 m • 2.0 m • 3.0 m • 5.0 m • 10.0 m • 15.0 m 	6XV1 870-8AE30 6XV1 870-8AE50 6XV1 870-8AH10 6XV1 870-8AH15 6XV1 870-8AH20 6XV1 870-8AH30 6XV1 870-8AH50 6XV1 870-8AN10 6XV1 870-8AN15	3RK1 902-4BA00-5AA0
		6ES7 194-6KA00-0XA0

Note:

You can find more information in Catalog ST 70 and in the Industry Mall at www.siemens.com/industrymall

PROFINET/Industrial Ethernet

Motion Control System SIMOTION

The SIMOTION system

Overview



The system approach

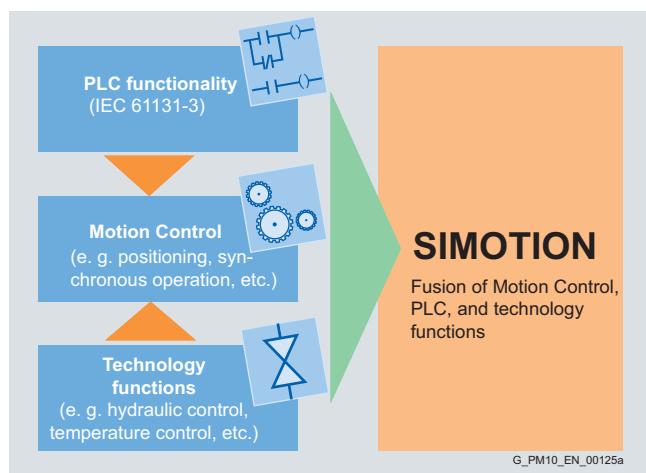

SIMOTION is recommended for all machines with Motion Control tasks – from simple to high-performance. The focus is on a simple and flexible solution for the greatest possible range of Motion Control tasks.

SIMOTION is based on the fusion of Motion Control with two other control functions which are found in most machines: PLC and technology functions.

This approach means that Motion Control of axes and control of the complete machine can be implemented within the same system. The same applies to technology functions, such as pressure control of a hydraulic axis. A seamless switch can be made from position-controlled positioning mode to pressure control.

Combining the three open-loop control functions of Motion Control, PLC and technology functions has the following benefits:

- Reduced engineering overhead and increased machine performance
- Fast system response – Time-critical interfaces between the individual components are no longer required
- Simple, uniform and transparent programming as well as diagnostics of the entire machine

The SIMOTION system is made up of three components:

Engineering system

SCOUT enables Motion Control, PLC and technology functions to be incorporated in one comprehensive, integrated system and provides all the necessary tools: From programming and parameterization through testing and commissioning, to diagnostics.

Runtime system

The runtime system offers a high-performance execution system for cyclic and sequential tasks. The runtime software modules make the different PLC, Motion Control and technology functions available. By selecting the appropriate modules, the overall functionality of the system can be flexibly adapted to the machine.

Hardware platforms

The hardware platforms are the basis of the SIMOTION Motion Control System. The application created with the engineering system and the associated runtime software modules can be implemented on different hardware platforms.

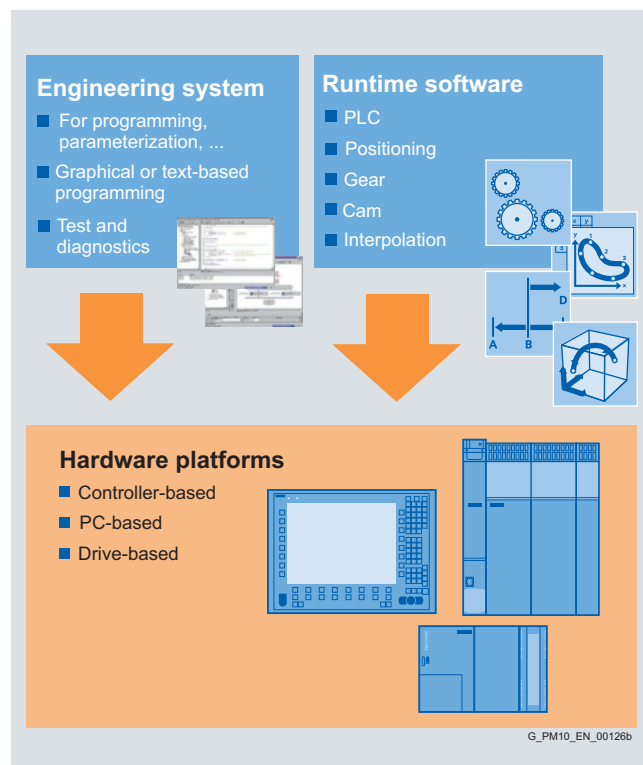

The fast path to the automation solution

Thanks to the SIMOTION system components and the concept of ready-to-apply standard applications and complete machine solutions called SIMOTION Easy Set (Ready to Run), it is possible to reduce engineering costs, speed up project completion times and implement successful automation systems more quickly.

Overview

SIMOTION D – Compact and integrated in the drive



In SIMOTION D, the SIMOTION functionality is integrated directly in the closed-loop control module of the SINAMICS S120 drive system. Therefore, the complete system (consisting of the open-loop control and the drive) is extremely compact and powerful.

SIMOTION D is finely scalable – starting with the compact SIMOTION D410 Control Unit for single-axis applications up to the powerful SIMOTION D4x5-2 multi-axis system for up to 128 axes.

This flexibility ensures a quick response to changing requirements in automation without having to change the system.

The SIMOTION D Control Units are available in the following versions:

- SIMOTION D410 are compact Control Units for single-axis applications and are snapped on to the SINAMICS S120 PM340 Power Modules in blocksize format.
- SIMOTION D4x5/D4x5-2 are Control Units for multi-axis applications in the SINAMICS S120 booksize format and are available in the following performance versions:
 - SIMOTION D425 (BASIC performance)
Control Unit for up to 16 axes
 - SIMOTION D435 (STANDARD performance)
Control Unit for up to 32 axes
 - SIMOTION D445-1 (HIGH performance)
Control Unit for up to 64 axes
 - SIMOTION D445-2 DP/PN (HIGH performance)
Control Unit for up to 64 axes
 - SIMOTION D455-2 DP/PN (ULTRA-HIGH performance)
Control Unit for up to 128 axes

With SIMOTION D, the PLC, Motion Control and technology functions as well as the SINAMICS S120 drive software run on shared control hardware. The IEC 61131-3-compliant PLC integrated in SIMOTION D means that the system is not just capable of controlling motion sequences, but that the entire machine can also be controlled with a single compact unit.

For visualization and operation, SIMATIC HMI devices can be connected via PROFIBUS, PROFINET or Ethernet depending on the SIMOTION D version. Distributed I/O is connected via PROFIBUS or PROFINET.

SIMOTION C – Modularity and flexibility



SIMOTION C is a Motion Controller based on the SIMATIC S7 300 design.

It is available in two versions which differ in terms of their interfaces, but not with respect to Motion Control functionality or performance. In addition to the already integrated interfaces, both controllers can be expanded using I/O modules from the SIMATIC S7 300 range.

Version C240 with its four drive and encoder interfaces is ideal for machine automation applications and the operation of drives with analog setpoint interface or stepper drives. As a result, this version is particularly suitable for machine retrofits.

Version C240 PN with its three PROFINET ports, which support PROFINET with IRT as well as TCP/IP and RT communication, is used to automate machines on the basis of PROFINET. It is capable of operating PROFINET drives with PROFIdrive, as well as PROFINET I/Os, such as SIMATIC ET 200S High Speed.

Both versions are equipped additionally with two PROFIBUS interfaces via which drives with PROFIdrive profile as well as standard I/Os can be connected. In addition, both controllers feature an Industrial Ethernet interface, thus offering further communication options.

PROFINET/Industrial Ethernet

Motion Control System SIMOTION

Hardware platforms

Overview (continued)

SIMOTION P – Open for multiple tasks



The SIMOTION P350-3 can be operated by a variety of different panel fronts. These are available in various screen sizes and can either be operated using a keyboard and mouse, or a touch screen. The SIMOTION P320-3 can be linked to the SIMOTION fronts by means of the Remote Panel PC Kit.

SIMOTION P350-3 is available in either a PROFIBUS or PROFINET version for the connection of I/Os, while SIMOTION P320-3 is available only as a PROFINET version.

SIMOTION P is a PC-based Motion Control System. An Embedded PC for Motion Control has been added to the portfolio of PC-based controls. As a result, the well-proven SIMOTION P350-3 with Windows XP Professional operating system is now available for applications other than high-end tasks, as was previously the case. SIMOTION P320-3 has been created for Embedded PC Motion Control applications. Thanks to the Embedded Windows operating system and elimination of rotating parts in the PC, the SIMOTION P320-3 is particularly compact and ideal for applications in harsh environments. Both PCs are equipped with the usual real-time expansion for SIMOTION. This means that in addition to SIMOTION machine applications, it is possible to run other PC applications at any time including, for example, the SIMOTION engineering system, an operator application, a process data evaluation routine or standard PC applications.

With its excellent processor performance, SIMOTION P350-3 has been developed especially for applications with exacting performance requirements (such as hydraulic applications with highly dynamic position and pressure control loops). SIMOTION P320-3 is particularly suitable for harsh operating environments. Its small footprint makes it the preferred choice for many applications in which available space and rugged design play a key role.

Overview

Motion Control architectures with SIMOTION and SINAMICS

With SIMOTION and SINAMICS, a range of different automation structures can be implemented over PROFINET. In this case, central architectures comprising a controller (e.g. SIMOTION P) are supported as well as decentralized, distributed architectures with several distributed controllers (e.g. SIMOTION D with SINAMICS S120).

When SIMOTION is integrated in a complete automation system, hierarchic automation structures often result.

Thanks to the ability to configure SIMOTION as controller and device concurrently on the same PROFINET interface (I-Device), both hierarchic automation structures and modular machine concepts can be implemented easily and without additional components:

- On the one hand, SIMOTION as a device can communicate with a higher-level controller, e.g. a SIMATIC S7 PLC or a non-Siemens PLC.
- On the other hand, SIMOTION can also communicate with local IO devices, such as drives and I/O modules, in the role of IO Controller.

Via controller-to-controller and controller-to-device relationships based on PROFINET IO with IRT, it is also possible to synchronize several axes via several SIMOTION IO Controllers. This functionality is known as distributed synchronous operation.

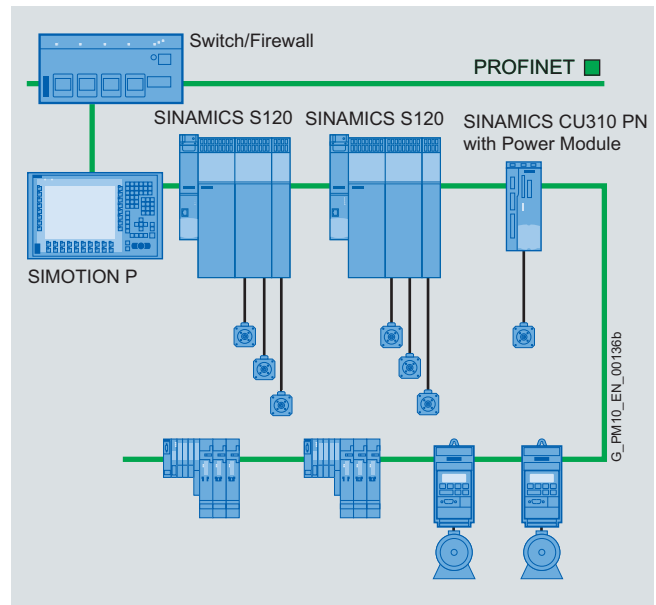

Central Motion Control architecture

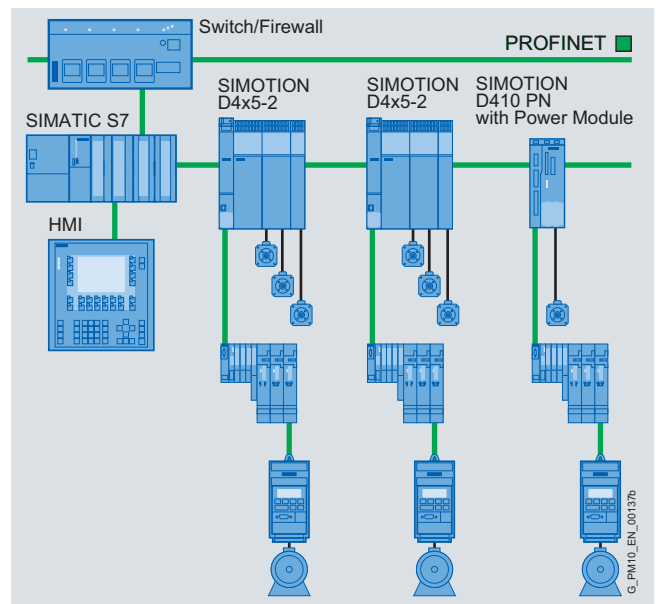

Distributed Motion Control architecture

PROFINET/Industrial Ethernet

Motion Control System SIMOTION

PROFINET for SIMOTION

Overview

PROFINET for SIMOTION						
	C240 PN	P320-3	P350-3	D410 PN	D4x5	D4x5-2 DP/PN
						
	Onboard interface	Onboard interface	MCI-PN Communication Board	Onboard interface	CBE30 Communication Board	Onboard interface
PROFINET functionality through	Is part of the basic functionality of the controller	Is part of the basic functionality of the controller		Is part of the basic functionality of the Control Unit		Is part of the basic functionality of the Control Unit
PROFINET interfaces	Integrated 3-port switch	Integrated 3-port switch	Integrated 4-port switch	Integrated 2-port switch	Integrated 4-port switch	Integrated 3-port switch
Communication as	Controller and device	Controller and device	Controller and device	Controller and device	Controller and device	Controller and device
Protocols	TCP, UDP, RT, IRT	TCP, UDP, RT, IRT	TCP, UDP, RT, IRT	TCP, UDP, RT, IRT	TCP, UDP, RT, IRT	TCP, UDP, RT, IRT

G_PM10_EN_00208

PROFINET for SIMOTION

SIMOTION is fully integrated into the PROFINET communication. Interaction with the following PROFINET components is possible:

- Distributed I/O with SIMOTION
- SINAMICS with SIMOTION
- SIMOTION as an IO-Device with a SIMATIC S7 CPU
- Active network components (e.g. SCALANCE) with SIMOTION and SINAMICS
- Wireless with SIMOTION and SINAMICS
- PROFIsafe to a SIMATIC F-CPU. The PROFIsafe message frames are routed from SIMOTION to the lower-level drives.

When an automation topology is configured, the real-time classes RT and IRT can be used alongside each other on the same network or cable. It must, however, be noted that not all devices support both real-time classes RT and IRT. For devices that should be synchronized with IRT, it is important that all the PROFINET components that lie in between support the IRT real-time class, especially the SCALANCE switches of the X200 family.

Overview

PROFIdrive – The standardized drive profile for PROFIBUS and PROFINET

PROFIdrive defines the device behavior and the access procedure to internal drive data for electrical drives on PROFIBUS and PROFINET, from simple frequency converters up to high-performance servo controllers.

It contains a detailed description of how the communication functions "slave-to-slave communication", "constant bus cycle time" and "isochronous operation" are used for drive applications. In addition, it clearly specifies all device characteristics which influence interfaces connected to a controller over PROFIBUS or PROFINET. This includes the sequence control, encoder interface, standardization of values, definition of standard messages, and access to drive parameters, etc.

The PROFIdrive profile supports both central as well as distributed motion control concepts.

What are profiles?

Profiles specify specific properties and responses for devices and systems in automation. In this manner, manufacturers and users pursue the goal of defining common standards. Devices and systems that comply with a multi-vendor profile can interoperate on a fieldbus and can be operated interchangeably to a certain extent.

Do different profile types exist?

A distinction is made between application profiles (general or specific) and system profiles:

- Application profiles (also known as device profiles) mainly refer to devices (e.g. drives) and contain an agreed selection of bus communication modes, as well as specific device applications.
- System profiles describe system classes and include the master functionality, program interfaces and integration methods.

Is PROFIdrive future-proof?

PROFIdrive has been specified by PROFIBUS and PROFINET International (PI) and has been laid down in IEC 61800-7 as a future-proof standard.

The basic philosophy: Keep it simple

The PROFIdrive profile tries to keep the drive interface as simple as possible and free from technology functions. This philosophy ensures that reference models as well as the functionality and performance of the PROFIBUS/PROFINET master have no or very little influence on the drive interface.

One drive profile – Different application categories

The integration of drives into automation solutions depends strongly upon the drive task. To cover the extensive range of drive applications from the simple frequency converter up to highly dynamic, synchronized multi-axis systems with a single profile, PROFIdrive defines six application categories which define most drive applications:

- Category 1 – Standard drives (such as pumps, fans, stirring units, etc.)
- Category 2 – Standard drives with technology functions
- Category 3 – Positioning drives
- Category 4 – Motion control drives with central, higher-level motion control intelligence and the patented "Dynamic Servo Control" position control concept
- Category 5 – Motion control drives with central, higher-level motion control intelligence and position setpoint interface
- Category 6 – Motion control drives with distributed motion control intelligence integrated in the drives

PROFINET/Industrial Ethernet

Motion Control System SIMOTION

PROFIdrive for SIMOTION

Design

The device model of PROFIdrive

PROFIdrive defines a device model based on function modules which cooperate in the device and generate the intelligence of the drive system. These modules have objects assigned to them which are described in the profile and are defined with respect to their functions. The overall functionality of a drive is therefore described through the sum of its parameters.

In contrast to other drive profiles, PROFIdrive defines only the access mechanisms to the parameters as well as a subset of approx. 30 profile parameters such as the fault buffer, drive control and device identification.

All other parameters are vendor-specific which gives drive manufacturers great flexibility with respect to implementing function modules. The elements of a parameter are accessed acyclically via data records.

As a communication protocol, PROFIdrive uses DP-V0, DP-V1, and the DP-V2 expansions for PROFIBUS including the functions "Slave-to-slave communication" and "Isochronous operation", or PROFINET IO with real-time classes RT and IRT.

More information

For further information on SIMOTION and SINAMICS, see Catalog PM 21 and the Internet at: www.siemens.com/simotion

2

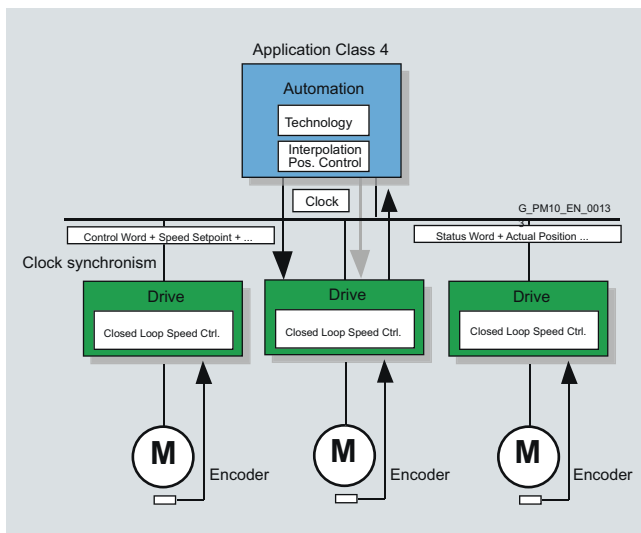

PROFIdrive for Motion Control

Utilization category 4 is the most important for highly dynamic and highly complex Motion Control tasks. This application category describes in detail the master/slave relationship between the Controller and the drives which are connected to each other over PROFIBUS and PROFINET.

The DSC (Dynamic Servo Control) function significantly improves the dynamic response and stiffness of the position control loop by minimizing the dead times which usually occur for speed setpoint interfaces with an additional, relatively simple feedback network in the drive. The position control loop is closed in the drive which permits very fast position control cycles (e.g. 125 µs for SINAMICS S120) and thus limits dead times exclusively to the control behavior.

PROFIdrive for SIMOTION

In SIMOTION, the drive interface is realized in accordance with the PROFIdrive V4 profile and utilization categories 1 to 4 (category 4 with and without DSC).

When SINAMICS S120 operates with SIMOTION, utilization category 4 with DSC is used as standard.

Overview

SINUMERIK 840D sl with SINAMICS S120

The SINUMERIK 840D sl offers modularity, open architecture, flexibility, uniform operation, programming and visualization and provides a system platform with future-oriented functions for nearly all technologies. Integrated into the SINAMICS S120 drive system and complemented by the SIMATIC S7-300 automation system, the SINUMERIK 840D sl forms a complete digital system that is best suited for the mid to upper performance range.

The SINUMERIK 840D sl distinguishes itself through its flexibility, maximum dynamics, precision, and optimum integration in networks.

The SINUMERIK 840D sl combines CNC, HMI, PLC, closed-loop control and communication tasks on one SINUMERIK NCU. The NCU modules are available in three expansion stages with different power.

SINAMICS S120 can be used to solve complex drive tasks for a very wide spectrum of industrial applications, and has been designed as a modular system toolbox. From a wide range of matched components and functions, the user selects just the combination that best suits his own particular requirements. All SINUMERIK 840D sl and SINAMICS S120 components, including the motors and encoders, are interconnected via the joint interface DRIVE-CLiQ.

Application

SINUMERIK 840D sl is used worldwide:

- Turning, drilling, milling, grinding, laser machining, nibbling and punching technologies
- Tool and Mold Making
- Press control
- High-Speed Cutting
- Woodworking and textile processing
- Handling
- Transfer lines
- Rotary transfer machines
- Large-scale and jobshop production

The SINUMERIK is available as an export version for use in countries where approval is required.

Integration

The following components can be connected to the SINUMERIK 840D sl:

- SINUMERIK operator panel front with TCU, PCU 50.3
- Machine control panel, Push Button Panel
- SINUMERIK handheld units
- Distributed PLC I/O via PROFIBUS DP and PROFINET connection
- SINAMICS S120 drive system
- Feed and main spindle motors

More information

More detailed information on the SINUMERIK 840D sl and SINAMICS S120 is provided in Catalog NC 61.

Further information is available on the Internet at:
www.siemens.com/sinumerik

PROFINET/Industrial Ethernet

Operating and monitoring devices

Key Panels SIMATIC HMI KP8/KP8F

Overview

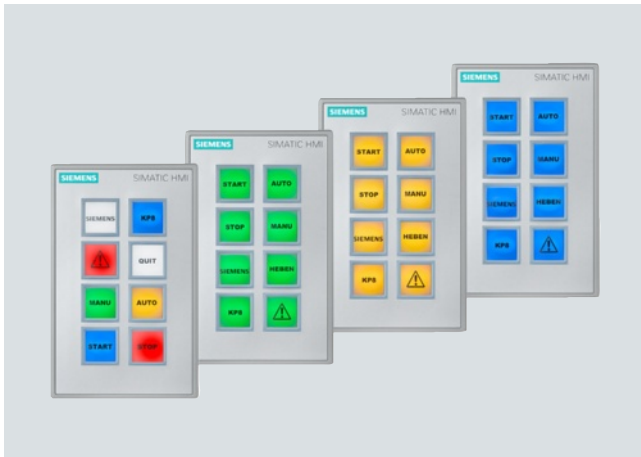

SIMATIC HMI Key Panel KP8 PN/KP8F PN

- The KP8 PN and KP8F PN Key Panels are the innovative successor to the PP7 Push Button Panel
- The following two versions are available:
 - a *PROFINET* version each with 8 large backlit keys
 - a *PROFINET failsafe* version (with connection option e.g. an EMERGENCY-STOP push-button) each with 8 large backlit keys
- High flexibility in the smallest space at an extremely reasonable price
- On the rear, 8 I/O PINs are available as standard. These I/O PINs can be used for the connection of additional control elements.

Ordering data

Order No.

SIMATIC HMI Key Panel KP8 PN

6AV3 688-3AY36-0AX0

Push Button Panel for PROFINET with 8 short-stroke keys with multi-colored LEDs, 8 configurable DE/DA pins, 24 V DC can be looped through

SIMATIC HMI Key Panel KP8F PN

6AV3 688-3AF37-0AX0

Push Button Panel for PROFINET with PROIsafe, 8 short-stroke buttons with multi-colored LEDs, 8 configurable DE/DA pins, 24 V DC can be looped through, 2 safety inputs

Blank front

6AV3 688-3XY38-3AX0

Blank front for KP8 and KP8F in combination with HMI PRO devices

12-pole connector set for KP8 PN

6AV6 671-3XY38-4AX0

Pack of 10

16-pole connector set for KP8F PN

6AV6 671-3XY48-4AX0

Pack of 10

Note:

For further information see Catalog ST 80 / ST PC and Industry Mall at www.siemens.com/industrymall

Overview

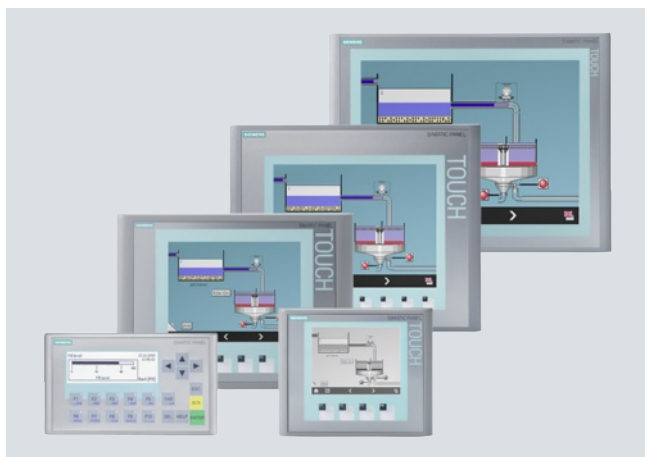

- Ideal entry series from 3" to 15" for the operation and monitoring of compact machines and systems
- Clear process representation by the use of pixel graphics displays
- Intuitive operation by touch and tactile function keys
- Equipped with all necessary basic functions such as signaling system, recipe management, graph representation, vector graphics and language switching
- Simple connection to the controller via integrated Ethernet interface (TCP/IP, PROFINET) or separate version with RS485/422

Ordering data	Order No.
SIMATIC HMI KP300 Basic mono PN	6AV6 647-0AH11-3AX0
SIMATIC HMI KTP400 Basic mono PN	6AV6 647-0AA11-3AX0
SIMATIC HMI KTP600 Basic mono PN	6AV6 647-0AB11-3AX0
SIMATIC HMI KTP600 Basic color DP	6AV6 647-0AC11-3AX0
SIMATIC HMI KTP600 Basic color PN	6AV6 647-0AD11-3AX0
SIMATIC HMI KTP1000 Basic color DP	6AV6 647-0AE11-3AX0
SIMATIC HMI KTP1000 Basic color PN	6AV6 647-0AF11-3AX0
SIMATIC HMI TP1500 Basic color PN	6AV6 647-0AG11-3AX0
Starter kit SIMATIC S7-1200 + KP300 Basic mono PN	6AV6 651-7HA01-3AA1
Starter kit SIMATIC S7-1200 + KTP400 Basic mono PN	6AV6 651-7AA01-3AA1
Starter kit SIMATIC S7-1200 + KTP600 Basic color PN	6AV6 651-7DA01-3AA1
Starter kits consist of:	
<ul style="list-style-type: none"> • the respective SIMATIC HMI Basic Panel <ul style="list-style-type: none"> - SIMATIC HMI KP300 Basic mono PN - SIMATIC HMI KTP400 Basic mono PN - SIMATIC HMI KTP600 Basic color PN • SIMATIC S7-1200 CPU 1212C AC/DC/Rly • SIMATIC S7-1200 Simulator Module SIM 1274 • SIMATIC STEP 7 BASIC CD • SIMATIC S7-1200 HMI Manual Collection CD • Ethernet CAT5 cable, 2 m 	
Configuration	
All device versions: SIMATIC WinCC Basic/Comfort/Professional or SIMATIC STEP 7 Basic (with integrated WinCC Basic)	see Catalog ST 80 / ST PC
4"-15" device versions: SIMATIC WinCC flexible Compact	see Catalog ST 80 / ST PC
Documentation (to be ordered separately)	
You can find the manual for the Basic Panels on the Internet at:	http://support.automation.siemens.com
SIMATIC HMI Manual Collection	6AV6 691-1SA01-0AX0
Electronic documentation, on DVD	
5 languages (English, French, German, Italian, Spanish); contains: all currently available user manuals, equipment manuals and communication manuals for SIMATIC HMI	

Note:

For further information see Catalog ST 80 / ST PC and Industry Mall at www.siemens.com/industrymall

PROFINET/Industrial Ethernet

Operating and Monitoring Devices

SIPLUS Basic Panels

Overview

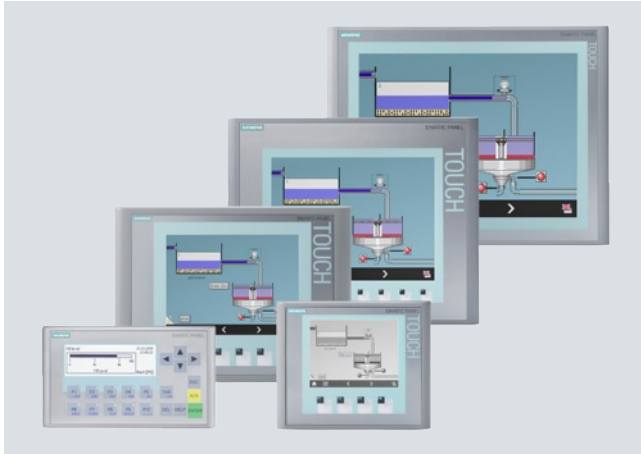

- Ideal entry series from 3.8" to 15" for the operation and monitoring of compact machines and systems
- Clear process representation by the use of pixel graphics displays
- Intuitive operation by touch and tactile function keys
- Equipped with all necessary basic functions such as signaling system, recipe management, graph representation, vector graphics and language switching
- Simple connection to the controller via integrated Ethernet interface or separate version with RS485/422

Note:

SIPLUS extreme products are based upon Siemens Industry standard products. The content listed here was taken over from the relevant standard products. Information specific to SIPLUS extreme has been added.

	SIPLUS HMI KTP400 Basic mono PN	SIPLUS HMI KTP600 Basic color PN	SIPLUS HMI KTP1000 Basic color DP	SIPLUS HMI KTP1000 Basic color PN	SIPLUS HMI TP1500 Basic color PN
Order no.	6AG1 647-0AA11-2AX0	6AG1 647-0AD11-2AX0	6AG1 647-0AE11-4AX0	6AG1 647-0AF11-4AX0	6AG1 647-0AG11-4AX0
Order number based on	6AV6 647-0AA11-3AX0	6AV6 647-0AD11-3AX0	6AV6 647-0AE11-3AX0	6AV6 647-0AF11-3AX0	6AV6 647-0AG11-3AX0
Ambient temperature range	-10 ... +60 °C	-25 ... +60 °C	0 ... +50 °C	0 ... +50 °C	0 ... +50 °C
Conformal coating	Coating of the PCB and the electronic components				
Technical specifications	The technical specifications of the standard product apply, with the exception of the ambient conditions.				
Ambient conditions					
Relative air humidity	5 ... 100 % condensation permitted				
Biologically active substances	Conformity with EN 60721-3-3, Class 3B2 mould-, fungal-, fungus spore (excepting fauna)				
Chemically active substances	Conformity with EN 60721-3-3, Class 3C4 inc. salt spray and ISA -S71.04 severity level G1; G2; G3; GX ^{1) 2)}				
Mechanically active substances	Conformity with EN 60721-3-3, Class 3S4 inc. sand, dust ²⁾				
Air pressure (depending upon maximum stated positive temperature range)	1080 ... 795 hPa (-1000 ... +2000 m) see ambient temperature range 795 ... 658 hPa (+2000 ... +3500 m) derating 10 K 658 ... 540 hPa (+3500 ... +5000 m) derating 20 K				

¹⁾ ISA -S71.04 severity level GX: Long-term load: S
 O₂ < 4.8 ppm; H₂S < 9.9 ppm; Cl < 0.2 ppm; HCl < 0.66 ppm;
 HF < 0.12 ppm; NH < 49 ppm; O₃ < 0.1 ppm; NO_x < 5.2 ppm
 limit value (max. 30 min/d):
 SO₂ < 14.8 ppm; H₂S < 49.7 ppm; Cl < 1.0 ppm; HCl < 3.3 ppm;
 HF < 2.4 ppm; NH < 247 ppm; O₃ < 1.0 ppm; NO_x < 10.4 ppm

²⁾ The supplied connector covers must remain on the unused interface during operation in a corrosive gas atmosphere!

You can find technical documentation on SIPLUS here:
www.siemens.com/siplus-extreme

Ordering data	Order No.	Order No.
SIPLUS HMI KTP400 Basic mono PN Extended ambient temperature range -10 ... +60 °C and for areas with extraordinary medial load (conformal coating); Ambient temperature -10 ... +60 °C	6AG1 647-0AA11-2AX0	SIPLUS HMI KTP1000 Basic color PN For areas with extraordinary medial load (conformal coating); Ambient temperature 0 ... +50 °C
SIPLUS HMI KTP600 Basic color PN Extended ambient temperature range -25 ... +60 °C and for areas with extraordinary medial load (conformal coating); Ambient temperature -25 ... +60 °C	6AG1 647-0AD11-2AX0	SIPLUS HMI TP1500 Basic color PN For areas with extraordinary medial load (conformal coating); Ambient temperature 0 ... +50 °C
SIPLUS HMI KTP1000 Basic color DP For areas with extraordinary medial load (conformal coating); Ambient temperature 0 ... +50 °C	6AG1 647-0AE11-4AX0	Accessories See SIMATIC Basic Panels

PROFINET/Industrial Ethernet

Operating and Monitoring Devices

Comfort Panels – Standard

Overview



- Excellent HMI functionality for demanding applications
- Widescreen TFT displays with 4.3", 7.0", 9.0" and 12.1" diagonals (all 16 million colors) with up to 40% more visualization area as compared to the predecessor devices
- Integrated high-end functionality with archives, scripts, PDF/Word/Excel viewer, Internet Explorer, Media Player
- Dimmable displays from 0 to 100% via PROFlenergy, via the HMI project or via a controller
- Up-to-date industrial design
- Upright installation for all touch devices
- Optimal selection option: four Touch and four Key versions are available
- Data security in the event of power failure for the device and for the SIMATIC HMI memory card
- Innovative service and commissioning concept through second SD card (automatic backup)
- Easy project transfer via standard cable (standard Ethernet cable, standard USB cable)
- Maximum performance with short screen refresh times
- Suitable for harsh industrial environments thanks to extended approvals, such as Ex 2/22 and approvals for marine applications and for cast aluminum fronts from 7" upwards
- Wide range of communication options: PROFIBUS and PROFINET onboard, with 7" and above, 2 x PROFINET with integrated switch
- Key-operated devices with LED in every function key and new text input mechanism, similar to the keypads of mobile phones
- Key-operated devices with stamped keys for optimum tactile feedback
- All keys have a service life of 2 million operations
- Configuring with the WinCC engineering software of the TIA Portal

Ordering data

Order No.

SIMATIC HMI Comfort Panels, Touch

SIMATIC HMI KTP400 Comfort, Key and Touch	6AV2 124-2DC01-0AX0
SIMATIC HMI TP700 Comfort	6AV2 124-0GC01-0AX0
SIMATIC HMI TP900 Comfort	6AV2 124-0JC01-0AX0
SIMATIC HMI TP1200 Comfort	6AV2 124-0MC01-0AX0

SIMATIC HMI Comfort Panels, Key

SIMATIC HMI KP400 Comfort, Key	6AV2 124-1DC01-0AX0
SIMATIC HMI KP700 Comfort, Key	6AV2 124-1GC01-0AX0
SIMATIC HMI KP900 Comfort, Key	6AV2 124-1JC01-0AX0
SIMATIC HMI KP1200 Comfort, Key	6AV2 124-1MC01-0AX0

Starter kits for HMI Comfort Panels

Consisting of:
 The respective HMI Comfort Panel
 SIMATIC WinCC Comfort
 SIMATIC HMI Manual Collection (DVD), 5 languages
 Ethernet cable, 2 m
 SIMATIC HMI memory card
 2 GByte
 10 protective membranes for touch screen devices

Starter kit for HMI KTP400 Comfort, Key and Touch	6AV2 181-4DB20-0AX0
Starter kit for HMI TP700 Comfort	6AV2 181-4GB00-0AX0
Starter kit for HMI TP900 Comfort	6AV2 181-4JB00-0AX0
Starter kit for HMI TP1200 Comfort	6AV2 181-4MB00-0AX0
Starter kit for HMI KP400 Comfort, Key	6AV2 181-4DB10-0AX0
Starter kit for HMI KP700 Comfort, Key	6AV2 181-4GB10-0AX0
Starter kit for HMI KP900 Comfort, Key	6AV2 181-4JB10-0AX0
Starter kit for HMI KP1200 Comfort, Key	6AV2 181-4MB10-0AX0

Note:

For further information see Catalog ST 80 / ST PC and Industry Mall at www.siemens.com/industrymall

Overview



SIMATIC Mobile Panel

- Mobile control panel for operating plant and machinery directly from any place
- Enables an ideal view of the workpiece or process and at the same time direct access and visual contact to the control panel
- Flexible use due to easy reconnection during operation (Mobile Panel 177 and Mobile Panel 277) or wireless freedom (Mobile Panel 277(F) IWLAN)
- Pixel-graphics, high-luminance color display with touch screen (analog/resistive)
- PROFIBUS or PROFINET communication, PROFINET via WLAN with Mobile Panel 277(F) IWLAN
- Freely configurable and inscribable function keys (with LED) (not on Mobile Panel 277 10")

SIMATIC Mobile Panel 177 and SIMATIC Mobile Panel 277

- Two three-stage OK buttons;
Optional versions with:
 - STOP button
 - STOP button, handwheel, key-operated switch and illuminated pushbutton (not with Mobile Panel 277 10")
- Communication options using serial, MPI/PROFIBUS or PROFINET coupling
- Connection point recognition for locally identifying the device by means of the connection point ID
- Fast system availability after plugging into the junction boxes
- The coupling for control purposes and the power supply are provided through the junction box and the connecting cable

SIMATIC Mobile Panel 277(F) IWLAN

- Wireless, mobile control panel for operating plant and machinery flexibly and independently of location
- WLAN communication in accordance with IEEE 802.11 a (b/g) and support of PROFINET
- Powerful batteries and flexible concept for changing permit battery replacement "on the fly" without interrupting operation
- Limited effective range and local identification of the device due to the use of transponder technology
- Low-cost, safety-oriented mobile operation and monitoring using RFID technology (MOBY D) for plant with safety equipment already installed (e.g. robot cells)
- Optional versions with: Handwheel, key-operated switch and illuminated pushbutton
- Fail-safe control elements of the SIMATIC Mobile Panel 277F IWLAN using PROFIsafe:
 - Two three-stage OK buttons
 - Emergency-stop pushbuttons

Ordering data

SIMATIC Mobile Panel 177 PN (PROFINET)¹⁾

- With integrated OK button
- With integrated OK button and STOP button
- With integrated OK button, STOP button, handwheel, key-operated switch and illuminated pushbutton

Order No.

6AV6 645-0BA01-0AX0
6AV6 645-0BB01-0AX0
6AV6 645-0BC01-0AX0

SIMATIC Mobile Panel 277 8"¹⁾

- With integrated OK button
- With integrated OK button and STOP button
- With integrated OK button, STOP button, handwheel, key-operated switch and two illuminated pushbuttons

6AV6 645-0CA01-0AX0
6AV6 645-0CB01-0AX0
6AV6 645-0CC01-0AX0

SIMATIC Mobile Panel 277 10"

- With integrated OK button and STOP button

6AV6 645-0BE02-0AX0

SIMATIC Mobile Panel 277 IWLAN V2 (RoW version)

- Communication via WLAN (PROFINET)
- Communication via WLAN (PROFINET) with integrated handwheel, key-operated switch and two illuminated pushbuttons

6AV6 645-0DD01-0AX1
6AV6 645-0DE01-0AX1

SIMATIC Mobile Panel 277F IWLAN V2 PROFIsafe (RoW version)

- Communication via WLAN (PROFINET) with OK button and EMERGENCY-STOP pushbutton
- Communication via WLAN (PROFINET) with OK button and EMERGENCY-STOP pushbutton with integrated handwheel, key-operated switch, and two illuminated pushbuttons
- RFID tag version: Communication via WLAN (PROFINET) with OK button and EMERGENCY-STOP pushbutton with integrated handwheel, key-operated switch, and two illuminated pushbuttons

Order No.

6AV6 645-0EB01-0AX1
6AV6 645-0EC01-0AX1
6AV6 645-0EF01-0AX1

SIMATIC Mobile Panel 277 IWLAN V2 (USA version)

- Communication via WLAN (PROFINET)
- Communication via WLAN (PROFINET) with integrated handwheel, key-operated switch and two illuminated pushbuttons

6AV6 645-0FD01-0AX1
6AV6 645-0FE01-0AX1

¹⁾ The system components (connecting cables and junction boxes) must be ordered separately.

PROFINET/Industrial Ethernet

Operating and Monitoring Devices

Mobile Panels

2

Ordering data	Order No.	Order No.
SIMATIC Mobile Panel 277F IWLAN V2 PROFIsafe (USA version) <ul style="list-style-type: none"> with OK button and EMERGENCY-STOP pushbutton with OK button and EMERGENCY-STOP button with integrated handwheel, key-operated switch, and two illuminated pushbuttons with OK button and EMERGENCY-STOP button with integrated handwheel, key-operated switch, and two illuminated pushbuttons (tag version) 	6AV6 645-0GB01-0AX1 6AV6 645-0GC01-0AX1 6AV6 645-0GF01-0AX1	Accessories for Mobile Panel 277 IWLAN/277(F) IWLAN Note: Please order the table-top power supply or charging station as well. Required for charging the battery <ul style="list-style-type: none"> Table-top power supply incl. power cable for EU, US, UK, JP (only suitable for operation under laboratory/office conditions) Charger V2 for safe storage and charging of device incl. lock for securing the device in the charger. Charging capabilities for up to two additional batteries Additional battery with LED indicator for indicating the charge status Transponder V2 incl. batteries (3x AA) V1 transponder incl. batteries (3x AA) (essential for operating in plants with Mobile Panels 277(F) IWLAN V1) Service pack V2 for Mobile Panel 277(F) IWLAN V2 contains accessories pack for Mobile Panel 277 (labeling strip cover), battery compartment cover (device), cover left/right (charger), power supply connector counterpart (charger), replacement key (charger) Service pack V1 for Mobile Panel 277(F) IWLAN V1 contains accessories pack for Mobile Panel 277 (labeling strip cover), battery compartment cover (device), backup battery, cover left/right (charger), power supply connector counterpart (charger), replacement key (charger)
Mobile Panel 177 PN Plus starter kit consisting of Mobile Panel 177 PN with integrated OK button, STOP button, handwheel, key-operated switch, and illuminated pushbutton, PN Plus junction box, PN connecting cable, 10 m, wall bracket, SIMATIC WinCC flexible Compact, SIMATIC HMI Manual Collection (DVD), 5 languages (German, English, French, Italian, Spanish), Software Update Service for 1 year	6AV6 651-5DA01-0AA0	
Starter package consisting of Mobile Panel 277 PN with integrated OK button, STOP button, handwheel, key-operated switch, and illuminated pushbutton, PN Plus junction box, PN connecting cable, 10 m, wall bracket, SIMATIC WinCC flexible Standard 2008, SIMATIC HMI Manual Collection (DVD), 5 languages (German, English, French, Italian, Spanish), Software Update Service for 1 year	6AV6 651-5FB01-0AA0	
Starter kit SIMATIC Mobile Panel 277(F) IWLAN (RoW version) for <ul style="list-style-type: none"> Mobile Panel 277 IWLAN V2 Mobile Panel 277F IWLAN V2 	6AV6 651-5GA01-0AA1 6AV6 651-5HA01-0AA1	
		6AV6 671-5CN00-0AX2 6AV6 671-5CE00-0AX1 6AV6 671-5CL00-0AX0 6AV6 671-5CM00-0AX1 6AV6 671-5CM00-0AX0 6AV6 671-5CA00-0AX2 6AV6 671-5CA00-0AX1
		Access Points SCALANCE W and Power Supplies PS791 Configuration with SIMATIC WinCC flexible
		See Chapter 8 see Catalog ST 80 / ST PC

Ordering data	Order No.	Order No.
<i>Documentation (to be ordered separately)</i>		<i>System components for Mobile Panels</i>
Mobile Panel 177 Operating Instructions <ul style="list-style-type: none"> German English French Italian Spanish 	6AV6 691-1DK01-0AA0 6AV6 691-1DK01-0AB0 6AV6 691-1DK01-0AC0 6AV6 691-1DK01-0AD0 6AV6 691-1DK01-0AE0	PN junction box for Mobile Panel (PROFINET) <ul style="list-style-type: none"> Basic Plus
		6AV6 671-5AE01-0AX0 6AV6 671-5AE11-0AX0
Mobile Panel 277 Operating Instructions <ul style="list-style-type: none"> German English French Italian Spanish 	6AV6 691-1DL01-0AA0 6AV6 691-1DL01-0AB0 6AV6 691-1DL01-0AC0 6AV6 691-1DL01-0AD0 6AV6 691-1DL01-0AE0	PN connecting cable (PROFINET) Standard cables <ul style="list-style-type: none"> 2 m 5 m 8 m 10 m 15 m 20 m 25 m
		6XV1 440-4BH20 6XV1 440-4BH50 6XV1 440-4BH80 6XV1 440-4BN10 6XV1 440-4BN15 6XV1 440-4BN20 6XV1 440-4BN25
Mobile Panel 277F IWLAN V2 Operating Instructions <ul style="list-style-type: none"> German English French Italian Spanish 	6AV6 691-1DQ01-2AA1 6AV6 691-1DQ01-2AB1 6AV6 691-1DQ01-2AC1 6AV6 691-1DQ01-2AD1 6AV6 691-1DQ01-2AE1	Accessories see Catalog ST 80 / ST PC
Mobile Panel 277 IWLAN V2 Operating Instructions <ul style="list-style-type: none"> German English French Italian Spanish 	6AV6 691-1DM01-2AA1 6AV6 691-1DM01-2AB1 6AV6 691-1DM01-2AC1 6AV6 691-1DM01-2AD1 6AV6 691-1DM01-2AE1	
User Manual WinCC flexible Compact/Standard/Advanced <ul style="list-style-type: none"> German English French Italian Spanish 	6AV6 691-1AB01-3AA0 6AV6 691-1AB01-3AB0 6AV6 691-1AB01-3AC0 6AV6 691-1AB01-3AD0 6AV6 691-1AB01-3AE0	
User Manual WinCC flexible Communication <ul style="list-style-type: none"> German English French Italian Spanish 	6AV6 691-1CA01-3AA0 6AV6 691-1CA01-3AB0 6AV6 691-1CA01-3AC0 6AV6 691-1CA01-3AD0 6AV6 691-1CA01-3AE0	
SIMATIC HMI Manual Collection Electronic documentation, on DVD 5 languages (English, French, German, Italian, Spanish); contains: all currently available user manuals, manuals and communication manuals for SIMATIC HMI	6AV6 691-1SA01-0AX0	

Note:

For further information see Catalog ST 80 / ST PC and Industry Mall at www.siemens.com/industrymall

PROFINET/Industrial Ethernet

Operating and Monitoring Devices

SIMATIC Panels

Overview



SIMATIC Panels

SIMATIC panels are compact and robust operator panels for use directly on the machine – finely graded in power and comfort.

Devices with a PROFINET connection are used in solutions based upon the Industrial Ethernet standard for automation.

SIMATIC TP 177B DP/PN

- Touch Panel with comprehensive functionality for the operation and monitoring of machines and plant
- Pixel graphics display with analog touch screen
 - 4.3" TFT widescreen color or
 - 5.7" STN blue mode/color
- PROFINET interface for the on-board color versions
- Drivers for other manufacturers' controllers are also available
- Message buffer contents are retained even when the panel is switched off with no battery
- Extra 4 function keys on the 4" version for optimal operating efficiency
- The TP 177B PN/DP is also available with a high-grade steel front (EN 1672-2). The high-grade steel front also complies with the higher requirements, e.g. from the food industry.

SIMATIC OP 177B DP/PN

- Touch/key panel with comprehensive functionality for the operation and monitoring of machines and plant
- Message buffer contents are retained even when the panel is switched off with no battery
- Pixel graphics STN display blue mode/color with analog touch screen and extra 32 function keys
- Ethernet with the on-board color versions
- Drivers for other manufacturers' controllers are also available
- Installation compatible to OP17

SIMATIC TP 277 6"

- Touch Panel with comprehensive functionality for the operation and monitoring of machines and plant
- Message buffer contents are retained even when the panel is switched off with no battery
- Pixel-graphics TFT display with 256 colors and touch screen
- Interfaces for communication with Siemens SIMATIC S7 (e.g. MPI, PROFIBUS DP) are on board
- Ethernet on board
- Use of scripts and archives
- Drivers for other manufacturers' controllers are also available
- Installation compatible to TP 270 6" and MP 270B 6"

SIMATIC OP 277 6"

- Operator Panel with comprehensive functionality for the operation and monitoring of machines and plant
- Message buffer contents are retained even when the panel is switched off with no battery
- Pixel-graphics TFT display with 256 colors
- 36 system keys, 24 freely configurable and inscribable function keys (18 with LED)
- Interfaces for communication with Siemens SIMATIC S7 (e.g. MPI, PROFIBUS DP) are on board
- Ethernet on board
- Use of scripts and archives
- Drivers for other manufacturers' controllers are also available
- Installation compatible to OP 270 6"

Ordering data	Order No.	Order No.	
SIMATIC TP 177B Touch Panel with <ul style="list-style-type: none"> • 4.3" TFT widescreen color display (256 colors) • 5.7" STN color display (256 colors) incl. mounting accessories	6AV6 642-0BD01-3AX0 6AV6 642-0BA01-1AX1	SIMATIC OP 177B Operator panel with 5.7" STN display, <ul style="list-style-type: none"> • Color (256 colors) incl. mounting accessories	6AV6 642-0DA01-1AX1
SIPLUS HMI TP 177B (medial load) Touch Panel with <ul style="list-style-type: none"> • 4.3" TFT widescreen color display (256 colors) • 5.7" STN color display (256 colors) 	6AG1 642-0BD01-2AX0 6AG1 642-0BA01-4AX1	SIPLUS HMI OP 177B color PN/DP (medial load) Operator Panel with 5.7" STN display, <ul style="list-style-type: none"> • Color (256 colors) incl. mounting accessories	6AG1 642-0DA01-4AX1
TP 177B 4" starter kit Consisting of: <ul style="list-style-type: none"> • TP 177B with 4.3" TFT widescreen color display (256 colors) • SIMATIC WinCC flexible Compact configuration software • SIMATIC HMI Manual Collection (DVD), 5 languages (English, French, German, Italian, Spanish) • MPI cable (5 m) (for download and test purposes only) 	6AV6 652-2KA00-0AA0	OP 177B starter kit Consisting of: <ul style="list-style-type: none"> • OP 177B with STN display, color • SIMATIC WinCC flexible Compact configuration software • SIMATIC HMI Manual Collection (DVD), 5 languages (English, French, German, Italian, Spanish) • MPI cable (5 m) (for download and test purposes only), PC/PPI cable 	6AV6 551-2HA01-1AA0
TP 177B 6" starter kit Consisting of: <ul style="list-style-type: none"> • TP 177B with 5.7" STN color display (256 colors) • SIMATIC WinCC flexible Compact configuration software • SIMATIC HMI Manual Collection (DVD), 5 languages (English, French, German, Italian, Spanish) • MPI cable (5 m) (for download and test purposes only), PC/PPI cable 	6AV6 551-2EA01-1AA0	SIMATIC TP 277 6" Touch Panel with 5.7" TFT display, color (256 colors), incl. mounting accessories	6AV6 643-0AA01-1AX0
		SIPLUS HMI TP 277 6" (medial load) Touch Panel with 5.7" TFT display, color (256 colors), incl. mounting accessories	6AG1 643-0AA01-4AX0
		SIMATIC OP 277 6" Operator Panel with 5.7" TFT display, color (265 colors), incl. mounting accessories	6AV6 643-0BA01-1AX0

PROFINET/Industrial Ethernet

Operating and Monitoring Devices

SIMATIC Panels

Ordering data

Order No.

Order No.

Configuration software

- With SIMATIC WinCC flexible or SIMATIC WinCC

See HMI Software

Configuration set TP 177B / OP177B

Consisting of:
SIMATIC WinCC flexible Compact engineering software,
SIMATIC HMI Manual Collection (DVD), 5 languages (English, French, German, Italian and Spanish),
PC/PPi cable Multimaster,
MPI cable (5 m)
(for download and test purposes only)

- with SIMATIC WinCC flexible Compact engineering software

6AV6 621-0AA01-0AA0

Configuration set TP 277 / OP 277

Consisting of:

- WinCC flexible Standard engineering software
- Documentation DVD, 5 languages (English, French, German, Italian, Spanish)
- RS 232 cable (5 m)
- MPI cable, 5 m (for download and test purposes only)

6AV6 622-0BA01-0AA0

Documentation (to be ordered separately)

Operating Instructions TP 177micro/TP 177A/TP 177B/ OP 177B (WinCC flexible)

- German
- English
- French
- Italian
- Spanish

6AV6 691-1DG01-0AA1

6AV6 691-1DG01-0AB1

6AV6 691-1DG01-0AC1

6AV6 691-1DG01-0AD1

6AV6 691-1DG01-0AE1

Operating Instructions TP 277 / OP 277

- German
- English
- French
- Italian
- Spanish

6AV6 691-1DH01-0AA0

6AV6 691-1DH01-0AB0

6AV6 691-1DH01-0AC0

6AV6 691-1DH01-0AD0

6AV6 691-1DH01-0AE0

User Manual WinCC flexible Compact/Standard/Advanced

- German
- English
- French
- Italian
- Spanish

6AV6 691-1AB01-3AA0

6AV6 691-1AB01-3AB0

6AV6 691-1AB01-3AC0

6AV6 691-1AB01-3AD0

6AV6 691-1AB01-3AE0

User Manual WinCC flexible Communication

- German
- English
- French
- Italian
- Spanish

6AV6 691-1CA01-3AA0

6AV6 691-1CA01-3AB0

6AV6 691-1CA01-3AC0

6AV6 691-1CA01-3AD0

6AV6 691-1CA01-3AE0

SIMATIC HMI Manual Collection

6AV6 691-1SA01-0AX0

Electronic documentation, on DVD
5 languages (English, French, German, Italian, Spanish);
contains: all currently available user manuals, manuals and communication manuals for SIMATIC HMI

Accessories

see Catalog ST 80 / ST PC

Note:

For further information see Catalog ST 80 / ST PC and Industry Mall at www.siemens.com/industrymall

2

Overview



Multi Panels (MP)

Based on Windows CE, Multi Panels combine the robustness of operator panels with the flexibility of PCs. Like operator panels, they are used for operating and monitoring machinery on site. With ultimate performance they are suitable for demanding applications and their functionality can be expanded by installing additional Windows CE applications (Multi Panel and panel options).

SIMATIC MP 177

- PLC functionality can be directly integrated in the MP 177 platform via options
- The Multi Panel can be usefully extended with the Sm@rtService and Sm@rtAccess options
- Pixel-graphics 5.7" TFT widescreen color display (64k colors)
- All interfaces on-board, e.g. MPI, PROFIBUS DP, USB, PROFINET (Ethernet TCP/IP)
- The MP 177 6" Touch can also be supplied as a package, complete with a WinAC MP 177. For configuring the MP 177, a WinCC flexible 2008 SP1 Compact, Standard or Advanced is required.

SIMATIC MP 277

- Multi Panel with extensive functionality for operating and monitoring machinery on site
- Pixel-graphics TFT display with 64k colors in sizes of 7.5" and 10.4"
- Versions with touch or key functionality
- MPI, USB, PROFIBUS and PROFINET interfaces on-board
- Message buffer contents are retained even when the panel is switched off with no battery
- SD-/Multi Media Card Slot
- Operating system Window CE 5.0
- Configuration with SIMATIC WinCC flexible 2005 SP1 Standard or Advanced
- Can also be supplied with stainless steel front (EN 1672-2) and therefore meets the higher requirements e.g. in the food and drinks industry.

SIMATIC MP 377

- PLC functionality can be directly integrated in the MP 377 platform via options
- Pixel-graphics 12.1" or 15.1" or 19" widescreen color display (64k colors)
- MP 377 12" Touch, MP 377 15" Touch and MP 377 19" Touch: Touch screen (analog/resistive)
- MP 377 12" keys: 38 system keys, 36 freely configurable and inscribable function keys (36 with LED)
- The MP 377 15" Touch is also available with a stainless steel front (DIN EN 1672-2). The stainless steel front also complies with the higher requirements, e.g. from the food industry.
- All interfaces on-board, e.g. MPI, PROFIBUS DP, USB, PROFINET (Ethernet TCP/IP)

PROFINET/Industrial Ethernet

Operating and Monitoring Devices

SIMATIC Multi Panels (MP)

2

Ordering data	Order No.	Order No.
<i>SIMATIC MP 177</i>		
SIMATIC HMI MP 177 6" Touch min. WinCC flexible 2008 required	6AV6 642-0EA01-3AX0	
SIPLUS HMI MP 177 6" Touch (medial load) min. WinCC flexible 2008 required	6AG1 642-0EA01-4AX0	
SIMATIC MP 177 6" Touch starter kit Consisting of: • SIMATIC MP 177 6" Touch • SIMATIC WinAC MP ²⁾ • Single License for WinAC MP 177 on USB flash drive ¹⁾ • Electronic documentation for WinAC MP • Standard SD card 256 MB (empty)	6AV6 652-2JC01-2AA0	
<i>SIMATIC MP 277</i>		
Multi Panel (including installation accessories) with • 8" color TFT display, Touch • 8" color TFT display, keyboard • 10" color TFT display, Touch • 10" color TFT display, keyboard	6AV6 643-0CB01-1AX1 6AV6 643-0DB01-1AX1 6AV6 643-0CD01-1AX1 6AV6 643-0DD01-1AX1	
SIPLUS HMI MP 277 (medial load) Multi Panel (incl. installation accessories) with • 10" color TFT display, Touch	6AG1 643-0CD01-4AX1	
SIMATIC MP 277 8" Touch Starter Package Consisting of: • SIMATIC MP 277 8" Touch • SIMATIC WinCC flexible 2007 • SIMATIC HMI Manual Collection • MPI cable, 5 m (for download and test purposes only) • PC/PPI cable (RS 232)	6AV6 652-3MB01-0AA0	
SIMATIC MP 277 10" Touch Starter Package Consisting of: • SIMATIC MP 277 10" Touch • SIMATIC WinCC flexible 2007 • SIMATIC HMI Manual Collection • MPI cable, 5 m (for download and test purposes only) • PC/PPI cable (RS 232)	6AV6 652-3PB01-0AA0	
MP 277 special offer package Consisting of: • SIMATIC MP 277 10" Touch • SIMATIC THIN CLIENT 10" Touch • SIMATIC WinCC flexible 2008 • SIMATIC HMI Manual Collection • Ethernet cable, 2 m • MPI cable, 5 m (for download and test purposes only) • Sm@rtAccess (Single License)	6AV6 652-3PB01-2AA0	
<i>SIMATIC MP 377</i>		
Multi Panel (including installation accessories) with • 12" color TFT display, Touch • 12" color TFT display, keyboard • 15" color TFT display, Touch • 19" color TFT display, Touch	6AV6 644-0AA01-2AX0 6AV6 644-0BA01-2AX1 6AV6 644-0AB01-2AX0 6AV6 644-0AC01-2AX1	
SIPLUS HMI MP 377 (medial load) Multi Panel (incl. installation accessories) with • 12" color TFT display, Touch • 15" color TFT display, Touch	6AG1 644-0AA01-4AX0 6AG1 644-0AB01-4AX0	
Starter packages SIMATIC MP 377 consisting of: SIMATIC MP 377, SIMATIC WinCC flexible Standard 2008, SIMATIC HMI Manual Collection, MPI cable, 5 m (for download and test purposes only) • MP 377 12" Touch • MP 377 15" Touch	6AV6 652-4FA01-0AA0 6AV6 652-4GA01-0AA0	
Configuration set MP 377 consisting of: • WinCC flexible Standard engineering software • Documentation DVD, 5 languages (German, English, French, Italian, Spanish) • RS 232 cable (5 m) • MPI cable, 5 m (for download and test purposes only)	6AV6 622-0BA01-0AA0	
<i>Documentation (to be ordered separately)</i>		
MP 277 Operating Instructions • German • English • French • Italian • Spanish	6AV6 691-1DJ01-0AA0 6AV6 691-1DJ01-0AB0 6AV6 691-1DJ01-0AC0 6AV6 691-1DJ01-0AD0 6AV6 691-1DJ01-0AE0	
User manual MP 177 6" Touch • German • English • French • Italian • Spanish	6AV6 691-1DP02-0AA0 6AV6 691-1DP02-0AB0 6AV6 691-1DP02-0AC0 6AV6 691-1DP02-0AD0 6AV6 691-1DP02-0AE0	
MP 377 Operating Instructions • German • English • French • Italian • Spanish	6AV6 691-1DR01-0AA0 6AV6 691-1DR01-0AB0 6AV6 691-1DR01-0AC0 6AV6 691-1DR01-0AD0 6AV6 691-1DR01-0AE0	
<i>Accessories</i>		see Catalog ST 80 / ST PC

¹⁾ Can only be used for license handling

Note:

For further information see Catalog ST 80 / ST PC and Industry Mall at www.siemens.com/industrymall

Overview



Rack PCs are flexible, fault-tolerant industrial PC systems for powerful yet compact applications using 19" technology.

Three device classes are available for various requirements:

SIMATIC IPC547 – maximum performance at an attractive price

SIMATIC IPC647 – maximum compactness combined with maximum industrial functionality

SIMATIC IPC847 – maximum expandability and industrial functionality

Shared industrial functionality

- Maximum system performance for complex automation tasks and computationally intensive PC tasks in the industrial environment through use of Intel Core processors
- Designed for 24-hour continuous operation
- Monitoring and diagnostics functions (e.g. temperature, fan, watchdog)
- RAID1 configuration (mirrored drives), optionally in "hot swap" frames
- Compact dimensions for installation in control cabinets only 500 mm deep
- Dust protection thanks to overpressure ventilation concept with fan on the front and dust filter
- Lockable front panel or front door
- Service-friendly equipment design due to prepared telescopic rail mounting
- Universal implementation as an industrial workstation or server
- Operating system preinstalled and activated for fast startup
- Fast restoration of the delivery status of the HDD thanks to restore DVD
- High flexibility and expandability of components
- PCI and PCI-Express expansion slots
- Independent industrial product design

PROFINET/Industrial Ethernet

Industrial PC / Rack PC

Rack PC

Overview (continued)

SIMATIC IPC547D and SIMATIC IPC547C – maximum performance at an attractive price

- Maximum processor performance in maximum configuration without loss of power (throttling) at ambient temperatures of up to 40 °C
- Optional RAID5 configuration (striping with parity) in "hot swap" frames
- Redundant AC power supply, optional
- Low noise output thanks to controlled fans
- Status and alarm LEDs at the front for signaling critical system states
- Availability for at least 1.5 years
- Guaranteed spare parts availability for at least 3 years

NEW with SIMATIC IPC547D:

- Intel Core i processors 2nd generation
- Hard disks with capacities up to 1 TB for large volumes of data
- Solid-State Drive (SSD), SLC optional

SIMATIC IPC647C and SIMATIC Rack PC 647B – maximum compactness combined with maximum industrial functionality

- Maximum compactness due to 3 free PCI/PCI Express slots for installing long expansion cards and integrated interfaces for communication, e.g. integrated PROFIBUS/MPI or PROFINET interface
- High thermal stability up to 50°C even at maximum processor performance
- High vibration/shock resistance thanks to special hard disk holders
- Service-friendly device design due, for example, to the replacement of filters/fans from the front without the need for tools, or opening of the enclosure with just one screw.
- Front LED concept for efficient self-diagnostics, e.g. monitoring of the hard disks in RAID1 configurators, fans or the status display for Ethernet, PROFINET and PROFIBUS.
- Integrated PROFIBUS DP/MPI or PROFINET interface (optional)
- High continuity of the components/design
- Motherboard developed and manufactured by Siemens
- Availability for 3 to 5 years
- Guaranteed spare parts availability for at least 5 years

NEW with SIMATIC IPC647C:

- Intel Core i processors
- Hard disks with capacities up to 500 GB for large volumes of data
- ECC memory, optional
- Solid-State Drive (SSD), SLC optional
- Redundant AC power supply, optional (available soon)
- Enhanced server functionality (available soon): Hardware RAID PCIe x8 controller, SAS hard disks in hot-swap frame with capacities up to 1 TB for large volumes of data

SIMATIC IPC847C – maximum expandability and industrial functionality

- Maximum expandability due to 11 free PCI/PCI Express slots for installing long expansion cards and integrated interfaces for communication, e.g. integrated PROFIBUS/MPI or PROFINET interface
- High thermal stability up to 50°C even at maximum processor performance
- High vibration/shock resistance thanks to special hard disk holders
- Intel Core i processors
- Optional RAID5 configuration (striping with parity) in "hot swap" frames
- Enhanced server functionality (available soon): Hardware RAID PCIe x8 controller, SAS hard disks in hot-swap frame with capacities up to 1 TB for large volumes of data
- Redundant AC power supply, optional
- Hard disks with capacities up to 500 GB for large volumes of data
- ECC memory, optional
- Solid-State Drive (SSD), SLC optional
- Service-friendly device design due, for example, to the replacement of filters/fans from the front without the need for tools, or opening of the enclosure with just one screw.
- Front LED concept for efficient self-diagnostics, e.g. monitoring of the hard disks in RAID1 configurators, fans or the status display for Ethernet, PROFINET and PROFIBUS.
- Integrated PROFIBUS DP/MPI or PROFINET interface (optional)
- High continuity of the components/design
- Motherboard developed and manufactured by Siemens
- 3 to 5 years availability
- Guaranteed spare parts availability for at least 5 years

Overview (continued)

	SIMATIC IPC547D	SIMATIC IPC647C	SIMATIC IPC847C
Design			
19" rack	4 HU	2 HU	4 HU
Prepared for telescopic rails	•	•	•
Horizontal/vertical installation	• / •	• / –	• / •
19" mounting bracket can be removed from outside	•	•	•
Tower Kit (optional)	•	–	•
General features			
Processor	<ul style="list-style-type: none"> • Intel Core i7-2600 (4C/8T, 3.40 GHz) • Intel Core i5-2400 (4C/4T, 3.10 GHz) • Intel Pentium Dual Core G850 (2C/2T, 2.90 GHz) 	<ul style="list-style-type: none"> • Intel Core i7-610E (2C/4T, 2.53 GHz) • Intel Core i5-520E (2C/4T, 2.4 GHz) • Intel Core i3-330E (2C/4T, 2.13 GHz) 	<ul style="list-style-type: none"> • Intel Core i7-610E (2C/4T, 2.53 GHz) • Intel Core i5-520E (2C/4T, 2.4 GHz) • Intel Core i3-330E (2C/4T, 2.13 GHz)
Main memory	• 1 GB, expandable up to 32 GB	1 GB, expandable up to 8 GB, optional ECC	1 GB, expandable up to 8 GB, optional ECC
Slots for expansions (all long)	<ul style="list-style-type: none"> • 4 x PCI • 1 x PCI-Express x16 • 1 x PCI-Express x16 (4 lanes) • 1 x PCI-Express x8 (1 lane) 	<ul style="list-style-type: none"> • 2 x PCI • 1 x PCI-Express x16 or <ul style="list-style-type: none"> • 1 x PCI • 1 x PCI-Express x8 (4-lane) • 1 x PCI-Express x16 	<ul style="list-style-type: none"> • 7 x PCI • 1 x PCI-Express x16 • 3 x PCI-Express x4 or <ul style="list-style-type: none"> • 7 x PCI • 1 x PCI-Express x16
Onboard graphics	<ul style="list-style-type: none"> • 1 x DisplayPort • 1 x DVI-I • 1 x VGA (via adapter cable, optional) 	<ul style="list-style-type: none"> • 1 x DVI-I • 1 x VGA (via adapter cable, optional) 	<ul style="list-style-type: none"> • 1 x DVI-I • 1 x VGA (via adapter cable, optional)
Graphics card (optional)	• PCI-Express x16 (2 x VGA or 2 x DVI-D)	• PCI-Express x16 (2 x VGA or 2 x DVI-D)	• PCI-Express x16 (2 x VGA or 2 x DVI-D)
Operating system			
without	•	•	•
Preinstalled and activated, supplied on restore CD	<ul style="list-style-type: none"> • Windows XP Professional Multi-Language (32-bit) • Windows 7 Ultimate Multi-Language (32/64-bit) • Windows Server 2008 incl. 5 Clients Multi-Language (32-bit)³⁾ • Windows Server 2008 R2 incl. 5 Clients Multi-Language (64-bit)³⁾ 	<ul style="list-style-type: none"> • Windows XP Professional Multi-Language (32-bit) • Windows 7 Ultimate Multi-Language (32/64-bit)³⁾ • Windows Server 2008 incl. 5 Client Multi-Language • Windows Server 2008 R2 incl. 5 Client Multi-Language (64-bit)³⁾ 	<ul style="list-style-type: none"> • Windows XP Professional Multi-Language (32-bit) • Windows 7 Ultimate Multi-Language (32/64-bit)³⁾ • Windows Server 2008 incl. 5 Client Multi-Language • Windows Server 2008 R2 incl. 5 Client Multi-Language (64-bit)³⁾
Order separately	–	RMOS3 V3.50	RMOS3 V3.50
Project-specific on request	<ul style="list-style-type: none"> • Linux¹⁾ • Other 	<ul style="list-style-type: none"> • Linux¹⁾ • Other 	<ul style="list-style-type: none"> • Linux¹⁾ • Other
Interfaces			
PROFIBUS/MPI	–	12 Mbit/s (CP 5611-compatible), optional	12 Mbit/s (CP 5611-compatible), optional
PROFINET	–	3 x RJ45 (CP 1616-compatible), optional	3 x RJ45 (CP 1616-compatible), optional
Ethernet	2 x 10/100/1000 Mbit/s	2 x 10/100/1000 Mbit/s	2 x 10/100/1000 Mbit/s
USB 2.0 (high current)	11 x, 2 of which at front, 1 x internal	7 x, 2 of which at front, 1 x internal	7 x, 2 of which at front, 1 x internal
VGA	• optional	• optional	• optional
DVI	•	•	•
DisplayPort	•	–	–

- Available
- Not available

¹⁾ Suitable for specific Linux versions in accordance with the specifications of the Siemens manufacturer's declaration "Suited for Linux", see www.siemens.com/simatic-pc/suited-for-linux (Linux is a trademark of Linus Torvald)

²⁾ Restrictions when using DVD±R/RW and hard disks in swap frame.

³⁾ Available soon

PROFINET/Industrial Ethernet

Industrial PC / Rack PC

Rack PC

Overview (continued)

	SIMATIC IPC547D	SIMATIC IPC647C	SIMATIC IPC847C
Drives			
SATA hard disks			
• Internal installation	•	–	•
• Installation at the front in the swap frame	•	•	•
• Internal installation in drive holder (shock and vibration-damped)	–	•	•
RAID1/5 configuration	• / •	• / –	• / •
Solid-State Drive (SSD), SLC	•	•	•
Hard disks SAS			
Installation at the front in the swap frame	–	•	•
RAID1/5 configuration with HW RAID controller PCI x 8	– / –	• / –	• / •
Optical drives			
DVD-ROM	•	–	•
DVD±R/RW	•	•	•
AC power supply			
Redundant (optional)	•	• 2)	•
Ambient conditions ¹⁾			
Vibration/shock load during operation	0.2 g / 1 g	0.5 g / 5 g	0.5 g / 5 g
Ambient temperature during operation	With maximum configuration: 5 ... 40 °C	With maximum configuration: 5 ... 50 °C	With maximum configuration: 5 ... 50 °C

- Available
- Not available

1) Restrictions when using DVD±R/RW and hard disks in swap frame.

2) Available soon

	SIMATIC IPC547C	SIMATIC Rack PC 647B
Design		
19" rack	4 HU	2 HU
Prepared for telescopic rails	•	•
Horizontal/vertical installation	• / •	• / –
19" mounting bracket can be removed from outside	•	•
Tower Kit (optional)	•	–
General features		
Processor	<ul style="list-style-type: none"> • Intel Core2 Quad Q9400 (4C/4T, 2.66 GHz) • Intel Core2 Duo E8400 (2C/2T, 3.00 GHz) • Intel Pentium Dual Core E5300 (2C/2T, 2.60 GHz) 	<ul style="list-style-type: none"> • Intel Core2 Duo T7400 (2C/2T, 2.16 GHz) • Intel Core2 Duo T5500 (2C/2T, 1.66 GHz) • Intel Celeron M 440 (1C/1T, 1.86 GHz)
Main memory	• 1 GB, expandable up to 16 GB	512 MB, expandable to 4 GB
Slots for expansions (all long)	<ul style="list-style-type: none"> • 4 x PCI • 1 x PCI-Express x16 • 1 x PCI-Express x8 (1 Lane) • 1 x PCI-Express x1 	<ul style="list-style-type: none"> • 2 x PCI • 1 x PCI-Express x16 (PEG) or <ul style="list-style-type: none"> • 1 x PCI • 1 x PCI-Express x4 • 1 x PCI-Express x16 (PEG)
Onboard graphics	<ul style="list-style-type: none"> • 1 x VGA • 1 x DVI-D (via adapter card, optional) 	<ul style="list-style-type: none"> • 1 x VGA • 1 x DVI-D (via adapter card, optional)
Graphics card (optional)	• PCI-Express x16 (2 x VGA or 2 x DVI-D)	PCI-Express x16 (2 x VGA or 2 x DVI)

Overview (continued)

	SIMATIC IPC547C	SIMATIC Rack PC 647B
Operating system		
without	•	•
Preinstalled/supplied on Restore CD	<ul style="list-style-type: none"> • Windows XP Professional Multi-Language • Windows Vista Ultimate Multi-Language • Windows 7 Ultimate Multi-Language • Windows Server 2003 R2 incl. 5 Client Multi-Language • Windows Server 2008 incl. 5 Client Multi-Language 	<ul style="list-style-type: none"> • Windows XP Professional Multi-Language • Windows Vista Ultimate Multi-Language • Windows Server 2003 incl. 5 Client Multi-Language
Order separately	–	RMOS3 V3.50
Project-specific on request	<ul style="list-style-type: none"> • Linux ¹⁾ • Other 	<ul style="list-style-type: none"> • Linux ¹⁾ • Other
Interfaces		
PROFIBUS/MPI	–	12 Mbit/s (CP 5611-compatible), optional
PROFINET	–	3 x RJ45 (CP 1616-compatible), optional
Ethernet	2 x 10/100/1000 Mbit/s	2 x 10/100/1000 Mbit/s
USB 2.0 (high current)	9 x 2° of which at front, 1 x internal	6 x, 2° of which at front
VGA / audio	1 x / yes	1 x / yes
DVI	• optional	• optional
Drives		
SATA hard disks	•	–
• Internal installation	•	•
• Installation at the front in the swap frame	•	•
• Internal installation in drive holder (shock and vibration-damped)	–	•
RAID1/5 configuration	• / •	• / –
SSD (Solid-State Drive)	–	–
Optical drives		
DVD-ROM	•	–
DVD±R/RW	•	•
Floppy	•	–
AC power supply		
Redundant (optional)	•	–
Ambient conditions ²⁾		
Vibration/shock load during operation	0.2 g / 1 g	0.5 g / 5 g
Ambient temperature during operation	With maximum configuration: 5 ... 40 °C	With maximum configuration: 5 ... 50 °C

- Available
- Not available

¹⁾ Suitable for specific Linux versions in accordance with the specifications of the Siemens manufacturer's declaration "Suited for Linux", see www.siemens.com/simatic-pc/suited-for-linux (Linux is a trademark of Linus Torvald)

²⁾ Restrictions when using DVD±R/RW and hard disks in swap frame.

PROFINET/Industrial Ethernet

Industrial PC / Rack PC

Rack PC

Benefits

Rugged design

The overall design aims to achieve maximum safety for electromagnetic, vibration and shock loads. A well-designed pressurized ventilation concept ensures that even the maximum configuration can support high operating temperatures – and dust protection is included.

Service-friendly device design

Particular attention was paid to making servicing extremely simple. PC components (e.g. slots, memory modules) are readily accessible. Fan filters and fans can be replaced without tools even when unit is built-in.

Performance

Thanks to the use of the latest generation of Intel Pentium Dual Core to Core i 2nd processors, SIMATIC Rack PCs are flexibly scalable for your application.

System availability

SIMATIC racks can be ordered in custom configurations and are supplied ready for use. The design's high system availability can be further extended by means of additional data backup options (e.g. RAID1 or RAID5 system, redundant power supply, SIMATIC IPC Image & Partition Creator) and efficient self-diagnostics software (SIMATIC IPC DiagMonitor).

Integrated interfaces

Two onboard Gbit Ethernet interfaces are available for communication in the office world or at the control level. Integrated USB interfaces on the rear and front panels make connecting I/O devices from the PC world (e.g. external hard disks for mobile data backup, keyboard and/or mouse for operation) child's play. For advanced graphics applications, a spare PCI Express slot and a high-performance graphics card for the connection of two monitors are available.

Expandability

With up to 11 free PC slots, the SIMATIC Rack PC offers maximum leeway for expansions for installation in space-saving cabinets with a depth of just 500 mm.

Continuity

The SIMATIC Rack PC models can be ordered for a period of at least 1.5 years; spare parts remain obtainable for at least 3 years after active marketing is concluded. Long-term functionality of the hardware and software is also ensured. Long-term availability of PC components from the Intel embedded line ensures high investment protection.

More information

Further information can be found on the Internet at:

www.siemens.com/simatic-pc

Information material can be ordered or downloaded from the Internet:

www.siemens.com/simatic/printmaterial

Overview



The SIMATIC IPC547D is a rugged industrial PC in 19" rack design (4 HU).

It offers:

- Maximum performance
- Attractive price
- Intel Core i technology

PROFINET/Industrial Ethernet

Industrial PC / Rack PC

SIMATIC IPC547D

2

Ordering data	Order No.
Configuration ³⁾	
SIMATIC IPC547D	6AG4 104 - 2 ■■■■ - ■■■■
<u>Interfaces:</u> 2 x Gbit LAN (RJ45), 1 x DisplayPort, 1 x SCI-I, 8 x USB at the rear, 2 x USB at the front, 1 x USB internal, 1 x serial (COM1), 2 x PS/2, audio, 7 slots (all long): 4 x PCI, 1 x PCIe x16, 1 x PCIe x16 (4 lanes), 1 x PCIe x8 (1 lane); slots: 6 (3 x 5.25", 1 x 3.5" externally accessible; 2 x 3.5" internally accessible); temperature and fan monitoring, watchdog, card retainer	
<u>Processors</u>	
• Pentium Dual Core G850 (2C/2T, 2.90 GHz, 3 MB Last Level Cache, EM64T, VT)	A
• Core i5-2400 (4C/4T, 3.10 GHz, 6 MB Last Level Cache, Turbo Boost 2.0, EM64T, VT-x/-d, iAMT)	C
• Core i7-2600 (4C/8T, 3.40 GHz, 8 MB Last Level Cache, Turbo Boost 2.0, EM64T, VT-x/-d, iAMT)	D
<u>Drives</u>	
• 500 GB HDD SATA; internal	A
• 1 TB HDD SATA; internal	B
• RAID1, 1 TB (2 x 1 TB HDD SATA, mirror disks); internal ¹⁾	D
• Solid-State Drive SATA 50 GB (SLC); internal	E
• 500 GB HDD SATA in swap frame; front	G
• 2 x 500 GB HDD SATA in swap frame; front	H
• RAID1, 1 TB (2 x 1 TB HDD SATA, mirror disks) in swap frame; for hot swapping; at the front	P
• RAID5, 2 TB (3 x 1 TB HDD SATA, striping with parity) in swap frame; for hot swapping; at the front	R
• Solid-State Drive SATA 50 GB (SLC) in swap frame; at the front	S
• RAID1, 1 TB (2 x 1 TB HDD SATA, mirror disks) in swap frame; hot swapping; at the front + Solid-State Drive SATA 50 GB (SLC) in swap frame; at the front (operating system if available on SSD)	T
<u>Memory configuration</u>	
• 1 GB DDR3 SDRAM (1 x 1 GB), single channel	0
• 2 GB DDR3 SDRAM (2 x 1 GB), dual channel	1
• 4 GB DDR3 SDRAM (2 x 2 GB), dual channel	2
• 8 GB DDR3 SDRAM ²⁾ (2 x 4 GB), dual channel	3
• 16 GB DDR3 SDRAM ²⁾ (4 x 4 GB), dual channel	4

1) Not in combination with redundant power supply
 2) Can only be used on 64-bit operating systems
 3) Available soon

Ordering data	Order No.
Configuration ³⁾	
SIMATIC IPC547D (continued)	6AG4 104 - 2 ■■■■ - ■■■■
<u>Swap media:</u>	
• DVD-ROM	1
• DVD±RW Drive	2
<u>Expansions (hardware)</u>	
• Without expansions (HW); onboard graphics	0
• No expansions (HW); onboard graphics; DVI-I VGA-compliant adapter cable for onboard graphics	1
• Serial (COM2) & parallel (LPT); onboard graphics	2
• Serial (COM2) and parallel (LPT); onboard graphics; DVI-I VGA-compliant adapter cable for onboard graphics	3
• Serial (COM2) & parallel (LPT) + PCIe x16 graphics card (Dual Head: 2 x VGA or 2 x DVI-D), 512 MB	4
<u>Operating systems (preinstalled and activated)</u>	
• Windows XP Professional, MUI (Eng, Ger, Fr, It, Sp), 32 bit, SP3	B
• Windows 7 Ultimate, MUI (Eng, Ger, Fr, It, Sp), 32 bit, SP1 supplied	E
• Windows 7 Ultimate, MUI (Eng, Ger, Fr, It, Sp), 64 bit, SP1 supplied	F
• Windows Server 2008 Standard Edition incl. 5 clients, MUI ⁴⁾ (Eng, Ger, Fr, It, Sp), 32 bit, SP1, SP2 supplied	P
• Windows Server 2008 R2 ⁴⁾ Standard Edition incl. 5 Clients, MUI (Eng, Fr, Ger, It, Sp), 64-bit, SP1 supplied	Q
• Without operating system	X
<u>Expansions (software)</u>	
• SIMATIC IPC DiagMonitor V4.3 Software enclosed	A
• SIMATIC IPC Image & Partition Creator V3.2 software included	B
• SIMATIC IPC DiagMonitor V4.3 + Image & Partition Creator V3.2 software included	C
• Without expansions (software)	X
<u>Power supply, with country-specific cable:</u>	
• 100/240 V AC industrial power supply; power cable for Europe	0
• 100/240 V AC industrial power supply; USA power cable	4
• 100/240 V AC industrial power supply; power cable for China	5
• 2 x 100/240 V AC redundant industrial power supply; without power cable	6

For an up-to-date overview, see the SIMATIC PC online configurator at: www.siemens.com/ipc-configurator

Ordering data	Order No.	Order No.
<i>Preferred versions (ex-stock)</i>		
SIMATIC IPC547D	6AG4 104-2AA01-0XX0	
Pentium Dual Core G850 (2C/2T, 2.90 GHz, 3 MB Last Level Cache, EM64T, VT); 500 GB HDD SATA internal; 1 GB DDR3 SDRAM (1 x 1 GB), single channel; DVD-ROM; interfaces: 2 x Gbit LAN (RJ45), 1 x serial, 8 x USB rear, 2 x USB front, 1 x USB internal, 2 x PS/2, audio; 100/240 V industrial power supply, power cable for Europe; without operating system		
Core i5-2400 (4C/4T, 3.10 GHz, 6 MB Last Level Cache, Turbo Boost 2.0, EM64T, VT-x/-d, iAMT); RAID1, 1 TB (2 x 1 TB HDD SATA, mirror disks) in swap frame, for hot swapping, at the front; 4 GB DDR3 SDRAM (2 x 2 GB) dual channel; DVD±RW; interfaces: 2 x Gbit LAN (RJ45), 2 x serial, 1 x parallel, 8 x USB rear, 2 x USB front, 1 x USB internal, 2 x PS/2, Audio; 100/240V industrial power supply, power cable for Europe; without operating system	6AG4 104-2CP22-2XX0	
Core i7-2600 (4C/8T, 3.40 GHz, 8 MB Last Level Cache, Turbo Boost 2.0, EM64T, VT-x/-d, iAMT); RAID1, 1 TB (2 x 1 TB HDD SATA, mirror disks) in swap frame, for hot swapping, at the front; 8 GB DDR3 SDRAM (2 x 4 GB), dual channel; DVD±RW; interfaces: 2 x Gbit LAN (RJ45), 2 x serial, 1 x parallel, 8 x USB rear, 2 x USB front, 1 x USB internal, 2 x PS/2, audio; 100/240 V industrial power supply, power cable for Europe, Windows 7 Ultimate MUI (Eng, Ger, Fr, It, Sp), 64-bit, SP1 supplied	6AG4 104-2DP32-2FX0	
<i>Accessories</i>		
Memory expansion		
• 1 GB DDR3 1333 SDRAM, DIMM (1 x 1 GB)		6ES7 648-2AJ40-0LA0
• 2 GB DDR3 1333 SDRAM, DIMM, kit for dual-channel technology (2 x 1 GB)		6ES7 648-2AJ50-0LB0
• 4 GB DDR3 1333 SDRAM, DIMM, kit for dual-channel technology (2 x 2 GB)		6ES7 648-2AJ60-0LB0
• 8 GB DDR3 1333 SDRAM, DIMM, kit for dual-channel technology (2 x 4 GB)		6ES7 648-2AJ70-0LB0
Tower Kit	for converting the computer into an industrial tower PC	6ES7 648-1AA00-0XC0
Retainer	for pin assignment of the internal USB port	6ES7 648-1AA00-0XK0
Power cable, straight, 3 m long		
• Austria, Belgium, Finland, France, Germany, Netherlands, Spain, Sweden		6ES7 900-0AA00-0XA0
• United Kingdom		6ES7 900-0BA00-0XA0
• Switzerland		6ES7 900-0CA00-0XA0
• USA		6ES7 900-0DA00-0XA0
• Italy		6ES7 900-0EA00-0XA0
• China		6ES7 900-0FA00-0XA0
Rack unit for low-profile HDD swap frame	for 3.5" hard disk, SATA (without hard disk)	6ES7 648-0EG00-1BA0
<i>Expansion components</i>		
SIMATIC PC keyboard German/international		
• USB port		6ES7 648-0CB00-0YA0
• incl. 4-way USB hub		6ES7 648-0CD00-0YA0
SIMATIC PC USB mouse	(optical, 3-button) for programming device and PC with adapter	6ES7 790-0AA01-0XA0
SIMATIC IPC USB FlashDrive	8 GB, USB 2.0, metal enclosure, bootable	6ES7 648-0DC50-0AA0
SIMATIC IPC Service USB FlashDrive	8 GB, USB 2.0, metal enclosure, bootable, with BIOS-Manager, Image & Partition Creator pre-installed, incl. CD	6AV7 672-8JD01-0AA0
Communication products	see Catalog ST 80 / ST PC	
RMOS real-time operating system	see Catalog ST 80 / ST PC	
<i>Note:</i>		
Software Packages with SIMATIC WinCC flexible, SIMATIC WinCC and SIMATIC WinAC RTX (F) can be ordered together with the SIMATIC IPC with a price advantage.		
You can find more information in Catalog ST 80 / ST PC and in the Industry Mall at www.siemens.com/industrymall		

PROFINET/Industrial Ethernet

Industrial PC / Rack PC

SIMATIC IPC547C

Overview

2



The SIMATIC IPC547C is a rugged industrial PC in 19" rack design (4 HU).

It offers:

- Maximum performance
- Attractive price
- Intel Core 2 Quad technology

Ordering data	Order No.	Order No.
Configuration ³⁾		
SIMATIC IPC547C	6AG4 104 - 1	SIMATIC IPC547D (continued)
Interfaces: 2 x Gbit LAN (RJ45); 1 x serial (COM1); 6 x USB rear, 2x USB front, 1 x USB internal; 2 x PS/2; audio; 7 slots (4x PCI long, 1 x PCIe x16, 1 x PCIe x8 (1 lane), 1 x PCIe x1); slots: 6 (3 x 5.25", 1 x 3.5" externally accessible; 2 x 3.5" internally accessible) temperature and fan monitoring, watchdog; card retainer		Swap media:
<u>Processor/motherboard</u>		• DVD-ROM; without FDD
• Pentium Dual Core E5300 (2.6 GHz, 800 MHz FSB, 2 MB L2 cache, EM64-T)	A	• DVD±RW; without FDD
• Core2 Duo E8400 (3.0 GHz, 1333 MHz FSB, 6 MB L2 cache, EM64-T, VT)	C	• DVD-ROM & FDD
• Core2 Quad Q9400 (2.66 GHz, 1333 MHz FSB, 6 MB L2 cache, EM64-T, VT)	D	• DVD±RW & FDD
<u>Hard disks:</u>		<u>Expansion (hardware)</u>
• 250 GB HDD SATA; internal	A	• Without expansions
• 500 GB HDD SATA; internal	B	• Serial (COM2) and parallel (LPT)
• RAID1, 500 GB (2 x 500 GB HDD SATA, mirror disks); internal ¹⁾	D	• Serial (COM2) and parallel (LPT) + DVI extension adapter (DVI-D)
• 500 GB HDD SATA in swap frame; at the front	G	• Serial (COM2) & parallel (LPT) + PCIe x16 graphics card (Dual Head: 2 x VGA or 2 x DVI), 256 MB
• 2 x 500 GB HDD SATA in swap frame; at the front	H	<u>Operating system</u> (preinstalled and activated)
• RAID1, 500 GB (2 x 500 GB HDD SATA, mirror disks) in swap frames; for hot swapping; at the front	P	• Windows XP Professional, MUI (Eng, Ger, Fr, It, Sp), 32 bit, SP3
• RAID5, 1 TB (3 x 500 GB HDD SATA, striping with parity) in swap frame; hot swapping; at the front	R	• Windows Vista Ultimate, MUI (Eng, Ger, Fr, It, Sp), 32 bit, SP1, SP2 supplied
<u>Memory configuration:</u>		• Windows 7 Ultimate, MUI (Eng, Ger, Fr, It, Sp), 32 bit
• 1 GB DDR2 SDRAM (1 x 1 GB), single channel	0	• Windows Server 2003 R2 Standard Edition incl. 5 clients, MUI (Eng, Ger, Fr, It, Sp), 32 bit, SP2
• 2 GB DDR2 SDRAM (2 x 1 GB), dual channel	1	• Windows Server 2008 Standard Edition incl. 5 clients, MUI (Eng, Ger, Fr, It, Sp), 32 bit, SP1, SP2 supplied
• 4 GB DDR2 SDRAM (2 x 2 GB), dual channel	2	• Without operating system
• 8 GB DDR2 SDRAM ²⁾ (4 x 2 GB), dual channel	3	<u>Expansion (software)</u>
		• SIMATIC IPC DiagMonitor V4.2 software included
		• SIMATIC IPC Image & Partition Creator V3.1 software included
		• SIMATIC IPC DiagMonitor V4.2 and Image & Partition Creator V3.1 software included
		• Without software
		<u>Power supply,</u> <u>with country-specific cable:</u>
		• 100/240 V AC industrial power supply; power cable for Europe
		• 100/240 V AC industrial power supply; power cable for China
		• 2 x 100/240 V AC redundant industrial power supply; without power cable

1) Not in combination with redundant power supply

2) Can only be used on 64-bit operating systems

3) For an up-to-date overview, see the SIMATIC PC online configurator at: www.siemens.com/ipc-configurator

PROFINET/Industrial Ethernet

Industrial PC / Rack PC

SIMATIC IPC547C

2

Ordering data

Order No.

Preferred versions (ex-stock)

SIMATIC IPC547C

- Pentium Dual Core E5300 (2.6 GHz, 800 MHz FSB, 2 MB L2 Cache, EM64-T); 250 GB HDD SATA internal; 1 GB DDR2 SDRAM (1 x 1 GB), single channel; DVD-ROM & FDD; interfaces: 2 x Gbit LAN (RJ45), 2 x serial, 1 x parallel, 6 x USB rear, 2 x USB front, 1 x USB internal, 2 x PS/2, audio; 100/240 V industrial power supply, power cable for Europe; without operating system
- Core2 Duo E8400 (3.0 GHz, 1333 MHz FSB, 6 MB L2 Cache, EM64-T, VT); 250 GB HDD SATA internal; 1 GB DDR2 SDRAM (1 x 1 GB) single channel DVD±RW & FDD; interfaces: 2 x Gbit LAN (RJ45), 2 x serial, 1 x parallel, 6 x USB rear, 2 x USB front, 1 x USB internal, 2 x PS/2, audio; 100/240 V industrial power supply, power cable for Europe; Windows XP Professional MUI (Eng, Ger, Fr, It, Sp), 32-bit, SP3
- Core2 Quad Q9400 (2.66 GHz, 1333 MHz FSB, 6 MB L2 Cache, EM64-T, VT); 250 GB HDD SATA internal; 2 GB DDR2 SDRAM (2 x 1 GB), dual channel; DVD±RW & FDD, interfaces: 2 x Gbit LAN (RJ45), 2 x serial, 1 x parallel, 6 x USB rear, 2 x USB front, 1 x USB internal, 2 x PS/2, audio; 100/240 V industrial power supply, power cable for Europe, Windows XP Professional MUI (Eng, Ger, Fr, It, Sp), 32-bit SP3

6AG4 104-1AA03-1XX0

6AG4 104-1CA04-1BX0

6AG4 104-1DA14-1BX0

Order No.

Accessories

Memory expansion

- 1 GB DDR2 800 DIMM
- 2 GB DDR2 800, DIMM, kit for dual channel technology
- 4 GB DDR2 800, DIMM, kit for dual channel technology

6ES7 648-2AF40-0JAO

6ES7 648-2AF50-0JBO

6ES7 648-2AF60-0JBO

Tower Kit

for converting the computer into an industrial tower PC

6ES7 648-1AA00-0XC0

Retainer

for pin assignment of the internal USB port

6ES7 648-1AA00-0XJO

Power cable, straight, 3 m long

- Austria, Belgium, Finland, France, Germany, Netherlands, Spain, Sweden
- United Kingdom
- Switzerland
- USA
- Italy
- China

6ES7 900-0AA00-0XA0

6ES7 900-0BA00-0XA0

6ES7 900-0CA00-0XA0

6ES7 900-0DA00-0XA0

6ES7 900-0EA00-0XA0

6ES7 900-0FA00-0XA0

Rack unit for low-profile HDD swap frame

for 3.5" hard disk, SATA (without hard disk)

6ES7 648-0EG00-1BA0

Expansion components

SIMATIC PC keyboard German/international

- USB port
- incl. 4-way USB hub

6ES7 648-0CB00-0YAO

6ES7 648-0CD00-0YAO

SIMATIC PC USB mouse

(optical, 3-button) for PG and PC with PS/2-adaptor

6ES7 790-0AA01-0XA0

SIMATIC IPC USB FlashDrive

8 GB, USB 2.0, metal enclosure, bootable

6ES7 648-0DC50-0AA0

SIMATIC IPC Service USB FlashDrive

8 GB, USB 2.0, metal enclosure, bootable, with BIOS-Manager, Image & Partition Creator pre-installed, incl. CD

6AV7 672-8JD01-0AA0

Communication products

see Catalog ST 80 / ST PC

RMOS real-time operating system

see Catalog ST 80 / ST PC

- 1) Not in combination with redundant power supply
- 2) Can only be used on 64-bit operating systems
- 3) For an up-to-date overview, see the SIMATIC PC online configurator at: www.siemens.com/ipc-configurator

Note:

Software Packages with SIMATIC WinCC flexible, SIMATIC WinCC and SIMATIC WinAC RTX (F) can be ordered together with the SIMATIC IPC with a price advantage.

You can find more information in Catalog ST 80 / ST PC and in the Industry Mall at www.siemens.com/industrymall

Overview



The SIMATIC IPC647C is a very rugged, high-performance industrial PC in 19" rack design (2 HMs) with excellent industrial functionality.

It offers:

- Extreme compactness
- Extreme ruggedness
- Intel Core i technology

PROFINET/Industrial Ethernet

Industrial PC / Rack PC

SIMATIC IPC647C

Ordering data

Order No.

Configuration ¹⁾

SIMATIC IPC647C

6AG4 112-1 ■■■■ - ■■■■

Interfaces:
2 x 10/100/1000 Mbit/s Ethernet (RJ45); 1 x graphic (DVI-I); 2 x COM; 1 x LPT; 2 x PS/2; 4 x USB 2.0 at rear; 2 x USB 2.0 at front; 1 x USB 2.0 internal; audio; temperature and fan monitoring, watchdog; card retainer

Processor/motherboard

- Core i3-330E (2C/4T, 2.13 GHz, 3 MB cache), motherboard without fieldbus **G**
- Core i3-330E (2C/4T, 2.13 GHz, 3 MB cache), motherboard with PROFIBUS/MPI **H**
- Core i3-330E (2C/4T; 2.13 GHz, 3 MB cache), motherboard with PROFINET (3 x RJ45, CP 1616-compatible) ²⁾ **J**
- Core i5-520E (2C/4T, 2.4 GHz, 3 MB cache, TB, iAMT, VT), motherboard without fieldbus **K**
- Core i5-520E (2C/4T, 2.4 GHz, 3 MB cache, TB, iAMT, VT), motherboard with PROFIBUS/MPI **L**
- Core i5-520E (2C/4T; 2.4 GHz, 3 MB cache, TB, iAMT, VT), motherboard with PROFINET (3 x RJ45, CP 1616-compatible) ²⁾ **M**
- Core i7-610E (2C/4T, 2.53 GHz, 4 MB cache, TB, iAMT, VT), motherboard without field bus **N**
- Core i7-610E (2C/4T, 2.53 GHz, 4 MB cache, TB, iAMT, VT), motherboard with PROFIBUS/MPI **P**
- Core i7-610E (2C/4T; 2.53 GHz, 4 MB cache, TB, iAMT, VT), motherboard with PROFINET (3 x RJ45, CP 1616-compatible) ²⁾ **R**

Order No.

Configuration ¹⁾

SIMATIC IPC647C (continued)

6AG4 112-1 ■■■■ - ■■■■

Hard disks:

- 250 GB HDD SATA; 0.5 g vibration, 5 g shock, internal **A**
- 500 GB HDD SATA; 0.5 g vibration, 5 g shock, internal **B**
- 2 x 500 GB HDD SATA; 0.5 g vibration, 5 g shock, internal **C**
- RAID1 500 GB (2 x 250 GB HDD SATA, mirror disks); 0.5 g vibration, 5 g shock, internal **D**
- 250 GB HDD SATA in swap frame; front **H**
- 500 GB HDD SATA in swap frame; front **K**
- 2 x 500 GB HDD SATA in swap frame; front **M**
- RAID1 500 GB (2 x 250 GB HDD SATA) in swap frame, for hot swapping; front **P**
- 32 GB SSD (SLC) SATA, internal **S**
- 32 GB SSD (SLC) SATA in swap frame; front **T**

Memory configuration:

- 1 GB DDR3 SDRAM (1 x 1 GB), single channel **0**
- 2 GB DDR3 SDRAM (1 x 2 GB), single channel **1**
- 4 GB DDR3 SDRAM (2 x 2 GB), dual channel **2**
- 6 GB DDR3 SDRAM (1 x 2 GB, 1 x 4 GB), dual channel **3**
- 8 GB DDR3 SDRAM (2 x 4 GB), dual channel **4**
- 2 GB DDR3 SDRAM, ECC (2 x 1 GB), dual channel **5**
- 4 GB DDR3 SDRAM, ECC (2 x 2 GB), dual channel **6**
- 8 GB DDR3 SDRAM, ECC (2 x 4 GB), dual channel **7**

¹⁾ For an up-to-date overview, see the SIMATIC PC online configurator at: www.siemens.com/ipc-configurator

²⁾ Not in combination with Windows 7 and Windows Server 2008

Ordering data	Order No.	Ordering data	Order No.
<p>Configuration¹⁾</p> <p>SIMATIC IPC647C (continued)</p> <p><u>Swap media:</u></p> <ul style="list-style-type: none"> • CompactFlash drive, at front 0 • DVD±RW 1 • without swap medium 8 <p><u>Bus module / hardware expansion</u></p> <ul style="list-style-type: none"> • Bus modules 3 slots: 2 x PCI; 1 x PCIe x16; without hardware expansions 0 • Bus modules 3 slots: 2 x PCI; 1 x PCIe x16; DVI-VGA adapter (1 x VGA) for onboard graphics 1 • Bus modules 3 slots: 2 x PCI; 1 x PCIe x16 assigned; + graphics card PCIe x16, 2 x DP (2 x DVI-D via 2 x DP-DVI adapters) 2 • Bus modules 3 slots: 2 x PCI; 1 x PCIe x16 assigned; + graphics card PCIe x16, 2 x DP (2 x VGA via 2 x DP-VGA adapters) 3 • Bus modules 3 slots: 1 x PCI; 1 x PCIe x8 (4-lane); 1 x PCIe x16; without HW expansions 4 • Bus modules 3 slots: 1 x PCI; 1 x PCIe x8 (4-lane); 1 x PCIe x16; DVI-VGA adapter (1 x VGA) for onboard graphics 5 • Bus modules 3 slots: 1 x PCI; 1 x PCIe x8 (4-lane); 1 x PCIe x16 assigned; + graphics card PCIe x16, 2 x DP (2x DVI-D via 2x DP-DVI adapters) 6 • Bus modules 3 slots: 1 x PCI; 1 x PCIe x8 (4-lane); 1 x PCIe x16 assigned; + graphics card PCIe x16, 2 x DP (2x VGA via 2x DP-VGA adapters) 7 	<p>6AG4 112-1</p>	<p>Configuration¹⁾</p> <p>SIMATIC IPC647C (continued)</p> <p><u>Operating system (preinstalled and activated)</u></p> <ul style="list-style-type: none"> • Windows XP Professional, MUI (Eng, Ger, Fr, It, Sp), SP3, 32-bit B • Windows 7 Ultimate, MUI (Eng, Ger, Fr, It, Sp), 32-bit E • Windows Server 2008 Standard Edition incl. 5 clients, MUI (Eng, Fr, Ger, It, Sp), SP2, 32-bit P • Without operating system X <p><u>Expansion (software)</u></p> <ul style="list-style-type: none"> • SIMATIC IPC DiagMonitor 4.2 included A • SIMATIC IPC Image Creator software 3.1 included B • SIMATIC IPC DiagMonitor 4.2 and Image Creator Software 3.1 included C • Without software X <p><u>Power supply, with country-specific cable:</u></p> <ul style="list-style-type: none"> • 100/240 V AC industrial power supply with Namur; power cable for Europe 0 • 100/240 V AC industrial power supply with Namur; power cable for United Kingdom 1 • 100/240 V AC industrial power supply with Namur; power cable for Switzerland 2 • 100/240 V AC industrial power supply with Namur; power cable for USA 3 • 100/240 V AC industrial power supply with Namur; power cable for Italy 4 • 100/240 V AC industrial power supply with Namur; power cable for China 5 	<p>6AG4 112-1</p>

1) For an up-to-date overview, see the SIMATIC PC online configurator at: www.siemens.com/ipc-configurator

PROFINET/Industrial Ethernet

Industrial PC / Rack PC

SIMATIC IPC647C

Ordering data

Accessories

Memory expansion

- 1 GB DDR3 1066 SDRAM, DIMM
- 2 GB DDR3 1066 SDRAM, DIMM
- 4 GB DDR3 1066 SDRAM, DIMM
- 1 GB DDR3 1066 SDRAM, DIMM, ECC
- 2 GB DDR3 1066 SDRAM, DIMM, ECC
- 4 GB DDR3 1066 SDRAM, DIMM, ECC

6ES7 648-2AJ40-0KA0

6ES7 648-2AJ50-0KA0

6ES7 648-2AJ60-0KA0

6ES7 648-2AJ40-1KA0

6ES7 648-2AJ50-1KA0

6ES7 648-2AJ60-1KA0

Hard disk slide-in unit for swap frame

SIMATIC PC accessories, slide-in HDD swap frame, low-profile, for 3.5" hard disk, serial ATA (without hard disk)

6ES7 648-0EG00-1BA0

Power cable, straight, 3 m long

- Austria, Belgium, Finland, France, Germany, Netherlands, Spain, Sweden
- United Kingdom
- Switzerland
- USA
- Italy
- China

6ES7 900-0AA00-0XA0

6ES7 900-0BA00-0XA0

6ES7 900-0CA00-0XA0

6ES7 900-0DA00-0XA0

6ES7 900-0EA00-0XA0

6ES7 900-0FA00-0XA0

Order No.

Retainer

for pin assignment of the internal USB port

6ES7 648-1AA00-0XK0

SIMATIC PC keyboard

German/international,
• USB port
• incl. 4-way USB hub

6ES7 648-0CB00-0YA0
6ES7 648-0CD00-0YA0

SIMATIC PC mouse

(optical, 3-button)
for PG and PC with adapter

6ES7 790-0AA01-0XA0

SIMATIC IPC USB FlashDrive

8 GB, USB 2.0, metal enclosure, bootable

6ES7 648-0DC50-0AA0

SIMATIC IPC Service USB FlashDrive

8 GB, USB 2.0, metal enclosure, bootable, with BIOS-Manager, Image & Partition Creator pre-installed, incl. CD

6AV7 672-8JD01-0AA0

Communication products

see Catalog ST 80 / ST PC

RMOS real-time operating system

see Catalog ST 80 / ST PC

Note:

Software Packages with SIMATIC WinCC flexible, SIMATIC WinCC and SIMATIC WinAC RTX (F) can be ordered together with the SIMATIC IPC with a price advantage.

You can find more information in Catalog ST 80 / ST PC and in the Industry Mall at www.siemens.com/industrymall

Overview



The SIMATIC IPC847C is a very robust, high-performance industrial PC in 19" rack design (4 HU) with excellent industrial functionality.

It offers:

- Maximum expandability
- Extreme ruggedness
- Intel Core i technology

PROFINET/Industrial Ethernet

Industrial PC / Rack PC

SIMATIC IPC847C

2

Ordering data

Order No.

Configuration ¹⁾

SIMATIC IPC847C

Interfaces: 2 x 10/100/1000 Mbit/s Ethernet (RJ45);
 1 x graphic (DVI-I); 2 x COM;
 1 x LPT; 2 x PS/2;
 4 x USB 2.0 at rear;
 2 x USB 2.0 at front;
 1 x USB 2.0 internal; audio;
 temperature and fan monitoring,
 watchdog; card retainer

Processor, motherboard:

- Core i3-330E (2C/4T, 2.13 GHz, 3 MB cache), motherboard without fieldbus **G**
- Core i3-330E (2C/4T, 2.13 GHz, 3 MB cache), motherboard with PROFIBUS/MPI **H**
- Core i3-330E (2C/4T; 2.13 GHz, 3 MB cache), motherboard with PROFINET (3 x RJ45, CP 1616-compatible) ²⁾ **J**
- Core i5-520E (2C/4T, 2.4 GHz, 3 MB cache, TB, iAMT, VT), motherboard without fieldbus **K**
- Core i5-520E (2C/4T, 2.4 GHz, 3 MB cache, TB, iAMT, VT), motherboard with PROFIBUS/MPI **L**
- Core i5-520E (2C/4T; 2.4 GHz, 3 MB cache, TB, iAMT, VT), motherboard with PROFINET (3 x RJ45, CP 1616-compatible) ²⁾ **M**
- Core i7-610E (2C/4T, 2.53 GHz, 4 MB cache, TB, iAMT, VT), motherboard without field bus **N**
- Core i7-610E (2C/4T, 2.53 GHz, 4 MB cache, TB, iAMT, VT), motherboard with PROFIBUS/MPI **P**
- Core i7-610E (2C/4T; 2.53 GHz, 4 MB cache, TB, iAMT, VT), motherboard with PROFINET (3 x RJ45, CP 1616-compatible) ²⁾ **R**

6AG4 114 - 1 ■■■■ - ■■■■

Order No.

Configuration ¹⁾

SIMATIC IPC847C (continued)

Hard disks:

- 250 GB HDD SATA; 0.5 g vibration, 5 g shock, internal **A**
- 500 GB HDD SATA; 0.5 g vibration, 5 g shock, internal **B**
- 2 x 500 GB HDD SATA; 0.5 g vibration, 5 g shock, internal **C**
- RAID1 500 GB (2 x 500 GB HDD SATA, mirror disks); 0.5 g vibration, 5 g shock, internal **D**
- 250 GB HDD SATA; 0.3 g vibration, 3 g shock, internal **G**
- 250 GB HDD SATA in swap frame; front **H**
- 500 GB HDD SATA in swap frame; front **K**
- 2 x 500 GB HDD SATA in swap frame; front **M**
- RAID1 500 GB (2 x 500 GB HDD SATA) in swap frame, for hot swapping; front **P**
- RAID5 1 TB (3 x 500 GB HDD SATA) in swap frame, for hot swapping; front **R**
- 32 GB SSD (SLC) SATA, internal **S**
- 32 GB SSD (SLC) SATA in swap frame; front **T**

Memory configuration:

- 1 GB DDR3 SDRAM (1 x 1 GB), single channel **0**
- 2 GB DDR3 SDRAM (1 x 2 GB), single channel **1**
- 4 GB DDR3 SDRAM (2 x 2 GB), dual channel **2**
- 6 GB DDR3 SDRAM (1 x 2 GB, 1 x 4 GB), dual channel **3**
- 8 GB DDR3 SDRAM (2 x 4 GB), dual channel **4**
- 2 GB DDR3 SDRAM, ECC (2 x 1 GB), dual channel **5**
- 4 GB DDR3 SDRAM, ECC (2 x 2 GB), dual channel **6**
- 8 GB DDR3 SDRAM, ECC (2 x 4 GB), dual channel **7**

6AG4 114 - 1 ■■■■ - ■■■■

¹⁾ For an up-to-date overview, see the SIMATIC PC online configurator at: www.siemens.com/ipc-configurator

²⁾ Not in combination with Windows 7 and Windows Server 2008



Ordering data	Order No.	Order No.
SIMATIC IPC847C (continued)	6AG4 114 - 1	6AG4 114 - 1
<u>Swap media:</u>		
• DVD-ROM	1	
• DVD+/-RW	2	
• Without swap medium	8	
<u>Bus module / hardware expansion</u>		
• Bus module, 8 slots: 7 x PCI, 1 x PCIe x16; without hardware expansions	0	
• Bus module, 8 slots: 7 x PCI; 1x PCIe x16; DVI-VGA adapter (1 x VGA) for onboard graphics	1	
• Bus module, 8 slots: 7x PCI; 1x PCIe x16 assigned; + graphic card PCIe x16, 2 x DP (2 x DVI-D via 2 x DP-DVI adapters)	2	
• Bus module, 8 slots: 7x PCI; 1x PCIe x16 assigned; + graphic card PCIe x16, 2 x DP (2 x VGA via 2 x DP-VGA adapters)	3	
• Bus module, 11 slots: 7 x PCI, 1 x PCIe x16, 3 x PCIe x4; without hardware expansions	4	
• Bus module, 11 slots: 7 x PCI, 1x PCIe x16, 3 x PCIe x4; + DVI-VGA adapter (VGA) for onboard graphics	5	
• Bus module, 11 slots: 7 x PCI; 1x PCIe x16 assigned, 3 x PCIe x4; + graphic card PCIe x16, 2 x DP (2 x DVI-D via 2 x DP-DVI adapters)	6	
• Bus module, 11 slots: 7x PCI; 1x PCIe x16 assigned; 3x PCIe x4; + graphic card PCIe x16, 2 x DP (2 x VGA via 2 x DP-VGA adapters)	7	
<u>Configuration 1)</u>		<u>Configuration 1)</u>
SIMATIC IPC847C (continued)		SIMATIC IPC847C (continued)
<u>Operating system (preinstalled and activated)</u>		<u>Operating system (preinstalled and activated)</u>
• Windows XP Professional, MUI (Eng, Ger, Fr, It, Sp), SP3, 32 bit		B
• Windows 7 Ultimate, MUI (Eng, Ger, Fr, It, Sp), 32 bit		E
• Windows Server 2008 Standard Edition incl. 5 clients, MUI (Eng, Fr, Ger, It, Sp), SP2, 32 bit		P
• Without operating system		X
<u>Software expansion</u>		<u>Software expansion</u>
• SIMATIC IPC DiagMonitor 4.2 included		A
• SIMATIC IPC Image Creator software 3.1 included		B
• SIMATIC IPC DiagMonitor 4.2 & Image Creator software 3.1 included		C
• Without software		X
<u>Power supply, country-specific cable</u>		<u>Power supply, country-specific cable</u>
• 100/240 V AC industrial power supply with Namur; power cable for Europe		0
• 100/240 V AC industrial power supply with Namur; power cable for United Kingdom		1
• 100/240 V AC industrial power supply with Namur; power cable for Switzerland		2
• 100/240 V AC industrial power supply with Namur; power cable for USA		3
• 100/240 V AC industrial power supply with Namur; power cable for Italy		4
• 100/240 V AC industrial power supply with Namur; power cable for China		5
• 100/240 V AC industrial redundant power supply unit with Namur; without power cable		6

1) For an up-to-date overview, see the SIMATIC PC online configurator at: www.siemens.com/ipc-configurator

PROFINET/Industrial Ethernet

Industrial PC / Rack PC

SIMATIC IPC847C

Ordering data

Accessories

Memory expansion

- 1 GB DDR3 1066 SDRAM, DIMM
- 2 GB DDR3 1066 SDRAM, DIMM
- 4 GB DDR3 1066 SDRAM, DIMM
- 1 GB DDR3 1066 SDRAM, DIMM, ECC
- 2 GB DDR3 1066 SDRAM, DIMM, ECC
- 4 GB DDR3 1066 SDRAM, DIMM, ECC

Order No.

6ES7 648-2AJ40-0KA0

6ES7 648-2AJ50-0KA0

6ES7 648-2AJ60-0KA0

6ES7 648-2AJ40-1KA0

6ES7 648-2AJ50-1KA0

6ES7 648-2AJ60-1KA0

Hard disk slide-in unit for swap frame

6ES7 648-0EG00-1BA0

SIMATIC PC accessories, slide-in unit for low-profile HDD swap frame, for 3.5" hard disk, serial ATA (without hard disk)

Filter mats

A5E01064980

For Rack PC 847B and IPC847C
Packing unit 10 units

Power cable, straight, 3 m long

- Austria, Belgium, Finland, France, Germany, Netherlands, Spain, Sweden
- United Kingdom
- Switzerland
- USA
- Italy
- China

6ES7 900-0AA00-0XA0

6ES7 900-0BA00-0XA0

6ES7 900-0CA00-0XA0

6ES7 900-0DA00-0XA0

6ES7 900-0EA00-0XA0

6ES7 900-0FA00-0XA0

Order No.

Tower Kit

for converting the computer into an industrial tower PC

6ES7 648-1AA00-0XD0

Retainer

for pin assignment of the internal USB port

6ES7 648-1AA00-0XK0

SIMATIC PC keyboard

German/international,
• USB port
• incl. 4-way USB hub

6ES7 648-0CB00-0YA0

6ES7 648-0CD00-0YA0

SIMATIC PC mouse

(optical, 3-button) for programming device and PC with adapter

6ES7 790-0AA01-0XA0

SIMATIC IPC USB FlashDrive

8 GB, USB 2.0, metal enclosure, bootable

6ES7 648-0DC50-0AA0

SIMATIC IPC Service USB FlashDrive

8 GB, USB 2.0, metal enclosure, bootable, with BIOS-Manager, Image & Partition Creator pre-installed, incl. CD

6AV7 672-8JD01-0AA0

Communication products

see Catalog ST 80 / ST PC

RMOS real-time operating system

see Catalog ST 80 / ST PC

Note:

Software Packages with SIMATIC WinCC flexible, SIMATIC WinCC and SIMATIC WinAC RTX (F) can be ordered together with the SIMATIC IPC with a price advantage.

You can find more information in Catalog ST 80 / ST PC and in the Industry Mall at www.siemens.com/industrymall

Overview

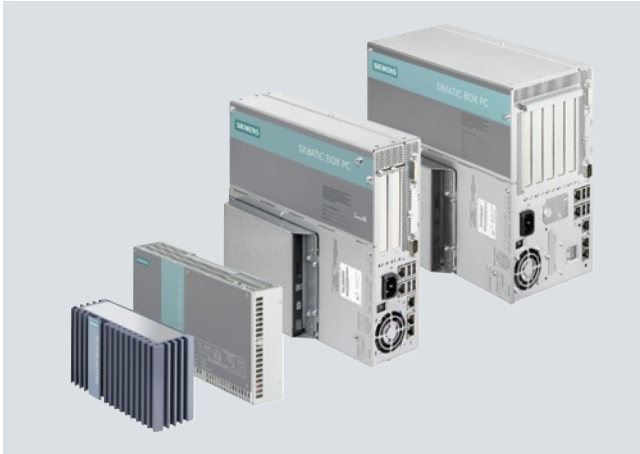

SIMATIC Box PC provide mechanical engineers, plant engineers and control cabinet makers with particularly rugged industrial PC systems for use in powerful yet compact applications.

The following device classes are available for various requirements:

- *SIMATIC IPC227 (Nanobox PC)* – the new Nanobox PC with maximum flexibility – absolutely maintenance-free
- *SIMATIC IPC427 (Microbox PC)* – ultra-compact and maintenance-free: The flexible embedded industrial PC
- *SIMATIC IPC627 (Box PC)* – maximum performance in the most restricted space
- *SIMATIC IPC827 (Box PC)* – maximum performance with high expandability

Shared industrial functionality:

- Extreme compactness
- Certification for global marketing
- System-tested with SIMATIC components
- High vibration/shock load during operation
- Wide operational temperature range
- Robust data storage with CompactFlash or Solid-State Drive (SSD)
- Integrated PROFIBUS or PROFIBUS/MPI interface (optional)
- Varied mounting possibilities for flexibility with installation
- Designed for 24-hour continuous operation
- Integrated parameterizable monitoring functions (temperature, fan, watchdog)
- High service friendliness
- Operating system preinstalled and activated for fast startup
- Motherboard developed and manufactured by Siemens
- Availability for 3 to 5 years
- Repairs and spare parts service for 5 years
- High continuity of the components/design
- Installation and software compatible with predecessor model
- Long-term availability of PC components from the Intel embedded line

PROFINET/Industrial Ethernet

Industrial PC / Box PC

Box PC

Overview (continued)

SIMATIC IPC227D – for implementation of simple control, data collection or communication tasks

- Maximum compactness with approx. 1 liter enclosure volume with integrated industrial power supply for minimum space requirements in the control cabinet
- Maximum flexibility thanks four mounting options and interfaces on one side suitable for every installation situation
- Optimum variety of interfaces due to a large number of integrated interfaces such as a selectable serial port (RS232/RS485/CAN) and 2 x teaming-capable Gigabit LAN
- Maximum industrial functionality due to closed enclosure for optimum dust protection and non-volatile retentive memory
- Further device options for optimum adaptation to the application with additional PCIe slot or RS232 interfaces or digital I/O

SIMATIC IPC427 (Microbox PC) – ultra-compact and maintenance-free: the flexible embedded industrial PC

- Fanless operation
- High performance with highly compact design
- Optimized for embedded applications
- Expandable with as many as 3 PC/104-Plus or PCI-104 I/O cards
- Flexible installation options due to DIN rail/wall/front upright mounting, even outside a control cabinet

SIMATIC IPC627 (Box PC) – maximum performance in the most restricted space

- Maximum system performance for complex measuring, control and visualization tasks
- Highly compact for space-saving installation with compact enclosure design (6 liters in volume)
- Flexible, space-saving installation with mounting brackets or portrait assembly kits
- Rugged design for direct installation in the machine
- RAID1 controller onboard
- Maximum processor performance up to ambient temperature of 55 °C
- High shock/vibration resistance in all possible mounting positions
- High system availability
- Battery-backed SRAM as memory for WinAC data
- 2 x 7-segment display and 2 signal LEDs (freely programmable)

SIMATIC IPC827 (Box PC) – maximum performance with high expandability

- Maximum system performance for complex measuring, control and visualization tasks
- High flexibility with 5 expansion slots and integral interfaces
- Flexible, space-saving installation with mounting brackets or portrait assembly kits
- Rugged design for direct installation in the machine
- RAID1 controller onboard
- Maximum processor performance up to ambient temperature of 55 °C
- High shock/vibration resistance in all possible mounting positions
- All interfaces on one side to allow optimum installation in control cabinet
- 2 CompactFlash drives, both accessible from the outside
- High system availability
- Battery-backed SRAM as memory for WinAC data
- 2 x 7-segment display and 2 signal LEDs (freely programmable)

Overview (continued)

	SIMATIC IPC227D (Nanobox PC)	SIMATIC IPC427C (Microbox PC)	SIMATIC IPC627C (Box PC)	SIMATIC IPC827C (Box PC)
Design				
Rail or wall mounting	•	•	–	–
Wall or portrait mounting	• Also: Side mounting	•	•	•
General features				
Processor	<ul style="list-style-type: none"> Intel Atom E660 1.3 GHz Intel Atom E620 600 MHz Intel Atom E640 1.0 GHz 	<ul style="list-style-type: none"> Intel Core2 Duo 1.2 GHz, 800 MHz FSB, 3 MB SLC Intel Core2 Solo 1.2 GHz, 800 MHz FSB, 3 MB SLC Intel Celeron M 1.2 GHz, 800 MHz FSB, 1 MB SLC 	<ul style="list-style-type: none"> Intel Core i7-620E, 2.53 GHz, 2 cores, 4 threads, 4 MB cache, TB, HT, VT-x, VT-d Intel Core i3-330E, 2.13 GHz, 2 cores, 4 threads, 3 MB cache, HT, VT-x Intel Celeron P4505, 1.86 GHz, 2 cores, 2 MB cache 	<ul style="list-style-type: none"> Intel Core i7-620E, 2.53 GHz, 2 cores, 4 threads, TB, HT, VT-x, VT-d, AMT 4 MB cache Intel Core i3-330E, 2.13 GHz, 2 cores, 4 threads, HT, VT-x, 3 MB cache Intel Celeron P4505, 1.86 GHz, 2 cores, 2 MB cache
Main memory	512 MB, 1 GB, 2 GB	1 GB, (2/4 GB optional) DDR3 SDRAM	1 GB, expandable up to 4 GB, optional ECC	1 GB, expandable up to 4 GB, optional ECC
Static RAM	512 KB (MRAM)	2 MB	2 MB	2 MB
Free slots for expansions	1 x PCIe with PCIe enclosure option	Up to 3 x PCI-104 (with expansion frame)	2 x PCI or 1 x PCI-Express x16 / 1 x PCI (175 mm / 265 mm)	3 x PCI (290/290/240 mm), 1 PCI-Express x (185 mm), 1 x PCI-Express x16 (240 mm)
Graphics	Onboard	Onboard	Onboard	Onboard
Operating system				
without	•	•	•	•
Preinstalled and activated / supplied on restore CD	<ul style="list-style-type: none"> Windows XP Embedded Standard 2009, in combination with CF card of 2 GB or more, solid-state drive, or hard drive Windows XP Professional MUI (in combination with solid-state drive or hard drive) 	<ul style="list-style-type: none"> Windows Embedded Standard 2009, in combination with CF card ≥ 2 GB, solid-state drive, or hard drive Windows XP Professional Multi-Language; in combination with solid-state drive or hard drive Windows 7 Ultimate MUI Windows Embedded Standard 7 	<ul style="list-style-type: none"> Windows XP Professional MUI Windows Embedded Standard 2009 English on 8 GB CompactFlash Windows 7 Ultimate MUI 	<ul style="list-style-type: none"> Windows XP Professional MUI Windows Embedded Standard 2009 English on 8 GB CompactFlash Windows 7 Ultimate MUI
Order separately	–	RMOS3 V3.50	RMOS3 V3.50	RMOS3 V3.50
Project-specific on request	<ul style="list-style-type: none"> Linux ¹⁾ Other 	<ul style="list-style-type: none"> Linux ¹⁾ Other 	<ul style="list-style-type: none"> Linux ¹⁾ Other 	<ul style="list-style-type: none"> Linux ¹⁾ Other
Interfaces				
PROFINET onboard	Via standard Ethernet	3 x RJ45 (CP 1616 compatible) onboard, optional	3 x RJ45 (CP 1616 compatible) onboard, optional	3 x RJ45 (CP 1616 compatible) onboard, optional
PROFIBUS/MPI	–	12 Mbit/s (CP 5611-compatible), optional	12 Mbit/s (CP 5611-compatible) onboard, optional	12 Mbit/s (CP 5611-compatible) onboard, optional
Ethernet	2 x 10/100/1000 Mbit/s	2 x 10/100/1000 Mbit/s	2 x 10/100/1000 Mbit/s	1 x 10/100/1000 Mbit/s
USB 2.0 (high current)	4 x	4 x	4 x	4 x
VGA, LVDS, DVI	1 x DVI-D	1 x DVI-I (DVI and VGA)	1 x DVI-I	1 x DVI-I

- Available
- Not available

¹⁾ Suitable for specific Linux versions in accordance with the specifications of the Siemens manufacturer's declaration "Suited for Linux", see www.siemens.com/simatic-pc/suited-for-linux (Linux is a trademark of Linus Torvald).

PROFINET/Industrial Ethernet

Industrial PC / Box PC

Box PC

Overview (continued)

	SIMATIC IPC227D (Nanobox PC)	SIMATIC IPC427C (Microbox PC)	SIMATIC IPC627C (Box PC)	SIMATIC IPC827C (Box PC)
Drives				
Hard disks	1 x 2.5" (optional)	1 x 2.5" (optional)	<ul style="list-style-type: none"> • 1 x 3.5" • 2 x 2.5" • RAID1/2 x 2.5" 	<ul style="list-style-type: none"> • 1 x 3.5" • 2 x 2.5" • RAID1/2 x 2.5"
Solid State Drive	1 x 2.5" Solid-State Drive (optional)	1 x 2.5" (optional SATA)	1 x 2.5" SATA (optional)	1 x 2.5" SATA (optional)
FlashDrive	1 x externally accessible	<ul style="list-style-type: none"> • 1 x externally accessible • 1 x internal, in place of HDD, SSD (optional) 	<ul style="list-style-type: none"> • 1 x at the front, externally accessible • 1 x internal, in place of HDD (optional) 	<ul style="list-style-type: none"> • 1 x at the front, externally accessible • 1 x at the front, in place of HDD (optional)
Optical drives	-	-	DVD R/W	DVD R/W
Ambient conditions				
Vibration/shock load during operation		1 g / 15 g (with Flash drive)	1 g / 5 g	1 g / 5 g
Ambient temperature during operation	0 °C ... 50 °C	With maximum configuration: 0 ... 50/55 °C (with flash drive) 5 ... 40 °C (with hard disk)	With maximum configuration: 5 ... 45 °C 5 ... 50/55 °C (with 20/10 W load on PCI/PCI-Express bus)	With maximum configuration: 5 ... 45 °C 5 ... 50/55 °C (with 20/10 W load on PCI/PCI-Express bus)

- Available
- Not available

Benefits

Compact dimensions

The SIMATIC IPC227D is a particularly compact and energy-efficient PC in the Nano format. The heart of the Nanobox PC with particularly many mounting options are high-performance Intel Atom processors of the latest generation.

The SIMATIC IPC427 (Microbox PC) is an ultra-compact and rugged device for DIN rail mounting, portrait or wall mounting, and for use in the machine: mounting depth from 47 mm.

With a maximum mounting depth of 100 mm (80 mm without DVD drive), the SIMATIC IPC627 (Box PC) can be used even in the smallest of spaces. In addition, space-saving portrait mounting is possible with the SIMATIC Box IPC627/IPC827.

Rugged design

All designs aim to achieve maximum safety in the case of vibration and shock loads. For example, a special vibration-absorbing suspension of the hard disk ensures operational reliability, even at very high mechanical loads. A flash drive slot, which is easily accessible from outside, or the solid-state drive (SSD) in the single level cell (SLC) architecture, which is particularly suitable for industrial applications, is available for setting up low-maintenance, fault-tolerant, diskless systems. Thanks to its fan-free design and use of CompactFlash cards, the Microbox PC and the new Nanobox PC are especially suitable for maintenance-free 24-hour continuous operation.

Service-friendly device design

The Box PC can simply be folded out for speedy component replacement. The inside of the device is easily accessible for future expansions.

Integrated interfaces

On Box PCs, all interfaces are located on one side. Box PCs can be interfaced with the control/cell level via onboard Ethernet interfaces and communicate in the field via an integrated PROFIBUS interface, which is available as an option. External monitors or displays can be connected via a VGA or DVI-I interface.

Flexibility

Especially the SIMATIC IPC827 with its 5 free PC slots offers many expansion options. All Box PCs have CE certification for use in industrial applications and domestic/commercial applications and can therefore be used in building automation or public installations in addition to industrial applications.

Continuity

Thanks to motherboards developed and manufactured in-house, the SIMATIC Box PCs offer very high continuity and security of investment. The SIMATIC Box PC models can normally be ordered for a period of three years and spare parts are obtainable for at least 5 years after active marketing is concluded.

More information

Further information can be found on the Internet at:

www.siemens.com/simatic-pc

Information material can be ordered or downloaded from the Internet:

www.siemens.com/simatic/printmaterial

Overview



SIMATIC IPC227D available for implementing simple control, data collector or communication tasks:

- Maximum compactness with approx. 1 liter enclosure volume or more with integrated industrial power supply for minimum space requirements in the control cabinet
- Maximum flexibility thanks four mounting options and interfaces on one side suitable for every installation situation
- Optimum variety of interfaces due to a large number of integrated interfaces such as a selectable serial port (RS232/RS485/CAN) and 2 x teaming-capable Gigabit LAN
- Maximum industrial functionality due to closed enclosure for optimum dust protection and non-volatile retentive memory
- Further device options for optimum adaptation to the application with additional PCIe slot or RS232 interfaces or digital I/O

PROFINET/Industrial Ethernet

Industrial PC / Box PC

SIMATIC IPC227D

2

Ordering data

Order No.

Order No.

Configuration

SIMATIC IPC227D

Interfaces: 2 x Gbit LAN (RJ45), 1 x serial (COM1), 4 x USB

Processors / memory configuration / retentivity

- Atom E660 (1.3 GHz), 2 GB RAM
- Atom E660 (1.3 GHz), 2 GB RAM, retentivity
- Atom E640 (1.0 GHz), 1 GB RAM
- Atom E640 (1.0 GHz), 1 GB RAM, retentivity
- Atom E620 (600 MHz), 512 MB RAM
- Atom E620 (600 MHz), 512 MB RAM, retentivity

Drives

- Without drive, with CF slot
- 250 GB HDD SATA
- 50 GB solid-state drive SATA (SLC)
- 2 GB SIMATIC PC CompactFlash
- 4 GB SIMATIC PC CompactFlash
- 8 GB SIMATIC PC CompactFlash

COM interface

- COM1: RS232
- COM1: RS485
- COM1: CAN

on request

Configuration

SIMATIC IPC227D

Operating system

- Without operating system
- Windows Embedded Standard 2009 preinstalled (CF from 2 GB/SSD/HD)
- XP-Prof. MUI preinstalled on SSD / HD
- Windows Embedded Standard 7 preinstalled (CF from 4 GB/SSD/HD)
- Windows 7 MUI preinstalled on SSD / HD

Software bundles

- Without RTX/HMI software
- RTX: WinAC RTX 2010
- RTX-F: WinAC RTX F 2010
- HMI: WinCC RT Advanced 128 PT
- HMI: WinCC RT Advanced 512 PT
- HMI: WinCC RT Advanced 2048 PT
- HMI: WinCC RT Advanced 4096 PT
- HMI/RTX: RT 128 PT
- HMI/RTX: RT 512 PT
- HMI/RTX: RT 2048 PT
- HMI/RTX: RT 4096 PT

Device versions

- Basis
- PCIe (1 slot)
- COM (COM2-4: RS232)
- IO (4x dig. inputs/outputs each)

Mounting accessories

- Standard mounting rail
- Wall mounting
- Portrait mounting
- Side mounting

on request

Note:

Software Packages with SIMATIC WinCC flexible, SIMATIC WinCC and SIMATIC WinAC RTX (F) can be ordered together with the SIMATIC IPC with a price advantage.

You can find more information in Catalog ST 80 / ST PC and in the Industry Mall at www.siemens.com/industrymall

Overview

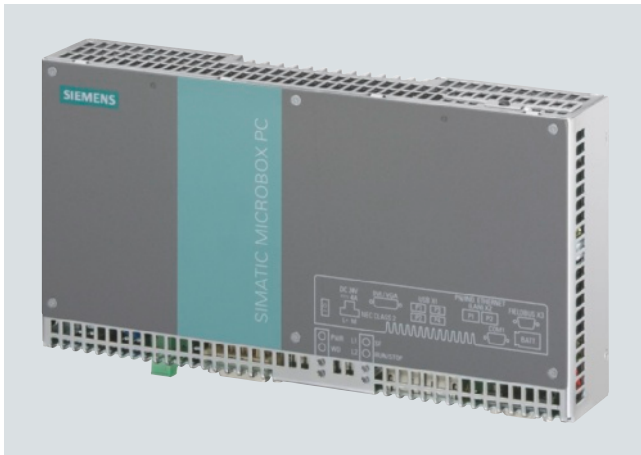

The Microbox PC SIMATIC IPC427C is the powerful embedded industrial PC for use at the machine:

- Ultra-compact
- Maintenance-free
- Intel Core2 Duo technology

PROFINET/Industrial Ethernet

Industrial PC / Box PC

SIMATIC IPC427C

2

Ordering data

Order No.

Configuration

SIMATIC IPC427C

6ES7 647 - 7 B ■ ■ ■ - ■ ■ ■ 0

Intel Celeron M 1.2 MHz, 800 MHz FSB, SLC 0 KB; 512 MB DDR3 RAM; without HD; without flash drive; without operating system; 24 V DC industrial power supply

Processor:

- Intel Celeron M 1.2 GHz, 800 MHz FSB **A**
- Intel Celeron M 1.2 GHz, 800 MHz FSB, PROFIBUS **B**
- Intel Celeron M 1.2 GHz, 800 MHz FSB, CAN **D**
- Core2 Solo 1.2 GHz, 800 MHz FSB SLC, 3 MB **E**
- Core2 Solo 1.2 GHz, 800 MHz FSB SLC, 3 MB, PROFIBUS **F**
- Core2 Solo 1.2 GHz, 800 MHz FSB SLC, 3 MB, PROFINET **G**
- Core2 Duo 1.2 GHz, 800 MHz FSB SLC, 3 MB **J**
- Core2 Duo 1.2 GHz, 800 MHz FSB SLC, 3 MB, PROFIBUS **K**
- Core2 Duo 1.2 GHz, 800 MHz FSB SLC, 3 MB, PROFINET **L**

Memory configuration:

- 1 GB DDR3 1066, SODIMM **2**
- 2 GB DDR3 1066, SODIMM **3**
- 4 GB DDR3 1066, SODIMM **4**

Expansion (HW):

- No expansion (HW) **0**
- Second RS232 interface in expansion rack **1**

1) For an up-to-date overview, see the SIMATIC PC online configurator at: www.siemens.com/ipc-configurator

2) XP Embedded on 2 GB CompactFlash or hard disk. XP Professional or Windows 7 only with hard disk/SSD.

Order No.

Configuration

SIMATIC IPC427C

6ES7 647 - 7 B ■ ■ ■ - ■ ■ ■ 0

Drives exchangeable (accessible)

- Without drive **0**
- 256 MB CompactFlash **1**
- 2 GB CompactFlash **2**
- 4 GB CompactFlash **3**
- 8 GB CompactFlash **4**

Drives internal (not accessible)

- Without internal drive **X**
- 250 GB HDD SATA **A**
- 32 GB solid-state drive SATA **D**
- 256 MB CompactFlash internal **M**
- 2 GB CompactFlash internal **N**
- 4 GB CompactFlash internal **P**
- 8 GB CompactFlash internal **Q**

Operating system (preinstalled and activated) 2)

- Without operating system **X**
- Windows Embedded Standard 2009 preinstalled on internal drive **A**
- Windows XP Professional MUI preinstalled on internal drive **B**
- Windows 7 Ultimate MUI preinstalled on internal drive **C**
- Windows 7 Embedded Standard preinstalled on internal drive **D**

Ordering data	Order No.	Order No.
Accessories		Portrait assembly kit
Memory expansion		Interfaces to the front
• 1 GB DDR3 1066 SDRAM, SODIMM	6ES7 648-2AH40-0KA0	6ES7 648-1AA20-0YB0
• 2 GB DDR3 1066 SDRAM, SODIMM	6ES7 648-2AH50-0KA0	SIMATIC PC keyboard German/international, USB port
• 4 GB DDR3 1066 SDRAM, SODIMM	6ES7 648-2AH60-0KA0	6ES7 648-0CB00-0YA0
Expansion kit PC/104	6ES7 648-2AH30-0KA0	SIMATIC PC keyboard German/international, USB port, incl. 4-port USB hub
For integration of PC/104 modules in the SIMATIC Microbox PC; packing unit contains 6 expansion frames		6ES7 648-0CD00-0YA0
SIMATIC PC adapter cable	6ES7 648-3AB00-0XA0	USB mouse (optical, 3-button) for PG and PC with adapter
DVI-I to VGA, 250 mm		6ES7 790-0AA01-0XA0
		SIMATIC PC CompactFlash
		• 256 MB
		6ES7 648-2BF02-0XC0
		• 2 GB
		6ES7 648-2BF02-0XF0
		• 4 GB
		6ES7 648-2BF02-0XG0
		• 8 GB
		6ES7 648-2BF02-0XH0
		SIMATIC PC USB FlashDrive
		8 GB, USB 2.0, metal enclosure, bootable
		6ES7 648-0DC50-0AA0
		SIMATIC IPC Service USB FlashDrive
		8 GB, USB 2.0, metal enclosure, bootable, with BIOS-Manager, Image & Partition Creator pre-installed, incl. CD
		6AV7 672-8JD01-0AA0

Note:

Software Packages with SIMATIC WinCC flexible, SIMATIC WinCC and SIMATIC WinAC RTX (F) can be ordered together with the SIMATIC IPC with a price advantage.

You can find more information in Catalog ST 80 / ST PC and in the Industry Mall at www.siemens.com/industrymall

PROFINET/Industrial Ethernet

Industrial PC / Box PC

SIMATIC IPC627C

Overview

2



The SIMATIC IPC627C Box PC is ideally suited to high-performance PC applications installed at the machine.

It offers:

- Maximum performance in the smallest space
- Intel Core i7 technology



Ordering data	Order No.	Order No.	
Configuration 1)			
SIMATIC IPC627C	6ES7 647 - 6 C ■ ■ ■ ■ - ■ ■ ■ ■ 0	SIMATIC IPC627C	
<p>HD graphics onboard, 128 MB dyn. shared memory; 2 x 10/100/1000 Mbit/s Ethernet RJ45; 4 x USB V2.0 (high current); 1 x serial (COM1), RAID controller onboard; CompactFlash drive No. 1 at front (without CF); watchdog, temp./fan monitoring;</p> <p><u>Processor/motherboard:</u></p> <ul style="list-style-type: none"> • Celeron P4505 (2C/2T, 1.86 GHz, 2 MB cache) • Celeron P4505 (2C/2T, 1.86 GHz, 2 MB cache), PROFIBUS/MPI, 2 MB battery- backed SRAM • Celeron P4505 (2C/2T, 1.86 GHz, 2 MB cache), PROFINET (3 x RJ45, CP 1616-compatible), 2 MB battery-backed SRAM • Core i3-330E (2C/4T, 2.13 GHz, HT, VT, 3 MB cache) • Core i3-330E (2C/4T, 2.13 GHz, HT, VT, 3 MB cache), PROFIBUS/MPI, 2 MB battery- backed SRAM • Core i3-330E (2C/4T, 2.13 GHz, HT, VT, 3 MB cache), PROFINET (3 x RJ45, CP 1616-compatible), 2 MB battery-backed SRAM • Core i7-610E (2C/4T, 2.53 GHz, TB, HT, VT, AMT, 4 MB cache) • Core i7-610E (2C/4T, 2.53 GHz, TB, HT, VT, AMT, 4 MB cache), PROFIBUS/MPI, 2 MB battery- backed SRAM • Core i7-610E (2C/4T, 2.53 GHz, TB, HT, VT, AMT, 4 MB cache), PROFINET (3 x RJ45, CP 1616- compatible), 2 MB battery- backed SRAM <p><u>Memory configuration</u></p> <ul style="list-style-type: none"> • 1 GB DDR3 1066, DIMM • 2 GB DDR3 1066 DIMM • 3 GB DDR3 1066 DIMM • 4 GB DDR3 1066 DIMM • 2 GB DDR3 1066 DIMM, ECC • 4 GB DDR3 1066 DIMM, ECC <p><u>Country-specific version/ power supply</u></p> <ul style="list-style-type: none"> • 100/240 V AC industrial power supply with Namur; European cable • 100/240 V AC industrial power supply with Namur; UK cable • 100/240 V AC industrial power supply with Namur; CH cable 	<p>A</p> <p>B</p> <p>C</p> <p>D</p> <p>E</p> <p>F</p> <p>G</p> <p>H</p> <p>J</p> <p>0</p> <p>1</p> <p>2</p>	<p>Configuration 1)</p> <p>SIMATIC IPC627C</p> <p><u>Country-specific version/ power supply</u> (continued)</p> <ul style="list-style-type: none"> • 100/240 V AC industrial power supply with Namur; USA cable • 100/240 V AC industrial power supply with Namur; Italian cable • 100/240 V AC industrial power supply with Namur; Chinese cable • 24 V DC industrial power supply <p><u>PC slots</u></p> <ul style="list-style-type: none"> • 2 x PCI free • 1 x PCI, 1x PCIe (x16) free <p><u>Drives</u></p> <ul style="list-style-type: none"> • 250 GB HDD SATA • 250 GB HDD SATA; DVD+/-RW • 500 GB HDD SATA • 500 GB HDD SATA; DVD+/-RW • 2 x 250 GB SATA (2.5") • 2 x 250 GB SATA (2.5") + DVD+/-RW • RAID1 2 x 250 GB SATA (2.5") • RAID1 2 x 250 GB SATA (2.5"); DVD+/-RW • 32 GB SATA solid state drive (SLC) • 32 GB SATA solid state drive (SLC); DVD+/-RW • CompactFlash drive No. 2 installed, DVD+/-RW • CompactFlash drive No. 2 installed • DVD+/-RW • Without drives <p><u>Operating system</u> (preinstalled and activated)</p> <ul style="list-style-type: none"> • Windows XP Professional MUI, SP3 (Eng, Ger, Fr, It, Sp) • Windows 7 Ultimate, MUI (Eng, Ger, Fr, It, Sp) • Windows Embedded Standard 2009 English on 8 GB CompactFlash • Without operating system <p><u>Expansion</u></p> <ul style="list-style-type: none"> • No expansion (software) • SIMATIC IPC DiagMonitor software included • SIMATIC IPC Image&Partition Creator software included • SIMATIC IPC DiagMonitor, Image & Partition Creator software included 	<p>6ES7 647 - 6 C ■ ■ ■ ■ - ■ ■ ■ ■ 0</p> <p>3</p> <p>4</p> <p>5</p> <p>6</p> <p>0</p> <p>1</p> <p>A</p> <p>B</p> <p>C</p> <p>D</p> <p>E</p> <p>F</p> <p>G</p> <p>H</p> <p>J</p> <p>K</p> <p>U</p> <p>V</p> <p>W</p> <p>X</p> <p>0</p> <p>1</p> <p>2</p> <p>3</p>

1) For an up-to-date overview, see the SIMATIC PC online configurator at: www.siemens.com/ipc-configurator

PROFINET/Industrial Ethernet

Industrial PC / Box PC

SIMATIC IPC627C

Ordering data

Order No.

Accessories

Memory expansions

- 1 GB DDR3 1066, DIMM
- 1 GB DDR3 1066 DIMM; ECC
- 2 GB DDR3 1066, DIMM
- 2 GB DDR3 1066, DIMM; ECC
- 4 GB DDR3 1066, DIMM
- 4 GB DDR3 1066, DIMM; ECC

6ES7 648-2AJ40-0KA0

6ES7 648-2AJ40-1KA0

6ES7 648-2AJ50-0KA0

6ES7 648-2AJ50-1KA0

6ES7 648-2AJ60-0KA0

6ES7 648-2AJ60-1KA0

PCI expansion card with COM1 and LPT

6ES7 648-2CA01-0AA0

Graphics adapter cable

- DVI-I acc. to VGA, 250 mm long
- DVI-I acc. to VGA and DVI-D, 250 mm long (Y cable)

6ES7 648-3AB00-0XA0

6ES7 648-3AE00-0XA0

Portrait assembly kit

- Interfaces upward/downward
- Interfaces to the front

6ES7 648-1AA10-0YA0

6ES7 648-1AA10-0YB0

SIMATIC PC, 230 V AC power cable

angled, 3 m for Box PC and Panel PC for

- Austria, Belgium, Finland, France, Germany, Netherlands, Spain, Sweden
- United Kingdom
- Switzerland
- USA
- Italy
- China

6ES7 900-1AA00-0XA0

6ES7 900-1BA00-0XA0

6ES7 900-1CA00-0XA0

6ES7 900-1DA00-0XA0

6ES7 900-1EA00-0XA0

6ES7 900-1FA00-0XA0

Order No.

Expansion components

SIMATIC PC keyboard

German/international, USB connection

6ES7 648-0CB00-0YA0

SIMATIC PC mouse

(optical, 3-button); for PG and PC with adapter

6ES7 790-0AA01-0XA0

CompactFlash card

- Compact Flash, 4 GB, Industrial Grade - DIAG
- Compact Flash, 8 GB, Industrial Grade - DIAG

6ES7 648-2BF02-0XG0

6ES7 648-2BF02-0XH0

SIMATIC IPC USB FlashDrive

8 GB, USB 2.0, metal enclosure, bootable

6ES7 648-0DC50-0AA0

SIMATIC IPC Service USB FlashDrive

8 GB, USB 2.0, metal enclosure, bootable, with BIOS-Manager, Image & Partition Creator pre-installed, incl. CD

6AV7 672-8JD01-0AA0

Communication products

see Catalog ST 80 / ST PC

Power supply units and UPS

see Catalog ST 80 / ST PC

RMOS3 real-time operating system

see Catalog ST 80 / ST PC

Note:

Software Packages with SIMATIC WinCC flexible, SIMATIC WinCC and SIMATIC WinAC RTX (F) can be ordered together with the SIMATIC IPC with a price advantage.

You can find more information in Catalog ST 80 / ST PC and in the Industry Mall at www.siemens.com/industrymall

Overview



The SIMATIC IPC827C Box PC is a rugged and flexibly expandable control cabinet PC for machine-level usage in 24-hour continuous operation at ambient temperatures of up to 55 °C.

It offers:

- Maximum performance and high expandability
- with Intel Core i technology

PROFINET/Industrial Ethernet

Industrial PC / Box PC

SIMATIC IPC827C

2

Ordering data

Order No.

Configuration

SIMATIC IPC827C

6ES7 647 - 6 P ■ ■ ■ - ■ ■ ■ 0

Processor

- Celeron P 4505 (2C/2T, 1.86 GHz, 2 MB cache) **A**
- Celeron P 4505 (2C/2T, 1.86 GHz, 2 MB cache); PROFIBUS/MPI; 2 MB battery-backed SRAM **B**
- Celeron P 4505 (2C/2T, 1.86 GHz, 2 MB cache); PROFINET (3 x RJ45, CP 1616-compatible); 2 MB battery-backed SRAM **C**
- Core i3-330E (2C/4T, 2.13 GHz, HT, VT, 3 MB cache) **D**
- Core i3-330E (2.13 GHz, HT, VT, 3 MB cache); PROFIBUS/MPI; 2 MB battery-backed SRAM **E**
- Core i3-330 (2C/4T, 2.13 GHz, HT, VT, 3 MB cache); PROFINET (3 x RJ45, CP 1616-compatible); 2 MB battery-backed SRAM **F**
- Core i7-610E (2C/4T, 2.53 GHz, TB, HT, VT, AMT, 4 MB cache) **G**
- Core i7-610E (2C/4T, 2.53 GHz, TB, HT, VT, AMT, 4 MB cache); PROFIBUS/MPI; 2 MB battery-backed SRAM **H**
- Core i7-610E (2C/4T, 2.53 GHz, TB, HT, VT, AMT, 4 MB cache); PROFINET (3 x RJ45, CP 1616-compatible); 2 MB battery-backed SRAM **J**

Memory configuration:

- 1 GB DDR3 1066 DIMM **0**
- 2 GB DDR3 1066 DIMM **1**
- 3 GB DDR3 1066 DIMM **2**
- 4 GB DDR3 1066 DIMM **3**
- 2 GB DDR3 1066 DIMM, ECC **5**
- 4 GB DDR3 1066 DIMM, ECC **6**

Power supply

- 100/240 V AC industrial power supply with Namur; European cable **0**
- 100/240 V AC industrial power supply with Namur; UK cable **1**
- 100/240 V AC industrial power supply with Namur; Swiss cable **2**
- 100/240 V AC industrial power supply with Namur; USA cable **3**

Order No.

Configuration

SIMATIC IPC827C

6ES7 647 - 6 P ■ ■ ■ - ■ ■ ■ 0

Power supply (continued)

- 100/240 V AC industrial power supply with Namur; Italian cable **4**
- 100/240 V AC industrial power supply with Namur; Chinese cable **5**
- 24 V DC industrial power supply **6**

Expansions (HW)

- 3x PCI, 2x PCIe (x4), 1x PCIe (x16) vacant **0**

Mass storage

- 250 GB HDD SATA **A**
- 250 GB HDD SATA; DVD+/-RW **B**
- 500 GB HDD SATA **C**
- 500 GB HDD SATA; DVD+/-RW **D**
- 2x 250 GB SATA (2.5") **E**
- 2x 250 GB SATA (2.5"); DVD+/-RW **F**
- RAID1 2x 250 GB SATA (2.5") **G**
- RAID1 2x 250 GB SATA (2.5"); DVD+/-RW **H**
- Solid State Drive 32 GB (SLC) **J**
- Solid State Drive 32 GB (SLC); DVD+/-RW **K**
- DVD+/-RW **W**
- Without drives **X**

Operating system (preinstalled and activated)

- Windows XP Prof. MUI, SP3 (English, German, French, Italian, Spanish) **A**
- Windows 7 Ultimate MUI (English, German, French, Italian, Spanish) **B**
- Windows XP Embedded Standard 2009 English on 8 GB CompactFlash **F**
- Without operating system **X**

Expansion software

- No expansion (software) **0**
- SIMATIC IPC DiagMonitor software included **1**
- SIMATIC IPC Image&Partition Creator included **4**
- SIMATIC IPC DiagMonitor & Image&Partition Creator included **5**

Note:

Windows Embedded only without RAID option

Ordering data	Order No.	Order No.
Accessories		Expansion components
Memory expansions		SIMATIC PC keyboard
• 1 GB DDR3 1066 DIMM	6ES7 648-2AJ40-0KA0	German/international, USB port
• 1 GB DDR3 1066 DIMM, ECC	6ES7 648-2AJ40-1KA0	SIMATIC PC mouse
• 2 GB DDR3 1066 DIMM	6ES7 648-2AJ50-0KA0	(optical, 3-button)
• 2 GB DDR3 1066 DIMM, ECC	6ES7 648-2AJ50-1KA0	for PG and PC with adapter
• 4 GB DDR3 1066 DIMM	6ES7 648-2AJ60-0KA0	CompactFlash card
• 4 GB DDR3 1066 DIMM, ECC	6ES7 648-2AJ60-1KA0	• CompactFlash, 4 GB, industrial grade - DIAG
PCI expansion card with COM1 and LPT	6ES7 648-2CA01-0AA0	• CompactFlash, 8 GB, industrial grade - DIAG
Graphic adapter cable		SIMATIC IPC USB FlashDrive
• DVI-I acc. to VGA, 250 mm long	6ES7 648-3AB00-0XA0	8 GB, USB 2.0, metal enclosure, bootable
• DVI-I acc. to VGA and DVI-D, 250 mm long (Y cable)	6ES7 648-3AE00-0XA0	SIMATIC IPC Service USB FlashDrive
Portrait assembly kit		8 GB, USB 2.0, metal enclosure, bootable, with BIOS Manager, Image & Partition Creator ready- installed, incl. CD
• Interfaces upward/downward	6ES7 648-1AA30-0YA0	Communication products
• Interfaces to the front	6ES7 648-1AA30-0YB0	see Catalog ST 80 / ST PC
Power cable		For power supplies and uninterruptible power supplies
SIMATIC PC, power cable for 230 V AC, angled, 3 m for Box PC and Panel PC for		see Catalog ST 80 / ST PC
• Germany, France, Spain, Netherlands, Belgium, Sweden, Austria, Finland	6ES7 900-1AA00-0XA0	RMOS3 real-time operating system
• United Kingdom	6ES7 900-1BA00-0XA0	see Catalog ST 80 / ST PC
• Switzerland	6ES7 900-1CA00-0XA0	
• USA	6ES7 900-1DA00-0XA0	
• Italy	6ES7 900-1EA00-0XA0	
• China	6ES7 900-1FA00-0XA0	

Note:

Software Packages with SIMATIC WinCC flexible, SIMATIC WinCC and SIMATIC WinAC RTX (F) can be ordered together with the SIMATIC IPC with a price advantage.

You can find more information in Catalog ST 80 / ST PC and in the Industry Mall at www.siemens.com/industrymall

PROFINET/Industrial Ethernet

Industrial PC / SIMATIC Panel PC

SIMATIC Panel PC

Overview

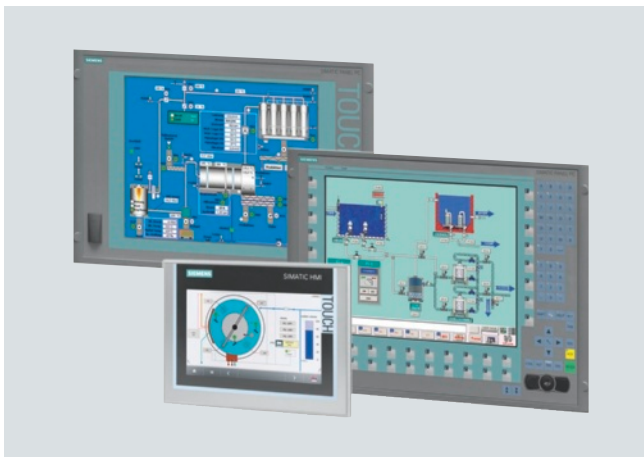

SIMATIC Panel PCs are suitable thanks to their high industrial compatibility both for use in control cabinets, consoles and control panels, as well as directly on the machine. Typical areas of application can be found in both production and process automation.

There is a broad range of robust, high-performance SIMATIC Panel PCs available for different requirements.

Shared industrial functionality

- High-quality components and modules with a high MTBF (mean time between failure), which also ensure 24-hour operation in the extended temperature range.
- High swing/shock capacity of the devices through special hard-disk suspensions, locked connectors and card retainers
- Rugged housing model with high electromagnetic compatibility (EMC) and integrated industrial power supplies (also as per NAMUR)
- Service-friendly device design
- Bright, brilliant displays in different sizes up to 19"
- Same front panel mounting dimensions and uniform front design across all device families
- Rugged fronts protected from dust, humidity and chemical substances (front-side IP65 / NEMA 4 degrees of protection)

SIMATIC HMI IPC277D

for implementing simple visualization and control tasks

- High degree of flexibility for selecting rugged widescreen fronts from 7" to 12" for a more freely configurable display area
- High resolution, large viewing angle, and up to 100% dimmable backlighting for a brilliant display with optimized power consumption
- Absolutely maintenance-free due to the use of CompactFlash and SSD as mass storage and fanless operation up to 50 °C ambient temperature
- Maximum industrial functionality due to non-volatile retentive memory
- Ready-to-use embedded bundles with visualization or/and control software

SIMATIC HMI IPC477C

Ultra-compact and maintenance-free Panel PC in embedded technology

- Compact design (only 61 to 69 mm mounting depth for 12" to 19" display)
- No rotating parts (without fan and hard disk)
- High security due to the Microsoft Windows XP Embedded Standard 2009 operating system
- Ready-to-use devices with optionally preinstalled software
 - HMI: Innovative HMI software WinCC flexible (incl. archives and recipes)
 - RTX: with real-time capable software PLC WinAC RTX
- Retentive memory on board (NV-RAM, usable with WinAC RTX)

SIMATIC HMI IPC577C

Industrial functionality and openness at an attractive price

- Full PC openness and performance boost with Intel Core2 Duo processors
- Rugged design for industrial use
- Can be expanded using a PCI slot and additional interfaces
- More rugged due to SSD (solid-state drive) or CompactFlash
- The configurator (best-fit for the customer) makes ordering more flexible
- Compact design

SIMATIC HMI IPC677C

Maximum performance, flexibility and availability

- Rugged, expandable industrial PC with different front panels
- Rugged design for industrial use
- Complete PC openness
- Optional PROFIBUS or PROFINET onboard
- All CPUs with dual core

SIMATIC Panel PC 677B

Flexibility and compactness with maximum performance

- High performance thanks to latest process technology from Intel
- Dual Core technology: Up to Intel Core2 Duo 2.16 GHz
- Compact structure with simultaneous expandability through PCI/PCIe slots
- Strong communication through two Ethernet and integrated PROFIBUS DP/MPI interfaces
- Control and computer units can be separated by up to 30 m
- RAID1 controller on board
- Retentive memory on board (NV-RAM, usable with WinAC RTX)

Overview (continued)

	SIMATIC HMI IPC277D	SIMATIC HMI IPC477C	SIMATIC HMI IPC577C	SIMATIC HMI IPC677C
Design				
Centralized configuration	•	•	•	•
Distributed configuration (via remote kit)	–	–	–	–
Display				
Size	7"/9"/12" widescreen	12"/15"/19" TFT	12"/15"/19" TFT	12"/15"/19" TFT
Resolution	800 x 480/ 800 x 480/ 1280 x 800	800 x 600/ 1024 x 768/ 1280 x 1024	800 x 600/ 1024 x 768/ 1280 x 1024	800 x 600/ 1024 x 768/ 1280 x 1024
Operator controls				
Membrane keyboard	–	• 1)	• 1)	• 1)
Touch screen	•	•	•	•
General features				
Power supply 24 V DC / 110/240 V AC	• / –	• / –	• / •	• / – / •
Processor	Intel Atom E640, 1.0 GHz	Intel Celeron M 1.2 GHz, Intel Core2 Solo 1.2 GHz or Intel Core2 Duo 1.2 GHz	Intel Celeron M 1.2 GHz, Intel Core2 Solo 1.2 GHz or Intel Core2 Duo 1.86 GHz	Intel Celeron P4505, 1.86 GHz, 2 cores, 2 MB cache; Intel Core i3-330E, 2.13 GHz, 2 cores, 4 threads, 3 MB cache, HT, VT-x; Intel Core i7-620E, 2.53 GHz, 2 cores, 4 threads, 4 MB, cache, TB, HT, VT-x, VT-d
Main memory	1 GB	1 GB, 2 GB or 4 GB	1 GB, 2 GB or 4 GB	1 GB expandable to 4 GB or 2 GB /4 GB with ECC
Expansion slots	1 x CF slot for CompactFlash Card (externally accessible)	1 x CF slot for CompactFlash Card (externally accessible)	1 x PCI ³⁾ ; 1 x CF slot for CompactFlash Card (externally accessible)	2 x PCI or 1 x PCI and 1 x PCIe x16 CompactFlash Card (externally accessible)
Operating system	None; Windows Embedded Standard 2009 or XP Professional MUI	Without; Windows Embedded 2009 or XP Professional MUI; Windows 7 Ultimate MUI or Windows Embedded Standard 7	None; Windows Embedded 2009 or XP Professional MUI	Without operating system, Windows XP Professional MUI, Windows 7 Ultimate MUI, Windows Embedded Standard 2009 on CF
Interfaces				
PROFIBUS/MPI	–	•	•	•
PROFINET (RT/IRT)	• / –	•	•	•
Ethernet	2 x 10/100/1000 Mbit	10/100/1000 Mbit	10/100/1000 Mbit	2 x 10/100/1000 Mbit
PS/2 (mouse/keyboard)	–	–	–	–
USB	•	•	•	•
Serial interface	•	•	•	•
Parallel interface	–	–	–	–
Audio in/out	–	–	–	–
Graphics interface	–	•	•	•

- Available
- Not available

1) 12"/15" displays

2) All slots with card retainer

PROFINET/Industrial Ethernet

Industrial PC / SIMATIC Panel PC

SIMATIC Panel PC

Overview (continued)

	SIMATIC HMI IPC277D	SIMATIC HMI IPC477C	SIMATIC HMI IPC577C	SIMATIC HMI IPC677C
Ambient conditions				
Vibration load during operation		1 g	1 g ³⁾	1 g
Shock loading during operation		5 g	5 g ³⁾	5 g
Permissible temperature during operation with maximum configuration	+0 °C ... +50 °C	+0 °C ... +45 °C ⁶⁾	+0 °C ... +45 °C ⁶⁾	+5 °C ... +50 °C ⁶⁾
Power loss in maximum configuration				
12" display		40 W ⁴⁾	55 W ⁵⁾	140 W ⁵⁾
15" display		45 W ⁴⁾	57 W ⁵⁾	140 W ⁵⁾
19" display		60 W ⁴⁾	84 W ⁵⁾	163 W ⁵⁾

³⁾ Valid with CF or SSD; with HDD: 5 g/0.5 g;

⁴⁾ 3 W taken into account for each PCI/PCIe slot

⁵⁾ 15 W taken into account for each PCI/PCIe slot

⁶⁾ 0 °C to +50 °C; max. +50 °C in installation space; max. 40 °C if at the front

SIMATIC Panel PC 677B	
Design	
Centralized configuration	•
Distributed configuration (via remote kit)	• ²⁾
Display	
Size	12"/15"/15" INOX/19" TFT
Resolution	800 x 600/ 1024 x 768/ 1280 x 1024
Operator controls	
Membrane keyboard	• ¹⁾
Touch screen	•
General features	
Power supply 24 V DC / 110/230 V AC	• / •
Processor	Intel Celeron M 1.86 GHz; Intel Core2 Duo 1.66 GHz; Intel Core2 Duo 2.16 GHz
Main memory	1 GB; 2 GB; 3 GB; 4 GB
Expansion slots	2 x PCI or 1x PCI and 1x PCIe x4 ³⁾ ; 1 x CF slot (externally accessible)
Operating system	Without; Windows 2000 Professional MUI; Windows XP Professional MUI; Windows Vista Ultimate MUI; Windows 2003 Standard Server; Windows XP embedded on CF

SIMATIC Panel PC 677B	
Interfaces	
PROFIBUS/MPI	•
PROFINET	•
Ethernet	2 x 10/100/1000 Mbit
PS/2 (mouse/keyboard)	–
USB	•
Serial interface	•
Parallel interface	–
Audio in/out	–
Graphics interface	•
Ambient conditions	
Vibration load during operation	1 g
Shock loading during operation	5 g
Permissible temperature during operation with maximum configuration	+5 °C ... +50 °C; max. 50 °C in installation space, max. 40 °C at the front ⁴⁾
Power loss in maximum configuration	
12"/15" display	140 W ⁵⁾
19" display	163 W ⁵⁾

- Available
- Not available

- 1) 12"/15" displays
- 2) With optional expansion rack
- 3) All slots with card retainer
- 4) For 19" Touch
- 5) 15 W taken into account for each PCI/PCIe slot

Benefits

High degree of industrial capability

The entire construction is designed for purely industrial use. Thus, for example, a special vibration-absorbing suspension of the hard disk ensures operational reliability, even at high mechanical loads. SIMATIC Panel PCs are thus designed for a vibration load of 1 g (Panel PC 577B: 0.25 g) and a shock load of 5 g (Panel PC 577B: 1 g) during operation.

Performance

Thanks to the use of the latest Intel processors from ULV (Ultra Low Voltage) to Intel Core technology, SIMATIC Panel PCs are flexibly scalable for your application.

- Scalable computing power
- Highest computing power
- Latest Intel processor technology
- Dual Core, ULV, Atom

Investment security

High component continuity and guaranteed availability of spare parts for up to 5 years after product phase-out are ensured e.g. through the development and production of our own motherboards. This enables long-lasting machine concepts without renewed engineering effort.

Service-friendly device design

Upgrades and exchange of components are easy thanks to the device design.

Integrated interfaces

The different already-integrated interfaces allow for various communication and expansion options. Many models are already equipped with Gigabit Ethernet and PROFIBUS DP/MPI interface.

Extendibility

Depending on the model, ISA, PCI, PCI Express, PC/104 Plus and PC/104 slots are available for individual expandability. This enables the further use of existing and new expansion cards.

Compact dimensions

Considering the desired expandability, SIMATIC Panel PCs have an extremely low mounting depth and can thus be used in very narrow installation locations.

Options

Various options enable an individual solution for your industrial application. Thus, the operator control unit can be operated separately from the computer unit by up to 30 m. The direct control key module increases the operating safety in that it can be used to run the process independently of the operating system and without delay directly on PROFIBUS DP/MPI.

Individually expandable system availability

- RAID1 configuration – high system stability through redundant data management
- SIMATIC IPC DiagMonitor – Monitoring of the operating states and early detection of problems locally and in the network
- SIMATIC PC/PG Image & Partition Creator – downtime minimization through preventative data backup
- SITOP and Masterguard power supply (UPS) – Bridging of voltage dips

More information

Additional information is available on the Internet at:

www.siemens.com/simatic-panel-pc

PROFINET/Industrial Ethernet

Industrial PC / SIMATIC Panel PC

SIMATIC HMI IPC277D

Overview



SIMATIC HMI IPC277D for implementing simple visualization and control tasks

- Offers great flexibility in the selection of rugged widescreen fronts
- From 7" to 12" for more freely configurable display area
- High resolution, large viewing angle, and up to 100% dimmable backlighting for a brilliant display with optimized power consumption
- Absolutely maintenance-free due to the use of CompactFlash and SSD as mass storage and fanless operation up to 50 °C ambient temperature
- Maximum industrial functionality due to non-volatile retentive memory
- Ready-to-use embedded bundles with visualization or/and control software

The following front installation versions are available:

- 7" Touch
- 9" Touch
- 12" Touch
- 15" / 19" available soon
- All fronts as widescreen version

Ordering data	Order No.	Order No.
<p>Configuration</p> <p>SIMATIC HMI IPC277D</p> <p>Interfaces: 2 x Gbit LAN (RJ45), 1 x serial (COM1), 3 x USB</p> <p><u>Operating unit</u></p> <ul style="list-style-type: none"> • Touch 7" TFT • Touch 9" TFT • Touch 12" TFT • Touch 15" TFT, front USB interface • Touch 19" TFT, front USB interface <p><u>Processors / memory configuration / retentivity</u></p> <ul style="list-style-type: none"> • Atom E660 (1.3 GHz), 2 GB RAM • Atom E660 (1.3 GHz), 2 GB RAM, retentivity • Atom E640 (1.0 GHz), 1 GB RAM • Atom E640 (1.0 GHz), 1 GB RAM, retentivity <p><u>Drives</u></p> <ul style="list-style-type: none"> • Without drive, with CF slot • 2 GB SIMATIC IPC Compact-Flash • 4 GB SIMATIC IPC Compact-Flash • 8 GB SIMATIC IPC Compact-Flash • 50 GB solid-state drive SATA (SLC) <p><u>Operating system</u></p> <ul style="list-style-type: none"> • Without operating system • Windows Embedded Standard 2009 preinstalled (CF from 2 GB/SSD) • XP-Prof. MUI preinstalled on SSD • Windows Embedded Standard 7 preinstalled (CF from 4 GB/SSD) • Windows 7 MUI preinstalled on SSD <p><u>Software bundles</u></p> <ul style="list-style-type: none"> • Without RTX/HMI software • RTX: WinAC RTX 2010 • RTX-F: WinAC RTX F 2010 • HMI: WinCC RT Advanced 128 PT • HMI: WinCC RT Advanced 512 PT • HMI: WinCC RT Advanced 2048 PT • HMI: WinCC RT Advanced 4096 PT • HMI/RTX: RT 128 PT • HMI/RTX: RT 512 PT • HMI/RTX: RT 2048 PT • HMI/RTX: RT 4096 PT 	<p>on request</p>	<p>Accessories</p> <p>Touch pen</p> <p>6AV7 672-1JB00-0AA0</p> <p>Undetachable pen for operation of the touch devices, mounting of the support on the control cabinet or directly on the PRO unit</p> <p><u>Note:</u></p> <p>Software Packages with SIMATIC WinCC flexible, SIMATIC WinCC and SIMATIC WinAC RTX (F) can be ordered together with the SIMATIC IPC with a price advantage.</p> <p><u>Please note:</u></p> <p>The HMI IPC277D with Bundle SW is always supplied with inserted CF card. The licenses are on the supplied USB flash drive.</p> <p>You can find more information in Catalog ST 80 / ST PC and in the Industry Mall at www.siemens.com/industrymall</p>

PROFINET/Industrial Ethernet

Industrial PC / SIMATIC Panel PC

SIMATIC HMI IPC477C

Overview

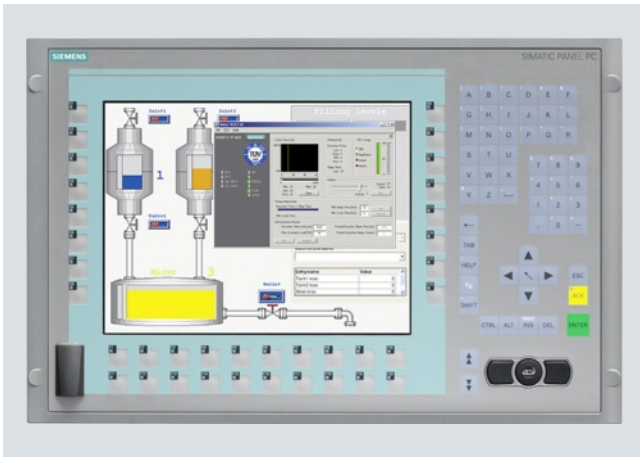

Embedded PC platform with extremely high industrial compatibility for demanding tasks in the field of PC-based automation

- Maintenance-free
(no rotating components such as fan and hard disk)
- Rugged construction:
The PC is resistant to even the harshest mechanical stress and is extremely reliable in operation
- Compact design (only 61-69 mm installation depth for 12"-19")
- Battery-backed retentive memory onboard
- High investment protection
- Fast integration capability

The following front versions are available:

- Built-in versions
 - 12" and 15" TFT Touch
 - 12" and 15" TFT Key
 - 19" Touch
- Support arm versions
 - PRO 15" and PRO 19" Touch
 - Fully enclosed device with degree of protection IP65 for mounting on a support arm/stand

2

PROFINET/Industrial Ethernet Industrial PC / SIMATIC Panel PC

SIMATIC HMI IPC477C



Ordering data	Order No.	Ordering data	Order No.
<p>Configuration</p> <p>SIMATIC HMI IPC477C and IPC477C PRO</p> <p>("built to order" versions with a delivery time of max. 15 working days and with original part repair, if not preferred type)</p> <p>SIMATIC HMI IPC477C</p> <p>Embedded and fan-free 5 x USB (500 mA), of which 1 x on the front, battery-backed retentive memory onboard, 24 V DC power supply with On/Off switch</p> <p>SIMATIC HMI IPC477C PRO</p> <p>Embedded and fan-free with fully enclosed IP65 enclosure; 5 x USB (500 mA), of which 1 x on the front, battery-backed retentive memory onboard, 24 V DC power supply with On/Off switch</p> <p><u>Front Panels</u></p> <ul style="list-style-type: none"> • 12" TFT Touch (not for PRO versions) ¹⁾ • 12" TFT Key (not for PRO versions) • 15" TFT Touch (not for PRO versions) ¹⁾ • 15" TFT Key (not for PRO versions) • 19" TFT Touch (not for PRO versions) ¹⁾ • 15" TFT Touch (IP65 enclosure; PRO) • 15" TFT Key (IP65 enclosure; PRO) <p><u>Processors and fieldbus</u></p> <ul style="list-style-type: none"> • Celeron M 1.2 GHz, 2 x PROFINET (IE) ¹⁾ • Celeron M 1.2 GHz, 2 x PROFINET (IE), 1 x PROFIBUS DP 12 ¹⁾ • Core2 Solo 1.2 GHz, 2 x PROFINET (IE) ¹⁾ • Core2 Solo 1.2 GHz, 2 x PROFINET (IE), 1 x PROFIBUS ¹⁾ • Core2 Solo 1.2 GHz, 1 x PROFINET (IE), 1 x PROFINET (RT/IRT) (3 ports) • Core2 Duo 1.2 GHz, 2 x PROFINET (IE) ¹⁾ • Core2 Duo 1.2 GHz, 2 x PROFINET (IE), 1 x PROFIBUS ¹⁾ • Core2 Duo 1.2 GHz, 1 x PROFINET (IE), 1 x PROFINET (RT/IRT) (3 ports) 	<p>6AV7 88 - A - - - - 0</p> <p>4</p> <p>3</p> <p>4 0</p> <p>4 1</p> <p>4 2</p> <p>4 3</p> <p>4 5</p> <p>3 6</p> <p>3 7</p> <p>A</p> <p>B</p> <p>D</p> <p>E</p> <p>F</p> <p>G</p> <p>H</p> <p>J</p>	<p>Configuration</p> <p>SIMATIC HMI IPC477C and IPC477C PRO</p> <p><u>Main memory (DDR3 RAM), 1 bank</u></p> <ul style="list-style-type: none"> • 1 GB • 2 GB ¹⁾ • 4 GB <p><u>Second mass storage (installed and formatted)</u></p> <ul style="list-style-type: none"> • Without ¹⁾ • CompactFlash 2 GB ¹⁾ • CompactFlash 4 GB ¹⁾ • CompactFlash 8 GB ¹⁾ • SSD (Solid State Drive), min. 32 GB <p><u>Mass storage (built-in, operating system pre-installed)</u></p> <ul style="list-style-type: none"> • CompactFlash 2 GB (only with Windows Embedded Standard 2009) ¹⁾ • CompactFlash 4 GB ¹⁾ • CompactFlash 8 GB ¹⁾ • SSD (Solid State Disk), min. 32 GB <p><u>Operating system (preinstalled and activated)</u></p> <ul style="list-style-type: none"> • Windows Embedded Standard 2009 ¹⁾ • Windows XP Professional Multi-Language, only with SSD; without SIMATIC software • Windows Embedded Standard 7 ²⁾ • Windows 7 Ultimate, MUI (Eng, Ger, Fr, It, Sp) only with SSD; without SIMATIC software <p>SIMATIC HMI IPC477C (PRO) with SIMATIC software</p>	<p>6AV7 88 - A - - - - 0</p> <p>1</p> <p>2</p> <p>3</p> <p>0</p> <p>2</p> <p>3</p> <p>4</p> <p>6</p> <p>2</p> <p>3</p> <p>4</p> <p>6</p> <p>B A</p> <p>D A</p> <p>E A</p> <p>G A</p> <p>see Catalog ST 80 / ST PC</p>

1) Preferred types with replacement devices in exchange
 2) Only with CF > 4 GB or SSD and from 2 GB main memory

Note:
 Software Packages with SIMATIC WinCC flexible, SIMATIC WinCC and SIMATIC WinAC RTX (F) can be ordered together with the SIMATIC IPC with a price advantage.

PROFINET/Industrial Ethernet

Industrial PC / SIMATIC Panel PC

SIMATIC HMI IPC477C

Ordering data

Order No.

Accessories

Protective film for Panel PCs 477/577/677

For protecting the touch screen against dirt/scratches

- for 12" Touch
- for 15" Touch (not for PRO)
- for 19" Touch

6AV7 671-2BA00-0AA0

6AV7 671-4BA00-0AA0

6AV7 672-1CE00-0AA0

Labeling membranes for Panel PCs 477/577/677

For labeling soft keys and function keys, blank, supplied in sets of 10

6AV7 672-0DA00-0AA0

Touch pen

Captive pen for operation of the touch devices, mounting of the support on the control cabinet or directly on the PRO unit

6AV7 672-1JB00-0AA0

Order No.

Expansion components

SIMATIC IPC DiagMonitor V4.2

Software tool for monitoring SIMATIC IPCs, incl. manual, on CD-ROM (German/English)

6ES7 648-6CA04-2YX0

SIMATIC IPC Image & Partition Creator V3.1

Software tool for preventive data backup and hard disk partitioning for SIMATIC IPCs, incl. manual on CD-ROM (German, English)

6ES7 648-6AA03-1YA0

SIMATIC IPC USB FlashDrive

8 GB, USB 2.0, metal enclosure, bootable

6ES7 648-0DC50-0AA0

SIMATIC IPC Service USB FlashDrive

8 GB, USB 2.0; metal enclosure, bootable, Image & Partition Creator pre-installed, incl. CD

6AV7 672-8JD01-0AA0

SINUMERIK disk drive 3.5", USB 1.1

with 1 m connecting cable

6FC5 235-0AA05-1AA2

Industrial USB Hub 4

4 x USB 2.0, IP65 for control cabinet door or DIN rail

6AV6 671-3AH00-0AX0

CompactFlash Card

- 2 GB
- 4 GB
- 8 GB

6ES7 648-2BF02-0XF0

6ES7 648-2BF02-0XG0

6ES7 648-2BF02-0XH0

Please be sure to note:

The HMI IPC477C is delivered as standard with an inserted CF card. The licenses are located on the supplied USB flash drive.

Note:

You can find more information in Catalog ST 80 / ST PC and in the Industry Mall at www.siemens.com/industrymall

Overview

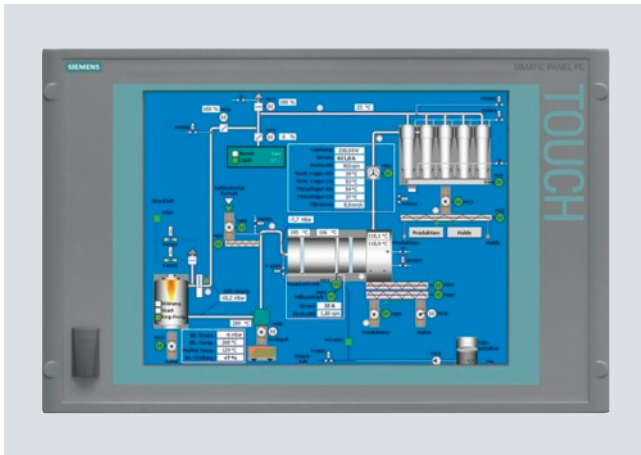

Rugged, expandable industry PC for demanding tasks in the area of PC-based automation with various control units (front panels):

- Rugged and compact design for industrial use
- Full PC openness
 - Windows Embedded Standard or Windows XP Professional, or without operating system
 - CF card, HDD, SSD
 - DVD drive
- Expandable using a PCI slot
- Optionally with PROFIBUS or PROFINET (RT/IRT) onboard
- Installation-compatible with Panel PC 577B
 - Touch screen control units with 12", 15" and 19" TFT display
 - 12" and 15" TFT Key
- High degree of investment protection

PROFINET/Industrial Ethernet

Industrial PC / SIMATIC Panel PC

SIMATIC HMI IPC577C

2

Ordering data

Order No.

Configuration

SIMATIC HMI IPC577C

6AV7 885 - ■ ■ ■ ■ ■ - ■ ■ ■ ■ ■

Front Panels

- 12" TFT Touch
- 12" TFT Key
- 15" TFT Touch
- 15" TFT Key
- 19" TFT Touch

0
1
2
3
5

Main boards (processor with fieldbus interfaces)

- Celeron M 1.2 GHz, 1 MB cache, 800 MHz FSB
 - with PROFINET (Industrial Ethernet); 2x LAN 1 Gbit/s
- Core2 Solo 1.2 GHz, 3 MB cache, 800 MHz FSB
 - with PROFINET (Industrial Ethernet), 2x LAN 1 Gbit/s
 - with PROFIBUS DP12/MPI (CP 5611-compatible), 2x LAN 1 Gbit/s
 - with PROFINET (RT/IRT) 3 ports, 1x LAN 1 Gbit/s
- Core2 Duo 1.86 GHz, 6 MB cache, 1066 MHz FSB
 - with PROFINET (Industrial Ethernet), 2x LAN 1 Gbit/s
 - with PROFIBUS DP12/MPI (CP 5611-compatible), 2x LAN 1 Gbit/s
 - with PROFINET (RT/IRT) 3 ports, 1x LAN 1 Gbit/s

A A
A D
A E
A F
A K
A L
A M

RAM

- 1 GB RAM, DDR3
- 2 GB RAM, DDR3
- 4 GB RAM, DDR3

1
2
3

Second mass storage and/or drive (formatted without operating system)

- No second mass storage/drive
- DVD-RW drive
- HDD + DVD-RW drive
- SSD + DVD-RW drive
- SSD min. 32 GB (Solid-State Drive)
- HDD min. 250 GB

0
1
2
3
6
8

¹⁾ Multi-Language means: Ge/E/F/I/SP/CHIN traditional/CHIN simplified/Korean/Japanese

Order No.

Configuration (continued)

SIMATIC HMI IPC577C

6AV7 885 - ■ ■ ■ ■ ■ - ■ ■ ■ ■ ■

First mass storage (formatted, optionally with operating system):

- Without
- HDD min. 250 GB (no, if 2nd mass storage HDD or SSD)
- 2 GB CompactFlash
- 4 GB CompactFlash
- 8 GB CompactFlash
- Solid State Drive (no, if 2nd mass storage HDD or SSD)

0
1
2
3
4
6

Operating system (pre-installed on first mass storage)

- Without operating system
- Windows Embedded Standard 2009
- Windows XP Professional Multi-Language ¹⁾
- Windows Embedded Standard 7
- Windows 7 Ultimate Multi-Language ¹⁾

A
B
D
E
G

Expansion (software)

- Without expansion
- IPC DiagMonitor V4.2 enclosed
- IPC Image & Partition Creator
- IPC DiagMonitor V4.2 and Image & Partition Creator V3.1 enclosed

A
B
C
D

Power supply

- 100/240 V AC industrial power supply with Namur
- 100/240 V AC industrial power supply with Namur; power cable for Europe
- 100/240 V AC industrial power supply with Namur; power cable for the USA
- 100/240 V AC industrial power supply with Namur; CN power cable
- 100/240 V AC industrial power supply with Namur; IT power cable
- 100/240 V AC industrial power supply with Namur; CH cable
- 100/240 V AC industrial power supply with Namur; UK cable
- 24 V DC industrial power supply

1
2
3
4
5
6
7
8

Note:

Software Packages with SIMATIC WinCC flexible, SIMATIC WinCC and SIMATIC WinAC RTX (F) can be ordered together with the SIMATIC IPC with a price advantage.

Ordering data	Order No.	Order No.
Accessories		Expansion components
Protective film for SIMATIC HMI IPC577C, set of 10 For protecting the touch screen against dirt/scratches <ul style="list-style-type: none"> • for 12" Touch • for 15" Touch • for 19" Touch 	6AV7 671-2BA00-0AA0 6AV7 671-4BA00-0AA0 6AV7 672-1CE00-0AA0	SIMATIC IPC DiagMonitor V4.2 6ES7 648-6CA04-2YX0 Software tool for monitoring SIMATIC IPCs, incl. manual, on CD-ROM (German/English)
Labeling strips for Key devices For labeling soft keys and function keys, blank, supplied in sets of 10	6AV7 672-0DA00-0AA0	SIMATIC IPC Image & Partition Creator V3.1 6ES7 648-6AA03-1YA0 Software tool for preventive data backup and hard disk partitioning for SIMATIC IPCs, incl. manual on CD-ROM (German, English).
Touch pen Captive pen for operation of the touch devices, mounting of the support on the control cabinet	6AV7 672-1JB00-0AA0	SIMATIC IPC USB FlashDrive 6ES7 648-0DC50-0AA0 8 GB, USB 2.0; metal enclosure, bootable
		SIMATIC IPC Service USB FlashDrive 6AV7 672-8JD01-0AA0 8 GB, USB 2.0; metal enclosure, bootable, Image & Partition Creator pre-installed, incl. CD
		SINUMERIK disk drive 3.5", USB 1.1 6FC5 235-0AA05-1AA2 with 1 m connecting cable
		Industrial USB Hub 4 6AV6 671-3AH00-0AX0 4x USB 2.0 interfaces, IP65 for mounting on control cabinet door or on standard mounting rail
		Communication components
		PCI interface card 6ES7 648-2CA01-0AA0 with COM1, COM2 and LPT interfaces

Note:

You can find more information in Catalog ST 80 / ST PC and in the Industry Mall at www.siemens.com/industrymall

PROFINET/Industrial Ethernet

Industrial PC / SIMATIC Panel PC

SIMATIC HMI IPC677C

Overview

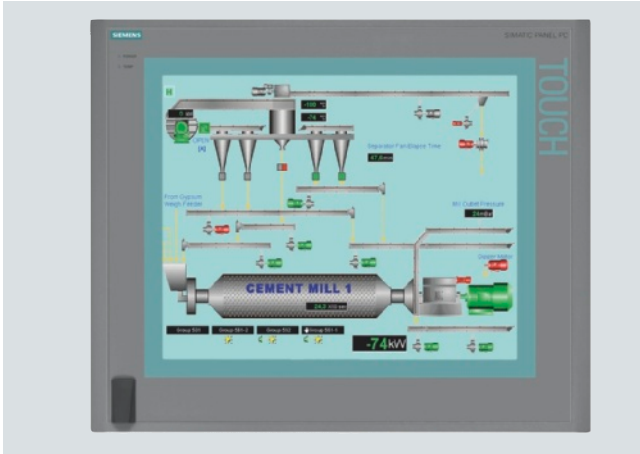

SIMATIC HMI IPC677C

PC platform with high degree of industrial compatibility for demanding tasks in the area of PC-based automation.

Rugged construction:

The PC is resistant to the harshest mechanical stress and is reliable in operation.

- Compact design
- High degree of investment protection
- Fast integration capability
- Front panel versions:
 - 12", 15" and 19" TFT Touch
 - 12" and 15" TFT Keys
 - 15" TFT Touch INOX with stainless steel front for special requirements, e.g. in the food, beverages and tobacco industries

PROFINET/Industrial Ethernet Industrial PC / SIMATIC Panel PC

SIMATIC HMI IPC677C



Ordering data	Order No.	Ordering data	Order No.
<p>Configuration (job-oriented production and delivery)</p> <p>SIMATIC HMI IPC677C</p> <p>Front panels</p> <ul style="list-style-type: none"> • 12" TFT Touch • 12" TFT Key • 15" TFT Touch • 15" TFT Key • 19" TFT Touch <p>Front options</p> <ul style="list-style-type: none"> • With front USB interface • Without front USB interface • INOX front, without front USB, with 15" TFT Touch only • 19" TFT Touch with Atex 22 and UL Class 1 Division 2 certification <p>Power supply</p> <ul style="list-style-type: none"> • 24 V DC • 110/230 V AC, power cable for Europe • 110/230 V AC, without power cable • 110/230 V AC, power cable for UK • 110/230 V AC, power cable for CH • 110/230 V AC, power cable for the USA • 110/230 V AC, power cable for Italy • 110/230 V AC, power cable for China <p>Processor</p> <ul style="list-style-type: none"> • Intel Celeron 1.86 GHz (2 Mbyte shared cache), 2 cores • Intel Celeron 1.86 GHz (2 Mbyte shared cache), 2 cores, PROFIBUS MPI, 2 Mbyte buffered SRAM • Intel Celeron 1.86 GHz (2 Mbyte shared cache), 2 cores, PROFINET MPI (3x RJ45, CP 1616-compatible), 2 Mbyte buffered SRAM • Intel Core i3, 2.13 GHz (3 MB shared cache), 2 cores, hyper-threading • Intel Core i3, 2.13 GHz (3 MB shared cache), 2 cores, hyper-threading, PROFIBUS MPI, 2 MB buffered SRAM • Intel Core i3, 2.13 GHz (3 MB shared cache), 2 cores, hyper-threading, PROFINET (3x RJ45, CP 1616-compatible), 2 MB buffered SRAM • Intel Core i7, 2.53 GHz (4 MB shared cache), 2 cores, hyper-threading, turbo boost • Intel Core i7, 2.53 GHz (4 MB shared cache), 2 cores, hyper-threading, turbo boost, PROFIBUS MPI, 2 MB buffered SRAM • Intel Core i7, 2.53 GHz (4 MB shared cache), 2 cores, hyper-threading, turbo boost, PROFINET (3 x RJ45, CP 1616-compatible), 2 MB buffered SRAM 	<p>6AV7 89 - - - - -</p> <p>0 1 2 3 4</p> <p>0 1 3 4</p> <p>A B C D E F G H</p> <p>A B C D E F G H J</p>	<p>Configuration</p> <p>SIMATIC HMI IPC677C</p> <p>Main memory</p> <ul style="list-style-type: none"> • 1 GB DDR3 • 2 GB DDR3 • 3 GB DDR3 • 4 GB DDR3 • 2 GB DDR3 with ECC • 4 GB DDR3 with ECC <p>Mass storage</p> <ul style="list-style-type: none"> • 250 GB SATA hard disk • 500 GB SATA hard disk • RAID1 dual hard disk module 2 x 250 GB SATA, preconfigured • Dual hard disk module 2 x 250 GB SATA • 32 GB SSD • Second CF card slot, internal, empty (not with Windows XP or Windows 7) instead of hard disk or SSD • Without mass memory <p>Optical drives</p> <ul style="list-style-type: none"> • Without • DVD±RW±R combo drive <p>Communication interfaces</p> <ul style="list-style-type: none"> • 2x PCI free • 1x PCI, 1x PCIe (x16) free <p>Operating system (preinstalled and activated)</p> <ul style="list-style-type: none"> • Without operating system • Windows XP Professional Multi-Language¹⁾ • Windows 7 Ultimate Multi-Language¹⁾ • Windows Embedded Standard on 8 GB CF card²⁾ <p>Software extension</p> <ul style="list-style-type: none"> • Without • SIMATIC IPC DiagMonitor V4.2 enclosed • SIMATIC IPC Image & Partition Creator V3.1 enclosed • SIMATIC IPC DiagMonitor V4.2, Image & Partition Creator V3.1 enclosed <p>¹⁾ Multi-Language means: Ge/E/F//SP/CHIN ²⁾ Only without RAID 1 option</p> <p>Note: Software Packages with SIMATIC WinCC flexible, SIMATIC WinCC and SIMATIC WinAC RTX (F) can be ordered together with the SIMATIC IPC with a price advantage.</p>	<p>6AV7 89 - - - - -</p> <p>0 1 2 3 5 6</p> <p>0 1 2 3 4 5 8</p> <p>0 1</p> <p>A B</p> <p>A 0 B 0 C 0 D 0</p> <p>0 1 2 3</p>

PROFINET/Industrial Ethernet

Industrial PC / SIMATIC Panel PC

SIMATIC HMI IPC677C

2

Ordering data

Order No.

IPC677C stock versions

12" TFT Touch

with Windows XP Prof. MUI,
110/230 V AC power supply,
Core i3 2.13 GHz, 2 x PCI
1 GB RAM, 250 GB HDD
DVD±R/RW burner
PROFIBUS/MPI, NVRAM

6AV7 890-0BE00-1AB0

12" TFT Key

with Windows XP Prof. MUI,
110/230 V AC power supply,
Core i3 2.13 GHz, 2 x PCI
1 GB RAM, 250 GB HDD
DVD±R/RW burner
PROFIBUS/MPI, NVRAM

6AV7 891-0BE00-1AB0

15" TFT Touch

with Windows XP Prof. MUI,
110/230 V AC power supply,
Core i3 2.13 GHz, 2 x PCI
1 GB RAM, 250 GB HDD
DVD±R/RW burner
PROFIBUS/MPI, NVRAM

6AV7 892-0BE00-1AB0

15" TFT Key

with Windows XP Prof. MUI,
110/230 V AC power supply,
Core i3 2.13 GHz, 2 x PCI
1 GB RAM, 250 GB HDD
DVD±R/RW burner
PROFIBUS/MPI, NVRAM

6AV7 893-0BE00-1AB0

19" TFT Touch

with Windows XP Prof. MUI,
110/230 V AC power supply,
Core i3 2.13 GHz, 2 x PCI
1 GB RAM, 250 GB HDD
DVD±R/RW burner
PROFIBUS/MPI, NVRAM

6AV7 894-0BE00-1AB0

Accessories

Protective foil for Panel PC 477/577/677/ Flat Panel, set of 10

For protecting the touch screen
against dirt/scratches

- for 12" Touch
- for 15" Touch
- for 19" Touch

6AV7 671-2BA00-0AA0
6AV7 671-4BA00-0AA0
6AV7 672-1CE00-0AA0

Labeling strips for Panel PC 477/577/677 key devices

For labeling soft keys and
function keys, blank,
supplied in sets of 10

6AV7 672-0DA00-0AA0

Memory expansion

- 1 GB DDR3 DIMM
- 2 GB DDR3 DIMM
- 1 GB DDR3 DIMM with ECC
- 2 GB DDR3 DIMM with ECC

6ES7 648-2AJ40-0KA0
6ES7 648-2AJ50-0KA0
6ES7 648-2AJ40-1KA0
6ES7 648-2AJ50-1KA0

Non-heating apparatus cable for SIMATIC Box and Panel PC

SIMATIC PC power cable,
230 V AC, angled, 3 m,
for:

- Germany
- United Kingdom
- Switzerland
- USA
- Italy
- China

6ES7 900-1AA00-0XA0
6ES7 900-1BA00-0XA0
6ES7 900-1CA00-0XA0
6ES7 900-1DA00-0XA0
6ES7 900-1EA00-0XA0
6ES7 900-1FA00-0XA0

Touch pen

Captive pen for operation of the
touch devices, mounting of the
support on the control cabinet

6AV7 672-1JB00-0AA0

Expansion components

SIMATIC IPC DiagMonitor V4.2

Software tool for monitoring
SIMATIC IPCs, incl. manual,
on CD-ROM (German/English)

6ES7 648-6CA04-2YX0

SIMATIC IPC Image & Partition Creator V3.1

Software tool for preventive data
backup and hard disk partitioning
for SIMATIC IPCs, incl. manual on
CD-ROM (German, English)

6ES7 648-6AA03-1YA0

SIMATIC IPC USB FlashDrive

8 GB, USB 2.0, metal enclosure,
bootable

6ES7 648-0DC50-0AA0

SIMATIC IPC Service USB FlashDrive

8 GB, USB 2.0; metal enclosure,
bootable, Image & Partition
Creator pre-installed, incl. CD

6AV7 672-8JD01-0AA0

Industrial USB Hub 4

4 x USB 2.0 interfaces,
IP65 for mounting on control
cabinet door or DIN rail

6AV6 671-3AH00-0AX0

Uninterruptible power supplies

SITOP Power, 15 A DC UPS module with USB interface

with charger unit
for 24 V lead battery,
input 24 V DC/16 A,
output 24 V DC/15 A

6EP1 931-2EC42

SITOP Power, battery module 24 V/3.2 Ah

for DC UPS module 15 A

6EP1 935-6MD11

Communication components

PCI interface card

With COM1, COM2
and LPT interfaces

6ES7 648-2CA01-0AA0

Note:

You can find more information in Catalog ST 80 / ST PC and
in the Industry Mall at www.siemens.com/industrymall

Overview

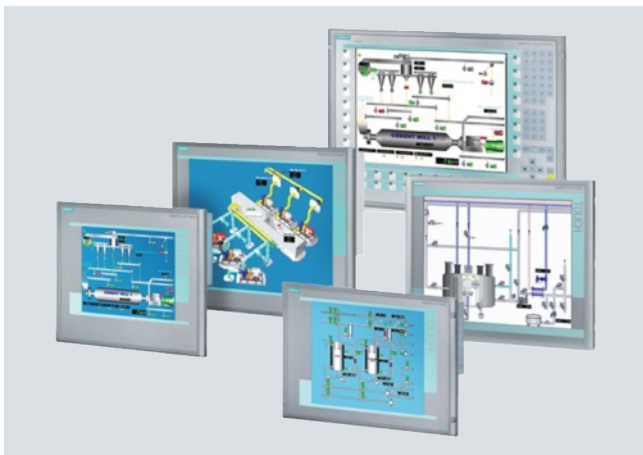

The Flat Panels are rugged industry-standard LCD monitors.

- Installation:
 - They are equally suited to installation in the machine, in control cabinets, consoles and gantries or in 19" racks.
 - As a device with all-round IP65 protection for mounting on a supporting arm/stand
- Type of operator control:
 - Simple display devices without operator functionality
 - Optional devices with touch control
 - Rear connection of I/O devices (optional)

PROFINET/Industrial Ethernet

Industry monitors and Thin Clients

SIMATIC Flat Panels

2

Ordering data

Order No.

Standard configuration

Flat Panel Monitor

6AV7 861 - 0 - A A 0

Display size

- 12" Standard
- 12" Extended
- 15"
- 19"

1 1 2 3 0 1 1 1

Operator functionality

- Display devices without operator functionality
- Touch screen (analog/resistive)

A T 1 1

Power supply

- 24 V DC (not for Extended versions since these always have AC and DC)
- 100 to 230 V AC (incl. Euro power supply cable) and 24 V DC

A 0 B 1 1

Version

- Standard, can be located up to 5 m away
- Extended, can be located up to 30 m away, marine approvals
Dimmable background illumination
Ex22

0 1 1

Flat Panel Monitor

- 12" Key
- 15" Key
- PRO 15" Touch
- PRO 19" Touch

6AV7 861-1KB10-1AA0
6AV7 861-2KB10-1AA0
6AV7 861-5TB10-1AA0
6AV7 861-6TB10-1AA0

Order No.

Accessories

Cover foils

For protecting the touch screen against dirt and scratches
Pack with 10 units

- for 12" Touch
- for 15" Touch
- for 19" Touch

6AV7 671-2BA00-0AA0

6AV7 671-2BA00-0AA0

6AV7 671-4BA00-0AA0

6AV7 672-1CE00-0AA0

Mounting elements for Panel PC 57x/67x/Flat Panel

For screw mounting, e. g. in 19" rack cabinet

6AV7 672-8KE00-0AA0

Touch pen

Undetachable pen for operation of the touch devices, mounting of the support on the control cabinet or directly on the PRO unit

6AV7 672-1JB00-0AA0

Connection cables for Standard, Extended and PRO versions

- Video (VGA)
 - 3.0 m
 - 5.0 m
- Video (DVI-D)
 - 3.0 m
 - 5.0 m
- USB for optional touch screen
 - 3.0 m
 - 5.0 m

6AV7 860-0AH30-0AA0

6AV7 860-0AH50-0AA0

6AV7 860-0BH30-0AA0

6AV7 860-0BH50-0AA0

6AV7 860-0CH30-0AA0

6AV7 860-0CH50-0AA0

Connection cables for Extended and PRO versions

- Cable set 10 m (DVI-D, CAT5 cable (USB), USB transmitter module)
- Cable set 15 m (DVI-D, CAT5 cable (USB), USB transmitter module)
- Cable set 20 m (DVI-D, CAT5 cable (USB), USB transmitter module)
- Cable set 30 m (DVI-D, CAT5 cable (USB), USB transmitter module)

6AV7 860-1EX21-0AA1

6AV7 860-1EX21-5AA1

6AV7 860-1EX22-0AA1

6AV7 860-1EX23-0AA1

Note:

You can find more information in Catalog ST 80 / ST PC and in the Industry Mall at www.siemens.com/industrymall

Overview

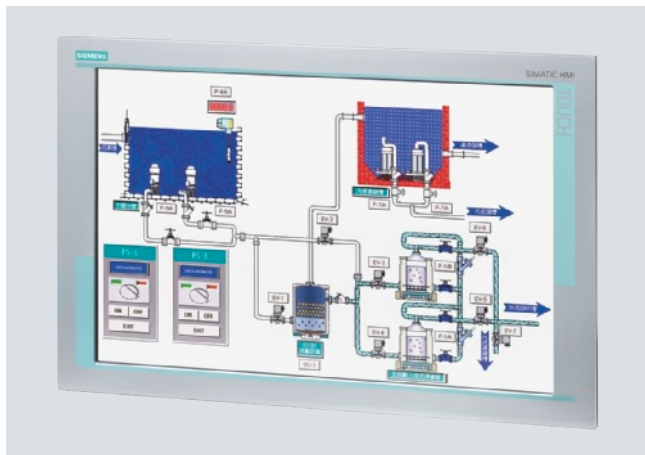

The SIMATIC HMI SCD 1900 is a rugged, industry-standard PC monitor.

It is used as operator control unit in all types of industrial and standard PC. Standard interfaces permit a wide range of possible applications.

Built-in versions:

- Built-in unit (for control cabinets, control desks, and gantries)
- 19" built-in units (for 19" racks)

Type of operator control:

- Panels with touch control

Ordering data

Order No.

SCD monitors 1900

6AV7 862-2TA00-1AA0

Accessories

Cable for connecting to the graphics interface of the PC

- VGA cable 3.0 m
- VGA cable 5.0 m
- DVI-D cable, 3.0 m
- DVI-D cable, 5.0 m

6AV7 860-0AH30-0AA0

6AV7 860-0AH50-0AA0

6AV7 860-0BH30-0AA0

6AV7 860-0BH50-0AA0

USB cable for connecting the touch screen

- 3.0 m
- 5.0 m

6AV7 860-0CH30-0AA0

6AV7 860-0CH50-0AA0

External power supply for SCD 1900

6AV7 860-2AD06-0AA0

100-230 V AC, 50-60 Hz; incl. mounting accessories for optional installation at the device.

Note:

You can find more information in Catalog ST 80 / ST PC and in the Industry Mall at www.siemens.com/industrymall

PROFINET/Industrial Ethernet

Industry monitors and Thin Clients

SIMATIC Thin Client

Overview



SIMATIC Thin Clients are very economical operator panels which can be used flexibly in various distributed applications. They can be used as (additional) operator stations on a SIMATIC industrial PC or also on a SIMATIC Panel.

The following versions are available:

- The rack-mounting versions SIMATIC Thin Client 10" Touch and SIMATIC Thin Client 15" Touch
- The support arm version SIMATIC Thin Client PRO 15" Touch with a rugged and very compact aluminum enclosure which is completely IP65 protected

The SIMATIC HMI Thin Client Ex is available for hazardous areas. This device differs technically from the devices mentioned above.

Ordering data

Order No.

SIMATIC Thin Client

- 10" Touch device
- 15" Touch device

6AV6 646-0AA21-2AX0
6AV6 646-0AB21-2AX0

Starter packages

SIMATIC Thin Client with Sm@rtAccess

(License to operate SmartAccess on the server)

- Touch device 10" with Sm@rtAccess license (panels)
- Touch device 15" with Sm@rtAccess license (panels)
- Touch device 15" PRO with Sm@rtAccess license (panels)
- Touch device 10" with Sm@rtAccess license for WinCC flexible 2008 Runtime
- Touch device 15" with Sm@rtAccess license for WinCC flexible 2008 Runtime
- Touch device 15" PRO with Sm@rtAccess license for WinCC flexible 2008 Runtime

6AV6 653-6AA01-2AA0

6AV6 653-6BA01-2AA0

6AV6 653-6CA01-2AA0

6AV6 653-6DA01-2AA0

6AV6 653-6EA01-2AA0

6AV6 653-6FA01-2AA0

Option packages

IP65 set (upgrade from IP54 to IP65)

6AV6 671-6AP00-0AX0

Touch pen SIMATIC HMI Touch devices

6AV7 672-1JB00-0AA0

Cover membrane 10"

6AV6 671-3DC00-0AX0

(10 units per packing unit)

Cover foils 15"

6AV6 574-1AD00-4EX0

Accessories

Accessories for follow-up ordering

see Catalog ST 80 / ST PC

Note:

You can find more information in Catalog ST 80 / ST PC and in the Industry Mall at www.siemens.com/industrymall

PROFINET/Industrial Ethernet

SIMATIC Identification systems / RFID systems

SIMATIC RF180C/RF182C

Overview



SIMATIC RF180C/RF182C are communication modules for direct connection of SIMATIC identification systems to PROFINET IO/Ethernet. The readers (SLGs) of the RFID systems MOBY D/U, SIMATIC RF300/RF600 as well as MV400 (RF180C only) can be operated on the SIMATIC RF180C/RF182C.

Due to the high degree of protection and its ruggedness, SIMATIC RF180C/RF182C is ideally suited to use at the machine level. The uniform plug-in connection system ensures rapid commissioning.

Ordering data

Order No.

SIMATIC RF180C communication module

6GT2 002-0JD00

For PROFINET, for connecting 2 readers; without a connection block

SIMATIC RF182C communication module

6GT2 002-0JD10

For Ethernet for connecting 2 readers, without connection block

PROFINET connection block for SIMATIC RF180C/RF182C, M12 d-coded, 7/8" (5-pole)

6GT2 002-1JD00

PROFINET connection block for SIMATIC RF180C/RF182C, push pull RJ45

6GT2 002-2JD00

PROFINET connection block for SIMATIC RF182C, M12 d-coded, 7/8" (4-pole)

6GT2 002-4JD00

Accessories for RFID

Reader cable for MOBY U

PUR material, CMG approved, suitable for cable carriers

- 2 m
- 5 m

6GT2 091-4FH20

6GT2 091-4FH50

Reader cable for MOBY D

PUR material, CMG approved, suitable for cable carriers, 2 m

6GT2 691-4FH20

Reader cable for SIMATIC RF200 / RF300 / RF600 / MV420 / MV440

Or extension cable MOBY U/D and SIMATIC RF200 / RF300 / RF600 / MV400, PUR material, CMG approval, suitable for cable carriers, straight connector

- 2 m
- 5 m
- 10 m
- 20 m
- 50 m
- 2 m, plug angled at reader

6GT2 891-4FH20

6GT2 891-4FH50

6GT2 891-4FN10

6GT2 891-4FN20

6GT2 891-4FN50

6GT2 891-4JH20

M12 sealing caps for unused reader connections

10 units minimum order quantity, price per 100 units

3RX9 802-0AA00

PROFINET/Industrial Ethernet

SIMATIC Identification systems / RFID systems

SIMATIC RF180C/RF182C

Ordering data

Order No.

Accessories for network connection M12, 7/8" (5-pole)

IE Connecting Cable M12-180/M12-180

Pre-assembled IE FC TP Trailing Cable GP 2 x 2 (PROFINET Type C) with two 4-pin M12 plugs (D-coded) up to 85 m, IP65/IP67 degree of protection
Length:

- 0.3 m
- 0.5 m
- 1.0 m
- 1.5 m
- 2.0 m
- 3.0 m
- 5.0 m
- 10.0 m
- 15.0 m

6XV1 870-8AE30
6XV1 870-8AE50
6XV1 870-8AH10
6XV1 870-8AH15
6XV1 870-8AH20
6XV1 870-8AH30
6XV1 870-8AH50
6XV1 870-8AN10
6XV1 870-8AN15

7/8"-plug-in cable for power supply

5-core 5 x 1.5 mm², suitable for cable carriers, pre-assembled with two 5-pole 7/8" connectors (axial cable outlet) up to 50 m max.;
Length:

- 1.5 m
- 2.0 m
- 3.0 m
- 5.0 m
- 10.0 m
- 15.0 m
- additional special lengths with 90° or 180° cable outlet

6XV1 822-5BH15
6XV1 822-5BH20
6XV1 822-5BH30
6XV1 822-5BH50
6XV1 822-5BN10
6XV1 822-5BN15

See <http://support.automation.siemens.com/WW/view/en/26999294>

IE FC M12 Plug PRO

M12 plug-in connector (D-coded, IP65/IP67) that can be assembled in the field, metal enclosure, FastConnect connection method, for SCALANCE X208PRO and IM 154-4 PN; 1 item

6GK1 901-0DB20-6AA0

7/8" plug-in connector

axial cable outlet, 5-pole, plastic casing, for assembly in the field, for ET 200, 1 pack = 5 items

- Male pins
- Socket insert

6GK1 905-0FA00
6GK1 905-0FB00

IE M12 Panel Feedthrough

Control cabinet feedthrough for conversion from M12 connection method (D coded, IP65/IP67) to RJ45 connection method (IP20)

- 1 pack = 5 units

6GK1 901-0DM20-2AA5

PROFINET cable from M12 (D-coded) to RJ45 especially for commissioning and testing

Length 2 m

6GF3440-8BB1

¹⁾ This cable is available in different lengths (see "Cabling technology")

Order No.

Accessories for network connection M12, 7/8" (5-pole) (continued)

IE FC RJ45 PLUG 180

RJ45 plug connector for Industrial Ethernet with a rugged metal housing and integrated insulation displacement contacts for connecting Industrial Ethernet FC installation cables; 180° cable outlet; for network components and CPs/CPU with Industrial Ethernet interface

- 1 pack = 1 item
- 1 pack = 10 items
- 1 pack = 50 items

6GK1 901-1BB10-2AA0
6GK1 901-1BB10-2AB0
6GK1 901-1BB10-2AE0

Sealing caps 7/8"

Pack with 10 units

6ES7 194-3JA00-0AA0

Accessories for push pull RJ45 network connection

Power Plug PRO

1 plug (IP65/67) suitable for on-site assembly

6GK1 907-0AB10-6AA0

IE RJ45 Plug PRO

RJ45-plug connector suitable for on-site assembly in degree of protection IP65/67; plastic enclosure, insulation displacement technology, for SCALANCE X-200IRT PRO and SIMATIC ET 200pro switches; 1 package = 1 unit

6GK1 901-1BB10-6AA0

Cover caps for push pull sockets

(1L+/ 2L+), 5 units per pack

6ES7 194-4JA50-0AA0

Cover caps for push pull sockets RJ45,

5 units per pack

6ES7 194-4JD50-0AA0

Accessories for network connection M12, 7/8" (4-pole)

Network wiring with M12

Accessories as for M12, 7/8" (5-pole)

Power supply with 7/8" (4-pole)

No cables and connectors from Siemens

Accessories for network connection cable

IE FC TP Standard Cable GP 2 x 2 (Type A)

4-core, shielded TP installation cable for connection to IE FC Outlet RJ45/ IE FC RJ45 Plug; PROFINET-compliant; with UL approval; sold by the meter; max. length 1,000 m; minimum order 20 m

6XV1 840-2AH10

Energy cable 5 x 1.5

Energy cable with trailing capability with 5 copper cores (1.5 mm²) for connecting to 7/8" plug-in connector; sold by the meter; max. length 1,000 m; minimum order 20 m

6XV1 830-8AH10

DVD "RFID Systems Software & Documentation"

6GT2 080-2AA20

Note:

You can find more information in Catalog ID 10 and in the Industry Mall at www.siemens.com/industrymall

PROFINET/Industrial Ethernet

SIMATIC Identification systems / Code reading systems

SIMATIC MV420

Overview



The SIMATIC MV420 supplements the portfolio of basic, compact and integrated code readers. The MV420 is particularly suited for close up to mid-range reading distances (ca. 15 mm to 220 mm).

SIMATIC MV420 is an optical code reading system that has been specially designed for detecting and evaluating a variety of machine readable codes in the packaging industry (e.g. F&B, pharmaceuticals and tobacco) and industrial production (e.g. automotive, electronics and solar). The list of readable codes includes all standard matrix codes and bar codes which are reliably detected - mostly independent of the printing technology applied and carrier medium used. One key feature of the unit is its ability to read data matrix codes (DMC). The SIMATIC MV420 device family is flexible, reliable and easy to use.

The MV420 also features integrated optics, which can be adjusted to the required reading distances. The unit also includes integrated high-performance lighting for its size. All of the components are housed in an extremely compact enclosure with a high degree of protection IP67.

Highlights at a glance:

- Compact design with degree of protection IP67
- Integrated optics: variable reading distances
- Integrated high-performance lighting
- Web server technology: parameterizable with regular Web browser
- Interfaces: Ethernet, PROFINET, RS232, DI/DO and direct connection to RFID communication modules (ASM)
- Exceptionally high reading speeds, depending on the model

Further important product characteristics are:

- Excellent read algorithms based on the code reading systems SIMATIC MV440 and VS130-2 and many years of experience in the market.
- No special knowledge required for reliable parameterization of reading features. Parameterization usually only required for hard to read codes. "Setup" is performed automatically by presenting a readable code pattern.
- Autotrigger mode (availability depends on model): Automatically detects when a code is in front of the reader, ensuring that no external trigger signal is required. No proximity switch or cable is required for the trigger. This feature is also useful for applications in which a proximity switch cannot be used, such as for objects that are linked together.
- Multicode (availability depends on model): Reads multiple codes in one step within the same image field.
- ID-Genius (availability depends on model): a high-performance code reading algorithm for difficult DPM data matrix codes.
- Code quality evaluation: displays the key quality parameters of the code to be read.
- Customized user interface can be easily generated with SIMATIC WinCC flexible /WinCC.
- Web-based user interface; can run on a variety of platforms meeting the following requirements: Internet browser (IE 6.0 or higher), JAVA-VM (MS, SUN).
- Password protected user interface with integrated access rights administration.
- Web-based user interface available for easy integration with an HMI device. The browser and JAVA VM requirements previously mentioned also apply in this case.
- 6 language versions are available (operator interface, manual and online help are available in German, English, French, Spanish, Italian, and Chinese).

2

PROFINET/Industrial Ethernet

SIMATIC Identification systems / Code reading systems

SIMATIC MV420

2

Ordering data	Order No.	Order No.
SIMATIC MV420 SR-B Basic model without multicode and ID-Genius algorithm	6GF3420-0AA20	
SIMATIC MV420 SR-P Performance model Very vast reading speeds; with multicode and ID Genius algorithm	6GF3 420-0AA40	
<i>Accessories</i>		
Mounting bracket for SIMATIC MV420	6GF3 420-0AC00-1AA0	
Plug-in power supply (EU, US) For demo and lab operation (for office environment only)	6GF3 420-0AC00-1PS0	
Built-in ring lamp White, suitable for mounting in SIMATIC MV420 SR-B (6GF420-0AA20) and SIMATIC MV420 SR-P (6GF3420-0AA40)	6GF3 420-0AC00-2LTO	
Cable power supply DIO RS232 Power IO RS232 cable, M16 pre- assembled at one end, other end unconnected. Various lengths: <ul style="list-style-type: none">• 10 m• 30 m	6GF3 440-8BA2 6GF3 440-8BA4	
<i>Cable Ethernet / PROFINET</i>		
IE Connecting Cable from M12 (D-coded) to RJ45 for commissioning and testing Length: 2 m	6GF3 440-8BB1	
IE Connecting Cable M12-180/IE FC RJ45 Plug-145 for commissioning, service and installation Pre-assembled IE FC TP trailing cable GP 2 x 2 (PROFINET type C) with M12 plug (D-coded) and IE FC RJ45 plug, IP65/IP67 degree of protection Length: <ul style="list-style-type: none">• 2 m• 3 m• 5 m• 10 m• 15 m	6XV1 871-5TH20 6XV1 871-5TH30 6XV1 871-5TH50 6XV1 871-5TN10 6XV1 871-5TN15	
<i>Cable Ethernet / PROFINET (continued)</i>		
Industrial Ethernet cable (M12-180/M12-180) for installation Pre-assembled IE FC P Trailing Cable GP 2 x 2 (PROFINET Type C) with two 4-pin M12 connectors (D-coded, up to 85 m), IP65/67 degree of protection, RJ45 assembly possible with plug-in connector 6GK1 901-1BB10-2AA0 (see below). Length: <ul style="list-style-type: none">• 0.3 m• 0.5 m• 1 m• 1.5 m• 2 m• 3 m• 5 m• 10 m• 15 m	6XV1 870-8AE30 6XV1 870-8AE50 6XV1 870-8AH10 6XV1 870-8AH15 6XV1 870-8AH20 6XV1 870-8AH30 6XV1 870-8AH50 6XV1 870-8AN10 6XV1 870-8AN15	
IE FC RJ45 PLUG 180 RJ45 plug connector for Industrial Ethernet with a rugged metal housing and integrated insulation displacement contacts for connecting Industrial Ethernet FC installation cables; 180° cable outlet; for network components and CPs/CPU with Industrial Ethernet interface <ul style="list-style-type: none">• 1 pack = 1 item• 1 pack = 10 items• 1 pack = 50 items	6GK1 901-1BB10-2AA0 6GK1 901-1BB10-2AB0 6GK1 901-1BB10-2AE0	
For further cables, see "Cabling technology".		
<i>Cable for communication module interface</i>		
Adapter cable for RFID communication modules (ASM) M16 connector (MV420) to M12 connector (ASM); length: 2 m; expandable to any length with standard communication module cables	6GF3 420-0AC00-2CB0	
Cable for communication module interface Standard ASM cable for instal- lation, assembled plug-in cable for ASM 456, RF170C, RF180C and RF182C Various lengths: <ul style="list-style-type: none">• 2 m• 5 m• 10 m• 20 m• 50 m	6GT2 891-4FH20 6GT2 891-4FH50 6GT2 891-4FN10 6GT2 891-4FN20 6GT2 891-4FN50	

Note:

You can find more information in Catalog ID 10 and in the Industry Mall at www.siemens.com/industrymall

Overview



SIMATIC MV440 front view, with built-in ring lamp and protective barrel D65



SIMATIC MV440 with built-in ring lamp and protective barrel D65

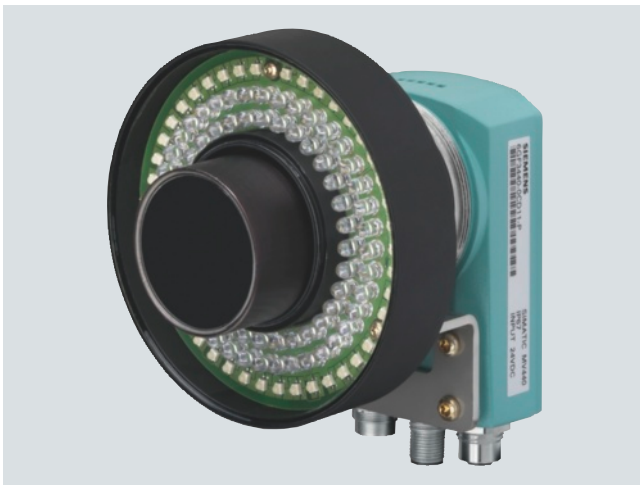

SIMATIC MV440 with external ring light and protective barrel D50

The SIMATIC MV440 readers have been specially developed for use in industrial production. The devices offer professional decoding algorithms for machine-readable codes and text recognition in one device for production and logistics. The SIMATIC MV440 device family is characterized by flexibility, reliability and ease of use.

The list of readable codes includes all common matrix and barcodes which, regardless of the printing technology and the carrier medium used, are recognized reliably. A special feature of the device is its ability to read Data Matrix Code (DMC), which is frequently used especially in production for direct part marking (DPM) and places the highest requirements on the readers.

The operating range of the devices reaches from close range 7 cm to distant range 300 cm. Due to the freely selectable lenses and lighting, the working range as well as implementation in applications with special requirements is almost unrestricted. Integration in industrial automation environments is via standardized fieldbus technology such as PROFINET (onboard M12, PoE or via ASM module) or PROFIBUS (via ASM module, M12), but open interfaces are also supported.

PROFINET/Industrial Ethernet

SIMATIC Identification systems/ Code reading systems

SIMATIC MV440

2

Ordering data	Order No.	Order No.
SIMATIC MV440 SR For one and two dimensional codes, optional: Text recognition (OCR) and verification, variable image field and distance. Resolution: 640 x 480 pixels PoE; IP67 using protective barrel for lens and sealing caps, otherwise IP40; package comprises reader, CD and plastic protective barrel for lens.	6GF3 440-1CD10	
SIMATIC MV440 HR For one and two dimensional codes, optional: Text recognition (OCR) and verification, variable image field and distance. Resolution: 1024 x 768 pixels PoE; IP67 using protective barrel for lens and sealing caps, otherwise IP40; package comprises reader, CD and plastic protective barrel for lens.	6GF3 440-1GE10	
SIMATIC MV440 UR For one and two dimensional codes, optional: Text recognition (OCR) and verification, variable image field and distance. Resolution: 1600 x 1200 pixels PoE; IP67 using protective barrel for lens and sealing caps, otherwise IP40; package comprises reader, CD and plastic protective barrel for lens.	6GF3 440-1LE10	
Optional software modules Text recognition module "Text-Genius" License for the module "Text-Genius", supplied on USB flash drive; executable on SIMATIC MV440 firmware V3.0 and higher (MV440 not included in the scope of supply).	6GF3 400-OSL01	
Verification module "Veri-Genius" License for the module "Veri-Genius", supplied on USB flash drive; executable on SIMATIC MV440 firmware V4.0 and higher (MV440 not included in the scope of supply).	6GF3 400-OSL02	
		Accessories Mounting accessories Mounting plate for reader Dimensions W x H x D (mm) 80 x 80 x 60, plate thickness: 4 mm
		Lenses with fixed focal length, adjustable aperture and focus Mini lens 8.5 mm, 1:1.5 PENTAX C815B (TH) D = 42 mm, L = 47 mm, not suitable in combination with built-in ring lights.
		Mini lens 12 mm, 1:1.4 PENTAX H1214-M (KP) D = 29.5 mm, L = 35.7 mm
		Mini lens 16 mm, 1:1.4 PENTAX C1614-M (KP) D = 29.5 mm, L = 37.2 mm
		Mini lens 25 mm, 1:1.4 PENTAX C2514-M (KP) D = 29.5 mm, L = 38.9 mm
		Mini lens 35 mm, 1:1.6 PENTAX C3516-M (KP) D = 29.5 mm, L = 41.4 mm
		Mini lens 50 mm, 1:2.8 PENTAX C5028-M (KP) D = 29.5 mm, L = 38 mm
		Mini lens 75 mm, 1:2.8 PENTAX C7528-M (KP) D = 34 mm, L = 63.6 mm, not suitable in combination with protective barrel for lens D65, suitable in combination with protective barrel for lens D50.
		Protective barrel for lens Protective barrel for lens D65 made of metal, for built-in ring lights, internal diameter 57 mm, max. lens length 57 mm, IP67 degree of protection.
		<ul style="list-style-type: none"> • Glass front pane • Plastic front pane
		Protective barrel for lens D65 made of plastic; to achieve IP67 degree of protection; suitable for all versions of MV440 and for use with built-in ring lights; max. internal diameter 55 mm, max. lens length 48 mm
		Protective barrel for lens D50 made of metal, for external ring lights, internal diameter 41 mm, length from joint 65 mm IP65 degree of protection. With 3 cm extension piece for particularly long lenses.
		
		<ul style="list-style-type: none"> • Glass front pane • Plastic front pane

PROFINET/Industrial Ethernet

SIMATIC Identification systems/ Code reading systems

SIMATIC MV440

Ordering data	Order No.	Order No.
Built-in ring lights <ul style="list-style-type: none"> Built-in ring light, red Light source: Red LED (630 nm), range of illumination 800 mm, mounting materials included, IP67 degree of protection when using protective barrel for lens. Built-in ring light, white Light source: LED white (440 nm ... 650 nm), flash duration 20 μs to 10 ms, range of illumination up to 800 mm, mounting materials included, IP67 degree of protection when using protective barrel for lens. 	6GF3 440-8DA11 6GF3 440-8DA2	Mounting plate for external ring lights Dimensions W x H x D (mm) 92 x 79 x 42, plate thickness: 4 mm. Cable for external ring lights suitable for 6GF9 004-7AA01, ... -7BA01, ... -8BA01, ... -8CA01, ...-8DA01, M12, open end, 4-pole, non-trailing type, length 10 m. Cable for external ring lights suitable for 6GF9 004-7AA01, ... -7BA01, ... -8BA01, ... -8CA01, ...-8DA01, M12-90 male connector / M12-180 female connector, 4-pole length 10 m. Rail-mounted power supply for external ring lights suitable for 6GF9 004-7AA01, ... -7BA01, ... -8BA01, ... -8CA01, ...-8DA01, input voltage 110 V ... 230 V AC, output voltage 16.5 V DC. SCALANCE X108PoE 6 x 10/100 Mbit/s RJ45 electrical ports, 2 x 10/100 Mbit/s RJ45 electrical PoE ports Cable power supply DIO RS232 Power IO RS232 cable, M16 pre-assembled at one end, other end unconnected. <ul style="list-style-type: none"> Length 10 m Length 30 m IE Connecting Cable from M12 (D-coded) to RJ45 for commissioning and testing length: 2 m
External ring lights Figure shows metal ring light with protective barrel for lens; 2 small mounting brackets enclosed <ul style="list-style-type: none"> Ring light, metal, IR, diffuse Light source infrared LED Light source 850 nm, range of illumination 75 mm ... 250 mm, suitable for protective barrel for lens D50, dimensions W x H x D (mm) 116 x 116 x 42, IP67 degree of protection. Ring light, metal, IR, clear Light source infrared LED, light source 850 nm, range of illumination 500 mm ... 3 000 mm, suitable for protective barrel for lens D50, dimensions W x H x D (mm) 116 x 116 x 42, IP65 degree of protection. Ring light, metal, red, diffuse Light source red LED Range of illumination 75 mm ... 250 mm, suitable for protective barrel for lens D50, dimensions W x H x D (mm) 116 x 116 x 42, IP67 degree of protection. Ring light, metal, red, clear Light source red LED, range of illumination 150 mm ... 2 000 mm, suitable for protective barrel for lens D50, dimensions W x H x D (mm) 116 x 116 x 42, IP67 degree of protection. Ring light, metal, red, clear Light source red LED, range of illumination 500 mm ... 3 000 mm, suitable for protective barrel for lens D50, dimensions W x H x D (mm) 116 x 116 x 42, IP67 degree of protection. 	6GF9 004-7AA01 6GF9 004-7BA01 6GF9 004-8BA01 6GF9 004-8CA01 6GF9 004-8DA01	6GF3 440-8CA 6GF3 440-8BC4 6GF9 002-8CG 6GF9 002-8PS 6GK5 108-0PA00-2AA3 6GF3 440-8BA2 6GF3 440-8BA4 6GF3 440-8BB1

PROFINET/Industrial Ethernet

SIMATIC Identification systems/ Code reading systems

SIMATIC MV440

2

Ordering data

Order No.

Order No.

IE Connecting Cable M12-180/IE FC RJ45 Plug-145 for commissioning, service and installation

Pre-assembled IE FC TP trailing cable GP 2 x 2 (PROFINET type C) with M12 plug (D-coded) and IE FC RJ45 plug, IP65/IP67 degree of protection
Length:

- 2 m
- 3 m
- 5 m
- 10 m
- 15 m

6XV1 871-5TH20
6XV1 871-5TH30
6XV1 871-5TH50
6XV1 871-5TN10
6XV1 871-5TN15

IE Connecting Cable (M12-180/M12-180) for installation

Pre-assembled IE FC P Trailing Cable GP 2 x 2 (PROFINET Type C) with two 4-pin M12 connectors (D-coded) up to 85 m, IP65/67 degree of protection, RJ45 assembly possible with plug-in connector
6GK1 901-1BB10-2AA0 (see below).
Length:

- 0.3 m
- 0.5 m
- 1 m
- 1.5 m
- 2 m
- 3 m
- 5 m
- 10 m
- 15 m

6XV1 870-8AE30
6XV1 870-8AE50
6XV1 870-8AH10
6XV1 870-8AH15
6XV1 870-8AH20
6XV1 870-8AH30
6XV1 870-8AH50
6XV1 870-8AN10
6XV1 870-8AN15

IE FC RJ45 PLUG 180

RJ45 plug connector for Industrial Ethernet with a rugged metal housing and integrated insulation displacement contacts for connecting Industrial Ethernet FC installation cables; 180° cable outlet; for network components and CPs/CPUs with Industrial Ethernet interface

- 1 pack = 1 item
- 1 pack = 10 items
- 1 pack = 50 items

6GK1 901-1BB10-2AA0
6GK1 901-1BB10-2AB0
6GK1 901-1BB10-2AE0

For further cables, see "Cabling technology".

Cable for communication module interface

ASM cable for connection to communication modules, e.g. ASM 456, RF160C, RF170C, RF180C, and RF182C, plug-in cable pre-assembled for SIMATIC MV440.
Available in the following lengths:

- 2 m
- 5 m
- 10 m
- 20 m
- 50 m

6GT2 891-4FH20
6GT2 891-4FH50
6GT2 891-4FN10
6GT2 891-4FN20
6GT2 891-4FN50

Note:

You can find more information in Catalog ID 10 and in the Industry Mall at www.siemens.com/industrymall

Motor starters for operation in the field, high degree of protection

M200D motor starters for PROFINET

Overview

The intelligent, highly flexible M200D PROFIBUS / PROFINET motor starters are the most functional motor starters of the SIRIUS motor starter family in the high degree of protection IP65 for PROFIBUS / PROFINET communication.

They start and protect motors and loads up to 5.5 kW. Direct-on-line and reversing starter versions are available in a mechanical version and also an electronic version (the latter with soft start function).

The particularly robust M200D PROFIBUS / PROFINET motor starters are characterized by numerous functions which can be flexibly parameterized. Their modular design comprises a motor starter module and a communication module.

The M200D PROFINET motor starters enable TIA-integrated parameterization through PROFINET from STEP 7 – in familiar, user-friendly manner with the same look-and-feel as PROFIBUS.

Functionality

- For basic functionality see Chapter 6 "AS-Interface" --> "Motorstarter M200D" --> "General data" --> "Overview"
- Electronic version also with soft start function
- Robust and widely used M12 connection method for the digital inputs and outputs and the PROFIBUS/PROFINET bus connection
- All four digital inputs and two digital outputs exist in the cyclic process image. This provides complete transparency of the process on the control level
- Full TIA integration: All digital inputs and outputs exist in the cyclic process image and are visible through the bus, providing maximum flexibility and excellent adaptability to the application.
- Flexible assignment of the digital inputs and outputs with all available assignable input actions
- Extensive diagnostics concept using LEDs and through the bus with the TIA-compatible mechanisms
- Expanded diagnostics using data records
- Complete plant monitoring using statistics data record and current value monitoring by means of data records
- Parameterization through PROFIBUS / PROFINET bus with the aid of data records from the user program
- Control of the motor starter using a command data record from the user program
- Removable modular control unit – quicker device replacement and therefore lower costs when device outages occur – since existing wiring is on the control unit and only one device needs to be replaced
- Parameterization in Step 7 HW config using Motor Starter ES (ordering option for start-up software)
- Start-up and diagnostics with the aid of Motor Starter ES (ordering option for start-up software)
- Trace function through Motor Starter ES for optimized start-up and tracking of process and device values

Only with PROFINET:

- Just one bus system from the MES level to the devices – no routers
- More stations on the bus and possible configuration of flexible bus structures
- Automatic re-parameterization in case of device replacement thanks to proximity detection
- Wireless integration of plant segments in difficult environments using WLAN
- Easier expansion of the system thanks to a higher number of stations on the bus and elimination of terminating resistors



M200D motor starter modules for PROFIBUS / PROFINET (without communication module)



M200D communication modules for PROFINET

Mounting and installation

The M200D PROFINET / PROFINET motor starter comprises a communication module and a motor starter module. Therefore only the motor starter module has to be replaced when replacing devices. This saves time and money. The communication module remains as an active station on the bus and all other system components continue running. This prevents downtime.

The integrated plug-in technology significantly reduces the wiring outlay: Connecting cables can be plugged directly onto the motor starter module. The PROFINET bus is connected cost-effectively using an M12 connection on the device. All versions have identical enclosure dimensions for easier system design and conversion.

PROFINET/Industrial Ethernet

Motor starters for operation in the field, high degree of protection

M200D motor starters for PROFINET

Overview (continued)

Parameterization and configuration

All motor protection functions, limit values and reactions can be defined by parameterization.

The user has several user-friendly options for parameterization. In addition to parameterization directly from STEP 7, which also permits automatic re-parameterization in case of device replacement, it is possible to use the user-friendly Motor Starter ES start-up software. By connecting a programming device directly to PROFIBUS / PROFINET and the Motor Starter ES start-up software, the devices can also be conveniently programmed from a central point through the bus. Parameters can also be changed during operation from the user program using the data record mechanism so that the function of the motor starter is adapted to the process when required. With the aid of a PC and the Motor Starter ES software, it is also possible to perform the parameterization through the local point-to-point interface on site.

Functions can be flexibly assigned to the digital inputs and outputs, adapting them to all possible conveyor applications. All digital inputs and outputs exist in the cyclic process image. All limit values for monitoring functions and their reactions are parameterizable and therefore adaptable to the application. It is designed to be compatible with other SIRIUS M200D motor starter products and the frequency converter and the ET 200pro peripheral system.

Only with the M200D PROFINET motor starter

Thanks to the integrated proximity detection, the device name does not need to be issued manually when a device is replaced. The name is issued automatically by the neighboring devices which note the "names" of the devices in their proximity. Therefore, no additional start-up measures are required when replacing a device.

The new motor starter generation is characterized by high functionality, maximum flexibility and the highest level of automation. The PROFINET is recommended in particular for expansive and highly automated system components because the possibility of monitoring devices and systems with data records (statistical data, measured values and device diagnostics) guarantees an in-depth view of the plant from the control room and therefore increases plant availability.

Operation

The motor starters record the actual current flow. Evaluating the current of the parameterizable solid-state overload protection increases the availability of the drives, as do reliable signals concerning the overshooting or undershooting of setpoint values.

Diagnostics and maintenance

Diagnostics is provided through numerous mechanisms – and can be used as the customer prefers.

The motor starter is TIA-diagnostics compatible, which means that when a fault is identified, a diagnostics alarm is distributed, which in a SIMATIC controller invokes the diagnostics-OB. The fault can be evaluated as usual in the user program.

The M200D motor starter offers a large variety of diagnostics data through data records. Its functionality is without equal on the market. There are extensive options for reading out data from the motor starter for monitoring devices, systems or processes.

The motor starter is equipped internally with 3 logbooks for device faults, motor starter trips and events, which are issued with a time stamp. These logbooks can be read out of the motor starter at any time in the form of data records and provide the plant operator with plenty of information about the state of his plant and process which he can use to carry out improvements.

With the slave pointer and statistical data functions it is possible to read out, for example, the maximum internal current values or the number of motor starter connection operations for plant monitoring purposes. This enables process deviations to be monitored or commissioning to be optimized. The user can draw conclusions about the actual load conditions of the devices in his process and on this basis can optimize his plant maintenance intervals.

The device diagnostics data record contains details of all the states of the motor starter, the device configuration and the communication as a basis for central device and plant monitoring.

The installation and maintenance functions (I&M) are used to store information (I&M) on the modules used in the motor starter as well as data (I&M), which can be specified by the user during configuration, such as location designations. I&M functions serve for troubleshooting faults and localizing changes in hardware at a plant or checking the system configuration. Reordering a device is particularly easy as a result.

The integrated maintenance timer can be used to implement preventative maintenance and avoid plant downtimes through look-ahead servicing.

Another new feature is the integrated TRACE function with the Motor Starter ES software. It can be used to record measured values as a function of time following a trigger event. This enables process flows to be recorded and their timing optimized.

Local control of a drive is possible using the ordering option with integrated manual operation. This is yet another new development which distinguishes the M200D PROFIBUS / PROFINET motor starter from the rest of the market and adds innovative technology, maximum availability and transparency to the system.

PROFINET/Industrial Ethernet

Motor starters for operation in the field, high degree of protection

M200D motor starters for PROFINET

Overview (continued)

M200D PROFINET motor starters with PROFlenergy

Increasing energy prices, far-reaching ecological problems worldwide and the threat of climate change make it necessary for you to be more conscious about your use of energy.

Active and effective energy management is possible with PROFlenergy.

PROFlenergy is a manufacturer-independent profile on PROFINET, which can be used by all manufacturers, has been standardized by PNO¹⁾ and supports the switching off of electrical devices during dead time and the measurement of energy flow.

¹⁾ In the PNO (PROFIBUS Nutzerorganisation e. V. – PROFIBUS User Organization), manufacturers and users have come together to agree on the standardized communication technologies PROFIBUS and PROFINET.

Switching off during dead times

PROFlenergy supports the targeted switching-off of loads during dead time.

These can be planned short breaks of a few minutes (such as lunch breaks), longer periods of dead time (such as nights) or unplanned dead time. Energy is always saved when no power is required.

Measuring and visualizing the energy flow as a basis of energy management

The objective of energy management is to optimize the use of energy in a company – from the purchasing of energy through to the consumption of energy – economically and ecologically.

Analyses of energy consumption over time can be used to control energy flows, avoid energy peaks, improve ratings and thus save costs.

PROFlenergy enables consumption data to be read off from the devices in a unified form. This is recorded during operation and can be displayed on a control panel, for example, or on overlying energy management software packages. This ensures that the measured variables are in a uniform manufacturer-independent form and structure that is available to the user for further processing. These PROFlenergy functions thus provide the basis for active load and energy management during operation.

PROFlenergy in the M200D PROFINET motor starter

The M200D PROFINET motor starter supports "switching during dead time" and "current measurement values" of the motor current using PROFlenergy. These are called commands, because they trigger a reaction in the M200D motor starter.

PROFINET/Industrial Ethernet

Motor starters for operation in the field, high degree of protection

M200D motor starters for PROFINET

Overview (continued)



**SIRIUS M200D
PROFIBUS**



**SIRIUS M200D
PROFINET**

Device functions (firmware features)

Slave on the bus

Fieldbus	✓ PROFIBUS to M12	✓ PROFINET to M12
Adjustable number of stations	✓ 1 ... 125	✓ 1 ... 128 with CPU 315, CPU 317 1 ... 1256 with CPU 319

Parameterization

DIP switches	✓ For address setting and terminating resistor	--
ES Motor Starter	✓ Through bus, optical interface	
PROFIBUS / PROFINET data records	✓	
From STEP 7 / HW config	✓	

Diagnostics

Acyclic through data records	✓
Support of diagnostics alarm	✓

Process image

Process image	✓ 2Byte PAE/ 2Byte PAA
---------------	------------------------

Data channels

Local optical interface (manual local)	✓
Through Motor Starter ES local interface	✓
Using Motor Starter ES through bus	✓

Data records (acyclic)

Parameterization	✓ Using DS 131 (DS = data record)	
Diagnostics	✓ Device-specific DS 92	
Measured values	✓ Measured values DS 94	
Statistics	✓ Statistical data DS 95	
Commands	✓ Using DS 93	
Slave pointer	✓ Slave pointer DS 96	
Logbook	✓ Using Motor Starter ES and data records: device fault DS 72, DS 73 trips, DS 75 events	
Device identification	✓ Using DS 100	
I&M data	✓ Using DS 231 ... 234	✓ Using data records 0xAFF0 ... 0xAFF3

Inputs

Number	✓ 4
• of these in the process image	✓ 4
Input action	✓ Parameterizable: flexibly assignable action (see manual)
Quick-Stop	✓ Parameterizable: latching, non-latching

✓ Function is available.

-- Function not available.

PROFINET/Industrial Ethernet

Motor starters for operation in the field, high degree of protection

M200D motor starters for PROFINET

Overview (continued)



**SIRIUS M200D
PROFIBUS**



**SIRIUS M200D
PROFINET**

Device functions (firmware features)

Outputs

Number	✓ 2
• of these in the process image	✓ 2
Output action	✓ Parameterizable: flexibly assignable action (see manual)

Brake output

180 V DC/ 230/400 V AC / none	✓
-------------------------------	---

Motor protection

Overload protection	✓ Electronic, wide range 1:10
Short-circuit protection	✓
Full motor protection	✓
Temperature sensor	✓ Parameterizable using ES Motor Starter, data record: PTC or Thermoclick or deactivated

Device functions

Repair switch	✓
Current limit monitoring bottom	✓ Parameterizable
Current limit monitoring top	✓ Parameterizable
Zero current detection	✓ Parameterizable: tripping, warning
Blocking current	✓ Parameterizable
Unbalance	✓ Parameterizable
Load type	✓ Parameterizable: 1- and 3-phase
Shutdown class	✓ Parameterizable using ES Motor Starter, data record: CLASS 5, 10, 15, 20
Protection against voltage failure	✓ Parameterizable: activated/deactivated

Support for PROFlenergy profile

Switching during dead times	--	✓
Measured current values of the motor current	--	✓

Soft starter control function

Soft start function	✓
Bypass function	✓ Only electronic version

✓ Function is available.

-- Function not available.

PROFINET/Industrial Ethernet

Motor starters for operation in the field, high degree of protection

M200D motor starters for PROFINET communication modules, motor starter modules

Benefits

M200D PROFINET motor starters with PROFlenergy

Both standards and laws are making environmental protection and energy management increasingly important, as is the desire to cut energy costs in production facilities and thus ensure a sustainable competitive advantage.

It is thus an objective within industry to save energy and actively reduce CO₂ emissions. By the careful use of valuable resources, the manufacturer-independent PROFlenergy profile on PROFINET can make an active contribution to environmental protection.

Application

M200D PROFIBUS / PROFINET motor starters are particularly suitable for fully TIA-integrated, highly automated conveyor applications which meet all needs with regard to the monitoring of devices and systems and preventative maintenance.

Adaptability of the motor starter functions and maximum flexibility of the device enable a broad range of application without any limits. The PROFINET-specific expansions are the best assurance of a future-proof investment.

Selection and ordering data



M200D motor starter module PROFIBUS/PROFINET (without communication module)

M200D PROFINET motor starter

Version	Order No.
---------	-----------

M200D communication modules for PROFINET

Communication module for PROFINET M12 termination 7/8"	3RK1 335-0AS01-0AA0
------------------------------------------------------------------	----------------------------

M200D motor starter modules for PROFIBUS / PROFINET

Electromechanical starter (with integrated protection)	3RK1 395-6	S41-	AD
		K	L
Setting range for rated operational current / A			
• 0.15 ... 2			
• 1.5 ... 12			
Direct-on-line starters/ reversing starters			
• Direct-on-line starters			0
• Reversing starters			1
• Direct-on-line starters with manual local operation			2
• Reversing starters with manual local operation			3
Brake actuation			
• Without brake actuation			0
• Brake actuation (230/400 V AC)			3
• Brake actuation (180 V DC)			5
Electronic starter (with thyristors)	3RK1 395-6	S71-	AD
		K	L
Direct-on-line starter/ reversing starter			
• Direct-on-line starters			0
• Reversing starters			1
• Direct-on-line starters with manual local operation			2
• Reversing starters with manual local operation			3
Brake actuation			
• Without brake actuation			0
• Brake actuation (230/400 V AC)			3
• Brake actuation (180 V DC)			5

2

PROFINET/Industrial Ethernet

Motor starters for operation in the field, high degree of protection

Accessories
for M200D motor starters for PROFINET

Overview

Note:

Accessories for all SIRIUS M200D motor starters (regardless of communication connection) see Chapter 6 "AS-Interface" --> "SIRIUS M200D motor starter" --> "Accessories"

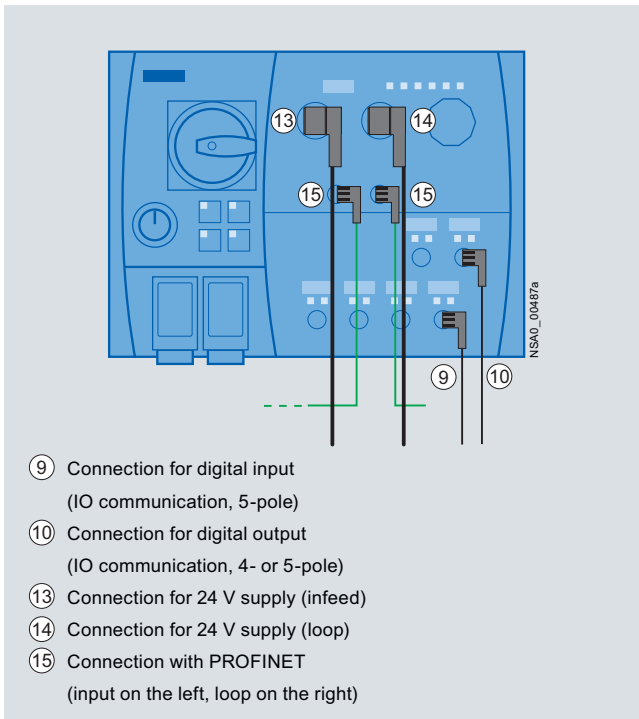



Communication connection using PROFINET and digital inputs and outputs

PROFINET/Industrial Ethernet

Motor starters for operation in the field, high degree of protection

Accessories for M200D motor starters for PROFINET





Overview (continued)

	Version	Order No.
<i>Motor control with PROFINET</i>		
	⑮ M12 plugs, angled Screw fixing, 4-pole screw terminals, max. 0.75 mm ² , angled, D-coded <ul style="list-style-type: none"> • 4 male contacts 	3RK1 902-2DA00
	⑮ Control cables, assembled at one end M12 for screw fixing, angled, 4-pole, D coded, <ul style="list-style-type: none"> • 4 male contacts, 3 m • 4 male contacts, 5 m • 4 male contacts, 10 m 	3RK1 902-2HB30 3RK1 902-2HB50 3RK1 902-2HC10
	⑮ Control cables, assembled at both ends M12 for screw fixing, angled at both ends, 4-pole, D coded, male contacts at both ends <ul style="list-style-type: none"> • 3 m • 5 m • 10 m 	3RK1 902-2NB30 3RK1 902-2NB50 3RK1 902-2NC10

Further accessories

PROFINET IE FC TP Standard Cable GP 2 x 2 sold by the meter	6XV1 840-2AH10
PROFINET IE FC TP Trailing Cable 2 x 2 sold by the meter	6XV1 840-3AH10
PROFINET IE FC TP Trailing Cable GP 2 x 2 sold by the meter	6XV1 870-2D
PROFINET IE FC TP Torsion Cable 2 x 2 sold by the meter	6XV1 870-2F
PROFINET IE FC TP Marine Cable, 4-core sold by the meter	6XV1 840-4AH10
Power cables 5-core, 5 x 1.5 mm ² , trailing, sold by the meter, minimum order quantity 20 m, maximum order quantity 1,000 m	6XV1 830-8AH10

More connection technology products can be found at our "Siemens Automation Solution Partners" www.siemens.com/automation/partnerfinder under the "Distributed Field Installation System" technology.

	Version	Order No.
<i>Connection for 24-V power supply of the M200D PROFIBUS/PROFINET</i>		
	Plug On M200D, 7/8" for screw fixing, angled, 1.5 mm ² screw connection <ul style="list-style-type: none"> • ⑮ 5 female contacts 	3RK1 902-3DA00
	<ul style="list-style-type: none"> • ⑭ 5 male contacts 	3RK1 902-3BA00
		
	⑮ Supply lines, assembled at one end 7/8" for screw fixing, angled, 1.5 mm ² <ul style="list-style-type: none"> • 5 female contacts, 3 m • 5 female contacts, 5 m • 5 female contacts, 10 m 	3RK1 902-3GB30 3RK1 902-3GB50 3RK1 902-3GC10
	⑮ ⑭ Supply lines, assembled at both ends 7/8" for screw fixing, angled at both ends, 5-pole pin/socket, 1.5 mm ² <ul style="list-style-type: none"> • 3 m • 5 m • 10 m 	3RK1 902-3NB30 3RK1 902-3NB50 3RK1 902-3NC10

Overview

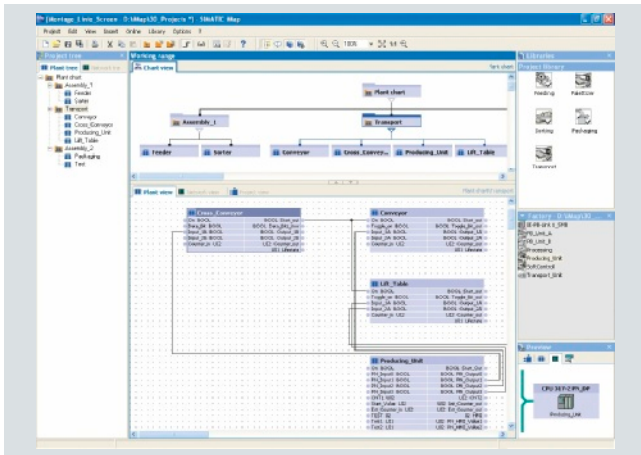

- Component-based software tool for configuring the communication in distributed automation solutions
- For easy graphical configuration of the communication between subsystems and machine-to-machine communication in the production line
- Based on the PROFINET standard
- Open for PROFINET devices from various manufacturers on Industrial Ethernet
- Runs under Windows 2000, Windows XP Professional and Windows 2003 Server

Ordering data

SIMATIC iMap V3.0

Target system:

CPU 31x-2 PN/DP,
CPU 319-3 PN/DP, S
SIMATIC WinAC PN,
SIMATIC NET IE/PB Link,
SIMATIC NET CP 343-1,
SIMATIC NET CP 343-1
Advanced,
SIMATIC NET CP 443-1
Advanced,
distributed I/O devices with own
CPU, PROFINET CBA OPC
server, devices on the
Industrial Ethernet based on the
PROFINET CBA standard,
SIMATIC OPs,
SIMATIC ProTool/Pro

Requirements:

Windows 2000 Prof. with Service
Pack 4 or later or Windows XP
Prof. with Service Pack 1 or later
or Windows 2003 Server with
Service Pack 1 or later;
on PG or PC with Pentium
processor,
min. 1 GHz; STEP 7 V5.3 or later
with Service Pack 3, PN OPC
Server V6.3 or later

Delivery form:

German, English,
with electronic documentation

Floating License

Software Update Service
(requires current software
version)

Upgrade to V3.0, floating license

Order No.

6ES7 820-0CC04-0YA5

6ES7 820-0CC01-0YX2

6ES7 820-0CC04-0YE5

Note:

You can find more information in Catalog ST 70 and
in the Industry Mall at www.siemens.com/industrymall

PROFINET/Industrial Ethernet

Software and tools

BANYnet bus analysis and diagnostics

Overview

BANYnet is a tool based on Microsoft Windows for documentation, monitoring, diagnostics, recording and analysis of Ethernet and PROFIBUS networks.

- Management of all IP and MAC addresses in the network
- Generation of a network overview map
- Automatic scanning of network
- Monitoring of network nodes for "Failure", "Newly added", "Not registered"
- Reading out of data, message frame types and error statistics from the network components
- Display of bus load
- Recording of message frame traffic
- Recording of PROFINET communication
- Recording of PROFIBUS communication
- Comprehensive trigger, filter and sorting functions

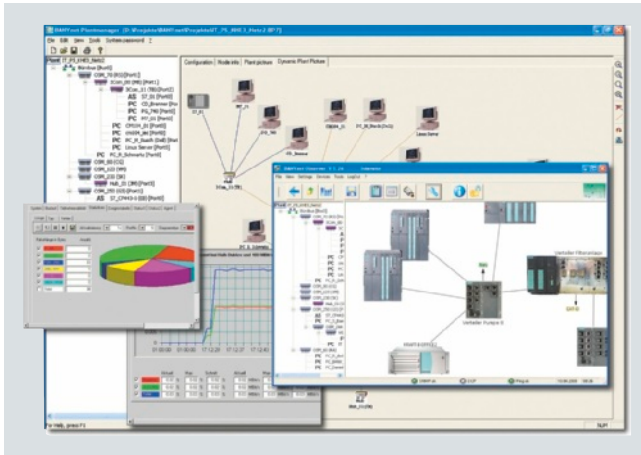

BANYnet plant configuration

Benefits

get Designed for Industry

- Continuously updated overview of the configured network (number/type of components)
- Permanent bus load display ensures sufficient performance in the network
- Fast localization of errors in network components
- Network optimization through statistics on type and length of message frame, cycle time, etc.

Application

The functionality for this is distributed as follows between five independent program modules:

- The Plant Manager of BANYnet Ethernet offers valuable support toward configuration of your plant through management of IP and MAC addresses, automatic generation of the plant display, and import and export functions.
- The Observer scans the network using various protocols, and displays safety-related changes in the network topology both in an overview and in a hierarchy.
- The Plant Diagnostics reads the configuration data as well as comprehensive message frame type and error statistics from the SNMP-capable network components, and provides information to assist searching for errors in the Ethernet network. Data such as bus load or lifelist are evaluated and displayed online.
- The Bus Analysis records the message frame traffic on one or more Ethernet buses synchronously, and interprets the message frames throughout all levels, including SIMATIC S7/PCS 7 and PROFINET. Comprehensive trigger, filter and sorting functions allow fast localization of errors.
- The Profibus Scope records the message frame traffic of a PROFIBUS network using a CP 5512, and interprets the message frames accordingly. Comprehensive trigger, filter and sorting functions allow fast localization of errors.

Function

The **Plant Manager** is used to configure the database of the BANYnet project. All information required is created in data structures. An import/export function allows data exchange with other programs. A user-friendly plant overview is automatically generated from the data structures. The Plant Manager can therefore be used for both documentation and configuration of Ethernet networks. Tables provide detailed information on the properties of the nodes. Furthermore, any type of information can be assigned to the individual nodes for documentation purposes.

The **Plant Diagnostics** scans the system data of SNMP-capable network nodes (e.g. switches, PCs), and thus provides information on the configured nodes. The bus load display of the individual ports (numeric or graphic) and the list of nodes provide great assistance in locating errors in the Ethernet network.

Statistics functions provide information on the number of individual message frame types (packet lengths, message frame types, error types, etc.). The events (traps) sent by the switch can be displayed in a list.

Parameterization of the SCALANCE X and OSM/ESM Industrial Ethernet switches is supported in addition, e.g. IP address, port configuration or firmware update.

Function (continued)

The **Bus Analysis** allows user-friendly analysis of recorded files (import/export of Netmon or Sniffer files is also possible) over several interfaces simultaneously (e.g. for redundancy analyses) by means of the integral BANYmon. Errors can be rapidly located using predefined or user-generated filter and sorting functions. When one of the listed message frames is clicked, the associated detailed information is output. SIMATIC S5/S7/PCS 7-specific message frames are interpreted and displayed according to their type (e.g. redundant message frames, alarm-8 message frames, etc.).

When using a CP 1616, PROFINET data traffic can be recorded without time losses and with complete message frame interpretation.

The **Observer** permits user-friendly and reliable dynamic monitoring of your network. The actual state is compared with the project created in the Plant Manager, and changes are displayed immediately. In order to locate events such as errors or the penetration of unknown nodes, it is possible to graphically trace the network hierarchy back to the source. In addition, these events are saved in log files for later analysis and documentation.

Furthermore, the scanned data can be imported into the project and updated supplementary to the Plant Manager.

The **PROFIBUS Scope** permits recording, saving and user-friendly analysis of bus events. It supports all baud rates from 9.6 kbit/s to 12 Mbit/s, and determines these automatically. The recording can be carried out in a linear buffer or a cyclic buffer of selectable size. Long-term recording is possible in this manner. The start and end of recording can be automated using triggers. The data quantities can be reduced during the recording using predefined or user-created filter and sorting functions, and errors can be easily located by means of the subsequent analysis. When a listed message frame is clicked, its detailed information is output. The SIMATIC S7/PCS 7-specific message frames are interpreted and displayed depending on their type (e.g. redundant message frames, alarm-8 message frames, etc.). The following protocols are interpreted: DP, FDL, DPV1, DPV2, FMS and S7.

The BANYnet function for executing several recordings in parallel can be used for the **redundancy analysis**. BANYnet PROFIBUS is connected to the redundant bus segments for this purpose. Since the recorded message frames are assigned synchronous time stamps, the communication flow information can be easily compared. This allows fast and exact locating of redundancy problems.

Note:

The computer with the BANYnet PROFIBUS program package requires a CP 5512 (PC card) for the PROFIBUS connection.

Ordering data

Order No.

BANYnet bus analysis and diagnostics

Program package for PC/PG for Microsoft Windows NT/2000/XP SP2 and electronic documentation on CD, dual language (German, English), software protected by USB dongle

- **BANYnet Ethernet** for Industrial Ethernet networks
- **BANYnet PROFIBUS** for PROFIBUS networks; (CP 5512 is required)
- **BANYnet Ethernet and PROFIBUS** for Ethernet and PROFIBUS networks; (CP 5512 is required)

9AE4 100-1DB00

9AE4 100-1DE00

9AE4 100-1DF00

CP 5512 communication processor

PC card (CardBus, 32 bit) for connection of a programming device or notebook to PROFIBUS or MPI, under 32 bit in connection with PROFIBUS SOFTNET software or STEP 7; German/English

6GK1 551-2AA00

Communication processor CP 1616

PCI Card (32 bit; 3.3/5 V universal keyed) with ASIC ERTEC 400 for connecting PCs to PROFINET IO with 4-Port-Real-Time-Switch (RJ45); incl. IO Base Software for PROFINET IO Controller and NCM PC; single license for one installation, runtime software, software and electronic manual on CD-ROM, Class A, for 32-bit Windows XP Professional and Windows 7; other operating systems via Development Kit DK-16xx PN IO; German/English

6GK1 161-6AA01

More information

Support can be found at:
www.siemens.com/simatic-net/ik-info

PROFINET/Industrial Ethernet

Software and tools

BANY PN IO

Overview



- Network analysis BANY PN IO
- Comprising hardware and software components
- USB memory expansion possible
- Frame recording with 10 ns resolution
- Automatic PROFINET analysis
- Online value tracking
- Packet generator with feedback analysis
- Control interface using script or TCP commands

Benefits

- Direct and immediate online analysis in real time and precise statement of the quality of the network.
- Recording at all speeds without losses and exact time stamping by hardware-based processing.
- When analyzing and monitoring PROFINET components, it is possible to match and verify the frame structure, the frame times and the frame synchronization.
- Fast error analyses and improved performance in plant operation, in particular in networks in which products of different vendors are being used.
- Active measurements on the network with a packet generator: Feed in of frame sequences, delay time measurements, network reactions.
- Simple reproduction of automation of test scenarios / measurements controlled by scripts.

Application

BANY PN IO is the analysis tool for Ethernet / PROFINET. It is made up of a hardware component and a Windows application that communicate with each other over Ethernet. The hardware is controlled and has parameters assigned by the application (triggers, filters, start, stop etc.), the application also downloads the recorded data and statistics to the analysis computer where they are interpreted, displayed and saved.

The many functions of BANY PN IO are implemented in individual modules. The modular structure allows target-oriented localization of error sources and the detection of weak points long before problems occur. The following modules are available:

- **Frame recording** allows the precise recording of frames on Ethernet / PROFINET.
- **PROFINET analysis** automatically detects all relevant bus parameters (number of frames, bus cycles, etc.) online in real time and displays them in tables and graphically.
- **Online value tracking** allows the user to extract and record any variables and values of the communications partners from the frame traffic.
- With the **packet generator**, recorded or self-generated frame sequences can be fed into the Ethernet network and the reaction of the network measured automatically.
- Control of all functions by script or a remote interface (Ethernet, TCP) is possible.

Design

- Module in housing without fan (with bracket for mounting on a DIN rail)
- Power supply 24 V (does not ship with product)
- Four independent RJ45 analysis interfaces for connection to Ethernet
- One RJ45 interface for Ethernet connection of the module to the host PC
- Internal memory with 2 GB (can be set as a ring buffer)
- Binary hardware inputs and outputs (can be used as trigger inputs and outputs)
- USB Interface for connection of external storage media

Product versions

Standard version:

Includes the frame recording and PROFINET analysis modules.

Premium version:

Includes the frame recording, PROFINET analysis, online value tracking and packet generator modules.

The option of controlling with a script or by applications is available with both versions.

Function

All the functions of the BANY PN IO are controlled by the "BANYscope" program that ships with the product. This Windows application is connected to the BANYsys module via an Ethernet connection. This is possible via a direct connection, via a network or via a VPN tunnel.

The four analysis ports can be used by all function modules but not at the same time. They need to be enabled and assigned to the module being used.

On completion of the parameter assignment and after starting the relevant analysis function, the connection between BANY PN IO and "BANYScope" can be terminated, in other words, the module then works alone.

The **frame recording** provides a comfortable option of recording communication on Ethernet connections at speeds from Fast Ethernet to gigabit Ethernet.

The design of BANY PN IO completely in FPGA technology allows error-free recording of all data with time stamping of 10 ns. Even bad frames are not automatically discarded but can be saved and evaluated.

The four recording ports can be used independently for recording. If a "Test Access Point" (TAP) is used to monitor the frames instead of a hub or a switch mirror port, it is possible to interconnect ports; in other words, to bundle their data streams and to save and evaluate them together.

To allow the recording to be controlled effectively, freely programmable filters and triggers are available. Apart from the standard filters and functions such as addresses, protocols and patterns, there are also special functions that can trigger on frame timeouts and bad frames (CRC error, undersize error etc.). The integrated hardware inputs can also be used to fire triggers using external binary signals.

The data is saved in the internal RAM (2 GB capacity) that can also be set as a ring buffer. At the end of the recording, the data is loaded and saved either on the PC via the Ethernet host connection or on an external storage medium connected via USB.

If it is necessary to record larger volumes of data, the data can also be streamed to the PC during the recording and saved there.

All frames are saved in a file in "pcap" format that can, for example, be read by Wireshark.

PROFINET analysis automatically detects all important parameters of a PROFINET system. BANY PN IO analyzes the frame traffic in real time in terms of frame type, cycle times and many other important characteristics of the network.

During the analysis, all PROFINET nodes are listed in table. The following information is displayed and updated cyclically for each node:

PROFINET class, number of sent/received packets, desired cycle time, min/max cycle time, min/max cycle time deviation.

The number of frames sent by each node per time unit can be visualized in a cycle time diagram. These are displayed graphically in a distribution curve. At a glance, it is possible to see how well the PROFINET component keeps to the cycle.

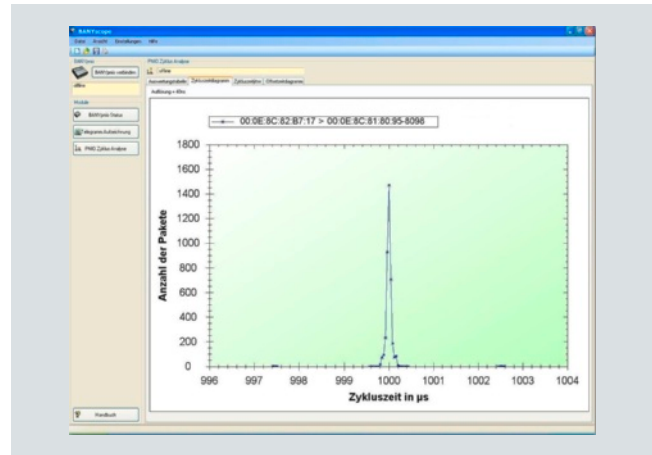

During the analysis of PROFINET IRT, not only the degree to which individual components adhere to the cycle is important, but also the offset of the time of sending within the cycle; in other words, its behavior in conjunction with the other communications partners in the network. The offset diagram can display the distribution curves of all nodes in the cycle to allow a statement to be made regarding the quality within the entire network and the time slice distribution of its nodes.

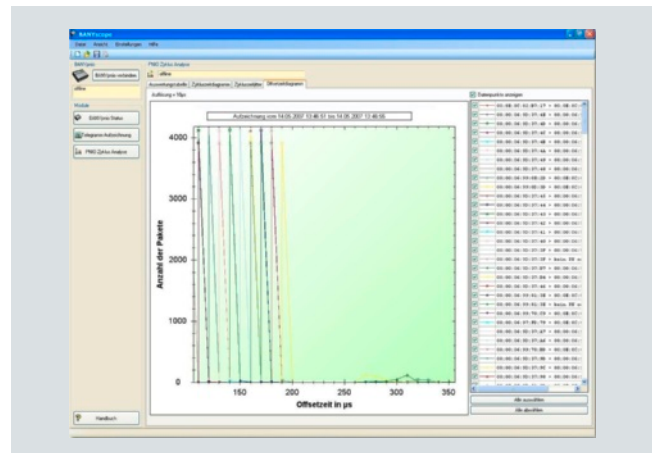

Based on intuitively structured filter menus, the **online value tracking** provides a simple and uncomplicated means of extracting data from the frame traffic. In contrast to the frame recording, complete frames are not saved here but rather individual values of the relevant communications partners transferred via PROFINET.

This means, for example, that the setpoint of a controller, the speed of a motor etc. can be read directly from PROFINET and saved with a time stamp (resolution 10 ns). This is displayed in a table or graphically in the form of a curve that represents the values over time online and in real time.

To be able to select the values, the address of the node, the byte position of the value within the frame and the number of bytes to be read must be specified in the filter. The size of the values is limited to 8 bytes. All available formats can be interpreted (binary, integer, analog, ...).

Up to four values can be recorded simultaneously. There is no limit to the recording time.

PROFINET/Industrial Ethernet

Software and tools

BANY PN IO

Function (continued)

The **packet generator** allows any Ethernet frames to be injected into the network. To allow this, all four analysis ports are available and are independent of each other. As an alternative, the ports can also be coupled together in pairs as sender/receiver to be able to read in sent frames and to verify the read frames with the sent frames.

The frames to be sent are transferred to the module as input in the form of "pcap" files. These inputs can either be generated by recording or can be created as new frames using the integrated pcap editor.

Each port has its own menu for setting the relevant send options. Among other things, the packets can be sent as follows:

- Cyclically (with breaks)
- As a fixed percentage of bus load
- With a specified number of repetitions
- For a specified time etc.

At the end of the action, all important parameters (bus load, duration etc.) are output as statistics.

All the modules listed above can also be remotely controlled by a **script**. To allow this, each action taken by the user is logged in the integrated script window. The log can be saved, edited and transferred later to BANYscope when this is called. All the instructions in the script are then executed. This allows automated test sequences, for example for setting up test automats. The manual contains an overview of all the script commands that can be used.

As an alternative, the script commands can also be transferred using a remote interface (via TCP/IP) by another application to BANYscope. When TCP is used as the transfer interface, the application does not need to be located on the same computer as BANYscope, only in the same network. A sample program in C# ships with the product.

Ordering data

Order No.

BANY PNIO Standard

BANYsys module and BANYscope software.
Function modules included:

- Frame recording
- PROFINET analysis

9AE4 121-1AA00

BANY PNIO Premium

BANYsys module and BANYscope software.
Function modules included:

- Frame recording
- PROFINET analysis
- Online value tracking
- Packet generator

9AE4 121-1AB00

Plug-in power supply

24 V / 2.5 A
(with IEC socket for non-heating devices)

9AE4 130-1AA00

TAP C1P-100

Test Access Point for Fast Ethernet incl. power supply unit, crossover cable, TP cable and soft bag

9AE4 130-2AA00

TAP C1P-100

Test Access Point for Fast Ethernet with 24 V connector

9AE4 130-2AA10

TAP C1P-1G

Test Access Point for gigabit Ethernet incl. power supply unit, crossover cable, TP cable and soft bag

9AE4 130-2AB00

Overview

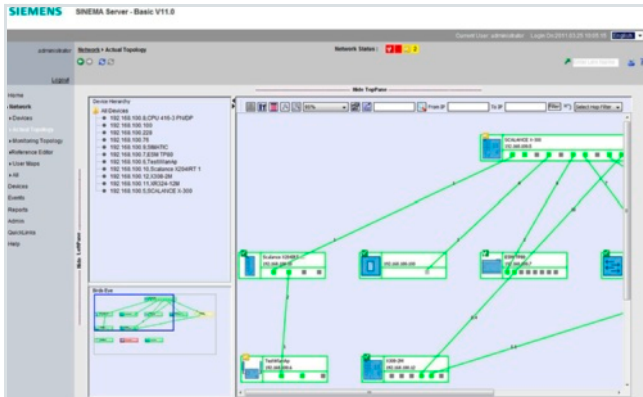

SINEMA Server is a web-based network monitoring software that significantly reduces the response time to communications problems in industrial networks, and thus avoids downtimes and saves costs.

- Simple operator input even for plant operators or service personnel, to enable autonomous detection and correction of communications problems
- Graphical representation of industrial network structures (automatic topology detection)
- Standardized network documentation (reports for SLAs, i.e. **S**ervice **L**evel **A**greements)
- Simple operation via web browser or via an HMI/SCADA application, without special IT knowledge
- Automatic saving of network data such as network topology and device information
- Low installation and maintenance costs, especially thanks to the use of pre-installed industrial PCs (SIMATIC IPC427C Microbox PC)

Benefits

get Designed for Industry

- Simple error detection and location thanks to clear graphical and tabular display (e.g. color-coded representation of cables and devices in a network topology)
- Reaction-free integration into existing industrial networks and connection to existing HMI-SCADA systems with the help of OPC and Web technology
- Shortening of signaling channels and avoidance of standstills by means of automatic alarm forwarding, e.g. per e-mail to an administrator or per OPC to an HMI/SCADA system.
- Traceability of changes in the network (devices and connections) and verification of availability by means of network report
- Lower procurement costs and no costly training and maintenance license costs in comparison to IT network management systems
- High degree of flexibility for the topology display through automatic identification and customizable display

Application

Application examples

With SINEMA Server, the benefits of a network diagnostics solution, long-familiar in the IT environment, can now also be used for industry and its HMI/SCADA systems (e.g. in WinCC and PCS 7).

Network information prepared by SINEMA Server can be called up by any clients via a Web browser or OPC interface.

The software is suitable for applications with 20 to max. 250 devices per SINEMA Server station, identifiable via IP address:

- Network monitoring in factory and process automation networks, e.g.
 - Robot cells
 - Bottling machines and packaging machines
 - Pharmaceutical and chemical plants
- Network monitoring in industry-related applications, e.g.
 - Logistics processes
 - Power generation and distribution
 - Infrastructure projects

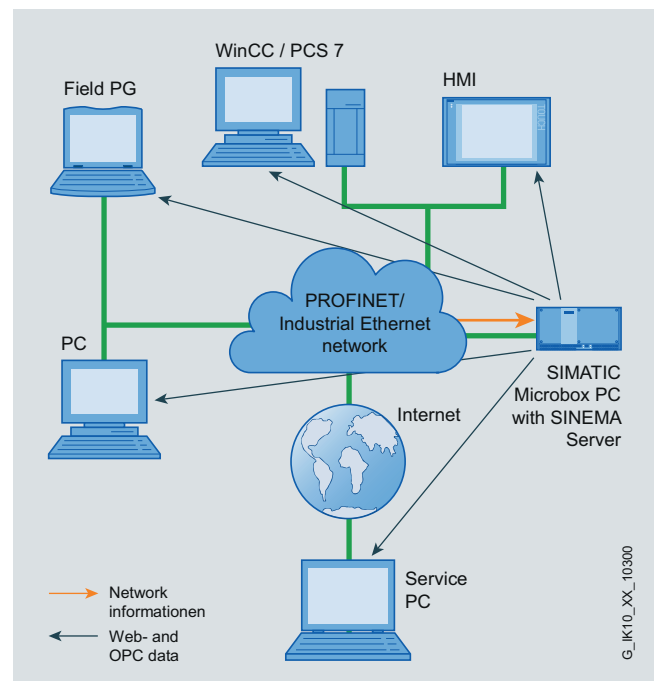

Clients call up the network information prepared by SINEMA Server

PROFINET/Industrial Ethernet

Software and tools

SINEMA server

Design

Product versions

The number of Ethernet devices to be monitored must be taken into account when selecting the software license. Each device that can be identified via the IP address, e.g. a SCALANCE X Industrial Ethernet switch, is assigned an IP address regardless of the number of ports.

Different product licenses are available depending on the number of supported network devices:

SINEMA SERVER Basic 50

- Supports the diagnosis of up to 50 IP devices

SINEMA SERVER Basic 100

- Supports the diagnosis of up to 100 IP devices

SINEMA SERVER Basic 250

- Supports the diagnosis of up to 250 IP devices

Function

Automatic detection and monitoring of network stations

SINEMA Server is especially suitable for operating and maintenance personnel in process and production plants who are responsible for round-the-clock uninterrupted operation of the automation systems and networks.

All the collected network data can be displayed via a Web-based interface on every PC in the network with the help of a browser (Microsoft Internet Explorer or Mozilla Firefox). No other software need be installed to display the network data.

SINEMA Server continuously represents the device status and connection status from the network graphically in different colors, and indicates difficulties before they become problems. In this way, operators can see immediately if a device has failed or a connection is overloaded.

Looming failures of network components indicated by an increase in the number of error message frames are also detected and displayed graphically.

Additional information about the network stations, the connection, or an event can also be displayed.

Standardized diagnostics of Ethernet, PROFINET and WLAN devices

SINEMA Server uses standardized Ethernet protocols such as ICMP (Internet Control Message Protocol), DCP (Discovery and Configuration Protocol) and SNMP (Simple Network Management Protocol) for detecting and diagnosing network devices.

Network stations and their connections are automatically detected and continuously monitored by entering the IP scan ranges and the SNMP passwords.

As delivered, essential vendor-neutral and standardized data (type, status and number of interfaces and connections from SNMP-MIBs) is detected, as well as other information specific to Siemens devices, such as the status of the redundancy manager in the case of SCALANCE X and wireless signal information in the case of SCALANCE W.

The device information is read out automatically at pre-defined intervals and saved in a database.

The current data can be clearly sorted and displayed at any time in list form and as a property dialog for each device.

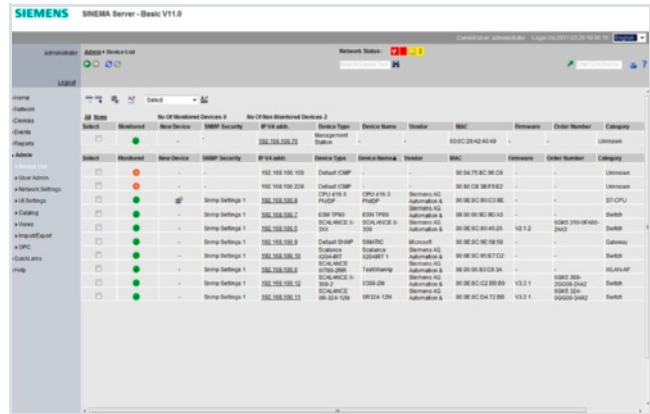

Fault detection in the network

- Failure of devices and interfaces/ports
- Faults and failure of ring redundancy
- Malfunctioning of devices and interfaces/ports
- Overload of devices and interfaces/ports
- Loss of IP addresses
- Discovering new, unknown devices
- Discovery of new and modified interfaces/port connections (topology)
- Sporadic communication failures
- Duplicate IP addresses

Reporting and analysis of network events

SINEMA Server receives and generates network alarms and saves these with a time stamp in a message database. These messages are displayed in a table and contain all the important information about events on the network, such as the failure of devices and/or connections.

Filtering and sorting functions allow fast analysis of the data according to specific criteria such as source, priority, number of repetitions, and time stamp.

Alarm messages can be forwarded quickly and automatically by e-mail to those responsible (e.g. production and maintenance personnel) or via OPC to an HMI/SCADA system.

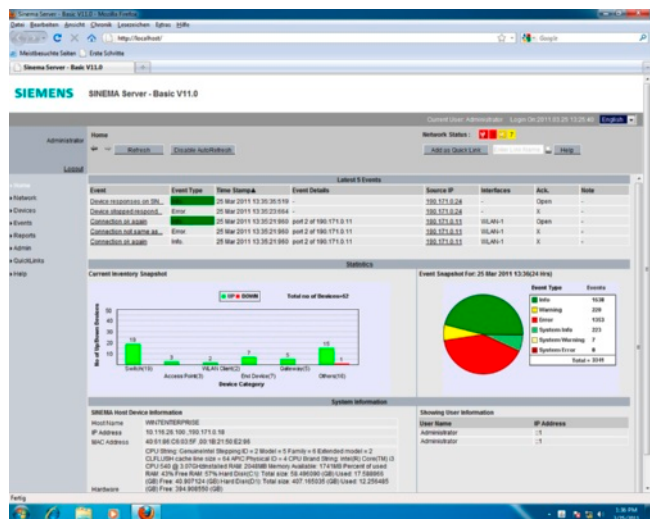

Ordering data	Order No.		Order No.
<p>SINEMA Server Basic V11</p> <p>Network monitoring software for Industrial Ethernet and PROFINET networks, runtime software, software and electronic manual on CD-ROM, license key on USB flash memory; software for installation on PC hardware with 32-bit Windows XP, Windows 2003 Server R2 and Windows 7; English/German</p> <ul style="list-style-type: none"> • For 50 devices that can be identified via IP address • For 100 devices that can be identified via IP address • For 250 devices that can be identified via IP address 	<p>6GK1 781-1BA01-1AA0</p> <p>6GK1 781-1DA01-1AA0</p> <p>6GK1 781-1HA01-1AA0</p>	<p>Accessories</p> <p>SIMATIC IPC427C</p> <p>Intel Celeron M 1.2 MHz, 800 MHz FSB, SLC 0 KB; 512 MB DDR3 RAM; without HD; without flash drive; without operating system; 24 V DC industrial power supply</p> <p>Minimum hardware requirements for SINEMA Server:</p> <p><i>Processor:</i> Core2 Duo 1.2 GHz, 800 MHz FSB, 3 MB SLC;</p> <p><i>memory configuration:</i> 2 GB DDR3 1066, SODIMM;</p> <p><i>internal drives:</i> 250 GB HDD SATA;</p> <p><i>operating system:</i> Windows XP Professional</p>	<p>6ES7 647-7B...-...0</p> <p>Note: Other versions can be ordered via the SIMATIC IPC427C configurator at: www.siemens.com/ipc-configurator</p>

PROFINET/Industrial Ethernet

PROFINET Technology components

Enhanced Real-Time Ethernet Controller ERTEC

Overview

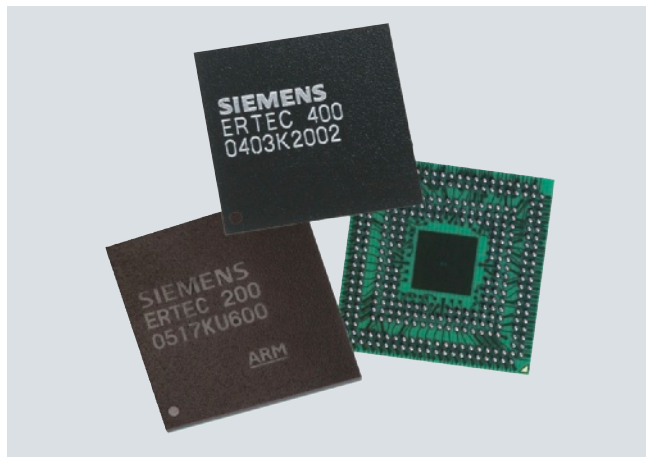

With the Industrial Ethernet ASICs of the ERTEC family (**E**nhanced **R**eal-**T**ime **E**thernet **C**ontroller), devices and systems can be connected to PROFINET without great effort. The high-performance Ethernet controllers with 32-bit microprocessor as well as integral real-time switch for Real Time Ethernet have been specially developed for industrial use.

These Ethernet controllers handle all the data transmission for PROFINET IO in real time (RT) and isochronous real time (IRT) and thus offload the application processor. Thanks to the integral 2-port switch (ERTEC 200) or 4-port switch (ERTEC 400), there are no costs for external switches. Flexible topologies such as star, tree and linear topologies can be implemented without any other external network components.

- ERTEC 200 with an integral 2-port switch for developing simple or modular PROFINET field devices. It also contains integral PHYs for linking the Ethernet controllers to the physical communication network.
- ERTEC 400 with 4 integral ports and one integral PCI interface for developing controllers and network components.

The DK-ERTEC 200 PN IO and DK-ERTEC 400 PN IO Development Kits enable the uncomplicated development of PROFINET field devices thanks to fast and simple integration of the PROFINET IO functionalities based on the ERTEC. The ERTEC 200 PN IO Starter Kit is especially suitable for low-cost introduction to PROFINET field device development.

Ordering data

Order No.

ERTEC 400 (lead-free)

ASIC ERTEC 400 for connection to switched Ethernet 10/100 Mbit/s, Ethernet controller with integrated 4-port switch, ARM 946 RISC and PCI interface (V2.2), data preparation for real-time and isochrone real-time for PROFINET IO

- 70 units (individual tray),
- 350 units (drypack, 5 trays)

6GK1 184-0BB01-0AA1
6GK1 184-0BB01-0AA2

Development Kit DK-ERTEC 400 PN IO

6GK1 953-0CA00

ERTEC 200 (lead-free)

ASIC ERTEC 200 for connection to switched Ethernet 10/100 Mbit/s, Ethernet controller with integrated 2-port switch, ARM 946 processor and integrated PHYs real-time for PROFINET IO

- 70 units (individual tray),
- 350 units (drypack, 5 trays)

6GK1 182-0BB01-0AA1
6GK1 182-0BB01-0AA2

Development Kit DK-ERTEC 200 PN IO

6GK1 953-0BA00

ERTEC 200 PN IO Starter Kit

6ES7 195-3BD00-0YA0

Note:

You can find more information in Catalog ST 70 and in the Industry Mall at www.siemens.com/industrymall

More information

You can find further information, technical data and manuals on the Enhanced Real-Time Ethernet Controller ERTEC on the Internet:

www.siemens.com/ertec

You can find more information on the Internet at:

<http://support.automation.siemens.com/WW/view/en/18977720/133300>

Support

The competent and experienced staff at the PROFINET Competence Centers in Europe and the U.S. offer free telephone advice as well as individual and agreed development and support on-site – from the initial information all the way to conclusion of the development with certification.

If you have any questions, your contact partner will be pleased to help:

Germany and Europe

Siemens AG
Communication, Development & Certification (ComDeC)
P.O. Box 2355
90713 Fürth, Germany
Tel.: +49 (911) 750-2080
Fax: +49 (911) 750-2100
E-mail: http://comdec@siemens.com

USA and International

PROFI Interface Center (PIC)
One Internet Plaza
PO Box 4991
Johnson City, TN 37604
Tel.: +1 (423) - 262 - 2687
Fax: +1 (423) - 262 - 2103
E-mail: http://pic.industry@siemens.com

PROFINET/Industrial Ethernet

PROFINET Technology components

Development kit for ERTEC

Overview



With the help of the development kits for the Enhanced Real-Time Ethernet Controller ERTEC, compact or modular PROFINET IO field devices can be developed in a short time and without great effort.

The DK-ERTEC 200 PN IO and DK-ERTEC 400 PN IO development kits enable comprehensive implementation of the PROFINET IO functionality. The low-cost starter kit is suitable as an introduction to PROFINET technology and can later be upgraded to a full DK-ERTEC 200 PN IO.

New: Since Version 3.2, the innovative functions Shared Device, MRP and PROFlenergy have been included in the development packages and can be integrated into PROFINET IO field devices at no additional expense.

Ordering data

Order No.

ERTEC development kits

- DK-ERTEC 200 PN IO
 - DK-ERTEC 400 PN IO
- ERTEC 200 PN IO Starter Kit
PROFI-safe starter kit V3.4

6GK1 953-0BA00
6GK1 953-0CA00
6ES7 195-3BD00-0YA0
6ES7 195-3BF02-0YA0

ERTEC ASICs

ERTEC 200

ASIC ERTEC 200 for connection to switched Ethernet 10/100 Mbit/s, Ethernet controller with integrated 2-port switch, ARM 946 processor and integrated PHYs real-time for PROFINET IO

- 70 units (individual trays),
- 350 units (drypack, 5 trays)

6GK1 182-0BB01-0AA1
6GK1 182-0BB01-0AA2

ERTEC 400

ASIC ERTEC 400 for connection to switched Ethernet 10/100 Mbit/s, Ethernet controller with integrated 4-port switch, ARM 946 RISC and PCI (V2.2), data preparation for real-time and isochronous real-time for PROFINET IO

- 70 units (individual trays),
- 350 units (drypack, 5 trays)

6GK1 184-0BB01-0AA1
6GK1 184-0BB01-0AA2

Accessories

PROFINET IO product line license for one product line

6ES7 195-3BC10-0YA0

Note:

You can find more information in Catalog ST 70 and in the Industry Mall at www.siemens.com/industrymall

PROFINET/Industrial Ethernet

PROFINET Technology components

Development kit for Standard Ethernet Controllers

Overview



With the help of the development kit for Standard Ethernet Controllers, PROFINET IO Devices can be developed on the basis of a Standard Ethernet Controller.

Benefits

- Easy development of PROFINET field devices with real-time communication (RT)
- Optimally interacting software components for developing PROFINET field devices.
- With the help of detailed instructions, this provides a simple introduction to PROFINET IO technology for device manufacturers.
- Easy creation of a specific GSD file thanks to the supplied example GSD file.
- Shorter development times due to a "ready-to-use" application example and a system modification for an ARM9-based controller manufactured by Digi.
- Easy porting to other 32-bit microcontrollers and other 32 bit real-time operating systems through the consistent use of hardware interfaces and operating system abstraction interfaces.

Application

The development kit for Standard Ethernet Controllers enables the development of a PROFINET field device on the basis of a Standard Ethernet Controller. To enable its use to be as platform-independent as possible, the PROFINET IO stack supplied in the source code has been optimized for simple porting. This development kit offers everything required for developing PROFINET field devices with real time (RT).

Design

The CD of the development kit for standard Ethernet controllers contains the following components:

- PROFINET IO device stack in source code
- Application example based on an ARM9 controller manufactured by Digi
- Documentation material in English and German
- GSD file
- Software example for PROFINET IO controller test partner (test partner is not included in the scope of supply of the hardware)

Ordering data

Order No.

Development kit for standard Ethernet controller

6ES7 195-3BC00-0YA0

For Ethernet processor

Accessories

PROFINET IO product line license for one product line

6ES7 195-3BC10-0YA0

More information

You can find further information, technical data and manuals on the development kit for Standard Ethernet Controllers on the Internet:

www.siemens.com/ertec

You can find more information on the Internet at:

<http://support.automation.siemens.com/WWW/view/en/18977720/133300>

Licensing

The development kit for Standard Ethernet Controllers contains a development license that authorizes the user to develop and test PROFINET IO Devices on the basis of the PROFINET IO device stack included in the scope of delivery.

For the production of series devices, one product line license must also be obtained for each product line under the Order No. 6ES7 195-3BC10-0YA0.

For further details of the currently applicable licensing rules, contact our Competence Center ComDeC and PIC.

Support

The competent and experienced staff at the PROFINET Competence Centers in Europe and the U.S. offer free telephone advice as well as individual and agreed development and support on-site – from the initial information all the way to conclusion of the development with certification.

If you have any questions, your contact partner will be pleased to help:

Germany and Europe

Siemens AG
Communication, Development & Certification (ComDeC)
P.O. Box 2355
90713 Fürth, Germany
Tel.: +49 (911) 750-2080
Fax: +49 (911) 750-2100
E-mail: [http://comdec@siemens.com](mailto:comdec@siemens.com)

USA and International

PROFI Interface Center (PIC)
One Internet Plaza
PO Box 4991
Johnson City, TN 37604
Tel.: +1 (423) - 262 - 2687
Fax: +1 (423) - 262 - 2103
E-mail: [http://pic.industry@siemens.com](mailto:pic.industry@siemens.com)

Overview



PN	DP-M	DP-S	ASi-M		
●	●				

- Compact router between Industrial Ethernet and PROFIBUS
- Connection to Industrial Ethernet with 10/100 Mbit/s full/half duplex connection with autosensing for automatic switchover
- Connection to PROFIBUS with 9.6 kbit/s to 12 Mbit/s incl. 45.45 kbit/s for PROFIBUS PA
- PROFINET IO proxy; connection of PROFIBUS DP slaves to PROFINET IO controller according to PROFINET standard:
 - From the viewpoint of the IO controller, all DP slaves are handled like I/O devices with Ethernet interface, i.e. the IE/PB Link PN IO is their proxy.
- Cross-network programming device/operator panel communication by S7 routing, i.e. all S7 stations can be remotely programmed by the programming device on the Industrial Ethernet or PROFIBUS.
- Cross-network access to data of S7 stations for visualization by means of S7 OPC server and S7 routing;
 - Via the IE/PB Link PN IO access can be made from the PC on the Industrial Ethernet (e.g. for HMI applications with OPC Client interface) by means of S7 OPC server, to all data of the S7 stations on the PROFIBUS.
- Module replacement without the need for a programming device, using the C-PLUG swap media for backing up the configuration data

Benefits



PROFINET applications

- Protection of investment due to simple connection of PROFIBUS DP slaves to PROFINET IO controller
- Enables the use also in plants with PROFIsafe applications
- Independence from individual vendors through support of the PROFINET standard for distributed field devices

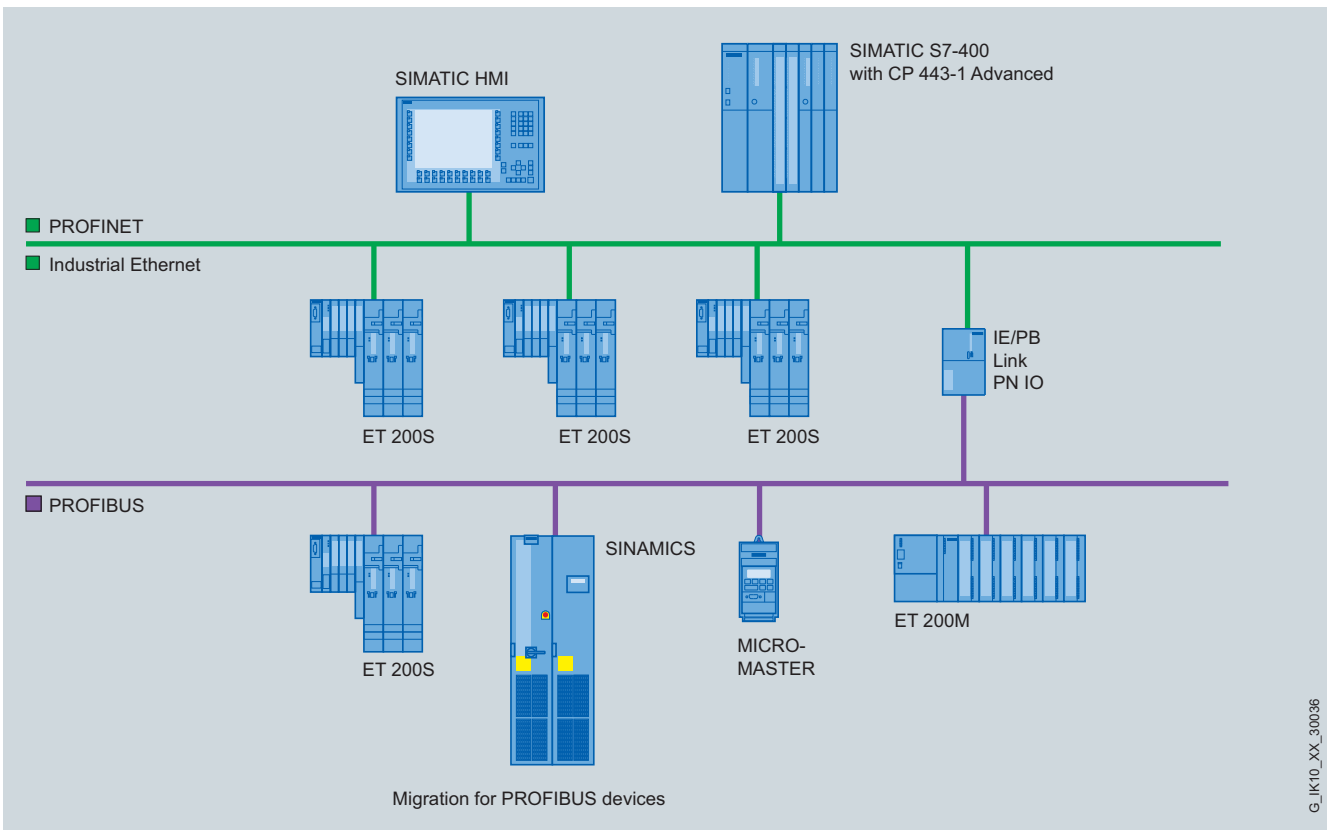

Configuration example of PROFIBUS and PROFINET
PROFIBUS devices can be seamlessly integrated into PROFINET over the IE/PB Link PN IO as proxy.

PROFINET/Industrial Ethernet

Network transitions

IE/PB Link PN IO

Benefits (continued)

Applications in the case of vertical integration

- Worldwide access to data of the PROFIBUS stations via Industrial Ethernet and Internet for vertical integration
- Optimization of a plant from a central location
- Access to process data from all enterprise levels
- Loading of STEP 7 programs from a central location

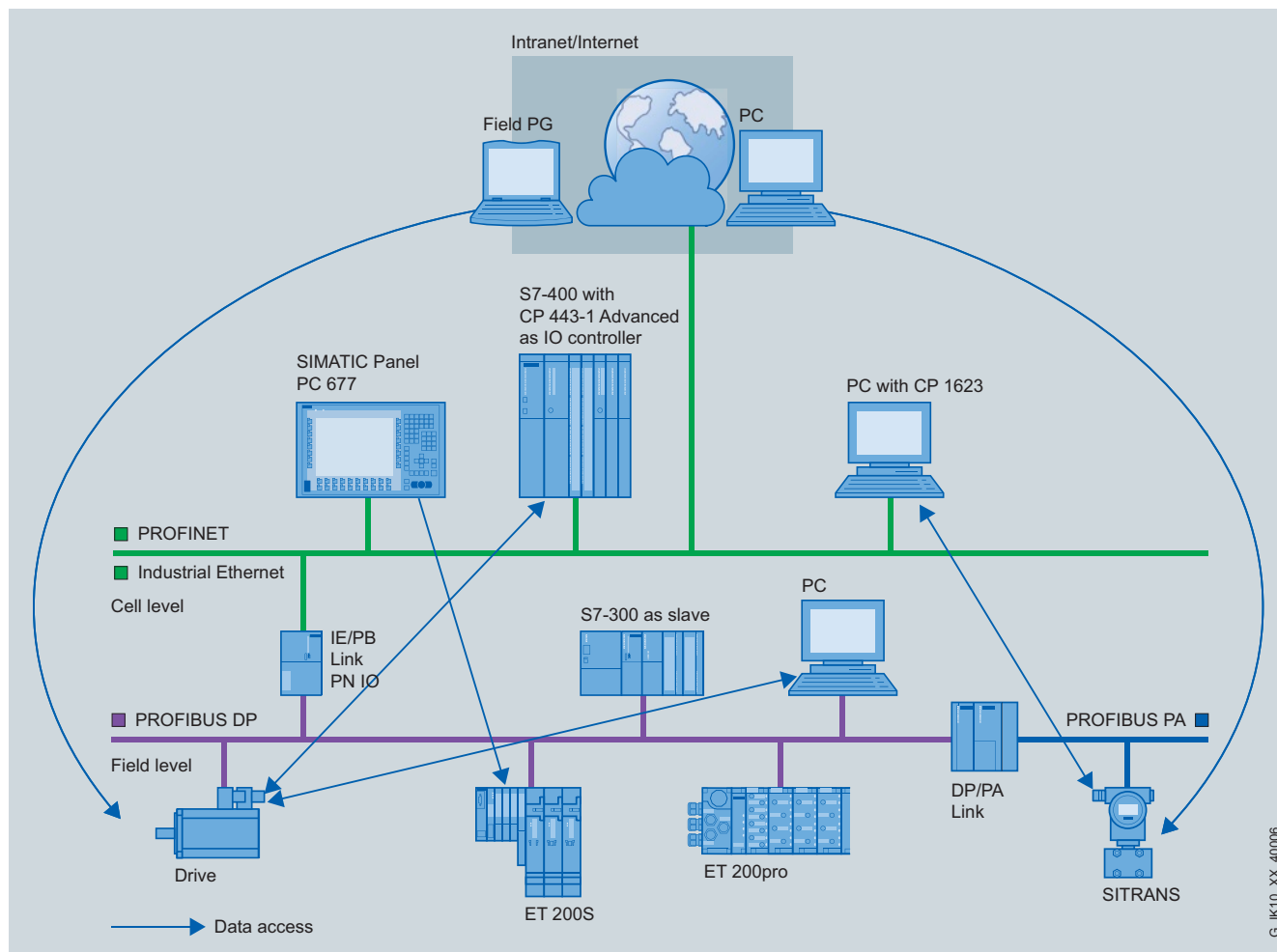

Configuration example of IE/PB Link PN IO as network transition from Industrial Ethernet to PROFIBUS for vertical integration

G_IK10_XX_40006

Application

As an autonomous component, the IE/PB Link PN IO provides a seamless transition between Industrial Ethernet and PROFIBUS.

Using the IE/PB Link PN IO as a proxy, you can continue to use existing PROFIBUS devices (also with PROFIsafe functionality, V2.0 or higher) and integrate them into a PROFINET application.

The IE/PB Link PN IO also offers the following functions:

- S7 routing
 - permits cross-network PG/OP communication, in other words, all S7 stations on Industrial Ethernet or PROFIBUS can be programmed remotely using the programming device
 - Access can be made to visualization data of the S7 stations on the PROFIBUS from HMI stations on the Industrial Ethernet.
- Data record routing (PROFIBUS DP)
 - It is possible, for example, to use SIMATIC PDM (on the PC) on Industrial Ethernet to parameterize and diagnose a PROFIBUS field device via the IE/PB Link PN IO.

Design

The IE/PB Link PN IO exhibits all the advantages of the SIMATIC design:

- Compact design; the rugged plastic casing features on the front:
 - one RJ45 port for connection to Industrial Ethernet.
 - one 9-pin Sub-D socket for connection to PROFIBUS
 - one 2-pin terminal strip for connecting the external supply voltage of 24 V DC.
 - Diagnostic LEDs
- Connection is by means of the IE FC RJ45 Plug 180 with 180° cable exit or by means of a standard patch cable
- Simple mounting; the IE/PB Link PN IO is mounted on an S7-300 DIN rail.
- Can be operated without a fan
- Fast device replacement in the event of a fault by using the optional C-PLUG swap medium (not included in scope of supply)

Function

PROFINET

- PROFINET IO proxy; connection of PROFIBUS DP slaves to PROFINET IO controller with real-time property, according to PROFINET standard

Additional functionality for vertical integration

- S7 routing
 - permits cross-network PG communication, in other words, all S7 stations on Industrial Ethernet or PROFIBUS can be programmed remotely using the programming device.
 - Access can be made to visualization data of S7 stations on the PROFIBUS from HMI stations on the Industrial Ethernet.
- Data record routing (PROFIBUS DP)
 - Using this option, the IE/PB Link PN IO can be used as a router for data records that are forwarded to field devices (DP slaves). SIMATIC PDM (Process Device Manager) is a tool that creates data sets of this type for parameterizing and diagnosing field devices.
 - Application: It is possible, for example, to use SIMATIC PDM (on the PC) on Industrial Ethernet to set parameters and run diagnostics for PROFIBUS PA field device over the IE/PB Link PN IO and DP/PA coupler.

The additional functions for vertical integration can also be used in an existing PROFIBUS application without PROFINET for connection to a higher-level Industrial Ethernet.

In this case, the IE/PB Link PN IO is used as an additional DP-Master Class 2 on a PROFIBUS segment for linking to the Industrial Ethernet and offers the above functions.

Diagnosis

Extensive diagnostic options are available via STEP 7 or SNMP, including:

- Diagnosis of the assigned PROFIBUS field devices; using the IE/PB Link PN IO as a proxy, the connected DP slaves can be diagnosed in the same manner as PROFINET IO devices (even in the user program of the PROFINET IO controller)
- General diagnostics and statistics functions
- Connection diagnostics
- Diagnostic buffer
- Integration into network management systems through the support of SNMP V1 MIB-II

Configuration

STEP 7 V5.4 or higher or the TIA Portal V11.0 is required for configuring the full functional scope of the IE/PB Link PN IO.

For the IE/PB Link PN IO, STEP 7 automatically generates the necessary parameters, e.g. the ones that assign addresses, and all necessary routing information.

The configuration data for PROFINET IO created with STEP 7 is saved on the IO controller. Attention must however be paid to the memory capacity. The initialization data for the Ethernet interface is backed up on the C-PLUG (Configuration Plug) swap media. The IE/PB Link PN IO can be swapped in the event of failure without a programming device, because the relevant user and configuration data is saved on the IO controller or on the C-PLUG.

PROFINET/Industrial Ethernet

Network transitions

IE/PB Link PN IO

Technical specifications

Product type designation	IE/PB Link PN IO
Data transmission rates	
<ul style="list-style-type: none"> Industrial Ethernet PROFIBUS 	10/100 Mbit/s autosensing 9.6 kbit/s to 12 Mbit/s incl. 45.45 kbit/s (PROFIBUS PA)
Interfaces	
<ul style="list-style-type: none"> Connection to Industrial Ethernet - 10BaseT/100BaseT Connection to PROFIBUS Connection for power supply 	RJ45 9-pin Sub-D socket 2-pin terminal block
Voltage supply	24 V DC (+/-5 %)
Current consumption (at rated voltage)	
<ul style="list-style-type: none"> external from 24 V DC, max. 	600 mA
Power loss	approx. 10 W
Perm. ambient conditions	
<ul style="list-style-type: none"> Operating temperature Transport/storage temperature Relative humidity, max. 	0 °C ... +60 °C - 40 °C ... +70 °C 95 % at +25 °C
Design	
<ul style="list-style-type: none"> Module format Dimensions (W x H x D) in mm Weight 	S7-300 construction 80 x 125 x 120 approx. 600 g
Degree of protection	IP20
Configuration	
Configuration software for PROFINET and additional functions	STEP 7/NCM S7, V5.3 SP1 or higher

Performance data

PROFINET communication

PROFINET IO performance data	
<ul style="list-style-type: none"> Number of DP slaves on the IE/PB Link PN IO (PROFINET IO-Devices for PROFINET IO) Number of DP inputs, max. Number of DP outputs, max. 	64 2048 byte 2048 byte
Additional functionality	
<ul style="list-style-type: none"> Number of S7 connections Number of DSGW connections 	max. 32 max. 32

Ordering data

Order No.

IE/PB Link PN IO	6GK1 411-5AB00
Router between Industrial Ethernet and PROFIBUS with PROFINET IO functionality, TCP/IP, S7 routing and data record routing, 10/100 Mbit/s Fast Ethernet, 9.6 to 12 Mbit/s PROFIBUS; including electronic manual on CD-ROM German, English, French, Spanish, Italian	
IE FC TP Standard Cable GP 2 x 2 (Type A)	6XV1 840-2AH10
4-core, shielded TP installation cable for connection to IE FC Outlet RJ45/IE FC RJ45 Plug; PROFINET-compliant; with UL approval; sold by the meter; max. length 1000 m, minimum order 20 m	
IE FC RJ45 Plug 180	
RJ45 plug connector for Industrial Ethernet with a rugged metal enclosure and integrated insulation displacement contacts for connecting Industrial Ethernet FC installation cables; with 180° cable outlet; for network components and CPs/CPUs with Industrial Ethernet interface	
<ul style="list-style-type: none"> 1 pack = 1 unit 1 pack = 10 units 1 pack = 50 units 	6GK1 901-1BB10-2AA0 6GK1 901-1BB10-2AB0 6GK1 901-1BB10-2AE0
IE FC Stripping Tool	6GK1 901-1GA00
Preadjusted stripping tool for fast stripping of the Industrial Ethernet FC cables	
Compact Switch Module CSM 377	6GK7 377-1AA00-0AA0
Unmanaged switch for connection of a SIMATIC S7-300-CPU, ET 200M and as many as three further nodes to Industrial Ethernet operating at 10/100 Mbit/s; 4 x RJ45 ports; external 24 V DC power supply, LED diagnostics, S7-300 module including electronic Manual on CD-ROM	
C-PLUG	6GK1 900-0AB00
Swap medium for simple replacement of devices in the event of a fault; for storing configuration or engineering and application data; can be used for SIMATIC NET products with C-PLUG slot	

2

Ordering data	Order No.	Order No.
PROFIBUS FC Standard Cable GP Standard type with special design for fast mounting, 2-core, shielded,	6XV1 830-0EH10	
PROFIBUS FastConnect bus connector RS485 Plug 180 with insulation displacement terminals, with 180° cable outlet, for industrial PC, SIMATIC HMI OP, OLM; max. transmission rate 12 Mbit/s	6GK1 500-0FC10	
PROFIBUS FastConnect Stripping Tool Preadjusted stripping tool for fast stripping of PROFIBUS FastConnect bus cables	6GK1 905-6AA00	
S7-300 mounting rail	6ES7 390-1AB60-0AA0	
S7-300 PS 307 load power supply 24 V DC	6ES7 307-1BA00-0AA0	
STEP 7 Version 5.5 <i>Target system:</i> SIMATIC S7-300/400, SIMATIC C7, SIMATIC WinAC <i>Requirements:</i> Windows XP Prof., Windows 7 Professional/Ultimate <i>Type of delivery:</i> German, English, French, Spanish, Italian; including license key on USB stick, with electronic documentation <ul style="list-style-type: none"> Floating license on DVD Rental license for 50 hours Software Update Service on DVD (requires current software version) Upgrade Floating License 3.x/4.x/5.x to V5.5; on DVD Trial License STEP 7 V5.5; on DVD, 14 day trial 	6ES7 810-4CC10-0YA5 6ES7 810-4CC10-0YA6 6ES7 810-4BC01-0YX2 6ES7 810-4CC10-0YE5 6ES7 810-4CC10-0YA7	6ES7 822-1AA01-0YA5 6ES7 822-1AA01-0YA7 6ES7 822-1AA01-0XE5 6ES7 822-1AA01-0XC5 6ES7 822-1AA01-0YC5 6ES7 822-1AA00-0YL5 6ES7 822-1AA00-0YM5 6ES7 810-5CC04-0YE2 6ES7 810-5CC00-0YM2
		STEP 7 Professional Engineering Software V11 <i>Target system:</i> SIMATIC S7-300/400, SIMATIC C7, SIMATIC WinAC <i>Requirements:</i> Windows XP Professional SP3 (32 bit), Windows 7 Professional (32 bit), Windows 7 Enterprise (32 bit), Windows 7 Ultimate (32 bit), Microsoft Server 2003 R2 Std. SP2 (32 bit), Microsoft Server 2008 Std. SP2 (32 bit) <i>Type of delivery:</i> German, English, Chinese, Italian; French, Spanish <ul style="list-style-type: none"> STEP 7 Professional V11, floating license STEP 7 Professional V11, trial license Upgrade STEP 7 Professional 2006/2010 to STEP 7 Professional V11, floating license PowerPack & Upgrade STEP 7 V5.4/V5.5 to STEP 7 Professional V11, floating license Powerpack STEP 7 Basic V11 to STEP 7 Professional V11, floating license STEP 7 Professional V11, Software Update Service, 1 year; current software version required STEP 7 Professional V11, Software Update Service Compact, 1 year; current software version required STEP 7 Professional Software Update Service; 1 year; for STEP 7 Professional and STEP 7 Professional in the TIA Portal, requires current software version STEP 7 Professional Software Update Service Compact; 1 year; for STEP 7 Professional and STEP 7 Professional in the TIA Portal, requires current software version

More information
www.siemens.com/profinet

PROFINET/Industrial Ethernet

Network transitions

IE/WSN-PA LINK

Overview



- The IE/WSN-PA LINK is a network transition for the connection of WirelessHART field devices (HART V7.1) to Industrial Ethernet, as an alternative or supplement to the wired connection.
- Connection of up to 100 WirelessHART devices
- Approved for operation in hazardous areas in Zone 2
- Open TCP/IP communication and Modbus TCP via the Ethernet interface
- Can be used with HART-OPC servers of the HART Communication Foundation

Note:

A general introduction to WirelessHART and information on the WirelessHART adapter and the WirelessHART field devices can be found in Catalog FI 01 or on the Internet at www.siemens.com/wirelesshart

Benefits



- Extended possible solutions for connecting process industry field devices by means of alternative or supplementary WirelessHART communication
- Reliable data transmission using intermeshed network technology; the self-organizing network with alternative paths enables radio obstacles to be bypassed
- Reduction of cabling costs under difficult installation conditions, e.g. if the field devices are located on inaccessible plant components or are only required temporarily
- To improve process monitoring and for maintenance tasks, sensors can be retrofitted
- Existing transmitters can be integrated wirelessly into maintenance and diagnostics systems by means of WirelessHART adapters
- Without additional software, restricted monitoring is possible via web services and the integrated web server of the IE/WSN-PA LINK.

Application

The IE/WSN-PA LINK connects wireless HART field devices by radio to the Ethernet. On the radio side, the IE/WSN-PA LINK supports the WirelessHART standard and on the Ethernet side the TCP/IP and Modbus TCP communication.

The IE/WSN-PA LINK thus enables wireless diagnostics, maintenance and process monitoring.

Monitoring

WirelessHART is particularly suitable for use in plant sections that are to be included in monitoring, but which do not have any existing MSR cabling, e.g. external tank stores or other installations where high cabling costs are anticipated. Data for the visualization can be retrieved from the IE/WSN-PA link via Industrial Ethernet or Modbus TCP.

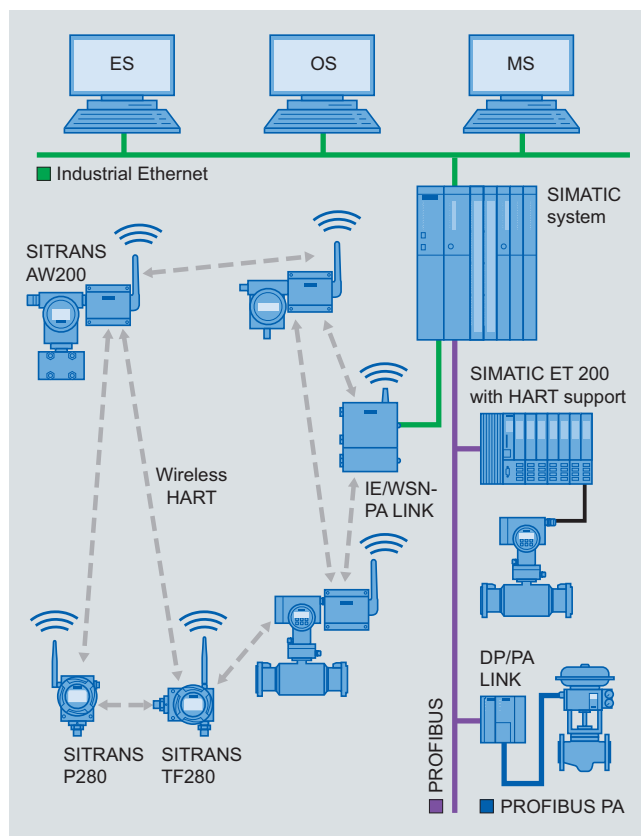

Monitoring of process states via WirelessHART

Application (continued)

Retrofitting for diagnostics and maintenance

For this application, wireless adapters are looped into the 4-20 mA interface or screwed directly onto the HART device. The acyclic HART message frames are transmitted by radio between IE/WSN-PA LINK and a wireless adapter. Without affecting the operation of the plant, the wireless adapter modulates the acyclic HART message frames to the 4-20 mA interface or extracts them from the 4-20 mA interface.

The IE/WSN-PA LINK collects the data of all wireless adapters and transfers it via Industrial Ethernet to the diagnostics and maintenance station.

If greater distances between the IE/WSN-PA LINK and the monitoring station are to be spanned without cabling, this can be implemented by means of Industrial Wireless LAN with the access points and client modules of the SCALANCE W family.

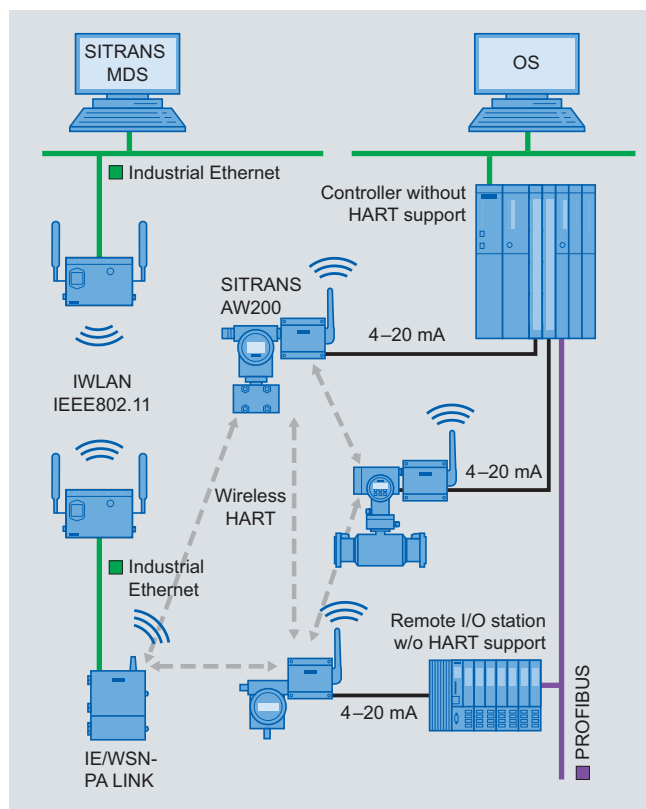

Retrofitting of plants for diagnostics and maintenance

Design

- 2 x 10/100/1000 Mbit/s RJ45 ports, electrical (no integral switch; interfaces can be used, for example, for continuous connection to the plant network as well as the temporary connection of a PC)
- 1 x screw terminal for connection to Modbus RTU via RS485
- 1 x screw terminal for the 24 V DC connection
- Rugged metal enclosure with IP65 protection for use outdoors, also in hazardous zone 2
- Mounting: wall or mast mounting (vertical); U-bolts for mast mounting are included in the scope of delivery.

Product versions

- With integral, non-detachable antenna
- With N connector for connection of external antennas

Function

WirelessHART

The IE/WSN-PA LINK establishes on the radio side an inter-meshed wireless sensor network for communication with wireless field devices (e.g. transmitters). The data from the wireless field devices is received by the IE/WSN-PA LINK and transmitted via Industrial Ethernet to the connected systems. The supported wireless network is an open wireless network specified by the HART Communication Foundation (HCF) in accordance with the WirelessHART (HART V7.1) standard.

On the field device side, the IE/WSN-PA LINK requires field devices that support WirelessHART (HART). Existing field devices can be integrated by means of wireless adapters into the WirelessHART communication. To this end, the adapters are looped into the 4-20 mA interface. In addition, as many as four standard HART field devices with external power supply can be connected to the adapter in multidrop mode. Individually connected devices can be operated with the battery of the adapter.

The adapter wirelessly transmits all data and process values of the connected devices. The advantage of this solution is that tried and tested devices can continue to be used.

Industrial Ethernet

Via the Ethernet interface the IE/WSN-PA LINK supports the use of the HART OPC server and the Modbus TCP protocol.

Configuration

The configuration is web-based, without additional software, and performed from the PC. By means of the web user interface it is also possible to display the device states and measured values of the WirelessHART devices.

PROFINET/Industrial Ethernet

Network transitions

IE/WSN-PA LINK

Integration

Integration into automation systems

The IE/WSN-PA LINK can be integrated into automation systems via Ethernet or Modbus TCP. Communication modules (CP 343-1 or CP 443-1) are required to connect the IE/WSN-PA LINK to SIMATIC S7-300/400. Function blocks and technical support can be found at:

www.siemens.com/simatic-net/ik-info

Integration in PCS 7

For integration of the IE/WSN-PA LINK into PCS 7 you can obtain function blocks and technical support at:

www.siemens.com/simatic-net/ik-info

Technical specifications

Order No.	6GK1 411-6CA40-0AA0	6GK1 411-6CA40-0BA0
Product type designation	IE/WSN-PA LINK	IE/WSN-PA LINK
Data transmission rate		
• at interface 1	10 ... 100 Mbit/s	10 ... 100 Mbit/s
• at interface 2	10 ... 100 Mbit/s	10 ... 100 Mbit/s
• at interface 3	9.6 to 57.6 kbit/s	9.6 to 57.6 kbits
Interfaces		
Number of electrical connections		
• at interface 1 in accordance with Industrial Ethernet	1	1
• at interface 2 in accordance with Industrial Ethernet	1	1
• at interface 3 in accordance with RS 485	1	1
• For power supply	1	1
Design of electrical connection		
• at interface 1 in accordance with Industrial Ethernet	RJ 45 port	RJ 45 port
• at interface 2 in accordance with Industrial Ethernet	RJ 45 port	RJ 45 port
• at interface 3 in accordance with RS 485	2-pin terminal strip	2-pin terminal strip
• For power supply	3-pin terminal strip	3-pin terminal strip
Interfaces Wireless		
Number of radio cards permanently installed	1	1
Number of internal antennas	1	0
Number of electrical connections for external antenna(s)	0	1
Design of electrical connection for external antenna(s)	-	N-Connector
Supply voltage, current consumption, power loss		
Type of power supply	DC	DC
Supply voltage, external	24 V	24 V
• Minimum	20 V	20 V
• Maximum	28 V	28 V
Current consumed from external power supply at 24 V DC, maximum	0.5 A	0.5 A
Effective power loss, maximum	12 W	12 W

Technical specifications (continued)

Order No.	6GK1 411-6CA40-0AA0	6GK1 411-6CA40-0BA0
Product type designation	IE/WSN-PA LINK	IE/WSN-PA LINK
Permitted ambient conditions		
Ambient temperature		
• During operating phase	-40 ... +60 °C	-40 ... +60 °C
• During storage	-40 ... +85 °C	-40 ... +85 °C
• During transport	-40 ... +85 °C	-40 ... +85 °C
Relative humidity at 25 °C without condensation during operating phase, maximum	90 %	90 %
IP degree of protection	IP 65	IP 65
Design, dimensions and weights		
Housing width	229 mm	229 mm
Housing height		
• Without antenna	306 mm	306 mm
• With antenna	354 mm	354 mm
Housing depth	89 mm	89 mm
Net weight	4.54 kg	4.54 kg
Type of mounting		
• Wall mounting	Yes	Yes
• Mast mounting	Yes	Yes
Type of mounting	Material for mast mounting included in scope of delivery	Material for mast mounting included in scope of delivery
Radio frequencies		
Radio frequency with WirelessHART in the 2.4 GHz frequency band		
• Start value	2.4 GHz	2.4 GHz
• Full-scale value	2.5 GHz	2.5 GHz
Performance data WirelessHART		
Number of WirelessHART devices which can be operated	100	100
Network latency		
• Maximum with 100 field devices and WirelessHART network	10 s	10 s
• Maximum with 50 field devices and WirelessHART network	5 s	5 s
Transition link between two devices with WirelessHART network		
• Maximum	100 m	100 m
• Note	The values may deviate if obstacles affecting radio transmission are present	The values may deviate if obstacles affecting radio transmission are present
HART protocol is supported	Yes	Yes
Product properties, functions, components		
General		
Protocol is supported		
• Address Resolution Protocol (ARP)	Yes	Yes
• HTTP	Yes	Yes
• HTTPS	Yes	Yes
• Modbus TCP	Yes	Yes
• Modbus TCP secure	Yes	Yes
• Modbus RTU	Yes	Yes
Product functions		
Management, configuration, programming		
Product function		
• Web-based management	Yes	Yes
• DHCP client	Yes	Yes

PROFINET/Industrial Ethernet

Network transitions

IE/WSN-PA LINK

Technical specifications (continued)

Order No.	6GK1 411-6CA40-0AA0	6GK1 411-6CA40-0BA0
Product type designation	IE/WSN-PA LINK	IE/WSN-PA LINK
Product functions Diagnostics		
Product function		
• Web-based diagnostics	Yes	Yes
• WirelessHART diagnostics via Modbus	Yes	Yes
Product functions Security		
Product function		
• Password protection – multilevel	Yes	Yes
• WirelessHART join key	Yes	Yes
• ACL – MAC-based	Yes	Yes
• WirelessHART network ID	Yes	Yes
SSL protocol is supported	Yes	Yes
Encryption principle	AES 128 bit	AES 128 bit
Product functions Time		
NTP protocol is supported	Yes	Yes
Standards, specifications, approvals		
Standard for WirelessHART	HART V 7.1	HART V 7.1
Standard for wireless communication IEEE 802.15.4	Yes	Yes
Certificate of suitability		
• CE mark	Yes	Yes
• Referred to CSA	CSA Division 2 & Dust Ignition-proof for Class I, Division 2, Groups A, B, C, and D. Dust Ignition-proof for Class II, Groups E, F, and G / Suitable for Class III Hazardous Locations. / Install per Siemens drawing A5E02467236A. Temperature Code: T4 (-40 °C < Ta < 60 °C) CSA Enclosure Type 4X	CSA Division 2 & Dust Ignition-proof for Class I, Division 2, Groups A, B, C, and D. Dust Ignition-proof for Class II, Groups E, F, and G / Suitable for Class III Hazardous Locations. / Install per Siemens drawing A5E02467236A. Temperature Code: T4 (-40 °C < Ta < 60 °C) CSA Enclosure Type 4X
• Referred to FM	FM Division 2, Non-Incendive for Class I, Division 2, Groups A, B, C, and D. Dust Ignition-proof for Class II, III, Division 1, Groups E, F, and G / Indoor and outdoor locations / NEMA Type 4X Temperature Code: T4 (-40 °C < Ta < 60 °C)	FM Division 2, Non-Incendive for Class I, Division 2, Groups A, B, C, and D. Dust Ignition-proof for Class II, III, Division 1, Groups E, F, and G / Indoor and outdoor locations / NEMA Type 4X Temperature Code: T4 (-40 °C < Ta < 60 °C)
• Referred to ATEX	ATEX type n, see note: Certificate number: Baseefa10ATEX0044X, ATEX marking: Ex II 3 G, Ex nA nL IIC T4 (-40 °C ≤ Ta ≤ 60 °C), rated voltage: 28 V, ATEX Dust Ignition-proof: Certificate number: Baseefa10ATEX0045X, ATEX marking: II 3 D, Ex tD A22 IP66 T135 (-40 °C ≤ Ta ≤ 60 °C), rated voltage: 28 V. Note on type n: Conditions for safe handling during installation: The device does not pass the 500 V insulation test in accordance with paragraph 6.8.1 of EN 60079-15:2005. This must be taken into account when installing the device.	ATEX type n, see note: Certificate number: Baseefa10ATEX0044X, ATEX marking: Ex II 3 G, Ex nA nL IIC T4 (-40 °C ≤ Ta ≤ 60 °C), rated voltage: 28 V, ATEX Dust Ignition-proof: Certificate number: Baseefa10ATEX0045X, ATEX marking: II 3 D, Ex tD A22 IP66 T135 (-40 °C ≤ Ta ≤ 60 °C), rated voltage: 28 V. Note on type n: Conditions for safe handling during installation: The device does not pass the 500 V insulation test in accordance with paragraph 6.8.1 of EN 60079-15:2005. This must be taken into account when installing the device.
• Referred to IECEx	IECEx type n, see note: Certificate number: IECEx BAS 10.0014X, Ex nA nL IIC T4 (-40 °C ≤ Ta ≤ 60 °C), rated voltage: 28 V, IECEx Dust Ignition-proof, see note: Certificate number: IECEx BAS 10.0015X, Ex tD A22 IP66 T135 (-40 °C ≤ Ta ≤ 60 °C), rated voltage: 28 V. Note on type n: Conditions for safe handling during installation: The device does not pass the 500 V insulation test in accordance with paragraph 6.8.1 of EN 60079-15:2005. This must be taken into account when installing the device.	IECEx type n, see note: Certificate number: IECEx BAS 10.0014X, Ex nA nL IIC T4 (-40 °C ≤ Ta ≤ 60 °C), rated voltage: 28 V, IECEx Dust Ignition-proof, see note: Certificate number: IECEx BAS 10.0015X, Ex tD A22 IP66 T135 (-40 °C ≤ Ta ≤ 60 °C), rated voltage: 28 V. Note on type n: Conditions for safe handling during installation: The device does not pass the 500 V insulation test in accordance with paragraph 6.8.1 of EN 60079-15:2005. This must be taken into account when installing the device.
• Referred to NEMA	-	-
Wireless approval	FCC and IC approval	IC approval

Ordering data	Order No.	Order No.
IE/WSN-PA LINK Gateway between WirelessHART and Industrial Ethernet; transmission frequency: 2.4 GHz <ul style="list-style-type: none"> • With integral, non-detachable antenna • N connector for connection of external antennas 	6GK1 411-6CA40-0AA0 6GK1 411-6CA40-0BA0	Accessories IE FC M12 Plug PRO M12 plug-in connector suitable for on-site assembly (D-coded, IP65/IP67), metal housing, FastConnect connection system, for connecting HARTING adapter cables to the Industrial Ethernet <ul style="list-style-type: none"> • 1 unit
Antennas Antennas with omni-directional characteristics; country permits, compact instructions (hard copy), German/English <u>Wall or mast-mounting</u> <ul style="list-style-type: none"> • Antenna ANT792-6MN Antenna gain including N-Connect connector 6 dBi, 2.4 GHz <u>Roof mounting</u> <ul style="list-style-type: none"> • ANT795-6MN antenna Antenna gain incl. N-Connect connector 6/8 dBi, 2.4/5 GHz • Antenna mounting tool (ANT795-6MN) Mounting tool for installation of ANT795-6MN under a roof 	6GK5 792-6MN00-0AA6 6GK5 795-6MN00-0AA6 6GK5 795-6MN01-0AA6	IE FC TP Standard Cable GP 2 x 2 (Type A) 4-core, shielded TP installation cable for connection to IE FC Outlet RJ45/IE FC RJ45 Plug; PROFINET-compatible; with UL approval; sold by the meter; max. length 1000 m, minimum order quantity 20 m
LP798-1N Lightning Protector Lightning protector with N/N female/female connector, IP65 (-40 to +100 °C)	6GK5 798-2LP00-2AA6	IE FC Stripping Tool Preadjusted stripping tool for fast stripping of the Industrial Ethernet FC cables
Antenna cables IWLAN N-Connect male/male flexible connection cable Flexible connecting cable for connecting an external antenna; assembled with two N-Connect male connectors <ul style="list-style-type: none"> • 1 m • 2 m • 5 m • 10 m 	6XV1 875-5AH10 6XV1 875-5AH20 6XV1 875-5AH50 6XV1 875-5AN10	Network components for IWLAN see "Industrial Wireless Communication"
HF coupling N-Connect male/male connector for connecting the LP798-1N lightning protector	6GK5 798-0CP00-1AA0	HARTING adapter cable ¹⁾ M12 female NPT 1/2 thread to RJ45 11 cm, (minimum order quantity: 10); The adapter is provided for easy connection of the link to the Industrial Ethernet;
		SITOP compact 24 V/ 0.6 A 1-phase power supply with wide-range input 85 – 264 V AC/110 – 300 V DC, stabilized output voltage 24 V, rated output current value 0.6 A, slim design

¹⁾ When using the Harting adapter cable for the Ethernet connection, the requirements for intrinsic safety approval are not applicable. When used in an application relevant to intrinsic safety guidelines, it requires acceptance by the appropriate approval agency.

More information

Current approvals can be found on the Internet at:
<http://support.automation.siemens.com/WW/view/en/46374734>

PROFINET/Industrial Ethernet

Network transitions

PN/PN coupler

Overview



- Maximum data exchange of 256-byte input data and 256-byte output data between two PROFINET networks
- Maximum of 16 input/output ranges for the exchange of data
- Electrical isolation between the two PROFINET IO subnets
- Redundant power supply
- Supported Ethernet services
 - ping
 - arp
 - network diagnostics (SNMP/MIB-2)
- Diagnostic interrupts
- ReturnOfSubmodule interrupts

Application

The PN/PN coupler is used to link two Ethernet subnets with one another and to exchange data. The maximum size of the data which can be transferred is 256 byte input data and 256 byte output data.

As a device, the PN/PN coupler has two PROFINET interfaces, each of which has two ports and each of which is linked to another subnet.

During configuring, two IO devices are produced from this one PN/PN coupler which means that there is one IO device for each station with its own subnet. The other part of the PN/PN coupler in each case is known as the bus node. Once configuring is complete, the two parts are joined.

Design

The PN/PN Coupler is located within a 120 mm enclosure. It is installed with a DIN rail (7.5 mm or 15 mm).

The coupler is connected to the PROFINET PN IO networks using RJ45 plug-in connectors.

Function

The PN/PN coupler continuously copies the output data of one network to the input data of the other network (and vice versa).

Parameterization

You either configure the PN/PN coupler using STEP 7 or a configuring tool which uses a GSD file to integrate the PN/PN coupler. You can use STEP 7 to set the required length of the input and output data. The output data of one side of the PN/PN coupler serve as input data for the other side, and vice versa.

You configure the I/O ranges using universal modules which are plugged into slots on the PN/PN coupler like real modules from the hardware catalog in the HW configuration. The universal modules span an I/O range over which data is exchanged between the two PROFINET subnets. The local CPU uses slot's configured inputs to read the values which the CPU of the other slot writes using the bus node's configured outputs. The local CPU uses slot's configured outputs to write values which the CPU of the other subnet receives using the bus node's configured inputs.

Function (continued)

Example

The following example shows that both networks are independent of one another. This means that the user gives each PROFINET I/O network its own device name.

In the following picture, you can see device name "Subnet1" in network 1 and "Subnet2" in network 2:

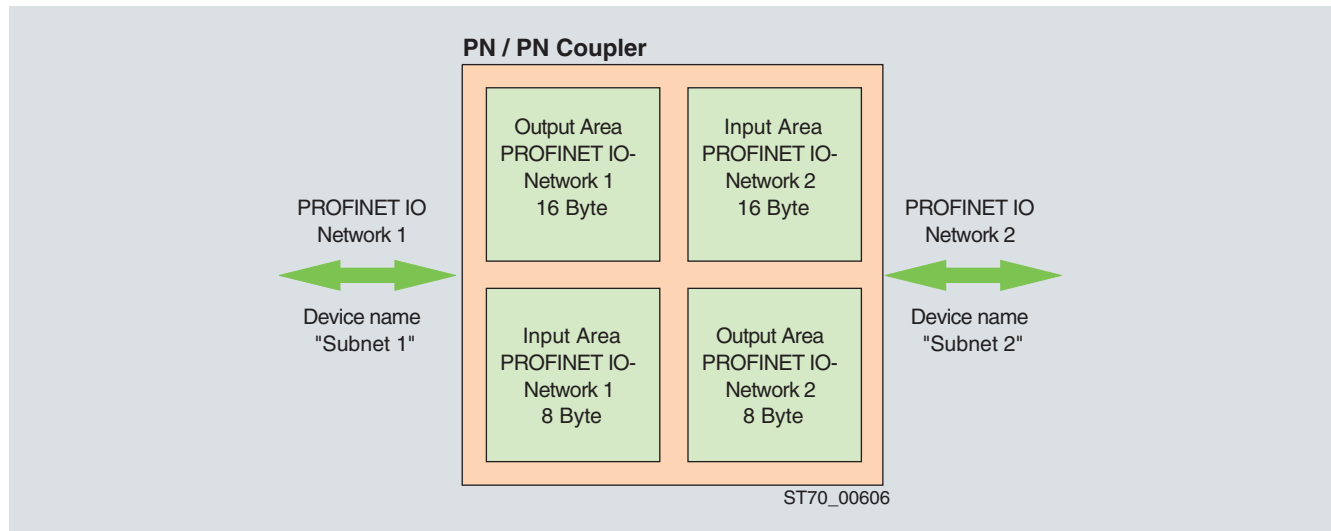

Main FC of the PN/PN coupler (example)

Ordering data

Order No.

PN/PN coupler

6ES7158-3AD01-0XA0

for connecting two PROFINET networks

Power supply connector

Spare part;
for connecting the 24 V DC supply voltage

- with push-in terminals
- with screw-type terminals

6ES7 193-4JB00-0AA0
6ES7 193-4JB50-0AA0

PROFINET/Industrial Ethernet

Partner solutions

deviceWISE Embedded Edition for SIMATIC S7

Overview

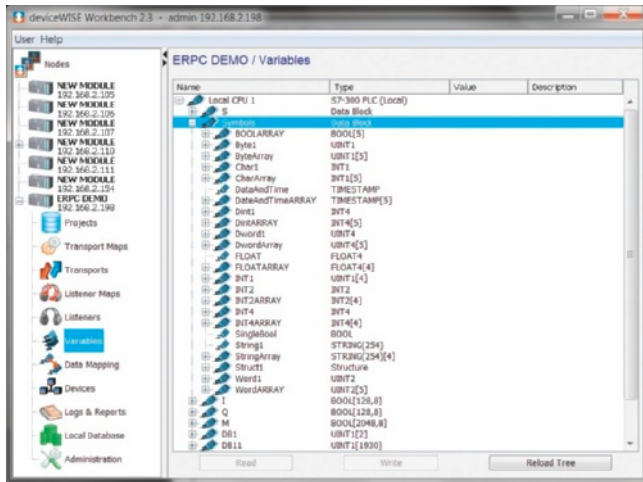

- deviceWISE Embedded for S7 is a software package that can be loaded into the CP 343-1 ERPC communication processor as a firmware extension
- It facilitates intelligent and direct communication from the S7-300 to IT applications at the management level (e.g. databases)
- No programming is required in SIMATIC

Benefits

- High-speed integration of machine controllers into IT applications, e.g. reading or writing to databases by means of parameterization without any programming effort in the S7-300
- Reliable delivery of critical process data by means of store & forward functionality as well as in-built local database
- Complex preprocessing of data in the PLC with numerous trigger options
- Supports standard protocols such as OPC UA or XML-DA directly from the PLC

Application

deviceWISE Embedded for S7 offers the database interface of the SIMATIC S7 with CP 343-1 ERPC to various ERP or MES systems for vertical integration.

Database communication

deviceWISE Embedded for S7 establishes direct connections from the PLC to the leading database systems. The user can perform a host of operations on the linked databases, such as:

- Documentation of production data in the database
- Updating of existing entries, e.g. recording and saving new data as the production of a component progresses
- Retrieval of data from the database, e.g. recipes or configuration data for the current production

Message-queue communication

The software enables the user to communicate directly with the Enterprise Service Bus (ESB) and transfer data from the controller to applications in the enterprise IT system. Messages can be sent and received in ASCII or XML. User-specific data formats can also be defined.

Device communication

deviceWISE Embedded for S7 is used predominantly for communication with enterprise applications. In addition, the software can establish connections to other automation devices and transfer data from other PLC systems, RFID readers, or cameras into the data area of the S7-CPU. This is done via the backplane bus and enables flexible mapping of data from the widest variety of devices into the data blocks of the PLC.

Function

The deviceWISE Embedded for S7 software includes a user-friendly tool – the workbench – for the configuration and management of data.

This enables one or more deviceWISE modules to be addressed without any programming overhead.

The workbench offers a wide range of drag & drop mechanisms and enables trigger conditions to be defined. This significantly reduces the possibilities of errors when entering addresses or field names. In addition, it is possible in the workbench to process raw data into useful information and transport it from programmable controllers to databases or message queues in the IT environment of an enterprise.

deviceWISE Embedded for S7 offers the following functions:

Direct connection to the following SQL databases:

- IBM DB2
- IBM DB2/400 (for OS/400 systems)
- Oracle
- Oracle Manufacturing Operations Center
- Microsoft SQL Server
- MySQL

Direct connection to the following messaging systems:

- IBM Websphere MQ
- IBM MQTT
- IBM SIB/JMS
- TCP

Extensive preprocessing of the data

Using deviceWISE Embedded for S7, extensive preprocessing of data (e.g. mathematical operations, flow diagram processing), the use of a local SQL database, and an in-built FTP server/client functionality are possible.

Error handling and correction by means of:

- Store and forward for all enterprise transactions
- E-mail notification in the event of faults
- Fault signaling to the PLC

Direct connection to other terminals

deviceWISE Embedded for S7 allows the direct connection of the CP 343-1 ERPC communication processor to the following terminals:

- PLC systems (Siemens, Rockwell, Mitsubishi, Omron)
- Camera systems
- RFID readers

In addition, open-standard protocols such as Modbus TCP, OPC UA or XML-DA are supported.

More information

The software is available at:

ILS Technology LLC;
5300 Broken Sound Blvd.
Suite 150
Boca Raton, FL, U.S.A., 33487

Phone: +1-561-982-9898 x124
Fax.: +1-561-982-8638

E-mail: devicewise@ilstechnology.com

You can find further information on the Internet at:
www.ilstechnology.com/erpc

PROFINET/Industrial Ethernet

Notes

2

PROFIBUS

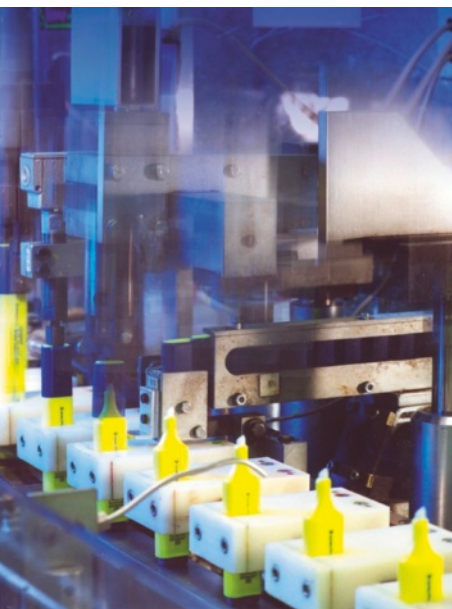

3/4	Introduction	3/89	Optical networks with OLM
3/5	Process or field communication	3/89	Overview of FC-FOCs
3/9	Data communication	3/91	FC glass fiber-optic cable
3/11	Communication overview	3/96	FC FO termination kit
3/12	Configuration examples	3/97	Glass fiber-optic cable
3/14	Topologies	3/112	Plastic and PCF fiber-optic cable
3/16	Network components	3/119	PCF-FOC termination kit
3/16	Overview of network components	3/122	OLM Optical Link Module
3/18	Network selection criteria	3/135	SIPLUS OLM Optical Link Module
3/21	Connection examples	3/137	Optical networks with OBT and integrated interface
3/23	Electrical networks (RS485)	3/137	Plastic and PCF fiber-optic cable
3/23	PROFIBUS FastConnect	3/143	ECOFAS ^T Fiber Optic Hybrid Cable
3/25	PROFIBUS bus cables	3/147	PCF-FOC termination kit
3/37	ECOFAS ^T bus cables	3/150	Optical bus terminal OBT
3/42	Energy cables	3/153	System interfaces for SIMATIC S7
3/48	RS485 bus connector	3/153	Overview
3/56	830-1T connecting cable	3/154	<u>Communication for SIMATIC S7-1200</u>
3/57	830-2 connecting cable	3/154	CM 1242-5
3/58	PROFIBUS M12 and 7/8" connecting cable/connector	3/158	CM 1243-5
3/65	Bus terminals	3/162	<u>Communication for SIMATIC S7-300</u>
3/68	Active RS 485 terminating element	3/162	CP 342-5
3/69	Repeater RS 485 for PROFIBUS	3/166	SIPLUS CP 342-5
3/71	Diagnostic repeater for PROFIBUS DP	3/167	CP 342-5 FO
3/72	Power Rail Booster	3/172	CP 343-5
3/73	SINUMERIK Analog Drive Interface for 4 axes ADI 4	3/176	<u>Communication for SIMATIC S7-400</u>
3/74	Electrical networks (PROFIBUS PA)	3/176	CP 443-5 Basic
3/74	Introduction	3/180	CP 443-5 Extended
3/77	SpliTConnect	3/185	SIPLUS CP 443-5 Extended
3/80	Bus cables	3/185	<u>Communication for SIMATIC S7-mEC with CP 5603</u>
3/83	Active field distributors		
3/85	PA network transitions		
3/86	Electrical networks (FOUNDATION Fieldbus)		
3/86	Bus cables		

PROFIBUS

3/186	System interfaces for PG/PC/IPC	3/267	Motor starters for operation in the field, high degree of protection
3/186	<u>Communication for PC-based systems</u> Overview	Ch. 6	<u>SIRIUS M200D motor starters</u> General data
3/187	Performance data	3/267	M200D motor starters for PROFIBUS
3/188	Connection options to SIMATIC IPC	3/270	M200D motor starters for PROFIBUS communication modules, motor starter modules
3/189	CP 5603	3/271	Accessories for M200D motor starters for PROFIBUS
3/196	CP 5613 A2	3/273	<u>Software</u> Motor Starter ES
3/202	CP 5614 A2	3/277	SIRIUS Motor Starter Function Block Library for SIMATIC PCS 7
3/209	CP 5623		
3/215	CP 5624	3/279	ECOFAST motor starters
3/222	CP 5611 A2	3/279	General data
3/226	CP 5621	3/280	Motor starters for PROFIBUS Motor starters for AS-Interface, Accessories
3/230	CP 5711	3/281	ECOFAST Motor starters – Software
3/235	SOFTNET for PROFIBUS		
3/238	OPC Server for PROFIBUS	3/282	SIMOCODE 3UF motor management and control devices
3/241	S7 OPC Redundancy for PROFIBUS	3/282	<u>SIMOCODE pro 3UF7</u> General data
3/243	Connection options for SIMATIC HMI	3/288	Basic units
3/243	<u>System interfaces with WinCC flexible</u>	3/289	Expansion modules
3/244	SIMATIC S7	3/290	Failsafe expansion modules
3/247	SIMATIC WinCC flexible RT	3/291	Accessories
3/249	SIMATIC WinCC	3/295	3UF18 current transformers for overload protection
3/254	<u>System interfaces with WinCC (TIA Portal)</u>		
3/255	System interfaces with WinCC (TIA Portal) SIMATIC S7	3/296	SIRIUS 3RK3 modular safety system
3/257	System interfaces with WinCC (TIA Portal) SIMATIC WinCC (TIA Portal) Runtime	3/296	General data
3/258	System interfaces with WinCC (TIA Portal) WinCC Runtime Communication	3/297	Central modules, expansion modules, interface modules, operating and monitoring modules
3/261	Network transitions	3/298	Accessories
3/261	DP/DP coupler		
3/262	PA network transitions		
Ch. 6	DP/AS-i LINK Advanced		
Ch. 6	DP/AS-Interface Link 20E		
Ch. 6	DP/AS-i F-Link		

3/300	Energy management	3/325	Vision sensors
3/300	PC-based energy management system	3/325	SIMATIC VS120
3/302	SIMATIC-based energy management system	3/326	Lenses
3/303	7KM PAC measuring devices	3/327	Engineering/ Network Management/Diagnostics
3/304	7KM PAC3100 measuring devices	3/327	STEP 7 Professional/Basic V11
3/305	7KM PAC3200 measuring devices	3/329	STEP 7
3/306	7KM PAC4200 measuring devices	3/331	SIMATIC PDM Process Device Manager
3/307	Expansion modules for 7KM PAC measuring devices	3/336	BANYnet bus analysis and diagnostics
3/309	Configuring, visualizing and controlling with SIMATIC	3/338	PROFIBUS Components
3/310	SIMATIC powerrate	3/338	PROFIBUS DP ASICs
3/312	SIMATIC PCS 7 Library PAC3200	3/341	Connections/interfaces
3/313	3WL/3VL function block library for SIMATIC PCS 7	3/342	Development kits
3/314	PAC3200 function block library for SIMATIC WinCC	3/344	Partner solutions
3/315	Configuring, visualizing and controlling with SENTRON	3/344	Delphi-S7, Delphi-DPLib and Delphi-DPSofnetSlave
3/316	powermanager		
3/319	powerconfig		
3/320	SIMATIC identification systems		
3/320	Communication modules ASM 456, SIMATIC RF160C		
3/322	Code reading system SIMATIC VS130-2		

Introduction

Overview

- Bus system
 - for process and field communication with field devices from different manufacturers
 - and for data communication acc. to IEC 61158/61784
- PROFIBUS – the fieldbus standard in production and process engineering comprises:
 - Specification of the standards for the physical characteristics of the bus and the access procedure
 - Specification of the user protocol and the user interface
- Offers openness for interfacing to standardized non-Siemens components
- Process or field communication
 - PROFIBUS DP for fast, cyclic data exchange with field devices
 - PROFIBUS PA for applications in process automation and in the intrinsically safe area
- Data communication
 - PROFIBUS FMS for data communication between programmable controllers of different manufacturers

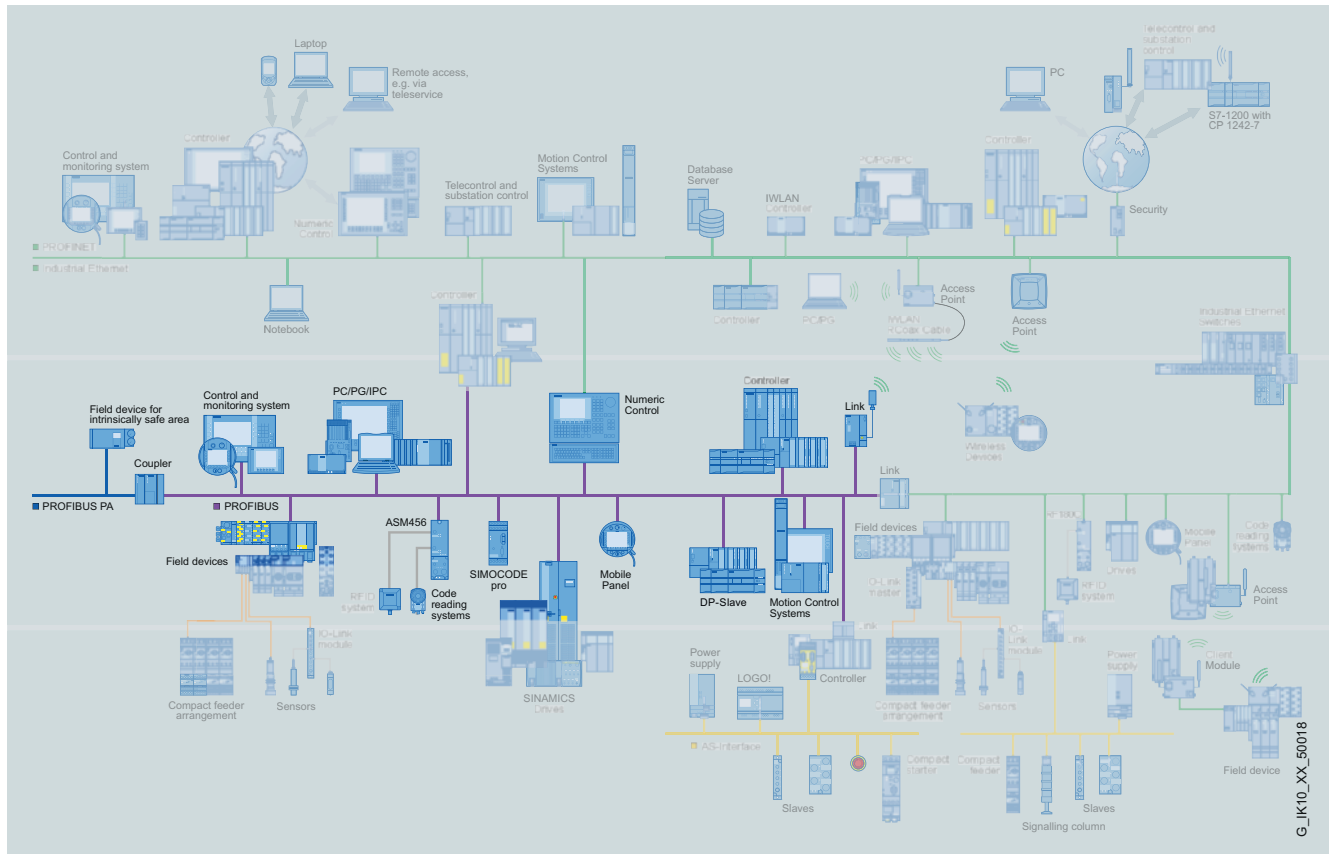

PROFIBUS in the communication landscape

Benefits

- PROFIBUS is a powerful, open, and rugged bus system that ensures trouble-free communication.
- The system is fully standardized, which enables trouble-free connection of standardized components from a variety of manufacturers.
- Configuration, commissioning, and troubleshooting can be carried out from any location. This results in user-defined communication relationships that are very versatile, simple to implement, and easy to change.
- Fast assembly and commissioning on site with the help of the FastConnect wiring system.
- Continuous monitoring of network components through a simple and effective signaling concept.
- High security of investment since existing networks can be extended without any adverse effects.
- High availability through ring redundancy with OLM.

More information

Please always note the supplementary conditions for the specified SIMATIC NET products (order numbers 6GK..., 6XV1...), which you can view on the Internet pages below:

www.siemens.com/simatic-net/ik-info

get **Designed for Industry**

Overview

Communication functions

Process or field communication (PROFIBUS DP, PROFIBUS PA) is used to link field devices to a programmable controller, HMI system or control system.

Interfacing is performed over integrated interfaces on the CPU or through interface modules (IMs) and communications modules (CPs, CMs).

With modern high-performance automation systems, it is often more effective to link more than one PROFIBUS DP line to one system, not just to increase the number of I/O devices that can be connected, but also to enable individual production areas to be handled independently of one another (segmentation).

PROFIBUS standardized to IEC 61158/61784 is a high-performance, open, rugged fieldbus system with short response times and the following protocols:

PROFIBUS DP

(Distributed I/O) is used to connect distributed I/O stations, such as SIMATIC ET 200 with extremely fast response times in accordance with the IEC 61158/EN 50170 standard.

PROFIBUS PA

(Process Automation) extends PROFIBUS DP with failsafe transmission technology in accordance with the international standard IEC 61158-2.

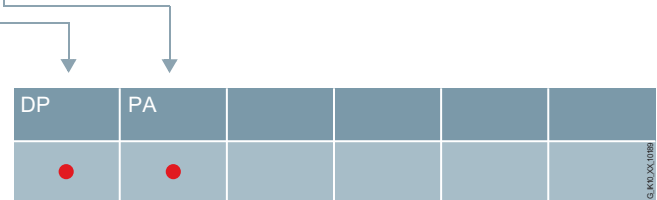

PROFIBUS

Introduction

Process or field communication

Overview (continued)

PROFIBUS is used to connect field devices, e.g. distributed I/O devices or drives, to automation systems such as SIMATIC S7, or PCs.

PROFIBUS is used when I/O devices are widely distributed on the machine or in the plant (e.g. at the field level) and can be combined into one station (e.g. ET 200), typically more than 16 inputs/outputs.

The actuators and sensors are connected to field devices. The field devices are supplied with output data in accordance with the master/slave technique and transfer input data to the programmable controller or PC.

High-performance tools such as STEP 7 are available for configuring and parameterizing the I/O devices. Testing and start-up is possible over PROFIBUS DP from any connection point using these tools.

3

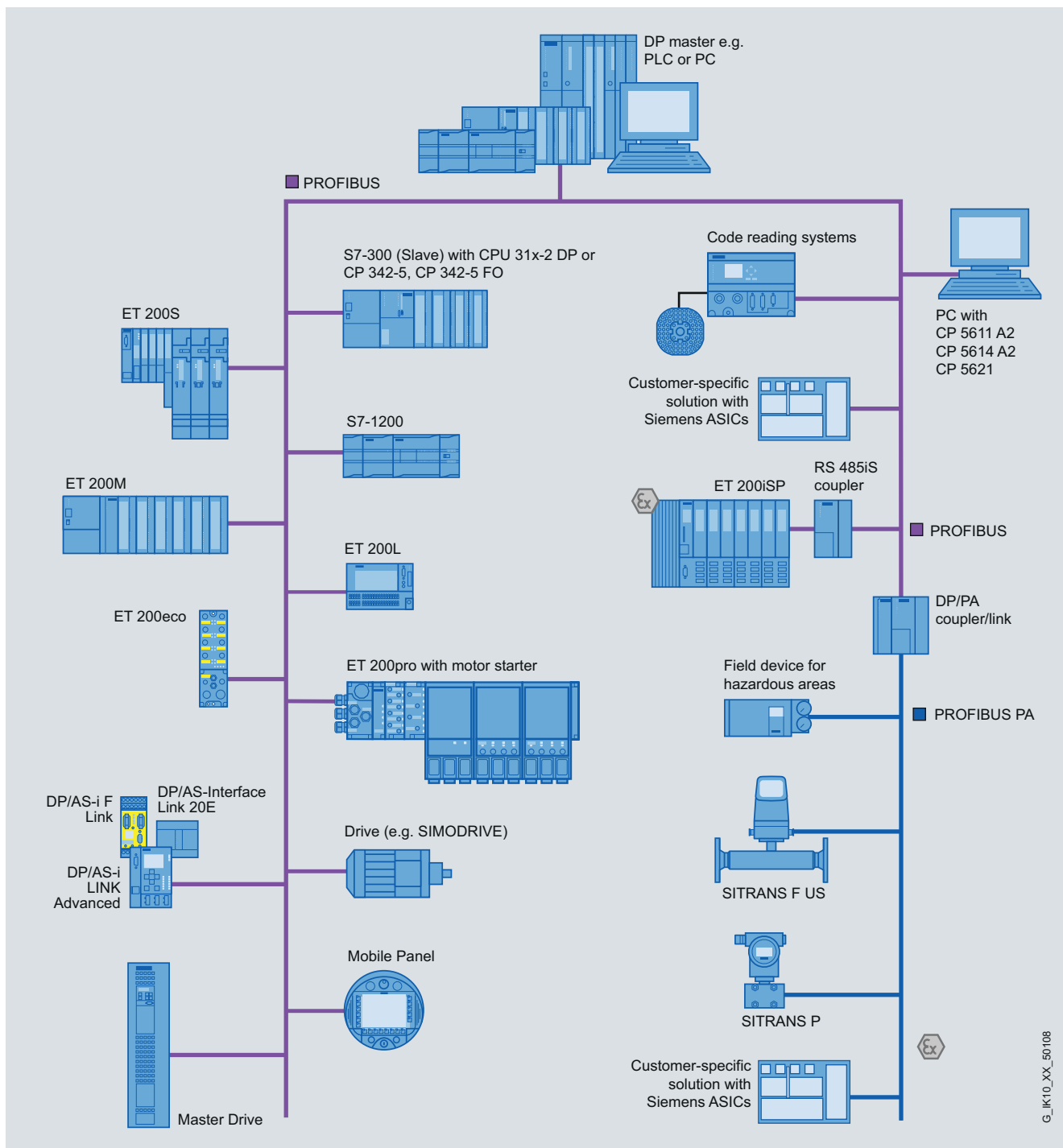

PROFIBUS DP slaves

G_IK10_XX_50108

Overview (continued)

DP device types

PROFIBUS DP distinguishes between two different master classes and different DP functions:

DP Master Class 1

The DP master Class 1 is the central component on PROFIBUS DP. The central controller or PC exchanges information with distributed stations (DP slaves) in a fixed, repeated message cycle.

DP Master Class 2

Devices of this type are used (programming, configuration or control devices) during start-up, for configuring the DP system or for controlling the plant during normal operation (diagnostics). A DP master Class 2 can be used, for example, to read the input, output, diagnostics and configuration data of the slaves.

DP slave

A DP slave is an I/O device that reads in input data and forwards output data to the I/O. The volume of input and output data depends on the device and can be up to 244 bytes.

The functional scope can differ between DP masters of Class 1 and 2 or DP slaves. This determines the performance and availability of a communication processor.



DP-V0

The DP master functions (DP-V0) comprise configuration, parameterization, read input data and write outputs in cycles, read diagnostics data.

DP-V1

The additional DP function expansions (DP-V 1) make it possible to perform non-isochronous read and write functions as well as acknowledgement of alarms at the same time as processing cyclic data communication. These extended DP functions comprise acyclic access to the parameters and measured values of a slave (e.g. field devices of process automation and intelligent HMI devices). This type of slave must be supplied with extensive parameter data during start-up and during normal operation. Data transferred in acyclic mode (e.g. parameterization data) are only rarely changed, in comparison to the cyclic measured values, and are transferred at lower priority in parallel with the cyclic high-speed useful data transfer. Alarm acknowledgement by the master ensures reliable transfer of the alarms from DP slaves.

DP-V2

The DP master functions (DP-V2) comprise functions for isochronous mode and direct data communication between DP slaves.

Isochronous mode

Isochronous mode is implemented by means of a signal with a constant bus cycle for the bus system. This isochronous, constant cycle is sent by the master to all bus stations in the form of a global control message. The master and slave can then synchronize their applications with this signal. The jitter of this signal from cycle to cycle must be less than 1 μ s for typical drive applications.

Direct data communication between DP slaves

The publisher/subscriber model is used to implement the direct data communication between slaves. Slaves declared as publishers make their input data (corresponds to response message to their own master) available to other slaves, the subscribers, for reading. Direct slave-to-slave communication is performed cyclically.

PROFIBUS

Introduction

Process or field communication

Integration

3

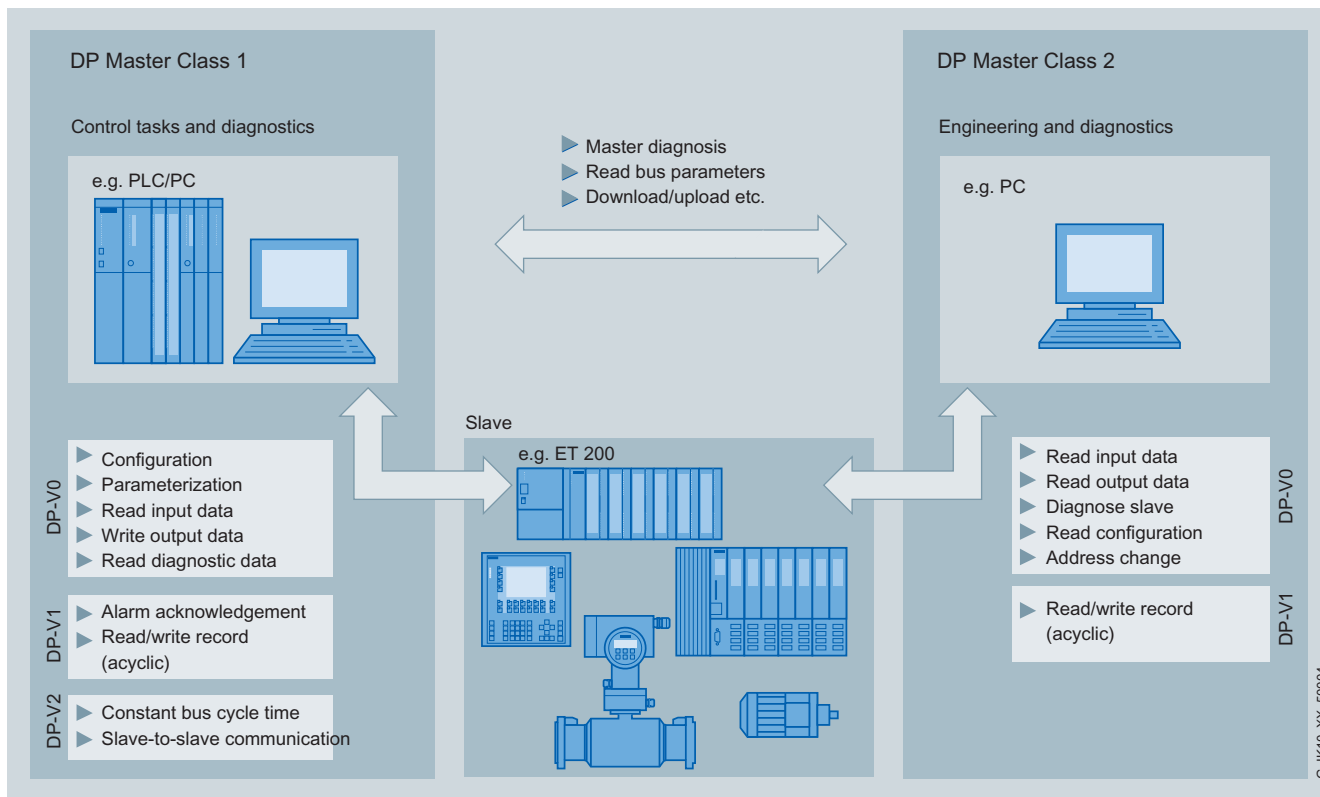

G_IK10_XX_50004

DP Master Classes

Overview

Communication functions

Data communication (e.g. PROFIBUS FMS) serves to exchange data between programmable controllers or between a programmable controller and intelligent partners (PC, computers, etc.).

The following communication functions are available for this purpose:

FMS communication

This is a standardized protocol for data communication via PROFIBUS.

- PROFIBUS FMS (Fieldbus Message Specification)

This is ideally suited to communication from different automation systems (e.g. PLCs, PCs) from different manufacturers at the cell level with only a few stations (max. 16). Communication with field devices using the FMS interface is also possible.

With the FMS services READ, WRITE and INFORMATION REPORT, read or write access to variables of the communication partner is possible from the user program by means of a variable index or variable name, or the user program can transfer its own variable values to a communications partner. Partial access to variables is supported. The communication is processed over acyclic connections (master-to-master, master-to-slave), over acyclic connections with a slave initiative or with cyclic connections (master-to-slave). The INFORMATION REPORT is can also be used to send a message to all stations on the network using a broadcast service. The FMS service IDENTIFY (request for identification characteristics of the partner) and STATUS (request partner status) can also be activated.

OPC-Server

The basic principle of OPC (Openness, Productivity & Collaboration) is that OPC client applications communicate with the OPC server over a standardized, open and manufacturer-independent interface.

The appropriate OPC servers are included in the scope of supply of the respective communication software.

PG/OP communication

Comprises integral communication functions that are used by the SIMATIC programmable controllers to perform data communication with HMI devices (e.g. TD/OP) and SIMATIC PG (STEP 7). PG/OP communication is supported by MPI, PROFIBUS and Industrial Ethernet networks.

S7 routing

With the aid of S7 routing it is possible to use the programming device communication across networks.

S7 communication

S7 communication is the integral communication function, which has been optimized within the SIMATIC. It enables PCs and workstations to be connected. The maximum volume of useful data per task is 64 KB. S7 communication offers simple, powerful communication services and provides a network-independent software interface for MPI, PROFIBUS and Industrial Ethernet networks.

Open communication

The open communication (SEND/RECEIVE) allows the SIMATIC S7 controllers to communicate with other SIMATIC S7 and SIMATIC S5 controllers, PCs, and third-party systems.



Overview (continued)

System connections

For many data terminals, communications processors (CPs) are available that already have the communications functions implemented in the firmware and that therefore relieve the data terminal of communications tasks (e.g. flow control, blocking, etc.).

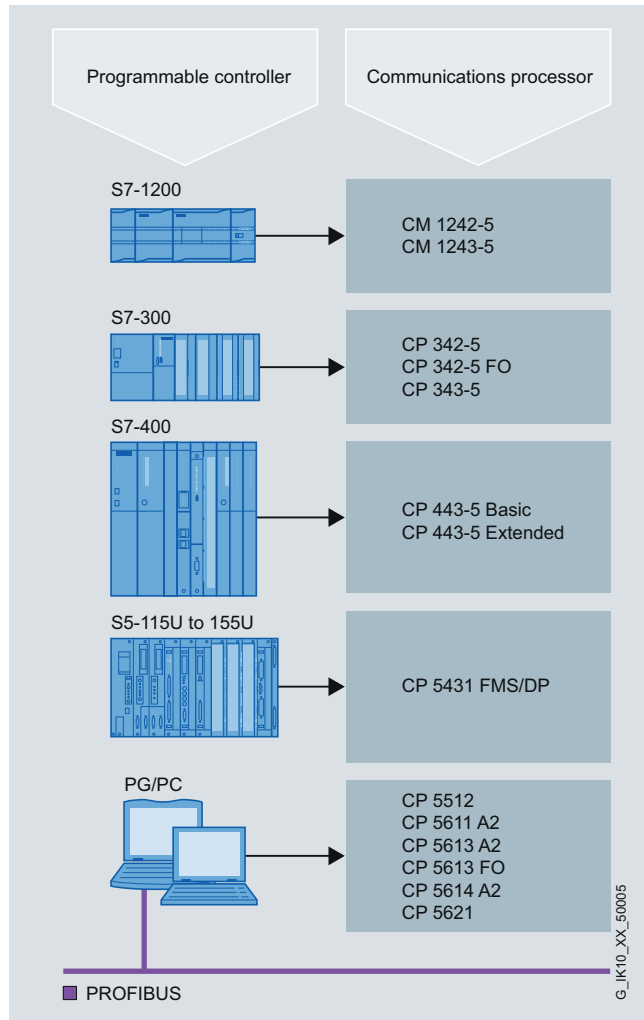

PROFIBUS system connections for SIMATIC and PC

Communication overview

3

Function

	Hardware	PROFIBUS DP			PG/OP	S7 communication		Open communication	Time	
		DP master Class 1	DP master Class 2	DP slave		Standard system	High-availability communication		Send/Receive ¹⁾	Sending stations
S7-1200	CM 1243-5 CM 1242-5	•		•	•	•				
SIMATIC S7-300	CP 342-5/ CP 342-5 FO	•	•	•	•	•	•			
SIMATIC S7-400	CP 443-5 Extended	•	•		•	•	•	•	•	•
SIMATIC S7mEC	CP 5603	•	•	•	•	•		•		

¹⁾ SDA and SDN services of PROFIBUS Layer 2 (FDL)

• suitable
○ not applicable

G_IK10_XX_50188

Communications overview for SIMATIC

Hardware	Software	Operation system (64 Bit)		Operation system (32 Bit)			Other operation systems	OPC	PROFIBUS DP ⁵⁾			PG/OP	S7 communication	Open communication ⁷⁾	
		Windows 7 Professional / Ultimate ⁸⁾	Windows Server 2008 R2 ⁸⁾	Vista Business / Ultimate + SP1/2 ⁹⁾	Windows XP Pro + SP3 ⁹⁾	Windows Server 2008 + SP1/2 ⁹⁾			Windows Server 2003 R2 / SP2 ⁹⁾	DP MasterClass 1	DP MasterClass 2				DP slave
CP 5603 (PCI-104) CP 5613 A2 CP 5613 FO CP 5614 A2 (PCI 32 Bit) CP 5623 CP 5624 (PCIe x1)	CP with DP-Base ^{1) 4)}	•	•	•	•	•	•	•	•	•	•	• ²⁾	•		•
	DK-5613	○ ⁶⁾	○ ⁶⁾	○ ⁶⁾	○ ⁶⁾	○ ⁶⁾	○ ⁶⁾	○ ⁶⁾	•	•	•	•			
	HARDNET-PB DP (DP-5613) ⁴⁾	•	•	•	•	•	•	•	•	•	• ²⁾		•		•
	HARDNET-PB S7 (S7-5613)	•	•	•	•	•	•	•	•	•	•		•	•	•
	S7 OPC Redundancy for PROFIBUS		•						•				•		
CP 5611 A2 (PCI 32 Bit) CP 5621 (PCIe x1) CP 5512 (CardBus 32 Bit) CP 5711 (USB V2.0)	SOFTNET-PB DP	•	•	•	•	•		•	• ²⁾³⁾	• ²⁾³⁾					•
	SOFTNET-PB DP Slave	•	•	•	•	•		•				• ²⁾			
	SOFTNET-PB S7	•	•	•	•	•		•				•	•	•	
	S7 OPC Redundancy for PROFIBUS		•			•							•		
	STEP 7		•	•	•	•							•		

You can find more information on the Internet <http://www.siemens.com.simatic-net/ik-info>
If you have questions on LINUX projects please contact via e-mail it4industry@siemens.com

1) Included in scope of supply of the hardware
2) DP master and DP slaves cannot be operated simultaneously
3) Master Class 1 and Master Class 2 cannot be operated simultaneously on one CP (Exceptions: CP 5614 A2/ CP 5624)
4) DP-Base and DP-5613 cannot be operated simultaneously

5) DP master and DP slave only possible with CP 5614/CP 5624
6) With porting via DK-5613
7) SEND/RECEIVE based on the FDL interface
8) on SIMATIC NET CD V8.1
9) on SIMATIC NET CD Edition 2008

• suitable
○ suitable under certain conditions
not applicable

G_IK10_XX_50058

Communications overview for PG/PC

PROFIBUS

Introduction

Configuration examples

Integration

Configuration example for process or field communication

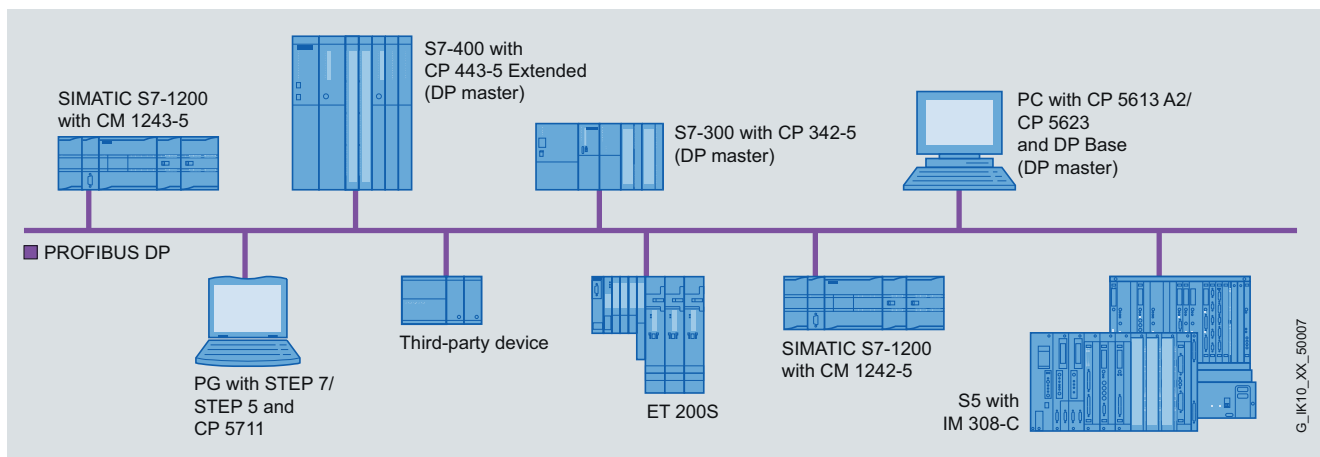

PROFIBUS DP configuration for SIMATIC S5/S7 and PG/PC

Configuration example for data communication

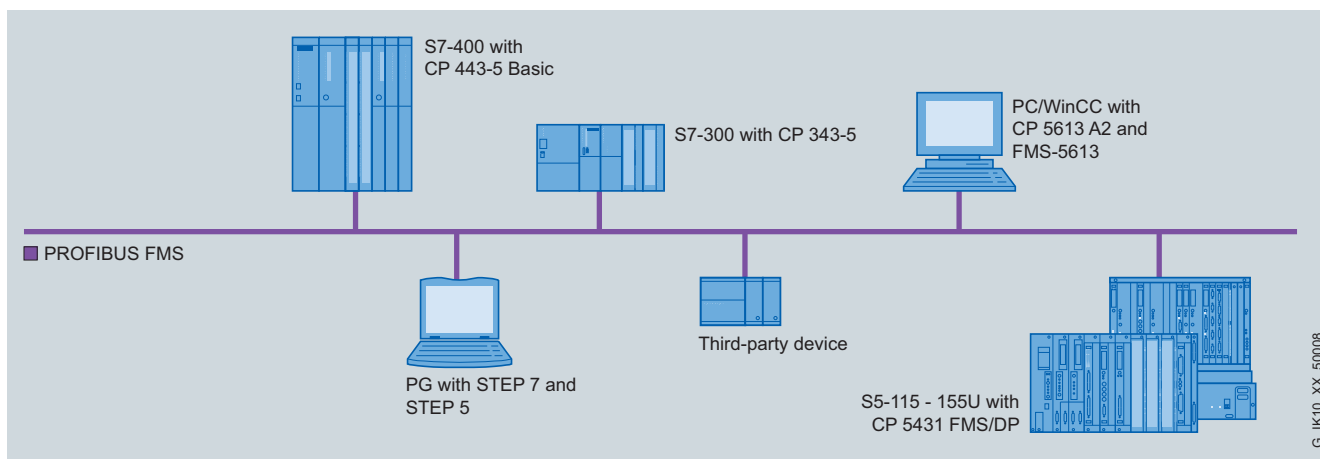

PROFIBUS FMS configuration for SIMATIC S5/S7 and PG/PC

Integration (continued)

Configuration example for PG/OP communication

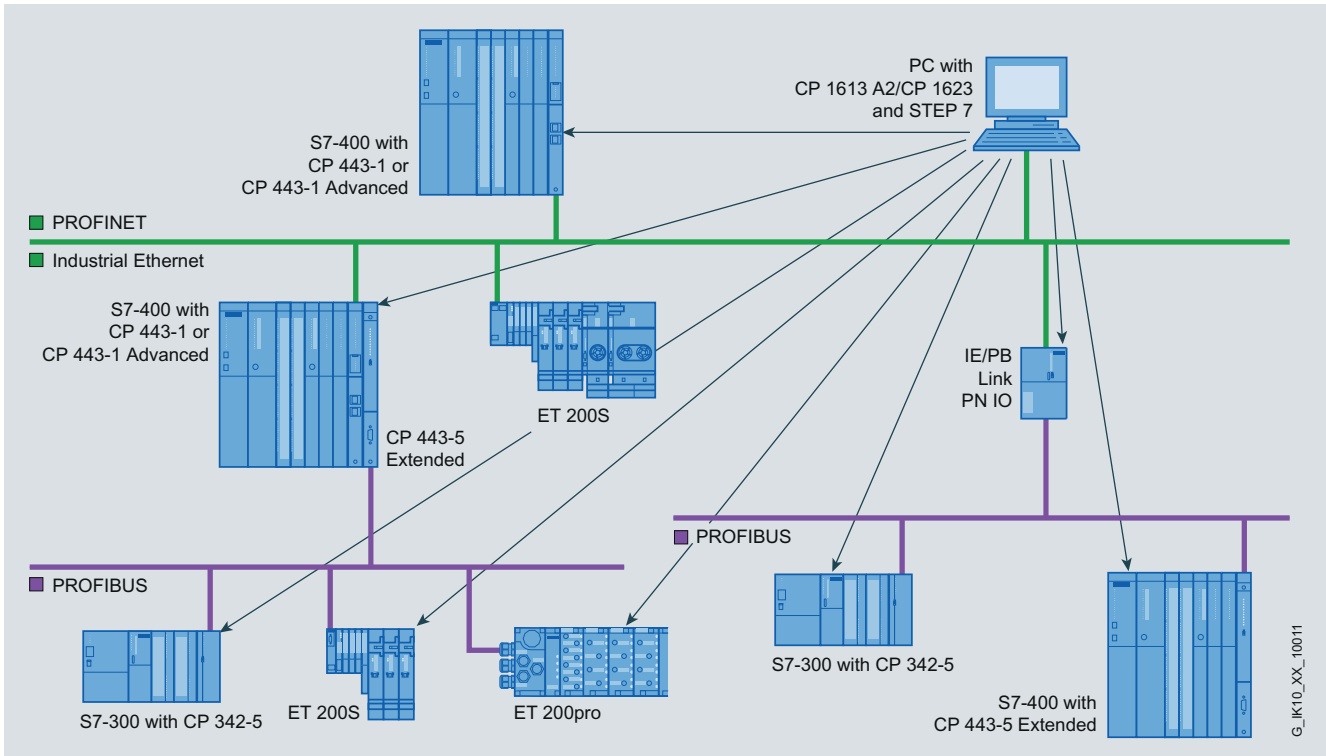

PG/OP communication for transparent access to configuration and diagnostic data of the connected PROFIBUS nodes by means of S7 routing

PROFIBUS

Introduction

Topologies

Overview

Siemens offers a comprehensive range of PROFIBUS network components for electrical and optical transmission technology.

PROFIBUS is standardized in accordance with IEC 61158/EN 50170 for universal automation (PROFIBUS FMS and PROFIBUS DP), and in accordance with IEC 61158-2 for process automation (PROFIBUS PA).

Electrical network

- The electrical network uses a shielded twisted pair cable. The RS 485 interface works with voltage differences. It is therefore less sensitive to interference than a voltage or current interface. With PROFIBUS, the stations are connected to the bus via a bus terminal or a bus connector (max. 32 stations per segment).
- The individual segments are connected via repeaters.
- The transmission rate can be set in steps from 9.6 kbit/s to 12 Mbit/s.
- The maximum segment length depends on the transmission rate.
- The electrical network can be configured as a bus or tree structure
- For applications in the intrinsically-safe area, the transmission technology compliant with IEC 61158-2 is used with PROFIBUS PA. The transmission rate in this case is 31.25 kbit/s.

Characteristics

- High-grade bus cable
- Transmission method: RS 485 (acc. to EIA)
- Bus topology with bus terminals and bus connectors for connecting PROFIBUS stations
- Transmission method in accordance with IEC 61158/EN 50170 for universal automation (PROFIBUS FMS/DP), and in accordance with IEC61158-2 for the intrinsically-safe area (PROFIBUS PA)
- The DP transmission system of RS 485 (bit coding by means of differential voltage signals) is converted to IEC 61158-2 (bit coding by means of current signals) using the network components (DP/PA coupler or DP/PA link)
- Simple, universal installation and grounding concept
- Easy installation

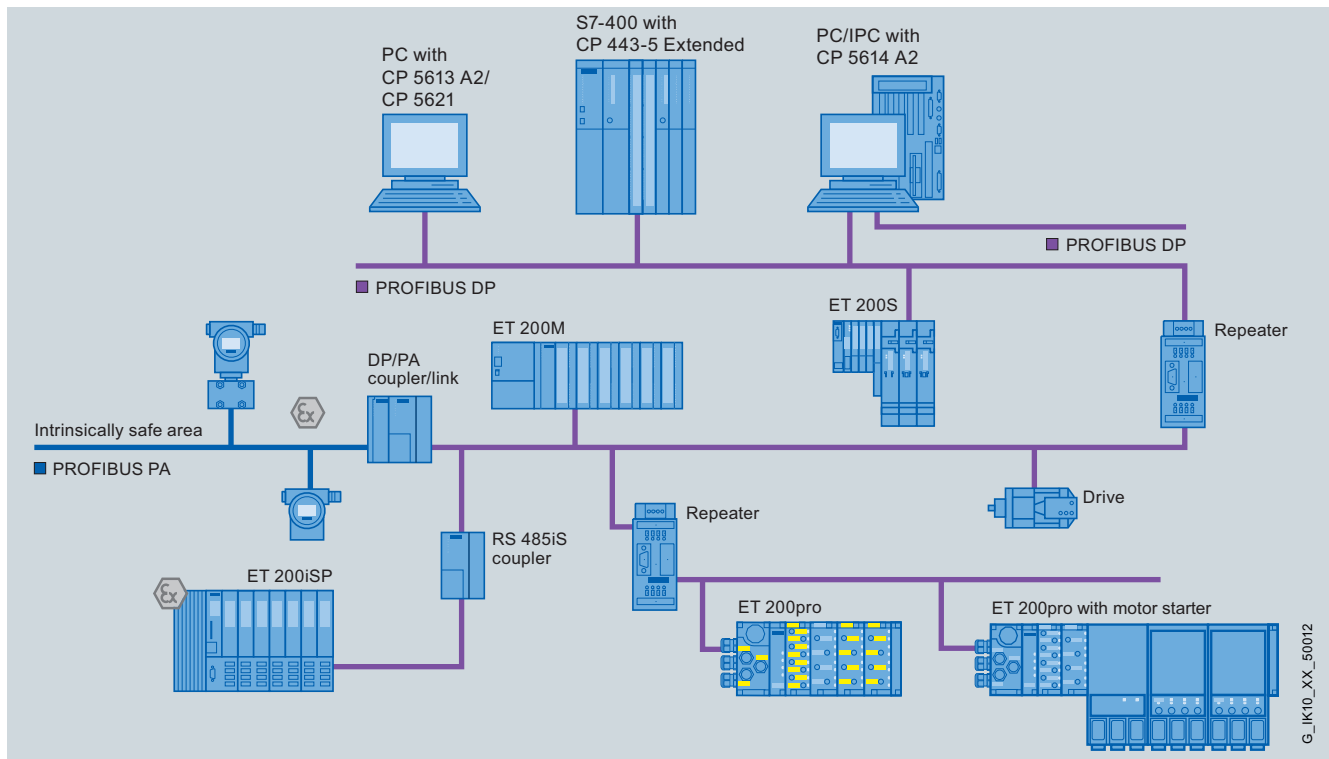

Electrical PROFIBUS network configuration

Overview (continued)

Optical network

The fiber-optic cable variant of PROFIBUS has the following characteristics:

- Transmission link is insensitive to electromagnetic influences
- Suitable for long ranges
- Galvanic isolation
- Uses either plastic, PCF or glass fiber-optic cables
- Avoidance of overvoltage and equipotential bonding problems

Optical PROFIBUS with OLMs

Using optical link modules (OLM) it is possible to construct an optical network in a linear, ring, or star topology. The maximum distance between two OLMs is 15 km. The transmission rate can be set in steps from 9.6 kbit/s to 12 Mbit/s.

Optical PROFIBUS with integral interface and OBT

The optical PROFIBUS with integral interface and OBT is constructed in a linear topology. A cost-optimized solution is available for this in the form of devices with integral optical interface. Terminal equipment with an RS 485 interface can be connected via an Optical Bus Terminal (OBT). The maximum distance between two nodes is 50 m in the case of plastic fiber-optic cables. Special fiber-optic cables are available to cover distances of up to 400 m.

Hybrid network

Hybrid electrical and optical networks are possible. The transition between both media is implemented by the OLM.

In station-to-station communication on the bus, there is no difference between two-wire technology and fiber-optic technology. A maximum of 127 stations can be connected to one PROFIBUS network.

The optical transmission technology offers the following advantages:

- Fiber-optic cables made of plastic or glass are not susceptible to electromagnetic interference and therefore render the EMC measures required for electrical networks unnecessary
- No additional lightning protection concept is required in the outdoor area
- The potentials on the modules are automatically separated thanks to the characteristics of the conductor
- With fiber-optic cables, long distances to field devices can be bridged.

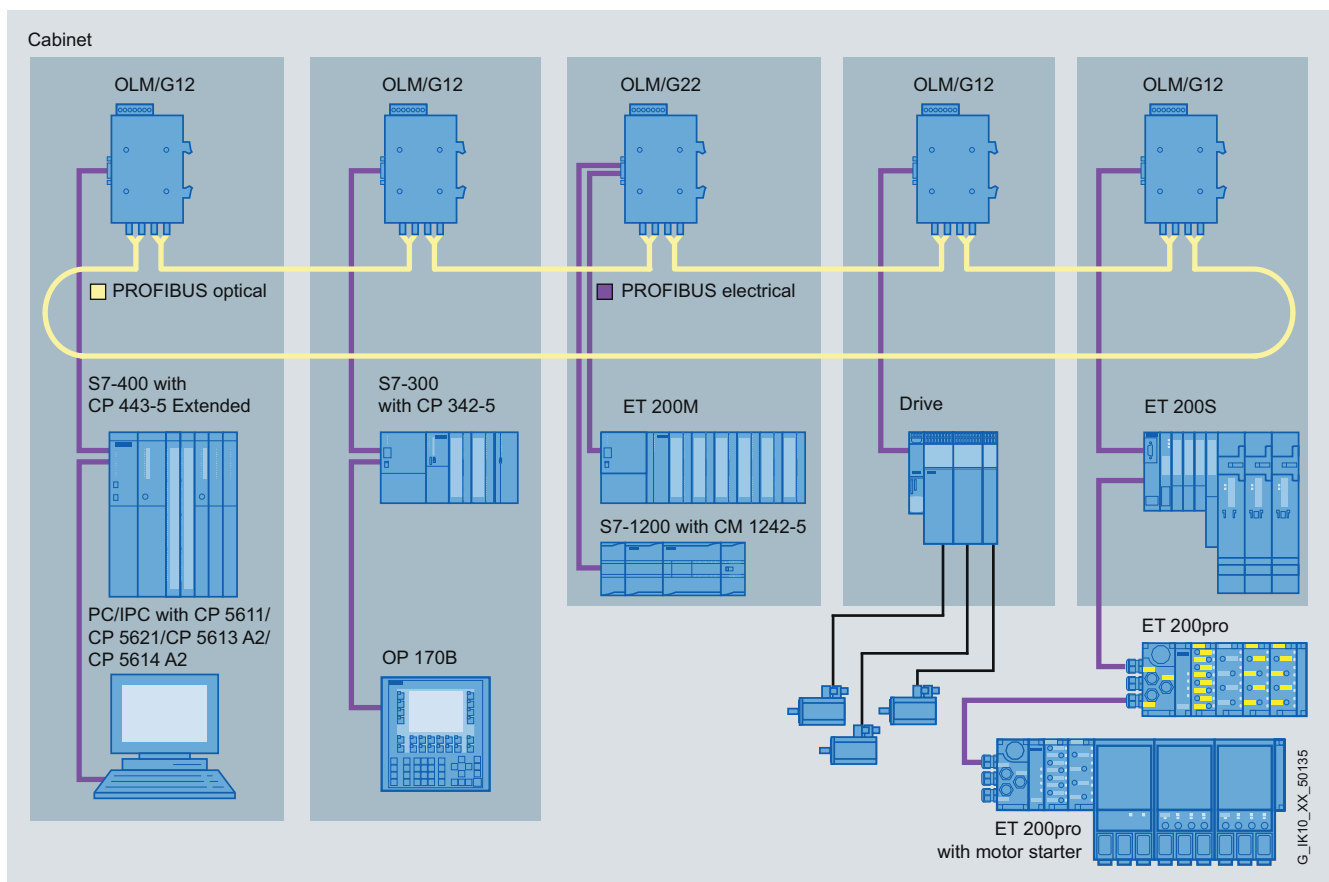

Network configuration combining electrical and optical PROFIBUS

More information

Please always note the supplementary conditions for the specified SIMATIC NET products (order number 6GK..., 6XV1...) that you can view on the Internet pages shown below:

www.siemens.com/simatic-net/ik-info

PROFIBUS

Network components

Overview of network components













Overview

PROFIBUS	Maximum cable length for PROFIBUS connections						
	Type of fibre	0 - 80 m	0 - 100 m	0 - 200 m	0 - 400 m	0 - 3,000 m	0 - 10,000 m
PB FC Bus Cables							
PB FC Standard Cable GP / PB FC Standard Cable GP IS			● ⁴⁾	● ⁵⁾			
PB FC Robust Cable			● ⁴⁾	● ⁵⁾			
PB FC Food Cable			● ⁴⁾	● ⁵⁾			
PB FC Ground Cable			● ⁴⁾	● ⁵⁾			
PB FC Flexible Cable			● ⁴⁾	● ⁵⁾			
PB FC Trailing Cable			● ⁴⁾	● ⁵⁾			
PB FC FRNC Cable GP			● ⁴⁾	● ⁵⁾			
PB Festoon Cable GP			● ⁴⁾	● ⁵⁾			
PB Torsion Cable			● ⁴⁾	● ⁵⁾			
PYR FR Marine Cable			● ⁴⁾	● ⁵⁾			
PB Hybrid Standard Cable GP ¹⁾							
PB Hybrid Robust Cable ¹⁾							
PB FC Process Cable ¹⁾							
PB Cable for ET 200X ¹⁾							
PB ECOFAST Bus Cables							
PB ECOFAST Hybrid Cable ¹⁾							
PB ECOFAST Hybrid Cable GP ¹⁾							
PB Glass FOC with PB OLM							
FO Standard Cable GP	Multimode (50/125)					● ²⁾	● ³⁾
FO Ground Cable	Multimode (50/125)					● ²⁾	● ³⁾
FO Trailing Cable	Multimode (50/125)					● ²⁾	● ³⁾
FO Trailing Cable GP	Multimode (50/125)					● ²⁾	● ³⁾
INDOOR FO Indoor cable	Multimode (62.5/125)					● ²⁾	● ³⁾
FO Standard cable	Multimode (62.5/125)					● ²⁾	● ³⁾
Flexible FO Trailing cable	Multimode (62.5/125)					● ²⁾	● ³⁾
PB Plastic/POF/PCF FOC with PB OLM							
PB Plastic FO Standard Cable	Step index (980/1000)	●					
PB PCF FO Standard Cable	Step index (200/230)				●		
PCF Standard Cable GP	Step index (200/230)				●		
PCF Trailing Cable	Step index (200/230)				●		
PCF Trailing Cable GP	Step index (200/230)				●		
¹⁾ Dependent on current load ²⁾ at 860 nm ³⁾ at 1310 nm ⁴⁾ at 12 Mbit/s ⁵⁾ at 1.5 Mbit/s Longer cables possible if data rate is reduced; see PROFIBUS Manual for further information							

G_IK10_XX_50196

Overview of network components

Overview (continued)

		Options for connecting PROFIBUS cables with plugs, terminals or devices												
		Electrical							Optical					
		PROFIBUS FC bus cables	PROFIBUS bus cables	Connecting cables	ECOFAST cable	Hybrid cable	Power cable	PROFIBUS FC Bus cable (PROFIBUS PA)	Bus terminal	Fiber-optic cable 50/125 µm	Fiber-optic cable 62.5/125 µm	PCF fiber optic cable 200/230 µm	POF-FOC 980/1000 µm	Fiber-optic cable with BFOC connector
PROFIBUS FC Standard Cable PROFIBUS FC Standard Cable IS GP PROFIBUS FC Standard Cable PROFIBUS FC Food Cable PROFIBUS FC Ground Cable PROFIBUS FC FRNC Cable PROFIBUS FC Trailing Cable	PROFIBUS Fisetoon Cable PROFIBUS Flexible Cable	Connecting cable 830-2 Connecting cable 830-1T PROFIBUS M12 plug-in cable	ECOFAST Hybrid Cable GP ECOFAST Hybrid Cable GP	PROFIBUS Hybrid Standard Cable GP PROFIBUS Hybrid Robust Cable	Power Cable 5 x 1.5	PB FC Process Cable	12M bus terminal	FO Standard Cable GP FO Trailing Cable GP FO Ground Cable	FIBER OPTIC standard cable INDOOR Fiber Optic indoor cable Flexible Fiber Optic trailing cable SIENOPYR marine duplex fiber-optic cable	PCF Standard Cable GP PCF Trailing Cable GP PCF Trailing Cable GP	Plastic fiber optic standard cable	Preassembled FOC with BFOC connector	Preassembled FOC with simplex connector	
Electrical	 PB FastConnect connector	•	•											
	 PB bus connector	•	•											
	 ECOFAST connector				•									
	 PB M12 plug / socket (B-coded)	•	•											
	 7/8" Power con						•							
	 PB devices with Sub-D / M12 connector			•				•						
	 ET 200pro	•	•			•								
	 Bus terminal 12M	•	•											
	 SplitConnect system						•							
Optical	 BFOC connector							•	•	•				
	 PB devices with BFOC connection											•		
	 Simplex connector									•	•			
	 PB devices with simplex connection												•	

G_IK10_XX_50013

PROFIBUS

Network components

Network selection criteria

Overview

Criteria	Electrical network		Optical network		
	RS 485 conforming to IEC 61158/ 61784	IEC 61158-2 (PA)	Plastic	PCF	Glass
EMC	● ● ● ○	● ● ● ○	● ● ● ●	● ● ● ●	● ● ● ●
Inter-building networking	● ● ○ ○ ¹⁾	● ● ○ ○	● ○ ○ ○	● ● ● ○ ⁵⁾	● ● ● ● ⁵⁾
Operating distance	● ● ○ ○ ²⁾	● ● ○ ○	● ○ ○ ○	● ● ○ ○	● ● ● ●
Suitability for high transmission rate	● ● ● ○ ⁴⁾	-	● ● ● ●	● ● ● ●	● ● ● ●
Simple plug fitting	● ● ● ●	● ● ● ●	● ● ● ○	● ● ● ○ ³⁾	● ● ● ○ ³⁾
Simple cable laying	● ● ● ○	● ● ● ○	● ● ○ ○	● ● ○ ○	● ● ○ ○
Equipotential bonding measures required	Yes	Yes	No	No	No
Performance spectrum for special applications	● ● ● ●	● ○ ○ ○	● ○ ○ ○	● ○ ○ ○	● ● ○ ○
Used for moving nodes	● ● ○ ○ ⁶⁾	-	● ● ○ ○ ⁶⁾	● ● ○ ○ ⁶⁾	● ● ○ ○ ⁶⁾
Use in intrinsically safe area	-	● ● ● ●	-	-	-
1) Lightning protection measures required 2) Depending on transmission rate 3) Trained personnel and special tools necessary 4) Careful cable laying necessary 5) Outdoor cable required 6) Trailing cable required			● ● ● ● suitable ● ● ● ○ ● ● ○ ○ partly suitable ● ○ ○ ○ - not applicable		

G_IK10_XX_50010

Summary of network selection criteria for transmission media

Overview (continued)

Criteria		Electrical network	Optical network	
		Electrical PROFIBUS	with OLM	with integr. interface/ OBT
Transition media	Plastic ¹⁾	-	●	●
	PCF	-	●	●
	Glass	-	●	-
	Shielded two-core cable	●	-	-
Distances	max. network size	9.6 km ⁵⁾	90 km	9.6 km
	between two nodes	up to 1 km ³⁾	up to 15 km ²⁾	up to 300 m ²⁾
Topology	Bus	●	-	-
	Line	-	●	●
	Tree	●	●	-
	Ring	-	●	-
Transmission protocols		all	all	DP
Connection of nodes via	OLM	-	●	-
	Integrated interfaces	●	-	● ⁴⁾
	Bus terminal	●	-	●
	Bus connector	●	-	-
Electr. network segments connectable		●	●	-
1) Plastic optical fiber is also referred to as polymer optical fiber (POF) 2) Depending on type of cable used 3) Depending on data rate used and performance 4) Integrated interfaces (ET 200M, ET 200X) 5) for PROFIBUS PA 1.9 km		● suitable - Irrelevant to this application		G_IK10_XX_50133

Selection criteria for electrical and optical networks

PROFIBUS

Network components

Network selection criteria

Overview (continued)

	Electrical network		Optical network	
	RS 485 in accordance with IEC 61158/EN 50170	IEC 61158-2 (PA)	with OLM	with integral interface/OBT
Network topology	Bus, tree	Bus, tree	Linear bus, star, ring	Linear bus
Transmission media	Shielded twisted-pair cable	Shielded twisted-pair cable for intrinsically-safe and non-intrinsically-safe areas	Plastic fiber optic cable PCF optic cable Glass fiber optic cable	Plastic fiber optic cable PCF optic cable
Tools and accessories	FastConnect stripping tool	FastConnect stripping tool	Tools for preparing BFOC connectors for plastic fiber optic cables	Tools for preparing Simplex connectors for plastic fiber optic cables
Connectors	Bus connector	SplitConnect system	BFOC connector	Simplex connector
Connection components	Bus terminal	SplitConnect system	OLM	OBT
Prepared cables	830-1T connecting cable 830-2 connecting cable	—	INDOOR cable with BFOC Standard glass cable with BFOC Trailing cable with BFOC Standard PCF cable with BFOC Standard plastic cable with BFOC	Standard PCF cable with Simplex connectors and pull cord feature
Lightning protection	Primary protection Secondary protection	to be implemented through design measures	Not required	Not required
Electrical network segment can be connected via	repeater	—	Optical Link Module (OLM)	Optical Bus Terminal (OBT)
Diagnostics tool	BT 200 hardware test device	Not available	Signal contact and integral measuring sockets; level measuring device on request	Level measuring device on request
Documentation	Manual for PROFIBUS networks	Manual for PROFIBUS networks	Manual for PROFIBUS networks	Manual for PROFIBUS networks

G_IK10_XX_50016

PROFIBUS network components and accessories

	Electrical PROFIBUS	Optical PROFIBUS/OLM	Optical PROFIBUS/int./OBT
Electrical PROFIBUS	Repeater	OLM	OBT
Optical PROFIBUS/OLM	OLM	OLM	OBT + OLM
Optical PROFIBUS/int./OBT	OBT	OBT + OLM	OBT, integr. optics

G_IK10_XX_50017

Transitions between the transmission media

Integration

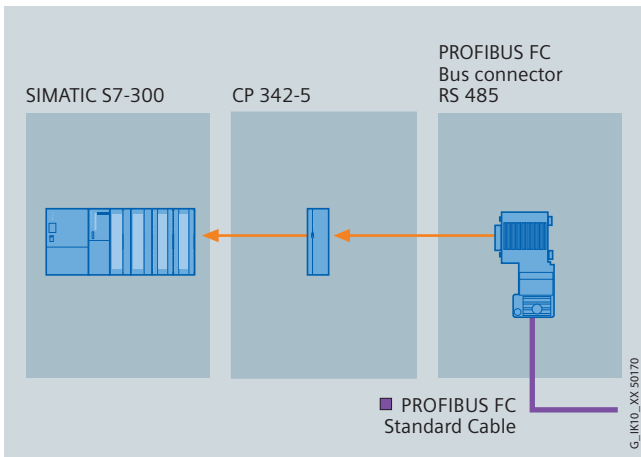

Typical connection for electrical networking with PROFIBUS FastConnect RS485 bus connector

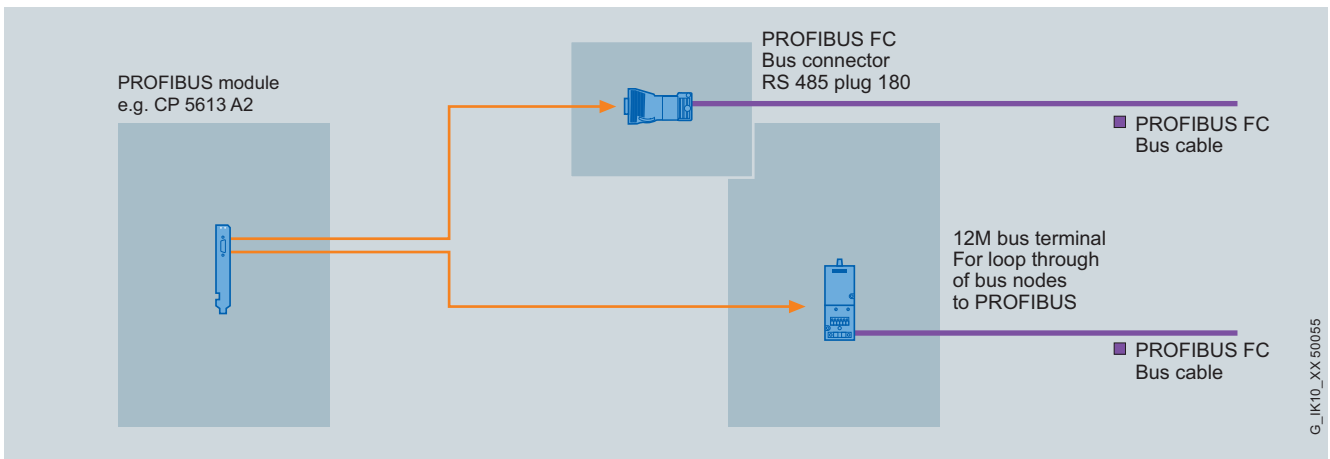

Typical connection for electrical networking with PROFIBUS FastConnect RS485 bus connector or bus terminal

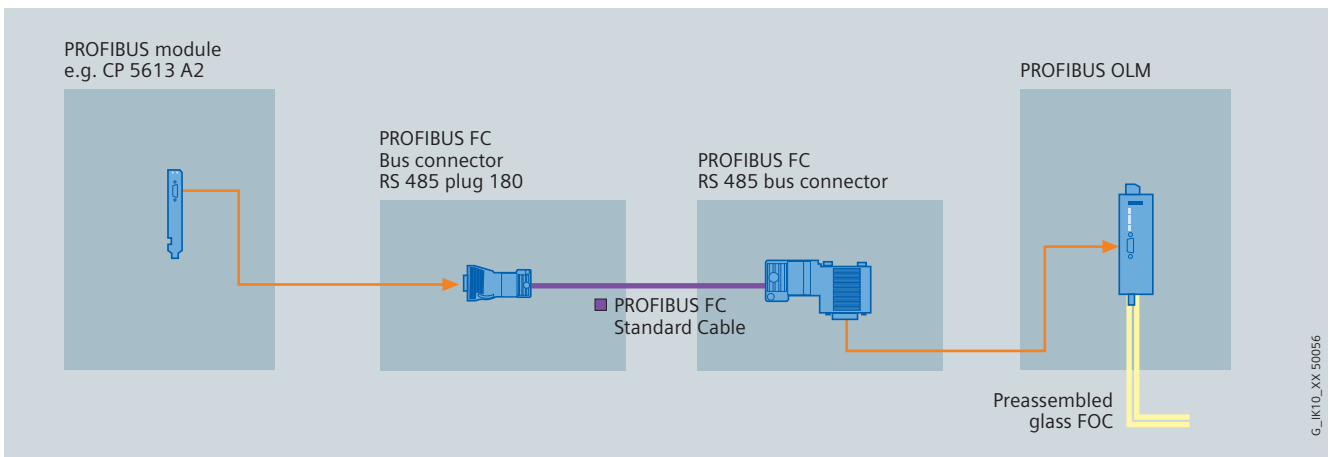

Connection example of optical networking

PROFIBUS

Network components

Connection examples

Integration (continued)

3

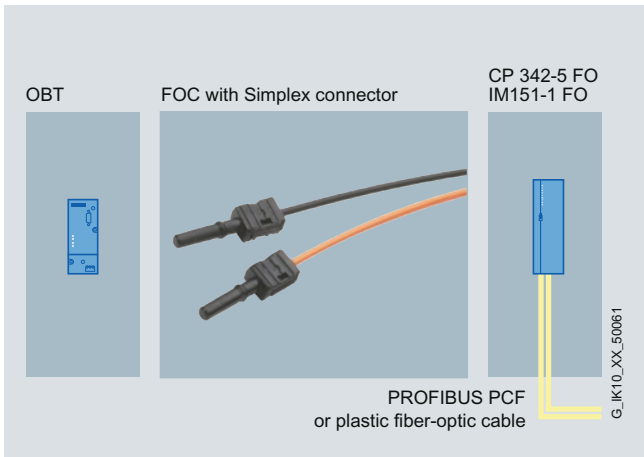

Connection example of optical networking with fiber-optic cables and Simplex connectors

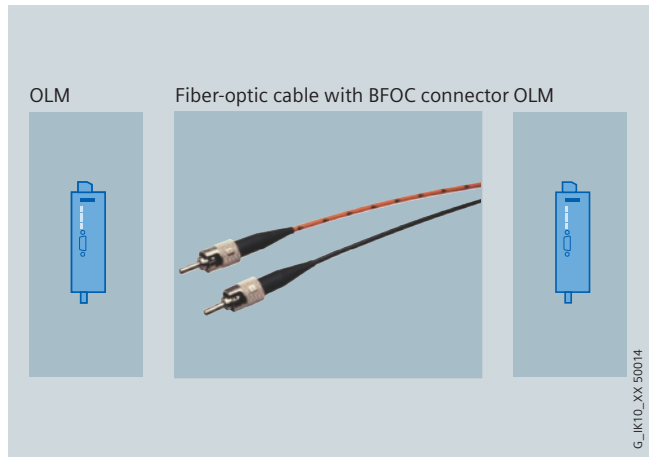

Connection example of optical networking with fiber-optic cables and BFOC connectors

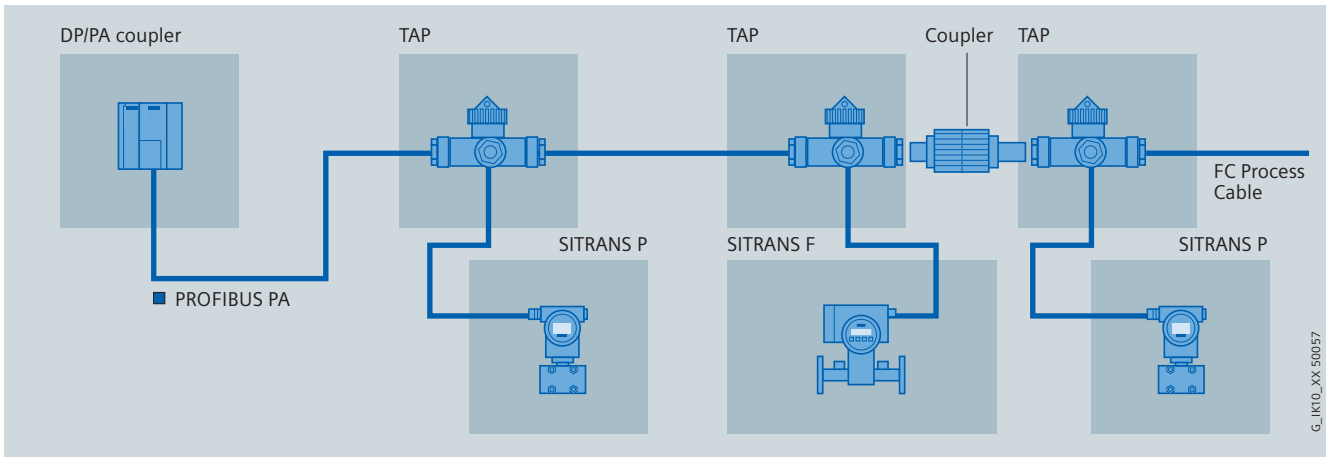

Connection example of an intrinsically-safe network with PROFIBUS PA

Overview



- Quick and easy assembly of PROFIBUS copper cables
- Assembly mistakes such as short-circuits between the shield and core are excluded

Benefits

g e t **Designed for Industry**

- Shorter connection times for terminals by stripping of the outer cladding and woven shield in one step
- Installation faults, such as short-circuits between the shield and cores, are excluded
- Easy assembly due to preset insulation stripping tool (FC stripping tool)
- Termination can be checked in the assembled state through the transparent cover for the insulation piercing terminals thanks to color coding.

Design

The system comprises 3 compatible components:

- FastConnect bus cables for rapid installation
- FastConnect stripping tool
- FastConnect bus connector for PROFIBUS

The PROFIBUS FastConnect bus cables can also be connected to conventional bus connectors.

Function

The FastConnect stripping method enables fast and easy connection of PROFIBUS connectors to the PROFIBUS cables.

The special structure of the FastConnect bus cables enables the use of the FastConnect stripping tool with which the outer casing and the woven shield can be stripped in one operation with perfect precision. The cable prepared in this way is connected in the FastConnect bus connector using the insulation displacement method.

PROFIBUS

Electrical networks (RS485)

PROFIBUS FastConnect

Application

PROFIBUS FastConnect is a system for fast and easy assembly of PROFIBUS copper cables.

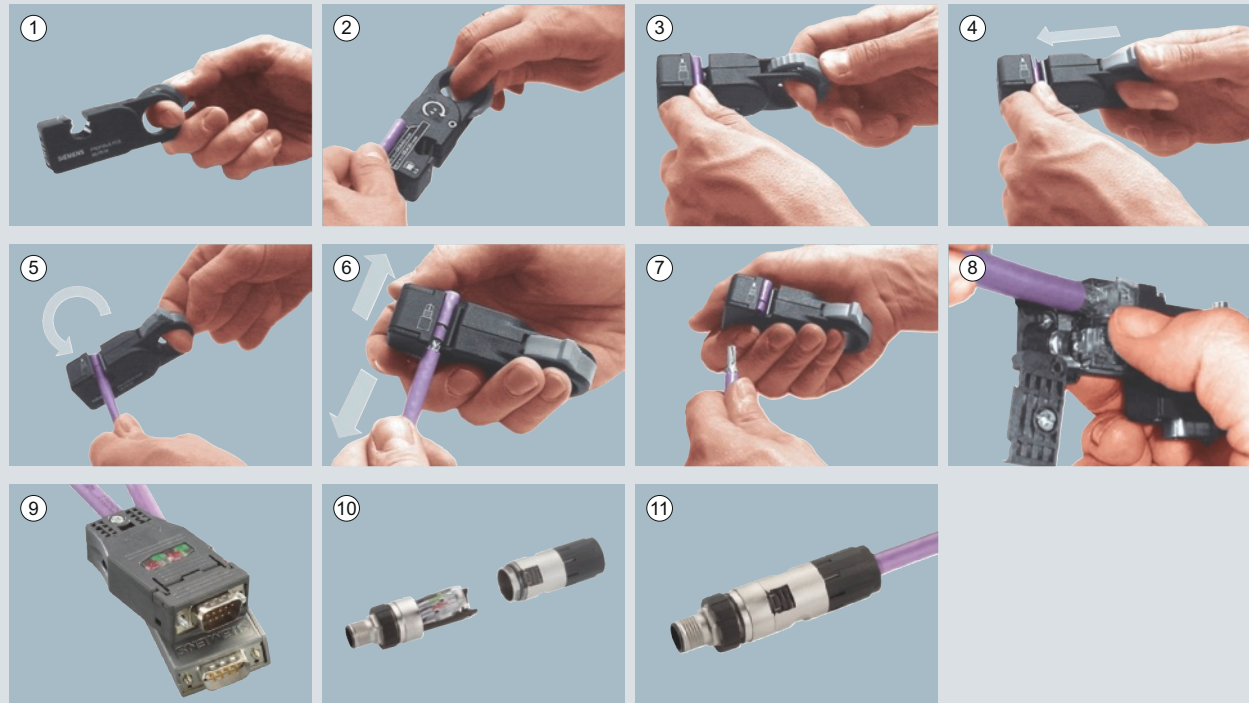

G_JK10_XX_50001

Steps in assembling PROFIBUS copper cables with PROFIBUS FastConnect

Overview



- Different variants for different application areas (e.g. underground cables, trailing cables, hazardous area Zone 1 and Zone 2)
- High interference immunity thanks to double shielding
- Flame-retardant bus cable (halogen-free)
- Easy length measurement thanks to printed meter markings
- UL approvals

Benefits

get Designed for Industry

- Flexible application possibilities thanks to special bus cables
- Network is immune to interference thanks to double shielded cables and a uniform grounding concept
- Time saving due to simple and FastConnector assembly with FastConnect cables
- Silicon-free, therefore particularly suitable for use in the automotive industry (e.g. on paint shop conveyors)

Application

For the construction of PROFIBUS DP networks, different cable types are offered to suit the different types of applications. The listed bus cables should always be used. For further information on network configuration, see the PROFIBUS network manual.

UL approvals

UL listing (safety standard) for network cables is especially necessary for the American and Canadian markets. The requirements for the appropriate approvals depend on where the cable is routed within the building. This applies to all cables which have to be routed from a machine to a remote control cabinet and are positioned on cable racks secured on the building. Cables with UL approval have "GP" (General Purpose) added to their name.

Ex approval

Cables for intrinsically safe PROFIBUS DP applications have "IS" (intrinsically safe) added to their names

Design

Shielded, twisted-pair cable with circular cross-section

The following applies for all PROFIBUS bus cables:

- The double shield makes it especially suitable for routing through industrial areas with strong electro-magnetic fields
- System-wide grounding concept can be implemented using the external shield of the bus cable and the grounding terminals on the bus terminal
- Printed meter marks

Cable types

The shape of the FastConnect (FC) bus cables is radially symmetric and allows an insulation stripping tool to be used. This means that bus connectors can be assembled quickly and easily.

- PROFIBUS FC Standard Cable GP: Standard bus cable specially designed for fast installation
- PROFIBUS FC Standard Cable IS GP: Standard bus cable with special design for quick installation for intrinsically safe distributed I/O systems
- PROFIBUS FC Robust Cable: Special cable for use in corrosive atmospheres and under severe mechanical loading
- PROFIBUS FC Food Cable: The PE casing of the cable makes this cable suitable for use in the food and tobacco industry
- PROFIBUS FC Ground Cable: Special cable for laying underground. It differs from the PROFIBUS bus cable in that it has an additional sheath
- PROFIBUS FC Flexible Cable: Flexible (stranded conductors), halogen-free bus cable with PUR sheath for occasional moving
- PROFIBUS FC Trailing Cable: Bus cable specially designed for forced motion control in a trailing cable, e.g. with continuously moving machine parts (stranded core)
- PROFIBUS FC FRNC Cable GP: Two-core, shielded, flame-retardant, halogen-free bus cable with Copolymer outer sheath FRNC (Flame Retardant Non Corrosive)

Bus cables without FastConnect technology (due to type of construction)

- PROFIBUS Festoon Cable GP: Flexible bus cable (stranded cores) specially designed for festoon suspension. For round cables, cable-carrying trolleys are recommended
- PROFIBUS Torsion Cable: Bus cable for highly flexible applications: Special cable (stranded cores) for use on moving parts of machines (5 million torsion movements on 1 m length of cable, $\pm 180^\circ$)
- PROFIBUS Hybrid Cable GP: Rugged hybrid cable suitable for trailing with two copper conductors for data transmission and two copper conductors for the power supply of ET 200pro
- SIENOPYR FR marine cable: Halogen-free, non-crush, flame-retardant, marine-approved cable for permanent installation on ships and offshore platforms indoors and on open deck. Sold by the meter.

PROFIBUS

Electrical networks (RS485)

PROFIBUS bus cables

Technical specifications

Order No.	6XV1 830-0EH10	6XV1 831-2A	6XV1 830-0JH10	6XV1 830-0GH10
Product type designation	PROFIBUS FC Standard Cable GP	PROFIBUS FC Standard Cable IS GP	PROFIBUS FC Robust Cable	PROFIBUS FC Food Cable
Product description	Standard bus cable (2-core), sold by the meter, in bulk	Standard bus cable for fast assembly, sold by the meter, in bulk	Special bus cable (2-core), sold by the meter, in bulk	Bus cable (2-core), sold by the meter, in bulk
Suitability for use	Standard cable of special design for fast assembly with fixed installation	Use for intrinsically-safe distributed I/O systems, for fixed installation	Use in chemically and mechanically stressed environments	Use in the F & B industry
Cable designation	02YSY (ST) CY 1x2x0.64/2.55-150 VI KF 40 FR	02YSY (ST) CY 1x2x0.64/2.55 BL KF40 FR	02YSY (ST) C11Y 1x2x0.64/2.55-150 VI KF 40 FR	02YSY (ST) C2Y 1x2x0.64/2.55-150 KF 40
Cable length	-	-	-	-
Electrical specifications				
Attenuation factor per length				
• Max. at 9.6 kHz	2.5 dB/km	2.5 dB/km	2.5 dB/km	2.5 dB/km
• Max. at 38.4 kHz	4 dB/km	4 dB/km	4 dB/km	4 dB/km
• Max. at 4 MHz	22 dB/km	22 dB/km	22 dB/km	22 dB/km
• Max. at 16 MHz	42 dB/km	42 dB/km	42 dB/km	42 dB/km
Characteristic impedance				
• Rated value	150 Ω	150 Ω	150 Ω	150 Ω
• at 9.6 kHz	270 Ω	270 Ω	270 Ω	270 Ω
• at 38.4 kHz	185 Ω	185 Ω	185 Ω	185 Ω
• at 3 MHz ... 20 MHz	150 Ω	150 Ω	150 Ω	150 Ω
Relative symmetrical tolerance				
• of characteristic impedance at 9.6 kHz	10 %	10 %	10 %	10 %
• of characteristic impedance at 38.4 kHz	10 %	10 %	10 %	10 %
• of characteristic impedance at 3 MHz to 20 MHz	10 %	10 %	10 %	10 %
Max. loop resistance per length	110 Ω/km	110 Ω/km	110 Ω/km	110 Ω/km
Max. shield resistance per length	9.5 Ω/km	9.5 Ω/km	9.5 Ω/km	9.5 Ω/km
Capacitance per length at 1 kHz	28.5 pF/m	28.5 pF/m	28.5 pF/m	28.5 pF/m
Operating voltage, rms value	100 V	100 V	100 V	100 V
Mechanical data				
Number of electrical cores	2	2	2	2
Design of shield	Overlapping aluminum-clad foil, sheathed in a braided screen of tinned copper wires	Overlapping aluminum-clad foil, sheathed in a braided screen of tinned copper wires	Overlapping aluminum-clad foil, sheathed in a braided screen of tinned copper wires	Overlapping aluminum-clad foil, sheathed in a braided screen of tinned copper wires
Design of electrical connection	Yes	Yes	Yes	Yes
FastConnect				
Outer diameter				
• of inner conductor	0.65 mm	0.64 mm	0.65 mm	0.65 mm
• of core insulation	2.55 mm	2.55 mm	2.55 mm	2.55 mm
• of inner sheath of cable	5.4 mm	5.4 mm	5.4 mm	5.4 mm
• of cable sheath	8 mm	8 mm	8 mm	8 mm
Symmetrical tolerance of outer diameter of cable sheath	0.4 mm	0.4 mm	0.4 mm	0.4 mm
Outer diameter of cable sheath - Note	-	-	-	-
Material				
• of core insulation	PE	PE	PE	PE
• of inner sheath of cable	PVC	PVC	PVC	PVC
• of the cable sheath	PVC	PVC	PUR	PE
- Note	-	-	-	Outer shield made of PE particularly suitable for the food sector

Technical specifications (continued)

Order No.	6XV1 830-0EH10	6XV1 831-2A	6XV1 830-0JH10	6XV1 830-0GH10
Product type designation	PROFIBUS FC Standard Cable GP	PROFIBUS FC Standard Cable IS GP	PROFIBUS FC Robust Cable	PROFIBUS FC Food Cable
Color				
• of core insulation of data cores	Red / green	Red / green	Red / green	Red / green
• of the cable sheath	Violet	Blue	Violet	Black
Bending radius				
• with single bending	150 mm	75 mm	150 mm	30 mm
• With repeated bending	300 mm	150 mm	300 mm	60 mm
Maximum tensile load	100 N	100 N	100 N	100 N
Weight per length	80 kg/km	80 kg/km	71 kg/km	67 kg/km
Permitted ambient conditions				
Ambient temperature				
• During operation	-40 ... +75 °C	-40 ... +75 °C	-40 ... +60 °C	-40 ... +60 °C
• During storage	-40 ... +75 °C	-40 ... +75 °C	-40 ... +60 °C	-40 ... +60 °C
• During transport	-40 ... +75 °C	-40 ... +75 °C	-40 ... +60 °C	-40 ... +60 °C
• During mounting	-40 ... +75 °C	-40 ... +75 °C	-40 ... +60 °C	-40 ... +60 °C
Ambient conditions for operation	-	-	-	-
IP degree of protection	-	-	-	-
Behavior in fire	Flame-retardant in accordance with IEC 60332-3-24 (Category C) and UL 1685 (CSA FT 4)	Flame-retardant in accordance with IEC 60332-3-24 (Category C)	Flame-retardant in accordance with IEC 60332-1	Flammable
Chemical resistance				
• against mineral oil	Limited resistance	Limited resistance	Resistant	Limited resistance
• against grease	Limited resistance	Limited resistance	Resistant	Limited resistance
• against water	-	-	-	-
Radiological resistance to UV radiation	Resistant	Resistant	Resistant	Resistant
Product properties, functions, components				
General				
Product property				
• Halogen-free	No	No	No	No
• Silicon-free	Yes	Yes	Yes	Yes
Cable length				
• at 12 Mbit/s maximum	100 m	100 m	100 m	100 m
• at 1.5 Mbit/s maximum	200 m	200 m	200 m	200 m
Standards, specifications, approvals				
UL listing at 300 V rating	Yes: CMG / CL3 / Sun Res	Yes: CMG / CL3 / Sun Res	Yes: CMX	No
UL-Style at 600 V rating	Yes	Yes	No	No
Certificate of suitability				
• RoHS compliance	Yes	Yes	Yes	Yes
Marine classification corporation				
• Germanischer Lloyd (GL)	No	No	No	No
• Llyods Register of Shipping (LRS)	No	No	No	No

PROFIBUS

Electrical networks (RS485)

PROFIBUS bus cables

Technical specifications (continued)

Order No.	6XV1 830-3FH10	6XV1 831-2K	6XV1 830-3EH10	6XV1 831-2L
Product type designation	PROFIBUS FC Ground Cable	PROFIBUS FC Flexible Cable	PROFIBUS FC Trailing Cable	PROFIBUS FC Trailing Cable
Product description	Special bus cable (2-core) with additional outer shield, sold by the meter, in bulk	Flexible bus cable (4-core), sold by the meter, in bulk	Highly flexible bus cable (2-core), sold by the meter, in bulk	Highly flexible bus cable (2-core), sold by the meter, in bulk
Suitability for use	For use as buried cable	For occasionally moved machine components	Continuous movement in a trailing cable	Continuous movement in a trailing cable
Cable designation	02YSY (ST) CY2Y 1x2x0.64/2.55-150 SW KF 40	02YH (ST) C11Y 1x2x0.65/2.56-150 LI KF40 FRNC FC VI	02YY (ST) C11Y 1x2x0.65/2.56-150 LI KF 40 FR petrol	02YY (ST) C11Y 1x2x0.65/2.56-150 LI KF 40 FR VT FC
Cable length	-	-	-	-
Electrical specifications				
Attenuation factor per length				
• Max. at 9.6 kHz	2.5 dB/km	3 dB/km	3 dB/km	3 dB/km
• Max. at 38.4 kHz	4 dB/km	4 dB/km	4 dB/km	4 dB/km
• Max. at 4 MHz	22 dB/km	25 dB/km	25 dB/km	25 dB/km
• Max. at 16 MHz	42 dB/km	49 dB/km	49 dB/km	49 dB/km
Characteristic impedance				
• Rated value	150 Ω	150 Ω	150 Ω	150 Ω
• at 9.6 kHz	270 Ω	270 Ω	270 Ω	270 Ω
• at 38.4 kHz	185 Ω	185 Ω	185 Ω	185 Ω
• at 3 MHz ... 20 MHz	150 Ω	150 Ω	150 Ω	150 Ω
Relative symmetrical tolerance				
• of characteristic impedance at 9.6 kHz	10 %	10 %	10 %	10 %
• of characteristic impedance at 38.4 kHz	10 %	10 %	10 %	10 %
• of characteristic impedance at 3 MHz to 20 MHz	10 %	10 %	10 %	10 %
Max. loop resistance per length	110 Ω/km	133 Ω/km	133 Ω/km	133 Ω/km
Max. shield resistance per length	9.5 Ω/km	14 Ω/km	14 Ω/km	14 Ω/km
Capacitance per length at 1 kHz	28.5 pF/m	28 pF/m	28 pF/m	28 pF/m
Operating voltage, rms value	100 V	100 V	100 V	100 V
Mechanical data				
Number of electrical cores	2	2	2	2
Design of shield	Overlapping aluminum-clad foil, sheathed in a braided screen of tinned copper wires	Overlapping aluminum-clad foil, sheathed in a braided screen of tinned copper wires	Overlapping aluminum-clad foil, sheathed in a braided screen of tinned copper wires	Overlapping aluminum-clad foil, sheathed in a braided screen of tinned copper wires
Design of electrical connection FastConnect	Yes	Yes	Yes	Yes
Outer diameter				
• of inner conductor	0.65 mm	0.67 mm	0.67 mm	0.67 mm
• of core insulation	2.55 mm	2.56 mm	2.56 mm	2.56 mm
• of inner sheath of cable	5.4 mm	5.4 mm	5.4 mm	5.4 mm
• of cable sheath	10.8 mm	8 mm	8 mm	8 mm
Symmetrical tolerance of outer diameter of cable sheath	0.5 mm	0.4 mm	0.4 mm	0.4 mm

Technical specifications (continued)

Order No.	6XV1 830-3FH10	6XV1 831-2K	6XV1 830-3EH10	6XV1 831-2L
Product type designation	PROFIBUS FC Ground Cable	PROFIBUS FC Flexible Cable	PROFIBUS FC Trailing Cable	PROFIBUS FC Trailing Cable
Outer diameter of cable sheath - Note	The cable (diameter 8.0 mm \pm 0.4 mm) has an additional black outer shield (diameter 10.8 mm \pm 0.5 mm) as protection against destruction when used as a buried cable. Because of the outer diameter > 8 mm: bus connectors can only be connected following removal of the outer shield.	-	-	-
Material				
• of core insulation	PE	PE	PE	PE
• of inner sheath of cable	PVC	FRNC	PVC	PVC
• of cable sheath	PE / PVC	PUR	PUR	PUR
- Note	PVC (cable shield), PE (additional outer shield)	-	-	-
Color				
• of core insulation of data cores	Red / green	Red / green	Red / green	Red / green
• of cable sheath	Black	Violet	Petrol	Violet
Bending radius				
• with single bending	41 mm	40 mm	40 mm	40 mm
• With repeated bending	81 mm	120 mm	120 mm	120 mm
• With continuous bending	-	-	-	-
Number of bending cycles	-	-	3 000 000	3 000 000
• Note	-	-	Suitable as trailing cable for 3 million bending cycles with a bending radius of 120 mm (15x D), and an acceleration of 4 m/s ²	Suitable as trailing cable for 3 million bending cycles with a bending radius of 120 mm (15x D), and an acceleration of 4 m/s ²
Number of torsion cycles with torsion by \pm 180° on 1 m cable length	-	-	-	-
Maximum tensile load	100 N	100 N	100 N	100 N
Weight per length	117 kg/km	70 kg/km	77 kg/km	77 kg/km
Permitted ambient conditions				
Ambient temperature				
• During operation	-40 ... +60 °C	-20 ... +60 °C	-40 ... +60 °C	-40 ... +60 °C
• During storage	-40 ... +60 °C	-40 ... +60 °C	-40 ... +60 °C	-40 ... +60 °C
• During transport	-40 ... +60 °C	-40 ... +60 °C	-40 ... +60 °C	-40 ... +60 °C
• During mounting	-40 ... +60 °C	-40 ... +60 °C	-40 ... +60 °C	-40 ... +60 °C
Ambient conditions for operation	-	Restricted segment lengths (see Manual for PROFIBUS networks)	Restricted segment lengths (see Manual for PROFIBUS networks)	Restricted segment lengths (see Manual for PROFIBUS networks)
Behavior in fire	Flammable	Flame-retardant in accordance with IEC 60332-1-2	Flame-retardant in accordance with IEC 60332-1-2	Flame-retardant in accordance with IEC 60332-1-2
Chemical resistance				
• against mineral oil	Limited resistance	Resistant	Resistant	Resistant
• against grease	Limited resistance	Resistant	Resistant	Resistant
• against water	-	-	-	-
Radiological resistance to UV radiation	Resistant	Resistant	Resistant	Resistant

PROFIBUS

Electrical networks (RS485)

PROFIBUS bus cables

Technical specifications (continued)

Order No.	6XV1 830-3FH10	6XV1 831-2K	6XV1 830-3EH10	6XV1 831-2L
Product type designation	PROFIBUS FC Ground Cable	PROFIBUS FC Flexible Cable	PROFIBUS FC Trailing Cable	PROFIBUS FC Trailing Cable
Product properties, functions, components				
General				
Product property				
• Halogen-free	No	Yes	No	No
• Silicon-free	Yes	Yes	Yes	Yes
Cable length				
• at 1.5 Mbit/s maximum	200 m	200 m	200 m	200 m
• at 12 Mbit/s maximum	100 m	100 m	100 m	100 m
Standards, specifications, approvals				
UL listing at 300 V rating	No	Yes: CMX	Yes: CMX	Yes: CMX
UL-Style at 600 V rating	No	No	No	No
Certificate of suitability	-	-	-	-
• RoHS compliance	Yes	Yes	Yes	Yes
Marine classification association				
• Germanischer Lloyd (GL)	No	No	No	No
• Lloyds Register of Shipping (LRS)	No	No	No	No

Order No.	6XV1 830-0LH10	6XV1 830-3GH10	6XV1 830-0PH10	6XV1 830-0MH10
Product type designation	PROFIBUS FC FRNC Cable GP	PROFIBUS Festoon Cable GP	PROFIBUS Torsion Cable	SIENOPYR FR Marine Cable
Product description	Highly flamed retardant, halogen-free bus cable (2-core), sold by the meter, in bulk	Flexible bus cable (2-core), sold by the meter, in bulk	Highly flexible bus cable (2-core), sold by the meter, in bulk	Bus cable (2-core), sold by the meter, in bulk
Suitability for use	Halogen-free cable, suitable for indoor use	Special for use on festoons	Use in moved machine components	Cable for installation on ships and offshore units
Cable designation	02YSH (ST) CH 1x2x0.64/2.55-150 VI KF 25 FRNC FC	02YS (ST) CY 1x2x0.65/2.56 LI petrol FR	02Y (ST) C 11Y 1x2x0.8/2.56-150 LI FR VI	M-02Y (ST) CH X 1 x 2 x 0.35 100 V
Cable length	-	-	-	-
Electrical specifications				
Attenuation factor per length				
• at 9.6 kHz maximum	2.5 dB/km	3 dB/km	2.5 dB/km	3 dB/km
• at 38.4 kHz maximum	4 dB/km	4 dB/km	3 dB/km	5 dB/km
• at 4 MHz maximum	22 dB/km	25 dB/km	25 dB/km	22 dB/km
• at 16 MHz maximum	42 dB/km	49 dB/km	49 dB/km	45 dB/km
Characteristic impedance				
• rated value	150 Ω	150 Ω	150 Ω	150 Ω
• at 9.6 kHz	270 Ω	270 Ω	270 Ω	250 Ω
• at 38.4 kHz	185 Ω	185 Ω	185 Ω	185 Ω
• at 3 MHz ... 20 MHz	150 Ω	150 Ω	150 Ω	150 Ω
Relative symmetrical tolerance				
• of characteristic impedance at 9.6 kHz	10 %	10 %	10 %	10 %
• of characteristic impedance at 38.4 kHz	10 %	10 %	10 %	10 %
• of characteristic impedance at 3 MHz to 20 MHz	10 %	10 %	10 %	10 %
Max. loop resistance per length	110 Ω/km	133 Ω/km	98 Ω/km	110 Ω/km
Max. shield resistance per length	9.5 Ω/km	19 Ω/km	14 Ω/km	-
Capacitance per length at 1 kHz	28.5 pF/m	28 pF/m	29 pF/m	-
Operating voltage, rms value	100 V	100 V	100 V	100 V

Technical specifications (continued)

Order No.	6XV1 830-0LH10	6XV1 830-3GH10	6XV1 830-0PH10	6XV1 830-0MH10
Product type designation	PROFIBUS FC FRNC Cable GP	PROFIBUS Festoon Cable GP	PROFIBUS Torsion Cable	SIENOPYR FR Marine Cable
Mechanical data				
Number of electrical cores	2	2	2	2
Design of shield	Overlapping aluminum-clad foil, sheathed in a braided screen of tinned copper wires	Overlapping aluminum-clad foil, sheathed in a braided screen of tinned copper wires	Overlapping aluminum-clad foil, sheathed in a braided screen of tinned copper wires	Overlapping aluminum-clad foil, sheathed in a braided screen of tinned copper wires
Design of FastConnect electrical connection	Yes	No	No	No
Outer diameter				
• of inner conductor	0.65 mm	0.67 mm	0.8 mm	0.67 mm
• of core insulation	2.55 mm	2.56 mm	2.56 mm	-
• of inner sheath of cable	5.4 mm	5.8 mm	6 mm	8 mm
• of the cable sheath	8 mm	8 mm	8 mm	10.3 mm
Symmetrical tolerance of outer diameter of cable sheath	0.4 mm	0.3 mm	0.4 mm	0.5 mm
Outer diameter of cable sheath - Note	-	-	-	Outer diameter > 8 mm: bus connectors can only be connected following removal of the outer shield
Material				
• of core insulation	PE	PE	PE	PE
• of inner sheath of cable	FRNC	-	-	Halogen-free polymer (HM4)
• of the cable sheath	FRNC	PVC	PUR	Halogen-free cross-linked polymer
- Note	-	-	-	-
Color				
• of core insulation of data cores	Red / green	Red / green	Red / green	Red / green
• of the cable sheath	Violet	Petrol	Violet	Black
Bending radius				
• With single bending	60 mm	30 mm	30 mm	103 mm
• With repeated bending	80 mm	70 mm	60 mm	206 mm
• With continuous bending	-	-	-	-
Number of bending cycles	-	-	-	-
• Note	-	-	Not suitable for festoon mounting	-
Number of torsion cycles with torsion by $\pm 180^\circ$ on 1 m cable length	-	-	5 000 000	-
Maximum tensile load	100 N	80 N	100 N	100 N
Weight per length	72 kg/km	64 kg/km	65 kg/km	109 kg/km
Permissible ambient conditions				
Ambient temperature				
• During operation	-25 ... +80 °C	-40 ... +80 °C	-25 ... +75 °C	-40 ... +80 °C
• During storage	-25 ... +80 °C	-40 ... +80 °C	-40 ... +80 °C	-40 ... +80 °C
• During transport	-25 ... +80 °C	-40 ... +80 °C	-40 ... +80 °C	-40 ... +80 °C
• During mounting	-25 ... +80 °C	-40 ... +80 °C	-25 ... +75 °C	-10 ... +80 °C
Ambient conditions for operation	-	-	-	At ambient temperatures below -10 °C the cables must not be exposed to any more vibrations than those normally encountered in marine applications.

PROFIBUS

Electrical networks (RS485)

PROFIBUS bus cables

Technical specifications (continued)

Order No.	6XV1 830-0LH10	6XV1 830-3GH10	6XV1 830-0PH10	6XV1 830-0MH10
Product type designation	PROFIBUS FC FRNC Cable GP	PROFIBUS Festoon Cable GP	PROFIBUS Torsion Cable	SIENOPYR FR Marine Cable
Behavior in fire	Flame-retardant in accordance with IEC 60332-3-24 (Category C), IEC 60332-3-22 (Category A)	Flame-retardant in accordance with IEC 60332-3-24 (Category C)	Flame-retardant in accordance with IEC 60332-1-2	Flame-retardant in accordance with IEC 60332-3-24
Chemical resistance <ul style="list-style-type: none"> • against mineral oil • against grease • against water 	Limited resistance Limited resistance -	Limited resistance Limited resistance -	Resistant Resistant -	Resistant Resistant Limited resistance
Radiological resistance to UV radiation	Resistant	Resistant	Resistant	Resistant
Product properties, functions, components				
General				
Product property <ul style="list-style-type: none"> • Halogen-free • Silicon-free 	Yes Yes	No Yes	Yes Yes	Yes Yes
Cable length <ul style="list-style-type: none"> • at 1.5 Mbit/s maximum • at 12 Mbit/s maximum 	200 m 100 m	200 m 100 m	200 m 60 m	200 m 100 m
Standards, specifications, approvals				
UL listing at 300 V rating	Yes: CM / CL3 / Sun Res	Yes: CMG / PLCT / Sun Res / Oil Res	Yes: CMX	No
UL-Style at 600 V rating	Yes	Yes	No	No
Certificate of suitability <ul style="list-style-type: none"> • RoHS compliance 	Yes	-	Yes	-
Marine classification association <ul style="list-style-type: none"> • Germanischer Lloyd (GL) • Lloyds Register of Shipping (LRS) 	No No	No No	No No	Yes Yes

Technical specifications (continued)

Order No.	6XV1 860-2R	6XV1 860-2S
Product type designation	PROFIBUS Hybrid Standard Cable GP	PROFIBUS Hybrid Robust Cable
Product description	Hybrid cable (data and power cores), sold by the meter, in bulk	Hybrid cable (data and power cores), sold by the meter, in bulk
Suitability for use	Hybrid cable suitable as trailing cable, for data and power supply to ET 200pro	Rugged cable for data and power supply to ET 200pro in mechanically stressed environments. Cable resistant to spatter in accordance with HD22.2 S3 / 5
Cable designation	02Y(ST)C 1x2x0.65/2.56-150LI LIY-Z Y 2x1x1.5 VI	02Y(ST)C 1x2x0.65/2.56-150LI LIH-Z 11Y 2x1x1.5 VI FRNC
Cable length	-	-
Electrical specifications		
Attenuation factor per length		
• Max. at 9.6 kHz	0.004 dB/m	0.004 dB/m
• Max. at 4 MHz	0.025 dB/m	0.025 dB/m
• Max. at 16 MHz	0.049 dB/m	0.049 dB/m
Characteristic impedance		
• Rated value	150 Ω	150 Ω
• at 9.6 kHz	270 Ω	270 Ω
• at 38.4 kHz	185 Ω	185 Ω
• at 3 MHz ... 20 MHz	150 Ω	150 Ω
Relative symmetrical tolerance		
• of characteristic impedance at 9.6 kHz	10 %	10 %
• of characteristic impedance at 38.4 kHz	10 %	10 %
• of characteristic impedance at 3 MHz to 20 MHz	10 %	10 %
Max. loop resistance per length	138 Ω/km	138 Ω/km
Max. shield resistance per length	10 Ω/km	10 Ω/km
Capacitance per length at 1 kHz	30 pF/m	30 pF/m
Inductance per length	-	-
Operating voltage, rms value	300 V	300 V
Conductor cross-section of power core	1.5 mm ²	1.5 mm ²
Continuous current of power cores	7.5 A	7.5 A
Mechanical data		
Design of shield	Overlapping aluminum-clad foil, sheathed in a braided screen of tin-plated copper wires	Overlapping aluminum-clad foil, sheathed in a braided screen of tin-plated copper wires
Number of electrical cores	2	2
Design of electrical connection FastConnect	No	No
Outer diameter		
• of core insulation	2.56 mm	2.56 mm
• of inner sheath of cable	-	-
• of the cable sheath	11 mm	11 mm
Symmetrical tolerance of outer diameter of cable sheath	0.5 mm	0.5 mm
Outer diameter of cable sheath - Note	-	-

PROFIBUS

Electrical networks (RS485)

PROFIBUS bus cables

Technical specifications (continued)

Order No.	6XV1 860-2R	6XV1 860-2S
Product type designation	PROFIBUS Hybrid Standard Cable GP	PROFIBUS Hybrid Robust Cable
Material		
• of core insulation	PE	PE
• of inner sheath of cable	-	-
• of the cable sheath	PVC	PUR
- Note	-	-
Color		
• of core insulation of data cores	Red / green	Red / green
• of core insulation of power cores	Black	Black
• of the cable sheath	Violet	Violet
Bending radius		
• Minimum permitted single bending radius	44 mm	44 mm
• Minimum permitted repeated bending radius	125 mm	125 mm
Number of bending cycles	1.000.000	3.000.000
• Note	Suitable as trailing cable for 1 million bending cycles with a bending radius of 125 mm and an acceleration of 2.5 m/s ²	Suitable as trailing cable for 3 million bending cycles with a bending radius of 125 mm and an acceleration of 2.5 m/s ²
Number of torsion cycles with torsion by ± 180° on 1 m cable length	-	-
Maximum tensile load	450 N	450 N
Weight per length	140 kg/km	135 kg/km
Permissible ambient conditions		
Ambient temperature		
• During operation	-40 ... +75 °C	-40 ... +75 °C
• During storage	-40 ... +75 °C	-40 ... +75 °C
• During transport	-40 ... +75 °C	-40 ... +75 °C
• During mounting	-40 ... +75 °C	-40 ... +75 °C
Behavior in fire	Flame-retardant in accordance with IEC 60332-1-2	Flame-retardant in accordance with IEC 60332-1-2
Chemical resistance		
• against mineral oil	Limited resistance	Resistant
• against grease	Limited resistance	Resistant
• against water	-	-
Radiological resistance to UV radiation	Not resistant	Resistant
Product properties, functions, components		
General		
Product property		
• Halogen-free	No	Yes
• Silicon-free	Yes	Yes
Standards, specifications, approvals		
UL listing at 300 V rating	Yes: CMG	Yes: CMX
UL-Style at 600 V rating	No	No
Certificate of suitability		
• RoHS compliance	Yes	Yes

Ordering data	Order No.	Order No.
<p>PROFIBUS FC Standard Cable GP</p> <p>Standard type with special design for fast mounting, 2-core, shielded,</p> <p>Sold by the meter; max. length 1000 m, minimum order 20 m</p> <p>Not pre-assembled</p> <ul style="list-style-type: none"> • 20 m • 50 m • 100 m • 200 m • 500 m • 1000 m <p>In spool box</p> <ul style="list-style-type: none"> • 50 m • 100 m 	<p>6XV1 830-0EH10</p> <p>6XV1 830-0EN20</p> <p>6XV1 830-0EN50</p> <p>6XV1 830-0ET10</p> <p>6XV1 830-0ET20</p> <p>6XV1 830-0ET50</p> <p>6XV1 830-0EU10</p> <p>6XV1 830-1EN50</p> <p>6XV1 830-1ET10</p>	<p>PROFIBUS FC Trailing Cable</p> <p>2-core, shielded</p> <p>Sold by the meter; max. length 1000 m, minimum order 20 m</p> <ul style="list-style-type: none"> • Sheath color: Petrol • Sheath color: Violet <p>6XV1 830-3EH10</p> <p>6XV1 831-2L</p>
		<p>PROFIBUS Festoon Cable GP</p> <p>2-core, shielded</p> <p>Sold by the meter; max. length 1000 m, minimum order 20 m</p> <p>6XV1 830-3GH10</p>
		<p>PROFIBUS FC FRNC Cable GP</p> <p>2-core, shielded, nonflammable, with copolymer outer sheath FRNC</p> <p>Sold by the meter; max. length 1000 m, minimum order 20 m</p> <p>6XV1 830-0LH10</p>
<p>PROFIBUS FC Standard Cable IS GP</p> <p>Standard type with special design for quick assembly, 2-core, shielded, for intrinsically safe distributed I/O systems</p> <p>Sold by the meter; max. length 1000 m, minimum order 20 m</p>	<p>6XV1 831-2A</p>	<p>PROFIBUS Torsion Cable</p> <p>2-core, shielded</p> <p>Sold by the meter; max. length 1000 m, minimum order 20 m</p> <p>6XV1 830-0PH10</p>
<p>PROFIBUS FC Robust Cable</p> <p>2-core, shielded</p> <p>Sold by the meter; max. length 1000 m, minimum order 20 m</p>	<p>6XV1 830-0JH10</p>	<p>PROFIBUS Hybrid Standard Cable GP</p> <p>PROFIBUS hybrid cable suitable as trailing cable and resistant to welding spatter, with 2 power conductors (1.5 mm²) for supply of data and power to ET 200pro</p> <p>6XV1 860-2R</p>
<p>PROFIBUS FC Food Cable</p> <p>2-core, shielded</p> <p>Sold by the meter; max. length 1000 m, minimum order 20 m</p>	<p>6XV1 830-0GH10</p>	<p>PROFIBUS Hybrid Robust Cable</p> <p>Rugged PROFIBUS hybrid cable for supply of data and power to ET 200pro</p> <p>6XV1 860-2S</p>
<p>PROFIBUS FC Ground Cable</p> <p>2-core, shielded</p> <p>Sold by the meter; max. length 1000 m, minimum order 20 m</p>	<p>6XV1 830-3FH10</p>	<p><i>Special bus cables</i></p> <p>SIENOPYR PROFIBUS shipboard cable</p> <p>Copper cable for ships and offshore units</p> <p>Sold by the meter; max. length 1000 m, minimum order 20 m</p> <p>6XV1 830-0MH10</p>
<p>PROFIBUS FC Flexible Cable</p> <p>2-core, shielded</p> <p>Sold by the meter; max. length 1000 m, minimum order 20 m</p>	<p>6XV1 831-2K</p>	

PROFIBUS

Electrical networks (RS485)

PROFIBUS bus cables

Ordering data

Order No.

Additional components

PROFIBUS FastConnect Stripping Tool

6GK1 905-6AA00

Preadjusted stripping tool for fast stripping of PROFIBUS FastConnect bus cables

PROFIBUS FastConnect Blade Cassettes

6GK1 905-6AB00

Spare blade cassettes for PROFIBUS FastConnect stripping tool, 5 units

PROFIBUS FastConnect bus connector RS485 with 90° cable outlet

6ES7 972-0BA52-0XA0
6ES7 972-0BB52-0XA0

With insulation displacement terminals, max. transfer rate 12 Mbit/s

- Without PG interface
- With PG interface

PROFIBUS FastConnect bus connector RS485 Plug 180

6GK1 500-0FC10

With 180° cable outlet, insulation displacement

Accessories

Lightning protection modules for reliable transmission between buildings with overvoltage protection ²⁾

Basic protection

- Basic section **919506**
- Protection module Type B **919510**
- Protective housing **906055**
- Terminal element **919508**

Low-voltage protection

- Basic section **919506**
- Protection module **919570**
- Terminal element **919508**

SIMATIC NET Manual Collection

6GK1 975-1AA00-3AA0

Electronic manuals for communication systems, communication protocols, and communication products; on DVD; German/English

¹⁾ Further language versions and manuals can be found with the respective products on: www.siemens.com/automation/csi/net

²⁾ Order from:
DEHN & Söhne
Hans-Dehn-Str. 1
92318 Neumarkt/Opf, Germany

More information

Installation instructions

The bus cables are supplied by the meter. If a bus segment must be assembled using two sections (e.g. > 1000 m segment length), bushings can be used for this purpose (low-impedance connection between cores with clamps, connect shields over a wide area).

FastConnect

The FastConnect stripping tool can be used to strip the outer sheath and shield of the new FastConnect bus cables to the right length in one step.

In this way, the bus connectors (except 6ES7 972-0BA30-0XA0) can be connected easily and quickly to the bus cable.

Cable routing

During storage, transport and cable laying, keep both ends sealed with a shrink-on cap.

Comply with the permissible bending radii and tensile load!

An underground cable must be used if cables are laid outside buildings e.g. directly in the ground, in sand or in concrete building blocks or when routed through protective pipes made of steel or plastic above or below ground.

Comply with overvoltage protection guidelines for underground laying.

Note:

You can order components supplementary to the SIMATIC NET cabling range from your local contact.

Technical advice on this subject is available from:

J. Hertlein
I IA SC IC PRM 4
Phone: +49 (0)911/750 44 65
E-mail: juergen.hertlein@siemens.com

Overview



In the ECOFAST system, all devices with bus capability are connected to PROFIBUS DP using the bus cables.

The bus cable is implemented as a hybrid cable and contains:

- PROFIBUS DP in copper RS 485;
- Four additional copper cores for carrying 24 V DC:
 - 24 V DC, not switched (for electronics and inputs)
 - 24 V DC, switched (for outputs, disconnectable e.g. for EMERGENCY OFF)

The ECOFAST hybrid cables are sold by the meter or in fixed lengths preassembled with ECOFastConnector (Han Brid) and socket.

Benefits

- Savings in wiring, installation, commissioning and operation as result of standardized connection system (copper or fiber-optic) with high degree of protection (IP65)
- With ECOFAST, the turnaround times for offers, planning and engineering of machines and plants can be reduced
- ECOFAST permits fast and problem-free startup of automation and drive systems
- Minimization of sources of error by means of standardized interfaces and plug connectors.
- With ECOFAST plants remain highly available: No interruption of power and fieldbus when replacing equipment.

Technical specifications

Order No.	6XV1 830-7AH10	6XV1 860-2P	Order No.	6XV1 830-7AH10	6XV1 860-2P
Product type designation	PROFIBUS ECOFAST Hybrid Cable	PROFIBUS ECOFAST Hybrid Cable GP	Product type designation	PROFIBUS ECOFAST Hybrid Cable	PROFIBUS ECOFAST Hybrid Cable GP
Product description	ECOFAST hybrid cable (data and power cores), sold by the meter, in bulk	ECOFAST hybrid cable (data and power cores), sold by the meter, in bulk	Characteristic impedance		
Suitability for application	Hybrid cable for connection of ECOFAST nodes	Hybrid cable for connection of ECOFAST nodes, UL approval	<ul style="list-style-type: none"> • Rated value • At 9.6 kHz • At 38.4 kHz • At 3 MHz ... 20 MHz 	150 Ω 270 Ω 185 Ω 150 Ω	150 Ω 270 Ω 185 Ω 150 Ω
Cable designation	02Y (ST)C 1x2x0.65/2.56 - 150 LI LIH-Z 11Y 4x1x1.5 VI FRNC	02Y (ST)C 1x2x0.65/2.56 - 150 LI LIY-Z Y 4x1x1.5 VI	Relative symmetrical tolerance		
Cable length	-	-	<ul style="list-style-type: none"> • of characteristic impedance at 9.6 kHz • of characteristic impedance at 38.4 kHz • of characteristic impedance at 3 MHz to 20 MHz 	10 % 10 % 10 %	10 % 10 % 10 %
Electrical specifications			Max. loop resistance per length	138 Ω/km	138 Ω/km
Attenuation factor per length			Max. shield resistance per length	15 Ω/km	15 Ω/km
<ul style="list-style-type: none"> • Max. at 9.6 MHz • Max. at 4 MHz • Max. at 16 MHz 	0.004 dB/m 0.025 dB/m 0.049 dB/m	0.004 dB/m 0.025 dB/m 0.049 dB/m	Capacitance per length at 1 kHz	30 pF/m	30 pF/m
			Inductance per length	-	-
			Operating voltage, rms value	100 V	600 V
			Conductor cross-section of power core	1.5 mm ²	1.5 mm ²
			Continuous current of power cores	12 A	12 A

PROFIBUS

Electrical networks (RS485)

ECOFAST bus cables

Technical specifications (continued)

Order No.	6XV1 830-7AH10	6XV1 860-2P
Product type designation	PROFIBUS ECOFAST Hybrid Cable	PROFIBUS ECOFAST Hybrid Cable GP
Mechanical data		
Design of shield	Overlapping aluminum-clad foil, sheathed in a braided screen of tin-plated copper wires	Overlapping aluminum-clad foil, sheathed in a braided screen of tin-plated copper wires
Number of electrical cores	4	4
Design of electrical connection FastConnect	No	No
Outer diameter		
• of core insulation	2.56 mm	2.56 mm
• of inner sheath of cable	-	-
• of the cable sheath	11 mm	11 mm
Symmetrical tolerance of outer diameter of cable sheath	0.3 mm	0.3 mm
Outer diameter of cable sheath - Note	-	-
Material		
• of core insulation	PE	PE
• of inner sheath of cable	-	-
• of the cable sheath	PUR	PVC
Material of cable sheath - Note	-	-
Color		
• of core insulation of data cores	Red / green	Red / green
• of core insulation of power cores	Black	Black
• of the cable sheath	Violet	Violet
Bending radius		
• Minimum permitted single bending radius		
• Minimum permitted repeated bending radius	82.5 mm	110 mm
Number of bending cycles	5 000 000	1 000 000
• Note	Suitable as trailing cable for 5 million bending cycles with a bending radius of 82.5 mm (7.5x D), and an acceleration of 2.5 m/s ²	Suitable as trailing cable for 1 million bending cycles with a bending radius of 166 mm (15x D), and an acceleration of 4.0 m/s ²
Number of torsion cycles with torsion by ± 180° on 1 m cable length	-	-
Maximum tensile load	300 N	300 N
Weight per length	150 kg/km	154 kg/km

Order No.	6XV1 830-7AH10	6XV1 860-2P
Product type designation	PROFIBUS ECOFAST Hybrid Cable	PROFIBUS ECOFAST Hybrid Cable GP
Permissible ambient conditions		
Ambient temperature		
• During operation	-40 ... +60 °C	-30 ... +80 °C
• During storage	-40 ... +60 °C	-30 ... +80 °C
• During transport	-40 ... +60 °C	-30 ... +80 °C
• During mounting	-40 ... +60 °C	-30 ... +80 °C
Behavior in fire	Flame-retardant in accordance with IEC 60332-1	Flame-retardant in accordance with IEC 60332-3-24 (Category C)
Chemical resistance		
• Mineral oil	Limited resistance	Limited resistance
• Grease	Limited resistance	Limited resistance
• Water	-	-
Radiological resistance to UV radiation	Resistant	Resistant
Product properties, functions, components General		
Product property		
• Halogen-free	Yes	Yes
• Silicon-free	Yes	Yes
Standards, specifications, approvals		
UL-Listing at 300 V rating	No	Yes: CM / CL3 / SunRes / OilRes
UL-Style at 600 V rating	No	Yes
Certificate of suitability		
• RoHS compliance	Yes	Yes

Technical specifications (continued)

Order No.	6GK1 905-0CA00	6GK1 905-0CB00	6GK1 905-0CC00	6GK1 905-0CD00
Product type designation	PB ECOFAST Hybrid Plug 180	PB ECOFAST Hybrid Plug 180	PB ECOFAST Hybrid Plug angled	PB ECOFAST Hybrid Plug angled
Product description	ECOFAST Hanbrid connector with pin insert	ECOFAST Hanbrid connector with socket insert	ECOFAST Hanbrid connector with pin insert, angled	ECOFAST Hanbrid connection with socket insert, angled
Suitability for application	For connection to ECOFAST hybrid cables, transmission of data and energy	For connection to ECOFAST hybrid cables, transmission of data and energy	For connection to ECOFAST hybrid cables, transmission of data and energy	For connection to ECOFAST hybrid cables, transmission of data and energy
Transmission rate				
Transmission rate with PROFIBUS	9.6 kbit/s ... 12 Mbit/s	9.6 kbit/s ... 12 Mbit/s	9.6 kbit/s ... 12 Mbit/s	9.6 kbit/s ... 12 Mbit/s
Interfaces				
Number of electrical connections				
• for PROFIBUS cables	1	1	1	1
• for network components or terminal equipment	1	1	1	1
Design of electrical connection				
• for PROFIBUS cables	integrated crimp contacts for 6-core ECOFAST hybrid cables	integrated crimp contacts for 6-core ECOFAST hybrid cables	integrated crimp contacts for 6-core ECOFAST hybrid cables	integrated crimp contacts for 6-core ECOFAST hybrid cables
• for network components or terminal equipment	Hanbrid connector with pin insert	Hanbrid connector with socket insert	Hanbrid connector with pin insert	Hanbrid connector with socket insert
Mechanical data				
Design of terminating resistor	-	-	-	-
Enclosure material	Plastic	Plastic	Plastic	Plastic
Design, dimensions and weights				
Type of cable outlet	180 degree cable outlet	180 degree cable outlet	90 degree cable outlet	90 degree cable outlet
Width	27 mm	27 mm	27 mm	27 mm
Height	27 mm	27 mm	38.4 mm	38.4 mm
Depth	71 mm	71 mm	54.6 mm	54.6 mm
Net weight	40 g	40 g	40 g	40 g
Permissible ambient conditions				
Ambient temperature				
• During operation	-20 ... +70 °C	-20 ... +70 °C	-20 ... +70 °C	-20 ... +70 °C
• During storage	-40 ... +80 °C	-40 ... +80 °C	-40 ... +80 °C	-40 ... +80 °C
• During transport	-40 ... +80 °C	-40 ... +80 °C	-40 ... +80 °C	-40 ... +80 °C
IP degree of protection	IP65/67	IP65/67	IP65/67	IP65/67
Chemical resistance to water	Resistant	Resistant	Resistant	Resistant
Product properties, functions, components				
General				
Product property silicon-free	Yes	Yes	Yes	Yes
Product component strain relief	Yes	Yes	Yes	Yes
Standards, specifications, approvals				
Certificate of suitability: RoHS conformity	Yes	Yes	Yes	Yes

PROFIBUS

Electrical networks (RS485)

ECOFAST bus cables

Technical specifications (continued)

Order No.	6GK1 905-0DA10
Product type designation	PB ECOFAST Terminating Plug
Product description	ECOFAST bus terminating plug connector with pin insert and integral terminating resistors
Suitability for application	As terminating plug connector for PROFIBUS DP
Transmission rate	
Transmission rate with PROFIBUS	9.6 kbit/s ... 12 Mbit/s
Interfaces	
Number of electrical connections	-
• for PROFIBUS cables	-
• for network components or terminal equipment	1
Design of electrical connection	
• for PROFIBUS cables	-
• for network components or terminal equipment	Hanbrid connector with socket insert
Mechanical data	
Design of terminating resistor	Resistor combination integrated
Enclosure material	Plastic
Design, dimensions and weights	
Type of cable outlet	180 degree cable outlet
Width	27 mm
Height	27 mm
Depth	71 mm
Net weight	40 g
Permissible ambient conditions	
Ambient temperature	
• During operation	-20 ... +70 °C
• During storage	-40 ... +80 °C
• During transport	-40 ... +80 °C
IP degree of protection	IP65/67
Chemical resistance to water	Resistant
Product properties, functions, components	
General	
Product property silicon-free	Yes
Product component strain relief	Yes
Standards, specifications, approvals	
Certificate of suitability: RoHS conformity	Yes

Ordering data

PROFIBUS ECOFAST Hybrid Cable - Cu

Trailing cable (PUR sheath), with two shielded Cu wires for PROFIBUS DP plus four Cu wires of 1.5 mm²

Sold by the meter;
max. quantity 1000 m;
minimum order 20 m;

Not pre-assembled

- 20 m
- 50 m
- 100 m

Pre-assembled
with ECOFAST male and female connectors, fixed length

- 0.5 m
- 1.0 m
- 1.5 m
- 3 m
- 5 m
- 10 m
- 15 m
- 20 m
- 25 m
- 30 m
- 35 m
- 40 m
- 45 m
- 50 m

Pre-assembled
with two ECOFAST Connectors, variable length

PROFIBUS ECOFAST Hybrid Cable GP

Trailing cable with 4 x Cu and 2 x Cu, shielded, with UL approval

Sold by the meter;
max. quantity 1000 m;
minimum order 20 m;

Not pre-assembled

- 20 m
- 50 m
- 100 m

Pre-assembled
with ECOFAST male and female connectors

- 0.5 m
- 1 m
- 1.5 m
- 3 m
- 5 m
- 10 m
- 15 m
- 20 m
- 25 m
- 30 m
- 35 m
- 40 m
- 45 m
- 50 m

Order No.

6XV1 830-7AH10

6XV1 830-7AN20
6XV1 830-7AN50
6XV1 830-7AT10

6XV1 830-7BH05
6XV1 830-7BH10
6XV1 830-7BH15
6XV1 830-7BH30
6XV1 830-7BH50
6XV1 830-7BN10
6XV1 830-7BN15
6XV1 830-7BN20
6XV1 830-7BN25
6XV1 830-7BN30
6XV1 830-7BN35
6XV1 830-7BN40
6XV1 830-7BN45
6XV1 830-7BN50

6XV1 860-2P

6XV1 860-4PN20
6XV1 860-4PN50
6XV1 860-4PT10

6XV1 860-3PH05
6XV1 860-3PH10
6XV1 860-3PH15
6XV1 860-3PH30
6XV1 860-3PH50
6XV1 860-3PN10
6XV1 860-3PN15
6XV1 860-3PN20
6XV1 860-3PN25
6XV1 860-3PN30
6XV1 860-3PN35
6XV1 860-3PN40
6XV1 860-3PN45
6XV1 860-3PN50

Ordering data	Order No.	More information
<i>Additional components</i>		
<p>PROFIBUS Cu bus connector</p> <p>with 2 x Cu shielded and 4 x Cu 1.5 mm²; type of contact: POF, Han D for 24 V; tool: crimping tool, polishing set; 5 units; with assembly instructions</p> <ul style="list-style-type: none"> • with pin insert • with socket insert 	<p>6GK1 905-0CA00 6GK1 905-0CB00</p>	<p>You can order components supplementary to the SIMATIC NET cabling range from your local contact.</p> <p>Technical advice on this subject is available from:</p> <p>J. Hertlein I IA SC IC PRM 4 Phone: +49 (0)911/750 44 65 E-mail: juergen.hertlein@siemens.com</p>
<p>PROFIBUS ECOFAST Hybrid Plug angled;</p> <p>with 2 x Cu shielded and 4 x Cu 1.5 mm²; 5 units; with installation instructions</p> <ul style="list-style-type: none"> • Male pins • Female pins; 	<p>6GK1 905-0CC00 6GK1 905-0CD00</p>	
<p>ECOFAST Terminating Plug</p> <p>Bus termination plug-in connector for PROFIBUS DP; with 2 x Cu and 4 x Cu 1.5 mm²; male pins, integrated termination resistors</p> <ul style="list-style-type: none"> • Pack of 1 • Pack of 5 	<p>6GK1 905-0DA10 6GK1 905-0DA00</p>	
<p>Data T piece</p> <p>For 2 x 24 V auxiliary voltage (switched and non-switched) and PROFIBUS DP</p> <ul style="list-style-type: none"> • for Cu RS 485 • for fiber-optic cable 	<p>3RK1 911-2AG00 3RK1 911-2AH00</p>	
<p>Addressing plug</p> <p>For setting the PROFIBUS DP addresses</p>	<p>6ES7 194-1KB00-0XA0</p>	

PROFIBUS

Electrical networks (RS485)

Energy cables

Overview

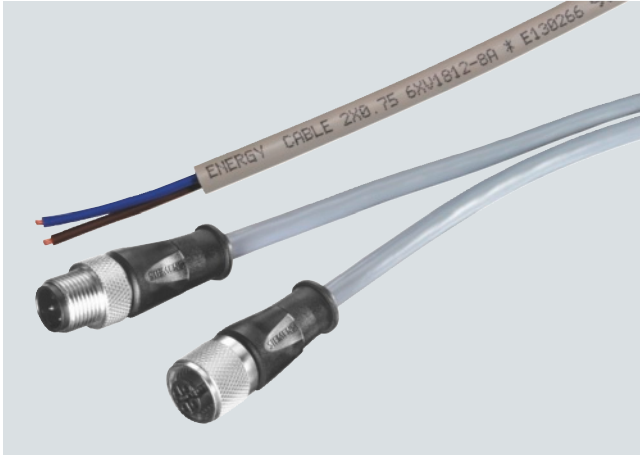

- Different versions (5-core, 2-core) for different fields of application
- Pre-assembled M12 plug-in cables for energy transfer
- Rugged cable design for installation in industrial applications
- UL approvals
- Easy length measurement thanks to printed meter markings

Benefits

get Designed for Industry

- Flexible application possibilities thanks to rugged cable design
- Silicon-free, therefore particularly suitable for use in the automotive industry (e.g. on paint shop conveyors)

Application

Different cable types are needed to supply power to Industrial Ethernet/PROFINET or PROFIBUS. The listed power cables should always be used. They are used for devices with IP65/67 degree of protection to connect the signaling contact or 24-V supply of the SCALANCE X and SCALANCE W components (power cable 2x0.75) and for the power supply (power cable 5x1.5 for ET 200).

In addition, preassembled power connecting cables (4 x 0.75) are available in different lengths for the power supply of the ET 200 (M12 Power Connecting Cable).

UL approvals

As a result of appropriate UL styles, the cables can be used worldwide.

Design

Rugged 2-core, 4-core or 5-core cable with circular cross-section for connection of signaling contact and power supply to IP65/67 components in industrial areas.

Cable types

The following cables with industrial capability are available for connection of the power supply and signaling contact:

- Energy cable 2 x 0.75; power cable for connection of signaling contact and 24 V supply voltage to SCALANCE X and SCALANCE W components
- Energy cable 5 x 1.5; power cable for connection of 24 V power supply of ET 200 using 7/8" plug connectors
- M12 Power Connecting Cable M12-180/M12-180; 4-core M12 power connecting cables (A-coded) with straight cable outlet for 24 V power supply of the ET 200 (pre-assembled)

Technical specifications

Order No.	6XV1 812-8A	6XV1 830-8AH10
Product type designation	Energy Cable 2 x 0.75	Energy Cable 5 x 1.5
Product description	Energy cable (2-core), sold by the meter, in bulk	Energy cable (5-core), sold by the meter, in bulk
Suitability for application	Connection of signaling contact and 24 V power supply to SCALANCE X and SCALANCE W	Power supply of ET 200 modules with 7/8" power interface
Cable designation	L-YY-2x1x0.75 GR	L-Y11Y-Z 5x1x1.5 GR
Cable length	-	-
Electrical specifications		
Operating voltage, rms value	600 V	600 V
Conductor cross-section of power core	0.75 mm ²	1.5 mm ²
Continuous current of power cores	6 A	16 A
Mechanical data		
Number of electrical cores	2	5
Outer diameter		
• of inner conductor	1.3 mm	1.55 mm
• of core insulation	2.5 mm	2.73 mm
• of the cable sheath	7.4 mm	10.5 mm
Symmetrical tolerance of outer diameter of cable sheath	0.3 mm	0.3 mm
Outer diameter of cable sheath - Note	-	-
Material		
• of core insulation	PVC	PVC
• of the cable sheath	PVC	PUR
- Note	-	-
Color		
• of core insulation of power cores	Brown / blue	Black
• of the cable sheath	Gray	Gray
Bending radius		
• With single bending	19 mm	27 mm
• With repeated bending	45 mm	63 mm
Maximum tensile load	100 N	500 N
Weight per length	70 kg/km	149 kg/km
Permissible ambient conditions		
Ambient temperature		
• During operation	-20 ... +80 °C	-40 ... +80 °C
• During storage	-20 ... +80 °C	-40 ... +80 °C
• During transport	-20 ... +80 °C	-40 ... +80 °C
• During mounting	-20 ... +80 °C	-40 ... +80 °C
Behavior in fire	Flame-retardant in accordance with IEC 60332-1	Flame-retardant in accordance with IEC 60332-1
Chemical resistance		
• Mineral oil	Limited resistance	Resistant
• Grease	Limited resistance	Resistant
• Water	-	-
Radiological resistance against UV radiation	Resistant	Resistant
Product properties, functions, components		
General		
Product property		
• Halogen-free	No	No
• Silicon-free	Yes	Yes
Standards, specifications, approvals		
UL-Listing at 300 V rating	Yes: CL3	No
UL-Style at 600 V rating	Yes	Yes
Certificate of suitability		
• RoHS compliance	Yes	Yes

PROFIBUS

Electrical networks (RS485)

Energy cables

Technical specifications (continued)

Order No.	6XV1 801-5DH10
Product type designation	POWER CONNECTING CABLE M12-180/M12-180
Product description	Flexible connecting cable (4-core), preferred length, preassembled with a 4-pin M12 plug and a 4-pin M12 socket (A-coded)
Suitability for application	Cable for connecting the 24 V power supply to ET 200eco PN with IP65/67 protection
Cable designation	LI9YH-Y 4x0.75
Cable length	1 m
Electrical specifications	
Operating voltage, rms value	300 V
Conductor cross-section of power core	0.75 mm ²
Continuous current of power cores	-
Mechanical data	
Number of electrical cores	4
Outer diameter	
• of inner conductor	1.1 mm
• of core insulation	1.7 mm
• of the cable sheath	5.7 mm
Outer diameter of cable sheath - Note	-
Symmetrical tolerance of outer diameter of cable sheath	0.2 mm
Material	
• of core insulation	PP
• of the cable sheath	PVC
- Note	-
Color	
• of core insulation of power cores	Brown / white / blue / black
• of the cable sheath	Gray
Bending radius	
• With single bending	57 mm
• With repeated bending	57 mm
Maximum tensile load	15 N
Weight per length	54 kg/km

Order No.	6XV1 801-5DH10
Product type designation	POWER CONNECTING CABLE M12-180/M12-180
Permissible ambient conditions	
Ambient temperature	
• During operation	-25 ... +80 °C
• During storage	-25 ... +80 °C
• During transport	-25 ... +80 °C
• During mounting	- ... 80 °C
• Note	With moving applications, an operating temperature of -5 to +80 °C is permitted
Ambient conditions for operation	-
IP degree of protection	IP65/67
Behavior in fire	Flame-retardant in accordance with UL 758 (CSA FT 1)
Chemical resistance	
• Mineral oil	Limited resistance
• Grease	Limited resistance
• Water	-
Radiological resistance to UV radiation	Not resistant
Product properties, functions, components	
General	
Product property	
• Halogen-free	No
• Silicon-free	Yes
Standards, specifications, approvals	
UL listing at 300 V rating	-
UL-Style at 600 V rating	-
Certificate of suitability	UL approval
• RoHS compliance	Yes

Technical specifications (continued)

Order No.	6GK1 905-0FA00	6GK1 905-0FB00	6GK1 905-0FC00
Product type designation	7/8" connector	7/8" connector	7/8" Power T-Tap PRO
Product description	7/8" connector with pin insert, 5-pin	7/8" connector with female contact insert, 5-pin	Energy T-piece with two 7/8" female contact inserts and one 7/8" pin insert, each 5-pin
Suitability for application	For field assembly for ET 200	For field assembly for ET 200	For energy connection and energy distribution to ET 200pro modules
Transmission rate			
Transmission rate with PROFIBUS	-	-	-
Interfaces			
Maximum number of electrical connections for network components or terminal equipment	1	1	3
Number of electrical connections for network components or terminals	7/8" connector (pin insert)	7/8" connector (female contact insert)	7/8" connector (2 x female contact insert, 1 x pin insert)
Mechanical data			
Enclosure material	Metal	Metal	Metal
Design, dimensions and weights			
Type of cable outlet	180 degree cable outlet	180 degree cable outlet	-
Width	27 mm	27 mm	58.5 mm
Height	27 mm	27 mm	73.5 mm
Depth	83 mm	83 mm	26.5 mm
Net weight	50 g	50 g	112 g
Permissible ambient conditions			
Ambient temperature			
• During operation	-40 ... +70 °C	-40 ... +70 °C	-40 ... +70 °C
• During storage	-40 ... +80 °C	-40 ... +80 °C	-40 ... +80 °C
• During transport	-40 ... +80 °C	-40 ... +80 °C	-40 ... +80 °C
Relative humidity at 25 °C without condensation during operation, maximum	-	-	-
IP degree of protection	IP65/67	IP65/67	IP65/67
Chemical resistance to water	Resistant	Resistant	Resistant
Product properties, functions, components			
General			
Product property silicon-free	Yes	Yes	Yes
Product component strain relief	Yes	Yes	Yes
Standards, specifications, approvals			
Certificate of suitability: RoHS conformity	Yes	Yes	Yes

PROFIBUS

Electrical networks (RS485)

Energy cables

Technical specifications (continued)

Order No.	6GK1 908-0DC10-6AA3	6GK1 907-0DC10-6AA3	6GK1 907-0DB10-6AA3
Product type designation	Signaling Contact M12 Cable Connector	Power M12 Cable Connector PRO	Power M12 Plug PRO
Product description	M12 connecting socket for signal contact, 5-pin, B-coded	M12 Power connecting socket, 4-pin, A-coded	M12 Power connector, 4-pin, A-coded
Suitability for application	For connection to SCALANCE X208PRO for signal contact	For connection to SCALANCE W-700 / X208PRO for 24 V DC power supply	For connection to PS791-1PRO power supply for 24 V DC power supply
Transmission rate			
Transmission rate with PROFIBUS	-	-	-
Interfaces			
Maximum number of electrical connections for network components or terminal equipment	1	1	1
Number of electrical connections for network components or terminals	M12 connector (B-coded, 5-pin)	M12 connector (female contact insert, A-coded, 4-pin)	M12 connector (pin insert, A-coded, 4-pin)
Mechanical data			
Enclosure material	Plastic	Plastic	Plastic
Design, dimensions and weights			
Type of cable outlet	180 degree cable outlet	180 degree cable outlet	180 degree cable outlet
Width	14 mm	19 mm	19 mm
Height	14 mm	19 mm	19 mm
Depth	59 mm	73 mm	73 mm
Net weight	37 g	40 g	40 g
Permissible ambient conditions			
Ambient temperature			
• During operation	-40 ... +70 °C	-40 ... +70 °C	-40 ... +70 °C
• During storage	-40 ... +80 °C	-40 ... +80 °C	-40 ... +80 °C
• During transport	-40 ... +80 °C	-40 ... +80 °C	-40 ... +80 °C
Relative humidity at 25 °C without condensation during operation, maximum	-	-	-
IP degree of protection	IP65/67	IP65/67	IP65/67
Chemical resistance to water	Resistant	Resistant	Resistant
Product properties, functions, components			
General			
Product property silicon-free	Yes	Yes	Yes
Product component strain relief	Yes	Yes	Yes
Standards, specifications, approvals			
Certificate of suitability: RoHS conformity	Yes	Yes	Yes

Ordering data	Order No.	Order No.
Energy cable 2 x 0.75 Energy cable with trailing capability with 2 copper cores (0.75 mm ²) for connecting to M12 plug-in connector; <u>sold by the meter</u> ; max. 1000 m; minimum order quantity 20 m	6XV1 812-8A	
Energy cable 5 x 1.5 Energy cable with trailing capability with 5 copper cores (1.5 mm ²) for connecting to 7/8" plug-in connector; <u>sold by the meter</u> ; max. 1000 m; minimum order quantity 20 m	6XV1 830-8AH10	
M12 Power Connecting Cable M12-180/M12-180 Flexible 4-core power connecting cable, assembled with A-coded 5-pin M12 connector and A-coded, 5-pin M12 socket to supply the ET 200 with 24 V DC; length: <ul style="list-style-type: none"> • 0.3 m • 0.5 m • 1.0 m • 1.5 m • 2.0 m • 3.0 m • 5.0 m • 10 m • 15 m 	6XV1 801-5DE30 6XV1 801-5DE50 6XV1 801-5DH10 6XV1 801-5DH15 6XV1 801-5DH20 6XV1 801-5DH30 6XV1 801-5DH50 6XV1 801-5DN10 6XV1 801-5DN15	Additional components 7/8" plug-in connector Plug with axial cable outlet for field assembly for ET 200, 5-core, plastic enclosure, 1 pack = 5 items <ul style="list-style-type: none"> • Male pins • Socket insert 7/8" Power T-Tap PRO Power T-piece for ET 200 with two 7/8" socket inserts and one 7/8" pin insert 1 pack = 5 items
		6GK1 905-0FA00 6GK1 905-0FB00
		6GK1 905-0FC00
		Signaling Contact M12 Cable Connector PRO Socket for connection of SCALANCE X208PRO for signaling contact; 5-pole, B-coded, with assembly instructions; 3 items
		6GK1908-0DC10-6AA3
		Power M12 Cable Connector PRO Socket for connection of SCALANCE W-700 for 24 V DC supply voltage; 4-pole, A-coded, with assembly instructions, 3 items
		6GK1 907-0DC10-6AA3
		Power M12 Plug PRO Plug for connection to PS791-1PRO power supply for 24 V DC supply voltage; 4-pole, A-coded, with assembly instructions, 3 items
		6GK1 907-0DB10-6AA3
		SIMATIC NET Manual Collection Electronic manuals for communication systems, communication protocols, and communication products; on DVD, German/English
		6GK1 975-1AA00-3AA0

More information

Cable routing:

During storage, transport and cable laying, keep both ends sealed with a shrink-on cap.

Comply with the permissible bending radii and tensile load!

Note:

You can order components supplementary to the SIMATIC NET cabling range from your local contact.

Technical advice on this subject is available from:

J. Hertlein

I IA SC IC PRM 4

Tel.: +49 (0)911/750 44 65

E-mail: juergen.hertlein@siemens.com

PROFIBUS

Electrical networks (RS485)

RS485 bus connector

Overview



- Used for connecting PROFIBUS nodes to the PROFIBUS bus cable
- Easy installation
- FastConnect plugs ensure extremely short assembly times due to their insulation-displacement technology
- Integrated terminating resistors (not in the case of 6ES7 972-0BA30-0XA0)
- PG connection with special bus connector possible without additional installation of network nodes.

Application

The RS485 bus connectors for PROFIBUS are used for connecting a PROFIBUS node or a PROFIBUS network component to the bus cable for PROFIBUS.

Design

Several different versions of the bus connector are available, each optimized for the devices to be connected:

- Bus connector with axial cable outlet (180°), e.g. for PCs and SIMATIC HMI OPs, for transmission rates up to 12 Mbit/s with integrated bus terminating resistor.
- Bus connector with vertical cable outlet (90°);

This connector permits a vertical cable outlet (with or without PG interface) for transmission rates of up to 12 Mbit/s with integral bus terminating resistor. At a transmission rate of 3, 6 or 12 Mbit/s, the SIMATIC S5/S7 plug-in cable is required for the connection between bus connector with PG-interface and programming device.

- Bus connector with 30° cable outlet (low-cost version) without PG interface for transmission rates of up to 1.5 Mbit/s and without integrated bus terminating resistor.
- PROFIBUS FastConnect bus connector RS485 (90° or 180° cable outlet) with transmission rates up to 12 Mbit/s for fast and easy assembly using insulation displacement connection technology (for rigid and flexible wires).

Function

The bus connector is plugged directly to the PROFIBUS interface (9-pin Sub-D connector) of the PROFIBUS node or a PROFIBUS network component.

The incoming and outgoing PROFIBUS bus cable is connected through four terminals in the connector.

The line termination integrated in the bus connector can be connected through an externally accessible switch (not with 6ES7 972-0BA30-0XA0). Here, incoming and outgoing bus cables are separated in the connector (isolating function).

This is mandatory at both ends of a PROFIBUS segment.

Integration

Bus connector	6ES7 972-0BA12-0XA0 6ES7 972-0BB12-0XA0 6AG1 972-0BB12-2XA0 ¹⁾	6ES7 972-0BA42-0XA0 6ES7 972-0BB42-0XA0 6AG1 972-0BB42-7XA0 ¹⁾	6ES7 972-0BA30-0XA0 ²⁾
Cable outlet	90° cable outlet	35° cable outlet	30° cable outlet
Use in PLC			
S7-200/-300/-400®	• ³⁾	•	•
S7-1200 with CM 1241, CM 1242-5; CM 1243-5		•	
S7-mEC with CP 5603	•	•	•
C7-633 DP, C7-634 DP, C7-635, C7-636	•	•	•
S5-115U to S5-155U	•	•	•
I/O device			
ET 200M/ET 200B/ET 200L/ ET 200S	•	•	•
Interface			
IM 308-C	•	•	•
CP 5431 FMS/DP	•	•	•
CP 342-5/CP 343-5/CP 443-5/ IM 467	•	•	
CP 5511/CP 5512/CP 5711/ CP 5603	•	•	•
CP 561x/CP 562x	•	•	
SIMATIC OP			
OLM/OBT	•	•	
Repeater RS 485	•	•	
Diagnostics repeater	•	•	

- Suitable for the application

¹⁾ SIPLUS module for extended temperature range (-25 °C to +60 °C) and exceptional media stress (conformal coating)

²⁾ Flexible bus cables cannot be used with this connector, max. 1.5 Mbit/s

³⁾ S7-400:
Cannot be used with MPI/DP interface when DP interface is assigned;
cannot be used with IFM1 interface when IFM2 interface is assigned

PROFIBUS

Electrical networks (RS485)

RS485 bus connector

Integration (continued)

Bus connector	6ES7 972-0BA52-0XA0 6ES7 972-0BB52-0XA0	6ES7 972-0BA60-0XA0 6ES7 972-0BB60-0XA0	6GK1 500-0FC10	6GK1 500-0EA02
Cable outlet	90° cable outlet	35° cable outlet	180° cable outlet	180° cable outlet
Use in PLC				
S7-200/-300/-400	•	•		
S7-1200 with CM 1241, CM 1242-5; CM 1243-5		•		
S7-mEC with CP 5603	•	•	•	•
C7-633 DP, C7-634 DP, C7-635, C7-636	•	•		
S5-115U to S5-155U	•	•		
I/O device				
ET 200M/ET 200B/ET 200L/ ET 200S	•	•		
Interface				
IM 308-C	•	•		
CP 5431 [®] FMS/DP	•	•		
CP 342-5/CP 343-5/CP 443-5/ IM 467	•	•		
CP 5511/CP 5512/CP 5711/ CP 5603	•	•	•	•
CP 561x/CP 562x			•	•
SIMATIC OP			•	•
OLM/OBT	•	•	•	•
Repeater RS 485	•	•		
Diagnostics repeater	•	•		

- Suitable for the application

Technical specifications

Order No.	6ES7 972-0BA12-0XA0	6ES7 972-0BB12-0XA0	6ES7 972-0BA42-0XA0	6ES7 972-0BB42-0XA0	6ES7 972-0BA30-0XA0
Product type designation	PROFIBUS bus connector, RS485, screw-type, without PG socket, 90°	PROFIBUS bus connector, RS485, screw-type, with PG socket, 90°	PROFIBUS bus connector, RS485, screw-type, without PG socket, 35°	PROFIBUS bus connector, RS485, screw-type, with PG socket, 35°	PROFIBUS bus connector, RS485, FastConnect, without PG socket, 30°
Product description	PROFIBUS bus connector, RS485, screw-type, without PG socket, 90°	PROFIBUS bus connector, RS485, screw-type, with PG socket, 90°	PROFIBUS bus connector, RS485, screw-type, without PG socket, 35°	PROFIBUS bus connector, RS485, screw-type, with PG socket, 35°	PROFIBUS bus connector, RS485, FastConnect, without PG socket, 30°
Suitability for use	For connecting PROFIBUS stations to the PROFIBUS bus cable	For connecting PROFIBUS stations to the PROFIBUS bus cable	For connecting PROFIBUS stations to the PROFIBUS bus cable	For connecting PROFIBUS stations to the PROFIBUS bus cable	For connecting PROFIBUS stations to the PROFIBUS bus cable
Transmission rate					
Transmission rate with PROFIBUS	9.6 kbit/s ... 12 Mbit/s	9.6 kbit/s ... 12 Mbit/s	9.6 kbit/s ... 12 Mbit/s	9.6 kbit/s ... 12 Mbit/s	9.6 kbit/s ... 1.5 Mbit/s
Interfaces					
Number of electrical connections	2	2	2	2	2
• for PROFIBUS cables	1	1	1	1	1
• for network components or terminal equipment					
Design of electrical connection	Screw	Screw	Screw	Screw	Integrated insulation displacement terminal for 2-core PB FC installation cables
• for PROFIBUS cables					
• for network components or terminal equipment	9-pin sub-D connector	9-pin sub-D connector	9-pin sub-D connector	9-pin sub-D connector	9-pin sub-D connector
• FastConnect		No	No	No	Yes
Mechanical data					
Design of terminating resistor	Integrated resistor combination, can be connected via slide switch	Integrated resistor combination, can be connected via slide switch	Integrated resistor combination, can be connected via slide switch	Integrated resistor combination, can be connected via slide switch	No integrated terminating resistor
Enclosure material	Plastic	Plastic	Plastic	Plastic	Plastic
Design, dimensions and weights					
Type of cable outlet	90 degree cable outlet	90 degree cable outlet	35 degree cable outlet	35 degree cable outlet	30 degree cable outlet
Width	15.8 mm	15.8 mm	15.8 mm	15.8 mm	15 mm
Height	64 mm	64 mm	54 mm	54 mm	57.6 mm
Depth	35.6 mm	35.6 mm	39.5 mm	39.5 mm	39.5 mm
Net weight	10 g	10 g	60 g	67 g	46 g

PROFIBUS

Electrical networks (RS485)

RS485 bus connector

Technical specifications (continued)

Order No.	6ES7 972-0BA12-0XA0	6ES7 972-0BB12-0XA0	6ES7 972-0BA42-0XA0	6ES7 972-0BB42-0XA0	6ES7 972-0BA30-0XA0
Product type designation	PROFIBUS bus connector, RS485, screw-type, without PG socket, 90°	PROFIBUS bus connector, RS485, screw-type, with PG socket, 90°	PROFIBUS bus connector, RS485, screw-type, without PG socket, 35°	PROFIBUS bus connector, RS485, screw-type, with PG socket, 35°	PROFIBUS bus connector, RS485, FastConnect, without PG socket, 30°
Permitted ambient conditions					
Ambient temperature					
• During operation	0 ... 60 °C	0 ... 60 °C	0 ... 60 °C	0 ... 60 °C	0 ... 60 °C
• During storage	-40 ... +70 °C	-40 ... +70 °C	-40 ... +70 °C	-40 ... +70 °C	-40 ... +70 °C
• During transport	-40 ... +70 °C	-40 ... +70 °C	-40 ... +70 °C	-40 ... +70 °C	-40 ... +70 °C
Relative humidity at 25 °C without condensation during operation, maximum	-	95 %	95 %	95 %	95 %
IP degree of protection	IP20	IP20	IP20	IP20	IP20
Chemical resistance to water	-	-	-	-	-
Product properties, functions, components					
General					
Product property silicon-free	Yes	Yes	Yes	Yes	Yes
Product component					
• PG connection socket	No	Yes	No	Yes	No
• Strain relief	Yes	Yes	Yes	Yes	Yes
Standards, specifications, approvals					
Certificate of suitability					
• RoHS compliance	Yes	Yes	Yes	Yes	Yes
• UL approval	Yes	Yes	Yes	Yes	Yes

Technical specifications (continued)

Order No.	6ES7 972-0BA52-0XA0	6ES7 972-0BB52-0XA0	6ES7 972-0BA60-0XA0	6ES7 972-0BB60-0XA0
Product type designation	PROFIBUS bus connector, RS485, FastConnect, without PG socket, 90°	PROFIBUS bus connector, RS485, FastConnect, with PG socket, 90°	PROFIBUS bus connector, RS485, FastConnect, without PG socket, 35°	PROFIBUS bus connector, RS485, FastConnect, with PG socket, 35°
Product description	PROFIBUS bus connector, RS485, FastConnect, without PG socket, 90°	PROFIBUS bus connector, RS485, FastConnect, with PG socket, 90°	PROFIBUS bus connector, RS485, FastConnect, without PG socket, 35°	PROFIBUS bus connector, RS485, FastConnect, with PG socket, 35°
Suitability for use	For connecting PROFIBUS stations to the PROFIBUS bus cable	For connecting PROFIBUS stations to the PROFIBUS bus cable	For connecting PROFIBUS stations to the PROFIBUS bus cable	For connecting PROFIBUS stations to the PROFIBUS bus cable
Transmission rate				
Transmission rate with PROFIBUS	9.6 kbit/s ... 12 Mbit/s	9.6 kbit/s ... 12 Mbit/s	9.6 kbit/s ... 12 Mbit/s	9.6 kbit/s ... 12 Mbit/s
Interfaces				
Number of electrical connections				
• for PROFIBUS cables	2	2	2	2
• for network components or terminal equipment	1	1	1	1
Design of electrical connection				
• for PROFIBUS cables	Integrated insulation displacement terminal for 2-core PB FC installation cables	Integrated insulation displacement terminal for 2-core PB FC installation cables	Integrated insulation displacement terminal for 2-core PB FC installation cables	Integrated insulation displacement terminal for 2-core PB FC installation cables
• for network components or terminal equipment	9-pin sub-D connector	9-pin sub-D connector	9-pin sub-D connector	9-pin sub-D connector
• FastConnect	Yes	Yes	Yes	Yes
Mechanical data				
Design of terminating resistor	Integrated resistor combination, can be connected via slide switch	Integrated resistor combination, can be connected via slide switch	Integrated resistor combination, can be connected via slide switch	Integrated resistor combination, can be connected via slide switch
Enclosure material	Plastic	Plastic	Plastic	Plastic
Design, dimensions and weights				
Type of cable outlet	90 degree cable outlet	90 degree cable outlet	35 degree cable outlet	35 degree cable outlet
Width	15.8 mm	15.8 mm	15.8 mm	15.8 mm
Height	59 mm	59 mm	54 mm	54 mm
Depth	35.6 mm	35.6 mm	39.5 mm	39.5 mm
Net weight	10 g	10 g	29 g	34 g
Permissible ambient conditions				
Ambient temperature				
• During operation	0 ... 60 °C	0 ... 60 °C	0 ... 60 °C	0 ... 60 °C
• During storage	-40 ... +70 °C	-40 ... +70 °C	-40 ... +70 °C	-40 ... +70 °C
• During transport	-40 ... +70 °C	-40 ... +70 °C	-40 ... +70 °C	-40 ... +70 °C
Relative humidity at 25 °C without condensation during operation, maximum	95 %	95 %	95 %	95 %
IP degree of protection	IP20	IP20	IP20	IP20
Chemical resistance to water				
Product properties, functions, components				
General				
Product property silicon-free	Yes	Yes	Yes	Yes
Product component				
• PG connection socket	No	Yes	No	Yes
• Strain relief	Yes	Yes	Yes	Yes
Standards, specifications, approvals				
Certificate of suitability				
• RoHS compliance	Yes	Yes	Yes	Yes
• UL approval	Yes	Yes	Yes	Yes

PROFIBUS

Electrical networks (RS485)

RS485 bus connector

Technical specifications (continued)

Order No.	6GK1 500-0EA02	6GK1 500-0FC10
Product type designation	PROFIBUS bus connector RS 485	PROFIBUS FC bus connector RS 485
Product description	Bus connector with axial cable outlet (180°)	Bus connector with axial cable outlet (180°)
Suitability for use	For connecting PROFIBUS stations to the PROFIBUS bus cable	For connecting PROFIBUS stations to the PROFIBUS bus cable
Transmission rate		
Transmission rate with PROFIBUS	9.6 kbit/s ... 12 Mbit/s	9.6 kbit/s ... 12 Mbit/s
Interfaces		
Number of electrical connections		
• for PROFIBUS cables	2	2
• for network components or terminal equipment	1	1
Design of electrical connection		
• for PROFIBUS cables	Terminal blocks	Integrated insulation displacement contacts for 2-core PB FC installation cables
• for network components or terminal equipment	9-pin sub-D connector	9-pin sub-D connector
• FastConnect	No	Yes
Mechanical data		
Design of terminating resistor	Integrated resistor combination, can be connected via slide switch. Disconnect function: If a resistor is activated, the outgoing bus is disconnected	Integrated resistor combination, can be connected via slide switch. Disconnect function: If a resistor is activated, the outgoing bus is disconnected.
Enclosure material	Metal	Plastic
Design, dimensions and weights		
Type of cable outlet	180° cable outlet	180 degree cable outlet
Width	15 mm	16 mm
Height	57 mm	62 mm
Depth	39 mm	34.5 mm
Net weight	100 g	40 g
Permissible ambient conditions		
Ambient temperature		
• During operation	0 ... 60 °C	0 ... 60 °C
• During storage	-25 ... +80 °C	-25 ... +80 °C
• During transport	-25 ... +80 °C	-25 ... +80 °C
Relative humidity at 25 °C without condensation during operation, maximum	75 %	75 %
IP degree of protection	IP20	IP20
Chemical resistance to water	-	-
Product properties, functions, components		
General		
Product property silicon-free	Yes	Yes
Product component		
• PG connection socket	No	No
• Strain relief	Yes	Yes
Standards, specifications, approvals		
Certificate of suitability		
• RoHS compliance	Yes	Yes
• UL approval	No	Yes

Ordering data	Order No.	Order No.
RS485 bus connector with axial cable outlet (180°) For industrial PC, SIMATIC HMI OP, OLM; max. transmission rate 12 Mbit/s	6GK1 500-0EA02	PROFIBUS FastConnect bus connector RS485 with 90° cable outlet with insulation displacement terminals, max. transmission rate 12 Mbit/s Without PG interface <ul style="list-style-type: none"> • 1 unit • 100 units With PG interface <ul style="list-style-type: none"> • 1 unit • 100 units
SIPLUS DP PB RS485 connector with axial cable outlet (180°) for medial stress; Based-on 6GK1 500-0EA02	6AG1 500-0EA02-2AA0	
RS485 bus connector with cable outlet (90°) With screw-terminals, max. transmission rate 12 Mbit/s <ul style="list-style-type: none"> • Without PG interface • With PG interface 	6ES7 972-0BA12-0XA0 6ES7 972-0BB12-0XA0	6ES7 972-0BA52-0XA0 6ES7 972-0BA52-0XB0 6ES7 972-0BB52-0XA0 6ES7 972-0BB52-0XB0
SIPLUS DP PB RS485 connector with 90° cable outlet for extended temperature range -25 ... +60 °C <ul style="list-style-type: none"> • without PG interface Based on 6ES7 972-0BA12-0XA0 • with PG interface Based on 6ES7 972-0BB12-0XA0 	6AG1 972-0BA12-2XA0 6AG1 972-0BB12-2XA0	PROFIBUS FastConnect RS485 bus connector with angled cable outlet (35°) with insulation displacement terminals, max. transmission rate 12 Mbit/s <ul style="list-style-type: none"> • Without PG interface • With PG interface
RS485 bus connector with angled cable outlet (35°) With screw-terminals, max. transmission rate 12 Mbit/s <ul style="list-style-type: none"> • Without PG interface • With PG interface 	6ES7 972-0BA42-0XA0 6ES7 972-0BB42-0XA0	PROFIBUS FastConnect bus connector RS485 Plug 180 with insulation displacement terminals, with 180° cable outlet, for industrial PC, SIMATIC HMI OP, OLM; max. transmission rate 12 Mbit/s
SIPLUS DP PB RS485 connector with inclined cable outlet (35°) for extended temperature range -25 ... +60 °C <ul style="list-style-type: none"> • without PG interface Based on 6ES7 972-0BA41-0XA0 • with PG interface Based on 6ES7 972-0BB41-0XA0 	6AG1 972-0BA42-7XA0 6AG1 972-0BB42-7XA0	SIMATIC S5/S7 plug-in cable for PROFIBUS Preassembled with two 9-pin sub-D connectors; max. transmission rate 12 Mbit/s; 3 m
RS485 bus connector with cable outlet (30°) With screw-terminals, low-cost variant, max. transmission rate 1.5 Mbit/s	6ES7 972-0BA30-0XA0	SIMATIC NET Manual Collection Electronic manuals for communication systems, communication protocols, and communication products; on DVD; German/English

PROFIBUS

Electrical networks (RS485)

830-1T connecting cable

Overview



- Prefabricated cable for fast and cost-effective connection of PROFIBUS nodes to OLM and OBT
- Flexible PROFIBUS connecting cable

Benefits

get Designed for Industry

- Trouble-free connection of end stations through pre-assembled connecting leads
- Reliable data transmission to the end station in EMC-exposed environment through direct cable shielding and termination.

Design

The 830-1T connecting cable consists of a twisted-pair cable (wires made of stranded copper) with a woven shield.

It has a 9-pin Sub-D plug at both ends.

Both cable ends are terminated by a resistor combination (cannot be switched off).

Function

The PROFIBUS 830-1T connecting cable is used for connecting the electrical PROFIBUS interface to the PROFIBUS nodes (OLM, OBT and data terminals) for data transmission rates of up to 12 Mbit/s.

Ordering data

830-1T PROFIBUS connecting cable

for terminal connection, pre-assembled, with two Sub-D plugs, 9-pin terminated at both ends

- 1.5 m long
- 3 m long

Order No.

6XV1 830-1CH15
6XV1 830-1CH30

PROFIBUS

Electrical networks (RS485)

830-2 connecting cable

Overview



- Prefabricated cable for connection of PROFIBUS nodes (e.g. HMI) to PLCs
- Flexible PROFIBUS connection cable for up to 12 Mbit/s

Benefits

get Designed for Industry

- Trouble-free connection of end stations through pre-assembled connecting leads
- Direct connection of a PG through the PG interface without interrupting the connection between the stations.

Design

The 830-2 connecting cable comprises a standard PROFIBUS bus cable. It is preassembled with two 9-pin connectors (6GK1 500-0EA02 and 6ES7 972-0BB11-0XA0). One plug of the preassembled connecting cable is equipped with a PG interface.

Function

The 830-2 connecting cable is used to connect PROFIBUS nodes (e.g. HMI) to automation devices for transmission rates up to 12 Mbit/s.

Ordering data

Order No.

830-2 PROFIBUS connecting cable

Preassembled, with two 9-pin connectors

- 3 m long
- 5 m long
- 10 m long

6XV1 830-2AH30
6XV1 830-2AH50
6XV1 830-2AN10

PROFIBUS

Electrical networks (RS485)

PROFIBUS M12 and 7/8" connecting cable/connector

Overview



Flexible connecting cables and FastConnect (FC) plug-in connectors that can be assembled in the field for transmission of data (up to 12 Mbit/s) or for power supply between PROFIBUS nodes with degree of protection IP65

PROFIBUS M12 plug-in cable

- Preassembled plug-in cable (PROFIBUS FC Trailing Cable) for connecting PROFIBUS nodes (e.g. SIMATIC ET 200) to degree of protection IP65
- For transmission rates up to 12 Mbit/s

7/8" connecting cable

- Preassembled plug-in cable for supplying power to PROFIBUS nodes (e.g. SIMATIC ET 200) to degree of protection IP65

PROFIBUS FC M12 Plug PRO (D-coded) and 7/8" plug-in connector

- For establishing direct connections between devices on PROFIBUS installation and power cables with M12 or 7/8" connections
- Excellent EMC shielding and deflection (metal housing)
- Easy assembly due to integrated FastConnect technology (FC M12 Plug)
- Viewable contact area prevents errors

Benefits

get Designed for Industry

- Time-saving and fault-free connection of terminal stations by means of prefabricated connection cables
- Easy assembly on site for application-specific M12 and 7/8" plug-in cables by means of FC M12 and 7/8" plug-in connectors that can be assembled in the field

Design

M12 plug-in cable

- Comprises the PROFIBUS Trailing Cable
- Pre-assembled with two 5-pole M12 male/female connectors; B-coded

7/8" plug-in cable

- Comprises the Energy Cable 5 x 1.5 mm²
- Pre-assembled with two 5-pole 7/8" male/female connectors

Technical specifications

Order No.	6XV1 830-3DH10
Product type designation	PROFIBUS M12 connecting cable
Product description	Flexible connecting cable (2-core), preferred length, preassembled with two 5-pin M12 plugs/sockets (B-coded)
Suitability for application	Cable for connecting PROFIBUS nodes (e.g. SIMATIC ET 200) in IP 65 protection
Cable designation	02YY (ST) C11Y 1x2x0.65/2.56-150 LI KF 40 FR petrol
Cable length	1 m

Electrical specifications

Attenuation factor per length	
• Max. at 9.6 kHz	0.003 dB/m
• Max. at 38.4 kHz	0.004 dB/m
• Max. at 4 MHz	0.025 dB/m
• Max. at 16 MHz	0.049 dB/m
Characteristic impedance	
• Rated value	150 Ω
• at 9.6 kHz	270 Ω
• at 38.4 kHz	185 Ω
• at 3 MHz ... 20 MHz	150 Ω
Relative symmetrical tolerance	
• of characteristic impedance at 9.6 kHz	10 %
• of characteristic impedance at 38.4 kHz	10 %
• of characteristic impedance at 3 MHz to 20 MHz	10 %
Max. loop resistance per length	133 Ω/km
Max. shield resistance per length	14 Ω/km
Capacitance per length at 1 kHz	28 pF/m
Operating voltage, rms value	100 V

Mechanical data

Number of electrical cores	2
Design of shield	Overlapping aluminum-clad foil, surrounded by a braided screen of tin-plated copper wires
Design of electrical connection FastConnect	Yes
Outer diameter	
• of inner conductor	0.67 mm
• of core insulation	2.56 mm
• of inner sheath of cable	5.4 mm
• of the cable sheath	8 mm
Symmetrical tolerance of outer diameter of cable sheath	0.4 mm
Outer diameter of cable sheath - Note	-
Material	
• of core insulation	PE
• of inner sheath of cable	PVC
• of the cable sheath	PUR
- Note	-

Order No.	6XV1 830-3DH10
Product type designation	PROFIBUS M12 connecting cable
Color	
• of core insulation of data cores	Red / green
• of the cable sheath	Petrol
Bending radius	
• with single bending	40 mm
• with repeated bending	120 mm
• With continuous bending	-
Number of bending cycles	3 000 000
• Note	Suitable as trailing cable for 3 million bending cycles with a bending radius of 120 mm (15x D), and an acceleration of 4 m/s ²
Number of torsion cycles with torsion by ± 180° on 1 m cable length	-
Maximum tensile load	100 N
Weight per length	77 kg/km
Permitted ambient conditions	
Ambient temperature	
• During operation	-40 ... +60 °C
• During storage	-40 ... +60 °C
• During transport	-40 ... +60 °C
• During mounting	-40 ... +60 °C
Ambient conditions for operation	Restricted segment lengths (see Manual for PROFIBUS networks)
IP degree of protection	IP65/67
Behavior in fire	Flame-retardant in accordance with IEC 60332-1-2
Chemical resistance	
• against mineral oil	Resistant
• against grease	Resistant
• against water	-
Radiological resistance to UV radiation	Resistant
Product properties, functions, components	
General	
Product property	
• Halogen-free	No
• Silicon-free	Yes
Standards, specifications, approvals	
UL listing at 300 V rating	Yes: CMX
UL-Style at 600 V rating	No
Certificate of suitability	
• RoHS compliance	Yes
Marine classification corporation	
• Germanischer Lloyd (GL)	No
• Lloyds Register of Shipping (LRS)	No

PROFIBUS

Electrical networks (RS485)

PROFIBUS M12 and 7/8" connecting cable/connector

Technical specifications (continued)

Order No.	6XV1 822-5BH10
Product type designation	7/8" connecting cable
Product description	Connecting cable (5-core), preferred length, preassembled with two 5-pin 7/8" plugs/sockets
Suitability for use	Power supply of ET 200 modules with 7/8" power interface in IP65 protection
Cable designation	L-Y11Y-Z 5x1x1.5 GR
Cable length	1 m
Electrical specifications	
Operating voltage, rms value	600 V
Conductor cross-section of power core	1.5 mm ²
Continuous current of power cores	16 A
Mechanical data	
Number of electrical cores	5
Outer diameter	
• of inner conductor	1.55 mm
• of core insulation	2.73 mm
• of the cable sheath	10.5 mm
Symmetrical tolerance of outer diameter of cable sheath	0.3 mm
Outer diameter of cable sheath - Note	-
Material	
• of core insulation	PVC
• of the cable sheath	PUR
- Note	-
Color	
• of core insulation of power cores	Black
• of the cable sheath	Gray
Bending radius	
• With single bending	27 mm
• With repeated bending	63 mm
Maximum tensile load	500 N
Weight per length	149 kg/km

Order No.	6XV1 822-5BH10
Product type designation	7/8" connecting cable
Permissible ambient conditions	
Ambient temperature	
• During operation	-40 ... +80 °C
• During storage	-40 ... +80 °C
• During transport	-40 ... +80 °C
• During mounting	-40 ... +80 °C
• Note	-
Ambient conditions for operation	-
IP degree of protection	IP65/67
Behavior in fire	Flame-retardant in accordance with IEC 60332-1
Chemical resistance	
• Mineral oil	resistant
• Grease	resistant
• Water	-
Radiological resistance to UV radiation	resistant
Product properties, functions, components	
General	
Product property	
• Halogen-free	No
• Silicon-free	Yes
Standards, specifications, approvals	
UL listing at 300 V rating	No
UL-Style at 600 V rating	Yes
Certificate of suitability	-
• RoHS compliance	Yes

Technical specifications (continued)

Order No.	6GK1 905-0EA10	6GK1 905-0EB10	6GK1 905-0EA00	6GK1 905-0EB00
Product type designation	PB FC M12 Plug PRO	PB FC M12 Cable Connector PRO	PB M12 connector	PB M12 connector
Product description	M12 connector with male contact insert, 5-pin, B-coded	M12 connector with female contact insert, 5-pin, B-coded	M12 connector with male contact insert, 5-pin, B-coded	M12 connector with female contact insert, 5-pin, B-coded
Suitability for use	For connecting electrical PB FC bus cables to ET 200 PRO, suitable for quick assembly, with FastConnect system	For connecting electrical PB FC bus cables to ET 200 PRO, suitable for quick assembly, with FastConnect system	For connecting electrical PB bus cables to ET 200	For connecting electrical PB bus cables to ET 200
Transmission rate				
Transmission rate with PROFIBUS	9.6 kbit/s ... 12 Mbit/s	9.6 kbit/s ... 12 Mbit/s	9.6 kbit/s ... 12 Mbit/s	9.6 kbit/s ... 12 Mbit/s
Interfaces				
Number of electrical connections				
• for PROFIBUS cables	1	1	1	1
• for network components or terminal equipment	1	1	1	1
Design of electrical connection				
• for PROFIBUS cables	Integrated insulation displacement contacts for 2-core PB FC installation cables	Integrated insulation displacement contacts for 2-core PB FC installation cables	Integrated screw contacts for 2-wire PB installation cables	Integrated screw contacts for 2-wire PB installation cables
• for network components or terminal equipment	M12 connector (pin insert, 4-pin, B-coded)	M12 connector (female contact insert, 5-pin, B-coded)	M12 connector (pin insert, 4-pin, B-coded)	M12 connector (female contact insert, 5-pin, B-coded)
• FastConnect	Yes	Yes	No	No
Mechanical data				
Design of terminating resistor	-	-	-	-
Enclosure material	Metal	Metal	Metal	Metal
Design, dimensions and weights				
Type of cable outlet	180 degree cable outlet	180 degree cable outlet	180 degree cable outlet	180 degree cable outlet
Width	19 mm	19 mm	19 mm	19 mm
Height	19 mm	19 mm	19 mm	19 mm
Depth	73 mm	73 mm	73 mm	73 mm
Net weight	40 g	40 g	40 g	40 g
Permissible ambient conditions				
Ambient temperature				
• During operation	-40 ... +70 °C	-40 ... +70 °C	-40 ... +70 °C	-40 ... +70 °C
• During storage	-40 ... +80 °C	-40 ... +80 °C	-40 ... +80 °C	-40 ... +80 °C
• During transport	-40 ... +80 °C	-40 ... +80 °C	-40 ... +80 °C	-40 ... +80 °C
IP degree of protection	IP65/67	IP65/67	IP65/67	IP65/67
Chemical resistance to water	resistant	resistant	resistant	resistant
Product properties, functions, components				
General				
Product property silicon-free	Yes	Yes	Yes	Yes
Product component				
• PG connection socket	-	-	-	-
• Strain relief	Yes	Yes	Yes	Yes
Standards, specifications, approvals				
Certificate of suitability				
• RoHS compliance	Yes	Yes	Yes	Yes
• UL approval	Yes	Yes	No	No

PROFIBUS

Electrical networks (RS485)

PROFIBUS M12 and 7/8" connecting cable/connector

Technical specifications (continued)

Order No.	6GK1 905-0FA00	6GK1 905-0FB00	6GK1 905-0FC00
Product type designation	7/8" connector	7/8" connector	7/8-Zoll Power T-Tap PRO
Product description	7/8" connector with pin insert, 5-pin	7/8" connector with female contact insert, 5-pin	Energy T-piece with two 7/8" female contact inserts and one 7/8" pin insert, each 5-pin
Suitability for use	For field assembly for ET 200	For field assembly for ET 200	For energy connection and energy distribution to ET 200pro modules
Transmission rate			
Transmission rate with PROFIBUS	-	-	-
Interfaces			
Maximum number of electrical connections for network components or terminal equipment	1	1	3
Number of electrical connections for network components or terminals	7/8" connector (pin insert)	7/8" connector (female contact insert)	7/8" connector (2 x female contact inserts, 1 x pin insert)
Mechanical data			
Enclosure material	Metal	Metal	Metal
Design, dimensions and weights			
Type of cable outlet	180 degree cable outlet	180 degree cable outlet	-
Width	27 mm	27 mm	58.5 mm
Height	27 mm	27 mm	73.5 mm
Depth	83 mm	83 mm	26.5 mm
Net weight	50 g	50 g	112 g
Permissible ambient conditions			
Ambient temperature			
• During operation	-40 ... +70 °C	-40 ... +70 °C	-40 ... +70 °C
• During storage	-40 ... +80 °C	-40 ... +80 °C	-40 ... +80 °C
• During transport	-40 ... +80 °C	-40 ... +80 °C	-40 ... +80 °C
IP degree of protection	IP65/67	IP65/67	IP65/67
Chemical resistance to water	resistant	resistant	resistant
Product properties, functions, components			
General			
Product property silicon-free	Yes	Yes	Yes
Product component strain relief	Yes	Yes	Yes
Standards, specifications, approvals			
Certificate of suitability: RoHS conformity	Yes	Yes	Yes

PROFIBUS

Electrical networks (RS485)

PROFIBUS M12 and 7/8"
connecting cable/connector

Ordering data	Order No.	Order No.
PROFIBUS M12 plug-in cable Pre-assembled with two 5-pole M12 male/female connectors up to 100 m max.; length: <ul style="list-style-type: none"> • 0.3 m • 0.5 m • 1.0 m • 1.5 m • 2.0 m • 3.0 m • 5.0 m • 10 m • 15 m Further special lengths with 90° or 180° cable outlet	6XV1 830-3DE30 6XV1 830-3DE50 6XV1 830-3DH10 6XV1 830-3DH15 6XV1 830-3DH20 6XV1 830-3DH30 6XV1 830-3DH50 6XV1 830-3DN10 6XV1 830-3DN15 See http://support.automation.siemens.com/WW/view/en/26999294	6GK1 905-0EA00 6GK1 905-0EB00
7/8" plug-in cable For power supply; pre-assembled with two 5-pole 7/8" male/female connectors up to 50 m max.; length: <ul style="list-style-type: none"> • 0.3 m • 0.5 m • 1.0 m • 1.5 m • 2.0 m • 3.0 m • 5.0 m • 10 m • 15 m Additional special lengths with 90° or 180° cable outlet	6XV1 822-5BE30 6XV1 822-5BE50 6XV1 822-5BH10 6XV1 822-5BH15 6XV1 822-5BH20 6XV1 822-5BH30 6XV1 822-5BH50 6XV1 822-5BN10 6XV1 822-5BN15 See http://support.automation.siemens.com/WW/view/en/26999294	6GK1 905-0FA00 6GK1 905-0FB00
		6GK1 905-0EA10
		6GK1 905-0EB10
		6GK1 905-0FA00 6GK1 905-0FB00
		6XV1 830-8AH10
		6GK1 905-0FC00

Plug-in connector for assembly in the field

PROFIBUS M12 connectors

5-pole, B-coded, metal casing, 1 pack = 5 items

- Male pins
- Socket insert

PROFIBUS FC M12 Plug PRO

M12 plug-in connector (B-coded) that can be assembled in the field, 5-pin, metal enclosure, FastConnect technology, pin insert;

- 1 pack = 5 items

PROFIBUS FC M12 Cable Connector PRO

M12 plug-in connector (B-coded) that can be assembled in the field, 5-pin, metal enclosure, FastConnect technology, socket insert;

- 1 pack = 5 items

7/8" plug-in connector

5-pole, plastic casing, 1 pack = 5 items

- Male pins
- Socket insert

Energy cables

Energy Cable (5 x 1.5 mm²)

Energy cable with trailing capability with 5 copper cores (1.5 mm²) for connecting to 7/8" plug-in connector; sold by the meter; max. 1000 m; minimum order quantity 20 m

7/8" Power T-Tap PRO

Power T-piece for ET 200 with two 7/8" socket inserts and one 7/8" pin insert
1 pack = 5 items

PROFIBUS

Electrical networks (RS485)

PROFIBUS M12 and 7/8"
connecting cable/connector

Dimensional drawings

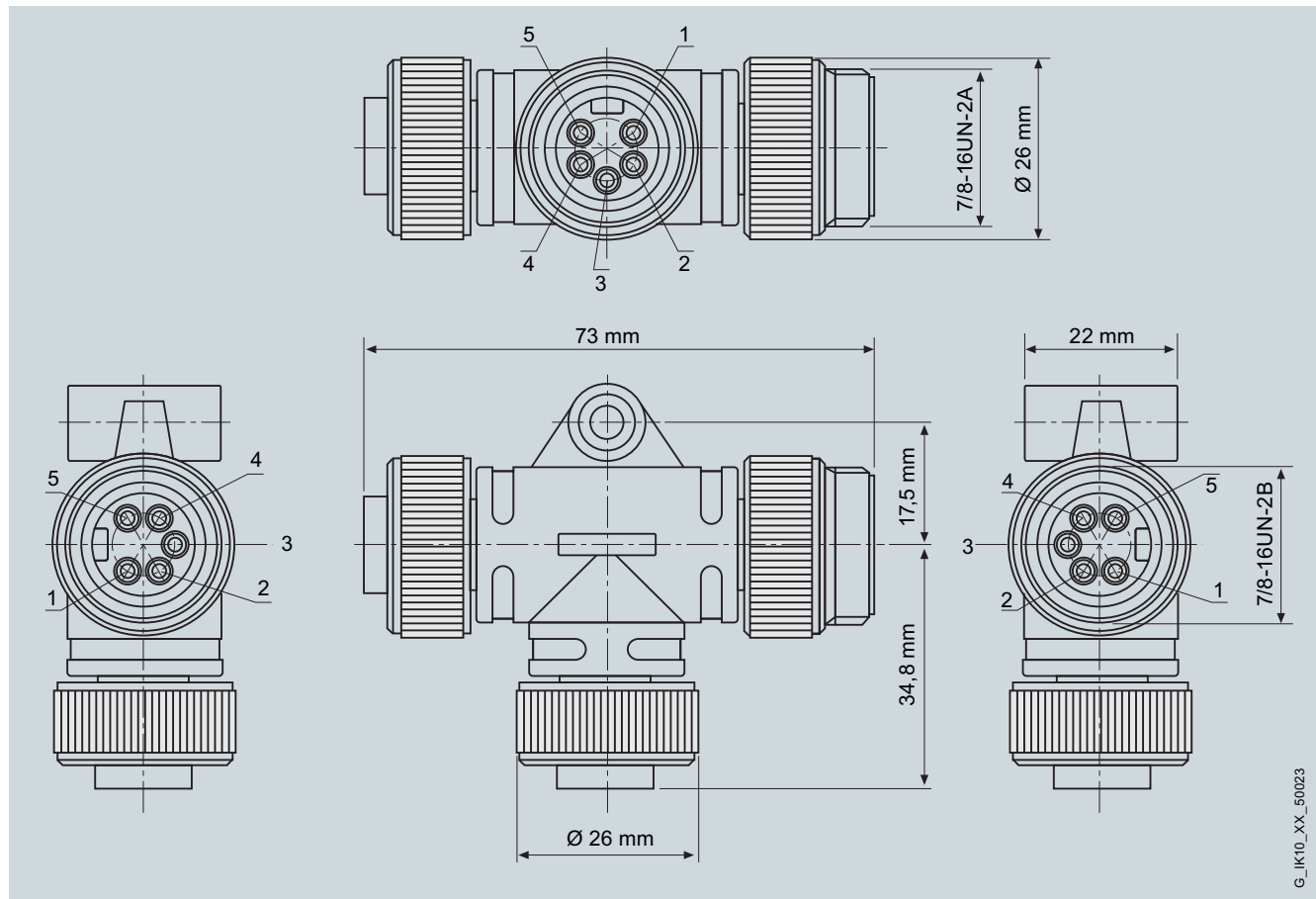

7/8" Power T-Tap PRO

More information

Special lengths with 90° or 180° cable outlet

You can find more information on the Internet at:

<http://support.automation.siemens.com/WW/view/en/26999294>

G_IK10_XX_50023

Overview



- For connecting PROFIBUS nodes with an RS485 interface to a segment
- Versions with transmission rates from 9.6 kbit/s to 12 Mbit/s
- Clear and easy mounting (can be snapped onto DIN rail)
- Clear location of faulty bus termination when bus terminal 12M is used
- PG connection with special bus terminal and PG connecting cable possible without additional installation of network nodes for bus terminal RS485.

Benefits

get Designed for Industry

- Easy and clearly comprehensible connection of PROFIBUS stations thanks to preassembled, integrated connecting cable
- Simple cabinet pre-wiring by connecting the PROFIBUS connecting cable with integrated interfaces

Application

The PROFIBUS bus terminals enable a bus station to be connected to a PROFIBUS network.

- Pre-wired device connection for PROFIBUS node
- Easy connection of stations to PROFIBUS networks through insertion of the radial line with Sub-D plug
- Implementation of multipoint connections by directly interconnecting several bus terminals (up to 32 stations per segment) with the 12M bus terminal.

Design

Different versions are available:

- Up to 1.5 Mbit/s
Bus terminal RS485
- Up to 12 Mbit/s
Bus terminal 12M

Applicable to all versions:

- IP20 enclosure.
- Wall mounting or mounting on deep standard DIN rail possible.
- External 6-pin terminal block for connection of incoming and outgoing bus cable and equipotential bonding conductors.
- Integrated connecting cable with Sub-D plug for connection of nodes.
- Combination of terminating resistors can be connected by means of rotary switch.

The following additionally applies to the bus terminal 12M:

- Ranges for transmission rates can be adjusted by means of rotary switches.
- Supply to the bus terminal 12M by the connected PROFIBUS node (5 V DC/90 mA) via 9-pin Sub-D socket.
- For maximum segment lengths, see Technical Specifications.
- Incoming and outgoing bus cables are disconnected when inserting the terminating resistors.

PROFIBUS

Electrical networks (RS485)

Bus terminals

Function

- Connection of stations over flexible connecting cable with Sub-D connector
- Easy connection of the bus cable over the terminal block
- No bus interruption in response to a missing terminal
- Bus termination is possible over integral termination resistor combinations.

The following also applies to the 12M bus terminal

- Unique localization of faulty termination within a segment (the incoming and outgoing bus cables are cut for inserting the resistor combinations)
- When the 12M bus terminal is used in a segment with RS 485 bus terminals, the configuration rules for the RS 485 bus terminal apply (see manual for PROFIBUS networks).



System connection with PROFIBUS bus terminals e.g. for SIMATIC S7

PROFIBUS

Electrical networks (RS485)

Bus terminals

Technical specifications		Ordering data	Order No.
Order No.	6GK1 500-0AA10	Bus terminal RS485 for PROFIBUS	6GK1 500-0AB00
Product type designation	PROFIBUS bus terminal 12M	Transmission rate 9.6 kbit/s to 1500 kbit/s with plug-in cable 3.0 m long	
Transmission rate		Bus terminal RS485 for PROFIBUS	6GK1 500-0DA00
• Maximum	12 Mbit/s	With installed programmer port and plug-in cable 1.5 m long	
• Minimum	9.6 kbit/s	PROFIBUS bus terminal 12M	6GK1 500-0AA10
Cable length		Bus terminal for connection of PROFIBUS stations up to 12 Mbit/s with plug-in cable 1.5 m long	
• At 1.5 Mbit/s, maximum	200 m	SIMATIC NET Manual Collection	6GK1 975-1AA00-3AA0
• At 12 Mbit/s, maximum	100 m	Electronic manuals for communication systems, communication protocols, and communication products; on DVD; German/English	
• At 500 kbit/s, maximum	400 m		
• At transmission rate 9.5 kbit/s ... 187.5 kbit/s, maximum	1000 m		
Suitability for use			
• For interfacing			
- IM 308-C	Yes		
- IM 467	Yes		
- SIMATIC 505 FIM	Yes		
• For PLC			
- SIMATIC 505	-		
- SIMATIC S5-95U/DP	Yes		
• For central processing unit			
- CPU 215	Yes		
- CPU 313	Yes		
- CPU 314	Yes		
- CPU 315	Yes		
- CPU 315-2 DP	Yes		
- CPU 316	Yes		
- CPU 413-2 DP	Yes		
- CPU 414-2 DP	Yes		
• For communications processor			
- CP 342-5	Yes		
- CP 343-5	Yes		
- CP 443-5 Basic	Yes		
- CP 443-5 Extended	Yes		
- CP 5431 FMS/DP	Yes		
- CP 5511	-		
- CP 5512	-		
- CP 5611	Yes		
- CP 5613 A2	Yes		
- CP 5614 A2	Yes		
• For network components			
- DP/AS-Interface Link 20E	Yes		
- DP/RS 232 Link	Yes		
- PROFIBUS DP RBC	Yes		
- RS 485 repeater	Yes		
• For I/O device			
- ET 200B	Yes		
- ET 200eco	-		
- ET 200L	-		
- ET 200M	-		
- ET 200M with IM 153	Yes		
- ET 200S	-		
- ET 200X	-		
- ET 200U with IM 318-C	Yes		

PROFIBUS

Electrical networks (RS485)

Active RS 485 terminating element

Overview



- Terminates bus segments at data transmission rates of 9.6 kbit/s to 12 Mbit/s
- Power supply independent of bus stations.

Designed for Industry

- Terminal-independent bus termination through onboard power supply

Application

The active RS 485 terminating resistance is used to terminate bus segments. Power supply is independent of the stations. The terminating resistor is supplied with power separately from the other I/O components, either permanently or with a voltage applied ahead of the I/Os. By terminating the bus system the stations (e.g. ET 200S) can be coupled and decoupled selectively without malfunctions.

Design

- 1 terminal block for the segment connection
- Terminal block for power supply (24 V DC external)

Function

The active RS 485 terminating element terminates the PROFIBUS and therefore ensures a defined level of the RS 485 signal and suppression of reflections on the line. Since it is operated independently of the field devices, they can be decoupled from the bus without reactions.

Technical specifications

6ES7 972-0DA00-0AA0	
General information	
• 24 V DC	Yes
• permissible range, lower limit (DC)	20.4 V
• permissible range, upper limit (DC)	28.8 V
Current consumption, typ.	30 mA
Bus cables	Screw terminal block
PROFIBUS DP	
• Transmission rate, max.	12 Mbit/s; 9.6 ... 12 Mbit/s
Operating temperature	
• Min.	0 °C
• max.	60 °C
Storage/transport temperature	
• Min.	-40 °C
• max.	70 °C
Relative humidity	
• Operation, max.	95 %; at +25 °C
Degree and class of protection	
IP20	Yes
Connection method	
Power supply	Screw terminal block
Dimensions and weight	
Dimensions	
• Width	60 mm
• Height	70 mm
• Depth	43 mm
Weight	
• Weight, approx.	95 g

Ordering data

Order No.

Active RS 485 terminating element for PROFIBUS

6ES7 972-0DA00-0AA0

For terminating bus segments for data transmission rates of 9.6 kbit/s to 12 Mbit/s

Overview



- Automatic data transmission rate search
- Data transmission rate of 45.45 kbit/s possible
- 24 V DC voltage display
- Display bus activity segment 1 and 2
- Isolation of segment 1 and 2 possible by switch
- Isolation of the right segment part when terminating resistor is inserted
- Decoupling of segment 1 and segment 2 in the event of static interference

Designed for Industry

- To increase the number of stations and the expansion
- Galvanic isolation of segments
- Startup assistance
 - switch for disconnecting segments
 - display of bus activity
 - isolation of segment with incorrectly inserted terminating resistor

Please also have a look at the diagnostics repeater which in addition to the normal repeater functionality also has comprehensive diagnostics functions for physical line diagnosis. It is described under "Distributed I/O/Diagnostics/Diagnostics repeater for PROFIBUS DP".

Application

The RS 485 IP20 repeater connects two PROFIBUS or MPI bus segments using the RS 485 system with up to 32 stations. Data transmission rates of 9.6 kbit/s to 12 Mbit/s are then possible.

Design

- Housing to degree of protection IP20.
- 2 terminal blocks for connecting the segment
- Terminal block for supply voltage (24 V DC external).
- PG/OP interface.

Function

Mode of operation

- Increasing the number of stations (max. 127) and the expansion
- Regenerating the signals in amplitude and time
- Electrical isolation of the connected bus systems

Data transmission rate	Max. segment length
9.6 kbit/s	1000 m
19.2 kbit/s	1000 m
45.45 kbit/s	1000 m
93.75 kbit/s	1000 m
187.5 kbit/s	1000 m
500 kbit/s	400 m
1500 kbit/s	200 m
3000 kbit/s	100 m
6000 kbit/s	100 m
12000 kbit/s	100 m

PROFIBUS

Electrical networks (RS485)

Repeater RS 485 for PROFIBUS

Technical specifications

6ES7 972-0AA02-0XA0	
General information	
• 24 V DC	Yes
• permissible range, lower limit (DC)	20.4 V
• permissible range, upper limit (DC)	28.8 V
Current consumption, max.	100 mA; (100 mA without loads at PG/OP socket; 130 mA load at PG/OP socket (5 V/90 mA); 200 mA load at PG/OP socket (24 V/100 mA))
Bus cables	2 terminal blocks
PROFIBUS DP	
• Transmission rate, max.	12 Mbit/s; 9.6 kbit/s to 12 Mbit/s
Operating temperature	
• Min.	0 °C
• max.	60 °C
Storage/transport temperature	
• Min.	-40 °C
• max.	70 °C
Relative humidity	
• Operation, max.	95 %; at 25 °C
Degree and class of protection	
IP20	Yes
Connection method	
Power supply	Terminal block
Dimensions and weight	
Dimensions	
• Width	45 mm
• Height	128 mm
• Depth	67 mm
Weight	
• Weight, approx.	350 g

Ordering data

RS 485 repeater for PROFIBUS
Transfer rate
up to max. 12 Mbit/s, 24 V DC,
enclosure IP20

Order No.

6ES7 972-0AA02-0XA0

Overview



- RS 485 repeater with online line diagnostics for PROFIBUS DP
- DP standard PROFIBUS slave (DP-V1)
- Automatic determination of fault types and locations
- Data transmission rate 9.6 kbit/s to 12 Mbit/s
- Connection through FastConnect using the insulation displacement method

Ordering data

RS 485 Diagnostic Repeater
For connection of 1 or 2 segments to PROFIBUS DP; with online diagnostics functions for monitoring the bus cables

Order No.

6ES7 972-0AB01-0XA0

Accessories

RS 485 bus connector with 90° cable outlet

With screw terminals
Max. transfer rate 12 Mbit/s

- Without PG interface
- With PG interface

6ES7 972-0BA12-0XA0
6ES7 972-0BB12-0XA0

PROFIBUS FastConnect bus connector RS 485 with 90° cable outlet

With insulation displacement terminals
Max. data transfer rate 12 Mbit/s

Without PG interface

- 1 unit
- 100 units

6ES7 972-0BA52-0XA0
6ES7 972-0BA52-0XB0

With PG interface

- 1 unit
- 100 units

6ES7 972-0BB52-0XA0
6ES7 972-0BB52-0XB0

RS 485 bus connector with angled cable outlet (35°)

With screw terminals,
max. transfer rate 12 Mbit/s

- Without PG interface
- With PG interface

6ES7 972-0BA42-0XA0
6ES7 972-0BB42-0XA0

PROFIBUS FastConnect RS 485 bus connector with angular cable outlet (35°)

With insulation displacement terminals,
max. transfer rate 12 Mbit/s

- Without PG interface
- With PG interface

6ES7 972-0BA60-0XA0
6ES7 972-0BB60-0XA0

PROFIBUS FastConnect Stripping Tool

Preadjusted stripping tool for fast stripping of PROFIBUS FastConnect bus cables

Order No.

6GK1 905-6AA00

PROFIBUS FC Standard Cable

Standard type with special design for quick mounting, 2-core, shielded, sold by the meter, max. delivery unit 1000 m, minimum order quantity 20 m

6XV1 830-0EH10

S7 Manual Collection

Electronic manuals on DVD, multi-language: S7-200, TD 200, S7-300, M7-300, C7, S7-400, M7-400, STEP 7, Engineering Tools, Runtime Software, SIMATIC DP (Distributed I/O), SIMATIC HMI (Human Machine Interface), SIMATIC NET (Industrial Communication)

6ES7 998-8XC01-8YE0

S7 Manual Collection update service for 1 year

Scope of delivery: Current DVD "S7 Manual Collection" and the three subsequent updates

6ES7 998-8XC01-8YE2

BT 200 Hardware Tester

with point-to-point cable for station testing, with test connector for wiring test, without charging unit, with operating instructions in German/English/French

6ES7 181-0AA01-0AA0

Connecting cable for PROFIBUS

12 Mbit/s, for PG connection to PROFIBUS DP, preassembled with 2 x 9-pin sub D connector, 3.0 m

6ES7 901-4BD00-0XA0

PROFIBUS

Electrical networks (RS485)

Power Rail Booster

Overview



- The device for low-cost PROFIBUS DP transfer over contact conductors and slip rings to degree of protection IP20
- Permissible baud rates from 9600 bit/s to 500 kbit/s, self-optimizing
- Permissible busbar length:
From 25 m at 500 kbit/s to 1200 m at 9600 bit/s
- Configuring with PRB Checker software
- Up to 125 nodes per segment
- Transparent for data communication:
The power rail booster does not reserve DP addresses
- Easy to install due to connection without terminating resistor and filter element
- Diagnostics LED for power supply, bus activity and group errors
- Isolated electronic changeover contact for external group error display or diagnostic alarm
- Uninterruptible communication beyond segment limits using the "PRB segment controller"

Application

The power rail booster supports connection of a PROFIBUS DP through a contact wire, such as can be implemented on monorail conveyors or high-bay storage and retrieval systems, thus ensuring continued use of the wide range of PROFIBUS DP system services, such as diagnostics and PROFIsafe safety engineering through a bus.

Monorail conveyors

Vehicle control for monorail conveyors can be achieved cost-effectively with a concept based on SIMATIC standard components. High availability, short response times and easy expansion can be achieved by using distributed controllers, such as SIMATIC ET 200S with IM 151-7 CPU. These can also be programmed by the user with SIMATIC STEP 7 via the contact wires.

High-bay storage and retrieval systems

The maintenance-hungry data photoelectric barriers used in high-bay storage and retrieval systems can be replaced, thus increasing plant availability.

Applications with slip rings

The power rail booster enables cost-effective routing of PROFIBUS DP through rotating axes even in the case of large diameters.

Design

The power rail booster can be snapped on to a 15 mm or a 7.5 mm standard DIN rail.

Function

How it works

- For safe data transmission of the PROFIBUS DP signals via the contact conductors, the signal levels are raised to an interference-immune level and injected into the contact conductors.

Manual and configuring

The manual for the Power Rail Booster can be downloaded from the Internet in English, German and French. The "PRB Checker" software tool for easy configuration of contact conductor networks is available for downloading.

Technical specifications

Degree of protection	IP20
Dimensions (W x H x D, with connector) in mm	90 x 132 x 75
Supply voltage	24 V DC
Power consumption	max. 20 W
Data transmission rate, max.	500 kbit/s, self-adjusting
Cable length (depends on baud rate), max.	1200 m
Shock-hazard protected voltage	Yes, to EN 61131-2
Stations per PRB segment, max.	125
Operation without terminating resistance	Yes
Operation without filter	Yes
Wiring options: Line / star	Yes / Yes

Ordering data

Order No.

Power Rail Booster
Signal amplifier for PROFIBUS DP transmission over contact cables, max. 500 kbit/s

6ES7 972-4AA02-0XA0

PRB segment controller
Automatic change-over switch between PRB segments

6ES7 972-4AA50-0XA0

PROFIBUS Electrical networks (RS485)

SINUMERIK Analog Drive Interface for 4 axes ADI 4

Overview



The SINUMERIK Analog Drive Interface for 4 axes ADI 4 can be used to operate up to 4 drives with analog setpoint interface.

- Connection via PROFIBUS DP
- Motion Control functionality (isochronous mode)

Technical specifications

Order No.	6FC5211-0BA01-0AA4
Product type designation	SINUMERIK Analog Drive Interface for 4 axes ADI 4
Input voltage	24 V DC
Power consumption, max.	30.2 W
Degree of protection according to EN 60529 (IEC 60529)	IP20
Humidity rating based on EN 60721-3-3	Class 3K5 condensation and icing excluded. Low air temperature 0 °C (32 °F)
Relative humidity	
• Storage	5 ... 95 % at 25 °C (77 °F)
• Transport	5 ... 95 % at 25 °C (77 °F)
• Operation	5 ... 95 % at 25 °C (77 °F)
Ambient temperature	
• Storage	-20 ... +55 °C (-4 ... +131 °F)
• Transport	-40 ... +70 °C (-40 ... +158 °F)
• Operation	0 ... 55 °C (32 ... 131 °F)
Dimensions	
• Width	48.5 mm (1.91 in)
• Height	325 mm (12.8 in)
• Depth	154.4 mm (6.1 in)
Weight, approx.	1.5 kg (3.31 lb)
Approvals, according to	CE, cULus

Ordering data

SINUMERIK Analog Drive Interface for 4 axes ADI 4
Interface module for running up to 4 drives with an analog setpoint interface

Order No.

6FC5 211-0BA01-0AA4

PROFIBUS

Electrical networks (PROFIBUS PA)

Introduction

Overview



Direct interfacing of the devices in the field, especially in the hazardous area, together with the information content of the communication, are of significant importance in the process industry. PROFIBUS PA, which permits both digital data transmission and the power supply on a two-wire line with the intrinsically-safe MBP transmission technology (Manchester Coded; Bus Powered) is tailored to these requirements. It is optimally suitable for direct integration of solenoid valves, sensors, and pneumatic actuators positioned in operating environments up to Ex zone 1/21 or 0/20 into the process control system.

The typical response time of a transmitter of approx. 10 ms indicates that short cycle times can be achieved with the PROFIBUS PA even in the case of a segment configuration with up to 31 devices. Practically all typical applications of the process industry can be implemented, both in small and large plants. Bidirectional communication and high information content allow enhanced diagnostics for fast and exact fault detection and elimination. The standardized communications services guarantee interoperability and replaceability between multi-vendor field devices and remote parameterization of the field devices during operation.

Safety communication with the PROFIsafe profile

The PROFIsafe profile allows seamless integration of safety communication into the PROFIBUS PA. You need not configure a separate safety bus for your safety-related applications. The PROFIBUS PA with the PROFIsafe profile is incorporated in "Safety Integrated for Process Automation". This comprehensive range of products and services from Siemens for failsafe, fault-tolerant applications in the process industry offers you attractive and cost-effective alternatives to separate safety systems.

Redundant architectures

You can define the degree of redundancy separately for the controller, fieldbus and I/O levels of your plant depending on the automation task and the derived safety requirements, and match them to the field instrumentation (Flexible Modular Redundancy, FMR). You can find an overview of the redundant architectures of PROFIBUS PA under "Design".

Network transition PROFIBUS PA to PROFIBUS DP

The PA link is preferred as the gateway from PROFIBUS PA to PROFIBUS DP. When using the PA link, the transmission rate on the PROFIBUS DP is independent of the subordinate PROFIBUS PA segments. The configuration of the PA link depends on the fieldbus architecture. The types of coupler described in the section "PA routers" can be used for the configuration. With a small amount of data (small quantity framework) and low timing requirements, the DP/PA coupler can also be operated in stand-alone mode as a gateway.

Benefits

Advantages provided by distributed field automation with application of the PROFIBUS PA profile included low hardware overhead, cost-effective engineering, increased operational safety and problem-free maintenance. These advantages are underlined by the following features:

- Modularity and uniformity from the sensor up to the control level permit new plant concepts
- Implementation of intrinsically-safe applications through use of the fieldbus in hazardous areas
- Redundant PROFIBUS PA architectures (ring and line topologies with coupler redundancy) support Flexible Modular Redundancy (FMR) from the automation system (controller) down to a PA field device
- Safety-related and fault-tolerant applications with low device and cabling requirements
- Reduced configuration costs through simple, central engineering of the field devices (PROFIBUS PA and HART with SIMATIC PDM, also cross-vendor)
- Simple installation using two wire cable for common power supply and data transmission
- Reduced commissioning costs through simplified loop check
- Low servicing costs thanks to simple wiring and comprehensive diagnostics facilities

Design

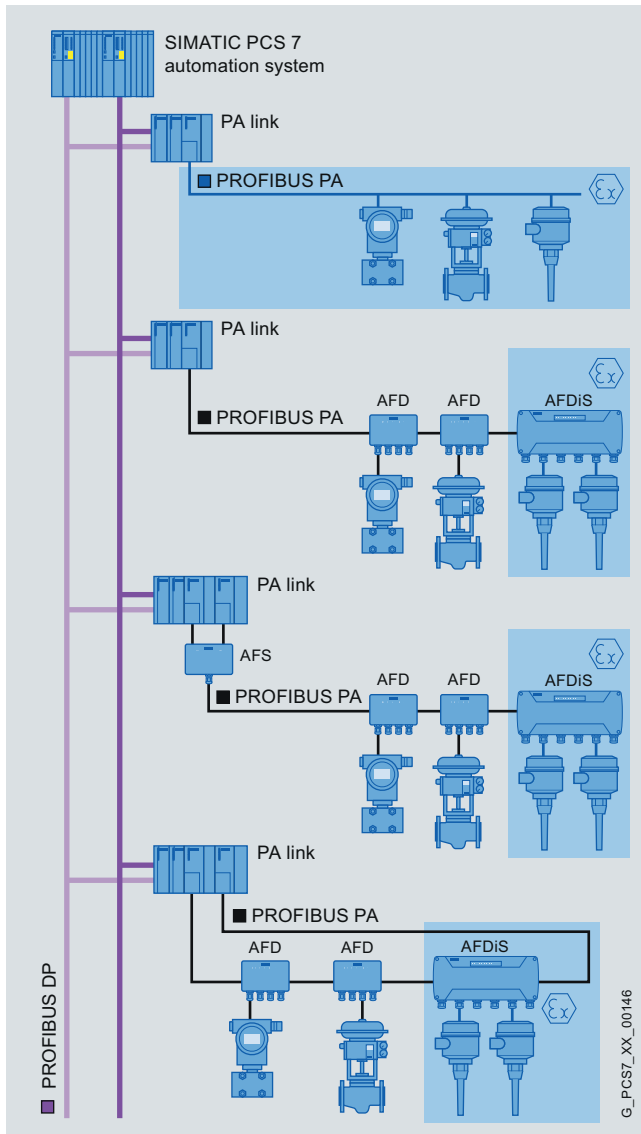

Basic PROFIBUS PA design versions when using the PA link as the PA network transition

Basic PROFIBUS PA design versions are shown at this point. The PA link is used as the PA router in these configuration examples.

However, the PA router can only be implemented per DP/PA coupler. The PROFIBUS DP connection is then directly on the coupler instead of per interface module.

The number of PROFIBUS PA devices is limited according to the specifications in section "Technical data".

Line architecture with single coupler

Max. 5 PROFIBUS PA lines (line segments) can be operated via single couplers (max. 3 for mixed configurations with ring or coupler redundancy) on a PA link as PA router, equipped with up to 5 DP/PA couplers.

In the line architecture with individual couplers, each line segment is connected to one DP/PA coupler of the PA router. The PA router can be connected to a single or redundant PROFIBUS DP.

The FDC 157-0 the first choice as the DP/PA coupler. When using this coupler, the PA devices can be integrated into the line segment via active field distributors AFD (approval for Ex zone 2/22) or AFDiS (approval for Ex zone 1/21). The PA devices are connected to these field distributors via short-circuit-proof spur lines.

Up to 8 field distributors of type AFD, up to 5 field distributors of type AFDiS, or up to 5 field distributors of both types in any mix can be operated as alternatives in a line segment. The last field distributor at the end of the line leading away from the DP/PA coupler automatically activates its bus terminating resistor.

Intrinsically-safe PA devices in hazardous areas in accordance with Ex zone 1/21 or 0/20 are primarily integrated into a bus segment by means of active field distributors AFDiS. For PA devices in Ex zone 1/21, the connection via a line segment on the PA router with DP/PA coupler Ex [i] is a possible alternative. The devices are integrated separately into the line segment via SplitConnect Taps (via spur line or directly via SplitConnect M12 outlet). A SplitConnect terminator is required for the bus termination of the segment.

By grouping individual devices in different line segments, Flexible Modular Redundancy is possible at device level.

Line architecture with redundant coupler

The PA link operable as a PA router on a single or redundant PROFIBUS DP can only be equipped with one redundant DP/PA coupler pair. This can be used either for a line architecture with Active Field Splitter (AFS) or for a ring architecture.

In the line architecture, the AFS is connected to the redundant DP/PA coupler pair (2 x FDC 157-0) in the PA router. It connects the line segment connected to it to the active of the two redundant DP/PA couplers. A DP/PA coupler can be replaced without interrupting the ongoing operation.

The PA devices are integrated into the line segment as in the line architecture with individual couplers via active field distributors AFD/AFDiS. The limits with regard to the number of field distributors are also identical (up to 8 AFD, up to 5 AFDiS or up to 5 AFD/AFDiS in any combination).

PROFIBUS

Electrical networks (PROFIBUS PA)

Introduction

Design (continued)

Ring architecture with coupler and media redundancy

With the redundant DP/PA coupler pair (2 x FDC 157-0) of a PA router, a ring segment with automatic bus termination can also be implemented instead of a line segment with AFS. Apart from the ring segment, only line segments with individual couplers can be configured on this PA router. The PA router can be connected to a single or a redundant PROFIBUS DP.

Integration of the PA field devices into the ring segment is carried out via active field distributors AFD or AFDiS whose number is limited as with the line architectures (up to 8 AFD, up to 5 AFDiS or up to 5 AFD/AFDiS in any combination). These field distributors have electrically decoupled, short-circuit-proof spur line connections for connecting the PA devices.

At the device level, flexible modular redundancy is possible by grouping individual devices on different field distributors.

Special advantages of the ring architecture:

- High availability
- Transparent redundancy management of the intelligent DP/PA couplers FDC 157-0 for the host system
- Active bus terminators for automatic bus termination in the DP/PA couplers FDC 157-0 and the AFDs permit:
 - Automatic, smooth isolation of faulty subsegments in the event of a short-circuit or open-circuit
 - Modification of the ring configuration or instrumentation during operation, including the addition or removal of ring segments
- Safety-related and fault-tolerant applications with low device and cabling requirements

Cable lengths of bus segments and spur lines

The PROFIBUS PA is based on electrical transmission components. A shielded two-wire cable is used for digital data transmission and for the power supply of the field devices.

With line, tree and ring topologies, bus segments up to approx. 1.9 km can be configured. If AFDs are used, the length of the spur lines for connecting devices and the quality of the cable used must also be considered when calculating the total length of the bus segment. Spur lines on the AFDiS are not relevant to the total length of the bus segment.

The length for spur lines is as follows with bus segments with active field distributors AFD/AFDiS:

- Up to 120 m in accordance with IEC 61158-2
- Up to 60 m in accordance with IEC 60079-27 (FISCO)

With active field distributors AFD, these maximum values may be reduced depending on the number of spur lines of the bus segment (for details, see Section "Technical data"). With active field distributors AFDiS, this reduction is canceled by the integrated repeater function.

Intrinsically-safe PA devices in hazardous areas are preferably integrated into a bus segment by means of active field distributors AFDiS. For PA devices in Ex zone 1/21, the connection via a line segment on the PA router with DP/PA coupler Ex [i] is a possible alternative. In such a configuration the max. possible length per spur line is reduced to 30 m and per bus segment to 1 km.

Bus segments are terminated either automatically (with architectures with active field distributors AFD/AFDiS) or with the passive terminating element for PROFIBUS PA (SplitConnect terminator).

Technical specifications

PROFIBUS PA	
Data transmission	MBP
Transmission rate	31.25 kbit/s
Cable	2-wire shielded
Type of protection	EEx(ia/ib)
Topology	Line, tree, ring
Active field distributors per segment/coupler	
• AFD	8
• AFDiS or AFD/AFDiS combined	5
PA devices per segment/coupler	31
PA devices per PA link	64
Max. current for all PA field devices of a segment (for PA gateways with FDC 157-0 coupler)	1 A
Cable length per segment, dependent on transmission rate	1 900 m: standard 1 900 m: EEx(ib) 1 000 m: EEx(ia)

Bus segments with AFD

Max. spur line length related to the total number of spur lines

Number of spur lines (1 device per spur line)

• 1 to 12 spur lines	120 m
• 13 to 14 spur lines	90 m
• 15 to 18 spur lines	60 m
• 19 to 24 spur lines	30 m
• 25 to 31 spur lines	1 m

Bus segments with AFDiS

Max. spur line length independent of total number of spur lines

Number of spur lines (1 device per spur line)

• 1 to 31 spur lines	
- Not intrinsically-safe	120 m
- Intrinsically-safe acc. to FISCO	60 m

Overview



- Used for constructing fieldbus segments as per IEC 61158-2 (e.g. PROFIBUS PA) with field device interface points
- Easy assembly of the bus cable thanks to the FastConnect system (FastConnect stripping tool, FC process cable compliant with IEC 61158-2)
- The terminal devices can be connected using the FC Process Cable in accordance with IEC 61158-2 or the SplitConnect M12 Outlet/M12 Jack
- Combination of terminating resistors can be integrated (SplitConnect terminator)

Benefits

g e t **Designed for Industry**

- Easy connection of terminals due to use of the FastConnect system
- Wide variety of applications thanks to modular SplitConnect system
- Reduction in number of types and parts thanks to uniform connection system for PROFIBUS PA

3

Application

- The SplitConnect Tap enables the design of fieldbus segments according to IEC 61158-2 (e.g. PROFIBUS PA) with terminal device connection points.
- The SplitConnect Coupler can be used to construct a PROFIBUS PA hub by connecting SplitConnect Taps in series.
- By replacing the contacting screw with the SplitConnect terminator, the SplitConnect tap can be used as a bus terminating element.

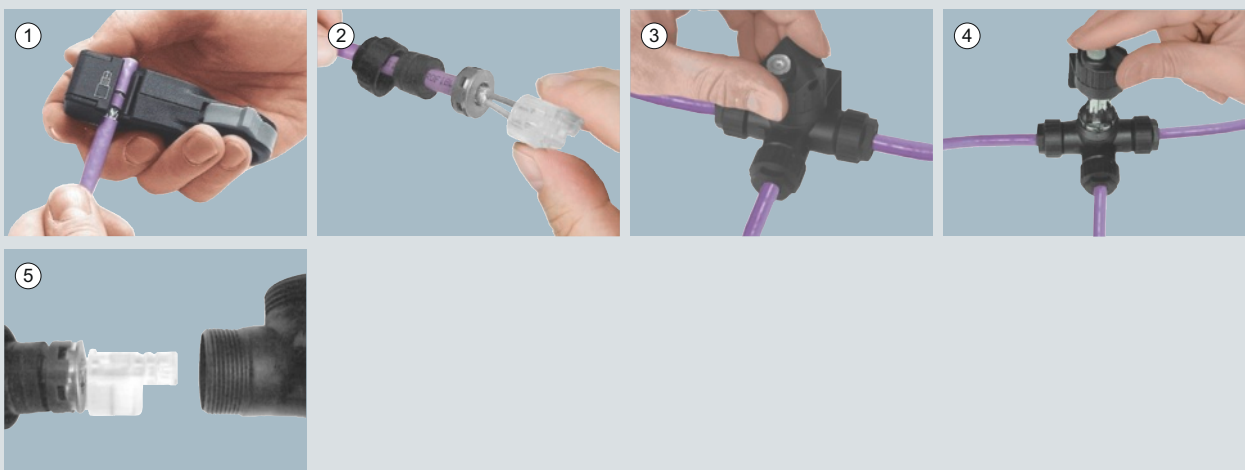

G_IK10_XX_50011

PROFIBUS

Electrical networks (PROFIBUS PA)

SpliTConnect

Design



Function

- The SpliTConnect tap enables configuration of fieldbus segments according to IEC 61158-2 (e.g. PROFIBUS PA) and connection of terminals
- Easy pre-assembly of the SpliTConnect taps through the FastConnect connection system (FastConnect stripping tool, FC Process Cable)
- Connection of the terminals directly through FC Process Cable or SpliTConnect M12 outlet

- Rugged plastic casing made of PBT (polybutylene terephthalate) in IP67 design
- UV-resistant, making it possible to use outdoors
- Complete shielding by means of integrated metal enclosure
- Easier cable connection through the use of FC process cable
- Contacting and connection of the FC process cable by means of ID contacts using contacting screw
- Additional grounding of the SpliTConnect tap possible by using a contacting screw
- DIN rail mounting or wall mounting possible

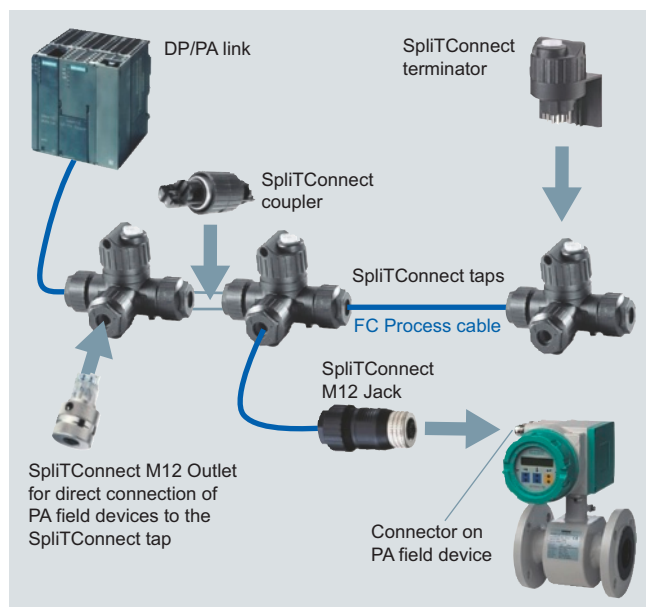

PROFIBUS

Electrical networks (PROFIBUS PA)

SplitConnect

Technical specifications		Ordering data	Order No.
Order No.	6GK1 905-0AA00	SplitConnect Tap	6GK1 905-0AA00
Product type designation	Split Connect Tap	For assembling PROFIBUS PA segments and connecting PA field devices, insulation displacement method, IP67	
Mechanical data		Type of delivery: 1 package = 10 items	
Design of cable entry		SplitConnect M12 outlet	6GK1 905-0AB10
Enclosure material	PBT (polybutylene terephthalate)	Element for direct connection of PROFIBUS PA field devices to the SplitConnect tap through M12 connection	
Design, dimensions and weights		Type of delivery: 1 package = 5 items	
Width	84 mm	SplitConnect coupler	6GK1 905-0AC00
Height	54 mm	Coupling element for connecting SplitConnect taps in series to configure star points	
Depth	49 mm	Type of delivery: 1 package = 10 items	
Net weight	170 g	SplitConnect terminator (Ex version)	6GK1 905-0AD00
Permitted ambient conditions		For terminating PROFIBUS PA segments, can be used in hazardous areas	
Ambient temperature		Type of delivery: 1 package = 5 items	
• During operation	-40 ... +85 °C	SplitConnect terminator (non-Ex version)	6GK1 905-0AE00
• During storage	-40 ... +85 °C	For terminating PROFIBUS PA segments, cannot be used in hazardous area	
• During transport	-40 ... +85 °C	Type of delivery: 1 package = 5 items	
IP degree of protection	IP67	SplitConnect M12 jack	6GK1 905-0AF00
		Connector element for direct connection of PROFIBUS PA field devices to the PROFIBUS PA segment through M12 connection	
		Type of delivery: 1 package = 5 items	

PROFIBUS

Electrical networks (PROFIBUS PA)

Bus cables

Overview

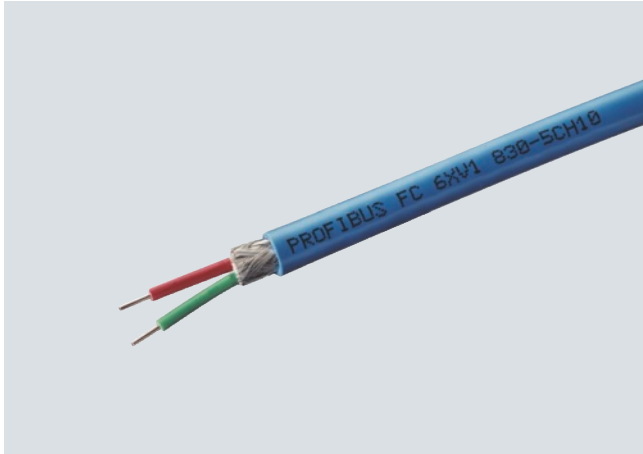

- Bus cable for fieldbus systems according to IEC 61158-2, e.g. PROFIBUS PA
- High interference immunity thanks to double shielding
- Different variants for different applications (hazardous areas, non-hazardous areas)
- Easy length measurement thanks to printed meter markings

Benefits

get Designed for Industry

- Length can easily be determined due to meter length markings printed on the cable
- Complete range of cables for hazardous and non-hazardous areas
- Reduction of types and parts thanks to a uniform connection system for PROFIBUS PA

Application

For the construction of fieldbus networks according to IEC 61158-2 (for example PROFIBUS PA), different color-coded cable types are available for the different types of applications (hazardous, non-hazardous areas).

UL approvals

Different cable variants are offered with appropriate UL approvals for laying in cable bundles and cable racks according to the specifications of NEC (National Electrical Code) Article 800/725.

Design

- Shielded, twisted-pair cable with circular cross-section
- System-wide grounding concept can be implemented using the external shield of the bus cable and the grounding terminals of the SplitConnect system.
- Printed meter marks.

Cable types

- FC Process Cable:
Special bus cable compliant with IEC 61158-2 for use in hazardous (Ex) and non-hazardous (non-Ex) areas.
- Bus segments with RS485 and IEC 61158-2 transmission procedures are linked by means of the segment coupler/link.

Technical specifications

Order No.	6XV1 830-5FH10	6XV1 830-5EH10
Product type designation	PROFIBUS FC Process Cable GP	PROFIBUS FC Process Cable GP
Product description	Bus cable (2-core), sold by the meter, in bulk	Bus cable (2-core), sold by the meter, in bulk
Suitability for application	Use for fieldbus systems in accordance with IEC 61158-2 (e.g. PROFIBUS PA), suitable for non-hazardous applications	Use for fieldbus systems in accordance with IEC 61158-2 (e.g. PROFIBUS PA), suitable for hazardous applications
Cable designation	02YSY (ST) CY 1x2x1.0/2.55-100 SW OE FR	02YSY (ST) CY 1x2x1.0/2.55-100 BL OE FR
Cable length	-	-
Electrical specifications		
Maximum attenuation factor per length at 38.4 kHz	3 dB/km	3 dB/km
Characteristic impedance		
• Rated value	100 Ω	100 Ω
• At 31.25 kHz	100 Ω	100 Ω
Relative symmetrical tolerance of characteristic impedance at 31.25 kHz	20 %	20 %
Max. loop resistance per length	44 Ω/km	44 Ω/km
Max. shield resistance per length	6.5 Ω/km	6.5 Ω/km
Capacitance per length at 1 kHz	92 pF/m	92 pF/m
Inductance per length	0.65 μH/m	0.65 μH/m
Operating voltage, rms value	100 V	100 V
Mechanical data		
Number of electrical cores	2	2
Design of shield	Overlapping aluminum-clad foil, sheathed in a braided screen of tin-plated copper wires	Overlapping aluminum-clad foil, sheathed in a braided screen of tin-plated copper wires
Design of electrical connection FastConnect	Yes	Yes
Outer diameter		
• of inner conductor	1.05 mm	1.05 mm
• of core insulation	2.55 mm	2.55 mm
• of inner sheath of cable	5.4 mm	5.4 mm
• of cable sheath	8 mm	8 mm
Symmetrical tolerance of outer diameter of cable sheath	0.4 mm	0.4 mm
Outer diameter of cable sheath - Note	-	-
Material		
• of core insulation	PE	PE
• of inner sheath of cable	PVC	PVC
• of cable sheath	PVC	PVC
- Note	-	-
Color		
• of core insulation of data cores	Red / green	Red / green
• of cable sheath	Black	Blue
Bending radius		
• With single bending	40 mm	40 mm
• With repeated bending	80 mm	80 mm
Maximum tensile load	150 N	150 N
Weight per length	103 kg/km	103 kg/km

PROFIBUS

Electrical networks (PROFIBUS PA)

Bus cables

Technical specifications (continued)

Order No.	6XV1 830-5FH10	6XV1 830-5EH10
Product type designation	PROFIBUS FC Process Cable GP	PROFIBUS FC Process Cable GP
Permitted ambient conditions		
Ambient temperature		
• During operation	-40 ... +80 °C	-40 ... +80 °C
• During storage	-40 ... +80 °C	-40 ... +80 °C
• During transport	-40 ... +80 °C	-40 ... +80 °C
• During mounting	-20 ... +80 °C	-20 ... +80 °C
Ambient conditions for operation	Transmission rate of the cable: 31.25 kbit/s	Transmission rate of the cable: 31.25 kbit/s
IP degree of protection	-	-
Behavior in fire	Flame-retardant in accordance with IEC 60332-3-24 (Category C)	Flame-retardant in accordance with IEC 60332-3-24 (Category C)
Chemical resistance		
• Mineral oil	Limited resistance	Limited resistance
• Grease	Limited resistance	Limited resistance
• Water	-	-
Radiological resistance to UV radiation	Resistant	Resistant
Product properties, functions, components		
General		
Product property		
• Halogen-free	No	No
• Silicon-free	Yes	Yes
Standards, specifications, approvals		
UL-Listing at 300 V rating	Yes: CMG / CL3 / Sun Res	Yes: CMG / CL3 / Sun Res
UL-Style at 600 V rating	Yes	Yes
Certificate of suitability		
• RoHS compliance	Yes	Yes

Ordering data

PROFIBUS FC Process Cable

- 2-core, shielded
- Blue for Ex applications
 - Black for non-Ex applications

Sold by the meter:
Max. quantity 1,000 m;
minimum order 20 m

PROFIBUS FastConnect Stripping Tool

Stripping tool for fast stripping of the PROFIBUS FastConnect bus cable

PROFIBUS FastConnect Blade Cassettes

Spare blade cassettes for PROFIBUS FastConnect stripping tool, 5 units

SIMATIC NET Manual Collection

Electronic manuals for communication systems, communication protocols, and communication products; on DVD; German/English

Order No.

6XV1 830-5EH10
6XV1 830-5FH10

6GK1 905-6AA00

6GK1 905-6AB00

6GK1 975-1AA00-3AA0

More information

Installation instruction

FastConnect

The FastConnect stripping tool can be used to strip the outer sheath and shield of the FC Process Cable to the required lengths for PROFIBUS PA.

Thus the use of the FastConnect stripping tool and SplitConnect tap permits the easy connection of field devices to, for example, the PROFIBUS PA bus system.

Cable routing

During storage, transport and cable laying, keep both ends sealed with a shrink-on cap.

Comply with the permissible bending radii and tensile load!

Note:

You can order components supplementary to the SIMATIC NET cabling system from your local contact.

Technical advice on this subject is available from:

J. Hertlein
I IA SC IC PRM 4
Phone: +49 (0)911/750 44 65
E-mail: juergen.hertlein@siemens.com

Overview



Active field distributor AFD

The active field distributor (AFD) can be operated in environments in accordance with Ex zone 2/22. It can integrate up to 4 PA (PROFIBUS PA) or FF (FOUNDATION Fieldbus H1) field devices via short-circuit-proof spur line connections into a fieldbus segment (line/ring) with automatic bus termination. This fieldbus segment can be connected to a single or redundant PROFIBUS DP via a PA or FF router and it can thus be seamlessly integrated into the SIMATIC PCS 7 process control system.

Up to 8 active field distributors AFD with a total of up to 31 connected field devices can be operated per fieldbus segment. The number of field devices is also limited by the current consumption of the field devices. A current of 1 A is available for all field devices of a segment.

An AFD in a ring segment can be replaced during operation without failure of the segment.

For compliance with IP65 protection, it is necessary to protect unused spur line connections by plugs.

Active field distributor AFDiS

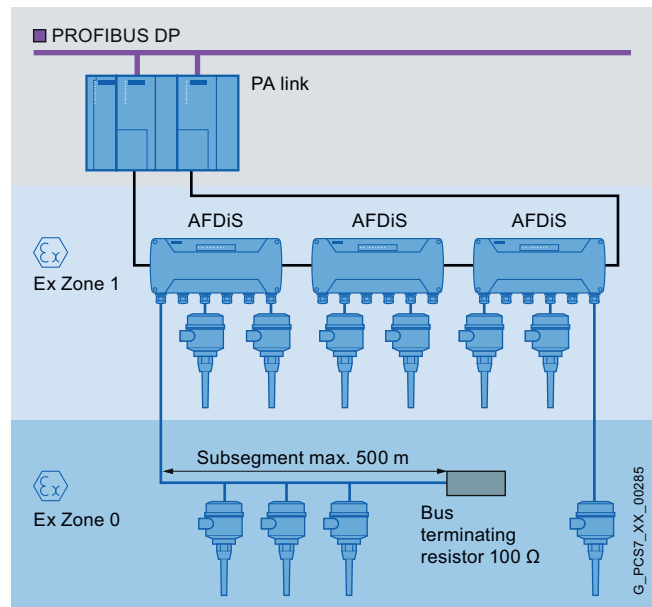

The active field distributor AFDiS (Active Field Distributor intrinsic Safety) can be operated in environments in accordance with Ex zone 1/21 and 2/22. It can integrate up to 6 intrinsically-safe PA (PROFIBUS PA) or FF (FOUNDATION Fieldbus H1) field devices into a fieldbus segment (line/ring) via its intrinsically-safe, short-circuit-proof spur line connections. Instead of the spur line, it is also possible to use a subsegment for 3 to 4 devices with a max. length of 500 m at connection S1 of the AFDiS. The spur lines with type of protection Ex [ia] as well as the subsegment can be routed into Zone 0/20.

Up to 5 field distributors AFDiS with a total of up to 31 field devices can be operated in a fieldbus segment. The limitation to 5 field distributors is also mandatory for mixed operation of AFD and AFDiS.

The number of field devices per segment additionally depends on the current consumption of the devices. A current of 1 A is available for all field devices of the segment.

With the integrated repeater function, the AFDiS has the following advantages compared to the AFD:

- Spur line lengths are independent of the total number of spur lines in the bus segment
- Spur line lengths need not be taken into account when determining the total length of the bus segment

Under the following conditions, an AFDiS in a ring segment can be replaced during operation without failure of the segment: Installation in zone 2/22; no mixed operation with AFD.

For compliance with IP66 protection, it is necessary to protect unused spur line connections by plugs.

Active field splitter AFS

The active field splitter (AFS) connects a PA or FF line segment with a redundant coupler pair of a PA or FF router. The AFS interconnects the line segment with the respective active coupler.

To guarantee IP65 protection, it is necessary to protect an unused connection by a plug.

PROFIBUS

Electrical networks (PROFIBUS PA)

Active field distributors

Technical specifications

Active field distributor (AFD)

General data

Connection of field devices	<ul style="list-style-type: none"> Standard-compliant field devices for PROFIBUS PA or FOUNDATION Fieldbus H1 Max. 4 per AFD Max. 31 per fieldbus segment Operating environment up to zone 2 or 22 The max. current consumption of all field devices of the fieldbus segment is 1 A
-----------------------------	----------------------------------------------------------------------------------------------------------------------------------------------------------------------------------------------------------------------------------------------------------------------------------------------------------------------------------------

Degree of protection	IP65
----------------------	------

Voltages, currents, potentials

Rated supply voltage	16 V DC (16 ... 32 V)
Voltage U_{\max}	35 V
Reverse polarity protection	Yes
Internal power consumption	Max. 25 mA or 59 mA with AFD at end of cable (open main line connection)
Current I_{\max} per spur line X1 to X4	60 mA

Status, interrupts, diagnostics

Diagnostic displays:	
• Status main line PA1, PA2	Green LED
• Fault main line PA1, PA2	Red LED
• Status/fault spur line X1 to X4	Green LED

Climatic conditions

Permissible operating temperature	-25 ... +70 °C
-----------------------------------	----------------

Dimensions and weight

Dimensions (W x H x D) in mm	175 x 57 x 105; with screw gland 175 x 57 x 105
Weight	Approx. 700 g

Active field distributor AFDiS

General data

Connection of field devices	<ul style="list-style-type: none"> Standard-compliant field devices for PROFIBUS PA or FOUNDATION Fieldbus H1 Max. 6 per AFD Max. 31 per fieldbus segment Operating environment up to zone 1 or 21 The max. current consumption of all field devices of the fieldbus segment is 1 A
-----------------------------	----------------------------------------------------------------------------------------------------------------------------------------------------------------------------------------------------------------------------------------------------------------------------------------------------------------------------------------

Degree of protection	IP66
----------------------	------

Voltages, currents, potentials

Power supply	Via bus, no auxiliary power necessary
Rated supply voltage, permissible range	16 ... 32 V DC
Polarity reversal protection (only in connection with DP/PA coupler)	Yes; up to 1 A
Overvoltage protection	No
Current consumption	
• At 28 V input voltage	$\leq 64 \text{ mA} + (0.838 \cdot \text{aggregate current of all the field devices})$
• At 24 V input voltage	$\leq 67 \text{ mA} + (1.008 \cdot \text{aggregate current of all the field devices})$
• At 20 V input voltage	$\leq 74 \text{ mA} + (1.246 \cdot \text{aggregate current of all the field devices})$
Power loss	Min. 1.4 W; max. 5.9 W
Grounding	Direct, via connecting bar
Electrical isolation between main line and spur lines	Yes
Test voltage	2 550 V DC, 2 s

Connections, interfaces

<u>Main line</u>	
Number of connections	2
Interfaces	PROFIBUS PA and FOUNDATION Fieldbus H1
Automatic bus terminator	Yes
<u>Spur cables</u>	
Number of connections	6
Short-circuit-proof	Yes
Intrinsically-safe acc. to FISCO	Yes
Current I_{\max} on spur line S1	60 mA
Current I_{\max} on spur lines S2 to S6	40 mA
Current I_{\max} in total for all field devices	180 mA
Short-circuit current (test current)	5 mA
Debounce logic	Yes
No-load voltage	Max. 15.3 V
Current output to field devices	Max. 260 mA

PROFIBUS

Electrical networks (PROFIBUS PA)

Active field distributors

Technical specifications (continued)

Active field distributor AFDiS (continued)

Status, interrupts, diagnostics

Status display	Yes
Diagnostics function	Yes
Diagnostic indicator LED	Yes

Climatic conditions

Permissible operating temperature	-40 ... +70 °C
Permissible storage/transport temperature	-40 ... +85 °C
Relative humidity during operation	Max. 95 %

Approvals for potentially explosive atmospheres

• Gas	Zone 1 and Zone 2
• Dust	Zone 21 and Zone 22

Dimensions and weight

Dimensions (W x H x D) in mm	380 x 85 x 170
Weight	approx. 4 500 g

Active field splitter AFS

General data

Connection of field devices	<ul style="list-style-type: none"> • Max. 31 per fieldbus segment • Operating environment up to zone 2 or 22 • The max. current consumption of all field devices of the fieldbus segment is 1 A
Degree of protection	IP65

Voltages, currents, potentials

Rated supply voltage	16 V DC (16 ... 32 V)
Reverse polarity protection	Yes
Overvoltage protection	Yes
Voltage failure bridging	5 ms
Current consumption	≤ 25 mA
Power loss	Max. 1 W
Output current for supplying all field devices of the fieldbus segment (for dimensioning the device configuration)	1 A

Status, interrupts, diagnostics

Diagnostic displays:	
• Status main line PA1, PA2	Green LED
• Fault main line PA1, PA2	Red LED

Climatic conditions

Permissible operating temperature	-25 ... +70 °C
-----------------------------------	----------------

Dimensions and weight

Dimensions (W x H x D) in mm	125 x 57 x 80; with screw gland 175 x 57 x 105
Weight	approx. 700 g

Ordering data

Order No.

Active field distributor AFD
with 4 short-circuit-proof spur line connections for the integration of standard-compliant PA or FF field devices

6ES7 157-0AF81-0XA0

Active Field Distributor AFDiS (Active Field Distributor intrinsic Safety)
with 6 short-circuit-proof spur line connections for the integration of standard-compliant intrinsically-safe PA or FF field devices

6ES7 157-0AG83-0XA0

Active field splitter (AFS)
for the interconnection of a bus line segment with the active coupler of a PA or FF router with redundant coupler pair

6ES7 157-0AF82-0XA0

Accessories

Profile rail adapter
for mounting an active field distributor AFD or AFS on a mounting rail, optional

6ES7 157-0AF83-0XA0

Cable gland for active field splitter AFS

Can be ordered from:
Jacob GmbH
www.jacob-gmbh.de
Order No. 50.616 M/EMV

Fastener for HSK-Ex standard cable glands
For use as plugs for unused connections on AFD and AFS

Can be ordered from:
Hummel elektrotechnik GmbH
www.hummel-group.com
Order No. 1.296.0901.11

Sealing plugs
for unused connections on AFDiS (10 units)

6ES7 157-0AG80-1XA1

PA-Network transitions

see page 3/262 and the following

PROFIBUS

Electrical networks (FOUNDATION Fieldbus)

Bus cables

Overview

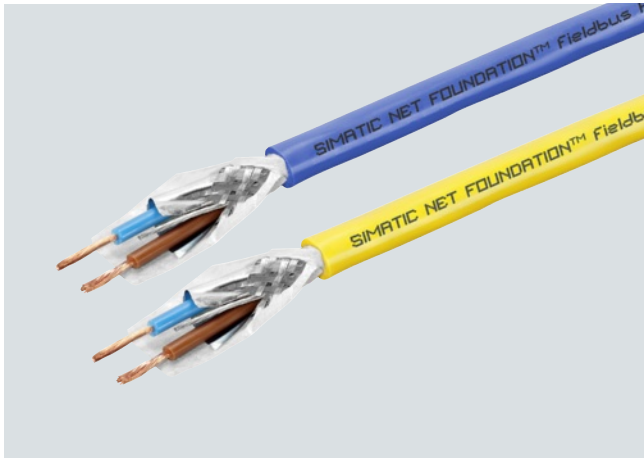

- Bus cable for fieldbus systems according to IEC 61158-2, e.g. FOUNDATION Fieldbus
- High noise immunity due to double shielding
- Different variants for different applications (hazardous, non-hazardous)

Benefits

get Designed for Industry

- Easy length measurement with printed meter markers
- Reduction in number of types and parts thanks to uniform connection system for FOUNDATION Fieldbus
- Cable design with shield wire for easy shield contact at the end device

Application

For setting up fieldbus networks according to IEC 61158-2 (e.g. FOUNDATION Fieldbus), different color-coded cable types are available to suit different types of applications (hazardous, non-hazardous areas).

UL approvals

Cable variants are available with appropriate UL approvals for laying in cable bundles and cable racks according to the specifications of NEC (National Electrical Code) Article 800/725.

Design

- Shielded, twisted-pair cable with circular cross-section
- Integrated grounding concept can be achieved with the outer shield of the bus cable
- Printed meter marks.

Cable types

- FOUNDATION Fieldbus cable:
Special bus cable compliant with IEC 61158-2 for use in hazardous and non-hazardous areas.
- Bus segments with RS485 and IEC 61158-2 transmission procedures are linked by the segment SIMATIC FF Link.

PROFIBUS

Electrical networks (FOUNDATION Fieldbus)

Bus cables

Technical specifications

Order No.	6XV1 830-5HH10	6XV1 830-5GH10
Product type designation	FOUNDATION Fieldbus cable	FOUNDATION Fieldbus cable
Product description	Bus cable (2-core), sold by the meter, in bulk	Bus cable (2-core), sold by the meter, in bulk
Suitability for application	Use for fieldbus systems in accordance with IEC 61158-2 (e.g. Foundation Fieldbus), suitable for non-hazardous applications	Use for fieldbus systems in accordance with IEC 61158-2 (e.g. Foundation Fieldbus), suitable for hazardous applications
Cable designation	2X(ST)CY 1X2X1.1/2.85-100 LI GE FR OE	2X(ST)CY 1X2X1.1/2.85-100 LI BL FR OE
Cable length	-	-
Electrical specifications		
Attenuation factor per length		
• At 9.6 kHz maximum	-	-
• At 38.4 kHz maximum	0.003 dB/m	0.003 dB/m
• At 4 MHz maximum	-	-
• At 16 MHz maximum	-	-
Characteristic impedance		
• Rated value	100 Ω	100 Ω
• At 9.6 kHz	-	-
• At 38.4 kHz	100 Ω	100 Ω
• at 3 MHz ... 20 MHz	-	-
Relative symmetrical tolerance		
• of characteristic impedance at 9.6 kHz	-	-
• of characteristic impedance at 38.4 kHz	20 %	20 %
• of characteristic impedance at 3 MHz to 20 MHz	-	-
Max. loop resistance per length	46 Ω/km	46 Ω/km
Max. shield resistance per length	10 Ω/km	10 Ω/km
Capacitance per length at 1 kHz	65 pF/m	65 pF/m
Operating voltage, rms value	300 V	300 V

Order No.	6XV1 830-5HH10	6XV1 830-5GH10
Product type designation	FOUNDATION Fieldbus cable	FOUNDATION Fieldbus cable
Mechanical data		
Number of electrical cores	2	2
Design of shield	Overlapping aluminum-clad foil, sheathed in a braided screen of tin-plated copper wires with shield wire	Overlapping aluminum-clad foil, sheathed in a braided screen of tin-plated copper wires with shield wire
Design of electrical connection FastConnect	No	No
Outer diameter		
• of inner conductor	1.17 mm	1.17 mm
• of core insulation	2.85 mm	2.85 mm
• of inner sheath of cable	6.4 mm	6.4 mm
• of cable sheath	8.5 mm	8.5 mm
Symmetrical tolerance of outer diameter of cable sheath	0.3 mm	0.3 mm
Outer diameter of cable sheath - Note	-	-
Material		
• of core insulation	PE	PE
• of inner sheath of cable	-	-
• of the cable sheath	PVC	PVC
- Note	-	-
Color		
• of core insulation of data cores	blue / brown	blue / brown
• of the cable sheath	Yellow	Blue
Bending radius		
• with single bending	34 mm	34 mm
• with repeated bending	68 mm	68 mm
• with continuous bending	-	-
Number of bending cycles	-	-
• Note	-	-
Number of torsion cycles with torsion by ± 180° on 1 m cable length	-	-
Maximum tensile load	100 N	100 N
Weight per length	98 kg/km	98 kg/km

PROFIBUS

Electrical networks (FOUNDATION Fieldbus)

Bus cables

Technical specifications (continued)

Order No.	6XV1 830-5HH10	6XV1 830-5GH10
Product type designation	FOUNDATION Fieldbus cable	FOUNDATION Fieldbus cable
Permitted ambient conditions		
Ambient temperature		
• During operation	-40 ... +105 °C	-40 ... +105 °C
• During storage	-40 ... +105 °C	-40 ... +105 °C
• During transport	-40 ... +105 °C	-40 ... +105 °C
• During mounting	-40 ... +105 °C	-40 ... +105 °C
Ambient conditions for operation	Transmission rate of the cable: 31.25 kbit/s	Transmission rate of the cable: 31.25 kbit/s
IP degree of protection	-	-
Behavior in fire	Flame-retardant in accordance with IEC 60332-1-2	Flame-retardant in accordance with IEC 60332-1-2
Chemical resistance		
• against mineral oil	Limited resistance	Limited resistance
• against grease	Limited resistance	Limited resistance
• against water	-	-
Radiological resistance against UV radiation	Resistant	Resistant
Product properties, functions, components		
General		
Product property		
• Halogen-free	No	No
• Silicon-free	Yes	Yes
Standards, specifications, approvals		
UL listing at 300 V rating	Yes: CMG / PLTC# / Sun Res	Yes: CMG / PLTC / Sun Res
UL style at 600 V rating	No	No
Certificate of suitability	-	-
• RoHS compliance	Yes	Yes
Marine classification society		
• Germanischer Lloyd (GL)	No	No
• Llyods Register of Shipping (LRS)	No	No

Ordering data

Order No.

FOUNDATION Fieldbus Cable

- 2-core, shielded
- Blue for Ex applications
- Orange for non-hazardous applications

Sold by the meter:
Max. quantity 1000 m,
minimum order 20 m

6XV1 830-5GH10
6XV1 830-5HH10

More information

Cable routing

During storage, transport and cable laying, keep both ends sealed with a shrink-on cap.

Comply with the permissible bending radii and tensile load!

Note:

You can order components supplementary to the SIMATIC NET cabling system from your local contact.

Technical advice on this subject is available from:

J. Hertlein
I IA SC IC PRM 4
Tel.: +49 (0)911/750 44 65
E-mail: juergen.hertlein@siemens.com

Overview

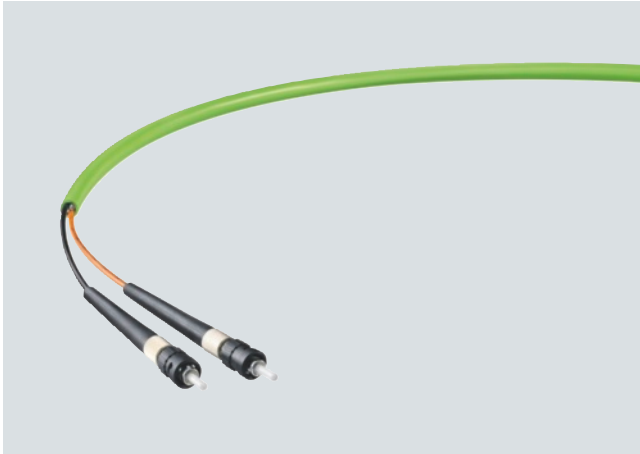

- Simple on-site assembly of glass FOC in the field
- Optical signal transmission
- No radiation emission from the cable
- Unaffected by external noise fields
- No grounding problems
- Electrical isolation
- Low weight
- Simple laying of cables

Design

Fiber-optic cables with glass core (62.5/200/230) are offered for the FastConnect fiber-optic cable system:

- FC glass fiber-optic cable; duplex cable for indoor and outdoor fiber-optic networks

The fiber structure corresponds to that of the PCF. This allows simple assembly on site.

Sheath material	Application
PVC	Standard use in indoor and outdoor areas of industrial applications
PUR	Highly mobile applications (tow chains) for high mechanical or chemical stress in harsh industrial environments
PE	Routing of cables in moist areas indoors and outdoors, and for direct burying in earth
FRNC	Standard applications with high fire protection requirements

Approvals

UL listing (safety standard) for network lines is especially necessary for the American and Canadian markets. The requirements for the appropriate approvals depend on where the cable is routed within the building. This applies to all cables which have to be routed from a machine to a remote control cabinet and are positioned on cable racks secured in the building. These cables are identified by the suffix "GP" (general purpose) in the product name and have the corresponding UL approvals.

PROFIBUS

Optical networks with OLM

Overview of FC-FOCs

Application

The fiber-optic cable (FOC) is used for the transmission of signals in very extensive plants and where there are significant potential differences within a plant. The light beam is guided by total reflection at the transition from core to cladding which has a lower refractive index than the core.

The FastConnect fiber-optic (FC FO) system enables fast on-site assembly of glass fiber-optic cables with the right lengths to suit the respective application.

Assembly with FastConnect for glass fiber-optic cables

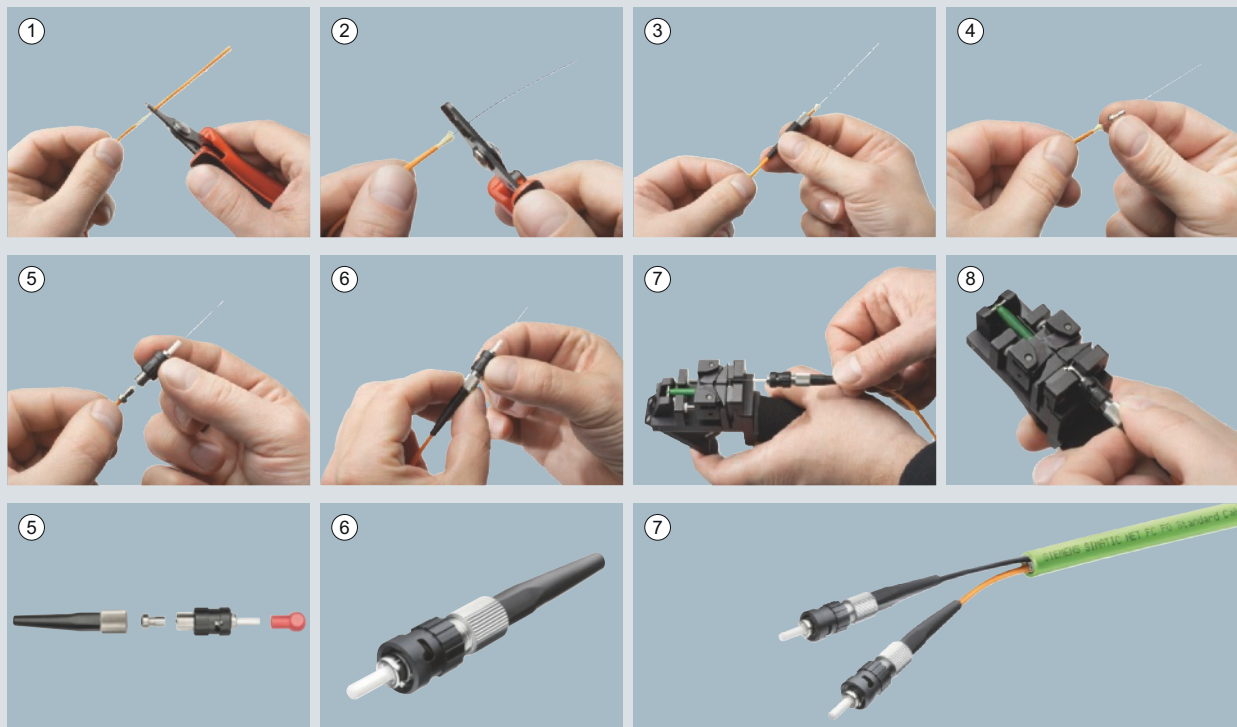

G_JK10_XX_10321

Steps for assembly of PROFIBUS fiber-optic cables with PROFIBUS FastConnect

Overview

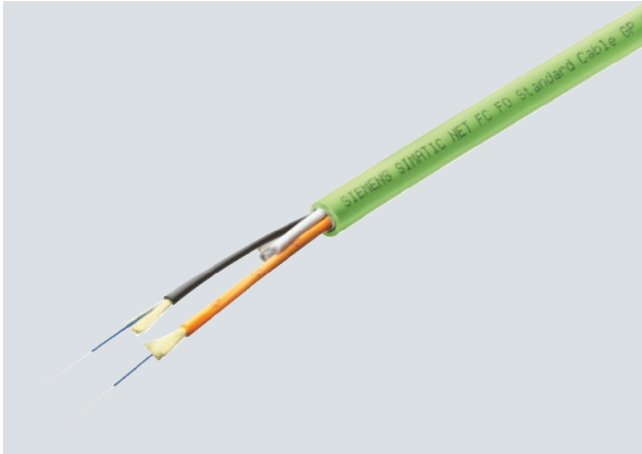

- FastConnect standard fiber-optic cable for use in optical Industrial Ethernet and PROFIBUS networks
- For all users who want to install and assemble the glass fiber-optic cables themselves over longer distances on site for office or industrial applications.
- Simple FastConnect SC/BFOC connector assembly on site
- Rugged construction for industrial applications both indoors and outdoors
- High interference immunity, as they are not sensitive to electromagnetic interference
- Extensive range of approvals (UL approvals)

Benefits

get Designed for Industry

- Avoidance of excessive cable lengths in the control cabinet, as the fiber-optic cables can be assembled to the right length on site
- Easy installation of cables in buildings, as cables can be pulled in without connectors attached
- Simple extension of installed glass fiber-optic cables via SC and BFOC couplers
- Devices with different connection method (SC or BFOC) can easily be connected to one another using self-assembled adapter cables
- Electrical isolation of Industrial Ethernet/PROFINET/PROFIBUS devices
- Unaffected by electromagnetic interference
- Tap-proof: no radiation from cable

Application

SIMATIC NET FastConnect glass fiber-optic cables are used to construct optical indoor and outdoor Industrial Ethernet/PROFINET and PROFIBUS networks. Devices with integral optical interface (SC or BFOC connection technology) are, for example, optical link modules (OLM) and SCALANCE X Industrial Ethernet switches.

FastConnect glass fiber-optic cables are to be assembled on site using FastConnect SC or FastConnect BFOC connectors. A corresponding assembly kit (FC FO Termination Kit) is available for this purpose. The Termination Kit permits the stripping and the "cleaving" of the fiber in the assembled connector, as is familiar from PCF fiber-optic cables. To extend existing lines, a BFOC or SC coupler may be used depending on the connection technology.

Design

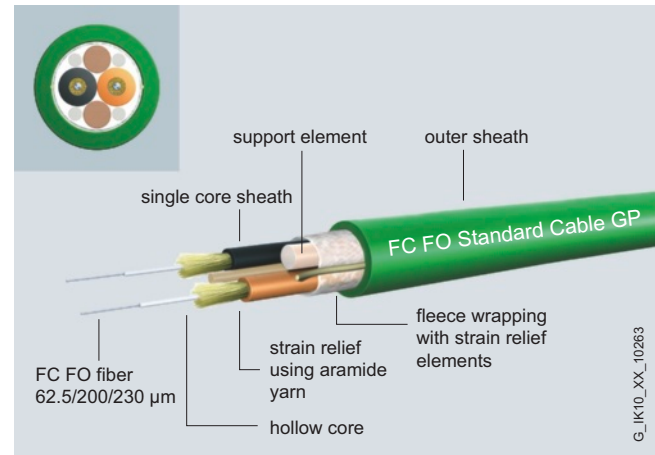

FC FO Standard Cable GP (General Purpose)

rugged round cable with green outer sheath, Kevlar strain relief elements, and 62.5/200/230 FC FO fibers for indoor/outdoor applications

FC FO Trailing Cable

rugged round cable with green outer sheath, Kevlar strain relief elements and 62.5/200/230 FC FO fibers for use in tow chains and moving applications

Maximum cable length between two devices:

- 3000 m for 100 Mbit/s Ethernet or for PROFIBUS
- 350 m for 1000 Mbit/s Ethernet (1000Base-SX)
- 550 m for 1000 Mbit/s Ethernet (1000Base-LX)

The maximum cable lengths can be assembled from partial lengths using FastConnect couplings (SC or BFOC; maximum two couplings, approx. 2.5 dB attenuation per coupling). It is also possible to combine existing installed, conventional 62.5/125 μm multimode glass fiber-optic cable sections with the FastConnect fiber-optic cables.

PROFIBUS

Optical networks with OLM

FC glass fiber-optic cable

Technical specifications

Order No.	6XV1 847-2A	6XV1 847-2C
Product type designation	FC FO Standard Cable GP	FC FO Trailing Cable
Product description	Glass fiber-optic cable for field assembly, cut-to-length, non-assembled	Flexible glass fiber-optic cable for field assembly, cut-to-length, non-assembled
Suitability for application	Cable for fixed routing in cable ducts and conduits, UL approval	Cable for high mechanical loading for use in trailing cables indoors and outdoors
Design of preassembled FO cable	Can be fitted with four BFOC or SC connectors	Can be fitted with four BFOC or SC connectors
Cable designation	AT-V(ZN)YY 2GK 62.5/200/230	AT-V(ZN)Y(ZN)11Y 2GK 62.5/200/230
Cable length	-	-
Optical data		
Attenuation factor per length		
• Max. at 850 nm	3.2 dB/km	3.2 dB/km
• Max. at 1300 nm	0.9 dB/km	0.9 dB/km
• Max. at 1550 nm	-	-
Bandwidth length product		
• At 850 nm	200 GHz·m	200 GHz·m
• At 1300 nm	500 GHz·m	500 GHz·m
Mechanical data		
Number of fibers per FO core	1	1
Number of FO cores per FO cable	2	2
Design of FO fiber	Multi-mode gradient fiber 62.5/200/230 µm	Multi-mode gradient fiber 62.5/200/230 µm
Design of FO core	Fixed core	Fixed core
Design of FO cable	Splittable cable	Splittable cable
Outer diameter		
• of optical fiber	62.5 µm	62.5 µm
• of optical fiber sheath	230 µm	230 µm
• of FO core sheath	2.2 mm	2.2 mm
• of cable	7.2 mm	8.8 mm
Symmetrical deviation		
• of outer diameter of FO core sheath	0.1 mm	0.1 mm
• of outer diameter of cable	0.5 mm	0.5 mm
Material		
• of optical fiber core	Quartz glass	Quartz glass
• of optical fiber sheath	ETFE	ETFE
• of FO core sheath	PVC	PVC
• of FO cable sheath	PVC	PUR
• of the strain relief	Aramide fibers	Aramide fibers (double-ply)
Color		
• of FO core sheath	Orange/black	Orange/black
• of cable sheath	Green	Green
Bending radius		
• Minimum permitted single bending radius	70 mm	130 mm
• Minimum permitted repeated bending radius	105 mm	175 mm
• With continuous bending	-	-
Number of bending cycles	-	5 000 000
Maximum tensile load	100 N	800 N
Short-term lateral force per length	500 N/cm	500 N/cm
Continuous lateral force per length	300 N/cm	300 N/cm
Weight per length	49 kg/km	65 kg/km

Technical specifications (continued)

Order No.	6XV1 847-2A	6XV1 847-2C
Product type designation	FC FO Standard Cable GP	FC FO Trailing Cable
Permitted ambient conditions		
Ambient temperature		
• During operation	-40 ... +85 °C	-25 ... +75 °C
• During storage	-40 ... +85 °C	-30 ... +75 °C
• During transport	-40 ... +85 °C	-30 ... +75 °C
• During mounting	-5 ... +50 °C	-5 ... +50 °C
Ambient conditions for operation	-	-
IP degree of protection	-	-
Behavior in fire	Flame-retardant in accordance with IEC 60332-1-2 and IEC 60332-3-22 (Cat. A)	Flame-retardant in accordance with IEC 60332-1-2
Chemical resistance		
• to mineral oil	Limited resistance	Resistant
• to grease	Limited resistance	Resistant
• to water	Not resistant	Not resistant
Radiological resistance to UV radiation	Resistant	Resistant
Product properties, functions, components		
General		
Product property		
• Halogen-free	No	No
• Silicon-free	Yes	Yes
Product component: protection against rodents	No	No
Cable length with glass FOC		
• Maximum with 100BaseFX and Industrial Ethernet	3 000 m	3 000 m
• Maximum with 1000BaseSX and Industrial Ethernet	350 m	350 m
• Maximum with 1000BaseLX and Industrial Ethernet	550 m	550 m
• Maximum with PROFIBUS	3 000 m	-
Standards, specifications, approvals		
Certificate of suitability	UL approval: OFN (NEC Article 770, UL 1651) / CSA approval: OFN 90 Cel, FT1, FT4 (CSA Standard C22.2 No 232-M1988)	-
• RoHS compliance	Yes	Yes

PROFIBUS

Optical networks with OLM

FC glass fiber-optic cable

Technical specifications (continued)

Order No.	6GK1 900-1LB00-0AC0	6GK1 900-1GB00-0AC0	6GK1 900-1LP00-0AB0	6GK1 900-1GP00-0AB0
Product type designation	FC FO SC Plug	FC FO BFOC Plug	FC FO SC Coupler	FC FO BFOC Coupler
Product description	SC plug for FastConnect assembly	BFOC plug for FastConnect assembly	FC coupler for FastConnect assembly	BFOC coupler for FastConnect assembly
Suitability for application	For connection of glass fiber-optic cables, suitable for fast mounting with the FastConnect FO system	For connection of glass fiber-optic cables, suitable for fast mounting with the FastConnect FO system	-	-
Transmission rate				
Transmission rate				
• 1 with Industrial Ethernet	10 Mbit/s	10 Mbit/s	10 Mbit/s	10 Mbit/s
• 2 with Industrial Ethernet	100 Mbit/s	100 Mbit/s	100 Mbit/s	100 Mbit/s
• 3 with Industrial Ethernet	1 000 Mbit/s	1 000 Mbit/s	1 000 Mbit/s	1 000 Mbit/s
• with PROFIBUS	9.6 kbit/s ... 12 Mbit/s	9.6 kbit/s ... 12 Mbit/s	9.6 kbit/s ... 12 Mbit/s	9.6 kbit/s ... 12 Mbit/s
Interfaces				
Number of optical connections for fiber-optic cables	1	1	1	1
Number of optical connections for network components or terminals	SC connector	BFOC connector	SC coupling	BFOC coupling
Design of electrical connection FastConnect	Yes	Yes	Yes	Yes
Mechanical data				
Enclosure material	Metal and plastic	Metal and plastic	Metal and plastic	Metal and plastic
Design, dimensions and weights				
Type of cable outlet	180 degree cable outlet	180 degree cable outlet	180 degree cable outlet	180 degree cable outlet
Width	8 mm	10 mm	9 mm	11 mm
Height	8 mm	10 mm	35 mm	11 mm
Depth	49 mm	22 mm	28 mm	29.5 mm
Net weight	20 g	-	20 g	-
Permitted ambient conditions				
Ambient temperature				
• During operation	-40 ... +85 °C	-40 ... +85 °C	-40 ... +85 °C	-40 ... +85 °C
• During storage	-40 ... +85 °C	-40 ... +85 °C	-40 ... +85 °C	-40 ... +85 °C
• During transport	-40 ... +85 °C	-40 ... +85 °C	-40 ... +85 °C	-40 ... +85 °C
Relative humidity at 25 °C without condensation during operation, maximum	95 %	95 %	95 %	95 %
IP degree of protection	IP20	IP20	IP20	IP20
Chemical resistance to water	-	-	-	-
Product properties, functions, components				
General				
Product property silicon-free	Yes	Yes	Yes	Yes
Product component strain relief	Yes	Yes	Yes	Yes
Standards, specifications, approvals				
Certificate of suitability: RoHS conformity	Yes	Yes	Yes	Yes

Ordering data	Order No.
FC FO standard cable GP 62.5/200/230 FC FO standard cable for fixed routing indoors with PVC sheath; sold by the meter	6XV1 847-2A
FC FO trailing cable FC FO trailing cable for use in tow chains and moving applications; sold by the meter	6XV1 847-2C
FC FO termination kit Assembly case for local assembly of FC SC and FC BFOC connectors to FC FO standard cable, comprising a stripping tool, Kevlar cutters, fiber breaking tool and microscope	6GK1 900-1GL00-0AA0
FC SC plug Screw connector for on-site assembly on FC fiber-optic cable; (1 pack = 10 duplex plugs + cleaning cloths)	6GK1 900-1LB00-0AC0
FC BFOC plug Screw connector for on-site assembly on FC fiber-optic cable; (1 pack = 20 units + cleaning cloths)	6GK1 900-1GB00-0AC0
FC SC coupler FC SC duplex coupling; (1 pack = 5 units)	6GK1 900-1LP00-0AB0
FC BFOC coupler FC BFOC coupling; (1 pack = 10 units)	6GK1 900-1GP00-0AB0
SIMATIC NET Manual Collection Electronic manuals for communication systems, communication protocols, and communication products; on DVD; German/English	6GK1 975-1AA00-3AA0

More information

You can order components supplementary to the SIMATIC NET cabling range from your local contact.

Technical advice on this subject is available from:

J. Hertlein
 I IA SC IC PRM 4
 Phone: +49 (0)911/750 44 65
 E-mail: juergen.hertlein@siemens.com

PROFIBUS

Optical networks with OLM

FC FO termination kit

Overview



- Compact, rugged assembly case for FastConnect glass fiber-optic cables
- Simple fitting of SC and BFOC connectors to FastConnect glass fiber-optic cables
- The quality of the assembly can be checked using the enclosed microscope

Benefits

get Designed for Industry

- Simple installation of the unassembled cable
- Flexible connector assembly possible on site (SC/BFOC connectors)
- Prevention of faults by simply checking the assembled connectors using a microscope
- Simple repair of FC glass fiber-optic cables in the field

Application

SIMATIC NET FC glass fiber-optic cables are used to construct optical indoor and outdoor Industrial Ethernet/PROFINET and PROFIBUS networks. They are easy to assemble on-site using the termination kit with SC or BFOC connectors. The maximum cable length between two Industrial Ethernet/PROFINET or PROFIBUS devices is 3000 m in the case of 100 Mbit/s Ethernet or PROFIBUS.

Design

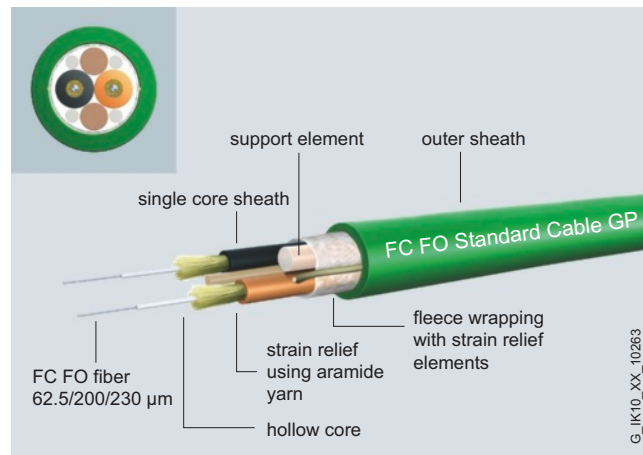

Cable construction FC glass optical fiber

The kit is available in an assembly case for on-site installation of FC SC and FC BFOC connectors on FC glass fiber-optic cables. It consists of a stripping tool, buffer stripping tool, Kevlar scissors, fiber breaking tool and microscope.

Ordering Data

Order No.

FC FO Termination Kit

Assembly case for local assembly of FC SC and FC BFOC connectors to FC FO standard cable, comprising a stripping tool, Kevlar cutters, fiber breaking tool and microscope

6GK1 900-1GL00-0AA0

More information

You can order components supplementary to the SIMATIC NET cabling range from your local contact.

Technical advice on this subject is available from:

J. Hertlein
 I IA SC IC PRM 4
 Phone: +49 (0)911/750 44 65
 E-mail: juergen.hertlein@siemens.com

Overview



- Used for the optical Industrial Ethernet and PROFIBUS networks
- Rugged design for industrial applications indoors and outdoors
- Halogen-free design for installation inside buildings
- Trailing cable for the special application of forced motion control
- High immunity to noise thanks to insensitivity to electro-magnetic fields
- Available preassembled
- Extensive approvals (UL)

Benefits

get Designed for Industry

- Easy to lay with
 - preassembled cables
 - no grounding problems
 - very light fiber optic cable.
- Tap-proof, no radiation from the cable
- Silicon-free, therefore suitable for use in the automotive industry (e.g. in paint shops)
- Avoidance of overvoltage and equipotential bonding problems

Application

Marine duplex fiber-optic cable SIENOPYR

Halogen-free, non-crush, flame-retardant, marine-approved fiber-optic cable for permanent installation on ships and on offshore platforms indoors and on open deck. Sold by the meter.

Fiber-optic indoor cable

Halogen-free fiber-optic cable, non-crush, flame-retardant, for installation inside buildings (e.g. in production halls and in building automation). Supplied in fixed lengths, pre-assembled with 4 BFOC connectors.

Standard FOC/FRNC cable

Fiber-optic cables for the following application areas indoors and outdoors

- For routing above ground
- For installation inside buildings.

Sold by the meter and in fixed lengths, pre-assembled with 4 BFOC connectors.

Fiber-optic trailing cable

Fiber-optic cables for the special application of forced motion control, such as in continuously moving machine parts (in trailing cables) indoors and outdoors. Two cable variants are available for this application:

- FO Trailing Cable; Cable for high mechanical stress, PUR outer sheath, no UL approval
- FO Trailing Cable GP (general purpose); Cable for low mechanical stress, PVC outer sheath, with UL approval

Sold by the meter and in fixed lengths, pre-assembled with 4 BFOC connectors.

Fiber-optic outdoor cable

Waterproof cable (lengthwise and sideways) for use outdoors with non-metallic protection against rodents for laying into the ground.

Sold by the meter and in fixed lengths, pre-assembled with 4 BFOC connectors.

Note:

Special tools and specially trained personnel are required for pre-assembling glass fiber-optic cables.

PROFIBUS

Optical networks with OLM

Glass fiber-optic cable

Application (continued)

Application Examples

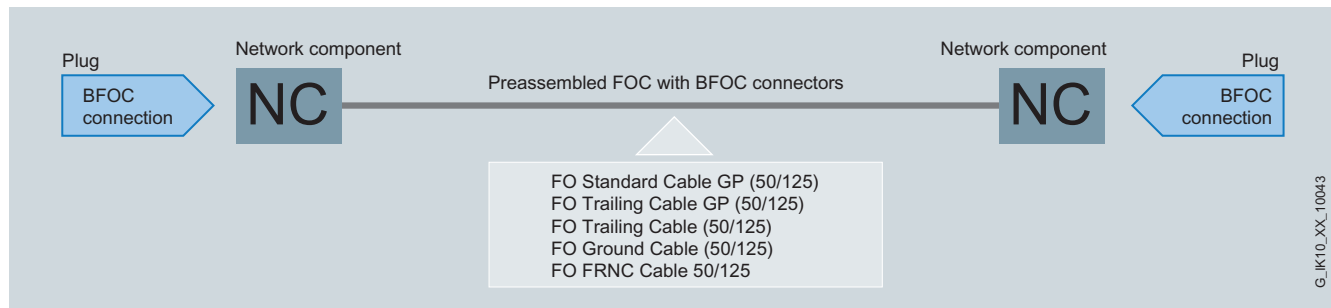

Use of pre-assembled fiber-optic cables with BFOC connectors (12 Mbit/s)

Design

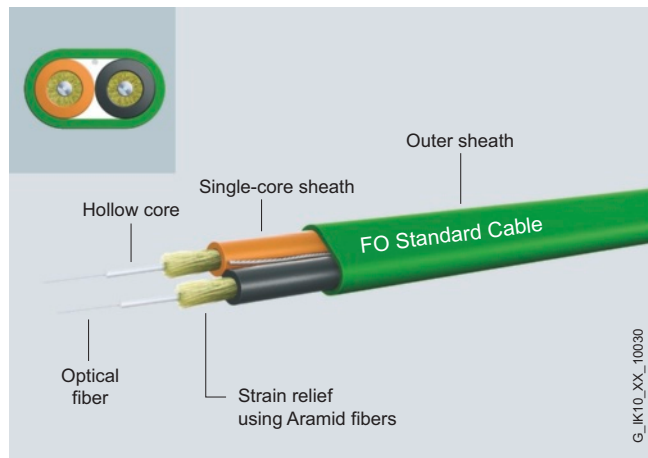

In order to span very long distances, the use of singlemode cables with a 9 μm fiber is recommended.

Cable types	50/125 μm	62.5/125 μm	9/125 μm
FO standard cable GP (50/125/1400)	●	—	—
FO FRNC cable (50/125/1400)	●	—	—
FO trailing cable (50/125/1400)	●	—	—
FO trailing cable GP (50/125/1400)	●	—	—
FO ground cable (50/125/1400)	●	—	—
FO robust cable GP (50/125/900)	●	—	—
Fiber-optic standard cable (62.5/125/900)	—	●	—
INDOOR fiber-optic cable (62.5/125/900)	—	●	—
Flexible fiber-optic trailing cable (62.5/125/1400)	—	●	—
SIENOPYR marine duplex fiber-optic cable (62.5/125/900)	—	●	—
FO robust cable GP (4E9/125/900)	—	—	●

Technical specifications

Order No.	6XV1 873-2A	6XV1 873-2B	6XV1 873-2G
Product type designation	FO Standard Cable GP	FO FRNC Cable GP	FO Ground Cable
Product description	Glass fiber-optic cable, sold by the meter, in bulk	Glass fiber-optic cable, sold by the meter, in bulk	Glass fiber-optic cable, sold by the meter, in bulk
Suitability for application	Cable for indoor and outdoor use, UL approval	Halogen-free cable for indoor and outdoor use, for fixed installation, UL approval	Cable with longitudinal and lateral water tightness with non-metallic protection against rodents for outdoor use and for direct laying in soil
Design of preassembled FO cable	Can be fitted with four BFOC or SC connectors	Can be fitted with four BFOC or SC connectors	Can be fitted with four BFOC or SC connectors
Cable designation	AT-W(ZN)YY 2x1 G 50/125	AT-W(ZN)HH 2G 50/125 UV	AT-WQ(ZN)Y(ZN)B2Y 2G 50/125
Cable length	-	-	-
Optical data			
Attenuation factor per length			
• Max. at 850 nm	2.7 dB/km	2.7 dB/km	2.7 dB/km
• Max. at 1300 nm	0.7 dB/km	0.7 dB/km	0.7 dB/km
• Max. at 1550 nm	-	-	-
Bandwidth length product			
• At 850 nm	600 GHz·m	600 GHz·m	600 GHz·m
• At 1300 nm	1 200 GHz·m	1 200 GHz·m	1 200 GHz·m
Mechanical data			
Number of fibers per FO core	1	1	1
Number of FO cores per FO cable	2	2	2
Design of FO fiber	Multimode graded-index fiber 50/125 µm, OM 2	Multimode graded-index fiber 50/125 µm, OM 2	Multimode graded-index fiber 50/125 µm, OM 2
Design of FO core	Hollow core, filled, diameter 1400 µm	Hollow core, filled, diameter 1400 µm	Hollow core, filled, diameter 1400 µm
Design of FO cable	Splittable	Splittable	Splittable
Outer diameter			
• of optical fiber	50 µm	50 µm	50 µm
• of optical fiber sheath	125 µm	125 µm	125 µm
• of FO core sheath	2.9 mm	2.9 mm	2.9 mm
• of cable	-	9.2 mm	10.5 mm
Symmetrical deviation			
• of outer diameter of FO core sheath	0.1 mm	0.1 mm	0.1 mm
• of outer diameter of cable	-	0.3 mm	0.5 mm
Width of cable sheath	7.4 mm	-	-
Symmetrical tolerance of cable sheath width	-	-	-
Thickness of cable sheath	4.5 mm	-	-
Symmetrical tolerance of cable sheath thickness	-	-	-
Material			
• of optical fiber core	Quartz glass	Quartz glass	Quartz glass
• of optical fiber sheath	Quartz glass	Quartz glass	Quartz glass
• of FO core sheath	PVC	FRNC	PVC
• of FO cable sheath	PVC	FRNC	PE
• of the strain relief	Aramide fibers	Aramide fibers	Aramide fibers
Color			
• of FO core sheath	Orange/black	Orange/black	Orange/black
• of the cable sheath	Green	Green	Black

PROFIBUS

Optical networks with OLM

Glass fiber-optic cable

Technical specifications (continued)

Order No.	6XV1 873-2A	6XV1 873-2B	6XV1 873-2G
Product type designation	FO Standard Cable GP	FO FRNC Cable GP	FO Ground Cable
Bending radius			
• Minimum permitted single bending radius	45 mm	90 mm	105 mm
• Minimum permitted repeated bending radius	65 mm	135 mm	155 mm
• With continuous bending	-	-	-
Number of bending cycles	-	-	-
Maximum tensile load	500 N	1 200 N	800 N
Short-term lateral force per length	600 N/cm	500 N/cm	500 N/cm
Continuous lateral force per length	400 N/cm	-	300 N/cm
Weight per length	40 kg/km	85 kg/km	90 kg/km
Permitted ambient conditions			
Ambient temperature			
• During operation	-25 ... +80 °C	-40 ... +70 °C	-40 ... +75 °C
• During storage	-25 ... +80 °C	-40 ... +70 °C	-40 ... +75 °C
• During transport	-25 ... +80 °C	-40 ... +70 °C	-40 ... +75 °C
• During mounting	-5 ... +50 °C	-5 ... +50 °C	-5 ... +50 °C
Ambient conditions for operation	-	-	-
IP degree of protection	-	-	-
Behavior in fire	Flame-retardant in accordance with IEC 60332-1-2 and IEC 60332-3-22 (Cat. A)	Flame-retardant in accordance with IEC 60332-1-2 and IEC 60332-3-22 (Cat. A)	Flammable
Chemical resistance			
• against mineral oil	Limited resistance	Limited resistance	Resistant
• against grease	Limited resistance	Limited resistance	Resistant
• against water	-	-	Resistant
Radiological resistance to UV radiation	Resistant	Resistant	Resistant
Product properties, functions, components			
General			
Product property			
• Halogen-free	No	Yes	No
• Silicon-free	Yes	Yes	Yes
Product component: protection against rodents	No	No	Yes
Cable length with glass FOC			
• Maximum with 100BaseFX and Industrial Ethernet	5 000 m	5 000 m	5 000 m
• Maximum with 1000BaseSX and Industrial Ethernet	750 m	750 m	750 m
• Maximum with 1000BaseLX and Industrial Ethernet	2 000 m	2 000 m	2 000 m
• Maximum with PROFIBUS	3 000 m	3 000 m	3 000 m
Standards, specifications, approvals			
Certificate of suitability	UL approval: OFN (NEC Article 770, UL 1651) / CSA approval: OFN 90 Cel, FT1, FT4 (CSA standard C22.2 No 232-M1988)	UL approval: OFN (NEC Article 770, UL 1651) / CSA approval: OFN (CSA standard C22.2 No 232-M1988)	-
• RoHS compliance	Yes	Yes	Yes

Technical specifications (continued)

Order No.	6XV1 873-2C	6XV1 873-2D
Product type designation	FO Trailing Cable	FO Trailing Cable GP
Product description	Glass fiber-optic cable, sold by the meter, in bulk	Glass fiber-optic cable, sold by the meter, in bulk
Suitability for application	Flexible cable for use in trailing cables with high mechanical stress, without UL approval	Flexible cable for use in trailing cables with high mechanical stress, UL approval
Design of preassembled FO cable	Can be fitted with four BFOC or SC connectors	Can be fitted with four BFOC or SC connectors
Cable designation	AT-W(ZN)Y(ZN)11Y 2G 50/125	AT-W(ZN)Y(ZN)Y 2G 50/125
Cable length	-	-
Optical data		
Attenuation factor per length		
• Max. at 850 nm	2.7 dB/km	2.7 dB/km
• Max. at 1300 nm	0.7 dB/km	0.7 dB/km
• Max. at 1550 nm	-	-
Bandwidth length product		
• At 850 nm	600 GHz·m	600 GHz·m
• At 1300 nm	1 200 GHz·m	1 200 GHz·m
Mechanical data		
Number of fibers per FO core	1	1
Number of FO cores per FO cable	2	2
Design of FO fiber	Multimode graded-index fiber 50/125 µm, OM 2	Multimode graded-index fiber 50/125 µm, OM 2
Design of FO core	Hollow core, filled, diameter 1400 µm	Hollow core, filled, diameter 1400 µm
Design of FO cable	Splittable	Splittable
Outer diameter		
• of optical fiber	50 µm	50 µm
• of optical fiber sheath	125 µm	125 µm
• of FO core sheath	2.9 mm	2.9 mm
• of cable	10.5 mm	10.5 mm
Symmetrical deviation		
• of outer diameter of FO core sheath	0.1 mm	0.1 mm
• of outer diameter of cable	0.5 mm	0.5 mm
Material		
• of optical fiber core	Quartz glass	Quartz glass
• of optical fiber sheath	Quartz glass	Quartz glass
• of FO core sheath	PVC	PVC
• of FO cable sheath	PUR	PVC
• of the strain relief	Aramide fibers	Aramide fibers
Color		
• of FO core sheath	Orange/black	Orange/black
• of the cable sheath	Green	Green
Bending radius		
• Minimum permitted single bending radius	150 mm	150 mm
• Minimum permitted repeated bending radius	200 mm	200 mm
• With continuous bending	-	-
Number of bending cycles	5 000 000	3 500 000
Maximum tensile load	800 N	800 N
Short-term lateral force per length	700 N/cm	700 N/cm
Continuous lateral force per length	400 N/cm	400 N/cm
Weight per length	90 kg/km	90 kg/km

PROFIBUS

Optical networks with OLM

Glass fiber-optic cable

Technical specifications (continued)

Order No.	6XV1 873-2C	6XV1 873-2D
Product type designation	FO Trailing Cable	FO Trailing Cable GP
Permitted ambient conditions		
Ambient temperature		
• During operation	-40 ... +80 °C	-25 ... +80 °C
• During storage	-40 ... +80 °C	-25 ... +80 °C
• During transport	-40 ... +80 °C	-25 ... +80 °C
• During mounting	-5 ... +50 °C	-5 ... +50 °C
Ambient conditions for operation	-	-
IP degree of protection	-	-
Behavior in fire	Flammable	Flame-retardant in accordance with IEC 60332-1-2 and IEC 60332-3-22 (Cat. A)
Chemical resistance		
• against mineral oil	Resistant	Limited resistance
• against grease	Resistant	Limited resistance
• against water	-	-
Radiological resistance to UV radiation	Resistant	Resistant
Product properties, functions, components General		
Product property		
• Halogen-free	No	No
• Silicon-free	Yes	Yes
Product component: protection against rodents	No	No
Cable length with glass FOC		
• Maximum with 100BaseFX and Industrial Ethernet	5 000 m	5 000 m
• Maximum with 1000BaseSX and Industrial Ethernet	750 m	750 m
• Maximum with 1000BaseLX and Industrial Ethernet	2 000 m	2 000 m
• Maximum with PROFIBUS	3 000 m	3 000 m
Standards, specifications, approvals		
Certificate of suitability	-	UL approval: OFN (NEC Article 770, UL 1651) / CSA approval: OFN 90 Cel, FT1, FT4 (CSA Standard C22.2 No232-M1988)
• RoHS compliance	Yes	Yes

Technical specifications (continued)

Order No.	6XV1 820-5AH10	6XV1 820-7AH10
Product type designation	Fiber Optic Standard Cable	INDOOR Fiber Optic Cable
Product description	Flexible glass fiber-optic cable, sold by the meter, in bulk	Glass fiber-optic cable, sold by the meter, in bulk
Suitability for application	Cable for indoor and outdoor use	Crush-resistant, halogen-free and flame-retardant cable for indoor use
Design of preassembled FO cable	can be fitted with four BFOC connectors	can be fitted with four BFOC connectors
Cable designation	AT-V(ZN)YY 2X1 G 62.5/125	I-V(ZN)HH 2x1 G 62.5/125
Cable length	-	-
Optical data		
Attenuation factor per length		
• Max. at 850 nm	3.1 dB/km	3.1 dB/km
• Max. at 1300 nm	0.8 dB/km	0.8 dB/km
• Max. at 1550 nm	-	-
Bandwidth length product		
• At 850 nm	200 GHz·m	200 GHz·m
• At 1300 nm	600 GHz·m	600 GHz·m
Mechanical data		
Number of fibers per FO core	1	1
Number of FO cores per FO cable	2	2
Design of FO fiber	Multimode graded-index fiber 62.5/125 µm, OM 2	Multimode graded-index fiber 62.5/125 µm, OM 2
Design of FO core	Compact core, diameter 900 µm	Solid core, diameter 900 µm
Design of FO cable	Splittable outer cable	Splittable inner cable
Outer diameter		
• of optical fiber	62.5 µm	62.5 µm
• of optical fiber sheath	125 µm	125 µm
• of FO core sheath	3.5 mm	2.9 mm
• of cable	-	-
Symmetrical deviation		
• of outer diameter of FO core sheath	-	0.1 mm
• of outer diameter of cable	-	-
Width of cable sheath	9.8 mm	6.8 mm
Symmetrical tolerance of cable sheath width	-	-
Thickness of cable sheath	6.3 mm	3.9 mm
Symmetrical tolerance of cable sheath thickness	-	-
Material		
• of optical fiber core	Quartz glass	Quartz glass
• of optical fiber sheath	Quartz glass	Quartz glass
• of FO core sheath	PVC	FRNC
• of FO cable sheath	PVC	FRNC
• of the strain relief	Aramide fibers with additionally integrated compression protection elements	Aramide fibers
Color		
• of FO core sheath	Gray	Gray
• of the cable sheath	Black	Orange

PROFIBUS

Optical networks with OLM

Glass fiber-optic cable

Technical specifications (continued)

Order No.	6XV1 820-5AH10	6XV1 820-7AH10
Product type designation	Fiber Optic Standard Cable	INDOOR Fiber Optic Cable
Bending radius		
• Minimum permitted single bending radius	80 mm	30 mm
• Minimum permitted repeated bending radius	80 mm	50 mm
Maximum tensile load	1 500 N	200 N
Short-term lateral force per length	-	300 N/cm
Continuous lateral force per length	150 N/cm	100 N/cm
Weight per length	70 kg/km	30 kg/km
Permitted ambient conditions		
Ambient temperature		
• During operation	-20 ... +60 °C	-20 ... +60 °C
• During storage	-25 ... +70 °C	-25 ... +70 °C
• During transport	-25 ... +70 °C	-25 ... +70 °C
• During mounting	-5 ... +50 °C	-5 ... +50 °C
IP degree of protection	-	-
Behavior in fire	Flame-retardant in accordance with IEC 60332-1-2 and IEC 60332-3-22 (Cat. A)	Flame-retardant in accordance with IEC 60332-1-2 and IEC 60332-3-22 (Cat. A)
Chemical resistance		
• against mineral oil	Not resistant	Not resistant
• against grease	Not resistant	Not resistant
• against water	-	-
Radiological resistance to UV radiation	Resistant	Not resistant
Product properties, functions, components		
General		
Product property		
• Halogen-free	No	Yes
• Silicon-free	Yes	Yes
Product component: protection against rodents	No	No
Cable length with glass FOC		
• Maximum with 100BaseFX and Industrial Ethernet	4 000 m	4 000 m
• Maximum with 1000BaseSX and Industrial Ethernet	350 m	350 m
• Maximum with 1000BaseLX and Industrial Ethernet	550 m	550 m
• Maximum with PROFIBUS	3 000 m	3 000 m
Standards, specifications, approvals		
Certificate of suitability		
• RoHS compliance	Yes	Yes

Technical specifications (continued)

Order No.	6XV1 820-6AH10	6XV1 830-0NH10
Product type designation	Flexible Fiber Optic Trailing Cable	SIENOPYR Marine Duplex FO Cable
Product description	Flexible glass fiber-optic cable, sold by the meter, in bulk	Glass fiber-optic cable, SIENOPYR marine cable, sold by the meter, non-assembled
Suitability for application	Flexible cable for indoor and outdoor use in trailing cables	For fixed installation on ships and offshore units, in all rooms and exposed decks, marine approval assigned
Design of preassembled FO cable	can be fitted with four BFOC connectors	can be fitted with four BFOC connectors
Cable designation	AT-W11Y(ZN)11Y 2 G 62.5/125	MI-VHH 2G 62.5/125 3.1B200 + 0.8F600 + 2x1Cu 300V
Cable length	-	-
Optical data		
Attenuation factor per length		
• Max. at 850 nm	3.1 dB/km	3.1 dB/km
• Max. at 1300 nm	0.8 dB/km	0.8 dB/km
• Max. at 1550 nm	-	-
Bandwidth length product		
• At 850 nm	200 GHz·m	200 GHz·m
• At 1300 nm	600 GHz·m	600 GHz·m
Mechanical data		
Number of fibers per FO core	1	1
Number of FO cores per FO cable	2	2
Design of FO fiber	Multimode graded-index fiber 62.5/125 µm, OM 2	Multimode graded-index fiber 62.5/125 µm, OM 2
Design of FO core	Hollow core, filled, diameter 1400 µm	Solid core
Design of FO cable	Splittable outer cable	Splittable outer cable
Outer diameter		
• of optical fiber	62.5 µm	62.5 µm
• of optical fiber sheath	125 µm	125 µm
• of FO core sheath	3.5 mm	2.9 mm
• of cable	12.9 mm	13.3 mm
Symmetrical deviation		
• of outer diameter of FO core sheath	-	-
• of outer diameter of cable	-	0.5 mm
Material		
• of optical fiber core	Quartz glass	Mineral glass
• of optical fiber sheath	Quartz glass	-
• of FO core sheath	PUR	Polyolefin
• of FO cable sheath	PUR	SHF1 mixture
• of the strain relief	Aramide fibers, plus central element made of glass-reinforced plastic	Aramide fibers
Color		
• of FO core sheath	Black	-
• of the cable sheath	Black	Black
Bending radius		
• Minimum permitted single bending radius	150 mm	133 mm
• Minimum permitted repeated bending radius	150 mm	266 mm
• With continuous bending	-	-
Number of bending cycles	100 000	-
Maximum tensile load	1 000 N	250 N
Short-term lateral force per length	-	-
Continuous lateral force per length	-	-
Weight per length	130 kg/km	220 kg/km

PROFIBUS

Optical networks with OLM

Glass fiber-optic cable

Technical specifications (continued)

Order No.	6XV1 820-6AH10	6XV1 830-0NH10
Product type designation	Flexible Fiber Optic Trailing Cable	SIENOPYR Marine Duplex FO Cable
Permitted ambient conditions		
Ambient temperature		
• During operation	-30 ... +60 °C	-40 ... +80 °C
• During storage	-30 ... +70 °C	-40 ... +80 °C
• During transport	-30 ... +70 °C	-40 ... +80 °C
• During mounting	-30 ... +60 °C	-10 ... +50 °C
Ambient conditions for operation	-	At temperatures below -10 °C, the cables must not be exposed to any movements in excess of the vibrations and oscillations which are normal on ships
IP degree of protection	-	-
Behavior in fire	Flammable	Flame-retardant in accordance with IEC 60332-3 (Cat. A)
Chemical resistance		
• against mineral oil	Resistant	-
• against grease	Resistant	-
• against water	-	-
Radiological resistance to UV radiation	Resistant	Resistant
Product properties, functions, components		
General		
Product property		
• Halogen-free	Yes	Yes
• Silicon-free	Yes	Yes
Product component: protection against rodents	No	No
Cable length with glass FOC		
• Maximum with 100BaseFX and Industrial Ethernet	4 000 m	-
• Maximum with 1000BaseSX and Industrial Ethernet	350 m	-
• Maximum with 1000BaseLX and Industrial Ethernet	550 m	-
• Maximum with PROFIBUS	3 000 m	3 000 m
Standards, specifications, approvals		
Certificate of suitability	-	-
• RoHS compliance	Yes	Yes
Marine classification corporation		
• Bureau Veritas (BV)	-	Yes
• Germanischer Lloyd (GL)	-	Yes
• Lloyds Register of Shipping (LRS)	-	Yes

Technical specifications (continued)

Order No.	6XV1 873-2R	6XV1 843-2R
Product type designation	MM FO Robust Cable GP	SM FO Robust Cable GP
Product description	Glass fiber-optic cable, sold by the meter, in bulk	Glass fiber-optic cable, sold by the meter, in bulk
Suitability for application	Cable with longitudinal and lateral water tightness with non-metallic protection against rodents for outdoor and indoor use and for direct laying in soil	Cable with longitudinal and lateral water tightness with non-metallic protection against rodents for outdoor and indoor use and for direct laying in soil
Design of preassembled FO cable	Can be fitted with two BFOC, SC and LC duplex plugs	Can be fitted with two BFOC, SC and LC duplex plugs
Cable designation	AT-V(ZN)H(ZN)BH 2G50/125	AT-V(ZN)H(ZN)BH 4E9/125
Cable length	-	-
Optical data		
Attenuation factor per length		
• Max. at 850 nm	2.7 dB/km	-
• Max. at 1300 nm	1 dB/km	0.5 dB/km
• Max. at 1550 nm	-	0.5 dB/km
Bandwidth length product		
• At 850 nm	600 GHz·m	-
• At 1300 nm	1 200 GHz·m	-
Mechanical data		
Number of fibers per FO core	1	1
Number of FO cores per FO cable	2	4
Design of FO fiber	Multimode graded-index fiber 50/125/245 µm, OM2	Single-mode fiber 4E9/125/900, OS1 and OS2
Design of FO core	Solid core, diameter 900 µm	Solid core, diameter 900 µm
Design of FO cable	Splittable	Splittable
Outer diameter		
• of optical fiber	50 µm	9 µm
• of optical fiber sheath	125 µm	125 µm
• of FO core sheath	2.2 mm	2.2 mm
• of cable	7.5 mm	9 mm
Material		
• of optical fiber core	Quartz glass	Quartz glass
• of optical fiber sheath	Quartz glass	Quartz glass
• of FO core sheath	PE flame-retardant	PE flame-retardant
• of FO cable sheath	PE flame-retardant	PE flame-retardant
• of the strain relief	Aramide fibers and glass roving	Aramide fibers, plus central support element and glass roving
Color		
• of FO core sheath	Orange / black, with directional arrow	Orange / black, with directional arrow (numbering of the core pairs with 1 and 2)
• of the cable sheath	Black	Black
Bending radius		
• Minimum permitted single bending radius	25 mm	90 mm
• Minimum permitted repeated bending radius	40 mm	135 mm
• With continuous bending	-	-
Number of bending cycles	-	-
Maximum tensile load	1 000 N	1 000 N
Short-term lateral force per length	600 N/cm	600 N/cm
Continuous lateral force per length	200 N/cm	200 N/cm
Weight per length	67 kg/km	89 kg/km

PROFIBUS

Optical networks with OLM

Glass fiber-optic cable

Technical specifications (continued)

Order No.	6XV1 873-2R	6XV1 843-2R
Product type designation	MM FO Robust Cable GP	SM FO Robust Cable GP
Permitted ambient conditions		
Ambient temperature		
• During operation	-40 ... +70 °C	-40 ... +70 °C
• During storage	-40 ... +70 °C	-40 ... +70 °C
• During transport	-40 ... +70 °C	-40 ... +70 °C
• During mounting	-20 ... +60 °C	-20 ... +60 °C
Behavior in fire	Flame-retardant in accordance with IEC 60332-3-24	Flame-retardant in accordance with IEC 60332-3-24
Chemical resistance		
• against mineral oil	Limited resistance	Limited resistance
• against grease	Limited resistance	Limited resistance
• against water	Resistant	Resistant
Radiological resistance to UV radiation	Resistant	Resistant
Product properties, functions, components		
General		
Product property		
• Halogen-free	Yes	Yes
• Silicon-free	Yes	Yes
Product component: protection against rodents	Yes	Yes
Cable length with glass FOC		
• Maximum with 100BaseFX and Industrial Ethernet	5 000 m	26 000 m
• Maximum with 1000BaseSX and Industrial Ethernet	750 m	-
• Maximum with 1000BaseLX and Industrial Ethernet	2 000 m	5 000 m
• Maximum with PROFIBUS	3 000 m	15 000 m
Standards, specifications, approvals		
Certificate of suitability		
• RoHS compliance	Yes	Yes

Technical specifications (continued)

Order No.	6GK1 901-0DA20-0AA0
Product type designation	BFOC connector set
Product description	BFOC connector set
Suitability for application	for the connection of glass fiber-optic cables
Transmission rate	
Transmission rate	
• 1 with Industrial Ethernet	10 Mbit/s
• 2 with Industrial Ethernet	100 Mbit/s
• 3 with Industrial Ethernet	1 000 Mbit/s
• with PROFIBUS	9.6 kbit/s ... 12 Mbit/s
Interfaces	
Number of optical connections for fiber-optic cables	1
Number of optical connections for network components or terminals	BFOC connector
Design of electrical connection FastConnect	No
Mechanical data	
Enclosure material	Metal and plastic
Design, dimensions and weights	
Type of cable outlet	180 degree cable outlet
Width	10 mm
Height	10 mm
Depth	10 mm
Net weight	8 g
Permitted ambient conditions	
IP degree of protection	IP20
Chemical resistance to water	-
Product properties, functions, components	
General	
Product property silicon-free	Yes
Product component strain relief	Yes
Standards, specifications, approvals	
Certificate of suitability: RoHS conformity	Yes

Ordering data

Order No.

FO standard cable GP 50/125/1400 ²⁾	
Multimode cable, sold by the meter; max. length 1000 m; minimum order 20 m;	6XV1 873-2A
<u>Preferred lengths</u> ¹⁾ pre-assembled with 4 BFOC connectors	
• 0.5 m	6XV1 873-3AH05
• 1 m	6XV1 873-3AH10
• 2 m	6XV1 873-3AH20
• 3 m	6XV1 873-3AH30
• 5 m	6XV1 873-3AH50
• 10 m	6XV1 873-3AN10
• 15 m	6XV1 873-3AN15
• 20 m	6XV1 873-3AN20
• 30 m	6XV1 873-3AN30
• 40 m	6XV1 873-3AN40
• 50 m	6XV1 873-3AN50
• 80 m	6XV1 873-3AN80
• 100 m	6XV1 873-3AT10
• 150 m	6XV1 873-3AT15
• 200 m	6XV1 873-3AT20
• 300 m	6XV1 873-3AT30
FO FRNC cable 50/125/1400 ²⁾	
Multimode cable, sold by the meter; max. length 1000 m; minimum order 20 m;	6XV1 873-2B
FO trailing cable 50/125/1400 ²⁾	
Multimode cable, sold by the meter; max. length 1000 m; minimum order 20 m;	6XV1 873-2C
<u>Preferred lengths</u> ¹⁾ pre-assembled with 4 BFOC connectors	
• 3 m	6XV1 873-3CH30
• 5 m	6XV1 873-3CH50
• 10 m	6XV1 873-3CN10
• 20 m	6XV1 873-3CN20
• 50 m	6XV1 873-3CN50
• 100 m	6XV1 873-3CT10
FO trailing cable GP 50/125/1400 ²⁾	
Multimode cable, sold by the meter; max. length 1000 m; minimum order 20 m;	6XV1 873-2D
<u>Preferred lengths</u> ¹⁾ pre-assembled with 4 BFOC connectors	
• 3 m	6XV1 873-3DH30
• 5 m	6XV1 873-3DH50
• 10 m	6XV1 873-3DN10
• 20 m	6XV1 873-3DN20
• 50 m	6XV1 873-3DN50
• 100 m	6XV1 873-3DT10

¹⁾ Special fiber-optic cables, lengths and accessories available on request

²⁾ Special tools and specially trained personnel are required for pre-assembling glass fiber-optic cables

PROFIBUS

Optical networks with OLM

Glass fiber-optic cable

Ordering data	Order No.	Order No.	
FO ground cable 50/125/1400 ²⁾ Multimode cable, <u>sold by the meter</u> ; max. length 2000 m; minimum order 20 m; <u>Preferred lengths</u> ¹⁾ pre-assembled with 4 BFOC connectors <ul style="list-style-type: none"> • 100 m • 200 m • 300 m 	6XV1 873-2G 6XV1 873-3GT10 6XV1 873-3G T20 6XV1 873-3G T30	INDOOR FIBER OPTIC CABLE (62.5/125/900), segmentable ²⁾ Multimode cable, <u>sold by the meter</u> ; max. delivery unit 2000 m minimum order 20 m <u>Preferred lengths</u> ; pre-assembled with 4 BFOC connectors <ul style="list-style-type: none"> • 0.5 m • 1 m • 2 m • 3 m • 5 m • 10 m • 15 m • 20 m • 25 m • 50 m • 75 m • 100 m 	6XV1 820-7AH10 6XV1 820-7BH05 6XV1 820-7BH10 6XV1 820-7BH20 6XV1 820-7BH30 6XV1 820-7BH50 6XV1 820-7BN10 6XV1 820-7BN15 6XV1 820-7BN20 6XV1 820-7BN25 6XV1 820-7BN50 6XV1 820-7BN75 6XV1 820-7BT10
FO Robust Cable GP 50/125/900 ²⁾ Multimode cable, <u>sold by the meter</u> ; max. length 2000 m; minimum order 20 m;	6XV1 873-2R		
Standard FIBER OPTIC CABLE (62.5/125/900), segmentable ²⁾ Multimode cable, <u>sold by the meter</u> ; max. delivery unit 2000 m minimum order 20 m <u>Preferred lengths</u> ¹⁾ pre-assembled with 4 BFOC plugs <ul style="list-style-type: none"> • 1 m • 2 m • 3 m • 4 m • 5 m • 10 m • 15 m • 20 m • 30 m • 40 m • 50 m • 55 m • 60 m • 65 m • 70 m • 75 m • 80 m • 100 m • 120 m • 130 m • 150 m • 200 m • 250 m • 300 m 	6XV1 820-5AH10 6XV1 820-5BH10 6XV1 820-5BH20 6XV1 820-5BH30 6XV1 820-5BH40 6XV1 820-5BH50 6XV1 820-5BN10 6XV1 820-5BN15 6XV1 820-5BN20 6XV1 820-5BN30 6XV1 820-5BN40 6XV1 820-5BN50 6XV1 820-5BN55 6XV1 820-5BN60 6XV1 820-5BN65 6XV1 820-5BN70 6XV1 820-5BN75 6XV1 820-5BN80 6XV1 820-5BT10 6XV1 820-5BT12 6XV1 820-5BT13 6XV1 820-5BT15 6XV1 820-5BT20 6XV1 820-5BT25 6XV1 820-5BT30	FLEXIBLE FIBER OPTIC CABLE trailing cable (62.5/125/1400), segmentable ²⁾ Multimode cable, <u>sold by the meter</u> ; max. delivery unit 2000 m minimum order 20 m <u>Preferred lengths</u> ; pre-assembled with 4 BFOC connectors <ul style="list-style-type: none"> • 1 m • 2 m • 3 m • 5 m • 10 m • 15 m • 20 m • 30 m • 50 m • 75 m • 100 m 	6XV1 820-6AH10 6XV1 820-6BH10 6XV1 820-6BH20 6XV1 820-6BH30 6XV1 820-6BH50 6XV1 820-6BN10 6XV1 820-6BN15 6XV1 820-6BN20 6XV1 820-6BN30 6XV1 820-6BN50 6XV1 820-6BN75 6XV1 820-6BT10
		SIENOPYR marine duplex fiber-optic cable (62.5/125/900) Fiber-optic cable for routing on ships and offshore platforms Multimode cable, <u>sold by the meter</u> ; max. delivery unit 1000 m minimum order 20 m	6XV1 830-0NH10
		FO Robust Cable GP 4E9/125/900 ²⁾ Single-mode cable, <u>sold by the meter</u> ; max. length 2000 m; minimum order 20 m;	6XV1 843-2R

¹⁾ Special fiber-optic cables, lengths and accessories available on request

²⁾ Special tools and specially trained personnel are required for pre-assembling glass fiber-optic cables

Ordering data	Order No.
<i>Accessories</i>	
Multimode FO BFOC connector set for FO standard cable (50/125/1400), FO ground cable (50/125/1400), flexible FO trailing cable, INDOOR FO cable (62.5/125/900), 20 units	6GK1 901-0DA20-0AA0
Multimode FO LC duplex plug LC duplex plug (10 units) for INDOOR FO cable (62.5/125/900), FO robust cable GP (50/125/900), FO standard cable (62.5/125/900)	6GK1 901-0RB10-2AB0
Singlemode FO LC duplex plug LC duplex plug (10 units) for FO robust cable GP (4E9/125/900)	6GK1 901-0SB10-2AB0
PROFIBUS network manual ³⁾	See www.siemens.com/automation/csi/net
SIMATIC NET Manual Collection Electronic manuals for communication systems, communication protocols, and communication products; on DVD; German/English	6GK1 975-1AA00-3AA0

³⁾ Further manuals can be found for the respective products at www.siemens.com/automation/csi/net

More information

You can order components and demonstration materials supplementary to the SIMATIC NET cabling range from your local contact.

Technical advice on this subject is available from:

J. Hertlein
 I IA SC IC PRM 4
 Phone: +49 (0)911/750 44 65
 E-mail: juergen.hertlein@siemens.com

PROFIBUS

Optical networks with OLM

Plastic and PCF fiber-optic cable

Overview

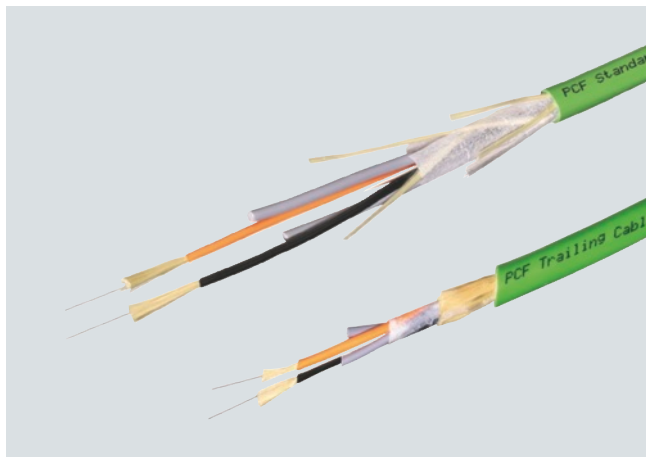

- Electrical isolation of PROFIBUS devices and PROFIBUS segments
- Protection of the transmission path against electromagnetic interference
- Up to 80 m cable length with plastic fiber-optic cables and up to 400 m with PCF fiber-optic cables
- Rugged fiber-optic standard cables, designed for industrial applications
- Extensive approvals (UL)

Benefits

get Designed for Industry

- Plastic and PCF fiber-optic cables can be pre-assembled on site
- Time savings when commissioning thanks to pre-assembled cables
- Protection of the transmission route against electromagnetic interference
- Tap-proof, as the cable does not emit radiation
- Avoidance of overvoltage and equipotential bonding problems

Application

SIMATIC NET plastic and PCF fiber-optic cables are used together with OLM/P for establishing optical PROFIBUS networks or for optical linking of segments using RS 485 technology in indoor and outdoor applications.

Plastic fiber-optic cables and segmented PCF fiber-optic cables can be assembled on-site with 2 x 2 BFOC connectors. The maximum cable length between two OLM/P is 80 m.

Longer cable lengths up to 400 m can be achieved using PCF fiber-optic cables. These cables are also available pre-assembled with 4 BFOC connectors.

Design

Different types of plastic and PCF fiber-optic cables are offered:

Plastic fiber-optic cables

- **Plastic FOC, standard cable;** rugged round cable with violet PVC outer sheath and Kevlar tension components as well as two plastic fibers with a rugged polyamide inner sheath. For indoor applications; cable lengths up to 80 m.
- **Plastic FOC, duplex core;** two flat cores with PVC inner sheath and without outer sheath for indoor applications with low mechanical stress such as laboratory setups or inside cabinets; cable length to 50 m.

PCF fiber optic cables

- **PCF fiber-optic cable, standard cables:** Rugged round cables with violet/green PVC outer sheath and Kevlar strain relief elements for applications indoor/outdoors; cable lengths up to 400 m; the following cable versions are available:
 - PCF fiber optic standard cable; with violet PVC outer sheath for indoor applications. The cable is not suitable for assembly in the field; (only available pre-assembled with an insertion tool)
 - PCF Standard Cable GP (general purpose); with green PVC outer sheath for indoor and outdoor applications. The cable is suitable for assembly in the field.
- **PCF fiber optic trailing cable;** rugged round cable with green outer sheath and Kevlar tension elements for trailing cable applications; cable lengths of up to 400 m. The cables are suitable for assembly in the field. The following cable versions are available:
 - PCF Trailing Cable; cable for high mechanical stress, PUR outer sheath, no UL approval
 - PCF Trailing Cable GP (general purpose); cable for low mechanical stress, PVC outer sheath, with UL approval

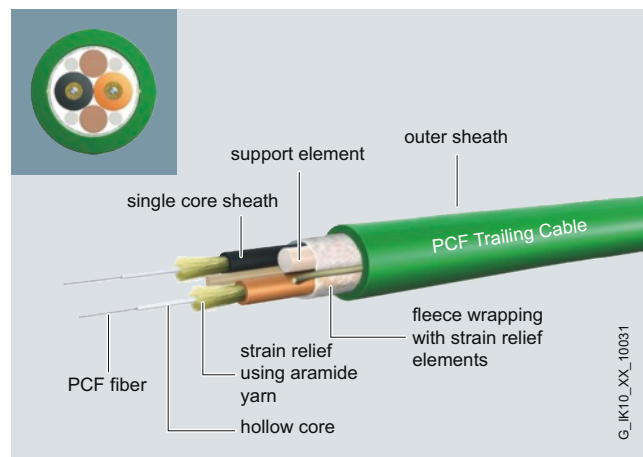

Technical specifications

Order No.	6XV1 821-2AN50	6XV1 821-0AH10	6XV1 821-1BN75
Product type designation	PROFIBUS Plastic Fiber Optic Duplex Core	PROFIBUS Plastic Fiber Optic Standard Cable	PROFIBUS PCF Fiber Optic Standard Cable
Product description	Fiber-optic cable with poly-optical fiber (flat duplex core), 50 m ring, non-assembled	Fiber-optic cable with poly-optical fiber, sold by the meter, non-assembled	Polymer clad fiber cable, preferred length, preassembled
Suitability for application	Indoor applications with low mechanical stress (e.g. laboratory setups or within cabinets), cable lengths up to 50 m	Cable for indoor applications	Cable for indoor applications
Design of preassembled FO cable	Can be fitted with four Simplex connectors	Can be fitted with four Simplex connectors	Fitted with four BFOC connectors
Cable designation	V-2Y 2x1 P 980/1000	I-V4Y(ZN)Y 2P 980/1000	I-V(ZN)Y 2K 200/230
Cable length	50 m	-	75 m
Optical data			
Maximum damping factor per length at 650 nm	0.01 dB/m	0.16 dB/m	0.01 dB/m
Bandwidth length product at 650 nm	1 GHz·m	1 GHz·m	17 GHz·m
Mechanical data			
Number of fibers per FO core	1	1	1
Number of FO cores per FO cable	2	2	2
Design of FO fiber	Step index fiber 980/1000 µm	Step index fiber 980/1000 µm	Step index fiber 200/230 µm
Design of FO core	-	-	-
Design of FO cable	-	-	-
Outer diameter			
• of optical fiber	980 µm	980 µm	200 µm
• of optical fiber sheath	1 000 µm	1 000 µm	230 µm
• of FO core sheath	2.2 mm	2.2 mm	2.2 mm
• of cable	-	7.8 mm	4.7 mm
Symmetrical deviation			
• of outer diameter of FO core sheath	0.1 mm	0.1 mm	0.1 mm
• of outer diameter of cable	-	0.3 mm	-
Symmetrical tolerance of cable sheath width	-	-	-
Material			
• of optical fiber core	Polymethylmethacrylate (PMMA)	Polymethylmethacrylate (PMMA)	Quartz glass
• of optical fiber sheath	Fluoridated special polymer	Fluoridated special polymer	Fluoridated special polymer
• of FO core sheath	PE	PA	PVC
• of FO cable sheath	-	PVC	PVC
• of the strain relief	-	Kevlar fibers	Kevlar fibers
Color			
• of FO core sheath	Gray	Orange/black	Orange/black
• of cable sheath	-	Violet	Violet

PROFIBUS

Optical networks with OLM

Plastic and PCF fiber-optic cable

Technical specifications (continued)

Order No.	6XV1 821-2AN50	6XV1 821-0AH10	6XV1 821-1BN75
Product type designation	PROFIBUS Plastic Fiber Optic Duplex Core	PROFIBUS Plastic Fiber Optic Standard Cable	PROFIBUS PCF Fiber Optic Standard Cable
Bending radius			
• Minimum permitted single bending radius	25 mm	100 mm	47 mm
• Minimum permitted repeated bending radius	25 mm	150 mm	70 mm
Maximum tensile load	10 N	100 N	200 N
Short-term lateral force per length	30 N/cm	100 N/cm	100 N/cm
Continuous lateral force per length	400 N/m	-	-
Weight per length	7.6 kg/km	65 kg/km	22 kg/km
Permitted ambient conditions			
Ambient temperature			
• During operation	-55 ... +85 °C	-30 ... +70 °C	-30 ... +70 °C
• During storage	-55 ... +85 °C	-30 ... +70 °C	-30 ... +70 °C
• During transport	-55 ... +85 °C	-30 ... +70 °C	-30 ... +70 °C
• During mounting	-5 ... +50 °C	0 ... 50 °C	-5 ... +50 °C
Ambient conditions for operation	-	-	-
IP degree of protection	-	-	IP20
Behavior in fire	Flame-retardant in accordance with flame test VW-1 acc. to UL 1581	Flame-retardant in accordance with IEC 60332-1-2	Flame-retardant in accordance with IEC 60332-1-2
Chemical resistance			
• Mineral oil	Limited resistance	Limited resistance	Limited resistance
• Grease	Limited resistance	Limited resistance	Limited resistance
• Water	-	-	-
Radiological resistance against UV radiation	Not resistant	Not resistant	Not resistant
Product properties, functions, components			
General			
Product property			
• Halogen-free	Yes	No	No
• Silicon-free	Yes	Yes	Yes
Product component: protection against rodents	No	No	No
Cable length with plastic optical fiber			
• Maximum with Industrial Ethernet	-	-	-
• Maximum with PROFIBUS	80 m	80 m	-
Standards, specifications, approvals			
Certificate of suitability	-	UL approval: OFN (NEC Article 770, UL 1651) / CSA approval: OFN (CSA standard C22.2 No232-M1988)	-
• RoHS compliance	Yes	Yes	Yes

Technical specifications (continued)

Order No.	6XV1 861-2A	6XV1 861-2C	6XV1 861-2D
Product type designation	PCF Standard Cable GP	PCF Trailing Cable	PCF Trailing Cable GP
Product description	Polymer clad fiber cable, sold by the meter, non-assembled	Polymer clad fiber cable, sold by the meter, non-assembled	Polymer clad fiber cable, sold by the meter, non-assembled
Suitability for application	Cable for fixed installation for indoor and outdoor use, UL approval	Cable for use with high mechanical stress and moving applications (e.g. trailing cables), without UL approval	Cable for use with high mechanical stress and moving applications (e.g. trailing cables), UL approval
Design of preassembled FO cable	Can be fitted with SC RJ, SC RJ Plug PRO, BFOC and Simplex connectors	Can be fitted with SC RJ, SC RJ Plug PRO, BFOC and Simplex connectors	Can be fitted with SC RJ, SC RJ Plug PRO, BFOC and Simplex connectors
Cable designation	AT-V(ZN)YY 2K 200/230	AT-V(ZN)Y(ZN)11Y 2K 200/230	AT-V(ZN)Y(ZN)Y 2K 200/230
Cable length	-	-	-
Optical data			
Maximum damping factor per length at 660 nm	10 dB/km	10 dB/km	10 dB/km
Bandwidth length product at 650 nm	17 GHz·m	17 GHz·m	17 GHz·m
Mechanical data			
Number of fibers per FO core	1	1	1
Number of FO cores per FO cable	2	2	2
Design of FO fiber	Step index fiber 200/230 µm	Step index fiber 200/230 µm	Step index fiber 200/230 µm
Design of FO core	-	-	-
Design of FO cable	-	-	-
Outer diameter			
• of optical fiber	200 µm	200 µm	200 µm
• of optical fiber sheath	230 µm	230 µm	230 µm
• of FO core sheath	2.2 mm	2.2 mm	2.2 mm
• of cable	7.2 mm	8.8 mm	8.8 mm
Symmetrical deviation			
• of outer diameter of FO core sheath	0.1 mm	0.1 mm	0.1 mm
• of outer diameter of cable	0.5 mm	0.5 mm	0.5 mm
Material			
• of optical fiber core	Quartz glass	Quartz glass	Quartz glass
• of optical fiber sheath	Special polymer	Special polymer	Special polymer
• of FO core sheath	PVC	PVC	PVC
• of FO cable sheath	PVC	PUR	PVC
• of the strain relief	Aramide fibers	Aramide fibers	Aramide fibers
Color			
• of FO core sheath	Orange/black	Orange/black	Orange/black
• of cable sheath	Green	Green	Green

PROFIBUS

Optical networks with OLM

Plastic and PCF fiber-optic cable

Technical specifications (continued)

Order No.	6XV1 861-2A	6XV1 861-2C	6XV1 861-2D
Product type designation	PCF Standard Cable GP	PCF Trailing Cable	PCF Trailing Cable GP
Bending radius			
• Minimum permitted single bending radius	70 mm	130 mm	130 mm
• Minimum permitted repeated bending radius	105 mm	175 mm	175 mm
• With continuous bending	-	-	-
Number of bending cycles	-	5 000 000	5 000 000
Maximum tensile load	100 N	800 N	800 N
Short-term lateral force per length	500 N/cm	500 N/cm	500 N/cm
Continuous lateral force per length	300 N/cm	300 N/cm	300 N/cm
Weight per length	45 kg/km	85 kg/km	85 kg/km
Permitted ambient conditions			
Ambient temperature			
• During operation	-40 ... +90 °C	-25 ... +75 °C	-25 ... +75 °C
• During storage	-40 ... +90 °C	-30 ... +75 °C	-30 ... +75 °C
• During transport	-40 ... +90 °C	-30 ... +75 °C	-30 ... +75 °C
• During mounting	-5 ... +50 °C	-5 ... +50 °C	-5 ... +50 °C
Behavior in fire	Flame-retardant in accordance with IEC 60332-1-2 and IEC 60332-3-22 (Cat. A)	Flame-retardant	Flame-retardant in accordance with IEC 60332-1-2 and IEC 60332-3-22 (Cat. A)
Chemical resistance			
• Mineral oil	Limited resistance	Resistant	Limited resistance
• Grease	Limited resistance	Resistant	Limited resistance
• Water	-	-	-
Radiological resistance against UV radiation	Resistant	Resistant	Resistant
Product properties, functions, components			
General			
Product property			
• Halogen-free	No	No	No
• Silicon-free	Yes	Yes	Yes
Product component: protection against rodents	No	No	No
Cable length with polymer clad fiber			
• Maximum with Industrial Ethernet	100 m	100 m	100 m
• Maximum with PROFIBUS	400 m	400 m	400 m
Standards, specifications, approvals			
Certificate of suitability	UL approval: OFN (NEC Article 770, UL 1651) / CSA approval: OFN 90 Cel, FT1, FT4 (CSA standard C22.2 No232-M1988)	-	UL approval: OFN (NEC Article 770, UL 1651) / CSA approval: OFN 90 Cel, FT1, FT4 (CSA standard C22.2 No232-M1988)
• RoHS compliance	Yes	Yes	Yes

Technical specifications (continued)

Order No.	6GK1 905-1PA00
Product type designation	PB BFOC Plug POF
Product description	BFOC connector
Suitability for application	For assembly of PB plastic fiber optic cables for OLM/P.
Transmission rate	
Transmission rate	
• 1 with Industrial Ethernet	-
• 2 with Industrial Ethernet	-
• 3 with Industrial Ethernet	-
• with PROFIBUS	9.6 kbit/s ... 12 Mbit/s
Interfaces	
Number of optical connections for fiber-optic cables	1
Number of optical connections for network components or terminals	BFOC connector
Design of electrical connection FastConnect	No
Mechanical data	
Enclosure material	Metal
Design, dimensions and weights	
Type of cable outlet	180 degree cable outlet
Width	10 mm
Height	10 mm
Depth	10 mm
Net weight	10 g
Permitted ambient conditions	
IP degree of protection	IP20
Chemical resistance to water	-
Product properties, functions, components	
General	
Product property silicon-free	Yes
Product component strain relief	Yes
Standards, specifications, approvals	
Certificate of suitability: RoHS conformity	Yes

Ordering data

Order No.

PROFIBUS Plastic Fiber Optic, standard cable

Rugged round cable with 2 plastic fiber-optic cores, PVC outer sheath and PA inner sheath, for indoor use

Without connector

- Sold by the meter
- 50 m ring
- 100 m ring

6XV1 821-0AH10
6XV1 821-0AN50
6XV1 821-0AT10

Preferred lengths
pre-assembled with 2 x 2 BFOC plugs, lash length 20 cm each, for connecting OLM/P..

- 1 m
- 2 m
- 5 m
- 10 m
- 15 m
- 20 m
- 25 m
- 30 m
- 50 m
- 65 m
- 80 m

6XV1 821-0BH10
6XV1 821-0BH20
6XV1 821-0BH50
6XV1 821-0BN10
6XV1 821-0BN15
6XV1 821-0BN20
6XV1 821-0BN25
6XV1 821-0BN30
6XV1 821-0BN50
6XV1 821-0BN65
6XV1 821-0BN80

PROFIBUS Plastic Fiber Optic, duplex core

Plastic fiber-optic cable with 2 cores, PVC outer sheath, for use in environments with low mechanical stress, without connector

- 50 m ring

6XV1 821-2AN50

PROFIBUS Plastic Fiber Optic, stripping tool set

Tools for removing the outer sheath or core sheath of PROFIBUS Plastic Fiber Optic cables

6GK1 905-6PA10

PROFIBUS Plastic Fiber Optic, BFOC connector set

20 BFOC plugs for assembly of PROFIBUS Plastic Fiber Optic cables for OLM/P..

6GK1 905-1PA00

PROFIBUS Plastic Fiber Optic, BFOC crimping tool

For assembly of BFOC plug on PROFIBUS Plastic Fiber Optic cables

6GK1 905-6PB00

PROFIBUS Plastic Fiber Optic, BFOC polishing set

Polishing set for grinding and polishing the BFOC plug face for PROFIBUS Plastic Fiber Optic cables with OLM/P..

6GK1 905-6PS00

PROFIBUS

Optical networks with OLM

Plastic and PCF fiber-optic cable

Ordering data

PROFIBUS PCF Fiber Optic standard cable

PCF fiber-optic cable with 2 cores, PVC outer sheath, for bridging large distances up to 400 m,

Preferred lengths
pre-assembled
with 2 x 2 BFOC plugs,
lash length 20 cm each,
with insertion tool mounted on one end for connecting OLM/P..

- 75 m
- 100 m
- 150 m
- 200 m
- 250 m
- 300 m
- 400 m

Order No.

6XV1 821-1BN75
6XV1 821-1BT10
6XV1 821-1BT15
6XV1 821-1BT20
6XV1 821-1BT25
6XV1 821-1BT30
6XV1 821-1BT40

PROFIBUS PCF Standard Cable GP 200/230

Standard cable, segmentable, sold by the meter;
max. quantity 2000 m;
minimum order 20 m;

Preferred lengths
pre-assembled
with 4 BFOC connectors

- 75 m
- 100 m
- 150 m
- 200 m
- 250 m
- 300 m
- 400 m

6XV1 861-2A

6XV1 861-3AN75
6XV1 861-3AT10
6XV1 861-3AT15
6XV1 861-3AT20
6XV1 861-3AT25
6XV1 861-3AT30
6XV1 861-3AT40

PROFIBUS PCF Trailing Cable 200/230

Trailing cable, segmentable, sold by the meter;
max. quantity 2000 m;
minimum order 20 m;

Preferred lengths
pre-assembled
with 4 BFOC connectors

- 75 m
- 100 m
- 150 m
- 200 m
- 250 m
- 300 m
- 400 m

Order No.

6XV1 861-2C

6XV1 861-3CN75
6XV1 861-3CT10
6XV1 861-3CT15
6XV1 861-3CT20
6XV1 861-3CT25
6XV1 861-3CT30
6XV1 861-3CT40

PROFIBUS PCF Trailing Cable GP 200/230

Trailing cable, segmentable, sold by the meter;
max. quantity 2000 m;
minimum order 20 m;

Preferred lengths
pre-assembled
with 4 BFOC connectors

- 75 m
- 100 m
- 150 m
- 200 m
- 250 m
- 300 m
- 400 m

6XV1 861-2D

6XV1 861-3DN75
6XV1 861-3DT10
6XV1 861-3DT15
6XV1 861-3DT20
6XV1 861-3DT25
6XV1 861-3DT30
6XV1 861-3DT40

SIMATIC NET Manual Collection

Electronic manuals for communication systems, communication protocols, and communication products;
on DVD;
German/English

6GK1 975-1AA00-3AA0

More information

You can order components and demonstration materials supplementary to the SIMATIC NET cabling range from your local contact.

Technical advice on this subject is available from:

J. Hertlein
I IA SC IC PRM 4
Phone: +49 (0)911/750 44 65
E-mail: juergen.hertlein@siemens.com

Overview



- Compact, rugged assembly case for PCF fiber-optic cables
- Special versions for easy assembly of HP Simplex and BFOC plugs on PCF fiber-optic cables
- The quality of the assembly can be checked using the enclosed microscope

Benefits

get Designed for Industry

- Easy installation of the unassembled cables in industrial plants
- Flexible assembly of connectors on PCF fiber-optic cables on site (HP Simplex, BFOC connectors)
- Mistakes are avoided with easy visual inspection of the assembled connector on site using a microscope
- PCF fiber-optic cables are easily repaired on site by installing a new PCF cable

Application

SIMATIC NET PCF fiber-optic conductors are used to construct optical indoor and outdoor PROFIBUS DP networks. They are easy to assemble on site with 2 x 2 Simplex connectors or 2 x 2 BFOC connectors. The maximum cable length between two DP devices is 300 m and between two OLMs 400 m.

PROFIBUS DP devices with integrated optical interface (Simplex connection technology) include, for example, OBT, CP 342-5 FO, CP 5613 FO, IM 153-2 FO, IM 467 FO.

Design

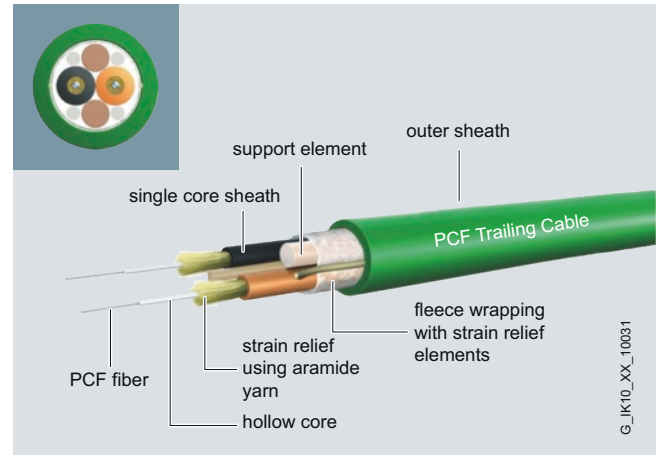

Two versions of the assembly case are available for PCF fiber-optic cables:

- Assembly case for HP Simplex connectors; for on-site pre-assembly of HP Simplex connectors; comprising a stripping tool, buffer stripping tool, Kevlar cutters, fiber breaking tool, crimping tool and microscope
- Assembly case for BFOC connectors; for on-site pre-assembly of BFOC connectors; comprising a stripping tool, buffer stripping tool, Kevlar cutters, fiber breaking tool and microscope

PROFIBUS

Optical networks with OLM

PCF-FOC termination kit

Technical specifications

Order No.	6GK1 900-0KB00-0AC0	6GK1 900-0HB00-0AC0
Product type designation	PB Simplex Plug PCF	PB BFOC Plug PCF
Product description	Simplex crimp connector for PCF fiber-optic cables with plastic cladding	BFOC screw connector for PCF fiber-optic cables with plastic cladding
Suitability for use	for the connection of PCF fiber-optic cables	for the connection of PCF fiber-optic cables
Transmission rate		
Transmission rate		
• 1 with Industrial Ethernet	-	-
• 2 with Industrial Ethernet	-	-
• 3 with Industrial Ethernet	-	-
• with PROFIBUS	9.6 kbit/s ... 12 Mbit/s	9.6 kbit/s ... 12 Mbit/s
Interfaces		
Number of optical connections for fiber-optic cables	1	1
Design of optical connection for network components or terminals	Simplex connector	BFOC connector
Design of FastConnect electrical connection	No	No
Mechanical data		
Enclosure material	Plastic	Metal and plastic
Design, dimensions and weights		
Type of cable outlet	180 degree cable outlet	180 degree cable outlet
Width	9.4 mm	10 mm
Height	6.1 mm	10 mm
Depth	29.9 mm	10 mm
Net weight	20 g	8 g
Permissible ambient conditions		
IP degree of protection	IP20	IP20
Chemical resistance to water	-	-
Product properties, functions, components		
General		
Product property silicon-free	Yes	Yes
Product component strain relief	Yes	Yes
Standards, specifications, approvals		
Certificate of suitability: RoHS conformity	Yes	Yes

Ordering data	Order No.
Termination Kit for Simplex plug Assembly case for local assembly of PCF Simplex connectors; comprising a stripping tool, buffer stripping tool, Kevlar cutters, fiber breaking tool, crimping tool and microscope	6GK1 900-0KL00-0AA0
Termination Kit for BFOC plug Assembly case for local assembly of BFOC connectors; comprising a stripping tool, buffer stripping tool, Kevlar cutters, fiber breaking tool, and microscope	6GK1 900-0HL00-0AA0
<i>Connector</i>	
Simplex connector with cleaning materials; 50 crimp connectors for assembly on PCF fiber-optic cables on site	6GK1 900-0KB00-0AC0
BFOC connector with cleaning materials; 20 screw connectors for assembly on PCF fiber-optic cables on site	6GK1 900-0HB00-0AC0

More information

You can order components supplementary to the SIMATIC NET cabling range from your local contact.

Technical advice on this subject is available from:

J. Hertlein

I IA SC IC PM 1

Tel.: +49 (0)911/750 44 65

E-mail: juergen.hertlein@siemens.com

PROFIBUS

Optical networks with OLM

OLM Optical Link Module

Overview



- Construction of optical PROFIBUS networks (line, star, ring) with glass, PCF and plastic fiber optic cables
- High availability can be achieved using a redundant power supply and redundant cable routing
- Function monitoring by means of signaling contact
- All PROFIBUS data transmission rates from 9.6 kbit/s to 12 Mbit/s inclusive 45.45 kbit/s for PROFIBUS PA
- Monitoring of the fiber optic cable routes on LEDs for channel monitoring or using a voltmeter across measurement terminals

Benefits

get **Designed for Industry**

- High availability of the network thanks to redundant optical ring
- Fast fault localization due to signaling of the fiber-optic line quality to LEDs and signaling contact (e.g. import of the level value of the fiber-optic line quality via an analog module into a programmable logic controller)
- Large range due to use of glass fiber optic cables in lengths of up to 15 km
- OLM/G12-EEC for outdoor use down to -25 °C

Application

With the PROFIBUS OLM (Optical Link Modules), optical PROFIBUS networks can be established in linear, star and redundant ring topologies.

The data transfer rate of a fiber optic line is independent of the distance and can be up to 12 Mbit/s.

Possible applications for OLMs include:

- System buses based on PROFIBUS
- Networking between buildings using glass fiber optic cable
- Mixed networks with electrical and optical segments
- Networks covering a wide area (road tunnels, traffic control systems)
- Networks with high availability requirements (redundant ring networks)

Design

The OLMs have a compact metal housing. It is suitable for mounting on a standard rail or for wall mounting with a mounting plate.

The 24 V power supply is fed in through a terminal block and can be redundantly connected.

The signaling contact allows a digital signal to be transferred to PLCs or HMI systems for evaluation.

OLMs can be combined with each other and individual stations or complete electrical segments can be integrated into the optical PROFIBUS network through an electrical interface. With the PROFIBUS OLM P22 and OLM G22, two electric PROFIBUS segments can be connected separated from each other.

OLMs are available with one or two fiber optic interfaces with BFOC connectors for different types of fiber optic cables:

- Plastic fiber-optic cables (980/1000 μm) can be used for single lengths of up to 80 m. They can also be assembled with BFOC cable connectors on site.
- PCF fiber-optic cables (200/230 μm) can be used for single lengths of up to 400 m. They are offered preassembled with four BFOC plugs and an insertion tool.
- Glass fiber multimode fiber-optic cables (62.5/125 μm) such as the SIMATIC NET Fiber Optic cables can be used for long distances of up to 3000 m. They must be ordered preassembled with 4 BFOC plugs or as a FastConnect FO system for assembly on site.
- Singlemode fiber-optic cables (10/125 μm or 9/125 μm fibers) can be used for extremely long distances up to 15 km.

Function

- Automatic detection of all PROFIBUS data transmission rates 9.6 kbit/s to 12 Mbit/s inclusive 45.45 kbit/s (PROFIBUS PA)
- Construction of the following network topologies: Line, star, redundant ring
- High availability due to media redundancy. The distance between two OLMs in the redundant ring is only limited by the optical range of the modules
- RS485 interface with segment capability (Sub-D female connector)
- Unrestricted multimaster operation: Expanded segmentation functions for localization of faults to fiber optic and RS485 segments
- Fast localization of faults:
 - Indication of module status through floating signaling contact
 - Checking the fiber optic cable route quality on LEDs
 - Checking the fiber optic cable route quality Measurement output for optical receiver for logging and plausibility checking of the fiber optic path attenuation with a voltmeter
- High cascading depth: Line and redundant ring up to 124 OLM (only limited by monitoring times)

Integration

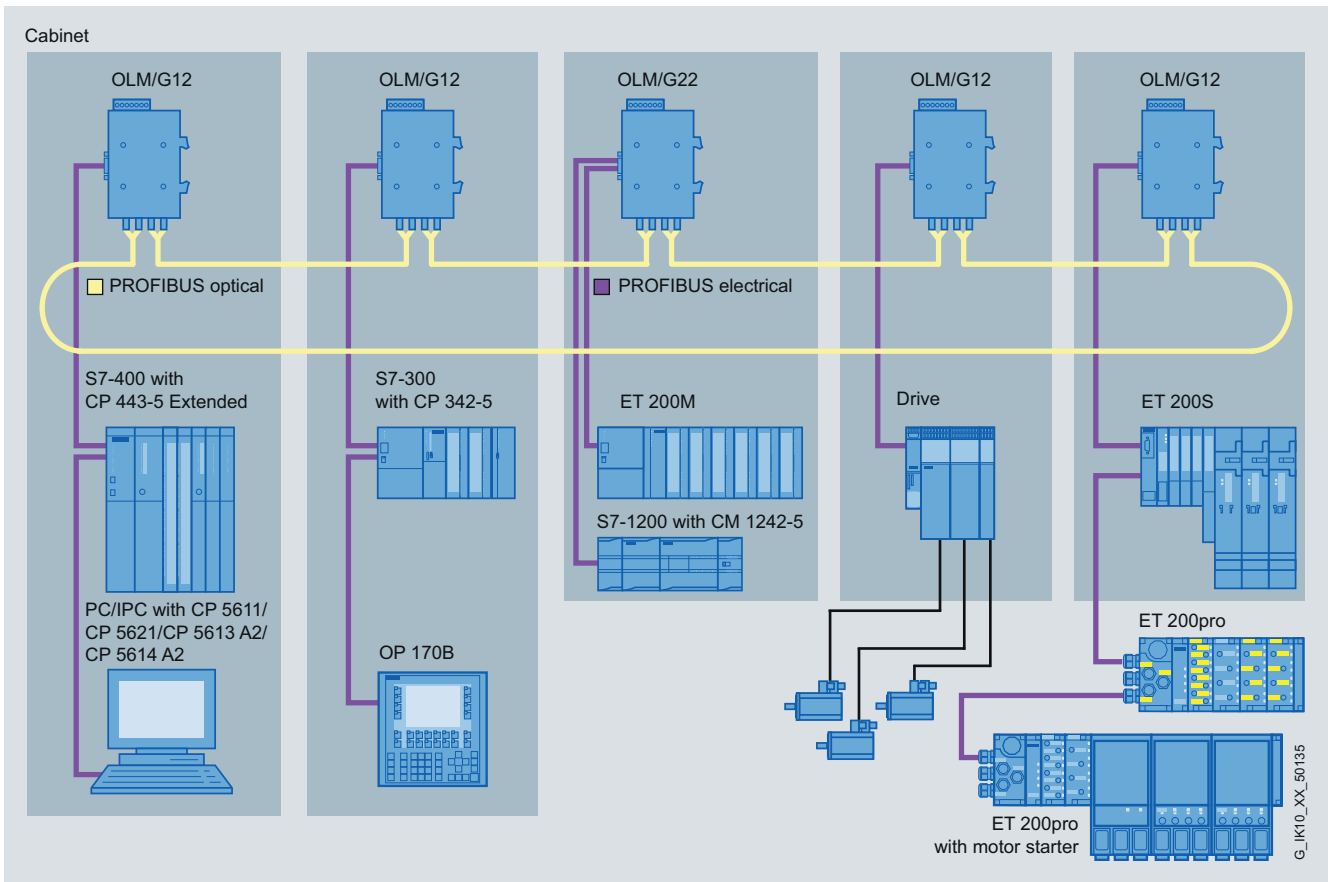

Example of a system configuration with OLM for PROFIBUS in a ring structure

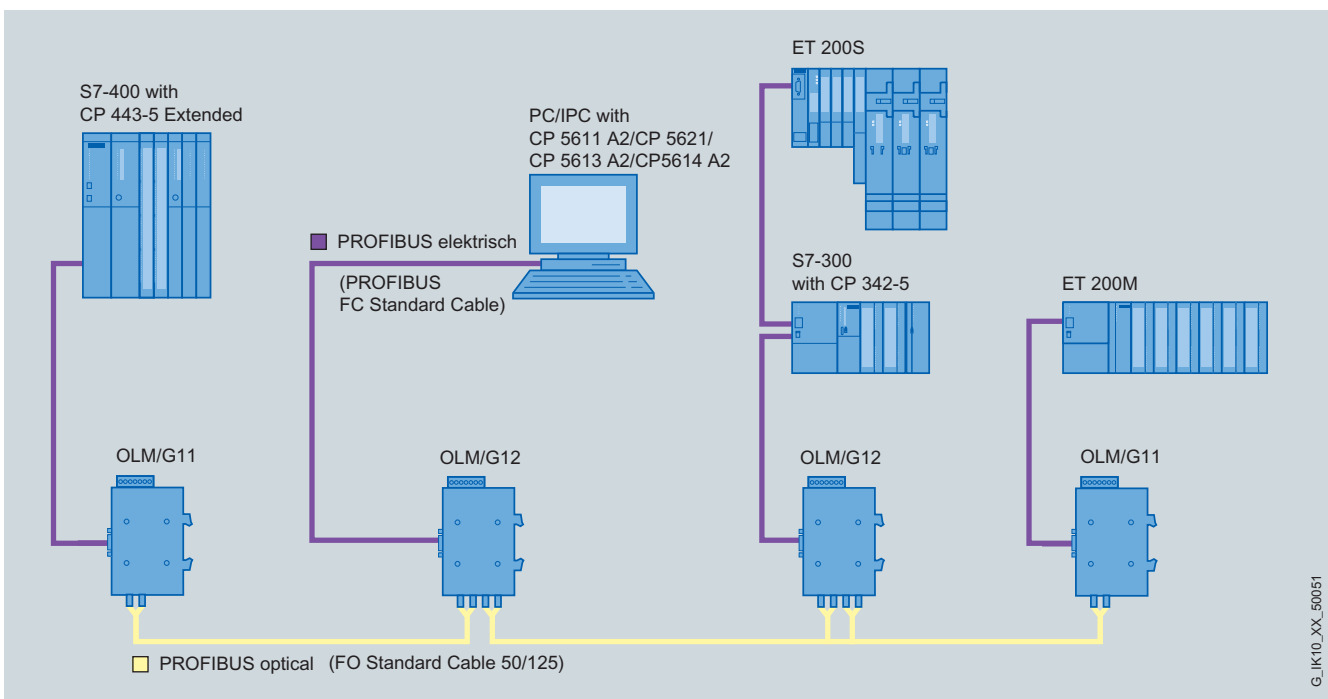

Optical line topology with PROFIBUS OLM G11/G12

PROFIBUS

Optical networks with OLM

OLM Optical Link Module

Integration (continued)

3

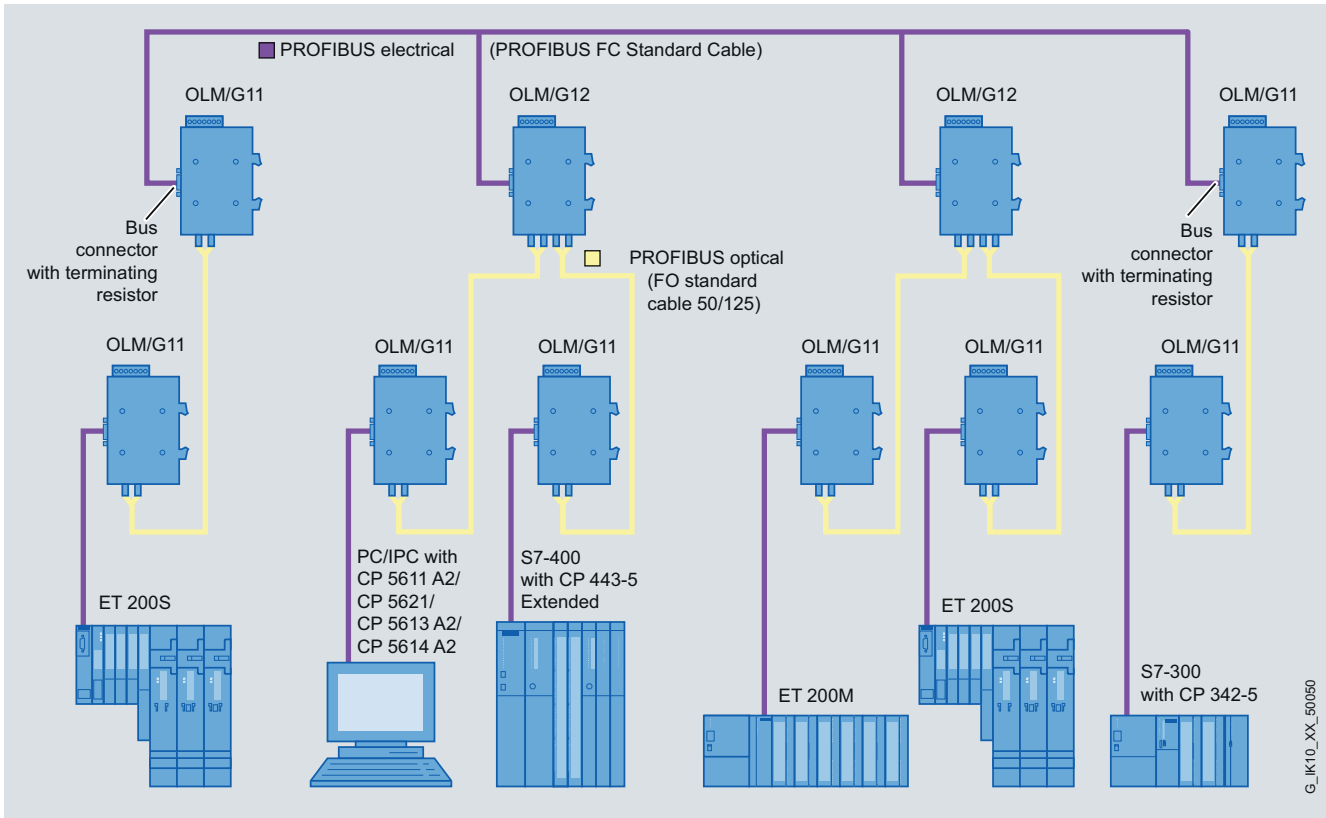

G_IK10_XX_50050

Optical star topology with PROFIBUS OLM G11/G12

Technical specifications

Order No.	6GK1 503-2CA00	6GK1 503-3CA00	6GK1 503-4CA00
Product type designation	PROFIBUS OLM P11	PROFIBUS OLM P12	PROFIBUS OLM P22
Transmission rate			
Transmission rate			
• with PROFIBUS	9.6 kbit/s ... 12 Mbit/s	9.6 kbit/s ... 12 Mbit/s	9.6 kbit/s ... 12 Mbit/s
• with PROFIBUS PA	45.45 kbit/s	45.45 kbit/s	45.45 kbit/s
Interfaces			
Maximum number of electrical/ optical connections for network components or terminal equipment	2	3	4
Number of electrical connections			
• for network components or terminal equipment	1	1	2
• for measuring instrument	1	1	1
• for signaling contact	1	1	1
• for power supply	1	1	1
• for redundant power supply	1	1	1
Design of electrical connection			
• for network components or terminal equipment	9-pin sub-D socket	9-pin sub-D socket	9-pin sub-D socket
• For measuring instrument	2-pin terminal block	2-pin terminal block	2-pin terminal block
• for power supply and signaling contact	5-pin terminal block	5-pin terminal block	5-pin terminal block
Number of optical connections for fiber-optic cables	1	2	2
Design of optical connection for fiber-optic cables	BFOC port	BFOC port	BFOC port
Optical data			
Attenuation factor of the FOC transmission link			
• for glass FOC with 10/125 µm or 9/125 µm at 0.5 dB/km, max.	-	-	-
• for glass FOC with 50/125 µm at 3 dB/km, max.	-	-	-
• for glass FOC with 62.5/125 µm			
- at 1 dB/km maximum	-	-	-
- at 3.5 dB/km maximum	-	-	-
• for PCF FOC with 200/230 µm at 10 dB/km	-	-	-
• for POF FOC with 980/1000 µm at 230 dB/km	13 dB	13 dB	13 dB
Signal delay time in bit time	6.5 bit	6.5 bit	6.5 bit
Injectable optical power relative to 1 mW			
• for glass FOC with 10/125 µm or 9/125 µm at 0.5 dB/km	-	-	-
• for glass FOC with 50/125 µm at 3 dB/km	-	-	-
• for glass FOC with 62.5/125 µm			
- at 1 dB/km	-	-	-
- at 3.5 dB/km	-	-	-
• of the FOC transmission link			
- for PCF FOC with 200/230 µm at 10 dB/km	-17 dB	-	-
- for POF FOC with 980/1000 µm at 230 dB/km	-5 dB	-	-

PROFIBUS

Optical networks with OLM

OLM Optical Link Module

Technical specifications (continued)

Order No.	6GK1 503-2CA00	6GK1 503-3CA00	6GK1 503-4CA00
Product type designation	PROFIBUS OLM P11	PROFIBUS OLM P12	PROFIBUS OLM P22
optical sensitivity relative to 1 mW			
• for glass FOC with 10/125 µm or 9/125 µm at 0.5 dB/km	-	-	-
• for glass FOC with 50/125 µm at 3 dB/km	-	-	-
• for glass FOC with 62.5/125 µm			
- at 1 dB/km	-	-	-
- at 3.5 dB/km	-	-	-
• of the FOC transmission link			
- for PCF FOC with 200/230 µm at 10 dB/km	-25 dB	-	-
- for POF FOC with 980/1000 µm at 230 dB/km	-25 dB	-	-
Wavelength			
• for glass FOC with 10/125 µm or 9/125 µm compatible with interface at 0.5 dB/km	-	-	-
• for glass FOC with 50/125 µm compatible with interface at 3 dB/km	-	-	-
• for glass FOC with 62.5/125 µm compatible with interface			
- at 1 dB/km	-	-	-
- at 3.5 dB/km	-	-	-
• of the FOC transmission link			
- for PCF FOC with 200/230 µm at 10 dB/km	660 nm	660 nm	660 nm
- for POF FOC with 980/1000 µm at 230 dB/km	660 nm	660 nm	660 nm
Cable length			
• for glass FOC with 10/125 µm or 9/125 µm at 0.5 dB/km, max.	-	-	-
• for glass FOC with 50/125 µm at 3 dB/km, max.	-	-	-
• for glass FOC with 62.5/125 µm			
- at 1 dB/km maximum	-	-	-
- at 3.5 dB/km maximum	-	-	-
• for PCF FOC with 200/230 µm at 10 dB/km maximum	400 m	400 m	400 m
• for POF FOC with 980/1000 µm at 230 dB/km, max.	80 m	80 m	80 m
Inputs/outputs			
Operating voltage of signaling contacts with DC rated value	24 V	24 V	24 V
Operating current of signaling contacts with DC maximum	0.1 A	0.1 A	0.1 A
Supply voltage, current consumption, power loss			
Type of power supply	DC	DC	DC
DC power supply			
• Rated value	24 V	24 V	24 V
• Minimum	18.8 V	18.8 V	18.8 V
• Maximum	28.8 V	28.8 V	28.8 V
Product component: fusing at power supply input	Yes	Yes	Yes
Type of fusing of power supply input	-	-	-
Maximum current consumed at 24 V DC	0.2 A	0.2 A	0.2 A
Effective power loss at 24 V DC	-	-	-

Technical specifications (continued)

Order No.	6GK1 503-2CA00	6GK1 503-3CA00	6GK1 503-4CA00
Product type designation	PROFIBUS OLM P11	PROFIBUS OLM P12	PROFIBUS OLM P22
Permitted ambient conditions			
Ambient temperature			
• During operation	0 ... 60 °C	0 ... 60 °C	0 ... 60 °C
• During storage	-40 ... +70 °C	-40 ... +70 °C	-40 ... +70 °C
• During transport	-40 ... +70 °C	-40 ... +70 °C	-40 ... +70 °C
Relative humidity at 25 °C without condensation during operation, maximum	95 %	95 %	95 %
IP degree of protection	IP40	IP40	IP40
Design, dimensions and weights			
Type of construction	Compact	Compact	Compact
Width	39.5 mm	39.5 mm	39.5 mm
Height	112 mm	112 mm	112 mm
Depth	74.5 mm	74.5 mm	74.5 mm
Net weight	340 g	340 g	340 g
Type of mounting			
• 35 mm DIN rail mounting	Yes	Yes	Yes
• Wall mounting	Yes	Yes	Yes
Product properties, functions, components			
General			
Product function: Ring redundancy	Yes	Yes	Yes
Standards, specifications, approvals			
Standard			
• for EMC of FM	FM3611: Class 1, Division 2, Group A, B, C, D / T4, Class 1, Zone 2, Group IIC, T4	FM3611: Class 1, Division 2, Group A, B, C, D / T4, Class 1, Zone 2, Group IIC, T4	FM3611: Class 1, Division 2, Group A, B, C, D / T4, Class 1, Zone 2, Group IIC, T4
• for hazardous zone	EN 60079-0: 2006, EN 60079-15: 2005, EN 60079-28: 2007, II 3 (2) G Ex nA [opis] IIC T4 KEMA 09 ATEX 0173X	EN 60079-0: 2006, EN 60079-15: 2005, EN 60079-28: 2007, II 3 (2) G Ex nA [opis] IIC T4 KEMA 09 ATEX 0173X	EN 60079-0: 2006, EN 60079-15: 2005, EN 60079-28: 2007, II 3 (2) G Ex nA [opis] IIC T4 KEMA 09 ATEX 0173X
• for CSA and UL safety	UL 60950-1, CSA C22.2 No. 60950-1	UL 60950-1, CSA C22.2 Nr. 60950-1	UL 60950-1, CSA C22.2 No. 60950-1
• for hazardous zone of CSA and UL	UL 1604 and UL 2279-15 (Hazardous Location), CSA C22.2 No. 213-M1987, Class 1 / Division 2 / Group A, B, C, D / T4, Class 1 / Zone 2 / Group IIC / T4	UL 1604 and UL 2279-15 (Hazardous Location), CSA C22.2 No. 213-M1987, Class 1 / Division 2 / Group A, B, C, D / T4, Class 1 / Zone 2 / Group IIC / T4	UL 1604 and UL 2279-15 (Hazardous Location), CSA C22.2 No. 213-M1987, Class 1 / Division 2 / Group A, B, C, D / T4, Class 1 / Zone 2 / Group IIC / T4
• For emitted interference	EN 61000-6-4 (Class A)	EN 61000-6-4 (Class A)	EN 61000-6-4 (Class A)
• For noise immunity	EN 61000-6-2	EN 61000-6-2	EN 61000-6-2
Certificate of suitability	EN 61000-6-2, EN 61000-6-4	EN 61000-6-2, EN 61000-6-4	EN 61000-6-2, EN 61000-6-4
• CE mark	Yes	Yes	Yes
• C-Tick	Yes	Yes	Yes
Marine classification society			
• American Bureau of Shipping Europe Ltd. (ABS)	Yes	Yes	Yes
• Bureau Veritas (BV)	Yes	Yes	Yes
• Det Norske Veritas (DNV)	Yes	Yes	Yes
• Germanischer Lloyd (GL)	Yes	Yes	Yes
• Lloyds Register of Shipping (LRS)	Yes	Yes	Yes
• Nippon Kaiji Kyokai (NK)	Yes	Yes	Yes

PROFIBUS

Optical networks with OLM

OLM Optical Link Module

Technical specifications (continued)

Order No.	6GK1 503-2CB00	6GK1 503-3CB00	6GK1 503-4CB00
Product type designation	PROFIBUS OLM G11	PROFIBUS OLM G12	PROFIBUS OLM G22
Transmission rate			
Transmission rate			
• with PROFIBUS	9.6 kbit/s ... 12 Mbit/s	9.6 kbit/s ... 12 Mbit/s	9.6 kbit/s ... 12 Mbit/s
• with PROFIBUS PA	45.45 kbit/s	45.45 kbit/s	45.45 kbit/s
Interfaces			
Maximum number of electrical/optical connections for network components or terminal equipment	2	3	4
Number of electrical connections			
• for network components or terminal equipment	1	1	2
• for measuring instrument	1	1	1
• for signaling contact	1	1	1
• for power supply	1	1	1
• for redundant power supply	1	1	1
Design of electrical connection			
• for network components or terminal equipment	9-pin sub-D socket	9-pin sub-D socket	9-pin sub-D socket
• for measuring instrument	2-pin terminal block	2-pin terminal block	2-pin terminal block
• for power supply and signaling contact	5-pin terminal block	5-pin terminal block	5-pin terminal block
Number of optical connections for fiber-optic cables	1	2	2
Design of optical connection for fiber-optic cables	BFOC port	BFOC port	BFOC port
Optical data			
Attenuation factor of the FOC transmission link			
• for glass FOC with 10/125 µm or 9/125 µm at 0.5 dB/km, max.	-	-	-
• for glass FOC with 50/125 µm at 3 dB/km, max.	10 dB	10 dB	10 dB
• for glass FOC with 62.5/125 µm			
- at 1 dB/km maximum	-	-	-
- at 3.5 dB/km maximum	12 dB	12 dB	12 dB
• for PCF FOC with 200/230 µm at 10 dB/km	-	-	-
• for POF FOC with 980/1000 µm at 230 dB/km	-	-	-
Signal delay time in bit time	6.5 bit	6.5 bit	6.5 bit
Injectable optical power relative to 1 mW			
• for glass FOC with 10/125 µm or 9/125 µm at 0.5 dB/km	-	-	-
• for glass FOC with 50/125 µm at 3 dB/km	-16 dB	-16 dB	-16 dB
• for glass FOC with 62.5/125 µm			
- at 1 dB/km	-	-	-
- at 3.5 dB/km	-13 dB	-13 dB	-13 dB
• of the FOC transmission link			
- for PCF FOC with 200/230 µm at 10 dB/km	-	-	-
- for POF FOC with 980/1000 µm at 230 dB/km	-	-	-

Technical specifications (continued)

Order No.	6GK1 503-2CB00	6GK1 503-3CB00	6GK1 503-4CB00
Product type designation	PROFIBUS OLM G11	PROFIBUS OLM G12	PROFIBUS OLM G22
optical sensitivity relative to 1 mW			
• for glass FOC with 10/125 µm or 9/125 µm at 0.5 dB/km	-	-	-
• for glass FOC with 50/125 µm at 3 dB/km	-28 dB	-28 dB	-28 dB
• for glass FOC with 62.5/125 µm			
- at 1 dB/km	-	-	-
- at 3.5 dB/km	-28 dB	-28 dB	-28 dB
• of the FOC transmission link			
- for PCF FOC with 200/230 µm at 10 dB/km	-	-	-
- for POF FOC with 980/1000 µm at 230 dB/km	-	-	-
Wavelength			
• for glass FOC with 10/125 µm or 9/125 µm compatible with interface at 0.5 dB/km	-	-	-
• for glass FOC with 50/125 µm compatible with interface at 3 dB/km	860 nm	860 nm	860 nm
• for glass FOC with 62.5/125 µm compatible with interface			
- at 1 dB/km	-	-	-
- at 3.5 dB/km	860 nm	860 nm	860 nm
• of the FOC transmission link			
- for PCF FOC with 200/230 µm at 10 dB/km	-	-	-
- for POF FOC with 980/1000 µm at 230 dB/km	-	-	-
Cable length			
• for glass FOC with 10/125 µm or 9/125 µm at 0.5 dB/km, max.	-	-	-
• for glass FOC with 50/125 µm at 3 dB/km, max.	3 km	3 km	3 km
• for glass FOC with 62.5/125 µm			
- at 1 dB/km maximum	-	-	-
- at 3.5 dB/km maximum	3 km	3 km	3 km
• for PCF FOC with 200/230 µm at 10 dB/km maximum	-	-	-
• for POF FOC with 980/1000 µm at 230 dB/km, max.	-	-	-
Inputs/outputs			
Operating voltage of signaling contacts with DC rated value	24 V	24 V	24 V
Maximum operating current of signal contacts with DC	0.1 A	0.1 A	0.1 A
Supply voltage, current consumption, power loss			
Type of power supply	DC	DC	DC
DC power supply			
• Rated value	24 V	24 V	24 V
• Minimum	18.8 V	18.8 V	18.8 V
• Maximum	28.8 V	28.8 V	28.8 V
Product component: fusing of power supply input	Yes	Yes	Yes
Type of fusing of power supply input	-	-	-
Maximum current consumed at 24 V DC	0.2 A	0.2 A	0.2 A
Effective power loss at 24 V DC	-	-	-

PROFIBUS

Optical networks with OLM

OLM Optical Link Module

Technical specifications (continued)

Order No.	6GK1 503-2CB00	6GK1 503-3CB00	6GK1 503-4CB00
Product type designation	PROFIBUS OLM G11	PROFIBUS OLM G12	PROFIBUS OLM G22
Permitted ambient conditions			
Ambient temperature			
• During operation	0 ... 60 °C	0 ... 60 °C	0 ... 60 °C
• During storage	-40 ... +70 °C	-40 ... +70 °C	-40 ... +70 °C
• During transport	-40 ... +70 °C	-40 ... +70 °C	-40 ... +70 °C
Relative humidity at 25 °C without condensation during operation, maximum	95 %	95 %	95 %
IP degree of protection	IP40	IP40	IP40
Design, dimensions and weights			
Type of construction	Compact	Compact	Compact
Width	39.5 mm	39.5 mm	39.5 mm
Height	112 mm	112 mm	112 mm
Depth	74.5 mm	74.5 mm	74.5 mm
Net weight	340 g	340 g	340 g
Type of mounting			
• 35 mm DIN rail mounting	Yes	Yes	Yes
• Wall mounting	Yes	Yes	Yes
Product properties, functions, components			
General			
Product function: Ring redundancy	Yes	Yes	Yes
Standards, specifications, approvals			
Standard			
• for EMC of FM	FM3611: Class 1, Division 2, Group A, B, C, D / T4, Class 1, Zone 2, Group IIC, T4	FM3611: Class 1, Division 2, Group A, B, C, D / T4, Class 1, Zone 2, Group IIC, T4	FM3611: Class 1, Division 2, Group A, B, C, D / T4, Class 1, Zone 2, Group IIC, T4
• for hazardous zone	EN 60079-0: 2006, EN 60079-15: 2005, EN 60079-28: 2007, II 3 (2) G Ex nA [opis] IIC T4 KEMA 09 ATEX 0173X	EN 60079-0: 2006, EN 60079-15: 2005, EN 60079-28: 2007, II 3 (2) G Ex nA [opis] IIC T4 KEMA 09 ATEX 0173X	EN 60079-0: 2006, EN 60079-15: 2005, EN 60079-28: 2007, II 3 (2) G Ex nA [opis] IIC T4 KEMA 09 ATEX 0173X
• for CSA and UL safety	UL 60950-1, CSA C22.2 No. 60950-1	UL 60950-1, CSA C22.2 No. 60950-1	UL 60950-1, CSA C22.2 No. 60950-1
• for hazardous zone of CSA and UL	UL 1604 and UL 2279-15 (Hazardous Location), CSA C22.2 No. 213-M1987, Class 1 / Division 2 / Group A, B, C, D / T4, Class 1 / Zone 2 / Group IIC / T4	UL 1604 and UL 2279-15 (Hazardous Location), CSA C22.2 No. 213-M1987, Class 1 / Division 2 / Group A, B, C, D / T4, Class 1 / Zone 2 / Group IIC / T4	UL 1604 and UL 2279-15 (Hazardous Location), CSA C22.2 No. 213-M1987, Class 1 / Division 2 / Group A, B, C, D / T4, Class 1 / Zone 2 / Group IIC / T4
• for emitted interference	EN 61000-6-4 (Class A)	EN 61000-6-4 (Class A)	EN 61000-6-4 (Class A)
• for noise immunity	EN 61000-6-2	EN 61000-6-2	EN 61000-6-2
Certificate of suitability	EN 61000-6-2, EN 61000-6-4	EN 61000-6-2, EN 61000-6-4	EN 61000-6-2, EN 61000-6-4
• CE mark	Yes	Yes	Yes
• C-Tick	Yes	Yes	Yes
Marine classification corporation			
• American Bureau of Shipping Europe Ltd. (ABS)	Yes	Yes	Yes
• Bureau Veritas (BV)	Yes	Yes	Yes
• Det Norske Veritas (DNV)	Yes	Yes	Yes
• Germanischer Lloyd (GL)	Yes	Yes	Yes
• Lloyds Register of Shipping (LRS)	Yes	Yes	Yes
• Nippon Kaiji Kyokai (NK)	Yes	Yes	Yes

Technical specifications (continued)

Order No.	6GK1 503-2CC00	6GK1 503-3CC00	6GK1 503-3CD00
Product type designation	PROFIBUS OLM G11-1300	PROFIBUS OLM G12-1300	PROFIBUS OLM G12 EEC
Transmission rate			
Transmission rate			
• with PROFIBUS	9.6 kbit/s ... 12 Mbit/s	9.6 kbit/s ... 12 Mbit/s	9.6 kbit/s ... 12 Mbit/s
• with PROFIBUS PA	45.45 kbit/s	45.45 kbit/s	45.45 kbit/s
Interfaces			
Maximum number of electrical/ optical connections for network components or terminal equipment	2	3	3
Number of electrical connections			
• for network components or terminal equipment	1	1	1
• for measuring instrument	1	1	1
• for signaling contact	1	1	1
• for power supply	1	1	1
• for redundant power supply	1	1	1
Design of electrical connection			
• for network components or terminal equipment	9-pin sub-D socket	9-pin sub-D socket	9-pin sub-D socket
• for measuring instrument	2-pin terminal block	2-pin terminal block	2-pin terminal block
• for power supply and signaling contact	5-pin terminal block	5-pin terminal block	5-pin terminal block
Number of optical connections for fiber-optic cables	1	2	2
Design of optical connection for fiber-optic cables	BFOC port	BFOC port	BFOC port
Optical data			
Attenuation factor of the FOC transmission link			
• for glass FOC with 10/125 µm or 9/125 µm at 0.5 dB/km, max.	8 dB	8 dB	-
• for glass FOC with 50/125 µm at 3 dB/km, max.	-	-	10 dB
• for glass FOC with 62.5/125 µm			
- at 1 dB/km maximum	10 dB	10 dB	-
- at 3.5 dB/km maximum	-	-	12 dB
• for PCF FOC with 200/230 µm at 10 dB/km	-	-	-
• for POF FOC with 980/1000 µm at 230 dB/km	-	-	-
Signal delay time in bit time	6.5 bit	6.5 bit	6.5 bit
Injectable optical power relative to 1 mW			
• for glass FOC with 10/125 µm or 9/125 µm at 0.5 dB/km	-19 dB	-19 dB	-
• for glass FOC with 50/125 µm at 3 dB/km	-	-	-16 dB
• for glass FOC with 62.5/125 µm			
- at 1 dB/km	-17 dB	-17 dB	-
- at 3.5 dB/km	-	-	-13 dB
• of the FOC transmission link			
- for PCF FOC with 200/230 µm at 10 dB/km	-	-	-
- for POF FOC with 980/1000 µm at 230 dB/km	-	-	-

PROFIBUS

Optical networks with OLM

OLM Optical Link Module

Technical specifications (continued)

Order No.	6GK1 503-2CC00	6GK1 503-3CC00	6GK1 503-3CD00
Product type designation	PROFIBUS OLM G11-1300	PROFIBUS OLM G12-1300	PROFIBUS OLM G12 EEC
optical sensitivity relative to 1 mW			
• for glass FOC with 10/125 µm or 9/125 µm at 0.5 dB/km	-29 dB	-29 dB	-
• for glass FOC with 50/125 µm at 3 dB/km	-	-	-28 dB
• for glass FOC with 62.5/125 µm			
- at 1 dB/km	-29 dB	-29 dB	-
- at 3.5 dB/km	-	-	-28 dB
• of the FOC transmission link			
- for PCF FOC with 200/230 µm at 10 dB/km	-	-	-
- for POF FOC with 980/1000 µm at 230 dB/km	-	-	-
Wavelength			
• for glass FOC with 10/125 µm or 9/125 µm at 0.5 dB/km compatible with interface at 0.5 dB/km	1 310 nm	1 310 nm	-
• for glass FOC with 50/125 µm compatible with interface at 3 dB/km	-	-	860 nm
• for glass FOC with 62.5/125 µm compatible with interface			
- at 1 dB/km	1 310 nm	1 310 nm	-
- at 3.5 dB/km	-	-	860 nm
• of the FOC transmission link			
- for PCF FOC with 200/230 µm at 10 dB/km	-	-	-
- for POF FOC with 980/1000 µm at 230 dB/km	-	-	-
Cable length			
• for glass FOC with 10/125 µm or 9/125 µm at 0.5 dB/km, max.	15 km	15 km	-
• for glass FOC with 50/125 µm at 3 dB/km, max.	-	-	3 km
• for glass FOC with 62.5/125 µm			
- at 1 dB/km maximum	10 km	10 km	-
- at 3.5 dB/km maximum	-	-	3 km
• for PCF FOC with 200/230 µm at 10 dB/km maximum	-	-	-
• for POF FOC with 980/1000 µm at 230 dB/km, max.	-	-	-
Inputs/outputs			
Operating voltage of signaling contacts with DC rated value	24 V	24 V	24 V
Maximum operating current of signal contacts with DC	0.1 A	0.1 A	0.1 A
Supply voltage, current consumption, power loss			
Type of power supply	DC	DC	DC
Power supply with DC			
• Rated value	24 V	24 V	24 V
• Minimum	18.8 V	18.8 V	18.8 V
• Maximum	28.8 V	28.8 V	28.8 V
Product component: fusing of power supply input	Yes	Yes	Yes
Type of fusing of power supply input	-	-	-
Maximum current consumed at 24 V DC	0.2 A	0.2 A	0.2 A
Effective power loss at 24 V DC	-	-	-

Technical specifications (continued)

Order No.	6GK1 503-2CC00	6GK1 503-3CC00	6GK1 503-3CD00
Product type designation	PROFIBUS OLM G11-1300	PROFIBUS OLM G12-1300	PROFIBUS OLM G12 EEC
Permitted ambient conditions			
Ambient temperature			
• During operation	0 ... 60 °C	0 ... 60 °C	-25 ... +60 °C
• During storage	-40 ... +70 °C	-40 ... +70 °C	-40 ... +70 °C
• During transport	-40 ... +70 °C	-40 ... +70 °C	-40 ... +70 °C
Relative humidity at 25 °C without condensation during operation, maximum	95 %	95 %	95 %
IP degree of protection	IP40	IP40	IP40
Design, dimensions and weights			
Type of construction	Compact	Compact	Compact
Width	39.5 mm	39.5 mm	39.5 mm
Height	112 mm	112 mm	112 mm
Depth	74.5 mm	74.5 mm	74.5 mm
Net weight	340 g	340 g	340 g
Type of mounting			
• 35 mm DIN rail mounting	Yes	Yes	Yes
• Wall mounting	Yes	Yes	Yes
Product properties, functions, components			
General			
Product function: Ring redundancy	Yes	Yes	Yes
Standards, specifications, approvals			
Standard			
• for EMC of FM	FM3611: Class 1, Division 2, Group A, B, C, D / T4, Class 1, Zone 2, Group IIC, T4	FM3611: Class 1, Division 2, Group A, B, C, D / T4, Class 1, Zone 2, Group IIC, T4	FM3611: Class 1, Division 2, Group A, B, C, D / T4, Class 1, Zone 2, Group IIC, T4
• for hazardous zone	EN 60079-0: 2006, EN 60079-15: 2005, II 3 G Ex nA II T4 KEMA 07 ATEX 0003X	EN 60079-0: 2006, EN 60079-15: 2005, II 3 G Ex nA II T4 KEMA 07 ATEX 0003X	EN 60079-0: 2006, EN 60079-15: 2005, EN 60079-28: 2007, II 3 (2) G Ex nA [opis] IIC T4 KEMA 09 ATEX 0173X
• for CSA and UL safety	UL 60950-1, CSA C22.2 No. 60950-1	UL 60950-1, CSA C22.2 No. 60950-1	UL 60950-1, CSA C22.2 No. 60950-1
• for hazardous zone of CSA and UL	UL 1604 and UL 2279-15 (Hazardous Location), CSA C22.2 No. 213-M1987, Class 1 / Division 2 / Group A, B, C, D / T4, Class 1 / Zone 2 / Group IIC / T4	UL 1604 and UL 2279-15 (Hazardous Location), CSA C22.2 No. 213-M1987, Class 1 / Division 2 / Group A, B, C, D / T4, Class 1 / Zone 2 / Group IIC / T4	UL 1604 and UL 2279-15 (Hazardous Location), CSA C22.2 No. 213-M1987, Class 1 / Division 2 / Group A, B, C, D / T4, Class 1 / Zone 2 / Group IIC / T4
• for emitted interference	EN 61000-6-4 (Class A)	EN 61000-6-4 (Class A)	EN 61000-6-4 (Class A)
• for noise immunity	EN 61000-6-2	EN 61000-6-2	EN 61000-6-2
Certificate of suitability	EN 61000-6-2, EN 61000-6-4	EN 61000-6-2, EN 61000-6-4	EN 61000-6-2, EN 61000-6-4
• CE mark	Yes	Yes	Yes
• C-Tick	Yes	Yes	Yes
Marine classification society			
• American Bureau of Shipping Europe Ltd. (ABS)	Yes	Yes	Yes
• Bureau Veritas (BV)	Yes	Yes	Yes
• Det Norske Veritas (DNV)	Yes	Yes	Yes
• Germanischer Lloyd (GL)	Yes	Yes	Yes
• Lloyds Register of Shipping (LRS)	Yes	Yes	Yes
• Nippon Kaiji Kyokai (NK)	Yes	Yes	Yes

PROFIBUS

Optical networks with OLM

OLM Optical Link Module

3

Ordering data	Order No.	Ordering data	Order No.
PROFIBUS OLM/P11 Optical link module with 1 x RS 485 and 1 x plastic fiber-optic interface (2 BFOC sockets), with signaling contact and measuring output incl. 2 BFOC plugs for plastic fiber-optic cables	6GK1 503-2CA00	PROFIBUS OLM/G11-1300 Optical link module with 1 x RS 485 and 1 x glass fiber-optic interface (2 BFOC sockets), 1300 nm wavelength for large distances up to 15 km, with signaling contact and measuring output	6GK1 503-2CC00
PROFIBUS OLM/P12 Optical link module with 1 x RS 485 and 2 x plastic fiber-optic interface (4 BFOC sockets), with signaling contact and measuring output incl. 4 BFOC plugs for plastic fiber-optic cables	6GK1 503-3CA00	PROFIBUS OLM/G12-1300 Optical link module with 1 x RS 485 and 2 x glass fiber-optic interface (4 BFOC sockets), 1300 nm wavelength for large distances up to 15 km, with signaling contact and measuring output	6GK1 503-3CC00
PROFIBUS OLM/P22 Optical link module with 2 x RS 485 and 2 x plastic fiber-optic interface (4 BFOC sockets), with signaling contact and measuring output incl. 4 BFOC plugs for plastic fiber-optic cables	6GK1 503-4CA00	PROFIBUS OLM/G12 EEC Optical link module with 1 x RS 485 and 2 x glass fiber-optic interface (4 BFOC sockets), for standard distances up to 3000 m, for extended temperature range -25 °C to +60 °C, with signaling contact and measuring output	6GK1 503-3CD00
PROFIBUS OLM/G11 Optical link module with 1 x RS 485 and 1 x glass fiber-optic interface (2 BFOC sockets), for standard distances, with signaling contact and measuring output	6GK1 503-2CB00	PROFIBUS OLM mounting plate For wall mounting of PROFIBUS OLM V4	6GK1 503-8AA00
PROFIBUS OLM/G12 Optical link module with 1 x RS 485 and 2 x glass fiber-optic interface (4 BFOC sockets), for standard distances up to 3000 m, with signaling contact and measuring output	6GK1 503-3CB00	SITOP compact 24 V/ 0.6 A 1-phase power supply with wide-range input 85 – 264 V AC/ 110 – 300 V DC, stabilized output voltage 24 V, rated output current value 0.6 A, slim design	6EP1 331-5BA00
PROFIBUS OLM/G22 Optical link module with 2 x RS 485 and 2 x glass fiber-optic interface (4 BFOC sockets), for standard distances up to 3000 m, with signaling contact and measuring output	6GK1 503-4CB00		

Overview



- Construction of optical PROFIBUS networks (line, star, ring) with glass, PCF and plastic fiber-optic cables
- High availability can be achieved using a redundant power supply and redundant cable routing
- Function monitoring by means of signaling contact
- All PROFIBUS data transmission rates from 9.6 kbit/s to 12 Mbit/s including 45.45 kbit/s for PROFIBUS PA
- Monitoring of the fiber-optic cable routes on LEDs for channel monitoring or using a voltmeter across measurement terminals

Note:

SIPLUS extreme products are based on Siemens Industry standard products. The contents listed here were taken from the respective standard products. SIPLUS extreme-specific information was added.

SIPLUS PROFIBUS	OLM/P11	OLM/G11	OLM/G 11-1300
Order number	6AG1 503-2CA00-2AA0	6AG1 503-2CB00-2AA0	6AG1 503-2CC00-4AA0
Order No. based on	6GK1 503-2CA00	6GK1 503-2CB00	6GK1 503-2CC00
Ambient temperature range	-25 ... +60 °C	-25 ... +60 °C	0 ... +60 °C
Conformal coating	Coating of the printed circuit boards and the electronic components		
Technical data	The technical data of the standard product applies except for the ambient conditions.		

SIPLUS PROFIBUS	OLM/P12	OLM/G12	OLM/G 12-1300
Order number	6AG1 503-3CA00-2AA0	6AG1 503-3CB00-2AA0	6AG1 503-3CC00-4AA0
Order No. based on	6GK1 503-3CA00	6GK1 503-3CB00	6GK1 503-3CC00
Ambient temperature range	-25 ... +60 °C	-25 ... +60 °C	0 ... +60 °C
Conformal coating	Coating of the printed circuit boards and the electronic components		
Technical data	The technical data of the standard product applies except for the ambient conditions.		

Ambient conditions

Relative humidity	5 ... 100 % Condensation permissible
Biologically active substances	Conformity with EN 60721-3-3, Class 3B2 mold and fungal spores (except fauna)
Chemically active substances	Conformity with EN 60721-3-3, Class 3C4 incl. salt mist and ISA-S71.04 severity level G1; G2; G3; GX ¹⁾²⁾
Mechanically active substances	Conformity with EN 60721-3-3, Class 3S4 including conductive sand, dust ²⁾
Air pressure (depending on the highest positive temperature range specified)	1080 ... 795 hPa (-1000 ... +2000 m) see ambient temperature range 795 ... 658 hPa (+2000 ... +3500 m) derating 10 K 658 ... 540 hPa (+3500 ... +5000 m) derating 20 K

- 1) ISA-S71.04 severity level GX: Long-term load:
SO₂ < 4.8 ppm; H₂S < 9.9 ppm; Cl < 0.2 ppm; HCl < 0.66 ppm;
HF < 0.12 ppm; NH < 49 ppm; O₃ < 0.1 ppm; NOX < 5.2 ppm
Limit value (max. 30 min/d):
SO₂ < 17.8 ppm; H₂S < 49.7 ppm; Cl < 1.0 ppm; HCl < 3.3 ppm;
HF < 2.4 ppm; NH < 247 ppm; O₃ < 1.0 ppm; NOX < 10.4 ppm
- 2) The supplied plug covers must remain in place over the unused interface when operated in atmospheres containing corrosive gases!

The technical documentation on SIPLUS can be found here:
www.siemens.com/siplus-extreme

PROFIBUS

Optical networks with OLM

SIPLUS OLM Optical Link Module

Ordering data	Order No.	Ordering data	Order No.
SIPLUS PROFIBUS OLM/P11 (extended temperature range) Optical link module with 1 x RS 485 and 1 x plastic fiber- optic interface (2 BFOC sockets), with signaling contact and measuring output incl. 2 BFOC plugs for plastic fiber-optic cables	6AG1 503-2CA00-2AA0	SIPLUS PROFIBUS OLM/G11-1300 (extended temperature range) Optical link module with 1 x RS 485 and 1 x glass fiber- optic interface (4 BFOC sockets), 1300 nm wavelength for large distances up to 15 km, with signaling contact and measuring output	6AG1 503-2CC00-4AA0
SIPLUS PROFIBUS OLM/P12 (extended temperature range) Optical link module with 1 x RS 485 and 2 x plastic fiber- optic interface (4 BFOC sockets), with signaling contact and measuring output incl. 4 BFOC plugs for plastic fiber-optic cables	6AG1 503-3CA00-2AA0	SIPLUS PROFIBUS OLM/G12-1300 Optical link module with 1 x RS 485 and 2 x glass fiber- optic interface (4 BFOC sockets), 1300 nm wavelength for large distances up to 15 km, with signaling contact and measuring output	6AG1 503-3CC00-4AA0
SIPLUS PROFIBUS OLM/G11 (extended temperature range) Optical link module with 1 x RS 485 and 1 x glass fiber- optic interface (4 BFOC sockets), for standard distances up to 3000 m, with signaling contact and measuring output	6AG1 503-2CB00-2AA0	PROFIBUS OLM mounting plate For wall mounting of PROFIBUS OLM V4	6GK1 503-8AA00
SIPLUS PROFIBUS OLM/G12 Optical link module with 1 x RS 485 and 2 x glass fiber- optic interface (4 BFOC sockets), for standard distances up to 3000 m, with signaling contact and measuring output	6AG1 503-3CB00-2AA0	SIMATIC NET Manual Collection Electronic manuals for communication systems, communication protocols, and communication products; on DVD; German/English	6GK1 975-1AA00-3AA0

3

Optical networks with OBT and integrated interface

Plastic and PCF fiber-optic cable

Overview



- Electrical isolation of DP devices
- Protection of the transmission path against electromagnetic interference
- Up to 50 m cable length with plastic fiber-optic cables and up to 300 m with PCF fiber-optic cables
- Rugged fiber-optic standard cables, designed for industrial applications
- Hybrid cable for the shared transmission of data and power supply
- Extensive approvals (UL)

Benefits

get Designed for Industry

- Plastic and PCF fiber-optic cables can be pre-assembled on site
- Easy connector assembly on site
- Time savings on start-up thanks to pre-assembled cables
- Protection of the transmission path against electromagnetic interference
- Tap-proof, because the cable does not radiate
- A cable for the shared transmission of data and power

Application

SIMATIC NET plastic and PCF fiber-optic conductors are used to construct optical indoor PROFIBUS DP networks.

Plastic fiber-optic cables and segmented PCF fiber-optic cables can be assembled easily on site with 2 x 2 simplex plugs. The maximum cable length between two DP devices is 50 m.

Longer cable lengths up to 300 m can be achieved using PCF fiber-optic cables. These cables are also available pre-assembled with 4 simplex plugs.

Devices with integrated optical interface (Simplex connection technology) include, for example, OBT, CP 342-5 FO, CP 5613 FO, IM 153-2 FO, IM 467 FO.

Design

Different types of plastic and PCF fiber-optic cables are offered:

- **Plastic FOC, duplex core;**
Two flat cores with PVC inner sheath and without outer sheath for indoor applications with low mechanical stress such as laboratory setups or inside cabinets. Cable lengths up to 50 m.
- **Plastic FOC, standard cable;**
Rugged round cable with violet PVC outer sheath and Kevlar tension components as well as two plastic fibers with a rugged polyamide inner sheath. For indoor applications with cable lengths up to 50 m.
- **PCF fiber-optic cable, standard cables:**
 - PCF Fiber Optic standard cable;
rugged round cable with violet PVC outer sheath and Kevlar tension components for indoor applications with cable lengths of up to 300 m.
The cable is not suitable for assembly in the field (only available pre-assembled with an insertion tool)
 - PCF Standard Cable GP (general purpose);
rugged round cable with green PVC outer sheath and Kevlar tension elements for indoor and outdoor applications with cable lengths of up to 300 m;
the cable is suitable for assembly in the field.
- **PCF fiber-optic trailing cable;**
Rugged round cable with green outer sheath and Kevlar tension elements for trailing cable applications with cable lengths of up to 300 m. The cable is suitable for assembly in the field.
Two cable variants are available for this application:
 - PCF Trailing Cable;
cable for high mechanical stress, PUR outer sheath, no UL approval
 - PCF Trailing Cable GP (general purpose);
cable for low mechanical stress, PVC outer sheath, with UL approval

PROFIBUS

Optical networks with OBT and integrated interface

Plastic and PCF fiber-optic cable

Technical specifications

Order No.	6XV1 821-2AN50	6XV1 821-0AH10	6XV1 821-1CN50
Product type designation	PROFIBUS Plastic Fiber Optic Duplex Core	PROFIBUS Plastic Fiber Optic Standard Cable	PROFIBUS PCF Fiber Optic Standard Cable
Product description	Fiber-optic cable with poly-optical fiber (flat duplex core), 50 m ring, non-assembled	Fiber-optic cable with poly-optical fiber, sold by the meter, non-assembled	Polymer clad fiber cable, preferred length, preassembled
Suitability for application	Indoor applications with low mechanical stress (e.g. laboratory setups or within cabinets), cable lengths up to 50 m	Cable for indoor applications	Cable for indoor applications
Design of preassembled FO cable	Can be fitted with four Simplex connectors	Can be fitted with four Simplex connectors	Can be fitted with four Simplex connectors
Cable designation	V-2Y 2x1 P 980/1000	I-V4Y(ZN)Y 2P 980/1000	I-V(ZN)Y 2K 200/230
Cable length	50 m	-	50 m
Optical data			
Maximum damping factor per length at 650 nm	0.01 dB/m	0.16 dB/m	0.01 dB/m
Bandwidth length product at 650 nm	1 GHz·m	1 GHz·m	17 GHz·m
Mechanical data			
Number of fibers per FO core	1	1	1
Number of FO cores per FO cable	2	2	2
Design of FO fiber	Step index fiber 980/1000 µm	Step index fiber 980/1000 µm	Step index fiber 200/230 µm
Design of FO core	-	-	-
Design of FO cable	-	-	-
Outer diameter			
• of optical fiber	980 µm	980 µm	200 µm
• of optical fiber sheath	1 000 µm	1 000 µm	230 µm
• of FO core sheath	2.2 mm	2.2 mm	2.2 mm
• of cable	-	7.8 mm	4.7 mm
Symmetrical deviation			
• of outer diameter of FO core sheath	0.1 mm	0.1 mm	0.1 mm
• of outer diameter of cable	-	0.3 mm	-
Material			
• of optical fiber core	Polymethylmethacrylate (PMMA)	Polymethylmethacrylate (PMMA)	Quartz glass
• of optical fiber sheath	Fluoridated special polymer	Fluoridated special polymer	Fluoridated special polymer
• of FO core sheath	PE	PA	PVC
• of FO cable sheath	-	PVC	PVC
• of strain relief	-	Kevlar fibers	Kevlar fibers
Color			
• of FO core sheath	Gray	Orange/black	Orange/black
• of cable sheath	-	Violet	Violet
Bending radius			
• Minimum permitted single bending radius	25 mm	100 mm	47 mm
• Minimum permitted repeated bending radius	25 mm	150 mm	70 mm
• With continuous bending	-	-	-
Number of bending cycles	-	-	-
Maximum tensile load	10 N	100 N	200 N
Short-term lateral force per length	30 N/cm	100 N/cm	100 N/cm
Continuous lateral force per length	400 N/m	-	-
Weight per length	7.6 kg/km	65 kg/km	22 kg/km

Technical specifications (continued)

Order No.	6XV1 821-2AN50	6XV1 821-0AH10	6XV1 821-1CN50
Product type designation	PROFIBUS Plastic Fiber Optic Duplex Core	PROFIBUS Plastic Fiber Optic Standard Cable	PROFIBUS PCF Fiber Optic Standard Cable
Permitted ambient conditions			
Ambient temperature			
• During operation	-55 ... +85 °C	-30 ... +70 °C	-30 ... +70 °C
• During storage	-55 ... +85 °C	-30 ... +70 °C	-30 ... +70 °C
• During transport	-55 ... +85 °C	-30 ... +70 °C	-30 ... +70 °C
• During mounting	-5 ... +50 °C	0 ... 50 °C	-5 ... +50 °C
Ambient conditions for operation	-	-	-
IP degree of protection	-	-	IP20
Behavior in fire	Flame-retardant in accordance with flame test VW-1 acc. to UL 1581	Flame-retardant in accordance with IEC 60332-1-2	Flame-retardant in accordance with IEC 60332-1-2
Chemical resistance			
• Mineral oil	Limited resistance	Limited resistance	Limited resistance
• Grease	Limited resistance	Limited resistance	Limited resistance
• Water	-	-	-
Radiological resistance against UV radiation	Not resistant	Not resistant	Not resistant
Product properties, functions, components			
General			
Product property			
• Halogen-free	Yes	No	No
• Silicon-free	Yes	Yes	Yes
Product component: protection against rodents	No	No	No
Cable length with plastic optical fiber			
• Maximum with Industrial Ethernet	-	-	-
• Maximum with PROFIBUS	80 m	80 m	-
Standards, specifications, approvals			
Certificate of suitability	-	UL approval: OFN (NEC Article 770, UL 1651) / CSA approval: OFN (CSA standard C22.2 No232-M1988)	-
• RoHS compliance	Yes	Yes	Yes

PROFIBUS

Optical networks with OBT and integrated interface

Plastic and PCF fiber-optic cable

Technical specifications (continued)

Order No.	6XV1 861-2A	6XV1 861-2C	6XV1 861-2D
Product type designation	PCF Standard Cable GP	PCF Trailing Cable	PCF Trailing Cable GP
Product description	Polymer clad fiber cable, sold by the meter, non-assembled	Polymer clad fiber cable, sold by the meter, non-assembled	Polymer clad fiber cable, sold by the meter, non-assembled
Suitability for use	Cable for fixed installation for indoor and outdoor use, UL approval	Cable for use with high mechanical stress and moving applications (e.g. trailing cables), without UL approval	Cable for use with high mechanical stress and moving applications (e.g. trailing cables), UL approval
Design of preassembled FO cable	Can be fitted with SC RJ, SC RJ Plug PRO, BFOC and Simplex connectors	Can be fitted with SC RJ, SC RJ Plug PRO, BFOC and Simplex connectors	Can be fitted with SC RJ, SC RJ Plug PRO, BFOC and Simplex connectors
Cable designation	AT-V(ZN)YY 2K 200/230	AT-V(ZN)Y(ZN)11Y 2K 200/230	AT-V(ZN)Y(ZN)Y 2K 200/230
Cable length	-	-	-
Optical data			
Maximum damping factor per length at 660 nm	10 dB/km	10 dB/km	10 dB/km
Bandwidth length product at 650 nm	17 GHz·m	17 GHz·m	17 GHz·m
Mechanical data			
Number of fibers per FO core	1	1	1
Number of FO cores per FO cable	2	2	2
Design of FO fiber	Step index fiber 200/230 µm	Step index fiber 200/230 µm	Step index fiber 200/230 µm
Outer diameter			
• of optical fiber	200 µm	200 µm	200 µm
• of optical fiber sheath	230 µm	230 µm	230 µm
• of FO core sheath	2.2 mm	2.2 mm	2.2 mm
• of cable	7.2 mm	8.8 mm	8.8 mm
Symmetrical deviation			
• of outer diameter of FO core sheath	0.1 mm	0.1 mm	0.1 mm
• of outer diameter of cable	0.5 mm	0.5 mm	0.5 mm
Material			
• of optical fiber core	Quartz glass	Quartz glass	Quartz glass
• of optical fiber sheath	Special polymer	Special polymer	Special polymer
• of FO core sheath	PVC	PVC	PVC
• of FO cable sheath	PVC	PUR	PVC
• of the strain relief	Aramide fibers	Aramide fibers	Aramide fibers
Color			
• of FO core sheath	Orange/black	Orange/black	Orange/black
• of the cable sheath	Green	Green	Green
Bending radius			
• Minimum permitted single bending radius	70 mm	130 mm	130 mm
• Minimum permitted repeated bending radius	105 mm	175 mm	175 mm
• With continuous bending	-	-	-
Number of bending cycles	-	5 000 000	5 000 000
Maximum tensile load	100 N	800 N	800 N
Short-term lateral force per length	500 N/cm	500 N/cm	500 N/cm
Continuous lateral force per length	300 N/cm	300 N/cm	300 N/cm
Weight per length	45 kg/km	85 kg/km	85 kg/km

Technical specifications (continued)

Order No.	6XV1 861-2A	6XV1 861-2C	6XV1 861-2D
Product type designation	PCF Standard Cable GP	PCF Trailing Cable	PCF Trailing Cable GP
Permissible ambient conditions			
Ambient temperature			
• During operation	-40 ... +90 °C	-25 ... +75 °C	-25 ... +75 °C
• During storage	-40 ... +90 °C	-30 ... +75 °C	-30 ... +75 °C
• During transport	-40 ... +90 °C	-30 ... +75 °C	-30 ... +75 °C
• During mounting	-5 ... +50 °C	-5 ... +50 °C	-5 ... +50 °C
Ambient conditions for operation	-	-	-
IP degree of protection	-	-	-
Behavior in fire	Flame-retardant in accordance with IEC 60332-1-2 and IEC 60332-3-22 (Cat. A)	Flame-retardant	Flame-retardant in accordance with IEC 60332-1-2 and IEC 60332-3-22 (Cat. A)
Chemical resistance			
• Mineral oil	Limited resistance	Resistant	Limited resistance
• Grease	Limited resistance	Resistant	Limited resistance
• Water	-	-	-
Radiological resistance to UV radiation	Resistant	Resistant	Resistant
Product properties, functions, components			
General			
Product property			
• Halogen-free	No	No	No
• Silicon-free	Yes	Yes	Yes
Product component: protection against rodents	No	No	No
Cable length with polymer clad fiber			
• Maximum for Industrial Ethernet	100 m	100 m	100 m
• Maximum for PROFIBUS	400 m	400 m	400 m
Standards, specifications, approvals			
Certificate of suitability	UL approval: OFN (NEC Article 770, UL 1651) / CSA approval: OFN 90 Cel, FT1, FT4 (CSA standard C22.2 No232-M1988)	-	UL approval: OFN (NEC Article 770, UL 1651) / CSA approval: OFN 90 Cel, FT1, FT4 (CSA standard C22.2 No232-M1988)
• RoHS compliance	Yes	Yes	Yes

Ordering data

Ordering data	Order No.	Order No.
PROFIBUS Plastic Fiber Optic standard cable		6GK1 905-6PA10
Rugged round cable with 2 plastic fiber-optic cores, PVC outer sheath and PA inner sheath, for indoor use; without connector		PROFIBUS Plastic Fiber Optic stripping tool set
• Sold by the meter	6XV1 821-0AH10	Tools for removing the outer sheath or core sheath of Plastic Fiber Optic cables
• 50 m ring	6XV1 821-0AN50	PROFIBUS PCF Fiber Optic standard cable
• 100 m ring	6XV1 821-0AT10	PCF fiber-optic cable with 2 cores, PVC outer sheath, for covering larger distances up to 300 m, for connecting devices to the optical PROFIBUS DP
PROFIBUS Plastic Fiber Optic duplex core		<u>Preferred lengths</u>
Plastic fiber-optic cable with 2 cores, PVC outer sheath, for use in environments with low mechanical stress; without connector		Precut/preassembled with 2 × 2 Simplex connectors, arm length 30 cm each, with aid for pulling in at one end
• 50 m ring	6XV1 821-2AN50	• 50 m
PROFIBUS Plastic Fiber Optic simplex plug/polishing set	6GK1 901-0FB00-0AA0	• 75 m
100 simplex connectors and 5 polishing sets for assembling PROFIBUS plastic fiber optic cables for the optical PROFIBUS DP		• 100 m
		• 150 m
		• 200 m
		• 250 m
		• 300 m
		6XV1 821-1CN50
		6XV1 821-1CN75
		6XV1 821-1CT10
		6XV1 821-1CT15
		6XV1 821-1CT20
		6XV1 821-1CT25
		6XV1 821-1CT30

PROFIBUS

Optical networks with OBT and integrated interface

Plastic and PCF fiber-optic cable

3

Ordering data	Order No.	Order No.
PROFIBUS PCF Standard Cable GP 200/230 Standard cable, segmentable, sold by the meter; max. quantity 2000 m; minimum order 20 m; <u>Preferred lengths:</u> pre-assembled with 4 Simplex connectors <ul style="list-style-type: none"> • 50 m • 75 m • 100 m • 150 m • 200 m • 250 m • 300 m 	6XV1 861-2A 6XV1 861-7AN50 6XV1 861-7AN75 6XV1 861-7AT10 6XV1 861-7AT15 6XV1 861-7AT20 6XV1 861-7AT25 6XV1 861-7AT30	Plug-in adapter For assembling the plastic Simplex connector in combination with IM 467 FO, CP 342-5 FO, IM 151 FO and IM 153-2 FO, 50 units Termination Kit for Simplex Plug Assembly case for local assembly of PCF Simplex connectors; comprising a stripping tool, buffer stripping tool, Kevlar cutters, fiber breaking tool, crimping tool and microscope Termination Kit for BFOC Plug Assembly case for local assembly of BFOC connectors; comprising a stripping tool, buffer stripping tool, Kevlar cutters, fiber breaking tool, and microscope Simplex Plug Crimp connector with cleaning materials; 50 connectors for assembly on PCF fiber-optic cables on site BFOC Plug Screw connector with cleaning materials; 20 connectors for assembly on PCF fiber-optic cables on site SIMATIC NET Manual Collection Electronic manuals for communication systems, communication protocols, and communication products; on DVD; German/English
PROFIBUS PCF Trailing Cable 200/230 Trailing cable, segmentable, sold by the meter; max. quantity 2000 m; minimum order 20 m; <u>Preferred lengths:</u> pre-assembled with 4 Simplex connectors <ul style="list-style-type: none"> • 50 m • 75 m • 100 m • 150 m • 200 m • 250 m • 300 m 	6XV1 861-2C 6XV1 861-7CN50 6XV1 861-7CN75 6XV1 861-7CT10 6XV1 861-7CT15 6XV1 861-7CT20 6XV1 861-7CT25 6XV1 861-7CT30	6ES7 195-1BE00-0XA0 6GK1 900-0KL00-0AA0 6GK1 900-0HL00-0AA0 6GK1 900-0KB00-0AC0 6GK1 900-0HB00-0AC0
PROFIBUS PCF Trailing Cable GP 200/230 Trailing cable, segmentable, sold by the meter; max. length 2000 m; minimum order quantity 20 m; <u>Preferred lengths:</u> pre-assembled with 4 Simplex connectors <ul style="list-style-type: none"> • 50 m • 75 m • 100 m • 150 m • 200 m • 250 m • 300 m 	6XV1 861-2D 6XV1 861-7DN50 6XV1 861-7DN75 6XV1 861-7DT10 6XV1 861-7DT15 6XV1 861-7DT20 6XV1 861-7DT25 6XV1 861-7DT30	6GK1 975-1AA00-3AA0

More information

You can order components supplementary to the SIMATIC NET cabling range from your local contact.

Technical advice on this subject is available from:

J. Hertlein
 I IA SC IC PRM 4
 Phone: +49 (0)911/750 44 65
 E-mail: juergen.hertlein@siemens.com

Optical networks with OBT and integrated interface

ECOFAST Fiber Optic Hybrid Cable

Overview



- Electrical isolation of DP devices
- Protection of the transmission path against electromagnetic interference
- Up to 50 m cable length with plastic fiber-optic cable
- Rugged fiber-optic cables, designed for industrial applications
- Hybrid cable for the shared transmission of data and power supply

Benefits

get Designed for Industry

- Savings in wiring, installation, commissioning and operation as result of standardized connection system (copper or fiber-optic) with high degree of protection (IP65)
- With ECOFAST, the turnaround times for offers, planning and engineering of machines and plants can be reduced:
- ECOFAST permits fast and problem-free startup of automation and drive systems
- Minimization of sources of error by means of standardized interfaces and plug connectors.
- With ECOFAST plants remain highly available: No interruption of power and field bus when replacing equipment.

Application

The ECOFAST Fiber Optic Hybrid Cable of SIMATIC NET is used to construct optical PROFIBUS DP networks indoors. It is particularly suitable for connecting DESINA components installed at machine level, and is easy to assemble on site. The maximum cable length between two DP devices is 50 m.

Design

The rugged, hybrid trailing cable contains two plastic fiber-optic cables for data transmission and four copper wires (1.5 mm²) for supplying power to DESINA¹⁾ stations.

¹⁾ DESINA is the trademark for **DE**centralized and **St**andardized **IN**stall**A**tion technology for machine tools.

ECOFAST Fiber Optic Hybrid Cable

Technical specifications

Order No.	6XV1 830-6CH10
Product type designation	ECOFAST Fiber Optic Hybrid Cable (DESINA-conformant)
Product description	ECOFAST hybrid cable (optical fibers and power cores), sold by the meter, in bulk
Suitability for application	Devices in conformance with DESINA (e.g. for ET 200X), for design of optical PROFIBUS DP indoor networks
Cable designation	I-(ZN)V4Y11Y 2P 980/1000 + 4x1.5
Cable length	-
Electrical specifications	
Operating voltage, rms value	100 V
Conductor cross-section of power core	1.5 mm ²
Continuous current of power cores	12 A
Optical data	
Maximum damping factor per length at 660 nm	280 dB/km
Bandwidth length product at 650 nm	10 GHz·m
Mechanical data	
Number of fibers per FO core	1
Number of FO cores per FO cable	2
Design of FO fiber	Step index fiber 980/1000 µm
Design of FO core	-
Design of FO cable	Splittable
Number of electrical cores	4
Outer diameter	
• of optical fiber	980 µm
• of optical fiber sheath	1 000 µm
• of FO core sheath	2.2 mm
• of cable	10.6 mm
Material	
• of optical fiber core	Polymethylmethacrylate (PMMA)
• of optical fiber sheath	Fluoridated special polymer
• of FO core sheath	PA
• of FO cable sheath	PUR
• of the strain relief	-

Order No.	6XV1 830-6CH10
Product type designation	ECOFAST Fiber Optic Hybrid Cable (DESINA-conformant)
Color	
• of core insulation of power cores	Black
• of FO core sheath	Black / orange
• of the cable sheath	-
Minimum permitted repeated bending radius	110 mm
Number of bending cycles	5 000 000
• Note	Suitable as trailing cable for 5 million bending cycles with a bending radius of 106 mm (10x D)
Maximum tensile load	60 N
Short-term lateral force per length	10 N/cm
Continuous lateral force per length	1 N/cm
Permitted ambient conditions	
Ambient temperature	
• During operation	-20 ... +60 °C
• During storage	-20 ... +60 °C
• During transport	-20 ... +60 °C
• During mounting	-5 ... +50 °C
• Note	-
Behavior in fire	Flame-retardant in accordance with IEC 60332-1
Chemical resistance	
• Mineral oil	Limited resistance
• Grease	Limited resistance
• Water	-
Radiological resistance to UV radiation	Resistant
Product properties, functions, components	
General	
Product property	
• Halogen-free	No
• Silicon-free	Yes
Standards, specifications, approvals	
UL-Listing at 300 V rating	No
UL-Style at 600 V rating	No
Certificate of suitability	-
• RoHS compliance	Yes

Technical specifications (continued)

Order No.	6GK1 905-0BA00	6GK1 905-0BB00
Product type designation	PB ECOFAST FO Hybrid Plug 180	PB ECOFAST FO Hybrid Plug180
Product description	ECOFAST FO Hanbrid connector with socket insert	ECOFAST FO Hanbrid connector with socket insert
Suitability for application	For connection to ECOFAST FO hybrid cables (DESINA-compliant), transmission of data and energy	For connection to ECOFAST FO hybrid cables (DESINA-compliant), transmission of data and energy
Transmission rate		
Transmission rate with PROFIBUS	9.6 kbit/s ... 12 Mbit/s	9.6 kbit/s ... 12 Mbit/s
Interfaces		
Number of electrical connections		
• for PROFIBUS cables	-	-
• for network components or terminal equipment	-	-
Design of electrical connection		
• for PROFIBUS cables	-	-
• for network components or terminal equipment	-	-
Number of optical connections for fiber-optic cables	1	1
Number of optical connections for network components or terminals	Hanbrid connector with pin insert	Hanbrid connector with socket insert
Mechanical data		
Design of terminating resistor	-	-
Enclosure material	Plastic	Plastic
Design, dimensions and weights		
Type of cable outlet	180 degree cable outlet	180 degree cable outlet
Width	27 mm	27 mm
Height	27 mm	27 mm
Depth	71 mm	71 mm
Net weight	40 g	40 g
Permitted ambient conditions		
Ambient temperature		
• During operation	-20 ... +70 °C	-20 ... +70 °C
• During storage	-40 ... +80 °C	-40 ... +80 °C
• During transport	-40 ... +80 °C	-40 ... +80 °C
IP degree of protection	IP65/67	IP65/67
Chemical resistance to water	Resistant	Resistant
Product properties, functions, components		
General		
Product property silicon-free	Yes	Yes
Product component strain relief	Yes	Yes
Standards, specifications, approvals		
Certificate of suitability: RoHS conformity	Yes	Yes

PROFIBUS

Optical networks with OBT and integrated interface

ECOFAS^T Fiber Optic Hybrid Cable

Ordering data

Order No.

ECOFAS^T fiber optic hybrid cable (DESINA-compatible)

Trailing cable with
2 plastic fiber-optic conductors
and 4 copper cores,
1.5 mm² for use in DESINA-
compatible devices only

Sold by the meter;
max. quantity 1000 m,
minimum order 20 m

Not pre-assembled

- 20 m
- 50 m
- 100 m

Preassembled
with 2 DESINA connectors

- 1.5 m
- 3 m
- 5 m
- 10 m
- 15 m

ECOFAS^T Fiber Optic Hybrid Plug 180, DESINA-compatible (ECOFAS^T FOC)

2 x FO; 4 x 1.5 mm² Cu

- With male pins
(Hanbrid connector)
- With female pins
(Hanbrid connector)

SIMATIC NET Manual Collection

Electronic manuals for
communication systems,
communication protocols, and
communication products;
on DVD;
German/English

6XV1 830-6CH10

6XV1 830-6CN20

6XV1 830-6CN50

6XV1 830-6CT10

6XV1 830-6DH15

6XV1 830-6DH30

6XV1 830-6DH50

6XV1 830-6DN10

6XV1 830-6DN15

6GK1 905-0BA00

6GK1 905-0BB00

6GK1 975-1AA00-3AA0

More information

You can order components supplementary to the SIMATIC NET cabling range from your local contact.

Technical advice on this subject is available from:

J. Hertlein
I IA SC IC PRM 4
Phone: +49 (0)911/750 44 65
E-mail: juergen.hertlein@siemens.com

Overview

- Compact, rugged assembly case for PCF fiber-optic cables
- Special versions for easy assembly of HP Simplex and BFOC plugs on PCF fiber-optic cables
- The quality of the assembly can be checked using the enclosed microscope

Benefits

get Designed for Industry

- Easy installation of the unassembled cables in industrial plants
- Flexible assembly of connectors on PCF fiber-optic cables on site (HP Simplex, BFOC connectors)
- Mistakes are avoided with easy visual inspection of the assembled connector on site using a microscope
- PCF fiber-optic cables are easily repaired on site by installing a new PCF cable

Application

SIMATIC NET PCF fiber-optic conductors are used to construct optical indoor and outdoor PROFIBUS DP networks. They are easy to assemble on site with 2 x 2 Simplex connectors or 2 x 2 BFOC connectors. The maximum cable length between two DP devices is 300 m and between two OLMs 400 m.

PROFIBUS DP devices with integrated optical interface (Simplex connection technology) include, for example, OBT, CP 342-5 FO, CP 5613 FO, IM 153-2 FO, IM 467 FO.

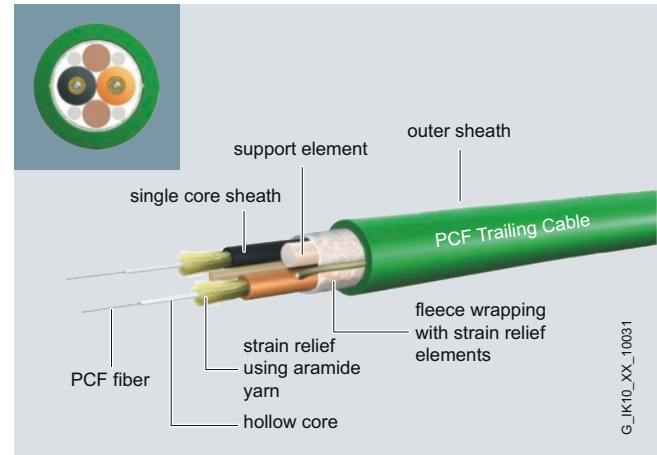
Design

Two versions of the assembly case are available for PCF fiber-optic cables:

- Assembly case for HP Simplex connectors; for on-site pre-assembly of HP Simplex connectors; comprising a stripping tool, buffer stripping tool, Kevlar cutters, fiber breaking tool, crimping tool and microscope
- Assembly case for BFOC connectors; for on-site pre-assembly of BFOC connectors; comprising a stripping tool, buffer stripping tool, Kevlar cutters, fiber breaking tool and microscope.

Optical networks with OBT and integrated interface

PCF-FOC termination kit

Technical specifications

Order No.	6GK1 900-0KB00-0AC0	6GK1 900-0HB00-0AC0
Product type designation	PB Simplex Plug PCF	PB BFOC Plug PCF
Product description	Simplex crimp connector for PCF fiber-optic cables with plastic cladding	BFOC screw connector for PCF fiber-optic cables with plastic cladding
Suitability for use	for the connection of PCF fiber-optic cables	for the connection of PCF fiber-optic cables
Transmission rate		
Transmission rate		
• 1 with Industrial Ethernet	-	-
• 2 with Industrial Ethernet	-	-
• 3 with Industrial Ethernet	-	-
• with PROFIBUS	9.6 kbit/s ... 12 Mbit/s	9.6 kbit/s ... 12 Mbit/s
Interfaces		
Number of optical connections for fiber-optic cables	1	1
Design of optical connection for network components or terminals	Simplex connector	BFOC connector
Design of FastConnect electrical connection	No	No
Mechanical data		
Enclosure material	Plastic	Metal and plastic
Design, dimensions and weights		
Type of cable outlet	180 degree cable outlet	180 degree cable outlet
Width	9.4 mm	10 mm
Height	6.1 mm	10 mm
Depth	29.9 mm	10 mm
Net weight	20 g	8 g
Permissible ambient conditions		
IP degree of protection	IP20	IP20
Chemical resistance to water	-	-
Product properties, functions, components		
General		
Product property silicon-free	Yes	Yes
Product component strain relief	Yes	Yes
Standards, specifications, approvals		
Certificate of suitability: RoHS conformity	Yes	Yes

Ordering data	Order No.
Termination Kit for Simplex plug Assembly case for local assembly of PCF Simplex connectors; comprising a stripping tool, buffer stripping tool, Kevlar cutters, fiber breaking tool, crimping tool and microscope	6GK1 900-0KL00-0AA0
Termination Kit for BFOC plug Assembly case for local assembly of BFOC connectors; comprising a stripping tool, buffer stripping tool, Kevlar cutters, fiber breaking tool, and microscope	6GK1 900-0HL00-0AA0
<i>Connector</i>	
Simplex plug with cleaning materials; 50 crimp connectors for assembly on PCF fiber-optic cables on site	6GK1 900-0KB00-0AC0
BFOC plug with cleaning materials; 20 screw connectors for assembly on PCF fiber-optic cables on site	6GK1 900-0HB00-0AC0

More information

You can order components supplementary to the SIMATIC NET cabling range from your local contact.

Technical advice on this subject is available from:

J. Hertlein

I IA SC IC PM 1

Tel.: +49 (0)911/750 44 65

E-mail: juergen.hertlein@siemens.com

PROFIBUS

Optical networks with OBT and integrated interface

Optical bus terminal OBT

Overview



- For connecting a PROFIBUS station without an integrated fiber-optic cable interface or an RS 485 segment to an optical line
- Quick and easy installation of the plastic fiber-optic cable without the need for special tools

Benefits

get Designed for Industry

- Option of connecting existing devices or an RS 485 segment with electrical interface to the optical PROFIBUS
- "Socket outlet" for connecting mobile devices (e.g. programming devices) without interruption of the bus
- Time saved through simple and fast connector mounting without special tools

Application

The OBT (Optical Bus Terminal) is used to connect a PROFIBUS station without integral optical interface or a PROFIBUS DP RS485 segment to an optical line. Existing DP devices are then provided with the advantages of optical data transmission.

The PROFIBUS station is connected to the RS 485 interface of the OBT via a cable terminated at both ends, e.g. connecting cable 830-1T. The OBT is integrated into the optical line using two optical interfaces.

The following optical transmission media can be connected to the OBT:

- Plastic fiber-optic cables can be used up to an individual segment length of 50 m. They can be configured very easily on site with 2 x 2 Simplex connectors.
- PCF ¹⁾ fiber-optic cables can be used for an individual segment length up to 300 m. These cables are preassembled. The OBT supports all PROFIBUS data transmission rates up to 12 Mbit/s.

¹⁾ Also known as HCS[®] fiber-optic cable: HCS[®] is a registered trademark of Lucent Technologies.

Design

The OBT has a compact plastic housing. It is suitable for mounting on a DIN rail or for wall mounting with a mounting plate with the aid of two holes drilled right through.

The OBT has the following connections:

- 9-pin sub-D socket for connecting the PROFIBUS DP node such as programming device (PG), PC, operator panel (OP), S7-300 or nodes without integral optics, e.g. ET 200S or PROFIBUS DP components from other suppliers or a PROFIBUS DP-RS 485 segment.
- Two optical interfaces for the connection of plastic and PCF fiber-optic cables with Simplex connectors (connection to CP 342-5 FO, CP 5613 FO, IM 153-2 FO, IM 467 FO or to ET 200 with integrated optics)
- 24 V DC infeed for power supply.

Function

- Connection of a station with RS 485 interface via connecting cable 830-1T or PROFIBUS cable with bus connectors (terminated at both ends) or an RS 485 segment
- Provision of an electrical connection point on the optical line (e.g. PG connection for startup and diagnostics)
- Support for all PROFIBUS data rates from 9.6 kbit/s to 12 Mbit/s including 45.45 kbit/s for PROFIBUS PA
- Regeneration of the signals in amplitude and time
- Cascade depth when using user-defined bus parameters up to 126 stations
- Galvanic isolation of the station via fiber optic cable
- Simple diagnostics via LED display for operating voltage as well as for receipt of data CH1, CH2 and CH3.

Integration

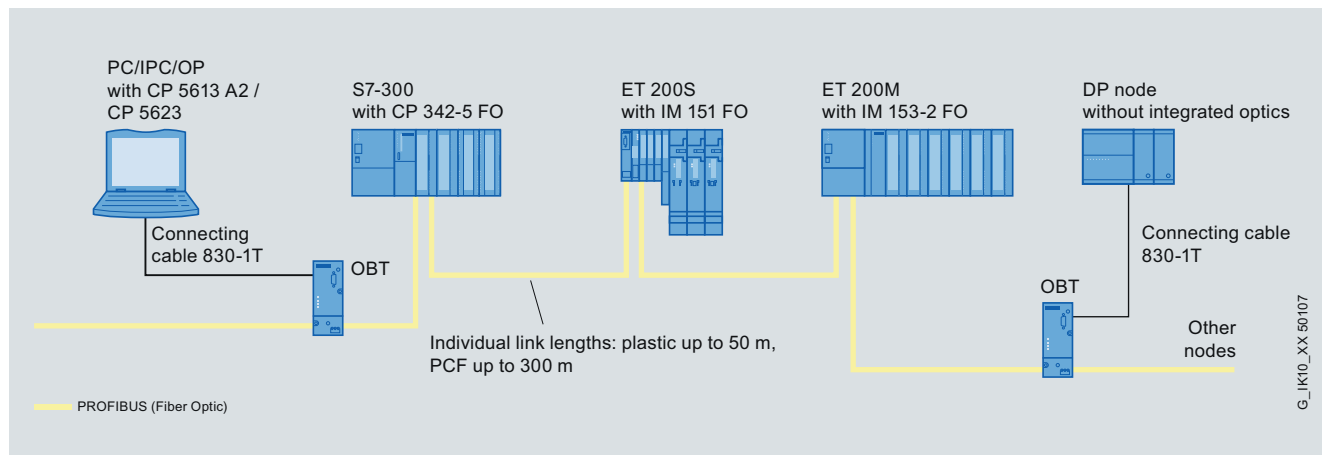

System configuration of optical PROFIBUS DP with PROFIBUS OBT

Technical specifications

Order No.	6GK1 500-3AA10	Order No.	6GK1 500-3AA10
Product type designation	PROFIBUS OBT	Product type designation	PROFIBUS OBT
Transmission rate		Minimum optical sensitivity relative to 1 mW of the FO transmission link	
Transmission rate		• for PCF FOC with 200/230 μm at 10 dB/km	-22 dB
• with PROFIBUS	9.6 kbit/s ... 12 Mbit/s	• for POF FOC with 980/1000 μm at 230 dB/km	-20 dB
• with PROFIBUS PA	45.45 kbit/s		
Interfaces		Wavelength of the FOC transmission link	
Maximum number of electrical/optical connections for network components or terminal equipment	3	• for PCF FOC with 200/230 μm at 10 dB/km	660 nm
Number of electrical connections		• for POF FOC with 980/1000 μm at 230 dB/km	660 nm
• for network components or terminal equipment	1		
• for power supply	1	Cable length	
Design of electrical connection		• for PCF FOC with 200/230 μm at 10 dB/km maximum	300 m
• for network components or terminal equipment	9-pin D-sub socket	• for POF FOC with 980/1000 μm at 230 dB/km, max.	50 m
• for power supply	3-pin terminal block		
Number of optical connections for fiber-optic cables	2	Supply voltage, current consumption, power loss	
Design of optical connection for fiber-optic cables	Duplex port	Type of power supply	DC
Optical data		DC power supply	
Attenuation factor of the FOC transmission link		• Rated value	24 V
• for PCF FOC with 200/230 μm at 10 dB/km	3 dB	• Minimum	19.2 V
• for POF FOC with 980/1000 μm at 230 dB/km	13 dB	• Maximum	28.8 V
Signal delay time in bit time	6.5 bit	Permitted ambient conditions	
Injectable optical power relative to 1 mW of the FO transmission link		Ambient temperature	
• for PCF FOC with 200/230 μm at 10 dB/km	-16 dB	• During operation	0 ... 60 °C
• for POF FOC with 980/1000 μm at 230 dB/km	-5.9 dB	• During storage	-40 ... +70 °C
		• During transport	-40 ... +70 °C
		Relative humidity at 25 °C without condensation during operation, maximum	95 %
		IP degree of protection	IP30

PROFIBUS

Optical networks with OBT and integrated interface

Optical bus terminal OBT

Technical specifications (continued)

Order No.	6GK1 500-3AA10
Product type designation	PROFIBUS OBT
Design, dimensions and weights	
Type of construction	Compact
Width	50.5 mm
Height	138 mm
Depth	78 mm
Net weight	400 g
Type of mounting	
• 35 mm DIN rail mounting	Yes
• Wall mounting	Yes
Standards, specifications, approvals	
Standard	
• for EMC of FM	FM3611: Class 1, Division 2, Group A, B, C, D / T4, Class 1, Zone 2, Group IIC, T4
• for hazardous zone	EN 60079-0: 2006, EN 60079-15: 2005, II 3 G Ex nA II T4 KEMA 07 ATEX 0145X
• for CSA and UL safety	UL 60950-1, CSA C22.2 No. 60950-1
• for hazardous zone of CSA and UL	-
• for emitted interference	EN 61000-6-4 (Class A)
• for noise immunity	EN 61000-6-2
Certificate of suitability	EN 61000-6-2, EN 61000-6-4
• CE mark	Yes
• C-Tick	Yes
Marine classification society	
• American Bureau of Shipping Europe Ltd. (ABS)	No
• Bureau Veritas (BV)	No
• Det Norske Veritas (DNV)	No
• Germanischer Lloyd (GL)	No
• Lloyds Register of Shipping (LRS)	No

Ordering data

Order No.

PROFIBUS OBT	6GK1 500-3AA10
Optical bus terminal for connecting a PROFIBUS node or an RS485 segment without an integrated optical interface to the optical PROFIBUS; without a Simplex connector	
PROFIBUS plug-in cable 830-1T	
For connecting a data terminal, completely pre-assembled with two sub-D connectors, 9-pin	
• 1.5 m	6XV1 830-1CH15
• 3 m	6XV1 830-1CH30
SITOP compact 24 V/ 0.6 A	6EP1 331-5BA00
1-phase power supply with wide-range input 85 – 264 V AC/ 110 – 300 V DC, stabilized output voltage 24 V, rated output current value 0.6 A, slim design	

Overview

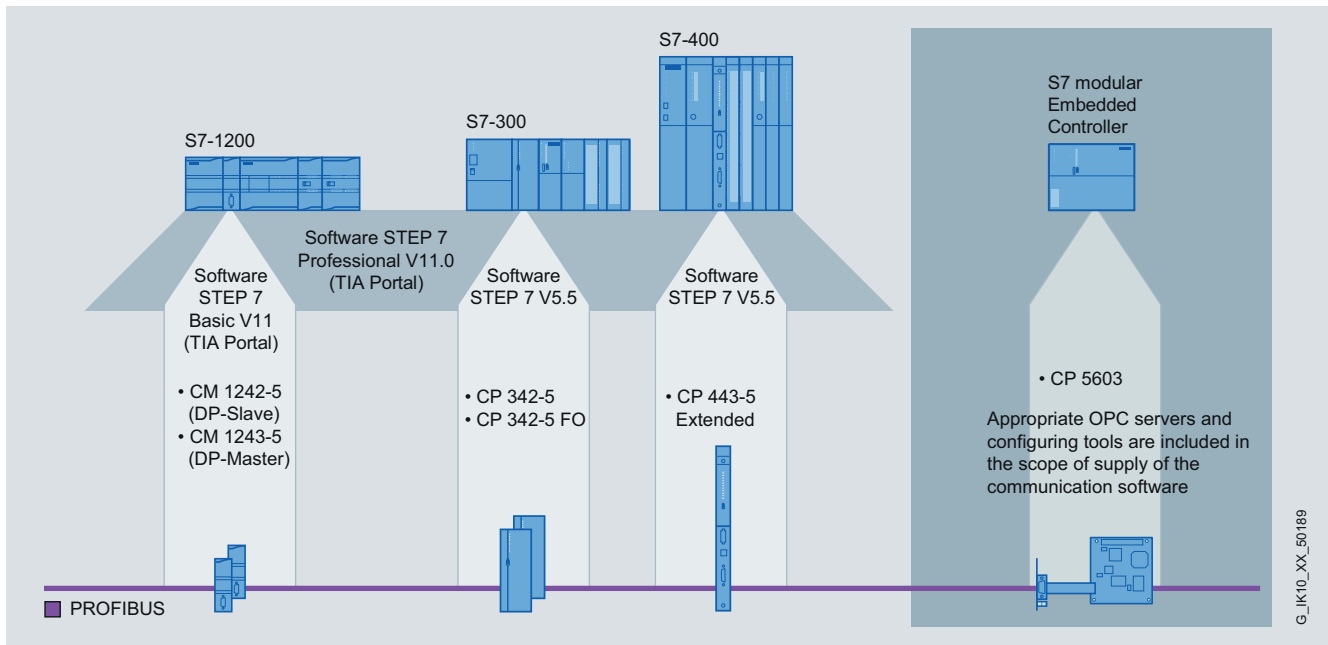

PROFIBUS communication for SIMATIC S7

CPs with standard functions

- CM 1242-5 and CM 1243-5 for SIMATIC S7-1200 for connection to PROFIBUS as DP slave or DP master
- CP 342-5 and CP 343-5 for SIMATIC S7-300 for connection to PROFIBUS DP or PROFIBUS FMS
- CP 443-5 Extended and CP 443-5 Basic for the connection to PROFIBUS DP or PROFIBUS FMS
- Designed for use in harsh industrial environments
- Shipbuilding certification for use on ships and offshore units
- High-speed data transfer due to transfer rates of up to 12 Mbit/s

CPs with function expansions

- CP 342-5 FO with integral optical interface for connecting the SIMATIC S7-300 to the optical PROFIBUS DP

PROFIBUS

Communication for SIMATIC S7-1200

CM 1242-5

Overview



DP-M	DP-S	FMS	PG/OP	S7
	●			

The CM 1242-5 communication module is used to connect a SIMATIC S7-1200 to PROFIBUS as a DP slave and has the following characteristics:

- PROFIBUS DPV1 slave in accordance with IEC 61158
- Module replacement without PG supported
- Power is supplied via the backplane bus so that no extra cabling is required
- Support of all standard baud rates from 9.6 kbit/s to 12 Mbit/s
- Compact industry-standard enclosure in S7-1200 design for mounting on a standard mounting rail
- Fast commissioning thanks to easy configuration using STEP 7 without additional programming overhead

The CM 1242-5 is intended for use in factory automation. Low-cost PROFIBUS-based automation solutions can be created on the basis of the S7-1200 for optimal production.

Benefits

get Designed for Industry

PROFIBUS-based systems can be operated effectively for lower operating and maintenance costs:

- Low costs since an automation solution requires no fixed wiring and less hardware
- Fast response to faults thanks to comprehensive diagnostics options
- Optimized plant and inventory management

The CM 1242-5 also offers further benefits especially for the requirements of micro-automation solutions:

- Uncomplicated connection of the S7-1200 to PROFIBUS without extra power supply
- Low-cost implementation of automation solutions based on PROFIBUS
- Fast commissioning, as no programming overhead is required

Application

The CM 1242-5 is designed for use in factory automation.

With the CM 1242-5, low-cost, distributed automation solutions can be implemented on the basis of the S7-1200, or in simple cases even complete plant automation systems. It can be used in all sectors of discrete automation. These include, for example:

- Automotive
- Pharmaceuticals
- Semiconductors
- Food processing industry

Design



The CM 1242-5 offers all the benefits of the S7-1200 design.

- Rugged, compact plastic enclosure
- Easily accessible connection and diagnostics elements, protected by front flaps
- Removable connecting terminals
- Simple mounting on the mounting rail of the S7-1200
- 9-pin sub-D socket for the bus interface to PROFIBUS

The CM 1242-5 is plugged into the left-hand system bus interface of the S7-1200. Power is supplied via the system bus of the S7-1200 so that no extra cabling is required. The rugged RS485 interface is located on the underside of the module, protected by the lower front flap.

3

Function

The CM 1242-5 provides the communication services for integrating an S7-1200 into an automation solution as a PROFIBUS DP slave.

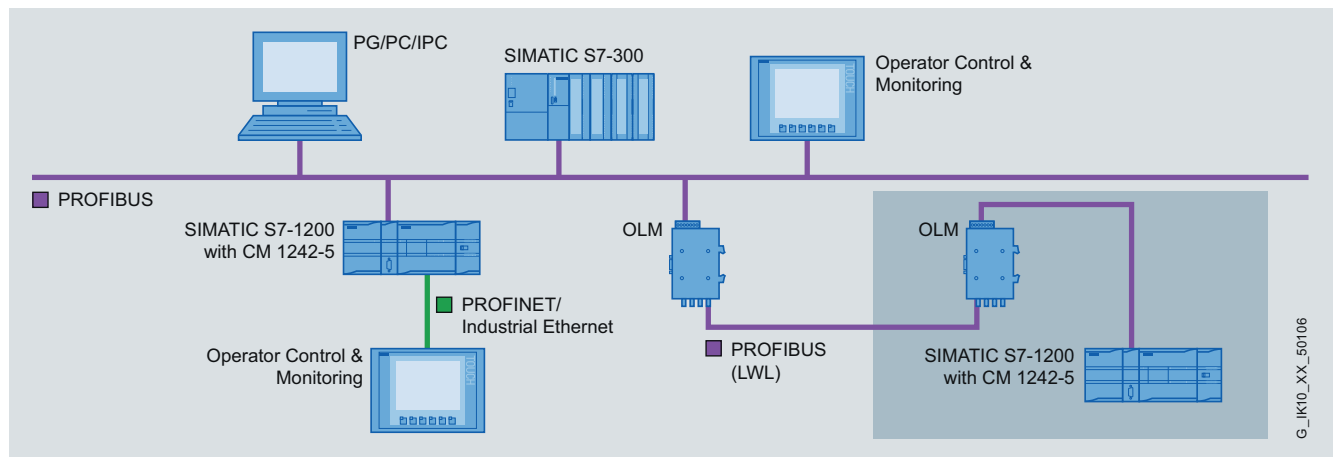

PROFIBUS DP slave

The CM 1242-5 works as a DPV1 slave in accordance with IEC 6158, handles data traffic completely autonomously, and thus relieves the CPU of communication tasks.

The data areas of the distributed I/Os are transferred consistently between CP and CPU.

Diagnosis

Extensive diagnostic options are available via STEP 7, including

- Operating state of the CM
- General diagnostics functions
- Connection diagnostics
- Message buffer

STEP 7 Basic V11 or higher is required for configuring the full functional scope of the CP 1242-5.

PROFIBUS

Communication for SIMATIC S7-1200

CM 1242-5

Technical specifications

Order No.	6GK7 242-5DX30-0XE0
Product type designation	CM 1242-5
Transmission rate	
Transmission rate at interface 1 in accordance with PROFIBUS	9.6 kbit/s ... 12 Mbit/s
Interfaces	
Number of electrical connections	
• at interface 1 in accordance with PROFIBUS	1
• for power supply	0
Design of electrical connection	
• at interface 1 in accordance with PROFIBUS	9-pin D-sub socket (RS485)
• for power supply	-
Supply voltage, current consumption, power loss	
Type of power supply	DC
Supply voltage	
• 1 from backplane bus	5 V
• External	-
Relative positive tolerance at 24 V DC	-
Relative negative tolerance at 24 V DC	-
Current consumed	
• from backplane bus at 5 V DC, typical	0.15 A
• from external power supply at 24 V DC	
- Typical	-
- Maximum	-
Effective power loss	0.75 W
Permitted ambient conditions	
Ambient temperature	
• with vertical installation during operation	0 ... 45 °C
• with horizontal installation during operation	0 ... 55 °C
• During storage	-40 ... +70 °C
• During transport	-40 ... +70 °C
• Note	-
Relative humidity at 25 °C without condensation during operation, maximum	95 %
IP degree of protection	IP20
Design, dimensions and weights	
Module format	S7-1200 compact module, single width
Width	30 mm
Height	100 mm
Depth	75 mm
Net weight	0.115 kg
Product properties, functions, components	
General	
Maximum number of modules per CPU	3
Number of modules - Note	-

Order No.	6GK7 242-5DX30-0XE0
Product type designation	CM 1242-5
Performance data	
<u>Performance data open communication</u>	
Number of possible connections for open communication by means of SEND/RECEIVE blocks, maximum	-
Data volume as user data per connection for open communication by means of SEND/RECEIVE blocks, maximum	-
<u>Performance data PROFIBUS DP</u>	
Service as DP master DPV1	-
Number of DP slaves that can be operated on DP master	-
Data volume	
• of address area of the inputs as DP master, total	-
• of address area of the outputs as DP master, total	-
• of address area of the inputs per DP slave	-
• of address area of the outputs per DP slave	-
• of address area of the diagnostic data per DP slave	-
Service as DP slave	
• DPV0	Yes
• DPV1	Yes
Data volume	
• of address area of the inputs as DP slave, total	240 bytes
• of address area of the outputs as DP slave, total	240 bytes
<u>Performance data S7 communication</u>	
Number of possible connections for S7 communication	
• Maximum	-
• For PG connections, maximum	-
• For PG/OP connections, maximum	-
• Note	-
<u>Performance data multiprotocol operation</u>	
Number of active connections in multiprotocol mode	
• Maximum without DP	-
• Maximum with DP	-
Product functions Management, configuration, programming	
Configuration software required	STEP 7 Basic V11.0 or higher

3

Ordering data	Order No.	Order No.
CM 1242-5 communication module Communication module for electrical connection of SIMATIC S7-1200 to PROFIBUS as a DPV1 slave	6GK7 242-5DX30-0XE0	STEP 7 Basic engineering software V11 <i>Target system:</i> SIMATIC S7-1200 controllers and the associated I/O <i>Requirement:</i> Windows XP Home SP3, Windows XP Professional SP3 (32 bit), Windows 7 Home Premium (32 bit), Windows 7 Professional (32 bit), Windows 7 Enterprise (32 bit), Windows 7 Ultimate (32 bit), Microsoft Server 2003 R2 Std. SP2 (32 bit), Microsoft Server 2008 Std. SP2 (32 bit) <i>Delivery package:</i> German, English, Chinese, Italian, French, Spanish <ul style="list-style-type: none"> • Single license • Upgrade STEP 7 Basic V10.5 to STEP 7 Basic V11, single license • Powerpack STEP 7 Basic V11 to STEP 7 Prof. V11, floating license • STEP 7 Basic V11, trial license
Accessories PROFIBUS FastConnect connector RS485 With 90° cable outlet; insulation displacement technology, max. transmission rate 12 Mbit/s <ul style="list-style-type: none"> • Without PG interface • With PG interface 	6ES7 972-0BA52-0XA0 6ES7 972-0BB52-0XA0	
PROFIBUS FC standard cable 2-core bus cable, shielded, special design for fast mounting, delivery unit: max. 1000 m, minimum order 20 m, sold by the meter	6XV1 830-0EH10	
PROFIBUS FastConnect stripping tool Stripping tool for fast stripping of the PROFIBUS FastConnect bus cable	6GK1 905-6AA00	
PROFIBUS bus terminal 12M Bus terminal for connection of PROFIBUS nodes at up to 12 Mbit/s with connecting cable	6GK1 500-0AA10	

PROFIBUS

Communication for SIMATIC S7-1200

CM 1243-5

Overview



DP-M	DP-S	FMS	PG/OP	S7
●			●	●

The CM 1243-5 communication module is used to connect a SIMATIC S7-1200 to PROFIBUS as a DP master and has the following characteristics:

- PROFIBUS DPV1 master in accordance with IEC 61158
- Support of up to 16 PROFIBUS DP slaves
- Communication with other S7 controllers based on S7 communication
- Allows the connection of programming devices and operator panels with a PROFIBUS interface to the S7-1200
- Module replacement without PG supported
- Support of all standard baud rates from 9.6 kbit/s to 12 Mbit/s
- Compact industry-standard enclosure in S7-1200 design for mounting on a standard mounting rail
- Fast commissioning thanks to easy configuration using STEP 7 without additional programming overhead

The CM 1243-5 is intended for use in factory automation. Low-cost PROFIBUS-based automation solutions can be created on the basis of the S7-1200 for optimal production.

Benefits

get Designed for Industry

PROFIBUS-based systems can be operated effectively for lower operating and maintenance costs:

- Low costs since an automation solution requires no fixed wiring and less hardware
- Fast response to faults thanks to excellent diagnostics options
- Optimized plant and inventory management

The CM 1243-5 also offers further benefits especially for the requirements of micro-automation solutions:

- Uncomplicated connection of the S7-1200 to PROFIBUS
- Low-cost implementation of automation solutions based on PROFIBUS
- Fast commissioning, as no programming overhead is required

Use of PROFIBUS-based micro-automation solutions enables optimal operation of the plant and problem-free production.

Application

The CM 1243-5 is designed for use in factory automation, particularly for mechanical engineering

With the CM 1243-5, low-cost, distributed automation solutions can be implemented on the basis of the S7-1200, or in simple cases even complete plant automation systems. It can be used in all sectors of discrete automation. These include, for example:

- Automotive
- Pharmaceuticals
- Semiconductors
- Food processing industry

In mechanical engineering, the S7-1200 can be used with the CM 1243-5 as a central control unit, with sensors, actuators or the HMI devices connected direct via PROFIBUS.

- Pick-and-place machines
- Metalworking machines
- Packaging machinery
- Printing machines
- Textile machines
- Filling machines

Design



The CM 1243-5 offers all the benefits of the S7-1200 design.

- Rugged, compact plastic enclosure
- Easily accessible connection and diagnostics elements, protected by front flaps
- Removable connecting terminals
- Simple mounting on the mounting rail of the S7-1200
- 9-pin sub-D socket for the bus interface to PROFIBUS
- 3-pin plug-in terminal strip for connection of the 24 V DC external supply voltage

The CM 1243-5 is plugged into the left-hand system bus interface of the S7-1200. The power is supplied via a 3-pin terminal strip on top of the module. The rugged RS485 interface is located on the underside of the module, protected by the lower front flap.

3

Function

The CM 1243-5 provides access to different communication services on the basis of PROFIBUS:

- PROFIBUS DP (according to IEC 61158, master)
- PG/OP communication
- S7 communication

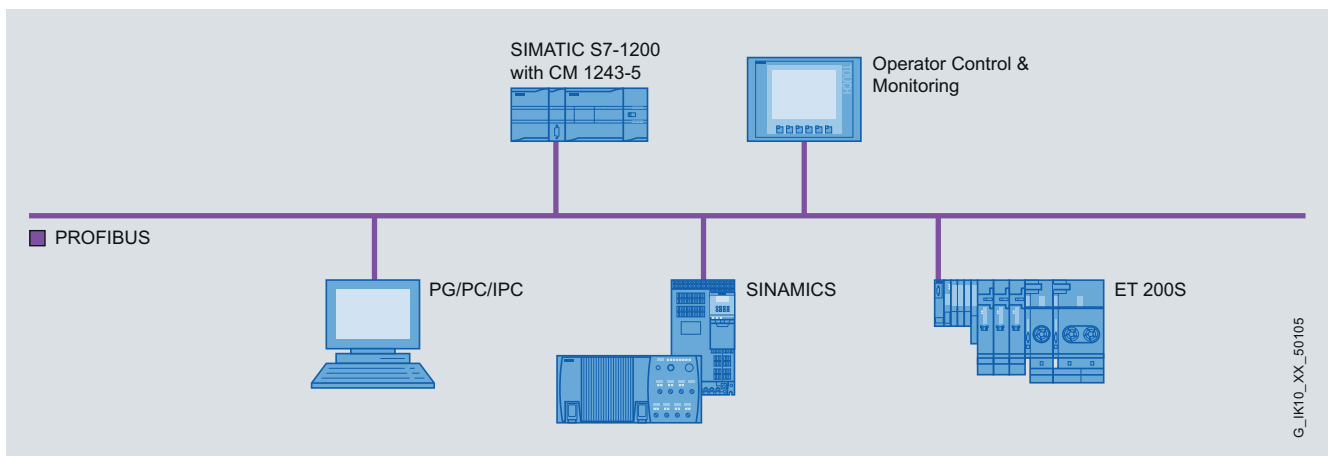

PROFIBUS DP master

The CM 1243-5 works as a DP-V1 master in accordance with IEC 61158, handles data traffic completely autonomously, and thus relieves the CPU of communication tasks.

The data areas of the distributed I/Os are transferred consistently between CP and CPU. As a DP master, it allows the connection of up to 16 PROFIBUS-compliant DP slaves

PG/OP communication

The S7-1200 to which the CM 1243-5 is connected can be programmed with the help of PG/OP communication.

S7 communication

Communication with the following other systems can be implemented with the mechanisms familiar from the S7 world (Put/Get) on the basis of S7 communication:

- To other SIMATIC S7 programmable controllers
- To HMI devices
- To PCs, laptops, field PGs with PROFIBUS cards

Diagnosis

Extensive diagnostic options are available via STEP 7, including

- Operating state of the CM
- General diagnostics and statistics functions
- Connection diagnostics
- Message buffer

STEP 7 Basic V11 or higher is required for configuring the full functional scope of the CP 1243-5.

PROFIBUS

Communication for SIMATIC S7-1200

CM 1243-5

Technical specifications

Order No.	6GK7 243-5DX30-0XE0
Product type designation	CM 1243-5
Transmission rate	
Transmission rate at interface 1 in accordance with PROFIBUS	9.6 kbit/s ... 12 Mbit/s
Interfaces	
Number of electrical connections	
• at interface 1 in accordance with PROFIBUS	1
• for power supply	1
Design of electrical connection	
• at interface 1 in accordance with PROFIBUS	9-pin D-sub socket (RS485)
• for power supply	3-pin terminal strip
Supply voltage, current consumption, power loss	
Type of power supply	DC
Supply voltage	
• 1 from backplane bus	-
• External	24 V
Relative positive tolerance at 24 V DC	20 %
Relative negative tolerance at 24 V DC	20 %
Current consumed	
• from backplane bus at 5 V DC, typical	-
• from external power supply at 24 V DC	
- Typical	0.1 A
- Maximum	-
Effective power loss	2.4 W
Permitted ambient conditions	
Ambient temperature	
• with vertical installation during operation	0 ... 45 °C
• with horizontal installation during operation	0 ... 55 °C
• During storage	-40 ... +70 °C
• During transport	-40 ... +70 °C
• Note	-
Relative humidity at 25 °C without condensation during operation, maximum	95 %
IP degree of protection	IP20
Design, dimensions and weights	
Module format	S7-1200 compact module, single width
Width	30 mm
Height	100 mm
Depth	75 mm
Net weight	0.134 kg
Product properties, functions, components	
General	
Number of modules	
• Per CPU, maximum	1
• Note	-

Order No.	6GK7 243-5DX30-0XE0
Product type designation	CM 1243-5
Performance data	
<u>Performance data open communication</u>	
Number of possible connections for open communication by means of SEND/RECEIVE blocks, maximum	-
Data volume as user data per connection for open communication by means of SEND/RECEIVE blocks, maximum	-
<u>Performance data PROFIBUS DP</u>	
Service as DP master DPV1	Yes
Number of DP slaves that can be operated on DP master	16
Data volume	
• of address area of the inputs as DP master, total	512 bytes
• of address area of the outputs as DP master, total	512 bytes
• of address area of the inputs per DP slave	244 bytes
• of address area of the outputs per DP slave	244 bytes
• of address area of the diagnostic data per DP slave	240 bytes
Service as DP slave	
• DPV0	-
• DPV1	-
Data volume	
• of address area of the inputs as DP slave, total	-
• of address area of the outputs as DP slave, total	-
<u>Performance data S7 communication</u>	
Number of possible connections for S7 communication	
• Maximum	8
• For PG connections, maximum	1
• For PG/OP connections, maximum	3
• Note	max. 4 connections to other S7 stations
<u>Performance data multiprotocol operation</u>	
Number of active connections in multiprotocol mode	
• Maximum without DP	8
• Maximum with DP	8
Product functions	
Management, configuration, programming	
Configuration software required	STEP 7 Basic V11.0 or higher

3

Ordering data	Order No.	Order No.
CM 1243-5 communication module Communication module for electrical connection of SIMATIC S7-1200 to PROFIBUS as a DPV1 master	6GK7 243-5DX30-0XE0	STEP 7 Basic engineering software V11 <i>Target system:</i> SIMATIC S7-1200 controllers and the associated I/O <i>Requirement:</i> Windows XP Home SP3, Windows XP Professional SP3 (32 bit), Windows 7 Home Premium (32 bit), Windows 7 Professional (32 bit), Windows 7 Enterprise (32 bit), Windows 7 Ultimate (32 bit), Microsoft Server 2003 R2 Std. SP2 (32 bit), Microsoft Server 2008 Std. SP2 (32 bit) <i>Delivery package:</i> German, English, Chinese, Italian, French, Spanish <ul style="list-style-type: none"> • Single license • Upgrade STEP 7 Basic V10.5 to STEP 7 Basic V11, single license • Powerpack STEP 7 Basic V11 to STEP 7 Prof. V11, floating license • STEP 7 Basic V11, trial license
Accessories PROFIBUS FastConnect connector RS485 With 90° cable outlet; insulation displacement technology, max. transmission rate 12 Mbit/s <ul style="list-style-type: none"> • Without PG interface • With PG interface 	6ES7 972-0BA52-0XA0 6ES7 972-0BB52-0XA0	
PROFIBUS FC standard cable 2-core bus cable, shielded, special design for fast mounting, delivery unit: max. 1000 m, minimum order 20 m, sold by the meter	6XV1 830-0EH10	
PROFIBUS FastConnect stripping tool Stripping tool for fast stripping of the PROFIBUS FastConnect bus cable	6GK1 905-6AA00	
PROFIBUS bus terminal 12M Bus terminal for connection of PROFIBUS nodes at up to 12 Mbit/s with connecting cable	6GK1 500-0AA10	

PROFIBUS

Communication for SIMATIC S7-300

CP 342-5

Overview



DP-M	DP-S	FMS	PG/OP	S7/S5	
●	●		●	●	

- PROFIBUS DP master or slave with electrical interface for connecting the SIMATIC S7-300 to PROFIBUS at up to 12 Mbit/s (including 45.45 kbit/s)
- Communication services:
 - PROFIBUS DP
 - PG/OP communication (OP multiplexing)
 - S7 communication (client, server)
 - Open communication (SEND/RECEIVE)
- Easy configuration and programming over PROFIBUS
- Cross-network programming device communication through S7 routing
- Modules can be replaced without the need for a PG

Benefits



- Expansion of the process I/O at SIMATIC S7-300 by several PROFIBUS DP interfaces
- Flexible utilization of the process I/O through dynamic activation of DP slaves
- Subprocess-oriented configuration of an automation solution by implementing several CPs
- Optimization of applications and many application options through sending of data with S7 communication
- Comprehensive control and monitoring through multiplex function with OP communication
- Suitable for closed loop control tasks due to SYNC and FREEZE.

Application

The CP 342-5 is the communications processor of the SIMATIC S7-300 for the PROFIBUS DP bus system.

The CP 342-5 relieves the CPU from communication tasks.

Communication possibilities of the S7-300 using communication modules:

- As DP master or slave for PROFIBUS DP V0 according to IEC 61158/EN 50170
- Communication with programming devices and HMI devices
- Communication with other SIMATIC S7 systems
- Communication with SIMATIC S5 programmable controllers

The number of CPs that can be used is dependent on the performance range of the CPU and on the communications services used.

Design

The CP 342-5 offers all the advantages of SIMATIC S7-300 system design:

- Compact design; single standard width of the SM modules of the SIMATIC S7-300
- 9-pin Sub-D socket for connection to PROFIBUS
- 4-pin terminal block for connecting the external supply voltage of 24 V DC
- Simple assembly; The CP 342-5 is mounted on the S7-300 DIN rail and connected to adjacent modules by means of the bus connectors. Slots 4 to 11 in subracks 0 to 3 (coupled through the IM 360/361) can be used for the CP 342-5
- In combination with IM 360/361, the CP 342-5 can also be used in an expansion rack (ER)
- User-friendly wiring; Sub-D socket and the terminal block are easily accessible.
- The CP 342-5 can be operated without a fan; a back-up battery or a memory module is not required

Function

The CP 342-5 provides access to different communication services of the PROFIBUS bus system:

- PROFIBUS DP (according to IEC 61158/61784, master or slave)
- PG/OP communication
- S7 communication (client, server)
- Open communication (SEND/RECEIVE)

PROFIBUS DP master

The CP 342-5 operates as a DP-V0 Master according to IEC 61158/EN 61784 Volume 2 and processes the data transfer completely independently. It supports the services of the Master Classes 1 and 2.

The data areas of the distributed I/Os are transferred consistently between CP and CPU. This applies to the use of the CP as DP Master and as DP Slave. As DP Master, it permits connections to:

- SIMATIC S7-300, such as CP 342-5 as DP slave
- DP slaves of the distributed I/O system ET 200 (integrate as DP-V0 slave)
- PCs, e.g. with CP 5512, CP 5611 A2, CP 5621, CP 5614 A2 and SOFTNET-PB DP slave or DP-Base

The CP 342-5 also offers the SYNC, FREEZE and shared input/output functions, as well as the activation/deactivation of slaves.

PROFIBUS DP slave

The CP 342-5 as a DP-V0 slave permits the SIMATIC S7-300 to exchange data with other PROFIBUS DP masters, which allows a hybrid setup between SIMATIC S5/S7, PCs, ET 200 and other field devices to PROFIBUS DP. Function calls are required for the DP communication. These (DP-SEND/DP-RECV) must be integrated in the STEP 7 user program.

PG/OP communication

PG/OP communication allows all S7 stations connected to the network to be remotely programmed.

- S7 routing
With the aid of S7 routing it is possible to use programming device communication across networks.
Via the CP 342-5 as many as 16 TD/OPs can be merged into one S7-300 station. This requires only one connection resource in the S7-CPU (multiplex channel). The multiplex channel supports the acyclic HMI services.

S7 communication

S7 communication is used for the coupling:

- between SIMATIC S7 automation systems
- to HMI devices (OPs).
- to PCs, e.g. with CP 5512, CP 5611 A2, CP 5621 and SOFTNET-PB S7 or CP 5613 A2, CP 5613 FO, CP 5614 A2, CP 5623, CP 5624 and HARDNET-PB S7.

Communication with PG and OP takes place without further configuration. In addition, the central controller can also be programmed and configured on a distributed basis via the CP 342-5.

The client functionality is provided by means of loadable communication blocks.

Open communication (SEND/RECEIVE)

Based on Layer 2 (FDL) of PROFIBUS, the CP 342-5 offers a simple, optimized interface for process or field communication.

This interface offers integrated, high-performance communication between SIMATIC S5, SIMATIC S7, SIMATIC 505 and PC. SEND/RECEIVE provides not only the SDA service (PLC/PLC connections) but also the SDN service (broadcast, multicast).

The communication partners are the automation systems:

- SIMATIC S7
with CP 342-5, CP 343-5, CP 443-5 Extended and Basic
- SIMATIC S5
with S5-95U with PROFIBUS interface, S5-115U/H, S5-135U, S5-155U/H with CP 5431 FMS/DP
- SIMATIC 505
with CP 5434-FMS
- PCs
with CP 5512, CP 5611 A2, CP 5621, CP 5613 A2, CP 5613 FO, CP 5614 A2, CP 5623, CP 5624
- Non-Siemens systems that are equipped with an FDL interface.

To use SEND/RECEIVE, function calls are required (PLC-SEND/PLC-RECEIVE), which must be linked into the STEP 7 user program.

Diagnostics

Extensive diagnostic options are available via STEP 7, including:

- Status of the CP
- General diagnostics and statistics functions
- Connection diagnostics
- Bus statistics
- Message buffer

STEP 7 V5.1 SP2 or higher, or the TIA Portal V11, is required for configuring the full functional scope of the CP 342-5. In Version V5 or higher of STEP 7, the configuration data of the CP can also optionally be stored on the CPU and is retained even if there is a power failure. A module can therefore be replaced without having to reload the configuration data from a programming device. The CPU transfers the configuration data to the CP during start-up. Attention should therefore be paid to the memory capacity of the S7-CPU.

Configuration and programming of all SIMATIC S7 controllers connected to the network is possible over the network.

The function blocks for PROFIBUS DP are included in the standard library of STEP 7. The function blocks for using the open communication (SEND/RECEIVE) and S7 communication (S7 client) can be found in the SIMATIC NET library following installation of STEP 7.

PROFIBUS

Communication for SIMATIC S7-300

CP 342-5

Technical specifications

Order No.	6GK7 342-5DA02-0XE0
Product type designation	CP 342-5
Transmission rate	
Transmission rate at interface 1 in accordance with PROFIBUS	9.6 kbit/s ... 12 Mbit/s
Interfaces	
Number of electrical connections	
• at interface 1 in accordance with PROFIBUS	1
• for power supply	1
Design of electrical connection	
• at interface 1 in accordance with PROFIBUS	9-pin D-sub socket (RS485)
• for power supply	4-pin terminal strip
Supply voltage, current consumption, power loss	
Type of power supply	DC
Power supply	
• 1 from backplane bus	5 V
• External	24 V
Relative positive tolerance at 24 V DC	20 %
Relative negative tolerance at 24 V DC	15 %
Current consumed	
• from backplane bus at 5 V DC, typical	0.15 A
• from external power supply with 24 V DC	
- Typical	0.25 A
- Maximum	-
Effective power loss	5 W
Permitted ambient conditions	
Ambient temperature	
• During operation	0 ... 60 °C
• During storage	-40 ... +70 °C
• During transport	-40 ... +70 °C
• Note	-
Relative humidity at 25 °C without condensation during operation, maximum	95 %
IP degree of protection	IP20
Design, dimensions and weights	
Module format	S7-300 compact module, single-width
Width	40 mm
Height	125 mm
Depth	120 mm
Net weight	0.3 kg
Product properties, functions, components	
General	
Number of modules	
• Per CPU, maximum	4
• Note	-

Order No.	6GK7 342-5DA02-0XE0
Product type designation	CP 342-5
Performance data	
<u>Performance data</u>	
<u>Open communication</u>	
Number of possible connections for open communication by means of SEND/RECEIVE blocks, maximum	16
Data volume as user data per connection for open communication by means of SEND/RECEIVE blocks, maximum	240 byte
<u>Performance data</u>	
<u>PROFIBUS DP</u>	
Service as DP master DPV0	Yes
Number of DP slaves operable on DP master	124
Data volume	
• of address area of inputs as DP master, total	2 160 byte
• of address area of outputs as DP master, total	2 160 byte
• of address area of inputs per DP slave	244 byte
• of address area of outputs per DP slave	244 byte
• of address area of diagnostics data per DP slave	240 byte
Service as DP slave	
• DPV0	Yes
• DPV1	No
Data volume	
• of address area of inputs as DP slave, total	240 byte
• of address area of outputs as DP slave, total	240 byte
<u>Performance data</u>	
<u>S7 communication</u>	
Number of possible connections for S7 communication	
• Maximum	16
<u>Performance data</u>	
<u>Multiprotocol operation</u>	
Number of active connections in multiprotocol mode	
• Maximum without DP	32
• Maximum with DP	28
Product functions	
Management, configuration, programming	
Configuration software required	STEP 7 V5.1 SP2 or higher

Ordering data	Order No.	Order No.
CP 342-5 communication processor Communication processor for electrical connection of SIMATIC S7-300 to PROFIBUS at up to 12 Mbit/s, with electronic manual on CD-ROM	6GK7 342-5DA02-0XE0	
STEP 7 Version 5.5 <i>Target system:</i> SIMATIC S7-300/400, SIMATIC C7, SIMATIC WinAC <i>Requirements:</i> Windows XP Prof., Windows 7 Professional/Ultimate <i>Type of delivery:</i> German, English, French, Spanish, Italian; incl. license key on USB flash drive, with electronic documentation <ul style="list-style-type: none"> Floating License on DVD Rental license for 50 hours Software Update Service on DVD (requires current software version) Upgrade Floating License 3.x/4.x/5.x to V5.4; on DVD Trial license STEP 7 V5.4; on DVD, operational for 14 days 	6ES7 810-4CC10-0YA5 6ES7 810-4CC10-0YA6 6ES7 810-4BC01-0YX2 6ES7 810-4CC10-0YE5 6ES7 810-4CC10-0YA7	STEP 7 Professional Engineering Software V11 <i>Target system:</i> SIMATIC S7-300/400, SIMATIC C7, SIMATIC WinAC <i>Requirements:</i> Windows XP Professional SP3 (32 bit), Windows 7 Professional (32 bit), Windows 7 Enterprise (32 bit), Windows 7 Ultimate (32 bit), Microsoft Server 2003 R2 Std. SP2 (32 bit), Microsoft Server 2008 Std. SP2 (32 bit) <i>Type of delivery:</i> German, English, Chinese, Italian, French, Spanish <ul style="list-style-type: none"> STEP 7 Professional V11, floating license STEP 7 Prof. V11, trial license Upgrade STEP 7 Prof. 2006/2010 to STEP 7 Prof. V11, floating license PowerPack & Upgrade STEP 7 V5.4/V5.5 to STEP 7 Prof. V11, floating license Powerpack STEP 7 Basic V11 to STEP 7 Prof. V11, floating license STEP 7 Professional V11, Software Update Service, 1 year; current software version required STEP 7 Professional V11, Software Update Service Compact, 1 year; current software version required STEP 7 Professional Software Update Service; 1 year; for STEP 7 Professional and STEP 7 Professional in the TIA Portal, requires current software version STEP 7 Professional Software Update Service Compact; 1 year; for STEP 7 Professional and STEP 7 Professional in the TIA Portal, requires current software version
		6ES7 822-1AA01-0YA5 6ES7 822-1AA01-0YA7 6ES7 822-1AA01-0XE5 6ES7 822-1AA01-0XC5 6ES7 822-1AA01-0YC5 6ES7 822-1AA00-0YL5 6ES7 822-1AA00-0YM5 6ES7 810-5CC04-0YE2 6ES7 810-5CC00-0YM2
		PROFIBUS FastConnect bus connector RS485 With 90° cable outlet; insulation displacement technology, max. transmission rate 12 Mbit/s (1 unit) <ul style="list-style-type: none"> Without PG interface With PG interface
		PROFIBUS bus connector IP20 With connection to PPI, MPI, PROFIBUS <ul style="list-style-type: none"> Without PG interface With PG interface
		PROFIBUS bus terminal 12M Bus terminal for connection of PROFIBUS nodes at up to 12 Mbit/s with connecting cable
		SIMATIC S7-300 DM 370 Dummy module; used for module replacement

PROFIBUS

Communication for SIMATIC S7-300

SIPLUS CP 342-5

Overview



DP-M	DP-S	FMS	PG/OP	S7/S5	
●	●		●	●	

- PROFIBUS DP master or slave with electrical interface for connecting the SIMATIC S7-300 and the SIMATIC C7 to PROFIBUS at up to 12 Mbit/s (including 45.45 kbit/s)
- Communication services:
 - PROFIBUS DP-V0
 - PG/OP communication (OP multiplexing)
 - S7 communication (client, server)
 - S5-compatible communication (SEND/RECEIVE)
- Easy configuration and programming over PROFIBUS
- Cross-network programming device communication through S7 routing
- Modules can be replaced without the need for a PG

Note:

SIPLUS extreme products are based on Siemens Industry standard products. The contents listed here were taken from the respective standard products. SIPLUS extreme-specific information was added.

SIPLUS CP 342-5		
Order number	6AG1 342-5DA02-2XE0	6AG1 342-5DA02-4XE0
Order No. based on	6GK7 342-5DA02-0XE0	6GK7 342-5DA02-0XE0
Ambient temperature range	-25 ... +60 °C	0 ... +60 °C
Conformal coating	Coating of the printed circuit boards and the electronic components	
Technical data	The technical data of the standard product applies except for the ambient conditions.	

Ambient conditions

Relative humidity	5 ... 100 % Condensation permissible
Biologically active substances	Conformity with EN 60721-3-3, Class 3B2 mold and fungal spores (except fauna)
Chemically active substances	Conformity with EN 60721-3-3, Class 3C4 incl. salt mist and ISA-S71.04 severity level G1; G2; G3; GX ^{1) 2)}
Mechanically active substances	Conformity with EN 60721-3-3, Class 3S4 including conductive sand, dust ²⁾
Air pressure (depending on the highest positive temperature range specified)	1080 ... 795 hPa (-1000 ... +2000 m) see ambient temperature range 795 ... 658 hPa (+2000 ... +3500 m) derating 10 K 658 ... 540 hPa (+3500 ... +5000 m) derating 20 K

¹⁾ ISA-S71.04 severity level GX: Long-term load:
SO₂ < 4.8 ppm; H₂S < 9.9 ppm; Cl < 0.2 ppm; HCl < 0.66 ppm;
HF < 0.12 ppm; NH < 49 ppm; O₃ < 0.1 ppm; NOX < 5.2 ppm
Limit value (max. 30 min/d):

SO₂ < 17.8 ppm; H₂S < 49.7 ppm; Cl < 1.0 ppm; HCl < 3.3 ppm;
HF < 2.4 ppm; NH < 247 ppm; O₃ < 1.0 ppm; NOX < 10.4 ppm

²⁾ The supplied plug covers must remain in place over the unused interface when operated in atmospheres containing corrosive gases!

The technical documentation on SIPLUS can be found here:
www.siemens.com/siplus-extreme

Ordering data	Order No.
SIPLUS CP 342-5 communication processor (extended temperature range and medial exposure) Communication processor for electrical connection of SIMATIC S7-300 to PROFIBUS at up to 12 Mbit/s, with electronic manual on CD-ROM	
Ambient temperature range -25 ... +60 °C	6AG1 342-5DA02-2XE0
Ambient temperature range 0 ... +60 °C, only medial exposure	6AG1 342-5DA02-4XE0
Accessories	See SIMATIC CP 342-5 communication processor

Overview



DP-M	DP-S	FMS	PG/OP	S7/S5	
●	●		●	●	

- PROFIBUS DP master or slave with optical interface for connecting the SIMATIC S7-300 to PROFIBUS at up to 12 Mbit/s (including 45.45 kbit/s)
- Direct connection to the optical PROFIBUS network over the integrated fiber-optic interface for plastic and PCF fiber-optic cables
- Communication services:
 - PROFIBUS DP
 - PG/OP communication (OP multiplexing)
 - S7 communication (client, server)
 - Open communication (SEND/RECEIVE)
- Easy configuration and programming over PROFIBUS
- Cross-network programming device communication through S7 routing
- Modules can be replaced without the need for a PG

Benefits

get Designed for Industry

- The fiber-optic technology is used when
 - the environment is subject to strong EMC interference,
 - strong potential differences exist and
 - high transmission rates are required.
- The CP 342-5 FO is connected directly to the optical PROFIBUS and is therefore specially suited to harsh industrial environments
- Expansion of the process I/O at SIMATIC S7-300 by several PROFIBUS DP interfaces
- Optimization of applications and many application options through sending of data with S7 communication
- Comprehensive control and monitoring through multiplex function with OP communication
- Suitable for closed loop control tasks due to SYNC and FREEZE

Application

The CP 342-5 FO is the communications processor of the SIMATIC S7-300 for the PROFIBUS DP optical bus system.

The CP 342-5 FO has a fiber optic interface that facilitates interference-immune connections even in environments with severe levels of radio interference.

It relieves the CPU of communications tasks.

Communication of the SIMATIC S7-300 with:

- the distributed I/O system ET 200 with integral optical interface
- SIMATIC S7-400 with IM 467 FO and CP 342-5 FO
- PC with CP 5613 FO
- Remaining PROFIBUS nodes via the optical bus terminal (OBT)

The number of CPs that can be used is dependent on the performance range of the CPU and on the communications services used.

Design

The CP 342-5 FO offers all the advantages of SIMATIC S7-300 system design:

- Compact design; single standard width of the SM modules of the SIMATIC S7-300
- Integrated fiber-optic cable interface; 2 female duplex connectors for direct connection to the optical PROFIBUS over 2 x 2 male simplex connectors and 2 plug-in adapters
- 4-pin terminal block for connecting the external supply voltage of 24 V DC
- Easy installation; the CP 342-5 FO is snap-mounted on the S7-300 DIN rail and connected to adjacent modules through the bus connectors. There are no slot rules.
- In combination with IM 360/361, the CP 342-5 FO can also be used in an expansion rack (ER).
- User-friendly wiring; female FOC connector and the terminal block are easily accessible.
- The CP 342-5 FO can be operated without a fan; a back-up battery or a memory module are not required.

PROFIBUS

Communication for SIMATIC S7-300

CP 342-5 FO

Function

The CP 342-5 FO provides access to different communication services of the PROFIBUS bus system:

- PROFIBUS DP (according to IEC 61 158/61784, master or slave)
- PG/OP communication
- S7 communication
- Open communication (SEND/RECEIVE)

PROFIBUS DP master

The CP 342-5FO operates as a DP-V0 Master according to IEC 61 158/EN 50 170 Volume 2 and processes the data transfer completely independently. It supports the services of the Master Classes 1 and 2.

The data areas of the distributed I/Os are transferred consistently between CP and CPU. This applies to the use of the CP as DP Master and as DP Slave. As DP Master, it permits connections to:

- The distributed IO system ET 200 with integral optical interface (incorporate as DP-V0 Slave)
- SIMATIC S7-300 with CP 342-5 FO as slave
- The remaining DP-V0 slaves via the optical bus terminal (OBT).

The CP 342-5 FO also offers the SYNC, FREEZE and shared input/output functions, as well as the activation/deactivation of slaves.

PROFIBUS DP slave

The CP 342-5 FO as a DP-V0 Slave allows the SIMATIC S7-300 to exchange data with the SIMATIC S7-400 and with other PROFIBUS DP masters via the OBT. which allows a hybrid setup between SIMATIC S5/S7, PCs, ET 200 and other field devices to PROFIBUS DP. Function calls are required for DP communication, both as master and as slave. These (DP-SEND/DP-RECV) are shipped with STEP 7 and must be integrated in the user program.

PG/OP communication

PG/OP communication allows all S7 stations connected to the network to be remotely programmed.

- S7 routing:
With the aid of S7 routing it is possible to use programming device communication across networks.
Via the CP 342-5 FO as many as 16 TD/OPs can be merged into one S7-300 station. This requires only one connection resource in the S7-CPU (multiplex channel). The multiplex channel supports the acyclic HMI services.

S7 communication

S7 communication is used for the coupling

- between SIMATIC S7 automation systems
- to HMI devices (OPs).
- to PCs, e.g. with CP 5512, CP 5611 A2, CP 5621 and SOFTNET-PB S7 or CP 5613 A2, CP 5613 FO, CP 5614 A2, CP 5623, CP 5624 and HARDNET-PB S7

Communication with PG and OP takes place without further configuration. In addition, the central controller can also be programmed and configured on a distributed basis via the CP 342-5 FO.

The client functionality is provided by means of loadable communication blocks.

Open communication (SEND/RECEIVE)

Based on Layer 2 (FDL) of PROFIBUS (IEC 61158/EN 50170), the CP 342-5 FO offers a simple, optimized interface for process or field communication. This interface offers integrated, high-performance communication between SIMATIC S5, SIMATIC S7, SIMATIC 505 and PC.

SEND/RECEIVE provides not only the SDA service (PLC/PLC connections) but also the SDN service (broadcast, multicast).

The communication partners are the automation systems:

- SIMATIC S7
with CP 342-5, CP 343-5, CP 443-5 Extended and Basic
- SIMATIC S5
with S5-95U with PROFIBUS interface, S5-115U/H, S5-135U, S5-155U/H with CP 5431 FMS/DP
- SIMATIC 505
with CP 5434-FMS
- PCs
CP 5512, CP 5611 A2, CP 5621, CP 5613 A2, CP 5613 FO, CP 5614 A2, CP 5623, CP 5624
- Non-Siemens systems that are equipped with an FDL interface.

To use SEND/RECEIVE, function calls are required (PLC-SEND/PLC-RECEIVE), which must be linked into the STEP 7 user program.

Function (continued)

Diagnostics

Extensive diagnostic options are available via STEP 7, including:

- Status of the CP
- General diagnostics and statistics functions
- Connection diagnostics
- Bus statistics
- Message buffer

STEP 7 V5.1 SP2 or higher, or the TIA Portal V11, is required for configuring the full functional scope of the CP 342-5 FO. In Version V5 or higher of STEP 7, the configuration data of the CP can also optionally be stored on the CPU and is retained

even if there is a power failure. A module can therefore be replaced without having to reload the configuration data from a programming device. The CPU transfers the configuration data to the CP during start-up. Attention should therefore be paid to the memory capacity of the S7-CPU.

Configuration and programming of all SIMATIC S7 controllers connected to the network is possible over the network.

The function blocks for PROFIBUS DP are included in the standard library of STEP 7. The function blocks for using the open communication (SEND/RECEIVE) and the S7 communication (S7 client) can be found in the SIMATIC NET library following installation of STEP 7.

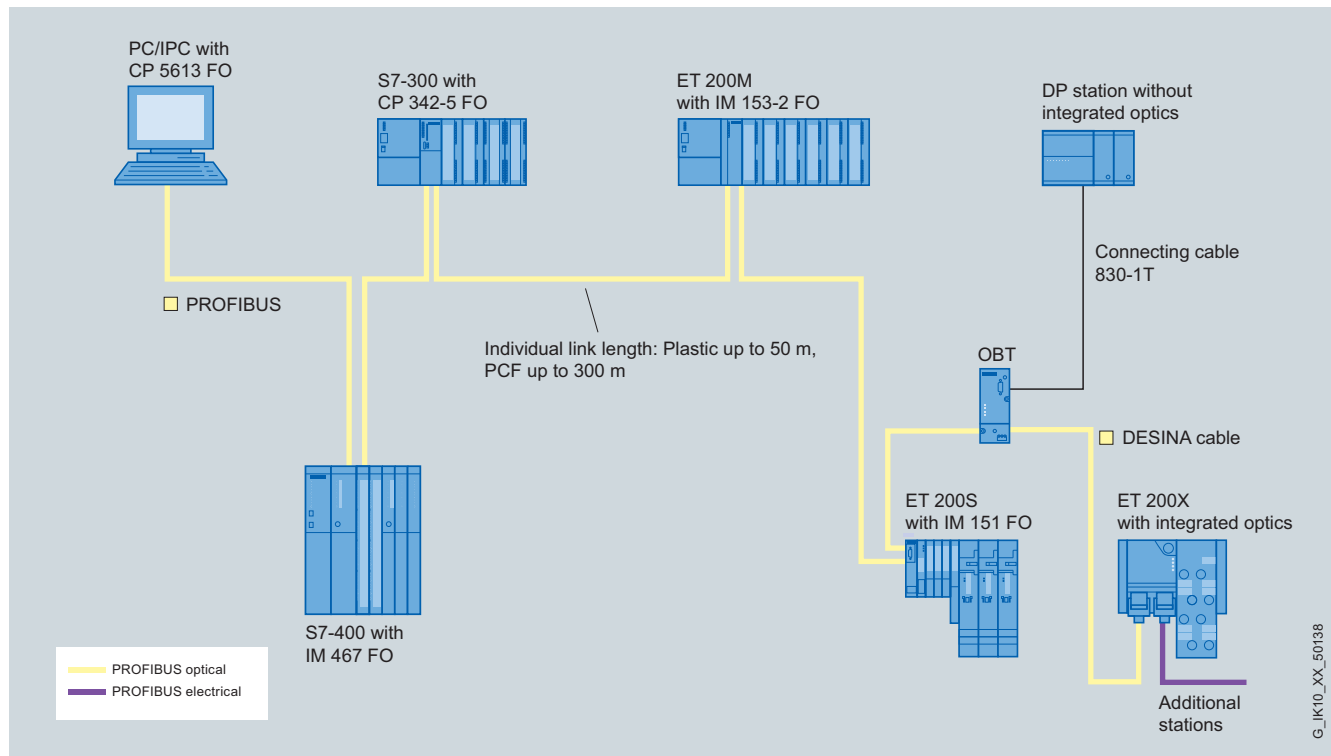

System configuration of optical PROFIBUS DP with CP 342-5 FO

PROFIBUS

Communication for SIMATIC S7-300

CP 342-5 FO

Technical specifications

Order No.	6GK7 342-5DF00-0XE0
Product type designation	CP 342-5 FO
Transmission rate	
Transmission rate at interface 1 in accordance with PROFIBUS	9.6 kbit/s ... 12 Mbit/s
Interfaces	
Number of optical connections at interface 1 in accordance with PROFIBUS	2
Number of electrical connections for power supply	1
Design of optical connection at interface 1 in accordance with PROFIBUS	Duplex socket
Design of electrical connection for power supply	4-pin terminal strip
Supply voltage, current consumption, power loss	
Type of power supply	DC
Power supply	
• 1 from backplane bus	5 V
• External	24 V
Relative positive tolerance at 24 V DC	20 %
Relative negative tolerance at 24 V DC	15 %
Current consumed	
• from backplane bus at 5 V DC, typical	0.15 A
• from external power supply with 24 V DC	
- Typical	0.25 A
- Maximum	-
Effective power loss	6 W
Permitted ambient conditions	
Ambient temperature	
• During operation	0 ... 60 °C
• During storage	-40 ... +70 °C
• During transport	-40 ... +70 °C
• Note	-
Relative humidity at 25 °C without condensation during operation, maximum	95 %
IP degree of protection	IP20
Design, dimensions and weights	
Module format	Compact module
Width	40 mm
Height	125 mm
Depth	120 mm
Net weight	0.3 kg
Product properties, functions, components	
General	
Number of modules	
• Per CPU, maximum	4
• Note	-
Cable length	
• With polymer clad fiber cable, maximum	300 m
• With plastic optical fiber cable, maximum	50 m

Order No.	6GK7 342-5DF00-0XE0
Product type designation	CP 342-5 FO
Performance data	
<u>Performance data</u>	
<u>Open communication</u>	
Number of possible connections for open communication by means of SEND/RECEIVE blocks, maximum	16
Data volume as user data per connection for open communication by means of SEND/RECEIVE blocks, maximum	240 byte
<u>Performance data</u>	
<u>PROFIBUS DP</u>	
Service as DP master DPV0	Yes
Number of DP slaves operable on DP master	124
Data volume	
• of address area of inputs as DP master, total	2 160 byte
• of address area of outputs as DP master, total	2 160 byte
• of address area of inputs per DP slave	244 byte
• of address area of outputs per DP slave	244 byte
• of address area of diagnostics data per DP slave	240 byte
Service as DP slave	
• DPV0	Yes
• DPV1	-
Data volume	
• of address area of inputs as DP slave, total	240 byte
• of address area of outputs as DP slave, total	240 byte
<u>Performance data</u>	
<u>S7 communication</u>	
Number of possible connections for S7 communication	
• Maximum	16
<u>Performance data</u>	
<u>Multiprotocol operation</u>	
Number of active connections in multiprotocol mode	
• Maximum without DP	32
• Maximum with DP	28
Product functions	
Management, configuration, programming	
Configuration software required	STEP 7 V5.1 SP2 or higher

3

Ordering data	Order No.	Order No.
CP 342-5 FO communication processor Communication processor for optical connection of SIMATIC S7-300 to PROFIBUS to 12 Mbit/s with electronic manual on CD-ROM	6GK7 342-5DF00-0XE0	
STEP 7 Version 5.5 <i>Target system:</i> SIMATIC S7-300/400, SIMATIC C7, SIMATIC WinAC <i>Requirements:</i> Windows XP Prof., Windows 7 Professional/Ultimate <i>Type of delivery:</i> German, English, French, Spanish, Italian; incl. license key on USB flash drive, with electronic documentation <ul style="list-style-type: none"> Floating License on DVD Rental license for 50 hours Software Update Service on DVD (requires current software version) Upgrade Floating License 3.x/4.x/5.x to V5.4; on DVD Trial license STEP 7 V5.4; on DVD, operational for 14 days 	6ES7 810-4CC10-0YA5 6ES7 810-4CC10-0YA6 6ES7 810-4BC01-0YX2 6ES7 810-4CC10-0YE5 6ES7 810-4CC10-0YA7	STEP 7 Professional Engineering Software V11 <i>Target system:</i> SIMATIC S7-300/400, SIMATIC C7, SIMATIC WinAC <i>Requirements:</i> Windows XP Professional SP3 (32 bit), Windows 7 Professional (32 bit), Windows 7 Enterprise (32 bit), Windows 7 Ultimate (32 bit), Microsoft Server 2003 R2 Std. SP2 (32 bit), Microsoft Server 2008 Std. SP2 (32 bit) <i>Type of delivery:</i> German, English, Chinese, Italian, French, Spanish <ul style="list-style-type: none"> STEP 7 Professional V11, floating license STEP 7 Prof. V11, trial license Upgrade STEP 7 Prof. 2006/2010 to STEP 7 Prof. V11, floating license PowerPack & Upgrade STEP 7 V5.4/V5.5 to STEP 7 Prof. V11, floating license PowerPack STEP 7 Basic V11 to STEP 7 Prof. V11, floating license STEP 7 Professional V11, Software Update Service, 1 year; current software version required STEP 7 Professional V11, Software Update Service Compact, 1 year; current software version required STEP 7 Professional Software Update Service; 1 year; for STEP 7 Professional and STEP 7 Professional in the TIA Portal, requires current software version STEP 7 Professional Software Update Service Compact; 1 year; for STEP 7 Professional and STEP 7 Professional in the TIA Portal, requires current software version
		6ES7 822-1AA01-0YA5 6ES7 822-1AA01-0YA7 6ES7 822-1AA01-0XE5 6ES7 822-1AA01-0XC5 6ES7 822-1AA01-0YC5 6ES7 822-1AA00-0YL5 6ES7 822-1AA00-0YM5 6ES7 810-5CC04-0YE2 6ES7 810-5CC00-0YM2
		PROFIBUS Plastic Fiber Optic, Simplex Connector/ Polishing Set 100 simplex connectors and 5 polishing sets for assembling PROFIBUS plastic fiber optic cables for the optical PROFIBUS DP
		PROFIBUS Plastic Fiber Optic, Stripping Tool Set Tools for removing the outer sheath or core sheath of Plastic Fiber Optic cables
		Plug-in adapter For assembling the plastic Simplex connector in combination with CP 342-5 FO, IM 467 FO, IM 153-2 FO and IM 151 FO 50 units

PROFIBUS

Communication for SIMATIC S7-300

CP 343-5

Overview



DP-M	DP-S	FMS	PG/OP	S7/S5	
		●	●	●	

Connection of SIMATIC S7-300 to PROFIBUS at up to 12 Mbit/s (including 45.45 kbit/s)

- Communication services:
 - PG/OP communication
 - S7 communication
 - Open communication (SEND/RECEIVE)
 - PROFIBUS FMS
- Easy configuration and programming over PROFIBUS
- Can be easily integrated into the S7-300 system
- Cross-network programming device communication through S7 routing
- Modules can be replaced without the need for a PG

Benefits

get Designed for Industry

- Simple integration of the SIMATIC S7 into a multi-vendor automation group by means of PROFIBUS FMS
- Extensive reduction of workload for the user of PROFIBUS FMS specification due to simple configuration and independent data conversion of data on the CP
- Sub-process-oriented design of an automation solution through the use of several CPs
- Integration of the SIMATIC S7-300 into existing systems by means of open communication
- Universal application of the CP due to the parallel use of different communication services on one CP

Application

The CP 343-5 communications processor is the module required for SIMATIC S7-300 and SIMATIC C7 for the PROFIBUS bus system.

It offloads communication tasks from the CPU.

S7-300 communication options using communication modules:

- FMS communication with PROFIBUS FMS stations through PROFIBUS
- Communication with programming devices, human machine interface devices
- Communication with other SIMATIC S7 systems
- Communication with SIMATIC S5 PLCs
- The number of CPs that can be operated depends on the performance range of the CPU and the communication services used.

Design

The CP 343-5 offers all the advantages of the SIMATIC S7-300 design:

- Compact construction; single standard width of the SIMATIC S7-300 SM modules
- If the adjacent module cannot be aligned without a gap when replacing earlier versions of modules, a dummy module must be used
- 9-pin Sub-D socket for the bus interface to PROFIBUS
- 4-pin terminal strip for connection of the 24 V DC external supply voltage
- Easy installation; the CP 343-5 is mounted on the rail of the S7-300 and connected to the adjacent modules by means of the bus connectors. For the CP 343-5 the slots 4 through 11 in module racks 0 through 3 (linked via IM 360/361) are permissible
- The CP 343-5 can also be operated in the expansion rack (ER) in conjunction with the IM 360/361
- User-friendly wiring. Sub-D socket and terminal strip are easily accessible
- The CP 343-5 can be operated without a fan. A back-up battery or memory module are not required.

Function

The CP 343-5 provides the user with various communication services of the PROFIBUS bus system:

- PG/OP communication
- S7 communication (PG, OP, S7 controllers)
- Open communication (SEND/RECEIVE)
- PROFIBUS FMS (to IEC 61158/61784)

PG/OP communication

PG/OP communication allows all S7 stations connected to the network to be remotely programmed.

- S7 routing
With the aid of routing it is possible to use programming device communication across networks.

S7 communication

S7 communication is used for the coupling

- between SIMATIC S7 automation systems (CP 343-5 server only)
- to HMI devices (OPs).
- to SIMATIC 505
- to PCs, e.g. with CP 5512, CP 5611 A2, CP 5621 and SOFTNET-PB S7 or CP 5613 A2, CP 5613 FO, CP 5614 A2, CP 5623, CP 5624 and HARDNET-PB S7.

Communication with PG and OP takes place without further configuration. In addition, the central controller can also be programmed and configured on a distributed basis via the CP 343-5.

Open communication (SEND/RECEIVE)

Based on Layer 2 (FDL) of PROFIBUS (IEC 61158/61784), the CP 343-5 offers a simple, optimized interface for process or field communication.

This interface offers integrated, high-performance communication between SIMATIC S5, SIMATIC S7, SIMATIC 505 and PC. SEND/RECEIVE provides not only the SDA service (PLC/PLC connections) but also the SDN service (broadcast, multicast).

The communication partners are the automation systems:

- SIMATIC S7
with CP 342-5, CP 343-5, CP 443-5 Extended and Basic
- SIMATIC S5
with S5-95U with PROFIBUS interface, S5-115U/H, S5-135U, S5-155U/H with CP 5431 FMS/DP,
- SIMATIC 505 with CP 5434-FMS
- PCs with CP 5512, CP 5611 A2, CP 5621, CP 5613 A2, CP 5613 FO, CP 5614 A2, CP 5623, CP 5624
- Non-Siemens systems that are equipped with an FDL interface.

To use SEND/RECEIVE, function calls are required (PLC-SEND/PLC-RECEIVE), which must be linked into the STEP 7 user program.

PROFIBUS FMS

PROFIBUS FMS, according to PROFIBUS IEC 61158/61784, permits the transmission of messages via various FMS services:

- READ, WRITE;
for read or write access to variables of the communication partner from the user program (by means of a variable index or variable name),
for the transfer of its own variable values to the communication partner. Partial access to variable values is supported. The communication is processed over acyclic connections (master/master, master/slave), over acyclic connections with a slave initiative and cyclic connections.
- INFORMATION REPORT;
(Report) permits unconfirmed transmission of variables by an FMS server. This job type is used particularly for transmission on broadcast FMS connections.
- IDENTIFY;
for requesting the identification features of the communication partner
- STATUS;
for requesting the partner status

Diagnostics

Extensive diagnostic options are available via STEP 7, including:

- Status of the CP
- General diagnostics and statistics functions
- Connection diagnostics
- Bus statistics
- Message buffer

Configuration

STEP 7 V5.1 SP2 or higher is required for configuring the full functional scope of the CP 343-5. In Version V5 or higher of STEP 7, the configuration data of the CP can also optionally be stored on the CPU and is retained even if there is a power failure. A module can therefore be replaced without having to reload the configuration data from a programming device. The CPU transfers the configuration data to the CP during start-up. Attention should therefore be paid to the memory capacity of the S7-CPU.

Configuration and programming of all SIMATIC S7 controllers connected to the network is possible over the network.

The function blocks for using the open communication (SEND/RECEIVE) and FMS can be found in the SIMATIC NET library following installation of STEP 7.

PROFIBUS

Communication for SIMATIC S7-300

CP 343-5

Technical specifications

Order No.	6GK7 343-5FA01-0XE0
Product type designation	CP 343-5
Transmission rate	
Transmission rate at interface 1 in accordance with PROFIBUS	9.6 kbit/s ... 12 Mbit/s
Interfaces	
Number of electrical connections	
• at interface 1 in accordance with PROFIBUS	1
• for power supply	1
Design of electrical connection	
• at interface 1 in accordance with PROFIBUS	9-pin D-sub socket (RS485)
• for power supply	4-pin terminal strip
Supply voltage, current consumption, power loss	
Type of power supply	DC
Power supply	
• 1 from backplane bus	5 V
• External	24 V
Relative positive tolerance at 24 V DC	20 %
Relative negative tolerance at 24 V DC	15 %
Current consumed	
• from backplane bus at 5 V DC, typical	0.15 A
• from external power supply with 24 V DC	
- Typical	0.25 A
- Maximum	-
Effective power loss	5 W
Permitted ambient conditions	
Ambient temperature	
• During operation	0 ... 60 °C
• During storage	-40 ... +70 °C
• During transport	-40 ... +70 °C
• Note	-
Relative humidity at 25 °C without condensation during operation, maximum	95 %
IP degree of protection	IP20
Design, dimensions and weights	
Module format	S7-300 compact module, single-width
Width	40 mm
Height	125 mm
Depth	120 mm
Net weight	0.3 kg
Product properties, functions, components	
General	
Number of modules	
• Per CPU, maximum	4
• Note	-

Order No.	6GK7 343-5FA01-0XE0
Product type designation	CP 343-5
Performance data	
<u>Performance data</u> <u>Open communication</u>	
Number of possible connections for open communication by means of SEND/RECEIVE blocks, maximum	16
Data volume as user data per connection for open communication by means of SEND/RECEIVE blocks, maximum	240 byte
<u>Performance data</u> <u>FMS functions</u>	
Number of possible connections with FMS connection, maximum	16
Data volume of variables	
• Maximum with READ request	237 byte
• Maximum with WRITE and REPORT requests	233 byte
Number of variables	
• Configurable from server to FMS partner	256
• Loadable from server onto FMS partner	256
<u>Performance data</u> <u>S7 communication</u>	
Number of possible connections for S7 communication	
• Maximum	16
<u>Performance data</u> <u>Multiprotocol operation</u>	
Number of active connections in multiprotocol mode	48
Product functions Management, configuration, programming	
Configuration software required	STEP 7 V5.1 SP3 and higher and NCM S7 for PROFIBUS

3

Ordering data	Order No.		Order No.
CP 343-5 communication processor Communication processor for connection of S7-300 to PROFIBUS, FMS, open communication, PG/OP and S7 communication; with electronic manual on CD-ROM	6GK7 343-5FA01-0XE0	PROFIBUS FastConnect bus connector RS485 With 90° cable outlet; insulation displacement technology; max. transmission rate 12 Mbit/s (1 unit) <ul style="list-style-type: none"> • Without PG interface • With PG interface 	6ES7 972-0BA52-0XA0 6ES7 972-0BB52-0XA0
STEP 7 Version 5.5 <i>Target system:</i> SIMATIC S7-300/400, SIMATIC C7, SIMATIC WinAC <i>Requirements:</i> Windows XP Prof., Windows 7 Professional/Ultimate <i>Type of delivery:</i> German, English, French, Spanish, Italian; incl. license key on USB flash drive, with electronic documentation <ul style="list-style-type: none"> • Floating License on DVD • Rental license for 50 hours • Software Update Service on DVD (requires current software version) • Upgrade Floating License 3.x/4.x/5.x to V5.4; on DVD • Trial license STEP 7 V5.4; on DVD, operational for 14 days 	6ES7 810-4CC10-0YA5 6ES7 810-4CC10-0YA6 6ES7 810-4BC01-0YX2 6ES7 810-4CC10-0YE5 6ES7 810-4CC10-0YA7	PROFIBUS bus connector IP20 With connection to PPI, MPI, PROFIBUS <ul style="list-style-type: none"> • Without PG interface • With PG interface 	6ES7 972-0BA12-0XA0 6ES7 972-0BB12-0XA0
		PROFIBUS bus terminal 12M Bus terminal for connection of PROFIBUS nodes at up to 12 Mbit/s with connecting cable	6GK1 500-0AA10
		SIMATIC S7-300 DM 370 Dummy module; used for module replacement	6ES7 370-0AA01-0AA0

PROFIBUS

Communication for SIMATIC S7-400

CP 443-5 Basic

Overview



DP-M	DP-S	FMS	PG/OP	S7/S5	
		●	●	●	

- Connection of the S7-400 to PROFIBUS
- Communication services:
 - PG/OP communication
 - S7 communication
 - Open communication (SEND/RECEIVE)
 - PROFIBUS FMS
- Time synchronization
- Easy programming and configuration over PROFIBUS
- Cross-network programming device communication through S7 routing
- Can be easily integrated into the SIMATIC S7-400 system
- Modules can be replaced without the need for a PG
- SIMATIC H system operation for redundant S7 communication

Benefits

get Designed for Industry

- Simple integration of the SIMATIC S7 into a multi-vendor automation group by means of PROFIBUS FMS
- Application in fault-tolerant systems due to redundant S7 communication
- Extensive reduction of workload for the user of PROFIBUS FMS specification due to simple configuration and independent data conversion of data on the CP
- Plant-wide clock time thanks to clock synchronization
- Integration of the SIMATIC S7-400 into existing systems by means of open communication
- Universal application of the CP due to the parallel use of different communication services on one CP

Application

The CP 443-5 Basic communications processor is the module required for SIMATIC S7-400 for the PROFIBUS bus system.

It offloads communication tasks from the CPU.

Communications options of the S7-400 through communications modules:

- FMS communication with PROFIBUS stations through PROFIBUS
- Communication with programming devices, human machine interface devices
- Communication with other SIMATIC S7 systems
- Communication with SIMATIC S5 PLCs

The number of CPs that can be operated depends on the performance range of the CPU and the communication services used.

Design

The CP 443-5 communications processor features all the advantages of the SIMATIC S7-400 design:

- Compact construction; 9-pin Sub-D socket for connection to PROFIBUS
- Single-width module
- Easy installation; the CP 443-5 is mounted on the S7-400 rack and connected to the other modules of the S7-400 by means of the backplane bus. No slot rules apply in this case.
- User-friendly wiring; the Sub-D socket is easily accessible and simple to operate.
- The CP 443-5 Basic can be operated without a fan. A backup battery or memory module is not required
- When using SEND/RECEIVE, the number of operable modules depends on the S7-400 CPU used.

Function

The CP 443-5 Basic provides access to different communication services of the PROFIBUS bus system:

- PG/OP communication
- S7 communication (S7 controllers)
- Open communication (SEND/RECEIVE)
- PROFIBUS FMS (to IEC 61158/61784)
- Time synchronization

PG/OP communication

PG/OP communication allows all S7 stations connected to the network to be remotely programmed.

- S7 routing
With the aid of routing it is possible to use programming device communication across networks.

S7 communication

S7 communication is used for the coupling

- between SIMATIC S7 automation systems
- to programming devices (PG/OP communication)
- To PCs,
e.g. with CP 5512, CP 5611 A2, CP 5621 and SOFTNET-PB S7 or CP 5613 A2, CP 5613 FO, CP 5614 A2, CP 5623, CP 5624 and HARDNET-PB S7
- to HMI devices (OPs).
- For redundant S7 communication, the CP 443-5 Basic can also be used in SIMATIC H systems.

Open communication (SEND/RECEIVE)

Based on Layer 2 (FDL) of PROFIBUS, the CP 443-5 Basic offers a simple, optimized interface for data communication. This interface offers integrated, high-performance communication between SIMATIC S5, SIMATIC S7 and the PC. It provides the services SDA (PLC/PLC connections) and SDN (Broadcast/Multicast).

The communication partners are the automation systems:

- SIMATIC S7
with CP 342-5, CP 343-5, CP 443-5 Extended and Basic
- SIMATIC S5
with S5-95U with PROFIBUS interface, S5-115U/H, S5-135U, S5-155U/H with CP 5431 FMS/DP
- SIMATIC 505
with CP 5434-FMS
- PCs
with CP 5512, CP 5611 A2, CP 5621, CP 5613 A2, CP 5613 FO, CP 5614 A2, CP 5623, CP 5624
- Non-Siemens systems that are equipped with an FDL interface.

To use SEND/RECEIVE, function calls are required (PLC-SEND/PLC-RECEIVE), which must be linked into the STEP 7 user program.

PROFIBUS FMS

PROFIBUS FMS, according to IEC 61158/61784, permits the transmission of messages via various FMS services:

- READ, WRITE;
for read or write access to variables of the communication partner from the user program (by means of a variable index or variable name), for the transfer of its own variable values to the communication partner.
Partial access to variables is supported. The communication takes place over acyclic connections (master/master, master/slave), over acyclic connections with a slave initiative and cyclic connections (master/slave).
- INFORMATION REPORT;
(Report) permits unconfirmed transmission of variables by an FMS server. This job type is used particularly for transmission on broadcast FMS connections.
- IDENTIFY;
for requesting the identification features of the communication partner
- STATUS;
for requesting the partner status

Time synchronization

The CP 443-5 Basic is capable of forwarding the time of day of the S7-400 CPU to PROFIBUS. Conversely, the CP 443-5 Basic of the S7-400 CPU can make an existing time of day available on the PROFIBUS.

Diagnostics

Extensive diagnostic options are available via STEP 7, including:

- Status of the CP
- General diagnostics and statistics functions
- Connection diagnostics
- Bus statistics
- Message buffer

Configuration

STEP 7 V5.1 SP2 or higher is required for configuring the full functional scope of the CP 443-5 Basic. In Version V5 or higher of STEP 7, the configuration data of the CP can also optionally be stored on the CPU and is retained even if there is a power failure. A module can therefore be replaced without having to reload the configuration data from a programming device. The CPU transfers the configuration data to the CP during start-up.

Configuration and programming of all SIMATIC S7 controllers connected to the network is possible over the network.

The function blocks for using the open communication (SEND/RECEIVE) can be found in the SIMATIC NET library following installation of STEP 7.

PROFIBUS

Communication for SIMATIC S7-400

CP 443-5 Basic

Technical specifications

Order No.	6GK7 443-5FX02-0XE0
Product type designation	CP 443-5 Basic
Transmission rate	
Transmission rate at interface 1 in accordance with PROFIBUS	9.6 kbit/s ... 12 Mbit/s
Interfaces	
Number of electrical connections at interface 1 in accordance with PROFIBUS	1
Design of electrical connection at interface 1 in accordance with PROFIBUS	9-pin D-sub socket (RS485)
Supply voltage, current consumption, power loss	
Type of power supply	DC
Power supply 1 from backplane bus	5 V
Relative symmetrical tolerance at 5 V DC	5 %
Current input from backplane bus with 5 V DC, typical	1 A
Effective power loss	5.5 W
Permitted ambient conditions	
Ambient temperature	0 ... 60 °C
• During operation	-40 ... +70 °C
• During storage	-40 ... +70 °C
• During transport	-
• Note	-
Relative humidity at 25 °C without condensation during operation, maximum	95 %
IP degree of protection	IP20
Design, dimensions and weights	
Module format	S7-400 compact module, single-width
Width	25 mm
Height	290 mm
Depth	210 mm
Net weight	0.65 kg
Product properties, functions, components	
General	
Number of modules	14
• Per CPU, maximum	-
• Note	-

Order No.	6GK7 443-5FX02-0XE0
Product type designation	CP 443-5 Basic
Performance data	
<u>Performance data</u>	
<u>Open communication</u>	
Number of possible connections for open communication by means of SEND/RECEIVE blocks, maximum	32
Data volume as user data per connection for open communication by means of SEND/RECEIVE blocks, maximum	240 byte
<u>Performance data</u>	
<u>FMS functions</u>	
Number of possible connections with FMS connection, maximum	48
Data volume of variables	
• Maximum with READ request	237 byte
• Maximum with WRITE request	233 byte
Number of variables	
• Configurable from server to FMS partner	512
• Loadable from server onto FMS partner	2 640
<u>Performance data</u>	
<u>S7 communication</u>	
Number of possible connections for S7 communication	
• Maximum	48
<u>Performance data</u>	
<u>Multiprotocol operation</u>	
Number of possible connections, of which 2 reserved for PG/OP communication in multiprotocol mode, maximum	59
Product functions	
Management, configuration, programming	
Configuration software required	STEP 7 V5.2 SP1 and higher and NCM S7 for PROFIBUS

Ordering data	Order No.	Order No.
<p>CP 443-5 Basic communications processor</p> <p>Communications processor for connection of S7-400 to PROFIBUS, FMS, open communication, PG/OP and S7 communication; with electronic manual on CD-ROM</p>	6GK7 443-5FX02-0XE0	<p>PROFIBUS FastConnect bus connector RS485</p> <p>With 90° cable outlet; insulation displacement technology, max. transmission rate 12 Mbit/s (1 unit)</p> <ul style="list-style-type: none"> • Without PG interface • With PG interface <p>6ES7 972-0BA52-0XA0 6ES7 972-0BB52-0XA0</p>
<p>STEP 7 Version 5.5</p> <p><i>Target system:</i> SIMATIC S7-300/400, SIMATIC C7, SIMATIC WinAC</p> <p><i>Requirements:</i> Windows XP Prof., Windows 7 Professional/Ultimate</p> <p><i>Type of delivery:</i> German, English, French, Spanish, Italian; incl. license key on USB flash drive, with electronic documentation</p> <ul style="list-style-type: none"> • Floating License on DVD • Rental license for 50 hours • Software Update Service on DVD (requires current software version) • Upgrade Floating License 3.x/4.x/5.x to V5.4; on DVD • Trial license STEP 7 V5.4; on DVD, operational for 14 days 	<p>6ES7 810-4CC10-0YA5 6ES7 810-4CC10-0YA6 6ES7 810-4BC01-0YX2</p> <p>6ES7 810-4CC10-0YE5 6ES7 810-4CC10-0YA7</p>	<p>PROFIBUS bus connector IP20</p> <p>With connection to PPI, MPI, PROFIBUS</p> <ul style="list-style-type: none"> • Without PG interface • With PG interface <p>6ES7 972-0BA12-0XA0 6ES7 972-0BB12-0XA0</p> <p>PROFIBUS bus terminal 12M</p> <p>6GK1 500-0AA10</p> <p>Bus terminal for connection of PROFIBUS nodes at up to 12 Mbit/s with connecting cable</p>

PROFIBUS

Communication for SIMATIC S7-400

CP 443-5 Extended

Overview



DP-M	DP-S	FMS	PG/OP	S7/S5	
●			●	●	

- PROFIBUS DP master with electrical interface for connecting the SIMATIC S7-400 to PROFIBUS at up to 12 Mbit/s (including 45.45 kbit/s)
- For setting up additional PROFIBUS DP lines
- Communication services:
 - PROFIBUS DP
 - PG/OP communication
 - S7 communication
 - Open communication (SEND/RECEIVE)
- Time synchronization
- Easy programming and configuration over PROFIBUS
- Cross-network programming device communication through S7 routing
- Can be easily integrated into the SIMATIC S7-400 system
- Module replacement without PG
- SIMATIC H system operation for redundant S7 communication or DP master communication
- Data record routing (PROFIBUS DP)
- Adding or modifying distributed I/O during operation

Benefits

get Designed for Industry

- Increased plant availability thanks to redundant connection of the process I/O (e.g. ET 200M) in the SIMATIC S7-400 H system
- Particularly suitable for closed-loop control tasks thanks to SYNC/FREEZE and equidistant bus cycle
- Sub-process-oriented design of an automation solution through the use of several CPs
- Universal application of the CP due to the parallel use of different communication services on one CP
- Lower costs due to flexible and reaction-free commissioning by means of CiR (Configuration in RUN)

Application

The CP 443-5 Extended is the communications processor of the SIMATIC S7-400 for the PROFIBUS bus system.

It relieves the CPU of communication tasks and supports additional connections.

Communication possibilities of the S7-400 using communication modules:

- As master for PROFIBUS DP according to IEC 61158/EN 50170
- Communication with programming devices and HMI devices
- Communication with other SIMATIC S7 systems
- Communication with SIMATIC S5 programmable controllers

The number of CPs that can be used is dependent on the performance range of the CPU and on the communications services used.

Design

The CP 443-5 Extended communications processor features all the advantages of the SIMATIC S7-400 design:

- Compact construction; 9-pin Sub-D socket for connection to PROFIBUS DP
- Single-width module
- Easy installation; the CP 443-5 is mounted on the S7-400 rack and connected to the other modules of the S7-400 by means of the backplane bus.
- User-friendly wiring; the Sub-D socket is easily accessible and simple to operate.
- The CP 443-5 Extended can be operated without a fan. A backup battery or memory module is not required
- A maximum of 14 CPs can be operated.

If the CP 443-5 Extended is used as a DP Master, at least four and as many as 10 additional PROFIBUS DP lines can be set up in the central rack. The number of possible PROFIBUS DP lines depends on the SIMATIC S7-400 CPU that is used.

When using S7-communication, no slot allocation rules apply. The number of operable S7 connections depends on the S7-400 CPU.

When using SEND/RECEIVE, the number of operable modules also depends on the S7-400 CPU.

Function

The CP 443-5 Extended provides access to different communication services of the PROFIBUS bus system:

- PROFIBUS DP (according to IEC 61158/61784)
- PG/OP communication
- S7 communication (S7 controllers)
- Open communication (SEND/RECEIVE)
- Time synchronization

Master for PROFIBUS DP

The CP 443-5 Extended operates as DP-V1 master. It processes data transfer autonomously and allows slaves to be connected, such as CP 342-5 as DP slave, DP slaves of the ET 200 distributed I/O system, etc. This means that the CP 443-5 Extended is able to connect the S7-400 station to PROFIBUS DP and is the ideal expansion to the integral DP master interfaces of the S7-400 CPUs for establishing additional PROFIBUS DP lines.

The CP 443-5 Extended can also be used in the SIMATIC S7 H system as a redundant DP master.

The CP 443-5 Extended is a DP-V1 master, i.e. it also supports the acyclic standard services incl. interrupt handling.

The CP 443-5 Extended also supports the SYNC and FREEZE functions, constant bus cycle time, direct slave-to-slave traffic, data set routing and changes to the configuration of the assigned distributed I/O during normal operation.

During normal operation, it is also possible to activate or deactivate DP slaves. This supports the step-by-step start-up of subprocesses, for example.

A diagnostic repeater allows the line to be diagnosed during operation, enabling line faults to be detected at an early stage. The CP 443-5 Extended supports operation with diagnostic repeater (including activation of topology identification in the diagnostic repeater).

The distributed I/Os are handled like central I/Os from the user's point of view. This means that there are no differences between the CP 443-5 Extended and the integral DP master interface of the S7-400 CPU with regard to configuration and parameterization. Depending on the scale of the system, the CP 443-5 Extended has extremely short response times.

PG/OP communication

PG/OP communication allows all S7 stations connected to the network to be remotely programmed.

- S7 routing
With the aid of routing it is possible to use programming device communication across networks.

S7 communication

S7 communication is used for the coupling

- between SIMATIC S7 automation systems
- to programming devices (PG/OP communication)
- to PCs,
e.g. with CP 5512, CP 5611 A2, CP 5621 and SOFTNET-PB S7 or CP 5613 A2, CP 5613 FO, CP 5614 A2, CP 5623, CP 5624 and HARDNET-PB S7
- to HMI devices (OPs).

For redundant S7 communication, the CP 443-5 Extended can also be used in SIMATIC H systems.

Open communication (SEND/RECEIVE)

SIMATIC S7-400 is integrated into existing systems by means of open communication.

Based on Layer 2 (FDL) of PROFIBUS, the CP 443-5 Extended offers a simple, optimized interface for process or field communication. This interface offers uniform, high-performance communication between SIMATIC S5, SIMATIC S7 and the PC. It provides the services SDA (PLC/PLC connections) and SDN (Broadcast, Multicast).

The communication partners are the programmable controllers

- SIMATIC S7
with CP 342-5, CP 343-5, CP 443-5 Extended and Basic
- SIMATIC S5
with S5-95U with PROFIBUS interface, S5-115U/H, S5-135U, S5-155U/H with CP 5431 FMS/DP
- SIMATIC 505
with CP 5434-FMS
- PCs
with CP 5512, CP 5611 A2, CP 5621, CP 5613 A2, CP 5613 FO, CP 5614 A2, CP 5623, CP 5624
- Non-Siemens systems that are equipped with an FDL interface.

To use SEND/RECEIVE, function calls are required (PLC-SEND/PLC-RECEIVE), which must be linked into the STEP 7 user program.

Function (continued)**Time synchronization**

Time synchronization is used to define plant-wide time-of-day.

The CP 443-5 Extended is capable of forwarding the time of day of the S7-400 CPU to PROFIBUS. Conversely, the CP of the S7-400 CPU can make an existing time of day available on PROFIBUS.

The CP 443-5 Extended supports

- The time-stamping of distributed process signals in combination with IM 153
- Time status value, daylight-saving time changeover, synchronization status

Data set routing

The CP 443-5 Extended supports the data set routing function. With this option, the CP can be used as a router for data sets that have to be sent to field devices (DP slaves). SIMATIC PDM (Process Device Manager) is a tool that creates data sets of this type for parameterizing and diagnosing field devices.

Application:

It is possible, for example, to use SIMATIC PDM (on the PC) to set parameters and perform diagnostics for a PA field device over Industrial Ethernet, S7-400 (CP 443-1, CP 443-5 Extended) and DP/PA Coupler/Link.

Diagnostics

Extensive diagnostic options are available via STEP 7, including:

- Status of the CP
- General diagnostics and statistics functions
- Connection diagnostics
- Bus statistics
- Message buffer
- Support of operation with diagnostic repeater

CiR – Configuration in RUN

With CiR, it is possible to add or modify distributed I/O devices during normal operation.

- Adding PROFIBUS DP/PA slaves
- Adding/removing modules (e.g. I/O modules) in a modular DP slave (e.g. ET 200M and DP/PA Link)

Configuration

STEP 7 V5.1 SP2 or higher, or the TIA Portal V11, is required for configuring the full functional scope of the CP 443-5 Extended.

DP configuration/programming is performed for the CP 443-5 Extended in the same manner as for DP configuration/programming of the integrated DP interfaces of the SIMATIC S7-400 CPUs with STEP 7.

The configuring data of the CPs are always saved on the CPU and are retained even after a PLC failure. A module can therefore be replaced without having to reload the configuration data from a programming device. The CPU transfers the configuration data to the CP during start-up.

Configuration and programming of all SIMATIC S7 controllers connected to the network is possible over the network.

The function blocks for using the open communication (SEND/RECEIVE) can be found in the SIMATIC NET library following installation of STEP 7.

Technical specifications

Order No.	6GK7 443-5DX04-0XE0
Product type designation	CP 443-5 Extended
Transmission rate	
Transmission rate at interface 1 in accordance with PROFIBUS	9.6 kbit/s ... 12 Mbit/s
Interfaces	
Number of electrical connections at interface 1 in accordance with PROFIBUS	1
Design of electrical connection at interface 1 in accordance with PROFIBUS	9-pin D-sub socket (RS485)
Supply voltage, current consumption, power loss	
Type of power supply	DC
Power supply 1 from backplane bus	5 V
Relative symmetrical tolerance at 5 V DC	5 %
Current input from backplane bus with 5 V DC, typical	1 A
Effective power loss	5.5 W
Permitted ambient conditions	
Ambient temperature	
• During operation	0 ... 60 °C
• During storage	-40 ... +70 °C
• During transport	-40 ... +70 °C
• Note	-
Relative humidity at 25 °C without condensation during operation, maximum	95 %
IP degree of protection	IP20
Design, dimensions and weights	
Module format	S7-400 compact module, single-width
Width	25 mm
Height	290 mm
Depth	210 mm
Net weight	0.65 kg
Product properties, functions, components	
General	
Number of modules	14
• Per CPU, maximum	
• Note	The number of CPs which can be used as DP masters depends of the number of CP 443-1 Advanced used in the S7-400 station as PROFINET IO-Controllers. A total of 10 CPs can be used, as PROFINET IO-Controller (CP 443-1 Advanced) -> maximum 4, as DP master (CP 443-5 Extended) -> maximum 10

Order No.	6GK7 443-5DX04-0XE0
Product type designation	CP 443-5 Extended
Performance data	
<u>Performance data</u>	
<u>Open communication</u>	
Number of possible connections for open communication by means of SEND/RECEIVE blocks, maximum	32
Data volume as user data per connection for open communication by means of SEND/RECEIVE blocks, maximum	240 byte
<u>Performance data</u>	
<u>PROFIBUS DP</u>	
Service as DP master DPV1	Yes
Number of DP slaves operable on DP master	125
Data volume	
• of address area of inputs as DP master, total	4 096 byte
• of address area of outputs as DP master, total	4 096 byte
• of address area of inputs per DP slave	244 byte
• of address area of outputs per DP slave	244 byte
<u>Performance data</u>	
<u>S7 communication</u>	
Number of possible connections for S7 communication	
• Maximum	48
<u>Performance data</u>	
<u>Multiprotocol operation</u>	
Number of active connections in multiprotocol mode	
• Maximum without DP	59
• Maximum with DP	55
Product functions	
Management, configuration, programming	
Configuration software required	STEP 7 V5.4 SP4 and higher and NCM S7 for PROFIBUS

PROFIBUS

Communication for SIMATIC S7-400

CP 443-5 Extended

Ordering data

Order No.

Order No.

Communications processor CP 443-5 Extended

for connection of the SIMATIC S7-400 to PROFIBUS

Extended version for PROFIBUS DP; with electronic manual on CD-ROM

6GK7 443-5DX04-0XE0**STEP 7 Version 5.5***Target system:*

SIMATIC S7-300/400, SIMATIC C7, SIMATIC WinAC

Requirements:

Windows XP Prof., Windows 7 Professional/Ultimate

Type of delivery:

German, English, French, Spanish, Italian; incl. license key on USB flash drive, with electronic documentation

- Floating License on DVD
- Rental license for 50 hours
- Software Update Service on DVD (requires current software version)
- Upgrade Floating License 3.x/4.x/5.x to V5.4; on DVD
- Trial license STEP 7 V5.4; on DVD, operational for 14 days

6ES7 810-4CC10-0YA5**6ES7 810-4CC10-0YA6****6ES7 810-4BC01-0YX2****6ES7 810-4CC10-0YE5****6ES7 810-4CC10-0YA7****STEP 7 Professional Engineering Software V11***Target system:*

SIMATIC S7-300/400, SIMATIC C7, SIMATIC WinAC

Requirements:

Windows XP Professional SP3 (32 bit), Windows 7 Professional (32 bit), Windows 7 Enterprise (32 bit), Windows 7 Ultimate (32 bit), Microsoft Server 2003 R2 Std. SP2 (32 bit), Microsoft Server 2008 Std. SP2 (32 bit)

Type of delivery:

German, English, Chinese, Italian, French, Spanish

- STEP 7 Professional V11, floating license **6ES7 822-1AA01-0YA5**
- STEP 7 Prof. V11, trial license **6ES7 822-1AA01-0YA7**
- Upgrade STEP 7 Prof. 2006/2010 to STEP 7 Prof. V11, floating license **6ES7 822-1AA01-0XE5**
- PowerPack & Upgrade STEP 7 V5.4/V5.5 to STEP 7 Prof. V11, floating license **6ES7 822-1AA01-0XC5**
- PowerPack STEP 7 Basic V11 to STEP 7 Prof. V11, floating license **6ES7 822-1AA01-0YC5**
- STEP 7 Professional V11, Software Update Service, 1 year; current software version required **6ES7 822-1AA00-0YL5**
- STEP 7 Professional V11, Software Update Service Compact, 1 year; current software version required **6ES7 822-1AA00-0YM5**
- STEP 7 Professional Software Update Service; 1 year; for STEP 7 Professional and STEP 7 Professional in the TIA Portal, requires current software version **6ES7 810-5CC04-0YE2**
- STEP 7 Professional Software Update Service Compact; 1 year; for STEP 7 Professional and STEP 7 Professional in the TIA Portal, requires current software version **6ES7 810-5CC00-0YM2**

PROFIBUS FastConnect bus connector RS485

With 90° cable outlet; insulation displacement technology, max. transmission rate 12 Mbit/s (1 unit)

- Without PG interface **6ES7 972-0BA52-0XA0**
- With PG interface **6ES7 972-0BB52-0XA0**

PROFIBUS bus connector IP20

With connection to PPI, MPI, PROFIBUS

- Without PG interface **6ES7 972-0BA12-0XA0**
- With PG interface **6ES7 972-0BB12-0XA0**

PROFIBUS bus terminal 12M

Bus terminal for connection of PROFIBUS nodes at up to 12 Mbit/s with connecting cable

6GK1 500-0AA10

3

PROFIBUS

Communication for SIMATIC S7-400

SIPLUS CP 443-5 Extended

Overview



DP-M	DP-S	FMS	PG/OP	S7/S5	
●			●	●	

- DP-V1 master connection of the S7-400 to PROFIBUS
- For setting up additional PROFIBUS DP lines
- Communication services:
 - PROFIBUS DP
 - PG/OP communication
 - S7 communication
 - S5-compatible communication (SEND/RECEIVE)
- Clock synchronization
- Easy programming and configuration over PROFIBUS
- Cross-network programming device communication through S7 routing
- Can be easily integrated into the SIMATIC S7-400 system
- Module replacement without PG
- SIMATIC H system operation for redundant S7 communication or DP master communication
- Data record routing (PROFIBUS DP)
- Adding or modifying distributed I/O during operation

Note:

SIPLUS extreme products are based on Siemens Industry standard products. The contents listed here were taken from the respective standard products. SIPLUS extreme-specific information was added.

SIPLUS CP 443-5-Extended

Order number	6AG1 443-5DX04-4XE0
Order No. based on	6GK7 443-5DX04-0XE0
Ambient temperature range	0 ... +60 °C
Conformal coating	Coating of the printed circuit boards and the electronic components
Technical data	The technical data of the standard product applies except for the ambient conditions
Ambient conditions	
Relative humidity	5 ... 100 % Condensation permissible
Biologically active substances	Conformity with EN 60721-3-3, Class 3B2 mold and fungal spores (except fauna)
Chemically active substances	Conformity with EN 60721-3-3, Class 3C4 incl. salt mist and ISA-S71.04 severity level G1; G2; G3; GX ¹⁾²⁾
Mechanically active substances	Conformity with EN 60721-3-3, Class 3S4 including conductive sand, dust ²⁾
Air pressure (depending on the highest positive temperature range specified)	1080 ... 795 hPa (-1000 ... +2000 m) see ambient temperature range 795 ... 658 hPa (+2000 ... +3500 m) derating 10 K 658 ... 540 hPa (+3500 ... +5000 m) derating 20 K

- 1) ISA-S71.04 severity level GX: Long-term load:
SO₂ < 4.8 ppm; H₂S < 9.9 ppm; Cl < 0.2 ppm; HCl < 0.66 ppm;
HF < 0.12 ppm; NH < 49 ppm; O₃ < 0.1 ppm; NOX < 5.2 ppm
Limit value (max. 30 min/d):
SO₂ < 17.8 ppm; H₂S < 49.7 ppm; Cl < 1.0 ppm; HCl < 3.3 ppm;
HF < 2.4 ppm; NH < 247 ppm; O₃ < 1.0 ppm; NOX < 10.4 ppm
- 2) The supplied plug covers must remain in place over the unused interface when operated in atmospheres containing corrosive gases!

The technical documentation on SIPLUS can be found here:
www.siemens.com/siplus-extreme

Ordering data

SIPLUS CP 443-5 Extended communications processor

(medial exposure)
for connection of the SIMATIC S7-400 to PROFIBUS

Extended version for PROFIBUS DP;
with electronic manual on CD-ROM

Accessories

Order No.

6AG1 443-5DX04-4XE0

See SIMATIC CP 443-5 Extended

Communication for SIMATIC S7-mEC with CP 5603

see page 3/189 and the following

PROFIBUS

System interfaces for PG/PC/IPC

Communication for PC-based systems Overview

Overview



Software



- ▶ You will find software for the PC products running under Windows with the corresponding authorization diskettes on the SIMATIC NET software CD.
- ▶ Development Kits are available for use in various operating system environments (e.g. for CP 5613 A2 or CP 5614 A2).
- ▶ As a rule, the necessary configuration tools are included in the software packages.
- ▶ Manuals in PDF format and extensive supplementary information on SIMATIC NET products and communication can be found in the SIMATIC NET Manual Collection which is enclosed with the software products.

SIMATIC NET
Manual Collection



Hardware

CPs with an internal microprocessor

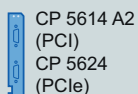
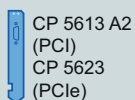

CPs without an internal microprocessor

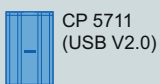
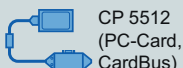
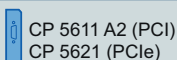

G. IK10_XX_50184

PC card with an internal microprocessor

Recommended solution for:

- PC-based control systems (Soft Control, PLC, Numeric Control, Robot Control)
- Process control systems
- Operator control and monitoring systems (HMI)
- PROFIBUS DP slave interface (CP 5614 A2)
- PROFIBUS plants with large quantity framework (more than 8 stations)
- Multi-protocol operation
- Use of several CPs in one system
- Designs with fiber-optic interface (FO)

PC card without an internal microprocessor

Recommended solution for:

- Configuring tools (e.g. STEP 7)
- PROFIBUS DP diagnostics station (e.g. with COM PROFIBUS or as DP master Class 2)
- PROFIBUS DP slave connection
- PROFIBUS systems with up to 8 stations
- Mono protocol mode

System connection for PG/PC/IPC

Overview

The following communications processors are available for connecting to the programming device or PC:

- CPs with an internal microprocessor:
CP 5613 A2 (PCI), CP 5613 FO (PCI), CP 5614 A2 (PCI), CP 5623 (PCIe), CP 5624 (PCIe)
- CPs without an internal microprocessor:
CP 5512 (PC Card/CardBus), CP 5611 A2 (PCI), CP 5621 (PCIe), CP 5711 (USB)

Performance of PROFIBUS CPs

The maximum performance specifies how much digital input/output data can be read or written in 1 ms from the PROFIBUS application over the respective PROFIBUS CP (regardless of the physical characteristics of the bus).

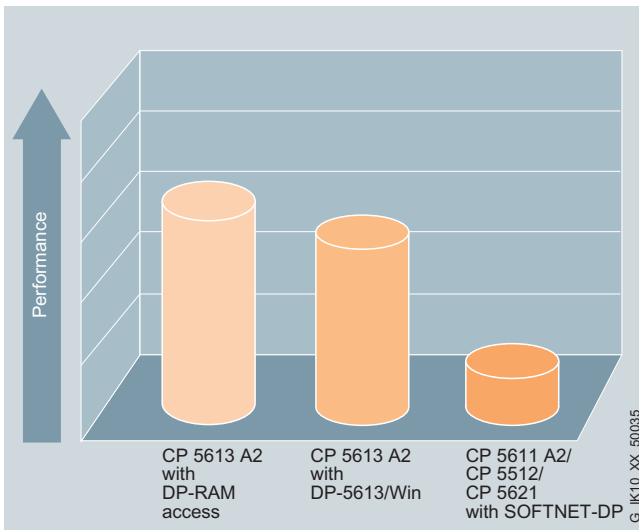

Performance under almost identical CPU loading

CPU loading and access time

If event access (using interrupts) and polling access are compared, it can be shown that the CPU loading can be significantly reduced with the CP 5613 A2 using the event/filter mechanism – for the same data throughput.

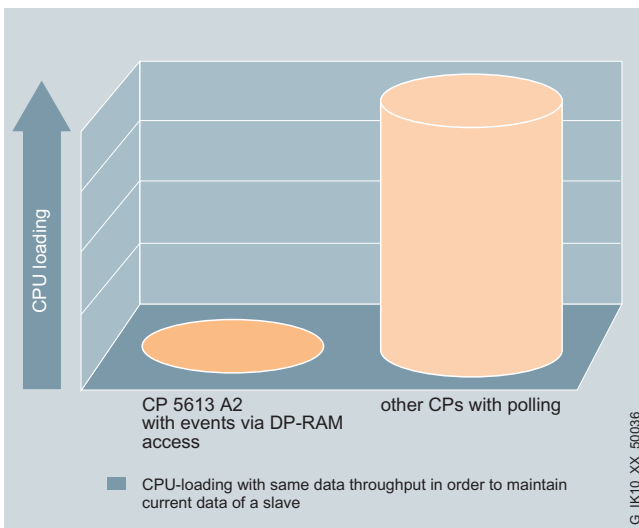

Comparison of loading on the CPU with event access and with polling access

Performance data of PROFIBUS CPs

		CP 5613 A2/ CP 5613 FO	CP 5614 A2	CP 5512/ CP 5611 A2/ CP 5621
Number of connectable DP slaves	Max.	122	122	60
Number of FDL tasks waiting	Max.	120	120	100
Number of PG/OP and S7 connections	Max.	50 ¹⁾	50 ¹⁾	8
Number of FMS connections	Max.	40 ²⁾	40 ²⁾	-

Note:

¹⁾ for credit = 1; PDU size ≤ 480 bytes

²⁾ for credit = 1; max. 2 x CP 5613 A2 / CP 5613 FO / CP 5614 A2

Configuration with NCM PC

The PC can be configured either in STEP 7 or in NCM PC Version V5.1+SP2 and higher. Both tools offer the same look and feel and create the same database. This means that uniform configuration is possible for the communication functions open communication, S7 communication and for the DP protocol and FMS protocol. Data only has to be entered once and data consistency is assured.

- With NCM PC and STEP 7 from Version V5.1+SP2 upwards, a PC similar to a SIMATIC S7 station can be configured and loaded over a network. This applies both to the local station on which NCM PC or STEP 7 is installed and to the remote station that is addressed over the network.

Note:

NCM PC does not contain a conversion function for LDBs that were created using COML S7. Reconfiguration is necessary.

More information

You can find more information on the Internet at:

<http://support.automation.siemens.com/WW/view/en/15227599>

PROFIBUS Communication for PC-based systems

Connection options to SIMATIC IPC

Overview

3

Communication hardware	Communication software	Operating system environment of the communication software								SIMATIC Industrial PC/ Field PG								Embedded Systems				
		Windows 7 Professional / Ultimate	Windows Server 2008 R2	Windows Server 2008 + SP1/2	Vista Business / Ultimate + SP1/2	Windows XP Pro + SP3	Windows Server 2003 + SP1/2	Windows Server 2003 R2 / SP2	other operating systems	Field PG M3	SIMATIC IPC847C	SIMATIC IPC647C	SIMATIC IPC547C, SIMATIC HMI IPC577D	SIMATIC IPC627C	SIMATIC IPC827C	SIMATIC IPC427C	Windows XP Embedded + SP1/SP2/FP 2007	SIMATIC IPC427C	SIMATIC HMI IPC477C	SIMATIC HMI IPC677C	SIMATIC IPC627C	SIMATIC S7 modular Embedded Controller
CPs and software for Industrial Ethernet																						
CP 5603 (PCI-104)	CP with DP-Base	●	●	●	●	●	●	●	-	-	-	-	-	-	●	●	●	●	-	-	-	
	HARDNET-PB DP DK 1) (DK-5613, DP-base)	○	○	○	○	○	○	○	○	-	-	-	-	-	○	○	○	○	-	-	○ ⁵⁾	
	HARDNET-PB DP (DP-5613)	●	●	●	●	●	●	●	-	-	-	-	-	-	●	●	●	●	-	-	-	
	HARDNET-PB S7 (S7-5613)	●	●	●	●	●	●	●	-	-	-	-	-	-	●	●	●	●	-	-	-	
	S7 OPC Redundancy for PROFIBUS	-	●	-	-	-	-	-	-	-	-	-	-	-	●	●	●	●	-	-	-	
CP 5613 A2, CP 5614 A2 (PCI 32 Bit)	CP mit DP-Base	●	●	●	●	●	●	●	-	-	●	●	●	●	-	-	-	-	●	●	-	
	HARDNET-PB DP DK 1) (DK-5613, DP-base)	○	○	○	○	○	○	○	○	-	○	○	○	○	○	○	○	○	○	○	-	
	HARDNET-PB DP (DP-5613)	●	●	●	●	●	●	●	-	-	●	●	●	●	-	-	-	-	●	●	-	
	HARDNET-PB S7 (S7-5613)	●	●	●	●	●	●	●	-	-	●	●	●	●	-	-	-	-	●	●	-	
	S7 OPC Redundancy for PROFIBUS	-	●	-	-	-	-	-	-	-	-	●	●	●	-	-	-	-	●	●	-	
CP 5623, CP 5624 (PCIe x1)	CP with DP-Base	●	●	●	●	●	●	●	-	-	● ⁴⁾	-	●	○ ⁴⁾	●	-	-	-	○ ⁴⁾	○ ⁴⁾	-	
	HARDNET-PB DP DK 1) (DK-5613, DP-base)	○	○	○	○	○	○	○	○	-	○	-	○	○	○	○	-	-	○ ⁴⁾	○ ⁴⁾	-	
	HARDNET-PB DP (DP-5613)	●	●	●	●	●	●	●	-	-	● ⁴⁾	-	●	○ ⁴⁾	●	-	-	-	○ ⁴⁾	○ ⁴⁾	-	
	HARDNET-PB S7 (S7-5613)	●	●	●	●	●	●	●	-	-	● ⁴⁾	-	●	○ ⁴⁾	●	-	-	-	○ ⁴⁾	○ ⁴⁾	-	
	S7 OPC Redundancy for PROFIBUS	-	●	-	-	-	-	-	-	-	● ⁴⁾	-	●	○ ⁴⁾	●	-	-	-	○ ⁴⁾	○ ⁴⁾	-	
CP 5611 A2 (PCI 32 Bit)	SOFTNET-PB DP	●	●	●	●	●	●	●	-	-	●	●	●	●	-	-	-	-	●	●	-	
	SOFTNET-PB DP Slave	●	●	●	●	●	●	●	-	-	●	●	●	●	-	-	-	-	●	●	-	
	SOFTNET-PB S7	●	●	●	●	●	●	●	-	-	●	●	●	●	-	-	-	-	●	●	-	
	S7 OPC Redundancy for PROFIBUS	-	●	-	-	-	-	-	-	-	●	●	●	●	-	-	-	-	○ ⁴⁾	○ ⁴⁾	-	
CP 5621 (PCIe x1)	SOFTNET-PB DP	●	●	●	●	●	●	●	-	-	● ⁴⁾	-	●	○ ⁴⁾	●	-	-	-	○ ⁴⁾	○ ⁴⁾	-	
	SOFTNET-PB DP Slave	●	●	●	●	●	●	●	-	-	● ⁴⁾	-	●	○ ⁴⁾	●	-	-	-	○ ⁴⁾	○ ⁴⁾	-	
	SOFTNET-PB S7	●	●	●	●	●	●	●	-	-	● ⁴⁾	-	●	○ ⁴⁾	●	-	-	-	○ ⁴⁾	○ ⁴⁾	-	
	S7 OPC Redundancy for PROFIBUS	-	●	-	-	-	-	-	-	-	● ⁴⁾	-	●	○ ⁴⁾	●	-	-	-	○ ⁴⁾	○ ⁴⁾	-	
CP 5512 (Cardbus 32 Bit)	SOFTNET-PB DP	-	-	●	●	●	●	●	-	-	-	-	-	-	-	-	-	-	-	-	-	
	SOFTNET-PB DP Slave	-	-	●	●	●	●	●	-	-	-	-	-	-	-	-	-	-	-	-	-	
	SOFTNET-PB S7	-	-	●	●	●	●	●	-	-	-	-	-	-	-	-	-	-	-	-	-	
CP 5711 (USB V2.0)	SOFTNET-PB DP	●	●	●	●	●	●	●	-	-	●	●	●	●	●	●	●	●	●	●	●	
	SOFTNET-PB DP Slave	●	●	●	●	●	●	●	-	-	●	●	●	●	●	●	●	●	●	●	●	
	SOFTNET-PB S7	●	●	●	●	●	●	●	-	-	●	●	●	●	●	●	●	●	●	●	●	
	S7 OPC Redundancy for PROFIBUS	-	●	-	-	-	-	-	-	-	●	●	●	●	●	●	●	●	●	●	●	
SIMATIC PG/PC	SOFTNET-PB DP	●	●	●	●	●	●	●	-	-	○ ²⁾	○ ²⁾	-	○ ²⁾	○ ²⁾	●	○ ²⁾	●	○ ²⁾	○ ²⁾	-	
	SOFTNET-PB DP Slave	●	●	●	●	●	●	●	-	-	○ ²⁾	○ ²⁾	-	○ ²⁾	○ ²⁾	●	○ ²⁾	●	○ ²⁾	○ ²⁾	-	
	SOFTNET-PB S7	●	●	●	●	●	●	●	-	-	○ ²⁾	○ ²⁾	-	○ ²⁾	○ ²⁾	●	○ ²⁾	●	○ ²⁾	○ ²⁾	-	
	S7 OPC Redundancy for PROFIBUS	-	●	-	-	-	-	-	-	-	○ ²⁾	○ ²⁾	-	○ ²⁾	○ ²⁾	●	○ ²⁾	●	○ ²⁾	○ ²⁾	-	

1) In order to use these CPs in other operating system environments, it is required to port HARDNET DP Development Kits (DK-5613) into the respective operating system. You can request the HARDNET DP DK in the Internet under www.siemens.com/simatic-net/dk5613.

2) integrated PROFIBUS interface is optional

3) depending on available memory and processor performance there could be restrictions

4) depending on the slots of the selected PC version

5) EM-PCI 104 expansion module is required

Notes

- Please always note the supplementary conditions for the specified SIMATIC NET products that you can view on the Internet pages shown below.
- for further details on XP embedded, see <http://support.automation.siemens.com/WWW/view/de/21661049>
- further details on system requirements and operating environments can be found in the Readme file of the communication products on the SIMATIC NET PC Software CD V8.1
- Updates and supplements to the catalog entries, as well as the above tables can be viewed at <http://www.siemens.com/simatic-net/ik-info>

● suitable

- not suitable

○ suitable under certain conditions

G_IK10_XX_50025

Note:

The operating systems listed refer exclusively to the communication products specified!

For the actual operating system that is available and has been released, please refer to the description of the corresponding IPC.

PROFIBUS

Communication for PC-based systems

CP 5603

Overview



DP-M	DP-S	FMS	OPC	PG/OP	S7/S5
●	●	●	●	●	●

- PCI-104 interface card with own microprocessor for connecting embedded systems with PCI-104 interface to PROFIBUS at up to 12 Mbit/s
- Function compatible with CP 5613 A2
- Communication services:
 - PROFIBUS DP master Class 1 and 2 or DP slave according to IEC 61158/61784
 - PG/OP communication with STEP 5 and STEP 7
 - S7 communication with HARDNET-PB S7 software package
 - Open communication (SEND/RECEIVE) based on the FDL interface
 - PROFIBUS FMS according to IEC 61158/61784 with FMS-5613 software package
- Extensive diagnostics options for installation, commissioning and operation of the module
- Event and filter mechanism for reducing the load on the host CPU
- Multiprotocol operation and parallel operation of up to three CPs
- The appropriate OPC server and configuration tools are included in the scope of delivery of the respective communication software
- Linux-based development kit with driver sources for integration into "non-Windows" environments

Note:

FMS-5613 supports up to two CP 5603/CP 5613 A2/5614 A2/CP 5623/CP 5624 processors

Benefits

get **Designed for Industry**

- Fast process data exchange; access to process data by means of direct access to the dual port RAM of the hardware
- High computing performance in the PG/PC; reduces workload of host CPU by preprocessing the communication on the hardware
- Use of different operating system environments; driver as source code for porting to different operating system environments
- Use also in motion control applications; real-time capable data exchange through constant bus cycle time

Application



The CP 5603 allows the connection of embedded systems with a PC/104 Plus interface to PROFIBUS.

The CP 5603 also provides high-performance support to control tasks on the embedded system (PC-based Control, Numeric Control, Robot Control).

PROFIBUS

Communication for PC-based systems

CP 5603

Function

PROFIBUS DP

Access to process data with DP-Base

The CP 5603 is operated as PROFIBUS DP master module that keeps the process image (input/output and diagnostics data) in the dual port RAM (memory area on the CP). The hardware of the CP 5603 independently executes the high-performance exchange of data with the PROFIBUS slaves. The user accesses the Dual Port RAM directly.

The process data of the slaves is always consistent, i.e. the user receives the data of a slave from one and the same DP cycle.

Parallel operation of the HARDNET-PB S7 and DP-Base software is not possible.

Event filter mechanism

The user receives up-to-date data over two access mechanisms:

- Cyclic polling of the DP slaves (higher loading for host CPU)
- Notification by innovative event/filter mode when changing the input data of a slave (minimum loading for host CPU)

The two alternatives can also be combined. This allows users to optimize the PC to their applications.

The event/filter mechanism can be used additionally for

- Notification by means of an interrupt of the diagnostic messages from slaves
- In equidistance mode, signaling by means of interrupt:
 - Start DP cycle
 - End of cyclic data exchange with the DP slaves

FastLogic

FastLogic means that the CP 5603 can react autonomously to as many as 4 plant statuses. This results in a short response time and independence from the host application, e.g. fast shutdown of devices.

DP programming interface

The DP programming interface (DP-Base) of the CP 5603 has the following functionality:

- DP-Master Class 1 including acyclic DP expansions
- DP-Master Class 2 including acyclic DP expansions
- DP slave

The process data is accessed directly via the dual port RAM. The DP RAM interface not only offers fast access as DP master/slave but also a basis for porting to other operating system environments (e.g. VxWorks, QNX, RMOS, RTX).

Administrative function calls (initialization and management services, as well as diagnostic functions) are provided through a library (DP_BASE.DLL or DPS_BASE.DLL).

HARDNET-PB DP Development Kit

The HARDNET-PB DP Development Kit provides access to the functions DP master Class 1 including acyclic DP expansions

The HARDNET DP Development Kit software enables the CP 5603 communications processor to be integrated into any operating system environments. The kit contains the necessary source code, including the descriptions in PDF format, and can be downloaded free of charge from the Internet.

Access to process data with HARDNET-PB DP

DP Master Class 1

The CP 5603 operates as a DP Master Class 1 according to IEC 61158/61784 and processes the data transfer with the distributed stations (DP slaves) completely autonomously. The central controller exchanges information with the DP slaves (e.g. ET 200S) in a specified, constantly repeating message cycle. The DP programming interface (DPLib.DLL) provides the PC programmer with function calls for data exchange. The DP interface also provides the SYNC and FREEZE functions as well as activation and deactivation of slaves.

The DP function expansions relating to Master Class 1 make it possible to perform acyclic read and write functions (DS_READ, DS_WRITE) as well as acknowledgement of alarms (ALARM_ACK) at the same time as processing cyclic data communication. Data that are to be transferred in acyclic mode (e.g. parameterization data) are only rarely changed in comparison to the cyclic measured values, and are transferred at lower priority in parallel with the cyclic high-speed user data transfer. The alarm acknowledgment at the Master safeguards the transmission of the alarms from DP slaves.

Parallel operation of the DP-Base and HARDNET-PB DP software is not possible.

DP Master Class 2

In addition to the DP Master Class 1 services, the CP 5603 (in combination with the DP programming interface) also offers DP master class 2 services according to IEC 61158/61784. Devices of this type (programming devices, configuring devices, or operator panels) are used during the commissioning and for configuring the DP system, or for operating the system while it is running (diagnostics). The DP programming interface provides the following services:

- Master diagnosis
- Slave diagnosis
- Reading the input/output of a slave
- Reading configuration data
- Changing slave address

The extended DP functions comprise acyclic access to the parameters and measured values of a slave (e.g. field devices of process automation and intelligent HMI devices). This type of slave must be supplied with extensive parameter data during start-up and during normal operation (DS_READ, DS_WRITE).

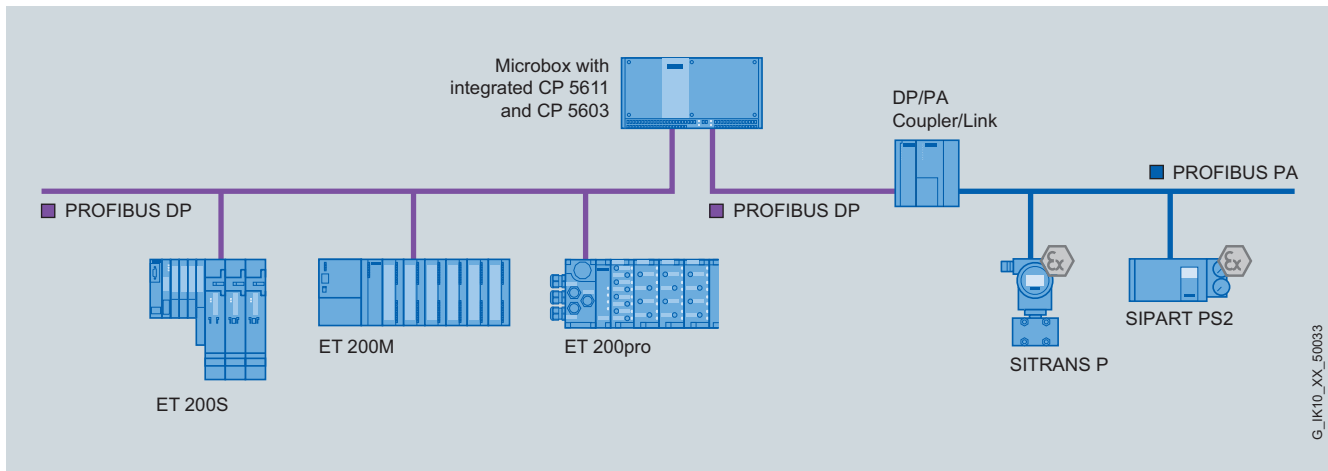
Function (continued)

PROFIBUS DP connection with embedded PC SIMATIC Microbox

Software for PG/OP communication

This software allows the programming of SIMATIC S5/S7 controllers (except for SIMATIC S5-95U) via PROFIBUS in combination with STEP 5/STEP 7. The PG/OP communication for the CP 5603 is already available after installation of the CP 5603 (DP base). No additional software package is necessary.

Open communication
(SEND/RECEIVE based on the FDL interface)

SEND/RECEIVE (FDL interface) is already available following installation of the CP 5603 (DP-Base) and provides services for data transfer, diagnostics and management. No additional software package is necessary.

Software for S7 communication (HARDNET-PB S7)

SIMATIC S7 system components communicate with each other using S7 communication functions. The S7 programming interface provides PG/PC user programs with access to SIMATIC S7 system components. This provides easy, flexible access to the data of the SIMATIC S7.

The S7 communication provides the following services:

Administrative services

- Connection management
- Mini database
- Trace

Data transfer services

- Read/write variables
- BSEND/BRECEIVE (up to 64 KB per task)

PROFIBUS

Communication for PC-based systems

CP 5603

Function (continued)**Software for PROFIBUS FMS (FMS-5613)**

With the FMS programming interface, PGs/PCs can exchange different manufacturer data with FMS-capable controllers (e.g. S5 and S7) and field devices. Open communication is assured by using the FMS interface.

The FMS interface offers the following services:

- Administrative services
- CRL management services
- FMS connection management services

- Object directory management services for clients and server
- Variable services for clients and servers (Read, Write, Information Report)
- Server functionality
- VFD (Virtual Field Device) services for clients and servers
- Bus access information services (live list)
- Trace and mini-database

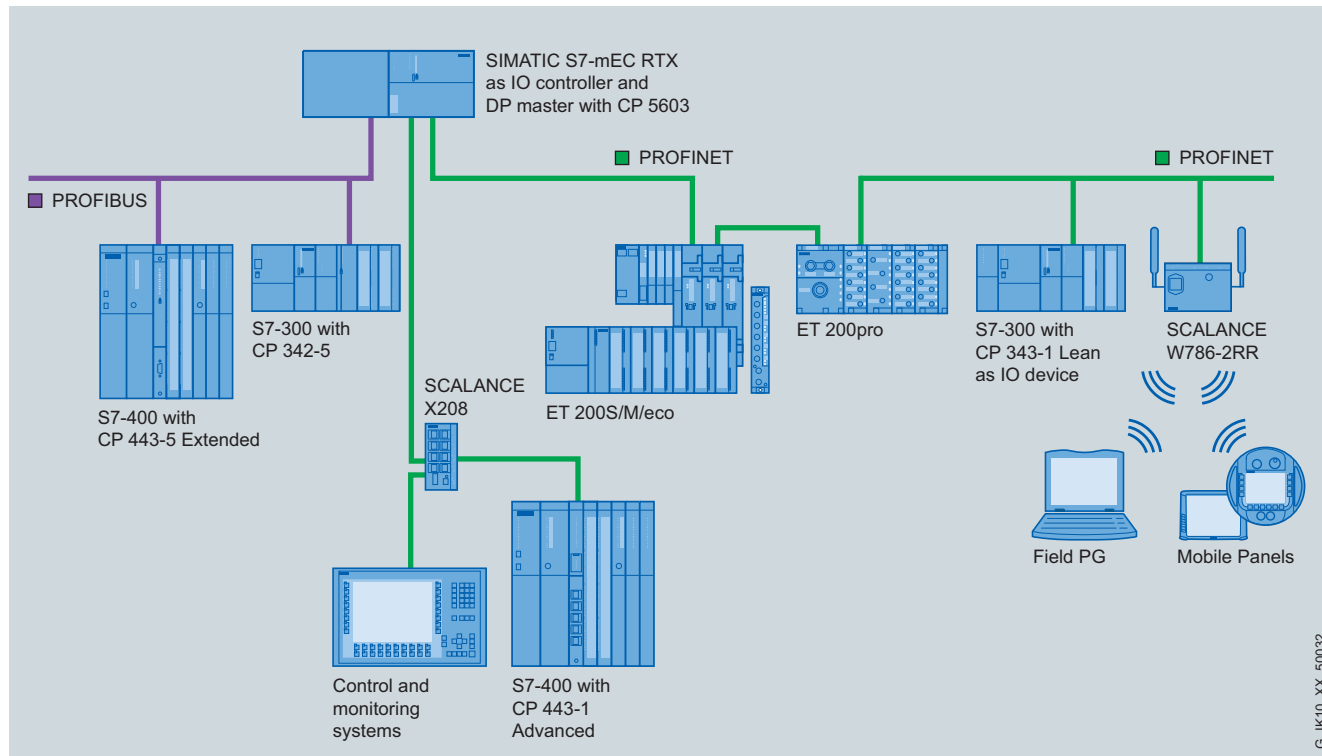

Connecting the SIMATIC to the S7 modular embedded controller via PROFIBUS

User interfaces**OPC interface**

The OPC server included in the respective software package can be used as the standard programming interface for the PROFIBUS DP, open communication, S7 communication and PROFIBUS FMS for linking automation technology applications to OPC-capable Windows applications (Office, HMI systems, etc.).

Programming interface via C-Library

The programming interfaces for existing applications are implemented as Dynamic Link Libraries (DLL). The released compilers can be found in the readme file of the SIMATIC NET CD products at www.siemens.com/automation/csi/net.

For Borland programming interfaces (e.g. DELPHI), partner solutions from SoftwareOption are offered.

For solutions for other operating systems, see HARDNET-PB DP Development Kit.

Configuration

- The S7 communication protocol, open communication protocol, DP protocol (DP-V0/DP-V1/DP-V2) and FMS protocol are configured in STEP 7 or NCM PC V5.1 +SP2.
- The configuration tool NCM PC is included in the PROFIBUS software packages.

Diagnostics

Comprehensive diagnostic tools are available (for installation, start-up and operation) for the module itself and for the PROFIBUS DP network. These tools can be used for quick and easy start-up of a PROFIBUS network with a CP 5603.

Technical specifications

Order No.	6GK1 560-3AA00
Product type designation	CP 5603
Data transmission rate	
Transmission rate at interface 1 in accordance with PROFIBUS	9.6 kbit/s to 12 Mbit/s
Interfaces	
Number of electrical connections at interface 1 in accordance with PROFIBUS	1
Design of electrical connection	
• at interface 1 in accordance with PROFIBUS	9-pin D-sub socket (RS 485)
• of the backplane bus	PCI-104 (32 bit)
Supply voltage, current consumption, power loss	
Type of power supply	DC
Supply voltage 1 from backplane bus	5 V
Relative symmetric tolerance at 5 V DC	5 %
Current consumption 1 from backplane bus with DC, maximum	0.66 A
Effective power loss	3.3 W
Permitted ambient conditions	
Ambient temperature	
• During operation	0 ... 70 °C
• During storage	-40 ... +70 °C
• During transport	-40 ... +70 °C
Relative humidity at 25 °C without condensation during operation, maximum	85 %
IP degree of protection	IP00
Design, dimensions and weights	
Module format	PCI -104
Width	90 mm
Height	21 mm
Depth	96 mm
Net weight	80 g
Type of mounting	Screw mounting
Product properties, functions, components	
General	
Number of plug-in cards of same design which can be inserted per PC station	3
Number of modules - Note	FMS-5613 supports a maximum of two CP 5603 / CP 5613 A2 / CP 5614 A2 / CP 5623 / CP 5624 processors
Performance data	
<u>Performance data</u> <u>Open communication</u>	
Software required for open communication by means of SEND/RECEIVE	FDL driver included in scope of delivery of CP
Number of possible connections for open communication by means of SEND/RECEIVE, maximum	80
<u>Performance data</u> <u>PROFIBUS DP</u>	
Software required for DP master function	No
Service as DP master	
• DPV0	Yes
• DPV1	Yes
• DPV2	Yes

Order No.	6GK1 560-3AA00
Product type designation	CP 5603
Number of DP slaves operable on DP master	124
Data volume	
• of address area of inputs as DP master, total	30 256 bytes
• of address area of outputs as DP master, total	30 256 bytes
• of address area of inputs per DP slave	244 bytes
• of address area of outputs per DP slave	244 bytes
• of address area of diagnostics data per DP slave	244 bytes
Software required for DP slave function	No
Service as DP slave	
• DPV0	Yes
• DPV1	Yes
Data volume	
• of address area of inputs as DP slave, total	244 bytes
• of address area of outputs as DP slave, total	244 bytes
<u>Performance data</u> <u>FMS functions</u>	
Software required for FMS communication	Yes, FMS-5613
Number of possible connections with FMS connection, maximum	40
<u>Performance data</u> <u>S7 communication</u>	
Software required for S7 communication	Yes, HARDNET-PB S7 (S7-5613)
Number of possible connections for S7/PG communication, maximum	50
<u>Performance data</u> <u>Multiprotocol operation</u>	
Number of active connections for multiprotocol operation	50
Number of configurable connections per PC station	207
Product functions	
Management, configuration, programming	
Configuration software required	NCM PC included in scope of delivery
Product functions Diagnostics	
Product function: Port diagnostics	Yes
Standards, specifications, approvals	
Standard	
• For EMC	2004/108/EC
• For CSA and UL safety	CAN/CSA C22.2 & UL 60950-1, UL 508
• For emitted interference	EN 61000-6-3, EN 61000-6-4
• For noise immunity	EN 61000-6-1, EN 61000-6-2
Certificate of suitability	
• CE mark	Yes
• C-Tick	Yes
Accessories	
Accessories	Optional: Expansion frame for SIMATIC Microbox and withdrawable drawer for SIMATIC S7 modular embedded controller

PROFIBUS

Communication for PC-based systems

CP 5603

3

Ordering data	Order No.	Order No.
CP 5603 communications processor PCI-104 card for connection to PROFIBUS incl. DP-Base software with NCM PC; DP-RAM interface for DP master or DP slave, incl. PG and FDL protocols; single license for one installation, runtime software, software and electronic manual on CD-ROM, Class A, for operating system support see SIMATIC NET software; German/English	6GK1 560-3AA00	
Software upgrade For CP 5603, CP 5613 A2 and CP 5623 to Edition 2008 or V8.1	6GK1 561-3AA01-3AE0	
CP 5603 Microbox Package For use of CP 5603 in Microbox 420/427B/427C; consisting of CP 5603 module and Microbox expansion frame	6GK1 560-3AU00	
CP 5603 expansion rack For use in Microbox 420/427B/427C with mounting material	6GK1 560-3AA00-0AU0	
CP 5603 mEC Package For use of CP 5603 in SIMATIC S7-MEC; consisting of CP 5603 and withdrawable unit for CP 5603 for installation in the EM PCI-104 expansion module of the SIMATIC S7-MEC	6GK1 560-3AE00	
CP 5603 insert plate Metal plate with RS485 cutout for inserting for the S7 modular embedded controller	6GK1 560-3AA00-0AE0	
HARDNET-PB DP Development Kit HARDNET-PB DP Development Kit software for CP 5603, CP 5613, CP 5613 A2, CP 5623, CP 5613 FO, CP 5614, CP 5614 A2, CP 5624; for integration into other operating system environments on systems with a PCI slot	See www.siemens.com/simatic-net/dk5613	
		HARDNET-PB DP Software for DP, incl. PG and FDL protocol, OPC server and NCM PC; runtime software, software and electronic manual on CD-ROM, license key on USB flash drive, Class A, for CP 5603, CP 5613 A2, CP 5623, CP 5614 A2, CP 5624; HARDNET-PB DP V8.1 For 32/64-bit: Windows 7 Professional/Ultimate; for 64-bit: Windows 2008 Server R2 English/German • Single license for one installation
		6GK1 713-5DB08-1AA0
		DP-5613 Edition 2008 for 32 Bit Windows XP Professional SP2/3; Windows 2003 Server R2, SP2; Windows Vista Business/Ultimate SP1; Windows 2008 Server; English/German • Single license for one installation
		6GK1 713-5DB71-3AA0
		Software Update Service For 1 year with automatic extension; requirement: current software version
		6GK1 713-5DB00-3AL0
		Upgrade • From Edition 2006 or 2007 to DP-5613 Edition 2008 or HARDNET-PB DP V8.1 • From V6.0, V6.1, V6.2 or V6.3 to DP-5613 Edition 2008 or HARDNET-PB DP V8.1
		6GK1 713-5DB00-3AE0
		6GK1 713-5DB00-3AE1

Ordering data	Order No.	Ordering data	Order No.
HARDNET-PB S7 Software for S7 communication, incl. PG and FDL protocol, OPC server and NCM PC; runtime software, software and electronic manual on USB flash drive, Class A, for CP 5603, CP 5613 A2, CP 5623, CP 5614 A2, CP 5624;		FMS-5613 Edition 2008 Software for FMS protocol incl. PG/OP communication; FDL, FMS-OPC server and NCM PC; runtime software, software and electronic manual on USB flash drive, Class A, for 32-bit Windows XP Professional SP2/3; Windows 2003 Server R2, SP2; Windows Vista Business/Ultimate SP1; Windows 2008 Server; for CP 5603, CP 5613, CP 5613 A2, CP 5623, CP 5613 FO, CP 5614, CP 5614 A2, CP 5624; German/English	
HARDNET-PB S7 V8.1 For 32/64-bit: Windows 7 Professional/Ultimate; for 64-bit: Windows 2008 Server R2 English/German • Single license for one installation	6GK1 713-5CB08-1AA0	• Single license for one installation	6GK1 713-5FB71-3AA0
S7-5613 Edition 2008 for 32 Bit Windows XP Professional SP2/3; Windows 2003 Server R2, SP2; Windows Vista Business/Ultimate SP1; Windows 2008 Server; English/German • Single license for one installation	6GK1 713-5CB71-3AA0	Software Update Service For 1 year with automatic extension; requirement: current software version	6GK1 713-5FB00-3AL0
Software Update Service For 1 year with automatic extension; requirement: current software version	6GK1 713-5CB00-3AL0	Upgrade • From Edition 2006 or 2007 to FMS-5613 Edition 2008 • From V6.0, V6.1, V6.2 or V6.3 to FMS-5613 Edition 2008	6GK1 713-5FB00-3AE0 6GK1 713-5FB00-3AE1
Upgrade • From Edition 2006 or 2007 to S7-5613 Edition 2008 or HARDNET-PB S7 V8.1 • From V6.0, V6.1, V6.2 or V6.3 to S7-5613 Edition 2008 or HARDNET-PB S7 V8.1	6GK1 713-5CB00-3AE0 6GK1 713-5CB00-3AE1	PROFIBUS FC Standard Cable GP Standard type with special design for quick assembly, 2-core, shielded, sold in meters; delivery unit max. 1000 m, minimum order 20 m	6XV1 830-0EH10
		PROFIBUS FastConnect bus connector RS485 Plug 180 With 180° cable outlet, insulation displacement	6GK1 500-0FC10
		PROFIBUS bus terminal 12M Bus terminal for connection of PROFIBUS stations up to 12 Mbit/s with plug-in cable 1.5 m long	6GK1 500-0AA10
		PROFIBUS FastConnect Stripping Tool Preset stripping tool for fast stripping of PROFIBUS FastConnect bus cables	6GK1 905-6AA00

More information

You can find the HARDNET-PB DP Development Kit on the Internet at:

www.siemens.com/simatic-net/dk5613

PROFIBUS

Communication for PC-based systems

CP 5613 A2

Overview

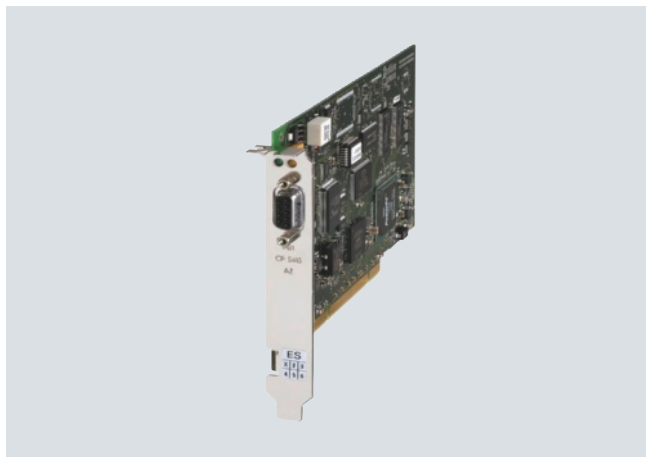

DP-M	DP-S	FMS	OPC	PG/OP	S7/S5
●		●	●	●	●

- PCI card (universal keyed 5 V/3.3 V) with own microprocessor for connection of PCs and SIMATIC PG/PC to PROFIBUS at up to 12 Mbit/s
- Communication services:
 - PROFIBUS DP master according to IEC 61158/61784 on a PCI card
 - PG/OP communication with STEP 5 and STEP 7
 - S7 communication with HARDNET-PB S7 software package
 - Open communication (SEND/RECEIVE) based on the FDL interface
 - PROFIBUS FMS according to IEC 61158/61784 with FMS-5613 software package
- Comprehensive diagnostics possibilities for installation, commissioning and operation of the module
- High performance over direct dual-port RAM access
- Event and filter mechanisms to reduce the loading on the host CPU
- Multiprotocol operation and parallel operation of up to four CPs
- Implementation in Motion Control applications is possible because a constant bus cycle time is supported
- The appropriate OPC servers and configuration tools are included in the scope of supply of the respective communications software.

Benefits

get Designed for Industry

- Fast process data exchange; access to process data by means of direct access to the dual port RAM of the hardware
- High computing performance in the PG/PC; reduces workload of host CPU by preprocessing the communication on the hardware
- Use of different operating system environments; driver as source code for porting to different operating system environments
- Use also in motion control applications; real-time capable data exchange through constant bus cycle time

Application



The CP 5613 A2 supports the connection of a SIMATIC PG/PC and PCs with a PCI slot to PROFIBUS.

The CP 5613 A2 provides high-performance support for control tasks on the PC (PC based Control, Numeric Control, Robot Control).

Design

- Short PCI card
- Operation possible in 3.3V and 5V PCI slots (universal keyed)
- 33 MHz or 66 MHz PCI clock
- Operation possible as 32-bit card in a 64-bit PCI X-slot
- 9-pin sub-D socket for connection to PROFIBUS
- Diagnostics LEDs
- Parallel operation of up to four CPs ¹⁾

The module is installed by means of PCI standard mechanisms (Plug&Play).

If the CP 5613 A2 is used as DP master or in a PG/OP on a PROFIBUS DP, the connection is made

- **to the electrical PROFIBUS** via
 - Bus connector and PROFIBUS bus cable or
 - bus terminal (e.g. bus terminal 12M) and PROFIBUS bus cable
- **to the optical PROFIBUS with OLM** via
 - bus cable with two bus connectors or
 - PROFIBUS plug-in cable 830-1T
- **to the optical PROFIBUS with OBT and integrated interface** via
 - bus cable with two bus connectors or
 - PROFIBUS plug-in cable 830-1T

¹⁾ FMS-5613 supports up to two CP 5603/CP 5613 A2/5614 A2/CP 5623/CP 5624 processors.

Function

PROFIBUS DP

Access to process data with DP-Base

The CP 5613 A2 is operated as a PROFIBUS DP master module that stores the process image (input/output and diagnostics data) in the dual-port RAM (memory area on the CP). High-performance data transfer to and from the PROFIBUS slaves is performed autonomously by the hardware of the CP 5613 A2. The user accesses the dual-port RAM directly. The process data of the slaves are always consistent, i.e. the user receives the data of a slave from one and the same DP cycle.

Parallel operation of the HARDNET-PB DP and DP-Base software is not possible.

Event filter mechanism

The user receives up-to-date data over two access mechanisms:

- Cyclic polling of the DP slaves (higher loading for host CPU)
- Notification through event/filter mode on changing the input data of a slave (minimal loading for host CPU)

Both alternatives can be combined. This allows users to optimize use of the PC for their applications.

The event/filter mechanism can be used additionally for

- Notification by means of an interrupt of the diagnostic alarms from slaves
- During operation with constant bus cycle time, signaling by means of interrupt:
 - Start DP cycle
 - End of cyclic data communication with DP slaves

FastLogic

FastLogic means that the CP 5613 A2 can react autonomously to 4 plant statuses. This results in a short response time and independence from the host application, e.g. fast shutdown of devices.

DP programming interface

The DP programming interface (DP-Base) of the CP 5613 A2 features the following functions:

- DP master class 1 including acyclic DP expansions
- DP master class 2 including acyclic DP expansions

The process data is accessed directly through the dual-port RAM. The DP RAM interface not only offers fast access as DP master but also a basis for porting to other operating system environments (e.g. VXWorks, QNX, RMOS, RTX).

Administrative function calls (initialization and management services) are offered in a library (DP_BASE.DLL).

HARDNET-PB DP Development Kit

The HARDNET-PB DP Development Kit provides access to the functions DP master Class 1 including acyclic DP expansions

The HARDNET-PB DP Development Kit software is used to integrate the CP 5613 A2 and CP 5614 A2 communications processors into any operating system environment. The kit contains the necessary source code, including the descriptions in PDF format, and can be downloaded free of charge from the Internet.

Access to process data with HARDNET-PB DP

DP Master Class 1

The CP 5613 A2 operates as a DP master Class 1 according to IEC 61158/EN 50170 and processes data communication with the distributed stations (DP slaves) completely autonomously. The central controller exchanges information with the DP slaves (e.g. ET 200S) in a specified, constantly repeating message cycle. The DP programming interface (DPLib.DLL) provides the PC programmer with function calls for data transfer. The DP interface also provides the SYNC and FREEZE functions as well as activation and deactivation of slaves.

The DP function expansions for masters Class 1 make it possible to perform acyclic read and write functions (DS_READ, DS_WRITE) as well as acknowledgement of alarms (ALARM_ACK) at the same time as processing cyclic data communication. Data that are to be transferred in acyclic mode (e.g. parameterization data) are only rarely changed in comparison to the cyclic measured values, and are transferred at lower priority in parallel with the cyclic high-speed user data transfer. Alarm acknowledgement by the master ensures reliable transfer of the alarms from DP slaves.

Parallel operation of the DP-Base and HARDNET-PB DP software is not possible.

DP Master Class 2

Apart from the DP master Class 1 services, the CP 5613 A2 also offers DP master class 2 services to IEC 61158/EN 50170 in conjunction with the DP programming interface. Devices of this type (programming, configuration or operating devices) are used during start-up, for configuring the DP system or for operating the system during normal operation (diagnostics). The DP programming interface provides the following services:

- Master diagnostics
- Slave diagnostics
- Reading the inputs/outputs of a slave
- Reading the configuration data
- Changing slave addresses.

The extended DP functions comprise acyclic access to the parameters and measured values of a slave (e.g. field devices of process automation and intelligent HMI devices). This type of slave must be supplied with extensive parameter data during start-up and during normal operation (DS_READ, DS_WRITE).

Function (continued)**Software for PG/OP communication**

This software supports programming of the SIMATIC S5/S7 controllers (with the exception of SIMATIC S5-95U) over PROFIBUS in combination with STEP 5/STEP 7. PG/OP communication for the CP 5613 is already available after the CP 5613 A2 (DP-Base) has been installed. No additional software packages are required.

Open communication (SEND/RECEIVE based on the FDL interface)

SEND/RECEIVE (FDL interface) is already available following installation of the CP 5613 A2 (DP-Base) and provides services for data transfer, diagnostics and management. No additional software packages are required.

Software for S7 communication (HARDNET-PB S7)

SIMATIC S7 system components communicate with each other using S7 communication functions. The S7 programming interface provides programming device/PC user programs with access to SIMATIC S7 system components. This provides easy, flexible access to the data of the SIMATIC S7 controller.

The following services are available with S7 communication:

Administrative services

- Connection management
- Mini database
- Trace

Data transfer services

- Read/write variables
- BSEND/BRECEIVE (up to 64 KB per task)

Software for PROFIBUS FMS (FMS-5613)

With the FMS programming interface, PGs/PCs can exchange different manufacturer data with FMS-capable controllers (e.g. S5 and S7) and field devices. Open communication is assured by using the FMS interface.

The FMS interface offers the following services:

- Administrative services
- CRL management services
- FMS connection management services
- Object directory management services for clients and server
- Variable services for clients and servers (Read, Write, Information Report)
- Server functionality
- VFD services (Virtual Field Device) for clients and servers
- Bus access information services (Live list)
- Trace and mini database

User interfaces**OPC interface**

The OPC server included in the respective software package can be used as the standard programming interface for the PROFIBUS DP, open communication, S7 communication and PROFIBUS FMS protocols for linking automation technology applications to OPC-capable Windows applications (Office, HMI systems, etc.).

Programming interface through C library

The programming interfaces for existing applications are implemented as Dynamic Link Libraries (DLL). You can find the released compilers in the Readme file of the SIMATIC NET CD products at www.siemens.com/automation/csi/net.

For Borland programming interfaces (e.g. DELPHI), partner solutions from SoftwareOption are offered.

For solutions for other operating systems, see HARDNET-PB DP Development Kit.

Configuration

- S7 communication protocol, open communication protocol, DP protocol (DP-V0/DP-V1/DP-V2) and FMS protocol are configured in STEP 7 or NCM PC V5.1+SP2 and higher.
- The configuration tool NCM PC is included in the PROFIBUS software packages.

Diagnostics

Comprehensive diagnostic tools are available (for installation, start-up and operation) for the module itself and for the PROFIBUS DP network. These tools can be used for quick and easy start-up of a PROFIBUS network with a CP 5613 A2.

Technical specifications

Order No.	6GK1 561-3AA01
Product type designation	CP 5613 A2
Transmission rate	
Transmission rate at interface 1 in accordance with PROFIBUS	9.6 kbit/s ... 12 Mbit/s
Interfaces	
Number of electrical connections at interface 1 in accordance with PROFIBUS	1
Design of electrical connection	
• at interface 1 in accordance with PROFIBUS	9-pin D-sub socket (RS 485)
• of backplane bus	PCI (32 bit 3.3 V/5 V Universal Key 33/66 MHz)
Supply voltage, current consumption, power loss	
Type of power supply	DC
Power supply 1 from backplane bus	5 V
Relative symmetrical tolerance at 5 V DC	5 %
Maximum current input 1 from backplane bus with DC	0.8 A
Effective power loss	4 W
Permitted ambient conditions	
Ambient temperature	
• During operation	5 ... 50 °C
• During storage	-40 ... +70 °C
• During transport	-40 ... +70 °C
Relative humidity at 25 °C without condensation during operation, maximum	85 %
IP degree of protection	IP00
Design, dimensions and weights	
Module format	PCI
Width	18 mm
Height	107 mm
Depth	168 mm
Net weight	100 g
Product properties, functions, components	
General	
Number of plug-in cards of same design which can be inserted per PC station	4
Number of modules - Note	FMS-5613 supports up to two CP 5603 / CP 5613 A2 / CP 5614 A2 / CP 5623 / CP 5624
Performance data	
<u>Performance data Open communication</u>	
Software required for open communication by means of SEND/RECEIVE	FDL driver included in scope of delivery of CP
Number of possible connections for open communication by means of SEND/RECEIVE, maximum	80
<u>Performance data PROFIBUS DP</u>	
Software required for DP master function	No
Service as DP master	
• DPV0	Yes
• DPV1	Yes
• DPV2	Yes

Order No.	6GK1 561-3AA01
Product type designation	CP 5613 A2
Number of DP slaves operable on DP master	124
Data volume	
• of address area of inputs as DP master, total	30 256 bytes
• of address area of outputs as DP master, total	30 256 bytes
• of address area of inputs per DP slave	244 bytes
• of address area of outputs per DP slave	244 bytes
• of address area of diagnostics data per DP slave	244 bytes
Software required for DP slave function	No
Service as DP slave	
• DPV0	Yes
• DPV1	Yes
Data volume	
• of address area of inputs as DP slave, total	244 bytes
• of address area of outputs as DP slave, total	244 bytes
<u>Performance data FMS functions</u>	
Software required for FMS communication	Yes, FMS-5613
Number of possible connections with FMS connection, maximum	40
<u>Performance data S7 communication</u>	
Software required for S7 communication	Yes, HARDNET-PB S7 (S7-5613)
Number of possible connections for S7/PG communication, maximum	50
<u>Performance data Multiprotocol operation</u>	
Number of active connections in multiprotocol mode	50
Number of configurable connections per PC station	207
Product functions Management, configuration, programming	
Configuration software required	NCM PC included in scope of delivery
Product functions Diagnostics	
Product function: Port diagnostics	Yes
Standards, specifications, approvals	
Standard	
• For EMC	89/336/EEC
• For CSA and UL safety	CAN/CSA C22.2 & UL 60950-1, UL 1950
• For emitted interference	EN 50081-1, EN 50081-2
• For noise immunity	EN 50082-1, EN 50082-2
Certificate of suitability	
• CE mark	Yes
• C-Tick	Yes

PROFIBUS

Communication for PC-based systems

CP 5613 A2

3

Ordering data

Order No.

Order No.

CP 5613 A2 communication processor

PCI card (32-bit; 3.3 V/5 V)
for connection to PROFIBUS incl.
DP-Base software with NCM PC;
DP-RAM interface for DP master,
incl. PG and FDL protocols;
single license for one installation,
runtime software, software and
electronic manual on CD-ROM,
Class A, for operating system
support see SIMATIC NET
software;
German/English

6GK1 561-3AA01

Software Upgrade

For CP 5603, CP 5613 A2 and
CP 5623 to Edition 2008 or V8.1

6GK1 561-3AA01-3AE0

HARDNET-PB DP Development Kit

HARDNET-PB DP Development
Kit software for
CP 5613/CP 5614/ CP 5613 A2/
CP 5614 A2/ CP 5613 FO
for integration into other operating
system environments on systems
with a PCI slot

See www.siemens.com/simatic-net/dk5613

HARDNET-PB DP

Software for DP,
incl. PG and FDL protocol,
OPC server and NCM PC;
runtime software, software and
electronic manual on CD-ROM,
license key on USB flash drive,
Class A, for
CP 5603, CP 5613 A2, CP 5623,
CP 5614 A2, CP 5624;

HARDNET-PB DP V8.1

For 32/64-bit:
Windows 7 Professional/Ultimate;
for 64-bit:
Windows 2008 Server R2
English/German

- Single license for one installation

6GK1 713-5DB08-1AA0

DP-5613 Edition 2008

for 32 Bit
Windows XP Professional SP2/3;
Windows 2003 Server R2, SP2;
Windows Vista Business/Ultimate
SP1; Windows 2008 Server;
English/German

- Single license for one installation

6GK1 713-5DB71-3AA0

Software Update Service

For 1 year
with automatic extension;
requirement:
current software version

6GK1 713-5DB00-3AL0

Upgrade

- From Edition 2006 or 2007
to DP-5613 Edition 2008 or
HARDNET-PB DP V8.1
- From V6.0, V6.1, V6.2 or V6.3
to DP-5613 Edition 2008 or
HARDNET-PB DP V8.1

6GK1 713-5DB00-3AE0

6GK1 713-5DB00-3AE1

HARDNET-PB S7

Software for S7 communication,
incl. PG and FDL protocol,
OPC server and NCM PC;
runtime software, software and
electronic manual on USB flash
drive, Class A, for
CP 5603, CP 5613 A2, CP 5623,
CP 5614 A2, CP 5624;

HARDNET-PB S7 V8.1

For 32/64-bit:
Windows 7 Professional/Ultimate;
for 64-bit:
Windows 2008 Server R2
English/German

- Single license for one installation

6GK1 713-5CB08-1AA0

S7-5613 Edition 2008

for 32 Bit
Windows XP Professional SP2/3;
Windows 2003 Server R2, SP2;
Windows Vista Business/Ultimate
SP1; Windows 2008 Server;
English/German

- Single license for one installation

6GK1 713-5CB71-3AA0

Software Update Service

For 1 year
with automatic extension;
requirement:
current software version

6GK1 713-5CB00-3AL0

Upgrade

- From Edition 2006 or 2007
to S7-5613 Edition 2008 or
HARDNET-PB S7 V8.1
- From V6.0, V6.1, V6.2 or V6.3
to S7-5613 Edition 2008 or
HARDNET-PB S7 V8.1

6GK1 713-5CB00-3AE0

6GK1 713-5CB00-3AE1

FMS-5613 Edition 2008

Software for FMS protocol,
including PG/OP communication,
FDL, FMS-OPC server
and NCM PC;
runtime software,
software and electronic manual
on USB flash drive,
Class A for 32-bit W
indows XP Professional SP2/3,
Windows 2003 Server R2, SP2,
Windows Vista Business/Ultimate
SP1; Windows 2008 Server;
for CP 5613, CP 5613 A2,
CP 5613 FO, CP 5614,
CP 5614 A2;
German/English

- Single license for one installation

6GK1 713-5FB71-3AA0

Software Update Service

For 1 year with automatic
extension;
requirement: current software
version

6GK1 713-5FB00-3AL0

Upgrade

- From Edition 2006 or 2007
to FMS-5613 Edition 2008
- From V6.0, V6.1, V6.2 or V6.3
to FMS-5613 Edition 2008

6GK1 713-5FB00-3AE0

6GK1 713-5FB00-3AE1

Ordering data	Order No.
PROFIBUS FC Standard Cable GP Standard type with special design for quick assembly, 2-core, shielded, sold in meters; delivery unit max. 1000 m, minimum order 20 m	6XV1 830-0EH10
PROFIBUS FastConnect bus connector RS485 Plug 180 With 180° cable outlet, insulation displacement	6GK1 500-0FC10
PROFIBUS bus terminal 12M Bus terminal for connection of PROFIBUS stations up to 12 Mbit/s with plug-in cable 1.5 m long	6GK1 500-0AA10
PROFIBUS FastConnect Stripping Tool Preset stripping tool for fast stripping of PROFIBUS FastConnect bus cables	6GK1 905-6AA00

More information

You can find the HARDNET-PB DP Development Kit on the Internet.

You will find more information on the Internet at:

www.siemens.com/simatic-net/dk5613

The CP 5613 A2 module can also be used under the LINUX and UNIX operating systems. Information on the available LINUX distributors and UNIX operating systems can be found at:

www.siemens.com/simatic-net/ik-info

PROFIBUS

Communication for PC-based systems

CP 5614 A2

Overview

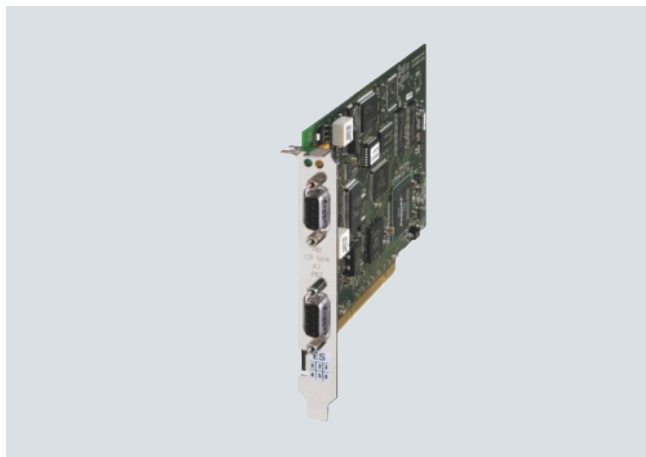

DP-M	DP-S	FMS	OPC	PG/OP	S7/S5
●	●	●	●	●	●

- PCI card (universal keyed 5 V/3.3 V) with own microprocessor for connection of PCs and SIMATIC PG/PC to PROFIBUS at up to 12 Mbit/s
- Communication services:
 - PROFIBUS DP master and slave interface according to IEC 61158/61784 on one PCI card
 - PG/OP communication with STEP 5 and STEP 7
 - S7 communication with HARDNET-PB S7 software package
 - Open communication (SEND/RECEIVE) based on the FDL interface
 - PROFIBUS FMS according to IEC 61158/61784 with FMS-5613 software package
- Comprehensive diagnostics possibilities for installation, commissioning and operation of the module
- High performance over direct dual-port RAM access
- Event and filter mechanisms to reduce the loading on the host CPU
- Multiprotocol operation and parallel operation of up to four CPs
- Implementation of Motion Control applications is possible because a constant bus cycle time is supported
- The appropriate OPC servers and configuration tools are included in the scope of supply of the respective communications software.

Benefits

get **Designed for Industry**

- Fast access to process data by means of direct access to the dual port RAM of the hardware
- High computing performance in the PG/PC; reduces workload of host CPU by preprocessing the communication on the hardware
- Use of different operating system environments; driver as source code for porting to different operating system environments
- Reduced number of slots; through parallel operation as DP master and DP slave
- Can also be used in typical motion control applications
- Real-time capable data exchange in constant bus cycle time mode

Application



The CP 5614 A2 supports the connection of a SIMATIC PG/PC and PCs with a PCI slot to PROFIBUS. It can be either a DP-Master or a DP-Slave.

Two different PROFIBUS networks can then be connected in a hierarchic structure on a PC with a PROFIBUS card and data can be transferred between the two.

The CP 5614 A2 provides high-performance support for control tasks on the PC (PC based Control, Numeric Control, Robot Control).

Design

- Short PCI card
- Operation possible in 3.3 V and 5 V PCI slots (universal keyed)
- 33 MHz or 66 MHz PCI clock
- Operation possible as 32-bit card in a 64-bit PCI X-slot
- 2 x 9-pin sub-D socket for connection to PROFIBUS
- Diagnostics LEDs
- Parallel operation of up to four CPs ¹⁾

The module is installed by means of PCI standard mechanisms (Plug&Play).

If the CP 5614 A2 is used as DP master, DP slave, or in a PG/OP on a PROFIBUS DP, the connection is made:

- **to the electrical PROFIBUS** via
 - Bus connector and PROFIBUS bus cable or
 - bus terminal (e.g. bus terminal 12M) and PROFIBUS bus cable
- **to the optical PROFIBUS with OLM** via
 - bus cable with two bus connectors or
 - PROFIBUS plug-in cable 830-1T
- **to the optical PROFIBUS with OBT and integrated interface** via
 - bus cable with two bus connectors or
 - PROFIBUS plug-in cable 830-1T

¹⁾ FMS-5613 supports up to two CP 5603/CP 5613 A2/5614 A2/CP 5623/CP 5624 processors.

Function

PROFIBUS DP

Access to process data

The CP 5614 A2 is operated as a PROFIBUS DP master and DP slave module that stores the process image (input/output and diagnostics data) in the dual-port RAM. High-performance data transfer to and from the PROFIBUS slaves is performed autonomously by the hardware of the CP 5614 A2. The user accesses the dual-port RAM directly.

The process data of the slaves is always consistent, i.e. the user receives the data of a slave from one and the same DP cycle.

Parallel operation of the HARDNET-PB DP software (DP master) and DP-Base software (DP master, DP slave) is not possible.

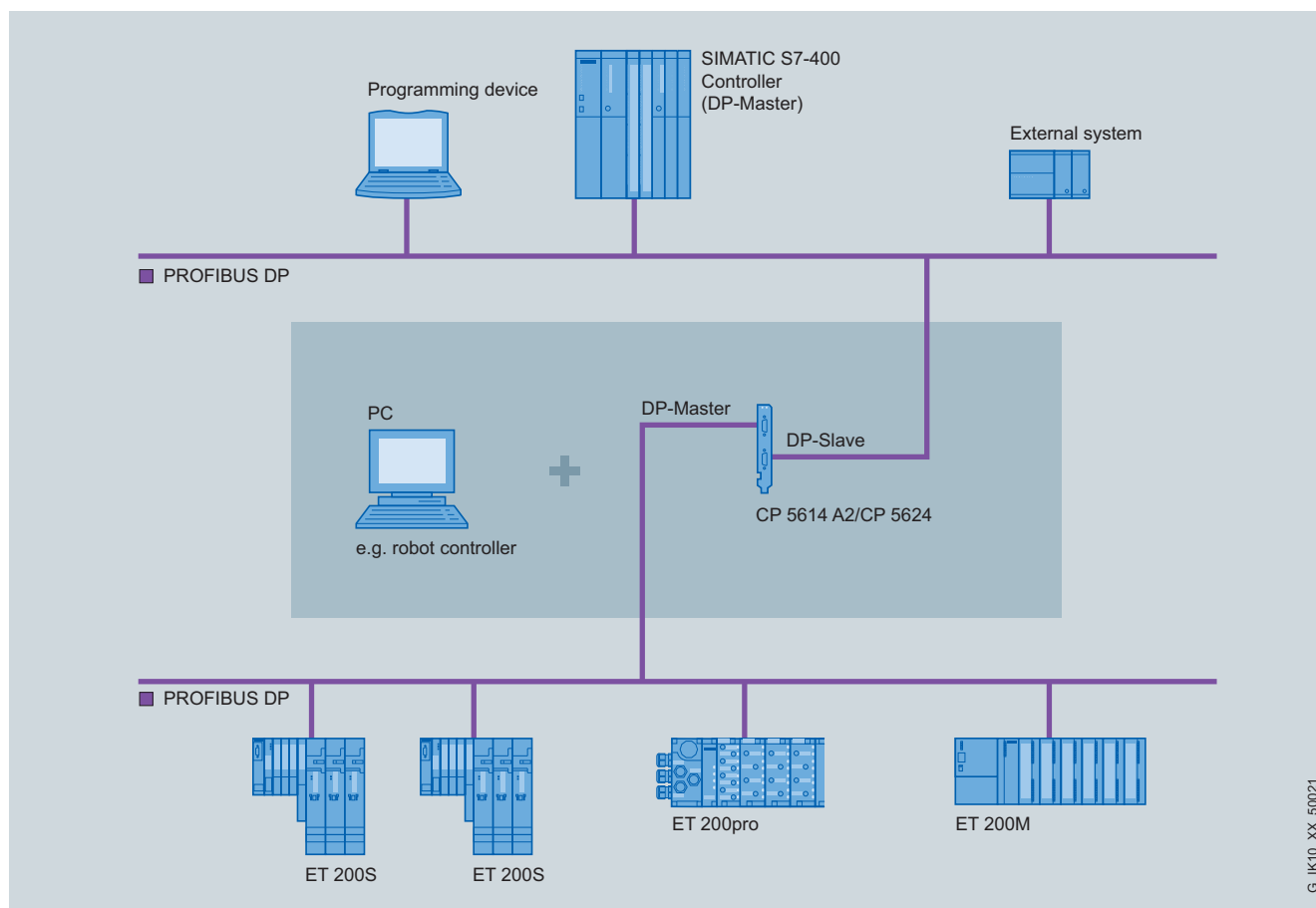

Configuration example CP 5613 A2 as DP master and DP slave

Event filter mechanism

The user receives up-to-date data over two access mechanisms:

- Cyclic polling of the DP slaves (high loading for host CPU)
- Notification through a new type of event/filter mode on changing the input data of a slave (minimal loading for host CPU)

Both alternatives can be combined. This allows users to optimize use of the PC for their applications.

The event/filter mechanism can be used additionally for

- Notification by means of an interrupt of the diagnostic alarms from slaves
- During operation with constant bus cycle time, signaling by means of interrupt:
 - Start DP cycle
 - End cyclic data communication with DP slaves

FastLogic

FastLogic means that the CP 5614 A2 can react autonomously to 4 plant statuses. This results in a short response time and independence from the host application, e.g. fast shutdown of devices.

DP programming interface

The DP master programming interfaces of the CP 5613 A2 and CP 5614 A2 are identical.

The DP programming interface of the CP 5614 A2 features the following functions:

- DP slave
- DP master Class 1 including acyclic DP expansions
- DP master Class 2 including acyclic DP expansions

Function (continued)

The process data is accessed directly through the dual-port RAM. The DP RAM interface not only offers fast access as DP master/slave but also a basis for porting to other operating system environments (e.g. VXWorks, QNX, RMOS, RTX).

Administrative function calls (initialization and management services as well as diagnostic functions) are provided through a DP master and DP slave library (DP_BASE.DLL and DPS_BASE.DLL).

A transfer mechanism (PC application) can be activated in the software as a linking component for data transfer between the master and slave interface.

Defined I/O data can be transferred in this manner between the master interface and the slave interface.

The two connected PROFIBUS networks can be operated with different PROFIBUS bus parameters because they are independent of each other.

HARDNET-PB DP Development Kit

The HARDNET-PB DP Development Kit provides access to the functions DP master Class 1 and DP slave (incl. acyclic DP expansions)

The HARDNET-PB DP Development Kit software is used to integrate the CP 5613 A2 and CP 5614 A2 communications processors into any operating system environment. The kit contains the necessary source code, including the descriptions in PDF format, and can be downloaded free of charge from the Internet.

Access to process data with HARDNET-PB DP**DP Master Class 1**

The CP 5614 A2 operates as a DP master Class 1 according to IEC 61158/61784 and processes the data transfer with the distributed stations (DP slaves) completely autonomously. The central controller exchanges information with the DP slaves (e.g. ET 200S) in a specified, constantly repeating message cycle. The DP programming interface (DPLib.DLL) provides the PC programmer with function calls for data transfer. The DP interface also provides the SYNC and FREEZE functions as well as activation and deactivation of slaves.

The DP function expansions for masters Class 1 make it possible to perform acyclic read and write functions (DS_READ, DS_WRITE) as well as acknowledgement of alarms (ALARM_ACK) at the same time as processing cyclic data communication. Data that are to be transferred in acyclic mode (e.g. parameterization data) are only rarely changed in comparison to the cyclic measured values, and are transferred at lower priority in parallel with the cyclic high-speed user data transfer. Alarm acknowledgement by the master ensures reliable transfer of the alarms from DP slaves (DS_READ, DS_WRITE).

Parallel operation of the DP-Base and HARDNET-PB DP software is not possible.

DP Master Class 2

Apart from the DP master Class 1 services, the CP 5614 A2 also offers DP master Class 2 services according to IEC 61158/61784 in conjunction with the DP programming interface. Devices of this type (programming, configuration or operating devices) are used during commissioning, for configuring the DP system, or for operating the system during normal operation (diagnostics). The DP programming interface provides the following services:

- Master diagnostics
- Slave diagnostics
- Reading the inputs/outputs of a slave
- Reading the configuration data
- Changing slave addresses.

The extended DP functions comprise acyclic access to the parameters and measured values of a slave (e.g. field devices of process automation and intelligent HMI devices). This type of slave must be supplied with extensive parameter data during start-up and during normal operation. (DS_READ, DS_WRITE).

Software for PG/OP communication

This software supports programming of the SIMATIC S5/S7 controllers (with the exception of SIMATIC S5-95U) over PROFIBUS in combination with STEP 5/STEP 7. PG/OP communication for the CP 5614 A2 is already available after the CP 5614 A2 (DP-Base) has been installed. No additional software packages are required.

Open communication (SEND/RECEIVE) based on the FDL interface

SEND/RECEIVE (FDL interface) is already available following installation of the CP 5614 A2 (DP-Base) and provides services for data transfer, diagnostics and management. No additional software packages are required.

Software for S7 communication (HARDNET-PB S7)

SIMATIC S7 system components communicate with each other using S7 communication functions. The S7 programming interface provides programming device/PC user programs with access to SIMATIC S7 system components. This provides easy, flexible access to the data of the SIMATIC S7 controller.

The following services are available with S7 communication:

Administrative services

- Connection management
- Mini database
- Trace

Data transfer services

- Read/write variables
- BSEND/BRECEIVE (up to 64 KB per task)

Function (continued)

Software for PROFIBUS FMS (FMS-5613)

With the FMS programming interface, PGs/PCs can exchange different manufacturer data with FMS-capable controllers (e.g. S5 and S7) and field devices. Open communication is assured by using the FMS interface.

The FMS interface offers the following services:

- Administrative services
- CRL management services
- FMS connection management services
- Object directory management services for clients and server
- Variable services for clients and servers (Read, Write, Information Report)
- Server functionality
- VFD services (Virtual Field Device) for clients and servers
- Bus access information services (Live list)
- Trace and mini database

User interfaces

OPC interface

The OPC server included in the respective software package can be used as the standard programming interface for the PROFIBUS DP (DP master and DP slave), open communication, S7 communication and PROFIBUS FMS protocols for linking automation technology applications to OPC-capable Windows applications (Office, HMI systems, etc.).

Programming interface through C library

The programming interfaces for existing applications are implemented as Dynamic Link Libraries (DLL). You can find the released compilers in the Read file of the SIMATIC NET CD products at www.siemens.com/automation/csi/net.

For Borland programming interfaces (e.g. DELPHI), partner solutions from SoftwareOption are offered.

For solutions for other operating systems, see HARDNET-PB DP Development Kit.

Configuration

- S7 communication protocol, open communication protocol, DP protocol (DP-V0/DP-V1/DP-V2) and FMS protocol are configured in STEP 7 or NCM PC V5.1+SP2 and higher.
- The configuration tool NCM PC is included in the PROFIBUS software packages.

Diagnostics

Comprehensive diagnostic tools are available (for installation, start-up and operation) for the module itself and for the PROFIBUS DP network. These tools can be used for quick and easy start-up of a PROFIBUS DP network with a CP 5614 A2.

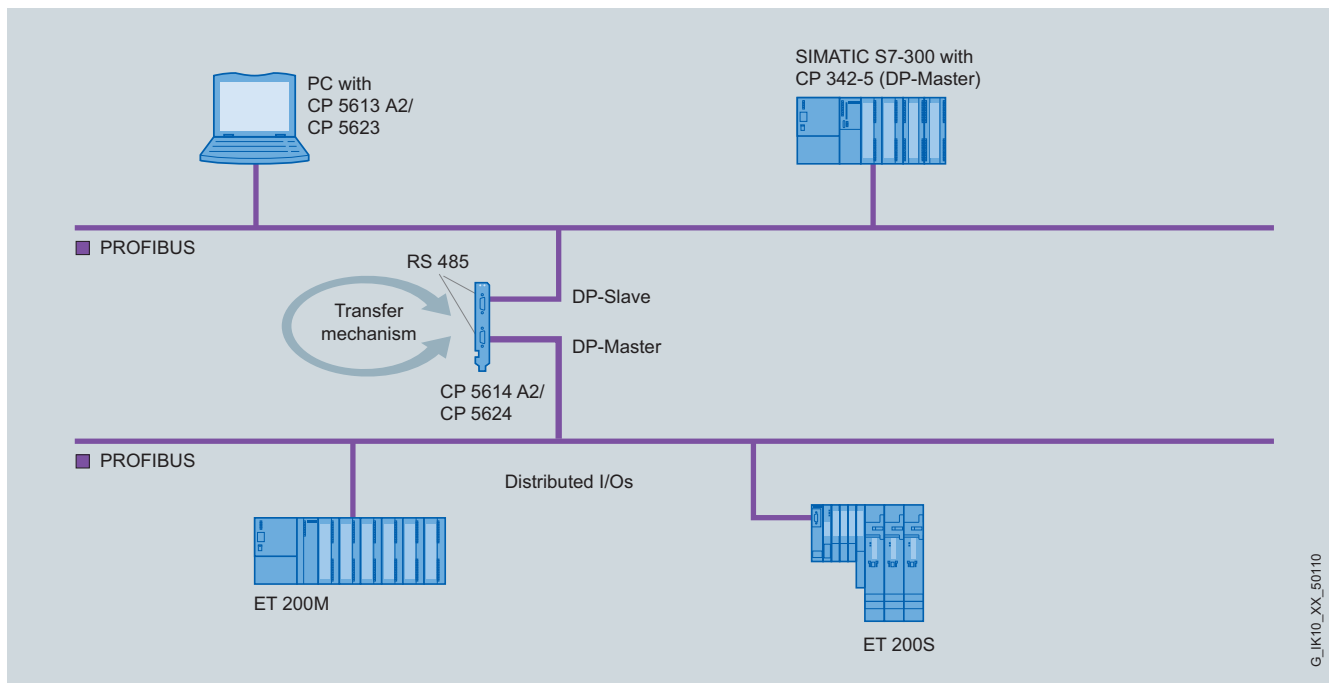

Configuration example for CP 5614 A2

PROFIBUS

Communication for PC-based systems

CP 5614 A2

Technical specifications

Order No.	6GK1 561-4AA01
Product type designation	CP 5614 A2
Transmission rate	
Transmission rate	
• at interface 1 in accordance with PROFIBUS	9.6 kbit/s ... 12 Mbit/s
• at interface 2 in accordance with PROFIBUS	9.6 kbit/s ... 12 Mbit/s
Interfaces	
Number of electrical connections	
• at interface 1 in accordance with PROFIBUS	1
• at interface 2 in accordance with PROFIBUS	1
Design of electrical connection	
• at interface 1 in accordance with PROFIBUS	9-pin D-sub socket (RS 485)
• at interface 2 in accordance with PROFIBUS	9-pin D-sub socket (RS 485)
• of backplane bus	PCI (32 bit 3.3 V/5 V Universal Key 33/66 MHz)
Supply voltage, current consumption, power loss	
Type of power supply	DC
Power supply 1 from backplane bus	5 V
Relative symmetrical tolerance at 5 V DC	5 %
Maximum current input 1 from backplane bus with DC	0.9 A
Effective power loss	4.5 W
Permitted ambient conditions	
Ambient temperature	
• During operation	5 ... 50 °C
• During storage	-40 ... +70 °C
• During transport	-40 ... +70 °C
Relative humidity at 25 °C without condensation during operation, maximum	85 %
IP degree of protection	IP00
Design, dimensions and weights	
Module format	PCI
Width	18 mm
Height	107 mm
Depth	168 mm
Net weight	120 g
Product properties, functions, components	
General	
Number of plug-in cards of same design which can be inserted per PC station	4
Number of modules - Note	FMS-5613 supports up to two CP 5603 / CP 5613 A2 / CP 5614 A2 / CP 5623 / CP 5624

Order No.	6GK1 561-4AA01
Product type designation	CP 5614 A2
Performance data	
<u>Performance data</u>	
<u>Open communication</u>	
Software required for open communication by means of SEND/RECEIVE	FDL driver included in scope of delivery of CP
Number of possible connections for open communication by means of SEND/RECEIVE, maximum	80
<u>Performance data</u>	
<u>PROFIBUS DP</u>	
Software required for DP master function	No
Service as DP master	
• DPV0	Yes
• DPV1	Yes
• DPV2	Yes
Number of DP slaves operable on DP master	124
Data volume	
• of address area of inputs as DP master, total	30 258 bytes
• of address area of outputs as DP master, total	30 256 bytes
• of address area of inputs per DP slave	244 bytes
• of address area of outputs per DP slave	244 bytes
• of address area of diagnostics data per DP slave	244 bytes
Software required for DP slave function	No
Service as DP slave	
• DPV0	Yes
• DPV1	Yes
Data volume	
• of address area of inputs as DP slave, total	244 bytes
• of address area of outputs as DP slave, total	244 bytes
<u>Performance data</u>	
<u>FMS functions</u>	
Software required for FMS communication	Yes, FMS-5613
Number of possible connections with FMS connection, maximum	40
<u>Performance data</u>	
<u>S7 communication</u>	
Software required for S7 communication	Yes, HARDNET-PB S7 (S7-5613)
Number of possible connections for S7/PG communication, maximum	50
<u>Performance data</u>	
<u>Multiprotocol operation</u>	
Number of active connections in multiprotocol mode	50
Number of configurable connections per PC station	207

3

Technical specifications (continued)		Ordering data	Order No.
Order No.	6GK1 561-4AA01	CP 5614 A2 communication processor	6GK1 561-4AA01
Product type designation	CP 5614 A2	PCI card (32-bit; 3.3 V/5 V) master and slave connection to PROFIBUS incl. DP-Base software with NCM PC; DP-RAM interface for DP master, incl. PG and FDL protocols; single license for one installation, runtime software, software and electronic manual on CD-ROM, Class A, for operating system support see SIMATIC NET software; German/English	
Product functions Management, configuration, programming			
Configuration software required	NCM PC included in scope of delivery		
Product functions Diagnostics			
Product function: Port diagnostics	Yes		
Standards, specifications, approvals			
Standard		Software Upgrade	6GK1 561-3AA01-3AE0
• For EMC	89/336/EEC	for CP 5614 A2 and CP 5624 to Edition 2008 or V8.1	
• For CSA and UL safety	CAN/CSA C22.2 & UL 60950-1, UL 1950	HARDNET-PB DP Development Kit	See www.siemens.com/simatic-net/dk5613
• For emitted interference	EN 50081-1, EN 50081-2	HARDNET-PB DP Development Kit software for CP 5613/CP 5614/ CP 5613 A2/ CP 5614 A2/ CP 5613 FO for integration into other operating system environments on systems with a PCI slot	
• For noise immunity	EN 50082-1, EN 50082-2		
Certificate of suitability		HARDNET-PB DP	
• CE mark	Yes	Software for DP, incl. PG and FDL protocol, OPC server and NCM PC; runtime software, software and electronic manual on CD-ROM, license key on USB flash drive, Class A, for CP 5603, CP 5613 A2, CP 5623, CP 5614, CP 5614 A2, CP 5624;	
• C-Tick	Yes	HARDNET-PB DP V8.1	
		For 32/64-bit: Windows 7 Professional/Ultimate; for 64-bit: Windows 2008 Server R2 English/German	
		• Single license for one installation	6GK1 713-5DB08-1AA0
		DP-5613 Edition 2008	
		for 32 Bit Windows XP Professional SP2/3; Windows 2003 Server R2, SP2; Windows Vista Business/Ultimate SP1; Windows 2008 Server; English/German	
		• Single license for one installation	6GK1 713-5DB71-3AA0
		Software Update Service	6GK1 713-5DB00-3AL0
		For 1 year with automatic extension; requirement: current software version	
		Upgrade	
		• From Edition 2006 or 2007 to DP-5613 Edition 2008 or HARDNET-PB DP V8.1	6GK1 713-5DB00-3AE0
		• From V6.0, V6.1, V6.2 or V6.3 to DP-5613 Edition 2008 or HARDNET-PB DP V8.1	6GK1 713-5DB00-3AE1

PROFIBUS

Communication for PC-based systems

CP 5614 A2

3

Ordering data	Order No.	Order No.
HARDNET-PB S7 Software for S7 communication, incl. PG and FDL protocol, OPC server and NCM PC; runtime software, software and electronic manual on USB flash drive, Class A, for CP 5603, CP 5613 A2, CP 5623, CP 5614 A2, CP 5624;		Software Update Service For 1 year with automatic extension; requirement: current software version
HARDNET-PB S7 V8.1 For 32/64-bit: Windows 7 Professional/Ultimate; for 64-bit: Windows 2008 Server R2 English/German • Single license for one installation	6GK1 713-5CB08-1AA0	Upgrade • From Edition 2006 or 2007 to FMS-5613 Edition 2008 • From V6.0, V6.1, V6.2 or V6.3 to FMS-5613 Edition 2008
S7-5613 Edition 2008 for 32 Bit Windows XP Professional SP2/3; Windows 2003 Server R2, SP2; Windows Vista Business/Ultimate SP1; Windows 2008 Server; English/German • Single license for one installation	6GK1 713-5CB71-3AA0	PROFIBUS FC Standard Cable GP Standard type with special design for quick assembly, 2-core, shielded, sold in meters; delivery unit max. 1000 m, minimum order 20 m
Software Update Service For 1 year with automatic extension; requirement: current software version	6GK1 713-5CB00-3AL0	PROFIBUS FastConnect bus connector RS485 Plug 180 With 180° cable outlet, insulation displacement
Upgrade • From Edition 2006 or 2007 to S7-5613 Edition 2008 or HARDNET-PB S7 V8.1 • From V6.0, V6.1, V6.2 or V6.3 to S7-5613 Edition 2008 or HARDNET-PB S7 V8.1	6GK1 713-5CB00-3AE0 6GK1 713-5CB00-3AE1	PROFIBUS bus terminal 12M Bus terminal for connection of PROFIBUS stations up to 12 Mbit/s with plug-in cable 1.5 m long
FMS-5613 Edition 2008 Software for FMS protocol, including PG/OP communication, FDL, FMS-OPC server and NCM PC; runtime software, software and electronic manual on USB flash drive, Class A for 32-bit Windows XP Professional SP2/3, Windows 2003 Server R2, SP2, Windows Vista Business/Ultimate SP1; Windows 2008 Server; for CP 5613, CP 5613 A2, CP 5613 FO, CP 5614, CP 5614 A2, German/English • Single license for one installation	6GK1 713-5FB71-3AA0	PROFIBUS FastConnect Stripping Tool Preset stripping tool for fast stripping of PROFIBUS FastConnect bus cables

More information

You can find the HARDNET-PB DP Development Kit on the Internet.

www.siemens.com/simatic-net/dk5613

Overview



DP-M	DP-S	FMS	OPC	PG/OP	S7/S5
●	●	●	●	●	●

- PCI Express card (PCIe x1) with own microprocessor for connecting PCs and SIMATIC PG/PC to PROFIBUS at up to 12 Mbit/s
- Communication services:
 - PROFIBUS DP master Class 1 and 2 or DP slave according to IEC 61158/61784 on a PCI card
 - PG/OP communication with STEP 5 and STEP 7
 - S7 communication with HARDNET-PB S7 software package
 - Open communication (SEND/RECEIVE) based on the FDL interface
 - PROFIBUS FMS according to IEC 61158/61784 with FMS-5613 software package
- Extensive diagnostics options for installation, commissioning and operation of the module
- Event and filter mechanism for reducing the load on the host CPU
- Multiprotocol operation and parallel operation of up to four CPs
- The appropriate OPC servers and configuration tools are included in the scope of supply of the respective communication software

Benefits

get Designed for Industry

- Fast access to process data by means of direct access to the dual port RAM of the hardware
- High computing performance in the PG/PC; reduces workload of host CPU by preprocessing the communication on the hardware
- Use of different operating system environments; driver as source code for porting to different operating system environments
- Preventive maintenance measures; deriving of measures by evaluating system runtime and ambient temperature
- Use also in motion control applications; real-time capable data exchange through constant bus cycle time

Application



The CP 5623 supports the connection of SIMATIC PG/PC and PCs with PCI Express slot to PROFIBUS.

The CP 5623 provides high-performance support for control tasks on the PC (PC based Control, Numeric Control, Robot Control).

Design

- Short PCI Express card
- Can also be operated in PCI Express x4, x8 or x16 slots
- 9-pin sub-D socket for connection to PROFIBUS
- Diagnostic LEDs
- Parallel operation of up to four CPs¹⁾

The module is installed by means of PCI standard mechanisms (Plug&Play).

If the CP 5623 is used as DP master or in a PG/OP on a PROFIBUS DP, the connection is made:

- **to the electrical PROFIBUS** via
 - bus connector and PROFIBUS bus cable or
 - bus terminal (e.g. bus terminal 12M) and PROFIBUS bus cable
- **to the optical PROFIBUS with OLM** via
 - bus cable with two bus connectors or
 - PROFIBUS plug-in cable 830-1T
- **to the optical PROFIBUS with OBT and integrated interface** via
 - bus cable with two bus connectors or
 - PROFIBUS plug-in cable 830-1T

¹⁾ FMS-5613 supports up to two CP 5603/CP 5613 A2/5614 A2/CP 5623/CP 5624 processors.

PROFIBUS

Communication for PC-based systems

CP 5623

Function

PROFIBUS DP

Access to process data with DP-Base

The CP 5623 is operated as PROFIBUS DP master module that keeps the process image (input/output and diagnostics data) in the dual port RAM (memory area on the CP). The hardware of the CP 5623 independently executes the high-performance exchange of data with the PROFIBUS slaves. The user accesses the dual-port RAM directly.

The process data of the slaves is always consistent, i.e. the user receives the data of a slave from one and the same DP cycle.

Parallel operation of the HARDNET-PB DP and DP-Base software is not possible.

3

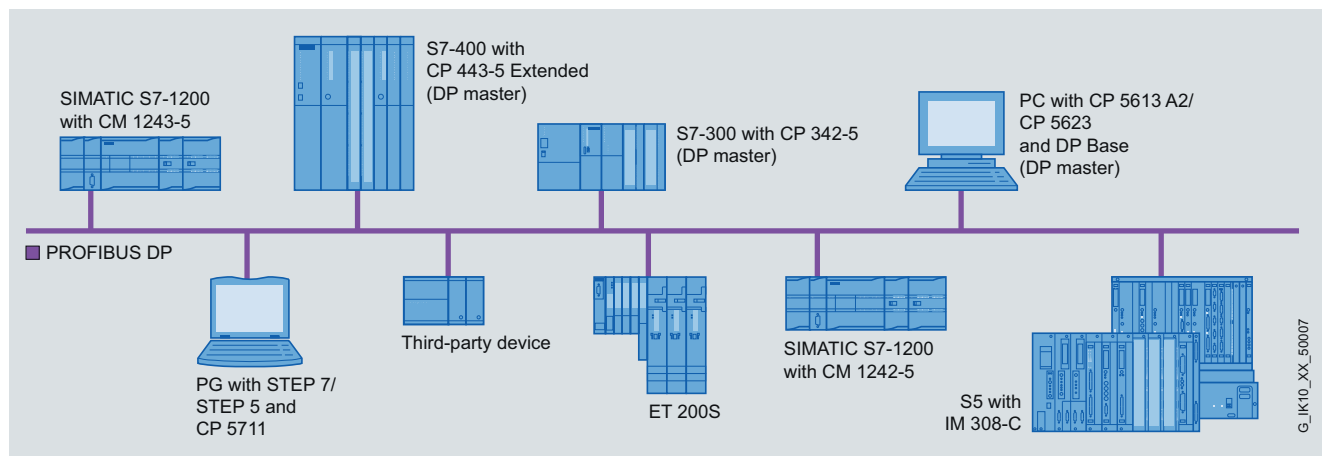

Example configuration of PROFIBUS DP for SIMATIC S5/S7 and PG/PC

Event filter mechanism

The user receives up-to-date data over two access mechanisms:

- Cyclic polling of the DP slaves (higher loading for host CPU)
- Notification by means of event/filter mode when changing the input data of a slave (minimal loading for host CPU)

Both alternatives can be combined. This allows users to optimize use of the PC for their applications.

The event/filter mechanism can be used additionally for

- Notification by means of an interrupt of the diagnostic messages from slaves
- During operation with constant bus cycle time, signaling by means of interrupt:
 - Start DP cycle
 - End of cyclic data exchange with DP slaves

FastLogic

FastLogic means that the CP 5623 can react autonomously to as many as four plant statuses. This results in a short response time and independence from the host application, e.g. fast shutdown of devices.

DP programming interface

The DP programming interface (DP-Base) of the CP 5623 has the following functionality:

- DP master class 1 including acyclic DP expansions
- DP master class 2 including acyclic DP expansions
- DP slave

The process data is accessed directly through the dual-port RAM. The DP RAM interface not only offers fast access as DP master/slave but also a basis for porting to other operating system environments (e.g. VXWorks, QNX, RMOS, RTX).

Administrative function calls (initialization and management services, as well as diagnostic functions) are provided through a library (DP_BASE.DLL or DPS_BASE.DLL).

HARDNET-PB DP Development Kit

The HARDNET-PB DP Development Kit provides access to the functions DP master Class 1 including acyclic DP expansions

The HARDNET-PB DP Development Kit software enables the CP 5623 communications processor to be integrated into any operating system environments. The kit contains the necessary source code, including the descriptions in PDF format, and can be downloaded free of charge from the Internet.

Function (continued)

Access to process data with HARDNET-PB DP

DP Master Class 1

The CP 5623 operates as a DP master Class 1 according to IEC 61158/61784 and processes data communication with the distributed stations (DP slaves) completely autonomously. The central controller exchanges information with the DP slaves (e.g. ET 200S) in a specified, constantly repeating message cycle. The DP programming interface (DPLib.DLL) provides the PC programmer with function calls for data transfer. The DP interface also provides the SYNC and FREEZE functions as well as activation and deactivation of slaves.

The DP function expansions for masters Class 1 make it possible to perform acyclic read and write functions (DS_READ, DS_WRITE) as well as acknowledgement of alarms (ALARM_ACK) at the same time as processing cyclic data communication. Data that are to be transferred in acyclic mode (e.g. parameterization data) are only rarely changed in comparison to the cyclic measured values, and are transferred at lower priority in parallel with the cyclic high-speed user data transfer. Alarm acknowledgement by the master ensures reliable transfer of the alarms from DP slaves.

Parallel operation of the DP-Base and HARDNET-PB DP software is not possible.

DP Master Class 2

Apart from the DP master Class 1 services, the CP 5623 also offers DP master class 2 services to IEC 61158/61784 in conjunction with the DP programming interface. Devices of this type (programming, configuration or operating devices) are used during start-up, for configuring the DP system or for operating the system during normal operation (diagnostics). The DP programming interface provides the following services:

- Master diagnostics
- Slave diagnostics
- Reading the inputs/outputs of a slave
- Reading configuration data
- Changing slave addresses.

The extended DP functions comprise acyclic access to the parameters and measured values of a slave (e.g. field devices of process automation and intelligent HMI devices). This type of slave must be supplied with extensive parameter data during start-up and during normal operation (DS_READ, DS_WRITE).

Software for PG/OP communication

This software supports programming of the SIMATIC S5/S7 controllers (with the exception of SIMATIC S5-95U) over PROFIBUS in combination with STEP 5/STEP 7. The PG/OP communication for the CP 5623 is already available following installation of the CP 5623 (DP-Base). No additional software packages are required.

Open communication (SEND/RECEIVE on the basis of the FDL interface)

SEND/RECEIVE (FDL interface) is already available following installation of the CP 5623 (DP-Base) and provides services for data transfer, diagnostics and management. No additional software packages are required.

Software for S7 communication (HARDNET-PB S7)

SIMATIC S7 system components communicate with each other using S7 communication functions. The S7 programming interface provides programming device/PC user programs with access to SIMATIC S7 system components. This makes for easy and flexible access to SIMATIC S7 data.

The following services are available with S7 communication:

Administrative services

- Connection management
- Mini database
- Trace

Data transfer services

- Read/write variables
- BSEND/BRECEIVE (up to 64 KB per task)

Software for PROFIBUS FMS (FMS-5613)

With the FMS programming interface, PGs/PCs can exchange different manufacturer data with FMS-capable controllers (e.g. S5 and S7) and field devices. Open communication is assured by using the FMS interface.

The FMS interface offers the following services:

- Administrative services
- CRL management services
- FMS connection management services
- Object directory management services for clients and server
- Variable services for clients and servers (Read, Write, Information Report)
- Server functionality
- VFD services (Virtual Field Device) for clients and servers
- Bus access information services (live list)
- Trace and mini database

User interfaces

OPC interface

The OPC server included in the respective software package can be used as the standard programming interface for the PROFIBUS DP, open communication, S7 communication and PROFIBUS FMS in order to connect automation technology applications to OPC-compatible Windows applications (Office, HMI systems, etc.)

Programming interface via C-library

The programming interfaces for existing applications are implemented as Dynamic Link Libraries (DLL). The released compilers can be found in the readme file of the SIMATIC NET CD products at www.siemens.com/automation/csi/net.

For Borland programming interfaces (e.g. DELPHI), partner solutions from SoftwareOption are offered.

For solutions for other operating systems, see HARDNET-PB DP Development Kit.

Configuration

- The S7 communication protocol, open communication protocol, DP protocol (DP-V0/DP-V1/DP-V2), and FMS protocol are configured in STEP 7 or NCM PC V5.1 +SP2.
- The NCM PC configuration tool is included in the scope of delivery of the PROFIBUS software packages.

Diagnostics

Comprehensive diagnostic tools are available (for installation, start-up and operation) for the module itself and for the PROFIBUS DP network. These tools can be used for quick and easy start-up of a PROFIBUS network with a CP 5623.

PROFIBUS

Communication for PC-based systems

CP 5623

Technical specifications

Order No.	6GK1 562-3AA00
Product type designation	CP 5623
Data transmission rate	
Transmission rate at interface 1 in accordance with PROFIBUS	9.6 kbit/s to 12 Mbit/s
Interfaces	
Number of electrical connections at interface 1 in accordance with PROFIBUS	1
Design of electrical connection	
• at interface 1 in accordance with PROFIBUS	9-pin D-sub socket (RS 485)
• of the backplane bus	PCI Express x1
Supply voltage, current consumption, power loss	
Type of power supply	DC
Power supply	
• 1 from backplane bus	3.3 V
• 2 from backplane bus	12 V
Relative symmetrical tolerance	
• At 3.3 V with DC	9 %
• At 12 V with DC	8 %
Current consumed	
• Maximum 1 from backplane bus with DC	0.72 A
• Maximum 2 from backplane bus with DC	0.25 A
Effective power loss	3 W
Permitted ambient conditions	
Ambient temperature	
• During operation	5 ... 60 °C
• During storage	-20 ... +60 °C
• During transport	-20 ... +60 °C
Relative humidity at 25 °C without condensation during operation, maximum	85 %
IP degree of protection	IP00
Design, dimensions and weights	
Module format	PCI Express x1 (half length)
Width	21.6 mm
Height	126.3 mm
Depth	180.5 mm
Net weight	102 g
Product properties, functions, components	
General	
Number of plug-in cards of same design which can be inserted per PC station	4
Number of modules - Note	FMS-5613 supports a maximum of two CP 5603 / CP 5613 A2 / CP 5614 A2 / CP 5623 / CP 5624 processors

Order No.	6GK1 562-3AA00
Product type designation	CP 5623
Performance data	
<u>Performance data</u>	
<u>Open communication</u>	
Software required for open communication by means of SEND/RECEIVE	FDL driver included in scope of delivery of CP
Number of possible connections for open communication by means of SEND/RECEIVE, maximum	80
<u>Performance data</u>	
<u>PROFIBUS DP</u>	
Software required for DP master function	No
Service as DP master	
• DPV0	Yes
• DPV1	Yes
• DPV2	Yes
Number of DP slaves operable on DP master	124
Data volume	
• of address area of inputs as DP master, total	30 256 bytes
• of address area of outputs as DP master, total	30 256 bytes
• of address area of inputs per DP slave	244 bytes
• of address area of outputs per DP slave	244 bytes
• of address area of diagnostics data per DP slave	244 bytes
Software required for DP slave function	No
Service as DP slave	
• DPV0	Yes
• DPV1	Yes
Data volume	
• of address area of inputs as DP slave, total	244 bytes
• of address area of outputs as DP slave, total	244 bytes
<u>Performance data</u>	
<u>FMS functions</u>	
Software required for FMS communication	Yes, FMS-5613
Number of possible connections with FMS connection, maximum	40
<u>Performance data</u>	
<u>S7 communication</u>	
Software required for S7 communication	Yes, HARDNET-PB S7 (S7-5613)
Number of possible connections for S7/PG communication, maximum	50
<u>Performance data</u>	
<u>Multiprotocol operation</u>	
Number of active connections in multiprotocol mode	50
Number of configurable connections per PC station	207

3

Technical specifications (continued)		Ordering data	Order No.
Order No.	6GK1 562-3AA00	CP 5623 communications processor	6GK1 562-3AA00
Product type designation	CP 5623	PCI Express x1 card (32 bit) for connection to PROFIBUS incl. DP-Base software with NCM PC; DP-RAM interface for DP master or DP slave, incl. PG and FDL protocols; single license for one installation, runtime software, software and electronic manual on CD-ROM, Class A, for operating system support see SIMATIC NET software; German/English	
Product functions Management, configuration, programming			
Configuration software required	NCM PC included in scope of delivery		
Product functions Diagnostics			
Product function: Port diagnostics	Yes		
Standards, specifications, approvals			
Standard			
• For EMC	2004/108/EC	Software upgrade	6GK1 561-3AA01-3AE0
• For CSA and UL safety	CAN/CSA C22.2 & UL 60950-1	For CP 5603, CP 5613 A2 and CP 5623 to Edition 2008 or V8.1	
• For emitted interference	EN 61000-6-3, EN 61000-6-4	HARDNET-PB DP Development Kit	see www.siemens.com/simatic-net/dk5613
• For noise immunity	EN 61000-6-1, EN 61000-6-2	HARDNET-PB DP Development Kit software for CP 5603, CP 5613, CP 5613 A2, CP 5623, CP 5613 FO, CP 5614, CP 5614 A2, CP 5624; for integration into other operating system environments on systems with a PCI or PCI Express slot	
Certificate of suitability		HARDNET-PB DP	
• CE mark	Yes	Software for DP, incl. PG and FDL protocol, OPC server and NCM PC; runtime software, software and electronic manual on CD-ROM, license key on USB flash drive, Class A, for CP 5603, CP 5613 A2, CP 5623, CP 5614 A2, CP 5624;	
• C-Tick	Yes	HARDNET-PB DP V8.1	
		For 32/64-bit: Windows 7 Professional/Ultimate; for 64-bit: Windows 2008 Server R2 English/German • Single license for one installation	6GK1 713-5DB08-1AA0
		DP-5613, 2008 Edition	
		for 32 Bit Windows XP Professional SP2/3; Windows 2003 Server R2, SP2; Windows Vista Business/Ultimate SP1; Windows 2008 Server; English/German • Single license for one installation	6GK1 713-5DB71-3AA0
		Software Update Service	6GK1 713-5DB00-3AL0
		For 1 year with automatic extension; requirement: current software version	
		Upgrade	
		• From Edition 2006 or 2007 to DP-5613 Edition 2008 or HARDNET-PB DP V8.1	6GK1 713-5DB00-3AE0
		• From V6.0, V6.1, V6.2 or V6.3 to DP-5613 Edition 2008 or HARDNET-PB DP V8.1	6GK1 713-5DB00-3AE1

PROFIBUS

Communication for PC-based systems

CP 5623

3

Ordering data**Order No.****Order No.****HARDNET-PB S7**

Software for S7 communication, incl. PG and FDL protocol, OPC server and NCM PC; runtime software, software and electronic manual on USB flash drive, Class A, for CP 5603, CP 5613 A2, CP 5623, CP 5614 A2, CP 5624;

HARDNET-PB S7 V8.1

For 32/64-bit:
Windows 7 Professional/Ultimate;
for 64-bit:
Windows 2008 Server R2
English/German

- Single license for one installation

6GK1 713-5CB08-1AA0**S7-5613 Edition 2008**

for 32 Bit
Windows XP Professional SP2/3;
Windows 2003 Server R2, SP2;
Windows Vista Business/Ultimate
SP1; Windows 2008 Server;
English/German

- Single license for one installation

6GK1 713-5CB71-3AA0**Software Update Service****6GK1 713-5CB00-3AL0**

For 1 year
with automatic extension;
requirement:
current software version

Upgrade

- From Edition 2006 or 2007 to S7-5613 Edition 2008 or HARDNET-PB S7 V8.1
- From V6.0, V6.1, V6.2 or V6.3 to S7-5613 Edition 2008 or HARDNET-PB S7 V8.1

6GK1 713-5CB00-3AE0**6GK1 713-5CB00-3AE1****FMS-5613 Edition 2008**

Software for FMS protocol incl. PG/OP communication; FDL, FMS-OPC server and NCM PC; runtime software, software and electronic manual on USB stick, Class A, for 32-bit Windows XP Professional SP2/3; Windows 2003 Server R2, SP2; Windows Vista Business/Ultimate SP1; Windows 2008 Server; for CP 5603, CP 5613, CP 5613 A2, CP 5623, CP 5613 FO, CP 5614, CP 5614 A2, CP 5624; German/English

- Single license for one installation

6GK1 713-5FB71-3AA0**Software Update Service****6GK1 713-5FB00-3AL0**

For 1 year
with automatic extension;
requirement:
current software version

Upgrade

- From Edition 2006 or 2007 to FMS-5613 Edition 2008
- From V6.0, V6.1, V6.2 or V6.3 to FMS-5613 Edition 2008

6GK1 713-5FB00-3AE0**6GK1 713-5FB00-3AE1****PROFIBUS FC Standard Cable GP****6XV1 830-0EH10**

Standard type with special design for quick assembly, 2-core, shielded, sold in meters; delivery unit max. 1000 m, minimum order 20 m

PROFIBUS FastConnect bus connector RS485 Plug 180**6GK1 500-0FC10**

With 180° cable outlet, insulation displacement

PROFIBUS bus terminal 12M**6GK1 500-0AA10**

Bus terminal for connection of PROFIBUS stations up to 12 Mbit/s with plug-in cable 1.5 m long

PROFIBUS FastConnect Stripping Tool**6GK1 905-6AA00**

Preset stripping tool for fast stripping of PROFIBUS FastConnect bus cables

More information

You can find the HARDNET-PB DP Development Kit on the Internet.

You will find more information on the Internet at:
www.siemens.com/simatic-net/dk5613

The CP 5623 module can also be used under LINUX and UNIX operating systems. Information on the available LINUX distributors and UNIX operating systems can be found at:
www.siemens.com/simatic-net/ik-info

Overview



DP-M	DP-S	FMS	OPC	PG/OP	S7/S5
●	●	●	●	●	●

- PCI Express card (PCIe x1) with own microprocessor for connecting PCs and SIMATIC PG/PC to PROFIBUS at up to 12 Mbit/s
- Two 9-pin sub-D sockets for parallel operation as DP master and DP slave
- Communication services:
 - PROFIBUS DP master and slave interface according to IEC 61158/61784 on one PCI card
 - PG/OP communication with STEP 5 and STEP 7
 - S7 communication with HARDNET-PB S7 software package
 - Open communication (SEND/RECEIVE) based on the FDL interface
 - PROFIBUS FMS according to IEC 61158/61784 with FMS-5613 software package
- Extensive diagnostics options for installation, commissioning and operation of the module
- Event and filter mechanism for reducing the load on the host CPU
- Multiprotocol operation and parallel operation of up to four CPs
- The appropriate OPC servers and configuration tools are included in the scope of supply of the respective communication software

Benefits

get **Designed for Industry**

- Fast access to process data by means of direct access to the dual port RAM of the hardware
- High computing performance in the PG/PC; reduces workload of host CPU by preprocessing the communication on the hardware
- Use of different operating system environments; driver as source code for porting to different operating system environments
- Saving of slots through parallel operation as DP master and DP slave
- Preventive maintenance measures; deriving of measures by evaluating system runtime and ambient temperature
- Use also in motion control applications; real-time capable data exchange through constant bus cycle time

Application



The CP 5624 supports the connection of SIMATIC PG/PC and PCs with PCI Express slot to PROFIBUS. It can be both DP master and DP slave.

This enables two different PROFIBUS networks to be connected in a hierarchical structure to a PC and to exchange data using one PROFIBUS card.

The CP 5624 provides high-performance support for control tasks on the PC (PC based Control, Numeric Control, Robot Control).

Design

- Short PCI Express card
- Can also be operated in PCI Express x4, x8 or x16 slots
- 2 x 9-pin sub-D socket for connection to PROFIBUS
- Diagnostic LEDs
- Parallel operation of as many as four CPs ¹⁾

The module is installed by means of PCI standard mechanisms (Plug&Play).

If the CP 5624 is used as DP master, DP slave, or in a PG/OP on a PROFIBUS DP, the connection is made:

- **to the electrical PROFIBUS** via
 - bus connector and PROFIBUS bus cable or
 - bus terminal (e.g. bus terminal 12M) and PROFIBUS bus cable
- **to the optical PROFIBUS with OLM** via
 - bus cable with two bus connectors or
 - PROFIBUS plug-in cable 830-1T
- **to the optical PROFIBUS with OBT and integrated interface** via
 - bus cable with two bus connectors or
 - PROFIBUS plug-in cable 830-1T

¹⁾ FMS-5613 supports up to two CP 5603/CP 5613 A2/5614 A2/CP 5623/CP 5624 processors.

PROFIBUS

Communication for PC-based systems

CP 5624

Function

PROFIBUS DP

Access to process data

The CP 5624 is operated as PROFIBUS DP master and DP slave module, which keeps the process image (input/output and diagnostic data) in the dual port RAM. The hardware of the CP 5624 independently executes the high-performance exchange of data with the PROFIBUS slaves. The user accesses the dual-port RAM directly.

The process data of the slaves are always consistent, i.e. the user receives the data of a slave from one and the same DP cycle.

Parallel operation of the HARDNET-PB DP software (DP master) and DP-Base software (DP master, DP slave) is not possible.

3

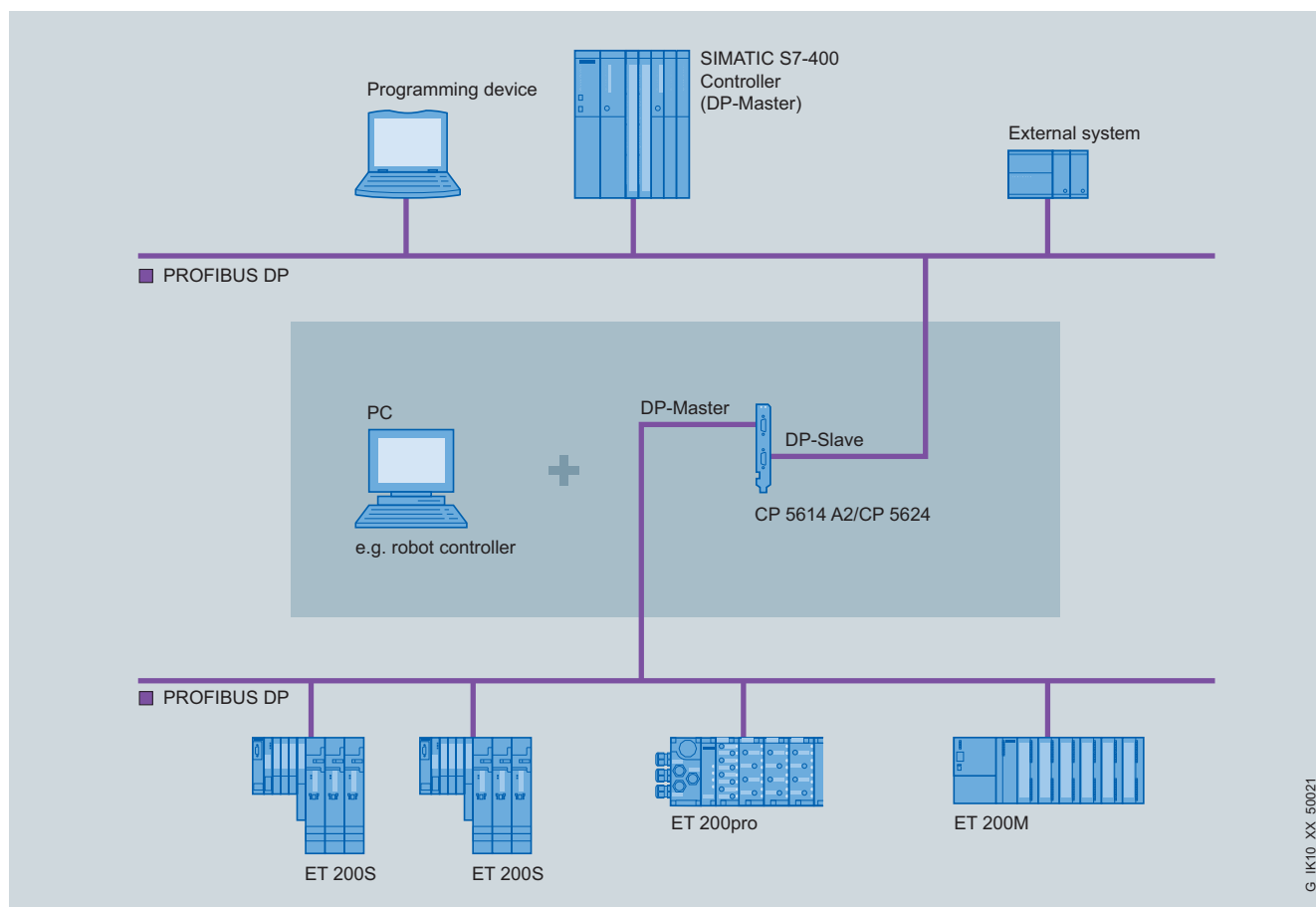

Example configuration of CP 5624 as DP master and DP slave

Event filter mechanism

The user receives up-to-date data over two access mechanisms:

- Cyclic polling of the DP slaves (high loading for host CPU)
- Notification through a new type of event/filter mode on changing the input data of a slave (minimal loading for host CPU)

Both alternatives can be combined. This allows users to optimize use of the PC for their applications.

The event/filter mechanism can be used additionally for

- Notification by means of an interrupt of the diagnostic messages from slaves
- During operation with constant bus cycle time, signaling by means of interrupt:
 - Start DP cycle
 - End cyclic data communication with DP slaves

FastLogic

FastLogic means that the CP 5624 can react autonomously to as many as four plant statuses. This results in a short response time and independence from the host application, e.g. fast shutdown of devices.

DP programming interface

The DP programming interface of the CP 5624 has the following functionality:

- DP slave
- DP master Class 1 including acyclic DP expansions
- DP master Class 2 including acyclic DP expansions

The process data is accessed directly through the dual-port RAM. The DP RAM interface not only offers fast access as DP master/slave but also a basis for porting to other operating system environments (e.g. VXWorks, QNX, RMOS, RTX).

G_IK10_XX_50021

Function (continued)

Administrative function calls (initialization and management services as well as diagnostic functions) are provided through a DP master and DP slave library (DP_BASE.DLL and DPS_BASE.DLL).

A transfer mechanism (PC application) can be activated in the software as a linking component for data transfer between the master and slave interface.

Defined I/O data can be transferred in this manner between the master interface and the slave interface.

The two connected PROFIBUS networks can be operated with different PROFIBUS bus parameters because they are independent of each other.

HARDNET-PB DP Development Kit

The HARDNET-PB DP Development Kit provides access to the functions DP master Class 1 and DP slave (incl. acyclic DP expansions)

The HARDNET-PB DP Development Kit software enables the CP 5624 communications processor to be integrated into any operating system environments. The kit contains the necessary source code, including the descriptions in PDF format, and can be downloaded free of charge via the Internet.

Access to process data with HARDNET-PB DP

DP Master Class 1

The CP 5624 operates as a DP master Class 1 according to IEC 61158/61784 and processes data communication with the distributed stations (DP slaves) completely autonomously. The central controller exchanges information with the DP slaves (e.g. ET 200S) in a specified, constantly repeating message cycle. The DP programming interface (DPLib.DLL) provides the PC programmer with function calls for data transfer. The DP interface also provides the SYNC and FREEZE functions as well as activation and deactivation of slaves.

The DP function expansions for masters Class 1 make it possible to perform acyclic read and write functions (DS_READ, DS_WRITE) as well as acknowledgement of alarms (ALARM_ACK) at the same time as processing cyclic data communication. Data that are to be transferred in acyclic mode (e.g. parameterization data) are only rarely changed in comparison to the cyclic measured values, and are transferred at lower priority in parallel with the cyclic high-speed user data transfer. Alarm acknowledgement by the master ensures reliable transfer of the alarms from DP slaves (DS_READ, DS_WRITE).

Parallel operation of the DP-Base and HARDNET-PB DP software is not possible.

DP Master Class 2

Apart from the DP master Class 1 services, the CP 5624 also offers DP master class 2 services to IEC 61158/61784 in conjunction with the DP programming interface. Devices of this type (programming, configuration or operating devices) are used during start-up, for configuring the DP system, or for operating the system during normal operation (diagnostics). The DP programming interface provides the following services:

- Master diagnostics
- Slave diagnostics
- Reading the inputs/outputs of a slave
- Reading configuration data
- Changing slave addresses

The extended DP functions comprise acyclic access to the parameters and measured values of a slave (e.g. field devices of process automation and intelligent HMI devices). This type of slave must be supplied with extensive parameter data during start-up and during normal operation. (DS_READ, DS_WRITE).

Software for PG/OP communication

This software supports programming of the SIMATIC S5/S7 controllers (with the exception of SIMATIC S5-95U) over PROFIBUS in combination with STEP 5/STEP 7. The PG/OP communication for the CP 5624 is already available following installation of the CP 5624 (DP-Base). No additional software packages are required.

Open communication (SEND/RECEIVE on the basis of the FDL interface)

SEND/RECEIVE (FDL interface) is already available following installation of the CP 5624 (DP-Base) and provides services for data transfer, diagnostics and management. No additional software packages are required.

Software for S7 communication (HARDNET-PB S7)

SIMATIC S7 system components communicate with each other using S7 communication functions. The S7 programming interface provides programming device/PC user programs with access to SIMATIC S7 system components. This makes for easy and flexible access to SIMATIC S7 data.

The following services are available with S7 communication:

Administrative services

- Connection management
- Mini database
- Trace

Data transfer services

- Read/write variables
- BSEND/BRECEIVE (up to 64 KB per task)

Software for PROFIBUS FMS (FMS-5613)

With the FMS programming interface, PGs/PCs can exchange different manufacturer data with FMS-capable controllers (e.g. S5 and S7) and field devices. Open communication is assured by using the FMS interface.

The FMS interface offers the following services:

- Administrative services
- CRL management services
- FMS connection management services
- Object directory management services for clients and server
- Variable services for clients and servers (Read, Write, Information Report)
- Server functionality
- VFD services (Virtual Field Device) for clients and servers
- Bus access information services (live list)
- Trace and mini database

PROFIBUS

Communication for PC-based systems

CP 5624

Function (continued)**User interfaces****OPC interface**

The OPC server included in the respective software package can be used as the standard programming interface for the PROFIBUS DP (DP master and DP slave), open communication, S7 communication and PROFIBUS FMS in order to connect automation technology applications to OPC-compatible Windows applications (Office, HMI systems, etc.).

Programming interface via C-library

The programming interfaces for existing applications are implemented as Dynamic Link Libraries (DLL). The released compilers can be found in the readme file of the SIMATIC NET CD products at www.siemens.com/automation/csi/net.

For Borland programming interfaces (e.g. DELPHI), partner solutions from SoftwareOption are offered.

For solutions for other operating systems, see HARDNET-PB DP Development Kit.

Configuration

- The S7 communication protocol, open communication protocol, DP protocol (DP-V0/DP-V1/DP-V2) and FMS protocol are configured in STEP 7 or NCM PC version V5.1 +SP2 or higher.
- The NCM PC configuration tool is included in the scope of delivery of the PROFIBUS software packages.

Diagnostics

Comprehensive diagnostic tools are available (for installation, start-up and operation) for the module itself and for the PROFIBUS DP network. These tools can be used for quick and easy start-up of a PROFIBUS DP network with a CP 5624.

3

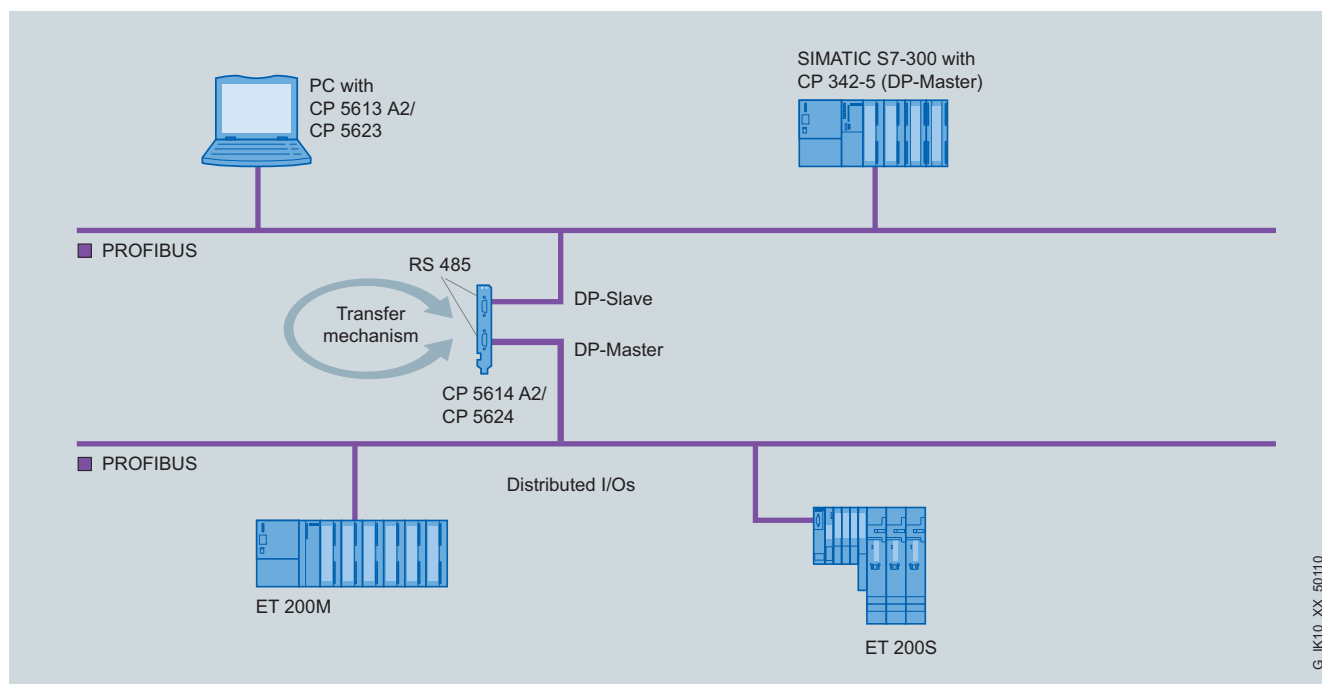

Configuration example for CP 5624

G_IK10_XX_50110

Technical specifications

Order No.	6GK1 562-4AA00	Order No.	6GK1 562-4AA00
Product type designation	CP 5624	Product type designation	CP 5624
Data transmission rate		Performance data	
Data transmission rate		<u>Performance data</u>	
• at interface 1 in accordance with PROFIBUS	9.6 kbit/s to 12 Mbit/s	<u>Open communication</u>	
• at interface 2 in accordance with PROFIBUS	9.6 kbit/s to 12 Mbit/s	Software required for open communication by means of SEND/RECEIVE	FDL driver included in scope of delivery of CP
Interfaces		Number of possible connections for open communication by means of SEND/RECEIVE, maximum	80
Number of electrical connections		<u>Performance data</u>	
• at interface 1 in accordance with PROFIBUS	1	<u>PROFIBUS DP</u>	
• at interface 2 in accordance with PROFIBUS	1	Software required for DP master function	No
Design of electrical connection		Service as DP master	
• at interface 1 in accordance with PROFIBUS	9-pin D-sub socket (RS 485)	• DPV0	Yes
• at interface 2 in accordance with PROFIBUS	9-pin D-sub socket (RS 485)	• DPV1	Yes
• of the backplane bus	PCI Express x1	• DPV2	Yes
Supply voltage, current consumption, power loss		Number of DP slaves operable on DP master	124
Type of power supply	DC	Data volume	
Power supply		• of address area of inputs as DP master, total	30 256 bytes
• 1 from backplane bus	3.3 V	• of address area of outputs as DP master, total	30 256 bytes
• 2 from backplane bus	12 V	• of address area of inputs per DP slave	244 bytes
Relative symmetrical tolerance		• of address area of outputs per DP slave	244 bytes
• At 3.3 V with DC	9 %	• of address area of diagnostics data per DP slave	244 bytes
• At 12 V with DC	8 %	Software required for DP slave function	No
Current consumed		Service as DP slave	
• Maximum 1 from backplane bus with DC	0.75 A	• DPV0	Yes
• Maximum 2 from backplane bus with DC	0.3 A	• DPV1	Yes
Effective power loss	3.6 W	Data volume	
Permitted ambient conditions		• of address area of inputs as DP slave, total	244 bytes
Ambient temperature		• of address area of outputs as DP slave, total	244 bytes
• During operation	5 ... 60 °C	<u>Performance data</u>	
• During storage	-20 ... +60 °C	<u>FMS functions</u>	
• During transport	-20 ... +60 °C	Software required for FMS communication	Yes, FMS-5613
Relative humidity at 25 °C without condensation during operation, maximum	85 %	Number of possible connections with FMS connection, maximum	40
IP degree of protection	IP00	<u>Performance data</u>	
Design, dimensions and weights		<u>S7 communication</u>	
Module format	PCI Express x1 (half length)	Software required for S7 communication	Yes, HARDNET-PB S7 (S7-5613)
Width	21.6 mm	Number of possible connections for S7/PG communication, maximum	50
Height	126.3 mm	<u>Performance data</u>	
Depth	180.5 mm	<u>Multiprotocol operation</u>	
Net weight	117 g	Number of active connections in multiprotocol mode	50
Product properties, functions, components		Number of configurable connections per PC station	207
General			
Number of plug-in cards of same design which can be inserted per PC station	4		
Number of modules - Note	FMS-5613 supports a maximum of two CP 5603 / CP 5613 A2 / CP 5614 A2 / CP 5623 / CP 5624 processors		

PROFIBUS

Communication for PC-based systems

CP 5624

Technical specifications (continued)

Order No.	6GK1 562-4AA00
Product type designation	CP 5624
Product functions Management, configuration, programming	
Configuration software required	NCM PC included in scope of delivery
Product functions Diagnostics	
Product function: Port diagnostics	Yes
Standards, specifications, approvals	
Standard	
• For EMC	2004/108/EC
• For CSA and UL safety	CAN/CSA C22.2 & UL 60950-1
• For emitted interference	EN 61000-6-3, EN 61000-6-4
• For noise immunity	EN 61000-6-1, EN 61000-6-2
Certificate of suitability	
• CE mark	Yes
• C-Tick	Yes

Ordering data

Order No.

CP 5624 A2 communication processor	6GK1 562-4AA00
PCI Express x1 card (32 bit) for master and slave connection to PROFIBUS incl. DP-Base software with NCM PC; DP-RAM interface for DP master, incl. PG and FDL protocols; single license for one installation, runtime software, software and electronic manual on CD-ROM, Class A, for operating system support see SIMATIC NET software; German/English	
Software upgrade	6GK1 561-3AA01-3AE0
for CP 5614 A2 and CP 5624 to Edition 2008 or V8.1	
HARDNET-PB DP Development Kit	see www.siemens.com/simatic-net/dk5613
HARDNET-PB DP Development Kit software for CP 5603, CP 5613, CP 5613 A2, CP 5623, CP 5613 FO, CP 5614, CP 5614 A2, CP 5624; for integration into other operating system environments on systems with a PCI or PCI Express slot	
HARDNET-PB DP	
Software for DP, incl. PG and FDL protocol, OPC server and NCM PC; runtime software, software and electronic manual on CD-ROM, license key on USB flash drive, Class A, for CP 5603, CP 5613 A2, CP 5623, CP 5614 A2, CP 5624;	
HARDNET-PB DP V8.1	
For 32/64-bit: Windows 7 Professional/Ultimate; for 64-bit: Windows 2008 Server R2 English/German	
• Single license for one installation	6GK1 713-5DB08-1AA0
DP-5613, 2008 Edition	
for 32 Bit Windows XP Professional SP2/3; Windows 2003 Server R2, SP2; Windows Vista Business/Ultimate SP1; Windows 2008 Server; English/German	
• Single license for one installation	6GK1 713-5DB71-3AA0
Software Update Service	6GK1 713-5DB00-3AL0
For 1 year with automatic extension; requirement: current software version	
Upgrade	
• From Edition 2006 or 2007 to DP-5613 Edition 2008 or HARDNET-PB DP V8.1	6GK1 713-5DB00-3AE0
• From V6.0, V6.1, V6.2 or V6.3 to DP-5613 Edition 2008 or HARDNET DP V8.1	6GK1 713-5DB00-3AE1

3

Ordering data	Order No.
HARDNET-PB S7	
Software for S7 communication, incl. PG and FDL protocol, OPC server and NCM PC; runtime software, software and electronic manual on USB flash drive, Class A, for CP 5603, CP 5613 A2, CP 5623, CP 5614 A2, CP 5624;	
HARDNET-PB S7 V8.1	
For 32/64-bit: Windows 7 Professional/Ultimate; for 64-bit: Windows 2008 Server R2 English/German	
• Single license for one installation	6GK1 713-5CB08-1AA0
S7-5613 Edition 2008	
for 32 Bit Windows XP Professional SP2/3; Windows 2003 Server R2, SP2; Windows Vista Business/Ultimate SP1; Windows 2008 Server; English/German	
• Single license for one installation	6GK1 713-5CB71-3AA0
Software Update Service	
For 1 year with automatic extension; requirement: current software version	6GK1 713-5CB00-3AL0
Upgrade	
• From Edition 2006 or 2007 to S7-5613 Edition 2008 or HARDNET-PB S7 V8.1	6GK1 713-5CB00-3AE0
• From V6.0, V6.1, V6.2 or V6.3 to S7-5613 Edition 2008 or HARDNET-PB S7 V8.1	6GK1 713-5CB00-3AE1
FMS-5613 Edition 2008	
Software for FMS protocol incl. PG/OP communication; FDL, FMS-OPC server and NCM PC; runtime software, software and electronic manual on USB flash drive, Class A, for 32-bit Windows XP Professional SP2/3; Windows 2003 Server R2, SP2; Windows Vista Business/ Ultimate SP1; Windows 2008 Server; for CP 5603, CP 5613, CP 5613 A2, CP 5623, CP 5613 FO, CP 5614, CP 5614 A2, CP 5624; German/English	
• Single license for one installation	6GK1 713-5FB71-3AA0
Software Update Service	
For 1 year with automatic extension; requirement: current software version	6GK1 713-5FB00-3AL0
Upgrade	
• From Edition 2006 or 2007 to FMS-5613 Edition 2008	6GK1 713-5FB00-3AE0
• From V6.0, V6.1, V6.2 or V6.3 to FMS-5613 Edition 2008	6GK1 713-5FB00-3AE1
PROFIBUS FastConnect bus connector RS 485 Plug 180	
with 180° cable outlet	6GK1 500-0FC10
PROFIBUS bus terminal 12M	
Bus terminal for connection of PROFIBUS nodes at up to 12 Mbit/s with connecting cable	6GK1 500-0AA10

More information

You can find the HARDNET-PB DP Development Kit on the Internet.

You can find more information on the Internet at:
www.siemens.com/simatic-net/dk5613

PROFIBUS

Communication for PC-based systems

CP 5611 A2

Overview



DP-M	DP-S	FMS	OPC	PG/OP	S7/S5
●	●		●	●	●

- PCI card (universal-keyed 5 V/3.3 V) for connecting PCs and SIMATIC PG/PC to PROFIBUS at up to 12 Mbit/s and to the MPI interface of SIMATIC S7
- Communication services:
 - PROFIBUS DP Master Class 1 incl. acyclic DP expansions with SOFTNET-PB DP software package
 - PROFIBUS DP Master Class 2 incl. acyclic DP expansions with SOFTNET-PB DP software package
 - PROFIBUS DP slave with SOFTNET-PB DP Slave software package
 - PG/OP communication with STEP 5 or STEP 7
 - S7 communication with SOFTNET-PB S7 software package
 - Open communication (SEND/RECEIVE on basis of the FDL interface) with SOFTNET-PB DP or SOFTNET-PB S7 software package
- Can be used with:
 - STEP 7, STEP 7-Micro/Win, ProTool, ProTool/Pro, SIMATIC PDM (for PG/OP communication)
 - COM PROFIBUS
 - SOFTNET-PB S7 (for S7 communication)
 - SOFTNET-PB DP, SOFTNET-PB DP slave (for DP)
- The appropriate OPC servers and configuration tools are included in the scope of supply of the respective communications software.

Benefits

get Designed for Industry

- Interface for portable PCs (e.g. for diagnostics and commissioning)
- Easy installation and startup
- Optimally matched to SOFTNET
- OPC as standard interface
- Uniform procedure and configuration functions for NCM PC and STEP 7
- Flexible use possible in PG/PC through PCI 3.3/5 V, 33/66 MHz and compatibility with 64-bit PCI X-slot

Application



The CP 5611 A2 is used to connect programming devices and PCs to PROFIBUS and to the multipoint MPI interface of SIMATIC S7:

- for programming devices and PCs with a PCI slot

Design

- Short PCI card
- Operation possible in 3.3 V and 5 V PCI slots (universal keyed)
- 33 MHz or 66 MHz PCI clock
- Operation possible as 32-bit card in a 64-bit PCI X-slot
- 9-pin sub-D socket for connection to PROFIBUS

Function

Various software packages can be used to operate the CP 5611 A2, which allows the user to execute programming device functions and PC functions over PROFIBUS and the multipoint interface MPI.

Only one CP can be used per PG or PC. Similarly only one protocol (PROFIBUS DP, S7 communication or FDL) can be used per CP.

The following software packages support the CP 5611 A2:

- STEP 7 V3.2 and higher; drivers for the CP 5611 A2 are included in the scope of supply of STEP 7.
- SOFTNET-S7 V3.2 and higher; this package allows the S7 programming interface to be used.
- SOFTNET-DP V3.2 and higher; the CP 5611 A2 can be used as a PROFIBUS DP master Class 1 or 2.
- SOFTNET DP slave V3.2 and higher; for using the CP 5611 A2 as a PROFIBUS DP slave.
- COM PROFIBUS V3.3 and higher; the CP 5611 A2 can be used in combination with this package for start-up or diagnostics (DP online functions) for PROFIBUS DP systems.
- STEP 7-Micro/WIN V2.1 and higher; hardware basis for the programming software of the SIMATIC S7-200 programmable controller
- ProTool, ProTool/Pro; the CP 5611 A2 can be used as a hardware basis for the configuration tool for all SIMATIC Operator Panels, Touch Panels and Text Displays.
- NCM PC; drivers for the CP 5611 A2 are included in the scope of supply
- WinCC/WinCC flexible; drivers for the CP 5611 A2 are included in the scope of supply

Technical specifications

Order No.	6GK1 561-1AA01	6GK1 561-1AM01
Product type designation	CP 5611 A2	CP 5611 A2 MPI
Transmission rate		
Transmission rate at interface 1 in accordance with PROFIBUS	9.6 kbit/s ... 12 Mbit/s	9.6 kbit/s ... 12 Mbit/s
Interfaces		
Number of electrical connections at interface 1 in accordance with PROFIBUS	1	1
Design of electrical connection		
• at interface 1 in accordance with PROFIBUS	9-pin D-sub socket (RS 485)	9-pin D-sub socket (RS 485)
• of backplane bus	PCI (32 bit 3.3 V/5 V Universal Key 33/66 MHz)	PCI (32 bit 3.3 V/5 V Universal Key 33/66 MHz)
Supply voltage, current consumption, power loss		
Type of power supply	DC	DC
Power supply 1 from backplane bus	5 V	5 V
Relative symmetrical tolerance at 5 V DC	5 %	5 %
Maximum current input 1 from backplane bus with DC	0.5 A	0.5 A
Effective power loss	2.5 W	2.5 W
Permitted ambient conditions		
Ambient temperature		
• During operation	5 ... 55 °C	5 ... 40 °C
• During storage	-20 ... +60 °C	-20 ... +60 °C
• During transport	-20 ... +60 °C	-20 ... +60 °C
Relative humidity at 25 °C without condensation during operation, maximum	95 %	95 %
IP degree of protection	IP00	IP00
Design, dimensions and weights		
Module format	PCI	PCI
Width	18 mm	18 mm
Height	102 mm	111 mm
Depth	130 mm	129 mm
Net weight	100 g	400 g
Product properties, functions, components		
General		
Number of plug-in cards of same design which can be inserted per PC station	1	1
Number of modules - Note	-	-
Performance data		
<u>Performance data</u>		
<u>Open communication</u>		
Software required for open communication by means of SEND/RECEIVE	Yes, SOFTNET-PB DP / SOFTNET-PB DP Slave / SOFTNET-PB S7	Yes, SOFTNET-PB DP / SOFTNET-PB DP Slave / SOFTNET-PB S7
Number of possible connections for open communication by means of SEND/RECEIVE, maximum	50	50

PROFIBUS

Communication for PC-based systems

CP 5611 A2

Technical specifications (continued)

Order No.	6GK1 561-1AA01	6GK1 561-1AM01
Product type designation	CP 5611 A2	CP 5611 A2 MPI
<u>Performance data</u> <u>PROFIBUS DP</u>		
Software required for DP master function	Yes, SOFTNET-PB DP	Yes, SOFTNET-PB DP
Service as DP master		
• DPV0	Yes	Yes
• DPV1	No	No
• DPV2	No	No
Number of DP slaves operable on DP master	64	64
Data volume		
• of address area of inputs as DP master, total	14 640 bytes	14 640 bytes
• of address area of outputs as DP master, total	14 640 bytes	14 640 bytes
• of address area of inputs per DP slave	244 bytes	244 bytes
• of address area of outputs per DP slave	244 bytes	244 bytes
• of address area of diagnostics data per DP slave	244 bytes	244 bytes
Software required for DP slave function	Yes, SOFTNET-PB DP Slave	Yes, SOFTNET-PB DP Slave
Service as DP slave		
• DPV0	Yes	Yes
• DPV1	No	No
Data volume		
• of address area of inputs as DP slave, total	122 bytes	122 bytes
• of address area of outputs as DP slave, total	122 bytes	122 bytes
<u>Performance data</u> <u>S7 communication</u>		
Software required for S7 communication	Yes, SOFTNET-PB S7	Yes, SOFTNET-PB S7
Number of possible connections for S7/PG communication, maximum	8	8
<u>Performance data</u> <u>Multiprotocol operation</u>		
Number of configurable connections per PC station	207	207
Product functions Management, configuration, programming		
Configuration software required	NCM PC included in scope of delivery of required software product	NCM PC included in scope of delivery of required software product
Product functions Diagnostics		
Product function: Port diagnostics	Yes	Yes
Standards, specifications, approvals		
Standard		
• For EMC	89/336/EEC	89/336/EEC
• For CSA and UL safety	CAN/CSA C22.2 & UL 60950-1, UL 1950	CAN/CSA C22.2 & UL 60950-1, UL 1950
• For emitted interference	EN 61000-6-3	EN 61000-6-3
• For noise immunity	EN 61000-6-2	EN 61000-6-2
Certificate of suitability		
• CE mark	Yes	Yes
• C-Tick	Yes	Yes
Accessories		
Accessories	Optional: MPI cable	Included in scope of delivery: MPI cable

Ordering data	Order No.	Order No.
CP 5611 A2 communication processor <ul style="list-style-type: none"> • PCI card (32-bit) for connection of a programming device or PC to PROFIBUS • PCI card (32-bit) CP 5611 A2 and MPI cable, 5 m 	6GK1 561-1AA01 6GK1 561-1AM01	Software Update Service For 1 year with automatic extension; requirement: current software version Upgrade <ul style="list-style-type: none"> • From Edition 2006 to SOFTNET-DP Edition 2008 or V8.1 • From V6.0, V6.1, V6.2 or V6.3 to SOFTNET-DP Edition 2008 or V8.1
SOFTNET-PB S7 Software for S7 communication, incl. FDL protocol with OPC server and NCM-PC, runtime software, software and electronic manual on CD-ROM, license key on USB flash drive, Class A; for CP 5512, CP 5611, CP 5611 A2, CP 5711, CP 5621;		6GK1 704-5DW00-3AL0 6GK1 704-5DW00-3AE0 6GK1 704-5DW00-3AE1
SOFTNET-PB S7 V8.1 For 32/64-bit: Windows 7 Professional/Ultimate; for 64-bit: Windows 2008 Server R2 English/German <ul style="list-style-type: none"> • Single license for one installation 	6GK1 704-5CW08-1AA0	SOFTNET-PB DP slave Software for DP slave, with DP OPC server and NCM PC, single license for one installation, runtime software, software and electronic manual on CD-ROM, license key on USB flash drive, Class A; for CP 5611 A2, CP 5711, CP 5621;
SOFTNET-S7 Edition 2008 (V7.1) for 32 Bit Windows XP Professional SP2/3; Windows 2003 Server R2, SP2; Windows Vista Business/Ultimate SP1; Windows 2008 Server; English/German <ul style="list-style-type: none"> • Single license for one installation 	6GK1 704-5CW71-3AA0	SOFTNET-PB DP Slave V8.1 For 32/64-bit: Windows 7 Professional/Ultimate; for 64-bit: Windows 2008 Server R2 English/German <ul style="list-style-type: none"> • Single license for one installation
Software Update Service For 1 year with automatic extension; requirement: current software version	6GK1 704-5CW00-3AL0	SOFTNET-DP Slave Edition 2008 (V7.1) for 32 Bit Windows XP Professional SP2/3; Windows 2003 Server R2, SP2; Windows Vista Business/Ultimate SP1; Windows 2008 Server; English/German <ul style="list-style-type: none"> • Single license for one installation
Upgrade <ul style="list-style-type: none"> • From Edition 2006 to SOFTNET-S7 Edition 2008 or V8.1 • From V6.0, V6.1, V6.2 or V6.3 to SOFTNET-S7 Edition 2008 or V8.1 	6GK1 704-5CW00-3AE0 6GK1 704-5CW00-3AE1	SOFTNET-DP Slave Edition 2008 (V7.1) for 32 Bit Windows XP Professional SP2/3; Windows 2003 Server R2, SP2; Windows Vista Business/Ultimate SP1; Windows 2008 Server; English/German <ul style="list-style-type: none"> • Single license for one installation
SOFTNET-PB DP Software for DP protocol (master class 1 and 2), incl. FDL protocol with OPC server and NCM PC, runtime software, software and electronic manual on CD-ROM, license key on USB flash drive; for CP 5611 A2, CP 5711, CP 5621;		Software Update Service For 1 year with automatic extension; requirement: current software version
SOFTNET-PB DP V8.1 For 32/64-bit: Windows 7 Professional/Ultimate; for 64-bit: Windows 2008 Server R2 English/German <ul style="list-style-type: none"> • Single license for one installation 	6GK1 704-5DW08-1AA0	Upgrade <ul style="list-style-type: none"> • From Edition 2006 to SOFTNET-DP Slave Edition 2008 or V8.1 • From V6.0, V6.1, V6.2 or V6.3 to SOFTNET-DP Slave Edition 2008 or V8.1
SOFTNET-DP Edition 2008 (V7.1) for Windows XP Professional SP2/3; Windows 2003 Server R2, SP2; Windows Vista Business/Ultimate SP1; Windows 2008 Server; English/German <ul style="list-style-type: none"> • Single license for one installation 	6GK1 704-5DW71-3AA0	PROFIBUS FastConnect bus connector RS 485 Plug 180 With 180° cable outlet
		PROFIBUS bus terminal 12M Bus terminal for connection of PROFIBUS stations for up to 12 Mbit/s with plug-in cable

PROFIBUS

Communication for PC-based systems

CP 5621

Overview



DP-M	DP-S	FMS	OPC	PG/OP	S7/S5
●	●		●	●	●

- PCI Express card (PCIe x1) for connection of PCs and SIMATIC PG/PC to PROFIBUS at up to 12 Mbit/s and to the MPI of the SIMATIC S7
- Communication services:
 - PROFIBUS DP Master Class 1 incl. acyclic DP expansions with SOFTNET-PB DP software package
 - PROFIBUS DP Master Class 2 incl. acyclic DP expansions with SOFTNET-PB DP software package
 - PROFIBUS DP slave with SOFTNET-PB DP Slave software package
 - PG/OP communication with STEP 5 or STEP 7
 - S7 communication with SOFTNET-PB S7 software package
 - Open communication (SEND/RECEIVE on basis of the FDL interface) with SOFTNET-PB DP or SOFTNET-PB S7 software package
- Can be used with:
 - STEP 7, STEP 7-Micro/Win, ProTool, ProTool/Pro, SIMATIC PDM (for PG/OP communication)
 - COM PROFIBUS
 - SOFTNET-PB S7 (for S7 communication)
 - SOFTNET-PB DP, SOFTNET-PB DP slave (for DP)
- The appropriate OPC server and configuration tools are included in the scope of supply of the respective communication software.

Benefits

get Designed for Industry

- Connection for portable PCs (e.g. for diagnostics and commissioning)
- Simple installation and commissioning
- Optimally coordinated with SOFTNET
- OPC as standard interface
- Standardized procedure and configuration functionality for NCM PC and STEP 7
- Can be used flexibly as PCIe x1 card in PC/IPC with PCI Express x1, x4, x8 or x16 slots

Application



The CP 5621 permits the connection of programming devices (PGs) and PCs to PROFIBUS and to the multipoint interface (MPI) of the SIMATIC S7:

- for PGs/PCs with PCI Express slot

Design

- Short PCI card
- 9-pin sub-D socket for connection to PROFIBUS
- Operation in the PCI Express x1, x4, x8 or x16 slots is possible

Function

The CP 5621 is operated under various software packages and offers the user the opportunity of performing functions of the programming devices and PCs by means of PROFIBUS and the multipoint interface (MPI).

Only one CP can be used per PG or PC. Likewise, only one protocol (PROFIBUS DP, S7-communication or FDL) can be used per CP.

The following software packs support the CP 5621:

- STEP 7 V5.4 SP 4 or higher; Drivers for the CP 5621 are included in the scope of delivery of STEP 7.
- SOFTNET-S7 V7.0 or higher; This package enables the S7 programming interface to be used.
- SOFTNET-DP V7.0 or higher; This enables the CP 5621 to be used as PROFIBUS DP Master Class 1 or Class 2.
- SOFTNET-DP Slave V7.0 or higher; For use of the CP 5621 as PROFIBUS DP slave
- STEP 7-Micro/WIN; Hardware basis for the programming software of the SIMATIC S7-200 automation system
- ProTool, ProTool/Pro; The CP 5621 can be used as the hardware basis for the configuration tool for all SIMATIC Operator Panels, Touch Panels and Text Displays.
- NCM PC; Drivers for the CP 5621 are included in the scope of supply (beginning with SIMATIC NET CD, 2007 Edition).
- WinCC/WinCC Flexible; Drivers for the CP 5621 are included in the scope of supply (beginning with SIMATIC NET CD Edition 2007).

Technical specifications

Order No.	6GK1 562-1AA00	6GK1 562-1AM00
Product type designation	CP 5621	CP 5621 MPI
Transmission rate		
Transmission rate at interface 1 in accordance with PROFIBUS	9.6 kbit/s ... 12 Mbit/s	9.6 kbit/s ... 12 Mbit/s
Interfaces		
Number of electrical connections at interface 1 in accordance with PROFIBUS	1	1
Design of electrical connection		
• at interface 1 in accordance with PROFIBUS	9-pin D-sub socket (RS 485)	9-pin D-sub socket (RS 485)
• of backplane bus	PCI Express x1	PCI Express x1
Supply voltage, current consumption, power loss		
Type of power supply	DC	DC
Power supply		
• 1 from backplane bus	3.3 V	3.3 V
• 2 from backplane bus	12 V	12 V
Relative symmetrical tolerance		
• At 3.3 V with DC	9 %	9 %
• At 12 V with DC	8 %	8 %
Current consumed		
• Max. 1 from backplane bus with DC	0.4 A	0.4 A
• Max. 2 from backplane bus with DC	0.18 A	0.18 A
Effective power loss	2.2 W	2.2 W
Permitted ambient conditions		
Ambient temperature		
• During operation	5 ... 55 °C	5 ... 55 °C
• During storage	-20 ... +60 °C	-20 ... +60 °C
• During transport	-20 ... +60 °C	-20 ... +60 °C
Relative humidity at 25 °C without condensation during operation, maximum	85 %	85 %
IP degree of protection	IP00	IP00
Design, dimensions and weights		
Module format	PCI Express x1	PCI Express x1
Width	18 mm	18 mm
Height	111 mm	111 mm
Depth	129 mm	129 mm
Net weight	100 g	100 g
Product properties, functions, components		
General		
Number of plug-in cards of same design which can be inserted per PC station	1	1
Number of modules - Note	-	-
Performance data		
<u>Performance data</u>		
<u>Open communication</u>		
Software required for open communication by means of SEND/RECEIVE	Yes, SOFTNET-PB DP / SOFTNET-PB DP slave / SOFTNET-PB S7	Yes, SOFTNET-PB DP / SOFTNET-PB DP slave / SOFTNET-PB S7
Number of possible connections for open communication by means of SEND/RECEIVE, maximum	50	50

PROFIBUS

Communication for PC-based systems

CP 5621

Technical specifications (continued)

Order No.	6GK1 562-1AA00	6GK1 562-1AM00
Product type designation	CP 5621	CP 5621 MPI
<u>Performance data</u> <u>PROFIBUS DP</u>		
Software required for DP master function	Yes, SOFTNET-PB DP	Yes, SOFTNET-PB DP
Service as DP master		
• DPV0	Yes	Yes
• DPV1	No	No
• DPV2	No	No
Number of DP slaves operable on DP master	64	64
Data volume		
• of address area of inputs as DP master, total	14 640 bytes	14 640 bytes
• of address area of outputs as DP master, total	14 640 bytes	14 640 bytes
• of address area of inputs per DP slave	244 bytes	244 bytes
• of address area of outputs per DP slave	244 bytes	244 bytes
• of address area of diagnostics data per DP slave	244 bytes	244 bytes
Software required for DP slave function	Yes, SOFTNET-PB DP Slave	Yes, SOFTNET-PB DP Slave
Service as DP slave		
• DPV0	Yes	Yes
• DPV1	No	No
Data volume		
• of address area of inputs as DP slave, total	122 bytes	122 bytes
• of address area of outputs as DP slave, total	122 bytes	122 bytes
<u>Performance data</u> <u>S7 communication</u>		
Software required for S7 communication	Yes, SOFTNET-PB S7	Yes, SOFTNET-PB S7
Number of possible connections for S7/PG communication, maximum	8	8
<u>Performance data</u> <u>Multiprotocol operation</u>		
Number of configurable connections per PC station	207	207
Product functions Management, configuration, programming		
Configuration software required	NCM PC included in scope of delivery of required software product	NCM PC included in scope of delivery of required software product
Product functions Diagnostics		
Product function: Port diagnostics	Yes	Yes
Standards, specifications, approvals		
Standard		
• For EMC	2004/108/EC	89/336/EEC
• For CSA and UL safety	CAN/CSA C22.2 & UL 60950-1, UL 508	CAN/CSA C22.2 & UL 60950-1, UL 508
• For emitted interference	EN 61000-6-3, EN 61000-6-4	EN 61000-6-3, EN 61000-6-4
• For noise immunity	EN 61000-6-1, EN 61000-6-2	EN 61000-6-1, EN 61000-6-2
Certificate of suitability		
• CE mark	Yes	Yes
• C-Tick	Yes	Yes
Accessories		
Accessories	Optional: MPI cable	Included in scope of delivery: MPI cable

Ordering data	Order No.	Order No.
Communication processor CP 5621 <ul style="list-style-type: none"> • PCI Express x1 card (32-bit) for connection of a PG or PC to PROFIBUS • PCI Express x1 card (32-bit) CP 5621 and MPI cable, 5 m 	6GK1 562-1AA00 6GK1 562-1AM00	SOFTNET-DP Edition 2008 (V7.1) for Windows XP Professional SP2/3; Windows 2003 Server R2, SP2; Windows Vista Business/Ultimate SP1; Windows 2008 Server; English/German <ul style="list-style-type: none"> • Single license for one installation
SOFTNET-PB S7 Software for S7 communication, incl. FDL protocol with OPC server and NCM-PC, runtime software, software and electronic manual on CD-ROM, license key on USB flash drive, Class A; for CP 5611 A2, CP 5711, CP 5621;		Software Update Service For 1 year with automatic extension; requirement: current software version
SOFTNET-PB S7 V8.1 For 32/64-bit: Windows 7 Professional/Ultimate; for 64-bit: Windows 2008 Server R2 English/German <ul style="list-style-type: none"> • Single license for one installation 	6GK1 704-5CW08-1AA0	Upgrade <ul style="list-style-type: none"> • From Edition 2006 to SOFTNET-DP Edition 2008 or V8.1 • From V6.0, V6.1, V6.2 or V6.3 to SOFTNET-DP Edition 2008 or V8.1
SOFTNET-S7 Edition 2008 (V7.1) for 32 Bit Windows XP Professional SP2/3; Windows 2003 Server R2, SP2; Windows Vista Business/Ultimate SP1; Windows 2008 Server; English/German <ul style="list-style-type: none"> • Single license for one installation 	6GK1 704-5CW71-3AA0	SOFTNET-PB DP slave Software for DP slave, with DP OPC server and NCM PC, single license for one installation, runtime software, software and electronic manual on CD-ROM, license key on USB flash drive, Class A; for CP 5611 A2, CP 5711, CP 5621;
Software Update Service For 1 year with automatic extension; requirement: current software version	6GK1 704-5CW00-3AL0	SOFTNET-PB DP Slave V8.1 For 32/64-bit: Windows 7 Professional/Ultimate; for 64-bit: Windows 2008 Server R2 English/German <ul style="list-style-type: none"> • Single license for one installation
Upgrade <ul style="list-style-type: none"> • From Edition 2006 to SOFTNET-S7 Edition 2008 or V8.1 • From V6.0, V6.1, V6.2 or V6.3 to SOFTNET-S7 Edition 2008 or V8.1 	6GK1 704-5CW00-3AE0 6GK1 704-5CW00-3AE1	SOFTNET-DP Slave Edition 2008 (V7.1) For 32-bit Windows XP Professional SP2/3; Windows 2003 Server R2, SP2; Windows Vista Business/Ultimate SP1; Windows 2008 Server; English/German <ul style="list-style-type: none"> • Single license for one installation
SOFTNET-PB DP Software for DP protocol (master class 1 and 2), incl. FDL protocol with OPC server and NCM PC, runtime software, software and electronic manual on CD-ROM, license key on USB flash drive; for CP 5611 A2, CP 5711, CP 5621;		Software Update Service For 1 year with automatic extension; requirement: current software version
SOFTNET-PB DP V8.1 For 32/64-bit: Windows 7 Professional/Ultimate; for 64-bit: Windows 2008 Server R2 English/German <ul style="list-style-type: none"> • Single license for one installation 	6GK1 704-5DW08-1AA0	Upgrade <ul style="list-style-type: none"> • From Edition 2006 to SOFTNET-DP Slave Edition 2008 or V8.1 • From V6.0, V6.1, V6.2 or V6.3 to SOFTNET-DP Slave Edition 2008 or V8.1
		PROFIBUS FastConnect bus connector RS 485 Plug 180 With 180° cable outlet
		PROFIBUS bus terminal 12M Bus terminal for connection of PROFIBUS stations for up to 12 Mbit/s with plug-in cable
		6GK1 500-0FC10 6GK1 500-0AA10

PROFIBUS

Communication for PC-based systems

CP 5711

Overview



DP-M	DP-S	FMS	OPC	PG/OP	S7/S5
●	●		●	●	●

- USB adapter for the connection of PCs and SIMATIC PG/PC to PROFIBUS DP or MPI via USB 2.0
- Operation in extended temperature range of -20 °C to +60 °C
- Active PROFIBUS termination to supply the PROFIBUS network as end station of a segment
- Robust USB connection due to mechanical locking of the USB connector to the CP 5711 enclosure
- Communication services:
 - PROFIBUS DP master Class 1 and 2 according to IEC 61158/61784 with SOFTNET-PB DP software package
 - PROFIBUS DP slave with SOFTNET-PB DP Slave software package
 - PG/OP communication with STEP 5 or STEP 7 software package
 - S7 communication with SOFTNET-PB S7 software package
 - Open communication (SEND/RECEIVE on basis of the FDL interface) with SOFTNET-PB DP or SOFTNET-PB S7 software package
- PROFIBUS connection with up to 12 Mbit/s
- Can be used with:
 - STEP 7, STEP 7 Micro/WIN, WinCC/WinCC flexible, NCM PC, SIMATIC PDM (for PG/OP communication)
 - SOFTNET-PB S7 (for S7 communication)
 - SOFTNET-PB DP, SOFTNET-PB DP slave (for DP)
- The appropriate OPC servers and configuration tools are included in the scope of supply of the respective communication software

Benefits

get **Designed for Industry**

- Portability and flexibility: Connection for portable PCs, e.g. for diagnostics and commissioning
- Low-cost PROFIBUS controller and device solutions for embedded PCs (without PCI or PC104 bus)
- Fault-free connection to the PROFIBUS diagnosis at all times due to permanent installation on PROFIBUS and connection via USB in the event of maintenance and diagnosis
- Easy installation and commissioning due to plug & play technology

Application



The CP 5711 enables the connection of SIMATIC PG/PC and PCs with USB interface to PROFIBUS and to the multi-point interface (MPI) of SIMATIC S7.

Design

- USB V2.0 connection
- Adapter with 9-pin sub-D socket for connection to PROFIBUS

Function

The CP 5711 is a USB V2.0 adapter that can be used on either a USB V2.0 port (bandwidth 480 Mbit/s) or a USB V1.1 port (1.5 Mbit/s). It can be used with various software packages and offers users the ability to perform functions of the programming devices and PCs/OPs via PROFIBUS and the multi-point interface (MPI).

The CP 5711 is powered directly via the USB interface of the PC system. Regardless of whether the USB cable is plugged in or unplugged, the active power supply of the PROFIBUS network is drawn from the external 24 V DC power supply unit.

Optional for the use of the CP 5711 in control cabinets or in the vicinity of SIMATIC S7 controllers, a mounting adapter (DIN rail) is available to attach the CP to the 35 mm DIN rail.

Only one CP per PG/PC/OP can be operated. Likewise, only one protocol (PROFIBUS DP, S7 communication, or FDL) can be used per CP.

Function (continued)

The following software packages support the CP 5711:

- STEP 7 from V5.4 SP5; drivers for the CP 5711 are included with STEP 7.
- SOFTNET-S7 from V7.1; the S7 programming interface can be used with this package.
- SOFTNET-DP from V7.1; with this, the CP 5711 can be used as PROFIBUS DP master Class 1 or 2.
- SOFTNET-DP slave from V7.1; for operating the CP 5711 as PROFIBUS DP slave
- STEP 7-Micro/WIN; drivers for the CP 5711 are included with STEP 7-Micro/WIN.
- WinCC/WinCC flexible; the CP 5711 can be used as a hardware basis for the configuration tool for SIMATIC Operator Panels, Touch Panels, and Text Displays.
- NCM PC; under Windows XP Professional
- SIMATIC PDM; drivers for the CP 5711 are included with SIMATIC PDM.

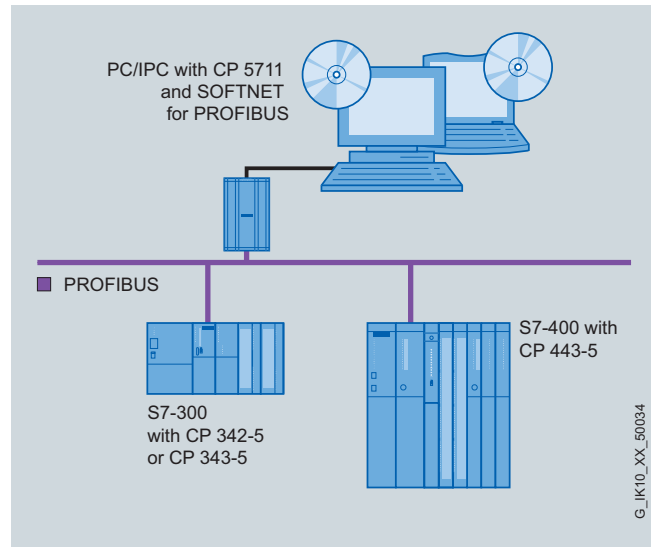

Diagnostics

Numerous diagnostic tools are available for the CP 5711. For support, the module also includes comprehensive LED diagnostics. Operating and signal states can be recognized quickly via five LEDs.

Configuration

- The S7 communication and open communication protocols can be configured in STEP 7 or NCM PC.

The NCM PC configuration tool is included with the software packages SOFTNET-PB S7 and SOFTNET-PB DP for PROFIBUS.

Technical specifications

Order No.	6GK1 571-1AA00	6GK1 571-1AM00
Product type designation	CP 5711	CP 5711 MPI
Transmission rate		
Transmission rate at interface 1 in accordance with PROFIBUS	9.6 kbit/s to 12 Mbit/s	9.6 kbit/s to 12 Mbit/s
Interfaces		
Number of electrical connections at interface 1 in accordance with PROFIBUS	1	1
Number of interfaces in accordance with USB	1	1
Number of electrical connections for power supply	1	1
Design of electrical connection		
• at interface 1 in accordance with PROFIBUS	9-pin D-sub socket (RS 485)	9-pin D-sub socket (RS 485)
• for power supply	2-pin terminal block	2-pin terminal block
• of the USB port	Standard B socket with mechanical locking	Standard B socket with mechanical locking
Standard for USB 2.0 ports	Yes	Yes
Supply voltage, current consumption, power loss		
Type of power supply	DC	DC
Type of power supply: optional external supply	Yes	Yes

PROFIBUS

Communication for PC-based systems

CP 5711

Technical specifications (continued)

Order No.	6GK1 571-1AA00	6GK1 571-1AM00
Product type designation	CP 5711	CP 5711 MPI
Power supply		
• From USB	5 V	5 V
• External	24 V	24 V
- Minimum	18 V	18 V
- Maximum	30 V	30 V
• Note	Power supply directly from USB if provided sufficiently by PC / external supply possible as alternative	Power supply directly from USB if provided sufficiently by PC / external supply possible as alternative
Relative symmetrical tolerance		
• At 5 V with DC	5 %	5 %
• At 24 V with DC	5 %	5 %
Current consumed		
• From USB	0.5 A	0.5 A
• Maximum from external power supply with 24 V DC	0.3 A	0.3 A
Effective power loss	2.5 W	2.5 W
Permitted ambient conditions		
Ambient temperature		
• During operation	0 ... 60 °C	5 ... 60 °C
• During storage	-40 ... +60 °C	-20 ... +60 °C
• During transport	-40 ... +60 °C	-20 ... +60 °C
Relative humidity at 25 °C without condensation during operation, maximum	85 %	85 %
IP degree of protection	IP20	IP20
Design, dimensions and weights		
Module format	USB V2.0 adapter	USB V2.0 adapter
Width	85 mm	85 mm
Height	137 mm	137 mm
Depth	35 mm	35 mm
Net weight	300 g	500 g
Type of mounting:	Yes	Yes
35 mm DIN rail mounting		
Type of mounting	Mounting on DIN rail with optional rail support	Mounting on DIN rail with optional rail support
Product properties, functions, components		
General		
Number of plug-in cards of same design which can be inserted per PC station	1	1
Number of modules - Note	-	-
Performance data		
<u>Performance data</u>		
<u>Open communication</u>		
Software required for open communication by means of SEND/RECEIVE	Yes, SOFTNET-PB DP / SOFTNET-PB DP slave / SOFTNET-PB S7	Yes, SOFTNET-PB DP / SOFTNET-PB DP slave / SOFTNET-PB S7
Number of possible connections for open communication by means of SEND/RECEIVE, maximum	50	50
<u>Performance data</u>		
<u>PROFIBUS DP</u>		
Software required for DP master function	Yes, SOFTNET-PB DP	Yes, SOFTNET-PB DP
Service as DP master		
• DPV0	Yes	Yes
• DPV1	No	No
• DPV2	No	No

Technical specifications (continued)

Order No.	6GK1 571-1AA00	6GK1 571-1AM00
Product type designation	CP 5711	CP 5711 MPI
Number of DP slaves operable on DP master	64	64
Data volume		
• of address area of inputs as DP master, total	15 616 bytes	15 616 bytes
• of address area of outputs as DP master, total	15 616 bytes	15 616 bytes
• of address area of inputs per DP slave	244 bytes	244 bytes
• of address area of outputs per DP slave	244 bytes	244 bytes
• of address area of diagnostics data per DP slave	244 bytes	244 bytes
Software required for DP slave function	Yes, SOFTNET-PB DP Slave	Yes, SOFTNET-PB DP Slave
Service as DP slave		
• DPV0	Yes	Yes
• DPV1	No	No
Data volume		
• of address area of inputs as DP slave, total	122 bytes	122 bytes
• of address area of outputs as DP slave, total	122 bytes	122 bytes
<u>Performance data</u> <u>S7 communication</u>		
Software required for S7 communication	Yes, SOFTNET-PB S7	Yes, SOFTNET-PB S7
Number of possible connections for S7/PG communication, maximum	8	8
<u>Performance data</u> <u>Multiprotocol operation</u>		
Number of configurable connections per PC station	207	207
Product functions Management, configuration, programming		
Configuration software required	NCM PC included in scope of delivery of required software product	NCM PC included in scope of delivery of required software product
Product functions Diagnostics		
Product function: Port diagnostics	Yes	Yes
Standards, specifications, approvals		
Standard		
• For EMC	2004/108/EC	2004/108/EC
• For CSA and UL safety	CAN/CSA C22.2 & UL 60950-1	CAN/CSA C22.2 & UL 60950-1
• For emitted interference	EN 61000-6-3, EN 61000-6-4	EN 61000-6-3, EN 61000-6-4
• For noise immunity	EN 61000-6-1, EN 61000-6-2	EN 61000-6-1, EN 61000-6-2
Certificate of suitability		
• CE mark	Yes	Yes
• C-Tick	Yes	Yes
Accessories		
Accessories	Optional: MPI cable, rail support	Included in scope of delivery: MPI cable / optional: rail support

PROFIBUS

Communication for PC-based systems

CP 5711

3

Ordering data	Order No.	Order No.
CP 5711 communication processor for connection of a programming device or notebook to PROFIBUS or MPI, under 32 bit in connection with PROFIBUS SOFTNET software or STEP 7; German/English <ul style="list-style-type: none"> • USB V2.0 adapter • USB V2.0 adapter CP 5711 and MPI cable, 5 m 	6GK1 571-1AA00 6GK1 571-1AM00	SOFTNET-DP Edition 2008 (V7.1) for Windows XP Professional SP2/3; Windows 2003 Server R2, SP2; Windows Vista Business/Ultimate SP1; Windows 2008 Server; English/German <ul style="list-style-type: none"> • Single license for one installation
Mounting rail support for CP 5711 Compartment for CP 5711 enclosure; fastened mechanically to 35 mm DIN rail	6GK1 571-1AA00-0AH0	Software Update Service For 1 year with automatic extension; requirement: current software version
SOFTNET-PB S7 Software for S7 communication, incl. FDL protocol with OPC server and NCM-PC, runtime software, software and electronic manual on CD-ROM, license key on USB flash drive, Class A; for CP 5611 A2, CP 5711, CP 5621;		Upgrade <ul style="list-style-type: none"> • From Edition 2006 to SOFTNET-DP Edition 2008 or V8.1 • From V6.0, V6.1, V6.2 or V6.3 to SOFTNET-DP Edition 2008 or V8.1
SOFTNET-PB S7 V8.1 For 32/64-bit: Windows 7 Professional/Ultimate; for 64-bit: Windows 2008 Server R2 English/German <ul style="list-style-type: none"> • Single license for one installation 	6GK1 704-5CW08-1AA0	SOFTNET-PB DP slave Software for DP slave, with DP OPC server and NCM PC, single license for one installation, runtime software, software and electronic manual on CD-ROM, license key on USB flash drive, Class A; for CP 5611 A2, CP 5711, CP 5621;
SOFTNET-S7 Edition 2008 (V7.1) for 32 Bit Windows XP Professional SP2/3; Windows 2003 Server R2, SP2; Windows Vista Business/Ultimate SP1; Windows 2008 Server; English/German <ul style="list-style-type: none"> • Single license for one installation 	6GK1 704-5CW71-3AA0	SOFTNET-PB DP Slave V8.1 For 32/64-bit: Windows 7 Professional/Ultimate; for 64-bit: Windows 2008 Server R2 English/German <ul style="list-style-type: none"> • Single license for one installation
Software Update Service For 1 year with automatic extension; requirement: current software version	6GK1 704-5CW00-3AL0	SOFTNET-DP Slave Edition 2008 (V7.1) for 32 Bit Windows XP Professional SP2/3; Windows 2003 Server R2, SP2; Windows Vista Business/Ultimate SP1; Windows 2008 Server; English/German <ul style="list-style-type: none"> • Single license for one installation
Upgrade <ul style="list-style-type: none"> • From Edition 2006 to SOFTNET-S7 Edition 2008 or V8.1 • From V6.0, V6.1, V6.2 or V6.3 to SOFTNET-S7 Edition 2008 or V8.1 	6GK1 704-5CW00-3AE0 6GK1 704-5CW00-3AE1	Software Update Service For 1 year with automatic extension; requirement: current software version
SOFTNET-PB DP Software for DP protocol (master class 1 and 2), incl. FDL protocol with OPC server and NCM PC, runtime software, software and electronic manual on CD-ROM, license key on USB flash drive; for CP 5611 A2, CP 5711, CP 5621;		Upgrade <ul style="list-style-type: none"> • From Edition 2006 to SOFTNET-DP Slave Edition 2008 or V8.1 • From V6.0, V6.1, V6.2 or V6.3 to SOFTNET-DP Slave Edition 2008 or V8.1
SOFTNET-PB DP V8.1 For 32/64-bit: Windows 7 Professional/Ultimate; for 64-bit: Windows 2008 Server R2 English/German <ul style="list-style-type: none"> • Single license for one installation 	6GK1 704-5DW08-1AA0	PROFIBUS FastConnect bus connector RS485 Plug 180 With 180° cable outlet

PROFIBUS

Communication for PC-based systems

SOFTNET for PROFIBUS

Overview

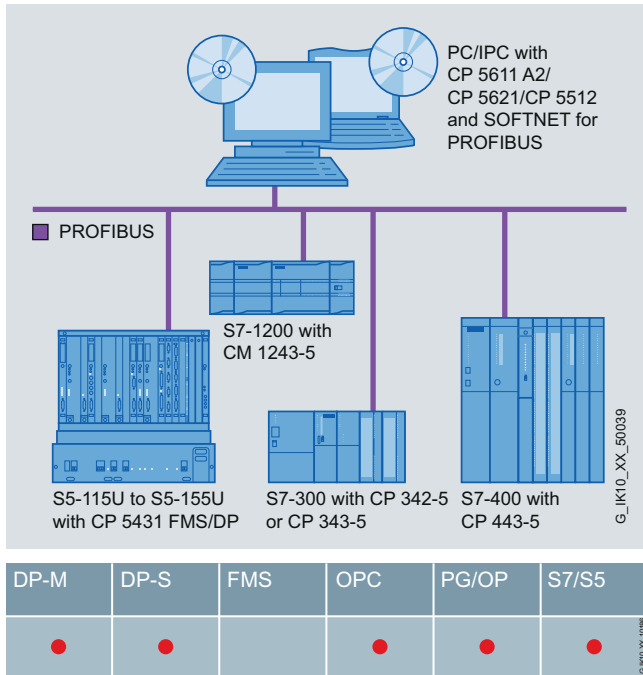

- Software for coupling PCs/programming devices and notebooks to programmable controllers
- Communication services:
 - PROFIBUS DP master Class 1 and 2 with acyclic expansions
 - PROFIBUS DP slave
 - PG/OP communication
 - S7 communication
 - Open communication (SEND/RECEIVE) based on the FDL interface
- The appropriate OPC servers are included in the scope of supply of the respective communication software
- Can be used with:
 - CP 5512 (PC card, CardBus 32-bit)
 - CP 5611 A2 (PCI, 32-bit)
 - CP 5711 (USB V2.0)
 - CP 5621 (PCIe x1)
 - Integral PROFIBUS interfaces of SIMATIC PGs/PCs

Benefits

get Designed for Industry

- Maximum transparency due to integrated communication with SIMATIC via PROFIBUS and OPC as the standard interface
- Low-cost connection
 - as PROFIBUS DP master class 1 or master class 2 with SOFTNET-PB DP
 - as PROFIBUS DP slave with SOFTNET-PB DP slave
 - to S7 communication with SOFTNET-PB S7
- Simple and low-cost commissioning thanks to uniform procedure and configuration functionality with NCM PC and STEP 7

Application



With SOFTNET for PROFIBUS, PCs can be connected to programmable controllers, such as SIMATIC S7, over PROFIBUS.

The following user interfaces are available:

- DP protocol
- PG/OP communication for SIMATIC S7
- S7 communication
- Open communication (SEND/RECEIVE) based on the FDL interface

SOFTNET is available for the following interfaces:

- CP 5512 (PC card, CardBus 32-bit)
- CP 5611 A2 (PCI, 32-bit)
- CP 5711 (USB V2.0)
- CP 5621 (PCIe x1)
- Integral PROFIBUS interfaces of SIMATIC PGs/PCs

The operating systems that are supported are listed in the ordering data for the SOFTNET software.

Function

Software for DP protocol (SOFTNET-PB DP)**DP Master Class 1**

SOFTNET-PB DP provides DP Master Class 1 functionality in combination with the CP 5512, CP 5611 A2 or CP 5621. The central controller exchanges information with the DP slaves (e.g. ET 200S) in a specified, constantly repeating message cycle. The DP programming interface (DPLib.DLL) provides the PC programmer with function calls for data transfer. The DP interface also provides the SYNC and FREEZE functions as well as activation and deactivation of slaves.

The DP function expansions for masters of Class 1 make it possible to perform read and write functions (DS_READ, DS_WRITE) as well as acknowledgement of alarms (ALARM_ACK) at the same time as processing cyclic data communication. Data that are to be transferred in acyclic mode (e.g. parameterization data) are only rarely changed in comparison to the cyclic measured values, and are transferred at lower priority in parallel with the cyclic high-speed user data transfer. Alarm acknowledgement by the master ensures reliable transfer of the alarms from DP slaves (DS_READ, DS_WRITE, DS_DATA_TRANSPORT).

DP Master Class 2

In addition to DP master Class 1 services, SOFTNET-PB DP also provides DP Master Class 2 services. Devices of this type are used (programming, configuration or control devices) during start-up, for configuring the DP system or for controlling the plant during normal operation (diagnostics). The DP programming interface provides the following services: Reading master diagnostics, slave diagnostics, inputs/outputs of a slave, configuration data and modifying slave addresses. These extended DP functions comprise non-isochronous access to the parameters and measured values of a slave (e.g. field devices of process automation and intelligent HMI devices). This type of slave must be supplied with extensive parameter data during start-up and during normal operation (DS_READ, DS_WRITE, DS_DATA_TRANSPORT).

DP slave (SOFTNET-PB DP slave)

A DP slave is an I/O station that reads in input data and transfers output data to the I/O. The volume of input and output information is determined by the user application and can be a maximum of 122 bytes each. For the slave interface, a simple example GSD file is provided that can be adapted by the user to the slave application. This GSD file can be configured using any configuration tool which complies with the PROFIBUS DP specification IEC 61158/EN 50170, e.g. STEP 7 or NCM PC.

Software for PG/OP communication

Special programming device packages are not required for the CP 5512, CP 5611 A2, CP 5711 and CP 5621, because the drivers are included in the STEP 7 scope of supply.

Software for S7 communication (SOFTNET-PB S7)

SIMATIC S7 system components communicate with each other using S7 communication functions. The S7 programming interface provides programming device/PC user programs with access to SIMATIC S7 system components. This provides easy, flexible access to the data of the SIMATIC S7 controller.

The following services are available with S7 communication:

Administrative services

- Connection management
- Mini database
- Trace

Data transfer services

- Read/write variables
- BSEND/BRECEIVE (up to 64 KB per task)

Software for open communication (SEND/RECEIVE based on the FDL interface)

This interface based on Layer 2 is used for communication between

- PG/PC and SIMATIC S5
- PG/PC and SIMATIC S7
- PG/PC and PG/PC

used

SEND/RECEIVE offers the following services:

- Management services
- Connection establishment services
- Data transfer services

This interface is included in SOFTNET-PB DP and SOFTNET-PB S7. No configuration is necessary.

User interfaces**OPC interface**

The OPC server included in the respective software package can be used as the standard programming interface for the PROFIBUS DP, open communication and S7 communication protocols for linking automation technology applications to OPC-capable Windows applications (Office, HMI systems, etc.).

Mode of operation

With SOFTNET, the complete protocol stack is processed in the PC.

This architecture means that in contrast to the CP 5613 or CP 5614 products, the performance of the SOFTNET packages is dependent on the configuration or loading of the PC used.

Configuration

- The S7 communication protocol, open communication protocol and DP protocol are configured in STEP 7/NCM PC V5.1 + SP2 and higher.
- The configuration tool NCM PC is included in the PROFIBUS software packages.

Technical specifications

Performance data	CP 5512/CP 5611 A2/ CP 5621/CP 5711
<u>Mono protocol mode</u>	
Number of connectable DP slaves	max. 60
Number of FDL tasks waiting	max. 50
Number of PG/OP and S7 connections	max. 8
• DP master	DP-V0, DP-V1 with SOFTNET-PB DP
• DP slave	DP-V0, DP-V1 with SOFTNET-PB DP slave

Ordering data	Order No.	Order No.
<p>SOFTNET-PB S7</p> <p>Software for S7 communication, incl. FDL protocol with OPC server and NCM-PC, runtime software, software and electronic manual on CD-ROM, license key on USB flash drive, Class A; for CP 5611 A2, CP 5711, CP 5621;</p> <p>SOFTNET-PB S7 V8.1</p> <p>For 32/64-bit: Windows 7 Professional/Ultimate; for 64-bit: Windows 2008 Server R2 English/German</p> <ul style="list-style-type: none"> • Single license for one installation 	6GK1 704-5CW08-1AA0	<p>SOFTNET-DP Edition 2008 (V7.1)</p> <p>for Windows XP Professional SP2/3; Windows 2003 Server R2, SP2; Windows Vista Business/Ultimate SP1; Windows 2008 Server; English/German</p> <ul style="list-style-type: none"> • Single license for one installation <p>6GK1 704-5DW71-3AA0</p>
<p>SOFTNET-S7 Edition 2008 (V7.1)</p> <p>for 32 Bit Windows XP Professional SP2/3; Windows 2003 Server R2, SP2; Windows Vista Business/Ultimate SP1; Windows 2008 Server; English/German</p> <ul style="list-style-type: none"> • Single license for one installation <p>6GK1 704-5CW71-3AA0</p>		6GK1 704-5CW00-3AL0
<p>Software Update Service</p> <p>For 1 year with automatic extension; requirement: current software version</p> <p>Upgrade</p> <ul style="list-style-type: none"> • From Edition 2006 to SOFTNET-S7 Edition 2008 or V8.1 • From V6.0, V6.1, V6.2 or V6.3 to SOFTNET-S7 Edition 2008 or V8.1 	6GK1 704-5CW00-3AE0	
<p>SOFTNET-PB DP</p> <p>Software for DP protocol (master class 1 and 2), incl. FDL protocol with OPC server and NCM PC, runtime software, software and electronic manual on CD-ROM, license key on USB flash drive; for CP 5611 A2, CP 5711, CP 5621;</p> <p>SOFTNET-PB DP V8.1</p> <p>For 32/64-bit: Windows 7 Professional/Ultimate; for 64-bit: Windows 2008 Server R2 English/German</p> <ul style="list-style-type: none"> • Single license for one installation 	6GK1 704-5CW00-3AE1	<p>SOFTNET-PB DP Slave V8.1</p> <p>For 32/64-bit: Windows 7 Professional/Ultimate; for 64-bit: Windows 2008 Server R2 English/German</p> <ul style="list-style-type: none"> • Single license for one installation <p>6GK1 704-5SW08-1AA0</p>
<p>SOFTNET-PB DP</p> <p>Software for DP protocol (master class 1 and 2), incl. FDL protocol with OPC server and NCM PC, runtime software, software and electronic manual on CD-ROM, license key on USB flash drive; for CP 5611 A2, CP 5711, CP 5621;</p> <p>SOFTNET-PB DP V8.1</p> <p>For 32/64-bit: Windows 7 Professional/Ultimate; for 64-bit: Windows 2008 Server R2 English/German</p> <ul style="list-style-type: none"> • Single license for one installation 		6GK1 704-5CW00-3AE0
<p>SOFTNET-PB DP V8.1</p> <p>For 32/64-bit: Windows 7 Professional/Ultimate; for 64-bit: Windows 2008 Server R2 English/German</p> <ul style="list-style-type: none"> • Single license for one installation 	6GK1 704-5DW08-1AA0	<p>Software Update Service</p> <p>For 1 year with automatic extension; requirement: current software version</p> <p>6GK1 704-5SW00-3AL0</p>
<p>SOFTNET-PB DP V8.1</p> <p>For 32/64-bit: Windows 7 Professional/Ultimate; for 64-bit: Windows 2008 Server R2 English/German</p> <ul style="list-style-type: none"> • Single license for one installation 		6GK1 704-5SW00-3AE0

PROFIBUS

Communication for PC-based systems

OPC Server for PROFIBUS

Overview

- Standardized, open multi-vendor interface
- Interfacing of OPC-capable Windows applications to DP, FMS, S7 communication and open communication (SEND/RECEIVE) based on the FDL interface
- OPC Scout with browser functionality as an OPC client and OCX-Data-Control/.NET Data Control for simple OPC client creation
- The relevant OPC servers are supplied with each communication software package

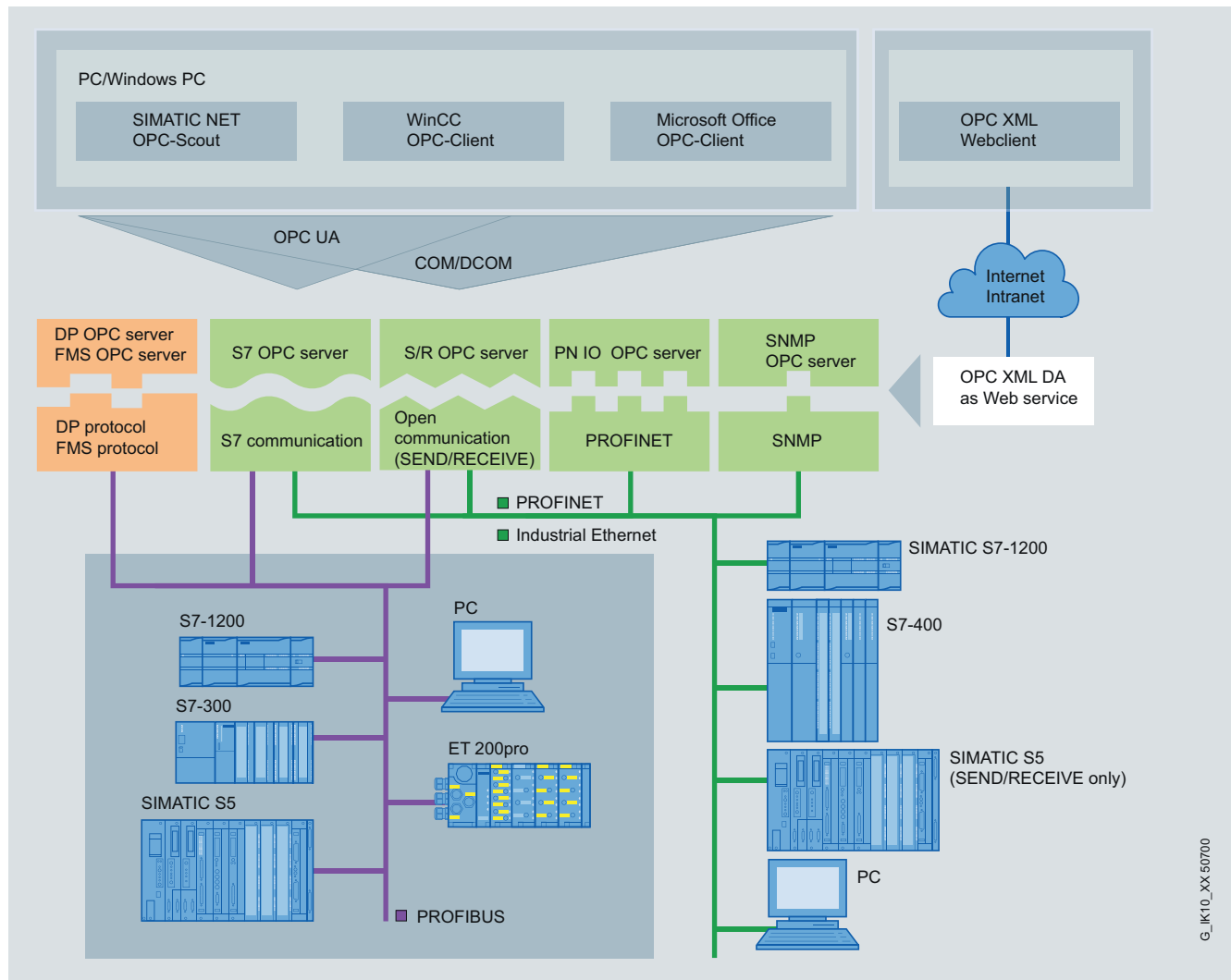

System integration with OPC server

Benefits

get Designed for Industry

- Different networks and protocols can be easily used thanks to the uniform interface
- Reduced training and familiarization costs
- Easy interfacing in the system environment and office applications over C++, Visual Basic and .NET interfaces
- Fast creation of applications
- Easy handling and cost-effective because the corresponding OPC server is included in the scope of supply of the respective communications software

G_IK10_XX 50700

Application



OPC (Openness, Productivity & Collaboration) is implemented as an expansion of the COM (Component Object Model) communications interface and DCOM (Distributed COM) for the user software.

The basic principle of OPC is that OPC client applications communicate with the OPC server over a standardized, open and manufacturer-independent interface.

It is also possible to connect to OPC-capable Windows applications (Microsoft Office or HMI systems) that are already available on the market.

The following communications interfaces are available over OPC for PROFIBUS:

- DP communication for PROFIBUS DP
- DP-V0 Master Class 1 and Master Class 2
DP-V1 Master Class 1 and Master Class 2
PROFIdrive V3 interface for profile server
- FMS communication for PROFIBUS FMS
- S7 communication
- Open communication (SEND/RECEIVE) based on the FDL interface

The OPC server offers:

- Data Access interface 2.05
- Alarm&Event interface 1.1
- OPC XML DA interface 1.0
- Integration of automation products of different manufacturers
- The same, easy-to-use user interface for different components
- Can be accessed from every computer in the LAN
- High-performance data access over the Custom Interface (C++, NET)
- Easy to use with the "Automation Interface" (VB, NET) or the supplied OCX Data Control or .NET Data Control
- Grouping of variables (items); this way large quantities of data can be processed in a short time
- Other compilers can be used via the OPC server, however, the compiler must support the COM interface (Microsoft component model)

Function

- Open standardization of the addressing using logical names for objects from an automation component or an automation system
- Supports STEP 7 symbols
- Efficient data transfer from a process component to an application for further processing
- One client application can use several servers simultaneously
- Simultaneous execution of more than one client is possible on one OPC server
- The communication protocols can be operated in parallel
- Interfaces
 - "Custom Interface" for high-performance C++/.NET applications
 - "Automation Interface" for easily created Visual Basic applications (or similar)
 - OCX Data Control or .NET Data Control for simple connection to Windows applications that support COM/DCOM
 - XML DA interface;
Data access to S7 CPUs is therefore possible over the Internet.

Configuration

The communication parameters are configured using only the tools of the configuration software (configuration console, SIMATIC NCM PC or STEP 7 V5.1 + SP2 and higher)

PROFIBUS

Communication for PC-based systems

OPC Server for PROFIBUS

Function (continued)

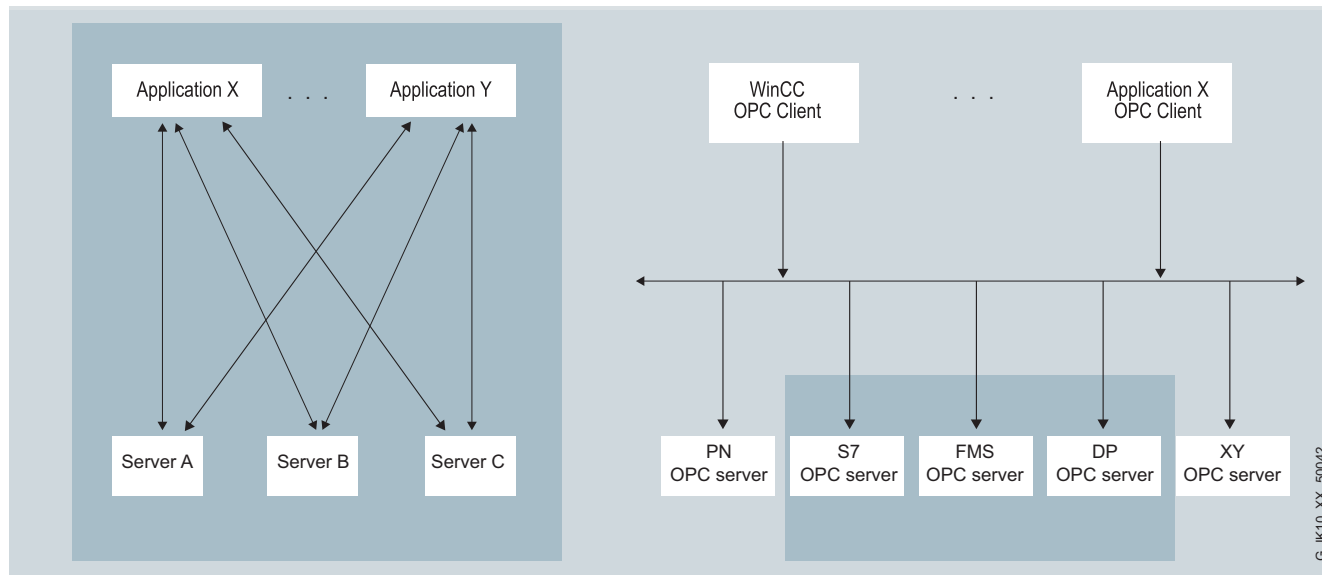

Comparison of conventional client/server architecture with an OPC architecture

Technical specifications

<p>Programming</p>	<ul style="list-style-type: none"> • Synchronous and asynchronous reading and writing of variables • Monitoring of variables using the OPC server with a signal to the client when a change occurs • Use of quantity operations; so a large amount of data can be processed in a short time. 	<p>Product versions</p> <p>HARDNET-PB DP</p> <p>HARDNET-PB S7</p> <p>FMS-5613</p> <p>SOFTNET-PB S7</p> <p>SOFTNET-PB DP</p> <p>SOFTNET-PB DP slave</p>	<p>include OPC servers for:</p> <p>PROFIBUS DP, XML-DA</p> <p>S7 communication, XML-DA</p> <p>FMS communication, XML-DA</p> <p>S7 communication, XML-DA</p> <p>PROFIBUS DP, XML-DA</p> <p>PROFIBUS DP, Slave XML-DA</p>
<p>Interfaces</p>	<ul style="list-style-type: none"> • Custom Interface (C++, NET); for high OPC performance • Automation Interface (VB, Excel, Access, Delphi, ...) for ease-of-use • Graphics with OCX or .NET Data Control; for configuring instead of programming • OPC XML-Interface for Data Access 	<p>CP 5603/CP 5613 A2/CP 5623/CP 5614 A2 and CP 5624 with DP-Base software</p>	<p>Open communication (FDL) PROFIBUS DP Master, Access to DP-slave of the CP 5614 A2/CP 5624, XML-DA</p>
<p>Protocols</p>	<ul style="list-style-type: none"> • S7 communication • Open communication (SEND/RECEIVE) • PROFIBUS DP • PROFIBUS FMS 		

PROFIBUS

Communication for PC-based systems

S7 OPC Redundancy for PROFIBUS

Overview

OPC (**O**penness, **P**roductivity & **C**ollaboration) is a standardized, open, and vendor-independent interface that is widely used in automation. OPC UA (**U**nified **A**rchitecture) is the result of consistent further development of this standard, offering additional functions such as security or redundancy.

S7 OPC Redundancy is a software product compliant with the OPC UA standard that enables the redundant configuration of OPC UA servers to SIMATIC S7. The availability of automation data to operator control and monitoring systems is guaranteed thanks to the redundant use of OPC UA servers. This requires neither additional cabling for synchronizing the redundant OPC UA servers, nor additional programming overhead in the PC. The OPC UA servers are synchronized via high-performance Industrial Ethernet network access points at 10/100 and 1000 Mbps. S7 OPC Redundancy represents an integrated customer solution for all SIMATIC NET S7 SOFTNET and HARDNET software products in the automation world.

Benefits

- Enhanced plant availability thanks to redundant OPC UA servers that guarantee plant access for operator control and monitoring systems
- Secures investments thanks to the use of existing applications (OPC clients) and flexible application options, regardless of the SIMATIC S7 controller used
- Improved utilization of IT resources thanks to even distribution of the OPC clients among the redundant OPC servers
- Easy and low-cost commissioning thanks to uniform procedure and configuration functionality with NCM PC and STEP 7

Application

The redundant OPC UA server software enables redundant configuration of SIMATIC NET OPC UA servers. Failure of one OPC UA server, as a result of power outage or system failure, for example, results in immediate use of the other OPC UA server, and continuation of the existing OPC UA client connection. This ensures increased availability of automation data to operator control and monitoring systems.

Design

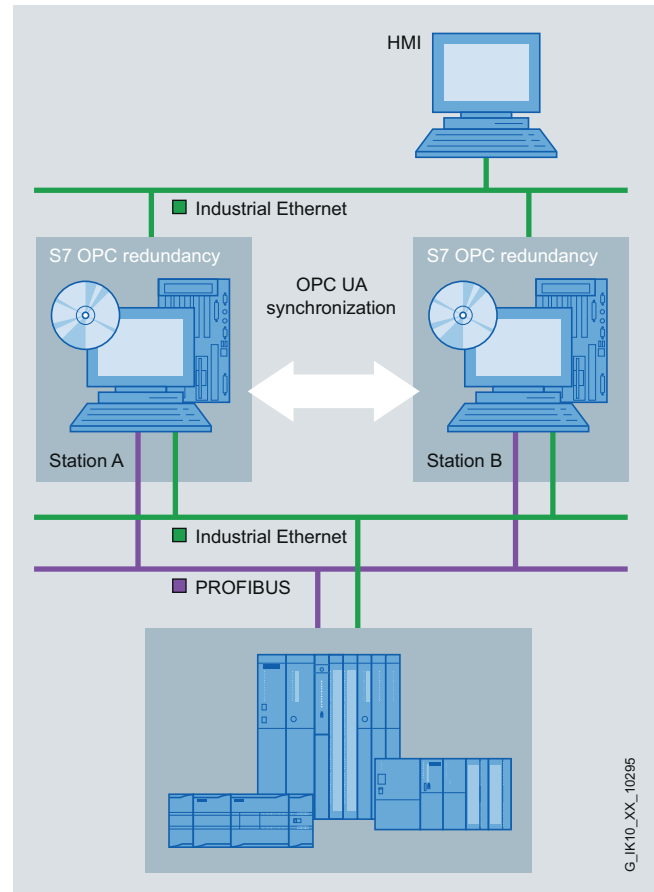

Redundant use of OPC servers

A redundant OPC UA server system comprises the following:

Server PC

with

- Operating system for Windows server
- SOFTNET-PB S7 or HARDNET-PB S7 software based on OPC UA server
- S7 OPC Redundancy software

The redundant operation of up to two OPC UA servers is possible.

Client PC (HMI)

- Software for OPC clients that supports OPC UA (incl. reconnect functionalities in accordance with OPC UA specification)

The communication parameters are configured using STEP 7 or SIMATIC NET NCM PC. The NCM PC configuration tool is included in the scope of delivery of the SIMATIC NET PC products.

PROFIBUS

Communication for PC-based systems

S7 OPC Redundancy for PROFIBUS

Function

S7 OPC Redundancy enables the setup of redundant OPC UA servers, thus ensuring plant access for the operator control and monitoring systems.

This means, for example, that the information synchronization between two SIMATIC NET S7 OPC servers via the S7 OPC Redundancy software package is guaranteed. This is handled transparently for the OPC Client application so that in the event of a fault, the redundant OPC server takes over the tasks from the failed OPC server system.

Data exchange between the OPC clients and the OPC servers takes place via the standardized OPC UA communication. Communication with the SIMATIC S7 controller takes place using the S7 protocol. This is ensured by the software products SIMATIC NET SOFTNET or HARDNET-S7 for PROFIBUS that are necessary as the basis for SIMATIC NET IE S7 OPC Redundancy.

The S7 OPC Redundancy software package supports:

- High availability;
Failure of one OPC UA server results in immediate use of the other OPC UA server, and continuation of the existing OPC UA client connection. The basis for this is the OPC UA synchronization that ensures synchronization of the necessary client information.
- Load compensation;
Even distribution of OPC clients among the available OPC servers

Configuration

All configuration is performed with STEP 7 or SIMATIC NCM PC, V5.5 SP1 or higher. The NCM PC configuration tool is included in the scope of delivery of the corresponding packages.

Ordering data

Order No.

S7 OPC Redundancy

Software for redundant OPC servers, Runtime software, software and electronic manual on CD-ROM, license key on USB stick, Class A

S7 OPC Redundancy V8.1 for PROFIBUS

for 64-bit
Windows 2008 server R2;
English/German

- Single license
for one installation

Software Update Service

for 1 year
with automatic extension;
requirement:
Current software version

6GK1 706-5CW08-1AA0

6GK1 706-5CW00-3AL0

Overview

SIMATIC Basic Panel, Touch Panels (TP), Operator Panels (OP), Mobile Panel, Multifunctional Platforms (MP)¹⁾ and the SIMATIC HMI software package for PC WinCC flexible Runtime support HMI functionality in conjunction with:

- SIMATIC S7
- SIMATIC S5
- SIMATIC 505
- SIMOTION
- SINUMERIK²⁾
- Non-Siemens controllers:
 - Allen Bradley - DF1, DH485 and Ethernet IP protocols
 - GE Fanuc - SNP/SNPX protocol
 - LG GLOFA GM - dedicated protocol
 - Mitsubishi - FX and MP 4 protocols
 - Modicon - Modbus RTU and TCP/IP protocols
 - Omron I - Link/MultiLink protocol
 - Telemecanique - UNI-TELWAY protocol

For more detailed information, refer to the WinCC flexible user manual, the "Windows-based systems communication" manual, and the WinCC flexible online help.

- 1) For the sake of simplicity, SIMATIC TP/OP/MP is always used in the text below. This is not restrictive, as the information is valid for all systems referred to above. If there are constraints, direct reference is made to them in the text.
- 2) Required under WinCC flexible: "SINUMERIK HMI copy license WinCC flexible CE" and "SINUMERIK HMI copy license OA". For configuring, a "SINUMERIK HMI engineering package WinCC flexible" is also necessary.

Note:

Interface options for HMI devices: See the individual device descriptions.

Extended functionality with WinCC flexible

WinCC flexible supports OPC communication for Multi Panel and WinCC flexible Runtime and HTTP communication for all panels with integrated Ethernet interface. Both OPC and HTTP communication can be used in parallel with the process links to SIMATIC S7/S5/505 or non-Siemens PLCs.

OPC Data Access

(MP 277, MP 377, WinCC flexible Runtime only)

OPC Data Access is an open standard for exchanging both local and remote variables between various applications via Industrial Ethernet. The original version of OPC is based on Microsoft COM/DCOM and, therefore, requires a Microsoft Windows-based PC operating system (not Windows CE) on both clients and servers. As OPC XML, communication is based on the Internet standard SOAP/XML and is, therefore, suitable for embedded systems with Windows CE.

Options that are required: WinCC flexible/OPC server

HTTP communication for the variable exchange between SIMATIC HMI systems

(only TP 177B DP/PN, OP 177B DP/PN, Mobile Panel 177 PN, TP 277, OP 277, Mobile Panel 277, Mobile Panel 277 IWLAN, MP 277, MP 377, WinCC flexible Runtime)

Communication based on HTTP message frames enables variables to be exchanged between SIMATIC HMI systems.

Options that are required: WinCC flexible/Sm@rt Access

Communication standard	SIMATIC HMI				WinCC flexible Runtime	Connection via
	TP 177B DP/PN OP 177B DP/PN Mobile Panel 177 PN MP 177	TP 277 OP 277	Mobile Panel 277 ⁶⁾ Mobile Panel 277 IWLAN MP 277 MP 377			
OPC Data Access V2.05a + OPC Data Access XML V1.00						
OPC client (COM/DCOM)	–	–	–	•		Industrial Ethernet (see catalog IK PI)
OPC server (COM/DCOM)	–	–	–	• ¹⁾		Industrial Ethernet (see catalog IK PI)
OPC XML client (SOAP/XML)	–	–	–	• ²⁾		Industrial Ethernet (see catalog IK PI)
OPC XML server (SOAP/XML)	–	–	• ³⁾	–		Industrial Ethernet (see catalog IK PI)
HTTP communication for variable exchange between SIMATIC HMI systems						
HTTP client	• ⁴⁾	• ⁴⁾	• ⁴⁾	• ⁵⁾		Industrial Ethernet (see catalog IK PI)
HTTP server	• ⁴⁾	• ⁴⁾	• ⁴⁾	• ⁵⁾		Industrial Ethernet (see catalog IK PI)

- System interface possible
- System interface not possible

- 1) Option WinCC flexible/OPC Server for WinCC flexible Runtime required
- 2) Only with DCOM/XML gateway included in the scope of delivery of WinCC flexible for access to MP 277, MP 377 and MP 370 OPC XML servers
- 3) Option WinCC flexible/OPC Server for SIMATIC Multi Panel required
- 4) Option WinCC flexible/Sm@rtAccess for SIMATIC Panel required
- 5) Option WinCC flexible/Sm@rtAccess for WinCC flexible Runtime required
- 6) Depending on the terminal box used

Overview

The following types of interface are supported in respect of the link between SIMATIC HMI Panels and SIMATIC WinCC flexible Runtime with SIMATIC S7:

- **PPI interface:**
Interface between SIMATIC HMI Panels and SIMATIC S7-200 via PPI. Communication runs on the PPI protocol, a standard FB as with SIMATIC S5 is not required.
- **MPI interface:**
Interface between SIMATIC HMI Panels and SIMATIC S7 via the integrated PPI interface with S7-200 or MPI interface with S7-300/-400 or alternatively via the MPI interface of a separate interface module and the backplane bus to the SIMATIC S7-CPU. Communication runs on the MPI protocol (PG/OP communication), a standard FB as with SIMATIC S5 is not required.
- **PROFIBUS interface:**
Interface between SIMATIC HMI Panels and SIMATIC S7 via the integrated PROFIBUS interface on the CPU or alternatively via the PROFIBUS interface on a separate interface module and the backplane bus to the SIMATIC S7-CPU. Communication runs on the MPI protocol (PG/OP communication), a standard FB as with SIMATIC S5 is not required.
- **PROFINET interface:**
Interface between SIMATIC HMI Panels and SIMATIC S7 via the integrated PROFINET interface on the CPU or alternatively via the Industrial Ethernet interface on a separate interface module and the backplane bus to the SIMATIC S7-CPU. Communication runs on the MPI protocol (PG/OP communication), a standard FB as with SIMATIC S5 is not required.

The maximum possible number of S7 connections of a CPU is determined by its power (see Catalog ST 70); from the point of view of SIMATIC HMI Panels the following restrictions apply:

- OP 73micro, TP 177micro: 1 connection
- OP 73: max. 2 connections
- OP 77A, TP 177A, Basic Panel, OP 77B, TP177B, OP 177B, Mobile Panel 177: max. 4 connections
- TP 277, OP 277; Mobile Panel 277, MP 177, MP 277, MP 377: max. 6 connections
- PC with WinCC flexible Runtime: max. 8 connections

PPI interface

From the point of view of the concept, the PPI interface is a point-to-point connection between a SIMATIC HMI Panel (PPI master) or alternatively a PG (PPI master), and an S7-200 (PPI slave).

MPI interface/PROFIBUS interface/Industrial Ethernet interface

The multipoint-enabled communication interfaces of SIMATIC HMI Panels and SIMATIC S7 are used. Options are:

- Interface between one or a number of SIMATIC HMI Panels (MPI master) and one or a number of S7-1200/300/400s or WinAC (MPI master).
(possible network topology: **MPI/PROFIBUS/Industrial Ethernet**)
- Interface between one or a number of SIMATIC HMI Panels (MPI master) and one or a number of S7-200s (MPI slave) ¹⁾
(possible network topology: **PPI/MPI/PROFIBUS**)

Unlike PPI connections, MPI connections are static connections that are set up during booting and then monitored.

The original format of a master/master link has in the meantime been joined by a master/slave link, which has enabled integration of the S7-200 (except CPU 212). ¹⁾

In principle this type of information exchange between SIMATIC HMI Panels and SIMATIC S7 is independent of the network used, PPI, MPI, PROFIBUS or Industrial Ethernet: SIMATIC HMI Panels are S7 clients and SIMATIC S7 CPUs are S7 servers.

¹⁾ Constraints with regard to baud rate for S7-200; see Catalog ST 70.

Overview (continued)

Controller Target hardware (PROTOCOL) (physics)	SIMATIC HMI				Connection via
	TD 100C TD 200 TD 200C TD 400C	OP 73 micro TP 177micro	OP 73	OP 77A TP 177A	
SIMATIC S7 (PPI/MPI)					
via PPI on S7-200 (PPI)	• 1)	–	–	–	MPI cable 5)
via MPI or PROFIBUS (PG/OP communication) with S7-200	–	• 2)	• 3)	• 4)	MPI cable 5)
via MPI or PROFIBUS (PG/OP communication) with S7-300, -400	–	–	• 3)	• 4)	MPI cable 5)
via PPI network (PPI) with max. 1 x S7-200	• 1)	–	–	–	PPI network 6)
via PPI network (PG/OP communication) with max. 4 x S7-200	• 1)	• 2)	• 3)	• 4)	PPI network 6)
via MPI or PROFIBUS network (PG/OP communication) with max. 4 x S7-200	–	• 2)	• 3)	• 4)	MPI or PROFIBUS network 6)
via MPI or PROFIBUS network (PG/OP communication) with max. 4 x S7-300, -400, WinAC	–	–	• 3)	• 4)	MPI or PROFIBUS network 6)
via Industrial Ethernet (TCP/IP) (PG/OP communication) with max. 4 x S7-200, -300, -400, WinAC	–	–	–	–	Industrial Ethernet

- System interface possible
- System interface not possible

- 1) TD series can only be interfaced with max. 1 x S7-200 via PPI (PPI/MPI); network operation (parallel PG, etc.) possible; max. data transfer rate 187.5 kbit/s; cable included in scope of supply
- 2) OP 73micro, TP 177 micro can only be interfaced with max. 1 x S7-200 (MPI); network operation (parallel PG, etc.) possible; max. data transfer rate 187.5 kbit/s
- 3) OP 73 can only be interfaced with max. 2 x SIMATIC S7 (MPI); network operation (parallel PG, etc.) possible; max. data transfer rate 1.5 Mbit/s
- 4) Max. transmission rate 1.5 Mbit/s
- 5) MPI cable 6ES7 901-0BF00-0AA0 (max. 187.5 kbit/s) included in PG scope of delivery
- 6) Bus connector 6GK1 500-0EA02

PROFIBUS

Connection options for SIMATIC HMI

SIMATIC S7

Overview (continued)

Controller	SIMATIC HMI				
	Basic Panels	OP 77B TP 177B DP OP 177B DP TP 177B DP/PN OP 177B DP/PN Mobile Panel 177 DP Mobile Panel 177 PN	TP 277 OP 277 Mobile Panel 277 Mobile Panel 277 IWLAN MP 177 MP 277 MP 377	WinCC flexible Runtime	Connection via
Target hardware (PROTOCOL) (physics)					
SIMATIC S7 (PPI/MPI)					
via PPI on S7-200 (PPI)	–	• 1) 2)	• 1) 2)	• 1) 3)	MPI cable ¹¹⁾
via MPI or PROFIBUS (PG/OP communication) on S7-200	• 2)	• 2) 5)	• 2) 5)	• 3) 5)	MPI cable ¹¹⁾
via MPI or PROFIBUS (PG/OP communication) with S7-300, -400	• 2)	• 2)	• 2)	• 3)	MPI cable ¹¹⁾
via PPI network (PPI) with max. 1 x S7-200	–	• 1) 2)	• 1) 2)	• 1) 3)	PPI network ¹²⁾
via PPI network (PG/OP communication) with max. 4 x S7-200	• 2)	• 6)	–	–	PPI network ¹²⁾
via MPI or PROFIBUS network (PG/OP communication) with max. 4 x S7-200	• 2)	• 2) 5)	• 2) 5)	• 3) 5)	MPI or PROFIBUS network ¹²⁾
via MPI or PROFIBUS network (PG/OP communication) with max. 4 x S7-300, -400, WinAC	• 2)	• 2)	• 2)	• 3)	MPI or PROFIBUS network ¹²⁾
via Industrial Ethernet (TCP/IP) (PG/OP communication) with max. 4 x S7-200, -300, -400, WinAC	– 7)	• 7) 8)	• 8) 9)	• 10)	Industrial Ethernet

- System interface possible
- System interface not possible

- 1) Can only be interfaced with max. 1 x S7-200 via PPI (PPI); network operation (parallel PG, etc.) possible
- 2) Not Basic Panel PN, Mobile Panel 177 PN, Mobile Panel 277 IWLAN; Mobile Panel 177 DP, Mobile Panel 277 connection via special connecting cable and junction box (see Mobile Panel); Please refer to the manual for cable assignment
- 3) Connection via integrated MPI/PROFIBUS interface; use the CP 5611 A2 with a standard PC.
- 4) Max. transmission rate 1.5 Mbit/s
- 5) Only on passive S7-200; OP 77B (MPI) also on active S7-200
- 6) Only OP 77B (MPI)
- 7) Only Basic Panel PN, TP 177B DP/PN, OP 177B DP/PN, Mobile Panel 177 PN
- 8) Mobile Panel 177 PN, Mobile Panel 277 connection via special connecting cable and junction box (see Mobile Panel); Please refer to the manual for cable assignment
- 9) Mobile Panel 277 IWLAN (wireless interface, see Mobile Panel)
- 10) Connection via integrated Industrial Ethernet interface; use the CP 1612 with a standard PC
- 11) MPI cable 6ES7 901-0BF00-0AA0 (max. 187.5 kbit/s) included in PG scope of delivery (for download and test purposes only)
- 12) Bus connector 6GK1 500-0EA02

Overview

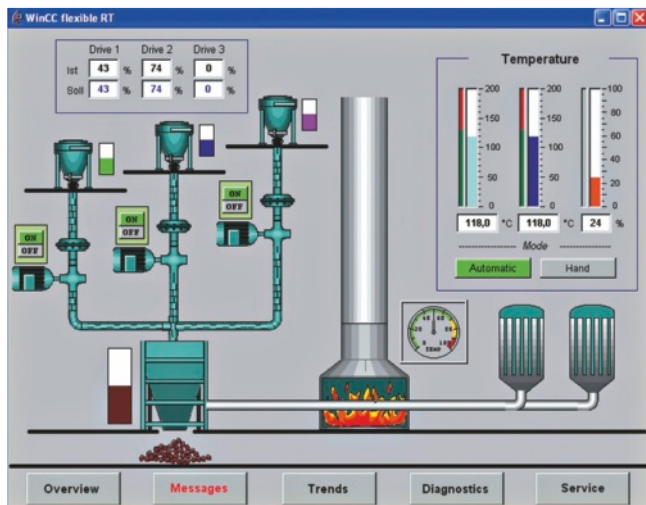

PC-based visualization software for single-user systems directly at the machine.

- Runs under Windows XP Professional and Windows 7 Professional, Ultimate, Enterprise
- Current version: SIMATIC WinCC flexible 2008 Runtime with Service Pack 2

SIMATIC WinCC flexible Runtime is configured with the SIMATIC WinCC flexible Advanced configuration software.

Benefits

- Optimum price/performance ratio thanks to individually scalable system functionality
- Functions for all visualization tasks: Operator functions, graphical and trend displays, signaling system, log system, archiving (option), recipe management (option), Audit Trail (option), process fault diagnostics (option)
- Flexible runtime functionality thanks to Visual Basic scripts
- Innovative service concepts with remote operation, diagnostics and administration via intranet and Internet as well as e-mail communication to increase availability (option)
- Support for simple distributed automation solutions based on TCP/IP networks at the machine level (option)

Integration

SIMATIC WinCC flexible Runtime supports linking to:

Protocol	PC interfaces
SIMATIC S7 via PPI	
S7-200	CP 5512 ²⁾ CP 5611 A2 ²⁾ CP 5621 ¹⁾ CP 5613 A2 CP 5614 A2 CP 5623 CP 5624 PC/PPI adapter ³⁾
SIMATIC S7 via MPI	
S7-200 (except CPU 212) ⁴⁾	CP 5512 ²⁾ CP 5611 A2 ²⁾ CP 5621 ¹⁾ CP 5711 ²⁾ CP 5613 A2 CP 5614 A2 CP 5623 CP 5624 PC adapter USB ⁶⁾ Teleservice V6.1
S7-300	
S7-400	
WinAC Basis (V3.0 and higher)	
WinAC RTX	
SIMATIC S7 via PROFIBUS DP ⁵⁾	
S7-215 ⁴⁾	CP 5512 ²⁾ CP 5611 A2 ²⁾ CP 5621 ¹⁾ CP 5711 ²⁾ CP 5613 A2 CP 5614 A2 CP 5623 CP 5624
S7-300 CPUs with integr. PROFIBUS interface	
S7-300 with CP 342-5	
S7-400 CPUs with integr. PROFIBUS interface	
S7-400 with CP 443-5 or IM 467	
WinAC Basis (V3.0 and higher)	
WinAC RTX	
SIMATIC S7 via integrated interface	
WinAC Basis (V2.0 and higher)	Internal system interface
WinAC RTX	
SIMOTION ⁷⁾	
SINUMERIK ⁸⁾	
Non-Siemens controllers	
1) WinCC flexible Runtime is passive (DP slave); the function block required for the link is included in the scope of delivery of WinCC flexible	
2) For Microbox 427 and Panel PC 477/577/677 via internal MPI/DP interface	
3) Only point-to-point to S7-200; no configuration download, operating systems: Windows 2000/XP; Order number: 6ES7 901-3CB30-0AX0	
4) Constraint with regard to baud rate for S7-200; see Catalog ST 70	
5) WinCC flexible RT is active; communication with S7 functions	
6) Only point-to-point to S7-300/-400; No configuration download, operating systems: Windows 2000/XP; order number: 6ES7 972-0CB20-0XA0 (USB)	
7) For further information, see Catalog PM 10	
8) "SINUMERIK HMI copy license OA" option required; for further information, see Catalog NC 60	

Application note

In parallel with each and every PLC link, WinCC flexible Runtime supports the use of the OPC Client channel; this enables, for example, connection to an SNMP OPC Server for the purpose of visualizing the data stored there. The SNMP OPC Server provides a means of monitoring network components of any type (e.g. switches) which support the SNMP protocol.

PROFIBUS

Connection options for SIMATIC HMI

SIMATIC WinCC flexible RT

Integration (continued)

Note:

You can find more information in Catalog ST 80 / ST PC and in the Industry Mall at www.siemens.com/industrymall

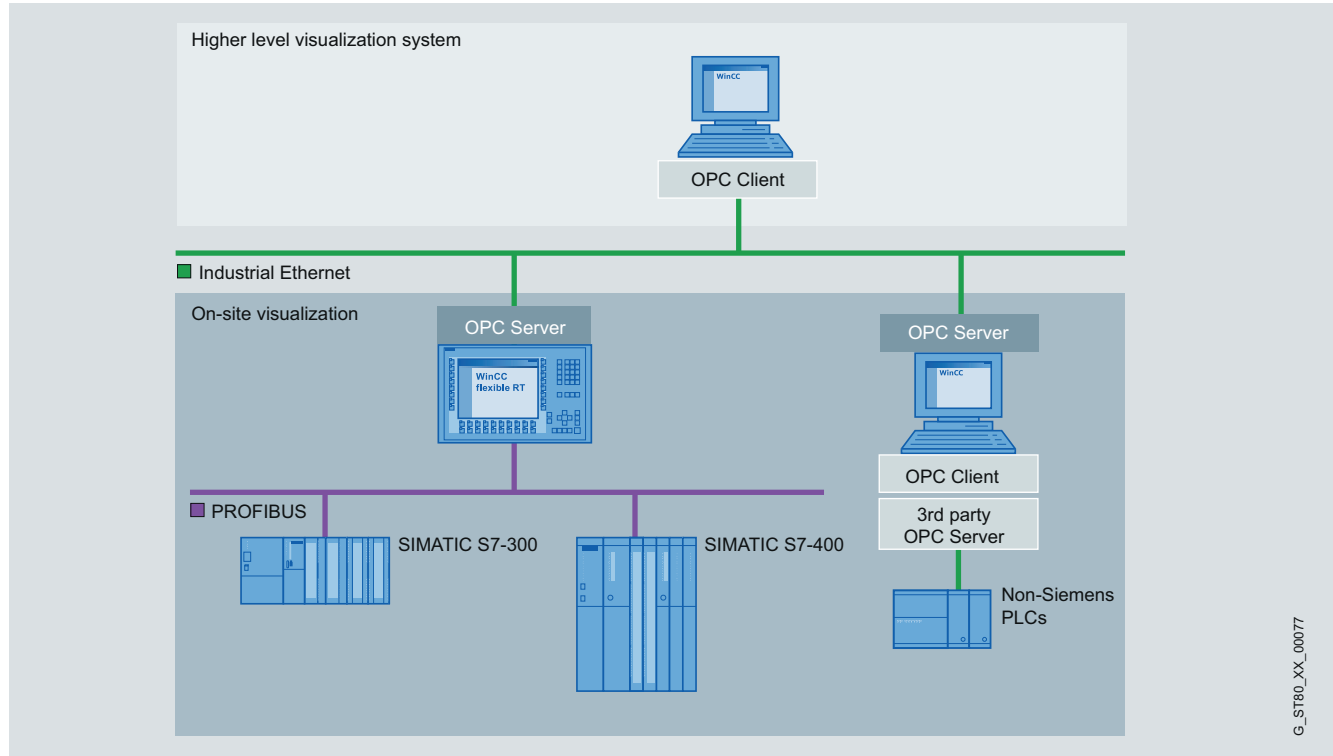

SIMATIC WinCC flexible Runtime application example

More information

Additional information is available in the Internet at:

www.siemens.com/wincc-flexible

Overview

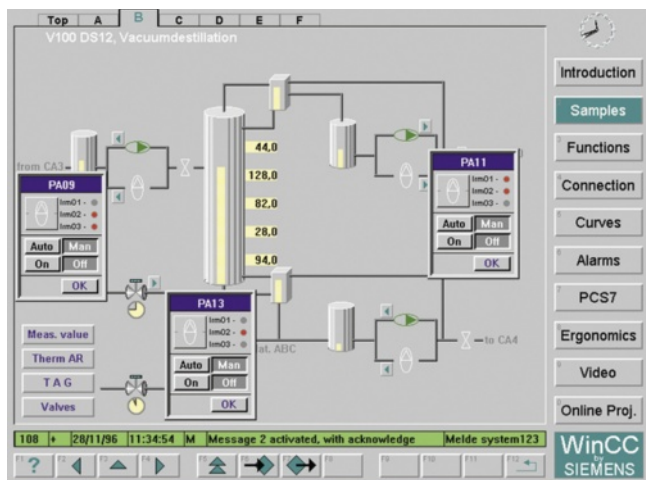

- PC-based operator control and monitoring system for visualizing and operating processes, production flows, machines and plants in all sectors – from the simple single-user station through to distributed multi-user systems with redundant servers and cross-location solutions with Web clients. WinCC is the information hub for corporation-wide vertical integration.
- The basic system configuration (WinCC basic software) includes industry-standard functions for signaling and acknowledging events, archiving of messages and measured values, logging of all process and configuration data, user administration and visualization.
- The WinCC basic software forms the core of a wide range of different applications. Based on the open programming interfaces, a wide range of WinCC options (from Siemens Industry Automation) and WinCC add-ons have been developed (by Siemens-internal and external partners).
- WinCC can be operated with every PC that meets the given HW requirements. Particularly the SIMATIC Panel PC and SIMATIC Rack PC product range is available for the industrial use of WinCC systems. SIMATIC PCs impress with their powerful PC technology, are designed for round-the-clock operation, and can be operated in both office areas and harsh industrial environments.
- Together with the Panel PC 477B, there are turnkey solutions as WinCC Standard Client and with the SIMATIC HMI IPC477C as WinCC Standard Client or Single Station. (See also Packages and HMI IPC477C)

Current versions:

- **SIMATIC WinCC V7.0 SP2:**
Executable with
 - Windows 7 (32-bit) Professional, Enterprise, Ultimate
 - Windows XP Professional SP3
 - Windows 2003 Server SP2 and Windows 2003 Server R2 SP2
 - Windows 2008 Server SP2 (32-bit)
contains the Microsoft SQL Server 2005 SP2
 - Use in virtual environments – for further information, see <http://support.automation.siemens.com/WW/view/en/49370459>
- **SIMATIC WinCC V6.2 SP3:**
Executable with
 - Windows XP Professional
 - Windows 2000 Professional
 - Windows Server 2003 and Windows Server 2003 R2
Contains the Microsoft SQL Server 2005 SP2

Integration

Integration in company-wide solutions (IT and business integration)

WinCC is strictly based on Microsoft technology, which provides for the greatest possible compatibility and integration ability. ActiveX and .net¹⁾ controls support technology and sector-specific expansions. Cross-manufacturer communication is also a simply exercise. The reason: WinCC can be used as an OPC client and server, and in addition to access to current process values, it also supports standards such as OPC HDA (Historical Data Access), OPC Alarm & Events, and OPC XML Data Access. Just as important: Visual Basic for Applications (VBA) for user-specific expansions of the WinCC Graphics Designer and Visual Basic Scripting (VBS) as an easy-to-learn, open runtime language. If desired, professional application developers can also use ANSI-C. And the access to the API programming interfaces is really simple with the Open-Development-Kit ODK.

WinCC integrates a powerful and scalable Historian function based on the Microsoft SQL Server 2005 in the basic system. Thus the user is given all possibilities: from high-performance archiving of current process data, to long-term archiving with high data compression, through to a central information turntable in form of a company-wide Process Historian. With the help of the option Central Archive Server, this can be created within the framework of a WinCC solution. Versatile clients and tools for evaluation, the open interfaces, special options (Connectivity Pack, Connectivity Station, IndustrialDataBridge) provide the basis for an effective IT and business integration.

¹⁾ Only supported by WinCC V7.0

Integration in automation solutions

WinCC is an open process visualization system and offers the option of connecting the most diverse control systems.

Released communication software

Only communication software with the listed (or higher) product versions should be used. Corresponding SIMATIC NET upgrades are available for the upgrading of older versions.

Number of connectable controls

For the number of the connectable controls via Industrial Ethernet CP 1613, the following applies for a message frame length of 512 bytes:

Type of coupling	Number of nodes
SIMATIC S5 Ethernet Layer 4 + TCP/IP	up to 60
SIMATIC S7 Protocol Suite	up to 64
SIMATIC 505 Ethernet Layer 4 + TCP/IP	up to 60

Via PROFIBUS, a maximum of 8 controls with CP 5611 and a maximum of 44 controls with CP 5613 can be connected. With approx. 10 or more controls, the usage of Industrial Ethernet is recommended.

Integration (continued)Mixed mode with different controls

With their multi-protocol stack, the communications processors CP 1613 and CP 5613 allow for the parallel operation of two protocols, e.g. for the mixed operation of different controls via a bus cable. WinCC supports the operation of two similar interface boards only in connection with the channels SIMATIC S5 Ethernet Layer 4 (2 x CP 1613), SIMATIC S7 Protocol Suite (2 x CP 1613, 2 x CP 5613) as well as PROFIBUS DP (4 x CP 5613; each CP 5613 max. 122 slaves). In addition to communication over industrial Ethernet CP 1613 or PROFIBUS CP 5613, one CP 5611 for communication with SIMATIC S7 via MPI can be used in each case.

Client-server communication

The communication between the clients and the server is achieved using the TCP/IP protocol. The construction of a separate PC-LAN is recommended. For small projects with correspondingly small message frame advent, a SIMATIC NET Industrial Ethernet can be used for both process communication (WinCC/Server ↔ PLC) and for the PC-PC communication (WinCC/client ↔ WinCC/server)

Channel-DLL PROFIBUS DP

In accordance with the PROFIBUS standard, DP/slaves are always permanently assigned to a DP master; i.e. a second WinCC station (DP/master) cannot access the same controls (DP/slave) This means that a redundant operation of two WinCC stations is not possible with the use of the PROFIBUS DP coupling.

Connection to controls from other manufacturers:

For the connection of controls from other manufacturers, OPC (OLE for Process Control) is recommended.

Current notes and information about OPC servers from various suppliers can be found at: www.opcfoundation.org

WinCC supports the standards:

- OPC Data Access 2.05a
- OPC Data Access 3.00
- OPC XML Data Access 1.00
(Connectivity Pack/Connectivity Station)
- OPC HDA 1.20 (Connectivity Pack/Connectivity Station)
- OPC A&E 1.10 (Connectivity Pack/Connectivity Station)

Coupling overview

Protocol	Description
<i>SIMATIC S7</i>	
SIMATIC S7 Protocol Suite	Channel DLL for S7 functions via MPI, PROFIBUS or Ethernet Layer 4 + TCP/IP
<i>Cross-manufacturer</i>	
OPC client ¹⁾ for DA, XML DA	Channel DLL for OPC communication, WinCC can acquire data from OPC server applications.
OPC server for DA, XML DA, A&E, HDA	Server applications for OPC communication; WinCC provides process data for OPC client
PROFIBUS FMS	Channel DLL for PROFIBUS FMS
PROFIBUS DP	Channel DLL for PROFIBUS DP

¹⁾ Application note:
The parallel usage of the OPC client channel allows, for example, the connection to an SNMP-OPC server for visualization of the data contained there. The SNMP-OPC server enables monitoring of any network components (e.g. switch) that support the protocol SNMP. You can find more information under SIMATIC NET Communications Systems/SNMP OPC Server.

Integration (continued)

Communications components for PG/PC for SIMATIC (for WinCC V7.0)

PROFIBUS	SIMATIC S5 PROFIBUS FDL	SIMATIC S7 Protocol Suite	PROFIBUS DP	PROFIBUS FMS	Order No.
<i>WinCC – channel DLL</i>					
SIMATIC S5 PROFIBUS FDL Channel DLL for S5-FDL	•				Included in the basic package
SIMATIC S7 Protocol Suite Channel DLL for S7 functions		•			Included in the basic package
PROFIBUS DP Channel DLL for PROFIBUS DP			•		Included in the basic package
PROFIBUS FMS Channel DLL for PROFIBUS FMS				•	Included in the basic package
<i>Communication components for extension of the OS/OP</i>					
CP 5611 A2 PCI card (32-bit) for the connection of PG/PC to PROFIBUS or MPI (communications software included in the WinCC basic package)		•			6GK1 561-1AA01
CP 5621 PCI Express X1 card (32-bit) for the connection of PG/PC to PROFIBUS or MPI (communications software included in WinCC basic package)		•			6GK1 562-1AA00
CP 5512 PCMCIA card (Cardbus 32-bit) for the connection of PG/PC to PROFIBUS or MPI (communications software included in WinCC basic package)		•			6GK1 551-2AA00
CP 5711 USB adapter for connecting a PG/PC to PROFIBUS or MPI (communications software included in the WinCC basic package)		•			6GK1 571-1AM00
CP 5613 A2 PCI card (32-bit) for connecting a PC to PROFIBUS (S7-5613 communications software or DP-5613 or FMS-5613 required)	•	•	•	•	6GK1 561-3AA01
CP 5623 PCI Express X1 card (32-bit) for connecting a PG/PC to PROFIBUS or MPI (S7-5613 communications software or DP-5613 or FMS-5613 required)	•	•	•	•	6GK1 562-3AA00
S7-5613 communications software for S7 functions + FDL • Version 8.0 SP1 ^{1) 2)} for (32-bit) Windows 7 • Edition 2008 SP2 (V7.1) ^{1) 2)} for Windows XP/2003 Server / (32-bit) 2008 Server	•	•			6GK1 713-5CB80-3AA0 6GK1 713-5CB71-3AA0
DP-5613 communications software for DP master + FDL • Version 8.0 SP1 ^{1) 2)} for (32-bit) Windows 7 • Edition 2008 SP2 (V7.1) ^{1) 2)} for Windows XP/2003 Server / (32-bit) 2008 Server	•		•		6GK1 713-5DB80-3AA0 6GK1 713-5DB71-3AA0
FMS-5613 communications software for PROFIBUS-FMS + FDL • Version 8.0 SP1 ^{1) 2)} for (32-bit) Windows 7 • Edition 2008 SP2 (V7.1) ^{1) 2)} for Windows XP/2003 Server / (32-bit) 2008 Server	•			•	6GK1 713-5FB71-3AA0

• System interface possible

¹⁾ See ordering data for SIMATIC NET upgrade package²⁾ SIMATIC NET Version 8.0 SP1 scope of supply includes SIMATIC NET Edition 2008 SP2 (V7.1)

PROFIBUS

Connection options for SIMATIC HMI

SIMATIC WinCC

Integration (continued)

Communications examples

3

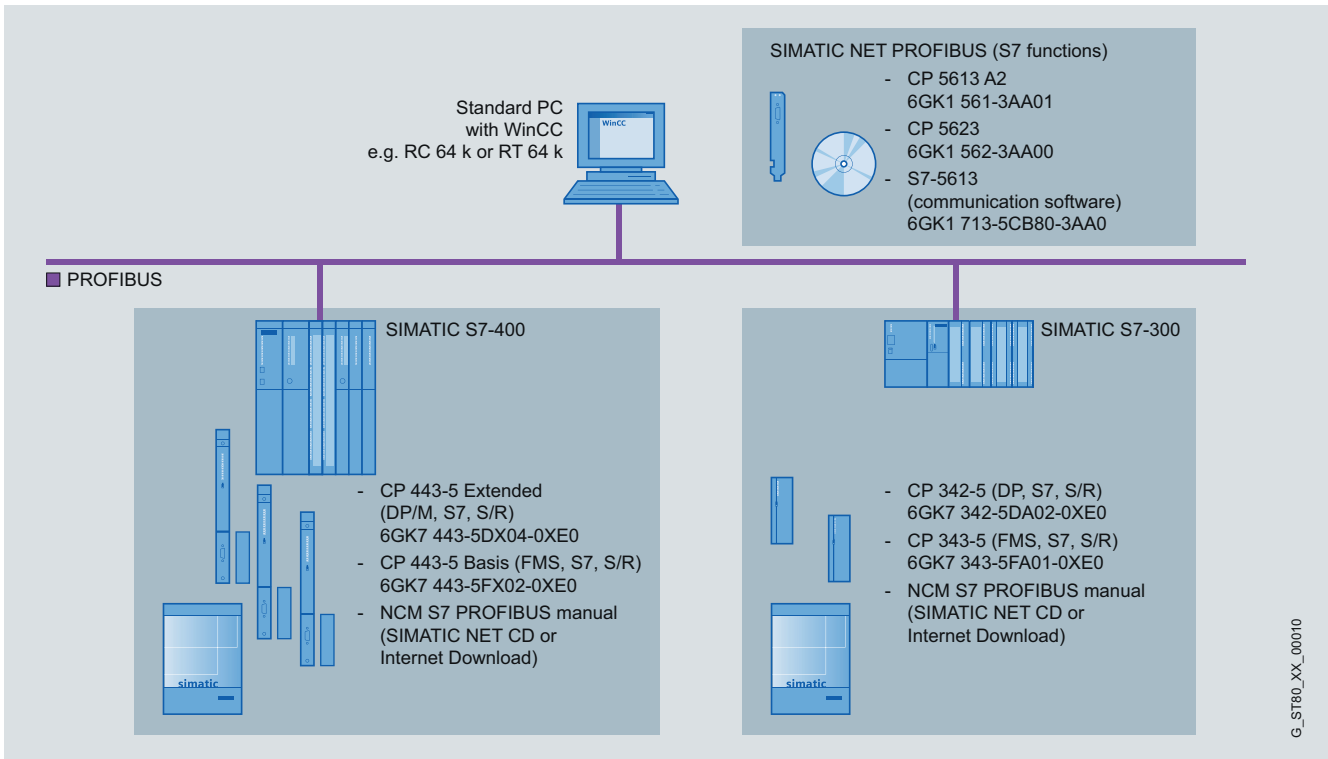

WinCC single-user system: PROFIBUS with S7 communication

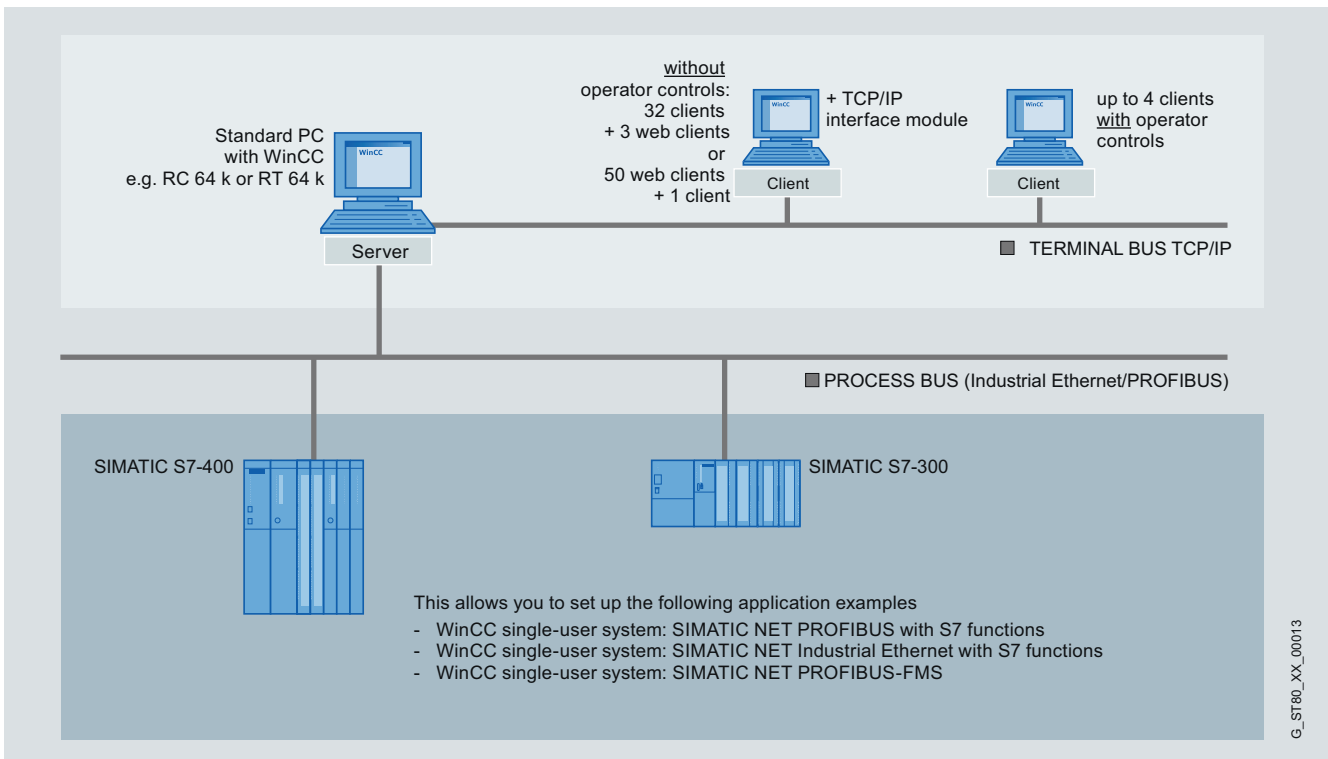

WinCC multi-user system with operable server

Integration (continued)

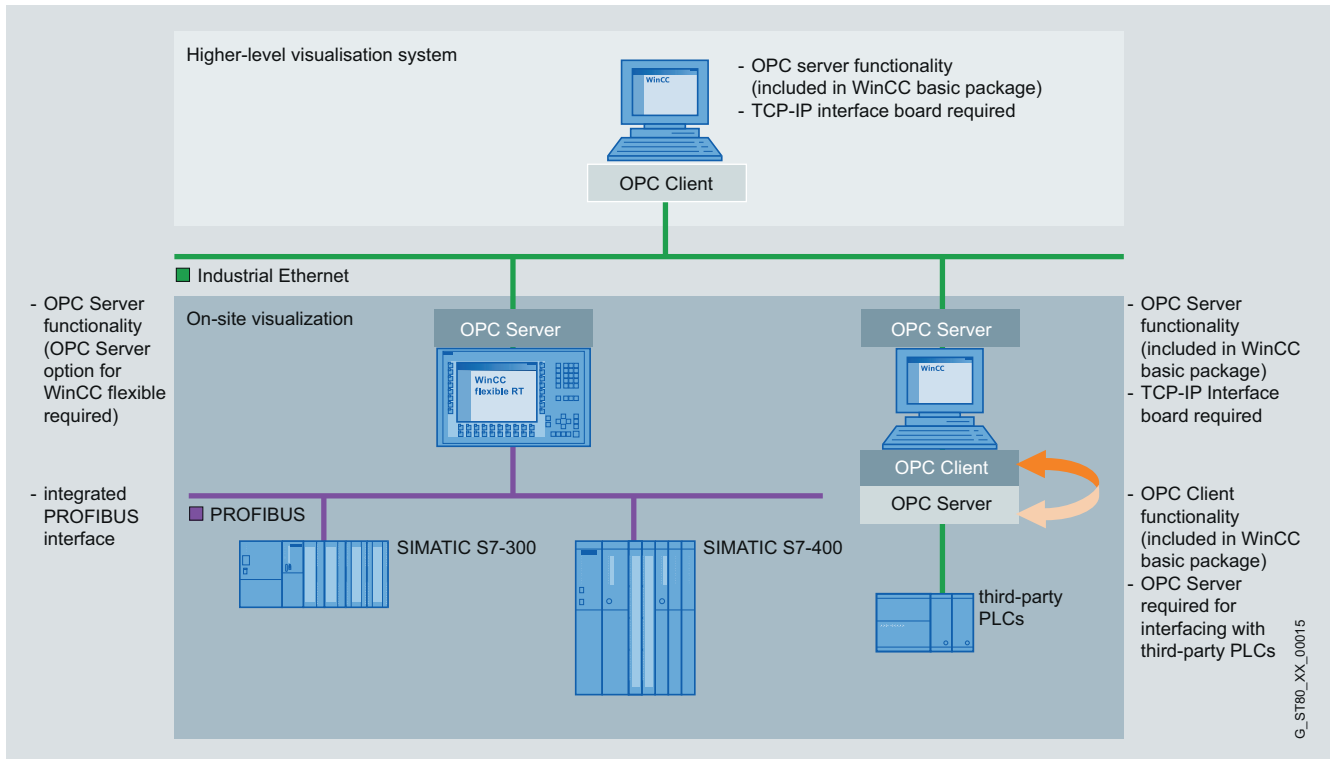

OPC coupling

Note:

You can find more information in Catalog ST 80 / ST PC and in the Industry Mall at www.siemens.com/industrymall

PROFIBUS

Connection options for SIMATIC HMI

System interfaces with WinCC (TIA Portal)

Overview

The SIMATIC Touch Panel (TP), Operator Panel (OP), Basic Panel, Comfort Panel, Mobile Panel, multifunctional platforms (MP) ¹⁾ offer HMI functionality for the control systems:

- SIMATIC S7
- SINUMERIK ²⁾
- Non-Siemens controllers:
 - Allen Bradley
 - Mitsubishi
 - Modicon
 - Omron

For more detailed information, refer to the WinCC flexible user manual, the "Windows-based systems communication" manual, and the WinCC flexible online help.

- 1) For the sake of simplicity, SIMATIC Panel is always used in the text below. This is not restrictive, as the information is valid for all systems referred to above. If there are constraints, direct reference is made to them in the text.
- 2) Required under WinCC flexible: "SINUMERIK HMI copy license WinCC flexible CE" and "SINUMERIK HMI copy license OA". For configuring, a "SINUMERIK HMI engineering package WinCC flexible" is also necessary.

OPC communication and HTTP communication are offered for all Panels with an integrated Ethernet interface. Both OPC and HTTP communication can be used in parallel with the process links to SIMATIC S7 or non-Siemens PLCs.

OPC communication

OPC Data Access is an open standard for exchanging both local and remote variables between various applications via Industrial Ethernet. The original version of OPC is based on Microsoft COM/DCOM and, therefore, requires a Microsoft Windows-based PC operating system (not Windows CE) on both clients and servers. As OPC XML, communication is based on the Internet standard SOAP/XML and is, therefore, suitable for embedded systems with Windows CE.

HTTP communication for variable exchange between SIMATIC HMI systems

Communication based on HTTP message frames enables variables to be exchanged between SIMATIC HMI systems.

Communication standard	SIMATIC HMI				
	Version	Comfort Panel	TP 177B DP/PN OP 177B DP/PN Mobile Panel 177 PN MP 177	TP 277 OP 277 Mobile Panel 277	MP 277 MP 377

OPC Data Access V2.05a + OPC Data Access XML V1.00

OPC DA Client (COM/DCOM)	–	–	–	–	•
OPC DA server (COM/DCOM)	–	–	–	–	•
OPC XML DA client (SOAP/XML)	–	–	–	–	• ¹⁾
OPC XML DA server (SOAP/XML)	•	–	–	•	–

HTTP communication for variable exchange between SIMATIC HMI systems

HTTP client	•	•	•	•	•
HTTP server	•	•	•	•	•

- System interface possible
- System interface not possible

¹⁾ Only through DCOM/XML gateway in scope of delivery of WinCC Advanced for access to OPC XML server of the SIMATIC Panel

Note:

You can find more information in Catalog ST 80 / ST PC and in the Industry Mall at www.siemens.com/industrymall

Overview

The following types of interface are differentiated in respect of the link between the SIMATIC Panels and SIMATIC S7 controllers:

- **PROFINET interface:**
Coupling of SIMATIC Panel to SIMATIC S7 controllers via Industrial Ethernet TCP/IP using the integrated PROFINET interface of the CPU or, alternatively, a PROFINET interface module.
- **MPI/PROFIBUS interface:**
Coupling of SIMATIC Panel to SIMATIC S7 controllers via MPI/PROFIBUS using the integrated MPI/PROFIBUS interface of the CPU for S7-300, S7-400 or the integrated PPI interface of the CPU in the case of S7-200 or, alternatively, a PROFIBUS interface module in the case of S7-1200, S7-300 and S7-400.
- **PPI interface:**
Coupling of SIMATIC Panel to SIMATIC S7-200 via PPI network using the integrated PPI interface of the CPU

The maximum possible number of S7 connections of one CPU is determined by its performance capacity (see Catalog ST 70); from the point of view of SIMATIC Panel, the following restrictions apply:

- OP 73: max. 2 connections
- OP 77A, TP 177A, Basic Panel, OP 77B, TP177B, OP 177B, Mobile Panel 177: max. 4 connections
- Comfort Panel, TP 277, OP 277; Mobile Panel 277, MP 177, MP 277, MP 377: max. 6 connections
- PC with PC WinCC Runtime Advanced: max. 8 connections

PPI interface

The PPI interface is a point-to-point connection between a SIMATIC Panel (PPI master) or alternatively a PG (PPI master) and an S7-200 (PPI slave).

MPI/PROFIBUS interface or PROFINET interface

The corresponding multipoint-enabled communication interfaces of SIMATIC Panels and SIMATIC S7 are used. The following are possible:

- Interface between one or a number of SIMATIC Panels (MPI master) and one or a number of S7-1200/300/400s or WinAC (MPI master). (possible network topology: MPI/PROFIBUS or Industrial Ethernet, TCP/IP)
- Interface between one or a number of SIMATIC Panels (MPI master) and one or a number of S7-200s (MPI slave) ¹⁾ (possible network topology: PPI, MPI/PROFIBUS)

Unlike PPI connections, MPI connections are static connections that are set up during booting and then monitored.

The original format of a master/master link has been joined by a master/slave link, which has enabled integration of the S7-200 (except CPU 212). ¹⁾

In principle this type of information exchange between SIMATIC Panels and SIMATIC S7 is independent of the network used, PPI, MPI/PROFIBUS or Industrial Ethernet: SIMATIC Panels are S7 clients and SIMATIC S7 CPUs are S7 servers.

¹⁾ Constraints with regard to baud rate for S7-200; see Catalog ST 70.

PROFIBUS

Connection options for SIMATIC HMI

System interfaces with WinCC (TIA Portal) SIMATIC S7

Overview (continued)

Controller	SIMATIC HMI					
Target hardware (PROTOCOL) (physics)	OP 73 OP 77A TP 177A	Basic Panel	Comfort Panel	OP 77B TP 177B DP OP 177B DP TP 177B DP/PN OP 177B DP/PN Mobile Panel 177 DP ¹⁾ Mobile Panel 177 PN ¹⁾	TP 277 OP 277 Mobile Panel 277 ¹⁾ MP 177 MP 277 MP 377	WinCC Runtime Advanced
SIMATIC S7-1200 ²⁾						
Via MPI or PROFIBUS network to max. 4 x <i>S7-1200</i> with PROFIBUS module (DP-Master) CM 1243-5	• 3) 4)	• 6)	•	• 5)	•	• 7)
SIMATIC S7-300, -400, Win AC ²⁾						
over MPI or PROFIBUS network to up to 4 x <i>S7-300, S7-400, WinAC</i>	• 3) 4)	• 6)	•	• 6)	•	• 7)
SIMATIC S7-200 ²⁾						
over MPI or PROFIBUS network (MPI protocol) to up to 4 x <i>S7-200</i>	• 3) 4)	• 6)	• 8)	• 6) 8)	• 8)	• 7) 8)
over PPI network (MPI protocol) to up to 4 x <i>S7-200</i>	• 3) 4)	• 6)	–	• 9)	–	–
over PPI network (PPI protocol) to max. 1 x <i>S7-200</i>	–	–	• 10)	• 10)	• 10)	• 7) 10)

- System interface possible
- System interface not possible

- 1) Mobile Panel connection via special connecting cable and junction box (see Mobile Panel), see Manual for cable layout.
- 2) Controllers can be combined as desired
- 3) OP 73 can only be interfaced with max. 2 x SIMATIC S7 (MPI); network operation (parallel PG, etc.) possible
- 4) Max. transfer rate: 1.5 Mbit/s
- 5) Only Basic Panel PN, TP 177B DP/PN, OP 177B DP/PN, Mobile Panel 177 PN
- 6) Not Basic Panel PN, Mobile Panel 177 PN
- 7) Connection via integrated MPI/PROFIBUS interface; use the CP 5611 A2 with a standard PC
- 8) Only on passive S7-200; OP 77B also on active S7-200
- 9) Only OP 77B
- 10) Can be interfaced via PPI to max. 1 x S7-200 (PPI); network operation (parallel PG, etc) is possible

Note:

You can find detailed information about cable layout in the WinCC online help.

You can find more information in Catalog ST 80 / ST PC and in the Industry Mall at www.siemens.com/industrymall

PROFIBUS

Connection options for SIMATIC HMI

System interfaces with WinCC (TIA Portal)
SIMATIC WinCC (TIA Portal) Runtime

Overview

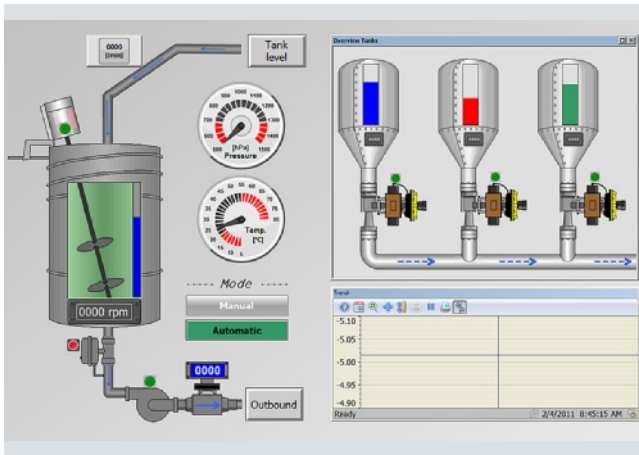

SIMATIC WinCC Runtime Advanced **visualization software**

- PC-based HMI solution for single-user systems directly at the machine
- Basic package for visualization, reporting and logging, user administration, can be expanded flexibly with VB scripts
- Basic package expandable by means of option packages
- Can be integrated into automation solutions based on TCP/IP networks
- Expanded service concepts with remote operation, diagnostics and administration over the intranet and Internet in combination with email communication

SIMATIC WinCC Runtime Professional **visualization software**

- PC-based operator control and monitoring system for visualization and operator control of processes, production flows, machines and plants in all sectors – from the simple single-user station through to distributed multi-user systems and cross-location solutions with web clients. WinCC Runtime Professional is the information hub for corporation-wide vertical integration.
- Industry-standard functions for signaling and acknowledging events, archiving of messages and measured values, logging of all process and configuration data, user administration, can be expanded flexibly with VB and C scripts
- Basic package expandable by means of option packages
- Also included are APIs for the Runtime to utilize the open programming interfaces

Note:

You can find more information in Catalog ST 80 / ST PC and in the Industry Mall at www.siemens.com/industrymall

PROFIBUS

Connection options for SIMATIC HMI

System interfaces with WinCC (TIA Portal) WinCC Runtime Communication

Overview

SIMATIC WinCC Runtime Advanced

WinCC Advanced is an open visualization system and offers the option of connecting the most diverse control systems.

Number of connectable controllers

WinCC Advanced permits the parallel coupling of up to 8 controllers.

Connection to third-party controllers

The following "Coupling overview" table lists third-party protocols and controllers which are directly supported by WinCC Advanced. Generally it is also possible to connect third-party controllers via OPC (OLE for Process Control).

Current notes and information about OPC servers from many different suppliers can be found at:

www.opcfoundation.org/

WinCC Advanced supports the standards:

- OPC Data Access 2.05a
- OPC XML Data Access 1.00 (client via DCOM/XML gateway)

Coupling overview for WinCC Runtime Advanced

Protocol	Description	PC interface
MPI, PROFIBUS (S7 communication)	Channel for communication via MPI, PROFIBUS with max. 8 x SIMATIC S7 controllers S7-1200 with CM 1243-5 (DP master), S7-300, S7-400, S7-200 (only passive S7-200)	CP 5611 A2 CP 5621 CP 5512 CP 5711 CP 5613 A2 CP 5623
PPI (PPI protocol)	Channel for communication via PPI with 1 x SIMATIC S7-200 (network operation, e.g. parallel PG possible)	CP 5611 A2 CP 5621 CP 5512 CP 5711 CP 5613 A2 CP 5623
Software interface (S7 communication)	Channel for communication via software interface with WinAC	
<i>SINUMERIK¹⁾</i>		
MPI (S7 communication)	Channel for communication via MPI with SINUMERIK 840D sl	CP 5611 A2 CP 5621 CP 5512 CP 5711 CP 5613 A2 CP 5623

¹⁾ "SINUMERIK Operate WinCC RT Advanced" license required; for further information, see NC 60 Catalog.

PROFIBUS Connection options for SIMATIC HMI

System interfaces with WinCC (TIA Portal)
WinCC Runtime Communication

Overview (continued)

SIMATIC WinCC Runtime Professional

WinCC Professional is an open process visualization system and offers the option of connecting the most diverse control systems.

Released communication software

Only communication software with the listed (or higher) product versions should be used. Corresponding SIMATIC NET upgrades are available for the upgrading of older versions.

Number of connectable controllers

With CP 1613, a maximum of 64 S7 controllers can be connected via Industrial Ethernet; with CP 5611 a maximum of 8 and with CP 5613 a maximum of 44 S7 controllers can be connected via PROFIBUS. With approx. 10 or more controllers, the use of Industrial Ethernet is recommended.

Client-server communication

Communication between the clients and the server is implemented using the TCP/IP protocol. The construction of a separate PC-LAN is recommended. For small projects with correspondingly small message frame advent, a SIMATIC NET Industrial Ethernet can be used for both process communication (WinCC/server ↔ PLC) and for PC-PC communication (WinCC/client ↔ WinCC/server)

Connection to third-party controllers

The following "Coupling overview" table lists third-party protocols and controllers which are directly supported by WinCC Professional. Generally it is also possible to connect third-party controllers via OPC (OLE for Process Control).

Current notes and information about OPC servers from many different suppliers can be found at:

www.opcfoundation.org/

Communications examples

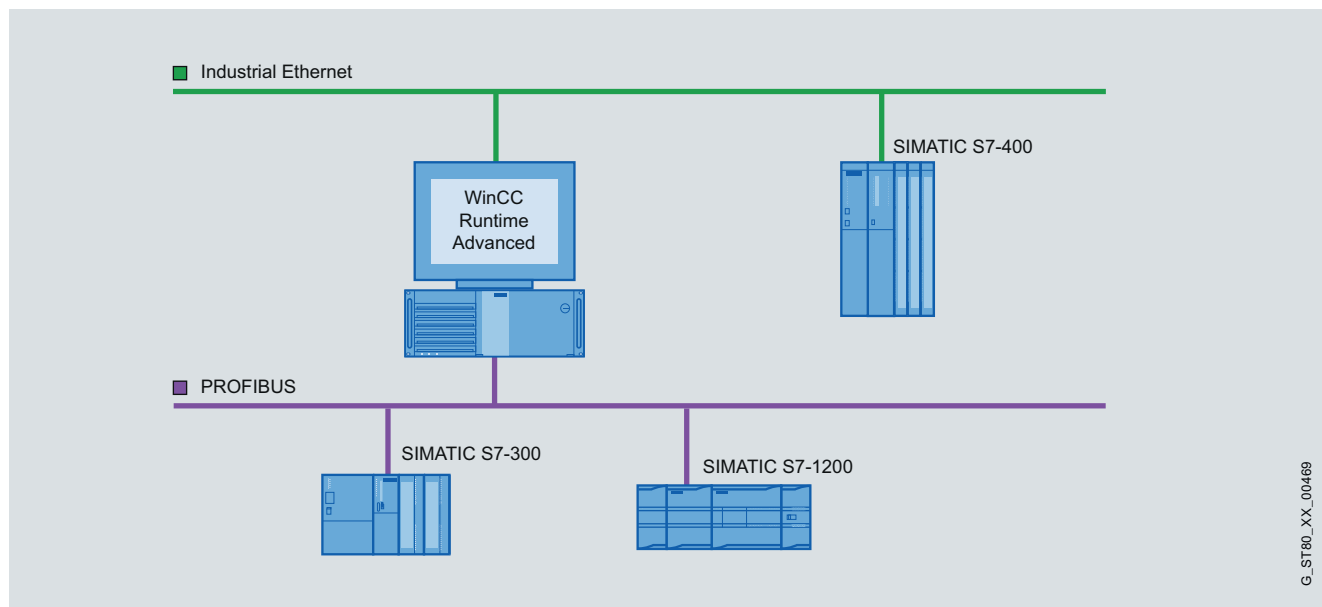

WinCC Runtime Advanced single-user system

WinCC Professional supports the standards:

- OPC Data Access 2.05a
- OPC Data Access 3.00
- OPC XML Data Access 1.00 (Connectivity Pack/Connectivity Station)
- OPC HDA 1.20 (Connectivity Pack/Connectivity Station)
- OPC A&E 1.10 (Connectivity Pack/Connectivity Station)

Coupling overview for WinCC Runtime Professional

Protocol	Description	PC interface
<i>SIMATIC S7</i>		
SIMATIC S7 Protocol Suite	Protocol Suite with channel units for communication with SIMATIC S7 via <ul style="list-style-type: none"> • MPI, PROFIBUS (S7 communication) to S7-1200 with CM 1243-5 (DP master), S7-300, S7-400 • Software interface (S7 communication) to WinAC 	CP 5611 A2 CP 5621 CP 5512 CP 5711 CP 5613 A2 CP 5623

PROFIBUS

Connection options for SIMATIC HMI

System interfaces with WinCC (TIA Portal)
WinCC Runtime Communication

Overview (continued)

3

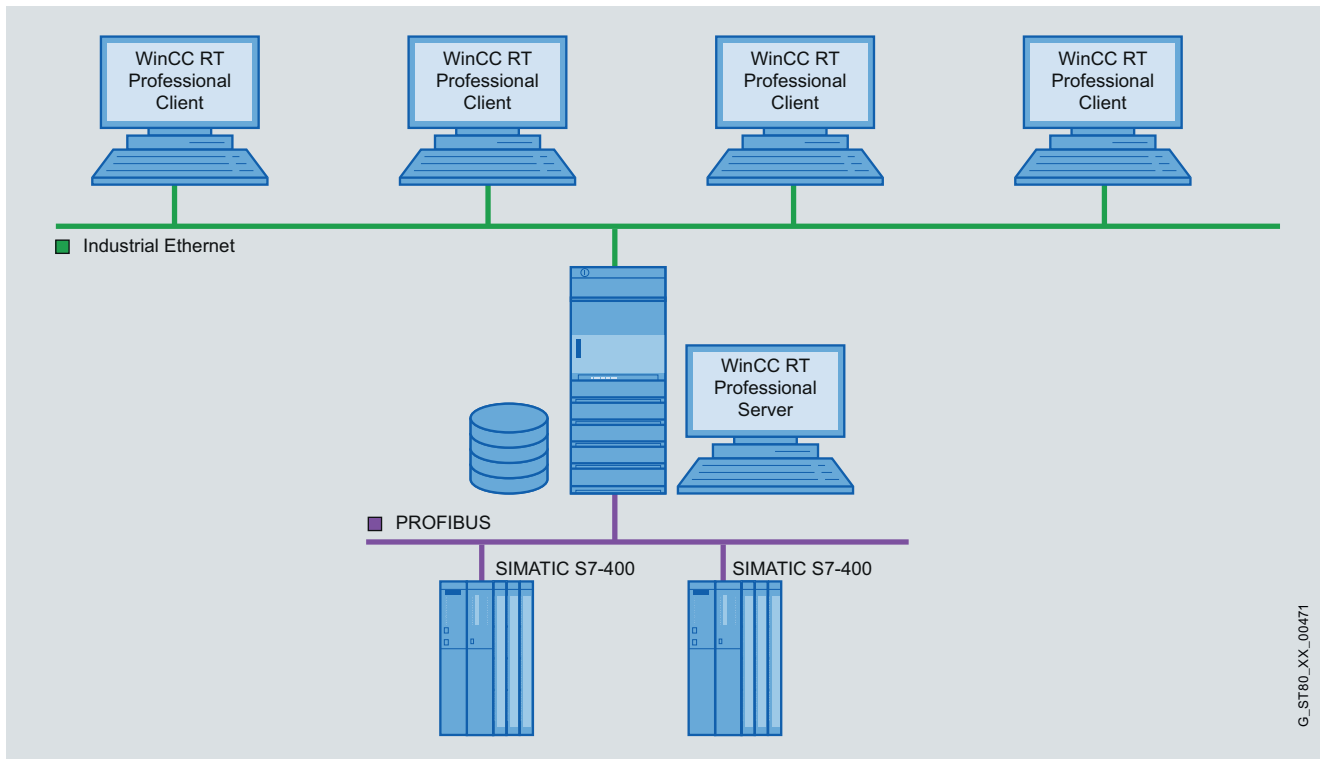

G_ST80_XX_00471

WinCC Runtime Professional multi-user system with operable server

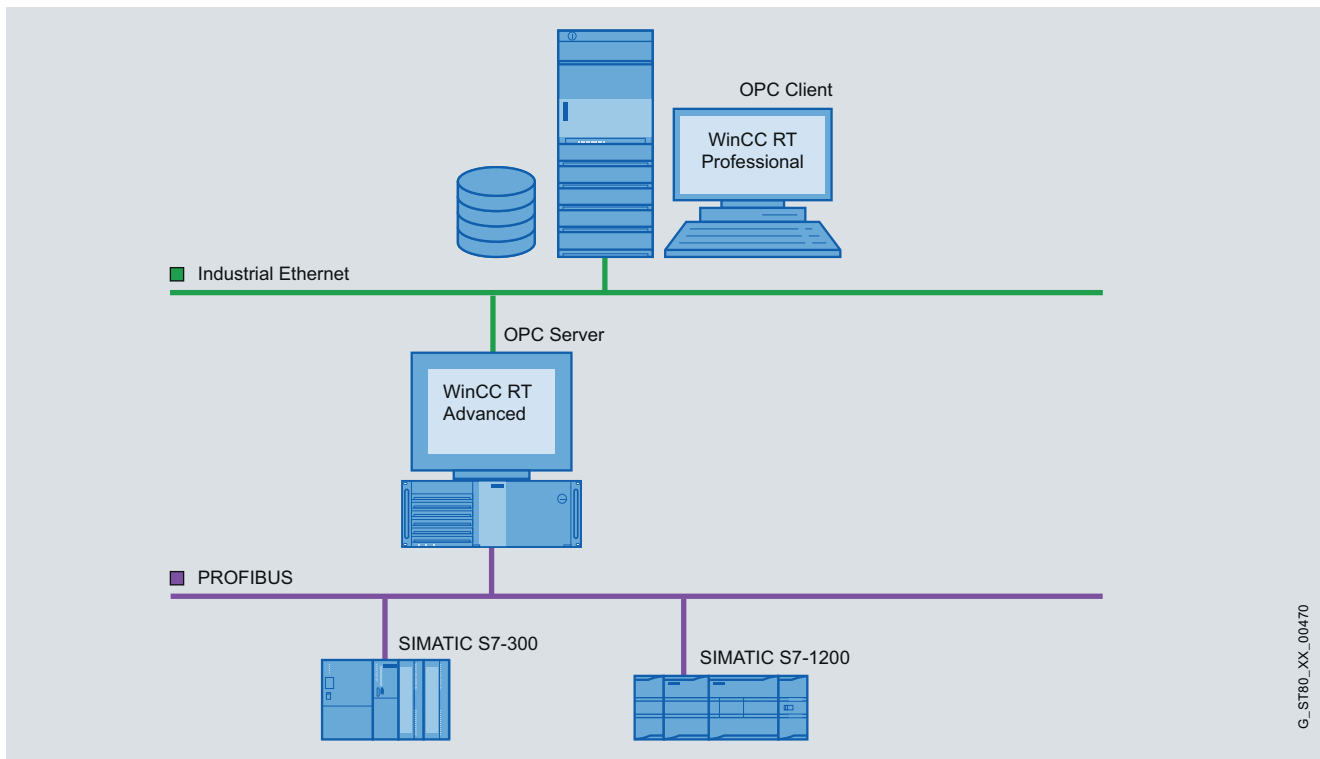

G_ST80_XX_00470

OPC coupling

Note:

You can find more information in Catalog ST 80 / ST PC and in the Industry Mall at www.siemens.com/industrymall

Overview



- Interconnecting two PROFIBUS DP networks
- The interchange of data between both DP networks takes place by internal copying in the coupler.

Application

The PROFIBUS DP/DP coupler interconnects two PROFIBUS DP networks. Byte data (0 ... 244 byte) is transferred from the DP master of the first network to the DP master of another network and vice versa.

The principle corresponds to the hardware wiring of inputs and outputs used today. The coupler has two independent DP interfaces with which the two DP networks are connected.

The DP/DP coupler is a slave on each DP network. The interchange of data between both DP networks takes place by internal copying in the coupler.

Design

The DP/DP transceiver is housed in a 40 mm casing of the S7-300 series. It can be mounted on a standard mounting rail (7.5 mm and 15 mm) as well as on a mounting rail for the S7 design.

The preferred arrangement is upright in a row, side by side, and without clearance.

The transceiver is connected to the PROFIBUS DP networks through an integral 9-pin sub-D connector.

Function

The DP/DP coupler continuously copies the output data from one network to the input data of the other network (and vice versa).

Functions

- Data exchange of up to 244 byte of input and output data of which up to 128 byte can be consistent
- Up to 16 input/output ranges for exchanging data
- If one side fails, the outputs on the other side maintain the previous value
- Support of DPV1 with full diagnostics
- Adjustment of DP/DP coupler either via switch or STEP 7
- Different baud rate settings are possible
- Electrical isolation between the two DP networks
- Power is supplied to both sides

Parameter assignment

The PROFIBUS DP addresses are set via two DIP switches on the top of the coupler.

The coupler is configured either with STEP 7 or with a configuring tool which integrates the DP/DP coupler with the help of a GSD file.

The data length is adjusted with the corresponding configuring tool.

Technical specifications

DP/DP transceiver	
PROFIBUS transmission rate	max. 12 Mbit/s
Interfaces	
• PROFIBUS DP	9-pin Sub-D connector
Supply voltage	24 V DC
Current consumption typ.	150 mA
Mounting	Upright (DIP switches above)
Perm. ambient conditions	
• Operating temperature	
- horizontal mounting	0 °C ... +60 °C
- all other mounting positions	0 °C ... +40 °C
• Transport/storage temperature	-40 °C ... +70 °C
• Relative humidity	10-95 % at +25 °C
Design	
• Dimensions (W x H x D) in mm	40 x 127 x 117
• Weight	approx. 250 g
Degree of protection	IP20

Ordering data

Order No.

DP/DP coupler

6ES7 158-0AD01-0XA0

Note:

The manual is available on the Internet free of charge.

PROFIBUS

Network transitions

PA network transitions

Overview



To create a smooth network transition between PROFIBUS DP and PROFIBUS PA, the SIMATIC product range offers two versions: the DP/PA coupler and the PA link.

The following criteria can be applied when choosing the network transition:

- DP/PA coupler:
For small quantity frameworks (volumes of data) and low timing requirements; limiting of data transfer rate on the PROFIBUS DP to 45.45 kbit/s
- PA link:
For large number of stations and high cycle time requirements; data transfer rate on the PROFIBUS DP up to 12 Mbit/s

Application

The two PA routers are based on two versions of the DP/PA coupler:

- Ex [i] DP/PA coupler (max. output current 110 mA) for implementation of PROFIBUS PA networks with a line or tree topology in environments up to Ex zone 1/21, not for redundant architectures (coupler redundancy, ring)
- FDC 1570 DP/PA coupler (max. output current 1 000 mA) for implementation of PROFIBUS PA networks with a line, tree or ring topology in environments up to Ex zone 2/22; can be used for the redundant architectures "Ring" and "Coupler redundancy"

DP/PA couplers are also integral components of the PA link (see design). The PA link connects PROFIBUS DP and PROFIBUS PA together, and decouples the transmission rates. In contrast to the DP/PA coupler which limits the data transmission rate on the PROFIBUS DP to 45.45 kbit/s, the PA link does not influence the performance of the PROFIBUS DP.

The PA link functions as a slave on the PROFIBUS DP and as a master on the PROFIBUS PA. From the viewpoint of the host PROFIBUS DP master, the PA link is a modular slave whose modules are the devices connected on the PROFIBUS PA. Addressing of these devices is carried out indirectly via the PA link that itself only requires one node address. The host PROFIBUS master can scan devices connected to the PA link all at once.

If the router is a DP/PA coupler, the nodes on the PROFIBUS PA are directly addressed by the PROFIBUS DP master (controller). The DP/PA coupler is an electrical node, but is transparent for communication between the master and PA field devices; it therefore does not require setting of parameters or addresses (exception: FDC 157-0 DP/PA coupler used as PROFIBUS diagnostics slave).

PROFIBUS diagnostics with FDC 157-0 DP/PA coupler, configured as PROFIBUS diagnostics slave

FDC 157-0 DP/PA couplers configured as PROFIBUS diagnostics slaves supply extensive diagnostic and status information via PROFIBUS for swift location and clearance of faults:

- I&M (Identification & Maintenance) data
- Current and voltage values on the main cable
- Redundancy status
- Wire breakage
- Short-circuit
- Signal level

To this end, each of these DP/PA couplers FDC 157-0 requires its own PROFIBUS address. This applies independent of use in a PA Link or as a PA router.

The PA link and DP/PA coupler approved for an extended temperature range are available for use in environments up to Ex zone 2/22. Both are operated with 24 V DC. Assembly is on an S7-300 rail with horizontal or vertical alignment.

Design

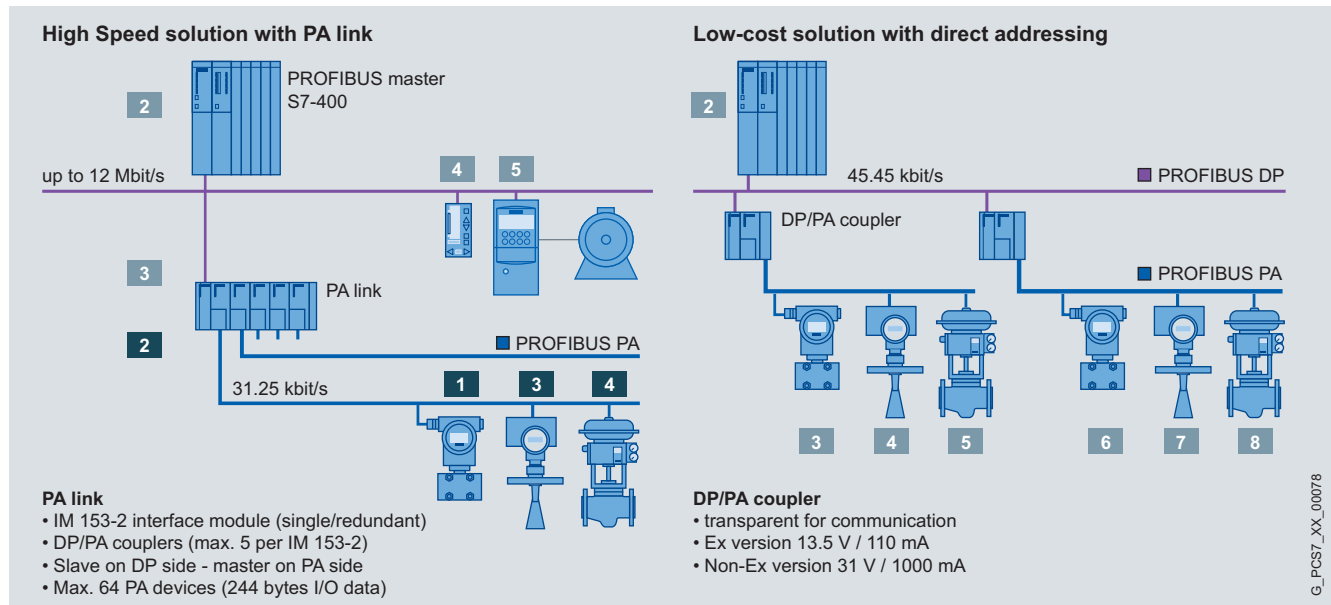

Configuration examples for PA link and DP/PA coupler

PA link

The PA link is a modular combination in S7-300 design consisting of the IM 153-2 High Feature PROFIBUS DP interface module (with optional redundancy) and up to 5 DP/PA couplers (FDC 157-0 or Ex [i]).

All components of the PA link are interconnected through the S7 backplane bus. The use of active bus modules as backplane bus allows hot swapping of individual modules and redundancy of the IM 153-2 High Feature PROFIBUS DP interface modules and the FDC 157-0 DP/PA coupler. If redundancy and changes during operation are not required, passive bus connectors can be used instead of active bus modules.

The PS 307 or PS 305 load power supply can be used for the 24 V DC. With a redundant IM 153-2 High Feature interface module for PROFIBUS DP, it is also recommendable to have a redundant 24 V DC supply, e.g. with two PS 307/PS 305 load power supplies.

The PROFIBUS PA bus segments designed with the DP/PA couplers are physically separated as regards current infeed, but form one bus system in communication terms. A PROFIBUS PA ring segment or a PROFIBUS PA line segment with coupler redundancy can be operated on a PA link. Further PROFIBUS PA line segments can be operated on this PA link using individual couplers. The FDC 157-0 DP/PA couplers provided for the ring coupling or coupler redundancy must always be located at the right-hand end of a sequence of up to 5 couplers.

The following basic components are available for configuring the PA link:

- IM 153-2 High Feature interface module for extended temperature range
- DP/PA coupler (Ex [i] and FDC 157-0)
- Components for redundant design and for hot swapping
 - Mounting rail for hot swapping (as an alternative to the standard mounting rail)
 - BM PS/IM for 1 load power supply and 1 IM 153-2 High Feature module, for extended temperature range
 - IM/IM (IM 157) bus module for two IM 153-2 High Feature modules, for redundant and non-redundant design and for extended temperature range
 - BM FDC for 1 DP/PA coupler Ex [i] or FDC 157-0, for extended temperature range (up to 5 DP/PA couplers possible per PA link)
 - BM FDC/FDC for 2 DP/PA couplers FDC 157-0, for extended temperature range

Additive option:

- PS 307 load power supply for 120/230 V AC; 24 V DC, version in 2, 5 or 10 A, or PS 305 load power supply for 24/48/60/110 V DC; 24 V DC, 2 A

PROFIBUS

Network transitions

PA network transitions

Technical specifications

DP/PA coupler

Bus connection

Connection for PROFIBUS PA

- DP/PA coupler Ex [i]

2 terminals of a 4-pole screw-type terminal, integral terminating resistor

- DP/PA coupler FDC 157-0

4-pole screw-type terminal for connection and looping through, selectable terminating resistor

Connection for PROFIBUS DP

9-pin Sub-D plug, contact assignment as described in IEC 61158/EN 50170

Module-specific data

Degree of protection

IP20

Transmission rate on PROFIBUS DP

45.45 kbit/s

Transmission rate on PROFIBUS PA

31.25 kbit/s

Communication protocol

PROFIBUS DP

Voltages, currents, potentials

Supply voltage

24 V DC (20.4 V ... 28.8 V)

Reverse polarity protection

Yes

Overvoltage protection

Yes

Voltage at coupler output (PA)

- DP/PA coupler Ex [i]
- DP/PA coupler FDC 157-0

13 V ... 14 V DC
31 ± 1 V DC

Voltage monitoring

15.5 V

Overvoltage monitoring

U > 35 V;
latching cutoff

Voltage failure bridging

Min. 5 ms

Current at coupler output (PA) for supplying the PA field devices

- DP/PA coupler Ex [i]
- DP/PA coupler FDC 157-0

max. 110 mA
max. 1 A

Galvanic isolation 24 V DC

- PROFIBUS DP/PROFIBUS PA
- PROFIBUS DP/supply
- PROFIBUS PA/supply
- All electric circuits/
functional grounding

Yes
Yes
Yes
Yes

Power consumption of modules (24 V DC)

- DP/PA coupler Ex [i]
- DP/PA coupler FDC 157-0

Max. 400 mA
max. 2.3 A

Power loss of the module

- DP/PA coupler Ex [i]
- DP/PA coupler FDC 157-0

Typ. 7 W
Typ. 13.4 W

Status, interrupts, diagnostics

Diagnostics displays DP/PA coupler Ex [i] and DP/PA coupler FDC 157-0

- PROFIBUS DP bus monitoring
- PROFIBUS PA bus monitoring
- 24 V DC power supply monitoring

Yellow LED "DP"
Yellow LED "PA"
Green "ON" LED

Additive diagnostics displays of the DP/PA coupler FDC 157-0

- Group error
- Bus error
- Monitoring DP/PA coupler (active coupler in redundant configuration)

Red LED "SF"
Red LED "BF"
Yellow LED "ACT"

Climatic conditions

Permissible operating temperature DP/PA coupler Ex [i] and DP/PA coupler FDC 157-0

- Horizontal installation
- Vertical installation

-25 ... +60 °C
-25 ... +40 °C

Dimensions and weight

Dimensions (W x H x D) in mm

80 x 125 x 130

Weight

- DP/PA coupler Ex [i]
- DP/PA coupler FDC 157-0

approx. 550 g
Approx. 515 g

Technical specifications (continued)

IM 153-2 High Feature (for extended temperature range)

Function	<p>Linking of PROFIBUS DP (9.6 kbit/s to 12 Mbit/s, slave functionality) and PROFIBUS PA (master functionality) with support of the "Configuration in Run" function</p> <p>The DP/PA link function is only implemented by extending the IM 153-2 High Feature with one or more DP/PA couplers. Stand-alone operation of the IM 153-2 High Feature is not possible.</p> <p>1 Y coupler, up to 5 DP/PA couplers or up to 64 slaves can be connected</p> <p>Isolation from the higher-level DP master system</p>
Bus connection	<ul style="list-style-type: none"> Connection for PROFIBUS DP <p>9-pin Sub-D plug, contact assignment as described in IEC 61158/EN 50170, Vol. 2</p>
Connectable lower-level components	
Number of couplers	max. 5
<ul style="list-style-type: none"> DP/PA coupler Y coupler 	1
Number of PA devices on PROFIBUS PA	max. 64
Module-specific data	
Degree of protection	IP20
Transmission rate of the higher level DP master system	9.6; 19.2; 45.45; 93.75; 187.5; 500 kbit/s; 1.5; 3; 6; 12 Mbit/s
Communication protocol	PROFIBUS DP
Frame length	Max. 244 bytes
<ul style="list-style-type: none"> I/O data Configuration frame Diagnostics frame Parameter assignment frame 	<p>Max. 244 bytes</p> <p>Max. 244 bytes</p> <p>Max. 244 bytes</p> <p>Max. 244 bytes</p>

Voltages, currents, potentials	
Supply voltage	24 V DC (20.4 V ... 28.8 V)
Reverse polarity protection	Yes
Voltage failure bridging	20 ms
Galvanic isolation	
<ul style="list-style-type: none"> to the higher-level DP master system to the DP/PA coupler or Y coupler 	<p>Yes</p> <p>No</p>
Power consumption of modules (24 V DC)	
<ul style="list-style-type: none"> In the PA link in the Y link 	<p>Max. 200 mA (at 20.4 V)</p> <p>Max. 400 mA (at 20.4 V)</p>
Power loss of the module	
<ul style="list-style-type: none"> In the PA link in the Y link 	<p>Max. 2.6 W (at 28.8 V)</p> <p>Max. 3.6 W (at 28.8 V)</p>
Infeed, mechanical design	4-pin screw terminal, short-circuiting link between PE and M24; the short-circuiting link must be removed for floating operation (independent of this, the DP interface is always floating)
Status, interrupts, diagnostics	
Diagnostic displays	
<ul style="list-style-type: none"> Group error Bus error on higher level DP master system Bus error on underlying bus system Module is active in redundancy mode 24 V DC power supply monitoring 	<p>Red LED "SF"</p> <p>Red LED "BF 1"</p> <p>Red LED "BF 2"</p> <p>Yellow LED "ACT"</p> <p>Green "ON" LED</p>
Climatic conditions	
Permissible operating temperature	
<ul style="list-style-type: none"> Horizontal installation Vertical installation 	<p>-25 ... +60 °C</p> <p>-25 ... +40 °C</p>
Dimensions and weight	
Dimensions (W x H x D) in mm	40 x 125 x 130
Weight	approx. 360 g

PROFIBUS

Network transitions

PA network transitions

3

Ordering data

DP/PA coupler

For transition from RS 485 to MBP

- DP/PA coupler Ex [i]
Fieldbus coupler between PROFIBUS DP and PROFIBUS PA, EEx(ia) version, max. output current 110 mA; degree of protection IP20; for extended temperature range, permissible operating temperature -25 ... +60 °C
- DP/PA coupler FDC 157-0
Fieldbus coupler between PROFIBUS DP and PROFIBUS PA, with redundancy capability; integrated PROFIBUS diagnostics slave; max. output current 1 A; degree of protection IP20; for extended temperature range, permissible operating temperature -25 ... +60 °C

Order No.

6ES7 157-0AD82-0XA0

6ES7 157-0AC83-0XA0

IM 153-2 High Feature

Interface module for PA Link and Y-Link; with redundancy capability; degree of protection IP20; for extended temperature range, permissible operating temperature -25 ... +60 °C

6ES7 153-2BA82-0XB0

Accessories

PS 307 load power supply

Including connecting comb; 120/230 V AC; 24 V DC

- 2 A; 40 mm wide
- 5 A; 60 mm wide
- 5 A, extended temperature range; 80 mm wide
- 10 A, 80 mm wide

6ES7 307-1BA01-0AA0

6ES7 307-1EA01-0AA0

6ES7 307-1EA80-0AA0

6ES7 307-1KA02-0AA0

PS 305 load power supply

24/48/60/110 V DC; 24 V DC

- 2 A, extended temperature range; 80 mm wide

6ES7 305-1BA80-0AA0

Standard profile rails

(without hot swapping function)

- 482 mm wide (19 inches)
- 530 mm wide

6ES7 390-1AE80-0AA0

6ES7 390-1AF30-0AA0

Components for hot swapping and for redundant design

Active bus modules for hot swapping

- BM PS/IM SIPLUS extreme for 1 load current supply and 1 IM 153-2 High Feature module; for "hot swapping" function, for extended temperature range, permissible operating temperature -25 ... +70 °C
- BM IM/IM for 2 IM 153-2 High Feature modules, for redundant and non-redundant configuration, for "hot swapping" function, for extended temperature range, permissible operating temperature -25 ... +60 °C
- BM FDC for 1 DP/PA coupler Ex [i] or FDC 157-0, for "hot swapping" function, for extended temperature range, permissible operating temperature -25 ... +60 °C
- BM FDC/FDC for 2 DP/PA couplers FDC 157-0, for "hot swapping" function, for extended temperature range, permissible operating temperature -25 ... +60 °C

Mounting rail for hot swapping

For max. 5 active bus modules

- 482 mm wide (19 inches)
- 530 mm wide
- 620 mm wide

Covers

4 backplane bus covers and 1 cover for active bus module

Order No.

6AG1 195-7HA00-2XA0

6ES7 195-7HD80-0XA0

6ES7 195-7HF80-0XA0

6ES7 195-7HG80-0XA0

6ES7 195-1GA00-0XA0

6ES7 195-1GF30-0XA0

6ES7 195-1GG30-0XA0

6ES7 195-1JA00-0XA0

Motor starters for operation in the field, high degree of protection

M200D motor starters for PROFIBUS

Overview

The intelligent, highly flexible M200D PROFIBUS / PROFINET motor starters are the most functional motor starters of the SIRIUS motor starter family in the high degree of protection IP65 for PROFIBUS / PROFINET communication.

They start and protect motors and loads up to 5.5 kW. Direct-on-line and reversing starter variants are available in a mechanical version and also an electronic version (the latter with soft start function).

The particularly robust M200D PROFIBUS / PROFINET motor starters are characterized by numerous functions which can be flexibly parameterized. Their modular design comprises a motor starter module and a communication module.

The M200D PROFINET motor starters enable TIA-integrated parameterization through PROFINET from STEP 7 – in familiar, user-friendly manner with the same look-and-feel as PROFIBUS.

Functionality

- For basic functionality see Chapter 6 "AS-Interface" --> "M200D motor starters" --> "General data" --> "Overview"
- Electronic version also with soft start function
- Robust and widely used M12 connection method for the digital inputs and outputs and the PROFIBUS/PROFINET bus connection
- All four digital inputs and two digital outputs exist in the cyclic process image. This provides complete transparency of the process on the control level
- Full TIA integration: All digital inputs and outputs exist in the cyclic process image and are visible through the bus, providing maximum flexibility and excellent adaptability to the application.
- Flexible assignment of the digital inputs and outputs with all available assignable input actions
- Extensive diagnostics concept using LEDs and through the bus with the TIA-compatible mechanisms
- Expanded diagnostics using data records
- Complete plant monitoring using statistics data record and current value monitoring by means of data records
- Parameterization through PROFIBUS / PROFINET bus with the aid of data records from the user program
- Control of the motor starter using a command data record from the user program
- Removable modular control unit – quicker device replacement and therefore lower costs when device outages occur – since existing wiring is on the control unit and only one device needs to be replaced
- Parameterization in Step 7 HW config using Motor Starter ES (ordering option for start-up software)
- Start-up and diagnostics with the aid of Motor Starter ES (ordering option for start-up software)
- Trace function through Motor Starter ES for optimized start-up and tracking of process and device values

Only with PROFINET:

- Just one bus system from the MES level to the devices – no routers
- More stations on the bus and possible configuration of flexible bus structures
- Automatic re-parameterization in case of device replacement thanks to proximity detection
- Wireless integration of plant segments in difficult environments using WLAN
- Easier expansion of the system thanks to a higher number of stations on the bus and elimination of terminating resistors



M200D motor starter module for PROFIBUS/PROFINET (without communication module)



M200D communication modules for PROFIBUS

Mounting and installation

The M200D PROFINET / PROFIBUS motor starter comprises a communication module and a motor starter module. Therefore only the motor starter module has to be replaced when replacing devices. This saves time and money. The communication module remains as an active station on the bus and all other system components continue running. This prevents downtime.

The integrated plug-in technology significantly reduces the wiring outlay: Connecting cables can be plugged directly onto the motor starter module. The PROFINET bus is connected cost-effectively using an M12 connection on the device. All versions have identical enclosure dimensions for easier system configuration and conversion.

PROFIBUS

Motor starters for operation in the field, high degree of protection

M200D motor starters for PROFIBUS

Overview (continued)

Parameterization and configuration

All motor protection functions, limit values and reactions can be defined by parameterization.

The user has several user-friendly options for parameterization. In addition to parameterization directly from STEP 7, which also permits automatic re-parameterization in case of device replacement, it is possible to use the user-friendly Motor Starter ES start-up software. By connecting a programming device directly to PROFIBUS / PROFINET and the Motor Starter ES start-up software, the devices can also be conveniently programmed from a central point through the bus. Parameters can also be changed during operation from the user program using the data record mechanism so that the function of the motor starter is

adapted to the process when required. With the aid of a PC and the Motor Starter ES software, it is also possible to perform the parameterization through the local point-to-point interface on site.

Functions can be flexibly assigned to the digital inputs and outputs, adapting them to all possible conveyor applications. All digital inputs and outputs exist in the cyclic process image. All limit values for monitoring functions and their reactions are parameterizable and therefore adaptable to the application. Consistency with other products of the SIRIUS M200D motor starter range and with the frequency converter and ET 200pro I/O system is assured.



**SIRIUS M200D
PROFIBUS**



**SIRIUS M200D
PROFINET**

Device functions (firmware features)

Slave on the bus

Fieldbus	✓ PROFIBUS to M12	✓ PROFINET to M12
Adjustable number of stations	✓ 1 ... 125	✓ 1 ... 128 with CPU 315, CPU 317 1 ... 1256 with CPU 319

Parameterization

DIP switches	✓ For address setting and terminating resistor	--
ES Motor Starter	✓ Through bus, optical interface	
PROFIBUS / PROFINET data records	✓	
From STEP 7 / HW config	✓	

Diagnostics

Acyclic through data records	✓
Support of diagnostics alarm	✓

Process image

Process image	✓ 2Byte PAE/ 2Byte PAA
---------------	------------------------

Data channels

Local optical interface (manual local)	✓
Through Motor Starter ES local interface	✓
Using Motor Starter ES through bus	✓

Data records (acyclic)

Parameterization	✓ Using DS 131 (DS = data record)	
Diagnostics	✓ Device-specific DS 92	
Measured values	✓ Measured values DS 94	
Statistics	✓ Statistical data DS 95	
Commands	✓ Using DS 93	
Slave pointer	✓ Slave pointer DS 96	
Logbook	✓ Using Motor Starter ES and data records: Device faults DS 72, tripping operation DS 73, events DS 75	
Device identification	✓ Using DS 100	
I&M data	✓ Using DS 231 ... 234	✓ Using data records 0xAFF0 ... 0xAFF3

Inputs

Number	✓ 4
• of these in the process image	✓ 4
Input action	✓ Parameterizable: flexibly assignable action (see manual)
Quick-Stop	✓ Parameterizable: latching, non-latching

✓ Function is available.

-- Function not available.

Motor starters for operation in the field, high degree of protection

M200D motor starters for PROFIBUS

Overview (continued)

SIRIUS M200D
PROFIBUSSIRIUS M200D
PROFINET

Device functions (firmware features)

Outputs

Number	✓ 2
• of these in the process image	✓ 2
Output action	✓ Parameterizable: flexibly assignable action (see manual)

Brake output

180 V DC / 230/400 V AC / none

✓

Motor protection

Overload protection	✓ Electronic, wide range 1:10
Short-circuit protection	✓
Full motor protection	✓
Temperature sensor	✓ Parameterizable using ES Motor Starter, data record: PTC or Thermoclick or deactivated

Device functions

Repair switch	✓
Current limit monitoring bottom	✓ Parameterizable
Current limit monitoring top	✓ Parameterizable
Zero current detection	✓ Parameterizable: tripping, warning
Blocking current	✓ Parameterizable
Unbalance	✓ Parameterizable
Load type	✓ Parameterizable: 1- and 3-phase
Shutdown class	✓ Parameterizable using ES Motor Starter, data record: CLASS 5, 10, 15, 20
Protection against voltage failure	✓ Parameterizable: activated/deactivated

Support for PROFlenergy profile

Switching during dead times	--	✓
Measured current values of the motor current	--	✓

Soft starter control function

Soft start function	✓
Bypass function	✓ Only electronic version

✓ Function is available.

-- Function not available.

Application

M200D PROFIBUS / PROFINET motor starters are particularly suitable for fully TIA-integrated, highly automated conveyor applications which meet all needs with regard to the monitoring of devices and systems and preventative maintenance.

Adaptability of the motor starter functions and maximum flexibility of the device enable a broad range of application without any limits. The PROFINET-specific expansions are the best assurance of a future-proof investment.

PROFIBUS

Motor starters for operation in the field, high degree of protection

M200D motor starters for PROFIBUS communication modules, motor starter modules

Selection and ordering data



M200D motor starter module PROFIBUS / PROFINET (without communication module)



Motor starter M200D PROFINET

3

Version	Order No.
<i>M200D communication modules for PROFIBUS</i>	
Communication modules for PROFIBUS M12 termination 7/8 inch	3RK1 305-0AS01-0AA0
<i>M200D motor starter modules for PROFIBUS / PROFINET</i>	3RK1 395-6 ■ S41- ■ AD ■
<i>Electromechanical starters (with integrated contactor)</i>	
Setting range for rated operational current / A	
• 0.15 ... 2	K
• 1.5 ... 12	L
Direct-on-line starters/reversing starters	
• Direct-on-line starters	0
• Reversing starters	1
• Direct-on-line starters with manual on-site operation	2
• Reversing starters with manual on-site operation	3
Brake control	
• Without brake control	0
• Brake control (230/400 V AC)	3
• Brake control (180 V DC)	5

Version	Order No.
<i>Electronic starters (with thyristors)</i>	3RK1 395-6 ■ S71- ■ AD ■
Setting range for rated operational current / A	
• 0.15 ... 2	K
• 1.5 ... 12	L
Direct-on-line starters/reversing starters	
• Direct-on-line starters	0
• Reversing starters	1
• Direct-on-line starters with manual on-site operation	2
• Reversing starters with manual on-site operation	3
Brake control	
• Without brake control	0
• Brake control (230/400 V AC)	3
• Brake control (180 V DC)	5

Motor starters for operation in the field, high degree of protection

Accessories
for M200D motor starters for PROFIBUS



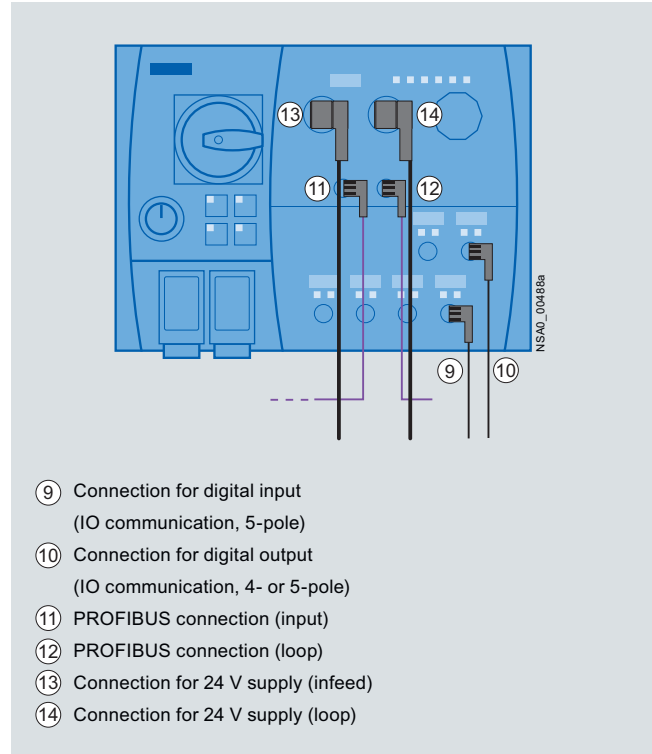

Overview

Accessories for all SIRIUS M200D motor starters (regardless of communication connection) see Chapter 6 "AS-Interface" --> "SIRIUS M200D motor starter" --> "Accessories"



Communication connection using PROFIBUS and digital inputs and outputs

3

Version	Order No.
Motor control with PROFIBUS	
 3RK1 902-1DA00 M12 plugs, angled Screw fixing, 5-pole screw terminals, max. 0.75 mm ² , B-coded, no terminating resistor • ⑪ 5 female contacts	3RK1 902-1DA00 3RK1 902-1BA00
 3RK1 902-1BA00 • ⑫ 5 male contacts	
 3RK1 902-1G. Control cables, assembled at one end M12, screw fixing, angled, B coded, no terminating resistor • ⑪ 5 female contacts, 3 m • ⑪ 5 female contacts, 5 m • ⑪ 5 female contacts, 10 m	3RK1 902-1GB30 3RK1 902-1GB50 3RK1 902-1GC10
 3RK1 902-1N. ⑪ ⑫ Control cables, assembled at both ends M12, screw fixing, angled, pin/socket 5-pole, B-coded, no terminating resistor • 3.0 m • 5.0 m • 10.0 m	

PROFIBUS

Motor starters for operation in the field, high degree of protection

Accessories for M200D motor starters for PROFIBUS

Overview (continued)

Version	Order No.
<i>Further accessories</i>	
PROFIBUS trailing cables Max. acceleration 4 m/s^2 , at least 3 000 000 bending cycles, bending radius at least 60 mm, 2-core, shielded, sold by the meter, minimum order quantity 20 m, maximum order quantity 1 000 m	6XV1 830-3EH10
PROFIBUS FC Food bus cables With PE outer sheath for operation in the food and beverage industry, 2-core, shielded, sold by the meter, minimum order quantity 20 m, maximum order quantity 1 000 m	6XV1 830-0GH10
PROFIBUS FC Robust bus cables With PUR outer sheath for operation in environments exposed to chemicals and mechanical loads, 2-core, shielded, sold by the meter, minimum order quantity 20 m, maximum order quantity 1 000 m	6XV1 830-0JH10
Power cables 5-core, $5 \times 1.5 \text{ mm}^2$, trailing, sold by the meter, minimum order quantity 20 m, maximum order quantity 1 000 m	6XV1 830-8AH10

Connection for 24-V power supply of the M200D PROFIBUS/PROFINET



3RK1 902-3DA00

Plug

On M200D, 7/8" for screw fixing, angled, 1.5 mm^2 screw connection

- ⑮ 5 female contacts

3RK1 902-3DA00



3RK1 902-3BA00

- ⑭ 5 male contacts

3RK1 902-3BA00



3RK1 902-3G.

⑮ Supply lines, assembled at one end

7/8" for screw fixing, angled, 1.5 mm^2

- 5 female contacts, 3 m
- 5 female contacts, 5 m
- 5 female contacts, 10 m

3RK1 902-3GB30

3RK1 902-3GB50

3RK1 902-3GC10



3RK1 902-3N.

⑮ ⑭ Supply lines, assembled at both ends

7/8" for screw fixing, angled at both ends, 5-pole pin/socket, 1.5 mm^2

- 3 m
- 5 m
- 10 m

3RK1 902-3NB30

3RK1 902-3NB50

3RK1 902-3NC10

More connection technology products can be found at "Siemens Solution Partners Automation" under the "Distributed Field Installation System" technology.

More information can be found on the Internet at: www.siemens.com/automation/partnerfinder.

Overview

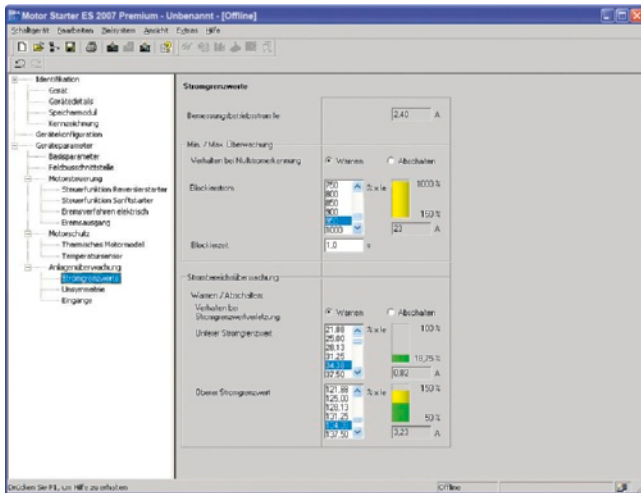

Motor Starter ES for parameterization, monitoring, diagnostics and testing of motor starters

Motor Starter ES is used for start-up, parameterization, diagnostics, documentation and the preventative maintenance of the motor starters in the SIMATIC ET 200S, ET 200pro, ECOFAST and M200D product families.

Interfacing is performed

- through the local interface on the device
- with PROFIBUS DP V1-compatible motor starters from any point in PROFIBUS or in PROFINET (applies for ET 200pro/ECOFAST/M200D)
- with PROFINET-compatible motor starters from any point in PROFINET or PROFIBUS (applies for M200D).

Using Motor Starter ES, the communication-capable motor starters are easily parameterized during start-up, monitored during normal operation and successfully diagnosed for service purposes. Preventative maintenance is supported by a function for reading out diverse statistical data (e.g. operating hours, operating cycles, cut-off currents, etc.). The user is supported during these procedures with comprehensive Help functions and plain text displays.

Motor Starter ES can either be used as a stand-alone program or it can be integrated into STEP 7 via an object manager.

Efficient engineering with three program versions

The Motor Starter ES software program is available in three versions which differ in their user-friendliness, scope of functions and price.

Motor Starter ES	Basic	Standard	Premium
ET 200S High Feature PROFIBUS IM	✓	✓	--
ET 200S High Feature PROFINET IM	✓	✓	--
ECOFAST AS-Interface High Feature	✓	✓	--
ECOFAST PROFIBUS	✓	✓	✓
ET 200pro PROFIBUS IM	✓	✓	✓
ET 200pro PROFINET IM	✓	✓	✓
M200D AS-Interface Standard	✓	✓	--
M200D PROFIBUS	✓	✓	✓
M200D PROFINET	✓	✓	✓

Motor Starter ES	Basic	Standard	Premium
Access through the local interface on the device	✓	✓	✓
Parameter assignment	✓	✓	✓
Operating	✓	✓	✓
Diagnostics	--	✓	✓
Creating typicals	--	✓	✓
Comparison functions	--	✓	✓
Standards-compliant printout according to EN ISO 7200	--	✓	✓
Service data (slave pointer, statistics data)	--	✓	✓
Access through PROFIBUS	--	--	✓
Access through PROFINET	--	--	✓
S7 Routing	--	--	✓
Teleservice through MPI	--	--	✓
STEP 7 object manager	--	--	✓
Trace function	--	✓	✓

✓ Function available

-- Function not available

More functions

- Standards-compliant printouts
The software tool greatly simplifies machine documentation. It enables parameterization printouts according to EN ISO 7200. The elements to be printed are easy to select and group as required.
- Easy creation of typicals
Typicals can be created for devices and applications with only minimum differences in their parameters. These typicals contain all the parameters which are needed for the parameterization. In addition it is possible to specify which of these parameters are fixed and which can be adapted, e.g. by the startup engineer.
- Teleservice through MPI
The Motor Starter ES Premium version supports the use of MPI Teleservice (comprising the Teleservice software and various Teleservice adapters) for remote diagnostics of the devices. This facilitates diagnostics and maintenance, and it shortens response times for service purposes.

Motor Starter ES

Overview (continued)

Types of delivery and license

Motor Starter ES is available as follows:

- Floating license – the license for any one user at any one time
 - authorizes any one user
 - regardless of the number of installations (unlike the single license which may be installed only once)
 - only the actual use of the program has to be licensed
 - trial license (free use of all program functions for 14 days for test and evaluation purposes, included on every product CD, available in the download file of the SIRIUS ES program in the Service&Support portal).

The following delivery versions are also available for Motor Starter ES 2007:

- Upgrade
Switching from an old to a new version with expanded functions, e.g. upgrade from Motor Starter ES 2006 to Motor Starter ES 2007
- Powerpack
Special pack for switching within the same software version to a more powerful version with more functionality, e.g. Powerpack Motor Starter ES 2007 for switching from Standard to Premium.
- Software Update Service
To keep you up to date at all times, we offer a special service which automatically supplies you with all service packs and upgrades.
- License Download
User-friendly license key download from our Mall (currently only for customers from Germany) as an easy and quick way for you to receive additional licenses for your software.

System requirements

Parameterization, start-up and diagnostics software Motor Starter ES 2007	For ECOFAST Motor Starter, SIMATIC ET 200S High-Feature Starter, SIMATIC ET 200pro Starter and M200D (AS-I Standard, PROFIBUS, PROFINET)
Operating system	Windows XP Professional (Service Pack 2, Service Pack 3), Windows 7 Professional (32 Bit), Enterprise (32 Bit), Ultimate (32 Bit)
Processor	≥ Pentium 800 MHz/≥ 1 GHz (Windows 7)
RAM	≥ 512 Mbyte/≥ 1 GB (Windows 7)
Monitor resolution	≥ 1 024 x 768
Free space on hard disk¹⁾	≥ 400 MB
CD-ROM/DVD drive	Yes (only when installing from CD)
Serial interface (COM)	Yes
PC cable/parameterization cable/connection cable	Yes
PROFIBUS card/PROFIBUS processor	Optional, for parameterization and diagnostics through PROFIBUS
Ethernet interface/PROFINET card	Optional, for parameterization and diagnostics through PROFINET

¹⁾ Additional free space recommended, e.g. for swap-out file.

Selection and ordering data

**Parameterization, start-up and diagnostics software
Motor Starter ES 2007**

For ECOFAST Motor Starter, SIMATIC ET 200S High-Feature Starter, SIMATIC ET 200pro Starter and M200D (AS-I Standard, PROFIBUS, PROFINET)

Version	Order No.
Motor Starter ES 2007 Basic	
 <p>Floating license for one user Engineering software, software and documentation on CD, 3 languages (German/English/French), communication through system interface</p> <ul style="list-style-type: none"> • License key on USB stick, Class A, including CD • License key download, Class A, no CD 	<p>3ZS1 310-4CC10-0YA5 3ZS1 310-4CE10-0YB5</p>
Motor Starter ES 2007 Standard	
<p>Floating license for one user Engineering software, software and documentation on CD, 3 languages (German/English/French), communication through system interface</p> <ul style="list-style-type: none"> • License key on USB stick, Class A, including CD • License key download, Class A, no CD 	<p>3ZS1 310-5CC10-0YA5 3ZS1 310-5CE10-0YB5</p>
<p>Upgrade for Motor Starter ES 2006 Floating license for one user, engineering software, software and documentation on CD, license key on USB stick, Class A, 3 languages (German/English/French), communication through the system interface</p>	3ZS1 310-5CC10-0YE5
<p>Powerpack for Motor Starter ES 2007 Basic Floating license for one user, engineering software, software and documentation on CD, license key on USB stick, Class A, 3 languages (German/English/French), communication through the system interface</p>	3ZS1 310-5CC10-0YD5
<p>Software Update Service For 1 year with automatic extension, assuming the current software version is in use, engineering software, software and documentation on CD, communication through the system interface</p>	3ZS1 310-5CC10-0YL5
Motor Starter ES 2007 Premium	
<p>Floating license for one user Engineering software, software and documentation on CD, 3 languages (German/English/French), communication through system interface or PROFIBUS</p> <ul style="list-style-type: none"> • License key on USB stick, Class A, including CD • License key download, Class A, no CD 	<p>3ZS1 310-6CC10-0YA5 3ZS1 310-6CE10-0YB5</p>
<p>Upgrade for Motor Starter ES 2006 Floating license for one user, engineering software, software and documentation on CD, license key on USB stick, Class A, 3 languages (German/English/French), communication through the system interface or PROFIBUS</p>	3ZS1 310-6CC10-0YE5
<p>Powerpack for Motor Starter ES 2007 Standard Floating license for one user, engineering software, software and documentation on CD, license key on USB stick, Class A, 3 languages (German/English/French), communication through the system interface or PROFIBUS</p>	3ZS1 310-6CC10-0YD5
<p>Software Update Service For 1 year with automatic extension, assuming the current software version is in use, engineering software, software and documentation on CD, communication through the system interface or PROFIBUS</p>	3ZS1 310-6CC10-0YL5

Note:

For description of the software versions see page 3/273.

PROFIBUS

Motor starters for operation in the field, high degree of protection – Software

Motor Starter ES

Accessories

Version	Order No.
<i>Optional accessories</i>	
<i>For ET 200S High-Feature motor starters</i>	
2DI 24 V DC COM control module For ET 200S High-Feature starter, Failsafe starter A	3RK1 903-0CH10
LOGO! PC cables	6ED1 057-1AA00-0BA0
<i>For ET 200pro and MD200D motor starters</i>	
RS232 interface cables Serial data connection between ET 200pro MS/FC, M200D and laptop/PC/PG or MS	3RK1 922-2BP00
<i>For ECOFAST High-Feature motor starters (interface cable)</i>	
PC cables	3RK1 911-0BN20
USB/serial adapters To connect a serial PC cable (for connection to the serial PC interface / RS 232), we recommend using modular safety system 3RK3, soft starter 3RW44, ET 200S/ECOFAST/ET 200pro motor starter, AS-i safety monitor and AS-i analyzer in conjunction with SIMOCODE pro 3UF7	3UF7 946-0AA00-0



3RK1 903-0CH10

Motor starters for operation in the field, high degree of protection – Software

SIRIUS Motor Starter Function Block Library
for SIMATIC PCS 7

Overview

With the SIRIUS motor starter PCS 7 function block library, SIRIUS ET 200S motor starters (direct-on-line and reversing starters, direct-on-line soft starters) can be easily and simply integrated into the SIMATIC PCS 7 process control system. The SIRIUS motor starter PCS 7 function block library contains the diagnostics and driver blocks corresponding to the SIMATIC PCS 7 diagnostics and driver concept as well as the elements (symbols and faceplates) required for operator control and process monitoring.

Integrated functionality for optimal process control for all process control systems

In addition to the general sensor technology, the motor feeder data is increasingly being integrated into the process control system. By integrating the SIRIUS ET 200S motor starter into the process control system, it becomes possible to prevent errors in the motor feeder simply and reliably, or to detect these errors quickly and rectify them. Downtimes are reduced to a minimum or can be prevented before they happen.

For example, the output and display of the key measured values established by the motor starter also represent a good aid to the assessing and monitoring of the current system status.

Easy integration with the PCS 7 function block library

The PCS 7 function block library can be used for simple and user-friendly integration of ET 200S motor starters into the SIMATIC PCS 7 process control system. The focus here is on simple configuration. The function of the blocks is based on the PCS 7 standard libraries and is optimally tailored to the functions of the ET 200S motor starters.

Users who have previously integrated motor feeders into conventional technology via signal blocks and motor or valve blocks or, for example, already have experience with SIMOCODE modules, are easily able to switch to ET 200S motor starters.

All blocks required for the automation systems are provided by the PCS 7 function block library – as are the block symbols and faceplates for the operator station required for monitoring and control.

Motor block for the direct control of the drive

The low-voltage motors started and protected by ET 200S motor starters (direct on-line and reversing starters, direct-on-line soft starters) can be integrated into the process automation via the motor blocks. This means that they form the interface between the process control system and the motors controlled by the ET 200S motor starters.

To reduce the amount of configuration work required, functions for signal processing and technological functions are integrated into one motor block.

The current in the motor feeder is detected by the ET 200S motor starter and monitored by the motor protection. The motor current is accessible from the I&C system via the motor blocks.

The block symbols and faceplates for the motor blocks display the motor feeders on the operator station and provide all the required information for monitoring and control as well as for detailed diagnostics.

Diagnostics blocks for motor starters

The diagnostics blocks are made visible by the messages and errors supplied by the motor starter. A key advantage of this is that the motor feeder can be analyzed in a specific way as required.

The faceplate for the diagnostics is opened from the motor block faceplate.

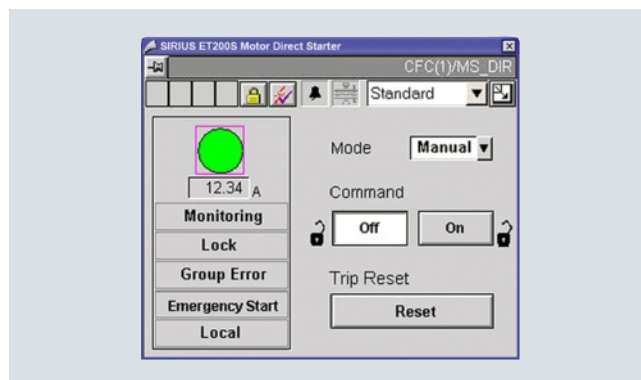

Faceplate of the motor block

Types of delivery and license

The SIRIUS motor starter PCS 7 function block library supplied on CD-ROM allows the user to run the required engineering software on the engineering station (single license) including the runtime software for executing the AS modules in an automation system (single license). If the AS modules are to be used in additional automation systems, the corresponding number of runtime licenses are required which are supplied without a data carrier.

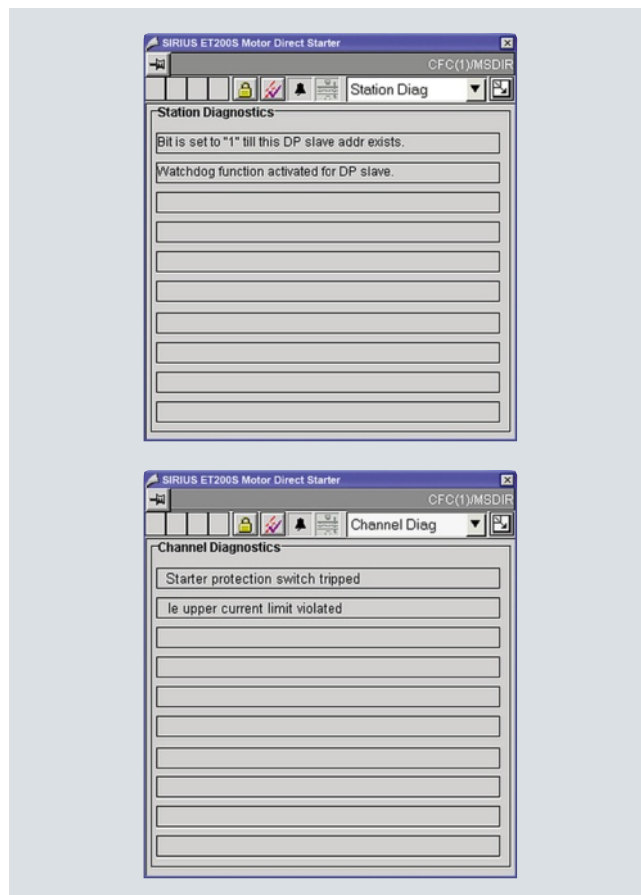

Faceplates for diagnostics

PROFIBUS

Motor starters for operation in the field, high degree of protection – Software

SIRIUS Motor Starter Function Block Library for SIMATIC PCS 7

Selection and ordering data

Version	Order No.
<i>SIRIUS Motor Starter Function Block Library for SIMATIC PCS 7</i>	
 <p>3ZS1 630-1XX00-0YA0</p> <p>Scope of supply: AS modules and faceplates for integrating SIRIUS motor starters into the PCS 7 process control system, for PCS 7 version V 6.1/V 7.0/V 7.1</p> <p>Engineering software For one engineering station (single license) including runtime software for execution of the AS module in an automation system (single license), German/English/French, type of delivery: on CD incl. electronic documentation in German/English</p>	3ZS1 630-1XX00-0YA0
<p>Runtime software For execution of the AS module in an automation system (single license), type of delivery: License without software and documentation</p>	3ZS1 630-2XX00-0YB0

Accessories

Version	Order No.
<i>Optional accessories</i>	
<p>Manual for function block library SIRIUS motor starters for SIMATIC PCS 7 For PCS 7 version V 6.1/V 7.0/V 7.1, German</p>	3ZX1 012-0CS16-0AB0
<p>GETTING STARTED for function block library SIRIUS motor starters for SIMATIC PCS 7 For PCS 7 version V 6.1/V 7.0/V 7.1, German</p>	3ZX1 012-0CS16-5AB1

Overview



ECOFAST soft starter

Distributed motor starters are used for switching and protecting loads locally. Versions with graded functional scope and with different installation possibilities ensure that both the functional requirements of the process and the constructional boundary conditions of the machine or installation are taken into account.

The following are available

- Single devices for geographically distributed motors and
- Isolated solutions (ET 200pro) for operating mechanisms installed close together.

ECOFAST motor starters are available as reversing starters (mechanical switching) and reversing soft starters (electronic switching), in each case for PROFIBUS DP and AS-Interface.

The ECOFAST motor starters can be installed close to the motor or mounted on the motor.

Brake contacts are available as an option for the starters. Two or four integrated digital inputs enable sensors to be scanned locally.

All starters are equipped throughout with standardized interfaces for data and power according to the ECOFAST specification:

- HanBrid for PROFIBUS DP and insulation piercing method for AS-Interface
- Han Q4/2 for the power supply
- Han 10e for motor connection

The starters can be connected using T pieces for data and T terminal connectors for power to prevent interruption.

Note:

For further information on ECOFAST, the field and power bus methods for decentral installation in IP65, see Chapter 10 "Energy Communication Field Installation System".

The 3RK1 922-3BA00 hand-held device is available for local operation.

Detailed technical specifications of the ECOFAST motor starters can be found in the manual "ECOFAST Motor Starters".

Motor Starter ES software

The Motor Starter ES software serves for the parameterization, monitoring, diagnostics and testing of motor starters. It can be used in graded power versions for ECOFAST motor starters and for the PROFIBUS DP and AS-Interface variants (see ECOFAST ES software, page 3/273).

PROFIBUS ECOFAST motor starters

Motor starters for PROFIBUS
Motor starters for AS-Interface, Accessories

Selection and ordering data

Switching function	Motor protection	Setting range/ performance range	Brake output	Order No.
<i>Motor starters for PROFIBUS DP</i>				
Mechanical (for reversing starters)	Thermistor	0.3 ... 9 A / 4 kW ¹⁾	No	3RK1 303-2AS54-1AA0
			400 V AC	3RK1 303-2AS54-1AA3
		Thermal motor model	0.3 ... 3 A/1.1 kW	No
	400 V AC			3RK1 303-5BS44-3AA3
	2.4 ... 9 A/4 kW		No	3RK1 303-5CS44-3AA0
			400 V AC	3RK1 303-5CS44-3AA3
Electronic soft (for reversing soft starters)	Full motor protection	0.3 ... 3 A/1.1 kW	No	3RK1 303-6BS74-3AA0
			400 V AC	3RK1 303-6BS74-3AA3
		2.4 ... 12 A/5.5 kW	No	3RK1 303-6DS74-3AA0
			400 V AC	3RK1 303-6DS74-3AA3
<i>Motor starters for AS-Interface</i>				
Mechanical (for reversing starters)	Thermistor	0.3 ... 9 A / 4 kW ¹⁾	No	3RK1 323-2AS54-1AA0
			400 V AC	3RK1 323-2AS54-1AA3
		Thermal motor model	0.3 ... 3 A/1.1 kW	No
	400 V AC			3RK1 323-5BS44-3AA3
	2.4 ... 9 A/4 kW		No	3RK1 323-5CS44-3AA0
			400 V AC	3RK1 323-5CS44-3AA3
Electronic soft (for reversing soft starters)	Full motor protection	0.3 ... 3 A/1.1 kW	No	3RK1 323-6BS74-3AA0
			400 V AC	3RK1 323-6BS74-3AA3
		2.4 ... 12 A/5.5 kW	No	3RK1 323-6DS74-3AA0
			400 V AC	3RK1 323-6DS74-3AA3

¹⁾ The range 0.3 ... 9 A is fixed (wide range) and cannot be set or modified manually.

Version	Order No.
<i>Accessories</i>	
 <p>Hand-held devices for ECOFAST motor starters, (also for ET 200pro and ET 200S High-Feature) for on-site operation.</p>	3RK1 922-3BA00
<p>Serial interface cable for the connection of a programming device/PC with ES motor starter to an ECOFAST starter for AS-Interface for the transmission of configuration data</p>	3RK1 911-0BN20
<p>Test plug set for testing the motor starter without communication connection (manual operation)</p>	3RK1 911-2AM00
<p>Mounting plate for ECOFAST Retaining bracket on the motor for fixing the mounted motor starter</p>	3RK1 911-3AA00

3RK1 922-3BA00

Overview

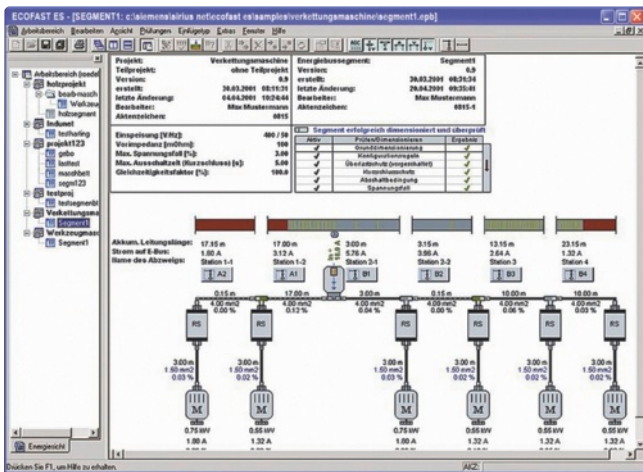

ECOFAST ES for the configuration, calculating and documentation of applications with the ECOFAST motor starter

The ECOFAST system is an open and innovative system solution for distributed applications with standardized components when equipping machines and plants for automation, controls and drives. The system therefore offers a high degree of safety and availability during operation in addition to high time and cost savings during planning and commissioning/installation.

The ECOFAST system uses the ECOFAST motor starter (see Chapter 9 "Motor starters for use in the field, high degree of protection" --> "ECOFAST motor starters"). The components are connected using the ECOFAST connection method (see Chapter 9 "Motor starters for use in the field, high degree of protection" --> "Energy Communication Field Installation System").

The convenient ECOFAST ES configuring software reduces configuring times even further and enables reliable configuring right from the start. ECOFAST ES reduces errors and effort during the configuration, calculation and documentation of applications.

System requirements

ECOFAST ES V 1.4 supports all standard PCs with the Windows operating system. Minimum hardware and software requirements need to be met to work with ECOFAST ES V 1.4; efficient operation is possible with the recommended values.

System requirements	Min.	Recommended
Operating system (with service pack)	Windows 2000 or Windows XP Professional	
Processor	Pentium 800 MHz	Pentium 1000 MHz ¹⁾
Graphics card	<ul style="list-style-type: none"> Resolution: 1024 x 768 / 1280 x 1024 Colors, number: 256 / True Color 	
Main memory	512 MB RAM	> 512 MB RAM
Free space on hard disk	At least 50 MB ²⁾	
CD-ROM drive³⁾	Yes, for the installation of ECOFAST ES V 1.4	

- 1) More powerful platforms may be necessary when working with options.
- 2) Additional free space recommended, e.g. for swap-out file.
- 3) CD-ROM drive not required for using ECOFAST ES V 1.4.



Selection and ordering data

Version	Order No.
---------	-----------

ECOFAST ES



3ZS1 200-0CC14-0YA0

ECOFAST ES, basic package V 1.4

- Graphic configuring tool for SIRIUS drive solutions
- Operator prompting for selecting products
 - Supply system configured according to standards
 - Documentation, parts lists, quantity lists
 - Operating languages: German, English, French
 - Type of delivery: CD, single license

3ZS1 200-0CC14-0YA0

PROFIBUS

SIMOCODE 3UF motor management and control devices

SIMOCODE pro 3UF7

General data

Overview



SIMOCODE pro V with current/voltage measuring module, failsafe expansion module and operator panel with display

SIMOCODE pro is a flexible, modular motor management system for motors with constant speeds in the low-voltage performance range. It optimizes the connection between I&C and motor feeder, increases plant availability and allows significant savings to be made during the construction, startup, operation and maintenance of a system.

When SIMOCODE pro is installed in the low-voltage switchboard, it is the intelligent interface between the higher-level automation system and the motor feeder and includes the following:

- Multifunctional, solid-state full motor protection which is independent of the automation system
- Integrated control functions instead of hardware for the motor control
- Detailed operating, service and diagnostics data
- Open communication through PROFIBUS DP, the standard for fieldbus systems
- Safety relay function for the failsafe disconnection of motors up to SIL 3 (IEC 61508/62061) or PL e with Category 4 (ISO 13849-1)

SIMOCODE ES is the software package for SIMOCODE pro parameterization, start-up and diagnostics.

Two series

SIMOCODE pro is structured into two functionally tiered series:

- SIMOCODE pro C, a compact system for direct-on-line starters and reversing starters or the actuation of a circuit breaker
- SIMOCODE pro V, a variable system with all control functions and with the possibility of expanding the inputs, outputs and functions of the system at will using expansion modules

Expansion possibilities	SIMOCODE pro C, Basic Unit 1	SIMOCODE pro V, Basic Unit 2 ¹⁾
Operator panel	✓	✓
Operator panel with display	--	✓
Current measuring modules	✓	✓
Current/voltage measuring modules	--	✓
Decoupling module	--	✓
Expansion modules:		
• Digital modules (max. 2)	--	✓
• Failsafe digital module (max. 1) ²⁾	--	✓
• Analog module (max. 1)	--	✓
• Ground-fault module (max. 1)	--	✓
• Temperature module (max. 1)	--	✓

✓ Available

-- Not available

¹⁾ When an operator panel with display and/or a decoupling module is used, more restrictions on the number of expansion modules connectable per basic unit must be observed, see page 3/286.

²⁾ The failsafe digital module can be used instead of one of the two digital modules.

Per feeder each system always comprises one basic unit and one separate current measuring module. The two modules are connected together electrically through the system interface with a connection cable and can be mounted mechanically connected as a unit (one behind the other) or separately (side by side). The motor current to be monitored is decisive only for the choice of the current measuring module.

An operator panel for mounting in the control cabinet door is optionally connectable through a second system interface on the basic unit. Both the current measuring module and the operator panel are electrically supplied by the basic unit through the connection cable. More inputs, outputs and functions can be added to basic unit 2 (SIMOCODE pro V) by means of optional expansion modules, thus supplementing the inputs and outputs already existing on the basic unit. With the DM-F Local and DM-F PROFIsafe failsafe digital modules it is also possible to integrate the failsafe disconnection of motors into the SIMOCODE pro V motor management system.

All modules are connected by connection cables. The connection cables are available in various lengths. The maximum distance between the modules (e.g. between the basic unit and the current measuring module) must not exceed 2.5 m. The total length of all the connection cables in a single system must not be more than 3 m.

Connection methods

Selection tables for the SIMOCODE pro motor management system can be found on the pages that follow.



Screw terminals

Benefits**General customer benefits**

- Integration of the whole motor feeder into the process control by means of a bus significantly reduces the wiring outlay between the motor feeder and PLC
- Decentralization of the automated processes by means of configurable control and monitoring functions in the feeder saves resources in the automation system and ensures full functionality and protection of the feeder even if the I&C or bus system fails
- The acquisition and monitoring of operational, service and diagnostics data in the feeder and process control system increases plant availability as well as maintenance and service-friendliness of the feeder
- The high degree of modularity allows users to perfectly implement their plant-specific requirements for each motor feeder
- The SIMOCODE pro system offers functionally graded and space-saving solutions for each customer application
- The replacement of the control circuit hardware with integrated control functions reduces the number of hardware components and the amount of wiring required and thus limits stock keeping costs and potential wiring errors.
- The use of solid-state full motor protection permits better utilization of the motors and ensures long-term stability of the tripping characteristic and reliable tripping even after years of service.

Multifunctional, solid-state full motor protection for rated motor currents up to 820 A

SIMOCODE pro offers comprehensive protection of the motor feeder by means of a combination of different, multi-step and delayable protection and monitoring functions:

- Inverse-time delayed solid-state overload protection (CLASS 5 to 40)
- Thermistor motor protection
- Phase failure/unbalance protection
- Stall protection
- Monitoring of adjustable limit values for the motor current
- Voltage and power monitoring
- Monitoring of the power factor (motor idling/load shedding)
- Ground-fault monitoring
- Temperature monitoring, e.g. over PT100/PT1000
- Monitoring of operating hours, downtime and number of starts, etc.

Recording of measuring curves

SIMOCODE pro can record measuring curves and therefore is able, for example, to present the progression of motor current during motor start-up.

Flexible motor control by integrated control functions (instead of comprehensive hardware interlocks)

Many predefined motor control functions have already been integrated into SIMOCODE pro, including all necessary logic operations and interlocks:

- Overload relays
- Direct-on-line and reversing starters
- Wye/delta starters (also with direction reversal)
- Two speeds, motors with separate windings (pole-changing switch); also with direction reversal
- Two speeds, motors with separate Dahlander windings (also with direction reversal)
- Positioner actuation
- Solenoid valve actuation
- Actuation of a circuit breaker
- Soft starter actuation (also with direction reversal)

These control functions are predefined in SIMOCODE pro and can be freely assigned to the inputs and outputs of the device (including PROFIBUS DP).

These predefined control functions can also be flexibly adapted to each customized configuration of a motor feeder by means of freely configurable logic modules (truth tables, counters, timers, edge evaluation, etc.) and with the aid of standard functions (power failure monitoring, emergency start, external faults, etc.), without additional auxiliary relays being necessary in the control circuit.

SIMOCODE pro dispenses with a lot of additional hardware and wiring in the control circuit, which results in a high level of standardization of the motor feeder in terms of its design and circuit diagrams.

Detailed operational, service and diagnostics data

SIMOCODE pro makes different operational, service and diagnostics data available and helps to detect potential faults in time and to prevent them by means of preventative measures. In the event of a malfunction, a fault can be diagnosed, localized and rectified very quickly – downtimes are avoided or kept to a minimum.

Operating data

- Motor switching state derived from the current flow in the main circuit
- All phase currents
- All phase voltages and phase-to-phase voltages
- Active power, apparent power and power factor
- Phase unbalance and phase sequence
- Time to trip
- Motor temperature
- Remaining cooling time, etc.

Service data

- Motor operating hours
- Motor downtimes
- Number of motor starts
- Number of overload trips
- Interval for compulsory testing of the enabling circuits
- Consumed power
- Internal comments stored in the device, etc.

Diagnostics data

- Numerous detailed early warning and fault messages
- Internal device fault logging with time stamp
- Time stamping of freely selectable status, alarm or fault messages, etc.

PROFIBUS

SIMOCODE 3UF motor management and control devices

SIMOCODE pro 3UF7

General data

Benefits (continued)

Easy operation and diagnostics

Operator panel

The operator panel is used to control the motor feeder and can replace all conventional pushbuttons and indicator lights to save space. It makes SIMOCODE pro or the feeder directly operable in the control cabinet. It features all the status LEDs available on the basic unit and externalizes the system interface for simple parameterization or diagnosis on a PC/PG.

Operator panel with display

As an alternative to the 3UF7 20 standard operator panel for SIMOCODE pro V there is also an operator panel with display: the 3UF7 21 is also able to indicate current measured values, operational and diagnostics data or status information of the motor feeder at the control cabinet. The pushbuttons of the operator panel can be used to control the motor while at the same time the display indicates current measured values, status information, fault messages or the device-internal fault protocol. Using the display settings each user can select for himself how the measured values are presented as standard and how the displayed unit is converted (e.g. °C -> °F).

Communication

SIMOCODE pro is equipped with an integral PROFIBUS DP interface (SUB-D or terminal connection) and can therefore replace all individual wiring (including marshalling racks), which would usually be required for exchanging data with the higher-level automation system, with a single 2-wire cable.

In conjunction with a failsafe controller (F-CPU), the DM-F PROFIsafe failsafe digital module also enables failsafe disconnection through the same PROFIBUS with the PROFIsafe profile.

SIMOCODE pro supports among other things:

- Baud rates up to 12 Mbit/s
- Automatic baud rate detection
- Communication with up to 3 masters
- Time synchronization over PROFIBUS (SIMATIC S7)
- Time stamp with high timing precision (SIMATIC S7)
- Cyclic services (DPV0) and acyclic services (DPV1)
- DPV1 communication after the Y-Link
- Failsafe communication through PROFIBUS/PROFIsafe in conjunction with the DM-F PROFIsafe (F-DO) failsafe digital module, etc.

Notes:

For SIMOCODE pro motor management and control devices with communication function see page 3/288 onwards.

For accessories see page 3/291 onwards.

For more information see Catalog IC 10 "Parameterization, Configuration and Visualizing for SIRIUS".

Autonomous operation

An essential feature of SIMOCODE pro is independent execution of all protection and control functions even if communication with the I&C system breaks down. If the bus or automation system fails, the full functionality of the feeder is ensured or a pre-defined response can be initiated, e.g. the feeder can be shut down in a controlled manner or certain configured control mechanisms can be performed (e.g. the direction of rotation can be reversed).

SIMOCODE pro is designed for mixed operation

Depending on functional requirements, the two systems can be used simultaneously without any problems and without any additional outlay in a low-voltage system. SIMOCODE pro C is fully upward-compatible to SIMOCODE pro V. The same components are used. The parameterization of SIMOCODE pro C can be transferred without any problems. Both systems have the same removable terminals and the same terminal designations.

PROFIBUS SIMOCODE 3UF motor management and control devices

SIMOCODE pro 3UF7
General data

Benefits (continued)

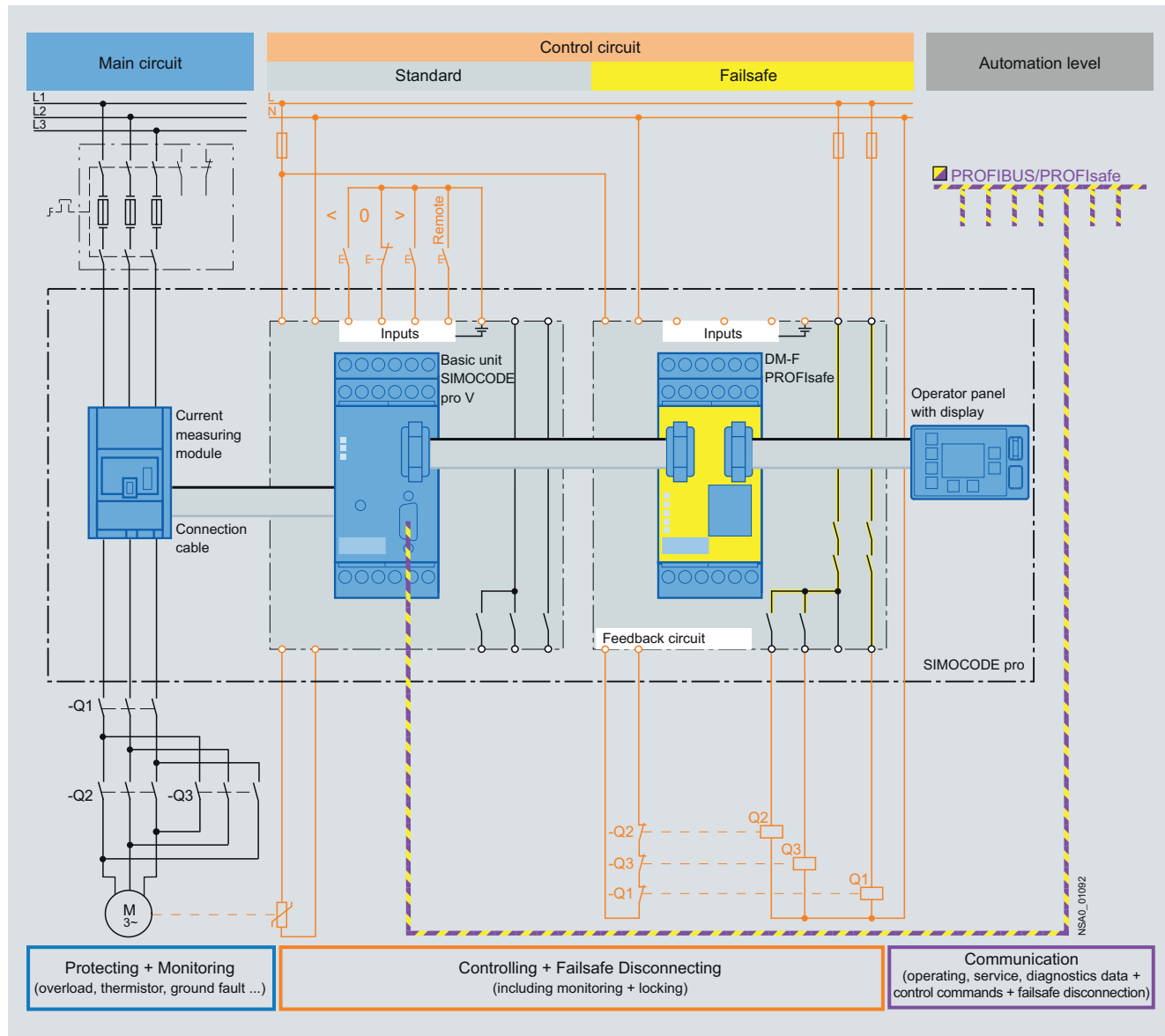

SIMOCODE pro combines all essential functions, including safety functions, through PROFIBUS/PROFIsafe for the motor feeder

PROFIBUS

SIMOCODE 3UF motor management and control devices

SIMOCODE pro 3UF7

General data

Applications

SIMOCODE pro is often used for automated processes where plant downtimes are very expensive (e.g. steel or cement industry) and where it is important to prevent plant downtimes through detailed operational, service and diagnostics data or to localize any faults very quickly.

SIMOCODE pro is modular and space-saving and especially suited for operation in motor control centers (MCC) in the process industry and for power plant technology.

Applications

Protection and control of motors

- in potentially explosive areas for types of protection EEx e/d according to ATEX directive 94/9/EC
- with heavy starting (paper, cement, metal and water industries)
- in high-availability plants (chemical, oil, raw material processing industry, power plants)

Note:

For more information on the subject "protection and control of motors in potentially explosive areas" see Catalog IC 10, Chapter "Appendix" --> "Standards and Approvals" --> "Ex Protection Certificates for SIRIUS Controls".

Safety technology for SIMOCODE pro

The safe disconnection of motors, in the process industry in particular, is becoming increasingly important as a result of new and revised standards and requirements in the safety technology field.

With the DM-F Local and DM-F PROFIsafe failsafe expansion modules it is easy to integrate functions for failsafe disconnection into the SIMOCODE pro V motor management system while retaining service-proven concepts. The strict separation of safety functions and operational functions proves particularly advantageous for planning, configuration and construction. Seamless integration into the motor management system leads to greater transparency for diagnostics and during operation of the system.

Suitable components for this purpose are the DM-F Local and DM-F PROFIsafe failsafe expansion modules, depending on the requirements:

- the DM-F Local failsafe digital module for when direct assignment between a failsafe hardware disconnect signal and a motor feeder is required, or
- the DM-F PROFIsafe failsafe digital module for when a failsafe controller (F-CPU) creates the signal for the disconnection and transmits it in a failsafe manner through PROFIBUS/PROFIsafe to the motor management system

More information

Configuration instructions when using an operator panel with display and/or a decoupling module

If you want to use an operator panel with display and/or a decoupling module in the SIMOCODE pro V system, then the following configuration instructions concerning the type and number of connectable expansion modules must be observed.

The following tables show the maximum possible configuration of the expansion modules for the various combinations.

The DM-F Local and DM-F PROFIsafe failsafe expansion modules behave like digital modules for standard applications in this situation.

Use of an operator panel with display

Digital module	Digital module	Analog module	Temperature module	Ground-fault module
----------------	----------------	---------------	--------------------	---------------------

Only operator panel with display for basic unit 2 (24 V DC or 110 ... 240 V AC/DC)

Max. 4 expansion modules can be used

Operator panel with display and current/voltage measurement with basic unit 2 (110 ... 240 V AC/DC)

Max. 3 expansion modules can be used or:

--	--	✓	✓	--
----	----	---	---	----

✓ Available

-- Not available

More information (continued)Use of a decoupling module
(voltage measurement in insulated networks)

Digital module	Digital module	Analog module	Temperature module	Ground-fault module
Basic unit 2 (24 V DC)				
✓ ¹⁾	✓ ¹⁾	✓	✓	✓
Basic unit 2 (110 ... 240 V AC/DC)				
✓	✓	--	✓	✓
✓ ¹⁾	✓ ¹⁾	✓	✓	--
✓	--	✓	✓	--
✓	--	✓	--	✓

✓ Available
-- Not available

1) No bistable relay outputs and no more than 5 of 7 relay outputs active simultaneously (> 3 s).

Use of a decoupling module
(voltage measurement in insulated networks)
in combination with an operator panel with display

Digital module	Digital module	Analog module	Temperature module	Ground-fault module
Basic unit 2 (24 V DC)				
✓	--	✓	✓	✓
✓	✓	--	✓	✓
Basic unit 2 (110 ... 240 V AC/DC)				
✓ ²⁾	--	✓	✓	✓
✓	✓	--	--	--
✓ ¹⁾	✓ ¹⁾	✓ ³⁾	--	--
✓	--	--	✓	✓

✓ Available
-- Not available

1) No bistable relay outputs and no more than 5 of 7 relay outputs active simultaneously (> 3 s).

2) No bistable relay outputs and no more than 3 of 5 relay outputs active simultaneously (> 3 s).

3) Analog module output is not used.

Protective separation

All circuits in SIMOCODE pro are safely separated from each other according to IEC 60947-1. That is, they are designed with double creepages and clearances. In the event of a fault, therefore, no parasitic voltages can arise in neighboring circuits. The instructions of Test Report No. 2668 must be complied with.

Types of protection EEx e and EEx d

The overload protection and the thermistor motor protection of the SIMOCODE pro system comply with the requirements for overload protection of explosion-protected motors to the type of protection:

- EEx d "flameproof enclosure" e.g. according to EN 50018 or EN 60079-1
- EEx e "increased safety" e.g. according to EN 50019 or EN 60079-7.

When using SIMOCODE pro devices with a 24 V DC control voltage, electrical separation must be ensured using a battery or a safety transformer according to EN 61558-2-6. EC type test certificate: BVS 06 ATEX F 001
Test report: BVS PP 05.2029 EG.

ATEX approval for operation in areas subject to explosion hazard

The SIRIUS SIMOCODE pro 3UF7 motor management system is certified for the protection of motors in areas subject to explosion hazard according to

- ATEX Ex I (M2); equipment group I, category M2 (mining)
- ATEX Ex II (2) GD; equipment group II, category 2 in area GD

See Catalog IC 10 "Appendix" --> "Standards and Approvals"
--> "Ex Protection Certificates for SIRIUS Controls".

Selection data for type-tested assemblies/load feeders

Configuration tables according to type of coordination 1 or 2 can be found in the manual "SIRIUS Configuration", Order No.: 3ZX1 012-0RA21-0AB0, the manual "Configuring SIRIUS Innovations", order no.: 3ZX1012-0RA21-1AB0 or the system manual SIMOCODE pro.

System manual

The SIMOCODE pro system manual describes the motor management system and its functions in detail. It provides information on configuration, start-up, servicing and maintenance. A typical example of a reversing starter application is used to teach the user quickly and practically how to use the system. In addition to help on how to identify and rectify faults in the event of a malfunction, the manual also contains special information for servicing and maintenance. For the selection of equipment and for configuration, it is recommended that the 3UF7 970-0AA0.-0 system manual be consulted.

A detailed description of the DM-F Local and DM-F PROFIsafe failsafe expansion modules is provided in the system manual "SIMOCODE pro Safety Failsafe Digital Modules", which can be downloaded from the Internet.







Internet

More information is available on the Internet at:
www.siemens.com/simocode

PROFIBUS SIMOCODE 3UF motor management and control devices





SIMOCODE pro 3UF7 Basic units

Selection and ordering data

Version	Current setting A	Mounting width mm	Screw terminals Order No.																				
SIMOCODE pro																							
 3UF7 000-1A.00-0	SIMOCODE pro C, Basic unit 1 PROFIBUS DP interface, 12 Mbit/s, RS 485 4 I/3 O freely assignable, input for thermistor connection, monostable relay outputs, rated control supply voltage U_s : <ul style="list-style-type: none"> • 24 V DC • 110 ... 240 V AC/DC 		3UF7 000-1AB00-0 3UF7 000-1AU00-0																				
 3UF7 010-1A.00-0	SIMOCODE pro V, Basic unit 2 PROFIBUS DP interface, 12 Mbit/s, RS 485 4 I/3 O freely assignable, input for thermistor connection, monostable relay outputs, can be expanded by expansion modules, rated control supply voltage U_s : <ul style="list-style-type: none"> • 24 V DC • 110 ... 240 V AC/DC 		3UF7 010-1AB00-0 3UF7 010-1AU00-0																				
 3UF7 100-1AA00-0	Current measuring modules <table border="1"> <tbody> <tr> <td rowspan="4">• Straight-through transformers</td> <td>0.3 ... 3</td> <td>45</td> <td>3UF7 100-1AA00-0</td> </tr> <tr> <td>2.4 ... 25</td> <td>45</td> <td>3UF7 101-1AA00-0</td> </tr> <tr> <td>10 ... 100</td> <td>55</td> <td>3UF7 102-1AA00-0</td> </tr> <tr> <td>20 ... 200</td> <td>120</td> <td>3UF7 103-1AA00-0</td> </tr> <tr> <td rowspan="3">• Busbar connections</td> <td>20 ... 200</td> <td>120</td> <td>3UF7 103-1BA00-0</td> </tr> <tr> <td>63 ... 630</td> <td>145</td> <td>3UF7 104-1BA00-0</td> </tr> </tbody> </table>		• Straight-through transformers	0.3 ... 3	45	3UF7 100-1AA00-0	2.4 ... 25	45	3UF7 101-1AA00-0	10 ... 100	55	3UF7 102-1AA00-0	20 ... 200	120	3UF7 103-1AA00-0	• Busbar connections	20 ... 200	120	3UF7 103-1BA00-0	63 ... 630	145	3UF7 104-1BA00-0	
• Straight-through transformers	0.3 ... 3	45		3UF7 100-1AA00-0																			
	2.4 ... 25	45		3UF7 101-1AA00-0																			
	10 ... 100	55		3UF7 102-1AA00-0																			
	20 ... 200	120	3UF7 103-1AA00-0																				
• Busbar connections	20 ... 200	120	3UF7 103-1BA00-0																				
	63 ... 630	145	3UF7 104-1BA00-0																				
	 3UF7 110-1AA00-0	Current/voltage measuring modules For SIMOCODE pro V Voltage measurement up to 690 V if required in connection with a decoupling module <table border="1"> <tbody> <tr> <td rowspan="4">• Straight-through transformers</td> <td>0.3 ... 3</td> <td>45</td> <td>3UF7 110-1AA00-0</td> </tr> <tr> <td>2.4 ... 25</td> <td>45</td> <td>3UF7 111-1AA00-0</td> </tr> <tr> <td>10 ... 100</td> <td>55</td> <td>3UF7 112-1AA00-0</td> </tr> <tr> <td>20 ... 200</td> <td>120</td> <td>3UF7 113-1AA00-0</td> </tr> <tr> <td rowspan="2">• Busbar connections</td> <td>20 ... 200</td> <td>120</td> <td>3UF7 113-1BA00-0</td> </tr> <tr> <td>63 ... 630</td> <td>145</td> <td>3UF7 114-1BA00-0</td> </tr> </tbody> </table>		• Straight-through transformers	0.3 ... 3	45	3UF7 110-1AA00-0	2.4 ... 25	45	3UF7 111-1AA00-0	10 ... 100	55	3UF7 112-1AA00-0	20 ... 200	120	3UF7 113-1AA00-0	• Busbar connections	20 ... 200	120	3UF7 113-1BA00-0	63 ... 630	145	3UF7 114-1BA00-0
• Straight-through transformers	0.3 ... 3	45	3UF7 110-1AA00-0																				
	2.4 ... 25	45	3UF7 111-1AA00-0																				
	10 ... 100	55	3UF7 112-1AA00-0																				
	20 ... 200	120	3UF7 113-1AA00-0																				
• Busbar connections	20 ... 200	120	3UF7 113-1BA00-0																				
	63 ... 630	145	3UF7 114-1BA00-0																				
 3UF7 150-1AA00-0	Decoupling module For connecting upstream from a current/voltage measuring module on the system interface when using voltage detection in insulated, high-resistance or asymmetrically grounded systems and in single-phase systems		3UF7 150-1AA00-0																				
 3UF7 200-1AA00-0	Operator panel Installation in control cabinet door or front plate, for plugging into basic unit, 10 LEDs for status indication and user-assignable buttons for controlling the motor		3UF7 200-1AA00-0																				
 3UF7 210-1AA00-0	Operator panel with display for SIMOCODE pro V¹⁾ Installation in control cabinet door or front plate, for plugging into basic unit 2, 7 LEDs for status indication and user-assignable buttons for controlling the motor, multilingual display, e.g. for indication of measured values, status information or fault messages		3UF7 210-1AA00-0																				

¹⁾ Only possible with basic unit 2, product version E03 and higher (from 12/2006).

Selection and ordering data (continued)



Version	Screw terminals	Order No.
<i>Expansion modules for SIMOCODE pro V</i>		
<p>With SIMOCODE pro V, it is possible to expand the type and number of inputs and outputs in steps. Each expansion module has two system interfaces on the front. Through the one system interface the expansion module is connected to the system interface of the SIMOCODE pro V using a connection cable; through the second system interface, further expansion modules or the operator panel can be connected. The power supply for the expansion modules is provided by the connection cable through basic unit 2.</p> <p><u>Note:</u> Please order connection cable separately, see page 3/291.</p>		
Digital modules		
<p>Up to two digital modules can be used to add additional binary inputs and relay outputs to the basic unit. The input circuits of the digital modules are supplied from an external power supply.</p> <p>4 binary inputs and 2 relay outputs, up to 2 digital modules can be connected per basic unit 2</p>		
		
3UF7 300-1AU00-0		
	<i>Relay outputs</i>	<i>Input voltage</i>
	Monostable	24 V DC
		110 ... 240 V AC/DC
	Bistable	24 V DC
		110 ... 240 V AC/DC
		3UF7 300-1AB00-0
		3UF7 300-1AU00-0
		3UF7 310-1AB00-0
		3UF7 310-1AU00-0
Analog module		
<p>The basic unit can be optionally expanded with analog inputs and outputs (0/4 ... 20 mA) by means of the analog module.</p> <p>2 inputs (passive) for input and 1 output for output of 0/4 ... 20 mA signals, max. 1 analog module can be connected per basic unit 2.</p>		
		
3UF7 400-1AA00-0		
		3UF7 400-1AA00-0
Ground-fault module		
<p>Instead of ground-fault monitoring using the current measuring modules or current/voltage measuring modules, it may be necessary, especially in high-impedance grounded networks, to implement ground-fault monitoring for smaller ground fault currents using a summation current transformer.</p> <p>1 input for connecting a summation current transformer 3UL22, up to 1 ground-fault module can be connected per basic unit 2</p> <p><u>Note:</u> For related summation current transformers for rated fault currents 0.3 A, 0.5 A or 1 A see Catalog IC 10.</p>		
		
3UF7 500-1AA00-0		
		3UF7 500-1AA00-0
Temperature module		
<p>Independently of the thermistor motor protection of the basic units, up to 3 analog temperature sensors can be evaluated using a temperature module.</p> <p>Sensor types: PT100/PT1000, KTY83/KTY84 or NTC</p> <p>3 inputs for connecting up to 3 analog temperature sensors, up to 1 temperature module can be connected per basic unit 2</p>		
		
3UF7 700-1AA00-0		
		3UF7 700-1AA00-0

PROFIBUS

SIMOCODE 3UF motor management and control devices







SIMOCODE pro 3UF7 Failsafe expansion modules

Selection and ordering data (continued)

Version	Screw terminals Order No.
<i>Failsafe expansion modules for SIMOCODE pro V</i>	
<p>Thanks to the failsafe expansion modules, SIMOCODE pro V can be expanded by adding the function of a safety relay for the failsafe disconnection of motors. A maximum of 1 failsafe digital module can be connected; it can be used instead of a digital module.</p> <p>The failsafe expansion modules, too, are equipped with two system interfaces at the front for making the connection to other system components. Unlike other expansion modules, power is supplied to the modules through a separate terminal connection.</p> <p><u>Note:</u> Please order connection cable separately, see page 3/291.</p>	
 <p>3UF7 320-1AB00-0</p> <p>DM-F Local failsafe digital modules ¹⁾</p> <p>For failsafe disconnection using a hardware signal 2 relay enabling circuits, joint switching; 2 relay outputs, common potential disconnected failsafe; inputs for sensor circuit, start signal, cascading and feedback circuit, safety function adjustable using DIP switches rated control supply voltage U_s:</p> <ul style="list-style-type: none"> • 24 V DC • 110 ... 240 V AC/DC 	<p>3UF7 320-1AB00-0 3UF7 320-1AU00-0</p>
 <p>3UF7 330-1AB00-0</p> <p>DM-F PROFIsafe failsafe digital modules ¹⁾</p> <p>For failsafe disconnection using PROFIBUS/PROFIsafe 2 relay enabling circuits, joint switching; 2 relay outputs, common potential disconnected failsafe; 1 input for feedback circuit; 3 binary standard inputs rated control supply voltage U_s:</p> <ul style="list-style-type: none"> • 24 V DC • 110 ... 240 V AC/DC 	<p>3UF7 330-1AB00-0 3UF7 330-1AU00-0</p>

¹⁾ Only possible with basic unit 2, product version E07 and higher (from 05/2011).

Selection and ordering data (continued)

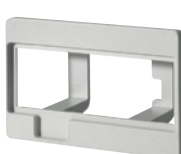
Version		Order No.
<i>Connection cables (essential accessory)</i>		
	<p>Connection cable</p> <p>In different lengths for connecting basic unit, current measuring module, current/voltage measuring module, operator panel or expansion modules or decoupling module:</p> <ul style="list-style-type: none"> • Length 0.025 m (flat) Important: Only suitable for connecting basic unit 2 to its expansion modules or for connecting expansion modules to each other; only when the front plates finish at the same height! • Length 0.1 m (flat) • Length 0.3 m (flat) • Length 0.5 m (flat) • Length 0.5 m (round) • Length 1.0 m (round) • Length 2.5 m (round) 	<p>3UF7 930-0AA00-0</p> <p>3UF7 931-0AA00-0</p> <p>3UF7 935-0AA00-0</p> <p>3UF7 932-0AA00-0</p> <p>3UF7 932-0BA00-0</p> <p>3UF7 937-0BA00-0</p> <p>3UF7 933-0BA00-0</p>
<i>PC cables and adapters</i>		
	<p>For PC/PG communication with SIMOCODE pro</p> <p>Through the system interface, for connecting to the serial interface of the PC/PG</p>	<p>3UF7 940-0AA00-0</p>
	<p>USB/serial adapters</p> <p>To connect an RS 232 PC cable to the USB port of a PC, we recommend using modular safety system 3RK3, soft starter 3RW44, ET 200S/ECOFASST/ET 200pro motor starter, AS-i safety monitor and AS-i analyzer in conjunction with SIMOCODE pro 3UF7</p>	<p>3UF7 946-0AA00-0</p>
<i>Memory modules</i>		
	<p>The memory module permits the complete parameter assignment of a system to be saved and transferred to a new system, e.g. when a device is replaced, without the need for additional aids or detailed knowledge of the the device</p>	<p>3UF7 900-0AA00-0</p>
<i>Interface covers</i>		
	<p>For system interface</p>	<p>3UF7 950-0AA00-0</p>
<i>Addressing plugs</i>		
	<p>For assigning the PROFIBUS addresses without using a PC or programming device on SIMOCODE pro through the system interface</p>	<p>3UF7 910-0AA00-0</p>
<i>Door adapters</i>		
	<p>For external connection of the system interface, e.g. outside a control cabinet</p>	<p>3UF7 920-0AA00-0</p>
<i>Adapters for operator panel</i>		
	<p>The adapter enables the smaller 3UF7 20 operator panel from SIMOCODE pro to be used in a front panel cutout in which previously, e.g. after a change of system, a larger 3UF5 2 operator panel from SIMOCODE-DP had been used; degree of protection IP54</p>	<p>3UF7 922-0AA00-0</p>

PROFIBUS

SIMOCODE 3UF motor management and control devices

SIMOCODE pro 3UF7 Accessories

Selection and ordering data (continued)

	Version	Order No.
Labeling strips		
 <p>3UF7 925-0AA02-0</p>	<ul style="list-style-type: none"> • For pushbuttons of the 3UF7 20 operator panel • For pushbuttons of the 3UF7 21 operator panel with display • For LEDs of the 3UF7 20 operator panel <p>Note: Pre-punched labeling strips for user-specific printing using the free inscription software "SIRIUS Label Designer" on a laser printer. Note the software version! Download from www.siemens.com/simocode.</p>	<p>3UF7 925-0AA00-0 3UF7 925-0AA01-0 3UF7 925-0AA02-0</p>
Push-in lugs		
 <p>3RB19 00-0B</p>	<p>For screw fixing e.g. on mounting plate, 2 units required per device</p> <ul style="list-style-type: none"> • Can be used with 3UF7 1.0, 3UF7 1.1 and 3UF7 1.2 • Can be used with 3UF7 0, 3UF7 3, 3UF7 4, 3UF7 5 and 3UF7 7 	<p>3RB19 00-0B 3RP19 03</p>
Terminal covers		
 <p>3RT19 56-4EA1</p>	<p>Covers for cable lugs and busbar connections</p> <ul style="list-style-type: none"> • Length 100 mm, can be used for 3UF7 1.3-1BA00-0 • Length 120 mm, can be used for 3UF7 1.4-1BA00-0 	<p>3RT19 56-4EA1 3RT19 66-4EA1</p>
 <p>3RT19 56-4EA2</p>	<p>Covers for box terminals</p> <ul style="list-style-type: none"> • Length 25 mm, can be used for 3UF7 1.3-1BA00-0 • Length 30 mm, can be used for 3UF7 1.4-1BA00-0 	<p>3RT19 56-4EA2 3RT19 66-4EA2</p>
 <p>3RT19 56-4EA2</p>	<p>Covers for screw terminals Between contactor and current measuring module or current/voltage measuring module for direct mounting</p> <ul style="list-style-type: none"> • Can be used for 3UF7 1.3-1BA00-0 • Can be used for 3UF7 1.4-1BA00-0 	<p>3RT19 56-4EA3 3RT19 66-4EA3</p>
Box terminal blocks		
 <p>3RT19 5.-4G</p>	<p>For round and ribbon cables</p> <ul style="list-style-type: none"> • Up to 70 mm², can be used for 3UF7 1.3-1BA00-0 • Up to 120 mm², can be used for 3UF7 1.3-1BA00-0 • Up to 240 mm², can be used for 3UF7 1.4-1BA00-0 	<p>3RT19 55-4G 3RT19 56-4G 3RT19 66-4G</p>
Bus termination modules		
	<p>With separate control supply voltage for terminating the bus following the last unit on the bus line Supply voltage:</p> <ul style="list-style-type: none"> • 115/230 V AC • 24 V DC 	<p>3UF1 900-1KA00 3UF1 900-1KB00</p>
System manuals		
 <p>3UF7 970-0AA01-0</p>	<p>SIMOCODE pro With token fee Languages:</p> <ul style="list-style-type: none"> • German • English • French 	<p>3UF7 970-0AA01-0 3UF7 970-0AA00-0 3UF7 970-0AA02-0</p>

Note:

The system manual "SIMOCODE pro Safety Failsafe Digital Modules" is available on the Internet at:
www.siemens.com/simocode

Selection and ordering data (continued)

Version	Order No.
<i>SIMOCODE ES 2007 Basic</i>	
 <p>Floating license for one user Engineering software, software and documentation on CD, 3 languages (German/English/French), communication through system interface</p> <ul style="list-style-type: none"> • License key on USB stick, Class A • License key download, Class A <p>3ZS1 312-4CC10-0YA5</p>	<p>3ZS1 312-4CC10-0YA5 3ZS1 312-4CE10-0YB5</p>
<i>SIMOCODE ES 2007 Standard</i>	
<p>Floating license for one user Engineering software, software and documentation on CD, 3 languages (German/English/French), communication through system interface, integrated graphics editor</p> <ul style="list-style-type: none"> • License key on USB stick, Class A • License key download, Class A 	<p>3ZS1 312-5CC10-0YA5 3ZS1 312-5CE10-0YB5</p>
<p>Upgrade for SIMOCODE ES 2004 and later Floating license for one user, engineering software, software and documentation on CD, license key on USB stick, Class A, 3 languages (German/English/French), communication through the system interface</p>	<p>3ZS1 312-5CC10-0YE5</p>
<p>Powerpack for SIMOCODE ES 2007 Basic Floating license for one user, engineering software, license key on USB stick, Class A, 3 languages (German/English/French), communication through the system interface</p>	<p>3ZS1 312-5CC10-0YD5</p>
<p>Software Update Service For 1 year with automatic extension, assuming the current software version is in use, engineering software, software and documentation on CD, communication through the system interface</p>	<p>3ZS1 312-5CC10-0YL5</p>
<i>SIMOCODE ES 2007 Premium</i>	
<p>Floating license for one user Engineering software, software and documentation on CD, 3 languages (German/English/French), communication through system interface or PROFIBUS, integrated graphics editor, STEP 7 Object Manager</p> <ul style="list-style-type: none"> • License key on USB stick, Class A • License key download, Class A 	<p>3ZS1 312-6CC10-0YA5 3ZS1 312-6CE10-0YB5</p>
<p>Upgrade for SIMOCODE ES 2004 and later Floating license for one user, engineering software, software and documentation on CD, license key on USB stick, Class A, 3 languages (German/English/French), communication through the system interface or PROFIBUS</p>	<p>3ZS1 312-6CC10-0YE5</p>
<p>Powerpack for SIMOCODE ES 2007 Standard Floating license for one user, engineering software, license key on USB stick, Class A, 3 languages (German/English/French), communication through PROFIBUS or the system interface</p>	<p>3ZS1 312-6CC10-0YD5</p>
<p>Software Update Service For 1 year with automatic extension, assuming the current software version is in use, engineering software, software and documentation on CD, communication through PROFIBUS or the system interface</p>	<p>3ZS1 312-6CC10-0YL5</p>

Note:

Please order PC cable separately, see page 3/291.

For more information see Catalog IC 10

"Parameterization, Configuration and Visualizing for SIRIUS".

PROFIBUS

SIMOCODE 3UF motor management and control devices

SIMOCODE pro 3UF7 Accessories

Selection and ordering data (continued)

Version		Order No.
<i>SIMOCODE pro function block library for SIMATIC PCS 7</i>		
 <p>3UF7 982-0AA00-0</p>	<p>Scope of supply: AS modules and faceplates for integrating SIMOCODE pro into the PCS 7 process control system</p> <p>Engineering software for one engineering station (single license) including runtime software for execution of the AS module in an automation system (single license), German/English/French, type of delivery: CD incl. electronic documentation</p> <ul style="list-style-type: none"> • For PCS 7 Version V 6.0 • For PCS 7 Version V 6.1 • For PCS 7 Version V 7.0 <p>Runtime software For execution of the AS module in an automation system (single license), type of delivery: license without software and documentation</p> <ul style="list-style-type: none"> • For PCS 7 Version V 6.x • For PCS 7 Version V 7.x <p>Upgrade for PCS 7 function block library SIMOCODE pro, V6.0 or V6.1 to version SIMOCODE pro V7.0 for integrating SIMOCODE pro into the PCS 7 process control system, for PCS 7 Version V7.0 (single license), German/English/French, type of delivery: CD incl. electronic documentation</p>	
<ul style="list-style-type: none"> • For PCS 7 Version V 6.0 		3UF7 982-0AA00-0
<ul style="list-style-type: none"> • For PCS 7 Version V 6.1 		3UF7 982-0AA02-0
<ul style="list-style-type: none"> • For PCS 7 Version V 7.0 		3UF7 982-0AA10-0
<ul style="list-style-type: none"> • For PCS 7 Version V 6.x 		3UF7 982-0AA01-0
<ul style="list-style-type: none"> • For PCS 7 Version V 7.x 		3UF7 982-0AA11-0
<ul style="list-style-type: none"> • For PCS 7 Version V 7.0 		3UF7 982-0AA13-0



Note:

For more information see Catalog IC 10 "Parameterization, Configuration and Visualizing for SIRIUS".

Overview

The 3UF18 current transformers are protection transformers and are used for actuating overload relays. Protection transformers are designed to ensure proportional current transfer up to a multiple of the primary rated current. The 3UF18 current transformers convert the maximum current of the corresponding operating range into the standard value of 1 A secondary.

Selection and ordering data

Mounting type	Operating range A	Screw terminals Order No.		
<i>For stand-alone installation</i>				
 3UF18 43	Screw fixing and snap-on mounting onto 35 mm standard mounting rail	0.25 ... 2.5 ¹⁾ 1.25 ... 12.5 ¹⁾ 2.5 ... 25 ¹⁾ 12.5 ... 50 16 ... 65 25 ... 100	3UF18 43-1BA00 3UF18 43-2AA00 3UF18 43-2BA00 3UF18 45-2CA00 3UF18 47-2DA00 3UF18 48-2EA00	
	<i>For mounting onto contactors and stand-alone installation</i>			
	 3UF18 68	Screw fixing	32 ... 130 50 ... 200 63 ... 250 100 ... 400 125 ... 500 160 ... 630 205 ... 820	3UF18 50-3AA00 3UF18 52-3BA00 3UF18 54-3CA00 3UF18 56-3DA00 3UF18 57-3EA00 3UF18 68-3FA00 3UF18 68-3GA00

¹⁾ The following setting ranges for the protection of EEx e motors are applicable:
 3UF18 43-1BA00, 0.25 ... 1.25 A;
 3UF18 43-2AA00, 1.25 ... 6.3 A;
 3UF18 43-2BA00, 2.5 ... 12.5 A.

Accessories

For contactor type	Order No.	
<i>Terminal covers</i>		
 3TX7 466-0A	For transformer/contactor combinations and stand-alone installation for transformer (cover required per connection side)	
	3UF18 45	3TX7 446-0A
	3UF18 48	3TX7 466-0A
	3UF18 50, 3UF18 52	3TX7 506-0A
	3UF18 54 to 3UF18 57	3TX7 536-0A
	3UF18 68-3FA00	3TX7 686-0A
3UF18 68-3GA00	3TX7 696-0A	
For covering the screw terminal for direct mounting on contactor (cover required per contactor/transformer combination)	3UF18 48	3TX7 466-0B
	3UF18 50, 3UF18 52	3TX7 506-0B
	3UF18 54 to 3UF18 57	3TX7 536-0B
	3UF18 68-3FA00	3TX7 686-0B
	3UF18 68-3GA00	3TX7 696-0B

PROFIBUS

3RK3 modular safety system

General data

Overview

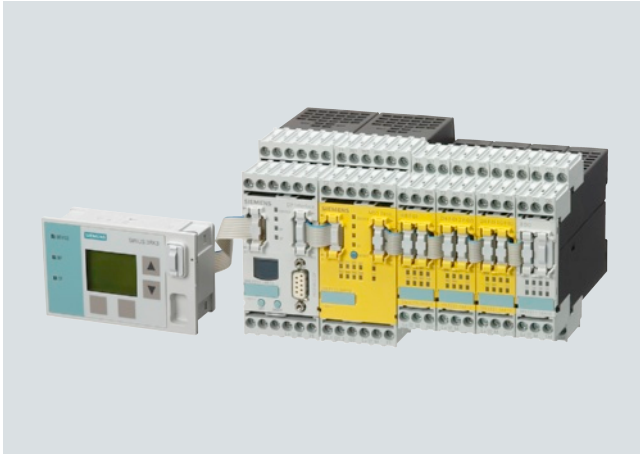

SIRIUS 3RK3 modular safety system

The 3RK3 modular safety system (MSS) is a freely parameterizable modular safety relay. Depending on the external circuit version, safety-oriented applications up to Category 4 according to EN 954-1, Performance Level e according to ISO 13849-1 or SIL3 according to IEC 62061 can be realized.

The modular safety relay enables the interconnection of several safety applications. Using the MSS ES graphical parameterization tool it is very easy to create the safety functions as well as their logical links on the PC. For example disconnection ranges, ON-delays, OFF-delays and other dependencies can be defined.

With the optional expansion modules, both safety-related and standard, the system is flexibly adapted to the required safety applications.

The MSS comprises the following system components:

- Central module
- Expansion modules
- Interface module
- Diagnostics module
- Parameterization software
- Accessories

The comprehensive error and status diagnostics provides the possibility of finding errors in the system and localizing signals from sensors. Plant downtimes can be reduced as a result.

The optional PROFIBUS DP interface module transfers diagnostics data to higher-level bus systems (e.g. PROFIBUS DP). These data are then available for further processing in the automation system.

Connection methods

On the following pages you will find selection tables for the modular safety system.



Screw terminals









Spring-type terminals

PROFIBUS 3RK3 modular safety system

Central modules, expansion modules, interface modules, operating and monitoring modules

Selection and ordering data

					
3RK3 111-1AA10	3RK3 211-1AA10 3RK3 221-1AA10 3RK3 231-1AA10 3RK3 242-1AA10	3RK3 251-1AA10	3RK3 311-1AA10 3RK3 321-1AA10	3RK3 511-1BA10	3RK3 611-3AA00
Version			Screw terminals	Spring-type terminals	
			Order No.	Order No.	

Central modules

3RK3 Basic

Central module with safety-orientated inputs and outputs

- 8 inputs
- 1 two-channel relay output
- 1 two-channel solid-state output

Max. 7 expansion modules can be connected

Note:

Memory module 3RK3 931-0AA00 is included in the scope of supply.

3RK3 111-1AA10

3RK3 111-2AA10

Expansion modules

4/8 F-DI

Safety-related input module

- 8 inputs

3RK3 211-1AA10

3RK3 211-2AA10

2/4 F-DI 1/2 F-RO

Safety-related input/output module

- 4 inputs
- 2 single-channel relay outputs

3RK3 221-1AA10

3RK3 221-2AA10

2/4 F-DI 2F-DO

Safety-related input/output module

- 4 inputs
- 2 two-channel solid-state outputs

3RK3 231-1AA10

3RK3 231-2AA10

4/8 F-RO

Safety-oriented output modules

- 8 single-channel relay outputs

3RK3 251-1AA10

3RK3 251-2AA10

4 F-DO

Safety-oriented output modules

- 4 two-channel solid-state outputs

3RK3 242-1AA10

3RK3 242-2AA10

8 DI

Standard input module

- 8 inputs

3RK3 321-1AA10

3RK3 321-2AA10

8 DO

Standard output module

- 8 solid-state outputs

3RK3 311-1AA10

3RK3 311-2AA10

Interface modules

DP interface

PROFIBUS DP interface, 12 Mbit/s, RS 485, 32 bit cyclic data exchange, acyclic exchange of diagnostics data

3RK3 511-1BA10

3RK3 511-2BA10

Operating and monitoring modules

Diagnostics module

3RK3 611-3AA00

--

Note:







Connection cable required, see page 3/298.

PROFIBUS

3RK3 modular safety system

Accessories

Selection and ordering data



	Version	Order No.
Connection cables (essential accessory)		
 3UF7 932-0AA00-0	For connection of Central module to expansion modules or interface module	Diagnostic module to central module or interface module
	3	• Length 0.025 m (flat)
	--	• Length 0.1 m (flat)
	--	• Length 0.3 m (flat)
	--	• Length 0.5 m (flat)
	--	• Length 0.5 m (round)
	--	• Length 1.0 m (round)
	--	• Length 2.5 m (round)
PC cables and adapters		
 3UF7 940-0AA00-0	PC cable for PC/PG communication with 3RK3 modular safety system Through the system interface, for connecting to the serial interface of the PC/PG	3UF7 940-0AA00-0
	USB/serial adapters To connect an RS 232 PC cable to the USB port of a PC, recommended for use in conjunction with 3RK3	3UF7 946-0AA00-0
Interface covers		
 3UF7 950-0AA00-0	For system interface	3UF7 950-0AA00-0
Memory modules		
 3RK3 931-0AA00	For parameterizing the 3RK3 modular safety system without a PC/PG through the system interface	3RK3 931-0AA00
Door adapters		
 3UF7 920-0AA00-0	For external connection of the system interface, e.g. outside a control cabinet	3UF7 920-0AA00-0
Push-in lugs		
 3RP19 03	For screw fixing e.g. on mounting plate, 2 units required per device Can be used for 3RK3	3RP19 03

- ✓ Available
-- Not available

Selection and ordering data (continued)

Parameterization, start-up and diagnostics software for the 3RK3

- Runs under Windows XP Professional (Service Pack 2 or 3), Windows 7 32 Bit Professional/Ultimate/Business
- Without PC cable

	Version	Order No.
<i>Modular Safety System ES 2008 Basic</i>		
 <p>3ZS1 314-4CC10-0YA5</p>	<p>Floating license for one user engineering software in limited-function version for diagnostics purposes, software and documentation on CD, 3 languages (German/English/French), communication through the system interface</p> <ul style="list-style-type: none"> • License key on USB stick, Class A • License key download, Class A 	<p>3ZS1 314-4CC10-0YA5 3ZS1 314-4CE10-0YB5</p>
<i>Modular Safety System ES 2008 Standard</i>		
 <p>3ZS1 314-5CC10-0YA5</p>	<p>Floating license for one user engineering software, software and documentation on CD, 3 languages (German/English/French), communication through the system interface</p> <ul style="list-style-type: none"> • License key on USB stick, Class A • License key download, Class A 	<p>3ZS1 314-5CC10-0YA5 3ZS1 314-5CE10-0YB5</p>
	<p>Powerpack Floating license for one user, engineering software, software and documentation on CD, license key on USB stick, Class A, 3 languages (German/English/French), communication through the system interface</p>	<p>3ZS1 314-5CC10-0YD5</p>
	<p>Software Update Service For 1 year with automatic extension, assuming the current software version is in use, engineering software, software and documentation on CD, communication through the system interface</p>	<p>3ZS1 314-5CC10-0YL5</p>

PROFIBUS

Energy management

PC-based energy management system

Overview



Components of the PC-based energy management system

Energy management system with the SENTRON product family

The SENTRON product family offers the user not only power management software in the form of SENTRON powermanager but also the corresponding hardware in the form of SENTRON measuring devices and 3WL/3VL circuit breakers for the realization of a complete energy management system.

The components are optimally coordinated with each other. For example, special drivers for the SENTRON devices are integrated in the powermanager software so that on the one hand the power data acquisition can take place without any great configuration effort and, on the other hand, the most important measured values or states are indicated by predefined displays.

This reduces the engineering work for the customer and gives the user the assurance of knowing that the device functions are optimally supported in the software.



User interface of powermanager

Energy management software powermanager

The energy management software powermanager is at the heart of the PC-based energy management system and

- is independent energy management software
- can be operated using a PC and measuring devices with Ethernet connection.
- is expandable from the simple standard application to a fully flexible customer solution.
- is fully scalable with regard to the number of devices and to the software's functions
- ensures the optimum integration of measuring devices from the 7KM PAC range, 3WL/3VL circuit breakers and other devices.

The powermanager energy management software includes a client/server installation for recording, preparing, displaying and archiving power data. These power data are supplied primarily by 7KM PAC measuring devices or 3WL/3VL circuit breakers, which are connected to the system through Ethernet.

The powermanager software is available in the "Expert", "Web" and "Distributed Systems" option packs.

Benefits

- Transparency of power flows
- Exact knowledge of the consumption profile
- Increase of power efficiency
- Optimization of power supply contracts
- Compliance with contractual terms
- Assignment of power costs to cost centers
- Optimization of plant maintenance
- Identification of critical plant conditions

Application

The PC-based energy management system is used wherever power flows need to be transparently displayed and monitored.

Industries

Energy efficiency thanks to power management with consistent monitoring and the resulting optimisation measures is important for all industries, e.g. in the manufacturing industry, in non-residential buildings, in the field of services, and in infrastructure projects. This has a particular impact on competitiveness, particularly in view of rising energy prices.

System configuration with powermanager

- Integration of measuring devices by means of predefined device templates for the 7KM PAC family and the 3WL/3VL circuit breakers
- Easy integration of existing modbus-capable detecting devices
- Communication through Standard Ethernet
- Integration of devices with RS485 interface (ModbusRTU) through Modbus gateway, e.g. the 7KM PAC4200 can be used as gateway

Applications (continued)

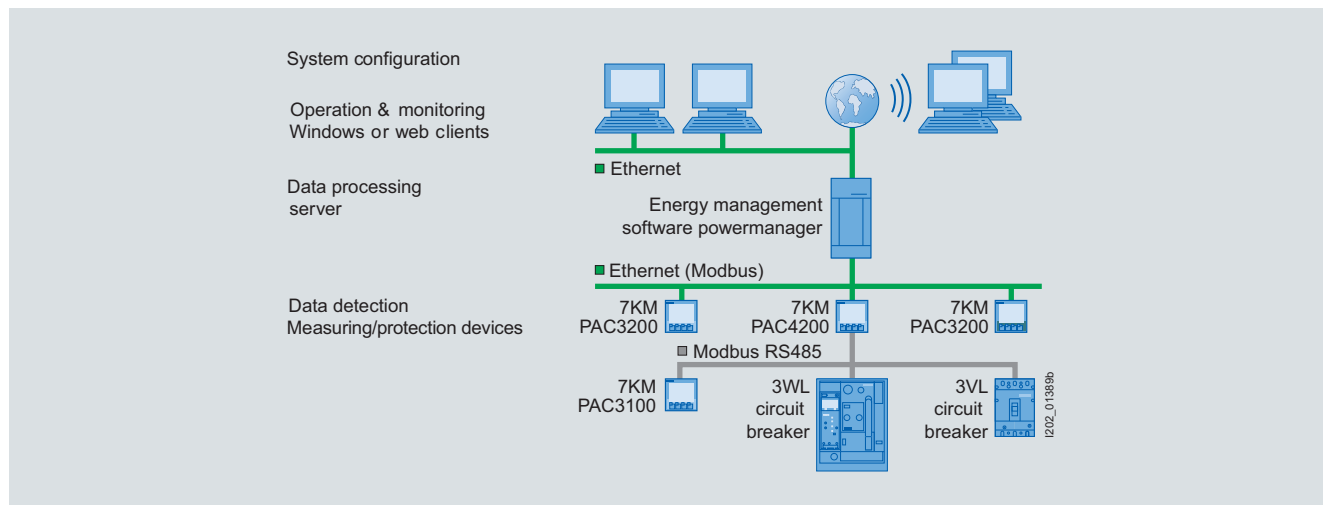

System overview

More information

Hardware components

The hardware components of the PC-based energy management system are

- the 7KM PAC measuring devices on Page 3/303
- the open 3WL circuit breakers in Catalog LV 10.1
- the 3VL molded case circuit breakers in Catalog LV 10.1

Software

The software for the PC-based energy management system is powermanager, see Catalog LV 10.1, Section "Configuring, visualizing and controlling with SENTRON".

Internet

You can find more information on the Internet at:
www.siemens.com/lowvoltage/energymanagement

PROFIBUS

Energy management

SIMATIC-based energy management system

Overview

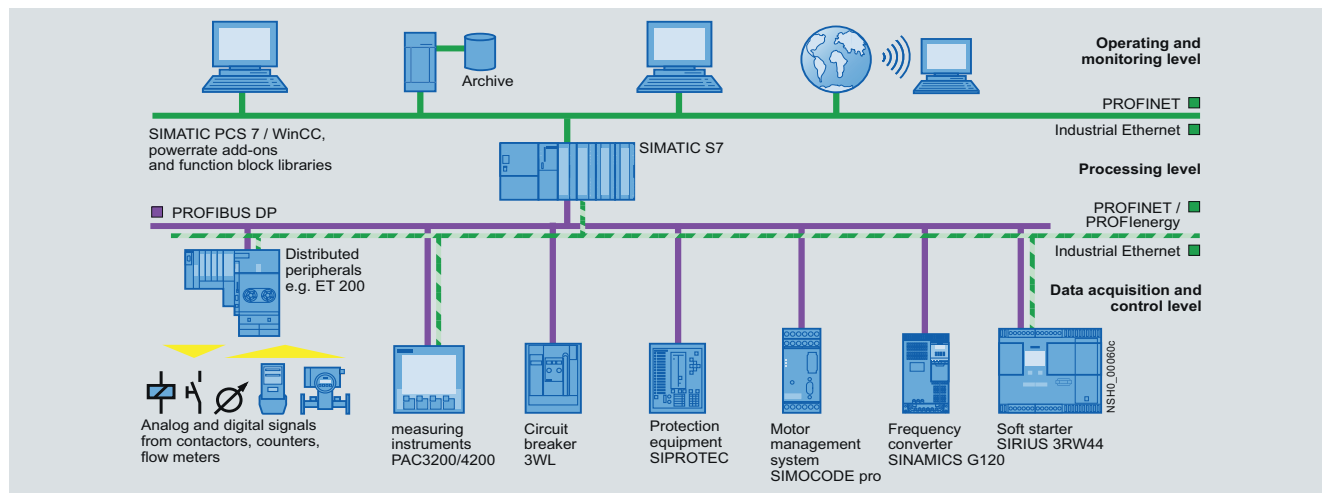

SIMATIC-based solutions for the process and manufacturing industry

Besides the high level of automation, a key feature of the process and manufacturing industry is a very high power consumption. It is only natural, therefore, to integrate an energy management system in the existing systems. The add-on SIMATIC powerrate for WinCC and PCS 7 makes it possible to provide transparency and control in power distribution and energy costs.

Integration of switching, safety and measuring devices

For complete integration of low-voltage power distribution components in process and SCADA systems, PROFIBUS DP interfaces and function block libraries are available, e.g. the PAC3200 function block library for SIMATIC WinCC and PCS 7. The software add-ons can therefore be used to display all the data supplied from the devices without major engineering work.

PROFINET and PROFlenergy

An increasing number of devices in automation technology offer PROFINET. There is also a Switched Ethernet PROFINET module for the 7KM PAC3200 and PAC4200 measuring device. PROFlenergy is a "Common Application Profile" from the PNO. Thanks to PROFlenergy it is possible to assemble an energy management system with standardized device interfaces.

SIMATIC powerrate

The SIMATIC powerrate software is at the heart of the SIMATIC-based energy management system and

- is an add-on to PCS 7 and WinCC which throws light on power consumption from the infeed to the load.
- continuously collects, archives and processes power data
- creates a load profile and works out potential savings based on exact knowledge of the load profile.
- monitors the contractually agreed power limit.
- enables the exact recording and evaluation of power consumption per batch through batch-related consumption recording.
- enables the monitoring or indication of switch status and, with suitable authorization, remote switching.
- shows selected measurements online and messages from the 7KM PAC3200 and PAC4200 measuring devices
- collects archived data, which can be exported to Excel and presented in various reports.

Benefits

- Increased energy efficiency due to exact knowledge of the load profile
- Optimization of power supply contracts
- Assignment of power costs to cost centers
- Optimization of plant maintenance
- Identification of critical plant conditions
- Reliable monitoring of the power limit through automatic load management

Application

The SIMATIC-based energy management system is used wherever power flows need to be transparently displayed and monitored, and also where it is necessary to effectively intervene above the process control level.

Industries

SIMATIC powerrate is used in all areas in which PCS 7 or WinCC is used and energy efficiency considerations play a major role.

More information

Hardware components

- the 7KM PAC measuring devices on Page 3/303
- the open 3WL circuit breakers in Catalog LV 10.1
- the 3VL molded case circuit breakers in Catalog LV 10.1

Software components

- SIMATIC powerrate
- PCS 7 function block library PAC3200
- WinCC function block library PAC3200

All software components can be found in Catalog LV 10.1.

You can find more information on the Internet at:
www.siemens.com/lowvoltage/energymanagement

Overview

Precise measuring with 7KM PAC3100, PAC3200 and PAC4200



The 7KM PAC measuring devices: PAC3200 (left), PAC3100 (center) and PAC4200 (right)

The 7KM PAC measuring devices are used to measure and indicate all relevant network parameters in low-voltage power distribution. They can be used for single-phase measurements as well as for multiphase measurements in 3 and 4-conductor networks (TN, TT, IT).

Power values for main distribution boards, electrical feeders or individual loads are recorded precisely and reliably, and important measured values are supplied in addition for assessing the state of the plant and the quality of the network.

More information

More information is available on the Internet at:
www.siemens.com/lowvoltage/energymanagement

Benefits

7KM PAC measuring device, general

The common features of all power monitoring devices in the 7KM PAC series:

- Simple mounting and commissioning
- High IP65 degree of protection (front side, when installed) permits usage in extremely dusty and wet environments
- Intuitive operation using 4 function buttons and multilingual plain text displays
- Easy adaptation to different systems using integrated and optional
 - Digital inputs and outputs
 - Communication interfaces
- Worldwide use
 - Min. 8 languages
 - International approvals
 - Developed and tested to European and international standards
- Low mounting depth

7KM PAC3200 and 7KM PAC4200 measuring device

Additional performance characteristics of the 7KM PAC3200 and 7KM PAC4200:

- Precise energy recording
- Versatile system integration
 - Integrated Ethernet interface
 - Optional communication modules available
 - Multifunctional digital inputs and outputs
 - Limit value monitoring
- Can be connected directly to power supply networks up to 690 V AC (UL-L), CATIII without voltage transformers.
- Easy-to-use configuration software included as standard

7KM PAC4200 measuring device

Additional performance characteristics of the 7KM PAC4200:



- Monitoring the plant status and the system quality
 - Basic information for evaluating network quality
 - Logging of plant history in the form of operation, control and system-related events
- Recording of the power range through power averaging (load profile)
- Daily energy meters for apparent, active and reactive energy across 365 days for cut-off date assessment
- Detection of gas, water, compressed air or other energy sources via pulse counter to the digital inputs
- Can be expanded using modules to up to 10 digital inputs and 6 digital outputs
- Meters for apparent, active and reactive energy for the precise detection of the power consumption of a partial process or manufacturing process
- 10/100 Mbit/s Ethernet interface with gateway function for the easy connection of devices with serial RS485 interface via expansion module PAC RS485 to an Ethernet network
- Comprehensive convenience indicators, such as user-defined displays, bar and status indicators, phase diagram and list and histogram graphics
- Satisfies the accuracy requirements of class 0.2S high-precision meters used by power supply companies according to IEC 62053-22, which are normally reserved for exacting industrial applications

PROFIBUS



7KM PAC measuring devices

7KM PAC3100 measuring devices

Selection and ordering data

Version	Order No.
  <p>7KM PAC3100 measuring device Control panel flush-mounting instrument 96 mm x 96 mm Screw terminals for connecting current and voltage AC/DC power supply unit with wide voltage range U_{AUX}: 100 ... 240 V AC $\pm 10\%$, 50/60 Hz 110 ... 250 V DC $\pm 10\%$ Measuring inputs U_e: max. 3 AC 480/277 V, 50/60 Hz I_e: /5 A</p> <p>7KM3 133-0BA00-3AA0</p>	<p>Screw terminals </p> <p>7KM3 133-0BA00-3AA0</p>

Accessories

Version	Order No.
<p><i>For PAC 3100/3200/4200</i></p>  <p>7KM PAC TMP2 mounting plate double-tiered adapter for mounting a measuring device on standard mounting rail</p> <ul style="list-style-type: none"> • Display faces forward • for possible manual intervention <p>7KM9 900-0XA00-0AA0</p>	<p>7KM9 900-0XA00-0AA0</p>
 <p>7KM PAC TMP mounting plate Adapter for mounting a measuring device on standard mounting rail</p> <ul style="list-style-type: none"> • Display faces backwards towards standard mounting rail • Read-out and evaluation of measurements solely via mains operation <p>7KM9 900-0YA00-0AA0</p>	<p>7KM9 900-0YA00-0AA0</p>

More information









Current transformers

- Suitable current transformers can be found
- in the Catalog LV 10.1 under "Molded case circuit breakers"
 - In the Industry Mall, section "Industry Automation and Drive Technologies"
 - > "Low-Voltage Power Distribution and Electrical Installation Technology"
 - > "Protection Equipment "
 - > "Molded Case Circuit Breakers"
 - > "3VL Molded Case Circuit Breakers"
 - > "3VL Molded Case Circuit Breakers up to 1600 A"
 - > "Accessories and Spare Parts"

Software components

For more information about the software components see Catalog LV 10.1 and on the Internet at:
www.siemens.com/lowvoltage/energymanagement

Selection and ordering data

	Version	Order No.
  <p>7KM2 112-0BA00-3AA0</p>	<p>7KM PAC3200 measuring device</p> <p>Control panel flush-mounting instrument 96 mm x 96 mm Screw terminals for connecting current and voltage AC/DC power supply unit with wide voltage range U_{AUX}: 95 ... 240 V AC $\pm 10\%$, 50/60 Hz 110 ... 340 V DC $\pm 10\%$</p> <p>Measuring inputs U_e: max. 3 AC 690/400 V, 50/60 Hz I_e: /1 A or /5 A</p>	<p>Screw terminals </p> <p>7KM2 112-0BA00-3AA0</p>
  <p>7KM2 111-1BA00-3AA0</p>	<p>7KM PAC3200 measuring device</p> <p>Control panel flush-mounting instrument 96 mm x 96 mm Screw terminals for connecting current and voltage DC power supply unit with extra-low voltage U_{AUX}: 22 ... 65 V DC $\pm 10\%$</p> <p>Measuring inputs U_e: max. 3 AC 500/289 V, 50/60 Hz I_e: /1 A or /5 A</p>	<p>Screw terminals </p> <p>7KM2 111-1BA00-3AA0</p>
  <p>7KM2 112-0BA00-2AA0</p>	<p>7KM PAC3200 measuring device</p> <p>Control panel flush-mounting instrument 96 mm x 96 mm Cable lug terminals for connecting current and voltage AC/DC power supply unit with wide voltage range U_{AUX}: 95 ... 240 V AC $\pm 10\%$, 50/60 Hz 110 ... 340 V DC $\pm 10\%$</p> <p>Measuring inputs U_e: max. 3 AC 690/400 V, 50/60 Hz I_e: /1 A or /5 A</p>	<p>Ring terminal lug connection </p> <p>7KM2 112-0BA00-2AA0</p>

More information









For accessories and information about current transformers and software components see Page 3/304

PROFIBUS

7KM PAC measuring devices

7KM PAC4200 measuring devices

Selection and ordering data

	Version	Order No.
  <p>7KM4 112-0BA00-3AA0</p>	<p>7KM PAC4200 measuring device</p> <p>Control panel flush-mounting instrument 96 mm x 96 mm Screw terminals for connecting current and voltage</p> <p>AC/DC power supply unit with wide voltage range U_{AUX}: 95 ... 240 V AC $\pm 10\%$, 50/60 Hz 110 ... 340 V DC $\pm 10\%$</p> <p>Measuring inputs U_e: max. 3 AC 690/400 V, 50/60 Hz I_e: /1 A or /5 A</p>	<p>Screw terminals </p> <p>7KM4 212-0BA00-3AA0</p>
  <p>7KM4 112-1BA00-3AA0</p>	<p>7KM PAC4200 measuring device</p> <p>Control panel flush-mounting instrument 96 mm x 96 mm Screw terminals for connecting current and voltage</p> <p>DC power supply unit with extra-low voltage U_{AUX}: 22 ... 65 V DC $\pm 10\%$</p> <p>Measuring inputs U_e: max. 3 AC 690/400 V, 50/60 Hz I_e: /1 A or /5 A</p>	<p>Screw terminals </p> <p>7KM4 212-1BA00-3AA0</p>
  <p>7KM4 112-0BA00-2AA0</p>	<p>7KM PAC4200 measuring device</p> <p>Control panel flush-mounting instrument 96 mm x 96 mm Cable lug terminals for connecting current and voltage</p> <p>AC/DC power supply unit with wide voltage range U_{AUX}: 95 ... 240 V AC $\pm 10\%$, 50/60 Hz 110 ... 340 V DC $\pm 10\%$</p> <p>Measuring inputs U_e: max. 3 AC 690/400 V, 50/60 Hz I_e: /1 A or /5 A</p>	<p>Ring terminal lug connection </p> <p>7KM4 212-0BA00-2AA0</p>

More information

For accessories and information about current transformers and software components see Page 3/304

Overview



From left to right:
Expansion module 7KM PAC Switched Ethernet PROFINET
Expansion module 7KM PAC PROFIBUS DP
Expansion module 7KM PAC RS485
Expansion module 7KM PAC 4DI/2DO

Expansion modules act as communication interfaces for 7KM measuring devices.

Communication modules are plugged in at the back of the measuring device. The device identifies the module automatically and presents the parameters of relevance for this module for selection in the parameterization menu.

7KM PAC Switched Ethernet PROFINET expansion module

The 7KM PAC Switched Ethernet PROFINET expansion module is a plug-in communication module for the 7KM PAC3200 and PAC4200 measuring devices.

- Standardized PROFlenergy interface to the measured variables.
- The measured variables can be individually selected using a GSDML file. This enables the use of cost-effective S7-CPU's.
- Easy parameter assignment using the device display and STEP 7.
- Integrated Ethernet Switching permits networking with short cables without additional switches.
- Direct integration in production machine networks using IRT (IRT = Isochronous-Real-Time).
- Full support of PROFINET IO (DHC, DNS, SNMP, SNTP).
- Device replacement without PG in the PROFINET network using LLDP.
- Deterministic reversing time through ring redundancy (MRP).
- Modbus TCP for communication with 7KM powermanager or powerconfig.
- 2 x Ethernet (RJ45) sockets.
- Baud rates 10 and 100 Mbit/s.
- Protocols PROFINET IO, PROFlenergy and Modbus TCP.
- No external auxiliary power necessary.
- Additional display via the device display and via LEDs on the module.

All measurement variables from 7KM PAC3200 and PAC4200 are individually selected and cyclically transmitted by means of the GSDML file. This enables optimum use of the process image of the PROFINET controller, e.g. CPU 315-2 PN/DP of SIMATIC S7.

The measured variables can be read out in acyclic mode using PROFlenergy, a PNO protocol profile. Thanks to PROFlenergy it is possible to assemble an energy management system with devices from various manufacturers using PROFINET.

7KM PAC PROFIBUS DP expansion module

The PAC PROFIBUS DP expansion module has the following features:

- Pluggable communication modules for 7KM PAC3200 and PAC4200 measuring devices
- Parameterizable from the front of the device or using parameterization software
- Using PROFIBUS DPV1, data can be transferred in both cyclic and acyclic modes
- Easy engineering thanks to integration into SIMATIC STEP 7 and/or simple integration via GSD file for other programming systems
- Optimum use of process image of a control for selection of individual measurement values for cyclical transfer
- All baud rates from 9.6 kbit/s up to 12 Mbit/s are supported
- Connection through 9-pole Sub-D connector according to IEC 61158
- No external auxiliary power necessary
- Additional display via the device display and via LEDs on the module

PROFIBUS

7KM PAC measuring devices

Expansion modules for 7KM PAC measuring devices

Overview (continued)

7KM PAC RS485 expansion module

The 7KM PAC RS485 expansion module has the following features:

- Pluggable 7KM PAC RS485 communication module for 7KM PAC3200 and PAC4200 measuring devices
- Parameterizable from the front of the device or using parameterization software
- Support for the Modbus RTU protocol
- Plug and play
- Baud rates 4.8 / 9.6 / 19.2 and 38.4 kbit/s are supported.
- Connection by means of 6-pole screw terminals
- No external auxiliary power necessary
- Status indication by LED on the module

The 7KM PAC RS485 expansion module is required for the gateway function of the 7KM PAC4200 to achieve simple devices with RS485 interface, such as the 7KM PAC3100, via Ethernet (Modbus TCP).





7KM PAC 4DI/2DO expansion module

The 7KM PAC 4DI/2DO expansion module is used to expand the 7KM PAC4200 measuring device to up to 10 digital inputs and 6 digital outputs.

It offers the following features:

- Up to two 7KM 4DI/2DO modules can be plugged onto a PAC4200.
- The 7KM PAC 4DI/2DO modules mean that the internal digital inputs and outputs can be expanded by up to 8 inputs and 4 outputs.
- The 4DI/2DO expansion modules can be parameterized via the front of the device or via the powerconfig configuration software.
- The digital inputs can be used without external voltage sources. They are self-powered.
- All functions of the integrated multifunctional inputs/outputs on the 7KM PAC4200 are also available in the 7KM PAC 4DI/2DO expansion module.
- Inputs and outputs can be used as an S0 interface conforming to IEC 62053-31.
- The connection is made via a 9-pole screw terminal.
- No external auxiliary power supply is required.

Selection and ordering data

	Version	Order No.
	7KM PAC Switched Ethernet PROFINET expansion module Expansion module for 7KM PAC3200 and PAC4200 (PROFINET)	7KM9 300-0AE00-0AA0
	7KM PAC PROFIBUS DP expansion module Expansion module for 7KM PAC3200 and PAC4200 (PROFIBUS DPV1)	7KM9 300-0AB00-0AA0
	7KM PAC RS485 expansion module Expansion module for 7KM PAC3200 and PAC4200 (Modbus RTU)	7KM9 300-0AM00-0AA0
	7KM PAC 4DI/2DO expansion module Expansion module for 7KM PAC4200	7KM9 200-0AB00-0AA0

More information

Software components

For more information about the software components see Catalog LV 10.1 and on the Internet at: www.siemens.com/lowvoltage/energymanagement

Overview

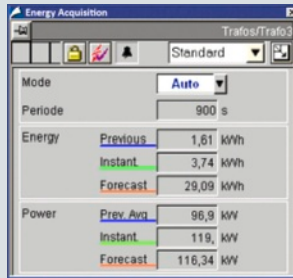
**SIMATIC powerrate**

SIMATIC WinCC powerrate is an add-on to PCS 7 and WinCC which throws light on power consumption from the infeed to the load.

- Identification of power-intensive consumer devices and processes in order to introduce measures for improving power efficiency
- Comparison of consumption profiles for greater efficiency of process design
- Optimizing the company according to energy parameters based on an assessment of consumption and costs
- Complying with the contractually agreed power limit, thus preventing higher power supply costs or penalty payments.

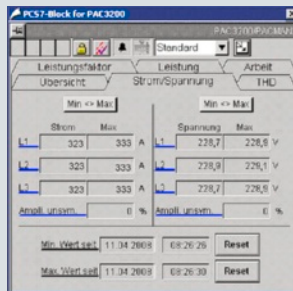
**SIMATIC PCS 7 Library PAC3200, SENTRON PAC3200 function block library for SIMATIC WinCC**

The function block libraries enable the seamless integration of the 7KM PAC3200 power monitoring device into the PSC 7 process world or into WinCC.

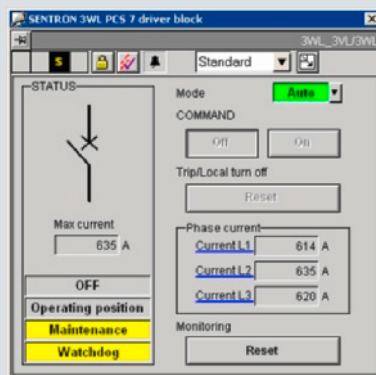
**3WL/3VL function block library for SIMATIC PCS 7**

The 3WL/3VL function block library enables the seamless integration of the 3WL/3VL circuit breaker in the PSC 7 process world.

PROFIBUS

Configuring, visualizing and controlling with SIMATIC

SIMATIC powerrate

Overview



SIMATIC powerrate is an add-on to PCS 7 and WinCC which throws light on power consumption from the infeed to the load. Power data are continuously collected, archived and processed further. With an exact knowledge of the consumption profile, it is possible to identify savings potential, optimize your power supply conditions and hence lower your power costs. Monitoring the contractually agreed power limit helps on the one hand to prevent unnecessarily high power prices or penalties and on the other hand to make full use of the fixed power limit.

Batch-related consumption recording enables the exact recording and evaluation of power consumption per batch.

The integration of switches through digital inputs/outputs enables the monitoring or indication of switch status and, with suitable authorization, remote switching. If connection is through DPV1 or PROFINET selected measured values and messages from the 7KM PAC3200 and PAC4200 measuring devices can be displayed online.

Data recorded and archived by SIMATIC powerrate can be exported to Excel and presented in various reports.

Support for the WinCC Web Navigator means that the SIMATIC powerrate functionality is also available over the web.

Full integration in PCS 7 and WinCC makes it easy to use standard interfaces or standard functionalities from PCS 7 or WinCC.

Components

SIMATIC powerrate is made up of the following components:

- Function blocks for the acquisition and processing of power data
- Faceplates for the presentation and processing of power data
- Components for implementing load management (calculating trends, monitoring limits, enabling/disabling loads)
- Function blocks for batch-related consumption recording
- Function blocks for the integration of measuring devices and switches
- Other components, for example for time synchronization, data buffering or data exchange with archives
- Faceplates for presenting results and for entering values (e.g. for configuration or from manual measured values)
- Excel-based reports for allocating power data to cost centers, for batch-related evaluation and for determining and presenting the duration curve
- Exporting data to Excel

System requirements

The SIMATIC powerrate library is released for the following PCS 7 versions:

- SIMATIC PCS 7 V7.1 SP2
- SIMATIC PCS 7 V7.1 SP1
- SIMATIC PCS 7 V7.1

The library is released for the following WinCC version with the associated STEP 7 versions:

- SIMATIC WinCC V7.0 SP2

PROFIBUS

Configuring, visualizing and controlling with SIMATIC

SIMATIC powerrate

Benefits

- Identification of power-intensive consumer devices and processes in order to introduce measures for improving power efficiency
- Comparison of consumption profiles for greater efficiency of process design
- Optimizing the company according to energy parameters based on an assessment of consumption and costs
- Complying with the contractually agreed power limit, thus preventing higher power supply costs or penalty payments
- Integration of the SENTRON 7KM PAC3200 and PAC4200 measuring devices, with a quick overview of selected measured values and signals
- Integration of switches, with an overview of switch status and switching possibilities
- Exact assignment and comparison of the consumption data of certain work processes through batch-related consumption recording

Applications

SIMATIC powerrate is used in all areas in which PCS 7 or WinCC is used and energy efficiency considerations play a major role. Full integration into PCS 7 or WinCC means that there is no need for a special system environment. Predefined modules and symbols give you the assurance of building on tested and certified product components, with interfaces which enable customized expandability.

Selection and ordering data

Version	Order No.
<i>SIMATIC powerrate V 4.0</i>	
Trial license Limited 30 day Engineering-/Runtime license	6AV6 372-1DE04-0AX7
Unlimited Engineering and AS-Runtime license ¹⁾ Also includes: • License for user/archive • PAC3200 function block library for PCS7 and WinCC • PAC3200 function block library, 3WL/3VL for PCS 7	6AV6 372-1DE04-0AX0
<i>SIMATIC powerrate V4.0 upgrade from V3.0 to V 4.0</i>	
Unlimited Engineering and AS-Runtime license ¹⁾ Also includes: • License for user/archive • PAC3200 function block library for PCS7 and WinCC • PAC3200 function block library, 3WL/3VL for PCS 7	6AV6 372-1DE04-0AX4

¹⁾ For operation on one WinCC / PCS 7 OS (single workstation system or server) and any number of automation systems (AS). A license is required for each WinCC / PCS 7 single workstation system or server if using additional WinCC single workstation systems or servers.

More information

Information about using SIMATIC powerrate is available from
Siemens AG, Technical Support
Tel.: +49 (0) 911 895 7 222
Fax.: +49 (0) 911 895 7 223
www.siemens.com/automation/support-request

You can find further general information on the Internet at:
www.siemens.com/powermanagementsystem

PROFIBUS

Configuring, visualizing and controlling with SIMATIC

SIMATIC PCS 7 Library PAC3200

Overview

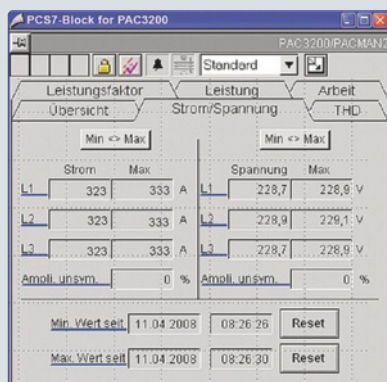

The PCS 7 function block library – SIMATIC PCS 7 Library PAC3200 – for the 7KM PAC3200 measuring device enables the seamless integration of the measuring device into the PCS 7 process world.

It comprises one driver block, one diagnostics block and the faceplates. The blocks in the SIMATIC S7 supply energy data to the faceplates in the user interface of the process control system, generate signals and guarantee connection to the maintenance system of PCS 7.

Faceplates

Faceplates serve as a user interface for operating and monitoring and enable technologically important values and functions of the 7KM PAC3200 measuring device to be displayed and performed as a PCS 7 object.

Both between the faceplates and the function blocks and between the function blocks and the 7KM PAC3200 measuring device, on the system side there are bidirectional communication connections that support the display of values in the faceplates and the forwarding of input data to the device.

This transforms the 7KM PAC3200 power monitoring device into an integral component of PCS 7.

The operating systems supported are the same as those for the SIMATIC PCS 7.

Benefits

- Full integration of 7KM PAC3200 power monitoring device in the PCS 7 process control system through PROFIBUS DPV1 using a certified PCS 7 add-on module
- Read-out and display of device data
- Input of limit values for monitoring by the driver block
- Resetting of values on the device (min/max values)

Applications

SIMATIC PCS 7 Library PAC3200 is used in all areas in which PCS 7 is used. Full integration in PCS 7 means that there is no need for a separate system environment. Predefined modules and symbols give you the assurance of building on tested and certified product components.

For challenging measurements the 7KM PAC4200 can also be used in the functional scope of the PAC3200.

In addition to the cyclic connection, there is also an acyclic connection for pure visualization tasks. The process image of the SIMATIC CPUs can be used more efficiently with the acyclic connection.

Selection and ordering data

SIMATIC PCS 7 V 6.1 SP3, PCS 7 V 7.0 SP3 and PCS 7 V7.1 without and with SP1/SP2

Version	Order No.
<i>SIMATIC PCS 7 Library PAC3200</i> ¹⁾	
Engineering license	3ZS2 781-1CC11-0YG0
<ul style="list-style-type: none"> • For operation on one PCS 7 OS (single workstation system or server) and an automation system (AS). • When using additional PCS 7 OS devices, you need an engineering license for each PCS 7 OS. 	
Runtime license	3ZS2 781-1CC10-6YH0
<ul style="list-style-type: none"> • For operation on an additional AS 	

¹⁾ For currently-supported SIMATIC PCS 7 versions see <http://support.automation.siemens.com>

Overview

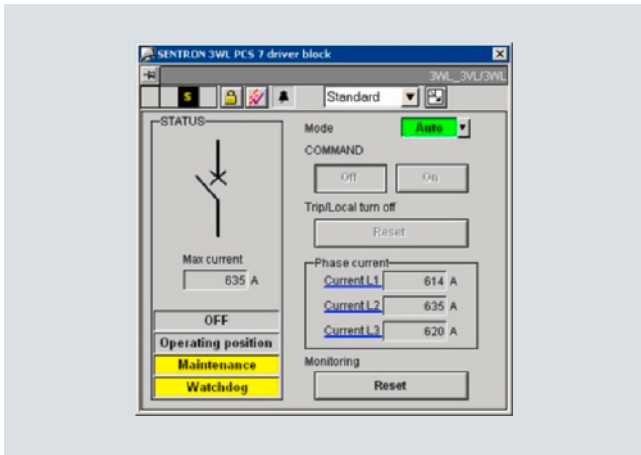

The PCS 7 3WL/3VL function block library enables the simple and seamless integration of the 3WL/3VL circuit breaker into the PCS 7 process world.

It comprises one driver block, one diagnostics block and the faceplates. The blocks in the SIMATIC S7 supply current, power and energy data to the faceplates in the user interface of the process control system, generate signals and guarantee connection to the maintenance system of PCS 7.

Faceplates

Faceplates serve as a user interface for operating and monitoring and make it easy for the circuit breaker to be displayed and operated as a PCS 7 object.

The 3WL/3VL function block library for SIMATIC PCS 7 provides for continual plant transparency. Critical plant states are recognized quickly and costs due to outages avoided. System availability is permanently increased.

This transforms the circuit breaker into an integral component of PCS 7.

The operating systems supported are the same as those for the SIMATIC PCS 7.

Benefits

- Full integration of the 3WL/3VL circuit breaker into the PCS 7 process control system through PROFIBUS DPV1 using a certified PCS 7 add-on module
- Remote switching and monitoring
- Read-out of maintenance information
- Automatic information in case of overload, short circuit and faults
- Read-out and display of device data
- Limit monitoring by the driver block
- Resetting of values on the device (min/max values)

Applications

The 3WL/3VL function block library for SIMATIC PCS 7 is used in all areas in which PCS 7 is used. Full integration in PCS 7 means that there is no need for a separate system environment. Predefined modules and symbols give you the assurance of building on tested and certified product components.

Selection and ordering data

SIMATIC PCS 7 V 6.1 SP3 and PCS 7 V 7.1 without and with SP1/2

Version	Order No.
<i>3WL/3VL function block library for SIMATIC PCS 7¹⁾</i>	
Engineering license	3ZS2 782-1CC10-0YG0
<ul style="list-style-type: none"> • For operation on one PCS 7 OS (single workstation system or server) and one automation system (AS). • When using additional PCS 7 OS devices, you need an engineering license for each PCS 7 OS. 	
Runtime license	3ZS2 782-1CC10-6YH0
<ul style="list-style-type: none"> • For operation on an additional AS 	

¹⁾ For currently-supported SIMATIC PCS 7 versions see <http://support.automation.siemens.com>

PROFIBUS

Configuring, visualizing and controlling with SIMATIC

PAC3200 function block library for SIMATIC WinCC

Overview

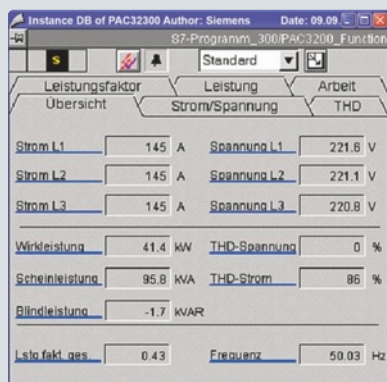

The PAC3200 function block library for SIMATIC WinCC enables the seamless integration of the 7KM PAC3200 power monitoring device into WinCC.

It comprises one driver block, one diagnostics block and the faceplates. The blocks in the SIMATIC S7 supply energy data to the faceplates in the user interface of WinCC, generate signals and guarantee connection to the signaling system of WinCC.

Faceplates

Faceplates serve as a user interface for operating and monitoring and enable technologically important values and functions of the 7KM PAC3200 power monitoring device to be displayed and performed in WinCC.

Both between the faceplates and the function blocks and between the function blocks and the 7KM PAC3200 measuring device, on the system side there are bidirectional communication connections that support the display of values in the faceplates and the forwarding of input data to the device.

This makes the 7KM PAC3200 measuring device an integral component of WinCC.

System requirements

The SENTRON PAC3200 function block library for SIMATIC WinCC is released for

- WinCC V 7.0
- WinCC V 7.0 SP2

WinCC options AS-OS Engineering and Basic Process Control must be installed. The function block library is available for S7-300, S7-400 and WinAC RTX.

At least one S7 CPU317-2DP is required for use in the S7-300 area. At least one S7 CPU414-2 is required for use in the S7-400 area.

Supported operating systems are the same as for SIMATIC WinCC.

Benefits

- Full integration of the 7KM PAC3200 measuring device in SIMATIC WinCC through PROFIBUS DPV1 The function block library is a certified WinCC add-on module
- Read-out and display of device data
- Input of limit values for monitoring by the driver block
- Resetting of values on the device (min/max values)

Applications

The PAC3200 function block library for SIMATIC WinCC is used in all areas in which WinCC is used. Predefined function blocks and symbols give you the assurance of building on tested and certified product components.

For challenging measurements the 7KM PAC4200 can also be used in the functional scope of the PAC3200.

In addition to the cyclic connection, there is also an acyclic connection for pure visualization tasks. The process image of the SIMATIC CPUs can be used more efficiently with the acyclic connection.

Selection and ordering data

SIMATIC WinCC V 7.0 and WinCC V 7.0 SP 2

Version	Order No.
SETRON PAC3200 function block library for SIMATIC WinCC ¹⁾	
Engineering license	3ZS2 791-1CC11-0YG0
<ul style="list-style-type: none"> • For operation on one WinCC OS (single workstation system or server) and one automation system (AS). • When using additional WinCC OS devices, you need an engineering license for each WinCC OS. 	
Runtime license	3ZS2 791-1CC10-6YH0
<ul style="list-style-type: none"> • For operation on an additional AS 	

¹⁾ For currently-supported SIMATIC WinCC versions see <http://support.automation.siemens.com>

Overview

**powermanager**

Energy management software for the SENTRON-based energy management system with the following main points:

- to identify savings potential
- to reduce power costs
- to ensure power availability

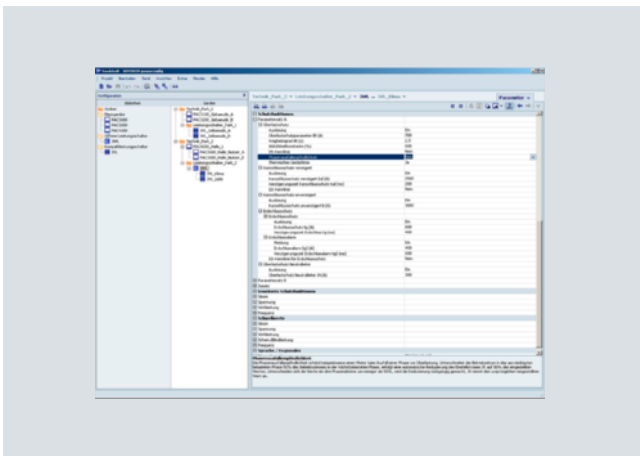
**powerconfig**

Commissioning and service tool for communication-capable SENTRON measuring devices and circuit breakers with following main points:

- Makes the parametrization of the devices easier, which gives rise to a considerable time saving, particularly when several devices have to be set up.
- With powerconfig the 3WL and 3VL circuit breakers and the 7KM PAC3100 / PAC3200 / PAC4200 measuring devices can be parameterized, documented, operated and monitored using various communication interfaces.

PROFIBUS

Configuring, visualizing and controlling with SENTRON

powermanager

Overview



Components of the PC-based energy management system



User interface of powermanager

Energy management system with the SENTRON product family

The SENTRON product family offers the user not only energy management software in the form of SENTRON powermanager but also the corresponding hardware in the form of SENTRON measuring devices and 3WL/3VL circuit breakers for the realization of a complete energy management system.

The components are optimally coordinated with each other. For example, special drivers for the SENTRON devices are integrated in the powermanager software so that on the one hand the power data acquisition can take place without any great configuration effort and, on the other hand, the most important measured values or states are indicated by predefined displays.

This reduces the engineering work for the customer and gives the user the assurance of knowing that the device functions are optimally supported in the software.

Features of powermanager

The energy management software powermanager is at the heart of the PC-based energy management system and

- is independent energy management software
- can be operated using a PC and measuring devices with Ethernet connection.
- is expandable from the simple standard application to a fully flexible customer solution.
- is fully scalable with regard to the number of devices and to the software's functions
- ensures the optimum integration of measuring devices from the 7KM PAC range, 3WL/3VL circuit breakers and other devices.

Benefits

- Transparency of power flows
- Exact knowledge of the consumption profile
- Increase of power efficiency
- Optimization of power supply contracts
- Compliance with contractual terms
- Assignment of power costs to cost centers
- Optimization of plant maintenance
- Identification of critical plant conditions

Standard package and options packs

Even in the standard package powermanager covers the normal requirements. With this package the user receives easy-to-operate power management software which enables the data detected by the measuring devices to be read out, presented, archived and processed in basic evaluations.

With the "Expert" option pack the user receives full flexibility for the presentation of graphic interfaces (e.g. single line presentations) in order to integrate his own images and devices.

With the "Web" option pack, data/images can be presented using a web browser.

With the "Distributed Systems" option pack it is possible to connect several distributed powermanager servers to form one complete system. This means, firstly, that distributed sites can be managed from a single location and, secondly, that the number of usable devices can thus be increased.

The system is, of course, expandable to the extent that it allows the customer to begin with the basic functionality of the powermanager and add the "Expert" option pack at a later date. Existing data and configurations can still be used after upgrading.

Application**Applications**

The product offers a standard power management solution which provides the user with the following basic functionality:

- Collection of measured quantities from the devices
- Presentation of the measured quantities from the devices in table form in a predefined standard view for 7KM PAC3100, PAC3200 and PAC4200 measuring devices and 3WL/3VL circuit breakers
- Free presentation of measured quantities possible, including from non-Siemens devices using generic Modbus drivers
- Archiving of measured quantities

- Monitoring of status and limits, with generation of corresponding signals
- Reserve curve display for visualizing the achieved data and online data
- Cost center reports based on predefined rates and the archived consumption data
- OPC server
- Configuration of the system including user management

This standard solution is designed with cost-efficiency and simple system start-up in mind.

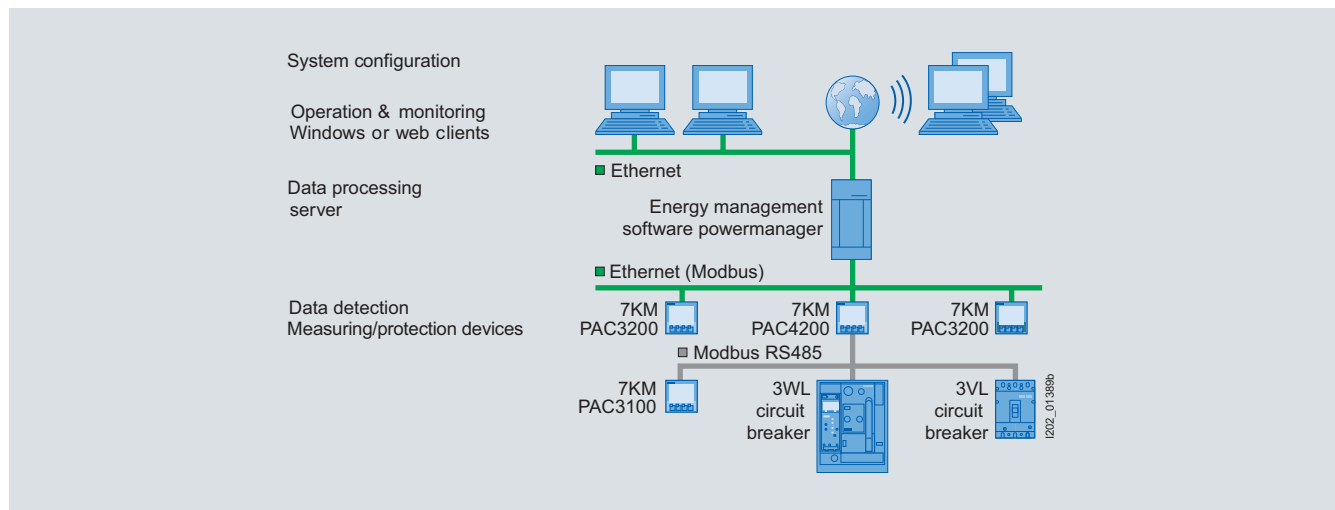
**System configuration**

- Integration of measuring devices by means of predefined device templates for the 7KM PAC family and the 3WL/3VL circuit breakers
- Easy integration of existing modbus-capable detecting devices
- Communication through Standard Ethernet
- Integration of devices with RS485 interface (ModbusRTU) through Modbus gateway, e.g. the 7KM PAC4200 can be used as gateway

Industries

Energy efficiency thanks to power management with consistent monitoring and the resulting optimisation measures is important for all industries, e.g. in the manufacturing industry, in non-residential buildings, in the field of services, and in infrastructure projects. This has a particular impact on competitiveness, particularly in view of rising energy prices.

System requirementsHardware requirements

- Processor: Intel Pentium IV 2.8 GHz (or better)
- RAM: at least 2 GB
- Hard disk: at least 1 GB free
- Graphics: VGA with at least 1280 x 1024 pixels and 16-bit color intensity

Supported operating systems

- Windows Vista: Business, Ultimate; SP1
- Windows XP: XP with SP2/SP3
- Windows 2003: Server 2003 Server (32-bit)

Supported Excel versions (required for reporting)

Excel 2000, Excel XP, Excel 2003, Excel 2007

PROFIBUS

Configuring, visualizing and controlling with SENTRON

powermanager

Selection and ordering data

Version	Order No.
<i>powermanager V 2.0</i>	
<ul style="list-style-type: none"> • Trial license up to 10 devices inc. "Expert" and "Web" option packs full product license limited to 30 days 	3ZS2 711-0CC20-0YA7
<ul style="list-style-type: none"> • Full product license, Lean up to 10 devices 	3ZS2 711-0CC20-0YA0
<ul style="list-style-type: none"> • Full product license, Standard up to 50 devices 	3ZS2 712-0CC20-0YA0
<ul style="list-style-type: none"> • Full product license, Advanced up to 100 devices 	3ZS2 713-0CC20-0YA0
<ul style="list-style-type: none"> • Full product license, Maximum up to 200 devices 	3ZS2 714-0CC20-0YA0
<ul style="list-style-type: none"> • Upgrade license from Lean to Standard 	3ZS2 712-0CC20-0YD0
<ul style="list-style-type: none"> • Upgrade license from Standard to Advanced 	3ZS2 713-0CC20-0YD0
<ul style="list-style-type: none"> • Upgrade license from Advanced to Maximum 	3ZS2 714-0CC20-0YD0
<ul style="list-style-type: none"> • Option pack "Up to 5 Clients" Expansion up to 5 clients 	3ZS2 710-3CC20-0YH0
<ul style="list-style-type: none"> • Option pack "From 5 to 10 Clients" Expansion from 5 to 10 clients (Requirement: Option pack "Up to 5 Clients") 	3ZS2 710-4CC20-0YH0
<ul style="list-style-type: none"> • Option pack "Expert" Option for creating and presenting any number of freely configured images 	3ZS2 710-2CC20-0YH0
<ul style="list-style-type: none"> • Option pack "Web" Option for access over the web (e.g. Internet Explorer) for up to 10 clients 	3ZS2 710-1CC20-0YH0
<ul style="list-style-type: none"> • Option pack "Distributed Systems (2)" Option for the connection of 2 autonomous powermanager systems for the exchange of measured values and alarms 	3ZS2718-1CC00-0YH0
<ul style="list-style-type: none"> • Option pack "Distributed Systems (5)" Option for the connection of 5 autonomous powermanager systems for the exchange of measured values and alarms 	3ZS2718-2CC00-0YH0
<ul style="list-style-type: none"> • Option pack "Distributed Systems (10)" Option for the connection of 10 autonomous powermanager systems for the exchange of measured values and alarms 	3ZS2718-3CC00-0YH0

More information

You can find more information on the Internet at:
www.siemens.com/powermanagementsystem

Overview

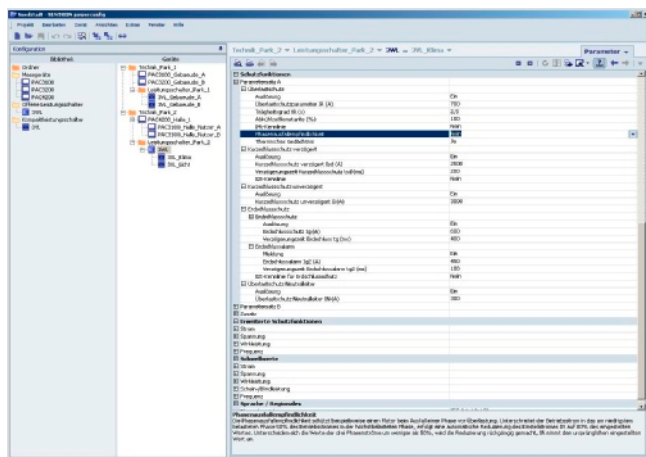

Setting the parameters of a SENTRON device

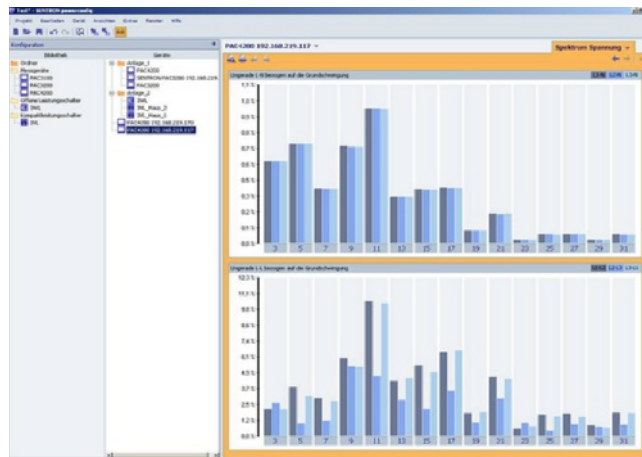

Display of current measured variables (harmonic)

The powerconfig software is the new combined commissioning and service tool for communication-capable SENTRON measuring devices and circuit breakers.

The PC-based tool makes the parametrization of the devices easier, which gives rise to a considerable time saving, particularly when several devices have to be set up.

With powerconfig the 3WL and 3VL circuit breakers and the SENTRON measuring devices with expansion modules can be parameterized, documented, operated and monitored using various communication interfaces.

Benefits

Parameterization, documentation, operation and monitoring in one software

- Documentation of measured values and settings
- Clear presentation of the available parameters including plausibility testing of the inputs
- Display of the available device statuses and measured values in standardized views
- Project-oriented storage of device data
- Consistent operation and usability
- Support of the various device communication interfaces (Modbus RTU, Modbus TCP)
- Supported languages: English and German
- Read-out and saving of device recordings (device-dependent)
- Update of the device firmware and loading of language packs (device-dependent)
- No programming knowledge required for operation
- Communication via PROFIBUS and PROFINET and connection to STEP 7 (in preparation)

Application

System requirements

Hardware requirements

- Processor: Intel Pentium III, 1 GHz (or better)
- RAM: at least 512 MB
- Hard disk: at least 1 GB free
- Color monitor with a minimum resolution of 1024 x 768 pixels

Supported operating systems

- Microsoft Windows XP Prof. 32Bit SP3. MUL OS
- Microsoft Windows 7 Professional (32Bit)
- Microsoft Windows 7 Ultimate (32Bit)
- Microsoft Windows 7 Home Basic (32Bit)

Required framework:

- Microsoft .NET V3.5 SP1

More information

powerconfig is available free of charge at <http://support.automation.siemens.com/WWW/view/en/50241697>

You can find more information on the Internet at: www.siemens.com/sentron

PROFIBUS

SIMATIC identification systems

Communication modules ASM 456, SIMATIC RF160C

Overview



ASM 456 communication module, SIMATIC RF160C

The cost-efficient ASM 456 and SIMATIC RF160C communication modules are stand-alone PROFIBUS DP slaves used to operate the RFID systems MOBY D/U and SIMATIC RF200 / RF300 / RF600 as well as the MV400 code reading systems via PROFIBUS DP:

- SIMATIC S7 (including FB/FC software)
- SINUMERIK
- PC, IPC, non-Siemens PLC
- SIMOTION (with integrated software library)

Thanks to their high degree of protection and ruggedness, they are particularly suitable for machine-level use. The modular structure with different PROFIBUS connection systems allows them to be used in all applications. The uniform plug-in connection system ensures rapid commissioning.

PROFIBUS SIMATIC identification systems

Communication modules
ASM 456, SIMATIC RF160C

Ordering data	Order No.	Order No.
ASM 456 communication module For connecting 2 readers to PROFIBUS DP-V1	6GT2 002-0ED00	
SIMATIC RF160C communication module For connecting 2 readers to PROFIBUS DP-V0	6GT2 002-0EF00	
<i>Accessory: ECOFAST connection</i>		
ECOFAST connection block	6ES7 194-3AA00-0AA0	
PROFIBUS ECOFAST HYBRID plug 180 • With male insert (5-pack) • With female insert (5-pack)	6GK1 905-0CA00 6GK1 905-0CB00	
PROFIBUS ECOFAST termination plug with terminating resistors	6GK1 905-0DA10	
ECOFAST hybrid cable (assembled)¹⁾	6XV1 830-7Bxxx	
ECOFAST hybrid cable (non-assembled)	6XV1 830-7AH10	
<i>Accessory: M12, 7/8" connection</i>		
M12 connection block, 7/8"	6ES7 194-3AA00-0BA0	
M12 terminating resistor for PROFIBUS Pack of 5, 1 pack minimum order quantity, price per pack.	6GK1 905-0EC00	
PROFIBUS cable with M12 connectors assembled¹⁾	6XV1 830-3Dxxx	
Supply voltage cable with 7/8" connectors assembled¹⁾	6XV1 822-5Bxxx	
PROFIBUS FC standard cable non-assembled	6XV1 830-0EH10	
PROFIBUS M12 connector Pack of 5, 1 pack minimum order quantity, price per pack. • With male insert • With female insert	6GK1 905-0EA00 6GK1 905-0EB00	
7/8" connector for voltage Pack of 5, 1 pack minimum order quantity, price per pack • With male insert • With female insert	6GK1 905-0FA00 6GK1 905-0FB00	
7/8" cover caps for unused 24 V extension, pack of 10, 1 pack minimum order quantity, price per pack	6ES7 194-3JA00-0AA0	
Energy cable 5 x 1.5 not assembled, stranded wire, trailing capability; minimum order quantity 20 m	6XV1 830-8AH10	
<i>Accessories for RFID</i>		
Reader cable for MOBY U PUR material, CMG approved, suitable for cable carriers		
2 m		6GT2 091-4FH20
5 m		6GT2 091-4FH50
Reader cable for MOBY D PUR material, CMG approved, suitable for cable carriers, 2 m		6GT2 691-4FH20
Reader cable for SIMATIC RF200 / RF300 / RF600 / MV400 Or extension cable MOBY U/D and SIMATIC RF200 / RF300 / RF600 / MV400, PUR material, CMG approved, suitable for cable carriers, straight connector		
2 m		6GT2 891-4FH20
5 m		6GT2 891-4FH50
10 m		6GT2 891-4FN10
20 m		6GT2 891-4FN20
50 m		6GT2 891-4FN50
2 m, plug angled at reader		6GT2 891-4JH20
M12 sealing caps for unused reader connections 10 units minimum order quantity, price per 100 units		3RX9 802-0AA00
DVD "RFID Systems S software & Documentation"		6GT2 080-2AA20

¹⁾ These cables are available in varying lengths

Note:

You can find more information in Catalog ID 10 and in the Industry Mall at www.siemens.com/industrymall

PROFIBUS

SIMATIC Identification systems

Code reading system
SIMATIC VS130-2

Overview



The SIMATIC VS130-2 has been specially developed for reading Data Matrix Codes (DMC) ECC200 in industrial environments. It can, however, also read other 2D codes and 1D codes.

The SIMATIC VS130-2 combines industry-standard code reading with industry-standard communication – PROFIBUS and PROFINET (optionally). The reader is perfectly integrated into the SIMATIC S7 automation environment using a standardized function block

The SIMATIC VS130-2 reads codes on many different components and surfaces, such as paper or plastic labels, plastic parts, printed circuit boards, metallic objects.

The SIMATIC VS130-2 reads codes of marked using different methods, e.g. printed, punched, lasered, drilled.

No parameters have to be entered by the user for adapting to the different carrier materials and marking types. "Training" is performed automatically by presenting a readable code pattern. Programming and parameterization are not required.

The user parameterizes the SIMATIC VS130-2 by means of a web-based user interface which runs on various platforms with the following requirements: Browser (IE5.5 and higher), JAVA-VM (MS, SUN).

The web-based operator interface is also used for controlling the device from an HMI device. The specified conditions also apply in this case regarding the browser and JAVA-VM.

The SIMATIC VS130-2

- offers a remote maintenance concept via a web-based user interface
- can be remote-controlled via integrated digital inputs, PROFIBUS or PROFINET IO
- is available as a complete package in several variants for different code sizes
- is available in 6 language versions (operator interface, manual and online help are available in German, English, French, Spanish, Italian, and Chinese).

Readable codes

1D codes (barcodes)

- Code 39,
- Code 128,
- Interleave 2/5,
- EAN13.

2D codes

- Data matrix code (DMC) according to ECC200,
- QR (alphanumeric characters; without sub-variants: truncated, macro, micro),
- PDF417 (without subvariants: macro, micro).

Ordering data	Order No.		Order No.
<p>SIMATIC VS130-2</p> <p>Complete package for object inspection; comprising sensor head, LED incident light (ring lamp 6GF9 004-8BA), processing unit and the following cables:</p> <ul style="list-style-type: none"> • Cable between processing unit and sensor head, for lengths see below • Cable between lighting and processing unit (except for reading system with variable field of view), for length see below • Cable for power supply, length 10 m • Cable for connecting digital I/O devices, length 10 m <p>Incl. documentation package for SIMATIC VS130-2.</p> <ul style="list-style-type: none"> • Field of view 70 mm x 50 mm <ul style="list-style-type: none"> - With cable length 2.5 m - With cable length 10 m • Field of view 40 mm x 30 mm <ul style="list-style-type: none"> - With cable length 2.5 m - With cable length 10 m • Field of view 20 mm x 15 mm <ul style="list-style-type: none"> - With cable length 2.5 m - With cable length 10 m • Variable field of view with 640 x 480 pixels and prepared for IP65 protective housing (note: Delivery without light and light cable). <ul style="list-style-type: none"> - With cable length 2.5 m - With cable length 10 m • Variable field of view with 1024 x 768 pixels and prepared for IP65 protective housing (note: Delivery without light and light cable). <ul style="list-style-type: none"> - With cable length 2.5 m - With cable length 10 m 	<p>6GF1 130-1BA</p> <p>6GF1 130-1BA01</p> <p>6GF1 130-2BA</p> <p>6GF1 130-2BA01</p> <p>6GF1 130-4BA</p> <p>6GF1 130-4BA01</p> <p>6GF1 130-3BB</p> <p>6GF1 130-3BB01</p> <p>6GF1 130-3BC</p> <p>6GF1 130-3BC01</p>	<p>Lenses</p> <p>See separate section "Lenses" on page 3/326</p> <p>Protective barrel for lens for external lighting, internal diameter: 41 mm, length from mount: 65 mm, IP65 degree of protection.</p> <p>Protective barrel for lens D50, glass Front pane: Glass</p> <p>Protective barrel for lens D50, PMMA Front pane: PMMA</p> <p>LED ring lamps (plastic) Dimensions H x W x D (mm) 102 x 102 x 26.5 IP65 degree of protection, not suitable for protective barrel for lens D50. Figure shows protective barrel for lens; 2 small mounting brackets enclosed</p> <p>LED ring light, red, diffuse Operating range 75 mm to 0.5 m</p> <p>LED ring light, red, clear Operating range 75 mm to 1000 mm</p> <p>LED ring light, infrared, diffuse Operating range 75 mm to 0.5 m</p> <p>LED ring lights (metal) Dimensions W x H x D (mm) 116 x 116 x 42, suitable for protective barrel for lens D50.</p> <p>LED ring light, infrared, diffuse Light source: 850 nm, range of illumination: 75 mm to 250 mm, degree of protection: IP65.</p> <p>LED ring light, infrared, clear Light source: 850 nm, range of illumination: 500 mm to 3 000 mm, degree of protection: IP65.</p> <p>LED ring light, red, diffuse Light source: 75 mm to 250 mm, degree of protection: IP67.</p> <p>LED ring light, red, clear Light source: 150 mm to 2 000 mm, degree of protection: IP67.</p> <p>LED ring light, red, clear Light source: 500 mm to 3 000 mm, degree of protection: IP67.</p> <p>Lamp multiplexer for connecting several ring lights to a VS130-2 evaluation unit</p>	<p>6GF9 002-7AA</p> <p>6GF9 002-7AA01</p> <p>6GF9 004-8BA</p> <p>6GF9 004-8CA</p> <p>6GF9 004-7AA</p> <p>6GF9 004-7AA01</p> <p>6GF9 004-7BA01</p> <p>6GF9 004-8BA01</p> <p>6GF9 004-8CA01</p> <p>6GF9 004-8DA01</p> <p>6GF9 002-7BA</p>

PROFIBUS SIMATIC Identification systems

Code reading system
SIMATIC VS130-2

3

Ordering data

Order No.

Cable

Power supply cable

Length 10 m, VS-side plug-in, one free end.
This cable is included in the VS130-2 complete package.

6GF9 002-8CA

Cable for LED ring light

M12-90 plug / M12-180 socket, trailing type, suitable for:
6GF9 004-7AA01, ...-7BA01, ...-8BA01, ...-8CA01 ...-8DA01, M12, 4-pin, in the following lengths

2.5 m

6GF9 002-8CE

10 m

6GF9 002-8CG

Digital communication cable

Length 10 m, VS-side plug-in, one free end. This cable is included in the VS130-2 complete package.

6GF9 002-8CB

Sensor cable

for sensor head connection

Length 10 m, pluggable at both ends, suitable for trailing.

Length 2.5 m

6GF9 002-8CD

Length 10 m

6GF9 002-8CF

This cable is included in the VS130-2 complete package.

Industrial Ethernet

crossed twisted-pair cable

4 x 2, RJ45/RJ45 connector, for commissioning, service and installation, Cat. 6, pre-assembled with 2 RJ45 connectors, length 2 m

6XV1 870-3RH20

Industrial Ethernet

twisted-pair cable

4 x 2, RJ45/RJ45 connector, for commissioning, service and installation, Cat. 6, pre-assembled with 2 RJ45 connectors, length 2 m

6XV1 870-3QH20

Supports

Support

for connecting the sensor head with the ring light and for fixing it at the mounting location and adjusting it.

Ring light holder, coaxial, solid

2 units

6GF9 002-7AB

Sensor head support, tri-plate

6GF9 002-7AD

Sensor head/ring light holder, solid

6GF9 002-7AC

IP65 protective enclosure for processing units

Contains DIN rail (TH35 according to EN 60715), IP65 degree of protection, ambient temperature (0 ... 50 °C), dimensions W x H x D (mm) 300 x 400 x 210

6GF9 002-7CA

Possible built-in components (example):

1 VS130-2 processing unit (6GF1 018-3BA),
1 lamp multiplexer (6GF9 002-7BA),
1 Industrial Ethernet Switch (6GK1 08-0BA00),
1 power supply 230 V/120 V AC 1.3/2.2 A;
24 V DC/5 A (6ES7307-1EA00-0AA0)

Cable glands (example):

1 VS100 power supply cable, D = 5.4 mm (6GF9 002-8CA),
1 sensor cable D = 6.8 mm (6GF9 002-8CD or 6GF9 002-8CF),
4 lighting cables D = 4.5 mm (6GF9 002-8CE or 6GF9002-8CG)
1 digital communication cable D = 7.4 mm (6GF9 002-8CB),
1 serial communication cable D = 5.0 mm (6ES790-1BF00-0XA0),
3 Ethernet cables with 2 RJ45 connectors (e.g.: 6XV1 850-2GH20),

Standard rail mounting

For mounting the VS130-2 processing unit on a standard rail support.

6GF9 002-7DA

Note:

You can find more information in the Industry Mall at www.siemens.com/industrymall

Overview



The SIMATIC VS120 has been specially developed for shape recognition in industrial environments. The Vision Sensor combines industry-standard, rugged recognition reliability and ease of operation with the safety of industry-standard communication – PROFIBUS and PROFINET. The Vision Sensor is perfectly integrated into the SIMATIC S7 automation environment using a standardized function block.

- Sensor for object finding and object shape testing in incident light
- VS120 finds and checks different objects and/or patterns, e.g.:
 - Printed symbols (product markings on labels, packaging, etc.)
 - Injection molded components
 - Ceramic elements
- Simple configuration by presenting the "good" object to be recognized. The "teach-in" is performed automatically when the training function of the device is activated.
- Parameters are assigned by means of a web-based user interface that is executable on different platforms to which the following requirements apply:
 - Browser (IE5.5 or higher)
 - JAVA-VM (MS, SUN)
- The web-based operator interface is also used for controlling the device from an HMI device. The requirements regarding the browser and JAVA VM also apply here.
- Remote maintenance concept using web-based operator interface.
- Can be remote controlled via integrated digital inputs, PROFIBUS, or PROFINET IO.
- Supplied as a complete package in several versions for different object sizes.

Ordering data

Order No.

SIMATIC VS120 Vision Sensor

Complete package for object inspection, comprising sensor head, LED overhead lighting unit, processing unit and the following cables:

- Cable between processing unit and sensor head, see below for length
- Cable between lighting and processing unit (except with Vision Sensors with variable field of view), see below for length
- Cable for power supply, length 10 m
- Cable for connecting digital I/O-devices, length 10 m

Incl. documentation package for SIMATIC VS120

- Field of view 70 mm x 50 mm
 - With cable length 2.5 m
 - With cable length 10 m
- Field of view 40 mm x 30 mm
 - With cable length 2.5 m
 - With cable length 10 m
- Field of view can be varied and is prepared for protective enclosure IP65 (Note: lights and light cables not included in delivery)
 - With cable length 2.5 m
 - With cable length 10 m

6GF1 120-1AA
6GF1 120-1AA01

6GF1 120-2AA
6GF1 120-2AA01

6GF1 120-3AB
6GF1 120-3AB01

Note:

You can find more information in the Industry Mall at www.siemens.com/industrymall

Overview

With a lens suitable for the respective image evaluation task, the size of the image field is determined for the camera image for the required operating distance.

High light intensity and the geometry of the image are extremely important for image evaluation (code reading, form recognition and position detection) High light intensity permits short shutter speeds and consequently a reduction of the blurring due to motion as well as maximizing the range.

Fault-free image geometry optimizes the fault tolerance of image analysis with regard to perspective and unevenness of the surface of the depicted object.

Lenses with fixed focal length and a settable aperture and focus are ideal for this purpose and are therefore preferred.

3

Ordering data

Order No.

Lenses for reading code and plain text and parts recognition

with fixed focal length, adjustable aperture and focus, with locking screw

- **Mini lens 8.5 mm, 1:1.5**
D = 42 mm, L = 47 mm;
successor type
for 6GF9001-1BE;
- **Mini lens 12 mm, 1:1.4**
D = 29.5 mm, L = 35.7 mm;
- **Mini lens 16 mm, 1:1.4**
D = 29.5 mm, L = 37.2 mm;
successor type
for 6GF9001-1BF;
- **Mini lens 25 mm, 1:1.4**
D = 29.5 mm, L = 38.9 mm;
successor type
for 6GF9001-1BG;
- **Mini lens 35 mm, 1:1.6**
D = 29.5 mm, L = 41.4 mm;
- **Mini lens 50 mm, 1:2.8**
D = 29.5 mm, L = 38.0 mm;
successor type
for 6GF9001-1AH;
- **Mini lens 75 mm, 1:2.8**
D = 34.0 mm, L = 63.6 mm;

6GF9 001-1BE01

6GF9 001-1BL01

6GF9 001-1BF01

6GF9 001-1BG01

6GF9 001-1BH01

6GF9 001-1BJ01

6GF9 001-1BK01

CS-Mount for C-Mount adapter ring 5 mm

6GF9 001-1AP02

Order No.

*Accessories for utilizing the mini lenses at close range:***Set of extension rings**

with 0.5 mm, 1.0 mm, 5.0 mm, 10.0 mm, 20.0 mm, 40 mm rings with 31 mm diameter C thread, to be screwed in between the lens and the camera body for image capture in the macro range.

6GF9 001-1BU

*Accessories for utilizing the mini lenses in telephoto range:***Focal length doubler**

D = 30.5 mm, L = 17.9 mm, with C-thread to be screwed in between the lens and camera to extend the focal length by a factor of 2.

Suitable lenses:
6GF9001-1BE01, ...-1BL01,
...-1BF01, ...-1BG01, ...-1BH01,
...-1BJ01, ...-1BK01

6GF9 001-1BV

*Filter for utilization of the mini lenses in the limited field of view:***Infrared filter**

Function:
Visible light is largely or completely filtered out, infrared light can pass through.
Application:
When used with infrared lamps, it is possible to achieve independence from daylight.
Suitable lenses:
6GF9001-1BL01, ...-1BF01,
...-1BG01, ...-1BH01, ...-1BJ01

6GF9 001-2AD

Blue filter

Function:
Blue light can pass through.
Application:
e.g. to improve the visualization of structures.
Suitable lenses:
6GF9001-1BL01, ...-1BF01,
...-1BG01, ...-1BH01, ...-1BJ01

6GF9 001-2AE

Polarization filter

Function:
Filters out light which is directed at right angles to the polarization direction of the filter.
Application:
e.g. to reduce reflections from metal.
Suitable lenses:
6GF9001-1BL01, ...-1BF01,
...-1BG01, ...-1BH01, ...-1BJ01

6GF9 001-2AF

Note:

You can find more information in the Industry Mall at www.siemens.com/industrymall

Overview

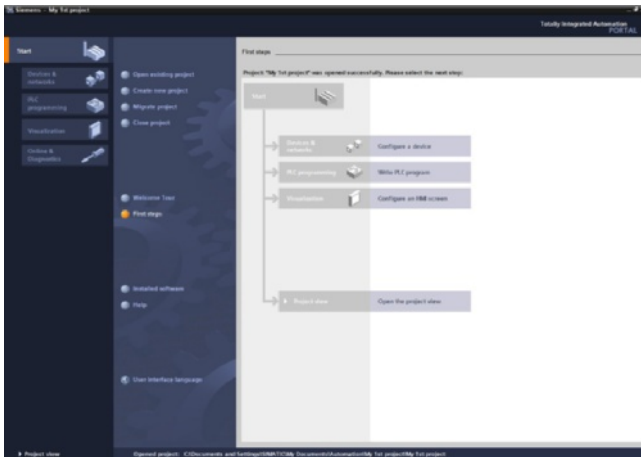

STEP 7 V11 (TIA Portal), portal view

Intuitive, efficient and future-oriented – the new engineering software for programming the S7 controllers

SIMATIC STEP 7 Professional V11 is the easy-to-use, integrated engineering system for the current SIMATIC S7-1200, S7-300, S7-400 controllers and WinAC.

SIMATIC STEP 7 Basic V11 is the successor to STEP 7 Basic V10.5 and supports the additional functions of the firmware 2.0 of the S7-1200 controller.

STEP 7 V11 is based on the new central engineering framework Totally Integrated Automation Portal (TIA Portal), which offers the user a uniform, efficient and intuitive solution to all automation tasks. TIA Portal forms the integrated working environment for IA and DT engineering software.

WinCC Basic for configuration of Basic Panels is included in the scope of supply.

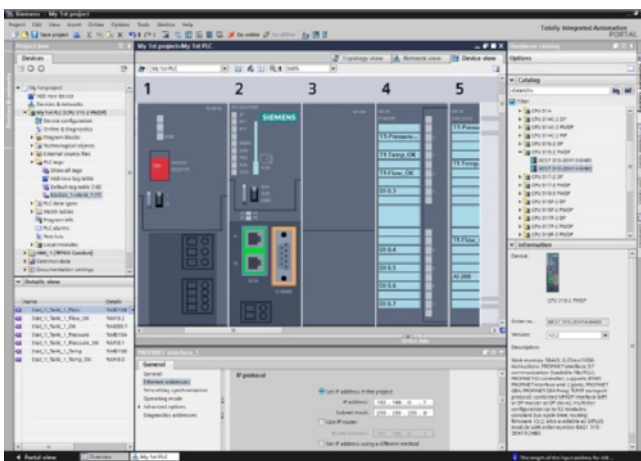

STEP 7 V11 (TIA Portal), device view: configuring and parameterizing in photographically realistic representation

STEP 7 Professional/Basic V11

Ordering data

Order No.

Order No.

**STEP 7 Professional /
Basic V11***Target system:*SIMATIC S7-1200, S7-300,
S7-400, WinAC*Requirement:*Windows XP Home SP3
(STEP 7 Basic only),
Windows XP Professional SP3
(32 bit),
Windows 7 Home Premium
(STEP 7 Basic only),
Windows 7 Professional (32 bit),
Windows 7 Enterprise (32 bit),
Windows 7 Ultimate (32 bit),
Microsoft Server 2003 R2 Std.
SP2 (32 bit),
Microsoft Server 2008 Std. SP2
(32 bit)*Form of delivery:*German, English, Chinese,
Italian, French, Spanish**STEP 7 Professional V11,
floating license****6ES7 822-1AA01-0YA5****STEP 7 Prof. V11,
trial license****6ES7 822-1AA01-0YA7****Upgrade STEP 7 Prof.
2006/2010
to STEP 7 Prof. V11,
floating license****6ES7 822-1AA01-0XE5****PowerPack & Upgrade
STEP 7 V5.4/V5.5
to STEP 7 Prof. V11,
floating license****6ES7 822-1AA01-0XC5****Powerpack STEP 7 Basic V11
to STEP 7 Prof. V11,
floating license****6ES7 822-1AA01-0YC5****STEP 7 Basic V11,
single license****6ES7 822-0AA01-0YA0****STEP 7 Basic V11,
trial license****6ES7 822-0AA01-0YA7****Upgrade STEP 7 Basic V10.5
to STEP 7 Basic V11,
single license****6ES7 822-0AA01-0YE0****Software Update Service**

For a period of 12 months and for a fixed price, the customer is automatically provided with all upgrades and service packs for each installed software package. The contract is automatically extended by a further year unless canceled up to 12 weeks prior to expiration. Requires the current software version

**Software Update Service
(Standard Edition)**

The delivery is implemented according to the number of ordered SUS products (e.g. 10 upgrade packages with 10 DVDs, 10 USB flash drives, etc.)

- STEP 7 Professional V11
- STEP 7 Professional and STEP 7 Professional in the TIA Portal
- STEP 7 Basic

6ES7 822-1AA00-0YL5**6ES7 810-5CC04-0YE2****6ES7 822-0AA00-0YL0****Software Update
Service (Compact Edition)**

The delivery items are combined. For several contracts, only 1 package with 1 data medium set, 1 USB flash drive with the corresponding number of licenses and the corresponding number of COLs will be supplied.

The delivery items to be combined must be ordered as one item.

- STEP 7 Professional V11
- STEP 7 Professional and STEP 7 Professional in the TIA Portal
- STEP 7 Basic

6ES7 822-1AA00-0YM5**6ES7 810-5CC00-0YM2****6ES7 822-0AA00-0YM0**Note:

You can find more information in Catalog ST 70 and in the Industry Mall at www.siemens.com/industrymall

Overview

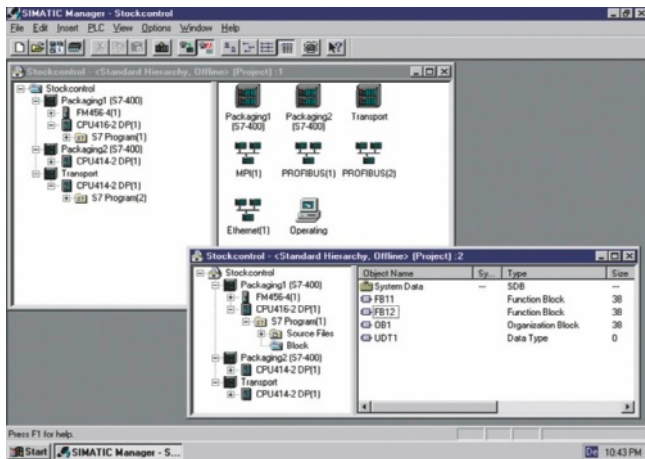

- STEP 7 basic software:
The standard tool for the SIMATIC S7, SIMATIC C7 and SIMATIC WinAC automation systems.
- Makes use of the full performance capabilities of the systems
- User-friendly functions for all phases of an automation project:
 - Configuring and parameterizing the hardware
 - Definition of communication
 - Programming
 - Testing, commissioning and service
 - Documentation, archiving
 - Operating, diagnostics functions

Ordering data

Order No.

STEP 7 Version 5.5

Target system:
SIMATIC S7-300/400,
SIMATIC C7, SIMATIC WinAC

Requirements:

Windows XP Prof.,
Windows 7 Professional / Ultimate

Delivery package:

German, English, French,
Spanish, Italian;
incl. license key on USB stick,
with electronic documentation

Floating license on DVD

6ES7 810-4CC10-0YA5

Rental license for 50 hours

6ES7 810-4CC10-0YA6

Software Update Service on DVD
(requires current software
version)

6ES7 810-4BC01-0YX2

Upgrade Floating License
3.x/4.x/5.x to V5.5; on DVD

6ES7 810-4CC10-0YE5

Trial License STEP 7 V5.5;
on DVD, 14 day trial

6ES7 810-4CC10-0YA7

STEP 7 Version 5.4 Japanese

Target system:
SIMATIC S7-300/400,
SIMATIC C7, SIMATIC WinAC

Requirements:

Windows XP Professional
Japanese

Delivery package:

English, Japanese;
incl. authorization disk 3,5",
without electronic documentation

Floating License Japanese
on DVD

6ES7 810-4CC08-0JA5

Upgrade Floating License
Japanese 3.x/4.x/5.x to V5.4;
on DVD

6ES7 810-4CC08-0JE5

STEP 7 Version 5.5, Chinese

Target system:
SIMATIC S7-300/400,
SIMATIC C7, SIMATIC WinAC

Requirements:

Windows XP Professional Chinese

Delivery package:

English, Chinese;
incl. license key on USB stick,
with electronic documentation

Floating License Chinese
on DVD

6ES7 810-4CC10-0KA5

Upgrade Floating License
Chinese 3.x/4.x/5.x to V5.5;
on DVD

6ES7 810-4CC10-0KE5

STEP 7

3

Ordering data	Order No.	Ordering data	Order No.
Documentation package STEP 7 basic information Comprising Getting Started, hardware configuration manual, programming manual, migration manual German English French Spanish Italian	6ES7 810-4CA08-8AW0 6ES7 810-4CA08-8BW0 6ES7 810-4CA08-8CW0 6ES7 810-4CA08-8DW0 6ES7 810-4CA08-8EW0	EPROM programming device, USB prommer To program SIMATIC memory cards and EPROM modules MPI cable For linking SIMATIC S7 and CP through MPI (5 m) <i>Components for connecting a PC to MPI and PROFIBUS</i> For PCs with a free PCI slot: <ul style="list-style-type: none"> • CP 5611 • CP 5611 MPI incl. MPI cable (5 m) For PCs with a free PCMCIA slot: <ul style="list-style-type: none"> • CP 5512 For Windows XP Professional For PCs without a free PCI slot: <ul style="list-style-type: none"> • PC adapter USB For connecting a PC to S7-300/-400/C7 through a USB interface; with USB cable (5 m) <i>Components for connecting the PC to Industrial Ethernet</i> For PCs with a free PCI slot: <ul style="list-style-type: none"> • Layer 2 Ethernet cards For PCs with a free PCMCIA slot: <ul style="list-style-type: none"> • SOFTNET-PB S7 V8.1 	6ES7 792-0AA00-0XA0 6ES7 901-0BF00-0AA0 6GK1 561-1AA01 6GK1 561-1AM01 6GK1 551-2AA00 6ES7 972-0CB20-0XA0 6GK1 704-5CW08-1AA0
STEP 7 reference manuals Consisting of STL, LAD and FBD manuals as well as a reference manual for standard and system functions for SIMATIC S7-300/400 German English French Spanish Italian	6ES7 810-4CA08-8AW1 6ES7 810-4CA08-8BW1 6ES7 810-4CA08-8CW1 6ES7 810-4CA08-8DW1 6ES7 810-4CA08-8EW1		
SIMATIC Manual Collection Electronic manuals on DVD, five languages: S7-200/300/400, C7, LOGO!, SIMATIC DP, PC, PG, STEP 7, engineering software, runtime software, PCS 7, SIMATIC HMI, SIMATIC NET	6ES7 998-8XC01-8YE0		
SIMATIC Manual Collection update service for 1 year Current "Manual Collection" DVD and the three subsequent updates	6ES7 998-8XC01-8YE2		

Note:

You can find more information in Catalog ST 70 and in the Industry Mall at www.siemens.com/industrymall

Overview

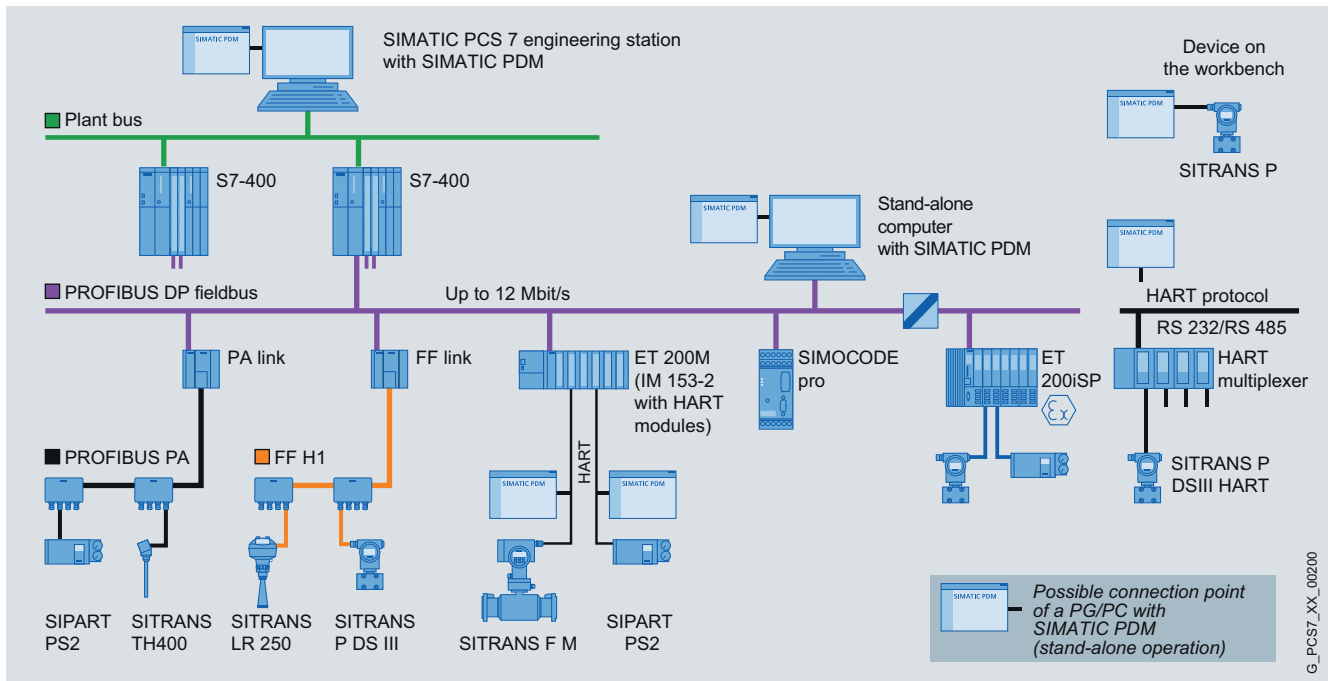

Configuration options with SIMATIC PDM

SIMATIC PDM (Process Device Manager) is a universal, vendor-independent tool for the configuration, parameterization, commissioning, diagnostics and servicing of intelligent field devices (sensors and actuators) and field components (remote I/Os, multiplexers, control-room devices, compact controllers), which in the following sections will be referred to simply as devices.

Using *one* software, SIMATIC PDM enables the processing of more than 2000 devices from Siemens and over 200 vendors worldwide on *one* homogeneous user interface.

The user interface satisfies the requirements of the VDI/VDE GMA 2187 and IEC 65/349/CD directives. Parameters and functions for all supported devices are displayed in a consistent and uniform fashion independent of their communications interface. Even complex devices with several hundred parameters can be represented clearly and processed quickly. Using SIMATIC PDM it is very easy to navigate in highly complex stations such as remote I/Os and even connected field devices.

From the viewpoint of device integration, SIMATIC PDM is the most powerful open device manager available in the world. Devices which previously were not supported can be easily integrated in SIMATIC PDM at any time by importing their device descriptions (EDD). This provides security for your investment and saves you investment costs, training expenses and follow-up costs.

SIMATIC PDM supports the operative system management in particular through:

- Uniform presentation and operation of devices
- Indicators for preventive maintenance and servicing
- Detection of changes in the project and device
- Increasing the operational reliability
- Reducing the investment, operating and maintenance costs
- Graded user privileges including password protection

When used in SIMATIC PCS 7, SIMATIC PDM is integrated in the asset management of the process control system. You can change directly to the SIMATIC PDM views from the diagnostics faceplates in the Maintenance Station.

The Process Device Manager provides more detailed information for all devices described by means of an Electronic Device Description (EDD), e.g.:

- Detailed diagnostics information (manufacturer information, information on error diagnostics and troubleshooting, further documentation)
- Information on changes (audit trail report)
- Parameter information

Ordering data

SIMATIC PDM belongs to the SIMATIC products which can be used both in the context of SIMATIC PCS 7 and in the extended context of Totally Integrated Automation (TIA). The product packages offered for different fields of application differ with regard to functionality, ordering data, and type of delivery. To provide a better overview and to avoid faulty ordering, the selection and ordering data for SIMATIC PCS 7 are listed separately.

Ordering data for SIMATIC PCS 7 applications**SIMATIC PDM V6.0**

	Order No.		Order No.
Product packages		PowerPacks for SIMATIC PDM V6.0	
SIMATIC PDM PCS 7 V6.0 Complete package for integration into the engineering toolset of the SIMATIC PCS 7 engineering system 6 languages (German, English, French, Italian, Spanish, Chinese), software class A, executes with Windows XP Professional Floating license for 1 user, with <ul style="list-style-type: none"> • SIMATIC PDM Basic • Integration in STEP 7 / PCS 7 • Routing via S7-400 • 128 TAGs Type of delivery: License key disk, certificate of license including terms and conditions; software SIMATIC PDM V6.0 and device library on CD/DVD	6ES7 658-3LX06-0YA5	SIMATIC PDM PowerPack for expanding the TAGs of SIMATIC PDM PCS 7 V6.0 6 languages (German, English, French, Italian, Spanish, Chinese), software class A, executes with Windows XP Professional Floating license for 1 user Type of delivery: License key disk, certificate of license including terms and conditions <ul style="list-style-type: none"> • From 128 TAGs to 512 TAGs • From 512 TAGs to 1 024 TAGs • From 1 024 TAGs to 2 048 TAGs • From 2 048 TAGs to unlimited number of TAGs 	6ES7 658-3XB06-2YD5 6ES7 658-3XC06-2YD5 6ES7 658-3XD06-2YD5 6ES7 658-3XH06-2YD5
Optional product components for SIMATIC PDM V6.0		Demonstration software	
SIMATIC PDM communication via standard HART multiplexer 6 languages (German, English, French, Italian, Spanish, Chinese), software class A, executes with Windows 2000 Professional or Windows XP Professional, floating license for 1 user Type of delivery: License key disk, certificate of license including terms and conditions	6ES7 658-3EX06-2YB5	SIMATIC PDM Demo V6.0 without online communication and storage functionality 6 languages (German, English, French, Italian, Spanish, Chinese), software class A, executes with Windows XP Professional Type of delivery: SIMATIC PDM V6.0 software and device library on CD/DVD	6ES7 658-3GX06-0YC8

Ordering data	Order No.	Order No.	
SIMATIC PDM V7.0			
<p>Product packages</p> <p>SIMATIC PDM PCS 7 V7.0 Complete package for integration into the engineering toolset of the SIMATIC PCS 7 engineering system</p> <p>5 languages (German, English, French, Italian, Spanish), software class A, executes with Windows XP Professional and Server 2003</p> <p>Floating license for 1 user, with</p> <ul style="list-style-type: none"> • SIMATIC PDM Basic and Extended • Integration in STEP 7 / PCS 7 • Routing via S7-400 • 100 TAGs <p>Note: SIMATIC PDM PCS 7 V7.0 requires the installation of SIMATIC PCS 7 V7.1+SP2 or higher!</p> <p>Type of delivery: License key memory stick, certificate of license including terms and conditions; software SIMATIC PDM V7.0 and device library on CD/DVD</p>	<p>6ES7 658-3LD07-0YA5</p>	<p>Optional product components for SIMATIC PDM V7.0</p> <p>SIMATIC PDM Communication FOUNDATION Fieldbus V7.0 5 languages (German, English, French, Italian, Spanish), software class A, executes with Windows XP Professional and Server 2003, floating license for 1 user</p> <p>Type of delivery: License key memory stick, certificate of license including terms and conditions</p>	<p>6ES7658-3QX07-2YB5</p>
<p>SIMATIC PDM PCS 7-FF V7.0 Complete package for integration into the engineering toolset of the SIMATIC PCS 7 engineering system</p> <p>5 languages (German, English, French, Italian, Spanish), software class A, executes with Windows XP Professional and Server 2003</p> <p>Floating license for 1 user, with</p> <ul style="list-style-type: none"> • SIMATIC PDM Basic and Extended • Integration in STEP 7 / PCS 7 • Routing via S7-400 • Communication FOUNDATION Fieldbus • 100 TAGs <p>Note: SIMATIC PDM PCS 7-FF V7.0 requires the installation of SIMATIC PCS 7 V7.1+SP2 or higher!</p> <p>Type of delivery: License key memory stick, certificate of license including terms and conditions; software SIMATIC PDM V7.0 and device library on CD/DVD</p>	<p>6ES7 658-3MD07-0YA5</p>	<p>SIMATIC PDM TAGs for SIMATIC PDM V7.0</p> <p>SIMATIC PDM TAGs Count Relevant Licenses (can be accumulated) for expanding the TAGs of SIMATIC PDM product packages V7.0 or higher</p> <p>Software class A, executes with Windows XP Professional and Server 2003</p> <p>Floating license for 1 user</p> <p>Type of delivery: License key memory stick, certificate of license including terms and conditions</p> <ul style="list-style-type: none"> • 10 TAGs • 100 TAGs • 1 000 TAGs 	<p>6ES7 658-3XC00-2YB5</p> <p>6ES7 658-3XD00-2YB5</p> <p>6ES7 658-3XE00-2YB5</p>

Ordering data

Order No.

Order No.

Ordering data for TIA applications

Product packages

Minimum configuration

SIMATIC PDM Single Point V6.0**6ES7 658-3HX06-0YA5**

for operation and parameterization of one field device; communication via PROFIBUS DP/PA or HART modem, including 1 TAG

cannot be expanded with respect to functions or with TAG option/PowerPack

6 languages (German, English, French, Italian, Spanish, Chinese), software class A, executes with Windows 2000 Professional or Windows XP Professional, floating license for 1 user

Type of delivery:

License key disk, certificate of license including terms and conditions; software SIMATIC PDM V6.0 and device library on CD/DVD

Basic configuration for individual product packages

SIMATIC PDM Basic V6.0

Product package for operation and parameterization of field devices and components, communication via PROFIBUS DP/PA, HART (modem, RS 232, PROFIBUS) and Modbus, including 4 TAGs

6 languages (German, English, French, Italian, Spanish, Chinese), software class A, executes with Windows 2000 Professional or Windows XP professional

Type of delivery:

License key disk, certificate of license including terms and conditions; software SIMATIC PDM V6.0 and device library on CD/DVD

- Floating license for 1 user
- Rental license for 50 hours

6ES7 658-3AX06-0YA5
6ES7 658-3AX06-0YA6

Application-specific configurations

SIMATIC PDM Service V6.0**6ES7 658-3JX06-0YA5**

Product package for stand-alone users for servicing, with

- SIMATIC PDM Basic V6.0
- 128 TAGs

6 languages (German, English, French, Italian, Spanish, Chinese), software class A, executes with Windows 2000 Professional or Windows XP Professional, floating license for 1 user

Type of delivery:

License key disk, certificate of license including terms and conditions; software SIMATIC PDM V6.0 and device library on CD/DVD

Application-specific configurations (continued)

SIMATIC PDM S7 V6.0**6ES7 658-3KX06-0YA5**

Product package for use in a SIMATIC S7 configuration environment, with

- SIMATIC PDM Basic V6.0
- Integration in STEP 7 / PCS 7
- 128 TAGs

6 languages (German, English, French, Italian, Spanish, Chinese), software class A, executes with Windows 2000 Professional or Windows XP Professional, floating license for 1 user

Type of delivery:

License key disk, certificate of license including terms and conditions; software SIMATIC PDM V6.0 and device library on CD/DVD

Optional product components for SIMATIC PDM V6.0

Integration in STEP 7 / SIMATIC PCS 7**6ES7 658-3BX06-2YB5**

only required for integration of SIMATIC PDM into HW Config

6 languages (German, English, French, Italian, Spanish, Chinese), software class A, executes with Windows 2000 Professional or Windows XP Professional, floating license for 1 user

Type of delivery:

License key disk, certificate of license including terms and conditions

Routing via S7-400**6ES7 658-3CX06-2YB5**

6 languages (German, English, French, Italian, Spanish, Chinese), software class A, executes with Windows 2000 Professional or Windows XP Professional, floating license for 1 user

Type of delivery:

License key disk, certificate of license including terms and conditions

Communication via standard HART multiplexer**6ES7 658-3EX06-2YB5**

6 languages (German, English, French, Italian, Spanish, Chinese), software class A, executes with Windows 2000 Professional or Windows XP Professional, floating license for 1 user

Type of delivery:

License key disk, certificate of license including terms and conditions

Ordering data	Order No.	More information
<i>TAG options/PowerPacks for SIMATIC PDM V6.0</i>		
<p>SIMATIC PDM TAG option for TAG expansion, additive to SIMATIC PDM Basic V6.0</p> <p>6 languages (German, English, French, Italian, Spanish, Chinese), software class A, executes with Windows 2000 Professional or Windows XP Professional, floating license for 1 user</p> <p>Type of delivery: License key disk, certificate of license including terms and conditions</p> <ul style="list-style-type: none"> • Up to 128 TAGs • Up to 512 TAGs • Up to 1 024 TAGs • Up to 2 048 TAGs 	<p>6ES7 658-3XA06-2YB5</p> <p>6ES7 658-3XB06-2YB5</p> <p>6ES7 658-3XC06-2YB5</p> <p>6ES7 658-3XD06-2YB5</p>	<p>Update/Upgrade</p> <p>All SIMATIC PDM product variants and combinations with Version 5.x can be upgraded to Version 6.0 per SIMATIC PDM Upgrade.</p> <p>Product configurations according to SIMATIC PDM PCS 7 V6.0 that are used in the SIMATIC PCS 7 process control system can be upgraded to V7.0 by means of an upgrade package. SIMATIC PCS 7 V7.1 + SP2 or higher must be installed, however, to permit the installation of the upgrade package for upgrading from SIMATIC PDM V6.0 to V7.0.</p> <p>A Software Update Service in the form of a subscription is also offered for SIMATIC PDM.</p> <p>For further information, see Sections "Updates/upgrades asynchronous to the PCS 7 version" and "Software Update Service" in Chapter "Update/upgrade packages" in Catalog SIMATIC PCS 7.</p>
<p>SIMATIC PDM PowerPack for TAG expansion, for any SIMATIC PDM V6.0 product packages</p> <p>6 languages (German, English, French, Italian, Spanish, Chinese), software class A, executes with Windows 2000 Professional or Windows XP Professional, floating license for 1 user</p> <p>Type of delivery: License key disk, certificate of license including terms and conditions</p> <ul style="list-style-type: none"> • From 128 TAGs to 512 TAGs • From 512 TAGs to 1 024 TAGs • From 1 024 TAGs to 2 048 TAGs • From 2 048 TAGs to unlimited number of TAGs 	<p>6ES7 658-3XB06-2YD5</p> <p>6ES7 658-3XC06-2YD5</p> <p>6ES7 658-3XD06-2YD5</p> <p>6ES7 658-3XH06-2YD5</p>	
<i>Demonstration software</i>		
<p>SIMATIC PDM Demo V6.0 without online communication and storage functionality</p> <p>6 languages (German, English, French, Italian, Spanish, Chinese), software class A, executes with Windows 2000 Professional or Windows XP professional</p> <p>Type of delivery: SIMATIC PDM V6.0 software and device library on CD/DVD</p>	<p>6ES7 658-3GX06-0YC8</p>	

PROFIBUS

Engineering/Network Management/Diagnostics

BANYnet bus analysis and diagnostics

Overview

BANYnet is a tool based on Microsoft Windows for documentation, monitoring, diagnostics, recording and analysis of Ethernet and PROFIBUS networks.

- Management of all IP and MAC addresses in the network
- Generation of a network overview map
- Automatic scanning of network
- Monitoring of network nodes for "Failure", "Newly added", "Not registered"
- Reading out of data, message frame types and error statistics from the network components
- Display of bus load
- Recording of message frame traffic
- Recording of PROFINET communication
- Recording of PROFIBUS communication
- Comprehensive trigger, filter and sorting functions

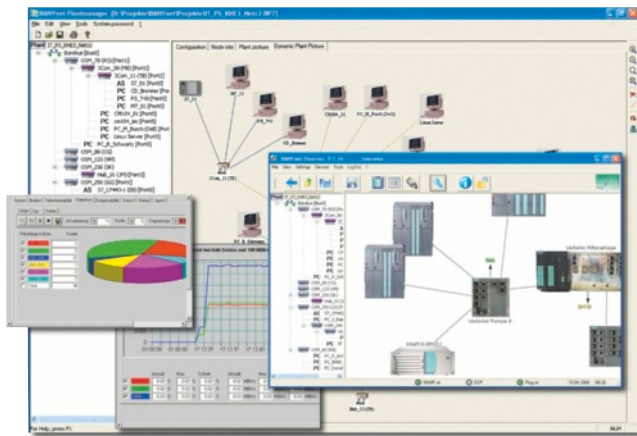

BANYnet plant configuration

Benefits

get Designed for Industry

- Continuously updated overview of the configured network (number/type of components)
- Permanent bus load display ensures sufficient performance in the network
- Fast localization of errors in network components
- Network optimization through statistics on type and length of message frame, cycle time, etc.

Application

The functionality for this is distributed as follows between five independent program modules:

- The Plant Manager of BANYnet Ethernet offers valuable support toward configuration of your plant through management of IP and MAC addresses, automatic generation of the plant display, and import and export functions.
- The Observer scans the network using various protocols, and displays safety-related changes in the network topology both in an overview and in a hierarchy.
- The Plant Diagnostics reads the configuration data as well as comprehensive message frame type and error statistics from the SNMP-capable network components, and provides information to assist searching for errors in the Ethernet network. Data such as bus load or lifelist are evaluated and displayed online.
- The Bus Analysis records the message frame traffic on one or more Ethernet buses synchronously, and interprets the message frames throughout all levels, including SIMATIC S7/PCS 7 and PROFINET. Comprehensive trigger, filter and sorting functions allow fast localization of errors.
- The Profibus Scope records the message frame traffic of a PROFIBUS network using a CP 5512, and interprets the message frames accordingly. Comprehensive trigger, filter and sorting functions allow fast localization of errors.

Function

The **Plant Manager** is used to configure the database of the BANYnet project. All information required is created in data structures. An import/export function allows data exchange with other programs. A user-friendly plant overview is automatically generated from the data structures. The Plant Manager can therefore be used for both documentation and configuration of Ethernet networks. Tables provide detailed information on the properties of the nodes. Furthermore, any type of information can be assigned to the individual nodes for documentation purposes.

The **Plant Diagnostics** scans the system data of SNMP-capable network nodes (e.g. switches, PCs), and thus provides information on the configured nodes. The bus load display of the individual ports (numeric or graphic) and the list of nodes provide great assistance in locating errors in the Ethernet network.

Statistics functions provide information on the number of individual message frame types (packet lengths, message frame types, error types, etc.). The events (traps) sent by the switch can be displayed in a list.

Parameterization of the SCALANCE X and OSM/ESM Industrial Ethernet switches is supported in addition, e.g. IP address, port configuration or firmware update.

Function (continued)

The **Bus Analysis** allows user-friendly analysis of recorded files (import/export of Netmon or Sniffer files is also possible) over several interfaces simultaneously (e.g. for redundancy analyses) by means of the integral BANYmon. Errors can be rapidly located using predefined or user-generated filter and sorting functions. When one of the listed message frames is clicked, the associated detailed information is output. SIMATIC S5/S7/PCS 7-specific message frames are interpreted and displayed according to their type (e.g. redundant message frames, alarm-8 message frames, etc.).

When using a CP 1616, PROFINET data traffic can be recorded without time losses and with complete message frame interpretation.

The **Observer** permits user-friendly and reliable dynamic monitoring of your network. The actual state is compared with the project created in the Plant Manager, and changes are displayed immediately. In order to locate events such as errors or the penetration of unknown nodes, it is possible to graphically trace the network hierarchy back to the source. In addition, these events are saved in log files for later analysis and documentation.

Furthermore, the scanned data can be imported into the project and updated supplementary to the Plant Manager.

The **PROFIBUS Scope** permits recording, saving and user-friendly analysis of bus events. It supports all baud rates from 9.6 kbit/s to 12 Mbit/s, and determines these automatically. The recording can be carried out in a linear buffer or a cyclic buffer of selectable size. Long-term recording is possible in this manner. The start and end of recording can be automated using triggers. The data quantities can be reduced during the recording using predefined or user-created filter and sorting functions, and errors can be easily located by means of the subsequent analysis. When a listed message frame is clicked, its detailed information is output. The SIMATIC S7/PCS 7-specific message frames are interpreted and displayed depending on their type (e.g. redundant message frames, alarm-8 message frames, etc.). The following protocols are interpreted: DP, FDL, DPV1, DPV2, FMS and S7.

The BANYnet function for executing several recordings in parallel can be used for the **redundancy analysis**. BANYnet PROFIBUS is connected to the redundant bus segments for this purpose. Since the recorded message frames are assigned synchronous time stamps, the communication flow information can be easily compared. This allows fast and exact locating of redundancy problems.

Note:

The computer with the BANYnet PROFIBUS program package requires a CP 5512 (PC card) for the PROFIBUS connection.

Ordering data

Order No.

BANYnet bus analysis and diagnostics

Program package for PC/PG for Microsoft Windows NT/2000/XP SP2 and electronic documentation on CD, dual language (German, English), software protected by USB dongle

- **BANYnet Ethernet**
for Industrial Ethernet networks
- **BANYnet PROFIBUS**
for PROFIBUS networks;
(CP 5512 is required)
- **BANYnet Ethernet and PROFIBUS**
for Ethernet and PROFIBUS networks;
(CP 5512 is required)

9AE4 100-1DB00

9AE4 100-1DE00

9AE4 100-1DF00

CP 5512 communication processor

PC card (CardBus, 32 bit) for connection of a programming device or notebook to PROFIBUS or MPI, under 32 bit in connection with PROFIBUS SOFTNET software or STEP 7; German/English

6GK1 551-2AA00

More information

Support can be found at:
www.siemens.com/simatic-net/ik-info

PROFIBUS

PROFIBUS components

PROFIBUS DP ASICs

Overview

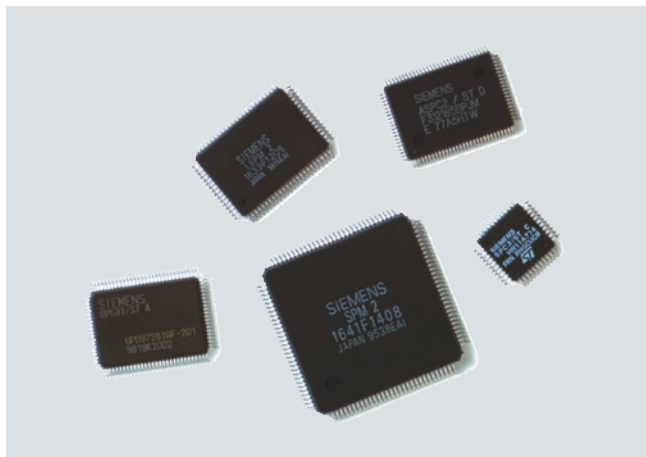

- Easy connection of field devices to PROFIBUS
- Integrated low power management
- Different ASICs for the different functional requirements and application areas

Application

The PROFIBUS DP ASICs allow equipment manufacturers to connect their devices to PROFIBUS easily.

They can be implemented at transmission rates of up to 12 Mbit/s.

The following blocks are available for different functional requirements and fields of application:

- Master applications:
ASPC 2
- Intelligent slaves:
SPC 3 and SPC3LV for PROFIBUS DP, with hardware-controlled bus access;
DPC 31 with integral 8031 core;
SPC 4-2.
- Connection in intrinsically safe systems:
SIM 1-2 for physical connection in intrinsically safe fieldbus systems as a Medium Attachment Unit for IEC 61158-2 at 31.25 kbit/s. Especially for combining with the SPC 4-2 and DPC 31.
- Simple slaves:
LSPM 2 with 32 input/output bits for confined spaces
- Connection to fiber-optic conductors:
FOCSI
module for electrical conditioning of signals already received or to be sent. The module ensures that the optically transmitted signals are properly electrically restored (retiming/retriggering)

For initial development, order quantities of 5/6 ASICs are possible (not suitable for batch assembly because the pins of the ASIC can be bent due to the packaging; packing units larger than 5/6 units must be used)

The number of ASICs per packing unit depends on the ASIC type (see ordering data).

The ASICs ASPC 2, SPC3, SPC3LV, DPC31, LSPM2 and FOCSI can also be supplied in a lead-free design.

Design

ASPC 2

The ASPC 2 is a preprocessing communications chip for master applications with a maximum transmission rate of 12 Mbit/s. The ASIC has not been disclosed. The brief user manual describes the pins and the electrical properties of the ASPC 2. A separate microprocessor and the appropriate firmware are required for operation. The firmware is tuned to the 80C165 processor and can be obtained by purchasing a license.

SPC 3

The SPC 3 is a preprocessing communications chip with a processor interface. The SPC 3 processes message frame identification, address identification, execution of the data back-up sequences and protocol processing for PROFIBUS DP.

Firmware is offered for the Siemens SPC 3 (see ordering data).

SPC 3LV

The product portfolio for intelligent PROFIBUS slave applications was expanded by a 3.3 V version. The SPC3LV is 100% compatible in terms of functions and pins to the 5 V version (SPC3).

DPC 31

The DPC 31 is a preprocessing communications module with a processor interface and an integrated processor core (C31 core).

It supports the connection of intelligent field devices as slaves on PROFIBUS DP and PROFIBUS PA.

The DPC 31 autonomously processes all communications tasks and has, in addition, an integral C31 core for further applications. It combines the communication properties of the ASICs SPC 3 and SPC 4-2 in one chip. The integrated C31 core can also be programmed as required. Firmware is offered for the Siemens ASIC DPC 31 (see ordering data).

SPC 4-2

The SPC 4-2 is a preprocessing communications chip with a processor interface. It is designed for combined applications and due to the Low Power Management function, it is ideally suited to use in intrinsically safe applications. Firmware is offered for the SPC 4-2 by the company TMG itec¹⁾. The signals are converted for PROFIBUS PA using the SIM 1-2 module.

¹⁾ Order from:
TMG itec
76137 Karlsruhe, Germany
Tel. +49 (0)721 82 80 60

Design (continued)

SIM 1-2

The SIM 1-2 supplements the SPC 4-2 or DPC 31. Only a few external components are required in addition to these ASICs to be able to connect field devices to an intrinsically safe network in accordance with PROFIBUS PA. In combination with the SPC 4-2 or DPC 31, the functions of a PROFIBUS PA slave can be processed from physical linking through to communication control.

SIM 1-2 supports all send and receive functions (including Jabber Control) as well as the high-resistance decoupling of auxiliary power from the bus cable. It provides an adjustable, stabilized supply voltage and also supports configuration of an electrically isolating power supply with just a few passive components.

The ASIC contains a special interface logic which provides a low-overhead, minimum power interface for galvanic signal separation as an alternative to the standard signal interface.

It can be connected to all Manchester encoders/decoders to the IEC 61 158-2 standard at 31.25 kbit/s.

LSPM 2

LSPM 2 is a single-chip solution with 32 input/output bits. It processes all bus communication autonomously. An additional microprocessor and firmware are not required. The compact MQFP casing with 80 pins makes it ideal for applications with low space requirements.

FOCSI

This ASIC functions as an expansion to the existing PROFIBUS ASICs. The FOCSI module (Fiber Optic Controller from Siemens) ensures proper electrical conditioning and transfer of the received/sent optical signal. To inject the signal into a fiber-optic conductor, apart from FOCSI, the appropriate optical transmitter and receiver will be required. FOCSI can be used with the PROFIBUS DP ASICs described above.

Additional ordering data available on request

Technical specifications

	LSPM 2	SPC 3	SPC 3LV	DPC 31
Protocol	PROFIBUS DP	PROFIBUS DP	PROFIBUS DP	PROFIBUS DP, PROFIBUS PA
Application range	simple slave application	intelligent slave application	intelligent slave application	intelligent slave application
Transmission rate, max.	12 Mbit/s	12 Mbit/s	12 Mbit/s	12 Mbit/s
Bus access	in ASIC	in ASIC	in ASIC	in ASIC
Automatic determination of transmission rate	yes	yes	yes	yes
Microprocessor required	no	yes	yes	integrated
Scope of firmware	not required	6 to 24 KB	6 to 24 KB	approx. 38 KB
Message buffer	-	1.5 KB	1.5 KB	6 KB
Power supply	5 V DC	5 V DC	3.3 V DC	3.3 V DC
Power loss, max.	0.35 W	0.5 W	<0.5 W	0.2 W
Permissible ambient temperature	-40 °C ... +75 °C	-40 °C ... +85 °C	-40 °C ... +85 °C	-40 °C ... +85 °C
Housing	MQFP, 80-pin	PQFP, 44-pin	PQFP, 44-pin	PQFP, 100-pin
Frame size	4 cm ²	2 cm ²	2 cm ²	4 cm ²
Delivery quantities (pcs.)	6/66/330/4950	6/96/750/960/4800	5/160/800/1000/4800	STEP B: 6/60/300/5100 STEP C1: 6/66/660/4620

	SPC 4-2	ASPC 2	SIM 1-2	FOCSI
Protocol	PROFIBUS DP PROFIBUS FMS PROFIBUS PA	PROFIBUS DP PROFIBUS FMS PROFIBUS PA	PROFIBUS PA	-
Application range	Intelligent slave application	Master application	Medium Attachment	Medium Management Unit
Transmission rate, max.	12 Mbit/s	12 Mbit/s	31.25 kbit/s	12 Mbit/s
Bus access	in ASIC	in ASIC	-	-
Automatic determination of transmission rate	yes	yes	-	-
Microprocessor required	yes	yes	-	-
Scope of firmware	3 ... 30 KB	80 KB	not required	not required
Message buffer	3 KB	1 MB (external)	-	-
Voltage supply	5 V DC, 3.3 V	5 V DC	via bus	3.3 V DC
Power loss, max.	0.6 W at 5 V 0.01 W at 3.3 V	0.9 W	0.05 W	0.75 W
Permissible ambient temperature	-40 °C ... +85 °C	-40 °C ... +85 °C	-40 °C ... +85 °C	-40 °C ... +85 °C
Housing	TQFP, 44-pin	P-MQFP, 100-pin	MLPQ, 40-pin	TQFP, 44-pin
Frame size	2 cm ²	4 cm ²	36 mm ²	2 cm ²
Delivery quantities (pcs.)	5/160	6/66/660/4620	30/60/1000	40

PROFIBUS

PROFIBUS components

PROFIBUS DP ASICs

3

Ordering data	Order No.	Order No.
ASIC ASPC 2 For constructing master interfaces (quantity discount) <ul style="list-style-type: none"> • 6 units (lead-free) • 66 units (lead-free) • 660 units (lead-free) • 4620 units (lead-free) 	6ES7 195-0AA05-0XA0 6ES7 195-0AA15-0XA0 6ES7 195-0AA25-0XA0 6ES7 195-0AA35-0XA0	
ASIC LSPM 2 For constructing simple slave interfaces (quantity discount) <ul style="list-style-type: none"> • 6 units (lead-free) • 66 units (lead-free) • 330 units (lead-free) • 4950 units (lead-free) 	6ES7 195-0BA02-0XA0 6ES7 195-0BA12-0XA0 6ES7 195-0BA22-0XA0 6ES7 195-0BA32-0XA0	
ASIC SPC 3 For constructing intelligent DP slave interfaces (quantity discounts) <ul style="list-style-type: none"> • 6 units (lead-free) • 96 units (lead-free) • 960 units (lead-free) • 4800 units (lead-free) • 750 units (lead-free) T&R 	6ES7 195-0BD04-0XA0 6ES7 195-0BD14-0XA0 6ES7 195-0BD24-0XA0 6ES7 195-0BD34-0XA0 6ES7 195-0BD44-0XA0	
ASIC SPC 3LV For constructing intelligent DP slave interfaces (quantity discounts) <ul style="list-style-type: none"> • 5 units (lead-free) • 160 units (lead-free) • 800 units (lead-free) • 4800 units (lead-free) • 1000 units (lead-free) T&R 	6ES7 195-0BG00-0XA0 6ES7 195-0BG10-0XA0 6ES7 195-0BG20-0XA0 6ES7 195-0BG30-0XA0 6ES7 195-0BG40-0XA0	
ASIC FOCSI Fiber Optic Controller from Siemens for conditioning signals for the optical PROFIBUS <ul style="list-style-type: none"> • 40 units (lead-free) 	6ES7 195-0EA20-0XA0	
		ASIC DPC 31 STEP B For constructing intelligent DP slave interfaces (quantity discounts) <ul style="list-style-type: none"> • 6 units (lead-free) • 60 units (lead-free) • 300 units (lead-free) • 5100 units (lead-free)
		6ES7 195-0BE02-0XA0 6ES7 195-0BE12-0XA0 6ES7 195-0BE22-0XA0 6ES7 195-0BE32-0XA0
		ASIC DPC 31 STEP C1 For constructing intelligent DP slave interfaces (quantity discounts) <ul style="list-style-type: none"> • 6 units (lead-free) • 66 units (lead-free) • 660 units (lead-free) • 4620 units (lead-free)
		6ES7 195-0BF02-0XA0 6ES7 195-0BF12-0XA0 6ES7 195-0BF22-0XA0 6ES7 195-0BF32-0XA0
		ASIC SPC 4-2 For constructing intelligent DP slave interfaces (quantity discounts) <ul style="list-style-type: none"> • 5 units for laboratory development (lead-free) • 160 units (lead-free, 1 tray)
		6GK1 588-3AA00 6GK1 588-3AA15
		ASIC SIM 1-2 For connection according to IEC H1 for PROFIBUS PA with a transmission rate of 31.25 kbit/s <ul style="list-style-type: none"> • 60 units (in tube) • 1000 units (tape & reel)
		6GK1 588-3BB02 6GK1 588-3BB21
		Accessories
		Firmware for Siemens ASIC SPC 3 <ul style="list-style-type: none"> • DP firmware • DPV1 firmware • DPV1 firmware upgrade
		6ES7 195-2BA00-0XA0 6ES7 195-2BA01-0XA0 6ES7 195-2BA02-0XA0
		Firmware for Siemens ASIC DPC 31 <ul style="list-style-type: none"> • DPV1 firmware
		6ES7 195-2BB00-0XA0

More information

Support

Please contact the following Competence Centers for any technical questions:

Germany and Europe

Siemens AG
 Communication, Development & Certification (ComDeC)
 PO Box 23555
 90713 Fürth, Germany
 Tel.: +49 (911) 750-2080
 Fax: +49 (911) 750-2100
 E-mail: <http://comdec@siemens.com>

USA and International

PROFI Interface Center (PIC)
 One Internet Plaza
 PO Box 4991
 Johnson City, TN 37602-4991
 Tel.: +1 (423) - 262 - 2969
 Fax: +1 (423) - 262 - 2103
 E-mail: <http://profibus.sea@siemens.com>

Overview

- PC slave board IM 182-1 for the connection of AT-compatible PCs as DP slaves

Application

The PROFIBUS DP interface module IM 182-2 makes it easy to connect a slave to PROFIBUS DP. It is based on the ASIC SPC3 of Siemens AG. The interface module can be implemented up to a transmission rate of 12 Mbit/s.

Design

IM 182-1 PC slave board

The simple IM 182-1 PC slave card (ISA bus) is based on the ASIC SPC 3. It contains all the physical bus components. A 9-pin Sub-D connector is used for connecting to PROFIBUS DP.

The firmware of the SPC 3 can be used as an accessory on the PC. The 1.5 KB RAM of the SPC 3 forms the interface to the host system. A driver for Windows NT is also offered.

Technical specifications

6ES7 182-0AA01-0XA0	
General information	
Application area	Slave applications
Delivery quantities (pcs.)	
• 5 V DC	Yes
Current consumption, typ.	250 mA
Hardware components/modules/ASIC	
ASIC	SPC 3
Scope of firmware	4 to 24 KB (incl. test program)
Programming devices	
Microprocessor type	Processor of the PG/PC
Interfaces	
PROFIBUS DP	
• Transmission rate, max.	12 Mbit/s
Protocols	
PROFIBUS DP protocol	Yes
Operating temperature	
• Min.	0 °C
• max.	60 °C
Dimensions and weight	
• PCB size, width	168 mm
• PCB size, height	105 mm

Ordering data

SIMATIC S5/S7 IM 182-1 PC slave board

For PROFIBUS DP, max. 12 Mbit/s

Accessories

Windows NT driver for IM 180 and IM 182

Firmware for Siemens ASIC SPC 3 and IM 182-1

- DP firmware
- DPV1 firmware
- DPV1 firmware upgrade

Order No.

6ES7 182-0AA01-0XA0

6ES7 195-2AC00-0XA0

6ES7 195-2BA00-0XA0

6ES7 195-2BA01-0XA0

6ES7 195-2BA02-0XA0

More information

Brochures

Information material for downloading can be found in the Internet:

www.siemens.com/simatic/printmaterial

Manuals

Manuals for PROFIBUS DP connections are available free in the Internet.

Support

Please contact the following Competence Centers for any technical questions:

Germany and Europe

Siemens AG
Communication, Development & Certification (ComDeC)
PO Box 23555
90713 Fürth, Germany
Tel.: +49 (911) 750-2080
Fax: +49 (911) 750-2100
E-mail: http://comdec@siemens.com

USA and International

PROFI Interface Center (PIC)
One Internet Plaza
PO Box 4991
Johnson City, TN 37602-4991
Tel.: +1 (423) - 262 - 2969
Fax: +1 (423) - 262 - 2103
E-mail: http://profibus.sea@siemens.com

PROFIBUS

PROFIBUS components

Development kits

Overview

Development kit

Using the development kits, PROFIBUS hardware and software applications can be developed and tested using the PROFIBUS ASICs DPC31.

The comprehensive, perfectly interacting hardware and software components considerably reduce the development costs for a PROFIBUS device.

The kits provide a fully functional hardware development environment which development engineers can build on with their special requirements for hardware and software. The kit documentation is supplied on CD in English and German.

The kits make our PROFIBUS know-how accessible to other users. The development team is available to provide advice to new users even with their own developments - this consultancy service is also a component part of the development kit.

Following completion of a development, devices can be certified by our experts in the PROFIBUS interface centers – we can help new users here, too.

PROFIBUS DP/PA development kit

The kit facilitates set up of PROFIBUS slaves with a variety of PROFIBUS standards:

- PROFIBUS DP-V1 (RS485)
- PROFIBUS PA (IEC 1158) and
- PROFIBUS based on fiber-optic cables.

The development environment shows applications implemented using PROFIBUS-ASICs DPC 31.

Hardware included:

- DPC 31 development board; for developing/testing proprietary applications
- CP 5613; serves as master interface for the PC (PCI card)
- Optical bus terminal; for conversion of copper cables to FOCs
- Pre-assembled PROFIBUS cables

Software included:

- Testing and simulation software under WinNT for use on the PC in connection with the CP 5613 master module
- Sample program for the DPC 31 board
- DPC 31 DPV1 original firmware, including developer license
- Parameterization software for CP 5613 "COM PROFIBUS" for DP operation

When developing PROFIBUS PA applications, order a PROFIBUS DP/PA coupler (6ES7 157-0AC80-0XA0) separately. The DP/PA coupler converts the PROFIBUS DP physical specifications into those of PROFIBUS PA. This module is not included in the development kit!

PROFIsafe starter kit V3.4

The PROFIsafe starter kit V3.4 is compatible with version 2.4 of the PROFIsafe profile, as specified in IEC 61784-3-3. It meets a series of user requirements such as multi-instance capability and variable process data length at runtime.

Along with all of the PI specifications required for development, the PROFIsafe starter kit contains the source files for the PROFIsafe driver software (PSD) and a comprehensive implementation manual in English and German. In addition, it includes various CRC calculation tools and tools for creating GSD files with security-related parameters.

Examples of adaptation of the PSD (PROFIsafe Driver) to current PROFIBUS and PROFINET stack interfaces provide assistance for adaptations that may be necessary. Special "slow motion monitors" allow the PROFIsafe protocol processes to be monitored in slow motion. A new feature is support for the iPar server and the TCI interface.

Example applications are provided on the CD-ROM for both PROFIBUS and PROFINET. The hardware components supplied in the development kits offer the user access to the PROFIsafe world, step-by-step.

The PROFIsafe starter kit consists of the following components:

- Current PROFIsafe specifications with current PROFIsafe certificate
- PROFIsafe driver software (as core component of the development package)
- Example GSD file for STEP7 (for PROFIBUS DP/PA development package and DK-ERTEC 200 PN IO)
- Example project for S7-319F (for PROFIBUS DP/PA development package and DK-ERTEC 200 PN IO)
- GSD tools (e.g. GSD editor and CRC calculation tool)
- iPar server software and instructions (FB24)
- Tool calling interface example and instructions
- F programming guidelines
- Layer stacks (V1SL and PN IO)
- Example firmware (for PROFIBUS DP/PA development package and DK-ERTEC 200 PN IO)
- Project for development environment example (for PROFIBUS DP/PA development package and DK-ERTEC 200 PN IO)
- Slow motion monitor (for PROFIBUS: PG-PC and CP5613, for PROFINET: PG-CP1616)
- Comprehensive documentation

Ordering data	Order No.
DP/PA development kit For PROFIBUS ASIC DPC 31 and SIM1, English/German	6ES7 195-3BA10-0YA0
PROFIsafe starter kit V3.4	6ES7 195-3BF02-0YA0

More information

Manuals

Manuals for PROFIBUS DP connections are available free in the Internet.

Support

Please contact the following Competence Centers for any technical questions:

Germany and Europe

Siemens AG
 Communication, Development & Certification (ComDeC)
 PO Box 23555
 90713 Fürth, Germany
 Tel.: +49 (911) 750-2080
 Fax: +49 (911) 750-2100
 E-mail: <http://comdec@siemens.com>

USA and International

PROFI Interface Center (PIC)
 One Internet Piazza
 PO Box 4991
 Johnson City, TN 37602-4991
 Tel.: +1 (423) - 262 - 2969
 Fax: +1 (423) - 262 - 2103
 E-mail: <http://profibus.sea@siemens.com>

PROFIBUS

Partner solutions

Delphi-S7, Delphi-DPLib and Delphi-DPSofnetSlave

Overview

The Delphi software products offer programming interfaces for Delphi developments with access to PROFIBUS.

The following protocols are available:

- PROFIBUS DP (Delphi-DPLib) for the DP-5613 software with CP 5613 A2/CP 5614 A2 or SOFTNET-DP with CP 5512, CP 5611 A2 or CP 5621
- PROFIBUS DP SOFTNET slave (Delphi-DPSofnetSlave) for all SIMATIC DP slave products for CP 5611 A2 or CP 5621
- S7 communication (Delphi-S7) for the S7-5613 software with CP 5613 A2/CP 5614 A2 or SOFTNET-S7 with CP 5512/CP 5611 A2 or CP 5621

The products enable easy access to the Siemens SIMATIC NET programming interfaces under Borland Delphi.

In its communication functions, the interface for Borland Delphi is analogous to the Siemens interface for the programming language C. All the services of the relevant communication protocols over PROFIBUS are supported.

Benefits



- Interfacing the Borland world to SIMATIC NET
- Developments are executable on computers with PCI, PCI Express, PCMCIA or PC card slots

Technical specifications

Type	Delphi-S7, Delphi-DPLib and Delphi-DPSofnetSlave for Borland Delphi
System requirements	<ul style="list-style-type: none"> • Borland Delphi 6.0 or higher • All Windows operating systems as of Windows NT 4.0 • CP 5512, CP 5611 A2, CP 5621, CP 5613 A2/CP 5614 A2 • Software packages for CP 5613 A2/CP 5614 A2 or CP 5512, CP 5611 A2, CP 5621

Ordering data

Order No.

Delphi-DPLib for Borland Delphi Including example program, documentation German and English	Delphi-DPLib
Delphi-DPSofnetSlave for Borland Delphi Including example program, documentation German and English	Delphi-DPSofnetSlave
Delphi-S7 for Borland Delphi or C++-Builder Including example program, documentation German and English	Delphi-S7
For more information contact:	SoftwareOption Outsourcing Services GmbH  SoftwareOption Outsourcing Services GmbH, Carsten Buchloh Waldstraße 30 D-52080 Aachen Tel.: +49 - (0)2405 - 47 16 727 Fax: +49 - (0)2405 - 47 16 729 E-mail: Carsten.Buchloh@SoftwareOption.de www.SoftwareOption.de Internet: www.SoftwareOption.de

Note:

Fully functional test versions are available for download on the Internet. You can also order the full versions online.

More information

You can find more information on the Internet at:
www.SoftwareOption.com

SIMATIC ET 200 Distributed I/O

4



4/2	Introduction
4/3	Systems for the control cabinet
4/3	ET 200S
4/4	ET 200S – Motor Starters and Safety Motor Starters
4/18	ET 200M
4/18	ET 200L
4/19	ET 200iSP
4/20	Systems without control cabinet
4/20	ET 200pro
4/21	ET 200pro – Motor starters
4/25	ET 200eco PN
4/26	ET 200eco

Introduction

Overview



SIMATIC ET 200 – offers the right solution for every application

SIMATIC ET 200 provides extremely wide range of distributed I/O systems – for solutions in the control cabinet or directly on the machine without a control cabinet and for use in areas where there is an explosion hazard. The modular design means that it is easy to scale and expand the ET 200 systems in small increments. Ready-installed add-on modules reduce the costs, whilst at the same time offering wide-ranging application options. An extremely wide range of combinations is possible: digital and analog inputs/outputs, intelligent modules with CPU functionality, safety systems, motor starters, pneumatics, frequency converters and various technology modules (e.g. for counting and positioning tasks).

Communication via PROFIBUS and PROFINET, uniform engineering, transparent diagnosis possibilities and the optimal connection to SIMATIC Controller and HMI devices provide evidence of the unique uniformity of Totally Integrated Automation.

PROFIBUS

PROFIBUS is the international standard (IEC 61158/61784) for the field area. As the only field bus it permits communication in both manufacturing- and process-related applications.

PROFIBUS is used to connect field devices such as distributed I/O stations or operating mechanisms to automation systems such as SIMATIC S7, SIMOTION, SINUMERIK or PCs.

PROFIBUS, which is standardized according to IEC 61158, is a powerful, open and robust field bus system with short response times. PROFIBUS is available in different physical forms for various applications.

PROFIBUS DP (distributed I/O)

Is used for the connection of distributed field devices, e.g. SIMATIC ET 200, or drives with very rapid response times. PROFIBUS DP is used when actuators/sensors are distributed on the machine or in the system (e.g. field level).

PROFINET

PROFINET is the open and cross-vendor Industrial Ethernet Standard (IEC 61158/61784) for automation.

Based upon Industrial Ethernet, PROFINET enables the direct communication of field devices (IO devices) with controllers (IO controllers) right through to the solution of clocked drive controls for Motion Control applications.

Since PROFINET is based upon Standard Ethernet according to IEEE 802.3, devices from the field level to the control level can be universally connected.

PROFINET thus leads to a universal communication, enables system-wide engineering and uses IT standards such as web server or FTP right through to the field level. Proven fieldbus systems, such as PROFIBUS or AS-Interface, are simple to integrate without changes to the existing devices.

AS-Interface

AS-Interface is the international standard (IEC 62026/EN 50295) providing an alternative to the cable harness to connect particularly economical sensors and actuators in the field area via a single 2-wire cable. The power supply to the individual stations also runs via this 2-wire cable. This means that AS-Interface is the ideal partner for the PROFIBUS DP field bus.

SIMATIC ET 200 Configurator

A tailor-made peripheral station in the click of a mouse: with the SIMATIC ET 200 Configurator

With the ET 200 Configurator first-class support is available even for the configuration of the ET 200 station. The software tool leads you through the configuration in a user-friendly, simple and convenient manner and automatically creates order lists inc. accessories. It also provides support for the adherence to limit values such as load currents, slot rules or parameters.

The configuration created in the ET 200 Configurator can easily be imported into STEP 7. This reduces the engineering cost and saves data having to be entered twice.

The software tool is clearly and transparently structured: six configuration views make the work simple and user friendly.

- General: general station data and a graphic depiction of the configured station
- Module selection: guided selection of the modules by module suggestions
- Limits: display of station sizes, weight, number of modules, load voltage, parameters, etc.
- Accessories: guided selection of the required accessories (module specific or station wide)
- Potential distribution: graphical representation of the potentials within a station
- Parts list: automatic generation of a clear parts list simplifies the ordering process

The ET 200 Configurator is part of the SIMATIC Selection Tools and is available as a configurator in the Industry Mall.

More information

- Catalogs ST 70, CA 01
- Internet: www.siemens.com/et200 (general)

Overview

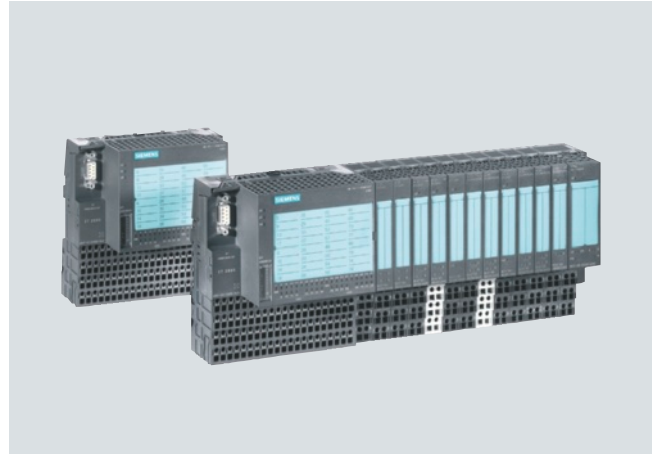
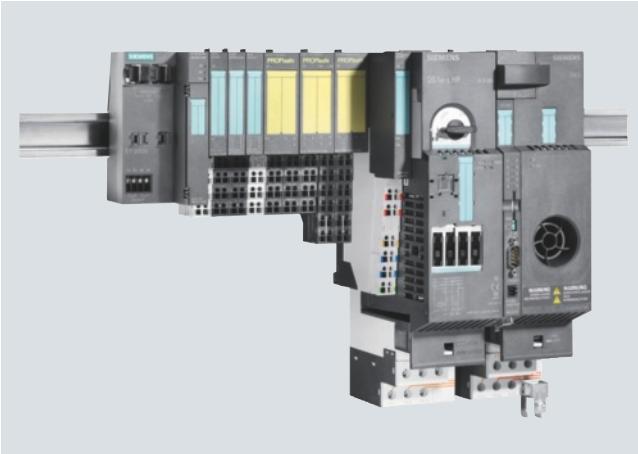

4

SIMATIC ET 200S

- Distributed I/O system with IP20 degree of protection and low wiring outlay even for time-critical tasks such as rapid adjustments
- With integral S7 CPU can be used as small control system:
 - also as failsafe PROFIsafe version
 - optionally with lower-level PROFIBUS DP
- Fine modular structure for precise matching to the automation task
- Interface module with PROFIBUS DP or PROFINET interface available
- Can be combined with digital and analog input or output modules, technology modules, motor starters and frequency converters for the control of drives up to 7.5 or 4 kW
- Exchange of modules during operation (hot swapping), permanent wiring with multiple conductor connection
- Channel-specific diagnosis for high availability
- Optionally with integral FO interface
- Transmission rate up to 12 Mbit/s
- FastConnect thanks to stripless quick-connect technology, screw- or spring-type terminals
- Ex approval according to Cat. 3 for Zone 2 according to ATEX 100 a
- Slot reservation with reserve modules
- Failsafe DI module with safety-oriented signal processing according to PROFIsafe
- Options handling – for extremely simple management of machine options

SIMATIC ET 200S COMPACT

- Block I/Os in IP20 degree of protection with 32 channels made up of terminal block and electronics block
- Expandable on a finely modular basis to up to 128 channels or max. 12 modules
- Entire ET 200S module spectrum usable (except PROFIsafe module)
- Separation of connection technology and electronics using permanent wiring
- Screw- and spring-type connection technology
- Standard terminal block in 2-wire technology; 3- and 4-wire technology via additional terminals
- Mounting on standard mounting rails
- Hot swapping for the expansion modules
- Communication with PROFIBUS
- Up to 100 bytes inputs and outputs (address area)

More information

- Catalogs ST 70, CA 01
- Internet:
 - www.siemens.com/et200s
 - www.siemens.com/et200 (general)

SIMATIC ET 200 Distributed I/O

Systems for the control cabinet

ET 200S Motor Starters and Safety Motor Starters

General data

ET 200S motor starters in the ET 200S I/O system

The SIMATIC ET 200S is the multifunctional and finely modular I/O system in degree of protection IP20 for exact adaptation to the automation task.

Interface modules (IM) are used for connecting the ET 200S to PROFIBUS DP or PROFINET. If interface modules with integrated S7-CPU are used, the ET 200S can act as a small control system.

The ET 200S is designed for combining with a large range of digital and analog input or output modules, technology modules, IO-Link master modules, pneumatic connections, or motor starters and frequency converters for the control of drives.

Device replacement is easy and quick thanks to permanent wiring and automatic re-parameterization. Hot swapping, i. e. the disconnection and connection of modules without prior isolation, guarantees high availability of the automation system along with extensive diagnostics information.

The ET 200S motor starters are connected to the control system and parameterized through the field bus using either PROFIBUS or PROFINET via IM modules which are also available with CPU functionality.

With the ET 200S motor starters, any AC loads can be protected and switched. The communication interface makes them ideal for operation in distributed control cabinets or control enclosures.

4

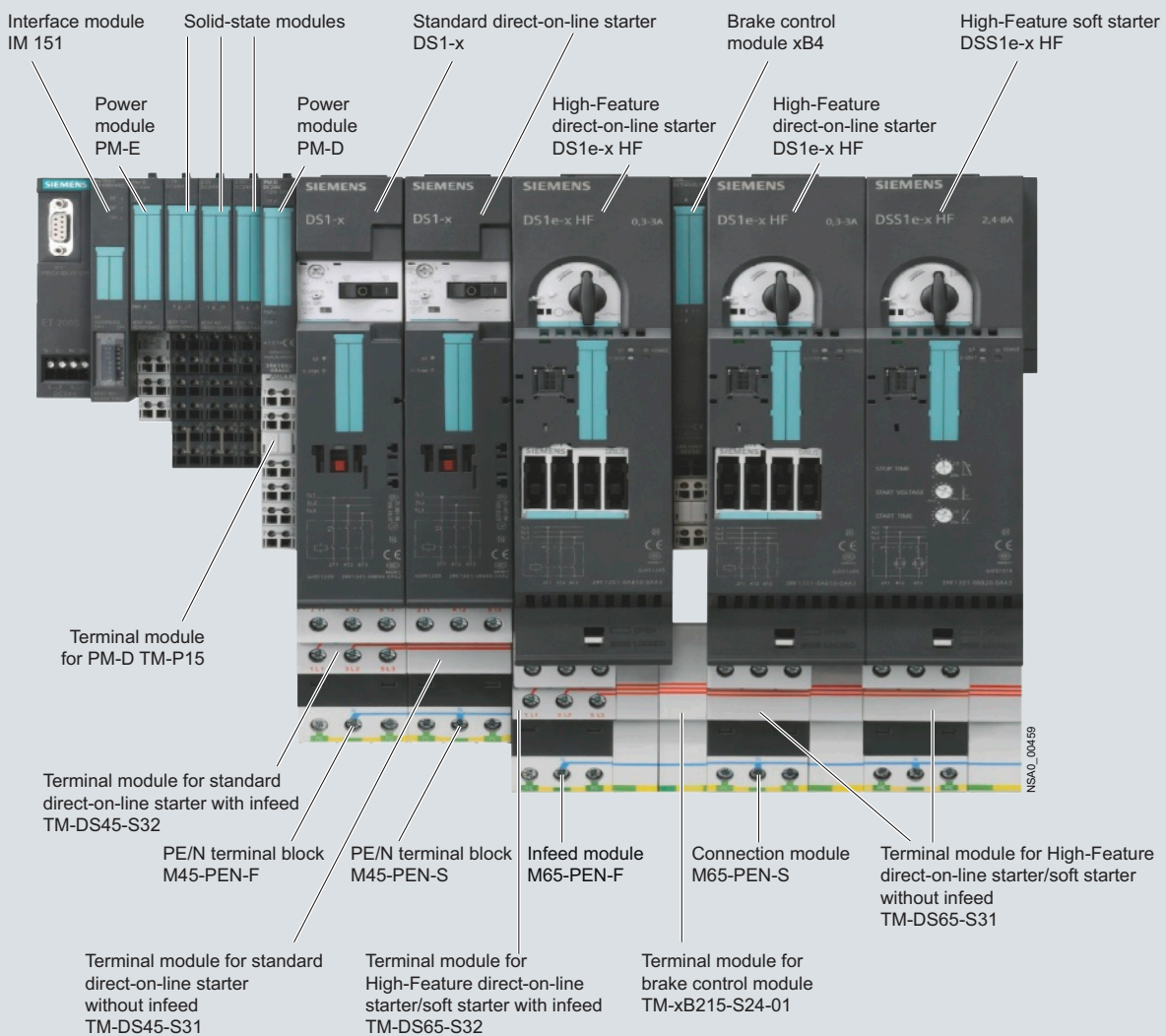

Interplay of ET 200S motor starter components in the ET 200S I/O system

Motor starter types

The ET 200S motor starters are available as direct-on-line, reversing (reversing) or soft starter versions:

- **Standard motor starters** up to 5.5 kW (direct-on-line and reversing starters)
- **High-Feature motor starters** up to 7.5 kW (direct-on-line, reversing and direct-on-line soft starters)

- **Failsafe motor starters** up to 7.5 kW (direct-on-line and reversing starters)
 - Properties of the High Feature motor starter
 - Failsafe functionality

General data (continued)

Innovation of the ET 200S High-Feature motor starters

The ET 200S High-Feature motor starters have undergone radical innovation and now support the acyclic services on PROFIBUS and PROFINET as well as PROFlenergy on PROFINET.

They are now:

- Even more flexible – flexible assignment of parameters
- Even better integrated in TIA (Totally Integrated Automation)
- Even more transparent – through comprehensive diagnostic data records
- Even more anticipatory – through maintenance functions
- Energy-efficient – through PROFlenergy

Basic functionality of the ET 200S motor starters

All versions of the ET 200S motor starters have the following functionality. The further specific functionality is described for the respective versions.

- Fully pre-wired motor starters for switching and protecting any AC loads up to 7.5 kW at 400 V AC and 500 V AC
- With self-assembling 40/50 A power bus, i.e. the load voltage is only supplied once for a group of motor starters
- All control supply voltages connected only once, i.e. when modules are added they are automatically connected to the next module
- Hot swapping is permissible
- Inputs and outputs for activating and signaling the status have been integrated
- Control of the motor starter from the control system and extensive diagnostics status via the cyclic process image
- Diagnostics capability for active monitoring of the switching and protection functions
- The signal states in the process image of the motor starter provide information about protective devices (short circuit or overload), the switching states of contactor(s) or soft starters, and system faults.
- Interface for controlling an expansion module, e.g. brake control module xB1...xB4 for controlling mechanical brakes in three-phase motors for 24 V DC and 500 V DC.
- Brake control module xB5 and xB6 for 400 V AC
- Can be combined with safety technology for use in safety-related system components (IEC 62 061 and ISO 13 849-1).

Mounting

As the motor starters are fully pre-wired, up to 80% of the wiring outlay can be saved. The control cabinets can be assembled far more quickly and compactly.

Expansions are easily possible through the subsequent adding of terminal modules. With their modular terminal design (10 mm²) the latter also do away with the distribution wiring otherwise required. Through the permanent wiring and the hot swapping function (disconnection and connection during operation) a motor starter can be replaced within seconds if necessary. The motor starters are therefore recommendable in particular for applications with special demands on availability.

Parameterization and configuration

Configuration is made easier by the fine modular structure.

When using the ET 200S motor starters, the list of parts per load feeder is reduced to two main items: The passive terminal module and the motor starter. This makes the ET 200S ideal for modular machine concepts as well.

All ET 200S motor starters are set up without fuses. Contactors and soft starters are activated through the integrated outputs. The inputs of the motor starters evaluate the signal states of the protective devices (short circuit or overload), the switching states of contactor(s) or soft starters, and system faults.

The motor starter protector signaling is freely programmable with regard to group fault signals (group fault at motor starter protector "Off"/group fault signal at motor starter protector "Off" only in case of "On" command from the motor starter).

Brake control modules and optional digital inputs and outputs

With one of the optional brake control modules (xB1-xB6), which is butt-mounted to the right of a motor starter, it is possible to control a mechanical holding brake on a three-phase motor from the process image of the motor starter.

Motors with 24 V DC brakes (xB1, xB3) as well as motors with 500 V DC brakes (xB2, xB4) can be controlled using the brake control modules xB1-xB4.

The modules xB5 (without digital input) and xB6 (with two digital inputs) have been added to the range in order to control a mechanical holding brake with a rated operational voltage of 400 V AC. A further motor brake voltage commonly found on the market is thus supported.

The 24 V DC brakes have an external supply and can be vented independently of the switching state of the motor starter. By contrast the 500 V DC brakes and the 400 V AC brakes usually have a direct supply from the terminal board of the motor through a rectifier module and therefore cannot be vented when the motor starter is switched off. These brakes cannot be used in combination with the DSS1e-x motor starter (soft starter).

The outputs of the brake control modules can be used alternatively for other purposes, e.g. for controlling DC valves.

With two digital inputs available on the brake control modules (xB3, xB4, xB6) and another two digital inputs available on the optional control module it is possible to realize autonomous special functions which work independently of the bus and the higher-level control system, e.g. as a quick stop on gate valve controls. The signals of these digital inputs are in the process image and are reported to the control system.

Power supply through terminal module

Power is supplied through the terminal modules for motor starters:

- The auxiliary voltages are fed in only once via the PM-D or PM-DFx power module which must be connected to the left of the first motor starter.
- The load voltage is fed in at the first (left) TM-xxxxS32 terminal module of a motor starter. The other TM-xxxxS31 terminal modules are automatically supplied with power through the integrated power bus when they are mounted side by side. If the power bus is utilized to its full capacity of 40 A for Standard motor starters or 50 A for High-Feature motor starters, a new supply must be fed in through an additional TM-xxxxS32 terminal module.

SIMATIC ET 200 Distributed I/O

Systems for the control cabinet

ET 200S Motor Starters and Safety Motor Starters

General data (continued)

TM-DS and TM-RS terminal modules for motor starters

- Mechanical modules in which the motor starter and expansion modules are inserted
- For constructing the permanent wiring and self-assembling voltage bus
- For connecting the motor connection cables
- Positive-locking connection to ensure enhanced vibration resistance

Terminal modules are purely mechanical components for accommodating the ET 200S peripherals. The self-assembling voltage buses integrated into the terminal modules reduce wiring outlay to the single infeed (both of auxiliary and load voltage). All modules following on the right are automatically supplied upon plugging the terminal modules together. The robust design and keyed connection technology enables use in harsh industrial conditions.

The TM-DS and TM-RS terminal modules are available in various versions for the Standard motor starters and the High-Feature motor starters.

Terminal modules with the suffix "-S32"

- The terminal modules with the suffix "-S32" have connection terminals for feeding into the integrated 40 A/50 A power bus and connection terminals for the motor connection cable. They are mounted at the beginning (left) of a power bus segment.
- To configure a new load group, another "-S32" terminal module is plugged in.
- The "-S32" terminal modules are supplied with three caps for closing the power bus contacts on the final terminal module of a segment.
- Optionally expandable with PE/N blocks

Terminal modules with the suffix "-S31"

- The terminal modules with the suffix "-S31" have only connection terminals for the motor connection cable. These terminal modules follow on the right after a "-S32" terminal module.
- Optionally expandable with PE/N blocks

All connection terminals of the terminal modules for motor starters are equipped with strong 10 mm² screw terminals.

Power module (see Catalog ST 70, page 9/152)

PM-D power modules are used for monitoring the two 24 V DC auxiliary voltages for the group of motor starters following on the right or for supplying power to the group of frequency converters following on the right.

Terminal module TM-P for power module PM-D (see Catalog ST 70, page 9/153)

- Connection by means of screw terminals
- Light colored enclosure for visual distinction
- Always before the first TM-DS/TM-RS

ET 200S Safety motor starters with integrated safety technology

The safety-related, communication-capable ET 200S motor starters offer the right solution for every safety application. The range extends from the simple local safety solution through to the user-friendly version with PROFI-safe, which can be used in conjunction with a safe control system (see "Safety modules local and PROFI-safe", page 4/11).

The safety engineering is an integral part and is therefore pre-wired at the factory.

The ET 200S Safety motor starters Solutions comprise:

- Safety modules (page 4/11)
- Standard motor starters (page 4/7)
- High-Feature motor starters (page 4/7)
- Failsafe motor starters (page 4/9)

System configuration with ET 200S motor starters

When constructing an ET 200S station with motor starters a distinction can be made between the following configurations:

- Conventional ET 200S motor starter solution consisting of:
 - PM-D module
 - Standard motor starter or High-Feature motor starter
- Safety motor starter ET 200S Solution local (see page 4/10)
- Safety motor starter ET 200S Solutions PROFI-safe (see page 4/14)

SIRIUS Motor Starter Function Block Library for SIMATIC PCS 7

With the SIRIUS motor starter PCS 7 function block library, SIRIUS ET 200S motor starters (direct-on-line and reversing starters, direct-on-line soft starters) can be easily and simply integrated into the SIMATIC PCS 7 process control system. The SIRIUS motor starter PCS 7 function block library contains the diagnostics and driver blocks corresponding with the diagnostics and driver concept of SIMATIC PCS 7 as well as the elements required for operation and monitoring (symbols and faceplates), (see Catalog IC 10, Chapter "Parameterizing, Configuration and Visualization for SIRIUS").

Configuration tool for ET 200S station

The "SIMATIC Selection Tool" enables the fast and accurate selection of SIMATIC hardware. It is available as a configurator in the Siemens Industry Mall free of charge. Assemble your stations (e.g. S7-1200, S7-300, S7-400, S7-400H) and select the desired distributed I/O (e.g. ET 200S, ET 200pro). You can transfer the Parts Lists you received to the Industry Mall shopping cart and place your order quickly, conveniently and with no problems.

You can find detailed information about the ET 200S system at:

www.siemens.com/ET200S

Here you will find a link to the SIMATIC Selection Tool.

Standard motor starters

Functionality of the Standard motor starters

- For basic functionality, see ET 200S motor starters and safety motor starters, General Data, Overview, page 4/5
- Direct-on-line and reversing starters up to 5.5 kW
- Power bus up to 40 A
- With circuit breaker and contactor assembly
- Integrated isolating function of the circuit breaker
- Can be combined with local safety technology for use in safety-related system components with F-Kit and PM-D F modules (see "Accessories" page 4/16)

Device functions (firmware features)

See Catalog ST 70, ET 200S Motor Starters and Safety Motor Starters, General Data, Overview, page 9/142.

High-feature motor starters

Functionality of the High-Feature motor starters

- For basic functionality, see ET 200S motor starters and safety motor starters, General Data, Overview, page 4/5
- Direct-on-line, reversing or soft starter up to 7.5 kW
- Available with wide range and in 3 setting ranges with 0.3...3 A, 2.4...8 A, 2.4...16 A
- With combination of starter circuit breaker, electronic overload protection (parameterizable), and contactor or soft starter
- Power bus up to 50 A
- Upper and lower current limits for plant and process monitoring
- Motor stall protection, zero current detection and asymmetry detection integrated
- The current motor current is measured and transmitted for diagnostics in the cyclic process image
- Control of the motor starter from the control system and extensive diagnostics status via the cyclic process image
- Optional digital inputs available in the cyclic process image and flexibly assignable with functions for adaptation to all applications
- Detection of the switching state of the starter circuit breaker via auxiliary switches and of the contactor via current evaluation
- Integrated isolating function using starter circuit breakers
- Local safety engineering possible (without failsafe kit in the case of the HF starter, because the function of the failsafe kit is already integrated)
- Front-mounting 2DI LC COM control module for another 2 parameterizable digital inputs
- Optional software "Motor Starter ES" for user-friendly commissioning and diagnostics (as of 11/2011 also available for the innovative .-0AB4 starters) (see Catalog Chapter 3)
- PROFIenergy capable¹⁾
 - Supplying the motor current in PROFIenergy format
 - Switching off during dead times
- Support of all DPV1 acyclic services on PROFIBUS and PROFINET¹⁾
 - Changing of parameters during operation, e.g. the rated operational current
 - Reading and writing acyclic data for exact diagnostics of the unit or process and for analysis of the plant status

¹⁾ Only for the innovated .-0AB4 starters

Selective protection concept for ET 200S High Feature motor starters

As a result of the selective protection concept (separate tripping of short circuit and overload) with solid-state overload evaluation, additional advantages are realized on the High-Feature motor starters – advantages which soon make themselves positively felt particularly in manufacturing processes with high plant stoppage costs:

- Only two versions up to 7.5 kW – hence little order variance and stock keeping
- All settings can be parameterized by bus – hence full TIA capability
- Separate signaling of overload and short circuit – enables selective diagnostics
- Overload can be acknowledged by remote reset – ideal for highly automated plants
- Current asymmetry monitoring – complete monitoring of the motor
- Stall protection – complete monitoring of the motor
- Emergency start function in case of overload – operation is possible in an emergency
- Current value transmission via bus – monitoring of the application
- Current limit monitoring
- Trip class can be parameterized – overload trip can be adapted to the application
- Type of coordination "2" – still functional after short circuit with magnitude of 50 kA
- Very high contact endurance

SIMATIC ET 200 Distributed I/O

Systems for the control cabinet

ET 200S Motor Starters and Safety Motor Starters

High-Feature motor starters (continued)



ET 200S High-Feature motor starters: DS1e-x direct-on-line starters (innovated .-0AB4 starters)



ET 200S High-Feature motor starters: DS1e-x soft starters (innovated .-0AB4 starters)



ET 200S High-Feature motor starters: Reversing starter RS1e-x (innovated .-0AB4 starter)

PROFInergy for ET 200S High-Feature motor starters ¹⁾

Increasing energy prices, far-reaching ecological problems worldwide and the threat of climate change make it necessary for you to be more conscious about your use of energy. Active and effective energy management is possible with PROFInergy.

PROFInergy is a manufacturer-independent profile on PROFINET, which can be used by all manufacturers, has been standardized by PNO¹⁾ and supports the shut-down of electrical devices during dead times and the read-out of measured values.

The ET 200S HF motor starter supplies the motor current in PROFInergy format and switches off during dead times.

¹⁾ In the PNO (PROFIBUS Nutzerorganisation e. V. - PROFIBUS User Organization), manufacturers and users have come together to agree on the standardized communication technologies PROFIBUS and PROFINET.

Support of all acyclic services on PROFIBUS and PROFINET ¹⁾

Thanks to the acyclic services, the ET 200S HF motor starters now offer plenty of diagnostics data via data records. There are extensive new options for reading out data from the motor starter for device, system or process monitoring. The motor starter is equipped internally with three logbooks for device faults, motor starter trips and events, which are issued with a time stamp. These logbooks can be read out of the motor starter on demand at any time and provide the plant operator with plenty of information about the state of his plant and process which he can use to carry out improvements.

¹⁾ Only for the innovated .-0AB4 starters

With the slave pointer and statistical data functions it is possible to read out, for example, the maximum internal current values or the number of motor starter connection operations. This enables process deviations to be monitored or commissioning to be optimized.

Statistical data or measured values make plant monitoring easy for the user.

The device diagnostics data record contains details of all the states of the motor starter, the device configuration and the communication as a basis for central device and plant monitoring.

The Installation and Maintenance Functions (I&M) store, firstly, information (I&M) about the modules used in the motor starter and, secondly, data (I&M) that can be defined during configuration, e.g. location designations. I&M functions are used for troubleshooting faults and localizing changes in hardware at a plant or checking the system configuration.

Supported data records:

- DS 0 S7-V1 system diagnostics (S7 diagnostics alarm)
- DS 72, 73, 75 logbooks, device faults, trips, events
- DS 92 device diagnostics
- DS 93 command
- DS 94 measured values
- DS 95 statistics
- DS 96 slave pointer
- DS 100 device identification
- DS 131 device parameters
- DS 134 maintenance
- DS 165 comment
- DS 226 PROFInergy technology function
- DS 231 I&M 0 (= device identification)
- DS 232 I&M 1 (= equipment identifier)
- DS 233 I&M 2 (= installation)
- DS 234 I&M 3 (= description)

Device functions (firmware features)

See Catalog ST 70, ET 200S Motor Starters and Safety Motor Starters, General Data, Overview, page 9/142.

Failsafe motor starters



ET 200S Failsafe motor starters: F-DS1e-x direct-on-line starters

The Failsafe motor starter has been developed on the basis of the High-Feature motor starter (-0AA4 starter). It differs in that, in addition to a motor starter protector and contactor assembly, a safe solid-state evaluation circuit is installed for error detection purposes which makes the motor starter failsafe.

If the contactor to be switched fails in an EMERGENCY-STOP case, the evaluation electronics detects a fault and opens the motor starter protector in the motor starter through a shunt release in a failsafe manner. The second redundant shutdown component is therefore no longer a main contactor, as is generally the case, but the motor starter protector installed in the motor.

All functions of the High-Feature starter are already integrated

The new failsafe motor starters are characterized by easy, space-saving assembly as well as minimal wiring outlay. Like the High-Feature starters, the Failsafe motor starters have a switching capacity of up to 7.5 kW (16 A) which is achieved with just two motor starter versions. Another important feature is the high availability due to the high short-circuit strength (type of coordination "2").

Use

The failsafe motor starter is predestined for use in combination with PROFIsafe (see figure ET 200S Safety Motor Starter Solution PROFIsafe with Failsafe Motor Starters on page 4/15). Another field of application is in combination with ASIsafe or safety relays (see example 2 on page 4/13 Failsafe Motor Starters with ASIsafe and 3TK28).

High degree of flexibility with safety technology

PROFIsafe solution with PM-D F PROFIsafe

In EMERGENCY-STOP applications, the Failsafe motor starters are selectively switched off through the upstream PM-D F PROFIsafe safety module. For each safety module, six switch-off groups can be formed. In the first delivery stage, the failsafe freely-programmable logic of the SIMATIC controller is used to interface with the relevant Failsafe sensor technology. The interface between PROFIsafe and installations that use conventional safety technologies is implemented through the F-CM Failsafe contact multiplier with four floating contacts.

Solution local with PM-D FX1

Failsafe motor starter with safety relay (Version 1) or ASIsafe (Version 2, see example 2, page 4/13): Signals with relevance for safety can be input to ET 200S through a PM-D F X1 infeed terminal module through the enabling circuits of the AS-i Safety Monitor or the safety relay to control the Failsafe motor starters which then selectively switch off the downstream motors.

SIMATIC ET 200 Distributed I/O Systems for the control cabinet

ET 200S Motor Starters and Safety Motor Starters

Safety modules local and PROFIsafe

ET 200S Safety motor starters Solutions local/PROFIsafe

The ET 200S Safety motor starter Solutions are preferred in all production and process automation fields in which the enhancement of plant availability and flexibility plays a key role.

- **ET 200S Safety motor starters Solutions local** are preferred from the safety technology point of view for locally restricted safety applications. These motor starters are not dependent on a safe control system.
- **ET 200S Safety motor starters Solutions PROFIsafe**, on the other hand, are often found in safety applications of the more complex type that are interlinked. In this case a safe control system is used with the bus systems PROFINET or PROFIBUS with the PROFIsafe profile.

The ET 200S Safety motor starters Solutions comprise:

- Safety modules (page 4/11)
- Standard motor starters (page 4/7)
- High-Feature motor starters (page 4/7)
- Failsafe motor starters (page 4/9)

Safety motor starter ET 200S Solution local

With the ET 200S Solutions safety motor starters there is no complicated and hence cost-intensive configuring and wiring compared to the conventional safety systems. The ET 200S Safety motor starter Solutions are designed for Category 4 according to ISO 13849-1 or SIL 3 IEC 62061.

They enable the use of safety-oriented direct-on-line starters or reversing starters in the SIMATIC ET 200S distributed I/O system on PROFINET or PROFIBUS. The fine modular architecture of the system permits optimum imaging of machine or plant applications.

Within an ET 200S station the Safety motor starters Solutions can also be combined with Standard motor starters or High Feature motor starters without safety functions or the SIMATIC ET 200S FC frequency converters up to max. 4 kW and up to Category 3 according to ISO 13849-1 or SIL 2 according to IEC 62061.

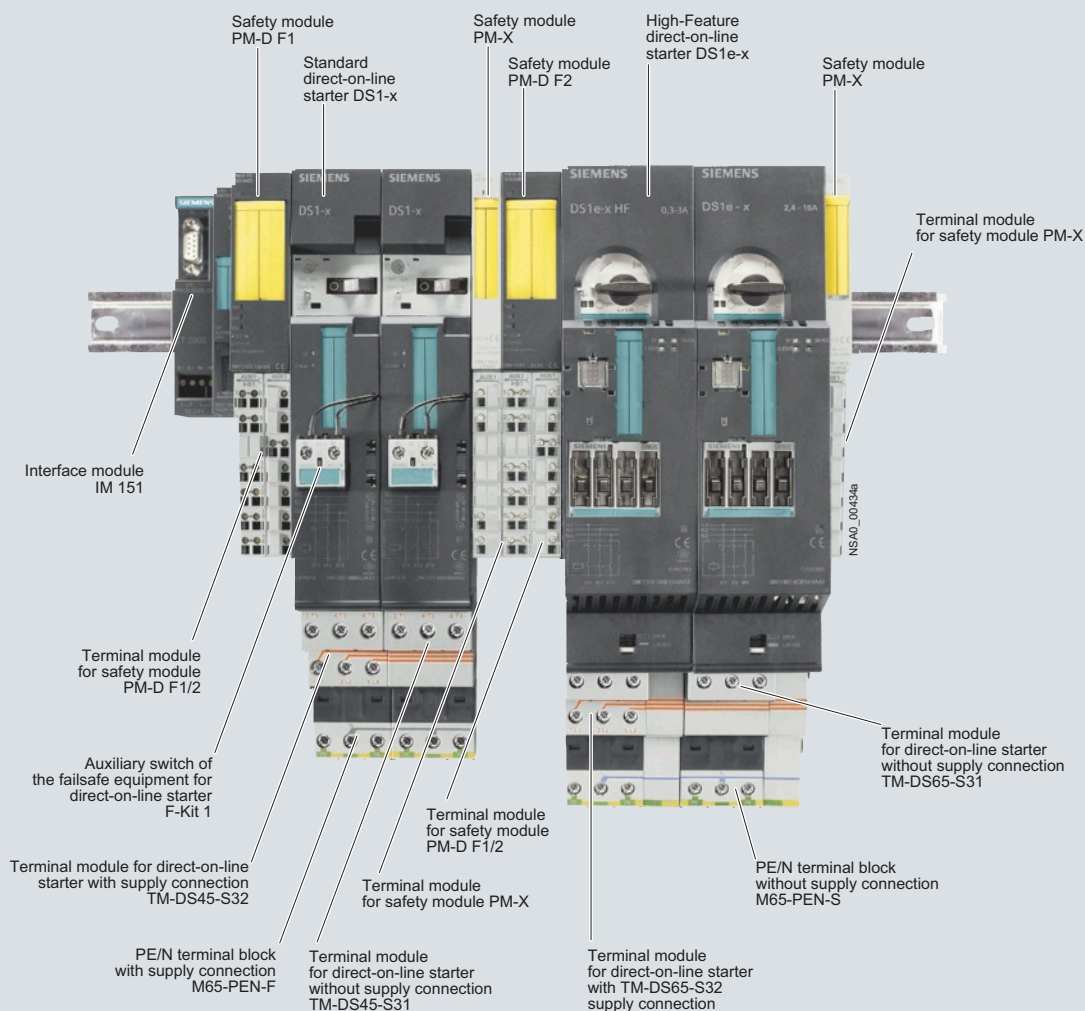

Interplay of ET 200S safety motor starters Solutions local components

Safety modules local and PROFIsafe (continued)

Components for ET 200S Safety motor starter Solution local

The ET 200S Safety motor starter Solutions local comprising:

Version 1 (see example 1, page 4/13):

- Safety modules PMD F1 ... 5
- PM-X module
- Standard motor starter or High-Feature motor starter

Version 2 (see example 2, page 4/13):

- PM-D FX1 safety module
- Failsafe motor starters

Functionality of the ET 200S Safety motor starters Solutions local

- For use of Standard, High-Feature or Failsafe motor starters in systems with safety categories 2 to 4 (according to ISO 13849-1)
- Can also be used in combination with external safety relays
- Can also be used to activate external safety systems
- No complex wiring for conventional safety technology
- Safety module available for function-monitored and automatic starting
- Safety module available for Stop category 0 and 1
- Safety module for monitoring the auxiliary voltages for motor starters
- Safety modules can be plugged into the TM-PF30 terminal modules

With Safety motor starters Solutions local the highest safety category can be reached according to ISO 13849-1 and IEC 62061. They can thus be used for evaluation of EMERGENCY-STOP circuits or for monitoring protective doors and also for time-delayed disconnections. With the contact multiplier the safety-relevant signals can also be made available to external systems.

All standard safety applications can be covered through combination of different TM-PF30 terminal modules. Needless to say, ET 200S motor starters can also be used in conjunction with external safety relays or with ASIsafe.

Safety motor starter Solutions local reduce wiring by up to 80% compared to conventional safety systems with local safety applications.

With the Safety motor starters Solutions local it is easy to configure several safety circuits. The safety sensors are connected directly and locally to the safety modules. These safety modules perform the work of the otherwise obligatory safety relays and safely shut down the downstream motor starters in accordance with the function selected. The crosslinks required for this are already integrated in the system and need no additional wiring. All signals from the safety modules are automatically relayed as diagnostic signals, e.g. in the event of crossover in the EMERGENCY-STOP circuit.

The safety module evaluates the signal state of the connected safety sensors and, using the integrated safety relays, shuts down the group(s) of downstream motor starters. The shutdown function is monitored by the module, and the auxiliary voltages likewise.

Safety-relevant system signals, e.g. due to an actuated EMERGENCY-STOP switch or a missing auxiliary voltage, are automatically generated and notified to the interface module. The latter assigns an unambiguous ID to the fault. Using the PROFIBUS DP diagnostics block, faults of this type can be identified and localized without a great deal of programming work.

PM-D F1/F2/F3/F4/F5 safety modules

- PM-D F1/F2/F3/F4 safety modules monitor auxiliary voltages and contain the complete functionality of a safety relay:
 - PM-D F1: For evaluation of EMERGENCY-STOP circuits with the function "monitored start"
 - PM-D F2: For the monitoring of protective doors with the function "automatic start".
 - PM-D F3: Expansion to PM-D F1/F2 for time-delayed tripping.
 - PM-D F4: For the expansion of safety circuits with other ET 200S motor starters, e.g. in a different tier.
 - PM-D F5: Transmits the status from PM-D F1 ... 4 via four floating enabling circuits to external safety devices (contact multipliers)
- The PM-D F1 and PM-D F2 modules can be combined with the PM-D F3 or PM-D F4 modules.
- A PM-D F5 can be positioned at any point between a PM-D F1 ... 4 and a PM-X¹⁾.
- Safety modules monitor the U1 and U2 auxiliary voltages. A voltage failure is relayed as a diagnostic signal over the bus.
 - No additional PM-D safety module is required when the safety modules are used.
 - Each safety circuit, beginning with a PM-D F1 ... 4, must be terminated with one PM-X each¹⁾.

¹⁾ See Catalog ST 70 Accessories for Safety Module Local, page 9/173



PM-D F1 safety module

PM-D FX1 safety module

The PM-D FX1 safety module is used for feeding in 1 to 6 switch-off groups. The infeed voltage can be switched using 1 to 6 external safety shutdown devices (either ASIsafe monitors or 3TK28 safety relays). This safety module is used in applications with external safety shutdown devices where there is a need for the fully selective safety shutdown of failsafe motor starters/frequency converters (see Example 2, page 4/13).

Terminal modules for (TM-PF30) safety module

For supplying load and sensor voltage to the potential bars of the motor starters, and for connection of the 2-channel sensor circuit (e.g. EMERGENCY-STOP pushbutton) and a reset button. Different terminal modules are available for the configuring of separate safety circuits or for the cascading of safety circuits, and for applications with time-delayed disconnection (see page 4/16).

SIMATIC ET 200 Distributed I/O

Systems for the control cabinet

ET 200S Motor Starters and Safety Motor Starters

Safety modules local and PROFIsafe (continued)

Terminal module (TM-X)

For connection of an external infeed contactor (2nd shutdown possibility). With terminals for contactor coil and feedback contact. Is always required to terminate a group of safety-oriented motor starters.

Failsafe Kit

The Failsafe Kit (F-Kit) must be added to each Standard motor starter in a safety segment in order to monitor the switching function.

F-Kit 1 supplements the DS1-x direct-on-line starter, F-Kit 2 the RS1-x reversing starter.

The F-Kits are comprised of:

- Contact supports for the terminal modules
- One or two auxiliary switch blocks for the contactor/contactors of the motor starter
- Connecting cables

High-Feature motor starters and their terminal modules come as standard with the functionality of the F-Kits integrated.

Components needed for applications with safety requirement

Components needed	Maximum achievable safety integrity according to ISO 13849-1 or IEC 62061				
	ISO 13849-1	PL b/c, Category 1	PL c, Category 2	PL d ¹⁾ , Category 3	PL d/PL e ¹⁾ , Category 4
	IEC 62061	SIL 1	SIL 1	SIL 2	SIL 3
PM-D		✓	–	–	–
PM-D F1/-F2/-F4		–	✓	✓	✓
PM-D F3		–	✓	✓	–
F-Kit 1 / F-Kit 2		–	✓ ²⁾	✓ ²⁾	✓ ²⁾
PM-X		–	✓	✓	✓
PM-D FX1		–	✓	✓	✓

¹⁾ An external infeed contactor is required in the main circuit (2-channel capability).

²⁾ F-Kit needed only for Standard motor starter; already integrated in High-Feature motor starter.

Possible combinations of safety and terminal modules

Terminal modules	PM-D F1	PM-D F2	PM-D F3	PM-D F4	PM-D F5	PM-X	PM-DFX1	FCM
TM-PF30 S47-B0	✓	✓	–	–	–	–	–	–
TM-PF30 S47-B1	✓	✓	–	–	–	–	–	–
TM-PF30 S47-C0	–	–	✓	✓	–	–	–	–
TM-PF30 S47-C1	–	–	✓	✓	–	–	–	–
TM-PF30 S47-D0	–	–	–	–	✓	–	–	–
TM-X15 S27-01	–	–	–	–	–	✓	–	–
TM-PFX30 S47-G0	–	–	–	–	–	–	✓	–
TM-PFX30 S47-G1	–	–	–	–	–	–	✓	–
TM-FCM30 S47	–	–	–	–	–	–	–	✓

Safety modules local and PROFIsafe (continued)

Examples

The diverse possible uses of the safety motor starter Solutions local are presented in the manual SIMATIC ET 200S Motor Starters in the context of typical sample applications.

Example 1:

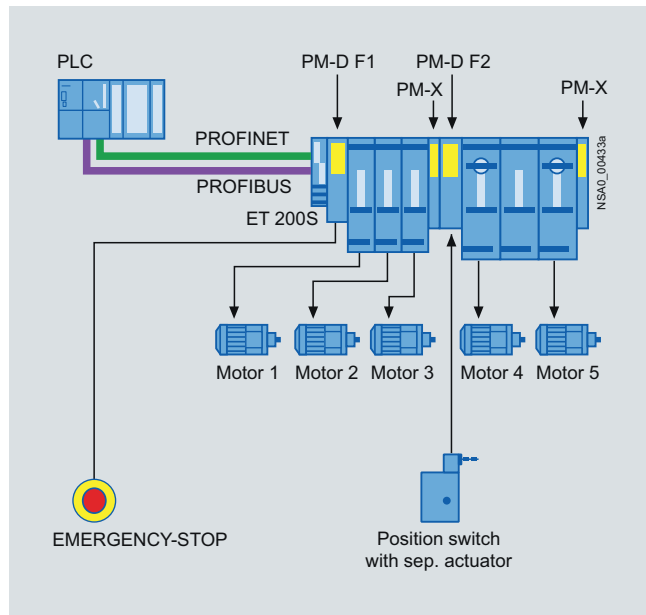

ET 200S Safety motor starter Solutions local with 2 safety circuits (= switch-off groups), Standard motor starters and High Feature motor starters.

Safety functional examples for easy, quick and low-cost implementations of applications with Safety motor starters Solutions local are available on the Internet:

You can find more information on the Internet at:

www.siemens.com/ET200S-motorstarter

Example 2:

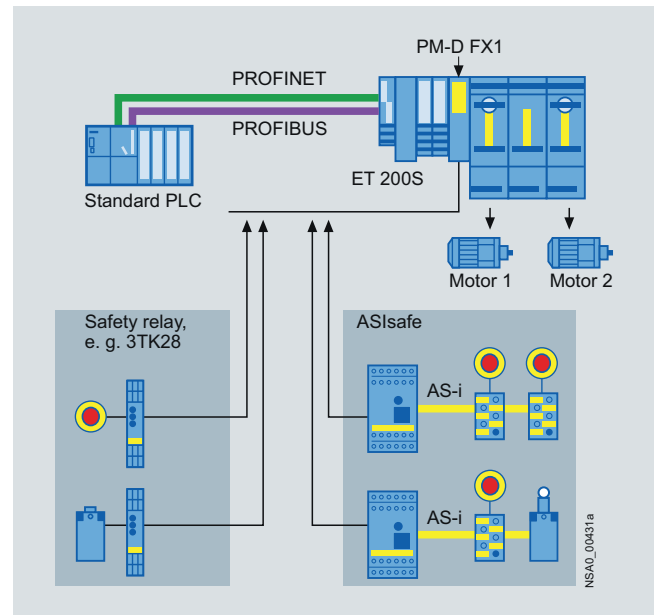

ET 200S safety motor starter Solutions local with 2 external safety combinations (= safety relays or ASIsafe monitors) and with Failsafe motor starters (PM-DFX1 application). 2 of the 6 available safe switch-off groups are used.

Signals with relevance for safety can be input to ET 200S through a PM-DFX1 infeed terminal module through the enabling circuits of the ASIsafe monitor or the safety relay to control the Failsafe motor starters which then selectively switch off the downstream motors.

SIMATIC ET 200 Distributed I/O

Systems for the control cabinet

ET 200S
Motor Starters and Safety Motor Starters

Safety modules local and PROFIsafe (continued)

ET 200S Safety motor starter Solutions PROFIsafe

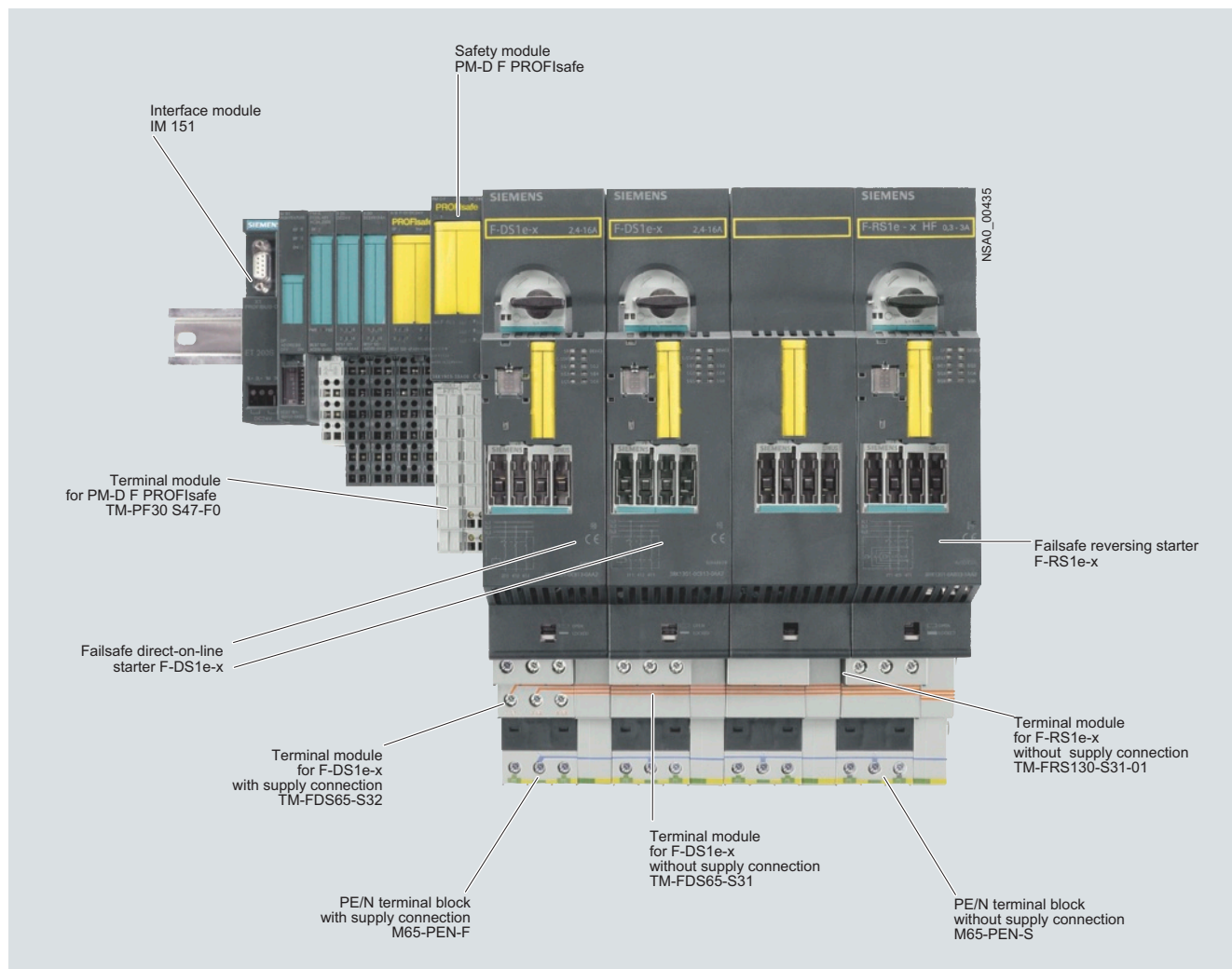

Interplay of ET 200S Safety motor starter Solutions PROFIsafe components

Components for ET 200S Safety motor Starter Solution PROFIsafe

The ET 200S Safety motor starter Solutions PROFIsafe consists of (see example, page 4/15):

- PMD F PROFIsafe safety modules
- Failsafe motor starters
- Safe control system is used with the PROFINET or PROFIBUS bus systems with the PROFIsafe profile

Functionality of the ET 200S Safety motor starter Solutions PROFIsafe

- For the use of Failsafe motor starters in plants with safety category 2 to 4 according to ISO 13849-1 and SIL 2 and 3 acc. to IEC 62061. The use of Standard or High-Feature motor starters is also possible with certain assemblies
- High flexibility (any assignment of sensors to motor starters using the PLC)
- Full selectivity of disconnection of the Failsafe motor starters
- No complex wiring for conventional safety systems, e.g. no infeed contactors even in the highest safety category

- Can also be used to activate external safety systems through F-CM contact multiplier
- Safety module available for any safety function
- Safety module available for Stop category 0 and 1
- Safety module for monitoring the auxiliary voltages for motor starters
- Safety modules can be plugged into the TM-PF30 terminal modules

Sensor and actuator assignment are freely configurable within the framework of the distributed safety concept:

The logic of the safety functions is implemented by software. Safety-oriented PROFIsafe communication and the use of a safety-oriented control system are required. Integration of the safety technology in the standard automation is realized through a single bus system (see Advantages of PROFIsafe), using PROFIBUS as well as PROFINET.

Safety modules local and PROFIsafe (continued)

High degree of flexibility with safety technology Failsafe motor starters for PROFIsafe

In EMERGENCY-STOP applications, the Failsafe motor starters are selectively switched off through the upstream PM-D F PROFIsafe safety module. For each safety module, six switch-off groups can be formed. In the first delivery stage, the failsafe freely-programmable logic of the SIMATIC controller is used to interface with the relevant Failsafe sensor technology.

F-CM contact multipliers

The interface between PROFIsafe and installations that use conventional safety technologies is implemented through the F-CM Failsafe contact multiplier with four floating contacts.

PM-D F PROFIsafe safety modules

The PM-D F PROFIsafe safety module receives the shutdown signal from the interface module of the ET 200S and safely switches off 1 to 6 switch-off groups. This safety module is used in PROFIsafe applications where there is a need for the selective shutdown of Failsafe motor starters/frequency converters.



PM-D F PROFIsafe with TM-PF30 S47-F0 terminal module

Terminal modules

The terminal assignment of the terminal modules for safe motor starters corresponds to the terminal assignment of the 45 and 65 mm terminal modules. The terminal modules for safe motor starters have a coding module in addition. This enables the safe motor starter to be assigned to one of the six switch-off groups.

The terminal module contains three coding elements which fully cover the three coding openings in the terminal module. The labeled coding element contains (in the chamber marked with the dash) the busbar tap; the non-labeled coding elements are used only to cover the coding openings. Switch-off group 1 (AG1 or SG1) is coded in the as-delivered state. The coding can be changed to switch-off group 2 by releasing the coding element and turning it through 180°. Changing the coding to switch-off group 3 is possible by exchanging the labeled and blank coding elements. In this case the dash on the labeled coding element must correlate with the dash of the required switch-off group (symbolized busbar).

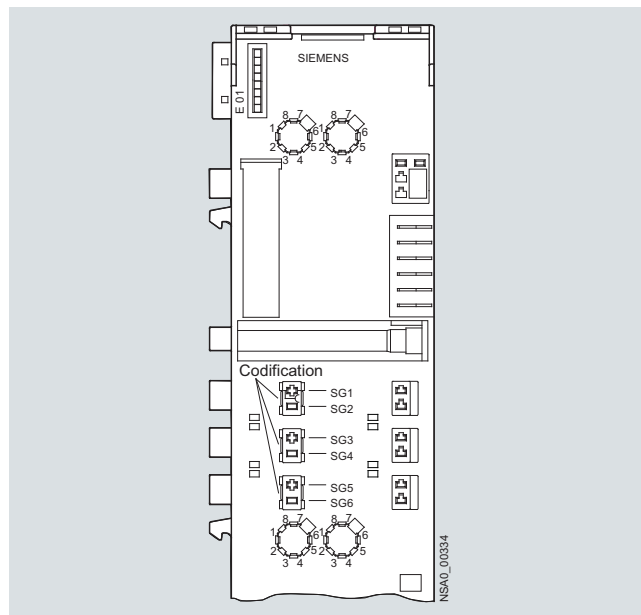

The Failsafe motor starters are assigned to one of the six possible switch-off groups.

Example:

The diverse possible uses of the Safety motor starter Solutions PROFIsafe are presented in the manual SIMATIC ET 200S Motor Starters in the context of typical sample applications.

Safety functional examples for easy, quick and low-cost implementations of applications with safety motor starters Solution PROFIsafe are available on the Internet:

You can find more information on the Internet at:

www.siemens.com/ET200S

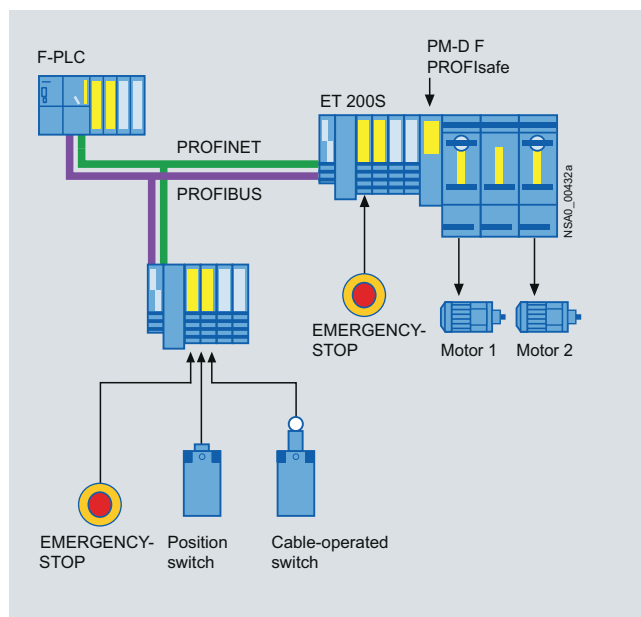

ET 200S Safety motor starters Solutions PROFIsafe with Failsafe motor starters and fully selective disconnection (PM-DF PROFIsafe application)

SIMATIC ET 200 Distributed I/O

Systems for the control cabinet

ET 200S Motor Starters and Safety Motor Starters

Safety modules local and PROFIsafe (continued)

Within an ET 200S station the Failsafe motor starters are assigned to one of 6 safety segments. For plants with distributed configuration the shutdown signals of these safety segments are preferably issued by a higher-level, safety-oriented control system through PROFIsafe. This permits the greatest flexibility for assigning the motor starters to different safety circuits.

Alternatively, an ET 200S F-CPU can also be used for control purposes.

If a safety-oriented SIMATIC CPU is used, the ET 200S is available as a safety-oriented peripheral. Nevertheless, in such a station it is possible to configure conventional motor starters and input/output modules mixed with modules with safety functions.

Thanks to the PROFIsafe profile, the safety functions are available in the complete network, which means that the Safety motor starter Solutions PROFIsafe enable the selective disconnection of a Failsafe motor starters or the disconnection of a group of Standard and High-Feature motor starters regardless of where and on which peripheral station the safe control devices were connected. As such, this solution provides an unprecedented level of flexibility and reduction of wiring for applications in wide-spread plants or with a sporadic demand for changes in the assignment of safety segments.

The PROFIsafe safety motor starters Solution are ideally suited for safety concepts with Cat. 2 to 4 according to ISO 13849-1 and up to SIL 3 according to IEC 62061.

Each safety module switches up to 6 switch-off groups for Failsafe motor starters/frequency converters.

4

Accessories

Accessories for Standard motor starters

Control kit

The control kit for the Standard motor starter provides the possibility of testing the motor during start-up or service by actuating the motor starter protector. Using the control kit with the motor starter protector tripped, the contactor is mechanically locked in ON position.

Control unit

With the control unit the contactor coils of the Standard motor starter can be directly controlled using 24 V DC. The motor starter can thus be started as normal using a local control station without PLC or bus.

Note:

The control unit cannot be used in combination with the safety technology or a brake control module.

DM-V15 distance module

- Passive module without bus connection and terminals
- Does not need a separate terminal module
- Follows a TM-DS45 or TM-RS90 or TM-xB if required
- Does not need to be taken into account when configuring the GSD file

The distance module is available for applications with high motor currents or high ambient temperatures involving Standard motor starters. It can be used to the right and left of a DS1-x direct-on-line starter or to the right of an xB1-4 brake module in order to improve heat removal to the side. The distance module is a completely passive module and does not need to be taken into account with regard to the control system during configuration. Details of the distance module can be found in the manual "SIMATIC ET 200S". If you have any queries concerning the use of the distance module, contact Technical Support for Siemens Low-Voltage Controls and Distribution (fax: +49(0)911/895-5907).

Accessories for High-Feature motor starters

2DI 24 V DC COM control module

The 2DI 24 V DC COM control module is plugged onto the interface on the front of the motor starter. The module provides two inputs which can receive signals from the process and be assigned directly to the starter.

The functionality can be selected from a list of various control functions as part of the PROFIBUS parameterization. Local control station, emergency start and quick stop, for example, are available as functions. The signal levels can also be parameterized (NO/NC). For more extensive control functions the two inputs of a xB3 or xB4 brake control module, which is plugged in alongside on the right, can be integrated in addition. The signal states of all inputs are transmitted in parallel with the internal use to the higher-level control system.

When a motor starter is replaced, the parameterization is automatically transmitted by download to the new starter. The inputs on the motor starter ensure autonomous operation, e.g. in the event of PLC failure, on the one hand and short response times through direct processing in the starter on the other hand. Another advantage results from the direct assignment of functions to modular machine concepts.

The 2DI 24 V DC COM control module has in addition a PC interface for connecting the Switch ES Motor Starter parameterization and diagnostics software (Version 2.0 and higher). The module works solely on High-Feature motor starters with ES Motor Starter interface. The Logo!-PC cable is used as connecting cable between the 2DI 24 V DC COM control module and the High-Feature motor starter.

Accessories (continued)

Accessories for Standard and High-Feature motor starters
PE/N bridge module

PE/N bridge modules are used to bridge gaps in the PE/N bus which are caused, for example, by using brake control modules, PM-D(F) power modules or PM-X connection modules. If a bridge module is used, the supply must not be fed in anew. They are available in widths of 15 and 30 mm.

L123 bridge modules

The L123 bridge modules are used to bridge gaps in the power bus (see above). They are available in widths of 15 and 30 mm.

Brake control module

For motors with mechanical brakes (see also ET 200S Motor Starters and Safety Motor Starters, General Data, Overview, Section Brake Control Module, page 4/5)

Terminal modules for brake control modules

The TM-xB terminal modules are used to accommodate the xB1, xB2, xB3 and xB4 brake control modules. The TM-xB terminal module must always follow directly after a terminal module for Standard motor starters, High-Feature motor starters or frequency converters as control of the solid-state braking switch is provided through an output of the motor starter/frequency converter. The xB215 terminal modules for the brake control modules have not only the terminals for connecting the cable for the motor brake but also the terminals of the two local acting inputs. These local inputs are not evaluated by a frequency converter, which is why the xB215 terminal module can only be switched behind a motor starter.

Accessories for Standard, High Feature, Failsafe motor starters
PE/N terminal blocks

The PE/N terminal block is required for direct connection of the protective conductor in the motor cable without intermediate terminals. It is plugged together with the terminal module for motor starters or frequency converters before the latter is mounted on the standard mounting rail. With two PE terminals and one N terminal the "-F" version is connected to the "-S32" terminal modules for motor starters or frequency converters. The "-S" version is combined with the "-S31" terminal module. The "F" terminal modules are delivered with two caps for closing the PE/N bus contacts on the final terminal module of a segment. The modules for the Standard motor starters have a width of 45 mm and the modules for the High-Feature motor starters and frequency converters have a width of 65 mm.

There is no electrical connection between the terminals of the PE/N terminal block and the integrated shielding of the frequency converter. The PE/N terminal block must therefore not be used for the shielding of the motor cable.

Accessories for Safety modules local

The Failsafe Kit (F-Kit) is required for Standard motor starters in a safety segment (see Safety Module local and PROFIsafe, Overview, page 4/12).

More information

- Catalogs ST 70, IC 10, CA 01
- Internet:
www.siemens.com/et200s
www.siemens.com/et200 (general)

SIMATIC ET 200 Distributed I/O Systems for the control cabinet

ET 200M

Overview



- Modular peripheral system in IP20 degree of protection, which is particularly suited for user-specific and complex automation tasks.
- Expandable by the signaling, communication and functional modules of the S7-300 automation system

- The explosion analog input and output modules with HART optimize the ET 200M for use in process engineering
- Can be used with redundant systems (S7-400H, S7-400F/FH)
- Consists of a PROFIBUS DP connection IM 153, up to 8 or 12 I/O modules of the S7-300 automation system (designed with bus connectors or with active bus modules) and possibly also a power supply
- Replacement of modules during operation (hot swapping) with active bus modules
- Optionally with integral FO interface
- Transmission rate up to 12 Mbit/s
- Ex approval according to Cat. 3 for Zone 2 according to ATEX 100 a
- Failsafe digital inputs and outputs and analog inputs for safety-oriented signal processing according to PROFIsafe
- Support of modules with expanded user data, e.g. HART modules with HART additional variables

More information

- Catalogs ST 70, CA 01
- Internet:
www.siemens.com/et200m
www.siemens.com/et200 (general)

ET 200L

Overview



The ET 200L is a small, compact I/O station in IP20 degree of protection.

The ET 200L is primarily used where few inputs/outputs are required in the lower performance range and where little space is available.

The ET 200L is a passive station (slave) in the PROFIBUS DP with transmission rates of up to 1.5 Mbit/s.

More information

- Catalogs ST 70, CA 01
- Internet:
www.siemens.com/et200l
www.siemens.com/et200 (general)

Overview

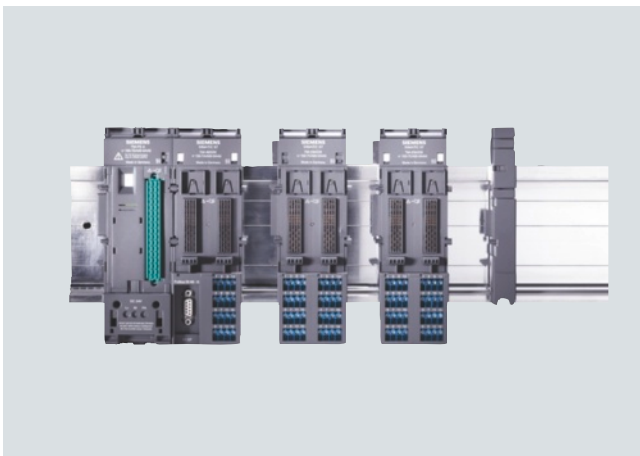

- Intrinsically safe distributed I/O system in IP30 degree of protection for use in gas and dust areas with an explosion hazard, i.e. in Zone 1 and 2 as well as 21 and 22
- Sensors and actuators can lie directly in Zone 0 and 20
- Individual configuration and flexible expansion thanks to modular design for optimal adaptation to the current automation task
- Permanent wiring permits prewiring without existing electronics
- Optimal integration into control systems (e.g. SIMATIC PCS 7)
- Parameterization via SIMATIC PDM
- Optimal integration of HART field devices (HART transparency)
- Failsafe digital inputs and outputs and analog inputs for safety-oriented signal processing according to PROFIsafe
- Connection to PROFIBUS DP via isolating transformers
- Module exchange (hot swapping) and configuration expansion (Configuration in Run) possible during operation
- Comprehensive diagnostic signals
- Moisture-resistant modules in temperature range -20 °C to +70 °C
- EMC according to NE 21 (on Namur recommendation)
- Full redundancy of PROFIBUS and power supply

More information

- Catalogs ST 70, CA 01
- Internet:
www.siemens.com/et200isp
www.siemens.com/et200 (general)

SIMATIC ET 200 Distributed I/O

Systems without control cabinet

ET 200pro

Overview

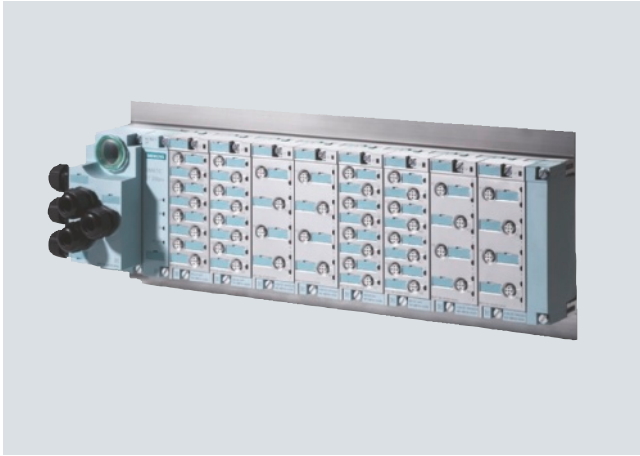

- Distributed I/O system in IP65/67 degree of protection for cabinet-free, machine-level use
- Small, multifunctional complete solution: Digital inputs/outputs, failsafe modules, motor starter up to 5.5 kW, frequency converter up to 1.5 kW, etc.

- Communication via PROFIBUS or PROFINET
- Mixture of failsafe modules and standard modules possible in a single station
- Free choice of connection technology: direct, ECOFAST or M12 7/8"
- Power module for simple realization of load groups
- Module exchange during operation (hot swapping)
- Simple assembly and permanent wiring
- Transmission rate up to 12 Mbit/s
- Comprehensive diagnostics: module- or channel-specific
- Intelligent motor starter for the starting and protection of motors and loads up to 5.5 kW
 - Versions: Direct-on-line and reversing starters - Standard and High Feature
- Frequency converter up to 1.5 kW in standard version and with integral safety functions
- Failsafe module with safety-oriented signal processing according to PROFIsafe

More information

- Catalogs ST 70, CA 01
- Internet:
 - www.siemens.com/et200pro
 - www.siemens.com/et200 (general)

4

General data



ET 200pro motor starter: Isolator module, Standard starter and High-Feature starter mounted on a wide module rack

Motor starters

- Only two versions up to 5.5 kW
- All settings can be parameterized by bus
- Comprehensive diagnostic signals
- Overload can be acknowledged by remote reset
- Current unbalance monitoring
- Stall protection
- Emergency start function in the event of overload
- Current value transmission by bus
- Current limit monitoring
- Direct-on-line or reversing starters
- Power bus can be plugged in using the new HAN Q4/2 plug-in connectors
- Conductor cross-sections up to 6 x 4 mm²
- 25 A per segment
(power looped through using jumper plug)
- In the Standard and High-Feature versions (with 4 DI onBoard)
- Electromechanical switching and electronic switching
- Electronic starter for direct activation or with integrated smooth-starter function
- Supplied with 400 V AC brake contact as an option

Isolator modules

The isolator module with switch disconnecter function is used for safe disconnection of the 400 V operational voltage during repair work in the plant and provides an integrated group fusing function (i.e. additional group short-circuit protection for all subsequently supplied motor starters).

Depending on the power distribution concept, all stations can be equipped with an isolator module as an option.

Safety applications

Safety local isolator module

With the Safety local modules

- Safety local isolator module and
- 400 V disconnecting module

it is possible to achieve safety category 4/SIL 3 with an appropriate connection.

Safety Solution PROFIsafe

With the Safety PROFIsafe modules

- F-Switch and
- 400 V disconnecting module

it is likewise possible to achieve safety category 4/SIL 3 with an appropriate connection.

Motor Starter ES software

Motor Starter ES software for parameterization, monitoring, diagnostics and testing of motor starters.
(See Chapter 3).

Functionality

With the ET 200pro motor starters, any AC loads can be protected and switched. They are an integral part of ET 200pro and have the high degree of protection IP65. This makes them ideal for operation in modular, distributed I/O without control cabinets or control enclosures.

The ET 200pro motor starters are available both with mechanical as well as electronic contacts

The ET 200pro electromechanical starters are offered as direct (DSe/DSe) and reversing starters (RSe/RSe) in the High Feature version with the following equipment:

- 4 digital inputs
- Device versions with or without control for externally fed brakes with 400 V AC
- With expanded parameterization capabilities.

The ET 200pro electronic starters are offered as direct (sDSSSte/sDSte) and reversing starters (sRSSSte/sRSte) in the High Feature version with the following equipment:

- 4 digital inputs
- With soft-start and smooth ramp-down function
- With the deactivated smooth start function as an electronic starter for applications with a high level of switching frequency
- Device versions with or without control for externally fed brakes with 400 V AC
- With expanded parameterization capabilities.

As the result of the protection concept with solid-state overload evaluation and the use of SIRIUS controls size S00, additional advantages are realized on the standard and High-Feature motor starters - advantages which soon make themselves positively felt particularly in manufacturing processes with high plant stoppage costs:

- Configuration is made easier by the fine modular structure. When using the ET 200pro motor starters, the list of parts per load feeder is reduced to two main units: the bus module and the motor starter. This makes the ET 200pro ideal for modular machine concepts or solutions for conveying systems and in machine-tool building.
- Expansions are easily possible through the subsequent adding of modules. The innovative plug-in technology also does away with the wiring needed up to now. Through the hot swapping function (disconnection and connection during operation) a motor starter can be replaced within seconds if necessary, without having to shut down the ET 200pro station and with it the process in the plant. The motor starters are therefore recommendable in particular for applications with special demands on availability. Storage costs are optimized in addition by the low level of variance (2 units up to 5.5 kW).

The ordering option for motor starters with a 400 V AC brake output provides the possibility of controlling motors with 400 V AC brakes. With four locally acting inputs available on the High-Feature motor starter it is possible to realize autonomous special functions which work independently of the bus and the higher level control system, e.g. as a quick stop on gate valve controls or limit position disconnectors. In parallel with this, the states of these inputs are signaled to the control system.

SIMATIC ET 200 Distributed I/O

Systems without control cabinet

ET 200pro Motor starters

General data (continued)

	Standard motor starters		High-Feature motor starters	
	DSe, RSe		DSe, RSe	sDSSSte, sDSte, sRSSSte, sRSte
Device functions				
Parameterizable rated operational current	Yes			
Parameterizable current limit values	No		Yes, 2 limit values	
Parameterizable response in case of current limit violation	No		Yes	
Zero current monitoring	Yes			
Parameterizable response in case of zero current violation	Yes			
Parameterizable current unbalance limit	No, fixed limit value (30 % × I_e)		Yes, 30 % ... 60 % × I_e	
Parameterizable response in case of unbalance limit violation	Yes			
Motor blocking monitoring	No		Yes	
Parameterizable blocking current limit	No		Yes, 150 % ... 1000 % × I_e	
Parameterizable blocking time limit	No		Yes, 1 ... 5 s	
Current value transmission	Yes			
Group warning diagnostics	No		Yes, parameterizable	
Group diagnostics	Yes, parameterizable			
Emergency start	Yes			
Digital inputs	No		Yes, 4 inputs	
• Parameterizable input signal	No		Yes, latching/ non-latching	
• Parameterizable input level	No		Yes, NC contacts/NO contacts	
• Parameterizable input signal delay	No		Yes, 10 ... 80 ms	
• Parameterizable input signal extension	No		Yes, 0 ... 200 ms	
• Parameterizable input control actions	No		Yes, 12 different actions	
400 V brake output	Yes, ordering option			
Parameterizable brake enabling delay	Yes, -2.5 ... 2.5 s			
Parameterizable holding time of the brake during stopping	Yes, 0 ... 25 s			
Parameterizable start-up type	No			Yes
Parameterizable ramp-down time	No			Yes
Parameterizable starting voltage	No			Yes
Parameterizable stopping voltage	No			Yes
Local device interface	Yes			
Firmware update	Yes, by trained personnel			
Thermal motor model	Yes			
Parameterizable trip class	No, CLASS 10 fixed		Yes, CLASS 5, 10, 15, 20	
Parameterizable response in case of overload of thermal motor model	No		Yes, 3 possible states	
Advance warning limit for motor heating	No		Yes, parameterizable 0 ... 95 %	
Advance warning limit time-related trip reserve	No		Yes, parameterizable 0 ... 500 s	
Parameterizable recovery time	No		Yes, 1 ... 30 min	
Parameterizable protection against voltage failure	No, permanently integrated		Yes	
Reversing start function	Yes, ordering option			
Parameterizable interlock time for reversing starters	No, 150 ms fixed		Yes, 0 ... 60s	
Integrated logbook functions	Yes, 3 device logbooks			
Integrated statistics data memory	Yes			
Parameterizable response in case of CPU / master stop	Yes			
Device indications				
• Group fault	SF LED (red)			
• Switching state	STATE LED (red, yellow, green)			
• Device status	DEVICE LED (red, yellow, green)			
• Digital inputs	No		IN 1 ... IN 4, LED	

Solutions local – Safety Module

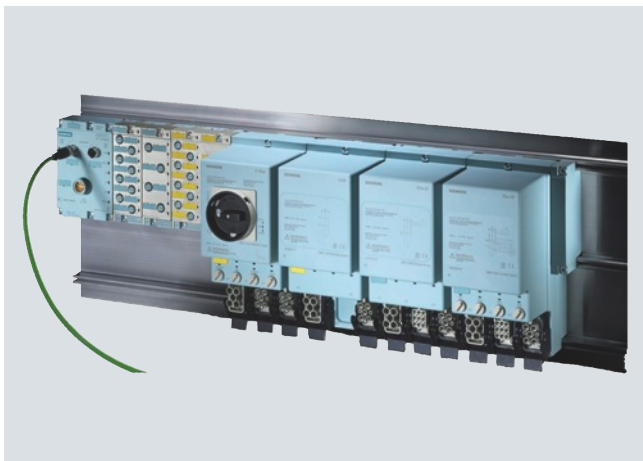

ET 200pro motor starter: Safety local isolator module, disconnecting module, Standard starter and High-Feature starter mounted on a wide module rack

Safety local isolator module

The Safety local isolator module is a repair switch with integrated safety evaluation functions that can be parameterized using DIP switches.

It is used for:

- Connection of a 1 or 2-channel EMERGENCY-STOP circuit up to Cat. 3-4/SIL 3 (protective door or EMERGENCY-STOP pushbuttons) and parameterizable start behavior
- Control of the 400 V disconnecting module by means of a safety rail signal

400 V disconnecting module

The 400 V disconnecting module enables the safe disconnection of an operational voltage of 400 V up to Category 3-4/SIL 3. For operation in a Safety Solution local application it functions only in combination with the Safety local isolator module.

For operation in a Safety PROFIsafe application it functions only in combination with the F-Switch.

F-Switch

Fail-safe digital inputs/outputs in degree of protection IP65/66/67 for near-machine, cabinet-free use.

Fail-safe digital inputs

- For the failsafe reading in of sensor information (1-/2-channel)
- Including integrated discrepancy evaluation for 2v2 signals
- Internal sensor supplies (incl. testing) available

Fail-safe digital outputs

- 3 failsafe PP-switching outputs for safe switching of the backplane busbars

The F-Switch is certified up to Cat. 4 (EN 954-1) and up to SIL 3 (IEC 61508) and has detailed diagnostics.

It supports PROFIsafe in PROFIBUS configurations as well as in PROFINET configurations.

Functionality

Safety local isolator module

The Safety local isolator module features the same functions as a standard isolator module with an additional local safety function.

The Safety local isolator module contains a 3TK28 41 module and is equipped with M12 terminals for the connection of external safety components.

Terminals 1 and 2 can be used to connect either 1-channel or 2-channel EMERGENCY-STOP circuits or protective door circuits (IN 1, IN 2).

For monitored starts, an external START switch can be connected to terminal 3.

The required safety functions can be set using 2 slide switches located under the left M12 opening.

In the event of an EMERGENCY-STOP, the Safety local isolator module trips the downstream 400 V disconnecting module. This safely isolates the 400 V circuit up to Cat. 4/SIL 3.

In combination with the 400 V disconnecting module, the Safety local isolator module can be used for safety applications up to Cat. 4/SIL 3 according to EN 13849-1 / IEC 61508 1-4.

400 V disconnecting module

The 400 V disconnecting module can be used together with the Safety local isolator module for local safety applications and together with the F-Switch for PROFIsafe safety applications.

It contains two contactors connected in series for safety-oriented disconnection of the main circuit.

The auxiliary circuit supply of the device is over a safety power rail in the backplane bus module.

The 400 V disconnecting module can be used together with the Safety local isolator module or with the F-Switch for safety applications up to Cat. 4/SIL 3 according to EN ISO13849-1 / IEC 61508 1-4.

F-Switch

The F-Switch is a failsafe solid-state module for PROFIsafe safety applications. It has two failsafe inputs and outputs for safe switching of the 24 V supply over backplane busbars. In combination with the 400 V disconnecting module it can be used in PROFIsafe applications for the failsafe disconnection of ET 200pro motor starters up to Cat. 4/SIL 3.

SIMATIC ET 200 Distributed I/O

Systems without control cabinet

ET 200pro Motor starters

Accessories

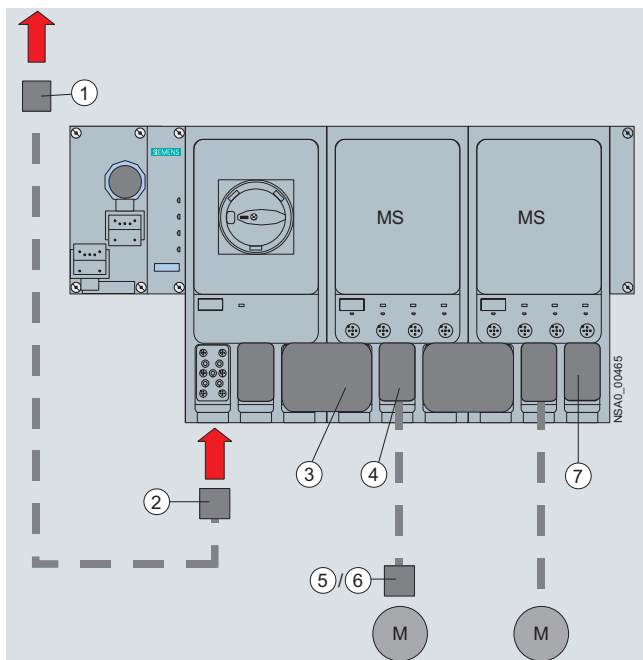

Basic design of an ET 200pro motor starter

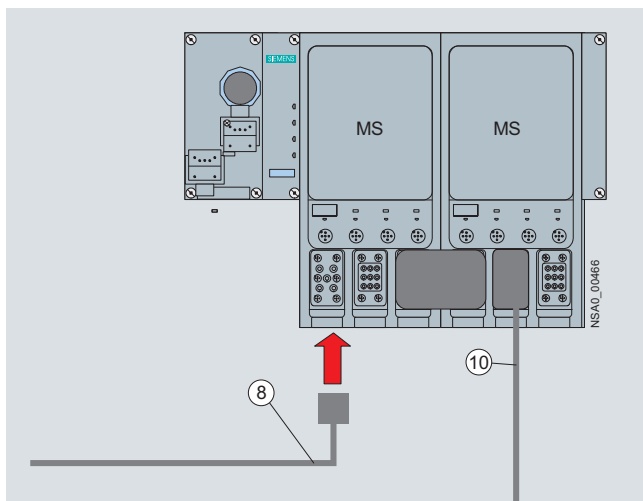

Infeed on the ET 200pro motor starter

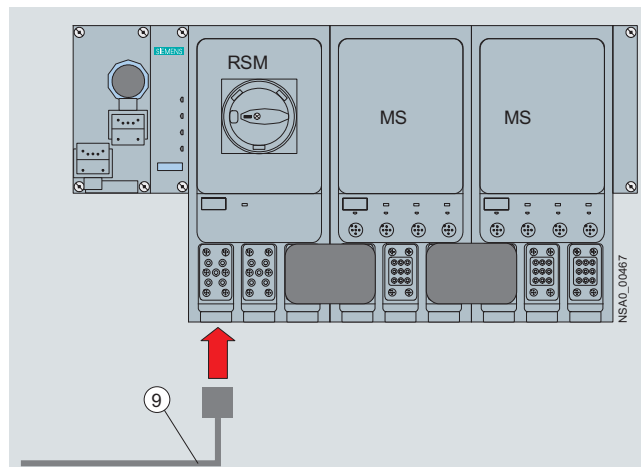

Infeed on the RSM isolator module

Legend:

- ① Power feeder plug (see Catalog ST 70, page 9/319)
- ② Power connection plug (see Catalog ST 70, page 9/319)
- ③ Power jumper plug (see Catalog ST 70, page 9/319)
- ④ Motor connection plug (see Catalog ST 70, page 9/319)
- ⑤ Motor plugs (see Catalog ST 70, page 9/319)
- ⑥ Motor plugs with EMC suppressor circuit (see Catalog ST 70, page 9/319)
- ⑦ Power loop-through plugs (see Catalog ST 70, page 9/319)
- ⑧ Power connection cables (see Catalog ST 70, page 9/319)
- ⑨ Power connection cables for isolator module (see Catalog ST 70, page 9/319)
- ⑩ Motor cable (see Catalog ST 70, page 9/320)

More information

- Catalogs ST 70, IC 10, CA 01
- Internet:
www.siemens.com/et200pro
www.siemens.com/et200 (general)

Overview



- Compact block I/Os for processing digital, analog and IO-Link signals for connecting to the PROFINET bus system
- Construction without control cabinet, degree of protection IP65/66/67 with M12 connection method
- Very robust and resistant metal casing and enclosure
- Compact module in two enclosure forms:
 - 30 mm x 200 mm x 37 mm (W x H x D, long and narrow enclosure) with 4 x M12 for digital signals
 - 60 mm x 175 mm x 37 mm (W x H x D, short and wide enclosure) with 8 x M12 for digital signals and IO-Link
 - 60 mm x 175 mm x 37 mm (W x H x D, short and wide enclosure) with 4 x M12 or 8 x M12 for analog signals
- PROFINET connection: 2 x M12 and automatic PROFINET addressing
- Data transmission rate 100 MBit/s
- LLDP proximity detection without PG and Fast Startup (starting within approx. 0.5 s)
- Supply and load voltage connection: 2 x M12
- Module variance:
 - 8 DI,
 - 16 DI,
 - 8 DO (2 A),
 - 8 DO (1.3 A),
 - 8 DO (0.5 A),
 - 16 DO (1.3 A),
 - 8 DI/DO (1.3 A),
 - 8 AI (U, I, TC, RTD),
 - 4 AO (U, I),
 - 4 IO-Link + 8 DI + 4 DO (1.3 A)
- Channel-specific diagnosis

More information

- Catalogs ST 70, CA 01
- Internet:
 - www.siemens.com/et200ecopn
 - www.siemens.com/et200 (general)

SIMATIC ET 200 Distributed I/O

Systems without control cabinet

ET 200eco

Overview



- Compact, economical, I/O peripherals for the processing of digital signals
- Cabinet-free design in IP65/67 degree of protection with flexible and rapid connection technology

- Consists of basic module and various connection blocks for application-adapted realization options:
 - ECOFAST: 2 x RS 485 hybrid field bus connections with identification plug for PROFIBUS address setting
 - M12: 2 x M12 and 2 x 7/8" with 2 rotary coding switches for PROFIBUS address assignment
- Connection block includes T functionality for bus and voltage supply so that the module can be removed from and reconnected to PROFIBUS without interruption during commissioning and service
- Module variance: 8DI, 16DI, 8DI/8DO (1.3 A), 8DI/8DO (2.0 A), 8DO (2.0 A), 16DO (0.5 A)
- Transmission rates up to 12 Mbit/s
- Failsafe DI module with 4/8 F-DI with safety-oriented signal processing according to PROFIsafe

More information

- Catalogs ST 70, CA 01
- Internet:
 - www.siemens.com/et200eco
 - www.siemens.com/et200 (general)

4

SIMATIC Ident Identification Systems

5



5/2	Introduction
5/4	Configuration examples
5/6	RFID systems
5/6	Introduction
5/7	SIMATIC RF200
5/7	SIMATIC RF300
5/8	MOBY D
5/8	SIMATIC RF600
5/9	MOBY U
5/9	RFID Software
5/10	Overview of technical specifications
5/12	Code reading systems
5/12	Introduction
5/14	Overview of technical specifications

Note

You can find detailed information on identification systems in the catalog "Industrial Identification Systems ID 10 · 2011" and on the Internet at:

www.siemens.com/ident

SIMATIC Ident Identification Systems

Introduction

Overview

SIMATIC Ident – for more economic production and logistics processes

Fiercer competition, stricter standards and legal regulations, shorter product life cycles, more individual customer requirements and increasingly globalized value-adding chains: to stay ahead in dynamic markets, companies must increase the efficiency of their value-adding chains – in production control, asset management, tracking & tracing as well as in supply chain management. Through the use of innovative identification technology, companies gain an important advantage.

But what is best: RFID or optical code reading systems? What is the right technology for the specific application? Where is alternative use relevant, where is joint use relevant, and how flexibly will you be able to respond to different requirements? Siemens can help you here. With SIMATIC Ident, we are offering you a comprehensive portfolio that covers all aspects of industrial identification, supplies you with the perfect solution for your requirements, and gives you flexibility for the future.

Both technologies build a single system.

The right identification technology depends on factors such as sensing distance, lighting conditions, single or repeat markings, as well as environmental effects such as temperature and pollution. Depending on the application, optical and RFID systems can be used in the same production line alongside each other in the form of a hybrid solution, e.g. DMC for direct part marking on the product and RFID for pallets or workpiece carriers.

Easy integration in Totally Integrated Automation

In this case, seamless interlinking of both technologies and the continuous integration into the automation or IT level is necessary.

With our SIMATIC Ident portfolio we can offer you the right solution for this:

Using joint communication modules and function blocks, SCALANCE switches or IWLAN Access Points, Siemens offers a complete connection to SIMATIC PLC for all applications.

This ensures that you have a system-wide, uniform software architecture as well as communication and saves considerable outlay and costs in engineering, commissioning and maintenance.

5

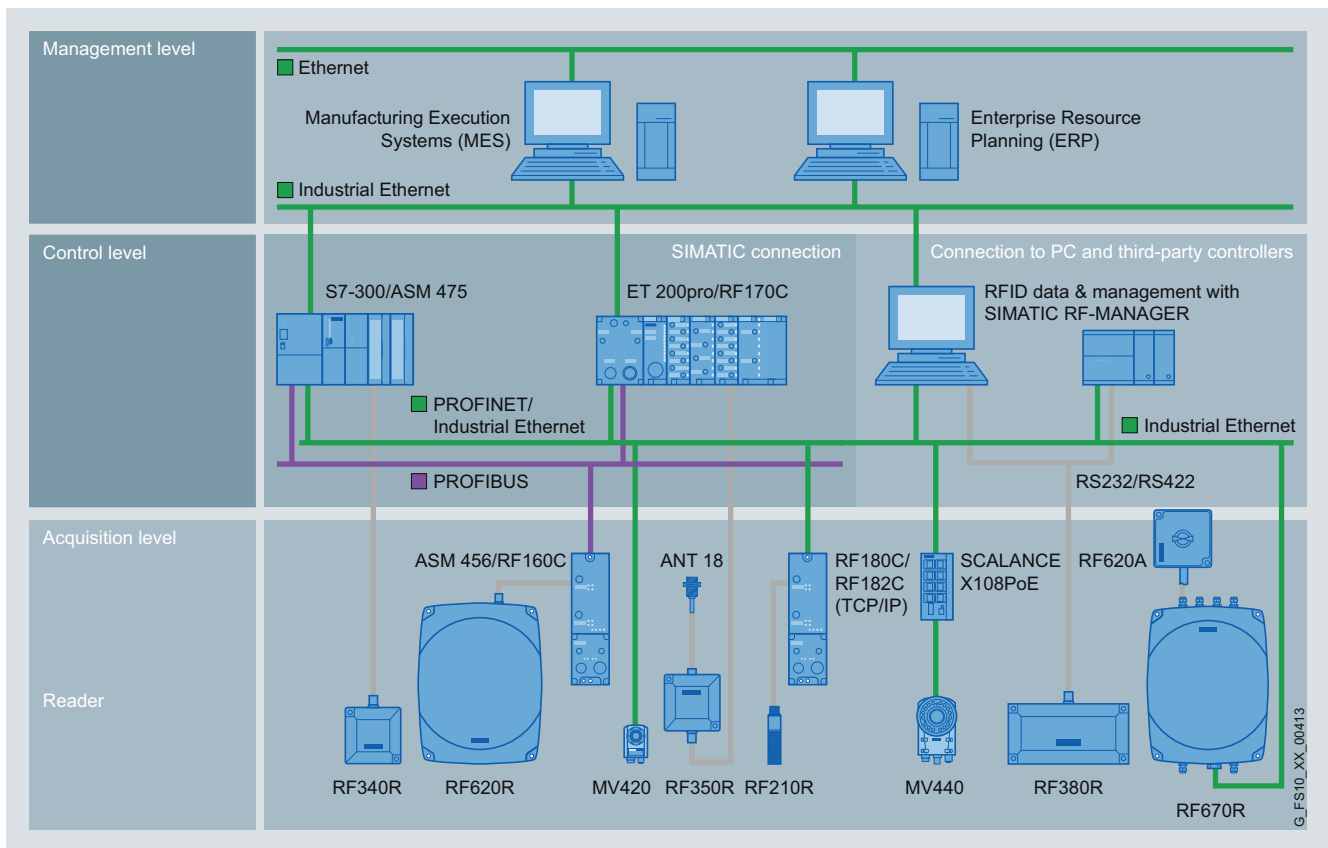

SIMATIC identification systems in the automation environment

Overview (continued)**Identification systems: RFID and optical codes**

Whether barcode, DMC, RFID or OCR: every technology has its specific strengths. Character recognition is used for cases in which codes must also be readable by persons, such as use-by dates.

2D codes and RFID impress customers with their high level of data security and have proved reliable even under harsh industrial conditions. The decisive criterion for an identification system: your individual application.

Code reading systems: Verification, identification

When higher performance is required, 2D codes are recommended as an alternative to barcodes, because they offer greater memory capacity and a better read rate. They can be applied inexpensively, e.g. together with shipping labels. They also enable the products to be marked directly (Direct Part Marking, DPM) using lasers, printing or nail punching, which is extremely resistant to external influences. 2D codes can be read with complete reliability even from a small viewing angle or under difficult lighting conditions.

With SIMATIC code reading systems, we offer you the ideal solution for reading and verifying 1D and 2D codes as well as for text recognition (OCR) - for the reliable tracing of production batches beyond the manufacturing plant.

RFID: Identification, mobile data storage

RFID is the ideal solution when there is no line of sight between the reader and the marking, large volumes of data or wide ranges are required, or the stored information has to be changed. Here the product or object is fitted with a memory chip that can be programmed and read using radio techniques. With low-cost Smart Labels available for logistics, rugged data memories for assembly lines as well as transponders with a wide range, RFID is perfectly suited to a variety of different applications.

Our intelligent SIMATIC RF system family offers you transparency without gaps. Data is therefore available at any time along the complete production and distribution chain – for perfect control and optimization of material flow and logistics.

SIMATIC Ident Identification Systems

Configuration examples

Overview (continued)

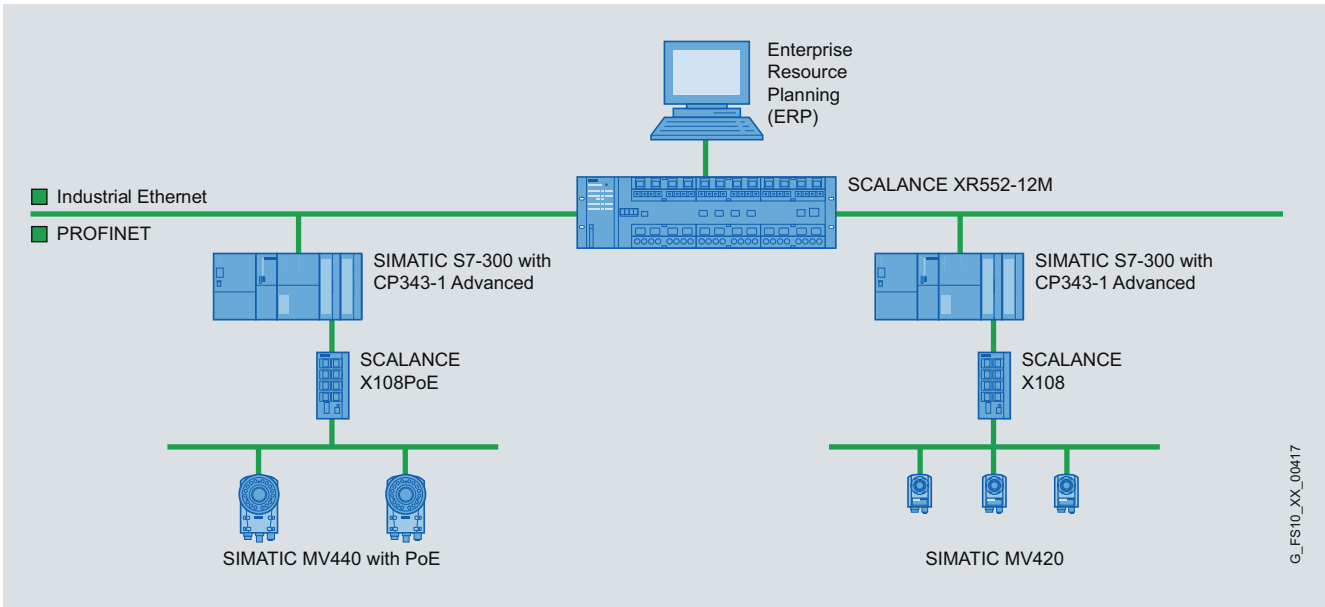

Tracking & Tracing

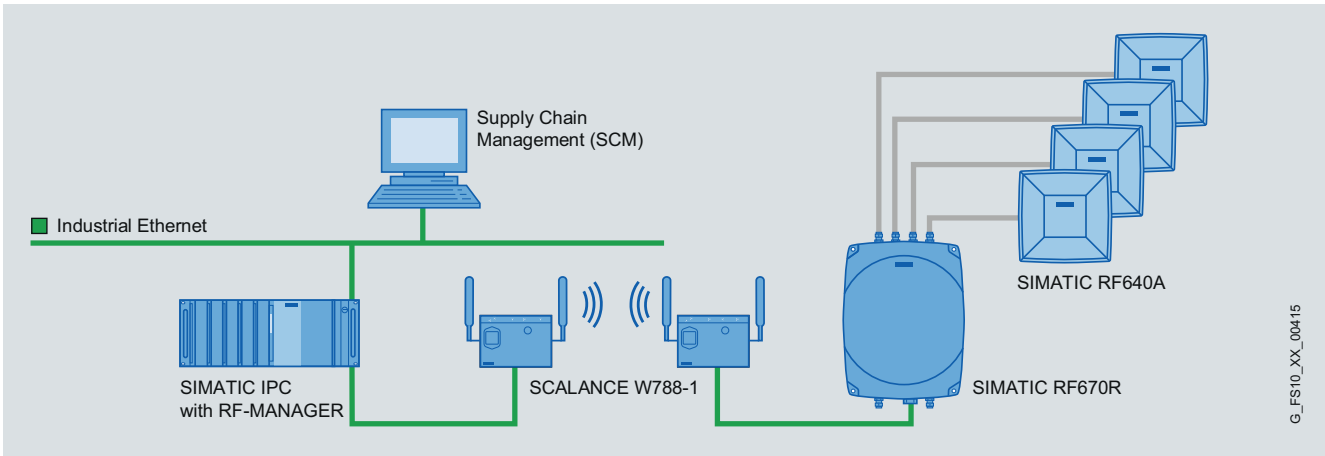

Logistics portal

5

Configuration examples

Overview (continued)

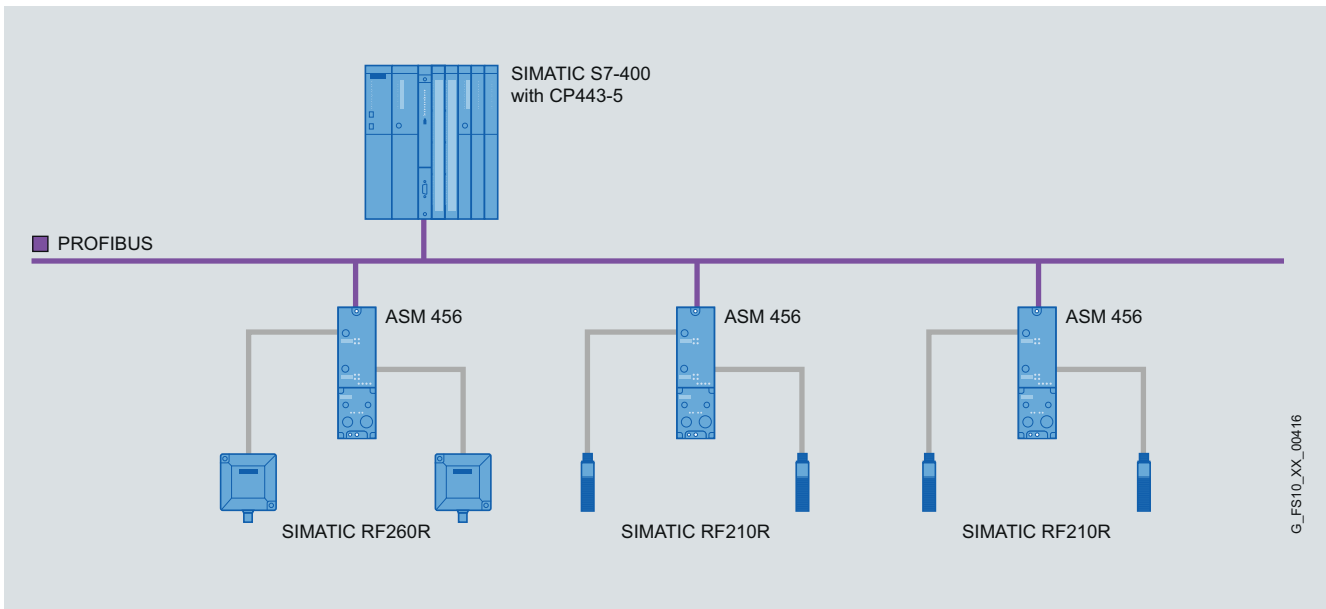

Assembly lines

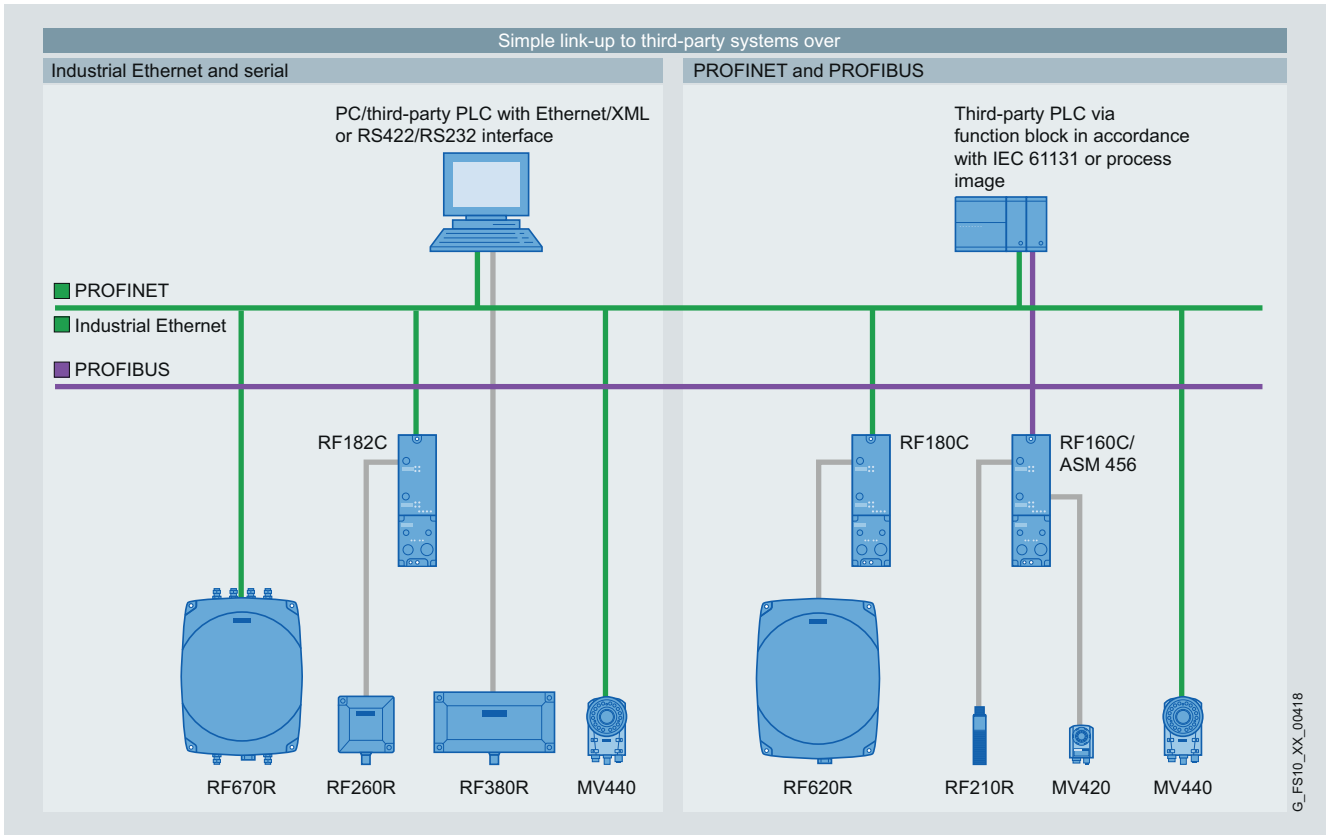

Integration in third-party systems

SIMATIC Ident Identification Systems

RFID systems

Introduction

Overview



RFID systems – for optimization of material flow and logistics

As the world-leading supplier of RFID systems, Siemens offers a unique scalable portfolio for flexible and cost-effective solutions.

RFID systems are offered for the most diverse requirements on performance, range, frequency range as well as HF and UHF.

Easy integration of the RFID systems via communication modules and pre-configured software blocks in the world of Totally Integrated Automation significantly reduces the outlay and costs for commissioning, diagnostics and maintenance.

Thanks to many years of experience in the area of RFID, Siemens is a competent partner for implementation of the most diverse solutions in all sectors, but especially in the areas of production and logistics.

Meaningful data from the outset

The RFID systems ensure that meaningful data accompanies a product or object from the very beginning. The transponders are attached to the product, product carrier, object, or its transport or packing unit and are written to contact-free. This means that all the application-specific data is located on the transponder. This is true whether you are dealing with vehicle body parts in the automotive industry or order picking boxes.

Up to 64 KB of data can be stored and individually read and supplemented when required at the various workstations or manufacturing stations. This all means that the flow of material and data is synchronized optimally.

Contactless data transfer and a high degree of industrial compatibility

Powerful readers (read/write devices) in various rugged designs ensure fast and reliable data transfer between the transponders and the higher-level systems (e.g. PLC, PC).

The data and power are transmitted inductively by an electromagnetic alternating field or by radio waves. This principle of contactless data transfer works reliably in the presence of contamination or through non-metallic materials.

Perfectly matched components

The RFID systems consist of perfectly matched individual components:

- Transponder
- Readers
- Antennas
- Communication modules for connection to the automation system (e.g., PROFIBUS, PROFINET)
- Software for system integration

For a wide range of applications in all sectors

- Production control
- Asset management
- Tracking & tracing
- Supply chain

Wide range of transponders

A wide range of different transponders is available using a variety of storage technologies (fixed code, EEPROM or FRAM/SRAM) and geometric designs. Their strength is not only their high level of data security but also the excellent high degree of protection against ambient conditions such as contamination, temperature fluctuations, washing water or shock load.

Flexible system integration

A wide range of communication modules, function blocks, as well as high-performance drivers and function libraries permits easy and quick integration into the application.

And best of all: SIMATIC RFID is part of Totally Integrated Automation and can be integrated easily and cost-effectively into the SIMATIC world.

For more details on the connection possibilities, see the respective chapters of the communication modules at PROFINET/Industrial Ethernet, PROFIBUS and ET 200 Distributed Peripherals.

Benefits

- Flexible and economic solutions thanks to the complete and scalable portfolio for the field of industrial identification.
- Simplified engineering, commissioning, diagnostics and maintenance through seamless integration into Totally Integrated Automation:
 - Integrated bus connection to an automation system, such as SIMATIC, SIMOTION or SINUMERIK via communication modules with PROFIBUS and PROFINET.
 - Simple S7 software integration via ready-to-use function blocks.
 - Integrated diagnostic functions.
- High degree of investment protection thanks to:
 - Open standards (e.g. ISO 15693, ISO 18000-6C).
 - Software compatibility between the RFID systems of Siemens AG.
 - Standardized communications interfaces.
- Openness through connection possibilities to different bus systems from different manufacturers and PC environments via communication modules.
- Worldwide Service and Support.

SIMATIC RF200

Overview



The RFID system SIMATIC RF200 is, thanks to its compact and low-cost reader, particularly suitable for use in industrial production in the areas of small assembly lines and intralogistics.

With RF200, identification tasks of medium-performance in the HF range (13.56 MHz, ISO 15693) can be implemented extremely cost effectively. RF200 readers can be operated with all ISO transponders of the product range of MOBY D (MDS Dxxx).

SIMATIC RF300

Overview



The RFID system SIMATIC RF300 is particularly suitable for use in industrial production in the areas of production control, assembly lines and conveyors.

SIMATIC RF300 is used to implement identification tasks with medium to high performance in the HF range (13.56 MHz).

Depending on the demands on the performance of the identification system, three versions of the system are available:

- A particularly economical solution with a link to SIMATIC S7-300 over the IQ-Sense interface for low requirements in terms of speed and data volume.
- Medium performance: System configuration with SIMATIC RF300 readers in ISO 15963 mode and low-cost MOBY D transponders.
- High performance: System configuration with SIMATIC RF300 readers in RF300 mode and SIMATIC RF300 transponders.

SIMATIC Ident Identification Systems

RFID systems

MOBY D

SIMATIC RF600

Overview



The RFID system MOBY D is particularly suitable for use in industrial production in the areas of production control, asset management and tracking & tracing.

MOBY D is used to implement identification tasks with medium to high performance (ISO 15693) in the HF range (13.56 MHz) that require particularly high ranges.

MOBY D offers a comprehensive portfolio of ISO 15693 transponders for a whole variety of requirements - from low-cost SmartLabels for simple identification tasks through rugged credit card formats, right up to transponders for use in especially harsh environments such as paint shops or in the laundry and cleaning industry.

Depending on the read/write distance, different readers are available with integrated or remote antennas.

Overview



Identification tasks in the UHF range (865 to 868 MHz and 902 to 928 MHz) that demand a wide range of up to 5 m are implemented with SIMATIC RF600. The system is suitable for storing and recording a unique identification according to the EPCglobal standard (Electronic Product Code) on products, containers or transport units. Storage of additional, freely-definable user data is also possible.

Various data carriers - from low-cost SmartLabels through to heat-resistant transponders that can be used for several thousand cycles - are available for industrial applications.

SIMATIC RF600 can be used with SIMATIC controllers and PC/IT systems.

5

MOBY U

RFID Software

Overview



MOBY U is used to implement identification tasks with medium to high performance in the microwave frequency range (2.4 ... 2.4835 GHz) that require particularly high ranges.

MOBY U eliminates familiar sources of interference, such as reflections, electromagnetic interference and overreach, by means of appropriate technical measures.

Correspondingly constructed antennas ensure a homogeneous transmission field to guarantee reliable recognition of the transponders (MDS) even from unfavorable locations.

In addition, special coding procedures ensure that the data transmission functions without errors and the data integrity is guaranteed. To achieve this, methods and algorithms that have been tried and tested in mobile radio technology (GSM, UMTS) have been transferred to the identification technology.

Overview

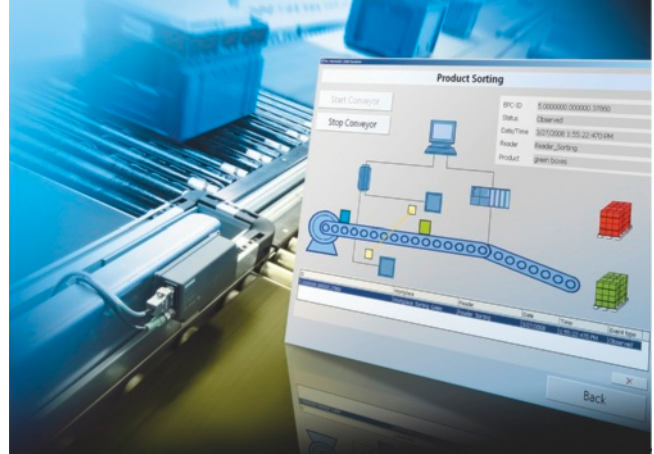

SIMATIC RF-MANAGER

The SIMATIC RF-MANAGER is a software tool designed for fast and simple creation and commissioning of RFID applications as well as their smooth operation in combination with a higher-level enterprise system or SIMATIC S7 controllers.



The current RF-MANAGER version supports read/write devices of the RFID systems RF300 and RF600. Depending on the scope of the RFID application, various software packages are available which differ in the number of supported readers (maximum 50).

SIMATIC Ident Identification Systems



RFID systems

Overview of technical specifications

Technical specifications

Frequency range	HF		
RFID system	SIMATIC RF200	SIMATIC RF300	MOBY D
			
Transmission frequency	13.56 MHz	13.56 MHz	13.56 MHz
Read/write distance, max.	130 mm	210 mm	900 mm
Protocol (air interface)	ISO 15693	RF300 ISO 15693	ISO 15693
Approvals	<ul style="list-style-type: none"> • EN 300330, 301489, CE (Europe) • FCC Part 15 (USA) • UL/CSA 	<ul style="list-style-type: none"> • EN 300330, 301489, CE (Europe) • FCC Part 15 (USA) • UL/CSA • Japan 	<ul style="list-style-type: none"> • EN 300330, 301489, CE (Europe) • FCC Part 15 (USA) • UL/CSA
Memory capacity, max.	992 byte (EEPROM)/ 2 000 byte (FRAM)	64 KB	992 byte (EEPROM)/ 2 000 byte (FRAM)
Data transmission rate reader – transponder			
• Read, max.	1.5 KB/s	7.8 KB/s	1.5 KB/s
• Writing, max.	0.5 KB/s	7.8 KB/s	0.5 KB/s
Multitag/Bulk capability	No	No	Yes
Special features	<ul style="list-style-type: none"> • Particularly compact designs • For particularly low-cost RFID solutions 	<ul style="list-style-type: none"> • High data transmission rate • Extended diagnostic possibilities 	<ul style="list-style-type: none"> • SIMATIC or PC/IT integration • Long sensing ranges with excellent interference immunity • External antennas for industrial applications

Technical specifications (continued)

Frequency range RFID system	UHF SIMATIC RF600	Microwave range MOBY U
		
Transmission frequency	865 ... 868 MHz (ETSI) 902 ... 928 MHz (FCC)	2.4 GHz
Read/write distance, max.	5 m	3 m
Protocol (air interface)	EPCglobal Class 1 Gen 2 ISO 18000-6C	ISO 18000-4
Approvals	<ul style="list-style-type: none"> • ETSI EN 302208, CE • FCC • UL 	<ul style="list-style-type: none"> • CE • FCC • UL
Memory capacity, max.	96 / 240 bit EPC 512 bit user memory	32 KB
Data transmission rate reader – transponder		
• Read, max.	160 kbit/s	8 kbit/s
• Write, max.	160 kbit/s	4.8 kbit/s
Multitag/Bulk capability	Yes	Yes
Special features	<ul style="list-style-type: none"> • SIMATIC or PC/IT integration • Configurable data processing in the readers • Special antennas for industrial applications 	<ul style="list-style-type: none"> • Active range limiting • High memory capacity

More information

Wireless approvals:

Current approvals can be found on the Internet at:
www.siemens.com/wireless-approvals

SIMATIC Ident Identification Systems

Code reading systems

Introduction

Overview



Code reading systems – Reading and verification of 1D/2D codes

For state-of-the-art production systems, tracing products and parts with machine-readable identification is a central requirement. A unique coding system permits the planning of each and every step of production for every part manufactured and changes within the production process or in the materials used. Direct marking of products also allows the implementation of specified legal requirements for tracing production batches throughout the production system.

What is Direct Part Marking (DPM)?

Direct Part Marking (DPM) indicates the application of a mark directly on the surface of a product without the use of a separate carrier material such as e.g. an adhesive label. This makes it possible to identify products in production and tracing them after delivery as well. So-called 2D codes have been used for years in a coding method that meets all user requirements. 2D codes consist of easy to implement, point-shaped basic elements. Laser and needle marking technologies are outstanding regarding durability, marking speed and material independence. Because of mechanical deformation, 2D codes can still be read using 2D read devices after multiple processing steps on metallic work pieces for example. 2D codes also provide the advantage of being able to encode data in more limited spaces than comparable barcodes or text.

The product range of Siemens code reading systems

Stationary code reading systems



SIMATIC MV440 and MV420 stationary code reading systems

The stationary code reading systems include compact basic and high-performance reading devices. The devices read various two-dimensional (2D) codes as well as one-dimensional (1D) barcodes. Many readers use data matrix print quality monitoring (verification) for process control.

SIMATIC MV440 can also read plain text (OCR stands for Optical Character Recognition)

Handheld reading systems



Handheld reading system SIMATIC HawkEye 40T

This handheld reading system is a powerful, high-resolution read device for either two-dimensional (2D) data matrix codes and/or one-dimensional bar codes (1D). The device can communicate with a host computer using RS232, USB, PS2 and Bluetooth depending on the selected version.

Overview (continued)

Verification systems

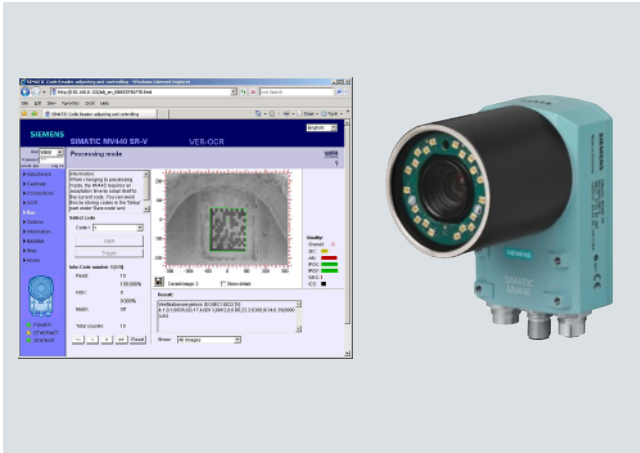

By using verification systems, the readability of marks is guaranteed throughout the entire production process regardless of any possible contamination or when using different read devices. Moreover, the marking can continue to be read after the production process throughout the lifespan of the product.

With the "Veri-Genius" verification license the SIMATIC MV440 can be expanded at any time by the verification functionality, in addition to reading 1D barcodes and 2D matrix codes. This license is supplied as a "Single License" on a USB flash drive and can be copied via the SIMATIC Automation License Manager (ALM) to the SIMATIC MV440 using a plug-in. The license is executable on any SIMATIC MV440 with firmware version 4.0 and higher.

Optical character recognition



With the OCR license "Text Genius" SIMATIC MV440 can also be used for text recognition in addition to reading 1D bar codes and 2D matrix codes. This is also known as OCR (Optical Character Recognition). It is also possible to read and compare plain text and machine-readable code in the same image field.

The license is supplied as a "Single License" on a USB stick and can be copied to the device with the SIMATIC Automation License Manager (ALM) using a plug-in. The license can be installed on a SIMATIC MV440 with firmware version 3.0 and higher.

Benefits



- Unique identification of products or product parts – Direct Part Marking is the key technology for tracing products
- Part-specific documentation of the production process
- Automation of the manufacturing process
- Verification for product liability cases (e.g. recall actions)

SIMATIC Ident Identification Systems

Overview of technical specifications

Technical specifications

Major differences

Code reading system	SIMATIC MV420	SIMATIC MV440	SIMATIC VS130-2
			
Enclosure	Very compact design, IP67	Compact design, IP67	Modular design (signal evaluator, sensor head and light separately), IP65
Sensor / resolution	CMOS 640 x 480 pixels 752 x 480 pixels	CCD 640 x 480 pixels 1024 x 768 pixels 1600 x 1200 pixels	CCD 640 x 480 pixels
Lens system	Flexible lens system (M12)	Freely selectable lenses due to C-Mount lens connection	Integrated fixed focus lens, or freely selectable lenses due to C-Mount lens connection
Lighting	Integrated lighting	Integrated or external lighting	External lighting
Commissioning and operation	<ul style="list-style-type: none"> • Integrated web server • Auto-optimizing of parameters • Languages: E/G/F/I/S/CH 	<ul style="list-style-type: none"> • Integrated web server • Auto-optimizing of parameters • Languages: E/G/F/I/S/CH 	<ul style="list-style-type: none"> • Integrated web server • Onboard operator controls • Auto-optimizing of parameters • Languages: E/G/F/I/S/CH
Communication	<ul style="list-style-type: none"> • PROFIBUS (via ASM module; M12) • PROFINET (onboard, M12 or via ASM module, different interfaces) • Ethernet (onboard, M12) • RS232 (onboard, M16) 	<ul style="list-style-type: none"> • PROFIBUS (via ASM module, M12) • PROFINET (onboard, M12 or via ASM module, different interfaces) • Ethernet (onboard, M12, PoE) • RS232 (onboard, M16) 	<ul style="list-style-type: none"> • PROFIBUS (onboard; DB9) • PROFINET (onboard, RJ45) • Ethernet
Text recognition	–	Polyfont	–
Verification	–	<ul style="list-style-type: none"> • ISO/IEC 16022:2000 • ISO/IEC 15415:2004 • AS9132 Rev A, 2005 • ISO/IEC 15416:2000 • ANSI X3.182-1990 • Siemens DPM • AIM DPM-1-2006 	ISO16022 based

AS-Interface

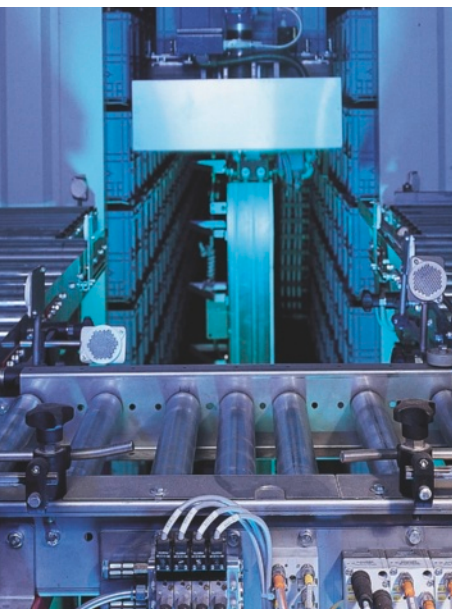

6/2	Introduction	6/68	<u>Special integrated solutions</u>
6/2	System overview	6/68	AS-Interface communication modules
6/4	AS-Interface specification	6/70	<u>Modules with special functions</u>
6/6	ASIsafe	6/70	Counter modules
6/6	Introduction	6/71	Ground-fault detection modules
6/8	AS-Interface safety monitors	6/71	Overvoltage protection module
6/11	AS-Interface safety modules	6/73	AS-Interface connection for LOGO!
6/14	3SF1 position switches	6/74	<u>Contactors and contactor assemblies</u>
6/15	– Plastic enclosures	6/74	SIRIUS 3RT20 contactors
6/17	– Metal enclosures	6/75	SIRIUS 3RA24 contactor assemblies for wye-delta starting
6/21	3SF1 position switches with separate actuator	6/76	SIRIUS 3RA27 function modules for AS-Interface
6/22	– Plastic enclosures	6/78	<u>Motor starters for operation in the control cabinet</u>
6/23	– Metal enclosures	6/78	SIRIUS 3RA6 compact feeders
6/24	– Accessories	6/81	– 3RA61 direct-on-line starter
6/25	3SF1 position switches with solenoid interlocking	6/82	– 3RA62 reversing starter
6/26	– Plastic enclosures	6/83	– Accessories
6/27	– Metal enclosures	6/88	– Add-on modules for AS-Interface
6/28	3SF1 hinge switches	6/90	– Infeed system for 3RA6
6/28	– Plastic enclosures	6/97	<u>Motor starters for operation in the field, high degree of protection</u>
6/29	– Metal enclosures	6/97	SIRIUS M200D motor starters
6/30	3SF2 cable-operated switches for AS-Interface	6/97	– General data
6/31	SIRIUS EMERGENCY-STOP mushroom pushbuttons for AS-Interface	6/98	– M200D motor starters for AS-Interface
6/34	AS-Interface F adapters for EMERGENCY-STOP devices	6/103	– Accessories
6/35	Masters	6/107	SIRIUS MCU motor starters
6/35	<u>Masters for SIMATIC S7</u>	6/107	– General data
6/35	CP 243-2	6/109	– MCU motor starters for AS-Interface
6/36	CP 343-2P, CP 343-2	6/114	Motor starters for AS-Interface, 24 V DC
6/38	Network transitions	6/117	<u>SINAMICS G110D distributed converters</u>
6/38	DP/AS-i LINK Advanced	6/121	<u>3SF5 pushbuttons and indicator lights</u>
6/41	DP/AS-Interface Link 20E	6/121	Enclosures and front panel modules for AS-Interface
6/43	DP/AS-i F-Link	6/121	– General data
6/47	IE/AS-i LINK PN IO	6/122	– With standard fittings
6/50	Slaves	6/123	– Components
6/50	<u>I/O modules for operation in the field, high degree of protection</u>	6/124	– Customized equipment
6/50	Digital I/O modules, IP67 – Introduction	6/125	– Front panel module
6/51	Digital I/O modules, IP67 – K60	6/130	<u>8WD4 signaling columns</u>
6/53	Digital I/O modules, IP68/IP69K – K60R	6/135	Power supply units and data couplings
6/55	Digital I/O modules, IP67 – K45	6/135	AS-Interface power supply units
6/57	Digital I/O modules, IP67 – K20	6/136	S22.5 data decoupling modules
6/59	Digital I/O modules, IP67 – User modules	6/138	Transmission media
6/60	Analog I/O modules, IP67 – K60	6/138	AS-Interface shaped cables
6/63	<u>I/O modules for operation in the control cabinet</u>	6/139	System components and accessories
6/63	Introduction	6/139	Repeater
6/64	SlimLine	6/140	Extension Plug
6/66	F90 module	6/141	Addressing units
6/67	Flat module	6/143	Analyser
		6/146	Other accessories
		6/149	Software
		6/149	AS-Interface Function Block Library for SIMATIC PCS 7

AS-Interface

Introduction

System overview Transmission technology

Overview

AS-Interface is an open, international standard according to EN 50295 and IEC 62026-2 for process and field communication. Leading manufacturers of actuators and sensors all over the world support the AS-Interface. Interested companies are provided with the electrical and mechanical specifications by the AS-Interface Association.

AS-Interface is a single master system. For automation systems from Siemens there are communication processors (CPs) and network transitions (links) which control the process or field communication as masters, and actuators and sensors which are activated as AS-Interface slaves.

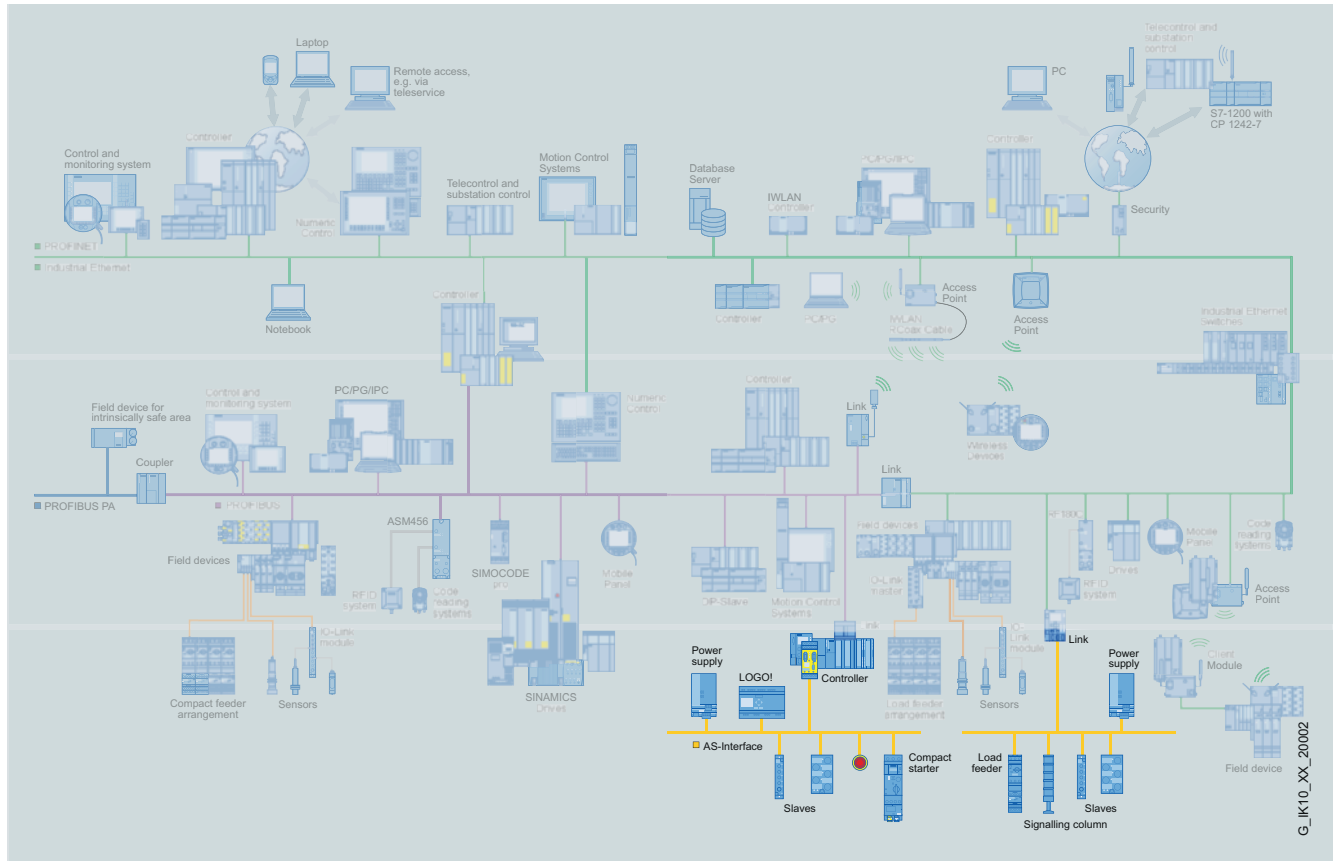

6

Benefits

get Designed for Industry

A key feature of AS-Interface technology is the use of a shared two-conductor cable for data transmission and the distribution of auxiliary power to the sensors/actuators. A power supply unit which meets the requirements of the AS-Interface transmission method and has an external data decoupling module if required is used for the distribution of auxiliary power. The AS-Interface cable used for the wiring is mechanically coded and hence protected against polarity reversal and can be easily contacted by the insulation piercing method.

Elaborately wired control cables in the control cabinet and marshalling racks can be replaced by AS-Interface.

The AS-Interface cable can be connected to any points thanks to a specially developed cable and connection by the insulation piercing method.

With this concept you become extremely flexible and achieve high savings.

Application

Operating modes

Generally, master interfaces have the following operating modes:

I/O data exchange

In this operating mode the inputs and outputs of the binary AS-Interface slaves are read and written.

Analog value transmission

AS-Interface masters according to the AS-Interface Specification V2.1 or V3.0 support integrated analog value processing. This means that data exchange with analog AS-Interface slaves is just as easy as with digital slaves.

Command interface

In addition to I/O data exchange with binary and analog AS-Interface slaves the AS-Interface masters provide a number of other functions through the command interface.

Hence it is possible, for example, for slave addresses to be issued, parameter values transferred or diagnostics information read out from user programs.

Overview

System components

To implement the communication, a system installation has the following main components:

- Master interface modules for central control units such as SIMATIC S7, ET 200 M distributed peripherals, or network transitions from PROFIBUS/PROFINET to AS-Interface
- Power supply units, if required in combination with a data decoupling module for the power supply to the slaves
- AS-Interface shaped cables
- Network components such as repeaters and extension plugs (cannot be used for AS-i Power24V networks)
- Modules for connection of standard sensors/actuators
- Actuators and sensors with integrated AS-i slave
- Safety modules for transmitting safety-oriented data through AS-Interface
- Addressing units for setting the slave addresses during commissioning

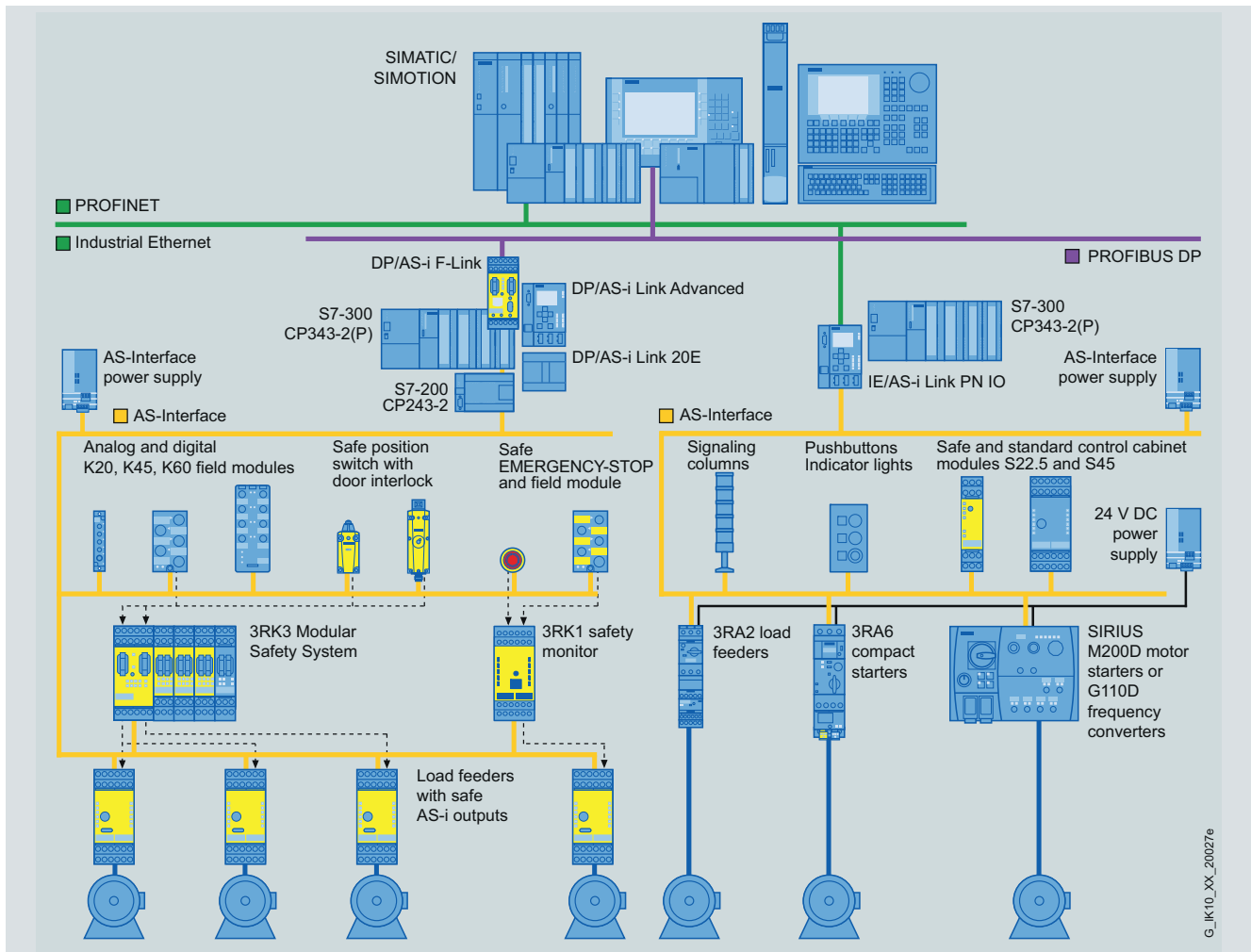

Example of a configuration with the system components

Features

Standard	EN 50295 / IEC 62026-2	Maximum cycle time	5 ms with full expansion using standard addresses, 10 ms with full expansion using A/B addresses, profile-specific for Spec. 3.0 slaves
Topology	Line, star or tree structure (same as electrical wiring)	Number of stations per AS-Interface line	31 slaves acc. to AS-Interface Spec. V2.0; 62 slaves (A/B technology) acc. to AS-Interface Spec. V2.1 and V3.0, integrated analog value transmission
Transmission medium	Unshielded two-conductor cable (2 x 1.5 mm ²) for data and auxiliary power	Number of binary sensors and actuators	Max. 124 DI/124 DO according to Spec. V2.0; max. 248 DI/186 DO according to Spec. V2.1; max. 496 DI/496 DO according to Spec. V3.0
Connection methods	Contacting of the AS-Interface cable by insulation piercing method	Access control	Cyclic polling master slave method, cyclic data transfer by host (PLC, PC)
Maximum cable length	100 m without a repeater 200 m with extension plug 300 m with two repeaters connected in series 600 m with extension plugs and two repeaters connected in parallel Larger cable lengths are possible when additional repeaters are connected in parallel	Error safeguard	Identification and repetition of faulty message frames

AS-Interface

Introduction

AS-Interface specification Specification 2.0, 2.1 and 3.0

Overview

Scope of the AS-Interface specification

AS-Interface specification	Maximum number of slaves			Number of digital inputs DI	Number of digital outputs DO
	Digital	Analog	ASIsafe		
Version 2.0	31	31	31	$31 \times 4 = 124$	$31 \times 4 = 124$
Version 2.1	62	31	31	$62 \times 4 = 248$	$62 \times 3 = 186$
Version 3.0	62	62	31	$62 \times 8 = 496$	$62 \times 8 = 496$

Basic data of AS-Interface Specification 2.0

- AS-Interface Specification 2.0 describes a fieldbus system with an AS-i master and up to 31 AS-i slaves.
- Each AS-i slave has up to 4 digital inputs and 4 digital outputs.
- With full expansion, the complete transmission of all input/output data requires max. 5 ms cycle time.

Expansions of AS-Interface Specification 2.1

AS-Interface Specification 2.1 enables the number of network stations to be doubled from 31 to 62 as follows:

- The standard slaves continue to occupy one AS-i address (1...31).
- Slaves with extended addressing divide an address into an A address (1A...31A) and a B address (1B...31B). Up to 62 A/B slaves can be connected accordingly to one AS-i network.
- Mixed operation of standard slaves and A/B slaves is possible without difficulty. The AS-i master identifies automatically which type of slave is connected. No special adjustments are required of the user.

Another function of the AS-Interface Specification V2.1 is the integrated analog value transmission function. Access to both analog values and digital values is possible without the need for any special function blocks.

Expansions of AS-Interface Specification 3.0

- AS-Interface Specification 3.0 enables the connection of a nearly 1000 digital inputs/outputs (profile S-7.A.A: 8DI/8DO as A/B slave).
- New profiles have also enabled the option of expanded addressing for analog slaves.
- Acceleration of analog value transmission through "Fast Analog Profile".
- Variable use of analog modules: Optional parameterization of resolution (12/14 bit) and 1 and 2-channel capability.
- Asynchronous serial protocol 100 baud or 50 baud, bidirectional.

AS-Interface masters

To be able to operate A/B slaves on an AS-Interface network you must use master modules that meet the minimum requirements of Specification 2.1.

The AS-i masters for S7-300 / ET 200M and all DP/AS-i links and IE/AS-i links comply with AS-Interface Specification 3.0 and support all new and previous slaves.

AS-Interface specification	Available masters
Version 2.1	CP 243-2 (S7-200)
Version 3.0	CP 343-2, 343-2P (S7-300 / ET 200M), DP/AS-i Link Advanced, DP/AS-i F-Link, DP/AS-Interface Link 20E, IE/AS-i Link PN IO

The AS-Interface specification relevant for the respective slave is noted in the Selection and ordering data.

The exact slave profile can be found in the system manual for AS-Interface.

Communication cycle

AS-Interface specification	Maximum cycle time (digital signals)
Version 2.0	5 ms
Version 2.1	5 ms with 31 slaves 10 ms with 62 slaves
Version 3.0	5 ms with 31 slaves 10 ms with 62 slaves, supplementary, up to 20 ms with A/B slaves using 4DI/4DO, up to 40 ms with A/B slaves using 8DI/8DO.

Each address is queried in max. 5 ms cycle time. If two A/B slaves are operated on one basic address (e.g. 12A and 12B), a maximum 10 ms will be required for updating the data of both slaves.

Whether an AS-Interface slave is a standard slave or an A/B slave can be seen in the section "Selection and ordering data" or the system manual for AS-Interface.

All slave types can be mixed and used on a single AS-Interface network.

More information

AS-Interface system manual

More information is available in the AS-Interface system manual.

The German-language AS-Interface System Manual can be downloaded free from the Internet at:

<http://support.automation.siemens.com/WW/view/de/26250840>

The English-language AS-Interface System Manual can be downloaded free from the Internet at:

<http://support.automation.siemens.com/WW/view/en/26250840>

A print version of the AS-Interface System Manual is also available in both English and German, see page 146.

Internet

You can find more information on the Internet at:

<http://support.automation.siemens.com/WW/view/en/10805888/130000>

Overview



Symbol for AS-i Power24V

Parallel wiring often dominates still, particularly in applications with very few I/Os. Although AS-Interface is similarly well suited for small applications, its use is often prevented by the cost of the 30 V AS-Interface power supply unit which is required in addition.

Through the expansion of AS-Interface with AS-i Power24V and the resulting possibility of using existing standard 24 V DC power supply units in AS-i networks, AS-Interface is now also attractive for applications with a very tight budget.

Data and power in standard AS-Interface networks up to now

One of the great advantages of AS-Interface is the ability to convey not only data but also the power needed for the connected slaves and sensors over the same unshielded two-conductor cable. This is owed to the service-proven AS-Interface power supply units which provide integrated data decoupling as well as overload and short-circuit protection and integrated ground fault monitoring.

The new technology

Through the expansion of AS-Interface with AS-i Power24V it is now also possible to use 24 V standard power supply units in AS-i networks. The communication technology of AS-Interface works at the same high level of quality with an operating voltage of both 30 V DC and 24 V DC.

Key data of AS-i Power24V

Number of slaves	Up to 62 standard slaves and up to 31 safe slaves
Topology	Any
Range	Up to 50 m
Components	<ul style="list-style-type: none"> • 24V power supply unit with little residual ripple • AS-i Power24V-capable data decoupling with integrated ground-fault detection • AS-i Power24V-capable masters, slaves and components

Requirements for operation of an AS-i Power24V network

- The maximum range of 50 m must be observed in order to reach slaves and sensors with a sufficient level of voltage (at least 20 V).
- The power supply units must comply with the PELV Standard (Protective Extra Low Voltage) and have a residual ripple of < 250 mVpp. We recommend power supply units from the SITOP range, see Catalog IC 10.
- When used in conjunction with standard 24 V power supply units, each AS-i network requires Power24V-capable data decoupling with adapted ground fault detection.
- For reliable operation of an AS-i network with 24 V voltage it is important that the masters, slaves and other components are approved for AS-i Power24V. AS-i Power24V-capable AS-i components can also be used without restriction in standard 30 V AS-i networks.
- The use of repeaters or extension plugs in AS-i Power24V networks is not permitted.

Benefits

AS-i Power24V networks incur no additional costs for an AS-Interface power supply unit because an already existing 24 V power supply unit can be used. This brings the user several benefits:

- The level of standardization of very small applications can be increased further.
- The additional advantages of a modern communication system in terms of commissioning, maintenance and diagnostics can be fully exploited.

Application

Construction of an AS-i Power24V network

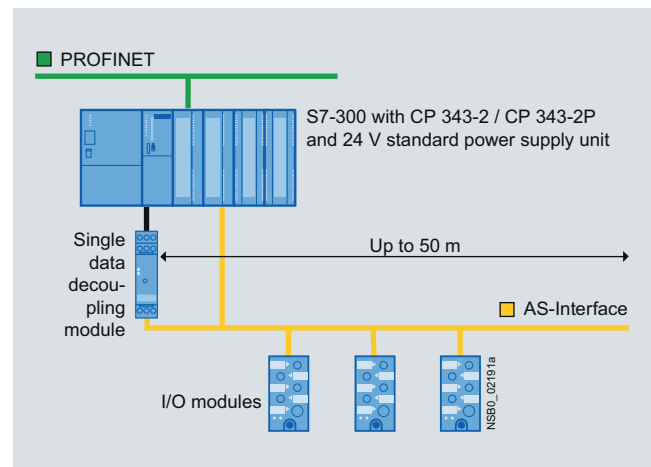

Construction of an AS-i Power24V network with an AS-Interface S22.5 data decoupling module (simple network)

More information

A complete overview of AS-i Power24V-capable units currently available from Siemens can be found at <http://support.automation.siemens.com/WW/view/en/42806066>

Details of AS-i Power24V can be found in the AS-Interface System Manual at <http://support.automation.siemens.com/WW/view/en/26250840>

AS-Interface

ASIsafe

Introduction

Overview

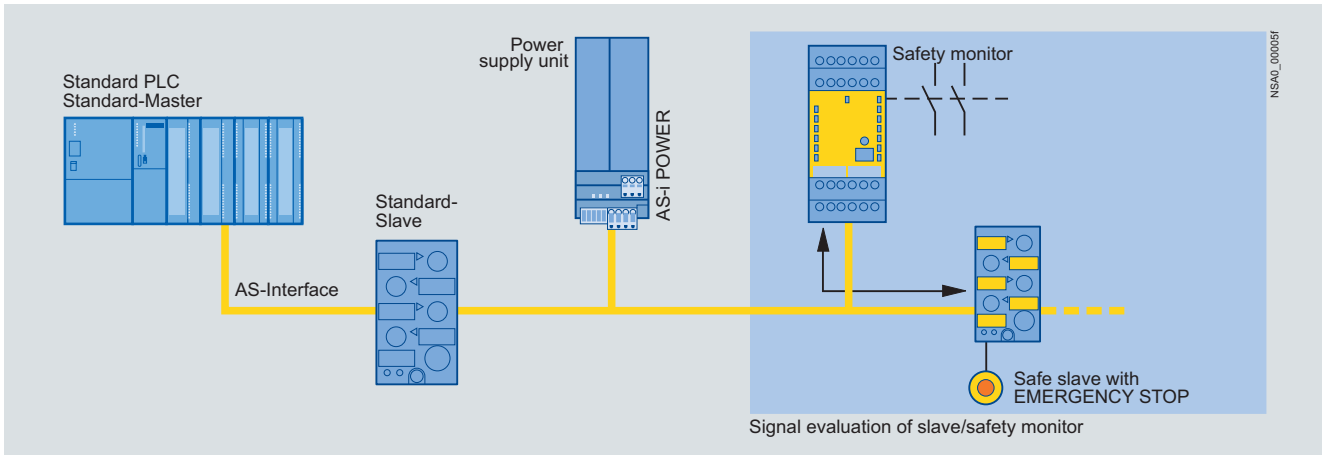

Secure communication and standard communication on AS-Interface

Safety is included

The ASIsafe concept supports the integration of safety-related components, such as EMERGENCY-STOP switches, protective door switches or safety light arrays, in the AS-Interface network. These are fully compatible with the familiar AS-Interface components (masters, slaves, power supplies, repeaters, etc.) in accordance with IEC 62026 and are operated in conjunction with them on the yellow AS-Interface cable.

A failsafe controller or a special master is not required. The master regards safety slaves like all other slaves and receives the safety data solely for information purposes. All existing AS-Interface networks can thus be expanded. ASIsafe makes sure that a maximum response time of 40 ms can be achieved. This is the time between the signal being applied to the input of the safe slave and the output on the safety monitor being switched off. With distributed disconnection through a safe AS-i output, the response time is extended by the time (30 ms) which the safe AS-i output requires in addition to the disconnection to a total of 70 ms (worst case).

Tested safety

The system was tested and approved by TÜV (Germany), NRTL (USA) and INRS (France). The transmission procedure for safety-oriented signals is configured for implementing applications up to Category 4 according to EN 954-1, up to PL e according to EN ISO 13849-1 and up to SIL 3 according to IEC 62061/IEC 61508.

Design

The design of the safety systems is identical to the wiring of AS-Interface as it is known today.

The family of safe AS-Interface products includes the safety monitor which monitors or disconnects the safe stations. The range of safe stations comprises the safety modules and the safety-related sensors with integrated interface. Sensors, monitors and safe AS-i outputs can be connected to any points of the AS-Interface network. Also, several monitors can be used on one network.

The components of ASIsafe

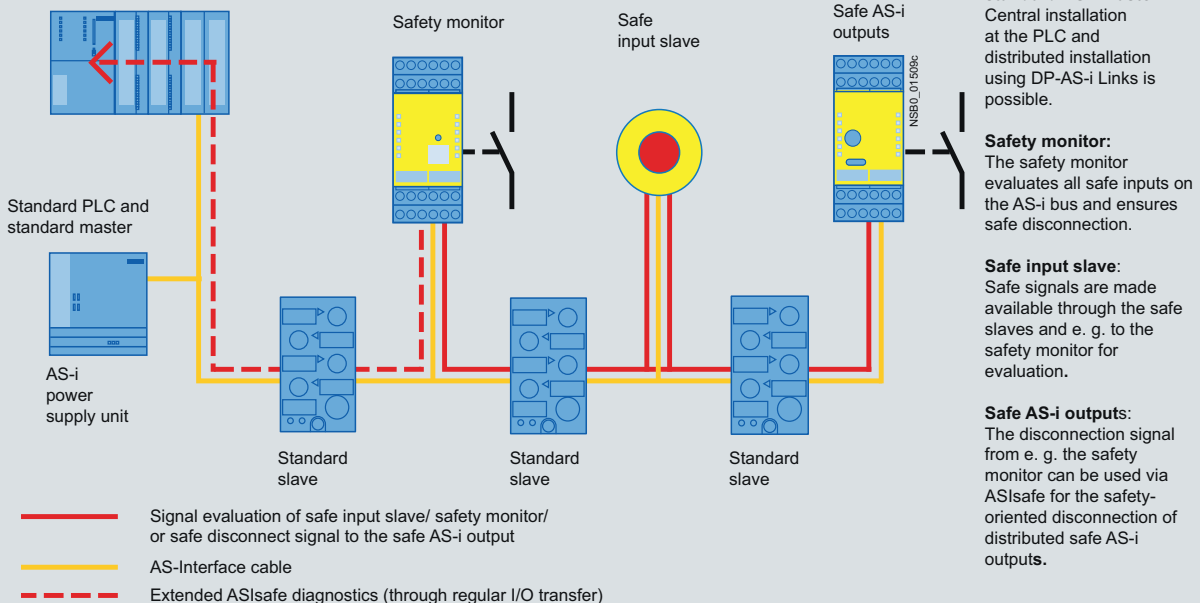

The ASIsafe components and their signal flows

6

Overview (continued)**Function**

Like the standard stations, the safe stations send their information to the master after master calls.

The safety monitor monitors this transmission from the safe stations to the master and switches to the safe state or sends a disconnect signal to one or more distributed safe AS-i outputs which switch in turn to the safe state.

The safety monitor provides OR logic, AND logic, timer functions, buffer storage, etc.

Software

With the ASIMON configuration software you can configure safety-oriented applications and transfer them into the monitor. The configuration comprises the input signals of the safe stations and the internal functions of the safety monitor.

The software also enables online diagnostics.

Integration

The existing infrastructure such as the master and the power supply unit can be used as before for integrating the safety systems in AS-Interface. For the safety systems the safety monitor is integrated as monitoring element and the safe stations as interface between the safe sensors and the system. The safe sensors can be used as before.

A detailed diagnosis of all parameterized modules of the safety monitor can be obtained using the PLC. The STEP 7 function blocks for the S7-200 and S7-300/400 are available on the internet at

<http://support.automation.siemens.com/WW/view/en/25239870/130000>

In addition an AS-i address should be set for the safety monitor via the configuration software. Evaluation is performed by means of function blocks in the PLC. With the aid of prefabricated WinCC flexible function units this evaluation can be visualized across the system on the existing SIMATIC HMI devices.

The screenshot shows a diagnostics interface titled "Permanent Fenster (Header)". At the top, there is a dropdown menu for "Anwahl ASI Monitor" set to "Monitor 2". Below this, the "Master Status" section displays: "Monitor: Schutzbetrieb, alles ok", "LED Kreis 1: grün, eingeschaltet", and "LED Kreis 2: grün, eingeschaltet".

Two "Device Status" grids are shown, one for "Kreis 1" and one for "Kreis 2". Each grid contains a 4x4 matrix of status indicators for addresses 32-41. The indicators are color-coded: green for "eingeschaltet", red for "ausgeschaltet", yellow for "bereit, warte auf Quitzbierung", and grey for "keine Kommunikation".

Below the grids, a legend explains the status indicators:

- Green: eingeschaltet
- Red: eingeschaltet, Abschalttimer läuft
- Yellow: bereit, warte auf Quitzbierung
- Grey: Test (aus->ein) erforderlich
- Red: ausgeschaltet
- Red: Fehler
- Grey: keine Kommunikation
- Blue: Konfigurationsbetrieb
- Grey: unbekannt / nicht benutzt

At the bottom, there are buttons for "AS-I Diagnose" and "Hauptmenü".

Diagnostics interface for ASIsafe components via S7-200 or S7-300

Benefits

- No failsafe PLC or special master is required for the ASIsafe Solution local (safety monitor)
- Alternatively integration in SIMATIC / SINUMERIK safety architectures with the aid of DP/AS-i F-Link (ASIsafe Solution PROFIsafe)
- Simple system structure thanks to standardized AS-Interface technique
- Safety-related and standard data on the same bus
- Existing systems can be expanded quickly and easily
- Optimum integration in TIA (Safety Diagnostics) and Safety Integrated
- Safe signals can be combined in groups
- Inclusion of the safety signals in the plant diagnostics, also on existing HMI panels
- Approved to Category 4 according to EN 954-1 or PL e according to EN ISO 13849-1 or SIL 3 according to IEC 61508
- ASIsafe is certified by TÜV (Germany), NRTL (USA) and INRS (France)

Application

Integrated safety technology in the AS-Interface system is used wherever EMERGENCY-STOP pushbuttons, protective door interlocks, stop Category 0 and 1, two-hand operator controls and light arrays now installed.

More information

More information and circuit examples for safety systems with AS-Interface Safety Monitor and DP/AS-i F-Link can be found on the Internet at

<http://support.automation.siemens.com/WW/view/en/24509484>

AS-Interface

ASIsafe

AS-Interface safety monitors

Overview



Safety monitor with screw terminals (removable terminals)

The safety monitor is the centerpiece of ASIsafe Solution local. It enables safety-orientated responding to signals from the ASIsafe (input) slaves on the same AS-i network and has 1-2 enabling circuits. A safe application is configured using a PC. Various application-specific operating modes can be selected for this. They include, for example, an EMERGENCY-STOP function, door tumbler and selection of stop Category 0 or Category 1.

To be able to make full use of the AS-Interface diagnostics options, the monitor can also be operated with an AS interface address if required. With the aid of the diagnostics module for STEP 7, which is included on the ASIsafe CD, the full diagnostics spectrum can be processed further in the higher-level PLC.

The AS-Interface safety monitor is currently offered in the latest Version 3 (Firmware V3.x) and is available in three expansion levels.

Both basic/expanded expansion levels are available with one or two-channeled configured enabling circuits.

The expanded safety monitor is also available as a version with integrated safe slave which can be used for the control of a safe AS-i output or for safe coupling of a switch signal on another safety monitor or F-Link.

The safety monitor is used in an AS-Interface bus system to monitor protective devices, e. g. protective doors, EMERGENCY-STOP switches, etc.

The safety monitor can be used up to Category 4 according to EN 954-1, to PL e according to EN ISO 13849-1 and to SIL 3 according to IEC 62061/IEC 61508.

Note:

Depending on the choice of safety components used, the complete safety system may also be classified in a lower safety category.

The safety monitor is mounted on the standard mounting rail. Disassembly from the standard mounting rail is quick and easy and requires no tools. With an additional accessory (push-in lugs), the safety monitor can also be screwed on.

Application

The safety monitor acts as a "bus-based safety relay". It provides a user-friendly introduction to safety-orientated communication over fieldbuses thanks to its simple configuration using the graphic PC software ASIMON. The standard infrastructure of the AS-i network (AS-i master under standard PLC, AS-i power supply unit) can still be used without restriction.

The monitor comes in three expansion levels:

- Basic safety monitor with starter set of modules and basic functionality
- Expanded safety monitor with expanded features and functionality
- The expanded safety monitor is also available as a version with integrated safe slave which can be used for the control of a distributed safe AS-i output or for safe coupling of a switch signal on another safety monitor or F-Link.

Basic safety monitor versus expanded safety monitor

	Basic	Expanded
Number of monitoring modules	32	48
Number of OR gates (inputs)	2	6
Number of AND gates (inputs)	--	6
Wildcards for monitoring modules	✓	✓
Deactivating of monitoring modules	✓	✓
Fault release	✓	✓
Diagnostics hold	✓	✓
A/B slaves for acknowledgment	✓	✓
Safe time functions	--	✓
"Button" function	--	✓
Debouncing of contacts	--	✓
Filtering out of brief disconnections	--	✓ (as of Version 3)
Control of safe AS-i output/safe coupling	--	✓ (in version with integrated safe slave)

✓ Available

-- Not available

Number of monitoring modules

The number of devices which the safety monitor can process is increased with the expanded safety monitor from 32 to 48. Applications of greater complexity and size can thus be simulated in the safety monitor.

Logic OR operation

At the logic operation level two elements can be linked by OR operations in the basic version and up to six in the expanded version.

Logic AND operation

In addition to the standard AND operation in the main path of an enabling circuit, an AND operation can also be inserted in an OR operation on the expanded safety monitor. More than two elements can be linked in this AND.

Application (continued)**Features of the basic safety monitor**

- Wildcards and deactivating of monitoring modules
Wildcards are available for the configuration. They are integrated in the configuration and diagnostics and can be easily activated if required. User-friendly configuring is thus possible even when system configurations change.
- Fault release:
If a module detects a fault, the AS-Interface safety monitor goes into fault status. A differentiated fault release (reset) is now possible for this scenario. The fault release can be activated by an AS-Interface standard slave, e. g. a pushbutton, and is effective only on module level. The great advantage of this is that the entire safety monitor is no longer reset but only the module which is locked in the fault.
- Diagnostics hold:
Disconnections can be "frozen" until an acknowledgment comes through a standard slave. This function provides valuable help in the event of short-time causes of disconnection.
- Also from Version 3 upwards:
The standard output data bits of safe input slaves can be processed for acknowledgment, fault release and other non-safety-oriented signals.

Additional features of the expanded safety monitor

The following additional features are provided by only the expanded safety monitor:

- Safe time functions:
Timers with the following functions are available:
 - ON-delay
 - OFF-delay and
 - Pulse
- "Button" function:
Additional acknowledgment option for restarting the system using an additional button. The button function can be assigned to any input or output signal of a standard slave through configuration in the ASIMON software.
- Debouncing of contacts:
For debouncing the contacts it is possible to set a bounce time after which a system restart takes place.
- Also from Version 3 upwards:
Filtering out of brief single-channel interruptions in the sensor circuit. A tolerance time can be set during which the brief opening of a safety-oriented input contact is ignored in order to increase plant availability.

Additional features of the expanded safety monitor with integrated safe slave

This new safety monitor type offers the additional features of the expanded safety monitor plus the following features:

- Filtering out of brief single-channel interruptions in the sensor circuit.
- Actuating a safe distributed actuator (safe output module of e.g. safe valves or motor starters) in parallel to the 2nd enabling circuit.
- Alternatively: Use as a "safe coupler" between two ASIsafe networks. A safe input signal on network 1 can thus act on an enabling circuit of network 2. A detour via a hard-wired safe input module on network 2 is not required in this case.

Configuration software ASIMON V3: New features

- Multi-window system
- Creation of the safety logic in graphic function diagram form, with changeover to former tree presentation possible
- No "preprocessing" of the safety logic
- Management of user-specific modules
- Downward compatibility:
 - Existing ASIMON V2 projects can be loaded
 - Can also be used on all former versions of the safety monitor – with the corresponding scope of functions
- Graphic printout of the safety logic
- Easier system start-up:
 - Teaching the code sequences of safe AS-i Slaves step-by-step
 - Manual input of code sequences also possible in addition
 - Selectable number of simulated slaves
- Simpler diagnostics using AS-Interface through assignment of a diagnostics index to the software function block
- Signaling the switching state of the signaling and relay outputs to higher-level PLCs using a simulated AS-Interface slave
- New functions for filtering out brief interruptions and for controlling a safe AS-i output or for safe coupling of two AS-i networks

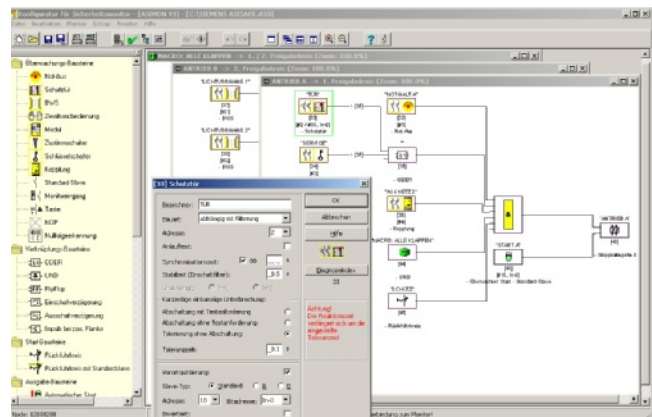



Interface of the configuration software ASIMON V3

AS-Interface

ASIsafe

AS-Interface safety monitors

Selection and ordering data

Version	Order No.	
 <p>3RK1 105-1BE04-0CA0</p>	Basic safety monitors Version 3 With screw terminals, removable terminals, width 45 mm <ul style="list-style-type: none"> • One enabling circuit (monitor type 1) • Two enabling circuits (monitor type 2) 	Screw terminals  3RK1 105-1AE04-0CA0 3RK1 105-1BE04-0CA0
	Expanded safety monitors Version 3 With screw terminals, removable terminals, width 45 mm <ul style="list-style-type: none"> • One enabling circuit (monitor type 3) • Two enabling circuits (monitor type 4) 	3RK1 105-1AE04-2CA0 3RK1 105-1BE04-2CA0
	Expanded safety monitor with integrated safe slave Version 3 With screw terminals, removable terminals, width 45 mm <ul style="list-style-type: none"> • Two enabling circuits including control of a safe AS-i output/ safe coupling (monitor type 6) 	3RK1 105-1BE04-4CA0
	Basic safety monitors Version 3 With spring-type terminals, removable terminals, width 45 mm <ul style="list-style-type: none"> • One enabling circuit (monitor type 1) • Two enabling circuits (monitor type 2) 	Spring-type terminals  3RK1 105-1AG04-0CA0 3RK1 105-1BG04-0CA0
	Expanded safety monitors Version 3 With spring-type terminals, removable terminals, width 45 mm <ul style="list-style-type: none"> • One enabling circuit (monitor type 3) • Two enabling circuits (monitor type 4) 	3RK1 105-1AG04-2CA0 3RK1 105-1BG04-2CA0
	Expanded safety monitor with integrated safe slave Version 3 With spring-type terminals, removable terminals, width 45 mm <ul style="list-style-type: none"> • Two enabling circuits including control of a safe AS-i output/ safe coupling (monitor type 6) 	3RK1 105-1BG04-4CA0

Accessories

 <p>3RK1 901-5AA00</p>	ASIsafe CD Included in the scope of supply: <ul style="list-style-type: none"> • ASIMON V3 configuration software on CD ROM, for PC with the 32-bit operating systems Windows XP, Windows Vista Business / Ultimate, Windows 7 	3RK1 802-2FB06-0GA1
	Cable sets Included in the scope of supply: <ul style="list-style-type: none"> • PC configuration cable for communication between PC (serial interface) and safety monitor, length approx. 1.50 m • Transfer cable between two safety monitors, length approx. 0.25 m 	3RK1 901-5AA00
	USB/serial adapters To connect a serial PC cable (for connection to serial PC interface/ RS 232) to the USB port of a PC, recommended for use in conjunction with AS-i safety monitor	3UF7 946-0AA00-0
	Sealable covers For securing against unauthorized configuration of the safety monitor	3RP1 902
	Push-in lugs For screw fixing	3RP1 903

Overview

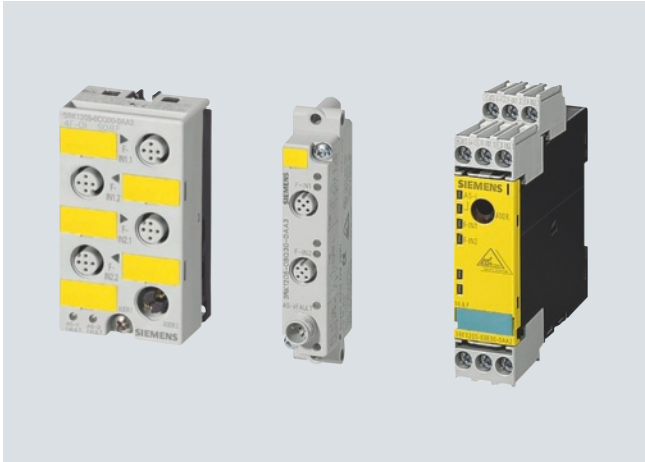

AS-Interface safety modules: K45F (left), K20F (center) and S22.5F (right)



S45F SlimLine module, safe AS-i output

Safety modules for AS-Interface (ASIsafe modules) are available for field use in degree of protection IP67 (K20F and K45F compact modules) and for the control cabinet (S22.5F SlimLine modules) in degree of protection IP20.

A very compact module with an optimum price /performance ratio is thus available for very application.

All modules for the connection of (mechanical) switches and safety sensors with contacts feature crossover monitoring of the connected sensor lead. On versions for the connection of solid-state switches and safety sensors (e. g. light arrays) the crossover monitoring must be performed by the sensor.

Following modules are available for selection:

K20F compact safety modules for operation in the field

Being only 20 mm wide, the K20F module is particularly well suited for applications where modules need to be arranged in an extremely confined space. The K20F modules are connected to the AS-Interface with a round cable with M12 cable box instead of with the AS-Interface flat cable. This enables extremely compact installation. The flexibility of the round cable means that it can also be used on moving machine parts without any problems. The K20 modules are also ideal for such applications as their non-encapsulated design makes them particularly light in weight.

K45F compact safety modules for operation in the field

The platform of the K45F modules covers the following variations:

- Connection of ("mechanical") switches/safety sensors with contacts:
 - K45F 2F-DI: Two safety-oriented inputs in operation up to Category 2 according to EN ISO 13849-1. If Category 4 is required, a two-channel input is available on the module.
 - K45F 2F-DI/2DO: There are also two standard outputs in addition to the safe inputs. Supplied from the yellow AS-i cable
 - K45F 2F-DI/2DO U_{aux} : same as K45F 2F-DI/2DO, but supplied from the black 24 V DC cable
 - K45F 4F-DI: four safety-oriented inputs in operation up to Category 2, two for Category 4. Extremely compact double slave (uses two full AS-i addresses).
- Connection of solid-state switches/safety sensors (non-contact protective devices, BWS):
 - K45F LS (light sensor): Safe input module for the connection of electronic safety sensors with testing semiconductor outputs (OSSD)
 In particular non-contact protective devices (BWS) such as active, optoelectronic light arrays and light curtains for Type 2 and Type 4 according to IEC/EN 61496 Transmitters as well as receivers are supplied with power from the yellow AS-i cable. Matching sensor cables and optionally a separate transmitter supply module are available as accessories.

S22.5F SlimLine safety modules for operation in control cabinets and local control cabinets

The S22.5F SlimLine safety module has two safety inputs. The safe connection of signals to ASIsafe networks in the control cabinet is also possible therefore.

For operation up to Category 2, both inputs can be assigned separately; if Category 4 is required, a two-channel input is available on the module.

In addition there are two S22.5F module versions which have two standard outputs in addition to the two safety inputs; power is supplied either from only the yellow AS-Interface cable or as auxiliary voltage from the black 24 V DC cable.

S45F SlimLine safety modules with safe outputs for the safe distributed disconnection of actuators

With the safe SlimLine-Module S45F, the shutdown signal, for example from the safety monitor, can be used through the ASIsafe for distributed safety-oriented deactivation.

To this end, the module has a dual-channel relay output with which an enabling circuit up to safety category 4 and Performance Level e according to EN ISO 13849-1 and SIL 3 according to EN 62061 / IEC 61508 can be deactivated safely. The response time for the entire system (safety monitor, S45F module, etc.) from the moment of the disconnect request to the actual disconnection is max. 70 ms.

As an additional possibility the module offers normal switching of the output using an AS-i standard output bit.









The module has 3 digital inputs and 2 digital outputs for the additional connection of sensors and actuators. These can be used, inter alia, for the necessary monitoring of the downstream contactors of the feedback circuit.

AS-Interface

ASIsafe

AS-Interface safety modules





Selection and ordering data

Version			Order No.	
	K20F compact safety modules			
	I/O type	U_{aux} 24 V		
	2 F-DI	--	3RK1 205-0BQ30-0AA3	
	K45F compact safety modules Modules supplied without mounting plate			
	I/O type	U_{aux} 24 V		
	2 F-DI	--	3RK1 205-0BQ00-0AA3	
	4 F-DI	--	3RK1 205-0CQ00-0AA3	
	2 F-DI/2 DO	--	3RK1 405-0BQ20-0AA3	
	2 F-DI/2 DO	✓	3RK1 405-1BQ20-0AA3	
	2 F-DI LS type 2 ¹⁾	--	3RK1 205-0BQ21-0AA3	
2 F-DI LS type 4 ²⁾	--	3RK1 205-0BQ24-0AA3		
	S22.5F SlimLine safety modules			
	Connection	I/O type	U_{aux} 24 V	
	Screw		2 F-DI	--
			2 F-DI/2 DO	--
			2 F-DI/2 DO	✓
	Spring		2 F-DI	--
2 F-DI/2 DO			--	
2 F-DI/2 DO			✓	
	S45F SlimLine safety modules			
	Connection	I/O type	U_{aux} 24 V	
	Screw		1F-RO/3DI/2DO	✓
			1F-RO/3DI/2DO	✓
	Spring		1F-RO/3DI/2DO	✓

¹⁾ Connection of Siemens light curtain FS 400 3RG7843 (type 2) through socket 1/3

²⁾ Connection of Siemens light curtain FS 400 3RG7846 (type 4) through socket 1/3, other makes through socket 2/3

Accessories

	Version	Order No.
 3RK1 901-2EA00	K45 mounting plates For mounting K45F <ul style="list-style-type: none"> • For wall mounting • For standard rail mounting 	3RK1 901-2EA00 3RK1 901-2DA00
	24 V supply modules for K45F LS (light sensor) <ul style="list-style-type: none"> • optional, for transmitter power supply for large protective field widths • Modules supplied without mounting plate 	3RK1 901-1NP00
 3RK1 901-1AA00	Input bridges for K45F <ul style="list-style-type: none"> • Black version • Red version 	3RK1 901-1AA00 3RK1 901-1AA01
 3RK1 901-1KA00	AS-Interface sealing caps M12 For free M12 sockets	3RK1 901-1KA00
 3RK1 901-1KA01	AS-Interface sealing caps M12, tamper-proof For free M12 sockets	3RK1 901-1KA01

AS-Interface

ASIsafe

3SF1 position switches

Overview

The 3SF1 position switches with safety-oriented communication can be directly connected using the AS-Interface bus system. The safety functions no longer have to be conventionally wired up.

With the 3SF1 position switches the ASIsafe electronics are integrated in the switch enclosure.



Examples of selection options in the modular system

Modular system

The 3SF1 1.4 and 3SF1 2.4 position switches are built as a modular system, which consists of the basic switch in different versions and a drive, which must be ordered separately. Thanks to the modular design of the switch the end user can select the right solution for his application from numerous versions and install it himself in a very short time.

Design

The 3SF1 switches are available in four different enclosure sizes:

- Plastic and metal enclosures according to EN 50047, 31 mm wide, with M12 plug
- Metal enclosures according to EN 50041, 40 mm wide, with M12 plug
- Plastic enclosures, 50 mm wide, with M12 plug and M12 socket
- Metal enclosures, 56 mm wide, with M12 plug and M12 socket

Display

The switches have a status display with three LEDs:

- LED 1 (yellow): F-IN1
- LED 2 (yellow): F-IN2
- LED 3 (green/red): AS-i/FAULT

Connection

Connection to the AS-Interface is connected to the yellow AS-Interface bus cable by means of a 4-pole M12 plug (plastic version).

The wide enclosures (50 or 56 mm) also have an M12 socket for connecting a second position switch. Category 4 according to EN 954-1 is thus achieved.

Benefits

The new generation of 3SF1 position switches offers:

- ASIsafe Electronics integrated in the enclosure, with low power consumption < 60 mA
- An extensive range of actuators
- Status display with three LEDs

Operating conditions

With the standard position switches, mechanical positions of moved machine parts are converted into electrical signals. Through their modular and uniform design and large number of versions, the devices can meet practically all requirements in industry.

Devices are available with enclosure versions to suit the particular ambient conditions. Different control tasks can be performed with the best contact blocks suited for the particular purpose. And many different actuator versions are available to match the mechanical configuration of the moved machined parts. Dimensions, fixing points and characteristics are largely in accordance with the EN 50041 or EN 50047 standards.

The devices are suitable for use in any climate.

Standards

The switches comply with the standards IEC 60947-1 (Low-Voltage Switchgear and Controlgear, General) and IEC 60947-5-1 (Electromechanical Control Circuit Devices).

The mechanical design of the switch corresponds to the requirements of the failsafe principle according to EN 1088.

Approvals

AS-Interface according to EN 50295 and IEC 62026-2.

With a 3SF1 position switch it is possible to achieve category 2 according to ISO 13849-1 (EN 954-1) or SIL 1 according to IEC 61508.

Categories 3 or 4 according to ISO 13849-1 (EN 954-1) or SIL 2 or 3 according to IEC 61508 can be achieved by using a second 3SE5 position switch.

The 3SF1 position switches are approved according to UL 508, UL 50 and UL 746-C.

Selection and ordering data

Modular system

For the ASIsafe version of the position switch, the basic switch and actuator must be ordered separately.

1 or 2 contacts · 3 LEDs · Degree of protection IP65 (31 mm) or IP66/IP67 (50 mm) · M12 plug

Version	Contacts	LEDs	Order No.	
<i>Basic switches (with rounded plunger¹⁾) · Enclosure width 31 mm according to EN 50047</i>				
 <p>ASIsafe basic switch</p>	With teflon plunger, with M12 plug, 4-pole; channel 1 on NC contact, channel 2 on NC contact			
	• Slow-action contacts	2 NC	24 V DC	⊕ 3SF1 234-1KC05-1BA1
	• Snap-action contacts	2 NC	24 V DC	⊕ 3SF1 234-1LC05-1BA1

Basic switches (with rounded plunger¹⁾) · Enclosure width 50 mm

 <p>ASIsafe basic switch</p>	With teflon plunger, with M12 plug, 4-pole, channel 1 on NC contact, channel 2 on M12 socket, right			
	• Slow-action contacts	1 NC	24 V DC	⊕ 3SF1 244-1KC05-1BA2
	• Snap-action contacts	1 NC	24 V DC	⊕ 3SF1 244-1LC05-1BA2

⊕ Positive opening according to IEC 60947-5-1, Appendix K, or positive drive for use in safety circuits.





¹⁾ For enclosures with widths of 31mm and 50mm, the basic switch is a complete unit with rounded plungers.

AS-Interface

ASIsafe

3SF1 position switches Plastic enclosures

Selection and ordering data (continued)

	Version	Diameter mm	Order No.
<i>Operating mechanisms</i>			
 Roller plungers	Roller plunger, type C according to EN 50047		
	<ul style="list-style-type: none"> • Plastic rollers • High-grade steel rollers 	10 10	<ul style="list-style-type: none"> ➔ 3SE5 000-0AD03 ➔ 3SE5 000-0AD04
 With central fixing	Roller plungers with central fixing		
	<ul style="list-style-type: none"> • Plastic rollers • High-grade steel rollers 	10 10	<ul style="list-style-type: none"> ➔ 3SE5 000-0AD10 ➔ 3SE5 000-0AD11
 Roller levers	Roller lever, type E according to EN 50047		
	<ul style="list-style-type: none"> • Metal lever, plastic roller • Metal lever, high-grade steel roller • High-grade steel lever, plastic roller • High-grade steel lever, high-grade steel roller 	13 13 13 13	<ul style="list-style-type: none"> ➔ 3SE5 000-0AE10 ➔ 3SE5 000-0AE11 ➔ 3SE5 000-0AE12 ➔ 3SE5 000-0AE13
	Angular roller levers		
	<ul style="list-style-type: none"> • Metal lever, plastic roller • Metal lever, high-grade steel roller • High-grade steel lever, plastic roller • High-grade steel lever, high-grade steel roller 	13 13 13 13	<ul style="list-style-type: none"> ➔ 3SE5 000-0AF10 ➔ 3SE5 000-0AF11 ➔ 3SE5 000-0AF12 ➔ 3SE5 000-0AF13
 Twist actuator	Twist actuator, plastic (without lever) switching right or left, adjustable		➔ 3SE5 000-0AK00
	Levers for twist actuators		
	Twist lever, type A acc. to EN 50047		
	<ul style="list-style-type: none"> • Metal lever, plastic roller • Metal lever, high-grade steel roller • Metal lever, roller with ball bearing • Metal lever, plastic roller • High-grade steel lever, plastic roller • High-grade steel lever, high-grade steel roller 	19 19 19 30 19 19	<ul style="list-style-type: none"> ➔ 3SE5 000-0AA21 ➔ 3SE5 000-0AA22 ➔ 3SE5 000-0AA23 ➔ 3SE5 000-0AA25 ➔ 3SE5 000-0AA31 ➔ 3SE5 000-0AA32
	Twist lever, length 30 mm, straight¹⁾		
	<ul style="list-style-type: none"> • Metal lever, plastic roller • Metal lever, plastic roller 	19 30	<ul style="list-style-type: none"> ➔ 3SE5 000-0AA24 ➔ 3SE5 000-0AA26
	Twist lever, adjustable length, with grid hole		
<ul style="list-style-type: none"> • Metal lever, plastic roller • Metal lever, high-grade steel roller • Metal lever, plastic roller • Metal lever, rubber roller • High-grade steel lever, plastic roller • High-grade steel lever, high-grade steel roller 	19 19 50 50 19 19	<ul style="list-style-type: none"> ➔ 3SE5 000-0AA60 ➔ 3SE5 000-0AA61 ➔ 3SE5 000-0AA67 ➔ 3SE5 000-0AA68 ➔ 3SE5 000-0AA62 ➔ 3SE5 000-0AA63 	
 Twist lever, adjustable length			

➔ Positive drive, for use in safety circuits.

¹⁾ Can be clinch mounted (turned through 180°, rear of lever).

Selection and ordering data**Modular system**

For the ASIsafe version of the position switch, the basic switch and actuator must be ordered separately.

2 contacts · 3 LEDs · Degree of protection IP66/IP67 · M12 plug

Version	Contacts	LEDs	Order No.
<i>Basic switches (with rounded plunger¹⁾ · Enclosure width 31 mm according to EN 50047</i>			
 <p>With teflon plunger, with M12 plug, 4-pole; channel 1 on NC contact, channel 2 on NC contact</p> <ul style="list-style-type: none"> • Slow-action contacts • Snap-action contacts 	2 NC	24 V DC	➔ 3SF1 214-1KC05-1BA1
	2 NC	24 V DC	➔ 3SF1 214-1LC05-1BA1

ASIsafe basic switch

➔ Positive opening according to IEC 60947-5-1, Appendix K, or positive drive for use in safety circuits.









¹⁾ For enclosures with widths of 31mm, the basic switch is a complete unit with rounded plungers.

AS-Interface

ASIsafe

3SF1 position switches Metal enclosures

Selection and ordering data (continued)

	Version	Diameter mm	Order No.
<i>Operating mechanisms</i>			
 Plain plungers	Plain plungers • High-grade steel plungers	10	⊕ 3SE5 000-0AB01
 Roller plungers	Roller plunger, type C according to EN 50047 • Plastic rollers	10	⊕ 3SE5 000-0AD03
	• High-grade steel rollers	10	⊕ 3SE5 000-0AD04
 With central fixing	Roller plungers with central fixing • Plastic rollers	10	⊕ 3SE5 000-0AD10
	• High-grade steel rollers	10	⊕ 3SE5 000-0AD11
 Roller levers	Roller lever, type E according to EN 50047 • Metal lever, plastic roller	13	⊕ 3SE5 000-0AE10
	• Metal lever, high-grade steel roller	13	⊕ 3SE5 000-0AE11
	• High-grade steel lever, plastic roller	13	⊕ 3SE5 000-0AE12
	• High-grade steel lever, high-grade steel roller	13	⊕ 3SE5 000-0AE13
 Angular roller levers	Angular roller levers • Metal lever, plastic roller	13	⊕ 3SE5 000-0AF10
	• Metal lever, high-grade steel roller	13	⊕ 3SE5 000-0AF11
	• High-grade steel lever, plastic roller	13	⊕ 3SE5 000-0AF12
	• High-grade steel lever, high-grade steel roller	13	⊕ 3SE5 000-0AF13
<i>Twist actuators with lever</i>			
 Twist actuator	Twist actuator, plastic (without lever) switching right or left, adjustable		⊕ 3SE5 000-0AK00
 Twist levers	Levers for twist actuators Twist lever, type A acc. to EN 50047 • Metal lever, plastic roller	19	⊕ 3SE5 000-0AA21
	• Metal lever, high-grade steel roller	19	⊕ 3SE5 000-0AA22
	• Metal lever, roller with ball bearing	19	⊕ 3SE5 000-0AA23
	• Metal lever, plastic roller	30	⊕ 3SE5 000-0AA25
	• High-grade steel lever, plastic roller	19	⊕ 3SE5 000-0AA31
	• High-grade steel lever, high-grade steel roller	19	⊕ 3SE5 000-0AA32
	Twist lever, length 30 mm, straight ¹⁾ • Metal lever, plastic roller	19	⊕ 3SE5 000-0AA24
• Metal lever, plastic roller	30	⊕ 3SE5 000-0AA26	
 Twist lever, adjustable length	Twist lever, adjustable length, with grid hole • Metal lever, plastic roller	19	⊕ 3SE5 000-0AA60
	• Metal lever, high-grade steel roller	19	⊕ 3SE5 000-0AA61
	• Metal lever, plastic roller	50	⊕ 3SE5 000-0AA67
	• Metal lever, rubber roller	50	⊕ 3SE5 000-0AA68
	• High-grade steel lever, plastic roller	19	⊕ 3SE5 000-0AA62
	• High-grade steel lever, high-grade steel roller	19	⊕ 3SE5 000-0AA63

⊕ Positive drive, for use in safety circuits.

¹⁾ Can be clinch mounted (turned through 180°, rear of lever).

Selection and ordering data (continued)**Modular system**

For the ASIsafe version of the position switch, the basic switch and actuator must be ordered separately.

1 or 2 contacts · 3 LEDs · Degree of protection IP66/IP67 · M12 plug





	Version	Contacts	LEDs	Order No.
Basic switches · Enclosure width 40 mm acc. to EN 50041				
	With M12 plug, 4-pole, channel 1 on NC contact, channel 2 on NC contact			
	<ul style="list-style-type: none"> • Slow-action contacts • Snap-action contacts 	2 NC 2 NC	24 V DC 24 V DC	⊕ ⊕
				3SF1 114-1KA00-1BA1 3SF1 114-1LA00-1BA1

ASIsafe basic switch

Basic switches · Enclosure width 56 mm				
	With M12 plug, 4-pole, channel 1 on NC contact, channel 2 on M12 socket, right			
	<ul style="list-style-type: none"> • Slow-action contacts • Snap-action contacts 	1 NC 1 NC	24 V DC 24 V DC	⊕ ⊕
				3SF1 124-1KA00-1BA2 3SF1 124-1LA00-1BA2

ASIsafe basic switch

⊕ Positive opening according to IEC 60947-5-1, Appendix K, or positive drive for use in safety circuits.

	Version	Diameter mm	Order No.
Operating mechanisms			
	Plain plungers		
	High-grade steel plungers		⊕ 3SE5 000-0AB01
	Rounded plungers, type B, acc. to EN 50041		
	High-grade steel plungers		⊕ 3SE5 000-0AC02
	Roller plungers, type C acc. to EN 50041		
	High-grade steel rollers	13	⊕ 3SE5 000-0AD02
	Roller levers		
	• Metal lever, plastic roller	22	⊕ 3SE5 000-0AE01
	• Metal lever, high-grade steel roller	22	⊕ 3SE5 000-0AE02
	• High-grade steel lever, plastic roller	22	⊕ 3SE5 000-0AE03
	Angular roller levers		
	• Metal lever, plastic roller	22	⊕ 3SE5 000-0AF01
	• Metal lever, high-grade steel roller	22	⊕ 3SE5 000-0AF02
	• High-grade steel lever, plastic roller	22	⊕ 3SE5 000-0AF03
	• High-grade steel lever, high-grade steel roller	22	⊕ 3SE5 000-0AF04





⊕ Positive drive, for use in safety circuits.

AS-Interface

ASIsafe

3SF1 position switches Metal enclosures

Selection and ordering data (continued)

Version	Diameter mm	Order No.	
<i>Twist actuators with lever</i>			
 Twist actuator	Twist actuator , metal (without lever)		
	<ul style="list-style-type: none"> • Switching right or left, adjustable • For fork levers, latching 	<ul style="list-style-type: none"> ➔ 3SE5 000-0AH00 ➔ 3SE5 000-0AT10 	
Levers for twist actuators			
 Twist levers	Twist levers 27 mm, type A, according to EN 50041		
	• Metal lever, plastic roller	19	➔ 3SE5 000-0AA01
	• Metal lever, high-grade steel roller	19	➔ 3SE5 000-0AA02
	• Metal lever, roller with ball bearing	19	➔ 3SE5 000-0AA03
	• Metal lever, 2 plastic rollers	19	➔ 3SE5 000-0AA04
	• Metal lever, plastic roller	30	➔ 3SE5 000-0AA05
	• Metal lever, plastic roller	50	➔ 3SE5 000-0AA07
	• Metal levers, rubber roller	50	➔ 3SE5 000-0AA08
	• High-grade steel lever, plastic roller	19	➔ 3SE5 000-0AA11
	• High-grade steel lever, high-grade steel roller	19	➔ 3SE5 000-0AA12
Twist lever, length 35 mm, cranked			
• Metal lever, plastic roller	19	➔ 3SE5 000-0AA15	
Twist lever, length 30 mm, straight ¹⁾			
• Metal lever, plastic roller	19	➔ 3SE5 000-0AA24	
• Metal lever, plastic roller	30	➔ 3SE5 000-0AA26	
Twist lever, adjustable length, with grid hole			
 Twist lever, adjustable length	• Metal lever, plastic roller	19	➔ 3SE5 000-0AA60
	• Metal lever, high-grade steel roller	19	➔ 3SE5 000-0AA61
	• Metal lever, plastic roller	50	➔ 3SE5 000-0AA67
	• Metal lever, rubber roller	50	➔ 3SE5 000-0AA68
	• High-grade steel lever, plastic roller	19	➔ 3SE5 000-0AA62
• High-grade steel lever, high-grade steel roller	19	➔ 3SE5 000-0AA63	
Fork lever (for switches with snap-action contacts only)			
 Fork lever	• 2 metal levers, 2 plastic rollers	19	➔ 3SE5 000-0AT01
	• 2 metal levers, 2 high-grade steel rollers	19	➔ 3SE5 000-0AT02
	• 2 high-grade steel levers, 2 plastic rollers	19	➔ 3SE5 000-0AT03
	• 2 high-grade steel levers, 2 high-grade steel rollers	19	➔ 3SE5 000-0AT04

➔ Positive drive, for use in safety circuits.

¹⁾ Can be clinch mounted (turned through 180°, rear of lever).

Overview

The 3SF1 position switches with safety-oriented communication can be directly connected using the AS-Interface bus system. The safety functions no longer have to be conventionally wired up.

With the 3SF1 position switches the ASIsafe electronics are integrated in the switch enclosure.



3SF1 position switches with separate actuator and with integrated ASIsafe electronics

3SF1 position switches with separate actuator have the same enclosures as the standard switches.

Operation

The actuator head is included in the scope of supply. For actuation from four directions it can be adjusted through $4 \times 90^\circ$. The switches can also be approached from above.

The actuators are not included in the scope of supply of the position switch and must be ordered separately from a choice of six versions to suit the application.

The actuator is encoded. Simple overruling by hand or auxiliary devices is impossible.

A high-grade steel blocking insert for attaching up to eight padlocks is available for even more safety.

A rubber cap to protect the metal enclosure from contamination is available for operation in dusty environments.

Display

The switches have a status display with three LEDs:

- LED 1 (yellow): F-IN1
- LED 2 (yellow): F-IN2
- LED 3 (green/red): AS-i/FAULT

Connection

Connection to the AS-Interface is by means of a 4-pole M12 plug (plastic version) connected to the yellow AS-Interface bus cable.

The wide enclosures (50 or 56 mm) also have an M12 socket for connecting a second position switch. Category 4 according to EN 954-1 is thus achieved.

Benefits

The new generation of 3SF1 position switches with separate actuator offers:

- ASIsafe Electronics integrated in the enclosure, with low power consumption $< 60 \text{ mA}$
- An extensive range of actuators
- Status display with three LEDs

Operating conditions

Position switches with separate actuator are used where the position of doors, covers or protective grills must be monitored for safety reasons.

The position switch can only be operated with the matching coded actuator. Simple overruling by hand or auxiliary devices is impossible.

Devices are available with enclosure versions to suit the particular ambient conditions. Different control tasks can be performed with the best contact blocks suited for the particular purpose. Dimensions, fixing points of the enclosure are in accordance with EN 50041 or EN 50047 standards.

The devices are suitable for use in any climate.

Standards

The switches comply with the standards IEC 60947-1 (Low-Voltage Switchgear and Controlgear, General) and IEC 60947-5-1 (Electromechanical Control Circuit Devices).

The mechanical design of the switch corresponds to the requirements of the failsafe principle according to EN 1088.

Approvals

AS-Interface according to EN 50295 and IEC 62026-2.

Category 3 acc. to ISO 13849-1 (EN 954-1) or SIL 2 acc. to IEC 61508 can be attained using a 3SF1 position switch.

Category 4 according to ISO 13849-1 (EN 954-1) or SIL 3 according to IEC 61508 can be achieved by using a second 3SE5 position switch.

The 3SF1 position switches are approved according to UL 508, UL 50 and UL 746-C.

AS-Interface





ASIsafe

3SF1 position switches with separate actuator Plastic enclosures

Overview

- Contacts: 1 or 2 slow-action contacts
- Status display with 3 LEDs 24 V DC;
1: F-IN1, 2: F-IN2, 3: AS-I/FAULT
- Degree of protection IP65 (31 mm) or IP66/IP67 (50 mm)



Selection and ordering data

	Version ¹⁾	Contacts	Order No.
<i>Enclosure width 31 mm according to EN 50047</i>			
	5 directions of approach M12 plug, 4-pole; channel 1 on NC contact, channel 2 on NC contact Slow-action contacts	2 NC	 3SF1 234-1QV40-1BA1
<i>Enclosure width 50 mm</i>			
	5 directions of approach M12 plug, 4-pole; channel 1 on NC, channel 2 on M12 socket, right Slow-action contacts	1 NC	 3SF1 244-1QV40-1BA2
ASIsafe			
 Positive opening according to IEC 60947-5-1, Appendix K. ¹⁾ Supplied without actuator. Please order separately.			

Overview

- Contacts: 1 or 2 slow-action contacts
- Status display with 3 LEDs 24 V DC;
1: F-IN1, 2: F-IN2, 3: AS-I/FAULT
- Degree of protection IP66/IP67

Selection and ordering data

	Version ¹⁾	Contacts	Order No.
<i>Enclosure width 31 mm according to EN 50047</i>			
	5 directions of approach M12 plug, 4-pole; channel 1 on NC contact, channel 2 on NC contact Slow-action contacts	2 NC	➔ 3SF1 214-1QV40-1BA1
<i>Enclosure width 40 mm according to EN 50041</i>			
	5 directions of approach M12 plug, 4-pole; channel 1 on NC contact, channel 2 on NC contact Slow-action contacts	2 NC	➔ 3SF1 114-1QV10-1BA1
<i>Enclosure width 56 mm</i>			
	5 directions of approach M12 plug, 4-pole; channel 1 on NC, channel 2 on M12 socket, right Slow-action contacts	1 NC	➔ 3SF1 124-1QV10-1BA2

➔ Positive opening according to IEC 60947-5-1, Appendix K.











¹⁾ Supplied without actuator. Please order separately.

AS-Interface

ASIsafe

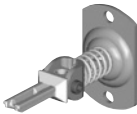
3SF1 position switches with separate actuator Accessories

Selection and ordering data

	Version	Order No.
<i>Actuators</i>		
Standard actuators		
	Standard actuators, length 75.6 mm	↻ 3SE5 000-0AV01
	With vertical fixing, length 53 mm	↻ 3SE5 000-0AV02
	With transverse fixing, length 47 mm	↻ 3SE5 000-0AV03
	With transverse fixing, plastic ¹⁾ Length 47 mm	↻ 3SE5 000-0AV11
Radius actuators		
	Approach from left, length 40 mm	↻ 3SE5 000-0AV04
	Approach from right, length 44.5 mm	↻ 3SE5 000-0AV06
	Universal radius actuator, length 69 mm	↻ 3SE5 000-0AV05
	Universal radius actuators, heavy-duty	
	• Length 67 mm	↻ 3SE5 000-0AV07-1AK2
	• Length 77 mm	↻ 3SE5 000-0AV07
<i>Optional accessories</i>		
	Protective caps made of black rubber for the actuator head, to protect the actuator openings from contamination (only for enclosure width 40 or 56 mm)	SE5 000-0AV08-1AA2
	Blocking inserts , high-grade steel, for actuator head, for up to 8 padlocks	3SE5 000-0AV08-1AA3

↻ Actuator can be used in safety circuits.

¹⁾ Not suitable for safety switches with interlocking.

3SF1 position switches with solenoid interlocking

Overview

The 3SF1 position switches with safety-oriented communication can be directly connected using the AS-Interface bus system. The safety functions no longer have to be conventionally wired up.

With the 3SF1 position switches the ASIsafe electronics are integrated in the switch enclosure.



3SF1 position switch with solenoid interlocking and with integrated ASIsafe electronics

Operation

The actuator head is included in the scope of supply. For actuation from four directions it can be adjusted through $4 \times 90^\circ$. The switches can also be approached from above.

The actuator is not included in the scope of supply for the position switch and must be ordered separately, with a choice of eight variations depending on application.

The actuator is encoded. Simple overruling by hand or auxiliary devices is impossible.

A high-grade steel blocking insert for attaching up to eight padlocks is available for even more safety.

A rubber cap to protect the enclosure from contamination is available for operation in dusty environments.

Solenoid interlocking

There are two versions for locking the actuator:

- Spring-actuated lock (closed-circuit principle) with various release mechanisms
- Magnetic field lock (open-circuit principle)

Display

The switches have a status display with four LEDs:

- LED 1 (green): AS-i
- LED 2 (red): FAULT
- LED 3 (yellow): F-IN1
- LED 4 (yellow): F-IN2

Connection

Connection to the AS-Interface is by means of a 4-pole M12 plug (plastic version) connected to the yellow AS-Interface bus cable (no additional supply of auxiliary power is required thanks to the low current consumption of the solenoid of max. 170 mA).

Benefits

The new generation of 3SF1 3 position switches with solenoid interlocking offers:

- More safety through higher locking forces:
 - 1300 N for the plastic version
 - 2600 N for the metal version
- Various release mechanisms: lock release, escape release and emergency release
- ASIsafe electronics integrated in the enclosure; connected through 4-pole M12 plug
- Current consumption of the solenoid max. 170 mA
- Two contact blocks as standard equipment, hence fewer versions needed
- Same dimensions for all enclosure versions: Plastic, metal
- An extensive range of actuators
- Status display with four LEDs

Operating conditions

The position switches with solenoid interlocking are exceptional safety-related devices which prevent an unforeseen or intentional opening of protective doors, protective grills or other covers as long as a dangerous situation is present (i.e. follow-on motion of the switched off machine).

The safety position switches with solenoid interlocking have the following functions:

- Enabling the machine or process with closed and locked protective device
- Locking the machine or process with opened protective device
- Position monitoring of the protective device and solenoid interlocking

Standards

The switches comply with the standards IEC 60947-1 (Low-Voltage Switchgear and Controlgear, General) and IEC 60947-5-1 (Electromechanical Control Circuit Devices).

The mechanical design of the switch corresponds to the requirements of the failsafe principle according to EN 1088.

Approvals

AS-Interface according to EN 50295 and IEC 62026-2.

The switches are approved for use with locking devices according to EN 1088 and EN 292, Parts 1 and 2.

The 3SF5 3 position switches with interlocking have a VDE test marking.

With a 3SF1 3 position switch it is possible to achieve category 3 according to ISO 13849-1 (EN 954-1) or SIL 2 according to IEC 61508.

Category 4 according to ISO 13849-1 (EN 954-1) or SIL 3 according to IEC 61508 can be achieved by using a second 3SE5 position switch.

The 3SF1 position switches are approved according to UL 508, UL 50 and UL 746-C.

AS-Interface

ASIsafe

3SF1 position switches with solenoid interlocking Plastic enclosures

Overview

5 directions of approach · Degree of protection IP66/IP67

- Slow-action contacts:
 - Version -1BA1: ASIsafe channel 1 on 1 NC contact from the actuator and channel 2 on 1 NC contact from the solenoid
 - Version -1BA3: ASIsafe channel 1 on the first NC contact from the actuator and channel 2 on the second NC contact from the actuator
 - Version -1BA4: ASIsafe channel 1 on 2 NC contacts from the actuator and channel 2 on 1 NC contact from the solenoid. A discrepancy between the two contacts of the actuator will be evaluated already in the switch.
- Solenoid: Rated operational voltage 24 V DC
- Locking force 1,300 N (1,000 N according to GS-ET 19)
- Status display with 4 LEDs 24 V DC;
 - 1: AS-i, 2: FAULT, 3: F-IN1, 4: F-IN2

Safety level

The new 3SF1 324-1S.21-1BA4 safety position switches are also suitable for several interlocks for protective doors – for secure diagnosis and fast ability to reclose the system.

They feature:

- feedback from the solenoid and
- the doors do not need to be opened after the magnet is released.



With AS-i safety monitor or in DP/AS-i F-Link it is possible to achieve SIL 2 according to IEC 61508 or PL d according to ISO 13849-1.

Comparison of versions

Version	Contacts Actuator / magnet	Attainable safety level	Diagnostics Magnet feedback	Reclose condition after the release of the magnet (depends on the type of evaluation)
3SF1 324-1S.21-1BA1	1 NC/1 NC	SIL 1 / PL c	4	Door must <u>not</u> be opened
	1 NC/1 NC	SIL 2 / PL d	4	Door must be opened
3SF1 324-1S.21-1BA3	2 NC	SIL 2 / PL d	--	Door must <u>not</u> be opened
3SF1 324-1S.21-1BA4	2 NC/1 NC	SIL 2 / PL d	4	Door must <u>not</u> be opened

6

Selection and ordering data

	Interlock ¹⁾	Contacts Actuator / magnet	Order No.
1,300 N locking force · Enclosure width 54 mm			
 3SF1 324-1SD21-...	Spring-actuated locks		
	• With auxiliary release	1 NC/1 NC	➔ 3SF1 324-1SD21-1BA1
	• With auxiliary release	2 NC / –	➔ 3SF1 324-1SD21-1BA3
	• With auxiliary release	2 NC/1 NC	➔ 3SF1 324-1SD21-1BA4
	• With auxiliary release with lock	1 NC/1 NC	➔ 3SF1 324-1SE21-1BA1
 3SF1 324-1SF21-...	• With escape release from the front		➔ 3SF1 324-1SF21-1BA1
	• With escape release from the front		➔ 3SF1 324-1SF21-1BA4
	• With escape release from the back and auxiliary release from the front		➔ 3SF1 324-1SG21-1BA1
	• With escape release from the back and auxiliary release from the front		➔ 3SF1 324-1SG21-1BA4
	• With emergency release from the back and auxiliary release from the front	1 NC/1 NC	➔ 3SF1 324-1SJ21-1BA1
 3SF1 324-1SB21-...	Magnetic field lock		
		1 NC/1 NC	➔ 3SF1 324-1SB21-1BA1
		2 NC / –	➔ 3SF1 324-1SB21-1BA3

➔ Positive opening according to IEC 60947-5-1, Appendix K.

¹⁾ Supplied without actuator. Please order separately.

Note:

For actuator and optional accessories, see page 6/24.



Overview**5 directions of approach · Degree of protection IP66/IP67**

- Slow-action contacts:
Version -1BA1: ASIsafe channel 1 on 1 NC contact from the actuator and channel 2 on 1 NC contact from the solenoid
- Solenoid: Rated operational voltage 24 V DC
- Locking force 2600 N (2000 N according to GS-ET 19)
- Status display with 4 LEDs 24 V DC;
1: AS-i, 2: FAULT, 3: F-IN1, 4: F-IN2

Safety level

Version	Contacts Actuator / magnet	Attainable safety level	Diagnostics Magnet feedback	Reclose condition after the release of the magnet (depends on the type of evaluation)
3SF1 324-1S.21-1BA1	1 NC/1 NC	SIL 1 / PL c	4	Door must <u>not</u> be opened
	1 NC/1 NC	SIL 2 / PL d	4	Door must be opened

Selection and ordering data

Interlock ¹⁾	Contacts Actuator / magnet	Order No.
<i>2600 N locking force · Enclosure width 54 mm</i>		
 3SF1 314-1SD21-...	Spring-actuated locks	
	• With auxiliary release	1 NC/1 NC → 3SF1 314-1SD11-1BA1
	• With auxiliary release with lock	1 NC/1 NC → 3SF1 314-1SE11-1BA1
	• With escape release from the front	1 NC/1 NC → 3SF1 314-1SF11-1BA1
	• With escape release from the back and auxiliary release from the front	1 NC/1 NC → 3SF1 314-1SG11-1BA1
 3SF1 314-1SF21-...	• With emergency release from the back and auxiliary release from the front	1 NC/1 NC → 3SF1 314-1SJ11-1BA1
	Magnetic field lock	1 NC/1 NC → 3SF1 314-1SB11-1BA1
 3SF1 314-1BF21-...		

→ Positive opening according to IEC 60947-5-1, Appendix K.

¹⁾ Supplied without actuator. Please order separately.

Note:

For actuator and optional accessories, see page 6/24.

AS-Interface

ASIsafe

3SF1 hinge switches Plastic enclosures

Overview

The 3SF1 hinge switches with safety-oriented communication can be directly connected using the AS-Interface bus system. The safety functions no longer have to be conventionally wired up.

With the 3SF1 position switches the ASIsafe electronics are integrated in the switch enclosure.

The hinge switches are provided for mounting on hinges. There are two actuator versions here:

- Hollow shaft, inner diameter 8 mm, outer 12 mm
- Solid shaft, diameter 10 mm





For the ASIsafe version of the hinge switch, the basic switch and twist actuator must be ordered separately. The basic switches correspond to the position switches of the standard version (only use versions with snap-action contacts).

The standards and approvals correspond to position switches 3SF1 (see page 6/14).

Selection and ordering data

Modular system

1 or 2 contacts · 3 LEDs · Degree of protection IP65 (31 mm) or IP66/IP67 (50 mm) · M12 plug

	Version	Contacts	LEDs	Order No.
<i>Basic switches - Enclosure width 31 mm acc. to EN 50047</i>				
	With teflon plunger, with M12 plug. 4-pole; channel 1 on NC contact, channel 2 on NC contact Snap-action contacts	2 NC	24 V DC →	3SF1 234-1LC05-1BA1
ASIsafe basic switch				
<i>Basic switches - Enclosure width 50 mm</i>				
	With teflon plunger, with M12 plug. 4-pole; channel 1 on NC contact, channel 2 on M12 socket, right Snap-action contacts	1 NC	24 V DC →	3SF1 244-1LC05-1BA2
ASIsafe basic switch				
<i>Actuator heads</i>				
	With hollow shaft • Operating angle 10°			3SE5 000-0AU21
Twist actuators with hollow shaft				
	With solid shaft • Operating angle 10°			3SE5 000-0AU22
Twist actuators with solid shaft				

→ Positive opening according to IEC 60947-5-1, Appendix K.

Overview

The 3SF1 hinge switches with safety-oriented communication can be directly connected using the AS-Interface bus system. The safety functions no longer have to be conventionally wired up.

With the 3SF1 position switches the ASIsafe electronics are integrated in the switch enclosure.

The hinge switches are provided for mounting on hinges. There are two actuator versions here:

- Hollow shaft, inner diameter 8 mm, outer 12 mm
- Solid shaft, diameter 10 mm





For the ASIsafe version of the hinge switch, the basic switch and twist actuator must be ordered separately. The basic switches correspond to the position switches of the standard version (only use versions with snap-action contacts).

The standards and approvals correspond to position switches 3SF1 (see page 6/14).

Selection and ordering data

Modular system

1 or 2 contacts · 3 LEDs · Degree of protection IP66/IP67 · M12 plug

	Version	Contacts	LEDs	Order No.
<i>Basic switches - Enclosure width 31 mm acc. to EN 50047</i>				
	With teflon plunger, with M12 plug, 4-pole; channel 1 on NC contact, channel 2 on NC contact • Snap-action contacts	2 NC	24 V DC →	3SF1 214-1LC05-1BA1
ASIsafe basic switch				
<i>Basic switches - Enclosure width 40 mm acc. to EN 50041</i>				
	With M12 plug, 4-pole, channel 1 on NC contact, channel 2 on NC contact Snap-action contacts	2 NC	24 V DC →	3SF1 114-1LA00-1BA1
ASIsafe basic switch				
<i>Basic switches - Enclosure width 56 mm</i>				
	With M12 plug, 4-pole, channel 1 on NC contact, channel 2 on M12 socket, right Snap-action contacts	1 NC	24 V DC →	3SF1 124-1LA00-1BA2
ASIsafe basic switch				
<i>Actuator heads</i>				
	Hollow shaft • Operating angle 10°			3SE5 000-0AU21
Twist actuators with hollow shaft				
	Solid shaft • Operating angle 10°			3SE5 000-0AU22
Twist actuators with solid shaft				
→ Positive opening according to IEC 60947-5-1, Appendix K.				

AS-Interface

ASIsafe

3SF2 cable-operated switches for AS-Interface

Overview

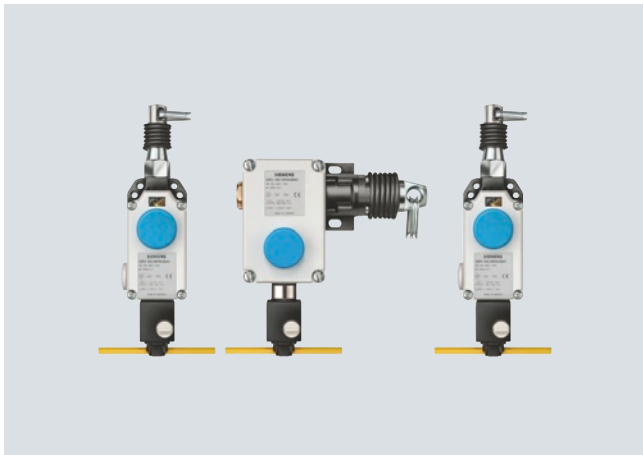

SIRIUS cable-operated switches are used for monitoring or for EMERGENCY-STOP devices on particularly endangered system sections.

AS-Interface cable-operated switches can be directly connected via the bus system AS-Interface with safety-oriented communication.



The safety functions no longer have to be conventionally wired up.

As the effective range of a cable-operated switch is only limited by the length of the trip-wire, large systems can also be protected.

Standards

The switches with positive latching are suitable for operation in EMERGENCY-STOP devices in according to ISO 13850. They can be used up to category 4 acc. to ISO 13849-1 (EN 954-1) or SIL 3 acc. to IEC 61508.

Selection and ordering data

Version	Basic switches	Contacts	Order No.
<i>Cable-operated switches with AS-i F adapter</i>			
 <p>Metal enclosure with dust protection, IP65, latching acc. to ISO 13850, with button reset, 2 NC contacts</p> <ul style="list-style-type: none"> For wire lengths up to 10 m, with alignment window 	3SE7 120-1BF00	2 NC	➔ 3SF2 120-1BF00-0BA1
 <ul style="list-style-type: none"> For wire lengths up to 25 m, with alignment window 	3SE7 150-1BF00	2 NC	➔ 3SF2 150-1BF00-0BA1
 <ul style="list-style-type: none"> For wire lengths up to 50 m 	3SE7 140-1BF00	2 NC	➔ 3SF2 140-1BF00-0BA1

➔ Positive opening according to IEC 60947-5-1, Appendix K.

Overview

EMERGENCY-STOP control devices can now be directly connected via the standard AS-Interface with safety-oriented communication. This only applies for the SIRIUS 3SB3 EMERGENCY-STOP mushroom pushbutton for front panel mounting and for mounting into an enclosure.

AS-Interface EMERGENCY-STOP enclosures



The enclosure is delivered fully equipped and wired up. It contains:



- EMERGENCY-STOP SIRIUS 3SB3 mushroom pushbutton with compulsory latching acc. to ISO 13850 and rotate-to-unlatch mechanism
- Contact blocks with two NC contacts
- F slave with 2 safe inputs
- Inscription labels

The plastic enclosures have a plastic EMERGENCY-STOP mushroom pushbutton, the metal enclosures have a metal EMERGENCY-STOP mushroom pushbutton.

The plastic enclosures are designed with a connecting terminal for the AS-Interface shaped cable (the cable is contacted using insulation piercing method and run past the outside of the enclosure). For the metal enclosures, the AS-Interface shaped cable (or round cable) is routed into the enclosure.

The enclosures can also be delivered with a M12 plug.

Selection and ordering data

	Version	Connection	Order No.
 5SF5 811-0AA08	AS-Interface EMERGENCY-STOP mushroom pushbutton in the plastic enclosure <ul style="list-style-type: none"> • Yellow top part of enclosure • Yellow top part of enclosure with protective collar • Yellow top part of enclosure 	Insulation piercing method	3SF5 811-0AA08
		Insulation piercing method	3SF5 811-0AB08
		M12 plugs	3SF5 811-0AA10
 3SF5 811-2AB08  3SF5 811-2AA10	AS-Interface EMERGENCY-STOP mushroom pushbutton in the metal enclosure <ul style="list-style-type: none"> • Yellow top part of enclosure • Yellow top part of enclosure with protective collar • Yellow top part of enclosure • Yellow top part of enclosure with protective collar 	Cable gland	3SF5 811-2AA08
		Cable gland	3SF5 811-2AB08
		M12 plugs	3SF5 811-2AA10
		M12 plugs	3SF5 811-2AB10

AS-Interface

















ASIsafe

SIRIUS EMERGENCY-STOP mushroom pushbuttons for AS-Interface

Selection and ordering data

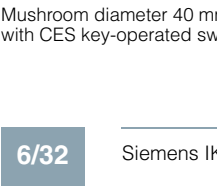
EMERGENCY-STOP control device acc. to ISO 13850 and IEC 60947-5-5

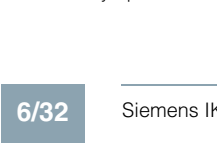













- With holder for mounting on front plates
- Connection with F adapter AS-Interface
- Yellow backing plates are to be ordered separately

	Version	Approval	Order No.
<i>With plastic enclosure</i>			
	EMERGENCY-STOP mushroom pushbuttons, Ø 32 mm, with positive latching according to ISO 13850, with rotate-to-unlatch mechanism		3SB30 00-1FA20
Mushroom diameter 32 mm			
	EMERGENCY-STOP mushroom pushbuttons, Ø 40 mm, with positive latching according to ISO 13850, with rotate-to-unlatch mechanism		3SB30 00-1HA20 3SB30 00-1HA26
Mushroom diameter 40 mm, with rotate-to-unlatch mechanism with switch position indication	<ul style="list-style-type: none"> • Without switch position indicator • With mechanical switch position indication 		
	EMERGENCY-STOP mushroom pushbuttons, Ø 40 mm, with positive latching acc. to ISO 13850, with pull-to-unlatch mechanism		3SB30 00-1TA20
Mushroom diameter 40 mm, pull-to-unlatch mechanism			
	EMERGENCY-STOP mushroom pushbuttons, Ø 60 mm, with positive latching according to ISO 13850, with rotate-to-unlatch mechanism		3SB30 00-1AA20
Mushroom diameter 60 mm			
	EMERGENCY-STOP mushroom pushbuttons, Ø 40 mm, with RONIS key-operated switches, lock No. SB 30, with positive latching according to ISO 13850, unlocking only possible using key		3SB30 00-1BA20
Mushroom diameter 40 mm, with RONIS key-operated switch			
	EMERGENCY-STOP mushroom pushbuttons, Ø 40 mm, with CES key-operated switches, lock no. SSG 10, with positive latching according to ISO 13850, unlocking only possible using key		3SB30 00-1KA20
Mushroom diameter 40 mm, with CES key-operated switch			
	EMERGENCY-STOP mushroom pushbuttons, Ø 40 mm, with BKS key-operated switches, lock no. S1, with positive latching according to ISO 13850, unlocking only possible using key		3SB30 00-1LA20
Mushroom diameter 40 mm, with CES key-operated switch			
	EMERGENCY-STOP mushroom pushbuttons, Ø 40 mm, with O.M.R. key-operated switch, lock No. 73037, with positive latching according to ISO 13850, unlocking only possible using key		3SB30 00-1MA20
Mushroom diameter 40 mm, with CES key-operated switch			

Selection and ordering data (continued)

EMERGENCY-STOP control device acc. to ISO 13850 and IEC 60947-5-5

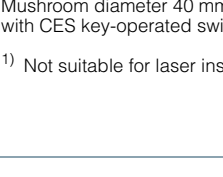
- With holder for mounting on front plates
- Connection with F adapter AS-Interface
- Yellow backing plates are to be ordered separately

	Version	Approval	Order No.
<i>With metal enclosure</i>			
	EMERGENCY-STOP mushroom pushbuttons, Ø 32 mm, with positive latching according to ISO 13850, with rotate-to-unlatch mechanism		3SB35 00-1FA20 3SB35 00-1FA20-0PA0
Mushroom diameter 32 mm	<ul style="list-style-type: none"> • Standard version • Solvent-resistant¹⁾ 		
	EMERGENCY-STOP mushroom pushbuttons, Ø 40 mm, with positive latching according to ISO 13850, with rotate-to-unlatch mechanism		3SB35 00-1HA20 3SB35 00-1HA20-0PA0 3SB35 00-1HA26
Mushroom diameter 40 mm, with rotate-to-unlatch mechanism with switch position indication	Without switch position indicator Without switch position indicator, solvent-resistant ¹⁾ With mechanical switch position indication		
	EMERGENCY-STOP mushroom pushbuttons, Ø 40 mm, with positive latching acc. to ISO 13850, with pull-to-unlatch mechanism		
Mushroom diameter 40 mm, pull-to-unlatch mechanism			3SB35 00-1TA20
	EMERGENCY-STOP mushroom pushbuttons, Ø 60 mm, with positive latching according to ISO 13850, with rotate-to-unlatch mechanism		3SB35 00-1AA20
Mushroom diameter 60 mm			3SB35 00-1BA20
	EMERGENCY-STOP mushroom pushbuttons, Ø 40 mm, with RONIS key-operated switches, lock No. SB 30, with positive latching according to ISO 13850, unlocking only possible using key		3SB35 00-1KA20
Mushroom diameter 40 mm, with RONIS key-operated switch			3SB35 00-1LA20
	EMERGENCY-STOP mushroom pushbuttons, Ø 40 mm, with BKS key-operated switches, lock no. S1, with positive latching according to ISO 13850, unlocking only possible using key		3SB35 00-1MA20
Mushroom diameter 40 mm, with CES key-operated switch			3SB35 00-1MA20
	EMERGENCY-STOP mushroom pushbuttons, Ø 40 mm, with O.M.R. key-operated switch, lock No. 73037, with positive latching according to ISO 13850, unlocking only possible using key		
Mushroom diameter 40 mm, with CES key-operated switch			

¹⁾ Not suitable for laser inscription.

AS-Interface

ASIsafe

AS-Interface F adapters for EMERGENCY-STOP devices

Overview





The AS-Interface F adapter is used to connect an EMERGENCY-STOP device according to ISO 13850 from the 3SB3 series to the AS-Interface bus system. The F adapter is suitable for control devices with mounting on front plates.

The F adapter has a safe AS-Interface 2I slave and is snapped from behind onto the EMERGENCY-STOP mushroom pushbutton. In the 2I/10 expanded version, an output is also available for actuating an indicator light with LED.

Depending on the version, screw terminals or spring-type terminals or the insulation piercing method are used for connecting to the AS-Interface bus cable. Addressing is performed using the AS-Interface connection or the integrated addressing socket.

Safety category 4 (SIL 3) is achieved with the adapter.

Selection and ordering data

	Version	Connection	Order No.	
 3SF5 402-1AA03	AS-Interface F adapter for EMERGENCY-STOP mushroom pushbutton 3SB3 For mounting on front plates	Screw terminals	• 2I	3SF5 402-1AA03
			• 2I/10, with output for LED control	3SF5 402-1AB03
		Spring-type terminals	• 2I	3SF5 402-1AA04
			• 2I/10, with output for LED control	3SF5 402-1AB04
		Insulation piercing method	• 2I	3SF5 402-1AA05
 3SF5 402-1AA05	• 2I/10, with output for LED control		3SF5 402-1AB05	
 3SF5 402-1AA05				

Overview



CP 243-2

The CP 243-2 is the AS-Interface master for the SIMATIC S7-200 and has the following features:

- Connection of up to 62 AS-Interface slaves
- Integrated analog value transmission (Analog Profiles 7.3 and 7.4)
- Supports all AS-Interface master functions according to the extended AS-Interface specification V2.1
- Indication of the operating state and readiness for operation of connected slaves by means of LEDs in the front panel
- Fault indications (e. g. AS-Interface voltage fault, configuration fault) by means of LEDs in the front panel
- Compact enclosure in the design of the SIMATIC S7-200

Design

The CP 243-2 is connected like an expansion module to the S7-200. It has:

- Two screw terminals for direct connection of the AS-Interface cable
- LEDs in the front panel for indicating the operating state and functional readiness of all connected slaves
- Two pushbuttons for indicating the status information of the slaves, for switching over the operating state and for adopting the existing ACTUAL configuration as the DESIRED configuration.

Function

The CP 243-2 supports all specified functions of the extended AS-Interface Specification V2.1.

In the process image of the S7-200 the CP 243-2 occupies one digital input byte (status byte), one digital output byte (control byte), and 8 analog input and 8 analog output words. The CP 243-2 thus occupies two (logic) slots. The operating mode of the CP 243-2 can be set with the status byte and the control byte using the user program. Depending on the operating mode, the CP 243-2 saves either the digital or analog I/O data of the AS-Interface slaves or diagnostic values in the analog address area of the S7-200, or it enables master calls (e.g. re-addressing of the slaves).

Configuration

All connected AS-Interface slaves are configured at the press of a button. No further configuration of the CP is required.

Benefits

get Designed for Industry

- More flexibility and versatility in the use of SIMATIC S7-200 as the result of the distinct increase in the number of digital and analog inputs/outputs available

- Shorter start-up times through simple configuration at the press of a button
- Reduction of standstill and servicing times in the event of a fault thanks to the LED indicators
- Status of the CP
 - Indication of all the slaves connected and their readiness for operation
 - Monitoring of the AS-Interface mains voltage

Application

The CP 243-2 is the AS-Interface master connection for the 22x CPUs of the SIMATIC S7-200. Through connection to AS-Interface the number of inputs and outputs available for S7-200 is greatly increased (max. 248 DI / 186 DO on the AS-Interface per CP).

Analog values (per CP a maximum of 31 standard analog slaves with up to 4 channels each) also become available on the AS-Interface for the S7-200 thanks to the integrated analog value processing. On the S7-200, up to two CP 243-2 communication processors can be operated simultaneously.

Selection and ordering data

Version	Screw terminals
 <p>CP 243-2 communication processors For connection of the SIMATIC S7-200 to AS-Interface; corresponds to AS-Interface Specification V2.1; dimensions (W x H x D / mm): 71 x 80 x 62 (dimensions without fixing lugs)</p>	<p>Order No. 6GK7 243-2AX01-0XA0</p>

6GK7 243-2AX01-0XA0

More information

The manuals are also available on the Internet at
<http://support.automation.siemens.com/WWW/view/en/10805937/133300>

AS-Interface Masters

Masters for SIMATIC S7
CP 343-2P, CP 343-2

Overview



CP 343-2P / CP 343-2

The CP 343-2P is the AS-Interface master for the SIMATIC S7-300 and the ET 200M distributed I/O station, with user-friendly parameterizing options.

The CP 343-2 is the basic version of the same module.

The CP 343-2P / CP 343-2 has the following features:

- Connection of up to 62 AS-Interface slaves
- Integrated analog value transmission (all analog profiles)
- Supports all AS-Interface master functions according to the AS-Interface Specification V3.0
- Status displays of operating states and indication of the readiness for operation of connected slaves by means of LEDs in the front panel
- Fault indication (e.g. AS-Interface voltage fault, configuration fault) by means of LEDs in the front panel
- Compact enclosure in the design of the SIMATIC S7-300
- Suitable for AS-i Power24V (product version 2 and higher / firmware version 3.1) and standard AS-i (30 V)
- Extra with the CP 343-2P: Supports detailed configuration of the AS-Interface-network with STEP 7 V5.2 and higher

Design

The CP 343-2P / CP 343-2 is connected like an I/O module to the S7-300. It has:

- Two terminal connections for direct connection of the AS-Interface cable
- LEDs in the front panel for indicating the operating state and the readiness for operation of all connected and activated slaves
- Pushbuttons for switching over the master operating state and for adopting the existing ACTUAL configuration of the AS-i slave as the DESIRED configuration

Function

The CP 343-2P / CP 343-2 supports all specified functions of the extended AS-Interface Specification V3.0.

The CP 343-2P / CP 343-2 occupies 16 bytes each in the I/O address area of the SIMATIC S7-300. The digital I/O data of the standard slaves and A slaves are saved in this area. The digital I/O data of the B slaves and the analog I/O data can be accessed with the S7 system functions.

If required, master calls can be performed with the command interface FC ASI_3422, e. g. read/write parameters, read/write configuration. The FC including a STEP7 sample program can be downloaded from the Internet at:

<http://support.automation.siemens.com/WW/view/en/5581657>

Configuration

All connected AS-Interface slaves are configured at the press of a button. No further configuration of the CP is required.

Additional features of the CP 343-2P

The CP 343-2P also supports configuring of the AS-Interface network with STEP 7 V5.2 and higher. Specifying the AS-i configuration in HW-Config facilitates the setting of slave parameters and documentation of the plant. Uploading the ACTUAL configuration of an already configured AS-Interface network is also supported. The saved configuration cannot be overwritten at the press of a button and is therefore tamper-proof.

Benefits



- Shorter start-up times through simple configuration at the press of a button
- Construction of flexible distributed structures by use in the DP-slave ET 200M
- Provides diagnostics of the AS-Interface networks
- Well suited also for complex applications thanks to connection options for 62 slaves and integral analog value processing
- Reduction of standstill and servicing times in the event of a fault thanks to the LED indicators:
 - Status of the AS-Interface network
 - Slaves connected and their readiness for operation
 - Monitoring of the AS-Interface mains voltage
- Lower costs for stock keeping and spare parts because the CP can be used for the SIMATIC S7-300 as well as for the ET 200M
- Extra with the CP 343-2P: Improved plant documentation and support for service assignments thanks to a description of the AS-Interface configuration in the STEP 7 project
- No need for the AS-i power supply unit with AS-i Power24V: The AS-Interface cable is supplied through an existing 24 V DC PELV power supply unit. An AS-i data decoupling module (e.g. 3RK1 901-1DE12-1AA0) is required for the decoupling, see page 136.
- Operation with an AS-Interface power supply unit (e.g. 3RX9 501-0BA00, see page 135) is also possible without restrictions.

Application



The CP 343-2P / CP 343-2 is the AS-Interface master connection for the SIMATIC S7-300 and the ET 200M.

Through connection to AS-Interface it is possible to access max. 248 DI/248 DO per CP, using 62 A/B slaves with 4DI/4DO each.



With the integrated analog value processing it is easy to transmit analog signals (per CP up to 62 A/B analog slaves with a maximum of two channels each or up to 31 A/B analog slaves with a maximum of 4 channels each).

The CP 343-2P is the further development of the CP 343-2 and contains its entire functionality. An existing STEP 7 user program for a CP 343-2 can thus be used without restrictions with a CP 343-2P. It is only in STEP 7 HW-Config that the two modules are configured differently, with the CP 343-2P offering additional options. This is why the CP 343-2P is recommended.

Selection and ordering data

Version	Order No.
 CP 343-2P communication processors For connection of SIMATIC S7-300 and ET 200M to AS-Interface; configuration of the AS-i network using the SET key or STEP 7 (V5.2 and higher); without front connector; corresponds to AS-Interface Specification V3.0; dimensions (W x H x D / mm): 40 x 125 x 120 6GK7 343-2AH11-0XA0	6GK7 343-2AH11-0XA0
 CP 343-2 communication processors Basic version for connection of SIMATIC S7-300 and ET 200M to AS-Interface Configuration of the AS-i network using the SET key; without front connector; corresponds to AS-Interface Specification V3.0; dimensions (W x H x D / mm): 40 x 125 x 120 6GK7 343-2AH01-0XA0	6GK7 343-2AH01-0XA0

Accessories

Version	Order No.
Front connectors, 20-pole <ul style="list-style-type: none"> • With screw terminals 	 6ES7 392-1AJ00-0AA0
Front connectors, 20-pole <ul style="list-style-type: none"> • With spring-type terminals 	 6ES7 392-1BJ00-0AA0

More information

The manuals are available on the Internet at <http://support.automation.siemens.com/WW/view/en/14310380/133300>

The AS-i function block library for PCS 7 to easily connect an AS-Interface to PCS 7, see Catalog IC 10 or in the Industry Mall under

www.siemens.com/industrymall

"Automation technology" --> "Industrial controls" --> "Planning, Configuration and Visualizing for SIRIUS" --> "AS-Interface function block library for SIMATIC PCS 7"

AS-Interface Network transitions

DP/AS-i LINK Advanced

Overview



DP/AS-i LINK Advanced

PN	DP-M	DP-S	ASi-M		
		●	●		IK0...10195

The DP/AS-i LINK Advanced is a compact Network transition between PROFIBUS (DP Slave) and AS-Interface, with the following features:

- Single and double AS-Interface master (according to AS-Interface Specification V3.0) for connection of 62 AS-Interface slaves or 124 AS-Interface slaves (with a double master)
- Integrated analog value transmission (all analog profiles)
- Integrated ground-fault monitoring for the AS-Interface cable
- User-friendly local diagnostics and start-up by means of a full graphic display and control keys or through a web interface with a standard browser on the PC screen
- Optimum TIA integration using STEP 7
- Integration in non-Siemens engineering tools using the PROFIBUS GSD file
- Vertical integration (standard web interface) through Industrial Ethernet
- Supply voltage from the AS-Interface shaped cable or alternatively with 24 V DC (optional)
- Suitable for AS-i Power24V (product version 4 and higher / firmware version 2.1.20) and standard AS-i (30 V)
- Module exchange without entering the connection parameters (PROFIBUS address etc) using C-PLUG (optional)

Design

- Compact plastic enclosure in degree of protection IP20 for standard rail mounting
- COMBICON plug-in screw terminals
- Compact design:
 - Pixel graphics display in the front panel for detailed indication of the operating state and readiness for operation of all connected AS-Interface slaves
 - 6 pushbuttons for starting up and testing the AS-Interface line directly on the DP/AS-i LINK Advanced
 - LED indication of the operating state of PROFIBUS DP and AS-Interface
 - Integrated Ethernet port (RJ45 socket) for user-friendly start-up, diagnostics and testing of DP/AS-i LINK Advanced through a web interface using a standard browser
- Small mounting depth thanks to recessed plug mounting
- Operation without fans and batteries

Functionality

Communication

The DP/AS-i LINK Advanced enables a PROFIBUS DP master to cyclically access the I/O data of all the slaves of a lower-level AS-Interface segment. Also supported are the expanded slave types with higher I/O data volume according to AS-i Specification V3.0.

The DP/AS-i LINK Advanced occupies the following address area:

- As a single master: 32 bytes of input data and 32 bytes of output data in which the I/O data of the connected AS-Interface slaves (standard and A/B slaves) of an AS-i line are stored.
- A double master occupies twice the number of bytes.

The size of the input/output image can be compressed so that only the actually required I/O address area is occupied in the system of the DP master.

The integrated evaluation of analog signals is just as easy as access to digital values because the analog process data also lie directly in the I/O address area of the CPU.

PROFIBUS DP-V1 Masters also provide the option of triggering AS-Interface Master calls over the acyclic PROFIBUS services (e. g. write parameters, amend addresses, read diagnostic values).

Using an operating display in AS-i Link it is possible to fully commission the lower-level AS-Interface line.

DP/AS-i LINK Advanced is equipped with an additional Ethernet port which enables use of the integrated web server. The web server can be called up with any standard web browser (e. g. Internet Explorer) without additional software. It allows all diagnostics information to be shown on the PC and the bus configuration and, if applicable, any adjustments, to be displayed. Firmware updates are also possible using this port.

The optional C-PLUG supports module exchange without entering the connection parameters (IP address etc.), keeping downtimes to a minimum in the event of a fault.

Diagnostics

The following diagnostics is possible using LEDs, the display and control keys, web interface or STEP 7:

- Operating state of the DP/AS-i LINK Advanced
- Status of the link as a PROFIBUS DP slave
- Diagnostics of the AS-Interface network
- Message frame statistics
- Standard diagnostics pages in the web interface for fast diagnostics access through Ethernet using a standard browser
- For the use of the web interfaces are no network settings on the PC necessary (Zeroconf procedure).
- The reporting of diagnostic events is optional via E-Mail or SNMP Trap possible. The integrated diagnostic buffer saves the events including time stamp.

Configuration

The DP/AS-i LINK Advanced can be configured as follows:

- With STEP 7 as of V5.4: With STEP 7 configuring the AS-Interface configuration can be uploaded in STEP 7. Can also be AS-Interface slaves from Siemens conveniently configure in HW Config (slave selection dialog).
- By adopting the ACTUAL configuration of the AS-Interface on the display
- Alternatively DP/AS-i LINK Advanced can be integrated into the engineering tool over the PROFIBUS GSD file (e. g. for STEP 7 versions below V5.4 or engineering tools from third-party software houses).

Benefits

get Designed for Industry

- Short start-up times through simple configuration at the press of a button and testing of the AS-Interface line using the display or web interface
- Reduction of standstill and servicing times in the event of a slave failure thanks to user-friendly diagnostics using the display or web interface and through simple module exchange with the help of the C-PLUG exchange medium
- Reduced amount of engineering work thanks to user-friendly configuration of Siemens slaves using the slave catalog in HW-Config (STEP 7)

- Costs saved by the double AS-Interface master when large volumes of project data are involved
- Saves the need for AS-i power pack with AS-i Power24V: The AS-Interface cable assembly is fed through an existing 24 V DC PELV power pack. For decoupling an AS-i data decoupling module is required, see power supply units and data decoupling modules.
- Standard mode with AS-Interface power supply (see power supply units and data decoupling modules) possible without restrictions, whereby no further operating voltage is required

Application

The DP/AS-i LINK Advanced is a PROFIBUS DP-V1 slave (according to EN 50170) and an AS-Interface master (based on AS-Interface Specification V3.0 according to IEC 62026-2). It enables transparent data access to AS-Interface from PROFIBUS DP.

Exchanging data with the PROFIBUS DP master

PROFIBUS DP masters (DP-V0) can exchange I/O data with AS-Interface in cyclic mode. PROFIBUS DP masters with acyclic services (DP-V1) are able in addition to initiate AS-Interface master calls (e. g. reading/writing the AS-i configuration during normal operation). As such, the DP/AS-i LINK Advanced is particularly well suited for a decentral construction and for connection of a lower-level AS-Interface network.

Single masters

For applications with typical volumes of project data it is sufficient to use the DP/AS-i LINK Advanced in its version as an AS-Interface single master. The single master can operate up to 248 DI/248 DO, using 62 A/B slaves with 4 DI/4 DO each.

Double masters

For applications with large volumes of project data the DP/AS-i LINK Advanced in its version as an AS-Interface double master is used. In this case, twice the volume of project data can be used on two AS-Interface lines running independently of each other. The double master can operate up to 496 DI/496 DO, using 2 AS-i networks with 62 A/B slaves each with 4DI/4DO each.

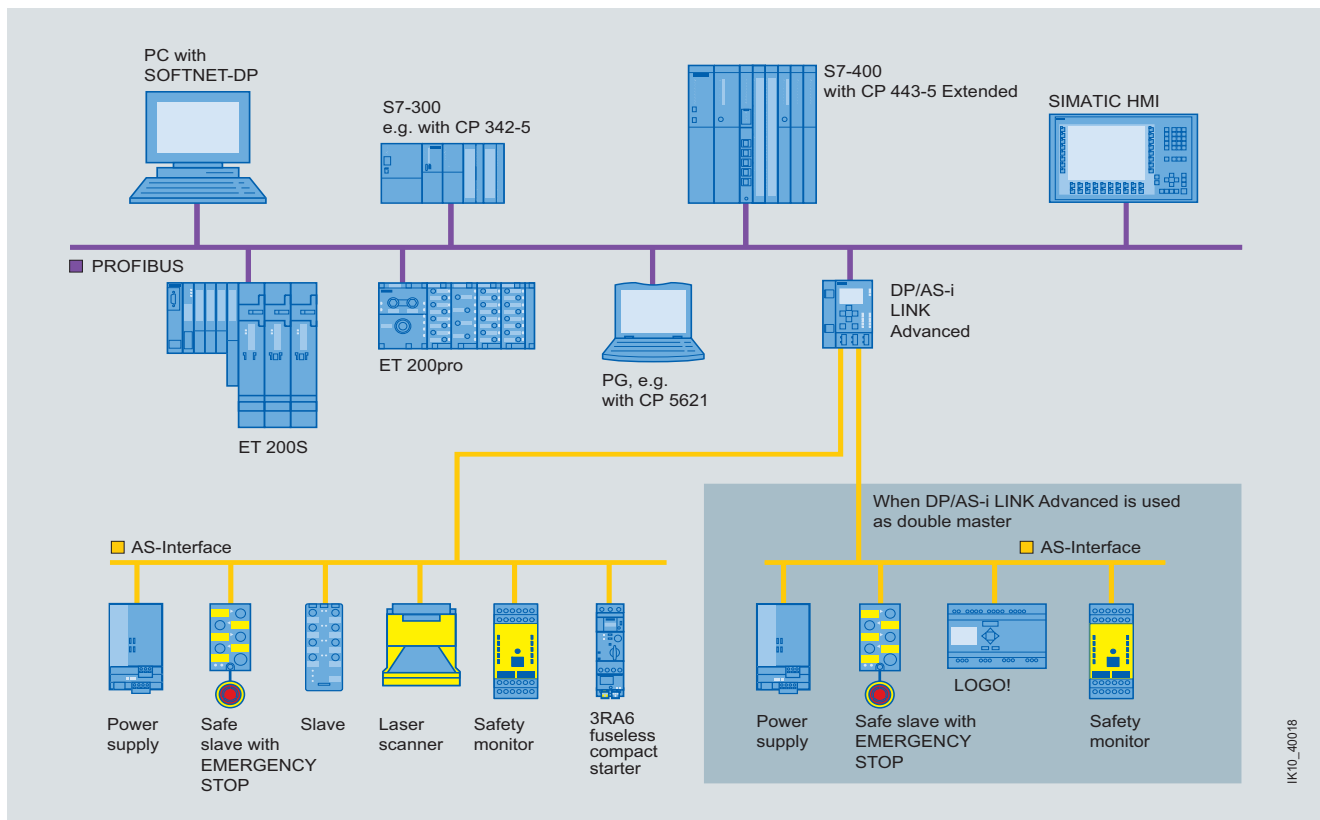

Integration of AS-Interface on PROFIBUS through DP/AS-i LINK Advanced as single/double master

AS-Interface

Network transitions

DP/AS-i LINK Advanced

Selection and ordering data

Version	Combicon connection Order No.
 <p>DP/AS-i LINK Advanced Network transition between PROFIBUS DP and AS-Interface; Degree of protection IP20; including COMBICON plug-in screw terminals for connection of an AS-Interface cable (two AS-Interface cables for double masters) and the optional 24 V supply; corresponds to AS-Interface Specification 3.0; dimensions (W x H x D / mm): 90 x 132 x 88.5</p> <ul style="list-style-type: none"> • Single master with display • Double master with display <p>DP/AS-i LINK Advanced</p>	<p>6GK1 415-2BA10 6GK1 415-2BA20</p>

Accessories

C-PLUG

Exchange medium for the simple exchange of devices in the event of a fault;
for accommodating configuration and application data; can be used in SIMATIC NET products
with a C-PLUG slot

6GK1 900-0AB00

PROFIBUS FastConnect Standard Cable GP

FastConnect standard type with special design
for fast installation, 2-core, shielded

6XV1 830-0EH10

PROFIBUS FastConnect

RS485 bus connectors with angled cable feeder (35°)

With insulation displacement connection the max. transmission rate is 12 Mbit/s
Activatable terminating resistor is integrated

- Without PG connection socket
- With PG connection socket

6ES7 972-0BA60-0XA0

6ES7 972-0BB60-0XA0

PROFIBUS FastConnect Stripping Tool

Preset stripping tool for speedy stripping of PROFIBUS FastConnect bus cables

6GK1 905-6AA00

IE FC RJ45 Plug 90

RJ45 plug-in connector for Industrial Ethernet, with robust metal enclosure and integrated
cutting and clamping contacts for connection of Industrial Ethernet FC installation cables;
with 90° cable feeder

- 1 pack = 1 units
- 1 pack = 10 units
- 1 pack = 50 units

6GK1 901-1BB20-2AA0

6GK1 901-1BB20-2AB0

6GK1 901-1BB20-2AE0

More information

The manuals are available on the Internet at
<http://support.automation.siemens.com/WWW/view/en/28602701/133300>

The AS-i function block library for PCS 7 to easily connect an
AS-Interface to PCS 7, see Catalog IC 10
or in the Industry Mall at

www.siemens.com/industrymall

"Automation technology" --> "Industrial controls" -->

"Planning, Configuration and Visualizing for SIRIUS" -->

"AS-Interface function block library for SIMATIC PCS 7"

Overview



DP/AS-Interface Link 20E

PN	DP-M	DP-S	ASi-M		
		●	●		

K10-10186

DP/AS-Interface Link 20E connects PROFIBUS DP to AS-Interface and has the following features.

- PROFIBUS DP slave and AS-Interface master
- Up to 62 AS-Interface slaves, each with 4 digital inputs and 4 digital outputs as well as analog slaves can be connected
- Integrated analog value transmission (all analog profiles)
- Supports all AS-Interface master functions according to the AS-Interface Specification V3.0
- Supply from AS-Interface cable; hence no additional power supply required
- Supports the uploading of the AS-Interface configuration in STEP 7 V5.2 and higher

Design

- Compact plastic enclosure in degree of protection IP20 for standard rail mounting
- LEDs in the front panel for indicating the operating state and functional readiness of all connected slaves
- Setting option for PROFIBUS DP address by pressing a button
- LED indication of the PROFIBUS DP slave address, DP bus faults and diagnostics
- Two pushbuttons for switching over the operating state and for adopting the existing ACTUAL configuration as the DESIRED configuration

Functionality

Communication

DP/AS-Interface Link 20E enables a DP master to access all the slaves of an AS-Interface network.

DP/AS-Interface Link 20E occupies as standard 32 bytes of input data and 32 bytes of output data in which the digital I/O data of the connected AS-Interface slaves (standard and A/B slaves) of an AS-i line are stored.

The size of the input/output image can be compressed so that only the actually required I/O address area is occupied in the system of the DP master.

The analog I/O data can be accessed with the S7 system functions for read/write data record.

Configuration

The DP/AS-Interface Link 20E is configured as follows:

- With STEP 7 as of Version V5.1 SP2:
With STEP 7 configuring the AS-Interface configuration can be uploaded in STEP 7 V5.2 and higher. Can also be AS-Interface slaves from Siemens conveniently configure in HW Config (slave selection dialog).
- By adopting the ACTUAL configuration of the AS-Interface by the using the SET pushbutton on the front panel.
- Alternatively, DP/AS-Interface Link 20E can be integrated by means of the PROFIBUS GSD file in the engineering tool (e. g. for STEP 7 V5.1 and lower or for non-Siemens engineering tools).

Benefits



- Reduction of installation costs because the power supply comes completely from the AS-Interface cable, making an additional power supply superfluous

- Short start-up times through simple configuration at the press of a button
- Reduction of standstill and servicing times in the event of a slave failure thanks to the LED indicators
- Easy and fast start-up through reading out the AS-Interface configuration

Application

The DP/AS-Interface Link 20E is a PROFIBUS DP slave (according to IEC 61158/IEC 61784) and an AS-Interface master (according to IEC 62026-2). It enables the AS-Interface to be operated on PROFIBUS DP.

DP/AS-Interface Link 20E can operate up to 248 DI / 248 DO when using 62 A/B slaves with 4DI/4DO each.

PROFIBUS DP masters (DP-V0) can exchange I/O data with AS-Interface in cyclic mode.

PROFIBUS DP masters with acyclic services (DP-V1) are able in addition to initiate AS-Interface master calls (e. g. reading/writing the AS-i configuration during normal operation).

AS-Interface Network transitions

DP/AS-Interface Link 20E

Application (continued)

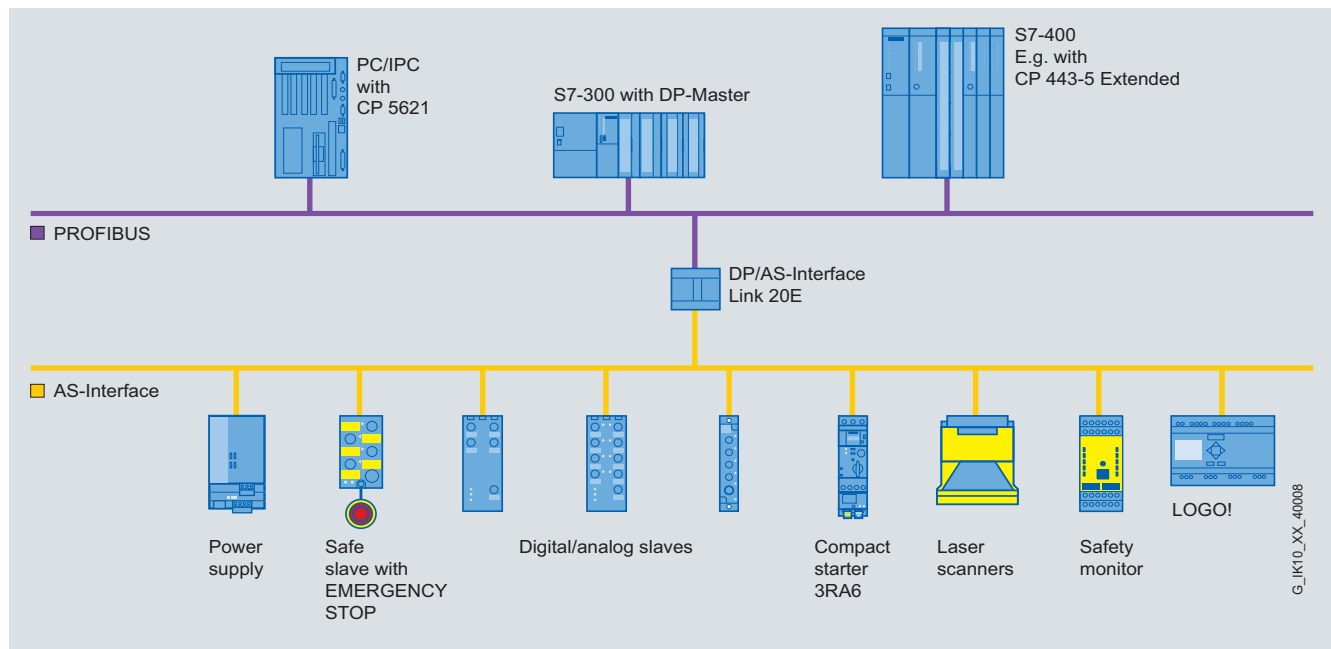

Transition from PROFIBUS DP to AS-Interface using DP/AS-Interface Link 20E

6

Selection and ordering data

Version	Screw terminals
	Order No.
 <p>DP/AS-Interface Link 20E Network transition between PROFIBUS DP and AS-Interface in degree of protection IP20; including screw terminals for connection of the AS-Interface cable; corresponds to AS-Interface Specification V3.0; dimensions (W x H x D / mm): 90 x 80 x 60 (dimensions without fixing lugs)</p>	<p>6GK1 415-2AA10</p>
<p>PROFIBUS FC Standard Cable GP FastConnect standard type with special design for fast installation, 2-core, shielded</p>	<p>6XV1 830-0EH10</p>
<p>PROFIBUS FastConnect RS485 bus connectors with 90° cable feeder With insulation displacement connection the max. transmission rate is 12 Mbit/s. Activatable terminating resistor is integrated</p> <ul style="list-style-type: none"> • Without PG connection socket • With PG connection socket 	<p>6ES7 972-0BA52-0XA0 6ES7 972-0BB52-0XA0</p>
<p>PROFIBUS FastConnect RS485 bus connectors with angled cable feeder (35°) With insulation displacement connection the max. transmission rate is 12 Mbit/s. Activatable terminating resistor is integrated</p> <ul style="list-style-type: none"> • Without PG connection socket • With PG connection socket 	<p>6ES7 972-0BA60-0XA0 6ES7 972-0BB60-0XA0</p>
<p>PROFIBUS FastConnect Stripping Tool Preset stripping tool for speedy stripping of PROFIBUS FastConnect bus cables</p>	<p>6GK1 905-6AA00</p>

6GK1 415-2AA10

Accessories

More information

The manuals are also available on the Internet at <http://support.automation.siemens.com/WWW/view/en/28602858/133300>

Overview



DP/AS-i F-Link

PN	DP-M	DP-S	ASi-M		
		●	●		

The DP/AS-i F-Link is a compact, safety-oriented network transition between PROFIBUS (DP Slave) and AS-Interface, with the following features:

- Monitoring the inputs of safety-oriented digital AS-i slaves (ASIsafe slaves) and forwarding of data through PROFIsafe. No additional safety-oriented components required for the AS-Interface (e. g. safety monitor)
- Can be used up to Category 4 according to EN 954-1, to PL e according to EN ISO 13849-1 and to SIL 3 according to IEC 62061/IEC 61508.
- Connection of up to 62 AS-Interface slaves
- Supports all AS-Interface master functions according to the AS-Interface Specification V3.0
- Typically easy transmission of non-safety-oriented input/output data of all AS-i slaves
- Integrated analog value transmission (all analog profiles)
- Direct integration in PROFIBUS networks.
Optional integration in PROFINET environments through PROFINET/PROFIBUS gateway (IE/PB Link PN IO) or through SIMATIC S7 315/317/319 F PN/DP or S7-416F-3 PN/DP
- Connection to ET 200S with IM-F-CPU using DP master module is possible
- Optimum TIA integration in STEP 7 using Object Manager, integration in non-Siemens engineering tools using PROFIBUS GSD file
- Local diagnostics using LEDs and display with control keys

Design

- Rugged, slim plastic enclosure, degree of protection IP20, for standard rail mounting or wall mounting (with adapter)
- Compact design:
 - LEDs in the front panel for indicating the operating state and functional readiness of all connected slaves
 - 2 buttons on the front for start-up and call up of diagnostics information
 - 4 LEDs for indication of the operating state of the device, of PROFIBUS DP and the AS-Interface network
 - Front PROFIBUS DP connection with sub D connector
 - Removable terminal blocks for connection of AS-i +/- and control supply voltage (over 24 V DC PELV power supply unit)
 - Narrow width (45 mm)
- Operation without fans and batteries
- Fast device replacement in the event of a fault

Functionality

Communication principle

The PROFIBUS DP master or the safe control communicates with the AS-Interface slaves over the DP/AS-i F-Link. The AS-Interface process data are mapped in different data areas for non-safety-oriented input and output data and safety-oriented input data.

Diagnostics

Extensive diagnostics is possible using the four LEDs, display and control keys or SIMATIC S7. Further details can be found in the manual.

Configuration

The DP/AS-i F-Link is configured as follows:

- With STEP 7 as of Version V5.4 SP1: In particular, Siemens AS-Interface slaves can be conveniently configured via the slave selection dialog.
- Uploading the actual configuration of an already configured AS-Interface network in a STEP 7 project is possible.
- Alternatively, DP/AS-i F-Link can be integrated by means of the PROFIBUS GSD file in the engineering tool
As a start-up aid, it is also possible to adopt the ACTUAL configuration in the appliance storage device directly on the appliance to activate the AS-interface slaves.

Programming

In contrast to the AS-Interface safety monitor, DP/AS-i F-Link is a pure gateway, which does not run through its own safety logic. Programming of the safety function is implemented at the level of the higher-level failsafe PLC, e. g.:

- With Distributed Safety, Version V5.4 SP1 or higher for SIMATIC S7-300F/416F
- With the SAFETY INTEGRATED "SI-Basic" or "SI-COMFORT NCU" Software for SINUMERIK 840D p/sl

The safety and standard range can access the digital and analog I/O data of the connected AS-Interface slaves directly through the I/O address area of the CPU.

AS-Interface

Network transitions

DP/AS-i F-Link

Benefits

get Designed for Industry

- Gaps in (bus-based) safety technology closed: safety-oriented signals (EMERGENCY-STOP, door tumbler, light curtains etc.) collected with AS-i and transferred to higher-level F-PLC. This enables:
 - Quick installation, easy commissioning: Use of AS-i virtues in the field now fully consistent for Safety Integrated
 - Cost-effective solution as ASIsafe is ideally suited for the collection of "fewer but more distributed failsafe bits".
- Price advantage: As a fully fledged AS-i master according to Specification V3.0, more input and outputs can be used, e. g.:
 - up to 248 DI / 248 DO when using 62 A/B slaves with 4DI/4DO each
 - up to 62 digital or analog slaves
- Investment protection:
 - Connection to PROFIBUS networks, such as DP/AS-i Link Advanced or DP/AS-Interface Link 20E
 - Downward compatibility to AS-Interface specification V2
 - Open for modern automation concepts with AS-i
- Teaching the code sequences of ASIsafe slaves is possible at the press of a button
- Reduced amount of engineering work thanks to user-friendly configuration of all AS-i slaves from Siemens using the slave selection dialog in HW-Config (STEP 7), including setting the F-parameter of the ASIsafe slaves modeled on PROFIsafe slaves
- Cost-savings thanks to programming of the safety logic with the familiar, powerful commands of the distributed safety packages from the failsafe SIMATIC PLC in F-FUP or F-FOP, incl. TUV-certified function blocks for typical safety applications
- Use in machine-tools under SINUMERIK 840 D (pl/sl) possible
- Reduction of standstill and servicing times in the event of a slave failure thanks to user-friendly diagnostics using the display and through simple module exchange (only a few settings by control keys are required, without use of the configuring tool)

Application

Links between PROFIsafe and ASIsafe

The DP/AS-i F-Link is a PROFIBUS DP-V1 slave (according to IEC 61508/ IEC 61784) and an AS-Interface master (based on AS-Interface Specification V3.0 according to IEC 62026-2). It enables transparent data access to AS-Interface from PROFIBUS DP. The DP/AS-i F-Link is also the only AS-i master with which safety-oriented input data can be passed from ASIsafe slaves via the PROFIsafe protocol to a failsafe CPU with PROFIBUS DP master. No additional safety cabling or monitoring is required (in particular no AS-Interface safety monitor). The transmission of binary values or analog values is possible depending on the slave type. All slaves according to AS-Interface Specification V2.0, V2.1 or V3.0 can be used as AS-i slaves.

PROFIBUS DP masters according to DP-V0 or DP-V1 can exchange I/O data with lower-level AS-i slaves in cyclic mode. PROFIBUS DP masters with acyclic services according to DP-V1 are able in addition to initiate AS-i command calls (e. g. reading/writing the AS-i configuration during normal operation). In addition to digital I/O data, analog data can also be saved permanently in the cyclic periphery of a failsafe S7-300/ S7-416 F-CPU.

In configuring mode the DP/AS-i F-Link reads in the configuration data of the peripherals on the AS-Interface. Slave addresses can be set using the display and the control keys, and the code sequences of safe AS-i slaves can be taught.

During operation, four display LEDs and the display provide detailed diagnostics information, which directly localizes the fault if required. Using the PLC user program it is possible to read out diagnostics data records and make them available to a higher-level operating and monitoring system (e. g. WinCC Flexible or TRANSLINE HMI).

Application (continued)

Network connectivity

The DP/AS-i F-Link can be used in PROFIBUS and PROFINET networks as follows:

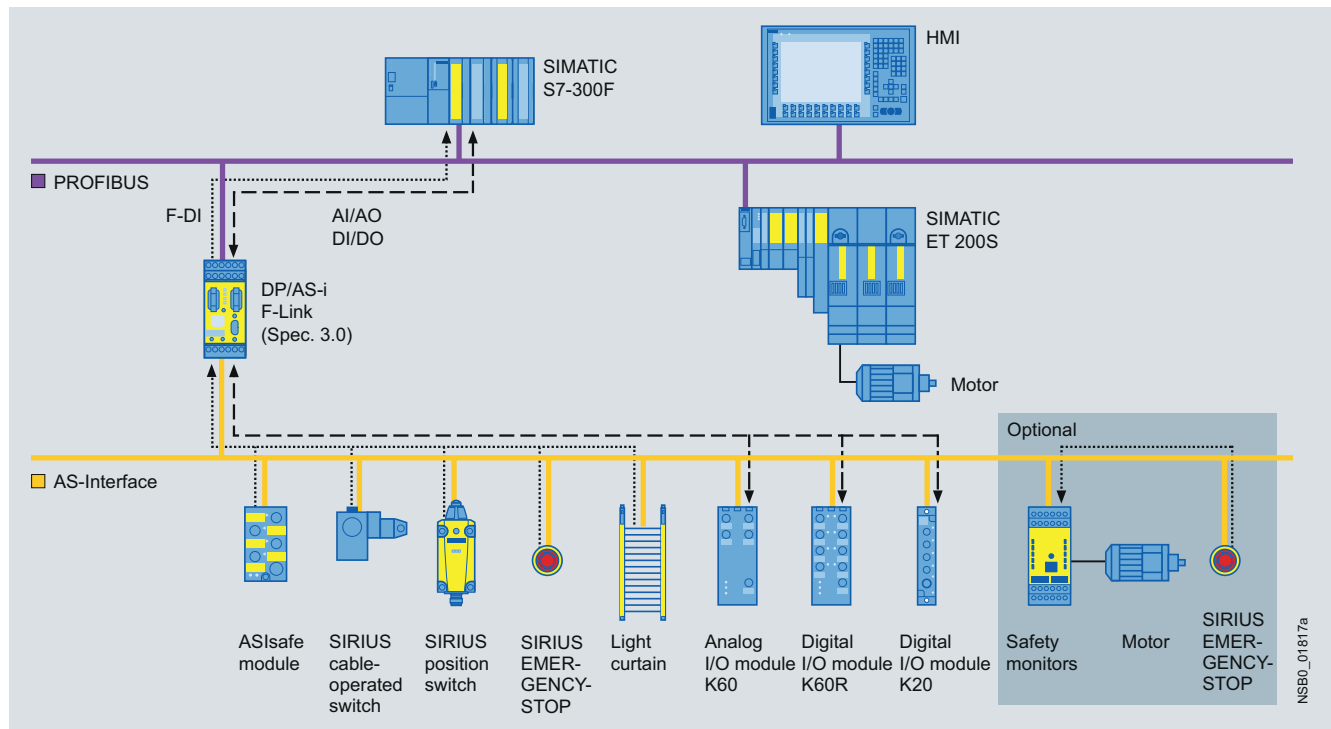

Integration in PROFIBUS networks under SIMATIC F PLC

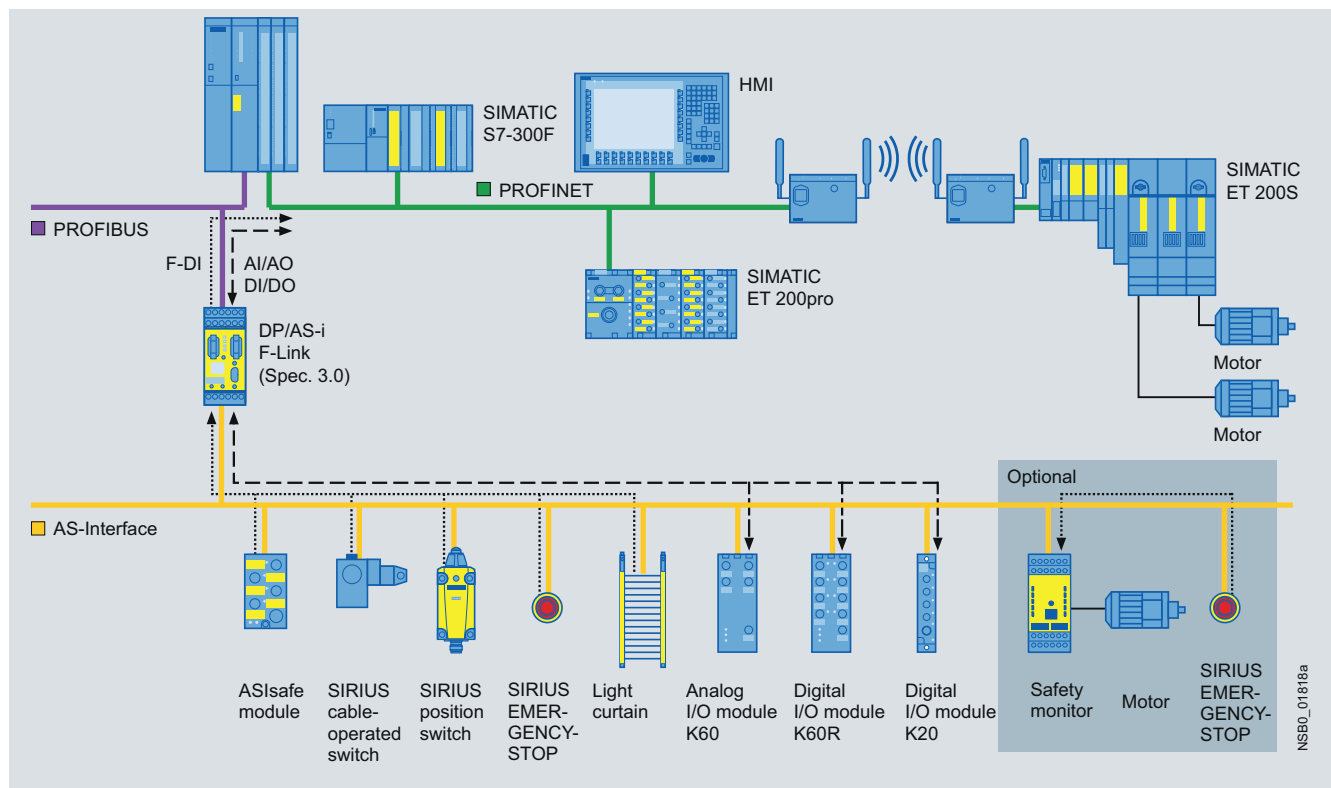

Integration in PROFINET networks under SIMATIC F-SPS (alternatively can also be integrated through IE/PB Link)

AS-Interface

Network transitions

DP/AS-i F-Link

Application (continued)

Further network connectivity options:

- Integration in PROFINET networks under SIMATIC F PLC through IE/PB Link
- Integration in SINUMERIK Power Line and Solution Line
- Integration under non-Siemens failsafe control systems using PROFIBUS GSD file, available on the Internet at <http://support.automation.siemens.com/WW/view/en/113250>

Selection and ordering data

Version		Order No.
 <p>DP/AS-i F-Link</p>	<p>DP/AS-i F-Link</p> <p>Network transition between PROFIBUS DP and AS-Interface for safety-oriented data transmission from ASIsafe to PROFIBUS DP – PROFIsafe in degree of protection IP20; corresponds to AS-Interface Specification V3.0; dimensions (W x H x D / mm): 45 x 104 x 120</p> <ul style="list-style-type: none"> • Screw terminals • Spring-type terminals 	<p>3RK3 141-1CD10</p> <p>3RK3 141-2CD10</p>

More information

More accessories for the PROFIBUS connection can be found on page 6/42.

The DP/AS-i F-Link manual is available at <http://support.automation.siemens.com/WW/view/en/24196041>

Circuit examples for safety systems with DP/AS-i F-Link are available at <http://support.automation.siemens.com/WW/view/en/24509484>

The F-Link Object Manager must be installed for configuring HW-Config (STEP 7). The Object Manager can be downloaded free of charge from the Internet at <http://support.automation.siemens.com/WW/view/en/24724923>

Overview



IE/AS-i LINK PN IO

PN	DP-M	DP-S	ASi-M		
●			●		

The IE/AS-i LINK PN IO is a compact network transition between PROFINET/Industrial Ethernet (PROFINET IO Device) and AS-Interface, with the following features:

- Single and double AS-Interface master (according to AS-Interface Specification V3.0) for connection of 62 AS-Interface slaves or 124 AS-Interface slaves (with a double master)
- Integrated analog value transmission (all analog profiles)
- Integrated ground-fault monitoring for the AS-Interface cable
- User-friendly local diagnostics and start-up by means of a full graphic display and control keys or through a web interface with a standard browser on the PC screen
- Optimum TIA integration using STEP 7
- Integration in non-Siemens engineering tools using the PROFINET GSD file
- Vertical integration (standard web interface) through Industrial Ethernet
- Supply via AS-Interface cable or with 24 V DC
- Suitable for AS-i Power24V (product version 2 and higher / firmware version 2.0.20) and standard AS-i (30 V)
- Module exchange without entering the connection parameters (IP address etc.) using C-PLUG (optional)
- Costs saved by the double AS-Interface master when large volumes of project data are involved

Design

- Compact plastic enclosure in degree of protection IP20 for standard rail mounting
- COMBICON plug-in screw terminals
- Compact design:
 - Pixel graphics display in the front panel for detailed indication of the operating state and readiness for operation of all connected AS-Interface slaves
 - Six pushbuttons for starting up and testing the AS-Interface line directly on the IE/AS-i LINK PN IO
 - LED indication of the operating state of PROFINET IO and AS-Interface
 - Integrated 2-port switch (RJ45 socket) for connection to Industrial Ethernet supports the line topology with an external switch
- Small mounting depth thanks to recessed plug mounting
- Operation without fans and batteries

Functionality

Communication

The IE/AS-i LINK PN IO enables a PROFINET IO controller to cyclically access the I/O data of all the slaves of a lower-level AS-Interface segment. Also supported are the expanded slave types with higher I/O data volume according to AS-i Specification V3.0.

The IE/AS-i LINK PN IO occupies the following address area:

- As a single master or IO controller with full expansion: 62 bytes of input data and 62 bytes of output data in which the I/O data of the connected AS-Interface slaves (standard and A/B slaves) of an AS-i line are stored.
- As double master, double the number of bytes.

The size of the input/output image can be compressed so that only the actually required I/O address area is occupied in the system of the DP master.

The integrated evaluation of analog signals is just as easy as access to digital values because the analog process data also lie directly in the I/O address area of the CPU.

PROFINET IO controllers are able in addition to initiate AS-Interface master calls (e. g. to write parameters, change addresses, read diagnostic values) through the acyclic PROFINET services.

Using an operating display in AS-Interface Link it is possible to fully commission the lower-level AS-i line.

The IE/AS-i LINK PN IO is equipped with two Ethernet ports which are connected by an internal switch. With the Ethernet it is possible in addition to use the integrated web server. The web server can be called up with any standard web browser (e. g. Internet Explorer) without additional software. It enables the PC to present all diagnostics information and to display the set bus configuration and parameters as well as their adaptation where applicable. Firmware updates are also possible using this port.

The optional C-PLUG supports module exchange without entering the connection parameters (IP address etc.), keeping downtimes to a minimum in the event of a fault.

Diagnostics

The following diagnostics is possible using the display and control keys, web interface or STEP 7:

- Operating state of the E/AS-i LINK PN IO
- Status of the link as a PROFINET IO device
- Diagnostics of the AS-Interface network
- Message frame statistics
- Standard diagnostics pages in the web interface for fast diagnostics access through Ethernet using a standard browser
- For the use of the web interfaces are no network settings on the PC necessary (Zeroconf procedure).
- The reporting of diagnostic events is optional via E-Mail or SNMP Trap possible. The integrated diagnostic buffer saves the events including time stamp.

Configuration

The IE/AS-i LINK PN IO is configured as follows:

- STEP 7 V5.4 or higher is required for configuring the full functional scope of the IE/AS-i LINK PN IO. With STEP 7 configuring the AS-Interface configuration can be uploaded in STEP 7 V5.4 SP2 and higher. Can also be AS-Interface slaves from Siemens conveniently configure in HW Config (slave selection dialog).
- Alternatively, E/AS-i LINK PN IO can be integrated by means of the PROFINET GSD file in the engineering tool (e. g. for STEP 7 V5.4 SP2 and lower or for non-Siemens engineering tools).

AS-Interface Network transitions

IE/AS-i LINK PN IO

Benefits



- Short start-up times through simple configuration at the press of a button and testing of the AS-Interface line using the display or web interface
- Reduction of standstill and servicing times in the event of a slave failure thanks to user-friendly diagnostics using the display or web interface

- Costs saved by the double AS-Interface master when large volumes of project data are involved
- Saves the need for AS-i power pack with AS-i Power24V: The AS-Interface cable assembly is fed through an existing 24 V DC PELV power pack. For decoupling an AS-i data decoupling module is required, see power supply units and data decoupling modules.
- Standard mode with AS-Interface power supply (see power supply units and data decoupling modules) possible without restrictions, whereby no further operating voltage is required

Application

The DP/AS-i LINK PN IO is a PROFINET IO device (according to IEC 61158/IEC 61784) and an AS-Interface master (based on AS-Interface Specification V3.0 according to IEC 62026-2). It enables transparent data access to AS-Interface from Industrial Ethernet.

Exchanging data with PROFINET IO controllers

PROFINET IO controllers can exchange I/O data with AS-Interface in cyclic mode and can perform AS-i master calls in addition with acyclic services (e. g. reading/writing the AS-i configuration during normal operation). As such, the IE/AS-i LINK PN IO is particularly well suited for a decentral construction and for connection of a lower-level AS-Interface network.

Single masters

For applications with typical volumes of project data it is sufficient to use the IE/AS-i LINK PN IO in its version as an AS-i single master. The single master can operate up to 248 DI/248 DO, using 62 A/B slaves with 4DI/4DO each.

Double masters

For applications with large volumes of project data the IE/AS-i LINK PN IO in its version as an AS-i double master is used. In this case, twice the volume of project data can be used on two AS-i lines running independently of each other. The double master can operate up to 496 DI/496 DO, using 2 AS-i networks with 62 A/B slaves each with 4DI/4DO each.

6

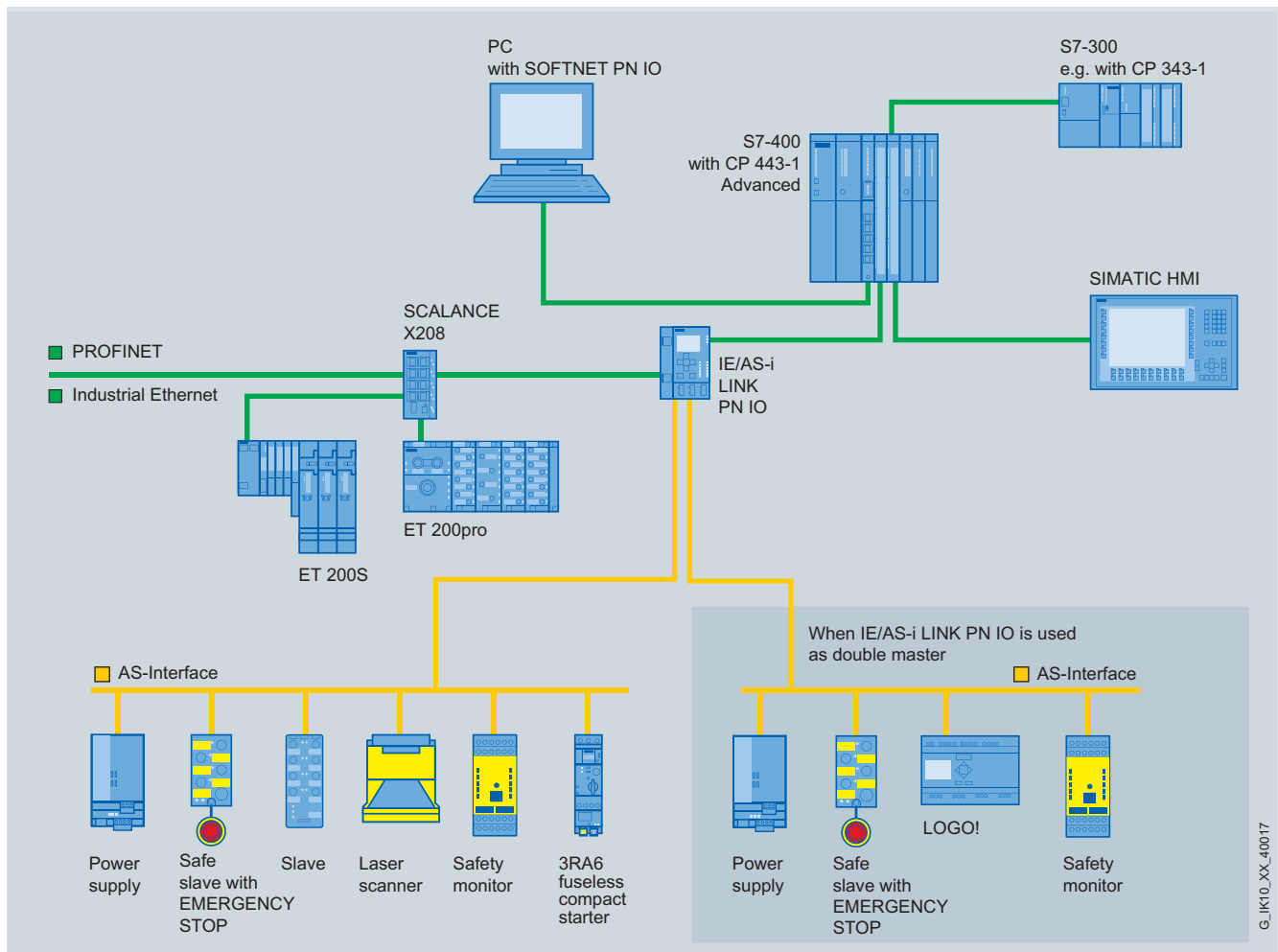

Integration of AS-Interface on PROFINET through IE/AS-i LINK PN IO as single/double master

Application (continued)

Wireless communication

Using an upstream IWLAN client module, e. g. SCALANCE W746-1PRO, an AS-Interface line can be integrated in the PROFINET world by wireless means.

Sample uses are applications which up to now have been performed with fault-prone tow chain or collector wire technology. Maintenance costs are thus reduced.

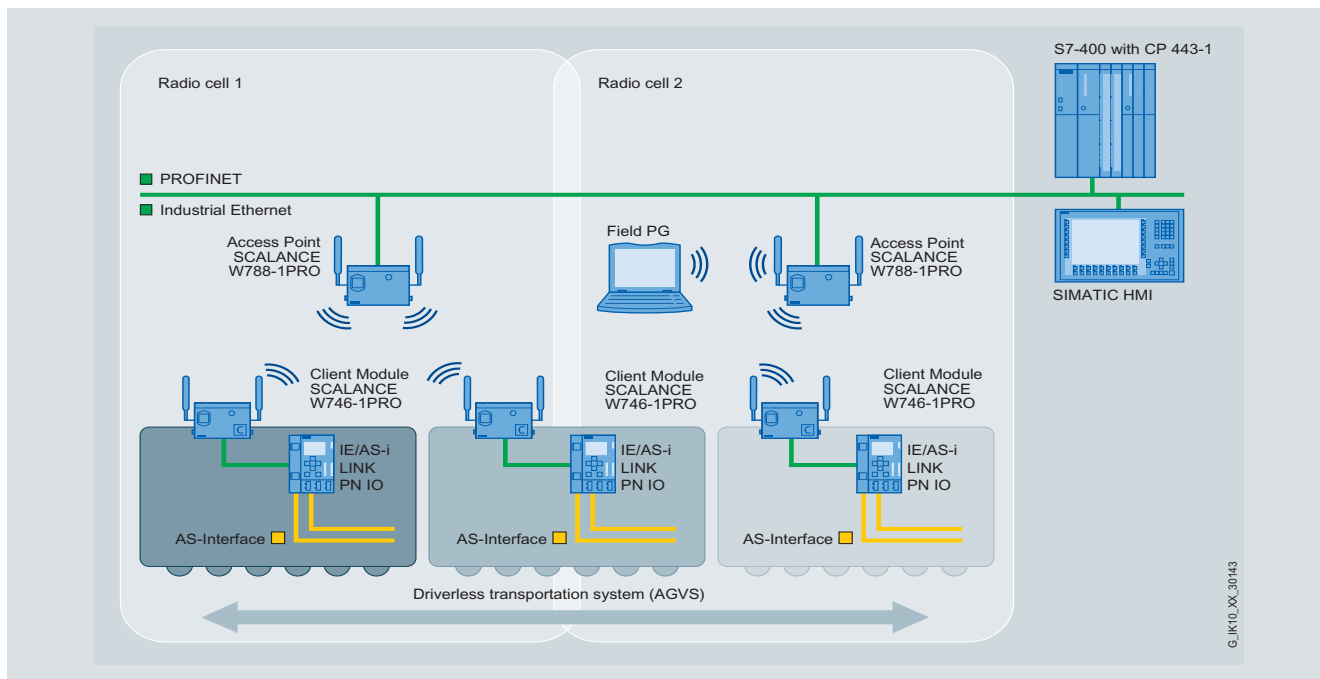

Wireless communication between Industrial Ethernet and AS-Interface components



Selection and ordering data

Version	Combicon connection Order No.
<p>IE/AS-i LINK PN IO</p> <p>Network transition between PROFINET/Industrial Ethernet and AS-Interface in degree of protection IP20; including COMBICON plug-in screw terminals for connection of an AS-Interface cable (two AS-Interface cables for double masters) and the optional 24 V supply; corresponds to AS-Interface Specification 3.0; dimensions (W x H x D / mm): 90 x 132 x 88.5</p> <ul style="list-style-type: none"> • Single master with display • Double master with display 	<p>6GK1 411-2AB10</p> <p>6GK1 411-2AB20</p>
<p>C-PLUG</p> <p>Exchange medium for the simple exchange of devices in the event of a fault; for accommodating configuration and application data; can be used in SIMATIC NET products with a C-PLUG slot</p>	<p>6GK1 900-0AB00</p>
<p>IE FC RJ45 Plug 90</p> <p>RJ45 plug-in connector for Industrial Ethernet, with robust metal enclosure and integrated cutting and clamping contacts for connection of Industrial Ethernet FC installation cables; with 90° cable feeder</p> <ul style="list-style-type: none"> • 1 pack = 1 units • 1 pack = 10 units • 1 pack = 50 units 	<p>6GK1 901-1BB20-2AA0</p> <p>6GK1 901-1BB20-2AB0</p> <p>6GK1 901-1BB20-2AE0</p>

IE/AS-i LINK PN IO

Accessories

More information

The manuals are available on the Internet at <http://support.automation.siemens.com/WWW/view/en/29992487/13330>

AS-Interface slaves

I/O modules for operation in the field, high degree of protection

Digital I/O modules, IP67 - Introduction

Overview



K60



K20

Three coordinated series of AS-Interface compact modules with digital and analog compact modules and a high degree of protection are available for operation in the field:

- Series K60 (digital and analog)
- Series K45 (digital)
- Series K20 (digital)

All compact modules are characterized by particularly simple handling. The K60 and K45 modules are mounted with a mounting plate. The mounting plate is used to receive the AS-Interface flat cables and enables mounting on a wall or standard mounting rail.

The K20 modules are directly mounted without a mounting plate and connected to the AS-Interface using a round cable.



K45

Connection types

For flexible connection of different sensors and actuators, the following PIN assignments are available on the I/O modules with M12 sockets:

Standard assignment

With the standard assignment, one sensor/actuator is connected per M12 socket. In this case the signal for the outputs is at PIN4 while the signal for the inputs is detected at PIN4 and PIN2. As the result, sensors can be connected directly to PIN2 and PIN4.

Y assignment

With the Y assignment, two sensors or two actuators can be connected to one M12 socket. In this case, both PIN4 and PIN2 are provided for respectively one sensor/actuator signal on each M12 socket.

Y-II assignment

The Y-II assignment offers the following options:

- Individual connection of a sensor/actuator to one M12 socket
- Connection of respectively two sensors/actuators to one M12 socket as follows:
 - The signal of the first sensor/actuator is connected to PIN4 of the first socket.
 - The signal of the second sensor/actuator is connected to PIN2 of the first socket and to PIN4 of the second socket.
 In this case, the second socket is not required and is closed with a sealing cap.

Overview of digital compact modules

The following table provides an overview of the important features of the digital compact modules.

Version	K60	K45	K20
8 inputs/2 outputs	✓	--	--
8 inputs	✓	--	--
4 inputs/4 outputs	✓	✓	✓
4 inputs/3 outputs	✓	--	--
4 inputs/2 outputs	✓	--	--
4 inputs	✓	✓	✓
2 inputs/2 outputs	--	✓	✓
4 outputs	✓	✓	✓
3 outputs	--	✓	--
AS-Interface connection	Flat cable / round cable	Flat cable	Round cable
I/O connection method	M12	M12/M8	M12/M8
Pin assignment	Standard/Y-II/Y	Standard/Y	Standard/Y
Degree of protection	IP65/IP67/IP68/IP69K	IP65/IP67	IP65/IP67
ATEX 3D (Zone 22)	✓	--	--
Extended address mode	✓	✓	✓

✓ Available

-- Not available

Overview

The K60 digital AS-Interface compact modules are characterized by optimized handling characteristics and user-friendliness. They permit the mounting times and start-up times of AS-Interface to be reduced by up to 40 %.

Assembly of the K60 modules is performed with a mounting plate which accommodates the AS-Interface shaped cables. Two different mounting plates are offered for

- Wall mounting
- Standard rail mounting

Addressing of the K60 modules is performed using an addressing socket integrated in the compact module. The addresses can also be assigned after installed.

K60 compact modules with a maximum of four digital inputs and outputs

These compact modules contain the communication electronics and the M12 standard connections for inputs and outputs. Using M12 standard connectors, a maximum of four sensors and four actuators can be simply and reliably connected to the compact module.

The mounting plate and the compact module are joined together by means of a screw, with simultaneous contacting of the AS-Interface cable by the service-proven insulation piercing method.

K60 compact modules with a maximum of eight digital inputs

These modules have eight digital inputs for connection through M12 plugs.

The module requires two AS-Interface addresses for processing all eight inputs. As with every compact module, the addressing can be performed through a double addressing socket.

K60 compact modules with a four digital inputs and outputs according to AS-Interface Specification 3.0

The new AS-i specification 3.0 adds a number of completely new features to the AS-Interface bus system. The extended address mode (A/B addresses) enables the connection of up to 62 slaves on one AS-i network. With the extended address mode according to Specification 3.0, four outputs are now possible even with A/B slaves (instead of only three outputs possible up to now with specification 2.1). Hence with full expansion of an AS-i network, there are now 248 inputs as well as 248 outputs available on one AS-i system. Modules with four inputs and four outputs as A/B slaves according to Specification 3.0 are also available as K60 compact modules.

Please note that these modules can be used only with a new master according to AS-i specification 3.0 (e.g. the new DP/AS-i LINK Advanced or IE/AS-i LINK PN IO) and that the cycle times for the outputs can extend to max. 20 ms.

K60 data couplers

An AS-Interface data coupler has been added to the K60 compact module range. Integrated in this module are two AS-i slaves which are connected to two different AS-i networks. Each of the two integrated slaves has four virtual inputs and four virtual outputs. The bidirectional data transmission of four data bits between two AS-i networks is thus possible in a simple and cost-effective manner. The data coupler need its own address in each AS-i network.

Each AS-i network works with a different cycle time depending on the number of stations. Hence two AS-i networks are not necessarily synchronous. For this reason the AS-i data coupler can be used to transmit only standard data and no safe data.

K60 compact modules for use in hazardous areas (ATEX)

Two versions of the K60 modules are available for operation in Zone 22 hazardous areas according to Classification II 3D (dusty atmosphere, non-conductive dust). The version with four inputs and four outputs has the designation (Ex) II 3D Ex tD A22 IP65X T75°C and the version with four inputs has the designation (Ex) II 3D Ex tD A22 IP65X T60°C.

Special conditions have to be observed for the safe operation of these devices. In particular the module must be protected by suitable protective measures from mechanical damage.

More information

Other conditions for safe operation see section Technical Information at

www.siemens.com/industrial-controls/support

AS-Interface slaves

I/O modules for operation in the field, high degree of protection

Digital I/O modules, IP67 - K60

Selection and ordering data

Version	Order No.					
 3RK1 400-1DQ00-0AA3	Digital I/O modules, IP67 – K60 <ul style="list-style-type: none"> • PNP transistor • Width 60 mm • Connection method: M12 • Modules supplied without mounting plate 					
	Type	Current carrying capacity of outputs	Slave type	Pin assignment	Sensor power supply off	
	8 inputs/ 2 outputs	2 A	A/B	Special	AS-i	3RK2 400-1HQ00-0AA3
	8 inputs	--	Standard	Y-II	AS-i	3RK1 200-0DQ00-0AA3
		--	A/B	Y-II	AS-i	3RK2 200-0DQ00-0AA3
		--	A/B	Y-II	U_{aux}	3RK2 200-1DQ00-1AA3
	4 inputs/ 4 outputs	2 A	Standard	Y-II	AS-i	3RK1 400-1DQ00-0AA3
		2 A	Standard	Standard	AS-i	3RK1 400-1CQ00-0AA3
		1 A	Standard	Y-II	AS-i	3RK1 400-1DQ01-0AA3
		1 A	Standard	Standard	AS-i	3RK1 400-1DQ03-0AA3
		2 A	A/B slave (Spec. 3.0)	Y-II	AS-i	3RK2 400-1DQ00-0AA3
	4 inputs/ 3 outputs	2 A	A/B slave (Spec. 3.0)	Y-II	U_{aux}	3RK2 400-1DQ00-1AA3
		2 A	A/B	Y-II	AS-i	3RK2 400-1FQ03-0AA3
	4 inputs/ 2 outputs	2 A	Standard	Y-II	AS-i	3RK1 400-1MQ00-0AA3
	4 inputs	--	Standard	Y-II	AS-i	3RK1 200-0CQ00-0AA3
	2x2 inputs/ 2x2 outputs	1 A	Standard	Y	AS-i	3RK1 400-1DQ02-0AA3
	4 outputs	2 A	Standard	Y-II	AS-i	3RK1 100-1CQ00-0AA3
Digital I/O modules IP67 – K60, version ATEX (Ex) II 3D Ex tD A22 IP65X T75°C/60°C <ul style="list-style-type: none"> • PNP transistor • Width 60 mm • Current carrying capacity of the inputs: 200 mA • Connection method: M12 • Modules supplied without mounting plate 						
Type	Current carrying capacity of outputs	Slave type	Pin assignment			
4 inputs/ 4 outputs	2 A	Standard	Y-II		3RK1 400-1DQ05-0AA3	
4 inputs	--	Standard	Y-II		3RK1 200-0CQ05-0AA3	
Digital I/O modules IP67 – K60 data couplers <ul style="list-style-type: none"> • Modules supplied without mounting plate 						
Type	Current carrying capacity of outputs	Slave type	Pin assignment			
Data coupler 4 inputs/ 4 outputs (virtual)	--	Standard	--		3RK1 408-8SQ00-0AA3	

Accessories



K60 mounting plates

Suitable for all K60 compact modules

- Wall mounting
- Standard rail mounting

3RK1 901-0CA00
3RK1 901-0CB01



AS-Interface sealing caps M12

For free M12 sockets

3RK1 901-1KA00



AS-Interface sealing caps M12, tamper-proof

For free M12 sockets

3RK1 901-1KA01



Sealing sets

- For K60 mounting plate and standard distributor
- Cannot be used for K45 mounting plate
- One set contains one straight and one shaped seal

3RK1 902-0AR00

AS-Interface slaves

I/O modules for operation in the field, high degree of protection

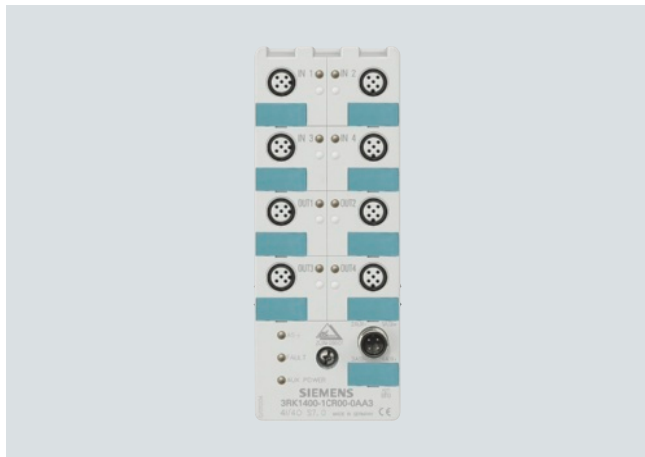
Digital I/O modules IP68/IP69K - K60R
Overview
Operation in particularly harsh environments

K60R module in degree of protection IP68/IP69K

Modules with degree of protection IP67 cannot be used in areas exposed to permanently high levels of humidity, in applications with drilling emulsions and cutting oils or when cleaning with high-pressure cleaners. The answer for these applications is provided by the expansion of the K60 compact modules with the K60R module with degree of protection IP68/IP69K.

The K60R modules are connected instead of the AS-Interface flat cable using a round cable with M12 cable box. The AS-Interface bus cable and the 24 V DC auxiliary voltage supply are routed in this case in a shared round cable.

Degree of protection IP68 permits many new applications, which were impossible with the former field modules with degree of protection IP67. In applications such as filling plants or machine-tools the K60R with degree of protection IP68 enables the module to be used directly in zones exposed to permanent loading by humidity. It is thus possible to make even more rigorous savings in wiring with AS-Interface. The IP68 test conditions can be found in the section "IP68/IP69K tests".

Cleaning with high-pressure cleaners, such as is regularly performed in the food drinks industry for instance, is possible without difficulty (IP69K).

In applications with tow chains, many users rely on placing the AS-Interface bus cable in a round cable. With the K60R module there is a round cable connection for direct connection to a round cable. No adapter is required.

Mounting

The same mounting plates are used as for the K60 modules. Instead of using flat cables the K60R is connected using a 4-pole round cable with an M12 connection. With the K60R the mounting plate thus serves only as a fixture and ground terminal.

Addressing

Addressing is performed using the same socket as for the bus connection. Connecting the module to the addressing unit takes place over a 3-pole standard M12 cable.

When the mounting is finished, the module is connected with the addressing cable to the addressing unit and addressed. The addressing cable is then removed and the module connected to the bus cable.

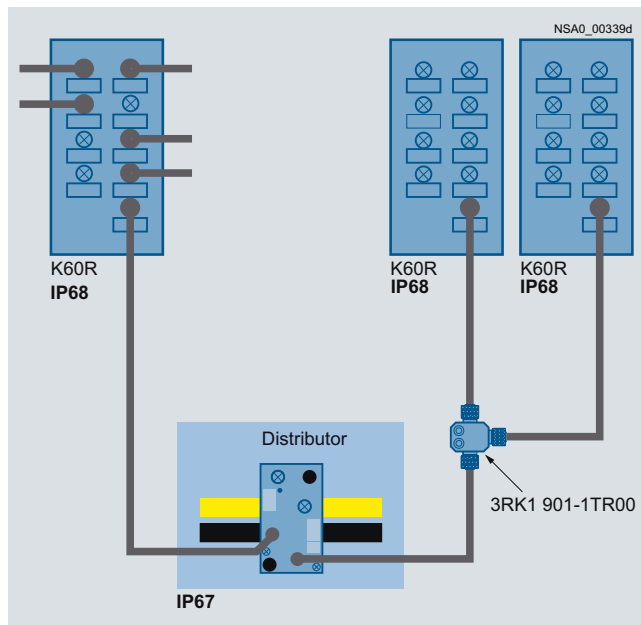
Connection

K60R connection options

In the IP67 environment the service-proven standard components are connected using flat cables. Spur lines are laid into the IP68 environment by means of an AS-Interface M12 feeder (3RK1 901-1NR...). The module is connected with a round cable to an M12 cable box. For this purpose the module has an M12 bus connection instead of the former addressing socket. The AS-Interface bus cable and the 24 V DC auxiliary voltage are routed together in a 4-pole round cable. There must be no ground conductor in this round cable. Connection to ground is made through the mounting plate.

In the IP68 environment only cables with extruded M12 plugs may be used.

To connect more than one K60R module to one spur line, the spur line can be split again using a T distributor (3RK1 901-1TR00) with degree of protection IP68.

Please note the following boundary conditions:

- The configuration guidelines for AS-Interface apply. For all M12 connecting cables the maximum permissible current is limited to 4 A. The cross-section of these cables amounts to just 0.34 mm². For connection of the K60R modules, the aforementioned M12 connecting cables can be used for the spur lines. The voltage drop caused by the ohmic resistance (approx. 0.11Ω/m) must be taken into account.
- For round cable connections with shared AS-i and U_{aux} in a single cable, the following maximum lengths apply:
 - per spur line from feeder to module: maximum 5 m
 - total of all round cable segments in an AS-Interface network: maximum 20 m

Tests IP68/IP69K

- K60R modules were tested with the following tests:
- Stricter test than IP67: 90 min at 1.8 m depth of water (IP67: 30 min at 1 m depth of water)
- Salt water test: Five months in salt water, 20 cm deep, at room temperature
- Test with particularly creepable oil: Five months completely under oil at room temperature

AS-Interface slaves

I/O modules for operation in the field, high degree of protection

Digital I/O modules IP68/IP69K - K60R

Overview (continued)







- Test with drilling emulsion: Five months at room temperature (components of the drilling emulsion: Anionic and non-ionic emulsifiers, paraffinic low-aromatic mineral oil, boric acid alkanolamines, corrosion inhibitors, oil content 40 %)
- Test in oil bath (Excelence 416 oil) with alternating oil bath temperature: 130 cycles of 15 to 55 °C, two months
- Cleaning with a high-pressure cleaner according to IP69K: 80 to 100 bar, 10 to 15 cm distance, time per side > 30 s, water temperature 80 °C

To simulate requirements as realistically as possible the modules were artificially aged prior to the tests by 15 temperature cycles of -25/+85 °C. During the test the modules were connected to 3RX1 connecting cables. Unassigned connections were closed with 3RK1 901-1KA00 sealing caps.

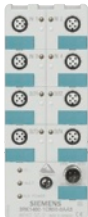
Note:

Sealing caps and M12 connections must be tightened with the correct torque.

Selection and ordering data

Version	Order No.																				
 <p>Digital I/O modules IP68/IP69K – K60R</p> <ul style="list-style-type: none"> • 4 inputs/4 outputs • Width 60 mm • IP68/IP69K • Standard assignment • Current carrying capacity: <ul style="list-style-type: none"> - 200 mA (inputs) - 2 A (outputs) • Standard slave • Modules supplied without mounting plate 	3RK1 400-1CR00-0AA3																				
<p>Accessories</p>  <p>K60 mounting plates Suitable for all K60 and K60R compact modules</p> <ul style="list-style-type: none"> • Wall mounting • Standard rail mounting 	3RK1 901-0CA00 3RK1 901-0CB01																				
 <p>AS-Interface sealing caps M12 For free M12 sockets</p>	3RK1 901-1KA00																				
 <p>AS-Interface M12 feeders</p> <table border="1"> <thead> <tr> <th>For flat cable</th> <th>For</th> <th>Cable length</th> <th>Cable end in feeder</th> <th></th> </tr> </thead> <tbody> <tr> <td>AS-i / U_{aux}</td> <td>M12 socket</td> <td>--</td> <td>Not available</td> <td>3RK1 901-1NR20</td> </tr> <tr> <td>AS-i / U_{aux}</td> <td>M12 cable box</td> <td>1 m</td> <td>Not available</td> <td>3RK1 901-1NR21</td> </tr> <tr> <td>AS-i / U_{aux}</td> <td>M12 cable box</td> <td>2 m</td> <td>Not available</td> <td>3RK1 901-1NR22</td> </tr> </tbody> </table>	For flat cable	For	Cable length	Cable end in feeder		AS-i / U_{aux}	M12 socket	--	Not available	3RK1 901-1NR20	AS-i / U_{aux}	M12 cable box	1 m	Not available	3RK1 901-1NR21	AS-i / U_{aux}	M12 cable box	2 m	Not available	3RK1 901-1NR22	
For flat cable	For	Cable length	Cable end in feeder																		
AS-i / U_{aux}	M12 socket	--	Not available	3RK1 901-1NR20																	
AS-i / U_{aux}	M12 cable box	1 m	Not available	3RK1 901-1NR21																	
AS-i / U_{aux}	M12 cable box	2 m	Not available	3RK1 901-1NR22																	
 <p>AS-Interface M12 feeders, 4-fold</p> <table border="1"> <thead> <tr> <th>For flat cable</th> <th>For</th> <th>Cable length</th> <th>Cable end in feeder</th> <th></th> </tr> </thead> <tbody> <tr> <td>AS-i / U_{aux}</td> <td>4-fold M12 socket delivery includes coupling module</td> <td>--</td> <td>Available</td> <td>3RK1 901-1NR04</td> </tr> </tbody> </table>	For flat cable	For	Cable length	Cable end in feeder		AS-i / U_{aux}	4-fold M12 socket delivery includes coupling module	--	Available	3RK1 901-1NR04											
For flat cable	For	Cable length	Cable end in feeder																		
AS-i / U_{aux}	4-fold M12 socket delivery includes coupling module	--	Available	3RK1 901-1NR04																	
 <p>M12-T distributors</p> <ul style="list-style-type: none"> • IP68 • 1 x M12 plug • 2 x M12 box 	3RK1 901-1TR00																				
 <p>M12 connecting cables</p> <ul style="list-style-type: none"> • 3-pole • For addressing AS-i slaves with M12 bus connection • Cable length 1.5 m 	3RK1 902-4PB15-3AA0																				

Overview



K45 compact modules

The K45 series of compact modules supplements the K60 large compact modules which have a proven track record in industry. They are the logical consequence for rounding off the bottom end of the existing product range.

The acclaimed advantages of the existing K60 compact modules are fully emulated by the far smaller K45 modules. Their footprint is the same as that of the user modules. However, they have a mounting depth which is only two-thirds of the user module and hence an exact match for the compact module family.

Yet in spite of these small dimensions all the modules have large labels and an integrated addressing socket.

Two mounting plates are offered for the K45 compact modules:

- The mounting plate for wall mounting has a hole pattern that is identical to that of the K60 compact modules. This means that K60 compact modules can be mounted together with K45 modules in an aligned arrangement. The flat cables can be inserted in the recesses of the mounting plates where they cause no hindrance.
- The mounting plate for standard rail mounting has a hole pattern that is identical to that of the user modules.

Mounting the flat cables is now easier than ever. The yellow and black AS-Interface flat cable can be inserted into the mounting plates from the left or right regardless of the position of the coding lug. The correct polarity of the applied voltages is always guaranteed.

Sensors/actuators are connected using M12 sockets. The 4I module can be ordered optionally with M8 connection sockets.

AS-Interface slaves

I/O modules for operation in the field, high degree of protection

Digital I/O modules, IP67 - K45

Selection and ordering data

Version						Order No.
 <p>Digital I/O modules, IP67 – K45</p> <ul style="list-style-type: none"> • PNP transistor • Width 45 mm • Current carrying capacity of the inputs: 200 mA • Modules supplied without mounting plate 						
Type	Current carrying capacity of outputs	Slave type	Pin assignment	U_{aux} 24 V	Connection methods	
4 inputs	--	Standard	Standard	--	M12	3RK1 200-0CQ20-0AA3
	--	Standard	Standard	--	M8 screw	3RK1 200-0CT20-0AA3
	--	Standard	Standard	--	M8 snap	3RK1 200-0CU20-0AA3
	--	A/B	Standard	--	M12	3RK2 200-0CQ20-0AA3
	--	A/B	Standard	--	M8 screw	3RK2 200-0CT20-0AA3
	--	A/B	Standard	--	M8 snap	3RK2 200-0CU20-0AA3
2 x 2 inputs	--	A/B	Y	--	M12	3RK2 200-0CQ22-0AA3
2 inputs/ 2 outputs	2 A ¹⁾	Standard	Standard	✓	M12	3RK1 400-1BQ20-0AA3
2 x (1 input/ 1 output)	0.2 A	Standard	Y	--	M12	3RK1 400-0GQ20-0AA3
4 x (1 input/ 1 output)	0.2 A	A/B (Spec. 3.0)	Y	--	M12	3RK2 400-0GQ20-0AA3
4 x (1 input/ 1 output)	0.5 A	A/B (Spec. 3.0)	Y	✓	M12	3RK2 400-1GQ20-1AA3
3 outputs	1 A	A/B	Standard	✓	M12	3RK2 100-1EQ20-0AA3
4 outputs	1 A	Standard	Standard	✓	M12	3RK1 100-1CQ20-0AA3
2 outputs/ 2 inputs	2 A	A/B	Standard	✓	M12	3RK2 400-1BQ20-0AA3
✓ Available						
-- Not available						

Accessories



3RK1 901-2EA00

K45 mounting plates

- For wall mounting
- For standard rail mounting

3RK1 901-2EA00
3RK1 901-2DA00



3RK1 901-1KA00

AS-Interface sealing caps

- For free M12 sockets
- For free M8 sockets

3RK1 901-1KA00
3RK1 901-1PN00



3RK1 901-1PN00

Cable terminating pieces

For sealing of open cable ends
(shaped AS-Interface cable) in IP67

3RK1 901-1MN00



3RK1 901-1MN00

¹⁾ The typical current carrying capacity per output increases with version "E12" from 1.5 to 2 A (available since approx. 07/2003).

AS-Interface slaves

I/O modules for operation in the field, high degree of protection

Digital I/O modules IP67 - K20
Overview

Digital I/O modules IP67 – K20

The K20 compact module range rounds off the AS-Interface compact modules with a particularly slim design and a width of a mere 20 mm. Thanks to its extremely compact dimensions, these modules are particularly suited for handling machine applications in the field of production engineering where modules need to be arranged in the smallest of spaces.

Robotics is yet another application area. Instead of the AS-Interface flat cable, the K20 modules are connected to AS-Interface over a round cable with M12 cable box.

The AS-Interface bus cable and the 24 V DC auxiliary power supply are routed in this case in a shared round cable. This enables extremely compact installation.

The flexibility of the round cable means that it can also be used on moving machine parts without any problems. The K20 modules are also ideal for such applications as their non-encapsulated design makes them particularly light in weight.

In applications with tow chains, many users rely on placing the AS-Interface bus cable in a round cable. In this case, the K20 modules support direct connection to the round cable. No flat to round cable adapter is required.

The K20 compact module range includes standard AS-Interface modules, as well as an ASIsafe version for the connection of fail-safe sensors, such as EMERGENCY-STOP pushbuttons or protective door monitoring. All standard AS-Interface K20 modules support, as far as technically possible, the expanded address mode (A/B addresses) according to AS-Interface specification 2.1, which enables connection of 62 stations to an AS-Interface network. The K20 module with four inputs and four outputs works in expanded address mode according to AS-Interface specification 3.0 which, for the first time, supports four outputs with an A/B slave, thus enabling 248 inputs and 248 outputs in a fully expanded AS-Interface network.

For particularly space-saving dimensions, the sensors and actuators are connected over M8 plug-in connectors. Alternatively, M12 connectors with Y assignment can be used.

6
Selection and ordering data















Version						Order No.
 3RK2 200-OCT30-0AA3	Digital I/O modules, IP67 – K20					
	Width 20 mm					
	Type	Current carrying capacity of outputs	Slave type	Pin assignment	Connection methods	
	4 inputs	--	A/B	Standard	M8	3RK2 200-OCT30-0AA3
		--	A/B	Y	M12	3RK2 200-OCQ30-0AA3
	2 inputs/ 2 outputs	1	A/B	Standard	M8	3RK2 400-1BT30-0AA3
		1	A/B	Y	M12	3RK2 400-1BQ30-0AA3
	4 outputs	1	A/B (Spec. 3.0)	Standard	M8	3RK2 100-1CT30-0AA3
	4 inputs/ 4 outputs	1	Standard	Standard	M8	3RK1 400-1CT30-0AA3
1		A/B (Spec. 3.0)	Standard	M8	3RK2 400-1CT30-0AA3	
2 safe inputs	--	Standard	Y-II	M12	3RK1 205-0BQ30-0AA3	

AS-Interface slaves

I/O modules for operation in the field, high degree of protection

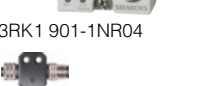
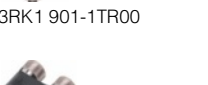
Digital I/O modules IP67 - K20

Selection and ordering data (continued)

Version		Order No.			
Accessories					
	AS-Interface sealing caps	3RK1 901-1KA00 3RK1 901-1PN00			
3RK1 901-1KA00	<ul style="list-style-type: none"> For free M12 sockets For free M8 sockets 				
					
3RK1 901-1PN00					
	AS-Interface compact distributors, for AS-Interface flat cable	3RK1 901-1NN10			
3RK1 901-1NN10	Current carrying capacity up to 8 A				
	AS-Interface M12 feeders				
3RX9 801-0AA00	For flat cable	Cable length	Cable end in feeder		
	AS-i	M12 socket	--	Available	3RK1 901-1NR10
3RK1 901-1NR10	AS-i	M12 socket	--	Not available	3RK1 901-1NR11
	AS-i	M12 cable box	1 m	Not available	3RK1 901-1NR11
	AS-i	M12 cable box	2 m	Not available	3RK1 901-1NR12
	AS-i / U _{aux}	M12 socket	--	Not available	3RK1 901-1NR20
3RK1 901-1NR11	AS-i / U _{aux}	M12 cable box	1 m	Not available	3RK1 901-1NR21
	AS-i / U _{aux}	M12 cable box	2 m	Not available	3RK1 901-1NR22
3RK1 901-1NR21					
					
3RK1 901-1NR21					
					
3RK1 901-1NR04					
	AS-Interface M12 feeders, 4-fold				
3RK1 901-1NR04	For flat cable	Cable length	Cable end in feeder		
	AS-i / U _{aux}	4-fold M12 socket delivery includes coupling module	--	Available	3RK1 901-1NR04
3RK1 901-1TR00					
	M12-T distributors				3RK1 901-1TR00
3RK1 901-1TR00	<ul style="list-style-type: none"> IP68 1 x M12 plug 2 x M12 box 				
	M12 Y-shaped coupler plugs				6ES7 194-1KA01-0XA0
6ES7 194-1KA01-0XA0	For connection of two sensors to one M12 socket with Y connector				
	M12 connecting cables				3RK1 902-4PB15-3AA0
3RK1 902-4PB15-3AA0	<ul style="list-style-type: none"> 3-pole For addressing AS-i slaves with M12 bus connection Cable length 1.5 m 				

Overview

The AS-Interface user modules are the first module generation for AS-Interface.

Today, innovated and further improved modules are available in the form of the K45 and K60 series of compact modules. We recommend replacing the user modules in future with the K45 compact module series. The user modules will be available for a limited time in order to meet the demand for replacements.

Note:

More information can be found in the Industry Mall at www.siemens.com/industrymall

Advantages of the K45 compact modules

The K45 compact modules provide extra advantages in addition to the functionality of the user modules:

- An integrated addressing socket enables the module to be addressed in the installed state
- Time is saved when mounting the module: Mounting with only one screw thanks to hinge system
- Extensive diagnostics by LED on the module (e. g. display of zero address, no communication with master, overload)
- Random insertion of the AS-Interface flat cable irrespective of the position of the profiled lug
- Smaller dimensions
- Versions with M12 and M8 connection sockets enable the direct connection of all sensors
- Modules in A/B technology enable up to 62 slaves on one AS-Interface network

Conversion table for user modules --> K45

User modules		Corresponding K45 type	
Order No.	Version	Order No.	Version
3RG9 001-0AA00	4 inputs (100 mA)	3RK1 200-0CQ20-0AA3	4 inputs (200 mA)
3RG9 001-0AG00	4 inputs (200 mA)	3RK1 200-0CQ20-0AA3	4 inputs (200 mA)
3RG9 001-0AH00	2 x 2 inputs	3RK2 200-0CQ22-0AA3	2 x 2 inputs A/B slave
3RG9 001-0AC00	2 inputs/2 outputs relay outputs	3RK1 400-1BQ20-0AA3	2 inputs/2 outputs solid-state outputs
3RG9 001-0CC00	2 inputs/2 outputs solid-state outputs	3RK1 400-1BQ20-0AA3	2 inputs/2 outputs solid-state outputs
3RG9 001-0AM00	2 inputs/2 outputs solid-state outputs U_{Aux} using M12 plug	3RK1 400-1BQ20-0AA3	2 inputs/2 outputs solid-state outputs U_{Aux} using black flat cable
3RG9 001-0AJ00	2 x (1 input/1 output) supply of I/O from AS-Interface cable	3RK1 400-0GQ20-0AA3	2 x (1 input/1 output) supply of I/O from AS-Interface cable
3RG9 001-0AB00	4 outputs relay outputs	3RK1 100-1CQ20-0AA3	4 inputs solid-state outputs
3RG9 001-0AL00	4 outputs U_{Aux} using M12 plug	3RK1 100-1CQ20-0AA3	4 outputs U_{Aux} using black flat cable
3RG9 001-0CB00	4 inputs solid-state outputs	3RK1 100-1CQ20-0AA3	4 inputs solid-state outputs

Note:

To use the K45 modules you require the 3RK1 901-2EA00 (wall mounting) or 3RK1 901-2DA00 (standard rail mounting) K45 mounting plates instead of the 3RG9 010-0AA00 and 3RG9 030-0AA00 coupling modules.

AS-Interface slaves

I/O modules for operation in the field, high degree of protection

Analog I/O modules, IP67 - K60

Overview



K60 analog compact module

AS-Interface analog modules from the K60 compact series detect or issue analog signals locally. These modules are linked to the higher-level controller through an AS-Interface master according to specification 2.1 or specification 3.0.

The analog modules are divided into five groups:

- Input module for sensors with current signal
- Input module for sensors with voltage signal
- Input module for sensors with thermal resistor
- Output module for current actuators
- Output module for voltage actuators

The input modules according to profile 7.3/7.4 are available with two or four input channels. It is possible in addition to convert the two-channel module to using only one input channel, thus enabling very short times before the analog value is available. The conversion is effected by means of a jumper plug at socket 3. The transmission times achieved with analog modules according to Profile 7.A.9 are shorter by half than those achieved with Profile 7.3/7.4. Operation is adjustable in this case, e. g. it is possible to choose with the ID1 Code whether the module is operated with one or two channels.

The output modules are configured as two-channel modules as standard.

The input and output channels are electrically separated from the AS-Interface network. If sensors with a higher power requirement are to be connected, more power can be supplied through the auxiliary voltage as an alternative to the internal supply.

In the manual the modules are presented in great detail along with their technical specifications and in-depth notes on operation. Sample function blocks round off the manual.



Benefits

- Analog modules are just as easy to integrate in AS-Interface as digital modules
- Analog values can be easily detected and issued locally
- Preprocessing of the analog value transmission in the master enables rapid evaluation of the analog values
- Up to four values can be detected using one analog module
- Faster transmission and conversion of analog values thanks to the new option for changing over to single-channel operation

In addition, Specification 3.0 now also offers:

- A/B technology, now also with analog modules
- On average, double fast transmission times (only 3 or 4 cycles, depending on the resolution selected)
- Variable adjustable mode: 12 bit or 14 bit resolution, 1 or 2-channel, selectable over the ID1 code
- Extra simple handling of analog processing with masters of Specification 3.0, the DP/AS-i LINK Advanced

Selection and ordering data





Version	Order No.			
 <p>Analog I/O modules IP67 – K60, analog profile 7.3</p> <ul style="list-style-type: none"> • Slave type: Standard • Width 60 mm • Modules supplied without mounting plate 	Inputs	Type	Measuring range	
	1 or 2 inputs (selectable using jumper plug at socket 3)	Current	4 ... 20 mA or ±20 mA (selectable)	3RK1 207-1BQ40-0AA3
		Voltage	± 10 V or 1 ... 5 V (selectable)	3RK1 207-2BQ40-0AA3
		Thermal resistance	Pt 100 or Ni 100 or 0 ... 600 Ω (selectable)	3RK1 207-3BQ40-0AA3
	4 inputs	Current	4 ... 20 mA or ±20 mA (selectable)	3RK1 207-1BQ44-0AA3
		Voltage	± 10 V or 1 ... 5 V (selectable)	3RK1 207-2BQ44-0AA3
		Thermal resistance	Pt 100 or Ni 100 or 0 ... 600 Ω (selectable)	3RK1 207-3BQ44-0AA3
	Outputs	Type	Output range	
	2 outputs	Current for 2-wire actuators	4 ... 20 mA or ±20 mA or 0 ... 20 mA (selectable)	3RK1 107-1BQ40-0AA3
		Voltage for 2-wire actuators	± 10 V or 0 ... 10 V or 1 ... 5 V (selectable)	3RK1 107-2BQ40-0AA3
 <p>Analog I/O modules IP67 – K60, analog profile 7.A.9</p> <ul style="list-style-type: none"> • Slave type: A/B (Spec. 3.0) • Width 60 mm • Modules supplied without mounting plate 	Inputs	Type	Measuring range	
	1 or 2 inputs (variably adjustable)	Current	4 ... 20 mA or ±20 mA (selectable)	3RK2 207-1BQ50-0AA3
		Voltage	± 10 V or 1 ... 5 V (selectable)	3RK2 207-2BQ50-0AA3

AS-Interface slaves

I/O modules for operation in the field, high degree of protection

Analog I/O modules, IP67 - K60

Selection and ordering data (continued)

Version	Order No.
Accessories	
<p>Manuals Only available to download on the Internet: www.siemens.com/automation/manuals</p>	
 <p>K60 mounting plates</p> <ul style="list-style-type: none"> • Wall mounting • Standard rail mounting 	<p>3RK1 901-0CA00 3RK1 901-0CB01</p>
 <p>M12 sealing caps</p>	<p>3RK1 901-1KA00</p>
 <p>Sealing sets</p> <ul style="list-style-type: none"> • For mounting plate K60 and distributor • Cannot be used for K45 mounting plate • One set contains one straight and one shaped seal 	<p>3RK1 902-0AR00</p>
 <p>Jumper plugs For changing over the 2-channel input modules</p>	<p>3RK1 901-1AA00</p>

Note:

More information can be found in the Industry Mall at www.siemens.com/industrymall

AS-Interface slaves I/O modules for operation in the control cabinet

Overview

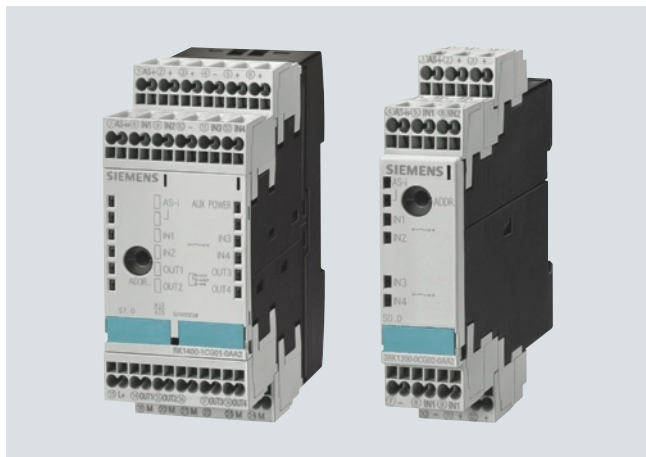

SlimLine S22.5/S45



Flat module



F90 module

For AS-Interface applications inside control cabinets there are various module series for the most diverse requirements:

- SlimLine S22.5
- SlimLine S45
- F90 module
- Flat module

All modules of these series can be snap-mounted directly on a standard mounting rail or be fastened using screws.

AS-Interface modules in IP20 have direct terminals for the AS-Interface cables and therefore do not require a base.



Series	Spectrum	Mounting on TH35 standard mounting rails according to EN 60715	Wall mounting using push-in lugs (Order No.: 3RP1 903)	Other possibilities
SlimLine S22.5	<ul style="list-style-type: none"> • 4I (standard and A/B modules) • 4O • 2I/2O (steady-state/relay outputs) • Counters ¹⁾ • Ground-fault detection modules ¹⁾ 	✓	✓	--
SlimLine S45	<ul style="list-style-type: none"> • 4I/4O (steady-state/relay outputs) • 4I/4O with floating I/Os • 4I/3O (A/B modules) • 4I/4O (A/B modules Spec. 3.0) 	✓	✓	--
F90 module	<ul style="list-style-type: none"> • 4I/4O (screw terminals) • 4I/4O (connection using Combicon connector) • 16I 	✓	--	--
Flat module	<ul style="list-style-type: none"> • 4I/4O (screw terminals) 	--	--	Integrated lugs for screw fixing

¹⁾ For more information about these modules see "Modules with Special Functions" from page 6/70

✓ Available

-- Not available

AS-Interface slaves

I/O modules for operation in the control cabinet

SlimLine

Overview

SlimLine modules of the S22.5 and S45 series

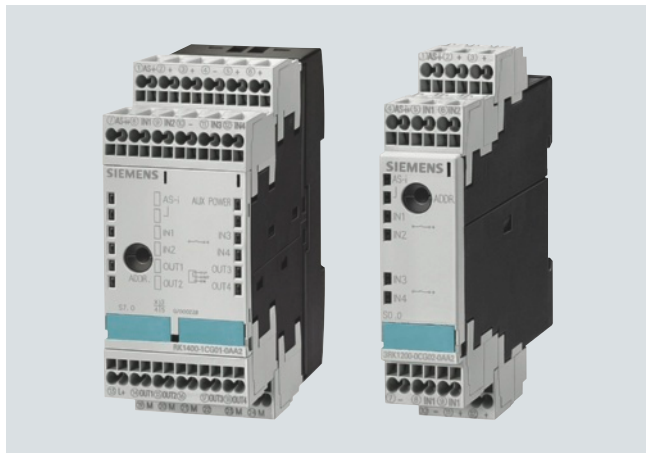

SlimLine S45 modules (left) and S22.5 modules (right)

The AS-Interface series of modules for the "SlimLine" control cabinet with degree of protection IP20 creates space in the cabinet and in distributed local boxes.

For these modules the priority was placed on a narrow type of construction. They have a width of only 22.5 mm or 45 mm.

Standard sensors/actuators and the AS-Interface cable can be connected using removable screw-type or spring-type terminals.

Integrated adapters enable mounting onto a standard mounting rail. Disassembly from the standard mounting rail is quick and easy and requires no tools.

With an additional accessory (push-in lugs), the modules can also be screwed on.

All modules are fitted at the front with LEDs which indicate the module's status.

An addressing socket integrated at the front enables the module to be addressed also when it is installed.

In addition to the digital input/output modules there are modules of design S22.5 with special functions. These include:

- Counter module
- Ground-fault detection module

More information about these modules, see

- the section "Modules with special functions" on page 6/70

• Industry Mall at:

www.siemens.com/industrymall

Section "Automation" -->

"SIRIUS Industrial Controls" --> "Industrial Communication" -->

"AS-Interface" --> "Slaves" --> "Modules with Special Functions"

The new AS-Interface Specification 3.0 adds a number of completely new features to the AS-Interface bus system. The extended address mode (A/B addresses) enables the connection of up to 62 slaves on one AS-Interface network. With the extended address mode according to specification 3.0, four outputs are now possible for the first time even with A/B slaves (instead of only three outputs possible up to now with specification 2.1). Hence with full expansion of an AS-Interface network, there are now 248 inputs as well as 248 outputs available on one AS-Interface system.

Modules with four inputs and four outputs as A/B slaves according to specification 3.0 are also available as SlimLine modules S45.

Note:

Please note that the modules according to Specification 3.0 can be used only with a new master according to AS-Interface Specification 3.0 (e.g. the new DP/AS-i LINK Advanced or IE/AS-i LINK PN IO) and that the cycle times for the outputs can extend to max. 20 ms.

AS-Interface slaves

I/O modules for operation in the control cabinet

SlimLine

Selection and ordering data

Version	Order No.
---------	-----------



3RK1 200-0CE00-0AA2



3RK1 400-0BG00-0AA2



3RK1 400-1CG00-0AA2

S22.5 SlimLine modules

- Inputs: PNP transistor
- Width 22.5 mm

Type	Connection	Slave type	Inputs	Outputs	Order No.
4 inputs	Screw	Standard	2-wire	--	3RK1 200-0CE00-0AA2
		Standard	2- and 3-wire	--	3RK1 200-0CE02-0AA2
		A/B slave	2- and 3-wire	--	3RK2 200-0CE02-0AA2
	Spring	Standard	2-wire	--	3RK1 200-0CG00-0AA2
		Standard	2- and 3-wire	--	3RK1 200-0CG02-0AA2
		A/B slave	2- and 3-wire	--	3RK2 200-0CG02-0AA2
2 inputs/ 2 outputs	Screw	Standard	2-wire	PNP transistor 2 A	3RK1 400-0BE00-0AA2
		Standard	2-wire	Relays	3RK1 402-0BE00-0AA2
	Spring	Standard	2-wire	PNP transistor 2 A	3RK1 400-0BG00-0AA2
		Standard	2-wire	Relays	3RK1 402-0BG00-0AA2
4 outputs	Screw	Standard	--	PNP transistor 1 A	3RK1 100-1CE00-0AA2
	Spring	Standard	--	PNP transistor 1 A	3RK1 100-1CG00-0AA2

S45 SlimLine modules

- Inputs: PNP transistor
- Width 45 mm

Type	Connection	Slave type	Inputs	Outputs	Order No.	
4 inputs/ 4 outputs	Screw	Standard	2- and 3-wire	PNP transistor 1 A	3RK1 400-1CE00-0AA2	
		Standard	2- and 3-wire	PNP transistor 2 A	3RK1 400-1CE01-0AA2	
		Standard	2- and 3-wire floating	PNP transistor 1 A floating	3RK1 402-3CE01-0AA2	
		Standard	2- and 3-wire	Relays	3RK1 402-3CE00-0AA2	
		A/B (Spec. 3.0)	2- and 3-wire	PNP transistor 2 A	3RK2 400-1CE01-0AA2	
		Spring	Standard	2- and 3-wire	PNP transistor 1 A	3RK1 400-1CG00-0AA2
	Standard		2- and 3-wire	PNP transistor 2 A	3RK1 400-1CG01-0AA2	
	Standard		2- and 3-wire floating	PNP transistor 1 A floating	3RK1 402-3CG01-0AA2	
	Standard		2- and 3-wire	Relays	3RK1 402-3CG00-0AA2	
	A/B (Spec. 3.0)		2- and 3-wire	PNP transistor 2 A	3RK2 400-1CG01-0AA2	
	4 inputs/ 3 outputs		Screw	A/B slave	2- and 3-wire	PNP transistor 2 A
		Spring	A/B slave	2- and 3-wire	PNP transistor 2 A	3RK2 400-1FG00-0AA2

Accessories

Sealable covers

To secure against unauthorized addressing

3RP1 902

Push-in lugs

For screw fixing





3RP1 903

AS-Interface slaves

I/O modules for operation in the control cabinet

F90 module

Selection and ordering data

Version						Order No.
 <p>F90 module</p> <ul style="list-style-type: none"> • Standard slave • Width 90 mm <p>3RG9 002-0DB00</p>	4 inputs/ 4 outputs	Screw		2- and 3-wire PNP transistor	PNP transistor 1 A	3RG9 002-0DB00
				2- and 3-wire PNP transistor	PNP transistor 2 A	3RG9 002-0DA00
				2- and 3-wire PNP transistor floating	PNP transistor 2 A	3RG9 002-0DC00
		Combicon		2- and 3-wire PNP transistor	PNP transistor 1 A	3RG9 004-0DB00
				2- and 3-wire PNP transistor	PNP transistor 2 A	3RG9 004-0DA00
				2- and 3-wire PNP transistor floating	PNP transistor 2 A	3RG9 004-0DC00
	16 inputs	Screw		PNP transistor	--	3RG9 002-0DE00
		Combicon		PNP transistor	--	3RG9 004-0DE00

Accessories

Combicon connector sets

For 4I/4O modules with Combicon connection; one set comprises:

- 4 x 5-pole plug for connection
- Standard sensors/actuators
- 2 x 4-pole plug for AS-Interface and external auxiliary voltage



3RX9 810-0AA00

AS-Interface slaves

I/O modules for operation in the control cabinet

Flat module

Selection and ordering data

Version	Screw terminals 
 <p>Flat module</p> <ul style="list-style-type: none"> • 4 inputs/4 outputs • 200 mA for all I/Os • Screw terminals <p>3RK1 400-0CE00-0AA3</p>	<p>Order No.</p> <p>3RK1 400-0CE00-0AA3</p>

AS-Interface slaves

Special integrated solutions

AS-Interface communication modules

Overview

AS-Interface communication modules for printed circuit board installation

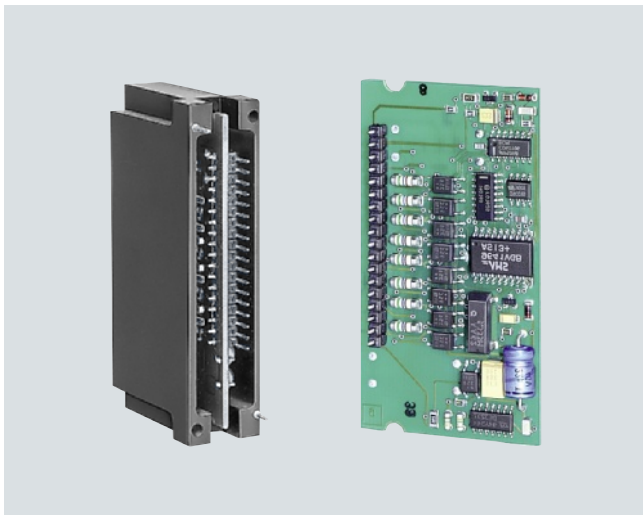

AS-Interface 3RK1 400-0CD00-0AA3 communication module (left)
AS-Interface 3RK2 400-1FD00-0AA2 communication cable (right)

3RK1 400-0CD00-0AA3 AS-Interface communication modules for printed circuit board installation

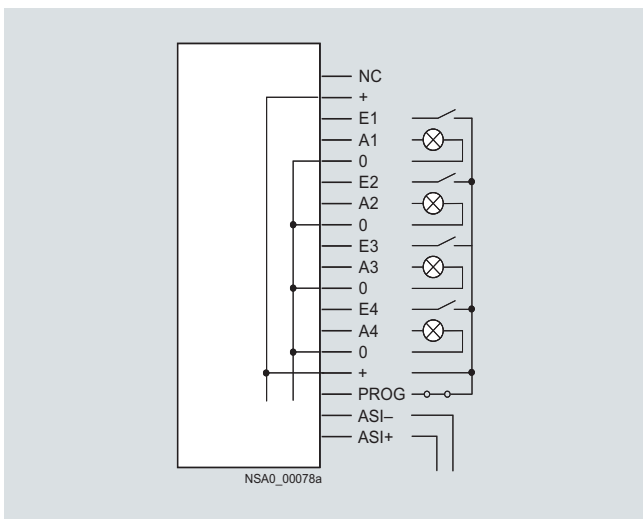

3RK1 400-0CD00-0AA3

With the 4I/4O module for printed circuit board mounting it is possible for up to four mechanical contacts to be queried or indicator lights to be operated, the necessary energy being provided by the AS-Interface system (yellow AS-Interface cable).

Note:

If the switching outputs are overloaded, the module does not respond to invoking by a master.

3RK1 400-0CD01-0AA3 AS-Interface communication modules for printed circuit board installation

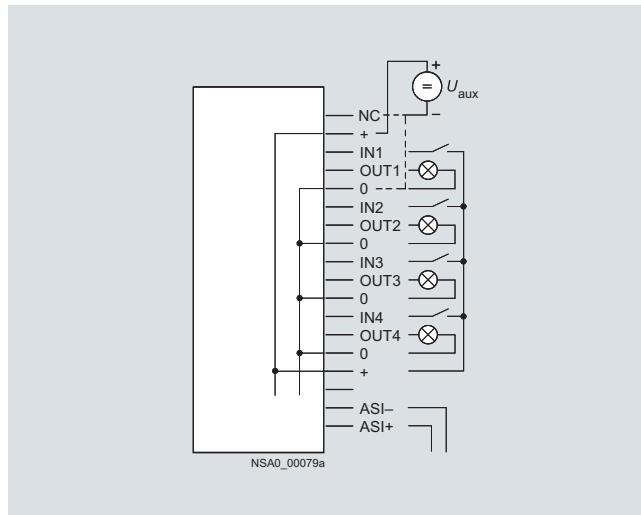

3RK1 400-0CD01-0AA3

With the 3RK1 400-0CD01-0AA3 4I/4O module for printed circuit board mounting it is possible for up to four mechanical contacts to be queried or indicator lights to be operated, the necessary energy for the inputs and outputs being provided from the auxiliary voltage (24 V PELV). If (+) is connected to $U_{aux} +$ and (NC) to $U_{aux} -$, the outputs are not short-circuit and overload proof; if $U_{aux} -$ is connected to (0), the outputs are overload and short-circuit proof (maximum summation current 200 mA). In this case the module does not respond even to invoking by a master when the switching outputs are overloaded.

3RG9 005-0SA00 AS-Interface communication modules for printed circuit board installation

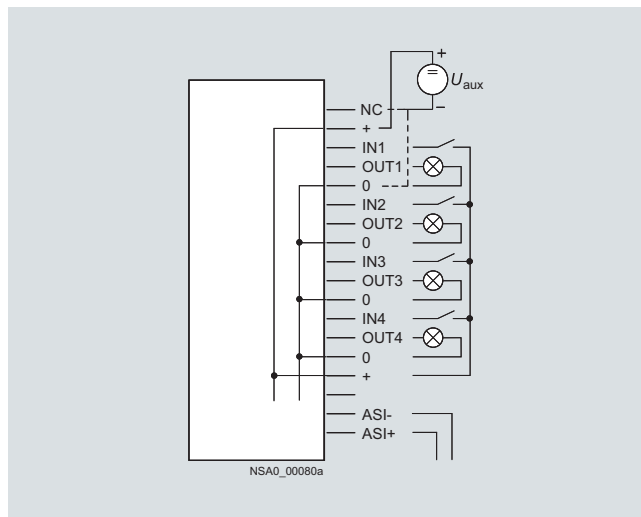

3RG9 005-0SA00

With the 4I/4O module for printed circuit board mounting it is possible for up to four mechanical contacts to be queried or indicator lights to be operated, the power for inputs and outputs being provided from an auxiliary voltage (24 V PELV). If (+) is connected to $U_{aux} +$ and (NC) to $U_{aux} -$, the outputs are not short-circuit and overload proof; if $U_{aux} -$ is connected to (0), the outputs are overload and short-circuit proof (maximum summation current 200 mA). In this case the module does not respond even to invoking by a master when the switching outputs are overloaded.

Overview (continued)

3RK1 400-1CD00-0AA2, 3RK2 400-1FD00-0AA2 AS-Interface communication modules for printed circuit board installation

Connection	Connection pad ¹⁾
AS-i +	27, 29
AS-i -	28, 30
Sensor+	17, 18, 23, 24
Sensor-	13, 14, 19, 20
IN1	21
IN2	22
IN3	15
IN4	16
U _{aux} + (L24+)	2, 4
U _{aux} - (M24)	1, 3
OUT1	9
OUT2	10
OUT3	5
OUT4	6 (not assigned for 3RK2 400-1FD00-0AA2 4I/3O module)
OUT-	7, 8
Not assigned	11, 12, 25, 26

¹⁾ Note: For pad numbering see Technical Specifications

With the 4I/4O or 4I/3O module for printed circuit board mounting it is possible for up to four mechanical contacts or 3-conductor sensors according to IEC 947-5-2 to be connected. Up to four indicator lights via the 4I/4O module or up to three indicator lights via the 4I/3O module can also be controlled. The power for short-circuit proof solid-state switching outputs is provided from an auxiliary voltage (24 V PELV).

Mounting is very easy using a "Card Edge Board-to-Board Connector". This connector can be ordered for vertical and horizontal mounting from the company AMP, for example:

- 180° version for vertical mounting (AMP): Order No. 530843-2
- 90° version for horizontal mounting (AMP): Order No. 650118-1

If the inputs are loaded with more than 200 mA, the module does not respond to invoking by a master.

3RK1 200-0CD00-0AA2 AS-Interface communication modules for printed circuit board installation

Connection	Connection pad ¹⁾
AS-i +	27, 29
AS-i -	28, 30
Sensor+	17, 18, 23, 24
Sensor-	13, 14, 19, 20
IN1	21
IN2	22
IN3	15
IN4	16
Not assigned	1, 2, 3, 4, 5, 6, 7, 8, 9, 10, 11, 12, 25, 26

¹⁾ Note: For pad numbering see Technical Specification.



With the 4I module for printed circuit board mounting it is possible for up to four mechanical contacts or 3-conductor sensors to be connected, the power for inputs being provided from AS-Interface cable.

Mounting is very easy using a "Card Edge Board-to-Board Connector". This connector can be ordered for vertical and horizontal mounting from the company AMP, for example:

- 180° version for vertical mounting (AMP): Order No. 530843-2
- 90° version for horizontal mounting (AMP): Order No. 650118-1

If the inputs are loaded with more than 200 mA, the module does not respond to invoking by a master.

Selection and ordering data

Version	Slave type	Order No.	
 3RK1 400-0CD00-0AA3	4 inputs/4 outputs <ul style="list-style-type: none"> • Supply of I/Os using AS-Interface cable (max. 200 mA) <ul style="list-style-type: none"> - Printed circuit board with solder pins, protected by enclosure • Supply of I/Os using external auxiliary voltage (24 V PELV) <ul style="list-style-type: none"> - Printed circuit board with solder pins, protected by enclosure - Printed circuit board with solder pins for horizontal mounting • Supply of outputs using external auxiliary voltage (24 V PELV) <ul style="list-style-type: none"> - Printed circuit board with gold-plated direct connector for 30-pole male connector socket for simple installation with direct connector 	Standard	3RK1 400-0CD00-0AA3
	<ul style="list-style-type: none"> - Printed circuit board with solder pins, protected by enclosure 	Standard	3RK1 400-0CD01-0AA3
	<ul style="list-style-type: none"> - Printed circuit board with solder pins for horizontal mounting 	Standard	3RG9 005-0SA00
	<ul style="list-style-type: none"> - Printed circuit board with gold-plated direct connector for 30-pole male connector socket for simple installation with direct connector 	Standard	3RK1 400-1CD00-0AA2
 3RG9 005-0SA00	4 inputs/3 outputs <ul style="list-style-type: none"> • Supply of outputs using external auxiliary voltage (24 V PELV) <ul style="list-style-type: none"> - Printed circuit board with gold-plated direct connector for 30-pole male connector socket for simple installation with direct connector 	A/B	3RK2 400-1FD00-0AA2
	4 inputs <ul style="list-style-type: none"> • Printed circuit board with gold-plated direct connector for 30-pole male connector socket for simple installation with direct connector 	Standard	3RK1 200-0CD00-0AA2

AS-Interface slaves

Modules with special functions

Counter modules

Overview



Counter module with spring-type terminals

The counter module is used to send hexadecimally coded count values (LSB=D0, MSB=D3) to a higher-level controller. The count value is increased by one for each valid count pulse at terminal 8. Beginning at 0, the module counts up to 15 and then begins again at 0. The controller adopts the current value and determines the number of pulses between two host invocations through subtraction from the previous value. The total number of count pulses is determined by adding these differences.

For the values sent to be unambiguous, no more than 15 count values are allowed between two host invocations or AS-Interface master invocations at terminal 8. The maximum permissible transmission frequency is calculated from these times:

$$f_{TRmax} = 15 / T_{max}$$

T_{max} : max. possible transmission time from the slave to the host

Another condition for the maximum frequency is the pulse shaped required. For the counter to accept a pulse as valid, a Low must have been applied at the input for at least 300 μ s and a High for at least 1 ms.

This results in a maximum frequency of $f_{Zmax} = 1 / 1.3 \text{ ms} = 769 \text{ Hz}$ independent of the control system (see figure).

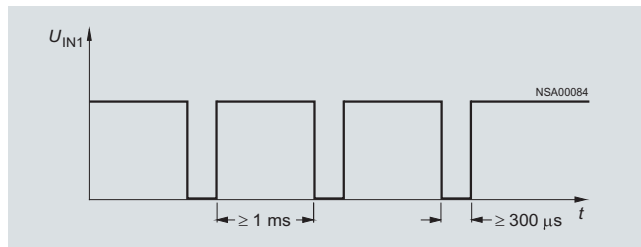

Maximum frequency for the counter module

If the time criterion stipulated in the graphic is violated, the count value is rejected.

The counter is active only for the reset parameter P2 (default). The counter is deleted when P2 is set, and the incoming count pulses are not registered until after P2 is reset again.

Note:

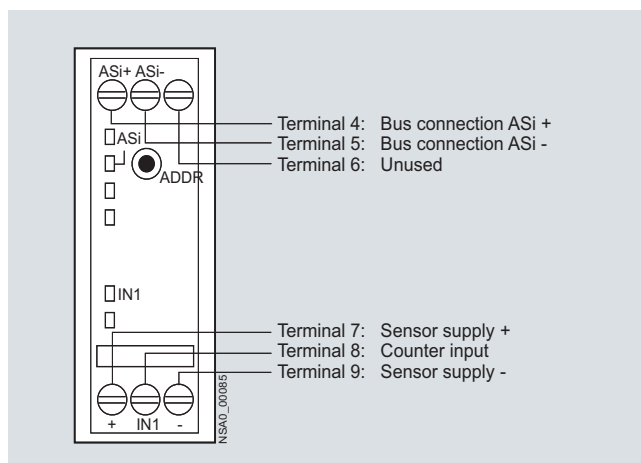

A customized function block is necessary or must be programmed.



Counter module connection options

6

Selection and ordering data

Version	Order No.
<p>Counter module</p> <p>Width 22.5 mm</p> <ul style="list-style-type: none"> • With screw terminals • With spring-type terminals 	<p> 3RK1 200-0CE03-0AA2</p> <p> 3RK1 200-0CG03-0AA2</p>
<p></p> <p>3RK1 200-0CE03-0AA2</p>	
<p></p> <p>3RK1 200-0CG03-0AA2</p>	

AS-Interface slaves

Modules with special functions

Ground-fault detection modules

Overview

"Ground faults in any control circuit must not lead to unintentional starting or potentially hazardous movements or prevent the machine from stopping." (EN 60204-1 / VDE 0113-1).

The AS-Interface ground-fault detection module is used to meet these requirements. Using this module from the SlimLine series, ground faults in AS-Interface systems can be reliably detected and reported.



The following ground faults are detected:

- Ground fault from AS-i "+"
- Ground fault from AS-i "-"
- Ground fault from sensors and actuators which are supplied from the AS-Interface voltage.

Note:

Not suitable for AS-Interface Power24V.

Selection and ordering data

Version	Order No.
Ground-fault detection module Width 22.5 mm <ul style="list-style-type: none"> • With screw terminals • With spring-type terminals 	 3RK1 408-8KE00-0AA2  3RK1 408-8KG00-0AA2



3RK1 408-8KE00-0AA2

Overvoltage protection module

6

Overview



AS-Interface overvoltage protection module

The AS-Interface overvoltage protection module protects downstream AS-Interface devices or individual sections in AS-Interface networks from conducted overvoltages which can be caused by switching operations and remote lightning strikes.

The location of the overvoltage protection module forms within the lightning protection zone concept the transition from zone 1 to 2/3. Direct lightning strikes must be coped with using additional protective measures at the transitions from lightning protection zone 0A to 1.

With the AS-Interface overvoltage protection module it is now also possible to integrate AS-Interface in the overall lightning protection concept of a plant or machine.

The module has the same design and degree of protection (IP67) as the AS-Interface K45 compact modules. It is a passive module without AS-i IC and as such does not need its own address on the AS-Interface network.

The module can be used to protect the AS-Interface cable and the cable for the auxiliary voltage from overvoltage.

Overvoltages are discharged through a ground cable with a green/yellow oil-proof outer sheath. This cable is fixed in the module and must be connected with low resistance to the system's ground.

Rated discharge current I_{sn}

The rated discharge current is the peak value of a surge current with waveform 8/20 microseconds, for which the overvoltage protection module is rated in according to a specific test program.

With waveform 8/20, 100 % of the value is achieved after 8 microseconds and 50 % after 20 microseconds.

Protection level U_p

The protection level of an overvoltage protection module is the highest momentary value of the voltage at the terminals, established in individual tests.

The protection level characterizes the capability of an overvoltage protection module to limit overvoltages to a residual level.

AS-Interface slaves

Modules with special functions

Overvoltage protection module

Overview (continued)

Configuration guidelines

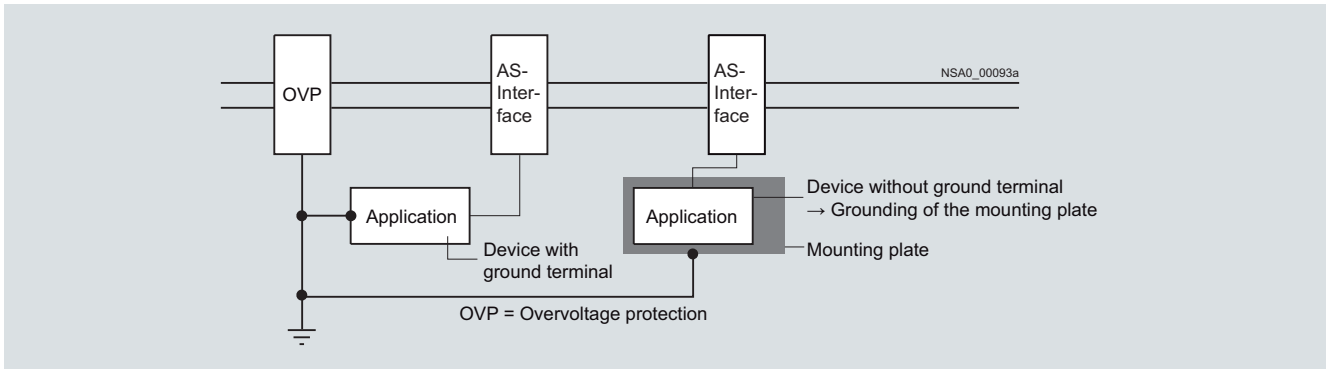

Configuration guidelines for overvoltage protection modules

The grounding of protection modules and the units to be protected must be effected through a shared grounding point

(equipotential bonding). If insulated devices are protected, their mounts must be included in the grounding points.

Sample application

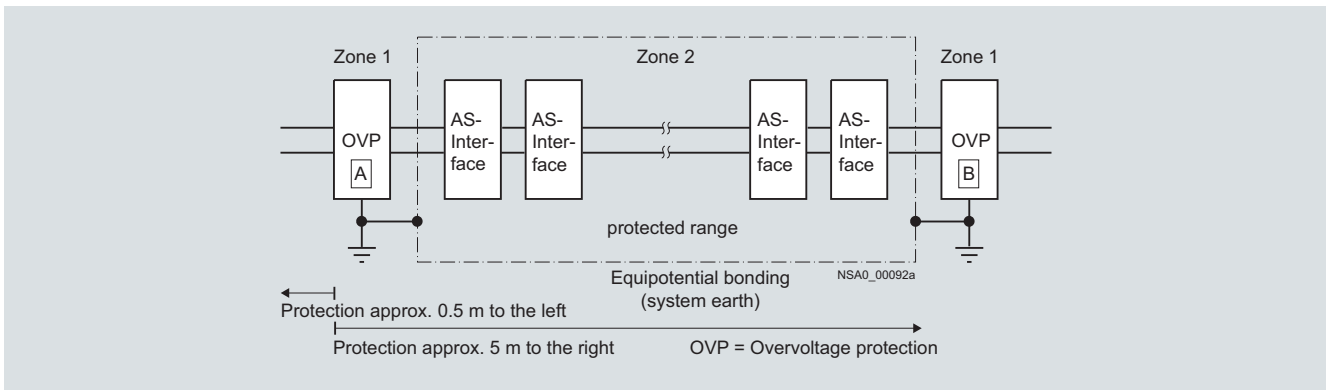

Sample application for overvoltage protection modules

Selection and ordering data

Version	Order No.
 <p>Overvoltage protection module</p> <p>3RK1 901-1GA00</p>	<p>3RK1 901-1GA01</p>

Overview

Every LOGO! can now be connected to the AS-Interface system



Using the AS-Interface connection for LOGO!, an intelligent slave can be integrated in the AS-Interface system. With the modular interface it becomes possible to integrate the different basic units in the system according to their functionality. Similarly, functionalities can be quickly and easily adapted to new requirements by exchanging the basic unit.

The interface module provides four inputs and four outputs on the system. These inputs and outputs do not actually exist in hardware terms, however, but are only virtually present through the interface on the bus.

AS-Interface connections for LOGO!

Selection and ordering data

Version		Order No.
 <p>3RK1 400-0CE10-0AA2</p>	<p>AS-Interface connections for LOGO!</p> <ul style="list-style-type: none"> • 4 virtual inputs • 4 virtual outputs 	<p>3RK1 400-0CE10-0AA2</p>

AS-Interface slaves

Contactors and contactor assemblies – Power contactors for switching motors

SIRIUS 3RT20 contactors

Overview

Contactors with communication interface, sizes S00 and S0

Contactor versions with a communication interface are required for the connection to the controller via IO-Link or AS-Interface. The connection is made via function modules, which are mounted on to the front side of the contactors.

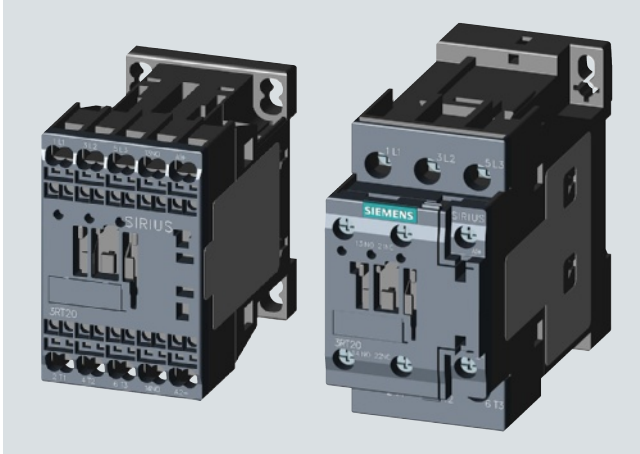

Contactors with communication interface in size S00 with spring-type terminals and size S0 with screw terminals

Standards

IEC 60947-1, EN 60947-1,
IEC 60947-4-1, EN 60947-4-1,
IEC 60947-5-1, EN 60947-5-1 (auxiliary switches)

The 3RT20 contactors for switching motors are climate-proof and are tested and suitable for use worldwide.

If the devices are used in ambient conditions which deviate from common industrial conditions (IEC 60721-3-3 "Stationary Use, Weather-Protected"), information must be obtained about possible restrictions with regard to the reliability and endurance of the device and possible protective measures. In this case contact our Technical Assistance.

The 3RT2 contactors are finger-safe according to EN 50274.

The contactors are suitable for screw fixing or for mounting on TH 35 standard mounting rails according to IEC 60715.

Contact reliability

If voltages ≤ 110 V and currents ≤ 100 mA are to be switched, the auxiliary contacts of the 3RT2 contactor or 3RH21 contactor relay should be used as they guarantee a high level of contact reliability.

These auxiliary contacts are suitable for solid-state circuits with currents ≥ 1 mA at a voltage ≥ 17 V.

Connection methods

The 3RT2 contactors are available with screw terminals or spring-type terminals.

Short-circuit protection of the contactors

For more information about short-circuit protection of contactors without overload relay, see Technical Specifications.

To assemble fuseless motor feeders you must select combinations of motor starter protector and contactor as explained in "3RA2 Load Feeders".

Motor protection

3RU21 thermal overload relays or 3RB30 solid-state overload relays can be fitted to the 3RT2 contactors for protection against overload. The overload relays must be ordered separately.

Ratings of induction motors

The quoted rating (in kW) refers to the output power on the motor shaft (according to the nameplate).

Control supply voltage

The contactors with communication interface are available with 24 V DC operation.

Note:

The selection and ordering data for 3RT10 contactors and 3RA23 reversing contactor assemblies with communication interface can be found in chapter 7, "IO-Link".

Note:

Further technical information is available at www.siemens.com/industrial-controls/support

under Product List:

- Technical specifications

under Entry List:

- Updates
- Downloads
- FAQ
- Manuals/operating instructions
- Characteristic curves
- Certificates

and at

www.siemens.com/industrial-controls/configurators

- Configurators

AS-Interface slaves

Contactors and Contactor Assemblies

SIRIUS 3RA24 contactor assemblies
for wye-delta starting

Overview

These 3RA24 contactor assemblies for wye-delta starting are designed for standard applications.

Note:

Contactor assemblies for wye-delta starting in special applications such as very heavy starting or wye-delta starting of special motors must be customized. Help with designing such special applications is available from Technical Assistance.





The 3RA24 contactor assemblies for wye-delta starting can be ordered as follows:

- complete, fully wired and tested, with electrical and mechanical interlocking
- as individual parts for customer assembly

A dead interval of 50 ms on reversing is already integrated in the function module for wye-delta starting. The auxiliary contacts used in the contactors (see Chapter 7, "IO-Link") are freely available.

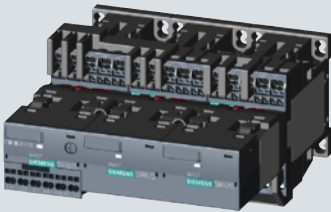
Selection and ordering data

Fully connected and tested contactor assemblies

					
3RA24 1.-8XE31-2BB4		3RA24 2.-8XE32-1BB4		3RA24 2.-8XE32-2BB4	
Rated data AC-3		Rated control supply voltage U_s ¹⁾		Screw terminals 	
Operational current I_e up to		Rating of induction motors at 50 Hz and		Spring-type terminals 	
400 V		230 V 400 V 500 V 690 V		Order No.	
A	kW	kW	kW	kW	V

DC operation

Size S00

For AS-Interface connection

12	3.3	5.5	7.2	9.2	24 DC
16	4.7	7.5	10.3	9.2	24 DC
25	5.5	11	11	11	24 DC

3RA24 15-8XH31-1BB4

3RA24 15-8XH31-2BB4

3RA24 16-8XH31-1BB4

3RA24 16-8XH31-2BB4

3RA24 17-8XH31-1BB4

3RA24 17-8XH31-2BB4

Size S0

For AS-Interface connection

25	7.1	11	15.6	19	24 DC
32 / 40	11.4	15 / 18.5	19	19	24 DC
50	--	22	19	19	24 DC

3RA24 23-8XH32-1BB4

3RA24 23-8XH32-2BB4

3RA24 25-8XH32-1BB4

3RA24 25-8XH32-2BB4

3RA24 26-8XH32-1BB4

3RA24 26-8XH32-2BB4

Components for customer assembly

Assembly kits with wiring modules and mechanical connectors are available for contactor assemblies for wye-delta starting. Contactors, overload relays, function modules for wye-delta starting, auxiliary switches for electrical interlocking – and if required also feeder terminals – must be ordered separately.

The wiring kits for sizes S00 and S0 contain the top and bottom main conducting path connections between the line and delta contactors (top) and between the delta and star contactors (bottom).

Selection of the contactors for customer assembly

Rated data AC-3 at AC 50 Hz 400 V			Size	Line/delta contactor	Star contactor	Complete order no.
Rating	Operational current I_e	Motor current				
kW	A	A				
5.5	12	9.5 ... 13.8	S00-S00-S00	3RT20 15-.BB41-0CC0	3RT20 15-.BB41-0CC0	3RA24 15-8XH31-.BB4
7.5	16	12.1 ... 17		3RT20 17-.BB41-0CC0	3RT20 15-.BB41-0CC0	3RA24 16-8XH31-.BB4
11	25	19 ... 25		3RT20 18-.BB41-0CC0	3RT20 16-.BB41-0CC0	3RA24 17-8XH31-.BB4
11	25	19 ... 25	S0-S0-S0	3RT20 24-.BB40-0CC0	3RT20 24-.BB40-0CC0	3RA24 23-8XH32-.BB4
15	32	24.1 ... 34		3RT20 26-.BB40-0CC0	3RT20 24-.BB40-0CC0	3RA24 25-8XH32-.BB4
18.5	40	34.5 ... 40		3RT20 26-.BB40-0CC0	3RT20 24-.BB40-0CC0	3RA24 25-8XH32-.BB4
22	50	31 ... 43		3RT20 27-.BB40-0CC0	3RT20 26-.BB40-0CC0	3RA24 26-8XH32-.BB4

AS-Interface slaves

Contactors and Contactor Assemblies





SIRIUS 3RA27 function modules for AS-Interface

Overview

The function modules for mounting onto contactors enable the assembly of starters and contactor assemblies for direct-on-line, reversing and wye-delta starting without any additional, complicated wiring of the individual components.

These include the fundamental control functions, such as time and sealing functions, which are used for the respective branches and can be connected to the controller via the bus system.

Selection and ordering data

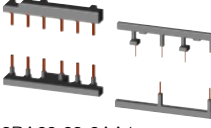
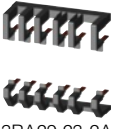
Version	Screw terminals	Spring-type terminals
Order No.	Order No.	Order No.
Function modules for direct-on-line starting		
 3RA27 12-1AA00  3RA27 12-2AA00	AS-Interface connection	3RA27 12-1AA00 3RA27 12-2AA00
Function modules for reversing starting ¹⁾		
 3RA27 12-1BA00  3RA27 12-2BA00	AS-Interface connection, comprising one basic and one coupling module	3RA27 12-1BA00 3RA27 12-2BA00
 3RA29 23-2AA1  3RA29 23-2AA2	Assembly kits for making 3-pole contactor assemblies The assembly kit contains: mechanical interlock; 2 connecting clips for 2 contactors, wiring modules on the top and bottom <ul style="list-style-type: none"> • For size S00 • For size S0 <ul style="list-style-type: none"> - For main, auxiliary and control current - Only for main current ²⁾ 	3RA29 13-2AA1 3RA29 13-2AA2 3RA29 23-2AA1 -- -- 3RA29 23-2AA2

Applicable contactors or reversing contactor assemblies with communication interface can be found in chapter 7, "IO-Link".

Note:



When using the function modules, no other auxiliary switches are allowed to be connected to the basic units.

- 1) Pre-wired contactor assemblies for reversing start with communication interface can be found in chapter 7, "IO-Link". When these contactor assemblies are used, the assembly kit for the wiring is already integrated.
- 2) Version in size S0 with spring-type terminals:
 Only the wiring modules for the main circuit are included.
 No connectors are included for the auxiliary and control circuit.

AS-Interface slaves Contactors and Contactor Assemblies

SIRIUS 3RA27 function modules for AS-Interface

Selection and ordering data (continued)

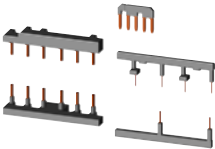
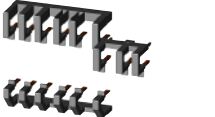
Version	Screw terminals	Spring-type terminals
Order No.	Order No.	Order No.
Function modules for wye-delta starting ¹⁾		
 3RA27 12-1CA00	AS-Interface connection , consisting of one basic module and two coupling modules	3RA27 12-1CA00
 3RA27 12-2CA00		3RA27 12-2CA00
Assembly kits for making 3-pole contactor assemblies		
The assembly kit contains: Mechanical interlock, 4 connecting clips for 3 contactors, star jumper, wiring modules above and below ²⁾		
 3RA29 23-2BB1	<ul style="list-style-type: none"> • For size S00 • For size S0 <ul style="list-style-type: none"> - For main, auxiliary and control current - Only for main current 	3RA29 13-2BB1
 3RA29 23-2BB2		3RA29 13-2BB2

Applicable contactors with communication interface can be found in chapter 7, "IO-Link".

Note:

When using the function modules, no other auxiliary switches are allowed to be connected to the basic units.

¹⁾ Complete contactor assemblies for wye-delta starting, including functional modules can be found on page 6/75.
²⁾ When using the function modules for wye-delta starting, the wiring modules for the auxiliary current are not required.

Version	Order No.
---------	-----------

Accessories

 3RA29 10-0	Sealable covers for 3RA27, 3RA28, 3RA29	3RA29 10-0
	Manual Function modules for AS-Interface	3ZX1 012-0RA27-0AB0

AS-Interface slaves

Motor starters for operation in the control cabinet

SIRIUS 3RA6 compact feeders General data

Overview

3RA6 fuseless compact feeders and infeed system for 3RA6



3RA62 reversing starters

Integrated functionality

The SIRIUS 3RA6 compact feeders are a generation of innovative load feeders with the integrated functionality of a motor starter protector, contactor and solid-state overload relay. In addition, various functions of optional mountable accessories (e.g. auxiliary switches, surge suppressors) are already integrated in the SIRIUS compact feeder.

Application

The SIRIUS compact feeders can be used wherever standard induction motors up to 32 A (approx. 15 kW/400 V) are directly started.

The compact feeders are not suitable for the protection of single-phase AC or DC loads.

Approvals according to IEC, UL, CSA and CCC standards have been issued for the compact feeders.

Low equipment variance

Thanks to wide setting ranges for the rated current and wide voltage ranges, the equipment variance is greatly reduced compared to conventional load feeders.

Very high operational reliability

Through the high short-circuit breaking capacity and defined shut-down when the end of service life is reached means that the SIRIUS compact feeder achieves a very high level of operational reliability that would otherwise have only been possible with considerable additional outlay. This sets it apart from devices with similar functionality.

Safe disconnection

The auxiliary switches (NC contacts) of the 3RA6 compact feeders are designed as mirror contacts. It is thus possible to use the devices for safe disconnection, e.g. emergency-stops, up to Category 2 (EN 954-1) and together with other redundancy switching devices up to Category 3 or 4.

Communications integration through AS-Interface

To enable communications integration through AS-Interface there is an AS-i add-on module available in several versions for mounting instead of the control circuit terminals on the SIRIUS compact feeder.

The design of the AS-i add-on module permits a group of up to 62 feeders with a total of four cables to be connected to the control system. This reduces wiring work considerably compared to the parallel wiring method.

Communications integration using IO-Link

SIRIUS 3RA64, 3RA65 compact feeders for IO-Link see Chapter 7: "IO-Link".

Permanent wiring/easy replacement

Using the SIRIUS infeed system for 3RA6 it is possible to carry out the wiring in advance without a compact feeder needing to be connected.

A compact feeder is very easily replaced simply by pulling it out of the device without disconnecting the wiring.



Even with screw connections or mounting on a standard mounting rail there is no need to disconnect any wiring (on account of the removable main and control circuit terminals) in order to replace a compact feeder.

Consistent solution from the infeed to the motor feeder

The SIRIUS infeed system for 3RA6 with integrated PE bar is offered as a user-friendly possibility of feeding in summation currents up to 100 A with a maximum conductor cross-section of 70 mm² and connecting the motor cable directly without additional intermediate terminals.

Screw and spring-type connections

The SIRIUS compact feeders and the infeed system for 3RA6 are available with screw and spring-type terminals.

	Screw terminals
	Spring-type terminals

System configurator for engineering

A free system configurator is available to reduce further the amount of engineering work for selecting the required compact feeders and matching infeed.

Types of infeed for the 3RA6 fuseless compact feeders

On the whole four different infeed possibilities are available:

- Parallel wiring
- Use of three-phase busbars (combination with SIRIUS motor starter protectors and SIRIUS contactors possible)
- 8US busbar adapters
- SIRIUS infeed system for 3RA6

To comply with the clearance and creepage distances demanded according to UL 508 there are the following infeed possibilities:

AS-Interface slaves

Motor starters for operation in the control cabinet

SIRIUS 3RA6 compact feeders
General data

Overview (continued)

Type of infeed	Feeder terminal (acc. to UL 508, type E)	Type
Parallel wiring	Terminal block for "Self-Protected Combination Motor Controller (Type E)"	3RV19 28-1H
Three-phase busbars	Three-phase infeed terminal for constructing "Type E Starters", UL 508	3RV19 25-5EB
Infeed systems for 3RA6	Infeed on left, 50/70 mm ² , screw terminal with 3 sockets, outgoing terminal with screw/spring-type connections, including PE bar	3RA68 13-8AB (screw terminals), 3RA68 13-8AC (spring-type terminals)

SIRIUS 3RA6 compact feeders

The SIRIUS 3RA6 compact feeders are universal motor feeders according to IEC 60947-6-2. As control and protective switching devices (CPS) they can connect, convey and disconnect the thermal, dynamic and electrical loads from short-circuit currents up to $I_{cs} = 53$ kA, i.e. they are practically weld-free. They combine the functions of a motor starter protector, a contactor and a solid-state overload relay in one enclosure. Direct-on-line starters with 45 mm width and reversing starters with 90 mm width are available as versions.

The reversing starter version comes with not only an internal electrical interlock but also with a mechanical interlock to prevent simultaneous actuation of both directions of rotation.

The compact feeders have isolating features in accordance with IEC 60947.2 and can be used as disconnector units (main control switch according to EN 60204 or DIN VDE 0113). Isolation is effected by moving the handle into the "OFF" position; disconnection by means of the control contacts is not enough.

3RA6 fuseless compact feeders are supplied for 5 different current setting ranges. The 3RA61 and 3RA62 have 3 control voltage ranges (AC/DC), the 3RA64 and 3RA65 have one control voltage range (DC):

Current setting range	At 400 V AC for induction motors		
	Standard output P	Rated control supply voltage for	
A	kW	3RA61, 3RA62 compact feeders	3RA64, 3RA65 compact feeders for IO-Link
		V AC/DC	V DC
0.1 ... 0.4	0.09	24	24
0.32 ... 1.25	0.37	42 ... 70	
1 ... 4	1.5	110 ... 240	
3 ... 12	5.5		
8 ... 32	15		

Note:

The 3RA1 load feeders can be used for fuseless load feeders > 32 A up to 100 A.

The SENTRON 3VL circuit breakers and the SIRIUS 3RT contactors can be used for fuseless load feeders > 100 A.

Operating conditions

The SIRIUS 3RA6 compact feeders are suitable for use in any climate. They are intended for use in enclosed rooms in which no severe operating conditions (such as dust, caustic vapors, hazardous gases) prevail. Suitable covers must be provided for installation in dusty and damp locations.

The SIRIUS compact feeders are generally designed to degree of protection IP20. The permissible ambient temperature during operation is -20 to +60 °C.

The rated short-circuit current I_{CS} according to IEC 60947-6-2 is 53 kA at 400 V.

Note:

The maximum permissible short-circuit currents of the device versions for the various forms of power supply and voltages are available on request from Technical Assistance:

Tel.: +49 (9 11) 8 95-59 00

E-mail: technical-assistance@siemens.com.

Overload tripping times

The overload tripping time can be set on the device to normal starting conditions (CLASS 10) and to heavy starting conditions (CLASS 20). As the breaker mechanism still remains closed after an overload, resetting is possible by either local manual reset or auto reset after 3 minutes cooling time.

With autoreset there is no need to open the control cabinet.

Diagnostics options

The compact feeder provides the following diagnostics options:

- With LEDs
 - Connection to the control voltage
 - Position of the main contacts
- With mechanical indication
 - Tripping due to overload
 - Tripping due to short circuit
 - Tripping due to malfunction (end of service life reached because of worn switching contacts or a worn switching mechanism or faults in the control electronics)

These states can also be evaluated in the higher-level control system:

- With parallel wiring using the integrated auxiliary and signaling switches of the compact starter
- With AS-Interface or IO-Link in even greater detail using the respective communication interface

Four complement versions for 3RA6 compact feeders

- For standard mounting rail or screw fixing: basic version including 1 pair of main circuit terminals and 1 pair of control circuit terminals
- For standard mounting rail or screw fixing when using the AS-i add-on module: without control circuit terminals because the AS-i add-on module is plugged on instead
- For use with the infeed system for 3RA6: without main circuit terminals because they are supplied with the infeed system and the expansion modules
- For use with the infeed system for 3RA6 and the AS-i add-on module: without terminal complement (also for reordering when replacing the compact starter)
- The control circuit terminals are always required by the compact starters for IO-Link; the main circuit terminals depend on the use of the infeed system.

More components of the 3RA6

Already integrated in the 3RA61/3RA62 – and connectable using the two 6-pole removable control circuit terminals – in addition to the control supply voltage are the signaling contacts "overload" (1 CO) and "short circuit / malfunction" (1 NO). The 3RA61 has two auxiliary contacts (1 NO + 1 NC) for indicating the position of the main contacts. Unlike the 3RA61 direct-on-line starter, the 3RA62 reversing starter has one auxiliary contact (1 NO) per direction of rotation per main contact.

AS-Interface slaves

Motor starters for operation in the control cabinet

SIRIUS 3RA6 compact feeders General data

Overview (continued)

Available for the 3RA61 and 3RA64 direct-on-line starters is a slot for an optional auxiliary switch block (optionally 2 NO, 2 NC or 1 NO + 1 NC) and for the 3RA62 and 3RA65 reversing starters there are two slots (for auxiliary switch blocks see "Accessories" on Page 6/84).

Unlike the direct-on-line starter, the 3RA62 reversing starter has one auxiliary contact (1 NO) per direction of rotation per main contact.

Positively-driven operation of the auxiliary contacts

Positively-driven operation between individual auxiliary circuits exists for the compact feeder in the version as a direct-on-line starter for parallel wiring (3RA61) between the auxiliary circuits of the NC contacts (NC 21-22) and the NO contacts (NO 13-14) in the basic unit.

In addition the optional auxiliary switch block offers positively driven contacts in the version 3RA69 13-1A, each with one NC contact and one NO contact.

Benefits

The SIRIUS 3RA6 compact feeders offer a number of benefits:

- Compact design saves space in the control cabinet
- Little planning and assembly work and far less wiring thanks to a single complete unit with one order number
- Little variance through 3 wide voltage ranges and 5 wide setting ranges for the rated current mean low stock levels
- High plant availability through integrated functionalities such as prevention of main contact welding and shut-down at end of service life
- Greater productivity through automatic device reset in case of overload and differentiated detection of overload and short-circuit
- Easy checking of the wiring and testing of the motor direction prior to start-up thanks to optional "control kits"
- Speedy replacement of devices thanks to removable terminals with spring-type and screw connections in the main and control circuit
- Efficient power distribution through the related SIRIUS infeed system for 3RA6
- Direct connection of the motor feeder cable to the SIRIUS infeed system for 3RA6 thanks to integrated PE bar
- Connecting and looping through incoming feeders up to a cross-section of 70 mm²
- When using the infeed system for 3RA6, possibility of directly connecting the motor cable without intermediate terminals
- Integration in Totally Integrated Automation thanks to the optional connection to AS-Interface or IO-Link

The SIRIUS 3RA6 compact feeders create the basis for high-availability and future-proof machine concepts.

**3RA61, 3RA62 compact feeders
3RA61 direct-on-line starters**

Selection and ordering data



Width 45 mm
 Rated short-circuit current $I_{CS} = 53 \text{ kA}$ at 400 V
 A set of 3RA69 40-0A adapters is required for screw fixing.

Standard induction motor 4-pole at 400 V AC ¹⁾ Standard output P	Setting range for solid-state overload release	Instantaneous electronic release
-------------------------------------------------------------------------------------	------------------------------------------------------	-------------------------------------

kW	A	A

Order No.	Order No.
-----------	-----------

For use with the infeed system for 3RA6 and with the AS-i add-on module or as a replacement device, without main and control circuit terminals

0.09	0.1 ... 0.4	56
0.37	0.32 ... 1.25	56
1.5	1 ... 4	56
5.5	3 ... 12	168
15	8 ... 32	448

3RA61 20-0A 30	--
3RA61 20-0B 30	--
3RA61 20-0C 30	--
3RA61 20-0D 30	--
3RA61 20-0E 30	--

Screw terminals	Spring-type terminals
-----------------	-----------------------

For standard mounting rail or screw mounting, including 1 pair of main circuit terminals and 1 pair of control circuit terminals

0.09	0.1 ... 0.4	56
0.37	0.32 ... 1.25	56
1.5	1 ... 4	56
5.5	3 ... 12	168
15	8 ... 32	448

3RA61 20-1A 32	3RA61 20-2A 32
3RA61 20-1B 32	3RA61 20-2B 32
3RA61 20-1C 32	3RA61 20-2C 32
3RA61 20-1D 32	3RA61 20-2D 32
3RA61 20-1E 32	3RA61 20-2E 32

For use in the infeed system for 3RA6, without main circuit terminals with 1 pair of control circuit terminals

0.09	0.1 ... 0.4	56
0.37	0.32 ... 1.25	56
1.5	1 ... 4	56
5.5	3 ... 12	168
15	8 ... 32	448

3RA61 20-1A 33	3RA61 20-2A 33
3RA61 20-1B 33	3RA61 20-2B 33
3RA61 20-1C 33	3RA61 20-2C 33
3RA61 20-1D 33	3RA61 20-2D 33
3RA61 20-1E 33	3RA61 20-2E 33

Order No. supplements for rated control supply voltage

- 24 V AC/DC
- 42 ... 70 V AC/DC
- 110 ... 240 V AC/DC

B	B
E	E
P	P

*For standard mounting rail or screw mounting when using the AS-i add-on module with 1 pair of main circuit terminals without control circuit terminals
 Rated control supply voltage 24 V AC/DC*

0.09	0.1 ... 0.4	56
0.37	0.32 ... 1.25	56
1.5	1 ... 4	56
5.5	3 ... 12	168
15	8 ... 32	448

3RA61 20-1AB34	3RA61 20-2AB34
3RA61 20-1BB34	3RA61 20-2BB34
3RA61 20-1CB34	3RA61 20-2CB34
3RA61 20-1DB34	3RA61 20-2DB34
3RA61 20-1EB34	3RA61 20-2EB34

¹⁾ Selection depends on the concrete startup and rated data of the protected motor.





AS-Interface slaves

Motor starters for operation in the control cabinet

3RA61, 3RA62 compact feeders
3RA62 reversing starters

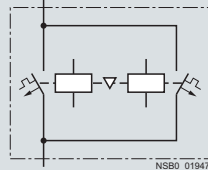
Selection and ordering data

		 <p>Reversing duty</p>	Width 90 mm Rated short-circuit current $I_{CS} = 53 \text{ kA}$ at 400 V Two sets of 3RA69 40-0A adapters are required for screw fixing.
3RA62 50-1CP32	3RA62 50-2DP32		
Standard induction motor 4-pole at 400 V AC ¹⁾	Setting range for electronic overload release	Instantaneous electronic release	
Standard output P			Order No.

For use with the infeed system for 3RA6 and with the AS-i add-on module or as a replacement device, without main and control circuit terminals

0.09	0,1 ... 0.4	56	3RA62 50-0A 30	--
0.37	0.32 ... 1.25	56	3RA62 50-0B 30	--
1.5	1 ... 4	56	3RA62 50-0C 30	--
5.5	3 ... 12	168	3RA62 50-0D 30	--
15	8 ... 32	448	3RA62 50-0E 30	--

Screw terminals 

Spring-type terminals 

For standard mounting rail or screw mounting, including 1 pair of main circuit terminals and 1 pair of control circuit terminals

0.09	0,1 ... 0.4	56	3RA62 50-1A 32	3RA62 50-2A 32
0.37	0.32 ... 1.25	56	3RA62 50-1B 32	3RA62 50-2B 32
1.5	1 ... 4	56	3RA62 50-1C 32	3RA62 50-2C 32
5.5	3 ... 12	168	3RA62 50-1D 32	3RA62 50-2D 32
15	8 ... 32	448	3RA62 50-1E 32	3RA62 50-2E 32

For use in the infeed system for 3RA6, without main circuit terminals with 1 pair of control circuit terminals

0.09	0,1 ... 0.4	56	3RA62 50-1A 33	3RA62 50-2A 33
0.37	0.32 ... 1.25	56	3RA62 50-1B 33	3RA62 50-2B 33
1.5	1 ... 4	56	3RA62 50-1C 33	3RA62 50-2C 33
5.5	3 ... 12	168	3RA62 50-1D 33	3RA62 50-2D 33
15	8 ... 32	448	3RA62 50-1E 33	3RA62 50-2E 33

Order No. supplements for rated control supply voltage

- 24 V AC/DC
- 42 ... 70 V AC/DC
- 110 ... 240 V AC/DC

B
E
P

B
E
P

For standard mounting rail or screw mounting when using the AS-i add-on module with 1 pair of main circuit terminals without control circuit terminals
Rated control supply voltage 24 V AC/DC

0.09	0,1 ... 0.4	56	3RA62 50-1AB34	3RA62 50-2AB34
0.37	0.32 ... 1.25	56	3RA62 50-1BB34	3RA62 50-2BB34
1.5	1 ... 4	56	3RA62 50-1CB34	3RA62 50-2CB34
5.5	3 ... 12	168	3RA62 50-1DB34	3RA62 50-2DB34
15	8 ... 32	448	3RA62 50-1EB34	3RA62 50-2EB34

¹⁾ Selection depends on the concrete startup and rated data of the protected motor.

AS-Interface slaves

Motor starters for operation in the control cabinet

SIRIUS 3RA6 compact feeders
Accessories

Overview

Accessories for SIRIUS 3RA6 compact feeders

The following accessories are available specially for the 3RA6 compact feeders:

- AS-i add-on module: see from Page 6/88 "AS-interface add-on modules"
- External auxiliary switch blocks: Snap-on auxiliary switch as versions 2 NO, 2 NC and 1 NO + 1 NC with screw or spring-type connections; the contacts of the auxiliary switch block open and close jointly with the main contacts of the compact feeder. The NC contacts are designed as mirror contacts.
- Control kit: aid for manually closing the main contacts in order to check the wiring and motor direction under conditions of short-circuit protection
- Adapter for screw fixing the compact feeder, including push-in lugs
- Main circuit terminals: Available with screw and spring-type terminals
- Main circuit terminals mixed connection method: With the main circuit terminals mixed connection method it is also possible in the main circuit to switch from screw terminals on the line side to spring-type terminals on the outgoing side. This enables for example the side-by-side mounting of several compact feeders and their cost-efficient connection using 3-phase busbars on the infeed side. The motors are then connected directly by the quick and reliably contacting spring-type connection method.

Accessories for UL applications

The terminal block for "Self-Protected Combination Motor Controller", type E is available for complying with the clearance and creepage distances demanded according to UL 508.

Accessories for infeed using three-phase busbar systems

The three-phase busbars can be used as an easy, time-saving and clearly arranged means of feeding SIRIUS 3RA6 compact feeders with screw connection. Motor starter protector sizes S00 and S0 can also be integrated.

The busbars are suitable for between 2 and 5 devices. However, any kind of extension up to a maximum summation current of 63 A is possible by clamping the tags of an additional busbar (rotated by 180°) underneath the terminals of the respective last motor starter protector.

A connecting piece is required for the combination with 3RV1 motor starter protector size S00. Motor starter protectors S00 and S0 of the 3RV2 series can be combined in any way (without a special connecting piece). The motor starter protectors are supplied by appropriate feeder terminals. Special feeder terminals are required for constructing "Type E Starters" according to UL/CSA.

The three-phase busbar systems are finger-safe but empty connection tags must be fitted with covers. They are designed for any short-circuit stress which can occur at the output side of connected SIRIUS 3RA6 compact feeders or motor starter protectors.

Busbar adapters for 60 mm systems

The compact starters are mounted directly with the aid of busbar adapters on busbar systems with 60 mm center-to-center clearance in order to save space and to reduce infeed times and costs. These feeders are suitable for copper busbars with a width from 12 to 30 mm. The busbars can be 4 to 5 mm or 10 mm thick.

The 8US busbar system can be loaded with a maximum summation current of 630 A.

The "reversing starter" version requires a device holder along side the busbar adapter for lateral mounting.

The compact feeders are snapped onto the adapter and connected on the line side. This prepared unit is then plugged directly onto the busbar system, and is thus connected both mechanically and electrically at the same time.

Note:

For more accessories such as incoming and outgoing terminals, flat copper profiles etc., see Catalog LV 10.1.

Accessories for operation with closed control cabinet doors







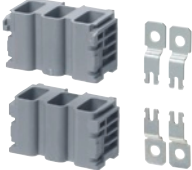

Door-coupling rotary operating mechanisms for standard and emergency-stop applications are available for operating the compact feeder with closed control cabinet doors.

AS-Interface slaves

Motor starters for operation in the control cabinet

SIRIUS 3RA6 compact feeders Accessories

Selection and ordering data

Version	Order No.
<i>Accessories specially for 3RA6 compact feeders</i>	
 3RA69 50-0A	Control kit For mechanical actuation of the compact feeder 3RA69 50-0A
 3RA69 40-0A	Adapters for screw fixing the compact feeder (set including push-in lugs) Direct-on-line starters require one set, reversing starters two sets. 3RA69 40-0A
 3RA69 11-1A	Auxiliary switch blocks for compact feeders <ul style="list-style-type: none"> • 2 NO • 2 NC • 1 NO +1 NC (these auxiliary contacts are positively driven.)
 3RA69 20-1A	Main circuit terminals (incoming and outgoing side) 3RA69 20-1A
 3RA69 20-1B	Control circuit terminals <ul style="list-style-type: none"> • For 3RA61 • For 3RA62
 3RA69 11-2A	Auxiliary switch blocks for compact feeders <ul style="list-style-type: none"> • 2 NO • 2 NC • 1 NO +1 NC (these auxiliary contacts are positively driven.)
 3RA69 20-2A	Main circuit terminals (incoming and outgoing side) 3RA69 20-2A
 3RA69 20-2B	Control circuit terminals <ul style="list-style-type: none"> • For 3RA61 • For 3RA62
	Screw terminals 
	3RA69 11-1A 3RA69 12-1A 3RA69 13-1A
	Spring-type terminals 
	3RA69 11-2A 3RA69 12-2A 3RA69 13-2A
	3RA69 20-2A
	3RA69 20-1B 3RA69 20-1C
	3RA69 20-2B 3RA69 20-2C

AS-Interface slaves Motor starters for operation in the control cabinet

SIRIUS 3RA6 compact feeders Accessories

Selection and ordering data (continued)

Version	Order No.
---------	-----------

Accessories specially for 3RA6 compact feeders (continued)



3RA69 20-3A

Main circuit terminals mixed connection method

- 1 set comprises:
- 1 joint block on the line side with screw terminals
 - 1 joint block on the outgoing side with spring-type terminals

3RA69 20-3A

Version	Order No.
---------	-----------

Terminals for "Self-Protected Combination Motor Controllers (Type E)" acc. to UL 508 for infeed through parallel wiring with compact feeders



3RV19 28-1H

Note:
UL 508 demands 1-inch clearance and 2-inch creepage distance at line side for "Combination Motor Controller Type E". Terminal blocks are not required for use according to CSA. These terminal blocks cannot be used in combination with 3RV19 .5 three-phase busbars.

Terminal blocks type E

For extended clearance and creepage distances (1 and 2 inch)

3RV19 28-1H

Number of compact feeders and motor starter protectors that can be connected	Modular spacing	Rated current I_n at 690 V	For motor starter protectors	Order No.
Without lateral accessories	mm	A	Size	

Three-phase busbars for infeed with 3RA6



3RV19 15-1AB



3RV19 15-1BB



3RV19 15-1CB



3RV19 15-1DB

For feeding several compact feeders and/or motor starter protectors with screw terminals, mounted side by side on standard mounting rails, insulated, with touch protection.

2	45	63	S00, S0 ¹⁾
3	45	63	S00, S0 ¹⁾
4	45	63	S00, S0 ¹⁾
5	45	63	S00, S0 ¹⁾

3RV19 15-1AB
3RV19 15-1BB
3RV19 15-1CB
3RV19 15-1DB

¹⁾ Not suitable for 3RV11/3RV21 motor starter protectors for motor protection with overload relay function and for 3RV17/3RV27 and 3RV18/3RV28 circuit breakers according to UL 489 / CSA C22.2 No.5-02. Joint clamping of 3RV1 motor starter protector sizes S00 and S0 is not possible on account of the different modular spacings and the different height of the terminals. The 3RV19 15-5DB connecting piece is available for connecting the compact feeders to the 3RV1 motor starter protector size S00. Motor starter protectors S00/S0 of the 3RV2 series can be jointly clamped; no connecting piece has to be used.

Version	Modular spacing	For motor starter protectors	Order No.
	mm	Size	

Covers for connection tags of the three-phase busbars



3RV19 15-6AB

Touch protection for empty positions

--

S00, S0

3RV19 15-6AB

6

AS-Interface slaves

Motor starters for operation in the control cabinet

SIRIUS 3RA6 compact feeders Accessories

Selection and ordering data (continued)

Conductor cross-section		Tightening torque	For compact feeders and motor starter protectors	Order No.
Solid or stranded	Finely stranded with end sleeve			
mm ²	mm ²	Nm	Size	

Three-phase feeder terminals for three-phase busbars



3RV19 25-5AB

Connection from top

2.5 ... 25

4 ... 16

10-4

4

S0

3RV19 25-5AB



3RV19 15-5B

Connection from below ¹⁾

2.5 ... 25

4 ... 16

10-4

Input: 4;
Output: 2 ... 2.5

S00, S0

3RV19 15-5B

Three-phase feeder terminals for constructing "Type E Starters" according to UL 508 for three-phase busbars

Connection from top

2.5 ... 25

4 ... 16

10-4

--

S0

3RV19 25-5EB

¹⁾ This terminal is connected in place of a switch, please take the space requirement into account.

Version

Order No.

Busbar adapters for 60 mm systems



8US12 11-1NS10

For flat copper profiles according to DIN 46433
Width: 12 ... 30 mm
Thickness: 4 ... 5 mm or 10 mm

8US12 11-1NS10

Device holders for lateral mounting along side the busbar adapter for 60 mm systems



8US12 50-1AA10

Required in addition to the busbar adapter for mounting a reversing starter

8US12 50-1AA10

Version

Color of handle

Version of extension shaft
mm

Order No.

Door-coupling rotary operating mechanisms for operating the compact feeder with closed control cabinet doors



3RV29 26-0B

The door-coupling rotary operating mechanisms consist of a knob, a coupling driver and a 130/330 mm long extension shaft (6 mm x 6 mm). The door-coupling rotary operating mechanisms are designed to degree of protection IP65. The door interlocking prevents accidental opening of the control cabinet door in the ON position of the motor starter protector. The OFF position can be locked with up to 3 padlocks.

Door-coupling rotary operating mechanisms

Black

130

3RV29 26-0B

EMERGENCY-STOP door-coupling rotary operating mechanisms

Red/yellow

130



3RV29 26-0C

AS-Interface slaves

Motor starters for operation in the control cabinet

SIRIUS 3RA6 compact feeders
Accessories

Selection and ordering data (continued)

Version	Order No.
Tools for opening spring-type terminals	
 Screwdrivers for all SIRIUS devices with spring-type terminals Length approx. 200 mm, 3.0 mm x 0.5 mm, titanium gray/black, partially insulated 3RA29 08-1A	Spring-type terminals  3RA29 08-1A
Blank labels	
 Unit labeling plates ¹⁾ for SIRIUS devices 20 mm x 7 mm, pastel turquoise 3RT19 00-1SB20	3RT19 00-1SB20
Documentation ²⁾	
System manual SIRIUS Compact Feeders and Accessories German	3RA69 91-0A

¹⁾ PC labeling system for individual inscription of unit labeling plates available from: murrplastik Systemtechnik GmbH www.murrplastik.com

²⁾ This manual and other language versions are currently available from the download center of the Service & Support portal at <https://support.automation.siemens.com/WW/view/en/27136554/133300> .

AS-Interface slaves

Motor starters for operation in the control cabinet

SIRIUS 3RA6 compact feeders Add-on modules for AS-Interface

Overview

Various AS-i add-on modules are available for communication of the 3RA6 compact feeder with the control system using AS-Interface:

- Standard version
- With two local inputs
- With two free external inputs
- With one free external input and one free external output
- With two free external outputs
- For local control

The AS-i add-on modules can be combined only in connection with compact feeders with a rated control supply voltage of 24 V AC/DC.

AS-i add-on module for on-site controller

With this new module it is also possible for the connected compact feeder to be operated directly using simple switches, i.e. without recourse to AS-i Communication, if required.

"Automatic" mode

NC contacts can be connected to the inputs Y2 and Y4 through the local terminals on the AS-i add-on module. If the "+" connections are connected simultaneously to both local inputs, the AS-i add-on module will be in "Automatic" mode, i.e. it will communicate with the control system through AS-Interface.

On-site control

Opening the two inputs Y2 and Y4 will result in the direct disconnection of the compact feeder. Operation through AS-i Communication is ended and the compact feeder can now be switched on and off directly using NO contacts (one NO contact per direction of rotation on the reversing starter).

"LED AUX Power" must light up green, the 24 V DC supply must be assured and the AS-i control supply voltage must no longer be applied.

Resetting to "Automatic" mode

Simultaneous application of a "1" signal at the local inputs. The availability bit DI 0 is switched to a "1" signal.

If AS-i Communication is reset, the motor is first switched off and then on again when requested by the control system.

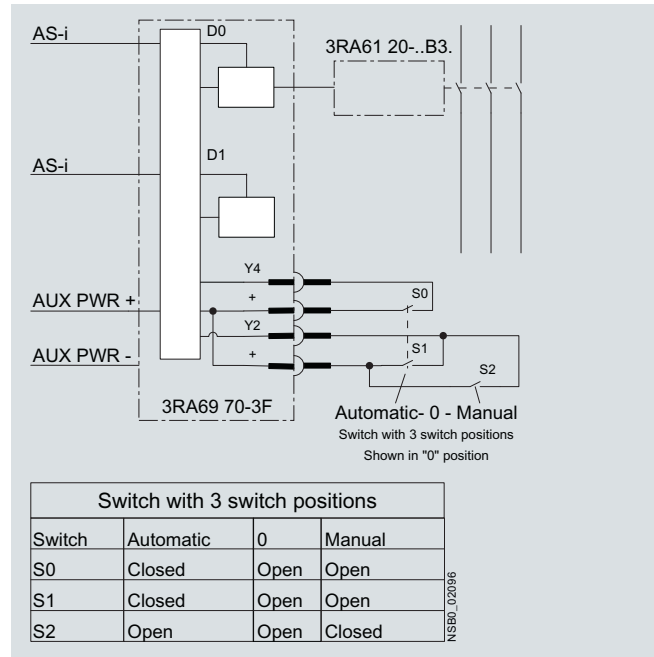

Circuit example for controlling a 3RA61 20 direct-on-line starter using an AS-i add-on module for on-site control

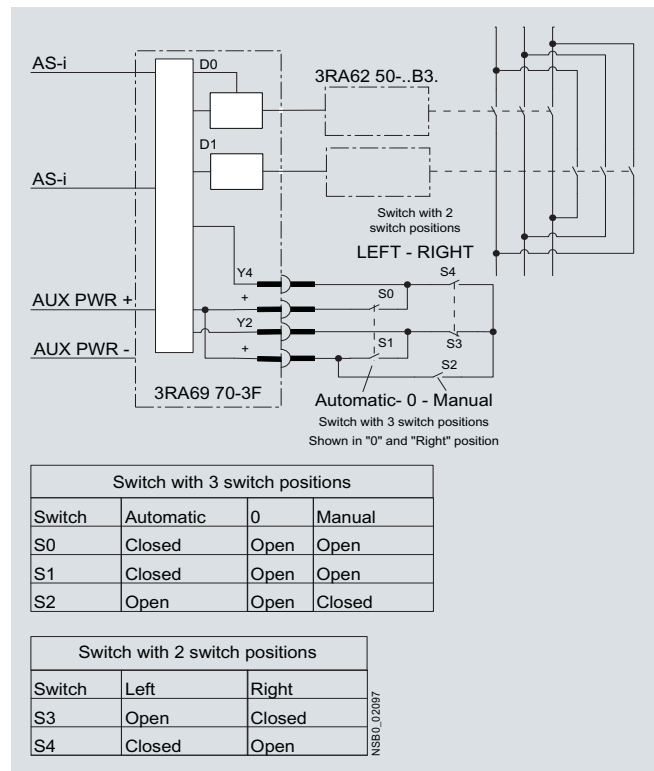

Circuit example for controlling a 3RA62 50 reversing starter using an AS-i add-on module for on-site control





6

AS-Interface slaves

Motor starters for operation in the control cabinet

SIRIUS 3RA6 compact feeders
Add-on modules for AS-Interface

Selection and ordering data

Version	Order No.
AS-i add-on modules	
 <p>3RA69 70-3A</p>	<p>Standard version For communication of the compact feeder with the control system using AS-Interface</p> <p>3RA69 70-3A</p>
 <p>3RA69 70-3B to -3F</p>	<p>With two local inputs For safe disconnection through local safety relays, e.g. cable-operated switches</p> <p>3RA69 70-3B</p>
	<p>With two free external inputs Replaces the digital standard inputs "Motor On" and "Group warning"</p> <p>3RA69 70-3C</p>
	<p>With one free external input and one free external output Replaces the digital standard input "Group warning"</p> <p>3RA69 70-3D</p>
	<p>With two free external outputs Only for direct-on-line starters, replaces the digital standard output "Motor left"</p> <p>3RA69 70-3E</p>
	<p>For local control Control of the compact feeder optionally using AS-Interface or local switches</p> <p>3RA69 70-3F</p>
Spare parts for AS-i add-on modules	
	<p>Connectors for data and auxiliary supply cable with 2 insulation piercing connecting devices for standard wires 2 x 0.5 ... 0.75 mm²</p> <ul style="list-style-type: none"> • flat, yellow, extender • flat, black, extender <p>3RK19 01-0NA00 3RK19 01-0PA00</p>
Accessories for AS-i add-on modules	
 <p>3RK19 04-2AB02</p>	<p>AS-Interface addressing unit V 3.0</p> <ul style="list-style-type: none"> • For AS-Interface modules and sensors and actuators with integrated AS-Interface in accordance with AS-i Specification V3.0 • For setting the AS-i address of standard slaves, and slaves with extended addressing mode (A/B slaves) • With input/output test function and many other -commissioning functions • Battery operation with 4 batteries type AA (IEC LR6, NEDA 15) • Scope of supply: <ul style="list-style-type: none"> - Addressing unit with 4 batteries - Addressing cable, with M12 plug to addressing plug (hollow plug), length 1.5m <p>3RK19 04-2AB02</p>

AS-Interface slaves

Motor starters for operation in the control cabinet

SIRIUS 3RA6 compact feeders Infeed system for 3RA6

Overview

The infeed system for 3RA6 compact feeders enables far less wiring in the main circuit and, thanks to the easy exchangeability of the compact feeders, reduces the usual downtimes for maintenance work during the plant's operating phase.

The infeed system provides the possibility of completely pre-wiring the main circuit without a compact feeder needing to be connected at the same time. As the result of the removable terminals in the main circuit, compact feeders can be integrated in an infeed system in easy manner (without the use of tools).

In addition, the integrated PE bar means it is optionally possible to connect the motor cable directly to the infeed system without additional intermediate terminals. The infeed system for 3RA6 compact feeders is designed for summation currents up to 100 A with a maximum conductor cross-section of up to 70 mm² on the feeder terminal block.

The infeed system can be mounted on a standard mounting rail or flat surfaces.

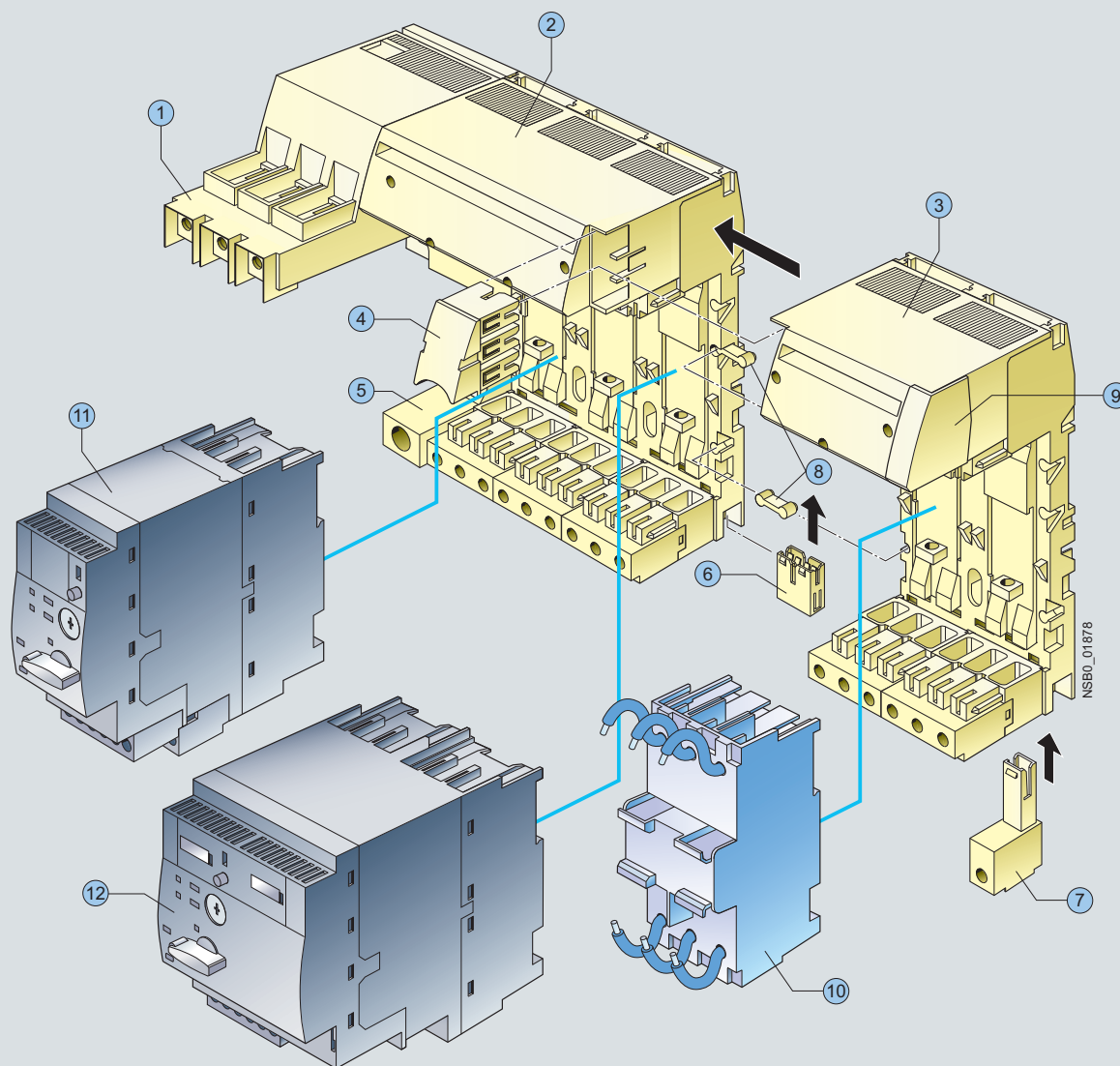

- | | |
|---------------------------------|------------------------------------------------------------|
| ① Feeder terminal | ⑦ PE pick-off |
| ② Three-socket expansion module | ⑧ Connecting wedges |
| ③ Two-socket expansion module | ⑨ End cover |
| ④ Expansion plug | ⑩ 45 mm adapter for SIRIUS motor starter protector size S0 |
| ⑤ PE infeed | ⑪ 3RA61 direct-on-line starter |
| ⑥ PE expansion plug | ⑫ 3RA62 reversing starter |

Infeed system for 3RA6 compact feeders

AS-Interface slaves

Motor starters for operation in the control cabinet

SIRIUS 3RA6 compact feeders
Infeed system for 3RA6

Overview (continued)

① Infeed

The 3-phase infeed is available with screw connection (25/35 mm² up to 63 A or 50/70 mm² up to 100 A) and spring-type connection (25/35 mm² up to 63 A).

The infeed with spring-type terminal can be fitted on the left as well on as the right to an expansion module.

The infeed with screw terminal is supplied only with a 3-socket expansion module and permanently fitted on the left side.

The infeeds with screw connection enable connection of the main conductors (L1, L2, L3) either from above or from below.

The infeed with screw connection is supplied complete with 1 end cover, the infeed with spring-type connection complete with 2 end covers.

② Three-socket expansion modules

The expansion module with 3 sockets for compact feeders is available with screw connection and with spring-type connection.

Expansion modules enable the infeed system to be expanded and can be fitted to each other in any number.

Two expansion modules are held together with the help of 2 connecting wedges and 1 expansion plug. These assembly parts are included in the scope of supply of the respective expansion module.

When the infeed system for 3RA6 is used, the compact feeders (plug-in modules) are easily mounted and removed even when live.

Optional possibilities:

- PE connection on motor outgoing side
- Outfeed for external auxiliary devices
- Connection to 3RV19 infeed system
- Integration of SIRIUS 3RV1 motor starter protectors size S0 (using 3RA68 90-0BA adapter)

③ Two-socket expansion modules

If only 2 instead of 3 additional sockets are required, then the 2-socket expansion module is the right choice. It has the same functionality as the 3-socket expansion module.

④ Expansion plug

Two expansion modules can be connected together using the expansion plug. Flexible expansion of the infeed system is thus possible.

⑤ PE infeeds

This module enables a PE cable to be connected.

The PE infeed can be ordered with screw connection and spring-type connection (35 mm²) and can be fitted on the right or left to the expansion block.

⑥ PE expansion plug

The PE expansion plug is inserted from below and enables two PE bars to be connected.

⑦ PE pick-off

The PE pick-off is available with screw connection and spring-type connection (6/10 mm²). It is snapped into the infeed system from below.

⑧ Connecting wedges

Two connecting wedges are used to hold together 2 expansion modules.

⑨ End covers

On the last expansion module of a row, the socket provided for the expansion plug can be covered by inserting the end cover.

⑩ 45 mm adapters for SIRIUS 3RV1 motor starter protectors

SIRIUS 3RV1 motor starter protectors size S0 with screw connection can be fitted to the adapter, enabling them to be plugged into the infeed system.

IP20 terminal covers for increasing finger-safety

Universally configured terminal covers are available for the 3-phase infeeds with screw connection 25/35 mm² and 50/70 mm²:

- 3RA68 80-2AB terminal covers for infeeds with screw connection 25/35 mm² (3RA68 12-8AB/AC)
- 3RA68 80-3AB terminal covers for infeed with screw connections 50/70 mm² (3RA68 13-8AB/AC)

The terminal covers can be used in two ways on the feeder terminals of the infeeds with screw connection 25/35 mm² and 50/70 mm² (see illustration):

- If the terminals are connected, the cables are also covered:
 - by approx. 14 mm with the 3RA68 80-2AB
 - by approx. 18 mm with the 3RA68 80-3AB
- On clamping points without connected cables, the covers can be turned once and then pushed over the clamping points for finger-safe covering of the metal parts.

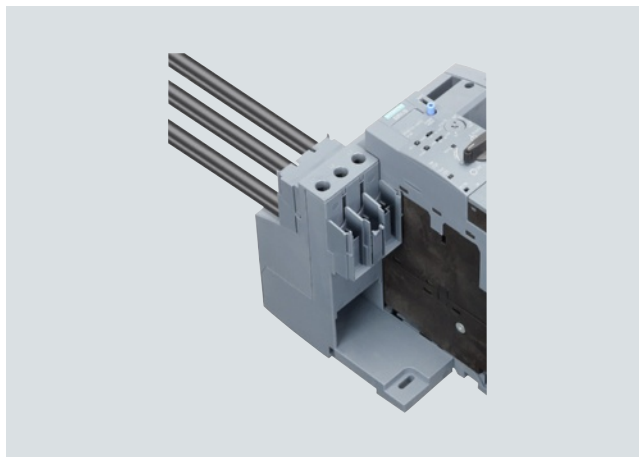

Use of the 3RA68 80-2AB terminal cover on the infeed with screw connection 25/35 mm² (3RA68 12-8AB/AC). The upper cover increases the finger-safety for the connected conductors. The identical lower cover is turned for use and prevents touching of the voltage-carrying metal parts of the feeder terminal.

Terminal blocks

Using the terminal block the 3 phases can be fed out of the system; this means that single-phase, two-phase and three-phase components can also be integrated in the system.

After the end cover is pulled out, the terminal block can be plugged onto an expansion module.

Expansion plug for SIRIUS 3RV19 infeed systems

After the end cover is pulled out, the expansion plug for the SIRIUS 3RV19 infeed system can be plugged onto an expansion module. It connects the infeed system for 3RA6 compact feeders with the SIRIUS 3RV19 infeed system.

AS-Interface slaves

Motor starters for operation in the control cabinet

SIRIUS 3RA6 compact feeders Infeed system for 3RA6

Overview (continued)

Maximum rated operational current

The following maximum rated operational currents apply for the components of the infeed system for 3RA6:

Component	Maximum rated operational current A
Infeed with screw connection 50/70 mm ²	100
Infeed with screw connection 25/35 mm ²	63
Infeed with spring-type connection 25/35 mm ²	63
Expansion plug	63

With side-by-side mounting of several expansion modules, the maximum rated operational current from the second expansion module to the end of the row is 63 A.

Proposal for upstream short-circuit protection devices

The following short-circuit data apply for the components of the infeed system for 3RA6 compact feeders:

Conductor cross-section mm ²	Inscriptions	Proposal for upstream short-circuit protection device
<i>Short-circuit protection for infeed block (25 mm²/35 mm²) with screw connection</i>		
2.5 ... 35	$I_{d, \max} = 19 \text{ kA}, I^2t = 440 \text{ kA}^2\text{s}$	3RV10 41-4JA10
<i>Short-circuit protection for infeed block (50/70 mm²) with screw connection</i>		
2.5 ... 70	$I_{d, \max} = \text{approx. } 22 \text{ kA}$	3RV10 41-4MA10
<i>Short-circuit protection for infeed block with spring-loaded connection</i>		
4	$I_{d, \max} = 9.5 \text{ kA}, I^2t = 85 \text{ kA}^2\text{s}$	3RV10 21-4DA10
6	$I_{d, \max} = 12.5 \text{ kA}, I^2t = 140 \text{ kA}^2\text{s}$	3RV10 31-4EA10
10	$I_{d, \max} = 15 \text{ kA}, I^2t = 180 \text{ kA}^2\text{s}$	3RV10 31-4HA10
16/25	$I_{d, \max} = 19 \text{ kA}, I^2t = 440 \text{ kA}^2\text{s}$	3RV10 41-4JA10
<i>Short-circuit protection for terminal block</i>		
1.5	$I_{d, \max} = 7.5 \text{ kA}$	5SY... 1)
2.5	$I_{d, \max} = 9.5 \text{ kA}$	
4	$I_{d, \max} = 9.5 \text{ kA}$	
6	$I_{d, \max} = 12.5 \text{ kA}$	



1) To prevent the possibility of short-circuits, the cables on the terminal block must be installed so that they are short-circuit proof according to EN 60439-1 Section 7.5.5.1.2.

AS-Interface slaves

Motor starters for operation in the control cabinet

SIRIUS 3RA6 compact feeders
Infeed system for 3RA6

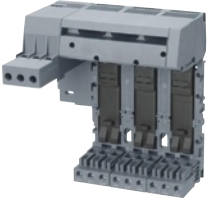
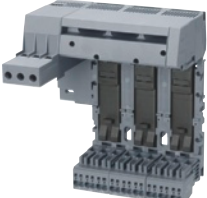
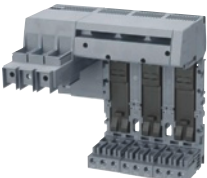
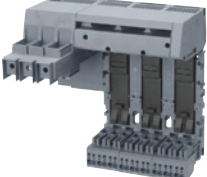
Selection and ordering data

Version	Order No.
Three-phase infeeds and expansion modules	
 <p>3RA68 12-8AB</p>	<p>Infeeds with screw connection 25/35 mm² left</p> <p>Infeed with screw connection at line side with a permanently fitted 3-socket expansion module with screw or spring-type connection on the outgoing side and integrated PE bar</p> <p>Expansion module with 3 sockets for 3 direct-on-line starters or 1 direct-on-line starter and 1 reversing starter</p> <ul style="list-style-type: none"> • Screw terminals on the outgoing side • Spring-type terminals on the outgoing side
 <p>3RA68 12-8AC</p>	
 <p>3RA68 13-8AB</p>	<p>Infeeds with screw connection 50/70 mm² left</p> <p>Infeed with screw connection at line side with a permanently fitted 3-socket expansion module with screw or spring-type connection on the outgoing side and integrated PE bar</p> <p>Expansion module with 3 sockets for 3 direct-on-line starters or 1 direct-on-line starter and 1 reversing starter, suitable for UL operation according to UL 508 Type E</p> <ul style="list-style-type: none"> • Screw terminals on the outgoing side • Spring-type terminals on the outgoing side
 <p>3RA68 13-8AC</p>	
 <p>3RA68 30-5AC</p>	<p>Infeeds with spring-type connection 25/35 mm² left or right</p> <p>Up to 63 A</p>

Screw terminals



3RA68 12-8AB



3RA68 12-8AC



Screw terminals



3RA68 13-8AB



3RA68 13-8AC



Spring-type terminals







3RA68 30-5AC

AS-Interface slaves

Motor starters for operation in the control cabinet

SIRIUS 3RA6 compact feeders
Infeed system for 3RA6

Selection and ordering data (continued)

Version	Order No.
Expansion modules	
 <p>3RA68 22-0AB</p>	<p>Two-socket expansion modules with screw or spring-type terminals and integrated PE bar with 2 sockets for 2 direct-on-line starters or 1 reversing starter Expansion plug and 2 connecting wedges are included in the scope of supply.</p> <ul style="list-style-type: none"> • Screw terminals
 <p>3RA68 22-0AC</p>	<ul style="list-style-type: none"> • Spring-type terminals
 <p>3RA68 23-0AB</p>	<p>Three-socket expansion modules with screw or spring-type terminals and integrated PE bar with 3 sockets for 3 direct-on-line starters or 1 direct-on-line starter and 1 reversing starter Expansion plug and 2 connecting wedges are included in the scope of supply.</p> <ul style="list-style-type: none"> • Screw terminals
 <p>3RA68 23-0AC</p>	<ul style="list-style-type: none"> • Spring-type terminals

6

AS-Interface slaves

Motor starters for operation in the control cabinet

SIRIUS 3RA6 compact feeders
Infeed system for 3RA6

Selection and ordering data (continued)









Version	Order No.
Accessories for infeed systems for 3RA6	
PE infeeds 25/35 mm²	
 <p>3RA68 60-6AB</p> <ul style="list-style-type: none"> • Screw terminals 	<p>Screw terminals </p> <p>3RA68 60-6AB</p>
 <p>3RA68 60-5AC</p> <ul style="list-style-type: none"> • Spring-type terminals 	<p>Spring-type terminals </p> <p>3RA68 60-5AC</p>
PE pick-offs 6/10 mm²	
 <p>3RA68 70-4AB</p> <ul style="list-style-type: none"> • Screw terminals 	<p>Screw terminals </p> <p>3RA68 70-4AB</p>
 <p>3RA68 70-3AC</p> <ul style="list-style-type: none"> • Spring-type terminals 	<p>Spring-type terminals </p> <p>3RA68 70-3AC</p>
Expansion plug	
 <p>3RA68 90-0EA</p> <p>PE expansion plugs</p>	<p>3RA68 90-0EA</p>
 <p>3RA68 90-1AB</p> <p>Expansion plugs between 2 expansion modules Is included in the scope of supply of the expansion modules.</p>	<p>3RA68 90-1AB</p>
 <p>3RA68 90-1AA</p> <p>Expansion plug for SIRIUS 3RV19 infeed system connects infeed system for 3RA6 to 3RV19 infeed system</p>	<p>3RA68 90-1AA</p>

AS-Interface slaves

Motor starters for operation in the control cabinet

SIRIUS 3RA6 compact feeders
Infeed system for 3RA6

Selection and ordering data (continued)

Version		Order No.
<i>Accessories for infeed systems for 3RA6 (continued)</i>		
 <p>3RA68 90-0BA</p>	<p>45 mm adapters for SIRIUS 3RV1 motor starter protectors size S0</p> <ul style="list-style-type: none"> Screw terminals (conductor cross-section AWG 10) 	<p>Screw terminals </p> <p>3RA68 90-0BA</p>
 <p>3RA68 80-2AB</p>	<p>Terminal covers for infeeds with screw connection IP 20 terminal covers for infeeds with screw connection 25/35 mm² (3RA68 12-8AB/AC) (2 units per pack)</p>	<p>3RA68 80-2AB</p>
 <p>3RA68 80-3AB</p>	<p>IP 20 terminal covers for infeeds with screw connection 50/70 mm² (3RA68 13-8AB/AC) (2 units per pack)</p>	<p>3RA68 80-3AB</p>
 <p>3RV19 17-5D</p>	<p>Terminal blocks for integration of single-phase, 2-phase and 3-phase external components</p> <ul style="list-style-type: none"> Spring-type terminals 	<p>Spring-type terminals </p> <p>3RV19 17-5D</p>
<i>Tools for opening spring-type terminals</i>		
 <p>3RA29 08-1A</p>	<p>Screwdriver For all SIRIUS devices with spring-type terminals</p> <p>Length approx. 200 mm, 3.0 mm x 0.5 mm, titanium gray/black, partially insulated</p>	<p>Spring-type terminals </p> <p>3RA29 08-1A</p>

Motor starters for operation in the field, high degree of protection

SIRIUS M200D motor starters
General data

Overview



SIRIUS M200D AS-i Basic motor starters with manual on-site operation

The intelligent, highly flexible SIRIUS M200D motor starters for distributed configurations are designed to start, monitor and protect motors and loads up to 5.5 kW.

The M200D motor starters are available in four versions:

M200D AS-i Basic	M200D AS-i Standard	M200D PROFIBUS	M200D PROFINET
Motor control with AS-i Communication		PROFIBUS	PROFINET
Mechanical or electronic switching	✓	✓	✓
Electronic switching with soft starter functionality	--	✓	✓

✓ Function is available

-- Function is not available

Basic functionality

All M200D motor starter versions have the following functions:

- Available as direct-on-line and reversing starters in a rugged design
- Electromechanical or solid-state switching version
- Little variance – only 2 device versions up to 5.5 kW thanks to wide range setting
- All versions have the same enclosure dimensions
- Degree of protection IP65
- Quick and failsafe wiring of system and motor cables using ISO 23570 plug-in connector technology (Q4/2 and Q8/0)
- Robust and widely used M12 connection method for digital inputs and outputs
- Integrated feeder connector monitoring
- Full motor protection through overload protection and a temperature sensor (PTC, TC)
- Short-circuit and overload protection integrated
- Integrated repair switch lockable with 3 locks (multi-level service)
- Uniform wiring to the G110D/G120D frequency converters and to the ET 200pro distributed peripherals system
- Extensive diagnostics concept using LEDs
- Optional integrated manual on-site controller with key-operated switch (ordering option)
- Optionally available brake actuation with voltages from 180 V DC (no rectifier needed in motor) or 230/400 V AC (order versions)

6

Benefits

M200D motor starters provide the following advantages for customers:

- High plant availability through plug-in capability of the main circuit, communication and IOs – relevant for installing and replacing devices
- Cabinet-free construction and near-motor installation thanks to the high degree of protection IP65
- The motor starters record the actual current flow for the parameterizable electronic motor overload protection. Reliable messages concerning the overranging or underranging of setpoint values for comprehensive motor protection. All motor protection functions can be defined by simple parameterization
- Low stock levels and low order costs through a wide setting range for the current or a wide setting range for the electronic motor protection of 1:10 (only 2 device versions up to 5.5 kW)
- The integrated wide range for the current enables a single device to cover numerous standard motors of different sizes
- Comprehensive offering of accessories, including ready-assembled cables
- The M200D motor starters can be installed with a few manual steps. The integrated plug-in technology significantly reduces the wiring outlay: preassembled cables can be plugged directly onto the motor starter module
- Easy and user-friendly installation because all versions have the same enclosure dimensions
- Fast and user-friendly commissioning using an optional manual on-site controller
- Increase of process speed through integrated functions such as "Quick-Stop" and "Disable Quick-Stop", e.g. at points and crossings
- Optional manual on-site controller with momentary-contact and latching operation for easier start-up and easier service

Application

The high degree of protection IP65 makes the M200D motor starters suitable in particular for use on extensive conveying systems such as are found in mail sorting centers, airports, automotive factories and the packing industry.

For simple operating mechanism tasks, particularly in conveyor applications, the new SINAMICS G110D frequency converter series with a performance range from 0.75 kW to 7.5 kW and degree of protection IP65 is the ideal partner for the M200D motor starters.

The SINAMICS G110D frequency converters permit continuous speed control of three-phase asynchronous motors and meet the requirements of conveyor applications with frequency control (for more information, see Catalog D 11.1 "SINAMICS G110, G120 ...").

AS-Interface slaves

Motor starters for operation in the field, high degree of protection

SIRIUS M200D motor starters M200D motor starters for AS-Interface

Overview

For motor control using AS-Interface there are the following M200D motor starter versions: SIRIUS M200D AS-i Basic and SIRIUS M200D AS-i Standard (for details of basic functionality see Page 6/97 "M200D motor starters" --> "General data" --> "Overview").

SIRIUS M200D AS-i Basic

Functionality

- Easy and fast on-site start-up through parameterization of local setting elements (DIP switches) and rotary coding switches for adjusting the rated operational current. The rotary coding switch has an OFF position for deactivating the overload protection with the help of the thermal motor model when using a temperature sensor.

Communication

- AS-i communication with A/B addressing according to Spec V2.1
- The AS-i bus is connected cost-effectively using an M12 connection on the device. Of the 4 digital inputs, 2 are contained in the process image and can therefore be used in the PLC program. The other 2 inputs are locally effective and permanently assigned with functions.
- The LEDs can provide comprehensive diagnostics of the device on the spot. In addition to diagnostics using the PAE process image, the device can create up to 15 different diagnostic signals per slave. The message with the highest priority can be read out through the AS-i communication. This is yet another new development which distinguishes the M200D AS-i Basic motor starter from the rest of the market and adds innovative technology, maximum availability and transparency to the system.

SIRIUS M200D AS-i Standard

The intelligent, highly flexible M200D AS-i Standard motor starters in A/B technology are designed to start and protect motors and loads up to 5.5 kW. They are available in direct-on-line or reversing starter versions, in a mechanical version and also an electronic version (the latter with soft start function).

The M200D AS-i Standard motor starter is the most functional member of the SIRIUS motor starter family in the high degree of protection IP65 for AS-i Communication. Consistency with other products of the SIRIUS M200D motor starter range and with the frequency converter and ET 200pro peripherals system is assured.

Functionality

- AS-i communication with A/B addressing according to Spec 3.0
- Electronic version also with soft start function
- AS-i slave profile 7AE/7A5 with process image 6I/4O
- Full TIA integration: All digital inputs and outputs exist in the cyclic process image and are visible through AS-i, providing maximum flexibility and best adaptability to the application.
- Additionally expanded diagnostics using data record through AS-i bus
- Complete plant monitoring using statistics data record and current value monitoring by means of data records
- Parameterization through AS-i bus with the help of data records or an expanded process image from the user program
- Control of the motor starter using a command data record from the user program
- Flexible assignment of the digital inputs and outputs with all available assignable input actions
- Parameterization using Motor Starter ES at the local interface (ordering option for start-up software)
- Diagnostics with the help of Motor Starter ES (ordering option for start-up software)

Mounting and installation

The M200D motor starters can be installed with a few manual steps. The integrated plug-in technology enables far lower wiring outlay. Connecting cables can be plugged directly onto the motor starter module. Swapping of the connecting wires and malfunctions within the plant are prevented by preassembled cables. The AS-i bus is connected cost-effectively using an M12 connection on the device. All versions have identical enclosure dimensions for easier system configuration and conversion.

Parameterization and configuration

The particularly robust M200D AS-i Standard motor starter is characterized by numerous functions which can be flexibly parameterized. It enables highly flexible parameterization through the AS-i bus using data records from the user program as well as user-friendly local parameterization using the Motor Starter ES start-up software through the local point-to-point interface.

Functions can be flexibly assigned to the digital inputs and outputs, adapting them to all possible conveyor applications. All motor protection functions, limit values and reactions can be defined by parameterization. The AS-i Standard is unique. In its 6I/4O process image the motor starter sends all 4 digital inputs and the digital output via the process image to the PLC in cyclic mode. System configuration and system documentation are facilitated not least by a number of CAX data.

Operation

The new motor starter generation is characterized by high functionality, maximum flexibility and the highest level of automation.

All digital inputs and outputs exist in the cyclic process image. All limit values for monitoring functions and their reactions are parameterizable and therefore adaptable to the application. The motor starters record the actual current flow. Evaluating the current of the parameterizable solid-state overload protection increases the availability of the drives, as do reliable messages concerning the overranging or underranging of setpoint values.

Diagnostics and maintenance

The M200D sets new standards for diagnostics. In addition to diagnostics using the PAE process image and diagnostics by "parameter echo" (up to 15 different diagnostic signals per slave can be read out via AS-i Communication), the possibility of reading out diagnostic data records is unique on the market.

The AS-i Standard is recommended in particular for expansive and highly automated plant parts because the possibility of monitoring devices and systems with data records (statistical data, measured values and device diagnostics) provides an in-depth view of the plant from the control room, guaranteeing the monitoring process and increasing plant availability.

The integrated maintenance timer can be used to implement preventative maintenance and avoid plant downtimes through look-ahead servicing.

Local on-site control of a drive is possible using the ordering option with integrated manual operation. This is yet another new development which distinguishes the M200D AS-i Standard motor starter from the rest of the market and adds innovative technology, maximum availability and transparency to the plant.

AS-Interface slaves

Motor starters for operation in the field, high degree of protection

SIRIUS M200D motor starters
M200D motor starters for AS-Interface

Overview (continued)



SIRIUS M200D
AS-i Basic



SIRIUS M200D
AS-i Standard

Device functions (firmware features)

Slave on the bus

Fieldbus	✓ AS-i	
Slave type	✓ A/B acc. to Spec 2.1	✓ A/B acc. to Spec 3.0
Profile	✓ 7.A.E	✓ 7.A.E & 7.A.5
Number of assigned AS-i addresses on the bus	✓ 1	✓ 2
Number of stations per AS-i master	✓ Maximum 62 devices	✓ Maximum 31 devices
AS-i master profile	✓ M3 and higher	✓ M4 and higher

Parameterization

DIP switches	✓	--
Potentiometer for rated operational current	✓	--
ES Motor Starter	--	✓
Data records through AS-i	--	✓

Diagnostics

Diagnostics through parameter channel	✓	
Acyclic through data records	--	✓
Expanded process image PAE 4 bytes	--	✓

Process image

Process image	✓ 4I/3O	✓ 6I/4O
---------------	---------	---------

Data channels

Local optical interface (manual local)	✓	
AS-i bus	✓	
Motor Starter ES through local interface	--	✓
Motor Starter ES through bus	--	

Data records ¹⁾ (acyclic)

Parameterization	--	✓
Diagnostics	--	✓
Measured values	--	✓
Statistics	--	✓
Commands	--	✓

Inputs

Number	✓ 4	
• of these in the process image	✓ 2 through AS-i	✓ 4 through AS-i
Input action	✓ Permanently assigned functions, see manual	✓ Parameterizable: Flexible
Quick-Stop	✓ Permanent function: latching, edge-triggered	✓ Parameterizable function: latching (edge-triggered), non-latching (level-triggered)

Outputs

Number	✓ 1	
Output action	✓ Permanent function: assigned with group fault	✓ Parameterizable: Function, see manual

Brake output

180 V DC / 230/400 V AC / none	✓	
--------------------------------	---	--

Motor protection

Overload protection	✓ Electronic, wide range 1:10	
Short-circuit protection	✓	
Full motor protection	✓	
Temperature sensor	✓ Parameterizable using DIP switches: PTC or Thermoclick or deactivated	✓ Parameterizable using ES Motor Starter, data record: PTC or Thermoclick or deactivated

✓ Function is available.
-- Function not available.

¹⁾ The data records are a reduced selection compared with PROFIBUS/PROFINET.

AS-Interface slaves

Motor starters for operation in the field, high degree of protection

SIRIUS M200D motor starters M200D motor starters for AS-Interface

Overview (continued)



SIRIUS M200D
AS-i Basic



SIRIUS M200D
AS-i Standard

Device functions (firmware features)

Device functions

Repair switch	✓	
Current limit monitoring bottom	--	✓ Parameterizable
Current limit monitoring top	--	✓ Parameterizable
Zero current detection	✓ Permanent function: disconnection, less than 18.75 % of the rated operational current I_e	✓ Parameterizable
Blocking current	✓ Permanent function: Starting up of the motor: tripping limit at 800 % of the rated operational current I_e for 10 s Active operation: Threshold for tripping "blocking current" at 400 % of the rated operational current I_e	✓ Parameterizable
Unbalance	✓ Permanent function: at 30 % of the rated operational current I_e (only mechanical MS)	✓ Parameterizable
Load type	✓ Permanent function: 3-phase	✓ Parameterizable: 1- and 3-phase
Shutdown class	✓ Parameterizable using DIP switches: CLASS 10/deactivated	Parameterizable using ES Motor Starter, data record: CLASS 5, 10, 15, 20
Protection against voltage failure	✓	✓ Parameterizable: Activated/deactivated
Soft starter control function		
Soft start function	--	✓ Only electronic version
Bypass function	--	✓ Only electronic version

✓ Function is available.

-- Function not available.

Application

The M200D AS-i standard is particularly suitable for highly automated applications in conveyor systems, which require that devices and plants be monitored to prevent or limit plant downtime. The option of planning the functions of the motor starter or its interfaces also makes fine-adjustment to the function of the motor starter in the application possible and hence, provides for extreme flexibility.

Motor starters for operation in the field, high degree of protection

M200D motor starters for AS-Interface
M200D Basic motor starters

Selection and ordering data



M200D AS-i Basic without manual on-site operation



M200D AS-i Basic with manual on-site operation

Version	Order No.
<i>Electromechanical starters (with integrated contactor)</i>	3RK1 315-6 ■ S41- ■ AA ■
Setting range for rated operational current / A	
• 0.15 ... 2	K
• 1.5 ... 12	L
Direct-on-line starters/ reversing starters	
• Direct-on-line starters	0
• Reversing starters	1
• Direct-on-line starters with manual local operation	2
• Reversing starters with manual local operation	3
Brake actuation	
• Without brake actuation	0
• Brake actuation (230/400 V AC)	3
• Brake actuation (180 V DC)	5

Version	Order No.
<i>Electronic starters (with thyristors)</i>	3RK1 315-6 ■ S71- ■ AA ■
Setting range for rated operational current / A	
• 0.15 ... 2	K
• 1.5 ... 12	N
Direct-on-line starters/ reversing starters	
• Direct-on-line starters	0
• Reversing starters	1
• Direct-on-line starters with manual local operation	2
• Reversing starters with manual local operation	3
Brake actuation	
• Without brake actuation	0
• Brake actuation (230/400 V AC)	3
• Brake actuation (180 V DC)	5

AS-Interface slaves

Motor starters for operation in the field, high degree of protection

M200D motor starters for AS-Interface
M200D Standard motor starters

Selection and ordering data



M200D AS-i Standard without manual on-site operation



M200D AS-i Standard with manual on-site operation

Version	Order No.
<i>Electromechanical starters (with integrated contactor)</i>	3RK1 325-6 ■ S41- ■ AA ■
Setting range for rated operational current / A	
• 0.15 ... 2	K
• 1.5 ... 12	L
Direct-on-line starters/ reversing starters	
• Direct-on-line starters	0
• Reversing starters	1
• Direct-on-line starters with manual local operation	2
• Reversing starters with manual local operation	3
Brake actuation	
• Without brake actuation	0
• Brake actuation (230/400 V AC)	3
• Brake actuation (180 V DC)	5

Version	Order No.
<i>Electronic starters (with thyristors)</i>	3RK1 325-6 ■ S71- ■ AA ■
Setting range for rated operational current / A	
• 0.15 ... 2	K
• 1.5 ... 12	L
Direct-on-line starters/ reversing starters	
• Direct-on-line starters	0
• Reversing starters	1
• Direct-on-line starters with manual local operation	2
• Reversing starters with manual local operation	3
Brake actuation	
• Without brake actuation	0
• Brake actuation (230/400 V AC)	3
• Brake actuation (180 V DC)	5

Motor starters for operation in the field, high degree of protection

SIRIUS M200D motor starters
Accessories

Overview

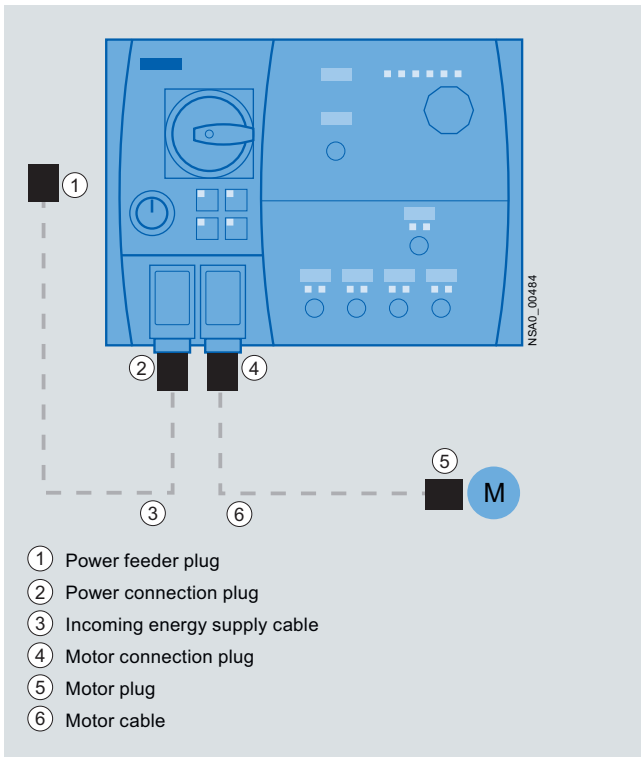

Power and motor connection on the M200D motor starter
(in this example: M200D for AS-i)

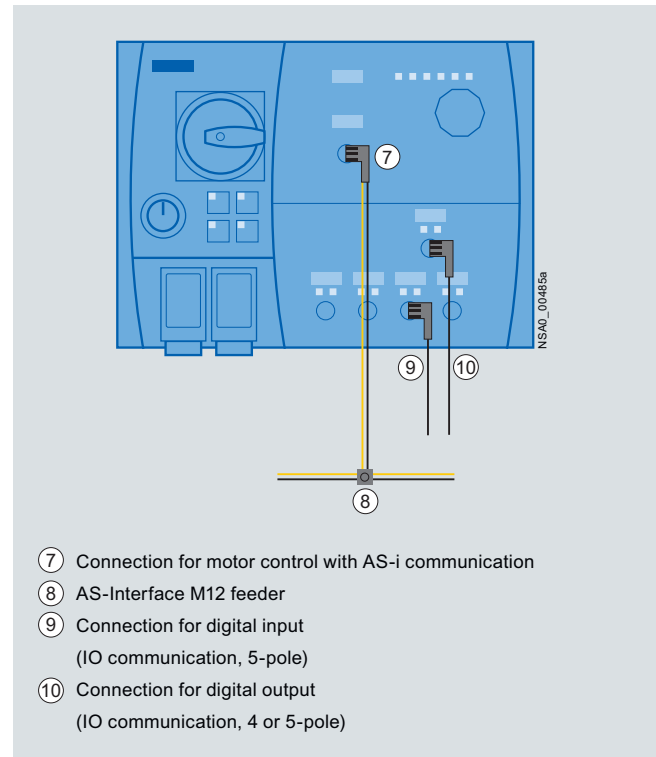

Communication connection using AS-Interface and
digital inputs and outputs

AS-Interface slaves

Motor starters for operation in the field, high degree of protection

SIRIUS M200D motor starters Accessories

Selection and ordering data

The accessories listed below represent a basic selection sorted by:

- Accessories for all M200D motor starters
- Accessories for M200D motor starters for AS-interface

Note:

More connection technology products can be found at "Siemens Solution Partners Automation" under the "Distributed Field Installation System" technology.





Version	Order No.
Mountable accessories	
M200D protective brackets	3RK1 911-3BA00
Incoming energy supply	
① Power feeder plugs Connector set for energy supply, e.g. for connecting to T terminal connectors, comprising a coupling enclosure, straight outgoing feeder (with bracket), pin insert for HAN Q4/2, incl. gland <ul style="list-style-type: none"> • 5 male contacts 2.5 mm² • 5 male contacts 4 mm² • 5 male contacts 6 mm² 	3RK1 911-2BS60 3RK1 911-2BS20 3RK1 911-2BS40
② Power connection plugs Connector set for energy supply for connection to M200D motor starters, comprising a cable-end connector hood, angular outgoing feeder, female insert for HAN Q4/2, incl. gland <ul style="list-style-type: none"> • 5 female contacts 2.5 mm² 2 female contacts 0.5 mm² • 5 female contacts 4 mm² 2 female contacts 0.5 mm² • 5 female contacts 6 mm² 2 female contacts 0.5 mm² 	3RK1 911-2BE50 3RK1 911-2BE10 3RK1 911-2BE30
② + ③ Power supply cable Assembled at one end with "N" and jumper pin 11 and 12 for plug monitoring, with HAN Q4/2, angular; open at one end; 5 x 4 mm ² <ul style="list-style-type: none"> • Length 1.5 m • Length 5.0 m 	3RK1 911-0DC13 3RK1 911-0DC33
Motor cables	
④ Motor connection plugs Connector set for motor cable for connection to M200D motor starters, comprising a cable-end connector hood, angular outgoing feeder, pin insert for HAN Q8/0, incl. gland <ul style="list-style-type: none"> • 8 male contacts 1.5 mm² • 6 male contacts 2.5 mm² 	3RK1 902-0CE00 3RK1 902-0CC00
⑤ Motor plugs Connector set for motor cable for connection to motors, comprising a cable-end connector hood, straight outgoing feeder, female insert for HAN 10e, incl. star jumper, incl. gland <ul style="list-style-type: none"> • 7 female contacts 1.5 mm² • 7 female contacts 2.5 mm² 	3RK1 911-2BM21 3RK1 911-2BM22
④ + ⑥ Motor cables, assembled at one end For connection to M200D motor starter, HAN Q8/0, angled, length 5 m <ul style="list-style-type: none"> • Motor cables for motor with brake, 4 x 1.5 mm² • Motor cables for motor without brake with thermistor, 6 x 1.5 mm² • Motor cable for motor with brake actuation, braking voltage 400 V AC or 180 V DC, 6 x 1.5 mm² • Motor cable for motor with brake actuation, braking voltage 400 V AC or 180 V DC and thermistor, 8 x 1.5 mm² • Motor cable for motor with brake actuation, braking voltage 230 V AC, 6 x 1.5 mm² • Motor cable for motor with brake actuation, braking voltage 230 V AC and thermistor, 8 x 1.5 mm² 	3RK1 911-0EB31 3RK1 911-0EF31 3RK1 911-0ED31 3RK1 911-0EG31 3RK1 911-0EH31 3RK1 911-0EE31

AS-Interface slaves

Motor starters for operation in the field, high degree of protection



SIRIUS M200D motor starters
Accessories

Selection and ordering data (continued)

Version	Order No.
Motor control with IO communication ¹⁾	
 M12 plugs Screw fixing, 5-pole screw terminals, max. 0.75 mm ² , A-coded, max. 4 A 3RK1 902-4BA00-5AA0	3RK1 902-4BA00-5AA0
 ⓫ M12 plugs, angled Screw fixing, 5-pole screw terminals, max. 0.75 mm ² , A-coded, max. 4 A 3RK1 902-4DA00-5AA0	3RK1 902-4DA00-5AA0
 Ⓞ, ⓫ Control cables, assembled at one end M12 plugs, angled, screw fixing, 5-pole, 5 x 0.34 mm ² , A-coded, black PUR sheath, max. 4 A <ul style="list-style-type: none"> • Cable length 1.5 m • Cable length 5 m • Cable length 10 m 3RK1 902-4H...-5AA0	3RK1 902-4HB15-5AA0 3RK1 902-4HB50-5AA0 3RK1 902-4HC01-5AA0
 Control cable, assembled at both ends Straight M12 plug, straight M12 socket, screw fixing, 3-pole, 3 x 0.34 mm ² , A-coded, black PUR sheath, max. 4 A <ul style="list-style-type: none"> • Cable length 1.5 m 3RK1 902-4PB15-3AA0	3RK1 902-4PB15-3AA0

¹⁾ For additional plug-in connections, see Catalog ID 10.

Further accessories





 Hand-held device for M200D motor starter, (also for ET 200pro, ET 200S High Feature and ECOFAST), for on-site operation. A 3RK1 922-2BP00 serial interface cable must be ordered separately. 3RK1 922-3BA00	3RK1 922-3BA00
RS 232 interface cables for serial data circuit 3RK1 922-2BP00	3RK1 922-2BP00
Dismantling tools for HAN Q4/2 3RK1 902-0AB00	3RK1 902-0AB00
Crimping tools for pins/sockets 4 mm² and 6 mm² 3RK1 902-0CW00	3RK1 902-0CW00
Crimping tools for male contacts and sockets up to 4 mm² (HAN Q8/0) 3RK1 902-0CT00	3RK1 902-0CT00
Dismantling tools for male contacts and sockets (HAN Q8/0) 3RK1 902-0AJ00	3RK1 902-0AJ00
USB interface cables, 2.5 m long 6SL3555-0PA00-2AA0	6SL3555-0PA00-2AA0
7/8" sealing caps 6ES7194-3JA00-0AA0	6ES7194-3JA00-0AA0
 AS-Interface sealing caps M12 For sealing unused input and output sockets – not for M12-AS-i connections (one set contains 10 sealing caps) 3RK1 901-1KA00	3RK1 901-1KA00

AS-Interface slaves



Motor starters for operation in the field, high degree of protection

SIRIUS M200D motor starters Accessories

Selection and ordering data (continued)

Version	Order No.																				
Only for M200D motor starters for AS-interface																					
Motor control with AS-i communication ¹⁾																					
 ⑦ Control cables, assembled at one end Angular M12 socket, screw fixing, 4-pole, 4 x 0.34 mm ² , A-coded, black PUR sheath, max. 4 A • Cable length 5 m 3RK1 902-4GB50-4AA0	3RK1 902-4GB50-4AA0																				
 ⑦ M12 socket, angled, screw fixing, 4-pole screw terminal, max. 0.75 mm ² , A-coded, max. 4 A 3RK1 902-4CA00-4AA0	3RK1 902-4CA00-4AA0																				
⑧ AS-Interface M12 feeder																					
 3RK1 901-1NR21	<table border="1"> <thead> <tr> <th>For flat cable</th> <th>For</th> <th>Cable length</th> <th>Cable end in feeder</th> <th></th> </tr> </thead> <tbody> <tr> <td>AS-i / U_{aux}</td> <td>M12 socket</td> <td>--</td> <td>Not available</td> <td>3RK1 901-1NR20</td> </tr> <tr> <td>AS-i / U_{aux}</td> <td>M12 cable box</td> <td>1 m</td> <td>Not available</td> <td>3RK1 901-1NR21</td> </tr> <tr> <td>AS-i / U_{aux}</td> <td>M12 cable box</td> <td>2 m</td> <td>Not available</td> <td>3RK1 901-1NR22</td> </tr> </tbody> </table>	For flat cable	For	Cable length	Cable end in feeder		AS-i / U _{aux}	M12 socket	--	Not available	3RK1 901-1NR20	AS-i / U _{aux}	M12 cable box	1 m	Not available	3RK1 901-1NR21	AS-i / U _{aux}	M12 cable box	2 m	Not available	3RK1 901-1NR22
For flat cable	For	Cable length	Cable end in feeder																		
AS-i / U _{aux}	M12 socket	--	Not available	3RK1 901-1NR20																	
AS-i / U _{aux}	M12 cable box	1 m	Not available	3RK1 901-1NR21																	
AS-i / U _{aux}	M12 cable box	2 m	Not available	3RK1 901-1NR22																	
 3RK1 901-1MN00	Cable terminating pieces For sealing of open cable ends (shaped AS-Interface cable) in IP67 3RK1 901-1MN00																				

Further accessories

 3RK1 904-2AB02	AS-Interface addressing unit V 3.0 <ul style="list-style-type: none"> • For AS-Interface modules and sensors and actuators with integrated AS-Interface in accordance with AS-i Specification V3.0 • For setting the AS-i address of standard slaves, and slaves with extended addressing mode (A/B slaves) • With input/output test function and many other -commissioning functions • Battery operation with 4 batteries type AA (IEC LR6, NEDA 15) • Scope of supply: <ul style="list-style-type: none"> - Addressing unit with 4 batteries - Addressing cable, with M12 plug to addressing plug (hollow plug), length 1.5 m 	3RK1 904-2AB02
 3RK1 902-4PB15-3AA0	M12 addressing cables to M12 <ul style="list-style-type: none"> • Standard M12 cable for addressing slaves with M12 connection, e.g. K60R modules • When using the current version of the 3RK1 904-2AB01 addressing unit • 1.5 m 	3RK1 902-4PB15-3AA0

Motor starters for operation in the field, high degree of protection

SIRIUS MCU motor starters
General data

Overview



3RK43 20-3.R51-.BA0

3RK43 20-3.Q54-.BA.

3RK43 20-5.Q64-.BA.

Portfolio of the SIRIUS 3RK43 MCU motor starter family

The SIRIUS MCU motor starter family (MCU = Motor Control Unit) rounds off the bottom end of the SIRIUS motor starter range.

This series of motor starters in a high degree of protection is a system solution for the cabinet-free controlling of AC loads in the field.

The MCU product range extends from I/O-controlled motor starters – addressing a central sub-distribution board via I/O stations – in a plastic enclosure for simple applications to motor starters with AS-i communication in a rugged metal enclosure for demanding tasks. (For full range, see Catalog IC 10 --> Motor starters for operation in the field, high degree of protection)

The MCU motor starters are completely pre-wired inside, have a high degree of protection and are designed for switching and protecting any AC loads. They are mostly used on standard induction motors in direct or reversing duty up to 5.5 kW at 400/500 V AC (electromechanical switching) and 400/460 V AC (electronic switching).

The motor and short-circuit protection integrated in the MCUs consists either of an electromechanical controlgear assembly or solid-state overload protection and a motor starter protector unit for short-circuit protection.

MCUs with metal enclosure are designed for the switching of induction motors. Integrated control of the electrically operated motor brake with a braking voltage of 230 V AC or 400 V AC is a standard feature. The braking voltage is routed to the motor over the motor cable.

SIRIUS MCU motor starters have the following main features:

- Direct-on-line or reversing starters
- Up to 5.5 kW
- High degree of protection, namely IP55 on MCU motor starters in a plastic enclosure and IP54 on motor starters in a metal enclosure, enables distributed configurations in the field and saves space in the control cabinet
- Electromechanical or electronic switching
- Easy and user-friendly control and monitoring through AS-Interface bus communication
- Controlled stopping through brake control 230 V AC or 400 V AC for motor brake
- Integrated lockable repair switch
- Comprehensive motor protection thanks to integrated overload and short-circuit protection with SIRIUS 3RV motor starter protectors or integrated solid-state overload relays (solid-state starters)
- Overload protection with thermal release (bimetal) or solid-state overload relay with wide range setting
- Power and load connection by means of an M screw

- Main power loop possible (daisy chain; max. 2 x 6 mm²)
- Robust and widely used M12 connection method for digital inputs and outputs to connect I/O stations and the AS-i bus connection increase flexibility and prevent errors in the system configuration.
- The LEDs (for AS-i bus connection) can provide comprehensive diagnostics of the device on the spot.
- Simple mounting for AS-i and external auxiliary voltage (24 V DC) over an M12 connection
- Manual operation: An integrated key-operated switch "MAN-0-AUTO" and a selector button for switching on, switching off and changing the direction of rotation for control purposes during commissioning or maintenance

MCU motor starters with AS-i bus connection in a plastic enclosure

This motor starter version offers an economical solution for controlling and monitoring conveyor belts, pumps, fans or compressors.

On this MCU the control commands and the status queries are sent over the AS-i bus. The yellow cable (bus) and the black AS-i cable for 24 V DC AUX are connected through a M12 plug.

The transparent enclosure top permits monitoring of the status LEDs. These MCUs come completely pre-wired inside.

MCU motor starters with AS-i bus connection in a metal enclosure for electromechanical or electronic switching

These MCUs with their rugged metal enclosure in degree of protection IP54 are ideal in particular for controlling and monitoring induction motors in harsh ambient conditions such as are often found in conveyor systems.

A special feature of this version is the manual local operation of the motor starter.

The key-operated switch "MAN-0-AUTO" for selecting Manual, 0 or Automatic mode prevents unauthorized changes of operating mode. In automatic mode the MCU is controlled through the AS-i bus.

In manual mode a selector button is used for switching on, switching off and changing the direction of rotation.

The status/diagnostics LEDs fitted to the cover indicate the current operating state of the motor starter.

Unlike the electromechanical starter, the solid-state motor starter has wear-free solid-state switching devices which guarantee a high switching frequency.

Another highlight of the electronic switching version is the solid-state overload relay for motor protection, which has a wide setting range for the motor current.

AS-Interface slaves

Motor starters for operation in the field, high degree of protection

SIRIUS MCU motor starters General data

Overview (continued)

			
	3RK43 20-3.R51-BA0	3RK43 20-3.Q54-BA.	3RK43 20-5.Q64-BA.
Type	SIRIUS MCU motor starters for AS-Interface		
	Plastic enclosures	Metal enclosures	Metal enclosures
	Electromechanical Switching	Electromechanical Switching	Electronic Switching

Device functions (software features)

Slave on the bus

Fieldbus	✓	AS-i	
Bus connection	✓	M12	
Slave type	✓	AS-i Spec 2.0	✓ A/B acc. to Spec 2.1
AS-i Slave Profile IO.ID.ID2	✓	3.0.F	✓ 7.A.E
Number of assigned AS-i addresses on the bus	✓	1	
Number of stations	✓	Maximum 31 devices	✓ Maximum 62 devices

Diagnostics

LEDs	✓		
------	---	--	--

Process image

Process image	✓	2I/2O	✓ 4I/3O
---------------	---	-------	---------

Data channels

Manual local operation	--		✓
------------------------	----	--	---

Inputs

Number	✓	1	✓ 2
• of these in the process image	✓	DI1	✓ DI2 / DI3
Connection	✓	Screw terminal, internal	✓ M12 – A coded
Input signal	✓	Switching contact or 2-wire Bero	✓ Switching contact or 2/3-wire Bero
Input level	✓	AS-i +	

Outputs

Number	✓	1 on the direct-on-line starter 0 on the reversing starter	✓ 1
• of these in the process image	✓	DO1	✓ DO2
Connection	✓	Screw terminal, internal	✓ M12 – A coded
Output level	✓	Relay contact, floating	✓ AUX-PWR+ (24 V DC)

Motor protection

Overload protection	✓	Thermal overload releases	✓ Electronic overload releases Wide range
Short-circuit protection	✓		
Auto-RESET	--		✓
Temperature sensor	--		✓ TC (Thermoclick)

Device functions

Response when repair switch is tripped	✓	Signal through AS-i	
Plug monitoring	--		Possible (with plug option)

✓ Function is available

-- Function not available.

AS-Interface slaves

Motor starters for operation in the field, high degree of protection

MCU motor starters for AS-Interface
Plastic enclosures, electromechanical switching

Overview

MCU for AS-i, plastic enclosure

- Direct-on-line or reversing starters up to 12 A at 400 V AC (50/60 Hz)
- Repair switches (black/gray) lockable with padlocks (max. 3 units)
- Integrated overload and short-circuit protection with SIRIUS 3RV motor starter protectors Class 10 with short-circuit breaking capacity $I_{cu} = 50 \text{ kA}$ at 400 V AC
- Overload protection with thermal release (bimetal)
- Transparent plastic enclosure with LED status displays for monitoring the AS-i status
- Degree of protection IP55
- Cable connections by means of M screws
- Main power loop possible (daisy chain; max. $2 \times 6 \text{ mm}^2$)
- AS-Interface through M12 plug-in terminal
- 4 x M20 glands enclosed
- Communication: AS-Interface 2I/2O (standard slaves)

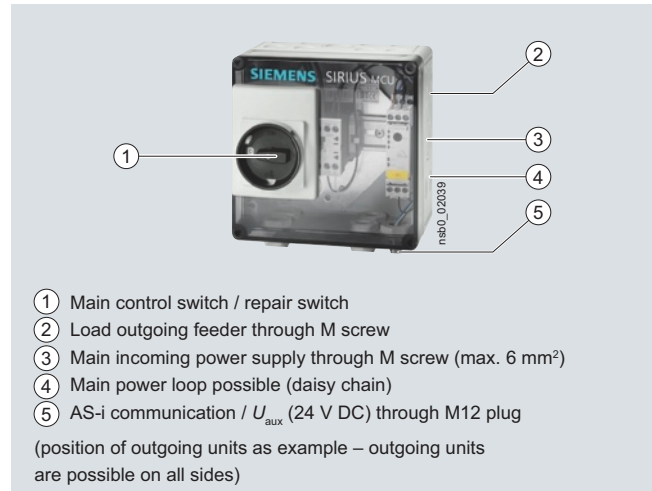

MCU for AS-i, plastic enclosure

Selection and ordering data

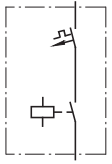
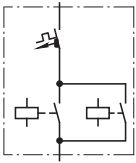
	Rated current I_e	Suitable for three-phase induction motors ¹⁾ with P	Setting range Thermal overload release	Order No.
	A	kW	A	
Direct-on-line starters				
 Direct-on-line start	0.63	0.18	0.45 ... 0.63	3RK43 20-3AR51-0BA0
	0.8	0.18	0.55 ... 0.8	3RK43 20-3BR51-0BA0
	1	0.25	0.7 ... 1	3RK43 20-3CR51-0BA0
	1.25	0.37	0.9 ... 1.25	3RK43 20-3DR51-0BA0
	1.6	0.55	1.1 ... 1.6	3RK43 20-3ER51-0BA0
	2	0.75	1.4 ... 2	3RK43 20-3FR51-0BA0
	2.5	0.75	1.8 ... 2.5	3RK43 20-3GR51-0BA0
	3.2	1.10	2.2 ... 3.2	3RK43 20-3HR51-0BA0
	4	1.50	2.8 ... 4	3RK43 20-3JR51-0BA0
	5	1.50	3.5 ... 5	3RK43 20-3KR51-0BA0
	6.3	2.20	4.5 ... 6.3	3RK43 20-3LR51-0BA0
	8	3.00	5.5 ... 8	3RK43 20-3MR51-0BA0
	10	4.00	7 ... 10	3RK43 20-3NR51-0BA0
12.5	5.50	9 ... 12.5	3RK43 20-3PR51-0BA0	
Reversing starters				
 Reversing duty	0.63	0.18	0.45 ... 0.63	3RK43 20-3AR51-1BA0
	0.8	0.18	0.55 ... 0.8	3RK43 20-3BR51-1BA0
	1	0.25	0.7 ... 1	3RK43 20-3CR51-1BA0
	1.25	0.37	0.9 ... 1.25	3RK43 20-3DR51-1BA0
	1.6	0.55	1.1 ... 1.6	3RK43 20-3ER51-1BA0
	2	0.75	1.4 ... 2	3RK43 20-3FR51-1BA0
	2.5	0.75	1.8 ... 2.5	3RK43 20-3GR51-1BA0
	3.2	1.10	2.2 ... 3.2	3RK43 20-3HR51-1BA0
	4	1.50	2.8 ... 4	3RK43 20-3JR51-1BA0
	5	1.50	3.5 ... 5	3RK43 20-3KR51-1BA0
	6.3	2.20	4.5 ... 6.3	3RK43 20-3LR51-1BA0
	8	3.00	5.5 ... 8	3RK43 20-3MR51-1BA0
	10	4.00	7 ... 10	3RK43 20-3NR51-1BA0
12.5	5.50	9 ... 12.5	3RK43 20-3PR51-1BA0	

¹⁾ Guide value for 4-pole standard motors at 50 Hz 400 V AC. The actual starting and rated data of the motor to be protected must be considered when selecting the units.

AS-Interface slaves

Motor starters for operation in the field, high degree of protection

MCU motor starters for AS-Interface Metal enclosures, electromechanical switching

Overview

MCU for AS-i, metal enclosure, electromechanical

- Direct-on-line or reversing starters up to 12 A
- Repair switches (black/gray) lockable with padlocks (max. 3 units)
- Short-circuit protection with SIRIUS 3RV motor starter protectors CLASS 10 with short-circuit breaking capacity $I_{cu} = 50 \text{ kA}$ at 400 V AC
- Overload protection with thermal release (bimetal)
- Manual operation and key-operated switch for operating mode selection
- LED status display of the operating states
- Metal enclosures
- Degree of protection IP54
- Switched brake control 400 V or 230 V
- Cable connections by means of M screws
- Main power loop possible (daisy chain; max. $2 \times 6 \text{ mm}^2$)
- 2 x M25 glands
- 1 x M12 plug for AS-i/auxiliary voltage (24 V DC)
- 2 x M12 socket for connection of 2 sensors
- 1 x M12 socket for connection of one actuator
- Communication: AS-Interface 4I/3O (slaves in A/B technology can be addressed)



MCU for AS-i, metal enclosure, electromechanical switching

AS-Interface slaves

Motor starters for operation in the field, high degree of protection

MCU motor starters for AS-Interface
Metal enclosures, electromechanical switching

Selection and ordering data

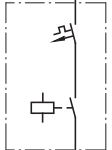
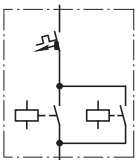
	Rated current I_e	Suitable for three-phase induction motors ¹⁾ with P	Setting range Thermal overload release	Order No.
	A	kW	A	
Direct-on-line starters				
	0.63	0.18	0.45 ... 0.63	3RK43 20-3AQ54- 0BA
	0.8	0.18	0.55 ... 0.8	3RK43 20-3BQ54- 0BA
	1	0.25	0.7 ... 1	3RK43 20-3CQ54- 0BA
	1.25	0.37	0.9 ... 1.25	3RK43 20-3DQ54- 0BA
	1.6	0.55	1.1 ... 1.6	3RK43 20-3EQ54- 0BA
	2	0.75	1.4 ... 2	3RK43 20-3FQ54- 0BA
	2.5	0.75	1.8 ... 2.5	3RK43 20-3GQ54- 0BA
	3.2	1.10	2.2 ... 3.2	3RK43 20-3HQ54- 0BA
	4	1.50	2.8 ... 4	3RK43 20-3JQ54- 0BA
	5	1.50	3.5 ... 5	3RK43 20-3KQ54- 0BA
	6.3	2.20	4.5 ... 6.3	3RK43 20-3LQ54- 0BA
	8	3.00	5.5 ... 8	3RK43 20-3MQ54- 0BA
	10	4.00	7 ... 10	3RK43 20-3NQ54- 0BA
	12.5	5.50	9 ... 12.5	3RK43 20-3PQ54- 0BA
Brake control / V				
• 230				2
• 400				3
Reversing starters				
	0.63	0.18	0.45 ... 0.63	3RK43 20-3AQ54- 1BA
	0.8	0.18	0.55 ... 0.8	3RK43 20-3BQ54- 1BA
	1	0.25	0.7 ... 1	3RK43 20-3CQ54- 1BA
	1.25	0.37	0.9 ... 1.25	3RK43 20-3DQ54- 1BA
	1.6	0.55	1.1 ... 1.6	3RK43 20-3EQ54- 1BA
	2	0.75	1.4 ... 2	3RK43 20-3FQ54- 1BA
	2.5	0.75	1.8 ... 2.5	3RK43 20-3GQ54- 1BA
	3.2	1.10	2.2 ... 3.2	3RK43 20-3HQ54- 1BA
	4	1.50	2.8 ... 4	3RK43 20-3JQ54- 1BA
	5	1.50	3.5 ... 5	3RK43 20-3KQ54- 1BA
	6.3	2.20	4.5 ... 6.3	3RK43 20-3LQ54- 1BA
	8	3.00	5.5 ... 8	3RK43 20-3MQ54- 1BA
	10	4.00	7 ... 10	3RK43 20-3NQ54- 1BA
	12.5	5.50	9 ... 12.5	3RK43 20-3PQ54- 1BA
Brake control / V				
• 230				2
• 400				3

¹⁾ Guide value for 4-pole standard motors at 50 Hz 400 V AC. The actual starting and rated data of the motor to be protected must be considered when selecting the units.

AS-Interface slaves

Motor starters for operation in the field, high degree of protection

MCU motor starters for AS-Interface Metal enclosures, electronic switching

Overview

MCU for AS-i, metal enclosure, electronic

- Direct-on-line or reversing starters up to 12 A
- Switching frequency up to 3 600/h
- Repair switches (black/gray) lockable with padlocks (max. 3 units)
- Short-circuit protection with SIRIUS 3RV motor starter protector
- Overload protection with solid-state overload relay
- Manual operation and key-operated switch for operating mode selection
- LED status display of the operating states
- Metal enclosures
- Degree of protection IP54
- Switched brake control 400 V or 230 V
- Cable connections by means of M screws
- Main power loop possible (daisy chain; max. $2 \times 6 \text{ mm}^2$)
- 2 x M25 glands
- 1 x M12 plug for AS-i/auxiliary voltage (24 V DC)
- 2 x M12 plugs for connection of 2 sensors
- 1 x M12 socket for connection of one actuator
- Communication: AS-Interface 4I/3O (slaves in A/B technology can be addressed)

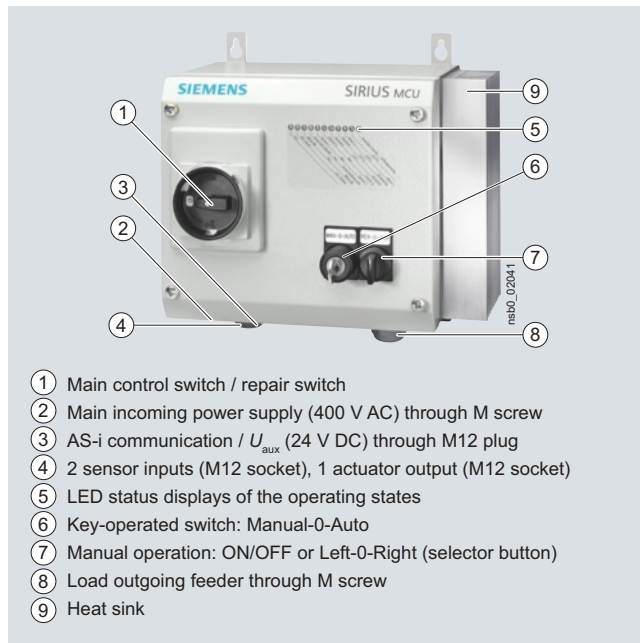

MCU for AS-i, metal enclosure, electronic switching

6

Selection and ordering data

	Rating for induction motor Rated value ¹⁾	Current setting value of the inverse-time delayed overload release I_e	Brake control	Order No.
	kW	A	V	
Direct-on-line starters				
	0.12 ... 0.37	0.32 ... 1.25	230	3RK43 20-5DQ64-0BA2
	0.55 ... 1.5	1 ... 4	230	3RK43 20-5JQ64-0BA2
	1.1 ... 5.5	3 ... 12	230	3RK43 20-5PQ64-0BA2
	0.12 ... 0.37	0.32 ... 1.25	400	3RK43 20-5DQ64-0BA3
	0.55 ... 1.5	1 ... 4	400	3RK43 20-5JQ64-0BA3
	1.1 ... 5.5	3 ... 12	400	3RK43 20-5PQ64-0BA3
Reversing starters				
	0.12 ... 0.37	0.32 ... 1.25	230	3RK43 20-5DQ64-1BA2
	0.55 ... 1.5	1 ... 4	230	3RK43 20-5JQ64-1BA2
	1.1 ... 5.5	3 ... 12	230	3RK43 20-5PQ64-1BA2
	0.12 ... 0.37	0.32 ... 1.25	400	3RK43 20-5DQ64-1BA3
	0.55 ... 1.5	1 ... 4	400	3RK43 20-5JQ64-1BA3
	1.1 ... 5.5	3 ... 12	400	3RK43 20-5PQ64-1BA3

¹⁾ Guide value for 4-pole standard motors at 50 Hz 400 V AC. The actual starting and rated data of the motor to be protected must be considered when selecting the units.

Motor starters for operation in the field, high degree of protection

MCU motor starters for AS-Interface
Accessories

Overview

The MCU motor starters are equipped with standardized interfaces for data and energy (option).

Notes:

See "Energy communication field installation system" for further information about the field and power bus methods for decentral installation in a high degree of protection.

Connection technology products coordinated with the SIRIUS MCU motor starters can be found at our

"Siemens Automation Solution Partners"

www.siemens.com/automation/partnerfinder

under "Distributed Field Installation System" technology.

AS-Interface slaves

Motor starters for operation in the field, high degree of protection

Motor starters for AS-Interface, 24 V DC General data

Overview

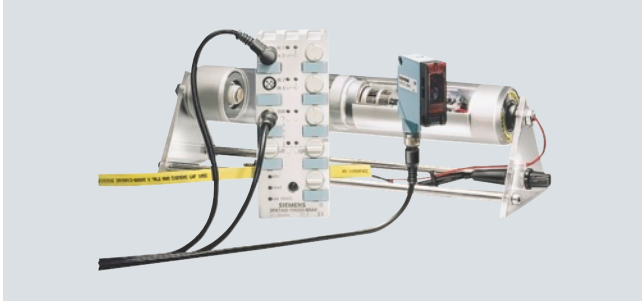

Connection of an actuator roller with integrated DC motor to an AS-Interface 24 V DC motor starter

With the K60 AS-Interface 24 V DC motor starters for the low-end performance range up to 70 W, it is now possible to connect 24 V DC motors and the associated sensors directly to the AS-Interface quickly and easily.

Three different versions are available:

- Single direct-on-line starters (without brake and reversible quick-stop function)
- Double direct-on-line starters (with brake and reversible quick-stop function)
- Reversing starters (with brake and reversible quick-stop function)

DC motors are connected to the module using M12 plug-in connections. The sensors and the module electronics can be supplied from the yellow AS-Interface cable. An auxiliary voltage (24 V DC) is only required for supplying the outputs, which can be provided via the black AS-Interface cable.

Quick-stop function

All AS-Interface 24 V DC motor starters feature a quick-stop function which can be switched on and off as required using a switch integrated into the module. The quick-stop function allows a connected motor to be disconnected immediately using an applied sensor signal (High). The switch for the quick-stop function is located alongside the input sockets and is protected by an M12 sealing cap.

Brake

The double direct-on-line starter and the single reversing starter versions feature an integrated permanently set brake function, i.e. as soon as the output signal is set to "0", the motor is braked.

Start-up using integrated buttons

Buttons integrated into the module (below the output sockets) can be used to set the motor used. The buttons are protected by an M12 sealing cap.

Note concerning double and reversing starters:

If an input with the quick-stop function receives a "High" signal, the corresponding output (e.g. quick-stop input 1 → output 1) is switched off within the device (the motor is braked). The manual key function (Key 1/2) for local operation is only permitted to be used during "CPU Stop" in the higher-level PLC.

Note concerning single direct-on-line starters:

If an input with the quick-stop function receives a "High" signal, the corresponding output (e.g. quick-stop input 1 → output 1) is switched off within the device (the motor runs down without being braked). The manual key function (Key 1) for local operation is only permitted to be used and defined during "CPU Stop" in the higher-level PLC.

Motor starters for operation in the field, high degree of protection

Motor starters for AS-Interface, 24 V DC
General data

Overview (continued)

Applications

Single direct starter without brake (with adjustable quick-stop function)

1st possibility: Connection to a maximum of four sensors without pollution indication

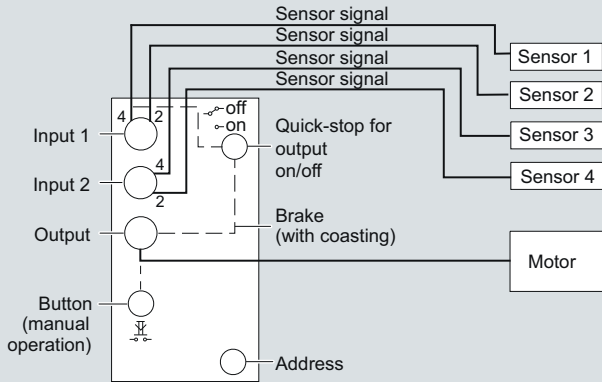

2nd possibility: Connection to a maximum of two sensors with pollution indication

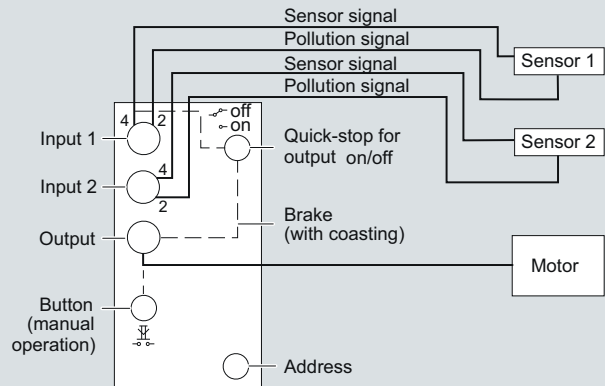

Double direct starter with brake (with adjustable quick-stop function)

1st possibility: Connection to a maximum of four sensors without pollution indication

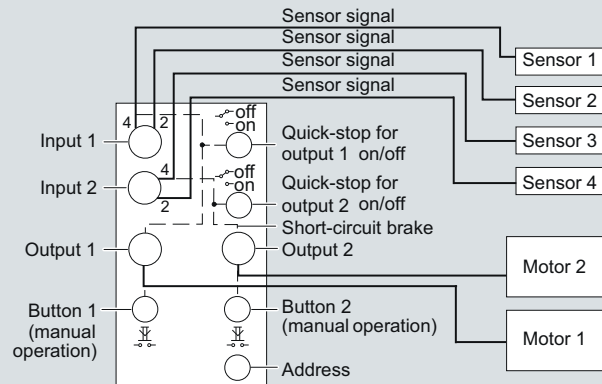

2nd possibility: Connection to a maximum of two sensors with pollution indication

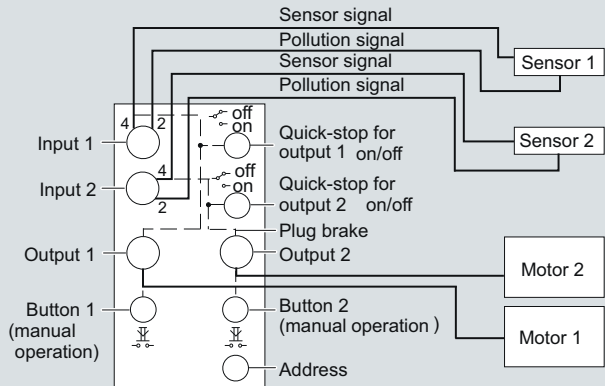

Single reversing starter with brake (with adjustable quick-stop function)

1st possibility: Connection to a maximum of four sensors without pollution indication

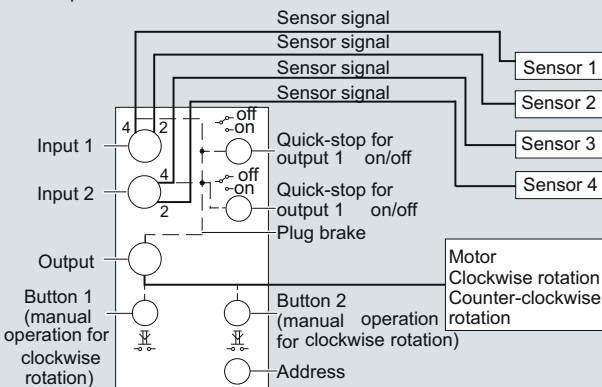

2nd possibility: Connection to a maximum of two sensors with pollution indication

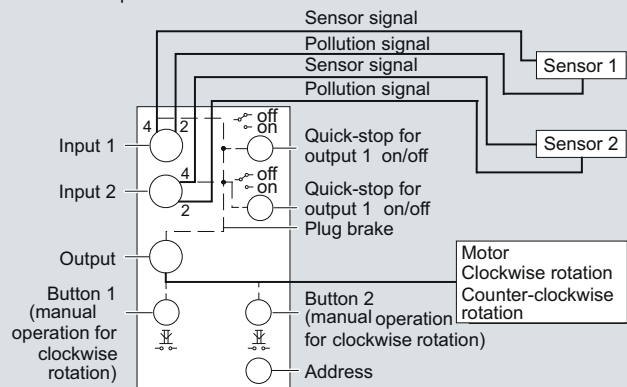

AS-Interface slaves

Motor starters for operation in the field, high degree of protection

Motor starters for AS-Interface, 24 V DC General data

Selection and ordering data

Version	Inputs/outputs	Current carrying capacity of outputs	Slave type	Order No.
---------	----------------	--------------------------------------	------------	-----------

Motor starters (width 60 mm)



Single direct-on-line starters ¹⁾	4 inputs / 1 output	2	Standard	3RK1 400-1NQ01-0AA4
Double direct-on-line starters ¹⁾	4 inputs / 2 outputs	1 x 3 or 2 x 2	Standard	3RK1 400-1MQ01-0AA4
Single reversing starters ¹⁾	4 inputs / 1 output	2.5	Standard	3RK1 400-1MQ03-0AA4

3RK1 400-1MQ01-0AA4

¹⁾ Modules supplied without mounting plate.

Version	Order No.
---------	-----------

Accessories



3RK1 901-0CA00

K60 mounting plates
Suitable for all K60 compact modules

- Wall mounting
- Standard rail mounting

3RK1 901-0CA00
3RK1 901-0CB01



3RK1 901-1KA00

AS-Interface sealing caps M12
For free M12 sockets

3RK1 901-1KA00

3RK1 901-1KA01

AS-Interface sealing caps M12, tamper-proof
For free M12 sockets

3RK1 901-1KA01

3RK1 902-0AR00

Sealing sets

- For K60 mounting plate and standard distributor
- Cannot be used for K45 mounting plate
- Set contains one straight and one shaped seal

3RK1 902-0AR00

AS-Interface slaves

SINAMICS G110D distributed frequency converters

General data

Overview

The new distributed frequency converter series SINAMICS G110D is the solution for demanding drive applications, particularly in the field of conveyor applications. The converter permits continuous speed control of three-phase asynchronous motors and meets the requirements of conveyor applications with frequency control. With its compact and flat design in IP65 degree of protection, it slots into the system optimally. The drive can be excellently linked into the Siemens TIA automation world using AS-Interface.

With its large performance range from 0.75 kW to 7.5 kW it is suitable for numerous distributed drive solutions.



Example: SINAMICS G110D size FSA

Reasons for distributed drive technology

- Modular drive solutions – and thus standardized mechatronic elements that can be tested individually
- Control cabinets are dispensed with, meaning that less space and cooling are required
- Long motor cables are dispensed with between converter and motor (less power loss, lower interference emissions and lower costs for shielded cables and additional filters)
- For conveyor applications with their large spatial range (e.g. in the automotive and logistics industries), the distributed installation methods bring great benefits

Siemens distributed drive family

For optimal realization of distributed drive solutions, Siemens offers an innovative range of frequency converters. The strengths of the individual family members permit a simple adaptation to extremely varied application requirements:

- Identical connection technology
- Identical installation dimensions of SINAMICS G110D and SINAMICS G120D
- Uniform commissioning and configuration tool

Products of the distributed drives family:

- SINAMICS G110D frequency converters
- SINAMICS G120D frequency converters
- SIMATIC ET 200S FC frequency converters
- SIMATIC ET 200pro FC frequency converters
- SIRIUS M200D motor starters

Device configuration

SINAMICS G110D is a compact converter in IP65 degree of protection which integrates the control unit (CU) and power module (PM) function units into a single device.

The control electronics controls and monitors the power electronics and the connected motor in several selectable control types. The digital and analog inputs on the device permit the simple wiring of sensors directly to the drive. The input signals can either be connected directly within the control unit and trigger autonomous local reactions, or they are passed to a central control system via AS-Interface where they are processed in the context of the system as a whole.

The power electronics supply the motor in a performance range from 0.75 kW to 7.5 kW. They are controlled by the microprocessor of the control system. For extremely reliable and flexible motor operation, the latest IGBT technology with pulse width modulation is used. Comprehensive protection functions provide a high degree of protection for the frequency converter and motor. The unusually flat mechanical design is optimized for use direct in the system. The compact frequency converter has the same hole dimensions for all powers (constant "footprint") and the dimensions are also identical to those of the SINAMICS G120D frequency converter. This makes the design, installation and conversion of the system considerably easier.

Up-to-date technical documentation (catalogs, dimensional drawings, certificates, manuals and operating instructions) are available on the Internet at:

www.siemens.com/sinamics-g110d/documentation and offline on the DVD-ROM CA 01 in the DT configurator. In addition, the DT configurator can be used on the Internet without installation. The DT configurator can be found in the Industry Mall at the following address: www.siemens.com/dt-configurator

STARTER commissioning tool

The STARTER commissioning tool (from V4.1.3) makes the commissioning and maintenance of the SINAMICS G110D converter easier. It offers operator prompting for quick and easy commissioning, combined with user-friendly and comprehensive functions for the drive solution.

6

AS-Interface slaves

SINAMICS G110D distributed frequency converters

General data

Benefits

- Wide performance range from 0.75 kW to 7.5 kW
- Rapid commissioning and maintenance thanks to expanded diagnostics functions and communication capability with AS-Interface in accordance with Specification 3.0
 - Reduction of interfaces
 - System-wide engineering
 - Simple handling
- The design, installation and conversion of the system are made much easier by the compact and space-saving design with its very flat form and identical hole dimensions for all powers; the dimensions are also identical to those of the SINAMICS G120D converter.
- Simple commissioning and maintenance thanks to identical, standardized plug-in connections for the bus, power and I/O connections (ISO 23570) over the entire performance range of the SINAMICS G110D and SINAMICS G120 D frequency converters.
- Use of the same plug for SIRIUS M200D motor starter
- Simple, consistent realization of complete, distributed system concepts by the scalable use of the products:
 - SIRIUS M200D (motor starters)
 - SINAMICS G110D (converters for simple conveyor applications)
 - SINAMICS G120D (converters for demanding conveyor applications)
- Very user friendly thanks to the use of the Intelligent Operator Panel (IOP) for parameterization, diagnostics and control and for the copying of drive parameters in the BOP
- Easy replacement thanks to plug-in connections and excellent ease of maintenance thanks to the use of a memory card
- Simple connection, configuration, data storage and control of the converter in complex systems by consistent integration into TIA (Totally Integrated Automation)
- Thanks to the optional maintenance switch it is easy to disconnect the converter from the network for servicing without having to provide for additional components or additional wiring outlay during configuration.
- The optional manual on-site operation allows rapid spatially restricted commissioning, manual pre-testing of the application on site and validation running to be performed without expensive options
- Thanks to the option of the direct connection of up to five sensors to the device, almost all drive-related information can be managed directly; a local pre-processing of the signals relieves the field bus whilst ensuring a rapid and reproducible response time
- Integrated EMC filter Class A (according to EN 55011)
- Integrated brake actuation, supported braking voltages 400 V AC / 180 V DC and 230 V AC / 205 V DC
- Integrated motor protection thanks to thermal motor model and evaluation of PTC, Thermo-Click or KTY 84 temperature sensors
- Simple device replacement and time-saving copying of parameters to the memory card by the optional memory card holder and the optional MMC memory card
- Engineering and commissioning with uniform engineering tools such as SIZER (from V3.2), STARTER (from V4.1.3) and Drive ES ensure rapid configuration and simple commissioning – with Drive ES Basic STARTER is integrated into STEP 7 providing the benefits of central data storage and consistent communication
- Software parameters for simple adaptation to 50 Hz or 60 Hz motors (IEC or NEMA motors)
- Increased robustness and longer service life due to painting of the electronics assemblies
- Certified worldwide according to CE, UL, c-tick

AS-Interface slaves

SINAMICS G110D distributed frequency converters

General data

Application

SINAMICS G110D is perfectly suited for simple conveyor applications in an industrial environment in which a distributed drive with communication capability is required. This is particularly true for distribution logistics and for airports.

SINAMICS G110D is also suitable for many other lower-performance applications in many fields, e.g. in the automotive industry, in the food and drinks industry (without tensides) and in the packaging industry.

Selection and ordering data

Rated power ¹⁾		Rated output current ²⁾	Input current	Size	SINAMICS G110D with integrated Class A line filter	SINAMICS G110D with integrated Class A line filter and integrated maintenance switch
kW	hp	A	A		Order No.	Order No.
3 AC 380 ... 500 V ³⁾						
0.75	1	2.3	2.0	FSA	6SL3511-0PE17-5AM0	6SL3511-1PE17-5AM0
1.5	1.5 ⁴⁾	4.3	3.8	FSA	6SL3511-0PE21-5AM0	6SL3511-1PE21-5AM0
3	4	7.7	7.0	FSA	6SL3511-0PE23-0AM0	6SL3511-1PE23-0AM0
4	5	10,2	9.1	FSB	6SL3511-0PE24-0AM0	6SL3511-1PE24-0AM0
5.5	7.5	13.2	12.2	FSC	6SL3511-0PE25-5AM0	6SL3511-1PE25-5AM0
7.5	10	19.0	17.9	FSC	6SL3511-0PE27-5AM0	6SL3511-1PE27-5AM0

- ¹⁾ Rated power based upon rated output current I_N .
The rated output current I_N underlies the load alternation at high overload (HO).
- ²⁾ The rated output current I_N underlies the load alternation at high overload (HO). These current values apply at 400 V and are given on the rating plate.
- ³⁾ Outside UL operation 500 V +10 % is possible.
- ⁴⁾ No standard assignment possible.

AS-Interface slaves

SINAMICS G110D distributed frequency converters

General data

Selection and ordering data (continued)

	Order No.		Order No.
Accessories		Accessories (continued)	
Manual on-site control with key-operated switch Simple operation for local operation and commissioning	6SL3 255-0AA00-4HA0	Plug-in connector set for braking resistor For the use or connection of other braking resistors to the SINAMICS G110D	6SL3 563-4RA00-0GA00
RS232 interface cables Connection cable for the commissioning of the SINAMICS G110D frequency converter with the STARTER commissioning tool	3RK1 922-2BP00	UL plug-in connector set For power and motor for the use of SINAMICS G110D in UL-compatible applications	6SL3 563-4UA00-0GA0
USB interface cable Connection cable for the commissioning of the SINAMICS G110D frequency converter with the STARTER commissioning tool	6SL3 555-0PA00-2AA0	Memory card The parameterization of a converter can be saved on the memory card. For service purposes, e.g. after replacement of a converter and retrieval of data from the memory card, the system is ready for use again immediately. <ul style="list-style-type: none"> SINAMICS Micro Memory Card (MMC) SIMATIC Memory Card (SD card) 	6SL3 254-0AM00-0AA0 6ES7 954-8LB00-0AA0
Braking resistors for SINAMICS G110D frequency converters For the reduction of excess power from the link <ul style="list-style-type: none"> Rated power 0.75 kW and 1.5 kW Rated power 3 kW and 4 kW Rated power 5.5 kW and 7.5 kW 	6SL3 501-0BE08-6AA0 6SL3 501-0BE12-1AA0 6SL3 501-0BE14-1AA0	Card holder for memory card The use of the memory card requires a card holder that can be plugged in both under the blanking cover and under the optional manual on-site controller	6SL3 555-0PM00-0AA0
Intelligent Operator Panel IOP Handheld For use with SIMATIC ET 200S FC or SIMATIC ET 200pro FC frequency converters Included in scope of supply: <ul style="list-style-type: none"> Intelligent Operator Panel IOP Handheld enclosure Batteries (4 × AA) Charger (international) RS232 connection cable (length 3 m, may only be used for SINAMICS G120 and SIMATIC ET 200S FC) USB cable (length 1 m) 	6SL3 255-0AA00-4HA0	Plug-in connector set for braking resistor For the use or connection of other braking resistors to the SINAMICS G110D	6SL3 563-4RA00-0GA00
Memory card The parameterization of a converter can be saved on the memory card. For service purposes, e.g. after replacement of a converter and retrieval of data from the memory card, the system is ready for use again immediately. <ul style="list-style-type: none"> SINAMICS Micro Memory Card (MMC) SIMATIC Memory Card (SD card) 	6SL3 254-0AM00-0AA0 6ES7 954-8LB00-0AA0	UL plug-in connector set For power and motor for the use of SINAMICS G110D in UL-compatible applications	6SL3 563-4UA00-0GA0
Card holder for memory card Use of the memory card requires a card holder that can be plugged in both under the blanking cover and under the optional manual on-site controller	6SL3 555-0PM00-0AA0	Plug protection bracket To protect the plug against shearing off due to mechanical effects <ul style="list-style-type: none"> For sizes FSA and FSB For size FSC 	6SL3 263-1HA20-0GA0 6SL3 263-1HC20-0GA0
		Adapters For installation of the SINAMICS G110D instead of a SIRIUS M200D motor starter	6SL3 263-1GA20-0GA0

Note:

For further information on technical data, accessories and ordering data see Catalog D 31 and Industry Mall at www.siemens.com/industrymall

AS-Interface slaves

3SF5 pushbuttons and indicator lights

AS-Interface enclosures and front panel modules

General data

Overview



Distributed command devices of the 3SB3 series can be quickly connected to the AS-Interface using AS-Interface enclosures. Using suitable components you can make your own enclosures with integrated AS-Interface or flexibly modify existing enclosures.

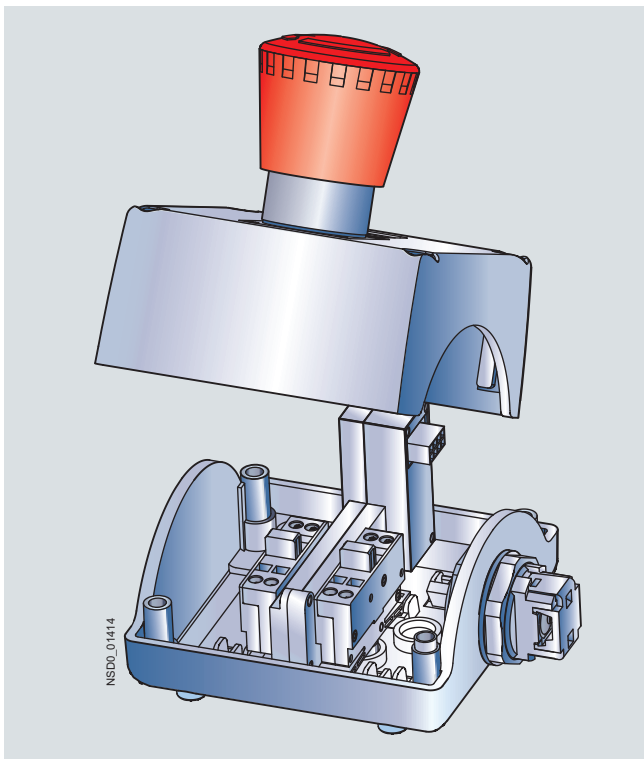

Enclosures

Color of enclosure cover:

- Gray, RAL 7035, or
- Yellow, RAL 1004, for EMERGENCY-STOP.

Color of enclosure base:

- Black, RAL 9005

Installation of AS-Interface slaves

The following slave types are available for connecting the command points:

- Slave in A/B technology with 4 inputs and 3 outputs
- Slave with 4 inputs and 4 outputs
- F Slave with two secure inputs for EMERGENCY-STOP mushroom pushbutton

The following table shows the maximum number of equippable slaves:

Enclosures for	Number of slaves for enclosures without EMERGENCY-STOP	Number of slaves for enclosures with EMERGENCY-STOP
1 command point	Not available	1 x F slave
2 command points	1 x slave 4I/4O or 4I/3O	Not available
3 command points	1 x slave 4I/4O or 4I/3O	1 x slave 4I/4O or 4I/3O + 1 x F slave
4 command points	2 x slave 4I/4O or 4I/3O ¹⁾	2 x slave 4I/4O or 4I/3O + 1 x F slave ¹⁾
6 command points	2 x slave 4I/4O or 4I/3O	2 x slave 4I/4O or 4I/3O + 1 x F slave

¹⁾ For metal enclosures with 4 command points, only 1 x slave 4I/4O or 4I/3O is possible.

Connection

For connecting a slave to contact blocks and lampholders and the connection element, one set of links is needed for each.

The connection elements are mounted in the front-end cable glands and are used for connection of the AS-Interface or for bringing unused inputs or outputs out of the enclosure.

For connection to AS-Interface can be selected between:

- Terminal for shaped AS-Interface cable.
The cable is contacted by the insulation piercing method and routed past the enclosure on the outside (possible only with plastic enclosure).
- Cable gland for the shaped AS-Interface cable or round cable. The cable is routed into the enclosure (preferable for metal enclosure).
- Connection using M12 plug.

If less than all inputs/outputs of the installed slaves in an enclosure are used for connecting the command devices, free inputs and outputs can be routed on request to the outside through an M12 socket on the top or bottom side of the enclosure.

To supply inputs with power, the S+ connection of the must be assigned to the socket, for outputs the OUT- connection must be assigned.

Addressing is performed using the AS-Interface connections or the integrated addressing socket. An external power supply is not required.

Note:

Dimensional drawings, manuals and further technical information can be found on the Internet at:
www.siemens.com/industrial-controls/support

AS-Interface slaves

3SF5 pushbuttons and indicator lights

AS-Interface enclosures and front panel modules With standard fittings

Overview

Enclosures with standard fittings are available with:

- 1 to 3 command points
- Operational voltage through AS-Interface (approx. 30 V)
- Vertical mounting type
- Plastic enclosures are equipped with plastic actuators and indicators, metal enclosures are equipped with metal actuators and indicators.





The enclosures without EMERGENCY-STOP each have one user module with 4I/3O; the enclosures with EMERGENCY STOP mushroom pushbuttons have a safe AS-Interface slave integrated in the enclosure.

Enclosures with EMERGENCY-STOP mushroom pushbuttons are fitted with two NC contact blocks, which are wired to the safe slave. The contact blocks and lampholders (with spring-type terminals) of the control device, and the AS-Interface slaves, are mounted in the base of the enclosure and are cable-connected.

The plastic enclosures are designed with a connection for the AS-Interface flat cable (the cable is run passed the outside of the enclosure). For metal enclosures, the AS-Interface cable is run inside the enclosure.

The enclosures with EMERGENCY-STOP mushroom pushbuttons have a yellow top part. They are also available with an M12 plug.

Selection and ordering data

	Version	Order No.
	AS-Interface enclosures, plastic, with standard fittings	
	<i>Equipment</i> (A, B, C = identification letters of the command positions)	<i>Number of command points</i>
	With M12 plug at the top	
	A = EMERGENCY-STOP mushroom pushbutton	1
3SF5 811-0AA08		3SF5 811-0AA10
	With terminal for insulation piercing method at the top	
	A = EMERGENCY-STOP mushroom pushbutton	1
3SF5 812-0DA00		3SF5 811-0AA08
	A = EMERGENCY-STOP mushroom pushbutton with protective collar	1
	B = Pushbutton green, label "I", A = Pushbutton red, label "O"	2
	B = Pushbutton white, label "I", A = Pushbutton black, label "O"	2
	C = Indicator light clear, label without inscription, B = Pushbutton green, label "I", A = Pushbutton red, label "O"	3
	C = Indicator light clear, label without inscription, B = Pushbutton white, label "I", A = Pushbutton black, label "O"	3
	C = Pushbutton black, label "II", B = Pushbutton black, label "I", A = Pushbutton red, label "O"	3
		3SF5 812-0DA00
		3SF5 812-0DB00
		3SF5 813-0DA00
		3SF5 813-0DC00
		3SF5 813-0DB00
	AS-Interface enclosures, metal, with standard fittings	
	<i>Equipment</i> (A, B, C = identification letters of the command positions)	<i>Number of command points</i>
	With M12 connector socket at the top	
	A = EMERGENCY-STOP mushroom pushbutton	1
3SF5 811-2AB08		3SF5 811-2AA10
	A = EMERGENCY-STOP mushroom pushbutton with protective collar	1
		3SF5 811-2AB10
	With cable gland at the top	
	A = EMERGENCY-STOP mushroom pushbutton, yellow top part of enclosure	1
3SF5 812-2DA00		3SF5 811-2AA08
	A = EMERGENCY-STOP mushroom pushbutton, yellow top part of enclosure, with protective collar	1
	B = Pushbutton green, label "I", A = Pushbutton red, label "O"	2
	B = Pushbutton white, label "I", A = Pushbutton black, label "O"	2
	C = Indicator light clear, label without inscription, B = Pushbutton green, label "I", A = Pushbutton red, label "O"	3
	C = Indicator light clear, label without inscription, B = Pushbutton white, label "I", A = Pushbutton black, label "O"	3
	C = Pushbutton black, label "II", B = Pushbutton black, label "I", A = Pushbutton red, label "O"	3
		3SF5 812-2DA00
		3SF5 812-2DB00
		3SF5 813-2DA00
		3SF5 813-2DC00
		3SF5 813-2DB00
		
3SF5 813-2DA00		

AS-Interface slaves









3SF5 pushbuttons and indicator lights

AS-Interface enclosures and front panel modules

Components

Selection and ordering data

For self-equipping of the enclosures

	Version	Order No.
	With plastic enclosure	<i>Number of command points</i>
	AS-Interface slaves F slave, 2 safe inputs, for plastic enclosure, EMERGENCY-STOP, without protective collar	1 ... 6 3SF5 500-0BA
3SF5 500-0BA	F slave, 2 safe inputs, for plastic or metal enclosure, EMERGENCY-STOP, with protective collar	1 3SF5 500-0DA
	A/B slave, 4I/3O for plastic enclosure	2 ... 6 3SF5 500-0BB
3SF5 500-0BB	Slave, 4I/4O, for plastic enclosure	2 ... 6 3SF5 500-0BC
	Sets of links	
	For F slave	3SF5 900-0BA
	For slave 4I/4O or A/B slave 4I(3O)	3SF5 900-0BB
	Connection elements	
	For AS-Interface shaped cable, connection by insulation piercing method, for plastic enclosure,	1 ... 3 4 ... 6 3SF5 900-0CA 3SF5 900-0CB
3SF5 900-0CA	For AS-Interface connection using M12 plug, for plastic enclosure	1 ... 3 4 ... 6 3SF5 900-0CC 3SF5 900-0CD
	For bringing out unused inputs and outputs via M12 socket, for plastic enclosure	1 ... 3 4 ... 6 3SF5 900-0CE 3SF5 900-0CF
3SF5 900-0CE	For AS-Interface shaped cable, cable is routed into the enclosure, for plastic or metal enclosure	1 ... 3 4 ... 6 3SF5 900-0CG 3SF5 900-0CH
	For round cable, cable is routed into the enclosure, for plastic or metal enclosure	1 ... 3 4 ... 6 3SF5 900-0CJ 3SF5 900-0CK
3SF5 900-0CG		
	For metal enclosures	<i>Number of command points</i>
	AS-Interface slaves F slave, 2 safe inputs, for metal enclosure, EMERGENCY-STOP, without protective collar	1 ... 6 3SF5 500-0CA
3SF5 500-0CB	F slave, 2 safe inputs, for plastic or metal enclosure, EMERGENCY-STOP, with protective collar	1 3SF5 500-0DA
	A/B slave, 4I/3O for metal enclosure	2 ... 6 3SF5 500-0CB
	Slave, 4I/4O for metal enclosure	2 ... 6 3SF5 500-0CC
	Sets of links	
	For F slave	3SF5 900-0BA
	For slave 4I/4O or A/B slave 4I(3O)	3SF5 900-0BB
	Connection elements	
	For AS-Interface connection using M12 plug, for metal enclosure	1 ... 3 4 ... 6 3SF5 900-2CC 3SF5 900-2CD
3SF5 900-0CG	For bringing out unused inputs/outputs through an M12 socket, for metal enclosure	1 ... 3 4 ... 6 3SF5 900-2CE 3SF5 900-2CF
	For AS-Interface shaped cable, cable is routed into the enclosure, for plastic or metal enclosure	1 ... 3 4 ... 6 3SF5 900-0CG 3SF5 900-0CH
3SF5 900-0CJ	For round cable, cable is routed into the enclosure, for plastic or metal enclosure	1 ... 3 4 ... 6 3SF5 900-0CJ 3SF5 900-0CK

Note:

Empty enclosures and elements for component arrangement can be found in the IC 10 catalog, chapter "Control and signaling devices" and in the Industry Mall under www.siemens.com/industrymall.

AS-Interface slaves

3SF5 pushbuttons and indicator lights

AS-Interface enclosures and front panel modules Customized equipment

Overview



The enclosures can be equipped with command devices as required for customized solutions to connect command devices to the AS-Interface.

Customized enclosures are available with 2 to 6 command positions.

One command point comprises:

- 1 actuator or indicator
- Up to 3 contact blocks or up to 2 contact blocks + 1 lampholder
- 1 inscription label

For plastic enclosures the command points are equipped as standard with plastic actuators and indicators, for metal enclosures they are equipped with metal actuators and indicators.

Installation of AS-Interface slaves

The following slave types are available for connecting the command points:

- Slave in A/B technology with 4 inputs and 3 outputs
- Slave with 4 inputs and 4 outputs
- F slave with 2 safe inputs for EMERGENCY-STOP

The following table shows the maximum number of equippable slaves:

Enclosures for	Number of slaves for enclosures without EMERGENCY-STOP	Number of slaves for enclosures with EMERGENCY-STOP
2 command points	1 x slave 4I/4O or 4I/3O	Version not available
3 command points	1 x slave 4I/4O or 4I/3O	1 x slave 4I/4O or 4I/3O + 1 x F slave
4 command points	2 x slave 4I/4O or 4I/3O ¹⁾	2 x slave 4I/4O or 4I/3O + 1 x F slave ¹⁾
6 command points	2 x slave 4I/4O or 4I/3O	2 x slave 4I/4O or 4I/3O + 1 x F slave

¹⁾ For metal enclosures with 4 command points, only 1 x slave 4I/4O or 4I/3O is possible.

Connection

The customized enclosure is delivered fully equipped and wired. For connection to AS-Interface can be selected between:

- Terminal for shaped AS-Interface cable.
The cable is contacted by the insulation piercing method and routed past the enclosure on the outside (possible only with plastic enclosure).
- Cable gland for the shaped AS-Interface cable or round cable. The cable is routed into the enclosure (preferable for metal enclosure).
- Connection using M12 plug.

If less than all inputs/outputs of the installed slaves in an enclosure are used for connecting the command devices, free inputs and outputs can be routed on request to the outside through an M12 socket on the top or bottom side of the enclosure. The desired pin arrangement of the M12 socket must be stated in the order documents

To supply inputs with power, the S+ connection of the must be assigned to the socket, for outputs the OUT- connection must be assigned.

Addressing is performed using the AS-Interface connections or the integrated addressing socket. An external power supply is not required.

EMERGENCY STOP

For enclosures with EMERGENCY STOP, the EMERGENCY-STOP mushroom pushbutton can be wired conventionally or via a secure AS-Interface slave, as desired.

For conventional wiring of the EMERGENCY-STOP mushroom pushbutton, up to three switching contacts can be selected for the EMERGENCY STOP. If the EMERGENCY STOP is prompted via AS-Interface, two contacts are possible for the safety circuit.

With conventional wiring, the scanning of one EMERGENCY-STOP contact block through AS-Interface is possible.

Selection and ordering data

The selection and ordering of the customized enclosure is made directly via the 3SB3/3SF5 configurator for pushbuttons and indicator lights.

An electronic order form will be generated for the additional options. The configurator is available in the electronic catalog CA 01 on CD-ROM or DVD or in the online catalog (Mall) on the Internet:

www.siemens.com/industrymall

Select the configurator for "Pushbuttons and indicator lights 3SB3, 3SF5" from the list of configurators.

Start the configuration with the list entry "Version" and select the "Customized enclosure ASI".

The list price of the complete enclosure is generated in the configurator for the customized equipment. Registration and login in the configurator is required for this.

Please send the resulting electronic order form along with your order to our Competence Center at

sirius-attach.aud@siemens.com

If you are unable to access either catalog, please contact our Technical Assistance.

AS-Interface slaves

3SF5 pushbuttons and indicator lights

AS-Interface enclosures and front panel modules

Front panel module

Overview

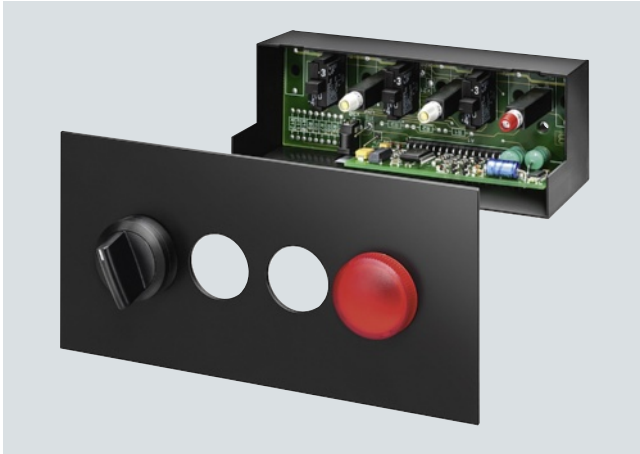

With the AS-Interface front panel module, 3SB3 control devices, which are mounted on to the front panels, can be connected to the AS-Interface bus system. Plastic or metal pushbuttons or indicator lights in round or square design can be used. Mushroom pushbuttons and acoustic signaling devices cannot be used.

The front panel module comprises:

- Slave 4I/4O
- 4 3SB3 commanding and signaling devices
- Accessories (lamps, name plates, mounting parts)

The selection of standard fittings is made through the ordering documents (see next page).

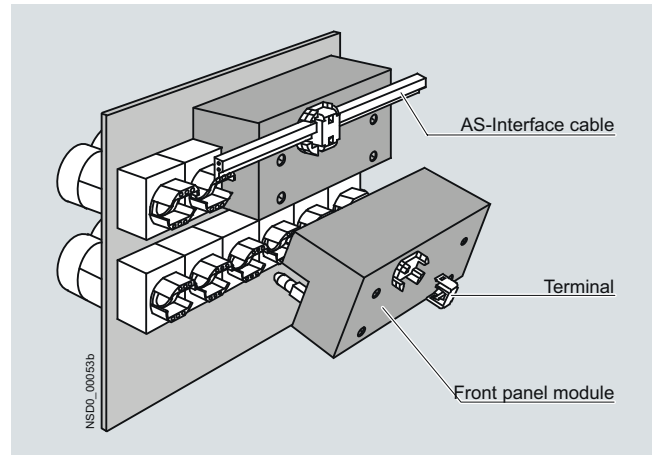

The front panel module is mounted on the back of the front panel on a group of four actuators and indicators arranged alongside or on top of each other and secured with screws. The contact blocks and lampholders are integrated in the module.

A 30 mm x 45 mm grid must be considered when mounting the control devices on to the front plate.

Connection to the AS-Interface shaped cable is by means of a terminal positioned on the rear of the module using the insulation piercing method.

Addressing is performed using the AS-Interface connections or the integrated addressing socket.

Selection and ordering data

Version	Order No.
AS-Interface front panel module for 3SB3 control devices	
4I/4O	3SF5 874-4AZ

AS-Interface slaves

3SF5 pushbuttons and indicator lights

AS-Interface enclosures and front panel modules

Front panel module

Selection and ordering data

To order the front panel module, please fill out the order form and include it with your order. These order documents cannot be generated via the 3SB3/3SF5 configurator. The electronic order form is available from our Technical Support:

Tel. +49 (0)911 895-59 00
 Fax +49 (0)911 895-59 07

Enter the desired options in the order form, e.g. type of actuators and indicators, switching contacts, lampholders or accessories (labels or the like). The codes that are to be entered in the form

can be obtained from the list of options that are subject to a surcharge.

The price of the device is made up of the basic price of the module and the additional prices for the fittings.

The additional prices include all components which depend on the selected configuration options (actuators and indicators, switching contacts, lampholders and accessories).

Order form

Front panel module order documentation		to sirius-attach.aud@siemens.com																										
Date	Purchaser's order reference	Supplier's order reference																										
1. Number of command points <input type="checkbox"/> 4 command points		2. Design of actuators <input type="checkbox"/> round, plastic <input type="checkbox"/> square, plastic <input type="checkbox"/> round, metal																										
3. Name plates <input type="checkbox"/> without <input type="checkbox"/> with name plate including glued in inscription label 12.5 mm × 27 mm <input type="checkbox"/> with name plate including glued in inscription label 27 mm × 27 mm																												
4. Equipment (top view of front side of switchboard)																												
Inscription of the name plates																												
Equipment (code)	A	B	C	D																								
	<input type="text"/>	<input type="text"/>	<input type="text"/>	<input type="text"/>																								
Version of switching elements	<table border="0"> <tr> <td style="text-align: center;">left</td> <td style="text-align: center;">right</td> </tr> <tr> <td><input type="checkbox"/> 1 NO</td> <td><input type="checkbox"/> 1 NO</td> </tr> <tr> <td><input type="checkbox"/> 1 NC</td> <td><input type="checkbox"/> 1 NC</td> </tr> </table>	left	right	<input type="checkbox"/> 1 NO	<input type="checkbox"/> 1 NO	<input type="checkbox"/> 1 NC	<input type="checkbox"/> 1 NC	<table border="0"> <tr> <td style="text-align: center;">left</td> <td style="text-align: center;">right</td> </tr> <tr> <td><input type="checkbox"/> 1 NO</td> <td><input type="checkbox"/> 1 NO</td> </tr> <tr> <td><input type="checkbox"/> 1 NC</td> <td><input type="checkbox"/> 1 NC</td> </tr> </table>	left	right	<input type="checkbox"/> 1 NO	<input type="checkbox"/> 1 NO	<input type="checkbox"/> 1 NC	<input type="checkbox"/> 1 NC	<table border="0"> <tr> <td style="text-align: center;">left</td> <td style="text-align: center;">right</td> </tr> <tr> <td><input type="checkbox"/> 1 NO</td> <td><input type="checkbox"/> 1 NO</td> </tr> <tr> <td><input type="checkbox"/> 1 NC</td> <td><input type="checkbox"/> 1 NC</td> </tr> </table>	left	right	<input type="checkbox"/> 1 NO	<input type="checkbox"/> 1 NO	<input type="checkbox"/> 1 NC	<input type="checkbox"/> 1 NC	<table border="0"> <tr> <td style="text-align: center;">left</td> <td style="text-align: center;">right</td> </tr> <tr> <td><input type="checkbox"/> 1 NO</td> <td><input type="checkbox"/> 1 NO</td> </tr> <tr> <td><input type="checkbox"/> 1 NC</td> <td><input type="checkbox"/> 1 NC</td> </tr> </table>	left	right	<input type="checkbox"/> 1 NO	<input type="checkbox"/> 1 NO	<input type="checkbox"/> 1 NC	<input type="checkbox"/> 1 NC
left	right																											
<input type="checkbox"/> 1 NO	<input type="checkbox"/> 1 NO																											
<input type="checkbox"/> 1 NC	<input type="checkbox"/> 1 NC																											
left	right																											
<input type="checkbox"/> 1 NO	<input type="checkbox"/> 1 NO																											
<input type="checkbox"/> 1 NC	<input type="checkbox"/> 1 NC																											
left	right																											
<input type="checkbox"/> 1 NO	<input type="checkbox"/> 1 NO																											
<input type="checkbox"/> 1 NC	<input type="checkbox"/> 1 NC																											
left	right																											
<input type="checkbox"/> 1 NO	<input type="checkbox"/> 1 NO																											
<input type="checkbox"/> 1 NC	<input type="checkbox"/> 1 NC																											

NSD0 00057d

5. Lamps for illuminated actuators and indicator lights

- 24 V incandescent lamp (will be used unless otherwise specified)
- 30 V incandescent lamp
- Super-bright LED (color of LED according to color of actuator/indicator)

6

AS-Interface slaves

3SF5 pushbuttons and indicator lights

AS-Interface enclosures and front panel modules
Front panel module

Selection and ordering data (continued)

Selection of equipping options according to order documentation

Version	Code according to colors													
	Black		Red		Yellow		Green		Blue		White		Clear	
Actuators and indicators														
Pushbuttons with flat button	D	BK	D	RD	D	YE	D	GN	D	BU	D	WH	D	CL
Illuminated pushbuttons with flat button	–		DL	RD	DL	YE	DL	GN	DL	BU	DL	WH	DL	CL
Pushbuttons with raised button	DH	BK	DH	RD	DH	YE	–		DH	BU	–		–	
Illuminated pushbutton with raised button	–		DHL	RD	DHL	YE	DHL	GN	DHL	BU	–		DHL	CL
Pushbutton with raised front ring	DHF	BK	DHF	RD	DHF	YE	DHF	GN	DHF	BU	DHF	WH	–	
Pushbutton with raised front ring, castellated ¹⁾	DFZ	BK	DFZ	RD	DFZ	YE	DFZ	GN	DFZ	BU	DFZ	WH	–	
Pushbutton with flat button	DS	BK	DS	RD	DS	YE	DS	GN	DS	BU	DS	WH	–	
Illuminated pushbutton with flat button	–		DLS	RD	DLS	YE	DLS	GN	DLS	BU	DLS	WH	DLS	CL
Indicator light, smooth lens	–		L	RD	L	YE	L	GN	L	BU	L	WH	L	CL

Selector switches with 2 switch positions

Switching sequence O–I, latching

Non-illuminated	K1	BK	K1	RD	–		K1	GN	–		K1	WH	–	
Illuminated	–		BK1	RD	BK1	YE	BK1	GN	BK1	BU	–		BK1	CL

Switching sequence O–I, momentary contact

Non-illuminated	K2	BK	K2	RD	–		K2	GN	–		K2	WH	–	
Illuminated	–		BK2	RD	BK2	YE	BK2	GN	BK2	BU	–		BK2	CL

Selector switches with 3 switch positions

Switching sequence I–O–II, latching

Non-illuminated	K4	BK	K4	RD	–		K4	GN	–		K4	WH	–	
Illuminated	–		BK4	RD	BK4	YE	BK4	GN	BK4	BU	–		BK4	CL

Switching sequence I–O–II, momentary contact

Non-illuminated	K5	BK	K5	RD	–		K5	GN	–		K5	WH	–	
Illuminated	–		BK5	RD	BK5	YE	BK5	GN	BK5	BU	–		BK5	CL

Switching sequence I–O–II, latching to the right, momentary contact to the left

Non-illuminated	K6	BK	K6	RD	–		K6	GN	–		K6	WH	–	
-----------------	----	----	----	----	---	--	----	----	---	--	----	----	---	--

Switching sequence I–O–II, latching to the left, momentary contact to the right

Non-illuminated	K7	BK	K7	RD	–		K7	GN	–		K7	WH	–	
-----------------	----	----	----	----	---	--	----	----	---	--	----	----	---	--

¹⁾ Only for plastic version.

Note:

More information on the actuators and indicator lights can be found in the IC 10 catalog, chapter "Control and signaling devices" and in the Industry Mall at:
www.siemens.com/industrymall.

AS-Interface slaves

3SF5 pushbuttons and indicator lights

AS-Interface enclosures and front panel modules

Front panel module

Selection and ordering data (continued)

Selection of equipping options according to order documentation

Version	Code Key can be removed in any position							
	O	I	II	O and I	O and II	I and II	I, O and II	

Key-operated switches with 2 switch positions

Switching sequence O-I, latching

RONIS type:										
Lock No. SB30	RSB	1A	RSB	1E	–	RSB	1AE	–	–	–
CES type:										
Lock No. SSG 10	CES	1A	CES	1E	–	CES	1AE	–	–	–
Lock No. LSG 1	CESL	1A	–	–	–	CESL	1AE	–	–	–
CES type with key monitoring										
Lock No. SSG 10	CES SU	1A								
BKS type:										
Lock No. S1	BKS	1A	BKS	1E	–	BKS	1AE	–	–	–
Lock No. E1 (for VW)	BKS A	1A	–	–	–	BKS A	1AE	–	–	–
Lock No. E2 (for VW)	BKS E	1A	–	–	–	BKS E	1AE	–	–	–
Lock No. E7 (for VW)	BKS C	1A	–	–	–	BKS C	1AE	–	–	–
Lock No. E9 (for VW)	BKS B	1A	–	–	–	BKS B	1AE	–	–	–
O.M.R. type										
Black, lock no. 73034	OMR BK 1A	OMR BK 1E	–	–	–	OMR BK1AE	–	–	–	–

Switching sequence O-I, momentary contact

RONIS type:										
Lock No. SB30	RSB	2A	–	–	–	–	–	–	–	–
CES type:										
Lock No. SSG 10	CES	2A	–	–	–	–	–	–	–	–
Lock No. LSG 1	CESL	2A	–	–	–	–	–	–	–	–
BKS type:										
Lock No. S1	BKS	2A	–	–	–	–	–	–	–	–
O.M.R. type										
Black, lock no. 73034	OMR BK 2A	–	–	–	–	–	–	–	–	–

Key-operated switches with 3 switch positions

Switching sequence I-O-II, latching

RONIS type:												
Lock No. SB30	RSB	4A	RSB	4E	RSB	4D	–	–	RSB	4ED	RSB	4EAD
CES type:												
Lock No. SSG 10	CES	4A	CES	4E	CES	4D	–	–	CES	4ED	CES	4EAD
CES type with key monitoring												
Lock No. SSG 10	CES SU	4A										
BKS type:												
Lock No. S1	BKS	4A	BKS	4E	BKS	4D	–	–	BKS	4ED	BKS	4EAD
O.M.R. type												
Black, lock no. 73034	OMR BK 4A	–	–	–	–	–	–	–	OMR BK 4ED	OMR BK 4EAD		

Switching sequence I-O-II, momentary contact

RONIS type:										
Lock No. SB30	RSB	5A	–	–	–	–	–	–	–	–
CES type:										
Lock No. SSG 10	CES	5A	–	–	–	–	–	–	–	–
BKS type:										
Lock No. S1	BKS	5A	–	–	–	–	–	–	–	–
O.M.R. type										
Black, lock no. 73034	OMR BK 5A	–	–	–	–	–	–	–	–	–

Note:

More information on the actuators and indicator lights can be found in the IC 10 catalog, chapter "Control and signaling devices" and in the Industry Mall at:

www.siemens.com/industrymall.

AS-Interface slaves

3SF5 pushbuttons and indicator lights

AS-Interface enclosures and front panel modules
Front panel module

Selection and ordering data (continued)

Selection of equipping options according to order documentation

Version	Code Key can be removed in any position						
	O	I	II	O and I	O and II	I and II	I, O and II

Key-operated switches with 3 switch positions

Switching sequence I–O–II, latching to the right, momentary contact to the left

RONIS type:										
Lock No. SB30	RSB	6A	–	RSB	6D	–	RSB	6AD	–	–
CES type:										
Lock No. SSG 10	CES	6A	–	CES	6D	–	CES	6AD	–	–
BKS type:										
Lock No. S1	BKS	6A	–	BKS	6D	–	BKS	6AD	–	–
O.M.R. type										
Black, lock no. 73034	OMR BK 6A	–	–	OMR BK 6D	–	–	OMR BK 6AD	–	–	–

Switching sequence I–O–II, latching to the left, momentary contact to the right

RONIS type:										
Lock No. SB30	RSB	7A	RSB	7E	–	RSB	7AE	–	–	–
CES type:										
Lock No. SSG 10	CES	7A	CES	7E	–	CES	7AE	–	–	–
BKS type:										
Lock No. S1	BKS	7A	BKS	7E	–	BKS	7AE	–	–	–
O.M.R. type										
Black, lock no. 73034	OMR BK 7A	–	OMR BK 7E	–	–	–	–	–	–	–

Note:

More information on the actuators and indicator lights can be found in the IC 10 catalog, chapter "Control and signaling devices" and in the Industry Mall at:
www.siemens.com/industrymall.

AS-Interface slaves

8WD4 signaling columns

General data

Overview

The 8WD4 signaling columns are flexible in design and versatile in use.

These are used for controlling complex processes in machines or automated processes or as visual or acoustic warning systems in emergency situations, e.g. for displaying individual stages of production.



8WD44 signaling columns with connection to AS-Interface cables

Two product series are available:

- 8WD42
 - Thermoplast enclosure, diameter 50 mm
 - Degree of protection IP54
- 8WD44
 - Thermoplast enclosure, diameter 70 mm
 - Advanced design and significantly improved illumination
 - Fast and flexible when connected through spring-type terminals (optional)
 - Integrated degree of protection IP65

Communication through AS-Interface

The 8WD4 signaling columns can be directly connected to the AS-Interface bus system through an adapter element that can be integrated in the column. Wiring outlay is reduced as the result.

Connection

8WD42:

The two-wire bus cable is fixed to the screw terminals in the connection element. The adapter element must be the first module to be mounted on the connection element. A maximum of 4 signaling elements can then be mounted on it.

The adapter element 8WD42 28-0BB is a standard slave.

8WD44:

The two-wire bus cable is fixed to the screw or spring-type terminals in the connection element. The adapter element must be the first module to be mounted on the connection element. The signaling elements can then be mounted on it.

The adapter element 8WD44 28-0BE is a standard slave. A maximum of 4 signaling elements can be mounted on it.







The adapter element 8WD44 28-0BD with A/B technology enables the connection of up to 62 slaves on one AS-Interface system. The addressing socket provides user-friendly parameterization of the AS-Interface elements. A maximum of 3 signaling elements can be mounted on it.

AS-Interface slaves

8WD4 signaling columns

8WD42 signaling columns, 50 mm diameter

Selection and ordering data

	Version	Rated voltage	Color	Order No.
Acoustic elements ¹⁾				
	Buzzer element 80 dB, Sound type pulsing or continuous tone, can be adjusted via a wire jumper	24 V AC/DC	Black	8WD42 20-0FA
Light elements for incandescent lamps/LED, base BA 15d ²⁾				
 	Continuous light elements	24 ... 230 V AC/DC	Red Green Yellow Clear Blue	8WD42 00-1AB 8WD42 00-1AC 8WD42 00-1AD 8WD42 00-1AE 8WD42 00-1AF
Light elements with integrated LED				
	Continuous light elements	24 V AC/DC	Red Green Yellow Clear ³⁾ Blue ³⁾	8WD42 20-5AB 8WD42 20-5AC 8WD42 20-5AD 8WD42 20-5AE 8WD42 20-5AF
 	Blinklight elements	24 V AC/DC	Red Green Yellow Clear Blue	8WD42 20-5BB 8WD42 20-5BC 8WD42 20-5BD 8WD42 20-5BE 8WD42 20-5BF
Adapter elements for AS-Interface				
	AS-Interface adapter elements With/without external auxiliary voltage, switchable • Standard AS-i	For 4 signaling elements	Black	8WD42 28-0BB
Connection elements ⁴⁾				
	Connection elements with cover Screw terminals • For mounting on pipes, angle mount- ing and floor mounting		Black	8WD42 08-0AA

¹⁾ One acoustic element can be mounted per signaling column.
One cover is contained in the scope of supply and permanently mounted
on the acoustic elements.

²⁾ The lamp is not included in the scope of supply. Please order separately.

³⁾ Start of delivery in October 2011.









⁴⁾ The connection element with cover is an essential part for assembling
the signaling columns.

AS-Interface slaves

8WD4 signaling columns

8WD42 signaling columns, 50 mm diameter

Selection and ordering data (continued)

Version		Order No.
Mounting		
	Feet, single	Plastic, for mounting on pipes Metal, for pipe lengths > 400 mm
		Plastic, for floor mounting (without pipe)
	Foldaway base for positioning in the grid 7.5° ¹⁾	Plastic, for mounting on pipes, incl. rubber seal
		Pipes, single
		Length 150 mm
		Length 250 mm
		Length 400 mm
		Length 1000 mm
	Sockets for feet	Side cable outlet (can also be used without feet)
		Side cable outlet, with magnetic fixing ²⁾
	Brackets for mounting with foot	
	Brackets for wall mounting (plastic)	Mounting without feet and pipe
	Adapters for single-hole mounting	Mounting without feet and pipe, with M18 thread and fixing nut
Lamps		
	Incandescent lamps, 5 W, 24 V AC/DC Base BA 15d	
	LEDs, 24 V AC/DC Base BA 15d	Red
		Green
		Yellow
		Clear
		Blue

¹⁾ Markings for 30°, 45°, 60° and 90°.

²⁾ For horizontal mounting, only 1 element is recommended.

AS-Interface slaves

8WD4 signaling columns

8WD44 signaling columns, 70 mm diameter

Selection and ordering data

	Version	Rated voltage	Color	Order No.
<i>Acoustic elements</i> ¹⁾				
	Buzzer element 85 dB, Sound type pulsing or continuous tone, can be adjusted via a wire jumper	24 V AC/DC	Black	8WD44 20-0FA
	Siren elements , multi-tone, 100 dB, 8 tones and volume are adjustable	24 V AC/DC	Black	8WD44 20-0EA2
	Siren elements 108 dB, IP40	24 V DC	Black	8WD44 20-0EA
<i>Light elements for incandescent lamps/LED, base BA 15d</i> ²⁾				
	Continuous light elements	12 ... 230 V AC/DC	Red	8WD44 00-1AB
			Green	8WD44 00-1AC
			Yellow	8WD44 00-1AD
			Clear	8WD44 00-1AE
			Blue	8WD44 00-1AF
	Blinklight elements	24 V AC/DC	Red	8WD44 20-1BB
			Green	8WD44 20-1BC
			Yellow	8WD44 20-1BD
			Clear	8WD44 20-1BE
			Blue	8WD44 20-1BF
			<i>Light elements with integrated flash lamp</i> ³⁾	
	Flashlight elements with integrated electronic flash	24 V DC	Red	8WD44 20-0CB
			Green	8WD44 20-0CC
			Yellow	8WD44 20-0CD
			Clear	8WD44 20-0CE
			Blue	8WD44 20-0CF
<i>Light elements with integrated LED</i>				
	Continuous light elements	24 V AC/DC	Red	8WD44 20-5AB
			Green	8WD44 20-5AC
			Yellow	8WD44 20-5AD
			Clear	8WD44 20-5AE
			Blue	8WD44 20-5AF
	Blinklight elements	24 V AC/DC	Red	8WD44 20-5BB
			Green	8WD44 20-5BC
			Yellow	8WD44 20-5BD
			Clear ⁴⁾	8WD44 20-5BE
			Blue ⁴⁾	8WD44 20-5BF
	Rotating light elements	24 V AC/DC	Red	8WD44 20-5DB
			Green	8WD44 20-5DC
			Yellow	8WD44 20-5DD
<i>Adapter elements for AS-Interface</i>				
	AS-Interface adapter elements With/without external auxiliary voltage, switchable			
	<ul style="list-style-type: none"> • A/B technology • Standard AS-i 	For 3 signaling elements For 4 signaling elements	Black Black	8WD44 28-0BD 8WD44 28-0BE
<i>Connection elements</i> ⁵⁾				
	Connection elements with cover		Black	
	Screw terminals			
	<ul style="list-style-type: none"> • For mounting on pipes • For mounting on bracket and floor 			8WD44 08-0AA 8WD44 08-0AB
	Spring-type terminals			
	<ul style="list-style-type: none"> • For mounting on pipes • For mounting on bracket and floor 			8WD44 08-0AD 8WD44 08-0AE
Cover (replacement)				8WD44 08-0XA

¹⁾ One acoustic element can be mounted per signaling column.
One cover is contained in the scope of supply and permanently mounted on the acoustic elements.

²⁾ The lamp is not included in the scope of supply. Please order separately.

³⁾ The lamp is included in the scope of supply.

⁴⁾ Start of delivery in October 2011.

⁵⁾ The connection element with cover is an essential part for assembling the signaling columns.

AS-Interface slaves

8WD4 signaling columns

8WD44 signaling columns, 70 mm diameter

Selection and ordering data (continued)

	Version	Order No.
Mounting		
	Foot with pipe Pipe length 100 mm	8WD43 08-0DA
	Feet, single Plastic, for mounting on pipes Metal, for pipe lengths > 400 mm	8WD43 08-0DB 8WD43 08-0DC
	Foldaway base for positioning in the grid 7.5° ¹⁾ Plastic, for mounting on pipes, incl. rubber seal	8WD44 08-0DF
	Pipes, single Length 100 mm Length 150 mm Length 250 mm Length 400 mm Length 1000 mm	8WD42 08-0EF 8WD43 08-0EE 8WD43 08-0EA 8WD43 08-0EB 8WD43 08-0ED
	Sockets for feet Side cable outlet (can also be used without feet) Side cable outlet, with magnetic fixing ²⁾	8WD43 08-0DD 8WD43 08-0DE
	Brackets for wall mounting (mounting without feet and pipe) For single-sided mounting For double-sided mounting	8WD43 08-0CA 8WD43 08-0CB
	Brackets for mounting with foot	8WD44 08-0CC
	Brackets for base mounting Mounting without feet and pipe	8WD44 08-0CD
	Adapter for mounting on pipes according to NPT Mounting on pipes, Ø 25 mm, with NPT 1/2" thread	8WD43 08-0DF
Lamps		
	Incandescent lamps, 5 W, 24 V AC/DC Base BA 15d	8WD43 28-1XX
	LEDs, 24 V AC/DC Base BA 15d Red Green Yellow Clear Blue	8WD44 28-6XB 8WD44 28-6XC 8WD44 28-6XD 8WD44 28-6XE 8WD44 28-6XF

¹⁾ Markings for 30°, 45°, 60° and 90°.

²⁾ For horizontal mounting, only 1 element is recommended.

AS-Interface

Power supply units and data decoupling modules

AS-Interface power supply units

Overview



AS-Interface power supply unit for 3A

AS-Interface power supply units feed 30 V DC into the AS-Interface cable and supply the AS-Interface components. They include power-optimized data decoupling for the separation of communication signals and control supply voltage. As the result, AS-Interface is able to convey both data and power along a single line. The power supply units are resistant to overloads and short circuits.

Dimensions

AS-Interface power supply units have compact dimensions in widths of 50 / 70 / 120 mm. No distances from other devices need to be observed when mounting the power supply units.

Features



- Higher rating: The power supply units deliver currents of 2.6 to 8 A.
- Integrated data decoupling: As the result, AS-Interface is able to convey both data and power along a single line.
- Integrated ground-fault detection: The power supply units perform the reliable detection and signaling of ground faults according to IEC 60204-1. The AS-Interface voltage can be disconnected automatically in the event of a ground fault.
- Integrated overload detection: An output overload is detected and reported over a diagnostics LED.
- Diagnostics memory: Any ground faults or overloads on the output side are stored in a diagnostics memory until the device is reset.
- Remote reset and remote signaling: Using relay contacts, a ground fault can be signaled and evaluated by a central controller and/or indicator light.
- Diagnostics LEDs: Three different LEDs indicate the status of the AS-Interface power supply locally at the power supply unit.
- Ultra-wide input range / two-phase connection: The ultra-wide input range of 120 to 500 V of the 8 A version means that the supply units can be used in virtually any network worldwide. In addition, this version dispenses with the need for an N conductor as the device can be connected directly between 2 phases of a network.
- Operation with 24 V DC: The 3 A power supply unit is also available as a version with a 24 V DC input. This power supply unit is suitable for use in battery-powered systems or in systems with UPS (uninterruptible power supply).
- Removable terminal blocks with spring-type connections: For easy exchanging of devices, each power supply unit has three removable terminal blocks: for the input side, for the output side and for Signal/Reset connections.

6

Benefits

- Complete solution for supplying AS-Interface networks while making full use of the maximum possible cable length of 100 m or 200 m (with an extension plug) per AS-i Segment
- Only AS-i masters and AS-i slaves need to be connected to the AS-Interface cable in order to operate AS-Interface
- Compact, space-saving dimensions
- Reliable power supply even for large numbers of AS-Interface modules with a high power requirement
- Integrated ground-fault and overload detection saves the need for additional components and enhances safety
- Fast fault detection and reduced downtimes thanks to diagnostics memory, remote signaling and remote reset
- Reduced downtimes as the result of removable terminal blocks which enable the fast exchanging of devices
- Ultra-wide input range of the 8 A version permits single-phase and two-phase operation and saves the need for an N conductor
- Can be used world-wide thanks to for example UL/CSA approval (UL 508)
- With the 2.6 A version the output power is restricted to max. 100 W for use in NEC Class 2 circuits.

Selection and ordering data

Version	Spring-type terminals	Order No.																		
 <p>AS-Interface power supply unit IP20</p> <ul style="list-style-type: none"> • AS-i single output 30 V DC • With integrated ground-fault detection • 2.6 A version with output power restricted to max. 100 W (for use in NEC Class 2 circuits) • Dimensions: Width: 50 mm (3 A / 2.6 A); 70 mm (5 A), 120 mm (8 A); Height: 125 mm; Depth: 125 mm 																				
 <p>3RX9 501-0BA00</p>	<table border="1"> <thead> <tr> <th>Output current</th> <th>Input voltage</th> <th>Order No.</th> </tr> </thead> <tbody> <tr> <td>2.6 A / max. 100 W</td> <td>120 / 230 V AC (selectable)</td> <td>3RX9 501-2BA00</td> </tr> <tr> <td>3 A</td> <td>120 / 230 V AC (selectable)</td> <td>3RX9 501-0BA00</td> </tr> <tr> <td>3 A</td> <td>24 V DC</td> <td>3RX9 501-1BA00</td> </tr> <tr> <td>5 A</td> <td>120 / 230 V AC (selectable)</td> <td>3RX9 502-0BA00</td> </tr> <tr> <td>8 A</td> <td>120/ 230 ... 500 V AC (selectable)</td> <td>3RX9 503-0BA00</td> </tr> </tbody> </table>	Output current	Input voltage	Order No.	2.6 A / max. 100 W	120 / 230 V AC (selectable)	3RX9 501-2BA00	3 A	120 / 230 V AC (selectable)	3RX9 501-0BA00	3 A	24 V DC	3RX9 501-1BA00	5 A	120 / 230 V AC (selectable)	3RX9 502-0BA00	8 A	120/ 230 ... 500 V AC (selectable)	3RX9 503-0BA00	
Output current	Input voltage	Order No.																		
2.6 A / max. 100 W	120 / 230 V AC (selectable)	3RX9 501-2BA00																		
3 A	120 / 230 V AC (selectable)	3RX9 501-0BA00																		
3 A	24 V DC	3RX9 501-1BA00																		
5 A	120 / 230 V AC (selectable)	3RX9 502-0BA00																		
8 A	120/ 230 ... 500 V AC (selectable)	3RX9 503-0BA00																		
3RX9 503-0BA00																				

AS-Interface

Power supply units and data decoupling modules

S22.5 data decoupling modules

Overview

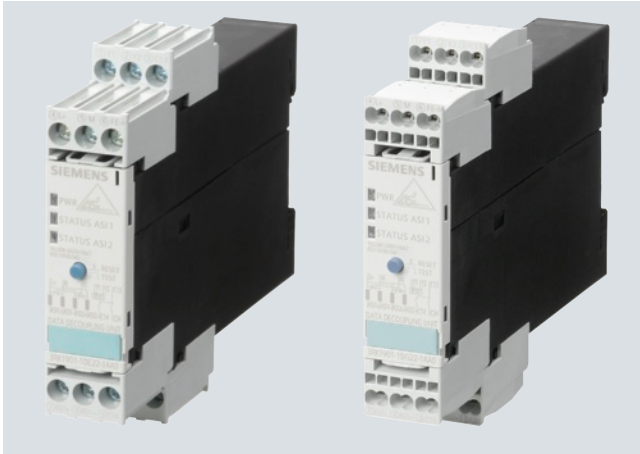

AS-Interface S22.5 double data decoupling modules
Left: screw terminal version, Right: spring-type terminal version

With the aid of the S22.5 data decoupling module, the AS-Interface network can also be supplied with 24 V DC or 30 V DC from a standard power supply unit and the transmission of data and power can be realized along one cable. The combination of data decoupling modules and standard power supply units is therefore a cost-efficient alternative to the service-proven AS-Interface power supply units. The quality of the data signals and the reliable operation of the AS-i network are not negatively affected as the result.

Features of the S22.5 data decoupling module

- Degree of protection IP20
- Narrow design: 22.5 mm wide
- Version with screw or spring-type terminals
- Versions for single and double data decoupling
- Connection of several AS-Interface networks to one power supply unit is possible
- Operation with 24 V DC or 30 V DC, grounded or non-grounded
- Adjustable current limiting up to 2 x 4 A
- Integrated ground-fault detection with fault storage
- Diagnostics LEDs and signaling contacts
- Reset by button or remote reset

Ground-fault detection

The integrated ground-fault detection works with a grounded and non-grounded supply: The connection of negative pole and ground (upstream from the data decoupling module) customary with 24 V DC power supplies is permitted. A ground fault to the negative or positive pole on the AS-Interface network (downstream from the data decoupling module) is detected and stored as a fault and will be signaled using LEDs and a relay contact.

Benefits

- Compatible expansion of the AS-Interface system
- An existing standard power supply unit with 24 V DC or 30 V DC can be used for supplying AS-i networks
- The AS-Interface system can also be used in tightly budgeted applications because no AS-Interface power supply unit needs to be purchased
- Applications benefit in addition from the advantages of a modern bus system:
 - High level of standardization
 - Additional diagnostics and maintenance information
 - Faster commissioning
- Easy and cost-efficient construction of single and multiple networks is possible

Application

The AS-Interface data decoupling module is designed for AS-Interface networks with 30 V supply or 24 V supply (AS-Interface Power24V).

Operation of an AS-i network with the data decoupling module and a 30 V DC standard power supply unit is technically equivalent to the use of an AS-Interface power supply unit and offers the service-proven features of AS-Interface for all applications.

AS-Interface Power24V uses a 24 V DC power supply unit in conjunction with a data decoupling module and is particularly suitable for

- Compact machines using AS-Interface input/output modules
- Applications in the control cabinet for AS-Interface integration of SIRIUS Innovation contactors and compact feeders (3RT2 contactors through 3RA27 function modules or 3RA6 compact feeders through AS-i 3RA69 add-on modules)

When using the double data decoupling module or additional data decoupling modules, several AS-Interface networks can be operated with a single power supply unit. This results in an additional cost advantage.

Note:

The length of an AS-i Power24V network is restricted to 50 m in order to limit the voltage drop along the cable.

AS-i masters, AS-i slaves and the sensors and actuators supplied through the AS-i cable must be designed for the reduced voltage. Sensors and actuators for the standard voltage range of 10...30 V can be supplied with sufficient voltage.

The power supply units must comply with the PELV Standard (Protective Extra Low Voltage) and have a residual ripple of < 250 mVpp. We recommend power supply units from the SITOP range, see Catalog IC 10.

AS-Interface Power supply units and data decoupling modules

S22.5 data decoupling modules



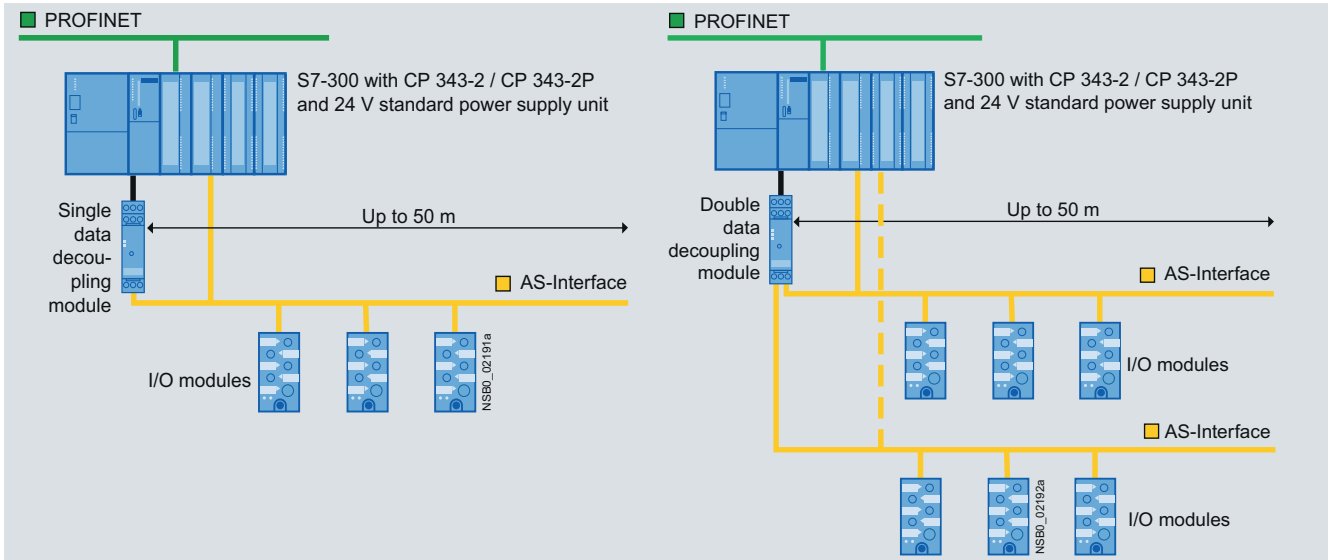

Application (continued)

Construction of an AS-i Power24V network with an AS-Interface S22.5 data decoupling module



Construction of an AS-i Power24V network with an AS-Interface S22.5 data decoupling module: Left: single network, Right: multiple network

Selection and ordering data

Version	Order No.
 <p>S22.5 data decoupling modules With screw terminals, removable terminals, width 22.5 mm, height 101 mm, depth 115 mm</p> <ul style="list-style-type: none"> • Single data decoupling module, 1 x 4 A • Double data decoupling module, 2 x 4 A <p>3RK1 901-1DE12-1AA0</p>	<p>Screw terminals </p> <p>3RK1 901-1DE12-1AA0 3RK1 901-1DE22-1AA0</p>
 <p>S22.5 data decoupling modules With spring-type terminals, removable terminals, width 22.5 mm, height 105 mm, depth 115 mm</p> <ul style="list-style-type: none"> • Single data decoupling module, 1 x 4 A • Double data decoupling module, 2 x 4 A <p>3RK1 901-1DG12-1AA0</p>	<p>Spring-type terminals </p> <p>3RK1 901-1DG12-1AA0 3RK1 901-1DG22-1AA0</p>

Circuit diagrams

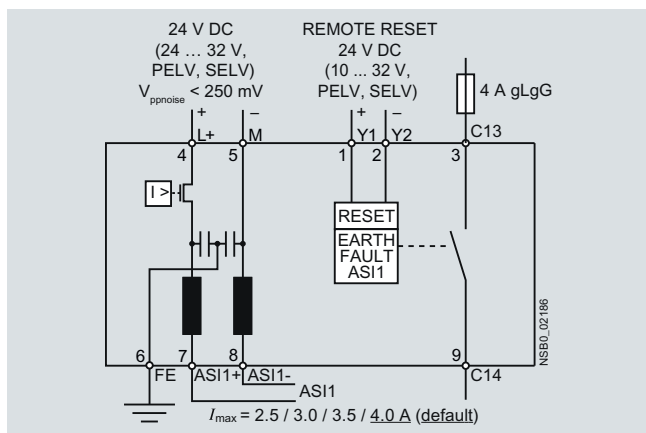

Single data decoupling module

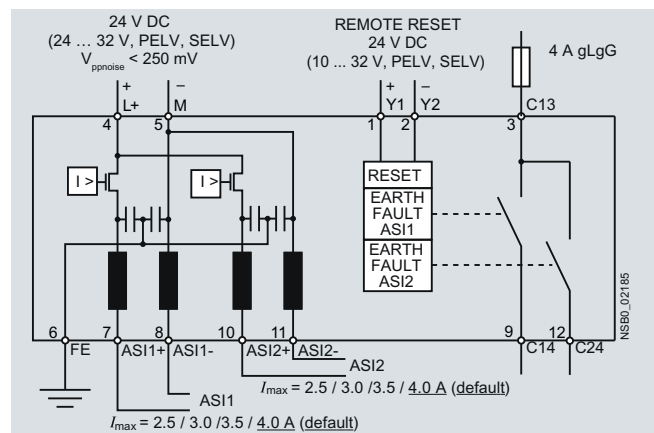

Double data decoupling module

AS-Interface

Transmission media

AS-Interface shaped cables

Overview



AS-Interface shaped cables

The actuator-sensor interface – the networking system used for the lowest field area – is characterized by very easy mounting and installation. A new connection method was developed specially for AS-Interface.

The stations are connected using the AS-Interface cable. This two-wire AS-Interface shaped cable has a trapezoidal shape, thus ruling out polarity reversal.

Connection is effected by the insulation piercing method. In other words, male contacts pierce the shaped AS-Interface cable and make reliable contact with the two wires. Cutting to length and stripping are superfluous. Consequently, AS-Interface stations (e. g. I/O modules, intelligent devices) can be connected in the shortest possible time and exchanging devices is quick.

To enable use in the most varied ambient conditions (e. g. in an oily environment), the AS-Interface cable is available in different materials (rubber, TPE, PUR).

For special applications it is also possible to use an unshielded standard round cable H05VV-F 2x1.5 mm² according to AS-i Specification. With AS-Interface, data and energy for the sensors (e.g. proximity switches BERO) and actuators (e. g. indicator lights) are transmitted over the yellow AS-Interface cable.

The black cable must be used for actuators with a 24 V DC supply (e. g. solenoid valves) and a high power requirement.

Suitable for operation in tow chains

The use of the AS-Interface shaped cables with TPE and PUR outer sheath was checked in a tow chain test with the following conditions:

Chain length	m	6
Travel	m	10
Bending radius	mm	75
Travel speed	m/s	4
Acceleration	m/s ²	4
Number of cycles		10 million
Duration of test		approx. 3 years (11000 cycles per day)

After termination of the 10 million cycles only slight wear was visible due to the lugs of the tow chain. No damage to the cores and core insulation could be detected.

Note:

When using a tow chain, the cables must be installed such that they are not subject to tensile forces. On no account may the cables be twisted, but must be routed flat through the tow chain.

Selection and ordering data

Version				Order No.	
 AS-Interface shaped cables	Material	Color	Quantity		
			Rubber	Yellow (AS-Interface)	100-m roll
			Yellow (AS-Interface)	1-km drum	3RX9 012-0AA00
			Black (24 V DC)	100-m roll	3RX9 020-0AA00
			Black (24 V DC)	1-km drum	3RX9 022-0AA00
	TPE		Yellow (AS-Interface)	100-m roll	3RX9 013-0AA00
			Yellow (AS-Interface)	1-km drum	3RX9 014-0AA00
			Black (24 V DC)	100-m roll	3RX9 023-0AA00
			Black (24 V DC)	1-km drum	3RX9 024-0AA00
	TPE special version according to UL Class 2		Yellow (AS-Interface)	100-m roll	3RX9 017-0AA00
			Black (24 V DC)	100-m roll	3RX9 027-0AA00
	PUR		Yellow (AS-Interface)	100-m roll	3RX9 015-0AA00
			Yellow (AS-Interface)	1-km drum	3RX9 016-0AA00
			Black (24 V DC)	100-m roll	3RX9 025-0AA00
		Black (24 V DC)	1-km drum	3RX9 026-0AA00	

AS-Interface

System components and accessories

Repeater

Overview



AS-Interface repeater

AS-Interface repeaters are used for extending the AS-Interface cable by 100 m per repeater and have the following features:

- Maximum two repeaters in series
- Parallel switching of several repeaters possible (star configuration option)
- Maximum size increase of an AS-Interface network to up to 500 m is thus possible
- Easy mounting
- IP67 module enclosure

Design of an AS-Interface network with repeaters

- Slaves can be used on both sides of the repeater
- AS-Interface power supply is required on both sides
- Electrical separation of the two AS-Interface shaped cable lines
- Installed in K45 module enclosure with mounting plate
- Separate indication of the correct AS-Interface voltage for each side
- Maximum two repeaters in series (max. cable length 300 m)
- Parallel switching of several repeaters possible (star configuration)
- Combination of series and parallel switching possible (max. range 500 m)

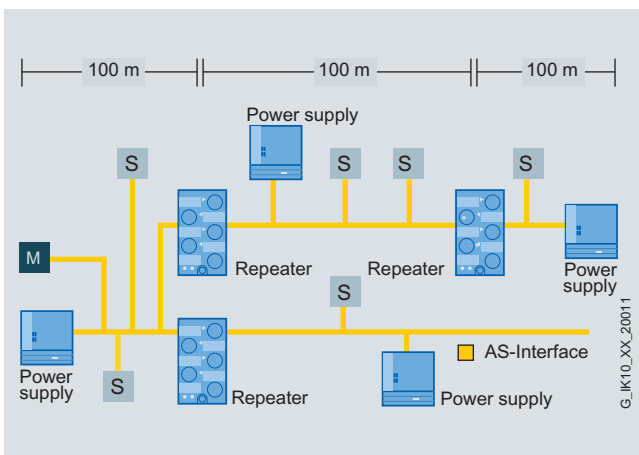

Design of an AS-Interface network with repeaters (example)

Benefits

get **Designed for Industry**

- More possibilities of use and greater freedom for plant planning through extension of the AS-Interface network
- Reduced downtime and servicing times in the event of a fault thanks to separate indication of the correct AS-Interface voltage for each side

Application

The repeater is used to lengthen the AS-Interface segment by 100 m. In this case there are AS-Interface slaves and one AS-Interface power supply on each side of the repeater.

Note:

The AS-Interface repeater is not suitable for AS-i Power24V networks. It is recommended for use in AS-Interface networks with AS-Interface power supply units (e.g. 3RX9 501-0BA00).

Selection and ordering data

Version	Order No.
 Repeaters for AS-Interface For cable extension, including mounting plate	6GK1 210-0SA01

6GK1 210-0SA01

6

AS-Interface

System components and accessories

Extension plug

Overview



AS-Interface extension plug (on AS-Interface M12 feeder)

With the extension plug/extension plug plus it is possible to double the cable length possible in an AS-Interface segment from 100 to 200 m.

The extension plug is a passive component, the extension plug plus is equipped in addition with an A/B slave.

The extension plug / extension plug plus has an M12 plug and can be connected with it to the AS-Interface M12 feeder with degree of protection IP67. Only one power supply unit is needed to supply power to the slaves on the up to 200 m long segment.

Design of an AS-Interface segment with an extension plug

To construct an AS-Interface segment with a cable length of more than 100 m and up to a maximum of 200 m, the extension plug or extension plug plus is installed at that point of the network which in a range of approx. ±10 m is furthest from the AS-Interface power supply unit. The extension plug is not allowed to be used in AS-Interface networks smaller than 100 m. As with all AS-Interface networks, any network structure (line, tree, star) is possible when using the extension plug/extension plug plus. Only one extension plug/extension plug plus is required per 200 m segment even with a tree or star structure.

Note:

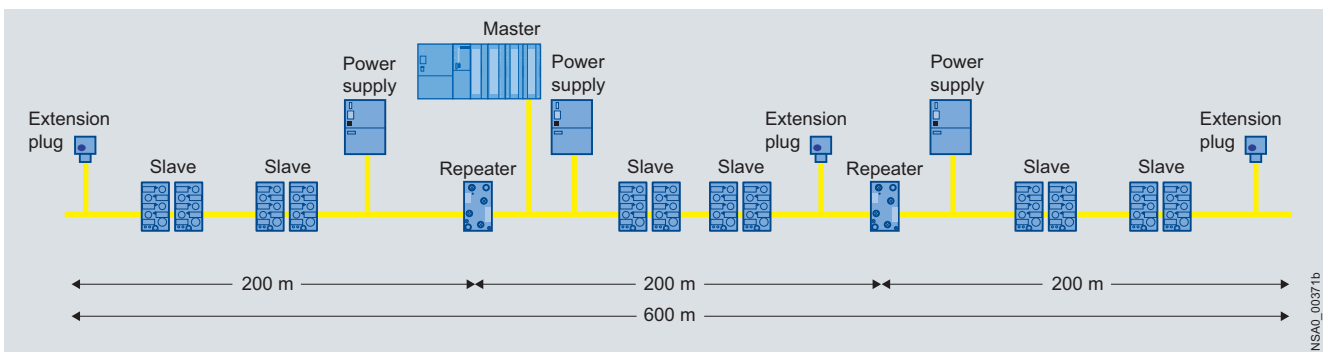

The AS-Interface extension plug and the extension plug plus are not suitable for AS-i Power24V networks. Both are recommended for use in AS-Interface networks with AS-Interface power supply units (e.g. 3RX9 501-0BA00).

6



Maximum network size with repeaters and extension plug (master at center of network)

Selection and ordering data

Version	Order No.
 <p>AS-Interface extension plug ¹⁾</p> <ul style="list-style-type: none"> • Doubling of the cable length to 200 m per AS-Interface segment • Undervoltage monitoring signal by means of diagnostics LED 	3RK1 901-1MX00
<p>AS-Interface extension plug plus ¹⁾</p> <ul style="list-style-type: none"> • Doubling of the cable length to 200 m per AS-Interface segment • Undervoltage monitoring signal through integrated AS-Interface slave to AS-Interface master 	3RK1 901-1MX01
<p>Accessories</p>  <p>AS-Interface M12 feeders</p> <ul style="list-style-type: none"> • For adaptation of shaped AS-Interface cable to a standard round cable • Insulation piercing method for connection of AS-Interface cable • M12 socket for connection of standard round cable • Degree of protection IP67 	3RX9 801-0AA00
 <p>AS-Interface M12 feeders</p> <ul style="list-style-type: none"> • Transition of AS-Interface cable without U_{aux}, with M12 socket • Insulation piercing method for connection of AS-Interface cable • M12 socket for connection of standard round cable • Max. 4A • Degree of protection IP67/IP68/IP69K 	3RK1 901-1NR10

¹⁾ For connection to the AS-Interface flat cable you need the AS-Interface M12 feeder, which must be ordered separately, see section "Accessories".

Overview



New addressing unit V 3.0 for AS-Interface

The addressing unit is used to each AS-Interface slave to assign an address to during commissioning. The device detects a connected slave module or a complete AS-i network and displays the found module in the LCD display. Via the on/down keys each address can be individually set. By turning the rotary switch to the setting are intuitive further commissioning functions selected. The innovative device has been to the current AS-i Specification V3.0 and can now also adapted the I/O data of the latest Slaves operator control.

Function

- Reading out and adjusting the slave address 0 to 31 or 1A to 31A, 1B to 31B, with automatic addressing aid and prevention of double addresses
- Reading out the slave profile (IO, ID, ID2)
- Reading out and adjusting the ID1 code
- Input/output test when commissioning the slaves: Input signals read and outputs write with all digital and analog slaves according to AS-Interface Specification V 3.0, including safe input slaves and complex CTT2 slaves
- Measuring the voltage on the AS-Interface cable (measuring range from 2 to 35 V)
- Indication of the operational current in case of direct connection of an AS-i slave (measuring range from 0 to 150 mA)
- Storage of complete network configurations (profiles of all slaves) to simplify the addressing
- Adjusting the Slave parameters for commissioning
- Reading out the identification and diagnostics of CTT2 slaves
- Reading out the code table of safe input slaves (ASIsafe)

Note:

The following applies to the operation of the addressing units to an AS-Interface cable assembly with connected power pack: The AS-Interface addressing unit is suitable for standard AS-i networks and AS-i Power24V networks (operational voltage on the AS-Interface cable min. 19 V).

Benefits







- Increased supply power to the slaves to 150 mA
- Better utilization of the battery capacity thanks to improved circuitry
- Support for the current AS-i Specification V3.0
- Expanded display for simultaneous displaying input and output states
- Clearly recognizable display of status digital inputs/outputs in binary format (0 / 1), optionally also available as hexadecimal values
- Intuitive display analog data either decimal, hexadecimal or as a percentage (e. g. 100 % Corresponds to input/output value 20 mA)
- I/O data of complex slaves (CTT2 profile) can be displayed
- Decoded display of the input data of safe input slaves, including code table
- Simplification of the operating steps when setting the slave address with automatic read back the set address
- Addressing cable, with even without screwing in tight into the M12 socket ready for operation, this faster availability of the addressing unit
- Proven compact housing with smooth keys and rotary switch
- Connection of standard AS-i networks with 30 V as well as networks is possible Power24V
- Complex slaves with high operating current can be addressed without external supply
- Longer operating time per battery pack
- Can be used with all types of digital and analog slaves
- Comprehensive and fast Input/Output test of plants, even if A/B modules with 4 DI / 4 DO and current analog modules with an A/B address
- Faster and more reliable commissioning of the AS-Interface modules
- One-hand operation possible, with unique selection of the functions
- Universal applicability for all AS-i networks

AS-Interface

System components and accessories

Addressing units

Selection and ordering data

	Version	Order No.
 <p>3RK1 904-2AB02</p>	<p>AS-Interface addressing unit V 3.0</p> <ul style="list-style-type: none"> • For AS-Interface modules and sensors and actuators with integrated AS-Interface in accordance with AS-i Specification V3.0 • For setting the AS-i address of standard slaves, and slaves with extended addressing mode (A/B slaves) • With input/output test function and many other commissioning functions • Battery operation with 4 batteries type AA (IEC LR6, NEDA 15) • Scope of supply: <ul style="list-style-type: none"> - Addressing unit with 4 batteries - Addressing cable, with M12 plug to addressing plug (hollow plug), length 1.5 m 	<p>3RK1 904-2AB02</p>
Accessories		
 <p>3RK1 902-4PB15-3AA0</p>	<p>Addressing cable, with M12 plug to addressing plug (hollow plug) ¹⁾</p> <ul style="list-style-type: none"> • Included in the scope of supply of the addressing unit • Length 1.5 m 	<p>Z236A</p>
 <p>3RK1 902-4PB15-3AA0</p>	<p>Addressing cable, with M12 plug to M12 socket ²⁾</p> <ul style="list-style-type: none"> • For addressing slaves with M12 connection, e.g. K20 or K60R modules or light curtains • Length 1.5 m, 3-pole, 3 x 0.34 mm² 	<p>3RK1 902-4PB15-3AA0</p>
 <p>3RX9 801-0AA00</p>	<p>AS-Interface M12 feeders</p> <ul style="list-style-type: none"> • For adaptation of AS-Interface cable to a standard round cable • Insulation piercing method for connection of AS-Interface cable • M12 socket for connection of standard round cable 	<p>3RX9 801-0AA00</p>
 <p>3RK1 901-1NR10</p>	<p>AS-Interface M12 feeders</p> <ul style="list-style-type: none"> • Transition of AS-Interface cable without U_{aux}, with M12 socket • Insulation piercing method for connection of AS-Interface cable • M12 socket for connection of standard round cable 	<p>3RK1 901-1NR10</p>
 <p>3RK1 902-4HB50-5AA0</p>	<p>Cable plug M12 ³⁾</p> <ul style="list-style-type: none"> • Extruded M12 plug (angled cable feeder 90°), other cable end open • Length: 5 m, 5-pole, color: Black 	<p>3RK1 902-4HB50-5AA0</p>
 <p>3RK1 902-4BA00-5AA0</p>	<p>M12 plug straight ³⁾</p> <ul style="list-style-type: none"> • For screw fixing, 5-pole screw terminal, max. 0.75 mm², • A-coded, max. 4 A 	<p>3RK1 902-4BA00-5AA0</p>

¹⁾ Can be ordered only from the following address:
 GMC-I Messtechnik GmbH
 Südwestpark 15, D-90449 Nuremberg
 Tel. +49 911 8602 - 0, Fax: +49 911 8602 - 669
 Email: info@gossenmetrawatt.com
 Internet: www.gossenmetrawatt.com

²⁾ Not included in scope of supply of the 3RK1 904-2AB02 addressing unit

³⁾ For connecting the addressing unit to an AS-i network via AS-Interface M12 feeder a connecting cable (M12 plug to M12 connector) is produced and requires the following wiring:
 - M12 cable plug Pin 1 / core brown <-> M12 plug: Pin 1
 - M12 cable plug: Pin 3 / core blue <-> M12 plug: Pin 3
 - Pin 2, 4, 5 not connected

Overview



AS-Interface analyzer

The AS-Interface analyzer is used to test AS-Interface networks. It enables systematic troubleshooting and permanent monitoring.

Installation errors, e. g. loose contacts or EMC interference under extreme loads, can be revealed by this device.

Thanks to the easy-to-use software the user can assess the quality of complete networks even if he lacks detailed specialist knowledge of AS-Interface. In addition it is an easy matter with the AS-Interface analyzer to create test logs from the records produced, thus providing documentation for start-ups and service assignments.

For advanced AS-Interface users there are trigger functions for detailed diagnostics.

Connection

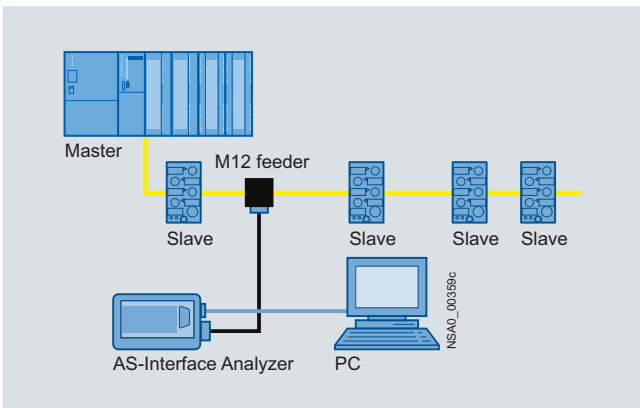

The AS-Interface analyzer follows the communication on the AS-Interface network as a passive station. The unit is supplied simultaneously from the AS-Interface cable.

This analyzer interprets the physical signals on the AS-Interface network and records the communication.

The data thus obtained are transferred through an RS 232 interface to a PC such as a notebook, for evaluation with the supplied diagnostics software.

Benefits

- Simple and user-friendly operation enables diagnostics of AS-Interface networks without help from specialists
- Speedy troubleshooting thanks to intuitive display in statistics mode
- Test logs provide verification of the state and quality of the installation for service and approval
- Recorded logs facilitate remote diagnostics by technical assistance
- Comprehensive trigger functions enable exact analysis
- Process data can be monitored online

Application

Online statistics

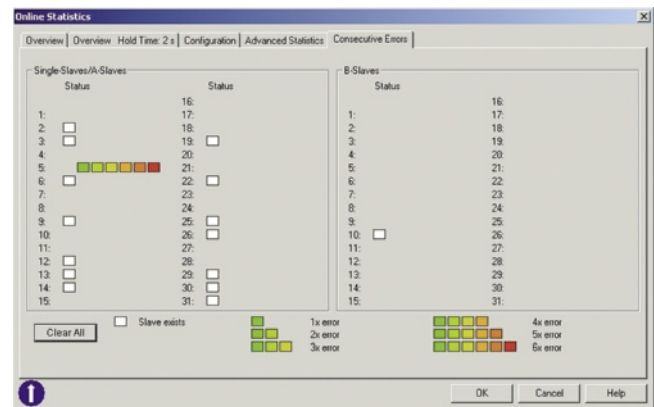
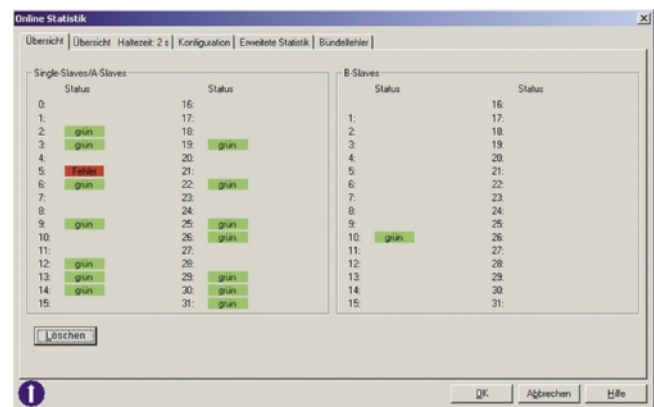

This mode provides a quick overview of the existing AS-Interface system. The error rates are presented per slave in a traffic-light function (green, yellow, red).

The bus configuration and the currently transmitted data of the slaves are shown in a well arranged presentation.

With the expanded statistics function it is possible to determine the error rates as the number of transmitted or faulty bus message frames.

The bundle error overview shows in steps how many multiple repetitions of message frames occurred in order to enable a selective and look-ahead assessment of the transmission quality.

AS-Interface

System components and accessories

Analyzer

Application (continued)

Data mode

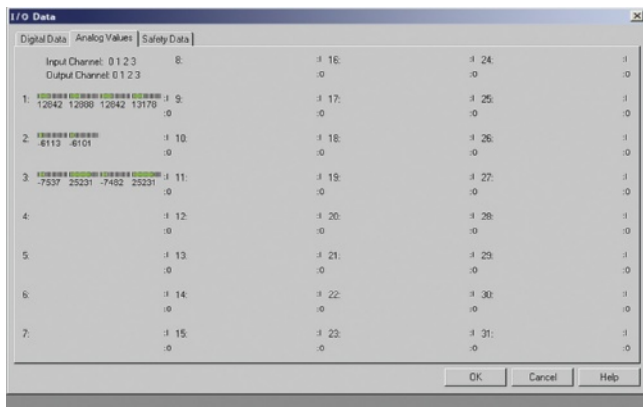
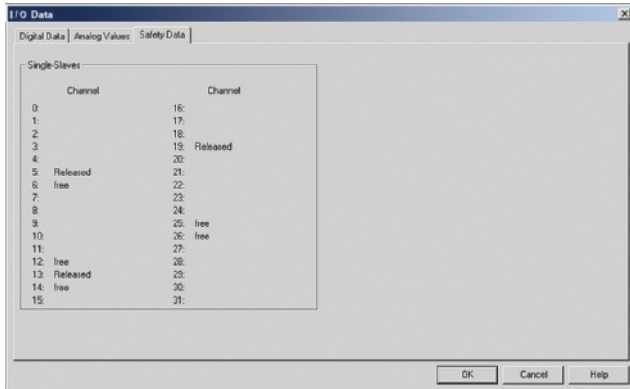

6

In this mode the analyzer now shows not only the digital input/output values but also the current analog values and the input status of the safety slaves.

Trace mode

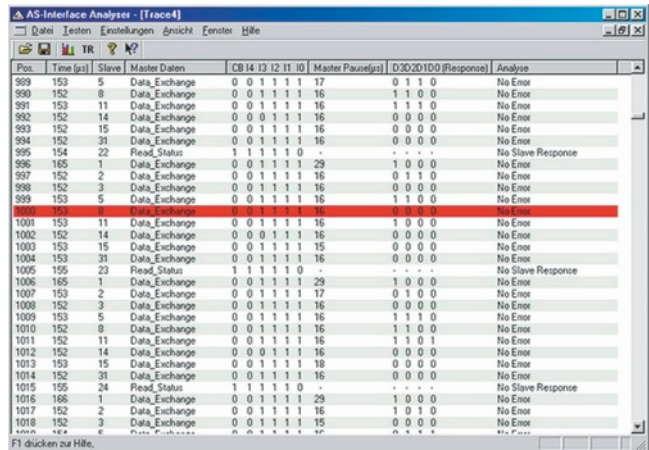

The presentation of message frames in the style of a classic field bus analyzer is indispensable for complex troubleshooting. Extensive trigger functions and recording and viewing filters are available for this purpose.

An external trigger input and trigger output round off the scope of functions in order to find even the most difficult errors.

For troubleshooting in connection with safety monitor applications, changes of status in the code tables of safety slaves are identified and assessed.

Test log







The recorded data of the online statistics are easy to output and document using a test log. Verification of the state of the plant can thus be provided for approvals or service assignments.

The new measurement assistant records the bus signals for an adjustable period, automating the creation of the test log. A standardized quality test of AS-i plants is thus possible.

Note:

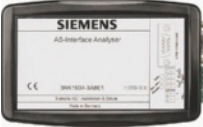
The AS-Interface Analyzer is suitable for standard AS-i networks and AS-i Power24V networks (operating voltage min. 20 V).

Selection and ordering data







Version		Order No.
 <p>3RK1 904-3AB01</p>	<p>AS-Interface analyzers</p> <ul style="list-style-type: none"> • For testing actuator/sensor interface systems • For service assignments in installations and networks with AS-Interface systems • Dimensions (W x H x D): 145 x 30 x 92 mm • Scope of supply: <ul style="list-style-type: none"> - AS-Interface analyzers - RS 232 cable for connecting to PC - USB/serial adapter / RS 232 adapter - Screwdriver - Magnetic adhesive tape for fastening the analyzer to metal surfaces - Service case with foam insert, dimensions (W x H x D / mm): approx. 260 x 70 x 200 - Diagnostics software (CD-ROM) for PC (Windows 95/98, ME, 2000, NT, XP, Vista Home Basic, Home Premium, Business, Ultimate, Windows 7) 	<p>3RK1 904-3AB01</p>
Accessories		
	<p>USB/serial adapters</p> <ul style="list-style-type: none"> • For connection to a USB port of a PC • USB/serial adapter included in scope of supply of the 3RK1 904-3AB01 analyzer 	<p>3UF7 946-0AA00-0</p>
 <p>3RX9 801-0AA00</p>	<p>AS-Interface M12 feeders</p> <ul style="list-style-type: none"> • For adaptation of shaped AS-Interface cable to a standard round cable • Insulation piercing method for connection of AS-Interface cable • M12 socket for connection of standard round cable • Degree of protection IP67 	<p>3RX9 801-0AA00</p>
 <p>3RK1 901-1NR10</p>	<p>AS-Interface M12 feeders</p> <ul style="list-style-type: none"> • Transition of AS-Interface cable without U_{aux}, with M12 socket • Insulation piercing method for connection of AS-Interface cable • M12 socket for connection of standard round cable • Max. 4A • Degree of protection IP67/IP68/IP69K 	<p>3RK1 901-1NR10</p>
 <p>3RK1 902-4HB50-5AA0</p>	<p>M12 cable plugs</p> <ul style="list-style-type: none"> • Cable: PUR, 5-pole • Length: 5 m • Color: Black • Extruded M12 plug (angled cable feeder 90°), other cable end open 	<p>3RK1 902-4HB50-5AA0</p>

AS-Interface

System components and accessories

Miscellaneous accessories



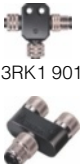







Selection and ordering data

Version	Order No.																																			
 <p>AS-Interface system manual Technical information and overview of the AS-Interface product range from Siemens, scope: approx. 600 pages</p> <ul style="list-style-type: none"> • German edition, paper version (black&white print) ¹⁾ • English edition, paper version (black&white print) ²⁾ 	<p>3RK2 703-3AB02-1AA1</p> <p>3RK2 703-3BB02-1AA1</p>																																			
 <p>AS-Interface compact distributors, for AS-Interface flat cable</p> <ul style="list-style-type: none"> • Current carrying capacity up to 8 A • Degree of protection IP67/IP68/IP69K 	3RK1 901-1NN10																																			
 <p>AS-Interface M12 feeders</p> <ul style="list-style-type: none"> • Degree of protection IP67 <table border="1"> <thead> <tr> <th>For flat cable</th> <th>For</th> <th>Cable length</th> <th>Cable end in feeder</th> <th></th> </tr> </thead> <tbody> <tr> <td>AS-i</td> <td>M12 socket</td> <td>--</td> <td>Available</td> <td>3RX9 801-0AA00</td> </tr> </tbody> </table>	For flat cable	For	Cable length	Cable end in feeder		AS-i	M12 socket	--	Available	3RX9 801-0AA00																										
For flat cable	For	Cable length	Cable end in feeder																																	
AS-i	M12 socket	--	Available	3RX9 801-0AA00																																
 <p>AS-Interface M12 feeders</p> <ul style="list-style-type: none"> • Degree of protection IP67/IP68/IP69K <table border="1"> <thead> <tr> <th>For flat cable</th> <th>For</th> <th>Cable length</th> <th>Cable end in feeder</th> <th></th> </tr> </thead> <tbody> <tr> <td>AS-i</td> <td>M12 socket</td> <td>--</td> <td>Not available</td> <td>3RK1 901-1NR10</td> </tr> <tr> <td>AS-i</td> <td>M12 cable box</td> <td>1 m</td> <td>Not available</td> <td>3RK1 901-1NR11</td> </tr> <tr> <td>AS-i</td> <td>M12 cable box</td> <td>2 m</td> <td>Not available</td> <td>3RK1 901-1NR12</td> </tr> <tr> <td>AS-i / U_{aux}</td> <td>M12 socket</td> <td>--</td> <td>Not available</td> <td>3RK1 901-1NR20</td> </tr> <tr> <td>AS-i / U_{aux}</td> <td>M12 cable box</td> <td>1 m</td> <td>Not available</td> <td>3RK1 901-1NR21</td> </tr> <tr> <td>AS-i / U_{aux}</td> <td>M12 cable box</td> <td>2 m</td> <td>Not available</td> <td>3RK1 901-1NR22</td> </tr> </tbody> </table>	For flat cable	For	Cable length	Cable end in feeder		AS-i	M12 socket	--	Not available	3RK1 901-1NR10	AS-i	M12 cable box	1 m	Not available	3RK1 901-1NR11	AS-i	M12 cable box	2 m	Not available	3RK1 901-1NR12	AS-i / U _{aux}	M12 socket	--	Not available	3RK1 901-1NR20	AS-i / U _{aux}	M12 cable box	1 m	Not available	3RK1 901-1NR21	AS-i / U _{aux}	M12 cable box	2 m	Not available	3RK1 901-1NR22	
For flat cable	For	Cable length	Cable end in feeder																																	
AS-i	M12 socket	--	Not available	3RK1 901-1NR10																																
AS-i	M12 cable box	1 m	Not available	3RK1 901-1NR11																																
AS-i	M12 cable box	2 m	Not available	3RK1 901-1NR12																																
AS-i / U _{aux}	M12 socket	--	Not available	3RK1 901-1NR20																																
AS-i / U _{aux}	M12 cable box	1 m	Not available	3RK1 901-1NR21																																
AS-i / U _{aux}	M12 cable box	2 m	Not available	3RK1 901-1NR22																																
 <p>AS-Interface M12 feeders, 4-fold</p> <p>Degree of protection IP67</p> <table border="1"> <thead> <tr> <th>For flat cable</th> <th>For</th> <th>Cable length</th> <th>Cable end in feeder</th> <th></th> </tr> </thead> <tbody> <tr> <td>AS-i / U_{aux}</td> <td>4-fold M12 socket delivery includes coupling module</td> <td>--</td> <td>Not available</td> <td>3RK1 901-1NR04</td> </tr> </tbody> </table>	For flat cable	For	Cable length	Cable end in feeder		AS-i / U _{aux}	4-fold M12 socket delivery includes coupling module	--	Not available	3RK1 901-1NR04																										
For flat cable	For	Cable length	Cable end in feeder																																	
AS-i / U _{aux}	4-fold M12 socket delivery includes coupling module	--	Not available	3RK1 901-1NR04																																
 <p>M12-T distributors</p> <ul style="list-style-type: none"> • IP68 • 1 x M12 plug • 2 x M12 box 	3RK1 901-1TR00																																			
 <p>M12 Y-shaped coupler plugs</p> <p>For connection of two sensors to one M12 socket with Y connector</p>	6ES7 194-1KA01-0XA0																																			

¹⁾ Free-of-charge download from the Internet at <http://support.automation.siemens.com/WWW/view/en/26250840>

²⁾ Free-of-charge download from the Internet at <http://support.automation.siemens.com/WWW/view/en/26250840>

Selection and ordering data (continued)







	Version	Order No.
 3RK1 901-1KA00	AS-Interface sealing caps M12 For free M12 sockets	3RK1 901-1KA00
 3RK1 901-1KA01	AS-Interface sealing caps M12, tamper-proof For free M12 sockets	3RK1 901-1KA01
 3RK1 901-1PN00	AS-Interface sealing caps M8 For free M8 sockets	3RK1 901-1PN00
 3RK1 901-1MD00	AS-Interface seals M20 <ul style="list-style-type: none"> • For AS-Interface cable, shaped • For insertion in M20 glands 	3RK1 901-1MD00
 3RK1 901-3QM00	Cable adapters for flat cables Connection of AS-Interface cable to metric gland with insulation piercing method <ul style="list-style-type: none"> • Continuation using standard cable <ul style="list-style-type: none"> - For M16 gland - For M20 gland • Continuation using pins <ul style="list-style-type: none"> - For M16 gland - For M20 gland 	3RK1 901-3QM00 3RK1 901-3QM10 3RK1 901-3QM01 3RK1 901-3QM11
 3RK1 901-3QA00	Cable clips for cable adapters	3RK1 901-3QA00
 3RK1 901-1MN00	Cable terminating pieces For sealing of open cable ends (shaped AS-Interface cable) in IP67	3RK1 901-1MN00
 3RK1 901-2EA00	K45 mounting plates <ul style="list-style-type: none"> • For wall mounting • For standard rail mounting 	3RK1 901-2EA00 3RK1 901-2DA00
 3RK1 901-0CA00	K60 mounting plates Suitable for all K60 compact modules <ul style="list-style-type: none"> • For wall mounting • For standard rail mounting 	3RK1 901-0CA00 3RK1 901-0CB01
 3RK1 902-0AR00	Sealing sets <ul style="list-style-type: none"> • For K60 mounting plate and standard distributor • Cannot be used for K45 mounting plate • One set contains one straight and one shaped seal 	3RK1 902-0AR00
	Inscription labels <ul style="list-style-type: none"> • For K45 and K60 compact modules • 20 x 9 mm, pastel turquoise • 19 frames with 20 labels each 	3RT1 900-1SB50

AS-Interface

System components and accessories

Miscellaneous accessories

Selection and ordering data (continued)

	Version	Order No.
 <p>3RK1 902-4GB50-4AA0</p>	<p>Control cables, assembled at one end Angular M12 socket for screw fixing, 4-pole, 4 x 0.34 mm² A-coded, black PUR sheath, max. 4 A</p> <ul style="list-style-type: none"> • Cable length 5 m 	<p>3RK1 902-4GB50-4AA0</p>
 <p>3RK1 902-4CA00-4AA0</p>	<p>Angular M12 socket for screw fixing, 4-pole screw terminals, max. 0.75 mm², A-coded, max. 4 A</p>	<p>3RK1 902-4CA00-4AA0</p>
 <p>3RK1 902-4BA00-5AA0</p>	<p>M12 plugs For screw fixing, 5-pole screw terminals, max. 0.75 mm², A-coded, max. 4 A</p>	<p>3RK1 902-4BA00-5AA0</p>
 <p>3RK1 902-4DA00-5AA0</p>	<p>M12 plugs, angled For screw fixing, 5-pole screw terminals, max. 0.75 mm², A-coded, max. 4 A</p>	<p>3RK1 902-4DA00-5AA0</p>
 <p>3RK1 902-4H...-5AA0</p>	<p>Control cables, assembled at one end M12 plugs, angled, for screw fixing, 5-pole, 5 x 0.34 mm², A-coded, black PUR sheath, max. 4 A</p> <ul style="list-style-type: none"> • Cable length 1.5 m • Cable length 5 m • Cable length 10 m 	<p>3RK1 902-4HB15-5AA0 3RK1 902-4HB50-5AA0 3RK1 902-4HC01-5AA0</p>
 <p>3RK1 902-4PB15-3AA0</p>	<p>Control cable, assembled at both ends Straight M12 plug, straight M12 socket, for screw fixing, 3-pole, 3 x 0.34 mm², A-coded, black PUR sheath, max. 4 A</p> <ul style="list-style-type: none"> • Cable length 1.5 m • Also for addressing AS-i slaves with M12 bus connection (e.g. K20, K60R compact modules, M200D motor starters) 	<p>3RK1 902-4PB15-3AA0</p>

Overview

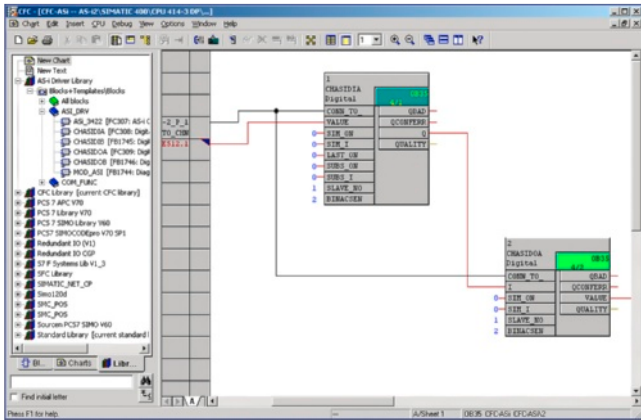

AS-Interface function block library for SIMATIC PCS 7: User interface

The AS-Interface function block library for PCS 7 is integrated in the SIMATIC PCS 7 process control system and expands it for integration of the AS-Interface system.

As the result, the advantages of AS-Interface such as the considerable reduction of wiring outlay for distributed actuators/sensors and very simple installation can also be used in a system based on PCS 7.

The library contains modules for accessing the I/O data of AS-i slaves, modules for diagnostics of the AS-i system, and a faceplate for the PCS 7 Maintenance Station.

The AS-i CP 343-2 / CP 343-2P masters are supported within an ET 200M station connected through PROFIBUS.

For direct connection to PROFIBUS it is possible to use DP/AS-i Link Advanced as an AS-i single master and double master.

Digital AS-i standard slaves and A/B slaves (according to AS-Interface Specification V 3.0) can be used on the CP 343-2 and CP 343-2P.

In combination with DP/AS-i LINK Advanced it is also possible to integrate analog AS-i slaves.

Hardware and software requirements

The library requires PCS 7 Version V 6.1, V 7.0 or V 7.1

Types of delivery and license

The function block library supplied on CD-ROM allows the user to run the required engineering software on the engineering station (single license) including the runtime software for executing the AS modules in an automation system (single license).

If the AS modules are to be used in additional automation systems, the corresponding number of runtime licenses are required which are supplied without a data carrier.

Selection and ordering data

Version	Order No.
AS-Interface function block library for PCS 7	
 <p>Scope of supply AS modules and faceplates for integrating AS-Interface into the PCS 7 process control system, for PCS 7 version V 6.1 V 7.0 or V 7.1</p> <p>Engineering software For one engineering station (single license) including runtime software for execution of the AS module in an automation system (single license), German/English/French, type of delivery: CD incl. electronic documentation</p> <p>Runtime software For execution of the AS module in an automation system (single license), type of delivery: License without software and documentation</p>	<p>3ZS1 635-1XX01-0YA0</p> <p>3ZS1 635-2XX01-0YB0</p>

3ZS1 635-1XX01-0YA0

AS-Interface

Notes

6

IO-Link



7/2	Introduction
7/2	Transmission technology
7/3	Communication overview
7/4	Masters
7/4	IO-Link master module for ET 200S
	IO-Link 4SI electronic module
7/5	4SI SIRIUS electronic module
7/6	IO-Link master module for ET 200eco PN
7/7	Input modules
7/7	General data
7/8	IO-Link K20 modules
7/9	Contactors and contactor assemblies
7/9	SIRIUS 3RT20 contactors, 3-pole, 3 ... 18.5 kW
7/11	SIRIUS 3RA23 reversing contactor assemblies
7/13	SIRIUS 3RA24 contactor assemblies for wye-delta starting
7/15	SIRIUS 3RA27 function modules for IO-Link
7/17	SIRIUS 3RB2 electronic overload relays
7/17	3RB24 for IO-Link, up to 630 A for high-feature applications
7/22	Accessories for 3RB24
7/24	SIRIUS 3RA6 compact feeders
7/24	SIRIUS 3RA64, 3RA65 compact feeders for IO-Link
7/26	Accessories for compact feeders for IO-Link
7/27	SIRIUS 3UG48 monitoring relays for stand-alone installation for IO-Link
7/27	General data
7/29	Line monitoring
7/31	Voltage monitoring
7/32	Current monitoring
7/33	Power factor and active current monitoring
7/35	Speed monitoring
7/37	Accessories
7/38	SIRIUS 3RS14, 3RS15 temperature monitoring relays for IO-Link
7/38	General data
7/40	Relay, digitally configurable for 1 sensor
7/42	Relay, digitally configurable for up to 3 sensors
7/44	Accessories

IO-Link Introduction

Transmission technology

Overview

IO-Link is a new communication standard for sensors and actuators - defined by the Profibus User Organization (PNO). IO-Link technology is based on the point-to-point connection of sensors and actuators to the control system.

Extensive parameter and diagnostics data are transmitted in addition to the cyclic operating data for the connected sensor/actuators. The simple, unshielded three-wire cable customary for standard sensors is used for this purpose.

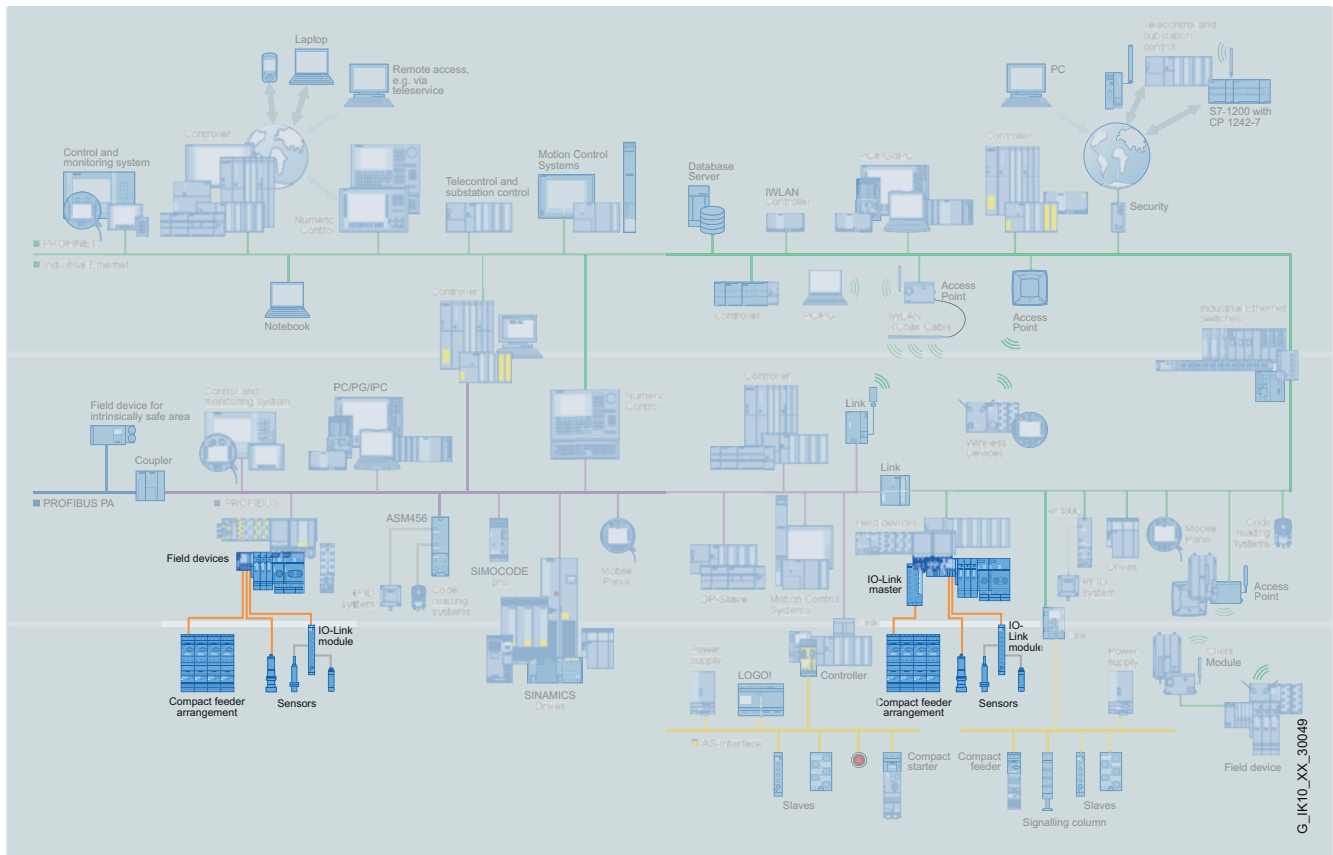

Compatibility of IO-Link

IO-Link guarantees compatibility between IO-Link-capable modules and standard modules as follows:

- IO-Link sensors can be operated both on IO-Link modules (master) and standard input modules.
- IO-Link sensors/actuators as well as today's standard sensors/actuators can be used on IO-Link masters.
- If conventional components are used in the IO-Link system, then of course only the standard functions are available at this point.

Enhanced through IO-Link input modules

IO-Link compatibility also permits connection of standard sensors/actuators, i. e. conventional sensors/actuators can also be connected to IO-Link. This is particularly effective with the IO-Link input modules, which allow several sensors to be connected at one time via a cable to the controller.

Analog signals

Another advantage of IO-Link technology is that analog signals are digitized already in the IO-Link sensor itself and are digitally transmitted by the IO-Link communication. As the result, faults are prevented and there is no extra cost for cable shielding.

Load Feeders and Motor Starters

Through IO-Link it is possible control not only sensors but also actuators in the form of load feeders and motor starters.

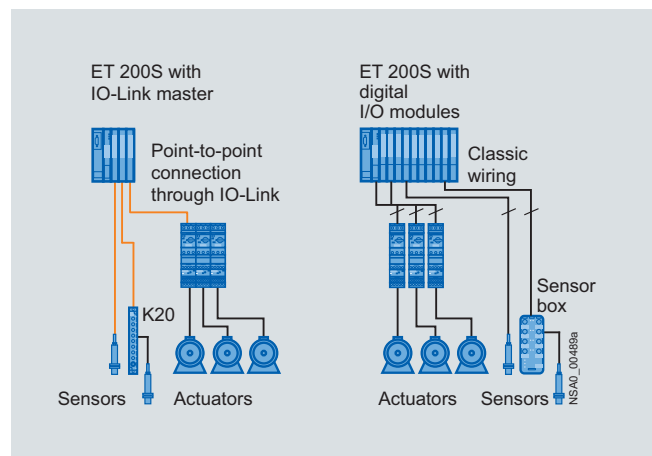

Possibilities for connecting load feeders and motor starters to IO-Link or in the conventional way

Overview



IO-Link product family

Benefits

The IO-Link system offers decisive advantages for connecting complex (intelligent) sensors/actuators:

- Dynamic changing of sensor/actuator parameters directly by the PLC
- Consistent storage of parameters enables devices to be exchanged during operation, without a PC or programming device, through re-parameterization from the PLC
- Fast commissioning thanks to central data storage
- Consistent diagnostics information as far as the sensor/actuator level
- Uniform and greatly reduced wiring of different sensors/actuators/controls
- Integrated communication: Transmission of process data and service data between sensors/actuators and the control system
- Uniform and transparent configuring and programming through use of a parameterization tool integrated in SIMATIC STEP 7 (Port Configurator Tool, PCT)
- Transparent representation of all parameter and diagnostics data

Application

IO-Link can be used in the following main applications:

- Easy connection of complex IO-Link sensors/actuators with a large number of parameters and diagnostic data to the control system
- Replacement of sensor boxes for connecting binary sensors with the IO-Link input modules optimized in terms of cabling
- Wiring-optimized connection of controls to the control system

In these cases, all the diagnostics data are transmitted to the higher-level control system through IO-Link. The parameter settings can be changed during operation. Central data storage means that it is possible to exchange an IO-Link sensor/actuator without a PC or programming device.

Integration in STEP 7

Integration of the device configuration in the STEP 7 environment guarantees:

- Easy and quick engineering
- Consistent data storage
- Speedy locating and rectifying of faults

IO-Link components

IO-Link masters



IO-Link 4SI electronic module

Masters

IO-Link master modules for ET 200S

- IO-Link 4SI electronic module
- SIRIUS 4SI electronic modules

IO-Link master modules for ET 200eco PN

IO-Link devices



IO-Link K20 modules with four inputs

Input modules

IO-Link K20 modules

- IO-Link general input modules
- IO-Link K20 modules

Industrial Controls

Switching devices

Power contactors for switching motors

- SIRIUS 3RT2 contactors, 3-pole, up to 18.5 kW

Contactors assemblies

- SIRIUS 3RA23 reversing contactor assemblies
- SIRIUS 3RA24 contactor assemblies for wye-delta starting

SIRIUS 3RA27 function module for IO-Link

- For direct-on-line starters
- For reversing starters
- For wye-delta starters

Motor starters for operation in the control cabinet

SIRIUS 3RA6 compact feeders

- 3RA64 direct-on-line starters
- 3RA65 reversing starters
- Infeed system for 3RA6

Overload relays

SIRIUS 3RB24 electronic overload relays

- Evaluation module
- Current measuring modules from 0.3 to 630 A
- Controlling direct, reversing and star-delta starters via IO-Link in conjunction with contactors
- Full motor protection
- Diagnostics and current value transmission via IO-Link

Monitoring Relays

SIRIUS 3UG48 monitoring relays

- Monitoring voltage, current, power, speed or $\cos\phi$ according to device design
- On/tripping delay time can be adjusted
- Can be digitally configured on the device and via IO-Link

Temperature monitoring relays

SIRIUS 3RS14, 3RS15

- Temperature monitoring with connected sensors
- Two limit values, can be adjusted separately
- Can be digitally configured on the device and via IO-Link



SIRIUS 3RA27 11 function module for IO-Link



Direct-on-line starter SIRIUS 3RA64



Overload relay SIRIUS 3RB24



Monitoring relay SIRIUS 3UG48



Temperature monitoring relay SIRIUS 3RS14, 3RS15

IO-Link Masters

IO-Link master module for ET 200S IO-Link 4SI electronic module

Overview



IO-Link 4SI electronic module for ET 200S

The 4SI IO-Link electronic module is an IO-Link master and enables easy integration of sensors and actuators from different manufacturers in the SIMATIC ET 200S multifunctional, distributed I/O system at a total of four ports.

Features



- Up to 4 IO-Link devices (3-wire connections) can be connected to each IO-Link master module.
- Up to 4 standard sensors (2-wire/3-wire connection) can be connected.
- The 4SI IO-Link electronic module has a width of 15 mm and can be used with the following universal terminal modules:
 - TM-E15S26-A1 (screw terminals)
 - TM-E15C26-A1 (spring-type terminals)
 - TM-E15N26-A1 (Fast Connect)
- Supports firmware update (STEP 7 V5.4 SP4 and higher).

Selection and ordering data

	Version	Connection	Order No.
	IO-Link 4SI electronic module	Screw terminals, spring-type terminals or Fast Connect	6ES7 138-4GA50-0AB0

6ES7 138-4GA50-0AB0

Accessories

	Version	Connection	Order No.
	Universal terminal module for ET 200S		
	• TM-E15S26-A1	Screw terminals	 6ES7 193-4CA40-0AA0
	• TM-E15C26-A1	Spring-type terminals	 6ES7 193-4CA50-0AA0
	• TM-E15N26-A1	Fast Connect	 6ES7 193-4CA80-0AA0

More information

The product manual "ET 200S for IO-Link 4SI electronic modules" is available on the Internet at <http://support.automation.siemens.com/WW/view/en/29825814>

Further information and technical specifications can be found in the catalog ST 70 and in the Industry Mall at www.siemens.com/industrymall

"Automation technology" --> "Industrial communication" --> "IO-Link" --> "Master" --> "IO-Link Master module for ET 200S".

Overview



4SI SIRIUS electronic module for ET 200S

The 4SI SIRIUS electronic module allows the simple and cost-effective connection of SIRIUS devices with the IO-Link to the multi-functional, decentralize peripheral system SIMATIC ET 200S at a total of four ports.

Features



- Up to 4 SIRIUS devices can be connected on to the 4 ports of the 4SI SIRIUS.
3RA6 compact feeders or load feeders with 3RA27 function modules can even be bundled in groups of 4 devices on one IO-Link port.
It is possible therefore to connect up to 16 load feeders to the control system at one IO-Link master module.
- The 4SI SIRIUS electronic module has a width of 15 mm and can be used with the following universal terminal modules:
 - TM-E15S26-A1 (screw terminals)
 - TM-E15C26-A1 (spring-type terminals)
 - TM-E15N26-A1 (Fast Connect)
- Supports firmware update (STEP 7 V5.4 SP5 and higher)

Selection and ordering data

	Version	Connection	Order No.
	4SI SIRIUS electronic module	Screw terminals, spring-type terminals or Fast Connect	3RK1 005-0LB00-0AA0

3RK1 005-00LB00-0AA0

Accessories

	Version	Connection	Order No.
	Universal terminal module for ET 200S		
	• TM-E15S26-A1	Screw terminals	 6ES7 193-4CA40-0AA0
	• TM-E15C26-A1	Spring-type terminals	 6ES7 193-4CA50-0AA0
	• TM-E15N26-A1	Fast Connect	 6ES7 193-4CA80-0AA0
	Product manual ET 200S for electronic module 4SI SIRIUS		
	• German		3ZX1012-0LB00-0AA0

More information

The product manual for the electronic module 4SI SIRIUS is also available at <http://support.automation.siemens.com/WW/view/en/37856470>

Further information and technical specifications can be found in the Industry Mall at "Automation technology" --> "Industrial communication" --> "IO-Link" --> "Master" --> "IO-Link Master module for ET 200S".

IO-Link Masters

IO-Link master module for ET 200eco PN

Overview

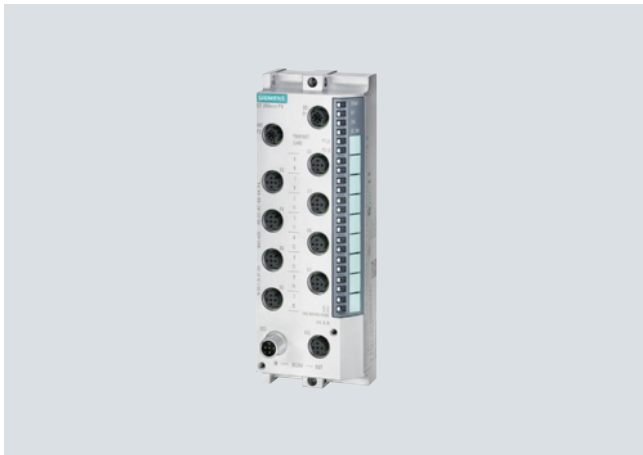

IO-Link master module for ET 200eco PN

The IO-Link master module ET 200eco PN belongs to the compact block I/O family ET 200eco PN.

Features

- Compact block I/Os for processing digital and IO-Link signals for connecting to the PROFINET bus system
- Construction without control cabinet, degree of protection IP67 with M12 connection method
- Very robust and resistant metal casing and enclosure
- Compact module in 60 mm x 175 mm x 37 mm casing (W x H x D, short and thick enclosure) with 8 x M12 for digital signals and IO-Link
- PROFINET connection: 2 x M12 and automatic PROFINET addressing
- Data transmission rate 100 MBit/s
- LLDP proximity detection without PG
- Supply and load voltage connection: 2 x M12
- Channel-specific diagnosis

Selection and ordering data

	Version	Connection	Order No.
	IO-Link master module for ET 200eco PN Block I/Os in IP65	M12	6ES7 148-6JA00-0AB0
	Accessories		See catalog ST 70 and Industry Mall at www.siemens.com/industrymall

6ES7 148-6JA00-0AB0

More information

The product manual for the distributed I/Os ET 200eco PN is available at <http://support.automation.siemens.com/WW/view/en/29999018>

Further information and technical specifications can be found in the catalog ST 70 and in the Industry Mall at "Automation technology" --> "Industrial communication" --> "IO-Link" --> "Master" --> "IO-Link Master module for ET 200eco PN".

Overview

IO-Link input modules

Using IO-Link technology it is basically possible to connect standard sensors to IO-Link masters. Such a direct connection of standard sensors to the IO-Link master does not, however, maximize the potential of IO-Link. The IO-Link Module technology provides the solution. Its use is a more economically attractive solution in comparison with the direct connection of a sensor.

IO-Link input modules are a sensible addition to the decentralize periphery ET 200S. The IO-Link input module technology enhances IO-Link via a pure point-to-point cable connection towards decentralized structures. The length of the cables for an IO-Link connection between an IO-Link module and IO-Link master can be a maximum of 20m. The use of sensor boxes with accordingly complex and error-prone wiring is no longer necessary.

Transmission of parameter and diagnostic signals

The IO-Link input modules also offer the possibility of conveying parameters and diagnosis messages. This enables for example the inputs of modules to be parameterized as NC contacts or NO contacts through IO-Link. An overload or short circuit in the sensor supply is signaled to the control system through the IO-Link master.

M8 and M12 terminals

M8 and M12 terminals are available for connecting the sensors. Connection to the IO-Link master is made using a standard M12 connecting cable.

Benefits

The use of IO-Link input modules has the following benefits:

- Economical use of innovative IO-Link technology also for binary sensors
- Optimum use of all ports of the IO-Link master
- Connection of several binary sensors/actuators to one port of the IO-Link master, hence low-cost connection of also binary sensors/actuators to the control system through IO-Link
- Reduction of digital input modules in the peripheral station
- Use of parameters also for binary sensors (e. g. NC contacts, NO contacts and input delay can be parameterized)
- Reduction of cabling and hence less risk of wiring errors by dispensing with sensor boxes
- Expansion toward distributed structures using pure point-to-point wiring
- Easy and elegant integration of sensors within a radius of 20 m around an ET 200S station
- Possibility of transmitting parameter and diagnostic signals (e. g. sensor supply overload)
- Can also be used in harsh conditions thanks to the very compact design and degree of protection IP67

Application

IO-Link input modules are particularly used where sensor boxes had previously been used for the connection of binary sensors.

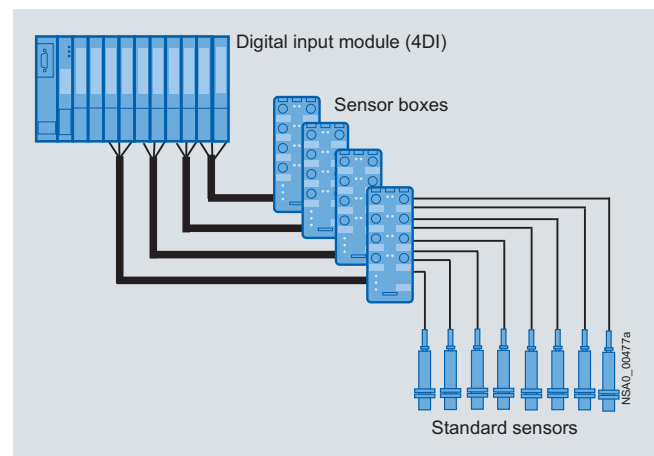

Previous technology with sensor boxes

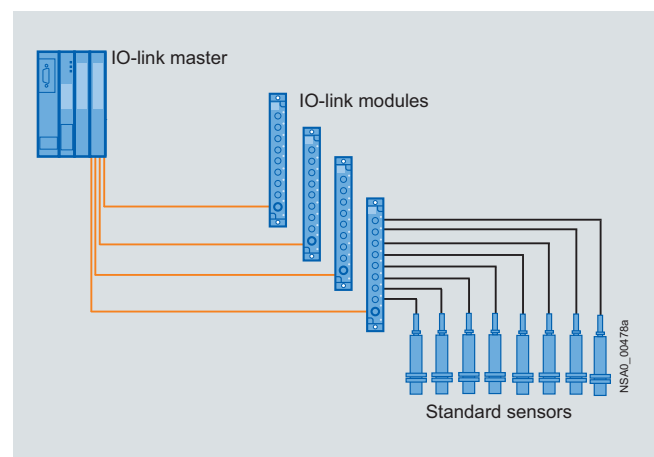



Technology with IO-Link input modules



IO-Link Input modules

IO-Link K20 modules

Selection and ordering data

	Type	Pin assignment	Connection methods	Order No.
 3RK5 010-0BA10-0AA0	IO-Link K20 modules			3RK5 010-0BA10-0AA0 3RK5 010-0CA00-0AA0
	• 4 inputs	Y	M12	
 3RK5 010-0CA00-0AA0	• 8 inputs	Standard	M8	

Accessories

	Version	Order No.
 3RK1 901-1KA00	M12 sealing caps For free M12 sockets	3RK1 901-1KA00
 3RK1 901-1PN00	M8 sealing caps For free M8 sockets	3RK1 901-1PN00

More information

Further information and technical specifications can be found in the Industry Mall at "Automation technology" --> "Industrial communication" --> "IO-Link" --> "Input modules" --> "IO-Link module K20".

Overview

Contactors with communication interface, sizes S00 and S0

Contactor versions with a communication interface are required for the connection to the controller via IO-Link or AS-Interface. The connection is made via function modules, which are mounted on to the front side of the contactors.

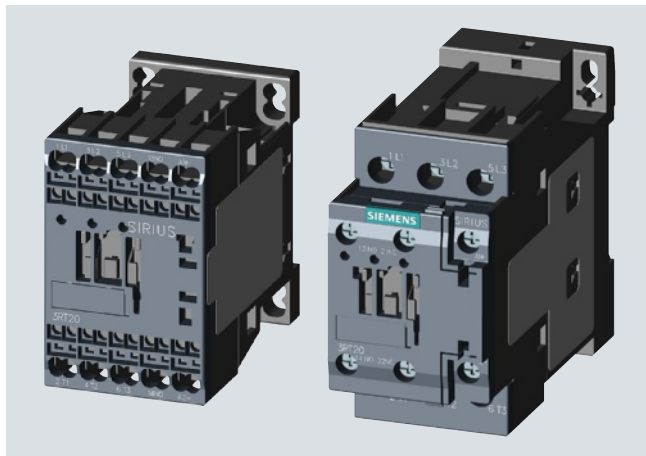

Contactors with communication interface in size S00 with spring-type terminals and size S0 with screw terminals

Standards

IEC 60947-1, EN 60947-1,
IEC 60947-4-1, EN 60947-4-1,
IEC 60947-5-1, EN 60947-5-1 (auxiliary switches)

The 3RT20 contactors for switching motors are climate-proof and are tested and suitable for use worldwide.

If the devices are used in ambient conditions which deviate from common industrial conditions (IEC 60721-3-3 "Stationary Use, Weather-Protected"), information must be obtained about possible restrictions with regard to the reliability and endurance of the device and possible protective measures. In this case contact our Technical Assistance.

The 3RT2 contactors are finger-safe according to EN 50274.

The contactors are suitable for screw fixing or for mounting on TH 35 standard mounting rails according to IEC 60715.

Contact reliability

If voltages ≤ 110 V and currents ≤ 100 mA are to be switched, the auxiliary contacts of the 3RT2 contactor or 3RH21 contactor relay should be used as they guarantee a high level of contact reliability.

These auxiliary contacts are suitable for solid-state circuits with currents ≥ 1 mA at a voltage ≥ 17 V.

Connection methods

The 3RT2 contactors are available with screw terminals or spring-type terminals.

Short-circuit protection of the contactors

For short-circuit protection of the contactors without overload relay, see "Technical specifications" (see note).

To assemble fuseless motor feeders you must select combinations of motor starter protector and contactor as explained in "3RA2 Load Feeders".

Motor protection

3RU21 thermal overload relays or 3RB30 electronic overload relays can be fitted to the 3RT2 contactors for protection against overload. The overload relays must be ordered separately.

Ratings of induction motors

The quoted rating (in kW) refers to the output power on the motor shaft (according to the nameplate).

Control supply voltage

The contactors with communication interface are available with 24 V DC operation.

Note:

Further technical information is available at www.siemens.com/industrial-controls/support

under Product List:

- Technical specifications

under Entry List:

- Updates
- Downloads
- FAQ
- Manuals/operating instructions
- Characteristic curves
- Certificates

and at

www.siemens.com/industrial-controls/configurators

- Configurators

Contactor and contactor assemblies

SIRIUS 3RT20 contactors, 3-pole, 3 ... 18.5 kW

Selection and ordering data

**DC operation · DC solenoid system
Rated control supply voltage 24 V**

3RT20 1.-1BB4.-0CC0		3RT20 1.-2BB4.-0CC0		3RT20 2.-1BB40-0CC0		3RT20 2.-2BB40-0CC0							
Rated data		Auxiliary contacts		Screw terminals		Spring-type terminals							
AC-2 and AC-3, T _U : Up to 60 °C		AC-1, T _U : 40 °C		<table border="1"> <thead> <tr> <th>Ident. No.</th> <th>Version</th> </tr> </thead> <tbody> <tr> <td></td> <td></td> </tr> <tr> <td></td> <td></td> </tr> </tbody> </table>		Ident. No.	Version						
Ident. No.	Version												
Operational current I _e up to	Rating of induction motors at 50 Hz and	Operational current I _e up to		Order No.		Order No.							
400 V	400 V	690 V											
A	kW	A											

For screw and snap-on mounting onto TH 35 standard mounting rail

Size S00

Contactor with communication interface

Terminal designations according to EN 50012 or EN 50005

- With auxiliary contact 1 NO, Ident. No. **10**

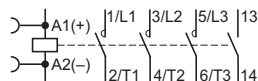

- With auxiliary contact 1 NC, Ident. No. **01**

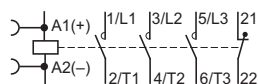

7	3	18	10	1	--	3RT20 15-1BB41-0CC0	3RT20 15-2BB41-0CC0
			01	--	1	3RT20 15-1BB42-0CC0	3RT20 15-2BB42-0CC0
9	4	22	10	1	--	3RT20 16-1BB41-0CC0	3RT20 16-2BB41-0CC0
			01	--	1	3RT20 16-1BB42-0CC0	3RT20 16-2BB42-0CC0
12	5.5	22	10	1	--	3RT20 17-1BB41-0CC0	3RT20 17-2BB41-0CC0
			01	--	1	3RT20 17-1BB42-0CC0	3RT20 17-2BB42-0CC0
16	7.5	22	10	1	--	3RT20 18-1BB41-0CC0	3RT20 18-2BB41-0CC0
			01	--	1	3RT20 18-1BB42-0CC0	3RT20 18-2BB42-0CC0

Size S0

Contactor with communication interface

Terminal designations according to EN 50012

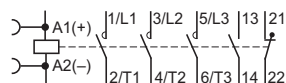

9	4	40	11	1	1	3RT20 23-1BB40-0CC0	3RT20 23-2BB40-0CC0
12	5.5	40	11	1	1	3RT20 24-1BB40-0CC0	3RT20 24-2BB40-0CC0
16	7.5	40	11	1	1	3RT20 25-1BB40-0CC0	3RT20 25-2BB40-0CC0
25	11	40	11	1	1	3RT20 26-1BB40-0CC0	3RT20 26-2BB40-0CC0
32	15	50	11	1	1	3RT20 27-1BB40-0CC0	3RT20 27-2BB40-0CC0
38	18.5	50	11	1	1	3RT20 28-1BB40-0CC0	3RT20 28-2BB40-0CC0

Overview



The 3RA23 contactor assemblies for reversing can be ordered as follows:

- complete, fully wired and tested, with mechanical and electrical interlocking
- as individual parts for customer assembly

The function modules for the connection to the controller are ordered separately in both cases.

The auxiliary contacts fitted in the contactors (see page 7/10) are freely available when the function modules are used.

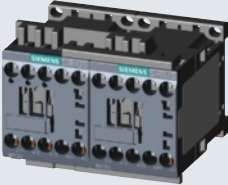
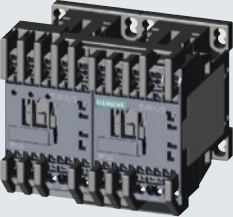
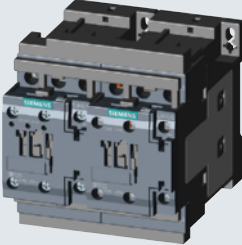
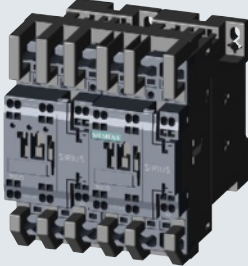
Selection and ordering data**Fully wired and tested contactor assemblies**

			
3RA23 1.-8XE30-1BB4	3RA23 1.-8XE30-2BB4	3RA23 24-8XE30-1BB4	3RA23 24-8XE30-2BB4
Rated data AC-2 and AC-3		Screw terminals	Spring-type terminals
Operational current I_e up to	Rating of induction motors at 50 Hz and		
400 V	230 V 400 V 500 V 690 V		
A	kW kW kW kW	Order No.	Order No.

24 V, DC operation

Size S00

With communication interface

7	2.2	3	3.5	4	3RA23 15-8XE30-1BB4	3RA23 15-8XE30-2BB4
9	3	4	4.5	5.5	3RA23 16-8XE30-1BB4	3RA23 16-8XE30-2BB4
12	3	5.5	5.5	5.5	3RA23 17-8XE30-1BB4	3RA23 17-8XE30-2BB4
16	4	7.5	7.5	7.5	3RA23 18-8XE30-1BB4	3RA23 18-8XE30-2BB4

Size S0

With communication interface

12	3	5.5	7.5	7.5	3RA23 24-8XE30-1BB4	3RA23 24-8XE30-2BB4
16	4	7.5	10	11	3RA23 25-8XE30-1BB4	3RA23 25-8XE30-2BB4
25	5.5	11	11	11	3RA23 26-8XE30-1BB4	3RA23 26-8XE30-2BB4
32	7.5	15	18.5	18.5	3RA23 27-8XE30-1BB4	3RA23 27-8XE30-2BB4
38	7.5	18.5	18.5	18.5	3RA23 28-8XE30-1BB4	3RA23 28-8XE30-2BB4

Contactors and contactor assemblies

SIRIUS 3RA23 reversing contactor assemblies

Selection and ordering data (continued)



Components for customer assembly

Assembly kits for all sizes are available for customer assembly of reversing contactor assemblies.

Contactors, overload relays and function modules for reversing starting should be ordered separately.

Selection of the contactors for customer assembly

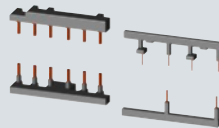
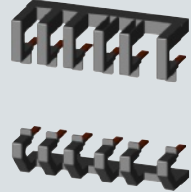
Rated data AC-2 and AC-3 for 50 Hz 400 V AC		Size	Order No.		
Rating kW	Operational current I_e A		Contactor	Assembly kit	Complete combination
3	7	S00	3RT20 15-.BB4.-0CC0	3RA29 13-2AA.	3RA23 15-8XB30-.BB4
4	9		3RT20 16-.BB4.-0CC0		3RA23 16-8XB30-.BB4
5.5	12		3RT20 17-.BB4.-0CC0		3RA23 17-8XB30-.BB4
7.5	16		3RT20 18-.BB4.-0CC0		3RA23 18-8XB30-.BB4
5.5	12	S0	3RT20 24-.BB40-0CC0	3RA29 23-2AA.	3RA23 24-8XB30-.BB4
7.5	16		3RT20 25-.BB40-0CC0		3RA23 25-8XB30-.BB4
11	25		3RT20 26-.BB40-0CC0		3RA23 26-8XB30-.BB4
15	32		3RT20 27-.BB40-0CC0		3RA23 27-8XB30-.BB4
18.5	38		3RT20 28-.BB40-0CC0		3RA23 28-8XB30-.BB4

				
			3RA29 23-2AA1	3RA29 23-2AA2
For contactors	Size	Version	Screw terminals 	Spring-type terminals 
Type			Order No.	Order No.

Assembly kits for making 3-pole contactor assemblies

3RT20 1	S00-S00	The assembly kit contains: mechanical interlock; 2 connecting clips for 2 contactors, wiring modules on the top and bottom • For main, auxiliary and control circuits
3RT20 2	S0-S0	The assembly kit contains: mechanical interlock; 2 connecting clips for 2 contactors, wiring modules on the top and bottom • For main, auxiliary and control circuits • Only for main circuit ¹⁾

3RA29 13-2AA1 **3RA29 13-2AA2**

3RA29 23-2AA1 --
-- **3RA29 23-2AA2**

¹⁾ Version in size S0 with spring-type terminals:
Only the wiring modules for the main circuit are included.
No connectors are included for the auxiliary and control circuit.

Overview

These 3RA24 contactor assemblies for wye-delta starting are designed for standard applications.

Note:

Contactor assemblies for wye-delta starting in special applications such as very heavy starting or wye-delta starting of special motors must be customized. Help with designing such special applications is available from Technical Assistance.





The 3RA24 contactor assemblies for wye-delta starting can be ordered as follows:

- complete, fully wired and tested, with electrical and mechanical interlocking
- as individual parts for customer assembly

A dead interval of 50 ms on reversing is already integrated in the function module for wye-delta starting. The auxiliary contacts fitted in the contactors (see page 7/10) are freely available.

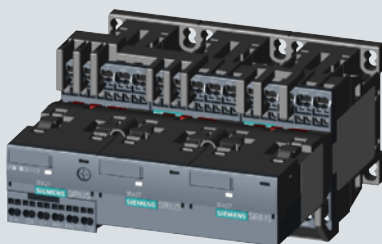
Selection and ordering data

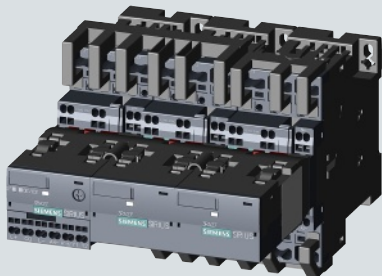
Fully wired and tested contactor assemblies

					
3RA24 1.-8XE31-2BB4		3RA24 2.-8XE32-1BB4		3RA24 2.-8XE32-2BB4	
Rated data AC-3		Rated control supply voltage U_s		Screw terminals 	
Operational current I_e up to		Rating of induction motors at 50 Hz and		Spring-type terminals 	
400 V	230 V	400 V	500 V	690 V	
A	kW	kW	kW	kW	V
Order No.		Order No.		Order No.	

24 V DC operation

Size S00

For IO-Link connection

12	3.3	5.5	7.2	9.2	24 DC
16	4.7	7.5	10.3	9.2	24 DC
25	5.5	11	11	11	24 DC

3RA24 15-8XE31-1BB4

3RA24 15-8XE31-2BB4

3RA24 16-8XE31-1BB4

3RA24 16-8XE31-2BB4

3RA24 17-8XE31-1BB4

3RA24 17-8XE31-2BB4

Size S0

For IO-Link connection

25	7.1	11	15.6	19	24 DC
32 / 40	11.4	15 / 18.5	19	19	24 DC
50	--	22	19	19	24 DC

3RA24 23-8XE32-1BB4

3RA24 23-8XE32-2BB4

3RA24 25-8XE32-1BB4

3RA24 25-8XE32-2BB4

3RA24 26-8XE32-1BB4

3RA24 26-8XE32-2BB4

Contactors and contactor assemblies

SIRIUS 3RA24 contactor assemblies for wye-delta starting

Selection and ordering data (continued)

Components for customer assembly

Assembly kits with wiring modules and mechanical connectors are available for contactor assemblies for wye-delta starting. Contactors, overload relays, function modules for wye-delta starting, auxiliary switches for electrical interlocking – and if required also feeder terminals – must be ordered separately.

The wiring kits for sizes S00 and S0 contain the top and bottom main conducting path connections between the line and delta contactors (top) and between the delta and star contactors (bottom).

Selection of the contactors for customer assembly

Rated data AC-3 at AC 50 Hz 400 V			Size	Order No.		Complete combination
Rating kW	Operational current I_e A	Motor current A		Line/delta contactor	Star contactor	
5.5	12	9.5 ... 13.8	S00-S00-S00	3RT20 15-.BB4.-0CC0	3RT20 15-.BB4.-0CC0	3RA24 15-8XE31-.BB4
7.5	16	12.1 ... 17		3RT20 17-.BB4.-0CC0	3RT20 15-.BB4.-0CC0	3RA24 16-8XE31-.BB4
11	25	19 ... 25		3RT20 18-.BB4.-0CC0	3RT20 16-.BB4.-0CC0	3RA24 17-8XE31-.BB4
11	25	19 ... 25	S0-S0-S0	3RT20 24-.BB40-0CC0	3RT20 24-.BB40-0CC0	3RA24 23-8XE32-.BB4
15	32	24.1 ... 34		3RT20 26-.BB40-0CC0	3RT20 24-.BB40-0CC0	3RA24 25-8XE32-.BB4
18.5	40	34.5 ... 40		3RT20 26-.BB40-0CC0	3RT20 24-.BB40-0CC0	3RA24 25-8XE32-.BB4
22	50	31 ... 43		3RT20 27-.BB40-0CC0	3RT20 26-.BB40-0CC0	3RA24 26-8XE32-.BB4

For contactors see page 7/10.

For contactors	Size	Version	Order No.	Order No.
			Screw terminals	Spring-type terminals
Type			Order No.	Order No.

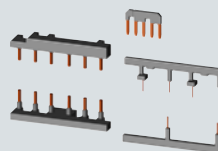

3RA29 23-2BB1

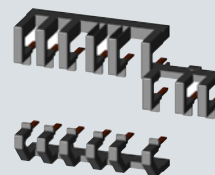

3RA29 23-2BB2

Assembly kits for making 3-pole contactor assemblies

3RT20 1	S00	The assembly kit contains: mechanical interlock, 4 connecting clips, star jumper, wiring modules on the top and bottom • For main, auxiliary and control circuits	3RA29 13-2BB1	3RA29 13-2BB2
3RT20 2	S0	The assembly kit contains: mechanical interlocking, 4 connecting clips, star jumper, wiring modules on the top and bottom ¹⁾ • For main, auxiliary and control circuits • Only for main circuit ²⁾	3RA29 23-2BB1 --	-- 3RA29 23-2BB2

¹⁾ When using the function modules for wye-delta starting, the wiring modules included in the assembly kit for the auxiliary current are not required.

²⁾ Version in size S0 with spring-type terminals:
Only the wiring modules for the main circuit are included.
No connectors are included for the auxiliary and control circuit.

Overview

The function modules for mounting onto contactors enable the assembly of starters and contactor assemblies for direct-on-line, reversing and wye-delta starting without any additional, complicated wiring of the individual components.

They include the key control functions required for the particular feeder, e.g. timing and interlocking, and can be connected to the controller by IO-Link.

Selection and ordering data

Version	Screw terminals 	Spring-type terminals 
	Order No.	Order No.

Function modules for direct-on-line starting



3RA27 11-1AA00



3RA27 11-2AA00

IO-Link connection
includes one module connector
for assembling an IO-Link group

3RA27 11-1AA00

3RA27 11-2AA00

Function modules for reversing starting ¹⁾



3RA27 11-1BA00



3RA27 11-2BA00

IO-Link connection,
comprising one basic
and one coupling module and
an additional module connector
for assembling an IO-Link group

3RA27 11-1BA00

3RA27 11-2BA00

Function modules for wye-delta starting ²⁾



3RA27 11-1CA00



3RA27 11-2CA00

IO-Link connection,
comprising one basic module
and two coupling modules,
plus an additional module connector
for assembling an IO-Link group

3RA27 11-1CA00

3RA27 11-2CA00

Matching contactors or reversing contactor assemblies with communication interface required (see pages 7/10 and 7/11).

Note:

When using the function modules, no other auxiliary switches are allowed to be connected to the basic units.







¹⁾ For prewired contactor assemblies for reversing starting with communication interface see page 7/11. When these contactor assemblies are used, the assembly kit for the wiring is already integrated.

²⁾ For complete contactor assemblies for wye-delta starting including function modules see page 7/13.

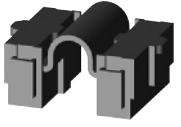
Contactors and contactor assemblies

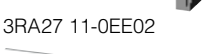
SIRIUS 3RA27 function modules for IO-Link

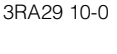
Selection and ordering data (continued)

	Version	Order No.
Accessories		
 <p>3RA27 11-0EE01</p>	Module connector set , comprising: <ul style="list-style-type: none"> • 2 module connectors, 14-pole, short • 2 interface covers 	3RA27 11-0EE01
 <p>3RA27 11-0EE02</p>	Module connector , 14-pole, 8 cm For size jump S00-S0 + 1 space	3RA27 11-0EE02
 <p>3RA27 11-0EE03</p>	Module connector , 14-pole, 21 cm For various space combinations	3RA27 11-0EE03
 <p>3RA27 11-0EE04</p>	Module connector , 10-pole, 8 cm For separate auxiliary voltage supply within an IO-Link group	3RA27 11-0EE04
 <p>3RA29 10-0</p>	Sealable covers for 3RA27, 3RA28, 3RA29	3RA29 10-0
 <p>3RA29 10-0</p>	Manual Function modules for IO-Link	3ZX1 012-0RA27-1AB1
Operator panels ¹⁾		
 <p>3RA69 35-0A</p>	Operator panel (set) , comprising: <ul style="list-style-type: none"> • 1 x operator panel • 1 x enabling module • 1 x interface cover • 1 x fixing terminal 	3RA69 35-0A
	Connection cable , length 2 m, 10- to 14-pole For connecting the operator panel to the communication module	3RA27 11-0EE11
	Enabling modules (replacement)	3RA69 36-0A
	Interface covers (replacement)	3RA69 36-0B

¹⁾ Suitable only for communication through IO-Link.

SIRIUS 3RB2 electronic overload relays

3RB24 for IO-Link, up to 630 A
for high-feature applications

Overview

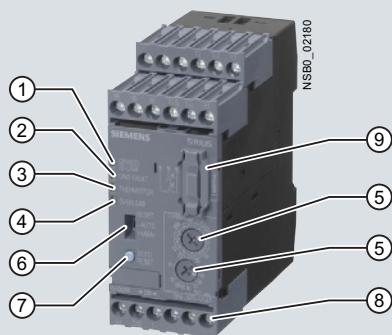

- ① Green LED "DEVICE/IO-Link":
A continuous green light signals that the device is working correctly; green flickering indicates communication via IO-Link.
- ② Red LED "GND FAULT":
A continuous red light signals ground-fault tripping.
- ③ Red LED "THERMISTOR":
A continuous red light signals ground-fault tripping.
- ④ Red LED "OVERLOAD":
A continuous red light signals an active overload trip; a flickering red light signals an imminent trip (overload warning).
- ⑤ Motor current and trip class setting:
Setting the device to the motor current and required trip class dependent on the start-up conditions is easy with the two rotary switches.
- ⑥ Selector switch for manual/automatic RESET:
With this switch you can choose between manual and automatic RESET.
- ⑦ Test/RESET button:
Enables testing of all important device components and functions, plus resetting of the device after a trip when manual RESET is selected.
- ⑧ Terminals (terminal block removable):
The generously-sized terminals permit connection of two conductors with different cross-sections for the auxiliary, control and sensor circuits. Choice of screw connection and spring-type connection.
- ⑨ Connection point for operator panel:
Facilitates connection of operator panel 3RA69 35-0A.

SIRIUS 3RB24 evaluation module

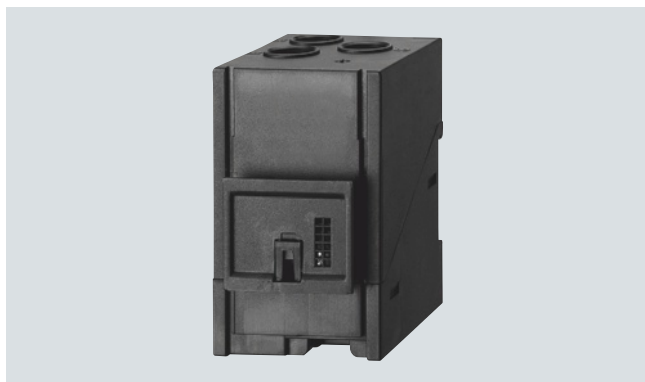

SIRIUS 3RB29 06 current measuring module

The modular electronic overload relay 3RB24, which is powered via IO-Link (with monostable auxiliary contacts) up to 630 A (up to 820 A possible with a series transformer) have been designed for inverse-time delayed protection of loads with normal and heavy starting (for "Function" see manual SIRIUS electronic overload relay 3RB24 for IO-Link) against excessive temperature rises due to overload, phase unbalance or phase failure. The evaluation module 3RB24 also offers an engine starter function: The contactors, which are connected via the auxiliary contacts, can also be actuated for operation via IO-Link. In this way, direct, reversing and star-delta starters up to 630 A (or 830 A) can be connected to the controller wirelessly via the IO-Link controller.

An overload, phase unbalance or phase failure result in an increase of the motor current beyond the set rated motor current.

This current rise is detected by means of a current measuring module and electronically evaluated by a special evaluation module which is connected to it. The evaluation electronics sends a signal to the auxiliary contacts. The auxiliary contacts then switch off the load by means of a contactor. The break time depends on the ratio between the tripping current and current setting I_e and is stored in the form of a long-term stable tripping characteristic ("Characteristic Curves" see www.siemens.com/industrial-controls/support). The "tripped" status is signaled by means of a continuously illuminated red "OVERLOAD" LED and also reported as a group fault via IO-Link.

The LED indicates imminent tripping of the relay due to overload, phase unbalance or phase failure by flickering when the current limit has been exceeded. This warning can also be reported to the higher-level PLC via IO-Link at the 3RB24 overload relay.

In addition to the described inverse-time delayed protection of loads against excessive temperature rises, the 3RB24 electronic overload relays also allow direct temperature monitoring of the motor windings (full motor protection) by connection with broken-wire interlock of a PTC sensor circuit. With this temperature-dependent protection, the loads can be protected against overheating caused, for example, indirectly by reduced coolant flow and which cannot be detected by means of the current alone. In the event of overheating, the devices switch off the contactor, and thus the load, by means of the auxiliary contacts. The "tripped" status is signaled by means of a continuously illuminated "THERMISTOR" LED and also reported as a group fault via IO-Link.

To the loads against incomplete ground faults due to damage to the insulation, humidity, condensation, etc., to protect the electronic overload relay 3RB24 offer the possibility of internal ground-fault detection (for details, see 3RB24 SIRIUS electronic overload relay for IO-Link manual, not possible in conjunction with contactor assembly for wye-delta starting). In the event of a ground fault, the 3RB24 relays trip instantaneously.

The "tripped" status is signaled by means of a flashing red LED "Ground Fault" and reported at the overload relay 3RB24 as a group fault via IO-Link.

IO-Link

SIRIUS 3RB2 electronic overload relays

3RB24 for IO-Link, up to 630 A
for high-feature applications

Overview (continued)

The reset after overload, phase unbalance, phase failure, thermistor or ground-fault tripping is performed manually by key on site, via IO-Link or by electrical remote RESET or automatically after the cooling time (motor model) or for thermistor protection after sufficient cooling. Power cuts in devices due to function monitoring (broken wire or short-circuit on the thermistor) can only be reset on-site (for "Function" see SIRIUS electronic overload relay 3RB24 for IO-Link manual). In conjunction with a function expansion module, the motor current measured by the microprocessor can be output in the form of an analog signal

DC 4 to 20 mA for operating rotary coil instruments or for feeding into analog inputs of programmable logic controllers.

The current values can be transmitted to the higher level controller via IO-Link.

The devices are manufactured in accordance with environmental guidelines and contain environmentally-friendly and reusable materials.

They comply with all important worldwide standards and approvals.

Overload relays overview – the correct contactor

Overload relays	Current measurement	Current range	Contactors (Type, size, rating in kW)							
			3RT20 1	3RT20 2	3RT10 3	3RT10 4	3RT10 5	3RT10 6	3RT10 7	3TF68/3TF69
Type	Type	A	S00	S0	S2	S3	S6	S10	S12	Size 14
			3/4/5.5/7.5	5.5/7.5/11	15/18.5/22	30/37/45	55/75/90	110/132/160	200/250	375/450

SIRIUS 3RB24 electronic overload relays ¹⁾



3RB24 83 +	3RB29 0	3RB29 0	3RB29 5	3RB29 6	3RB29 0 + 3UF18	3RT20 1	3RT20 2	3RT10 3	3RT10 4	3RT10 5	3RT10 6	3RT10 7	3TF68/3TF69
	0.3 ... 25	10 ... 100	20 ... 200	63 ... 630	630 ... 820	✓	✓	--	--	--	--	--	--
						✓	✓	✓	✓	--	--	--	--
						--	--	--	--	✓	--	--	--
						--	--	--	--	--	✓	✓	✓
						--	--	--	--	--	--	--	✓

✓ Can be used

-- Cannot be used

¹⁾ For technical specifications for the use of overload relays with trip class \geq CLASS 20, see "Short-circuit protection with fuses for motor feeders", see the configuration manual for SIRIUS innovations configuration – selection data for fused and fuseless load feeders and in the configuration manual "Configuring SIRIUS fuseless load feeders."

Connection methods

The 3RB24 electronic overload relays (evaluation modules) can be fitted on the auxiliary current side with screw connection (box terminals) or spring-type connections.



Screw terminals



Spring-type terminals

Type of protection "increased safety EEx e and explosion-proof enclosure EEx d" in accordance with ATEX Directive 94/9/EC

The electronic overload relay 3RB24 (monostable) are suitable for the overload protection of explosion-proof motors of types of protection EEx e and EEx d.

They comply with the requirements of EN 60079-7 (Electrical apparatus for areas subject to explosion hazards – Increased safety "e" as well as for flameproof enclosure "d"); see www.siemens.com/industrial-controls/atex.

EC type test certificate for Group II, Category (2)G/D has been submitted. On request.

Application**Industries**

The 3RB24 electronic overload relays are suitable for customers from all industries who want to guarantee optimum inverse-time delayed and temperature-dependent protection of their electrical loads (e.g. motors) under normal and heavy starting conditions (CLASS 5 to 30), minimize project completion times, inventories and power consumption, and optimize plant availability and maintenance management.

Application

The 3RB24 electronic overload relays have been designed for the protection of three-phase asynchronous and single-phase AC motors.

In addition to protection function, these devices can be used together with contactors as direct or reversing starters (star-delta (wye-delta) start also possible), which are controlled via IO-Link. This makes it possible to directly control drives via IO-Link from a higher-level controller or on site via the optional hand-held device lamps and also, for example, to return current values directly via IO-Link.

If single-phase AC motors are to be protected by the 3RB24 electronic overload relays, the main current paths of the current measuring modules must be series-connected (see "Circuit diagrams" www.siemens.com/industrial-controls/support).

Ambient conditions

The devices are insensitive to external influences, such as shocks, corrosive ambient conditions, aging and temperature fluctuations.

For the temperature range from -25 °C to $+60\text{ °C}$, the 3RB24 electronic overload relays compensate the temperature in accordance with IEC 60947-4-1.

Configuration notes for use of the devices below -25 °C or above $+60\text{ °C}$ on request.

SIRIUS 3RB2 electronic overload relays

3RB24 for IO-Link, up to 630 A
for high-feature applications

Selection and ordering data

3RB24 electronic overload relays (evaluation module) for full motor protection, stand-alone installation, CLASS 5, 10, 20 and 30, adjustable

Type	3RB24 83-4A.1
<i>Features and technical specifications</i>	
Overload protection, phase failure protection and unbalance protection	✓
Supplied from an external voltage	✓ 24 V DC through IO-Link
Direct-on-line or reversing starters (wye-delta starting also possible) controllable through IO-Link	✓
Auxiliary contacts	✓ 1 CO and 1 NO in series
Manual and automatic RESET	✓
Remote-RESET	✓ (electrically or via IO-Link)
4 LEDs for operating and status displays	✓
TEST function and self-monitoring	✓
Internal ground-fault detection	✓
Screw or spring-type terminals for auxiliary, control and sensor circuits	✓
Input for PTC sensor circuit	✓
Analog output	✓
IO-Link specific functions	
• Connection of direct-on-line, reversing and star-delta starters to the controller via IO-Link	✓
• On-site controlling of the starter using the hand-held device	✓
• Accessing process data (e.g. current values in all three phases) via IO-Link	✓
• Accessing parametrization and diagnostics data (e.g. tripped signals) via IO-Link	✓

✓ Available

7

			
		3RB24 83-4AA1	3RB24 83-4AC1
Size of contactor	Version	Screw terminals	Spring-type terminals
		⊕	⊕
		Order No.	Order No.

Evaluation modules

S00 ... S12

Monostable

3RB24 83-4AA1**3RB24 83-4AC1****Notes:**

Overload relays overview – the correct protection, see page 7/18.





Analog input modules, e.g. SM 331, must be configured for 4-wire measuring transducers. The analog input module may not supply current to the analog output of the 3RB24 relay.

SIRIUS 3RB2 electronic overload relays

3RB24 for IO-Link, up to 630 A
for high-feature applications

Selection and ordering data (continued)

Current measuring module for mounting onto contactors ¹⁾ and stand-alone installation ^{1) 2)} (necessary accessories)

	Contactor size ³⁾	Rating for induction motor, rated value ⁴⁾	Current setting value of the inverse-time delayed overload release	Short-circuit protection with fuse, type of coordination "2", gG operational class ⁵⁾	For overload relays	Order No.
		kW	A			
Sizes S00/S0 ^{2) 6)}						
	S00/S0	0.09 ... 1.1	0.3 ... 3	20	3RB24	3RB29 06-2BG1 3RB29 06-2DG1
		1.1 ... 11	2.4 ... 25	63		
Sizes S2/S3 ^{2) 6)}						
	S2/S3	5.5 ... 45	10 ... 100	315	3RB24	3RB29 06-2JG1
Size S6 ^{1) 6)}						
	S6 with busbar connection	11 ... 90	20 ... 200	315	3RB24	3RB29 56-2TH2
	For mounting to S6 contactors with box terminals				3RB24	3RB29 56-2TG2
Sizes S10/S12 ¹⁾						
	S10/S12 and size 14 (3TF68/ 3TF69)	37 ... 450	63 ... 630	800	3RB24	3RB29 66-2WH2

Note:

The connecting cable between the current measuring module and the evaluation module is not included in the scope of supply; please order separately.

- 1) The current measuring modules with an order no. ending with "2" are designed for mounting onto contactor and stand-alone installation. For 3TF68/3TF69 contactors, direct mounting is not possible.
- 2) The current measuring modules with an order no. ending with "1" are designed for stand-alone installation.

3) Observe maximum rated operational current of the devices.

4) Guide value for 4-pole standard motors at 50 Hz 400 V AC. The actual starting and rated data of the motor to be protected must be considered when selecting the units.

5) Maximum protection by fuse for overload relay, type of coordination "2". For fuse values in conjunction with contactors, see "Technical specifications" --> "Short-circuit protection with fuses for motor feeders", see www.siemens.com/industrial-controls/support.

6) The modules with an order no. including a "G" as the penultimate digit, are equipped with straight-through transformers.

Accessories

	Size of contactor	Version	For over-load relays	Order No.
Connecting cables (necessary accessories)				
	S00 ... S3	For connection between evaluation module and current measuring module	3RB24, 3RB29	3RB29 87-2B
	S00 ... S12	• Length 0.1 m (only for mounting of the evaluation module directly onto the current measuring module)		
3RB29 87-2.	S00 ... S12	• Length 0.5 m	3RB24, 3RB29	3RB29 87-2D

For more on general accessories, see page 7/22.

IO-Link

SIRIUS 3RB2 electronic overload relays

Accessories for 3RB24

Overview



Overload relays for IO-Link

The following optional accessories are available for the 3RB24 electronic overload relays:

- Operator panel for the evaluation modules 3RB24
- Manual for the evaluation modules 3RB24
- Sealable cover for the evaluation modules 3RB24
- Terminal covers for the 3RB29 current measuring modules size S6 and S10/S12
- Box terminal blocks for the 3RB29 current measuring modules size S6 and S10/S12
- Push-in lugs for screw fixing for the 3RB24 evaluation module and 3RB29 06 current measuring modules

Selection and ordering data

Accessories for overload relay 3RB24

	Version	For over-load relays	Order No.
Operator panel for evaluation modules			
 <p>3RA69 35-0A</p>	Operator panels (set) 1 set comprises: • 1 x operator panel • 1 x 3RA69 36-0A enabling module • Blanking cover 3RA69 36-0B • 1 x fixing terminal <u>Note:</u> The connecting cable between the evaluation module and the operator panel is not included in the scope of supply; please order separately.	3RB24	3RA69 35-0A
	Connecting cable Length 2 m (round), for connecting the evaluation module to the operator panel	3RB24	3UF79 33-0BA00-0
	Enabling modules (replacement)	3RB24	3RA69 36-0A
	Blanking covers	3RB24	3RA69 36-0B
Manual			
	Solid-state overload relays for IO-Link The manual is only printed on demand • German ¹⁾ • English ¹⁾ • French ¹⁾ • Spanish ¹⁾	3RB24	3ZX1012-0RB24-0AB0 3ZX1012-0RB24-0AC0 3ZX1012-0RB24-0AD0 3ZX1012-0RB24-0AE0

¹⁾ The manual is available online as a free PDF download in the Service & Support Portal at:
www.siemens.com/industrial-controls/support
 --> "Overload relay" --> "Service & Support"
 --> "Manuals / operating instructions".

Selection and ordering data (continued)

General accessories

Version	Size	For overload relays	Order No.	
Sealable covers for evaluation modules				
 3RB29 84-2	For covering the setting knobs	--	3RB24	3RB29 84-2

Terminal covers for current measuring modules

Covers for cable lugs and busbar connections

• Length 100 mm	S6	3RB29 56	3RT19 56-4EA1
• Length 120 mm	S10/S12	3RB29 66	3RT19 66-4EA1

Covers for box terminals

• Length 25 mm	S6	3RB29 56	3RT19 56-4EA2
• Length 30 mm	S10/S12	3RB29 66	3RT19 66-4EA2

Cover for screw connection

between contactor and overload relay, no box terminal (1 unit necessary per combination)	S6	3RB29 56	3RT19 56-4EA3
	S10/S12	3RB29 66	3RT19 66-4EA3

Box terminal blocks for current measuring modules



3RT19 5..-4G

For round and ribbon cables

• Up to 70 mm ²	S6 ¹⁾	3RB29 56	3RT19 55-4G
• Up to 120 mm ²	S6	3RB29 56	3RT19 56-4G
• Up to 240 mm ²	S10/S12	3RB29 66	3RT19 66-4G

For technical specifications on conductor cross-sections, see www.siemens.com/industrial-controls/support.

Push-in lugs for evaluation modules and current measuring modules



3RP19 03

for screw fixing the evaluation modules

--	3RB24	3RP19 03
----	-------	-----------------



3RB19 00-0B

for screw fixing the current measuring modules
(2 units per module)

S00 ...S3	3RB29 06	3RB19 00-0B
-----------	----------	--------------------

¹⁾ In the scope of supply for 3RT10 54-1 contactors (55 kW).

Version	Size	Color	For overload relays	Spring-type terminals Order No.	
Tools for opening screw-type connections					
 3RA29 08-1A	Screwdrivers For all SIRIUS devices with spring-type terminals	Length approx. 200 mm, 3.0 mm x 0.5 mm	Titanium gray/black, partially insulated	Main and auxiliary circuit connection: 3RB2	3RA29 08-1A

IO-Link

SIRIUS 3RA6 compact feeders

SIRIUS 3RA64, 3RA65 compact feeders for IO-Link

Overview

Communication integration using IO-Link

Up to 4 compact feeders in IO-Link version (reversing and direct-on-line starters) can be connected together and conveniently linked to the IO-Link master through a standardized IO-Link connection. The 4SI SIRIUS electronic modules are used e.g. as IO-Link masters for connection to the SIMATIC ET 200S distributed I/O system.

The IO-Link connection enables a high density of information in the local range.

The diagnostics data of the process collected by the 3RA6 compact feeder, e.g. short-circuit, end of service life, limit position etc., are not only indicated on the compact feeder itself but also transmitted to the higher-level control system through IO-Link.





Thanks to the optionally available operator panel, which can be installed in the control cabinet door, it is easy to control the 3RA6 compact feeder with IO-Link from the control cabinet door.

Note

For general data on 3RA6 compact feeders see Chapter 6 "AS-Interface" --> "3RA6 Compact Feeders--> "General data"

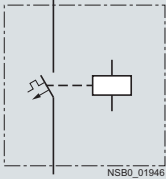
Selection and ordering data

3RA64 direct-on-line starters

		Direct-on-line start 		Rated control supply voltage 24 V DC Width 45 mm Rated short-circuit current $I_{CS} = 53 \text{ kA}$ at 400 V A set of 3RA69 40-0A adapters is required for screw fixing.	
3RA64 with 3RA69 11-1A auxiliary switch block					
Standard induction motor 4-pole at 400 V AC ¹⁾ Standard output P	Setting range for electronic overload release 	Instantaneous overcurrent release 	Screw terminals 	Spring-type terminals 	
kW	A	A	Order No.	Order No.	

For standard mounting rail or screw mounting,
including 1 pair of main circuit terminals and 1 pair of control circuit terminals

0.09	0.1 ... 0.4	56	3RA64 00-1AB42	3RA64 00-2AB42
0.37	0.32 ... 1.25	56	3RA64 00-1BB42	3RA64 00-2BB42
1.5	1 ... 4	56	3RA64 00-1CB42	3RA64 00-2CB42
5.5	3 ... 12	168	3RA64 00-1DB42	3RA64 00-2DB42
15	8 ... 32	448	3RA64 00-1EB42	3RA64 00-2EB42





For use in the infeed system for 3RA6,
without main circuit terminals with 1 pair of control circuit terminals

0.09	0.1 ... 0.4	56	3RA64 00-1AB43	3RA64 00-2AB43
0.37	0.32 ... 1.25	56	3RA64 00-1BB43	3RA64 00-2BB43
1.5	1 ... 4	56	3RA64 00-1CB43	3RA64 00-2CB43
5.5	3 ... 12	168	3RA64 00-1DB43	3RA64 00-2DB43
15	8 ... 32	448	3RA64 00-1EB43	3RA64 00-2EB43

¹⁾ Selection depends on the concrete startup and rated data of the protected motor.

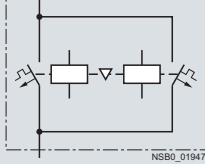
Selection and ordering data (continued)

3RA65 reversing starters

				Rated control supply voltage 24 V DC Width 90 mm Rated short-circuit current $I_{CS} = 53 \text{ kA}$ at 400 V Two sets of 3RA69 40-0A adapters are required for screw fixing.	
3RA65 with 3RA69 11-1A auxiliary switch blocks					
Standard induction motor 4-pole at 400 V AC ¹⁾ Standard output P	Setting range for electronic overload release	Instantaneous overcurrent release	Screw terminals	 Spring-type terminals	
			Order No.	Order No.	

For standard mounting rail or screw mounting,
including 1 pair of main circuit terminals and 1 pair of control circuit terminals

kW	A	A	Order No.	Order No.
0.09	0.1 ... 0.4	56	3RA65 00-1AB42	3RA65 00-2AB42
0.37	0.32 ... 1.25	56	3RA65 00-1BB42	3RA65 00-2BB42
1.5	1 ... 4	56	3RA65 00-1CB42	3RA65 00-2CB42
5.5	3 ... 12	168	3RA65 00-1DB42	3RA65 00-2DB42
15	8 ... 32	448	3RA65 00-1EB42	3RA65 00-2EB42

For use in the infeed system for 3RA6,
without main circuit terminals with 1 pair of control circuit terminals

kW	A	A	Order No.	Order No.
0.09	0.1 ... 0.4	56	3RA65 00-1AB43	3RA65 00-2AB43
0.37	0.32 ... 1.25	56	3RA65 00-1BB43	3RA65 00-2BB43
1.5	1 ... 4	56	3RA65 00-1CB43	3RA65 00-2CB43
5.5	3 ... 12	168	3RA65 00-1DB43	3RA65 00-2DB43
15	8 ... 32	448	3RA65 00-1EB43	3RA65 00-2EB43

¹⁾ Selection depends on the concrete startup and rated data of the protected motor.

IO-Link

SIRIUS 3RA6 compact feeders

Accessories for compact feeders for IO-Link

Overview

Accessories for SIRIUS 3RA6 compact feeders in IO-Link version



The following accessories are available specially for the 3RA64, 3RA65 compact feeders:

- The 4SI SIRIUS electronic module as IO-Link master allows for the simple and economical connection of SIRIUS controls with IO-Link (e.g. up to four groups of 4 compact starters) to the multifunctional SIMATIC ET 200S distributed I/O system.
- Additional connection cables for side-by-side mounting of up to 4 compact feeders
- Operator panel for on-site control and diagnostics of up to 4 compact feeders coupled to each other

Note

For accessories for all SIRIUS 3RA6 compact feeders see Chapter 6 "AS-Interface" --> "3RA6 Compact Feeders" --> "Accessories"

Selection and ordering data

Version	Order No.
<i>Accessories especially for 3RA64, 3RA65 Compact Feeders for IO-Link</i>	
 <p>Additional connection cables (flat) for side-by-side mounting of up to 4 compact feeders</p> <ul style="list-style-type: none"> • 10-pole <ul style="list-style-type: none"> - 8 mm ¹⁾ - 200 mm ¹⁾ • 14-pole <ul style="list-style-type: none"> - 8 mm ²⁾ - 200 mm 	<p>3RA69 32-0A 3RA69 33-0B</p>
 <p>Operator panel (incl. enabling module, blanking cover and mounting bracket)</p>	<p>3RA69 31-0A 3RA69 33-0C 3RA69 35-0A</p>
	3RA69 36-0A
	3RA69 36-0B
	3RA69 33-0A

¹⁾ 10-pole connection cables are required for EMERGENCY-STOP group concepts.

²⁾ Is included in the scope of supply of the SIRIUS 3RA6 compact starter in IO-Link version.

Overview



SIRIUS 3UG48 monitoring relays

The SIRIUS 3UG4 monitoring relays for electronic and mechanical variables monitor all important characteristics that allow conclusions to be drawn about the functionality of a plant. Both sudden disturbances and gradual changes, which may indicate the need for maintenance, are detected.

Thanks to their relay outputs, the monitoring relays permit direct disconnection of the affected system sections and alerting, e.g. by the triggering of a warning light. Thanks to adjustable delay times the 3UG4 monitoring relays can respond very flexibly to brief disturbances such as voltage dips or load changes and can thus avoid unnecessary alarms and disconnections and increase system availability.

3UG48 monitoring relays for IO-Link

The SIRIUS 3UG48 monitoring relays for IO-Link also offer many other options based upon the monitoring functions of the tried-and-tested SIRIUS 3UG4 monitoring relays:

- Measured value transmission to a controller, inc. resolution and unit, may be parametrizable as to which value is cyclically transmitted
- Transmission of alarm flag to a controller
- Full diagnosis capability by inquiry as to the cause of the fault in the diagnosis data set
- Remote parameterization is also possible, in addition to or instead of local parameterization
- Rapid parameterization of the same devices by duplication of the parametrization in the controller
- Parameter transmission by upload to a controller by IO-Link call or by parameter server (if IO-Link master from IO-Link Specification V 1.1 is used)
- Consistent central data storage in the event of parameter change locally or via a controller
- Automatic reparameterizing when devices are exchanged
- Blocking of local parameterization via IO-Link possible
- Faults are saved in parametrizable and non-volatile fashion to prevent an automatic start-up after voltage failure and make sure diagnosis data is not lost
- By connection to the automation level the option exists of parametrizing the monitoring relay at any time via a display unit or displaying the measured values in a control room or locally at the machine/control cabinet.

Even without communication via IO-Link the devices continue to function fully autonomously:

- Parameterization can take place locally at the device, independently of a controller.
- In the event of failure or before the controller becomes available the monitoring relays work as long as the control supply voltage (24 V DC) is present.
- If the monitoring relays are operated without the controller, the 3UG48 monitoring relays have, thanks to the integrated SIO mode, an additional semiconductor output, which switches when the adjustable warning threshold is exceeded.

Thanks to the combination of autonomous monitoring relay function and integrated IO-Link communication, redundant sensors and/or analog signal converters – which previously took over the transmission of measured values to a controller, leading to considerable extra cost and wiring outlay – are no longer needed.

Because the output relays are still present, the monitoring relays increase the functional reliability of the system, since the controller can only fulfill the control tasks if the current measured values are available, whereas the output relays can also be used for the disconnection of the system if limit values that cannot be reached during operation are exceeded.

The individual 3UG48 monitoring relays for IO-Link offer the following functions in different combinations:

- Phase sequence
- Phase failure, neutral conductor failure
- Phase asymmetry
- Undershooting and/or overshooting of limit values for voltage
- Undershooting and/or overshooting of limit values for current
- Undershooting and/or overshooting of limit values for the power factor
- Monitoring of the active current or the apparent current
- Undershooting and/or overshooting of limit values for speed

Note:

Further information on the IO-Link bus system can be found in Catalog IC 10, Chapter 2 "Industrial Communication".

Connection methods

The 3UG48 monitoring relays for IO-Link can be delivered with screw terminals or spring-type terminals.



Screw terminals



Spring-type terminals

SIRIUS 3UG48 monitoring relays for stand-alone installation for IO-Link

General data

Benefits

- Simple cyclical transmission of the current measured values, relay switching states and events to a controller
- Remote parametrization
- Automatic reparameterizing when devices are exchanged
- Simple duplication of identical or similar parameterizations
- Reduction of control current wiring
- Elimination of testing costs and wiring errors
- Reduction of configuration work
- Integration in TIA means clear diagnostics if a fault occurs
- Cost saving and space saving in control cabinet due to the elimination of AI and IO modules as well as analog signal converters and duplicated sensors

Application

The use of SIRIUS monitoring relays for IO-Link is particularly recommended for machines and plant in which these relays, in addition to their monitoring function, are to be connected to the automation level for the rapid, simple and fault-free provision of the current measured values and/or for remote parametrization.

The monitoring relays can either relieve the controller of monitoring tasks or, as a second monitoring entity in parallel to and independent of the controller, increase the reliability in the process or in the system. In addition, the elimination of AI and IO modules allows the width of the controller to be reduced despite significantly expanded functionality.

Design

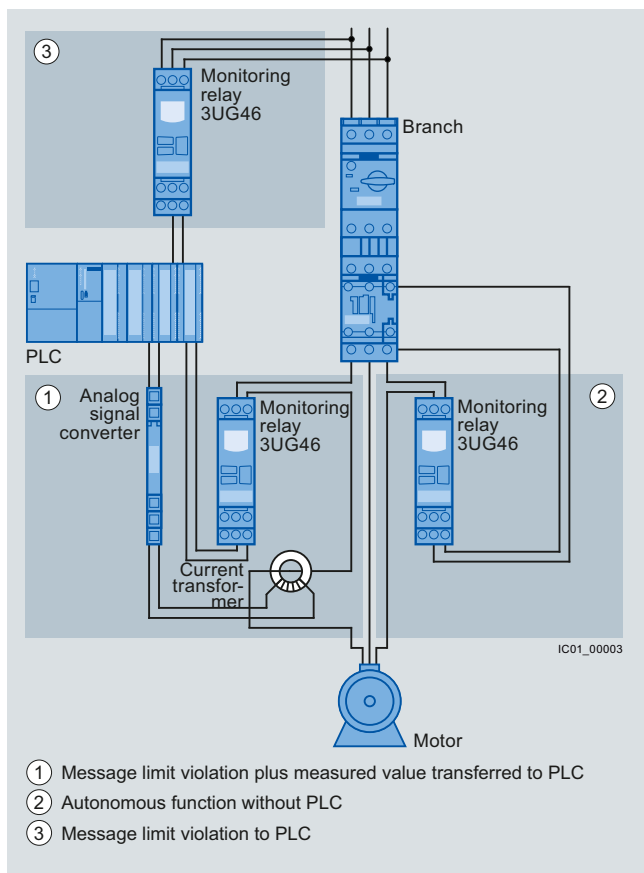

Use of conventional monitoring relays

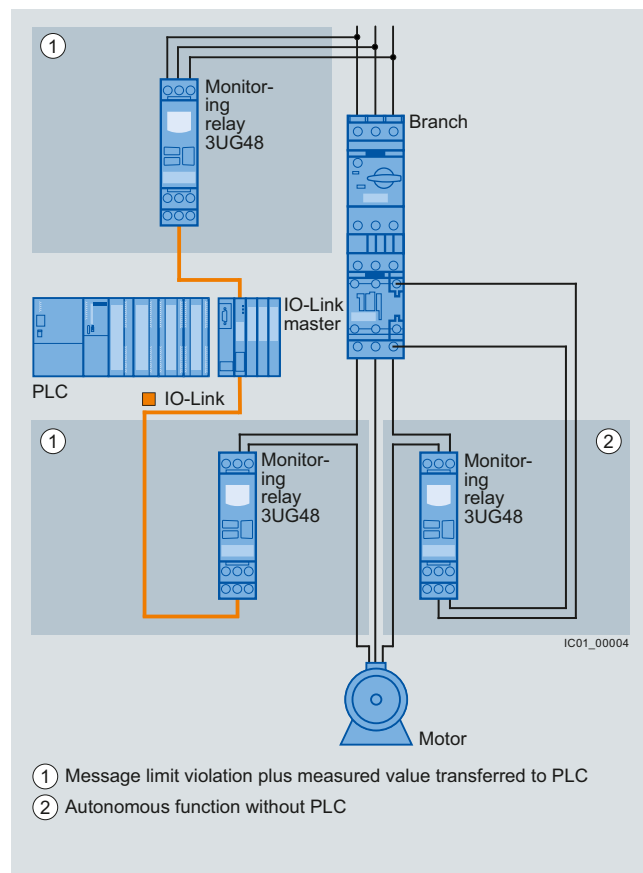

Monitoring relays for IO-Link

Notes:

Devices required for the communication via IO-Link:

- Any controller that supports the IO-Link (e.g. ET 200S with CPU or S7-300 plus ET 200S distributed peripherals, see Catalog ST 70)
- IO-Link master (IO-Link master 4SI IO-Link or 4SI SIRIUS interface module, which can connect all SIRIUS IO-Link devices to a controller, see page 7/4)

Each monitoring relay requires an IO-Link channel.

SIRIUS 3UG48 monitoring relays for stand-alone installation for IO-Link

Line monitoring

Overview

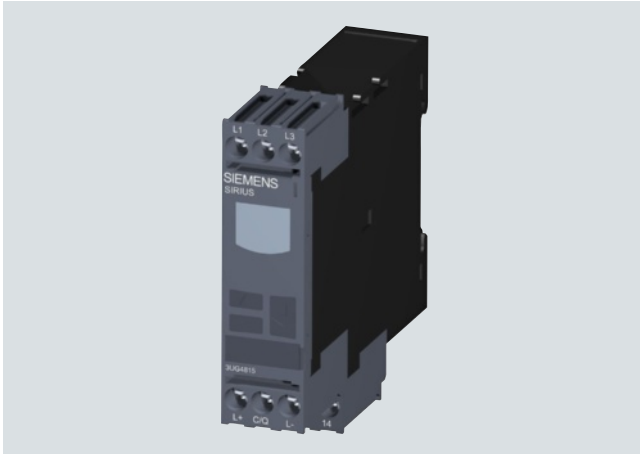

SIRIUS 3UG48 15 monitoring relay

Electronic line monitoring relays provide maximum protection for mobile machines, plants and hoisting equipment or for unstable networks. Network and voltage faults can thus be detected early and rectified before far greater damage ensues.

The line monitoring relays with IO-Link monitor phase sequence, phase failure (with or without N conductor monitoring), phase asymmetry and undervoltage and/or overvoltage.

Phase asymmetry is evaluated as the difference between the greatest and the smallest phase voltage relative to the greatest phase voltage. Undervoltage or overvoltage exist if the set limit values for at least one phase are overshoot or undershot. The rms value of the voltage is measured.

Benefits

- Can be used in any network from 160 to 630 V AC worldwide thanks to wide voltage range
- Variably adjustable to overshoot, undershoot or range monitoring
- Freely parameterizable delay times and RESET response
- Width 22.5 mm
- Display and transmission of actual value and network fault type to controller
- All versions with removable terminals
- All versions with screw or spring-type terminals

Application



Function	Application
Phase sequence	<ul style="list-style-type: none"> • Direction of rotation of the drive
Phase failure	<ul style="list-style-type: none"> • A fuse has tripped • Failure of the control supply voltage • Broken cable
Phase asymmetry	<ul style="list-style-type: none"> • Overheating of the motor due to asymmetrical voltage • Detection of asymmetrically loaded networks
Undervoltage	<ul style="list-style-type: none"> • Increased current at a motor with corresponding overheating • Unintentional resetting of a device • Network collapse, particularly with battery power
Overvoltage	<ul style="list-style-type: none"> • Protection of a plant against destruction due to overvoltage

SIRIUS 3UG48 monitoring relays for stand-alone installation for IO-Link

Line monitoring

Selection and ordering data

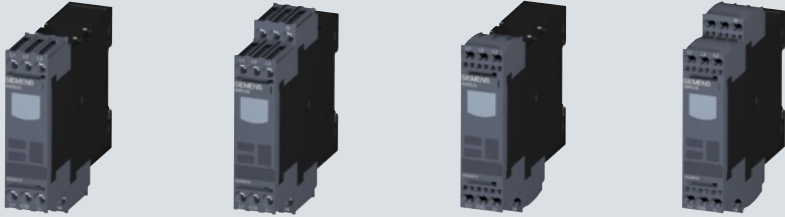
- Adjustable via IO-Link and locally, with illuminated LCD
- Power supply with 24 V DC via IO-Link or external auxiliary voltage
- Auto or manual RESET
- Open or closed-circuit principle
- 1 CO contact, 1 semiconductor output (in SIO mode)

										
Adjustable hysteresis	Under-voltage detection	Overtoltage detection	Stabilization time adjustable stDEL	Tripping delay time adjustable Del	Version of auxiliary contacts	Measurable mains voltage ¹⁾	Order No.	Order No.	Order No.	
			s	s		V AC				

Monitoring of phase sequence, phase failure, phase asymmetry, overvoltage and undervoltage

1 ... 20 V	✓	✓	0.1 ... 999.9	0.1 ... 999.9	1 W + 1 Q ²⁾	160 ... 690	3UG48 15-1AA40	3UG48 15-2AA40
------------	---	---	---------------	---------------	-------------------------	-------------	-----------------------	-----------------------

Monitoring of phase sequence, phase and N conductor failure, overvoltage and undervoltage

1 ... 20 V	✓	✓	0.1 ... 999.9	0,1 ... 999.9	1 W + 1 Q ²⁾	90 ... 400 against N	3UG48 16-1AA40	3UG48 16-2AA40
------------	---	---	---------------	---------------	-------------------------	----------------------	-----------------------	-----------------------

✓ Function available

1) Absolute limit values.

2) In SIO mode

Note:

For accessories, see page 7/37.

Scheduled start of delivery: October 2011

SIRIUS 3UG48 monitoring relays for stand-alone installation for IO-Link

Voltage monitoring

Overview

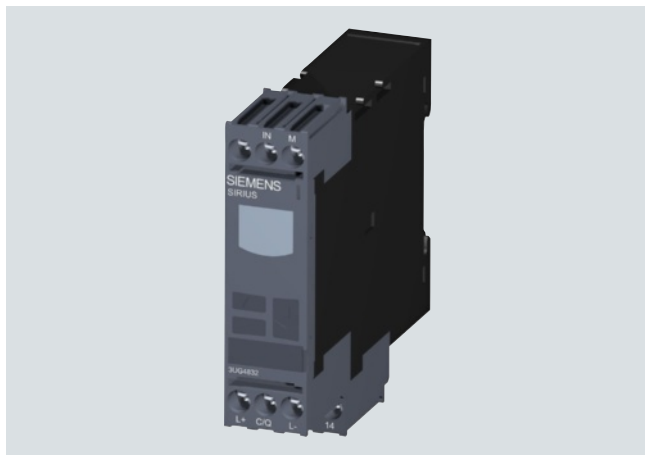

SIRIUS 3UG48 32 monitoring relay

The relays monitor single-phase AC voltages (rms value) and DC voltages against the set limit value for overshoot and undershoot.

Benefits

- Variably adjustable to overshoot, undershoot or range monitoring
- Freely parameterizable delay times and RESET response
- Width 22.5 mm
- Display and transmission of actual value and status messages to controller
- All versions with removable terminals
- All versions with screw or spring-type terminals

Application

- Protection of a plant against destruction due to overvoltage
- Switch-on of a plant at a defined voltage and higher
- Protection against overloaded control supply voltages, particularly with battery power

Selection and ordering data

- Adjustable via IO-Link and locally, with illuminated LCD
- Power supply with 24 V DC via IO-Link or external auxiliary voltage
- Auto or manual RESET
- Open or closed-circuit principle
- 1 CO contact, 1 semiconductor output (in SIO mode)

Measuring range	Adjustable hysteresis	ON-delay time adjustable onDel	Tripping delay time separately adjustable U▲Del/U▼Del	3UG48 32-1AA40	3UG48 32-2AA40
V AC/DC	V	s	s	Screw terminals ⊕	Spring-type terminals ⊕
Monitoring of voltage for overshoot and undershoot				Order No.	Order No.
10 ... 600	0.1 ... 300	0 ... 999.9	0 ... 999.9	3UG48 32-1AA40	3UG48 32-2AA40

Note:

For accessories, see page 7/37.

Scheduled start of delivery: October 2011

SIRIUS 3UG48 monitoring relays for stand-alone installation for IO-Link

Current monitoring

Overview

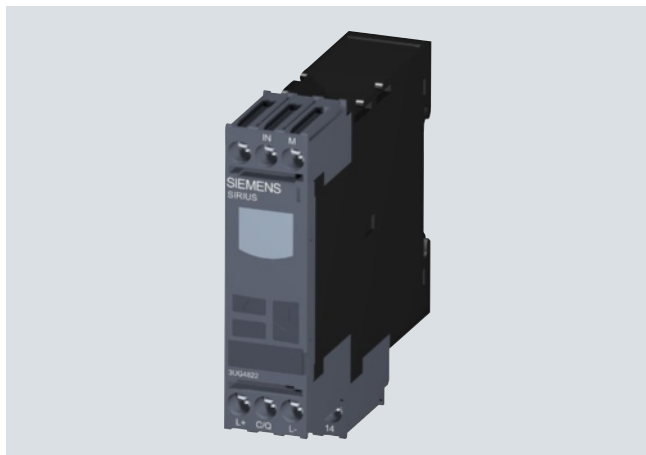

SIRIUS 3UG48 22 monitoring relay

The relays monitor single-phase AC (rms value) and DC currents against the set limit value for overshoot and undershoot.

Benefits

- Variably adjustable to overshoot, undershoot or range monitoring
- Freely parametrizable delay times and RESET response
- Width 22.5 mm
- Display and transmission of actual value and status messages to controller
- All versions with removable terminals
- All versions with screw or spring-type terminals

Application

- Overcurrent and undercurrent monitoring
- Monitoring the functionality of electrical loads
- Monitoring for broken conductors

Selection and ordering data

- Adjustable via IO-Link and locally, with illuminated LCD
- Power supply with 24 V DC via IO-Link or external auxiliary voltage
- Adjustable converter factor to display the measured primary current when external current transformer used
- Auto or manual RESET
- Open or closed-circuit principle
- 1 CO contact, 1 semiconductor output (in SIO mode)

7



3UG48 22-1AA40



3UG48 22-2AA40

Measuring range	Adjustable hysteresis	ON-delay time adjustable onDel	Tripping delay time separately adjustable /▲Del/▼Del	Screw terminals	Spring-type terminals
AC/DC A	A	s	s	⊕	⊕
Order No.				Order No.	

Monitoring of current for overshooting and undershooting

0.05 ... 10	0.01 ... 5	0.1 ... 999.9	0.1 ... 999.9
-------------	------------	---------------	---------------

3UG48 22-1AA40

3UG48 22-2AA40

Note:

For accessories, see page 7/37.

Scheduled start of delivery: October 2011

For AC currents $I > 10$ A it is possible to use commercially available current transformers, e.g. Siemens 4NC current converter, as accessories, see Catalog LV 10.1.

SIRIUS 3UG48 monitoring relays for stand-alone installation for IO-Link

Power factor and active current monitoring

Overview

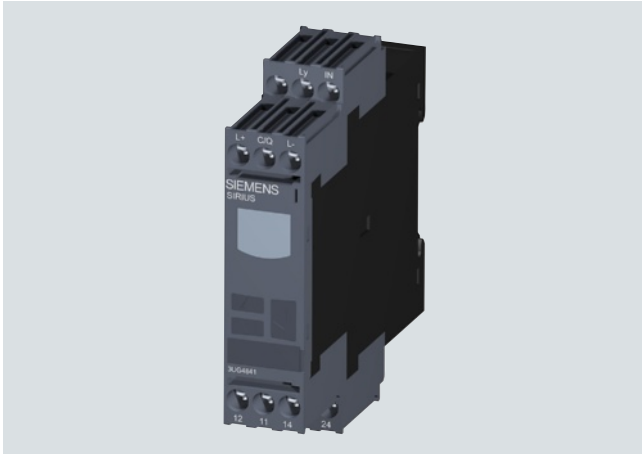

SIRIUS 3UG48 41 monitoring relay

The 3UG48 41 power factor and active current monitoring devices enable the load monitoring of motors.

Whereas power factor monitoring is used above all for monitoring no-load operation, the active current monitoring option can be used to observe and evaluate the load factor over the entire torque range.

Benefits

- Monitoring of even small single-phase motors with a no-load supply current below 0.5 A
- Simple determination of threshold values by the direct collection of measured variables on motor loading
- Range monitoring and active current measurement enable detection of cable breaks between control cabinets and motors, as well as phase failures
- Power factor and/or active current can be selected as the measurement principle
- Width 22.5 mm
- Display and transmission of actual value and status messages to controller
- All versions with removable terminals
- All versions with screw or spring-type terminals

Application

- No-load monitoring and load shedding, such as in the event of a V-belt tear
- Underload monitoring in the low performance range, e.g. in the event of pump no-load operation
- Monitoring of overload, e.g. due to a dirty filter system
- Power factor monitoring in networks for control of compensation equipment
- Broken cable between control cabinet and motor

SIRIUS 3UG48 monitoring relays for stand-alone installation for IO-Link

Power factor and active current monitoring

Selection and ordering data

- For monitoring the power factor and the active current I_{res} (p.f. $\times I$)
- Suitable for single- and three-phase currents
- Adjustable via IO-Link and locally, with illuminated LCD
- Power supply with 24 V DC via IO-Link or external auxiliary voltage
- Overshoot, undershoot or range monitoring
- Upper and lower limit values can be adjusted separately
- Permanent display of actual value and tripping state
- 1 CO contact each for undershoot and overshoot, 1 semiconductor output (in SIO mode)



3UG48 41-1CA40



3UG48 41-2CA40

Measuring range		Voltage range of the measuring voltage ¹⁾	Hysteresis		ON-delay time adjustable onDel	Tripping delay time separately adjustable U \blacktriangle Del/ U \blacktriangledown Del, φ \blacktriangle Del/ φ \blacktriangledown Del	Screw terminals	Spring-type terminals	
For power factor	For active current I_{res}	50/60 Hz AC	Adjustable for power factor	Adjustable for active current I_{res}	s	s			
Power factor	A	V	Power factor	A			Order No.	Order No.	

Monitoring of power factor and active current for overshooting and undershooting

0.1 ... 0.99	0.2 ... 10	90 ... 690	0.1 ... 0.2	0.1 ... 3	0 ... 999.9	0 ... 999.9	3UG48 41-1CA40	3UG48 41-2CA40
--------------	------------	------------	-------------	-----------	-------------	-------------	-----------------------	-----------------------

¹⁾ Absolute limit values.

Note:

For accessories, see page 7/37.

Scheduled start of delivery: October 2011

For AC active currents $I_{res} > 10$ A it is possible to use commercially available current transformers, e.g. Siemens 4NC current converter, as accessories, see Catalog LV 10.1.

SIRIUS 3UG48 monitoring relays for stand-alone installation for IO-Link

Speed monitoring

Overview

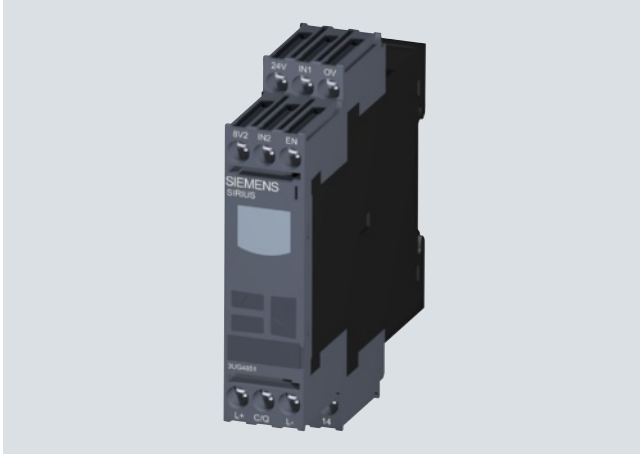

SIRIUS 3UG48 51 monitoring relay

3UG48 51 monitoring relays are used together with a sensor to monitor drives for overspeed and/or underspeed.

Furthermore, the relays are ideal for all functions where a continuous pulse signal needs to be monitored (e.g. belt travel monitoring, completeness monitoring, passing monitoring, clock-time monitoring).

Benefits

- Variably adjustable to overshoot, undershoot or range monitoring
- Freely parameterizable delay times and RESET response
- Display and transmission of actual value and fault type to controller
- Use of up to 10 sensors per revolution on motors rotating extremely slowly
- 2- or 3-wire sensors and sensors with a mechanical switching output or solid-state-output can be connected
- Auxiliary voltage for sensor integrated
- All versions with removable terminals
- All versions with screw or spring-type terminals

Application

- Slip or tear of a belt drive
- Overload monitoring
- Transport monitoring for completeness

SIRIUS 3UG48 monitoring relays for stand-alone installation for IO-Link

Speed monitoring

Selection and ordering data

- For speed monitoring in revolutions per minute (rpm)
- Two- or three-wire sensor with mechanical or electronic switching output can be connected
- Two-wire NAMUR sensor can be connected
- Sensor supply 24 V DC/50 mA integrated
- Input frequency 0.1 to 2 200 pulses per minute (0.0017 to 36.7 Hz)
- With or without enable signal for the drive to be monitored
- Adjustable via IO-Link and locally, with illuminated LCD
- Power supply with 24 V DC via IO-Link or external auxiliary voltage
- Overshoot, undershoot or range monitoring
- Number of pulses per revolution can be adjusted
- Upper and lower limit values can be adjusted separately
- Auto, manual or remote RESET options after tripping
- Permanent display of actual value and tripping state
- 1 CO contact, 1 semiconductor output (in SIO mode)



3UG48 51-1AA40



3UG48 51-2AA40

Measuring range	Adjustable hysteresis	ON-delay time adjustable onDel	Tripping delay time separately adjustable rpm▲Del/rpm▼Del	Pulses per revolution	Screw terminals	Spring-type terminals	
rpm	rpm	s	s		Order No.	Order No.	

Monitoring for overshooting and undershooting

0.1 ... 2 200	OFF 1 ... 99.9	0 ... 999.9	0 ... 999.9	1 ... 10
---------------	----------------	-------------	-------------	----------

3UG48 51-1AA40**3UG48 51-2AA40**Note:





For accessories, see page 7/37.

Scheduled start of delivery: October 2011

For suitable sensors see Catalog ID 10 "Sensors for Production Automation".

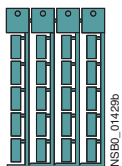
SIRIUS 3UG48 monitoring relays for stand-alone installation for IO-Link

Selection and ordering data

	Use	Version	Order No.
Blank labels			
 NSBD_01428b 3RT19 00-1SB20	For 3UG4	Unit labeling plates for SIRIUS devices 20 mm x 7 mm, pastel turquoise ¹⁾	3RT19 00-1SB20
	For 3UG4	Inscription labels for sticking for SIRIUS devices 19 mm x 6 mm, pastel turquoise 19 mm x 6 mm zinc yellow	3RT19 00-1SB60 3RT19 00-1SD60
Push-in lugs and covers			
 3RP19 03 3RP19 02	For 3UG4	Push-in lugs For screw fixing, 2 units are required for each device	3RP19 03
	For 3UG4	Sealable covers for securing against unauthorized adjustment of setting knobs	3RP19 02
Tools for opening spring-type terminals			
 3RA29 08-1A	For auxiliary circuit connections	Screwdrivers For all SIRIUS devices with spring-type terminals 3.0 mm x 0.5 mm, length approx. 200 mm, titanium gray/black, partially insulated	Spring-type terminals 
			3RA29 08-1A

¹⁾ PC labeling system for individual inscription of unit labeling plates available from:
murrplastik Systemtechnik GmbH
www.murrplastik.de.

SIRIUS 3RS14, 3RS15 temperature monitoring relays for IO-Link

General data

Overview



SIRIUS 3RS14, 3RS15 temperature monitoring relays

The temperature monitoring relays for IO-Link are used to measure temperatures in solid, liquid and gas media.

The temperature is calculated using a sensor in the medium, evaluated by the device and monitored up to two limit values for overshooting or undershooting a working range (window function).

In addition to warnings and a trip function in the case of temperature deviations, the devices can also be used as a temperature controller (one-point, two-point or three-point control).

The devices differ from one another in terms of the type and number of connectable temperature sensors.

- 3RS14: Connection for resistance sensor
- 3RS15: Connection for thermoelements

Function	Temperature monitoring relays		
	3RS14 40	3RS14 41	3RS15 40
Connectable sensor type			
Number of sensors monitored	1	3	1
Resistance sensor	✓	✓	--
Thermoelements	--	--	✓
Temperature monitoring			
Temperature monitoring – exceeded	✓	✓	✓
Temperature monitoring – undershoot	✓	✓	✓
Number of adjustable limit values	2	2	2

- ✓ Function supported
- Function not supported

Order no. scheme

Digit of the order no.	1. - 3.	4.	5.	6.	7.	8.	9.	10.	11.	12.			
	□□□	□	□	□	□	-	□	□	□	□			
Temperature monitoring relays	3 R S												
Device type		□	□										
Version and type of sensor				□	□								
Connection methods							□						
Number and type of outputs								□					
Control supply voltage									□				
Measuring range										□			
Special version										□			
Example	3	R	S	1	4	4	0	-	1	H	B	5	0

Note:

The order no. scheme is presented here merely for information purposes and for better understanding of the logic behind the order numbers.

For your orders, please use the order numbers quote in the catalog in the Selection and ordering data.

Connection methods

The temperature monitoring relays 3RS14, 3RS15 for IO-Link can be delivered with screw or spring-type terminals



Screw terminals



Spring-type terminals

SIRIUS 3RS14, 3RS15 temperature monitoring relays for IO-Link

General data

Design

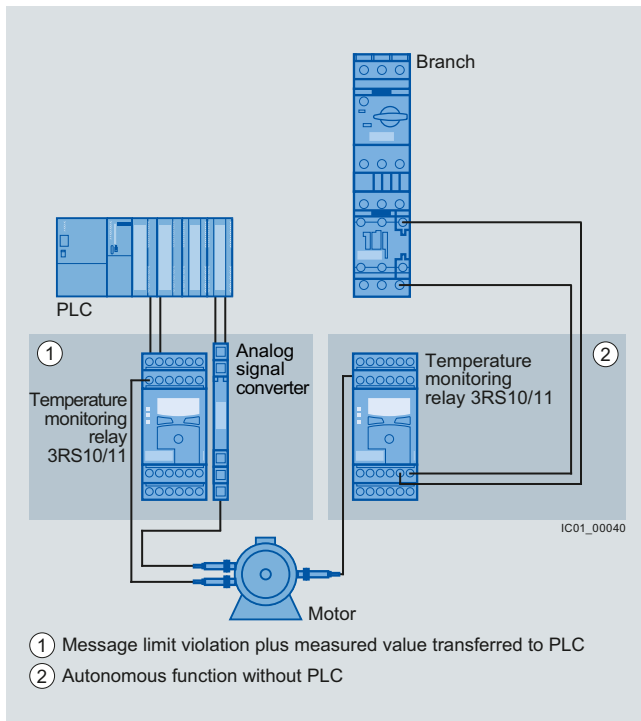

Conventional temperature monitoring relays

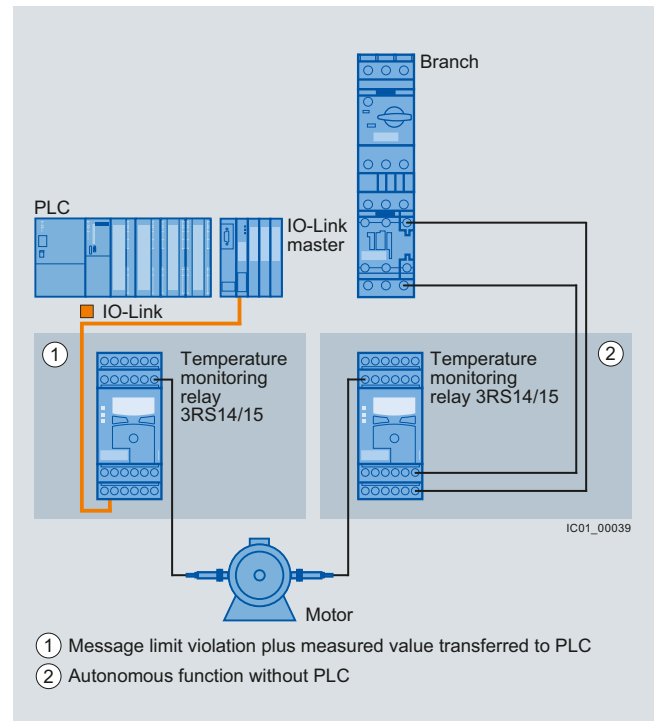

Temperature monitoring relays for IO-Link

Notes:

Devices required for the communication via IO-Link:

- Any controller that supports the IO-Link (e.g. ET 200S with CPU or S7-300 plus ET 200S distributed peripherals, see Catalog ST 70)
- IO-Link master (IO-Link master 4SI IO-Link or 4SI SIRIUS interface module, which can connect all SIRIUS IO-Link devices to a controller, see page 7/4)

Each monitoring relay requires an IO-Link channel.

SIRIUS 3RS14, 3RS15 temperature monitoring relays for IO-Link

Relay, digitally configurable for 1 sensor

Overview

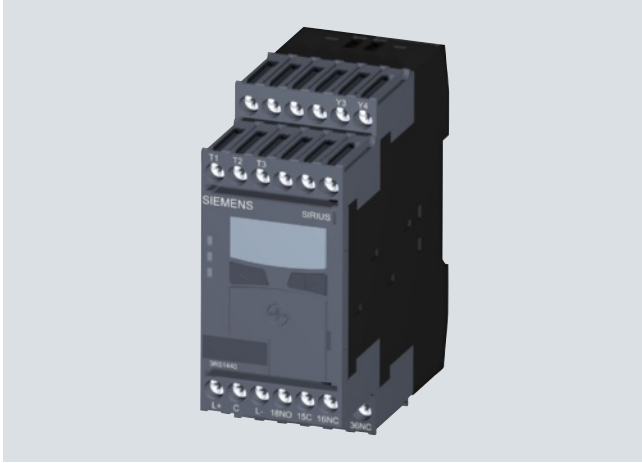

Digital monitoring relay SIRIUS 3RS14 40 for 1 sensor

The 3RS14 and 3RS15 temperature monitoring relays for IO-Link are used to measure temperatures in solid, liquid and gas media. The temperature is calculated using a sensor in the medium, evaluated by the device and monitored for overshooting or undershooting a working range (range monitoring). The digital temperature monitoring relays have two separately adjustable limit values, are non-volatile and can be operated as desired using the open- or closed-circuit principle.

The devices differ in terms of the number of temperature sensors which can be evaluated. The 3RS14 40 and 3RS15 40 for IO-Link temperature monitoring relays can be digitally adjusted for one sensor and represent an alternative to temperature controllers in the low-end section (two-point or three-point control).

The devices with two-point control can, for example, be used as a thermostat. The devices with three-point control can, for example, independently switch between heating and cooling.

The 3RS14 41 temperature monitoring relays for IO-Link can be digitally configured to evaluate up to three resistance sensors at one time. The devices were designed specifically for monitoring motor windings and positions.

The temperature monitoring relays are powered through the control supply voltages IO-Link (L+) and earth (L-) or via an external 24 V DC power supply.

Monitoring

When the temperature has reached the ϑ_1 limit value, the K1 output relay changes its switching state after the configured time t has expired (output relay K2 reacts accordingly at ϑ_2). The delay time can be adjusted.

The output relays return immediately to their original state once the temperature reaches the respective hysteresis value.

When the temperature has reached the top ϑ_1 limit value, the K1 output relay changes its switching state after the configured time t has expired. The output relay returns immediately to its original state once the temperature reaches the respective hysteresis value.

The K2 output relay reacts in the same way at the ϑ_2 lower threshold. Both limit values ϑ_1 and ϑ_2 can be parameterized for overshooting or undershooting the thresholds. This makes it possible to use a limit value for issuing an alarm signal to announce that a value a limit value is about to be overshoot or undershot.

Note:

The "Temperature monitoring mode" parameter can be used to set the desired type of monitoring (monitoring for overshooting or undershooting or range monitoring).

Benefits

- Very simple operation without complicated menu selections
- Two- or three-point control can be parameterized quickly
- All versions with removable terminals
- All versions with screw or spring-type terminals

Application

The temperature monitoring relays can be used in almost any application in which temperature overshoot or undershoot is not permitted, e.g. in the monitoring of set temperature limits and the output of alarm messages for:







- Plant and environment protection
- Temperature limits for process variables e.g. in the packaging industry or electroplating
- Temperature limits for district heating plants
- Exhaust temperature monitoring
- Controlling equipment and machines such as heating, climate and ventilation systems, solar collectors, heat pumps or warm water supplies
- Motor, bearing and gear oil monitoring
- Monitoring of coolants

SIRIUS 3RS14, 3RS15 temperature monitoring relays for IO-Link

Relay, digitally configurable for 1 sensor

Selection and ordering data

- To monitor temperatures with a resistance sensor or thermoelement
- Temperature range dependent on sensor type
- 99 to + 1 800 °C or - 146.2 to + 3 272 °F
- Short-circuit and open-circuit detection in sensor circuit
- Adjustable via IO-Link and locally, with illuminated LCD
- Power supply with 24 V DC via IO-Link or external auxiliary voltage
- Overshoot, undershoot or range monitoring
- Exact sensor type can be set
- 2 limit values, can be adjusted separately
- Adjustable open/closed-circuit principle
- Can be adjusted by hand or remote RESET (via an external contact)
- Actual value, tripping state for control displayed and conveyed, adjustable in °C or °F
- 1 CO contact per limit value
- 1 CO contact for monitoring sensors and devices

							
3RS14 40-1HB50		3RS15 40-1HB80		3RS14 40-2HB50		3RS15 40-2HB80	
Sensors	Measuring range (limit of measuring range dependent on sensor)	Hysteresis can be adjusted for 91 and 92	Tripping delay time can be adjusted for 91 and 92	Control supply voltage U_s	Screw terminals 	Spring-type terminals 	
		K	s	V DC	Order No.	Order No.	

Temperature monitoring relay, digitally configurable for a sensor, remnant fault storage can be selected

PT100/PT1000, KTY83/KTY84, NTC (resistance sensor) ¹⁾	- 50 ... + 750 °C or - 58 ... + 1 382 °F	0 ... 99	0 ... + 999.9	24	3RS14 40-1HB50	3RS14 40-2HB50
Type B, E, J, K, N, R, S, T or (thermoelements)	- 99 ... + 1 800 °C - 146.2 ... + 3 272 °F	0 ... 99	0 ... + 999.9	24	3RS15 40-1HB80	3RS15 40-2HB80

¹⁾ NTC-type B57227-K333-A1 (100 °C: 1.8 kΩ; 25 °C: 32.762 kΩ).

Note:

For accessories, see Page 7/44.

SIRIUS 3RS14, 3RS15 temperature monitoring relays for IO-Link

Relay, digitally configurable for up to 3 sensors

Overview

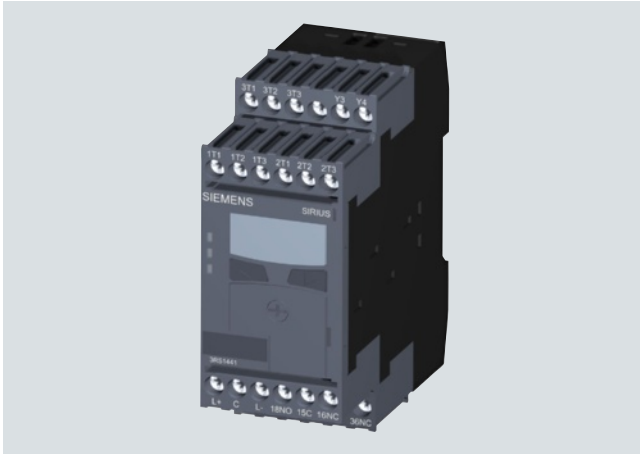

Digital monitoring relay SIRIUS 3RS14 41 for up to 3 sensors

The 3RS14 temperature monitoring relays can be used to measure temperatures in solid, liquid and gas media. The temperature is calculated using a sensor in the medium, evaluated by the device and monitored for overshooting or undershooting a working range (range monitoring). The devices show the measured temperature in °C or °F. The 3RS14 41 evaluation unit can evaluate up to 3 resistance sensors at one time.

Benefits

- Very simple operation without complicated menu selections
- Space-saving with 45 mm width
- Two- or three-point control can be parametrized quickly
- All versions with removable terminals
- All versions with screw or spring-type terminals

Application

The 3RS14 41 temperature monitoring relays can be used almost anywhere where several temperatures must be monitored at one time for overshooting, undershooting or staying within a certain range.

Monitoring of set temperature limits and output of alarm messages for:

- Plant and environment protection
- Temperature limits for process variables e.g. in the packaging industry or electroplating
- Controlling equipment and machines such as heating, climate and ventilation systems, solar collectors, heat pumps or warm water supplies
- Motor, bearing and gear oil monitoring
- Monitoring of coolants

SIRIUS 3RS14, 3RS15 temperature monitoring relays for IO-Link

Relay, digitally configurable for up to 3 sensors

Selection and ordering data

- For temperature monitoring with up to 3 resistance sensors
- Temperature range dependent on sensor type
-50 to +750 °C or -58 to +1 382 °F
- Short-circuit and open-circuit detection in sensor circuit
- Adjustable via IO-Link and locally, with illuminated LCD
- Power supply with 24 V DC via IO-Link or external auxiliary voltage
- Overshoot, undershoot or range monitoring
- Exact sensor type and number of sensors can be set
- 2 limit values, can be adjusted separately
- Adjustable open/closed-circuit principle
- Can be adjusted by hand or remote RESET (via an external contact)
- Actual value, tripping state for control displayed and conveyed, adjustable in °C or °F
- 1 CO contact per limit value
- 1 CO contact for monitoring sensors and devices



3RS14 41-1HB50



3RS14 41-2HB50

Sensors	Number of sensors that can be set	Measuring range (limit of measuring range dependent on sensor)	Hysteresis can be adjusted for 91 and 92	Tripping delay time can be adjusted for 91 and 92 DELAY	Control supply voltage U_s	Screw terminal	Spring-type terminals
		K	s	V DC			
						Order No.	Order No.

Temperature monitoring relay, digitally adjustable for up to 3 sensors, remnant fault storage can be selected

PT100/PT1000, KTY83/KTY84, NTC (resistance sensor) ¹⁾	1 ... 3 sensors	- 50 ... + 750 °C or - 58 ... + 1 382 °F	0 ... 99	0 ... + 999.9	24	3RS14 41-1HB50	3RS14 41-2HB50
------------------------------------------------------------------------------	--------------------	------------------------------------------------	----------	---------------	----	-----------------------	-----------------------

¹⁾ NTC type: B57227-K333-A1 (100 °C: 1.8 kΩ; 25 °C: 32.762 kΩ).





Note:

For accessories, see Page 7/44.

SIRIUS 3RS14, 3RS15 temperature monitoring relays for IO-Link

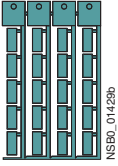
Accessories

Selection and ordering data

	Use	Version	Order No.
Blank labels			
 NSBDL 01429B 3RT19 00-1SB20	For 3RS1	Unit labeling plates for SIRIUS devices 20 mm x 7 mm, pastel turquoise ¹⁾	3RT19 00-1SB20
	For 3RS1	Inscription labels for sticking for SIRIUS devices 19 mm x 6 mm, pastel turquoise 19 mm x 6 mm zinc yellow	3RT19 00-1SB60 3RT19 00-1SD60
Push-in lugs and covers			
 3RP19 03	For 3RS1	Push-in lugs For screw fixing, 2 units are required for each device	3RP19 03
	For 3RS1	Sealing foil For securing against unauthorized adjustment of setting knobs	3TK28 20-0AA00
Tools for opening spring-type terminals			
 3RA29 08-1A	For auxiliary circuit connections	Screwdrivers For all SIRIUS devices with spring-type terminals 3.0 mm x 0.5 mm, length approx. 200 mm, titanium gray/black, partially insulated	Spring-type terminals  3RA29 08-1A

¹⁾ PC labeling system for individual inscription of unit labeling plates available from:
 murrplastik Systemtechnik GmbH
www.murrplastik.de.

Note:

For the appropriate sensors, see
www.siemens.com/temperature.

Industrial Wireless Communication



8/2	Introduction		
Ch. 9	Industrial Wireless Telecontrol		
9/12	CP 1242-7	8/103	IWLAN – Client Modules IEEE 802.11n
9/17	GSM/GPRS-Modem MD720-3	8/103	Overview
9/122	EGPRS-Router MD741-1	8/106	SCALANCE W748 RJ45 for use in the control cabinet
9/128	UMTS-Router SCALANCE M87x	8/110	SCALANCE W748 M12 for use in the indoor area
8/3	Industrial Wireless LAN (IWLAN)		
8/3	Introduction	8/115	IWLAN – Client Modules IEEE 802.11a/b/g
8/6	Application examples	8/115	Overview
8/10	Overview of network components	8/120	SCALANCE W740 for use in the control cabinet
8/15	IWLAN – Access Points IEEE 802.11n	8/128	SCALANCE W740 for use in the indoor area
8/15	Overview	8/136	IWLAN – Accessories
8/18	SCALANCE W788 RJ45 for use in control cabinet	8/136	IWLAN antennas
8/24	SCALANCE W788 M12 for the indoor area	8/154	IWLAN RCoax cables
8/31	SCALANCE W786 RJ45 for the outdoor area	8/161	IWLAN cabling technology
8/39	IWLAN – Controller and Controller Access Points IEEE 802.11n	8/165	Power supply PS791-1PRO
8/39	Overview	8/167	Power Supply PS791-2DC and PS791-2AC
8/43	Industrial Wireless LAN Controller SCALANCE WLC711	8/169	IWLAN – Wireless Devices
8/47	Controller Access Points SCALANCE W788C RJ45 for control cabinet	8/169	SIMATIC Mobile Panel 277(F) IWLAN
8/50	Controller Access Points SCALANCE W788C M12 for the indoor area	8/183	IM 154-6 PN IWLAN
8/53	Controller Access Points SCALANCE W786C RJ45 for the outdoor area	8/185	IWLAN – Network transition
8/58	IWLAN – Access Points IEEE 802.11a/b/g	8/185	IWLAN/PB Link PN IO
8/58	Overview	8/190	Engineering/ network management/ diagnostics
8/63	SCALANCE W784 for use in the control cabinet	8/190	SINEMA E
8/70	SCALANCE W788 for the indoor area	8/194	WirelessHART
8/79	SCALANCE W786 for the outdoor area	8/194	Introduction
8/98	IWLAN – Controller Access Points IEEE 802.11a/b/g	8/195	SITRANS P280
8/98	Controller Access Points SCALANCE W786 for the outdoor area	8/197	SITRANS TF280
		8/198	SITRANS AW200
		8/199	IE/WSN-PA LINK

Industrial Wireless Communication

Introduction

Overview

Wireless communications offer multiple new opportunities to the industry for the development of highly flexible and efficient automation solutions. Whether Industrial Wireless Telecontrol, IWLAN, or WirelessHART, the Siemens product line for Industrial Wireless Communications is reliable, robust and secure. The components are used under the toughest indoors and outdoors conditions. Their multiple applications in crane systems, automatic guided vehicle systems, or in remote operation / remote maintenance systems are a testimonial to their exceptional reliability.

Further information can be found under the product entries for GSM, GPRS and UMTS modems and routers in the section on Industrial Remote Communication.

Further information on WirelessHART can be found under the product entries for WirelessHART as well as in Catalog FI 01 and at www.siemens.com/wirelesshart

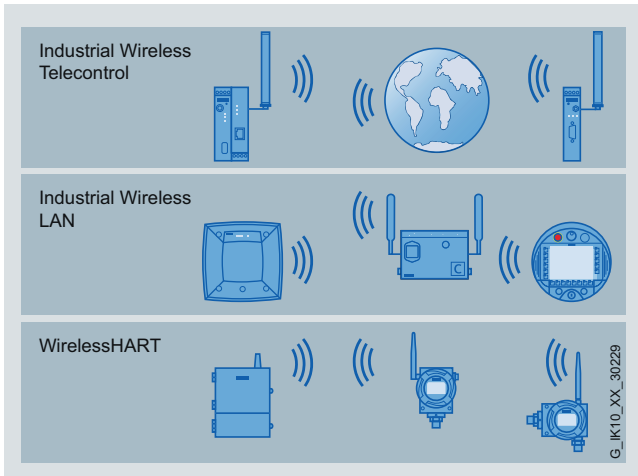

Wireless data transmission via Industrial Wireless TeleControl, Industrial Wireless LAN, and WirelessHART

Overview

SCALANCE W – wireless communication with Industrial Wireless LAN

The SCALANCE W products offer the combination of reliability, ruggedness and security in one product:

- For implementation at industrial and automation customer sites
- For outdoor environments with demanding climatic requirements
- For low-cost integration in the control cabinet or in devices

The Industrial Wireless LAN (IWLAN) technology provides an extension to the IEEE 802.11 standard that is particularly suited to demanding industrial applications with real-time and redundancy requirements. This provides customers with a unique wireless network, both for process-critical data and for uncritical communication. SCALANCE W products distinguish themselves by the reliability of their radio channel and the rugged type of construction with high requirements with respect to mechanical durability for which SIMATIC is known. To protect against unauthorized access, the products provide modern standard mechanisms for user identification (authentication) and encryption of data, and can at the same time be easily integrated into existing security concepts.

Radio infrastructure

Instead of copper cables and fiber-optic cables, wireless transmission techniques use radio waves. The propagation characteristics of the electromagnetic waves can differ considerably and depend on the spatial environment with the installed wireless infrastructure.

SCALANCE W modules use techniques such as antenna switchover (antenna diversity), high-quality receivers and fault-tolerant modulation procedures to enhance reception and to prevent interruption of radio communication. Extensions to the IEEE 802.11 standard also permit reliable, wireless transmission from PROFINET, form the basis for wireless safety applications and the transmission of video data with extremely short reply and update data.

Network solution with IWLAN

With mobile data terminals, for example, a continuous information flow from the management level down to the production level is possible.

The SINEMA E software is available for simplified planning and configuration of an IWLAN network with the help of simulation functions. It visualizes clearly and details wireless and device properties, thus reducing the configuring and startup overhead and helping to avoid configuring errors.

The IWLAN/PB Link PN IO is available for wireless-based connection of PROFIBUS devices.

This means that information can be provided quickly, reliably and easily at the right place and at the right time wirelessly.

Ruggedness and industrial suitability

The SCALANCE W products can be exposed to fluctuations in the extended temperature range, or continuous contact with dust and water. Rugged housing and design protection against shock and vibration enable use in harsh industrial environments.

The accessories such as antennas, power supplies and cabling are also part of this concept and suitable for use in industry.

Power and data are transferred over one cable with Power-over-Ethernet, thus saving investment and maintenance costs.

The swap medium C-PLUG (Configuration Plug) saves configuring data, making device replacement possible in a short time and without specially trained personnel. This minimizes standstill times and saves training costs.

Reliability of data communication

The international standard IEEE 802.11n makes wireless communication via IWLAN even more robust. Maximum benefit derives from using multiple path propagation (**M**ultiple **I**nput, **M**ultiple **O**utput (MIMO)). This allows the devices to use several antennas in parallel. A higher data transfer rate is thus achieved and fault susceptibility in environments with a high number of reflections is reduced.

SCALANCE W products with IWLAN in accordance with IEEE 802.11n support up to three "streams" in the send and receive directions.

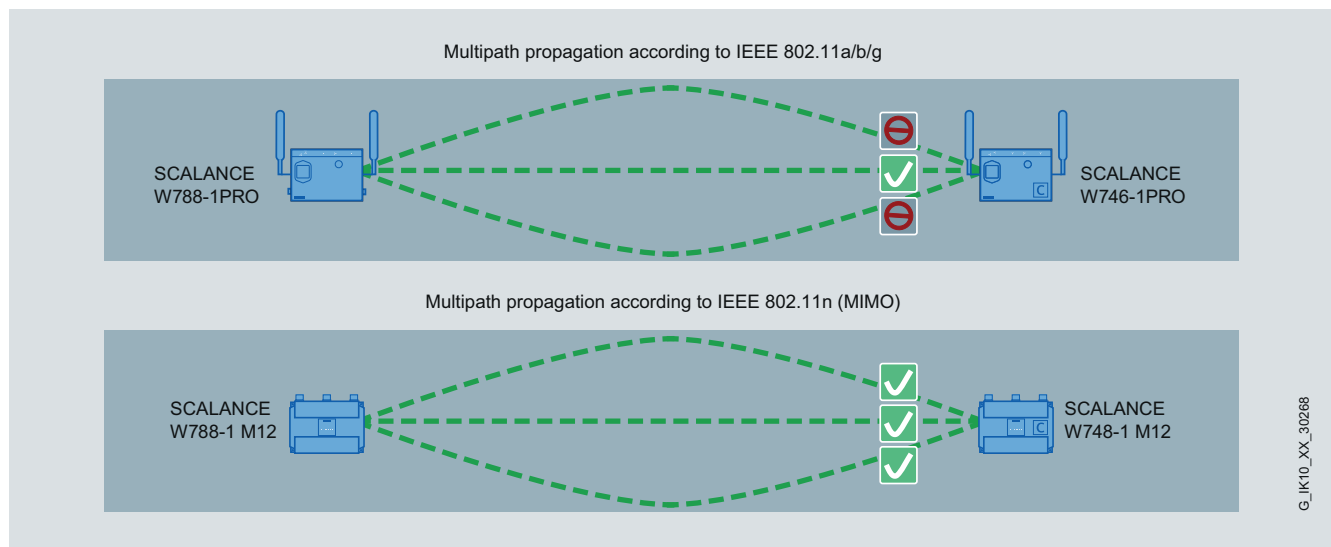

Multiple path propagation (MIMO) with SCALANCE W788-1PRO and SCALANCE W788-1 M12

Industrial Wireless Communication

Industrial Wireless LAN (IWLAN)

Introduction

Overview (continued)

Redundant network concepts can also be implemented wirelessly. Wireless channels are designed redundantly for this purpose, with a changeover time of a few milliseconds, so that the application is not influenced by packet repetitions or interference in the radio channel.

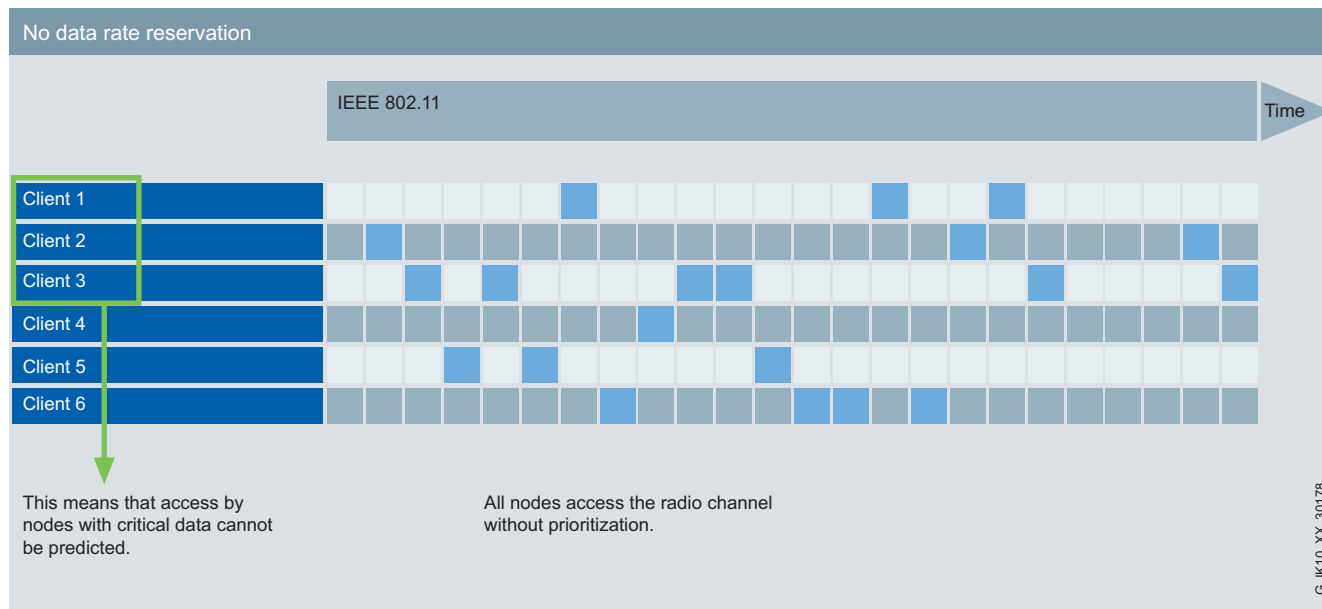

In standard WLAN, **all stations access** the radio channel in an uncoordinated manner. This means that access by stations with critical data cannot be predicted.

The iPCF function (support from device types with i features) permits cyclic data traffic in real time for several wirelessly linked PROFINET IO devices. In addition, this enables mobile stations to be transferred quickly from one radio field to another (roaming) so that PROFINET IO communication is not interrupted.

8

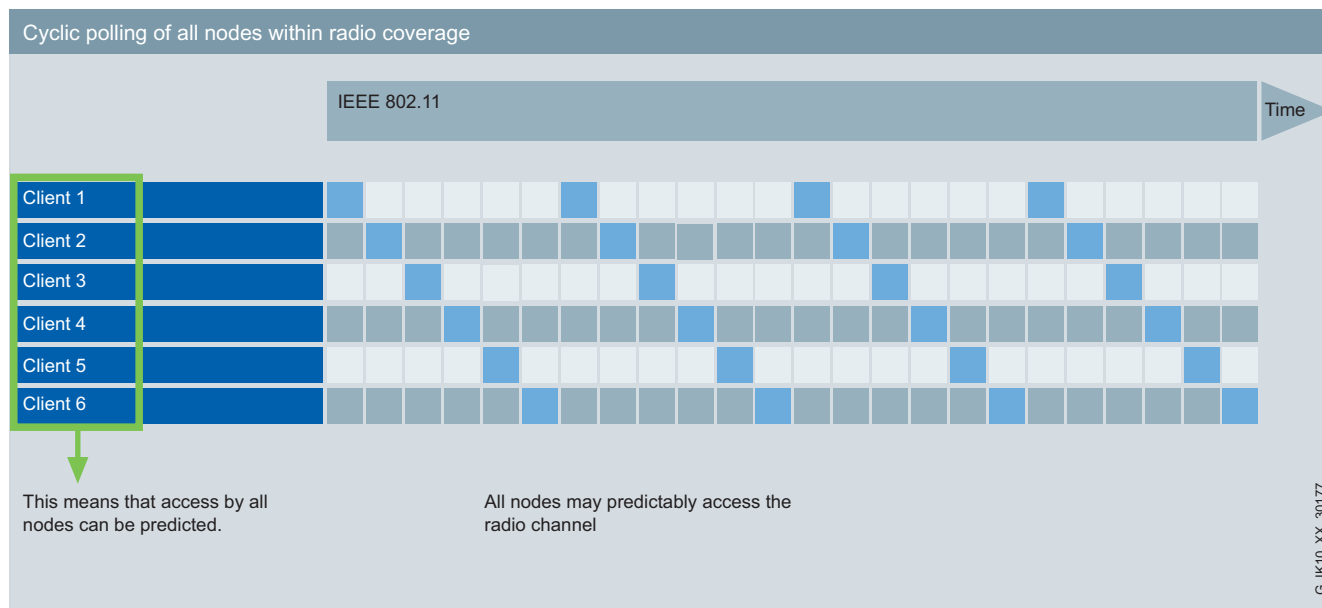

However, WLAN also provides a transmission mechanism based on standard WLAN in accordance with IEEE 802.11, which makes a defined data rate available to all stations. This means that access **by all stations** can be predicted.

Overview (continued)

Increased transmission rate

WLAN systems in accordance with IEEE 802.11a/b/g/h use a single channel for sending and receiving data. This achieves a maximum gross transmission rate of 54 Mbit/s.

Two channels are used simultaneously with the help of channel bonding. Gross transmission rates of up to 450 Mbit/s can be achieved in conjunction with the MIMO technology in accordance with IEEE 802.11n.

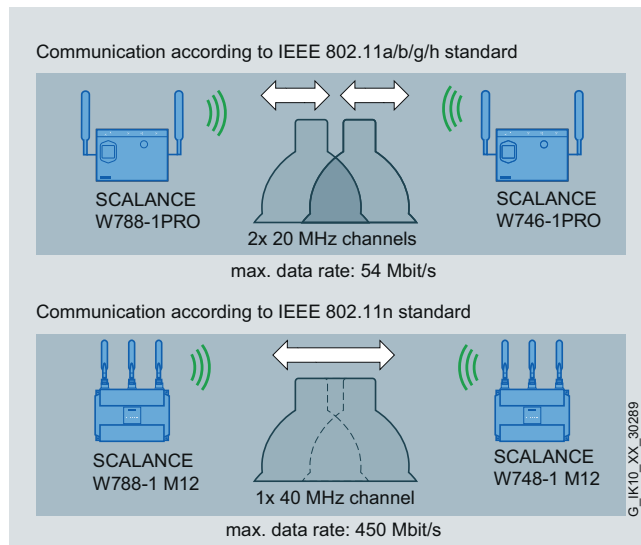

Increased transmission rate on IWLAN in accordance with IEEE 802.11n with the help of channel bonding

Benefits

get **Designed for Industry**

- High level of investment protection, as all products comply with the universally recognized IEEE 802.11 standard and are suitable for 2.4 GHz and 5 GHz
- Wear-free – saves maintenance and repair costs for connectors, trailing cables, sliding contacts or winding devices
- Reliable wireless connection, e.g. due to redundant connection, automatic roaming if there is a break in the cable connection from the access point (forced roaming), cyclic monitoring of the wireless link (link check), or monitoring for IP connections (IP Alive)
- Predictable data traffic (deterministic) and defined response times on the radio link
- Wireless transmission of standard and failsafe signals by means of PROFINET and PROFIsafe
- More economical installation in hazardous areas of Zone 2
- Rapid commissioning thanks to reduced overhead for installing the communication network when using the SINEMA E engineering tool. This provides support for planning, simulating and measuring an IWLAN radio link on-site (site survey)
- Integrated wireless network for data, voice and video beyond corporate divisions thanks to interfacing with the SCALANCE WLC IWLAN controller (support from SCALANCE W78xC device types)

Industrial Wireless Communication

Industrial Wireless LAN (IWLAN)

Application examples

Overview

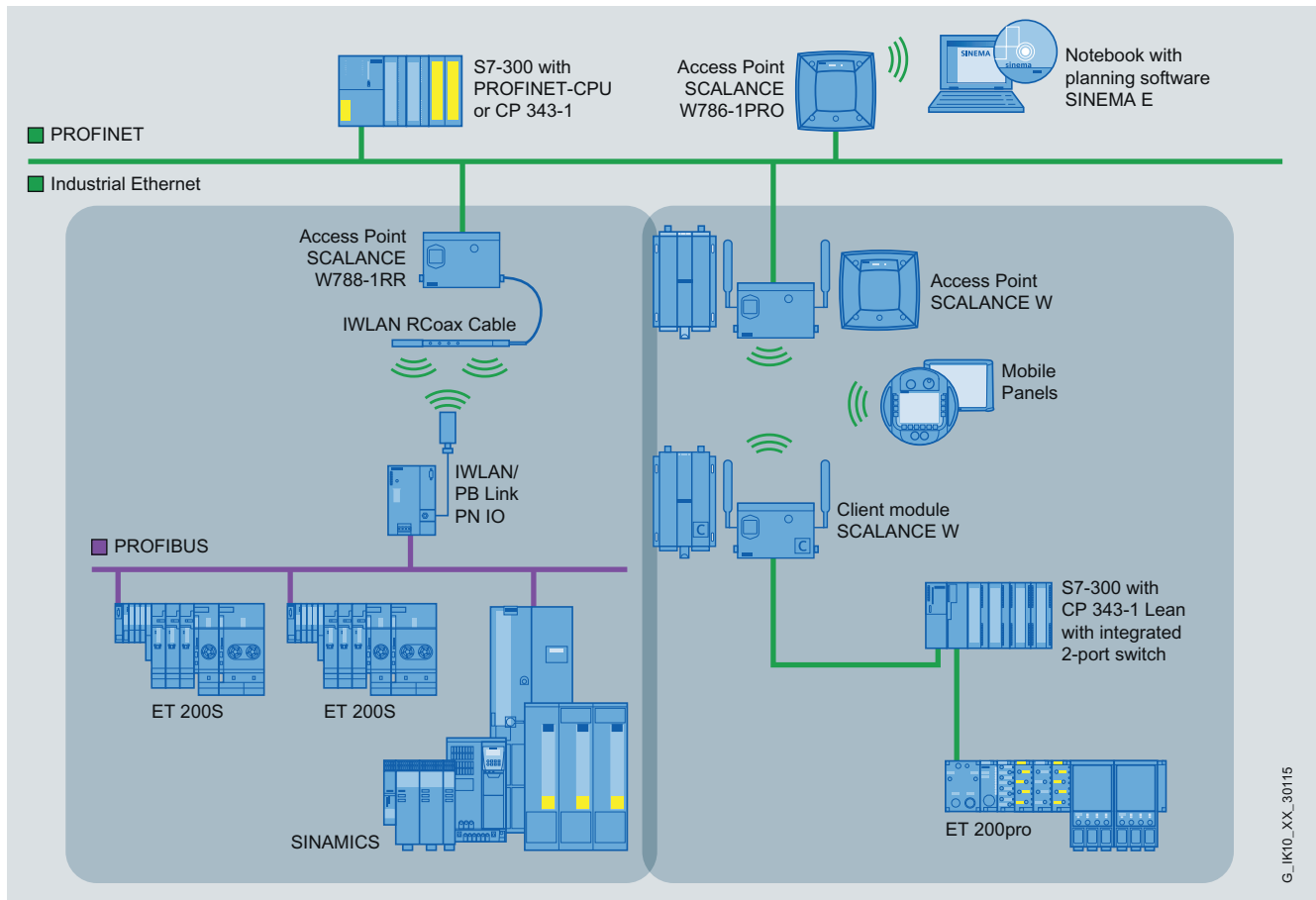

Wireless integration of PROFIBUS segments and PROFINET stations into an existing Industrial Ethernet network

An existing Ethernet network can be expanded by a wireless network without increased overhead.

With this, even an existing PROFIBUS line can be connected via the IWLAN/PB Link PN IO to an access point.

The radio connection is established to the mobile stations by connecting a SCALANCE W access point to the Ethernet network. The mobile stations are connected wirelessly, e.g. via the SCALANCE W746-1PRO Client Module, to which the mobile station is connected with a cable.

Access to the existing controllers or processes is possible without an excessive additional wiring overhead.

Overview (continued)

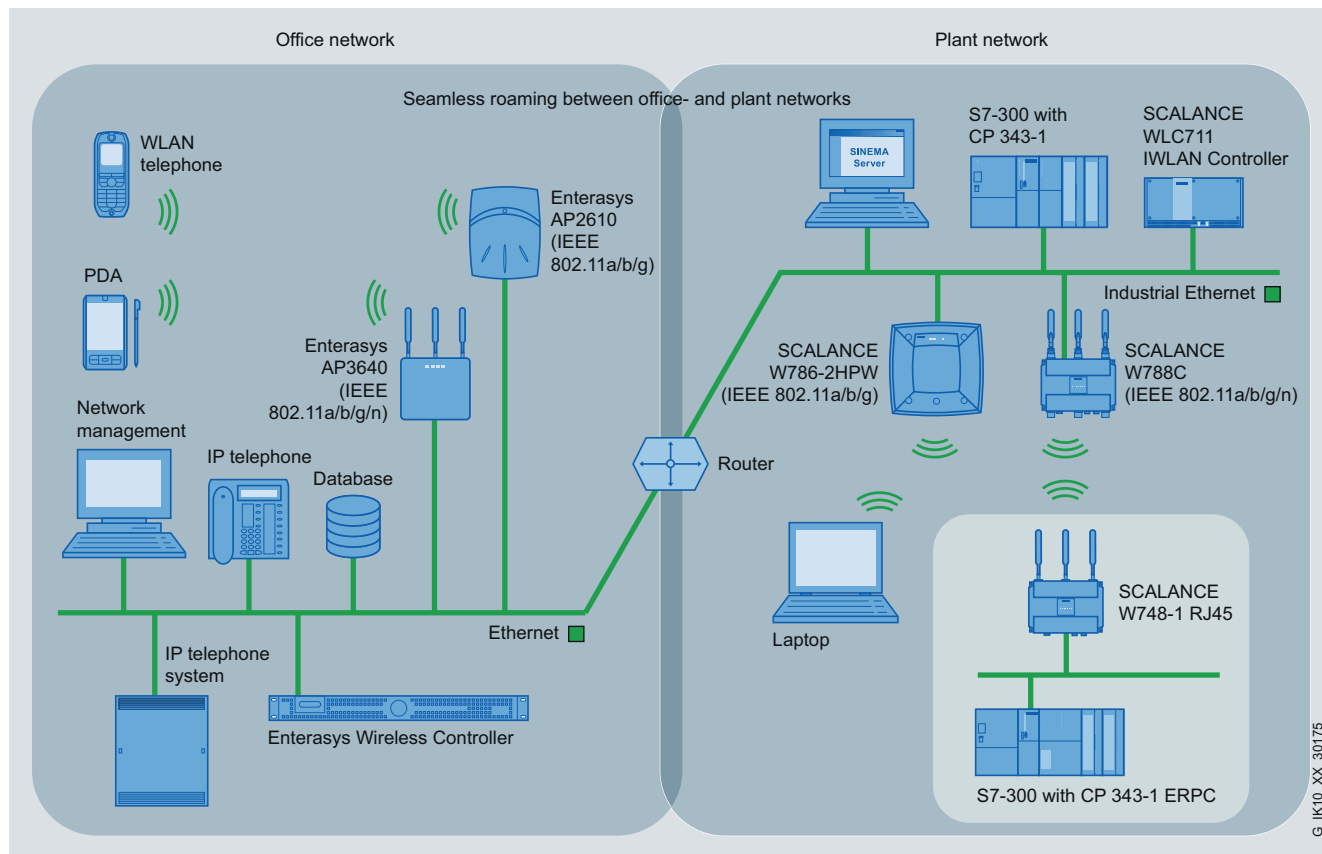

Uninterruptible roaming between the office and automation network by using wireless LAN controllers and industrial wireless LAN controllers

By using the SCALANCE WLC Industrial Wireless LAN Controller together with controller-based access points, it is possible to establish a single wireless infrastructure for the entire company. This achieves a high level of flexibility, as mobile stations (e.g. laptop, PDA, WLAN telephone) can move anywhere, switching seamlessly between the office and automation networks (roaming). This allows wireless access to data from any location within the company. Thanks to the use of a centralized security mechanism for each user group (Virtual Network Services VNS), the data here is protected against unauthorized access and manipulation.

The SCALANCE W78xC controller-based access points support the WLAN standards IEEE 802.11a/b/g and 802.11n, and they are connected via Gigabit Ethernet to the SCALANCE WLC IWLAN Controller.

The SCALANCE W786-2HPW controller-based access points support the WLAN standards IEEE 802.11a/b/g, and they are connected via Fast Ethernet to the SCALANCE WLC IWLAN Controller.

Operation always requires the SCALANCE WLC IWLAN Controller, which permits the configuration of access points in groups. This significantly increases the manageability of an extensive IWLAN infrastructure. Central management with the IWLAN controller also permits fault recording, monitoring and documentation of statistics.

Industrial Wireless Communication

Industrial Wireless LAN (IWLAN)

Application examples

Overview (continued)

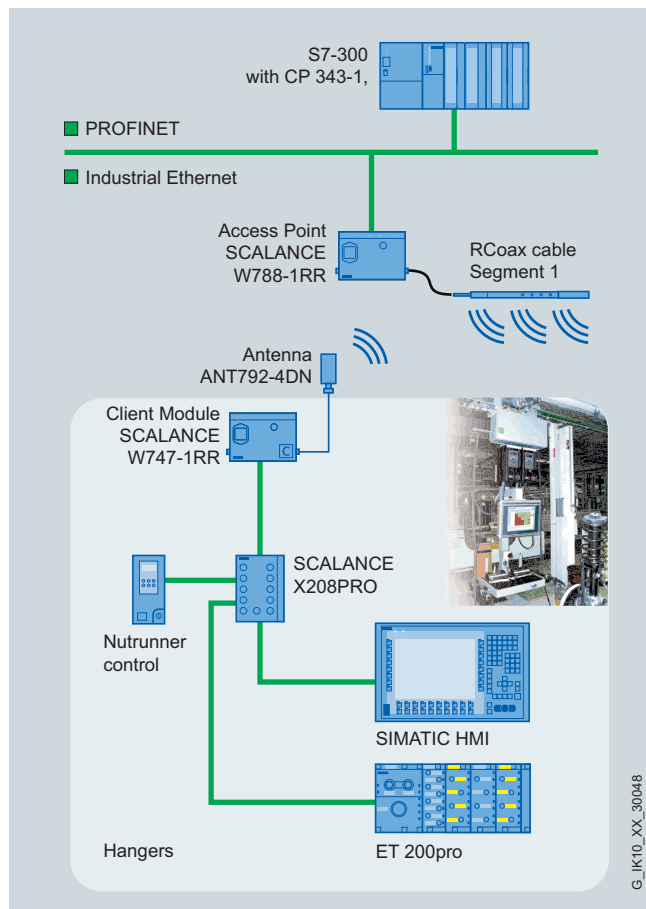

System solution for nutrunner controls with RCoax cable and SCALANCE W747-1RR

Wireless solutions with RCoax cable are typically used in the following applications:

- Crane control
- Overhead monorail conveyors
- Storage and retrieval systems
- Automated guided vehicle systems (AGVS)

An example of an application with a suspended monorail is a nutrunner controller in a car assembly plant.

An RCoax radiating cable is used along the coding rail to establish wireless data transfer between the monorail and the central controller. It generates a defined, spherical and reliable wireless field and is easy to lay.

The RCoax Cable is connected as an antenna to a stationary SCALANCE W788-1RR access point. This means the same mobile unit can be used for all applications and so a mobile nutrunner can be used for several cycles resulting in lower investment costs.

Maintenance costs and downtimes are reduced by reliable wireless and therefore wear-resistant data transmission to mobile communication partners

Downtimes are reduced because in the event of a fault, devices can be replaced without a programming device or specialist personnel by using the swap medium C-PLUG.

Overview (continued)

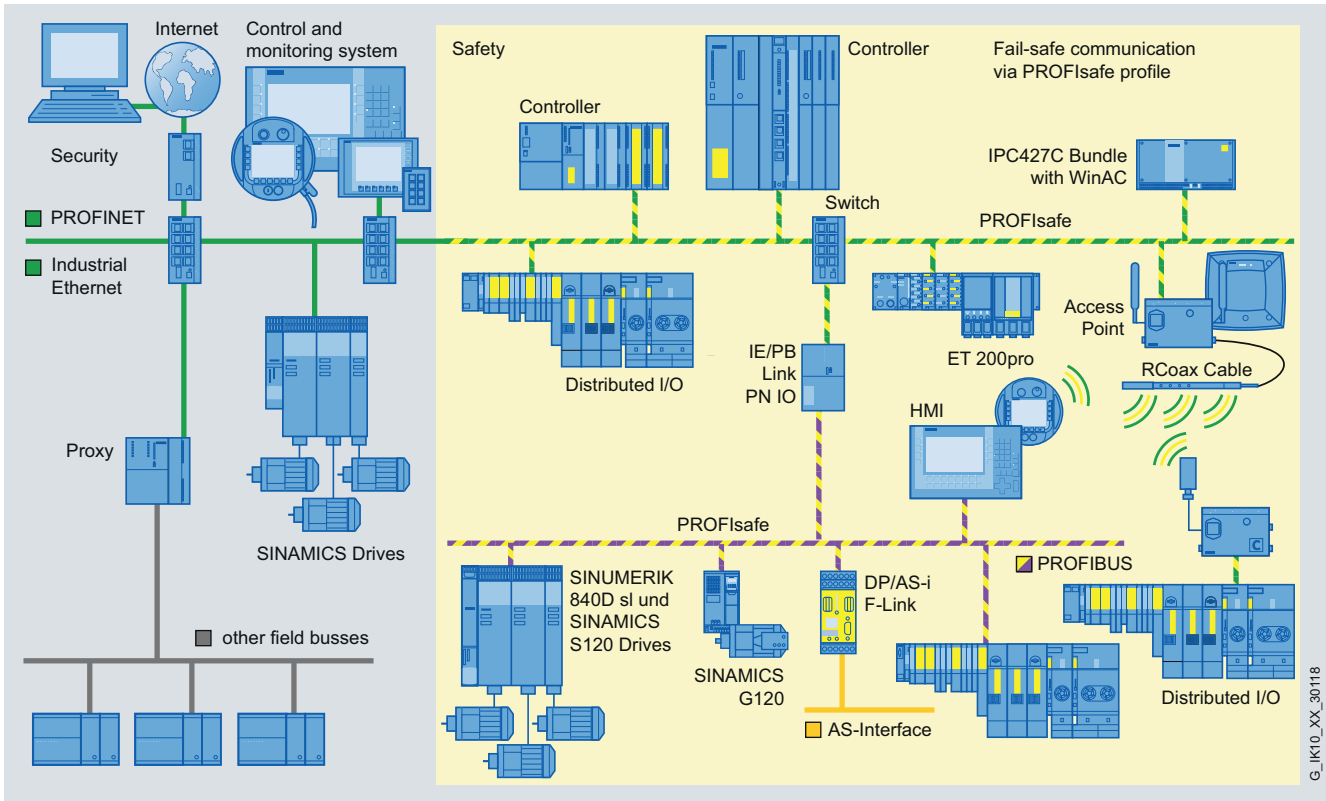

G_IK10_XX_30118

Fail-safe communication with PROFIsafe – via PROFIBUS, PROFINET and even wirelessly via Industrial Wireless LAN

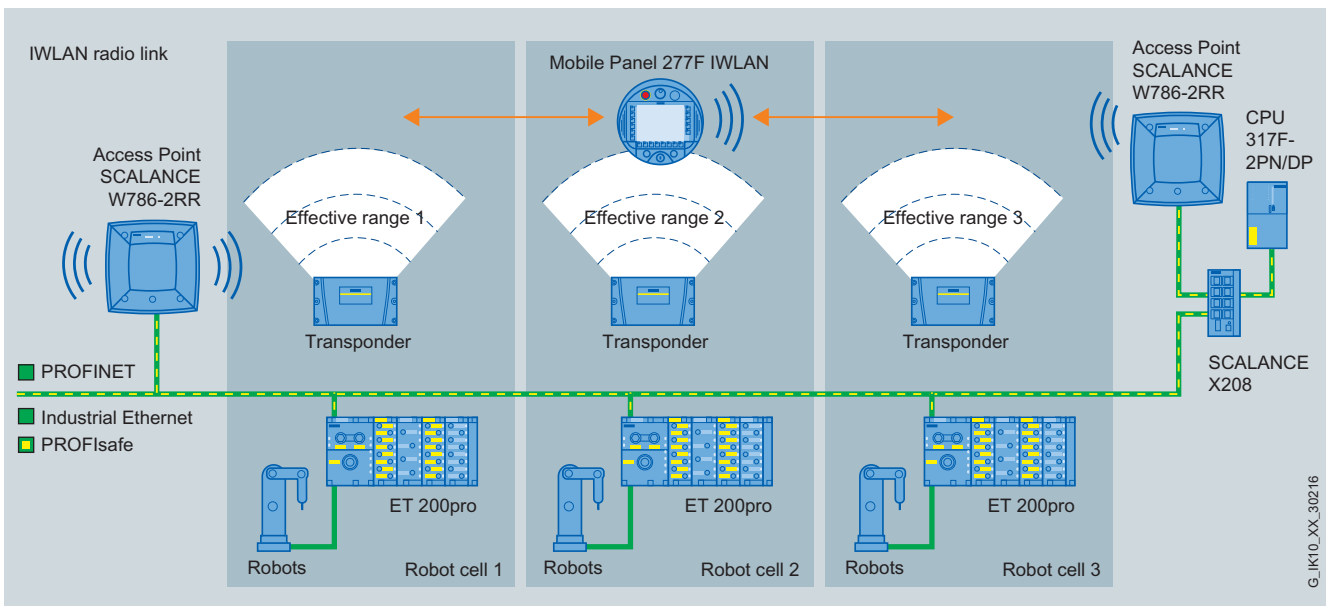

G_IK10_XX_30216

Programming of robots in the safety-related environment

For a number of years, standard automation has incorporated safety engineering - on the basis of SIMATIC S7 controllers, PROFIBUS and PROFIsafe.

This range has been expanded by PROFINET-enabled components, thus providing a complete product range with fail-safe controllers, fails I/O and a corresponding engineering environment.

PROFIsafe prevents errors such as address corruption, loss, delay, etc. when transmitting messages through continuous numbering of the PROFIsafe data, time monitoring, and authenticity monitoring using passwords and optimized CRC backup.













Fail-safe communication is thus also supported via industrial wireless LAN.

Industrial Wireless Communication

Industrial Wireless LAN (IWLAN)

Overview of network components

Overview













	Industrial Wireless LAN according to IEEE 802.11		Industrial Wireless LAN incl. iFeatures	
	Access Points	Client Modules	Access Points	Client Modules
For outside environments	W786 RJ45 / W786 SFP 		W786-2RR 	
For interior environments	W788 M12 	W748 M12 	W788-1RR / W788-2RR 	W747-1RR 
For cabinets	W788 RJ45 	W748 RJ45 	W784-1RR 	W747-1 
	W784-1 	W744-1 / W746-1 		IWLAN / PB Link PN IO 

G_IK10_XX_30279

SCALANCE W access points and client modules

Overview of network components

Overview (continued)

		Operation with SCALANCE WLC IWLAN controller	Operation with Entereasy WLAN controller	IEEE 802.11a/ b/ g/ h	IEEE 802.11n MIMO (Input x Output Streams)	Number of radio interfaces	Internal antennas	Connections for external antennas (R-SMA)	Connections for external antennas (N-Connect)	Cable-dependent interface	PoE (Power-over-Ethernet) IEEE 802.3at Type 1 (previously 802.3af)	Redundant power supply	Minimum operating temperature (°C)	Maximum operating temperature (°C)	IP protection class	Resistant to condensation	Resistant against salt spray	UV-resistant	For use in Ex zone 2 ¹⁾	Slot for removable storage (PLUG)	SSH/ HTTPS/ AAdmin password	WEP/ WPA/ WPA2	IEEE 802.11i, Hidden SSID	IEEE 802.1x (RADIUS)	EAP-TLS, EAP-TTLS, PEAP	IEEE 802.11e (QoS/WMM)	STP/ RSTP (IEEE 802.1d/w)	WDS (Wireless Distribution System)	IWLAN client operation possible	VLANs (Multi-SSID)	PROFINET IO Diagnostics	SNMP	Syslog		
	SCALANCE W788-1 M12			•	3x3	1		3	M12	•	•	-20	+60	65						•	•	•	•	•	•	•	•	•	•	•	•	•	•	•	
	SCALANCE W788-2 M12			•	3x3	2		6	M12	•	•	-20	+60	65						•	•	•	•	•	•	•	•	•	•	•	•	•	•	•	
	SCALANCE W788-1 RJ45			•	3x3	1		3	RJ45	•	•	-20	+60	30						•	•	•	•	•	•	•	•	•	•	•	•	•	•	•	
	SCALANCE W788-2 RJ45			•	3x3	2		6	RJ45	•	•	-20	+60	30						•	•	•	•	•	•	•	•	•	•	•	•	•	•	•	
	SCALANCE W786-1 RJ45			•	3x3	1		3	RJ45	•	•	-40	+60	65	•	•	•			•	•	•	•	•	•	•	•	•	•	•	•	•	•	•	
	SCALANCE W786-2 RJ45			•	3x3	2		6	RJ45	•	•	-40	+60	65	•	•	•			•	•	•	•	•	•	•	•	•	•	•	•	•	•	•	
	SCALANCE W786-2IA RJ45			•	3x3	2	6		RJ45	•	•	-40	+60	65	•	•	•			•	•	•	•	•	•	•	•	•	•	•	•	•	•	•	
	SCALANCE W786-2 SFP			•	3x3	2		6	SFP			-40	+60	65	•	•	•			•	•	•	•	•	•	•	•	•	•	•	•	•	•	•	
	SCALANCE W788C-2 RJ45	•	•	•	3x3	2		6	RJ45	•	•	-20	+60	30						•	•	•	•	•	•	•	•	•	•	•	•	•	•	•	•
	SCALANCE W788C-2 M12	•	•	•	3x3	2		6	M12	•	•	-20	+60	65						•	•	•	•	•	•	•	•	•	•	•	•	•	•	•	•
	SCALANCE W786C-2 RJ45	•	•	•	3x3	2		6	RJ45	•	•	-40	+60	65	•	•	•			•	•	•	•	•	•	•	•	•	•	•	•	•	•	•	•
	SCALANCE W786C-2IA RJ45	•	•	•	3x3	2	6		RJ45	•	•	-40	+60	65	•	•	•			•	•	•	•	•	•	•	•	•	•	•	•	•	•	•	•

• suitable

1) please follow installation instructions

G_IK10_XX_30280















Function overview of the SCALANCE W access points in accordance with IEEE 802.11n standard

Industrial Wireless Communication

Industrial Wireless LAN (IWLAN)

Overview of network components

Overview (continued)

		Operation with SCALANCE WLC IWLAN controller	Operation with Enterprise WLAN controller	IEEE 802.11a/ b/ g/ h	IEEE 802.11n MIMO	Number of radio interfaces	Internal antennas	Connections for external antennas (R-SMA)	Connections for external antennas (N-Connect)	Antenna diversity	Cable-dependent interface	PoE (Power-over-Ethernet) IEEE 802.3at Type 1 (previously 802.3af)	Redundant power supply	Minimum operating temperature (°C)	Maximum operating temperature (°C)	IP protection class	Resistant to condensation	Resistant against salt spray	UV-resistant	For use in Ex zone 2 ¹⁾	Slot for removable storage (PLUG)	iPCF-capable wireless interface	Supports forced roaming	SSH/ HTTPS/ AAdmin password	WEP/ WPA/ WPA2 IEEE 802.11i, Hidden SSID	IEEE 802.1x (RADIUS) EAP-TLS, EAP-TTLS, PEAP	IEEE 802.11e (QoS/WMM)	STP/ RSTP (IEEE 802.1d/w)	WDS (Wireless Distribution System)	Wireless redundancy between access points	IWLAN client operation possible	VLANs (Multi-SSID)	PROFINET IO Diagnostics	SNMP	Syslog			
	SCALANCE W788-1PRO		•		1	2				•	RJ45	•	•	-20	+60	65	•				•	•		•	•	•	•	•	•	•	•	•	•	•	•	•	•	
	SCALANCE W788-2PRO		•		2	4				•	RJ45	•	•	-20	+60	65	•				•	•		•	•	•	•	•	•	•	•	•	•	•	•	•	•	
	SCALANCE W788-1RR		•		1	2				•	RJ45	•	•	-20	+60	65	•				•	•	1	•	•	•	•	•	•	•	•	•	•	•	•	•	•	
	SCALANCE W788-2RR		•		2	4				•	RJ45	•	•	-20	+60	65	•				•	•	1	•	•	•	•	•	•	•	•	•	•	•	•	•	•	•
	SCALANCE W786-1PRO internal antenna		•		1	2				•	RJ45/ BFOC	•	•	-40	+70	65	•	•	•	•	•	•		•	•	•	•	•	•	•	•	•	•	•	•	•	•	•
	SCALANCE W786-1PRO external antenna		•		1	4				•	RJ45/ BFOC	•	•	-40	+70	65	•	•	•	•	•	•		•	•	•	•	•	•	•	•	•	•	•	•	•	•	•
	SCALANCE W786-2PRO internal antenna		•		2	4				•	RJ45/ BFOC	•	•	-40	+70	65	•	•	•	•	•	•		•	•	•	•	•	•	•	•	•	•	•	•	•	•	•
	SCALANCE W786-2PRO external antenna		•		2	4				•	RJ45/ BFOC	•	•	-40	+70	65	•	•	•	•	•	•		•	•	•	•	•	•	•	•	•	•	•	•	•	•	•
	SCALANCE W786-2RR internal antenna		•		2	4				•	RJ45	•	•	-40	+70	65	•	•	•	•	•	•	1	•	•	•	•	•	•	•	•	•	•	•	•	•	•	•
	SCALANCE W786-2RR external antenna		•		2	4				•	RJ45	•	•	-40	+70	65	•	•	•	•	•	•	1	•	•	•	•	•	•	•	•	•	•	•	•	•	•	•
	SCALANCE W786-2HPW internal antenna	•	•	•	2	4				•	RJ45/ BFOC	•	•	-40	+70	65	•	•	•	•	•			•	•	•	•	•	•	•	•	•	•	•	•	•	•	•
	SCALANCE W786-2HPW external antenna	•	•	•	2	4				•	RJ45/ BFOC	•	•	-40	+70	65	•	•	•	•	•			•	•	•	•	•	•	•	•	•	•	•	•	•	•	•
	SCALANCE W786-3PRO		•		3	6				•	RJ45/ BFOC	•	•	-40	+70	65	•	•	•	•	•		•	•	•	•	•	•	•	•	•	•	•	•	•	•	•	•
	SCALANCE W784-1		•		1	2				•	RJ45	•	•	-20	+60	30					•	•		•	•	•	•	•	•	•	•	•	•	•	•	•	•	
	SCALANCE W784-1RR		•		1	2				•	RJ45	•	•	-20	+60	30					•	•	1	•	•	•	•	•	•	•	•	•	•	•	•	•	•	•

• suitable

1) please follow installation instructions

G_JK10_XX_30183



Function overview of the SCALANCE W access points in accordance with IEEE 802.11a/b/g standard

Industrial Wireless Communication

Industrial Wireless LAN (IWLAN)

Overview of network components

Overview (continued)

		IEEE 802.11a/ b/ g/ h	IEEE 802.11n MIMO (Input x Output Streams)	Number of radio interfaces	Connections for external antennas (R-SMA)	Connections for external antennas (N-Connect)	Cable-dependent interface	PoE (Power-over-Ethernet) IEEE 802.3at Type 1 (previously 802.3af)	Redundant power supply	Minimum operating temperature (°C)	Maximum operating temperature (°C)	IP protection class	Resistant to condensation	For use in Ex zone 2 ¹⁾	Slot for removable storage (PLUG)	SSH/ HTTPS/ Admin password	WEP/ WPA/ WPA2 IEEE 802.11i	Number of connectable devices	DHCP Server	NAT/ PAT	PROFINET IO Diagnostics	SNMP	Syslog
	SCALANCE W748-1 M12	•	3x3	1		3	M12	•	•	-20	+60	65			•	•	•	8	•		•	•	•
	SCALANCE W748-1 RJ45	•	3x3	1	3		RJ45	•	•	-20	+60	65			•	•	•	8	•		•	•	•
• suitable		1) please follow installation instructions																					

G_IK10_XX_30281









Function overview of the SCALANCE W client modules in accordance with IEEE 802.11n standard

Industrial Wireless Communication

Industrial Wireless LAN (IWLAN)

Overview of network components

Overview (continued)

		IEEE 802.11a/ b/ g/ h	IEEE 802.11n MIMO	Number of radio interfaces	Internal antennas	Connections for external antennas (R-SMA)	Connections for external antennas (N-Connect)	Antenna diversity	Cable-dependent interface	PoE (Power-over-Ethernet) IEEE 802.3at Type 1 (previously 802.3af)	Redundant power supply	Minimum operating temperature (°C)	Maximum operating temperature (°C)	IP protection class	Resistant to condensation	For use in Ex zone 2 ¹⁾	Slot for removable storage (PLUG)	iPCF-capable wireless interface	SSH / HTTPS / Admin password	WEP/WPA/ WPA2 IEEE 802.11i	Number of connectable devices	DHCP-Server	NAT/ PAT	PROFINET IO Diagnostics	SNMP	Syslog
	SCALANCE W744-1PRO	•		1		2		•	RJ45	•	•	-20	+60	65	•	•	•		•	•	1				•	•
	SCALANCE W746-1PRO	•		1		2		•	RJ45	•	•	-20	+60	65	•	•	•		•	•	8	•	•	•	•	•
	SCALANCE W747-1RR	•		1		2		•	RJ45	•	•	-20	+60	65	•		•	1	•	•	8	•	•	•	•	•
	SCALANCE W744-1	•		1		2		•	RJ45	•	•	-20	+60	30		•	•		•	•	1	•	•	•	•	•
	SCALANCE W746-1	•		1		2		•	RJ45	•	•	-20	+60	30		•	•		•	•	8	•	•	•	•	•
	SCALANCE W747-1	•		1		2		•	RJ45	•	•	-20	+60	30		•	•	1	•	•	8	•	•	•	•	•
	IWLAN/PB Link PN IO	•		1		1			RS485 (DP-Master)		•	0	+60	20		•	•	1	• ³⁾	•	8				•	•
	Mobile Panel 277 IWLAN	•		1	2			•	RJ45 ²⁾		•	0	+40	65				1	•	•				•	•	
	ET 200pro IWLAN	•		1		2		•	RJ45 ²⁾			0	+55	67				1	•	•				•	•	

• suitable

1) please follow installation instructions

2) only for configuration download

3) no HTTPS

G_IK10_XX_30184

Function overview of the SCALANCE W client modules in accordance with IEEE 802.11a/b/g standard

Overview



The Access Points of the SCALANCE W780 product line are ideally suited for setting up Industrial Wireless LANs (IWLAN) for 2.4 GHz or 5 GHz. They can be used in all applications that require a high degree of operational reliability, even in extremely harsh ambient conditions.

- High transmission rates (up to 450 Mbit/s in conjunction with Channel Bonding) due to 3x3 MIMO technology (**M**ultiple **I**nput, **M**ultiple **O**utput); for this purpose, SCALANCE W Access Points use three streams each for simultaneous sending and receiving
- Suitable for any application:
 - SCALANCE W788 RJ45 for installation in a control cabinet
 - SCALANCE W788 M12 for cabinet-free installation indoors
 - SCALANCE W786 for outdoor environments with demanding climatic requirements
- Reliable thanks to rugged, impact-resistant housing, protected from water and dust (IP65), resistant to shock, vibration and electromagnetic fields
- Complex applications with redundancy requirements and high bandwidths, e.g. for video, by using IEEE 802.11n
- Configuration support by means of wizards and online help; easy management via web server and SNMP
- Fast replacement of devices in event of failure by means of optional C-PLUG (**C**onfiguration **P**lug)

Benefits

get Designed for Industry

- Reliable radio link, e.g. by using MIMO technology and monitoring of the radio link
- Cost savings due to one single radio network both for process-critical data and for non-critical communication
- Investment security because all products are compatible with the internationally recognized WLAN standard IEEE 802.11, suitable for the unlicensed frequency bands of 2.4 GHz and 5 GHz (ISM bands)
- Implementation of data-intensive applications such as video streaming through the support of the IEEE 802.11n standard including Channel Bonding
- Reduced operating costs, because there is no wear of rotating and moving plant sections
- Cost-effective connection to devices which are remote, difficult to access or mounted in hostile environments

Application

The Access Points of the SCALANCE W780 product line are designed for both industrial use and for demanding climatic requirements outdoors. Versions for low-cost integration in cabinets are also available. They offer a reliable radio connection, versatile redundancy mechanisms, and fast transfer of stations from one access point to the next (roaming). In this manner, processes can be monitored and production failures through machine downtimes avoided.

Due to the high degree of protection (IP65) and the extended temperature range from -40 °C to +60 °C, the Access Points are ideally suited for use in the outdoor area. SCALANCE W products are silicone-free and can therefore also be used in paint shops.

When using the RCoax cable (radiating cable), operation is particularly reliable in conveying technology and all track applications (e.g. storage and retrieval systems).

SCALANCE W786 versions are available with internal antennas for demanding environmental requirements.

Industrial Wireless Communication

IWLAN – Access Points IEEE 802.11n

Overview

Application (continued)

Application examples:

- Automated guided vehicle systems (AGVS) and suspended monorails; prevention of wear and high flexibility in the choice of route thanks to wireless transmission of data to the vehicles
- Crane; high flexibility through access to data communication with the moving unit independent of the location
- Mobile control console; reliable intervention in the process thanks to data communication over IWLAN with mobile units (e.g. Mobile Panel 277(F) IWLAN); the number of operator panels is therefore determined by the number of personnel and no longer by the number of control desks.
- Wireless access to field devices for configuration and testing
- Passenger transportation systems; transmission of high-quality video streams between the control center and buses or trains.
- Tunnel application; reliable radio link since the devices can handle multiple path propagation better by using the MIMO technology.
- Communication with moving stations (e.g. mobile controls and devices), container logistics, storage and retrieval machines, conveyor systems, conveyor belts, rotating machines, trucks
- Wireless coupling of communication segments and bridging of large distances for fast commissioning and for cost-effective networks in which cable routing would be extremely expensive (e.g. on public roads, rivers, lakes, train lines)

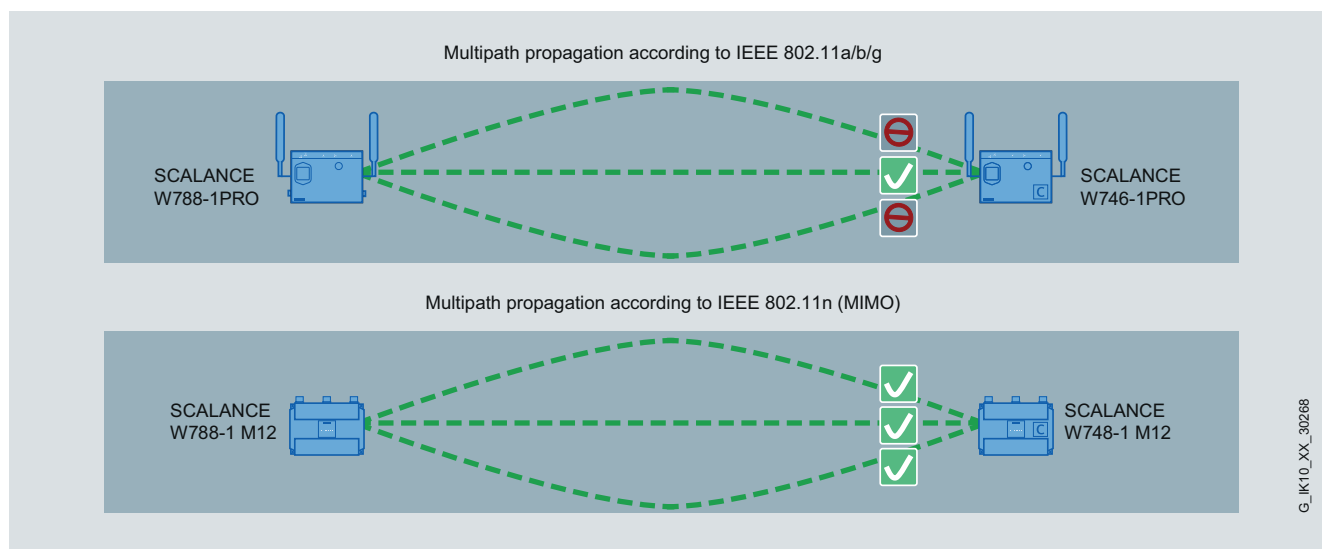

Multiple path propagation (MIMO) with SCALANCE W788-1PRO and SCALANCE W788-1 M12

Design

- Radio card (compatible with IEEE 802.11a/b/g/h/n) permanently installed in the device
- Designed without rotating parts (operation without fans)
- Antennas can either be connected by means of a screw connection (R-SMA, N-Connect) or they are integrated in the device
- Function LEDs for optical signaling of faults and operating states
- 1x PLUG slot

Function

A simple radio link can be established with a single Access Point (infrastructure mode). The Access Point provides an Industrial Ethernet interface for connection to the wireline network. Stations such as mobile controllers or a Field PG can move freely within the radio link and exchange data with other stations through this Access Point.

If the radio link of a single Access Point (radio cell) is insufficient, it can be expanded by further Access Points. The individual radio cells must overlap so that moving stations can be passed seamlessly from one Access Point to the next (roaming). This is performed invisibly to the application. The Access Points must be able to exchange data via Industrial Ethernet or a Wireless Distribution System (WDS).

If the Access Points are not connected to Industrial Ethernet using a wired connection (e.g. no cable tray available for data line), the operating mode "Wireless Distribution System" must be selected. An Access Point from the SCALANCE W780 product line can communicate via WDS with up to eight other Access Points which are not connected to the data network by a direct wired connection. Directional additional antennas can be used to achieve ranges of several thousand meters outdoors.

Apart from a reliable radio link, the SCALANCE W780 Access Points are characterized by their support of IT mechanisms:

- IEEE 802.11a/b/g/n for different frequency ranges
- IEEE 802.11h for use in the 5 GHz range outdoors
- IEEE 802.11e for Wireless Multimedia (WMM)
- IEEE 802.11i for security
- Construction of redundant networks with the Rapid Spanning Tree Protocol (RSTP)
- Virtual networks (VLAN) to logically separate, for example, different user groups
- Sending the log entries of the SCALANCE W devices to a Syslog server
- Modern security mechanisms (e.g. network security such as IEEE 802.1x, RADIUS, EAP mechanisms)
- In client mode: Network and Port Address Translation (NAT/PAT): Mapping of private IP addresses and ports to public addresses

Security

A high degree of data security is achieved by means of the WPA2/IEEE 802.11i mechanisms. These define modern procedures that control a regular exchange of the complete 128-bit code as well as performing the access check (authentication) of a station. The Advanced Encryption Standard (AES) is available for data encryption.

Access to the devices (HTTPS) is encrypted and secure logon (SSH) is possible. If a security concept with Virtual Private Networks (VPN) or the SCALANCE S range is required, the products can be integrated without any difficulty.

Diagnostics and management

- Web-based (HTTP/HTTPS) management tool for configuration and diagnostics using a standard browser
- LEDs for signaling operating states and fault conditions
- Signaling of faults by means of SNMP trap or e-mail to a network management tool, e.g. SINEMA-Server

Industrial Wireless Communication

IWLAN – Access Points IEEE 802.11n

SCALANCE W788 RJ45 for use in control cabinet

Overview



- Especially suitable for applications where the access point is to be mounted in the control cabinet
- Low-cost alternative for use indoors with less severe environmental conditions
- The rugged aluminum enclosure with degree of protection IP30 nevertheless provides protection against mechanical and electromagnetic stress in industrial areas

Design

- Rugged aluminum enclosure, shock and vibration-proof, for high mechanical requirements
- Dust protection with IP30 degree of protection
- For use at ambient temperatures from -20 °C to +60 °C
- Resistant to condensation
- Design suitable for installation in control cabinet
- 3 x R-SMA sockets for the connection of remote antennas (6 x R-SMA sockets for the versions with two wireless modules)
- Antenna placement optimized for the 3x3 MIMO technology; the antennas do not interfere with each other when they are mounted direct on the device
- 1 x RJ45 connection for 10/100/1000 Mbit/s with Power-over-Ethernet according to IEEE 802.3at Type 1 (corresponds to IEEE 802.3af)
- 2 x 24 V DC connection for redundant power infeed
- 1 x PLUG slot
- Function LEDs for optical signaling of faults and operating states
- Digital input for feeding in a signal from a sensor, for example, to an SNMP-based network management system
- Digital output for converting a command received over SNMP into a signal and switching a hardware function
- Mounting: Wall, S7 mounting rail or on 35 mm standard mounting rail

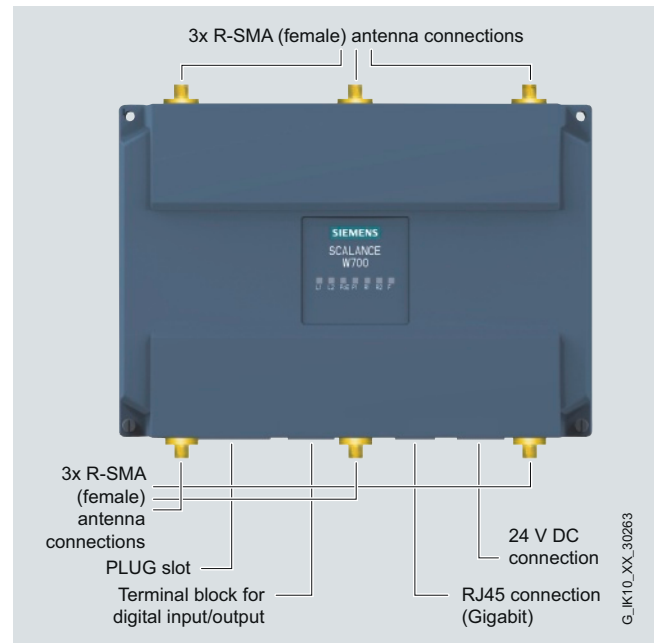

Design and interfaces of the SCALANCE W788-2 RJ45 Access Points

Product versions

SCALANCE W788-1 RJ45

- A wireless card permanently installed in the device

SCALANCE W788-2 RJ45

- Two wireless cards permanently installed in the device

Function

SCALANCE W788 RJ45 access points can also be operated as client modules. As an alternative, the SCALANCE W748 RJ45 Client Modules can be used for this mode.

In combination with the SCALANCE W748 RJ45 Client Modules with degree of protection IP30, an infrastructure can be set up in which great temperature differences and protection against dust and water play a somewhat less prominent role.

Technical specifications

Order No.	6GK5 788-1FC00-0AA0 6GK5 788-1FC00-0AB0 ¹⁾	6GK5 788-2FC00-0AA0 6GK5 788-2FC00-0AB0 ¹⁾
Product type designation	SCALANCE W788-1 RJ45	SCALANCE W788-2 RJ45
Transmission rate		
Transmission rate		
• with W-LAN, maximum	450 Mbit/s	450 Mbit/s
• with Industrial Ethernet	10 ... 1 000 Mbit/s	10 ... 1 000 Mbit/s
• Note	-	-
Interfaces		
Number of electrical connections		
• for network components or terminal equipment	1	1
• for power supply	1	1
• for redundant power supply	1	1
Design of electrical connection		
• for network components or terminal equipment	RJ45 socket	RJ45 socket
• for power supply	4-pin screw terminal, PoE	4-pin screw terminal, PoE
Number of optical connections for fiber-optic cables at 100 Mbit/s	-	-
Design of optical connection for fiber-optic cables at 100 Mbit/s	-	-
Design of swap medium C-Plug	Yes	Yes
Interfaces wireless		
Number of permanently installed wireless cards	1	2
Number of internal antennas	-	-
Number of electrical connections for external antenna(s)	3	6
Design of electrical connection for external antenna(s)	R-SMA female (socket)	R-SMA female (socket)
Inputs/outputs		
Number of digital inputs	1	1
Number of digital outputs	1	1
Design of electrical connection at the digital inputs/outputs	4-pin screw terminal	4-pin screw terminal
Signal range		
• at the digital input	24 V DC, safety extra low voltage	24 V DC, safety extra low voltage
• at the digital output	24 V DC/ 1 A	24 V DC/ 1 A
Supply voltage, current consumption, power loss		
Type of power supply	DC	DC
Power supply		
• 1 from terminal block	19.2 V	19.2 V
• 2 from terminal block	28.8 V	28.8 V
• From Power-over-Ethernet according to IEEE802.3at for Type 1 and IEEE802.3af	48 V	48 V
• From Power-over-Ethernet according to IEEE802.3at for Type 2	48 V	48 V

¹⁾ Wireless approval in the USA

Industrial Wireless Communication

IWLAN – Access Points IEEE 802.11n

SCALANCE W788 RJ45 for use in control cabinet

Technical specifications (continued)

Order No.	6GK5 788-1FC00-0AA0 6GK5 788-1FC00-0AB0 ¹⁾	6GK5 788-2FC00-0AA0 6GK5 788-2FC00-0AB0 ¹⁾
Product type designation	SCALANCE W788-1 RJ45	SCALANCE W788-2 RJ45
Permissible ambient conditions		
Ambient temperature		
• During operation	-20 ... +60 °C	-20 ... +60 °C
• During storage	-40 ... +70 °C	-40 ... +70 °C
• During transport	-40 ... +70 °C	-40 ... +70 °C
Relative humidity at 25 °C without condensation during operation, maximum	90 %	90 %
IP degree of protection	IP30	IP30
Ambient conditions for operation	-	-
Design, dimensions and weights		
Width of enclosure without antenna	200 mm	200 mm
Height of enclosure without antenna	158 mm	158 mm
Depth of enclosure without antenna	79 mm	79 mm
Net weight	1.7 kg	1.7 kg
Type of mounting: wall mounting	Yes	Yes
Wireless frequencies		
Wireless frequency		
• With WLAN in the 2.4 GHz frequency band	2.41 ... 2.48 GHz	2.41 ... 2.48 GHz
• with WLAN in the 5 GHz frequency band	4.9 ... 5.8 GHz	4.9 ... 5.8 GHz
Product properties, functions, components		
General		
Number of SSIDs	8	16
Product function		
• Dual client	-	-
• iHOP	-	-
• iPCF	-	-
• iPCF-MC	-	-
Number of iPCF-capable radio modules	-	-
Product functions		
Management, configuration, programming		
Number of manageable IP addresses in the client	8	8
Product function		
• CLI	Yes	Yes
• Web-based management	Yes	Yes
• MIB support	Yes	Yes
• TRAPs via e-mail	Yes	Yes
• Configuration with STEP 7	No	No
• Configuration with STEP 7 in the TIA Portal	No	No
• SMTP server	Yes	Yes
• Operation with IWLAN controller	No	No
• Operation with Enterasys WLAN controller	No	No
• Forced roaming with IWLAN	Yes	Yes
• WDS	Yes	Yes

¹⁾ Wireless approval in the USA

Technical specifications (continued)

Order No.	6GK5 788-1FC00-0AA0 6GK5 788-1FC00-0AB0 ¹⁾	6GK5 788-2FC00-0AA0 6GK5 788-2FC00-0AB0 ¹⁾
Product type designation	SCALANCE W788-1 RJ45	SCALANCE W788-2 RJ45
Protocol is supported		
• Address Resolution Protocol (ARP)	Yes	Yes
• ICMP	Yes	Yes
• Telnet	Yes	Yes
• HTTP	Yes	Yes
• HTTPS	Yes	Yes
• TFTP	Yes	Yes
• SNMP v1	Yes	Yes
• SNMP v2	Yes	Yes
• SNMP v3	Yes	Yes
• DCP	Yes	Yes
• LLDP	Yes	Yes
Identification & maintenance		
• I&MO - device-specific information	Yes	Yes
• I&M1 - higher-level designation/location designation	Yes	Yes
Product functions Diagnostics		
Product function		
• PROFINET IO diagnostics	Yes	Yes
• Link check	No	No
• Connection monitoring IP-Alive	No	No
• Localization by means of Aeroscout	No	No
• SysLog	Yes	Yes
Product functions VLAN		
Product function VLAN with IWLAN	Yes	Yes
Product functions DHCP		
Product function DHCP client	Yes	Yes
Product functions Redundancy		
STP/RSTP protocol is supported	Yes	Yes
Product functions Security		
Product function		
• ACL - MAC based	Yes	Yes
• IEEE 802.1x (radius)	Yes	Yes
• NAT/NAPT	No	No
• Access protection according to IEEE802.11i	Yes	Yes
• WPA/WPA2	Yes	Yes
• TKIP/AES	Yes	Yes
Protocol is supported SSH	Yes	Yes
Product functions Time		
SNTP protocol is supported	Yes	Yes

¹⁾ Wireless approval in the USA

Industrial Wireless Communication

IWLAN – Access Points IEEE 802.11n

SCALANCE W788 RJ45 for use in control cabinet

Technical specifications (continued)

Order No.	6GK5 788-1FC00-0AA0 6GK5 788-1FC00-0AB0 ¹⁾	6GK5 788-2FC00-0AA0 6GK5 788-2FC00-0AB0 ¹⁾
Product type designation	SCALANCE W788-1 RJ45	SCALANCE W788-2 RJ45
Standards, specifications, approvals		
Standard		
• for EMC of FM	-	-
• for hazardous zone	-	-
• for CSA and UL safety	UL 60950-1 CSA C22.2 No. 60950-1	UL 60950-1 CSA C22.2 No. 60950-1
• for hazardous zone of CSA and UL	-	-
Certificate of suitability		
• CE marking	Yes	Yes
• EC Declaration of Conformity	Yes	Yes
• C-Tick	Yes	Yes
• CCC	No	No
• Railroad application according to EN 50155	No	No
• e1 approval	No	No
• E1 approval	No	No
• NEMA4X	No	No
Standard for wireless communication		
• IEEE 802.11a	Yes	Yes
• IEEE 802.11b	Yes	Yes
• IEEE 802.11e	Yes	Yes
• IEEE 802.11g	Yes	Yes
• IEEE 802.11h	Yes	Yes
• IEEE 802.11i	Yes	Yes
• IEEE 802.11n	Yes	Yes
Wireless approval	You can find the latest list of countries at: www.siemens.com/simatic-net/ik-info	You can find the latest list of countries at: www.siemens.com/simatic-net/ik-info
Marine classification association		
• American Bureau of Shipping Europe Ltd. (ABS)	No	No
• Bureau Veritas (BV)	No	No
• Det Norske Veritas (DNV)	No	No
• Germanischer Lloyd (GL)	No	No
• Lloyds Register of Shipping (LRS)	No	No
• Nippon Kaiji Kyokai (NK)	No	No
• Polski Rejestr Statkow (PRS)	No	No
Accessories		
Accessories	24 V DC screw terminal and screw terminal for digital input and output included in scope of delivery	24 V DC screw terminal and screw terminal for digital input and output included in scope of delivery

¹⁾ Wireless approval in the USA

Industrial Wireless Communication

IWLAN – Access Points IEEE 802.11n

SCALANCE W788 RJ45 for use in control cabinet

Ordering data	Order No.	Order No.
SCALANCE W788 RJ45 access points		Accessories
IWLAN access points with built-in wireless interfaces; wireless networks IEEE 802.11a/b/g/h/n at 2.4/5 GHz up to 450 Mbit/s; WPA2/AES; Power over Ethernet (PoE), IP30 degree of protection (-20 °C to +60 °C); scope of supply: Mounting hardware, 4-pin screw terminal for 24 V DC; 4-pin screw terminal for digital input and output; manual on CD-ROM; German/English		C-PLUG Swap medium for simple replacement of devices in the event of a fault; for storing configuration data; can be used in SIMATIC NET products with PLUG slot
SCALANCE W788-1 RJ45 IWLAN Access Point with one built-in radio interface	6GK5 788-1FC00-0AA0	DIN rail mounting adapter DIN rail mounting adapter for SCALANCE W788 M12 and SCALANCE W788 RJ45; screw fixing for mounting on a 35 mm DIN rail to EN 50 022; scope of supply: 3 units per pack
• National approvals for operation outside the USA	6GK5 788-1FC00-0AB0	IE FC RJ45 Plug 4 x 2 RJ45 plug connector for Industrial Ethernet (10/100/1000 Mbit/s) with a rugged metal enclosure and integrated insulation displacement contacts for connecting Industrial Ethernet FC installation cables; 180° cable outlet; for network components and CPs/CPU with Industrial Ethernet interface
• National approvals for operation within the USA ¹⁾		• 1 pack = 1 unit • 1 pack = 10 units • 1 pack = 50 units
SCALANCE W788-2 RJ45 IWLAN Dual Access Point with two built-in radio interfaces	6GK5 788-2FC00-0AA0	IE FC Standard Cable GP 4x2 8-core, shielded TP installation cable for connection to IE FC RJ45 Plug 4x2 and IE M12 Plug PRO 4x2; PROFINET-compliant; with UL approval; sold by the meter; max. length 1000 m, minimum order 20 m
• National approvals for operation outside the USA	6GK5 788-2FC00-0AB0	
• National approvals for operation within the USA ¹⁾		IE FC Stripping Tool Preadjusted stripping tool for fast stripping of the Industrial Ethernet FC cables
		Antennas and miscellaneous IWLAN accessories
		see Industrial Wireless LAN/ accessories
		6GK1 900-0AB00
		6GK5 798-8ML00-0AB3
		6GK1 901-1BB11-2AA0 6GK1 901-1BB11-2AB0 6GK1 901-1BB11-2AE0
		6XV1 878-2A
		6GK1 901-1GA00

¹⁾ Please note national approvals at www.siemens.com/wireless-approvals

More information

Wireless approvals:

Current approvals can be found on the Internet at:
www.siemens.com/wireless-approvals

To assist in selecting the right products for Industrial Wireless Communication, the SIMATIC NET Selection Tool is available:

Online version:
www.siemens.com/snst

Offline version:
www.siemens.com/snst-download

Industrial Wireless Communication

IWLAN – Access Points IEEE 802.11n

SCALANCE W788 M12 for the indoor area

Overview



- Particularly suitable for industrial applications without control cabinets

Design

- Rugged aluminum enclosure, shock and vibration-proof, for high mechanical requirements
- High IP65 degree of protection against dust and water jets
- For use at ambient temperatures from -20 °C to +60 °C
- Resistant to condensation
- 3 x N-Connect sockets for the connection of remote antennas (6 x N-Connect sockets for the versions with two radio modules)
- Antenna placement optimized for the 3x3 MIMO technology; the antennas do not interfere with each other when they are mounted direct on the device
- 1 x M12 connection for 10/100/1000 Mbit/s with Power-over-Ethernet according to IEEE 802.3at Type 1 (corresponds to IEEE 802.3af)
- 1 x M12 socket for energy supply (24 V DC)
- 1 x PLUG slot
- Function LEDs for optical signaling of faults and operating states
- Mounting: Wall, S7 mounting rail or on 35 mm standard mounting rail

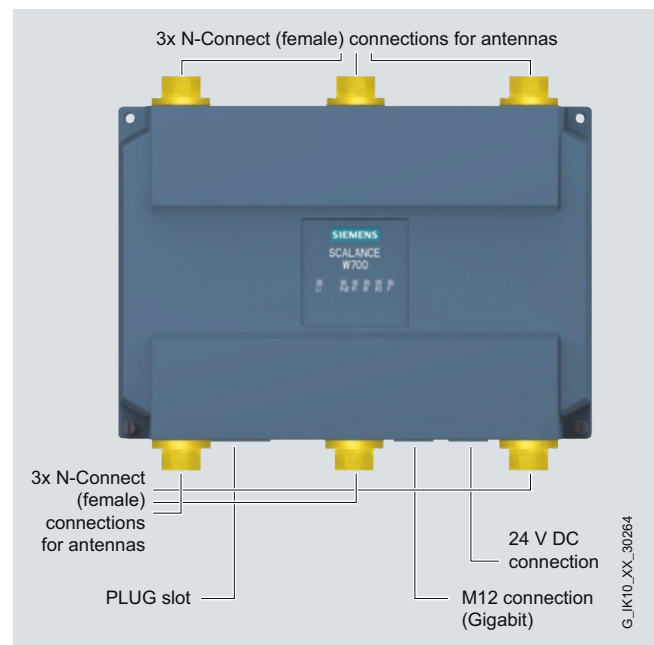

Design and interfaces of the SCALANCE W788-2 M12 Access Points

Product versions

SCALANCE W788-1 M12

- A radio card permanently installed in the device

SCALANCE W788-2 M12

- Two radio cards permanently installed in the device

Function

The devices can be installed at the location that is most favorable for the radio link. The housing and the connectors resist high levels of shock and vibration loading because all the connections are screwed or latched. To achieve optimal illumination for special applications, the supplied antennas can be replaced.

SCALANCE W788 M12 Access Points can also be operated as client modules. As an alternative, the SCALANCE W748 M12 client modules can be used for this mode.

The devices with two interfaces have two separate radio modules and behave like two separate devices in the radio network. This feature can be used to implement cost-effective solutions, e.g. when a radio interface is used for wireless connection of a distant production site and the second radio interface provides a radio link at the Access Point. Local stations can log in here and move around freely. Two separate radio modules, however, also permit the setup of redundant radio links so that a high level of availability can be achieved.

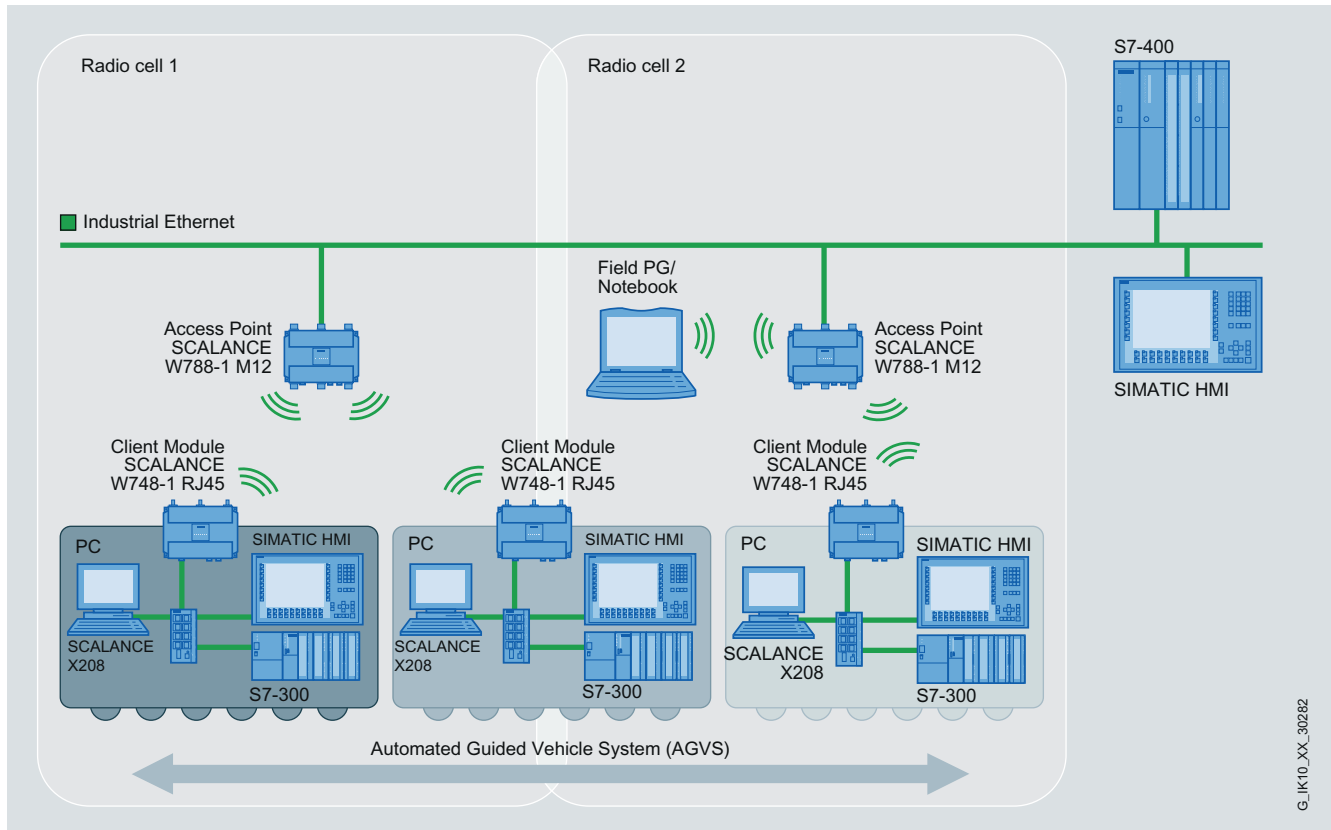

Roaming of moving units (e.g. Field PG and mobile controller) in a radio network with two Access Points

Stations, e.g. a Field PG M, can move freely in the RF field of the SCALANCE W788-1 M12 Access Points for mobile HMI. In addition, SCALANCE W748-1 M12 Client Modules connect mobile units with HMI, controller and PC wirelessly to the data network.

Provided that a delay (several 100 ms) caused by roaming in accordance with IEEE 802.11 is tolerated by all communication stations when switching the radio cells, the communication continues uninterrupted.

The Dual Access Point, SCALANCE W788-2 M12, can provide two separate radio links. For example, a Field PG can use one radio link for configuration. For a clear separation of the applications, the communication that is required for the application, e.g. S7 communication with a controller, can take place via the second radio link.

Industrial Wireless Communication

IWLAN – Access Points IEEE 802.11n

SCALANCE W788 M12 for the indoor area

Technical specifications

Order No.	6GK5 788-1GD00-0AA0 6GK5 788-1GD00-0AB0 ¹⁾	6GK5 788-2GD00-0AA0 6GK5 788-2GD00-0AB0 ¹⁾
Product type designation	SCALANCE W788-1 M12	SCALANCE W788-2 M12
Transmission rate		
Transmission rate		
• with W-LAN, maximum	450 Mbit/s	450 Mbit/s
• with Industrial Ethernet	10 ... 1 000 Mbit/s	10 ... 1 000 Mbit/s
• Note	-	-
Interfaces		
Number of electrical connections		
• for network components or terminal equipment	1	1
• for power supply	1	1
• for redundant power supply	1	1
Design of electrical connection		
• for network components or terminal equipment	M12 interface (8-pin, A-coded), PoE	M12 interface (8-pin, A-coded), PoE
• for power supply	M12 interface (4-pin, A-coded), PoE	M12 interface (4-pin, A-coded), PoE
Number of optical connections for fiber-optic cables at 100 Mbit/s	-	-
Design of optical connection for fiber-optic cables at 100 Mbit/s	-	-
Design of swap medium C-Plug	Yes	Yes
Interfaces wireless		
Number of permanently installed radio cards	1	2
Number of internal antennas	-	-
Number of electrical connections for external antenna(s)	3	6
Design of electrical connection for external antenna(s)	N-Connect female (socket)	N-Connect female (socket)
Supply voltage, current consumption, power loss		
Type of power supply	DC	DC
Power supply		
• 1 from M12 power connector (A-coded) for redundant power supply	19.2 V	19.2 V
• 2 from M12 power connector (A-coded) for redundant power supply	28.8 V	28.8 V
• From Power-over-Ethernet according to IEEE802.3at for Type 1 and IEEE802.3af	48 V	48 V
• From Power-over-Ethernet according to IEEE802.3at for Type 2	48 V	48 V

¹⁾ Wireless approval in the USA

Technical specifications (continued)

Order No.	6GK5 788-1GD00-0AA0 6GK5 788-1GD00-0AB0 ¹⁾	6GK5 788-2GD00-0AA0 6GK5 788-2GD00-0AB0 ¹⁾
Product type designation	SCALANCE W788-1 M12	SCALANCE W788-2 M12
Permissible ambient conditions		
Ambient temperature		
• During operation	-20 ... +60 °C	-20 ... +60 °C
• During storage	-40 ... +70 °C	-40 ... +70 °C
• During transport	-40 ... +70 °C	-40 ... +70 °C
Relative humidity at 25 °C without condensation during operation, maximum	90 %	90 %
IP degree of protection	IP65	IP65
Ambient conditions for operation	-	-
Design, dimensions and weights		
Width of enclosure without antenna	200 mm	200 mm
Height of enclosure without antenna	176 mm	176 mm
Depth of enclosure without antenna	79 mm	79 mm
Net weight	1.7 kg	1.7 kg
Type of mounting: wall mounting	Yes	Yes
Type of mounting	-	-
Radio frequencies		
Radio frequency		
• with WLAN in the 2.4 GHz frequency band	2.41 ... 2.48 GHz	2.41 ... 2.48 GHz
• with WLAN in the 5 GHz frequency band	4.9 ... 5.8 GHz	4.9 ... 5.8 GHz
Product properties, functions, components		
General		
Number of SSIDs	8	16
Product function		
• Dual client	-	-
• iHOP	-	-
• iPCF	-	-
• iPCF-MC	-	-
Number of iPCF-capable radio modules	-	-

¹⁾ Wireless approval in the USA

Industrial Wireless Communication

IWLAN – Access Points IEEE 802.11n

SCALANCE W788 M12 for the indoor area

Technical specifications (continued)

Order No.	6GK5 788-1GD00-0AA0 6GK5 788-1GD00-0AB0 ¹⁾	6GK5 788-2GD00-0AA0 6GK5 788-2GD00-0AB0 ¹⁾
Product type designation	SCALANCE W788-1 M12	SCALANCE W788-2 M12
Product functions Management, configuration, programming		
Number of manageable IP addresses in the client	8	8
Product function		
• CLI	Yes	Yes
• Web-based management	Yes	Yes
• MIB support	Yes	Yes
• TRAPS via e-mail	Yes	Yes
• Configuration with STEP 7	No	No
• Configuration with STEP 7 in the TIA Portal	No	No
• SMTP server	Yes	Yes
• Operation with IWLAN controller	No	No
• Operation with Enterasys WLAN controller	No	No
• Forced roaming with IWLAN	Yes	Yes
• WDS	Yes	Yes
Protocol is supported		
• Address Resolution Protocol (ARP)	Yes	Yes
• ICMP	Yes	Yes
• Telnet	Yes	Yes
• HTTP	Yes	Yes
• HTTPS	Yes	Yes
• TFTP	Yes	Yes
• SNMP v1	Yes	Yes
• SNMP v2	Yes	Yes
• SNMP v3	Yes	Yes
• DCP	Yes	Yes
• LLDP	Yes	Yes
Identification & Maintenance		
• I&M0 - device-specific information	Yes	Yes
• I&M1 - higher-level designation/location designation	Yes	Yes
Product functions Diagnostics		
Product function		
• PROFINET IO diagnostics	Yes	Yes
• Link check	No	No
• Connection monitoring IP-Alive	No	No
• Localization by means of Aeroscout	No	No
• SysLog	Yes	Yes
Product functions VLAN		
Product function VLAN with IWLAN	Yes	Yes
Product functions DHCP		
Product function DHCP client	Yes	Yes
Product functions Redundancy		
STP/RSTP protocol is supported	Yes	Yes

¹⁾ Wireless approval in the USA

Technical specifications (continued)

Order No.	6GK5 788-1GD00-0AA0 6GK5 788-1GD00-0AB0 ¹⁾	6GK5 788-2GD00-0AA0 6GK5 788-2GD00-0AB0 ¹⁾
Product type designation	SCALANCE W788-1 M12	SCALANCE W788-2 M12
Product functions Security		
Product function		
• ACL - MAC based	Yes	Yes
• IEEE 802.1x (radius)	Yes	Yes
• NAT/NAPT	No	No
• Access protection according to IEEE802.11i	Yes	Yes
• WPA/WPA2	Yes	Yes
• TKIP/AES	Yes	Yes
SSH protocol is supported	Yes	Yes
Product functions Time		
SNTP protocol is supported	Yes	Yes
Standards, specifications, approvals		
Standard		
• for EMC of FM	-	-
• for hazardous zone	-	-
• for CSA and UL safety	UL 60950-1 CSA C22.2 No. 60950-1	UL 60950-1 CSA C22.2 No. 60950-1
• for hazardous zone of CSA and UL	-	-
Certificate of suitability		
• CE mark	Yes	Yes
• EC Declaration of Conformity	Yes	Yes
• C-Tick	Yes	Yes
• CCC	No	No
• Railroad application according to EN 50155	No	No
• e1 approval	No	No
• E1 approval	No	No
• NEMA4X	No	No
• Power-over-Ethernet according to IEEE802.3at for Type 1 and IEEE802.3af	Yes	Yes
• Power-over-Ethernet according to IEEE802.3at for Type 2	Yes	Yes
Standard for wireless communication		
• IEEE 802.11a	Yes	Yes
• IEEE 802.11b	Yes	Yes
• IEEE 802.11e	Yes	Yes
• IEEE 802.11g	Yes	Yes
• IEEE 802.11h	Yes	Yes
• IEEE 802.11i	Yes	Yes
• IEEE 802.11n	Yes	Yes
Wireless approval	You can find the latest list of countries at: www.siemens.com/simatic-net/ik-info	You can find the latest list of countries at: www.siemens.com/simatic-net/ik-info
Marine classification association		
• American Bureau of Shipping Europe Ltd. (ABS)	No	No
• Bureau Veritas (BV)	No	No
• Det Norske Veritas (DNV)	No	No
• Germanischer Lloyd (GL)	No	No
• Lloyds Register of Shipping (LRS)	No	No
• Nippon Kaiji Kyokai (NK)	No	No
• Polski Rejestr Statkow (PRS)	No	No
Accessories		
Accessories	-	-

¹⁾ Wireless approval in the USA

Industrial Wireless Communication

IWLAN – Access Points IEEE 802.11n

SCALANCE W788 M12 for the indoor area

Ordering data

Order No.

SCALANCE W788 M12 Access Points

IWLAN access points with built-in radio interfaces; radio networks IEEE 802.11a/b/g/h/n at 2.4/5 GHz up to 450 Mbit/s; WPA2/AES; Power over Ethernet (PoE), IP65 degree of protection (-20 °C to +60 °C); scope of supply: Mounting hardware; manual on CD-ROM, German/English

SCALANCE W788-1 M12

IWLAN Access Point with one built-in radio interface

- National approvals for operation outside the USA
- National approvals for operation within the USA¹⁾

6GK5 788-1GD00-0AA0

6GK5 788-1GD00-0AB0

SCALANCE W788-2 M12

IWLAN Dual Access Point with two built-in radio interfaces

- National approvals for operation outside the USA
- National approvals for operation within the USA¹⁾

6GK5 788-2GD00-0AA0

6GK5 788-2GD00-0AB0

¹⁾ Please note national approvals at www.siemens.com/wireless-approvals

Order No.

Accessories

C-PLUG

Swap medium for simple replacement of devices in the event of a fault; for storing configuration data; can be used in SIMATIC NET products with PLUG slot

6GK1 900-0AB00

DIN rail mounting adapter

DIN rail mounting adapter for SCALANCE W788 M12 and SCALANCE W788 RJ45; screw fixing for mounting on a 35 mm DIN rail to EN 50 022; scope of supply: 3 units per pack

6GK5 798-8ML00-0AB3

IE FC M12 Plug PRO 4 x 2

M12 plug-in connector suitable for on-site assembly (X-coded, IP65/IP67), metal enclosure, insulation/displacement fast connection method, for SCALANCE W

- 1 unit
- 8 units

6GK1 901-0DB30-6AA0
6GK1 901-0DB30-6AA8

IE FC Standard Cable GP 4 x 2

8-core, shielded TP installation cable for connection to IE FC RJ45 Plug 4 x 2 and IE M12 Plug PRO 4 x 2; PROFINET-compliant; with UL approval; sold by the meter; max. length 1000 m, minimum order 20 m

6XV1 878-2A

IE FC Stripping Tool

Preadjusted stripping tool for fast stripping of the Industrial Ethernet FC cables

6GK1 901-1GA00

Antennas and miscellaneous IWLAN accessories

see Industrial Wireless LAN/ accessories

More information

Wireless approvals:

Current approvals can be found on the Internet at: www.siemens.com/wireless-approvals

To assist in selecting the right products for Industrial Wireless Communication, the SIMATIC NET Selection Tool is available:

Online version:

www.siemens.com/snst

Offline version:

www.siemens.com/snst-download

Industrial Wireless Communication

IWLAN – Access Points IEEE 802.11n

SCALANCE W786 RJ45 for the outdoor area

Overview



- Especially well suited to applications with high climatic requirements when installed outdoors and in areas accessible to the public

Design

- Rugged plastic enclosure (plexi-glass type), shock and vibration-proof for severe mechanical loading
- High IP65 degree of protection against dust and water jets
- For use at ambient temperatures from -40 °C to +60 °C
- Resistant to condensation
- Resistant to UV radiation and saltwater spray
- Design for use outdoors
- 3 x R-SMA sockets for the connection of remote antennas (6 x R-SMA sockets or six internal antennas for the versions with two wireless modules)
- Version with 1 x RJ45 connection for 10/100/1000 Mbit/s with Power-over-Ethernet according to IEEE 802.3at Type 1 (corresponds to IEEE 802.3af)
- Version with two slots for SFP plug-in transceivers (optical 2-port switch)
- 1 x 24 V DC connection, optional operation with 12 to 24 V DC or 100 to 240 V AC with power supply integrated into device
- 1 x PLUG slot
- Function LEDs for optical signaling of faults and operating states
- Mounting: Wall or, with optional mounting set, on S7 mounting rail, 35 mm standard mounting rail, or on a pole

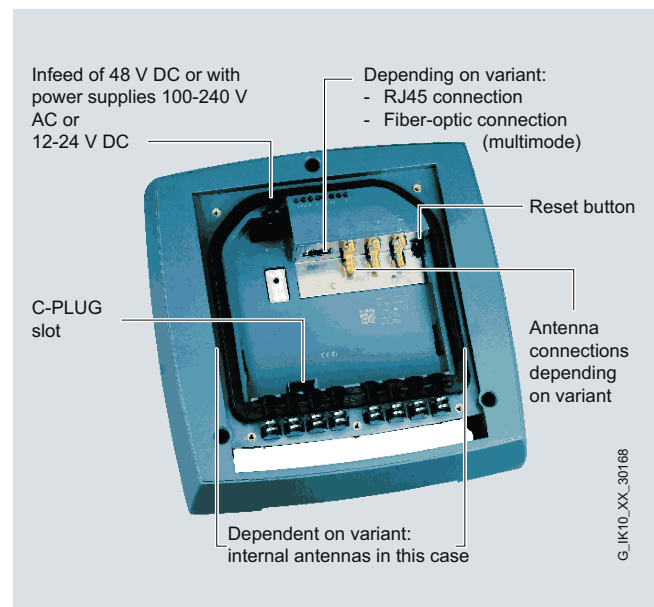

Design and interfaces of the SCALANCE W786 access points

Product versions

SCALANCE W786-1 RJ45

- A wireless card permanently installed in the device

SCALANCE W786-2 RJ45

- Two wireless cards permanently installed in the device
- Versions with:
 - Six internal antennas
 - Six connections for external antennas

SCALANCE W786-2 SFP

- Two wireless cards permanently installed in the device

Industrial Wireless Communication

IWLAN – Access Points IEEE 802.11n

SCALANCE W786 RJ45 for the outdoor area

Function

In the case of access points with two wireless modules, one module implements communication of the access points with each other. The wireless field for the station, e.g. an automated guided vehicle, is established by the second wireless module. Wireless coverage of larger areas can therefore be provided with the same device.

If the minimum length of standard Ethernet cables is insufficient due to the large distance of the access points from the wired network, SCALANCE W-786 can also be used in a version with SFP plug-in transceivers. Depending on the optical SFP plug-in transceiver used, ranges of up to 120 km can then be achieved.

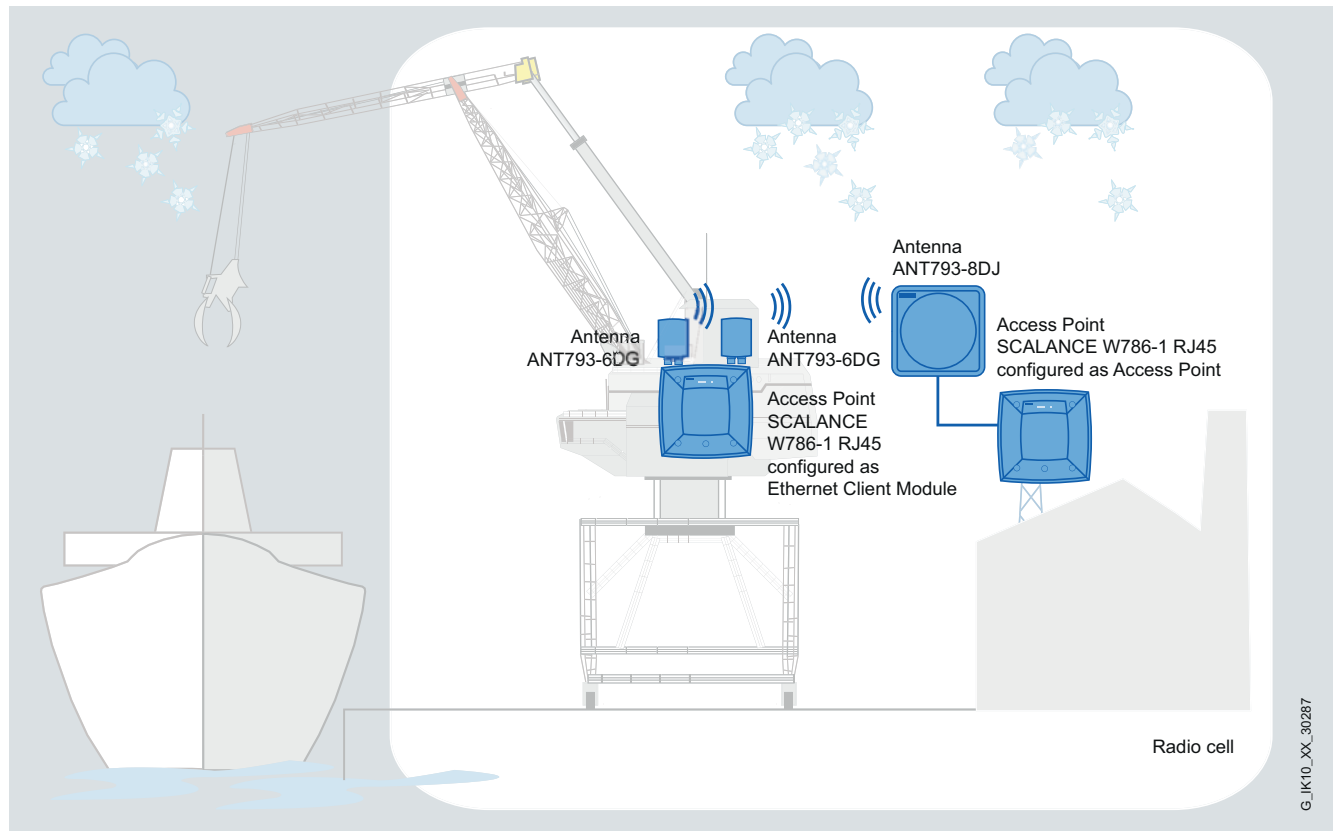

Use of the SCALANCE W786 product line in sectors subject to high climatic requirements

In the case of SCALANCE W786, this only concerns access points which can, however, be configured as client modules through Web-based management. Then, depending on the selected versions, a maximum of one wireless module will be available as a client.

Technical specifications

Order No.	6GK5 786-1FC00-0AA0 6GK5 786-1FC00-0AB0 ¹⁾	6GK5 786-2HC00-0AA0 6GK5 786-2HC00-0AB0 ¹⁾	6GK5 786-2FC00-0AA0 6GK5 786-2FC00-0AB0 ¹⁾	6GK5 786-2FE00-0AA0
Product type designation	SCALANCE W786-1 RJ45	SCALANCE W786-2IA RJ45	SCALANCE W786-2 RJ45	SCALANCE W786-2 SFP
Transmission rate				
Transmission rate	450 Mbit/s	450 Mbit/s	450 Mbit/s	450 Mbit/s
• with W-LAN, maximum	10 ... 1 000 Mbit/s	10 ... 1 000 Mbit/s	10 ... 1 000 Mbit/s	100 ... 1 000 Mbit/s
• with Industrial Ethernet	-	-	-	-
• Note	-	-	-	-
Interfaces				
Number of electrical connections	1	1	1	-
• for network components or terminal equipment	1	1	1	1
• for power supply	1	1	1	0
• for redundant power supply	1	1	1	0
Design of electrical connection	RJ45 socket	RJ45 socket	RJ45 socket	-
• for network components or terminal equipment	2-pin connector (24 V DC) or optionally available power supply adapter (4-pin 24 V DC or 3-pin 110 to 230 V AC)	2-pin connector (24 V DC) or optionally available power supply adapter (4-pin 24 V DC or 3-pin 110 to 230 V AC)	2-pin connector (24 V DC) or optionally available power supply adapter (4-pin 24 V DC or 3-pin 110 to 230 V AC)	2-pin connector (24 V DC) or optionally available power supply adapter (4-pin 24 V DC or 3-pin 110 to 230 V AC)
• for power supply	2-pin connector (24 V DC) or optionally available power supply adapter (4-pin 24 V DC or 3-pin 110 to 230 V AC)	2-pin connector (24 V DC) or optionally available power supply adapter (4-pin 24 V DC or 3-pin 110 to 230 V AC)	2-pin connector (24 V DC) or optionally available power supply adapter (4-pin 24 V DC or 3-pin 110 to 230 V AC)	2-pin connector (24 V DC) or optionally available power supply adapter (4-pin 24 V DC or 3-pin 110 to 230 V AC)
Number of optical connections for fiber-optic cables at 100 Mbit/s	-	-	-	2
Design of optical connection for fiber-optic cables at 100 Mbit/s	-	-	-	SFP slot
Number of optical connections for fiber-optic cables at 1000 Mbit/s	-	-	-	2
Design of optical connection for fiber-optic cables at 1000 Mbit/s	-	-	-	SFP slot
Design of swap medium C-Plug	Yes	Yes	Yes	Yes
Interfaces wireless				
Number of permanently installed wireless cards	1	2	2	2
Number of internal antennas	-	6	-	-
Number of electrical connections for external antenna(s)	3	-	6	6
Design of electrical connection for external antenna(s)	R-SMA female (socket)	-	R-SMA female (socket)	R-SMA female (socket)
Supply voltage, current consumption, power loss				
Type of power supply	DC	DC	DC	DC
Power supply	19.2 V	19.2 V	19.2 V	19.2 V
• 1 from terminal block	28.8 V	28.8 V	28.8 V	28.8 V
• 2 from terminal block	48 V	48 V	48 V	-
• From Power-over-Ethernet according to IEEE802.3at for Type 1 and IEEE802.3af	48 V	48 V	48 V	-
• From Power-over-Ethernet according to IEEE802.3at for Type 2	48 V	48 V	48 V	-
• From optionally integrated power supply	100 ... 240 V	100 ... 240 V	100 ... 240 V	100 ... 240 V
- With AC	12 ... 24 V	12 ... 24 V	12 ... 24 V	12 ... 24 V
- With DC	12 ... 24 V	12 ... 24 V	12 ... 24 V	12 ... 24 V

¹⁾ Wireless approval in the USA

Industrial Wireless Communication

IWLAN – Access Points IEEE 802.11n

SCALANCE W786 RJ45 for the outdoor area

Technical specifications (continued)

Order No.	6GK5 786-1FC00-0AA0 6GK5 786-1FC00-0AB0 ¹⁾	6GK5 786-2HC00-0AA0 6GK5 786-2HC00-0AB0 ¹⁾	6GK5 786-2FC00-0AA0 6GK5 786-2FC00-0AB0 ¹⁾	6GK5 786-2FE00-0AA0
Product type designation	SCALANCE W786-1 RJ45	SCALANCE W786-2IA RJ45	SCALANCE W786-2 RJ45	SCALANCE W786-2 SFP
Permissible ambient conditions				
Ambient temperature				
• During operation	-40 ... +60 °C	-40 ... +60 °C	-40 ... +60 °C	-40 ... +60 °C
• During storage	-40 ... +85 °C	-40 ... +85 °C	-40 ... +85 °C	-40 ... +85 °C
• During transport	-40 ... +85 °C	-40 ... +85 °C	-40 ... +85 °C	-40 ... +85 °C
Relative humidity at 25 °C without condensation during operation, maximum	100 %	100 %	100 %	100 %
IP degree of protection	IP65	IP65	IP65	IP65
Ambient conditions for operation	When using the 100 ... 240 V AC power supply, an operating temperature of -40 °C to +60 °C is permissible	When using the 100 ... 240 V AC power supply, an operating temperature of -40 °C to +60 °C is permissible	When using the 100 ... 240 V AC power supply, an operating temperature of -40 °C to +60 °C is permissible	When using the 100 ... 240 V AC power supply, an operating temperature of -40 °C to +60 °C is permissible
Design, dimensions and weights				
Width of enclosure without antenna	251 mm	251 mm	251 mm	251 mm
Height of enclosure without antenna	251 mm	251 mm	251 mm	251 mm
Depth of enclosure without antenna	72 mm	72 mm	72 mm	72 mm
Net weight	2.24 kg	2.24 kg	2.24 kg	2.24 kg
Type of mounting: wall mounting	Yes	Yes	Yes	Yes
Type of mounting	For mast mounting, 35 mm DIN rail mounting and S7-300 rail mounting, an additional retaining plate is required	For mast mounting, 35 mm DIN rail mounting and S7-300 rail mounting, an additional retaining plate is required	For mast mounting, 35 mm DIN rail mounting and S7-300 rail mounting, an additional retaining plate is required	For mast mounting, 35 mm DIN rail mounting and S7-300 rail mounting, an additional retaining plate is required
Wireless frequencies				
Wireless frequency				
• With WLAN in the 2.4 GHz frequency band	2.41 ... 2.48 GHz	2.41 ... 2.48 GHz	2.41 ... 2.48 GHz	2.41 ... 2.48 GHz
• With WLAN in the 5 GHz frequency band	4.9 ... 5.8 GHz	4.9 ... 5.8 GHz	4.9 ... 5.8 GHz	4.9 ... 5.8 GHz
Product properties, functions, components				
General				
Number of SSIDs	8	16	16	16
Product function				
• Dual client	-	-	-	-
• iHOP	-	-	-	-
• iPCF	-	-	-	-
• iPCF-MC	-	-	-	-
Number of iPCF-capable radio modules	-	-	-	-

¹⁾ Wireless approval in the USA

Technical specifications (continued)

Order No.	6GK5 786-1FC00-0AA0 6GK5 786-1FC00-0AB0 ¹⁾	6GK5 786-2HC00-0AA0 6GK5 786-2HC00-0AB0 ¹⁾	6GK5 786-2FC00-0AA0 6GK5 786-2FC00-0AB0 ¹⁾	6GK5 786-2FE00-0AA0
Product type designation	SCALANCE W786-1 RJ45	SCALANCE W786-2IA RJ45	SCALANCE W786-2 RJ45	SCALANCE W786-2 SFP
Product functions				
Management, configuration, programming				
Number of manageable IP addresses in the client	8	8	8	8
Product function				
• CLI	Yes	Yes	Yes	Yes
• Web-based management	Yes	Yes	Yes	Yes
• MIB support	Yes	Yes	Yes	Yes
• TRAPs via e-mail	Yes	Yes	Yes	Yes
• Configuration with STEP 7	No	No	No	No
• Configuration with STEP 7 in the TIA Portal	No	No	No	No
• SMTP server	Yes	Yes	Yes	Yes
• Operation with IWLAN controller	No	No	No	No
• Operation with Enterasys WLAN controller	No	No	No	No
• Forced roaming with IWLAN	Yes	Yes	Yes	Yes
• WDS	Yes	Yes	Yes	Yes
Protocol is supported				
• Address Resolution Protocol (ARP)	Yes	Yes	Yes	Yes
• ICMP	Yes	Yes	Yes	Yes
• Telnet	Yes	Yes	Yes	Yes
• HTTP	Yes	Yes	Yes	Yes
• HTTPS	Yes	Yes	Yes	Yes
• TFTP	Yes	Yes	Yes	Yes
• SNMP v1	Yes	Yes	Yes	Yes
• SNMP v2	Yes	Yes	Yes	Yes
• SNMP v3	Yes	Yes	Yes	Yes
• DCP	Yes	Yes	Yes	Yes
• LLDP	Yes	Yes	Yes	Yes
Identification & maintenance				
• I&M0 - device-specific information	Yes	Yes	Yes	Yes
• I&M1 - higher-level designation/location designation	Yes	Yes	Yes	Yes
Product functions Diagnostics				
Product function				
• PROFINET IO diagnostics	Yes	Yes	Yes	Yes
• Link check	No	No	No	No
• Connection monitoring IP-Alive	No	No	No	No
• Localization by means of Aeroscout	No	No	No	No
• SysLog	Yes	Yes	Yes	Yes
Product functions VLAN				
Product function VLAN with IWLAN	Yes	Yes	Yes	Yes
Product functions DHCP				
Product function DHCP client	Yes	Yes	Yes	Yes
Product functions Redundancy				
STP/RSTP protocol is supported	Yes	Yes	Yes	Yes

¹⁾ Wireless approval in the USA

Industrial Wireless Communication

IWLAN – Access Points IEEE 802.11n

SCALANCE W786 RJ45 for the outdoor area

Technical specifications (continued)

Order No.	6GK5 786-1FC00-0AA0 6GK5 786-1FC00-0AB0 ¹⁾	6GK5 786-2HC00-0AA0 6GK5 786-2HC00-0AB0 ¹⁾	6GK5 786-2FC00-0AA0 6GK5 786-2FC00-0AB0 ¹⁾	6GK5 786-2FE00-0AA0
Product type designation	SCALANCE W786-1 RJ45	SCALANCE W786-2IA RJ45	SCALANCE W786-2 RJ45	SCALANCE W786-2 SFP
Product functions Security				
Product function				
• ACL - MAC based	Yes	Yes	Yes	Yes
• IEEE 802.1x (radius)	Yes	Yes	Yes	Yes
• NAT/NAPT	No	No	No	No
• Access protection according to IEEE802.11i	Yes	Yes	Yes	Yes
• WPA/WPA2	Yes	Yes	Yes	Yes
• TKIP/AES	Yes	Yes	Yes	Yes
Protocol is supported SSH	Yes	Yes	Yes	Yes
Product functions Time				
SNTP protocol is supported	Yes	Yes	Yes	Yes
Standards, specifications, approvals				
Standard				
• for EMC of FM	-	-	-	-
• for hazardous zone	-	-	-	-
• for CSA and UL safety	UL 60950-1 CSA C22.2 No. 60950-1	UL 60950-1 CSA C22.2 No. 60950-1	UL 60950-1 CSA C22.2 No. 60950-1	UL 60950-1 CSA C22.2 No. 60950-1
• for hazardous zone of CSA and UL	-	-	-	-
Certificate of suitability				
• CE marking	Yes	Yes	Yes	Yes
• EC Declaration of Conformity	Yes	Yes	Yes	Yes
• C-Tick	Yes	Yes	Yes	Yes
• CCC	No	No	No	No
• Railroad application according to EN 50155	No	No	No	No
• e1 approval	No	No	No	No
• E1 approval	No	No	No	No
• NEMA4X	Yes	Yes	Yes	Yes
Standard for wireless communication				
• IEEE 802.11a	Yes	Yes	Yes	Yes
• IEEE 802.11b	Yes	Yes	Yes	Yes
• IEEE 802.11e	Yes	Yes	Yes	Yes
• IEEE 802.11g	Yes	Yes	Yes	Yes
• IEEE 802.11h	Yes	Yes	Yes	Yes
• IEEE 802.11i	Yes	Yes	Yes	Yes
• IEEE 802.11n	Yes	Yes	Yes	Yes
Wireless approval	You can find the latest list of countries at: www.siemens.com/simatic-net/ik-info	You can find the latest list of countries at: www.siemens.com/simatic-net/ik-info	You can find the latest list of countries at: www.siemens.com/simatic-net/ik-info	You can find the latest list of countries at: www.siemens.com/simatic-net/ik-info
Marine classification association				
• American Bureau of Shipping Europe Ltd. (ABS)	No	No	No	No
• Bureau Veritas (BV)	No	No	No	No
• Det Norske Veritas (DNV)	No	No	No	No
• Germanischer Lloyd (GL)	No	No	No	No
• Lloyds Register of Shipping (LRS)	No	No	No	No
• Nippon Kaiji Kyokai (NK)	No	No	No	No
• Polski Rejestr Statkow (PRS)	No	No	No	No
Accessories				
Accessories	24 V DC screw terminal included in scope of delivery	24 V DC screw terminal included in scope of delivery	24 V DC screw terminal included in scope of delivery	24 V DC screw terminal included in scope of delivery

¹⁾ Wireless approval in the USA

Industrial Wireless Communication

IWLAN – Access Points IEEE 802.11n

SCALANCE W786 RJ45 for the outdoor area

Ordering data	Order No.	Order No.
<p>SCALANCE W786 access points</p> <p>IWLAN access points with built-in radio interfaces; radio networks IEEE 802.11a/b/g/h/n at 2.4/5 GHz up to 450 Mbit/s; WPA2/AES; Power over Ethernet (PoE), IP65 degree of protection (-40°C to +60°C); scope of supply: Mounting hardware, 2-pin screw terminal for 24 V DC; manual on CD-ROM; German/English</p> <p>SCALANCE W786-1 RJ45</p> <p>IWLAN access points with <u>one</u> integrated wireless interface and RJ45 connection</p> <ul style="list-style-type: none"> • Connections for two external antennas <ul style="list-style-type: none"> - National approvals for operation outside the USA - National approvals for operation within the USA ¹⁾ <p>SCALANCE W786-2IA RJ45</p> <p>IWLAN access points with <u>two</u> integrated wireless interfaces and RJ45 connection</p> <ul style="list-style-type: none"> • Six internal antennas <ul style="list-style-type: none"> - National approvals for operation outside the USA - National approvals for operation within the USA ¹⁾ <p>SCALANCE W786-2 RJ45</p> <p>IWLAN access points with <u>two</u> integrated wireless interfaces and RJ45 connection</p> <ul style="list-style-type: none"> • Six connections for external antennas <ul style="list-style-type: none"> - National approvals for operation outside the USA - National approvals for operation within the USA ¹⁾ <p>SCALANCE W786-2 SFP</p> <p>IWLAN access points with <u>two</u> integrated wireless interfaces and RJ45 connection</p> <ul style="list-style-type: none"> • Six internal antennas <ul style="list-style-type: none"> - National approvals for operation outside the USA 	<p>6GK5 786-1FC00-0AA0</p> <p>6GK5 786-1FC00-0AB0</p> <p>6GK5 786-2HC00-0AA0</p> <p>6GK5 786-2HC00-0AB0</p> <p>6GK5 786-2FC00-0AA0</p> <p>6GK5 786-2FC00-0AB0</p> <p>6GK5 786-2FE00-0AA0</p>	<p>Accessories</p> <p>C-PLUG</p> <p>Swap medium for simple replacement of devices in the event of a fault; for storing configuration data; can be used in SIMATIC NET products with PLUG slot</p> <p>Power supply PS791-2DC</p> <p>24 V DC power supply for installation in SCALANCE W786 products; operating instructions in German/English</p> <p>Power supply PS791-2AC</p> <p>110 V AC to 230 V AC power supply for installation in the SCALANCE W786 products; operating instructions in German/English</p> <p>MS1 mounting set</p> <p>Mounting set for fixing the SCALANCE W786 products onto an S7-300 mounting rail or a 35 mm standard DIN rail</p> <p>IE FC RJ45 Plug 4 x 2</p> <p>RJ45 plug connector for Industrial Ethernet (10/100/1000 Mbit/s) with a rugged metal enclosure and integrated insulation displacement contacts for connecting Industrial Ethernet FC installation cables; 180° cable outlet; for network components and CPs/CPU with Industrial Ethernet interface</p> <ul style="list-style-type: none"> • 1 pack = 1 unit • 1 pack = 10 units • 1 pack = 50 units <p>6GK1 900-0AB00</p> <p>6GK5 791-2DC00-0AA0</p> <p>6GK5 791-2AC00-0AA0</p> <p>6GK5 798-8MG00-0AA0</p> <p>6GK1 901-1BB11-2AA0</p> <p>6GK1 901-1BB11-2AB0</p> <p>6GK1 901-1BB11-2AE0</p>

¹⁾ Please note national approvals at www.siemens.com/wireless-approvals

Industrial Wireless Communication

IWLAN – Access Points IEEE 802.11n

SCALANCE W786 RJ45 for the outdoor area

Ordering data

Order No.

Accessories (continued)

IE FC Standard Cable GP 4 x 2

8-core, shielded TP installation cable for connection to IE FC RJ45 Plug 4 x 2 and IE M12 Plug PRO 4 x 2; PROFINET-compliant; with UL approval; sold by the meter; max. length 1000 m, minimum order 20 m

6XV1 878-2A

IE FC Stripping Tool

Preadjusted stripping tool for fast stripping of the Industrial Ethernet FC cables

6GK1 901-1GA00

Antennas and miscellaneous IWLAN accessories

see Industrial Wireless LAN/ accessories

SFP plug-in transceiver and fiber-optic cables

see Media modules for modular SCALANCE X-300 managed

More information

Wireless approvals:

Current approvals can be found on the Internet at:
www.siemens.com/wireless-approvals

To assist in selecting the right products for Industrial Wireless Communication, the SIMATIC NET Selection Tool is available:

Online version:
www.siemens.com/snst

Offline version:
www.siemens.com/snst-download

Industrial Wireless Communication

IWLAN – Controller and Controller Access Points IEEE 802.11n

Overview

Overview

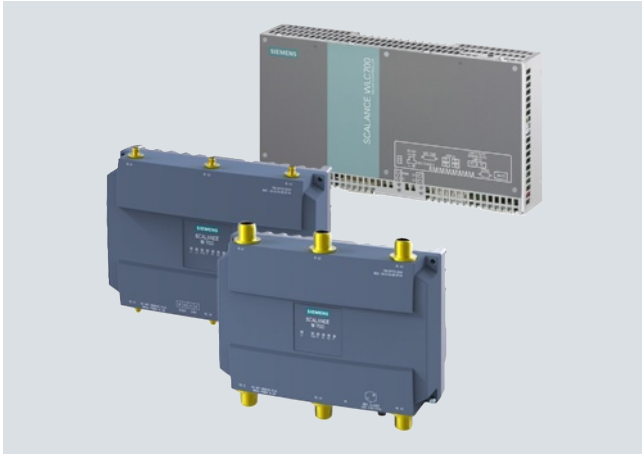

The network infrastructures in the industrial and office areas are coming ever-closer together. This applies also in the area of wireless communication, causing a constant increase in the number of access points and WLAN clients to be managed. If such networks are established with a large number of stand-alone access points, with each one having to be configured separately, this results in huge costs for initial configuration and operation.

Central wireless LAN controllers enable low-cost, user-friendly and secure operation of large WLAN infrastructures here. Management of the WLAN clients connected to such WLANs is significantly simplified thanks to their division into user groups with different security policies.

The SCALANCE WLC711 Wireless LAN Controller is an IWLAN controller for centralized management of a wireless LAN in the industrial environment (configuration, diagnostics, firmware updates, access control, security settings, coordination).

- Fast establishment of a new WLAN or expansion of an existing WLAN with the help of the SCALANCE W786C, SCALANCE W788C and SCALANCE W786-2HPW controller-based access points
- Parallel operation of different services (e.g. communication between programmable controllers, Internet access, Voice-over-IP telephony and video transmission) on the same controller-based WLAN infrastructure
- Seamless transition between production WLAN and corporate WLAN
- Cost savings in commissioning and operation as well as increased reliability and security thanks to the central management functions of the IWLAN controller in comparison to a WLAN comprising stand-alone access points that have to be configured individually

Benefits

get **Designed for Industry**

- Cost reductions and thus significant cost savings in commissioning and operating larger IWLAN installations (ten access points and more) thanks to configuring from a central location
- Investment protection thanks to seamless integration into existing IWLAN installations or into an existing corporate WLAN
- Saving on redundant infrastructures (e.g. separate network for Internet access and voice transmission) thanks to multiple use of the same infrastructure for different services
- Avoidance of a single point of failure thanks to optional parallel operation of two controllers; the WLAN remains functional even if the controller(s) fail(s)
- Increased reliability when operating the IWLAN through complete, coordinated portfolio of controllers, industrial access points and SCALANCE W Client Modules, as well as the suitable accessories (antennas, connecting cables, power supplies)

Industrial Wireless Communication

IWLAN – Controller and Controller Access Points IEEE 802.11n

Overview

Application

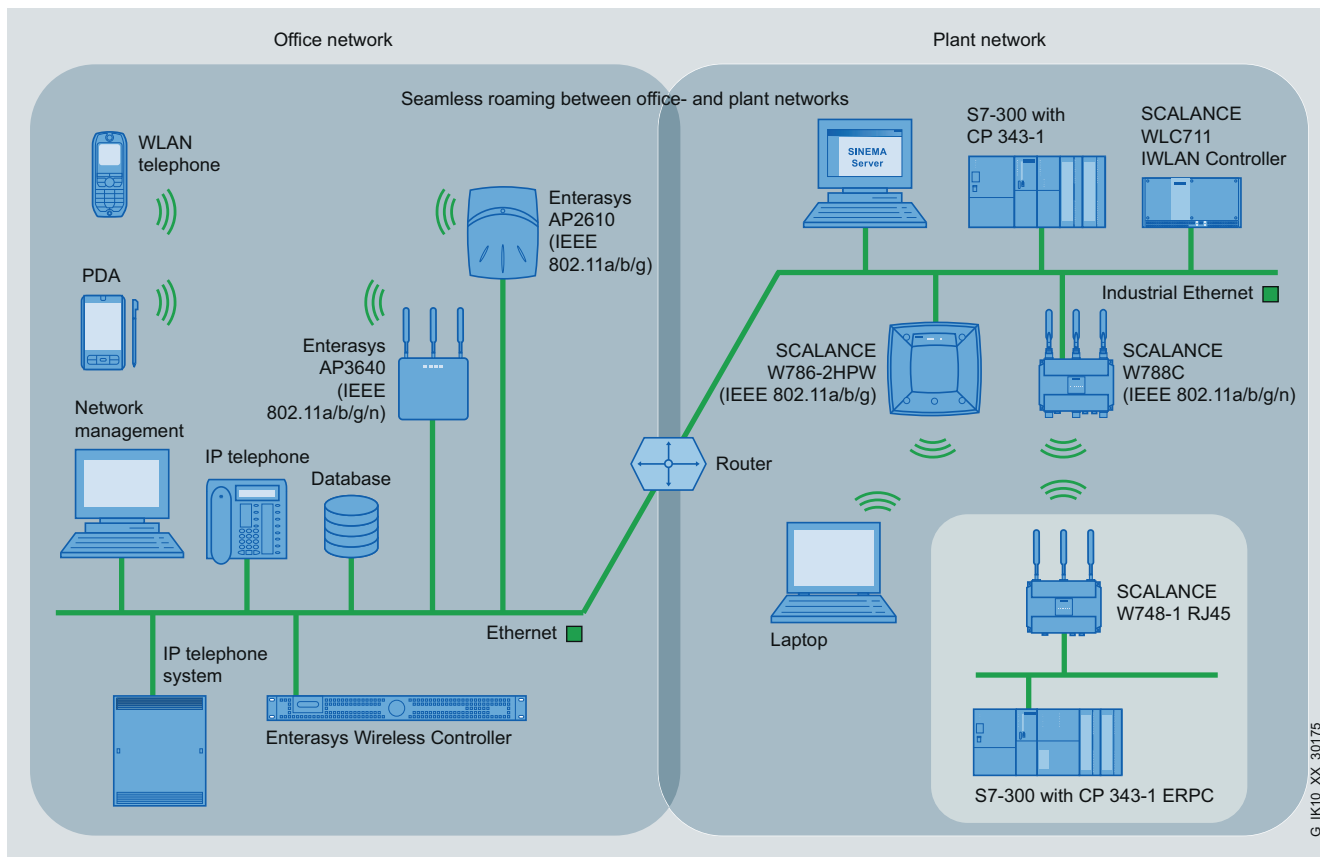

Company-wide WLAN based on Enterasys Wireless Controller and SCALANCE WLC IWLAN Controller

The SCALANCE WLC711 IWLAN Controller is the optimal solution for IWLAN installations from 10 up to 32 access points. Through the use of the SCALANCE W Access Points and Client Modules, different applications in the industrial environment or a comparable environment can communicate via a centrally managed IWLAN. SCALANCE W Access Points for controller operation are available for use both outdoors and for cabinet-free use in the industrial environment (e.g. in the production hall).

The WLC711 IWLAN Controller can be integrated into the corporate WLAN and thus enables the implementation of an integrated WLAN in the office, outdoor and industrial areas. This allows operation of mobile WLAN phones and laptops in the same wireless network, while complying with security policies for different user groups, and guaranteeing defined quality of service (QoS) for different devices.

Application (continued)

Application examples

With the SCALANCE WLC711 IWLAN Controller, the benefits of a controller solution, long-familiar in corporate networks, now also become available to typical industrial and industry-related applications:

- Plant-wide wireless infrastructures in factory automation and process automation, e.g. for mobile operator input or logistics applications
- Industry-related applications, e.g. crane systems and road/underground rail tunnels where IWLAN is required for transmitting visualization, video, and voice data

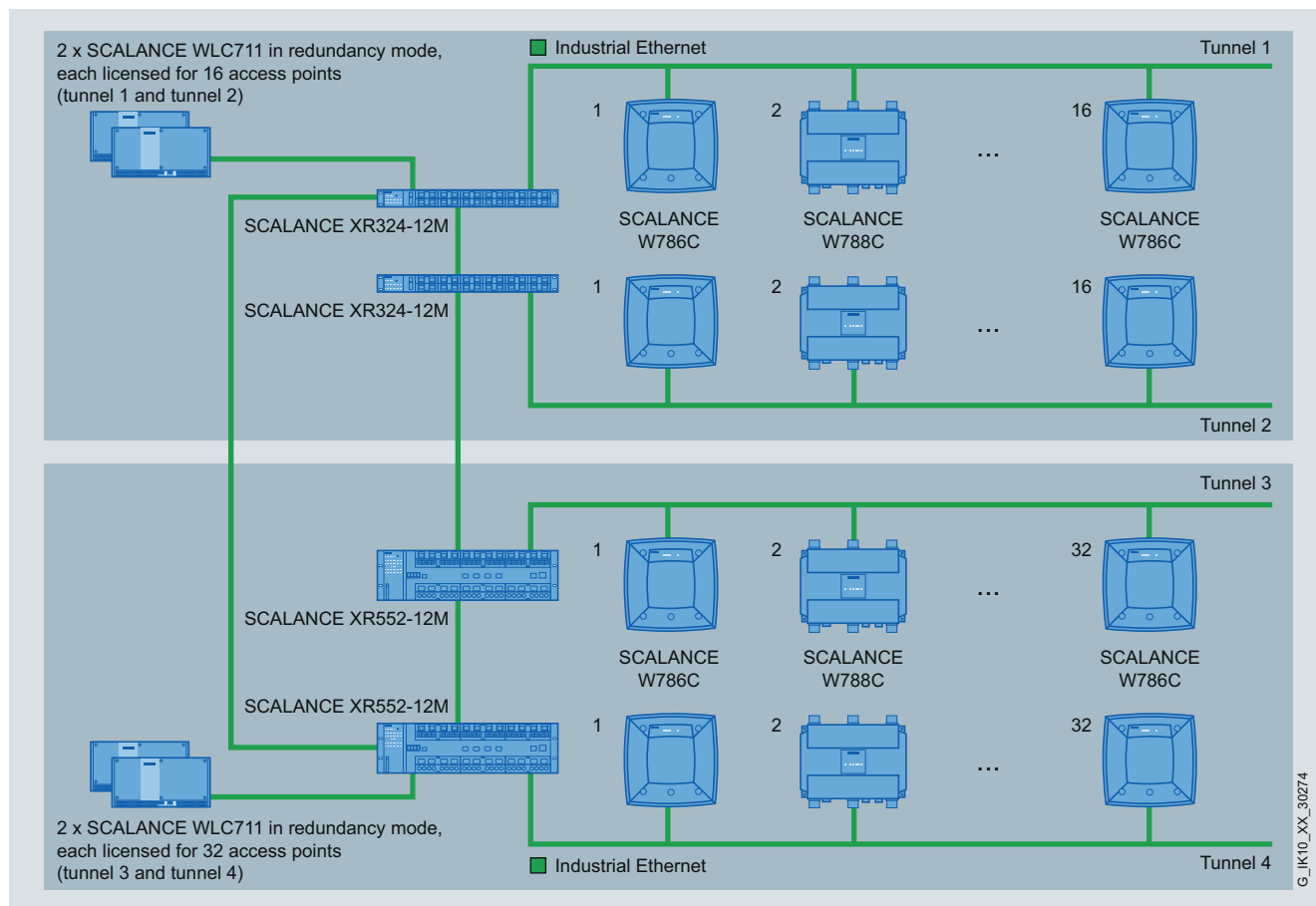

SCALANCE WLC711 IWLAN Controller in redundancy mode

Design

WLC711 IWLAN Controller

- 24 V DC power supply
- Enclosure in the design of the SIMATIC Microbox IPC, in degree or protection IP20 for installation in the control cabinet
- Two 10/100/1000 Mbit/s electrical RJ45 ports
- DIN rail and wall mounting possible
- Ambient temperature in operation 5 °C to 40 °C

Controller-based access points

- Radio card permanently installed in the device
- Versions available that support the WLAN standards IEEE 802.11a/b/g/n and IEEE 802.11a/b/g
- Versions available with RJ45 electrical port and BFOC optical port
- Antennas can either be connected by means of a screw connection (R-SMA, N-Connect) or they are integrated in the device. The antennas can be replaced within the IWLAN range
- Function LEDs for optical signaling of faults and operating states

Industrial Wireless Communication

IWLAN – Controller and Controller Access Points IEEE 802.11n

Overview

Function

Fundamental principles of the controller-based Industrial Wireless LAN

The IWLAN controller enables centralized management of an Industrial Wireless LAN. It automatically detects new access points, establishes the connection to these, and manages and coordinates access points and clients. Thanks to the Layer 3 architecture, access points located in different Layer 2 subnetworks can also be managed. This function allows wireless expansion of an existing Ethernet network without having to make changes to the existing network topology.

With the IWLAN controller, the IWLAN wireless infrastructure can be divided into logical, service-based networks (**V**irtual **N**etwork **S**ervices). Different services, security requirements and access criteria can thus be reliably managed, and different user groups such as administrators, commissioning engineers, or visitors can use the same wireless network.

In the same way, different applications such as Voice-over-IP (VoIP), video and Internet access can use the same infrastructure. The result is optimal capacity utilization of the IWLAN network.

If applications with high reliability and availability requirements are to communicate wirelessly, two IWLAN controllers can be operated redundantly.

The controller-based access points of the SCALANCE W78xC series can only be used with the IWLAN controller and can only be configured using the IWLAN controller.

The IWLAN controller connects, manages and coordinates all access point and clients such that the WLAN environment appears like several IP subnetworks with central management. The individual connections are additionally managed here, and the stations can therefore move securely and reliably throughout the complete radio network.

Diagnostics and management functions

As well as centralized management and wireless network configuration, the WLC711 IWLAN controller also offers error recording, wireless network monitoring, and documentation of network statistics.

More information

Supplementary WLAN solutions for office environments can be found on the Internet at:

www.enterasys.com

Industrial Wireless Communication IWLAN – Controller and Controller Access Points IEEE 802.11n

Industrial Wireless LAN Controller SCALANCE WLC711

Overview

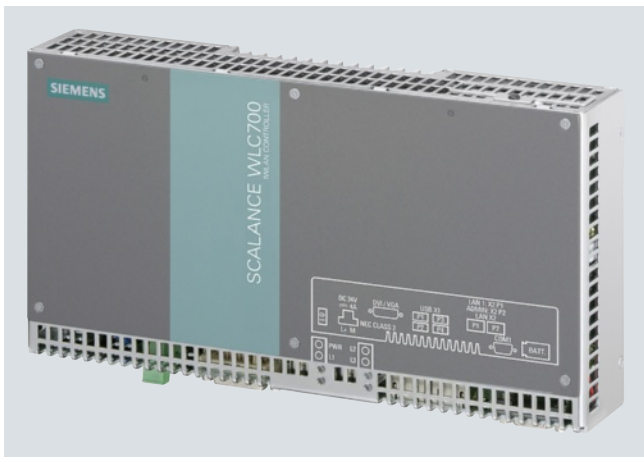

- Support for up to 32 access points in standard operation
- Support for up to 64 access points in redundant operation with two IWLAN controllers
- Supplied with license for 16 access points; expandable with license to 32 access points in standard operation
- Simultaneous support for up to 512 WLAN clients
- Support for up to 8 VNS segments
- Automatic detection of new access points
- Support for the SCALANCE W78xC controller-based access points (IEEE 802.11a/b/g/n) and W786-2HPW (IEEE 802.11a/ b/ g)

Application

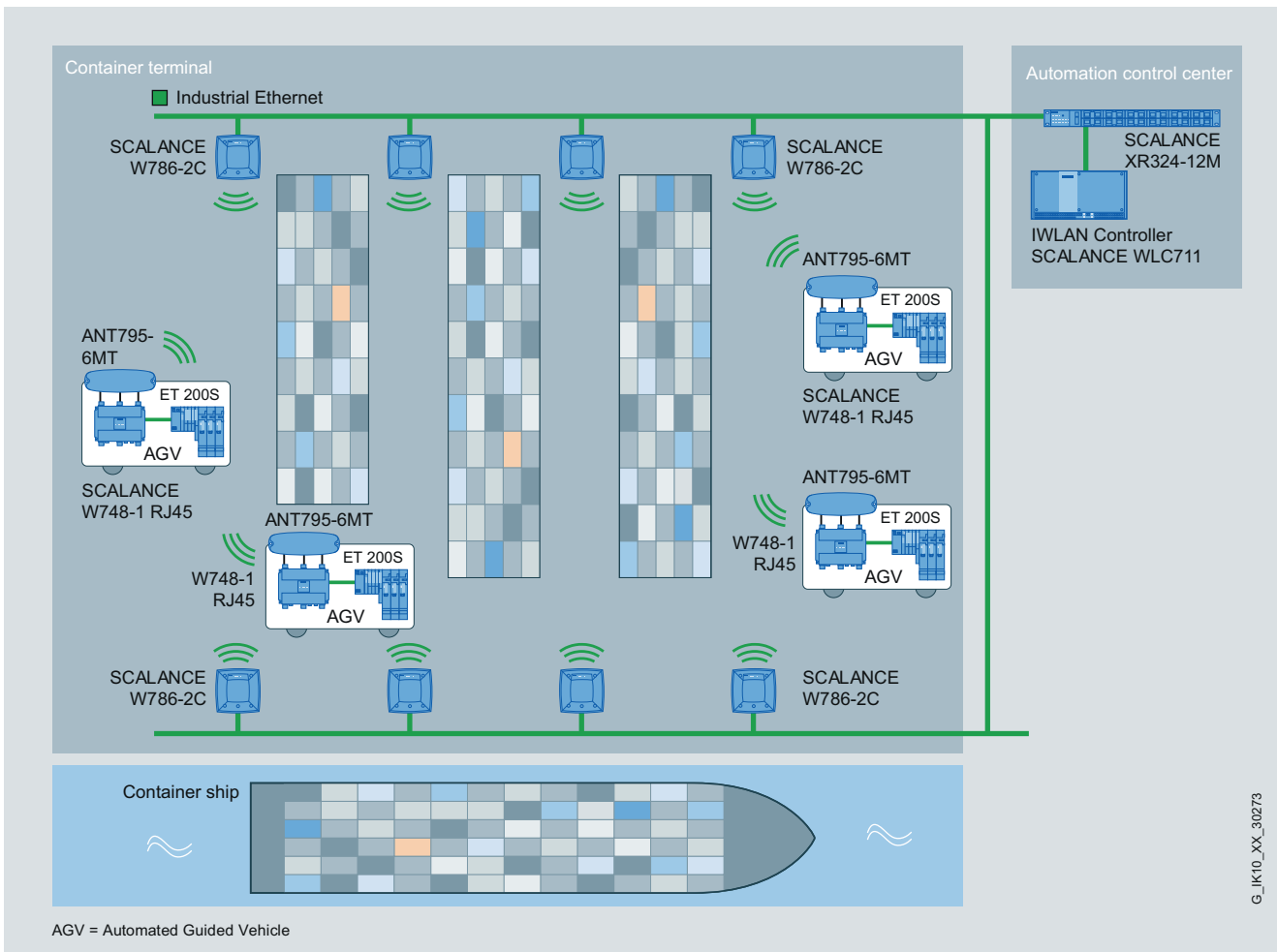

Controller-based IWLAN for applications with a large number of access points, e.g. in a container terminal

Industrial Wireless Communication

IWLAN – Controller and Controller Access Points IEEE 802.11n

Industrial Wireless LAN Controller SCALANCE WLC711

Design

Product versions

SCALANCE WLC711 IWLAN Controller

- IWLAN controller licensed for the connection of up to 16 SCALANCE W78xC and SCALANCE W786-2HPW controller-based access points

License Key WLC-700

- Capacity upgrade for SCALANCE WLC-700 for supporting up to 32 SCALANCE W78xC and SCALANCE W786-2HPW controller-based access points

Technical specifications

Order No.	6GK5 711-0XC00-1AA0 6GK5 711-0XC00-1AB0 ¹⁾ 6GK5 711-0XC00-1AD0 ²⁾
Product type designation	SCALANCE WLC711
Transmission rate	
Transmission rate with Industrial Ethernet	10 ... 1 000 Mbit/s
Interfaces	
Number of electrical connections	
• for network components or terminal equipment	2
• for power supply	1
Design of electrical connection	
• for network components or terminal equipment	RJ45 socket
• for power supply	2-pin screw terminal
Supply voltage, current consumption, power loss	
Type of power supply	DC
Supply voltage 1 from terminal block	24 V
Typical current consumed at 24 V DC	4 A
Effective power loss at 24 V DC, typically	20 W
Permissible ambient conditions	
Ambient temperature	
• During operation	5 ... 40 °C
• During storage	-40 ... +60 °C
• During transport	-40 ... +60 °C
Relative humidity at 25 °C without condensation during operation, maximum	95 %
IP degree of protection	IP20
Ambient conditions for operation	-
Design, dimensions and weights	
Width	262 mm
Height	142 mm
Depth	47 mm
Net weight	2 kg
Type of mounting	
• 35 mm DIN rail mounting	Yes
• Wall mounting	Yes
Type of mounting	Wall mounting using supplied cabinet brackets

¹⁾ Wireless approval in the USA

²⁾ Wireless approval in Japan

Order No.	6GK5 711-0XC00-1AA0 6GK5 711-0XC00-1AB0 ¹⁾ 6GK5 711-0XC00-1AD0 ²⁾
Product type designation	SCALANCE WLC711
Product functions Management, configuration, programming	
Product function	
• CLI	Yes
• Web-based management	Yes
• MIB support	Yes
• WDS	Yes
Protocol is supported	
• Address Resolution Protocol (ARP)	No
• ICMP	Yes
• Telnet	Yes
• HTTP	Yes
• HTTPS	Yes
• TFTP	Yes
• SNMP v1	-
• SNMP v2	Yes
• SNMP v3	Yes
• DCP	No
• LLDP	No
Product functions Diagnostics	
Product function SysLog	Yes
Product functions VLAN	
Product function VLAN with IWLAN	Yes
Product functions DHCP	
Product function DHCP client	No
Product functions Security	
Product function	
• IEEE 802.1x (radius)	Yes
• NAT/NAPT	No
• Access protection according to IEEE802.11i	Yes
• WPA/WPA2	Yes
• TKIP/AES	Yes
Protocol is supported SSH	Yes
Product functions Time	
Protocol is supported	
• NTP	Yes
• SNTP	No

Industrial Wireless Communication

IWLAN – Controller and Controller Access Points IEEE 802.11n

Industrial Wireless LAN Controller
SCALANCE WLC711

Technical specifications (continued)

Order No.	6GK5 711-0XC00-1AA0 6GK5 711-0XC00-1AB0 ¹⁾ 6GK5 711-0XC00-1AD0 ²⁾	Order No.	6GK5 711-0XC00-1AA0 6GK5 711-0XC00-1AB0 ¹⁾ 6GK5 711-0XC00-1AD0 ²⁾
Product type designation	SCALANCE WLC711	Product type designation	SCALANCE WLC711
Product functions		Standards, specifications, approvals	
IWLAN controller		Certificate of suitability	
Number of supported access points		• CE marking	Yes
• in standard mode with an IWLAN controller	16	• EC Declaration of Conformity	Yes
• in redundancy mode with two IWLAN controllers	32	• C-Tick	Yes
Product function of the IWLAN controller:	When supplied with basic license, 16 access points are supported in standard mode and 32 access points in redundancy mode. With capacity upgrade, 32 access points are supported in standard mode and 64 access points in redundancy mode.	• CCC	No
Number of supported WLAN clients per IWLAN controller	512	• Railroad application according to EN 50155	No
Number of VNS segments per IWLAN controller	8	• e1 approval	No
Product function		• E1 approval	No
• Pre-standard (CAPWAP)	Yes	• NEMA4X	No
• Integral VLAN-VNS	Yes	• Power-over-Ethernet according to IEEE802.3at for Type 1 and IEEE802.3af	No
• Auto detection of new access points	Yes	• Power-over-Ethernet according to IEEE802.3at for Type 2	No
• CDR/RADIUS accounting	Yes	Standard for wireless communication	
• Dynamic Radio Management	Yes	• IEEE 802.11a	Yes
• VoIP QoS mapping (DSCP/TCP-on-WMM)	Yes	• IEEE 802.11b	Yes
• VoIP roaming between IP subnetworks	Yes	• IEEE 802.11e	Yes
• VoIP roaming between several IWLAN controllers	Yes	• IEEE 802.11g	Yes
Load distribution function	DRM (Dynamic Radio/ RF Management), Packet Fairness, Flexible Client Access (Airtime Fairness), Load Balancing, Band-Steering	• IEEE 802.11h	Yes
Backup function for IWLAN controller	Redundancy mode with two IWLAN controllers (64 access points in total)	• IEEE 802.11i	Yes
Switching function	Traffic bridged at controller/ traffic bridged locally at wireless access point	• IEEE 802.11n	Yes
Design of the interface for public network access	Internal captive portal (Web redirection)	Wireless approval	You can find the latest list of countries at: www.siemens.com/simatic-net/ik-info
Product function of the IWLAN controller		Accessories	
		Accessories	24 V DC screw terminal and 2 cabinet brackets included in scope of delivery

¹⁾ Wireless approval in the USA

²⁾ Wireless approval in Japan

Industrial Wireless Communication

IWLAN – Controller and Controller Access Points IEEE 802.11n

Industrial Wireless LAN Controller SCALANCE WLC711

Ordering data	Order No.	More information
<p>SCALANCE WLC711 IWLAN Controller</p> <p>IWLAN controller licensed for the connection of up to 16 SCALANCE W78xC and SCALANCE W786-2HPW controller-based access points</p> <ul style="list-style-type: none"> • National approvals for operation outside North America, Canada, and Japan (RoW) • National approvals for operation in North America, including Canada (NAM) ¹⁾ • National approvals for operation in Japan (JP) ¹⁾ 	<p>6GK5 711-0XC00-1AA0</p> <p>6GK5 711-0XC00-1AB0</p> <p>6GK5 711-0XC00-1AD0</p>	<p>Wireless approvals:</p> <p>Current approvals can be found on the Internet at: www.siemens.com/wireless-approvals</p> <p>To assist in selecting the right products for Industrial Wireless Communication, the SIMATIC NET Selection Tool is available:</p> <p>Online version: www.siemens.com/snst</p> <p>Offline version: www.siemens.com/snst-download</p>
<p>License Key WLC-700</p> <p>Capacity upgrade for SCALANCE WLC-700 for supporting up to 32 SCALANCE W78xC and SCALANCE W786-2HPW controller-based access points</p>	<p>6GK5 907-1SB00</p>	
<p>Accessories</p> <p>IE TP Cord RJ45/RJ45</p> <p>TP cable 4 x 2 with 2 RJ45 connectors</p> <ul style="list-style-type: none"> • 0.5 m • 1 m • 2 m • 6 m • 10 m 	<p>6XV1 870-3QE50</p> <p>6XV1 870-3QH10</p> <p>6XV1 870-3QH20</p> <p>6XV1 870-3QH60</p> <p>6XV1 870-3QN10</p>	
<p>LOGO!Power 24 V/4 A</p> <p>Stabilized power supply; Input: 100 ... 240 V AC, output: 24 V DC/4 A</p>	<p>6EP1 332-1SH52</p>	

¹⁾ Please note national approvals at www.siemens.com/wireless-approvals

Industrial Wireless Communication

IWLAN – Controller and Controller Access Points IEEE 802.11n

Controller Access Points SCALANCE W788C RJ45 for control cabinet

Overview



- SCALANCE W788C-2 RJ45 controller-based access points can only be operated on the SCALANCE WLC IWLAN Controller
- Support for the WLAN standard IEEE 802.11n, 3x3 MIMO (compatible with IEEE 802.11a/b/g/h)
- Especially suitable for applications where the access point is to be mounted in the control cabinet
- Low-cost alternative for use indoors with less severe environmental conditions
- The rugged aluminum enclosure with degree of protection IP30 nevertheless provides protection against mechanical and electromagnetic stress in industrial areas

Design

- Rugged aluminum enclosure, shock and vibration-proof, for high mechanical requirements
- Dust protection with IP30 degree of protection
- For use at ambient temperatures from -20 °C to +60 °C
- Resistant to condensation
- Design suitable for installation in control cabinet
- Two built-in wireless cards
- 6 x R-SMA (female) sockets for the connection of remote antennas
- Antenna placement optimized for the 3x3 MIMO technology; the antennas do not interfere with each other when they are mounted direct on the device
- 1 x RJ45 connection for 10/100/1000 Mbit/s with Power-over-Ethernet according to IEEE 802.3at Type 1 (corresponds to IEEE 802.3af)
- 2 x 24 V DC connection for redundant power infeed
- Mounting: Wall, S7 mounting rail or on 35 mm standard mounting rail

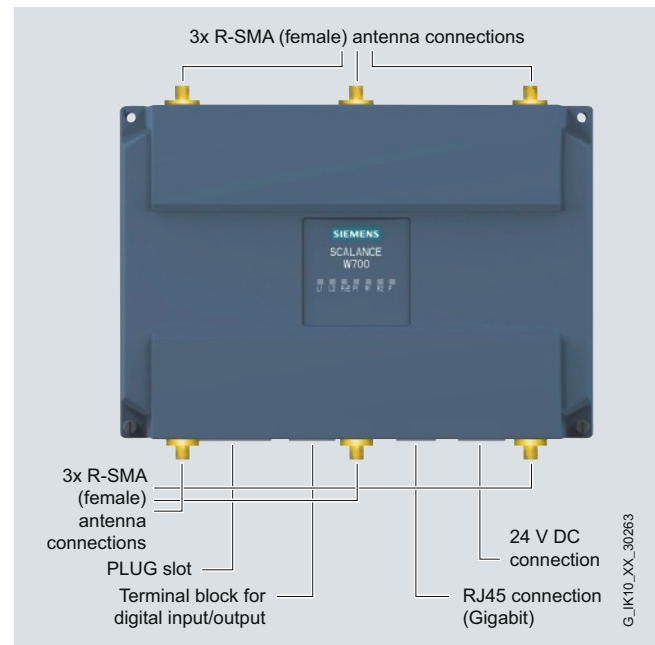

Design and interfaces of the SCALANCE W788C-2 RJ45 controller-based access points

Product versions

SCALANCE W788C-2 RJ45 (controller-based)

- Two wireless cards permanently installed in the device

Industrial Wireless Communication

IWLAN – Controller and Controller Access Points IEEE 802.11n

Controller Access Points SCALANCE W788C RJ45 for control cabinet

Technical specifications

Order No.	6GK5 788-2FC00-1AA0
Product type designation	SCALANCE W788C-2 RJ45
Transmission rate	
Transmission rate	
• with W-LAN, maximum	450 Mbit/s
• with Industrial Ethernet	10 ... 1 000 Mbit/s
• Note	-
Interfaces	
Number of electrical connections	
• for network components or terminal equipment	1
• for power supply	1
• for redundant power supply	1
Design of electrical connection	
• for network components or terminal equipment	RJ45 socket
• for power supply	4-pin screw terminal, PoE
Number of optical connections for fiber-optic cables at 100 Mbit/s	-
Design of optical connection for fiber-optic cables at 100 Mbit/s	-
Design of swap medium C-Plug	No
Interfaces wireless	
Number of permanently installed wireless cards	2
Number of internal antennas	-
Number of electrical connections for external antenna(s)	6
Design of electrical connection for external antenna(s)	R-SMA female (socket)
Supply voltage, current consumption, power loss	
Type of power supply	DC
Power supply	
• 1 from terminal block	19.2 V
• 2 from terminal block	28.8 V
• From Power-over-Ethernet according to IEEE802.3af Type 1 and IEEE802.3af	48 V
• From Power-over-Ethernet according to IEEE802.3at for Type 2	48 V
Permissible ambient conditions	
Ambient temperature	
• During operation	-20 ... +60 °C
• During storage	-40 ... +70 °C
• During transport	-40 ... +70 °C
Relative humidity at 25 °C without condensation during operation, maximum	90 %
IP degree of protection	IP30
Ambient conditions for operation	-

Order No.	6GK5 788-2FC00-1AA0
Product type designation	SCALANCE W788C-2 RJ45
Design, dimensions and weights	
Width of enclosure without antenna	200 mm
Height of enclosure without antenna	158 mm
Depth of enclosure without antenna	79 mm
Net weight	1.7 kg
Type of mounting: wall mounting	Yes
Type of mounting	-
Wireless frequencies	
Wireless frequency	
• With WLAN in the 2.4 GHz frequency band	2.41 ... 2.48 GHz
• With WLAN in the 5 GHz frequency band	4.9 ... 5.8 GHz
Product functions Management, configuration, programming	
Product function	
• Operation with IWLAN controller	Yes
• Operation with Enterasys WLAN controller	Yes
Standards, specifications, approvals	
Standard	
• for EMC of FM	-
• for hazardous zone	-
• for CSA and UL safety	UL 60950-1 CSA C22.2 No. 60950-1
• for hazardous zone of CSA and UL	-
Certificate of suitability	
• CE marking	Yes
• EC Declaration of Conformity	Yes
• C-Tick	Yes
• CCC	No
• Railroad application according to EN 50155	No
• e1 approval	No
• E1 approval	No
• NEMA4X	No
Standard for wireless communication	
• IEEE 802.11a	Yes
• IEEE 802.11b	Yes
• IEEE 802.11g	Yes
• IEEE 802.11h	Yes
• IEEE 802.11n	Yes
Wireless approval	You can find the latest list of countries at: www.siemens.com/simatic-net/ik-info
Marine classification association	
• American Bureau of Shipping Europe Ltd. (ABS)	No
• Bureau Veritas (BV)	No
• Det Norske Veritas (DNV)	No
• Germanischer Lloyd (GL)	No
• Lloyds Register of Shipping (LRS)	No
• Nippon Kaiji Kyokai (NK)	No
• Polski Rejestr Statkow (PRS)	No
Accessories	
Accessories	24 V DC screw terminal and screw terminal for digital input and output included in scope of delivery

Industrial Wireless Communication

IWLAN – Controller and Controller Access Points IEEE 802.11n

Controller Access Points
SCALANCE W788C RJ45 for control cabinet

Ordering data	Order No.
SCALANCE W788C RJ45 Controller access points	
<p>IWLAN access points for operating with the SCALANCE WLC IWLAN Controller; with two built-in wireless interfaces; wireless networks IEEE 802.11a/b/g/h/n at 2.4/5 GHz up to 450 Mbit/s; WPA2/AES; Power over Ethernet (PoE), IP65 degree of protection (-20 °C to +60 °C); scope of delivery: Mounting hardware; manual on CD-ROM, German/English</p> <ul style="list-style-type: none"> • SCALANCE W788C-2 RJ45 with R-SMA female connections for six external antennas 	6GK5 788-2FC00-1AA0
Accessories	
<p>DIN rail mounting adapter</p> <p>DIN rail mounting adapter for SCALANCE W788 M12 and SCALANCE W788 RJ45; screw fixing for mounting on a 35 mm DIN rail to EN 50 022; scope of supply: 3 units per pack</p>	6GK5798-8ML00-0AB3
<p>IE FC RJ45 Plug 4 x 2</p> <p>RJ45 plug connector for Industrial Ethernet (10/100/1000 Mbit/s) with a rugged metal enclosure and integrated insulation displacement contacts for connecting Industrial Ethernet FC installation cables; 180° cable outlet; for network components and CPs/CPU's with Industrial Ethernet interface</p> <ul style="list-style-type: none"> • 1 pack = 1 unit • 1 pack = 10 units • 1 pack = 50 units 	6GK1 901-1BB11-2AA0 6GK1 901-1BB11-2AB0 6GK1 901-1BB11-2AE0
<p>IE FC Standard Cable GP 4 x 2</p> <p>8-core, shielded TP installation cable for connection to IE FC RJ45 Plug 4 x 2 and IE M12 Plug PRO 4 x 2; PROFINET-compliant; with UL approval; sold by the meter; max. length 1000 m, minimum order 20 m</p>	6XV1 878-2A
<p>IE FC Stripping Tool</p> <p>Preadjusted stripping tool for fast stripping of the Industrial Ethernet FC cables</p>	6GK1 901-1GA00
<p>Antennas and miscellaneous IWLAN accessories</p>	see Industrial Wireless LAN/ accessories

More information

Wireless approvals:

Current approvals can be found on the Internet at:
www.siemens.com/wireless-approvals

To assist in selecting the right products for Industrial Wireless Communication, the SIMATIC NET Selection Tool is available:

Online version:
www.siemens.com/snst

Offline version:
www.siemens.com/snst-download

Industrial Wireless Communication

IWLAN – Controller and Controller Access Points IEEE 802.11n

Controller Access Points SCALANCE W788C M12 for the indoor area

Overview



- SCALANCE W788C-2 M12 controller-based access points can only be operated on the SCALANCE WLC IWLAN Controller
- Support for the WLAN standard IEEE 802.11n, 3x3 MIMO (compatible with IEEE 802.11a/b/g/h)
- Particularly suitable for industrial applications without control cabinets

Design

- Rugged aluminum enclosure, shock and vibration-proof, for high mechanical requirements
- High IP65 degree of protection against dust and water jets
- For use at ambient temperatures from -20 °C to +60 °C
- Resistant to condensation
- 6 x N-Connect (female) sockets for the connection of remote antennas
- Antenna placement optimized for the 3x3 MIMO technology; the antennas do not interfere with each other when they are mounted direct on the device
- 1 x M12 connection for 10/100/1000 Mbit/s with Power-over-Ethernet according to IEEE 802.3at Type 1 (corresponds to IEEE 802.3af)
- 1 x M12 socket for energy supply (24 V DC)
- Mounting: Wall, S7 mounting rail or on 35 mm standard mounting rail

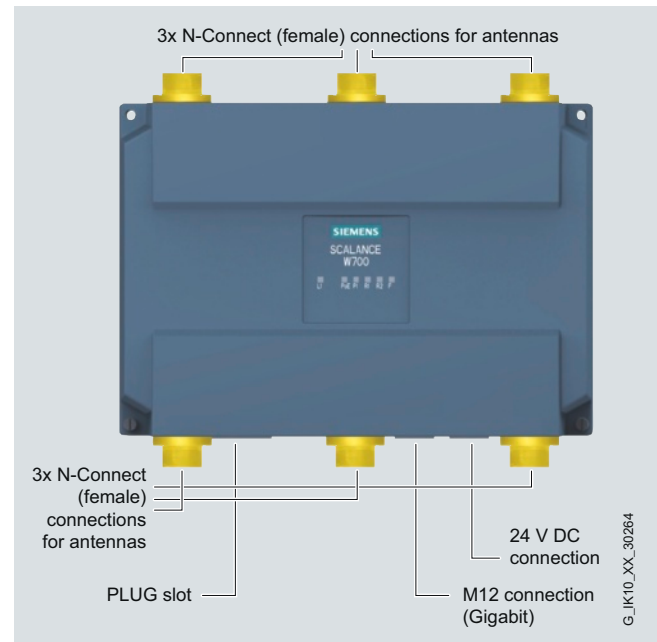

Design and interfaces of the SCALANCE W788C-2 M12 controller-based access points

Product versions

SCALANCE W786C-2 M12 (controller-based)

- Two wireless cards permanently installed in the device

Industrial Wireless Communication

IWLAN – Controller and Controller Access Points IEEE 802.11n

Controller Access Points
SCALANCE W788C M12 for the indoor area

Technical specifications

Order No.	6GK5 788-2GD00-1AA0
Product type designation	SCALANCE W788C-2 M12
Transmission rate	
Transmission rate	450 Mbit/s
• with W-LAN, maximum	10 ... 1 000 Mbit/s
• with Industrial Ethernet	-
• Note	-
Interfaces	
Number of electrical connections	1
• for network components or terminal equipment	1
• for power supply	1
• for redundant power supply	1
Design of electrical connection	M12 interface (8-pin, A-coded), PoE
• for network components or terminal equipment	M12 interface (4-pin, A-coded), PoE
• for power supply	M12 interface (4-pin, A-coded), PoE
Number of optical connections for fiber-optic cables at 100 Mbit/s	-
Design of optical connection for fiber-optic cables at 100 Mbit/s	-
Design of swap medium C-Plug	No
Interfaces wireless	
Number of permanently installed wireless cards	2
Number of internal antennas	-
Number of electrical connections for external antenna(s)	6
Design of electrical connection for external antenna(s)	N-Connect female (socket)
Supply voltage, current consumption, power loss	
Type of power supply	DC
Power supply	19.2 V
• 1 from M12 power connector (A-coded) for redundant power supply	28.8 V
• 2 from M12 power connector (A-coded) for redundant power supply	48 V
• From Power-over-Ethernet according to IEEE802.3at for Type 1 and IEEE802.3af	48 V
• From Power-over-Ethernet according to IEEE802.3at for Type 2	48 V
Permissible ambient conditions	
Ambient temperature	-20 ... +60 °C
• During operation	-40 ... +70 °C
• During storage	-40 ... +70 °C
• During transport	-40 ... +70 °C
Relative humidity at 25 °C without condensation during operation, maximum	90 %
IP degree of protection	IP65
Ambient conditions for operation	-

Order No.	6GK5 788-2GD00-1AA0
Product type designation	SCALANCE W788C-2 M12
Design, dimensions and weights	
Width of enclosure without antenna	200 mm
Height of enclosure without antenna	176 mm
Depth of enclosure without antenna	79 mm
Net weight	1.7 kg
Type of mounting: wall mounting	Yes
Wireless frequencies	
Wireless frequency	2.41 ... 2.48 GHz
• With WLAN in the 2.4 GHz frequency band	2.41 ... 2.48 GHz
• with WLAN in the 5 GHz frequency band	4.9 ... 5.8 GHz
Product functions Management, configuration, programming	
Product function	Yes
• Operation with IWLAN controller	Yes
• Operation with Enterasys WLAN controller	Yes
Standards, specifications, approvals	
Standard	-
• for EMC of FM	-
• for hazardous zone	-
• for CSA and UL safety	UL 60950-1 CSA C22.2 No. 60950-1
• for hazardous zone of CSA and UL	-
Certificate of suitability	Yes
• CE marking	Yes
• EC Declaration of Conformity	Yes
• C-Tick	Yes
• CCC	No
• Railroad application according to EN 50155	No
• e1 approval	No
• E1 approval	No
• NEMA4X	No
Standard for wireless communication	Yes
• IEEE 802.11a	Yes
• IEEE 802.11b	Yes
• IEEE 802.11g	Yes
• IEEE 802.11h	Yes
• IEEE 802.11n	Yes
Wireless approval	You can find the latest list of countries at: www.siemens.com/simatic-net/ik-info
Marine classification association	No
• American Bureau of Shipping Europe Ltd. (ABS)	No
• Bureau Veritas (BV)	No
• Det Norske Veritas (DNV)	No
• Germanischer Lloyd (GL)	No
• Lloyds Register of Shipping (LRS)	No
• Nippon Kaiji Kyokai (NK)	No
• Polski Rejestr Statkow (PRS)	No

Industrial Wireless Communication

IWLAN – Controller and Controller Access Points IEEE 802.11n

Controller Access Points SCALANCE W788C M12 for the indoor area

Ordering data

Order No.

SCALANCE W788C M12 Controller Access Points

IWLAN access points for operating with the SCALANCE WLC IWLAN Controller; with two built-in wireless interfaces; wireless networks IEEE 802.11a/b/g/h/n at 2.4/5 GHz up to 450 Mbit/s; WPA2/AES; Power over Ethernet (PoE), IP65 degree of protection (-20 °C to +60 °C); scope of delivery: Mounting hardware; manual on CD-ROM, German/English

- **SCALANCE W788C-2 M12** with N-Connect female connections for six external antennas

6GK5 788-2GD00-1AA0

Accessories

IE FC M12 Plug PRO 4 x 2

M12 plug-in connector suitable for on-site assembly (X-coded, IP65/IP67), metal enclosure, insulation/displacement fast connection method, for SCALANCE W

- 1 unit
- 8 units

6GK1 901-0DB30-6AA0
6GK1 901-0DB30-6AA8

DIN rail mounting adapter

DIN rail mounting adapter for SCALANCE W788 M12 and SCALANCE W788 RJ45; screw fixing for mounting on a 35 mm DIN rail to EN 50 022; scope of supply: 3 units per pack

6GK5 798-8ML00-0AB3

IE FC Standard Cable GP 4 x 2

8-core, shielded TP installation cable for connection to IE FC RJ45 Plug 4 x 2 and IE M12 Plug PRO 4 x 2; PROFINET-compliant; with UL approval; sold by the meter; max. length 1000 m, minimum order 20 m

6XV1 878-2A

IE FC Flexible Cable GP 4 x 2

8-core, shielded TP installation cable for connection to IE FC RJ45 Plug 4 x 2 and IE M12 Plug PRO 4 x 2 for occasional movement; PROFINET-compliant; with UL approval; sold by the meter; max. length 1000 m, minimum order 20 m

6XV1 878-2B

IE FC Stripping Tool

Preadjusted stripping tool for fast stripping of the Industrial Ethernet FC cables

6GK1 901-1GA00

Antennas and miscellaneous IWLAN accessories

see Industrial Wireless LAN/ accessories

More information

Wireless approvals:

Current approvals can be found on the Internet at:
www.siemens.com/wireless-approvals

To assist in selecting the right products for Industrial Wireless Communication, the SIMATIC NET Selection Tool is available:

Online version:
www.siemens.com/snst

Offline version:
www.siemens.com/snst-download

Industrial Wireless Communication

IWLAN – Controller and Controller Access Points IEEE 802.11n

Controller Access Points
SCALANCE W786C RJ45 for the outdoor area

Overview



- SCALANCE W786C-2 controller-based access points can only be operated on the SCALANCE WLC IWLAN Controller
- Support for the WLAN standard IEEE 802.11n, 3x3 MIMO (compatible with IEEE 802.11a/b/g/h)
- Especially well suited to applications with high climatic requirements when installed outdoors and in areas accessible to the public

Design

- Rugged plastic enclosure (plexi-glass type), shock and vibration-proof for severe mechanical loading
- High IP65 degree of protection against dust and water jets
- For use at ambient temperatures from -40 °C to +60 °C
- Resistant to condensation
- Resistant to UV radiation and saltwater spray
- Design for use outdoors
- 6 x R-SMA sockets for the connection of remote antennas or six internal antennas
- Version with 1 x RJ45 connection for 10/100/1000 Mbit/s with Power-over-Ethernet according to IEEE 802.3at Type 1 (corresponds to IEEE 802.3af)
- 1 x 24 V DC connection, optional operation with 12 to 24 V DC or 100 to 240 V AC with power supply integrated into device
- Mounting: Wall or, with optional mounting set, on S7 mounting rail, 35 mm standard mounting rail, or on a pole

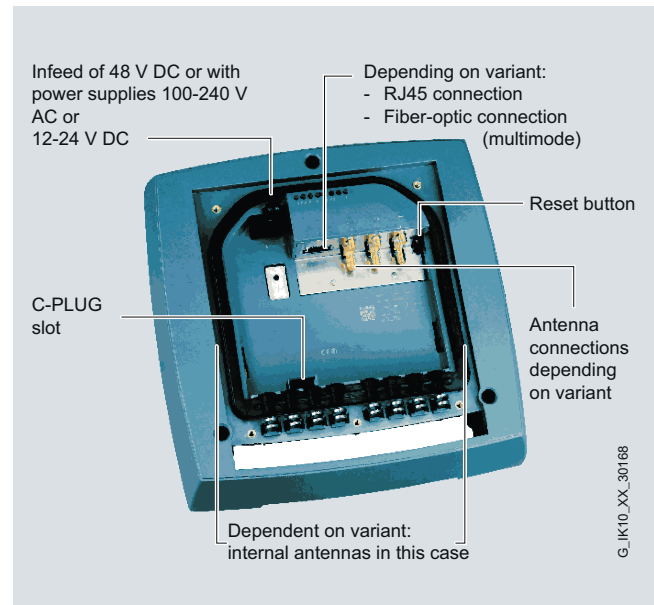

Design and interfaces of the SCALANCE W786C-2 controller-based access points

Product versions

SCALANCE W786C-2 (controller-based)

- Two wireless cards permanently installed in the device
- Versions with:
 - Six internal antennas
 - Six connections for external antennas

Industrial Wireless Communication

IWLAN – Controller and Controller Access Points IEEE 802.11n

Controller Access Points SCALANCE W786C RJ45 for the outdoor area

Technical specifications

Order No.	6GK5 786-2HC00-1AA0	6GK5 786-2FC00-1AA0
Product type designation	SCALANCE W786C-2IA RJ45	SCALANCE W786C-2 RJ45
Transmission rate		
Transmission rate		
• with W-LAN, maximum	450 Mbit/s	450 Mbit/s
• with Industrial Ethernet	10 ... 1 000 Mbit/s	10 ... 1 000 Mbit/s
• Note	-	-
Interfaces		
Number of electrical connections		
• for network components or terminal equipment	1	1
• for power supply	1	1
• for redundant power supply	1	1
Design of electrical connection		
• for network components or terminal equipment	RJ45 socket	RJ45 socket
• for power supply	2-pin connector (24 V DC) or optionally available power supply adapter (4-pin 24 V DC or 3-pin 110 to 230 V AC)	2-pin connector (24 V DC) or optionally available power supply adapter (4-pin 24 V DC or 3-pin 110 to 230 V AC)
Number of optical connections for fiber-optic cables at 100 Mbit/s	-	-
Design of optical connection for fiber-optic cables at 100 Mbit/s	-	-
Number of optical connections for fiber-optic cables at 1000 Mbit/s	-	-
Design of optical connection for fiber-optic cables at 1000 Mbit/s	-	-
Design of swap medium C-Plug	No	No
Interfaces wireless		
Number of permanently installed wireless cards	2	2
Number of internal antennas	6	-
Number of electrical connections for external antenna(s)	-	6
Design of electrical connection for external antenna(s)	-	R-SMA female (socket)
Supply voltage, current consumption, power loss		
Type of power supply	DC	DC
Power supply		
• 1 from terminal block	19.2 V	19.2 V
• 2 from terminal block	28.8 V	28.8 V
• From Power-over-Ethernet according to IEEE802.3at for Type 1 and IEEE802.3af	48 V	48 V
• From Power-over-Ethernet according to IEEE802.3at for Type 2	48 V	48 V
• From optionally integrated power supply		
- With AC	100 ... 240 V	100 ... 240 V
- With DC	12 ... 24 V	12 ... 24 V

Industrial Wireless Communication

IWLAN – Controller and Controller Access Points IEEE 802.11n

Controller Access Points
SCALANCE W786C RJ45 for the outdoor area

Technical specifications (continued)

Order No.	6GK5 786-2HC00-1AA0	6GK5 786-2FC00-1AA0
Product type designation	SCALANCE W786C-2IA RJ45	SCALANCE W786C-2 RJ45
Permissible ambient conditions		
Ambient temperature		
• During operation	-40 ... +60 °C	-40 ... +60 °C
• During storage	-40 ... +85 °C	-40 ... +85 °C
• During transport	-40 ... +85 °C	-40 ... +85 °C
Relative humidity at 25 °C without condensation during operation, maximum	100 %	100 %
IP degree of protection	IP65	IP65
Ambient conditions for operation	When using the 100 ... 240 V AC power supply, an operating temperature of -40 °C to +60 °C is permissible	When using the 100 ... 240 V AC power supply, an operating temperature of -40 °C to +60 °C is permissible
Design, dimensions and weights		
Width of enclosure without antenna	251 mm	251 mm
Height of enclosure without antenna	251 mm	251 mm
Depth of enclosure without antenna	72 mm	72 mm
Net weight	2.24 kg	2.24 kg
Type of mounting: wall mounting	Yes	Yes
Type of mounting	For mast mounting, 35 mm DIN rail mounting and S7-300 rail mounting, an additional retaining plate is required	For mast mounting, 35 mm DIN rail mounting and S7-300 rail mounting, an additional retaining plate is required
Wireless frequencies		
Wireless frequency		
• With WLAN in the 2.4 GHz frequency band	2.41 ... 2.48 GHz	2.41 ... 2.48 GHz
• With WLAN in the 5 GHz frequency band	4.9 ... 5.8 GHz	4.9 ... 5.8 GHz
Product functions		
Management, configuration, programming		
Product function		
• Operation with IWLAN controller	Yes	Yes
• Operation with Enterasys WLAN controller	Yes	Yes

Industrial Wireless Communication

IWLAN – Controller and Controller Access Points IEEE 802.11n

Controller Access Points SCALANCE W786C RJ45 for the outdoor area

Technical specifications (continued)

Order No.	6GK5 786-2HC00-1AA0	6GK5 786-2FC00-1AA0
Product type designation	SCALANCE W786C-2IA RJ45	SCALANCE W786C-2 RJ45
Standards, specifications, approvals		
Standard		
• for EMC of FM	-	-
• for hazardous zone	-	-
• for CSA and UL safety	UL 60950-1 CSA C22.2 No. 60950-1	UL 60950-1 CSA C22.2 No. 60950-1
• for hazardous zone of CSA and UL	-	-
Certificate of suitability		
• CE marking	Yes	Yes
• EC Declaration of Conformity	Yes	Yes
• C-Tick	Yes	Yes
• CCC	No	No
• Railroad application according to EN 50155	No	No
• e1 approval	No	No
• E1 approval	No	No
• NEMA4X	Yes	Yes
• Power-over-Ethernet according to IEEE802.3at for Type 1 and IEEE802.3af	Yes	Yes
• Power-over-Ethernet according to IEEE802.3at for Type 2	Yes	Yes
Standard for wireless communication		
• IEEE 802.11a	Yes	Yes
• IEEE 802.11b	Yes	Yes
• IEEE 802.11g	Yes	Yes
• IEEE 802.11h	Yes	Yes
• IEEE 802.11n	Yes	Yes
Wireless approval	You can find the latest list of countries at: www.siemens.com/simatic-net/ik-info	You can find the latest list of countries at: www.siemens.com/simatic-net/ik-info
Marine classification association		
• American Bureau of Shipping Europe Ltd. (ABS)	No	No
• Bureau Veritas (BV)	No	No
• Det Norske Veritas (DNV)	No	No
• Germanischer Lloyd (GL)	No	No
• Lloyds Register of Shipping (LRS)	No	No
• Nippon Kaiji Kyokai (NK)	No	No
• Polski Rejestr Statkow (PRS)	No	No
Accessories		
Accessories	24 V DC screw terminal included in scope of delivery	24 V DC screw terminal included in scope of delivery

Industrial Wireless Communication

IWLAN – Controller and Controller Access Points IEEE 802.11n

Controller Access Points
SCALANCE W786C RJ45 for the outdoor area

Ordering data	Order No.	Order No.
SCALANCE W786C Controller access points		
<p>IWLAN access points for operating with the SCALANCE WLC IWLAN Controller; with two built-in wireless interfaces; wireless networks IEEE 802.11a/b/g/h/n at 2.4/5 GHz up to 450 Mbit/s; WPA2/AES; Power over Ethernet (PoE), IP65 degree of protection (-40°C to +60°C); scope of delivery: Mounting hardware, 2-pin screw terminal for 24 V DC; manual on CD-ROM; German/English</p> <ul style="list-style-type: none"> • SCALANCE W786C-2IA RJ45 with six internal antennas • SCALANCE W786C-2 RJ45 with R-SMA female connections for six external antennas 	<p>6GK5 786-2HC00-1AA0</p> <p>6GK5 786-2FC00-1AA0</p>	<p>IE FC RJ45 Plug 4 x 2</p> <p>RJ45 plug connector for Industrial Ethernet (10/100/1000 Mbit/s) with a rugged metal enclosure and integrated insulation displacement contacts for connecting Industrial Ethernet FC installation cables; 180° cable outlet; for network components and CPs/CPU with Industrial Ethernet interface</p> <ul style="list-style-type: none"> • 1 pack = 1 unit • 1 pack = 10 units • 1 pack = 50 units <p>6GK1 901-1BB11-2AA0 6GK1 901-1BB11-2AB0 6GK1 901-1BB11-2AE0</p>
Accessories		
<p>Power supply PS791-2DC</p> <p>12 to 24 V DC power supply for installation in SCALANCE W786C-2 products; operating instructions in German/English</p>	6GK5 791-2DC00-0AA0	<p>IE FC Standard Cable GP 4 x 2</p> <p>8-core, shielded TP installation cable for connection to IE FC RJ45 Plug 4 x 2 and IE M12 Plug PRO 4 x 2; PROFINET-compliant; with UL approval; sold by the meter; max. length 1000 m, minimum order 20 m</p> <p>6XV1 878-2A</p>
<p>Power supply PS791-2AC</p> <p>110 to 230 V AC power supply for installation in SCALANCE W786C-2 products; operating instructions in German/English</p>	6GK5 791-2AC00-0AA0	<p>IE FC Stripping Tool</p> <p>Preadjusted stripping tool for fast stripping of the Industrial Ethernet FC cables</p> <p>6GK1 901-1GA00</p>
<p>MS1 mounting set</p> <p>Mounting set for fixing the SCALANCE W786C-2 products onto an S7-300 mounting rail or a 35 mm standard mounting rail</p>	6GK5 798-8MG00-0AA0	<p>Antennas and miscellaneous IWLAN accessories</p> <p>See Industrial Wireless LAN/ accessories</p>

More information

Wireless approvals:

Current approvals can be found on the Internet at:
www.siemens.com/wireless-approvals

To assist in selecting the right products for Industrial Wireless Communication, the SIMATIC NET Selection Tool is available:

Online version:
www.siemens.com/snst

Offline version:
www.siemens.com/snst-download

Industrial Wireless Communication

IWLAN – Access Points IEEE 802.11a/b/g

Overview

Overview



The access points of the SCALANCE W780 product line are optimized for the configuration of Industrial Wireless LAN (IWLAN) wireless networks for 2.4 GHz or 5 GHz with data transmission rates up to 54 Mbit/s. They can be used in all applications that require a high degree of operational reliability, even under extremely harsh environmental conditions.

- Suitable for any application:
 - SCALANCE W784 for installation in a cabinet or integration in devices
 - SCALANCE W788 for cabinet-free installation indoors
 - SCALANCE W786 for outdoor environments with demanding climatic requirements
- Reliable thanks to rugged, impact-resistant housing, protected from water and dust (IP65), resistant to shock, vibration and electromagnetic fields
- Approved for operation in hazardous areas in Zone 2
- Demanding applications with real-time and redundancy requirements, such as PROFINET with PROFI-safe
- In conformance with standards, as it supports IEEE 802.11; expansions with software functions, especially for applications demanding high reliability, e.g. channel hopping procedure (iHOP), cyclic real-time data traffic, and very high-speed roaming (iPCF)
- Support with planning, simulation, configuration, site survey and documentation with the SINEMA E engineering tool, wizards and online help; easy management with Web server and SNMP
- Quick commissioning of Access Points with the optional swap medium PRESET-PLUG and quick device exchange in case of faults with the optional swap medium C-PLUG (Configuration Plug)

Benefits

get Designed for Industry

- Predictable data traffic (strict real-time requirements) and defined response times on the wireless link
- Reliable wireless link, e.g. due to redundant connection and cyclic monitoring of the wireless path
- Cost savings due to one single radio network both for process-critical data and for non-critical communication
- Investment security because all products are compatible with the internationally recognized WLAN standard IEEE 802.11, suitable for the unlicensed frequency bands of 2.4 GHz and 5 GHz (ISM bands)
- Reduced operating costs, because there is no wear of rotating and moving plant sections
- Cost-effective connection to devices which are remote, difficult to access or in hostile environments

Application

The Access Points of the SCALANCE W780 product line are designed for both industrial use and for demanding climatic requirements outdoors. Versions for the inexpensive integration in cabinets or in devices are also available. They offer a reliable radio connection, versatile redundancy mechanisms, and fast transfer of stations from one access point to the next (roaming). In this manner, processes can be monitored and production failures through machine downtimes avoided. In addition, Industrial Wireless LAN (IWLAN) can be used in time-critical applications associated with production automation (PROFINET IO) or for safety-related signals (PROFI-safe).

Due to the high degree of protection (IP65) and the extended temperature range from -40 °C to +70 °C, the Access Points are ideally suited for use in the outdoor area. SCALANCE W products are silicone-free and can therefore also be used in paint plants.

When using the RCoax cable (radiating cable), operation is particularly reliable in conveying technology and all track applications (e.g. storage and retrieval systems).

SCALANCE W786 versions are available with internal antennas for demanding environmental requirements.

Application (continued)

Application examples:

- Automated guided vehicles and suspended monorails; prevention of wear and high flexibility in the choice of route thanks to wireless transmission of data to the vehicles
- Crane; high flexibility through access to data communication with the moving unit independent of the location
- Mobile control console; reliable intervention in the process thanks to data communication over IWLAN with mobile units (e.g. Mobile Panel 277(F) IWLAN); the number of operator panels is therefore determined by the number of personnel and no longer by the number of control desks.
- Wireless access to field devices for configuration and testing
- Communication with moving stations (e.g. mobile controls and devices), container logistics, storage and retrieval machines, conveyor systems, conveyor belts, rotating machines, trucks
- Wireless coupling of communication segments and bridging of large distances for fast commissioning and for cost-effective networks in which cable routing would be extremely expensive (e.g. on public roads, rivers, lakes, train lines)
- Localization of personnel and machines using WLAN tags and localization software from AeroScout

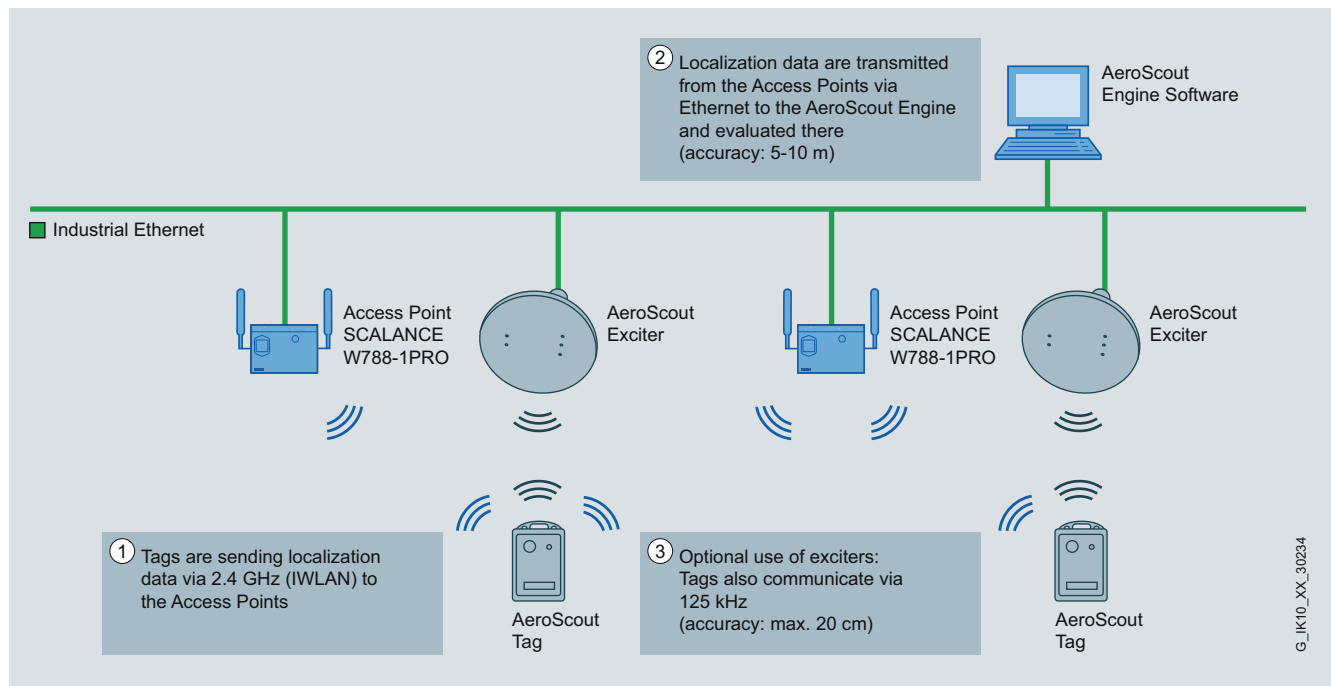

Localization of personnel and machines via an IWLAN infrastructure

Design

- Wireless card (compatible with IEEE 802.11a/b/g/h) permanently installed in the device
- Designed without rotating parts (operation without fans)
- Antennas can either be connected by means of a screw connection (R-SMA) or integrated into a device (SCALANCE W786 only)
- Function LEDs for optical signaling of faults and operating states
- 1 x C-PLUG/PRESET-PLUG slot

Industrial Wireless Communication

IWLAN – Access Points IEEE 802.11a/b/g

Overview

Function

A simple wireless link can be constructed from a single access point (infrastructure mode). The access point provides an Industrial Ethernet interface for connection to the wireline network. Stations, such as mobile controllers or a Field PG can move freely within the wireless link and exchange data with other stations through this access point.

If the wireless link of a single access point (wireless cell) is insufficient, it can be expanded by further access points. The individual wireless cells must overlap so that moving stations can be passed seamlessly from one access point to the next (roaming). This is performed invisibly to the application. The access points must be able to exchange data via Industrial Ethernet or a Wireless Distribution System (WDS).

If the Access Points are not connected to Industrial Ethernet using a wired connection (e.g. no cable tray available for data line), the operating mode "Wireless Distribution System" must be selected. An Access Point from the SCALANCE W780 product line can communicate via WDS with up to eight other Access Points which are not connected to the data network by a direct wired connection. Directional additional antennas can be used to achieve ranges of several thousand meters outdoors.

Apart from a reliable radio link, the SCALANCE W780 Access Points are characterized by their support of IT mechanisms:

- IEEE 802.11a/b/g for different frequency ranges
- IEEE 802.11h for use in the 5 GHz range outdoors
- IEEE 802.11e for Wireless Multimedia (WMM)
- IEEE 802.11i for security
- Construction of redundant networks with the Rapid Spanning Tree Protocol (RSTP)
- Virtual networks (VLAN) to logically separate, for example, different user groups
- Sending the log entries of the SCALANCE W devices to a Syslog server
- Modern security mechanisms (e.g. network security such as IEEE 802.1x, RADIUS, EAP mechanisms)
- In client mode:
Network and Port Address Translation (NAT/PAT):
Mapping of private IP addresses and ports to public addresses

Security

A high degree of data security is achieved by means of the WPA2/IEEE 802.11i mechanisms. These define modern procedures that control a regular exchange of the complete 128-bit code as well as performing the access check (authentication) of a station. The Advanced Encryption Standard (AES) is available for data encryption.

Access to the devices (HTTPS) is encrypted and secure logon (SSH) is possible. If a security concept with Virtual Private Networks (VPN) or the SCALANCE S range is required, the products can be integrated without any difficulty.

iFeatures (only for RR versions of the access points)

iPCF (Industrial Point Coordination Function)

The **iPCF** mode is recommended for applications with a requirement for real-time and predictable response times (deterministic response), even during roaming of moving stations from one access point to the next. This ensures that wireless PROFINET IO is supported and that safety-related signals, e.g. emergency stop, can be integrated into the wireless link. This means that even video signals from moving stations can be transmitted with a high level of quality.

The iPCF mechanism expands the IEEE 802.11 standard and must be available on both the station and the access point (e.g. SCALANCE W788-1RR). In a wireless link in which iPCF is used, no IEEE 802.11-compliant stations can be operated.

iPCF is recommended for applications where wireless network nodes move along predefined paths (e.g. suspended monorail). RCoax leaky wave cables or directional antennas must be used for this purpose.

Note:

The IWLAN/PB Link PN IO gateway also supports iPCF

Function (continued)

iPCF-MC (iPCF Management Channel)

iPCF-MC is available as further development of iPCF. This mode should be used if IWLAN stations that also support iPCF-MC (e.g. Client Modules SCALANCE W747-1RR, Mobile Panel 277F IWLAN) move freely about in the coverage area (especially when using omni-directional antennas) and are to exchange data deterministically. This functionality can only be implemented in combination with RR access point versions with at least two wireless interfaces.

Note:

Due to the lower bandwidth when using iPCF-MC, we recommend the iPCF mode for transmitting video signals.

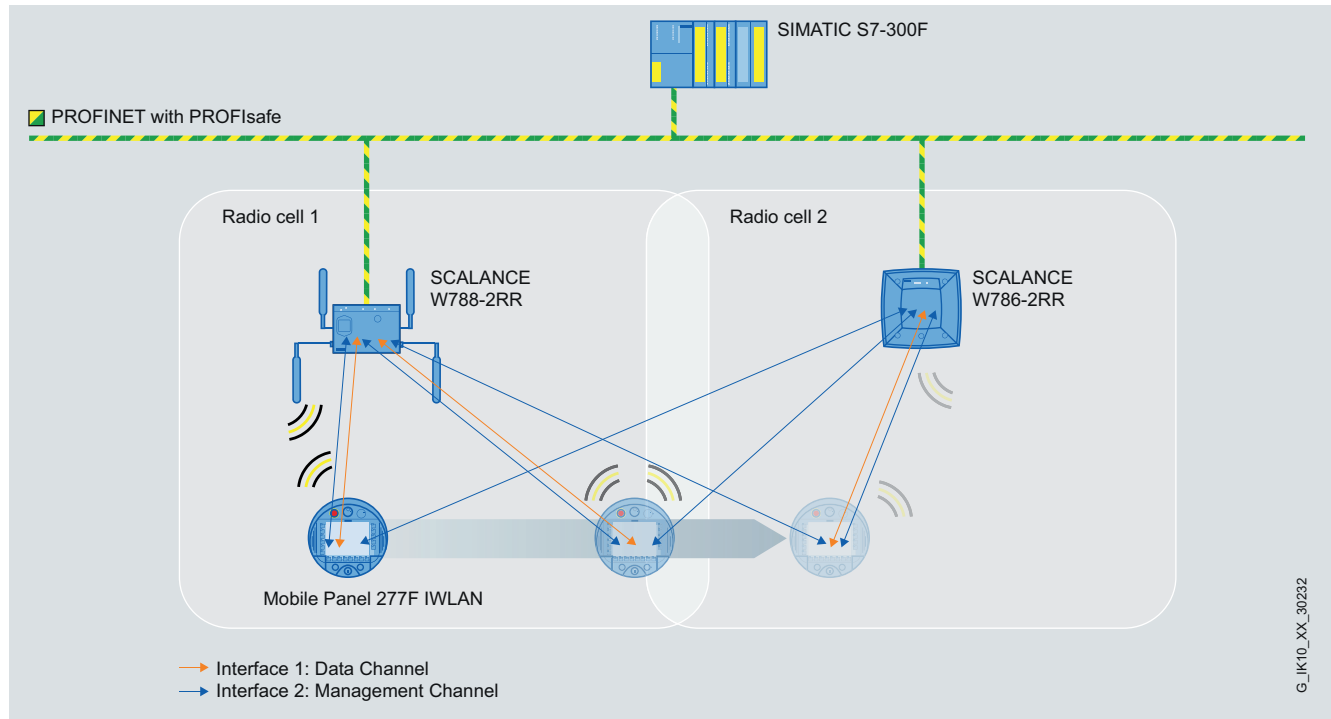

Roaming of a mobile panel between two access points while maintaining error-free communication with iPCF-MC

Industrial Wireless Communication

IWLAN – Access Points IEEE 802.11a/b/g

Overview

Function (continued)

iHOP

With the supplementary function **iHOP**, the access point changes the channel in coordination with its clients. If it detects interferences which are caused, for example, by sporadically active WLANs on a channel, it avoids the affected channel temporarily. Hopping to the other channel is carried out so rapidly that usually the application is not impaired by the channel change. If the interferences occur throughout the complete frequency band, it is even possible to change to another frequency band (e.g. from 2.4 to 5 GHz).

This guarantees reliable communication even with interferences in the wireless field.

Note:
These iFeatures cannot be used in parallel.

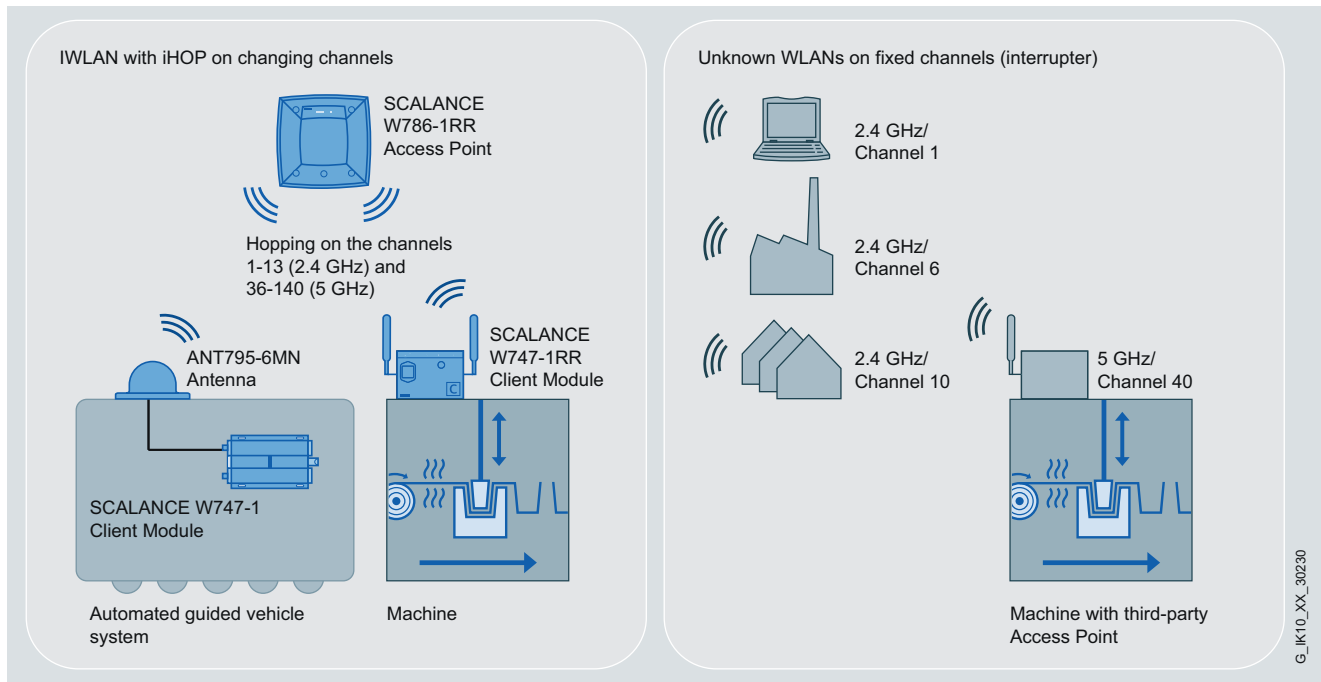

Coordinated changing of channels by means of a channel hopping procedure (iHOP) to avoid disrupters

8

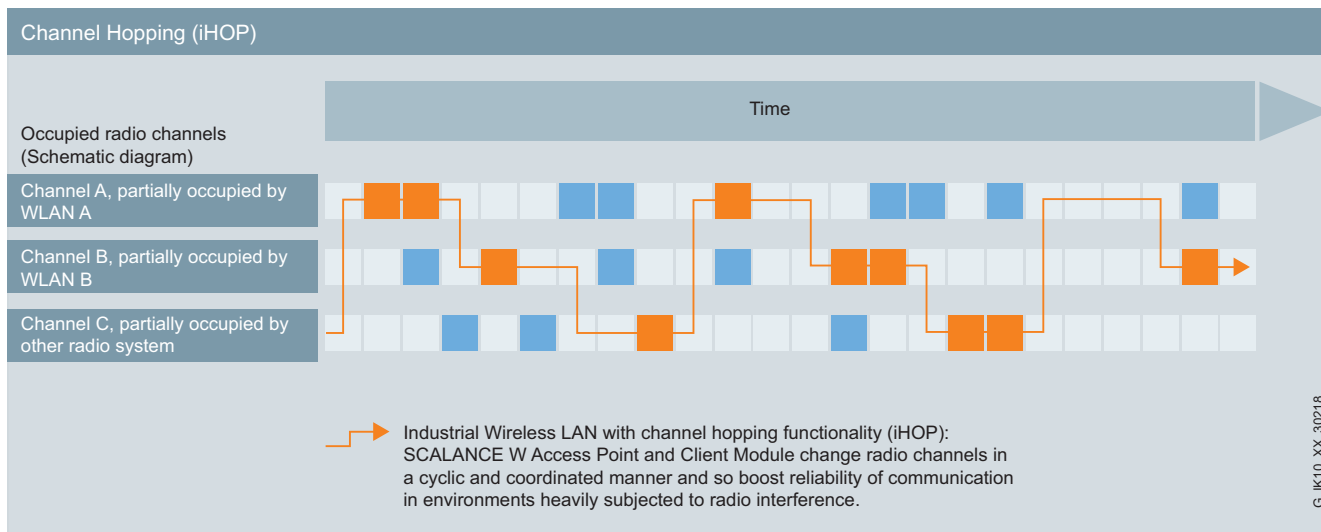

iHOP function for SCALANCE W access points

Diagnostics and management

- Web-based (HTTP/HTTPS) management tool for configuration and diagnostics using a standard browser
- Planning, configuration, simulation and measurement of the wireless link on site (Site Survey) with SINEMA E
- LEDs for signaling operating states and fault conditions
- Signaling of faults by means of SNMP trap or e-mail to a network management tool, e.g. SINEMA-Server

Industrial Wireless Communication

IWLAN – Access Points IEEE 802.11a/b/g

SCALANCE W784 for use in the control cabinet

Overview



- Especially suitable for applications where the access point is to be mounted in the control cabinet
- Low-cost alternative for use indoors with less severe environmental conditions
- The rugged aluminum enclosure with degree of protection IP30 nevertheless provides protection against mechanical and electromagnetic stress in industrial areas

Design

- Low-profile, compact aluminum enclosure, shock and vibration-proof for high mechanical requirements
- Dust protection with IP30 degree of protection
- For use at ambient temperatures from -20 °C to +60 °C
- Construction and design suitable for integration in a device or for installation in a cabinet
- 2 x R-SMA sockets for the connection of remote antennas
- 1 x RJ45 connection for 10/100 Mbit/s with Power-over-Ethernet according to IEEE 802.3at Type 1 (corresponds to IEEE 802.3af)
- 1 x 24 V DC connection for redundant power infeed
- 1 x C-PLUG slot
- Function LEDs for optical signaling of faults and operating states
- Mounting: Wall or, with optional mounting set, on S7 mounting rail, 35 mm standard mounting rail

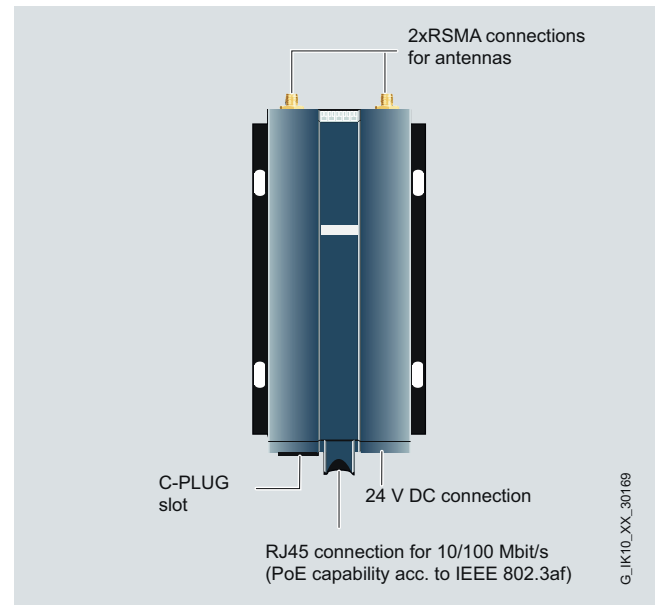

Design and interfaces of the SCALANCE W784 access points

Product versions

SCALANCE W784-1

- A wireless card permanently installed in the device

SCALANCE W784-1RR

- A radio card permanently installed in the device for establishing wireless connections with iPCF

Industrial Wireless Communication

IWLAN – Access Points IEEE 802.11a/b/g

SCALANCE W784 for use in the control cabinet

Function

SCALANCE W784 access points for control cabinet installation can also be operated as client modules. As an alternative, the SCALANCE W740 client modules can be used for this mode.

In combination with the SCALANCE W740 Client Modules with degree of protection IP30, an infrastructure can be set up in which great temperature differences and protection against dust and water play a somewhat less prominent role.

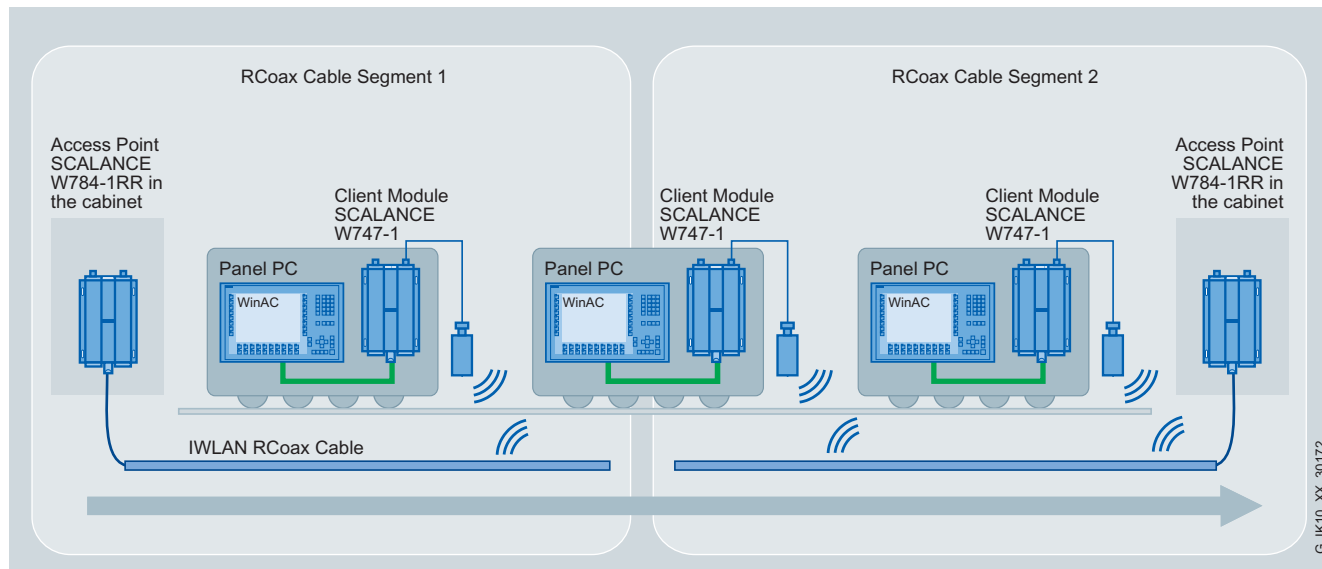

Implementing an automatic guided transport system in a wireless link with SCALANCE W784-1RR and RCoax cable.

The mobile automated guided vehicles are integrated in the IWLAN wireless field over the SCALANCE W747-1 Ethernet Client Modules. Both the Access Points and the Client Modules are in the control cabinet.

Technical specifications

Order No.	6GK5 784-1AA30-2AA0 6GK5 784-1AA30-2AB0 ¹⁾	6GK5 784-1AA30-6AA0 6GK5 784-1AA30-6AB0 ¹⁾
Product type designation	SCALANCE W784-1	SCALANCE W784-1RR
Transmission rate		
Transmission rate	54 Mbit/s	54 Mbit/s
• with W-LAN, maximum	10 ... 100 Mbit/s	10 ... 100 Mbit/s
• with Industrial Ethernet	Due to the simultaneous use of several radio channels, a transmission rate of 108 Mbit/s is possible (turbo mode)	Due to the simultaneous use of several radio channels, a transmission rate of 108 Mbit/s is possible (turbo mode)
• Note		
Interfaces		
Number of electrical connections		
• for network components or terminal equipment	1	1
• for power supply	1	1
• for redundant power supply	1	1
Design of electrical connection		
• for network components or terminal equipment	RJ45 socket	RJ45 socket
• for power supply	4-pin screw terminal, PoE	4-pin screw terminal, PoE
Design of swap medium C-Plug	Yes	Yes

¹⁾ Wireless approval in the USA

Technical specifications (continued)

Order No.	6GK5 784-1AA30-2AA0 6GK5 784-1AA30-2AB0 ¹⁾	6GK5 784-1AA30-6AA0 6GK5 784-1AA30-6AB0 ¹⁾
Product type designation	SCALANCE W784-1	SCALANCE W784-1RR
Interfaces wireless		
Number of permanently installed wireless cards	1	1
Number of electrical connections for external antenna(s)	2	2
Design of electrical connection for external antenna(s)	R-SMA female (socket)	R-SMA female (socket)
Supply voltage, current consumption, power loss		
Type of power supply	DC	DC
Supply voltage		
• 1 from terminal block	24 V	24 V
• 2 from terminal block	48 V	48 V
• From Power-over-Ethernet according to IEEE802.3at for Type 1 and IEEE802.3af	48 V	48 V
Current consumed		
• At 24 V DC, typical	0.23 A	0.23 A
• At 48 V DC, typical	0.12 A	0.12 A
• With Power-over-Ethernet according to IEEE802.3at for Type 1 and IEEE802.3af, typical	0.12 A	0.12 A
Effective power loss		
• At 24 V DC, typical	6 W	6 W
• At 48 V DC, typical	6 W	6 W
• With Power-over-Ethernet according to IEEE802.3at for Type 1 and IEEE802.3af, typical	6 W	6 W
Permissible ambient conditions		
Ambient temperature		
• During operation	-20 ... +60 °C	-20 ... +60 °C
• During storage	-40 ... +70 °C	-40 ... +70 °C
• During transport	-40 ... +70 °C	-40 ... +70 °C
Relative humidity at 25 °C without condensation during operation, maximum	90 %	90 %
IP degree of protection	IP30	IP30
Ambient conditions for operation	-	-
Design, dimensions and weights		
Width of enclosure without antenna	100 mm	100 mm
Height of enclosure without antenna	205 mm	205 mm
Depth of enclosure without antenna	20 mm	20 mm
Net weight	0.29 kg	0.29 kg
Type of mounting		
• S7-300 rail mounting	-	-
• Wall mounting	Yes	Yes
Type of mounting	For mounting on 35 mm DIN rail and S7-300 rail, an additional adapter plate is required	For mounting on 35 mm DIN rail and S7-300 rail, an additional adapter plate is required

¹⁾ Wireless approval in the USA

Industrial Wireless Communication

IWLAN – Access Points IEEE 802.11a/b/g

SCALANCE W784 for use in the control cabinet

Technical specifications (continued)

Order No.	6GK5 784-1AA30-2AA0 6GK5 784-1AA30-2AB0 ¹⁾	6GK5 784-1AA30-6AA0 6GK5 784-1AA30-6AB0 ¹⁾
Product type designation	SCALANCE W784-1	SCALANCE W784-1RR
Wireless frequencies		
Wireless frequency		
• With WLAN in the 2.4 GHz frequency band	2.41 ... 2.48 GHz	2.41 ... 2.48 GHz
• With WLAN in the 5 GHz frequency band	4.9 ... 5.8 GHz	4.9 ... 5.8 GHz
Product properties, functions, components		
General		
Number of SSIDs	8	8
Product function		
• Dual client	No	Yes
• iHOP	No	Yes
• iPCF	No	Yes
• iPCF-MC	No	No
Number of iPCF-capable radio modules	0	1
Product functions		
Management, configuration, programming		
Number of manageable IP addresses in the client	8	8
Product function		
• CLI	Yes	Yes
• Web-based management	Yes	Yes
• MIB support	Yes	Yes
• TRAPs via e-mail	Yes	Yes
• Configuration with STEP 7	Yes	Yes
• Configuration with STEP 7 in the TIA Portal	Yes	Yes
• SMTP server	Yes	Yes
• Operation with IWLAN controller	No	No
• Operation with Enterasys WLAN controller	No	No
• iQoS	Yes	Yes
• Forced roaming with IWLAN	Yes	Yes
• WDS	Yes	Yes
Protocol is supported		
• Address Resolution Protocol (ARP)	Yes	Yes
• ICMP	Yes	Yes
• Telnet	Yes	Yes
• HTTP	Yes	Yes
• HTTPS	Yes	Yes
• TFTP	Yes	Yes
• SNMP v1	Yes	Yes
• SNMP v2	Yes	Yes
• SNMP v3	Yes	Yes
• DCP	Yes	Yes
• LLDP	Yes	Yes
Identification & maintenance		
• I&MO – device-specific information	Yes	Yes
• I&M1 – higher-level designation/ location designation	Yes	Yes

¹⁾ Wireless approval in the USA

Technical specifications (continued)

Order No.	6GK5 784-1AA30-2AA0 6GK5 784-1AA30-2AB0 ¹⁾	6GK5 784-1AA30-6AA0 6GK5 784-1AA30-6AB0 ¹⁾
Product type designation	SCALANCE W784-1	SCALANCE W784-1RR
Product functions Diagnostics		
Product function		
• PROFINET IO diagnostics	Yes	Yes
• Link check	Yes	Yes
• Connection monitoring IP-Alive	Yes	Yes
• Localization by means of Aeroscout	Yes	Yes
• SysLog	Yes	Yes
Product functions VLAN		
Product function VLAN with IWLAN	Yes	Yes
Product functions DHCP		
Product function DHCP client	Yes	Yes
Product functions Redundancy		
STP/RSTP protocol is supported	Yes	Yes
Product functions Security		
Product function		
• ACL – MAC based	Yes	Yes
• IEEE 802.1x (radius)	Yes	Yes
• NAT/NAPT	Yes	Yes
• Access protection according to IEEE802.11i	Yes	Yes
• WPA/WPA2	Yes	Yes
• TKIP/AES	Yes	Yes
Protocol is supported SSH	Yes	Yes
Product functions Time		
SNTP protocol is supported	Yes	Yes
Standards, specifications, approvals		
Standard		
• for EMC of FM	FM 3611: Class I, Division 2, Groups A,B,C,D, T4 / Class 1, Zone 2, Group IIC, T4	FM 3611: Class I, Division 2, Groups A,B,C,D, T4 / Class 1, Zone 2, Group IIC, T4
• for hazardous zone	EN 60079-15:2005, EN 60079-0:2006, II 3 G Ex nA II T4 KEMA 07 ATEX 0145X (only approved in connection with an enclosure with degree of protection of at least IP 54)	EN 60079-15:2005, EN 60079-0:2006, II 3 G Ex nA II T4 KEMA 07 ATEX 0145X (only approved in connection with an enclosure with degree of protection of at least IP 54)
• for CSA and UL safety	UL 60950-1 CSA C22.2 No. 60950-1	UL 60950-1 CSA C22.2 No. 60950-1
• for hazardous zone of CSA and UL	ISA 12.12.01-2000, CSA C22.2 No. 213-M1987, CL. 1, Div. 2, GP. A,B,C,D, T4 / CL. 1, Zone 2, GP IIC, T4 / CL. 1, Zone 2, AEx nC IIC, T4 (only approved in connection with an enclosure with degree of protection of at least IP 54)	ISA 12.12.01-2000, CSA C22.2 No. 213-M1987, CL. 1, Div. 2, GP. A,B,C,D, T4 / CL. 1, Zone 2, GP IIC, T4 / CL. 1, Zone 2, AEx nC IIC, T4 (only approved in connection with an enclosure with degree of protection of at least IP 54)
Certificate of suitability		
• CE marking	Yes	Yes
• EC Declaration of Conformity	Yes	Yes
• C-Tick	Yes	Yes
• CCC	No	No
• Railroad application according to EN 50155	Yes	Yes
• e1 approval	Yes	Yes
• E1 approval	Yes	Yes
• Power-over-Ethernet according to IEEE802.3at for Type 1 and IEEE802.3af	Yes	Yes

¹⁾ Wireless approval in the USA

Industrial Wireless Communication

IWLAN – Access Points IEEE 802.11a/b/g

SCALANCE W784 for use in the control cabinet

Order No.	6GK5 784-1AA30-2AA0 6GK5 784-1AA30-2AB0 ¹⁾	6GK5 784-1AA30-6AA0 6GK5 784-1AA30-6AB0 ¹⁾
Product type designation	SCALANCE W784-1	SCALANCE W784-1RR
Standard for wireless communication		
• IEEE 802.11a	Yes	Yes
• IEEE 802.11b	Yes	Yes
• IEEE 802.11e	Yes	Yes
• IEEE 802.11g	Yes	Yes
• IEEE 802.11h	Yes	Yes
• IEEE 802.11i	Yes	Yes
• IEEE 802.11n	No	No
Wireless approval	You can find the latest list of countries at: www.siemens.com/simatic-net/ik-info	You can find the latest list of countries at: www.siemens.com/simatic-net/ik-info
Marine classification association		
• American Bureau of Shipping Europe Ltd. (ABS)	Yes	Yes
• Bureau Veritas (BV)	Yes	Yes
• Det Norske Veritas (DNV)	No	No
• Germanischer Lloyd (GL)	Yes	Yes
• Lloyds Register of Shipping (LRS)	Yes	Yes
• Nippon Kaiji Kyokai (NK)	Yes	Yes
• Polski Rejestr Statkow (PRS)	No	No
Accessories		
Accessories	24 V DC screw terminal included in scope of delivery	24 V DC screw terminal included in scope of delivery

¹⁾ Wireless approval in the USA

Ordering data	Order No.	Order No.
<p>SCALANCE W784 access points</p> <p>IWLAN access points with built-in wireless interfaces; wireless networks IEEE 802.11a/b/g/h at 2.4/5 GHz up to 54 Mbit/s; WPA2/AES; Power over Ethernet (PoE), IP30 degree of protection (-20 °C to +60 °C); scope of supply: Mounting hardware, 24 V DC screw terminal; manual on CD-ROM; German/English</p> <p>SCALANCE W784-1</p> <p>IWLAN Access Points with <u>one</u> built-in radio interface</p> <ul style="list-style-type: none"> • National approvals for operation outside the USA • National approvals for operation within the USA¹⁾ 	<p>6GK5 784-1AA30-2AA0</p> <p>6GK5 784-1AA30-2AB0</p>	<p>SCALANCE W784-1RR</p> <p>IWLAN Access Point with <u>one</u> built-in radio interface for establishment of radio links with iPCF</p> <ul style="list-style-type: none"> • National approvals for operation outside the USA • National approvals for operation within the USA¹⁾ <p>6GK5 784-1AA30-6AA0</p> <p>6GK5 784-1AA30-6AB0</p>

¹⁾ Please note national approvals at www.siemens.com/wireless-approvals

Industrial Wireless Communication

IWLAN – Access Points IEEE 802.11a/b/g

SCALANCE W784 for use in the control cabinet

Ordering data	Order No.	Order No.
<i>Accessories</i>		
C-PLUG Swap medium for simple replacement of devices in the event of a fault; for storing configuration data; can be used in SIMATIC NET products with PLUG slot	6GK1 900-0AB00	IE FC RJ45 Plug 180 2x2 RJ45 plug connector for Industrial Ethernet with a rugged metal enclosure and integrated insulation-displacement contacts for connecting Industrial Ethernet FC installation cables; with a 180° cable outlet; for network components and CPs/CPU with Industrial Ethernet interface • 1 pack = 1 unit • 1 pack = 10 units • 1 pack = 50 units
PRESET-PLUG Swap medium for simple initial startup of SCALANCE W access points and client modules, as well as IWLAN/PB Link PN IO	6GK5 798-8AB00	IE FC Standard Cable GP 2 x 2 4-core, shielded TP installation cable for connection to IE FC Outlet RJ45/ IE FC RJ45 Plug; PROFINET-compliant; with UL approval; sold by the meter; max. length 1000 m, minimum order 20 m
SIMATIC Mobile Panel 277F IWLAN <ul style="list-style-type: none"> • Communication via WLAN (PROFINET) with acknowledgement button and emergency stop button • Communication via WLAN (PROFINET) with acknowledgment button and emergency stop button with integrated handwheel, key-operated switch, and two illuminated pushbuttons Note: Please also order the desktop power supply or battery charger!	6AV6 645-0DB01-0AX0 6AV6 645-0DC01-0AX0	IE FC Stripping Tool Preadjusted stripping tool for fast stripping of the Industrial Ethernet FC cables
<ul style="list-style-type: none"> • Table-top power supply incl. power cable for EU, US, UK, JP (only suitable for operation under laboratory/office conditions) • Charger for safe storage and charging the device incl. lock for securing the device in the charger. Charging capabilities for up to two additional batteries • Additional battery with LED indicator for indicating the charge status • Transponder incl. batteries (3x AA) 	6AV6 671-5CN00-0AX1 6AV6 671-5CE00-0AX0 6AV6 671-5CL00-0AX0 6AV6 671-5CM00-0AX0	IE TP Cord RJ45/RJ45 TP cable 4 x 2 with 2 RJ45 connectors • 0.5 m • 1 m • 2 m • 6 m • 10 m
		MS2 mounting set Mounting set for fixing the SCALANCE W784 products onto an S7-300 mounting rail or a 35 mm standard DIN rail
		Antennas and miscellaneous IWLAN accessories See Industrial Wireless LAN/ accessories

More information

Wireless approvals:

Current approvals can be found on the Internet at:
www.siemens.com/wireless-approvals

To assist in selecting the right products for Industrial Wireless Communication, the SIMATIC NET Selection Tool is available:

Online version:
www.siemens.com/snst

Offline version:
www.siemens.com/snst-download

Industrial Wireless Communication

IWLAN – Access Points IEEE 802.11a/b/g

SCALANCE W788 for the indoor area

Overview



- Particularly suitable for industrial applications without control cabinets.

Design

- Rugged metal enclosure, shock and vibration-proof for high mechanical requirements in industrial applications designed without cabinets
- High IP65 degree of protection against dust and water jets
- For use at ambient temperatures from -20 °C to +60 °C
- Resistant to condensation
- 2 x R-SMA sockets for the connection of remote antennas (4 x R-SMA for the versions with two radio modules)
- 1 x hybrid socket for data and energy line for infeed over the IE FC Modular Outlet or for supplying with Power-over-Ethernet according to IEEE 802.3at Type 1 (corresponds to IEEE 802.3af)
- 1 x M12 socket for redundant power infeed (18 to 32 V DC, 48 V DC), e.g. in conjunction with the PS791-1PRO (90 to 265 V AC) power supply
- 1 x C-PLUG slot
- Function LEDs for optical signaling of faults and operating states
- Mounting: Wall, S7-300 mounting rail (90 mm length, vertically mounted, bolts included in scope of supply), or with optional mounting aid on 35 mm DIN rail

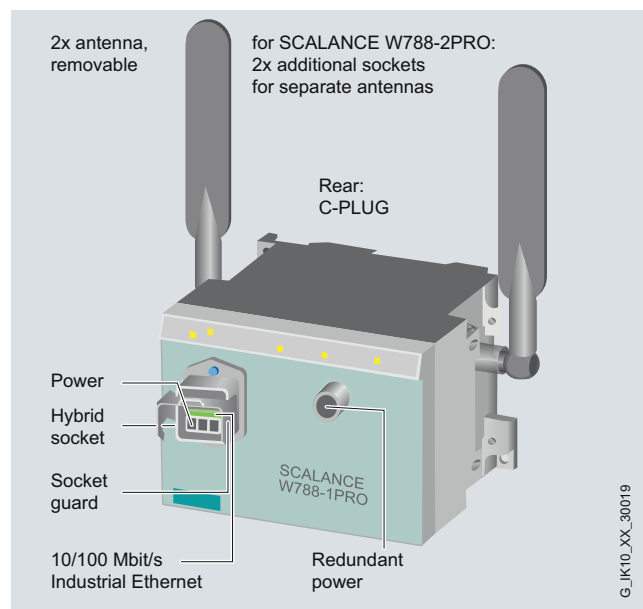

Design and interfaces of the SCALANCE W788 access points

Product versions

SCALANCE W788-1PRO

- A wireless card permanently installed in the device

SCALANCE W788-1RR

- A radio card permanently installed in the device for establishing wireless connections with iPCF

SCALANCE W788-2PRO

- Two wireless cards permanently installed in the device

SCALANCE W788-1RR

- Two wireless cards permanently installed in the device for establishing wireless connections with iPCF

Function

The devices can be installed at the location that is most favorable for the wireless field. The enclosures and the connectors resist high levels of shock and vibration loading because all the connections are screwed or latched. To achieve optimal illumination for special applications, the supplied antennas can be replaced.

SCALANCE W788 access points can also be operated as client modules. As an alternative, the SCALANCE W740 client modules can be used for this mode.

The devices with two interfaces have two separate wireless modules and behave like two separate devices in the wireless network. This feature can be used to implement cost-effective solutions, e.g. when a wireless interface is used for wireless connection of a distant production site and the second wireless interface provides a wireless field at the access point. Local stations can log in here and move around freely. Two separate wireless modules, however, also permit the setup of redundant wireless fields so that a high level of operational reliability can be achieved.

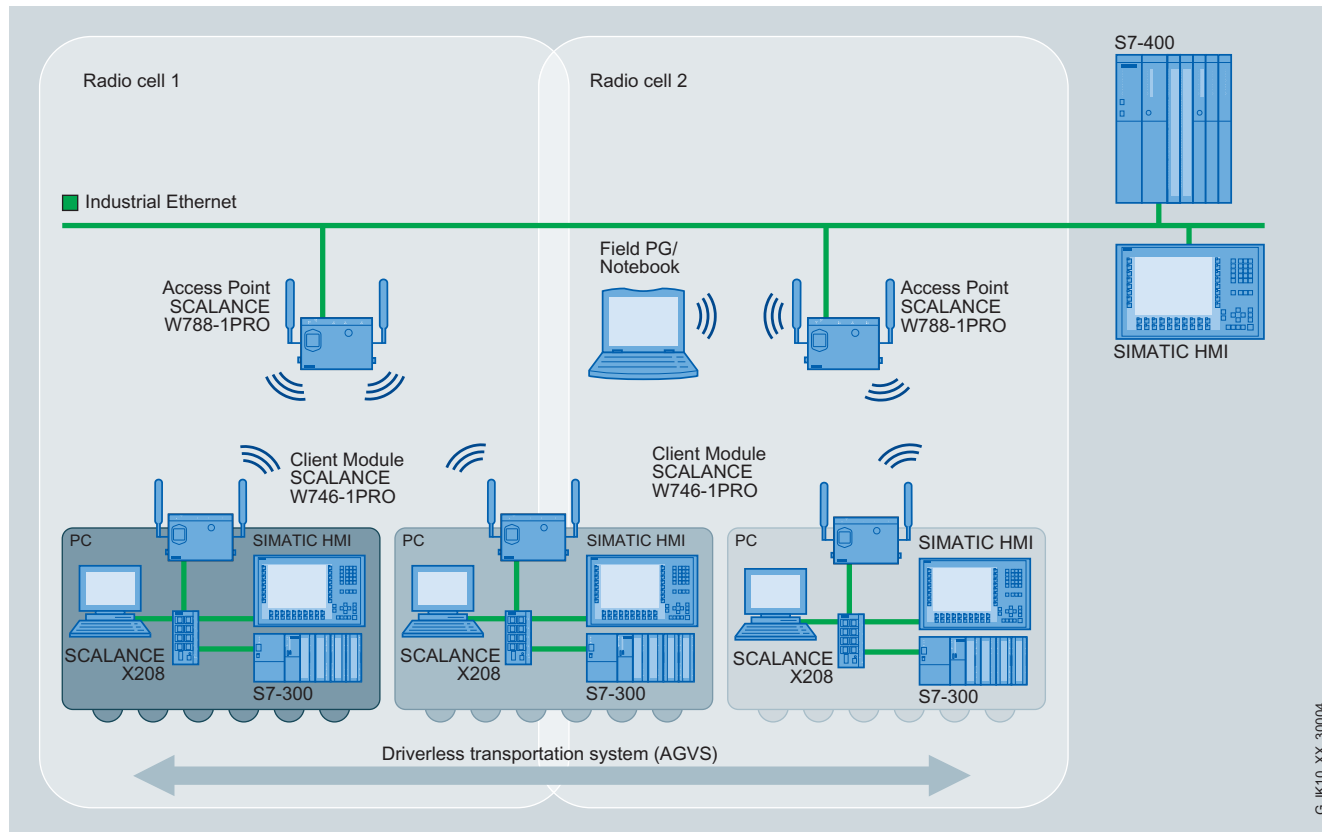

Roaming of moving units (e.g. Field PG and mobile controller) in a wireless network with two access points

Stations, e.g. a Field PG M, can move freely in the wireless field of the SCALANCE W788-1PRO access points for mobile HMI. In addition, SCALANCE W746-1PRO connects mobile HMI, controller and PC units wirelessly to the data network.

The IWLAN wireless coverage of SCALANCE W788-1PRO permits S7 communication and open communication between the devices on the AGVs and stationary S7-400, as well as on the stationary SIMATIC HMI device.

Provided that a delay (several 100 ms) caused by roaming in accordance with IEEE 802.11 is tolerated by all communication stations when switching the wireless cells, the communication continues uninterrupted.

If very fast update times are necessary, e.g. for PROFINET IO communication, access points and client modules that support the iPCF function for very fast roaming and deterministic data traffic are to be used, for example SCALANCE W788-1RR and W747-1RR.

When an extremely reliable wireless field is essential, it is recommended that the RCoax Cable is used as an alternative to conventional antennas. This leaky-wave cable is a special antenna along which a wireless field propagates and which is therefore suitable for applications in which, for example, nodes move along a rail but must have non-contact connection to the data network to prevent wear from collector wires.

Industrial Wireless Communication

IWLAN – Access Points IEEE 802.11a/b/g

SCALANCE W788 for the indoor area

Function (continued)

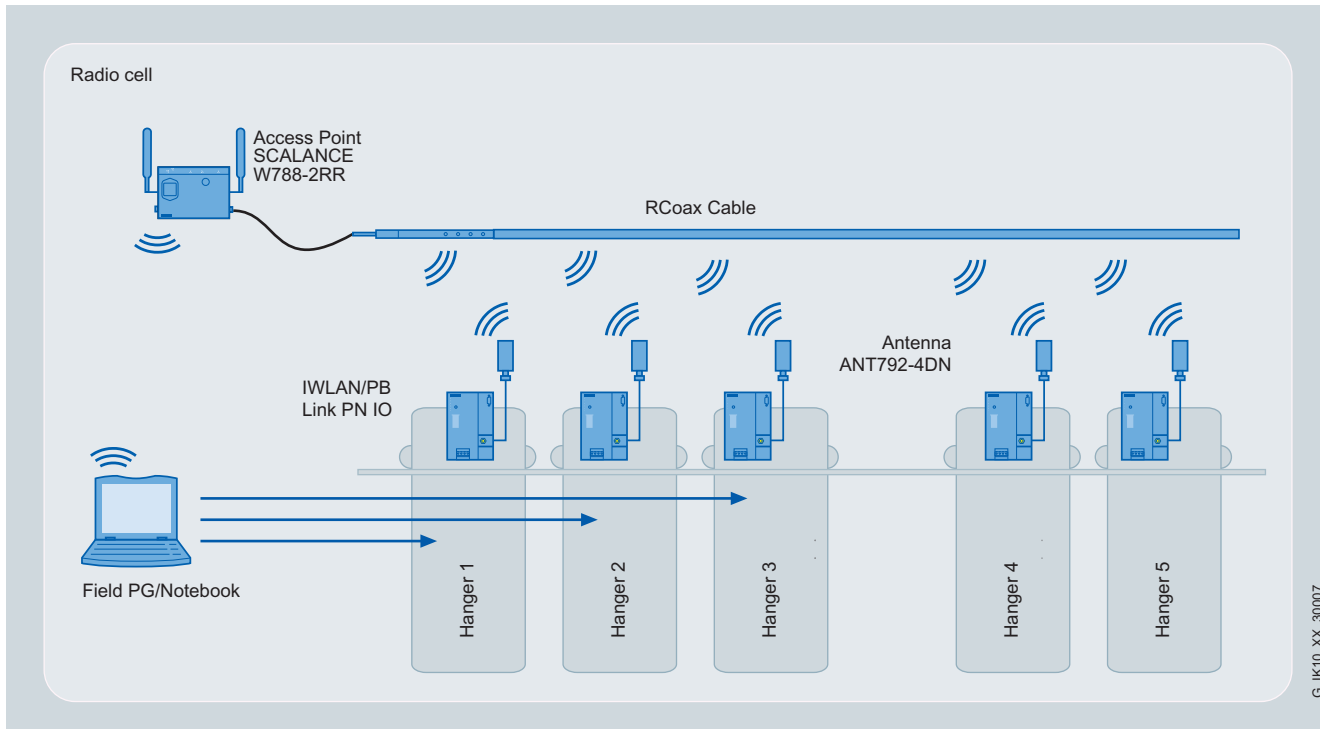

G_IK10_XX_30007

The Field PG accesses a wireless interface of SCALANCE W788-2RR for configuring, the other interface carries out communication with the RCoax cable using iPCF

The dual access point, SCALANCE W788-2RR, can provide two separate wireless fields. For example, a Field PG can use one wireless field for configuration. For clear separation of the appli-

cations an RCoax cable can be used to implement contactless PROFINET I/O data communication with the mobile suspension gear over an IWLAN/PB Link.

Technical specifications

Order No.	6GK5 788-1AA60-2AA0 6GK5 788-1AA60-2AB0 ¹⁾	6GK5 788-2AA60-2AA0 6GK5 788-2AA60-2AB0 ¹⁾	6GK5 788-1AA60-6AA0 6GK5 788-1AA60-6AB0 ¹⁾	6GK5 788-2AA60-6AA0 6GK5 788-2AA60-6AB0 ¹⁾
Product type designation	SCALANCE W788-1PRO	SCALANCE W788-2PRO	SCALANCE W788-1RR	SCALANCE W788-2RR
Transmission rate				
Transmission rate	54 Mbit/s	54 Mbit/s	54 Mbit/s	54 Mbit/s
• with W-LAN, maximum	10 ... 100 Mbit/s	10 ... 100 Mbit/s	10 ... 100 Mbit/s	10 ... 100 Mbit/s
• with Industrial Ethernet	Due to the simultaneous use of several radio channels, a transmission rate of 108 Mbit/s is possible (turbo mode)	Due to the simultaneous use of several radio channels, a transmission rate of 108 Mbit/s is possible (turbo mode)	Due to the simultaneous use of several radio channels, a transmission rate of 108 Mbit/s is possible (turbo mode)	Due to the simultaneous use of several radio channels, a transmission rate of 108 Mbit/s is possible (turbo mode)
• Note				
Interfaces				
Number of electrical connections				
• for network components or terminal equipment	1	1	1	1
• for power supply	1	1	1	1
• for redundant power supply	1	1	1	1
Design of electrical connection				
• for network components or terminal equipment	Hybrid socket, RJ45 integrated	Hybrid socket, RJ45 integrated	Hybrid socket, RJ45 integrated	Hybrid socket, RJ45 integrated
• for power supply	M12 interface (4-pin, A-coded), hybrid socket, PoE	M12 interface (4-pin, A-coded), hybrid socket, PoE	M12 interface (4-pin, A-coded), hybrid socket, PoE	M12 interface (4-pin, A-coded), hybrid socket, PoE
Design of swap medium C-Plug	Yes	Yes	Yes	Yes

¹⁾ Wireless approval in the USA

Technical specifications (continued)

Order No.	6GK5 788-1AA60-2AA0 6GK5 788-1AA60-2AB0 ¹⁾	6GK5 788-2AA60-2AA0 6GK5 788-2AA60-2AB0 ¹⁾	6GK5 788-1AA60-6AA0 6GK5 788-1AA60-6AB0 ¹⁾	6GK5 788-2AA60-6AA0 6GK5 788-2AA60-6AB0 ¹⁾
Product type designation	SCALANCE W788-1PRO	SCALANCE W788-2PRO	SCALANCE W788-1RR	SCALANCE W788-2RR
Interfaces/wireless				
Number of permanently installed wireless cards	1	2	1	2
Number of electrical connections for external antenna(s)	2	4	2	4
Design of electrical connection for external antenna(s)	R-SMA female (socket)	R-SMA female (socket)	R-SMA female (socket)	R-SMA female (socket)
Supply voltage, current consumption, power loss				
Type of power supply	DC	DC	DC	DC
Power supply				
• 1 from M12 power connector (A-coded) for redundant power supply	24 V	24 V	24 V	24 V
• 2 from M12 power connector (A-coded) for redundant power supply	48 V	48 V	48 V	48 V
• 1 from IE hybrid cable 2x2 + 4x0.34	24 V	24 V	24 V	24 V
• 2 from IE hybrid cable 2x2 + 4x0.34	48 V	48 V	48 V	48 V
• From Power-over-Ethernet according to IEEE802.3at for Type 1 and IEEE802.3af	48 V	48 V	48 V	48 V
Current consumed				
• At 24 V DC, typical	0.25 A	0.295 A	0.25 A	0.295 A
• At 48 V DC, typical	0.125 A	0.15 A	0.125 A	0.15 A
• With Power-over-Ethernet according to IEEE802.3at for Type 1 and IEEE802.3af, typical	0.125 A	0.15 A	0.125 A	0.15 A
Effective power loss				
• At 24 V DC, typical	7 W	7 W	7 W	9 W
• At 48 V DC, typical	7 W	7 W	7 W	9 W
• With Power-over-Ethernet according to IEEE802.3at for Type 1 and IEEE802.3af, typical	7 W	7 W	7 W	9 W
Permissible ambient conditions				
Ambient temperature				
• During operation	-20 ... +60 °C	-20 ... +60 °C	-20 ... +60 °C	-20 ... +60 °C
• During storage	-40 ... +70 °C	-40 ... +70 °C	-40 ... +70 °C	-40 ... +70 °C
• During transport	-40 ... +70 °C	-40 ... +70 °C	-40 ... +70 °C	-40 ... +70 °C
Relative humidity at 25 °C without condensation during operation, maximum	100 %	100 %	100 %	100 %
IP degree of protection	IP65	IP65	IP65	IP65
Ambient conditions for operation	When used under explosion protection conditions (Zone 2), the SCALANCE W788-xPRO/RR or W74x-1PRO/RR product must be installed in an enclosure that complies at least with IP54 according to EN 60529 within the scope of EN 50021.	When used under explosion protection conditions (Zone 2), the SCALANCE W788-xPRO/RR or W74x-1PRO/RR product must be installed in an enclosure that complies at least with IP54 according to EN 60529 within the scope of EN 50021.	When used under explosion protection conditions (Zone 2), the SCALANCE W788-xPRO/RR or W74x-1PRO/RR product must be installed in an enclosure that complies at least with IP54 according to EN 60529 within the scope of EN 50021.	When used under explosion protection conditions (Zone 2), the SCALANCE W788-xPRO/RR or W74x-1PRO/RR product must be installed in an enclosure that complies at least with IP54 according to EN 60529 within the scope of EN 50021.

¹⁾ Wireless approval in the USA

Industrial Wireless Communication

IWLAN – Access Points IEEE 802.11a/b/g

SCALANCE W788 for the indoor area

Technical specifications (continued)

Order No.	6GK5 788-1AA60-2AA0 6GK5 788-1AA60-2AB0 ¹⁾	6GK5 788-2AA60-2AA0 6GK5 788-2AA60-2AB0 ¹⁾	6GK5 788-1AA60-6AA0 6GK5 788-1AA60-6AB0 ¹⁾	6GK5 788-2AA60-6AA0 6GK5 788-2AA60-6AB0 ¹⁾
Product type designation	SCALANCE W788-1PRO	SCALANCE W788-2PRO	SCALANCE W788-1RR	SCALANCE W788-2RR
Design, dimensions and weights				
Width of enclosure without antenna	125 mm	125 mm	125 mm	125 mm
Height of enclosure without antenna	88 mm	88 mm	88 mm	88 mm
Depth of enclosure without antenna	108 mm	108 mm	108 mm	108 mm
Net weight	1.05 kg	1.05 kg	1.05 kg	1.05 kg
Type of mounting				
• S7-300 rail mounting	Yes	Yes	Yes	Yes
• Wall mounting	Yes	Yes	Yes	Yes
Wireless frequencies				
Wireless frequency				
• With WLAN in the 2.4 GHz frequency band	2.41 ... 2.48 GHz	2.41 ... 2.48 GHz	2.41 ... 2.48 GHz	2.41 ... 2.48 GHz
• With WLAN in the 5 GHz frequency band	4.9 ... 5.8 GHz	4.9 ... 5.8 GHz	4.9 ... 5.8 GHz	4.9 ... 5.8 GHz
Product properties, functions, components				
General				
Number of SSIDs	8	16	8	16
Product function				
• Dual client	No	No	Yes	Yes
• iHOP	No	No	Yes	Yes
• iPCF	No	No	Yes	Yes
• iPCF-MC	No	No	No	Yes
Number of iPCF-capable radio modules	0	0	1	1
Product functions				
Management, configuration, programming				
Number of manageable IP addresses in the client	8	8	8	8
Product function				
• CLI	Yes	Yes	Yes	Yes
• Web-based management	Yes	Yes	Yes	Yes
• MIB support	Yes	Yes	Yes	Yes
• TRAPs via e-mail	Yes	Yes	Yes	Yes
• Configuration with STEP 7	Yes	Yes	Yes	Yes
• Configuration with STEP 7 in the TIA Portal	Yes	Yes	Yes	Yes
• SMTP server	Yes	Yes	Yes	Yes
• Operation with IWLAN controller	No	No	No	No
• Operation with Enterasys WLAN controller	No	No	No	No
• iQoS	Yes	Yes	Yes	Yes
• Forced roaming with IWLAN	Yes	Yes	Yes	Yes
• WDS	Yes	Yes	Yes	Yes
Protocol is supported				
• Address Resolution Protocol (ARP)	Yes	Yes	Yes	Yes
• ICMP	Yes	Yes	Yes	Yes
• Telnet	Yes	Yes	Yes	Yes
• HTTP	Yes	Yes	Yes	Yes
• HTTPS	Yes	Yes	Yes	Yes
• TFTP	Yes	Yes	Yes	Yes
• SNMP v1	Yes	Yes	Yes	Yes
• SNMP v2	Yes	Yes	Yes	Yes
• SNMP v3	Yes	Yes	Yes	Yes
• DCP	Yes	Yes	Yes	Yes
• LLDP	Yes	Yes	Yes	Yes

¹⁾ Wireless approval in the USA

Technical specifications (continued)

Order No.	6GK5 788-1AA60-2AA0 6GK5 788-1AA60-2AB0 ¹⁾	6GK5 788-2AA60-2AA0 6GK5 788-2AA60-2AB0 ¹⁾	6GK5 788-1AA60-6AA0 6GK5 788-1AA60-6AB0 ¹⁾	6GK5 788-2AA60-6AA0 6GK5 788-2AA60-6AB0 ¹⁾
Product type designation	SCALANCE W788-1PRO	SCALANCE W788-2PRO	SCALANCE W788-1RR	SCALANCE W788-2RR
Identification & maintenance				
• I&M0 - device-specific information	Yes	Yes	Yes	Yes
• I&M1 - higher-level designation/ location designation	Yes	Yes	Yes	Yes
Product functions Diagnostics				
Product function				
• PROFINET IO diagnostics	Yes	Yes	Yes	Yes
• Link check	Yes	Yes	Yes	Yes
• Connection monitoring IP-Alive	Yes	Yes	Yes	Yes
• Localization by means of Aeroscout	Yes	Yes	Yes	Yes
• SysLog	Yes	Yes	Yes	Yes
Product functions VLAN				
Product function VLAN with IWLAN	Yes	Yes	Yes	Yes
Product functions DHCP				
Product function DHCP client	Yes	Yes	Yes	Yes
Product functions Redundancy				
STP/RSTP protocol is supported	Yes	Yes	Yes	Yes
Product functions Security				
Product function				
• ACL - MAC based	Yes	Yes	Yes	Yes
• IEEE 802.1x (radius)	Yes	Yes	Yes	Yes
• NAT/NAPT	Yes	Yes	Yes	Yes
• Access protection according to IEEE802.11i	Yes	Yes	Yes	Yes
• WPA/WPA2	Yes	Yes	Yes	Yes
• TKIP/AES	Yes	Yes	Yes	Yes
Protocol is supported SSH	Yes	Yes	Yes	Yes
Product functions Time				
SNTP protocol is supported	Yes	Yes	Yes	Yes
Standards, specifications, approvals				
Standard				
• for EMC of FM	FM 3611: Class I, Division 2, Groups A,B,C,D, T4 / Class 1, Zone 2, Group IIC, T4	FM 3611: Class I, Division 2, Groups A,B,C,D, T4 / Class 1, Zone 2, Group IIC, T4	FM 3611: Class I, Division 2, Groups A,B,C,D, T4 / Class 1, Zone 2, Group IIC, T4	FM 3611: Class I, Division 2, Groups A,B,C,D, T4 / Class 1, Zone 2, Group IIC, T4
• for hazardous zone	EN 60079-15:2005, EN 60079-0:2006, II 3 G Ex nA II T4 KEMA 07 ATEX 0145X	EN 60079-15:2005, EN 60079-0:2006, II 3 G Ex nA II T4 KEMA 07 ATEX 0145X	EN 60079-15:2005, EN 60079-0:2006, II 3 G Ex nA II T4 KEMA 07 ATEX 0145X	EN 60079-15:2005, EN 60079-0:2006, II 3 G Ex nA II T4 KEMA 07 ATEX 0145X
• for CSA and UL safety	UL 60950-1 CSA C22.2 No. 60950-1	UL 60950-1 CSA C22.2 No. 60950-1	UL 60950-1 CSA C22.2 No. 60950-1	UL 60950-1 CSA C22.2 No. 60950-1
• for hazardous zone of CSA and UL	ISA 12.12.01-2000, CSA C22.2 No. 213-M1987, CL. 1, Div. 2, GP. A,B,C,D, T4 / CL. 1, Zone 2, GP IIC, T4 / CL. 1, Zone 2, AEx nC IIC, T4	ISA 12.12.01-2000, CSA C22.2 No. 213-M1987, CL. 1, Div. 2, GP. A,B,C,D, T4 / CL. 1, Zone 2, GP IIC, T4 / CL. 1, Zone 2, AEx nC IIC, T4	ISA 12.12.01-2000, CSA C22.2 No. 213-M1987, CL. 1, Div. 2, GP. A,B,C,D, T4 / CL. 1, Zone 2, GP IIC, T4 / CL. 1, Zone 2, AEx nC IIC, T4	ISA 12.12.01-2000, CSA C22.2 No. 213-M1987, CL. 1, Div. 2, GP. A,B,C,D, T4 / CL. 1, Zone 2, GP IIC, T4 / CL. 1, Zone 2, AEx nC IIC, T4

¹⁾ Wireless approval in the USA

Industrial Wireless Communication

IWLAN – Access Points IEEE 802.11a/b/g

SCALANCE W788 for the indoor area

Technical specifications (continued)

Order No.	6GK5 788-1AA60-2AA0 6GK5 788-1AA60-2AB0 ¹⁾	6GK5 788-2AA60-2AA0 6GK5 788-2AA60-2AB0 ¹⁾	6GK5 788-1AA60-6AA0 6GK5 788-1AA60-6AB0 ¹⁾	6GK5 788-2AA60-6AA0 6GK5 788-2AA60-6AB0 ¹⁾
Product type designation	SCALANCE W788-1PRO	SCALANCE W788-2PRO	SCALANCE W788-1RR	SCALANCE W788-2RR
Certificate of suitability				
• CE marking	Yes	Yes	Yes	Yes
• EC Declaration of Conformity	Yes	Yes	Yes	Yes
• C-Tick	Yes	Yes	Yes	Yes
• CCC	No	No	No	No
• Railroad application according to EN 50155	Yes	Yes	Yes	Yes
• e1 approval	Yes	Yes	Yes	Yes
• E1 approval	Yes	Yes	Yes	Yes
• Power-over-Ethernet according to IEEE802.3at for Type 1 and IEEE802.3af	Yes	Yes	Yes	Yes
Standard for wireless communication				
• IEEE 802.11a	Yes	Yes	Yes	Yes
• IEEE 802.11b	Yes	Yes	Yes	Yes
• IEEE 802.11e	Yes	Yes	Yes	Yes
• IEEE 802.11g	Yes	Yes	Yes	Yes
• IEEE 802.11h	Yes	Yes	Yes	Yes
• IEEE 802.11i	Yes	Yes	Yes	Yes
• IEEE 802.11n	No	No	No	No
Wireless approval	You can find the latest list of countries at: www.siemens.com/simatic-net/ik-info	You can find the latest list of countries at: www.siemens.com/simatic-net/ik-info	You can find the latest list of countries at: www.siemens.com/simatic-net/ik-info	You can find the latest list of countries at: www.siemens.com/simatic-net/ik-info
Marine classification association				
• American Bureau of Shipping Europe Ltd. (ABS)	Yes	Yes	Yes	Yes
• Bureau Veritas (BV)	Yes	Yes	Yes	Yes
• Det Norske Veritas (DNV)	No	No	No	No
• Germanischer Lloyd (GL)	Yes	Yes	Yes	Yes
• Lloyds Register of Shipping (LRS)	Yes	Yes	Yes	Yes
• Nippon Kaiji Kyokai (NK)	Yes	Yes	Yes	Yes
• Polski Rejestr Statkow (PRS)	Yes	Yes	Yes	Yes
Accessories				
Accessories	2 antennas, hybrid connector included in scope of delivery	2 antennas, hybrid connector included in scope of delivery	2 antennas, hybrid connector included in scope of delivery	2 antennas, hybrid connector included in scope of delivery

¹⁾ Wireless approval in the USA

Industrial Wireless Communication

IWLAN – Access Points IEEE 802.11a/b/g

SCALANCE W788 for the indoor area

Ordering data	Order No.	Ordering data	Order No.	
SCALANCE W788 access points IWLAN access points with built-in wireless interfaces; wireless networks IEEE 802.11a/b/g/h at 2.4/5 GHz up to 54 Mbit/s; WPA2/AES; Power over Ethernet (PoE), IP65 degree of protection (-20°C to +60°C); scope of supply: two ANT795-4MR antennas, IP67 hybrid plug-in connector, mounting hardware, manual on CD-ROM, German/English		Accessories		
SCALANCE W788-1PRO IWLAN Access Point with <u>one</u> built-in radio interface <ul style="list-style-type: none"> National approvals for operation outside the USA National approvals for operation within the USA¹⁾ 		6GK5 788-1AA60-2AA0	C-PLUG Swap medium for simple replacement of devices in the event of a fault; for storing configuration data; can be used in SIMATIC NET products with PLUG slot	6GK1 900-0AB00
SCALANCE W788-2PRO IWLAN Dual Access Point with <u>two</u> built-in radio interfaces <ul style="list-style-type: none"> National approvals for operation outside the USA National approvals for operation within the USA¹⁾ 		6GK5 788-1AA60-2AB0	PRESET-PLUG Swap medium for simple initial startup of SCALANCE W access points and client modules, as well as IWLAN/PB Link PN IO	6GK5 798-8AB00
SCALANCE W788-1RR IWLAN Access Point with <u>one</u> built-in radio interface for establishment of radio links with iPCF <ul style="list-style-type: none"> National approvals for operation outside the USA National approvals for operation within the USA¹⁾ 		6GK5 788-2AA60-2AA0	SIMATIC Mobile Panel 277F IWLAN <ul style="list-style-type: none"> Communication via WLAN (PROFINET) with acknowledgement button and emergency stop button Communication via WLAN (PROFINET) with acknowledgment button and emergency stop button with integrated handwheel, key-operated switch, and two illuminated pushbuttons 	6AV6 645-0DB01-0AX0
SCALANCE W788-2RR IWLAN Dual Access Point with <u>two</u> built-in radio interfaces for establishment of radio links with iPCF <ul style="list-style-type: none"> National approvals for operation outside the USA National approvals for operation within the USA¹⁾ 		6GK5 788-2AA60-2AB0	Note: Please also order the desktop power supply or battery charger! <ul style="list-style-type: none"> Table-top power supply incl. power cable for EU, US, UK, JP (only suitable for operation under laboratory/office conditions) Charger for safe storage and charging the device incl. lock for securing the device in the charger. Charging capabilities for up to two additional batteries Additional battery with LED indicator for indicating the charge status Transponder incl. batteries (3x AA) 	6AV6 645-0DC01-0AX0
		6GK5 788-1AA60-6AA0		6AV6 671-5CN00-0AX1
		6GK5 788-1AA60-6AB0		6AV6 671-5CE00-0AX0
		6GK5 788-2AA60-6AA0		6AV6 671-5CL00-0AX0
		6GK5 788-2AA60-6AB0		6AV6 671-5CM00-0AX0

¹⁾ Please note national approvals at www.siemens.com/wireless-approvals

Industrial Wireless Communication

IWLAN – Access Points IEEE 802.11a/b/g

SCALANCE W788 for the indoor area

Ordering data	Order No.	Order No.
<i>Accessories</i> (continued)		
IE FC RJ45 modular outlet with power insert FastConnect RJ45 modular outlet for Industrial Ethernet with a replaceable insert for 1 x 24 V and 1 x 100 Mbit/s interface	6GK1 901-1BE00-0AA3	IP 67 hybrid connector Connector for connecting SCALANCE W700 to Industrial Ethernet and Power over Ethernet (PoE), with assembly instructions, 1 unit
IE Hybrid Cable 2x2 + 4x0.34 4-wire, shielded installation cable; sold by the meter; up to 1000 m, minimum order 20 m	6XV1 870-2J	
IE FC RJ45 Plug 180 2x2 RJ45 plug connector for Industrial Ethernet with a rugged metal enclosure and integrated insulation-displacement contacts for connecting Industrial Ethernet FC installation cables; with a 180° cable outlet; for network components and CPs/CPUs with Industrial Ethernet interface <ul style="list-style-type: none"> • 1 pack = 1 unit • 1 pack = 10 units • 1 pack = 50 units 	6GK1 901-1BB10-2AA0 6GK1 901-1BB10-2AB0 6GK1 901-1BB10-2AE0	Power M12 Cable Connector PRO Terminal socket for connection of SCALANCE W700 for 24 V DC supply voltage; 4-pole, A-coded, with assembly instructions, 3 units
IE FC Standard Cable GP 2 x 2 4-core, shielded TP installation cable for connection to IE FC Outlet RJ45/ IE FC RJ45 Plug; PROFINET-compliant; with UL approval; sold by the meter; max. length 1000 m, minimum order 20 m	6XV1 840-2AH10	
IE FC Stripping Tool Preadjusted stripping tool for fast stripping of the Industrial Ethernet FC cables	6GK1 901-1GA00	PS791-1PRO Power Supply AC/DC power supply, 10 W, IP65 (-20 to +60 °C), input: 90 V - 265 V AC, output: 24 V DC, metal housing; scope of supply: AC power 3+PE cable connector, DC power cord M12, mounting hardware; operating instructions German/English
IE TP Cord RJ45/RJ45 TP cable 4 x 2 with 2 RJ45 connectors <ul style="list-style-type: none"> • 0.5 m • 1 m • 2 m • 6 m • 10 m 	6XV1 870-3QE50 6XV1 870-3QH10 6XV1 870-3QH20 6XV1 870-3QH60 6XV1 870-3QN10	6GK1 907-0DC10-6AA3 6ES7 191-1PS00-0AA6 6ES7 194-1JB10-0XA0
		IE Hybrid RJ45 Socket Dust Cover Dust cap for RJ45 connection socket (Industrial Ethernet/PoE) of SCALANCE W700
		Antennas and miscellaneous IWLAN accessories See Industrial Wireless LAN/ accessories

More information

Wireless approvals:

Current approvals can be found on the Internet at:
www.siemens.com/wireless-approvals

To assist in selecting the right products for Industrial Wireless Communication, the SIMATIC NET Selection Tool is available:

Online version:
www.siemens.com/snst

Offline version:
www.siemens.com/snst-download

Industrial Wireless Communication

IWLAN – Access Points IEEE 802.11a/b/g

SCALANCE W786 for the outdoor area

Overview



- Especially well suited to applications with high climatic requirements when installed outdoors and in areas accessible to the public

Design

- Rugged plastic enclosure (plexi-glass type), shock and vibration-proof for severe mechanical loading
- High IP65 degree of protection against dust and water jets
- For use at ambient temperatures from -40 °C to +70 °C
- Resistant to condensation
- Resistant to UV radiation and saltwater spray
- Up to 6 x R-SMA sockets for the connection of remote antennas
- Version with 1 x RJ45 connection for 10/100 Mbit/s with Power-over-Ethernet according to IEEE 802.3at Type 1 (corresponds to IEEE 802.3af)
- Version with 1 x BFOC connection for 10/100 Mbit/s multimode FOC
- 1 x 48 V DC connection (also redundant power infeed), optional operation on 12 ... 24 V DC or 100 ... 240 V AC with power supply integrated into device
- 1 x C-PLUG slot
- Function LEDs for optical signaling of faults and operating states
- Mounting: Wall or, with optional mounting set, on S7 mounting rail, 35 mm standard mounting rail, or on a pole

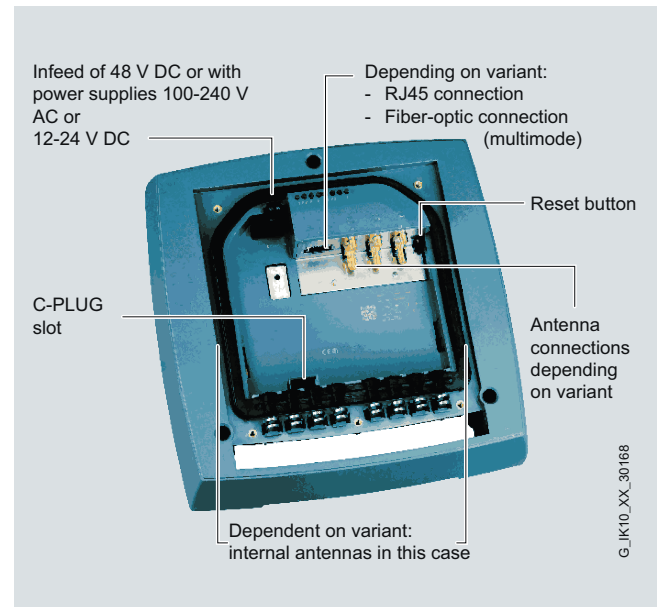

Design and interfaces of the SCALANCE W786 access points

Product versions

SCALANCE W786-1PRO

- A wireless card permanently installed in the device
- Versions with:
 - RJ45 connection and two internal antennas
 - RJ45 connection and two connections for external antennas
 - Fiber-optic connection and two internal antennas
 - Fiber-optic connection and two connections for external antennas

SCALANCE W786-2PRO

- Two wireless cards permanently installed in the device
- Versions with:
 - RJ45 connection and four internal antennas
 - RJ45 connection and four connections for external antennas
 - Fiber-optic connection and four internal antennas
 - Fiber-optic connection and four connections for external antennas

SCALANCE W786-3PRO

- Three wireless cards permanently installed in the device
- Versions with:
 - RJ45 connection and six connections for external antennas
 - Fiber-optic connection and six connections for external antennas

SCALANCE W786-2RR

- Two wireless cards permanently installed in the device; for establishing wireless connections with iPCF
- Versions with:
 - RJ45 connection and four internal antennas
 - RJ45 connection and four connections for external antennas

Industrial Wireless Communication

IWLAN – Access Points IEEE 802.11a/b/g

SCALANCE W786 for the outdoor area

Function

Where access points with three wireless modules (e.g. W786-3PRO) are used, communication between the access points is implemented with two modules each. The wireless field for the station, e.g. an automated guided vehicle, is established by the third wireless module. This means that larger directional radio paths can be established and communication with the stations is also possible.

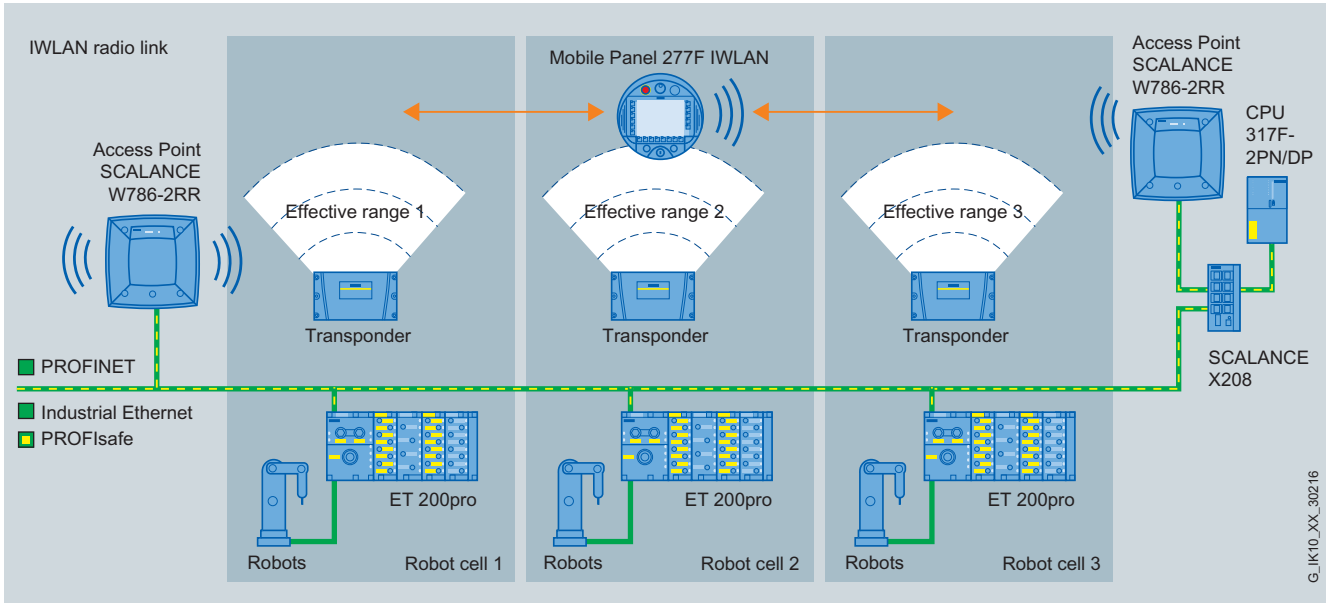

Programming of robots in the safety-related environment

In this configuration three effective ranges are defined, in which robots can be programmed using the Mobile Panel 277(F) IWLAN (teaching). If a fault occurs during the programming, e.g. on leaving the safety-related areas or in the case of unforeseen incidents, the plant is brought to the safe state with the aid of the integrated emergency-stop procedure using the IWLAN structure implemented with SCALANCE W786-2RR. The safety of the entire plant is achieved by means of PROFINET with the PROFIsafe protocol which is implemented not only on the PROFINET controller (CPU 317F-2 PN/DP), but also on the PROFINET device (Mobile Panel 277(F) IWLAN). The SCALANCE W786-2RR that has the iPCF mechanism ensures that the response times necessary for the functional safety are adhered to.

Function (continued)

If the minimum length of standard Ethernet cables is insufficient due to the large distance of the access points from the wired network, SCALANCE W786 can also be used in a version with BFOC connectors (multimode fiber-optic cable).

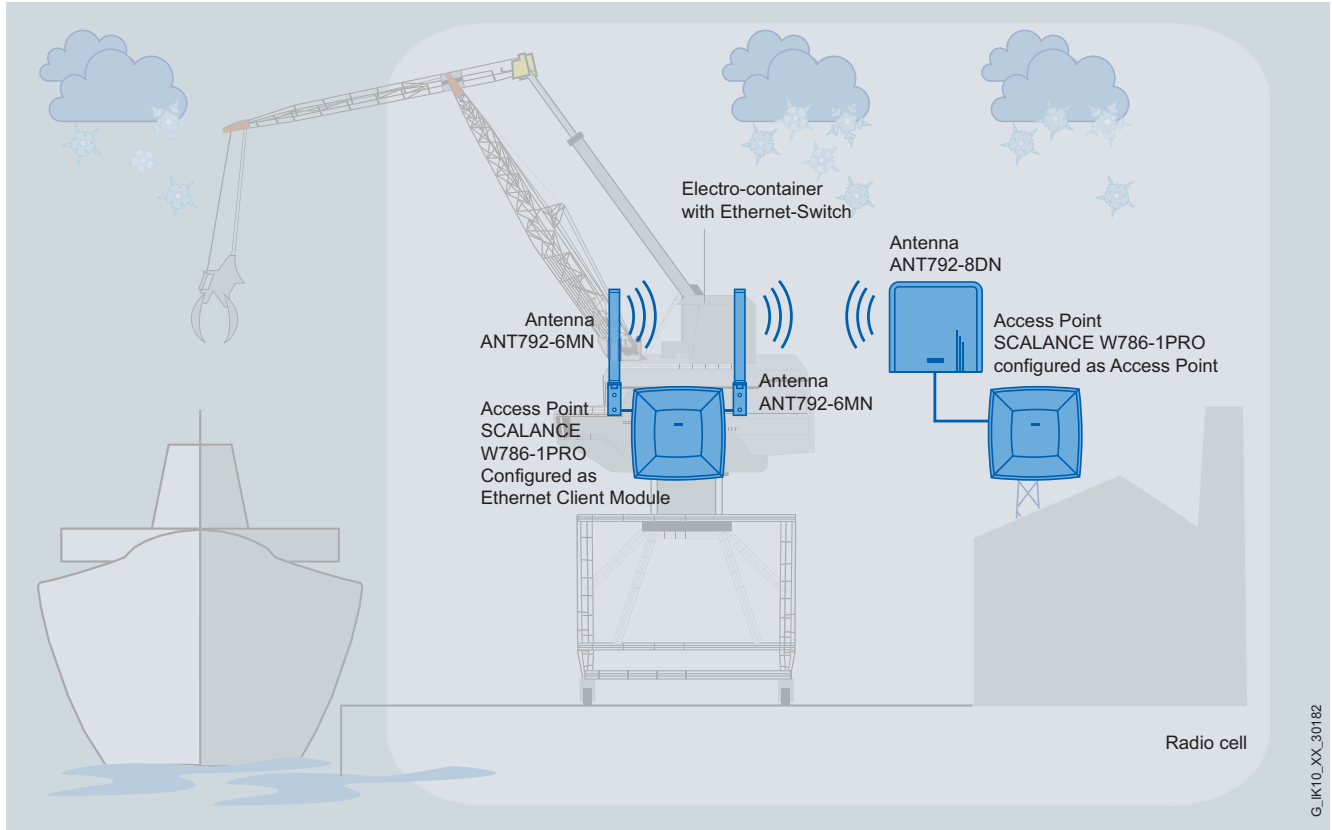

Use of the SCALANCE W786 product line in sectors subject to high climatic requirements

In the case of SCALANCE W786, this only concerns access points which can, however, be configured as client modules through Web-based management. Then, depending on the selected version, a maximum of one wireless module will be available as a client.

Industrial Wireless Communication

IWLAN – Access Points IEEE 802.11a/b/g

SCALANCE W786 for the outdoor area

Technical specifications

Order No.	6GK5 786-1BA60-2AA0 6GK5 786-1BA60-2AB0 ¹⁾	6GK5 786-1AA60-2AA0 6GK5 786-1AA60-2AB0 ¹⁾	6GK5 786-1BB60-2AA0 6GK5 786-1BB60-2AB0 ¹⁾	6GK5 786-1AB60-2AA0 6GK5 786-1AB60-2AB0 ¹⁾
Product type designation	SCALANCE W786-1PRO	SCALANCE W786-1PRO	SCALANCE W786-1PRO	SCALANCE W786-1PRO
Data transfer rate				
Data transfer rate				
• with W-LAN, maximum	54 Mbit/s	54 Mbit/s	54 Mbit/s	54 Mbit/s
• with Industrial Ethernet	10 ... 100 Mbit/s	10 ... 100 Mbit/s	10 ... 100 Mbit/s	10 ... 100 Mbit/s
• Note	Due to the simultaneous use of several radio channels, a transmission rate of 108 Mbit/s is possible (turbo mode)	Due to the simultaneous use of several radio channels, a transmission rate of 108 Mbit/s is possible (turbo mode)	Due to the simultaneous use of several radio channels, a transmission rate of 108 Mbit/s is possible (turbo mode)	Due to the simultaneous use of several radio channels, a transmission rate of 108 Mbit/s is possible (turbo mode)
Interfaces				
Number of electrical connections				
• for network components or terminal equipment	1	1	-	-
• for power supply	1	1	1	1
• For redundant power supply	1	1	1	1
Design of electrical connection				
• for network components or terminal equipment	RJ45 socket	RJ45 socket	-	-
• for power supply	2-pin connector (48 V DC) or optionally available power supply adapter (4-pin 12 to 24 V DC or 3-pin 100 to 240 V AC)	2-pin connector (48 V DC) or optionally available power supply adapter (4-pin 12 to 24 V DC or 3-pin 100 to 240 V AC)	2-pin connector (48 V DC) or optionally available power supply adapter (4-pin 12 to 24 V DC or 3-pin 100 to 240 V AC)	2-pin connector (48 V DC) or optionally available power supply adapter (4-pin 12 to 24 V DC or 3-pin 100 to 240 V AC)
Number of optical connections for fiber-optic cables at 100 Mbit/s	-	-	1	1
Design of optical connection for fiber-optic cables at 100 Mbit/s	-	-	Duplex multimode FOC (ST)	Duplex multimode FOC (ST)
Design of swap medium C-Plug	Yes	Yes	Yes	Yes
Interfaces wireless				
Number of permanently installed wireless cards	1	1	1	1
Number of internal antennas	2	-	2	-
Number of electrical connections for external antenna(s)	-	2	-	2
Design of electrical connection for external antenna(s)	-	R-SMA female (socket)	-	R-SMA female (socket)
Supply voltage, current consumption, power loss				
Type of supply voltage	DC	DC	DC	DC
Supply voltage				
• 1 from terminal block	48 V	48 V	48 V	48 V
• 2 from terminal block	-	-	-	-
• From Power-over-Ethernet according to IEEE802.3at for Type 1 and IEEE802.3af	48 V	48 V	48 V	48 V
• From optionally integrated power supply				
- With AC	100 ... 240 V	100 ... 240 V	100 ... 240 V	100 ... 240 V
- With DC	12 ... 24 V	12 ... 24 V	12 ... 24 V	12 ... 24 V

¹⁾ Wireless approval in the USA

Technical specifications (continued)

Order No.	6GK5 786-1BA60-2AA0 6GK5 786-1BA60-2AB0 ¹⁾	6GK5 786-1AA60-2AA0 6GK5 786-1AA60-2AB0 ¹⁾	6GK5 786-1BB60-2AA0 6GK5 786-1BB60-2AB0 ¹⁾	6GK5 786-1AB60-2AA0 6GK5 786-1AB60-2AB0 ¹⁾
Product type designation	SCALANCE W786-1PRO	SCALANCE W786-1PRO	SCALANCE W786-1PRO	SCALANCE W786-1PRO
Current consumed				
• At 24 V DC, typical	0.28 A	0.28 A	0.34 A	0.34 A
• At 48 V DC, typical	0.14 A	0.14 A	0.17 A	0.17 A
• At 230 V AC, typical	0.03 A	0.03 A	0.04 A	0.04 A
• With Power-over-Ethernet according to IEEE802.3af for Type 1 and IEEE802.3af, typical	0.14 A	0.14 A	0.34 A	0.34 A
Effective power loss				
• At 24 V DC, typical	6.5 W	6.5 W	8 W	8 W
• At 48 V DC, typical	6.5 W	6.5 W	8 W	8 W
• At 230 V AC, typical	6.5 W	6.5 W	8 W	8 W
• With Power-over-Ethernet according to IEEE802.3af for Type 1 and IEEE802.3af, typical	6.5 W	6.5 W	8 W	8 W
Permissible ambient conditions				
Ambient temperature				
• During operation	-40 ... +70 °C	-40 ... +70 °C	-40 ... +70 °C	-40 ... +70 °C
• During storage	-40 ... +85 °C	-40 ... +85 °C	-40 ... +85 °C	-40 ... +85 °C
• During transport	-40 ... +85 °C	-40 ... +85 °C	-40 ... +85 °C	-40 ... +85 °C
Relative humidity at 25 °C without condensation during operation, maximum	100 %	100 %	100 %	100 %
IP degree of protection	IP65	IP65	IP65	IP65
Ambient conditions for operation	When using the 100 ... 240 V AC power supply, an operating temperature of -40 °C to +60 °C is permissible	When using the 100 ... 240 V AC power supply, an operating temperature of -40 °C to +60 °C is permissible	When using the 100 ... 240 V AC power supply, an operating temperature of -40 °C to +60 °C is permissible	When using the 100 ... 240 V AC power supply, an operating temperature of -40 °C to +60 °C is permissible
Design, dimensions and weights				
Width of enclosure without antenna	251 mm	251 mm	251 mm	251 mm
Height of enclosure without antenna	251 mm	251 mm	251 mm	251 mm
Depth of enclosure without antenna	72 mm	72 mm	72 mm	72 mm
Net weight	2.24 kg	2.24 kg	2.24 kg	2.24 kg
Type of mounting				
• S7-300 rail mounting	-	-	-	-
• Wall mounting	Yes	Yes	Yes	Yes
Type of mounting	For mast mounting, 35 mm DIN rail mounting and S7-300 rail mounting, an additional retaining plate is required	For mast mounting, 35 mm DIN rail mounting and S7-300 rail mounting, an additional retaining plate is required	For mast mounting, 35 mm DIN rail mounting and S7-300 rail mounting, an additional retaining plate is required	For mast mounting, 35 mm DIN rail mounting and S7-300 rail mounting, an additional retaining plate is required
Wireless frequencies				
Wireless frequency				
• With WLAN in the 2.4 GHz frequency band	2.41 ... 2.48 GHz	2.41 ... 2.48 GHz	2.41 ... 2.48 GHz	2.41 ... 2.48 GHz
• with WLAN in the 5 GHz frequency band	4.9 ... 5.8 GHz	4.9 ... 5.8 GHz	4.9 ... 5.8 GHz	4.9 ... 5.8 GHz
Product properties, functions, components				
General				
Number of SSIDs	8	8	8	8
Product function				
• Dual client	No	No	No	No
• iHOP	No	No	No	No
• iPCF	No	No	No	No
• iPCF-MC	No	No	No	No
Number of iPCF-capable radio modules	0	0	0	0

¹⁾ Wireless approval in the USA

Industrial Wireless Communication

IWLAN – Access Points IEEE 802.11a/b/g

SCALANCE W786 for the outdoor area

Technical specifications (continued)

Order No.	6GK5 786-1BA60-2AA0 6GK5 786-1BA60-2AB0 ¹⁾	6GK5 786-1AA60-2AA0 6GK5 786-1AA60-2AB0 ¹⁾	6GK5 786-1BB60-2AA0 6GK5 786-1BB60-2AB0 ¹⁾	6GK5 786-1AB60-2AA0 6GK5 786-1AB60-2AB0 ¹⁾
Product type designation	SCALANCE W786-1PRO	SCALANCE W786-1PRO	SCALANCE W786-1PRO	SCALANCE W786-1PRO
Product functions				
Management, configuration, programming				
Number of manageable IP addresses in the client	8	8	8	8
Product function				
• CLI	Yes	Yes	Yes	Yes
• Web-based management	Yes	Yes	Yes	Yes
• MIB support	Yes	Yes	Yes	Yes
• TRAPs via e-mail	Yes	Yes	Yes	Yes
• Configuration with STEP 7	Yes	Yes	Yes	Yes
• Configuration with STEP 7 in the TIA Portal	Yes	Yes	Yes	Yes
• SMTP server	Yes	Yes	Yes	Yes
• Operation with IWLAN controller	No	No	No	No
• Operation with Enterasys WLAN controller	No	No	No	No
• iQoS	Yes	Yes	Yes	Yes
• Forced roaming with IWLAN	Yes	Yes	Yes	Yes
• WDS	Yes	Yes	Yes	Yes
Protocol is supported				
• Address Resolution Protocol (ARP)	Yes	Yes	Yes	Yes
• ICMP	Yes	Yes	Yes	Yes
• Telnet	Yes	Yes	Yes	Yes
• HTTP	Yes	Yes	Yes	Yes
• HTTPS	Yes	Yes	Yes	Yes
• TFTP	Yes	Yes	Yes	Yes
• SNMP v1	Yes	Yes	Yes	Yes
• SNMP v2	Yes	Yes	Yes	Yes
• SNMP v3	Yes	Yes	Yes	Yes
• DCP	Yes	Yes	Yes	Yes
• LLDP	Yes	Yes	Yes	Yes
Identification & maintenance				
• I&M0 - device-specific information	Yes	Yes	Yes	Yes
• I&M1 - higher-level designation/location designation	Yes	Yes	Yes	Yes
Product functions Diagnostics				
Product function				
• PROFINET IO diagnostics	Yes	Yes	Yes	Yes
• Link check	Yes	Yes	Yes	Yes
• Connection monitoring IP-Alive	Yes	Yes	Yes	Yes
• Localization by means of Aeroscout	Yes	Yes	Yes	Yes
• SysLog	Yes	Yes	Yes	Yes
Product functions VLAN				
Product function VLAN with IWLAN	Yes	Yes	Yes	Yes
Product functions DHCP				
Product function DHCP client	Yes	Yes	Yes	Yes
Product functions Redundancy				
STP/RSTP protocol is supported	Yes	Yes	Yes	Yes

¹⁾ Wireless approval in the USA

Technical specifications (continued)

Order No.	6GK5 786-1BA60-2AA0 6GK5 786-1BA60-2AB0 ¹⁾	6GK5 786-1AA60-2AA0 6GK5 786-1AA60-2AB0 ¹⁾	6GK5 786-1BB60-2AA0 6GK5 786-1BB60-2AB0 ¹⁾	6GK5 786-1AB60-2AA0 6GK5 786-1AB60-2AB0 ¹⁾
Product type designation	SCALANCE W786-1PRO	SCALANCE W786-1PRO	SCALANCE W786-1PRO	SCALANCE W786-1PRO
Product functions Security				
Product function				
• ACL - MAC based	Yes	Yes	Yes	Yes
• IEEE 802.1x (radius)	Yes	Yes	Yes	Yes
• NAT/NAPT	Yes	Yes	Yes	Yes
• Access protection according to IEEE802.11i	Yes	Yes	Yes	Yes
• WPA/WPA2	Yes	Yes	Yes	Yes
• TKIP/AES	Yes	Yes	Yes	Yes
Protocol is supported SSH	Yes	Yes	Yes	Yes
Product functions Time				
SNTP protocol is supported	Yes	Yes	Yes	Yes
Standards, specifications, approvals				
Standard				
• for EMC of FM	FM 3611: Class I, Division 2, Groups A,B,C,D, T4 / Class 1, Zone 2, Group IIC, T4	FM 3611: Class I, Division 2, Groups A,B,C,D, T4 / Class 1, Zone 2, Group IIC, T4	FM 3611: Class I, Division 2, Groups A,B,C,D, T4 / Class 1, Zone 2, Group IIC, T4	FM 3611: Class I, Division 2, Groups A,B,C,D, T4 / Class 1, Zone 2, Group IIC, T4
• for hazardous zone	EN 60079-15:2005, EN 60079-0:2006, II 3 G Ex nA II T4 KEMA 07 ATEX 0145X	EN 60079-15:2005, EN 60079-0:2006, II 3 G Ex nA II T4 KEMA 07 ATEX 0145X	EN 60079-15:2005, EN 60079-0:2006, II 3 G Ex nA II T4 KEMA 07 ATEX 0145X	EN 60079-15:2005, EN 60079-0:2006, II 3 G Ex nA II T4 KEMA 07 ATEX 0145X
• for CSA and UL safety	UL 60950-1 CSA C22.2 No. 60950-1	UL 60950-1 CSA C22.2 No. 60950-1	UL 60950-1 CSA C22.2 No. 60950-1	UL 60950-1 CSA C22.2 No. 60950-1
• for hazardous zone of CSA and UL	UL 1604, CSA C22.2 No. 213-M1987, CL. 1, Div. 2, GP. A,B,C,D, T4 / CL. 1, Zone 2, GP IIC, T4	UL 1604, CSA C22.2 No. 213-M1987, CL. 1, Div. 2, GP. A,B,C,D, T4 / CL. 1, Zone 2, GP IIC, T4	UL 1604, CSA C22.2 No. 213-M1987, CL. 1, Div. 2, GP. A,B,C,D, T4 / CL. 1, Zone 2, GP IIC, T4	UL 1604, CSA C22.2 No. 213-M1987, CL. 1, Div. 2, GP. A,B,C,D, T4 / CL. 1, Zone 2, GP IIC, T4
Certificate of suitability				
• CE marking	Yes	Yes	Yes	Yes
• EC Declaration of Conformity	Yes	Yes	Yes	Yes
• C-Tick	Yes	Yes	Yes	Yes
• CCC	No	No	No	No
• Railroad application according to EN 50155	No	No	No	No
• e1 approval	Yes	Yes	Yes	Yes
• E1 approval	Yes	Yes	Yes	Yes
• NEMA4X	Yes	Yes	Yes	Yes
• Power-over-Ethernet according to IEEE802.3at for Type 1 and IEEE802.3af	Yes	Yes	Yes	Yes
Standard for wireless communication				
• IEEE 802.11a	Yes	Yes	Yes	Yes
• IEEE 802.11b	Yes	Yes	Yes	Yes
• IEEE 802.11e	Yes	Yes	Yes	Yes
• IEEE 802.11g	Yes	Yes	Yes	Yes
• IEEE 802.11h	Yes	Yes	Yes	Yes
• IEEE 802.11i	Yes	Yes	Yes	Yes
• IEEE 802.11n	No	No	No	No
Wireless approval	You can find the latest list of countries at: www.siemens.com/simatic-net/ik-info	You can find the latest list of countries at: www.siemens.com/simatic-net/ik-info	You can find the latest list of countries at: www.siemens.com/simatic-net/ik-info	You can find the latest list of countries at: www.siemens.com/simatic-net/ik-info

¹⁾ Wireless approval in the USA

Industrial Wireless Communication

IWLAN – Access Points IEEE 802.11a/b/g

SCALANCE W786 for the outdoor area

Technical specifications (continued)

Order No.	6GK5 786-1BA60-2AA0 6GK5 786-1BA60-2AB0 ¹⁾	6GK5 786-1AA60-2AA0 6GK5 786-1AA60-2AB0 ¹⁾	6GK5 786-1BB60-2AA0 6GK5 786-1BB60-2AB0 ¹⁾	6GK5 786-1AB60-2AA0 6GK5 786-1AB60-2AB0 ¹⁾
Product type designation	SCALANCE W786-1PRO			
Marine classification association				
• American Bureau of Shipping Europe Ltd. (ABS)	Yes	Yes	Yes	Yes
• Bureau Veritas (BV)	Yes	Yes	Yes	Yes
• Det Norske Veritas (DNV)	No	No	No	No
• Germanischer Lloyd (GL)	Yes	Yes	Yes	Yes
• Lloyds Register of Shipping (LRS)	Yes	Yes	Yes	Yes
• Nippon Kaiji Kyokai (NK)	Yes	Yes	Yes	Yes
• Polski Rejestr Statkow (PRS)	No	No	No	No
Accessories				
Accessories	48 V DC screw terminal included in scope of delivery	48 V DC screw terminal included in scope of delivery	48 V DC screw terminal included in scope of delivery	48 V DC screw terminal included in scope of delivery

¹⁾ Wireless approval in the USA

Order No.	6GK5 786-2BA60-2AA0 6GK5 786-2BA60-2AB0 ¹⁾	6GK5 786-2AA60-2AA0 6GK5 786-2AA60-2AB0 ¹⁾	6GK5 786-2BB60-2AA0 6GK5 786-2BB60-2AB0 ¹⁾	6GK5 786-2AB60-2AA0 6GK5 786-2AB60-2AB0 ¹⁾
Product type designation	SCALANCE W786-2PRO			
Data transfer rate				
Data transfer rate				
• with W-LAN, maximum	54 Mbit/s	54 Mbit/s	54 Mbit/s	54 Mbit/s
• with Industrial Ethernet	10 ... 100 Mbit/s	10 ... 100 Mbit/s	10 ... 100 Mbit/s	10 ... 100 Mbit/s
• Note	Due to the simultaneous use of several radio channels, a transmission rate of 108 Mbit/s is possible (turbo mode)	Due to the simultaneous use of several radio channels, a transmission rate of 108 Mbit/s is possible (turbo mode)	Due to the simultaneous use of several radio channels, a transmission rate of 108 Mbit/s is possible (turbo mode)	Due to the simultaneous use of several radio channels, a transmission rate of 108 Mbit/s is possible (turbo mode)
Interfaces				
Number of electrical connections				
• for network components or terminal equipment	1	1	-	-
• for power supply	1	1	1	1
• for redundant power supply	1	1	1	1
Design of electrical connection				
• for network components or terminal equipment	RJ45 socket	RJ45 socket	-	-
• for power supply	2-pin connector (48 V DC) or optionally available power supply adapter (4-pin 12 to 24 V DC or 3-pin 100 to 240 V AC)	2-pin connector (48 V DC) or optionally available power supply adapter (4-pin 12 to 24 V DC or 3-pin 100 to 240 V AC)	2-pin connector (48 V DC) or optionally available power supply adapter (4-pin 12 to 24 V DC or 3-pin 100 to 240 V AC)	2-pin connector (48 V DC) or optionally available power supply adapter (4-pin 12 to 24 V DC or 3-pin 100 to 240 V AC)
Number of optical connections for fiber-optic cables at 100 Mbit/s	-	-	1	1
Design of optical connection for fiber-optic cables at 100 Mbit/s	-	-	Duplex multimode FOC (ST)	Duplex multimode FOC (ST)
Design of swap medium C-Plug	Yes	Yes	Yes	Yes

¹⁾ Wireless approval in the USA

Technical specifications (continued)

Order No.	6GK5 786-2BA60-2AA0 6GK5 786-2BA60-2AB0 ¹⁾	6GK5 786-2AA60-2AA0 6GK5 786-2AA60-2AB0 ¹⁾	6GK5 786-2BB60-2AA0 6GK5 786-2BB60-2AB0 ¹⁾	6GK5 786-2AB60-2AA0 6GK5 786-2AB60-2AB0 ¹⁾
Product type designation	SCALANCE W786-2PRO	SCALANCE W786-2PRO	SCALANCE W786-2PRO	SCALANCE W786-2PRO
Interfaces wireless				
Number of permanently installed wireless cards	2	2	2	2
Number of internal antennas	4	-	4	-
Number of electrical connections for external antenna(s)	-	4	-	4
Design of electrical connection for external antenna(s)	-	R-SMA female (socket)	-	R-SMA female (socket)
Supply voltage, current consumption, power loss				
Type of supply voltage	DC	DC	DC	DC
Supply voltage				
• 1 from terminal block	48 V	48 V	48 V	48 V
• 2 from terminal block	-	-	-	-
• From Power-over-Ethernet according to IEEE802.3at for Type 1 and IEEE802.3af	48 V	48 V	48 V	48 V
• From optionally integrated power supply				
- With AC	100 ... 240 V	100 ... 240 V	100 ... 240 V	100 ... 240 V
- With DC	12 ... 24 V	12 ... 24 V	12 ... 24 V	12 ... 24 V
Current consumed				
• At 24 V DC, typical	0.34 A	0.34 A	0.4 A	0.4 A
• At 48 V DC, typical	0.17 A	0.17 A	0.2 A	0.2 A
• At 230 V AC, typical	0.04 A	0.04 A	0.05 A	0.05 A
• With Power-over-Ethernet according to IEEE802.3at for Type 1 and IEEE802.3af, typical	0.34 A	0.34 A	0.2 A	0.2 A
Effective power loss				
• At 24 V DC, typical	8 W	8 W	9.5 W	9.5 W
• At 48 V DC, typical	8 W	8 W	9.5 W	9.5 W
• At 230 V AC, typical	8 W	8 W	9.5 W	9.5 W
• With Power-over-Ethernet according to IEEE802.3at for Type 1 and IEEE802.3af, typical	8 W	8 W	9.5 W	9.5 W
Permissible ambient conditions				
Ambient temperature				
• During operation	-40 ... +70 °C	-40 ... +70 °C	-40 ... +70 °C	-40 ... +70 °C
• During storage	-40 ... +85 °C	-40 ... +85 °C	-40 ... +85 °C	-40 ... +85 °C
• During transport	-40 ... +85 °C	-40 ... +85 °C	-40 ... +85 °C	-40 ... +85 °C
Relative humidity at 25 °C without condensation during operation, maximum	100 %	100 %	100 %	100 %
IP degree of protection	IP65	IP65	IP65	IP65
Ambient conditions for operation	When using the 100 ... 240 V AC power supply, an operating temperature of -40 °C to +60 °C is permissible	When using the 100 ... 240 V AC power supply, an operating temperature of -40 °C to +60 °C is permissible	When using the 100 ... 240 V AC power supply, an operating temperature of -40 °C to +60 °C is permissible	When using the 100 ... 240 V AC power supply, an operating temperature of -40 °C to +60 °C is permissible

¹⁾ Wireless approval in the USA

Industrial Wireless Communication

IWLAN – Access Points IEEE 802.11a/b/g

SCALANCE W786 for the outdoor area

Technical specifications (continued)

Order No.	6GK5 786-2BA60-2AA0 6GK5 786-2BA60-2AB0 ¹⁾	6GK5 786-2AA60-2AA0 6GK5 786-2AA60-2AB0 ¹⁾	6GK5 786-2BB60-2AA0 6GK5 786-2BB60-2AB0 ¹⁾	6GK5 786-2AB60-2AA0 6GK5 786-2AB60-2AB0 ¹⁾
Product type designation	SCALANCE W786-2PRO	SCALANCE W786-2PRO	SCALANCE W786-2PRO	SCALANCE W786-2PRO
Design, dimensions and weights				
Width of enclosure without antenna	251 mm	251 mm	251 mm	251 mm
Height of enclosure without antenna	251 mm	251 mm	251 mm	251 mm
Depth of enclosure without antenna	72 mm	72 mm	72 mm	72 mm
Net weight	2.24 kg	2.24 kg	2.24 kg	2.24 kg
Type of mounting	-	-	-	-
• S7-300 rail mounting	-	-	-	-
• Wall mounting	Yes	Yes	Yes	Yes
Type of mounting	For mast mounting, 35 mm DIN rail mounting and S7-300 rail mounting, an additional retaining plate is required	For mast mounting, 35 mm DIN rail mounting and S7-300 rail mounting, an additional retaining plate is required	For mast mounting, 35 mm DIN rail mounting and S7-300 rail mounting, an additional retaining plate is required	For mast mounting, 35 mm DIN rail mounting and S7-300 rail mounting, an additional retaining plate is required
Wireless frequencies				
Wireless frequency				
• With WLAN in the 2.4 GHz frequency band	2.41 ... 2.48 GHz	2.41 ... 2.48 GHz	2.41 ... 2.48 GHz	2.41 ... 2.48 GHz
• with WLAN in the 5 GHz frequency band	4.9 ... 5.8 GHz	4.9 ... 5.8 GHz	4.9 ... 5.8 GHz	4.9 ... 5.8 GHz
Product properties, functions, components				
General				
Number of SSIDs	16	16	16	16
Product function				
• Dual client	No	No	No	No
• iHOP	No	No	No	No
• iPCF	No	No	No	No
• iPCF-MC	No	No	No	No
Number of iPCF-capable radio modules	0	0	0	0
Product functions				
Management, configuration, programming				
Number of manageable IP addresses in the client	8	8	8	8
Product function				
• CLI	Yes	Yes	Yes	Yes
• Web-based management	Yes	Yes	Yes	Yes
• MIB support	Yes	Yes	Yes	Yes
• TRAPs via e-mail	Yes	Yes	Yes	Yes
• Configuration with STEP 7	Yes	Yes	Yes	Yes
• Configuration with STEP 7 in the TIA Portal	Yes	Yes	Yes	Yes
• SMTP server	Yes	Yes	Yes	Yes
• Operation with IWLAN controller	No	No	No	No
• Operation with Enterasys WLAN controller	No	No	No	No
• iQoS	Yes	Yes	Yes	Yes
• Forced roaming with IWLAN	Yes	Yes	Yes	Yes
• WDS	Yes	Yes	Yes	Yes

¹⁾ Wireless approval in the USA

Technical specifications (continued)

Order No.	6GK5 786-2BA60-2AA0 6GK5 786-2BA60-2AB0 ¹⁾	6GK5 786-2AA60-2AA0 6GK5 786-2AA60-2AB0 ¹⁾	6GK5 786-2BB60-2AA0 6GK5 786-2BB60-2AB0 ¹⁾	6GK5 786-2AB60-2AA0 6GK5 786-2AB60-2AB0 ¹⁾
Product type designation	SCALANCE W786-2PRO	SCALANCE W786-2PRO	SCALANCE W786-2PRO	SCALANCE W786-2PRO
Protocol is supported				
• Address Resolution Protocol (ARP)	Yes	Yes	Yes	Yes
• ICMP	Yes	Yes	Yes	Yes
• Telnet	Yes	Yes	Yes	Yes
• HTTP	Yes	Yes	Yes	Yes
• HTTPS	Yes	Yes	Yes	Yes
• TFTP	Yes	Yes	Yes	Yes
• SNMP v1	Yes	Yes	Yes	Yes
• SNMP v2	Yes	Yes	Yes	Yes
• SNMP v3	Yes	Yes	Yes	Yes
• DCP	Yes	Yes	Yes	Yes
• LLDP	Yes	Yes	Yes	Yes
Identification & maintenance				
• I&M0 - device-specific information	Yes	Yes	Yes	Yes
• I&M1 - higher-level designation/location designation	Yes	Yes	Yes	Yes
Product functions Diagnostics				
Product function				
• PROFINET IO diagnostics	Yes	Yes	Yes	Yes
• Link check	Yes	Yes	Yes	Yes
• Connection monitoring IP-Alive	Yes	Yes	Yes	Yes
• Localization by means of Aeroscout	Yes	Yes	Yes	Yes
• SysLog	Yes	Yes	Yes	Yes
Product functions VLAN				
Product function VLAN with IWLAN	Yes	Yes	Yes	Yes
Product functions DHCP				
Product function DHCP client	Yes	Yes	Yes	Yes
Product functions Redundancy				
STP/RSTP protocol is supported	Yes	Yes	Yes	Yes
Product functions Security				
Product function				
• ACL - MAC based	Yes	Yes	Yes	Yes
• IEEE 802.1x (radius)	Yes	Yes	Yes	Yes
• NAT/NAPT	Yes	Yes	Yes	Yes
• Access protection according to IEEE802.11i	Yes	Yes	Yes	Yes
• WPA/WPA2	Yes	Yes	Yes	Yes
• TKIP/AES	Yes	Yes	Yes	Yes
Protocol is supported SSH	Yes	Yes	Yes	Yes
Product functions Time				
SNTP protocol is supported	Yes	Yes	Yes	Yes

¹⁾ Wireless approval in the USA

Industrial Wireless Communication

IWLAN – Access Points IEEE 802.11a/b/g

SCALANCE W786 for the outdoor area

Technical specifications (continued)

Order No.	6GK5 786-2BA60-2AA0 6GK5 786-2BA60-2AB0 ¹⁾	6GK5 786-2AA60-2AA0 6GK5 786-2AA60-2AB0 ¹⁾	6GK5 786-2BB60-2AA0 6GK5 786-2BB60-2AB0 ¹⁾	6GK5 786-2AB60-2AA0 6GK5 786-2AB60-2AB0 ¹⁾
Product type designation	SCALANCE W786-2PRO	SCALANCE W786-2PRO	SCALANCE W786-2PRO	SCALANCE W786-2PRO
Standards, specifications, approvals				
Standard				
• for EMC of FM	FM 3611: Class I, Division 2, Groups A,B,C,D, T4 / Class 1, Zone 2, Group IIC, T4	FM 3611: Class I, Division 2, Groups A,B,C,D, T4 / Class 1, Zone 2, Group IIC, T4	FM 3611: Class I, Division 2, Groups A,B,C,D, T4 / Class 1, Zone 2, Group IIC, T4	FM 3611: Class I, Division 2, Groups A,B,C,D, T4 / Class 1, Zone 2, Group IIC, T4
• for hazardous zone	EN 60079-15:2005, EN 60079-0:2006, II 3 G Ex nA II T4 KEMA 07 ATEX 0145X	EN 60079-15:2005, EN 60079-0:2006, II 3 G Ex nA II T4 KEMA 07 ATEX 0145X	EN 60079-15:2005, EN 60079-0:2006, II 3 G Ex nA II T4 KEMA 07 ATEX 0145X	EN 60079-15:2005, EN 60079-0:2006, II 3 G Ex nA II T4 KEMA 07 ATEX 0145X
• for CSA and UL safety	UL 60950-1 CSA C22.2 No. 60950-1	UL 60950-1 CSA C22.2 No. 60950-1	UL 60950-1 CSA C22.2 No. 60950-1	UL 60950-1 CSA C22.2 No. 60950-1
• for hazardous zone of CSA and UL	UL 1604, CSA C22.2 No. 213-M1987, CL. 1, Div. 2, GP. A,B,C,D, T4 / CL. 1, Zone 2, GP IIC, T4	UL 1604, CSA C22.2 No. 213-M1987, CL. 1, Div. 2, GP. A,B,C,D, T4 / CL. 1, Zone 2, GP IIC, T4	UL 1604, CSA C22.2 No. 213-M1987, CL. 1, Div. 2, GP. A,B,C,D, T4 / CL. 1, Zone 2, GP IIC, T4	UL 1604, CSA C22.2 No. 213-M1987, CL. 1, Div. 2, GP. A,B,C,D, T4 / CL. 1, Zone 2, GP IIC, T4
Certificate of suitability				
• CE marking	Yes	Yes	Yes	Yes
• EC Declaration of Conformity	Yes	Yes	Yes	Yes
• C-Tick	Yes	Yes	Yes	Yes
• CCC	No	No	No	No
• Railroad application according to EN 50155	No	No	No	No
• e1 approval	Yes	Yes	Yes	Yes
• E1 approval	Yes	Yes	Yes	Yes
• NEMA4X	Yes	Yes	Yes	Yes
• Power-over-Ethernet according to IEEE802.3af for Type 1 and IEEE802.3af	Yes	Yes	Yes	Yes
Standard for wireless communication				
• IEEE 802.11a	Yes	Yes	Yes	Yes
• IEEE 802.11b	Yes	Yes	Yes	Yes
• IEEE 802.11e	Yes	Yes	Yes	Yes
• IEEE 802.11g	Yes	Yes	Yes	Yes
• IEEE 802.11h	Yes	Yes	Yes	Yes
• IEEE 802.11i	Yes	Yes	Yes	Yes
• IEEE 802.11n	No	No	No	No
Wireless approval	You can find the latest list of countries at: www.siemens.com/simatic-net/ik-info	You can find the latest list of countries at: www.siemens.com/simatic-net/ik-info	You can find the latest list of countries at: www.siemens.com/simatic-net/ik-info	You can find the latest list of countries at: www.siemens.com/simatic-net/ik-info
Marine classification association				
• American Bureau of Shipping Europe Ltd. (ABS)	Yes	Yes	Yes	Yes
• Bureau Veritas (BV)	Yes	Yes	Yes	Yes
• Det Norske Veritas (DNV)	No	No	No	No
• Germanischer Lloyd (GL)	Yes	Yes	Yes	Yes
• Lloyds Register of Shipping (LRS)	Yes	Yes	Yes	Yes
• Nippon Kaiji Kyokai (NK)	Yes	Yes	Yes	Yes
• Polski Rejestr Statkow (PRS)	No	No	No	No
Accessories				
Accessories	48 V DC screw terminal included in scope of delivery	48 V DC screw terminal included in scope of delivery	48 V DC screw terminal included in scope of delivery	48 V DC screw terminal included in scope of delivery

¹⁾ Wireless approval in the USA

Technical specifications (continued)

Order No.	6GK5 786-3AA60-2AA0 6GK5 786-3AA60-2AB0 ¹⁾	6GK5 786-3AB60-2AA0 6GK5 786-3AB60-2AB0 ¹⁾	6GK5 786-2BA60-6AA0 6GK5 786-2BA60-6AB0 ¹⁾	6GK5 786-2AA60-6AA0 6GK5 786-2AA60-6AB0 ¹⁾
Product type designation	SCALANCE W786-3PRO	SCALANCE W786-3PRO	SCALANCE W786-2RR	SCALANCE W786-2RR
Transmission rate				
Transmission rate • with W-LAN, maximum • with Industrial Ethernet • Note	54 Mbit/s 10 ... 100 Mbit/s Due to the simultaneous use of several radio channels, a transmission rate of 108 Mbit/s is possible (turbo mode)	54 Mbit/s 10 ... 100 Mbit/s Due to the simultaneous use of several radio channels, a transmission rate of 108 Mbit/s is possible (turbo mode)	54 Mbit/s 10 ... 100 Mbit/s Due to the simultaneous use of several radio channels, a transmission rate of 108 Mbit/s is possible (turbo mode)	54 Mbit/s 10 ... 100 Mbit/s Due to the simultaneous use of several radio channels, a transmission rate of 108 Mbit/s is possible (turbo mode)
Interfaces				
Number of electrical connections • for network components or terminal equipment • for power supply • for redundant power supply	1 1 1	- 1 1	1 1 1	1 1 1
Design of electrical connection • for network components or terminal equipment • for power supply	RJ45 socket 2-pin connector (48 V DC) or optionally available power supply adapter (4-pin 12 to 24 V DC or 3-pin 100 to 240 V AC)	- 2-pin connector (48 V DC) or optionally available power supply adapter (4-pin 12 to 24 V DC or 3-pin 100 to 240 V AC)	RJ45 socket 2-pin connector (48 V DC) or optionally available power supply adapter (4-pin 12 to 24 V DC or 3-pin 100 to 240 V AC)	RJ45 socket 2-pin connector (48 V DC) or optionally available power supply adapter (4-pin 12 to 24 V DC or 3-pin 100 to 240 V AC)
Number of optical connections for fiber-optic cables at 100 Mbit/s	-	1	-	-
Design of optical connection for fiber-optic cables at 100 Mbit/s	-	Duplex multimode FOC (ST)	-	-
Design of swap medium C-Plug	Yes	Yes	Yes	Yes
Interfaces wireless				
Number of permanently installed wireless cards	3	3	2	2
Number of internal antennas	-	-	4	-
Number of electrical connections for external antenna(s)	6	6	-	4
Design of electrical connection for external antenna(s)	R-SMA female (socket)	R-SMA female (socket)	-	R-SMA female (socket)
Supply voltage, current consumption, power loss				
Type of power supply	DC	DC	DC	DC
Supply voltage • 1 from terminal block • 2 from terminal block • From Power-over-Ethernet according to IEEE802.3at for Type 1 and IEEE802.3af • From optionally integrated power supply	48 V - 48 V	48 V - 48 V	48 V - 48 V	48 V - 48 V
- With AC - With DC	100 ... 240 V 12 ... 24 V	100 ... 240 V 12 ... 24 V	100 ... 240 V 12 ... 24 V	100 ... 240 V 12 ... 24 V

¹⁾ Wireless approval in the USA

Industrial Wireless Communication

IWLAN – Access Points IEEE 802.11a/b/g

SCALANCE W786 for the outdoor area

Technical specifications (continued)

Order No.	6GK5 786-3AA60-2AA0 6GK5 786-3AA60-2AB0 ¹⁾	6GK5 786-3AB60-2AA0 6GK5 786-3AB60-2AB0 ¹⁾	6GK5 786-2BA60-6AA0 6GK5 786-2BA60-6AB0 ¹⁾	6GK5 786-2AA60-6AA0 6GK5 786-2AA60-6AB0 ¹⁾
Product type designation	SCALANCE W786-3PRO	SCALANCE W786-3PRO	SCALANCE W786-2RR	SCALANCE W786-2RR
Current consumed				
• At 24 V DC, typical	0.4 A	0.46 A	0.34 A	0.34 A
• At 48 V DC, typical	0.2 A	0.23 A	0.17 A	0.17 A
• At 230 V AC, typical	0.05 A	0.05 A	0.04 A	0.04 A
• With Power-over-Ethernet according to IEEE802.3af for Type 1 and IEEE802.3af, typical	0.2 A	0.23 A	0.34 A	0.34 A
Effective power loss				
• At 24 V DC, typical	9.5 W	11 W	8 W	8 W
• At 48 V DC, typical	9.5 W	11 W	8 W	8 W
• At 230 V AC, typical	9.5 W	11 W	8 W	8 W
• With Power-over-Ethernet according to IEEE802.3af for Type 1 and IEEE802.3af, typical	9.5 W	11 W	8 W	8 W
Permissible ambient conditions				
Ambient temperature				
• During operation	-40 ... +70 °C	-40 ... +70 °C	-40 ... +70 °C	-40 ... +70 °C
• During storage	-40 ... +85 °C	-40 ... +85 °C	-40 ... +85 °C	-40 ... +85 °C
• During transport	-40 ... +85 °C	-40 ... +85 °C	-40 ... +85 °C	-40 ... +85 °C
Relative humidity at 25 °C without condensation during operation, maximum	100 %	100 %	100 %	100 %
IP degree of protection	IP65	IP65	IP65	IP65
Ambient conditions for operation	When using the 100 ... 240 V AC power supply, an operating temperature of -40 °C to +60 °C is permissible	When using the 100 ... 240 V AC power supply, an operating temperature of -40 °C to +60 °C is permissible	When using the 100 ... 240 V AC power supply, an operating temperature of -40 °C to +60 °C is permissible	When using the 100 ... 240 V AC power supply, an operating temperature of -40 °C to +60 °C is permissible
Design, dimensions and weights				
Width of enclosure without antenna	251 mm	251 mm	251 mm	251 mm
Height of enclosure without antenna	251 mm	251 mm	251 mm	251 mm
Depth of enclosure without antenna	72 mm	72 mm	72 mm	72 mm
Net weight	2.24 kg	2.24 kg	2.24 kg	2.24 kg
Type of mounting				
• S7-300 rail mounting	-	-	-	-
• Wall mounting	Yes	Yes	Yes	Yes
Type of mounting	For mast mounting, 35 mm DIN rail mounting and S7-300 rail mounting, an additional retaining plate is required	For mast mounting, 35 mm DIN rail mounting and S7-300 rail mounting, an additional retaining plate is required	For mast mounting, 35 mm DIN rail mounting and S7-300 rail mounting, an additional retaining plate is required	For mast mounting, 35 mm DIN rail mounting and S7-300 rail mounting, an additional retaining plate is required
Wireless frequencies				
Wireless frequency				
• With WLAN in the 2.4 GHz frequency band	2.41 ... 2.48 GHz	2.41 ... 2.48 GHz	2.41 ... 2.48 GHz	2.41 ... 2.48 GHz
• with WLAN in the 5 GHz frequency band	4.9 ... 5.8 GHz	4.9 ... 5.8 GHz	4.9 ... 5.8 GHz	4.9 ... 5.8 GHz

¹⁾ Wireless approval in the USA

Technical specifications (continued)

Order No.	6GK5 786-3AA60-2AA0 6GK5 786-3AA60-2AB0 ¹⁾	6GK5 786-3AB60-2AA0 6GK5 786-3AB60-2AB0 ¹⁾	6GK5 786-2BA60-6AA0 6GK5 786-2BA60-6AB0 ¹⁾	6GK5 786-2AA60-6AA0 6GK5 786-2AA60-6AB0 ¹⁾
Product type designation	SCALANCE W786-3PRO	SCALANCE W786-3PRO	SCALANCE W786-2RR	SCALANCE W786-2RR
Product properties, functions, components				
General				
Number of SSIDs	24	24	16	16
Product function				
• Dual client	No	No	Yes	Yes
• iHOP	No	No	Yes	Yes
• iPCF	No	No	Yes	Yes
• iPCF-MC	No	No	Yes	Yes
Number of iPCF-capable radio modules	0	0	1	1
Product functions				
Management, configuration, programming				
Number of manageable IP addresses in the client	8	8	8	8
Product function				
• CLI	Yes	Yes	Yes	Yes
• Web-based management	Yes	Yes	Yes	Yes
• MIB support	Yes	Yes	Yes	Yes
• TRAPs via e-mail	Yes	Yes	Yes	Yes
• Configuration with STEP 7	Yes	Yes	Yes	Yes
• Configuration with STEP 7 in the TIA Portal	Yes	Yes	Yes	Yes
• SMTP server	Yes	Yes	Yes	Yes
• Operation with IWLAN controller	No	No	No	No
• Operation with Enterasys WLAN controller	No	No	No	No
• iQoS	Yes	Yes	Yes	Yes
• Forced roaming with IWLAN	Yes	Yes	Yes	Yes
• WDS	Yes	Yes	Yes	Yes
Protocol is supported				
• Address Resolution Protocol (ARP)	Yes	Yes	Yes	Yes
• ICMP	Yes	Yes	Yes	Yes
• Telnet	Yes	Yes	Yes	Yes
• HTTP	Yes	Yes	Yes	Yes
• HTTPS	Yes	Yes	Yes	Yes
• TFTP	Yes	Yes	Yes	Yes
• SNMP v1	Yes	Yes	Yes	Yes
• SNMP v2	Yes	Yes	Yes	Yes
• SNMP v3	Yes	Yes	Yes	Yes
• DCP	Yes	Yes	Yes	Yes
• LLDP	Yes	Yes	Yes	Yes
Identification & maintenance				
• I&MO - device-specific information	Yes	Yes	Yes	Yes
• I&M1 - higher-level designation/location designation	Yes	Yes	Yes	Yes

¹⁾ Wireless approval in the USA

Industrial Wireless Communication

IWLAN – Access Points IEEE 802.11a/b/g

SCALANCE W786 for the outdoor area

Technical specifications (continued)

Order No.	6GK5 786-3AA60-2AA0 6GK5 786-3AA60-2AB0 ¹⁾	6GK5 786-3AB60-2AA0 6GK5 786-3AB60-2AB0 ¹⁾	6GK5 786-2BA60-6AA0 6GK5 786-2BA60-6AB0 ¹⁾	6GK5 786-2AA60-6AA0 6GK5 786-2AA60-6AB0 ¹⁾
Product type designation	SCALANCE W786-3PRO	SCALANCE W786-3PRO	SCALANCE W786-2RR	SCALANCE W786-2RR
Product functions Diagnostics				
Product function				
• PROFINET IO diagnostics	Yes	Yes	Yes	Yes
• Link check	Yes	Yes	Yes	Yes
• Connection monitoring IP-Alive	Yes	Yes	Yes	Yes
• Localization by means of Aer scout	Yes	Yes	Yes	Yes
• SysLog	Yes	Yes	Yes	Yes
Product functions VLAN				
Product function VLAN with IWLAN	Yes	Yes	Yes	Yes
Product functions DHCP				
Product function DHCP client	Yes	Yes	Yes	Yes
Product functions Redundancy				
STP/RSTP protocol is supported	Yes	Yes	Yes	Yes
Product functions Security				
Product function				
• ACL - MAC based	Yes	Yes	Yes	Yes
• IEEE 802.1x (radius)	Yes	Yes	Yes	Yes
• NAT/NAPT	Yes	Yes	Yes	Yes
• Access protection according to IEEE802.11i	Yes	Yes	Yes	Yes
• WPA/WPA2	Yes	Yes	Yes	Yes
• TKIP/AES	Yes	Yes	Yes	Yes
Protocol is supported SSH	Yes	Yes	Yes	Yes
Product functions Time				
SNTP protocol is supported	Yes	Yes	Yes	Yes
Standards, specifications, approvals				
Standard				
• for EMC of FM	FM 3611: Class I, Division 2, Groups A,B,C,D, T4 / Class 1, Zone 2, Group IIC, T4	FM 3611: Class I, Division 2, Groups A,B,C,D, T4 / Class 1, Zone 2, Group IIC, T4	FM 3611: Class I, Division 2, Groups A,B,C,D, T4 / Class 1, Zone 2, Group IIC, T4	FM 3611: Class I, Division 2, Groups A,B,C,D, T4 / Class 1, Zone 2, Group IIC, T4
• for hazardous zone	EN 60079-15:2005, EN 60079-0:2006, II 3 G Ex nA II T4 KEMA 07 ATEX 0145X	EN 60079-15:2005, EN 60079-0:2006, II 3 G Ex nA II T4 KEMA 07 ATEX 0145X	EN 60079-15:2005, EN 60079-0:2006, II 3 G Ex nA II T4 KEMA 07 ATEX 0145X	EN 60079-15:2005, EN 60079-0:2006, II 3 G Ex nA II T4 KEMA 07 ATEX 0145X
• for CSA and UL safety	UL 60950-1 CSA C22.2 No. 60950-1	UL 60950-1 CSA C22.2 No. 60950-1	UL 60950-1 CSA C22.2 No. 60950-1	UL 60950-1 CSA C22.2 No. 60950-1
• for hazardous zone of CSA and UL	UL 1604, CSA C22.2 No. 213-M1987, CL. 1, Div. 2, GP. A,B,C,D, T4 / CL. 1, Zone 2, GP IIC, T4	UL 1604, CSA C22.2 No. 213-M1987, CL. 1, Div. 2, GP. A,B,C,D, T4 / CL. 1, Zone 2, GP IIC, T4	UL 1604, CSA C22.2 No. 213-M1987, CL. 1, Div. 2, GP. A,B,C,D, T4 / CL. 1, Zone 2, GP IIC, T4	UL 1604, CSA C22.2 No. 213-M1987, CL. 1, Div. 2, GP. A,B,C,D, T4 / CL. 1, Zone 2, GP IIC, T4

¹⁾ Wireless approval in the USA

Technical specifications (continued)

Order No.	6GK5 786-3AA60-2AA0 6GK5 786-3AA60-2AB0 ¹⁾	6GK5 786-3AB60-2AA0 6GK5 786-3AB60-2AB0 ¹⁾	6GK5 786-2BA60-6AA0 6GK5 786-2BA60-6AB0 ¹⁾	6GK5 786-2AA60-6AA0 6GK5 786-2AA60-6AB0 ¹⁾
Product type designation	SCALANCE W786-3PRO	SCALANCE W786-3PRO	SCALANCE W786-2RR	SCALANCE W786-2RR
Certificate of suitability				
• CE marking	Yes	Yes	Yes	Yes
• EC Declaration of Conformity	Yes	Yes	Yes	Yes
• C-Tick	Yes	Yes	Yes	Yes
• CCC	No	No	No	No
• Railroad application according to EN 50155	No	No	No	No
• e1 approval	Yes	Yes	Yes	Yes
• E1 approval	Yes	Yes	Yes	Yes
• NEMA4X	Yes	Yes	Yes	Yes
• Power-over-Ethernet according to IEEE802.3at for Type 1 and IEEE802.3af	Yes	Yes	Yes	Yes
Standard for wireless communication				
• IEEE 802.11a	Yes	Yes	Yes	Yes
• IEEE 802.11b	Yes	Yes	Yes	Yes
• IEEE 802.11e	Yes	Yes	Yes	Yes
• IEEE 802.11g	Yes	Yes	Yes	Yes
• IEEE 802.11h	Yes	Yes	Yes	Yes
• IEEE 802.11i	Yes	Yes	Yes	Yes
• IEEE 802.11n	No	No	No	No
Wireless approval	You can find the latest list of countries at: www.siemens.com/simatic-net/ik-info	You can find the latest list of countries at: www.siemens.com/simatic-net/ik-info	You can find the latest list of countries at: www.siemens.com/simatic-net/ik-info	You can find the latest list of countries at: www.siemens.com/simatic-net/ik-info
Marine classification association				
• American Bureau of Shipping Europe Ltd. (ABS)	Yes	Yes	Yes	Yes
• Bureau Veritas (BV)	Yes	Yes	Yes	Yes
• Det Norske Veritas (DNV)	No	No	No	No
• Germanischer Lloyd (GL)	Yes	Yes	Yes	Yes
• Lloyds Register of Shipping (LRS)	Yes	Yes	Yes	Yes
• Nippon Kaiji Kyokai (NK)	Yes	Yes	Yes	Yes
• Polski Rejestr Statkow (PRS)	No	No	No	No
Accessories				
Accessories	48 V DC screw terminal included in scope of delivery	48 V DC screw terminal included in scope of delivery	48 V DC screw terminal included in scope of delivery	48 V DC screw terminal included in scope of delivery

¹⁾ Wireless approval in the USA

Industrial Wireless Communication

IWLAN – Access Points IEEE 802.11a/b/g

SCALANCE W786 for the outdoor area

Ordering data

Order No.

Order No.

SCALANCE W786 access points

IWLAN access points with built-in wireless interfaces; wireless networks IEEE 802.11a/b/g/h at 2.4/5 GHz up to 54 Mbit/s; WPA2/AES; Power over Ethernet (PoE), IP65 degree of protection (-40 °C to +70 °C); scope of supply: Mounting hardware, 2-pin screw terminal for 48 V DC; manual on CD-ROM; German/English;

SCALANCE W786-1PRO

IWLAN Access Points with one built-in radio interface

RJ45 connection

- Two internal antennas
 - National approvals for operation outside the USA
 - National approvals for operation within the USA¹⁾
- Connections for two external antennas
 - National approvals for operation outside the USA
 - National approvals for operation within the USA¹⁾

Fiber-optic cable connection

- Two internal antennas
 - National approvals for operation outside the USA
 - National approvals for operation within the USA¹⁾
- Connections for two external antennas
 - National approvals for operation outside the USA
 - National approvals for operation within the USA¹⁾

6GK5 786-1BA60-2AA0

6GK5 786-1BA60-2AB0

6GK5 786-1AA60-2AA0

6GK5 786-1AA60-2AB0

6GK5 786-1BB60-2AA0

6GK5 786-1BB60-2AB0

6GK5 786-1AB60-2AA0

6GK5 786-1AB60-2AB0

SCALANCE W786 access points (continued)

SCALANCE W786-2PRO

IWLAN Access Points with two built-in radio interfaces

RJ45 connection

- Four internal antennas
 - National approvals for operation outside the USA
 - National approvals for operation within the USA¹⁾
- Connections for four external antennas
 - National approvals for operation outside the USA
 - National approvals for operation within the USA¹⁾

6GK5 786-2BA60-2AA0

6GK5 786-2BA60-2AB0

6GK5 786-2AA60-2AA0

6GK5 786-2AA60-2AB0

Fiber-optic cable connection

- Four internal antennas
 - National approvals for operation outside the USA
 - National approvals for operation within the USA¹⁾
- Connections for four external antennas
 - National approvals for operation outside the USA
 - National approvals for operation within the USA¹⁾

6GK5 786-2BB60-2AA0

6GK5 786-2BB60-2AB0

6GK5 786-2AB60-2AA0

6GK5 786-2AB60-2AB0

SCALANCE W786-3PRO

IWLAN Access Points with three built-in radio interfaces

RJ45 connection

- Connections for six external antennas
 - National approvals for operation outside the USA
 - National approvals for operation within the USA¹⁾

6GK5 786-3AA60-2AA0

6GK5 786-3AA60-2AB0

Fiber-optic cable connection

- Connections for six external antennas
 - National approvals for operation outside the USA
 - National approvals for operation within the USA¹⁾

6GK5 786-3AB60-2AA0

6GK5 786-3AB60-2AB0

SCALANCE W786-2RR

IWLAN Dual Access Point with two built-in radio interfaces for establishment of radio links with iPCF

RJ45 connection

- Four internal antennas
 - National approvals for operation outside the USA
 - National approvals for operation within the USA¹⁾
- Connections for four external antennas
 - National approvals for operation outside the USA
 - National approvals for operation within the USA¹⁾

6GK5 786-2BA60-6AA0

6GK5 786-2BA60-6AB0

6GK5 786-2AA60-6AA0

6GK5 786-2AA60-6AB0

¹⁾ Please note national approvals at www.siemens.com/wireless-approvals

Industrial Wireless Communication

IWLAN – Access Points IEEE 802.11a/b/g

SCALANCE W786 for the outdoor area

Ordering data	Order No.	Order No.
Accessories		
C-PLUG Swap medium for simple replacement of devices in the event of a fault; for storing configuration data; can be used in SIMATIC NET products with PLUG slot	6GK1 900-0AB00	IE FC Standard Cable GP 2 x 2 4-core, shielded TP installation cable for connection to IE FC Outlet RJ45/ IE FC RJ45 Plug; PROFINET-compliant; with UL approval; sold by the meter; max. length 1000 m, minimum order 20 m
PRESET-PLUG Swap medium for simple initial startup of SCALANCE W access points and client modules, as well as IWLAN/PB Link PN IO	6GK5 798-8AB00	FO standard cable GP 50/125/1400 ¹⁾ Multimode cable, sold by the meter; max. length 1000 m; minimum order 20 m;
SIMATIC Mobile Panel 277F IWLAN <ul style="list-style-type: none"> • Communication via WLAN (PROFINET) with acknowledgement button and emergency stop button • Communication via WLAN (PROFINET) with acknowledgment button and emergency stop button with integrated handwheel, key-operated switch, and two illuminated pushbuttons Note: Please also order the desktop power supply or battery charger!	6AV6 645-0DB01-0AX0 6AV6 645-0DC01-0AX0	IE FC Stripping Tool Preadjusted stripping tool for fast stripping of the Industrial Ethernet FC cables
<ul style="list-style-type: none"> • Table-top power supply incl. power cable for EU, US, UK, JP (only suitable for operation under laboratory/office conditions) • Charger for safe storage and charging the device incl. lock for securing the device in the charger. Charging capabilities for up to two additional batteries • Additional battery with LED indicator for indicating the charge status • Transponder incl. batteries (3x AA) 	6AV6 671-5CN00-0AX1 6AV6 671-5CE00-0AX0 6AV6 671-5CL00-0AX0 6AV6 671-5CM00-0AX0	IE TP Cord RJ45/RJ45 TP cable 4 x 2 with 2 RJ45 connectors <ul style="list-style-type: none"> • 0.5 m • 1 m • 2 m • 6 m • 10 m
IE FC RJ45 Plug 180 2x2 RJ45 plug connector for Industrial Ethernet with a rugged metal enclosure and integrated insulation-displacement contacts for connecting Industrial Ethernet FC installation cables; with a 180° cable outlet; for network components and CPs/CPUs with Industrial Ethernet interface <ul style="list-style-type: none"> • 1 pack = 1 unit • 1 pack = 10 units • 1 pack = 50 units 	6GK1 901-1BB10-2AA0 6GK1 901-1BB10-2AB0 6GK1 901-1BB10-2AE0	Power supply PS791-2DC 24 V DC power supply for installation in SCALANCE W786 products; operating instructions in German/English
		Power supply PS791-2AC 110 V AC to 230 V AC power supply for installation in the SCALANCE W786 products; operating instructions in German/English
		MS1 mounting set Mounting set for fixing the SCALANCE W786 products onto an S7-300 mounting rail or a 35 mm standard DIN rail
		Antennas and miscellaneous IWLAN accessories See Industrial Wireless LAN/ accessories

More information

Wireless approvals:

Current approvals can be found on the Internet at:
www.siemens.com/wireless-approvals

To assist in selecting the right products for Industrial Wireless Communication, the SIMATIC NET Selection Tool is available:

Online version:
www.siemens.com/snst

Offline version:
www.siemens.com/snst-download

Industrial Wireless Communication

IWLAN – Controller Access Points IEEE 802.11a/b/g

Controller Access Points SCALANCE W786 for the outdoor area

Overview



- SCALANCE W786-2HPW controller-based access points can only be operated on the SCALANCE WLC IWLAN Controller and Enterasys Wireless Controller (previously HiPath Wireless Controller)
- Support for the WLAN standards IEEE 802.11a/b/g/h
- Especially well suited to applications with high climatic requirements when installed outdoors and in areas accessible to the public

Design

- Rugged plastic enclosure (plexi-glass type), shock and vibration-proof for severe mechanical loading
- High IP65 degree of protection against dust and water jets
- For use at ambient temperatures from -40 °C to +70 °C
- Resistant to condensation
- Resistant to UV radiation and saltwater spray
- Design for use outdoors
- Version with 1 x RJ45 connection for 10/100 Mbit/s with Power-over-Ethernet according to IEEE 802.3at Type 1 (corresponds to IEEE 802.3af)
- Version with 1 x fiber-optic connection (multimode) for 100 Mbit/s
- Version with 1 x 48 V DC connection, optional operation with 12 to 24 V DC or 100 to 240 V AC with power supply integrated into device
- Mounting: Wall or, with optional mounting set, on S7 mounting rail, 35 mm standard mounting rail, or on a pole

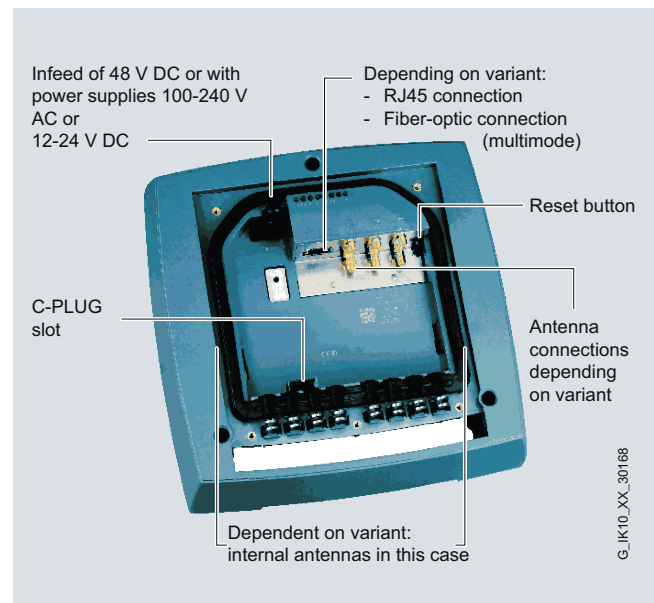

Design and interfaces of the SCALANCE W786-2HPW controller-based access points

Product versions

SCALANCE W786-2HPW (controller-based)

- Two wireless cards permanently installed in the device
- Versions with:
 - RJ45 connection and four internal antennas
 - RJ45 connection and four connections for external antennas
 - Fiber-optic multimode connection (BFOC) and four internal antennas
 - Fiber-optic multimode connection (BFOC) and four connections for external antennas

Function

If the minimum length of standard Ethernet cables is insufficient due to the large distance of the access points from the wired network, SCALANCE W786-2HPW can also be used in a version with BFOC connectors (multimode fiber-optic cable).

Industrial Wireless Communication

IWLAN – Controller Access Points IEEE 802.11a/b/g

Controller Access Points SCALANCE W786
for the outdoor area

Technical specifications

Order No.	6GK5 786-2BA60-1CA0	6GK5 786-2AA60-1CA0	6GK5 786-2BB60-1CA0	6GK5 786-2AB60-1CA0
Product type designation	SCALANCE W786-2HPW	SCALANCE W786-2HPW	SCALANCE W786-2HPW	SCALANCE W786-2HPW
Transmission rate				
Transmission rate	54 Mbit/s	54 Mbit/s	54 Mbit/s	54 Mbit/s
• with W-LAN, maximum	10 ... 100 Mbit/s	10 ... 100 Mbit/s	10 ... 100 Mbit/s	10 ... 100 Mbit/s
• with Industrial Ethernet	Due to the simultaneous use of several radio channels, a transmission rate of 108 Mbit/s is possible (turbo mode)	Due to the simultaneous use of several radio channels, a transmission rate of 108 Mbit/s is possible (turbo mode)	Due to the simultaneous use of several radio channels, a transmission rate of 108 Mbit/s is possible (turbo mode)	Due to the simultaneous use of several radio channels, a transmission rate of 108 Mbit/s is possible (turbo mode)
• Note				
Interfaces				
Number of electrical connections				
• for network components or terminal equipment	1	1	-	-
• for power supply	1	1	1	1
• For redundant power supply	1	1	1	1
Design of electrical connection				
• for network components or terminal equipment	RJ45 socket	RJ45 socket	-	-
• for power supply	2-pin connector (48 VDC) or optionally available power supply adapter (3-pin 24 V DC or 4-pin 110 to 230 V AC)	2-pin connector (48 VDC) or optionally available power supply adapter (3-pin 24 V DC or 4-pin 110 to 230 V AC)	2-pin connector (48 VDC) or optionally available power supply adapter (3-pin 24 V DC or 4-pin 110 to 230 V AC)	2-pin connector (48 VDC) or optionally available power supply adapter (3-pin 24 V DC or 4-pin 110 to 230 V AC)
Number of optical connections for fiber-optic cables at 100 Mbit/s	-	-	1	1
Design of optical connection for fiber-optic cables at 100 Mbit/s	-	-	Duplex multi-mode FOC (ST)	Duplex multi-mode FOC (ST)
Design of swap medium C-Plug	Yes	Yes	Yes	Yes
Interfaces Wireless				
Number of permanently installed radio cards	2	2	2	2
Number of internal antennas	4	-	4	-
Number of electrical connections for external antenna(s)	-	4	-	4
Design of electrical connection for external antenna(s)	-	R-SMA female (socket)	-	R-SMA female (socket)
Supply voltage, current consumption, power loss				
Type of power supply	DC	DC	DC	DC
Power supply				
• From Power-over-Ethernet according to IEEE802.3at for Type 1 and IEEE802.3af	48 V	48 V	48 V	48 V
• From Power-over-Ethernet according to IEEE802.3at for Type 2	-	-	-	-

Industrial Wireless Communication

IWLAN – Controller Access Points IEEE 802.11a/b/g

Controller Access Points SCALANCE W786 for the outdoor area

Technical specifications (continued)

Order No.	6GK5 786-2BA60-1CA0	6GK5 786-2AA60-1CA0	6GK5 786-2BB60-1CA0	6GK5 786-2AB60-1CA0
Product type designation	SCALANCE W786-2HPW	SCALANCE W786-2HPW	SCALANCE W786-2HPW	SCALANCE W786-2HPW
Current consumed				
• At 24 V DC, typical	0.34 A	0.34 A	0.4 A	0.4 A
• With Power-over-Ethernet according to IEEE802.3at for Type 1 and IEEE802.3af, typical	0.34 A	0.34 A	0.2 A	0.2 A
• With Power-over-Ethernet according to IEEE802.3at for Type 2, typical	-	-	-	-
Effective power loss				
• At 24 V DC, typical	8 W	8 W	9.5 W	9.5 W
• With Power-over-Ethernet according to IEEE802.3at for Type 1 and IEEE802.3af, typical	8 W	8 W	9.5 W	9.5 W
• With Power-over-Ethernet according to IEEE802.3at for Type 2, typical	-	-	-	-
Permitted ambient conditions				
Ambient temperature				
• During operation	-40 ... +70 °C	-40 ... +70 °C	-40 ... +70 °C	-40 ... +70 °C
• During storage	-40 ... +85 °C	-40 ... +85 °C	-40 ... +85 °C	-40 ... +85 °C
• During transport	-40 ... +85 °C	-40 ... +85 °C	-40 ... +85 °C	-40 ... +85 °C
Relative humidity at 25 °C without condensation during operation, maximum	100 %	100 %	100 %	100 %
IP degree of protection	IP65	IP65	IP65	IP65
Ambient conditions for operation	When using the 100 ... 240 V AC power supply, an operating temperature of -40 °C to +60 °C is permissible	When using the 100 ... 240 V AC power supply, an operating temperature of -40 °C to +60 °C is permissible	When using the 100 ... 240 V AC power supply, an operating temperature of -40 °C to +60 °C is permissible	When using the 100 ... 240 V AC power supply, an operating temperature of -40 °C to +60 °C is permissible
Design, dimensions and weights				
Width of enclosure without antenna	251 mm	251 mm	251 mm	251 mm
Height of enclosure without antenna	251 mm	251 mm	251 mm	251 mm
Depth of enclosure without antenna	72 mm	72 mm	72 mm	72 mm
Net weight	2.24 kg	2.24 kg	2.24 kg	2.24 kg
Type of mounting: wall mounting	Yes	Yes	Yes	Yes
Type of mounting	For mast mounting, 35 mm DIN rail mounting and S7-300 rail mounting, an additional retaining plate is required	For mast mounting, 35 mm DIN rail mounting and S7-300 rail mounting, an additional retaining plate is required	For mast mounting, 35 mm DIN rail mounting and S7-300 rail mounting, an additional retaining plate is required	For mast mounting, 35 mm DIN rail mounting and S7-300 rail mounting, an additional retaining plate is required
Radio frequencies				
Radio frequency				
• with WLAN in the 2.4 GHz frequency band	2.41 ... 2.48 GHz	2.41 ... 2.48 GHz	2.41 ... 2.48 GHz	2.41 ... 2.48 GHz
• With WLAN in the 5 GHz frequency band	4.9 ... 5.8 GHz	4.9 ... 5.8 GHz	4.9 ... 5.8 GHz	4.9 ... 5.8 GHz
Product functions Management, configuration, programming				
Product function				
• Operation with IWLAN controller	Yes	Yes	Yes	Yes
• Operation with Enterasys WLAN controller	Yes	Yes	Yes	Yes

Industrial Wireless Communication

IWLAN – Controller Access Points IEEE 802.11a/b/g

Controller Access Points SCALANCE W786 for the outdoor area

Technical specifications (continued)

Order No.	6GK5 786-2BA60-1CA0	6GK5 786-2AA60-1CA0	6GK5 786-2BB60-1CA0	6GK5 786-2AB60-1CA0
Product type designation	SCALANCE W786-2HPW	SCALANCE W786-2HPW	SCALANCE W786-2HPW	SCALANCE W786-2HPW
Standards, specifications, approvals				
Standard				
• for EMC of FM	FM 3611: Class I, Division 2, Groups A,B,C,D, T4 / Class 1, Zone 2, Group IIC, T4	FM 3611: Class I, Division 2, Groups A,B,C,D, T4 / Class 1, Zone 2, Group IIC, T4	FM 3611: Class I, Division 2, Groups A,B,C,D, T4 / Class 1, Zone 2, Group IIC, T4	FM 3611: Class I, Division 2, Groups A,B,C,D, T4 / Class 1, Zone 2, Group IIC, T4
• For hazardous zone	EN 60079-15:2005, EN 60079-0:2006, II 3 G Ex nA II T4 KEMA 07 ATEX 0145X	EN 60079-15:2005, EN 60079-0:2006, II 3 G Ex nA II T4 KEMA 07 ATEX 0145X	EN 60079-15:2005, EN 60079-0:2006, II 3 G Ex nA II T4 KEMA 07 ATEX 0145X	EN 60079-15:2005, EN 60079-0:2006, II 3 G Ex nA II T4 KEMA 07 ATEX 0145X
• for CSA and UL safety	UL 60950-1 CSA C22.2 No. 60950-1	UL 60950-1 CSA C22.2 No. 60950-1	UL 60950-1 CSA C22.2 No. 60950-1	UL 60950-1 CSA C22.2 No. 60950-1
• for Ex zone of CSA and UL	UL 1604, CSA C22.2 No. 213-M1987, CL. 1, Div. 2, GP. A, B, C, D, T4 / CL. 1, Zone 2, GP IIC, T4	UL 1604, CSA C22.2 No. 213-M1987, CL. 1, Div. 2, GP. A, B, C, D, T4 / CL. 1, Zone 2, GP IIC, T4	UL 1604, CSA C22.2 No. 213-M1987, CL. 1, Div. 2, GP. A, B, C, D, T4 / CL. 1, Zone 2, GP IIC, T4	UL 1604, CSA C22.2 No. 213-M1987, CL. 1, Div. 2, GP. A, B, C, D, T4 / CL. 1, Zone 2, GP IIC, T4
Certificate of suitability				
• CE mark	Yes	Yes	Yes	Yes
• EC Declaration of Conformity	Yes	Yes	Yes	Yes
• C-Tick	Yes	Yes	Yes	Yes
• CCC	No	No	No	No
• Railroad application according to EN 50155	No	No	No	No
• e1 approval	Yes	Yes	Yes	Yes
• E1 approval	Yes	Yes	Yes	Yes
• NEMA4X	Yes	Yes	Yes	Yes
• Power-over-Ethernet according to IEEE802.3af for Type 1 and IEEE802.3af	Yes	Yes	Yes	Yes
Standard for wireless communication				
• IEEE 802.11a	Yes	Yes	Yes	Yes
• IEEE 802.11b	Yes	Yes	Yes	Yes
• IEEE 802.11g	Yes	Yes	Yes	Yes
• IEEE 802.11h	Yes	Yes	Yes	Yes
• IEEE 802.11n	No	No	No	No
Wireless approval	You can find the latest list of countries at: www.siemens.com/simatic-net/ik-info	You can find the latest list of countries at: www.siemens.com/simatic-net/ik-info	You can find the latest list of countries at: www.siemens.com/simatic-net/ik-info	You can find the latest list of countries at: www.siemens.com/simatic-net/ik-info
Marine classification corporation				
• American Bureau of Shipping Europe Ltd. (ABS)	Yes	Yes	Yes	Yes
• Bureau Veritas (BV)	Yes	Yes	Yes	Yes
• Det Norske Veritas (DNV)	No	No	No	No
• Germanischer Lloyd (GL)	Yes	Yes	Yes	Yes
• Lloyds Register of Shipping (LRS)	Yes	Yes	Yes	Yes
• Nippon Kaiji Kyokai (NK)	Yes	Yes	Yes	Yes
• Polski Rejestr Statkow (PRS)	No	No	No	No
Accessories				
Accessories	48 V DC screw terminal included in scope of delivery	48 V DC screw terminal included in scope of delivery	48 V DC screw terminal included in scope of delivery	48 V DC screw terminal included in scope of delivery

Industrial Wireless Communication

IWLAN – Controller Access Points IEEE 802.11a/b/g

Controller Access Points SCALANCE W786 for the outdoor area

Ordering data	Order No.	Order No.
SCALANCE W786-2HPW Controller Access Points		
<p>IWLAN access points for operating with the SCALANCE WLC IWLAN Controller and Enterasys Wireless Controller (previously HiPath Wireless Controller); with two built-in wireless interfaces; wireless networks IEEE 802.11a/b/g/h at 2.4/5 GHz up to 54 Mbit/s; WPA2/AES; Power over Ethernet (PoE), IP65 degree of protection (-40 °C to +70 °C); scope of delivery: Mounting hardware, 2-pin screw terminal for 48 V DC; manual on CD-ROM; German/English</p> <p>RJ45 connection</p> <ul style="list-style-type: none"> • Four internal antennas • Connections for four external antennas <p>Fiber-optic cable connection</p> <ul style="list-style-type: none"> • Four internal antennas • Connections for four external antennas 	<p>6GK5 786-2BA60-1CA0</p> <p>6GK5 786-2AA60-1CA0</p> <p>6GK5 786-2BB60-1CA0</p> <p>6GK5 786-2AB60-1CA0</p>	<p>MS1 mounting set</p> <p>Mounting set for fixing the SCALANCE W786-2HPW products onto an S7-300 mounting rail or a 35 mm standard DIN rail</p> <p>IE FC RJ45 Plug 4 x 2</p> <p>RJ45 plug connector for Industrial Ethernet (10/100/1000 Mbit/s) with a rugged metal enclosure and integrated insulation displacement contacts for connecting Industrial Ethernet FC installation cables; 180° cable outlet; for network components and CPs/CPU with Industrial Ethernet interface</p> <ul style="list-style-type: none"> • 1 pack = 1 unit • 1 pack = 10 units • 1 pack = 50 units <p>IE FC Standard Cable GP 4 x 2</p> <p>8-core, shielded TP installation cable for connection to IE FC RJ45 Plug 4 x 2 and IE M12 Plug PRO 4 x 2; PROFINET-compatible; with UL approval; sold by the meter; max. length 1000 m, minimum order quantity 20 m</p> <p>IE FC Stripping Tool</p> <p>Preadjusted stripping tool for fast stripping of the Industrial Ethernet FC cables</p> <p><i>Antennas and miscellaneous IWLAN accessories</i></p>
Accessories		
<p>Power supply PS791-2DC</p> <p>12 to 24 V DC power supply for installation in the SCALANCE W786-2HPW products; operating instructions in German/English</p>	6GK5 791-2DC00-0AA0	6GK5 798-8MG00-0AA0
<p>Power supply PS791-2AC</p> <p>110 V AC to 230 V AC power supply for installation in the SCALANCE W786-2HPW products; operating instructions in German/English</p>	6GK5 791-2AC00-0AA0	<p>6GK1 901-1BB11-2AA0</p> <p>6GK1 901-1BB11-2AB0</p> <p>6GK1 901-1BB11-2AE0</p> <p>6XV1 878-2A</p> <p>6GK1 901-1GA00</p> <p>See Industrial Wireless LAN/ accessories</p>

More information

Wireless approvals:

Current approvals can be found on the Internet at:
www.siemens.com/wireless-approvals

To assist in selecting the right products for Industrial Wireless Communication, the SIMATIC NET Selection Tool is available:

Online version:
www.siemens.com/snst

Offline version:
www.siemens.com/snst-download

Overview



The Client Modules from the SCALANCE W748 product line are optimal for integrating Industrial Ethernet stations into Industrial Wireless LAN (IWLAN) for 2.4 GHz and 5 GHz.

- High transmission rates (up to 450 Mbit/s in conjunction with Channel Bonding) due to 3x3 MIMO technology (**M**ultiple **I**nterface, **M**ultiple **O**utput); for this purpose, SCALANCE W Client Modules use three streams each for simultaneous sending and receiving
- Suitable for any application:
 - SCALANCE W748 RJ45 for installation in a control cabinet
 - SCALANCE W748 M12 for cabinet-free installation
- Reliable thanks to rugged enclosure, protected from water and dust (IP65), resistant to shock, vibration and electromagnetic fields
- Complex applications with redundancy requirements and high bandwidths, e.g. for video, by using IEEE 802.11n
- Configuration support by means of wizards and online help; easy management via web server and SNMP
- Fast replacement of devices in event of failure by means of optional C-PLUG (Configuration Plug)

Benefits

get Designed for Industry

- Reliable radio link, e.g. by using MIMO technology and monitoring of the radio link
- Cost savings due to one single radio network both for process-critical data and for non-critical communication
- Investment security because all products are compatible with the internationally recognized WLAN standard IEEE 802.11, suitable for the unlicensed frequency bands of 2.4 GHz and 5 GHz (ISM bands)
- Implementation of data-intensive applications such as video streaming through the support of the IEEE 802.11n standard including Channel Bonding
- Reduced operating costs, because there is no wear of rotating and moving plant sections
- Cost-effective connection to devices which are remote, difficult to access or mounted in hostile environments

Application

The Client Modules of the SCALANCE W748 product line are designed for indoor and outdoor industrial applications as well as for low-cost integration in control cabinets. They provide a reliable wireless link with fast transfer from one access point to the next (roaming). In this manner, processes can be monitored and production failures through machine downtimes avoided.

The client modules with high IP65 degree of protection and extended temperature range from -20 to +60 °C are especially suitable for use outdoors. SCALANCE W products are silicone-free and can therefore also be used in paint shops.

The client modules with IP30 degree of protection are especially suitable for use in automated guided vehicle systems or suspended monorails.

When using the RCoax cable (radiating cable), operation is particularly reliable in conveying technology and all track applications (e.g. storage and retrieval systems).

Industrial Wireless Communication

IWLAN – Client Modules IEEE 802.11n

Overview

Application (continued)

Application examples:

- Automated guided vehicle systems (AGVS) and suspended monorails; prevention of wear and high flexibility in the choice of route thanks to wireless transmission of data to the vehicles
- Crane; high flexibility through access to data communication with the moving unit independent of the location
- Passenger transportation systems; transmission of high-quality video streams between the control center and buses or trains

- Tunnel application; reliable radio link since the devices can handle multiple path propagation better by using the MIMO technology
- Communication with moving stations (e.g. mobile controls and devices), container logistics, storage and retrieval machines, conveyor systems, conveyor belts, rotating machines, trucks
- Wireless coupling of communication segments and bridging of large distances for fast commissioning and for cost-effective networks in which cable routing would be extremely expensive (e.g. on public roads, rivers, lakes, train lines)

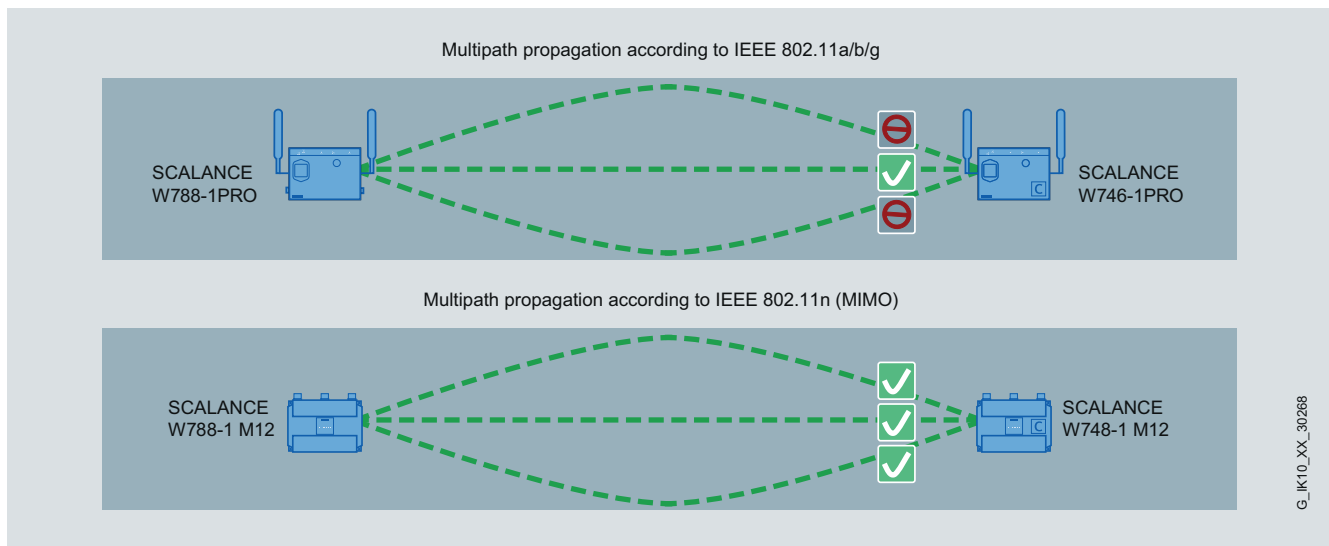

Multiple path propagation (MIMO) with SCALANCE W788-1PRO and SCALANCE W788-1 M12

Design

- Radio card (compatible with IEEE 802.11a/b/g/h/n) permanently installed in the device
- Designed without rotating parts (operation without fans)
- Antennas can either be connected by means of a screw connection (R-SMA, N-Connect) or they are integrated in the device
- Function LEDs for optical signaling of faults and operating states
- 1x PLUG slot

Function

Infrastructure mode

SCALANCE W748 Client Modules make it possible for a station with an Industrial Ethernet interface (e.g. a controller) to move seamlessly and with no wear in an Industrial Wireless LAN wireless field. The station registers in the wireless field via the Client Module and can exchange information with the entire data network. If the Client Module moves, for example, on an automated guided vehicle system, it is automatically and transparently transferred from one access point to the next (roaming).

This is possible over distances of up to 30 m indoors (approx. 100 m outdoors). Directional additional antennas can be used outdoors to achieve ranges of several thousand meters.

Apart from a reliable wireless link, the SCALANCE W748 Client Modules are characterized by their support of IT mechanisms:

- IEEE 802.11a/b/g/n for different frequency ranges
- IEEE 802.11h for use in the 5 GHz range outdoors
- IEEE802.11e for wireless multimedia (WMM)
- IEEE802.11i for security
- Selectable operation in infrastructure or ad-hoc mode
- Sending the log entries of the SCALANCE W devices to a Syslog server
- Modern security mechanisms (e.g. network security such as IEEE 802.1x, RADIUS, EAP mechanisms)
- Network and Port Address Translation (NAT/PAT) for mapping of private IP addresses and ports onto public addresses

Security

A high degree of data security is achieved by means of the WPA2/IEEE 802.11i mechanisms. These define modern procedures that control a regular exchange of the complete 128-bit code as well as performing the access check (authentication) of a station. The Advanced Encryption Standard (AES) is available for data encryption.

Access to the devices (HTTPS) is encrypted and secure logon (SSH) is possible. If a security concept with Virtual Private Networks (VPN) or the SCALANCE S range is required, the products can be integrated without any difficulty.

Functional scope

The SCALANCE W748 Client Modules can manage the wireless connection for up to eight connected devices with Ethernet interface. It is possible to integrate mobile units with a small Ethernet network (up to eight devices) into an IWLAN wireless field.

Diagnostics and management

- Web-based (HTTP/HTTPS) management tool for configuration and diagnostics using a standard browser
- LEDs for signaling operating states and fault conditions
- Signaling of faults by means of SNMP trap or e-mail to a network management tool, e.g. SINEMA-Server

Industrial Wireless Communication

IWLAN – Client Modules IEEE 802.11n

SCALANCE W748 RJ45
for use in the control cabinet

Overview



- Especially suitable for applications where the client module is to be mounted in the control cabinet
- Low-cost alternative for use indoors with less severe environmental conditions
- The rugged aluminum enclosure with degree of protection IP30 nevertheless provides protection against mechanical and electromagnetic stress in industrial areas

Design

- Rugged aluminum enclosure, shock and vibration-proof, for high mechanical requirements
- Dust protection with IP30 degree of protection
- For use at ambient temperatures from -20 °C to +60 °C
- Resistant to condensation
- Design suitable for installation in control cabinet
- 3 x R-SMA sockets for the connection of remote antennas
- Antenna placement optimized for the 3x3 MIMO technology; the antennas do not interfere with each other when they are mounted direct on the device
- 1 x RJ45 connection for 10/100/1000 Mbit/s with Power-over-Ethernet according to IEEE 802.3at Type 1 (corresponds to IEEE 802.3af)
- 2 x 24 V DC connection for redundant power infeed
- 1 x PLUG slot
- Function LEDs for optical signaling of faults and operating states
- Digital input for feeding in a signal from a sensor, for example, to an SNMP-based network management system
- Digital output for converting a command received over SNMP into a signal and switching a hardware function
- Mounting: Wall, S7 mounting rail or on 35 mm standard mounting rail

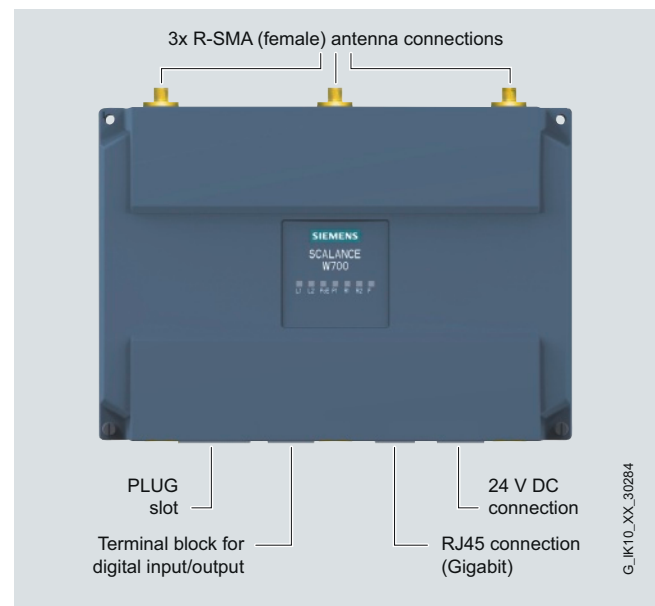

Design and interfaces of the SCALANCE W748-1 RJ45 Client Modules

Product versions

SCALANCE W748-1 RJ45

- A wireless card permanently installed in the device; for managing the wireless connection of up to eight connected devices

Industrial Wireless Communication

IWLAN – Client Modules IEEE 802.11n

SCALANCE W748 RJ45
for use in the control cabinet

Technical specifications

Order No.	6GK5 748-1FC00-0AA0 6GK5 748-1FC00-0AB0¹⁾
Product type designation	SCALANCE W748-1 RJ45
Transmission rate	
Transmission rate	
• with W-LAN, maximum	450 Mbit/s
• with Industrial Ethernet	10 ... 1 000 Mbit/s
• Note	-
Interfaces	
Number of electrical connections	
• for network components or terminal equipment	1
• for power supply	1
• for redundant power supply	1
Design of electrical connection	
• for network components or terminal equipment	RJ45 socket
• for power supply	4-pin screw terminal, PoE
Number of optical connections for fiber-optic cables at 100 Mbit/s	-
Design of optical connection for fiber-optic cables at 100 Mbit/s	-
Design of swap medium C-Plug	Yes
Interfaces wireless	
Number of permanently installed wireless cards	1
Number of internal antennas	-
Number of electrical connections for external antenna(s)	3
Design of electrical connection for external antenna(s)	R-SMA female (socket)
Inputs/outputs	
Number of digital inputs	1
Number of digital outputs	1
Design of electrical connection at the digital inputs/outputs	4-pin screw terminal
Signal range	
• at the digital input	24 V DC, safety extra low voltage
• at the digital output	24 V DC/ 1 A
Supply voltage, current consumption, power loss	
Type of power supply	DC
Power supply	
• 1 from terminal block	19.2 V
• 2 from terminal block	28.8 V
• From Power-over-Ethernet according to IEEE802.3at for Type 1 and IEEE802.3af	48 V
• From Power-over-Ethernet according to IEEE802.3at for Type 2	48 V

¹⁾ Wireless approval in the USA

Order No.	6GK5 748-1FC00-0AA0 6GK5 748-1FC00-0AB0¹⁾
Product type designation	SCALANCE W748-1 RJ45
Permissible ambient conditions	
Ambient temperature	
• During operation	-20 ... +60 °C
• During storage	-40 ... +70 °C
• During transport	-40 ... +70 °C
Relative humidity at 25 °C without condensation during operation, maximum	90 %
IP degree of protection	IP30
Ambient conditions for operation	-
Design, dimensions and weights	
Width of enclosure without antenna	200 mm
Height of enclosure without antenna	158 mm
Depth of enclosure without antenna	79 mm
Net weight	1.7 kg
Type of mounting: wall mounting	Yes
Type of mounting	S7-300 rail mounting
Wireless frequencies	
Wireless frequency	
• With WLAN in the 2.4 GHz frequency band	2.41 ... 2.48 GHz
• With WLAN in the 5 GHz frequency band	4.9 ... 5.8 GHz
Product properties, functions, components	
General	
Number of SSIDs	1
Product function	
• Dual client	-
• iHOP	-
• iPCF	-
• iPCF-MC	-
Number of iPCF-capable radio modules	-

Industrial Wireless Communication

IWLAN – Client Modules IEEE 802.11n

SCALANCE W748 RJ45
for use in the control cabinet

Technical specifications (continued)

Order No.	6GK5 748-1FC00-0AA0 6GK5 748-1FC00-0AB0 ¹⁾
Product type designation	SCALANCE W748-1 RJ45
Product functions Management, configuration, programming	
Number of manageable IP addresses in the client	8
Product function	
• CLI	Yes
• Web-based management	Yes
• MIB support	Yes
• TRAPs via e-mail	Yes
• Configuration with STEP 7	No
• Configuration with STEP 7 in the TIA Portal	No
• SMTP server	Yes
• Operation with IWLAN controller	-
• Operation with Enterasys WLAN controller	-
• Forced roaming with IWLAN	No
• WDS	No
Protocol is supported	
• Address Resolution Protocol (ARP)	Yes
• ICMP	Yes
• Telnet	Yes
• HTTP	Yes
• HTTPS	Yes
• TFTP	Yes
• SNMP v1	Yes
• SNMP v2	Yes
• SNMP v3	Yes
• DCP	Yes
• LLDP	Yes
Identification & maintenance	
• I&M0 - device-specific information	Yes
• I&M1 - higher-level designation/location designation	Yes
Product functions Diagnostics	
Product function	
• PROFINET IO diagnostics	Yes
• Link check	No
• Connection monitoring IP-Alive	No
• Localization by means of Aeroscout	No
• SysLog	Yes
Product functions VLAN	
Product function VLAN with IWLAN	No
Product functions DHCP	
Product function DHCP client	Yes
Product functions Redundancy	
STP/RSTP protocol is supported	No

Order No.	6GK5 748-1FC00-0AA0 6GK5 748-1FC00-0AB0 ¹⁾
Product type designation	SCALANCE W748-1 RJ45
Product functions Security	
Product function	
• ACL - MAC based	No
• IEEE 802.1x (radius)	Yes
• NAT/NAPT	Yes
• Access protection according to IEEE802.11i	Yes
• WPA/WPA2	Yes
• TKIP/AES	Yes
Protocol is supported SSH	Yes
Product functions Time	
SNTP protocol is supported	Yes
Standards, specifications, approvals	
Standard	
• for EMC of FM	-
• for hazardous zone	-
• for CSA and UL safety	UL 60950-1 CSA C22.2 No. 60950-1
• for hazardous zone of CSA and UL	-
Certificate of suitability	
• CE marking	Yes
• EC Declaration of Conformity	Yes
• C-Tick	Yes
• CCC	No
• Railroad application according to EN 50155	No
• e1 approval	No
• E1 approval	No
• NEMA4X	No
• Power-over-Ethernet according to IEEE802.3af for Type 1 and IEEE802.3af	
• Power-over-Ethernet according to IEEE802.3at for Type 2	
Standard for wireless communication	
• IEEE 802.11a	Yes
• IEEE 802.11b	Yes
• IEEE 802.11e	Yes
• IEEE 802.11g	Yes
• IEEE 802.11h	Yes
• IEEE 802.11i	Yes
• IEEE 802.11n	Yes
Wireless approval	You can find the latest list of countries at: www.siemens.com/simatic-net/ik-info
Marine classification association	
• American Bureau of Shipping Europe Ltd. (ABS)	No
• Bureau Veritas (BV)	No
• Det Norske Veritas (DNV)	No
• Germanischer Lloyd (GL)	No
• Lloyds Register of Shipping (LRS)	No
• Nippon Kaiji Kyokai (NK)	No
• Polski Rejestr Statkow (PRS)	No
Accessories	
Accessories	24 V DC screw terminal and screw terminal for digital input and output included in scope of delivery

¹⁾ Wireless approval in the USA

Industrial Wireless Communication

IWLAN – Client Modules IEEE 802.11n

SCALANCE W748 RJ45
for use in the control cabinet

Ordering data	Order No.	Order No.
SCALANCE W748 Client Modules		
<p>IWLAN Ethernet Client Modules with built-in wireless interface; wireless networks IEEE 802.11a/b/g/h/n at 2.4/5 GHz up to 450 Mbit/s; WPA2/AES; Power over Ethernet (PoE), IP30 degree of protection (-20 °C to +60 °C); scope of delivery: Mounting hardware, 4-pin screw terminal for 24 V DC; 4-pin screw terminal for digital input and output; manual on CD-ROM; German/English</p> <p>SCALANCE W748-1 RJ45</p> <p>For administration of the radio link of up to eight devices with Industrial Ethernet connection; IP30 degree of protection</p> <ul style="list-style-type: none"> National approvals for operation outside the USA National approvals for operation within the USA¹⁾ 		<p>IE FC RJ45 Plug 4 x 2</p> <p>RJ45 plug connector for Industrial Ethernet (10/100/1000 Mbit/s) with a rugged metal enclosure and integrated insulation displacement contacts for connecting Industrial Ethernet FC installation cables; 180° cable outlet; for network components and CPs/CPU's with Industrial Ethernet interface</p> <ul style="list-style-type: none"> 1 pack = 1 unit 1 pack = 10 units 1 pack = 50 units <p>6GK1 901-1BB11-2AA0 6GK1 901-1BB11-2AB0 6GK1 901-1BB11-2AE0</p>
	6GK5 748-1FC00-0AA0	6XV1 878-2A
	6GK5 748-1FC00-0AB0	
Accessories		
<p>C-PLUG</p> <p>Swap medium for simple replacement of devices in the event of a fault; for storing configuration data; can be used in SIMATIC NET products with PLUG slot</p>	6GK1 900-0AB00	
<p>DIN rail mounting adapter</p> <p>DIN rail mounting adapter for SCALANCE W788 M12 and SCALANCE W788 RJ45; screw fixing for mounting on a 35 mm DIN rail to EN 50 022; scope of supply: 3 units per pack</p>	6GK5 798-8ML00-0AB3	
		<p>IE FC Standard Cable GP 4 x 2</p> <p>8-core, shielded TP installation cable for connection to IE FC RJ45 Plug 4 x 2 and IE M12 Plug PRO 4 x 2; PROFINET-compliant; with UL approval; sold by the meter; max. length 1000 m, minimum order 20 m</p> <p>IE FC Stripping Tool</p> <p>Preadjusted stripping tool for fast stripping of the Industrial Ethernet FC cables</p> <p>6GK1 901-1GA00</p>
		<p>Antennas and miscellaneous IWLAN accessories</p> <p>See Industrial Wireless LAN/ accessories</p>

¹⁾ Please note national approvals at www.siemens.com/wireless-approvals

More information

Wireless approvals:

Current approvals can be found on the Internet at: www.siemens.com/wireless-approvals

To assist in selecting the right products for Industrial Wireless Communication, the SIMATIC NET Selection Tool is available:

Online version:
www.siemens.com/snst

Offline version:
www.siemens.com/snst-download

Industrial Wireless Communication IWLAN – Client Modules IEEE 802.11n

SCALANCE W748 M12 for use in the indoor area

Overview



- Particularly suitable for industrial applications without control cabinets

Application

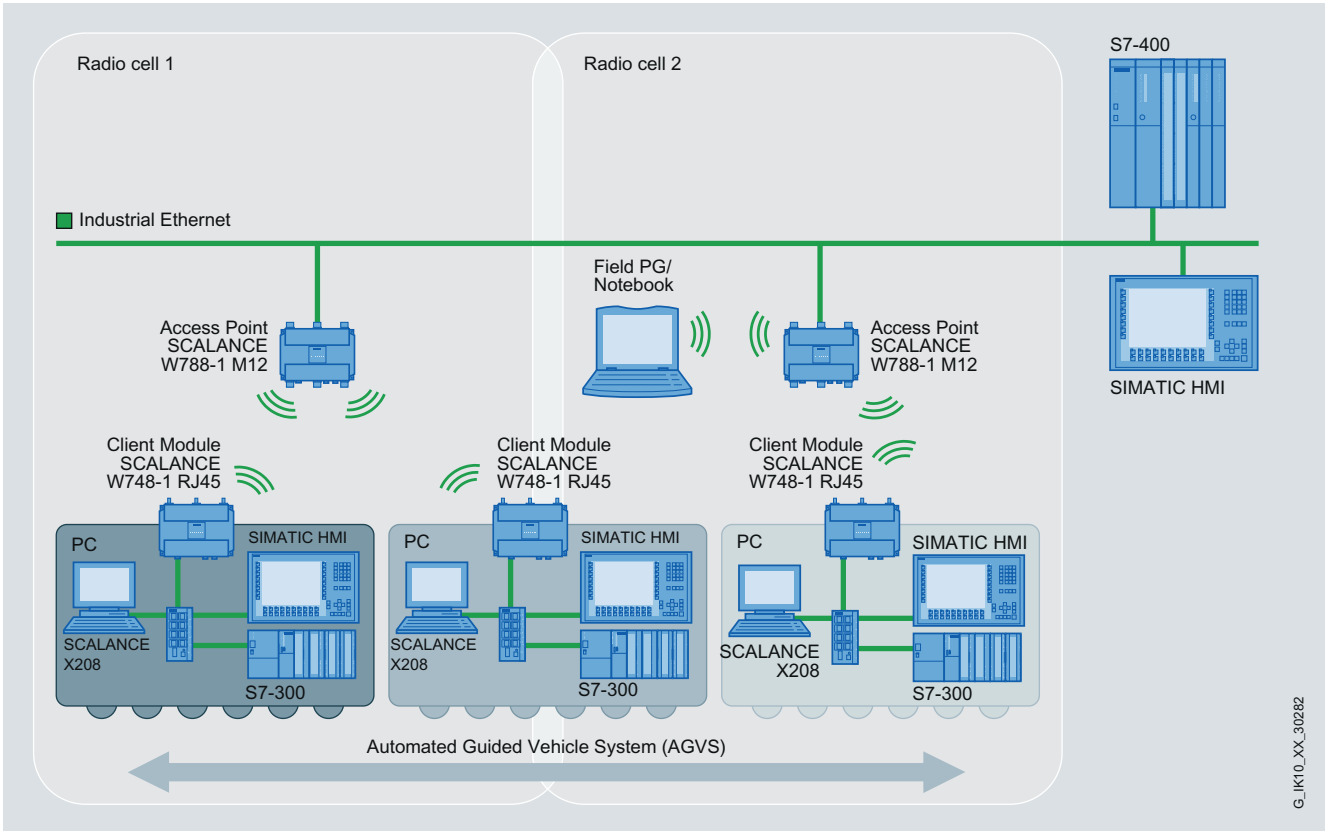

G_IK10_XX_30282

8

Mobile controls in an automated guided vehicle system

The controllers register via the Ethernet Client Modules W748-1 M12 in the wireless field and can move around freely there. This makes it possible to operate an automated guided vehicle system, for example.

Industrial Wireless Communication

IWLAN – Client Modules IEEE 802.11n

SCALANCE W748 M12 for use in the indoor area

Design

- Rugged aluminum enclosure, shock and vibration-proof, for high mechanical requirements
- High IP65 degree of protection against dust and water jets
- For use at ambient temperatures from -20 °C to +60 °C
- Resistant to condensation
- 3 x N-Connect sockets for the connection of remote antennas
- Antenna placement optimized for the 3x3 MIMO technology; the antennas do not interfere with each other when they are mounted direct on the device
- 1 x M125 connection for 10/100/1000 Mbit/s with Power-over-Ethernet according to IEEE 802.3at Type 1 (corresponds to IEEE 802.3af)
- 1 x M12 socket for energy supply (24 V DC)
- 1 x PLUG slot
- Function LEDs for optical signaling of faults and operating states
- Mounting: Wall, S7 mounting rail or on 35 mm standard mounting rail

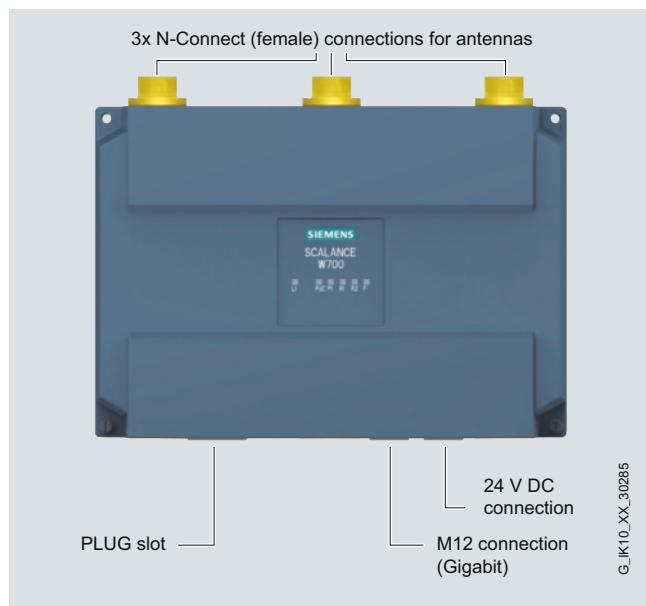

Design and interfaces of the SCALANCE W748-1 M12 Client Modules

Product versions

SCALANCE W748-1 M12

- A wireless card permanently installed in the device; for managing the wireless connection of up to eight connected devices

Technical specifications

Order No.	6GK5 748-1GD00-0AA0 6GK5 748-1GD00-0AB0 ¹⁾
Product type designation	SCALANCE W748-1 M12
Transmission rate	
Transmission rate	450 Mbit/s
• with W-LAN, maximum	10 ... 1 000 Mbit/s
• with Industrial Ethernet	-
• Note	-
Interfaces	
Number of electrical connections	1
• for network components or terminal equipment	1
• for power supply	1
• for redundant power supply	1
Design of electrical connection	M12 interface (8-pin, A-coded), PoE
• for network components or terminal equipment	M12 interface (4-pin, A-coded), PoE
• for power supply	
Number of optical connections for fiber-optic cables at 100 Mbit/s	-
Design of optical connection for fiber-optic cables at 100 Mbit/s	-
Design of swap medium C-Plug	Yes
Interfaces wireless	
Number of permanently installed wireless cards	1
Number of internal antennas	-
Number of electrical connections for external antenna(s)	3
Design of electrical connection for external antenna(s)	N-Connect female
Supply voltage, current consumption, power loss	
Type of power supply	DC
Power supply	19.2 V
• 1 from M12 power connector (A-coded) for redundant power supply	28.8 V
• 2 from M12 power connector (A-coded) for redundant power supply	48 V
• From Power-over-Ethernet according to IEEE802.3at for Type 1 and IEEE802.3af	48 V
• From Power-over-Ethernet according to IEEE802.3at for Type 2	48 V
Permissible ambient conditions	
Ambient temperature	-20 ... +60 °C
• During operation	-40 ... +70 °C
• During storage	-40 ... +70 °C
• During transport	100 %
Relative humidity at 25 °C without condensation during operation, maximum	IP65
IP degree of protection	-
Ambient conditions for operation	

¹⁾ Wireless approval in the USA

Industrial Wireless Communication

IWLAN – Client Modules IEEE 802.11n

SCALANCE W748 M12 for use in the indoor area

Technical specifications (continued)

Order No.	6GK5 748-1GD00-0AA0 6GK5 748-1GD00-0AB0 ¹⁾
Product type designation	SCALANCE W748-1 M12
Design, dimensions and weights	
Width of enclosure without antenna	200 mm
Height of enclosure without antenna	176 mm
Depth of enclosure without antenna	79 mm
Net weight	1.7 kg
Type of mounting: wall mounting	Yes
Type of mounting	S7-300 rail mounting
Wireless frequencies	
Wireless frequency	
• With WLAN in the 2.4 GHz frequency band	2.41 ... 2.48 GHz
• With WLAN in the 5 GHz frequency band	4.9 ... 5.8 GHz
Product properties, functions, components	
General	
Number of SSIDs	1
Product function	
• Dual client	-
• iHOP	-
• iPCF	-
• iPCF-MC	-
Number of iPCF-capable radio modules	-
Product functions	
Management, configuration, programming	
Number of manageable IP addresses in the client	8
Product function	
• CLI	Yes
• Web-based management	Yes
• MIB support	Yes
• TRAPs via e-mail	Yes
• Configuration with STEP 7	No
• Configuration with STEP 7 in the TIA Portal	No
• SMTP server	Yes
• Operation with IWLAN controller	-
• Operation with Enterasys WLAN controller	-
• Forced roaming with IWLAN	No
• WDS	No

¹⁾ Wireless approval in the USA

Order No.	6GK5 748-1GD00-0AA0 6GK5 748-1GD00-0AB0 ¹⁾
Product type designation	SCALANCE W748-1 M12
Protocol is supported	
• Address Resolution Protocol (ARP)	Yes
• ICMP	Yes
• Telnet	Yes
• HTTP	Yes
• HTTPS	Yes
• TFTP	Yes
• SNMP v1	Yes
• SNMP v2	Yes
• SNMP v3	Yes
• DCP	Yes
• LLDP	Yes
Identification & maintenance	
• I&M0 - device-specific information	Yes
• I&M1 - higher-level designation/location designation	Yes
Product functions Diagnostics	
Product function	
• PROFINET IO diagnostics	Yes
• Link check	No
• Connection monitoring IP-Alive	No
• Localization by means of Aeroscout	No
• SysLog	Yes
Product functions VLAN	
Product function VLAN with IWLAN	No
Product functions DHCP	
Product function DHCP client	Yes
Product functions Redundancy	
STP/RSTP protocol is supported	No
Product functions Security	
Product function	
• ACL – MAC based	No
• IEEE 802.1x (radius)	Yes
• NAT/NAPT	Yes
• Access protection according to IEEE802.11i	Yes
• WPA/WPA2	Yes
• TKIP/AES	Yes
Protocol is supported SSH	Yes
Product functions Time	
SNTP protocol is supported	Yes

Industrial Wireless Communication

IWLAN – Client Modules IEEE 802.11n

SCALANCE W748 M12 for use in the indoor area

Technical specifications (continued)		Ordering data	Order No.
Order No.	6GK5 748-1GD00-0AA0 6GK5 748-1GD00-0AB0 ¹⁾	SCALANCE W748 Client Modules IWLAN Ethernet Client Modules with built-in wireless interface; wireless networks IEEE 802.11a/b/g/h/n at 2.4/5 GHz up to 450 Mbit/s; WPA2/AES; Power over Ethernet (PoE), IP65 degree of protection (-20 °C to +60 °C); scope of delivery: Mounting hardware; manual on CD-ROM, German/English	
Product type designation	SCALANCE W748-1 M12		
Standards, specifications, approvals		SCALANCE W748-1 M12 for managing of the wireless connection of <u>up to eight</u> linked devices with Industrial Ethernet connection	
Standard		• National approvals for operation outside the USA	6GK5 748-1GD00-0AA0
• for EMC of FM	-	• National approvals for operation within the USA ¹⁾	6GK5 748-1GD00-0AB0
• for hazardous zone	-		
• for CSA and UL safety	UL 60950-1 CSA C22.2 No. 60950-1		
• for hazardous zone of CSA and UL	-		
Certificate of suitability			
• CE marking	Yes		
• EC Declaration of Conformity	Yes		
• C-Tick	Yes		
• CCC	No		
• Railroad application according to EN 50155	No		
• e1 approval	No		
• E1 approval	No		
• NEMA4X	No		
• Power-over-Ethernet according to IEEE802.3af for Type 1 and IEEE802.3af	Yes		
• Power-over-Ethernet according to IEEE802.3at for Type 2	Yes		
Standard for wireless communication			
• IEEE 802.11a	Yes		
• IEEE 802.11b	Yes		
• IEEE 802.11e	Yes		
• IEEE 802.11g	Yes		
• IEEE 802.11h	Yes		
• IEEE 802.11i	Yes		
• IEEE 802.11n	Yes		
Wireless approval	You can find the latest list of countries at: www.siemens.com/simatic-net/ik-info		
Marine classification association			
• American Bureau of Shipping Europe Ltd. (ABS)	No		
• Bureau Veritas (BV)	No		
• Det Norske Veritas (DNV)	No		
• Germanischer Lloyd (GL)	No		
• Lloyds Register of Shipping (LRS)	No		
• Nippon Kaiji Kyokai (NK)	No		
• Polski Rejestr Statkow (PRS)	No		
Accessories			
Accessories	-		

¹⁾ Wireless approval in the USA

Industrial Wireless Communication

IWLAN – Client Modules IEEE 802.11n

SCALANCE W748 M12 for use in the indoor area

Ordering data	Order No.	More information
<i>Accessories</i>		
C-PLUG Swap medium for simple replacement of devices in the event of a fault; for storing configuration data; can be used in SIMATIC NET products with PLUG slot	6GK1 900-0AB00	Wireless approvals: Current approvals can be found on the Internet at: www.siemens.com/wireless-approvals To assist in selecting the right products for Industrial Wireless Communication, the SIMATIC NET Selection Tool is available: Online version: www.siemens.com/snst Offline version: www.siemens.com/snst-download
DIN rail mounting adapter DIN rail mounting adapter for SCALANCE W788 M12 and SCALANCE W788 RJ45; screw fixing for mounting on a 35 mm DIN rail to EN 50 022; scope of supply: 3 units per pack	6GK5 798-8ML00-0AB3	
IE FC M12 Plug PRO 4 x 2 M12 plug-in connector suitable for on-site assembly (X-coded, IP65/IP67), metal enclosure, insulation/displacement fast connection method, for SCALANCE W <ul style="list-style-type: none"> • 1 unit • 8 units 	6GK1 901-0DB30-6AA0 6GK1 901-0DB30-6AA8	
IE FC Standard Cable GP 4 x 2 8-core, shielded TP installation cable for connection to IE FC RJ45 Plug 4 x 2 and IE M12 Plug PRO 4 x 2; PROFINET-compliant; with UL approval; <u>sold by the meter</u> ; max. length 1000 m, minimum order 20 m	6XV1 878-2A	
IE FC Stripping Tool Preadjusted stripping tool for fast stripping of the Industrial Ethernet FC cables	6GK1 901-1GA00	
<i>Antennas and miscellaneous IWLAN accessories</i>	See Industrial Wireless LAN/ accessories	

Overview



The Ethernet Client Modules from the SCALANCE W740 product line are optimal for integrating Industrial Ethernet stations into Industrial Wireless LANs (IWLANS) for 2.4 GHz and 5 GHz with transmission rates of up to 54 Mbit/s.

- Suitable for any application:
 - SCALANCE W74x-1 for installation in a cabinet or integration in devices
 - SCALANCE W74x-1PRO for cabinet-free installation
- Reliable thanks to rugged housing, protected from water and dust (IP65), resistant to shock, vibration and electromagnetic fields
- Approved for operation in hazardous areas in Zone 2
- Demanding applications with real-time and redundancy requirements, such as PROFINET with PROFINsafe
- In conformance with standards, as it supports IEEE 802.11; additional functional expansions with software functions, especially for applications demanding high reliability, e.g. channel hopping procedure (iHOP), cyclic real-time data traffic, and very high-speed roaming (iPCF)
- The SINEMA E engineering tool, wizards and online help support planning, simulation, configuration, site survey and documentation; easy management with the web server and SNMP
- Quick commissioning of Client Modules with the optional swap medium PRESET-PLUG and quick device exchange in case of faults with the optional swap medium C-PLUG (Configuration Plug)

Benefits

get Designed for Industry

- Predictable data traffic (strict real-time requirements) and defined response times on the wireless link
- Reliable wireless link, e.g. due to redundant connection and cyclic monitoring of the wireless path
- Cost savings due to one single radio network both for process-critical data and for non-critical communication
- Investment security because all products are compatible with the internationally recognized WLAN standard IEEE 802.11, suitable for the unlicensed frequency bands of 2.4 GHz and 5 GHz (ISM bands)
- Reduced operating costs, because there is no wear of rotating and moving plant sections
- Cost-effective connection to devices which are remote, difficult to access or in hostile environments

Application

The Client Modules of the SCALANCE W740 product line are designed for indoor and outdoor industrial applications as well as for low-cost integration in control cabinets. They provide a reliable radio link, which will transfer quickly from one Access Point to the next (roaming). In this manner, processes can be monitored and production failures through machine downtimes avoided. In addition, Industrial Wireless LAN (IWLAN) can be used in time-critical applications associated with production automation (PROFINET IO) or for safety-related signals (PROFINsafe).

The client modules with high IP65 degree of protection and extended temperature range from -20 to +60 °C are especially suitable for use outdoors. SCALANCE W products are silicone-free and can therefore also be used in paint shops.

The client modules with IP30 degree of protection are especially suitable for use in automated guided vehicle systems or suspended monorails.

When using the RCoax cable (radiating cable), operation is particularly reliable in conveying technology and all track applications (e.g. storage and retrieval systems).

Application examples:

- Automated guided vehicle systems (AGVS) and suspended monorails; prevention of wear and high flexibility in the choice of route thanks to wireless transmission of data to the vehicles
- Cranes; high flexibility through access to data communication with the moving unit independent of the location
- Communication with moving stations (e.g. mobile controls and devices), container logistics, storage and retrieval machines, conveyor systems, conveyor belts, rotating machines, trucks
- Wireless coupling of communication segments and bridging of large distances for fast commissioning and for cost-effective networks in which cable routing would be extremely expensive (e.g. on public roads, rivers, lakes, train lines)

Industrial Wireless Communication

IWLAN – Client Modules IEEE 802.11a/b/g

Overview

Design

- Wireless card (compatible with IEEE 802.11a/b/g/h) permanently installed in the device
- Designed without rotating parts (e.g. operation without fans)
- Antennas can be connected via screw-type connection (R-SMA)
- Function LEDs for optical signaling of faults and operating states
- 1 x C-PLUG-/PRESET-PLUG slot

Function

Infrastructure mode

SCALANCE W740 Client Modules make it possible for a station with an Industrial Ethernet interface (e.g. a controller) to move seamlessly and with no wear in an Industrial Wireless LAN wireless field. The station registers in the wireless field via the Ethernet Client Module and can exchange information with the entire data network. If the Ethernet Client Module moves, for example, on an automated guided vehicle system, it is automatically and transparently transferred from one access point to the next (roaming).

This is possible over distances of up to 30 m indoors (approx. 100 m outdoors). Directional additional antennas can be used outdoors to achieve ranges of several thousand meters.

Apart from a reliable wireless connection, the SCALANCE W740 Client Modules are characterized by excellent support from IT mechanisms:

- IEEE 802.11 a/b/g for different frequency ranges
- IEEE 802.11h for use in the 5 GHz frequency range outdoors
- IEEE802.11e für multimedia, wireless multimedia (WMM)
- IEEE802.11i for security

- Selectable operation of infrastructure- and Ad-Hoc modes
- Sending the log entries of the SCALANCE W devices to a Syslog server
- Modern security mechanisms (e.g. network security such as IEEE 802.1x, RADIUS, EAP mechanisms)
- Network and Port Address Translation (NAT/PAT) (mapping of private IP addresses and ports onto public addresses)

Security

A high degree of data security is achieved by means of the WPA2/IEEE 802.11i mechanisms. These define modern procedures that control a regular exchange of the complete 128-bit code as well as performing the access check (authentication) of a station. The Advanced Encryption Standard (AES) is available for data encryption. All encryption mechanisms are integrated in the products and do not incur any additional costs.

Access to the devices (HTTPS) is encrypted and secure logon (SSH) is possible. If a security concept with Virtual Private Networks (VPN) or the SCALANCE S range is required, the products can be integrated without any difficulty.

Functional scope

SCALANCE W744-1PRO and SCALANCE W744-1 can administer one single IP address, namely that of the connected device. They establish a wireless connection precisely from this mobile device to the wireless network. If the connected device is replaced, the Ethernet Client Module recognizes this automatically, and registers the new address. This reduces plant downtimes and sources of error.

The SCALANCE W746-1PRO and SCALANCE W746-1 Ethernet Client Modules can administer the wireless connection for up to eight devices with an Ethernet interface. It is possible to integrate mobile units with a small Ethernet network (up to eight devices) into an IWLAN wireless field.

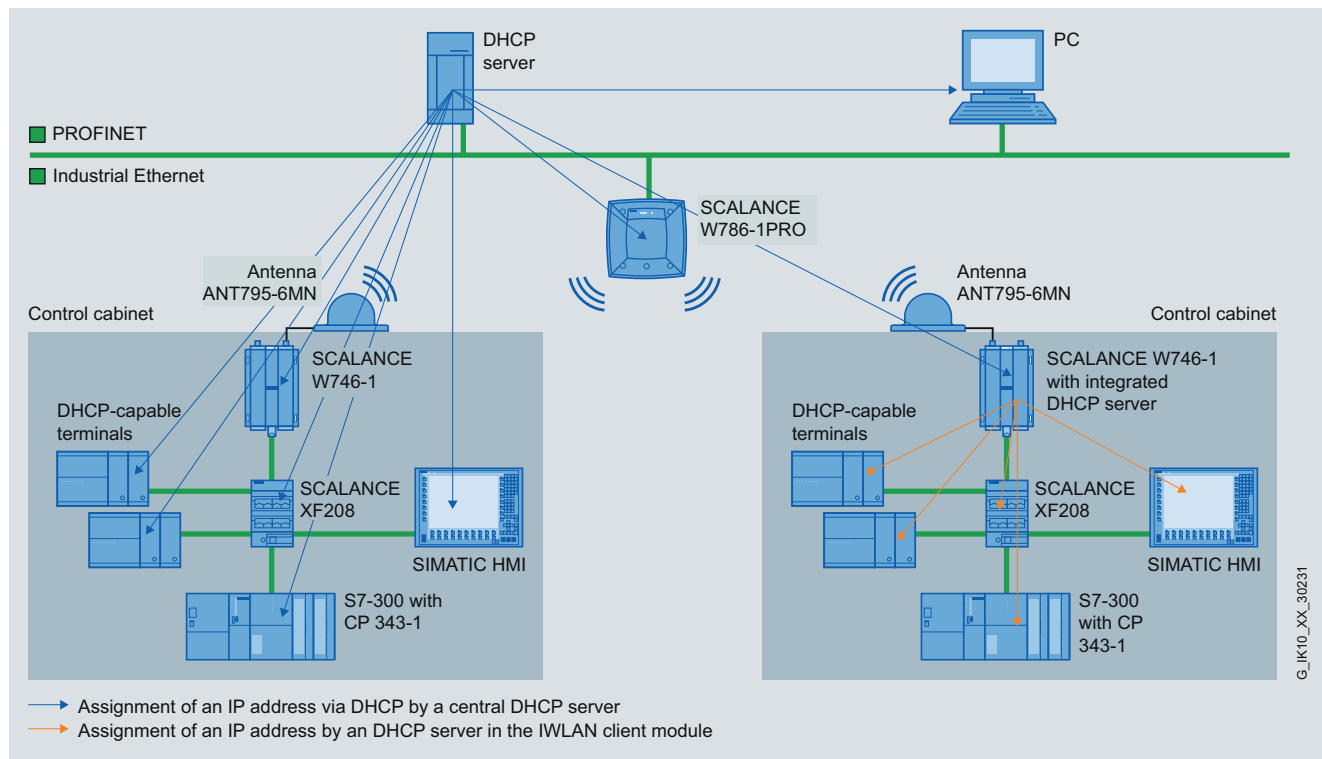

Assignment of dynamic IP addresses to wirelessly connected stations by a central DHCP server or integrated DHCP server of an IWLAN client module

Function (continued)

iFeatures (only for SCALANCE W747-1RR and W747-1)

iPCF (Industrial Point Coordination Function)

The **iPCF** mode is recommended for applications with a requirement for real-time and predictable response times (deterministic response), even during roaming of moving stations from one access point to the next. This ensures that wireless PROFINET IO is supported and that safety-related signals, e.g. emergency stop, can be integrated into the wireless link. This means that even video signals from moving stations can be transmitted with a high level of quality.

The iPCF mechanism expands the IEEE 802.11 standard and must be available on both the station and the access point (e.g. SCALANCE W788-1RR). In a wireless field in which iPCF is used, no IEEE 802.11-compliant stations can be operated.

iPCF is recommended for applications where wireless network nodes move along predefined paths (e.g. suspended monorail). RCoax leaky wave cables or directional antennas must be used for this purpose.

Note:

The IWLAN/PB Link PN IO gateway also supports iPCF

iPCF-MC (iPCF Management Channel)

iPCF-MC is available as further development of iPCF. This mode should be used if IWLAN stations that also support iPCF-MC (e.g. Client Modules SCALANCE W747-1RR, Mobile Panel 277F IWLAN) move freely about in the coverage area (especially when using omni-directional antennas) and are to exchange data deterministically. This functionality can only be implemented in combination with RR Access Point versions with at least two radio interfaces.

Note:

Due to the lower bandwidth when using iPCF-MC, we recommend the iPCF mode for transmitting video signals.

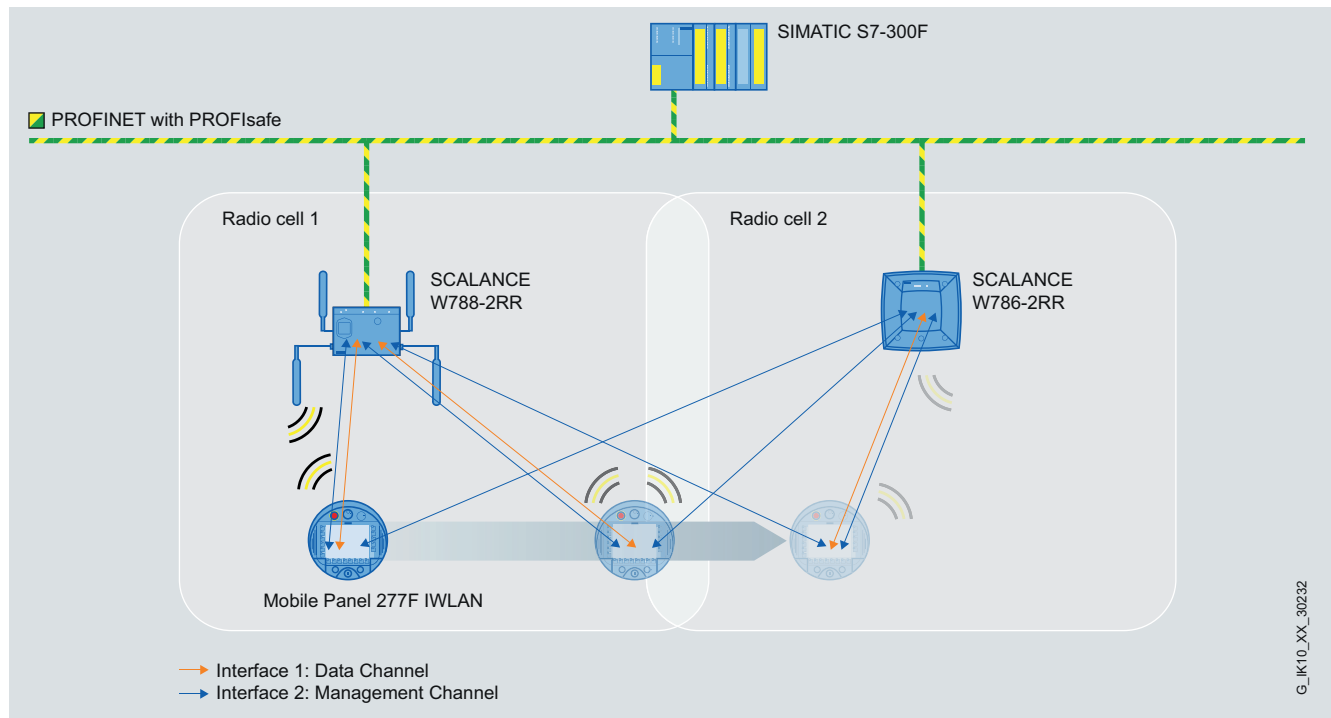

Roaming of a mobile panel between two access points while maintaining error-free communication with iPCF-MC

Industrial Wireless Communication

IWLAN – Client Modules IEEE 802.11a/b/g

Overview

Function (continued)

iHOP

With the supplementary function **iHOP**, the Access Point changes the channel in coordination with its clients. If it detects interferences which are caused, for example, by sporadically active WLANs on a channel, it avoids the affected channel temporarily. Hopping to the other channel is carried out so rapidly that usually the application is not impaired by the channel change. If the interferences occur throughout the complete frequency band, it is even possible to change to another frequency band (e.g. from 2.4 to 5 GHz). This guarantees reliable communication even with interferences in the wireless field.

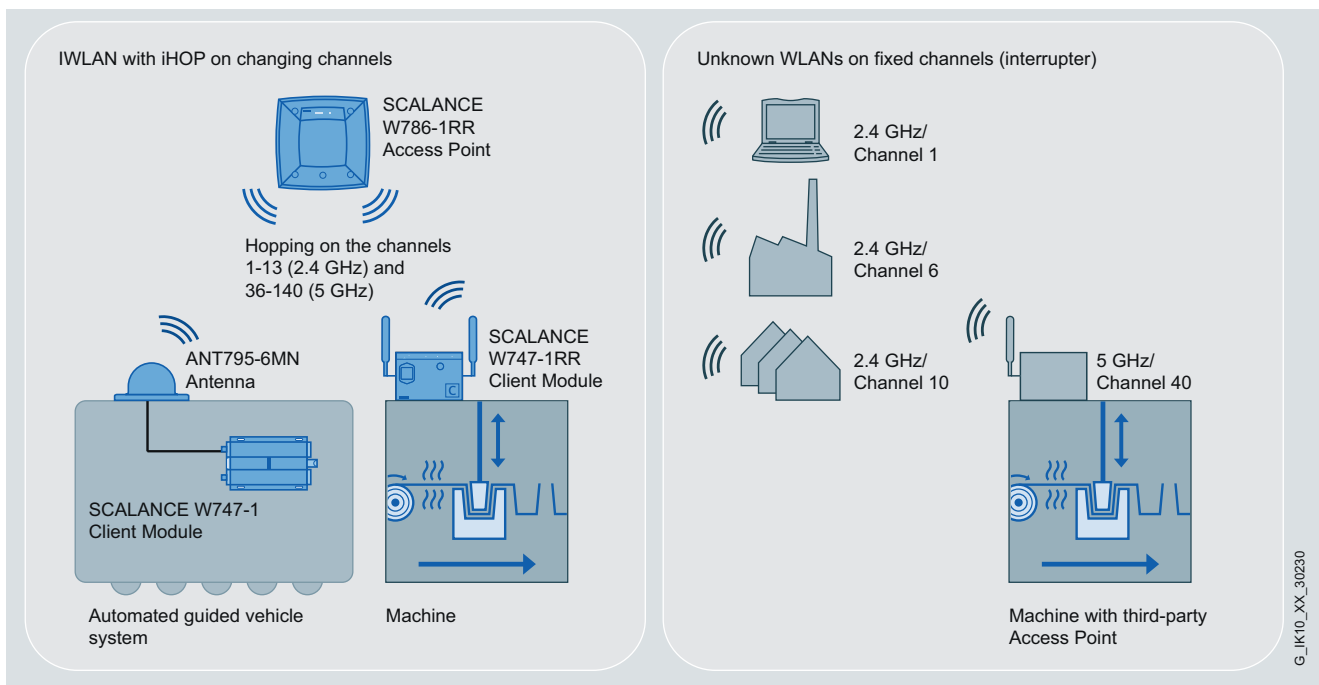

Coordinated changing of channels by means of a channel hopping procedure (iHOP) to avoid disrupters

8

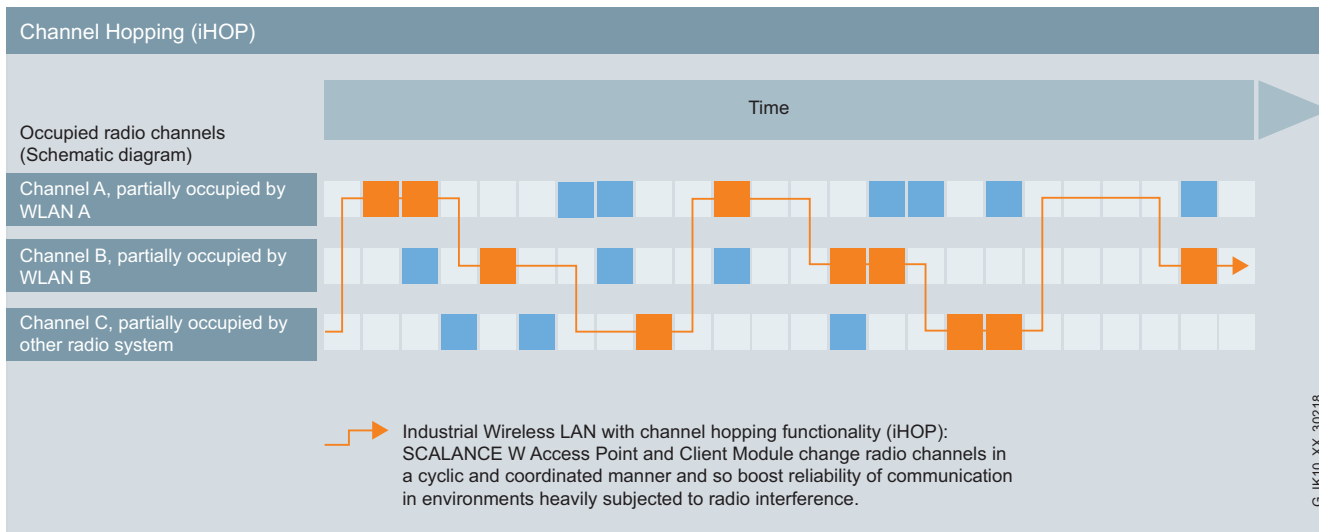

iHOP function for SCALANCE W Client Modules

Function (continued)

Dual Client

This function permits coupling of two Client Modules via an Industrial Ethernet Switch (e.g. SCALANCE X-200). One client is actively connected to an Access Point via IWLAN. The other client is in standby mode and continuously searches for an Access Point with better signal strength. If it finds one, its status changes to active and the previously active client switches to standby mode. Changeover between the clients is implemented without interrupting communication (seamless roaming).

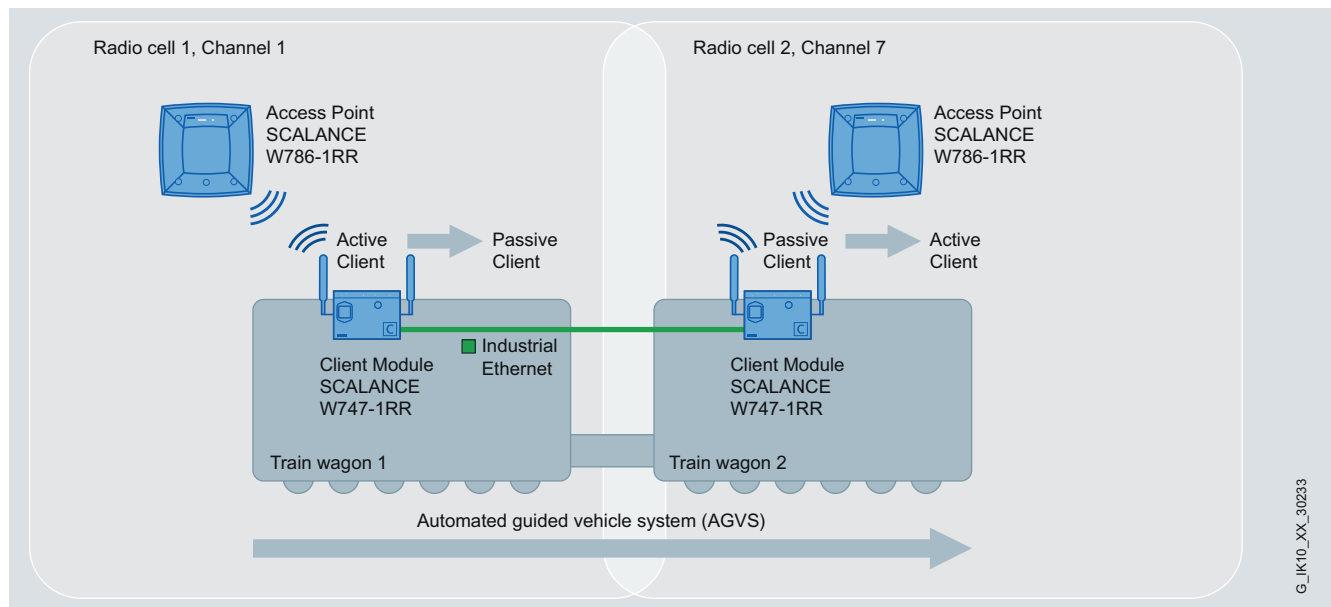

Two linked IWLAN client modules form a dual client to enable uninterrupted roaming, e.g. for fast moving vehicles

Note:

These iFeatures cannot be used in parallel.

Diagnostics and management

- Web-based (HTTP/HTTPS) management tool for configuration and diagnostics using a standard browser
- Planning, configuration, simulation and measurement of the wireless field on site (Site Survey) with SINEMA E
- LEDs for signaling operating states and fault conditions
- Signaling of faults by means of SNMP trap or e-mail to a network management tool, e.g. SINEMA-Server

Industrial Wireless Communication

IWLAN – Client Modules IEEE 802.11a/b/g

SCALANCE W740 for use in the control cabinet

Overview



- Especially suitable for applications where the client module is to be mounted in the control cabinet
- Low-cost alternative for use indoors with less severe environmental conditions
- The rugged aluminum enclosure with degree of protection IP30 nevertheless provides protection against mechanical and electromagnetic stress in industrial areas

Application

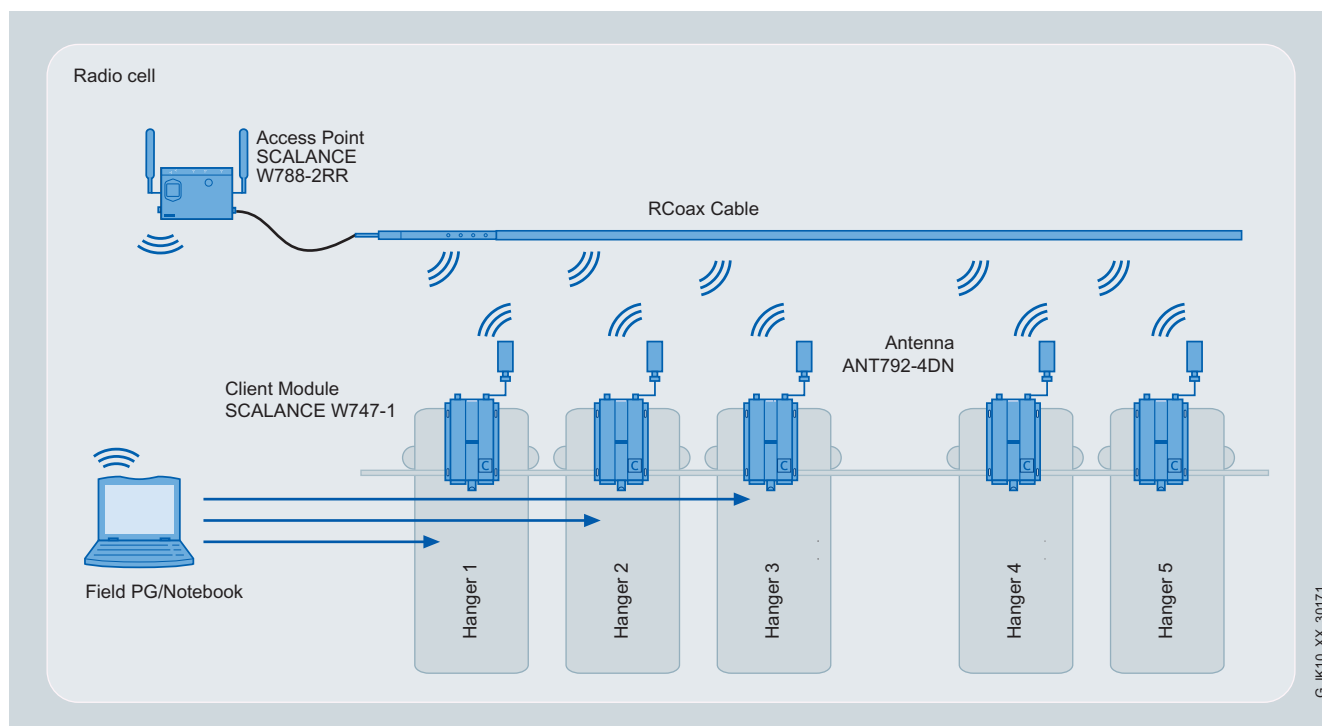

Use of the Ethernet Client Modules in a suspended monorail

The mobile units of a suspended monorail, for example, are linked to the IWLAN radio link via the Ethernet Client Modules SCALANCE W747-1. This is implemented by means of the SCALANCE W788-2RR Access Points and the RCoax cable. The Ethernet Client Modules are mounted in cabinets because of their mechanical characteristics.

Design

- Low-profile, compact aluminum enclosure, shock and vibration-proof for high mechanical requirements
- Dust protection with IP30 degree of protection
- For use at ambient temperatures from -20 °C to +60 °C
- Construction and design suitable for integration in a device or for installation in a cabinet
- 2 x R-SMA sockets for the connection of remote antennas
- 1 x RJ45 connection for 10/100 Mbit/s with Power-over-Ethernet according to IEEE 802.3at Type 1 (corresponds to IEEE 802.3af)
- 1 x 24 V DC connection for redundant power infeed
- 1 x C-PLUG slot
- Function LEDs for optical signaling of faults and operating states
- Mounting: Wall or, with optional mounting set, on S7 mounting rail, 35 mm standard mounting rail

Product versions

SCALANCE W744-1

- A wireless card permanently installed in the device; for managing the wireless connection of a connected device

SCALANCE W746-1

- A wireless card permanently installed in the device for managing the wireless connection of up to eight connected devices

SCALANCE W747-1

- A wireless card permanently installed in the device for managing the wireless connection with iPCF of up to eight connected devices

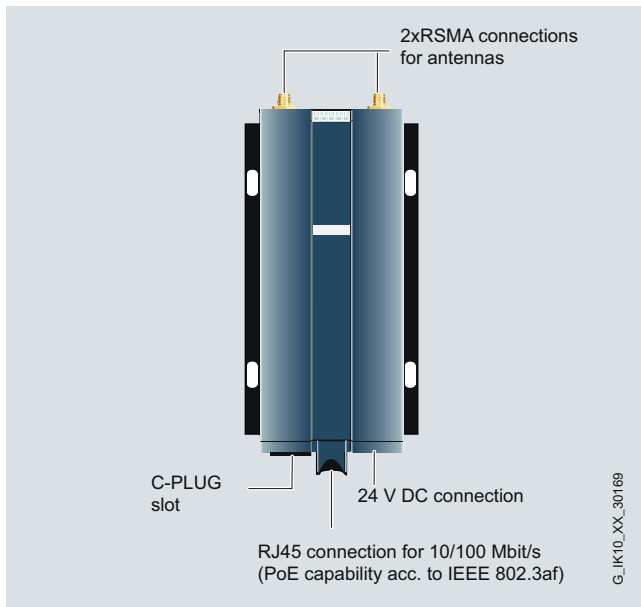

Configuration and interfaces for Client Modules SCALANCE W744-1, W746-1, W747-1

Industrial Wireless Communication

IWLAN – Client Modules IEEE 802.11a/b/g

SCALANCE W740 for use in the control cabinet

Technical specifications

Order No.	6GK5 744-1AA30-2AA0 6GK5 744-1AA30-2AB0 ¹⁾	6GK5 746-1AA30-4AA0 6GK5 746-1AA30-4AB0 ¹⁾	6GK5 747-1AA30-6AA0 6GK5 747-1AA30-6AB0 ¹⁾
Product type designation	SCALANCE W744-1	SCALANCE W746-1	SCALANCE W747-1
Transmission rate			
Transmission rate			
• with W-LAN, maximum	54 Mbit/s	54 Mbit/s	54 Mbit/s
• with Industrial Ethernet	10 ... 100 Mbit/s	10 ... 100 Mbit/s	10 ... 100 Mbit/s
• Note	Due to the simultaneous use of several radio channels, a transmission rate of 108 Mbit/s is possible (turbo mode)	Due to the simultaneous use of several radio channels, a transmission rate of 108 Mbit/s is possible (turbo mode)	Due to the simultaneous use of several radio channels, a transmission rate of 108 Mbit/s is possible (turbo mode)
Interfaces			
Number of electrical connections			
• for network components or terminal equipment	1	1	1
• for power supply	1	1	1
• for redundant power supply	1	1	1
Design of electrical connection			
• for network components or terminal equipment	RJ45 socket	RJ45 socket	RJ45 socket
• for power supply	4-pin screw terminal, PoE	4-pin screw terminal, PoE	4-pin screw terminal, PoE
Design of swap medium C-Plug	Yes	Yes	Yes
Interfaces wireless			
Number of permanently installed wireless cards	1	1	1
Number of electrical connections for external antenna(s)	2	2	2
Design of electrical connection for external antenna(s)	R-SMA female (socket)	R-SMA female (socket)	R-SMA female (socket)
Supply voltage, current consumption, power loss			
Type of power supply	DC	DC	DC
Power supply			
• 1 from terminal block	24 V	24 V	24 V
• 2 from terminal block	48 V	48 V	48 V
• From Power-over-Ethernet according to IEEE802.3at for Type 1 and IEEE802.3af	48 V	48 V	48 V
Current consumed			
• At 24 V DC, typical	0.23 A	0.23 A	0.23 A
• At 48 V DC, typical	0.12 A	0.12 A	0.12 A
• With Power-over-Ethernet according to IEEE802.3at for Type 1 and IEEE802.3af, typical	0.12 A	0.12 A	0.12 A
Effective power loss			
• At 24 V DC, typical	6 W	6 W	6 W
• At 48 V DC, typical	6 W	6 W	6 W
• With Power-over-Ethernet according to IEEE802.3at for Type 1 and IEEE802.3af, typical	6 W	6 W	6 W

¹⁾ Wireless approval in the USA

Technical specifications (continued)

Order No.	6GK5 744-1AA30-2AA0 6GK5 744-1AA30-2AB0 ¹⁾	6GK5 746-1AA30-4AA0 6GK5 746-1AA30-4AB0 ¹⁾	6GK5 747-1AA30-6AA0 6GK5 747-1AA30-6AB0 ¹⁾
Product type designation	SCALANCE W744-1	SCALANCE W746-1	SCALANCE W747-1
Permissible ambient conditions			
Ambient temperature			
• During operation	-20 ... +60 °C	-20 ... +60 °C	-20 ... +60 °C
• During storage	-40 ... +70 °C	-40 ... +70 °C	-40 ... +70 °C
• During transport	-40 ... +70 °C	-40 ... +70 °C	-40 ... +70 °C
Relative humidity at 25 °C without condensation during operation, maximum	90 %	90 %	90 %
IP degree of protection	IP30	IP30	IP30
Ambient conditions for operation	-	-	-
Design, dimensions and weights			
Width of enclosure without antenna	100 mm	100 mm	100 mm
Height of enclosure without antenna	205 mm	205 mm	205 mm
Depth of enclosure without antenna	20 mm	20 mm	20 mm
Net weight	0.29 kg	0.29 kg	0.29 kg
Type of mounting			
• S7-300 rail mounting	-	-	-
• Wall mounting	Yes	Yes	Yes
Type of mounting	For mounting on 35 mm DIN rail and S7-300 rail, an additional adapter plate is required	For mounting on 35 mm DIN rail and S7-300 rail, an additional adapter plate is required	For mounting on 35 mm DIN rail and S7-300 rail, an additional adapter plate is required
Wireless frequencies			
Wireless frequency			
• With WLAN in the 2.4 GHz frequency band	2.41 ... 2.48 GHz	2.41 ... 2.48 GHz	2.41 ... 2.48 GHz
• With WLAN in the 5 GHz frequency band	4.9 ... 5.8 GHz	4.9 ... 5.8 GHz	4.9 ... 5.8 GHz
Product properties, functions, components			
General			
Number of SSIDs	1	1	1
Product function			
• Dual client	No	No	Yes
• iHOP	No	No	Yes
• iPCF	No	No	No
• iPCF-MC	No	No	Yes
Number of iPCF-capable radio modules	0	0	1
Product functions			
Management, configuration, programming			
Number of manageable IP addresses in the client	1	8	8
Product function			
• CLI	Yes	Yes	Yes
• Web-based management	Yes	Yes	Yes
• MIB support	Yes	Yes	Yes
• TRAPs via e-mail	Yes	Yes	Yes
• Configuration with STEP 7	No	Yes	Yes
• Configuration with STEP 7 in the TIA Portal	No	Yes	Yes
• SMTP server	Yes	Yes	Yes
• Operation with IWLAN controller	No	No	No
• Operation with Enterasys WLAN controller	No	No	No
• iQoS	No	No	No
• Forced roaming with IWLAN	No	No	No
• WDS	No	No	No

¹⁾ Wireless approval in the USA

Industrial Wireless Communication

IWLAN – Client Modules IEEE 802.11a/b/g

SCALANCE W740 for use in the control cabinet

Technical specifications (continued)

Order No.	6GK5 744-1AA30-2AA0 6GK5 744-1AA30-2AB0 ¹⁾	6GK5 746-1AA30-4AA0 6GK5 746-1AA30-4AB0 ¹⁾	6GK5 747-1AA30-6AA0 6GK5 747-1AA30-6AB0 ¹⁾
Product type designation	SCALANCE W744-1	SCALANCE W746-1	SCALANCE W747-1
Protocol is supported			
• Address Resolution Protocol (ARP)	Yes	Yes	Yes
• ICMP	Yes	Yes	Yes
• Telnet	Yes	Yes	Yes
• HTTP	Yes	Yes	Yes
• HTTPS	Yes	Yes	Yes
• TFTP	Yes	Yes	Yes
• SNMP v1	Yes	Yes	Yes
• SNMP v2	Yes	Yes	Yes
• SNMP v3	Yes	Yes	Yes
• DCP	Yes	Yes	Yes
• LLDP	No	Yes	Yes
Identification & maintenance			
• I&MO – device-specific information	Yes	Yes	Yes
• I&M1 – higher-level designation/location designation	Yes	Yes	Yes
Product functions Diagnostics			
Product function			
• PROFINET IO diagnostics	No	Yes	Yes
• Link check	No	No	No
• Connection monitoring IP-Alive	No	No	No
• Localization by means of Aeroscout	No	No	No
• SysLog	Yes	Yes	Yes
Product functions VLAN			
Product function VLAN with IWLAN	No	No	No
Product functions DHCP			
Product function DHCP client	Yes	Yes	Yes
Product functions Redundancy			
STP/RSTP protocol is supported	-	-	-
Product functions Security			
Product function			
• ACL - MAC based	No	No	No
• IEEE 802.1x (radius)	Yes	Yes	Yes
• NAT/NAPT	No	Yes	Yes
• Access protection according to IEEE802.11i	Yes	Yes	Yes
• WPA/WPA2	Yes	Yes	Yes
• TKIP/AES	Yes	Yes	Yes
Protocol is supported SSH	Yes	Yes	Yes
Product functions Time			
SNTP protocol is supported	Yes	Yes	Yes

¹⁾ Wireless approval in the USA

Technical specifications (continued)

Order No.	6GK5 744-1AA30-2AA0 6GK5 744-1AA30-2AB0 ¹⁾	6GK5 746-1AA30-4AA0 6GK5 746-1AA30-4AB0 ¹⁾	6GK5 747-1AA30-6AA0 6GK5 747-1AA30-6AB0 ¹⁾
Product type designation	SCALANCE W744-1	SCALANCE W746-1	SCALANCE W747-1
Standards, specifications, approvals			
Standard			
• for EMC of FM	FM 3611: Class I, Division 2, Groups A,B,C,D, T4 / Class 1, Zone 2, Group IIC, T4	FM 3611: Class I, Division 2, Groups A,B,C,D, T4 / Class 1, Zone 2, Group IIC, T4	FM 3611: Class I, Division 2, Groups A,B,C,D, T4 / Class 1, Zone 2, Group IIC, T4
• for hazardous zone	EN 60079-15:2005, EN 60079-0:2006, II 3 G Ex nA II T4 KEMA 07 ATEX 0145X (only approved in connection with an enclosure with degree of protection of at least IP 54)	EN 60079-15:2005, EN 60079-0:2006, II 3 G Ex nA II T4 KEMA 07 ATEX 0145X (only approved in connection with an enclosure with degree of protection of at least IP 54)	EN 60079-15:2005, EN 60079-0:2006, II 3 G Ex nA II T4 KEMA 07 ATEX 0145X (only approved in connection with an enclosure with degree of protection of at least IP 54)
• for CSA and UL safety	UL 60950-1 CSA C22.2 No. 60950-1	UL 60950-1 CSA C22.2 No. 60950-1	UL 60950-1 CSA C22.2 No. 60950-1
• for hazardous zone of CSA and UL	ISA 12.12.01-2000, CSA C22.2 No. 213-M1987, CL. 1, Div. 2, GP, A,B,C,D, T4 / CL. 1, Zone 2, GP IIC, T4 / CL. 1, Zone 2, AEx nC IIC, T4 (only approved in connection with an enclosure with degree of protection of at least IP 54)	ISA 12.12.01-2000, CSA C22.2 No. 213-M1987, CL. 1, Div. 2, GP, A,B,C,D, T4 / CL. 1, Zone 2, GP IIC, T4 / CL. 1, Zone 2, AEx nC IIC, T4 (only approved in connection with an enclosure with degree of protection of at least IP 54)	ISA 12.12.01-2000, CSA C22.2 No. 213-M1987, CL. 1, Div. 2, GP, A,B,C,D, T4 / CL. 1, Zone 2, GP IIC, T4 / CL. 1, Zone 2, AEx nC IIC, T4 (only approved in connection with an enclosure with degree of protection of at least IP 54)
Certificate of suitability			
• CE marking	Yes	Yes	Yes
• EC Declaration of Conformity	Yes	Yes	Yes
• C-Tick	Yes	Yes	Yes
• CCC	No	No	No
• Railroad application according to EN 50155	Yes	Yes	Yes
• e1 approval	Yes	Yes	Yes
• E1 approval	Yes	Yes	Yes
• Power-over-Ethernet according to IEEE802.3at for Type 1 and IEEE802.3af	Yes	Yes	Yes
Standard for wireless communication			
• IEEE 802.11a	Yes	Yes	Yes
• IEEE 802.11b	Yes	Yes	Yes
• IEEE 802.11e	Yes	Yes	Yes
• IEEE 802.11g	Yes	Yes	Yes
• IEEE 802.11h	Yes	Yes	Yes
• IEEE 802.11i	Yes	Yes	Yes
• IEEE 802.11n	No	No	No
Wireless approval	You can find the latest list of countries at: www.siemens.com/simatic-net/ik-info	You can find the latest list of countries at: www.siemens.com/simatic-net/ik-info	You can find the latest list of countries at: www.siemens.com/simatic-net/ik-info
Marine classification association			
• American Bureau of Shipping Europe Ltd. (ABS)	Yes	No	No
• Bureau Veritas (BV)	Yes	No	No
• Det Norske Veritas (DNV)	No	No	No
• Germanischer Lloyd (GL)	Yes	No	No
• Lloyds Register of Shipping (LRS)	Yes	No	No
• Nippon Kaiji Kyokai (NK)	Yes	No	No
• Polski Rejestr Statkow (PRS)	Yes	No	No
Accessories			
Accessories	24 V DC screw terminal included in scope of delivery	24 V DC screw terminal included in scope of delivery	24 V DC screw terminal included in scope of delivery

¹⁾ Wireless approval in the USA

Industrial Wireless Communication

IWLAN – Client Modules IEEE 802.11a/b/g

SCALANCE W740 for use in the control cabinet

Ordering data

Order No.

Order No.

SCALANCE W740 Client Modules

IWLAN Ethernet Client Modules with built-in radio interface; radio networks IEEE 802.11a/b/g/h at 2.4/5 GHz to 54 Mbit/s; WPA/AES; Power over Ethernet (PoE) mounting hardware; 4-pin screw terminal for 24 V DC; manual on CD-ROM, German/English

SCALANCE W744-1

For administration of the radio link of one device with Industrial Ethernet connection; IP30 degree of protection

- National approvals for operation outside the USA
- National approvals for operation within the USA¹⁾

6GK5 744-1AA30-2AA0

6GK5 744-1AA30-2AB0

SCALANCE W746-1

For administration of the radio link of up to eight devices with Industrial Ethernet connection; IP30 degree of protection

- National approvals for operation outside the USA
- National approvals for operation within the USA¹⁾

6GK5 746-1AA30-4AA0

6GK5 746-1AA30-4AB0

SCALANCE W747-1

For administration of the radio link with iPCF of up to eight devices with Industrial Ethernet connection; IP30 degree of protection

- National approvals for operation outside the USA
- National approvals for operation within the USA¹⁾

6GK5 747-1AA30-6AA0

6GK5 747-1AA30-6AB0

Accessories

C-PLUG

Swap medium for simple replacement of devices in the event of a fault; for storing configuration data; can be used in SIMATIC NET products with PLUG slot

6GK1 900-0AB00

PRESET-PLUG

Swap medium for simple initial startup of SCALANCE W access points and client modules, as well as IWLAN/PB Link PN IO

6GK5 798-8AB00

SIMATIC Mobile Panel 277F IWLAN

- Communication via WLAN (PROFINET) with acknowledgement button and emergency stop button
- Communication via WLAN (PROFINET) with acknowledgment button and emergency stop button with integrated handwheel, key-operated switch, and two illuminated pushbuttons

6AV6 645-0DB01-0AX0

6AV6 645-0DC01-0AX0

Note:

Please also order the desktop power supply or battery charger!

- Table-top power supply incl. power cable for EU, US, UK, JP (only suitable for operation under laboratory/office conditions)
- Charger for safe storage and charging the device incl. lock for securing the device in the charger. Charging capabilities for up to two additional batteries
- Additional battery with LED indicator for indicating the charge status
- Transponder incl. batteries (3x AA)

6AV6 671-5CN00-0AX1

6AV6 671-5CE00-0AX0

6AV6 671-5CL00-0AX0

6AV6 671-5CM00-0AX0

¹⁾ Please note national approvals at www.siemens.com/wireless-approvals

Industrial Wireless Communication

IWLAN – Client Modules IEEE 802.11a/b/g

SCALANCE W740 for use in the control cabinet

Ordering data	Order No.
<i>Accessories</i> (continued)	
IE FC RJ45 Plug 180 2x2 RJ45 plug connector for Industrial Ethernet with a rugged metal enclosure and integrated insulation-displacement contacts for connecting Industrial Ethernet FC installation cables; with a 180° cable outlet; for network components and CPs/CPUs with Industrial Ethernet interface <ul style="list-style-type: none"> • 1 pack = 1 unit • 1 pack = 10 units • 1 pack = 50 units 	6GK1 901-1BB10-2AA0 6GK1 901-1BB10-2AB0 6GK1 901-1BB10-2AE0
IE FC Standard Cable GP 2 x 2 4-core, shielded TP installation cable for connection to IE FC Outlet RJ45/ E FC RJ45 Plug; PROFINET-compliant; with UL approval; sold by the meter; max. length 1000 m, minimum order 20 m	6XV1 840-2AH10
IE FC Stripping Tool Preadjusted stripping tool for fast stripping of the Industrial Ethernet FC cables	6GK1 901-1GA00
IE TP Cord RJ45/RJ45 TP cable 4 x 2 with 2 RJ45 connectors <ul style="list-style-type: none"> • 0.5 m • 1 m • 2 m • 6 m • 10 m 	6XV1 870-3QE50 6XV1 870-3QH10 6XV1 870-3QH20 6XV1 870-3QH60 6XV1 870-3QN10
MS2 mounting set Mounting set for fixing the SCALANCE W784 products onto an S7-300 mounting rail or a 35 mm standard DIN rail	6GK5 798-8MJ00-0AA0
Antennas and miscellaneous IWLAN accessories	See Industrial Wireless LAN/ accessories

More information

Wireless approvals:

Current approvals can be found on the Internet at:
www.siemens.com/wireless-approvals

To assist in selecting the right products for Industrial Wireless Communication, the SIMATIC NET Selection Tool is available:

Online version:
www.siemens.com/snst

Offline version:
www.siemens.com/snst-download

Industrial Wireless Communication IWLAN – Client Modules IEEE 802.11a/b/g

SCALANCE W740 for use in the indoor area

Overview



- Particularly suitable for industrial applications without control cabinets.

Application

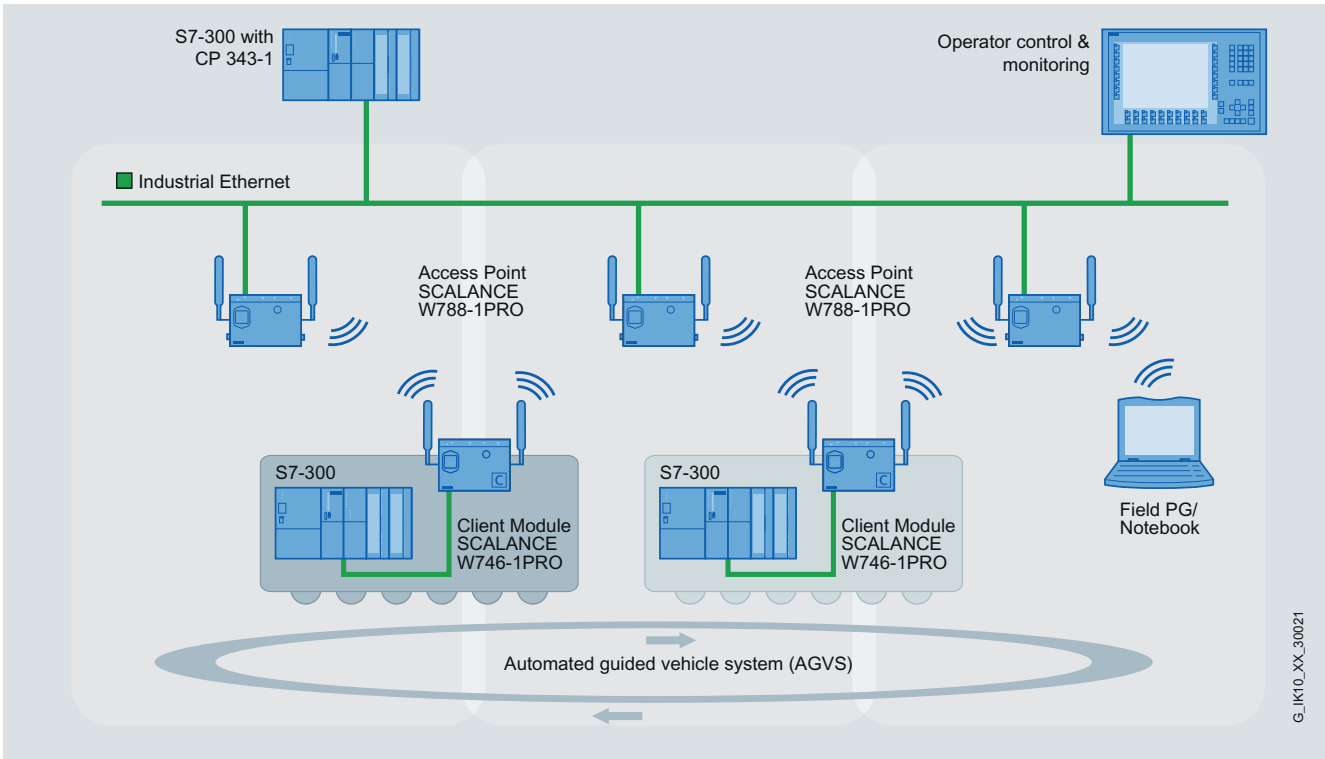

G_IK10_XX_30021

8

Mobile controls in an automated guided vehicle system

The controllers register via the Ethernet Client Modules W746-1PRO in the radio link and can move around freely there. This makes it possible to operate an automated guided vehicle system, for example.

Design

- Rugged metal enclosure, shock and vibration-proof for high mechanical requirements in industrial applications designed without cabinets
- High IP65 degree of protection against dust and water jets
- For use at ambient temperatures from -20 °C to +60 °C
- Resistant to condensation
- 2 x R-SMA sockets for the connection of remote antennas (4 x R-SMA for the versions with two radio modules)
- 1 x hybrid socket for data and energy line for infeed over the IE FC Modular Outlet or for supplying with Power-over-Ethernet according to IEEE 802.3at Type 1 (corresponds to IEEE 802.3af)
- 1 x M12 socket for redundant power infeed (18 to 32 V DC, 48 V DC), e.g. in conjunction with the PS791-1PRO (90 to 265 V AC) power supply
- 1 x C-PLUG slot
- Function LEDs for optical signaling of faults and operating states
- Mounting: Wall, S7-300 mounting rail (90 mm length, vertically mounted, bolts included in scope of supply), or with optional mounting aid on 35 mm DIN rail

Product versions

SCALANCE W744-1PRO

- A wireless card permanently installed in the device; for managing the wireless connection of a connected device

SCALANCE W746-1PRO

- A wireless card permanently installed in the device; for managing the wireless connection of up to eight connected devices

SCALANCE W747-1RR

- For establishing wireless connections with iPCF; a wireless card permanently installed in the device; for managing the wireless connection of up to eight connected devices

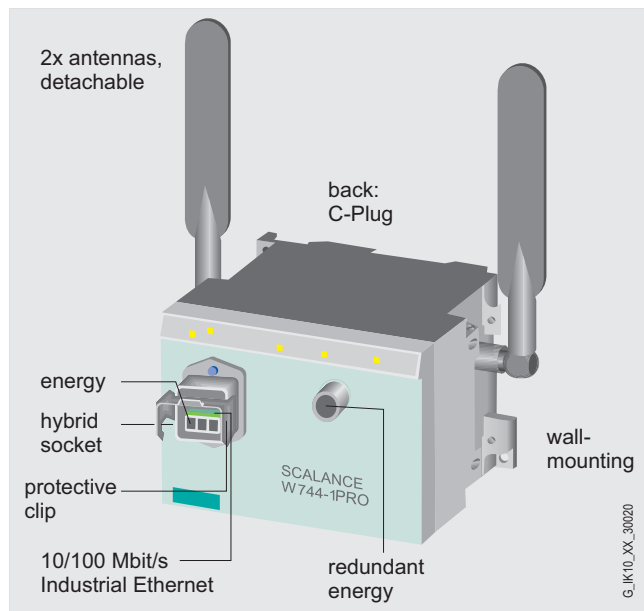

Configuration and interfaces for Client Modules SCALANCE W744-1PRO, W746-1PRO, W747-1RR

Industrial Wireless Communication

IWLAN – Client Modules IEEE 802.11a/b/g

SCALANCE W740 for use in the indoor area

Technical specifications

Order No.	6GK5 744-1AA60-2AA0 6GK5 744-1AA60-2AB0 ¹⁾	6GK5 746-1AA60-4AA0 6GK5 746-1AA60-4AB0 ¹⁾	6GK5 747-1AA60-6AA0 6GK5 747-1AA60-6AB0 ¹⁾
Product type designation	SCALANCE W744-1PRO	SCALANCE W746-1PRO	SCALANCE W747-1RR
Transmission rate			
Transmission rate • with W-LAN, maximum • with Industrial Ethernet • Note	54 Mbit/s 10 ... 100 Mbit/s Due to the simultaneous use of several radio channels, a transmission rate of 108 Mbit/s is possible (turbo mode)	54 Mbit/s 10 ... 100 Mbit/s Due to the simultaneous use of several radio channels, a transmission rate of 108 Mbit/s is possible (turbo mode)	54 Mbit/s 10 ... 100 Mbit/s Due to the simultaneous use of several radio channels, a transmission rate of 108 Mbit/s is possible (turbo mode)
Interfaces			
Number of electrical connections • for network components or terminal equipment	1	1	1
• for power supply	1	1	1
• for redundant power supply	1	1	1
Design of electrical connection • for network components or terminal equipment	Hybrid socket, RJ45 integrated	Hybrid socket, RJ45 integrated	Hybrid socket, RJ45 integrated
• for power supply	M12 interface (4-pin, A-coded), hybrid socket, PoE	M12 interface (4-pin, A-coded), hybrid socket, PoE	M12 interface (4-pin, A-coded), hybrid socket, PoE
Design of swap medium C-Plug	Yes	Yes	Yes
Interfaces wireless			
Number of permanently installed wireless cards	1	1	1
Number of electrical connections for external antenna(s)	2	2	2
Design of electrical connection for external antenna(s)	R-SMA female (socket)	R-SMA female (socket)	R-SMA female (socket)
Supply voltage, current consumption, power loss			
Type of power supply	DC	DC	DC
Supply voltage • 1 from M12 power connector (A-coded) for redundant power supply	24 V	24 V	24 V
• 2 from M12 power connector (A-coded) for redundant power supply	48 V	48 V	48 V
• 1 from IE hybrid cable 2x2 + 4x0.34	24 V	24 V	24 V
• 2 from IE hybrid cable 2x2 + 4x0.34	48 V	48 V	48 V
• From Power-over-Ethernet according to IEEE802.3at for Type 1 and IEEE802.3af	48 V	48 V	48 V
Current consumed • At 24 V DC, typical	0.25 A	0.25 A	0.25 A
• At 48 V DC, typical	0.13 A	0.13 A	0.13 A
• With Power-over-Ethernet according to IEEE802.3at for Type 1 and IEEE802.3af, typical	0.13 A	0.13 A	0.13 A
Effective power loss • At 24 V DC, typical	7 W	7 W	7 W
• At 48 V DC, typical	7 W	7 W	7 W
• With Power-over-Ethernet according to IEEE802.3at for Type 1 and IEEE802.3af, typical	7 W	7 W	7 W

¹⁾ Wireless approval in the USA

Technical specifications (continued)

Order No.	6GK5 744-1AA60-2AA0 6GK5 744-1AA60-2AB0 ¹⁾	6GK5 746-1AA60-4AA0 6GK5 746-1AA60-4AB0 ¹⁾	6GK5 747-1AA60-6AA0 6GK5 747-1AA60-6AB0 ¹⁾
Product type designation	SCALANCE W744-1PRO	SCALANCE W746-1PRO	SCALANCE W747-1RR
Permissible ambient conditions			
Ambient temperature			
• During operation	-20 ... +60 °C	-20 ... +60 °C	-20 ... +60 °C
• During storage	-40 ... +70 °C	-40 ... +70 °C	-40 ... +70 °C
• During transport	-40 ... +70 °C	-40 ... +70 °C	-40 ... +70 °C
Relative humidity at 25 °C without condensation during operation, maximum	100 %	100 %	100 %
IP degree of protection	IP65	IP65	IP65
Ambient conditions for operation	When used under explosion protection conditions (Zone 2), the SCALANCE W788-xPRO/RR or W74x-1PRO/RR product must be installed in an enclosure that complies at least with IP54 according to EN 60529 within the scope of EN 50021.	When used under explosion protection conditions (Zone 2), the SCALANCE W788-xPRO/RR or W74x-1PRO/RR product must be installed in an enclosure that complies at least with IP54 according to EN 60529 within the scope of EN 50021.	When used under explosion protection conditions (Zone 2), the SCALANCE W788-xPRO/RR or W74x-1PRO/RR product must be installed in an enclosure that complies at least with IP54 according to EN 60529 within the scope of EN 50021.
Design, dimensions and weights			
Width of enclosure without antenna	125 mm	125 mm	125 mm
Height of enclosure without antenna	88 mm	88 mm	88 mm
Depth of enclosure without antenna	108 mm	108 mm	108 mm
Net weight	1.05 kg	1.05 kg	1.05 kg
Type of mounting			
• S7-300 rail mounting	Yes	Yes	Yes
• Wall mounting	Yes	Yes	Yes
Wireless frequencies			
Wireless frequency			
• With WLAN in the 2.4 GHz frequency band	2.41 ... 2.48 GHz	2.41 ... 2.48 GHz	2.41 ... 2.48 GHz
• With WLAN in the 5 GHz frequency band	4.9 ... 5.8 GHz	4.9 ... 5.8 GHz	4.9 ... 5.8 GHz
Product properties, functions, components			
General			
Number of SSIDs	1	1	1
Product function			
• Dual client	No	No	Yes
• iHOP	No	No	Yes
• iPCF	No	No	Yes
• iPCF-MC	No	No	Yes
Number of iPCF-capable radio modules	0	0	1

¹⁾ Wireless approval in the USA

Industrial Wireless Communication

IWLAN – Client Modules IEEE 802.11a/b/g

SCALANCE W740 for use in the indoor area

Technical specifications (continued)

Order No.	6GK5 744-1AA60-2AA0 6GK5 744-1AA60-2AB0 ¹⁾	6GK5 746-1AA60-4AA0 6GK5 746-1AA60-4AB0 ¹⁾	6GK5 747-1AA60-6AA0 6GK5 747-1AA60-6AB0 ¹⁾
Product type designation	SCALANCE W744-1PRO	SCALANCE W746-1PRO	SCALANCE W747-1RR
Product functions Management, configuration, programming			
Number of manageable IP addresses in the client	1	8	8
Product function			
• CLI	Yes	Yes	Yes
• Web-based management	Yes	Yes	Yes
• MIB support	Yes	Yes	Yes
• TRAPs via e-mail	Yes	Yes	Yes
• Configuration with STEP 7	No	Yes	Yes
• Configuration with STEP 7 in the TIA Portal	No	Yes	Yes
• SMTP server	Yes	Yes	Yes
• Operation with IWLAN controller	No	No	No
• Operation with Enterasys WLAN controller	No	No	No
• iQoS	No	No	No
• Forced roaming with IWLAN	No	No	No
• WDS	No	No	No
Protocol is supported			
• Address Resolution Protocol (ARP)	Yes	Yes	Yes
• ICMP	Yes	Yes	Yes
• Telnet	Yes	Yes	Yes
• HTTP	Yes	Yes	Yes
• HTTPS	Yes	Yes	Yes
• TFTP	Yes	Yes	Yes
• SNMP v1	Yes	Yes	Yes
• SNMP v2	Yes	Yes	Yes
• SNMP v3	Yes	Yes	Yes
• DCP	Yes	Yes	Yes
• LLDP	No	Yes	Yes
Identification & maintenance			
• I&MO - device-specific information	Yes	Yes	Yes
• I&M1 - higher-level designation/location designation	Yes	Yes	Yes
Product functions Diagnostics			
Product function			
• PROFINET IO diagnostics	No	Yes	Yes
• Link check	No	No	No
• Connection monitoring IP-Alive	No	No	No
• Localization by means of Aeroscout	No	No	No
• SysLog	Yes	Yes	Yes
Product functions VLAN			
Product function VLAN with IWLAN	No	No	No
Product functions DHCP			
Product function DHCP client	Yes	Yes	Yes
Product functions Redundancy			
STP/RSTP protocol is supported	-	-	-

¹⁾ Wireless approval in the USA

Technical specifications (continued)

Order No.	6GK5 744-1AA60-2AA0 6GK5 744-1AA60-2AB0 ¹⁾	6GK5 746-1AA60-4AA0 6GK5 746-1AA60-4AB0 ¹⁾	6GK5 747-1AA60-6AA0 6GK5 747-1AA60-6AB0 ¹⁾
Product type designation	SCALANCE W744-1PRO	SCALANCE W746-1PRO	SCALANCE W747-1RR
Product functions Security			
Product function			
• ACL – MAC based	No	No	No
• IEEE 802.1x (radius)	Yes	Yes	Yes
• NAT/NAPT	No	Yes	Yes
• Access protection according to IEEE802.11i	Yes	Yes	Yes
• WPA/WPA2	Yes	Yes	Yes
• TKIP/AES	Yes	Yes	Yes
Protocol is supported SSH	Yes	Yes	Yes
Product functions Time			
SNTP protocol is supported	Yes	Yes	Yes
Standards, specifications, approvals			
Standard			
• for EMC of FM	FM 3611: Class I, Division 2, Groups A,B,C,D, T4 / Class 1, Zone 2, Group IIC, T4	FM 3611: Class I, Division 2, Groups A,B,C,D, T4 / Class 1, Zone 2, Group IIC, T4	FM 3611: Class I, Division 2, Groups A,B,C,D, T4 / Class 1, Zone 2, Group IIC, T4
• for hazardous zone	EN 60079-15:2005, EN 60079-0:2006, II 3 G Ex nA II T4 KEMA 07 ATEX 0145X	EN 60079-15:2005, EN 60079-0:2006, II 3 G Ex nA II T4 KEMA 07 ATEX 0145X	EN 60079-15:2005, EN 60079-0:2006, II 3 G Ex nA II T4 KEMA 07 ATEX 0145X
• for CSA and UL safety	UL 60950-1 CSA C22.2 No. 60950-1	UL 60950-1 CSA C22.2 No. 60950-1	UL 60950-1 CSA C22.2 No. 60950-1
• for hazardous zone of CSA and UL	ISA 12.12.01-2000, CSA C22.2 No. 213-M1987, CL. 1, Div. 2, GP. A,B,C,D, T4 / CL. 1, Zone 2, GP IIC, T4 / CL. 1, Zone 2, AEx nC IIC, T4	ISA 12.12.01-2000, CSA C22.2 No. 213-M1987, CL. 1, Div. 2, GP. A,B,C,D, T4 / CL. 1, Zone 2, GP IIC, T4 / CL. 1, Zone 2, AEx nC IIC, T4	ISA 12.12.01-2000, CSA C22.2 No. 213-M1987, CL. 1, Div. 2, GP. A,B,C,D, T4 / CL. 1, Zone 2, GP IIC, T4 / CL. 1, Zone 2, AEx nC IIC, T4
Certificate of suitability			
• CE marking	Yes	Yes	Yes
• EC Declaration of Conformity	Yes	Yes	Yes
• C-Tick	Yes	Yes	Yes
• CCC	No	No	No
• Railroad application according to EN 50155	Yes	Yes	Yes
• e1 approval	Yes	Yes	Yes
• E1 approval	Yes	Yes	Yes
• Power-over-Ethernet according to IEEE802.3at for Type 1 and IEEE802.3af	Yes	Yes	Yes
Standard for wireless communication			
• IEEE 802.11a	Yes	Yes	Yes
• IEEE 802.11b	Yes	Yes	Yes
• IEEE 802.11e	Yes	Yes	Yes
• IEEE 802.11g	Yes	Yes	Yes
• IEEE 802.11h	Yes	Yes	Yes
• IEEE 802.11i	Yes	Yes	Yes
• IEEE 802.11n	No	No	No
Wireless approval	You can find the latest list of countries at: www.siemens.com/simatic-net/ik-info	You can find the latest list of countries at: www.siemens.com/simatic-net/ik-info	You can find the latest list of countries at: www.siemens.com/simatic-net/ik-info
Marine classification association			
• American Bureau of Shipping Europe Ltd. (ABS)	Yes	No	No
• Bureau Veritas (BV)	Yes	No	No
• Det Norske Veritas (DNV)	No	No	No
• Germanischer Lloyd (GL)	Yes	No	No
• Lloyds Register of Shipping (LRS)	Yes	No	No
• Nippon Kaiji Kyokai (NK)	Yes	No	No
• Polski Rejestr Statkow (PRS)	Yes	No	No
Accessories			
Accessories	2 antennas, hybrid connector included in scope of delivery	2 antennas, hybrid connector included in scope of delivery	2 antennas, hybrid connector included in scope of delivery

¹⁾ Wireless approval in the USA

Industrial Wireless Communication

IWLAN – Client Modules IEEE 802.11a/b/g

SCALANCE W740 for use in the indoor area

Ordering data

Order No.

Order No.

SCALANCE W740 Client Modules

IWLAN Ethernet Client Modules with built-in radio interface; radio networks IEEE 802.11a/b/g/h at 2.4/5 GHz to 54 Mbit/s; WPA/AES; Power over Ethernet (PoE), mounting hardware; 4-pin screw terminal for 24 V DC; manual on CD-ROM, German/English

SCALANCE W744-1PRO

For administration of the radio link of one device with Industrial Ethernet connection; IP65 degree of protection; scope of delivery: 2 antennas ANT795-4MR, IP 67 hybrid plug connector

- National approvals for operation outside the USA
- National approvals for operation within the USA¹⁾

6GK5 744-1AA60-2AA0

6GK5 744-1AA60-2AB0

SCALANCE W746-1PRO

For administration of the radio link of up to eight devices with Industrial Ethernet connection; IP65 degree of protection; scope of delivery: 2 antennas ANT795-4MR, IP 67 hybrid plug connector

- National approvals for operation outside the USA
- National approvals for operation within the USA¹⁾

6GK5 746-1AA60-4AA0

6GK5 746-1AA60-4AB0

SCALANCE W747-1RR

For administration of the radio link with iPCF of up to eight devices with Industrial Ethernet connection; IP65 degree of protection; scope of delivery: 2 antennas ANT795-4MR, IP 67 hybrid plug connector

- National approvals for operation outside the USA
- National approvals for operation within the USA¹⁾

6GK5 747-1AA60-6AA0

6GK5 747-1AA60-6AB0

Accessories

C-PLUG

Swap medium for simple replacement of devices in the event of a fault; for storing configuration data; can be used in SIMATIC NET products with PLUG slot

6GK1 900-0AB00

PRESET-PLUG

Swap medium for simple initial startup of SCALANCE W access points and client modules, as well as IWLAN/PB Link PN IO

6GK5 798-8AB00

SIMATIC Mobile Panel 277F IWLAN

- Communication via WLAN (PROFINET) with acknowledgement button and emergency stop button
- Communication via WLAN (PROFINET) with acknowledgment button and emergency stop button with integrated handwheel, key-operated switch, and two illuminated pushbuttons

6AV6 645-0DB01-0AX0

6AV6 645-0DC01-0AX0

Note:

Please also order the desktop power supply or battery charger!

- Table-top power supply incl. power cable for EU, US, UK, JP (only suitable for operation under laboratory/office conditions)
- Charger for safe storage and charging the device incl. lock for securing the device in the charger. Charging capabilities for up to two additional batteries
- Additional battery with LED indicator for indicating the charge status
- Transponder incl. batteries (3x AA)

6AV6 671-5CN00-0AX1

6AV6 671-5CE00-0AX0

6AV6 671-5CL00-0AX0

6AV6 671-5CM00-0AX0

IE FC RJ45 modular outlet with power insert

FastConnect RJ45 modular outlet for Industrial Ethernet with a replaceable insert for 1 x 24 V and 1 x 100 Mbit/s interface

6GK1 901-1BE00-0AA3

IE Hybrid Cable 2x2 + 4x0.34

4-wire, shielded installation cable; sold by the meter, up to 1000 m, minimum order 20 m

6XV1 870-2J

IE FC RJ45 Plug 180 2x2

RJ45 plug connector for Industrial Ethernet with a rugged metal enclosure and integrated insulation-displacement contacts for connecting Industrial Ethernet FC installation cables; with a 180° cable outlet; for network components and CPs/CPU's with Industrial Ethernet interface

- 1 pack = 1 unit
- 1 pack = 10 units
- 1 pack = 50 units

6GK1 901-1BB10-2AA0
6GK1 901-1BB10-2AB0
6GK1 901-1BB10-2AE0

¹⁾ Please note national approvals at www.siemens.com/wireless-approvals

Industrial Wireless Communication

IWLAN – Client Modules IEEE 802.11a/b/g

SCALANCE W740 for use in the indoor area

Ordering data	Order No.
<i>Accessories (continued)</i>	
IE FC Standard Cable GP 2 x 2 4-core, shielded TP installation cable for connection to IE FC Outlet RJ45/ IE FC RJ45 Plug; PROFINET-compliant; with UL approval; sold by the meter; max. length 1000 m, minimum order 20 m	6XV1 840-2AH10
IE TP Cord RJ45/RJ45 TP cable 4 x 2 with 2 RJ45 connectors <ul style="list-style-type: none"> • 0.5 m • 1 m • 2 m • 6 m • 10 m 	6XV1 870-3QE50 6XV1 870-3QH10 6XV1 870-3QH20 6XV1 870-3QH60 6XV1 870-3QN10
IE FC Stripping Tool Preadjusted stripping tool for fast stripping of the Industrial Ethernet FC cables	6GK1 901-1GA00
IP 67 hybrid connector Connector for connecting SCALANCE W700 to Industrial Ethernet and Power over Ethernet (PoE), with assembly instructions, 1 unit	09 45 125 1300.00 Order directly from: HARTING Deutschland GmbH & Co. KG Postfach 24-51 32381 Minden, Germany Phone: +49 (0)571-8896-0 Fax: +49 (0)571-8896-354 E-mail: de.sales@HARTING.com Internet: www.HARTING.com
Power M12 Cable Connector PRO Terminal socket for connection of SCALANCE W700 for 24 V DC supply voltage; 4-pole, A-coded, with assembly instructions, 3 units	6GK1 907-0DC10-6AA3
PS791-1PRO Power Supply AC/DC power supply, 10 W, IP65 (-20 to +60 °C), input: 90 V - 265 V AC, output: 24 V DC, metal housing; scope of supply: AC power 3+PE cable connector, DC power cord M12, mounting hardware; operating instructions German/English	6GK5 791-1PS00-0AA6
IE Hybrid RJ45 Socket Dust Cover Dust cap for RJ45 connection socket (Industrial Ethernet/PoE) of SCALANCE W700	6ES7 194-1JB10-0XA0
Antennas and miscellaneous IWLAN accessories	See Industrial Wireless LAN/ accessories

More information

Wireless approvals:

Current approvals can be found on the Internet at:
www.siemens.com/wireless-approvals

To assist in selecting the right products for Industrial Wireless Communication, the SIMATIC NET Selection Tool is available:

Online version:
www.siemens.com/snst

Offline version:
www.siemens.com/snst-download

Industrial Wireless Communication

IWLAN – Accessories

IWLAN antennas

Overview



Remote antennas increase the reliability of wireless links by optimizing the receiving and emission of signals.

- Use in Industrial Wireless LAN (IWLAN) and WLAN in accordance with IEEE 802.11 at 2.4 GHz and 5 GHz with transmission rates of up to 450 Mbit/s
- Coordinated range of antennas for the most diverse applications both indoors and outdoors
- Antennas with two (dual-slant) or three (MIMO) connections for increased data throughput and increased reliability of the wireless connection thanks to selective use of multiple path propagation
- Suitable for use in hazardous areas (Zone 2); no special approvals necessary

Benefits

get Designed for Industry

- Investment protection thanks to compliance with the globally recognized standard IEEE 802.11 and – depending on the version – suitability for 2.4 GHz and/or 5 GHz
- Cost-effective connection to devices in remote, difficult-to-access, or hostile environments
- Establishment of a reliable IWLAN wireless infrastructure through the use of remote antennas, even if the access points and client modules are installed in the cabinet, for example

Application

Separate antennas optimize the transmission and receiving conditions and support the use of IWLAN products in a number of industrial applications. With directional antennas, conveyor lines or corridors can be covered by wireless or point-to-point links can be implemented at distances of up to several 1000 meters.

Alternatively, an omnidirectional antenna concentrates the wireless field around the antenna in the shape of a disc which enhances the quality of the connection.

Antennas with two or three connections enable transmission of the two to three streams usual with IEEE 802.11n, using just one antenna. They are available both with omnidirectional and directional characteristics.

Application examples:













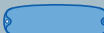







Omnidirectional antennas

- Coverage of an area which has at its center a pole for mounting the antenna
- Installation of the antenna on the roof in the case of automated guided vehicle systems for reliable data exchange with the vehicles
- Wide-area coverage of a production cell or robot station

Directional antennas

- Communication between buildings over long distances with the help of an antenna with narrow opening angle and high gain
- Selective coverage of warehouse/high-bay warehouse aisles with the help of a wide-angle antenna prevents interference with neighboring wireless fields

Design

Antennas exclusively for SCALANCE W-700 according to IEEE 802.11n						Antennas for SCALANCE W-700 according to IEEE 802.11n and 802.11a/b/g		Antennas exclusively for SCALANCE W-700 according to IEEE 802.11a/b/g	
with 1 connection		with 2 connections (dual)		with 3 connections (MIMO)		with 1 connection		with 1 connection	
	ANT795-4MA		ANT793-6DG		ANT795-6MT		ANT792-4DN		ANT795-4MR
	ANT795-4MC		ANT793-8DJ		ANT793-6DT		ANT793-4MN		ANT795-4MS
	ANT795-4MD		ANT793-8DK				ANT792-6MN		ANT795-6DN
	ANT795-6DC						ANT793-6MN		ANT793-8DN
							ANT792-8DN		
							ANT795-6MN		
							RCoax radiating cables		

Overview of IWLAN antennas

Function

Separate antennas are used to optimize the wireless field for the application. In industrial applications, this supports a reliable wireless field.

Antennas with several connections (dual or MIMO antennas)

Antennas with two connections combine two individual antennas, at 90° to each other, in one antenna enclosure. With these antennas, two data streams can be transferred simultaneously thanks to the two different polarization levels. Depending on the alignment of the polarization levels, these antennas are referred to as dual-slant (rotated through +/-45°) or vertical-horizontal.

Antennas with three connections contain three individual emitters that can be combined in one enclosure, either on different polarization levels (0°, +/-45°) or at a suitable distance from each other. The MIMO antennas can transmit three data streams simultaneously using multiple path propagation.

Transmission of several data streams results in increased data throughput and simultaneously a more reliable data transfer.

Directional effect

The suitable antenna is selected first by means of the wireless field characteristic. A distinction is made between omni-directional antennas and directional antennas.

Industrial Wireless Communication

IWLAN – Accessories

IWLAN antennas

Function (continued)

Omnidirectional antennas

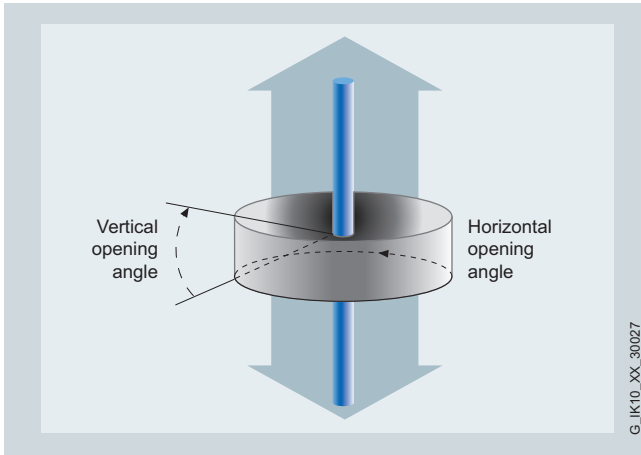

Omnidirectional antenna

With omni-directional antennas, the wireless field is emitted in every direction surrounding the antenna (horizontal opening angle: 360°), but it weakens as the distance increases. There is a concentration in the vertical direction which creates passive amplification of the wireless field. Many omni-directional antennas have extremely weak radiation directly below the antenna due to their type of construction. This property can be seen in the associated antenna diagram.

ANT795-4Mx

With these omni-directional antennas, the wireless field is concentrated at 2.4 GHz and 5 GHz in the vertical plane of the antenna. All antennas of this type have an opening angle of 30° in the vertical direction and an antenna gain of 4 dB. They are directly mounted on the R-SMA or N connector of the SCALANCE W enclosure.

For the use of SCALANCE W-700 in accordance with [IEEE 802.11n](#):

ANT795-4MA, ANT795-4MC and ANT795-4MD

The ANT795-4MC and ANT 795-4MD antennas can be rotated around only one axis, they have N-Connect connectors and degree of protection IP65, and they are used with the SCALANCE W788 M12 Access Points and the SCALANCE W748 M12 Client Modules.

The ANT795-4MA antenna features an additional joint, an R-SMA connector, and degree of protection IP30. It is therefore optimally suitable for the SCALANCE W788 RJ45 Access Points and the SCALANCE W748 RJ45 Client Modules.

For the use of SCALANCE W-700 in accordance with [IEEE 802.11a/b/g](#):

ANT795-4MR, ANT795-4MS

The ANT795-4MR antenna can only be rotated about one axis and, due to its IP65 degree of protection, it is mainly used for the SCALANCE W788 Access Points and the SCALANCE W744-1PRO, W746-1PRO and W747-1RR Client Modules. Two of these antennas are supplied with these access points or client modules.

The ANT795-4MS antenna features an additional joint and is therefore ideally suited to the SCALANCE W784 Access Points and the SCALANCE W744-1, W746-1 and W747-1 Client Modules.

ANT792-6MN, ANT793-6MN

With these omni-directional antennas, the wireless field is concentrated at 2.4 GHz (ANT792-6MN) and 5 GHz (ANT793-6MN) in the vertical plane of the antenna. The antennas have a gain of 6 dB and 5 dB respectively.

N-Connect is used as the connector and can be connected to SCALANCE W over an extension cable from the range of IWLAN cabling. Both antennas are supplied with a mounting aid (metal bracket) that supports wall or mast mounting. The antennas are therefore ideally suited, for example, to providing wireless coverage for a place that has a mast at its center on which they can be mounted.

ANT795-6MN, antenna mounting tool for ANT795-6MN

With this omni-directional antenna, the wireless field is concentrated at 2.4 GHz and 5 GHz in the vertical plane of the antenna. The antenna has a gain of 6 dB and 8 dB respectively.

N-Connect is used as the connector and can be connected to SCALANCE W over an extension cable from the range of IWLAN cabling. The antenna characteristic is such that good transmission properties also exist directly above and below the antenna. It is designed for mounting on a control cabinet or roof, but it can also be mounted under a roof, so it is suitable, for example, for the mobile units of an automated guided vehicle system. If it needs to be installed on a ceiling under a roof, the optional antenna mounting tool for ANT795-6MN is used.

ANT795-6MT

This antenna is an omnidirectional MIMO antenna with three QMA connections. The wireless field is concentrated at 2.4 GHz and 5 GHz in the vertical plane of the antenna. The antenna has a gain of 6 dB.

The antenna characteristic is such that good transmission properties also exist directly above and below the antenna. It is designed for mounting on a roof or (together with the supplied mounting bracket) under a ceiling, and it is thus suitable, for example, for the mobile units of an automated guided vehicle system.

The ANT795-6MT is connected to the SCALANCE W-700 Access Points in accordance with [IEEE 802.11n](#) via QMA/N-Connect male/female IWLAN adapter cables and the IWLAN flexible antenna connecting cables in the relevant length and connector version.

IWLAN antennas

Function (continued)

Directional antennas

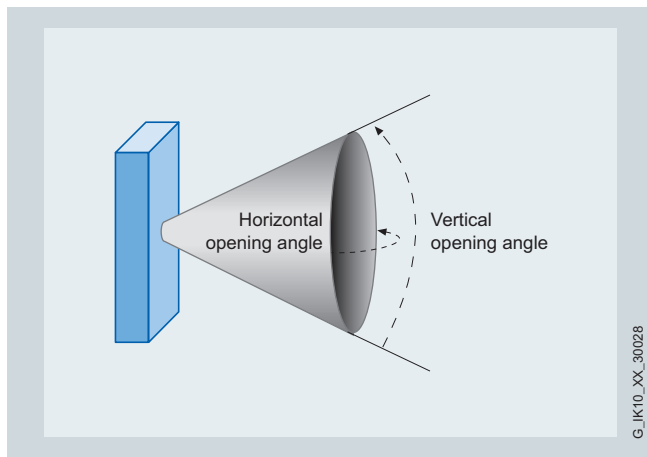

Directional antenna

With directional antennas, the wireless field is emitted both in the horizontal and vertical plane in the range of the opening angle. It is concentrated in these areas and generates passive amplification. They are ideally suited to wall or mast mounting. The direction can be aligned using the supplied mounting aid.

N-Connect is usually used as the connector and can be connected to SCALANCE W over an extension cable from the range of IWLAN cabling.

For the use of SCALANCE W-700 in accordance with IEEE 802.11n:

ANT795-6DC, ANT793-6DG and ANT793-6DT

The wireless field can be aligned at 2.4 GHz and 5 GHz using these wide-angle antennas. Each has an antenna gain of 9 dB.

Thanks to their characteristics, they are suitable, for example, for providing wireless coverage for an area in front of a wall.

The ANT795-6DC antenna is suitable for both frequency bands 2.4 and 5 GHz. It has an N-Connect connection. Two or three antennas of this type can also be used for covering several sectors.

ANT793-6DG is a dual-slant antenna with two N-Connect connections for the 5 GHz frequency band.

ANT793-6DT is a MIMO antenna with three QMA connections for the 5 GHz band.

The ANT795-6DT is connected to the SCALANCE W-700 Access Points in accordance with IEEE 802.11n via QMA/N-Connect male/female IWLAN adapter cables and the IWLAN flexible antenna connecting cables in the relevant length and connector version.

ANT792-8DN, ANT 793-8DJ and ANT793-8DK

These antennas enable genuine alignment of the wireless field. The wireless field is concentrated in a narrow cone due to the narrow opening angle. High passive gains and long ranges are therefore achieved.

Due to the high passive gain, the antennas are ideally suited to bridging large distances.

The ANT792-8DN antenna is suitable for the 2.4 GHz frequency band and has an antenna gain of 14 dB.

ANT793-8DJ (18 dB) and ANT793-8DK (23 dB) are strongly directional antennas with vertical-horizontal polarization. They each have two N-Connect connections.

For the use of SCALANCE W-700 in accordance with IEEE 802.11a/b/g:

ANT795-6DN

The wireless field can be aligned at 2.4 GHz and 5 GHz using this wide-angle antenna.

The antenna is suitable, for example, for providing wireless coverage for an area in front of a wall.

ANT792-8DN, ANT793-8DN

Genuine alignment of the wireless field at 2.4 GHz (ANT792-8DN) or 5 GHz (ANT793-8DN) is achieved using these antennas. The wireless field is concentrated in a narrow cone due to the narrow opening angle. High passive gains and long ranges are therefore achieved.

Due to the high passive gain, the antennas are ideally suited to bridging large distances over IWLAN.

Antenna for SCALANCE W-700							
ANT79	2	–	4	–	D	x	G_IK10_XX_30288
	↑		↑		↑		
Frequency	2	2,4 GHz	4	medium gain	D	directional antenna	
	3	5 GHz	6	high gain	M	omni-directional antenna	
	5	2,4 + 5 GHz	8	very high gain			
			Gain		Directivity		

The antenna name indicates the properties of the IWLAN antennas

Industrial Wireless Communication

IWLAN – Accessories

IWLAN antennas

Integration (continued)

Antennas especially for use with RCoax radiating cables

These antennas have been specially developed for use with the RCoax radiating cable. They are preferably used in environments in which nodes move within limited areas or exclusively along predefined paths. Typical applications are suspended monorails or high-bay racking systems where the antenna is within the near field of the radiating cable.

ANT793-4MN

With this omni-directional antenna, the wireless field is concentrated at 5 GHz in the vertical plane of the antenna. The antenna has a gain of 6 dB at 5.2 GHz and 5 dB at 5.7 GHz. The polarization of the antenna is vertical ($\lambda/8$ characteristic). N-Connect is used as the connector type, which can be connected to

SCALANCE W or the IWLAN/PB Link PN IO over an extension cable from the IWLAN connecting cable range.

ANT792-4DN

The wireless field is aligned at 2.4 GHz for this antenna. The antenna has a gain of 4 dB. The polarization of the antenna is circular, i.e. the receive path of the signals of both polarizations is amplified equally well. Signal strength fluctuations are weaker at 2.4 GHz.

N-Connect is used as the connector type, which can be connected to SCALANCE W or the IWLAN/PB-Link PN IO over an IWLAN extension cable.

Integration

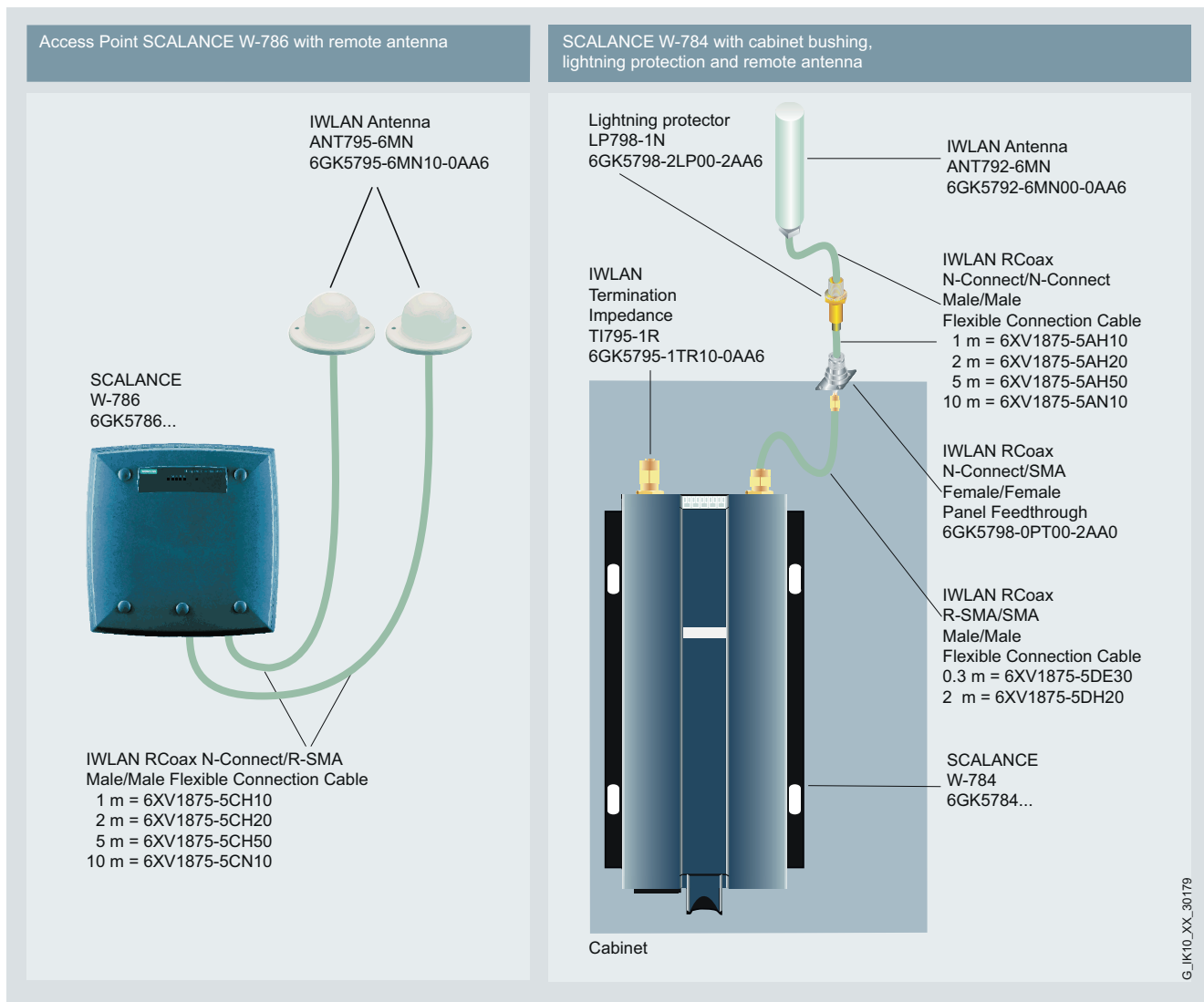

SCALANCE W using the range of accessories with direct connection of an antenna, mounting in a control cabinet and using a lightning protection element

Integration (continued)

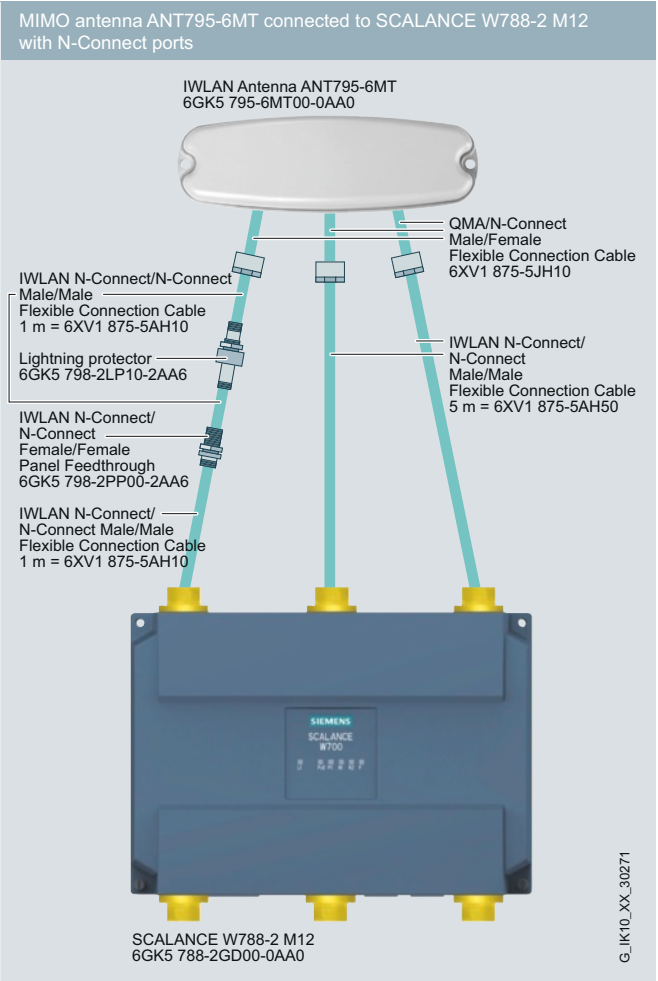
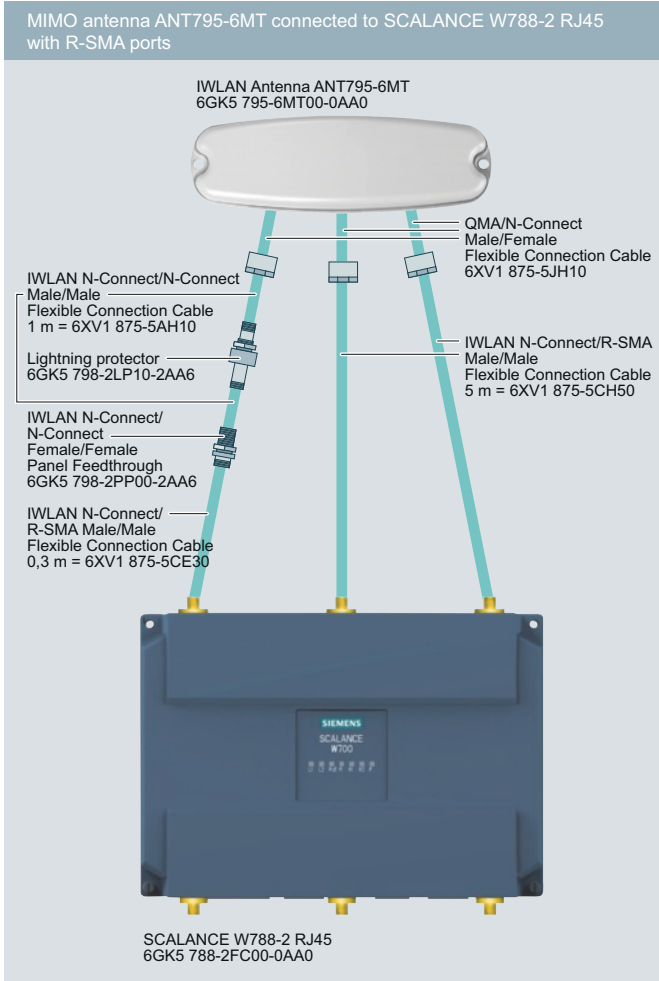

G_IK10_XX_30271

SCALANCE W788-1 RJ45 access points with MIMO antenna and SCALANCE W788-1 M12 with N-Connect connection

Industrial Wireless Communication

IWLAN – Accessories

IWLAN antennas

Integration (continued)

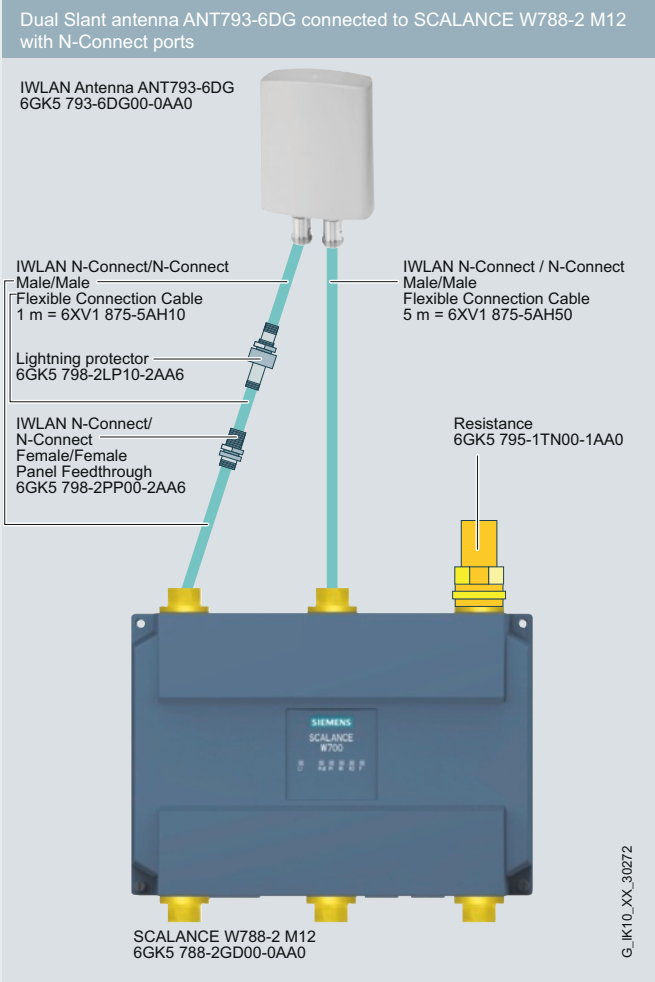
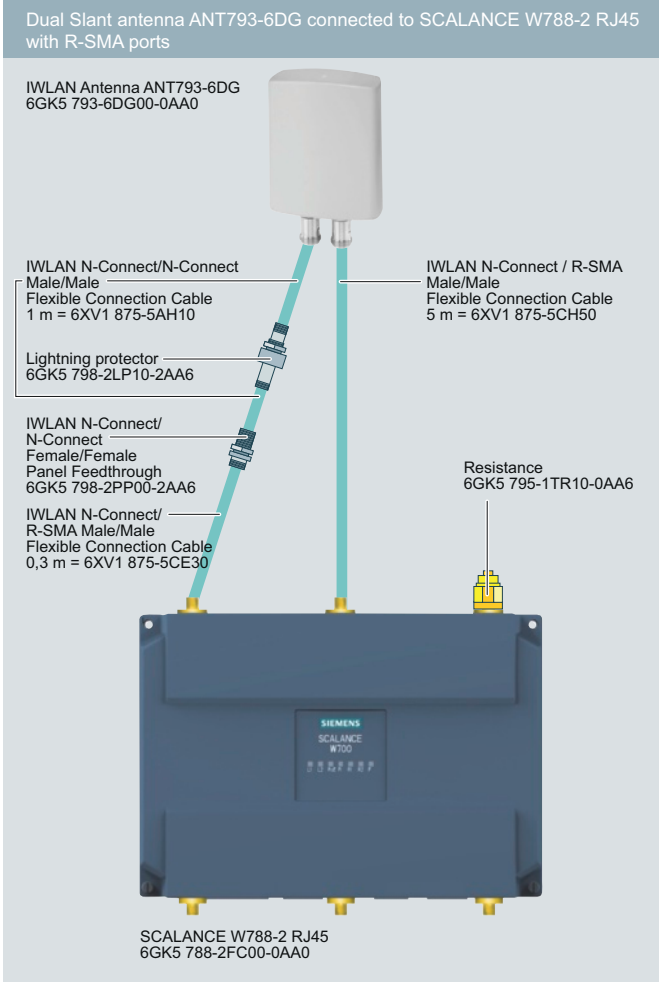

G_IK10_XX_30272

8

SCALANCE W788-1 RJ45 access points with dual slant antenna and SCALANCE W788-1 M12 with N-Connect connection

All antennas can be used with an N-Connect female connecting plug.

Technical specifications

Order No.	6GK5 795-4MC00-0AA3	6GK5 795-4MD00-0AA3	6GK5 795-4MR00-0AA6
Product type designation	ANT795-4MC antenna	ANT795-4MD antenna	ANT795-4MR antenna
Radio frequencies			
Radio frequency			
• With WLAN in the 2.4 GHz frequency band	2.4 ... 2.4835 GHz	2.4 ... 2.4835 GHz	2.4 ... 2.4835 GHz
• With WLAN in the 5 GHz frequency band 1	5.15 ... 5.35 GHz	5.15 ... 5.35 GHz	5.15 ... 5.35 GHz
• With WLAN in the 5 GHz frequency band 2	5.725 ... 5.85 GHz	5.725 ... 5.85 GHz	5.725 ... 5.85 GHz
Electrical specifications			
Impedance	50 Ω	50 Ω	50 Ω
Polarization	Linear vertical	Linear vertical	Linear vertical
Radiation characteristic	Omnidirectional	Omnidirectional	Omnidirectional
Antenna gain compared with the isotropic radiator of the WLAN antenna			
• In the 2.4 GHz frequency band	3 dB	3 dB	4 dB
• In the 5 GHz frequency band	5 dB	5 dB	5 dB
• With transmission frequency 5.2 GHz			
• With transmission frequency 5.7 GHz			
Maximum standing wave ratio	2	2	2
Beam angle of antenna			
• In the 2.4 GHz frequency band			
- Horizontal	360°	360°	360°
- Vertical	-	-	-
• In the 5 GHz frequency band			
- Horizontal	360°	360°	360°
- Vertical	-	-	-
Note on beam angle	-	-	-
Number of electrical connections of the antenna	1	1	1
Design of electrical connection of the antenna	N connector, female, straight	N connector, female, 90° angle	R-SMA connector, male, 90° angle
Maximum angle of inclination down	0°	0°	0°
Range with free view without hindrance	-	-	100 m
Note on range	-	-	Note: The range may be much less and depends on the spatial conditions, the wireless standard being used, the data rate, and the antenna at the opposite end
Permissible ambient conditions			
Ambient temperature			
• During operation	-20 ... +65 °C	-20 ... +65 °C	-20 ... +65 °C
• During storage	-20 ... +65 °C	-20 ... +65 °C	-20 ... +65 °C
• During transport	-20 ... +65 °C	-20 ... +65 °C	-20 ... +65 °C
• During mounting	--	--	--
IP degree of protection	IP65	IP65	IP65
Design, dimensions and weights			
Width	35 mm	35 mm	35 mm
Height	160 mm	160 mm	148 mm
Depth	13 mm	13 mm	13 mm
Diameter	-	-	-
Net weight	26 g	26 g	26 g
Type of mounting	-	-	-
• Mast mounting	No	No	No
• Wall mounting	No	No	No
• Ceiling mounting	No	No	No
• Directly on the device	Yes	Yes	Yes

Industrial Wireless Communication

IWLAN – Accessories

IWLAN antennas

Technical specifications (continued)

Order No.	6GK5 795-4MC00-0AA3	6GK5 795-4MD00-0AA3	6GK5 795-4MR00-0AA6
Product type designation	ANT795-4MC antenna	ANT795-4MD antenna	ANT795-4MR antenna
Product properties, functions, components			
General			
Product property silicon-free	Yes	Yes	Yes
Material of the outer sleeve	Polycarbonate	Polycarbonate	Polycarbonate
Standards, specifications, approvals			
Wireless approval	Current country-specific approvals can be found on the Internet at www.siemens.com/wireless-approvals	Current country-specific approvals can be found on the Internet at www.siemens.com/wireless-approvals	Current country-specific approvals can be found on the Internet at www.siemens.com/wireless-approvals

Order No.	6GK5 795-4MA00-0AA3	6GK5 795-4MS00-0AA6
Product type designation	ANT795-4MA antenna	ANT795-4MS antenna
Radio frequencies		
Radio frequency		
• With WLAN in the 2.4 GHz frequency band	2.4 ... 2.4835 GHz	2.4 ... 2.4835 GHz
• With WLAN in the 5 GHz frequency band 1	5.15 ... 5.35 GHz	5.15 ... 5.35 GHz
• With WLAN in the 5 GHz frequency band 2	5.725 ... 5.85 GHz	5.725 ... 5.85 GHz
Electrical specifications		
Impedance	50 Ω	50 Ω
Polarization	Linear vertical	Linear vertical
Radiation characteristic	Omnidirectional	Omnidirectional
Antenna gain compared with the isotropic radiator of the WLAN antenna		
• In the 2.4 GHz frequency band	3 dB	3 dB
• In the 5 GHz frequency band	5 dB	5 dB
Maximum standing wave ratio	2	2
Beam angle of antenna		
• In the 2.4 GHz frequency band		
- Horizontal	360°	360°
- Vertical	-	-
• In the 5 GHz frequency band		
- Horizontal	360°	360°
- Vertical	-	-
Note on beam angle	-	-
Number of electrical connections of the antenna	1	1
Design of electrical connection of the antenna	R-SMA connector, male, variable 0-90°	R-SMA connector, male variable 0-90°
Maximum angle of inclination down	0°	0°
Range with free view without hindrance	-	100 m
Note on range	-	Note: The range may be much less and depends on the spatial conditions, the wireless standard being used, the data rate, and the antenna at the opposite end
Permissible ambient conditions		
Ambient temperature		
• During operation	-20 ... +65 °C	-20 ... +65 °C
• During storage	-20 ... +65 °C	-20 ... +65 °C
• During transport	-20 ... +65 °C	-20 ... +65 °C
IP degree of protection	IP30	IP30

Technical specifications (continued)

Order No.	6GK5 795-4MA00-0AA3	6GK5 795-4MS00-0AA6
Product type designation	ANT795-4MA antenna	ANT795-4MS antenna
Design, dimensions and weights		
Width	35 mm	35 mm
Height	160 mm	160 mm
Depth	13 mm	13 mm
Diameter	-	-
Net weight	26 g	26 g
Type of mounting	-	-
• Mast mounting	No	No
• Wall mounting	No	No
• Ceiling mounting	No	No
• Directly on the device	Yes	Yes
Product properties, functions, components		
General		
Product property silicon-free	Yes	Yes
Material of the outer sleeve	Polycarbonate	Polycarbonate
Standards, specifications, approvals		
Wireless approval	Current country-specific approvals can be found on the Internet at www.siemens.com/wireless-approvals	Current country-specific approvals can be found on the Internet at www.siemens.com/wireless-approvals

Order No.	6GK5 792-6MN00-0AA6	6GK5 793-6MN00-0AA6	6GK5 795-6MN10-0AA6	6GK5 795-6MT00-0AA0
Product type designation	ANT792-6MN antenna	ANT793-6MN antenna	ANT795-6MN antenna	ANT795-6MT antenna
Radio frequencies				
Radio frequency				
• With WLAN in the 2.4 GHz frequency band	2.4 ... 2.5 GHz	-	2.4 ... 2.7 GHz	2.4 ... 2.69 GHz
• With WLAN in the 5 GHz frequency band 1	-	5.15 ... 5.875 GHz	3.4 ... 3.7 GHz	5.15 ... 5.35 GHz
• With WLAN in the 5 GHz frequency band 2	-	-	4.9 ... 5.935 GHz	5.47 ... 5.935 GHz
Electrical specifications				
Impedance	50 Ω	50 Ω	50 Ω	50 Ω
Polarization	Linear vertical	Linear vertical	Linear vertical	3 ports: Linear vertical
Radiation characteristic	Omnidirectional	Omnidirectional	Omnidirectional	Omnidirectional
Antenna gain compared with the isotropic radiator of the WLAN antenna				
• In the 2.4 GHz frequency band	6 dB	-	6 dB	4 dB
• In the 5 GHz frequency band	-	5 dB	8 dB	6 dB
Maximum standing wave ratio	1,8	1,5	1,8	1,5
Beam angle of antenna				
• In the 2.4 GHz frequency band				
- Horizontal	360°	-	360°	360°
- Vertical	30°	-	-	-
• In the 5 GHz frequency band				
- Horizontal	-	360°	150°	360°
- Vertical	-	25°	-	-
Note on beam angle	-	-	Take note of antenna diagram	-
Number of electrical connections of the antenna	1	1	1	3
Design of electrical connection of the antenna	N connector, female	N connector, female	N connector, female	QMA, female
Maximum angle of inclination down	0°	0°	0°	0°
Crosstalk attenuation between the antenna connections	-	-	-	20 dB
Front to back ratio	-	-	-	-

Industrial Wireless Communication

IWLAN – Accessories

IWLAN antennas

Technical specifications (continued)

Order No.	6GK5 792-6MN00-0AA6	6GK5 793-6MN00-0AA6	6GK5 795-6MN10-0AA6	6GK5 795-6MT00-0AA0
Product type designation	ANT792-6MN antenna	ANT793-6MN antenna	ANT795-6MN antenna	ANT795-6MT antenna
Maximum transmit power	25 W	6 W	75 W	10 W
Note on transmit power	-	At 25° ambient temperature	At 25° ambient temperature	At 25° ambient temperature
Range with free view without hindrance	200 m	200 m	200 m	-
Note on range	Note: The range may be much less and depends on the spatial conditions, the wireless standard being used, the data rate, and the antenna at the opposite end	Note: The range may be much less and depends on the spatial conditions, the wireless standard being used, the data rate, and the antenna at the opposite end	Note: The range may be much less and depends on the spatial conditions, the wireless standard being used, the data rate, and the antenna at the opposite end	-
Permissible ambient conditions				
Ambient temperature				
• During operation	-40 ... +80 °C	-45 ... +70 °C	-40 ... +80 °C	-40 ... +85 °C
• During storage	-40 ... +80 °C	-45 ... +70 °C	-40 ... +80 °C	-40 ... +85 °C
• During transport	-40 ... +80 °C	-45 ... +70 °C	-40 ... +80 °C	-40 ... +85 °C
IP degree of protection	IP65	IP65	IP65	IP65
Maximum wind load	3 N	3.9 N	10 N	-
Note on wind load	at 160 km/h	at 160 km/h	at 160 km/h	-
Design, dimensions and weights				
Width	50 mm	16 mm	86 mm	282 mm
Height	40 mm	160 mm	43 mm	32 mm
Depth	370 mm	16 mm	86 mm	92 mm
Diameter	-	-	-	-
Net weight	300 g	300 g	300 g	320 g
Type of mounting	-	-	-	-
• Mast mounting	Yes	Yes	No	No
• Wall mounting	Yes	Yes	Yes	Yes
• Ceiling mounting	No	No	Yes	Yes
• Directly on the device	No	No	No	No
Product properties, functions, components				
General				
Product property silicon-free	Yes	Yes	Yes	Yes
Material of the outer sleeve	Glass fiber	Polypropylene	Polycarbonate	Polycarbonate
Standards, specifications, approvals				
Certificate of suitability	-	-	Railway application in accordance with NF-F-16-101, NF-F-16-102	-
• RoHS compliance	Yes	Yes	Yes	Yes
• Railroad application according to EN 50124-1	-	-	Yes	-
• Railroad application according to EN 50155	-	-	Yes	-
Wireless approval	Current country-specific approvals can be found on the Internet at www.siemens.com/wireless-approvals	Current country-specific approvals can be found on the Internet at www.siemens.com/wireless-approvals	Current country-specific approvals can be found on the Internet at www.siemens.com/wireless-approvals	Current country-specific approvals can be found on the Internet at www.siemens.com/wireless-approvals

Technical specifications (continued)

Order No.	6GK5 795-6DC00-0AA0	6GK5 795-6DN00-0AA6	6GK5 793-6DG00-0AA0	6GK5 793-6DT00-0AA0
Product type designation	ANT795-6DC antenna	ANT795-6DN antenna	ANT793-6DG antenna	ANT793-6DT antenna
Radio frequencies				
Radio frequency				
• With WLAN in the 2.4 GHz frequency band	2.4 ... 2.5 GHz	2.4 ... 2.5 GHz	-	-
• With WLAN in the 5 GHz frequency band 1	5.15 ... 5.875 GHz	5.15 ... 5.875 GHz	5.15 ... 5.875 GHz	5.15 ... 5.875 GHz
• With WLAN in the 5 GHz frequency band 2	-	-	-	-
Electrical specifications				
Impedance	50 Ω	50 Ω	50 Ω	50 Ω
Polarization	Linear vertical	Linear vertical	Dual linear +/- 45° slant	3 ports: Vertical, +/- 45° slant
Radiation characteristic	Directional	Directional	Directional	Directional
Antenna gain compared with the isotropic radiator of the WLAN antenna				
• In the 2.4 GHz frequency band	9 dB	9 dB	-	-
• In the 5 GHz frequency band	9 dB	9 dB	9 dB	8 dB
• With transmission frequency 5.2 GHz				
• With transmission frequency 5.7 GHz				
Maximum standing wave ratio	2	1,5	2	1,7
Beam angle of antenna				
• In the 2.4 GHz frequency band				
- Horizontal	75°	75°	-	-
- Vertical	55°	55°	-	-
• In the 5 GHz frequency band				
- Horizontal	55°	55°	70°	65°
- Vertical	55°	55°	60°	65°
Note on beam angle	-	-	-	-
Number of electrical connections of the antenna	1	1	2	3
Design of electrical connection of the antenna	N connector, female	N connector, female	N connector, female	QMA, female
Maximum angle of inclination down	0°	0°	0°	0°
Crosstalk attenuation between the antenna connections	25 dB	-	20 dB	17 dB
Front to back ratio	15 dB	15 dB	20 dB	-
Maximum transmit power	10 W	10 W	10 W	2 W
Note on transmit power	At 25° ambient temperature	At 25° ambient temperature	At 25° ambient temperature	At 25° ambient temperature
Range with free view without hindrance	-	200 m	-	-
Note on range	-	Note: The range may be much less and depends on the spatial conditions, the wireless standard being used, the data rate, and the antenna at the opposite end	-	-

Industrial Wireless Communication

IWLAN – Accessories

IWLAN antennas

Technical specifications (continued)

Order No.	6GK5 795-6DC00-0AA0	6GK5 795-6DN00-0AA6	6GK5 793-6DG00-0AA0	6GK5 793-6DT00-0AA0
Product type designation	ANT795-6DC antenna	ANT795-6DN antenna	ANT793-6DG antenna	ANT793-6DT antenna
Permissible ambient conditions				
Ambient temperature				
• During operation	-40 ... +80 °C	-40 ... +80 °C	-40 ... +80 °C	-40 ... +85 °C
• During storage	-40 ... +80 °C	-40 ... +80 °C	-40 ... +80 °C	-40 ... +85 °C
• During transport	-40 ... +80 °C	-40 ... +80 °C	-40 ... +80 °C	-40 ... +85 °C
IP degree of protection	IP67	IP55	IP67	IP67
Maximum wind load	15 N	15 N	15 N	15 N
Note on wind load	at 160 km/h	at 160 km/h	from front at 160 km/h	from front at 160 km/h
Design, dimensions and weights				
Width	80 mm	101 mm	80 mm	80 mm
Height	101 mm	95 mm	101 mm	101 mm
Depth	35 mm	32 mm	35 mm	35 mm
Diameter	-	-	-	-
Net weight	110 g	110 g	110 g	270 g
Type of mounting				
• Mast mounting	Yes	Yes	Yes	Yes
• Wall mounting	Yes	Yes	Yes	Yes
• Ceiling mounting	No	No	No	No
• Directly on the device	No	No	No	No
Product properties, functions, components				
General				
Product property silicon-free	Yes	Yes	-	-
Material of the outer sleeve	Lexan EXL 9330	ASA	Lexan EXL 9330	Lexan EXL 9330
Standards, specifications, approvals				
Standard for hazardous zone	-	-	-	-
Certificate of suitability	-	-	-	-
• RoHS compliance	Yes	Yes	Yes	Yes
• UL approval	-	-	-	Yes
- Note	-	-	-	UL94-V0, UL746C F1
Wireless approval	Current country-specific approvals can be found on the Internet at www.siemens.com/wireless-approvals	Current country-specific approvals can be found on the Internet at www.siemens.com/wireless-approvals	Current country-specific approvals can be found on the Internet at www.siemens.com/wireless-approvals	Current country-specific approvals can be found on the Internet at www.siemens.com/wireless-approvals

Technical specifications (continued)

Order No.	6GK5 792-8DN00-0AA6	6GK5 793-8DN00-0AA6	6GK5 793-8DJ00-0AA0	6GK5 793-8DK00-0AA0
Product type designation	ANT792-8DN antenna	ANT793-8DN antenna	ANT793-6DJ antenna	ANT793-6DK antenna
Radio frequencies				
Radio frequency				
• With WLAN in the 2.4 GHz frequency band	2.4 ... 2.7 GHz	-	-	-
• With WLAN in the 5 GHz frequency band 1	-	5.15 ... 5.875 GHz	5.25 ... 5.875 GHz	5.15 ... 5.875 GHz
• With WLAN in the 5 GHz frequency band 2	-	-	-	-
Electrical specifications				
Impedance	50 Ω	50 Ω	50 Ω	50 Ω
Polarization	Linear vertical	Linear, horizontal or vertical	Dual linear vertical-horizontal	Dual linear vertical-horizontal
Radiation characteristic	Directional	Directional	Directional	Directional
Antenna gain compared with the isotropic radiator of the WLAN antenna				
• In the 2.4 GHz frequency band	14 dB	-	-	-
• In the 5 GHz frequency band	-	18 dB	18 dB	23 dB
Maximum standing wave ratio	1,5	1,9	1,7	1,7
Beam angle of antenna				
• In the 2.4 GHz frequency band				
- Horizontal	35°	-	-	-
- Vertical	30°	-	-	-
• In the 5 GHz frequency band				
- Horizontal	-	18°	17°	9°
- Vertical	-	18°	17°	9°
Note on beam angle	-	-	-	-
Number of electrical connections of the antenna	1	1	2	2
Design of electrical connection of the antenna	N connector, female	N connector, female	N connector, female	N connector, female
Maximum angle of inclination down	0°	0°	0°	0°
Crosstalk attenuation between the antenna connections	-	-	30 dB	40 dB
Front to back ratio	20 dB	30 dB	30 dB	35 dB
Maximum transmit power	75 W	6 W	6 W	6 W
Note on transmit power	At 25° ambient temperature	At 25° ambient temperature	At 25° ambient temperature	At 25° ambient temperature
Range with free view without hindrance	1 000 m	1 000 m	-	-
Note on range	<u>Note:</u> The range may be much less and depends on the spatial conditions, the wireless standard being used, the data rate, and the antenna at the opposite end	<u>Note:</u> The range may be much less and depends on the spatial conditions, the wireless standard being used, the data rate, and the antenna at the opposite end	-	-

Industrial Wireless Communication

IWLAN – Accessories

IWLAN antennas

Technical specifications (continued)

Order No.	6GK5 792-8DN00-0AA6	6GK5 793-8DN00-0AA6	6GK5 793-8DJ00-0AA0	6GK5 793-8DK00-0AA0
Product type designation	ANT792-8DN antenna	ANT793-8DN antenna	ANT793-6DJ antenna	ANT793-6DK antenna
Permissible ambient conditions				
Ambient temperature				
• During operation	-40 ... +80 °C	-45 ... +70 °C	-45 ... +70 °C	-45 ... +70 °C
• During storage	-40 ... +80 °C	-45 ... +70 °C	-45 ... +70 °C	-45 ... +70 °C
• During transport	-40 ... +80 °C	-45 ... +70 °C	-45 ... +70 °C	-45 ... +70 °C
• During mounting	-	-	-	-
IP degree of protection	IP23	IP65	IP67	IP67
Maximum wind load	57 N	104 N	104 N	389 N
Note on wind load	at 160 km/h	at 220 km/h	from front at 220 km/h	from front at 220 km/h
Design, dimensions and weights				
Width	200 mm	190 mm	190 mm	371 mm
Height	200 mm	190 mm	190 mm	371 mm
Depth	43 mm	30.5 mm	30.5 mm	40 mm
Diameter	-	-	-	-
Net weight	500 g	700 g	700 g	2 500 g
Type of mounting	-	-	-	-
• Mast mounting	Yes	Yes	Yes	Yes
• Wall mounting	Yes	Yes	Yes	Yes
• Ceiling mounting	No	No	No	No
• Directly on the device	No	No	No	No
Product properties, functions, components				
General				
Product property silicon-free	Yes	Yes	-	-
Material of the outer sleeve	ASA	Polypropylene	Polycarbonate/aluminum	Polycarbonate
Standards, specifications, approvals				
• RoHS compliance	Yes	Yes	Yes	Yes
Wireless approval	Current country-specific approvals can be found on the Internet at www.siemens.com/wireless-approvals	Current country-specific approvals can be found on the Internet at www.siemens.com/wireless-approvals	Current country-specific approvals can be found on the Internet at www.siemens.com/wireless-approvals	Current country-specific approvals can be found on the Internet at www.siemens.com/wireless-approvals

Technical specifications (continued)

Order No.	6GK5 792-4DN00-0AA6	6GK5 793-4MN00-0AA6
Product type designation	ANT792-4DN RCoax antenna	ANT793-4MN RCoax antenna
Radio frequencies		
Radio frequency		
• With WLAN in the 2.4 GHz frequency band	2.4 ... 2.4835 GHz	-
• With WLAN in the 5 GHz frequency band 1	-	5.15 ... 5.85 GHz
• With WLAN in the 5 GHz frequency band 2	-	-
Electrical specifications		
Impedance	50 Ω	50 Ω
Polarization	Circular clockwise	Vertical (lambda 5/8 characteristic)
Radiation characteristic	Directional	Omnidirectional
Antenna gain compared with the isotropic radiator of the WLAN antenna		
• In the 2.4 GHz frequency band	4 dB	-
• In the 5 GHz frequency band	-	6 dB
• With transmission frequency 5.2 GHz		
• With transmission frequency 5.7 GHz		
Maximum standing wave ratio	1,8	2
Beam angle of antenna		
• In the 2.4 GHz frequency band		
- Horizontal	90°	-
- Vertical	-	-
• In the 5 GHz frequency band		
- Horizontal	-	360°
- Vertical	-	40°
Note on beam angle	-	-
Number of electrical connections of the antenna	1	1
Design of electrical connection of the antenna	N connector, female	N connector, female
Maximum angle of inclination down	0°	0°
Crosstalk attenuation between the antenna connections	-	-
Front to back ratio	2.5 dB	-
Maximum transmit power	1 W	1 W
Permissible ambient conditions		
Ambient temperature		
• During operation	-40 ... +70 °C	-40 ... +70 °C
• During storage	-40 ... +70 °C	-40 ... +70 °C
• During transport	-40 ... +70 °C	-40 ... +70 °C
IP degree of protection	IP65	IP65
Design, dimensions and weights		
Width	-	-
Height	78.7 mm	78.7 mm
Depth	-	-
Diameter	30 mm	30 mm
Net weight	114 g	65 g
Product properties, functions, components		
General		
Product property silicon-free	Yes	Yes
Material of the outer sleeve	Polycarbonate	Polycarbonate
Standards, specifications, approvals		
• UL approval	-	Yes
- Note	-	UL94-V1
Wireless approval	Current country-specific approvals can be found on the Internet at www.siemens.com/wireless-approvals	Current country-specific approvals can be found on the Internet at www.siemens.com/wireless-approvals

Industrial Wireless Communication

IWLAN – Accessories

IWLAN antennas

Ordering data

Order No.

Order No.

Antennas with omnidirectional characteristic;

National approvals, compact instructions on paper, German/English

For mounting directly onto
SCALANCE W

Antenna gain incl. connector
4 dB, 2.4/5 GHz;

- **ANT795-4MC antenna;**
IP65 (-20 to +65 °C),
straight connection,
N-Connect male,
scope of delivery: 3 antennas
- **ANT795-4MD antenna;**
IP65 (-20 to +65 °C),
connection with fixed 90° angle,
N-Connect male,
scope of delivery: 3 antennas
- **ANT795-4MR antenna;**
IP65 (-20 to +65 °C),
scope of delivery: 1 antenna
- **ANT795-4MA / ANT795-4MS antenna;**
IP30; radial rotation possible
with additional joint;
R-SMA male
 - **ANT795-4MA;**
scope of delivery: 3 antennas
 - **ANT795-4MS;**
scope of delivery: 2 antennas

Wall or mast mounting

- **ANT792-6MN antenna**
Antenna gain incl.
N-Connect connector 6 dB,
2.4 GHz;
IP65 (-40 to +80 °C),
with terminating resistor
1 x TI795-1R;
incl. mounting hardware
- **ANT793-6MN antenna**
Antenna gain incl.
N-Connect connector 5 dB,
5 GHz;
IP65 (-45 to +70 °C),
with terminating resistor
1 x TI795-1R;
incl. mounting hardware

For mounting on a roof

- **ANT795-6MN antenna**
Antenna gain incl.
N-Connect connector 6/8 dB,
2.4/5 GHz;
IP65 (-40 to +80 °C),
with terminating resistor
1 x TI795-1R
- **ANT795-6MT antenna**
MIMO antenna with
3 QMA sockets,
antenna gain 6 dB,
2.4/5 GHz; (-40 to +85°C),
incl. fixing bracket
- **Antenna mounting tool (ANT795-6MN)**
Mounting aid for installing
ANT795-6MN below a roof

6GK5 795-4MC00-0AA3

6GK5 795-4MD00-0AA3

6GK5 795-4MR00-0AA6

6GK5 795-4MA00-0AA3

6GK5 795-4MS00-0AA6

6GK5 792-6MN00-0AA6

6GK5 793-6MN00-0AA6

6GK5 795-6MN10-0AA6

6GK5 795-6MT00-0AA0

6GK5 795-6MN01-0AA6

Directional antennas;

incl. mounting hardware;
compact instructions on paper,
German/English

Wall or mast mounting

- **ANT795-6DC antenna**
Wide-angle antenna,
slightly directional;
antenna gain incl. N-Connect
connector 9/9 dB,
2.4/5 GHz, -40 to +80 °C
- **ANT793-6DG antenna**
Dual-slant wide-angle antenna,
slightly directional;
antenna gain incl. two
N-Connect connectors 9 dB,
5 GHz, -40 bis +80 °C
- **ANT793-6DT antenna**
MIMO antenna with 3 QMA
sockets, wide-angle antenna,
slightly directional;
antenna gain 9 dB,
5 GHz, -40 to +85 °C
- **ANT795-6DN antenna**
Wide-angle antenna,
slightly directional;
antenna gain incl. N-Connect
connector 9/9 dB,
2.4/5 GHz, -40 to +80 °C;
with terminating resistor
1 x TI795-1R
- **ANT792-8DN antenna**
Antenna, strongly directional;
antenna gain incl. N-Connect
connector 14 dB, 2.4 GHz;
-40 to +80 °C;
with terminating resistor
1 x TI795-1R
- **ANT793-8DN antenna**
Antenna, strongly directional;
antenna gain incl. N-Connect
connector 19 dB, 5 GHz,
-45 to +70 °C;
with terminating resistor
1 x TI795-1R
- **ANT793-8DJ antenna**
Vertically-horizontally polarized
antenna, strongly directional;
antenna gain incl. two
N-Connect connectors 18 dB,
5 GHz; -45 to +70 °C
- **ANT793-8DK antenna**
Vertically-horizontally polarized
antenna, strongly directional;
antenna gain incl. two
N-Connect connectors 23 dB,
5 GHz; -45 to +70 °C

6GK5 795-6DC00-0AA0

6GK5 793-6DG00-0AA0

6GK5 793-6DT00-0AA0

6GK5 795-6DN00-0AA6

6GK5 792-8DN00-0AA6

6GK5 793-8DN00-0AA6

6GK5 793-8DJ00-0AA0

6GK5 793-8DK00-0AA0

Antennas for RCoax systems

- **ANT792-4DN antenna**
Circularly polarized RCoax helix
antenna for RCoax systems;
N-Connect female connection;
antenna gain at 2.4 GHz 1 dB
- **ANT793-4MN antenna**
Vertically polarized RCoax 5/8
antenna for RCoax systems;
N-Connect female connection;
antenna gain at 5.2 GHz/
5.7 GHz 6/5 dB

6GK5 792-4DN00-0AA6

6GK5 793-4MN00-0AA6

More information

To assist in selecting the right products for Industrial Wireless Communication, the SIMATIC NET Selection Tool is available at:

Online version:

www.siemens.com/snst

Offline version:

www.siemens.com/snst-download

You can order components supplementary to the SIMATIC NET cabling system from your local contact. Technical advice on this subject is available from:

J. Hertlein

I IA SC IC PRM 4

Phone +49 (0)911/750 44 65

E-mail: juergen.hertlein@siemens.com

Industrial Wireless Communication

IWLAN – Accessories

IWLAN RCoax cables

Overview



The RCoax cables are radiating cables that function as special antennas for the SCALANCE W Access Points in environments with complex radio coverage. Its design means that a defined, cone-shaped radio field is generated along the RCoax cable. The radiating cables are therefore perfectly suitable for use in all types of applications with track-bound vehicles.

- Rugged coaxial cable which can be easily installed
- Two cables for use in the frequency bands 2.4 GHz and 5 GHz
- Connection as external antenna to SCALANCE W780 Access Points
- Connection of mobile nodes via SCALANCE W740 Client Modules and IWLAN/PB Link PN IO using an antenna aligned to the RCoax
- Suitable for use in hazardous areas (Zone 2); no special approvals necessary

Benefits

get Designed for Industry

- Reliable coverage in areas problematic for radio
- Avoidance of greater than desired WLAN expansion by means of defined emission of the radio waves
- Cost savings thanks to direct substitution of sliding contacts, trailing cables, and data light barriers
- Highly flexible laying

Design

The RCoax cables were specially designed for the frequency band around 2.4 GHz or 5 GHz respectively.

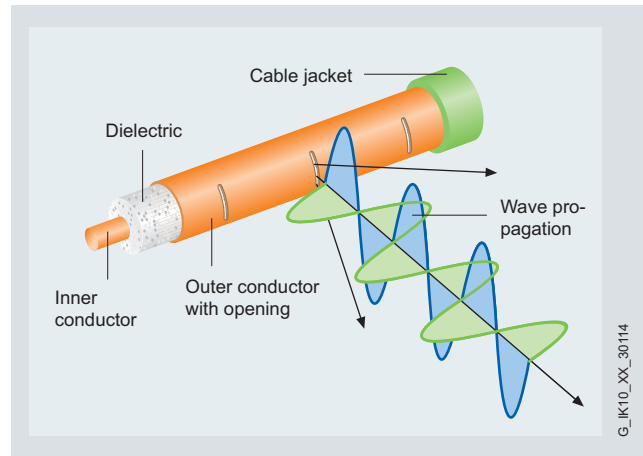

Openings are present in the outer conductor of the coaxial cable which permit the penetration and emission of radio waves. A defined radio field is then developed around the RCoax cables. Longitudinal damping and extraction loss are in a balanced relationship, which permits a long segment length of cable per SCALANCE W780 Access Point and an appropriate distance from the mobile station (SCALANCE W740, IWLAN/ PB Link PN IO) to the RCoax cable.

Coordinated accessories are available for assembly:

- IWLAN RCoax cable clip 1/2"
- IWLAN RCoax spacer 85 mm
- IWLAN RCoax threaded washer M6



Application

- In areas with demanding conditions for wireless coverage (e.g. in tunnels, channels and elevator shafts) where "unlimited" mobility is not of decisive importance, but where rather a mechanically wear-free and thus maintenance-free solution is required to ensure reliable data transmission: This is made possible by the defined radio field along the RCoax cable.
- The RCoax cables offer, especially for conveyor systems and every type of rail-mounted vehicle (suspended monorails, AGV systems) a wear-free and reliable wireless link.

Application examples

- Suspended monorail
- Automated guided vehicle systems (AGVS)
- Cranes
- Stacker cranes
- Transfer lines
- Tool-changing trolleys
- Tunnels
- Lifts

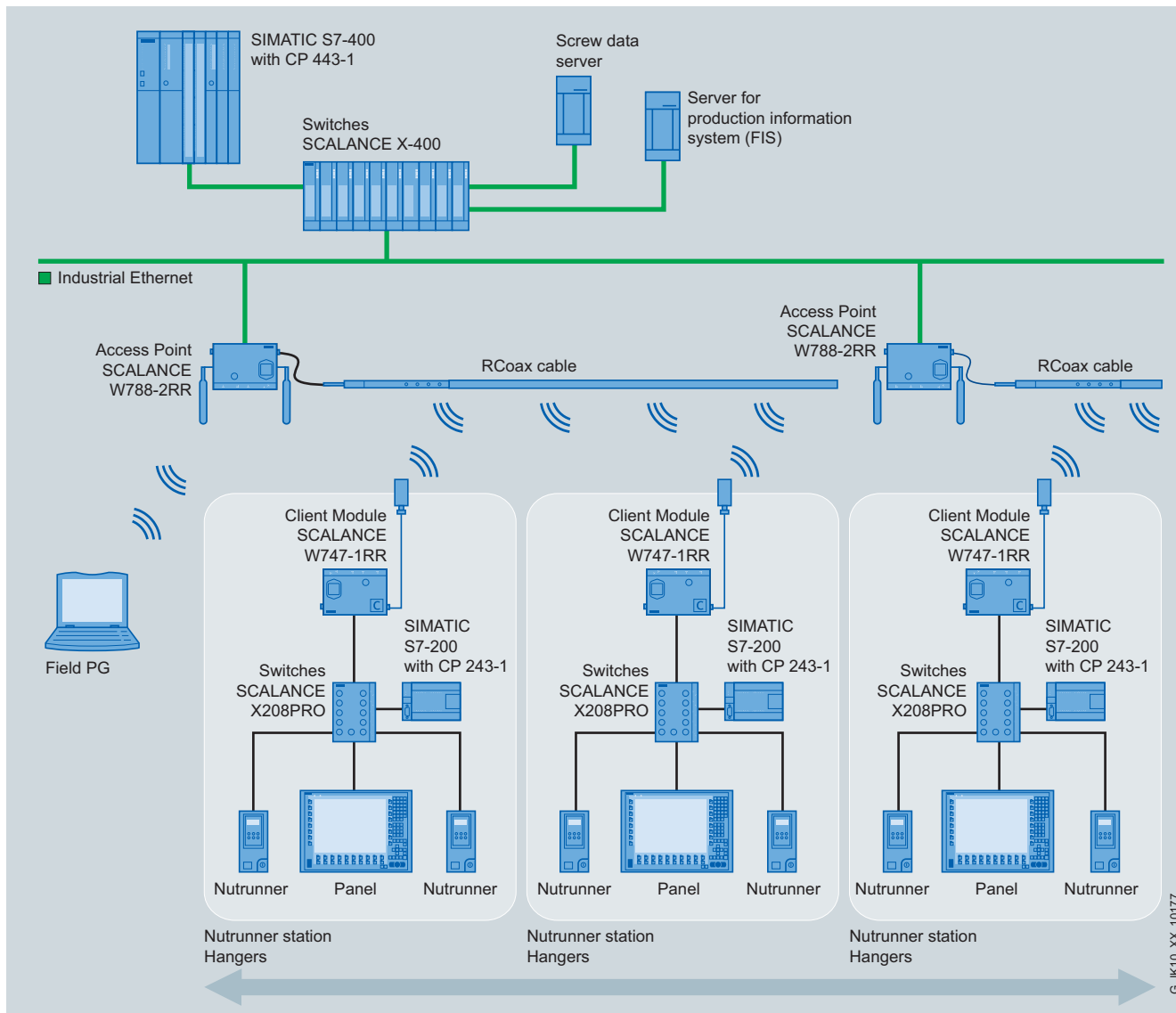

Configuration example with RCoax cable using example of a nutrunner control in automobile production

Industrial Wireless Communication

IWLAN – Accessories

IWLAN RCoax cables

Integration

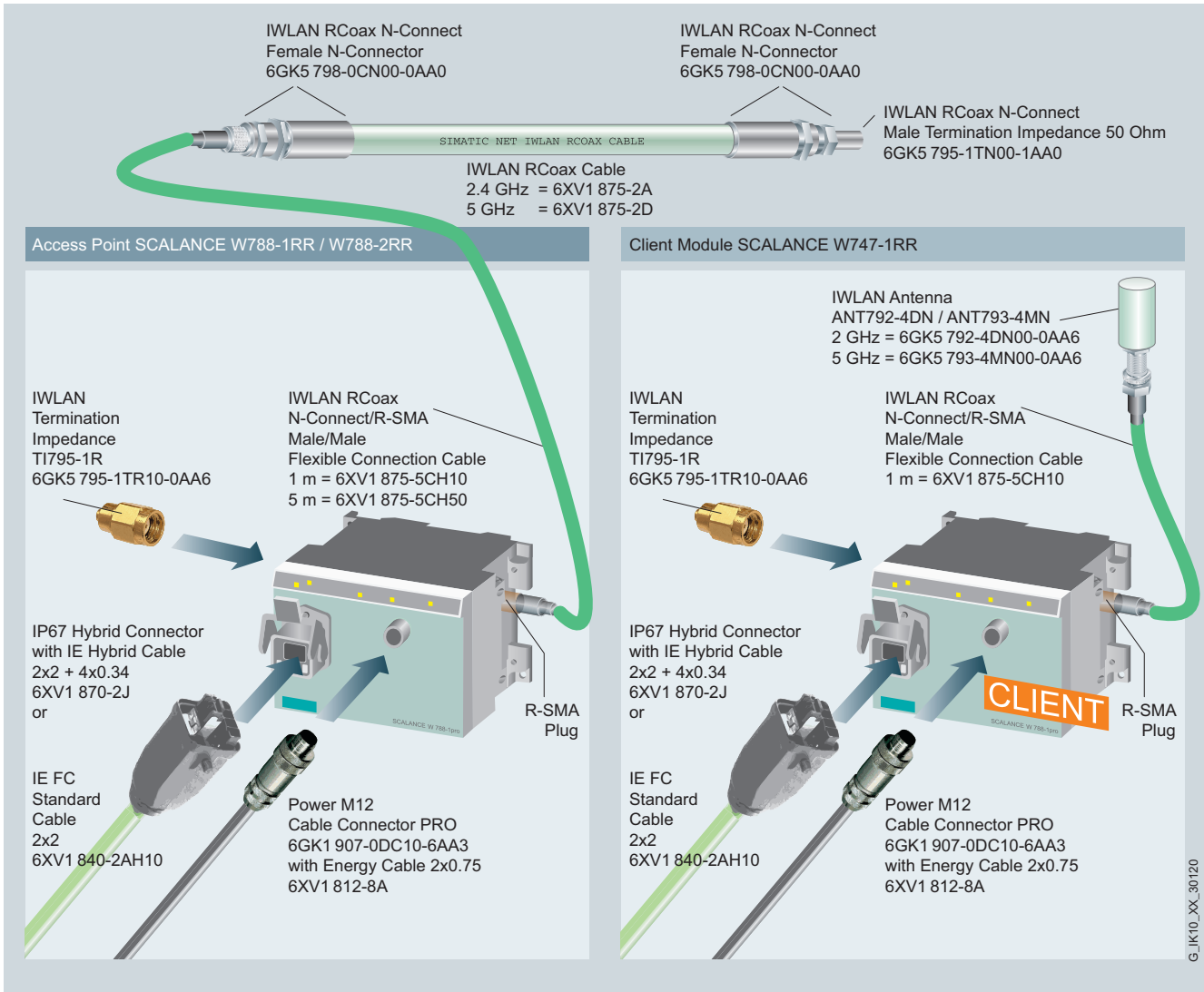

Connection example for an IWLAN RCoax system with connection to Industrial Ethernet

Integration (continued)

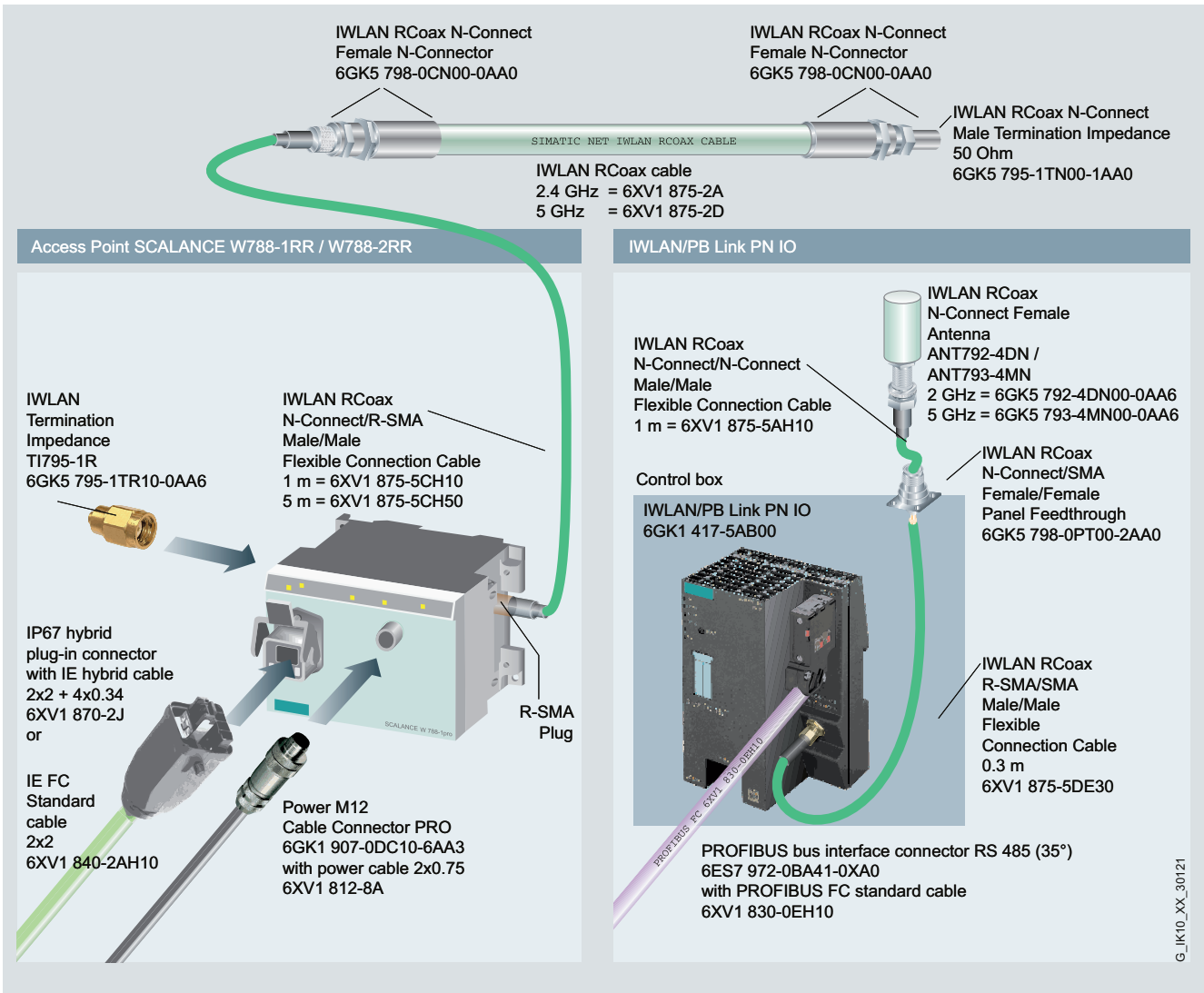

Connection example for an IWLAN RCoax system with interface to PROFIBUS

Industrial Wireless Communication

IWLAN – Accessories

IWLAN RCoax cables

Technical specifications

Order No.	6XV1 875-2A	6XV1 875-2D
Product type designation	IWLAN RCoax Cable 2 GHz	IWLAN RCoax Cable 5 GHz
Suitability for use	Suspended monorails, cranes, stacker cranes, or similar	Suspended monorails, cranes, stacker cranes, or similar
Wireless frequencies		
Wireless frequency		
• With WLAN in the 2.4 GHz frequency band	2.4 ... 2.485 GHz	-
• With WLAN in the 5 GHz frequency band 1	-	5.15 ... 5.85 GHz
• With WLAN in the 5 GHz frequency band 2	-	-
Electrical specifications		
Impedance	50 Ω	50 Ω
Attenuation factor per length		
• At 2.4 GHz		
- For cable mounting 10 mm over concrete at 20 °C	0.15 dB/m	-
- For cable mounting 15 mm over aluminum rail at 20 °C	0.17 dB/m	-
• At 5.15 GHz		
- For cable mounting 10 mm over concrete at 20 °C	-	22.5 dB/m
- For cable mounting 15 mm over aluminum rail at 20 °C	-	24.2 dB/m
• At 5.85 GHz		
- For cable mounting 10 mm over concrete at 20 °C	-	24 dB/m
- For cable mounting 15 mm over aluminum rail at 20 °C	-	27 dB/m
Attenuation factor per length Note	-	-
Tap loss		
• At 2.4 GHz at 20 °C	35 dB	-
• At 5.15 GHz at 20 °C	-	42 dB
• At 5.85 GHz at 20 °C	-	40 dB
• Note	c(50) applies to a distance of 10 cm between antenna and cable	c(50) applies to a distance of 10 cm between antenna and cable
Capacitance per length	76 pF/m	76 pF/m
DC resistance per length		
• of the inner conductor at 20 °C	1.48 Ω/km	1.48 Ω/km
• of the coaxial outer conductor at 20 °C	2.8 Ω/km	2.8 Ω/km
Relative velocity	88%	88%

Technical specifications (continued)

Order No.	6XV1 875-2A	6XV1 875-2D
Product type designation	IWLAN RCoax Cable 2 GHz	IWLAN RCoax Cable 5 GHz
Mechanical data		
Outer diameter		
• of inner conductor	4.8 mm	4.8 mm
• of the dielectric	12.4 mm	12.4 mm
• of the cable sheath	15.5 mm	15.5 mm
Thickness of cable sheath	1.3 mm	1.3 mm
Material		
• of the cable sheath	Halogen-free polyolefin AM3	Halogen-free polyolefin AM3
• of inner conductor	Copper-clad aluminum	Copper-clad aluminum
• of the dielectric	Polyethylene foam	Polyethylene foam
• of the coaxial outer conductor	Overlapping copper foil with slot groups bonded to cable jacket	Overlapping copper foil with slot groups bonded to cable jacket
Color of cable sheath	Pastel turquoise	Pastel turquoise
Bending radius		
• Minimum permitted single bending radius	20 cm	20 cm
• Minimum permitted repeated bending radius	-	-
Number of bending cycles	1	1
• Note	-	-
Maximum tensile load	1 100 N	1 100 N
Weight per length	0.232 kg/m	0.232 kg/m
Recommended spacing	0.5 m	0.5 m
Design of plug-in connection	-	-
Permissible ambient conditions		
Ambient temperature		
• During operation	-40 ... +85 °C	-40 ... +85 °C
• During storage	-70 ... +85 °C	-70 ... +85 °C
• During transport	--	--
• During mounting	-25 ... +60 °C	-25 ... +60 °C
IP degree of protection	-	-
Product properties, functions, components		
General		
Product property silicon-free	-	-
Standards, specifications, approvals		
Certificate of suitability		
• RoHS compliance	-	-
• UL approval	Yes	Yes
- Note	-	-
Wireless approval	Current country-specific approvals can be found on the Internet at www.siemens.com/wireless-approvals	Current country-specific approvals can be found on the Internet at www.siemens.com/wireless-approvals
Standard		
• For behavior in fire: Corrosive gas emission	IEC 60754-2	IEC 60754-2
• For behavior in fire: Smoke emission	IEC 60332-1 and IEC 60332-3 Cat. C	IEC 60332-1 and IEC 60332-3 Cat. C
• For behavior in fire: Flame resistance	IEC 61034	IEC 61034

Industrial Wireless Communication

IWLAN – Accessories

IWLAN RCoax cables

Ordering data	Order No.
IWLAN RCoax cables Radiating cable for complex radio environments as special antenna for SCALANCE W Access Points; for extended temperature range (-40 °C to + 85 °C); sold by the meter minimum order quantity 20 m <ul style="list-style-type: none"> • 2.4 GHz • 5 GHz 	6XV1 875-2A 6XV1 875-2D
Accessories	
IWLAN RCoax N-Connect stripping tool Stripping tool for fast stripping of RCoax cable on site	6GK1 901-1PH00
RCoax N-Connect female N-connector Plug connector for assembly on site; connection unit of RCoax cable for connection of further components, N-female connection.	6GK5 798-0CN00-0AA0
RCoax N-Connect male/male Coupler RF coupling for connecting an RCoax antenna to an RCoax cable; two N-Connect male connectors	6GK5 798-0CP00-1AA0
IWLAN RCoax cable clip 1/2" Cable holder for RCoax cable <ul style="list-style-type: none"> • 10 items • 100 items 	6GK5 798-8MB00-0AC1 6GK5 798-8MB00-0AM1
IWLAN RCoax threaded washer M6 Threaded washer M6 for RCoax cable clip 1/2", for assembly with M6 threaded bolts <ul style="list-style-type: none"> • 10 items • 100 items 	6GK5 798-8MC00-0AC1 6GK5 798-8MC00-0AM1
IWLAN RCoax spacer 85 mm Spacer 85 mm for RCoax cable clip 1/2" <ul style="list-style-type: none"> • 10 items • 100 items 	6GK5 798-8MD00-0AC1 6GK5 798-8MD00-0AM1

More information

Wireless approvals:

Current approvals can be found on the Internet at:
www.siemens.com/wireless-approvals

To assist in selecting the right products for Industrial Wireless Communication, the SIMATIC NET Selection Tool is available:

Online version:
www.siemens.com/snst

Offline version:
www.siemens.com/snst-download

Overview

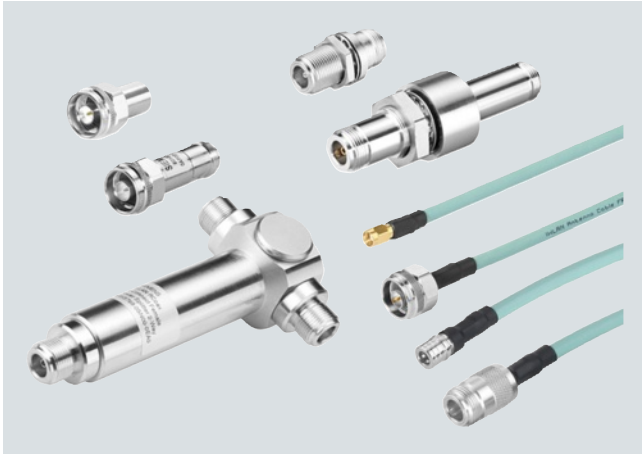

A comprehensive, coordinated range of coaxial accessories is offered for flexible combination and installation of the individual IWLAN components indoors and outdoors.

This range encompasses connecting cables as well as diverse connectors, lightning protection elements, a power splitter and an attenuator.

Benefits

get Designed for Industry

- Flexible use thanks to extensive, coordinated range
- Operation also outdoors with extended temperature range and protection against water and dust thanks to degree of protection IP65
- Components are suitable for use with SCALANCE W-700 including national approvals

Application

RCoax/antenna connecting cables

- The flexible IWLAN RCoax/antenna connecting cables are required for connecting RCoax segments or antennas with active devices.
- The cables offer low attenuation so that the quality of the radio signal is only reduced to a minimal extent.
- All antenna cables are flame-resistant, chemical-resistant and silicone-free.

Terminating resistors

- Terminating resistors are required for wireless termination of unused antenna connections at the access points and clients.
- RCoax segments must be terminated at the end with a terminating resistor.

Lightning protection elements

- When separate antennas are used outdoors, there is a risk of lightning strikes.
- A lightning protector can be used to prevent damage.

Cabinet feedthroughs

Together with the antenna connecting cables, the cabinet feedthroughs enable simple connection of remote antennas to the active components located in the control cabinet/box.

Attenuator

The 10 dB attenuator is always used when the transmitted power has to be reduced both in the send and receive directions. Typical application areas include short RCoax segments or directional wireless links, which are to be limited in extent.

Power splitter

- With the help of the power splitter, the transmission power of an access point is divided between two RCoax or antenna segments.
- This enables wireless coverage in two areas using just one access point.

Product versions

RCoax/antenna connecting cables

- Pre-assembled cable lengths (0.3 m to 10 m)
- Different connector types and combinations (N-Connect, R-SMA, SMA, QMA)

Terminating resistors

- TI795-1R: Terminating resistor 50 ohms for R-SMA antenna sockets
- TI795-1N: Terminating resistor 50 ohms for N-Connect antenna sockets or RCoax segments

Lightning protection elements

- LP798-2N: Maintenance-free lightning protection element for N-Connect connections
 - Quarter-wave system (lambda-quarter) for the frequency range 2 to 6 GHz
 - Represents a short-circuit for DC voltages so that all types of overvoltage can be reliably diverted
 - Not suitable for DC infeed via the antenna cable
- LP798-1N: Lightning protection element for N-Connect connections
 - With gas discharge arrester for the frequency range 0 to 6 GHz for N-Connect connections
 - Suitable for DC infeed via the antenna cable

Cabinet feedthroughs

- N-Connect female/SMA female with fastening flange for panel thicknesses up to 5.5 mm
- N-Connect female/N-Connect female without flange for panel thicknesses up to 4.5 mm
 - Can also be used to connect two antenna connecting cables

Industrial Wireless Communication

IWLAN – Accessories

IWLAN cabling technology

Technical specifications

Order No.	6XV1875-5Axxx	6XV1875-5Cxxx	6XV1875-5Dxxx	6XV1875-5Jxxx
Product type designation	IWLAN RCoax antenna N-Connect male/male flexible antenna connecting cable	IWLAN RCoax antenna N-Connect/R-SMA male/male flexible antenna connecting cable	IWLAN RCoax antenna N-Connect/SMA male/male flexible antenna connecting cable	IWLAN RCoax antenna QMA/N-Connect male/male flexible antenna connecting cable
Number of plug-in connections	2	2	2	2
Design of plug-in connection 1	N-Connect male	N-Connect male	N-Connect male	QMA male
Design of plug-in connection 2	N-Connect male	R-SMA male	SMA male	N-Connect female
Frequency range	≤ 6 GHz	≤ 6 GHz	≤ 6 GHz	≤ 6 GHz
Impedance	50 Ω	50 Ω	50 Ω	50 Ω
Capacity	82 pF/m	82 pF/m	82 pF/m	82 pF/m
Return loss	≥ -23 dB	≥ -23 dB	≥ -23 dB	-
Attenuation				
• at 2.4 GHz	0.53 dB/m	0.53 dB/m	0.53 dB/m	0.55 dB/m
• at 5.7 GHz	0.88 dB/m	0.88 dB/m	0.88 dB/m	0.93 dB/m
Ambient temperature				
• During operating phase	-40 °C to +80 °C	-40 °C to +80 °C	-40 °C to +80 °C	-40 °C to +80 °C
• during storage	-40 °C to +80 °C	-40 °C to +80 °C	-40 °C to +80 °C	-40 °C to +80 °C
• during transport	-40 °C to +80 °C	-40 °C to +80 °C	-40 °C to +80 °C	-40 °C to +80 °C
Smallest bending radius				
• for one-off bending	3.2 cm	3.2 cm	3.2 cm	3.2 cm
• for repeated bending	4.5 cm	4.5 cm	4.5 cm	5.8 cm
Tensile strength	30 ... 80 N	30 ... 80 N	30 ... 80 N	-
Net weight/m	75 g/m	75 g/m	75 g/m	-
Outer diameter	6.3 mm	6.3 mm	6.3 mm	-

Order No.	6GK5 795-1TR10-0AA6	6GK5 795-1TN00-0AA6	6GK5798-0SN0-0EA0	6GK5798-0AP00-4CA0
Product type designation	Termination Impedance TI795-1R	Termination impedance TI795-1N	Power splitter	Attenuator
Number of plug-in connections	1	1	3	2
Connection version	R-SMA male	N-Connect male	N-Connect female	N-Connect male / female
Frequency range	≤ 6 GHz	≤ 6 GHz	2.4 ... 6 GHz	≤ 6 GHz
Impedance	50 Ω	50 Ω	50 Ω	50 Ω
Return loss	> 25 dB/6 GHz	> 25 dB/6 GHz	≥ 24 dB	-
Insertion loss			≤ 3.05 dB	10 dB
Performance range	< 1 W	< 1 W	250 W	1 W
Ambient temperature				
• During operating phase	-40 °C to +70 °C	-40 °C to +70 °C	-25 °C to +110 °C	-40 °C to +70 °C
• during storage	-40 °C to +70 °C	-40 °C to +70 °C	-25 °C to +110 °C	-40 °C to +70 °C
• during transport	-40 °C to +70 °C	-40 °C to +70 °C	-25 °C to +110 °C	-40 °C to +70 °C
Degree of protection	IP65	IP65	IP67	-
Diameter	9 mm	21 mm	-	21 mm
Length	15 mm	34.5 mm	131.4 mm	45.7 mm
Width	-	-	71.4 mm	-
Depth	-	-	34 mm	-
Net weight	5 g	45 g	937 g	-

Technical specifications (continued)

Order No.	6GK5 798-2LP00-2AA6	6GK5 798-2LP10-2AA6
Product type designation	LP798-1N lightning protector	LP798-2N lightning protector
Transmission frequency	0 ... 6 GHz	2 ... 6 GHz
Electrical data		
Impedance	50 Ω	50 Ω
Mechanical data		
Design of plug-in connection	N-Connector female/female	N-Connector female/female
Permissible ambient conditions		
Ambient temperature		
• During operation	-40 ... +85 °C	-40 ... +85 °C
• During storage	-40 ... +85 °C	-40 ... +85 °C
• During transport	-40 ... +85 °C	-40 ... +85 °C
IP degree of protection	IP67	IP68
Design, dimensions and weights		
Width	54.8 mm	89.6 mm
Height	-	-
Depth	-	-
Diameter	22.8 mm	29 mm
Net weight	50 g	80 g
Type of mounting	-	-

Ordering data

	Order No.		Order No.
IWLAN RCoax antenna N-Connect/R-SMA Male/male flexible connection cable Flexible connecting cable for connecting an RCoax cable or antenna to a SCALANCE W-700 access point with R-SMA connections; pre-assembled with two connections, N-Connect male and R-SMA male • 0.3 m • 1 m • 2 m • 5 m • 10 m	6XV1 875-5CE30 6XV1 875-5CH10 6XV1 875-5CH20 6XV1 875-5CH50 6XV1 875-5CN10	IWLAN RCoax antenna QMA/N-Connect male/male Flexible connection cable Adapter cable for connecting a MIMO antenna with QMA connections to the flexible connecting cables; assembled with two connections QMA male and N-Connect female; 3 units • 1 m	6XV1 875-5JH10
IWLAN RCoax antenna N-Connect male/male Flexible connection cable Flexible connecting cable for connecting an RCoax cable or antenna to a SCALANCE W-700 access point with N-Connect connections; pre-assembled with two N-Connect male connections • 1 m • 2 m • 5 m • 10 m	6XV1 875-5AH10 6XV1 875-5AH20 6XV1 875-5AH50 6XV1 875-5AN10	IWLAN RCoax antenna R-SMA/SMA male/male Flexible connection cable Flexible cable for connecting an active device to components with RSMA and SMA connections, e.g. cabinet feedthrough; pre-assembled with two R-SMA male to SMA male connectors • 0.3 m • 2 m	6XV1 875-5DE30 6XV1 875-5DH20
		IWLAN RCoax antenna N-Connect male termination impedance TI795-1N Terminating resistance for RCoax cable and open wireless interfaces on SCALANCE W-700 devices with N-Connect connections, impedance 50 ohms, N-Connect male connection; IP65 (-40 to +70 °C)	6GK5 795-1TN00-1AA0

Industrial Wireless Communication

IWLAN – Accessories

IWLAN cabling technology

Ordering data	Order No.
IWLAN RCoax antenna RSMA male termination impedance TI795-1R Terminating resistance for open wireless interfaces on SCALANCE W-700 devices with RSMA connections, impedance 50 ohms, RSMA male connection; IP65 (-40 to +70 °C); 3 units	6GK5 795-1TR10-0AA6
Lightning protector LP798-1N Lightning protector with N/N female/female connection, IP67 (-40 to +85 °C), frequency range: 0 to 6 GHz	6GK5 798-2LP00-2AA6
LP798-2N lightning protector Lightning protector with N/N female/female connection, IP68 (-40 to +85 °C), quarter wave, frequency range: 2 to 6 GHz	6GK5 798-2LP10-2AA6
IWLAN RCoax antenna N-Connect female power splitter 2-way cable splitter, Y-element for dividing the RCoax cable or for using two antennas on one wireless interface	6GK5 798-0SN00-0EA0
IWLAN RCoax antenna N-Connect male/male coupler HF link for connecting two RCoax cables; two N-Connect male connectors	6GK5 798-0CP00-1AA0
IWLAN RCoax antenna N-Connect male/male attenuator Attenuator with N-Connect male/N-Connect female connectors <ul style="list-style-type: none"> • 10 dB 	6GK5 798-0AP00-4CA0
IWLAN RCoax antenna N-Connect/SMA female/female panel feedthrough Cabinet feedthrough with fastening flange for wall thicknesses up to 5.5 mm, SMA female and N-Connect female connections	6GK5 798-0PT00-2AA6
IWLAN RCoax antenna N-Connect/N-Connect female/female panel feedthrough Cabinet feedthrough for wall thicknesses up to 4.5 mm, two N-Connect female connections	6GK5 798-2PP00-2AA0

More information

To assist in selecting the right products for Industrial Wireless Communication, the SIMATIC NET Selection Tool is available:

Online version:
www.siemens.com/snst

Offline version:
www.siemens.com/snst-download

You can order components supplementary to the SIMATIC NET cabling range from your local contact. Technical advice on this subject is available from:

J. Hertlein
 I IA SC IC PRM 4
 Phone +49 (0)911/750 44 65
 E-mail: juergen.hertlein@siemens.com

Overview



- The PS791-1 PRO power supply is an AC/DC power supply for input voltages of 90 to 265 V AC for numerous SCALANCE products with IP65 degree of protection.
- Mounting:
 - Wall mounting or on S7-300 rail, immediately under/next to the SCALANCE W788-xPRO and SCALANCE W788-xRR Access Points, SCALANCE W74x-1PRO and SCALANCE W74x-1RR Client Modules, or SCALANCE X-200PRO switches
- Robust metal housing with IP65 protection against water and dust
- Operating temperature -20 °C to +60 °C

Benefits

get Designed for Industry

- Reduced storage of replacement parts, as only one power supply unit is required for several SCALANCE products with IP65 degree of protection
- Global application due to wide input voltage range
- High reliability as power supply is short-circuit proof, secure against no-load operation and is able to bridge short breaks in the mains power
- Variety of possible applications thanks to:
 - wide range of input voltages
 - high degree of efficiency
 - low heat dissipation

Design

- Fanless design and rugged metal casing; High protection against dust and splashwater with IP65 degree of protection
- Operating temperatures from -20 °C to +60 °C
- Resistant to condensation
- Connection to AC network via AC Power 3+PE cable connector (included)
- Connection to SCALANCE products in degree of protection IP65
- In other applications, the Power M12 Plug PRO is used for the DC-output (to be ordered separately)
- Direct mounting is possible on the SCALANCE products with IP65 degree of protection using supplied installation material; also suitable for wall-mounting or mounting on standard mounting rail (S7-300)

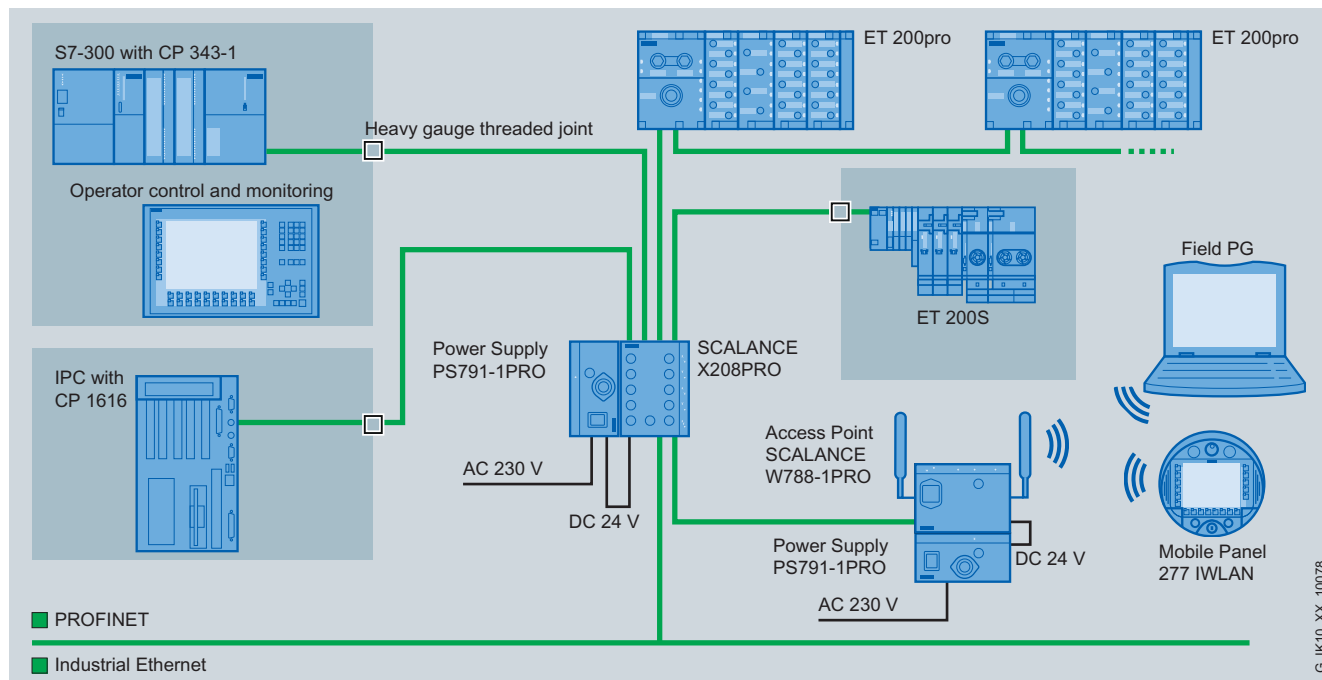

Example for the use of power supply PS791-1PRO with SCALANCE X and SCALANCE W

Note:

When SCALANCE W is connected to SCALANCE X208PRO, the power supply in the hybrid connector is not available; power must be supplied via the M12 plug connector.

Industrial Wireless Communication

IWLAN – Accessories

Power supply PS791-1PRO

Technical specifications

Order No.	6GK5 791-1PS00-0AA6
Product type designation	Power supply PS791-1PRO
Interfaces	<ul style="list-style-type: none"> • AC Power 3+PE cable connector for 100 ... 240 V AC feed • M12 Plug PRO or Power Cord M12 for 24 V DC output voltage • On/Off switch
Input voltage	90 ... 265 V AC at 47 ... 63 Hz
Output voltage	24 V DC, +-7 %, 0.42 A
Output power	10 W
System disturbances	Stored energy time at least 20 ms at 230 V AC
Permissible ambient conditions	
• Operating temperature	-20°C ... 60°C
• Transport/storage temperature	-40°C ... +85°C
• Relative humidity	100 %
Approvals	EMC: EN 55022 Class B, EN 61000-4; UL 1950, EN 60950;
Device failure	MTBF 600,000 h at full load, 25°C
Switching frequency	typ. 100 kHz
Degree of protection	IP65
Dimensions (W x H x D) in mm	125 x 60 x 130
Assembly	Wall/DIN rail mounting (S7-300) directly on SCALANCE devices
Weight	700 g

Ordering data

PS791-1PRO power supply	AC/DC power supply, 10 W, IP65 (-20 ... +60°C), input: 90 ... 265 V AC, output: 24 V DC, metal housing; scope of supply: AC power 3+PE cable connector, DC power cord M12, installation materials, instruction manual German/English
Power M12 Plug PRO	Plug for connection to PS791-1PRO power supply for 24 V DC supply voltage; 4-pole, A-coded, with assembly instructions, 3 items
AC Power 3+PE cable connector	Connection socket for connection of Power Supply PS791-1PRO to AC voltage supply, with assembly instructions, 5 items
Power cable 2 x 0.75	Connecting cable for power supply PS791-1PRO, sold by the meter

Order No.

6GK5 791-1PS00-0AA6

6GK1 907-0DB10-6AA3

6GK1 907-0FC10-0AA5

6XV1 812-8A

More information

You can order components supplementary to the SIMATIC NET cabling range from your local contact. Technical advice on this subject is available from:

J. Hertlein
I IA SC IC PRM 4
Phone +49 (0)911/750 44 65
E-mail: juergen.hertlein@siemens.com

Overview



PS791-2DC power supply adapter

- DC/DC power supply unit for input voltages from 12 to 24 V DC and an output voltage of 18 V DC for all SCALANCE W786 devices

PS791-2AC power supply adapter

- AC/DC power supply unit for input voltages from 100 to 240 V AC and an output voltage of 18 V DC for all SCALANCE W786 devices

Design



- Integral power supply adapter for SCALANCE W786
- Fan-free design
- Operating temperatures from -40 °C to +70 °C
- Resistant to condensation

Benefits

get Designed for Industry

- The PS791-2DC and PS791-2AC power supply adapters are designed specially for the SCALANCE W786 access points and are integrated direct into these
- Global application due to wide input voltage range
- High reliability as power supply is short-circuit proof, secure against no-load operation and is able to bridge short breaks in the mains power
- When the power supply adapter and Power-over-Ethernet (PoE) are used, redundant power supply of the access points can be achieved

Industrial Wireless Communication

IWLAN – Accessories

Power Supply PS791-2DC and PS791-2AC

Technical specifications

Order No.	6GK5 791-2DC00-0AA0	6GK5 791-2AC00-0AA0
Product type designation	Power supply PS791-2DC	Power supply PS791-2AC
Interfaces	<ul style="list-style-type: none"> Infeed: 4-pin screw terminal for DC Power Output voltage: 4-pin connector 	<ul style="list-style-type: none"> Infeed: 3-pin screw terminal for AC Power Output voltage: 4-pin connector
Input voltage	12 ... 24 V DC (min. 9 V DC, max. 32 V DC) safety extra-low voltage (SELV)	100 ... 240 V AC, 45 ... 65 Hz
Output voltage	18 V DC	18 V DC
Output power	14.4 W	14.4 W
Mains buffering	–	> 20 ms
Permissible ambient conditions		
• Operating temperature	-40 °C ... +70 °C	-40 °C ... +60 °C
Approvals	EMC: EN 61000-6-2:2005, EN 61000-6-3:2007	EMC: EN 61000-6-2:2005, EN 61000-6-3:2007
Safety regulations	EN 60950, UL 60950-1	EN 60950, UL 60950-1
Protection class	VDE 0805, VDE 0100	VDE 0805, VDE 0100
Degree of protection	IP65	IP65
Dimensions (W x H x D) in mm	133 x 45 x 30 mm	133 x 45 x 30 mm
Assembly	Installation in SCALANCE W786 and HiPath Wireless Outdoor Access Points	Installation in SCALANCE W786 and HiPath Wireless Outdoor Access Points
Weight	223 g	209 g

Ordering data

Power supply PS791-2DC
24 V DC power supply for
installation in SCALANCE W-786
products;
operating instructions in
German/English

Order No.

6GK5 791-2DC00-0AA0

Power supply PS791-2AC
110 V AC to 230 V AC power
supply for installation in the
SCALANCE W-786 products;
operating instructions
German/English

6GK5 791-2AC00-0AA0

More information

You can order components supplementary to the
SIMATIC NET cabling range from your local contact.
Technical advice on this subject is available from:

J. Hertlein
I IA SC IC PRM 4
Phone +49 (0)911/750 44 65
E-mail: juergen.hertlein@siemens.com

Function



- Input/output fields for displaying and changing of process values.
- Function keys are used for directly triggering functions and actions. Up to 16 functions can be configured simultaneously on function keys. The function keys can also be used directly as PROFINET IO. The function keys can also be reconfigured as system keys. A frequently used function such as "Acknowledge alarm" can thus be assigned to a function key.
- Auxiliary operator controls such as handwheels, key switches and illuminated pushbuttons can be assigned with a variable or as a direct actuation via PROFINET IO (direct keys).
- Buttons are used for direct triggering of functions and actions. Up to 16 functions can be configured simultaneously on buttons.
- Graphics can be used as symbols instead of text for "labeling" function keys or buttons. They can also be used as full-screen background images. In the configuration software, a comprehensive library is available containing graphics and a wide variety of objects. All editors with an OLE interface can be used as graphics editors (such as PaintShop, Designer or CorelDraw).
- Vector graphics simple geometric basic forms (e.g. lines, circles and rectangles) can be created directly in the configuration software.
- Text fields for labeling function keys, process displays, and process values in any font size.
- Trend views and bars are used for the graphic display of dynamic values.
- Display selection from the controller permits operator prompting from the controller.
- Presentation of HTML documents with MS Pocket Internet Explorer.
- Visual Basic Script, flexibility thanks to the implementation of new functions including linking to variables (comparison operations, loops, etc.).
- Language switching
 - 16 online languages, 32 configuration languages incl. Asiatic and Cyrillic character sets
 - Language-dependent texts and graphics
- User administration (security)
 - User-oriented access protection according to requirements of specific sectors
 - Authentication with user name and password
 - User-group-specific rights
- Signaling system
 - Discrete and analog alarms (edge alarms) as well as the ALARM_S message frame procedure for SIMATIC S7
 - Freely definable message classes (e.g. status/fault messages) for definition of acknowledgment response and display of alarm events
- Message buffer
 - Non-volatile, maintenance-free and battery-free message buffer. The messages remain stored when the mobile panel has the battery removed as well
- Recipe management
 - With additional data storage (on optional MultiMedia Card/SD Card)
 - Online/offline processing on the panel
 - Storage of recipe data in standard Windows format (CSV)
 - External processing using standard tools such as Excel and Access is possible
- Help texts for process images, messages and variables.
- Arithmetic functions
- Limit value monitoring for reliable process control of inputs and outputs.
- Indicator lights for machine and plant status indication.
- Scheduler for cyclic function processing.
- Dynamic positioning of objects and dynamic showing/hiding of objects
- Permanent window and template concept
 - Creation of screen templates:
- Simple maintenance and configuration thanks to:
 - Backup/restore of the project, operating system, recipe data records and firmware on the optional standard multi-media card/SD card
 - Backup and restoration of configuration, operating system, recipe data sets and firmware on a PC using ProSave
 - Project transfer/return transfer via PROFINET/WLAN
 - Automatic transfer detection
 - Individual brightness setting
 - Project simulation directly on the configuration computer
- WinCC flexible options
 - Sm@rtService for remote operator control and monitoring of SIMATIC HMI systems based on TCP/IP networks
 - Sm@rtAccess for communication between HMI systems based on TCP/IP networks. Remote access to recipe data records, passwords and HMI system-specific information, and much more. (Mobile Panel 277F IWLAN as server: View only)
 - OPC server: Communication with applications (e.g. MES, ERP, or applications in the office sector) from various manufacturers (see HMI software/runtime software SIMATIC WinCC flexible/WinCC flexible RT options)
 - Audit

Industrial Wireless Communication

IWLAN – Wireless Devices

SIMATIC Mobile Panel 277(F) IWLAN

Function (continued)

Configuration

Configuration is carried out with the SIMATIC WinCC flexible Standard or Advanced configuration software (see SIMATIC WinCC flexible HMI software/engineering software). SIMATIC WinCC flexible is the logical further development of the field-proven ProTool family. Projects generated using ProTool can be easily migrated to WinCC. If WinCC flexible is started directly from SIMATIC Manager, data in STEP 7 can be accessed directly when the panel is configured. Duplicated data input and data management is, therefore, avoided.



IWLAN infrastructure

The required IWLAN infrastructure is set up with the IWLAN Access Points SCALANCE W-780, preferably with the version SCALANCE W786-2RR, which fully supports all possible applications of the Mobile Panel 277(F) IWLAN. For operating a plant without fail-safe communication, the version SCALANCE W786-1PRO can also be used. The iPCF functionality (rapid roaming = fast, uninterrupted switchover between several access points) is only available with V2 panels upwards.

The Access Point provides an Industrial Ethernet interface for connection to the wired network.

In addition to a reliable radio link, the SCALANCE W-780 Access Points stand out due to their optimum support of standardized IT mechanisms:

- IEEE 802.11b/g/a/h for different frequency ranges
- IEEE 802.11e for multimedia, wireless multimedia (WMM) ¹⁾
- IEEE 802.11i for security ¹⁾
- Construction of redundant networks with the Rapid Spanning Tree Protocol (RSTP)
- Virtual networks (VLAN) to logically separate, for example, different user groups
- Sending the log entries of the SCALANCE W devices to a Syslog server

Wireless approvals

Only those wireless approvals printed on the mobile panel apply. Planned wireless approvals for all SIMATIC products can be found on the Internet at:

www.siemens.com/wireless-approvals

¹⁾ Not supported by Mobile Panel Wireless

Integration

The SIMATIC Mobile Panel 277(F) IWLAN communicates via the WLAN Standard IEEE 802.11 a(b/g) via PROFINET. The Mobile Panel 277F IWLAN devices also support PROFI-safe communication.

There are five device versions with V2:

For mobile operation and monitoring via WLAN:

- Mobile Panel 277 IWLAN V2
- Mobile Panel 277 IWLAN V2 with handwheel, key switch and illuminated pushbuttons

As fail-safe device for safety-oriented operation as well:

- Mobile Panel 277F IWLAN V2 with acknowledgement button and emergency stop button
- Mobile Panel 277F IWLAN V2 with acknowledgement button, emergency stop button, handwheel, key switch and illuminated pushbuttons
- Mobile Panel 277F IWLAN RFID Tag (for V2 only)

For the versions Mobile Panel 277F IWLAN (PROFI-safe), the following system prerequisites apply:

- The Mobile Panel must be connected as a safe device (PROFI-safe, Distributed Safety)
- Use of a SIMATIC F-CPU

SIMATIC Mobile Panel	5 GHz frequency band (IEEE 802.11a)	SIMATIC F-CPU (Distributed Safety)
277 IWLAN	Only WLAN utilization (HMI)	—
	When using transponders	!
	When using Profinet IO	—
277F IWLAN (fail-safe)	!	!
277F IWLAN (RFID Tag) (fail-safe)	•	!

• = Recommended

! = Requirement

— = Not required

The Mobile Panel 277(F) IWLAN can be connected to:

- SIMATIC S7-200/-300/-400 (one F-CPU required for integrating the Mobile Panel 277F IWLAN and SIMOTION (Mobile Panel 277 IWLAN V2 or higher, or Mobile Panel 277FIWLAN V2 or higher (WinCC flexible 2008 SP3 or higher))

Note:

Further information can be found under "System interfaces". The Function Manuals "Fail-Safe Operation of the Mobile Panel 277F IWLAN" are available for downloading in English, German, and Japanese.

<http://support.automation.siemens.com/WW/view/en/31255853>

Technical specifications

	6AV6 645-0DD01-0AX1	6AV6 645-0DE01-0AX1	6AV6 645-0EB01-0AX1	6AV6 645-0EC01-0AX1	6AV6 645-0EF01-0AX1
Display					
Size	7.5"	7.5"	7.5"	7.5"	7.5"
Display type	TFT, 65536 colors	TFT, 65536 colors	TFT, 65536 colors	TFT, 65536 colors	TFT, 65536 colors
Resolution (pixels)					
• Resolution (WxH in pixel)	640 x 480	640 x 480	640 x 480	640 x 480	640 x 480
Backlighting					
• MTBF backlighting (at 25 °C)	about 50,000 hours	about 50,000 hours	about 50,000 hours	about 50,000 hours	about 50,000 hours
Control elements					
Operating options	Keys and Touch	Keys and Touch	Keys and Touch	Keys and Touch	Keys and Touch
Function keys, programmable	18 function keys, 18 with LEDs	18 function keys, 18 with LEDs	18 function keys, 18 with LEDs	18 function keys, 18 with LEDs	18 function keys, 18 with LEDs
Connection for mouse/keyboard/barcode reader	USB / USB / USB	USB / USB / USB	USB / USB / USB	USB / USB / USB	USB / USB / USB
Keyboard fonts					
• Numeric/alphabetical input	Yes / Yes	Yes / Yes	Yes / Yes	Yes / Yes	Yes / Yes
Touch operation					
• Touch screen	Analog, resistive	Analog, resistive	Analog, resistive	Analog, resistive	Analog, resistive
Special operator controls					
• Emergency stop button			2-channel, positive latching	2-channel, positive latching	2-channel, positive latching
• Acknowledgement button			2-channel, number of positions: 3	2-channel, number of positions: 3	2-channel, number of positions: 3
• Key-operated switch		Yes, 3 switch settings		Yes, 3 switch settings	Yes, 3 switch settings
• Illuminated pushbutton		Yes		Yes	Yes
• Handwheel		Yes		Yes	Yes
Expansions for operator control of the process					
• DP direct LEDs (LEDs as S7 output I/O)	F1...F18	F1...F18	F1...F18	F1...F18	F1...F18
• DP direct keys (screen buttons and keys as S7 input I/O)	F1...F18, number of bytes for configurable keys: 10	F1...F18, number of bytes for configurable keys: 10	F1...F18, number of bytes for configurable keys: 10	F1...F18, number of bytes for configurable keys: 10	F1...F18, number of bytes for configurable keys: 10
Supply voltage					
Supply voltage	DC	DC	DC	DC	DC
Via charging station	Yes	Yes	Yes	Yes	Yes
Via table power supply	Yes	Yes	Yes	Yes	Yes
Main battery					
Rated voltage	7.2 V	7.2 V	7.2 V	7.2 V	7.2 V
Capacity	5 100 mA·h	5 100 mA·h	5 100 mA·h	5 100 mA·h	5 100 mA·h
Number of loading cycles, min	500	500	500	500	500
Charging time, typ.	4 h	4 h	4 h	4 h	4 h
Operating time, typ.	4 h	4 h	4 h	4 h	4 h
Display for battery capacity	Yes	Yes	Yes	Yes	Yes
Energy-saving mode	Yes	Yes	Yes	Yes	Yes
Battery replacement during operation	Yes	Yes	Yes	Yes	Yes
Processor					
Processor	ARM, 520 MHz	ARM, 520 MHz	ARM, 520 MHz	ARM, 520 MHz	ARM, 520 MHz
Memory					
Type	Flash / RAM	Flash / RAM	Flash / RAM	Flash / RAM	Flash / RAM
Usable memory for user data	6 MB usable memory for user data	6 MB usable memory for user data	6 MB usable memory for user data	6 MB usable memory for user data	6 MB usable memory for user data

Industrial Wireless Communication

IWLAN – Wireless Devices

SIMATIC Mobile Panel 277(F) IWLAN

Technical specifications (continued)

	6AV6 645-0DD01-0AX1	6AV6 645-0DE01-0AX1	6AV6 645-0EB01-0AX1	6AV6 645-0EC01-0AX1	6AV6 645-0EF01-0AX1
Type of output					
Status LEDs	Yes	Yes	Yes	Yes	Yes
LED for safe			Yes	Yes	Yes
LED for communication	Yes	Yes	Yes	Yes	Yes
LED for battery	Yes	Yes	Yes	Yes	Yes
Vibrations	Yes	Yes	Yes	Yes	Yes
Time of day					
Clock					
• Type	Hardware clock, battery backup, synchronizable	Hardware clock, battery backup, synchronizable	Hardware clock, battery backup, synchronizable	Hardware clock, battery backup, synchronizable	Hardware clock, battery backup, synchronizable
Interfaces					
Interfaces	1 x Ethernet (RJ45)	1 x Ethernet (RJ45)	1 x Ethernet (RJ45)	1 x Ethernet (RJ45)	1 x Ethernet (RJ45)
USB port	1 x USB	1 x USB	1 x USB	1 x USB	1 x USB
Multi Media Card slot	1 MMC/SD card slot	1 MMC/SD card slot	1 MMC/SD card slot	1 MMC/SD card slot	1 MMC/SD card slot
Industrial Ethernet					
• Industrial Ethernet interface	1 x Ethernet (RJ45)	1 x Ethernet (RJ45)	1 x Ethernet (RJ45)	1 x Ethernet (RJ45)	1 x Ethernet (RJ45)
• Wireless LAN	Yes	Yes	Yes	Yes	Yes
• Supports standards	according to IEEE 802.11a	according to IEEE 802.11a	according to IEEE 802.11a	according to IEEE 802.11a	according to IEEE 802.11a
• Supported channels (according to IEEE 802.11a)	Channel 34, channel 36, channel 38, channel 40, channel 42, channel 44, channel 46, channel 48, channel 52, channel 56, channel 60, channel 64, channel 149, channel 153, channel 157, channel 161	Channel 34, channel 36, channel 38, channel 40, channel 42, channel 44, channel 46, channel 48, channel 52, channel 56, channel 60, channel 64, channel 149, channel 153, channel 157, channel 161	Channel 34, channel 36, channel 38, channel 40, channel 42, channel 44, channel 46, channel 48, channel 52, channel 56, channel 60, channel 64, channel 149, channel 153, channel 157, channel 161	Channel 34, channel 36, channel 38, channel 40, channel 42, channel 44, channel 46, channel 48, channel 52, channel 56, channel 60, channel 64, channel 149, channel 153, channel 157, channel 161	Channel 34, channel 36, channel 38, channel 40, channel 42, channel 44, channel 46, channel 48, channel 52, channel 56, channel 60, channel 64, channel 149, channel 153, channel 157, channel 161
• Supported channels (according to IEEE 802.11b and IEEE 802.1g)	Channels 1 to 11, channel 12, channel 13, channel 14	Channels 1 to 11, channel 12, channel 13, channel 14	Channels 1 to 11, channel 12, channel 13, channel 14	Channels 1 to 11, channel 12, channel 13, channel 14	Channels 1 to 11, channel 12, channel 13, channel 14
• Country approval (radio)	Australia, Austria, Belgium, Bulgaria, Canada, China, Cyprus, Denmark, Estonia, Finland, France, Germany, UK, Greece, Hungary, Ireland, Iceland, Italy, Japan, Latvia, Liechtenstein, Lithuania, Luxembourg, Malta, the Netherlands, Norway, Poland, Portugal, Rumania, Sweden, Switzerland, Slovakia, Slovenia, Spain, South Korea, South Africa, Taiwan, Czech Republic, Turkey	Australia, Austria, Belgium, Bulgaria, Canada, China, Cyprus, Denmark, Estonia, Finland, France, Germany, UK, Greece, Hungary, Ireland, Iceland, Italy, Japan, Latvia, Liechtenstein, Lithuania, Luxembourg, Malta, the Netherlands, Norway, Poland, Portugal, Rumania, Sweden, Switzerland, Slovakia, Slovenia, Spain, South Korea, South Africa, Taiwan, Czech Republic, Turkey	Australia, Austria, Belgium, Bulgaria, Canada, China, Cyprus, Denmark, Estonia, Finland, France, Germany, UK, Greece, Hungary, Ireland, Iceland, Italy, Japan, Latvia, Liechtenstein, Lithuania, Luxembourg, Malta, the Netherlands, Norway, Poland, Portugal, Rumania, Sweden, Switzerland, Slovakia, Slovenia, Spain, South Korea, South Africa, Taiwan, Czech Republic, Turkey	Australia, Austria, Belgium, Bulgaria, Canada, China, Cyprus, Denmark, Estonia, Finland, France, Germany, UK, Greece, Hungary, Ireland, Iceland, Italy, Japan, Latvia, Liechtenstein, Lithuania, Luxembourg, Malta, the Netherlands, Norway, Poland, Portugal, Rumania, Sweden, Switzerland, Slovakia, Slovenia, Spain, South Korea, South Africa, Taiwan, Czech Republic, Turkey	Australia, Austria, Belgium, Bulgaria, Canada, China, Cyprus, Denmark, Estonia, Finland, France, Germany, UK, Greece, Hungary, Ireland, Iceland, Italy, Japan, Latvia, Liechtenstein, Lithuania, Luxembourg, Malta, the Netherlands, Norway, Poland, Portugal, Rumania, Sweden, Switzerland, Slovakia, Slovenia, Spain, South Korea, South Africa, Taiwan, Czech Republic, Turkey
• Encryption	WEP, WPA	WEP, WPA	WEP, WPA	WEP, WPA	WEP, WPA
• Supports rapid roaming	Yes	Yes	Yes	Yes	Yes

Technical specifications (continued)

	6AV6 645-0DD01-0AX1	6AV6 645-0DE01-0AX1	6AV6 645-0EB01-0AX1	6AV6 645-0EC01-0AX1	6AV6 645-0EF01-0AX1
Protocols					
PROFINET	Yes	Yes	Yes	Yes	Yes
Supports protocol for PROFINET IO	Yes	Yes	Yes	Yes	Yes
Supports protocol for PROFIsafe			Yes	Yes	Yes
EMC					
Emission of radio interference acc. to EN 55 011					
• Emission of radio interferences acc. to EN 55 011 (limit class A)	Yes; The product is designed for use in industrial environments. When used in residential areas, the emission of radio interference according to limit class B of EN 55011 must be ensured. For further information refer to the user documentation	Yes; The product is designed for use in industrial environments. When used in residential areas, the emission of radio interference according to limit class B of EN 55011 must be ensured. For further information refer to the user documentation	Yes; The product is designed for use in industrial environments. When used in residential areas, the emission of radio interference according to limit class B of EN 55011 must be ensured. For further information refer to the user documentation	Yes; The product is designed for use in industrial environments. When used in residential areas, the emission of radio interference according to limit class B of EN 55011 must be ensured. For further information refer to the user documentation	Yes; The product is designed for use in industrial environments. When used in residential areas, the emission of radio interference according to limit class B of EN 55011 must be ensured. For further information refer to the user documentation
Ambient conditions					
Operating temperature					
• Operation	0 °C to +40 °C	0 °C to +40 °C	0 °C to +40 °C	0 °C to +40 °C	0 °C to +40 °C
Storage/transport temperature					
• Transport, storage	-20 °C to +60 °C	-20 °C to +60 °C	-20 °C to +60 °C	-20 °C to +60 °C	-20 °C to +60 °C
Relative humidity					
• max. relative humidity	80 %	80 %	80 %	80 %	80 %
Drop height	1.2 m	1.2 m	1.2 m	1.2 m	1.2 m
Degree and class of protection					
IP65 enclosure	Yes	Yes	Yes	Yes	Yes
Standards, approvals, certificates					
Certifications	CE, cULus, C-TICK	CE, cULus, C-TICK	CE, cULus, C-TICK	CE, cULus, C-TICK	CE, cULus, C-TICK
TÜV safety certification			Yes	Yes	Yes
Safety Integrity Level to IEC 61508			3	3	3
Performance level acc. to EN ISO 13849-1			e	e	e
Safety category according to EN 954-1			Safety category according to EN 954-1 (enabling button, STOP button if present) 4	Safety category according to EN 954-1 (enabling button, STOP button if present) 4	Safety category according to EN 954-1 (enabling button, STOP button if present) 4
Operating systems					
Operating system	Windows CE	Windows CE	Windows CE	Windows CE	Windows CE
Configuration					
Configuration software					
• Configuration tool	WinCC flexible Standard Version 2008 SP2 and higher (to be ordered separately)	WinCC flexible Standard Version 2008 SP2 and higher (to be ordered separately)	WinCC flexible Standard Version 2008 SP2 and higher (to be ordered separately)	WinCC flexible Standard Version 2008 SP2 and higher (to be ordered separately)	WinCC flexible Standard Version 2008 SP2 and higher (to be ordered separately)

Industrial Wireless Communication

IWLAN – Wireless Devices

SIMATIC Mobile Panel 277(F) IWLAN

Technical specifications (continued)

	6AV6 645-0DD01-0AX1	6AV6 645-0DE01-0AX1	6AV6 645-0EB01-0AX1	6AV6 645-0EC01-0AX1	6AV6 645-0EF01-0AX1
Functionality under WinCC flexible					
Applications/options	Internet Explorer, Sm@rtService, Sm@rtAccess	Internet Explorer, Sm@rtService, Sm@rtAccess	Internet Explorer, Sm@rtService, Sm@rtAccess	Internet Explorer, Sm@rtService, Sm@rtAccess	Internet Explorer, Sm@rtService, Sm@rtAccess
Number of Visual Basic Scripts	50	50	50	50	50
Task planner	Yes	Yes	Yes	Yes	Yes
Help system	Yes	Yes	Yes	Yes	Yes
Status/control	With SIMATIC S7	With SIMATIC S7	With SIMATIC S7	With SIMATIC S7	With SIMATIC S7
With alarm logging system (incl. buffer and acknowledgment)					
• Number of messages	4 000	4 000	4 000	4 000	4 000
• Bit messages	Yes	Yes	Yes	Yes	Yes
• Analog messages	Yes	Yes	Yes	Yes	Yes
• Message buffer	Ring buffer (n x 512 entries), retentive, maintenance-free	Ring buffer (n x 512 entries), retentive, maintenance-free	Ring buffer (n x 512 entries), retentive, maintenance-free	Ring buffer (n x 512 entries), retentive, maintenance-free	Ring buffer (n x 512 entries), retentive, maintenance-free
Recipes					
• Recipes	300	300	300	300	300
• Data records per recipe	500	500	500	500	500
• Entries per data record	1000	1000	1000	1000	1000
• Recipe memory	64 KB integrated Flash, expandable	64 KB integrated Flash, expandable	64 KB integrated Flash, expandable	64 KB integrated Flash, expandable	64 KB integrated Flash, expandable
Number of process images					
• Process images	500	500	500	500	500
• Variables	2 048	2 048	2 048	2 048	2 048
• Limit values	Yes	Yes	Yes	Yes	Yes
• Multiplexing	Yes	Yes	Yes	Yes	Yes
Image elements					
• Text objects	10,000 text elements	10,000 text elements	10,000 text elements	10,000 text elements	10,000 text elements
• Graphics object	Bit maps, icons, vector graphics	Bit maps, icons, vector graphics	Bit maps, icons, vector graphics	Bit maps, icons, vector graphics	Bit maps, icons, vector graphics
• dynamic objects	Diagrams, bar graphs, sliders, analog display, invisible buttons	Diagrams, bar graphs, sliders, analog display, invisible buttons	Diagrams, bar graphs, sliders, analog display, invisible buttons	Diagrams, bar graphs, sliders, analog display, invisible buttons	Diagrams, bar graphs, sliders, analog display, invisible buttons
Lists					
• Text lists	500	500	500	500	500
• Graphics list	400	400	400	400	400
• Libraries	Yes	Yes	Yes	Yes	Yes
Archiving					
• Number of archives per project	20	20	20	20	20
• Number of measuring points per project	20	20	20	20	20
• Number of entries per archive	10 000	10 000	10 000	10 000	10 000
• Memory location	Multi Media Card	Multi Media Card	Multi Media Card	Multi Media Card	Multi Media Card
Security					
• Number of user groups	50	50	50	50	50
• Passwords exportable	Yes	Yes	Yes	Yes	Yes
• Number of user rights	32	32	32	32	32
Data carrier support					
• Multi Media Card	Yes	Yes	Yes	Yes	Yes
Logging					
• Recording/Printing	Alarms, report (shift report), PROFINET	Alarms, report (shift report), PROFINET	Alarms, report (shift report), PROFINET	Alarms, report (shift report), PROFINET	Alarms, report (shift report), PROFINET

Technical specifications (continued)

	6AV6 645-0DD01-0AX1	6AV6 645-0DE01-0AX1	6AV6 645-0EB01-0AX1	6AV6 645-0EC01-0AX1	6AV6 645-0EF01-0AX1
Languages					
• Languages	D, GB, F, I, E, CHN "traditional", CHN "simplified", DK, FIN, GR, J, KP / ROK, NL, N, PL, P, RUS, S, CZ / SK, TR, H	D, GB, F, I, E, CHN "traditional", CHN "simplified", DK, FIN, GR, J, KP / ROK, NL, N, PL, P, RUS, S, CZ / SK, TR, H	D, GB, F, I, E, CHN "traditional", CHN "simplified", DK, FIN, GR, J, KP / ROK, NL, N, PL, P, RUS, S, CZ / SK, TR, H	D, GB, F, I, E, CHN "traditional", CHN "simplified", DK, FIN, GR, J, KP / ROK, NL, N, PL, P, RUS, S, CZ / SK, TR, H	D, GB, F, I, E, CHN "traditional", CHN "simplified", DK, FIN, GR, J, KP / ROK, NL, N, PL, P, RUS, S, CZ / SK, TR, H
• Character sets	Tahoma, Arial, Courier New, WinCC flexible Standard, ideographic languages, all freely scalable	Tahoma, Arial, Courier New, WinCC flexible Standard, ideographic languages, all freely scalable	Tahoma, Arial, Courier New, WinCC flexible Standard, ideographic languages, all freely scalable	Tahoma, Arial, Courier New, WinCC flexible Standard, ideographic languages, all freely scalable	Tahoma, Arial, Courier New, WinCC flexible Standard, ideographic languages, all freely scalable
Transfer (upload/download)					
• Transfer of configuration	USB, Ethernet, automatic transfer recognition	USB, Ethernet, automatic transfer recognition	USB, Ethernet, automatic transfer recognition	USB, Ethernet, automatic transfer recognition	USB, Ethernet, automatic transfer recognition
• Wireless LAN	Yes	Yes	Yes	Yes	Yes
Process coupling					
• Connection to controller	S7-200, S7-300/400 see section on "System interfaces"	S7-200, S7-300/400 see section on "System interfaces"	S7-200, S7-300/400 see section on "System interfaces"	S7-200, S7-300/400 see section on "System interfaces"	S7-200, S7-300/400 see section on "System interfaces"
• Zones	Yes	Yes	Yes	Yes	Yes
- Number of zones per project, max.	254	254	254	254	254
- Number of transponders for zones per project, max.	255	255	255	255	255
• Effective range			Yes	Yes	Yes
- Number of effective ranges per project, max.			127	127	127
- Number of transponders for effective ranges per project, max.			127	127	127
• Transponder	Yes	Yes	Yes	Yes	Yes
- Number of transponders per project, max.	256	256	256	256	256
- Adjustable distance range	Yes	Yes	Yes	Yes	Yes
- Adjustable distance, min.	2 m	2 m	2 m	2 m	2 m
- Adjustable distance, max.	8 m	8 m	8 m	8 m	8 m
I/O					
I/O devices	Barcode reader	Barcode reader	Barcode reader	Barcode reader	Barcode reader
Mechanics/material					
Type of housing (front)	Plastic	Plastic	Plastic	Plastic	Plastic
Dimensions and weight					
Dimensions					
• Housing diameter/depth (mm)	Dia 290 mm / D 103 mm	Dia 290 mm / D 103 mm	Dia 290 mm / D 103 mm	Dia 290 mm / D 103 mm	Dia 290 mm / D 103 mm
Weight					
• Weight	2.2 kg	2.2 kg	2.2 kg	2.2 kg	2.2 kg

Industrial Wireless Communication

IWLAN – Wireless Devices

SIMATIC Mobile Panel 277(F) IWLAN

Technical specifications (continued)

	6AV6 645-0FD01-0AX1	6AV6 645-0FE01-0AX1	6AV6 645-0GB01-0AX1	6AV6 645-0GC01-0AX1	6AV6 645-0GF01-0AX1
Display					
Size	7.5"	7.5"	7.5"	7.5"	7.5"
Display type	TFT, 65536 colors	TFT, 65536 colors	TFT, 65536 colors	TFT, 65536 colors	TFT, 65536 colors
Resolution (pixels)					
• Resolution (WxH in pixel)	640 x 480	640 x 480	640 x 480	640 x 480	640 x 480
Backlighting					
• MTBF backlighting (at 25 °C)	about 50,000 hours	about 50,000 hours	about 50,000 hours	about 50,000 hours	about 50,000 hours
Control elements					
Operating options	Keys and Touch	Keys and Touch	Keys and Touch	Keys and Touch	Keys and Touch
Function keys, programmable	18 function keys, 18 with LEDs	18 function keys, 18 with LEDs	18 function keys, 18 with LEDs	18 function keys, 18 with LEDs	18 function keys, 18 with LEDs
Connection for mouse/keyboard/barcode reader	USB / USB / USB	USB / USB / USB	USB / USB / USB	USB / USB / USB	USB / USB / USB
Keyboard fonts					
• Numeric/alphabetical input	Yes / Yes	Yes / Yes	Yes / Yes	Yes / Yes	Yes / Yes
Touch operation					
• Touch screen	Analog, resistive	Analog, resistive	Analog, resistive	Analog, resistive	Analog, resistive
Special operator controls					
• Emergency stop button			2-channel, positive latching	2-channel, positive latching	2-channel, positive latching
• Acknowledgement button			2-channel, number of positions: 3	2-channel, number of positions: 3	2-channel, number of positions: 3
• Key-operated switch		Yes, 3 switch settings		Yes, 3 switch settings	Yes, 3 switch settings
• Illuminated pushbutton		Yes		Yes	Yes
• Handwheel		Yes		Yes	Yes
Expansions for operator control of the process					
• DP direct LEDs (LEDs as S7 output I/O)	F1...F18	F1...F18	F1...F18	F1...F18	F1...F18
• DP direct keys (screen buttons and keys as S7 input I/O)	F1...F18, number of bytes for configurable keys: 10	F1...F18, number of bytes for configurable keys: 10	F1...F18, number of bytes for configurable keys: 10	F1...F18, number of bytes for configurable keys: 10	F1...F18, number of bytes for configurable keys: 10
Supply voltage					
Supply voltage	DC	DC	DC	DC	DC
Via charging station	Yes	Yes	Yes	Yes	Yes
Via table power supply	Yes	Yes	Yes	Yes	Yes
Main battery					
Rated voltage	7.2 V	7.2 V	7.2 V	7.2 V	7.2 V
Capacity	5 100 mA·h	5 100 mA·h	5 100 mA·h	5 100 mA·h	5 100 mA·h
Number of loading cycles, min	500	500	500	500	500
Charging time, typ.	4 h	4 h	4 h	4 h	4 h
Operating time, typ.	4 h	4 h	4 h	4 h	4 h
Display for battery capacity	Yes	Yes	Yes	Yes	Yes
Energy-saving mode	Yes	Yes	Yes	Yes	Yes
Battery replacement during operation	Yes	Yes	Yes	Yes	Yes
Processor					
Processor	ARM, 520 MHz	ARM, 520 MHz	ARM, 520 MHz	ARM, 520 MHz	ARM, 520 MHz

Technical specifications (continued)

	6AV6 645-0FD01-0AX1	6AV6 645-0FE01-0AX1	6AV6 645-0GB01-0AX1	6AV6 645-0GC01-0AX1	6AV6 645-0GF01-0AX1
Memory					
Type	Flash / RAM	Flash / RAM	Flash / RAM	Flash / RAM	Flash / RAM
Usable memory for user data	6 MB usable memory for user data	6 MB usable memory for user data	6 MB usable memory for user data	6 MB usable memory for user data	6 MB usable memory for user data
Type of output					
Status LEDs	Yes	Yes	Yes	Yes	Yes
LED for safe			Yes	Yes	Yes
LED for communication	Yes	Yes	Yes	Yes	Yes
LED for battery	Yes	Yes	Yes	Yes	Yes
Vibrations	Yes	Yes	Yes	Yes	Yes
Time of day					
Clock					
• Type	Hardware clock, battery backup, synchronizable	Hardware clock, battery backup, synchronizable	Hardware clock, battery backup, synchronizable	Hardware clock, battery backup, synchronizable	Hardware clock, battery backup, synchronizable
Interfaces					
Interfaces	1 x Ethernet (RJ45)	1 x Ethernet (RJ45)	1 x Ethernet (RJ45)	1 x Ethernet (RJ45)	1 x Ethernet (RJ45)
USB port	1 x USB	1 x USB	1 x USB	1 x USB	1 x USB
Multi Media Card slot	1 MMC/SD card slot	1 MMC/SD card slot	1 MMC/SD card slot	1 MMC/SD card slot	1 MMC/SD card slot
Industrial Ethernet					
• Industrial Ethernet interface	1 x Ethernet (RJ45)	1 x Ethernet (RJ45)	1 x Ethernet (RJ45)	1 x Ethernet (RJ45)	1 x Ethernet (RJ45)
• Wireless LAN	Yes	Yes	Yes	Yes	Yes
• Supports standards	according to IEEE 802.11a	according to IEEE 802.11a	according to IEEE 802.11a	according to IEEE 802.11a	according to IEEE 802.11a
• Supported channels (according to IEEE 802.11a)	Channel 34, channel 36, channel 38, channel 40, channel 42, channel 44, channel 46, channel 48, channel 52, channel 56, channel 60, channel 64, channel 149, channel 153, channel 157, channel 161	Channel 34, channel 36, channel 38, channel 40, channel 42, channel 44, channel 46, channel 48, channel 52, channel 56, channel 60, channel 64, channel 149, channel 153, channel 157, channel 161	Channel 34, channel 36, channel 38, channel 40, channel 42, channel 44, channel 46, channel 48, channel 52, channel 56, channel 60, channel 64, channel 149, channel 153, channel 157, channel 161	Channel 34, channel 36, channel 38, channel 40, channel 42, channel 44, channel 46, channel 48, channel 52, channel 56, channel 60, channel 64, channel 149, channel 153, channel 157, channel 161	Channel 34, channel 36, channel 38, channel 40, channel 42, channel 44, channel 46, channel 48, channel 52, channel 56, channel 60, channel 64, channel 149, channel 153, channel 157, channel 161
• Supported channels (according to IEEE 802.11b and IEEE 802.1g)	Channels 1 to 11, channel 12, channel 13, channel 14	Channels 1 to 11, channel 12, channel 13, channel 14	Channels 1 to 11, channel 12, channel 13, channel 14	Channels 1 to 11, channel 12, channel 13, channel 14	Channels 1 to 11, channel 12, channel 13, channel 14
• Country approval (radio)	USA, Canada	USA, Canada	USA, Canada	USA, Canada	USA, Canada
• Encryption	WEP, WPA	WEP, WPA	WEP, WPA	WEP, WPA	WEP, WPA
• Supports rapid roaming	Yes	Yes	Yes	Yes	Yes
Protocols					
PROFINET	Yes	Yes	Yes	Yes	Yes
Supports protocol for PROFINET IO	Yes	Yes	Yes	Yes	Yes
Supports protocol for PROFIsafe			Yes	Yes	Yes

Industrial Wireless Communication

IWLAN – Wireless Devices

SIMATIC Mobile Panel 277(F) IWLAN

Technical specifications (continued)

	6AV6 645-0FD01-0AX1	6AV6 645-0FE01-0AX1	6AV6 645-0GB01-0AX1	6AV6 645-0GC01-0AX1	6AV6 645-0GF01-0AX1
EMC					
Emission of radio interference acc. to EN 55 011					
<ul style="list-style-type: none"> Emission of radio interferences acc. to EN 55 011 (limit class A) 	Yes; The product is designed for use in industrial environments. When used in residential areas, the emission of radio interference according to limit class B of EN 55011 must be ensured. For further information refer to the user documentation	Yes; The product is designed for use in industrial environments. When used in residential areas, the emission of radio interference according to limit class B of EN 55011 must be ensured. For further information refer to the user documentation	Yes; The product is designed for use in industrial environments. When used in residential areas, the emission of radio interference according to limit class B of EN 55011 must be ensured. For further information refer to the user documentation	Yes; The product is designed for use in industrial environments. When used in residential areas, the emission of radio interference according to limit class B of EN 55011 must be ensured. For further information refer to the user documentation	Yes; The product is designed for use in industrial environments. When used in residential areas, the emission of radio interference according to limit class B of EN 55011 must be ensured. For further information refer to the user documentation
Ambient conditions					
Operating temperature					
<ul style="list-style-type: none"> Operation 	0 °C to +40 °C	0 °C to +40 °C	0 °C to +40 °C	0 °C to +40 °C	0 °C to +40 °C
Storage/transport temperature					
<ul style="list-style-type: none"> Transport, storage 	-20 °C to +60 °C	-20 °C to +60 °C	-20 °C to +60 °C	-20 °C to +60 °C	-20 °C to +60 °C
Relative humidity					
<ul style="list-style-type: none"> max. relative humidity 	80 %	80 %	80 %	80 %	80 %
Drop height	1.2 m	1.2 m	1.2 m	1.2 m	1.2 m
Degree and class of protection					
IP65 enclosure	Yes	Yes	Yes	Yes	Yes
Standards, approvals, certificates					
Certifications	CE, cULus, C-TICK	CE, cULus, C-TICK	CE, cULus, C-TICK	CE, cULus, C-TICK	CE, cULus, C-TICK
TÜV safety certification			Yes	Yes	Yes
Safety Integrity Level to IEC 61508			3	3	3
Performance level acc. to EN ISO 13849-1			e	e	e
Safety category according to EN 954-1			Safety category according to EN 954-1 (enabling button, STOP button if present) 4	Safety category according to EN 954-1 (enabling button, STOP button if present) 4	Safety category according to EN 954-1 (enabling button, STOP button if present) 4
Operating systems					
Operating system	Windows CE	Windows CE	Windows CE	Windows CE	Windows CE
Configuration					
Configuration software					
<ul style="list-style-type: none"> Configuration tool 	WinCC flexible Standard Version 2008 SP2 and higher (to be ordered separately)	WinCC flexible Standard Version 2008 SP2 and higher (to be ordered separately)	WinCC flexible Standard Version 2008 SP2 and higher (to be ordered separately)	WinCC flexible Standard Version 2008 SP2 and higher (to be ordered separately)	WinCC flexible Standard Version 2008 SP2 and higher (to be ordered separately)
Functionality under WinCC flexible					
Applications/options	Internet Explorer, Sm@rtService, Sm@rtAccess	Internet Explorer, Sm@rtService, Sm@rtAccess	Internet Explorer, Sm@rtService, Sm@rtAccess	Internet Explorer, Sm@rtService, Sm@rtAccess	Internet Explorer, Sm@rtService, Sm@rtAccess
Number of Visual Basic Scripts	50	50	50	50	50
Task planner	Yes	Yes	Yes	Yes	Yes
Help system	Yes	Yes	Yes	Yes	Yes
Status/control	With SIMATIC S7	With SIMATIC S7	With SIMATIC S7	With SIMATIC S7	With SIMATIC S7
With alarm logging system (incl. buffer and acknowledgment)					
<ul style="list-style-type: none"> Number of messages Bit messages Analog messages Message buffer 	4 000 Yes Yes Ring buffer (n x 512 entries), retentive, maintenance-free	4 000 Yes Yes Ring buffer (n x 512 entries), retentive, maintenance-free	4 000 Yes Yes Ring buffer (n x 512 entries), retentive, maintenance-free	4 000 Yes Yes Ring buffer (n x 512 entries), retentive, maintenance-free	4 000 Yes Yes Ring buffer (n x 512 entries), retentive, maintenance-free

Technical specifications (continued)

	6AV6 645-0FD01-0AX1	6AV6 645-0FE01-0AX1	6AV6 645-0GB01-0AX1	6AV6 645-0GC01-0AX1	6AV6 645-0GF01-0AX1
Recipes					
• Recipes	300	300	300	300	300
• Data records per recipe	500	500	500	500	500
• Entries per data record	1000	1000	1000	1000	1000
• Recipe memory	64 KB integrated Flash, expandable	64 KB integrated Flash, expandable	64 KB integrated Flash, expandable	64 KB integrated Flash, expandable	64 KB integrated Flash, expandable
Number of process images					
• Process images	500	500	500	500	500
• Variables	2 048	2 048	2 048	2 048	2 048
• Limit values	Yes	Yes	Yes	Yes	Yes
• Multiplexing	Yes	Yes	Yes	Yes	Yes
Image elements					
• Text objects	10,000 text elements	10,000 text elements	10,000 text elements	10,000 text elements	10,000 text elements
• Graphics object	Bit maps, icons, vector graphics	Bit maps, icons, vector graphics	Bit maps, icons, vector graphics	Bit maps, icons, vector graphics	Bit maps, icons, vector graphics
• dynamic objects	Diagrams, bar graphs, sliders, analog display, invisible buttons	Diagrams, bar graphs, sliders, analog display, invisible buttons	Diagrams, bar graphs, sliders, analog display, invisible buttons	Diagrams, bar graphs, sliders, analog display, invisible buttons	Diagrams, bar graphs, sliders, analog display, invisible buttons
Lists					
• Text lists	500	500	500	500	500
• Graphics list	400	400	400	400	400
• Libraries	Yes	Yes	Yes	Yes	Yes
Archiving					
• Number of archives per project	20	20	20	20	20
• Number of measuring points per project	20	20	20	20	20
• Number of entries per archive	10 000	10 000	10 000	10 000	10 000
• Memory location	Multi Media Card	Multi Media Card	Multi Media Card	Multi Media Card	Multi Media Card
Security					
• Number of user groups	50	50	50	50	50
• Passwords exportable	Yes	Yes	Yes	Yes	Yes
• Number of user rights	32	32	32	32	32
Data carrier support					
• Multi Media Card	Yes	Yes	Yes	Yes	Yes
Logging					
• Recording/Printing	Alarms, report (shift report), PROFINET	Alarms, report (shift report), PROFINET	Alarms, report (shift report), PROFINET	Alarms, report (shift report), PROFINET	Alarms, report (shift report), PROFINET
Languages					
• Languages	D, GB, F, I, E, CHN "traditional", CHN "simplified", DK, FIN, GR, J, KP / ROK, NL, N, PL, P, RUS, S, CZ / SK, TR, H	D, GB, F, I, E, CHN "traditional", CHN "simplified", DK, FIN, GR, J, KP / ROK, NL, N, PL, P, RUS, S, CZ / SK, TR, H	D, GB, F, I, E, CHN "traditional", CHN "simplified", DK, FIN, GR, J, KP / ROK, NL, N, PL, P, RUS, S, CZ / SK, TR, H	D, GB, F, I, E, CHN "traditional", CHN "simplified", DK, FIN, GR, J, KP / ROK, NL, N, PL, P, RUS, S, CZ / SK, TR, H	D, GB, F, I, E, CHN "traditional", CHN "simplified", DK, FIN, GR, J, KP / ROK, NL, N, PL, P, RUS, S, CZ / SK, TR, H
Character sets					
• Character sets	Tahoma, Arial, Courier New, WinCC flexible Standard, ideographic languages, all freely scalable	Tahoma, Arial, Courier New, WinCC flexible Standard, ideographic languages, all freely scalable	Tahoma, Arial, Courier New, WinCC flexible Standard, ideographic languages, all freely scalable	Tahoma, Arial, Courier New, WinCC flexible Standard, ideographic languages, all freely scalable	Tahoma, Arial, Courier New, WinCC flexible Standard, ideographic languages, all freely scalable
Transfer (upload/download)					
• Transfer of configuration	USB, Ethernet, automatic transfer recognition	USB, Ethernet, automatic transfer recognition	USB, Ethernet, automatic transfer recognition	USB, Ethernet, automatic transfer recognition	USB, Ethernet, automatic transfer recognition
• Wireless LAN	Yes	Yes	Yes	Yes	Yes

Industrial Wireless Communication

IWLAN – Wireless Devices

SIMATIC Mobile Panel 277(F) IWLAN

Technical specifications (continued)

	6AV6 645-0FD01-0AX1	6AV6 645-0FE01-0AX1	6AV6 645-0GB01-0AX1	6AV6 645-0GC01-0AX1	6AV6 645-0GF01-0AX1
Process coupling					
• Connection to controller	S7-200, S7-300/400 see section on "System interfaces"	S7-200, S7-300/400 see section on "System interfaces"	S7-200, S7-300/400 see section on "System interfaces"	S7-200, S7-300/400 see section on "System interfaces"	S7-200, S7-300/400 see section on "System interfaces"
• Zones	Yes	Yes	Yes	Yes	
- Number of zones per project, max.	254	254	254	254	
- Number of transponders for zones per project, max.	255	255	255	255	
• Effective range			Yes	Yes	Yes
- Number of effective ranges per project, max.			127	127	127
- Number of transponders for effective ranges per project, max.			127	127	
• Transponder	Yes	Yes	Yes	Yes	
- Number of transponders per project, max.	256	256	256	256	
- Adjustable distance range	Yes	Yes	Yes	Yes	
- Adjustable distance, min.	2 m	2 m	2 m	2 m	
- Adjustable distance, max.	8 m	8 m	8 m	8 m	
I/O					
I/O devices	Barcode reader	Barcode reader	Barcode reader	Barcode reader	Barcode reader
Mechanics/material					
Type of housing (front)	Plastic	Plastic	Plastic	Plastic	Plastic
Dimensions and weight					
Dimensions					
• Housing diameter/depth (mm)	Dia 290 mm / D 103 mm	Dia 290 mm / D 103 mm	Dia 290 mm / D 103 mm	Dia 290 mm / D 103 mm	Dia 290 mm / D 103 mm
Weight					
• Weight	2.2 kg	2.2 kg	2.2 kg	2.2 kg	2.2 kg

Ordering data	Order No.	Order No.
SIMATIC Mobile Panel 277 IWLAN V2 (RoW version) <ul style="list-style-type: none"> • Communication via WLAN (PROFINET) • Communication via WLAN (PROFINET) with integrated handwheel, key-operated switch and two illuminated pushbuttons 	6AV6 645-0DD01-0AX1 6AV6 645-0DE01-0AX1	<p>Accessories</p> <p><u>Note:</u> Please order the table-top power supply or charging station as well. Required for charging the battery</p> <ul style="list-style-type: none"> • Table-top power supply incl. power cable for EU, US, UK, JP (only suitable for operation under laboratory/office conditions) • Charger V2 for safe storage and charging of device incl. lock for securing the device in the charger. Charging capabilities for up to two additional batteries • Additional battery with LED indicator for indicating the charge status • Transponder V2 incl. batteries (3x AA) • Transponder V1 incl. batteries (3x AA) (mandatory for operation in plants with Mobile Panels 277(F) IWLAN V1) • Service pack V2 for Mobile Panel 277(F) IWLAN V2 contains accessories pack for Mobile Panel 277 (labeling strip cover), battery compartment cover (device), cover left/right (charger), power supply connector counterpart (charger), replacement key (charger)
SIMATIC Mobile Panel 277F IWLAN V2 PROFIsafe (RoW version) <ul style="list-style-type: none"> • Communication via WLAN (PROFINET) with acknowledgement button and emergency stop button • Communication via WLAN (PROFINET) with acknowledgement button and emergency stop button with integrated handwheel, key-operated switch, and two illuminated pushbuttons • RFID tag version: Communication via WLAN (PROFINET) with acknowledgement button and emergency stop button with integrated handwheel, key-operated switch, and two illuminated pushbuttons 	6AV6 645-0EB01-0AX1 6AV6 645-0EC01-0AX1 6AV6 645-0EF01-0AX1	
SIMATIC Mobile Panel 277 IWLAN V2 (USA version) <ul style="list-style-type: none"> • Communication via WLAN (PROFINET) • Communication via WLAN (PROFINET) with integrated handwheel, key-operated switch and two illuminated pushbuttons 	6AV6 645-0FD01-0AX1 6AV6 645-0FE01-0AX1	
SIMATIC Mobile Panel 277F IWLAN V2 PROFIsafe (USA version) <ul style="list-style-type: none"> • with acknowledgement button and emergency stop button • with acknowledgement button and emergency stop button with integrated handwheel, key-operated switch, and two illuminated pushbuttons • with acknowledgement button and emergency stop button with integrated handwheel, key-operated switch, and two illuminated pushbuttons (tag version) 	6AV6 645-0GB01-0AX1 6AV6 645-0GC01-0AX1 6AV6 645-0GF01-0AX1	
Starter kit SIMATIC Mobile Panel 277(F) IWLAN (RoW version) for <ul style="list-style-type: none"> • Mobile Panel 277 IWLAN V2 • Mobile Panel 277F IWLAN V2 	6AV6 651-5GA01-0AA1 6AV6 651-5HA01-0AA1	

Industrial Wireless Communication

IWLAN – Wireless Devices

SIMATIC Mobile Panel 277(F) IWLAN

Ordering data

Order No.

SCALANCE W-786 Access Points for SIMATIC Mobile Panel 277(F) IWLAN

- IWLAN Access Points with integrated radio interfaces; radio networks; IEEE 802.11b/g/a/h at 2.4/5 GHz up to 54 Mbit/s. National approvals; WPA2/AES; Power over Ethernet (PoE), degree of protection IP65 (-40 °C to +70 °C); scope of delivery: Mounting hardware, 48 V DC terminal block; manual on CD-ROM; German/English;

SCALANCE W-786-2RR

IWLAN Dual Access Point with two integrated radio interface for setting up radio links with iPCF; RJ45 connection

Four internal antennas

- National approvals for operation outside the U.S.
- National approvals for operation within the U.S. ¹⁾

6GK5 786-2BA60-6AA0

6GK5 786-2BA60-6AB0

SCALANCE W-786-1PRO

IWLAN Access Points with built-in wireless interface RJ45 connection

Two internal antennas

- National approvals for operation outside the U.S.
- National approvals for operation within the U.S. ¹⁾

6GK5 786-1BA60-2AA0

6GK5 786-1BA60-2AB0

Further IWLAN Access Point versions:

SCALANCE W-784 Access Points

6GK5 784-1AA30-...

SCALANCE W-786 Access Points

6GK5 786-...

SCALANCE W-788 Access Points

6GK5 788-...

PS791-2DC power supply

- 24 V DC power supply for installation in SCALANCE W-786 products; operating instructions in German/English

6GK5 791-2DC00-0AA0

PS791-2AC power supply

- 110 V AC to 230 V AC power supply for installation in SCALANCE W-786 products; operating instructions in German/English

6GK5 791-2AC00-0AA0

Other compatible accessories

See catalog ST 80 / ST PC

¹⁾ Please note national approvals at www.siemens.com/wireless-approvals

Order No.

Configuration

with SIMATIC WinCC flexible

See catalog ST 80 / ST PC

Documentation

(to be ordered separately)

Mobile Panel 277F IWLAN V2 Operating Instructions

- German
- English
- French
- Italian
- Spanish

6AV6 691-1DQ01-2AA1

6AV6 691-1DQ01-2AB1

6AV6 691-1DQ01-2AC1

6AV6 691-1DQ01-2AD1

6AV6 691-1DQ01-2AE1

Mobile Panel 277 IWLAN V2 Operating Instructions

- German
- English
- French
- Italian
- Spanish

6AV6 691-1DM01-2AA1

6AV6 691-1DM01-2AB1

6AV6 691-1DM01-2AC1

6AV6 691-1DM01-2AD1

6AV6 691-1DM01-2AE1

User Manual WinCC flexible Compact/Standard/Advanced

- German
- English
- French
- Italian
- Spanish

6AV6 691-1AB01-3AA0

6AV6 691-1AB01-3AB0

6AV6 691-1AB01-3AC0

6AV6 691-1AB01-3AD0

6AV6 691-1AB01-3AE0

WinCC flexible Communication User Manual

- German
- English
- French
- Italian
- Spanish

6AV6 691-1CA01-3AA0

6AV6 691-1CA01-3AB0

6AV6 691-1CA01-3AC0

6AV6 691-1CA01-3AD0

6AV6 691-1CA01-3AE0

Accessories for Mobile Panels

See HMI accessories

The Function Manuals "Fail-Safe Operation of the Mobile Panel 277F IWLAN V1" are available for downloading in English, German, and Japanese.

<http://support.automation.siemens.com/WW/view/en/31255853>

More information

Additional information is available in the Internet at:

www.siemens.com/simatic-mobile-panels

Note:

Do you need a specific modification or addition to the products described here? Then take a look under "Customer-specific products". There, you will find information on ordering additional and standard industry products as well as possibilities for customer-specific modifications and adjustments.

Overview



Interface module for handling communication between ET 200pro and host PROFINET IO controllers over Industrial Wireless LAN (IWLAN) radio networks for 2.4 GHz or 5 GHz with data transfer rates up to 54 Mbit/s.

- Protection against illegal access, espionage, tapping and falsification through use of effective encryption mechanisms
- Fast exchange of devices through use of interchangeable medium MICRO MEMORY CARD

Ordering data

IM 154-6 PN HF IWLAN interface module

For communication between ET 200pro and host controllers over Industrial Wireless LAN (IWLAN) radio networks; support of PROFINET

With various national approvals; refer to the current list of approvals

With approval for USA

Order No.

6ES7 154-6AB00-0AB0

6ES7 154-6AB50-0AB0

Antennas with omnidirectional characteristic

Mounting directly on IM154-6 PN HF IWLAN

- ANT IM 154-6 IWLAN; 2 units

For wall or pipe mounting

- ANT 792-6MN; rod antenna N-Connect female 2.4 GHz; 1 unit
- ANT793-6MN; rod antenna N-Connect female 5 GHz; 1 unit

For use with the RCoax antenna system

- ANT 792-4DN; RCoax N-Connect female 2.4 GHz; 1 unit
- ANT793-4MN; RCoax N-Connect female 5 GHz; 1 unit

6ES7 194-4MA00-0AA0

6GK5 792-6MN00-0AA6

6GK5 793-6MN00-0AA6

6GK5 792-4DN00-0AA6

6GK5 793-4MN00-0AA6

Antenna cables IWLAN RCoax; N-Connect / R-SMA

1 m long

2 m long

5 m long

10 m long

IWLAN terminating resistor 50 Ohm for second R-SMA antenna socket, 3 units

6XV1 875-5CH10

6XV1 875-5CH20

6XV1 875-5CH50

6XV1 875-5CN10

6GK5 795-1TR10-0AA6

Order No.

Accessories

7/8" connecting cable to power supply

5-core, 5 x 1.5 mm², trailing type, pre-assembled with two 7/8" connectors

1.5 m long

2.0 m long

3.0 m long

5.0 m long

10 m long

15 m long

- Other special lengths with 90° or 180° cable outlet

6XV1 822-5BH15

6XV1 822-5BH20

6XV1 822-5BH30

6XV1 822-5BH50

6XV1 822-5BN10

6XV1 822-5BN15

See <http://support.automation.siemens.com/WWW/view/en/26999294>

Power line

5-core, 5 x 1.5 mm², trailing type, sold by the meter, minimum order quantity 20 m, maximum order quantity 1,000 m

6XV1 830-8AH10

7/8" cable connector

For ET 200eco, with axial cable outlet; with socket insert, pack of 5

6GK1 905-0FB00

Twisted Pair cables 4x2 with RJ45 connectors

0.5 m long

1 m long

2 m long

6 m long

10 m long

6XV1 870-3QE50

6XV1 870-3QH10

6XV1 870-3QH20

6XV1 870-3QH60

6XV1 870-3QN10

Crossed Twisted Pair cables 4x2 with RJ45 connectors

0.5 m long

1 m long

2 m long

6 m long

10 m long

6XV1 870-3RE50

6XV1 870-3RH10

6XV1 870-3RH20

6XV1 870-3RH60

6XV1 870-3RN10

Industrial Wireless Communication

IWLAN – Wireless Devices

IM 154-6 PN IWLAN

Ordering data	Order No.	Order No.	
<i>General accessories</i>			
ET 200pro rack <ul style="list-style-type: none"> Narrow, for interface, electronics and power modules <ul style="list-style-type: none"> - 500 mm - 1000 mm - 2000 mm, can be cut to length Compact, for interface, electronics and power modules <ul style="list-style-type: none"> - 500 mm - 1000 mm - 2000 mm, can be cut to length Wide, for interface, electronics, power modules and motor starters <ul style="list-style-type: none"> - 500 mm - 1000 mm - 2000 mm, can be cut to length Wide, for I/O modules and motor starters <ul style="list-style-type: none"> - 500 mm - 1000 mm - 2000 mm 	6ES7 194-4GA00-0AA0 6ES7 194-4GA60-0AA0 6ES7 194-4GA20-0AA0 6ES7 194-4GC70-0AA0 6ES7 194-4GC60-0AA0 6ES7 194-4GC20-0AA0 6ES7 194-4GB00-0AA0 6ES7 194-4GB60-0AA0 6ES7 194-4GB20-0AA0 6ES7 194-4GD00-0AA0 6ES7 194-4GD10-0AA0 6ES7 194-4GD20-0AA0	Spare fuse 12.5 A quick-response, for interface and power modules, 10 items per package unit Labels 20 x 7 mm, pale turquoise, 340 units per pack SIMATIC Micro Memory Card <ul style="list-style-type: none"> • 64 KB • 128 KB • 512 KB SIMATIC Manual Collection Electronic manuals on DVD, multi-language: S7-200, TD 200, S7-300, M7-300, C7, S7-400, M7-400, STEP 7, Engineering Tools, Runtime Software, SIMATIC DP (Distributed I/O), SIMATIC HMI (Human Machine Interface), SIMATIC NET (Industrial Communication) SIMATIC Manual Collection – Update service for 1 year Scope of delivery: Current DVD "S7 Manual Collection" and the three subsequent updates	6ES7 194-4HB00-0AA0 3RT1 900-1SB20 6ES7 953-8LF20-0AA0 6ES7 953-8LG20-0AA0 6ES7 953-8LJ30-0AA0 6ES7 998-8XC01-8YE0 6ES7 998-8XC01-8YE2

Note:

You can find more information in Catalog ST 70 and in the Industry Mall at www.siemens.com/industrymall

More information

Wireless approvals

Current approvals can be found on the Internet.

In Germany:

Further information can be found on the Internet at:

www.siemens.com/wireless-approvals

Outside Germany:

Further information can be found on the Internet at:

www.siemens.com/wireless-approvals

Overview



PN	DP-M	DP-S	ASi-M		
●	●				

- Compact router between Industrial Wireless LAN (IWLAN) and PROFIBUS
- Wireless connection to IWLAN (e.g. SCALANCE W Access Points) according to IEEE 802.11a/b/g/h with up to 54 Mbit/s at 2.4 GHz and 5 GHz
- PROFINET IO proxy; connection of PROFIBUS DP slaves to PROFINET IO controller according to PROFINET standard:
 - From the viewpoint of the IO controller, all DP slaves are handled like I/O devices with Ethernet interface, i.e. the IWLAN/PB Link PN IO is their proxy.
 - From the viewpoint of the DP slaves, the IWLAN/PB Link PN IO is the DP master
- High, deterministic data throughput and very fast roaming through support of iPCF; the iPCF mechanism represents an extension of the IEEE 802.11 standard and must be available both on the station and on the access point, e.g. SCALANCE W788-1RR
- Full support of the security options defined in the IEEE 802.11i standard for authentication via WPA2 with TLS, TTLS, PEAP
- High degree of protection against unauthorized access thanks to 128-bit encoding (AES)
- Direct substitution of solutions with Power Rail Booster for PROFIBUS with non-contact data transmission technology; Advantages: no wear of sliding contacts
- Cross-network PG/OP communication by means of S7 routing, i.e. all S7 stations can be remotely programmed using the programming device on the Industrial Ethernet or PROFIBUS.
- Cross-network access to data of S7 stations for visualization by means of S7 OPC server and S7 routing; via the IE/PB Link PN IO access can be made from the PC on the Industrial Ethernet (e.g. for HMI applications with OPC client interface) to all data of the S7 stations on the PROFIBUS by means of the S7 OPC server.
- Module replacement without the need for a programming device, using the C-PLUG swap media for backing up the configuration data
- Configuring in STEP 7

Benefits

get Designed for Industry

- High mobility; increased plant availability through wireless data transmission to mobile communication partners, e.g. to control an automated guided vehicle system (AGVS)
- Wear-free; contact-free technology with RCoax as a substitute for contact wires, e.g. for suspended monorails
- Investment protection; integration of PROFIBUS field devices into an IWLAN radio network
- Also enables use in plants with PROFI-safe applications
- Flexible use ensured by connecting the antenna best suited to the respective application (e.g. for operation on RCoax radiating cable)

Application

The IWLAN/PB Link PN IO supports the use of an IWLAN, for example with RCoax radiating cables, for wireless data transmission in the case of suspended monorails, storage and retrieval systems, or other applications with mobile stations. Support of PROFINET means that the wide variety of PROFIBUS system services, such as diagnostics over the bus, can still be utilized.

- Suspended monorails; vehicle controllers for suspended monorails can be implemented economically on the basis of SIMATIC components. High availability, short response times and easy expansion are achieved by using distributed controllers, such as SIMATIC ET 200S IM 151/CPU. With the aid of the IWLAN/PB Link PN IO, the vehicle controllers can continue to be used without change. The user can also program them remotely with STEP 7 over IWLAN.
- Storage and retrieval systems; with these systems, data light barriers requiring intensive maintenance and offering no flexibility can be replaced by an IWLAN solution. This enhances plant availability.

Industrial Wireless Communication

IWLAN – Network transition

IWLAN/PB Link PN IO

Design

The IWLAN/PB Link PN IO is snapped onto a standard mounting rail. The external dimensions are the same as those of the Power Rail Booster enclosure. The IP20 degree of protection ensures that the IWLAN/PB Link PN IO is suitable for installation in the control cabinet.

- Compact construction; the rugged plastic enclosure features the following on the front panel:
 - an R-SMA interface for connecting an antenna, e.g. for operation on the RCoax radiating cable
 - a 9-pin sub-D socket for connection to PROFIBUS
 - a 4-pin terminal strip for connecting the external supply voltage of 24 V DC.
 - Diagnostic LEDs
- Can be operated without a fan
- Fast device replacement in the event of a fault by using the optional C-PLUG swap medium (not included in scope of supply)

Function

PROFINET

- PROFINET IO proxy; wireless connection of PROFIBUS DP slaves to PROFINET IO Controller according to PROFINET standard. Using the IWLAN/PB Link PN IO as a proxy, you can continue to use existing PROFIBUS devices (also with PROFIsafe functionality, V2.0 or higher) and integrate them into a PROFINET application.

Vertical integration

- S7 routing; permits cross-network PG communication, in other words, all S7 stations on the IWLAN/Industrial Ethernet or PROFIBUS can be programmed remotely using the programming device. Access can be made to visualization data of S7 stations on the PROFIBUS from HMI stations on the IWLAN/Industrial Ethernet.
- Data set routing (PROFIBUS DP); using this option, the IWLAN/PB Link PN IO can be used as a router for data sets that are forwarded to field devices (DP slaves). SIMATIC PDM (**P**rocess **D**evice **M**anager) is a tool that creates data sets of this type for parameterizing and diagnosing field devices. It is possible, for example, to use SIMATIC PDM (on the PC) to set parameters and perform diagnostics for a PROFIBUS PA field device on the IWLAN/Industrial Ethernet over the IWLAN/PB Link PN IO and DP/PA Coupler/Link. The additional functions for vertical integration can also be used in an existing PROFIBUS application without PROFINET for connection to a higher-level IWLAN/Industrial Ethernet. In this case, the IWLAN/PB Link PN IO is used as an additional DP-Master Class 2 on a PROFIBUS segment for linking to the IWLAN/Industrial Ethernet and offers the above functions.

Diagnosis

Extensive diagnostic options are available via STEP 7 or SNMP, including:

- Diagnosis of the assigned PROFIBUS field devices; using the IWLAN/PB Link PN IO as a proxy, the connected DP slaves can be diagnosed in the same manner as PROFINET IO devices (even in the user program of the PROFINET IO controller)
- General diagnostics and statistics functions
- Connection diagnostics
- Diagnostic buffer
- Integration into network management systems through the support of SNMP V1 MIB-II

Configuration

STEP 7 V5.4 or higher or the TIA Portal is required for configuring the full functional scope of the IWLAN/PB Link PN IO.

For the IWLAN/PB Link PN IO, STEP 7 automatically generates the necessary parameters, e.g. the ones that assign addresses, and all necessary routing information.

The configuration data for PROFINET IO created with STEP 7 is saved on the IO controller. Attention must however be paid to the memory capacity. The initialization data for the Ethernet interface is backed up on the C-PLUG (Configuration Plug) swap media. The IWLAN/PB Link PN IO can be swapped in the event of failure without a programming device, because the relevant user and configuration data is saved on the IO controller or on the C-PLUG.

Integration

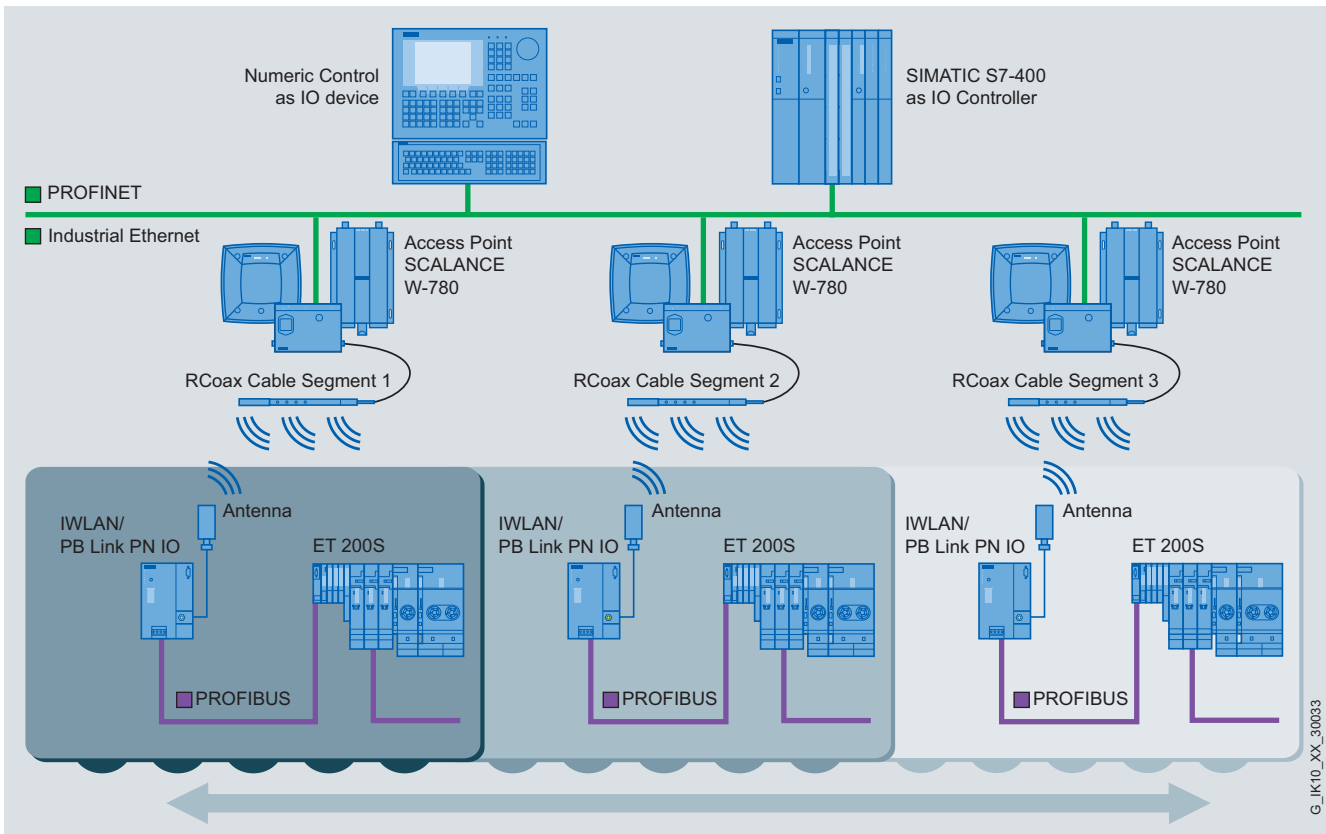

System solution with IWLAN/PB Link PN IO using example of suspended monorail

Industrial Wireless Communication

IWLAN – Network transition

IWLAN/PB Link PN IO

Technical specifications

Product type designation	IWLAN/PB Link PN IO
Transfer rates	
• Radio	1 ... 54 Mbit/s
- standards supported	IEEE 802.11a, 802.11b, 802.11g, 802.11h, 802.11i
• PROFIBUS	9.6 kbit/s to 12 Mbit/s incl. 45.45 kbit/s (PROFIBUS PA)
Interfaces	
• Connection to Industrial Wireless LAN	R-SMA antenna socket
• Connection to PROFIBUS	9-pin Sub-D socket
- maximum segment length for PROFIBUS ¹⁾	20 m
- maximum current consumption at the PROFIBUS interface with connection of network components (for example, optical network components)	100 mA at 5 V
• Connection for power supply	4-pin terminal block
Power supply ²⁾	2 supplies for 20.4 ... 28.8 V DC
Current consumption (at rated voltage)	
• external from 24 V DC, max.	300 mA
Power loss	approx. 6.5 W
Perm. ambient conditions	
• Operating temperature	0 ... + 60 °C
• Transport/storage temperature	- 40 ... + 70 °C
• Relative humidity, max.	95 % at +25 °C
Design	
• Module format	Power Rail Booster enclosure
• Dimensions (W x H x D) in mm	90 x 132 x 75
• Weight	approx. 300 g
Degree of protection	IP20
Configuration	
Configuration software	STEP 7/NCM S7 with V5.3 SP2 or later plus Hardware Support Package for IWLAN/PB Link PN IO

Product type designation	IWLAN/PB Link PN IO
<i>Performance data</i>	
PROFINET communication	
• Number of DP slaves on the IWLAN/PB Link PN IO (PROFINET IO-Devices for PROFINET IO)	max. 8
• Number of DP inputs	max. 256 byte
• Number of DP outputs	max. 256 byte
Additional functionality	
• Number of S7 connections	max. 8
• Number of DSGW connections	max. 8

- ¹⁾ A repeater is required if the specified length is exceeded
- ²⁾ The power supply is electrically isolated; a high-impedance connection (>700 kΩ) exists to the contact spring for mounting of the enclosure on the DIN rail).

Industrial Wireless Communication

IWLAN – Network transition

IWLAN/PB Link PN IO

Ordering data	Order No.	Order No.
IWLAN/PB Link PN IO Network transition between Industrial Wireless LAN and PROFIBUS with PROFINET IO functionality, TCP/IP, S7 routing, IEEE 802.11a/b/g/h at 2.4/5 GHz up to 54 Mbit/s, 9.6 Kbit/s to 12 Mbit/s PROFIBUS; including electronic manual on CD-ROM; German, English, French, Spanish, Italian <ul style="list-style-type: none"> • National approvals for operation outside the USA • National approvals for operation within the USA¹⁾ 	6GK1 417-5AB00 6GK1 417-5AB01	Accessoires C-PLUG Swap medium for simple replacement of devices in the event of a fault; for storing configuration or engineering and application data; can be used for SIMATIC NET products with C-PLUG slot 6GK1 900-0AB00
		PRESET-PLUG Swap medium for simple initial startup of IWLAN clients, e.g. IWLAN/PB Link PN IO 6GK5 798-8AB00
		PROFIBUS FC Standard Cable GP Standard type with special design for fast mounting, 2-core, shielded, 6XV1 830-0EH10
		PROFIBUS FastConnect bus connector RS485 Plug 180 with insulation displacement terminals, with 180° cable outlet, for industrial PC, SIMATIC HMI OP, OLM; max. transmission rate 12 Mbit/s 6GK1 500-0FC10
		PROFIBUS FastConnect Stripping Tool Preadjusted stripping tool for fast stripping of PROFIBUS FastConnect bus cables 6GK1 905-6AA00
		S7-300 PS 307 load power supply 24 V DC 6ES7 307-1BA00-0AA0
		Antennas and miscellaneous IWLAN accessories See Industrial Wireless LAN/ accessories

¹⁾ Please note national approvals at www.siemens.com/wireless-approvals

Industrial Wireless Communication

Engineering/network management/diagnostics

SINEMA E

Overview

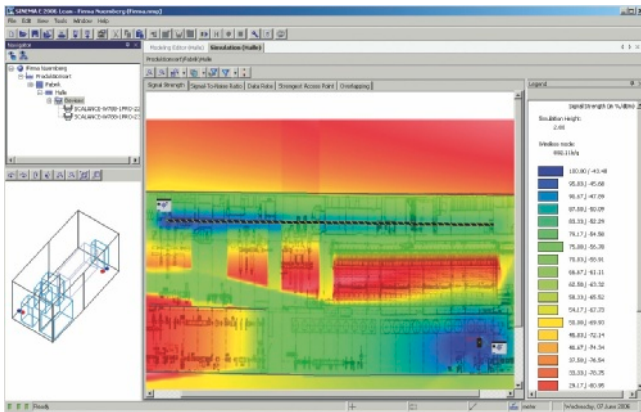

- Engineering tool for support with planning, configuration, simulation and measurement of an IWLAN radio field on site (Site Survey) according to the IEEE 802.11 a/b/g/h standard
- Automatic determination of the WLAN infrastructure for new and existing networks
- Optimization functions for minimization of channel interference
- Visualization and analysis of WLAN networks according to signal strength, data rate, signal-to-noise ratio, overlapping and applications (PROFINET, TCP/IP, Voice over WLAN)
- Configuration of single and multiple devices as well as uploading/downloading of IWLAN device parameters
- Site survey functions (measurements) for the acquisition, conditioning, evaluation and visualization of measured WLAN signals
- Integrated and expandable catalog entries for WLAN devices, antennas and radio hindrances as well as standard graphics formats for importing layout plans
- Report function for documenting the configured and measured WLAN infrastructure

Benefits

get Designed for Industry

- Quick and easy creation of WLAN applications for industrial and office environments indoors and outdoors thanks to functions for
 - automatic detection of the optimal WLAN infrastructure
 - minimization of channel interference
 - simulation of changes to device properties, to predict the operating principle of real networks
 - wizard-supported project and tender preparation
- Minimization of the configuration and start-up outlay thanks to grouped offline and online functions
- Reduction of configuration errors through inherent consistency check
- Analysis of the the performance of existing WLAN networks through measurement and evaluation functions
 - at the beginning or for verification of start-up
 - for troubleshooting and optimization during maintenance and servicing
- Report function including the planning and measurement results for offer generation, device installation instructions and plant documentation
- Extendable catalogs for integration of further
 - WLAN devices (to the IEEE 802.11 a/b/g/h standard)
 - obstacles to radio waves, through the measurement and/or input of attenuation values

Application

SINEMA E (**S**IMATIC **N**etwork **M**anager Engineering) is the generic term for the engineering of network products such as SCALANCE W.

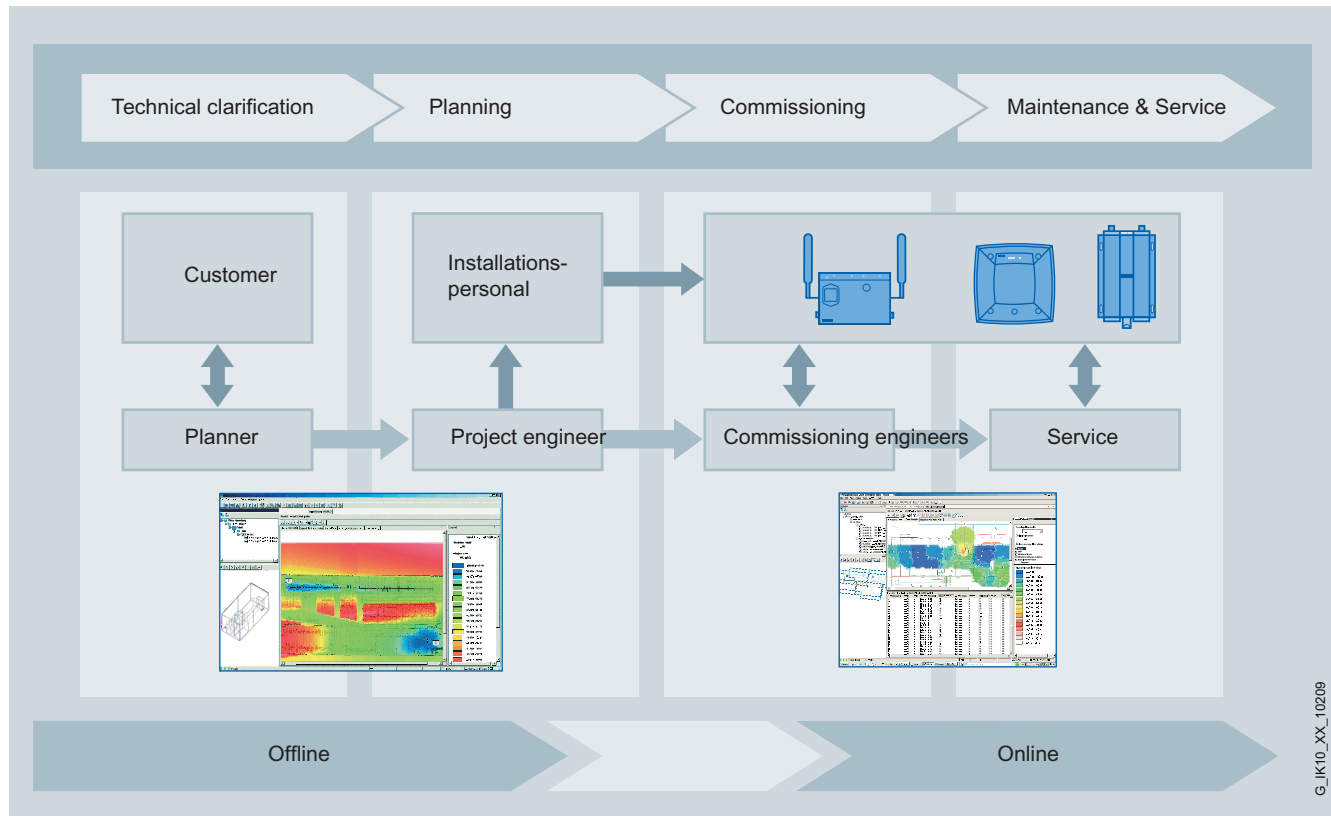

Application diagram of the SINEMA E software for planning and measuring WLAN networks

SINEMA E 2006 contains the following functions for the engineering of IWLAN networks:

Technical clarification

- Wizard-supported tender preparation

Planning

- Measurement (site survey) of an existing WLAN network
- Planning, simulation, and optimization of a WLAN infrastructure
 - Simultaneous configuring of device groups
 - Generation of a report with installation guidelines

Start-up

- Identification, upload/download from devices
- Measurement (site survey) for verification and optimization of planning
- Report for final documentation

Maintenance and service

- Optimization and fault rectification with the help of measurements (site survey)

The functional scope of the software is subdivided into "lean" and "standard" licenses. With the standard license, additional functions are possible for the acquisition, evaluation and visualization of measured WLAN signals (site survey) as well as extended simulation and planning (automatic placement, contour presentation, storage/comparison of simulations, extended filter options).

Industrial Wireless Communication

Engineering/network management/diagnostics

SINEMA E

Function

The SINEMA E software (**S**IMATIC **N**ETwork **M**ANager **E**ngineering) provides the user with various different tools for planning, configuration, simulation and measurement (site survey) of WLAN networks.

Modeling, simulation, visualization, and optimization

Special algorithms in **SINEMA E** allow the operating principle of WLAN networks to be predicted taking into account environmental sources of interference. Catalogs provided in the software that contain known sources of interference (e.g. walls, machines, and tools) make it easy to model even the most difficult environments at the office desk quickly and accurately. If required, obstacles specific to the environment can be accurately determined with local measurements and added to the catalog.

Using the software, the properties of Access Points and Client Modules, such as channel settings/transmitted power, and their antennas can be changed to ensure that the optimal configuration is achieved for the real network.

Following simulation, all signal parameters such as range, data rate, attenuation, etc. can be evaluated using several different views. At any time, therefore, the quality of the WLAN can be predicted inside and outside buildings and gaps in security can be closed.

The "standard" license also offers integrated expert functions such as automatic placement and channel optimization, which determine the necessary access points and optimize the device parameters. The "standard" license also supports visualization with contours, further filter options, the comparison of saved simulations and the creation of application profiles for PROFINET, TCP/IP, and Voice over WLAN.

Multi-device setting of access points and clients

The parameters of all SCALANCE W access points and clients are part of the SINEMA E project and can be set accordingly. Common parameters of these devices can be combined in a group and therefore set more rapidly.

Configuring with SINEMA E can also be carried out without the hardware being present. SINEMA E checks the consistency of the configuration, thus preventing faulty settings.

Initial startup and configuration

Simply by pressing a key, SINEMA E identifies all IWLAN nodes which can be accessed online, and transmits all basic parameters of these devices, such as IP addresses etc., during initial commissioning.

Further devices which are not yet included in the project are also detected, and their configuration data can be added to the project.

The initial startup can be carried out from any point in the same subnetwork. Further settings and configurations can then also be transmitted from other subnetworks in the Ethernet network to all devices in the project by pressing a key.

WLAN site survey (measurement), evaluation and visualization

SINEMA E is a complete tool for measurement (site survey) of existing WLAN networks according to the IEEE 802.11 a/b/g/h standard. WLAN signals can be measured using this at the start of planning or for verification during commissioning as well as for troubleshooting during maintenance and servicing.

The software saves received measured values of the WLAN adapter used with the coordinates in the floor plan and links them together. Different methods are available for measurement and evaluation to suit the application.

Standard measuring technique

The WLAN adapter used for measurement is always connected to a previously defined WLAN network (SSID). Properties such as speed, signal strength and roaming behavior of the existing client access point connection are determined.

For continuous measurements along a route, it is sufficient to set a start and end point to enable all additional measuring coordinates to be automatically determined by the software. The WLAN connection properties of a client can then be measured quickly even in the case of large areas.

Advanced measuring technique

All WLAN signals in the environment are scanned so that signals from known and unknown devices can be acquired.

Using the filter functions of SINEMA, such as minimum, maximum, average value, measurements from a wide range of different points in time can be combined and analyzed.

Sales wizard

For creating an offer for IWLAN applications of an industrial plant (Level 1)

SINEMA E report function

The report function supplies an up-to-date project overview at every phase of the engineering process.

A report always comprises a project device list with order numbers and antennas as well as installation coordinates inside and outside the modeling environment. The format and scope of the HTML report can be changed using the software. All the planning and measurement graphics can be inserted as well as later plant photos, logos, etc. without the need for any special software.

The report permits quotations to be generated at an early point in time, and devices can be installed for commissioning using the coordinates data. The report is an important document following commissioning and during service and maintenance.

Ordering data	Order No.	More information
<p>SINEMA E</p> <p>Engineering software for planning, configuring, simulating and measuring (Site Survey) industrial WLAN applications in office and industrial environments on PG/PC in accordance with the 802.11 a/b/g/h standard; software and electronic manual on CD-ROM, license key on diskette, Class A, for 32-bit Windows XP Professional +SP2; German/English</p> <ul style="list-style-type: none"> • SINEMA E 2006 Lean Planning, configuring and simulating WLAN applications • SINEMA E 2006 standard Extended planning, configuring, simulating and measuring (site survey) of WLAN applications (automatic placement, application profile, contour presentation, storage/comparison of simulations, extended filter options) • SINEMA E 2006 Powerpack Software upgrade from SINEMA E Lean to SINEMA E Standard 	<p>6GK1 781-0AA00-6AA0</p> <p>6GK1 782-0AA00-6AA0</p> <p>6GK1 782-4AA00-6AC0</p>	<p>You can find further information on the Internet at:</p> <p>www.siemens.com/sinema</p>

Industrial Wireless Communication

WirelessHART

Introduction

Overview

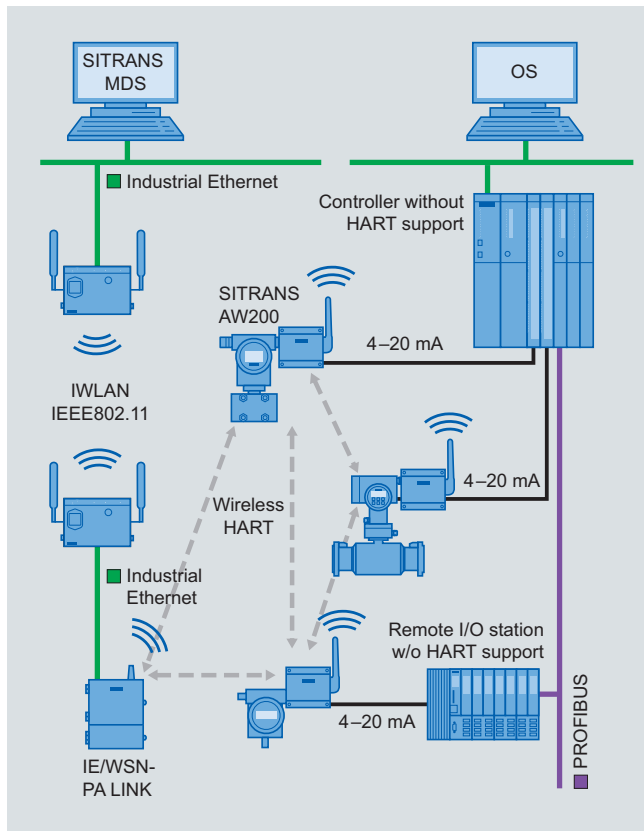

HART (**H**ighway **A**ddressable **R**emote **T**ransducer) is the protocol for bus-addressed field devices. It is not a fieldbus, but a version of the digital field communication that contains many of the functionalities of fieldbuses.

WirelessHART is the wireless HART communication to fieldbuses in the process industry. The HART Communication Foundation (HCF) specified WirelessHART and published it as part of the HART standard V7.1. The radio transmission is based on the wireless communications standard IEEE 802.15.4. High availability is achieved by means of the meshed network architecture (each field device is simultaneously a repeater) with redundant communication paths and constantly changing frequency channels (channel hopping). 128-bit encryption in conjunction with authentication and validation of each data packet ensures secure data transfer and prevents unauthorized access to the field devices.

As a basic principle, a WirelessHART network consists of WirelessHART field devices and a WirelessHART gateway that receives the data from the field devices and forwards it to the automation system.

Overview



SITRANS P280 for flexible and cost-effective applications in pressure monitoring

- Supports the WirelessHART standard (HART V 7.1)
- Very high security level for wireless data transmission
- Built-in local user interface (LUI) with 3-button operation
- Optimum representation and readability using graphical display (104 x 80 pixels) with integrated backlight
- Stand-by (deep sleep phase) can be activated and deactivated device with push of a button
- Battery power supply
- Battery life time up to 5 years
- Extend battery life time with switch off the HART modem interface
- Optimized power consumption through new design, and increase in battery life time
- Simple configuration thanks to SIMATIC PDM
- Device meets IP65 degree of protection
- Can be used for absolute and gauge pressure measurements

Note:

You can find more information in Catalog FI 01 and in the Industry Mall at www.siemens.com/industrymall

Industrial Wireless Communication

WirelessHART

SITRANS P280

Ordering data

Order No.

Configuration

SITRANS P280 WirelessHART pressure transmitter

(Required battery not included with delivery, see accessories)

7MP1120 - - - - - 0

Measuring cell filling

Dry measuring cell

0

Measuring span

Gauge pressure

- 0 ... 2 bar g (0 ... 29 psi g)
- 0 ... 10 bar g (0 ... 145 psi g)
- 0 ... 50 bar g (0 ... 725 psi g)
- 0 ... 200 bar g (0 ... 2900 psi g)
- 0 ... 400 bar g (0 ... 5800 psi g)

D
E
F
G
H

Absolute pressure

- 0 ... 2 bar a (0 ... 29 psi a)
- 0 ... 10 bar a (0 ... 145 psi a)
- 0 ... 50 bar a (0 ... 725 psi a)
- 0 ... 200 bar a (0 ... 2900 psi a)
- 0 ... 400 bar a (0 ... 5800 psi a)

M
N
P
Q
R

Wetted parts

Ceramic

K

Display

Digital display, visible

1

Enclosure

Die-cast aluminum

1

Process connection

G $\frac{1}{2}$ as per EN 837-1
½-14 NPT

0

1

Explosion protection

Without

A

Antenna

Variable, attached to device

A

Further designs

Please add "-Z" to Order No. and specify Order code(s) and plain text.

Stainless steel TAG plate

- Measuring point number (TAG Nr.) max. 16 digits entered in plain text
Y15:
- Measuring point message max. 27 characters entered in plain text:
Y16:

Order code

Y15

Y16

Accessoires

Lithium battery for SITRANS TF280/P280

7MP1990-0AA00

Mounting bracket, steel

7MF4997-1AC

Mounting bracket, stainless steel

7MF4997-1AJ

Cover, die-cast aluminum, without window

7MF4997-1BB

Cover, die-cast aluminum, with window

7MF4997-1BE

IE/WSN-PA LINK

see Chap. 8

HART modem with RS232 interface

7MF4997-1DA

HART modem with USB interface

7MF4997-1DB

SIMATIC PDM

see Chap. 9

More information

The PIA Life Cycle Portal is designed to support you in selecting the correct ordering numbers:

www.pia-portal.automation.siemens.com

Overview



SITRANS TF280 for flexible and cost-effective temperature measurements

- Supports the WirelessHART standard (HART V 7.1)
- Very high security level for wireless data transmission
- Built-in local user interface (LUI) with 3-button operation
- Optimum display and readability using graphics display (104 x 80 pixels) with integrated background lighting
- Stand-by (deep sleep phase) on device can be turned on and off with a push of a button
- Battery power supply
- Battery service life up to 5 years
- Extend battery service life with HART modem interface which can be shut off
- Optimized power consumption through new design, and increase in battery service life
- Simple configuration thanks to SIMATIC PDM
- Housing meets IP65 degree of protection
- Supports all Pt100 sensors as per IEC 751/ EN 60751

Note:

You can find more information in Catalog FI 01 and in the Industry Mall at www.siemens.com/industrymall

Ordering data

Order No.

Configuration

SITRANS TF280 WirelessHART Temperature transmitter

(Required battery not included with delivery, see accessories)

Connections/cable entry

Cable gland M20x1.5
Sensor pipe with Pt100, G½" male thread, pre-mounted and connected

Display

Digital display, visible

Enclosure

Die-cast aluminum

Explosion protection

Not included

Antenna

Variable, attached to device

7MP1110 - 0 A - 0 0

Further designs

Please add "-Z" to Order No. and specify Order code(s) and plain text.

Order code

Stainless steel TAG plate

Measuring point number (TAG Nr.) max. 16 digits entered in plain text
Y15:

Y15

Measuring point message max. 27 characters entered in plain text:
Y16:

Y16

Accessories

Lithium battery for SITRANS TF280/P280

7MP1990-0AA00

Mounting bracket, steel

7MF4997-1AC

Mounting bracket, stainless steel

7MF4997-1AJ

Cover, die-cast aluminum, without window

7MF4997-1BB

Cover, die-cast aluminum, with window

7MF4997-1BE

Thread adapter M20x1.5 (male thread) on ½"-14 NP (female thread)

7MP1990-0BA00

Thread adapter M20x1.5 (male thread) on G½B (female thread)

7MP1990-0BB00

IE/WSN-PA LINK

see Chap.. 9

HART modem with RS232 interface

7MF4997-1DA

HART modem with USB interface

7MF4997-1DB

1) Please order sensor separately.

More information

The PIA Life Cycle Portal is designed to support you in selecting the correct ordering numbers:

www.pia-portal.automation.siemens.com

Industrial Wireless Communication

WirelessHART

SITRANS AW200

Overview



SITRANS AW200 WirelessHART Adapter

The SITRANS AW200 WirelessHART adapter is a battery-powered communication component, which integrates HART and 4 ... 20 mA field devices into a WirelessHART network. On the wireless communication side, the adapter supports the WirelessHART standard. HART and 4 ... 20 mA field devices are connected on the field device side.

The SITRANS AW200 WirelessHART adapter

- supports the WirelessHART standard (HART V 7.1)
- features a very high degree of security for wireless data transmission
- integrates one 4 ... 20 mA field device or up to four HART field devices (in multidrop mode) into a WirelessHART network
- features intelligent energy management for the power supply of connected field devices
- can be easily parameterized using SIMATIC PDM

Note:

You can find more information in Catalog FI 01 and in the Industry Mall at www.siemens.com/industrymall

Ordering data

Order No.

Configuration

SITRANS AW200 adapter for WirelessHART communication 7MP3112 - 0 - 0 A A 0

WirelessHART adapter AW200 with 4 ... 20 mA- or HART interface

Without battery 1

Power supply

Battery powered A

Certificates and approvals ¹⁾

Ohne A

Enclosure

Polyester 0

Accessories

Lithium battery for SITRANS AW200

7MP3990-0AA00

Thread adapter for direct mounting of the adapter to a field device

7MF4997-1AC

- M20 thread adapter
- Thread adapter G $\frac{1}{2}$
- Thread adapter $\frac{1}{2}$ " - 14 NPT
- Thread adapter $\frac{3}{4}$ " - 14 NPT

7MP3990-0BA00

7MP3990-0BB00

7MP3990-0BC00

7MP3990-0BD00

Mounting bracket for attachment to wall/pipe Material: Stainless steel SS304, including cable gland

7MP3990-0CA00

¹⁾ Additional approvals in process.

More information

The PIA Life Cycle Portal is designed to support you in selecting the correct ordering numbers:

www.pia-portal.automation.siemens.com

Overview



- The IE/WSN-PA LINK is a gateway for the connection of WirelessHART field devices (HART V7.1) to Industrial Ethernet, as an alternative or supplement to the wired connection.
- Connection of up to 100 WirelessHART devices
- Approved for operation in hazardous areas in Zone 2
- Open TCP/IP communication and Modbus TCP via the Ethernet interface
- Can be used with HART-OPC servers of the HART Communication Foundation

Note:

A general introduction to WirelessHART and information on the WirelessHART adapter and the WirelessHART field devices can be found in Catalog FI 01 or on the Internet at www.siemens.com/wirelesshart

Benefits



- Extended possible solutions for connecting process industry field devices by means of alternative or supplementary WirelessHART communication
- Reliable data transmission using intermeshed network technology; the self-organizing network with alternative paths enables radio obstacles to be bypassed
- Reduction of cabling costs under difficult installation conditions, e.g. if the field devices are located on inaccessible plant components or are only required temporarily
- To improve process monitoring and for maintenance tasks, sensors can be retrofitted
- Existing transmitters can be integrated wirelessly into maintenance and diagnostics systems by means of WirelessHART adapters
- Without additional software, restricted monitoring is possible via web services and the integrated web server of the IE/WSN-PA LINK.

Application

The IE/WSN-PA LINK connects wireless HART field devices by radio to the Ethernet. On the radio side, the IE/WSN-PA LINK supports the WirelessHART standard and on the Ethernet side the TCP/IP and Modbus TCP communication.

The IE/WSN-PA LINK thus enables wireless diagnostics, maintenance and process monitoring.

Monitoring

WirelessHART is particularly suitable for use in plant sections that are to be included in monitoring, but which do not have any existing MSR cabling, e.g. external tank stores or other installations where high cabling costs are anticipated. Data for the visualization can be retrieved from the IE/WSN-PA LINK via Industrial Ethernet or Modbus TCP.

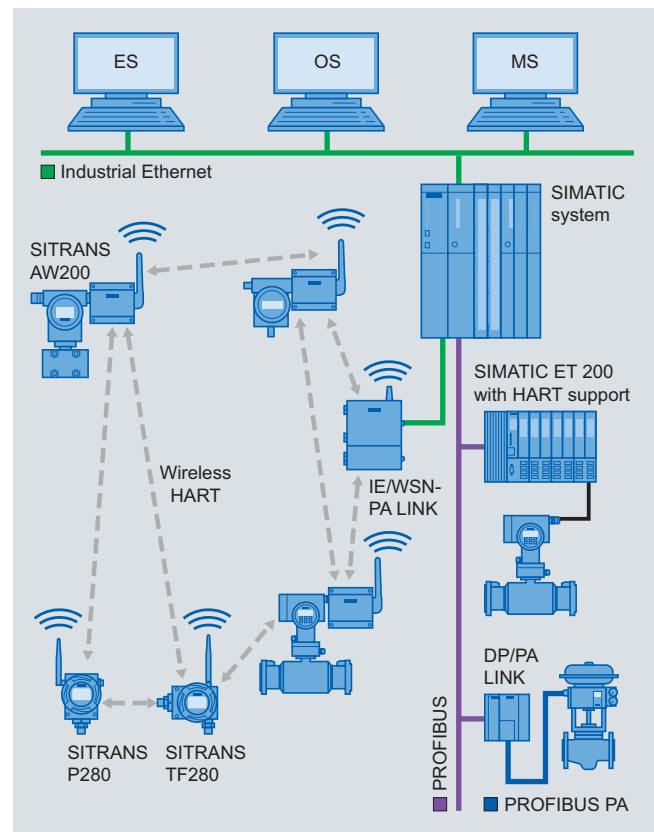

Monitoring of process states via WirelessHART

Industrial Wireless Communication

WirelessHART

IE/WSN-PA LINK

Application (continued)

Retrofitting for diagnostics and maintenance

For this application, wireless adapters are looped into the 4-20 mA interface or screwed directly onto the HART device. The acyclic HART message frames are transmitted by radio between IE/WSN-PA LINK and a wireless adapter. Without affecting the operation of the plant, the wireless adapter modulates the acyclic HART message frames to the 4-20 mA interface or extracts them from the 4-20 mA interface.

The IE/WSN-PA LINK collects the data of all wireless adapters and transfers it via Industrial Ethernet to the diagnostics and maintenance station.

If greater distances between the IE/WSN-PA LINK and the monitoring station are to be spanned without cabling, this can be implemented by means of Industrial Wireless LAN with the access points and client modules of the SCALANCE W family.

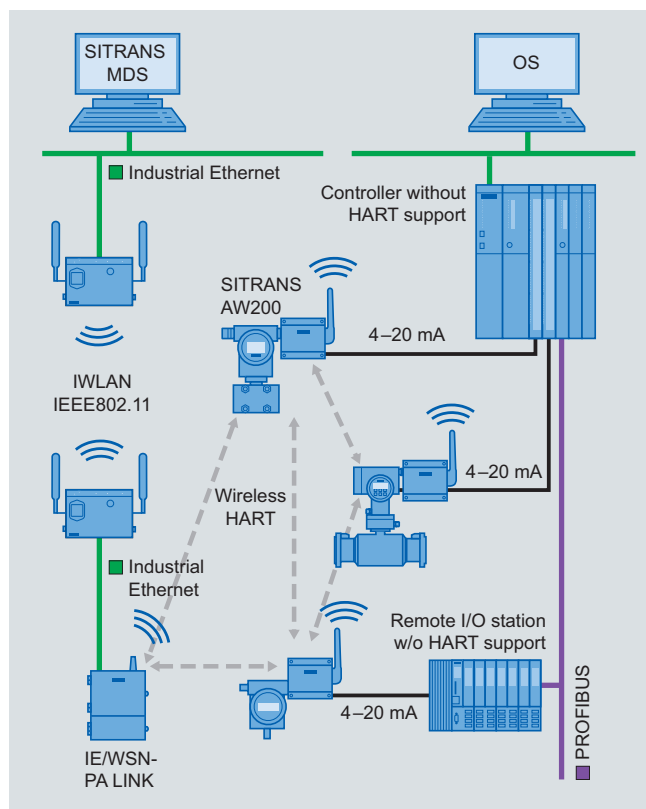

Retrofitting of plants for diagnostics and maintenance

Design

- 2 x 10/100/1000 Mbit/s RJ45 ports, electrical (no integral switch; interfaces can be used, for example, for continuous connection to the plant network as well as the temporary connection of a PC)
- 1 x screw terminal for connection to Modbus RTU via RS485
- 1 x screw terminal for the 24 V DC connection
- Rugged metal enclosure with IP65 protection for use outdoors, also in hazardous zone 2
- Mounting: wall or mast mounting (vertical); U-bolts for mast mounting are included in the scope of delivery.

Product versions

- With integral, non-detachable antenna
- With N connector for connection of external antennas

Function

WirelessHART

The IE/WSN-PA LINK establishes on the radio side an inter-meshed wireless sensor network for communication with wireless field devices (e.g. transmitters). The data from the wireless field devices is received by the IE/WSN-PA LINK and transmitted via Industrial Ethernet to the connected systems. The supported wireless network is an open wireless network specified by the HART Communication Foundation (HCF) in accordance with the WirelessHART (HART V7.1) standard.

On the field device side, the IE/WSN-PA LINK requires field devices that support WirelessHART (HART). Existing field devices can be integrated by means of wireless adapters into the WirelessHART communication. To this end, the adapters are looped into the 4-20 mA interface. In addition, as many as four standard HART field devices with external power supply can be connected to the adapter in multidrop mode. Individually connected devices can be operated with the battery of the adapter.

The adapter wirelessly transmits all data and process values of the connected devices. The advantage of this solution is that tried and tested devices can continue to be used.

Industrial Ethernet

Via the Ethernet interface the IE/WSN-PA LINK supports the use of the HART OPC server and the Modbus TCP protocol.

Configuration

The configuration is web-based, without additional software, and performed from the PC. By means of the web user interface it is also possible to display the device states and measured values of the WirelessHART devices.

Integration

Integration into automation systems

The IE/WSN-PA LINK can be integrated into automation systems via Ethernet or Modbus TCP. Communication modules (CP 343-1 or CP 443-1) are required to connect the IE/WSN-PA LINK to SIMATIC S7-300/400. Function blocks and technical support can be found at:

www.siemens.com/simatic-net/ik-info

Integration in PCS 7

For integration of the IE/WSN-PA LINK into PCS 7 you can obtain function blocks and technical support at:

www.siemens.com/simatic-net/ik-info

Technical specifications

Ordering data	6GK1 411-6CA40-0AA0	6GK1 411-6CA40-0BA0
Product type designation	IE/WSN-PA LINK	IE/WSN-PA LINK
Data transmission rate		
• at interface 1	10 ... 100 Mbit/s	10 ... 100 Mbit/s
• at interface 2	10 ... 100 Mbit/s	10 ... 100 Mbit/s
• at interface 3	9.6 to 57.6 kbit/s	9.6 to 57.6 kbit/s
Interfaces		
Number of electrical connections		
• at interface 1 in accordance with Industrial Ethernet	1	1
• at interface 2 in accordance with Industrial Ethernet	1	1
• at interface 3 in accordance with RS 485	1	1
• For power supply	1	1
Design of electrical connection		
• at interface 1 in accordance with Industrial Ethernet	RJ45 port	RJ45 port
• at interface 2 in accordance with Industrial Ethernet	RJ45 port	RJ45 port
• at interface 3 in accordance with RS 485	2-pin terminal strip	2-pin terminal strip
• For power supply	3-pin terminal strip	3-pin terminal strip
Interfaces Wireless		
Number of radio cards permanently installed	1	1
Number of internal antennas	1	0
Number of electrical connections for external antenna(s)	0	1
Design of electrical connection for external antenna(s)	-	N-Connector
Supply voltage, current consumption, power loss		
Type of power supply	DC	DC
Supply voltage, external	24 V	24 V
• Minimum	20 V	20 V
• Maximum	28 V	28 V
Current consumed from external power supply at 24 V DC, maximum	0.5 A	0.5 A
Effective power loss, maximum	12 W	12 W

Industrial Wireless Communication

WirelessHART

IE/WSN-PA LINK

Technical specifications (continued)

Ordering data	6GK1 411-6CA40-0AA0	6GK1 411-6CA40-0BA0
Product type designation	IE/WSN-PA LINK	IE/WSN-PA LINK
Permitted ambient conditions		
Ambient temperature		
• During operating phase	-40 ... +60 °C	-40 ... +60 °C
• During storage	-40 ... +85 °C	-40 ... +85 °C
• During transport	-40 ... +85 °C	-40 ... +85 °C
Relative humidity at 25 °C without condensation during operating phase, maximum	90 %	90 %
IP degree of protection	IP 65	IP 65
Design, dimensions and weights		
Housing width	229 mm	229 mm
Housing height		
• Without antenna	306 mm	306 mm
• With antenna	354 mm	354 mm
Housing depth	89 mm	89 mm
Net weight	4.54 kg	4.54 kg
Type of mounting		
• Wall mounting	Yes	Yes
• Mast mounting	Yes	Yes
Type of mounting	Material for mast mounting included in scope of delivery	Material for mast mounting included in scope of delivery
Radio frequencies		
Radio frequency with WirelessHART in the 2.4 GHz frequency band		
• Start value	2.4 GHz	2.4 GHz
• Full-scale value	2.5 GHz	2.5 GHz
Performance data WirelessHART		
Number of WirelessHART devices which can be operated	100	100
Network latency		
• Maximum with 100 field devices and WirelessHART network	10 s	10 s
• Maximum with 50 field devices and WirelessHART network	5 s	5 s
Transition link between two devices with WirelessHART network		
• Maximum	100 m	100 m
• Note	The values may deviate if obstacles affecting radio transmission are present	The values may deviate if obstacles affecting radio transmission are present
HART protocol is supported	Yes	Yes
Product properties, functions, components		
General		
Protocol is supported		
• Address Resolution Protocol (ARP)	Yes	Yes
• HTTP	Yes	Yes
• HTTPS	Yes	Yes
• Modbus TCP	Yes	Yes
• Modbus TCP secure	Yes	Yes
• Modbus RTU	Yes	Yes

Technical specifications (continued)

Ordering data	6GK1 411-6CA40-0AA0	6GK1 411-6CA40-0BA0
Product type designation	IE/WSN-PA LINK	IE/WSN-PA LINK
Product functions Management, configuration, programming		
Product function		
• Web-based management	Yes	Yes
• DHCP client	Yes	Yes
Product functions Diagnostics		
Product function		
• Web-based diagnostics	Yes	Yes
• WirelessHART diagnostics via Modbus	Yes	Yes
Product functions Security		
Product function		
• Password protection - multilevel	Yes	Yes
• WirelessHART join key	Yes	Yes
• ACL - MAC-based	Yes	Yes
• WirelessHART network ID	Yes	Yes
SSL protocol is supported	Yes	Yes
Encryption principle	AES 128 bit	AES 128 bit
Product functions Time		
NTP protocol is supported	Yes	Yes
Standards, specifications, approvals		
Standard for WirelessHART	HART V 7.1	HART V 7.1
Standard for wireless communication IEEE 802.15.4	Yes	Yes
Certificate of suitability		
• CE mark	Yes	Yes
• Referred to CSA	CSA Division 2 & Dust Ignition-proof for Class I, Division 2, Groups A, B, C, and D. Dust Ignition-proof for Class II, Groups E, F, and G / Suitable for Class III Hazardous Locations. / Install per Siemens drawing A5E02467236A. Temperature Code: T4 (-40°C < Ta < 60°C) CSA Enclosure Type 4X	CSA Division 2 & Dust Ignition-proof for Class I, Division 2, Groups A, B, C, and D. Dust Ignition-proof for Class II, Groups E, F, and G / Suitable for Class III Hazardous Locations. / Install per Siemens drawing A5E02467236A. Temperature Code: T4 (-40°C < Ta < 60°C) CSA Enclosure Type 4X
• Referred to FM	FM Division 2, Non-Incendive for Class I, Division 2, Groups A, B, C, and D. Dust Ignition-proof for Class II, III, Division 1, Groups E, F, and G / Indoor and outdoor locations / NEMA Type 4X Temperature Code: T4 (-40°C < Ta < 60°C)	FM Division 2, Non-Incendive for Class I, Division 2, Groups A, B, C, and D. Dust Ignition-proof for Class II, III, Division 1, Groups E, F, and G / Indoor and outdoor locations / NEMA Type 4X Temperature Code: T4 (-40°C < Ta < 60°C)
• Referred to ATEX	ATEX type n, see note: Certificate number: Baseefa10ATEX0044X, ATEX marking: Ex II 3 G, Ex nA nL IIC T4 (-40 °C ≤ Ta ≤ 60 °C), rated voltage: 28 V, ATEX Dust Ignition-proof: Certificate number: Baseefa10ATEX0045X, ATEX marking: II 3 D, Ex tD A22 IP66 T135 (-40 °C ≤ Ta ≤ 60 °C), rated voltage: 28 V. Note on type n: Conditions for safe handling during installation: The device does not pass the 500 V insulation test in accordance with paragraph 6.8.1 of EN 60079-15:2005. This must be taken into account when installing the device.	ATEX type n, see note: Certificate number: Baseefa10ATEX0044X, ATEX marking: Ex II 3 G, Ex nA nL IIC T4 (-40 °C ≤ Ta ≤ 60 °C), rated voltage: 28 V, ATEX Dust Ignition-proof: Certificate number: Baseefa10ATEX0045X, ATEX marking: II 3 D, Ex tD A22 IP66 T135 (-40 °C ≤ Ta ≤ 60 °C), rated voltage: 28 V. Note on type n: Conditions for safe handling during installation: The device does not pass the 500 V insulation test in accordance with paragraph 6.8.1 of EN 60079-15:2005. This must be taken into account when installing the device.
• Referred to IECEx	IECEx type n, see note: Certificate number: IECEx BAS 10.0014X, Ex nA nL IIC T4 (-40 °C ≤ Ta ≤ 60 °C), rated voltage: 28 V, IECEx Dust Ignition-proof, see note: Certificate number: IECEx BAS 10.0015X, Ex tD A22 IP66 T135 (-40 °C ≤ Ta ≤ 60 °C), rated voltage: 28 V. Note on type n: Conditions for safe handling during installation: The device does not pass the 500 V insulation test in accordance with paragraph 6.8.1 of EN 60079-15:2005. This must be taken into account when installing the device.	IECEx type n, see note: Certificate number: IECEx BAS 10.0014X, Ex nA nL IIC T4 (-40 °C ≤ Ta ≤ 60 °C), rated voltage: 28 V, IECEx Dust Ignition-proof, see note: Certificate number: IECEx BAS 10.0015X, Ex tD A22 IP66 T135 (-40 °C ≤ Ta ≤ 60 °C), rated voltage: 28 V. Note on type n: Conditions for safe handling during installation: The device does not pass the 500 V insulation test in accordance with paragraph 6.8.1 of EN 60079-15:2005. This must be taken into account when installing the device.
• Referred to NEMA	-	-
Wireless approval	FCC and IC approval	IC approval

Industrial Wireless Communication

WirelessHART

IE/WSN-PA LINK

Ordering data	Order No.	Order No.
IE/WSN-PA LINK Gateway between WirelessHART and Industrial Ethernet; transmission frequency: 2.4 GHz <ul style="list-style-type: none"> • With integral, non-detachable antenna • N connector for connection of external antennas 	6GK1 411-6CA40-0AA0 6GK1 411-6CA40-0BA0	Accessories IE FC M12 Plug PRO M12 plug-in connector suitable for on-site assembly (D-coded, IP65/IP67), metal housing, FastConnect connection system, for connecting HARTING adapter cables to the Industrial Ethernet <ul style="list-style-type: none"> • 1 unit
Antennas Antennas with omni-directional characteristics; country permits, compact instructions (hard copy), German/English <u>Wall or mast-mounting</u> <ul style="list-style-type: none"> • Antenna ANT792-6MN Antenna gain including N-Connect connector 6 dBi, 2.4 GHz 	6GK5 792-6MN00-0AA6	IE FC TP Standard Cable GP 2 x 2 (Type A) 4-core, shielded TP installation cable for connection to IE FC Outlet RJ45/IE FC RJ45 Plug; PROFINET-compatible; with UL approval; sold by the meter; max. length 1000 m, minimum order quantity 20 m
<u>Roof mounting</u> <ul style="list-style-type: none"> • ANT795-6MN antenna Antenna gain incl. N-Connect connector 6/8 dBi, 2.4/5 GHz • Antenna mounting tool (ANT795-6MN) Mounting tool for installation of ANT795-6MN under a roof 	6GK5 795-6MN00-0AA6 6GK5 795-6MN01-0AA6	IE FC Stripping Tool Preadjusted stripping tool for fast stripping of the Industrial Ethernet FC cables
LP798-1N Lightning Protector Lightning protector with N/N female/female connector, IP65 (-40 to +100 °C)	6GK5 798-2LP00-2AA6	HARTING adapter cable ¹⁾ M12 female NPT 1/2 thread to RJ45 11 cm, (minimum order quantity: 10); The adapter is provided for easy connection of the link to the Industrial Ethernet;
Antenna cables IWLAN N-Connect male/male flexible connection cable Flexible connecting cable for connecting an external antenna; assembled with two N-Connect male connectors <ul style="list-style-type: none"> • 1 m • 2 m • 5 m • 10 m 	6XV1 875-5AH10 6XV1 875-5AH20 6XV1 875-5AH50 6XV1 875-5AN10	SITOP compact 24 V/ 0.6 A 1-phase power supply with wide-range input 85 – 264 V AC/110 – 300 V DC, stabilized output voltage 24 V, rated output current value 0.6 A, slim design
HF coupling N-Connect male/male connector for connecting the LP798-1N lightning protector	6GK5 798-0CP00-1AA0	21 03 683 6420 Not included in the scope of delivery of the IE/WSN-PA link; You can find ordering information on the Internet at: www.harting.com/en/kontakt/adressen//
		6GK1 901-0DB20-6AA0 6XV1 840-2AH10 6GK1 901-1GA00

¹⁾ When using the Harting adapter cable for the Ethernet connection, the requirements for intrinsic safety approval are not applicable. When used in an application relevant to intrinsic safety guidelines, it requires acceptance by the appropriate approval agency.

More information

Current approvals can be found on the Internet at:
<http://support.automation.siemens.com/WW/view/en/46374734>

Industrial Remote Communication



9/2	Introduction	9/99	<u>Substations for IEC protocol</u>
9/3	Telecontrol	9/100	SIPLUS RIC bundles for IEC 60870-5-101
9/5	TeleControl Basic	9/102	SIPLUS RIC extreme bundles for IEC 60870-5-101
9/7	<u>TeleControl Basic for the control center</u>	9/103	SIPLUS RIC IEC 60870-5-101 library
9/7	Telecontrol Server Basic	9/104	SIPLUS RIC bundles for IEC 60870-5-103
9/12	<u>TeleControl Basic for the substations</u>	9/105	SIPLUS RIC extreme bundles for IEC 60870-5-103
9/12	CP 1242-7 GPRS module	9/106	SIPLUS RIC IEC 60870-5-103 library
9/17	MD720-3 GSM/GPRS modem	9/107	SIPLUS RIC bundles for IEC 60870-5-104
9/22	SIPLUS MD720-3 GSM/GPRS modem	9/109	SIPLUS RIC extreme bundles for IEC 60870-5-104
9/23	TeleControl Professional	9/110	SIPLUS RIC IEC 60870-5-104 library
9/29	<u>TeleControl Professional for the control center</u>	9/111	Telecontrol network
9/31	SINAUT ST7 Engineering Software	9/111	<u>Modems</u>
9/34	SINAUT ST7cc, Add-on for WinCC	9/113	MD2 dedicated line modem
9/38	WinCC/TeleControl	9/117	SIPLUS MD2 dedicated line modem
9/41	SIMATIC PCS 7 TeleControl	9/118	MD3 telephone modem
9/45	PCS 7 TeleControl Engineering Station	9/122	<u>GSM/GPRS/UMTS routers</u>
9/46	PCS 7 TeleControl Operator System	9/122	EGPRS Router MD741-1
9/48	SINAUT ST7sc SCADA Connect Software	9/127	SIPLUS EGPRS MD741-1 routers
9/52	<u>TeleControl Professional for the substations</u>	9/128	UMTS-Router SCALANCE M87x
9/56	<u>Substations for ST7 protocol</u>	9/140	Telecontrol – Accessories
9/59	TIM 3V-IE for WAN and Ethernet	9/140	LTOP overvoltage protection
9/67	SIPLUS TIM 3V-IE for WAN and Ethernet	9/143	Line transformer
9/68	TIM 3V-IE Advanced	9/144	ANT794-3M GSM/GPRS antenna
9/75	TIM 4R / TIM 4RD	9/146	ANT794-4MR GSM/GPRS antenna
9/79	TIM 4R-IE for WAN and Ethernet	9/148	PPI modem cable
9/87	SIPLUS TIM 4R-IE for WAN and Ethernet	9/149	Connecting cables
9/88	<u>Substations for DNP3 protocol</u>	9/150	DCF77 antennas
9/89	TIM 3V-IE DNP3	9/151	GPS receiver
9/94	TIM 4R-IE DNP3	9/153	Teleservice
		9/154	SIMATIC Teleservice

Industrial Remote Communication

Introduction

Introduction

Overview



Industrial Remote Communication offers efficient remote access to machines and plants with SIMATIC. Global remote access to far-flung plants, remote machines and mobile applications is gaining in significance – both in industry and in industry-related areas. With a comprehensive range of solutions for industrial remote access, Siemens offers the ideal basis for efficient and reliable monitoring and control of widely distributed plants and processes of any size.

In addition to efficient remote access (Remote Access), Industrial Remote Communication also offers with the network components the option of transparent data links to remote networks via public or private wide area networks (WAN).

In this way, for example, a video transmission in real time via mobile radio from the passenger cell of trains serves to increase passenger safety (video surveillance). In addition, applications such as data interfacing for ticket machines, infotainment services and Internet on board, or proactive monitoring of vehicle engineering (telemetry) are also possible.

Secure and flexible access worldwide

Industrial plants are often distributed over large areas – sometimes even across national borders. Siemens offers proven solutions for industrial remote access, such as flexible telecontrol systems and efficient remote maintenance. Whether in public infrastructure or in the manufacturing or process industries: With the components for Industrial Remote Access, Siemens offers comprehensive solutions for telecontrol and teleservice.

Telecontrol

Telecontrol involves the connection of distant process stations to one or more central control systems. Various different public or private networks can be used for communication for the purposes of monitoring and control. Event-driven or cyclic exchange of process data is performed with special telecontrol protocols and enables the operating personnel to manage the overall process effectively.

The telecontrol systems are based on SIMATIC. They supplement the SIMATIC system with corresponding hardware and software, and thus permit individual components to be networked over a WAN (Wide Area Network). The data for this is transmitted via classical WANs, e.g. dedicated cables, telephone network, wireless, but also via IP-based networks such as mobile networks or the Internet.

Teleservice (remote diagnostics and remote maintenance)

Teleservice is data exchange with physically remote technical plants (machines, plants, computers, etc.) for the purpose of error detection, diagnostics, maintenance, repair, or optimization.

Remote diagnostics and remote maintenance of production plants are indispensable in modern automation technology. They are more efficient and more cost-effective than an on-site service employee on site. This allows faults to be detected and cleared much faster, downtimes of machines are reduced and their availability is increased.

Siemens Remote Services

The service concept of "Siemens Remote Services" provides a powerful, secure platform for remote access to machines and plants. The inclusion of "Shared Experts" ensures effective support, not only from Siemens but also from the internal company specialists.

Overview

Industrial plants in the process industry or in public infrastructure areas are often spread across wide areas, sometimes even across national borders. The range of telecontrol products offers complete solutions with the following features:

- Connection of distributed process stations to one or more control centers
- Use of different public or private communication networks for monitoring and controlling the telecontrol substations
- Event-driven or cyclic exchange of the process data including time stamp via special telecontrol protocols
- Effective control of the overall process by the operating personnel
- Online access to the substations for diagnostics, remote programming and maintenance

TeleControl Basic

TeleControl Basic is a simple telecontrol and remote maintenance system optimized for substations connected wirelessly via GPRS.

It comprises the TeleControl Server Basic control center software and substations of the type SIMATIC S7-1200 or S7-200. In addition to communication between the control center and the substations, the system also enables internode communication between the substations.

Small-scale applications with few outstations can be implemented, as well as large-scale plants comprising up to 5000 outstations.

TeleControl Professional

TeleControl Professional includes telecontrol systems for extensive, expanded applications of the process industry. From SIMATIC PCS 7, SIMATIC WinCC or non-Siemens control systems using OPC, outstations based on SIMATIC S7-300 and S7-400 can be monitored and controlled. The outstations and substations can communicate with each other as well as with one or more control centers. TeleControl Professional has a modular design throughout and can be used with extreme flexibility.

Both telecontrol systems can be connected to a non-Siemens control center system (OPC client) via OPC.

Industrial Remote Communication Telecontrol

Introduction

Overview (continued)

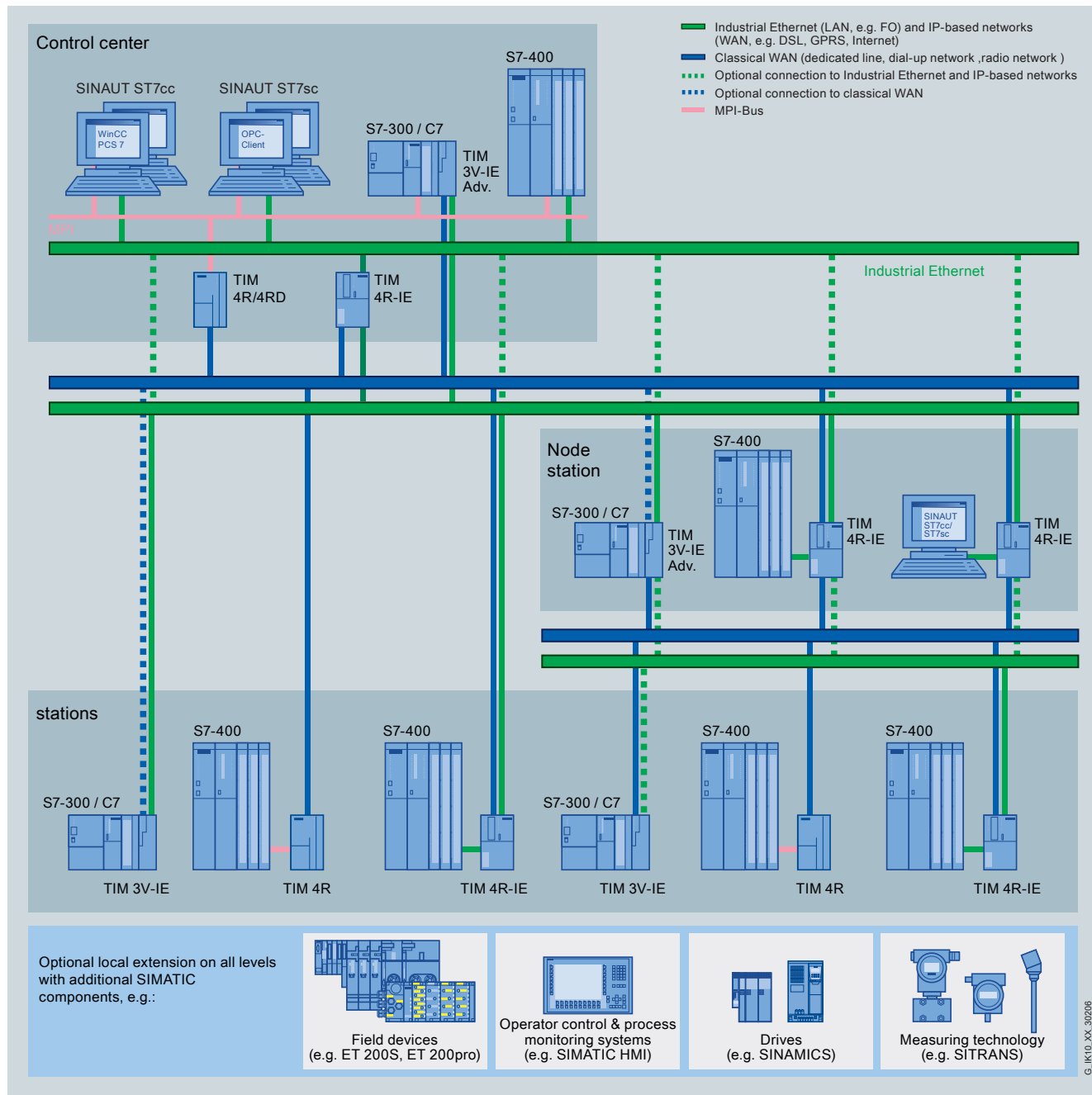

Example configuration for TeleControl Professional with SINAUT ST7

Benefits

- Secure and economic remote monitoring and control of process stations
- Global remote access to widely distributed machines and plants
- Quick and easy commissioning due to perfectly matched system components

More information

You can find more information on the Internet at:
www.siemens.com/telecontrol

G_1K110_XX_3/02/06

Overview

TeleControl Basic is based on SIMATIC S7-1200/S7-200 and is the low-cost solution for monitoring and controlling simple telecontrol stations.

With TeleControl Basic, up to 5000 substations can easily and securely communicate with one another and with the control center using GPRS (**G**eneral **P**acket **R**adio **S**ervice) mobile radio. They typically remain permanently online.

Benefits



Designed for Industry

- Saving of costs for design and maintenance of own radio system through use of existing mobile radio networks
- Low-cost GPRS volume tariffs reduce the monthly connection charges
- A GPRS connection is permanently online, i.e. it offers the advantages of a dedicated line
- Secure connection over public networks thanks to encrypted data transfer
- Support for bidirectional connections
 - Between station and control center
 - Between station and station
- Remote maintenance and remote programming of the substations during process operation

Application

TeleControl Basic is based on SIMATIC S7-1200/S7-200 and GPRS. It is particularly suitable wherever small data quantities have to be transmitted over wireless connections.

TeleControl Basic can be used as a low-cost fault signaling system, but thanks to the bidirectional communications facility, it is also suitable for simple telecontrol tasks for monitoring and control.

Depending on the performance power of the CPU in the substations, local automation tasks can be handled in addition to communication.

Main applications are the monitoring and control of non-mobile stations in the following sectors:

- Water and wastewater
- Drinking water purification and distribution
- Irrigation systems
- Oil and gas supplies
- District heating networks
- Automatic machines
- Traffic control systems
- Building monitoring
- Weather stations
- Lighthouses and buoys
- Wind power plants
- Photovoltaic plants
- Environmental monitoring equipment
- Intelligent advertising panels

In addition, TeleControl Basic can also be used to link mobile stations if central monitoring and/or control is required for these:

- Railway vehicles
- Special vehicles
- Local public transport
- Complex building machines
- Ships on rivers and in coastal areas

Design

TeleControl Basic consists of the following components:

- **CP 1242-7 GPRS communication module;** communication processor for GPRS and GSM communication for setting up substations of the type S7-1200
- **MD720-3;** modem for GPRS and GSM communication for the structure of SIMATIC S7 substations e.g. S7-200
- **TeleControl Server Basic** software package consisting of:
 - OPC server software for the PC control center; for data exchange with an OPC client, e.g. WinCC, PCS 7 or WinCC flexible
 - Connection manager for the PC control center; for establishing a secure GPRS connection with CP 1242-7 or SINAUT MD720-3, for monitoring these connections, and for data routing with internode communication between substations of the same type (S7-1200 or S7-200)

The CP 1242-7 is plugged straight into the S7-1200, and is connected to the CPU via the backplane bus. The substation is programmed and configured with STEP 7 Basic/Professional V11.

The MD720-3 modem has an RS232 interface and is connected to the S7-200 controller using the Siemens PPI adapter.

Industrial Remote Communication

TeleControl Basic

Introduction

Function

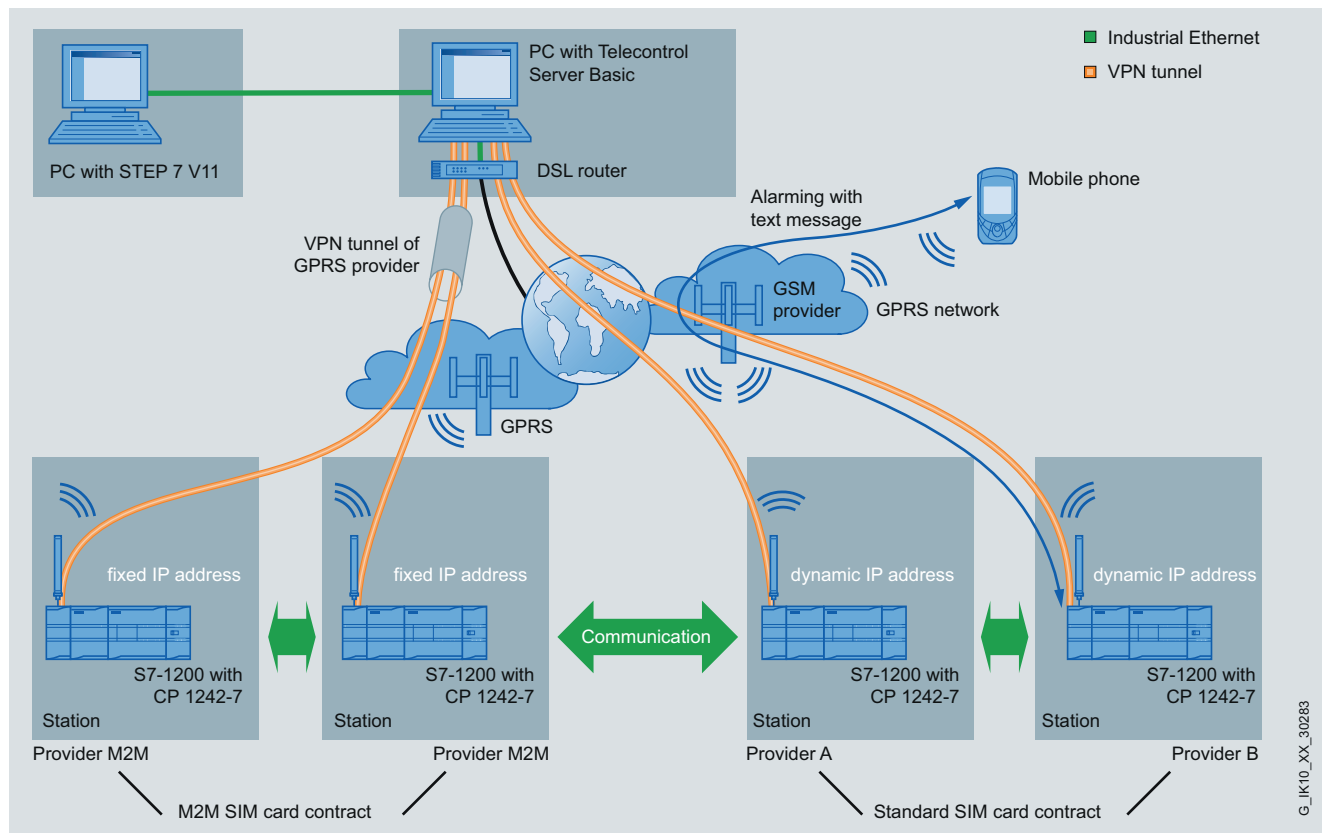

Communication options with TeleControl Basic

Process data communication

The TeleControl Server Basic software enables the connection of up to 5000 telecontrol stations to the control center via the OPC interface using GPRS.

TeleControl Server Basic is an OPC server software with special communications functions, which permit it to support connections to remote telecontrol substations. These controls are equipped with the CP 1242-7 or the MD720-3 modem. The GPRS service (**G**eneral **P**acket **R**adio **S**ervice) of a GSM network (**G**lobal **S**ystem for **M**obile Communication) is used for the connections.

Via these GPRS connections, the remote telecontrol substations can communicate with the TeleControl Server Basic software or with other S7 controllers connected with TeleControl Server Basic.

The PC on which TeleControl Server Basic is installed must be permanently accessible from the GPRS network. It must therefore be directly connected to the GPRS provider using a dedicated line, or permanently to the Internet, e.g. by means of DSL.

The TeleControl Basic software package includes a block library for the SIMATIC S7-200 controller. With the help of these blocks, users can implement the following types of data exchange with S7-200 substations.

For substations of the type S7-1200, the blocks for the CP 1242-7 are included in STEP 7 Basic V11.0

Alarm output per text message

The CP 1242-7 can receive and send text messages. A mobile phone or S7-1200 can be the communication partner.

Wake-up function

"Wake-up" of stations that change from standby mode to online mode for diagnostics purposes. The CP is wakened up by its communication partner (e.g. TeleControl Server Basic) by means of a wake-up call or a wake-up text message to establish the connection between them.

For security reasons, the communication partner must identify itself appropriately for the wake-up function, e.g. using the CLIP function.

Access to the substations using Teleservice

Telecontrol Server Basic includes the Teleservice function direct in STEP 7 Basic V11.0 for the CP 1242-7. This provides internationally active plant and machine manufacturers with global access to the S7-1200 stations.

Up to three telephone numbers can be saved on the SINAUT MD720-3 modem, from which a teleservice connection is permissible. If a call is made from one of the approved numbers, the MD720-3 interrupts the GPRS connection and switches through the teleservice connection to the PLC. The GPRS connection is reestablished at the end of the teleservice session.

Industrial Remote Communication

TeleControl Basic for the control center

TeleControl Server Basic

Overview

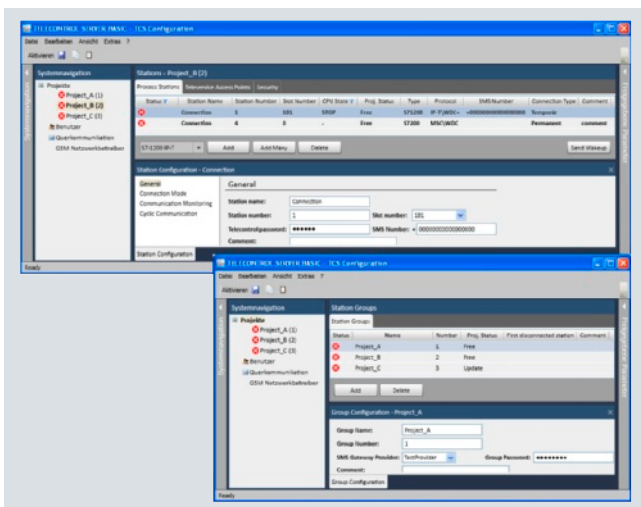

- Software package for the PC, comprising:
 - OPC server and connection manager for telecontrol and teleservice tasks (diagnostics with STEP 7 for the S7-1200)
 - OPC configuring software for the S7-1200 and S7-200
 - PLC block library for the S7-200
- GPRS operation
 - of the SIMATIC S7-1200 with CP 1242-7 via dynamic IP addresses with a standard mobile phone flat-rate contract
 - of the SIMATIC S7-200 with SINAUT modem MD720-3 via dynamic IP addresses with a standard mobile phone flat-rate contract
 - of the S7-1200 with CP 1242-7 via fixed IP addresses
- Connection of up to 5000 telecontrol stations to the control center via the OPC interface
- Operation and diagnostics of S7-1200 and S7-200 stations on an OPC server with different STEP 7 projects and separate users with user administration
- Integral teleservice gateway for diagnostics of S7-1200 stations via the CP 1242-7 with STEP 7 via the Internet, also with dynamic IP addresses. This works on every PC with STEP 7 and standard Internet access without parameterizing firewalls or routers.
- GPRS communication between S7-1200 or S7-200 stations by means of routing function (also when using dynamic IP addresses)
- Encrypted transmission for protection against data manipulation and tapping
- Import of SINAUT MICRO SC projects

Benefits

get Designed for Industry

- Setup of low-cost alarm signaling systems, monitoring systems, and telecontrol systems with SIMATIC S7-1200, S7-200 and HMI software with OPC interface (e.g. with WinCC, WinCC flexible)
- Low-cost connection of plants spread across national borders by operating SIMATIC S7 via public APNs (mobile wireless Internet gateway) with standard mobile phone flat-rate contracts, independently of individual mobile wireless operators
- Alternatively, GPRS mode of the SIMATIC S7 via private APNs of the mobile wireless operators for maximum security
- Optimized communication modes for GPRS save on data volumes and thus costs:
 - with permanent connection by means of optimized communication with effective frame format
 - Support for GPRS connections that are built up as required
- The multi-user capability and multi-project capability of the OPC server allow it to be used by system integrators who can allow their customers to use their own server for telecontrol applications. This achieves savings for customers (power costs, server maintenance).
- Teleservice:
 - TeleControl Server Basic provides internationally active plant and mechanical equipment manufacturers with global access to the S7-1200 via STEP 7 using the CP 1242-7. It only requires GPRS access of the S7 controller and a PC with STEP 7 and Internet access.
- The central control station can be located anywhere thanks to use of the Internet
- Investment protection thanks to migration of existing projects with SINAUT MICRO SC in TeleControl Server Basic
- Protection against tapping and manipulation of transmitted data between the S7-1200/S7-200 station and the OPC server of the TeleControl Server Basic by means of encryption algorithms
- Fast detection of faults thanks to clearly structured connection and station monitoring of all connected S7-1200 and S7-200 stations
- Fast creation of projects thanks to off-the-shelf sample applications

Industrial Remote Communication

TeleControl Basic for the control center

TeleControl Server Basic

Application

- Establishment of small to extremely extensive systems for monitoring and control with simple telecontrol stations
- Energy-saving concepts, e.g. through status-dependent speed control of pumps in remote stations
- Monitoring and control of non-mobile stations in the following sectors:
 - Sewage plants
 - Drinking water purification and distribution
 - Irrigation systems
 - Oil and gas supplies
 - District heating networks
 - Automatic machines
 - Traffic control systems
 - Building monitoring
 - Weather stations
 - Lighthouses and buoys
 - Wind farms
 - Photovoltaic plants
 - Environmental monitoring equipment
 - Intelligent advertising panels
- Connection of mobile stations if central monitoring and/or control is required for these, in the following areas:
 - Railway vehicles
 - Control of special vehicles
 - Local public transport
 - Complex building machines
- Ships in inland and coastal waters (see sample applications for satellite-supported live tracking with map representation and position-dependent control functions)
- Recording of environmental data
- Remote diagnosing of the SIMATIC S7-1200 with STEP 7 via the mobile wireless network and the Internet

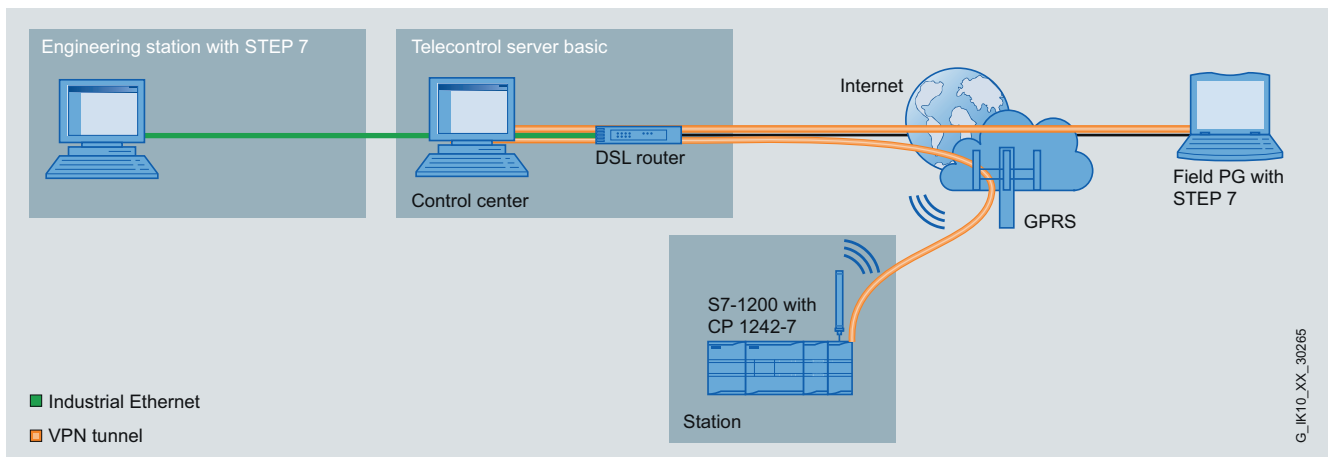

TeleControl Server Basic: Diagnosing an S7-1200 with dynamic or fixed IP address via the Internet and mobile wireless network

Design

The TeleControl Server Basic software package consists of:

- Block library for the SIMATIC S7-200 CPU
- OPC server software for the PC control center
 - for data exchange with an OPC client, e.g. WinCC or WinCC flexible
- Connection manager software for the PC control center
 - for establishing a secure GPRS connection between an S7 station with a CP 1242-7 or an MD720-3 modem, and the OPC server
 - for monitoring these connections
 - for data routing in the case of slave-to-slave communication between SIMATIC S7-1200 and S7-1200, and S7-200 and S7-200

Function

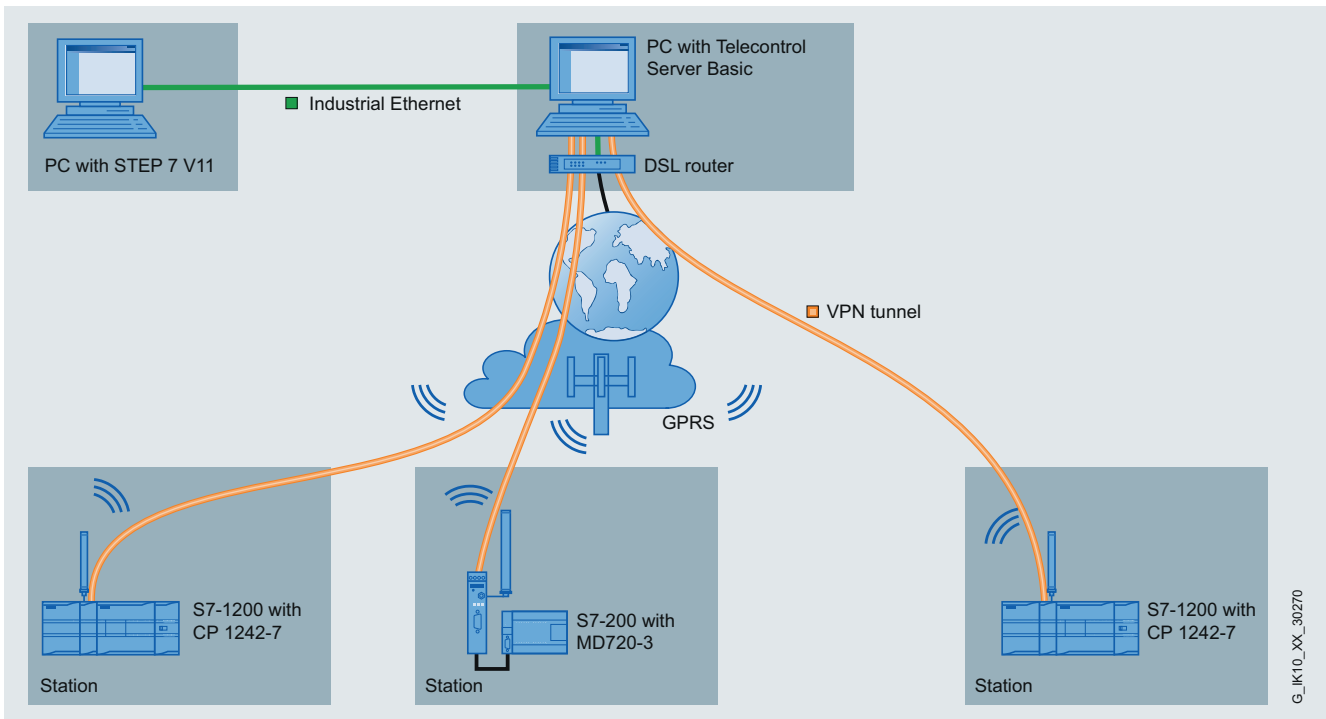

GPRS communication with CP 1242-7 and TeleControl Server Basic

- Connection of up to 5000 stations to one TeleControl Server Basic OPC server; by connecting several TeleControl Server Basic 5000 OPC servers to one OPC client, more than 5000 stations can be connected to one control center
- Support for large projects:
 - Multi-project-capable: Several STEP 7 telecontrol projects can be organized in up to 2000 groups
 - Multi-user-capable engineering: Simultaneous configuring by several users is possible
 - Support for configuring similar S7 stations
 - Step-by-step commissioning of stations and station groups
 - Expansions during runtime without interrupting operation
 - Shared operation of stations connected via private (M2M contract) or public APNs
- Access to variables of the SIMATIC S7-1200 and S7-200 via the OPC interface by means of WinCC, WinCC flexible or standard OPC clients for control systems
- Wireless communication between S7-1200 stations and S7-200 stations using the integral routing function via TeleControl Server Basic also with dynamic IP addresses
- Adjustable communication options:
 - Teleservice: STEP 7 diagnostics (V11 or higher) over the Internet; the S7-1200 GPRS Internet connection can be activated for teleservice either by the machine or plant operator, or via an authorized wake-up function by the programmer or maintenance technician (if this function has been enabled).
 - Permanent GPRS connection for cyclic or event-oriented data transfer (S7-200 and S7-1200)
 - Establishment of the GPRS connection if required by the OPC client (automatic wake-up via text message) or by the S7-1200 (S7-1200 only)
 - Configuration of monitoring time and time synchronization of S7 stations
- The PC on which the TeleControl Server Basic software is installed must be permanently accessible via a fixed IP address over the Internet, using DSL, for example, or it must have a dedicated line direct to the GPRS provider.

Security

- Password authentication for connection buildup by a SIMATIC S7-200 station
- Optional double user authentication in the case of diagnostics via the Teleservice gateway function of TeleControl Server Basic and the CP 1242-7
- Secured data traffic between S7, the Internet and TeleControl Server Basic by means of encryption algorithms

Industrial Remote Communication

TeleControl Basic for the control center

TeleControl Server Basic

Function (continued)

Diagnostics

- Integrated diagnostic functions for
 - Group status signal of a project in a tree structure
 - Status of each station (GSM diagnostics information, PLC status)
 - Monitoring of temporary GPRS connections
 - "Wake-up" of stations that change from standby mode to online mode for diagnostics purposes
 - STEP 7 diagnostics of the S7-1200 via the CP 1242-7 module (with dynamic or fixed IP provider address) from any PC with Internet access. The connection between the S7 and the STEP 7 PC to the TeleControl Server Basic is established here. The connection between STEP 7 and the S7 is established automatically via the Teleservice gateway function.
 - Establishment of the connection between the S7 and TeleControl Server Basic can also be optionally initiated via a mobile phone (authenticated).

Operation of TeleControl Server Basic together with SINAUT ST7

TeleControl Server Basic and SINAUT ST7 operate with different protocols during data transmission. It is possible to combine a TeleControl Server Basic system with a SINAUT ST7 system in one SCADA system. This is carried out in the PC of the control center via the OPC server of TeleControl Server Basic.

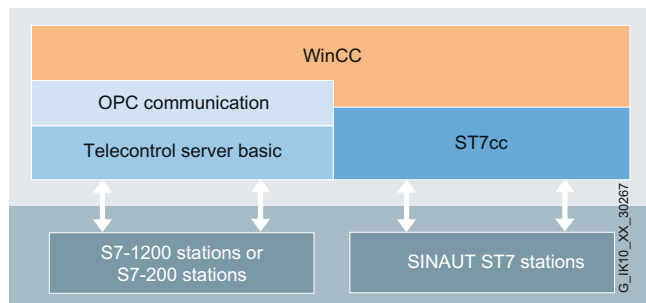

Merging of TeleControl Server Basic with SINAUT ST7 when using WinCC in the control center

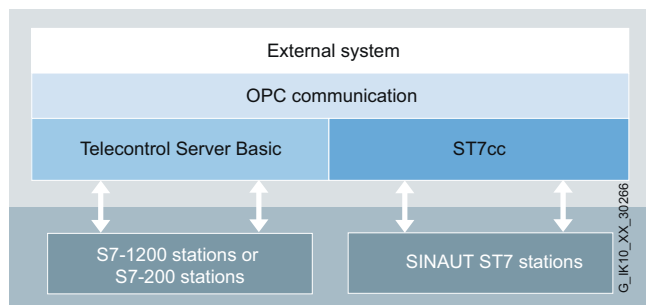

Merging of TeleControl Server Basic with SINAUT ST7 when using a non-Siemens system in the control center

Technical specifications

Product type designation	TeleControl Server Basic V2
Supported controllers	S7-1200 with CP1242-7 S7-200/S7-1200 with MD720-3 modem (block library included in the scope of supply)
Number of connections (stations) that can be operated (depending on the order version)	8, 64, 256, 1000, or 5000 connections
Number of STEP 7 projects that can be operated in parallel	2000 projects (structured representation, separation of the projects via programmable user rights)
Number of STEP 7 Teleservice connections that can be operated in parallel	5 connections per project (separation of the projects via programmable user rights)
Interfaces to the OPC Client	<ul style="list-style-type: none"> DCOM protocol OPC interface "Data Access Interface 3.0" Synchronous and asynchronous reading of variables
Interfaces and functions between the OPC server and SIMATIC S7	<ul style="list-style-type: none"> Writing of variables in the SIMATIC S7 in the case of value changes to OPC variables Transfer of SIMATIC S7 data to OPC variables (for event-driven communication from the SIMATIC S7) Activatable cyclic reading of variables; adjustable time interval Monitoring of connected SIMATIC S7 with time-of-day synchronization Routing of data packets between connected SIMATIC S7-1200 stations or between S7-200 stations Permanent GPRS connection; the tunnel is established from the GPRS modem Temporary GPRS connection (as required); the tunnel is established from the GPRS modem and can be initiated by a text message sent automatically by the OPC server ("wake-up"). Manual "wake-up" using a mobile phone is also possible. Via Internet access as server with public IP address (recommendation: fixed public Internet address)
Operating systems	Microsoft Windows 7 Professional (32-bit) Microsoft Windows 7 Enterprise (32-bit) Microsoft Windows 7 Ultimate (32-bit) Microsoft Windows 2008 Server (32-bit)
Diagnostics	Station group monitoring Station monitoring Connection monitoring STEP 7 Teleservice across Internet and router boundaries – S7-1200 only
Configuration	Integral configuration tool Multi-project-capable Multi-user-capable with user management Configurations can be expanded at runtime

Industrial Remote Communication

TeleControl Basic for the control center

TeleControl Server Basic

Ordering data	Order No.	Order No.
<p>TeleControl Server Basic</p> <p>Software for 8 to 5000 stations; Single License for one installation; OPC server for GPRS communication with SIMATIC S7-1200 and SIMATIC S7-200; connection management to remote GPRS stations; routing for connections between S7 GPRS stations; German and English operator interface; for Windows 7 Professional, Windows 7 Enterprise, Windows 7 Ultimate and Windows Server 2008 (32-bit); documentation on CD-ROM, German and English</p> <ul style="list-style-type: none"> • TeleControl Server Basic 8 Connection management for eight SIMATIC S7-1200 or S7-200 stations • TeleControl Server Basic 64 Connection management for 64 SIMATIC S7-1200 or S7-200 stations • TeleControl Server Basic 256 Connection management for 256 SIMATIC S7-1200 or S7-200 stations • TeleControl Server Basic 1000 Connection management for 1000 SIMATIC S7-1200 or S7-200 stations • TeleControl Server Basic 5000 Connection management for 5000 SIMATIC S7-1200 or S7-200 stations 	<p>6NH9 910-0AA20-0AA0</p> <p>6NH9 910-0AA20-0AB0</p> <p>6NH9 910-0AA20-0AC0</p> <p>6NH9 910-0AA20-0AD0</p> <p>6NH9 910-0AA20-0AE0</p>	<p><i>Accessories</i></p> <p>CP 1242-7 communication processor</p> <p>Communications processor for connecting SIMATIC S7-1200 to GSM/GPRS mobile wireless network</p> <p>6GK7 242-7KX30-0XE0</p> <hr/> <p>MD720-3 GSM/GPRS modem</p> <p>GPRS modem for IP-based data transmission over GSM networks, quad band, AT command interface, automatic establishment of GPRS connection, switchable to CSD mode, RS232, including gender changer for RS232/PPI adapter; manual on CD-ROM in German, English, Chinese, Russian</p> <p>6NH9 720-3AA00</p> <hr/> <p>ANT794-4MR antenna</p> <p>Quad band antenna, omnidirectional with 5 m cable</p> <p>6NH9 860-1AA00</p> <hr/> <p>ANT794-3M antenna</p> <p>Triband flat antenna, in enclosure with 1.2 m cable</p> <p>6NH9 870-1AA00</p>

Industrial Remote Communication

TeleControl Basic for the substations

CP 1242-7 GPRS module

Overview



The CP 1242-7 communication processor is used to connect a SIMATIC S7-1200 to the globally widespread GSM/GPRS mobile radio network and has the following characteristics:

- Worldwide wireless exchange of data between S7-1200 controllers and/or between S7-1200 controllers and control centers with an Internet connection
- Communication based on the GPRS (**G**eneral **P**acket **R**adio **S**ervice) mobile wireless service with data transmission speeds of up to 86 kbit/s in the downlink and 43 kbit/s in the uplink
- GPRS mode with fixed IP addresses and dynamic IP addresses with standard mobile phone contract
- Time synchronization on the basis of NTP (**N**etwork **T**ime **P**rotocol)
- On-demand connection buildup via voice call or text message
- Sending and receiving of text messages
- Clearly laid out LED signaling for fast and easy diagnostics
- Compact industrial enclosure in S7-1200 design for mounting on a standard mounting rail
- Fast commissioning thanks to easy configuration using STEP 7

In conjunction with the "TeleControl Server Basic" software, the CP 1242-7 forms a telecontrol system with further properties:

- Connection of up to 5000 telecontrol stations to the control center via an OPC interface
- Data buffering in the substations in the event of connection failures
- Central status monitoring of the substations
- No special provider services required for fixed IP addresses
- Teleservice access with STEP 7 to the substations via the Internet

Benefits

g e t Designed for Industry

Connection of the S7-1200 to a mobile wireless network turns the controller into a telecontrol substation (remote terminal unit) suitable for universal use.

- Data connection of difficult-to-access areas without high network infrastructure costs since the existing mobile wireless network can be used
- Machine maintenance without complicated integration into the end customer's IT networks
- Reduced maintenance and travel costs thanks to centralized management of remote automation solutions

The CP 1242-7 has been specially developed to meet the requirements of telecontrol systems in automation solutions:

- Avoidance of data loss thanks to rugged connection to the control center and buffering of the data
- Fast commissioning thanks to direct configuring using STEP 7

Application

- Data exchange and centralized data monitoring for automation solutions spread over large geographical areas
- Establishment of permanent or temporary communication link for mobile machines/vehicles without permanent location
- Global remote access to the end customer's machinery in compliance with IT security requirements
- Connection of difficult-to-access external stations without a network infrastructure

These applications can be found in the most diverse sectors:

- Water/wastewater treatment plants – pump/valve controllers
- Traffic and transportation – traffic light controls, lighting controls
- Power engineering – monitoring of transformer stations, meter readout
- Mechanical engineering – centralized remote maintenance of machines used around the world
- Wind energy – condition monitoring of wind turbines
- Vending machine manufacturers – monitoring, control of beverage vending machines

Industrial Remote Communication

TeleControl Basic for the substations

CP 1242-7 GPRS module

Design



The CP 1242-7 offers all the advantages of the S7-1200 design:

- Rugged, compact plastic enclosure
- Easily accessible connection and diagnostics elements, protected by front flaps
- Removable connecting terminals
- Simple mounting on the mounting rail of the S7-1200
- 3-pin plug-in terminal strip for connection of the 24 V DC external supply voltage
- SMA connection for GSM/GPRS antennas

The CP 1242-7 is plugged into the left-hand system bus interface of the S7-1200. The power is supplied via a 3-pin terminal strip on top of the module. The antenna socket and the SIM card slot are located on the underside of the module, protected by the lower front flap.

Function

In conjunction with the "TeleControl Server Basic" software, the CP 1242-7 forms a telecontrol system on the basis of mobile wireless communication.

The external stations can be connected to the control center either continuously or as required. A higher-level control center system can exchange data with all stations via OPC. A service PC with STEP 7 can connect to any station via the control center for maintenance purposes.

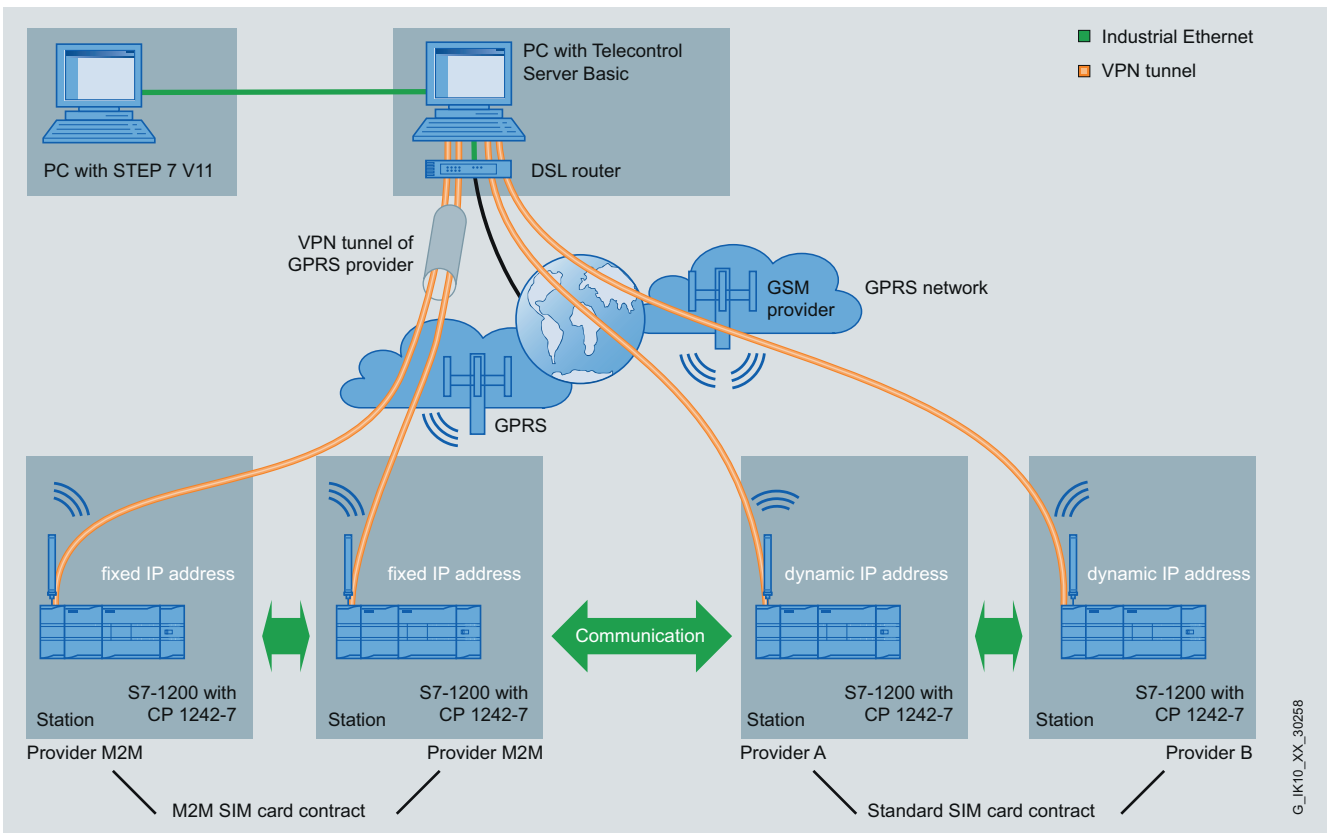

Connection of a SIMATIC S7-1200 with CP 1242-7 to the GSM/GPRS mobile wireless network.

Industrial Remote Communication

TeleControl Basic for the substations

CP 1242-7 GPRS module

Function (continued)

Operating modes

The CP 1242-7 can be used in two different operating modes:

Telecontrol server

In this mode, communication with the control center and other telecontrol stations is handled via a central telecontrol server. The CP 1242-7 is connected to the telecontrol server. The "TeleControl Server Basic" software forwards the data to the control station or other telecontrol stations and monitors it.

GPRS Direct

In this mode, the CP 1242-7 communicates direct with a control center or other telecontrol stations. In contrast to telecontrol mode, this requires no telecontrol server or additional software. This mode can be selected if there is a guarantee that the communication partners of the station can be reached using a unique address. To ensure this, special network operator services, frequently referred to as machine-to-machine (M2M), have to be used in normal cases.

Configuration

All the necessary information (provider data, access rights, operating modes) is configured with STEP 7. STEP 7 Basic V11 or higher is required for configuring the CP 1242-7.

The data can also be reconfigured during runtime. A special library function is available for this purpose.

Data buffering

Brief connection failures in the mobile wireless network are bridged by data buffering. When the connection has been restored, the buffered data is time-stamped and sent.

Time synchronization

The mechanism for time-of-day synchronization of the CP 1242-7 can be set dependent on the operating mode.

If a telecontrol server is used in the control center, the control center forwards the time of day to all substations. If TeleControl Server Basic is not used, synchronization can take place via an NTP server.

The CPU program can use this time to set the internal time-of-day for the station.

Function library

A function library for the following functions is available for the CP 1242-7:

- Data exchange: Send and receive functions enable data exchange with other stations or with the control center.
- Sending/receiving text messages
- Configuration: Reconfiguring can take place during operation with the help of a function block

Diagnostics/remote maintenance

An online connection to a remote S7-1200 station with CP 1242-7 can be established from STEP 7 via GPRS/Internet. After the connection has been established, all the familiar online functions for remote maintenance (download, diagnostics) are available.

Technical specifications

Order No.	6GK7 242-7KX30-0XE0
Product type designation	CP 1242-7
Transmission rate	
Transmission rate with GPRS transfer	
• For uplink maximum	43 kbit/s
• For downlink maximum	86 kbit/s
Wireless technology	
Type of mobile wireless service supported	
• SMS	Yes
• GPRS	Yes
Type of mobile wireless service-note	GPRS (Multislot Class 10)
Type of mobile wireless network supported	
• GSM	Yes
• UMTS	No
Operating frequency	
• 850 MHz	Yes
• 900 MHz	Yes
• 1800 MHz	Yes
• 1900 MHz	Yes
Transmit power	
• At operating frequency 850 MHz	2 W
• At operating frequency 900 MHz	2 W
• At operating frequency 1800 MHz	1 W
• At operating frequency 1900 MHz	1 W

Order No.	6GK7 242-7KX30-0XE0
Product type designation	CP 1242-7
Interfaces	
Number of electrical connections	
• for external antenna(s)	1
• for power supply	1
Number of slots for SIM cards	1
Design of electrical connection	
• for external antenna(s)	SMA socket (50 Ohm)
• for power supply	3-pin terminal strip
Design of SIM card slot	Slot under front flap
Supply voltage, current consumption, power loss	
Type of power supply	DC
External power supply	24 V
Relative positive tolerance at 24 V DC	20 %
Relative negative tolerance at 24 V DC	20 %
Current input from external power supply at 24 V DC	
• Typical	0.1 A
• Maximum	0.22 A
Effective power loss	2.4 W

Industrial Remote Communication

TeleControl Basic for the substations

CP 1242-7 GPRS module

Technical specifications (continued)

Order No.	6GK7 242-7KX30-0XE0
Product type designation	CP 1242-7
Permitted ambient conditions	
Ambient temperature	
• with vertical installation during operation	0 ... 45 °C
• with horizontal installation during operation	0 ... 55 °C
• During storage	-40 ... +70 °C
• During transport	-40 ... +70 °C
• Note	-
Relative humidity at 25 °C without condensation during operation, maximum	95 %
IP degree of protection	IP20
Design, dimensions and weights	
Module format	S7-1200 compact module, single width
Width	30 mm
Height	100 mm
Depth	75 mm
Net weight	0.133 kg
Product properties, functions, components	
General	
Number of modules	
• Per CPU, maximum	3
• Note	-
Performance data	
<u>Performance data open communication</u>	
Number of possible connections for open communication by means of TC blocks, maximum	5
Data volume as user data per send call, maximum	2 048 bytes
<u>Performance data S7 communication</u>	
Number of possible connections for S7 communication	
• Maximum	-
• For PG connections, maximum	-
• For PG/OP connections, maximum	-
• Note	-

Order No.	6GK7 242-7KX30-0XE0
Product type designation	CP 1242-7
<u>Performance data Telecontrol</u>	
Connection to the control center	TeleControl Server Basic
• Note	Connection to Scada system by means of OPC interface is supported
• by means of permanent connection	
• by means of on-demand connection	is supported
Protocol is supported	
• DNP3	No
• IEC 60870-5	No
Product function: data buffering if connection is aborted	Yes
• Note	up to 1000 message frames
Data volume as user data per station in telecontrol mode, maximum	2 048 bytes
<u>Performance data Teleservice</u>	
Diagnostics function: online diagnostics with SIMATIC STEP 7	Yes
Product function: program download with SIMATIC STEP 7	Yes
Product function: remote firmware update	No
Product functions Management, configuration, programming	
Configuration software required	STEP 7 Basic V11.0 or higher
Product functions Security	
Product function: password protection for teleservice access	Yes
Product function: encrypted data transmission	Yes
Product functions Time	
NTP protocol is supported	Yes

Industrial Remote Communication

TeleControl Basic for the substations

CP 1242-7 GPRS module

Ordering data	Order No.	Order No.
Communication processor CP 1242-7 ¹⁾ Communication processor for connecting SIMATIC S7-1200 to GSM/GPRS mobile wireless network	6GK7 242-7KX30-0XE0	STEP 7 Basic engineering software V11 <i>Target system:</i> SIMATIC S7-1200 controllers and the associated I/O <i>Requirement:</i> Windows XP Home SP3, Windows XP Professional SP3 (32 bit), Windows 7 Home Premium (32 bit), Windows 7 Professional (32 bit), Windows 7 Enterprise (32 bit), Windows 7 Ultimate (32 bit), Microsoft Server 2003 R2 Std. SP2 (32 bit), Microsoft Server 2008 Std. SP2 (32 bit) <i>Delivery package:</i> German, English, Chinese, Italian; French, Spanish <ul style="list-style-type: none"> • Single license • Upgrade STEP 7 Basic V10.5 to STEP 7 Basic V11, single license • Powerpack STEP 7 Basic V11 to STEP 7 Prof. V11, floating license • STEP 7 Basic V11, trial license
Accessories TeleControl Server Basic Software for <ul style="list-style-type: none"> • License for up to 8 stations • License for up to 64 stations • License for up to 256 stations • License for up to 1000 stations • License for up to 5000 stations 	6NH9 910-0AA20-0AA0 6NH9 910-0AA20-0AB0 6NH9 910-0AA20-0AC0 6NH9 910-0AA20-0AD0 6NH9 910-0AA20-0AE0	
ANT794-4MR antenna GSM quad-band antenna, omnidirectional with 5 m cable	6NH9 860-1AA00	
ANT794-3M antenna GSM tri-band flat antenna with 1.2 m connecting cable	6NH9 870-1AA00	

¹⁾ Please note national approvals at www.siemens.com/wireless-approvals

More information

To assist in selecting the right products for Industrial Wireless Communication, the SIMATIC NET Selection Tool is available at: www.siemens.com/snst

Wireless approvals

Current approvals can be found on the Internet at: www.siemens.com/wireless-approvals

Industrial Remote Communication

TeleControl Basic for the substations

MD720-3 GSM/GPRS modem

Overview



- GSM/GPRS mobile wireless modem with RS232 interface
- DIN rail mounting
- 24 V DC power supply
- Supports the GSM services CSD ¹⁾, SMS and GPRS
- Use with TeleControl Basic:
Data transfer over tunneled GPRS connection with SIMATIC S7
- Use with SINAUT ST7:
Data transmission via CSD, GPRS, transmission of text messages
- AT command interface: For remote maintenance via CSD with TS Adapter II or for transmitting text messages

¹⁾ CSD – **C**ircuit **S**witched **D**ata (data transmission via GSM dialup connection)

Benefits

g e t **Designed for Industry**

- Can be used worldwide due to quad band technology (observe national regulations!)
- Quick assembly due to standard rail mounting

For GPRS operation in combination with TeleControl Server Basic:

- Low operating costs for a permanent wireless online connection due to optimized communication with efficient message format
- Central control station is location-independent as result of Internet link between mobile radio provider and OPC server
- Secure connection over public networks through encrypted data transmission plus additional measures of the GPRS provider
- Simple configuration of wireless connected plants without specialist radio knowledge
- Modem replacement is possible by non-specialists since parameterization is carried out through the S7-200
- Cost savings thanks to remote servicing and remote programming
- Fast generation of applications by means of coordinated combination of automation components with the Micro Automation Set 21 (www.siemens.com/microset)

Industrial Remote Communication

TeleControl Basic for the substations

MD720-3 GSM/GPRS modem

Application

- GSM modem for the SINAUT ST7 telecontrol system for data transmission via dialup connection (CSD service)
- GSM modem for the TeleControl Basic system for data transmission via GPRS
- Construction of systems for monitoring and controlling of simple telecontrol stations
- Energy-saving concepts for plants, e.g. by means of status-dependent speed control of pumps in remote stations
- Control and monitoring of, for example:
 - Sewage treatment plants, water treatment
 - Oil and gas supplies
 - District heating networks
 - Power distribution
 - Pumping stations
 - Automatic machines
 - Traffic control systems
 - Buildings
 - Intelligent advertising panels
 - Weather stations
 - Lighthouses and buoys
 - Wind energy and photovoltaic plants
- Linking of mobile stations, with central monitoring/control of track vehicles, special vehicles, local public transport, complex building machines, ships on rivers and in coastal areas
- Remote programming and maintenance of the SIMATIC S7-200 via a GSM dialup connection (CSD service)

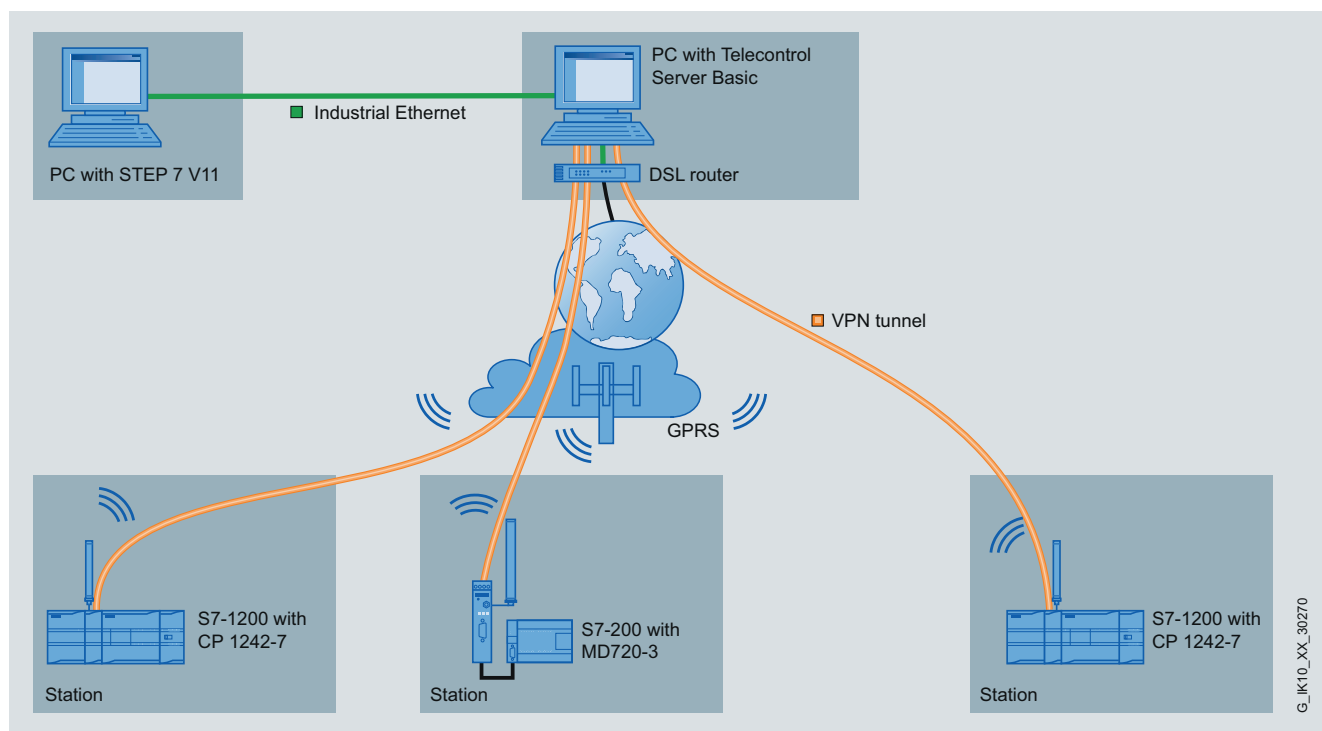

GPRS communication between SIMATIC S7-200 with MD720-3 and TeleControl Server Basic

G_IK10_XX_30270

Industrial Remote Communication

TeleControl Basic for the substations

MD720-3 GSM/GPRS modem

Design

- Rugged plastic enclosure for DIN rail mounting
- 9-pin Sub-D socket with RS232 interface (PPI adapter for SIMATIC S7-200 necessary)
- Diagnostics LEDs for modem status, field strength and connection check
- SET service key
- 4-pin screw terminal for connection to the 24 V DC supply voltage
- SMA connection for GSM/GPRS antennas

Function

- Quad-band GSM with the frequency bands 850/900/1800/1900 MHz
- GPRS Multislot Class 10 (gross: 13.4-27 kbit/s upload, 40-54 kbit/s download).
- Automatic establishment and holding of IP-based online connection over GPRS to the Internet
- Data exchange with PC-based application TeleControl Server Basic (router and OPC server); data exchange with further MD720-3 modems possible over routing of TeleControl Server Basic
- Hot switchover between GPRS and CSD (modem operation)
- CSD and GPRS connection controllable using AT commands
- Approved replacement for the GSM kit MC45 through compatible AT commands when used with SINAUT ST7 modules
- Sending of SMS and fax (via SMS) using GSM services
- Remote programming of S7-200 with MicroWin in GSM modem mode (CSD mode)
- Secure access to SIMATIC S7-200 data, also over mobile radio provider networks which do not provide public and fixed IP addresses for the modem

Configuration

- Parameterization using PLC blocks with the Micro/Win programming tool for SIMATIC S7-200;
- PLC blocks are part of TeleControl Server Basic
- AT command interface

Security

- Approval of up to 3 call numbers for incoming GSM connections (CLIP function) for teleservice
- User name and password for GSM connection
- Unlimited client and server operation even in protected GPRS networks with private IP addresses of the mobile radio providers
- Secure data transfer in GPRS mode between modem, Internet and TeleControl Server Basic using encryption algorithms

Diagnostics / maintenance

- Status of establishment of connection, and of an existing connection on front LED display
- Reading of configuration data over the RS232 interface
- Connection status to modem and to PLC can be monitored in TeleControl Basic
- Direct, additional access over GSM (modem operation) for teleservice (remote programming, remote diagnostics)

Industrial Remote Communication

TeleControl Basic for the substations

MD720-3 GSM/GPRS modem

Technical specifications

Order No.	6NH9 720-3AA00
Product type designation	GPRS modem MD 720-3
Transfer rate	
• RS232	300 bit/s to 57,600 bit/s
• GSM data calls	CSD 9,600 bit/s
• GPRS	
- Up to 2 uplinks	13.4 kbit/s to 27 kbit/s gross upload (modem to Internet); net approx. 30 % lower
- Up to 4 downlinks	40 kbit/s to 54 kbit/s gross download (Internet to modem); net is approx. 30 % lower
Interfaces	
• RS232	1 x 9-pin Sub-D socket
• Antenna connection	1 x SMA antenna socket (50 Ohm)
Frequency ranges	850, 900, 1800, 1900 MHz
Transmitted output power	2 W at 850, 900 MHz 1 W at 1800, 1900 MHz
Current consumption	
Send mode	
• at 12 V	430 mA
• at 24 V	140 mA
Receive mode	
• at 12 V	90 mA
• at 24 V	50 mA

Order No.	6NH9 720-3AA00
Product type designation	GPRS modem MD 720-3
Supply voltage	12 ... 30 V DC
Power loss	typ. 5 W max. 6.2 W
Permissible ambient conditions	
• Operating temperature	- 20 °C ... +60 °C
• Transport/storage temperature	- 25 °C ... +85 °C
• Relative humidity	Max. 95 % at +25 °C
Design	
• Dimensions (W x H x D) in mm	22.5 x 99 x 114
• Weight	Approx. 150 g
• Assembly	Standard rail
Degree of protection	IP40
Configuration	AT commands using S7-200 program blocks; MC45-compatible AT commands for use with SINAUT ST7 modules
National approvals	Current approvals can be found in the Internet at www.siemens.com/simatic-net/ik-info

Industrial Remote Communication

TeleControl Basic for the substations

MD720-3 GSM/GPRS modem

Ordering data	Order No.	Order No.
GSM/GPRS modem MD720-3 ¹⁾ GPRS modem for IP-based data transmission over GSM networks, quad band, AT command interface, automatic establishment of GPRS connection, switchable to CSD mode, RS232; including gender changer for RS232/PPI adapter; manual on CD-ROM in German, English, Chinese, Russian	6NH9 720-3AA00	
Accessories TeleControl Server Basic Software for 8 to 5000 stations; Single License for one installation; OPC server for GPRS communication with SIMATIC S7-1200 and SIMATIC S7-200; connection management to 8 remote GPRS stations; routing for connections between S7 GPRS stations; German and English operator interface; for Windows 7 Professional, Windows 7 Enterprise, Windows 7 Ultimate and Windows Server 2008 (32-bit); documentation on CD-ROM, German and English		
<ul style="list-style-type: none"> • TeleControl Server Basic 8 Connection management for eight SIMATIC S7-1200 or S7-200 stations • TeleControl Server Basic 64 Connection management for 64 SIMATIC S7-1200 or S7-200 stations • TeleControl Server Basic 256 Connection management for 256 SIMATIC S7-1200 or S7-200 stations • TeleControl Server Basic 1000 Connection management for 1000 SIMATIC S7-1200 or S7-200 stations • TeleControl Server Basic 5000 Connection management for 5000 SIMATIC S7-1200 or S7-200 stations 	6NH9 910-0AA20-0AA0 6NH9 910-0AA20-0AB0 6NH9 910-0AA20-0AC0 6NH9 910-0AA20-0AD0 6NH9 910-0AA20-0AE0	
		ANT794-3M GSM/GPRS antenna GSM tri-band flat antenna with 1.2 m connecting cable
		ANT794-4MR GSM/GPRS antenna Quad band antenna, omnidirectional with 5 m cable
		SIMATIC S7-200 PPI modem cable For connecting the S7-200 to the GSM/GPRS modem MD720-3
		Connecting cable For connecting a TIM3V-IE/TIM4 (RS232) with the GSM modem MD720-3 (access to GSM network). Also suitable for third-party modems or radio equipment with RS232 standard; cable length 2.5 m.
		SITOP compact 24 V/ 0.6 A 1-phase power supply with wide-range input 85 ... 264 V AC/110 ... 300 V DC, stabilized output voltage 24 V, rated output current value 0.6 A, slim design

¹⁾ Please note national approvals at www.siemens.com/wireless-approvals

More information

To assist in selecting the right products for Industrial Wireless Communication, the SIMATIC NET Selection Tool is available at: www.siemens.com/snst

Wireless approvals

Current approvals can be found on the Internet at: www.siemens.com/wireless-approvals

Industrial Remote Communication

TeleControl Basic for the substations

SIPLUS MD720-3 GSM/GPRS modem

Overview



- GSM/GPRS mobile radio modem with RS232 interface
 - DIN rail mounting:
 - 24 V DC power supply
 - Supports the GSM services CSD ¹⁾, SMS and GPRS
 - Use with SINAUT MICRO:
Data transmission via GPRS; switchable to CSD for remote maintenance (incoming call only)
 - Use with SINAUT ST7:
Data transmission via CSD, transmission of SMS
- ¹⁾ CSD – **C**ircuit **S**witched **D**ata (data transmission via GSM dialup connection)

Note:

SIPLUS extreme products are based on Siemens Industry standard products. The contents listed here were taken from the respective standard products. SIPLUS extreme-specific information was added.

SIPLUS MD702-3 GSM / GPRS modem

Order No.	6AG1 720-3AA00-7AA0
Order No. based on	6NH9 720-3AA00
Ambient temperature range	-25 ... +70 °C
Conformal coating	Coating of the printed circuit boards and the electronic components
Technical data	The technical data of the standard product applies except for the ambient conditions.

Ambient conditions

Relative humidity	5 ... 100 % Condensation permissible
Biologically active substances	Conformity with EN 60721-3-3, Class 3B2 mold and fungal spores (except fauna)
Chemically active substances	Conformity with EN 60721-3-3, Class 3C4 incl. salt mist and ISA-S71.04 severity level G1; G2; G3; GX ^{1) 2)}
Mechanically active substances	Conformity with EN 60721-3-3, Class 3S4 including conductive sand, dust ²⁾
Air pressure (depending on the highest positive temperature range specified)	1080 ... 795 hPa (-1000 ... +2000 m) see ambient temperature range 795 ... 658 hPa (+2000 ... +3500 m) derating 10 K 658 ... 540 hPa (+3500 ... +5000 m) derating 20 K

- ¹⁾ ISA-S71.04 severity level GX: Long-term load: SO₂ < 4.8 ppm; H₂S < 9.9 ppm; Cl < 0.2 ppm; HCl < 0.66 ppm; HF < 0.12 ppm; NH < 49 ppm; O₃ < 0.1 ppm; NOX < 5.2 ppm
Limit value (max. 30 min/d): SO₂ < 17.8 ppm; H₂S < 49.7 ppm; Cl < 1.0 ppm; HCl < 3.3 ppm; HF < 2.4 ppm; NH < 247 ppm; O₃ < 1.0 ppm; NOX < 10.4 ppm

- ²⁾ The supplied plug covers must remain in place over the unused interface when operated in atmospheres containing corrosive gases!

The technical documentation on SIPLUS can be found here:
www.siemens.com/siplus-extreme

Ordering data

Order No.

SIPLUS MD720-3 GSM/GPRS modem

6AG1 720-3AA00-7AA0

GPRS modem for IP-based data transmission over GSM networks, quad-band, AT command interface, automatic establishment of GPRS connection, switchable to CSD operation, RS232; manual on CD-ROM in German, English, Chinese, Russian

Accessories

see Ordering data for MD720-3 GSM/GPRS Modem

Overview

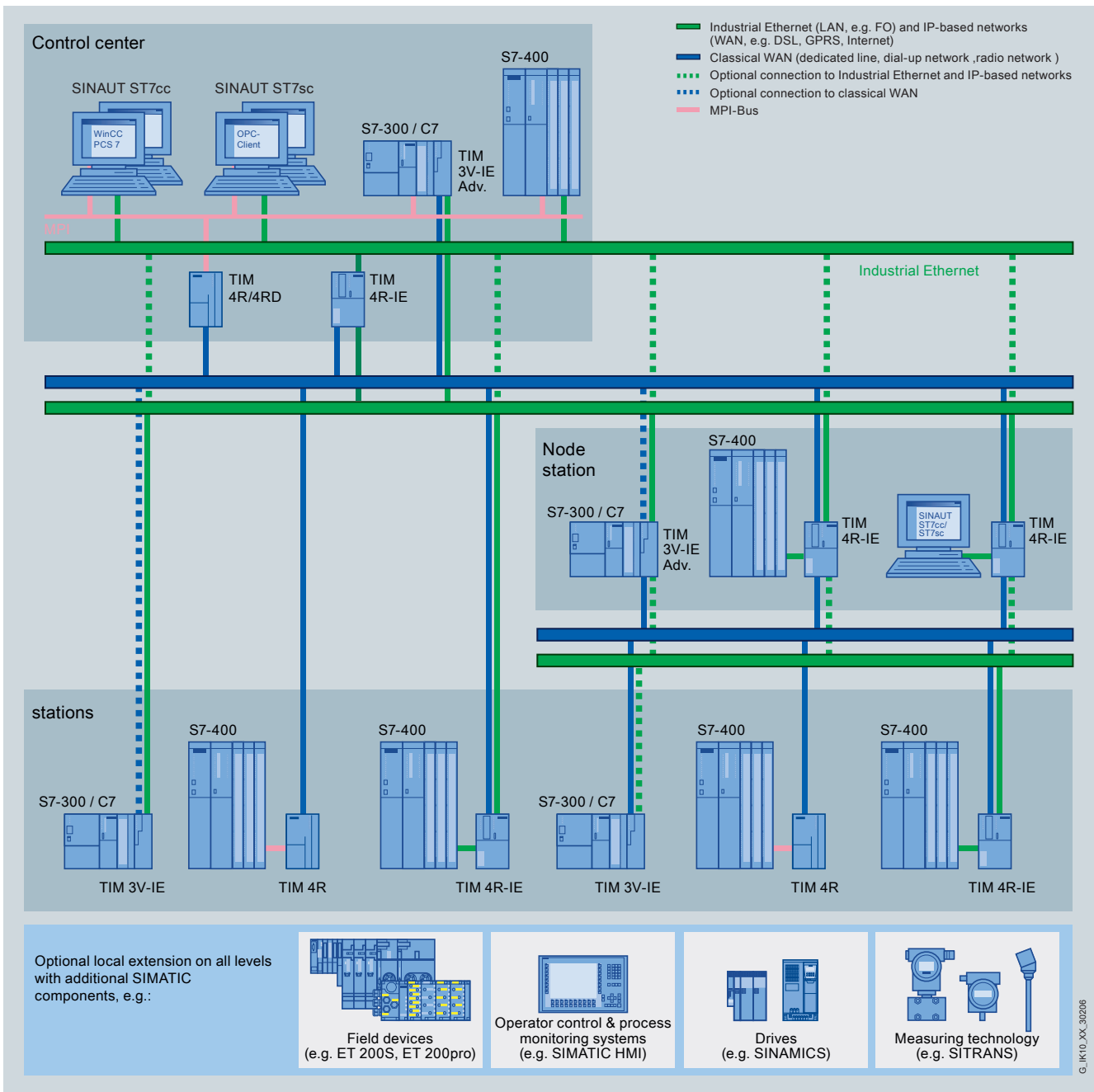

Example configuration for TeleControl Professional with SINAUT ST7

TeleControl Professional is a telecontrol system based on SIMATIC S7 (S7-300, S7-400, and WinCC/PCS 7) for fully-automatic monitoring and control of process terminals which exchange data with one or more control centers or with each other via a wide range of WAN media.

TeleControl Professional facilitates an integrated communications concept (TIA) and complete integration into the SIMATIC environment. The modular design and the support of a huge variety of network forms and operating modes including IP-based networks permit the design of flexible network structures that can also contain redundant links.

By using all forms of transmission media (e.g. dedicated line, wireless, dial-up networks, mobile wireless, DSL), the networks can be optimally adapted to the respective local conditions.

The SINAUT ST7 engineering software and STEP 7 permit simple and cost-effective configuration even of highly complex networks and their extensions.

The system also supports data exchange with devices of the previous system SINAUT ST1 (based on SIMATIC S5).

Industrial Remote Communication

TeleControl Professional

Introduction

Benefits

get Designed for Industry

- All conventional and IP-based WAN media can be combined as required, including path redundancy
- Event-driven data transmission incl. time-stamping
- Local data storage
- Remote programming and remote diagnostics
- Integrated operator control and monitoring concept for WinCC/PCS7 or connection to non-Siemens systems via OPC

Application

The TeleControl Professional system has proven itself in the smallest plants with only a few process stations, but also in complex networks with many hundreds of stations.

Examples of the range of uses:

- Safe supply of drinking water, gas or district heating for private and industrial consumers via branched networks
- Economical transportation of gas, oil or oil products through pipelines
- Reliable recording and transmission of process data from environmental monitoring systems
- Remote monitoring of wastewater systems
- Control of beacons, unit-type district heating power stations, conveyor systems or transportation systems

Design

The TeleControl Professional system is based on the SIMATIC systems S7-300 and S7-400 as well as on WinCC/PCS 7. It supplements these systems with the special SINAUT components listed below, comprising hardware as well as software.

Hardware Components

- TIM communication modules
- MD modem modules
- Mobile wireless components (GSM/GPRS/UMTS)
- Dedicated line accessories (overvoltage protection)
- Connecting cables

Software components

SINAUT ST7 Engineering Software

- SINAUT TD7 library; contains blocks for the SIMATIC S7 CPU
- SINAUT ST7 configuring and diagnostics software for the programming device

Software for the central control center

- SINAUT ST7cc; the SINAUT add-on for WinCC
- WinCC TeleControl; add-on for SIMATIC WinCC for telecontrol applications
- PCS 7 TeleControl; add-on for SIMATIC PCS 7 for telecontrol applications
- SINAUT ST7sc; software for interfacing ST7 with control centers that can operate as OPC clients

Function

Network configurations and operating modes

The telecontrol components support the set-up of complete hierarchical communication networks comprising terminals, node stations and control center.

For the exchange of information between the individual devices, conventional WANs can be used, such as dedicated-line, wireless and dialup networks as well as IP-based WANs such as DSL, GPRS, UMTS, Internet, etc.

There are no restrictions on the combination of WAN types in a project. Point-to-point, line and node network topologies can be set up. Hybrid configurations of these basic structures are also possible.

A station can be linked using two transmission paths to permit redundant data transmission. The two paths can be of the same type or different, e.g. dedicated line plus GPRS, or ISDN plus wireless.

The following network topologies are possible with SINAUT ST7 in the WAN:

- "Point-to-point"
- "Line"
- "Star"
- "Tree"
- "Ring"

The graphics below show examples of different network topologies that can be implemented with SINAUT ST7.

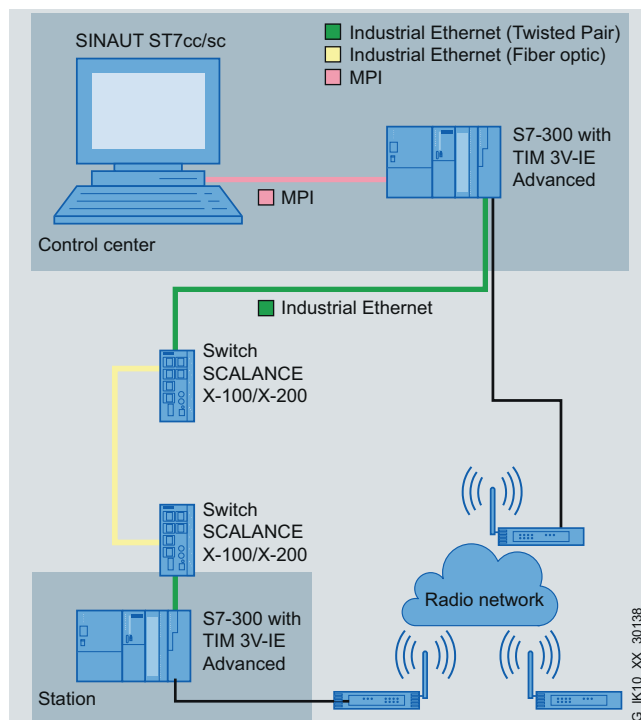

SINAUT ST7cc/sc control station with redundant WAN connection

Function (continued)

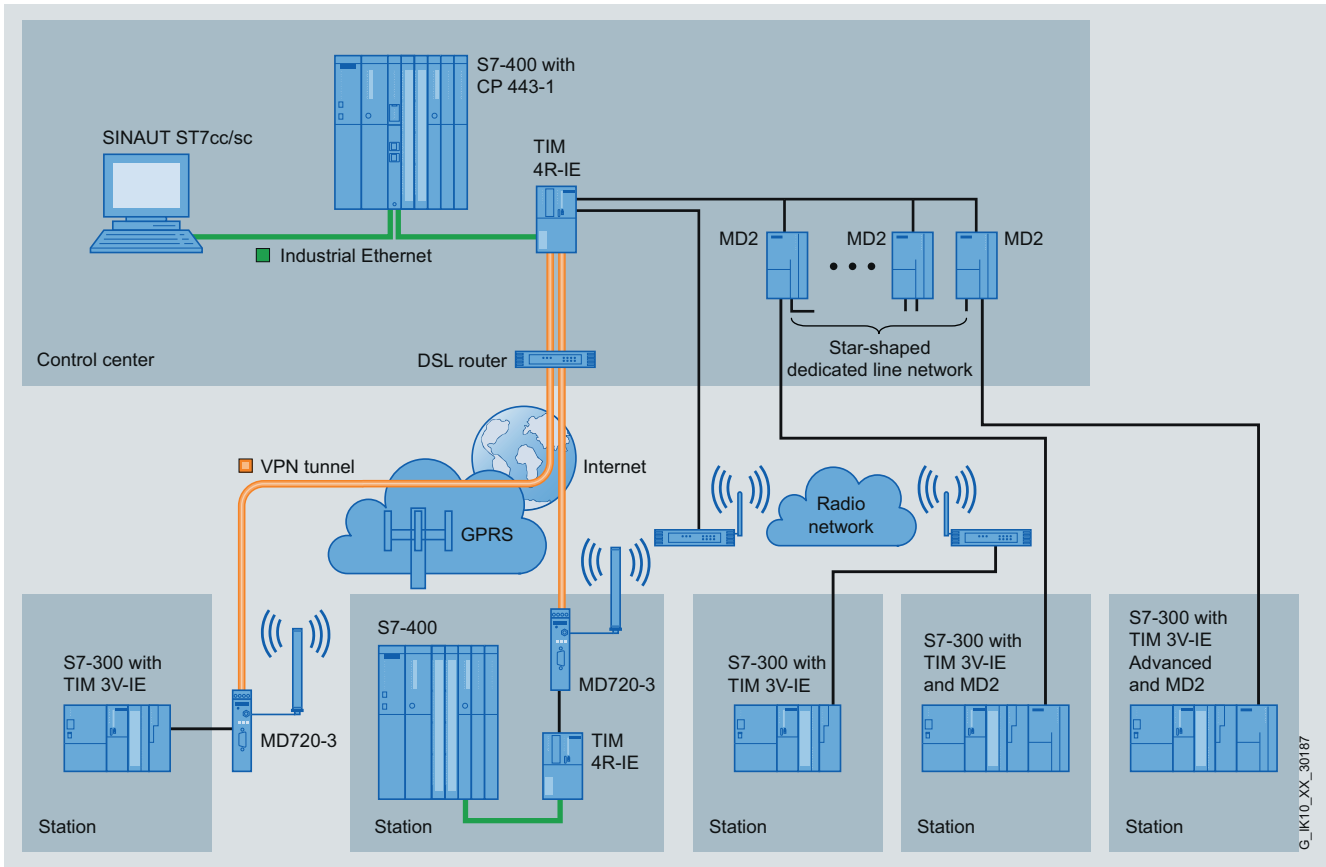

Different communication media in a SINAUT ST7 system

The control center

A number of different versions can be selected as components of the central control center:

SINAUT ST7cc;

PC control center based on WinCC; this is the ideal control center system for both SINAUT ST7 and SINAUT ST1. It has been designed specifically for event-driven and time-stamped data transmission on the SINAUT system and can be set up as a non-redundant or redundant system (to supplement the WinCC/PCS 7 redundancy package).

PCS 7 with PCS 7 TeleControl;

this is the ideal control center system for plants in which larger local automation tasks have to be combined with telecontrol connections. In addition to SINAUT ST7, remote stations with other communication protocols can be connected, e.g. over DNP3 or IEC -870-5-101/-104. ¹⁾

WinCC TeleControl;

control center system for plants with the WinCC HMI software, expanded with telecontrol connections. WinCC TeleControl offer connection of SIMATIC substations with TIM 3V-IE DNP3, TIM 4R-IE DNP3 or non-Siemens stations with DNP3 protocol, as well as telecontrol stations with IEC 870-5-101/-104.

SINAUT ST7sc;

OPC server for interfacing control centers from other vendors via the OPC Client function; the SINAUT telecontrol technology can also be connected to control center systems from other vendors via the "Data Access Interface". ST7sc features extensive buffer mechanisms which prevent data from being lost even if the OPC client fails. It can be connected to non-redundant or redundant clients.

Like the substations, the control center comprises a SIMATIC S7-300 or S7-400 PLC.

This solution is suitable for simpler control centers in which only an up-to-date process image of the process data available in the stations is required. The station process control can be influenced by entering commands, setpoints or parameters. This S7-300 or S7-400 control center can also be used to extend a PC control center (SINAUT ST7cc or ST7sc), e.g. for data output on a panel and/or as an emergency operating system.

¹⁾ More information see catalog ST PCS 7.1

Industrial Remote Communication

TeleControl Professional

Introduction

Design (continued)

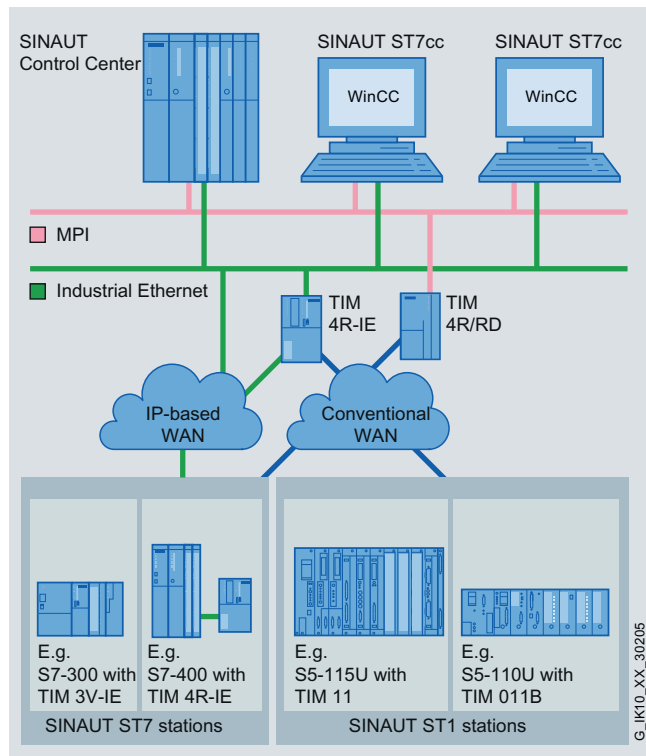

SINAUT ST7cc control center system with connected ST7 and ST1 stations

Classic WANs

The following conventional WANs can be used for data transmission:

- Copper dedicated lines, private or leased
- Private wireless networks (optionally with time slot procedure) TETRA
- Dial-up networks (analog/ISDN/GSM)

IP-based WANs

SINAUT communication, however, is also possible via IP-based networks:

- Wirelessly, by using special wireless systems optimized for Ethernet, e.g. the components of the SCALANCE W IWLAN system
- Via fiber-optic conductors, e.g. through use of SCALANCE X switches with optical ports; distances of up to 120 km can then be covered
- Via public networks and the Internet using DSL or GPRS/UMTS.

Change-driven data transmission

In the stations, the SINAUT software ensures that process data is transmitted between CPU and control center, e.g. ST7cc, and from CPU to CPU in the event of changes. Connection, CPU or control desk failures are displayed. A data update for all participating communication partners is performed automatically following debugging or startup of a CPU or of the control center.

Permanently correct time

To enable subsequent and correct archiving of process data in the control system, all data frames are already assigned a time tag at their place of origin. The entire network is synchronized automatically – including daylight saving time changeover.

Local data storage

A special property of the TIM communications module used in the SINAUT ST7 system is the capability for saving data which must not be lost in the event of a connection fault or if the partner fails. A memory capacity is provided for up to 56,000 message frames.

The memory capacity helps to save money on dial-up networks. Various priorities can be assigned to the data to be transmitted. At high priority, a dial-up connection is established immediately. At low priority, data is initially saved in the TIM. This data is transmitted on the next connection that is made with the partner for any reason, for example if an item of information with a high priority is to be transmitted, or if the partner sets up a connection in order to exchange data.

It is precisely because the TIM module can save data and transmit it at a later point in time with a time stamp that the use of a suitable control center system must be ensured. It must also be possible to continue to process this data, specifically as regards subsequent archiving, if the data is received in the control center delayed by a number of hours or even days. Also archive compressions such as the creation of mean, hourly and daily values cannot be performed until all data for the relevant period has been received. The standard SINAUT control center on the basis of WinCC, when supplemented with the SINAUT software ST7cc, is ideal for this task.

SINAUT remote programming and remote diagnostics

In industries in which SINAUT is used, the terminals are distributed across wide areas and are often situated in locations that are difficult to access. Faults which require a visit to be made to a terminal of this type are associated with long journeys. SINAUT ST7 can provide the ideal solution for such circumstances: Remote programming and diagnostics via the telecontrol network. All diagnostics and programming functions provided by SIMATIC and SINAUT for station automation and WAN communication can be used via the telecontrol path - without interrupting process data transmission.

Alarm messaging via text message

In order to alert standby service personnel, event-driven text messages can be sent to mobile phones from the CPUs. An acknowledgment that a message of this type has been received can be sent back to the sender CPU from the mobile phone. A text message can also be output as e-mail, fax or voice mail if the mobile service provider offers these options.

Integration

Protocols

SINAUT ST1 protocol

This protocol is used in the SINAUT ST1 system, which is based on the SIMATIC S5 system. However, the SINAUT ST7 system also supports this protocol. Existing SINAUT ST1 systems can be further expanded with the SINAUT ST7 system, or existing system components can be replaced with ST7 devices.

Possible operating modes:

- Polling
- Polling with time slot procedure
- Spontaneous operation (for dialup networks)

Please note that only modems/transmission devices suitable for 11-bit asynchronous characters may be used in both polling modes. However, "spontaneous" mode supports transmission with both 11-bit and 10-bit asynchronous characters.

SINAUT ST7 protocol

This protocol is a more advanced version of the ST1 protocol. It enables SINAUT communication via both conventional and IP-based WANs. In addition, the addressing options have been extended:

- Up to 10,000 stations can be addressed (maximum of 254 for ST1)
- Message frames contain a source and a target address, (ST1 message frames only contain a source or a target address).

The ST7 protocol also supports "PG routing", i.e. remote programming and remote diagnostics via the WAN without interrupting SINAUT data traffic. PG routing and data traffic share the available bandwidth on the transmission path; PG routing is simply allocated a higher priority.

Possible operating mode in the IP-based WAN:

- Spontaneous mode

Possible operating modes in the conventional WAN:

- Polling
- Polling with time-slot procedure
- Spontaneous operation (for dialup networks)

Modes

Polling

- In polling mode, data exchange is controlled from the controller. It calls the connected terminals (including node terminals) in sequence. Terminals with modified data send this data as soon as they are called. Terminals with no modified data at the present time simply acknowledge the call. Data from the CPU to the terminals can be transferred at any time between the individual calls.

The ST7 protocol supports direct data transmission between substations. During this type of communication, data is always exchanged via the polling control center TIM.

Polling with time-slot procedure

This mode is used on a radio network on which the use of the radio frequency assigned by the registration authorities has to be shared with other operators. Typically, each operator has 6 seconds per minute to exchange data with its terminals. Once this time has elapsed, the frequency must be enabled for the next operator. During the allocated time slot, this type of polling operates in the same way as standard polling.

The ST7 protocol supports direct data transmission between substations. During this type of communication, data is always exchanged via the polling control center TIM.

In order to exactly observe the time slot, the polling control center TIM must be directly supplied with the DCF77 or GPS time.

Spontaneous mode

Spontaneous mode for data exchange on dial-up networks: Different priorities (normal, high or interrupt) can be assigned to the data of the station or node station for transmission in the dial-up network. Data to be sent by the control center always have the high priority. If data with a high or alarm priority is awaiting transmission, a dial-up connection is established immediately. At normal priority, data is initially saved in the terminals. This data is transmitted on the next connection that is made with the partner for any reason, for example if an item of information with a high or alarm priority is to be transmitted, or if the partner sets up a connection in order to exchange data.

The message frames saved in the TIM are transmitted according to the FIFO principle, i.e. in the original chronological sequence, providing they are message frames with high or normal priority. If alarm message frames are present in the TIM buffer, these are always transmitted before the other message frames. Direct data transmission between substations is possible with the ST7 protocol.

Industrial Remote Communication

TeleControl Professional

Introduction

Integration (continued)

Spontaneous operation in the IP-based WAN

For transmission via an IP-based network, a permanent S7 connection is established in each case between two TIMs or between one TIM and the ST7cc/ST7sc. The two TIMs or the TIM and ST7cc/ST7sc exchange the data packages specific to SINAUT ST7 with application of the TCP/IP transport protocol. The transmission is performed with the resources of the S7 communication, in which the processing of the spontaneous data exchange depends on whether the transmitted volume of data is chargeable or not in the IP-based network.

Networks without volume tariff:

When data is transmitted, it is transferred immediately to the respective partner regardless of any priority. Data is transferred in accordance with the FIFO principle. This does not apply to message frames with "interrupt" priority. These are transferred before any other message frames that are available in the buffer.

Networks with volume tariff:

In an IP-based network such as the GPRS network, the priority of the individual data frames (normal, high or interrupt) is taken into consideration, as in the case of a dialup network. Data with normal priority is collected and transmitted in larger blocks, as soon as a specific size of block is achieved or, at the latest, when the specified TCP/IP Keep-alive interval has expired. This saves transmission volume because a reduced message frame overhead and fewer acknowledgment message frames are required. Important data with high or interrupt priority is transmitted immediately. Normal message frames that are buffered at this point are sent at the same time. Message frames with normal or high priority are transmitted in accordance with the FIFO principle.

Network configurations and topologies

All networks and all transmission media can be combined in any way in a telecontrol project – both with each other in "node structures", as well as in parallel in star topologies or in redundant configurations.

The graphics below show a selection of different topologies that can be implemented with the telecontrol components.

Basic topologies

Differently structured telecontrol networks can be implemented in the wide area network (WAN) based on the following four basic topologies.

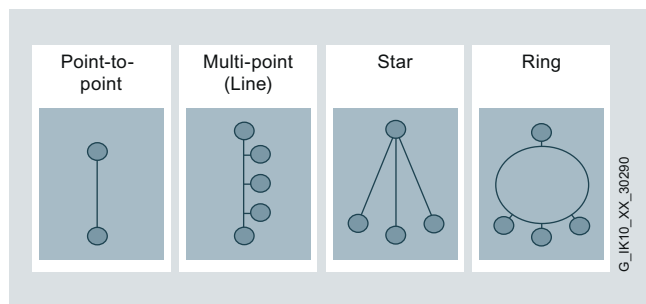

Media versions

Depending on the support provided by the selected telecontrol protocol, various transmission media are available for these basic topologies, e.g. dedicated line, private wireless networks, mobile radio networks, dial-up networks (wireless/landline), DSL over Internet.

Some of these media versions are shown in the example of the star topology.

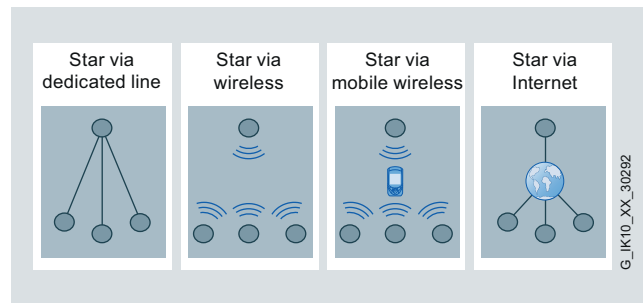

Combinations of basic topologies and media versions

Through a combination of several basic topologies of the same or different media versions, it is additionally possible to design more complex network topologies, even with redundant communication paths. This allows optimum adaptation to process requirements and to the existing infrastructure.

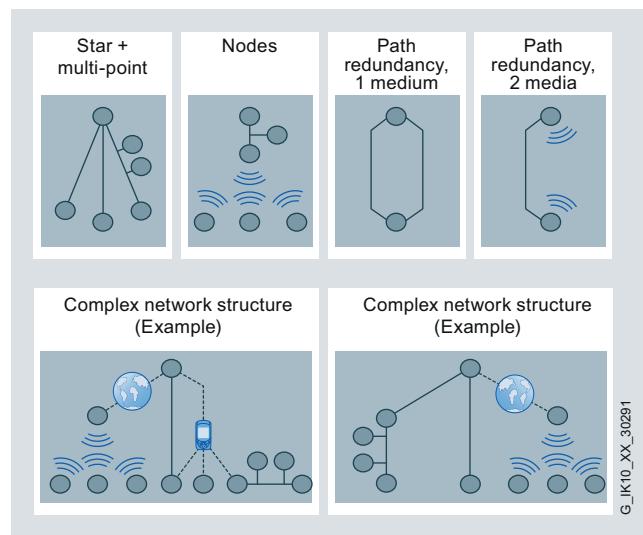

More information

You can find more information on the Internet at:

www.siemens.com/telecontrol

Overview

Design principle of a telecontrol system and plants with SIMATIC

Telecontrol involves the connection of distant process stations to one or more central control systems. A telecontrol system can be subdivided into the following components:

- Control center
- Communication network
- Substations

Various different public or private networks can be used for communication for the purposes of monitoring and control. The event-controlled or cyclic exchange of the process data takes place via special telecontrol protocols such as SINAUT ST1, SINAUT ST7, DNP3 or IEC 870-5-101/-104.

The control center

A number of different versions can be selected as components of the central control center:

SINAUT ST7cc;

PC control center based on WinCC; this is the ideal control center system for both SINAUT ST7 and SINAUT ST1. It has been designed specifically for event-driven and time-stamped data transmission on the SINAUT system and can be set up as a non-redundant or redundant system (to supplement the WinCC redundancy package).

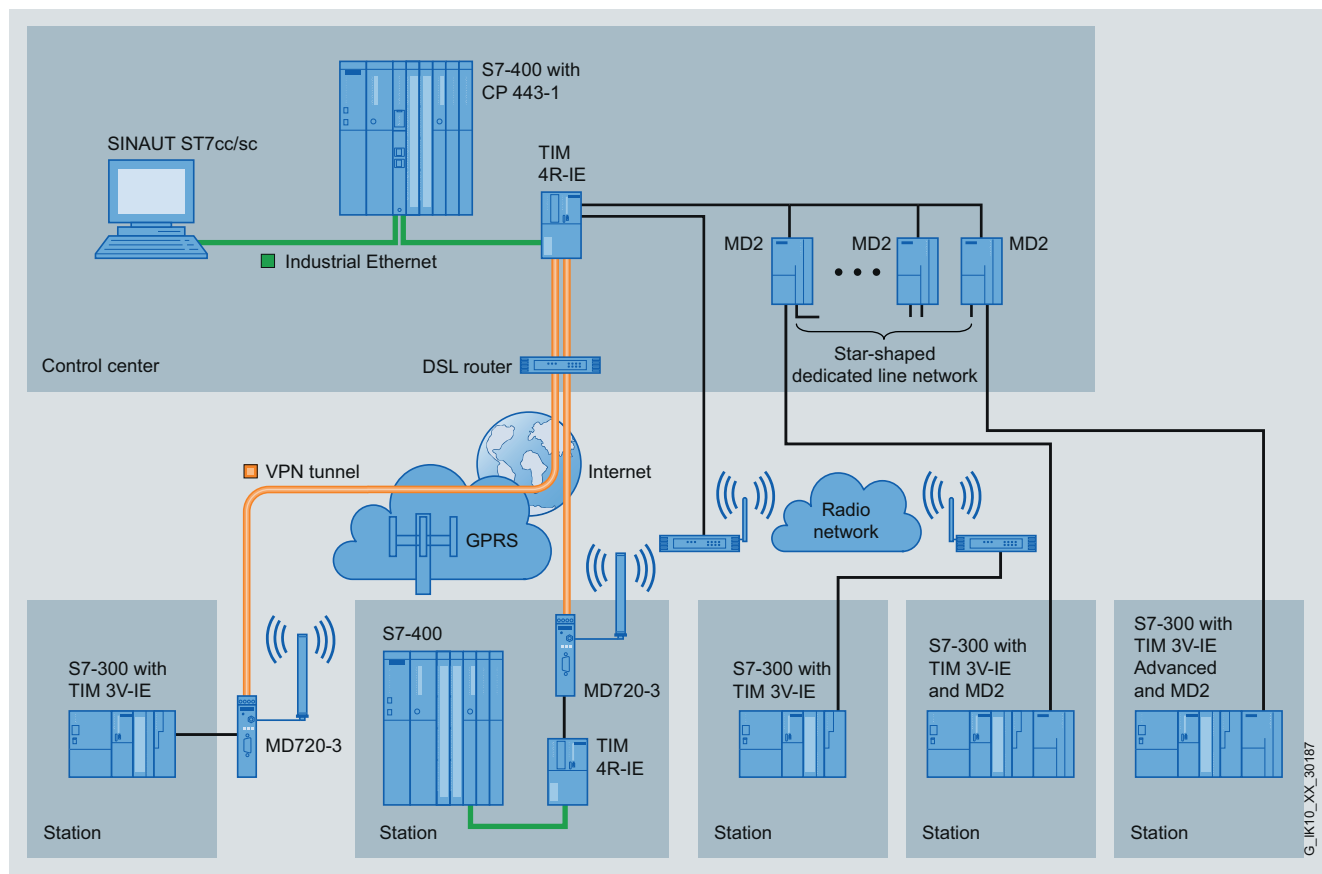

Industrial Remote Communication

TeleControl Professional for the control center

Introduction

Overview (continued)

PCS 7 with PCS 7 TeleControl;

this is the ideal control center system for plants in which larger local automation tasks have to be combined with telecontrol connections. In addition to SINAUT ST7, remote stations with other communication protocols can be connected, e.g. over DNP3 or IEC 870-5-101/-104.

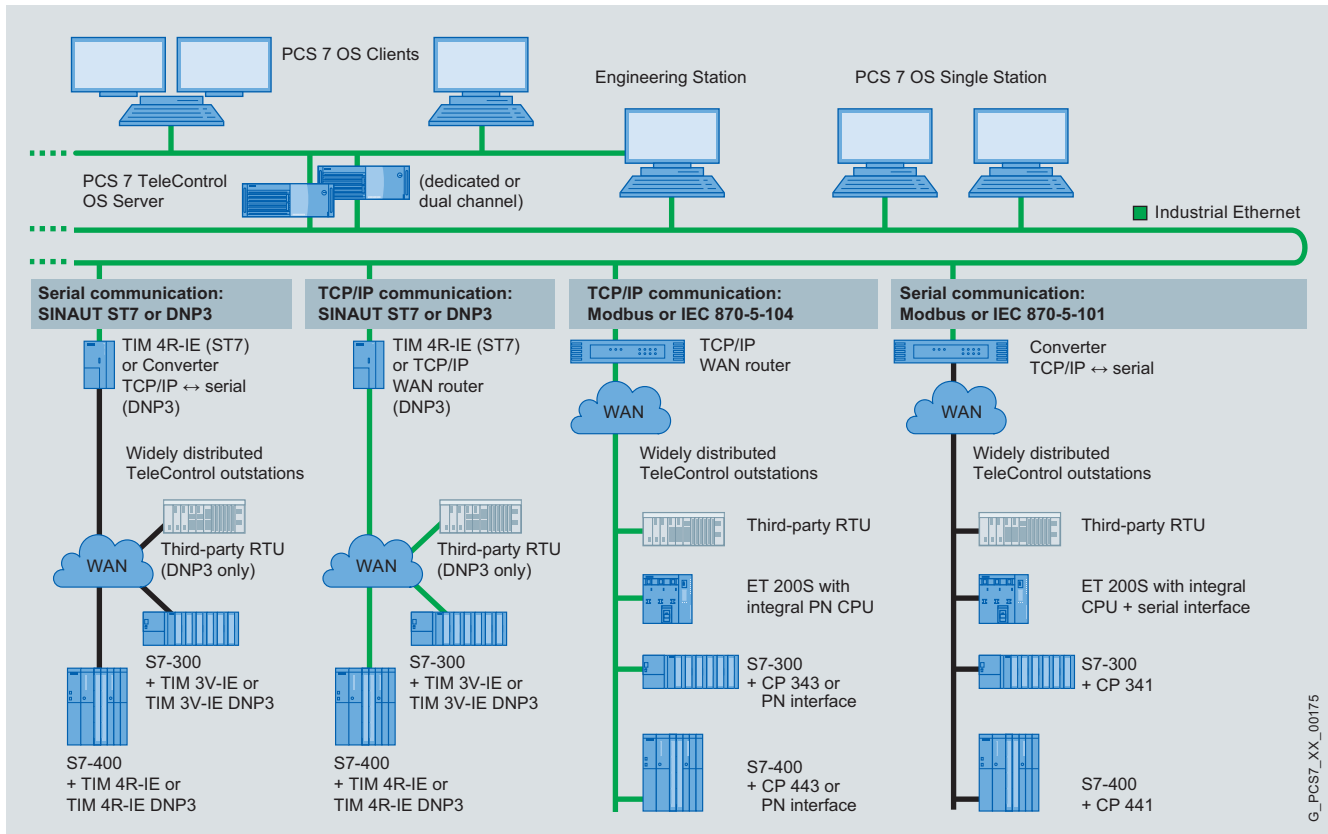

WinCC TeleControl;

control center system for plants with the WinCC HMI software, expanded with telecontrol connections. WinCC TeleControl offer connection of SIMATIC substations with TIM 3V-IE DNP3, TIM 4R-IE DNP3 or non-Siemens stations with DNP3 protocol, as well as telecontrol stations with IEC 870-5-101/-104.

SINAUT ST7sc;

OPC server for interfacing control centers from other vendors via the OPC Client function; the SINAUT telecontrol technology can also be connected to control center systems from other vendors via the "Data Access Interface". ST7sc features extensive buffer mechanisms which prevent data from being lost even if the OPC client fails. It can be connected to non-redundant or redundant clients.

SIMATIC S7 PLC as control center

Like the substations, the control center comprises a SIMATIC S7-300 or S7-400 PLC. This solution is suitable for simpler control centers in which only an up-to-date process image of the process data available in the stations is required. The station process control can be influenced by entering commands, setpoints or parameters. This S7-300 or S7-400 control center can also be used to extend a PC control center (SINAUT ST7cc or ST7sc), e.g. for data output on a panel and/or as an emergency operating system.

Industrial Remote Communication TeleControl Professional for the control center

SINAUT ST7 Engineering Software

Application

The SINAUT ST7 engineering software with the following components is required for configuring, diagnosing and operating a telecontrol system with the ST7 or DNP3 protocol:

- SINAUT ST7 configuration and diagnostics software
- SINAUT TD7 Library

The software package is a work package which can be used for any number of SINAUT projects without a licensing process.

Apart from ST1 and ST7 connections, the SINAUT ST7 engineering software Version V5.1 or higher also supports the DNP3-compliant TIM modules TIM 3V-IE DNP3 and TIM 4R-IE DNP3.

Function

SINAUT ST7 configuration and diagnostics software for STEP 7

- Executable under Windows XP, Vista or Server 2003; STEP 7 software V5.4 SP4 or higher must also be installed.
- Includes:
 - Module manager to supplement the HW Config STEP 7 tool; it displays and sets the parameters of the TIM modules in HW Config.
 - WAN Manager to supplement the NetPro STEP 7 tool; it displays and sets the parameters of the SINAUT WAN networks and network nodes in NetPro
 - The SINAUT ST7 configuration software is used for project-wide functions such as SINAUT connection configuration and SINAUT station management
 - SINAUT ST7 diagnostics and service tool; in addition to the diagnostics functions familiar to users of STEP 7, it also provides access to SINAUT-specific diagnostic information. The service tool can be used, for example, to upload new software to the TIM.

Module manager for SINAUT systems

A SINAUT ST7 folder is added to the SIMATIC 300 directory. This folder contains a list of all available TIM modules. The TIM module required in each case can be selected from this directory and installed in the S7 rack. A corresponding Properties dialog box can be called up to set the module parameters.

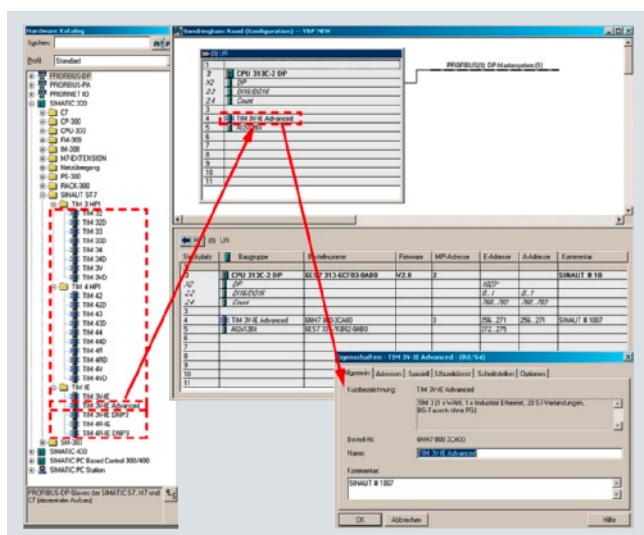

WAN Manager for SINAUT systems

In the catalog for the STEP 7 network configuration tool NetPro, the SINAUT "dedicated line" and "dial-up" networks are added to the "Subnets" directory. The SINAUT networks required in each case can be selected from this directory and installed in the NetPro window. With the SINAUT ST7 engineering software V5.0 and higher, the MSC-VPN tunnel protocol can also be used under the "Industrial Ethernet" network type for configuring the SINAUT data transmission via the Internet and GPRS.

The TIM modules can be assigned to these networks using the mouse or dialog boxes. Any erroneous connections are rejected immediately.

A corresponding Properties dialog box is called up to define the generally valid parameters for a network, e.g. ST7 or DNP3 protocol, transmission rate, etc.

The individual properties for each of the network nodes can be defined in a further dialog box, e.g. the dedicated telephone number for the connection to a dialup network.

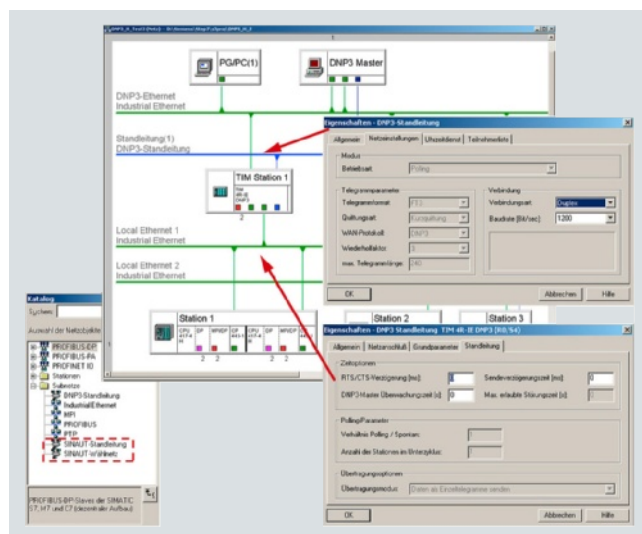

If necessary, the Properties dialog box for a TIM module can be opened in NetPro with the same property options as in HW Config.

Industrial Remote Communication TeleControl Professional for the control center

SINAUT ST7 Engineering Software

Function (continued)

SINAUT ST7 configuration software

The SINAUT ST7 configuration software is an independent configuration tool for the telecontrol system that can comprise ST1, ST7 or DNP3 modules; it includes:

- Connection configuration
- Station management
- SINAUT ST1 configuration overview

First, the "Connection configuration" tool is used to define the SINAUT stations (ST7 CPU, DNP3, ST7cc, ST7sc or ST1 device) between which a connection is required. For this purpose, the tool displays a list of all connections possible in the right-hand side of a two-section window. The tool has generated the list automatically using the network configured with NetPro (see WAN Manager for SINAUT systems). The user moves the connections actually required from the right-hand to the left-hand window using the pop-up menu.

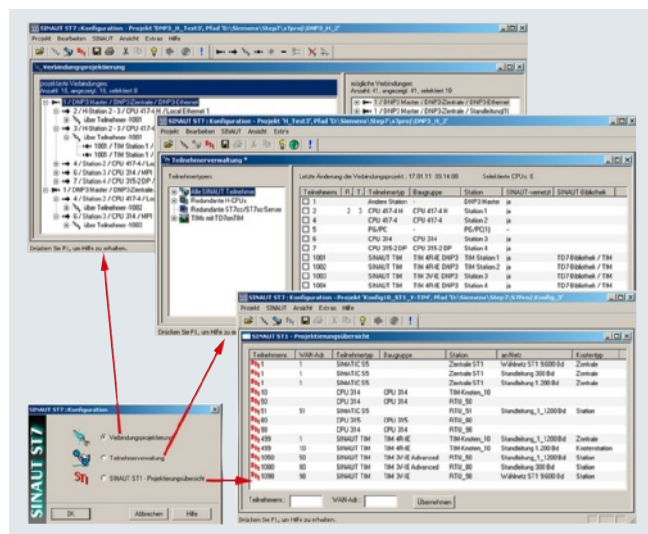

One of the features provided by the "Station management" tool is a list of all SINAUT devices. If necessary, station-specific modifications can be made, e.g. the SINAUT station numbers can be changed for the individual devices, or message texts can be configured to be sent as text messages. The station management tool also handles configuring of the data frames to be sent and received if frame generation and evaluation are to be carried out by the TIM (only possible for TIMs with TD7onTIM functionality). The tool generates the system data blocks (SDB) for the CPUs and TIMs from the configuration data. If the SINAUT TD7 software is used for the CPU, the tool also preprocesses the accounting and communication data blocks for the CPUs, which it stores in the CPU block library together with the blocks (FBs, FCs) which are essential to the CPUs for SINAUT communication.

The third tool, "SINAUT ST1 – Configuration overview" is only required for configuring systems which also feature SINAUT ST1 devices. This tool makes adjusting the addresses for SINAUT ST1 much easier.

SINAUT ST7 diagnostics and service tool

In addition to the diagnostics functions familiar to users of STEP 7, the SINAUT ST7 diagnostics and service tool also provides access to SINAUT-specific diagnostic information. The service tool can be used, for example, to upload new software to the TIM.

SINAUT TD7 library, blocks for the CPU

The SINAUT TD7 library is a software package with blocks for the CPU (TD7onCPU), in which TD7onCPU can be used for ST1 and ST7 systems, but not for DNP3 systems. The package has been designed so that it can run both on an S7-400 and on an S7-300 CPU. Only a small number of blocks have been designed specifically for the S7-300 or S7-400 CPU respectively.

In the stations, the SINAUT TD7 software ensures that process data is transmitted between CPU and control console, e.g. ST7cc, and from CPU to CPU in the event of changes. Connection, CPU or control desk failures are displayed. A data update for all participating communication partners is performed automatically following debugging or startup of a CPU or of the control desk. A time stamp can be assigned to data message frames if required.

The package essentially comprises:

Basic and auxiliary blocks

Most of these blocks are always required in the CPU, a small number are optional. The basic blocks handle central tasks such as startup, monitoring of connections and connection partners, general requests, time management, handling communication etc. The auxiliary blocks enter data frames, for example, in the send buffer or fetch them from the receive buffer, handle send and receive jobs for specific connections, or provide information as a result of searches.

Data-point typicals

These blocks are integrated into the CPU program on the basis of the data types and data volumes to be transmitted. In the event of changes to data, they create message frames or output received process data.

In order to operate correctly, the TD7onCPU package needs a number of data blocks which are generated by the SINAUT ST7 engineering software. These are:

Central accounting DB

This block contains all data required centrally, e.g. accounting data for all communication partners as well as for all connections to be managed.

Communication DBs

A separate communication DB is created for every connection with a sending and receive mailbox and all data required for controlling and monitoring this connection.

Industrial Remote Communication

TeleControl Professional for the control center

SINAUT ST7 Engineering Software

Technical specifications		Ordering data	Order No.
Product type designation	SINAUT Engineering Software V5.2 ¹⁾	SINAUT Engineering Software V5.2 ¹⁾	6NH7 997-0CA52-0AA0
Operating systems	Windows 7 Professional, Ultimate	on CD-ROM, comprising:	
STEP 7 versions	STEP 7 V5.5 incl. SP1	<ul style="list-style-type: none"> • SINAUT Engineering Software V5.2 for the programming device • SINAUT TD7 block library • Electronic manual in German and English 	
Product type designation	SINAUT ST7 Engineering Software V5.1	SINAUT ST7 Engineering Software V5.1	6NH7 997-0CA51-0AA0
Operating systems	MS Windows XP Professional SP 2, 3 MS Windows Server 2003 SP2 MS Windows Vista 32 Bit Ultimate and Business with or without SP1	on CD-ROM, comprising:	
STEP 7 versions	STEP 7 V5.4 SP4 or higher	<ul style="list-style-type: none"> • SINAUT ST7 Engineering Software V5.1 for the PG • SINAUT TD7 block library V2.2 • Electronic manual in German and English 	
		SINAUT ST7 Engineering Software: Update from Version V5.0 to V5.1	http://support.automation.siemens.com/WW/view/en/49104582
		SINAUT ST7 Engineering Software V5.0 Edition 09/2009 (Upgrade)	6NH7 997-0CA50-0GA0
		for STEP 7 V5.4 SP4, for owners of older versions of SINAUT ST7 engineering software	

¹⁾ Available soon

Industrial Remote Communication

TeleControl Professional for the control center

SINAUT ST7cc, Add-on for WinCC

Overview

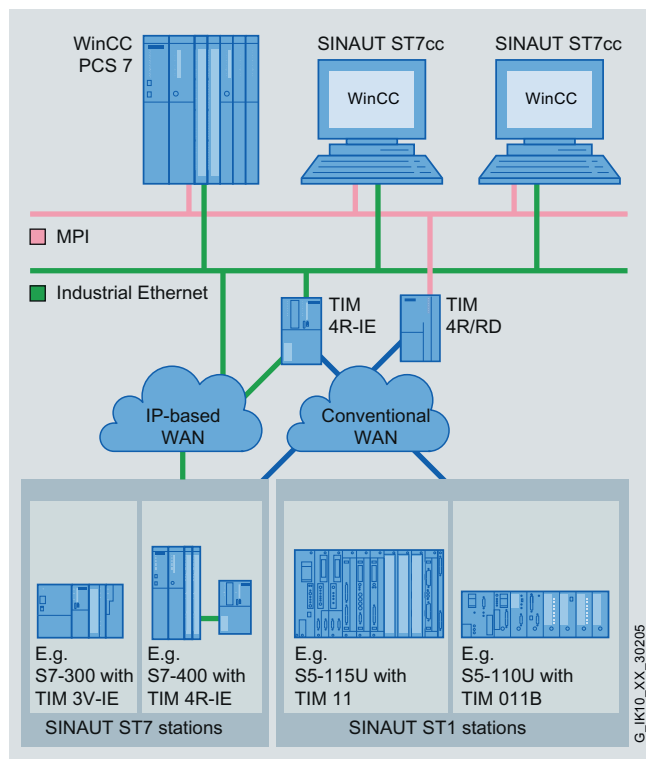

SINAUT ST7cc control center system (non-redundant or redundant) with connected ST7 and ST1 terminals

Based on SIMATIC WinCC, SINAUT ST7cc is the ideal control center system for both SINAUT ST7 and SINAUT ST1. It has been developed specifically for event-driven and time-stamped data transmission on the SINAUT telecontrol system.

A fault-tolerant ST7cc control center can be set up in conjunction with the WinCC redundancy package.

SINAUT ST7cc additionally assumes the function of a telecontrol center. There is therefore no need for a separate SIMATIC S7-CPU for this function.

Benefits

get Designed for Industry

- Interfacing of SIMATIC S7 substations to SIMATIC WinCC via conventional and IP-based telecommunications network
- Entry of messages, analog and count values in WinCC archive using the event times supplied by the substations
- Protection of investments in existing SINAUT ST1 systems, as ST1 stations can be connected
- Saving of time and reduction of costs through simple configuration without requiring detailed knowledge of SINAUT

Application

Based on SIMATIC WinCC, SINAUT ST7cc is the ideal control center system for both SINAUT ST7 and SINAUT ST1.

It has been developed specifically for event-driven and time-stamped data transmission on the telecontrol system. It avoids the possible loss of data inherent during cyclic polling in WinCC. It also ensures the use of the correct event times supplied by the substations for all messages and archive entries. The process image integrated into ST7cc contains all process data along with the status of all SINAUT stations in the network, and makes this data available directly to WinCC for high-speed process image visualization.

ST7ccConfig provides the user with an integrated configuring tool based on the data telegrams configured in the SINAUT ST7 or ST1 terminals. The WinCC tags are configured automatically and updated consistently to reflect any changes.

The additional use of the WinCC add-on ACRON is recommended for archives, protocols and reports in accordance with ATV Notice H260 or Hirthammer.

The Alarm Control Center software package is useful for alerting service personnel via text message, fax, e-mail or voice mail and is also available as a WinCC add-on.

A fault-tolerant ST7cc control center can be set up in conjunction with the WinCC redundancy package.

Design

SINAUT ST7cc is installed on a Windows PC. WinCC can also run on the same PC. However, client/server configurations are also possible, in which the ST7cc is located on the WinCC server.

The following software packages and licenses are required for an ST7cc control center that is configured as a single-channel or redundant system with WinCC. A license for the WinCC complete package is required. A runtime package may be sufficient if no configurations are required on the end computer. The WinCC redundancy package incl. license is also required for the redundant ST7cc.

The table below lists the software packages required for the ST7cc non-redundant/redundant system in detail.

ST7cc non-redundant system		ST7cc redundant system	
Number	Software package	Number	Software package
1	WinCC complete package ¹⁾	1	WinCC complete package ¹⁾
–	–	1	WinCC runtime package
–	–	1	WinCC redundancy package (with 2 licenses)
1	SIMATIC NET SOFTNET for IE license for CP software	2	SIMATIC NET SOFTNET for IE license for CP software
–	–	1	ST7cc redundancy package (with 2 licenses)
1	SW ST7cc S (with license for 6 stations) or SW ST7cc M (with license for 12 stations) or SW ST7cc L (with license for > 12 stations)	2	SW ST7cc S (with license for 6 stations) or SW ST7cc M (with license for 12 stations) or SW ST7cc L (with license for > 12 stations)

¹⁾ A runtime package may be sufficient if no configurations are required on the end computer.

One or several SINAUT ST7 TIM communications processors are connected to the ST7cc PC depending on the TIM type used either via the MPI bus or via Ethernet. Both ST7 and ST1 terminals can be connected to the TIMs, only ST7 terminals to the TIMs on the Ethernet.

Provision of current time of day:

- Time synchronization for TIMs connected via MPI to the ST7cc PC is only possible using a TIM equipped with a DCF77 receiver. This is then responsible for central synchronization of the ST7cc PC and all terminals.
- Time synchronization for TIMs connected via Ethernet to the ST7cc PC is via ST7cc.

Outside the reception area of the DCF77 real-time transmitter the use of a GPS receiver is recommended. This determines the local time from the satellite-based global positioning system (GPS).

Function

Functioning as a remote control center with convenient diagnostic functions

- Direct connection of SINAUT ST7 TIMs over MPI and Ethernet to ST7cc. A separate series-connected S7-300 or S7-400 controller is not required as a central remote control center.
- Provision of the most important status information for each SINAUT ST7 or ST1 station with visualization in WinCC using supplied station typicals (display typicals and faceplates).
- Control possibilities for the SINAUT stations over these faceplates.
- Tagging the process values from stations with an interrupted connection to ST7cc.
- General scanning of affected stations following the end of a transmission fault for updating the process image in ST7cc.
- For diagnostic purposes: Selective activation of recording of the message traffic for individual or all SINAUT stations. Message frame visualization and evaluation is performed in the same manner as by the TIM message frame monitor.
- Time synchronization by ST7cc for the TIMs that are connected to the ST7cc PC over Ethernet.

Preprocessing of process data

Preprocessing can be configured for binary values, analog values, and count values. They take into account the event time points and tag derived alarms and archive entries with correct time stamps.

- **Binary values**
 - Entry of current binary values into the assigned WinCC tags taking into account the time stamps supplied by SINAUT ST7 or ST1.
- **Analog values** (current and average values)
 - Floating-point numbers, integer values
 - Linear raw value conversion (raw value → physical value)
 - Entry of analog values (with or without linear raw value adaptation) in the associated WinCC tags
 - Entry of analog values (with or without linear raw value adaptation) into the WinCC archive taking into account the time stamps supplied by SINAUT ST7 or ST1.
- **Count values**
 - Overflow handling in the case of absolute counters.
 - Count value conversion using factors.
 - Generation of correct interval times.
 - Entry of currently accumulating interval quantities in the assigned WinCC tags.
 - Entry of complete interval quantities into the WinCC archive taking into account the time stamps supplied by SINAUT ST7 or ST1.
- **Setpoints**
 - Floating-point numbers, integer values
 - Linear raw value conversion (physical value → raw value) if required.

Simple, integrated configuration

Configuration of the overall system with ST7ccConfig is very user friendly. A separate WinCC configuration for tag management, archive and alarm system is limited to a few preparatory measures, such as the creation of archives and, in the case of WinCC, the definition of alarm classes and types.

Industrial Remote Communication

TeleControl Professional for the control center

SINAUT ST7cc, Add-on for WinCC

Technical specifications

Product type designation	SINAUT ST7cc V3.0
Operating systems	Windows 7 Professional (32-bit); Windows 7 Enterprise (32-bit); Windows 7 Ultimate (32-bit); Windows 2008 Server SP2 (32-bit)
WinCC versions	WinCC V7.0 SP2

Product type designation	SINAUT ST7cc V3.0
Configuration	ST7cc configuration tool V3.0 SINAUT ST7 Engineering Software V3.5, V3.6, V4.0, V4.1, V5.0, V5.1
• ST7cc • SINAUT system	
Quantity framework	Small license Medium license Large license
• 6 SINAUT terminals • 12 SINAUT terminals • for more than 12 SINAUT terminals	

Ordering data

SINAUT ST7cc

Software for connecting SINAUT stations to WinCC V7.0 SP2
Single license for 1 installation of the runtime software; configuration software and electronic manual on CD-ROM, 2 languages (German, English); operating systems:
Windows 2008 Server SP2;
Windows 7 (32 bit) Professional, Enterprise, Ultimate;
license key on USB stick;
German/English

- **ST7cc S**
Small license
for max. 6 SINAUT stations
- **ST7cc M**
Medium license for
max. 12 SINAUT stations
- **ST7cc L**
Large license
for more than 12 SINAUT
stations
- **ST7cc R**
Redundancy license for ST7cc
(contains 2 licenses);
two ST7cc S, M or L single
licenses are also required
- **ST7cc SM Powerpack**
License upgrade from ST7cc S
to ST7cc M
(from 6 to 12 stations)
- **ST7cc SL Powerpack**
License upgrade from ST7cc S
to ST7cc L
(from 6 to more than 12 stations)
- **ST7cc ML Powerpack**
License upgrade from ST7cc M
to ST7cc L
(from 12 to more than
12 stations)
- **ST7cc U Upgrade**
Upgrade of standard licenses
from ST7cc V2.7 to ST7cc V3.0
- **ST7cc UR Upgrade**
Upgrade of the redundancy
license from ST7cc R V2.7 to
ST7cc R V3.0

Order No.

6NH7 997-7CA30-0AA1
6NH7 997-7CA30-0AA2
6NH7 997-7CA30-0AA3
6NH7 997-8CA30-0AA0
6NH7 997-7AA30-0AD2
6NH7 997-7AA30-0AD3
6NH7 997-7AA30-0AE3
6NH7 997-7CA30-0GA1
6NH7 997-8CA30-0GA0

Order No.

Communication processor CP 5611 A2	6GK1 561-1AA01
PCI card (32-bit) for connecting a PG or PC to PROFIBUS/MPI; suitable for the connection of up to 8 TIM modules via MPI	
Communication processor CP 5611 A2 MPI	6GK1 561-1AM01
Comprising a 5611 PCI card (32-bit) and 5 m MPI cable	
SOFTNET-PB S7 V8.1	6GK1 704-5CW08-1AA0
For 32-bit Windows 7 Profes- sional/Ultimate	
SOFTNET-S7, 2008 Edition for CP 5611 A2/CP 5621	6GK1 704-5CW71-3AA0
Software for S7 communication incl. PG and FDL protocol, Single License for 1 installation, license key on USB flash drive	
Communication processor CP 5613 A2	6GK1 561-3AA01
PCI card (32-bit; 5 V) for connect- ing a PG or PC to PROFIBUS/MPI; suitable for the connection of up to 30 TIM modules via MPI	
Communication processor CP 5621	6GK1 562-1AA00
PCI Express x1 card (32-bit) for connection of a PG or PC to PROFIBUS	
• with MPI cable, 5 m	6GK1 562-1AM00
Communication processor CP 5623	6GK1 562-3AA00
PCI Express x1 card (32-bit) for connection of a PG or PC to PROFIBUS	
S7-5613 Edition 2008 for CP 5613 A2	6GK1 713-5CB71-3AA0
Software for 32-bit Windows XP Professional SP2/3; Windows 2003 Server R2, SP2; Windows Vista Business/ Ultimate SP1; single license for 1 installation, license key on USB stick	

Industrial Remote Communication

TeleControl Professional for the control center

SINAUT ST7cc, Add-on for WinCC

Ordering data	Order No.		Order No.
HARDNET PB S7 V8.1 for CP 5613 A2 For 32-bit Windows 7 Professional/Ultimate	6GK1 713-5CB08-1AA0		
Communication processor CP 1613 A2 PCI card (32-bit; 33 MHz/66 MHz; 3.3 V/5 V universal keyed) for connecting a PG or PC to Industrial Ethernet (10/100 Mbit/s); suitable for the connection of up to 120 TIM modules via Industrial Ethernet	6GK1 161-3AA01	S7-1613 Edition 2008 for CP 1613 A2/CP 1623 Software for S7 communication including PG communication, suitable for max. 120 connections, single license for 1 installation, license key on USB flash drive	6GK1 716-1CB71-3AA0
Communication processor CP 1623 PCI Express x1 card (32-bit) for connection of a PG or PC to Industrial Ethernet	6GK1 162-3AA00	SOFTNET-IE S7 V8.1 for Industrial Ethernet For 32-bit Windows 7 Professional/Ultimate, up to 64 connections	6GK1 704-1CW08-1AA0
HARDNET IE S7 V8.1 for CP 1613 A2/CP 1623 For 32-bit Windows 7 Professional/Ultimate	6GK1 716-1CB08-1AA0	SOFTNET-S7 Edition 2008 for Industrial Ethernet For 32-bit Windows XP Professional SP2/3; Windows 2003 Server R2, SP2; Windows Vista Business/Ultimate SP1; Windows 2008 Server	6GK1 704-1CW71-3AA0
		SOFTNET-IE S7 Lean V8.1 for Industrial Ethernet Up to 8 connections	6GK1 704-1LW08-1AA0
		SOFTNET-S7 Lean Edition 2008 for Industrial Ethernet Up to 8 connections	6GK1 704-1LW71-3AA0

Industrial Remote Communication

TeleControl Professional for the control center

WinCC/TeleControl

Overview

WinCC/TeleControl for WinCC V7.0 SP2 supports connection to outlying stations (Remote Terminal Units = RTUs) via telecontrol protocols.

Benefits

WinCC/TeleControl for WinCC V7.0 SP2 cannot only integrate newly configured RTUs, it can also integrate units which already exist in outlying areas by means of DNP3 or IEC 870-5-101/104 drivers.

For communication with the outstations, WinCC/TeleControl for WinCC V7.0 SP2 uses the SINAUT ST7 and DNP3 protocols (both via serial and TCP/IP communication connections) as well as IEC 870-5-101 (serial) and IEC 870-5-104 (Ethernet TCP/IP).

The serial RTU link is possible via the following components, which can be connected directly via WinCC (single station or server):

- SINAUT TIM communication modules (SINAUT ST7 telecontrol protocol)
- TCP/IP serial converter (telecontrol protocols DNP3, Modbus (not released for WinCC TC), IEC 870-5-101)

Equipment from MOXA or Lantronix, for example, can be used as TCP/IP serial converters.

By means of Ethernet TCP/IP, the RTUs can be connected directly or via TCP/IP WAN routers to the SIMATIC WinCC system bus (SINAUT ST7, DNP3, IEC 870-5-104 telecontrol protocols). When using the SINAUT ST7 telecontrol protocol, the SINAUT TIM communication module can be used in addition to the TCP/IP WAN router or as an alternative.

Integration

Integration of WinCC/ TeleControl for WinCC V7.0 SP2 into the WinCC SCADA system offers particular advantages for the water and waste water sectors, as well as oil and gas sectors, especially in the case of the following types of plant:

- Freshwater treatment and distribution
- Wastewater treatment plants
- Oil and gas pipelines and water pipes
- Oil and gas drilling fields and the associated treatment plants

In these types of plant, remote outstations such as pumping stations, valve stations or automated stations for wellheads must be integrated.

Through the support of communication protocols for RTUs such as SINAUT ST7, WinCC/ TeleControl for WinCC V7.0 SP2 supports the following advanced communication concepts:

- Reduction in the transferred data volume by means of event-controlled communication mechanisms for alarm and measured value information.
- Time-synchronization of RTUs and correct time stamping of all data in the RTU.
- Tolerance of lower bandwidth, high latency or lack of reliability of communication lines
- Prevention of data loss due to communications failure through data backup in the RTU
- Support of communication media with serial interface (dedicated lines, dial-up connections over analog telephone lines and ISDN lines), various radio devices (standard, spread spectrum modulation), microwave and GSM
- Support for TCP/IP-based WANs (Wide Area Networks) such as DSL, GPRS or Ethernet radio networks
- Support for redundant communication connections
- Expanded communication diagnostics functions for RTU communication links
- Remote programming of RTUs
- Support for different communication topologies – Point-to-point, multidrop (multistation mode) and hierarchic network structures
- High quality server redundancy scheme without data loss in the case of server failure

Through the support of communication protocols for RTUs such as IEC 60870-5 and DNP3, SIMATIC TeleControl for WinCC V7.0 SP2 supports the following advanced communication concepts:

- Reduction in the transferred data volume by means of event-controlled communication mechanisms for alarm and measured value information.
- Time-synchronization of RTUs and correct time stamping of all data in the RTU.
- Tolerance of lower bandwidth, high latency or lack of reliability of communication lines
- Prevention of data loss due to communications failure through data backup in the RTU (not all non-Siemens RTUs support this)
- Support of communication media with serial interface (dedicated lines, dial-up connections over analog telephone lines and ISDN lines), various radio devices (standard, spread spectrum modulation), microwave and GSM
- Support for TCP/IP-based WANs (Wide Area Networks) such as DSL, GPRS or Ethernet radio networks
- Support for redundant communication connections
- Expanded communication diagnostics functions for RTU communication links
- Remote programming of RTUs
- Support for different communication topologies – Point-to-point, multidrop (multistation mode) and hierarchic network structures
- High quality server redundancy scheme without data loss in the case of server failure

Integration (continued)

Outstations/remote terminal units

WinCC/ TeleControl for WinCC V7.0 SP2 supports the following preferred outstations for local distributed automation:

- Controller integrated into ET 200S (IEC 870-5-101/104 telecontrol protocols); for cost-sensitive applications, up to approx. 30 I/O signals or approx. 200 data points
- S7-300/S7-300F controller (SINAUT ST7, DNP3, IEC 870-5-101/104 telecontrol protocols); for extremely flexible configuration, up to 100 I/O signals or approx. 2000 data points

- S7-400/S7-400F controller (SINAUT ST7, DNP3, IEC 870-5-101/104 telecontrol protocols); up to 500 I/O signals or approx. 5000 data points
- S7-400/S7-400F redundant controller (IEC 870-5-101/104 and DNP3 telecontrol protocols); up to 500 I/O signals or approx. 5000 data points
- Third-party station with the IEC 870-5-101/104 and DNP3 telecontrol protocols (depending on type of station)

The following table provides an overview of the current options for connecting to these outstations:

Spectrum of outstations and integration versions							
Telecontrol protocol	SINAUT ST 7		DNP3		IEC 870-5-01	IEC 870-5-04	
Type of communication	Serial	Ethernet TCP/IP	Serial	Ethernet TCP/IP	Serial	Ethernet TCP/IP	
Interface	TIM 4R-IE	TCP/IP WAN router or/and TIM 4R-IE	TCP/IP serial converter	TCP/IP WAN router	TCP/IP serial converter	TCP/IP WAN router	
RTU/interface	ET 200S with integr. CPU (corresponding to S7-314)	-	-	-	IM 151-7 CPU or IM 151-8 PN/DP CPU as well as 1 SI module + SIPLUS RIC library	IM 151-8 PN/DP CPU + SIPLUS RIC library	
	S7-300/S7-300F	TIM 3V-IE	TIM 3V-IE	TIM 3V-IE DNP3	TIM 3V-IE DNP3	CP 341 + SIPLUS RIC library	CP 343 + IEC on S7 or integr. PN interface + SIPLUS RIC library
	S7-400/S7-400F	TIM 4R-IE	TIM 4R-IE	TIM 4R-IE DNP3	TIM 4R-IE DNP3	CP 441 + SIPLUS RIC library	CP 443 + SIPLUS RIC library or integr. PN interface + SIPLUS RIC library
	S7-400H/S7-400FH	-	-	TIM 4R-IE DNP3	TIM 4R-IE DNP3	ET 200M + 2 x CP 341 + SIPLUS RIC library	CP 443 + SIPLUS RIC library
	Third-party station	-	-	Depends on type of station		Depends on type of station	
Dial-up lines	•	-	•	-	-	-	
Dedicated line and radio networks	•	•	•	•	•	•	
Master/slave	•	•	•	•	•	•	
Peer-to-peer	•	•	-	-	•	•	
Mesh networks	•	•	•	•	•	•	
Time tagging in RTU	•	•	•	•	•	•	
RTU time synchronization	•	•	•	•	•	•	
Data buffering in RTU	•	•	•	•	• ¹⁾	• ¹⁾	
Routing with SIMATIC PDM	•	•	-	-	-	•	
International standard	-	-	•	•	•	•	

¹⁾ Data buffering is limited to two SIMATIC S7 data blocks. Depending on the SIMATIC CPU, this corresponds to approx. 800 to 3200 buffered frames.

Industrial Remote Communication

TeleControl Professional for the control center

WinCC/TeleControl

Ordering data	Order No.	Order No.	
<p>SIMATIC TeleControl 7.0 SP2 for WinCC Basic Engineering</p> <p>Software package with SIMATIC Telecontrol for WinCC 7.0 SP2 Engineering Software, 2 languages (English, German), executable with Windows XP Professional/Server 2003, Floating License for one user; electronic documentation on CD/DVD, 2 languages (English, German)</p> <p>Type of delivery: License key memory stick, Certificate of License incl. terms and conditions, SIMATIC WinCC Data Medium Package V7.0 + SP2 and CD "WinCC TeleControl Option V7.0 + SP2"</p>	6DL5 000-7AA07-0XA5	<p>SIMATIC TeleControl 7.0 SP2 for Server Runtime (256 stations)</p> <p>Software package with SIMATIC Telecontrol for WinCC 7.0 SP2 Runtime Software, 2 languages (English, German), executable with Windows Server 2003, Single License for one user; electronic documentation on CD/DVD, 2 languages (English, German)</p> <p>Type of delivery: License key memory stick, Certificate of License incl. terms and conditions, SIMATIC WinCC Data Medium Package V7.0 + SP2 and CD "WinCC TeleControl Option V7.0 + SP2"</p>	6DL5 002-7AE07-0XA0
<p>SIMATIC TeleControl 7.0 SP2 for Server Runtime (6 stations)</p> <p>Software package with SIMATIC Telecontrol for WinCC 7.0 SP2 Runtime Software, 2 languages (English, German), executable with Windows Server 2003, Single License for one user; electronic documentation on CD/DVD, 2 languages (English, German)</p> <p>Type of delivery: License key memory stick, Certificate of License incl. terms and conditions, SIMATIC WinCC Data Medium Package V7.0 + SP2 and CD "WinCC TeleControl Option V7.0 + SP2"</p>	6DL5 002-7AA07-0XA0	<p>Driver software for telecontrol protocols TeleControl SINAUT Driver</p> <p>Runtime license for one WinCC Single Station or one WinCC server, Single License for 1 installation Requirement: Software SIMATIC TELECONTROL 7.0 SP2 for WinCC Server Runtime (6, 12, 256 stations) Type of delivery: License key memory stick, Certificate of License incl. terms and conditions</p>	6DL5 101-8AX00-0XB0
<p>SIMATIC TeleControl 7.0 SP2 for Server Runtime (12 stations)</p> <p>Software package with SIMATIC Telecontrol for WinCC 7.0 SP2 Runtime Software, 2 languages (English, German), executable with Windows Server 2003, Single License for one user; electronic documentation on CD/DVD, 2 languages (English, German)</p> <p>Type of delivery: License key memory stick, Certificate of License incl. terms and conditions, SIMATIC WinCC Data Medium Package V7.0 + SP2 and CD "WinCC TeleControl Option V7.0 + SP2"</p>	6DL5 002-7AB07-0XA0	<p>TeleControl DNP3 Driver</p> <p>Runtime license for one WinCC Single Station or one WinCC server, Single License for 1 installation Requirement: Software SIMATIC TELECONTROL 7.0 SP2 for WinCC Server Runtime (6, 12, 256 stations) Type of delivery: License key memory stick, Certificate of License incl. terms and conditions</p>	6DL5 101-8EX00-0XB0
		<p>TeleControl IEC 870-5-101/-104 Driver</p> <p>Runtime license for one WinCC Single Station or one WinCC server, Single License for 1 installation Requirement: Software SIMATIC TELECONTROL 7.0 SP2 for WinCC Server Runtime (6, 12, 256 stations) Type of delivery: License key memory stick, Certificate of License incl. terms and conditions</p>	6DL5 101-8CX00-0XB0

Note:

You can find more information in Catalog ST 80 / ST PC and in the Industry Mall at www.siemens.com/industrymall

Overview

PCS 7 Add-on fit for SIMATIC PCS 7 V7

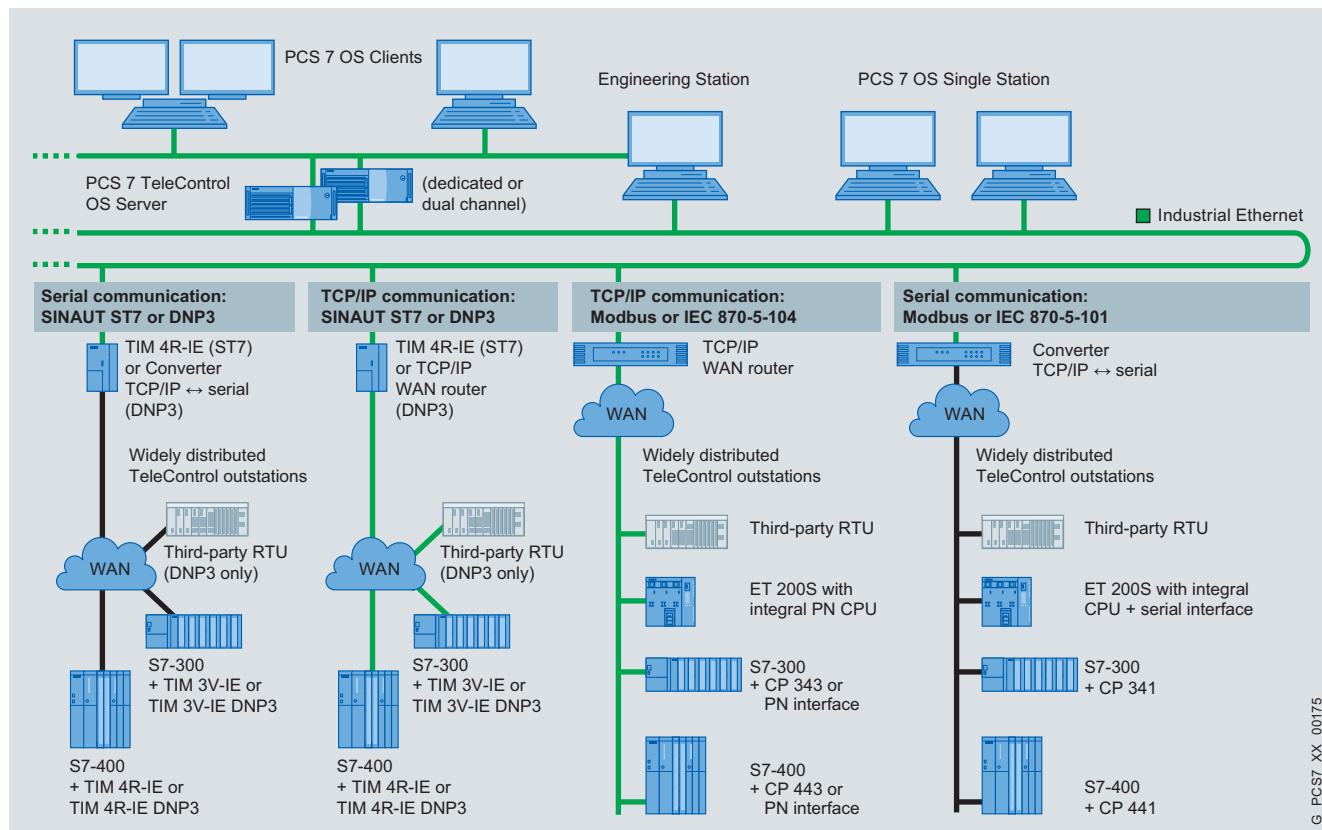

Integration and communication options with SIMATIC PCS 7 TeleControl V7.1

Plants are often scattered over very large grounds in the energy and transportation industries, and especially in the water & wastewater and oil & gas industries. In such cases it is necessary to integrate outstations for monitoring and controlling highly remote plant units (usually with a small or medium degree of automation) into the control system of the complete plant. This is carried out by means of telecontrol protocols over a WAN (Wide Area Network).

Conventional automation solutions for telecontrol systems use process control systems for the more complex central areas of the plant, and simpler Remote Terminal Units (RTUs) for the outstations, and then combine these separately configured plant units in a host network control system.

Direct integration of the telecontrol center

However, it is far more efficient if the telecontrol center for the RTUs is directly integrated into the process control system. The network control system as the superimposed integration level can then be omitted.

The SIMATIC PCS 7 TeleControl V7.1 products are suitable for integration of the telecontrol center into the process control and engineering of the SIMATIC PCS 7 V7.1 process control system. They support the RTU linking in different manners (see graphic "Integration and communication options with SIMATIC PCS 7 TeleControl V7.1" and table "Current connection possibilities for widely distributed telecontrol outstations").

Industrial Remote Communication

TeleControl Professional for the control center

SIMATIC PCS 7 TeleControl

Overview (continued)

As far as the scope and performance of the automation functions are concerned, the requirements of the widely distributed plant sections are usually in the bottom to mid range, which means you can use automation stations of reduced dimensions for the outstations. SIMATIC PCS 7 TeleControl V7.1 particularly supports the following outstations for distributed automation on site:

RTU category	RTU type ¹⁾	Possible telecontrol protocols
Small with up to approx. 30 I/Os For small, cost-sensitive applications	Controller integrated in SIMATIC ET 200S	Modbus, IEC 870-5-101, IEC 870-5-104
Medium with up to approx. 100 I/Os For medium sized applications	SIMATIC S7-300/S7-300F controller	SINAUT ST7, DNP3, Modbus, IEC 870-5-101, IEC 870-5-104
Large with up to approx. 500 I/Os For larger applications requiring higher performance	SIMATIC S7-400/S7-400F controller	SINAUT ST7, DNP3, Modbus, IEC 870-5-101, IEC 870-5-104
	SIMATIC S7-400H/S7-400FH controller	DNP3, IEC 870-5-101, IEC 870-5-104

¹⁾ Also in version "SIPLUS extreme", e.g. for environments with temperature from -25 °C to +70 °C, condensation, or medial exposure

Note:

You can find more information in Catalog ST PCS 7.1 and in the Industry Mall at www.siemens.com/industrymall.

Benefits

- SIMATIC PCS 7 TeleControl V7.1 cannot only integrate newly configured RTUs into SIMATIC PCS 7 V7.1, but also migrate units which already exist in outdoor areas.
- As a result of its high level of integration, automation based on SIMATIC PCS 7 TeleControl V7.1 offers decisive advantages compared to previous automation solutions with telecontrol engineering.
 - The uniform SIMATIC PCS 7 V7.1 software platform allows high efficiency during operation, and results in low costs for training, configuration and servicing.
 - The homogenous GUI for local and remote processes simplifies operation and simultaneously reduces the risk of an operator error.
- The Data Base Automation (DBA) software efficiently supports engineering and takes into account the conformity with SIMATIC PCS 7 V7.1.
 - DBA considerably facilitates project-specific adaptation of the system and importing of existing configurations in the course of migration.
 - Extensions can be added during plant operation.

Application

Remote control and monitoring of distributed stations, as well as data recording and transmission, with the following focal points:

- Water industry
 - Well, pumping and slide valve stations in water supply networks and irrigation plants
 - Pumping and slide valve stations in water and wastewater pipelines
 - Storm-water tanks and siphon stations in wastewater networks
 - Storage units (elevated tanks)
- Oil and gas industries
 - Compressor, pressure reduction, transfer, block valve, and metering stations in gas networks
 - Pumping and slide valve stations in oil pipelines
 - Automation on the wellhead of gas and oil wells
 - Stations for the injection of water or CO₂ in gas or oil fields
- Energy management, environmental protection, and transportation
 - Equipment for power generation and distribution
 - District heating
 - Traffic control systems
 - Tunnels
 - Railway stations
 - Lighthouses
 - Environmental monitoring equipment
 - Weather stations

Design

The telecontrol center for the outstations (RTUs) is integrated into the process control of the SIMATIC PCS 7 V7.1 process control system in the form of an operator station in single station or server design (also redundant as option). No additional automation system for conditioning and connecting telecontrol-specific data need be planned in the SIMATIC PCS 7 system. With large quantity frameworks, a PCS 7 TeleControl operator station (single station/server) is preferably responsible only for the telecontrol mode (dedicated). With small quantity frameworks, a server or a single station can also control SIMATIC PCS 7 automation systems in central plant areas in addition to the RTUs (dual-channel mode).

To enable engineering of the PCS 7 telecontrol operator station (single station/server), the functions of the engineering station of the SIMATIC PCS 7 V7.1 process control system are expanded by the DBA technology (Data Base Automation) and the SIMATIC PCS 7 TeleControl V7.1 block library.

For communication with the RTUs, SIMATIC PCS 7 TeleControl V7.1 uses the telecontrol protocols SINAUT ST7, DNP3 und Modbus (both via serial and TCP/IP communication connections) as well as IEC 870-5-101 (serial) and IEC 870-5-104 (Ethernet TCP/IP).

With serial RTU interfacing, the telecontrol connection can be implemented cost-effectively at the control center end (PCS 7 TeleControl OS as single station or server) using the following components:

- SINAUT TIM communication modules (SINAUT ST7 telecontrol protocol)
- TCP/IP converter - serial
e.g. devices from the company MOXA or Lantronix (DNP3, Modbus, IEC 870-5 101 telecontrol protocols)

By means of Ethernet TCP/IP, the outstations can be connected either directly or via TCP/IP WAN routers to the SIMATIC PCS 7 system bus (SINAUT ST7, DNP3, Modbus, IEC 870-5-104 telecontrol protocols). When using the SINAUT ST7 telecontrol protocol, the SINAUT TIM communication module can be used in addition to the TCP/IP WAN router or as an alternative.

Design (continued)

The following table shows the current connection possibilities depending on the type of RTU and type of communication.

Outstations for integration (RTU)									
Current range, communication options and features									
Telecontrol protocol		SINAUT ST7		Modbus		DNP3		IEC 870-5-101	IEC 870-5-104
Type of communication		Serial	Ethernet TCP/IP	Serial	Ethernet TCP/IP	Serial	Ethernet TCP/IP	Serial	Ethernet TCP/IP
Interface on the PCS 7 TeleControl OS		TIM 4R-IE	TCP/IP WAN router or/ and TIM 4R-IE	TCP/IP serial converter	TCP/IP WAN router	TCP/IP serial converter	TCP/IP WAN router	TCP/IP serial converter	TCP/IP WAN router
RTU/ interface	ET 200S with integral CPU (corresponds to S7-314)	–	–	IM 151-7 CPU or IM 151-8 PN/DP CPU as well as 1 SI Modbus module	IM 151-8 PN/DP CPU + S7 Open-Modbus software/ TCP PN-CPU	–	–	IM 151-7 CPU or IM 151-8 PN/DP CPU as well as 1 SI module + SIPLUS RIC library	IM 151-8 PN/DP CPU + SIPLUS RIC library
	S7-300/ S7-300F	TIM 3V-IE	TIM 3V-IE	CP 341	CP 343 + SW library	TIM 3V-IE DNP3	TIM 3V-IE DNP3	CP 341 + SIPLUS RIC library	CP 343 + SIPLUS RIC library or integral PN interface + SIPLUS RIC library
	S7-400/ S7-400F	TIM 4R-IE	TIM 4R-IE	CP 441	CP 443 + SW library	TIM 4R-IE DNP3	TIM 4R-IE DNP3	CP 441 + SIPLUS RIC library	CP 443 + SIPLUS RIC library or integral PN interface + SIPLUS RIC library
	S7-400H/ S7-400FH	–	–	–	–	TIM 4R-IE DNP3	TIM 4R-IE DNP3	ET 200M + 2 x CP 341 + SIPLUS RIC library	CP 443 + SIPLUS RIC library
	Third-party station	–	–	Depends on type of station		Depends on type of station		Depends on type of station	
Dialup lines		•	–	–	–	–	–	–	–
Dedicated lines and radio networks		•	•	•	•	•	•	•	•
Master/slave		•	•	•	•	•	•	•	•
Peer-to-peer		•	•	–	–	–	–	•	•
Mesh networks		•	•	–	–	•	•	•	•
Time tagging in RTU		•	•	–	–	•	•	•	•
RTU time synchronization		•	•	–	–	•	•	•	•
Data buffering in RTU		•	•	–	–	•	•	• ¹⁾	• ¹⁾
International standard		–	–	• (many versions)	• (many versions)	•	•	•	•

¹⁾ Data buffering is limited to two SIMATIC S7 data blocks. Depending on the SIMATIC CPU, this corresponds to ca. 800 to 3 200 buffered frames.

Industrial Remote Communication

TeleControl Professional for the control center

SIMATIC PCS 7 TeleControl

Design (continued)

The telecontrol protocols used by SIMATIC PCS 7 TeleControl for remote communication are matched to the conditions of the widely distributed communication infrastructure.

The WAN transmission media suitable for communication between the RTUs and the telecontrol center are diverse, e.g.

- Private networks
 - Wireless
 - Dedicated line
 - WLAN
- Public networks
 - GPRS
 - EGPRS
 - UMTS
 - DSL

Based on the four basic topological forms (point-to-point, multi-point, star and ring), differently structured telecontrol networks can be implemented with these media versions, e.g. star over wireless, dedicated line or DSL. Through a combination of several basic topologies of the same or different media versions, it is also possible to design more complex network topologies, even with redundant communication paths. Optimum adaptation to the local conditions and the infrastructure which may already exist is possible in this manner.

Migration of existing telecontrol systems

SINAUT ST1 stations based on SIMATIC S5

In the course of migration of existing plants, RTUs based on SIMATIC S5 can also be integrated via SIMATIC PCS 7 TeleControl into the process control system. In the process, the ST1 telecontrol protocol is converted into the ST7 protocol in the central TIM communication module.

Units with Modbus communication

SIMATIC PCS 7 TeleControl V7.1 cannot only integrate new RTUs into SIMATIC PCS 7 V7.1, it can also integrate plant sections which already exist outdoors, for example, plant sections which have a Modbus infrastructure. These sections can be integrated into SIMATIC PCS 7 using the Modbus protocol via serial lines or TCP/IP connections.

Whereas RTUs with Modbus TCP/IP interface can be integrated directly, third-party RTUs require special interface converters for telecontrol communication.

Third-party stations with telecontrol protocols

In addition to the Modbus telecontrol protocol, the DNP3 (serial and TCP/IP), IEC 870-5-101 (serial) and IEC 870-5-104 (TCP/IP) telecontrol protocols also support the control center interfacing of third-party RTUs in the course of migration. A prerequisite is that the RTU supports the corresponding protocol and that the required interface converters are available.

Third-party stations with OPC

Third-party RTUs for which an OPC server exists can be integrated into the process control with the PCS 7 TeleControl operator system using additional engineering services on the basis of the DBA technology. SIMATIC PCS 7 TeleControl then supports data exchange between the operator system (OPC client) and the RTU (OPC server) per OPC DA.

SINAUT LSX systems

Existing SINAUT LSX systems can also be migrated with SIMATIC PCS 7 TeleControl V7.1. The SIMATIC S7 controllers with the EDC telecontrol protocol (Event Driven Communication) installed in the SINAUT LSX system are integrated into SIMATIC PCS 7 TeleControl V7.1 per PCS 7 TeleControl S7 EDC drivers (for ordering data, refer to the following catalog section PCS 7 TeleControl operator system). Because the SINAUT LSX system can coexist at all levels next to the new system architecture as long as necessary, step-by-step modernization is possible without short-lived intermediate solutions.

More information

Detailed information, ordering data and technical specifications on the individual SIMATIC PCS 7 TeleControl products can be found in the catalog ST PCS 7.1 and on the internet at:

www.siemens.com/simatic-pcs7/telecontrol

Industrial Remote Communication

TeleControl Professional for the control center

PCS 7 TeleControl Engineering Station

Overview

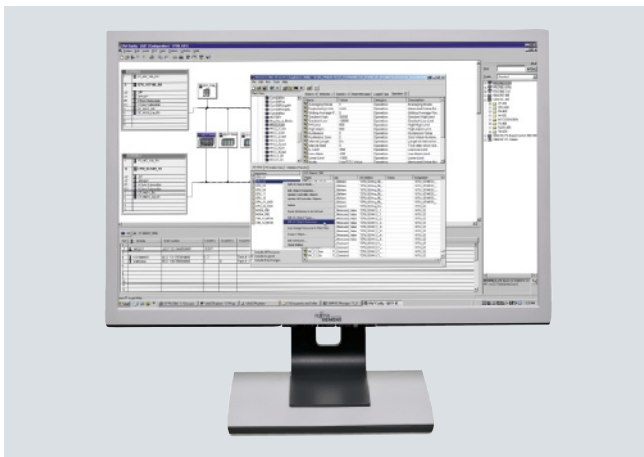

The PCS 7 TeleControl OS Engineering V7.1 software package is used to configure a SIMATIC PCS 7 industrial workstation of single station or server design as a SIMATIC PCS 7 TeleControl engineering station.

Ordering data

Order No.

PCS 7 TeleControl OS Engineering V7.1 (unlimited POs)

Software package with SIMATIC PCS 7 Engineering Software V7.1 + SP2, unlimited POs (cannot be used as operator station for productive operation)

Engineering software, 2 languages (German, English), software class A, executes with Windows XP Professional / Server 2003, floating license for 1 user

Electronic documentation on CD/DVD, 2 languages (German, English)

Type of delivery:

- License key memory stick, certificate of license including terms and conditions
- SIMATIC PCS 7 Software Media Package V7.1 + SP2
- CD "PCS 7 TeleControl Option V7.1 + SP2"

6DL5 000-8AF17-0XA5

PCS 7 TeleControl OS Engineering Component Option V7.1

To upgrade an existing SIMATIC PCS 7 Engineering Station V7.1 + SP2 (unlimited POs) for PCS 7 TeleControl V7.1 + SP2; software package without SIMATIC PCS 7 Engineering Software V7.1 + SP2

Engineering software, 2 languages (German, English), software class A, executes with Windows XP Professional / Server 2003, floating license for 1 user

Electronic documentation on CD, 2 languages (German, English)

Type of delivery:

- License key memory stick, certificate of license including terms and conditions
- CD "PCS 7 TeleControl Option V7.1 + SP2"

6DL5 000-8AF17-0XE5

Note:

You can find more information in Catalog ST PCS 7.1 and in the Industry Mall at www.siemens.com/industrymall.

Industrial Remote Communication

TeleControl Professional for the control center

PCS 7 TeleControl Operator System

Overview

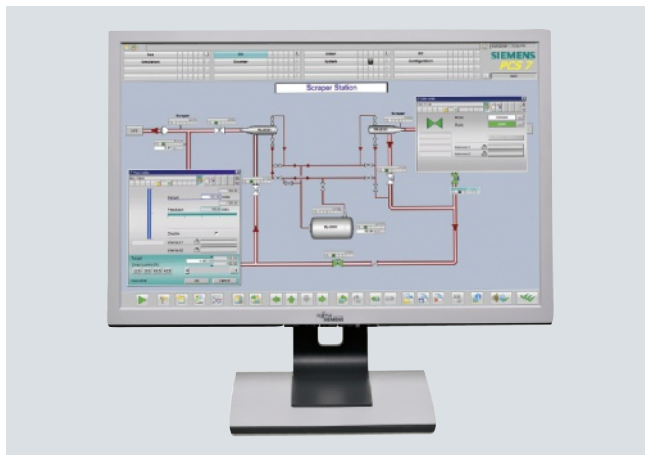

Uniform process control for central and remote units

The PCS 7 TeleControl OS software packages V7.1 offered for OS runtime mode are tailored to the architecture of the SIMATIC PCS 7 operator system V7.1. They support single-user systems (single stations) as well as multi-user systems with up to 12 servers/redundant pairs of servers and up to 32 clients.

Ordering data

Order No.

Order No.

PCS 7 TeleControl OS Single Station V7.1 (250 POs)

Software package with SIMATIC PCS 7 OS Software Single Station V7.1 + SP2, 250 POs, including 512 archive tags;

Runtime software, 2 languages (German, English), software class A, executes with Windows XP Professional, single license for 1 installation

Electronic documentation on CD/DVD, 2 languages (German, English)

Type of delivery:

- License key memory stick, certificate of license including terms and conditions
- SIMATIC PCS 7 Software Media Package V7.1 + SP2
- CD "PCS 7 TeleControl Option V7.1 + SP2"

6DL5 001-8AA17-0XA0

PCS 7 TeleControl OS Redundant Server V7.1

Software package with SIMATIC PCS 7 Server Redundancy V7.1 + SP2, 250 POs, including 512 archive tags (includes: WinCC/Redundancy and RS 232 connecting cable, 10 m)

Runtime software, 2 languages (German, English), software class A, executes with Windows Server 2003, single license for 2 installations

Electronic documentation on CD/DVD, 2 languages (German, English)

Type of delivery:

- License key memory stick, certificate of license including terms and conditions
- SIMATIC PCS 7 Software Media Package V7.1 + SP2
- CD "PCS 7 TeleControl Option V7.1 + SP2", RS 232 connecting cable, 10 m

6DL5 002-8BA17-0XA0

PCS 7 TeleControl OS Server V7.1

Software package with SIMATIC PCS 7 OS Software Server V7.1 + SP2, 250 POs, including 512 archive tags

Runtime software, 2 languages (German, English), software class A, executes with Windows Server 2003, single license for 1 installation

Electronic documentation on CD/DVD, 2 languages (German, English)

Type of delivery:

- License key memory stick, certificate of license including terms and conditions
- SIMATIC PCS 7 Software Media Package V7.1 + SP2
- CD "PCS 7 TeleControl Option V7.1 + SP2"

6DL5 002-8AA17-0XA0

PCS 7 TeleControl OS Runtime Component Option V7.1

To expand an existing SIMATIC PCS 7 OS V7.1 + SP2 (server/single station) for PCS 7 TeleControl V7.1 + SP2

Software package without SIMATIC PCS 7 OS Software V7.1 + SP2

Runtime software, 2 languages (German, English), software class A, executes with Windows XP Professional or Windows Server 2003, single license for 1 installation

Electronic documentation on CD, 2 languages (German, English)

Type of delivery:

- License key memory stick, certificate of license including terms and conditions
- CD "PCS 7 TeleControl Option V7.1 + SP2"

6DL5 002-8AA17-0XE0

Industrial Remote Communication

TeleControl Professional for the control center

PCS 7 TeleControl Operator System

Ordering data	Order No.	Order No.	
<p>PCS 7 TeleControl SINAUT Driver Runtime software, license for one OS single station or one OS server, software class A, executes with Windows XP Professional or Windows Server 2003, single license for 1 installation</p> <p>Requirement: Software PCS 7 TeleControl OS Single Station or PCS 7 TeleControl OS Server</p> <p>Type of delivery: • License key memory stick, certificate of license including terms and conditions</p>	6DL5 101-8AX00-0XB0	<p>PCS 7 TeleControl Modbus Driver Runtime software, license for one OS single station or one OS server, software class A, executes with Windows XP Professional or Windows Server 2003, single license for 1 installation</p> <p>Requirement: Software PCS 7 TeleControl OS Single Station or PCS 7 TeleControl OS Server</p> <p>Type of delivery: • License key memory stick, certificate of license including terms and conditions</p>	6DL5 101-8BX00-0XB0
<p>PCS 7 TeleControl DNP3 driver Runtime software, license for one OS single station or one OS server, software class A, executes with Windows XP Professional or Windows Server 2003, single license for 1 installation</p> <p>Requirement: Software PCS 7 TeleControl OS Single Station or PCS 7 TeleControl OS Server</p> <p>Type of delivery: • License key memory stick, certificate of license including terms and conditions</p>	6DL5 101-8EX00-0XB0	<p>PCS 7 TeleControl S7 EDC Driver Runtime software, license for one OS single station or one OS server, software class A, executes with Windows XP Professional or Windows Server 2003, single license for 1 installation</p> <p>Requirement: Software PCS 7 TeleControl OS Single Station or PCS 7 TeleControl OS Server</p> <p>Type of delivery: • License key memory stick, certificate of license including terms and conditions</p>	6DL5 101-8DX00-0XB0
<p>PCS 7 TeleControl IEC 870-5-101/-104 Driver Runtime software, license for one OS single station or one OS server, software class A, executes with Windows XP Professional or Windows Server 2003, single license for 1 installation</p> <p>Requirement: Software PCS 7 TeleControl OS Single Station or PCS 7 TeleControl OS Server</p> <p>Type of delivery: • License key memory stick, certificate of license including terms and conditions</p>	6DL5 101-8CX00-0XB0		

Note:

You can find more information in Catalog ST PCS 7.1 and in the Industry Mall at www.siemens.com/industrymall.

Industrial Remote Communication

TeleControl Professional for the control center

SINAUT ST7sc SCADA Connect Software

Overview

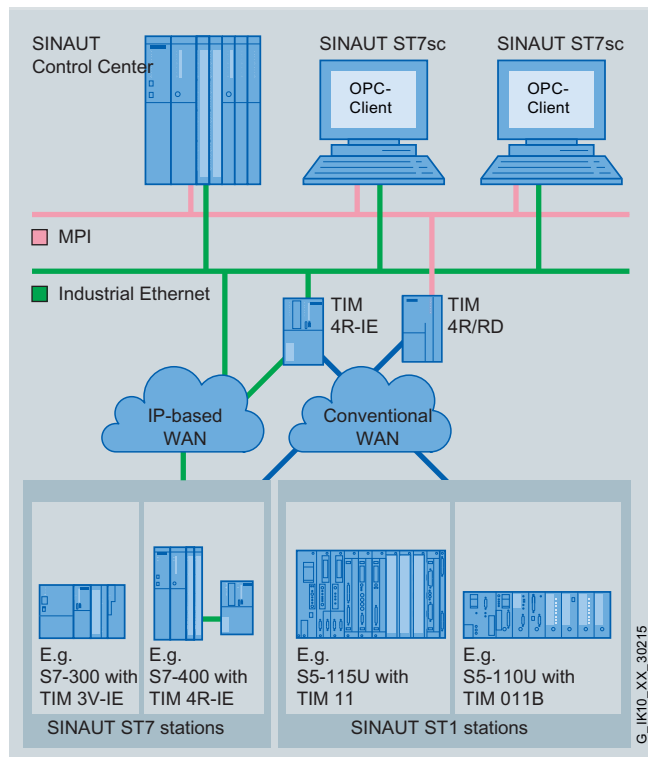

SINAUT ST7sc control center system (non-redundant or redundant) with connected ST7 and ST1 terminals

- The SCADA Connect Software SINAUT ST7sc permits the connection of telecontrol substations with ST7 and ST1 protocol to control center systems that can operate as OPC clients, e.g. iFIX from Intellution, InTouch from Wonderware, Micro SCADA from ABB.
- SINAUT ST7sc is also suitable for data exchange with other applications via OPC, e.g. with the Office application Excel.
- The OPC data can be exchanged either synchronously or asynchronously (change-controlled).
- The "Item Buffering" function prevents the loss of data on failure of the OPC client or if SINAUT terminals supply data at a faster rate than can be transferred via the OPC interface.
- System availability can be increased by connecting two ST7sc systems working in parallel to a redundant client system.
- SINAUT ST7sc additionally assumes the function of a telecontrol center. There is therefore no need for a separate SIMATIC S7-CPU for this function.

Benefits

get Designed for Industry

- Connection of SINAUT stations to HMI, SCADA and Office applications via OPC
- The "Item Buffering" procedure ensures seamless archiving
- Time and cost savings through simple configuration without requiring detailed knowledge of SINAUT

Application

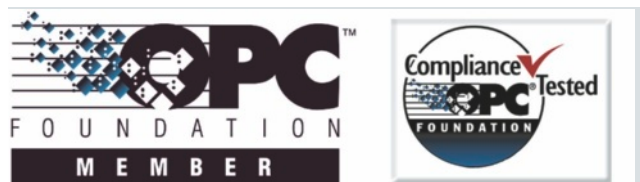

The TeleControl system allows substations to be networked with a control center via WAN (Wide Area Network) or Industrial Ethernet. This control center can also be a SIMATIC terminal or a PC-based control center, for example, WinCC with the SINAUT ST7cc add-on.

SINAUT ST7sc offers suppliers of other control center systems the option of connecting to substations with SINAUT ST7 without having to integrate a SINAUT interface. Communication is over OPC: As an OPC server, SINAUT ST7sc forms the interface between the telecontrol system and the third-party control system connected as an OPC client.

The OPC interface is also suitable for data exchange with other applications, for example, the Microsoft Office application Excel.

Design

SINAUT ST7sc is installed on a Windows PC (Windows 7, Windows 2008 Server). The OPC server function supports connection of one or more client applications. These clients are either connected over a suitable communication medium, e.g. Industrial Ethernet, with the server or they are installed on the same PC as SINAUT ST7sc.

Connection of one or more telecontrol substations to the ST7sc PC is carried out either via the MPI bus or Industrial Ethernet, depending on the TIM communication module used.

Provision of current time of day:

- For TIMs, that are connected over MPI to the ST7sc PC, time synchronization is only possible through a DCF77 receiver equipped with a TIM. This provides central time synchronization for the ST7sc PC and all other stations.
- For TIMs that are connected over Industrial Ethernet to the ST7sc PC, time synchronization is performed over ST7sc.

Outside the reception area of the DCF77 real-time transmitter the use of a GPS receiver is recommended. This determines the local time from the satellite-based global positioning system (GPS).

Function

In the case of a change, the telecontrol substation detects the process data and transfers it over the relevant WAN to SINAUT ST7sc. The received SINAUT messages are decoded here and stored in the ST7sc variable list as configured. An OPC client can read these received data from the ST7sc variable list via the OPC server interface "Data Access". This is performed either synchronously or asynchronously.

In the reverse direction, the OPC client can write data that is to be sent to a station (e.g. commands, set points, parameters) to the ST7sc variable list via the OPC server interface. These are converted to SINAUT data frames and sent via the WAN to the telecontrol substation specified by means of configuration.

A special feature of the telecontrol system is that process data are protected against loss. If the connection from the substation to the control room fails, for example, the local substation will save all the data changes that occur during the downtime complete with time stamps. This ensures that connection downtimes of several hours or even several days can be bridged without loss of data. So that the data saved in the substations will also arrive at the OPC client safely later, ST7sc contains the "item buffering" procedure, which helps to avoid data loss on the way to the OPC client:

- When the OPC "data access" interface that represents a process image is updated by the substations faster than the client can read it;
- When the OPC client is not available for a shorter or longer time or when the OPC communication path fails.

ST7sc normally only creates one "memory cell" per item in which the last status or value of the item is retained, but when the item buffering procedure is selected, one buffer is created per item in which all changes to the affected item are saved consecutively complete with time stamps. Saving is performed until the individual changes can be transferred to the OPC client.

The item buffering procedure requires an HMI application that can process time-stamped data even when the time stamp is several days old, e.g. following a long connection failure.

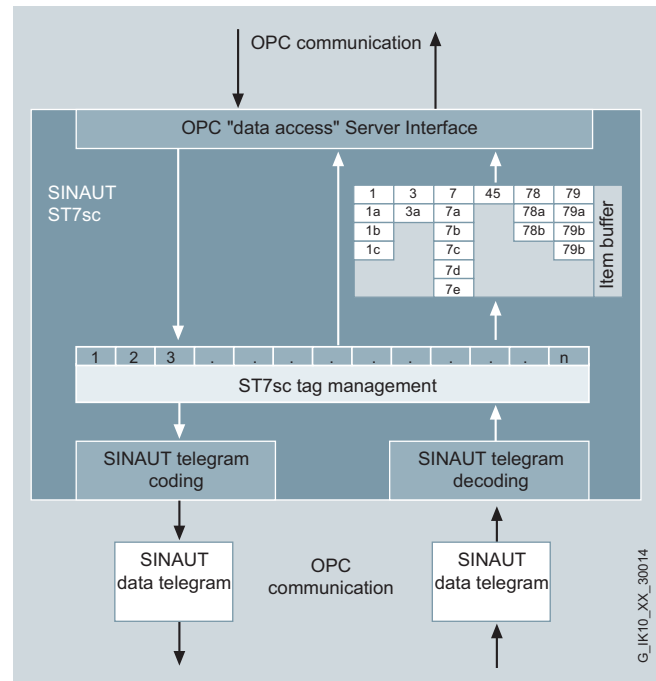

System configuration with SINAUT ST7sc

Redundant application

SINAUT ST7sc supports connection to a redundant client system. Two ST7sc systems must be used in this case. The data received from the stations are transferred by them in parallel and mutually independently to both clients and data are received from the clients that must be sent to the substations.

The redundancy mechanisms are located in this case on the client side:

- The client ensures that the data transferred in parallel is evaluated and compared correctly;
- The client transfers data to be sent to the substation once only to one of the two ST7sc, so that transmission is not duplicated.

Configuration

The ST7sc is configured using the ST7sc Config tool that is included in the scope of supply of the ST7sc software CD.

The documentation for the ST7sc and the Config tool is also located on this CD.

Industrial Remote Communication

TeleControl Professional for the control center

SINAUT ST7sc SCADA Connect Software

Technical specifications

Product type designation	SINAUT ST7sc V2.0	Product type designation	SINAUT ST7sc V2.0
Operating systems	Windows 7 Professional (32-bit); Windows 7 Enterprise (32-bit); Windows 7 Ultimate (32-bit); Windows 2008 Server SP2 (32-bit)	Configuration	ST7sc Config-Tool V2.0 SINAUT ST7 Engineering Software V3.5, V3.6, V4.0, V4.1, V5.0, V5.1
		<ul style="list-style-type: none"> ST7sc SINAUT system 	
		Quantity framework	Small license Medium license Large license
		<ul style="list-style-type: none"> 6 SINAUT terminals 12 SINAUT terminals for more than 12 SINAUT terminals 	

Ordering data

Order No.	Order No.	Order No.
SINAUT ST7sc		Communication processor CP 5611 A2
Software for connecting SINAUT stations to HMI, SCADA and Office applications via OPC; single license for 1 installation of the runtime software; configuration software and electronic manual on CD-ROM; operating systems: Windows 2008 Server SP2 (32 bit), Windows 7 (32 bit) Professional, Enterprise; license key on USB flash drive; German/English		PCI card (32-bit) for connecting a PG or PC to PROFIBUS/MPI; suitable for the connection of up to 8 TIM modules via MPI
<ul style="list-style-type: none"> SINAUT ST7sc V2.0 S Small license for max. 6 SINAUT stations SINAUT ST7sc V2.0 M Medium license for max. 12 SINAUT stations SINAUT ST7sc V2.0 L Large license for more than 12 SINAUT stations SINAUT ST7sc V2.0 SM License upgrade from ST7sc S to ST7sc M (from 6 to 12 stations) SINAUT ST7sc V2.0 SL License upgrade from ST7sc S to ST7sc L (from 6 to more than 12 stations) SINAUT ST7sc V2.0 ML License upgrade from ST7sc M to ST7sc L (from 12 to more than 12 stations) SINAUT ST7sc V2.0 U Upgrade of all licenses from V1.2 to V2.0 	6NH7 997-5CA20-0AA1 6NH7 997-5CA20-0AA2 6NH7 997-5CA20-0AA3 6NH7 997-5AA20-0AD2 6NH7 997-5AA20-0AD3 6NH7 997-5AA20-0AE3 6NH7 997-5CA20-0GA1	6GK1 561-1AA01 6GK1 561-1AM01 6GK1 704-5CW08-1AA0 6GK1 704-5CW71-3AA0 6GK1 561-3AA01 6GK1 562-1AA00 6GK1 562-1AM00 6GK1 562-3AA00
		Communication processor CP 5611 A2 MPI
		Comprising a 5611 PCI card (32-bit) and 5 m MPI cable
		SOFTNET-PB S7 V8.1
		For 32-bit Windows 7 Professional/Ultimate
		SOFTNET-S7, 2008 Edition for CP 5611 A2/CP 5621
		Software for S7 communication incl. PG and FDL protocol, Single License for 1 installation, license key on USB flash drive
		Communication processor CP 5613 A2
		PCI card (32-bit; 5 V) for connecting a PG or PC to PROFIBUS/MPI; suitable for the connection of up to 30 TIM modules via MPI
		Communication processor CP 5621
		PCI Express x1 card (32-bit) for connection of a PG or PC to PROFIBUS
		<ul style="list-style-type: none"> with MPI cable, 5 m
		Communication processor CP 5623
		PCI Express x1 card (32-bit) for connection of a PG or PC to PROFIBUS

Industrial Remote Communication

TeleControl Professional for the control center

SINAUT ST7sc SCADA Connect Software

Ordering data	Order No.	Order No.	
S7-5613 Edition 2008 for CP 5613 A2 Software for 32-bit Windows XP Professional SP2/3; Windows 2003 Server R2, SP2; Windows Vista Business/Ultimate SP1; single license for 1 installation, license key on USB stick	6GK1 713-5CB71-3AA0	S7-1613 Edition 2008 for CP 1613 A2/CP 1623 Software for S7 communication including PG communication, suitable for max. 120 connections, single license for 1 installation, license key on USB flash drive	6GK1 716-1CB71-3AA0
HARDNET-PB S7 V8.1 for CP 5613 A2 For 32-bit Windows 7 Professional/Ultimate	6GK1 713-5CB08-1AA0	SOFTNET-IE S7 V8.1 for Industrial Ethernet For 32-bit Windows 7 Professional/Ultimate up to 64 connections	6GK1 704-1CW08-1AA0
Communication processor CP 1613 A2 PCI card (32-bit; 33 MHz/66 MHz; 3.3 V/5 V universal keyed) for connecting a PG or PC to Industrial Ethernet (10/100 Mbit/s); suitable for the connection of up to 120 TIM modules via Industrial Ethernet	6GK1 161-3AA01	SOFTNET-S7 Edition 2008 for Industrial Ethernet For 32-bit Windows XP Professional SP2/3; Windows 2003 Server R2, SP2; Windows Vista Business/Ultimate SP1; Windows 2008 Server	6GK1 704-1CW71-3AA0
Communication processor CP 1623 PCI Express x1 card (32-bit) for connection of a PG or PC to Industrial Ethernet	6GK1 162-3AA00	SOFTNET-IE S7 Lean V8.1 for Industrial Ethernet Up to 8 connections	6GK1 704-1LW08-1AA0
HARDNET IE S7 V8.1 for CP 1613 A2/CP 1623 For 32-bit Windows 7 Professional/Ultimate	6GK1 716-1CB08-1AA0	SOFTNET-S7 Lean Edition 2008 for Industrial Ethernet Up to 8 connections	6GK1 704-1LW71-3AA0

Industrial Remote Communication

TeleControl Professional for the substations

Introduction

Overview

Design principle of a telecontrol system and plants with SIMATIC

Telecontrol involves the connection of distant process stations to one or more central control systems. A telecontrol system can be subdivided into the following components

- Control center
- Substations
- Communication network

Various different public or private networks can be used for communication for the purposes of monitoring and control. The event-driven or cyclic exchange of the process data takes place via special telecontrol protocols such as SINAUT ST7, DNP3.

Substations







With SIMATIC, Siemens offers a wide range of components for the different application areas for establishing telecontrol substations – Remote Terminal Units (RTUs).

The hardware basis is a PLC, in each case supplemented for the telecontrol function with special hardware and software components, e.g. TIM communication modules. All the local functions supported by the respective PLC for the connection of I/O via bus systems, connection of HMI or sensors, etc., are also available without restriction in the RTU configuration.

The individual solutions differ in the

- performance class (number of required IO signals and controller performance)
- support for the telecontrol protocols

The following table provides an overview of the different types of substations on offer with the essential features.

		Telecontrol protocols					Private networks			Public networks			
		SINAUT ST1	Telecontrol Basic	SINAUT ST7	DNP3	IEC 60870-104 TCP/IP	Wireless	Dedicated line	WLAN	GPRS	EGPRS	UMTS	DSL
	ET 200S	-	-	-	-	•	•	•	•	•	•	•	•
	S7-1200	-	•	-	-	-	-	-	-	•	-	-	-
	S7-200	-	•	-	-	-	-	-	-	•	-	-	-
	S7-300	•	•	•	•	•	•	•	•	•	•	•	•
	S7-400	•	-	•	•	•	•	•	•	•	•	•	•
	S7-400FH	-	-	-	•	•	•	•	•	•	•	•	•
	WinAC RTX	-	-	-	-	•	•	•	•	•	•	•	•

• suitable - not suitable

G_IK10_XX_30293

Classification of the different telecontrol substations (RTU types)

Overview (continued)

TIM communications modules

The hardware component for the telecontrol wireless station of a telecontrol substation is the TIM (**T**elecontrol **I**nterface **M**odule) communication module. It is used by the S7 CPU or control center PC for data exchange via the relevant telecontrol network, optionally with the SINAUT ST7, SINAUT ST1 or DNP3 protocol.

Different protocols cannot be combined in one communication network. However, communication networks with different protocols can always be combined in one project if they are connected to the central control center via separate interfaces.

Function

Each WAN interface of a TIM can be operated with the function "Station", "Node terminal" or "Control center" (exception: the function "Node terminal" is not available on the TIM 3V-IE, TIM 3V-IE DNP3, TIM 4R-IE DNP3, and the function "Control center" is not available on the TIM 3V-IE DNP3 and TIM 4R-IE DNP3). This enables the construction of the type of hierarchical communication structures required in classic WANs.

On IP-based networks, in which each partner has equal priority, this classification can be dismissed. The transmission via GPRS however represents an exception, as without special contracts with the GPRS Provider, direct communication from GPRS station to GPRS station is not possible. This can be solved by "re-routing" through a control center TIM, as in a classic WAN with cross-traffic on a dedicated leased line or wirelessly. In this case, the interfaces of the participating TIMs are to be set to the function "Control center" or "Station" in an IP-based network as well so that the correct path from "Station" to "Station" will be found automatically through the "Control center".

The TIM independently processes the data traffic via the network connected in each case and it does this according to the store-and-forward principle. For this purpose, the module has its own processor and a RAM for buffering data messages (depending on the type of TIM, between 10,000 and 56,000 message frames). The saving of the messages prevents a loss of data if the communication link is faulty or the partner fails. It also helps to reduce connection charges in dialup networks. If the optional backup battery is used for the TIM 4R-IE or TIM 4R-IE DNP3, stored data frames are not lost even if the 24 V supply voltage fails.

Reading and writing data that the TIM is to send or receive for a CPU can also be done with:

- **TD7onCPU**, the SINAUT TD7 software for the CPU, applicable to S7-300- and S7-400-CPU's as well as C7 compact control systems:
The SINAUT program in the CPU, configured with modules from the SINAUT TD7 library, acquires the process data to be transferred, checks it for changes and transfers the changes to the TIM for transmission over the WAN. Messages received without faults by the TIM via the WAN are forwarded to the local CPU. A block that has been integrated there for evaluating the specific message frame ensures that the received information is output to the outputs or data areas configured in the block.
This block library cannot be used in conjunction with TIM 3V-IE DNP3 or TIM 4R-IE DNP3.
- **TD7onTIM**, the SINAUT TD7 software integrated in the TIM (not present in the case of the TIM 4R / TIM 4RD), can be used with S7-300 CPU's and C7 compact control systems:
The TD7onTIM program configured by the user reads the process data to be transferred directly from the memory areas of the CPU inserted into the S7-300 rack (inputs, bit memories, DBs), checks them for changes and then transfers the changes to the send buffer of the TIM for transmission over the WAN. Data from message frames received without fault by the TIM via the WAN are directly written by the TIM into the configured memory areas of the CPU.

If required, the data acquired by "TD7onCPU" or "TD7onTIM" can be tagged with a time stamp and the "normal" or "high" priority identification for transmission over a chargeable network, e.g. dial-up or GPRS. "TD7onTIM" also allows extremely important data to be identified with the "Interrupt" priority. These have priority over all other message frames saved in the send buffer, i.e. they are transmitted before the others.

If the local SINAUT station is a control center PC, operator inputs are recorded by the PC program in accordance with the ST7cc/ST7sc configuration, and transferred with the configured destination address to the TIM. Messages received without faults by the TIM via the WAN are forwarded to the control center PC. Evaluation of the relevant frame is handled by the control system software.

The TIM first saves the data to be sent in its RAM buffer. The subsequent response of the TIM on sending this data is explained in the two following sections.

Industrial Remote Communication

TeleControl Professional for the substations

Introduction

Function (continued)

Communication via a classic WAN

The response of the TIM on sending the data depends on the WAN type and the TIM function that is set on the WAN interface:

- Dedicated line, wireless network;
if the interface is operated in the function "station" or "node terminal", the TIM waits to be polled by the control center before it transfers the stored data message frames. If there are no message frames available, polling is simply acknowledged.
If operated as a "control center", the TIM sends one of the message frames saved in the buffer following each completed poll + response (standard setting). If a larger number of message frames is to be sent between two polls, this can be specified when the TIM is configured.
- Dial-up network;
in "station" or "node terminal" mode, the TIM will initially not be active in the case of data with "normal" priority. In the case of data of "high" or "interrupt" priority, the TIM will immediately try to establish a link to the addressed partner in order to transfer the data. If data of "normal" priority is also available in the TIM buffer at this time, this will be transferred immediately. Data of "interrupt" priority will always be transferred first. The data of "high" and "normal" priority will subsequently be transferred in accordance with the FIFO principle, i.e. regardless of their respective priority.
If the interface is set to the "control center" function, the TIM will always try regardless of priority to establish a link to the addressed partner and to transfer the data.

The SINAUT ST7/ST1 protocol can be used for all WAN types and TIM functions. The DNP3 protocol only allows use of dedicated lines and wireless networks in the function "Station". The operating mode used depends on the type of WAN:

- Data exchange via dedicated line and wireless network usually takes place in "Polling" mode. In wireless networks with SINAUT ST7 protocol, the operating mode "Polling with time slot method" can be selected if required.
- On dial-up networks (only with SINAUT ST7/ST1 protocol), data exchange always takes place in "Spontaneous" mode.

Communication via an IP-based network

For transmission via an IP-based network, a permanent S7 connection via which the partners exchange the data packages is established in each case between two TIMs or between one TIM and the control system.

PG communication

PG communication allows all S7 stations connected to the LAN, e.g. Industrial Ethernet, to be remotely programmed. With the aid of S7 routing it is possible to use programming device communication across networks.

Cross-network PG communication functions with the SINAUT ST7 protocol for all classic and IP-based WANs. Remote programming and remote diagnosis of the stations connected to the WAN (CPUs and TIMs) is therefore possible.

In IP-based DNP3 networks, PG communication does not take place via the protocol itself, but via a separate PG connection (TCP/IP connection).

Diagnostics & service

The "SINAUT Diagnostics & Service Tool" provides comprehensive diagnostic functions and tools for commissioning and troubleshooting, e.g.:

- Operating status of the TIM
- Module status of the TIM
- General diagnostic information
- Diagnostics buffer of the TIM
- Status of the connections to local and remote communication partners (CPUs, TIMs, control systems)
- TIM frame monitor for recording the frame traffic
- Disabling and enabling stations in the dedicated line or wireless network, e.g. during commissioning

TIM modules with Ethernet interface also offer the following:

- Status and fill level of the send buffer, for each communication partner separately
- Diagnostic information regarding TD7onTIM

Configuration

The "SINAUT ST7 ES" configuring software is used for configuring the TIM. Modules from the "SINAUT TD7 module library" must be used for configuring the SINAUT program in the CPU (TD7onCPU). Both software packages are part of the SINAUT ST7 ES V5.1 engineering software. The SINAUT ST7 configuring software can be used provided that STEP 7 V5.4 with Service Pack 4 or later has been installed.

The configuration data – like the interface functionality, addresses of the communication participants, the telephone numbers of the partner in the dial-up network, etc. – that are required in each case can be saved in the Flash EPROM on every TIM or, in the case of the TIM 4R-IE or TIM 4R-IE DNP3, also on the optional plug-in C-PLUG. On all TIMs with Ethernet interface, the configuration data can also be stored on the memory card (MMC) of the CPU when installing in an S7-300 rack or in a C7 control system. The TIM can be replaced without the need for a programming device if the configuration data is saved in the CPU or in the C-PLUG.

Approvals

All TIM communication modules have the approvals CE, FM, ATEX, cUL508 (= UL508, CSA22.2) and cUL HazLoc. The TIM 3V-IE and TIM 4R-IE modules are also available in a SIPLUS version for the extended temperature range (-25 ... +70 °C).

Function (continued)**Functional overview of all TIM versions**

	TIM 3V-IE	TIM 3V-IE Advanced	TIM 3V-IE DNP3
Can be used in conjunction with			
• S7-300	•	•	•
• S7-400 and PC	–	–	–
Interfaces			
• MPI	–	–	–
• RJ45 Ethernet	1	1	1
• RS-232	1	1	1
• RS232/RS485	–	–	–
• Simultaneously operable	RS 232 or RJ45	RS 232 and RJ45	RS 232 and RJ45
Adjustable interface function			
• Station	•	•	–
• Service center	–	•	–
• Node station	–	•	–
Message buffer			
• Number of message frames	16000	32000	50,000 data points with one master
• Battery backup	–	–	–
Integrated DCF77 radio clock receiver	–	–	–
S7 connections via IP-based networks	8	20	–
Combinable with other TIMs in the S7-300 rack	–	•	–
Communication via MPI of the S7-300 CPU	–	•	–
TD7 library integrated in TIM (TD7onTIM)	•	•	•
Module replacement without PG	•	•	•

	TIM 4R-IE	TIM 4R	TIM 4RD	TIM 4R-IE DNP3
Can be used in conjunction with				
• S7-300	•	•	•	•
• S7-400 and PC via MPI	–	•	•	–
• S7-400 and PC via Ethernet	•	–	–	•
• S7-400H via Ethernet	–	–	–	•
Interfaces				
• MPI	–	1	1	–
• RJ45 Ethernet	2	–	–	2
• RS232/RS485	2	2	2	2
• Simultaneously operable	All	All	All	All
Adjustable interface function				
• Station	•	•	•	•
• Service center	•	•	•	–
• Node station	•	•	•	–
Message buffer				
• Number of message frames	56000	10000	10000	200,000 data points with one master
• Battery backup	•	–	–	•
Integrated DCF77 radio clock receiver	–	–	•	–
S7 connections via IP-based networks	64	–	–	2
Combinable with other TIMs in the S7-300 rack	•	•	•	–
Communication via MPI of the S7-300 CPU	•	•	•	•
TD7 library integrated in TIM (TD7onTIM)	•	–	–	•
Module replacement without PG	•	–	–	•

Industrial Remote Communication

TeleControl Professional – Substations for ST7 protocol

Introduction

Overview

Substations for ST7 protocol

The TIM communication module is housed in an S7-300 enclosure and is available in different versions:

TIM 3V-IE/TIM 3V-IE Advanced



The TIM 3V-IE is a SINAUT communication module for the SIMATIC S7-300. It has an RS232 interface to which a matching external modem can be connected for data transfer via a conventional WAN. It additionally possesses an RJ45 interface, which permits communication over IP-based networks. In the case of the TIM 3V-IE, SINAUT communication can be processed alternately via one of the two interfaces, while in the TIM 3V-IE Advanced both interfaces can be operated simultaneously.

TIM 4R / TIM 4RD



The TIM 4R is a SINAUT communication module with flexible application options:

- Suitable for installation in a SIMATIC S7-300 as a communication module
- Also as an independent device (without S7-300 CPU), it can be connected via its MPI to one or more SIMATIC S7-300/-400 and to the control center PC (SINAUT ST7cc or ST7sc).

Apart from its MPI port, the TIM 4R has two RS232/RS485 interfaces for data transmission via conventional WANs. The two WAN networks can be different, for example, dedicated line plus telephone network, and operated independently of one another, but also in a redundant combination.

The TIM 4R is optionally available with an integrated DCF77 radio clock receiver (TIM 4RD). From this module, it is possible to supply the date and time to all nodes in the telecontrol system.

TIM 4R-IE



The TIM 4R-IE has two RS232/RS485 interfaces for data transmission via conventional WANs and additionally two RJ45 interfaces for connection to IP-based networks (WAN or LAN).

This TIM can be used as communication processor in a SIMATIC S7-300, but it is especially suitable as telecontrol module for a SIMATIC S7-400 or control center PC (SINAUT ST7cc or ST7sc). It is then connected without S7-300 CPU as a stand-alone device via one of the two Ethernet interfaces to the S7-400 or the PC.

The four transmission paths can all be different and operated independently of one another, but also in any redundant combination.

Design

Configuration examples

The figure below shows a simple S7-300 station equipped with a TIM 3V-IE. The S7-300 can be connected via the RS232 interface of the TIM to a conventional WAN (e.g. dedicated line or dialup network), and via the RJ45 interface to an IP-based network, e.g. GPRS. If the S7-300 were equipped with a TIM 3V-IE Advanced, the two interfaces could be used simultaneously for SINAUT communication.

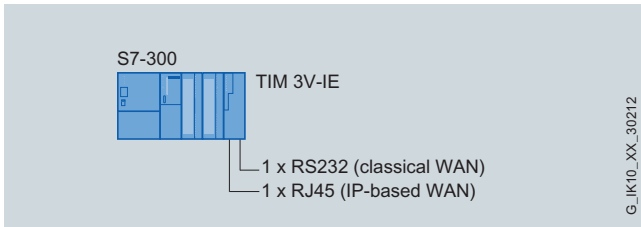

S7-300 with TIM 3V-IE

In the case of an S7-400, both a TIM 4R and a TIM 4R-IE can be used for data communication. In both cases the TIM is used as an independent device, i.e. without S7-300 CPU. The TIM 4R is connected to the S7-400 via MPI, while the TIM 4R-IE is connected via one of the two Ethernet interfaces of this module. The figures below illustrate the two alternatives.

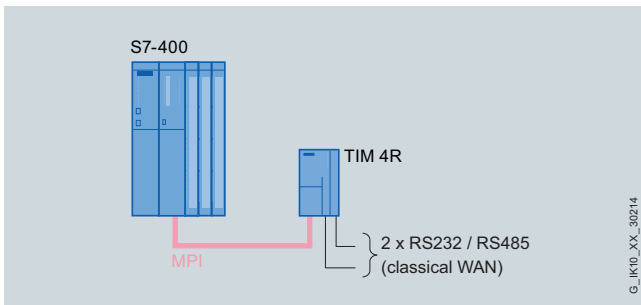

S7-400 with TIM 4R connected via MPI

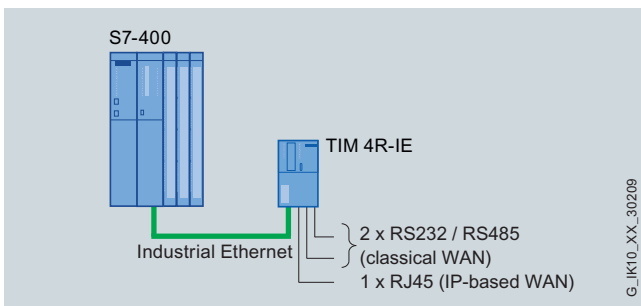

S7-400 with TIM 4R-IE connected via Industrial Ethernet

In the case of the TIM 4R, two conventional WANs can be connected by means of the two combined RS232/RS485 interfaces. The TIM 4R-IE has an additional connection for an IP-based network.

As on an S7-400, the control center PC (e.g. SINAUT ST7cc or ST7sc) is interfaced with the SINAUT telecontrol network via one or more TIM 4 modules. The two figures below show the alternatives with TIM 4R or TIM 4R-IE.

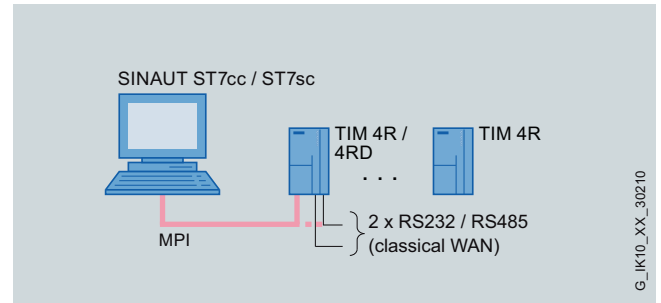

SINAUT ST7cc/ST7sc with one or more TIM 4R's on the MPI bus

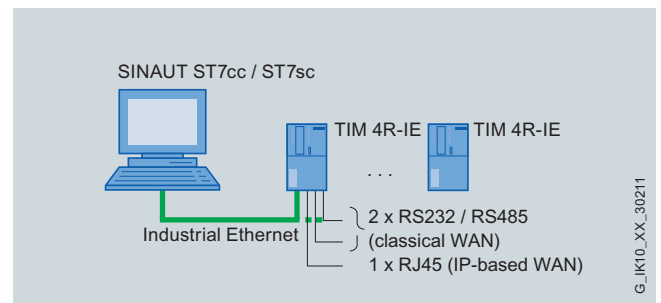

SINAUT ST7cc/ST7sc with one or more TIM 4R-IE's on the Industrial Ethernet

Industrial Remote Communication

TeleControl Professional – Substations for ST7 protocol

Introduction

Design (continued)

One of the TIM 4R modules could be a TIM 4RD with integral DCF77 radio clock receiver. This then synchronizes all TIMs connected to the MPI, as well as the control center PC (ST7cc or ST7sc). The synchronized TIMs then supply the date and time at regular intervals to their SINAUT stations connected via WAN. If no DCF77 time signal is available at the installation location of the TIM 4RD, a SINAUT GPS receiver can be connected to the TIM 4RD. The universally available global positioning system (GPS) is then used as a time source.

The synchronization of the TIM 4R-IE module clocks connected via Ethernet is performed by the control center PC (ST7cc or ST7sc). These TIMs then supply their SINAUT stations in turn.

If stations are connected by means of an IP-based network, the connection to the control center PC (ST7cc or ST7sc) may also be made directly, i.e. without any TIM 4R-IE on the PC. The figure below shows the example of a plant in which the stations are connected directly to the SINAUT control center by means of a fiber optic ring. The SINAUT stations in this directly connected IP-based network are synchronized via the control center PC.

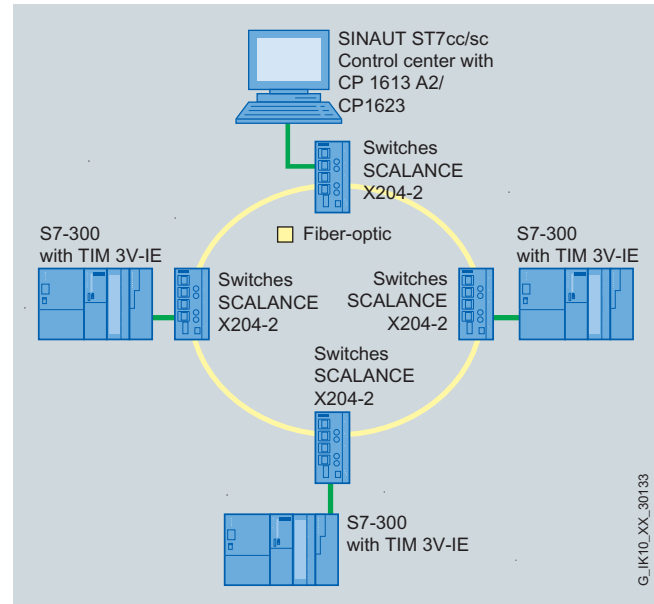

SINAUT ST7cc/ST7sc connected directly to SINAUT terminals via an IP-based network

In the case of more complex IP-based networks, and above all when using a redundant control center, the use of a control center TIM 4R-IE is recommended, since this permits improved monitoring of network behavior and optimization of the connection resources of the PC.

Industrial Remote Communication

TeleControl Professional – Substations for ST7 protocol

TIM 3V-IE for WAN and Ethernet

Overview



- SINAUT communications module TIM for SIMATIC S7-300 for use in a wide area network (WAN)
- IP communication via secure VPN (virtual private network) using the Internet
- Wireless communication via GPRS router, GPRS modem, or radio devices
- Wired communication via Ethernet, DSL, dialup modems or dedicated line modem
- Complete migration of existing wireless, dedicated line and dial-up technology to IP-based network
- Message frame memory for complete recording of data
- Simple configuration and operation without specialist IT knowledge

Benefits

get Designed for Industry

- Flexible option for connection to any IP-based or conventional WAN
- Economical station design and low connection costs due to GPRS connection with the MD720-3 and utilizing the S7-CPU 312 and 312C
- No additional mobile phone service for fixed IP addresses or contracts for private GPRS networks with bidirectional data traffic are necessary, as the VPN is integrated in the ST7 system. No more expensive and complex VPN configuration by IT specialists.
- Saving of traveling costs due to cost-effective remote programming, diagnostics, control and monitoring via the Internet
- Reduction in time and costs thanks to quick and user-friendly configuration of connections and data to be transferred with the SINAUT configuring software and block library
- Reliable storage of important data. Storage of data message frames (max. 16,000) including time stamp on TIM if the communication path is faulty or a partner has failed and to reduce connection costs for the dial-up network.
- Protection of investment for existing SINAUT ST1 systems through the integration of the SIMATIC S7-300

Application

- Low-cost automation of water/wastewater networks with both complex and simple structures
- Control and monitoring of energy distribution systems and supply stations, such as oil, gas or district heating networks
- Preventive maintenance (condition monitoring) of globally distributed systems
- Monitoring of logistics and traffic control systems
- Connection of plants with basic or high-level security and availability requirements
- Use in hybrid networks with dialup, wireless, Ethernet or Internet communication

Design

The TIM 3V-IE offers all the advantages of the SIMATIC S7-300 design:

- Compact design
- 9-pin Sub-D connector with an RS232 interface for connection to a conventional WAN via an appropriate modem
- RJ45 socket for connection to Industrial Ethernet or an IP-based network; industry-standard design with additional sleeve for connecting the IE FC RJ45 Plug 180
- 2-pin plug-in terminal strip for connection of the 24 V DC external supply voltage
- Front LEDs for indicating the module status and the communication
- Simple installation; the TIM 3V-IE is mounted on the rail of the S7-300 and connected to the adjacent modules by means of the bus connectors supplied with the TIM. No slot rules apply.
- Can be operated in the expansion rack (ER) in conjunction with the IM 360/361
- Can be operated without a fan
- A battery backup or memory module are not required

Industrial Remote Communication

TeleControl Professional – Substations for ST7 protocol

TIM 3V-IE for WAN and Ethernet

Function

- The TIM 3V-IE enables a SIMATIC S7-300 to exchange data with other SINAUT ST7 or ST1 stations via any SINAUT network. The important SINAUT property - saving data complete with a time stamp on the TIM in the event of an interrupted link or failure of the partner - is then available not only for conventional WANs, but also for IP-based networks. Important events, alarms, etc. are not lost and the integrity of information in control center system archives is assured.
- The TIM 3V-IE module is particularly suitable for configuring low-cost stations, but also allows a simple S7-300 control center to be implemented. The module cannot be used in a SINAUT node station or combined with other TIMs in a control center.
- The SINAUT TD7 software for the CPU (TD7onCPU) is now integrated in the TIM 3V-IE (TD7onTIM). This enables the smallest S7 CPUs 312 and 312C to be used, because in the most favorable situation, no CPU RAM is required any more for SINAUT. (This does not apply to communication with SINAUT ST1 partners or the transmission of text messages; in these cases, the SINAUT TD7 software must be used for the CPU (TD7onCPU).) One TIM 3V-IE can be used per S7-300 and one of the two interfaces (RS232 or RJ45) can be used for SINAUT communication (not both simultaneously). PG communication is possible at any time over the Ethernet interface.
- Message frame memory for up to 16000 data message frames
- Up to eight S7 connections via IP-based networks

Controllable communication modules:

- Control of the GSM/GPRS modems MD720-3 in GSM or GPRS mode. In GPRS mode, simple 128-bit encryption via the MD720-3 (MSC-VPN tunnel protocol).
- Operation via SIMATIC NET Ethernet components with high IPsec security standard (e.g. GPRS router or SCALANCE S)
- Use of SCALANCE fiber-optic switches for spanning long distances
- Wireless transmission via IWLAN with SCALANCE W over medium distances
- Dedicated line modem MD2 for point-to-point, point-to-multipoint or line connections
- Wireless devices from various manufacturers, also for private mobile radio using the time slot method
- Analog dial-up modem MD3 for the analog telephone network or point-to-point dedicated lines

Integration

Connection to IP-based networks

In addition to the RS232 interface, the TIM 3V-IE also has an RJ45 socket. This is suitable for the connection of IP-based networks (WAN or LAN). Depending on the application, various types of data communication equipment can be connected such as:

- SCALANCE X switches for Twisted Pair cable or fiber-optic cables
- SCALANCE W (IWLAN) and Ethernet radio devices from various manufacturers
- SCALANCE M873/875 for UMTS communication via mobile telephone networks
- EGPRS router MD741-1 for GPRS communication and EGPRS (EDGE) over mobile telephone networks
- GPRS/GSM modem MD720-3 for GPRS communication over mobile telephone networks
- DSL router and SCALANCE S
- Broadband systems such as OTN and PCM30

Configuration examples in IP-based networks

Connection via switches, e.g. SCALANCE X

Simple network structures can be built up in this manner, or complex ones that comprise a combination of star, line and ring structures. At the control desk (e.g. ST7cc) the use of a TIM 4R-IE is not necessary, i.e. the connection is made directly to the Ethernet interface of the PC.

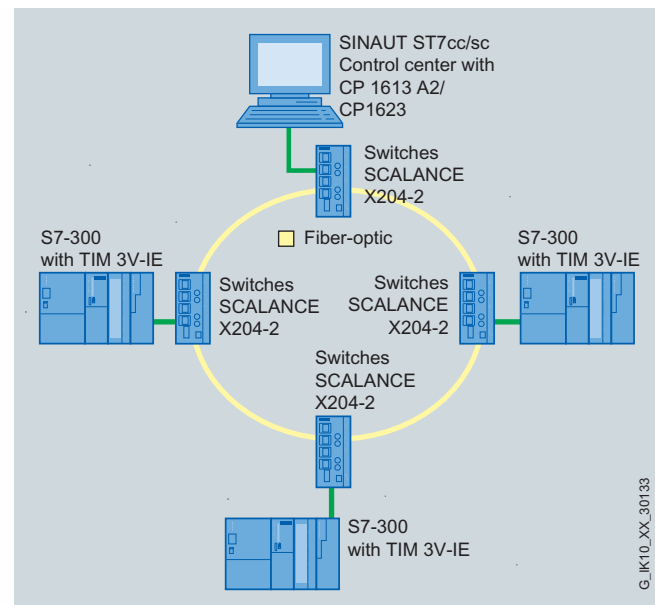

Industrial Remote Communication

TeleControl Professional – Substations for ST7 protocol

TIM 3V-IE for WAN and Ethernet

Integration (continued)

Wireless with Ethernet

When wired Ethernet communication is not possible, a wireless network can be installed using commercially available Ethernet wireless modems or with IWLAN. In order to decouple the networks, the connection in the control center can be made via a TIM 4R-IE, as in the example, or directly to the Ethernet interface of the PC.

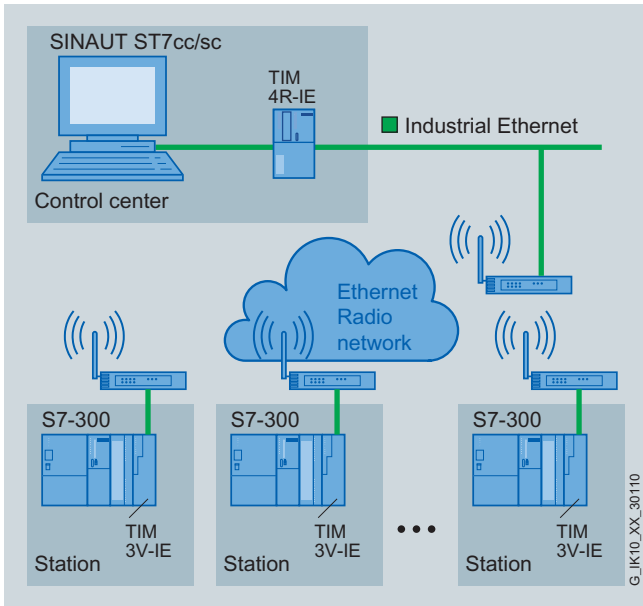

Transmission over DSL

The continuously falling flat rates for DSL connections make this medium an interesting alternative to a leased line or also a telephone connection. DSL routers must be used in the station and control center, preferably routers in combination with SCALANCE S (VPN), in order to establish secure connections using VPN tunnels. A permanent IP address is recommended for DSL connection of the control center, the IP addresses of the stations can be dynamically assigned.

In order to decouple the networks, the connection in the control center can be made via a TIM 4R-IE or directly to the Ethernet interface of the PC.

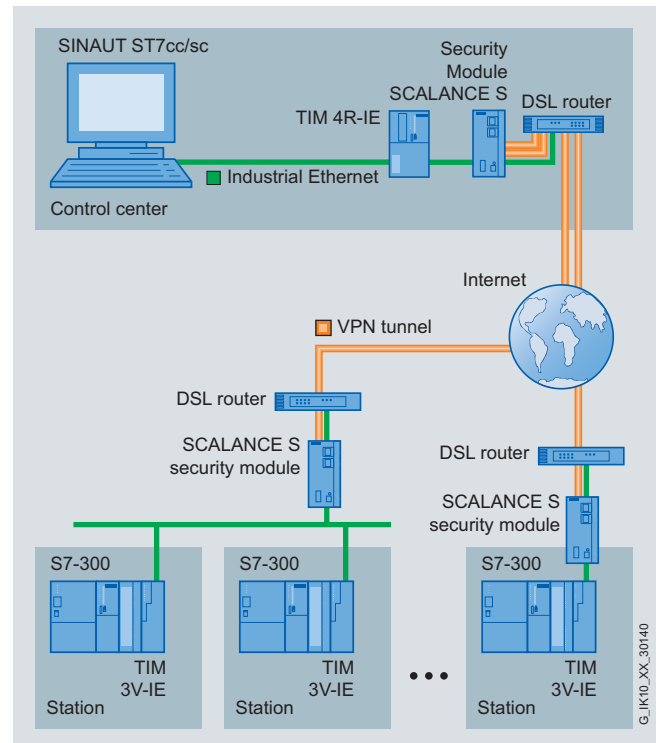

Industrial Remote Communication

TeleControl Professional – Substations for ST7 protocol

TIM 3V-IE for WAN and Ethernet

Integration (continued)

Transmission over the GPRS mobile telephone service and the Internet

Continuous coverage of GPRS in many countries as well as inexpensive volume tariffs allow wireless connection of stations to the control desk without the need to create a separate radio network for this purpose. The stations can be either stationary or mobile.

The wireless connection is constantly online and therefore has the same properties as a dedicated line: Data changes can be transferred immediately and station or connection failures are detected at an early stage.

GPRS with simple stations

A TIM 3V-IE is used in the stations together with the GSM/GPRS modem MD720-3 or a TIM3V-IE Advanced with DSL router. The simple VPN protocol MSC of the MD720-3 permits communication via GPRS access and Internet and via routers with NAT or NAPT conversion. The MSC tunnel connections correspond to dedicated lines that are permanently maintained with extremely low volumes of data. When using the MSC tunnel, a TIM 4R-IE must be used as a header station at which the tunnels end. The parameter setting of the MSC connection is performed in the SINAUT ST7 configuration software.

GPRS/UMTS with complex stations and enhanced security

The EGPRS router MD741-1, which is a combination of high-speed GPRS VPN router with enhanced data security (IPsec protocol) and firewall, is used in networked stations. In the stations, other devices connected via Industrial Ethernet to the MD741-1 for diagnosis and parameterization can be accessed from the control center.

For higher data rates, in place of the GPRS router MD741-1, the UMTS Router SCALANCE M875 can be implemented for use of the UMTS mobile radio network.

The control desk PC must be constantly accessible from the GPRS network. It must therefore be directly connected to the GPRS provider using a dedicated line or permanently to the Internet, e.g. by means of DSL. A SCALANCE S612 or S623¹⁾ Security Module performs the firewall function at the control desk and represents the remote stations for the VPN connections of the GPRS stations. The VPN is configured with the SIMATIC NET "Security Configuration Tool" and requires no special IT knowledge.

The IP address of the control center should preferably be permanent; those of the stations can be dynamically assigned.

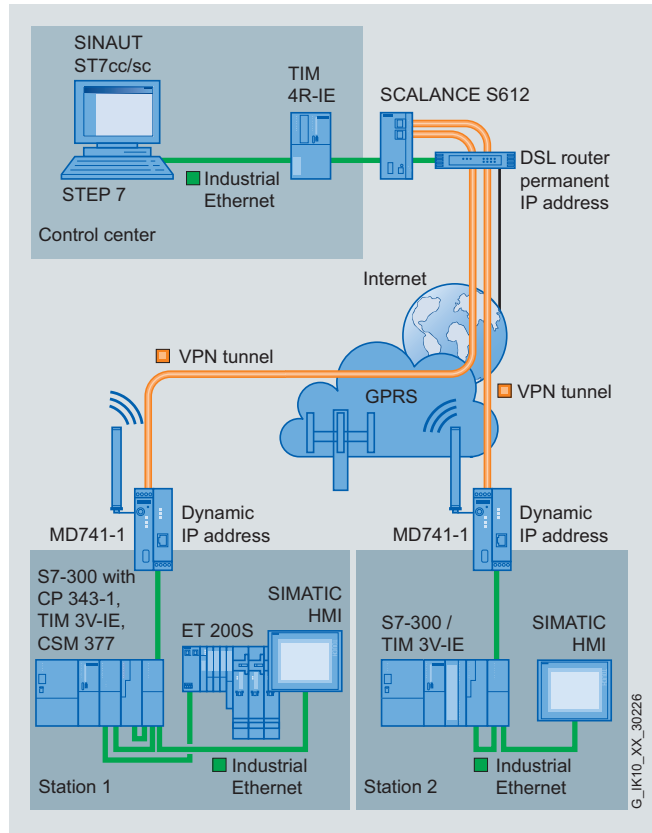
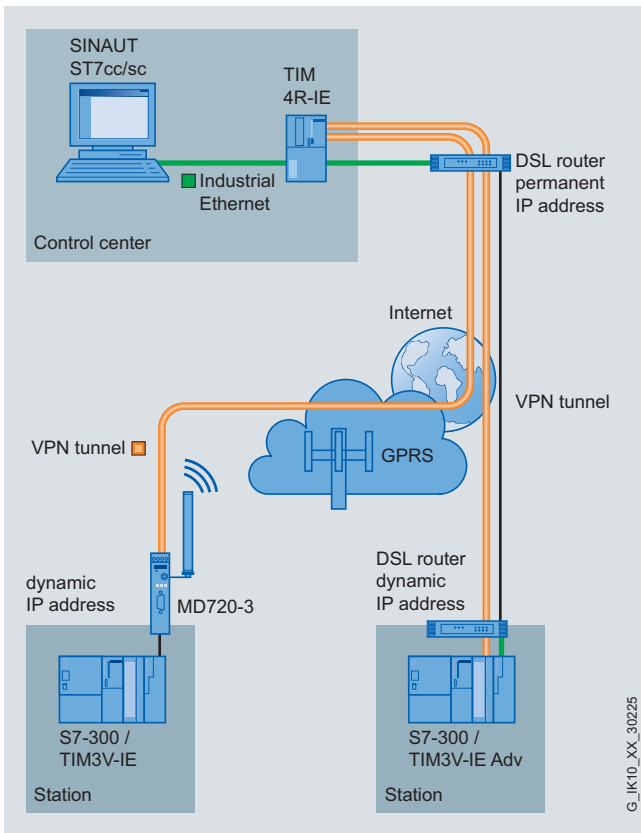

1) Available soon

Integration (continued)

Connection to a conventional WAN

Connection to a conventional WAN is via the floating RS232 interface of the TIM 3V-IE module, via which various modems or data communication equipment can be connected, depending on the application, such as:

- Dedicated line modem MD2 for point-to-point, point-to-multipoint or line connections
- Wireless devices from various manufacturers, also for private mobile radio using the time slot method
- Analog dial-up modem MD3 for the analog telephone network or point-to-point dedicated lines
- GSM modem MD720-3 for access to the mobile radio network via dial-up lines

Configuration examples in the conventional WAN

Use of the TIM 3V-IE in the mobile radio network (GSM)

The GSM modem MD720-3 is used for this purpose. At the control desk (ST7cc or ST7sc), it is connected through a TIM 4 module (e.g. TIM 4R-IE) that is connected to the PC via the Industrial Ethernet. The connections between the GSM modems are set up via GSM dial-up lines.

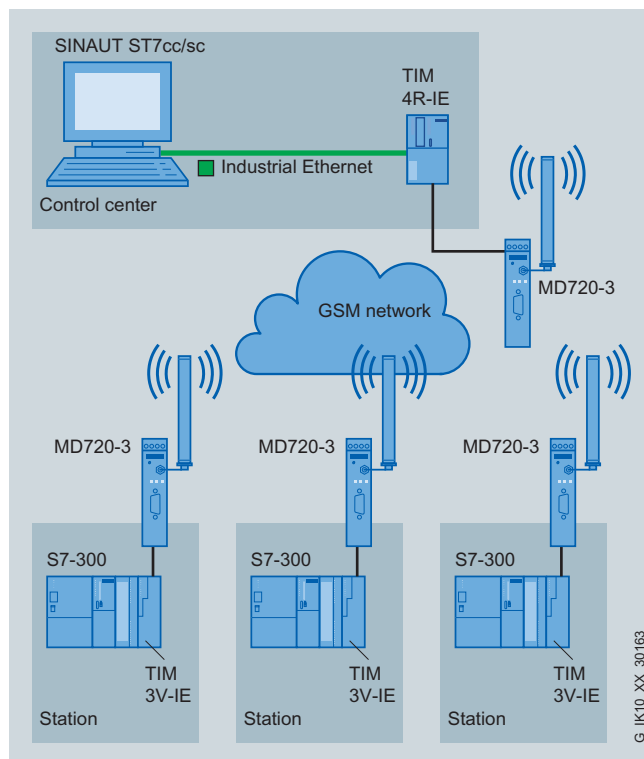

Use of the TIM 3V-IE in a private radio network

The radio network must be installed in accordance with the radio equipment that is approved in the relevant country (radio equipment is not included in the SINAUT product range). At the control desk (ST7cc or ST7sc), it is connected through a TIM 4 module (e.g. TIM 4R) that is connected to the PC via MPI. If a radio network is set up with time slot procedure, the TIM 4RD with DCF77 radio clock receiver must be used at the control desk.

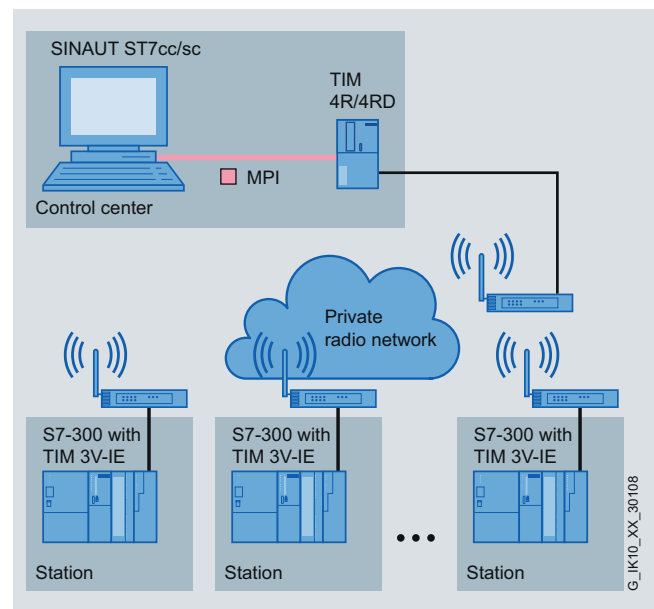

Industrial Remote Communication

TeleControl Professional – Substations for ST7 protocol

TIM 3V-IE for WAN and Ethernet

Technical specifications

Order No.	6NH7 800-3BA00
Product type designation	TIM 3V-IE
Transmission rate	
• With Industrial Ethernet	10 ... 100 Mbit/s
• In accordance with RS 232	50 ... 38 400 bit/s
Interfaces	
Number of interfaces in accordance with Industrial Ethernet	1
Number of electrical connections	
• For external data transmission in accordance with RS 232	1
• For power supply	1
Design of electrical connection	
• of the Industrial Ethernet interface	RJ45 port
• at interface 1 for external data transmission	9-pin D-sub male connector (RS232)
• at interface 2 for external data transmission	-
• For power supply	2-pin, pluggable terminal strip
Design of the swap medium C-Plug	No
Supply voltage, current consumption, power loss	
Type of power supply	DC
Power supply	24 V
• Minimum	20.4 V
• Maximum	28.8 V
Current consumed	
• Maximum from backplane bus for 24 V DC	0.2 A
• Maximum from external power supply for 24 V DC	0.2 A
Effective power loss	5.8 W
Product expansion: optional backup battery	No
Type of battery	-
Backup current	
• Typical	-
• Maximum	-

Order No.	6NH7 800-3BA00
Product type designation	TIM 3V-IE
Permitted ambient conditions	
Ambient temperature	
• During operation	0 ... 60 °C
• During storage	-40 ... +70 °C
• During transport	-40 ... +70 °C
Relative humidity at 25 °C without condensation during operation, maximum	95 %
IP degree of protection	IP20
Design, dimensions and weights	
Module format	S7-300 compact module, single- width
Width	40 mm
Height	125 mm
Depth	120 mm
Net weight	0.25 kg
Product properties, functions, components General	
Number of modules - Note	Number of TIM per S7-300: 1
Cable length	
• Maximum with RS232 interface	6 m
• Maximum with RS485 interface	-
Performance data	
<u>Performance data S7 communication</u>	
Number of possible connections for S7 communication	
• Maximum	8
• Maximum with PG connections	2
• For OP connections, maximum	8
• Note	-
Service	
• SINAUT ST7 using S7 communication	Yes
• PG/OP communication	Yes
<u>Performance data Multiprotocol operation</u>	
Number of active connections in multiprotocol mode	12

Industrial Remote Communication

TeleControl Professional – Substations for ST7 protocol

TIM 3V-IE for WAN and Ethernet

Technical specifications (continued)

Order No.	6NH7 800-3BA00
Product type designation	TIM 3V-IE
<u>Performance data</u>	
<u>Telecontrol</u>	
Suitability for use	
• TIM node station	No
• TIM station	Yes
• TIM control center	No
• Note	RS232 and Industrial Ethernet cannot be used simultaneously
Protocol is supported	
• TCP/IP	Yes
• DNP3	No
• SINAUT ST1 protocol	Yes
• SINAUT ST7 protocol	Yes
Product function: data buffering if connection is aborted	Yes
• Note	16,000 data frames
Memory capacity	
• of S7 CPU's main memory	
- Required on CPU for TD7 on CPU mode data blocks	20 Kibyte
- Required on TIM for TD7 on TIM mode data blocks	0 Kibyte
• Note	TD7onCPU: at least 20 KB, actual requirement depends on data quantity and functional scope TD7onTIM: 0 bytes in most favorable case
Product property: buffered message frame memory	No
Transmission format	
• 11 bits for SINAUT ST1 protocol with polling	Yes
• 10 or 11 bits for SINAUT ST1 protocol with spontaneous polling	Yes
• 10 bits for SINAUT ST7 protocol with multi-master polling	Yes
• 10 or 11 bits for SINAUT ST7 protocol with polling or spontaneous polling	Yes
Operating mode with scanning of data transmission	
• With dedicated line/radio link	
- With SINAUT ST1 protocol	Polling, polling with time slot procedure
- With SINAUT ST7 protocol	Polling, polling with time slot procedure, multi-master polling with time slot procedure
• With dial-up network	
- With SINAUT ST1 protocol	Spontaneous
- With SINAUT ST7 protocol	Spontaneous
Hamming distance	
• For SINAUT ST1 protocol	4
• For SINAUT ST7 protocol	4

Order No.	6NH7 800-3BA00
Product type designation	TIM 3V-IE
Product functions Management, configuration, programming	
Configuration software	
• Required	SINAUT ST7 ES
• Required for CPU configuration: SINAUT TD7 block library for CPU	Yes
• Required for PG configuration: SINAUT ST7 configuration software for PG	Yes
Storage location of TIM configuration data	On the TIM
Product functions Security Virtual Private Network	
Suitability for use of Virtual Private Network	Yes
Virtual Private Network mode - Note	VPN mode as MSC client with MSC protocol and password protection only possible together with GPRS modem with MSC capability
Product functions Time	
Product component: hardware real-time clock	-
Product property: buffered hardware real-time clock	-
Maximum accuracy of hardware real-time clock per day	-

Industrial Remote Communication

TeleControl Professional – Substations for ST7 protocol

TIM 3V-IE for WAN and Ethernet

Ordering data	Order No.	Order No.
TIM 3V-IE communication module With an RS232 interface for SINAUT communication via a conventional WAN or an IP-based network (WAN or LAN)	6NH7 800-3BA00	Accessories IE FC TP Standard Cable GP 2 x 2 (Type A) 4-core, shielded TP installation cable for connection to IE FC Outlet RJ45/IE FC RJ45 Plug; PROFINET-compliant; with UL approval; sold by the meter; max. length 1000 m, minimum order 20 m
SINAUT ST7 Engineering Software V5.1 on CD-ROM, comprising: <ul style="list-style-type: none"> • SINAUT ST7 Engineering Software V5.1 for the PG • SINAUT TD7 block library V2.2 • Electronic manual in German and English 	6NH7 997-0CA51-0AA0	IE FC RJ45 Plug 180 RJ45 plug connector for Industrial Ethernet with a rugged metal enclosure and integrated insulation displacement contacts for connecting Industrial Ethernet FC installation cables; with 180° cable outlet; for network components and CPs/CPUs with Industrial Ethernet interface <ul style="list-style-type: none"> • 1 pack = 1 unit • 1 pack = 10 units • 1 pack = 50 units
SINAUT ST7 Engineering Software Update from Version V5.0 to V5.1	http://support.automation.siemens.com/WW/view/en/49104582	IE FC Stripping Tool Preadjusted stripping tool for fast stripping of the Industrial Ethernet FC cables
SINAUT ST7 Engineering Software V5.0 09/2009 (Upgrade) for STEP 7 V5.4 SP4, for owners of older versions of SINAUT ST7 engineering software	6NH7 997-0CA50-0GA0	Connecting cable For connecting a TIM (RS232) with a SINAUT ST7 MD2, MD3 or MD4 (RS232) modem; cable length 1.5 m
		Connecting cable For connecting a TIM (RS232) with the GSM modem MD720-3; also suitable for third-party modems or radio equipment with standard RS232 interface; cable length 2.5 m
		Connecting cable with one end open for connecting a TIM (RS232) to a third-party modem or radio unit (RS232); cable length 2.5 m
		Connecting cable For connecting two TIM modules via their RS232 interface without modems ("null modem"); cable length 6 m
		6XV1 840-2AH10 6GK1 901-1BB10-2AA0 6GK1 901-1BB10-2AB0 6GK1 901-1BB10-2AE0 6GK1 901-1GA00 6NH7 701-4AL 6NH7 701-5AN 6NH7 701-4BN 6NH7 701-0AR

Industrial Remote Communication

TeleControl Professional – Substations for ST7 protocol

SIPLUS TIM 3V-IE for WAN and Ethernet

Overview



- SINAUT communication module SIPLUS TIM for SIMATIC S7-300 for use in a wide area network (WAN)
- IP communication via secure VPN (virtual private network) using the Internet
- Wireless communication via GPRS router, GPRS modem, or radio devices
- Wired communication via Ethernet, DSL, dialup modems or dedicated line modem
- Complete migration of existing wireless, dedicated line and dial-up technology to IP-based network
- Message frame memory for seamless recording of data
- Simple configuration and operation without specialist IT knowledge

Note:

SIPLUS extreme products are based on Siemens Industry standard products. The contents listed here were taken from the respective standard products. SIPLUS extreme-specific information was added.

SIPLUS TIM 3V-IE	
Order number	6AG1 800-3BA00-7AA0
Order No. based on	6NH7 800-3BA00
Ambient temperature range	-25 ... +70 °C
Conformal coating	Coating of the printed circuit boards and the electronic components
Technical data	The technical data of the standard product applies except for the ambient conditions.

Ambient conditions

Relative humidity	5 ... 100 % Condensation permissible
Biologically active substances	Conformity with EN 60721-3-3, Class 3B2 mold and fungal spores (except fauna)
Chemically active substances	Conformity with EN 60721-3-3, Class 3C4 incl. salt mist and ISA-S71.04 severity level G1; G2; G3; GX ^{1) 2)}
Mechanically active substances	Conformity with EN 60721-3-3, Class 3S4 including conductive sand, dust ²⁾
Air pressure (depending on the highest positive temperature range specified)	1080 ... 795 hPa (-1000 ... +2000 m) see ambient temperature range 795 ... 658 hPa (+2000 ... +3500 m) derating 10 K 658 ... 540 hPa (+3500 ... +5000 m) derating 20 K

- 1) ISA-S71.04 severity level GX: Long-term load: SO₂ < 4.8 ppm; H₂S < 9.9 ppm; Cl < 0.2 ppm; HCl < 0.66 ppm; HF < 0.12 ppm; NH₃ < 49 ppm; O₃ < 0.1 ppm; NO_x < 5.2 ppm
Limit value (max. 30 min/d): SO₂ < 17.8 ppm; H₂S < 49.7 ppm; Cl < 1.0 ppm; HCl < 3.3 ppm; HF < 2.4 ppm; NH₃ < 247 ppm; O₃ < 1.0 ppm; NO_x < 10.4 ppm
- 2) The supplied plug covers must remain in place over the unused interface when operated in atmospheres containing corrosive gases!

The technical documentation on SIPLUS can be found here:
www.siemens.com/siplus-extreme

Ordering data	Order No.
SIPLUS TIM 3V-IE communication module	6AG1 800-3BA00-7AA0
With an RS232 interface for SINAUT communication via a conventional WAN or an IP-based network (WAN or LAN)	
Software, connecting cables and other accessories	see ordering data for TIM 3V-IE for WAN and Ethernet

Industrial Remote Communication

TeleControl Professional – Substations for ST7 protocol

TIM 3V-IE Advanced

Overview



- SINAUT communications module TIM for SIMATIC S7-300 for use in wide area network (WAN) as station, node station, and control center
- IP communication via secure VPN (virtual private network) using the Internet
- Wireless communication via GPRS router, GPRS modem or radio devices
- Wired communication via Ethernet, DSL, dialup modems or dedicated line modem
- Complete migration of existing wireless, dedicated line and dial-up technology to IP-based network
- Message frame memory for complete recording of data and support of redundant communication paths
- Simple configuration and operation without specialist IT knowledge

Benefits

get Designed for Industry

- Flexible option for connection to any conventional or IP-based WAN
- Low-cost station setup by means of direct connection to DSL router or GPRS via MD720-3 modem and use of the S7-CPU 312 and 312C, because the SINAUT TD7 CPU software is integrated in the TIM 3V-IE Advanced. (This does not apply to communication with SINAUT ST1 partners and to the transmission of text messages; in this case the SINAUT TD7 software for the CPU (TD7onCPU) must be used, i.e. this software can still be used together with the TIM 3V-IE Advanced.)
- No additional mobile phone service for fixed IP addresses or contracts for private GPRS networks with bidirectional data traffic are necessary, as the VPN is integrated in the ST7 system. No more expensive and complex VPN configuration by IT specialists.
- Saving of traveling and maintenance costs due to cost-effective remote programming, diagnostics, control and monitoring via the Internet

- Reduction in time and costs thanks to quick and user-friendly configuration of connections and data to be transferred with the SINAUT configuring software and block library
- High availability of the connections thanks to possible redundant design of the communication paths (parallel operation of WAN networks supported on RJ45 and RS232 interface of the TIM 3V-IE Advanced)
- Reliable storage of important data. Storage of data message frames (max. 32,000) including time stamp on TIM if the communication path is faulty or a partner has failed and to reduce connection costs for the dial-up network.
- Protection of investment for existing SINAUT ST1 systems through the integration of the SIMATIC S7-300

Application

- Low-cost automation of water/wastewater networks with both complex and simple structures
- Control and monitoring of energy distribution systems and supply stations, such as oil, gas or district heating networks
- Preventive maintenance (condition monitoring) of globally distributed systems
- Monitoring of logistics and traffic control systems
- Connection of plants with basic or high-level security and availability requirements
- Use in hybrid networks with dialup, wireless, Ethernet or Internet communication

Design

The TIM 3V-IE Advanced offers all the advantages of the SIMATIC S7-300 design:

- Compact construction; single standard width of the SIMATIC S7-300 SM modules
- 9-pin Sub-D connector with an RS232 interface for connection to a conventional WAN via an appropriate modem
- RJ-45 socket for connection to Industrial Ethernet; or an IP-based network; industrial design with additional sleeve for inserting the IE FC RJ45 Plug 180
- 2-pin plug-in terminal strip for connection of the 24 V DC external supply voltage
- Front LEDs for indicating the module status and the communication
- Easy to mount; the TIM 3V-IE Advanced is mounted on the S7-300 mounting rail and connected to adjacent modules by means of the bus connectors. No slot rules apply.
- Can be operated in the expansion rack (ER) in conjunction with the IM 360/361
- Can be operated without a fan
- A battery backup or memory module are not required

Industrial Remote Communication

TeleControl Professional – Substations for ST7 protocol

TIM 3V-IE Advanced

Integration (continued)

Use in a node station

When used in a node station, TIM 3V-IE Advanced can, for example, exchange data over its RS232 interface over a radio network with the lower-level stations. It is then connected to the control desk over the RJ45 interface, e.g. over a fiber-optic cable, that is connected through SCALANCE X switches. In this configuration, data can be exchanged between each of the SINAUT stations regardless of which network they are situated in.

In this case, in order to disconnect the networks, the connection in the control center can be made via a TIM 4R-IE or, as in the example, directly to the Ethernet interface of the PC.

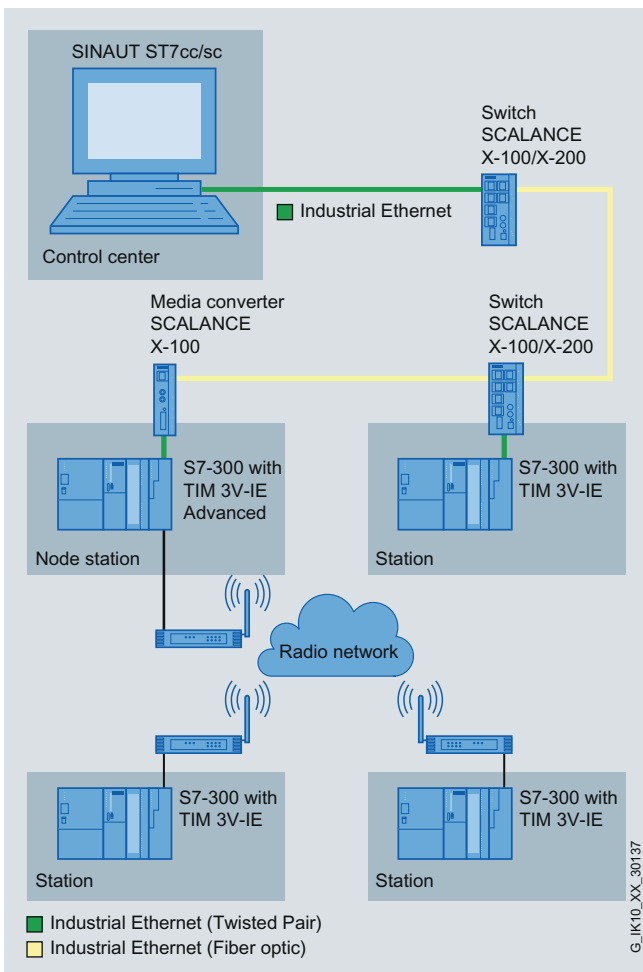

Redundant transmission paths

Using TIM 3V-IE Advanced, a station can be connected to the control desk over redundant paths. The TIM 3V-IE Advanced is used for this purpose both in the station and in the control center. The example includes a combination of fiber-optic cables and radio paths as redundant paths. The two TIMs coordinate data transmission: It takes place normally over the main path and only if it fails over the standby path. When the main path is restored, changeover back to this path is performed automatically.

The TIM 3V-IE Advanced in the control center has access to the MPI interface of the S7-300-CPU via the backplane bus, by which the TIM communicates with the control desk PC (e.g. ST7cc). Note that only certain types of CPU can be considered for this application. A TIM 4R-IE can be used in the control center as a replacement for the TIM 3V-IE Advanced. Without a S7-300-CPU, this TIM is connected to the control desk PC via one of the two Ethernet ports.

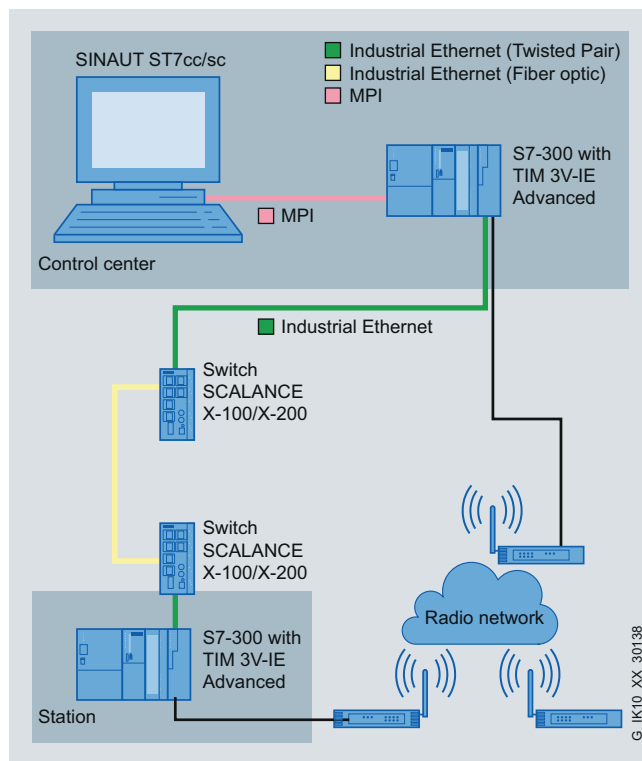

Note:

Use of the MPI port of the local CPU is possible with the following types of CPU: all versions of the CPUs 312, 312C, 313C, 314 and 314C, the CPUs 315-2 DP and 315F-2 DP.

Industrial Remote Communication

TeleControl Professional – Substations for ST7 protocol

TIM 3V-IE Advanced

Technical specifications

Order No.	6NH7 800-3CA00
Product type designation	TIM 3V-IE Advanced
Transmission rate	
Transmission rate with Industrial Ethernet	10 ... 100 Mbit/s
Transmission rate in accordance with RS 232	50 ... 38 400 bit/s
Interfaces	
Number of interfaces in accordance with Industrial Ethernet	1
Number of electrical connections	1
• For external data transmission in accordance with RS 232	1
• For power supply	1
Design of electrical connection	
• of the Industrial Ethernet interface	RJ45 port
• at interface 1 for external data transmission	9-pin D-sub male connector (RS232)
• at interface 2 for external data transmission	-
• For power supply	2-pin, pluggable terminal strip
Design of the swap medium C-Plug	No
Supply voltage, current consumption, power loss	
Type of power supply	DC
Power supply	24 V
• Minimum	20.4 V
• Maximum	28.8 V
Current consumed	
• Maximum from backplane bus for 24 V DC	0.2 A
• Maximum from external power supply for 24 V DC	0.2 A
Effective power loss	5.8 W
Product expansion: optional backup battery	No
Type of battery	-
Backup current	
• Typical	-
• Maximum	-
Permitted ambient conditions	
Ambient temperature	
• During operation	0 ... 60 °C
• During storage	-40 ... +70 °C
• During transport	-40 ... +70 °C
Relative humidity at 25 °C without condensation during operation, maximum	95 %
IP degree of protection	IP20

Order No.	6NH7 800-3CA00
Product type designation	TIM 3V-IE Advanced
Design, dimensions and weights	
Module format	S7-300 compact module, single- width
Width	40 mm
Height	125 mm
Depth	120 mm
Net weight	0.25 kg
Product properties, functions, components General	
Number of modules - Note	Number of TIM per S7-300: several, number depends on connection resources of S7-300 CPU
Cable length	
• Maximum with RS232 interface	6 m
• Maximum with RS485 interface	-
Performance data	
<u>Performance data S7 communication</u>	
Number of possible connections for S7 communication	
• Maximum	24
• Maximum with PG connections	4
• For OP connections, maximum	20
• Note	-
Service	
• SINAUT ST7 using S7 communication	Yes
• PG/OP communication	Yes
<u>Performance data Multiprotocol operation</u>	
Number of active connections in multiprotocol mode	24

Industrial Remote Communication

TeleControl Professional – Substations for ST7 protocol

TIM 3V-IE Advanced

Technical specifications (continued)

Order No.	6NH7 800-3CA00	Order No.	6NH7 800-3CA00
Product type designation	TIM 3V-IE Advanced	Product type designation	TIM 3V-IE Advanced
Performance data <u>Telecontrol</u>		Product functions Management, configuration, programming	
Suitability for use		Configuration software	
• TIM node station	Yes	• Required	SINAUT ST7 ES
• TIM station	Yes	• Required for CPU configuration: SINAUT TD7 block library for CPU	Yes
• TIM control center	Yes	• Required for PG configuration: SINAUT ST7 configuration software for PG	Yes
• Note	RS232 and Industrial Ethernet can be used simultaneously	Storage location of TIM configuration data	On the TIM
Protocol is supported		Product functions Security Virtual Private Network	
• TCP/IP	Yes	Suitability for use of Virtual Private Network	Yes
• DNP3	No	Product function	
• SINAUT ST1 protocol	Yes	• Password protection for VPN	Yes
• SINAUT ST7 protocol	Yes	• MSC client via GPRS modem with MSC capability	Yes
Product function: data buffering if connection is aborted	Yes	MSC protocol is supported	Yes
• Note	32,000 data frames	Number of possible connections	
Memory capacity		• As MSC client with VPN connection	1
• of S7 CPU's main memory		• As MSC server with VPN connection	0
- Required on CPU for TD7 on CPU mode data blocks	20 Kibyte	MSC protocol supported with Virtual Private Network	TCP/IP
- Required on TIM for TD7on TIM mode data blocks	0 Kibyte	Key length for MSC with Virtual Private Network	128 bits
• Note	TD7onCPU: at least 20 KB, actual requirement depends on data quantity and functional scope TD7onTIM: 0 bytes in most favorable case	Type of authentication with Virtual Private Network PSK	Yes
Product property: buffered message frame memory	No	Virtual Private Network mode - Note	-
Transmission format		Product functions Time	
• 11 bits for SINAUT ST1 protocol with polling	Yes	Product component: hardware real-time clock	-
• 10 or 11 bits for SINAUT ST1 protocol with spontaneous polling	Yes	Product property: buffered hardware real-time clock	-
• 10 bits for SINAUT ST7 protocol with multi-master polling	Yes	Maximum accuracy of hardware real-time clock per day	-
• 10 or 11 bits for SINAUT ST7 protocol with polling or spontaneous polling	Yes		
Operating mode with scanning of data transmission			
• With dedicated line/radio link			
- With SINAUT ST1 protocol	Polling, polling with time slot procedure		
- With SINAUT ST7 protocol	Polling, polling with time slot procedure, multi-master polling with time slot procedure		
• With dial-up network			
- With SINAUT ST1 protocol	Spontaneous		
- With SINAUT ST7 protocol	Spontaneous		
Hamming distance			
• For SINAUT ST1 protocol	4		
• For SINAUT ST7 protocol	4		

Industrial Remote Communication

TeleControl Professional – Substations for ST7 protocol

TIM 4R / TIM 4RD

Overview



- SINAUT communication module TIM for SIMATIC S7-300, S7-400 and PC
- For universal use in a SINAUT station, node station and control center
- Wireless communication via GSM modem or wireless devices
- Wired communication via dialup modems or dedicated line modem
- Message frame memory for seamless recording of data and support of redundant communication paths
- The TIM 4RD also features a built-in DCF77 radio clock receiver to supply the date/time to all SINAUT stations connected locally or, for use in a control center, to synchronize all SINAUT devices on the WAN.

Benefits

get Designed for Industry

- Flexible option for connection to any two conventional SINAUT networks
- Can be used universally with S7-300, S7-400, or control center PC.
- In the TIM 4RD version the correct date and time is always available, including summer/winter clock change.
- Reduction in time and costs thanks to quick and user-friendly configuration of connections and data to be transferred with the SINAUT configuring software and block library.
- Reliable storage of important data.
Storage of data message frames (approx. 10,000) including time stamp on TIM, if the communication path is faulty or a partner has failed and to reduce connection costs for the dial-up network.
- Remote programming and remote diagnostics (PC routing) in parallel with data transmission via the WAN connection saves time and money.
- Investment protection for existing SINAUT ST1 systems through the integration of the SIMATIC S7-300 and S7-400 by means of ST1-compatible communication.

Application

- Low-cost automation of water/wastewater networks with both complex and simple structures
- Control and monitoring of energy distribution systems and supply stations, such as oil, gas or district heating networks
- Preventive maintenance (condition monitoring) of globally distributed systems
- Monitoring of logistics and traffic control systems
- Connection of plants with basic or high availability requirements
- Use in classic SINAUT networks

Design

The TIM 4R/4RD offers all the advantages of the SIMATIC S7-300 design:

- Compact design; double standard width of SIMATIC S7-300 SM modules.
- 9-pin Sub-D connector with a combined RS 232/RS 485 interface for connection to a conventional WAN via an appropriate modem.
- RJ45 socket as a further combined RS232/RS485 interface. The supplied RJ45/Sub-D (6NH7700-0AS05) interface adapter cable in turn provides a 9-pin Sub-D connector for connection to a conventional WAN via an appropriate modem.
- MPI (9-pin sub-D socket) for connection of the TIM as a standalone device to one or more S7-CPU's or control center PCs.
- 4-pin plug-in terminal strip for connection of the 24 V DC external supply voltage
- Front LEDs for indicating the module status and the communication
- The DCF77 adapter cable (6NH7700-0AD15) supplied with the TIM 4RD provides a BNC connector for connection of the antenna cable.
- Easy to mount; The TIM is mounted on an S7-300 mounting rail; if integrated into an S7-300 as a CP, it is connected to adjacent modules by means of the bus connector supplied with the TIM. No slot rules apply. As a standalone device, it is linked via its MPI with one or more S7 CPU's or with one or more control center PCs.
- Can be operated in the expansion rack (ER) in conjunction with the IM 360/361
- Can be operated without a fan
- A battery backup or memory module are not required

Industrial Remote Communication

TeleControl Professional – Substations for ST7 protocol

TIM 4R / TIM 4RD

Function

The TIM 4R/4RD can be used as a standalone device, in other words, it is fully functional even without S7-300-CPU. In this stand-alone mode, the TIM is especially suitable as a SINAUT communications processor for the control desk PC (e.g. SINAUT ST7cc or ST7sc) or for a SIMATIC S7-400. The TIM is connected to the PC or S7-400 via the MPI (multi-point interface) of the TIM. If the control center is redundantly designed or if an S7-400 is additionally available there as a higher-level controller, then the TIM performs the SINAUT communication with the stations for all these devices connected to the local MPI bus.

The TIM 4R/4RD can also be built into a SIMATIC S7-300 as a CP, e.g. if these devices require redundant transmission paths there or function as node stations at which more than two standard WANs must be merged.

All the devices mentioned can exchange data with other SINAUT ST7 or ST1 partners with the aid of the TIM 4R/4RD via any two SINAUT networks that can also be operated in a redundant combination. All three interfaces can be used at the same time for SINAUT communication.

The TIM can buffer process data including time-stamps, which must not be lost in the event of a communication fault or the failure of a partner, until the partner is accessible again. Important events, interrupts, etc. are not lost and the integrity of information in control center system archives is assured.

The TIM 4RD with integral DCF77 radio clock receiver can be used in the control center as a master clock to synchronize all SINAUT stations that are accessible via the MPI bus and via the two RS232/RS485 WAN interfaces. In addition, this TIM is to be used in the control center if the SINAUT data transmission is processed via a wireless network with time slot procedure or if the "multi-master-polling with time-slot procedure" is used for two or more control centers. If no DCF77 time signal is available at the installation location of the TIM 4RD, a SINAUT GPS receiver can be connected to the TIM 4RD. The universally available global positioning system (GPS) is then used as a time source.

For setting up more complex control centers or node stations, several TIM 4RR/4RD modules can be used. Combinations with TIM 3V-IE Advanced, TIM 4R-IE and TIM 3 and other TIM 4 types are also possible.

SINAUT ST7 and thus also the TIM 4R/4RD are designed for data transmission via the widest range of WANs or combinations of WANs. Mixed classical SINAUT WANs (dedicated line, wireless, dial-up network) can be configured uniformly using SINAUT which saves both time and money.

Integration

Connection to a conventional WAN

For the connection to a conventional WAN the TIM 4R or 4RD provides two floating RS232/RS485 interfaces, to which various data communication devices can be connected, depending on the application, such as:

- Dedicated line modem MD2 for point-to-point, point-to-multipoint or line connections
- Wireless devices from various manufacturers, also for private mobile radio using the time slot method
- Analog dial-up modem MD3 for the analog telephone network or point-to-point dedicated lines
- GSM modem MD720-3 for access to the mobile radio network

Configuration examples with TIM 4R and TIM 4RD

Use in a node station

In a node station with a SIMATIC S7-400 the TIM 4R is connected to the S7-400 via its MPI and communicates, for example, by radio with the subordinate stations via one of the two RS232/RS485 interfaces. It is then connected to the control center via the second RS232/RS485 interface, e.g. via a dedicated line that is connected via an MD2 modem.

In a second node station, the TIM 4R is equipped in an S7-300 controller and also communicates via a radio network with the subordinate stations and with the control center by means of the dedicated line.

If one or both radio networks use the time slot procedure, a TIM 4RD with DCF77 radio clock receiver would have to be used instead of the TIM 4R, so that the time slot allocated in each case can be adhered to exactly.

In this configuration, data can be exchanged between all of the SINAUT stations regardless of which network they are situated in.

Redundant transmission paths

The TIM 4R can be used in the same way as the TIM 4R-IE for redundant transmission paths. The possible options are, however, restricted to the use of the serial interfaces of the TIM 4R and thus to the combination of conventional WAN connections.

Use in a control center

The TIM 4R is also suitable for use in a control center, either alone or in combination with other TIMs. In this way, for example, one TIM 4RD and one TIM 4R, which are both connected via their multipoint interface (MPI) with the control center PC (e.g. ST7cc), can be used. S7 controllers, which likewise exchange data with the SINAUT stations, can also be connected to the MPI bus - e.g. for controlling a dummy circuit diagram.

All conventional WANs such as dedicated-line, wireless or dial-up networks can be connected via the two RS232/RS485 interfaces of the TIM 4R or the TIM 4RD.

As the TIM 4RD has a built-in DCF77 radio clock receiver, it can provide the control system and all substations with the date and time. Wireless networks connected directly to this TIM can also be operated with the time slot procedure.

Industrial Remote Communication

TeleControl Professional – Substations for ST7 protocol

TIM 4R / TIM 4RD

Technical specifications

Product type designation	TIM 4R / TIM 4RD
Transfer rate	50 to 38,400 bits/s
Interfaces	
<ul style="list-style-type: none"> 1. Connection for external data transmission device 2. Connection for external data transmission device 	1 x 9-pin Sub D connector, RS232 can be switched to RS485 1x RJ45; conversion to 9-pin Sub D connector is possible over the interface adapter cable supplied, RS232 can be switched to RS485
<ul style="list-style-type: none"> MPI bus DCF77 antenna (TIM 4RD) 	1 x 9-pin Sub D socket 1 x BNC socket (via supplied DCF77 adapter cable)
<ul style="list-style-type: none"> Connection for supply voltage 	1 x 4-pin terminal block
Cable length	
<ul style="list-style-type: none"> RS232 RS485 	max. 6 m max. 30 m
Supply voltage	24 VDC; min. 20.4 V, max. 28.8 V
Current consumption	
<ul style="list-style-type: none"> from the backplane bus 	60 mA (only if the TIM is used as a CP in an S7-300 rack)
<ul style="list-style-type: none"> from 24 V DC 	500 mA
Power loss	12.3 W
Permissible ambient conditions	
<ul style="list-style-type: none"> Operating temperature Transport/storage temperature Relative humidity 	0 °C to +60 °C -40 °C to +70 °C Max. 95 % at +25 °C
Design	
<ul style="list-style-type: none"> Module format 	Compact module S7-300, double width
<ul style="list-style-type: none"> Dimensions (W x H x D) in mm Weight 	80 x 125 x 120 Approx. 300 g
Degree of protection	IP 20
Configuration	
<ul style="list-style-type: none"> Software for PG 	SINAUT ST7 configuring software for PG
<ul style="list-style-type: none"> Software for CPU 	SINAUT TD7 function block library for CPU
<ul style="list-style-type: none"> Storage of TIM configuration data 	On internal TIM flash memory
TIM interfaces can be operated with this function	
<ul style="list-style-type: none"> Terminal Node terminal Control center 	Yes Yes Yes

¹⁾ TD7onCPU can be used over the backplane bus with the following CPU types: All versions of CPUs 313C, 314 and 314C, CPUs 315-2 DP and 315F-2 DP, as well as all versions of the C7 units C7-633, C7-635 and C7-636

²⁾ The MPI port of the local CPU can be used with the following CPU types: All versions of CPUs 312, 312C, 313C, 314 and 314C as well as CPU 315-2 DP and CPU 315F-2 DP

Product type designation	TIM 4R / TIM 4RD
Number of TIM 4Rs per S7 CPU	More than one; number depends on the connection resources of the S7 CPU
Local communication in the rack of an S7-300	
<ul style="list-style-type: none"> Via backplane bus with local S7-300 CPU Via backplane bus with further local TIMs 	Yes, over TD7onCPU ¹⁾ Yes
<ul style="list-style-type: none"> Via MPI port of local S7-300 CPU ²⁾ with further CPUs and/or PCs 	Yes, through TD7onCPU (for S7-300 and S7-400) and S7 communication (for ST7cc/ST7sc)
Special communication in stand-alone mode	
<ul style="list-style-type: none"> Via MPI port of the TIM with CPUs and/or PCs 	Yes, through TD7onCPU (for S7-300 and S7-400) and S7 communication (for ST7cc/ST7sc)
User memory required in S7 CPU	Minimum 20 KB, actual requirement determined by data volume and functional scope
Message memory on TIM	about 10,000 message frames
Transmission protocols	
Available protocols	SINAUT ST7 SINAUT ST1
Operating mode for dedicated line/radio network	
<ul style="list-style-type: none"> SINAUT ST7 protocol 	Polling Polling with time-slot procedure Multi-master polling with time-slot procedure
<ul style="list-style-type: none"> SINAUT ST1 protocol 	Polling Polling with time-slot procedure
Operating mode for dial-up network	
<ul style="list-style-type: none"> SINAUT ST7 protocol SINAUT ST1 protocol 	spontaneous spontaneous
Asynchronous character format	
<ul style="list-style-type: none"> SINAUT ST7 protocol, polling or spontaneous 	10 or 11 bits
<ul style="list-style-type: none"> SINAUT ST7 protocol, multi-master polling 	10 bits
<ul style="list-style-type: none"> SINAUT ST1 protocol, polling 	11 bits
<ul style="list-style-type: none"> SINAUT ST1 protocol, spontaneous 	10 or 11 bits
Hamming distance d	
<ul style="list-style-type: none"> SINAUT ST1 protocol SINAUT ST7 protocol 	4 4

Industrial Remote Communication

TeleControl Professional – Substations for ST7 protocol

TIM 4R / TIM 4RD

Ordering data	Order No.	Order No.
Communication module TIM 4R With two combined RS232/485 interfaces for SINAUT communication via conventional WANs; incl. interface adapter cable 6NH7 700-0AS05 for the second serial RS232/485 interface for converting the internal connector (RJ45) to the 9-pin Sub-D connector required externally; with MPI interface	6NH7 800-4AA90	Accessories Connecting cable For connecting a TIM (RS232) with a SINAUT ST7 MD2, MD3 or MD4 (RS232) modem; cable length 1.5 m
Communication module TIM 4RD Same as TIM 4R, but with the addition of the DCF77 radio clock receiver incl. DCF77 adapter cable 6NH7 700-0AD15 for converting the internal connector to the external BNC connector required	6NH7 800-4AD90	Connecting cable For connecting a TIM (RS485) with a SINAUT ST7 MD2, MD3 or MD4 (RS485) modem; cable length 1.5 m
SINAUT ST7 Engineering Software V5.1 on CD-ROM, comprising: <ul style="list-style-type: none"> • SINAUT ST7 Engineering Software V5.1 for the PG • SINAUT TD7 Engineering Software V2.2 • Electronic manual in German and English 	6NH7 997-0CA51-0AA0	Connecting cable For connecting a TIM (RS232) with the GSM modem MD720-3. Also suitable for third-party modems or radio equipment with standard RS232 interface; cable length 2.5 m
SINAUT ST7 Engineering Software Update from Version V5.0 to V5.1	http://support.automation.siemens.com/WWW/view/en/49104582	Connecting cable With one end open for connecting a TIM (RS232) to a third-party modem or radio unit (RS232); cable length 2.5 m
SINAUT ST7 Engineering Software V5.0 Edition 09/2009 (Upgrade) for STEP 7 V5.4 SP4, for owners of older versions of SINAUT ST7 engineering software	6NH7 997-0CA50-0GA0	Connecting cable For connecting two TIM modules via their RS232 interface without modems ("null modem"); cable length 6 m
		Interface adapter cable (replacement)
		DCF77 adapter cable (replacement)
		DCF77 indoor antenna Incl. 10 m antenna cable with BNC connectors
		DCF77 outdoor antenna For mounting on a flat roof or wall; incl. 20 m antenna cable with BNC connectors
		DCF77 outdoor antenna For mounting on a mast; incl. 20 m antenna cable with BNC connectors
		Indirect lightning protection For DCF77 outdoor antenna
		GPS complete package For simulating the DCF77 time signal, comprising a GPS receiver, GPS outdoor antenna incl. 25 m cable, BNC adapter plug, configuration software, PC adapter cable, and documentation
		Indirect lightning protection For GPS outdoor antenna
		SITOP compact 24 V/ 0.6 A 1-phase power supply with wide-range input 85 ... 264 V AC/ 110 ... 300 V DC, stabilized output voltage 24 V, rated output current value 0.6 A, slim design

Industrial Remote Communication

TeleControl Professional – Substations for ST7 protocol

TIM 4R-IE for WAN and Ethernet

Overview



- SINAUT communications module TIM with four interfaces for SIMATIC S7-300 or as self-contained unit for the S7-400 for use in the wide area network (WAN)
- For universal use in a SINAUT station, node station and control center
- Internet communication via integrated MSC-VPN tunnel with direct connection to DSL router or operation via IPsec VPN with additional SIMATIC NET components
- Wireless communication via GPRS router, GPRS modem, or radio devices
- Wired communication via Ethernet, DSL, dialup modems or dedicated line modem
- Complete migration of existing wireless, dedicated line and dial-up technology to IP-based network
- Message frame memory for complete recording of data and support of redundant communication paths
- Simple configuration and operation without specialist IT knowledge

Benefits

get Designed for Industry

- Protection of investment by combining existing conventional networks with IP-based networks by means of flexible options for connection of up to four SINAUT networks
- Low-cost construction of the control center by direct connection as independent device to a DSL router, made possible by the integrated MSC-VPN protocol
- No additional mobile phone service for fixed IP addresses or contracts for private GPRS networks with bidirectional data traffic are necessary, as the VPN is integrated in the ST7 system. No more expensive and complex VPN configuration by IT specialists.
- High availability of the connections due to possible redundant design of the communication paths
- Reliable storage of important data. Storage of data message frames (approx. 56,000) including time stamp on TIM in the case of communication path malfunction or power failure
- Saving of time and money through fast and user-friendly configuration of the connections, as well as through remote programming and diagnostics (PG routing) parallel to the SINAUT data transmission via the WAN or Internet connection
- Easy maintenance through replacement of modules without PG

Application

- Use as self-contained central station for the low-cost automation of water/wastewater networks with both complex and simple structures
- Control and monitoring of energy distribution systems and supply stations, such as oil, gas or district heating networks
- Preventive maintenance (condition monitoring) of globally distributed systems
- Monitoring of logistics and traffic control systems
- Connection of plants with basic or high-level security and availability requirements
- Use in hybrid networks with dialup, wireless, Ethernet or Internet communication

Design

The TIM 4R-IE offers all the advantages of the SIMATIC S7-300 design:

- Compact construction; double standard width of SIMATIC S7-300 SM modules
- Two 9-pin Sub-D connectors with a combined RS 232/RS 485 interface for connection to a conventional WAN via an appropriate modem
- Two RJ45 sockets for connecting to Industrial Ethernet or a IP-based network; designed for industry with additional fixing collars for connecting the IE FC RJ45 Plug 180
- 2-pin plug-in terminal strip for connection of the 24 V DC external supply voltage
- Front LEDs for indicating the module status and the communication
- Easy to mount; the TIM is mounted to an S7-300-mounting rail; if integrated as a CP into an S7-300 it is connected to adjacent modules by means of the bus connector supplied with the TIM. No slot rules apply. As a standalone device, it is linked via one of its Ethernet interfaces with one or more S7-400 CPUs or with one or more control center PCs.
- Can be operated in the expansion rack (ER) in conjunction with the IM 360/361
- Can be operated without a fan
- A battery backup or memory module can be fitted as an option

Industrial Remote Communication

TeleControl Professional – Substations for ST7 protocol

TIM 4R-IE for WAN and Ethernet

Function

The TIM 4R-IE can be used as a standalone device, i.e. it is fully functional even without S7-300-CPU. In this stand-alone mode, the TIM is especially suitable as a SINAUT communications processor for the control desk PC (e.g. SINAUT ST7cc or ST7sc) or for a SIMATIC S7-400. The TIM is connected to the PC or S7-400 via one of its two Ethernet interfaces. If the control desk is redundantly designed or if an S7-400 is additionally available there as a higher-level controller, then the TIM performs the SINAUT communication with the stations for all these devices connected to the local Ethernet.

The TIM 4R-IE can also be built into a SIMATIC S7-300 as a CP, e.g. if these devices require redundant transmission paths there or function as node stations at which more than two networks must be merged.

All the devices mentioned can exchange data with other SINAUT ST7 or ST1 partners with the aid of the TIM 4R-IE and specifically via as many as four SINAUT networks that can also be operated in any redundant combination.

The important SINAUT property - saving data complete with a time stamp on the TIM in the event of an interrupted link or failure of the partner - is then available not only for conventional WANs, but also for IP-based networks. Important events, alarms, etc. are not lost and the integrity of information in control center system archives is assured. Additional security is offered by the optional backup battery of the TIM 4R-IE which prevents the loss of saved data message frames if the 24 V supply fails.

For setting up more complex control centers or node stations, several TIM 4R-IE modules can be used. Combinations with TIM 3V-IE Advanced and TIM 3 and other TIM 4 versions are also possible.

As a communication module for the control desk PC, the TIM reduces the number of S7 connections that the PC would otherwise have to maintain when directly linked to the stations via an IP-based network, to just one (1) connection. In addition, the TIM then separates the local Ethernet from the IP-based network to the stations. Only SINAUT and PG communication with the stations is allowed through. This prevents unnecessary traffic in the WAN which is often not broadband.

A TIM 4R-IE that is used at a redundant control desk reduces the data volume in a WAN and thus it reduces the costs for networks with volume tariffs, e.g. GPRS. If stations were connected directly to the redundant control desk (without central TIM 4R-IE), they would send each message frame twice in order to send data to both control desk PCs. In the case of a control center TIM 4R-IE, the stations only send their message frames once. The doubling of the message frames for supplying both PCs is then performed by the control center TIM 4R-IE.

For data transmission via conventional WANs, the TIM 4R-IE has other, special properties that predetermine its use as a "control center" TIM.

SINAUT ST7 and thus also the TIM 4R-IE are designed for data transmission via the widest range of WANs or combinations of WANs. Mixed networks comprising classical SINAUT WAN networks (dedicated line, wireless, dial-up network) and IP-based networks (fiber optic, DSL, GPRS, Internet etc.) can be configured uniformly using SINAUT, which saves both time and money.

For communication via the Internet, the integrated MSC-VPN tunnel protocol for direct access to DSL routers can be used. The TIM 4R-IE can operate here as an MSC server or MSC client. For communication via GPRS, either the router MD741-1 can be connected to the Industrial Ethernet interface (VPN IPsec) or the GSM/GPRS modem MD720-3 (MSC-VPN) to the RS232 interface.

- The TIM4R-IE has four interfaces for simple and redundant transmission paths:
 - Two combined RS232/RS485 interfaces for connection to standard WANs such as dedicated line, wireless or dial-up network
 - Two RJ45 interfaces for connection to IP-based networks (WAN or LAN) such as fiber-optics, DSL, GPRS, etc.
- Compact, double-width module that can be used in a wide variety of situations:
 - The TIM handles the SINAUT communication for one or more S7-400 controllers or control desk PCs (SINAUT ST7cc or ST7sc) as a stand-alone device (stand-alone without S7-300 CPU); the connection in this case is via Ethernet interfaces of the TIM
 - As a communications processor (CP) in an S7-300
- The two RJ45 interfaces can be configured either as an MSC-VPN server in the central office or as MSC-VPN client in a station. At the RS232 interface, an MD720-3 can be operated in GPRS mode as MSC-VPN client.
- The four transmission paths can all be different and operated independently of one another, but also in any redundant combination.
- Flexible creation of redundant transmission paths via two conventional WANs, via two IP-based networks or a combination of WAN + IP-based network.
- When installed as a CP in an S7-300, the following communication is also possible via the backplane bus:
 - With the CPU
 - Via the MPI of this CPU with other CPUs and control desk PCs (ST7cc, ST7sc) connected over the MPI bus.
 - With other TIMs in this rack
- Message frame memory for up to 56,000 data message frames
- Optional backup battery for backup of the stored data message frames and the hardware clock if the power fails
- Up to 62 S7 connections or 128 MSC-VPN tunnel connections (as control center) via IP-based networks and MPI (for S7-300-CPU)
- The SINAUT TD7 software for the CPU (TD7 on CPU) is integrated in the TIM (TD7onTIM); implemented with installation as CP in a S7-300
- Module replacement possible without PG
 - In stand-alone mode using the optional C-PLUG
 - When installed as a CP in an S7-300 over the memory card of the CPU
- PG communication is possible parallel to data communication at any time
- Several TIM 4R-IE can be used per S7-300, also together with one or more TIM 3V-IE Advanced
- Up to 128 S7 connections via IP-based networks (in MSC tunnel mode)

Function (continued)

Controllable communication modules:

- Control of the GSM/GPRS modems MD720-3 in the GSM or GPRS mode. In GPRS mode, simple 128-bit encryption via the MD720-3 (MSC-VPN tunnel protocol).
- Operation via SIMATIC NET Ethernet components with high IPsec security standard (e.g. GPRS router or SCALANCE S)
- Direct operation on a DSL router by means of MSC tunnel protocol
- Use of SCALANCE fiber-optic switches for spanning long distances
- Wireless transmission via IWLAN with SCALANCE W over medium distances
- Dedicated line modem MD2 for point-to-point, point-to-multipoint or line connections
- Wireless devices from various manufacturers, also for private mobile radio using the time slot method
- Analog dial-up modem MD3 for the analog telephone network or point-to-point dedicated lines

Special properties as "control center" TIM

For data transmission via conventional WANs, the TIM 4R-IE has other, special properties that predetermine its use as a "control center" TIM:

- In a dialup network the message "Failure of local node" can be switched off. If the control desk PC fails or is temporarily shut down, the control center TIM 4R-IE will not send any failure message to the stations in the dialup network and therefore saves transmission costs.
- One especially useful feature during commissioning is the possibility that SINAUT stations can be switched on and off on the control center TIM 4R-IE. This applies not only for stations that are connected via dedicated line/radio, but also for stations in the dial-up network. The last status set for each station is permanently stored on the TIM and is therefore not lost if the power fails or the TIM is restarted.
- For GPRS, dedicated lines and mobile networks, the message "Node faulty" can be suppressed on the TIM 4R-IE for a programmable period of time. A station failure is then no longer indicated after x unanswered calls (polls), but only when a recognized fault still exists after expiry of the programmed time. This enables the number of failure messages to be reduced in poor-quality networks and it also minimizes the additional message frame traffic that must be processed after each station is restored.

Optional C-PLUG

The most frequent application for the TIM 4R-IE will be its use as a communication module for the control desk PC or for an S7-400. The TIM then operates in standalone mode, i.e. without S7-300 CPU. The option of saving the TIM configuration data on the MMC card of the CPU, in order to exchange the TIM without a PG in the event of a fault, no longer applies. The saving of configuration data on the C-PLUG, which can be optionally equipped, solves this problem. This means that, even in stand-alone mode, a replacement of the TIM is possible without PG.

Integration

Connection to IP-based networks

In addition to the two combined RS232/RS485 interfaces, the TIM 4R-IE also has two RJ45 sockets. These are suitable for the connection of IP-based networks (WAN or LAN). Depending on the application, various types of data communication equipment can be connected such as:

- SCALANCE X switches for Twisted Pair cable or fiber-optic cables
- SCALANCE W (IWLAN) and Ethernet radio devices from various manufacturers
- SCALANCE M873/875 for UMTS communication via mobile telephone networks
- EGPRS router MD741-1 for GPRS communication and EGPRS (Edge) over mobile telephone networks
- DSL router in combination with SCALANCE S for VPN (IPsec)
- GPRS/GSM modem MD720-3 for GPRS communication via GSM mobile telephone networks using MSC-VPN tunnel protocol
- Directly on a DSL router by means of the MSC-VPN tunnel protocol integrated in the TIM
- Broadband systems such as OTN, PCM30

Connection to a conventional WAN

For the connection to a conventional WAN the TIM 4R-IE provides two floating RS232/RS485 interfaces, to which various data communication devices can be connected, depending on the application, such as:

- Dedicated line modem MD2 for point-to-point, point-to-multipoint or line connections
- Wireless devices from various manufacturers, also for private mobile radio using the time slot method
- Analog dial-up modem MD3 for the analog telephone network or point-to-point dedicated lines
- GPRS/GSM modem MD720-3 for access to the mobile telephone network

Industrial Remote Communication

TeleControl Professional – Substations for ST7 protocol

TIM 4R-IE for WAN and Ethernet

Integration (continued)

Configuration examples using TIM 4R-IE

Use in a node station

In a node station with a SIMATIC S7-400 the TIM 4R-IE is connected to the S7-400 via one of its two Ethernet interfaces and can, for example, exchange data by radio with the subordinate stations via an RS232/RS485 interface. It is then connected to the control center via the second Ethernet interface, e.g. via a fiber-optic cable that is connected through SCALANCE X switches and media converters.

In this configuration, data can be exchanged between all of the SINAUT stations regardless of which network they are situated in.

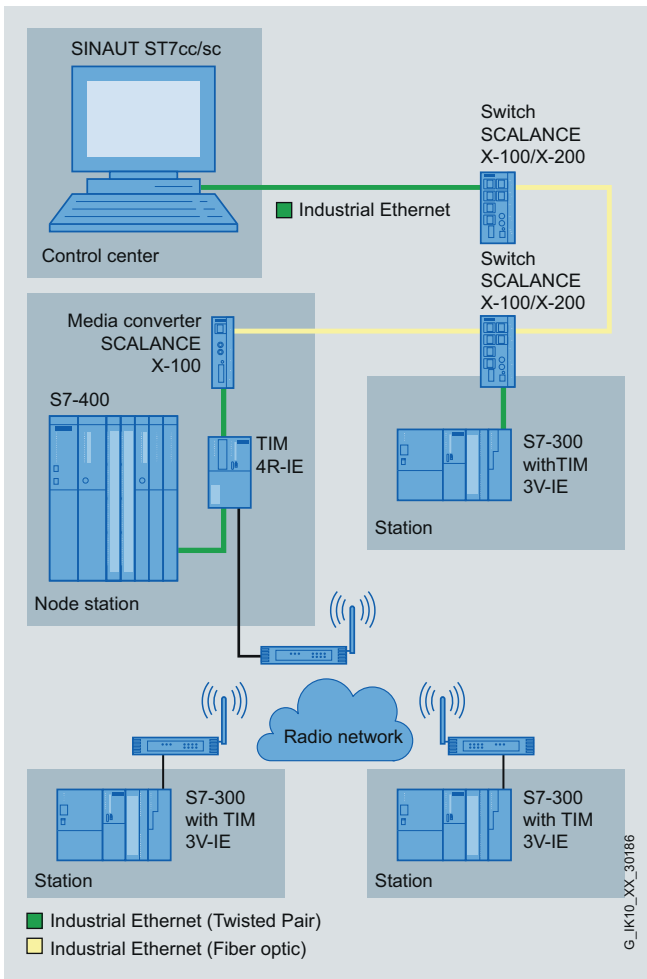

Redundant transmission paths

Using TIM 4R-IE, a station can be connected to the control center over redundant paths. The TIM 4R-IE is used for this purpose both in the station and in the control center. The example shows as redundant paths a combination of leased line and radio, i.e. two conventional WANs, for which the TIM 4R-IE offers corresponding connections (2 x RS232/RS485). The two TIMs coordinate the data transmission. It takes place normally over the main path and only if it fails over the standby path. When the main path is restored, changeover back to this path is performed automatically.

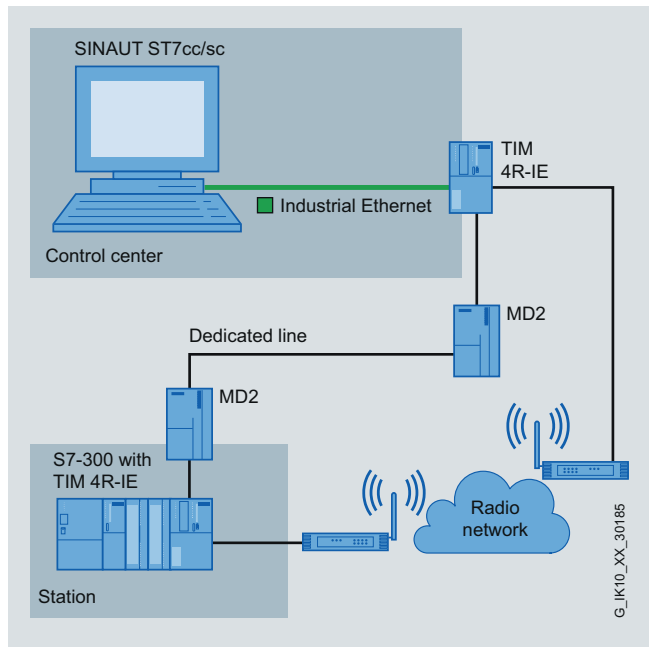

Industrial Remote Communication

TeleControl Professional – Substations for ST7 protocol

TIM 4R-IE for WAN and Ethernet

Integration (continued)

Use in a control center

The TIM 4R-IE is also suitable for use in a control center, either alone or in combination with other TIMs. The following example shows a TIM 4R-IE that is connected via one of its two Ethernet interfaces with the control center PC (e.g. ST7cc). An S7-400 is also connected to the Industrial Ethernet and this must also exchange data with the SINAUT stations. SINAUT stations are connected by means of GPRS using MSC-VPN via the second Ethernet port of the TIM, while a wireless network and point-to-point leased line network are connected via the two RS232/RS485 ports. For the point-to-point connection, the port of the

TIM is set to RS485. It is then possible to operate up to 30 SINAUT leased line modems on this port; the example shows MD2 modems.

If the stations in this network have to be provided with the date and time, the control center PC assumes the function of the clock-time master. Via the Ethernet connection, the TIM 4R-IE is regularly synchronized by the PC and it then takes over the synchronization of the connected stations.

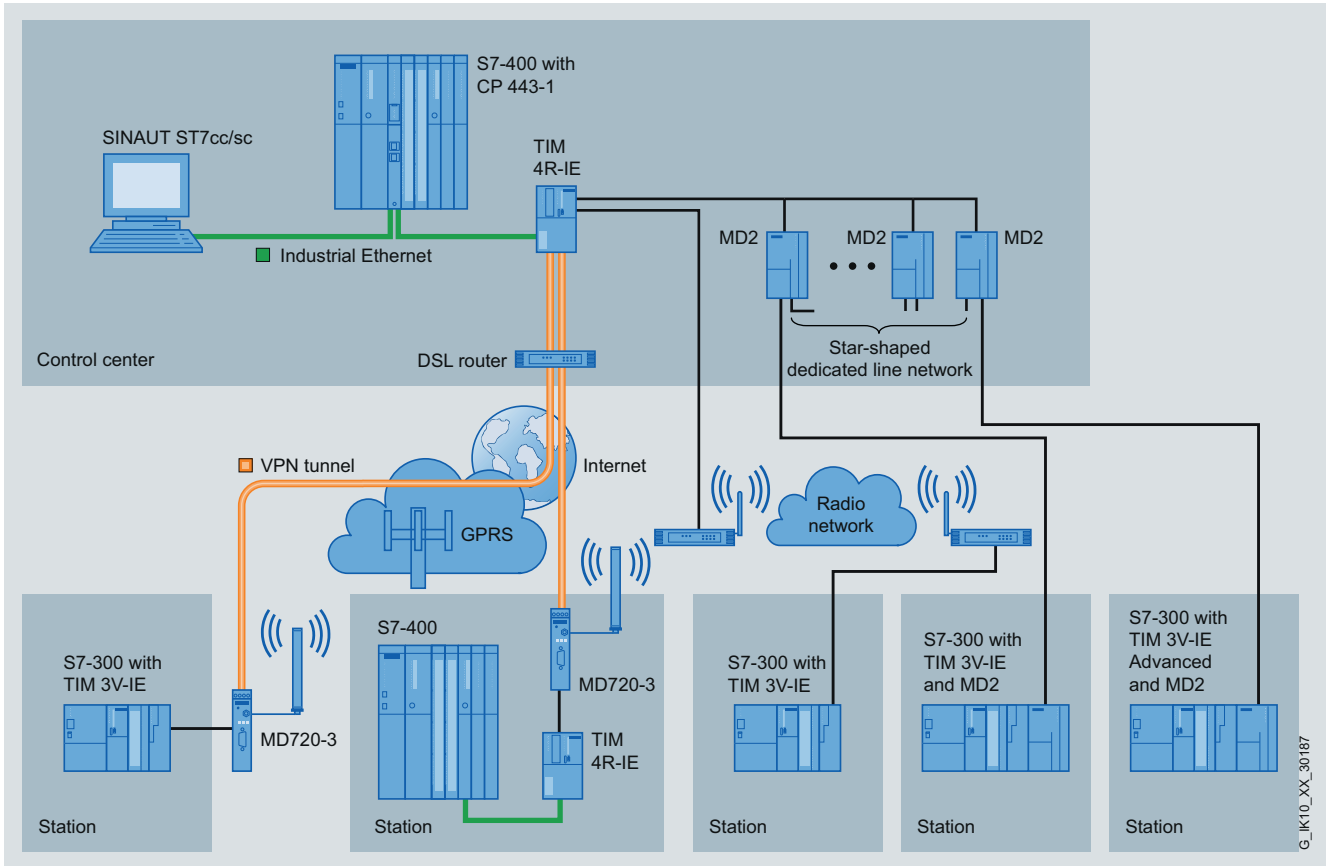

Industrial Remote Communication

TeleControl Professional – Substations for ST7 protocol

TIM 4R-IE for WAN and Ethernet

Technical specifications

Order No.	6NH7 800-4BA00	Order No.	6NH7 800-4BA00
Product type designation	TIM 4R-IE	Product type designation	TIM 4R-IE
Data transmission rate		Design, dimensions and weights	
Data transmission rate		Module format	Compact module S7-300 double width
• With Industrial Ethernet	10 ... 100 Mbit/s	Width	80 mm
• In accordance with RS 232	50 ... 38 400 bit/s	Height	125 mm
Interfaces		Depth	120 mm
Number of interfaces in accordance with Industrial Ethernet	2	Net weight	0.4 kg
Number of electrical connections		Product properties, functions, components	
• For external data transmission in accordance with RS 232	2	General	
• For power supply	1	Number of modules - Note	Number of TIM 4R-IE per S7-300/S7-400: several, number depends on connection resources of CPU
Design of electrical connection		Cable length	
• of the Industrial Ethernet interface	RJ45 port	• Maximum with RS232 interface	6 m
• at interface 1 for external data transmission	9-pin D-sub connector, RS232 switchable to RS485	• Maximum with RS485 interface	30 m
• at interface 2 for external data transmission	9-pin D-sub connector, RS232 switchable to RS485	Performance data	
• For power supply	2-pin, pluggable terminal strip	<u>Performance data S7 communication</u>	
Design of the swap medium C-Plug	Yes	Number of possible connections for S7 communication	
Supply voltage, current consumption, power loss		• Maximum	64
Type of power supply	DC	• Maximum with PG connections	2
Power supply	24 V	• For OP connections, maximum	62
• Minimum	20.4 V	• Note	-
• Maximum	28.8 V	Service	
Current consumed		• SINAUT ST7 using S7 communication	Yes
• Maximum from backplane bus for 24 V DC	0.2 A	• PG/OP communication	Yes
• Maximum from external power supply for 24 V DC	0.17 A	<u>Performance data Multiprotocol operation</u>	
Effective power loss	4.6 W	Number of active connections in multiprotocol mode	128
Product expansion: optional backup battery	Yes	<u>Performance data Telecontrol</u>	
Type of battery	Lithium AA / 3.6 V / 2.3 Ah	Suitability for use	
Backup current		• TIM node station	Yes
• Typical	100 µA	• TIM station	Yes
• Maximum	160 µA	• TIM control center	Yes
Permitted ambient conditions		• Note	-
Ambient temperature		Protocol is supported	
• During operation	0 ... 60 °C	• TCP/IP	Yes
• During storage	-40 ... +70 °C	• DNP3	No
• During transport	-40 ... +70 °C	• SINAUT ST1 protocol	Yes
Relative humidity at 25 °C without condensation during operation, maximum	95 %	• SINAUT ST7 protocol	Yes
IP degree of protection	IP20	Product function: data buffering if connection is aborted	Yes
		• Note	56,000 data frames

Industrial Remote Communication

TeleControl Professional – Substations for ST7 protocol

TIM 4R-IE for WAN and Ethernet

Technical specifications (continued)

Order No.	6NH7 800-4BA00	Order No.	6NH7 800-4BA00
Product type designation	TIM 4R-IE	Product type designation	TIM 4R-IE
Memory capacity		Product functions	
• of S7 CPU's main memory		Management, configuration, programming	
- Required for TD7 on CPU mode data blocks on CPU	20 Kibyte	Configuration software	
- Required for TD7 on TIM mode data blocks on TIM	0 Kibyte	• Required	SINAUT ST7 ES
• Note	TD7onCPU: at least 20 KB, actual requirement depends on data quantity and functional scope TD7onTIM: 0 bytes in most favorable case	• Required for CPU configuration: SINAUT TD7 block library for CPU	Yes
Product property: buffered message frame memory	Yes	• Required for PG configuration: SINAUT ST7 configuration software for PG	Yes
Transmission format		Storage location of TIM configuration data	On TIM-internal flash memory or on TIM in optional C-PLUG or on MMC of S7-300 CPU if TIM fitted in S7-300 PLC
• 11 bits for SINAUT ST1 protocol with polling	Yes	Product functions	
• 10 or 11 bits for SINAUT ST1 protocol with spontaneous polling	Yes	Security Virtual Private Network	
• 10 bits for SINAUT ST7 protocol with multi-master polling	Yes	Suitability for use of Virtual Private Network	Yes
• 10 or 11 bits for SINAUT ST7 protocol with polling or spontaneous polling	Yes	Product function	
Operating mode with scanning of data transmission		• Password protection for VPN	Yes
• With dedicated line/radio link		• MSC client via GPRS modem with MSC capability	Yes
- With SINAUT ST1 protocol	Polling, polling with time slot procedure	MSC protocol is supported	Yes
- With SINAUT ST7 protocol	Polling, polling with time slot procedure, multi-master polling with time slot procedure	Number of possible connections	
• With dial-up network		• As MSC client with VPN connection	1
- With SINAUT ST1 protocol	Spontaneous	• As MSC server with VPN connection	128
- With SINAUT ST7 protocol	Spontaneous	MSC protocol supported with Virtual Private Network	TCP/IP
Hamming distance		Key length for MSC with Virtual Private Network	128 bits
• For SINAUT ST1 protocol	4	Type of authentication with Virtual Private Network PSK	Yes
• For SINAUT ST7 protocol	4	Virtual Private Network mode - Note	-
		Product functions Time	
		Product component: hardware real-time clock	Yes
		Product property: buffered hardware real-time clock	Yes
		Maximum accuracy of hardware real-time clock per day	4 s

Industrial Remote Communication

TeleControl Professional – Substations for ST7 protocol

TIM 4R-IE for WAN and Ethernet

Ordering data	Order No.	Order No.
TIM 4R-IE communication module With two combined RS232/RS485 interfaces for SINAUT communication via conventional WANs and two RJ45 interfaces for SINAUT communication via IP-based networks (WAN or LAN)	6NH7 800-4BA00	
SINAUT ST7 Engineering Software V5.1 on CD-ROM, comprising: <ul style="list-style-type: none"> • SINAUT ST7 Engineering Software V5.1 for the PG • SINAUT TD7 block library V2.2 • Electronic manual in German and English 	6NH7 997-0CA51-0AA0	
SINAUT ST7 Engineering Software Update from Version V5.0 to V5.1	http://support.automation.siemens.com/WW/view/en/49104582	
SINAUT ST7 Engineering Software V5.0 Edition 09/2009 (Upgrade) for STEP 7 V5.4 SP4, for owners of older versions of SINAUT ST7 engineering software	6NH7 997-0CA50-0GA0	
		Accessories
		Backup battery 3.6 V/2.3 Ah for TIM 4R-IE
		IE FC TP Standard Cable GP 2 x 2 (Type A) 4-core, shielded TP installation cable for connection to IE FC Outlet RJ45/IE FC RJ45 Plug; PROFINET-compliant; with UL approval; sold by the meter; max. length 1000 m, minimum order 20 m
		IE FC RJ45 Plug 180 RJ45 plug connector for Industrial Ethernet with a rugged metal enclosure and integrated insulation displacement contacts for connecting Industrial Ethernet FC installation cables; with 180° cable outlet; for network components and CPs/CPUs with Industrial Ethernet interface <ul style="list-style-type: none"> • 1 pack = 1 unit • 1 pack = 10 units • 1 pack = 50 units
		IE FC Stripping Tool Preadjusted stripping tool for fast stripping of the Industrial Ethernet FC cables
		Connecting cable For connecting a TIM (RS232) with a SINAUT ST7 MD2, MD3 or MD4 (RS232) modem; cable length 1.5 m
		Connecting cable For connecting a TIM (RS485) with a SINAUT ST7 MD2, MD3 or MD4 (RS485) modem; cable length 1.5 m
		Connecting cable For connecting a TIM (RS232) with the GSM modem MD720-3; also suitable for third-party modems or radio equipment with standard RS232 interface; cable length 2.5 m
		Connecting cable with one end open for connecting a TIM (RS232) to a third-party modem or radio unit (RS232); cable length 2.5 m
		Connecting cable For connecting two TIM modules via their RS232 interface without modems ('Null modem'). Cable length 6 m
		SITOP compact 24 V/ 0.6 A 1-phase power supply with wide-range input 85 ... 264 V AC/ 110 ... 300 V DC, stabilized output voltage 24 V, rated output current value 0.6 A, slim design

Industrial Remote Communication

TeleControl Professional – Substations for ST7 protocol

SIPLUS TIM 4R-IE for WAN and Ethernet

Overview



- SINAUT communication module SIPLUS TIM with four interfaces for SIMATIC S7-300 or as self-contained unit for the S7-400 for use in a wide area network (WAN)
- For universal use in a SINAUT station, node station and control center
- Internet communication via integrated MSC-VPN tunnel with direct connection to DSL router or operation via IPsec VPN with additional SIMATIC NET components
- Wireless communication via GPRS router, GPRS modem, or radio devices
- Wired communication via Ethernet, DSL, dialup modems or dedicated line modem
- Complete migration of existing wireless, dedicated line and dial-up technology to IP-based network
- Message frame memory for seamless recording of data and support of redundant communication paths
- Simple configuration and operation without specialist IT knowledge

Note:

SIPLUS extreme products are based on Siemens Industry standard products. The contents listed here were taken from the respective standard products. SIPLUS extreme-specific information was added.

SIPLUS TIM 4R-IE	
Order number	6AG1 800-4BA00-7AA0
Order No. based on	6NH7 800-4BA00
Ambient temperature range	-25 ... +70 °C
Conformal coating	Coating of the printed circuit boards and the electronic components
Technical data	The technical data of the standard product applies except for the ambient conditions.

Ambient conditions

Relative humidity	5 ... 100 % Condensation permissible
Biologically active substances	Conformity with EN 60721-3-3, Class 3B2 mold and fungal spores (except fauna)
Chemically active substances	Conformity with EN 60721-3-3, Class 3C4 incl. salt mist and ISA-S71.04 severity level G1; G2; G3; GX ^{1) 2)}
Mechanically active substances	Conformity with EN 60721-3-3, Class 3S4 including conductive sand, dust ²⁾
Air pressure (depending on the highest positive temperature range specified)	1080 ... 795 hPa (-1000 ... +2000 m) see ambient temperature range 795 ... 658 hPa (+2000 ... +3500 m) derating 10 K 658 ... 540 hPa (+3500 ... +5000 m) derating 20 K

- ¹⁾ ISA-S71.04 severity level GX: Long-term load: SO₂ < 4.8 ppm; H₂S < 9.9 ppm; Cl < 0.2 ppm; HCl < 0.66 ppm; HF < 0.12 ppm; NH₃ < 49 ppm; O₃ < 0.1 ppm; NOX < 5.2 ppm
Limit value (max. 30 min/d): SO₂ < 17.8 ppm; H₂S < 49.7 ppm; Cl < 1.0 ppm; HCl < 3.3 ppm; HF < 2.4 ppm; NH₃ < 247 ppm; O₃ < 1.0 ppm; NOX < 10.4 ppm
- ²⁾ The supplied plug covers must remain in place over the unused interface when operated in atmospheres containing corrosive gases!

The technical documentation on SIPLUS can be found here:
www.siemens.com/siplus-extreme

Ordering data	Order No.
SIPLUS TIM 4R-IE communication module With two combined RS232/RS485 interfaces for SINAUT communication via conventional WANs and two RJ45 interfaces for SINAUT communication via IP-based networks (WAN or LAN)	6AG1 800-4BA00-7AA0
<i>Software, connecting cables and other accessories</i>	see ordering data for TIM 4R-IE for WAN and Ethernet

Industrial Remote Communication

TeleControl Professional – Substations for DNP3 protocol

Introduction

Overview

The TIM telecontrol communication module

TIM 3V-IE DNP3



The TIM 3V-IE DNP3 (DNP3 protocol) is a SINAUT communications module for the telecontrol substation with SIMATIC S7-300. It has an RS232 interface to which a suitable external dedicated line modem or wireless modem can be connected. It additionally possesses an RJ45 interface, which permits communication over IP-based networks. On the TIM 3V-IE DNP3, both interfaces can be operated simultaneously, e.g. to implement path redundancy to a DNP3 control center.

TIM 4R-IE DNP3



The TIM 4R-IE DNP3 (DNP3 protocol) has two RS232/RS485 interfaces for data transmission via conventional WANs (copper dedicated line, wireless) and additionally two RJ45 interfaces for connection to IP-based networks (WAN or LAN).

This TIM can be used as a communication processor in a SIMATIC S7-300, but it is especially suitable as a telecontrol module for a SIMATIC S7-400 or SIMATIC S7-400H. In this case it is connected to the S7-CPU as stand-alone device via one of its two Ethernet interfaces. The module can only be configured as a station module, but as such it can also be connected via Ethernet direct to a PC as the DNP3 control center.

The four transmission paths can all be different and operated independently of one another, but also in any redundant combination.

Design

Configuration examples

S7-300 or S7-400 substations can be connected to a WAN via the isolated serial interfaces of the TIM DNP3 modules, and specifically via different data communication devices depending on the application:

- Dedicated line modems for point-to-point, point-to-multipoint or line connections
- Fiber-optic cable modules (via RS485 converters)
- Wireless devices from various manufacturers

The S7-300 or S7-400 substations can be connected to Ethernet, i.e. to IP-based networks (LAN, IWLAN, DSL, GPRS, etc.) via the RJ45 interfaces of the TIM DNP3 modules.

Configuration example in classic WAN

Use in a station with transmission via a dedicated line network

The connection to the control center, e.g. with SIMATIC PCS 7 TeleControl, is implemented via the MD2 modem, which sets up the connection via a dedicated line.

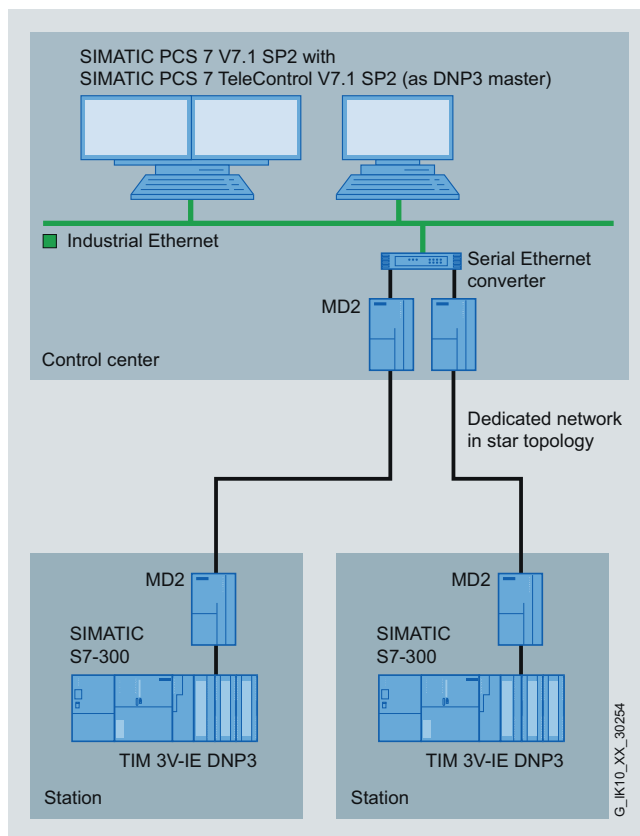

Configuration example in classic WAN

Industrial Remote Communication

TeleControl Professional – Substations for DNP3 protocol

TIM 3V-IE DNP3

Overview



In an S7 station, the communications module TIM 3V-IE DNP3 (**T**elecontrol **I**nterface **M**odule) processes the data traffic for the S7-CPU to the assigned master system SIMATIC PCS7 TeleControl V7.1 SP2 using the open protocol DNP3 (**D**istributed **N**etwork **P**rotocol).

- with the S7-300 housing, can be fully integrated into the S7-300 system
- RS232 port for connecting an external modem for data transmission via a conventional WAN
- RJ45 port for data transmission via IP-based networks

Benefits

get Designed for Industry

- Flexible option for connection to any conventional or IP-based WAN
- Connection to DNP3 master systems from third-party vendors is possible by using the open protocol DNP3
- Saving of traveling and maintenance costs due to cost-effective remote programming, diagnostics, control and monitoring via the Internet
- Reduction in time and costs thanks to quick and user-friendly configuration of connections and data to be transferred with the SINAUT configuration software and block library
- Reliable back-up of important data:
Storage of the DNP3 data points (max. 50,000 in the case of a master), including time stamp on the TIM if the communication path is faulty or a partner has failed

Application

- Low-cost automation of water/wastewater networks with both complex and simple structures
- Control and monitoring of energy distribution systems and supply stations, such as oil, gas or district heating networks
- Preventive maintenance (condition monitoring) of globally distributed systems
- Connection of plants with basic or high-level security and availability requirements
- Use in hybrid networks with dial-up, wireless, Ethernet or Internet communications

Design

The TIM 3V-IE DNP3 offers all the advantages of the SIMATIC S7-300 design:

- Compact design with S7-300 format
- 9-pin sub-D connectors with an RS232 interface for connection to a conventional WAN via an appropriate modem
- RJ45 socket for connection to Industrial Ethernet or an IP-based network;
industrial design with additional retaining collar, for connecting the IE FC RJ45 Plug 180
- 2-pin plug-in terminal strip for connection of the 24 V DC external supply voltage
- Front-panel LEDs for indicating the module status and the communication
- Easy installation;
the TIM 3V-IE DNP3 is mounted on the DIN rail of the S7-300 and connected to adjacent modules by means of the bus connector supplied with the TIM. No slot rules apply.
- Can be operated in the expansion rack (ER) in conjunction with the IM 360/361 interface modules
- Can be operated without a fan
- No backup battery or memory module is required

Industrial Remote Communication

TeleControl Professional – Substations for DNP3 protocol

TIM 3V-IE DNP3

Function

- Data transmission over the open protocol DNP3
- Extensive diagnostic functions with the option of logging the transmitted and received frames
- Time-of-day synchronization with the assigned DNP3 master system
- Remote programming in the case of IP-based networks

The TIM 3V-IE DNP3 communications module has its own processor and a RAM for buffering up to 50,000 data points. This prevents any loss of data in the event of a fault on the communication link or the failure of a communication partner.

Diagnostics

The SINAUT diagnostics and service tool of the SINAUT ST7 Engineering Software V5.1 provides comprehensive diagnostic functions, including:

- Operating status of the TIM module
- Module status of the TIM module
- General diagnostic information
- Diagnostic buffer of the TIM module
- Status of the connections to remote communication partners (e.g. SIMATIC PCS7 TeleControl V7.1 SP2)
- Status and level of the transmit buffer
- TIM frame monitor for recording the frame traffic

Configuration

The SINAUT ST7 engineering software V5.1 is used for configuring the TIM 3V-IE DNP3 module. Parameters are assigned with the aid of the SINAUT configuration software in STEP 7 HW Config and STEP 7 Netpro.

Integration

By means of a floating RS232 interface, the TIM 3V-IE DNP3 module is connected to a WAN, and specifically via various data communication devices depending on the application:

- Dedicated line modems for point-to-point, point-to-multipoint or line connections
- Fiber-optic cable modules (via RS485 converters)
- Wireless devices from various manufacturers

Via the RJ45 interface, the TIM 3V-IE DNP3 module can be connected to the Ethernet, i.e. to IP-based networks (LAN, IWLAN, DSL, GPRS, UMTS, etc.).

Configuration examples in conventional and IP-based WAN

Use in a station with transmission via a dedicated line network

The connection to the master station is via the MD2 modem, which sets up the connection via a dedicated line.

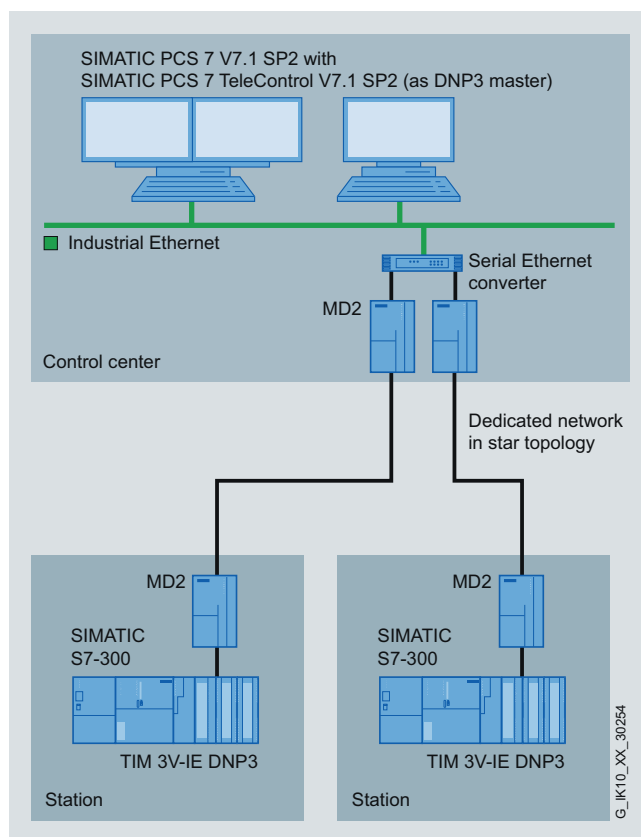

Industrial Remote Communication

TeleControl Professional – Substations for DNP3 protocol

TIM 3V-IE DNP3

Integration (continued)

Use in a station with transmission via Internet

The stations are connected by means of an Internet connection. In this case, DSL routers must be used in the station and control center – preferably in combination with SCALANCE S in order to establish secure connections using VPN tunnels.

Use in a station with transmission over the GSM mobile telephone service GPRS or UMTS

The stations are connected via the GSM mobile telephone service GPRS. In this case the GPRS router MD741-1 is used in the station and a SCALANCE S security module is used in the control center which ensures that the VPN connections are set up with the GPRS stations.

For higher data rates, in place of the GPRS router MD741-1, the UMTS Router SCALANCE M875 can be implemented for use of the UMTS mobile radio network.

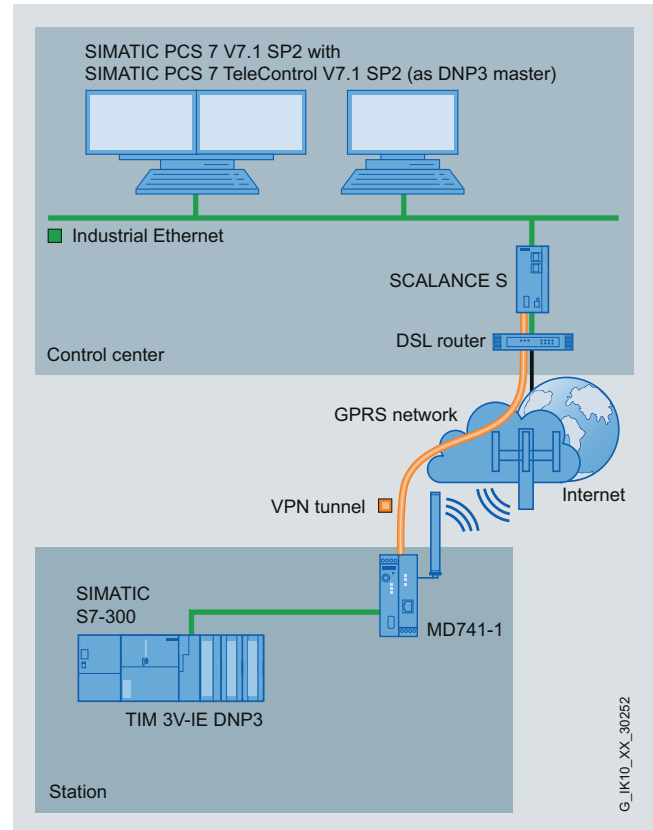
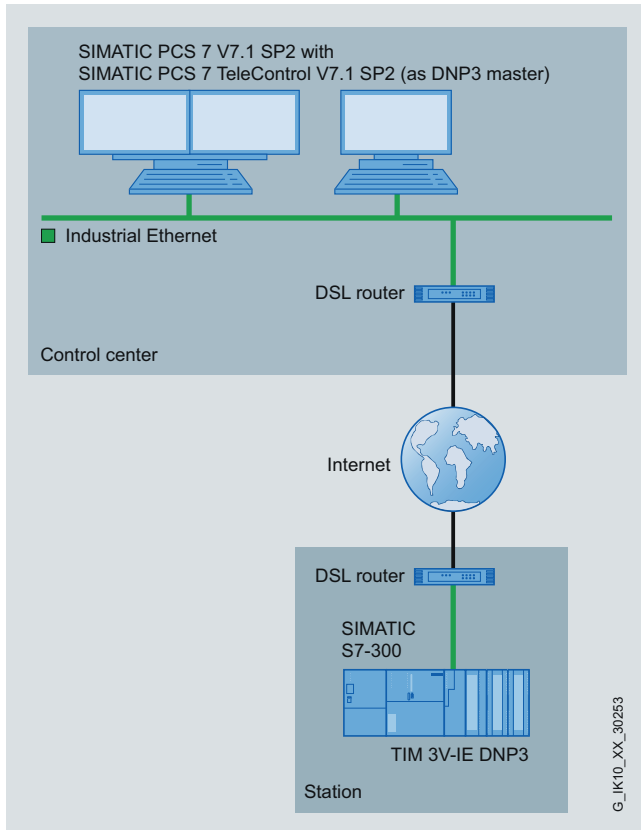

Industrial Remote Communication

TeleControl Professional – Substations for DNP3 protocol

TIM 3V-IE DNP3

Technical specifications

Order No.	6NH7 803-3BA00-0AA0
Product type designation	TIM 3V-IE DNP3
Transmission rate	
Transmission rate with Industrial Ethernet	10 ... 100 Mbit/s
Transmission rate in accordance with RS 232	300 ... 38 400 bit/s
Interfaces	
Number of interfaces in accordance with Industrial Ethernet	1
Number of electrical connections	1
• For external data transmission in accordance with RS 232	1
• for power supply	1
Design of electrical connection	
• of the Industrial Ethernet interface	RJ45 port
• at interface 1 for external data transmission	9-pin Sub-D connector (RS232)
• at interface 2 for external data transmission	-
• for power supply	2-pin, plug-in terminal strip
Design of swap medium C-Plug	No
Supply voltage, current consumption, power loss	
Type of power supply	DC
Supply voltage	24 V
• Minimum	20.4 V
• Maximum	28.8 V
Current consumed	
• Maximum from backplane bus for 24 V DC	0.2 A
• From external supply voltage at 24 V DC max.	0.2 A
Effective power loss	5.8 W
Product expansion: optional backup battery	No
Type of battery	-
Backup current	
• Typical	-
• Maximum	-
Permissible ambient conditions	
Ambient temperature	
• During operation	0 ... 60°C
• During storage	-40 ... +70°C
• During transport	-40 ... +70°C
Relative humidity at 25 °C without condensation during operation, maximum	95 %
IP degree of protection	IP20
Design, dimensions and weights	
Module format	Compact module S7-300 single-width
Width	40 mm
Height	125 mm
Depth	120 mm
Net weight	0.25 kg

Order No.	6NH7 803-3BA00-0AA0
Product type designation	TIM 3V-IE DNP3
Product properties, functions, components General	
Number of modules - Note	Number of TIMs per S7-300: 1
Cable length	
• With RS232 interface, maximum	6 m
• With RS485 interface, maximum	-
Performance data	
<u>Performance data S7 communication</u>	
Number of possible connections for S7 communication	
• Maximum	3
• For PG connections, maximum	2
• For OP connections, maximum	1
• Note	Only via LAN
Service	
• SINAUT ST7 via S7 communication	-
• PG/OP communication	Yes
<u>Performance data multiprotocol operation</u>	
Number of active connections in multiprotocol mode	-
<u>Performance data Telecontrol</u>	
Suitability for use	
• TIM node station	No
• TIM station	Yes
• TIM control center	No
• Note	-
Protocol is supported	
• TCP/IP	No
• DNP3	Yes
• SINAUT ST1 protocol	No
• SINAUT ST7 protocol	No
Number of DNP3 masters	
• With Ethernet, maximum	8
• With RS232 interface, maximum	1
Product function: data buffering if connection is aborted	Yes
• Note	50,000 data points with one master
Product functions Management, configuration, programming	
Configuration software required	SINAUT ST7 ES
Storage location of TIM configuration data	on the CPU or TIM
Product functions Time	
Product component: hardware real-time clock	-
Product property: buffered hardware real-time clock	-
Maximum accuracy of hardware real-time clock per day	-

Industrial Remote Communication

TeleControl Professional – Substations for DNP3 protocol

TIM 3V-IE DNP3

Ordering data	Order No.	Order No.	
TIM 3V-IE DNP3 communication module With an RS232 interface for SINAUT communication via a conventional WAN and an IP-based network (WAN or LAN)	6NH7 803-3BA00-0AA0		
SINAUT ST7 Engineering Software V5.1 on CD-ROM, comprising: <ul style="list-style-type: none"> • SINAUT ST7 Engineering Software V5.1 for the PG • SINAUT TD7 block library V2.2 • Electronic manual in German and English 	6NH7 997-0CA51-0AA0		
SINAUT ST7 Engineering Software Update from Version V5.0 to V5.1	http://support.automation.siemens.com/WW/view/en/49104582		
SINAUT ST7 Engineering Software V5.0 Edition 09/2009 (Upgrade) for STEP 7 V5.4 SP4, for owners of older versions of SINAUT ST7 engineering software	6NH7 997-0CA50-0GA0		
		Accessories	
		IE FC TP Standard Cable GP 2 x 2 (Type A) 4-core, shielded TP installation cable for connection to IE FC Outlet RJ45/ IE FC RJ45 Plug; PROFINET-compliant; with UL approval; sold by the meter; max. length 1000 m, minimum order 20 m	6XV1 840-2AH10
		IE FC RJ45 Plug 180 RJ45 plug connector for Industrial Ethernet with a rugged metal enclosure and integrated insulation displacement contacts for connecting Industrial Ethernet FC installation cables; with 180° cable outlet; for network components and CPs/CPUs with Industrial Ethernet interface <ul style="list-style-type: none"> • 1 pack = 1 unit • 1 pack = 10 units • 1 pack = 50 units 	6GK1 901-1BB10-2AA0 6GK1 901-1BB10-2AB0 6GK1 901-1BB10-2AE0
		IE FC Stripping Tool Preadjusted stripping tool for fast stripping of the Industrial Ethernet FC cables	6GK1 901-1GA00
		Connecting cable For connecting a TIM (RS232) with a SINAUT ST7 MD2, MD3 or MD4 (RS232) modem; cable length 1.5 m	6NH7 701-4AL
		Connecting cable For connecting a TIM (RS232) with the GSM modem MD720-3; also suitable for third-party modems or radio equipment with standard RS232 interface; cable length 2.5 m	6NH7 701-5AN
		Connecting cable with one end open for connecting a TIM (RS232) to a third-party modem or radio unit (RS232); cable length 2.5 m	6NH7 701-4BN
		Connecting cable For connecting two TIM modules via their RS232 interface without modems ('Null modem'). Cable length 6 m	6NH7 701-0AR

Industrial Remote Communication

TeleControl Professional – Substations for DNP3 protocol

TIM 4R-IE DNP3

Overview



In an S7 station, the communication module TIM 4R-IE DNP3 (Telecontrol Interface Module) processes the data traffic for the S7-CPU to the assigned master system SIMATIC PCS7 TeleControl V7.1 SP2 using the open protocol DNP3 (Distributed Network Protocol).

- With the double-width S7-300 housing, can be fully integrated into the S7-300 system
- Can be connected as a stand-alone to a SIMATIC S7-400 and SIMATIC S7-400 H System
- Two RS232/RS485 interfaces for the connection of an external modem for data transmission via a conventional WAN
- Two RJ45 interfaces for data transmission via IP-based networks
- By the use of physically separate connection paths, the module permits media redundancy without loss of data during the switchover

Benefits

get Designed for Industry

- High plant availability by means of end-to-end redundancy
- Connection to DNP3 master systems from third-party vendors is possible by using the open protocol DNP3
- Saving of traveling and maintenance costs due to cost-effective remote programming, diagnostics, control and monitoring via the Internet
- Reduction in time and costs thanks to quick and user-friendly configuration of connections and data to be transferred with the SINAUT configuration software and block library
- Reliable back-up of important data; Storage of the DNP3 data points (max. 200,000 in the case of a master), including time stamp on the TIM if the communication path is faulty or a partner has failed

Application

- Low-cost automation of water/wastewater networks with both complex and simple structures
- Control and monitoring of energy distribution systems and supply stations, such as oil, gas or district heating networks
- Preventive maintenance (condition monitoring) of globally distributed systems
- Connection of plants with basic or high-level security and availability requirements
- Use in hybrid networks with wireless, Ethernet or Internet communication

Design

The TIM 4R-IE DNP3 offers all the advantages of the SIMATIC S7-300 design:

- Compact design with double-width S7-300 format
- Two 9-pin sub-D connectors with a combined RS232/RS485 interface for connection to a conventional WAN via an appropriate modem
- Two RJ45 sockets for connection to Industrial Ethernet or an IP-based network; industrial design with additional retaining collar, for connecting the IE FC RJ45 Plug 180
- 2-pin plug-in terminal strip for connection of the 24 V DC external supply voltage
- Front-panel LEDs for indicating the module status and the communication
- Easy installation; the TIM 4R-IE DNP3 is mounted on the DIN rail of the S7-300 and connected to adjacent modules by means of the bus connector supplied with the TIM. No slot rules apply. For connection of an S7-400 station, it is linked as a stand-alone device via one of its Ethernet ports with one or more S7-400 CPUs.
- Can be operated in the expansion rack (ER) in conjunction with the IM 360/361 interface modules
- Can be operated without a fan
- A backup battery and a memory module (C-PLUG) can be installed as options

Industrial Remote Communication

TeleControl Professional – Substations for DNP3 protocol

TIM 4R-IE DNP3

Function

- Data transmission over the open protocol DNP3
- Media redundancy by the use of physically separated connection paths without the loss of data when switching over
- Extensive diagnostic functions with the option of logging the transmitted and received frames
- Time-of-day synchronization with the assigned DNP3 master system
- Remote programming in the case of IP-based networks
- Option for connecting a SIMATIC S7-400 and SIMATIC S7-400 H system

The communications module TIM 4R-IE DNP3 has its own processor and a RAM for buffering up to 200,000 data points. This prevents any loss of data in the event of a fault on the communication link or the failure of a communication partner.

Diagnostics

The SINAUT diagnostics and service tool of the SINAUT ST7 Engineering Software V5.1 provides comprehensive diagnostic functions, including:

- Operating status of the TIM module
- Module status of the TIM module
- General diagnostic information
- Diagnostic buffer of the TIM module
- Status of the connections to remote communication partners (e.g. SIMATIC PCS7 TeleControl V7.1 SP2)
- Status and level of the transmit buffer
- TIM frame monitor for recording the frame traffic

Configuration

The SINAUT configuration software V5.1 is used for configuring the TIM 4R-IE DNP3 module. Parameters are assigned with the aid of the SINAUT configuration software in STEP 7 HW Config and STEP 7 Netpro.

Integration

The TIM 4R-IE DNP3 module is connected to a WAN via two floating RS232/RS485 interfaces, and specifically via various data communication devices depending on the application:

- Dedicated line modems for point-to-point, point-to-multipoint or line connections
- Fiber-optic cable modules (via RS485 converters)
- Wireless devices from various manufacturers

Via two RJ45 interfaces, the TIM 4R-IE DNP3 module can be connected to the Ethernet, i.e. to IP-based networks (LAN, IWLAN, DSL, GPRS, UMTS, etc.).

Configuration examples in conventional and IP-based WAN

Use in a station with transmission via a dedicated line network

The connection to the master station is via the MD2 modem, which sets up the connection via a dedicated line.

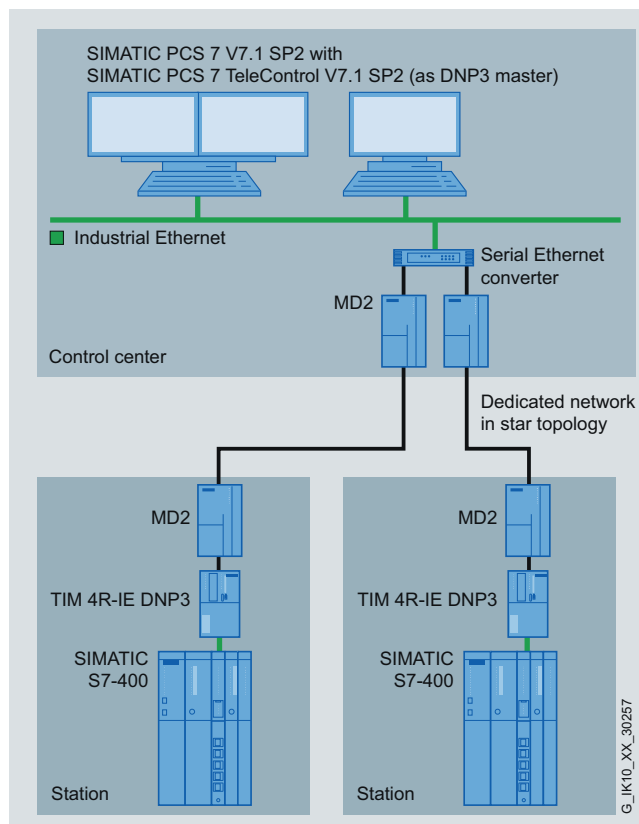

Use in a station with transmission via Internet

The stations are connected by means of an Internet connection. In this case, DSL routers must be used in the station and control center – preferably in combination with SCALANCE S in order to establish secure connections using VPN tunnels.

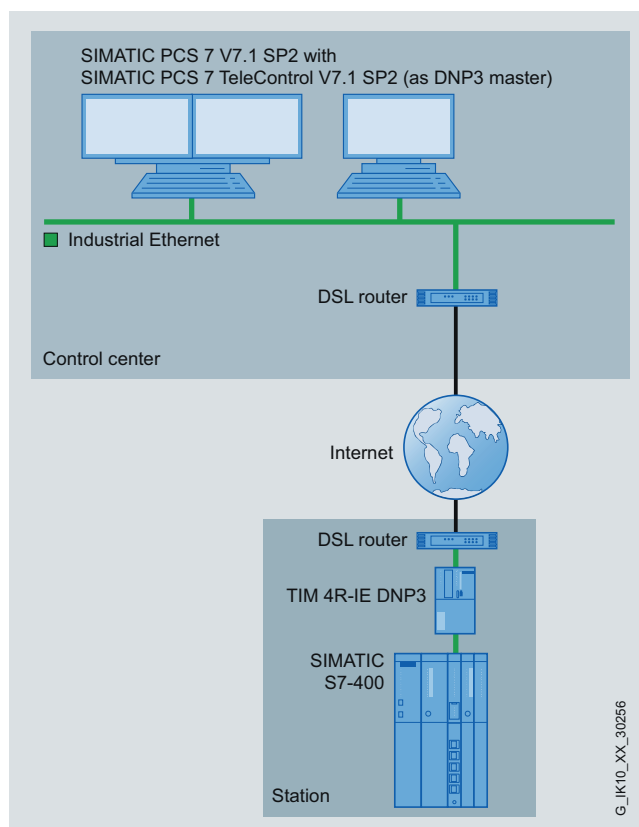

Industrial Remote Communication

TeleControl Professional – Substations for DNP3 protocol

TIM 4R-IE DNP3

Integration (continued)

Use in a station with transmission over the GSM mobile telephone service GPRS or UMTS

The stations are connected via the GSM mobile telephone service GPRS. In this case the GPRS router MD741-1 is used in the station and a SCALANCE S security module is used in the control center which ensures that the VPN connections are set up with the GPRS stations.

For higher data rates, in place of the GRPS router MD741-1, the UMTS Router SCALANCE M875 can be implemented for use of the UMTS mobile radio network.

Use in a station with path redundancy

The connection of the stations with a TIM 4R-IE DNP3 enables redundant connection paths to be set up. On the failure of the active connection (e.g. the Internet connection) a switch is made to the second connection path (e.g. WAN).

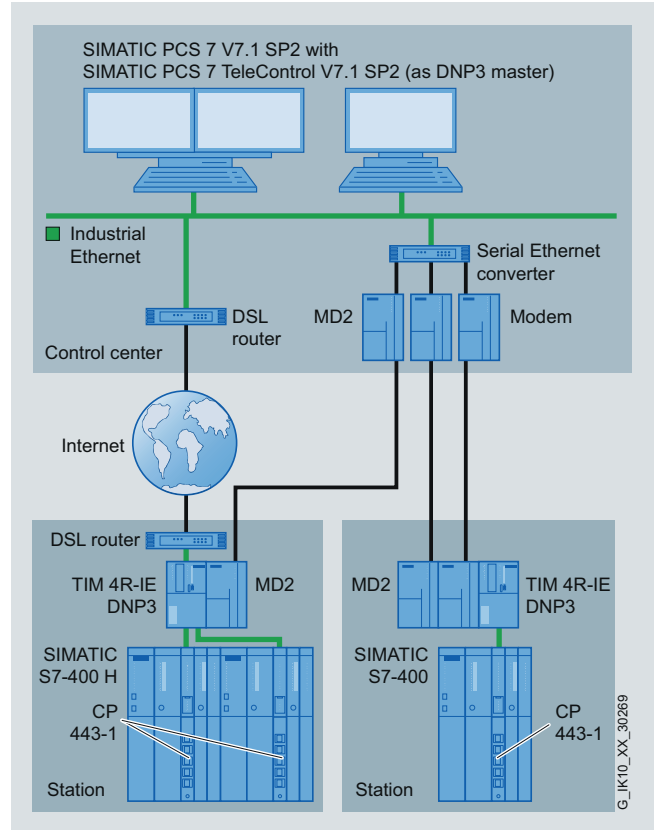
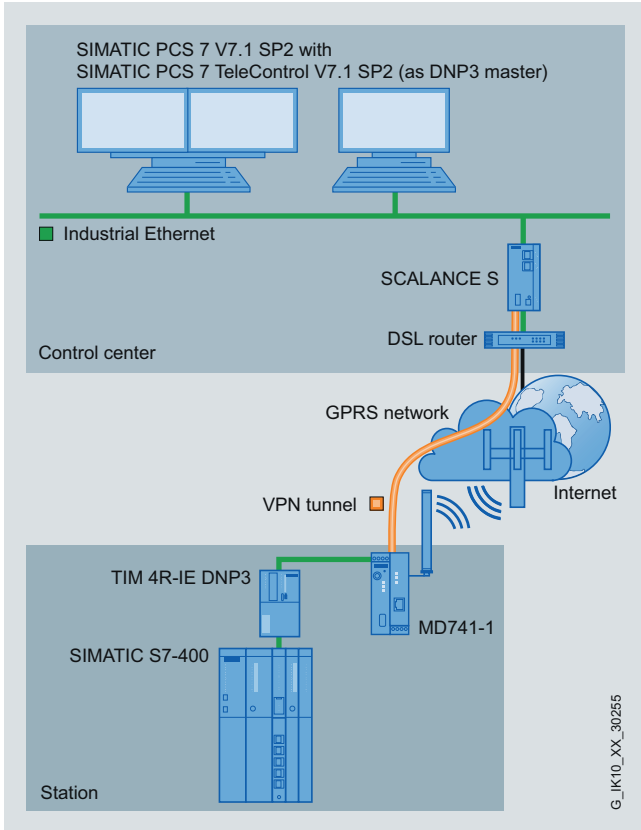

Industrial Remote Communication

TeleControl Professional – Substations for DNP3 protocol

TIM 4R-IE DNP3

Technical specifications

Order No.	6NH7 803-4BA00-0AA0
Product type designation	TIM 4R-IE DNP3
Transmission rate	
Transmission rate	
• for Industrial Ethernet	10 ... 100 Mbit/s
• in accordance with RS 232	300 ... 115 200 bit/s
Interfaces	
Number of interfaces in accordance with Industrial Ethernet	2
Number of electrical connections	
• For external data transmission in accordance with RS 232	2
• for power supply	1
Design of electrical connection	
• of the Industrial Ethernet interface	RJ45 port
• at interface 1 for external data transmission	9-pin Sub-D connector, RS232 switchable to RS485
• at interface 2 for external data transmission	9-pin Sub-D connector, RS232 switchable to RS485
• for power supply	2-pin, plug-in terminal strip
Design of swap medium C-Plug	Yes
Supply voltage, current consumption, power loss	
Type of power supply	DC
Supply voltage	24 V
• Minimum	20.4 V
• Maximum	28.8 V
Current consumed	
• Maximum from backplane bus for 24 V DC	0.2 A
• From external supply voltage at 24 V DC max.	0.17 A
Effective power loss	4.6 W
Product expansion: optional backup battery	Yes
Type of battery	Lithium AA / 3.6 V / 2.3 Ah
Backup current	
• Typical	100 µA
• Maximum	160 µA
Permissible ambient conditions	
Ambient temperature	
• During operation	0 ... 60°C
• During storage	-40 ... +70°C
• During transport	-40 ... +70°C
Relative humidity at 25 °C without condensation during operation, maximum	95 %
IP degree of protection	IP20
Design, dimensions and weights	
Module format	Compact module S7-300 double-width
Width	80 mm
Height	125 mm
Depth	120 mm
Net weight	0.4 kg

Order No.	6NH7 803-4BA00-0AA0
Product type designation	TIM 4R-IE DNP3
Product properties, functions, components General	
Number of modules - Note	Number of TIMs per S7-300 / S7-400: 1
Cable length	
• With RS232 interface, maximum	6 m
• With RS485 interface, maximum	30 m
Performance data	
<u>Performance data S7 communication</u>	
Number of possible connections for S7 communication	
• Maximum	5
• For PG connections, maximum	2
• For OP connections, maximum	1
Number of possible connections for S7 communication - Note	Only via LAN
Service	
• SINAUT ST7 via S7 communication	-
• PG/OP communication	Yes
<u>Performance data multiprotocol operation</u>	
Number of active connections in multiprotocol mode	-
<u>Performance data Telecontrol</u>	
Suitability for use	
• TIM node station	No
• TIM station	Yes
• TIM control center	No
Suitability for use - Note	-
Protocol is supported	
• TCP/IP	No
• DNP3	Yes
• SINAUT ST1 protocol	No
• SINAUT ST7 protocol	No
Number of DNP3 masters	
• With Ethernet, maximum	8
• With RS232 interface, maximum	1
Product function: data buffering if connection is aborted	Yes
• Note	200,000 data points with one master
Product functions Management, configuration, programming	
Configuration software required	SINAUT ST7 ES
Storage location of TIM configuration data	on the CPU or TIM
Product functions Time	
Product component: hardware real-time clock	Yes
Product property: buffered hardware real-time clock	Yes
Maximum accuracy of hardware real-time clock per day	4 s

Industrial Remote Communication

TeleControl Professional – Substations for DNP3 protocol

TIM 4R-IE DNP3

Ordering data	Order No.	Order No.
TIM 4R-IE DNP3 communication module With two combined RS232/RS485 interfaces for SINAUT communication via conventional WANs and two RJ45 interfaces for SINAUT communication via IP-based networks (WAN or LAN)	6NH7 803-4BA00-0AA0	IE FC Stripping Tool Preadjusted stripping tool for fast stripping of the Industrial Ethernet FC cables
SINAUT ST7 Engineering Software V5.1 on CD-ROM, comprising: <ul style="list-style-type: none"> • SINAUT ST7 Engineering Software V5.1 for the PG • SINAUT TD7 block library V2.2 • Electronic manual in German and English 	6NH7 997-0CA51-0AA0	Connecting cable For connecting a TIM (RS232) with a SINAUT ST7 MD2, MD3 or MD4 (RS232) modem; cable length 1.5 m
SINAUT ST7 Engineering Software V5.1 Update from Version V5.0 to V5.1 Software download		Connecting cable For connecting a TIM (RS485) with a SINAUT ST7 MD2, MD3 or MD4 (RS485) modem; cable length 1.5 m
SINAUT ST7 Engineering Software V5.0 Edition 09/2009 (Upgrade) for STEP 7 V5.4 SP4, for owners of older versions of SINAUT ST7 engineering software	6NH7 997-0CA50-0GA0	Connecting cable For connecting a TIM (RS232) with the GSM modem MD720-3; also suitable for third-party modems or radio equipment with standard RS232 interface; cable length 2.5 m
Accessories Backup battery 3.6 V/2.3 Ah for TIM 4R-IE DNP3	6ES7 971-0BA00	Connecting cable with one end open for connecting a TIM (RS232) to a third-party modem or radio unit (RS232); cable length 2.5 m
IE FC TP Standard Cable GP 2 x 2 (Type A) 4-core, shielded TP installation cable for connection to IE FC Outlet RJ45 / IE FC RJ45 Plug; PROFINET-compliant; with UL approval; sold by the meter; max. length 1000 m, minimum order 20 m	6XV1 840-2AH10	Connecting cable For connecting two TIM modules via their RS232 interface without modems ('Null modem'). Cable length 6 m
IE FC RJ45 Plug 180 RJ45 plug connector for Industrial Ethernet with a rugged metal enclosure and integrated insulation displacement contacts for connecting Industrial Ethernet FC installation cables; with 180° cable outlet; for network components and CPs/CPUs with Industrial Ethernet interface <ul style="list-style-type: none"> • 1 pack = 1 unit • 1 pack = 10 units • 1 pack = 50 units 	6GK1 901-1BB10-2AA0 6GK1 901-1BB10-2AB0 6GK1 901-1BB10-2AE0	SITOP compact 24 V/ 0.6 A 1-phase power supply with wide-range input 85 to 264 V AC/ 110 to 300 V DC, stabilized output voltage 24 V, rated output current value 0.6 A, slim design

Overview



IEC 60870-5-101, -103, -104 are standardized vendor-independent protocols. With SIPLUS RIC, they can be parameterized with SIMATIC Manager without the need for additional installations.

SIMATIC Controllers can also communicate with third-party products by means of the IEC protocols.

The SIPLUS RIC bundles usually comprise

- CPU
- Interface/communication module (if necessary)
- Memory Card
- CD with library and registration code.

SIPLUS RIC products require additional material to establish telecommunication links, e.g. TCP/IP converters – serial, dedicated line modems, media converters, TCP/IP routers, SCALANCE S security modules, switches, cables, etc.

In order to implement telecontrol networks, basic topologies including point-to-point, multi-point, star and ring can be configured using classic or TCP/IP-based media. These can be combined flexibly independent from existing infrastructure.

Classic WAN media (IEC 870-5-101 telecontrol protocol)

- Dedicated line via modem, e.g. SINAUT MD2
- Dedicated line over fiber-optic cables
- Private wireless networks

TCP/IP-based WAN media (IEC 870-5-104 telecontrol protocol)

- Ethernet networks, e.g. SCALANCE X with fiber-optic cables
- Industrial Wireless LAN with SCALANCE W
- Public networks and the Internet using DSL and/or GPRS/UMTS
- Satellite communication, e.g. with Inmarsat

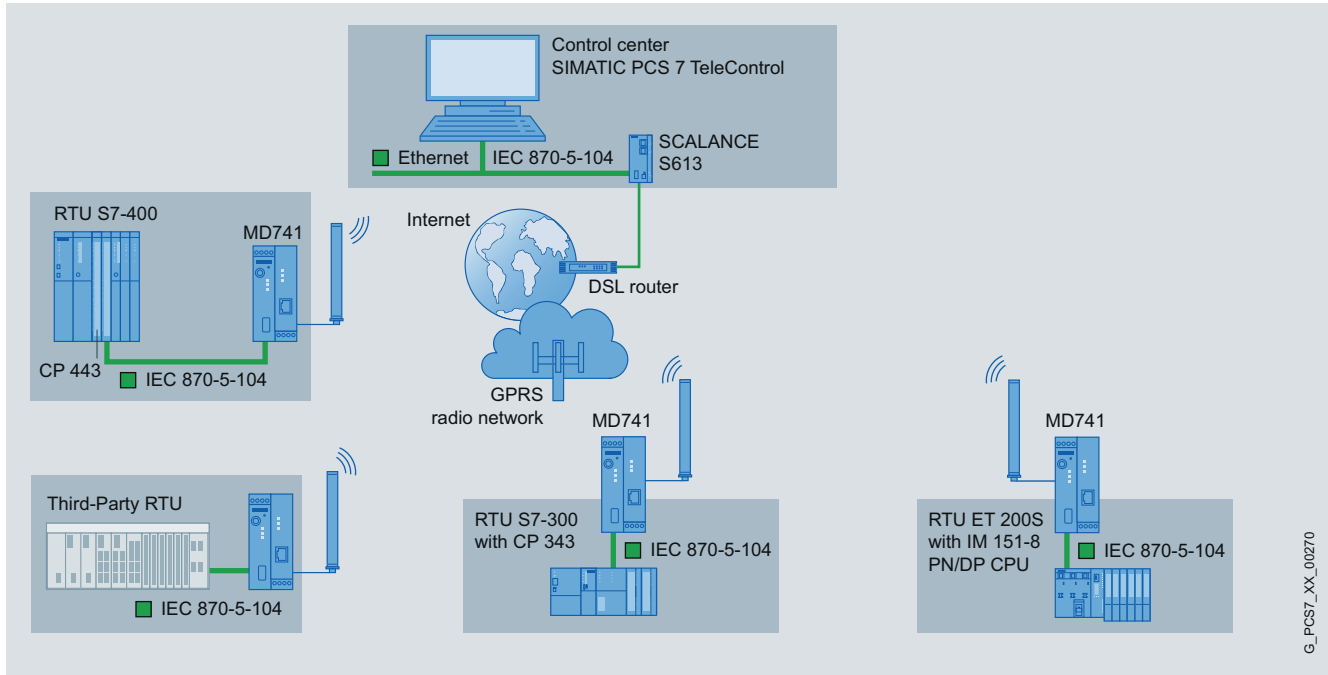

IEC 870-5-104 – example of TCP/IP-based WAN with GPRS radio network (star topology)

Industrial Remote Communication

TeleControl Professional – Substations for IEC protocol

SIPLUS RIC bundles for IEC 60870-5-101

Overview

With SIPLUS RIC, existing installations can be modernised and expanded with IEC protocols.

The IEC 60870-5-101 protocol is an international standard for telecontrol and has been approved by the International Electrotechnical Commission (IEC). It enables devices and equipment for telecontrol and substation automation technology from different manufacturers to communicate with each other. It is an asynchronous protocol for serial transmission (V.24/V.28, V.11).

The interaction between devices from different manufacturers is assured by an interoperability list. The profiles of the message types and functions used are matched to each other here.

The great advantage of the IEC 60870-5-101 protocol is its ruggedness in the data link layer (hamming distance 4) and the simple structure of the application layer.

Ordering data	Order No.	Ordering data	Order No.
<i>SIPLUS RIC bundle with SIMATIC ET 200S</i>		<i>SIPLUS RIC bundle with SIMATIC S7-300</i>	
SIPLUS RIC bundle T101 MA IM151-7 CP1 SIPLUS RIC IEC60870-5-101 master; with SIMATIC IM 151-7 CPU, MMC 128 KB, 1 SI interface module (RS232/RS485 interface)	6AG6 003-5AA00-1BA0	SIPLUS RIC bundle T101 MA CPU314 CPU340 SIPLUS RIC IEC60870-5-101 master; with SIMATIC CPU 314, MMC 128 KB, SIMATIC CP 340 (RS232 interface)	6AG6 003-1AA01-1BA0
SIPLUS RIC bundle T101 SL IM151-7 CP1 SIPLUS RIC IEC60870-5-101 slave; with SIMATIC IM 151-7 CPU, MMC 128 KB, 1 SI interface module (RS232/RS485 interface)	6AG6 003-5BA00-1BA0	SIPLUS RIC bundle T101 SL CPU314 CP340 SIPLUS RIC IEC60870-5-101 slave; with SIMATIC CPU 314, MMC 128 KB, SIMATIC CP 340 (RS232 interface)	6AG6 003-1BA01-1BA0
SIPLUS RIC bundle T101 MA IM151-8 CP1 SIPLUS RIC IEC60870-5-101 master; with SIMATIC IM 151-8 CPU, MMC 128 KB, 1 SI interface module (RS232/RS485 interface)	6AG6 003-5AA01-1BA0	SIPLUS RIC bundle T101 MA CPU314 CP341 SIPLUS RIC IEC60870-5-101 master; with SIMATIC CPU 314, MMC 128 KB, SIMATIC CP 341 (RS232 interface)	6AG6 003-1AA01-4BA0
SIPLUS RIC bundle T101 SL IM151-8 CP1 SIPLUS RIC IEC60870-5-101 slave; with SIMATIC IM 151-8 CPU, MMC 128 KB, 1 SI interface module (RS232/RS485 interface)	6AG6 003-5BA01-1BA0	SIPLUS RIC bundle T101 SL CPU314 CP341 SIPLUS RIC IEC60870-5-101 slave; with SIMATIC CPU 314, MMC 128 KB, SIMATIC CP 341 (RS232 interface)	6AG6 003-1BA01-4BA0
		SIPLUS RIC bundle T101 MA CPU315 CP341 SIPLUS RIC IEC60870-5-101 master; with SIMATIC CPU 315-2 DP, MMC 512 KB, SIMATIC CP 341 (RS232 interface)	6AG6 003-1AA02-4CA0
		SIPLUS RIC bundle T101 SL CPU315 CP341 SIPLUS RIC IEC60870-5-101 slave; with SIMATIC CPU 315-2 DP, MMC 512 KB, SIMATIC CP 341 (RS232 interface)	6AG6 003-1BA02-4CA0
		SIPLUS RIC bundle T101 MA CPU315F, CP341 SIPLUS RIC IEC60870-5-101 master; with SIMATIC CPU 315F-2 PN/DP, MMC 512 KB, SIMATIC CP 341 (RS232 interface)	6AG6 003-1AA10-4CA0

Industrial Remote Communication

TeleControl Professional – Substations for IEC protocol

SIPLUS RIC bundles for IEC 60870-5-101

Ordering data	Order No.	Order No.	
<i>SIPLUS RIC bundle with SIMATIC S7-300 (continued)</i>		<i>SIPLUS RIC bundle with SIMATIC S7-400</i>	
SIPLUS RIC bundle T101 SL CPU315F, CP341 SIPLUS RIC IEC60870-5-101 slave; with SIMATIC CPU 315F-2 PN/DP, MMC 512 KB, SIMATIC CP 341 (RS232 interface)	6AG6 003-1BA10-4CA0	SIPLUS RIC bundle T101 MA CPU412 CP441-1 SIPLUS RIC IEC60870-5-101 master; with SIMATIC CPU 412-1, 256 KB Flash EPROM memory card, SIMATIC CP 441-1 (RS232 interface)	6AG6 003-3AA00-1BA0
SIPLUS RIC bundle T101 MA CPU317-2 PN/DP SIPLUS RIC IEC60870-5-101 master; with SIMATIC CPU 317-2 PN/DP, MMC 2 MB, SIMATIC CP 341 (RS232 interface)	6AG6 003-1AA05-4DA0	SIPLUS RIC bundle T101 SL CPU412 CP441-1 SIPLUS RIC IEC60870-5-101 slave; with SIMATIC CPU 412-1, 256 KB Flash EPROM memory card, SIMATIC CP 441-1 (RS232 interface)	6AG6 003-3BA00-1BA0
SIPLUS RIC bundle T101 SL CPU317-2 PN/DP SIPLUS RIC IEC60870-5-101 slave; with SIMATIC CPU 317-2 PN/DP, MMC 2 MB, SIMATIC CP 341 (RS232 interface)	6AG6 003-1BA05-4DA0	SIPLUS RIC bundle T101 MA CPU412 CP441-2 SIPLUS RIC IEC60870-5-101 master; with SIMATIC CPU 412-1, 2 MB Flash EPROM memory card, SIMATIC CP 441-2 (2 x RS232 interface)	6AG6 003-3AA00-4BA0
SIPLUS RIC bundle T101 MA CPU319-3 PN/DP SIPLUS RIC IEC60870-5-101 master; with SIMATIC CPU 319-3 PN/DP, MMC 2 MB, SIMATIC CP 341 (RS232 interface)	6AG6 003-1AA06-4DA0	SIPLUS RIC bundle T101 SL CPU412 CP441-2 SIPLUS RIC IEC60870-5-101 slave; with SIMATIC CPU 412-1, 2 MB Flash EPROM memory card, SIMATIC CP 441-2 (2 x RS232 interface)	6AG6 003-3BA00-4BA0
SIPLUS RIC bundle T101 SL CPU319-3 PN/DP SIPLUS RIC IEC60870-5-101 slave; with SIMATIC CPU 319-3 PN/DP, MMC 2 MB, SIMATIC CP 341 (RS232 interface)	6AG6 003-1BA06-4DA0		

Industrial Remote Communication

TeleControl Professional – Substations for IEC protocol

SIPLUS RIC extreme bundles for IEC 60870-5-101

Overview

The IEC 60870-5-101 protocol is an international standard for telecontrol and has been approved by the International Electrotechnical Commission (IEC). It enables devices and equipment for telecontrol and substation automation technology from different manufacturers to communicate with each other. It is an asynchronous protocol for serial transmission (V.24/V.28, V.11). The interaction between devices from different manufacturers is assured by an interoperability list. The profiles of the message types and functions used are matched to each other here.

The great advantage of the IEC 60870-5-101 protocol is its ruggedness in the data link layer (hamming distance 4) and the simple structure of the application layer.

SIPLUS RIC extreme bundles

Refined versions for an extended ambient temperature range (-25 ... +70 °C) and exceptional medial exposure (Conformal Coating).

Ordering data	Order No.	Ordering data	Order No.
SIPLUS RIC extreme bundle with SIPLUS ET 200S (extended temperature range and medial exposure)		SIPLUS RIC extreme bundle with SIPLUS S7-300 (extended temperature range and medial exposure)	
SIPLUS RIC extreme bundle T101MA IM151-7 CP1 SIPLUS RIC IEC60870-5-101 master; with SIPLUS IM 151-7 CPU interface module, MMC 128 KB, SIPLUS 1 SI interface module (RS 232 interface)	6AG6 003-6AA00-1BA7	SIPLUS RIC extreme bundle T101MA CPU314 CP340 SIPLUS RIC IEC60870-5-101 master; with SIPLUS CPU 314, MMC 128 KB, SIPLUS CP 340 (RS 232 interface)	6AG6 003-2AA01-1BA7
SIPLUS RIC extreme bundle T101SL IM151-7 CP1 SIPLUS RIC IEC60870-5-101 slave; with SIPLUS IM 151-7 CPU interface module, MMC 128 KB, SIPLUS 1 SI interface module (RS 232 interface)	6AG6 003-6BA00-1BA7	SIPLUS RIC extreme bundle T101SL CPU314 CP340 SIPLUS RIC IEC60870-5-101 slave; with SIPLUS CPU 314, MMC 128 KB, SIPLUS CP 340 (RS 232 interface)	6AG6 003-2BA01-1BA7
SIPLUS RIC extreme bundle T101MA IM151-8 CP1 SIPLUS RIC IEC60870-5-101 master; with SIPLUS IM 151-8 CPU interface module, MMC 128 KB, SIPLUS 1 SI interface module (RS 232 interface)	6AG6 003-6AA01-1BA7	SIPLUS RIC extreme bundle T101 MA CPU315 SIPLUS RIC IEC60870-5-101 master; with SIPLUS CPU 315-2 DP, MMC 512 KB, SIPLUS CP 341 (RS 232 interface)	6AG6 003-2AA02-4CA7
SIPLUS RIC extreme bundle T101SL IM151-8 CP1 SIPLUS RIC IEC60870-5-101 slave; with SIPLUS IM 151-8 CPU interface module, MMC 128 KB, SIPLUS 1 SI interface module (RS 232 interface)	6AG6 003-6BA01-1BA7	SIPLUS RIC extreme bundle T101 SL CPU315 CP341 SIPLUS RIC IEC60870-5-101 slave; with SIPLUS CPU 315-2 DP, MMC 512 KB, SIPLUS CP 341 (RS 232 interface)	6AG6 003-2BA02-4CA7
		SIPLUS RIC extreme bundle T101 MA CPU317-2 PN/DP, CP341 SIPLUS RIC IEC60870-5-101 master; with SIPLUS CPU 317-2 PN/DP, MMC 2 MB, SIPLUS CP 341 (RS 232 interface)	6AG6 003-2AA05-4DA7
		SIPLUS RIC extreme bundle T101 SL CPU317-2 PN/DP, CP341 SIPLUS RIC IEC60870-5-101 slave; with SIPLUS CPU 317-2 PN/DP, MMC 2 MB, SIPLUS CP 341 (RS 232 interface)	6AG6 003-2BA05-4DA7

Industrial Remote Communication

TeleControl Professional – Substations for IEC protocol

SIPLUS RIC IEC 60870-5-101 library
Overview

If a SIMATIC PCS 7 system or an RTU based on WinAC RTX is to communicate with a SIMATIC PCS 7 TeleControl center or a control center of a third-party supplier using the IEC 60870 5 telecontrol standard, the IEC 60870 5 101 (serial) or IEC 60870 5 104 (TCP/IP) telecontrol protocols can be used in the SIMATIC automation systems.

Ordering data
Order No.
SIPLUS RIC PCS 7
**SIPLUS RIC PCS 7 software
T101 SL CP441**

Function block library for telecontrol protocol IEC 870-5-101; can be used with SIMATIC S7-400, CP 441-1 interface; runtime software for an automation system, Single License for 1 installation on AS single station

6AG6 003-0BA11-0AA0
**SIPLUS RIC PCS 7 software
T101 SL CP340/1**

Function block library for telecontrol protocol IEC 870-5-101; can be used with SIMATIC S7-400/400H, CP 340/341 interface; runtime software for an automation system, Single License for 1 installation on AS redundancy station

6AG6 003-0BA01-0AA0
SIPLUS RIC WinAC
**SIPLUS RIC WinAC software
T101, master and slave**

Function block library for telecontrol protocol IEC 60870-5-101, can be used with SIMATIC S7 modular embedded controller and SIMATIC IPC427C for WinAC RTX 2010; runtime software for an automation system, single license for 1 installation AS

6AG6 003-0BA50-0AA0

Industrial Remote Communication

TeleControl Professional – Substations for IEC protocol

SIPLUS RIC bundles for IEC 60870-5-103

Overview

The IEC 60870-5-103 protocol is an international standard and was approved by the International Electrotechnical Commission (IEC) in the 1990's. The protocol controls communication between one central unit and several protection devices. IEC 60870-5-103 is mainly used for asynchronous connections (V.24/V.28, RS232 or RS485). The protocol offers expansions for proprietary manufacturer-specific functions, so that compatibility can only be ensured with the help of the interoperability list.

Ordering data

Order No.

SIPLUS RIC bundle with SIMATIC ET 200S

SIPLUS RIC bundle T103 MA IM151-7 CPU **6AG6 003-5AC00-1BA0**

SIPLUS RIC IEC60870-5-103 master;
with SIMATIC IM 151-7 CPU, MMC 128 KB, 1 SI interface module (RS232/RS485 interface)

SIPLUS RIC bundle T103 MA IM151-8 PN/DP **6AG6 003-5AC01-0BA0**

SIPLUS RIC IEC60870-5-103 master;
with SIMATIC IM 151-8 CPU, MMC 128 KB, 1 SI interface module (RS232/RS485 interface)

SIPLUS RIC bundle with SIMATIC S7-300

SIPLUS RIC bundle T103 MA, CPU314 CP340 **6AG6 003-1AC01-3BA0**

SIPLUS RIC IEC60870-5-103 master;
with SIMATIC CPU 314, MMC 128 KB, SIMATIC CP 340 (RS422/RS485 interface)

SIPLUS RIC bundle T103 MA, CPU314 CP341 **6AG6 003-1AC01-6BA0**

SIPLUS RIC IEC60870-5-103 master;
with SIMATIC CPU 314, MMC 128 KB, SIMATIC CP 341 (RS422/RS485 interface)

SIPLUS RIC bundle T103 MA, CPU315-2 PN CP341 **6AG6 003-1AC02-6CA0**

SIPLUS RIC IEC60870-5-103 master;
with SIMATIC CPU 315-2 PN, MMC 128 KB, SIMATIC CP 341 (RS422/RS485 interface)

SIPLUS RIC bundle with SIMATIC S7-400

SIPLUS RIC bundle T103 MA CPU412 CP441-1 **6AG6 003-3AC00-3BA0**

SIPLUS RIC IEC60870-5-103 master;
with SIMATIC CPU 412-1, 256 KB Flash EPROM memory card, SIMATIC CP 441-1 (RS485 interface)

SIPLUS RIC bundle T103 MA CPU412 CP441-2 **6AG6 003-3AC00-6BA0**

SIPLUS RIC IEC60870-5-103 master;
with SIMATIC CPU 412-1, 256 KB Flash EPROM memory card, SIMATIC CP 441-2 (2 x RS485 interface)

Industrial Remote Communication TeleControl Professional – Substations for IEC protocol

SIPLUS RIC extreme bundles for IEC 60870-5-103

Overview

The IEC 60870-5-103 protocol is an international standard and was approved by the International Electrotechnical Commission (IEC) in the 1990s. The protocol controls communication between one central unit and several protection devices. IEC 60870-5-103 is mainly used for asynchronous connections (V.24/V.28, RS232 or RS485). The protocol offers expansions for proprietary manufacturer-specific functions, so that compatibility can only be ensured with the help of the interoperability list.

SIPLUS RIC extreme bundles

Refined versions for an extended ambient temperature range (-25 ... +70 °C) and exceptional medial exposure (Conformal Coating).

Ordering data

SIPLUS RIC extreme bundle with SIPLUS ET 200S
(extended temperature range and medial exposure)

SIPLUS RIC extreme bundle T103MA IM151-7 CP1

SIPLUS RIC IEC60870-5-103 master;
with SIPLUS IM 151-7 CPU,
MMC 128 KB,
SIPLUS 1 SI interface module
(RS232/RS485 interface)

6AG6 003-6AC00-1BA7

SIPLUS RIC extreme bundle T103MA IM151-8 CP1

SIPLUS RIC IEC60870-5-103 master;
with SIPLUS IM 151-8 CPU,
MMC 128 KB,
SIPLUS 1 SI interface module
(RS232/RS485 interface)

6AG6 003-6AC01-1BA7

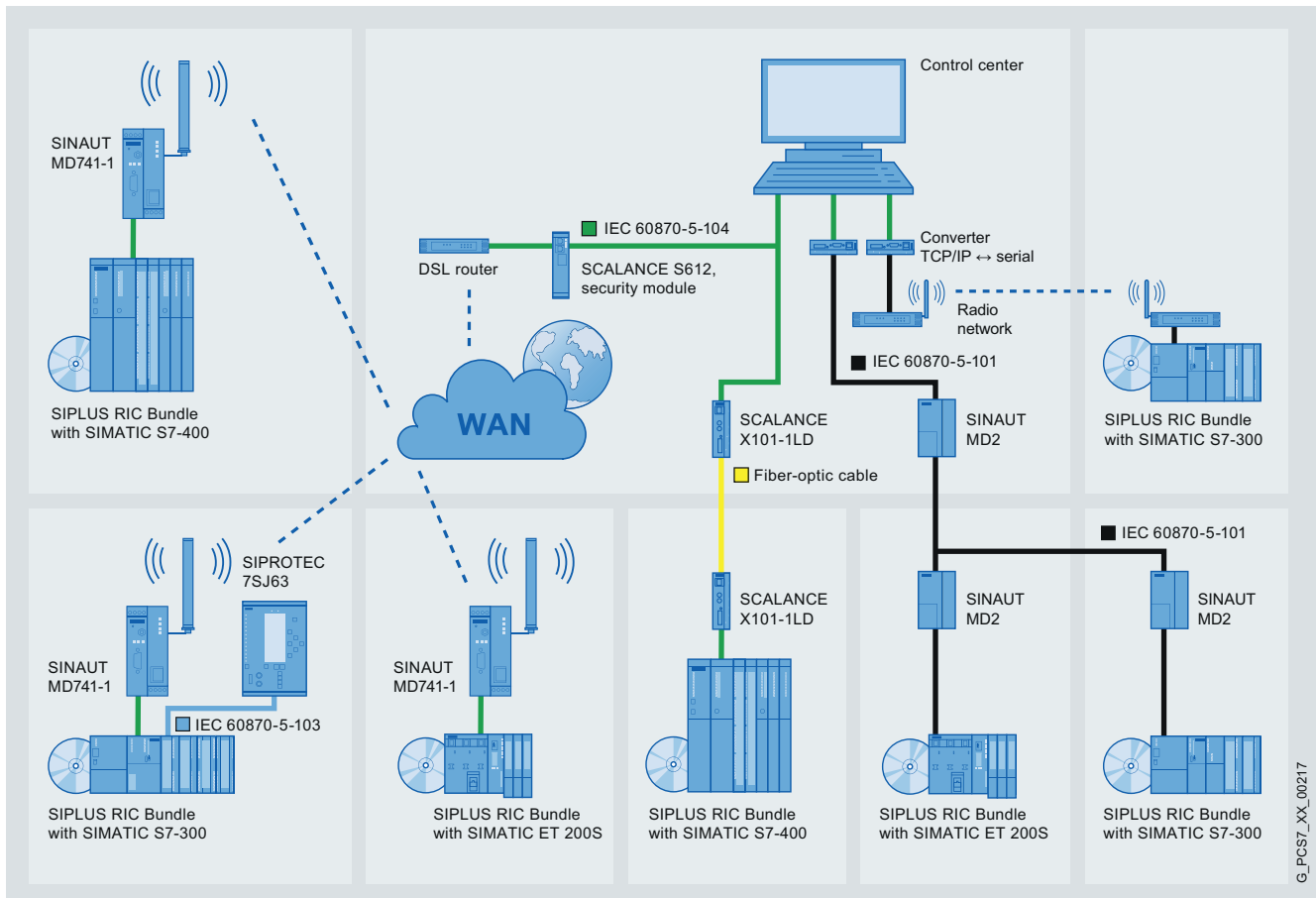

Flexible communication with SIPLUS RIC in Wide Area Network (WAN)

Industrial Remote Communication

TeleControl Professional – Substations for IEC protocol

SIPLUS RIC IEC 60870-5-103 library

Overview

If a SIMATIC PCS 7 system or an RTU based on WinAC RTX is to communicate with a protection device via the protection device protocol IEC 60870 5, the protection device protocol IEC 60870 5 103 (serial) can be used in SIMATIC automation systems.

The add-on software enables two protocols to be implemented on one SIMATIC CPU. This makes it possible, for example, to communicate with the control center via IEC 60870 101 or 104 and simultaneously with a protection device via IEC 60870 5 103.

Ordering data

Order No.

SIPLUS RIC PCS 7

SIPLUS RIC PCS 7 software T103 MA CP340/341

Function block library for protection device protocol IEC 60870-5-103; can be used with SIMATIC S7-400/400H, CP 340/341 interface; runtime software for an automation system, Single License for 1 installation on AS redundancy station

6AG6 003-0AC01-0AA0

SIPLUS RIC PCS 7 software T103 MA CP441

Function block library for protection device protocol IEC 60870-5-103; can be used with SIMATIC S7-400, CP 441-1 interface; runtime software for an automation system, Single License for 1 installation on AS single station

6AG6 003-0AC11-0AA0

SIPLUS RIC add-on software

SIPLUS RIC add-on software T103 MA CP 1SI

Additional activation for implementing 2 protocols on one CPU; for SIMATIC IM 151-7/-8, communication via 1 SI interface module

6AG6 003-0AC42-0AA0

SIPLUS RIC add-on software T103 MA CP340/1

Additional activation for implementing 2 protocols on one CPU; for SIMATIC S7-300/-400/-400H CPUs, communication via CP 340/341

6AG6 003-0AC02-0AA0

SIPLUS RIC add-on software T103 MA CP441

Additional activation for implementing 2 protocols on one CPU; for SIMATIC S7-400 standard CPUs (CPU 412 or higher), communication via CP 441

6AG6 003-0AC12-0AA0

SIPLUS RIC WinAC

SIPLUS RIC WinAC software T103, master

Function block library for protection device protocol IEC 870-5-103 master, can be used with SIMATIC S7 modular embedded controller and SIMATIC IPC427C for WinAC RTX 2010; runtime software for an automation system, single license for 1 installation AS

6AG6 003-0AC50-0AA0

Industrial Remote Communication

TeleControl Professional – Substations for IEC protocol

SIPLUS RIC bundles for IEC 60870-5-104

Overview

The IEC 60870-5-104 protocol defines the communication between the control center and substations for monitoring and controlling geographically distributed systems. The TCP/IP communication used takes place via IP-based networks (LAN/WAN). Interoperability between devices from different manufacturers is ensured for this protocol by an interoperability list.

Advantages of the TCP/IP-based connection are simultaneous data transfer through IEC 60870-5-104 to several devices and simultaneous diagnostics using SIMATIC Manager.

Security mechanisms are, however, not defined in the application area of IEC 60870-5-104. The encryption of user data (data integrity) and authentication of the communication partners are not incorporated in the IEC standard. Appropriate protective measures (see Industrial Security) must be implemented separately.

Ordering data	Order No.	Ordering data	Order No.
<i>SIPLUS RIC bundle with SIMATIC ET 200S</i>		<i>SIPLUS RIC bundle with SIMATIC S7-300</i>	
SIPLUS RIC bundle T104 MA IM151-8 PN/DP	6AG6 003-5AB01-0BA0	SIPLUS RIC bundle T104 MA CPU314, CP343-1	6AG6 003-1AB01-7BA0
SIPLUS RIC IEC60870-5-104 master; with SIMATIC IM 151-8 PN/DP, MMC 128 KB		SIPLUS RIC IEC60870-5-104 master; with SIMATIC CPU 314, MMC 128 KB, CP 343-1 Lean	
SIPLUS RIC bundle T104 MA IM151-8F PN/DP	6AG6 003-5AB11-0BA0	SIPLUS RIC bundle T104 SL CPU314, CP343-1	6AG6 003-1BB01-7BA0
SIPLUS RIC IEC60870-5-104 master; with SIMATIC IM 151-8F PN/DP, MMC 512 KB		SIPLUS RIC IEC60870-5-104 slave; with SIMATIC CPU 314, MMC 128 KB, CP 343-1 Lean	
SIPLUS RIC bundle T104 SL IM151-8 PN/DP	6AG6 003-5BB01-0BA0	SIPLUS RIC bundle T104 MA CPU315, CP343-1	6AG6 003-1AB02-7CA0
SIPLUS RIC IEC60870-5-104 slave; with SIMATIC IM 151-8 PN/DP, MMC 128 KB		SIPLUS RIC IEC60870-5-104 master; with SIMATIC CPU 315, MMC 512 KB, CP 343-1 Lean	
SIPLUS RIC bundle T104 SL IM151-8F PN/DP	6AG6 003-5BB11-0BA0	SIPLUS RIC bundle T104 SL CPU315, CP343-1	6AG6 003-1BB02-7CA0
SIPLUS RIC IEC60870-5-104 slave; with SIMATIC IM 151-8F PN/DP, MMC 512 KB		SIPLUS RIC IEC60870-5-104 slave; with SIMATIC CPU 315, MMC 512 KB, CP 343-1 Lean	
		SIPLUS RIC bundle T104 MA CPU315 PN	6AG6 003-1AB03-0CA0
		SIPLUS RIC IEC60870-5-104 master; with SIMATIC CPU 315-2 PN/DP, MMC 512 KB	

Industrial Remote Communication

TeleControl Professional – Substations for IEC protocol

SIPLUS RIC bundles for IEC 60870-5-104

Ordering data

Order No.

SIPLUS RIC bundle with SIMATIC S7-300 (continued)

SIPLUS RIC bundle T104 SL CPU315 PN SIPLUS RIC IEC60870-5-104 slave; with SIMATIC CPU 315-2 PN/DP, MMC 512 KB	6AG6 003-1BB03-0CA0
SIPLUS RIC bundle T104 MA CPU315-2 PN/DP CP343-1 SIPLUS RIC IEC60870-5-104 master; with SIMATIC CPU 315-2 PN/DP, MMC 512 KB, CP 343-1	6AG6 003-1AB03-8CA0
SIPLUS RIC bundle T104 SL CPU315-2 PN/DP CP343-1 SIPLUS RIC IEC60870-5-104 slave; with SIMATIC CPU 315-2 PN/DP, MMC 512 KB, CP 343-1	6AG6 003-1BB03-8CA0
SIPLUS RIC bundle T104 MA CPU315F SIPLUS RIC IEC60870-5-104 master; with SIMATIC CPU 315F-2 PN/DP, MMC 512 KB	6AG6 003-1AB11-0CA0
SIPLUS RIC bundle T104 SL CPU315F SIPLUS RIC IEC60870-5-104 slave; with SIMATIC CPU 315F-2 PN/DP, MMC 512 KB	6AG6 003-1BB11-0CA0
SIPLUS RIC bundle T104 MA CPU317 PN SIPLUS RIC IEC60870-5-104 master; with SIMATIC CPU 317-2 PN/DP, MMC 2 MB	6AG6 003-1AB05-0DA0
SIPLUS RIC bundle T104 SL CPU317 PN SIPLUS RIC IEC60870-5-104 slave; with SIMATIC CPU 317-2 PN/DP, MMC 2 MB	6AG6 003-1BB05-0DA0
SIPLUS RIC bundle T104 MA CPU319-3 PN/DP SIPLUS RIC IEC60870-5-104 master; with SIMATIC CPU 319-3 PN/DP, MMC 2 MB	6AG6 003-1AB06-0DA0
SIPLUS RIC bundle T104 SL CPU319-3 PN/DP SIPLUS RIC IEC60870-5-104 slave; with SIMATIC CPU 319-3 PN/DP, MMC 2 MB	6AG6 003-1BB06-0DA0

Order No.

SIPLUS RIC bundle with SIMATIC S7-400

SIPLUS RIC bundle T104 MA CPU412-1 CP443-1 SIPLUS RIC IEC60870-5-104 master; with SIMATIC CPU 412-1, 256 KB Flash EPROM memory card, CP 443-1	6AG6 003-3AB00-7BA0
SIPLUS RIC bundle T104 SL CPU412-1 CP443-1 SIPLUS RIC IEC60870-5-104 slave; with SIMATIC CPU 412-1, 256 KB Flash EPROM memory card, CP 443-1	6AG6 003-3BB00-7BA0
SIPLUS RIC bundle T104 MA CPU412-2 CP443-1 SIPLUS RIC IEC60870-5-104 master; with SIMATIC CPU 412-2, 1 MB Flash EPROM memory card, CP 443-1	6AG6 003-3AB01-7CA0
SIPLUS RIC bundle T104 SL CPU412-2 CP443-1 SIPLUS RIC IEC60870-5-104 slave; with SIMATIC CPU 412-2, 1 MB Flash EPROM memory card, CP 443-1	6AG6 003-3BB01-7CA0
SIPLUS RIC bundle T104 MA CPU414 PN SIPLUS RIC IEC60870-5-104 master; with SIMATIC CPU 414-3 PN/DP, 4 MB Flash EPROM memory card	6AG6 003-3AB04-0EA0
SIPLUS RIC bundle T104 SL CPU414 PN SIPLUS RIC IEC60870-5-104 slave; with SIMATIC CPU 414-3 PN/DP, 4 MB Flash EPROM memory card	6AG6 003-3BB04-0EA0
SIPLUS RIC bundle T104 MA CPU416 PN SIPLUS RIC IEC60870-5-104 master; with SIMATIC CPU 416-3 PN/DP, 16 MB Flash EPROM memory card	6AG6 003-3AB07-0GA0
SIPLUS RIC bundle T104 SL CPU416 PN SIPLUS RIC IEC60870-5-104 slave; with SIMATIC CPU 416-3 PN/DP, 16 MB Flash EPROM memory card	6AG6 003-3BB07-0GA0

Industrial Remote Communication

TeleControl Professional – Substations for IEC protocol

SIPLUS RIC extreme bundles for IEC 60870-5-104

Overview

The IEC 60870-5-104 protocol defines the communication between the control center and substations by means of a TCP/IP connection for monitoring and controlling geographically distributed systems. Communication takes place via IP-based networks (LAN/WAN). Interoperability between devices from different manufacturers is ensured for this protocol by an interoperability list.

A great advantage of the TCP/IP-based connection is the simultaneous data transfer through IEC 60870-5-104 to several devices and simultaneous diagnostics using SIMATIC Manager.

Security mechanisms are, however, not defined in the application area of IEC 60870-5-104. The encryption of user data (data integrity) and authentication of the communication partners are not incorporated in the IEC standard. Appropriate protective measures (see Industrial Security) must be implemented separately.

SIPLUS RIC extreme bundles

Refined versions for an extended ambient temperature range (-25 ... +70 °C) and exceptional medial exposure (Conformal Coating)

Ordering data	Order No.		Order No.
SIPLUS RIC extreme bundle with SIPLUS ET 200S (extended temperature range and medial exposure)		SIPLUS RIC extreme bundle with SIPLUS S7-400 (extended temperature range and medial exposure)	
SIPLUS RIC extreme bundle T104MA IM151-8 SIPLUS RIC IEC60870-5-104 master; with SIPLUS IM 151-8 CPU, MMC 128 KB	6AG6 003-6AB01-0BA7	SIPLUS RIC extreme bundle T104MA CPU416 PN SIPLUS RIC IEC60870-5-104 master; with SIPLUS CPU 416-3 PN/DP, Flash EPROM memory card 16 MB	6AG6 003-4AB07-0GA4
SIPLUS RIC extreme bundle T104SL IM151-8 SIPLUS RIC IEC60870-5-104 slave; with SIPLUS IM 151-8 CPU, MMC 128 KB	6AG6 003-6BB01-0BA7	SIPLUS RIC extreme bundle T104SL CPU416 PN SIPLUS RIC IEC60870-5-104 slave; with SIPLUS CPU 416-3 PN/DP, Flash EPROM memory card 16 MB	6AG6 003-4BB07-0GA4
SIPLUS RIC extreme bundle with SIPLUS S7-300 (extended temperature range and medial exposure)			
SIPLUS RIC extreme bundle T104MA CPU315 PN SIPLUS RIC IEC60870-5-104 master; with SIPLUS CPU 315-2 PN/DP, MMC 512 KB	6AG6 003-2AB03-0CA7		
SIPLUS RIC extreme bundle T104SL CPU315 PN SIPLUS RIC IEC60870-5-104 slave; with SIPLUS CPU 315-2 PN/DP, MMC 512 KB	6AG6 003-2BB03-0CA7		
SIPLUS RIC extreme bundle T104MA CPU317 PN SIPLUS RIC IEC60870-5-104 master; with SIPLUS CPU 317-2 PN/DP, MMC 2 MB	6AG6 003-2AB05-0DA7		
SIPLUS RIC extreme bundle T104SL CPU317 PN SIPLUS RIC IEC60870-5-104 slave; with SIPLUS CPU 317-2 PN/DP, MMC 2 MB	6AG6 003-2BB05-0DA7		

Industrial Remote Communication

TeleControl Professional – Substations for IEC protocol

SIPLUS RIC IEC 60870-5-104 library

Overview

If a SIMATIC PCS 7 system or an RTU based on WinAC RTX is to communicate with a SIMATIC PCS 7 TeleControl center or a control center of a third-party supplier using the IEC 60870-5 telecontrol standard, the IEC 60870-5-104 (TCP/IP) telecontrol protocol can be used in the SIMATIC automation systems.

Advantages of the TCP/IP-based connection are simultaneous data transfer through IEC 60870-5-104 to several devices and simultaneous diagnostics using SIMATIC Manager.

Security mechanisms are not defined in the application area of IEC 60870 5-104. An encryption of user data (data integrity) and authentication of the communication partners are not incorporated in the IEC standard. Appropriate protective measures (see Industrial Security) must be implemented separately.

Ordering data

Order No.

SIPLUS RIC PCS 7

SIPLUS RIC PCS 7 software T104 SL CP443

Function block library for telecontrol protocol IEC 60870-5-104; can be used with SIMATIC S7-400/400H, CP 443-1 interface; runtime software for an automation system, Single License for 1 installation

6AG6 003-0BB11-0AA0

SIPLUS RIC WinAC

SIPLUS RIC WinAC software T104, master and slave

Function block library for telecontrol protocol IEC 60870-5-104 master and slave, can be used with SIMATIC S7 modular embedded controller and SIMATIC IPC427C for WinAC RTX 2010; runtime software for an automation system, single license for 1 installation AS.

6AG6 003-0BB50-0AA0

Overview



SINAUT MD3 modem

Modems are used for wired transmission of signals and data between individual stations and the control center of a telecontrol system. Siemens offers appropriate modems for both dedicated lines and dial-up networks.

Like the TIM modules, these are accommodated in an S7-300 enclosure:

- **MD2;** dedicated-line modem for multi-point connection, can be tapped, can also be used as a repeater, max. 19,200 bit/s
- **MD3;** modem for the analog telephone network, max. 33,600 bit/s; can also be used as a dedicated-line modem for a point-to-point connection, max. 33,600 bit/s in voice band

These modems can be connected to the serial modem interface of a TIM module.

The modems are supplied together with the WAN connecting cable required in each case. Connecting cables for connecting the modems to a TIM must be ordered separately.

Benefits

get Designed for Industry

- Diverse application options for use in dedicated-line networks or for conventional telephone networks (analog, ISDN, GSM)
- Matched to the telecontrol system by means of the design of the SIMATIC S7-300
- Electrical isolation between power supply and WAN interface

Application

The modems can be used in other applications as dedicated-line modems or dial-up modems independently of the SINAUT ST7 system.

Due to the design and the electrical properties, the modems are suited above all for applications in the industrial sector.

Design

All three modem types are identically designed and offer all the advantages of the SIMATIC S7-300 design:

- Compact construction; double standard width of SIMATIC S7-300 SM modules
- RJ12 socket for connecting the modem to the WAN (leased line or dialup network)
- 9-pin Sub-D connector with an RS232 interface for connection to the serial interface of a communication module, e.g. TIM
- 9-pin Sub-D socket with an RS 485 interface for connection to the serial interface of a communication module, e.g. TIM
- 4-pin plug-in terminal strip for connection of the 24 V DC external supply voltage
- Front-panel LEDs indicating TXD, RXD, DTR, RTS/ONL, CTS/RI and DCD
- Simple installation; on a mounting rail of the S7-300, or on a 35 mm standard rail
- The SINAUT ST7 modems can be operated without a fan

Industrial Remote Communication

Telecontrol network – Modems

Modems

Design (continued)

Configuration examples

An MDx modem is connected to a TIM by means of a standard connecting cable of type 7701. The modem is mounted on a separate S7-300 mounting rail or on a 35 mm standard mounting rail (an appropriate adapter is available).

In an S7-400 with TIM 4R-IE the TIM and modem are mounted together on a separate S7-300 mounting rail. The TIM is connected to the CPU by means of one of its Ethernet interfaces. The TIM and MDx modem are connected by means of a standard connecting cable of type 7701.

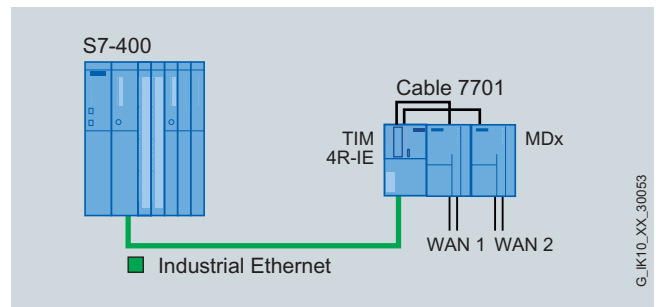
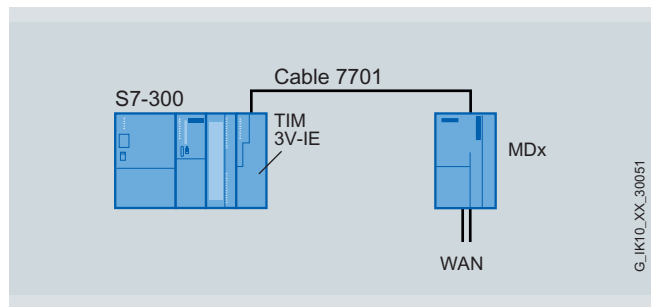

In the following configuration, the modem is accommodated to the far right in the rack. The TIM is connected to the adjacent module by means of a bus connector. There is no bus connector between TIM and modem. This means that no S7 modules may be used immediately to the right of the modem.

The next configuration shows the connection of a point-to-point dedicated line network to a TIM 4R-IE, which functions as a control center TIM, for example on the control center PC (e.g. SINAUT ST7cc or ST7sc). Each cable belonging to the point-to-point network is terminated with a modem in the control center. All these modems are connected by means of their RS485 interface to the RS232/RS485 interface of the TIM 4R-IE.

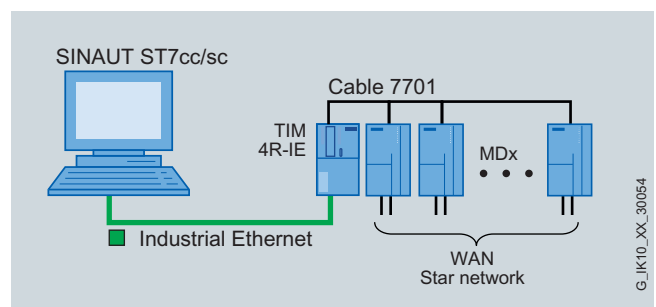
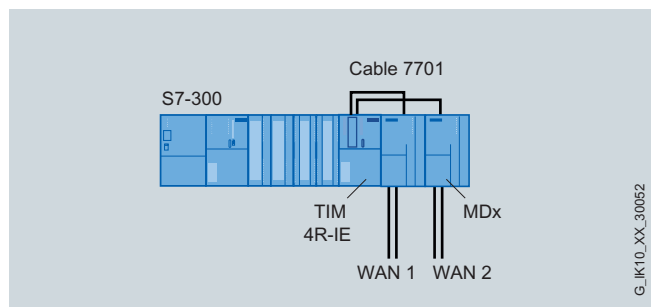

Industrial Remote Communication

Telecontrol network – Modems

MD2 dedicated line modem

Overview



- Frequency-modulated (FSK) dedicated line modem;
- Half-duplex data transfer over 2-wire dedicated line, duplex data transfer over 4-wire dedicated line
- Thanks to the modem's relaying ability, lines with several connected stations can also be implemented. The MD2 can also be used as repeater on 2-wire and 4-wire dedicated lines.
- Private or leased telephone lines can be used as dedicated lines. The MD2 is also suitable for connection to a radio device with modem input.

Benefits

get Designed for Industry

- RS232 and RS485 interface
- Isolation between voltage supply and RS232/RS485 interface
- 4 different transmission rates to select
- Supports tandem stations
- Integrated double transformer for the connection of two 2-wire lines
- Integrated repeater function for multiplication of range
- Suitable for connection to a wireless device with modem input

Application

The MD2 modem can be used as a dedicated-line modem independently of the SINAUT ST7 system. Due to its design and the electrical properties, the MD2 is especially suited for use in the industrial sector.

Examples of use outside the SINAUT ST7 system:

- Extension of Profibus and MPI links; see FAQ 23671172 (for PB) or 23671640 (for MPI)
- As leased line modem for S7-200; see Micro Automation Set MAS 17

The MD2 enables distances of up to 33 km (at 1200 bit/s), 27 km (at 2400 bit/s) and up to 11 km (at 9600 and 19,200 bit/s) to be spanned without amplifiers/repeaters (guide values for uncoiled communication cable of type 2 x 2 x 0.8 J-Y(St)Y). By interconnecting two MD2 modems to a repeater, the specified distances can be extended several times.

The MD2 modem permits the construction of network structures in the "point-to-point", "star" or "linear" configurations, as well as combinations of these basic structures. If the modem is used in the control center, a small star network comprising two 2-wire cables can be connected at the modem output. By connecting several MD2s (max. 32) by means of their RS485 interfaces, the star network can be expanded to a multiple of 2 x 2-wire.

For the arrangement of an MD2 along a line, the modem output can be switched to high impedance. This reduces the insertion loss to a minimum and thus only marginally reduces the maximal bridgeable distance. The very short transmitter make-times ensure a prompt execution of the data traffic with the "polling" used in the dedicated line network.

Apart from private dedicated lines, the MD2 can also be connected to Telekom leased lines. Corresponding approval exists. In the case of exclusively analog leased lines, the transmission rates 1200 and 2400 bit/s are possible, whereas for analog/digital-converted leased lines the speed is usually limited to 1200 bit/s for technical reasons.

The MD2 is also ideal for data transmission via a walkie-talkie with modem input. In order to switch the walkie-talkie on and off via its PTT input, a floating optical relay is integrated in the MD2 modem that is linked with the RTS signal of the RS232 interface. The two connections of the optical relay are available on the RJ12 socket.

As walkie-talkies usually only transmit voice signals in the 300 to 3000 Hz frequency range, the transmission rate with the MD2 modem is limited here to 1200 bit/s. For 2400 bit/s, the frequency range would have to exceed 3300 Hz.

Industrial Remote Communication

Telecontrol network – Modems

MD2 dedicated line modem

Design

The MD2 modem offers all the advantages of the SIMATIC S7-300 design:

- Compact construction; double standard width of SIMATIC S7-300 SM modules
- RJ12 socket for connecting the modem to the dedicated line
- 9-pin Sub-D connector with an RS232 interface for connecting the modem to the RS232/RS485 interface of the TIM
- 9-pin Sub-D connector with an RS485 interface for connecting the modem to the RS232/RS485 interface of the TIM
- 4-pin plug-in terminal strip for connection of the 24 V DC external supply voltage
- Front-panel LEDs indicating TXD, RXD, DTR, RTS/ONL, CTS/RI and DCD
- Easy installation; the modem is mounted on an S7-300 mounting rail; alternatively, it can be mounted on a 35mm standard rail using the adapter 6NH7760-OAA0, available separately.
- The modem can be operated without a fan.

Integration

Various ways in which the MD2 modem can be connected to a TIM or other MD2 modems, as well as to the dedicated line (via an LTOP overvoltage protection module), are illustrated below.

Connection of an MD2 to a TIM via the RS232 interface

One MD2 modem can be connected to a TIM via the RS232 interface. This technique can be used to set up "point-to-point" and "line" network configurations as well as a small star network (only with TIM 4) with only two 2-wire lines.

Connection of several MD2s to a TIM via the RS485 interface

Several MD2 modems can be connected to a TIM 4 via the RS485 interface. This type of interconnection is used if a number of dedicated lines have to be combined on a single WAN port on the TIM, i.e. if a star topology is connected, as illustrated schematically below.

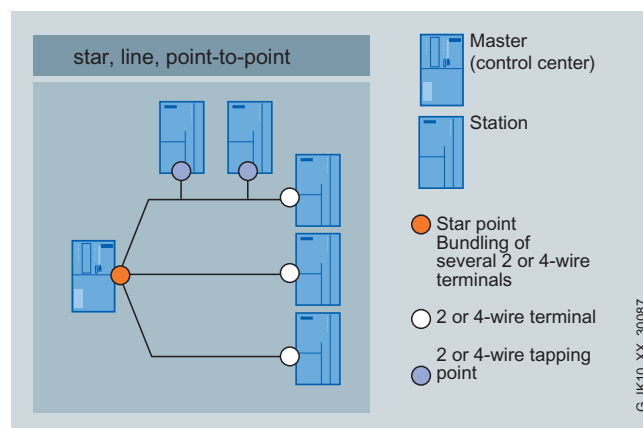

Calculating the maximum range (in km) based on transmission rate and wire diameter

The table below can be used to calculate approximate values for the maximum distance in km which can be covered by the MD2 modem, depending on transmission rate and wire diameter.

The values in the table are guide values for non-coil-loaded message lines type 2 x 2 x A J-Y(St)Y (A = core diameter in mm).

A level reserve of 4 dB was applied when calculating the maximum ranges. This should ensure that even in the event of deviations in cable characteristics, which experience has shown to be possible during operation, the level will always be sufficient to ensure fault-free data transmission.

Integration (continued)

Transfer rate (bit/s)	Maximum range (km)			
	Transmission level –6 dB ¹⁾		Transmission level 0 dB ¹⁾	
	With LTOP	Without LTOP	With LTOP	Without LTOP
<i>Core diameter 0.6 mm</i>				
1 200	21.7 – AST x 0.6	22 – AST x 0.3	25.7 – AST x 0.6	26 – AST x 0.3
2 400	17.6 – AST x 0.4	17.8 – AST x 0.2	20.8 – AST x 0.4	21 – AST x 0.2
9 600 / 19 200	7.2 – AST x 0.6	7.6 – AST x 0.1	8.6 – AST x 0.6	9 – AST x 0.1
<i>Core diameter 0.8 mm</i>				
1 200	28.3 – AST x 0.7	28.6 – AST x 0.4	33.5 – AST x 0.7	33.9 – AST x 0.4
2 400	23.2 – AST x 0.5	23.5 – AST x 0.2	27.5 – AST x 0.5	27.8 – AST x 0.2
9 600 / 19 200	9.6 – AST x 0.7	10.3 – AST x 0.1	11.5 – AST x 0.7	12.1 – AST x 0.1
<i>Core diameter 0.9 mm</i>				
1 200	36.2 – AST x 0.9	36.6 – AST x 0.5	42.8 – AST x 0.9	43.3 – AST x 0.5
2 400	29.6 – AST x 0.6	30 – AST x 0.2	35 – AST x 0.6	35.4 – AST x 0.2
9 600 / 19 200	11.9 – AST x 0.9	12.6 – AST x 0.1	14.2 – AST x 0.9	15 – AST x 0.1
<i>Core diameter 1.2 mm</i>				
1 200	50.1 – AST x 1.3	50.7 – AST x 0.7	59.3 – AST x 1.3	60 – AST x 0.7
2 400	43.4 – AST x 0.8	44 – AST x 0.3	51.4 – AST x 0.8	52 – AST x 0.3
9 600 / 19 200	17.2 – AST x 1.3	18.3 – AST x 0.2	20.5 – AST x 1.3	21.6 – AST x 0.2
<i>Core diameter 1.4 mm</i>				
1 200	59.2 – AST x 1.5	60 – AST x 0.8	70.1 – AST x 1.5	70.9 – AST x 0.8
2 400	54.3 – AST x 1	55 – AST x 0.4	64.3 – AST x 1	65 – AST x 0.4
9 600 / 19 200	20.6 – AST x 1.5	22 – AST x 0.2	24.6 – AST x 1.5	26 – AST x 0.2

AST = number of tandem stations

¹⁾ Not possible on leased telephone lines. Set transmission level to -9 dB.

Industrial Remote Communication

Telecontrol network – Modems

MD2 dedicated line modem

Technical specifications

Dedicated line modem MD2		Dedicated line modem MD2	
Interfaces		Transmission level can be set to	0 dB -6 dB -9 dB (for leased telephone lines) -15 dB
• Connection for dedicated line	1 x RJ12	Receiving level	0 ... -43 dB
• RS232 connection for data terminal equipment	1 x 9-pin Sub-D connector	Adjustable terminating resistor	600 ohms 150 ohms > 6 kOhms
• RS485 connection for data terminal equipment	1 x 9-pin Sub-D socket	• for 1200 and 2400 bit/s	
• Connection for supply voltage	1 x 4-pin terminal block	• for 9600 and 19200 bit/s	
Voltage supply	24 V DC	Clear to send	after 7 ms after 4 ms after 0.5 ms
Current consumption		• at 1200 bit/s	
• from 24 V DC	100 mA	• at 2400 bit/s	
Power loss	2.4 W	• at 9600 and 19200 bit/s	
Permissible ambient conditions		Minimum/maximum scanning frequency	1300 Hz/2100 Hz 2400 Hz/3300 Hz 20800 Hz/33600 Hz
• Operating temperature	0 °C ... +60 °C	• at 1200 bit/s	
• Transport/storage temperature	-40 °C ... +70 °C	• at 2400 bit/s	
• Relative humidity	max. 95 % at +25 °C	• at 9600 and 19200 bit/s	
Design		Asynchronous character format	10 or 11 bit
• Module format	Compact module S7-300, double width	Floating opto-relay output	60 V AC/DC 400 mA 3 ohms
• Dimensions (W x H x D) in mm	80 x 125 x 120	• Max. supply voltage	
• Weight	approx. 300 g	• Max. perm. continuous current	
Degree of protection	IP20	• Max. R _{on}	
Transmission path	2-wire, 2 x 2-wire or 4-wire, twisted pair cable, non-coil-loaded or lightly coil-loaded	Impulse strength	2.5 kV 2.5 kV
Modulation method	Phase-continuous binary frequency modulation (FSK)	<i>U</i> _{1,2/50} acc. to DIN VDE 0804 between power supply circuit and	
Data transmission rates via the dedicated line	1200 bit/s 2400 bit/s 9600 bit/s (not for leased telephone lines) 19200 bit/s (not for leased telephone lines)	• Power supply circuit and FSK trunk line circuits	
Operating mode		• Power supply circuit and opto-relay output	
• 2-wire or 2 x 2-wire	Half-duplex	Compatible with SINAUT modems	at 1200 bit/s at 1200, 2400 and 19200 bit/s
• 4-wire	Duplex or half-duplex	• MD100	
		• MD124	
		Approvals	EU approval CE 0682 X

Ordering data

	Order No.
MD2 dedicated-line modem	6NH7 810-0AA20
For multi-point connection, supports tandem stations, can also be used as a repeater, max. 19,200 bit/s; incl. WAN connecting cable 6NH7700-2AR60 (RJ12/RJ12) for connecting the modem with an LTOP overvoltage protection module	
MD2 Modem Operating Instructions	
Paper version	
• German	6NH7 811-0AA21
• English	6NH7 811-0AA22
Connecting cable	
For connecting a TIM with one of the SINAUT ST7 MD2, MD3 or MD4 modems; cable length 1.5 m	
• RS 232	6NH7 701-4AL
• RS 485 (not for TIM 3V-IE)	6NH7 701-4DL

Accessories

	Order No.
Connecting cable	6NH7 701-1CB
For connecting two MD2 modems (RS 232) in order to create a repeater; cable length 0.3 m	
RJ12/RJ12 connecting cable (replacement)	6NH7 700-2AR60
Line transformer with overvoltage protection	
• LTOP1 for 2-wire terminal	6NH9 821-0BC11
• LTOP2 for 4-wire terminal, 2 x 2-wire terminal or 2-wire tandem station	6NH9 821-0BC12
Adapter	6NH7 760-0AA
For mounting the MD2 modem on a 35 mm standard mounting rail	
SITOP compact 24 V/ 0.6 A	6EP1 331-5BA00
1-phase power supply with wide-range input 85 ... 264 V AC/110 ... 300 V DC, stabilized output voltage 24 V, rated output current value 0.6 A, slim design	

Industrial Remote Communication

Telecontrol network – Modems

SIPLUS MD2 dedicated line modem

Overview



- Frequency-modulated (FSK) dedicated line modem;
- Half-duplex data transfer over 2-wire dedicated line, duplex data transfer over 4-wire dedicated line
- Thanks to the modem's relaying ability, lines with several connected stations can also be implemented. The MD2 can also be used as repeater on 2-wire and 4-wire dedicated lines.
- Private or leased telephone lines can be used as dedicated lines. The MD2 is also suitable for connection to a radio device with modem input.

Note:

SIPLUS extreme products are based on Siemens Industry standard products. The contents listed here were taken from the respective standard products. SIPLUS extreme-specific information was added.

SIPLUS MD2 dedicated line modem

Order number	6AG1 810-0AA20-4AA0
Order No. based on	6NH7 810-0AA20
Ambient temperature range	0 ... +60 °C
Conformal coating	Coating of the printed circuit boards and the electronic components
Technical data	The technical data of the standard product applies except for the ambient conditions.

Ambient conditions

Relative humidity	5 ... 100 % Condensation permissible
Biologically active substances	Conformity with EN 60721-3-3, Class 3B2 mold and fungal spores (except fauna)
Chemically active substances	Conformity with EN 60721-3-3, Class 3C4 incl. salt mist and ISA-S71.04 severity level G1; G2; G3; GX ^{1) 2)}
Mechanically active substances	Conformity with EN 60721-3-3, Class 3S4 including conductive sand, dust ²⁾
Air pressure (depending on the highest positive temperature range specified)	1080 ... 795 hPa (-1000 ... +2000 m) see ambient temperature range 795 ... 658 hPa (+2000 ... +3500 m) derating 10 K 658 ... 540 hPa (+3500 ... +5000 m) derating 20 K

- 1) ISA-S71.04 severity level GX: Long-term load: SO₂ < 4.8 ppm; H₂S < 9.9 ppm; Cl < 0.2 ppm; HCl < 0.66 ppm; HF < 0.12 ppm; NH < 49 ppm; O₃ < 0.1 ppm; NOX < 5.2 ppm
Limit value (max. 30 min/d): SO₂ < 17.8 ppm; H₂S < 49.7 ppm; Cl < 1.0 ppm; HCl < 3.3 ppm; HF < 2.4 ppm; NH < 247 ppm; O₃ < 1.0 ppm; NOX < 10.4 ppm

- 2) The supplied plug covers must remain in place over the unused interface when operated in atmospheres containing corrosive gases!

The technical documentation on SIPLUS can be found here:
www.siemens.com/siplus-extreme

Ordering data

Order No.

SIPLUS MD2 dedicated line modem

6AG1 810-0AA20-4AA0

For multi-point connection, supports tandem stations, can also be used as a repeater, max. 19,200 bit/s; incl. WAN connecting cable 6NH7700-2AR60 (RJ12/RJ12) for connecting the modem with an LTOP overvoltage protection module

Software, connecting cables and other accessories

see ordering data for MD2 dedicated line modem

Industrial Remote Communication

Telecontrol network – Modems

MD3 telephone modem

Overview



- Dial-up modem for data transfer using the analog telephone network
- It can also be used as a dedicated line modem. Duplex data transfer is thus possible in the voice band over 2-wire dedicated lines.
- Private or leased telephone lines can be used as dedicated lines.

Benefits

get Designed for Industry

- RS232 and RS485 interface
- Isolation between voltage supply and RS232/RS485 interface
- Transmission rate on the telephone network and dedicated line max. 33600 bit/s

Application

The MD3 modem can be used as a telephone modem or dedicated-line modem independently of the SINAUT ST7 system. Due to its design and electrical properties, the MD3 is especially suited for use in the industrial sector.

Telephone modem

When used as a telephone modem, it enables connections to be set up with other MD3 or compatible modems, e.g. with the MD125 and MDM2425B DX modems that were used with the SINAUT ST1 system.

Dedicated-line modem

Apart from private dedicated lines, the MD3 can also be connected to Telekom leased lines. Corresponding approval exists. There are no restrictions in terms of the possible transmission rates either with exclusively analog leased lines or with analog/digital converted leased lines.

When used as a dedicated-line modem on private lines, the MD3 enables distances of up to 34 km (at 300 bit/s), 28 km (at 1200 to 19200 bit/s) and up to 19 km (at 33600 bit/s) to be spanned without amplifiers/repeaters (guide values for uncoiled communication cable of type 2 x 2 x 0.8 J-Y(St)Y).

When connected to Telekom leased lines, any distance can be spanned. Depending on the quality of the leased line in each case, the leased line provider guarantees sufficient reception signal level at both end points. The line qualities M1020 and M1025 are recommended.

Used as a dedicated-line modem, the MD3 enables networks to be constructed in "point-to-point" or "star" configurations. If the modem is used in the central office, the star network can be expanded to as many as 32 point-to-point connections by linking several MD3 modems via their RS485 interface.

Design

The MD3 modem offers all the advantages of the SIMATIC S7-300 design:

- Compact construction; double standard width of SIMATIC S7-300 SM modules
- RJ12 socket for connecting the modem via the supplied 6NH7700-3BR60 connecting cable to the telephone jack or the dedicated line
- 9-pin Sub-D connector with an RS232 interface for connecting the modem to the RS232/RS485 interface of the TIM
- 9-pin Sub-D connector with an RS485 interface for connecting the modem to the RS232/RS485 interface of the TIM
- 4-pin plug-in terminal strip for connection of the 24 V DC external supply voltage
- Front-panel LEDs indicating TXD, RXD, DTR, RTS/ONL, CTS/RI and DCD
- Easy installation; the modem is mounted on an S7-300 mounting rail; alternatively, it can be mounted on a 35mm standard rail using the adapter 6NH7760-0AA, available separately.
- The modem can be operated without a fan.

Integration

The diagrams below illustrate how the MD3 modem and the TIM module can be connected to the telephone outlet and which configurations are possible when the modem is used as a dedicated-line modem.

Telephone modem: Connection of the MD3 with a TIM and TAE6 telephone outlet

The diagram below illustrates how the MD3 modem, when operating in dial-up mode and using the standard connecting cable specified (the 6NH7700-3BR60 connecting cable is part of the scope of supply of the MD3), is connected to a TIM (via RS232) as well as to the telephone outlet (TAE6N socket). A telephone can be connected to the same telephone outlet in parallel with the modem (via the TAE6F socket).

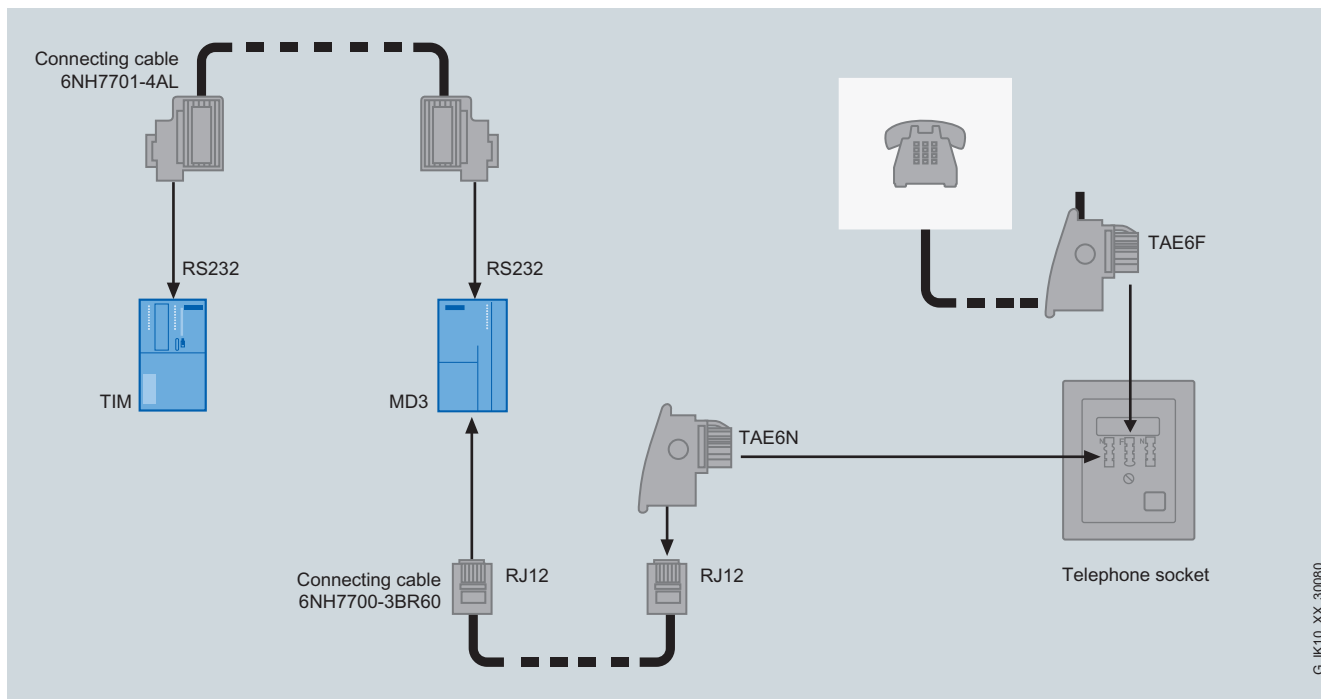

Connection of a MD3 with a TIM and TAE6 telephone outlet

Dedicated-line modem: Connection of an MD3 to a TIM via the RS232 interface

One MD3 modem can be connected to a TIM via the RS232 interface. This technique can be used to set up a "point-to-point" network configuration.

Dedicated-line modem: Connection of several MD3 to a TIM via the RS485 interface

Several MD3 modems can be connected to a TIM via the RS485 interface. This type of interconnection is used if several dedicated lines have to be combined on a single WAN port on the TIM, i.e. if a point-to-point network is connected.

Dedicated-line modem: Maximum range (in km) of the MD3 modem

The table below can be used to calculate approximate values for the maximum distance in km which can be covered by the MD3 modem, depending on transfer rate. The values in the table are guide values for non-coil-loaded message lines type 2 x 2 x 0.8 J-Y(St)Y.

A level reserve of 4 dB was applied when calculating the maximum ranges. This should ensure that even in the event of deviations in cable characteristics, which experience has shown to be possible during operation, the level will always be sufficient to ensure fault-free data transmission.

Transfer rate (bit/s)	Maximum range (km)			
	Transmission level -15 dB		Transmission level -10 dB	
	With LTOP	Without LTOP	With LTOP	Without LTOP
300	29	30	34	35
1200 to 19,200	23	24	28	29
33600	14	15	19	20

With terminating resistor $Z = Z_r$

Industrial Remote Communication

Telecontrol network – Modems

MD3 telephone modem

Technical specifications

MD3 telephone modem		MD3 telephone modem	
Interfaces		Telephone charge pulse filter can be set to:	12 kHz 16 kHz
• Connection for telephone network or dedicated line	1 x RJ12	Dial-up procedure	Voice frequency dialing Pulse dialing
• RS232 connection for data terminal equipment	1 x 9-pin Sub-D connector	Loop current component	Available; can be connected and disconnected
• RS485 connection for data terminal equipment	1 x 9-pin Sub-D socket	Loudspeaker	Available; can be connected and disconnected
• Connection for supply voltage	1 x 4-pin terminal block	Line matching	600 ohms Zr (frequency-dependent)
Voltage supply	24 V DC	Transmission level can be set to	-10 dB -15 dB
Current consumption		Asynchronous character format	10 or 11 bits
• from 24 V DC	200 mA	Standard dedicated-line profiles	300 bit/s (direct) 1200 bit/s (direct) 2400 bit/s (direct) 9600 bit/s (direct) 19200 bit/s (direct) 19200 bit/s (buffered) 33600 bit/s (buffered)
Power loss	4.8 W	Compatible with SINAUT modems (as telephone modem)	
Permissible ambient conditions		• MD125	1200 bit/s, duplex 2400 bit/s, duplex
• Operating temperature	0 °C ... +60 °C	- V.22	
• Transport/storage temperature	-40 °C ... +70 °C	- V.22 up to	
• Relative humidity	max. 95 % at +25 °C	• MDM2425B DX	2400 bit/s, duplex
Design		- V.22 up to	
• Module format	Compact module S7-300, double width	• MD3 (HW version < 4)	1200 bit/s, duplex 2400 bit/s, duplex 4800 bit/s, duplex 9600 bit/s, duplex 14400 bit/s, duplex
• Dimensions (W x H x D) in mm	80 x 125 x 120	- V.22	
• Weight	approx. 300 g	- V.22 up to	
Degree of protection	IP20	- V.32 up to	
Transmission path	Analog dial-up telephone network Dedicated line, 2-wire twisted pair cable, non-coil-loaded	- V.32 up to	
Available ITU transmission standards in analog telephone network		- V.32 up to	
• V.22	1200 bit/s, duplex		
• V.22 up to	2400 bit/s, duplex		
• V.32 up to	4800 bit/s, duplex		
• V.32 up to	9600 bit/s, duplex		
• V.32 up to	14400 bit/s, duplex		
• V.34 up to	19200 bit/s, duplex		
• V.34 up to	33600 bit/s, duplex		
Error correction	V.42 and MNP4		
Data compression	V.42bis and MNP5		
Modem control	AT commands V.25bis commands	Approvals	Europe U.S.A. Canada
		Recommended line quality on leased telephone lines	M1020 M1025

Industrial Remote Communication

Telecontrol network – Modems

MD3 telephone modem

Ordering data	Order No.	Order No.
<p>MD3 telephone modem</p> <p>For the analog telephone network, max. 33600 bit/s; can also be used as a dedicated-line modem for a point-to-point connection, max. 33600 bit/s in voice band; incl. WAN connecting cable 6NH7700-3BR60 (RJ12 -RJ12/TAE6) with snap-on TAE6N connector for connecting the modem to a telephone outlet (TAE6N or RJ12) or an LTOP overvoltage protection module (for dedicated-line operation)</p>	<p>6NH7 810-0AA30</p>	<p>Accessories</p> <p>Connecting cable</p> <p>For connecting a TIM with one of the SINAUT ST7 MD2, MD3 or MD4 modems; cable length 1.5 m</p> <ul style="list-style-type: none"> • RS 232 • RS 485 (not for TIM 3V-IE) <p>RJ12/RJ12 connecting cable with snap-on TAE6N connector (replacement)</p> <p>Line transformer with overvoltage protection (for dedicated line only)</p> <ul style="list-style-type: none"> • LTOP1 for 2-wire terminal <p>Adapter</p> <p>For mounting the MD3 modem on a 35 mm standard mounting rail</p> <p>SITOP compact 24 V/ 0.6 A</p> <p>1-phase power supply with wide-range input 85 ... 264 V AC/ 110 ... 300 V DC, stabilized output voltage 24 V, rated output current value 0.6 A, slim design</p>
<p>MD3 Modem Operating Instructions</p> <p>Paper version</p> <ul style="list-style-type: none"> • German • English 	<p>6NH7 811-0AA31 6NH7 811-0AA32</p>	<p>6NH7 701-4AL 6NH7 701-4DL</p> <p>6NH7 700-3BR60</p> <p>6NH9 821-0BC11</p> <p>6NH7 760-0AA</p> <p>6EP1 331-5BA00</p>

Industrial Remote Communication

Telecontrol network – GSM/GPRS/UMTS routers

EGPRS Router MD741-1

Overview



- EGPRS (GPRS with Edge) and GPRS router for wireless IP communication from Ethernet-based automation devices over GSM mobile radio networks
- Four times the transmission speed by means of EGPRS
- Integrated security functions with firewall and VPN (IPsec)

Benefits

get Designed for Industry

- Monitoring and controlling wirelessly connected telecontrol substations with low investment and operating costs
- Reduction in traveling costs and telephone charges due to remote programming and diagnostics by means of GPRS
- User-friendly diagnostics by means of terminal clients and short download times due to the higher speed with EGPRS
- High security thanks to IPsec-based VPN functionality and firewall
- Savings in configuring time thanks to the SCALANCE S Security Module through tailored VPN configuration
- Controlling and monitoring over the GPRS infrastructure of the mobile telephone providers with low-cost M2M standard contracts because VPN is integrated
- Easy planning and commissioning of substations without special wireless expertise
- Can be used worldwide thanks to quad-band technology (observe national regulations!)

Application

- The MD741-1 EGPRS router is universal. Due to its design and electrical characteristics, the EGPRS router is particularly suitable for use in industrial applications.
- Remote programming and maintenance worldwide by means of the high-speed EGPRS interface
- Energy-saving concepts for plants, e.g. through status-dependent speed control of pumps in remote stations
- Control and monitoring of
 - Sewage treatment plants, water treatment
 - Oil and gas supplies
 - District heating networks
 - Power distribution
 - Pumping stations
 - Traffic systems
 - Buildings
 - Wind generators and photovoltaic plants
- Linking of mobile stations, with central monitoring and control
- Remote diagnostics of SIMATIC S7 via GPRS with STEP 7

Design

- Rugged plastic housing for standard rail mounting
- RJ45 interface for Industrial Ethernet
- Diagnostic LEDs for modem status, field strength and connection control
- SET service button
- 4-pin screw terminal for connection to the 24 V DC power supply
- SMA antenna connection for GSM/EGPRS antenna

Function

- Quad band GSM with the frequency bands 850/900/1800/1900 MHz
- High-speed communication via EGPRS Multislot Class 12 in EGPRS networks; if there is no EGPRS network, automatic switchover to GPRS mode
- Automatic setup and holding of IP-based online connection to the Internet
- Bidirectional IP-based data communication with the telecontrol center, e.g. ST7cc or ST7sc; data is exchanged between telecontrol stations (inter-node communication) over a TIM communication module in the control center
- Integrated security functions with firewall and VPN (IPsec)
- Secure data communication with the SINAUT ST7 stations, also over mobile radio provider networks which do not provide public and fixed IP addresses for the modem

Function (continued)

Configuration

- Parameterization of the router using HTML Web browsers

Security

- VPN router for secure data transmission over public networks (IPSec protocol, 3DES data encryption, AES encryption, NAT-Traversal)
- Suitable VPN termination of the control center via SCALANCE S612 or S623¹⁾
- Firewall for protection from unauthorized access The dynamic packet filter checks data packets based on the source and target address (stateful packet inspection) and blocks undesirable data traffic (anti-spoofing)

Diagnostics / maintenance

- Connection buildup status and status of an existing connection via front LED display

Preconditions for implementing the EGPRS router MD741-1

- SIM card from a network operator that supports EGPRS

Integration

VPN termination over SCALANCE S

If a central router expected by IT personnel is not found in the control center, it is recommended that the VPN channel of the EGPRS router MD741-1 is terminated using a SCALANCE S module (SCALANCE S612 or S623¹⁾ with firmware V 2.0 or higher). The SCALANCE S configuring tool can be used to configure the VPN to suit the MD741-1. This saves the work involved in configuring the settings of a generally available router.

Telecontrol application example

The diagram below shows an S7-300 station with TIM 3V-IE and MD741-1 connected to the control center (e.g. SINAUT ST7cc or ST7sc) via EGPRS and Internet. The VPN channel of the MD741-1 is terminated in the control center by means of a SCALANCE S module (S612/623¹⁾). Behind the SCALANCE S module, a TIM 4R-IE is installed. For the control center, this module performs the SINAUT communication with the stations connected via the Internet as well as with the stations that are connected to the TIM 4R-IE via two other networks. Cross traffic between individual stations in the various networks is routed via the TIM 4R-IE.

As an option, the control center software can be augmented with the alarm control center (ACC) software package. This enables fault messages from the plant to be forwarded to service personnel by SMS, fax or e-mail.

¹⁾ Available soon

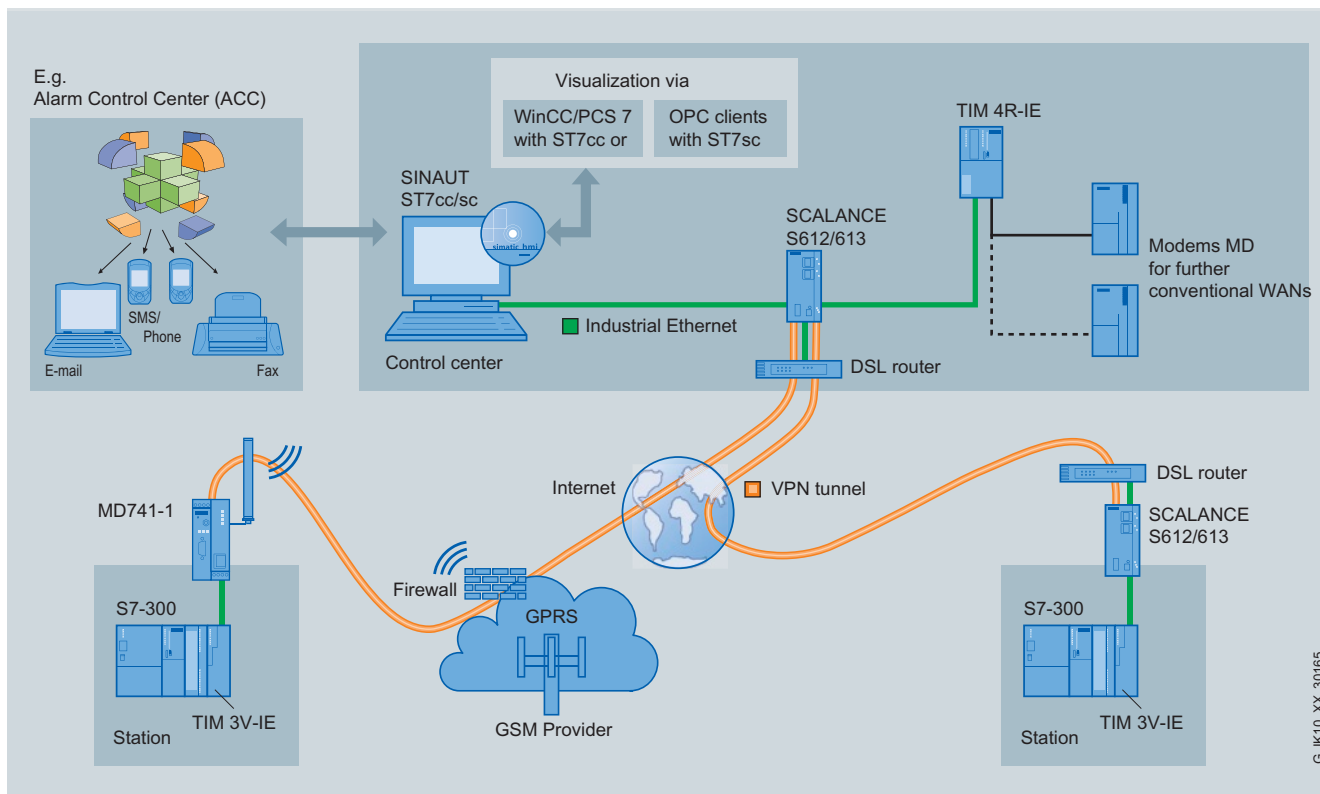

Secure telecontrol with SINAUT ST7 over IP-based networks

Industrial Remote Communication

Telecontrol network – GSM/GPRS/UMTS routers

EGPRS Router MD741-1

Integration (continued)

Application example for teleservice

Remote programming, parameterization and diagnosis can be performed securely via VPN from a service center that is connected over the Internet to machines and plant installed world-

wide. All the automation devices connected to the Ethernet port of the MD741-1 can be accessed.

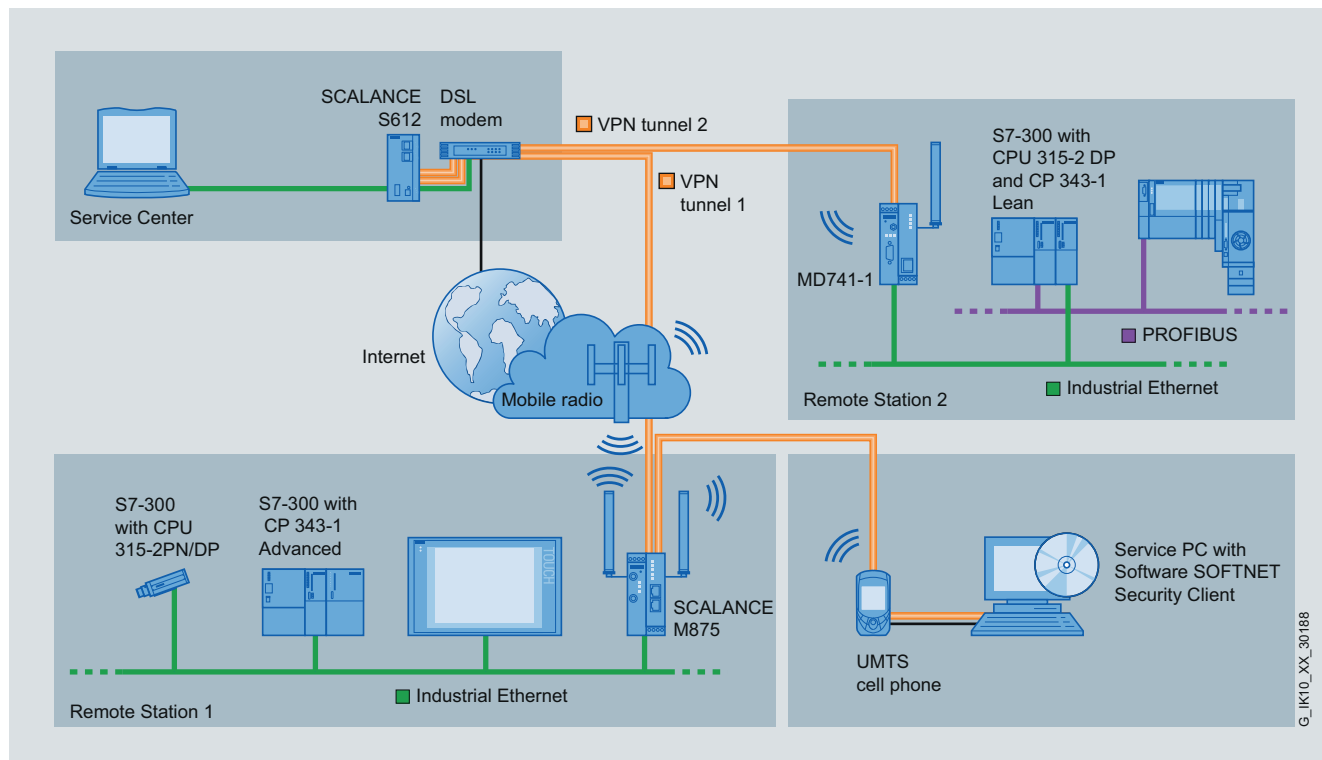

Typical remote access scenarios to distributed SIMATIC S7 stations via a secure EGPRS-based Internet connection

Technical specifications

Order No.	6NH9 741-1AA00
Product type designation	SINAUT MD 741-1 EGPRS router
Transmission rate	-
Transmission rate	
• 1 with Industrial Ethernet	10 Mbit/s
• 2 with Industrial Ethernet	100 Mbit/s
• For GSM transmission	9 600 bit/s
• For GPRS transmission	
- For downlink, maximum	85.6 kbit/s
- For uplink, maximum	42.8 kbit/s
• For eGPRS transmission	
- For downlink, maximum	238 kbit/s
- For uplink, maximum	118 kbit/s
Interfaces	-
Number of electrical connections	
• for network components or terminal equipment	2
• for external antenna(s)	1
• for power supply	1
Design of electrical connection	
• for network components or terminal equipment	RJ45 port (10/100 Mbit/s, TP, Auto-Crossover)
• for external antenna(s)	SMA antenna socket (50 Ohm)

Order No.	6NH9 741-1AA00
Product type designation	SINAUT MD 741-1 EGPRS router
Inputs/outputs	-
Number of electrical connections	
• for digital input signals	-
• for digital output signals	-
Design of electrical connection	
• for digital input signals	-
• for digital output signals	-
WAN connection	-
Type of mobile wireless network supported, GSM	Yes
Type of mobile wireless network supported	
• GPRS	Yes
• eGPRS	Yes
Operating frequency	
• 1 with GPRS transmission	850 MHz
• 2 with GPRS transmission	900 MHz
• 3 with GPRS transmission	1 800 MHz
• 4 with GPRS transmission	1 900 MHz
Type of GPRS time slot method: Multislot Class 10	Yes

G_IKT0_XX_30188

Technical specifications (continued)

Order No.	6NH9 741-1AA00
Product type designation	SINAUT MD 741-1 EGPRS router
Supply voltage, current consumption, power loss	-
Type of supply voltage	DC
Power supply	24 V
• Minimum	12 V
• Maximum	30 V
Current consumption, maximum	600 mA
Effective power loss, typical	4 W
Permissible ambient conditions	-
Ambient temperature	
• During operation	-20 ... +60 °C
• During storage	-40 ... +70 °C
Relative humidity at 25 °C during operating phase, maximum	95 %
IP degree of protection	IP20
Design, dimensions and weights	-
Design	Compact
Depth	114 mm
Height	99 mm
Width	45 mm
Net weight	280 g
Type of mounting: 35 mm DIN rail mounting	Yes
Product properties, functions, components General	-
Product function DynDNS client	Yes
Product functions Management, configuration, programming	-
Product function	
• CLI	No
• Web-based management	Yes
Protocol is supported	
• Telnet	Yes
• HTTP	Yes
• HTTPS	Yes
Type of configuring	Web Interface
Product functions Diagnostics	-
Product function	
• Packet size statistics	No
• Packet type statistics	No
• Error statistics	No
• SysLog	No
• Packet filter log	No
• System log	Yes
Product functions DHCP	-
Product function	
• DHCP client	Yes
• DHCP server - internal network	Yes
Product functions Routing	-
Router function	
• NAT (IP masquerading)	Yes
• Port forwarding	Yes
• NAT traversal	Yes
• DNS cache	Yes

Order No.	6NH9 741-1AA00
Product type designation	SINAUT MD 741-1 EGPRS router
Product functions Security	-
Configuration of firewall	Stateful inspection
Product function	
• Password protection	Yes
• Broadcast/Multicast/Unicast Limiter	-
• Broadcast blocking	-
Protocol is supported SSH	Yes
Suitability for use of virtual private network	Yes
Product function with VPN connection	T
Number of possible connections with VPN connection	10
Maximum number of network stations for internal network with VPN connection	-
Type of authentication with Virtual Private Network PSK	Yes
Protocol supported: IPsec Tunnel and Transport Mode	Yes
Key length	
• with IPsec DES with Virtual Private Network	56 bit
• 1 with IPsec AES with Virtual Private Network	128 bit
• 2 with IPsec AES with Virtual Private Network	192 bit
• 3 with IPsec AES with Virtual Private Network	256 bit
Type of Internet Key Exchange with Virtual Private Network Main Mode	Yes
Key length with IPsec 3DES with Virtual Private Network	168 bit
Type of Internet Key Exchange with Virtual Private Network Quick Mode	Yes
Type of packet authentication with Virtual Private Network	MD5, SHA-1
IETF profile with Virtual Private Network X.509v3 certificate	Yes
Product functions Time	-
Router function NTP	Yes
Standards, specifications, approvals	-
Standard	
• for EMC	-
• for EMC of FM	-
• for hazardous zone	EN 60079-15: II 3 G Ex nA IIC T4 Ta= -20 °C to 60 °C
• for CSA and UL safety	UL 60950-1, CSA C22.2 No. 60950-1
• for hazardous zone of CSA and UL	-
• for emitted interference	-
• for noise immunity	EN 61000-6-2
Certificate of suitability	EN 61000-6-2
• CE mark	Yes
• C-Tick	-
• E1 approval	-
• e1 approval	-

Industrial Remote Communication

Telecontrol network – GSM/GPRS/UMTS routers

EGPRS Router MD741-1

Ordering data	Order No.	Order No.
EGPRS router MD741-1 ¹⁾ For wireless IP communication by industrial Ethernet-based programmable controllers via GSM mobile radio networks; integrated firewall and VPN router (IPsec); quad band GSM; EGPRS Multislot Class 12	6NH9 741-1AA00	
Accessories		
IE FC RJ45 Plug 180 RJ45 plug connector for Industrial Ethernet with a rugged metal enclosure and integrated insulation displacement contacts for connecting Industrial Ethernet FC installation cables; with 180° cable outlet; for network components and CPs/CPUs with Industrial Ethernet interface <ul style="list-style-type: none"> • 1 pack = 1 unit • 1 pack = 10 units • 1 pack = 50 units 	6GK1 901-1BB10-2AA0 6GK1 901-1BB10-2AB0 6GK1 901-1BB10-2AE0	
ANT794-3M GSM/GPRS antenna GSM tri-band flat antenna with 1.2 m connecting cable	6NH9 870-1AA00	
ANT794-4MR GSM/GPRS antenna Quad band antenna, omnidirectional with 5 m cable	6NH9 860-1AA00	
		SCALANCE S Industrial Security Modules For protection of programmable controllers and automation networks, and for safeguarding of industrial communication; configuring tool and electronic manual on CD-ROM; German, English, French, Italian, Spanish <ul style="list-style-type: none"> • SCALANCE S612 uses the Stateful Inspection Firewall to protect network segments against unauthorized access; protects up to 32 devices up to 64 VPN tunnels simultaneously • SCALANCE S623²⁾ uses the stateful inspection firewall to protect network segments against unauthorized access; protects up to 64 devices, up to 128 VPN tunnels simultaneously; enhanced temperature range (-20 to +70 °C)
		6GK5 612-0BA00-2AA3 6GK5 623-0BA10-2AA3
		IE TP Cord RJ45/RJ45 TP cable 4 x 2 with 2 RJ45 connectors <ul style="list-style-type: none"> • 0.5 m • 1 m • 2 m • 6 m • 10 m
		6XV1 870-3QE50 6XV1 870-3QH10 6XV1 870-3QH20 6XV1 870-3QH60 6XV1 870-3QN10

1) Please note national approvals at www.siemens.com/wireless-approvals

2) Available soon

More information

To assist in selecting the right products for Industrial Wireless Communication, the SIMATIC NET Selection Tool is available at: www.siemens.com/snst

Wireless approvals

Current approvals can be found on the Internet at www.siemens.com/wireless-approvals

Industrial Remote Communication

Telecontrol network – GSM/GPRS/UMTS routers

SIPLUS MD741-1 EGPRS routers

Overview



- EGPRS (Edge GPRS) and GPRS router for wireless IP communication of Industrial Ethernet-based automation devices over GSM mobile networks
- EGPRS offers four times the transfer speed
- Integrated security features with firewall and VPN (IPsec)

Note:

SIPLUS extreme products are based on Siemens Industry standard products. The contents listed here were taken from the respective standard products. SIPLUS extreme-specific information was added.

SIPLUS MD741-1 EGPRS ROUTER

Order number	6AG1 741-1AA00-2AA0
Order No. based on	6NH9 741-1AA00
Ambient temperature range	-25 ... +60 °C
Conformal coating	Coating of the printed circuit boards and the electronic components
Technical data	The technical data of the standard product applies except for the ambient conditions.

Ambient conditions

Relative humidity	5 ... 100 % Condensation permissible
Biologically active substances	Conformity with EN 60721-3-3, Class 3B2 mold and fungal spores (except fauna)
Chemically active substances	Conformity with EN 60721-3-3, Class 3C4 incl. salt mist and ISA-S71.04 severity level G1; G2; G3; GX ^{1) 2)}
Mechanically active substances	Conformity with EN 60721-3-3, Class 3S4 including conductive sand, dust ²⁾
Air pressure (depending on the highest positive temperature range specified)	1080 ... 795 hPa (-1000 ... +2000 m) see ambient temperature range 795 ... 658 hPa (+2000 ... +3500 m) derating 10 K 658 ... 540 hPa (+3500 ... +5000 m) derating 20 K

- 1) ISA-S71.04 severity level GX: Long-term load: SO₂ < 4.8 ppm; H₂S < 9.9 ppm; Cl < 0.2 ppm; HCl < 0.66 ppm; HF < 0.12 ppm; NH₃ < 49 ppm; O₃ < 0.1 ppm; NO_x < 5.2 ppm
Limit value (max. 30 min/d): SO₂ < 17.8 ppm; H₂S < 49.7 ppm; Cl < 1.0 ppm; HCl < 3.3 ppm; HF < 2.4 ppm; NH₃ < 247 ppm; O₃ < 1.0 ppm; NO_x < 10.4 ppm

- 2) The supplied plug covers must remain in place over the unused interface when operated in atmospheres containing corrosive gases!

The technical documentation on SIPLUS can be found here:
www.siemens.com/siplus-extreme

Ordering data	Order No.
SIPLUS MD741-1 EGPRS router	6AG1741-1AA00-2AA0
For wireless IP communication by industrial Ethernet-based programmable controllers via GSM mobile radio networks; integrated firewall and VPN router (IPsec); quad band GSM; EGPRS Multislot Class 12	
<i>Software, connecting cables and other accessories</i>	see ordering data for MD2 dedicated line modem

Industrial Remote Communication

Telecontrol network – GSM/GPRS/UMTS routers

UMTS-Router SCALANCE M87x

Overview



- UMTS, EGPRS (Edge GPRS) and GPRS router for wireless IP communication of Industrial Ethernet-based PLCs over UMTS/GSM mobile wireless networks
- High data transfer rate thanks to UMTS
- Integrated security functions with firewall
- *SCALANCE M875*¹⁾
Use both as VPN server and as client (IPsec)

Benefits

get Designed for Industry

- Low investment and operating costs for operator control and monitoring of wirelessly connected telecontrol substations
- Reduced travel costs and telephone charges thanks to remote programming and remote diagnosis via UMTS
- High security thanks to integral firewall and VPN with IPsec (*SCALANCE M875* only)
- Utilization of existing UMTS/GSM infrastructure of the mobile radio providers
- Simple planning and commissioning of telecontrol substations without special radio expertise

Application

- Can be used in industrial and semi-industrial applications due to its design and electrical properties
- Remote programming and maintenance worldwide, e.g. with STEP 7 via the high-speed UMTS interface
- Linking of mobile stations, with central monitoring and control
- Energy-saving concepts in distributed systems, e.g. through status-dependent speed control of pumps in remote stations
- Control and monitoring of
 - Sewage treatment plants, water treatment
 - Oil and gas supplies
 - District heating networks
 - Power distribution
 - Pumping stations
 - Transportation systems
 - Buildings
 - Wind energy and photovoltaic plants
- Connection of telecontrol substations (e.g. SINAUT ST7) to control center via UMTS
- Video transmission e.g. from moving vehicles such as buses and trains
- Can be used worldwide due to:
 - UMTS: tri-band technology
 - GSM: quad-band technology

Note:

Country-specific approvals must be observed.

Due to the integral security functions, the *SCALANCE M875* UMTS router enables protected connection of distributed automation cells to a control center via the mobile wireless network, and it can be used within the scope of the Siemens Remote Service. This comprehensive service allows companies to task Siemens with the monitoring, control and maintenance of distant plants and machines via remote access.

Design

- Rugged plastic enclosure for standard rail mounting
- RJ45 interface for Industrial Ethernet
- Diagnostic LEDs for modem status, field strength, connection control, and DI/DO channels
- SET service button
- 4-pin screw terminal for connection to the 24 V DC power supply
- 4-pin screw terminal for one digital input and one digital output
- SMA antenna connection for UMTS/GSM antenna

Product versions

SCALANCE M873

- 1 x RJ45 port with 10/100 Mbit/s
- 1 x SMA antenna connection
- Support for UMTS with HSDPA (downlink: 3.6 Mbit/s, uplink: 384 kbit/s)
- Integral firewall function

*SCALANCE M875*¹⁾

- 2 x RJ45 ports with 10/100 Mbit/s
- 2 x SMA antenna connection (antenna diversity)
- Support for UMTS with HSDPA and HSUPA (downlink: 14.4 Mbit/s, uplink: 5.76 Mbit/s)
- Integral firewall function and VPN with IPsec
- Type approval as vehicle component in accordance with Directive 72/245/EEC in Version 2009/19/EC

¹⁾ Available soon

Industrial Remote Communication

Telecontrol network – GSM/GPRS/UMTS routers

UMTS-Router SCALANCE M87x

Function

- Tri-band UMTS with the frequency bands 850/1900/2100 MHz
- Quad band GSM with the frequency bands 850/900/1800/1900 MHz
- Without UMTS network, automatic switchover to EGPRS (Multislot Class 12) or GPRS mode
- Automatic setup and holding of IP-based online connection to the Internet
- Merging of distributed, IP-based networks via UMTS/GSM mobile radio networks
- Bi-directional IP-based data communication with the telecontrol center, e.g. ST7cc or ST7sc, WinCC or PCS7
- Integrated security functions with firewall
- Data exchange between telecontrol stations (slave-slave communication) via a TIM communication module in the service center
- Secure data communication with the SINAUT ST7 stations, also over mobile radio provider networks which do not provide public and fixed IP addresses for the modem
- Automatic and user-defined sending of text messages

Configuration

- User-friendly configuration of all network and firewall parameters of the router using the web browser

Security

- Router for data transmission via public networks with NAT functionality (NAT-Traversal)
- Suitable VPN termination of the control center via SCALANCE S
- Firewall for protection against unauthorized access; the dynamic packet filter checks data packets based on the source and target address (stateful packet inspection) and blocks undesirable data traffic (anti-spoofing)

Diagnostics / maintenance

- Status of connection buildup and of an existing connection via front LED display and web browser

Preconditions for using the SCALANCE M873 UMTS router

- SIM card from a UMTS network operator with HSDPA support, or alternatively a SIM card from a GSM network operator with EGPRS or GPRS support

Integration

Application example SCALANCE M873 Internet access without VPN or with VPN provider

A distributed S7-300 station is connected to the Internet with the help of the SCALANCE M873 UMTS router. This makes it possible to access the plant over the Internet via HTTP or HTTPS, and to monitor remote plant sections. It is also possible to inform service engineers, for example, of statuses by sending e-mails. The mobile radio provider's secure tunnels can be used for transmitting confidential information with the SCALANCE M873. The provider's APN (**A**ccess **P**oint **N**ame), to which the encrypted connection is established, is located at the network transition to the mobile wireless network. Availability varies depending on the network operator.

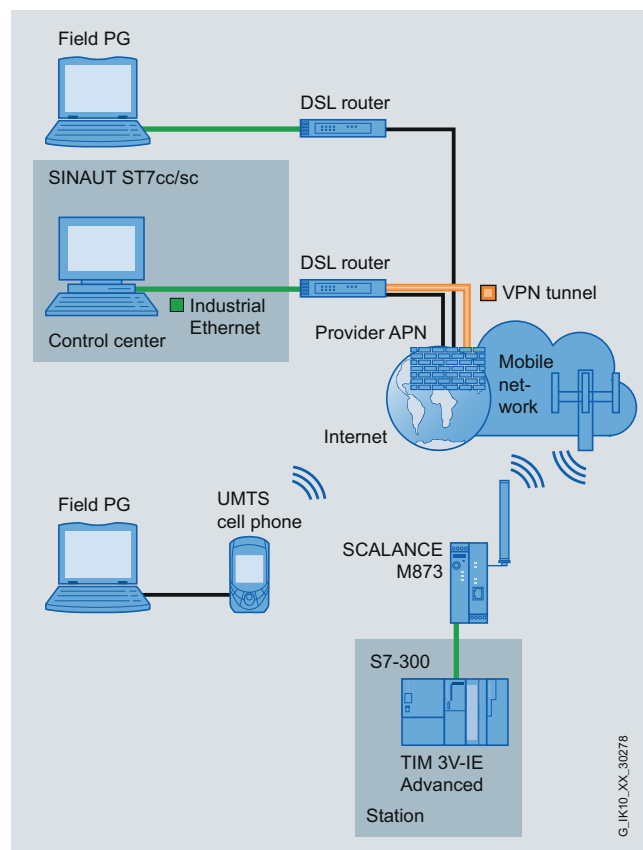

Typical remote access scenarios via an UMTS-based Internet connection

Industrial Remote Communication

Telecontrol network – GSM/GPRS/UMTS routers

UMTS-Router SCALANCE M87x

Integration (continued)

Application example: SCALANCE M875¹⁾ for remote maintenance with VPN tunnel

Classical applications such as remote programming, parameterization and diagnosis, but also monitoring of machines and plants installed worldwide can be performed securely via a VPN from a service center that is connected over the Internet. Any

IP-based devices, especially IP-based programmable controllers, which are downstream of the SCALANCE M875 in the local network, can be accessed.

Multimedia applications like video streaming can be implemented thanks to the increased bandwidth in the uplink.

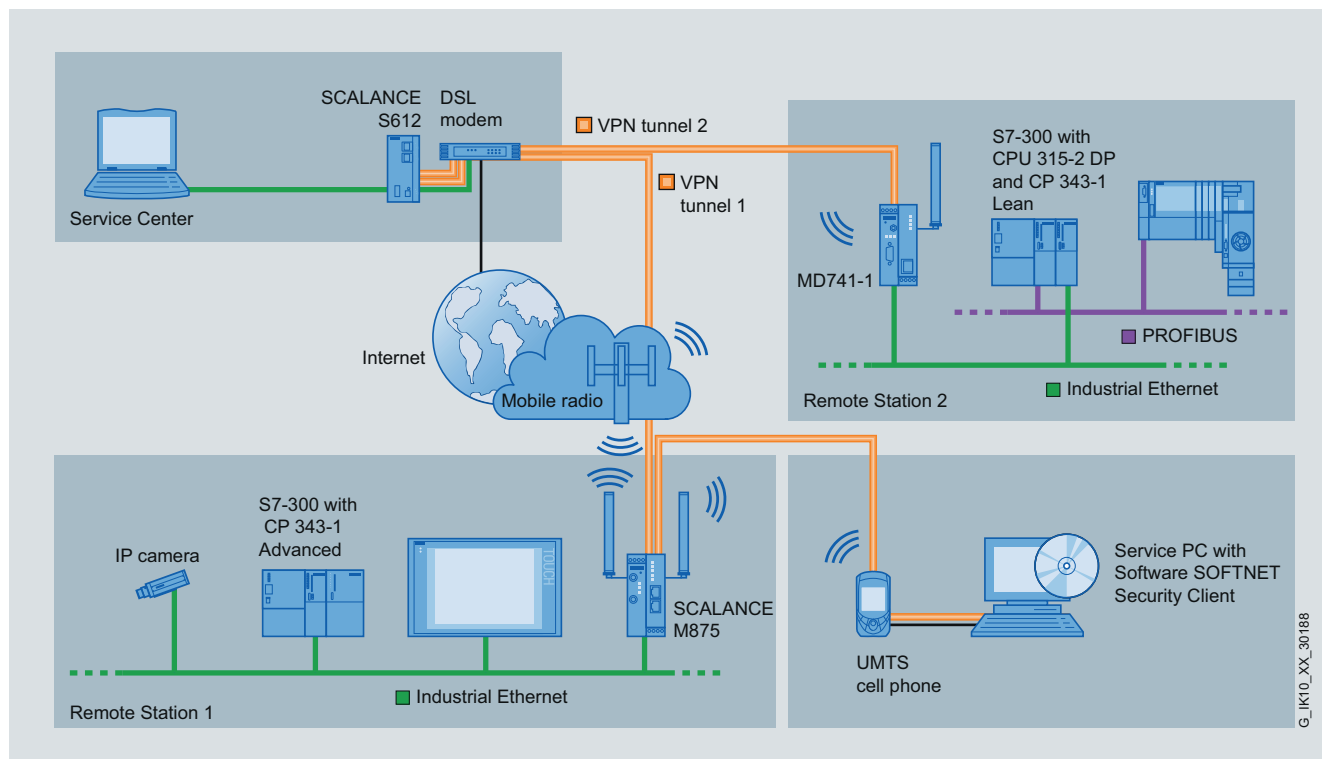

Typical remote access scenario via a secure UMTS-based Internet connection

¹⁾ Available soon

Integration (continued)

Application example, broadband data transmission in vehicles with SCALANCE M875¹⁾

The UMTS router SCALANCE M875, with its high down-link and uplink capacity, supports numerous data services with large bandwidth requirements via mobile wireless to and from vehicles. To increase the connection quality during motion, SCALANCE M875 is equipped with antenna diversity. Alternatively, sensitive data can be transmitted in a secure VPN tunnel.

Video transmission in real-time from the passenger cell is used to increase passenger safety (video surveillance). The video data from all vehicles is sent to a control central for monitoring and further processing.

In addition, applications such as data interfacing for ticket machines, infotainment services and Internet on board, or proactive monitoring of vehicle engineering (telemetry) are also possible.

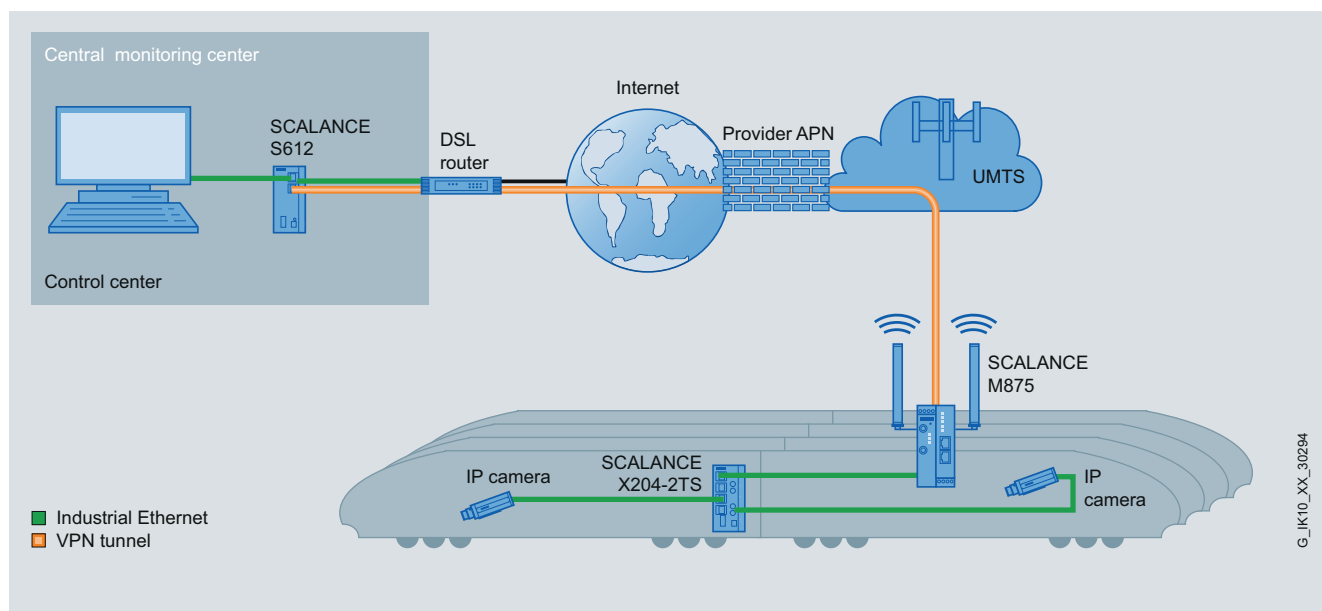

Broadband video data transmission over UMTS, protected via VPN, to increase passenger safety

¹⁾ Available soon

Industrial Remote Communication

Telecontrol network – GSM/GPRS/UMTS routers

UMTS-Router SCALANCE M87x

Integration (continued)

Application example for SINAUT ST7 with SCALANCE M875¹⁾

The diagram below shows an S7-300 station with TIM 3V-IE and SCALANCE M875 connected to the control center (SINAUT ST7cc or ST7sc) via UMTS and the Internet. Behind the SCALANCE S module, a TIM 4R-IE is installed. For the control center, this module performs the SINAUT communication with the stations connected via the Internet as well as with the sta-

tions that are connected to the TIM 4R-IE via two other networks. Cross traffic between individual stations in the various networks is routed via the TIM 4R-IE.

As an option, the control center software can be augmented with the alarm control center (ACC) software package. This enables fault messages from the plant to be forwarded to service personnel by SMS, fax or e-mail.

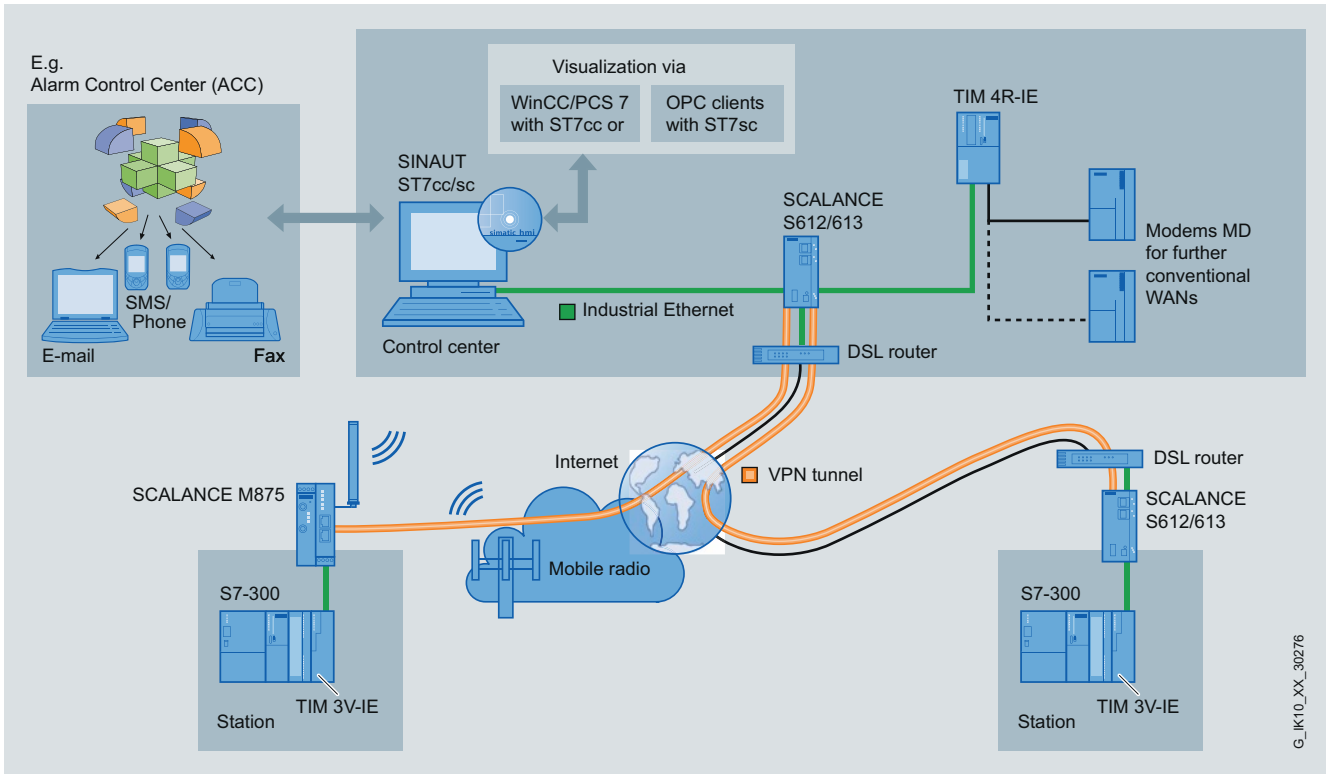

G_IK10_XX_30276

Secure telecontrol with SINAUT ST7 over IP-based networks

¹⁾ Available soon

Industrial Remote Communication

Telecontrol network – GSM/GPRS/UMTS routers

UMTS-Router SCALANCE M87x

Integration (continued)

Application example: SINAUT ST7 with SCALANCE M873

In the application given here, three S7-300 stations with a TIM module are connected to a control center (SINAUT ST7cc, ST7sc or STEP 7 with ST7 ES) via the Internet or the mobile wireless network. A TIM 4R-IE is installed in the control center. This module handles the SINAUT communication with the connected stations on behalf of the control center. To make the connection to the remote stations secure, the TIM 4R-IE establishes a VPN tunnel to the remote stations.

One station is connected with the help of a DSL router. The two other stations are connected to the control center either using an M873 UMTS router or an MD720 GSM modem over the mobile wireless network. Since the MD720 GSM modem establishes the VPN tunnel in the direction of the control center, a TIM 3V-IE module is used here. The two other stations are equipped with a TIM 3V-IE Advanced since the VPN tunnel must be established via the TIM module.

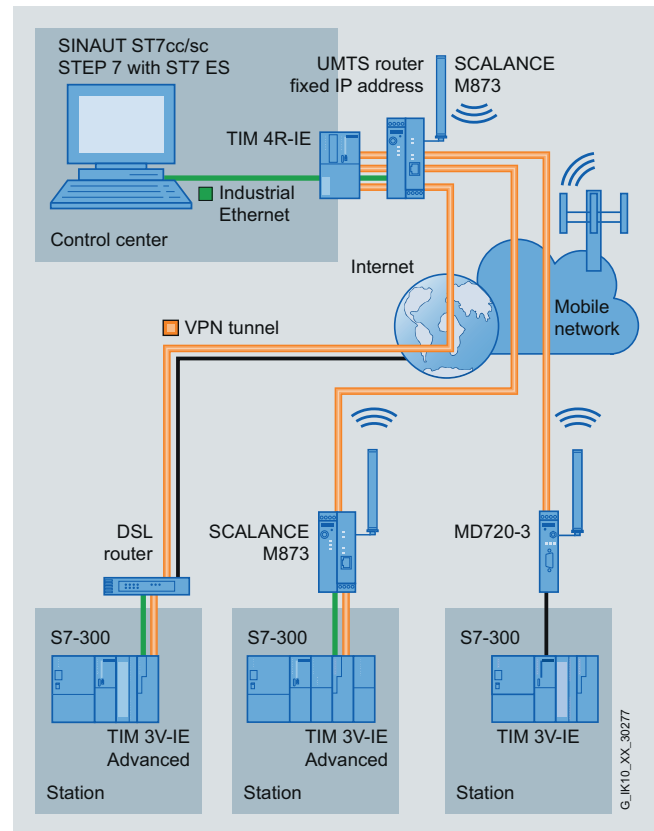

Secure telecontrol with SINAUT ST7 over secure VPN connections by means of TIM modules

Industrial Remote Communication

Telecontrol network – GSM/GPRS/UMTS routers

UMTS-Router SCALANCE M87x

Integration (continued)

Secure VPN communication with SIMATIC NET components

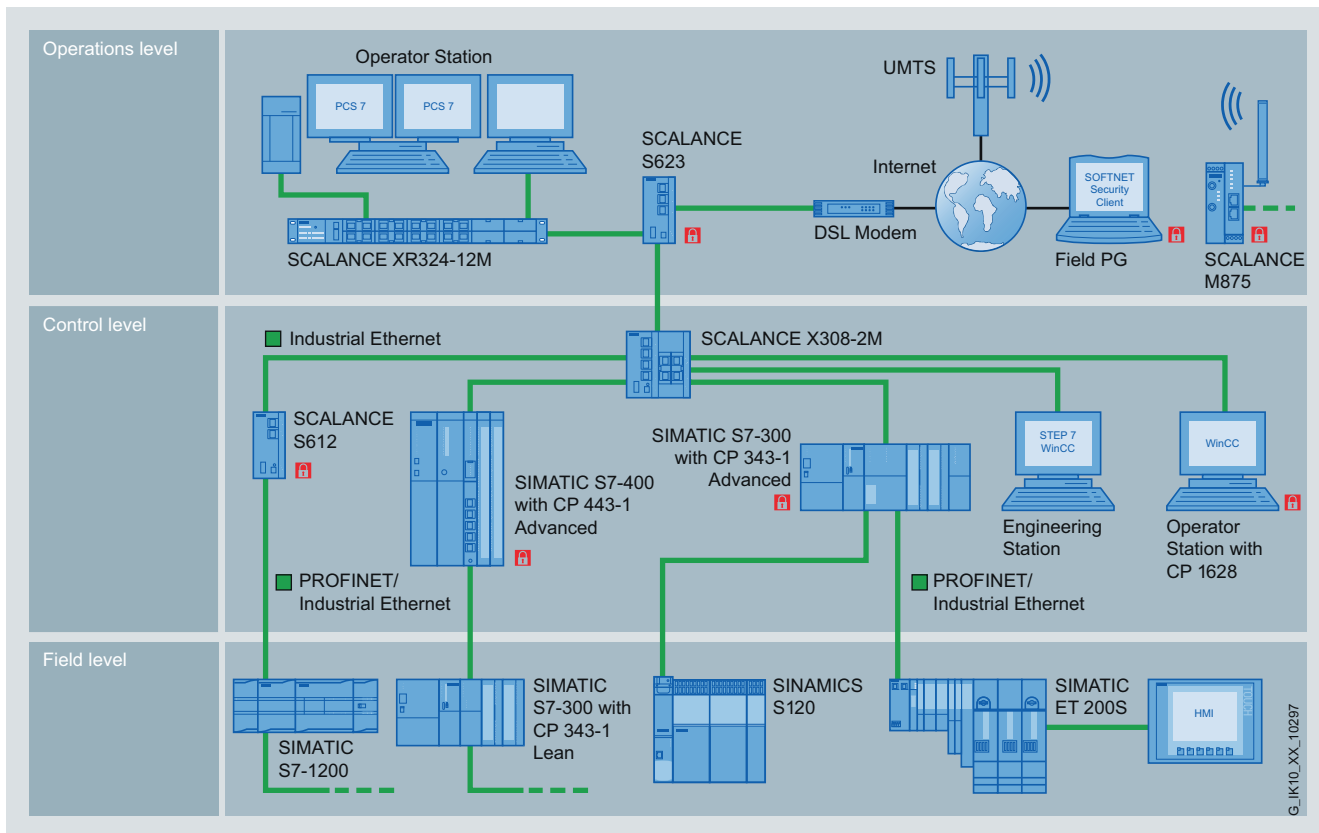

Secure VPN communication between SCALANCE M875, SCALANCE S623 and components with Security Integrated

Technical specifications

Order No.	6GK5 873-0AA10-1AA2	6GK5 875-0AA10-1AA2
Product type designation	SCALANCE M873	SCALANCE M875 ¹⁾
Transmission rate		
Transmission rate		
• 1 with Industrial Ethernet	10 Mbit/s	10 Mbit/s
• 2 with Industrial Ethernet	100 Mbit/s	100 Mbit/s
• For GSM transmission	9 600 bit/s	9 600 bit/s
• For GPRS transmission		
- For downlink, maximum	85.6 kbit/s	85.6 kbit/s
- For uplink, maximum	42.8 kbit/s	42.8 kbit/s
• For eGPRS transmission		
- For downlink, maximum	238 kbit/s	238 kbit/s
- For uplink, maximum	118 kbit/s	118 kbit/s
• For UMTS transmission		
- For downlink, maximum	3.6 Mbit/s	14.4 Mbit/s
- For uplink, maximum	0.384 Mbit/s	5.76 Mbit/s
Interfaces		
Number of electrical connections		
• for network components or terminal equipment	1	1
• for external antenna(s)	1	1
• for power supply	1	1
Design of electrical connection		
• for network components or terminal equipment	RJ45 port (10/100 Mbit/s, TP, Auto-Crossover)	RJ45 port (10/100 Mbit/s, TP, Auto-Crossover)
• for external antenna(s)	SMA antenna socket (50 Ohm)	SMA antenna socket (50 Ohm)
• for power supply	Terminal block	Terminal block
Inputs/outputs		
Number of electrical connections		
• for digital input signals	1	1
• for digital output signals	1	1
Design of electrical connection		
• for digital input signals	Terminal block	Terminal block
• for digital output signals	Terminal block	Terminal block
WAN connection		
Type of mobile wireless network supported, GSM	Yes	Yes
Type of mobile wireless network supported		
• GPRS	Yes	Yes
• eGPRS	Yes	Yes
Type of mobile wireless network supported, UMTS	Yes	Yes
Type of mobile wireless network supported		
• HSDPA	Yes	Yes
• HSUPA	No	Yes
Operating frequency		
• 1 with GPRS transmission	850 MHz	850 MHz
• 2 with GPRS transmission	900 MHz	900 MHz
• 3 with GPRS transmission	1 800 MHz	1 800 MHz
• 4 with GPRS transmission	1 900 MHz	1 900 MHz
• 1 with UMTS transmission	850 MHz	850 MHz
• 2 with UMTS transmission	1 900 MHz	1 900 MHz
• 3 with UMTS transmission	2 100 MHz	2 100 MHz
Type of GPRS time slot method: Multislot Class 10	Yes	Yes

¹⁾ Available soon

Industrial Remote Communication

Telecontrol network – GSM/GPRS/UMTS routers

UMTS-Router SCALANCE M87x

Technical specifications (continued)

Order No.	6GK5 873-0AA10-1AA2	6GK5 875-0AA10-1AA2
Product type designation	SCALANCE M873	SCALANCE M875 ¹⁾
Supply voltage, current consumption, power loss		
Type of supply voltage	DC	DC
Power supply	24 V	24 V
• Minimum	12 V	12 V
• Maximum	30 V	30 V
Current consumption, maximum	450 mA	450 mA
Effective power loss, typical	4 W	4 W
Permissible ambient conditions		
Ambient temperature		
• During operation	-20 ... +60 °C	-20 ... +60 °C
• During storage	-40 ... +70 °C	-40 ... +70 °C
Relative humidity at 25 °C during operating phase, maximum	95 %	95 %
IP degree of protection	IP20	IP20
Design, dimensions and weights		
Type of construction	Compact	Compact
Depth	114 mm	114 mm
Height	99 mm	99 mm
Width	45 mm	45 mm
Net weight	280 g	280 g
Type of mounting: 35 mm DIN rail mounting	Yes	Yes
Product properties, functions, components		
General		
Product function DynDNS client	Yes	Yes
Product functions Management, configuration, programming		
Product function		
• CLI	No	No
• Web-based management	Yes	Yes
• MIB support	No	No
• TRAPs via e-mail	No	No
Protocol is supported		
• Telnet	Yes	Yes
• HTTP	Yes	Yes
• HTTPS	Yes	Yes
Type of configuring	Web Interface	Web Interface
Product functions Diagnostics		
Product function		
• Packet size statistics	No	No
• Packet type statistics	No	No
• Error statistics	No	No
• SysLog	No	No
• Packet Filter Log	No	No
• System Log	Yes	Yes
Product functions DHCP		
Product function		
• DHCP client	Yes	Yes
• DHCP server - internal network	Yes	Yes
Product functions Routing		
Router function		
• NAT (IP masquerading)	Yes	Yes
• Port forwarding	Yes	Yes
• NAT traversal	Yes	Yes
• DNS cache	Yes	Yes

Technical specifications (continued)

Order No.	6GK5 873-0AA10-1AA2	6GK5 875-0AA10-1AA2
Product type designation	SCALANCE M873	SCALANCE M875 ¹⁾
Product functions Security		
Configuration of firewall	Stateful inspection	Stateful inspection
Product function		
• Password protection	Yes	Yes
• Packet Filter	Yes	Yes
• Broadcast/Multicast/ Unicast Limiter	-	-
• Broadcast blocking	-	-
Protocol is supported SSH	Yes	Yes
Suitability for use of virtual private network	No	Yes
Product function with VPN connection	F	T
Number of possible connections with VPN connection	-	10
Maximum number of network stations for internal network with VPN connection	-	-
Type of authentication with Virtual Private Network PSK	No	Yes
Protocol supported: IPsec Tunnel and Transport Mode	No	Yes
Key length		
• with IPsec DES with Virtual Private Network	-	56 bit
• 1 with IPsec AES with Virtual Private Network	-	128 bit
• 2 with IPsec AES with Virtual Private Network	-	192 bit
• 3 with IPsec AES with Virtual Private Network	-	256 bit
Type of Internet Key Exchange with Virtual Private Network Main Mode	No	Yes
Key length with IPsec 3DES with Virtual Private Network	-	168 bit
Type of Internet Key Exchange with Virtual Private Network Quick Mode	No	Yes
Type of packet authentication with Virtual Private Network	-	MD5, SHA-1
IETF profile with Virtual Private Network X.509v3 certificate	No	Yes
Product functions Time		
Router function NTP	Yes	Yes
Standards, specifications, approvals		
Standard		
• for EMC	-	-
• for EMC of FM	-	-
• for hazardous zone	-	-
• for CSA and UL safety	-	-
• for hazardous zone of CSA and UL	-	-
• for emitted interference	EN55022 Class A	EN55022 Class A
• for noise immunity	EN 61000-6-2	EN 61000-6-2
Certificate of suitability	EN 61000-6-2	EN 61000-6-2
• CE mark	Yes	Yes
• C-Tick	-	Yes
• E1 approval	-	Yes
• e1 approval	-	Yes

¹⁾ Available soon

Industrial Remote Communication

Telecontrol network – GSM/GPRS/UMTS routers

UMTS-Router SCALANCE M87x

Ordering data	Order No.	Order No.
<p>UMTS router SCALANCE M 87x</p> <p>UMTS router for wireless IP communication by industrial Ethernet-based programmable controllers via UMTS/GSM mobile radio networks; EGPRS Multislot Class 12</p> <ul style="list-style-type: none"> • SCALANCE M873¹⁾ with integral firewall; 1 x RJ45 port, 1 x antenna connection • SCALANCE M875^{1) 2)} with integral firewall and VPN with IPsec; 2 x RJ45 ports, 2 x antenna connections 	<p>6GK5 873-0AA10-1AA2</p> <p>6GK5 875-0AA10-1AA2</p>	<p>Communication processor CP 343-1 Advanced</p> <p>For connecting the SIMATIC S7-300 CPU to Industrial Ethernet: 1 x 10/100/1000 Mbit/s; 4 x 10/100 Mbit/s (IE switch); RJ45 ports; TCP; UDP; ISO; PROFINET IO-Controller and Device, S7 communication (client + server); open communication (SEND/RECEIVE); S7 routing; IP configuration via DHCP/block; extended Web diagnostics; time synchronization; IP Access Control List; IP routing; FTP; e-mail; PROFINET CBA; C-Plug</p> <ul style="list-style-type: none"> • With Security (Firewall + VPN) and PROFinergy (Controller + Device) <p>6GK7 343-1GX30-0XE0</p> <p>6GK7 343-1GX31-0XE0¹⁾</p>
<p>Accessories</p> <p>IE FC RJ45 Plug 180</p> <p>RJ45 plug connector for Industrial Ethernet with a rugged metal enclosure and integrated insulation displacement contacts for connecting Industrial Ethernet FC installation cables; with 180° cable outlet; for network components and CPs/CPUs with Industrial Ethernet interface</p> <ul style="list-style-type: none"> • 1 pack = 1 unit • 1 pack = 10 units • 1 pack = 50 units 	<p>6GK1 901-1BB10-2AA0</p> <p>6GK1 901-1BB10-2AB0</p> <p>6GK1 901-1BB10-2AE0</p>	<p>Communication processor CP 443-1 Advanced</p> <p>For connecting the SIMATIC S7-400 CPU to Industrial Ethernet: 1 x 10/100/1000 Mbit/s; 4 x 10/100 Mbit/s (IE SWITCH); RJ45 ports; ISO; TCP; UDP; PROFINET IO controller, S7 communication; open communication (SEND/RECEIVE); S7 routing; IP configuration via DHCP/block; IP Access Control List; time synchronization; expanded web diagnostics; Fast Startup; PROFinergy support; IP routing; FTP; web server; e-mail; PROFINET CBA</p> <ul style="list-style-type: none"> • With security (firewall/VPN) <p>6GK7 443-1GX30-0XE0</p> <p>6GK7 443-1GX31-0XE0¹⁾</p>
<p>ANT794-4MR antenna</p> <p>Quad band antenna for MD720-3 and MD741-1, omnidirectional with 5 m cable</p>	<p>6NH9 860-1AA00</p>	
<p>SCALANCE S industrial security modules</p> <p>For protection of programmable controllers and automation networks, and for safeguarding of industrial communication; configuring tool and electronic manual on CD-ROM; German, English, French, Italian; Spanish</p> <ul style="list-style-type: none"> • SCALANCE S612 uses the Stateful Inspection Firewall to protect network segments against unauthorized access; protects up to 32 devices up to 64 VPN tunnels simultaneously • SCALANCE S623²⁾ uses the stateful inspection firewall to protect network segments against unauthorized access; protects up to 64 devices, up to 128 VPN tunnels simultaneously; enhanced temperature range (-20 to +70 °C) 	<p>6GK5 612-0BA10-2AA3</p> <p>6GK5 623-0BA10-2AA3</p>	<p>IE TP Cord RJ45/RJ45</p> <p>TP cable 4 x 2 with 2 RJ45 connectors</p> <ul style="list-style-type: none"> • 0.5 m • 1 m • 2 m • 6 m • 10 m <p>6XV1 870-3QE50</p> <p>6XV1 870-3QH10</p> <p>6XV1 870-3QH20</p> <p>6XV1 870-3QH60</p> <p>6XV1 870-3QN10</p>

1) Please note national approvals at www.siemens.com/wireless-approvals

2) Available soon

More information

You can find more information on the topic of Industrial Security on the Internet at:

www.siemens.com/industrialsecurity

To assist in selecting the right products for Industrial Wireless Communication, the SIMATIC NET Selection Tool is available at:

www.siemens.com/snst

Wireless approvals

Current approvals can be found on the Internet at:

www.siemens.com/wireless-approvals

Industrial Remote Communication

Telecontrol – Accessories

LTOP overvoltage protection

Overview

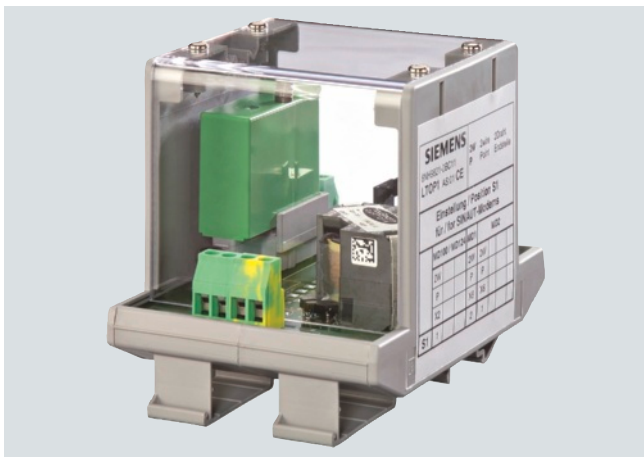

- Line transformer with overvoltage protection
- For electrical isolation of a dedicated line modem from the trunk line
- For protection against overvoltages that can be injected into a trunk line

Benefits

get Designed for Industry

- Reduces overvoltage to tolerable levels before they reach sensitive electronics circuits
- Electrically isolates line sections; prevents interference due to external voltages
- Limits damage to segments affected by overvoltage
- The protective components are housed in a plug-in OPM overvoltage module. The OPM can be replaced without interrupting the trunk line.

Application

Dedicated copper lines are susceptible to electromagnetic interference. The coupling of extraneous voltages can be inductive or capacitive, for example due to the effects of lightning. Direct conductive coupling is also possible due to bad insulation.

The LTOP overvoltage protection limits external voltage and overvoltage to a non-critical level. The floating transformer additionally provides electrical isolation, and the transfer of voltages to other cable sections are therefore prevented.

LTOP protects people and investments, and is therefore an essential safety element in private trunk line networks.

Note:

The LTOP modules are not suitable for protecting dial-up connections (telephone or ISDN network). Companies such as Phoenix and Dehn offer TAE6, S₀, RJ-12, and RJ-45 jacks with overvoltage protection.

Design

The protection concept consists of a combination of components that complement each other in terms of functionality:

- Surge arresters filled with noble gas as coarse protection (G1, G2)
- Inductance that limits the rise of the current (L1, L2)
- Metal-oxide varistor as surge protection (voltage-dependent resistor; R1)
- Translator for galvanic decoupling (T1)
- Suppressor diode for limiting the secondary voltage of the translator (V1)

The overvoltage protection module LTOP is available in two versions:

- **LTOP 1;** overvoltage protection module for use at the beginning or at the end of a 2-wire cable
- **LTOP 2;** overvoltage protection module for use at the beginning or at the end of a 4-wire cable or at a 2-wire grading point. At a 4-wire graded point, two LTOP2 units are needed.

Both LTOP versions feature screw-type terminals and an RJ12 Western jack. The WAN connecting cable (RJ12 - RJ12) that came with the MD2 and MD3 modems (used as dedicated line modem) can be connected directly to this RJ12 jack.

Function

The combination of arresters and limiters supplemented by the line transformer is more effective than galvanically-coupled protection concepts.

Leakage voltages place considerable strain on protective components in the OPM, slowly destroying them beyond repair. We therefore recommend that OPMs are replaced approximately once a year. In areas affected by frequent thunderstorms, this should be reduced to approximately every 6 months as a precautionary measure.

Integration

If necessary, several LTOP enclosures can be interconnected.

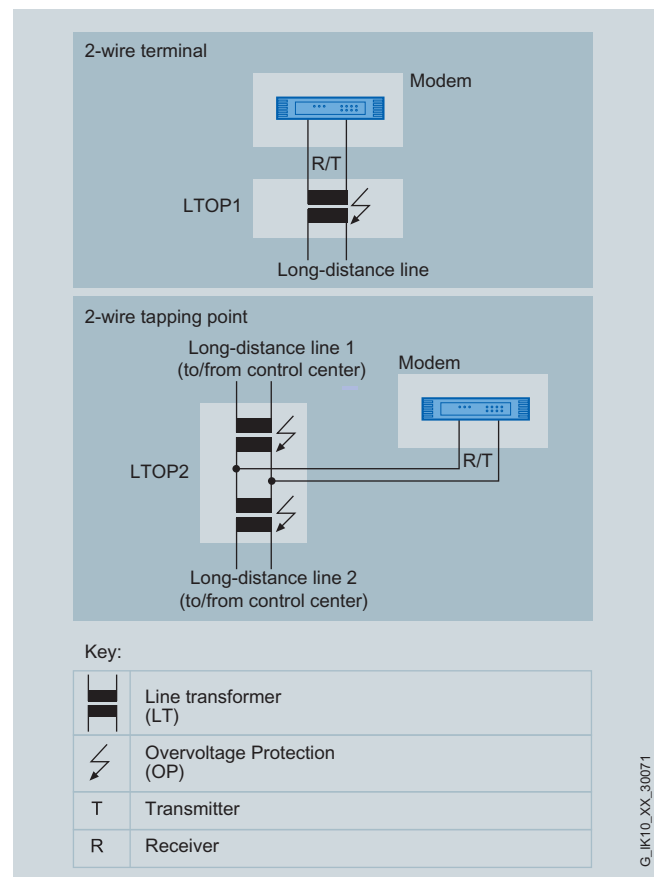

Configuration examples with LTOP

Industrial Remote Communication

Telecontrol – Accessories

LTOP overvoltage protection

Technical specifications

LTOP overvoltage protection						
Transmission paths	Private non-coil-loaded or coil-loaded trunk lines					
Transmission ratio	1 : 1; ± 5 % (e.g. 600/600 ohms in voice band)					
Transmission range	300 Hz to 35 kHz					
Frequency-dependent attenuation	Attenuation [dB]	Frequency [Hz]	Transmission rate [bit/s]			
			MD100	MD124	MD2	MD3
	0.2	1300 ... 3300	1200	1200 2400	1200 2400	All
	0.8	5200 ... 8400		4800		
	0.9	10400 ... 16800		9600		
1.0	20800 ... 30600		19200	9600 19200		
Insulation resistance	> 2000 MOhms					
Test voltage	4 kV, 50 Hz, 10 sec.					
Impulse withstand voltage	6 kV/2 J acc. to EN 60 099-1					
Nominal discharge current i_{sn} (8/20 μ s)	5 kA					
Output voltage limit at i_{sn}	approx. 15 V					
Trunk line connection	Screw terminals Cross-section 0.2 – 4 mm ² rigid wires Cross-section 0.2 – 2.5 mm ² flexible wires					
Modem connection	Screw terminals (wire cross-section see trunk line connection) or RJ12 socket for Western connector					
Installation location	As near as possible to where the cable enters the building					
Permissible ambient conditions	<ul style="list-style-type: none"> • Operating temperature 0 °C to +60 °C • Transport/storage temperature -40 °C to +70 °C • Relative humidity Max. 95 % at +25 °C 					
Design	<ul style="list-style-type: none"> • Dimensions (W x H x D) in mm 90 x 75 x 110 mm • Weight <ul style="list-style-type: none"> - LTOP1 300 g - LTOP2 320 g - OPM 10 g 					
Degree of protection	IP20					
Assembly	DIN rail TS35 (35 mm; EN 50 022)					

Ordering data

LTOP 1 overvoltage protection	6NH9 821-0BC11
Single line transformer, with one OPM overvoltage protection module for use at the start or end of a 2-wire line	
LTOP 2 overvoltage protection	6NH9 821-0BC12
2-way line transformer with two overvoltage protection modules (OPM) for use at the beginning or at the end of a 4-wire cable or at a 2-wire grading point	

Order No.

6NH9 821-0BC11

6NH9 821-0BC12

Order No.

Accessories

OPM

Overvoltage protection module for LTOP1 and LTOP2, plug-in (pack of 4)

6NH9 821-0BB00

Overview



- Quadruple transformer for the multiplication of the trunk line connection of a dedicated line modem from 1 x 2-wire to 4 x 2-wire

Application

In a controller, the quadruple transformer enables up to four point-to-point or line connections (each 2-wire) to be made in a start-type configuration, or a combination of both network topologies.

The transformer is only designed for a frequency range between 300 and 3400 Hz. In conjunction with the MD2 modem, transmission rates are limited to 1200 and 2400 bit/s.

Design

The quadruple transformer is housed in a sheet-steel enclosure. It is mounted on a 35 mm standard mounting rail.

The trunk line is connected by means of soldering tabs.

Integration

If several dedicated lines have to be combined on one WAN port of the TIM, i.e. if coupling a point-to-point network is involved, this can be achieved by connecting several MD2 modems in parallel. 2 x 2-wire terminals can be connected per MD2. With the aid of the fourfold translator, the number of 2-wire terminals per MD2 can be increased from 2 to 4. This means an additional attenuation of 6.5 dB for a transmission rate of 1200 bit/s, which results in a reduction of the max. range by approx. 6 km.

The following figure shows a possible configuration of the interconnection in the star point for max. 4 x 2-wire terminals with the aid of the fourfold transformer and other standard components (the plug-in cable 6NH7700-2AR60 is part of the scope of delivery of the MD2 modem).

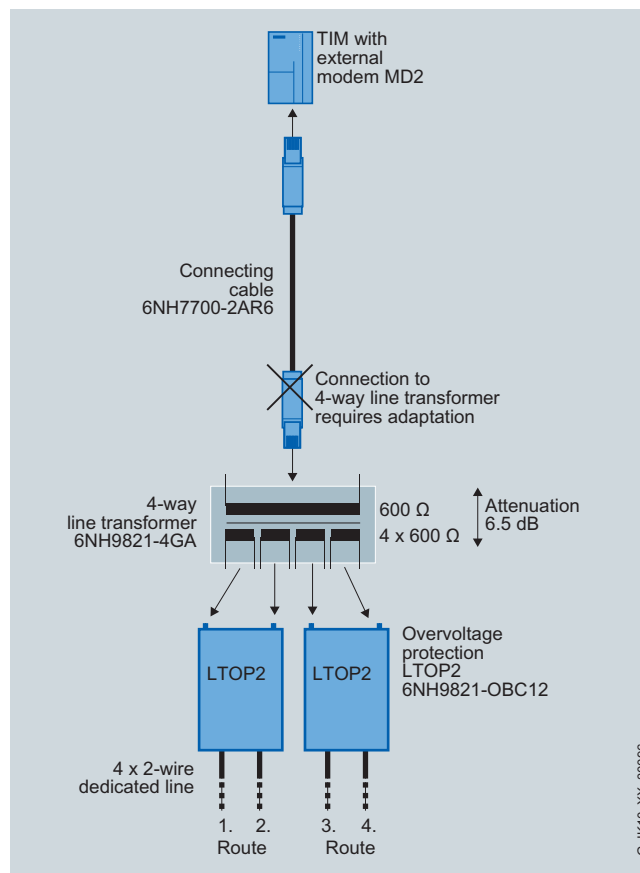

Note:

For configuring the terminals and tapping points in the stations, see dedicated line modem MD2.

Technical specifications

Frequency range	0.3 ... 3.4 kHz
Translation	600 : 4 x 600 ohms
Attenuation at 1200 bit/s	6.5 dB
Dielectric strength	2 kV
Dimensions (W x H x D) in mm	60 x 107 x 110
Weight	0.2 kg
Assembly	Standard mounting rail 35 mm

Ordering data

Quadruple transformer
600 ohms to 4 x 600 ohms

Order No.

6NH9821-4GA

Industrial Remote Communication

Telecontrol – Accessories

ANT794-3M GSM/GPRS antenna

Overview



- Flat panel antenna for mobile telephony for GSM 900/1800/1900
- Suitable for exterior and interior installation
- Electrically independent installation
- Ready for connection with cable for GSM/GPRS modems with SMA connection

Benefits

get Designed for Industry

- Durable mounting in plastic switching boxes
- Installation without specialist knowledge of high frequency
- Universal in use, also on grounded or non-grounded metal surfaces without adversely affecting the radiation properties

Application

- For use in GSM/GPRS networks
- Indoors and outdoors (IP64 degree of protection)
- Operating temperature -40 °C to +70 °C
- For installation in plastic control boxes

Design

- Emitters accommodated in protective plastic housing
- Installation using screws or adhesive pad

Technical specifications

Order No.	6NH9 870-1AA00
Product type designation	ANT794-3M antenna
Wireless frequencies	
Type of mobile wireless network supported	
• GSM	Yes
• UMTS	No
Operating frequency	
• 850 MHz	No
• 900 MHz	Yes
• 1800 MHz	Yes
• 1900 MHz	Yes
• 2200 MHz	No
Electrical specifications	
Radiation characteristic	Directional
Antenna gain	0 dB
Maximum voltage standing wave ratio	1.5
Number of electrical connections of the antenna	1 1
Design of electrical connection of the antenna	SMA connector
Front to back ratio	-
Maximum transmit power	10 W
Permissible ambient conditions	
Ambient temperature during operation	-40 ... +75 °C
IP degree of protection	IP64
Design, dimensions and weights	
Width	70.5 mm
Height	20.5 mm
Depth	146.5 mm
Diameter	-
Net weight	130 g
Type of mounting	Screw mounting
Length of the antenna cable	1.2 m
Product properties, functions, components	
General	
Material of the outer sleeve	ABS Polylac PA-765, light gray (RAL 7035)

ANT794-3M GSM/GPRS antenna

Ordering data

Order No.

GSM/GPRS antenna

ANT794-3M antenna

Antenna GSM triband flat panel antenna for 900/1800/1900 Mhz; electrically independent assembly, for indoor and outdoor areas; 1.2 m connecting cable connected permanently to the antenna ; SMA connector; including assembly adhesive pad

6NH9 870-1AA00

Dimensional drawings

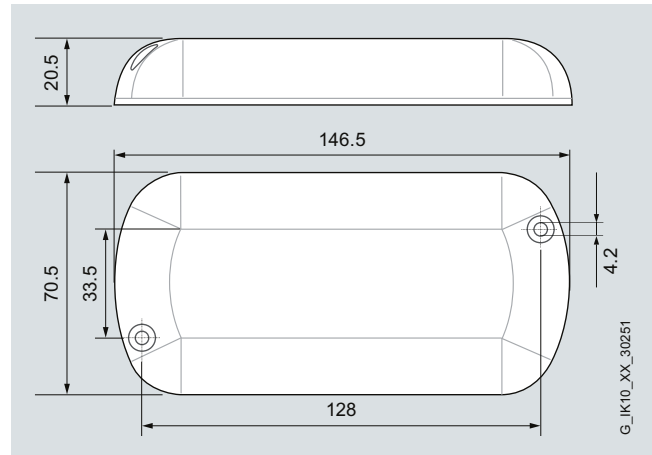

More information

The SIMATIC NET Selection Tool is available for supporting product selection for Industrial Wireless communication at: www.siemens.com/snst

Industrial Remote Communication

Telecontrol – Accessories

ANT794-4MR GSM/GPRS antenna

Overview



- Omnidirectional antenna for use in GSM/GPRS/UMTS networks
- Remote antenna for indoors/outdoors
- Suitable for quad band
- Complete with cable and mounting bracket for direct connection to SINAUT GPRS modems

Benefits

get Designed for Industry

- Weatherproof design allows installation outside buildings to improve the field strength
- Quad band technology permits international use

Application

- For use in GSM/GPRS/UMTS networks
- For indoors/outdoors (IP65 degree of protection)
- Operating temperature -40 °C to 70°C

Design

- Radiator accommodated in a plastic tube for protection
- RF cable with fixed connection to antenna
- Fixed and rugged vertical installation outside control cabinet

Technical specifications

Order No.	6NH9 860-1AA00
Product type designation	ANT794-4MR antenna
Wireless frequencies	
Type of mobile wireless network supported	
• GSM	Yes
• UMTS	Yes
Operating frequency	
• 850 MHz	Yes
• 900 MHz	Yes
• 1800 MHz	Yes
• 1900 MHz	Yes
• 2200 MHz	Yes
Electrical specifications	
Radiation characteristic	Omnidirectional
Antenna gain	0 dB
Maximum voltage standing wave ratio	2
Number of electrical connections of the antenna	1 1
Design of electrical connection of the antenna	SMA connector
Front to back ratio	-
Maximum transmit power	20 W
Permissible ambient conditions	
Ambient temperature during operation	-40 ... +70 °C
IP degree of protection	IP65
Design, dimensions and weights	
Width	24 mm
Height	193 mm
Depth	24 mm
Diameter	24 mm
Net weight	310 g
Type of mounting	Mounting bracket and mounting parts
Length of the antenna cable	5 m
Product properties, functions, components	
General	
Material of the outer sleeve	Hard PVC, UV-resistant

ANT794-4MR GSM/GPRS antenna

Ordering data

Order No.

GSM/GPRS antenna

ANT794-4MR antenna

GSM/GPRS quad band antenna; weather-resistant for indoor/outdoor use; 5 m cable with fixed connection to antenna; SMA connector; including mounting bracket, screws, wall plugs

6NH9 860-1AA00

Dimensional drawings

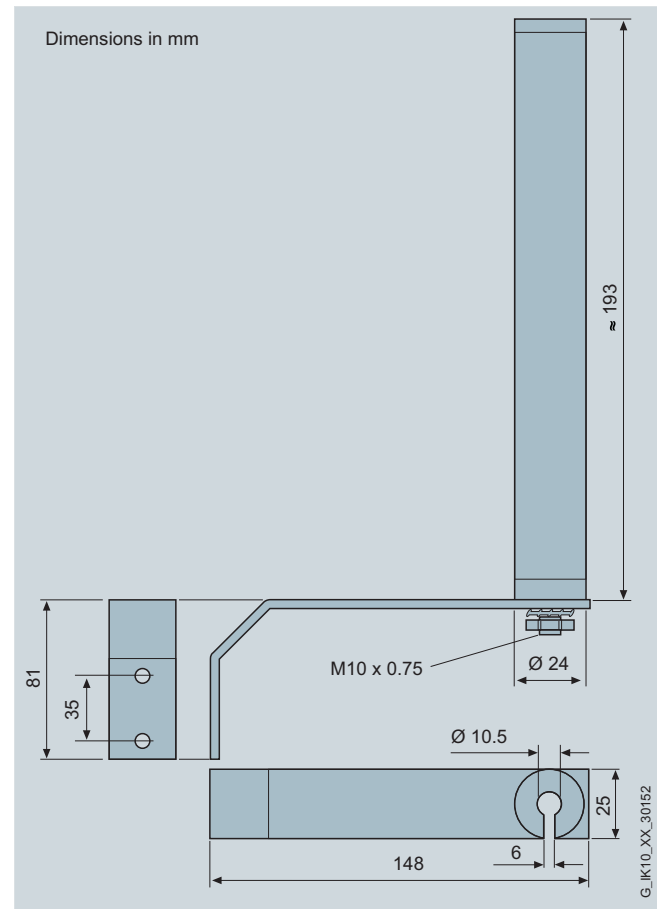

More information

To assist in selecting the right products for Industrial Wireless Communication, the SIMATIC NET Selection Tool is available at: www.siemens.com/snst

Industrial Remote Communication

Telecontrol – Accessories

PPI modem cable

Overview

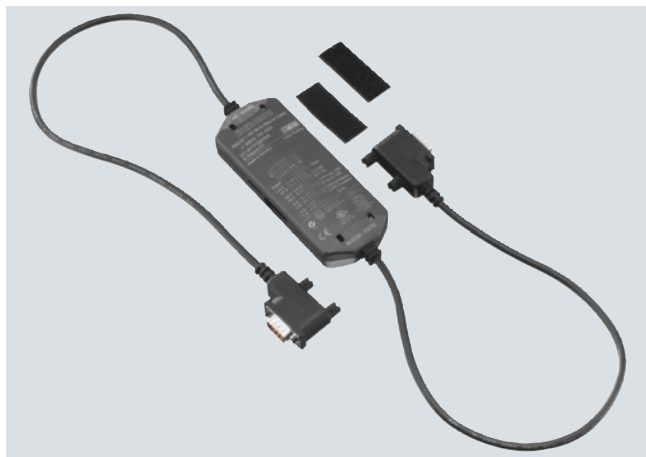

- Intelligent RS232/PPI multimaster cable for connecting modems with RS 232 interface to SIMATIC S7-200 (RS485)

Benefits

get Designed for Industry

- Matching cable length for control cabinet assembly
- No RS232 adapter (gender changer) required for modem connection
- Simple fixing of cable in control cabinet using Velcro fastener

Application

The intelligent RS 232/PPI multimaster cable can be used for the connection between modems and the S7-200. It is then possible to connect modems such as the GSM modem MD720-3 with RS232 interface to the PPI interface of the S7-200 without using a gender changer. As a result of the short cable lengths and the industrial Velcro fasteners, the PPI modem cable is suitable for use in control cabinets.

Design

- 24 V DC power supply via the RS485 interface of the SIMATIC S7-200
- Three LEDs for status display:
 - Tx, green: RS232 send
 - Rx, green: RS232 receive
 - PPI, green: RS485 send

Function

PPI mode:

- Signal conversion from RS232 to RS485
- Control of token in a multimaster PPI network (PPI master)
- Supports 10-bit modem protocol via RS232, and DPT and PPI protocols via RS485

Freeport mode:

- Signal conversion from RS232 to RS485
- Switchover between local and remote modes
- Configuration in local mode using DIP switches
- Configuration in remote mode using terminal program (e.g. MS Hyper Terminal)
- Supports AT modem commands and PIN for Siemens modems

Technical specifications

Order No.	6NH9 701-0AD
Product type identification	PPI modem cable
Power supply	from CPU
Protocols	
PPI	Yes; 10/11-bit
ASCII	Yes; Freeport
MPI	
Transmission rate (PPI), max.	187.5 kbit/s; 9.6/19.3/187.5 kbit/s; setting: DIP switch; RS232 not required
Status information/alarms/diagnostics	
Diagnostics LEDs	Tx (green): RS232 send display; Rx (green): RS232 receive display; PPI (green): RS485 send display
Electrical isolation	
Electrical isolation	1
Dimensions	
Approx. weight	300 g

Ordering data

PPI modem cable

For connecting modems with RS232 interface to SIMATIC S7-200

Order No.

6NH9 701-0AD

Overview

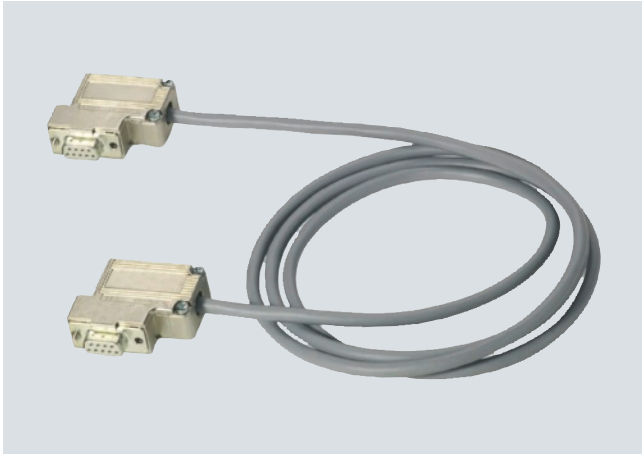

There is a series of standard connecting cables for connecting the SINAUT components to one another or to the respective WAN. Some of these cables are already supplied as a permanent item along with the hardware components and are listed in the ordering data of these components as spare parts.

Ordering data

Order No.

Connecting cable

For connecting a TIM with a SINAUT ST7 MD2, MD3 or MD4 modem;
cable length 1.5 m

- RS 232
Also suitable for interfacing the modems listed with a SIMATIC point-to-point CP such as the CP340, CP341 or CP441 with RS232 interface
- RS485

6NH7 701-4AL

6NH7 701-4DL

Connecting cable

For connecting two MD2 modems (RS 232) in order to create a repeater;
cable length 0.3 m

6NH7 701-1CB

Connecting cable

For connecting a TIM (RS232) with the GSM modem MD720-3; also suitable for third-party modems or radio equipment with standard RS232 interface;
cable length 2.5 m

6NH7 701-5AN

Connecting cable open at one end

For connecting a TIM (RS232) with a third-party modem or radio unit (RS232);
cable length 2.5 m

6NH7 701-4BN

Test cable

Connecting cable for connecting two TIMs via their RS232 interface without modems ("null modem");
cable length 6 m

6NH7 701-0AR

Industrial Remote Communication

Telecontrol – Accessories

DCF77 antennas

Overview



Every TIM module with an integrated DCF77 radio clock is supplied with an adapter cable which terminates in a BNC connector. Various accessories both for the DCF77 and for GPS can be connected to this.

- **DCF77 indoor antenna**

An indoor antenna can be used in buildings in which there are no sources of interference for the DCF77 signal. It should not be installed in the vicinity of televisions, monitors, thyristor controls, network cables or fluorescent lights.

- **DCF77 outdoor antenna for mounting on a flat roof, wall, or mast**

A professional radio clock system should be operated with an external antenna wherever possible. In contrast to an indoor antenna whose environment can change constantly due to the technical activity in the building, the conditions for an outdoor antenna are practically constant. Indirect lightning protection is strongly recommended for an outdoor antenna.

If the 6NH9831-2AA lightning protector is used, this should be installed as close to the entrance of the building as possible.

Technical specifications

Order No.	6NH9 831-0AA	6NH9 831-0DA	6NH9 831-0BA
Product type designation	DCF77 indoor antenna	DCF77 outdoor antenna for mast mounting	DCF77 outdoor antenna for flat roof or wall mounting
Electrical specifications			
Type of supply voltage	DC	DC	DC
Supply voltage from antenna cable	1.7 ... 5 V	1.7 ... 5 V	1.7 ... 5 V
Current consumption, maximum	-	-	-
Amplification	20 dB	20 dB	20 dB
Number of electrical connections of the antenna	-	-	-
Design of electrical connection of the antenna	BNC connector, female	BNC connector, female	BNC connector, female
Permissible ambient conditions			
Ambient temperature			
• During operation	0 ... 50 °C	-30 ... +80 °C	-30 ... +80 °C
• During storage	-50 ... +85 °C	-50 ... +85 °C	-50 ... +85 °C
• Note	Temperature ranges specified for 3 dB limit	Temperature ranges specified for 3 dB limit	Temperature ranges specified for 3 dB limit
IP degree of protection	IP50	IP65	IP65
Design, dimensions and weights			
Type of mounting	-	-	-
Type of mounting: flat-roof mounting	No	No	Yes
Length of the antenna cable	10 m	20 m	20 m

Ordering data

	Order No.	Order No.
DCF77 indoor antenna Incl. 10 m cable and BNC connectors	6NH9 831-0AA	Indirect lightning protector for DCF77 outdoor antenna 6NH9 831-2AA
DCF77 outdoor antenna Incl. 20 m cable and BNC connectors • for flat-roof or wall mounting • for mounting on a mast	6NH9 831-0BA 6NH9 831-0DA	

Overview



The reception of the DCF77 radio clock signal is limited to western Europe (approximately 800 km radius from Frankfurt am Main, Germany). In regions where this signal cannot be received, use of a GPS receiver is recommended to acquire the local time from a satellite-based GPS system (Global Positioning System).

For this situation, the SINAUT system includes a GPS receiver whose output signal simulates the DCF77 signal. This receiver can therefore be connected directly to the DCF77 receiver in the TIM and can supply the TIM with the current time.

This GPS receiver ships as a complete package and includes the following:

- GPS receiver module that can be snapped onto a 35-mm standard rail
- GPS outdoor antenna for wall or mast mounting, including 25 m antenna cable
- BNC adapter to connect the DCF77 adapter cable of the TIM to the BNC socket of the GPS receiver
- Software for configuring the GPS receiver (for Windows 3 x, 95, NT)
- PC adapter cable, length 1.5 m
- Documentation

Since the GPS antenna is an outdoor antenna, you should also install the lightning protection device provided for this purpose.

If 6NH9 831-8LA lightning protection is used, this should be installed whenever possible at the entrance to the building.

Industrial Remote Communication

Telecontrol – Accessories

GPS receiver

Technical specifications

GPS components

GPS receiver module

Interfaces	
• RS232/RS422 connection	1 x 9-pin Sub-D connector
• Pulse outputs	Screw terminals
• GPS input	1 x BNC socket
• DCF77 simulation output	1 x BNC socket
Power loss	3.5 W
Voltage supply	18 ... 60 V DC
Power consumption	3.5 VA

Ambient conditions

• Temperature (operation)	0..55 °C
• Temperature (storage)	-20..+75 °C
• Humidity	max. 95% no condensation

Design

• Casing material	Aluminum
• Dimensions (W x H x D) in mm	65 x 105 x 130
• Weight	approx. 600 g
Assembly	on 35 mm standard DIN rail

GPS antenna

Viewing angle	+ 10° above horizon
Impedance	50 Ω
Power gain	20 dB
Power supply via antenna cable	4.5 ... 7 V DC
Temperature range	
• Operation	-30 °C ... +85 °C
• Storage	-40 °C ... +85 °C
Humidity	100%
Protection Class	IP65
Type of use	Outdoor area

Indirect lightning protection

Input and output for antenna cable	one BNC socket for each
Grounding point	M 6 screwed joint
Design	
• Casing material	Aluminum
• Dimensions (W x H x D) in mm	250 x 105 x 95
• Weight	1.8 kg
Response rate	< 1 ns
Current-carrying capacity 8/20 μs wave	10 kA
Protective level at 6 kV 1.5/50 μs wave at input	< 12 V
Input impedance	50 ohms
Insertion loss	max. 3 dB
Temperature range	
• Operation	-20 °C ... +80 °C
• Storage	-40 °C ... +85 °C
Humidity	95% no condensation
Protection Class	IP40
Type of use	Indoors, protected

Ordering data

Order No.

GPS complete package

6NH9 831-8AA

For simulating the DCF77 time signal, comprising a GPS receiver, GPS outdoor antenna incl. 25 m cable, BNC adapter plug, configuration software, PC adapter cable, and documentation.

Indirect lightning protection for GPS outdoor antenna

6NH9 831-8LA

Overview



Teleservice (remote diagnostics and remote maintenance)

Teleservice involves data exchange with distant technical systems (machines, plants, computers, etc.) for the purpose of fault detection, diagnostics, maintenance, repair or optimization.

Machines and plants are increasingly operated in places which are far away from the supplier's premises. Despite this, plant builders must offer services to deal with faults or for preventive maintenance. Especially during the warranty period this can result in high costs. Teleservice helps to significantly reduce this risk.

There are a variety of possible applications for Teleservice. Plants can be diagnosed, values set and data transmitted from any place on earth via a telephone cable. Teleservice also enables the SIMATIC controllers to send text messages per SMS or e-mail, making a significant contribution to saving travel and personnel costs in service work.

Teleservice via IP-based networks

Optimum remote maintenance is based on reliable, permanently available, secured and economical data connections.

Depending on the application, SIMATIC NET provides the appropriate solution:

- For continuous connections or simultaneous access to several plants, a solution using the SCALANCE S and SCALANCE M security and communication components is recommended, both on the service and the plant side.
- For flexible access for remote maintenance from any Internet connection - whether in the office, home office or hotel room - SOFTNET Security Client is the right software solution for establishing a secure connection to the plants.
- For plants without wired network connection, the MD741-1 (EGPRS) and SCALANCE M (UMTS) mobile wireless routers establish remote maintenance access to the SCALANCE S in the service center.

In all cases, the communication is reliably protected by authentication and encryption via a VPN tunnel (**V**irtual **P**rivate **N**etwork) in order to rule out the possibility of attacks from outside.

Siemens Remote Services

The service concept of "Siemens Remote Services" provides a powerful, secure platform for remote access to machines and plants. The inclusion of "Shared Experts" ensures effective support, not only from Siemens but also from the internal company specialists.

Industrial Remote Communication

Teleservice

SIMATIC TeleService

Overview

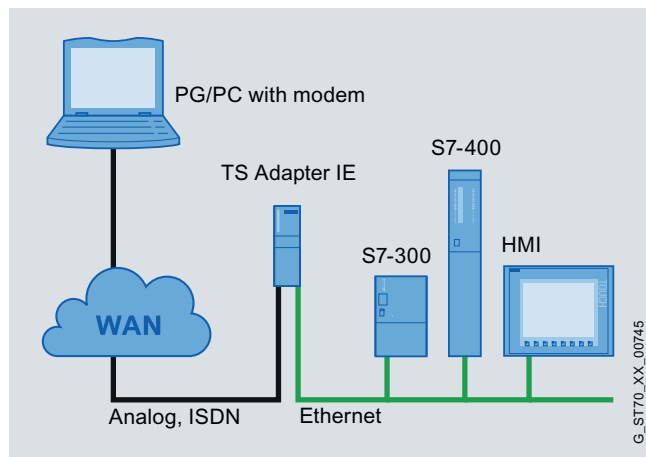

Teleservice with TS Adapter IE

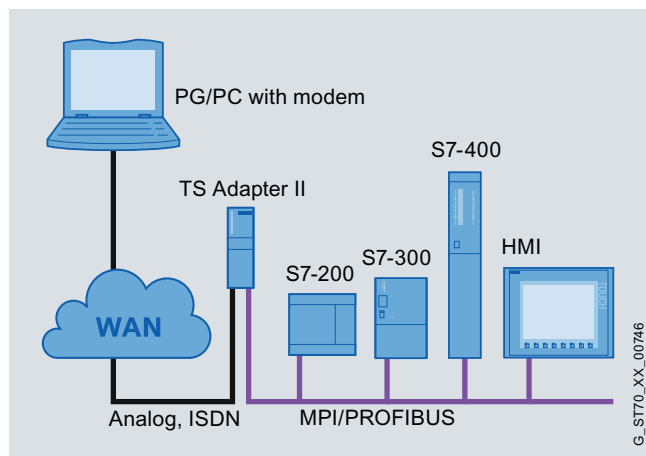

Teleservice with TS Adapter II

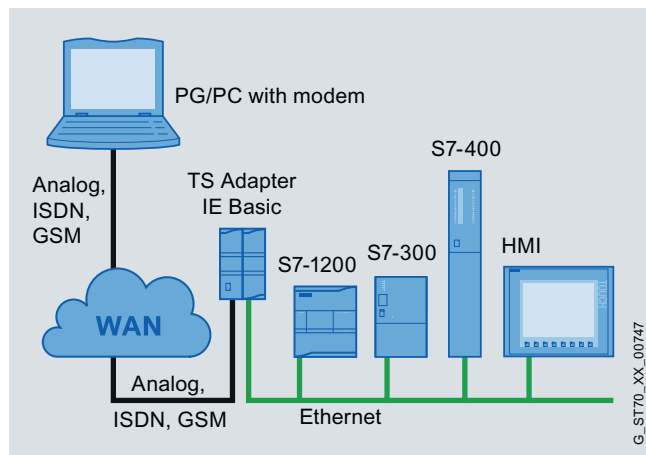

Teleservice with TS Adapter IE Basic

- For performing remote maintenance over the telephone network:
 - A PG/PC with an Engineering Tool installed, e.g. STEP 7, can access automation components (e.g. S7 CPUs) over the telephone network that are connected to the appropriate adapters over Industrial Ethernet or PROFIBUS.
- Comprising the TeleService software and different adapters:
 - TS Adapter II for connection to PPI, MPI or PROFIBUS DP
 - TS Adapter IE or TS Adapter IE Basic for connection to Industrial Ethernet
- Additional functions with TS Adapter II:
 - Establishing a connection from/to remote plants, e.g. for calling up process data from an automation system (*PG-to-AS remote coupling*).
 - Exchanging data between plants (*AS-to-AS remote coupling*): Exchange of process data between two SIMATIC automation systems.
 - Sending a *text message*: Sending a text message from a SIMATIC automation system via a GSM wireless modem.
- Additional functions with TS Adapter IE:
 - Remote operation of HMI devices: Access to the HMI device via an Internet browser installed on the adapter
 - Sending e-mails: Establishing a modem link to a dial-up server (e.g. to an Internet service provider): A SIMATIC CPU can send e-mails over an e-mail server that can be accessed in this manner.
 - Standard routing: A modem link can be established to an Internet service provider for accessing data on the Internet.

Application

With TeleService, remote servicing of SIMATIC S7 automation systems or HMI devices is possible using the programming device or PC over a fixed line or wireless network. With the help of TeleService, the connection to the automation components is extended over the telephone network to the programming device or PC. The functions to be performed, such as programming, are completed using the same tools and functionality as if the job was being done locally. The user has access to the familiar functions of STEP 7 and the Engineering Tools, comparable to a local MPI connection.

TeleService increases the effective availability of plants and machines. Access through TeleService means that technical services (e.g. maintenance, updating, and troubleshooting) can be performed cost-effectively from a central service center.

Apart from teleservice, a remote link to a programming device or PC can be established program-controlled using a function block call. This link allows process data to be exchanged between an S7 CPU and the programming device or PC with support from PRODAVE.

Design

Different components are required in accordance with the TeleService function.

For remote maintenance:

- TeleService engineering software (not required when using the TIA Portal).
- A modem at the programming device/PC end
- A TS adapter (TS Adapter II or TS Adapter IE), line-side.

Required in addition to the components for remote maintenance in the case of PG/PLC remote coupling:

- PRODAVE V5.0 and higher for PG/PC:
Toolbox for process data traffic between SIMATIC S7/C7 and the PC for autonomous processing of data traffic.
- "PG_DIAL" function block (included in TeleService software package) for the PLC.
- A TS Adapter II, line-side.

Required in addition to the components for remote maintenance in the case of PLC/PLC remote coupling:

- TS Adapter for the second PLC.
- "AS_DIAL" function block (included in TeleService software package) for the PLCs.
- A TS Adapter II, line-side.

For sending text messages:

- Engineering Software TeleService Version 5.2 and higher.
- GSM wireless modem on line side, Hayes-compatible.
- TS Adapter II, line-side.
- Modem cable for connecting the TS Adapter and modem (included in TS Adapter II package).

For sending e-mails:

- Engineering Software TeleService Version 6.1 and higher
- TS Adapter IE, line-side.
- Internet service provider and an e-mail server that can be accessed there.

For remote control of HMI devices:

- PG/PC with browser - e.g. Internet Explorer - and the Sm@rtViewer
- TS Adapter IE, line-side.
- SIMATIC HMI device with an installed Runtime option of WinCC flexible /Sm@rtService or /Sm@rtAccess.
For further information on WinCC flexible and the Sm@rt options, see www.siemens.com/simatic-wincc-flexible.

TS Adapter II

Main features of TS Adapter II:

- Single-width standard S7-300 housing.
- Mounted onto DIN or S7-profile rail, therefore no time-consuming cabinet installation required using a mounting plate.
- Integral modem, either analog or ISDN as required.
- USB interface for parameterization. This interface can also be used locally as a programming interface for the connected devices.
- Serial RS232 interface for connecting external modems (e.g. wireless modem).
- Firmware with update capability.
- Power supply over MPI or over external 24 V power supply.
- Connection of an external modem, e.g. a GSM wireless modem, over serial interface.
- Can be connected to:
 - MPI
 - PROFIBUS DP up to 12 Mbit/s (previously 1.5 Mbit/s)
 - PPI

Scope of delivery:

The following components are supplied with the TS Adapter II:

- DVD with driver
- TeleService software V6.1 (Can be used for 14 days. For further operation, a license is required)
- MPI cable, 0.8 m, for connecting the adapter to the MPI/DP interface.
- Standard telephone cable, 3 m, with RJ12 connectors (only for TS Adapter II modem).
- Standard telephone cable, 3 m, with RJ45 connectors (only for ISDN TS Adapter II).
- TAE6N plug (only for TS Adapter II modem).

When using the TS Adapter II modem outside Germany, a standard national telephone plug can be snapped onto the RJ12 connector. A TAE6N connector is supplied for Germany. In some countries, telephone sockets with RJ12 sockets are available, in which case telephone cables can be used without the need for a telephone plug.

For operation, TeleService Software Version 6.0 is required.

Industrial Remote Communication

Teleservice

SIMATIC TeleService

Design (continued)

TS Adapter IE

Main features of TS Adapter IE:

- Single-width standard S7-300 housing.
- Mounting on DIN or S7 rail.
- Integral modem, either analog or ISDN as required.
- Firmware with update capability.
- Power supply over external 24 V power supply.
- Serial interface for connection of an external modem, e.g. a GSM wireless modem.
- An RJ45 Ethernet interface (10/100 Mbit/s).
- Industry-compatible in accordance with SIMATIC standard.

Parameterization:

The TS Adapter IE can be parameterized locally or over a remote link. TeleService software V6.1 or an Internet browser is used for this purpose.

The firewall is parameterized easily by selecting and deselecting the appropriate services with a click of the mouse button. In "expert mode", the adapter can also be parameterized like a standard router.

Security:

Only dial-in access is possible: The service engineer dials into the adapter using a supplied telephone number. Authentication is performed by means of a user log-in with a password and Challenge Handshake Authentication Protocol (CHAP). Up to 8 user accounts can be created with different log-ins and passwords.

As an option, e.g. for security reasons or to save telephone charges, the TS Adapter IE will interrupt the connection following correct authentication and call the user back on the telephone number stored in the TS Adapter IE.

The implemented firewall protects the plant from unauthorized access over the Internet. By default, the firewall only permits S7 communication. The required services, e.g. Sm@rt-Access, Sm@rt-Service or PCAnywhere, can be individually enabled during parameterization. For sending e-mails, it is necessary to enable the SMTP protocol and to set the parameters for outgoing calls. It is also possible to block all incoming data packets during connection to the Internet.

Scope of delivery:

The following components are supplied with the TS Adapter IE:

- CD with drivers and TeleService V 6.1 software (can be used for 2 weeks without a license) including standard software for sending e-mails from S7 CPUs.
- Standard telephone cable, 3 m, with RJ12 connectors (only for TS Adapter IE modem).
- Standard telephone cable, 3 m, with RJ45 connectors (only for ISDN TS Adapter IE).
- TAE6N plug (only for TS Adapter IE modem).

When using the analog TS Adapter IE outside Germany, a standard country-specific telephone plug can be snapped onto the RJ12 connector. A TAE6N connector is supplied for Germany. In some countries, telephone sockets with RJ12 sockets are available, in which case telephone cables can be used without the need for a telephone plug.

TS Adapter IE Basic

The TS Adapter IE Basic in SIMATIC S7-1200 design is optimized for operation with SIMATIC S7-1200. It can also be used with S7-300 and S7-400. The adapter has a modular design and comprises the following:

- Basic unit TS Adapter IE Basic
- TS module
 - TS module modem: contains an analog modem for the connection to the analog telephone network.
 - TS module ISDN: contains a terminal adapter for the connection to the ISDN network.
 - TS module RS232: With RS232 interface for connecting an external modem.
 - TS module GSM: contains a wireless modem for connecting to the GSM/GPRS network.

Only the combination of a basic unit TS Adapter IE Basic and a TS module forms a complete functional unit (total unit). Basic unit and TS module are connected via a connector and assembled together.

The functions of the TS Adapter are implemented in the basic unit. The basic unit has an Ethernet interface for connecting to PGs, PCs, or automation system. The basic unit is supplied with 24 V DC and grounded via a socket board.

The TS modules form the electrical interface to the telephone network. They are supplied with electricity from the basic unit through the shared connector.

TS Adapter IE Basic (basic unit) and the TS module can be installed differently:

- Installing on the S7-300 standard rail. This requires an optionally available standard sectional rail adapter.
- Installation on a standard rail
- Wall mounting
- Enclosure mounting

Scope of supply

The following are supplied with the basic unit TS Adapter IE Basic:

- DVD "SIMATIC TeleService Edition" with software and documentation
- Support collar for Ethernet plug

Function

TeleService is stand-alone software and does not require the installation of other software products such as STEP 7.

When using the TIA Portal, the TeleService software is not required because the functions are already a component part of the TIA Portal.

The following functions are available for remote maintenance with TeleService:

- Support for the TS Adapter II, TS Adapter IE and TS Adapter IE Basic.
- Parameterization of the modem:
On the PG/PC side, parameterization using Windows tools is supported. On the line side, the TS Adapter (with default settings) performs parameterization.
- Electronic telephone book:
To support the administration of plants (e.g. telephone number, location).
- Multi-level access protection:
Prevents unauthorized connection build-up to a plant by means of a password and/or callback telephone number (callback function).
- Callback function:
The plant calls the service center back automatically following a TeleService call.
- Routing of the PG functionality:
Routing over TeleService is supported in the same manner as for a local connection. S7/M7 CPUs and CP modules with routing capability are required for this purpose.
- Import/export of the TS Adapter parameters:
The parameters can be saved in a file (*.tap) on the PG/PC and reloaded.
- Authorization via the Automation License Manager.
- For use with Windows 2000, Windows XP Home and Windows XP Professional.

TS Adapter II; TS Adapter IE and TS Adapter IE Basic provide additional functions.

TS Adapter II:

- Establishing a connection from/to remote plants, e.g. for calling up process data from an automation system (PG-to-AS remote coupling).
- Exchange of data between plants (AS-to-AS remote link):
- Exchange of process data between two SIMATIC automation systems.
- Sending a text message:
- Sending a text message from a SIMATIC automation system via a GSM wireless modem.

TS Adapter IE:

- Remote control of HMI devices:
The TS Adapter IE in combination with a browser installed on the PG/PC (e.g. Internet Explorer) and the Sm@rtViewer supports access over the telephone network to a SIMATIC HMI device with an installed Runtime option of WinCC flexible /Sm@rtService or /Sm@rtAccess. The HMI device or machine/plant can then be remotely controlled from the PG/PC.
- Sending e-mails:
The function block AS_MAIL (included in the scope of supply of the adapter or TeleService V6.1) can be used to send e-mails directly from a SIMATIC CPU over the TS Adapter IE. The TS Adapter IE builds up an outgoing modem connection to a dial-up server for this purpose, e.g. to an Internet service provider, and sends the e-mails via an e-mail server that can be accessed there. If the provider offers the service for converting e-mails to text messages, text messages can also be sent in this manner.
- Standard routing:
The TS Adapter IE allows a modem link to be established to an Internet service provider for accessing data on the Internet over this link. While the link is established, telephone dial-up and therefore remote maintenance and remote control is not possible.

TS Adapter IE Basic (in conjunction with a TS module):

- Remote maintenance over the telephone network:
The TS Adapter IE Basic enables an application running on the PG/PC, such as STEP 7, to access Industrial Ethernet-connected S7 and C7 automation components over the phone network. For this, the TS Adapter IE Basic requires the following:
 - a connection to the automation components via Industrial Ethernet, and
 - a modem connection to the PG/PC.
- Sending e-mails:
With the AS_MAIL function block, you can send e-mails from a SIMATIC CPU via the TS Adapter IE Basic. To do this, the TS Adapter IE Basic establishes an outgoing modem connection to a dial-up server, such as an Internet Service Provider (ISP), and sends the e-mails via a mail server accessible there.

To establish a remote connection through the telephone network you will alternatively need:

- TIA Portal V11.0 (contains all the necessary TeleService functions),
- TeleService V6.1 or
- Windows dial-up network

Industrial Remote Communication

Teleservice

SIMATIC TeleService

Technical specifications

Engineering Tool	DOCPRO
Type of license	Floating license
Software class	A
Current version	V5.4
Target system (recommended)	SIMATIC S7-300/400 SIMATIC C7
Operating system	Windows 2000 Professional Windows XP Professional Windows Vista Business/Ultimate
Required software packages	STEP 7 V5.4 or higher under Windows Vista V5.4 SP3 or higher
Disk space required in PG/PC	5 MB

TS Adapter IE	
Dimensions (W x H x D) in mm	125 x 110 x 40
Weight, approx.	approx. 370 g
Interfaces	
• Ethernet	RJ45 (10/100 Mbit/s)
• to an external modem	RS 232 (up to 115 kbaud)
• to the analog telephone network	RJ12
• to the ISDN telephone network	RJ45
Supply voltage, external or via multi-point interface	24 V DC
Current consumption of the TSA-IE ISDN	typ. 170 mA / max. 230 mA
Current consumption of the modem TSA IE	typ. 180 mA / max. 240 mA
Switch-on current, max.	0.7 A; 8 µs
Degree of protection	IP20
Temperature	
• Operation	±0 °C to +60 °C
• Storage/transport	-40 °C to +70 °C

TS Adapter II	
Dimensions (W x H x D) in mm	125 x 110 x 40
Weight, approx.	250 g
Interfaces	
• to S7/C7	RS 485 (up to 12 Mbit/s)
• to the PC	USB 1.1 (12 Mbit/s)
• to an external modem	RS 232 (up to 115 kbaud)
• to the analog telephone network	RJ12
• to the ISDN telephone network	RJ45
Supply voltage, external or via MPI interface	24 V DC
Current consumption	60 mA (typ.) / 120 mA (max.)
Starting current, max.	0.7 A; 8 µs
Degree of protection	IP20
Temperature	
• Operation	±0 °C to +60 °C
• Storage/transport	-40 °C to +70 °C

TS Adapter IE Basic (basic unit)	
Dimensions (W x H x D) in mm	30 x 100 x 75
Weight, approx.	100 g
Interfaces	
• Ethernet	RJ45 (10/100 Mbit/s)
• To the TS module	Proprietary (can only be used for TS modules)
Supply voltage, external	24 V DC
Current consumption	
• With TS module modem	Typ. 50 mA, max. 80 mA
• with TS module ISDN	Typ. 50 mA, max. 80 mA
• with TS module RS232	Typ. 40 mA, max. 60 mA
• with TS module GSM	Typ. 100 mA, max. 180 mA
Switch-on current, max.	240 mA
Degree of protection	IP20
Temperature	
• Operation	±0 °C to +60 °C (horizontal installation) ±0 °C to +40 °C (vertical installation)
• Storage	40 °C to +70 °C

Technical specifications (continued)

TS module modem

Dimensions (W x H x D) in mm, approximately	30 x 100 x 75
Weight, approx.	98 g
ITU transmission standards	<ul style="list-style-type: none"> • V.21, V.22, V.22bis, V.23, V.32, V.32bis, V.34, V.34x, K56flex, V.90, V.92
Other features	<ul style="list-style-type: none"> • Error correction and data compression • a/b interface • Hayes (AT) command set • All data formats • Dial procedures: dual-tone multiple-frequency (DTMF), pulse dialing

TS module RS232

Dimensions (W x H x D) in mm	30 x 100 x 75
Weight, approx.	100 g
Operating mode	Full duplex, asynchronous
Signals	TXD, RXD, DSR, CTS, RTS, DTR, DCD
Data transmission rate	2 400 ... 115 200 bit/s
Message frame	8 data bits (LSB first), no parity bit, 1 stop bit
Rule	according to RS232 standard
Connector	D-sub 9-pin, male (PC COMx)

TS module ISDN

Dimensions (W x H x D) in mm	30 x 100 x 75
Weight, approx.	92 g
Reports	
<ul style="list-style-type: none"> • D channel protocols • B channel protocols 	DSS1 (Euro-ISDN), 1TR6 V.110 (9600 bit/s, 19200 bit/s, 38400 bit/s) V.120 (64 kbit/s) X.75 (64 kbit/s)
Other features	<ul style="list-style-type: none"> • Multiple subscriber number (MSN) • AT command interpreter

TS module GSM

Dimensions (W x H x D) in mm	30 x 100 x 75
Weight, approx.	118 g
Transmission rate	
<ul style="list-style-type: none"> • GPRS Multislot Class 10 	
- Up to 2 uplinks	13.4 kbit/s ... 27 kbit/s upload gross
- Up to 4 downlinks	40 kbit/s ... 54 kbit/s download gross
Interfaces	
<ul style="list-style-type: none"> • SIM interface • Antenna connection 	3 V/1.8 V 1 x SMA antenna socket (50 Ohm)
Frequency ranges	Quad band: 850, 900, 1800, 1900 MHz
Transmitted output power	2 W at 850 MHz, 900 MHz 1 W at 1800 MHz, 1900 MHz

Industrial Remote Communication

Teleservice

SIMATIC TeleService

Ordering data	Order No.	Order No.
TeleService, Version 6.1 <i>Task:</i> Remote maintenance by means of wired or radio network <i>Target system:</i> SIMATIC S7-200, SIMATIC S7-300, SIMATIC S7-400, SIMATIC C7 <i>Requirement:</i> TS Adapter (STEP 7 not required) <i>Delivery package:</i> on CD, German, English, French, Spanish, Italian; with electronic documentation Floating License Floating License Upgrade (from each previous version) Software Update Service (requires current software version)		
TS Adapter II modem	6ES7 842-0CE00-0YE0	
With MPI connection and RS 232; 9-pin, male		
TS Adapter II ISDN	6ES7 842-0CE00-0YE4	
With MPI connection and RS 232; 9-pin, male		
TS Adapter IE modem	6ES7 842-0CA01-0YX2	
With Ethernet connection RJ45 (10/100 Mbit/s) and RS 232; 9-pin, male		
TS Adapter IE ISDN	6ES7 972-0CB35-0XA0	
With Ethernet connection RJ45 (10/100 Mbit/s) and RS 232; 9-pin, male		
USB cable	6ES7 972-0CC35-0XA0	
for parameterizing the TS adapter II, it can also be used for programming the connected devices. 5 m long		
		TS Adapter IE Basic
		Basic unit
		TS module modem
		6ES7 972-0EB00-0XA0
		TS module ISDN
		6ES7 972-0MM00-0XA0
		TS module RS232
		6ES7 972-0MD00-0XA0
		TS module GSM
		6ES7 972-0MS00-0XA0
		S7 mounting rail adapter
		6GK7 972-0MG00-0XA0
		For mounting the TS Adapter IE Basic on S7-300 mounting rail, width 60 mm
		SIMATIC Manual Collection
		6ES7 972-0SE00-7AA0
		Electronic manuals on DVD, multilingual: LOGO!, SIMADYN, SIMATIC bus components, SIMATIC C7, SIMATIC distributed I/O, SIMATIC HMI, SIMATIC Sensors, SIMATIC NET, SIMATIC PC Based Automation, SIMATIC PCS 7, SIMATIC PG/PC, SIMATIC S7, SIMATIC Software, SIMATIC TDC
		SIMATIC Manual Collection update service for 1 year
		6ES7 998-8XC01-8YE0
		Current "Manual Collection" DVD and the three subsequent updates
		SIMATIC Manual Collection update service for 1 year
		6ES7 998-8XC01-8YE2
		Current "Manual Collection" DVD and the three subsequent updates

ECOFAST



10/2	General data
10/4	Connection technology according to ISO 23570 and ECOFAST
10/4	<u>Communication via PROFIBUS DP</u>
10/5	Hybrid field bus connections
10/7	ECOFAST hybrid field bus connections in Cu-RS 485
10/11	ECOFAST fiber-optic hybrid cable
10/13	<u>Communication via AS-Interface</u>
10/14	AS-Interface shaped cable
10/15	<u>Power connection technology</u>
10/15	Power cables, plugs, power terminal connectors
10/18	Motor connection cables and plugs
10/20	<u>Accessories</u>
10/20	ECOFAST selection module
Ch. 3	Software
Ch. 3	ECOFAST ES

General data

Overview

ECOFAST (Energy and Communication Field Installation System) connects the components of an automation system (such as switching and control devices, I/O stations, motors and geared motors) using a uniform, standardized connection method for data and power.

ECOFAST is a solution for decentralization outside the control cabinet, with standardized connection methods for all components on a distributed installation basis, consistent for PROFIBUS DP and AS-Interface. ECOFAST sets standards in equipping machines and plants for automation, low-voltage controlgear and drives. ECOFAST is centered on the extensive decentralization and modularization of installations, combined with comprehensive diagnostics down to the component level.

Modern field and power bus technologies open up new possibilities for machinery and plant engineering. Decentrally conceived solutions are flexibly adaptable to the various applications in automated industrial tools.

This gives rise to advantages in terms of overall process costs. The standardized distributed installation technology with a high degree of protection (IP65) produces savings during

- Configuration
- Wiring
- Mounting
- Commissioning
- Operation

Features

- ECOFAST is a solution for a wide range of automation, drive and installation components with a high degree of protection.
- ECOFAST combines the components of an automation system with completely standardized connection methods for data and power according to ISO 23570.
- With ECOFAST, power and information are distributed and transmitted in a line.
- Parameters and control and diagnostics functionality are transmitted through PROFIBUS or AS-Interface for fast operation start-ups and troubleshooting.

Shorter time frames

With ECOFAST it is possible to shorten the time frames for the tendering, planning and configuring of machines and plants:

- Modular planning of machines and plants
- Compiling of tenders from ready-made modules
- Faster construction and mounting
- Cabinet-free construction with a high degree of protection
- Use of prefabricated and tested function units
- Faster installation on site
- Smaller plant footprints

Fast and smooth start-up

ECOFAST enables the fast and smooth start-up of automation and drive systems:

- Minimization of error sources through standardized interfaces and plug-in connectors
- Extensive diagnostics on the device and through the bus
- Improved EMC by direct coupling of switching unit and drive

High plant availability

ECOFAST maintains a high level of plant availability:

- Reduction of downtime thanks to the speedy and safe exchange of devices
- No interruption of the power and field bus while devices are being exchanged
- Automatic parameterizing when devices are exchanged
- Extensive status and diagnostics information
- Transmission of operating parameters (e.g. current values or status messages)

Components connected by ECOFAST

- Switchgear and control devices (direct-on-line starters, reversing starters, soft starters, frequency converters)
 - For near-motor or motor-mounted installation
 - As stand-alone device
 - As isolated solution
- I/O stations
- Motors and geared motors

For effective connection, installation components (cables, plugs, etc.) are used:

- For communication
- For power

ECOFAST in motor starters for operation in the field

The ECOFAST connection technology can be used to provide **power supply and communication** for motor starters for operation in the field:

- For ET 200pro motor starters
- For ECOFAST motor starters

The ECOFAST connection technology can be used for **power supply**:

- For M200D motor starters
- For MCU motor starters

The ECOFAST network topology

All interfaces for communication and power are completely standardized and comply with ISO 23570.

Communication via PROFIBUS DP (see page 10/4)

- Hybrid field bus connections (see page 10/5)
- PROFIBUS DP hybrid field bus cables (see page 10/7)
- Additional components (see page 10/10)
 - Hybrid plugs
 - Data T pieces
 - ECOFAST bus termination plug-in connectors

Communication via AS-Interface (see page 10/13)

- Yellow and black AS-Interface cable for data transmission (yellow) and auxiliary voltage (black)
- Connection of the AS-Interface cable by insulation piercing method

Power connection technology (see page 10/15)

- Power cables, plugs and power terminal connectors for the power supply (see page 10/16)
- Motor connection cables and plugs for the motor connection (see page 10/18)

(See figure "Schematic interface overview for ECOFAST network topology" page 10/3)

Overview (continued)

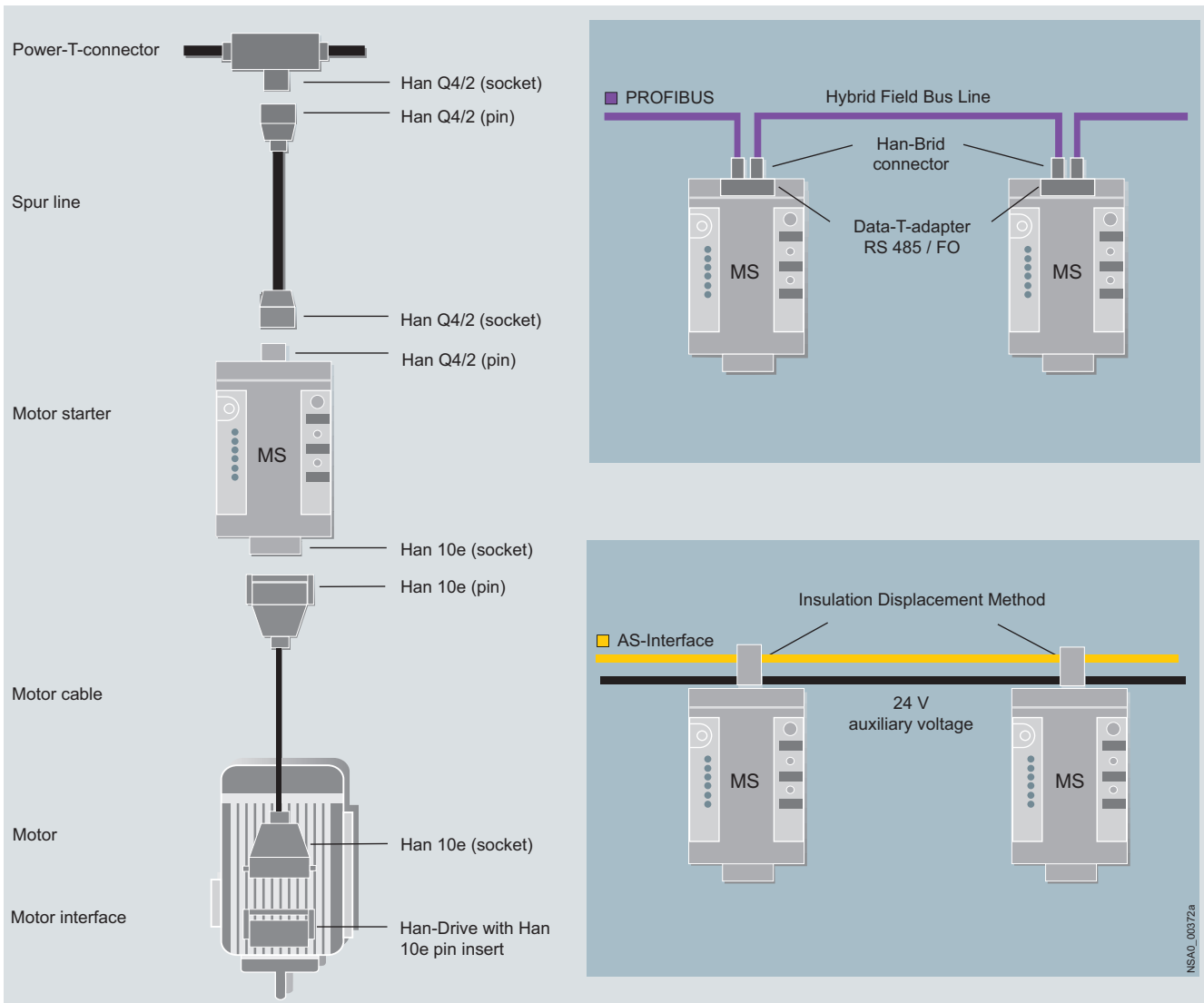

Schematic interface overview for ECOFAST network topology based upon the example of the ECOFAST motor starter:

- Left: Power feeder from power bus with spur line to the motor starter and motor cable for connection of the motor
- Connection via Han10e plug-in connection on the field device
- Connection via HanDrive/10e plug-in connector on the motor
- Motor connection cable as shielded or non-shielded version: Use of a frequency converter requires EMC shielding
- Right: Communication bus with PROFIBUS DP (top) or AS-Interface (bottom)

ECOFAST

Connection technology according to ISO 23570 and ECOFAST

Communication via PROFIBUS DP

Overview

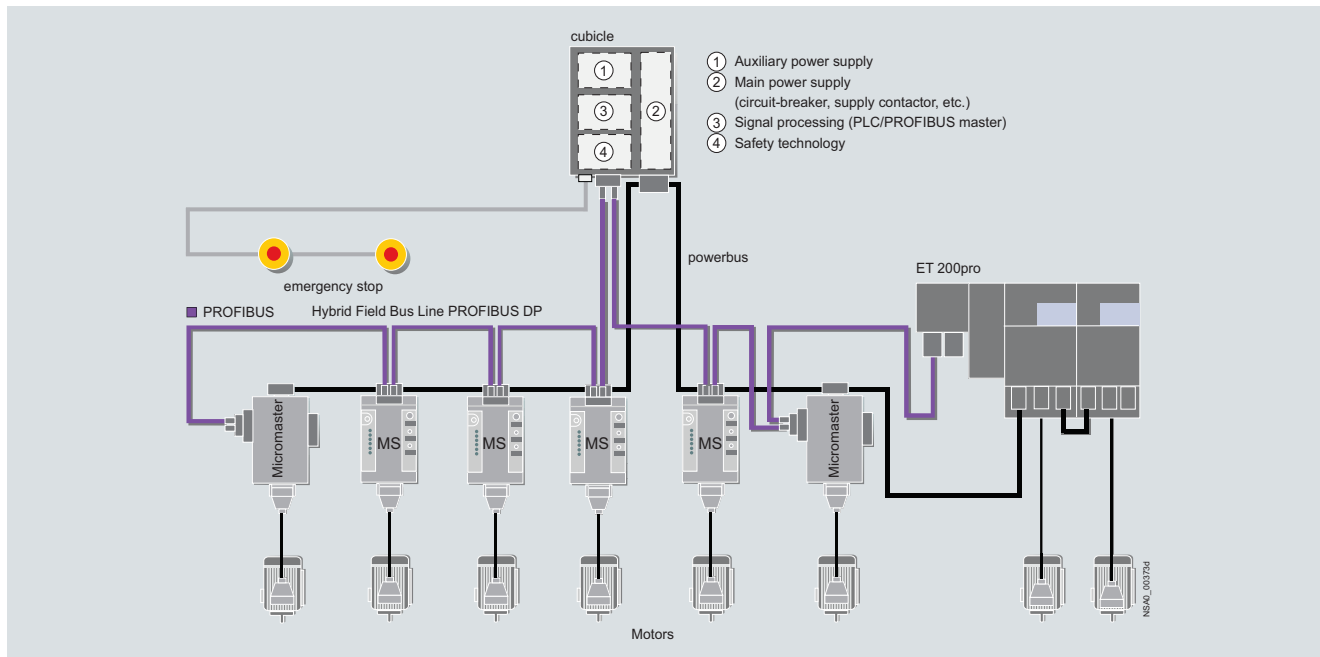

PROFIBUS DP network topology

Hybrid field bus connections

Hybrid field bus connections configured as control cabinet glands transmit data and power from the control cabinet (IP 20) into the field (IP65). They are the interface for jointly routing PROFIBUS DP and the auxiliary voltages into the hybrid field bus cable. The active hybrid field bus connections with signal re-fresher function can considerably increase the maximum PROFIBUS cable length when used in the field (see page 10/5).

Hybrid field bus cables

Four copper cores are available for the **transmission of voltage** in the hybrid field bus cables.

There are two transmission types for the **data transmission with PROFIBUS DP** in hybrid field bus cables:

- Electrically via two Cu-RS 485 copper cores (see ECOFAST hybrid field bus cables PROFIBUS DP in Cu-RS 485 page 10/7)
- Optically via two plastic fiber-optic cables (see ECOFAST Fiber Optic Hybrid Cable page 10/11)

HanBrid plug-in connectors

The hybrid field bus cables are connected to the data T pieces via HanBrid plug-in connections.

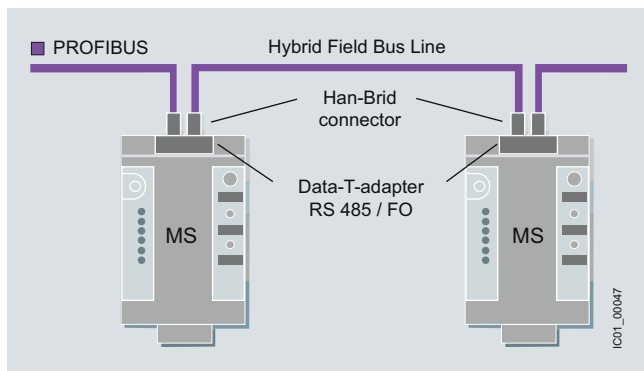

Connection of the field devices to PROFIBUS DP

Data T pieces

- PROFIBUS-DP connection**
 - Data T piece PROFIBUS-DP RS 485
 - 4 x Han-Brid D male/female 1.5 mm² for 10 A (2 x 24 V auxiliary voltage)
 - 2 x Han-Brid D male/female
- PROFIBUS-DP connection**
 - Data T piece PROFIBUS-DP FO
 - 4 x Han-Brid D male/female 1.5 mm² for 10 A (2 x 24 V auxiliary voltage)
 - 2 x Han-Brid LWL male/female
- Field device connection**
 - 25-pin Sub-D socket

Data T pieces

The data T pieces connect individual field devices to the ECOFAST hybrid field bus PROFIBUS DP. They ensure the interruption-free operation of the data bus when the field device is unplugged.

There are two T pieces in the ECOFAST system:

- Data T piece for PROFIBUS DP with copper cable (PROFIBUS DP RS 485) and 2 x 24 V auxiliary voltage (switched and non-switched)
- Data T piece for PROFIBUS DP with optical conductor (PROFIBUS DP FO) and 2 x 24 V auxiliary voltage (switched and non-switched)

NSA0_00189c

Overview



Hybrid field bus connection socket/socket (HanBrid)



Hybrid field bus connection socket/socket (M12)

Hybrid field bus connections configured as control cabinet glands transmit data and power from the control cabinet (IP 20) into the field (IP65). They are the interface for jointly routing PROFIBUS DP and the auxiliary voltages into the hybrid field bus cable.

Passive and active hybrid field bus connections

The hybrid field bus connections are available in two versions which differ in their functionality. They are:

- The passive version
- The active version with signal refresher function to considerably increase the maximum PROFIBUS cable length

Connection methods

The field side is connected using HanBrid or M12 plug-in connectors.

In the case of HanBrid, the following versions are available:

- Socket/socket for infeeding into the field
- Pin/socket for looping in the field

The M12 version is generally configured with socket/socket.

Following connections are available at the rear (cabinet side) in the case of the passive glands:

- Direct connection
- FastConnect connection

The active gland with refresher function has 9-pole Sub-D sockets for the rear connection.

Auxiliary power infeed

The HanBrid plug-in design offers the possibility of infeeding or looping through not only the Profibus signal but also 2 separate auxiliary voltages of 24 V DC (switched/unswitched) into the field. The terminal block with spring-type terminals at the rear (cabinet side) of the hybrid field bus connection provides a variety of interconnecting operations for these auxiliary voltages.

Passive hybrid field bus connections

- Gland from the control cabinet (IP20) into the field (IP65)
- HanBrid plug-in design socket/socket or pin/socket
- Direct connection or Fast-Connect connection for PROFIBUS at the rear
- Terminal block with spring-type terminals (0.25 ... 2.5 mm²) for infeeding or looping through the auxiliary voltages

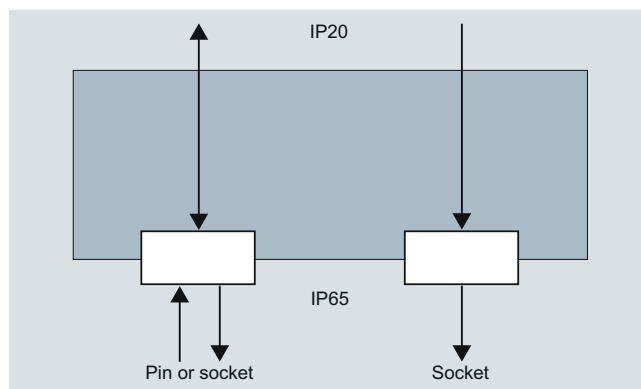

Hybrid field bus connection as passive control cabinet gland

Active hybrid field bus connections with refresher function

- Gland from the control cabinet (IP20) into the field (IP65)
- 3 independent, electrically separated Profibus segments
- Signal refresher function from and to all segments
- Automatic continuous baud rate detection
- Status/diagnostics displays with LEDs
- Cascading depth of a maximum 9 hybrid field bus connections
- HanBrid plug-in design socket/socket and pin/socket
- M12 plug-in design socket/socket
- 9-pole Sub D socket connection for PROFIBUS at the rear
- Terminal block with spring-type terminals (0.25 ... 2.5 mm²) for infeeding or looping through the auxiliary voltages

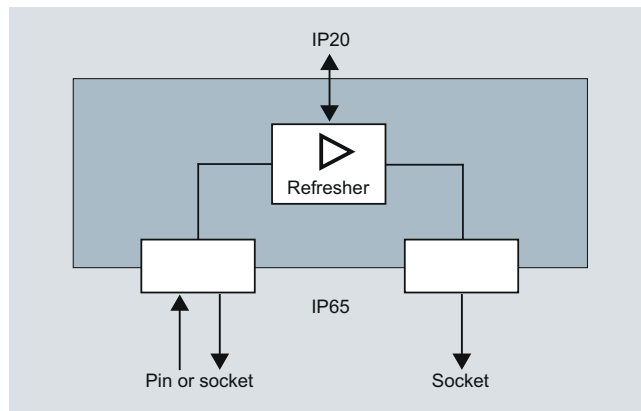

Hybrid field bus connection as active control cabinet gland with refresher function

ECOFAST

Connection technology according to ISO 23570 and ECOFAST

Communication via PROFIBUS DP Hybrid field bus connections

Technical specifications

Type		Passive hybrid field bus connections	Active hybrid field bus connections
<i>Mechanics and environment</i>			
Dimensions (W x H x D)	mm	93 x 103 x 65	
Cutout (W x H)	mm	80 x 90	
Temperature range	°C	-25 ... +60	
Degree of protection		IP20 internal / IP65 on field side	
Material/enclosures	mm	Plastic (black PC), flame retardant	
<i>Electrical specifications</i>			
Rated operational voltage			
• 24 V DC not switched (NS)	V DC	24, ±25 %	
• 24 V DC switched (S)	V DC	24, ±25 %	
Max. rated current	A	10	
Power supply		–	From 24 V DC not switched (NS)
Max. power consumption	mA	–	130
Mains buffering	ms	–	> 20
Baud rate detection		–	Automatic
Maximum cascading depth		–	9 hybrid field bus connections
Baud rates	kbit/s	9.6 / 19.2 / 45.45 / 93.75 / 187.5 / 500/1 500 / 3 000 / 6 000 / 12 000	
Electrical separation	V DC	500	

Selection and ordering data



Hybrid field bus connection on the field side:
With socket/socket (HanBrid)



With pin/socket (HanBrid)



With socket/socket (M12)

Link type/ function	Connection IP65	Connection IP20 (PROFIBUS)	Order No.
---------------------	-----------------	----------------------------	-----------

Hybrid field bus connections

Passive

• Cu/Cu, for feeding into the field	Socket/socket (2 x HanBrid)	Direct connection	3RK1 911-1AA22
• Cu/Cu, for looping through in the field	Pin/socket (2 x HanBrid)	Direct connection	3RK1 911-1AA32
• Cu/Cu, for feeding into the field	Socket/socket (2 x HanBrid)	PROFIBUS FastConnect bus connectors	3RK1 911-1AF22
• Cu/Cu, for looping through in the field	Pin/socket (2 x HanBrid)	PROFIBUS FastConnect bus connectors	3RK1 911-1AF32

Active (refresher)

• Cu/Cu, for feeding into the field	Socket/socket (2 x HanBrid)	9-pole Sub D socket	3RK1 911-1AJ22
• Cu/Cu, for looping through in the field	Pin/socket (2 x HanBrid)	9-pole Sub D socket	3RK1 911-1AJ32
• Cu/Cu, for feeding into the field	Socket/socket (2 x M12)	9-pole Sub D socket	3RK1 911-1AK22

¹⁾ When ordering, specify the length as well (example: length = 7.50 m).
Orders possible for minimum 10 cm module widths.

Connection technology according to ISO 23570 and ECOFAST

Communication via PROFIBUS DP
ECOFAST hybrid field bus connections in Cu-RS 485

Overview

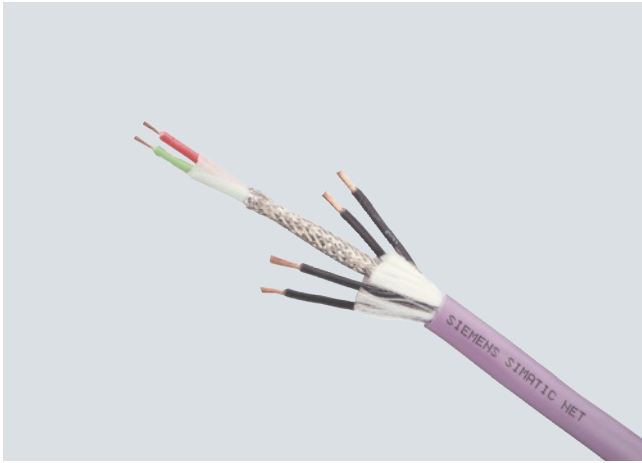

ECOFAST Hybrid Cable PROFIBUS DP in Cu-RS 485

All devices running in the field are connected to the PROFIBUS DP with the ECOFAST bus cables.

The bus cable is configured as a hybrid cable and contains:

- PROFIBUS DP in Cu-RS 485;
- Four additional copper cores for transmission of the 24 V DC voltage:
 - 24 V DC, not switched (for electronics and inputs)
 - 24 V DC, switched (for outputs, can be switched off, e.g. on EMERGENCY-STOP)

The ECOFAST hybrid cables are available by the meter or in pre-assembled lengths with ECOFAST connectors (Han Brid) and sockets.

Technical specifications

Type	6XV1 830-7AH10 PROFIBUS ECOFAST hybrid cables – copper	6XV1 860-2P PROFIBUS ECOFAST Hybrid Cable GP
Suitability for use	Connection for ECOFAST stations	Connection for ECOFAST stations
Cable designation	02Y (ST)C 1 x 2 x 0.65/2.56- 150 LI LIH-Z 11Y 4 x 1 x 1.5 VI FRNC	02Y (ST)C 1 x 2 x 0.65/2.56 -150 LI LIY-Z Y 4 x 1 x 1.5 VI

Electrical specifications

Damping dimension per length			
• At 16 MHz	dB/km	49	49
• At 4 MHz	dB/km	25	25
• At 9.6 MHz	dB/km	3	3
Shaft resistance			
• At 9.6 kHz	Ω	270	270
• At 38.4 kHz	Ω	185	185
• At 3 MHz ... 20 MHz	Ω	150	150
• Rated value	Ω	150	150
Symmetrical tolerance of the shaft resistance			
• At 3 MHz ... 20 MHz	Ω	±15	±15
• At 38.4 kHz	Ω	±18.5	±18.5
• At 9.6 MHz	Ω	±27	±27
Maximum loop resistance per length	Ω/km	138	138
Maximum shield resistance per length	Ω/km	15	15
Capacity per length at 1 kHz	nF/km	30	30
RMS value of operational voltage	V	100	100
Uninterrupted current of power cores	A	12	12

✓ Function is available

– Function is not available

ECOFAST

Connection technology according to ISO 23570 and ECOFAST

Communication via PROFIBUS DP

ECOFAST hybrid field bus connections in Cu-RS 485

Technical specifications (continued)

Type	6XV1 830-7AH10 PROFIBUS ECOFAST hybrid cables – copper	6XV1 860-2P PROFIBUS ECOFAST Hybrid Cable GP
Suitability for use	Connection for ECOFAST stations	Connection for ECOFAST stations
Cable designation	02Y (ST)C 1 x 2 x 0.65/2.56- 150 LI LIH-Z 11Y 4 x 1 x 1.5 VI FRNC	02Y (ST)C 1 x 2 x 0.65/2.56 -150 LI LIY-Z Y 4 x 1 x 1.5 VI
Mechanical specifications		
Cable sheath		
• Material	PUR	PVC
• External diameter mm	11	11
• Color	Violet	Violet
Power core		
• Conductor cross-section mm ²	1.5	1.5
• Color of core insulation	Black	Black
Ambient temperature		
• During mounting °C	-40 ... +60	-30 ... +80
• During operating phase °C	-40 ... +60	-30 ... +80
• During storage °C	-40 ... +60	-30 ... +80
• During transport °C	-40 ... +60	-30 ... +80
Bending radius		
• With single bend mm	38	77
• With several bends mm	85	110
Number of bending cycles	5 000 000	1 000 000 ¹⁾
Weight per length kg/km	150	154
Fire behavior	IEC 60332-1	IEC 60332-3-24 Category C
Chemical resistance		
• To mineral oil	Conditionally resistant	Conditionally resistant
• To grease	Conditionally resistant	Conditionally resistant
Radiological resistance to UV radiation resistance	–	✓
Product feature		
• Halogen-free	✓	–
• Silicone-free	✓	✓
UL listing at 300 V rating	–	✓ / CM, CL3, SunRes, OilRes
UL style at 600 V rating	–	✓

✓ Function is available

– Function is not available

¹⁾ At bending radius 15 x D.

Connection technology according to ISO 23570 and ECOFAST

Communication via PROFIBUS DP
ECOFAST hybrid field bus connections in Cu-RS 485

Selection and ordering data

Version	Order No.
PROFIBUS ECOFAST hybrid cables – copper	
Trailing cables (PUR sheath) with two copper conductors, shielded, for PROFIBUS DP and four copper cores with 1.5 mm ²	
Sold by the meter Delivery unit max. 1 000 m, minimum order quantity 20 m	6XV1 830-7AH10
Non-assembled	
• 20 m	6XV1 830-7AN20
• 50 m	6XV1 830-7AN50
• 100 m	6XV1 830-7AT10
Pre-assembled With ECOFAST plug and socket (HanBrid), fixed length	
• 0.5 m	6XV1 830-7BH05
• 1.0 m	6XV1 830-7BH10
• 1.5 m	6XV1 830-7BH15
• 3 m	6XV1 830-7BH30
• 5 m	6XV1 830-7BH50
• 10 m	6XV1 830-7BN10
• 15 m	6XV1 830-7BN15
• 20 m	6XV1 830-7BN20
• 25 m	6XV1 830-7BN25
• 30 m	6XV1 830-7BN30
• 35 m	6XV1 830-7BN35
• 40 m	6XV1 830-7BN40
• 45 m	6XV1 830-7BN45
• 50 m	6XV1 830-7BN50
With two ECOFAST connectors (HanBrid), variable length (can be ordered from your local Siemens representative)	
PROFIBUS ECOFAST Hybrid Cable GP	
Trailing cable with 4 x Cu and 2 x Cu, shielded with UL approval	
Sold by the meter Delivery unit max. 1 000 m, minimum order quantity 20 m	6XV1 860-2P
Non-assembled	
• 20 m	6XV1 860-4PN20
• 50 m	6XV1 860-4PN50
• 100 m	6XV1 860-4PT10
Assembled With ECOFAST plug and socket (HanBrid)	
• 0.5 m	6XV1 860-3PH05
• 1 m	6XV1 860-3PH10
• 1.5 m	6XV1 860-3PH15
• 3 m	6XV1 860-3PH30
• 5 m	6XV1 860-3PH50
• 10 m	6XV1 860-3PN10
• 15 m	6XV1 860-3PN15
• 20 m	6XV1 860-3PN20
• 25 m	6XV1 860-3PN25
• 30 m	6XV1 860-3PN30
• 35 m	6XV1 860-3PN35
• 40 m	6XV1 860-3PN40
• 45 m	6XV1 860-3PN45
• 50 m	6XV1 860-3PN50

ECOFAST

Connection technology according to ISO 23570 and ECOFAST

Communication via PROFIBUS DP

ECOFAST hybrid field bus connections in Cu-RS 485

Selection and ordering data (continued)

Version	Order No.
<i>Additional components</i>	
PROFIBUS copper bus connector With 2 x Cu shielded and 4 x Cu 1.5 mm ² ; contact type: POF, Han D for 24 V; tool: Crimping tool, polishing set; 5 units; with mounting instructions	
<ul style="list-style-type: none"> • With pin insert 	6GK1 905-0CA00
<ul style="list-style-type: none"> • With female insert 	6GK1 905-0CB00
PROFIBUS ECOFAST HybridPlug, angled; With 2 x Cu shielded and 4 x Cu 1.5 mm ² ; 5 units; with mounting instructions	
<ul style="list-style-type: none"> • Pin insert 	6GK1 905-0CC00
<ul style="list-style-type: none"> • Female inserts 	6GK1 905-0CD00
ECOFAST Terminating Plug Bus termination plug-in connector for PROFIBUS DP; with 2 x Cu and 4 x Cu 1.5 mm ² ; pin insert, integrated terminating resistors	
<ul style="list-style-type: none"> • Pack of 1 	6GK1 905-0DA10
<ul style="list-style-type: none"> • Pack of 5 	6GK1 905-0DA00
Data T piece for 2 x 24 V auxiliary voltage (switched and non-switched) and PROFIBUS DP	
<ul style="list-style-type: none"> • for Cu RS 485 	3RK1 911-2AG00
Addressing plug for setting the PROFIBUS DP address	6ES7 194-1KB00-0XA0

Supplementary components for the SIMATIC NET cabling range can be ordered from your local representative. Technical consulting is available at:

J. Hertlein

Tel.: +49 (0) 911/750 44 65

Fax: +49 (0) 911/750 99 91

E-mail: juergen.hertlein@siemens.com

Connection technology according to ISO 23570 and ECOFAST

Communication via PROFIBUS DP
ECOFAST fiber-optic hybrid cable

Overview



ECOFAST fiber-optic hybrid cable

The ECOFAST fiber-optic hybrid cable from SIMATIC NET is used for setting up optical PROFIBUS DP networks indoors.

The robust and trailing hybrid cable contains two plastic optical conductors for data transmission and four copper cables (1.5 mm²) for the power supply of DESINA¹⁾ stations.

It is particularly suitable for the connection of DESINA components installed near the machine and is easy to assemble on site. The maximum cable length between two DP units is 50 m.

- Hybrid cable for joint transmission of data and power supply
- Electrical separation of DP units
- Protection of the transmission path against electromagnetic faults
- Up to 50 m cable length with plastic optical conductor
- Robust fiber-optic cable, designed for industrial applications

¹⁾ DESINA is the trademark for **DE**centralized (distributed) and **St**andardized **IN**stallation technology on machine tools.

Technical specifications

Type	6XV1 830-6CH10 ECOFAST fiber-optic hybrid cable (DESINA-compatible)	
Suitability for use	DESINA-compatible devices, e.g. for ET 200X	
Cable designation of the ECOFAST Hybrid Cable	I-(ZN) J-V4Y 11Y2S 980/1000+4x1.5	
Version of the assembled FO cable	Sold by the meter, can be assembled locally with DESINA connectors or pre-assembled with two DESINA connectors	
<i>Electrical specifications</i>		
Damping dimension per length at 660 nm maximum	dB/km	280
Operational voltage rated value	V	300
Uninterrupted current of power cores	A	10
<i>Mechanical specifications</i>		
Number of electrical cores	4	
Number of conductors of the FO cable	2	
Version of the FO conductor fiber	Step index fiber	
Material		
• of the FO fiber core	Polymethylmethacrylate (PMMA)	
• of the FO fiber sheath	Fluorinated special polymer	
• of the sheath of the FO cable	PUR	
• of the sheath of the FO core	PA	
Color		
• of the sheath of the FO core	Black, orange	
• of the core insulation of power cores	Black	
• of the sheath of the hybrid cable	Violet	
Diameter of the FO fiber core	µm	980
Conductor cross-section of the power cores	mm ²	1.5

Type	6XV1 830-6CH10 ECOFAST fiber-optic hybrid cable (DESINA-compatible)	
<i>Mechanical specifications</i> (continued)		
External diameter		
• of the FO fiber sheath	µm	1 000
• of the sheath of the cable	mm	10.6
• of the sheath of the FO core	mm	2.2
- Lower deviation	mm	2.19
- Upper deviation	mm	2.21
Weight per length	kg/km	146
Maximum permitted short-term tensile loading	N	60
Short-term shear force per length	N/m	1 000
Bending radius with several bends with minimum permitted tensile loading	mm	110
Ambient temperature		
• During operating phase	°C	-20 ... +60
• During storage	°C	-20 ... +60
• During transport	°C	-20 ... +60
• During mounting	°C	-5 ... +50
• In the short circuit on the conductor	°C	+160 (max. 5 s)
Chemical resistance		
• To ASTM oil 2	Conditionally resistant	
• To grease	Conditionally resistant	
• To water	Conditionally resistant	
Radiological resistance to UV radiation resistance	-	
Fire behavior	IEC 60332-1	
Verification of suitability UL approval	-	
Product feature		
• Halogen-free	-	
• Silicone-free	✓	

- ✓ Function is available
- Function is not available

ECOFAST

Connection technology according to ISO 23570 and ECOFAST

Communication via PROFIBUS DP ECOFAST fiber-optic hybrid cable

Selection and ordering data

Version	Order No.
ECOFAST fiber-optic hybrid cable (DESINA-compatible)	
Trailing cable with 2 plastic optical conductors and 4 copper cores, 1.5 mm ² only for operation in DESINA-compatible devices	
Sold by the meter Delivery unit max. 1 000 m, minimum order quantity 20 m	6XV1 830-6CH10
Non-assembled	
• 20 m	6XV1 830-6CN20
• 50 m	6XV1 830-6CN50
• 100 m	6XV1 830-6CT10
Pre-assembled With 2 DESINA connectors	
• 1.5 m	6XV1 830-6DH15
• 3 m	6XV1 830-6DH30
• 5 m	6XV1 830-6DH50
• 10 m	6XV1 830-6DN10
• 15 m	6XV1 830-6DN15
ECOFAST fiber-optic hybrid plug 180, DESINA-compatible (ECOFAST FOC)	
2 x FO; 4 x 1.5 mm ² Cu	
• With pin insert (Hanbrid connectors)	6GK1 905-0BA00
• With female insert (Hanbrid connectors)	6GK1 905-0BB00
Data T piece	
For 2 x 24 V auxiliary voltage (switched and non-switched) and PROFIBUS DP	
• For FOC	3RK1 911-2AH00
Manual for PROFIBUS networks	
Paper version Network architecture, configuring, network components, mounting	
• German	6GK1 970-5CA20-0AA0
• English	6GK1 970-5CA20-0AA1
SIMATIC NET Manual Collection	
Electronic manuals for communication systems, protocols, products; on DVD; German/English	6GK1 975-1AA00-3AA0

Supplementary components for the SIMATIC NET cabling range can be ordered from your local representative. Technical consulting is available at:

J. Hertlein
Tel.: +49 (0) 911/750 44 65
Fax: +49 (0) 911/750 99 91
E-mail: juergen.hertlein@siemens.com

Overview

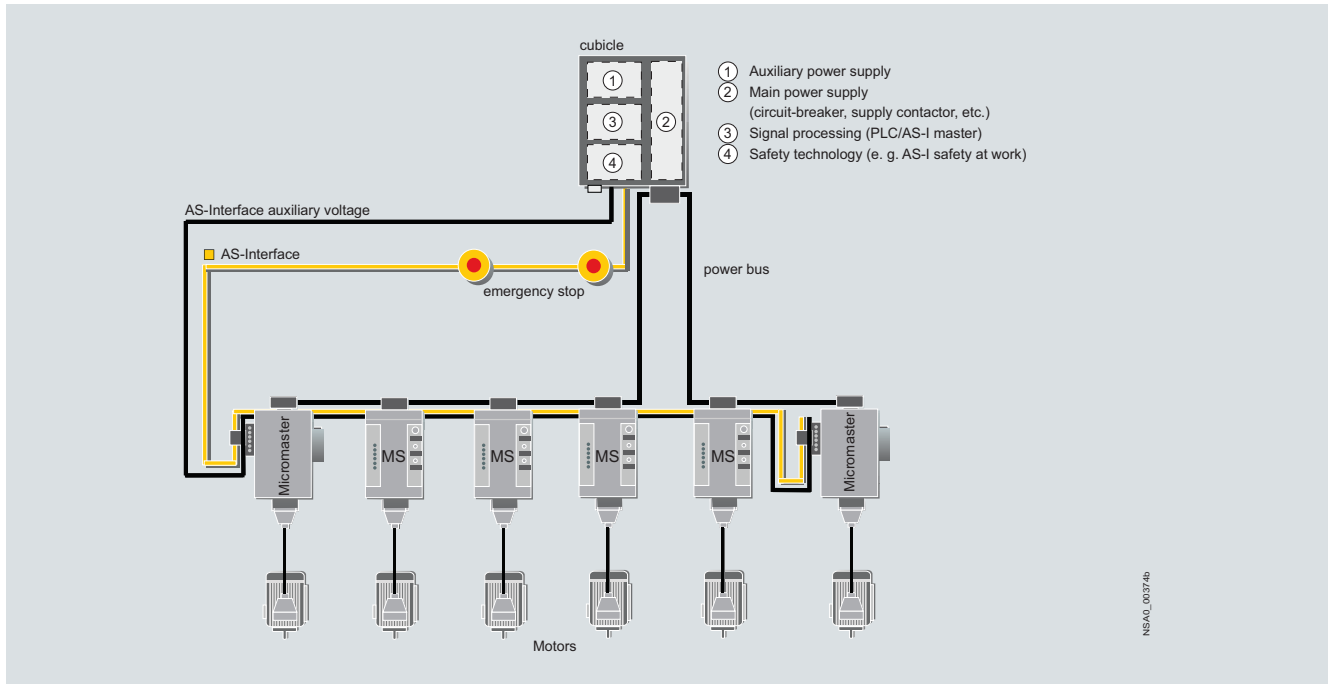

AS-Interface network topology

AS-Interface shaped cable

The two-core AS-Interface shaped cable is used in the communication via AS-Interface (see page 10/14):

- Yellow core for data transmission
- Black core for 24 V auxiliary voltage

Insulation piercing method

Connection is by means of the insulation piercing method which was developed especially for the AS-Interface (see page 10/14).

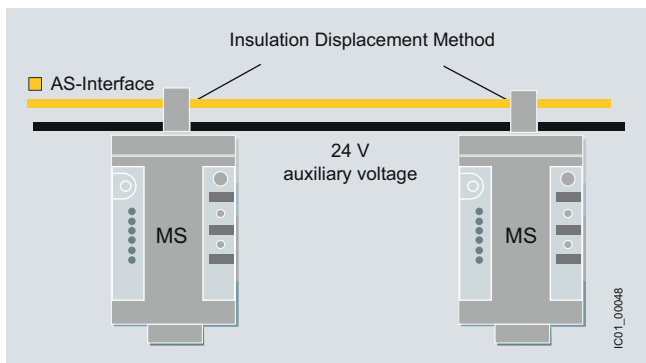

Connection at AS-Interface using insulation piercing method

ECOFAST

Connection technology according to ISO 23570 and ECOFAST

Communication via AS-Interface AS-Interface shaped cable

Overview



AS-Interface shaped cable

The **Actuator-Sensor Interface (AS-Interface)** - the networking system used for the lowest field area - is characterized by very easy mounting and installation. A new connection method was developed specially for the AS-Interface.

The stations are connected using the AS-Interface cable. This two-wire AS-Interface shaped cable has a trapezoidal shape, thus ruling out polarity reversal.

Connection is effected by the **insulation piercing method**. In other words, male contacts pierce the shaped AS-Interface cable and make reliable contact with the two wires. Cutting to length and stripping are superfluous. Consequently, AS-Interface stations (e. g. I/O modules, intelligent devices) can be connected in the shortest possible time and exchanging devices is quick.

To enable use in the most varied ambient conditions (e. g. in an oily environment), the AS-Interface cable is available in different materials (rubber, TPE, PUR).

For special applications it is also possible to use an unshielded standard round cable H05VV-F 2x1.5 mm² according to AS-i Specification. With AS-Interface, data and energy for the sensors (e.g. proximity switches BERO) and actuators (e. g. indicator lights) are transmitted over the yellow AS-Interface cable.

The black cable must be used for actuators with a 24 V DC supply (e.g. solenoid valves) and a high power requirement.

Suitable for operation in tow chains

The use of the AS-Interface shaped cables with TPE and PUR outer sheath was checked in a tow chain test with the following conditions:

Chain length	m	6
Travel	m	10
Bending radius	mm	75
Travel speed	m/s	4
Acceleration	m/s ²	4
Number of cycles		10 million
Duration of test		approx. 3 years (11 000 cycles per day)

After termination of the 10 million cycles only slight wear was visible due to the lugs of the tow chain. No damage to the cores and core insulation could be detected.

Note:

When using a tow chain, the cables must be installed such that they are not subject to tensile forces. On no account may the cables be twisted, but must be routed flat through the tow chain.

Selection and ordering data

	Material	Color	Quantity	Order No.	
	AS-Interface shaped cables				
	Rubber	Yellow (AS-Interface)	100-m roll	3RX9 010-0AA00	
			1-km drum	3RX9 012-0AA00	
		Black (24 V DC)	100-m roll	3RX9 020-0AA00	
			1-km drum	3RX9 022-0AA00	
	TPE	Yellow (AS-Interface)	100-m roll	3RX9 013-0AA00	
			1-km drum	3RX9 014-0AA00	
		Black (24 V DC)	100-m roll	3RX9 023-0AA00	
			1-km drum	3RX9 024-0AA00	
		TPE special version ¹⁾	Yellow (AS-Interface)	100-m roll	3RX9 017-0AA00
			Black (24 V DC)	100-m roll	3RX9 027-0AA00
	PUR	Yellow (AS-Interface)	100-m roll	3RX9 015-0AA00	
1-km drum			3RX9 016-0AA00		
Black (24 V DC)		100-m roll	3RX9 025-0AA00		
		1-km drum	3RX9 026-0AA00		

¹⁾ Special version according to UL Class

Overview

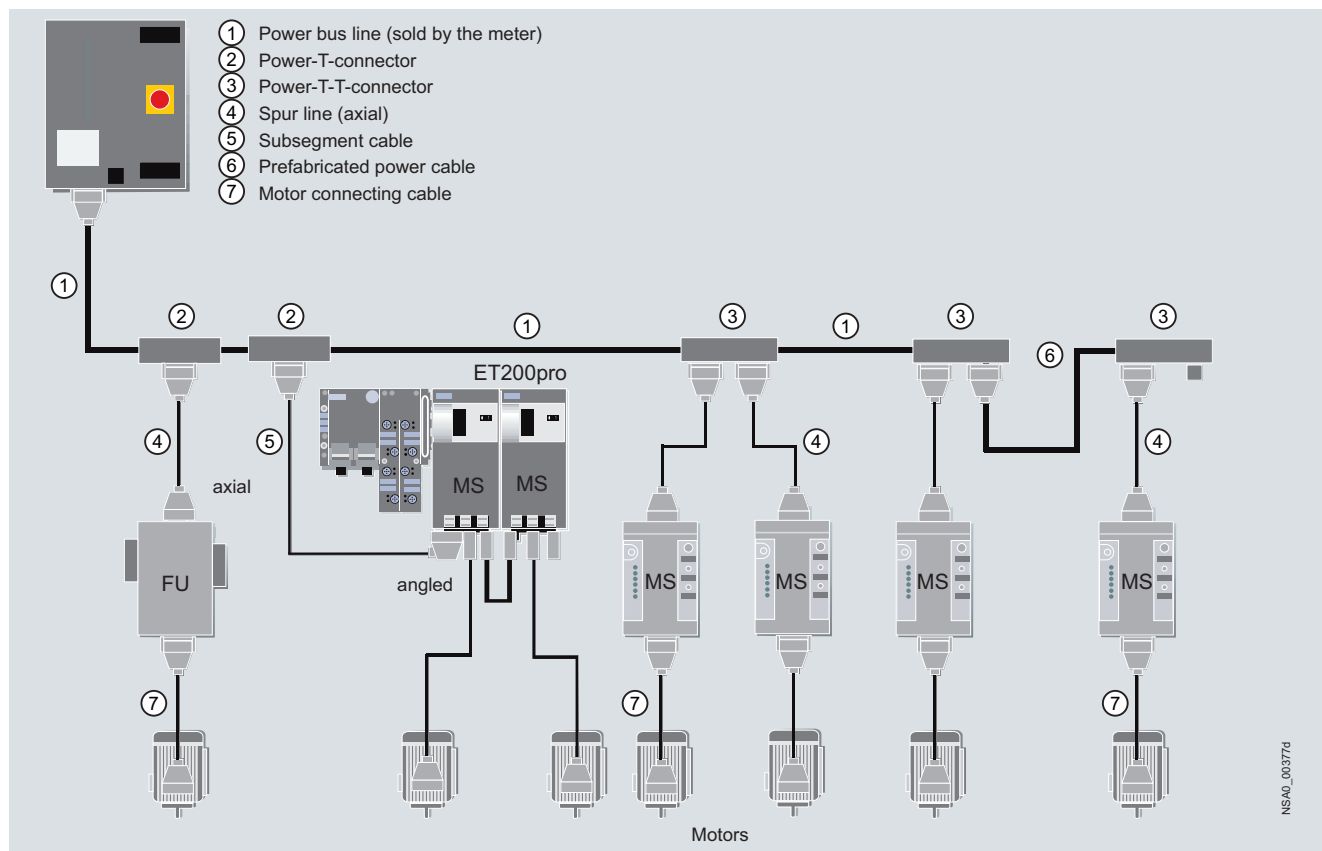

Power supply to the motors via the power bus with power T and TT terminal connectors, spur lines to the field devices and power loop-through via motor connection cables

Power bus

The power supply to the field devices (ECOFAST motor starter, ET 200pro motor starter, M200D motor starter, MCU motor starter or frequency converter) is provided via the power bus, in which the power T terminal connector ② or power double-T terminal connector ③ are connected by power bus cables ①.

Feeders

From the terminal connectors, spur lines ④ with Han Q4/2 plugs lead to the field devices from which the motors are supplied with power via motor connection cables ⑦.

Interruption-free thanks to power terminal connectors

In finger-safe connection technology the power T connectors (② see page 10/17) and power TT terminal connectors (③ see page 10/17) connect the components of a feeder to the power bus. They ensure interruption-free operation, i.e. when the components are plugged in the power bus is not interrupted.

Motor connection cables

This section describes only the motor cables for the connection of the motor with Han10e plug-in connectors on the motor starter. (+ motor connection cables see page 10/18)

Han Q8 plug-in connectors on the motor starter are required:

- For ET 200pro motor starters (see Catalog ST 70, Accessories for ET 200pro motor starters)
- For M200D motor starters (see Chapter 6, Accessories for M200D motor starters)
- For MCU motor starters (see Chapter 6) the M screw is used for the load feeder.

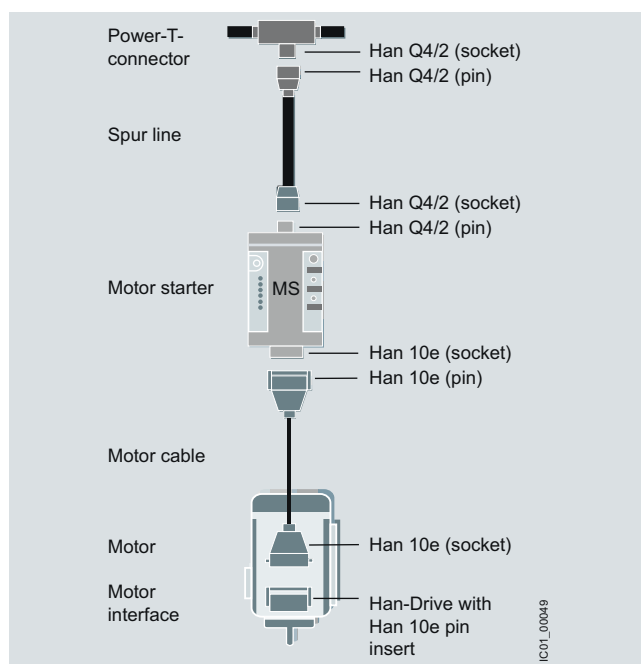

Power feeder from power bus with spur line to the motor starter and motor cable for connection of the motor

- Connection via Han10e plug-in connection on the motor starter (for ET 200pro/M200D in HAN Q8 version)
- Connection via HanDrive/10e plug-in connector on the motor
- Motor connection cable as shielded or non-shielded design: Use of a frequency converter requires EMC shielding

Connection technology according to ISO 23570 and ECOFAST

Power connection technology
Power cables, plugs, power terminal connectors

Selection and ordering data

Cross-section mm ²	Fixed length m	Any length ¹⁾ m	Order No.
① Power bus cables, non-assembled			
5 x 4	20	–	3RK1 911-0AG60
	50	–	3RK1 911-0AG70
	100	–	3RK1 911-0AG80
5 x 6	20	–	3RK1 911-0AH60
	50	–	3RK1 911-0AH70
	100	–	3RK1 911-0AH80
Power cables (new), preassembled			
④ Spur line/connection of switching devices/motor starters both ends with Han Q4/2 (pin/socket), axial cable routing			
5 x 4	–	< 3	3RK1 911-0CP21
	–	> 3.1 ... < 5	3RK1 911-0CP31
	–	> 5.1 ... < 10	3RK1 911-0CP41
	–	> 10.1 ... < 15	3RK1 911-0CP51
5 x 6	–	< 3	3RK1 911-0CP22
	–	> 3.1 ... < 5	3RK1 911-0CP32
	–	> 5.1 ... < 10	3RK1 911-0CP42
	–	> 10.1 ... < 15	3RK1 911-0CP52

¹⁾ When ordering, specify the length as well (example: length = 7.50 m).
Orders possible for minimum 10 cm module widths.

Enclosures	Usage	Contacts	Order No.
Connector set for energy supply HAN Q4/2			
2.5 mm ² / 4 mm ² / 6 mm ² , comprising:			
• Angled, e.g. for energy supply to motor starter			
1 cable-end connector hood with Pg16	1 female insert	5 female contacts 2.5 mm ²	3RK1 911-2BE50
1 cable-end connector hood with Pg16	1 female insert	5 female contacts 4 mm ²	3RK1 911-2BE10
1 cable-end connector hood with Pg16	1 female insert	5 female contacts 6 mm ²	3RK1 911-2BE30
• Straight, e.g. for energy supply to motor starter			
1 cable-end connector hood with Pg16	1 female insert	5 female contacts 2.5 mm ²	3RK1 911-2BR50
1 cable-end connector hood with Pg16	1 female insert	5 female contacts 4 mm ²	3RK1 911-2BR10
1 cable-end connector hood with Pg16	1 female insert	5 female contacts 6 mm ²	3RK1 911-2BR30
Connector set for power loop-through HAN Q4/2			
2.5 mm ² / 4 mm ² / 6 mm ² , comprising:			
• Angled e.g. for connection P&CM			
1 coupling enclosure with Pg16	1 pin insert	5 male contacts 2.5 mm ²	3RK1 911-2BF60
1 coupling enclosure with Pg16	1 pin insert	5 male contacts 4 mm ²	3RK1 911-2BF20
1 coupling enclosure with Pg16	1 pin insert	5 male contacts 6 mm ²	3RK1 911-2BF40
• Straight e.g. for connection on power T terminal connector			
1 coupling enclosure with Pg16	1 pin insert	5 male contacts 2.5 mm ²	3RK1 911-2BS60
1 coupling enclosure with Pg16	1 pin insert	5 male contacts 4 mm ²	3RK1 911-2BS20
1 coupling enclosure with Pg16	1 pin insert	5 male contacts 6 mm ²	3RK1 911-2BS40
Control cabinet gland HAN Q4/2 e.g. for installation in control cabinet or local switchboxes			3RK1 911-1BF00

Selection and ordering data (continued)

Version	Order No.
② Power T terminal connectors For 400 V AC for connection of feeders (e.g. motor starters) by means of standard round cable at any point of the power bus, by insulation displacement connection Use of preassembled bus segments <ul style="list-style-type: none"> • 2.5 mm²/4 mm² • 4 mm² / 6 mm² 	3RK1 911-2BF01 3RK1 911-2BF02
③ Power double-T terminal connectors For 400 V AC for connection of feeders (e.g. motor starters) by means of standard round cable at any point of the power bus, by insulation displacement connection <ul style="list-style-type: none"> • Use of preassembled bus segments • Connection of two motor starters possible • 4 mm² / 6 mm² 	3RK1 911-2BG02
Sealing set (comprising 2 seals) For power T / power double T terminal connector <ul style="list-style-type: none"> • For power cables with Ø 10 ... 13 mm • For power cables with Ø 13 ... 16 mm • For power cables with Ø 16 ... 19 mm • For power cables with Ø 19 ... 22 mm • Blanking plugs 	3RK1 911-5BA00 3RK1 911-5BA10 3RK1 911-5BA20 3RK1 911-5BA30 3RK1 911-5BA50
Version	Order No.
Miscellaneous accessories	
Crimping tools For male and female contacts <ul style="list-style-type: none"> • 1.5 and 2.5 mm² • 1.5, 2.5 and 4 mm² 	3RK1 902-0AH00 3RK1 902-0CT00
Dismantling tools <ul style="list-style-type: none"> • For male and female contacts for 9-pole inserts (e.g. HAN Q8) • For male and female contacts for 9-pole HAN Q4/2 inserts 	3RK1 902-0AJ00 3RK1 902-0AB00
Sealing caps For power socket connectors <ul style="list-style-type: none"> • 1 unit per pack • 10 units per pack 	3RK1 902-0CK00 3RK1 902-0CJ00

Connection technology according to ISO 23570 and ECOFAST

Power connection technology Motor connection cables and plugs

Selection and ordering data (continued)

Cross-section mm ²	Fixed length m	Any length ¹⁾ m	Order No.
① Motor connection cables			
• Preassembled at both ends with Han 10e (pin/socket), unshielded			
11 x 1.5	1.5	–	3RK1 911-0BK10
	–	< 2.9	3RK1 911-0CK20
	3	–	3RK1 911-0BK20
	–	> 3.1 ... < 4.9	3RK1 911-0CK30
	5	–	3RK1 911-0BK30
7 x 1.5	1.5	–	3RK1 911-0BH10
	–	< 2.9	3RK1 911-0CH20
	3	–	3RK1 911-0BH20
	–	> 3.1 ... < 4.9	3RK1 911-0CH30
	5	–	3RK1 911-0BH30
• Preassembled at both ends with Han 10e (pin/socket), shielded			
4 x 2.5	1.5	–	3RK1 911-0BU10
4 x 0.75	–	< 2.9	3RK1 911-0CU20
	3	–	3RK1 911-0BU20
	–	> 3.1 ... < 4.9	3RK1 911-0CU30
	5	–	3RK1 911-0BU30
• Preassembled at one end with Han 10e (pin), unshielded			
11 x 1.5	1.5	–	3RK1 911-0BJ10
	–	< 2.9	3RK1 911-0CJ20
	3	–	3RK1 911-0BJ20
	–	> 3.1 ... < 4.9	3RK1 911-0CJ30
	5	–	3RK1 911-0BJ30
7 x 1.5	1.5	–	3RK1 911-0BG10
	–	< 2.9	3RK1 911-0CG20
	3	–	3RK1 911-0BG20
	–	> 3.1 ... < 4.9	3RK1 911-0CG30
	5	–	3RK1 911-0BG30
• Preassembled at one end with Han 10e (pin), shielded			
4 x 2.5	1.5	–	3RK1 911-0BV10
4 x 0.75	–	< 2.9	3RK1 911-0CV20
	3	–	3RK1 911-0BV20
	–	> 3.1 ... < 4.9	3RK1 911-0CV30
	5	–	3RK1 911-0BV30
• Non-assembled			
4 x 2.5	20	–	3RK1 911-0BW60
4 x 0.75	50	–	3RK1 911-0BW70
	100	–	3RK1 911-0BW80

¹⁾ When ordering, specify the length as well (example: length = 7.50 m).
Orders possible for minimum 10 cm module widths.

Connection technology according to ISO 23570 and ECOFAST

Power connection technology
Motor connection cables and plugs

Selection and ordering data (continued)

Enclosures	Usage	Contacts	Order No.
Connector set for motor connection Han 10e			
• Unshielded			
1 coupling enclosure with Pg13, low	1 pin insert	6 male contacts 1.5 mm ²	3RK1 911-2BK00
1 coupling enclosure with Pg21, high	1 pin insert	6 male contacts 1.5 mm ²	3RK1 911-2BL00
Connection on motor			
1 cable-end connector hood with Pg16, low	1 female insert	6 female contacts 1.5 mm ²	3RK1 911-2BM00
1 cable-end connector hood with Pg21, high	1 female insert	6 female contacts 1.5 mm ²	3RK1 911-2BN00
• Shielded			
Outgoing feeder on motor starter			
1 coupling enclosure with M25	1 pin insert	7 male contacts 3 × 2.5 mm ² + 4 × 0.75 mm ²	3RK1 911-2BL10
Connection on motor including star bridge			
One cable-end connector hood with M25	1 female insert	7 female contacts 3 × 2.5 mm ² + 4 × 0.75 mm ²	3RK1 911-2BN10

Note:

More connection technology products can be found at "Siemens Solution Partners Automation" under the "Distributed Field Installation System" technology.

More information can be found on the Internet at:
www.siemens.com/automation/partnerfinder.

ECOFAST

Connection technology according to ISO 23570 and ECOFAST

Accessories: ECOFAST selection module

Overview



ECOFAST selection module

The selection module enables the selective shutdown of feeders on the power bus, e.g. for servicing purposes. The module is equipped accordingly with a lockable switch (repair switch). In addition it provides line protection for cross sectional transitions on the power bus and can be used for increasing the size of the power bus segments.

Spectrum:

- Modules with 8, 16 and 25 A rated current
- With feedback contact through M12 plug
- Generally with 6 mm² wiring

Selection and ordering data

Version	Order No.
A	
Selection module	
For the selective switch-off of feeders with maintenance switching function for line protection for cross-sectional transitions and for increasing the segment size with feedback contact M12	
<ul style="list-style-type: none"> • 8 • 16 • 25 	<p>3RK1 911-4AB08</p> <p>3RK1 911-4AB16</p> <p>3RK1 911-4AB25</p>

Appendix



11/2	Abbreviations, Explanations
11/18	Training
11/19	Course overview
11/20	Standards and approbations
11/20	CE marking
11/21	Quality management Certificates
11/22	Partner at Industry Automation and Drive Technologies
11/22	Siemens contacts worldwide
11/23	Siemens Solution Partner Automation
11/24	Online Services
11/24	Information and Ordering in the Internet and on DVD
11/25	Service & Support
11/25	The unmatched complete service for the entire life cycle
11/27	Knowledge Base on DVD Automation Value Card
11/28	Safety of electronic devices
11/29	Software Licenses
11/31	Index
11/35	Order No. Index
11/39	Fax form
11/40	Conditions of sale and delivery Export regulations

Abbreviations, Explanations

Term	Meaning	Explanation
1		
10 Gigabit Ethernet	—	Standard for 10 Gbit/s data transfer using fiber-optic and copper cables
1000BASE	—	Gigabit Ethernet; standard for 1000 Mbit/s data transfer on copper cables
100BaseFX	—	Fast Ethernet Standard for data transmission on glass fiber-optic cables
100BaseT	—	Fast Ethernet Standard
10Base2	—	Standard for the transmission of 10 Mbit/s Ethernet on thin coaxial cables; segment length: 185 m
10Base5	—	Standard for the transmission of 10 Mbit/s Ethernet on coaxial cables (yellow cable); segment length: 500 m
10BaseFL	—	Standard for the transmission of 10 Mbit/s Ethernet on glass fiber-optic cables (fiber link)
10BaseT	—	Standard for the transmission of 10 Mbit/s Ethernet on twisted-pair cables
3		
3G	—	Third-generation mobile radio standard (see also UMTS) with significantly higher data transmission rates and global availability
A		
Access point	—	Access Points enable wireless LANs to be connected to wired Ethernet networks. The device also enables the range of individual wireless LAN components to be extended.
ACL	Access Control List	List with MAC addresses that are authorized to access the radio network
Actuator	—	Actuator
Ad-hoc network	—	Radio network between two WLAN clients or terminals (e.g. laptops) (point-to-point)
AES	Advanced Encryption Standard	Powerful encryption mechanism in radio networks for protection against eavesdropping and unauthorized access
AGVS	Automated guided vehicle system	Moving, driverless machine components
ALI	Application Layer Interface	Interface to application layer; this forms the interface between an application process and the standardized interface of the application layer and vice versa.
Antenna diversity	—	Procedure in which a radio receiver is equipped with two antennas and can choose the better of two received signals
Antenna gain	—	Improvement (passive!) of the antenna due to suitable design in comparison with an isotropic radiator
ASIC	Application Specific Integrated Circuit	Application-specific IC
AS-Interface	Actuator-sensor interface	Cable for direct connection of simple binary sensors and actuators (transmission of small quantities of information)
ASPC 2	Advanced Siemens PROFIBUS Controller of the 2nd Generation	ASIC used in master modules of PROFIBUS interface modules for transmission rates up to 12 Mbit/s
ATEX	—	Approval for explosion-proof areas
ATM	Asynchronous Transfer Mode	Method by which the data traffic is transmitted in smaller packets of fixed length and by means of asynchronous time division multiplexing
AUI	Attachment Unit Interface	Interface compliant with IEEE 802.3
Autocrossover	—	Function that enables automatic crossover of send and receive cables at twisted pair interfaces.
Autonegotiation	—	Configuration protocol for Fast Ethernet. Before initiating the actual data transmission, network devices automatically negotiate a transmission mode (100 Mbit/s or 10 Mbit/s, full duplex or half duplex).

Abbreviations, Explanations

Term	Meaning	Explanation
A		
Autosensing	—	Ability of a device to detect the data rate automatically (10 Mbit/s or 100 Mbit/s) and to then send or receive at this rate.
AWG	American Wire Gauge	US standard. Also known as Brown and Sharp (B&S) Wire Gauge. It specifies the diameter of copper conductors.
B		
BERO	Contactless proximity limit switch with feedback oscillator	Proximity switch
BFOC	Bayonett Fiber Optic Connector	Standardized connector for glass fiber-optic cables with a bayonet-lock; also referred to as "ST" (see ST connector)
BRECV	—	Block-oriented reception of data
Bridge	—	A network component that interconnects network segments. It ensures that local data traffic remains local, i.e. that only data packets addressed to a node in another segment are forwarded. Faults in one network segment are restricted to that segment. In contrast to switches, bridges can only handle one data flow at a time. Bridges no longer have any market relevance.
Broadcast	Circular call in a computer network	Message, with which data packets are transmitted from one point to all stations in a network
BSEND	—	Block-oriented transmission of data
bursts	—	Momentarily increased network loading due to a data surge or alarm avalanche
C		
Category x components	—	Cabling components are divided into various categories depending on their transmission properties. Various physical limit values have been established for the individual categories (e.g. maximum signal attenuation at a defined transmission frequency). Category 3: Data transmission up to 16 MHz Category 4: Data transmission up to 20 MHz Category 5: Data transmission up to 100 MHz Category 6: Data transmission up to 200 MHz (draft standard)
CBA	Component Based Automation	Supports modularization in mechanical and plant engineering through the plant-wide, graphical grouping of distributed applications. Component based Automation based on the PROFINET standard of the PNO.
CC	Central controller	—
CD	Compact disc	—
CSD	C ircuit S witched D ata	Data transmission over a GSM dialup connection
CHAP	Challenge Handshake Authentication Protocol	Authentication protocol
Channel Bonding	—	Two channels are used simultaneously with the help of channel bonding. Gross transmission rates of up to 450 Mbit/s can be achieved in conjunction with the MIMO technology in accordance with IEEE 802.11n.
CI	Cyclic interface	—
CM	Communications Metallic	UL approval for copper cables for use in buildings in accordance with Section 800-53(d) of NEC. Flames do not spread upward from cable out of the cable tray in the Vertical Tray Flame Test in UL 1685, "Vertical-Tray Fire-Propagation and Smoke Release Test for Electrical and Optical-Fiber Cables".
CM	Communication Module	Module for communications tasks used in an automation system as a CPU interface expansion

Abbreviations, Explanations

Term	Meaning	Explanation
C		
CLI	Command Line Interface	Alphanumeric command interface for parameterization and diagnosis over a serial interface or TELNET
CLID	Calling Line Identification	Service feature
Client/server communication	Principle of connection setup	The network node that sets up a connection is termed the "client". A "server" on the other hand is the node to which a connection is set up.
CMG	—	UL Approval of a copper cable for laying in cable harnesses (general purpose)
CMIP	Common Management Information Protocol	—
CMIS	Common Management Information Service	—
CMP	Plenum cable (copper)	UL Approval of a copper cable for laying without additional protection in the space above dropped ceilings or below raised floors
CMR	Riser cable (copper)	UL Approval of a copper cable for laying between the floors of a building
CMX	—	Cable for use in buildings in a cable duct or non-flammable tube. The unprotected lines or cables must not exceed 3 m in length. CMX type cable may bear the title "Outdoor". This cable meets all the conditions of the VW-1 Flame Test Requirements as defined in UL 1581.
CoL	Certificate of License	Certificate accompanying a software product which documents the legal ownership of a software license.
Collision domain	—	In order to ensure the function of the Carrier Sense Multiple Access / Collision Detection (CSMA/CD) procedure, the delay of a data package from one station to the other is limited. Depending on the transmission rate, this delay gives a physically limited expansion of the network, known as the collision domain. For 10 Mbit/s Ethernet this is 4520 m, and for Fast Ethernet 412 m. Several collision domains can be connected with each other via bridges/switches. Full duplex permits expansions beyond a collision domain.
COM/DCOM	Component Object Model / Distributed Component Object Model	COM is a fundamental object model. It allows an object to make its functionality available to other components. DCOM is an extension of COM for communication over a network.
CP	Communication Processor	Interface module for communication tasks
CPU	Central Processing Unit	e.g. for SIMATIC S5/S7
CSD	Circuit Switched Data	Modem operation
CSMA/CD	Carrier Sense Multiple Access/Collision Detection	Collision access procedure for Industrial Ethernet bus systems as per IEEE 802.3
D		
DA	Destination Address	—
Data objects	—	Programming-related display of EIB bus nodes for the EIB configuration software ETS 2. Data objects can be linked to each other and represent the states of the EIB bus nodes. A bus node can comprise several data objects.
dBi	—	Unit of measurement of antenna gain compared to an isotropic omnidirectional antenna
DCP	Discovery and Configuration Protocol	Defines the allocation of the IP parameters with vendor-specific configuration/programming tools or in the plant-wide engineering, e.g. in the PROFINET interconnection editor

Abbreviations, Explanations

Term	Meaning	Explanation
D		
DDE	Dynamic Data Exchange	Windows interface
DDL	Direct Data Link	—
DDL M	Direct Data Link Mapper	—
Deterministic features	—	Predictable data traffic and defined response times
DHCP	Dynamic Host Configuration Protocol	De-facto standard for assigning dynamic IP addresses
Diversity	—	Radio receiver with two antennas for selecting the best signal
DLL	Dynamic Link Library	A collection of functions available to two or more programs, but which are loaded only once into the memory (Windows/Windows NT Feature).
DLPI	Data Link Protocol Interface	—
DNP3	Distributed Network Protocol	Communications standard for telecontrol systems; it is used as general transmission protocol between control station and sub-station
Domain services	—	An application service group which contains services for downloading/uploading of logically related memory areas.
DP	Distributed I/O	Input or output modules that are used by the CPU on a distributed basis. The PLC and the distributed I/O can be connected over the PROFIBUS DP bus system.
DPRAM	Dual Port Random Access Memory	—
DSSS	Direct Sequence Spread Spectrum	Spread spectrum transmission procedure (IEEE 802.11b)
DV	Data processing	Previously also referred to as Electronic Data Processing (EDP)
DVD	Digital Versatile Disk	Digital optical storage medium
E		
EEMS	Extended electromechanical interface	—
EGPRS	Enhanced GPRS	Method of increasing the data rate in GSM mobile networks by introducing an additional modulation procedure
EIB	European Installation Bus	Registered trademark of the European Installation Bus Association, Brussels
EIRP	Equivalent isotropic radiated power	The transmit power that must be fed to an isotropic radiator in order that it effectively emits the same performance as another antenna in a specific direction. An isotropic radiator is a theoretical antenna that radiates evenly in all directions (isotropically) and is assumed to be infinitely small.
E-mail	Electronic mail	Electronic mail for data transfer between computers, mobile telephones and pagers. E-mails can be sent by the user or automatically generated.
EMC	Electromagnetic compatibility	—
ER	Extension rack	Expansion component for SIMATIC
ERP	Enterprise Resource Planning	Term for systems and software solutions which coordinate the business process and help with planning, e.g. SAP R3, Peoplesoft, BAAN.
ERTEC	Enhanced Real-Time Ethernet Controller	The Industrial Ethernet ASIC is a high-performance Ethernet controller, optimized for PROFINET with integral switch functionality and processor

Abbreviations, Explanations

Term	Meaning	Explanation
E		
ESD	Electro static discharge	Electric strength
EU	Extension unit	—
Ex	Intrinsically safe protective measure to DIN EN 50020	Appropriately marked modules may also be used within hazardous areas. (Regulations must be observed!)
F		
FB	Function block	—
FC	FastConnect	Fast connection system for Ethernet and PROFIBUS cables and connectors
FC	Function Call	Sequence of functions
FDDI	Fiber Distributed Data Interface	High-speed network standardized by ANSI for data transmission over a range of up to 100 km with a bit rate of 100 Mbit/s. Twin fiber-optic cables in opposite directions serve as the transmission medium.
FDL	Fieldbus Data Link	Layer 2 with PROFIBUS; it comprises the field bus link control (FLC) and medium access control (MAC).
FDX	Full duplex	Capability of a device for sending and receiving data at the same time. In the case of full duplex, collision detection is deactivated. A full duplex capable device is able to buffer data packets.
FE	Fast Ethernet	Compared with 10 Mbps Ethernet, frames at 100 Mbps are transported much faster and therefore occupy the bus for a very short time.
Fetch	—	Fetching data from remote stations
FHSS	Frequency Hopping Spread Spectrum	Transmission procedure used, for example, in Bluetooth.
Filtering	—	A switch filters data traffic depending on the source and destination addresses in a data packet. An incoming data packet is routed by the switch to the port to which the data terminal with the appropriate destination address is connected.
FIFO principle	"First in, first out" principle	Data is transmitted in telecontrol systems regardless of the respective priority
FIM	Field Interface Module	—
Firewall	—	One or more computers which permit or block access to data on interconnected networks in accordance with prescribed security restrictions.
FM	—	US certificate for the installation of devices in hazardous locations (Factory Mutual Research)
FMS	Fieldbus Message Specification	Upper sublayer of Layer 7 with PROFIBUS; it encompasses the functions: protocol machine, generation of PDUs, coding/decoding and interpretation of the protocol data unit.
FO	fiber-optic	Fiber-optic cable
FO cable	Fiber-optic cable	Flexible optical medium/fiber made of glass or plastic in which light can be conducted in a controlled manner
Forced Roaming	—	Automatic roaming if the cable connection to the access points is broken
FRNC	Flame Retardant Non Corrosive	Flame-retardant, halogen-free cladding material for a cable

Abbreviations, Explanations

Term	Meaning	Explanation
F		
Full duplex	—	Capability of a device for sending and receiving data at the same time. In the case of full duplex, collision detection is deactivated.
Functional grounding	—	Function for internal ground monitoring used for protection against hazardous touch voltages
G		
Gateway	—	Intelligent connection between a local network and an external network with a completely different structure
GFK	Glass-fiber reinforced plastic	—
GHz	Gigahertz	Unit of frequency, e.g. 2.4 GHz
Gigabit Ethernet	—	Gigabit Ethernet (1 Gbit/s) is faster than Fast Ethernet by a factor of 10, occupying the bus for only one tenth of the time.
GMRP	GARP (Generic Attribute Registration Protocol) Multicast Registration Protocol	GMRP enables switches to control the forwarding of multicast messages. A host logs in or out for a multicast address. Accordingly, the managing switch forwards corresponding multicasts to the host or not. This constrains the flooding of multicasts and reduces the network load.
GP	General Purpose	UL listing (safety standard) for network cables is especially necessary for the American and Canadian markets. The requirements for the appropriate approvals depend on where the cable is routed within the building. This applies to all cables which have to be routed from a machine to a remote control cabinet and are positioned on cable racks secured on the building.
GPRS	General Packet Radio Service	A packet of networking mobile communications services based on GSM channels. GPRS enables fast communication at high transmission speeds and is chiefly of interest for mobile Internet access.
GPS	Global Positioning System	Satellite-supported system for determining the position of a GPS receiver. A GPS receiver can be localized precisely anywhere in the world using three of the total of 24 satellites. GPS receivers are typically built into navigation systems.
GSD	General Station Description	A GSD contains an XML-based description of the properties of IO devices such as communications parameters as well as number, type, configuration data, parameter and diagnostics information of modules
GSM	Global System for Mobile Communication	Global standard for mobile communication
GVRP	Generic VLAN Registration Protocol	—
H		
HARDNET	—	Software based on communications modules with internal microprocessor
HART	Highway Addressable Remote Transducer	Protocol for bus-addressed field devices; it is not a fieldbus, but a version of the digital field communication that contains many of the functionalities of fieldbuses
HCS	—	Trademark of Spectran Specialty Optics
H-communication	Fault-tolerant communication	Fault-tolerant, redundant communication with SIMATIC S7-H systems
HDX	Half Duplex	A device can either receive or send data at a given time.
HMI	Human Machine Interface	Operator control and process monitoring products/systems at Siemens
HSR	High Speed Redundancy	The HSR redundancy procedure is based on Hiper-Ring, a ring redundancy protocol developed by "Hirschmann Automation and Control" and Siemens and introduced in 1999.

Abbreviations, Explanations

Term	Meaning	Explanation
H		
HTB	Data handling block	HTB are standard function blocks that allow data transfer between boards outfitted with page frame addresses.
HTML	Hypertext Markup Language	Descriptive language for WWW (World Wide Web) pages
HTTP	Hypertext Transfer Protocol	Transmission protocol for Web pages on the Internet
Hub	—	Active network component with repeater functional scope, synonym for star coupler
I		
ICMP	Internet Control Message Protocol	Additional protocol on the Internet layer, alongside the Internet Protocol (IP); this is used to exchange error and information messages in IP, TCP, and UDP protocols. ICMP packets are always sent as IP datagrams. This serves to inform hosts of more favorable routes to a destination, provide information about routing problems, and break off connections due to problems in the data network. The ping and traceroute commands are based on ICMP. ICMP messages are divided into two classes: error messages and information messages.
IE	Industrial Ethernet	Cell network according to the international IEEE 802.3 (Ethernet) standard, designed for the industrial environment
IEC	International Electrotechnical Commission	Authority that oversees standardization in electrical engineering
IEEE	Institute of Electrical and Electronics Engineers	—
IEEE 802	Institute of Electrical and Electronics Engineers	LAN/WAN Standards Committee
IEEE 802.11	Institute of Electrical and Electronics Engineers	Standard for radio networks in the 2.4 GHz range with data rates up to 2 Mbit/s.
IEEE 802.11a	Institute of Electrical and Electronics Engineers	Standard for radio networks in the 5 GHz range with data rates up to 54 Mbit/s.
IEEE 802.11b	Institute of Electrical and Electronics Engineers	Standard for radio networks in the 2.4 GHz range with data rates up to 11 Mbit/s.
IEEE 802.11g	Institute of Electrical and Electronics Engineers	Standard for radio networks in the 2.4 GHz range with data rates up to 54 Mbit/s. Backward compatible with IEEE 802.11b.
IEEE 802.11i	Institute of Electrical and Electronics Engineers	Expanded safety architecture for the 802.11 standard, valid for IEEE 802.11a/b/g; includes TKIP and AES
IEEE 802.11n	Institute of Electrical and Electronics Engineers	The IEEE 802.11n standard uses the MIMO (Multiple In, Multiple Out) technique for data transmission. The expansion of transmission channels from 20 MHz to 40 MHz and the use of three antennas increases the gross data rate to 450 Mbit/s.
IEEE 802.3	Institute of Electrical and Electronics Engineers	Ethernet working group
IEEE 802.3af	Institute of Electrical and Electronics Engineers	Standard that defines the transmission of power and data over one cable (see Power-over-Ethernet)
IEEE 802.3u	Institute of Electrical and Electronics Engineers	Fast Ethernet working group
IGMP	Internet Group Management Protocol	Protocol for load limiting when using multicast-based protocols, e.g. for video monitoring
IM	Interface modules	Interface

Abbreviations, Explanations

Term	Meaning	Explanation
INA	Intel Network Architecture	—
<i>instabus</i>	—	<i>instabus</i> [®] is a registered trademark of Siemens AG which members of the "Insta Association" are also authorized to use
Intrinsically safe	—	Ex protection measure according to DIN
I/O	Input/Output	—
IO Controller	—	Controller for PROFINET IO in which the automation program executes
IO Device	—	Distributed field device that is assigned to an IO controller
IO supervisor	—	PG/PC with commissioning and diagnostics functions for PROFINET IO
IP	Internetwork Protocol	On its own, the IP protocol is without connections and invalid. The most important information is the unique IP address. The blocks of data are sent to the destination computer independently. IP does not negotiate anything with the destination computer. An end-to-end error check is not performed. Frames can arrive in a different order from the order they were sent in. TCP is responsible for rearranging them in the correct sequence.
IP Alive	—	Monitoring function for IP connections
iPCF	Industrial Point Co-ordination Function	Functional expansion of the IEEE 802.11 standard for applications with a requirement for real-time and deterministic (predictable response times). This facilitates rapid roaming of moving stations from one radio cell to the next and supports secure, wireless PROFINET IO communication with the SIMATIC Mobile Panel 277F IWLAN.
iPCF-MC	iPCF Management Channel	A further development of iPCF; this mode should be used if IWLAN stations that also support iPCF-MC move freely about in the coverage area (especially when using omni-directional antennas) and are to exchange data deterministically.
IPX	—	Protocols of ISO layers 1–4
IP20	—	Device protection class; protection against contact with the fingers and against penetration by solid foreign bodies with diameters in excess of 12 mm; no particular protection against water
IP30	—	Device protection class; protection against contact with tools, wires etc. with diameters in excess of 2.5 mm and against penetration by solid foreign bodies with diameters in excess of 2.5 mm; no particular protection against water
IP65	—	Device protection class; complete protection against contact and against ingress of dust; protection against splash water from all directions
IRT	Isochronous real time	Deterministic and isochronous real-time communication for PROFINET for the particularly stringent demands, for example, of motion control applications. Clock rates of less than 1 ms can be achieved by using corresponding hardware.
ISA	Industry Standard Architecture	—
ISDN	Integrated Services Digital Network	Digital network that integrates services
ISM-Band	Industrial, Scientific and Medical-Band	Frequency band for license-free use
ISO	International Organization for Standardization	International Standards Organization

Abbreviations, Explanations

Term	Meaning	Explanation
I		
ISP	Internet Service Provider	Internet services provider
IT	Information Technology with e-mail and web technology at Siemens	Acquisition, conditioning, transmission, distribution, utilization and processing of information
ITC	Instrumentation Tray Cable	Approval for IE FC TP standard cable
ITP (Category 5)	Industrial Twisted Pair	Highly efficient, shielded, twisted pair cable for universal applications (international cabling standard ISO/IEC 11801 and EN 50173)
IWLAN	Industrial Wireless LAN	Industry standard WLAN conforming to IEEE 802.11 standard
J		
JVM	Java Virtual Machine	Java is a cross-platform, object-oriented programming language similar to C++. The Java Compiler, however, does not generate native machine code, but a byte code that has to be interpreted. This is done with the aid of the "Java Virtual Machine".
K		
KNX	Konnex (EN 50090, ANSI EIA 776)	Universal bus system for all house and building systems; KNX was developed by the Konnex Association based on EIB (European Installation Bus).
L		
LAN	Local Area Network	Local area network
Layer 3 Routing	—	Function for communication between various IP subnetworks on the basis of Layer 3. Also referred to as IP routing.
LED	Light Emitting Diode	Light emitting diode
Link Aggregation	—	Procedure for bundling several physical interfaces into one logical channel. Used for increasing the data throughput between two Ethernet switches. Implementations can also link servers and other systems by means of link aggregation.
Link Check	—	Cyclic monitoring of a radio link
Link Class	—	In the link class, the quality of a complete connection (link) is described, from the active component to the data terminal (patch cable, patch field, installation cable, connection socket, connecting cable). This link must comply with the values specified in the standard for structured cabling ISO/IEC 1180. Contrary to this is the specification according to "categories" where only product requirements are defined, e.g. category 5 cable.
LLC	Logical Link Control	Standardized network protocol
LLDP	Link Layer Discovery Protocol	This is a multi-vendor protocol for topology support on the link layer which enables a device connected to an Ethernet to advertise its identity and properties to other devices. This information is stored in the management information base (MIB) and collected using the simple network management protocol (SNMP).
LLI	Lower Layer Interface	Part of layer 7 with PROFIBUS, in which layer 7 services are mapped onto layer 2 services
Load decoupling	—	Due to filtering, a switch ensures that local data traffic remains local. Local network loading of a segment is decoupled from the remainder of the network.
L2TP	Layer 2 Tunneling Protocol	—

Abbreviations, Explanations

Term	Meaning	Explanation
M		
MAC	Media Access Control	Bus access control
MAN	Metropolitan Area Network	Data network with the geographical range of a town
MAP	Manufacturing Automation Protocol	International standard for automation protocols
Media redundancy	—	Redundancy in the network infrastructure (cable and active components such as OLM or OSM/ORM)
MIB	Management Information Base	A file for generating device profiles; it enables other SNMP-enabled devices, for example, to be integrated into the OPC configuration through loading of MIBs in accordance with the SMI V1 and SMI V2 standard from STEP 7 V5.4
MIMO	Multiple Input, Multiple Output	Multiple path propagation in accordance with the international standard IEEE 802.11n. This allows the devices to use several antennas in parallel in order to achieve a higher transmission rate and reduce susceptibility to faults in environments with a high number of reflections.
MMS	Manufacturing Message Specification	User interface of MAP
Monoprotocol	—	Data can only be transferred through one protocol
MPI	Multi Point Interface	Multipoint-capable interface for SIMATIC S7
MRP	Media Redundancy Protocol	The Medium Redundancy Protocol (MRP) is based on a ring topology and guarantees reconfiguration times of 200 ms
Multicast	—	Multicast or Group calling in telecommunications signifies Message transmission from one point to a group (also termed Multipoint connection). The advantage of multicasting is that messages can be sent simultaneously to several stations or to a closed user group, without multiplying the bandwidth at the transmitting end by the number of recipients.
Multiple path propagation	—	Reflections of a radio wave off different objects in a room. This causes the radio wave to arrive at the receiver with variations of intensity and delay
Multiplex function	—	Multiplex function (with OP communication) increases the number of OPs that can be connected to a SIMATIC S7-300
Multi-protocol	—	Data can be transferred through one or two protocols
N		
NAT	Network Address Translation	Translation of private IP addresses into public addresses
NC	Numerical Control	Numerical control (machine tools)
NCM	Network and Communication Management	Tool for configuring communication connections, also a component of STEP 7
NDIS	Network Driver Interface Specification	Microsoft and 3Com interface
NEC	National Electrical Code	UL directive for the laying of cables in buildings
NIC	Network Interface Card	Line connection
N-measurement	—	Device installation measurement for subdivisions of the electrical installation
NTP	Network Time Protocol	Standardized protocol for synchronization of clocks in Computer systems over Communication networks
O		
ODI	—	NOVELL interface
OFDM	Orthogonal Frequency Division Multiplex	Modulation procedure for IEEE 802.11a/g

Abbreviations, Explanations

Term	Meaning	Explanation
O		
OFN	Optical Fiber Non-conductive	UL approval for fiber optic cables for use in buildings in accordance with Section 800-53(d) of NEC. Flames do not spread upward from cable out of the cable tray in the Vertical Tray Flame Test in UL 1685, "Vertical-Tray Fire-Propagation and Smoke Release Test for Electrical and Optical-Fiber Cables".
OFNG		UL Approval of a fiber optic cable for laying in cable harnesses (general purpose)
OFNP	Plenum cable (FOC)	UL Approval of a fiber optic cable for laying without additional protection in the space above dropped ceilings or below raised floors
OFNR	Riser cable (FOC)	UL Approval of a fiber optic cable for laying between the floors of a building
OLE	Object Linking and Embedding	Central architecture principle in Windows for the generation and editing of documents that contain objects generated by different applications
OLM	Optical link module	Network component for PROFIBUS
Omnidirectional	—	Antenna that radiates evenly through 360 degrees in both horizontal and vertical planes
OP	Operator Panel	—
OPC	Openness, Productivity, Collaboration	Standard interface for access to process data
OPC DA	OPC Data Access	Standard for Ethernet-based access to data of measurement and control devices, for the location of OPC servers and the simple browsing in the name spaces of the OPC servers on the basis on client/server communication
OPC UA	OPC Unified Architecture	OPC UA is the further development of the standard interface OPC and provides additional functions such as security and redundancy.
OSPF	Open Shortest Path First	Dynamic routing
P		
PA	Process Automation	Protocol profile, based on PROFIBUS DP with intrinsically safe transmission system to IEC 61158-2
PAN	Personal Area Network	Comparable with an ad-hoc network, for networking individual small devices a short distance from each other.
PAP	Password Authentication Protocol	Password authentication protocol
PAT	Port Address Translation	Translation of private ports into public addresses
PCF	Polymer clad fiber	Plastic-enclosed glass fiber
PCI	Peripheral Component Interconnect Express	Backplane bus in personal computers
PCIe	Peripheral Component Interconnect Express	Backplane bus in PC with, for example, a higher data transmission rate than the predecessor PCI
PCMCIA	Personal Computer, Memory Card, International Association	Standard for PC plug-in cards (credit card size). PCMCIA cards (Personal Computer Memory Card International Association) are used mainly input/output operations (e.g. modem) or memory expansions.
PCS 7	—	Siemens process control system
PDU	Protocol Data Unit	Protocol data unit
PG	Programming device	—
PI	Program instance	Communication object
PLC	Programmable logic controller	Device for open and closed loop control tasks
PN	PROFINET	Industrial Ethernet standard defined by the PNO

Abbreviations, Explanations

Term	Meaning	Explanation
P		
PNO	PROFIBUS Nutzerorganisation e.V.	Organization for PROFIBUS users and providers
PoE	Power over Ethernet	Transmission of power and data on a single cable
POF	Polymer optic fiber	Fiber optic cable made of light-conducting plastic
Polling	—	Addressed transmission call in centrally-oriented data networks polling mode. The poll is the command to a specific station to send messages. In this way the poll sequences control the data flow.
POP	Point of Presence	Dial-in node for an Internet service provider
PP	Push Button Panels	—
PPM	Parts per million	—
PPTP	Point-to-Point Tunneling Protocol	—
Process or field communication	—	Process or field communication is used for linking actuators/sensors to a CPU.
PROFIBUS	Process Field Bus	International fieldbus standard according to IEC 61158/61784
PROFIBUS DP	PROFIBUS DP for distributed I/O	Protocol profile according to IEC 61158/61784 for process or field communication for fast, cyclic data exchange with field devices
PROFIBUS PA	PROFIBUS for process automation	Protocol profile, based on PROFIBUS DP with intrinsically safe transmission system to IEC 61158-2.
PROFIdrive	—	PROFIBUS protocol profile, based on PROFIBUS DP, driven engineering profile (version 3, clock synchronization)
PROFInergy	—	Protocol profile that provides functions and mechanisms for PROFINET field devices that support energy-efficient production
Profile	—	Definition of options and parameters as a supplement to the standard, e.g. PROFIBUS profiles
PROFINET	—	Industrial Ethernet standard defined by the PNO
PROFINET device with proxy functionality	—	A PROFINET device that takes on the role of the master with regard to PROFIBUS devices. This makes it possible to link PROFIBUS slaves into the PROFINET communication. If the device has a local (internal) PROFIBUS, it has the role of DP master with regard to the local DP slaves.
PROFIsafe	—	Protocol profile in accordance with IEC 61508 that permits standard and safety-related communication on a bus. Communication between fail-safe controllers and fail-safe I/O is handled by PROFIsafe.
Protocol	—	Procedural regulation for data transmission. This regulation specifies both the message formats and the data flow during data transmission
Proxy	—	Representative object in the object model that maps the PROFINET view onto a field device or a group of field devices. The proxy on the PROFINET is the representative for one or more PROFIBUS devices
PST	Primary Setup Tool	Software tool for assigning IP addresses
PUR	Polyurethane	—
R		
RADIUS	Remote Authentication Dial-In User Service	Access control by means of servers
RAM	Random Access Memory	Random access memory

Abbreviations, Explanations

Term	Meaning	Explanation
R		
Rapid Spanning Tree Protocol	Configuration protocol specified in the IEEE-802.1w standard	The rapid spanning tree protocol is a further development of the spanning tree protocol (STP). It is used to avoid redundant network paths (loops) in the LAN, specifically when using switches; the reconfiguration time ranges from 2-3 seconds.
RBC	Remote Base Controller	—
RegTP	—	Regulation authority for telecommunications in Germany
Remote diagnostics and remote maintenance (teleservice)	—	Teleservice is data exchange with physically remote technical plants (machines, plants, computers, etc.) for the purpose of error detection, diagnostics, maintenance, repair, or optimization.
Requirement specification	Automation Protocol	Layers 5 through 7 of the ISO reference model
RIPv1/2	Routing Information Protocol	—
RJ45	Symmetrical connector for data cables	This is also known as a western connector or a western plug. This is a widely used plug connector in telephone and ISDN technology which is used in LAN installations in the office environment.
RM	Redundancy manager	Function for monitoring the network; the RM detects the failure of a transmission link in the ring or of a switch and activates the standby link
RMON	Remote Monitoring	Network administration function, e.g. collection of statistics information
Roaming	—	Free movement of wireless LAN stations across the cell boundaries of an access point. The station can switch from one radio cell to the next without any noticeable interruption
R-SMA	—	Reverse-SMA, connector for antennas in IWLAN
RSTP	Rapid Spanning Tree Protocol	The rapid spanning tree protocol is a further development of the spanning tree protocol (STP). The spanning tree protocol (STP) is used for avoiding redundant network paths (loops) in the LAN, specifically in switched environments; the reconfiguration time is in the range of 2-3 seconds.
RT	Real-time	Real-time communication in PROFINET
S		
SA	Source Address	Part of the IP header; contains the source address of the IP packet; 32 bits wide
SAP	Service Access Point	Service access point: an interface allowing the user to access services of the lower layer
SC connection technology	—	Standardized connection for glass fiber optic cables
SC RJ connection technology	—	Standardized connection for fiber optic conductors, e.g. for POF and PCF fiber optic cable
SDA service	Send Data with Acknowledge (open Layer 2 access)	Sending of acknowledged Layer 2 services
SDN	Send Data with No Acknowledge (open Layer 2 access)	Sending of unacknowledged Layer 2 services (broadcast, multicast)
SFB	System Function Block	A System Function Block (SFB) is a function block that is integrated in the S7 CPU. Because SFBs are part of the operating system, they are not loaded as part of the program. SFBs are blocks with a "memory". Instance data blocks must also be generated for SFBs and loaded as part of the program into the CPU
SFC	System function calls	Calls that are integrated into the operating system of the CPU, e.g. time functions or block transfer
SFM	System error signaling concept of SIMATIC	—

Abbreviations, Explanations

Term	Meaning	Explanation
S		
SFP	Small Form-factor Pluggable (coll. mini-GBIC)	Small standardized modules for network connections. SFPs are modular optical or electrical transceivers that are constructed as cable connectors in an SFP slot for extremely fast Ethernet. Network devices can therefore be easily changed to other media and the transceivers can be quickly replaced in the event of an error.
Shared LAN	—	All components in a shared LAN share the nominal data transmission rate. Shared LANs are constructed with repeaters/hubs.
Signal delay	—	Time that a data packet takes to travel through the network
Slot Time	—	Time elapsing between transmission of a call and reception of an answer or acknowledgment
SM	Signal module	Input and output modules for SIMATIC
SMTP	Simple Mail Transfer Protocol	Transmission protocol for e-mail
SNMP	Simple Network Management Protocol	Standardized protocol for the transport of network management information
SNTP	Simple Network Time Protocol	Standardized protocol for synchronization of clocks in Computer systems overCommunication networks
Socket interface	Standard communication for Industrial Ethernet	This facilitates data communication with computers through TCP/IP. On this interface, which is widespread in the PC and UNIX world, users can freely program their own protocols. The SEND/RECEIVE blocks are used as access to TCP/IP in SIMATIC S7.
SOFTNET	—	Software based on simple communications modules
SP	Service packs	Data that can easily be downloaded free of charge from the Internet.
Spanning Tree Protocol	Bridge configuration protocol specified in the IEEE-802.1d standard	The Spanning Tree Protocol is used to eliminate loops in any meshed networks. The reconfiguration time is in the region of 30 s.
SPC	Siemens PROFIBUS Controller	—
SSID	Service Set Identifier	Identification of a wireless network based on the IEEE 802.11 standard
S/STP	Screened Shielded Twisted Pair	In this cable construction the individual twisted pairs are wrapped in a foil shield. The two individually shielded pairs of conductors are then wrapped together in a braided copper shield.
Standby function	—	Function for redundant coupling network segments, such as for the coupling of redundant ring structures
ST connector	Straight-tip connector	Standardized connector for glass fiber-optic cables with bayonet lock (ST is a registered trademark of AT&T); see BFOC
STP	Spanning Tree Protocol (IEEE 802.1d Standard)	The Spanning Tree Protocol is used to eliminate loops in any meshed networks. The reconfiguration time is in the region of 30 s.
Switching	—	Establishing several links between the ports simultaneously. These links are established dynamically and temporarily in accordance with the data traffic.
SWR	Standing Wave Ratio	Ratio between the energy radiated by an antenna and the energy that the antenna reflects to the radio module
S₀ interface	—	Basic interface for ISDN for connecting data terminals
S7 routing	—	PG/OP communication via different networks
T		
TCP/IP	Transport Control Protocol/Internet Protocol	De-facto standard; Protocol for worldwide communication with the Ethernet.

Abbreviations, Explanations

Term	Meaning	Explanation
T		
Telecontrol	—	The connection of distant process stations to one or more central control systems. Various different public or private networks can be used for communication for the purposes of monitoring and control. Event-driven or cyclic exchange of process data is performed with special telecontrol protocols and enables the operating personnel to manage the overall process effectively.
Teleservice (remote diagnostics and remote maintenance)	—	Teleservice is data exchange with physically remote technical plants (machines, plants, computers, etc.) for the purpose of error detection, diagnostics, maintenance, repair, or optimization.
TD	Text Display	—
TF	Technological functions	Application layer 7 for Industrial Ethernet (includes user services)
TFTP	Trivial File Transfer Protocol	Standard for data transmission
Thin Client	—	The principle of thin client/server computing is based on the fundamental physical separation of data.
TIA	Totally Integrated Automation	Fully integrated and company-wide system for automation from Siemens for company-wide configuration/programming, data management and communication.
TKIP	Temporal Key Integrity Protocol	Procedure for changing the keys in the WLAN
Token	—	The bit pattern with control function in token ring and token bus LANs; it is often the same as a send authorization
Token Passing	—	A collision-free access method, the send authorization (token) circulates between nodes which form a logical ring
Topology	Configuration of cables between the various nodes	The major forms of topology are: <ul style="list-style-type: none"> • Linear • Tree • Ring • Star Combinations of all basic types are possible.
TP	Touch panel	—
TPC	Transmission power control	Automatic regulation of the transmit power in the 5 GHz band
Trap	—	When specific events occur, such as link up or link down, alarms with corresponding error messages can be transmitted by network components on the Ethernet. In SNMP these alarms are called "traps".
Triaxial cable	—	The SIMATIC NET 727-0 bus cable is based on the coaxial cable specified in the 10Base5 standard (IEEE 802.3) – but strengthened with a thick aluminum outer sheath for industrial use.
Twisted-pair	Data cable with twisted pairs of conductors	The twist in the wire pairs provides good transmission properties and prevents electromagnetic interference. Twisted-pair cables are available in different qualities for different transfer rates
U		
UDP	User Datagram Protocol	Connectionless data transmission, i.e. datagram service that does not guarantee secure transmission. Users must take their own measures to ensure secure transmission. Data is transmitted as a data block. Transmission of data without RFC 1006 is thus possible.
UL	Underwriters Laboratories	Certification for the US market
UMTS	Universal Mobile Telecommunications System	Standard for third-generation (3G) mobile voice, audio, image, video, and data communication with a transmission rate of several Mbit/s
URECV	—	Uncoordinated reception of data

Abbreviations, Explanations

Term	Meaning	Explanation
U		
USB	Universal Serial Bus	Standard for the connection of I/O devices. USB (Universal Serial Bus) supports relatively high data transmission rates and can be used to connect several devices to a single computer.
USEND	—	Uncoordinated transmission of data
V		
Variable Services	—	Application service group; it provides services for processing variables
VLAN	Local Area Network	Virtual LAN within a physical network. A widely used technical implementation of VLANs is partly defined in the IEEE 802.1Q standard.
VNS	Virtual Network Services	Centralized security mechanism for each user group that protects the data securely against unauthorized access and manipulation.
VPN	Virtual Private Network	Technology/network type for the secure transport of confidential data over potentially insecure IP networks, e.g. Internet
VRRP	Virtual Router Redundancy Protocol	Procedure for improving the availability of important gateways in local networks by means of redundant routers.
W		
WAN	Wide Area Network	Network that, in contrast to a LAN or MAN, can spread across countries or continents
WDS	Wireless Distribution System	Communication between two WLAN access points
WECA	Wireless Ethernet Compatibility Alliance	Alliance of wireless LAN product vendors who guarantee the compatibility of their products by means of testing.
WEP	Wired Equivalent Privacy	Encryption method for WLANs
Wi-Fi seal	Wireless Fidelity	Seal of the WECA identifying compatible and tested products .
WinCC	—	Open process visualization system for the operator control and process monitoring of SIMATIC HMI.
WirelessHART	—	Wireless HART communication to fieldbuses in the process industry. The HART Communication Foundation (HCF) specified WirelessHART and published it as a component of the HART Standard V7.1. The radio transmission is based on the wireless communications standard IEEE 802.15.4.
Wireless LAN	—	Wireless network
Workflow	—	Workflow systems are used when structuring and controlling workflows.
WPA	Wi-Fi Protected Access	Encryption mechanism in radio networks for protection against eavesdropping and unauthorized access
Write	—	The writing of data to remote stations
WS	Workstation	—
WWW	World Wide Web	Multimedia service on the Internet. Distributed hypertext information system on client/server architecture through HTTP protocol
X		
XML	Extensible Markup Language	Definition of a structured data description
XMP	X/Open Management Protocol	—
XTI	UNIX Transport Layer Interface	Layer 4 transport layer, standardized under UNIX
X.25	—	Interface between terminal and data transmission equipment for terminals which operate in packet mode in public data networks and are transported through dedicated lines

Appendix

Training

Faster and more applicable know-how: Hands-on training from the manufacturer

SITRAIN® – the Siemens Training for Industry – provides you with comprehensive support in solving your tasks.

Training by the market leader in automation and plant engineering enables you to make independent decisions with confidence. Especially where the optimum and efficient use of products and plants are concerned. You can eliminate deficiencies in existing plants, and exclude expensive faulty planning right from the beginning.



First-class know-how directly pays for itself: In shorter startup times, high-quality end products, faster troubleshooting and reduced downtimes. In other words, increased profits and lower costs.

Achieve more with SITRAIN

- Shorter times for startup, maintenance and servicing
- Optimized production operations
- Reliable configuration and startup
- Minimization of plant downtimes
- Flexible plant adaptation to market requirements
- Compliance with quality standards in production
- Increased employee satisfaction and motivation
- Shorter familiarization times following changes in technology and staff

Contact

Visit our site on the Internet at:

www.siemens.com/sitrain

or let us advise you personally.

SITRAIN Customer Support Germany:

Phone: +49 (0) 911 / 895 7575

Fax: +49 (0) 911 / 895 7576

E-Mail: info@sitrain.com

SITRAIN highlights

Top trainers

Our trainers are skilled teachers with direct practical experience. Course developers have close contact with product development, and directly pass on their knowledge to the trainers.

Practical experience

The practical experience of our trainers enables them to teach theory effectively. But since theory can be pretty drab, we attach great importance to practical exercises which can comprise up to half of the course time. You can therefore immediately implement your new knowledge in practice. We train you on state-of-the-art methodically/didactically designed training equipment. This training approach will give you all the confidence you need.

Wide variety

With a total of about 300 local attendance courses, we train the complete range of Siemens Industry products as well as interaction of the products in systems.

Tailor-made training

We are only a short distance away. You can find us at more than 50 locations in Germany, and in 62 countries worldwide. You wish to have individual training instead of one of our 300 courses? Our solution: We will provide a program tailored exactly to your personal requirements. Training can be carried out in our Training Centers or at your company.

The right mixture: Blended learning

"Blended learning" means a combination of various training media and sequences. For example, a local attendance course in a Training Center can be optimally supplemented by a teach-yourself program as preparation or follow-up. Additional effect: Reduced traveling costs and periods of absence.



Training program for SIMATIC NET

The SIMATIC NET trainings provide your employees the necessary overview and detailed skills for industrial communication. In addition to planning and configuration with SIMATIC NET, the use, programming, commissioning and servicing of the products are included in the training.

More information on course contents, dates and prices is available on the Internet at:

www.siemens.com/sitrain

Title	Target group	Duration	Short title
	Commissioning engineers, configuration engineers		
	Programmers		Service personnel
	Project managers, project team members		Operators, users
	Decision makers, sales personnel		Maintenance personnel

SIMATIC NET Communication Systems

Industrial Ethernet									
Industrial Ethernet System Course			✓	✓	✓	✓	✓	3 days	IK-IESYS
Security in Industrial Ethernet Networks	✓	✓						1 day	IK-IESECWS
PROFINET									
PROFINET System Course			✓	✓	✓	✓	✓	3 days	IK-PNSYS
Industrial Wireless Communication									
Industrial Wireless LAN System Course			✓	✓	✓		✓	2 days	IK-IWLANSYS
PROFIBUS									
PROFIBUS System Course			✓	✓	✓		✓	3 days	IK-PBSYS
SINAUT ST7									
Engineering SINAUT ST7			✓	✓	✓		✓	5 days	IK-SINAUT
Electromagnetic Compatibility (EMC)									
EMC for the practice for Engineering- and Service-Staff			✓	✓	✓		✓	2 days	MP-EMVPRA

Appendix

Standards and approbations

CE marking

Overview

In as far as the electronic products described in this Catalog are subject to requirements and protection goals stipulated in EG guidelines, the relevant EG conformity declarations for the competent authorities are held available at:

SIMATIC:

Siemens AG
Industry Sector
IA AS EWA
Postfach 1963
D-92209 Amberg
GERMANY

SIMATIC NET:

SIEMENS AG
Industry Sector
IA SC IC
Postfach 4848
D-90327 Nürnberg
GERMANY

SIMATIC HMI:

SIEMENS AG
Industry Sector
IA AS SM ID
Postfach 4848
D-90327 Nürnberg
GERMANY

SIMATIC NET products are designed for operation in industrial environments and comply with the following requirements:

Noise emissions:
EN 61000-6-4: 2007
Noise immunity:
EN 61000-6-2: 2005

Selected modules comply with stringent requirements with regard to emitted interference and are therefore allowed to be used in an industrial as well as in a domestic environment:

Noise emissions:
EN 61000-6-3: 2007
Noise immunity:
EN 61000-6-2: 2005

Please take details regarding the fulfillment of specific European standards (EN) from the technical documents (manuals) associated with the product. Prerequisite for the fulfillment of the aforementioned protection goals is strict observance of the installation guidelines described in the manuals during the installation and operation of the products.

The installation guidelines described in the manuals and the important notes concerning installation in cabinets and the use of shielded cables must be complied with when installing and operating the products described in this catalog.

Notes for machine manufacturers

The SIMATIC automation system is not a machine in the sense of the EC Machinery Directive. For SIMATIC therefore no Declaration of Conformity in terms of the EC Machinery – Directive 89/392/EEC or 2006/42/EC (new edition, applicable from end of 2009) may be issued.

The EC Machinery Directive regulates the requirements for a machine or sub-unit of a machine. Machine in this context is defined as an entity of connected parts or devices (see also EN 292-1, Para. 3.1).

SIMATIC is part of the electrical equipment of a machine and must therefore be included in the assessment of the machine as a whole.

As an electrical resource, SIMATIC is subject to the low-voltage directive that, like the machine directive, also covers all hazards as a "total safety directive".

The EN 60204-1 standard (Safety of machines, general requirements – for the electrical equipment of machines) applies for the electrical equipment of machines.

The following table should help you when drawing up your declaration of conformity and shows which criteria apply to SIMATIC in accordance with EN 60204-1:2006/A1:2009. You can obtain – further information from the enclosed declaration of conformity in accordance with the low-voltage and EMC directive (with the list of standards complied with).

EN 60204-1	Topic/criterion	Notes
Paragraph 4	General requirements	The requirements are met when the equipment is assembled/ installed in accordance with the installation guidelines. Please note the relevant information in the manuals
Paragraph 11.2	Digital input/output interfaces	The requirements are met
Paragraph 12.3	Programmable equipment	The requirements are met when the equipment is installed in lockable cabinets to protect against alteration of the memory contents by unauthorized persons.
Paragraph 20.4	Voltage tests	The requirements are met

Certificates, authorizations, approbations, declarations of conformity

An overview of the certificates available for SIMATIC NET products (CE, UL, CSA, FM, shipping authorizations) and classification figures (MTBF) can be found in the Internet at:

www.siemens.com/simatic-net

Other certificates for SIMATIC products can be found in the Internet at:

SIMATIC

www.siemens.com/simatic/certificates

Industrial Controls

www.siemens.com/industrial-controls/support

The lists are continuously updated. The data for products which has not yet been included in the overview is continuously collected and prepared for the subsequent edition.

You can find certificates, approbations, verification certificates or characteristic curves under:

Support\Infomaterial\Certificates



or by going directly to the Link Box:

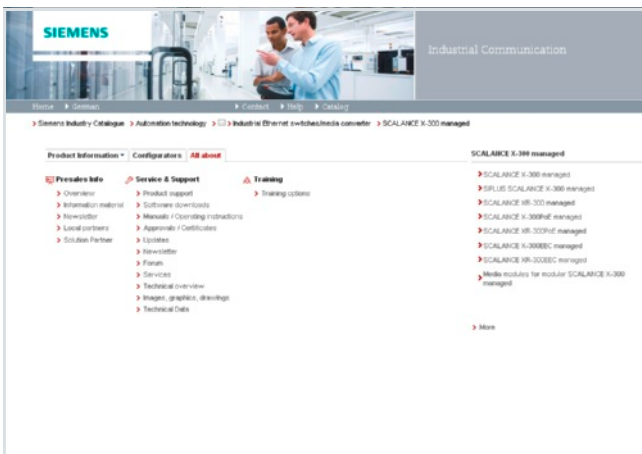

Quality management

The quality management system of the Industry Sector, Industry Automation division, complies with the international standard EN ISO 9001.

The products and systems described in this catalog are sold under application of a quality management system certified by DQS and TÜV (German Technical Inspectorate) in accordance with ISO 9001.

The certificates are recognized in all EQ Net countries.

DQS Registered Certificate Nos.:

Siemens AG
Industry Sector
Industry Automation

- Industrial Automation Systems
Reg.-No.: 001323 QM08
- Sensors and Communication
Reg.-No.: 000656 QM08
- Control Components and Systems Engineering
Reg.-No.: 001108 QM08

Drive Technologies

- Motion Control Systems
Reg.-No.: 001258 QM08

Appendix Partner at Industry Automation and Drive Technologies

Siemens contacts worldwide

Overview



At Siemens Industry Automation and Drive Technologies, more than 85 000 people are resolutely pursuing the same goal: long-term improvement of your competitive ability. We are committed to this goal. Thanks to our commitment, we continue to set new standards in automation and drive technology. In all industries – worldwide.

At your service locally, around the globe for consulting, sales, training, service, support, spare parts ... on the entire Industry Automation and Drive Technologies range.

Your personal contact can be found in our Contacts Database at: www.siemens.com/automation/partner

You start by selecting a

- Product group,
- Country,
- City,
- Service.

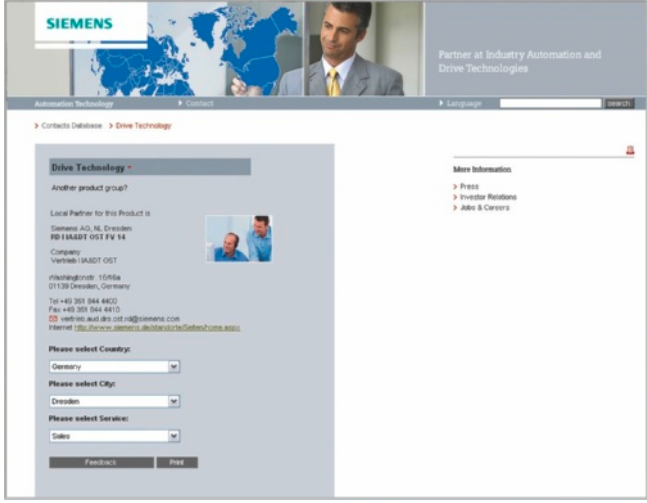
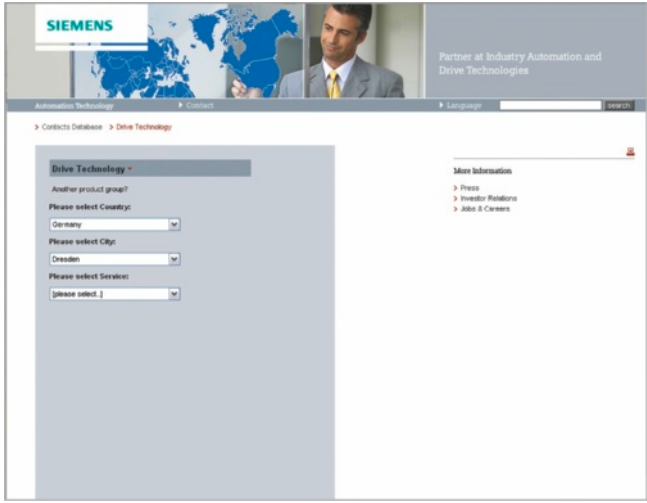

Overview

Siemens Solution Partner Automation



Solution Partner: Highest quality - guaranteed

The products and systems from Siemens Industry Automation and Drive Technologies offer the ideal platform for all automation applications.

Under the name of Siemens Solution Partner Automation, selected system integrators around the world act as uniformly qualified solution providers for the Siemens range of products and services in the fields of automation and drives. Day after day, they utilize their qualified product and system know-how as well as their excellent industry expertise to your advantage – for all requirements.

The partner emblem is the guarantee and indicator of proven quality. The basis for this are defined quality features that identify Solution Partners as reliable and competent solution providers:

- **Solution quality**
Always a good result with tried and tested solutions expertise.
- **Expert quality**
Certified technical competence ensures maximum efficiency.
- **Project quality**
With proven project experience straight to the target.
- **Portfolio quality**
Comprehensive portfolio for state-of-the-art solutions from a single source.

Solution Partner Finder

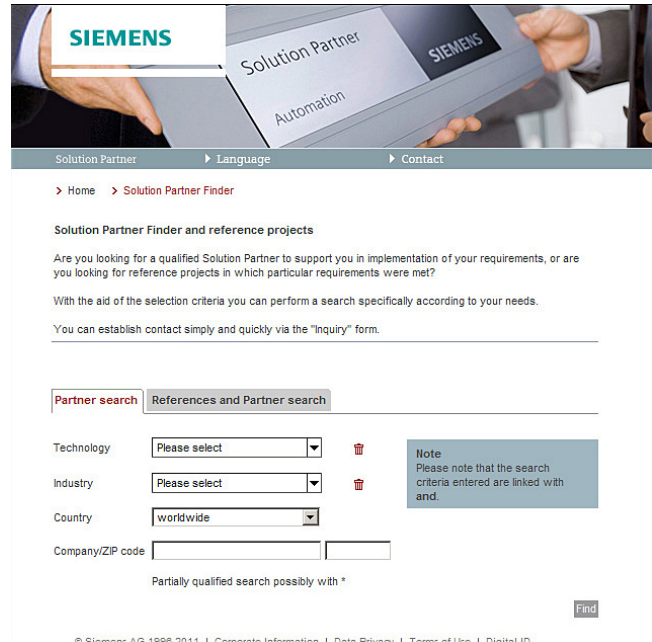

The Siemens Solution Partner Program helps you to find the optimum partner for your specific requirements.

Support is provided by the Solution Partner Finder, a comprehensive online platform that showcases the profiles of all our solution partners. You can convince yourself of the competence of the respective Solution Partner by means of the references provided. Various search criteria are available for this purpose.

Once you have located a partner, you are only one small step away from contacting them.

Find the right partner here for your specific task and convince yourself of the solution competence provided:

www.siemens.com/automation/partnerfinder

Additional information on the Siemens Solution Partner Program is available online at:

www.siemens.com/automation/solutionpartner

Appendix Online Services

Information and Ordering in the Internet and on DVD

Siemens Industry Automation and Drive Technologies in the WWW



A detailed knowledge of the range of products and services available is essential when planning and configuring automation systems. It goes without saying that this information must always be fully up-to-date.

Siemens Industry Automation and Drive Technologies has therefore built up a comprehensive range of information in the World Wide Web, which offers quick and easy access to all data required.

Under the address

www.siemens.com/industry

you will find everything you need to know about products, systems and services.

Product Selection Using the Interactive Catalog CA 01 of Industry



Detailed information together with convenient interactive functions:

The interactive catalog CA 01 covers more than 80 000 products and thus provides a full summary of the Siemens Industry Automation and Drive Technologies product base.

Here you will find everything that you need to solve tasks in the fields of automation, switchgear, installation and drives. All information is linked into a user interface which is easy to work with and intuitive.

After selecting the product of your choice you can order at the press of a button, by fax or by online link.

Information on the interactive catalog CA 01 can be found in the Internet under

www.siemens.com/automation/ca01

or on DVD.

Easy Shopping with the Industry Mall

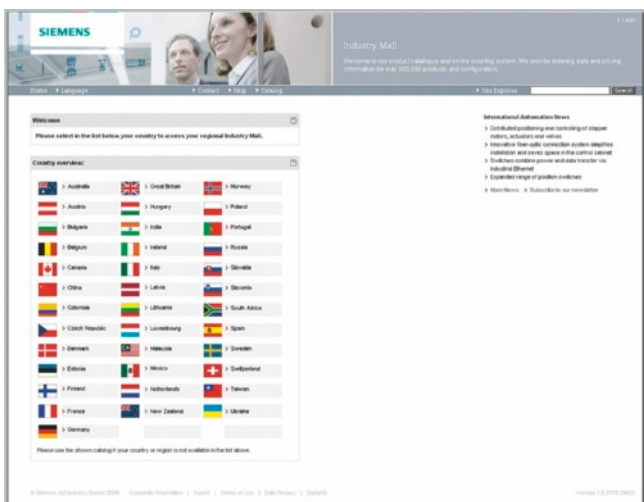

The Industry Mall is the virtual department store of Siemens AG in the Internet. Here you have access to a huge range of products presented in electronic catalogs in an informative and attractive way.

Data transfer via EDIFACT allows the whole procedure from selection through ordering to tracking of the order to be carried out online via the Internet.

Numerous functions are available to support you.

For example, powerful search functions make it easy to find the required products, which can be immediately checked for availability. Customer-specific discounts and preparation of quotes can be carried out online as well as order tracking and tracing.

Please visit the Industry Mall on the Internet under:

www.siemens.com/industrymall

The unmatched complete service for the entire life cycle

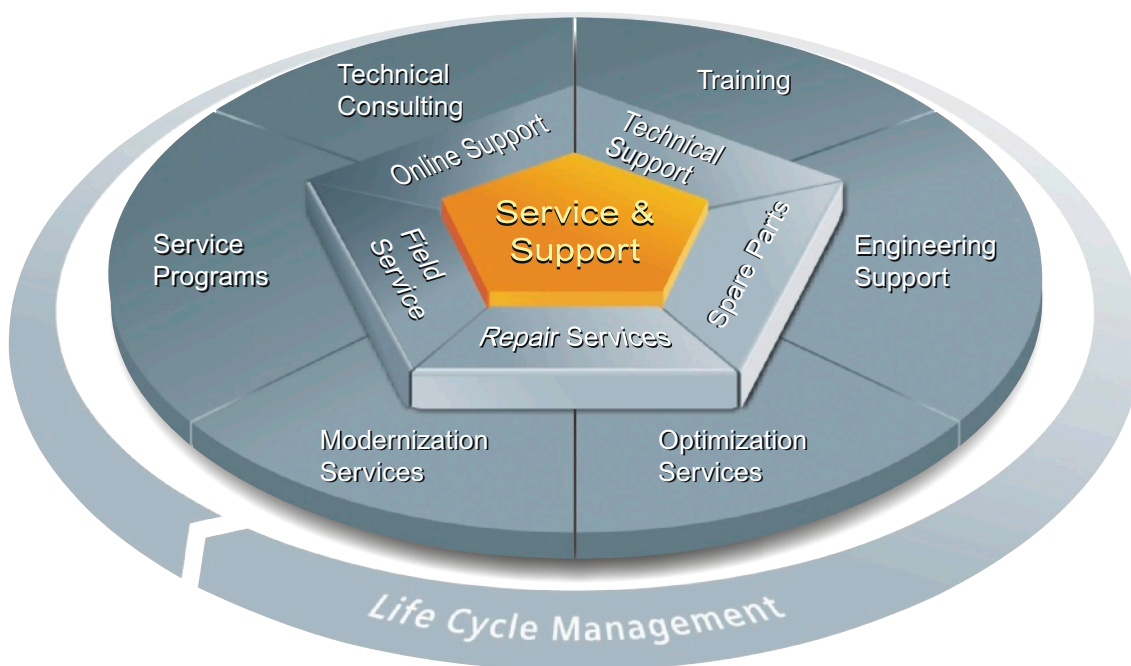

For machine constructors, solution providers and plant operators: The service offering from Siemens Industry, Automation and Drive Technologies includes comprehensive services for a wide range of different users in all sectors of the manufacturing and process industry.

To accompany our products and systems, we offer integrated and structured services that provide valuable support in every phase of the life cycle of your machine or plant - from planning and implementation through commissioning as far as maintenance and modernization.

Our Service & Support accompanies you worldwide in all matters concerning automation and drives from Siemens. We provide direct on-site support in more than 100 countries through all phases of the life cycle of your machines and plants.

You have an experienced team of specialists at your side to provide active support and bundled know-how. Regular training courses and intensive contact among our employees - even across continents - ensure reliable service in the most diverse areas.

Online Support

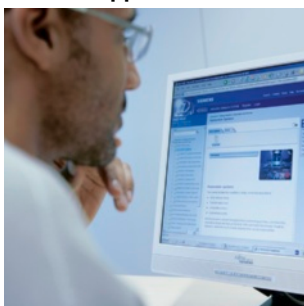

The comprehensive online information platform supports you in all aspects of our Service & Support at any time and from any location in the world.

www.siemens.com/automation/service&support

Technical Consulting

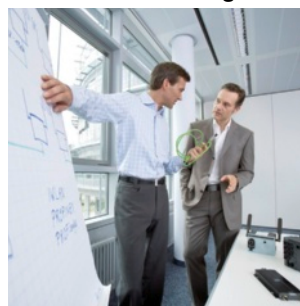

Support in planning and designing your project: From detailed actual-state analysis, definition of the goal and consulting on product and system questions right through to the creation of the automation solution.

Technical Support

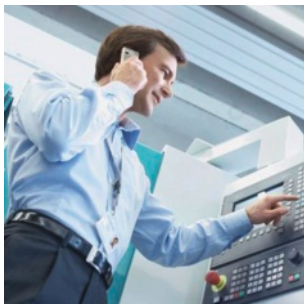

Expert advice on technical questions with a wide range of demand-optimized services for all our products and systems.

www.siemens.com/automation/support-request

Training

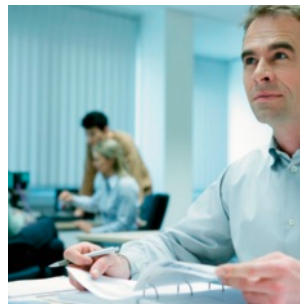

Extend your competitive edge - through practical know-how directly from the manufacturer.

www.siemens.com/sitrain

Contact information is available in the Internet at:
www.siemens.com/automation/partner

Appendix

Service & Support

The unmatched complete service for the entire life cycle

Engineering Support

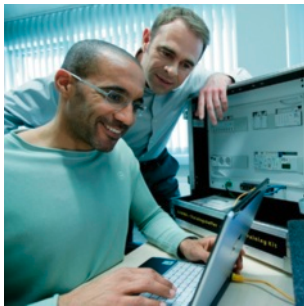

Support during project engineering and development with services fine-tuned to your requirements, from configuration through to implementation of an automation project.

Modernization



You can also rely on our support when it comes to modernization - with comprehensive services from the planning phase all the way to commissioning.

Field Service



Our Field Service offers you services for commissioning and maintenance - to ensure that your machines and plants are always available.

Service programs

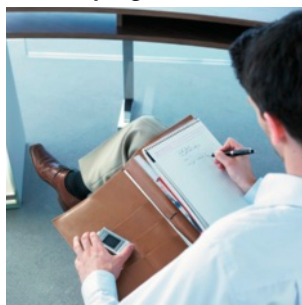

Our service programs are selected service packages for an automation and drives system or product group. The individual services are coordinated with each other to ensure smooth coverage of the entire life cycle and support optimum use of your products and systems.

The services of a Service Program can be flexibly adapted at any time and used separately.

Spare parts



In every sector worldwide, plants and systems are required to operate with constantly increasing reliability. We will provide you with the support you need to prevent a standstill from occurring in the first place: with a worldwide network and optimum logistics chains.

Examples of service programs:

- Service contracts
- Plant IT Security Services
- Life Cycle Services for Drive Engineering
- SIMATIC PCS 7 Life Cycle Services
- SINUMERIK Manufacturing Excellence
- SIMATIC Remote Support Services

Advantages at a glance:

- Reduced downtimes for increased productivity
- Optimized maintenance costs due to a tailored scope of services
- Costs that can be calculated and therefore planned
- Service reliability due to guaranteed response times and spare part delivery times
- Customer service personnel will be supported and relieved of additional tasks
- Comprehensive service from a single source, fewer interfaces and greater expertise

Repairs



Downtimes cause problems in the plant as well as unnecessary costs. We can help you to reduce both to a minimum - with our worldwide repair facilities.

Optimization

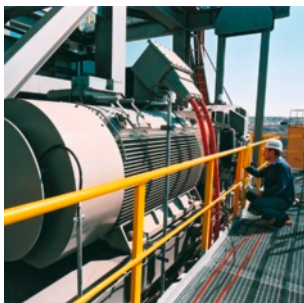

During the service life of machines and plants, there is often a great potential for increasing productivity or reducing costs. To help you achieve this potential, we are offering a complete range of optimization services.

Contact information is available in the Internet at:
www.siemens.com/automation/partner

Knowledge Base on DVD



For locations without online connections to the Internet there are excerpts of the free part of the information sources available on DVD (Service & Support Knowledge Base). This DVD contains all the latest product information at the time of production (FAQs, Downloads, Tips and Tricks, Updates) as well as general information on Service & Support.

The DVD also includes a full-text search and our Knowledge Manager for targeted searches for solutions. The DVD will be updated every 4 months.

Just the same as our online offer in the Internet, the Service & Support Knowledge Base on DVD comes complete in 5 languages (German, English, French, Italian, Spanish).

You can order the **Service & Support Knowledge Base** DVD from your Siemens contact.

Order no. **6ZB5310-0EP30-0BA2**

Automation Value Card



Small card - great support

The Automation Value Card is an integral component of the comprehensive service concept with which Siemens Automation and Drives will accompany you in each phase of your automation project.

It doesn't matter whether you want just specific services from our Technical Support or want to purchase something on our Online portal, you can always pay with your Automation Value Card. No invoicing, transparent and safe. With your personal card number and associated PIN you can view the state of your account and all transactions at any time.

Services on card. This is how it's done.

Card number and PIN are on the back of the Automation Value Card. When delivered, the PIN is covered by a scratch field, guaranteeing that the full credit is on the card.

By entering the card number and PIN you have full access to the Service & Support services being offered. The charge for the services procured is debited from the credits on your Automation Value Card.

All the services offered are marked in currency-neutral credits, so you can use the Automation Value Card worldwide.

Order your Automation and Value Card easily and comfortably like a product with your sales contact.

Automation Value Card order numbers

Credits	Order no.
200	6ES7 997-0BA00-0XA0
500	6ES7 997-0BB00-0XA0
1 000	6ES7 997-0BC00-0XA0
10 000	6ES7 997-0BG00-0XA0

Detailed information on the services offered is available on our Internet site at:

www.siemens.com/automation/service&support

Service & Support à la Card: Examples

Technical Support

"Priority"	Priority processing for urgent cases
"24 h"	Availability round the clock
"Extended"	Technical consulting for complex questions
"Mature Products"	Consulting service for products that are not available any more

Support Tools in the Support Shop

Tools that can be used directly for configuration, analysis and testing

Safety of electronic devices

Overview

The information listed here is mainly of a fundamental nature and applies regardless of the type and vendor of the electronic control system.

Reliability

The reliability of devices and components is being driven as high as possible by employing extensive and cost-effective measures in development and production.

This includes

- Selection of high-quality components;
- Worst-case design calculation of all circuits;
- Systematic and computer-controlled testing of all subcontracted components;
- Burn-in of all large-scale integrated circuits (e.g. processors, memories etc.);
- Measures to prevent static charging when working at or with MOS circuits;
- Visual checks at various stages of production;
- In-circuit testing of all modules, i.e. computer-aided testing of all components and their interaction in the circuit;
- Hot endurance run at high ambient temperature over several days;
- Meticulous computer-controlled final testing;
- Statistical evaluation of all returns for immediate introduction of remedial actions.

These measures are regarded as basic measures in safety engineering. They prevent or keep control of the majority of potential faults.

Risks

Wherever faults are liable to cause injury to persons or damage to property it is necessary to introduce measures aimed in particular at the safety of the plant and, therefore, of the control system. Special, plan-specific directives exist for these applications and need to be taken into account when configuring the control system.

In the case of safety-relevant electronic control systems the measures needing to be taken to prevent or keep control of faults are aimed at the risk presented by the plant. In such a case the basic measures listed above are no longer sufficient above a certain level of hazard potential. Additional measures have to be implemented and certified (e.g. dual-channel arrangements, tests, checksums etc.) for the control system.

Division into a safe and a non-safe zone

In practically all plants there are parts which perform safety-related functions (e.g. emergency stop pushbuttons, mesh guards, two-hand controls). In order not to have to consider the complete control system in terms of safety engineering it is customary to divide the control system into a **safe** and a **non-safe** zone. No special requirements are imposed on the safety of the control system in the non-safe zone because there would be no impact on the safety of the plant if the electronics failed in this case. In the safe zone, on the other hand, you are only allowed to use control systems and/or circuits which satisfy the directives in question.

The following zonal divisions are customary in practice:

- Control systems with little safety engineering, e.g. machine control systems.
- Control systems with balanced zones, e.g. chemical plants, aerial ropeways.
- Control systems with mainly safety engineering, e.g. incineration plants.

Important

Even if a maximum of design-based safety is achieved in the configuration of an electronic control systems – e.g. through multi-edge configuration – it is still essential to closely follow the instructions in the operating manuals as otherwise wrong actions may suspend precautions for preventing potential faults or may create additional sources of danger.

Overview

Software types

Software requiring a license is categorized into types. The following software types have been defined:

- Engineering software
- Runtime software

Engineering software

This includes all software products for creating (engineering) user software, e.g. for configuring, programming, parameterizing, testing, commissioning or servicing.

Data generated with engineering software and executable programs can be duplicated for your own use or for use by third-parties free-of-charge.

Runtime software

This includes all software products required for plant/machine operation, e.g. operating system, basic system, system expansions, drivers, etc.

The duplication of the runtime software and executable programs created with the runtime software for your own use or for use by third-parties is subject to a charge.

You can find information about license fees according to use in the ordering data (e.g. in the catalog). Examples of categories of use include per CPU, per installation, per channel, per instance, per axis, per control loop, per variable, etc.

Information about extended rights of use for parameterization/configuration tools supplied as integral components of the scope of delivery can be found in the readme file supplied with the relevant product(s).

License types

Siemens Industry Automation & Drive Technologies offers various types of software license:

- Floating license
- Single license
- Rental license
- Trial license

Floating license

The software may be installed for internal use on any number of devices by the licensee. Only the concurrent user is licensed. The concurrent user is the person using the program. Use begins when the software is started. A license is required for each concurrent user.

Single license

Unlike the floating license, a single license permits only one installation of the software.

The type of use licensed is specified in the ordering data and in the Certificate of License (CoL). Types of use include for example per device, per axis, per channel, etc.

One single license is required for each type of use defined.

Rental license

A rental license supports the "sporadic use" of engineering software. Once the license key has been installed, the software can be used for a specific number of hours (the operating hours do not have to be consecutive).

One license is required for each installation of the software.

Trial license

A trial license supports "short-term use" of the software in a non-productive context, e.g. for testing and evaluation purposes. It can be transferred to another license.

Factory license

With the Factory License the user has the right to install and use the software at one permanent establishment only. The permanent establishment is defined by one address only. The number of hardware devices on which the software may be installed results from the order data or the Certificate of License (CoL).

Certificate of license

The Certificate of License (CoL) is the licensee's proof that the use of the software has been licensed by Siemens. A CoL is required for every type of use and must be kept in a safe place.

Downgrading

The licensee is permitted to use the software or an earlier version/release of the software, provided that the licensee owns such a version/release and its use is technically feasible.

Delivery versions

Software is constantly being updated.

The following delivery versions

- PowerPack
- Upgrade

can be used to access updates.

Existing bug fixes are supplied with the ServicePack version.

PowerPack

PowerPacks can be used to upgrade to more powerful software. The licensee receives a new license agreement and CoL (Certificate of License) with the PowerPack. This CoL, together with the CoL for the original product, proves that the new software is licensed.

A separate PowerPack must be purchased for each original license of the software to be replaced.

Software Licenses

Overview (continued)*Upgrade*

An upgrade permits the use of a new version of the software on the condition that a license for a previous version of the product is already held.

The licensee receives a new license agreement and CoL with the upgrade. This CoL, together with the CoL for the previous product, proves that the new version is licensed.

A separate upgrade must be purchased for each original license of the software to be upgraded.

Software Update Service

The SIMATIC NET Software Update Service includes automatic delivery of the relevant updates of the SIMATIC NET PC software CD, which is available following the signing of the contract.

The CD contains SIMATIC NET software for Industrial Ethernet, PROFINET, OPC server and PROFIBUS, so that your software is always up to date.

The following boundary conditions apply:

- The customer must already have a current software version, so an update/upgrade may be required beforehand.
- The update service is valid for one year following the date specified in the order.
- It shall be extended automatically for a further year, provided that it is not cancelled 3 months in advance by the customer or by the responsible Siemens partner.
- When the contract is extended, the customer will be invoiced for the cost of a further year.

ServicePack

ServicePacks are used to debug existing products. ServicePacks may be duplicated for use as prescribed according to the number of existing original licenses.

License key

Siemens Industry Automation & Drive Technologies supplies software products with and without license keys.

The license key serves as an electronic license stamp and is also the "switch" for activating the software (floating license, rental license, etc.).

The complete installation of software products requiring license keys includes the program to be licensed (the software) and the license key (which represents the license).

Detailed explanations concerning license conditions can be found in the "Terms and Conditions of Siemens AG" or under www.siemens.com/industrymall (Industry Mall Online-Help System)

Numerics

3RA61, 3RA62 compact feeders		ASIsafe	6/6	Connection technology according to ISO 23570 and ECOFAST	10/4, 10/7
• 3RA61 direct-on-line starters	6/81	B		Connections/interfaces	3/341
• 3RA62 reversing starters	6/82	BANY PN IO	2/736	Contactors and contactor assemblies ..	6/75, 7/9
3RB24 for IO-Link, up to 630 A for high-feature applications	7/17	BANYnet bus analysis and diagnostics	2/734, 3/336	• Power contactors for switching motors ..	6/74
3RK3 modular safety system	3/296	Basic Panels – Standard	2/651	Controller Access Points	
3SF1 hinge switches	6/28	Box PC	2/683	• SCALANCE W786 for the outdoor area	8/98
3SF1 position switches	6/14	Bus cables	3/80, 3/86	• SCALANCE W786C RJ45 for the outdoor area	8/53
• 3SF1 position switches with separate actuator	6/21	Bus terminals	3/65	• SCALANCE W788C M12 for the indoor area	8/50
• 3SF1 position switches with solenoid interlocking	6/25	C		• SCALANCE W788C RJ45 for control cabinet	8/47
3SF2 cable-operated switches for AS-Interface	6/30	Cabling technology	2/28, 2/31, 2/32, 2/34, 2/38, 2/41, 2/46, 2/50, 2/60, 2/65, 2/68, 2/73, 2/79, 2/83, 2/88, 2/94, 2/100, 2/102, 2/107, 2/108, 2/109, 2/124, 2/130	Controllers	
3SF5 pushbuttons and indicator lights	6/121	Catalog improvement suggestions	11/38	• Embedded bundles	2/467
3UF18 current transformers for overload protection	3/295	CE marking	11/19	• Embedded controllers	2/464
3WL/3VL function block library for SIMATIC PCS 7	3/313	Central modules, expansion modules, interface modules, operating and monitoring modules	3/297	• Modular controllers	
7KM PAC measuring devices	3/303	CM 1242-5	3/154	- SIMATIC S7-1200	2/420
7KM PAC3100 measuring devices	3/304	CM 1243-5	3/158	- SIMATIC S7-300	2/432
7KM PAC3200 measuring devices	3/305	CNC controls	2/649	- SIMATIC S7-400	2/450
7KM PAC4200 measuring devices	3/306	Code reading systems	5/12	• PC-based controllers	2/461
830-1T connecting cable	3/56	• SIMATIC VS130-2	3/322	Counter modules	6/70
830-2 connecting cable	3/57	Comfort Panels – Standard	2/654	CP 1242-7 GPRS module	9/12
8WD4 signaling columns	6/130	Communication for PC-based systems	2/542, 2/543, 2/547, 2/551, 2/555, 2/560, 2/565, 2/570, 2/573, 2/576, 2/578, 2/581, 2/583, 2/585, 2/587, 2/589, 3/187, 3/188, 3/189, 3/196, 3/202, 3/209, 3/215, 3/222, 3/226, 3/230, 3/235, 3/238, 3/241	CP 1604	2/543
• 8WD42, 50 mm diameter	6/131	Communication for PC-based systems		CP 1612 A2	2/551
• 8WD44, 70 mm diameter	6/133	• PROFIBUS		CP 1613 A2	2/555
A		- Overview	3/186	CP 1616	2/547
Abbreviations, Explanations	11/1	• PROFINET/Industrial Ethernet		CP 1623	2/560
Accessories	2/609, 2/611, 2/613, 3/298, 3/299, 7/37, 7/44	- Introduction	2/539	CP 1628	2/565
Accessories for 3RB24	7/22	- Performance data	2/541	CP 243-1	2/482
Accessories for compact feeders for IO-Link	7/26	Communication for SIMATIC S7-1200	3/154	CP 342-5	3/162
Accessories for M200D motor starters		Communication for SIMATIC S7-200	2/482	CP 342-5 FO	3/167
• PROFIBUS	3/271	Communication for SIMATIC S7-300		CP 343-1	2/492
• PROFINET	2/731	• PROFINET/Industrial Ethernet	2/486	CP 343-1 Advanced	2/500
Active field distributors	3/83	• PROFIBUS	3/162	CP 343-1 BACnet	2/517
Active RS 485 terminating element	3/68	Communication modules for SIMATIC S7-400		CP 343-1 ERC	2/511
Addressing units	6/141	• PROFINET/Industrial Ethernet	2/522	CP 343-1 Lean	2/486
Analog I/O modules, IP67 - K60	6/60	• PROFIBUS	3/176	CP 343-5	3/172
Analyzer	6/143	Communication for SIMATIC S7-1200	3/154	CP 443-1	2/522
ANT794-3M GSM/GPRS antenna	9/144	Communication for SIMATIC S7-200	2/482	CP 443-1 Advanced	2/528
ANT794-4MR GSM/GPRS antenna	9/146	Communication for SIMATIC S7-300		CP 443-5 Basic	3/176
Application examples	8/6	• PROFINET/Industrial Ethernet	2/486	CP 443-5 Extended	3/180
AS-i cable-operated switches	6/30	• PROFIBUS	3/176	CP 5603	3/189
AS-Interface	1/20	Communication modules for SIMATIC S7-400		CP 5611 A2	3/222
AS-Interface communication modules	6/68	• PROFINET/Industrial Ethernet	2/522	CP 5613 A2	3/196
AS-Interface connections for LOGO!	6/73	• PROFIBUS	3/176	CP 5614 A2	3/202
AS-Interface enclosures and front panel modules		Communication modules ASM 456, SIMATIC RF160C	3/320	CP 5621	3/226
• General data	6/121	Communication overview	2/8, 3/11, 7/3	CP 5623	3/209
• Components	6/123	Communication via AS-Interface	10/13	CP 5624	3/215
• Customized equipment	6/124	• AS-Interface shaped cable	10/14	CP 5711	3/230
• Front panel module	6/125	Communication via PROFIBUS DP	10/4	C-PLUG	2/609
AS-Interface enclosures and front panel modules With standard fittings	6/122	• ECOFAST fiber-optic hybrid cable	10/11	CPU 1211C	2/420
AS-Interface F adapters for EMERGENCY-STOP devices	6/34	• ECOFAST hybrid field bus connections in Cu-RS 485	10/7	CPU 1212C	2/424
AS-Interface Function Block Library for SIMATIC PCS 7	6/149	• Hybrid field bus connections	10/5	CPU 1214C	2/428
AS-Interface power supply units	6/135	Compact switch modules		CPU 314C-2 PN/DP	2/432
AS-Interface safety modules	6/11	• CSM 1277 unmanaged	2/136	CPU 315-2 PN/DP	2/434
AS-Interface safety monitors	6/8	• CSM 377 unmanaged	2/140	CPU 315F-2 PN/DP	2/442
AS-Interface shaped cables	6/138	• SIPLUS NET CSM 1277	2/139	CPU 317-2 PN/DP	2/437
AS-Interface specification		Conditions of sale and delivery		CPU 317F-2 PN/DP	2/445
• AS-i Power24V expansion	6/5	Export regulations	11/40	CPU 319-3 PN/DP	2/440
• Specification 2.0, 2.1 and 3.0	6/4	Configuration examples	3/12, 5/4	CPU 319F-3 PN/DP	2/448
		Configuring, Visualizing and Controlling		CPU 412-2 PN	2/450
		• with SENTRON	3/315	CPU 414-3 PN/DP	2/452
		• with SIMATIC	3/309	CPU 414F-3 PN/DP	2/457
		Connecting cables	9/149	CPU 416-3 PN/DP	2/454
		Connection examples	3/21	CPU416F-3 PN/DP	2/459
		Connection options to SIMATIC PCs	2/542, 3/188	CU240D PN and CU240D PN-F Control Units	2/410
				CU305 Control Unit	2/414

Index

CUC310-2 Control Unit
for single-axis drives 2/417
Current monitoring 7/32

D

Data communication 2/7, 3/9
DCF77 antennas 9/150
Delphi-S7, Delphi-DPLib and
Delphi-DPSofnetSlave 3/344
Development kits
• for ERTEC 2/743
• for Standard Ethernet Controllers 2/744
deviceWISE Embedded Edition
for SIMATIC S7 2/758
Diagnostic repeater for PROFIBUS DP 3/71
Digital I/O modules IP67
• K20 6/57
• Introduction 6/50
• K45 6/55
• K60 6/51
• User modules 6/59
Digital I/O modules IP68/IP69K
• K60R 6/53
Distributed frequency converters
SINAMICS G120D 2/406
DP/AS-i F-Link 6/43
DP/AS-i LINK Advanced 6/38
DP/AS-Interface Link 20E 6/41
DP/DP coupler 3/261
Drive systems
• SINAMICS G 2/406
• SINAMICS G120D
Distributed Frequency Converter 2/410
• SINAMICS S
High Performance Drives 2/412

E

ECOFASST bus cables 3/37
ECOFASST ES 3/281
ECOFASST Fiber Optic Hybrid Cable 3/143
ECOFASST motor starters 3/279
ECOFASST motor starters – Software 3/281
ECOFASST selection module 10/20
EGPRS Router MD741-1 9/122
Electrical networks
• FOUNDATION Fieldbus 3/86
• PROFIBUS PA 3/74
• RS485 3/23
Energy cables 2/68, 3/42
Energy management 3/300
Engineering/Network Management/
Diagnostics
• PROFIBUS 3/327
• Industrial Wireless Communication 8/190
Enhanced Real-Time
Ethernet Controller ERTEC 2/742
ET 200eco 4/26
ET 200eco PN 2/640, 4/25
ET 200iSP 4/19
ET 200M 4/18
ET 200M – Interface modules 2/627
ET 200pro 4/20
ET 200pro – Interface modules 2/630
ET 200S 4/3
ET 200S
Motor Starters and Safety Motor Starters 4/4
Expansion modules for 7KM PAC 3/307
Extension plug 6/140

F

F90 module 6/66
Fax form 11/38

FC FO termination kit 2/107, 3/96
FC glass fiber-optic cable 3/91
FC glass fiber-optic cables 2/102
Flat module 6/67

G

Glass fiber-optic cables 2/109, 3/97
GPS receiver 9/151
Ground-fault detection modules 6/71
GSM/GPRS MD720-3 modem 9/17

H

HARDNET-IE S7-REDCONNECT 2/570
Hardware platforms 2/643

I

I/O modules for operation
in the control cabinet 6/63
I/O modules for operation in the field,
high degree of protection 6/50
IE Connecting Cable M12-180/M12-180 2/79
IE FC M12 Plug PRO 2/46
IE FC Outlet RJ45 2/83
IE FC RJ45 Modular Outlet 2/88
IE FC RJ45 Plug 2 x 2 2/34
IE FC RJ45 Plug 4 x 2 2/38
IE FC TP Cable 2 x 2 2/50
IE FC TP Cable 4 x 2 2/60
IE Hybrid Cable 2/65
IE Push Pull Plug PRO 2/41
IE TP Cord 2/73
IE/AS-i LINK PN IO 6/47
IE/PB Link PN IO 2/745
IE/WSN-PA LINK 2/750, 8/199
IM 151-3 PN 2/617
IM 151-8 F PN/DP CPU 2/624
IM 151-8 PN/DP CPU 2/620
IM 153-4 PN 2/627
IM 154-4 PN 2/630
IM 154-6 PN IWLAN 2/632, 8/183
IM 154-8 F PN/DP CPU 2/637
IM 154-8 PN/DP CPU 2/634
Index 11/30
Industrial bus systems 1/12
Industrial communication
with Totally Integrated Automation 1/10
Industrial Ethernet 1/14, 2/4, 2/7, 2/23
Industrial Ethernet FastConnect 2/32
Industrial Ethernet security 2/392
Industrial Ethernet switches /
media converters 2/132
Industrial PC
• Box PC 2/683
• Rack PC 2/663
• SIMATIC Panel PC 2/698
Industrial Remote Communication 1/26
Industrial Twisted Pair –
cables/connectors 2/94
Industrial Wireless Communication 1/24
Industrial Wireless LAN (IWLAN) 8/3
Industrial Wireless LAN Controller
SCALANCE WLC711 8/43
Industry monitors
and Thin Clients 2/713
Information and Ordering
in the Internet and on DVD 11/24
Input modules 7/17
IO-Link K20 modules 7/8
IO-Link master module for
• ET 200eco PN 7/6

• ET 200S
– 4SI SIRIUS electronic module 7/5
– IO-Link 4SI electronic module 7/4
IWLAN

• Access Points
IEEE 802.11a/b/g 8/58
• Access Points
IEEE 802.11n 8/15
• Accessories 8/136
• Client Modules I
IEEE 802.11a/b/g 8/115
• Client Modules
IEEE 802.11n 8/103
• Controller Access Points
IEEE 802.11a/b/g 8/98
• Controller and
Controller Access Points
IEEE 802.11n 8/39
• Network transition 8/185
IWLAN antennas 8/136
IWLAN cabling technology 8/161
IWLAN RCoax cables 8/154
IWLAN/PB Link PN IO 8/185

K

Key Panels
SIMATIC HMI KP8/KP8F 2/650
Knowledge Base on DVD
Automation Value Card 11/26

L

Lenses 3/326
Line monitoring 7/29
Line transformer 9/143
LTOP overvoltage protection 9/140

M

M200D motor starters for AS-Interface
• M200D Basic motor starters 6/101
• M200D Standard motor starters 6/102
M200D motor starters for PROFIBUS 3/267
• Communication modules,
motor starter modules 3/270
M200D motor starters for PROFINET 2/725
• Communication modules,
motor starter modules 2/730
Master interface module
for IM 151 CPU interface modules 2/621
Masters for
• AS-Interface 6/35, 7/4
• Masters for SIMATIC S7
– CP 243-2 6/35
– CP 343-2P, CP 343-2 6/36
MCU motor starters for AS-Interface
• Accessories 6/113
• Metal enclosures,
electromechanical switching 6/110
• Metal enclosures,
electronic switching 6/112
• Plastic enclosures,
electromechanical switching 6/109
MD2 dedicated line modem 9/113
MD3 telephone modem 9/118
Media modules for modular
• SCALANCE X-300 managed 2/328
• SCALANCE XR-500 managed 2/375
Miscellaneous accessories 6/146
Mobile Panels 2/655
MOBY D 5/8
Modems 9/111
Modules with special functions 6/70
Motion Control architectures
with SIMOTION 2/645
Motion Control System SIMOTION 2/642
Motor Starter ES 3/273

Motor starters for AS-Interface, 24 V DC General data 6/114	PROFIBUS 1/18	Service & Support 11/25
Motor starters for operation in the control cabinet 6/78, 6/90	PROFIBUS bus cables 3/25	SICLOCK time synchronization 2/613
Motor starters for operation in the field, high degree of protection 2/725, 3/267, 6/97, 6/107, 6/114	PROFIBUS components 3/338	Siemens contacts worldwide 11/22
• Software 3/273	PROFIBUS DP ASICs 3/338	Siemens Solution Partner Automation 11/23
MOTOR STARTERS FOR PROFIBUS Motor Starters for AS-Interface, Accessories 3/280	PROFIBUS FastConnect 3/23	SIMATIC ET 200eco 2/640
N	PROFIBUS M12 and 7/8" connecting cable/connector 3/58	SIMATIC ET 200S
Network components 3/16	PROFIdrive for SIMOTION 2/647	• Interface modules 2/617
Network selection criteria 2/23, 3/18	PROFINET 1/16, 2/24	• Interface modules with integrated CPU 2/620
Network transitions	PROFINET for SIMOTION 2/646	SIMATIC Flat Panels 2/713
• PROFINET/Industrial Ethernet 2/745	PROFINET	SIMATIC HMI IPC277D 2/702
• PROFIBUS 3/261	Technology components 2/742	SIMATIC HMI IPC277D Bundles 2/472
• AS-Interface 6/38	Q	SIMATIC HMI IPC477C 2/704
Network transitions	Quality management	SIMATIC HMI IPC477C bundles 2/474
O	Certificates 11/21	SIMATIC HMI IPC577C 2/707
OLM Optical Link Module 3/122	R	SIMATIC HMI IPC677C 2/710
Online Services 11/24	Rack PC 2/663	SIMATIC identification systems 3/320
OPC server for Industrial Ethernet 2/578	Relay, digitally configurable for 1 sensor 7/40	• RFID systems 2/717
OPC Server for PROFIBUS 3/238	Relay, digitally configurable for up to 3 sensors 7/42	• Code reading systems 2/719
Operating and Monitoring Devices 2/650	Repeater 6/139	SIMATIC iMap 2/733
Optical bus terminal OBT 3/150	Repeater RS 485 for PROFIBUS 3/69	SIMATIC IPC227D 2/687
Optical networks with OBT and integrated interface 3/137	RFID Software 5/9	SIMATIC IPC227D Bundles 2/467
Optical networks with OLM 3/89	RFID systems 5/6	SIMATIC IPC427C 2/689
Order No. Index 11/35	RS485 bus connector 3/48	SIMATIC IPC427C bundles 2/469
Overview of FC-FOCs 2/100, 3/89	S	SIMATIC IPC547C 2/672
Overview of FOCs 2/108	S22.5 data decoupling modules 6/136	SIMATIC IPC547D 2/669
Overview of network components 3/16, 8/10	S7 OPC Redundancy	SIMATIC IPC627C 2/692
Overview of passive network components . 2/28	for Industrial Ethernet 2/581	SIMATIC IPC647C 2/675
Overview of Twisted Pair 2/31	S7 OPC Redundancy for PROFIBUS 3/241	SIMATIC IPC827C 2/695
Overvoltage protection module 6/71	Safety of electronic devices 11/27	SIMATIC IPC847C 2/679
P	SCALANCE S 2/393	SIMATIC Mobile Panel 277(F) IWLAN 8/169
PA routers 3/262	SCALANCE W740	SIMATIC Multi Panels 2/661
PAC3200 function block library for SIMATIC WinCC 3/314	• for use in the control cabinet 8/120	SIMATIC Multi Panels (MP) 2/661
Partner at Industry Automation and Drive Technologies 11/22	• for use in the indoor area 8/128	SIMATIC MV420 2/719
Partner solutions 2/758, 3/344	SCALANCE W748 M12	SIMATIC MV440 2/721
PC-based power management system 3/300	for use in the indoor area 8/110	SIMATIC Panel PC 2/698
PCF-FOC termination kit 3/119, 3/147	SCALANCE W748 RJ45	SIMATIC Panels 2/658
PCS 7 TeleControl Engineering Station 9/45	for use in the control cabinet 8/106	SIMATIC PCS 7 Library PAC3200 3/312
PCS 7 TeleControl Operator System 9/46	SCALANCE W784	SIMATIC PCS 7 TeleControl 9/41
Plastic and PCF fiber-optic cable .. 3/112, 3/137	for use in the control cabinet 8/63	SIMATIC PDM Process Device Manager .. 3/331
PN/PN coupler 2/756	SCALANCE W786 for the outdoor area 8/79	SIMATIC powerfate 3/310
POF and PCF fiber-optic cables 2/124	SCALANCE W786 RJ45	SIMATIC RF180C/RF182C 2/717
POF/PCF FOC termination kit 2/130	for the outdoor area 8/31	SIMATIC RF300 5/7
Power connection technology	SCALANCE W788 for the indoor area 8/70	SIMATIC S7 2/592, 2/602, 3/244
• Motor connection cables and plugs 10/18	SCALANCE W788 M12	SIMATIC S7-modular Embedded Controller
• Power cables, plugs, power terminal connectors 10/15	for the indoor area 8/24	• EC31 2/464
Power factor and active current monitoring 7/33	SCALANCE W788 RJ45	• Expansion modules 2/466
Power Rail Booster 3/72	for use in control cabinet 8/18	SIMATIC TeleService 9/154
Power supply for modular SCALANCE X-500 managed 2/389	SCALANCE X-000 unmanaged 2/144	SIMATIC Thin Client 2/716
Power supply PS791-1PRO 2/611, 8/165	SCALANCE X005 unmanaged 2/145	SIMATIC VS120 3/325
Power Supply PS791-2DC and PS791-2AC 8/167	SCALANCE X-100 unmanaged 2/159	SIMATIC WinAC MP 2/477
Power supply units and data decoupling modules 6/135	SCALANCE X-100 unmanaged / media converters 2/158	SIMATIC WinAC ODK 2/463
powerconfig 3/319	SCALANCE X-200 managed 2/181	SIMATIC WinAC RTX 2/461
powermanager 3/316	SCALANCE X-200IRT managed 2/211	SIMATIC WinAC RTX F 2/462
PPI modem cable 9/148	SCALANCE X-300 managed 2/234	SIMATIC WinCC 2/596, 3/249
Process or field communication 3/5	SCALANCE X-300EEC managed 2/291	SIMATIC WinCC (TIA Portal) Runtime 2/604
	SCALANCE X-300PoE managed 2/273	SIMATIC WinCC flexible RT 2/594, 3/247
	SCALANCE X-400 managed (Layer 3) 2/344	SIMATIC-based power management system 3/302
	SCALANCE X-500 managed (Layer 3) 2/365	SIMOCODE 3UF motor management and control devices 3/282
	SCALANCE XB-000 unmanaged 2/150	SIMOCODE pro 3UF7
	SCALANCE XF-200 managed 2/203	• Accessories 3/291
	SCALANCE XF-200IRT managed 2/229	• Basic units 3/288
	SCALANCE XR-300 managed 2/263	• Expansion modules 3/289
	SCALANCE XR-300EEC managed 2/314	• Failsafe expansion modules 3/290
	SCALANCE XR-300PoE managed 2/281	• General data 3/282
	SCALANCE XR-500 managed (Layer 3) ... 2/366	SINAMICS G110D
	SCD monitors 1900 2/715	distributed frequency converters 6/117
		SINAMICS S110 servo converters 2/412

Index

- SINAMICS S120 drive system 2/415
- SINAUT ST7 Engineering Software 9/31
- SINAUT ST7cc, Add-on for WinCC 9/34
- SINAUT ST7sc
- SCADA Connect Software 9/48
- SINEMA E 8/190
- SINEMA server 2/739
- SINUMERIK Analog Drive Interface for 4 axes ADI 4 3/73
- SINUMERIK CNC automation system 2/649
- SIPLUS Basic Panels 2/652
- SIPLUS CP 342-5 3/166
- SIPLUS CP 343-1 2/498
- SIPLUS CP 343-1 Advanced 2/509
- SIPLUS CP 343-1 Lean 2/491
- SIPLUS CP 443-1 2/527
- SIPLUS CP 443-2 Advanced 2/537
- SIPLUS CP 443-5 Extended 3/185
- SIPLUS CPU 1211C 2/422
- SIPLUS CPU 1212C 2/426
- SIPLUS CPU 1214C 2/430
- SIPLUS CPU 315-2 PN/DP 2/436
- SIPLUS CPU 315F-2 PN/DP 2/444
- SIPLUS CPU 317-2 PN/DP 2/439
- SIPLUS CPU 317F-2 PN/DP 2/447
- SIPLUS CPU 416-3 PN/DP 2/456
- SIPLUS EGPRS MD741-1 routers 9/127
- SIPLUS GSM/GPRS MD720-3 modem 9/22
- SIPLUS IM 151-3PN 2/619
- SIPLUS IM 151-8 F PN/DP CPU 2/626
- SIPLUS IM 153-4 PN IO 2/629
- SIPLUS IM151-8 PN/DP CPU 2/622
- SIPLUS master interface module for IM 151 CPU 2/623
- SIPLUS MD2 dedicated line modem 9/117
- SIPLUS OLM Optical Link Module 3/135
- SIPLUS RIC bundles
- for IEC 60870-5-101 9/100
 - for IEC 60870-5-103 9/104
 - for IEC 60870-5-104 9/107
- SIPLUS RIC extreme bundles
- for IEC 60870-5-101 9/102
 - for IEC 60870-5-103 9/105
 - for IEC 60870-5-104 9/109
- SIPLUS RIC IEC 60870-5-101 library 9/103
- SIPLUS RIC IEC 60870-5-103 library 9/106
- SIPLUS RIC IEC 60870-5-104 library 9/110
- SIPLUS SCALANCE X-100 unmanaged ... 2/169
- SIPLUS SCALANCE X-100 unmanaged / media converter 2/180
- SIPLUS SCALANCE X-200 managed 2/201
- SIPLUS SCALANCE X-200IRT managed .. 2/228
- SIPLUS SCALANCE X-300 managed 2/261
- SIPLUS TIM 3V-IE for WAN and Ethernet ... 9/67
- SIPLUS TIM 4R-IE for WAN and Ethernet ... 9/87
- SIRIUS 3RA23 reversing contactor assemblies 7/11
- SIRIUS 3RA24 contactor assemblies for wye-delta starting 6/75, 7/13
- SIRIUS 3RA27 function modules
- for AS-Interface 6/76
 - for IO-Link 7/15
- SIRIUS 3RA6 compact feeders 7/24
- Accessories 6/83
 - Add-on modules for AS-Interface 6/88
 - General data 6/78
 - Infeed system for 3RA6 6/90
- SIRIUS 3RA64, 3RA65 compact feeders for IO-Link 7/24
- SIRIUS 3RB2 electronic overload relays 7/17
- SIRIUS 3RS14, 3RS15 temperature monitoring relays for IO-Link ... 7/38
- SIRIUS 3RT20 contactors 6/74
- 3-pole, 3 ... 18.5 kW 7/9
- SIRIUS 3UG48 monitoring relays for stand-alone installation for IO-Link 7/27
- SIRIUS EMERGENCY-STOP mushroom pushbuttons for AS-Interface ... 6/31
- SIRIUS M200D motor starters
- General data 6/97
 - Accessories 6/103
 - M200D motor starters for AS-Interface ... 6/98
- SIRIUS MCU motor starters General data 6/107
- SIRIUS Motor Starter Function Block Library for SIMATIC PCS 7 3/277
- SITRANS AW200 Wireless HART adapter 8/198
- SITRANS P280 8/195
- SITRANS TF280 8/197
- Slaves 6/73
- SlimLine 6/64
- SNMP OPC server 2/583
- SOFTBUS for Linux 2/589
- SOFTNET for Industrial Ethernet 2/573
- SOFTNET for PROFIBUS 3/235
- SOFTNET PN IO 2/576
- SOFTNET PN IO Linux 2/585
- SOFTNET Security Client 2/402
- SOFTNET-S7/Linux 2/587
- Software (AS-Interface) 6/149
- Software and tools (PROFINET) 2/733
- Software Licenses 11/29
- Special integrated solutions 6/68
- Speed monitoring 7/35
- SplitConnect 3/77
- Standards and approbations 11/20
- STEP 7 3/329
- STEP 7 Professional/Basic V11 3/327
- System components and accessories 6/139
- System interfaces for PG/PC/IPC 2/539, 3/186
- System interfaces for SIMATIC HMI 2/591, 3/243
- System interfaces for SIMATIC S7 2/479, 3/153
- System interfaces with WinCC (TIA Portal) 2/601, 3/254
- System interfaces with WinCC (TIA Portal)
- SIMATIC S7 3/255
 - SIMATIC WinCC (TIA Portal) Runtime ... 3/257
 - WinCC Runtime Communication 3/258
- System interfaces with WinCC flexible 2/591, 3/243
- System overview (AS-Interface)
- Communication overview 6/3
 - Transmission technology 6/2
- Systems for the control cabinet 4/3
- Systems without control cabinet 4/20
- TeleControl Professional 9/23
- Stations for DNP3 protocol 9/88
 - Stations for IEC protocol 9/99
 - Stations for ST7 protocol 9/56
 - for the control center 9/29
 - for the stations 9/52
- Telecontrol Server Basic 9/7
- Teleservice 9/153
- The SIMOTION system 2/642
- The unmatched complete service for the entire life cycle 11/25
- TIM 3V-IE Advanced 9/68
- TIM 3V-IE DNP3 9/89
- TIM 3V-IE for WAN and Ethernet 9/59
- TIM 4R / TIM 4RD 9/75
- TIM 4R-IE DNP3 9/94
- TIM 4R-IE for WAN and Ethernet 9/79
- Training 11/18
- Transmission media 6/138
- Transmission technology 7/2
- U**
- UMTS-Router SCALANCE M87x 9/128
- V**
- Vision sensors 3/325
- Voltage monitoring 7/31
- W**
- WinCC Runtime Communication 2/605
- WinCC/TeleControl 9/38
- Wireless Devices 8/169, 8/183
- WirelessHART 8/194
- T**
- Telecontrol 9/3
- Accessories 9/140
- TeleControl Basic 9/5
- TeleControl Basic for the control center 9/7
- TeleControl Basic for the stations 9/17
- TeleControl Basic for the substations 9/12
- Telecontrol network
- GSM/GPRS/UMTS routers 9/122
 - Modems 9/111

2XV

2XV9 450-	2/432, 2/586, 2/588, 2/590, 2/614, 2/615, 2/616
-----------------	----------------------------------------------------

3RA

3RA23 15-	7/11
3RA23 16-	7/11
3RA23 17-	7/11
3RA23 18-	7/11
3RA23 24-	7/11
3RA23 25-	7/11
3RA23 26-	7/11
3RA23 27-	7/11
3RA23 28-	7/11
3RA24 15-	6/75, 7/13
3RA24 16-	6/75, 7/13
3RA24 17-	6/75, 7/13
3RA24 23-	6/75, 7/13
3RA24 25-	6/75, 7/13
3RA24 26-	6/75, 7/13
3RA27 11-	7/15, 7/16
3RA27 12-	6/76, 6/77
3RA29 08-	6/87, 6/96, 7/23, 7/37, 7/44
3RA29 10-	6/77
3RA29 13-	6/76, 6/77, 7/12, 7/14
3RA29 23-	6/76, 6/77, 7/12, 7/14
3RA61 20-	6/81
3RA62 50-	6/82
3RA64 00-	7/24
3RA65 00-	7/25
3RA68 12-	6/93
3RA68 13-	6/93
3RA68 22-	6/94
3RA68 23-	6/94
3RA68 30-	6/93
3RA68 60-	6/95
3RA68 70-	6/95
3RA68 80-	6/96
3RA68 90-	6/95, 6/96
3RA69 11-	6/84
3RA69 12-	6/84
3RA69 13-	6/84
3RA69 20-	6/84, 6/85
3RA69 31-	7/26
3RA69 32-	7/26
3RA69 33-	7/26
3RA69 35-	7/16, 7/22, 7/26
3RA69 36-	7/16, 7/22, 7/26
3RA69 40-	6/84
3RA69 50-	6/84
3RA69 70-	6/89
3RA69 91-	6/87

3RB

3RB19 00-	3/291, 7/23
3RB24 83-	7/20
3RB29 06-	7/21
3RB29 56-	7/21
3RB29 66-	7/21
3RB29 87-	7/21

3RG

3RG9 00	6/66, 6/69
---------------	------------

3RK

3RK1 005-	7/5
3RK1 100-	6/52, 6/56, 6/65
3RK1 105-	6/10
3RK1 107-	6/61

3RK1 200-	6/52, 6/56, 6/65, 6/69, 6/70
3RK1 205-	6/12, 6/57
3RK1 207-	6/61
3RK1 303-	3/279
3RK1 305-	3/269
3RK1 315-	6/101
3RK1 323-	3/279
3RK1 325-	6/102
3RK1 335-	2/730
3RK1 395-	2/730, 3/269
3RK1 400-	6/52, 6/54, 6/56, 6/57, 6/65, 6/67, 6/69, 6/73, 6/116
3RK1 402-	6/65
3RK1 405-	6/12
3RK1 408-	6/52, 6/71
3RK1 802-	6/10
3RK1 901-	6/10, 6/13, 6/52, 6/54, 6/56, 6/58, 6/62, 6/72, 6/105, 6/106, 6/116, 6/137, 6/140, 6/142, 6/145, 6/146, 6/147, 7/8
3RK1 902-	2/635, 2/636, 2/638, 2/639, 2/641, 2/732, 3/270, 3/271, 6/52, 6/54, 6/58, 6/62, 6/104, 6/105, 6/106, 6/116, 6/142, 6/145, 6/147, 6/148, 10/17
3RK1 903-	3/275
3RK1 904-	6/106, 6/142, 6/145
3RK1 911	3/41
3RK1 911-	3/275, 3/279, 6/104, 10/6, 10/10, 10/12, 10/16, 10/17, 10/18, 10/19, 10/20
3RK1 922-	3/275, 3/279, 6/105, 6/120
3RK19 01-	6/89
3RK19 04-	6/89
3RK2 100-	6/56, 6/57
3RK2 200	6/56
3RK2 200-	6/52, 6/57, 6/65
3RK2 207-	6/61
3RK2 400	6/57
3RK2 400-	6/52, 6/56, 6/65, 6/69
3RK2 703-	6/146
3RK3 111-	3/296
3RK3 141-	6/46
3RK3 211-	3/296
3RK3 221-	3/296
3RK3 231-	3/296
3RK3 242-	3/296
3RK3 251-	3/296
3RK3 311-	3/296
3RK3 321-	3/296
3RK3 511-	3/296
3RK3 611-	3/296
3RK3 931-	3/297
3RK43 20-	6/109, 6/111, 6/112
3RK5 010-	7/8

3RP

3RP1 902	6/10, 6/65
3RP1 903	6/10, 6/65
3RP19 02	7/37
3RP19 03	3/291, 3/297, 7/23, 7/37, 7/44

3RS

3RS14 40-	7/41
3RS14 41-	7/43
3RS15 40-	7/41

3RT

3RT1 900-	2/641, 6/147, 8/184
3RT19 00-	6/87, 7/37, 7/44
3RT19 55-	3/291, 7/23
3RT19 56-	3/291, 7/23
3RT19 66-	3/291, 7/23
3RT20 15-	7/10

3RT20 16-	7/10
3RT20 17-	7/10
3RT20 18-	7/10
3RT20 23-	7/10
3RT20 24-	7/10
3RT20 25-	7/10
3RT20 26-	7/10
3RT20 27-	7/10
3RT20 28-	7/10

3RV

3RV10 .. -	6/92
3RV19 .. -	6/85, 6/86, 6/96
3RV29 26-	6/86

3RX

3RX9 010-	6/138, 10/14
3RX9 012-	6/138, 10/14
3RX9 013-	6/138, 10/14
3RX9 014-	6/138, 10/14
3RX9 015-	6/138, 10/14
3RX9 016-	6/138, 10/14
3RX9 017-	6/138, 10/14
3RX9 020-	6/138, 10/14
3RX9 022-	6/138, 10/14
3RX9 023-	6/138, 10/14
3RX9 024-	6/138, 10/14
3RX9 025-	6/138, 10/14
3RX9 026-	6/138
3RX9 027-	6/138, 10/14
3RX9 50- -	6/135
3RX9 801-	6/58, 6/140, 6/142, 6/145, 6/146
3RX9 802-	2/630, 2/636, 2/639, 2/641, 2/717, 3/320
3RX9 810-	6/66

3SB

3SB30 00-	6/32
3SB35 00-	6/33

3SE

3SE5 000- 6/16, 6/18, 6/19, 6/20, 6/24, 6/28, 6/29

3SF

3SF1 114-	6/19, 6/23, 6/29
3SF1 124-	6/19, 6/23, 6/29
3SF1 214-	6/17, 6/23, 6/29
3SF1 234-	6/15, 6/22, 6/28
3SF1 244-	6/15, 6/22, 6/28
3SF1 314-	6/27
3SF1 324-	6/26
3SF2 120-	6/30
3SF2 140-	6/30
3SF2 150-	6/30
3SF5 402-	6/34
3SF5 500-	6/123
3SF5 811-	6/31, 6/122
3SF5 812-	6/122
3SF5 813-	6/122
3SF5 874-	6/125
3SF5 900-	6/123

3TK

3TK28 20-	7/44
-----------------	------

3TX

3TX7	3/294
------------	-------

Order No. Index

3UF

3UF1 900-	3/291
3UF18	3/294
3UF7	3/287, 3/288, 3/289
3UF7 900-	3/290
3UF7 910-	3/290
3UF7 920-	3/290, 3/297
3UF7 922-	3/290
3UF7 925-	3/291
3UF7 93	3/290, 3/297
3UF7 94	3/290, 3/297
3UF7 946-	3/275, 3/290, 3/297, 6/10, 6/145
3UF7 950-	3/290, 3/297
3UF7 970-	3/291
3UF7 982-	3/293
3UF79 33-	7/22

3UG

3UG48 1. -	7/30
3UG48 22-	7/32
3UG48 32-	7/31
3UG48 41-	7/34
3UG48 51-	7/36

3ZS

3ZS1 200-	3/280
3ZS1 310-	3/274
3ZS1 312-	3/292
3ZS1 314-	3/298
3ZS1 630-	3/277
3ZS1 635-	6/149
3ZS2 71. -	3/317
3ZS2 781-	3/311
3ZS2 782-	3/312
3ZS2 791-	3/313

3ZX

3ZX1 012-	3/277, 6/77, 7/16
3ZX1012-	7/5, 7/22

6AG

6AG1 101-	2/180
6AG1 104-	2/169
6AG1 138-	2/623
6AG1 151-	2/619, 2/622, 2/626
6AG1 153-	2/629
6AG1 195-	3/265
6AG1 202-	2/228
6AG1 204-	2/202
6AG1 211-	2/423
6AG1 212-	2/202, 2/427
6AG1 214-	2/431
6AG1 277-	2/139
6AG1 308-	2/262
6AG1 315-	2/436, 2/444
6AG1 317-	2/439, 2/447
6AG1 342-	3/165
6AG1 343-	2/491, 2/499, 2/510
6AG1 416-	2/456
6AG1 443-	2/527, 2/538, 3/184
6AG1 500-	3/55
6AG1 503-	3/135
6AG1 647-	2/653
6AG1 720-	9/22
6AG1 741-	9/127
6AG1 800-	9/67, 9/87
6AG1 810-	9/117
6AG1 972-	3/55
6AG4 070-	2/471

6AG4 104-	2/670, 2/671, 2/673, 2/674
6AG4 112-	2/676, 2/677
6AG4 114-	2/680, 2/681
6AG6 003-	9/100, 9/101, 9/102, 9/103, 9/104, 9/105, 9/106, 9/107, 9/108, 9/109, 9/110

6AV

6AV2 1. -	2/654
6AV3 688-	2/650
6AV6 372-	3/310
6AV6 551-	2/659
6AV6 574-	2/716
6AV6 621-	2/660
6AV6 622-	2/660, 2/662
6AV6 642-	2/659, 2/662
6AV6 643-	2/659, 2/662
6AV6 644-	2/662
6AV6 645	8/97
6AV6 645-	2/655, 2/656, 8/69, 8/77, 8/126, 8/134, 8/181
6AV6 646-	2/716
6AV6 647-	2/651
6AV6 651-	2/651, 2/656, 8/181
6AV6 652-	2/477, 2/478, 2/659, 2/662
6AV6 653-	2/716
6AV6 671-	2/476, 2/650, 2/656, 2/657, 2/706, 2/709, 2/716, 8/69, 8/77, 8/97, 8/126, 8/134, 8/181
6AV6 691-	2/651, 2/657, 2/660, 2/662, 8/182
6AV7 671-	2/476, 2/706, 2/709, 2/712, 2/714
6AV7 672-	2/471, 2/473, 2/476, 2/671, 2/674, 2/678, 2/682, 2/691, 2/694, 2/697, 2/703, 2/709, 2/712, 2/714, 2/716
6AV7 860-	2/714, 2/715
6AV7 861-	2/714
6AV7 862-	2/715
6AV7 883-	2/475, 2/476, 2/705
6AV7 884-	2/475, 2/476, 2/705
6AV7 885-	2/708
6AV7 89. -	2/711, 2/712

6DL

6DL5 000-	9/40, 9/45
6DL5 001-	9/46
6DL5 002-	9/40, 9/46
6DL5 101-	9/40, 9/47

6ED

6ED1 057-	3/275
-----------------	-------

6EP

6EP1 331-	2/149, 2/157, 2/168, 2/179, 2/200, 2/210, 2/227, 2/233, 2/260, 2/280, 2/401, 2/755, 3/133, 3/151, 8/204, 9/21, 9/78, 9/86, 9/98, 9/116, 9/121
6EP1 332-	2/272, 2/364, 8/46
6EP1 333-	2/290
6EP1 931-	2/712
6EP1 933-	2/313, 2/327
6EP1 935-	2/712

6ES5

6ES5 710-	2/618, 2/620, 2/625
-----------------	---------------------

6ES7

6ES7 138-	2/621, 7/4
6ES7 141-	2/640
6ES7 142-	2/640
6ES7 144-	2/640
6ES7 145-	2/640
6ES7 147-	2/640
6ES7 148-	2/640, 2/641, 7/6
6ES7 151-	2/617, 2/620, 2/624
6ES7 153-	2/628, 3/265
6ES7 154-	2/630, 2/632, 2/634, 2/637, 8/183
6ES7 157-	3/85, 3/265
6ES7 158-	2/757, 3/260
6ES7 181-	3/71
6ES7 182-	3/340
6ES7 193-	2/618, 2/620, 2/621, 2/625, 2/757, 7/4, 7/5
6ES7 194-	2/630, 2/631, 2/632, 2/634, 2/636, 2/637, 2/639, 2/641, 2/718, 3/41, 3/320, 6/58, 6/105, 6/146, 8/78, 8/135, 8/183, 8/184, 10/10
6ES7 195-	2/628, 2/742, 2/743, 2/744, 3/141, 3/170, 3/265, 3/339, 3/340, 3/342
6ES7 211-	2/420
6ES7 212-	2/424, 2/425
6ES7 214-	2/428
6ES7 221-	2/420, 2/424, 2/428
6ES7 222-	2/420, 2/424, 2/428
6ES7 223-	2/420, 2/424, 2/428
6ES7 231-	2/420, 2/424, 2/428
6ES7 232-	2/420, 2/424, 2/428
6ES7 241-	2/420, 2/424, 2/428
6ES7 274-	2/420, 2/424, 2/428
6ES7 290-	2/425, 2/429
6ES7 291-	2/421, 2/425, 2/429
6ES7 292-	2/421, 2/425, 2/429
6ES7 298-	2/421, 2/425, 2/429
6ES7 305-	3/265
6ES7 307-	2/749, 3/265, 8/189
6ES7 314-	2/432
6ES7 315-	2/434, 2/442
6ES7 317-	2/437, 2/445
6ES7 318-	2/440, 2/448
6ES7 370-	3/164, 3/174
6ES7 390-	2/628, 2/749, 3/265
6ES7 391-	2/432, 2/434, 2/437, 2/440, 2/443, 2/446, 2/449
6ES7 392-	2/432, 2/433
6ES7 398-	2/432, 2/434, 2/437, 2/440, 2/442, 2/443, 2/445, 2/446, 2/448, 2/449, 2/450, 2/452, 2/454, 2/458, 2/460
6ES7 412-	2/450
6ES7 414-	2/452, 2/457
6ES7 416-	2/454, 2/459
6ES7 498-	2/450, 2/451, 2/452, 2/453, 2/454, 2/455, 2/457, 2/458, 2/459, 2/460
6ES7 647-	2/690, 2/693, 2/696, 2/741
6ES7 648-	2/471, 2/476, 2/671, 2/674, 2/678, 2/682, 2/691, 2/694, 2/697, 2/706, 2/709, 2/712
6ES7 658-	3/331, 3/332, 3/333, 3/334
6ES7 671-	2/461, 2/462, 2/477
6ES7 675-	2/470, 2/471
6ES7 677-	2/465, 2/466
6ES7 790-	2/471, 2/671, 2/674, 2/678, 2/682, 2/691, 2/694, 2/697
6ES7 792-	2/620, 2/624, 3/329
6ES7 806-	2/463

6ES7

6ES7 810-	2/485, 2/490, 2/497, 2/508, 2/516, 2/521, 2/526, 2/536, 2/749, 3/164, 3/170, 3/174, 3/178, 3/183, 3/327, 3/328, 3/329
6ES7 820-	2/508, 2/536, 2/733
6ES7 822-	2/421, 2/425, 2/429, 2/490, 2/497, 2/508, 2/516, 2/526, 2/536, 2/749, 3/156, 3/160, 3/164, 3/170, 3/183, 3/327, 9/16
6ES7 833-	2/442, 2/445, 2/448, 2/457, 2/459, 2/624, 2/637
6ES7 842-	9/159
6ES7 900-	2/391, 2/671, 2/674, 2/678, 2/682, 2/694, 2/697, 2/712
6ES7 901-	2/432, 2/434, 2/437, 2/440, 2/442, 2/445, 2/448, 2/450, 2/452, 2/454, 2/457, 2/459, 3/55, 3/71, 3/329, 9/159
6ES7 910-	2/434, 2/437, 2/440
6ES7 912-	2/432, 2/434, 2/437, 2/440, 2/442, 2/445, 2/448, 2/450, 2/452, 2/454, 2/457, 2/459
6ES7 952-	2/450, 2/452, 2/454, 2/457, 2/459
6ES7 953-	2/432, 2/434, 2/437, 2/440, 2/442, 2/445, 2/448, 2/450, 2/620, 2/624, 2/628, 2/634, 2/637, 8/184
6ES7 954-	6/120
6ES7 954 -	2/421, 2/425, 2/429
6ES7 964-	2/452, 2/454, 2/457, 2/459
6ES7 971-	9/86, 9/98
6ES7 972-	2/433, 2/434, 2/435, 2/437, 2/438, 2/440, 2/441, 2/443, 2/446, 2/449, 2/451, 2/453, 2/455, 2/458, 2/460, 3/36, 3/55, 3/68, 3/70, 3/71, 3/72, 3/156, 3/160, 3/164, 3/174, 3/178, 3/183, 3/329, 6/40, 6/42, 9/159
6ES7 998-	2/432, 2/434, 2/437, 2/440, 2/442, 2/445, 2/448, 2/451, 2/453, 2/455, 2/458, 2/460, 2/618, 2/628, 2/631, 3/71, 3/329, 8/184, 9/159

6FC

6FC5 211-	3/73
6FC5 235-	2/476, 2/706, 2/709

6FL

6FL4 343-	2/521
-----------------	-------

6GF

6GF1 120-	3/324
6GF1 130-	3/322
6GF3 400-	2/722
6GF3 420-	2/720
6GF3 420-	2/720
6GF3 440-	2/718, 2/720, 2/722, 2/723
6GF9 001-	2/722, 3/325
6GF9 002-	2/722, 2/723, 3/322, 3/323
6GF9 004-	2/723, 3/322

6GK1

6GK1 160-	2/461, 2/462, 2/471, 2/546
6GK1 161-	2/461, 2/462, 2/550, 2/553, 2/559, 2/572, 2/735, 9/51
6GK1 162-	2/404, 2/564, 2/569, 2/572, 9/51
6GK1 182-	2/742, 2/743
6GK1 184-	2/742, 2/743
6GK1 210-	6/139
6GK1 411-	2/748, 2/755, 6/49, 8/204
6GK1 415-	6/40, 6/42
6GK1 417-	8/189
6GK1 500-	2/433, 2/435, 2/438, 2/441, 2/443, 2/446, 2/449, 2/451, 2/453, 2/455, 2/458, 2/460, 2/749, 3/36, 3/55, 3/67, 3/151, 3/156, 3/160, 3/164, 3/174, 3/178, 3/183, 3/194, 3/200, 3/213, 3/220, 3/224, 3/228, 3/233, 8/189
6GK1 503-	3/133
6GK1 551-	2/735, 3/329, 3/336
6GK1 560-	2/461, 2/462, 2/465, 2/466, 2/471, 3/193
6GK1 561-	2/461, 2/462, 3/193, 3/199, 3/206, 3/212, 3/219, 3/224, 3/329, 9/36, 9/50
6GK1 562-	2/461, 2/462, 3/212, 3/219, 3/228, 9/36, 9/50
6GK1 571-	3/233
6GK1 588-	3/339
6GK1 704-	2/401, 2/404, 2/485, 2/490, 2/496, 2/507, 2/515, 2/525, 2/526, 2/534, 2/535, 2/553, 2/554, 2/575, 2/577, 3/224, 3/228, 3/233, 3/236, 3/329, 9/36, 9/50, 9/51
6GK1 706-	2/554, 2/575, 2/580, 2/582, 2/584, 3/241
6GK1 713-	3/193, 3/194, 3/199, 3/206, 3/207, 3/212, 3/213, 3/219, 3/220, 9/36, 9/51
6GK1 716-	2/559, 2/564, 2/569, 2/572, 9/51
6GK1 781-	2/741, 8/193
6GK1 782-	8/193
6GK1 900-	2/44, 2/106, 2/107, 2/129, 2/131, 2/168, 2/199, 2/200, 2/210, 2/227, 2/233, 2/280, 2/364, 2/401, 2/496, 2/610, 2/617, 2/748, 3/95, 3/96, 3/120, 3/141, 3/148, 6/40, 6/49, 8/23, 8/30, 8/37, 8/69, 8/77, 8/97, 8/109, 8/114, 8/126, 8/134, 8/189
6GK1 901-	2/37, 2/40, 2/44, 2/48, 2/58, 2/59, 2/64, 2/67, 2/78, 2/87, 2/93, 2/98, 2/123, 2/138, 2/143, 2/149, 2/168, 2/179, 2/199, 2/200, 2/210, 2/227, 2/233, 2/260, 2/280, 2/313, 2/342, 2/343, 2/363, 2/364, 2/388, 2/401, 2/411, 2/421, 2/425, 2/429, 2/433, 2/435, 2/438, 2/441, 2/443, 2/446, 2/449, 2/451, 2/453, 2/455, 2/458, 2/460, 2/489, 2/496, 2/507, 2/516, 2/521, 2/526, 2/535, 2/617, 2/618, 2/620, 2/625, 2/628, 2/631, 2/635, 2/638, 2/641, 2/718, 2/720, 2/724, 2/748, 2/755, 3/111, 3/140, 3/170, 6/40, 6/49, 8/23, 8/30, 8/37, 8/38, 8/49, 8/52, 8/57, 8/69, 8/78, 8/97, 8/102, 8/109, 8/114, 8/127, 8/134, 8/135, 8/160, 8/204, 9/66, 9/74, 9/86, 9/93, 9/98, 9/126, 9/138
6GK1 905-	2/72, 2/411, 2/630, 2/636, 2/639, 2/718, 2/749, 3/36, 3/41, 3/47, 3/63, 3/71, 3/79, 3/82, 3/117, 3/140, 3/145, 3/156, 3/160, 3/170, 3/194, 3/200, 3/207, 3/213, 3/320, 6/40, 6/42, 8/183, 8/189, 10/10, 10/12
6GK1 907-	2/44, 2/72, 2/200, 2/227, 2/612, 2/631, 2/641, 2/718, 3/47, 8/78, 8/135, 8/166
6GK1 908-	2/72, 2/200, 3/47
6GK1 953-	2/742, 2/743
6GK1 970-	10/12
6GK1 975-	2/59, 2/64, 2/72, 2/78, 2/87, 2/98, 2/106, 2/123, 2/129, 3/36, 3/47, 3/55, 3/67, 3/82, 3/95, 3/111, 3/118, 3/135, 3/141, 3/145

6GK5

6GK5 004-	2/157
6GK5 005-	2/149, 2/157, 2/485
6GK5 008-	2/157
6GK5 101-	2/179, 2/226
6GK5 104-	2/168
6GK5 106-	2/168
6GK5 108-	2/168, 2/723
6GK5 112-	2/168
6GK5 116-	2/168
6GK5 124-	2/168
6GK5 200-	2/226, 2/618
6GK5 201-	2/226, 2/618
6GK5 202-	2/226, 2/618
6GK5 204-	2/199, 2/210, 2/226, 2/233, 2/433, 2/435, 2/438, 2/441, 2/443, 2/446, 2/449, 2/451, 2/453, 2/455, 2/458, 2/460, 2/496, 2/526, 2/535, 2/546, 2/550, 2/620, 2/625
6GK5 206-	2/199, 2/210
6GK5 208-	2/199, 2/210, 2/630, 2/634, 2/638
6GK5 212-	2/199
6GK5 216-	2/199
6GK5 224-	2/199
6GK5 302-	2/312
6GK5 304-	2/259
6GK5 306-	2/259
6GK5 307-	2/259, 2/312
6GK5 308-	2/259, 2/279, 2/508, 2/515, 2/535
6GK5 310-	2/259
6GK5 320-	2/259
6GK5 324-	2/272, 2/290, 2/327
6GK5 408-	2/363
6GK5 414-	2/363
6GK5 490-	2/364
6GK5 491-	2/363
6GK5 492-	2/363
6GK5 495-	2/363
6GK5 498-	2/364
6GK5 528-	2/374
6GK5 552-	2/374
6GK5 597-	2/374
6GK5 598-	2/391
6GK5 602-	2/401, 2/404
6GK5 612-	2/401, 9/126, 9/138
6GK5 623-	2/401, 2/404, 9/126, 9/138
6GK5 711-	8/46
6GK5 744-	8/126, 8/134
6GK5 746-	8/126, 8/134
6GK5 747-	8/126, 8/134
6GK5 748-	8/109, 8/113
6GK5 784-	8/68, 8/182
6GK5 786-	8/37, 8/57, 8/96, 8/102, 8/182
6GK5 788-	8/23, 8/30, 8/49, 8/52, 8/77
6GK5 791-	2/200, 2/612, 8/37, 8/57, 8/78, 8/97, 8/102, 8/135, 8/166, 8/168, 8/182
6GK5 792-	2/632, 2/755, 8/152, 8/183, 8/204
6GK5 793-	2/632, 8/152, 8/183
6GK5 795-	2/755, 8/152, 8/163, 8/164, 8/183, 8/204
6GK5 798-	2/755, 8/23, 8/30, 8/37, 8/49, 8/52, 8/57, 8/69, 8/77, 8/97, 8/102, 8/109, 8/114, 8/126, 8/127, 8/134, 8/160, 8/164, 8/189, 8/204
6GK5 873-	9/138
6GK5 875-	2/405, 9/138
6GK5 905-	2/374
6GK5 907-	8/46
6GK5 99 -	2/342, 2/387

Order No. Index

6GK7

6GK7 242-	3/156, 9/11, 9/16
6GK7 243-	2/485, 3/160, 6/35
6GK7 277-	2/138, 2/421, 2/425, 2/429
6GK7 342-	3/164, 3/170
6GK7 343-	2/405, 2/489, 2/496, 2/507, 2/515, 3/174, 6/37, 9/138
6GK7 377-	2/143, 2/433, 2/435, 2/438, 2/441, 2/443, 2/446, 2/449, 2/489, 2/496, 2/508, 2/521, 2/628, 2/748
6GK7 443-	2/405, 2/525, 2/534, 3/178, 3/183, 9/138

6GT

6GT2 002-	2/717, 3/320
6GT2 080-	2/718, 3/320
6GT2 091-	2/717, 3/320
6GT2 691-	2/717, 3/320
6GT2 891-	2/717, 2/720, 2/724, 3/320

6NH

6NH7 700-	9/78, 9/116, 9/121
6NH7 701-	9/21, 9/66, 9/74, 9/78, 9/86, 9/93, 9/98, 9/116, 9/121, 9/149
6NH7 760-	9/116, 9/121
6NH7 800-	9/66, 9/74, 9/78, 9/86
6NH7 803-	9/93, 9/98
6NH7 810-	9/116, 9/121
6NH7 811-	9/116, 9/121
6NH7 997-	9/33, 9/36, 9/50, 9/66, 9/74, 9/78, 9/86, 9/93, 9/98
6NH9 701-	9/21, 9/148
6NH9 720-	9/11, 9/21
6NH9 741-	2/405, 9/126
6NH9 821-	9/116, 9/121, 9/142, 9/143
6NH9 831-	9/78, 9/150, 9/152
6NH9 860-	2/405, 9/11, 9/16, 9/21, 9/126, 9/138, 9/147
6NH9 870-	9/11, 9/16, 9/21, 9/126, 9/145
6NH9 910-	9/11, 9/16, 9/21

6SL

6SL3 040-	2/414, 2/418
6SL3 054-	2/414, 2/419
6SL3 066-	2/418
6SL3 072-	2/411, 2/418
6SL3 074-	2/414, 2/419
6SL3 254-	2/411, 6/120
6SL3 255-	6/120
6SL3 263-	6/120
6SL3 500-	2/411
6SL3 501-	6/120
6SL3 511-	6/119
6SL3 544-	2/410
6SL3 555-	6/105, 6/120
6SL3 563-	6/120

6XV

6XV1 440-	2/657
6XV1 801-	2/72, 2/82, 2/641, 3/47
6XV1 812-	2/72, 2/93, 2/612, 3/47, 8/166
6XV1 820-	2/122, 2/123, 3/110
6XV1 821-	3/117, 3/118, 3/140
6XV1 822-	2/411, 2/630, 2/635, 2/638, 2/718, 3/63, 3/320, 8/183
6XV1 830-	2/45, 2/72, 2/123, 2/433, 2/435, 2/438, 2/441, 2/443, 2/446, 2/449, 2/451, 2/453, 2/455, 2/458, 2/460, 2/630, 2/636, 2/639, 2/718, 2/732, 2/749, 3/35, 3/40, 3/47, 3/56, 3/57, 3/63, 3/71, 3/82, 3/88, 3/110, 3/145, 3/151, 3/156, 3/160, 3/194, 3/200, 3/207, 3/213, 3/271, 3/320, 6/40, 6/42, 8/183, 8/189, 10/9, 10/12
6XV1 831-	3/35
6XV1 840-	2/37, 2/44, 2/48, 2/58, 2/143, 2/149, 2/168, 2/179, 2/199, 2/210, 2/226, 2/233, 2/260, 2/279, 2/312, 2/342, 2/363, 2/388, 2/401, 2/433, 2/435, 2/438, 2/441, 2/443, 2/446, 2/449, 2/451, 2/453, 2/455, 2/458, 2/460, 2/489, 2/496, 2/507, 2/521, 2/526, 2/535, 2/617, 2/620, 2/625, 2/628, 2/631, 2/635, 2/638, 2/718, 2/732, 2/748, 2/755, 8/69, 8/78, 8/97, 8/127, 8/135, 8/204, 9/66, 9/74, 9/86, 9/93, 9/98
6XV1 843-	2/123, 2/199, 2/210, 2/260, 2/363, 3/110
6XV1 847-	2/106, 2/168, 2/199, 2/210, 2/260, 2/363, 3/95
6XV1 850-	2/78, 2/87, 2/98
6XV1 851-	2/98
6XV1 860-	3/35, 3/40, 10/9
6XV1 861-	2/45, 2/129, 2/226, 3/118, 3/141
6XV1 870-	2/37, 2/40, 2/44, 2/48, 2/58, 2/64, 2/67, 2/78, 2/82, 2/93, 2/138, 2/157, 2/200, 2/260, 2/279, 2/312, 2/343, 2/363, 2/388, 2/411, 2/421, 2/425, 2/429, 2/485, 2/507, 2/516, 2/535, 2/546, 2/550, 2/554, 2/559, 2/564, 2/569, 2/630, 2/631, 2/635, 2/636, 2/638, 2/639, 2/641, 2/718, 2/720, 2/724, 2/732, 3/323, 8/46, 8/69, 8/78, 8/97, 8/127, 8/134, 8/135, 8/183, 9/126, 9/138
6XV1 871-	2/37, 2/45, 2/48, 2/58, 2/82, 2/720, 2/724
6XV1 873-	2/121, 2/122, 2/157, 2/168, 2/199, 2/210, 2/226, 2/260, 2/363, 2/433, 2/435, 2/438, 2/441, 2/443, 2/446, 2/449, 2/451, 2/453, 2/455, 2/458, 2/460, 3/109, 3/110, 8/97
6XV1 874-	2/45, 2/129, 2/226
6XV1 875-	2/755, 8/160, 8/163, 8/183, 8/204
6XV1 878-	2/40, 2/48, 2/64, 2/312, 2/507, 2/516, 2/535, 8/23, 8/30, 8/38, 8/49, 8/52, 8/57, 8/102, 8/109, 8/114

7KM

7KM2 111-	3/304
7KM2 112-	3/304
7KM3 133-	3/303
7KM4 212-	3/305
7KM9 200-	3/307
7KM9 300-	3/307
7KM9 900-	3/303

7MF

7MF4 997-	8/196, 8/197, 8/198
-----------------	---------------------

7MP

7MP1110-	8/197
7MP1120-	8/196
7MP1 990-	8/196, 8/197
7MP3 112-	8/198
7MP3 990-	8/198

8US

8US12 11-	6/86
8US12 50-	6/86

8WD

8WD42 00-	6/131
8WD42 08-	6/131, 6/132, 6/134
8WD42 20-	6/131
8WD42 28-	6/131
8WD43 08-	6/132, 6/134
8WD43 28-	6/132, 6/134
8WD44 00-	6/133
8WD44 08-	6/132, 6/133, 6/134
8WD44 20-	6/133
8WD44 28-	6/132, 6/133, 6/134

9AE

9AE4 100-	2/735, 3/336
9AE4 121-	2/738
9AE4 130-	2/738

A5E

A5E01064980	2/682
-------------------	-------

Appendix

Catalog improvement suggestions

Fax form

To

Siemens AG
 I IA SE ITS PRI 1
 Mr. Fregien
 Gleiwitzer Str. 555
 90475 Nürnberg

Fax: +49 (911) 895-4837

E-mail: dirk.fregien@siemens.com

Your address

Name

Job

Company/Department

Street/No.

Postal code/City

Tel. No./Fax

E-mail address

Your opinion is important to us!

Our catalog should be an important and frequently used document. For this reason we are continuously endeavoring to improve it.

A small request on our part to you:
 Please take time to fill in the following form and fax it to us.
 Thank You!

We invite you to grade our catalog on a point system from 1 (= good) to 6 (= poor):

Do the contents of the catalog live up to your expectations?

Do the technical details meet your expectations?

Is the information easy to find?

How would you assess the graphics and tables?

Can the texts be readily understood?

Did you find any printing errors?

Conditions of sale and delivery Export regulations

Terms and Conditions of Sale and Delivery

By using this catalog you can acquire hardware and software products described therein from Siemens AG subject to the following terms. Please note! The scope, the quality and the conditions for supplies and services, including software products, by any Siemens entity having a registered office outside of Germany, shall be subject exclusively to the General Terms and Conditions of the respective Siemens entity. The following terms apply exclusively for orders placed with Siemens AG.

For customers with a seat or registered office in Germany

The "General Terms of Payment" as well as the "General Conditions for the Supply of Products and Services of the Electrical and Electronics Industry" shall apply.

For software products, the "General License Conditions for Software Products for Automation and Drives for Customers with a Seat or registered Office in Germany" shall apply.

For customers with a seat or registered office outside of Germany

The "General Terms of Payment" as well as the "General Conditions for Supplies of Siemens. Automation and Drives for Customers with a Seat or registered Office outside of Germany" shall apply.

For software products, the "General License Conditions for Software Products for Automation and Drives for Customers with a Seat or registered Office outside of Germany" shall apply.

General

The dimensions are in mm. In Germany, according to the German law on units in measuring technology, data in inches only apply to devices for export.

Illustrations are not binding.

Insofar as there are no remarks on the corresponding pages, - especially with regard to data, dimensions and weights given - these are subject to change without prior notice.

The prices are in € (Euro) ex works, exclusive packaging.

The sales tax (value added tax) is not included in the prices. It shall be debited separately at the respective rate according to the applicable legal regulations.

Prices are subject to change without prior notice. We will debit the prices valid at the time of delivery.

Surcharges will be added to the prices of products that contain silver, copper, aluminum, lead and/or gold if the respective basic official prices for these metals are exceeded. These surcharges will be determined based on the official price and the metal factor of the respective product.

The surcharge will be calculated on the basis of the official price on the day prior to receipt of the order or prior to the release order.

The metal factor determines the official price as of which the metal surcharges are charged and the calculation method used. The metal factor, provided it is relevant, is included with the price information of the respective products.

An exact explanation of the metal factor and the text of the Comprehensive Terms and Conditions of Sale and Delivery can be downloaded at:

www.siemens.com/automation/salesmaterial-as/catalog/en/terms_of_trade_en.pdf

Export regulations

Our obligation to fulfill this agreement is subject to the proviso that the fulfillment is not prevented by any impediments arising out of national and international foreign trade and customs requirements or any embargos and/or other sanctions.

If you transfer goods (hardware and/ or software and/ or technology as well as corresponding documentation, regardless of the mode of provision) delivered by us or works and services (including all kinds of technical support) performed by us to a third party worldwide, you shall comply with all applicable national and international (re-) export control regulations.

If required to conduct export control checks, you, upon request by us, shall promptly provide us with all information pertaining to particular end customer, destination and intended use of goods, works and services provided by us, as well as any export control restrictions existing.

The products listed in this catalog / price list may be subject to European / German and/or US export regulations.

Therefore, any export requiring a license is subject to approval by the competent authorities.

According to current provisions, the following export regulations must be observed with respect to the products featured in this catalog / price list:

AL	<p>Number of the <u>German Export List</u></p> <p>Products marked other than "N" require an export license.</p> <p>In the case of software products, the export designations of the relevant data medium must also be generally adhered to.</p> <p>Goods labeled with an "<u>AL" not equal to "N"</u> are subject to a European or German export authorization when being exported out of the EU.</p>
ECCN	<p><u>Export Control Classification Number</u></p> <p>Products marked other than "N" are subject to a reexport license to specific countries.</p> <p>In the case of software products, the export designations of the relevant data medium must also be generally adhered to.</p> <p>Goods labeled with an "<u>ECCN" not equal to "N"</u> are subject to a US re-export authorization.</p>

Even without a label or with an "AL: N" or "ECCN: N", authorization may be required due to the final destination and purpose for which the goods are to be used.

The deciding factors are the AL or ECCN export authorization indicated on order confirmations, delivery notes and invoices.

Errors excepted and subject to change without prior notice.

Industry Automation, Drive Technologies and Low-Voltage Power Distribution

Further information can be obtained from our branch offices listed in the appendix or at www.siemens.com/automation/partner

Interactive Catalog on DVD	<i>Catalog</i>		
for Industry Automation, Drive Technologies and Low Voltage Distribution	CA 01		
Drive Systems			
<u>Variable-Speed Drives</u>			
SINAMICS G110, SINAMICS G120	D 11.1		
Standard Inverters			
SINAMICS G110D, SINAMICS G120D			
Distributed Inverters			
SINAMICS G130 Drive Converter Chassis Units	D 11		
SINAMICS G150 Drive Converter Cabinet Units			
SINAMICS GM150, SINAMICS SM150	D 12		
Medium-Voltage Converters			
SINAMICS S120 Chassis Format Units and Cabinet Modules	D 21.3		
SINAMICS S150 Converter Cabinet Units			
SINAMICS DCM Converter Units	D 23.1		
<u>Three-phase Induction Motors</u>	D 84.1		
• H-compact			
• H-compact PLUS			
Asynchronous Motors Standardline	D 86.1		
Synchronous Motors with Permanent-Magnet Technology, HT-direct	D 86.2		
DC Motors	DA 12		
SIMOREG DC MASTER 6RA70 Digital Chassis Converters	DA 21.1		
SIMOREG K 6RA22 Analog Chassis Converters	DA 21.2		
<i>PDF: SIMOREG DC MASTER 6RM70 Digital Converter Cabinet Units</i>	DA 22		
SIMOVERT PM Modular Converter Systems	DA 45		
SIEMOSYN Motors	DA 48		
MICROMASTER 420/430/440 Inverters	DA 51.2		
MICROMASTER 411/COMBIMASTER 411	DA 51.3		
SIMOVERT MASTERDRIVES Vector Control	DA 65.10		
SIMOVERT MASTERDRIVES Motion Control	DA 65.11		
Synchronous and asynchronous servomotors for SIMOVERT MASTERDRIVES	DA 65.3		
SIMODRIVE 611 universal and POSMO	DA 65.4		
SIMOTION, SINAMICS S120 and Motors for Production Machines	PM 21		
SINAMICS S110	PM 22		
The Basic Positioning Drive			
<u>Low-Voltage Three-Phase-Motors</u>			
IEC Squirrel-Cage Motors	D 81.1		
MOTOX Geared Motors	D 87.1		
<u>Automation Systems for Machine Tools SIMODRIVE</u>	NC 60		
• Motors			
• Converter Systems SIMODRIVE 611/POSMO			
<u>Automation Systems for Machine Tools SINAMICS</u>	NC 61		
• Motors			
• Drive System SINAMICS S120			
<u>Mechanical Driving Machines</u>			
FLENDER Standard Couplings	MD 10.1		
FLENDER SIG Standard industrial gear unit	MD 30.1		
Low-Voltage Power Distribution and Electrical Installation Technology			
Protection, Switching, Measuring & Monitoring Devices	LV 10.1		
Switchboards and Distribution Systems	LV 10.2		
GAMMA Building Management Systems	ET G1		
<i>PDF: DELTA Switches and Socket Outlets</i>	ET D1		
SICUBE System Cubicles and Cubicle Air-Conditioning	LV 50		
SIVACON 8PS Busbar Trunking Systems	LV 70		
Motion Control	<i>Catalog</i>		
SINUMERIK & SIMODRIVE	NC 60		
Automation Systems for Machine Tools			
SINUMERIK & SINAMICS	NC 61		
Equipment for Machine Tools			
SINUMERIK 828D BASIC T/BASIC M, SINAMICS S120 Combi and 1FK7/1PH8 motors	NC 82		
SIMOTION, SINAMICS S120 and Motors for Production Machines	PM 21		
SINAMICS S110	PM 22		
The Basic Positioning Drive			
Drive and Control Components for Cranes	CR 1		
Power Supply and System Cabling			
Power supply SITOP	KT 10.1		
System cabling SIMATIC TOP connect	KT 10.2		
Process Instrumentation and Analytics			
Field Instruments for Process Automation	FI 01		
SIREC Recorders and Accessories	MP 20		
SIPART, Controllers and Software	MP 31		
Products for Weighing Technology	WT 10		
<i>PDF: Process Analytical Instruments</i>	PA 01		
<i>PDF: Process Analytics, Components for the System Integration</i>	PA 11		
Safety Integrated			
Safety Technology for Factory Automation	SI 10		
SIMATIC HMI/PC-based Automation			
Human Machine Interface Systems/PC-based Automation	ST 80/ ST PC		
SIMATIC Ident			
Industrial Identification Systems	ID 10		
SIMATIC Industrial Automation Systems			
Products for Totally Integrated Automation and Micro Automation	ST 70		
SIMATIC PCS 7 Process Control System	ST PCS 7		
Add-ons for the SIMATIC PCS 7 Process Control System	ST PCS 7.1		
<i>PDF: Migration solutions with the SIMATIC PCS 7 Process Control System</i>	ST PCS 7.2		
SIMATIC NET			
Industrial Communication	IK PI		
SINVERT Photovoltaics			
Inverters and Components for Photovoltaic Installations	RE 10		
SIRIUS Industrial Controls			
SIRIUS Industrial Controls	IC 10		
SIRIUS Industrial Controls (selected content from catalog IC 10)	IC 90		
System Solutions			
Applications and Products for Industry are part of the interactive catalog CA 01			

Siemens AG
Industry Sector
Postfach 48 48
90026 NÜRNBERG
GERMANY

Subject to change without prior notice
Order No. E86060-K6710-A101-B7-7600
P.8301.01.02 / Dispo 26001
KG 0911 10. KRO 1792 En / [IWI TSTS](#)
Printed in Germany
© Siemens AG 2011

www.siemens.com/automation

The information provided in this catalog contains descriptions of characteristics of performance which in case of actual use do not always apply as described or which may change as a result of further development of the products. An obligation to provide the respective characteristics shall only exist if expressly agreed in terms of contract. Availability and technical specifications are subject to change without notice.
All product designations may be trademarks or product names of Siemens AG or supplier companies whose use by third parties for their own purposes could violate the rights of the owners.