

HIKOKI

Hand Shear Model CE 16SA

Handling instructions

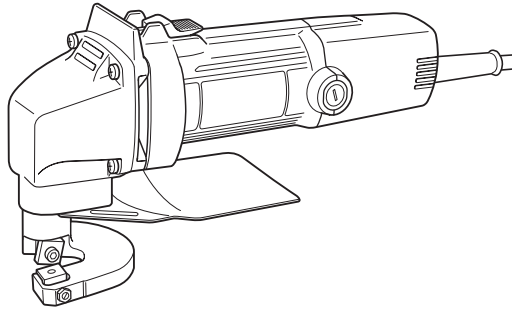

Note:

Before using this Electric Power Tool, carefully read through these **HANDLING INSTRUCTIONS** to ensure efficient, safe operation. It is recommended that these **INSTRUCTIONS** be kept readily available as an important reference when using this power tool.



EXPLANATION OF SYMBOL

 Class II tool

GENERAL POWER TOOL SAFETY WARNINGS

WARNING

Read all safety warnings and all instructions.

Failure to follow the warnings and instructions may result in electric shock, fire and/or serious injury.

Save all warnings and instructions for future reference. The term "power tool" in the warnings refers to your mains-operated (corded) power tool or battery-operated (cordless) power tool.

1) Work area safety

- a) **Keep work area clean and well lit.**
Cluttered or dark areas invite accidents.
- b) **Do not operate power tools in explosive atmospheres, such as in the presence of flammable liquids, gases or dust.**
Power tools create sparks which may ignite the dust or fumes.
- c) **Keep children and bystanders away while operating a power tool.**
Distractions can cause you to lose control.

2) Electrical safety

- a) **Power tool plugs must match the outlet. Never modify the plug in any way. Do not use any adapter plugs with earthed (grounded) power tools.**
Unmodified plugs and matching outlets will reduce risk of electric shock.
- b) **Avoid body contact with earthed or grounded surfaces, such as pipes, radiators, ranges and refrigerators.**
There is an increased risk of electric shock if your body is earthed or grounded.
- c) **Do not expose power tools to rain or wet conditions.**
Water entering a power tool will increase the risk of electric shock.
- d) **Do not abuse the cord. Never use the cord for carrying, pulling or unplugging the power tool. Keep cord away from heat, oil, sharp edges or moving parts.**
Damaged or entangled cords increase the risk of electric shock.
- e) **When operating a power tool outdoors, use an extension cord suitable for outdoor use.**
Use of a cord suitable for outdoor use reduces the risk of electric shock.
- f) **If operating a power tool in a damp location is unavoidable, use a residual current device (RCD) protected supply.**
Use of an RCD reduces the risk of electric shock.

3) Personal safety

- a) **Stay alert, watch what you are doing and use common sense when operating a power tool. Do not use a power tool while you are tired or under the influence of drugs, alcohol or medication.**
A moment of inattention while operating power tools may result in serious personal injury.
- b) **Use personal protective equipment. Always wear eye protection.**

Protective equipment such as dust mask, non-skid safety shoes, hard hat, or hearing protection used for appropriate conditions will reduce personal injuries.

- c) **Prevent unintentional starting. Ensure the switch is in the off-position before connecting to power source and/or battery pack, picking up or carrying the tool.**

Carrying power tools with your finger on the switch or energising power tools that have the switch on invites accidents.

- d) **Remove any adjusting key or wrench before turning the power tool on.**

A wrench or a key left attached to a rotating part of the power tool may result in personal injury.

- e) **Do not overreach. Keep proper footing and balance at all times.**

This enables better control of the power tool in unexpected situations.

- f) **Dress properly. Do not wear loose clothing or jewellery. Keep your hair, clothing and gloves away from moving parts.**

Loose clothes, jewellery or long hair can be caught in moving parts.

- g) **If devices are provided for the connection of dust extraction and collection facilities, ensure these are connected and properly used.**

Use of dust collection can reduce dust related hazards.

4) Power tool use and care

- a) **Do not force the power tool. Use the correct power tool for your application.**

The correct power tool will do the job better and safer at the rate for which it was designed.

- b) **Do not use the power tool if the switch does not turn it on and off.**

Any power tool that cannot be controlled with the switch is dangerous and must be repaired.

- c) **Disconnect the plug from the power source and/or the battery pack from the power tool before making any adjustments, changing accessories, or storing power tools.**

Such preventive safety measures reduce the risk of starting the power tool accidentally.

- d) **Store idle power tools out of the reach of children and do not allow persons unfamiliar with the power tool or these instructions to operate the power tool.**

Power tools are dangerous in the hands of untrained users.

- e) **Maintain power tools. Check for misalignment or binding of moving parts, breakage of parts and any other condition that may affect the power tools operation.**

If damaged, have the power tool repaired before use.

Many accidents are caused by poorly maintained power tools.

- f) **Keep cutting tools sharp and clean.**

Properly maintained cutting tools with sharp cutting edges are less likely to bind and are easier to control.

- g) **Use the power tool, accessories and tool bits etc. in accordance with these instructions, taking into account the working conditions and the work to be performed.**

Use of the power tool for operations different from those intended could result in a hazardous situation.

5) Service

- a) Have your power tool serviced by a qualified repair person using only identical replacement parts.
This will ensure that the safety of the power tool is maintained.

PRECAUTION

Keep children and infirm persons away.

When not in use, tools should be stored out of reach of children and infirm persons.

SPECIFICATIONS

Voltage (by areas)*		(110 V, 120 V, 127 V, 220 V, 230 V, 240 V) ~
Input		400 W*
Cutting capacity	Mild steel plate (400N/mm ²)	1.6 mm
	Stainless steel plate (600N/mm ²)	1.2 mm
	Aluminum plate (200N/mm ²)	2.3 mm
Number of strokes at no load		4700 min ⁻¹
Weight (without cord)		1.7 kg

*Be sure to check the nameplate on product as it is subject to change by areas.

STANDARD ACCESSORIES

- (1) Thickness gauge 1
 - (2) Hexagon bar wrench 1
- Standard accessories are subject to change without notice.

APPLICATIONS

- For shearing steel plate, brass plate, copper plate, aluminum plate, stainless steel plate, tin plate, and other metal plates, also leather and fiberboard.

PRIOR TO OPERATION

1. Power source

Ensure that the power source to be utilized conforms to the power requirements specified on the product nameplate.

2. Power switch

Ensure that the power switch is in the OFF position. If the plug is connected to a receptacle while the power switch is in the ON position, the power tool will start operating immediately, which could cause a serious accident.

3. Extension cord

When the work area is removed from the power source, use an extension cord of sufficient thickness and rated capacity. The extension cord should be kept as short as practicable.

4. Adjusting the horizontal gap between the shearing blades

Adjust the horizontal gap between the shearing blades (A in Fig. 1) at approximately 1/10 the steel plate thickness to be sheared, according to the following procedures. (Fig. 2)

- (1) Loosen the hexagonal socket bolts fastening the stationary blade. Loosen the M4 lock nut, and push back the M4 slotted set screws slightly.

PRECAUTIONS ON USING THE HAND SHEAR

1. Beware of sharp panel edges.
The edge of the plate just cut by the hand shear is very sharp. Take care in not getting hurt by the sharp edge.
2. Start cutting only after the blade attains the proper speed.
After turning on the power switch, wait until the blade attains the proper speed, then start cutting.
3. Preserve the power cord.
Be sure that the power cord is not abraded or cut by the sharp edge of the cut panel.

- (2) From the supplied thickness gauges, select one that is 1/10 the thickness of the panel to be cut. Thickness of each thickness gauge is marked thereon. Insert the gauge in between the blades, then tighten the hexagonal socket bolts very loosely. Next, use a screwdriver to turn the M4 slotted set screws to position the stationary blade until it hits the thickness gauge.
- (3) If the space between blades is larger than the thickness of the panel to be cut, there will be burrs for a less than clean cut.
If the space between blades is too narrow, cutting speed will be affected. For cutting in a curved line, making the space a little bigger will make the cutting easier.
- (4) After adjustment, tighten the M4 nuts securely so they will not loosen during operation.
- (5) Securely tighten the hexagonal socket bolts fastening the stationary blade.

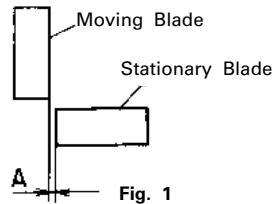

Fig. 1

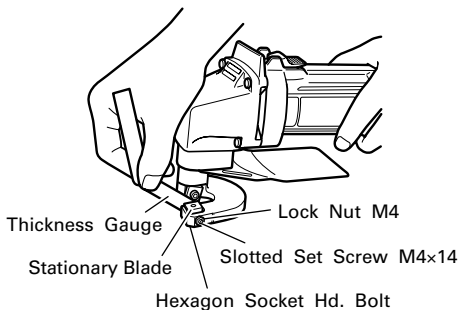

Fig. 2

5. RCD

The use of a residual current device with a rated residual current of 30mA or less at all times is recommended.

CUTTING

CAUTION

- Do not attempt to cut panels of thicknesses that are beyond the capability of the hand shear. Doing so will result in premature breakage of the hand shear.
- Perform the cutting operation only after the panel is fixed securely.

When cutting thin panels, level the unit horizontally, as shown in Fig. 3.

To facilitate smooth cutting of thick panels, if the cut-off side goes toward the left, (Fig. 3) raise the rear of the unit slightly. And if the cut-off side goes toward the right, lower the rear of the unit slightly.

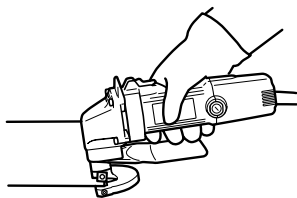

Fig. 3

BLADE REPLACEMENT

The hand shear uses disposable blades. Each blade has 8 cutting edges, as shown in Fig. 4. After a cutting edge cuts 400 meters of panel, cutting performance will fall. Then use another cutting edge. After all 8 cutting edges are used and worn, replace the blade.

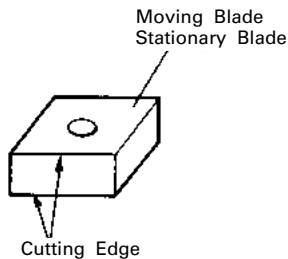

Fig. 4

MAINTENANCE AND INSPECTION

1. Inspecting the blade

Using a worn or chipped blade will put an excessive burden on the motor and affect work performance. Therefore, always use a well-cutting blade.

2. Inspecting the mounting screws

Regularly inspect all mounting screws and ensure that they are properly tightened. Should any of the screws be loose, retighten them immediately. Failure to do so could result in serious hazard.

3. Maintenance of the motor

The motor unit winding is the very "heart" of the power tool. Exercise due care to ensure the winding does not become damaged and/or wet with oil or water.

4. Inspecting the carbon brushes (Fig. 5)

The motor employs carbon brushes which are consumable parts. Since an excessively worn carbon brush can result in motor trouble, replace the carbon brush with a new one having the same carbon brush No. shown in the figure when it becomes worn to or near the "wear limit". In addition, always keep carbon brushes clean and ensure that they slide freely within the brush holders.

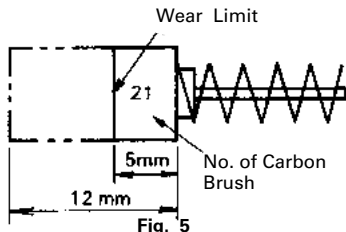

Fig. 5

5. Replacing carbon brushes

Disassemble the brush cap with a screwdriver. The carbon brush can then be easily removed.

6. Service parts list

- A: Item No.
- B: Code No.
- C: No. Used
- D: Remarks

CAUTION

Repair, modification and inspection of HiKOKI Power Tools must be carried out by a HiKOKI Authorized Service Center.

This Parts List will be helpful if presented with the tool to the HiKOKI Authorized Service Center when requesting repair or other maintenance.

In the operation and maintenance of power tools, the safety regulations and standards prescribed in each country must be observed.

MODIFICATIONS

HiKOKI Power Tools are constantly being improved and modified to incorporate the latest technological advancements.

Accordingly, some parts (i.e. code numbers and/or design) may be changed without prior notice.

NOTE

Due to HiKOKI's continuing program of research and development, the specifications herein are subject to change without prior notice.

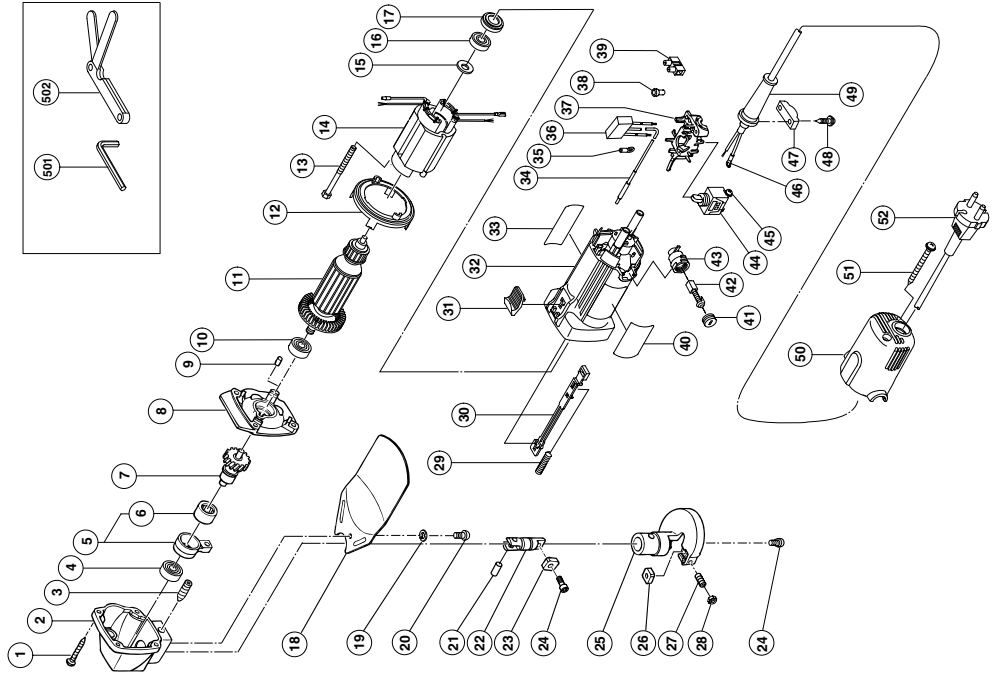

A	B	C	D	A	B	C	D
1	957-580	4	D5x30	41	936-551	2	
2	998-003	1		42	999-021	2	
3	998-008	1	M8x20	43	313-777	2	
4	608-VVM	1	608VVC2PS2L	44	314-603	1	M3.5x6
5	998-004	1	"6"	45	305-499	2	
6	993-163	1	M152112	46	980-063	1	
7	998-006	1		47	937-631	1	
8	998-002	1		48	984-750	2	D4x16
9	931-701	1		49	953-327	1	D8.8
10	608-VVM	1	608VVC2PS2L	49.2	938-051	1	D10.1
11	360-622C	1	110V	50	314-433	1	
11.1	360-622U	1	120V-127V "10, 15, 16"	51	301-815	2	D4x45
11.2	360-622U	1	220V-230V	52	---	1	
11.3	360-622E	1	240V	501	943-277	1	3MM
11.4	360-622F	1		502	949-128	1	
12	306-840	1					
13	982-021	2	D4x70				
14.1	340-567C	1	110V				
14.2	340-567D	1	120V-127V				
14.3	340-567E	1	220V-230V				
14.4	340-567F	1	240V				
15	942-204	1					
16	626-VVM	1	626VVC2PS2L				
17	309-929	1					
18	998-010	1					
19	949-454	1	M5				
20	949-237	1	M5x15				
21	993-546	1	D6				
22	998-005	1					
23	998-000	1					
24	949-812	2	M4x10				
25	998-007	1					
26	998-001	1					
27	998-009	1	M4x14				
28	949-565	1	M4				
29	314-429	1					
30	314-427	1					
31	314-428	1	"17"				
32	314-438	1					
33	---	1					
34	314-854	1					
35	311-741	1					
36	994-273	1					
37	314-432	1					
38	959-140	1					
39	938-307	1					
40	---	1					



Koki Holdings Co., Ltd.

Shinagawa Intercity Tower A, 15-1, Konan 2-chome,
Minato-ku, Tokyo, Japan

806

Code No. C99126712 N
Printed in Japan