



OMEN by HP 15 Laptop PC

Maintenance and Service Guide

© Copyright 2018 HP Development Company, L.P.

Bluetooth is a trademark owned by its proprietor and used by HP Inc. under license. DTS, the Symbol, & DTS and the Symbol together are registered trademarks, and DTS Sound is a trademark of DTS, Inc. © DTS, Inc. All Rights Reserved. Intel and Celeron are trademarks of Intel Corporation in the U.S. and other countries. SD Logo is a trademark of its proprietor.

The information contained herein is subject to change without notice. The only warranties for HP products and services are set forth in the express warranty statements accompanying such products and services. Nothing herein should be construed as constituting an additional warranty. HP shall not be liable for technical or editorial errors or omissions contained herein.

First Edition: May 2018

Document Part Number: L31592-001

Product notice

This guide describes features that are common to most models. Some features may not be available on your computer.

Not all features are available in all editions of Windows 10. This computer may require upgraded and/or separately purchased hardware, drivers, and/or software to take full advantage of Windows 10 functionality. See <http://www.microsoft.com> for details.

Important Notice about Customer Self-Repair Parts

 **CAUTION:** Your computer includes Customer Self-Repair parts and parts that should only be accessed by an authorized service provider. See Chapter 5, "Removal and replacement procedures for Customer Self-Repair parts," for details. Accessing parts described in Chapter 6, "Removal and replacement procedures for Authorized Service Provider only parts," can damage the computer or void your warranty.

Safety warning notice

 **WARNING!** To reduce the possibility of heat-related injuries or of overheating the device, do not place the device directly on your lap or obstruct the device air vents. Use the device only on a hard, flat surface. Do not allow another hard surface, such as an adjoining optional printer, or a soft surface, such as pillows or rugs or clothing, to block airflow. Also, do not allow the AC adapter to contact the skin or a soft surface, such as pillows or rugs or clothing, during operation. The device and the AC adapter comply with the user-accessible surface temperature limits defined by the International Standard for Safety of Information Technology Equipment (IEC 60950-1).

Table of contents

| | |
|--|-----------|
| 1 Product description | 1 |
| 2 External component identification | 11 |
| Right side | 11 |
| Left side | 12 |
| Rear | 13 |
| Display | 15 |
| Keyboard area | 16 |
| TouchPad | 16 |
| Lights | 17 |
| Button | 18 |
| Special keys | 19 |
| Action keys | 20 |
| Bottom | 21 |
| Labels | 21 |
| 3 Illustrated parts catalog | 23 |
| Computer major components | 24 |
| Display assembly subcomponents | 27 |
| Miscellaneous parts | 28 |
| 4 Removal and replacement preliminary requirements | 30 |
| Tools required | 30 |
| Service considerations | 30 |
| Plastic parts | 30 |
| Cables and connectors | 30 |
| Drive handling | 31 |
| Grounding guidelines | 32 |
| Electrostatic discharge damage | 32 |
| Packaging and transporting guidelines | 33 |
| Workstation guidelines | 33 |
| 5 Removal and replacement procedures for Customer Self-Repair parts | 35 |
| Component replacement procedures | 35 |
| Base enclosure | 35 |
| Hard drive (HDD) | 38 |

| | |
|---|-----------|
| Solid-state drive (SSD) | 40 |
| Memory modules | 41 |
| WLAN module | 43 |
| 6 Removal and replacement procedures for Authorized Service Provider parts | 45 |
| Component replacement procedures | 45 |
| Battery | 46 |
| Speakers | 47 |
| Smart card board | 48 |
| Fans | 49 |
| Power connector cable | 52 |
| Audio board | 53 |
| USB board | 54 |
| System board | 55 |
| Heat sink | 58 |
| TouchPad board | 60 |
| Power button board | 62 |
| Display assembly | 64 |
| Keyboard/top cover | 71 |
| 7 Using Setup Utility (BIOS) | 72 |
| Starting Setup Utility (BIOS) | 72 |
| Updating Setup Utility (BIOS) | 72 |
| Determining the BIOS version | 72 |
| Downloading a BIOS update | 73 |
| 8 Using HP PC Hardware Diagnostics | 74 |
| Using HP PC Hardware Diagnostics Windows (select products only) | 74 |
| Downloading HP PC Hardware Diagnostics Windows | 74 |
| Downloading the latest HP PC Hardware Diagnostics Windows version | 75 |
| Downloading HP Hardware Diagnostics Windows by product name or number (select products only) | 75 |
| Installing HP PC Hardware Diagnostics Windows | 75 |
| Using HP PC Hardware Diagnostics UEFI | 75 |
| Starting HP PC Hardware Diagnostics UEFI | 76 |
| Downloading HP PC Hardware Diagnostics UEFI to a USB flash drive | 76 |
| Downloading the latest HP PC Hardware Diagnostics UEFI version | 76 |
| Downloading HP PC Hardware Diagnostics UEFI by product name or number (select products only) | 76 |
| Using Remote HP PC Hardware Diagnostics UEFI settings (select products only) | 77 |
| Downloading Remote HP PC Hardware Diagnostics UEFI | 77 |

| | |
|---|-----------|
| Downloading the latest Remote HP PC Hardware Diagnostics UEFI version | 77 |
| Downloading Remote HP PC Hardware Diagnostics UEFI by product name or number | 77 |
| Customizing Remote HP PC Hardware Diagnostics UEFI settings | 77 |
| 9 Specifications | 79 |
| 10 Backing up, restoring, and recovering | 80 |
| Using Windows tools | 80 |
| Creating HP Recovery media (select products only) | 80 |
| Using HP Recovery Manager to create recovery media | 81 |
| Before you begin | 81 |
| Creating the recovery media | 81 |
| Using the HP Cloud Recovery Download Tool to create recovery media | 82 |
| Restoring and recovery | 82 |
| Restoring, resetting, and refreshing using Windows tools | 82 |
| Restoring using HP Recovery Manager and the HP Recovery partition | 82 |
| Recovering using HP Recovery Manager | 82 |
| Recovering using the HP Recovery partition (select products only) | 83 |
| Recovering using HP Recovery media | 83 |
| Changing the computer boot order | 84 |
| Removing the HP Recovery partition (select products only) | 84 |
| 11 Power cord set requirements | 85 |
| Requirements for all countries | 85 |
| Requirements for specific countries and regions | 86 |
| 12 Recycling | 88 |
| Index | 89 |

1 Product description

| Category | Details | OMEN by HP– Discrete N17E-G2 Graphics with NVIDIA N17E-G2 (GeForce GTX 1070) | OMEN by HP– Discrete N17E-G1 Graphics with NVIDIA N17E-G2 (GeForce GTX 1060) | OMEN by HP– Discrete N17P-G1 Graphics with NVIDIA N17P-G1 (GeForce GTX 1050 Ti) | OMEN by HP– Discrete N17P-G0 Graphics with NVIDIA N17P-G0 (GeForce GTX 1050) |
|---------------------|---|---|---|--|---|
| Product Name | OMEN by HP 15 Laptop PC Model Number (Service Tag Down): 15-dc0000~15-dc0999 CTO Model: 15t-dc000 | √ | √ | √ | √ |
| Processor | Intel® 8th generation Intel Core® i7 Processors Intel Core i7-8750H (2.2 GHz, turbo up to 4.1 GHz), 2666 MHz/9 MB L3, Hexa core, TDP 45 W | √ | √ | √ | √ |
| | Intel 8th generation Intel Core i5 Processors Intel Core i5-8300H (2.3G Hz, turbo up to 4.0 GHz), 2666 MHz/8 MB L3, Quad core, TDP 45 W | | √ | √ | √ |
| Chipset | Intel HM370 | √ | √ | √ | √ |
| Graphics | Supports HD decode, DX11, and HDMI | √ | √ | √ | √ |
| | Supports Optimus | | | √ | √ |
| | Supports FPS (GPU Performance Scaling) | √ | √ | √ | √ |
| | Supports G-Sync (Internal and External) | √ | √ | | |
| | Limited to N17E GPU | | | | |
| | Supports Virtual Reality (VR) | √ | √ | | |
| | Oculus VR rule: >= 8 GB memory + >= 512 GB storage + Win OS + GTX 1070/GTX 1060 only | | | | |
| | Mixed Reality ready | √ | √ | √ | √ |
| | Minimum hardware configuration rules for enabling MR ready: CPU: Hybrid GPU: Core-i5 or greater Discrete GPU: | | | | |

| Category | Details | OMEN by HP– Discrete N17E-G2 Graphics with NVIDIA N17E-G2 (GeForce GTX 1070) | OMEN by HP– Discrete N17E-G1 Graphics with NVIDIA N17E-G2 (GeForce GTX 1060) | OMEN by HP– Discrete N17P-G1 Graphics with NVIDIA N17P-G1 (GeForce GTX 1050 Ti) | OMEN by HP– Discrete N17P-G0 Graphics with NVIDIA N17P-G0 (GeForce GTX 1050) |
|----------|---|---|---|--|---|
| | <p>Core-i5 or greater Graphics: Discrete: Nvidia GTX 1050 or greater Display: HDMI 1.4/Display Port 1.2 or greater Memory: 8GB DDR4 or greater Storage: >10GB additional free space Windows Display Driver Model (WDDM) 2.2 required for supporting MR ready</p> | | | | |
| | Internal Graphics: | | | | |
| | Intel UHD Graphics 630 | | | √ | √ |
| | Discrete Graphics: | | | | |
| | <p>NVIDIA N17E-G2 (GeForce GTX 1070) Max-Q with up to 8192 MB of dedicated video memory (256 Mx32 GDDR5 8 Gbps x 8 PCs, 1.5 V/8 Gbps)</p> <p>Support G-Sync only. Limited to FHD 144 Hz/UHD 60 Hz panel/ Core-i7 CPU.</p> | √ | | | |
| | <p>NVIDIA N17E-G1 (GeForce GTX 1060) with up to 6144 MB of dedicated video memory (256 Mx32 GDDR5 8 Gbps x 6 PCs, 1.5 V/8 Gbps)</p> <p>Support G-Sync only Limited to FHD 144 Hz/UHD 60 Hz panel/ Core-i7 CPU.</p> | | √ | | |
| | <p>NVIDIA N17E-G1 (GeForce GTX 1060) with up to 3072 MB of dedicated video memory (128 Mx32 GDDR5 8 Gbps x 6 PCs, 1.5 V/8 Gbps)</p> <p>Support Non-G-Sync only, limited to FHD 60Hz panel , Bridge Hynix A die/ Micron B die 256 Mx32 1.5(5) V 8 Gbps / 1.35 V 7 Gbps onto GDDR5 256 Mx32 1.5 V 7 Gbps.</p> | | | √ | |
| | Hybrid Graphics: | | | | |

| Category | Details | OMEN by HP– Discrete N17E-G2 Graphics with NVIDIA N17E-G2 (GeForce GTX 1070) | OMEN by HP– Discrete N17E-G1 Graphics with NVIDIA N17E-G2 (GeForce GTX 1060) | OMEN by HP– Discrete N17P-G1 Graphics with NVIDIA N17P-G1 (GeForce GTX 1050 Ti) | OMEN by HP– Discrete N17P-G0 Graphics with NVIDIA N17P-G0 (GeForce GTX 1050) |
|--------------|--|---|---|--|---|
| | NVIDIA N17P-G1 (GeForce GTX 1050 Ti) with up to 4096 MB of dedicated video memory (256 Mx32 GDDR5 7 Gbps x 4 PCs, 1.5 V/7 Gbps) Support Non-G-Sync only | | | √ | |
| | NVIDIA N17P-G0 (GeForce GTX 1050) with up to 4096 MB of dedicated video memory (256 Mx32 GDDR5 7 Gbps x 4 PCs, 1.5 V/7 Gbps) Support Non-G-Sync only | | | | √ |
| | NVIDIA N17P-G0 (GeForce GTX 1050) with up to 2048 MB of dedicated video memory (128 Mx32 GDDR5 7 Gbps x 4 PCs, 1.5 V/7 Gbps) Support Non-G-Sync only | | | | √ |
| Panel | FHD WLED AntiGlare (1920x1080) slim-flat (3.2mm) UWVA, 45% CG, 60Hz, eDP, narrow bezel , typical brightness: 220 nits | | √ | √ | √ |
| 15.6 in | FHD WLED AntiGlare (1920x1080) uslim-flat (2.6mm) UWVA, 72% CG, 144Hz, eDP+PSR, G-Sync supportable, narrow bezel , typical brightness: 300 nits | √ | √ | √ | √ |
| | 15.6" UHD WLED AntiGlare (3840x2160) uslim-flat (2.6mm) UWVA, 72% CG, 60Hz, eDP+PSR, G-Sync supportable, narrow bezel , typical brightness: 340 nits | √ | √ | √ | √ |
| | 15.6" FHD (1920x1080) Anti-Glare WLED UWVA 45 220 eDP ultraslim 60Hz PRC/KOR, narrow bezel | | √ | √ | √ |
| | 15.6" UHD (3840x2160) Anti-Glare WLED UWVA 72 340 eDP 1.3+PSR ultraslim 60Hz PRC/KOR, narrow bezel | √ | √ | √ | √ |

| Category | Details | OMEN by HP– Discrete N17E-G2 Graphics with NVIDIA N17E-G2 (GeForce GTX 1070) | OMEN by HP– Discrete N17E-G1 Graphics with NVIDIA N17E-G2 (GeForce GTX 1060) | OMEN by HP– Discrete N17P-G1 Graphics with NVIDIA N17P-G1 (GeForce GTX 1050 Ti) | OMEN by HP– Discrete N17P-G0 Graphics with NVIDIA N17P-G0 (GeForce GTX 1050) |
|---|---|---|---|--|---|
| | Microsoft HDR Streaming Capable | | | ✓ | ✓ |
| | Brightness: >= 300nits / Color depth: 8 bits / iGPU 10-bit HW Decode | | | | |
| Memory | 4096MB (4096MB x 1) | ✓ | ✓ | ✓ | ✓ |
| Supports up to 16.0 GB maximum system memory | 8192 MB (8192 MB x 1) | ✓ | ✓ | ✓ | ✓ |
| Two SODIMM slots - customer accessible/ upgradeable | 12288 MB (8192 MB x1 + 4096 MB x1) | ✓ | ✓ | ✓ | ✓ |
| | 16384 MB (16384 MB x 1 or 8192 MB x 2) | ✓ | ✓ | ✓ | ✓ |
| DDR4-2666 Dual Channel Support | 32768 MB (16384 MB x 2) | ✓ | ✓ | ✓ | ✓ |
| Hard Drives | Support all 7 mm/7.2 mm/9.5 mm, SATA 2.5" HDDs - customer accessible/upgradeable (share the same bracket) | ✓ | ✓ | ✓ | ✓ |
| | Support M.2 PCIe/SATA SSD - customer accessible/upgradeable | | | | |
| | Support SSD+HDD - customer accessible/ upgradeable | | | | |
| | Accelerometer / HDD protection support | | | | |
| | Single HDD configurations: | ✓ | ✓ | ✓ | ✓ |
| | 1 TB (7200) 9.5 mm/7.2 mm | | | | |
| | PCIe NVMe TLC M.2 SSD: | ✓ | ✓ | ✓ | ✓ |
| | 256 GB | | | | |
| | 512 GB | | | | |
| | Dual Storage Configurations: | | | | |
| | 128 GB PCIe NVMe TLC M.2 SSD + 1 TB (7200) 9.5 mm/7.2 mm HDD | ✓ | ✓ | ✓ | ✓ |
| | 256 GB PCIe NVMe TLC M.2 SSD + 1 TB (7200) 9.5 mm/7.2 mm HDD | ✓ | ✓ | ✓ | ✓ |

| Category | Details | OMEN by HP– Discrete N17E-G2 Graphics with NVIDIA N17E-G2 (GeForce GTX 1070) | OMEN by HP– Discrete N17E-G1 Graphics with NVIDIA N17E-G2 (GeForce GTX 1060) | OMEN by HP– Discrete N17P-G1 Graphics with NVIDIA N17P-G1 (GeForce GTX 1050 Ti) | OMEN by HP– Discrete N17P-G0 Graphics with NVIDIA N17P-G0 (GeForce GTX 1050) |
|------------------------|---|---|---|--|---|
| | 512 GB PCIe NVMe TLC M. 2 SSD + 1 TB (7200) 9.5 mm/7.2 mm HDD | √ | √ | √ | √ |
| | 256 GB PCIe NVMe TLC M. 2 SSD + 2 TB (5400) 9.5 mm/7.2 mm HDD | √ | √ | √ | √ |
| | Intel Optane (3D Xpoint) Solution PCIe Gen3x2 M. 2 SSD: 16 GB (Optane MEM) + 1 TB (7200) 9.5 mm/7.2 mm HDD | √ | √ | √ | √ |
| Audio and video | HP Wide Vision HD Camera - indicator LED, USB 2.0, HD BSI sensor, f2.0, WDR, 88° WFOV Dual array digital microphone with appropriate beam- forming, echo- cancellation, noise- suppression software 720p by 30 frames per second | √ | √ | √ | √ |
| | BANG & OLUFSEN audio with OMEN Audio Control Panel Support HP Audio Boost 2.0 (with discrete amplifier) Support Headphone X Dual speakers | √ | √ | √ | √ |
| Ethernet | Integrated 10/100/1000 NIC | √ | √ | √ | √ |
| Wireless | Integrated Wireless options with dual antennas (M.2/PCIe): Realtek RTL8822BE 802.11 ac 2x2 WiFi + BT 4.2 Combo Adapter (MU- MIMO supported) | √ | √ | √ | √ |
| | Integrated Wireless options with dual antennas (M.2/MIPI/ BRI): | √ | √ | √ | √ |

| Category | Details | OMEN by HP– Discrete N17E-G2 Graphics with NVIDIA N17E-G2 (GeForce GTX 1070) | OMEN by HP– Discrete N17E-G1 Graphics with NVIDIA N17E-G2 (GeForce GTX 1060) | OMEN by HP– Discrete N17P-G1 Graphics with NVIDIA N17P-G1 (GeForce GTX 1050 Ti) | OMEN by HP– Discrete N17P-G0 Graphics with NVIDIA N17P-G0 (GeForce GTX 1050) |
|--------------------------------|--|---|---|--|---|
| | Intel Dual Band Wireless-AC 9560 802.11 AC 2x2 WiFi + BT5 Combo Adapter (non-vPro) (MU-MIMO supported) | | | | |
| | Compatible with Miracast-certified devices | ✓ | ✓ | ✓ | ✓ |
| Internal card expansion | One M.2 slot for WLAN | ✓ | ✓ | ✓ | ✓ |
| | One M.2 slot for SSD | | | | |
| Ports | Hot Plug / Unplug and auto detect for correct output to wide-aspect vs. standard aspect video | ✓ | ✓ | ✓ | ✓ |
| | HP Smart Plug AC adapter (4.0 mm barrel) | | | | |
| | Headphone/microphone combo jack | | | | |
| | Microphone-in | | | | |
| | High-definition multimedia interface (HDMI) v2.0 supporting: up to 4096x2160 @ 60 Hz with HDCP 2.2 | | | | |
| | Mini Display Port | | | | |
| | RJ-45 / Ethernet | | | | |
| | AC Smart Pin adapter plug | | | | |
| | USB 3.0 ports | ✓ | ✓ | ✓ | ✓ |
| | 3 (1 on the left side ; 1 on the right side; 1 on the rear side) | | | | |
| | Support HP Sleep & Charge (rear port only) | | | | |
| | USB Type-C ports | ✓ | ✓ | ✓ | ✓ |
| | 1x USB 3.1 Gen 2 with Thunderbolt™ Gen 3 technology (on the rear side) | | | ✓ | ✓ |
| | 1x USB 3.1 Gen 1 (on the rear side) | ✓ | ✓ | | |
| | Support data transfer | ✓ | ✓ | ✓ | ✓ |
| | Support Display Port 1.2 out up to 4096x2304 (60Hz) | | | | |

| Category | Details | OMEN by HP– Discrete N17E-G2 Graphics with NVIDIA N17E-G2 (GeForce GTX 1070) | OMEN by HP– Discrete N17E-G1 Graphics with NVIDIA N17E-G2 (GeForce GTX 1060) | OMEN by HP– Discrete N17P-G1 Graphics with NVIDIA N17P-G1 (GeForce GTX 1050 Ti) | OMEN by HP– Discrete N17P-G0 Graphics with NVIDIA N17P-G0 (GeForce GTX 1050) |
|----------------------------------|---|---|---|--|---|
| | Support HP Sleep & Charge | | | | |
| | Support Display Port 1.2 out up to 4096x2304 (60Hz) | √ | √ | √ | √ |
| | Support HP Sleep & Charge | √ | √ | √ | √ |
| | Intel Thunderbolt 3 SP design | √ | √ | | |
| External media cards | HP 2-in-1 multifunction Digital Media Reader Slot with push-push technology. Reads data from and writes data to digital memory cards such as micro SD/SDHC/SDXC. | √ | √ | √ | √ |
| Keyboard/pointing devices | <p>Full-size backlit 3-coat paint island-style keyboard with numeric key pad, 2-zone lighting, Dragon Red with red backlight</p> <p>Full-size backlit 3-coat paint island-style keyboard with numeric key pad, 4-zone lighting, white with RGB backlight</p> <p>Special highlight for WASD keys, support 26-key NKRO Anti-Ghosting keys</p> <p>TouchPad requirements:</p> <p>TouchPad with image sensor</p> <p>Multitouch gestures enabled (2-finger scroll, pinch, rotate, 2-finger click, 3-finger flick)</p> <p>Support for modern trackpad gestures</p> <p>Taps enabled as default</p> | √ | √ | √ | √ |
| Power requirements | 4 cell polymer battery - 70 Whr (4550 mAh) | √ | √ | √ | √ |
| | 3 cell polymer battery - 52.5 Whr (4550 mAh) | | | √ | √ |

| Category | Details | OMEN by HP– Discrete N17E-G2 Graphics with NVIDIA N17E-G2 (GeForce GTX 1070) | OMEN by HP– Discrete N17E-G1 Graphics with NVIDIA N17E-G2 (GeForce GTX 1060) | OMEN by HP– Discrete N17P-G1 Graphics with NVIDIA N17P-G1 (GeForce GTX 1050 Ti) | OMEN by HP– Discrete N17P-G0 Graphics with NVIDIA N17P-G0 (GeForce GTX 1050) |
|-------------------------|---|---|---|--|---|
| | Support battery fast charge | √ | √ | √ | √ |
| | Barrel type AC adapters: | | | | |
| | 135 W AC adapter with power cords | | | | √ |
| | 150 W AC adapter with power cords | | | √ | |
| | 200 W AC adapter with power cords | √ | √ | | |
| | Duckhead with power cord: | | | | |
| | 1 M premium power cord with sticker label (C5) - Black For adapter <= 90 W, and worldwide except Japan | | | √ | √ |
| | 1 M premium power cord with sticker label (C13) - Black For adapter >= 200 W | √ | √ | | |
| Security | Trusted platform module (TPM) 2.0 | √ | √ | √ | √ |
| | Mini security cable lock | | | | |
| Operating system | Preinstalled: | √ | √ | √ | √ |
| | Windows 10 | | | | |
| | Windows 10 Pro | √ | √ | √ | √ |
| | For developed market (ML) | | | | |
| | Windows 10 Home ML | √ | √ | √ | √ |
| | Windows 10 Home Plus ML i7 + >4 GB, or, any CPU + >=1080 p screen + >=8 GB | √ | √ | √ | √ |
| | For emerging market (EM/SL) | | | | |
| | Windows 10 Home EM/SL | √ | √ | √ | √ |
| | Windows 10 Home Plus EM/SL i7 + >4 GB, or, any CPU + >=1080 p screen + >=8 GB | √ | √ | √ | √ |



| Category | Details | OMEN by HP– Discrete N17E-G2 Graphics with NVIDIA N17E-G2 (GeForce GTX 1070) | OMEN by HP– Discrete N17E-G1 Graphics with NVIDIA N17E-G2 (GeForce GTX 1060) | OMEN by HP– Discrete N17P-G1 Graphics with NVIDIA N17P-G1 (GeForce GTX 1050 Ti) | OMEN by HP– Discrete N17P-G0 Graphics with NVIDIA N17P-G0 (GeForce GTX 1050) |
|-----------------------|---|---|---|--|---|
| | For China Market: | | | | |
| | CPPP Windows 10 Home High End China Language Edition i7 + > 4GB, or, Any CPU + >=1080p screen + >=8GB | √ | √ | √ | √ |
| | CPPP Windows 10 Home China Language Edition i7 + > 4GB, or, Any CPU + >=1080p screen + >=8GB | √ | √ | √ | √ |
| | For India Market: | | | | |
| | Windows 10 Home EM/SL IPPP i7 + > 4GB, or, Any CPU + >=1080p screen + >=8GB | √ | √ | √ | √ |
| | Windows 10 Home Plus EM/SL IPPP i7 + >4 GB, or, any CPU + >=1080 p screen + >=8 GB | √ | √ | √ | √ |
| | For Indonesia Market: | | | | |
| | Windows 10 Home Plus EM/SL Indonesia PPP i7 + >4 GB, or, any CPU + >=1080 p screen + >=8 GB | √ | √ | √ | √ |
| | Windows 10 Home EM/SL Indonesia PPP | √ | √ | √ | √ |
| | For APAC Market: | | √ | | |
| | Windows 10 Home Plus EM/SL APAC PPP i7 + >4 GB, or, any CPU + >=1080 p screen + >=8 GB | √ | √ | √ | √ |
| | Windows 10 Home EM/SL APAC PPP | √ | √ | √ | √ |
| | FreeDOS 2.0 Not supported on Touch models | √ | √ | √ | √ |
| Serviceability | End-user replaceable parts: AC adapter Memory | √ | √ | √ | √ |

| Category | Details | OMEN by HP– Discrete N17E-G2 Graphics with NVIDIA N17E-G2 (GeForce GTX 1070) | OMEN by HP– Discrete N17E-G1 Graphics with NVIDIA N17E-G2 (GeForce GTX 1060) | OMEN by HP– Discrete N17P-G1 Graphics with NVIDIA N17P-G1 (GeForce GTX 1050 Ti) | OMEN by HP– Discrete N17P-G0 Graphics with NVIDIA N17P-G0 (GeForce GTX 1050) |
|----------|------------|---|---|--|---|
| | Hard drive | | | | |
| | SSD | | | | |

2 External component identification

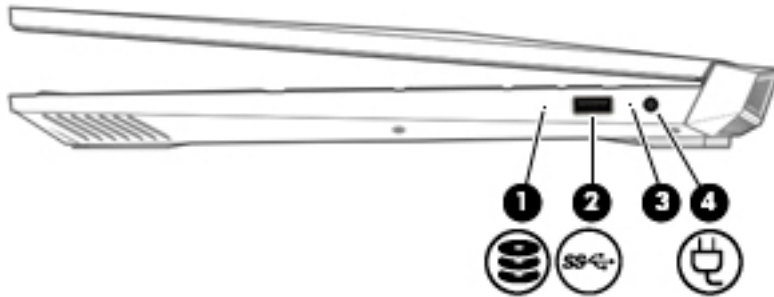

Right side

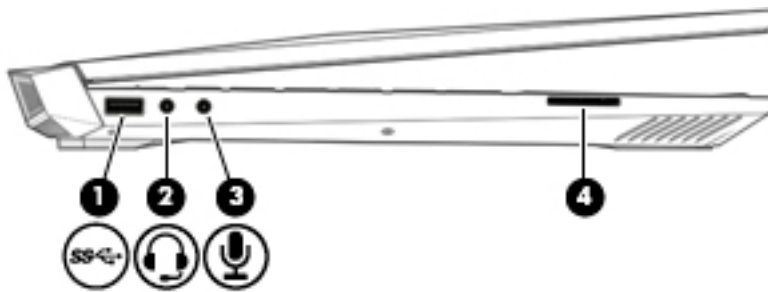

| Component | Description |
|---|--|
| (1)  Drive light | <ul style="list-style-type: none">• Blinking white: The hard drive is being accessed.• Amber: HP 3D DriveGuard has temporarily parked the hard drive. |
| (2)  USB SuperSpeed port | Connects a USB device, such as a cell phone, camera, activity tracker, or smartwatch, and provides high-speed data transfer. |
| (3) AC adapter and battery light | <ul style="list-style-type: none">• White: The AC adapter is connected and the battery is fully charged.• Blinking white: The AC adapter is disconnected and the battery has reached a low battery level.• Amber: The AC adapter is connected and the battery is charging.• Off: The battery is not charging. |
| (4) Power connector | Connects an AC adapter. |

Left side







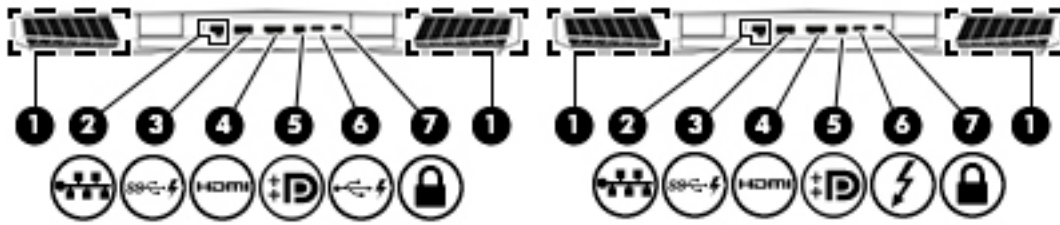

| Component | Description |
|---|--|
| (1)  | <p>USB SuperSpeed port</p> <p>Connects a USB device, such as a cell phone, camera, activity tracker, or smartwatch, and provides high-speed data transfer.</p> |
| (2)  | <p>Audio-out (headphone)/Audio-in (microphone) combo jack</p> <p>Connects optional powered stereo speakers, headphones, earbuds, a headset, or a television audio cable. Also connects an optional headset microphone. This jack does not support optional standalone microphones.</p> <p>WARNING! To reduce the risk of personal injury, adjust the volume before putting on headphones, earbuds, or a headset. For additional safety information, refer to the <i>Regulatory, Safety, and Environmental Notices</i>.</p> <p>To access this guide:</p> <ul style="list-style-type: none">▲ Select the Start button, select HP Help and Support, and then select HP Documentation. <p>NOTE: When a device is connected to the jack, the computer speakers are disabled.</p> |
| (3)  | <p>Audio-in (microphone) jack</p> <p>Connects an optional computer headset microphone, stereo array microphone, or monaural microphone.</p> |
| (4) | <p>Memory card reader</p> <p>Reads optional memory cards that enable you to store, manage, share, or access information.</p> <p>To insert a card:</p> <ol style="list-style-type: none">1. Hold the card label-side up, with connectors facing the computer.2. Insert the card into the memory card reader, and then press in on the card until it is firmly seated. <p>To remove a card:</p> <ul style="list-style-type: none">▲ Press in on the card, and then remove it from the memory card reader. |

Rear

 **NOTE:** Refer to the image that most closely matches your computer.



| Component | Description |
|-----------|---|
| (1) | <p>Vents</p> <p>Enable airflow to cool internal components.</p> <p>NOTE: The computer fan starts up automatically to cool internal components and prevent overheating. It is normal for the internal fan to cycle on and off during routine operation.</p> |
| (2) | <p> RJ-45 (network) jack/status lights</p> <p>Connects a network cable.</p> <ul style="list-style-type: none"> White: The network is connected. Amber: Activity is occurring on the network. |
| (3) | <p> USB SuperSpeed port with HP Sleep and Charge</p> <p>Connects a USB device, provides high-speed data transfer, and even when the computer is off, charges most products such as a cell phone, camera, activity tracker, or smartwatch.</p> |
| (4) | <p> HDMI port</p> <p>Connects an optional video or audio device, such as a high-definition television, any compatible digital or audio component, or a high-speed High-Definition Multimedia Interface (HDMI) device.</p> |
| (5) | <p> Mini Dual-Mode DisplayPort</p> <p>Connects an optional digital display device, such as a high-performance monitor or projector.</p> |
| (6) | <p> USB Type-C port with HP Sleep and Charge</p> <p>Connects a USB device that has a Type-C connector, and even when the computer is off, charges most products such as a cell phone, camera, activity tracker, or smartwatch.</p> <p>– and –</p> <p>Connects a display device that has a USB Type-C connector, providing DisplayPort output.</p> <p>NOTE: Cables and/or adapters (purchased separately) may be required.</p> |
| (6) | <p> USB Type-C Thunderbolt port with HP Sleep and Charge</p> <p>Connects and charges most USB devices that have a Type-C connector, such as a cell phone, camera, activity tracker, or smartwatch, and provides high-speed data transfer.</p> <p>– and –</p> <p>Connects a display device that has a USB Type-C connector, providing DisplayPort output.</p> <p>NOTE: Your computer may also support a Thunderbolt docking station.</p> |

| Component | Description |
|------------------------------|--|
| (7) Mini security cable slot | <p data-bbox="890 222 1423 279">NOTE: Cables and/or adapters (purchased separately) may be required.</p> <p data-bbox="890 300 1353 327">Attaches an optional security cable to the computer.</p> <p data-bbox="890 348 1423 422">NOTE: The security cable is designed to act as a deterrent, but it may not prevent the computer from being mishandled or stolen.</p> |

Display

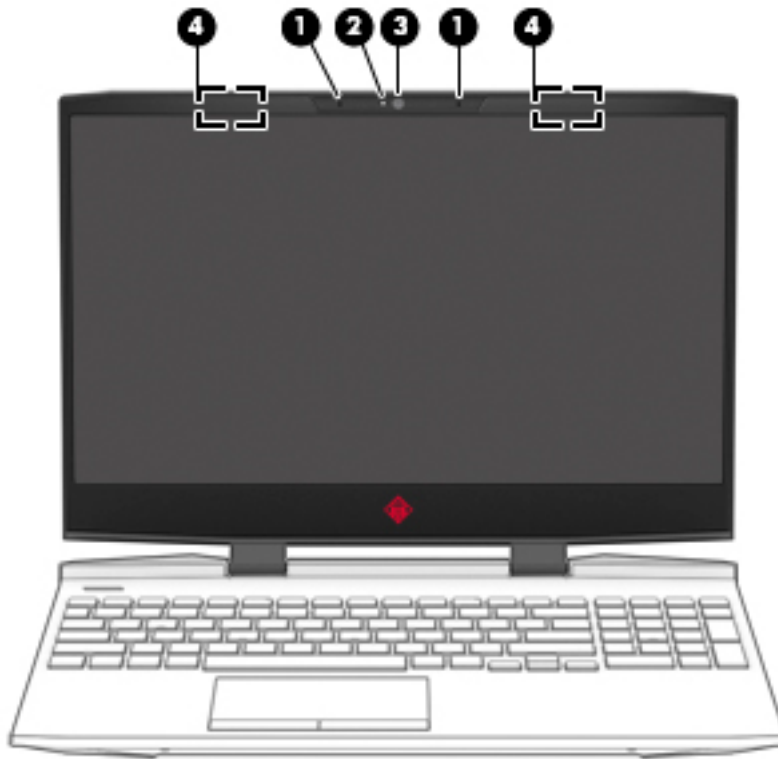

| Component | Description |
|--------------------------|---|
| (1) Internal microphones | Record sound. |
| (2) Camera light | On: The camera is in use. |
| (3) Camera(s) | Allow(s) you to video chat, record video, and record still images. NOTE: Camera functions vary depending on the camera hardware and software installed on your product. |
| (4) WLAN antennas* | Send and receive wireless signals to communicate with wireless local area networks (WLANs). |

*The antennas are not visible from the outside of the computer. For optimal transmission, keep the areas immediately around the antennas free from obstructions.

For wireless regulatory notices, see the section of the *Regulatory, Safety, and Environmental Notices* that applies to your country or region.

To access this guide:

1. Type `support` in the taskbar search box, and then select the **HP Support Assistant** app.
– or –
Click the question mark icon in the taskbar.
2. Select **My PC**, select the **Specifications** tab, and then select **User Guides**.

Keyboard area

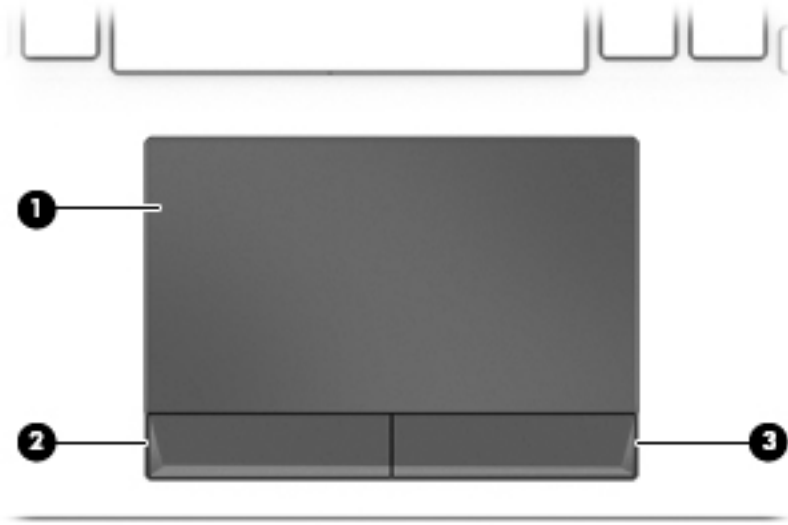

TouchPad



| Component | Description |
|-----------|--|
| (1) | TouchPad zone Reads your finger gestures to move the pointer or activate items on the screen. |
| (2) | Left TouchPad button Functions like the left button on an external mouse. |
| (3) | Right TouchPad button Functions like the right button on an external mouse. |

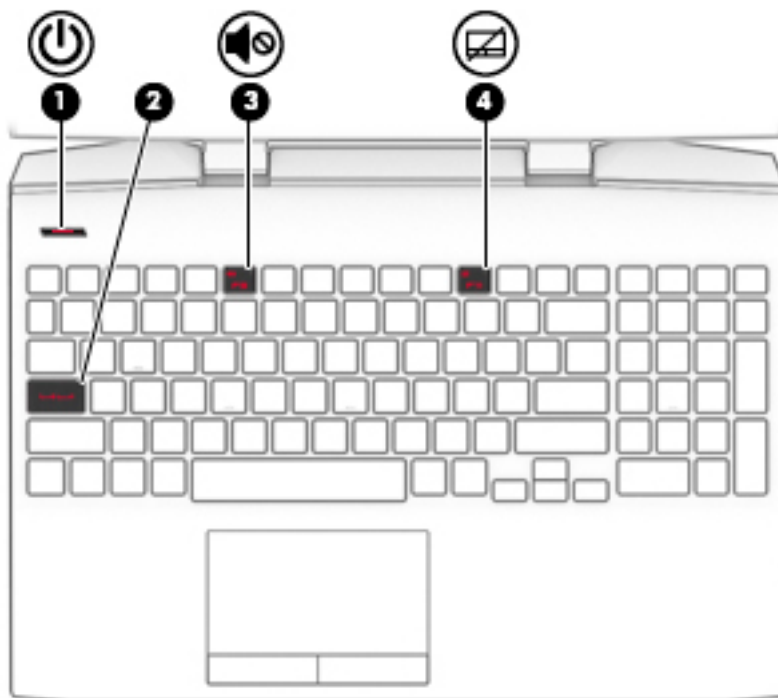

Lights



| Component | Description |
|---|---|
| (1)  Power light | <ul style="list-style-type: none">• On: The computer is on.• Blinking: The computer is in the Sleep state, a power-saving state. The computer shuts off power to the display and other unneeded components.• Off: The computer is off or in Hibernation. Hibernation is a power-saving state that uses the least amount of power. |
| (2) Caps lock light | On: Caps lock is on, which switches the key input to all capital letters. |
| (3)  Mute light | <ul style="list-style-type: none">• On: Computer sound is off.• Off: Computer sound is on. |
| (4) TouchPad light | <ul style="list-style-type: none">• On: The TouchPad is off.• Off: The TouchPad is on. |

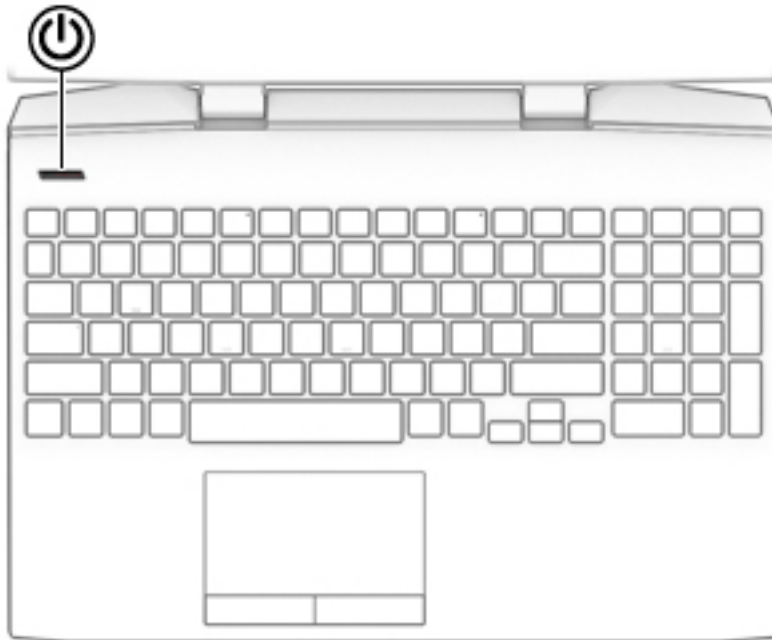

Button

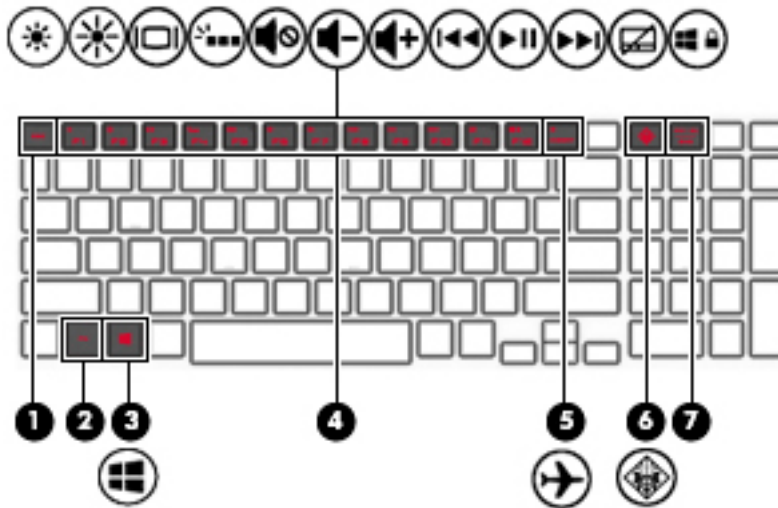

| Component | Description |
|---|--|
|  Power button | <ul style="list-style-type: none">• When the computer is off, press the button to turn on the computer.• When the computer is on, press the button briefly to initiate Sleep.• When the computer is in the Sleep state, press the button briefly to exit Sleep.• When the computer is in Hibernation, press the button briefly to exit Hibernation. <p>CAUTION: Pressing and holding down the power button results in the loss of unsaved information.</p> <p>If the computer has stopped responding and shutdown procedures are ineffective, press and hold the power button down for at least 5 seconds to turn off the computer.</p> <p>To learn more about your power settings, see your power options:</p> <ul style="list-style-type: none">▲ Right-click the Power icon , and then select Power Options. |

Special keys











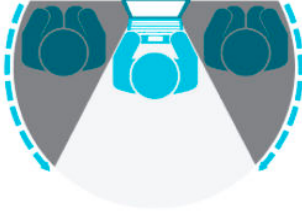





| Component | Description |
|---|--|
| (1) <code>esc</code> key | Displays system information when pressed in combination with the <code>fn</code> key. |
| (2) <code>fn</code> key | Executes specific functions when pressed in combination with another key. |
| (3)  Windows key | Opens the Start menu. NOTE: Pressing the Windows key again will close the Start menu. |
| (4) Action keys | Execute frequently used system functions. NOTE: On select products, the <code>f4</code> action key turns the keyboard backlight feature off or on. |
| (5)  Airplane mode key (also referred to as the wireless button) | Turns the airplane mode and wireless feature on or off. NOTE: A wireless network must be set up before a wireless connection is possible. |
| (6)  OMEN key | Opens the OMEN Command Center software. |
| (7) END/PRT SC key | Turns the END mode on or off. – or – Prints the screen image. ▲ Press and hold the key in combination with the <code>fn</code> key. |

Action keys

An action key performs the function indicated by the icon on the key. To determine which keys are on your product, see [Special keys on page 19](#).

- ▲ To use an action key, press and hold the key.

| Icon | Description |
|---|--|
|  | Helps prevent side-angle viewing from onlookers. If needed, decrease or increase brightness for well-lit or darker environments. Press the key again to turn off the privacy screen. |
|  | |
|  | Decreases the screen brightness incrementally as long as you hold down the key. |
|  | Increases the screen brightness incrementally as long as you hold down the key. |
|  | Opens the “How to get help in Windows 10” webpage. |
|  | Switches the screen image between display devices connected to the system. For example, if a monitor is connected to the computer, repeatedly pressing this key alternates the screen image from the computer display to the monitor display to a simultaneous display on both the computer and the monitor. |
|  | Turns the keyboard backlight off or on. NOTE: To conserve battery power, turn off this feature. |
|  | Plays the previous track of an audio CD or the previous section of a DVD or a Blu-ray Disc (BD). |
|  | Starts, pauses, or resumes playback of an audio CD, a DVD, or a BD. |
|  | Plays the next track of an audio CD or the next section of a DVD or a BD. |
|  | Stops audio or video playback of a CD, a DVD, or a BD. |
|  | Decreases speaker volume incrementally while you hold down the key. |
|  | Increases speaker volume incrementally while you hold down the key. |

| Icon | Description |
|---|---|
|  | Mutes or restores speaker sound. |
|  | Turns the airplane mode and wireless feature on or off. NOTE: The airplane mode key is also referred to as the wireless button. NOTE: A wireless network must be set up before a wireless connection is possible. |

Bottom

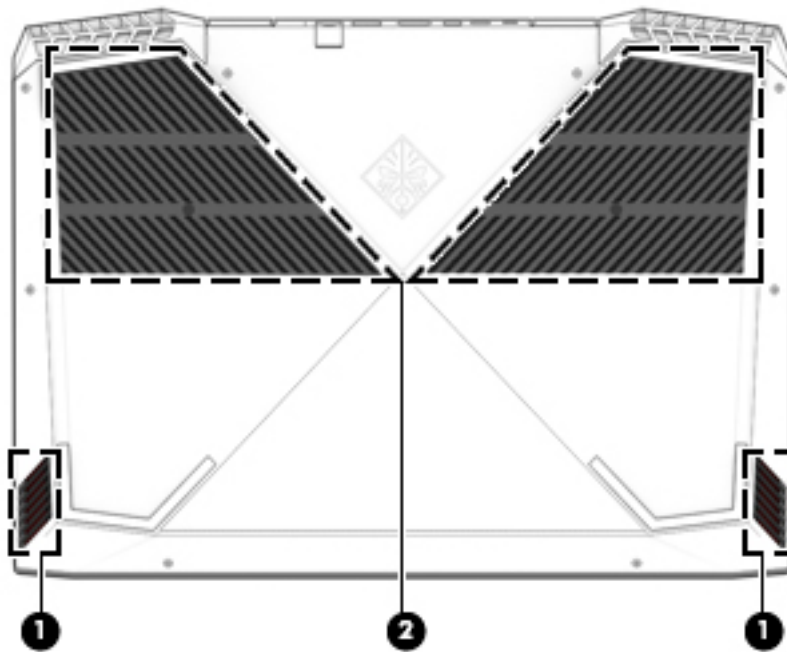

| Component | Description |
|-----------|--|
| (1) | Speakers Produce sound. |
| (2) | Vents Enable airflow to cool internal components. NOTE: The computer fan starts up automatically to cool internal components and prevent overheating. It is normal for the internal fan to cycle on and off during routine operation. |

Labels

The labels affixed to the computer provide information you may need when you troubleshoot system problems or travel internationally with the computer. Labels may be in paper form or imprinted on the product.

 **IMPORTANT:** Check the following locations for the labels described in this section: the bottom of the computer, inside the battery bay, under the service door, on the back of the display, or on the bottom of a tablet kickstand.

- Service label—Provides important information to identify your computer. When contacting support, you may be asked for the serial number, the product number, or the model number. Locate this information before you contact support.

Your service label will resemble one of the examples shown below. Refer to the illustration that most closely matches the service label on your computer.

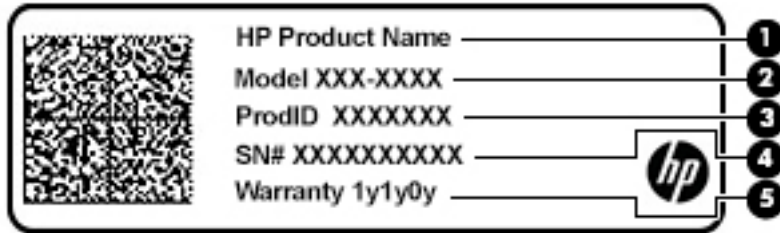

Component

- (1) HP product name
- (2) Model number
- (3) Product ID
- (4) Serial number
- (5) Warranty period

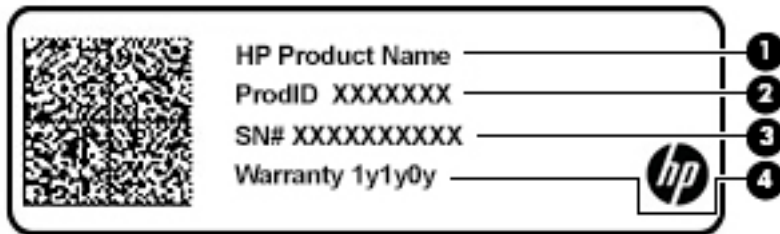

Component

- (1) HP product name
- (2) Product ID
- (3) Serial number
- (4) Warranty period

- Regulatory label(s)—Provide(s) regulatory information about the computer.
- Wireless certification label(s)—Provide(s) information about optional wireless devices and the approval markings for the countries or regions in which the devices have been approved for use.

3 Illustrated parts catalog



NOTE: HP continually improves and changes product parts. For complete and current information on supported parts for your computer, go to <http://partsurfer.hp.com>, select your country or region, and then follow the on-screen instructions.

Computer major components

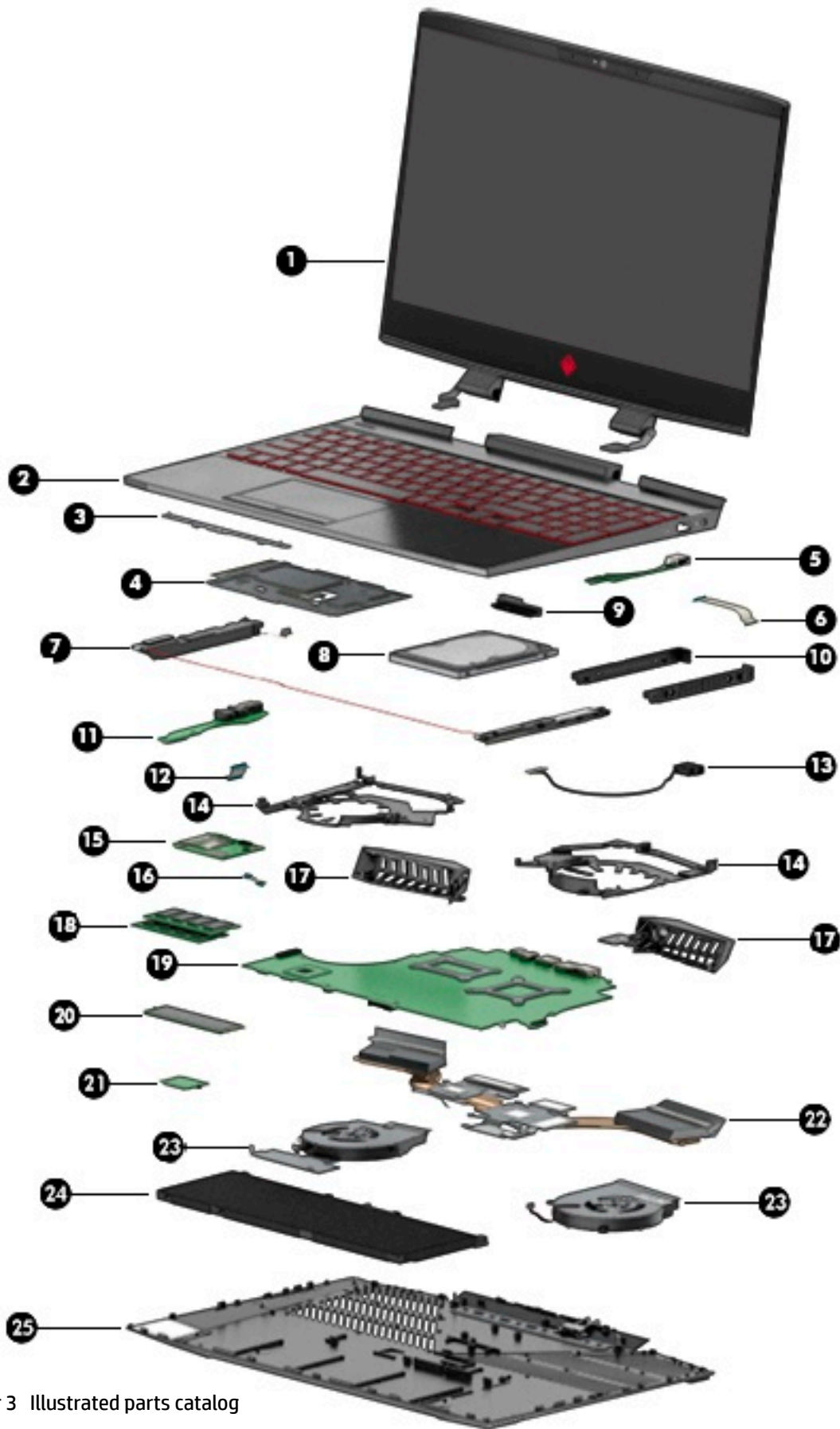

| Item | Component | Spare part number |
|------|---|-------------------|
| (1) | Display assembly: The display assembly is spared at the subcomponent level only. For more display assembly spare part information, see Display assembly subcomponents on page 27 . | |
| (2) | Keyboard/top cover (includes keyboard cable). For a complete list of keyboard/top covers see Keyboard/top cover on page 71 . | |
| (3) | TouchPad bracket | L24356-001 |
| (4) | TouchPad board | L24355-001 |
| (5) | USB connector board (includes audio jack and USB port) | L24349-001 |
| (6) | USB connector board cable | L24350-001 |
| (7) | Speakers (include left and right speakers and cables) | L24364-001 |
| (8) | Hard drive | |
| | 1 TB 7200 RPM SATA RAW 9.5 mm | 766644-001 |
| | 2 TB 5400 RPM SATA RAW 7 MM 2.5 IN | 912487-850 |
| | Hard drive dummy | L24367-001 |
| (9) | Hard drive cable connector | 929450-001 |
| (10) | Hard drive brackets | 929561-001 |
| (11) | Audio board | L24345-001 |
| | Audio cable, not shown | L24346-001 |
| (12) | Power connector board | L24347-001 |
| (13) | Power connector cable (includes cable and double-sided adhesive) | L24348-001 |
| (14) | Fan support brackets (left and right) | |
| | N17E | L24362-001 |
| | N17P | L24363-001 |
| (15) | Smart card reader board | L24351-001 |
| | Smart card reader cable, not shown | L24352-001 |
| (16) | DC in jack | |
| | N17P-12 P 4.5 mm 150 W | 926204-001 |
| | N17E-12 STD 4.5 mm 200 W | 938137-001 |
| (17) | Vent support brackets (left and right), part of the Plastics Kit | L24361-001 |
| (18) | Memory | |
| | SODIMM 8 GB 2666 MHz 1.2 v DDR4 | 937236-850 |
| | SODIMM 16 GB 2666 MHz 1.2 v DDR4 | 937438-850 |
| | SODIMM 4 GB 2666 MHz 1.2 v DDR4 | L10598-850 |
| (19) | System board (includes HDMI port, micro-SD card reader slot, USB port, WLAN slot, LVDS slot, DC in slot, and replacement thermal material). For a complete list of system board descriptions see System board on page 55 . | |
| (20) | SSD | |

| Item | Component | Spare part number |
|-------------|--|--------------------------|
| | 128 GB 2280 PCIe3x4 NVMe TLC | L24339-001 |
| | 256 GB 2280 M2 PCIe3x4 SSNVMe TLC | L24340-001 |
| | 512 GB 2280 M2 PCIe3x4 SSNVMe TLC | L24341-001 |
| | 16 GB 2280 PCIe3x2 NVMe 3D X | L24342-001 |
| (21) | WLAN module: | |
| | Realtek RTL8822BE 802.11 ac 2x2 WiFi + BT 4.2 Combo Adapter (MU-MIMO supported) | 915623-001 |
| | Intel Dual Band Wireless-AC 9560 802.11 AC 2x2 WiFi + BT5 Combo Adapter (non-vPro) (MU-MIMO supported) | L22634-001 |
| (22) | Heat sink (includes replacement thermal material) | |
| | N17E | L24357-001 |
| | N17P | L24358-001 |
| (23) | Fans (left and right includes replacement thermal material) | |
| | N17E | L24359-001 |
| | N17P | L29081-001 |
| (24) | Battery | |
| | 4 cell 70 Wh 4.55 Ah LI SR04070XL-PL | 917724-855 |
| | 3 cell 52 Wh 4.55 Ah LI SR03052XL-PL | L08855-855 |
| (25) | Base enclosure | |
| | N17E | L24353-001 |
| | N17P | L24354-001 |

Display assembly subcomponents

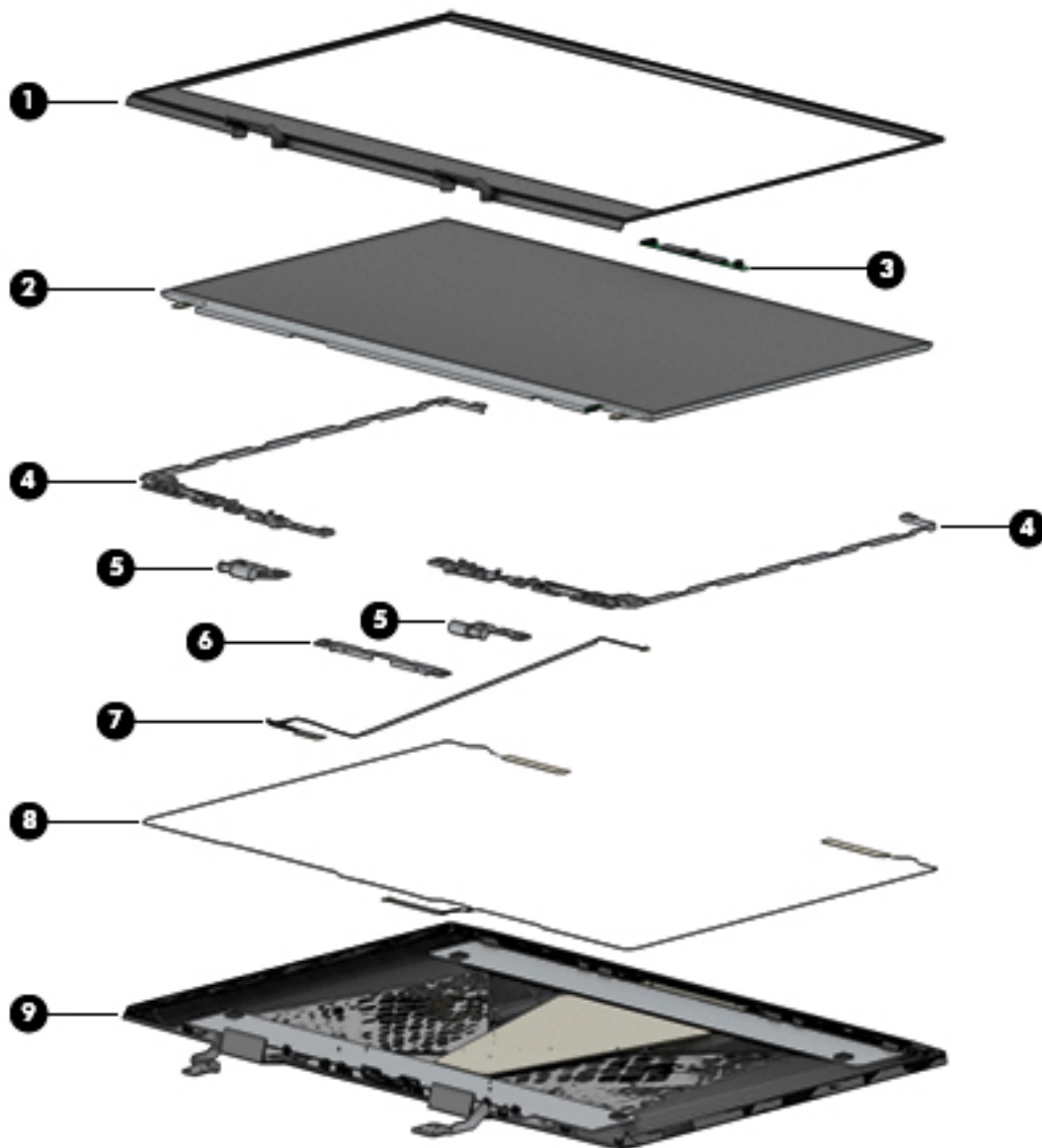

| Item | Component | Spare part number |
|------|--|-------------------|
| (1) | Display bezel | L24389-001 |
| (2) | Display panel: | |
| | 15.6 in, FHD 60 Hz NB | L24374-001 |
| | 15.6 in, FHD 144Hz NB | L24376-001 |
| | 15.6 in, UHD 60 Hz NB | L24378-001 |
| (3) | Camera/microphone module (includes double-sided adhesive) | L24391-001 |
| (4) | Display hinge (includes left and right display hinges) | L24386-001 |
| (5) | Display hinge bracket , includes display tape | L24387-001 |

| Item | Component | Spare part number |
|------|--|-------------------|
| (6) | Display support bracket | L24385-001 |
| (7) | Display panel cable (includes camera/microphone module cable) | |
| | FHD 60 Hz, 30 pin | L24382-001 |
| | FHD 144 Hz/UHD, 40 pin | L24384-001 |
| (8) | WLAN antenna (includes left and right WLAN cables and transceivers) | L24380-001 |
| (9) | Display enclosure/Back cover (includes rubber padding, antenna, and shielding): | |
| | 0.5 mm, for FHD 60 Hz LCD panel | L24379-001 |
| | 1.1 mm, for FHD 144 Hz/UHD LCD panel | L32773-001 |

Miscellaneous parts

| Component | Spare part number |
|---|-------------------|
| AC adapter: | |
| 150 W PFC SMART 4.5 mm Slim | 917649-850 |
| 200 W PFC SMART SLIM 4.5 mm | L00818-850 |
| 135 W PFC SMART SLIM RC 4.5 mm | L15534-001 |
| 135 W PFC SMART SLIM RC 4.5 mm, for Latin America | L15534-101 |
| Case, HP 15.6 Chroma Geo Rev sleeve | L07806-101 |
| Display tape | L24392-001 |
| Dongle, USB-C to USB-A | 833960-001 |
| HDMI to VGA adapter | 701943-001 |
| Power cord (1.00 m): | |
| For use in Argentina, C13 | L22104-001 |
| For use in Argentina, C5 | L22106-001 |
| For use in Australia, C13 | L22327-001 |
| For use in Australia, C5 | L22339-001 |
| For use in Denmark, C13 | L22334-001 |
| For use in Denmark, C5 | L22322-001 |
| For use in Europe, C13 | L22333-001 |
| For use in Europe, C5 | L22321-001 |
| For use in India, C13 | L22624-001 |
| For use in India, C5 | L22343-001 |
| For use in Israel, C13 | L22335-001 |
| For use in Israel, C5 | L22323-001 |

| Component | Spare part number |
|---|--------------------------|
| For use in Italy, C13 | L22103-001 |
| For use in Italy, C5 | L22105-001 |
| For use in Japan, C13 | L22344-001 |
| For use in Japan, C5 | L22330-001 |
| For use in North America, C5 | L22319-001 |
| For use in North America, C13 | L22331-001 |
| For use in the People's Republic of China, C13 | L22341-001 |
| For use in the People's Republic of China, C5 | L21930-001 |
| For use in South America, C13 | L22337-001 |
| For use in South America, C5 | L22325-001 |
| For use in South Korea, C13 | L22340-001 |
| For use in South Korea, C5 | L22328-001 |
| For use in Switzerland, C13 | L22336-001 |
| For use in Switzerland, C5 | L22324-001 |
| For use in Taiwan, C13 | L22342-001 |
| For use in Taiwan, C5 | L22329-001 |
| For use in Thailand, C13 | L22338-001 |
| For use in Thailand, C5 | L22326-001 |
| For use in the United Kingdom, C13 | L22332-001 |
| For use in the United Kingdom, C5 | L22320-001 |
| Optical drive , USB external DVDRW drive | 747080-001 |
| Screw Kit | L24368-001 |

4 Removal and replacement preliminary requirements

Tools required

You will need the following tools to complete the removal and replacement procedures:

- Flat-bladed screw driver
- Magnetic screw driver
- Phillips P0 screw driver

Service considerations

The following sections include some of the considerations that you must keep in mind during disassembly and assembly procedures.



NOTE: As you remove each subassembly from the computer, place the subassembly (and all accompanying screws) away from the work area to prevent damage.

Plastic parts



CAUTION: Using excessive force during disassembly and reassembly can damage plastic parts. Use care when handling the plastic parts. Apply pressure only at the points designated in the maintenance instructions.

Cables and connectors



CAUTION: When servicing the computer, be sure that cables are placed in their proper locations during the reassembly process. Improper cable placement can damage the computer.

Cables must be handled with extreme care to avoid damage. Apply only the tension required to unseat or seat the cables during removal and insertion. Handle cables by the connector whenever possible. In all cases, avoid bending, twisting, or tearing cables. Be sure that cables are routed in such a way that they cannot be caught or snagged by parts being removed or replaced. Handle flex cables with extreme care; these cables tear easily.

Drive handling

 **CAUTION:** Drives are fragile components that must be handled with care. To prevent damage to the computer, damage to a drive, or loss of information, observe these precautions:

Before removing or inserting a drive, shut down the computer. If you are unsure whether the computer is off or in Hibernation, turn the computer on, and then shut it down through the operating system.

Before handling a drive, be sure that you are discharged of static electricity. While handling a drive, avoid touching the connector.

Before removing a diskette drive or optical drive, be sure that a diskette or disc is not in the drive and be sure that the optical drive tray is closed.

Handle drives on surfaces covered with at least one inch of shock-proof foam.

Avoid dropping drives from any height onto any surface.

After removing drive, place it in a static-proof bag.

Avoid exposing a drive to products that have magnetic fields, such as monitors or speakers.

Avoid exposing a drive to temperature extremes or liquids.

If a drive must be mailed, place the drive in a bubble pack mailer or other suitable form of protective packaging and label the package "FRAGILE."

Grounding guidelines

Electrostatic discharge damage

Electronic components are sensitive to electrostatic discharge (ESD). Circuitry design and structure determine the degree of sensitivity. Networks built into many integrated circuits provide some protection, but in many cases, ESD contains enough power to alter device parameters or melt silicon junctions.

A discharge of static electricity from a finger or other conductor can destroy static-sensitive devices or microcircuitry. Even if the spark is neither felt nor heard, damage may have occurred.

An electronic device exposed to ESD may not be affected at all and can work perfectly throughout a normal cycle. Or the device may function normally for a while, then degrade in the internal layers, reducing its life expectancy.

⚠ CAUTION: To prevent damage to the computer when you are removing or installing internal components, observe these precautions:

Keep components in their electrostatic-safe containers until you are ready to install them.

Before touching an electronic component, discharge static electricity by using the guidelines described in this section.

Avoid touching pins, leads, and circuitry. Handle electronic components as little as possible.

If you remove a component, place it in an electrostatic-safe container.

The following table shows how humidity affects the electrostatic voltage levels generated by different activities.

⚠ CAUTION: A product can be degraded by as little as 700 V.

| Typical electrostatic voltage levels | | | |
|--------------------------------------|-------------------|----------|---------|
| Event | Relative humidity | | |
| | 10% | 40% | 55% |
| Walking across carpet | 35,000 V | 15,000 V | 7,500 V |
| Walking across vinyl floor | 12,000 V | 5,000 V | 3,000 V |
| Motions of bench worker | 6,000 V | 800 V | 400 V |
| Removing DIPS from plastic tube | 2,000 V | 700 V | 400 V |
| Removing DIPS from vinyl tray | 11,500 V | 4,000 V | 2,000 V |
| Removing DIPS from Styrofoam | 14,500 V | 5,000 V | 3,500 V |
| Removing bubble pack from PCB | 26,500 V | 20,000 V | 7,000 V |
| Packing PCBs in foam-lined box | 21,000 V | 11,000 V | 5,000 V |

Packaging and transporting guidelines

Follow these grounding guidelines when packaging and transporting equipment:

- To avoid hand contact, transport products in static-safe tubes, bags, or boxes.
- Protect ESD-sensitive parts and assemblies with conductive or approved containers or packaging.
- Keep ESD-sensitive parts in their containers until the parts arrive at static-free workstations.
- Place items on a grounded surface before removing items from their containers.
- Always be properly grounded when touching a component or assembly.
- Store reusable ESD-sensitive parts from assemblies in protective packaging or nonconductive foam.
- Use transporters and conveyors made of antistatic belts and roller bushings. Be sure that mechanized equipment used for moving materials is wired to ground and that proper materials are selected to avoid static charging. When grounding is not possible, use an ionizer to dissipate electric charges.

Workstation guidelines

Follow these grounding workstation guidelines:

- Cover the workstation with approved static-shielding material.
- Use a wrist strap connected to a properly grounded work surface and use properly grounded tools and equipment.
- Use conductive field service tools, such as cutters, screw drivers, and vacuums.
- When fixtures must directly contact dissipative surfaces, use fixtures made only of static-safe materials.
- Keep the work area free of nonconductive materials, such as ordinary plastic assembly aids and Styrofoam.
- Handle ESD-sensitive components, parts, and assemblies by the case or PCM laminate. Handle these items only at static-free workstations.
- Avoid contact with pins, leads, or circuitry.
- Turn off power and input signals before inserting or removing connectors or test equipment.

Equipment guidelines

Grounding equipment must include either a wrist strap or a foot strap at a grounded workstation.

- When seated, wear a wrist strap connected to a grounded system. Wrist straps are flexible straps with a minimum of one megohm $\pm 10\%$ resistance in the ground cords. To provide proper ground, wear a strap snugly against the skin at all times. On grounded mats with banana-plug connectors, use alligator clips to connect a wrist strap.
- When standing, use foot straps and a grounded floor mat. Foot straps (heel, toe, or boot straps) can be used at standing workstations and are compatible with most types of shoes or boots. On conductive floors or dissipative floor mats, use foot straps on both feet with a minimum of one megohm resistance between the operator and ground. To be effective, the conductive must be worn in contact with the skin.

The following grounding equipment is recommended to prevent electrostatic damage:

- Antistatic tape
- Antistatic smocks, aprons, and sleeve protectors
- Conductive bins and other assembly or soldering aids
- Nonconductive foam
- Conductive computer workstations with ground cords of one megohm resistance
- Static-dissipative tables or floor mats with hard ties to the ground
- Field service kits
- Static awareness labels
- Material-handling packages
- Nonconductive plastic bags, tubes, or boxes
- Metal tote boxes
- Electrostatic voltage levels and protective materials

The following table lists the shielding protection provided by antistatic bags and floor mats.

| Material | Use | Voltage protection level |
|-----------------------|------------|--------------------------|
| Antistatic plastics | Bags | 1,500 V |
| Carbon-loaded plastic | Floor mats | 7,500 V |
| Metallized laminate | Floor mats | 5,000 V |

5 Removal and replacement procedures for Customer Self-Repair parts

This chapter provides removal and replacement procedures for Customer Self-Repair parts.

 **NOTE:** The Customer Self-Repair program is not available in all locations. Installing a part not supported by the Customer Self-Repair program may void your warranty. Check your warranty to determine if Customer Self-Repair is supported in your location.

Component replacement procedures

 **NOTE:** Details about your computer, including model, serial number, product key, and length of warranty, are on the service tag at the bottom of your computer. See [Labels on page 21](#) for details.

 **NOTE:** HP continually improves and changes product parts. For complete and current information on supported parts for your computer, go to <http://partsurfer.hp.com>, select your country or region, and then follow the on-screen instructions.

There are as many as 12 screws that must be removed, replaced, and/or loosened when servicing Customer Self-Repair parts. Make special note of each screw size and location during removal and replacement.

Base enclosure

| Description | Spare part number |
|-----------------------|-------------------|
| Base enclosure | |
| N17P | L24354-001 |
| N17E | L24353-001 |

Before removing the base enclosure, follow these steps:

1. Turn off the computer. If you are unsure whether the computer is off or in Hibernation, turn the computer on, and then shut it down through the operating system.
2. Disconnect the power from the computer by unplugging the power cord from the computer.
3. Disconnect all external devices from the computer.

Remove the base enclosure:

1. Turn the computer upside down on a flat surface.
2. Remove the two Phillips 10 mm screws **(1)**.

3. Remove the six Phillips 4 mm screws (2).

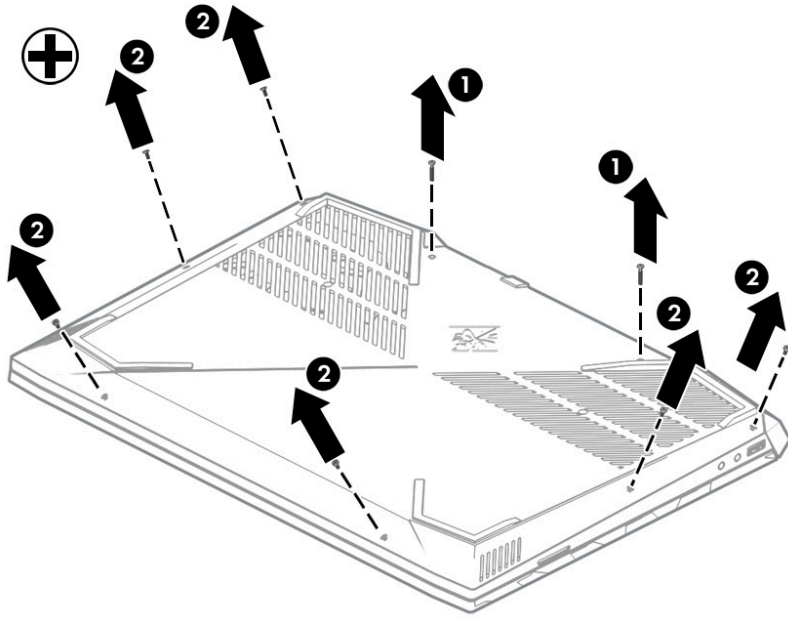

4. Open the display (1) at a 90 degree angle and then place the display back down.

5. Push in on the top cover (2), and then release the clips (3) securing the base enclosure.

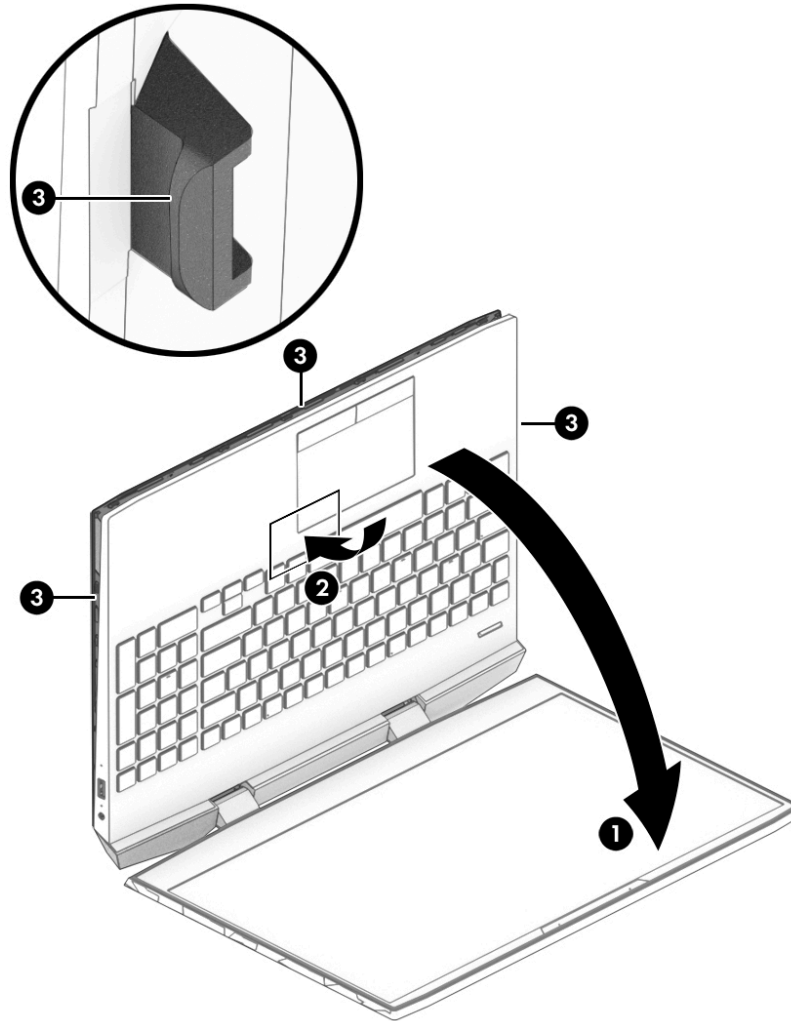

6. Shake the left and right sides (1) to release the base enclosure, and then lift the base enclosure (2) to remove it.

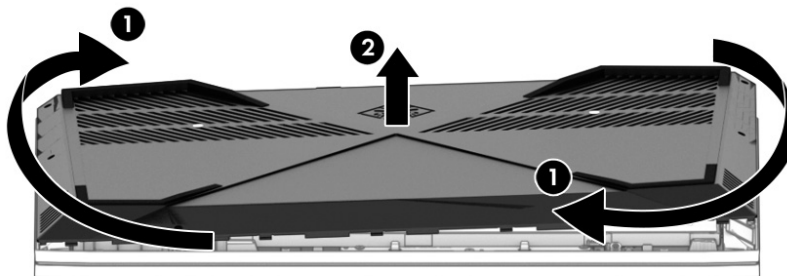

Reverse the removal procedures to install the base enclosure.

Hard drive (HDD)

| Description | Spare part number |
|------------------------------------|-------------------|
| Hard drive | |
| 1 TB 7200 RPM SATA RAW 9.5 mm | 766644-001 |
| 2 TB 5400 RPM SATA RAW 7 MM 2.5 IN | 912487-850 |
| Hard drive dummy | L24367-001 |
| Hard drive cable connector | |
| | 929450-001 |
| Hard drive brackets | |
| | 929561-001 |

Before removing the hard drive, follow these steps:

1. Turn off the computer. If you are unsure whether the computer is off or in Hibernation, turn the computer on, and then shut it down through the operating system.
2. Disconnect the power from the computer by unplugging the power cord from the computer.
3. Disconnect all external devices from the computer.
4. Remove the base enclosure (see [Base enclosure on page 35](#)).

Remove the hard drive:

1. Release the HDD cable (1) from the system board.
2. Lift the hard drive release tab (2)
3. Lift the drive (3) to remove it.

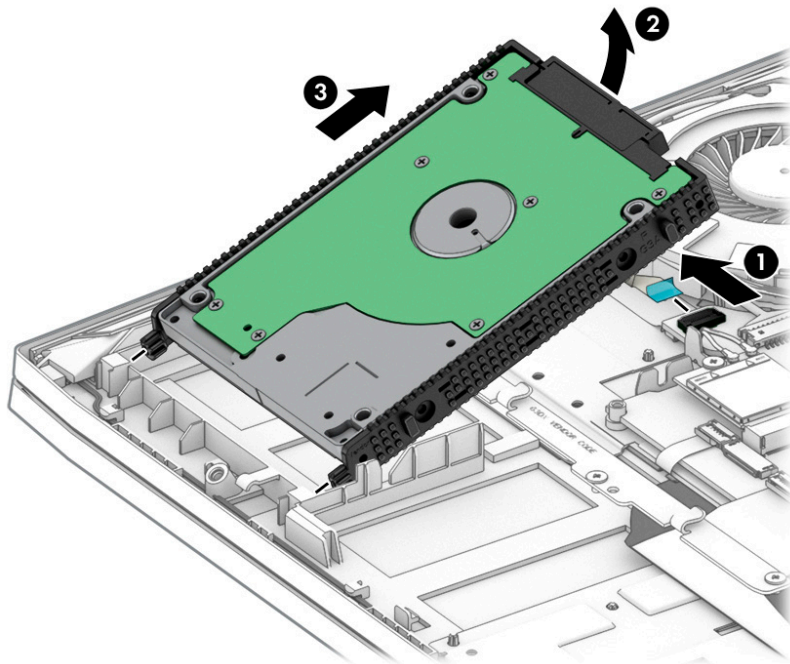

4. If it is necessary to replace the hard drive bracket, remove the brackets **(1)** from the hard drive, and then remove the cable connector **(2)** from the hard drive.

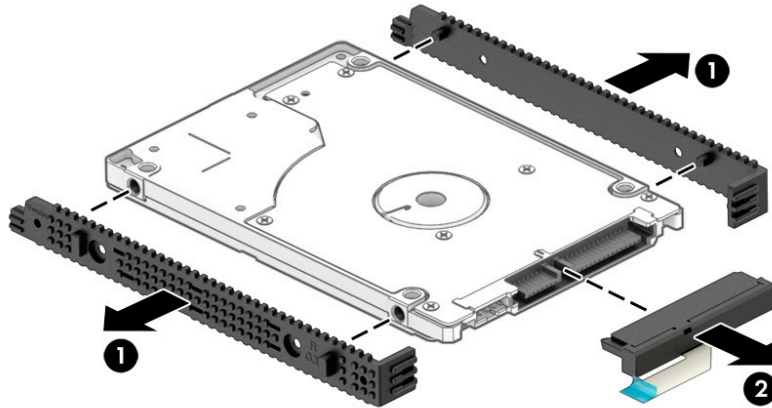

Reverse this procedure to install the hard drive.

Solid-state drive (SSD)

| Description | Spare part number |
|-----------------------------------|-------------------|
| SSD | |
| 128 GB 2280 PCIe3x4 NVMe TLC | L24339-001 |
| 256 GB 2280 M2 PCIe3x4 SSNVMe TLC | L24340-001 |
| 512 GB 2280 M2 PCIe3x4 SSNVMe TLC | L24341-001 |
| 16 GB 2280 PCIe3x2 NVMe 3D X | L24342-001 |

Before removing the solid-state drive, follow these steps:

1. Turn off the computer. If you are unsure whether the computer is off or in Hibernation, turn the computer on, and then shut it down through the operating system.
2. Disconnect the power from the computer by unplugging the power cord from the computer.
3. Disconnect all external devices from the computer.
4. Remove the base enclosure (see [Base enclosure on page 35](#)).

Remove the solid-state drive:

1. Remove the Phillips M2.0×2.0 screw **(1)** that secures the drive to the system board.
2. Remove the drive by pulling it away from the connector **(2)**.

 **NOTE:** M.2 solid-state drives are designed with notches to prevent incorrect insertion.

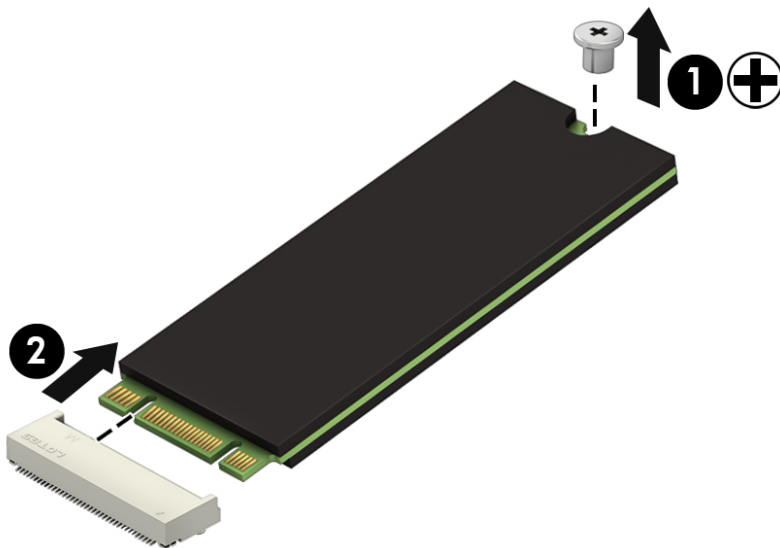

Reverse this procedure to install the solid-state drive.

Memory modules

 **NOTE:** Primary and expansion memory is installed in a side-by-side configuration in the bottom of the computer.

If only one memory module is installed, it must be installed in the socket labeled '1'.

 **NOTE:** Two additional memory slots are available under the system board. These are not customer self-repair parts.

| Description | Spare part number |
|------------------------------|-------------------|
| 4 GB, 2666 MHz, 1.2 v, DDR4 | L10598-850 |
| 8 GB, 2666 MHz, 1.2 v, DDR4 | 937236-850 |
| 16 GB, 2666 MHz, 1.2 v, DDR4 | 937438-850 |

Update BIOS before adding memory modules

Before adding new memory, make sure you update the computer to the latest BIOS.

 **CAUTION:** Failure to update the computer to the latest BIOS prior to installing new memory may result in various system problems.

To update BIOS:

1. Navigate to www.hp.com.
2. Click **Support & Drivers** > click **Drivers & Software**.
3. In the **Enter a product name/number** box, type the computer model information, and then click **Search**.
4. Click the link for the computer model.
5. Select the operating system, and then click **Next**.
6. Under **Step 2: Select a Download**, click the **BIOS** link.
7. Click the link for the most recent BIOS.
8. Click the **Download** button, and then follow the on-screen instructions.

Before removing the memory module, follow these steps:

1. Shut down the computer. If you are unsure whether the computer is off or in Hibernation, turn the computer on, and then shut it down through the operating system.
2. Disconnect all external devices connected to the computer.
3. Disconnect the power from the computer by first unplugging the power cord from the AC outlet, and then unplugging the AC adapter from the computer.
4. Remove the base enclosure (see [Base enclosure on page 35](#)).

Remove the memory module:

1. Spread the retaining tabs **(1)** on each side of the memory module slot to release the memory module. (The edge of the module opposite the slot rises away from the computer.)

2. Remove the memory module **(2)** by pulling the module away from the slot at an angle.

 **NOTE:** Memory modules are designed with a notch to prevent incorrect insertion into the memory module slot.

 **NOTE:** The computer uses two memory sockets. The socket labeled '2' houses the expansion memory module and the socket labeled '1' houses the primary memory module. The removal procedure is the same for both memory sockets.

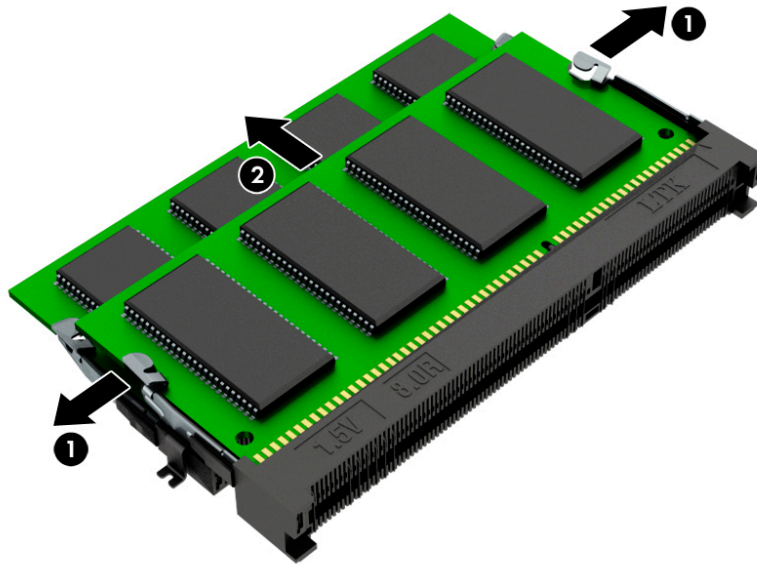

Reverse this procedure to install a memory module.

WLAN module

| Description | Spare part number |
|--|-------------------|
| Realtek RTL8822BE 802.11 ac 2x2 WiFi + BT 4.2 Combo Adapter (MU-MIMO supported) | 915623-001 |
| Intel Dual Band Wireless-AC 9560 802.11 AC 2x2 WiFi + BT5 Combo Adapter (non-vPro) (MU-MIMO supported) | L22634-001 |

 **CAUTION:** To prevent an unresponsive system, replace the wireless module only with a wireless module authorized for use in the computer by the governmental agency that regulates wireless devices in your country or region. If you replace the module and then receive a warning message, remove the module to restore device functionality, and then contact support.

Before removing the WLAN module, follow these steps:

1. Shut down the computer. If you are unsure whether the computer is off or in Hibernation, turn the computer on, and then shut it down through the operating system.
2. Disconnect all external devices connected to the computer.
3. Disconnect the power from the computer by first unplugging the power cord from the AC outlet and then unplugging the AC adapter from the computer.
4. Remove the base enclosure (see [Base enclosure on page 35](#)).

To remove the WLAN module:

1. Disconnect the WLAN antenna cables **(1)** from the terminals on the WLAN module.



NOTE: The #1 WLAN antenna cable is connected to the WLAN module Main terminal. The #2 WLAN antenna cable is connected to the WLAN module Aux terminal.

2. Remove the Phillips PM2.0×3.0 screw **(2)** that secures the WLAN module to the system board. (The WLAN module tilts up.)

3. Remove the WLAN module by pulling the module away from the slot at an angle (3).

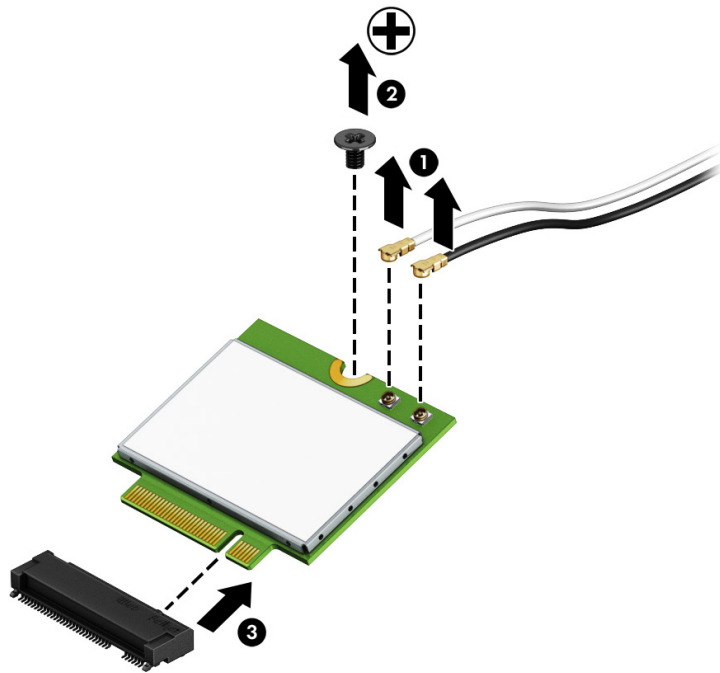

 **NOTE:** If the WLAN antennas are not connected to the terminals on the WLAN module, the protective sleeves must be installed on the antenna connectors, as shown in the following illustration.

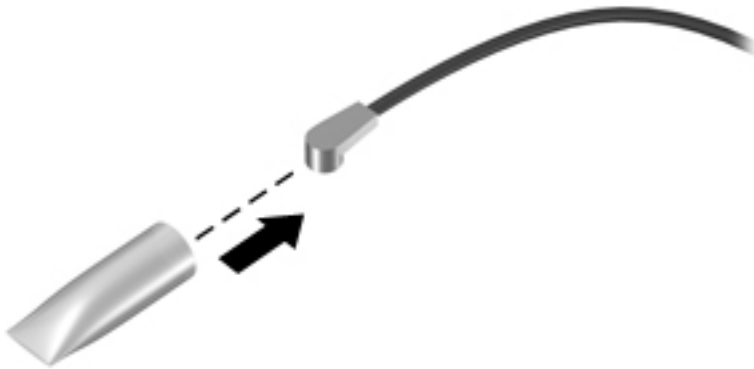

Reverse this procedure to install the WLAN module.

6 Removal and replacement procedures for Authorized Service Provider parts

This chapter provides removal and replacement procedures for Authorized Service Provider only parts.

 **CAUTION:** Components described in this chapter should only be accessed by an authorized service provider. Accessing these parts can damage the computer or void the warranty.

CAUTION: This computer does not have user-replaceable parts. Only HP authorized service providers should perform the removal and replacement procedures described here. Accessing the internal part could damage the computer or void the warranty.

Component replacement procedures

 **NOTE:** Details about your computer, including model, serial number, product key, and length of warranty, are on the service tag at the bottom of your computer. See [Labels on page 21](#) for details.

 **NOTE:** HP continually improves and changes product parts. For complete and current information on supported parts for your computer, go to <http://partsurfer.hp.com>, select your country or region, and then follow the on-screen instructions.

There are as many as 47 screws that must be removed, replaced, and/or loosened when servicing Authorized Service Provider only parts. Make special note of each screw size and location during removal and replacement.

Battery

| Description | Spare part number |
|--------------------------------------|-------------------|
| 4 cell 70 Wh 4.55 Ah LI SR04070XL-PL | 917724-855 |
| 3 cell 52 Wh 4.55 Ah LI SR03052XL-PL | L08855-855 |

Before removing the battery, follow these steps:

1. Shut down the computer. If you are unsure whether the computer is off or in Hibernation, turn the computer on, and then shut it down through the operating system.
2. Disconnect all external devices connected to the computer.
3. Disconnect the power from the computer by first unplugging the power cord from the AC outlet, and then unplugging the AC adapter from the computer.
4. Remove the base enclosure (see [Base enclosure on page 35](#)).

Remove the battery:

1. Remove the four Phillip 6 mm screws (1).
2. Lift the battery (2) and then pull the battery (3) forward to remove the battery from the computer.

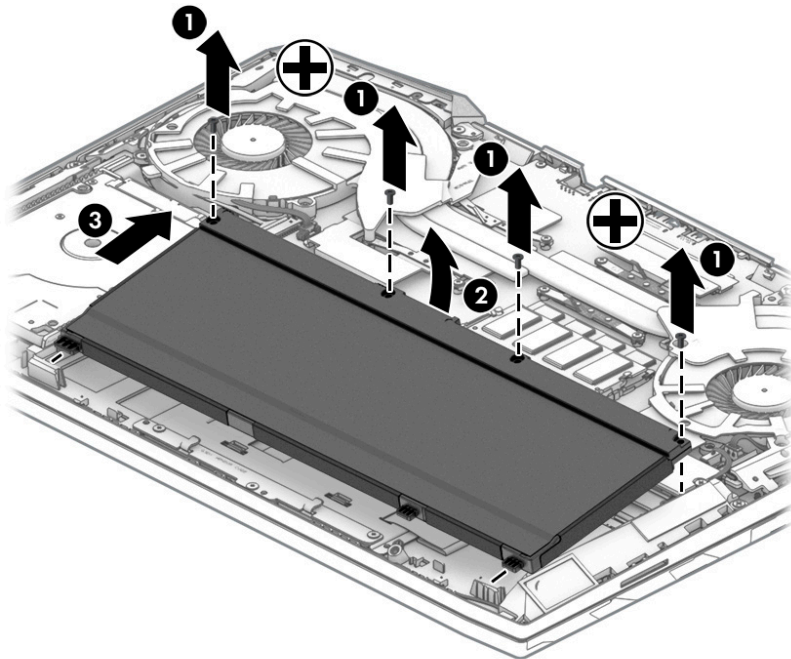

Reverse this procedure to install the battery.

Speakers

| Description | Spare part number |
|-----------------------------------|-------------------|
| Speaker assembly (includes cable) | L14368-001 |

Before removing the speaker, follow these steps:

1. Turn off the computer. If you are unsure whether the computer is off or in Hibernation, turn the computer on, and then shut it down through the operating system.
2. Disconnect the power from the computer by unplugging the power cord from the computer.
3. Disconnect all external devices from the computer.
4. Remove the any smart cards and memory cards.
5. Remove the base enclosure (see [Base enclosure on page 35](#)).
6. Remove the battery (see [Battery on page 46](#)).
7. Remove the hard drive (see [Hard drive \(HDD\) on page 38](#)).
8. Remove the SSD (see [Solid-state drive \(SSD\) on page 40](#)).

Remove the speakers:

1. Disconnect the speaker cable **(1)** from the system board.
2. Remove the two Phillips 6 mm screws **(2)** that secure the speakers to the computer.
3. Release the speaker cable **(3)** from the clips that secure it to the computer.
4. Lift the speakers **(4)** to remove them from the computer.

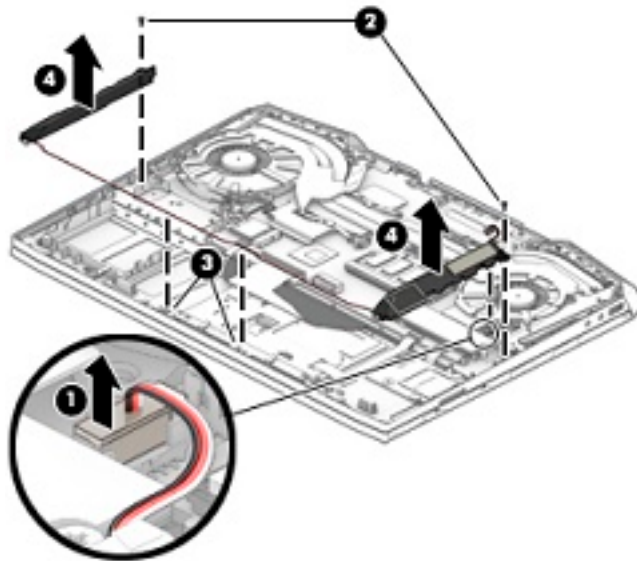

Reverse this procedure to install the speakers.

Smart card board

| Description | Spare part number |
|------------------|-------------------|
| Smart card board | L14374-001 |

Before removing the card reader, follow these steps:

1. Turn off the computer. If you are unsure whether the computer is off or in Hibernation, turn the computer on, and then shut it down through the operating system.
2. Disconnect the power from the computer by unplugging the power cord from the computer.
3. Disconnect all external devices from the computer.
4. Remove the any smart cards and memory cards.
5. Remove the base enclosure (see [Base enclosure on page 35](#)).
6. Remove the battery (see [Battery on page 46](#)).
7. Remove the hard drive (see [Hard drive \(HDD\) on page 38](#)).
8. Remove the SSD (see [Solid-state drive \(SSD\) on page 40](#)).

Remove the smart card reader:

 **NOTE:** Before you remove the smart card reader, make sure nothing (memory card or plastic insert) is inserted in the reader.

1. Disconnect the smart card reader cable **(1)** from the connector on the system board.
2. Remove the two Phillips screws **(2)** that secure the smart card reader to the computer.
3. Remove the smart card reader from the computer **(3)**.

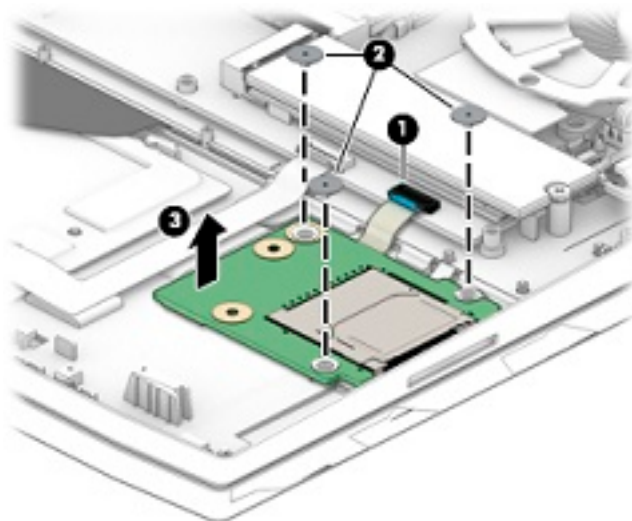

Reverse this procedure to install the smart card reader.

Fans

| Description | Spare part number |
|------------------------------|-------------------|
| Fans | |
| N17E | L24359-001 |
| N17P | L29081-001 |
| Fans support brackets | |
| N17E | L24362-001 |
| N17P | L24363-001 |
| Vent support brackets | |
| | L24361-001 |

Before removing the fans, follow these steps:

1. Turn off the computer. If you are unsure whether the computer is off or in Hibernation, turn the computer on, and then shut it down through the operating system.
2. Disconnect the power from the computer by unplugging the power cord from the computer.
3. Disconnect all external devices from the computer.
4. Remove the any smart cards and memory cards.
5. Remove the base enclosure (see [Base enclosure on page 35](#)).
6. Remove the battery (see [Battery on page 46](#)).
7. Remove the hard drive (see [Hard drive \(HDD\) on page 38](#)).
8. Remove the SSD (see [Solid-state drive \(SSD\) on page 40](#)).

Remove the vent support brackets:

1. Release the four Phillips 3 mm flat large head screws **(1)** that secure the brackets to the computer.

2. Rotate the brackets **(2)** down to remove them from the computer.

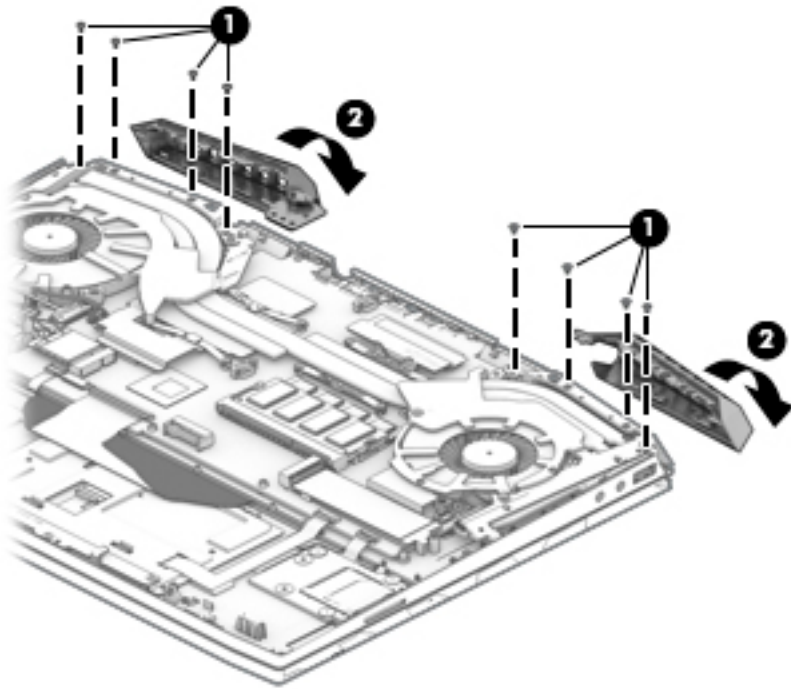

Remove the fan brackets:

1. Release the three screws **(1)** that secure the fan brackets to the computer.
2. Remove the fan brackets **(2)** from the computer.

 **NOTE:** To completely remove the right bracket, disconnect the power connector cable from the system board (see [Power connector cable on page 52](#)).

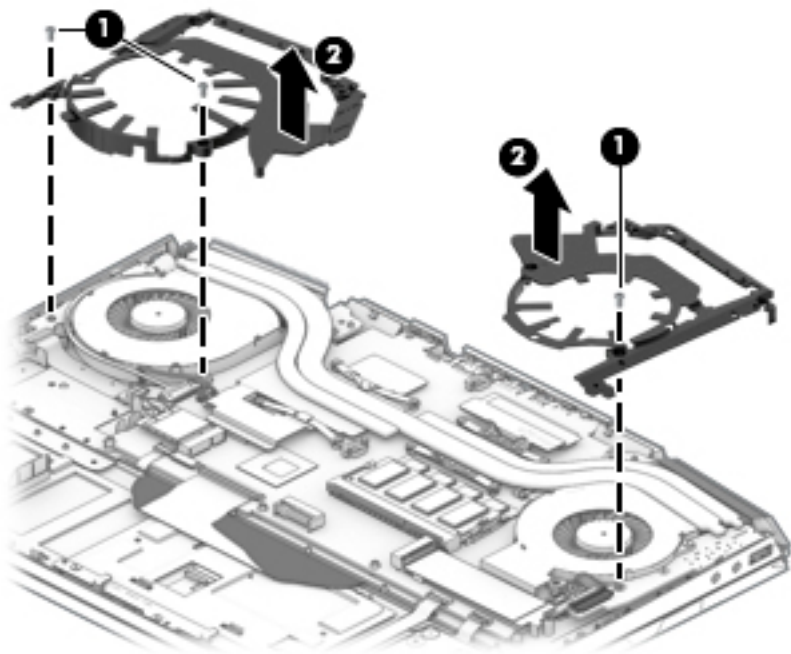

Remove the fans:

1. Disconnect the fan cable **(1)**.
2. Remove the Phillips M5 screws **(2)** that secure the fan to the computer.
3. Remove the fans from the computer **(3)**.

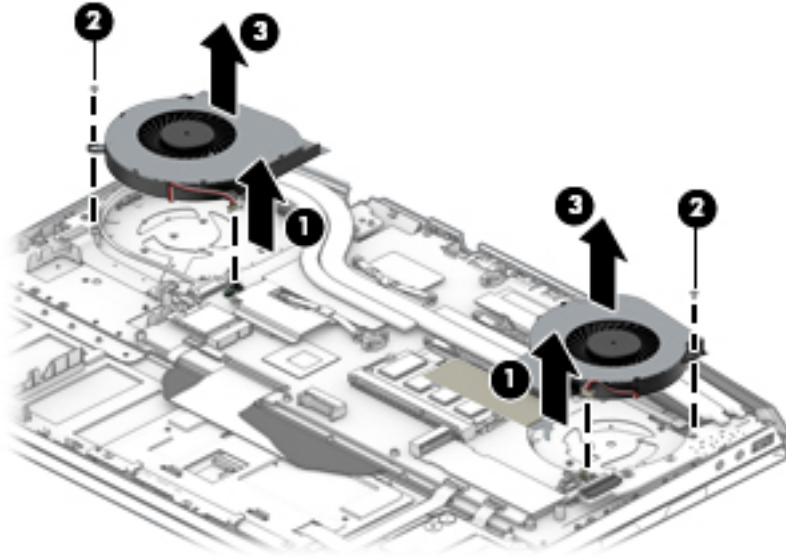

Reverse this procedure to install the fans.

Power connector cable

| Description | Spare part number |
|-----------------------|-------------------|
| Power connector cable | L24348-001 |

Before removing the power connector cable, follow these steps:

1. Turn off the computer. If you are unsure whether the computer is off or in Hibernation, turn the computer on, and then shut it down through the operating system.
2. Disconnect the power from the computer by unplugging the power cord from the computer.
3. Disconnect all external devices from the computer.
4. Remove the any smart cards and memory cards.
5. Remove the base enclosure (see [Base enclosure on page 35](#)).
6. Remove the battery (see [Battery on page 46](#)).
7. Remove the hard drive (see [Hard drive \(HDD\) on page 38](#)).
8. Remove the SSD (see [Solid-state drive \(SSD\) on page 40](#)).
9. Remove the right fan bracket (see [Fans on page 49](#)).

Remove the power connector cable:

1. Release the connector **(1)** at angle from under the heat sink.
2. Disconnect the power connector cable **(2)** from the connector on the system board.
3. Remove the power connector from the computer **(3)**.

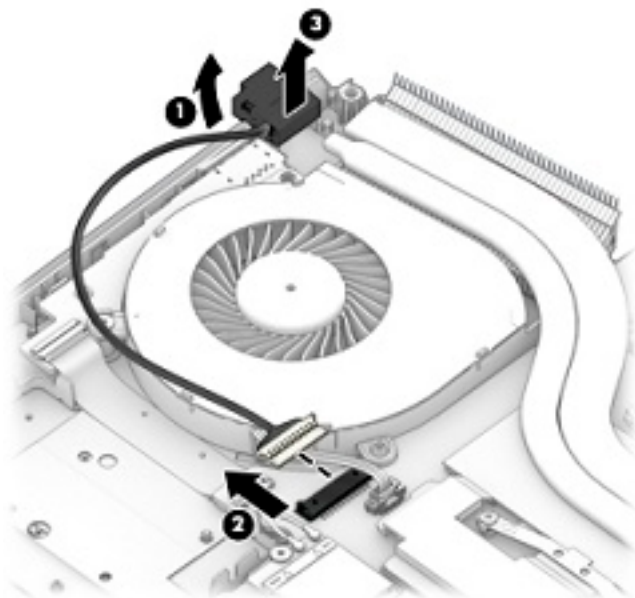

Reverse this procedure to install the power connector cable.

Audio board

| Description | Spare part number |
|-------------|-------------------|
| Audio board | L24346-001 |

Before removing the audio board, follow these steps:

1. Turn off the computer. If you are unsure whether the computer is off or in Hibernation, turn the computer on, and then shut it down through the operating system.
2. Disconnect the power from the computer by unplugging the power cord from the computer.
3. Disconnect all external devices from the computer.
4. Remove the any smart cards and memory cards.
5. Remove the base enclosure (see [Base enclosure on page 35](#)).
6. Remove the battery (see [Battery on page 46](#)).
7. Remove the hard drive (see [Hard drive \(HDD\) on page 38](#)).
8. Remove the SSD (see [Solid-state drive \(SSD\) on page 40](#)).
9. Remove the left fan (see [Fans on page 49](#)).

Remove the audio board:

1. Disconnect the audio board cable **(1)** from the connector on the system board.
2. Remove the audio board from the computer **(2)**.

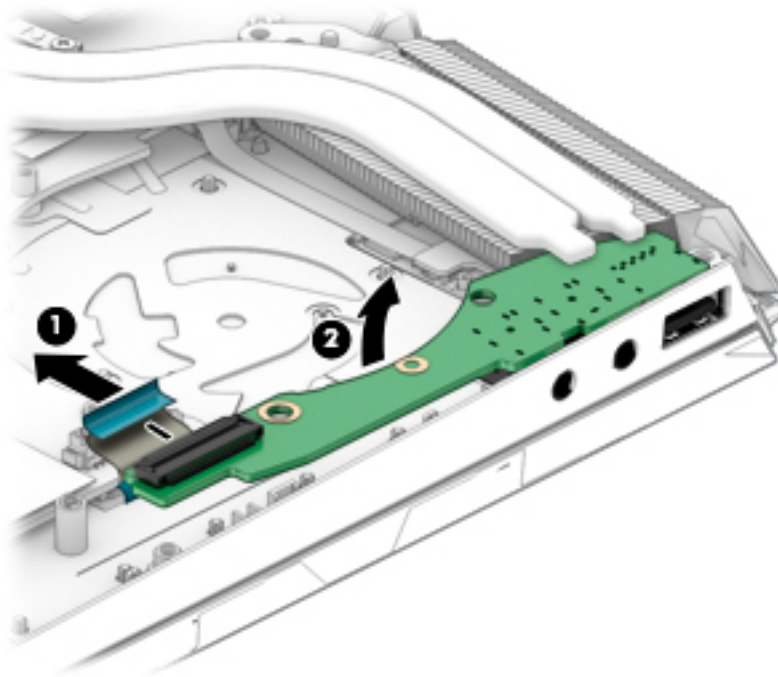

Reverse this procedure to install the audio board.

USB board

| Description | Spare part number |
|-----------------|-------------------|
| USB board | L24349-001 |
| USB board cable | L24350-001 |

Before removing the USB board, follow these steps:

1. Turn off the computer. If you are unsure whether the computer is off or in Hibernation, turn the computer on, and then shut it down through the operating system.
2. Disconnect the power from the computer by unplugging the power cord from the computer.
3. Disconnect all external devices from the computer.
4. Remove the any smart cards and memory cards.
5. Remove the base enclosure (see [Base enclosure on page 35](#)).
6. Remove the battery (see [Battery on page 46](#)).
7. Remove the hard drive (see [Hard drive \(HDD\) on page 38](#)).
8. Remove the SSD (see [Solid-state drive \(SSD\) on page 40](#)).
9. Remove the right fan (see [Fans on page 49](#)).

Remove the USB board:

1. Disconnect the USB board cable (1) from the connector on the system board.
2. Remove the USB board from the computer (2).

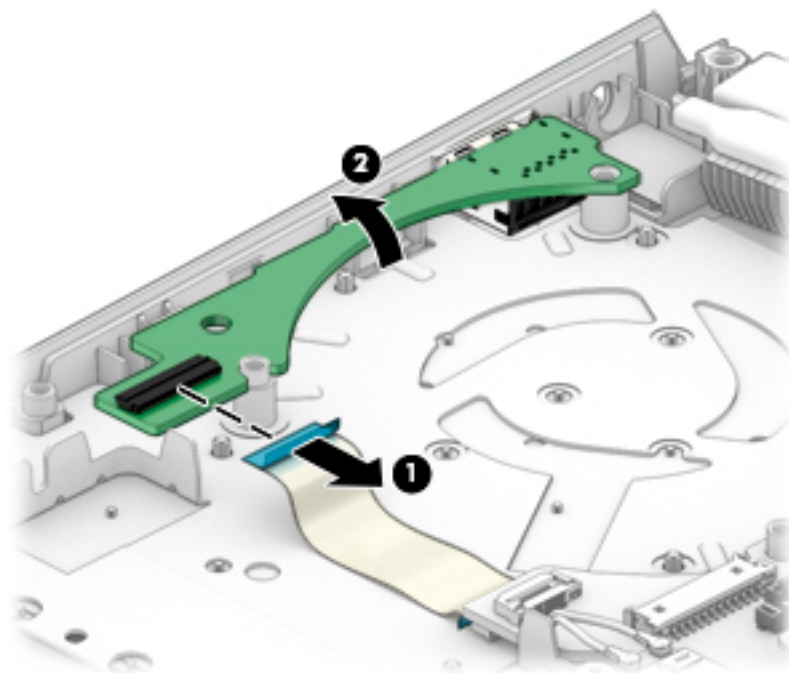

Reverse this procedure to install the USB board.

System board



NOTE: All system board spare part kits include replacement thermal material.

All system boards use the following part numbers:

xxxxxx-001: Non-Windows operating systems

xxxxxx-601: Windows operating system

| Description | Spare part number |
|---|-------------------|
| Intel Core i5-8300H (2.3 GHz, turbo up to 4.0 GHz), 2666 MHz/8 MB L3, Quad core, TDP 45 W, Discrete N17P-G0 Graphics with NVIDIA N17P-G0 (GeForce GTX 1050), 2 GB | L24327-xx1 |
| Intel Core i5-8300H (2.3 GHz, turbo up to 4.0 GHz), 2666 MHz/8 MB L3, Quad core, TDP 45 W, Discrete N17P-G0 Graphics with NVIDIA N17P-G0 (GeForce GTX 1050), 4 GB | L24329-xx1 |
| Intel Core i7-8750H (2.2 GHz, turbo up to 4.1 GHz), 2666 MHz/9 MB L3, Hexa core, TDP 45 W, Discrete N17P-G0 Graphics with NVIDIA N17P-G0 (GeForce GTX 1050), 4 GB | L24330-xx1 |
| Intel Core i7-8750H (2.2 GHz, turbo up to 4.1 GHz), 2666 MHz/9 MB L3, Hexa core, TDP 45 W, Discrete N17P-G1 Graphics with NVIDIA N17P-G1 (GeForce GTX 1050 Ti), 4 GB | L24331-xx1 |
| Intel Core i7-8750H (2.2 GHz, turbo up to 4.1 GHz), 2666 MHz/9 MB L3, Hexa core, TDP 45 W, Discrete N17E-G1 Graphics with NVIDIA N17E-G2 (GeForce GTX 1060), 3 GB | L24332-xx1 |
| Intel Core i7-8750H (2.2 GHz, turbo up to 4.1 GHz), 2666 MHz/9 MB L3, Hexa core, TDP 45 W, Discrete N17E-G2 Graphics with NVIDIA N17E-G2 (GeForce GTX 1070), 8 GB | L24333-xx1 |
| Intel Core i7-8750H (2.2 GHz, turbo up to 4.1 GHz), 2666 MHz/9 MB L3, Hexa core, TDP 45 W, Discrete N17E-G1 Graphics with NVIDIA N17E-G2 (GeForce GTX 1060), 6 GB | L24334-xx1 |
| Intel Core i7-8750H (2.2 GHz, turbo up to 4.1 GHz), 2666 MHz/9 MB L3, Hexa core, TDP 45 W, Discrete N17E-G1 Graphics with NVIDIA N17E-G2 (GeForce GTX 1060), 6 GB, fGSync | L24335-xx1 |
| Intel Core i7-8750H (2.2 GHz, turbo up to 4.1 GHz), 2666 MHz/9 MB L3, Hexa core, TDP 45 W, Discrete N17P-G0 Graphics with NVIDIA N17P-G0 (GeForce GTX 1050), 2 GB | L24336-xx1 |
| Intel Core i5-8300H (2.3 GHz, turbo up to 4.0 GHz), 2666 MHz/8 MB L3, Quad core, TDP 45 W, Discrete N17E-G1 Graphics with NVIDIA N17E-G2 (GeForce GTX 1060), 4 GB | L24337-xx1 |
| Intel Core i5-8300H (2.3 GHz, turbo up to 4.0 GHz), 2666 MHz/8 MB L3, Quad core, TDP 45 W, Discrete N17E-G1 Graphics with NVIDIA N17E-G2 (GeForce GTX 1060), 3 GB | L24338-xx1 |
| Intel Core i5-8300H (2.3 GHz, turbo up to 4.0 GHz), 2666 MHz/8 MB L3, Quad core, TDP 45 W, Discrete N17E-G1 Graphics with NVIDIA N17E-G2 (GeForce GTX 1060), 6 GB | L25148-xx1 |

Before removing the system board, follow these steps:

1. Turn off the computer. If you are unsure whether the computer is off or in Hibernation, turn the computer on, and then shut it down through the operating system.
2. Disconnect the power from the computer by unplugging the power cord from the computer.
3. Disconnect all external devices from the computer.
4. Remove the any smart cards and memory cards.
5. Remove the base enclosure (see [Base enclosure on page 35](#)).
6. Remove the battery (see [Battery on page 46](#)).
7. Remove the hard drive (see [Hard drive \(HDD\) on page 38](#)).

8. Remove the SSD (see [Solid-state drive \(SSD\) on page 40](#)).
9. Remove the power connector cable (see [Power connector cable on page 52](#)).
10. Remove the fans (see [Fans on page 49](#)).

When replacing the system board, be sure to remove the following components (as applicable) from the defective system board and install on the replacement system board:

- Heat sink (see [Heat sink on page 58](#))

Remove the system board:

1. Make sure to disconnect the following cables from the system board:
 - (1) Drive cable
 - (2) Power connector cable
 - (3) Fan cable
 - (4) Display cable
 - (5) Fan cable
 - (6) Audio cable
 - (7) Speaker cable
 - (8) Smart card cable
 - (9) TouchPad cable
 - (10) Keyboard cable
 - (11) Backlight cable

 **NOTE:** The fan cables were disconnected from the system board when the fans were removed.

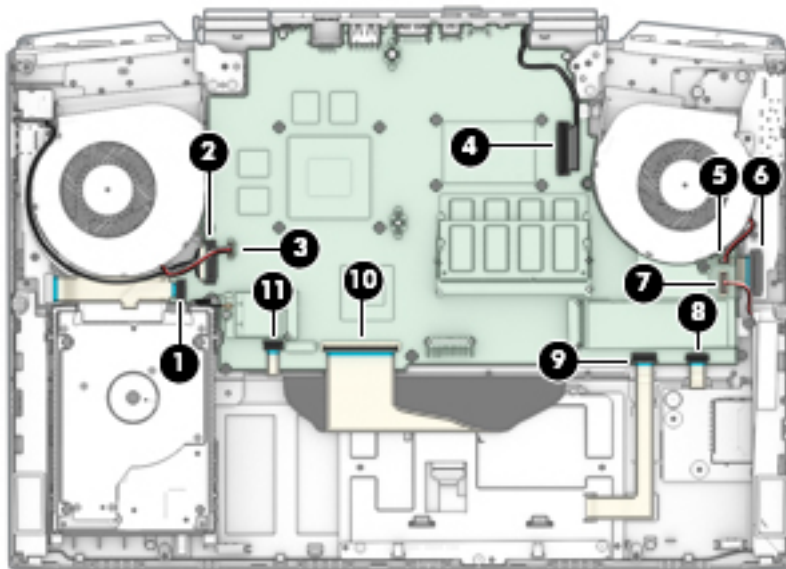

2. Remove the plastic guides (1) and M2.5x4 Phillips head screws (2).

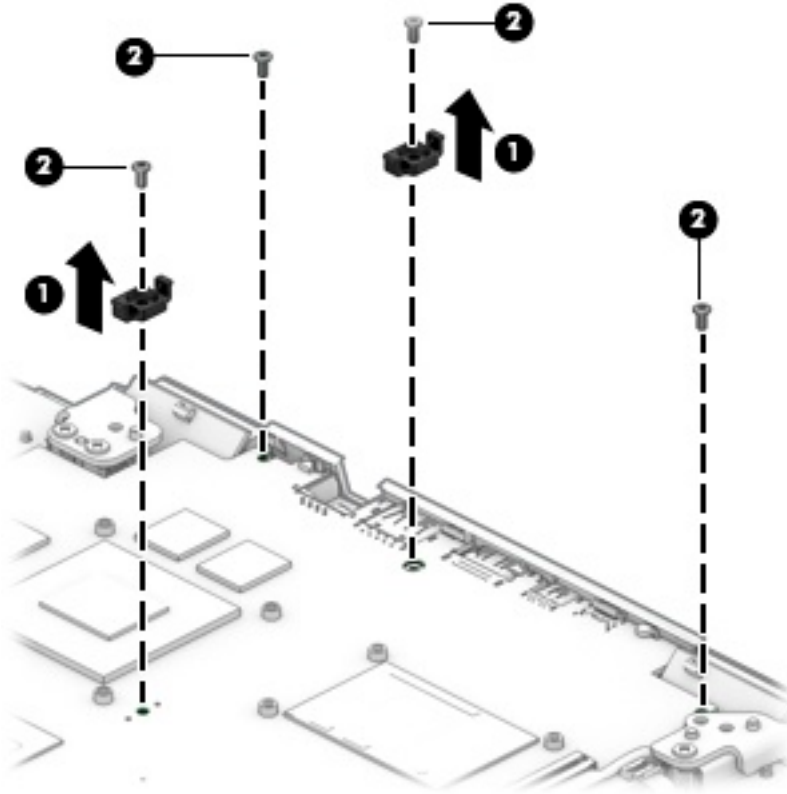

3. Pull the system board (1) up to disengage the connectors, and then remove the system board (2).

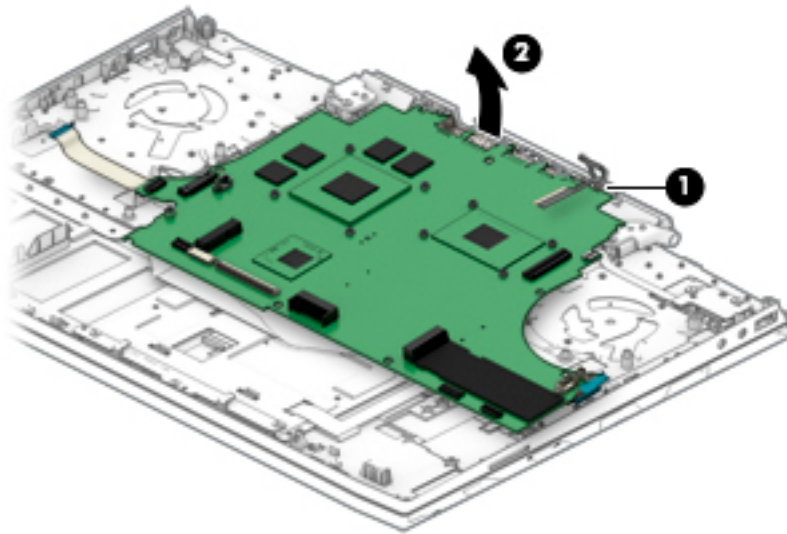

4. Release the USB cable **(1)**, and then disconnect the audio board cable **(2)** from the bottom of the system board.

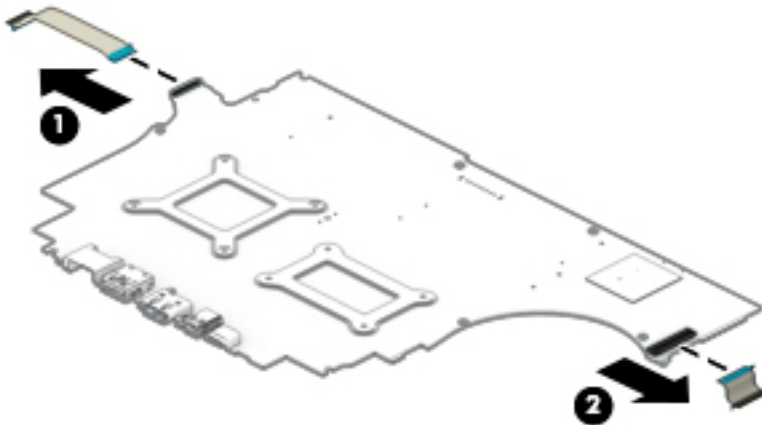

Reverse this procedure to install the system board.

Heat sink

| Description | Spare part number |
|------------------|-------------------|
| Heat sink | |
| N17E | L24357-001 |
| N17P | L24358-001 |

Before removing the heat sink, follow these steps:

1. Turn off the computer. If you are unsure whether the computer is off or in Hibernation, turn the computer on, and then shut it down through the operating system.
2. Disconnect the power from the computer by unplugging the power cord from the computer.
3. Disconnect all external devices from the computer.
4. Remove the any smart cards and memory cards.
5. Remove the base enclosure (see [Base enclosure on page 35](#)).
6. Remove the battery (see [Battery on page 46](#)).
7. Remove the hard drive (see [Hard drive \(HDD\) on page 38](#)).
8. Remove the SSD (see [Solid-state drive \(SSD\) on page 40](#)).
9. Remove the power connector cable (see [Power connector cable on page 52](#)).
10. Remove the fans (see [Fans on page 49](#)).

Remove the heat sink:

1. Remove the eight Phillips head screws **(1)** that secure the heat sink to the system board.

2. Remove the heat sink (2).

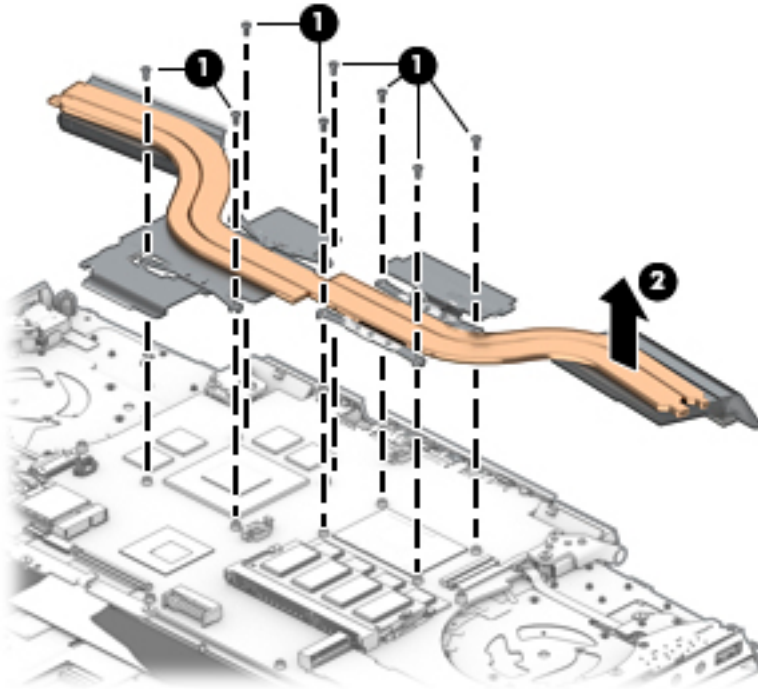

 **NOTE:** The thermal material must be thoroughly cleaned from the surfaces of the heat sink and the system board components each time the heat sink is removed. Thermal paste is used on the processor (1) and (3) and the heat sink section (2) and (4) that services it.

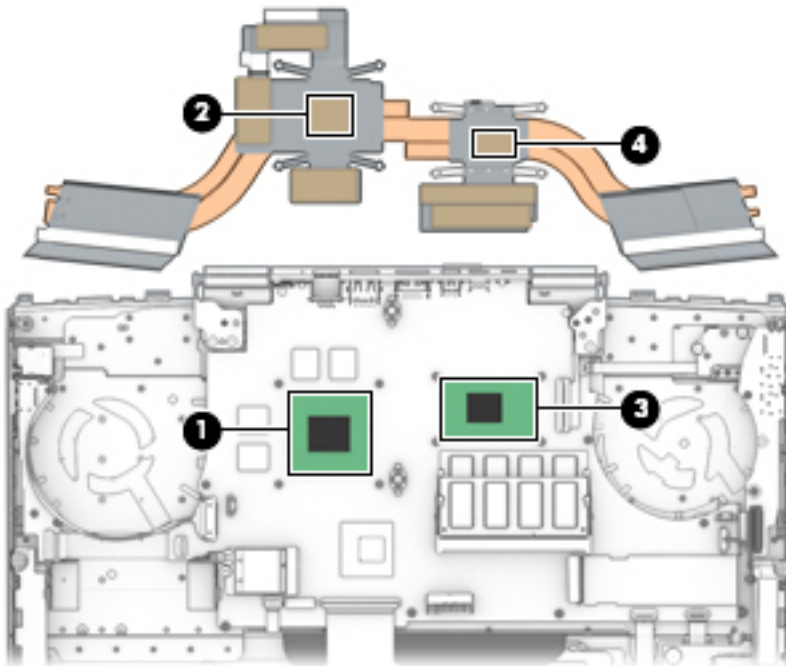

Reverse this procedure to install the heat sink.

TouchPad board

| Description | Spare part number |
|------------------|-------------------|
| TouchPad bracket | L24356-001 |
| TouchPad board | L24355-001 |

Before removing the TouchPad board, follow these steps:

1. Turn off the computer. If you are unsure whether the computer is off or in Hibernation, turn the computer on, and then shut it down through the operating system.
2. Disconnect the power from the computer by unplugging the power cord from the computer.
3. Disconnect all external devices from the computer.
4. Remove the base enclosure (see [Base enclosure on page 35](#)).
5. Remove the battery (see [Battery on page 46](#)).
6. Remove the hard drive (see [Hard drive \(HDD\) on page 38](#)).
7. Remove the SSD (see [Solid-state drive \(SSD\) on page 40](#)).
8. Release the speaker cables from the TouchPad click board bracket (see [Speakers on page 47](#)).

To remove the TouchPad board:

1. Remove the three Phillips 5 mm screws **(1)** that secure the TouchPad board bracket to the computer.
2. Remove the bracket **(2)** from the computer.

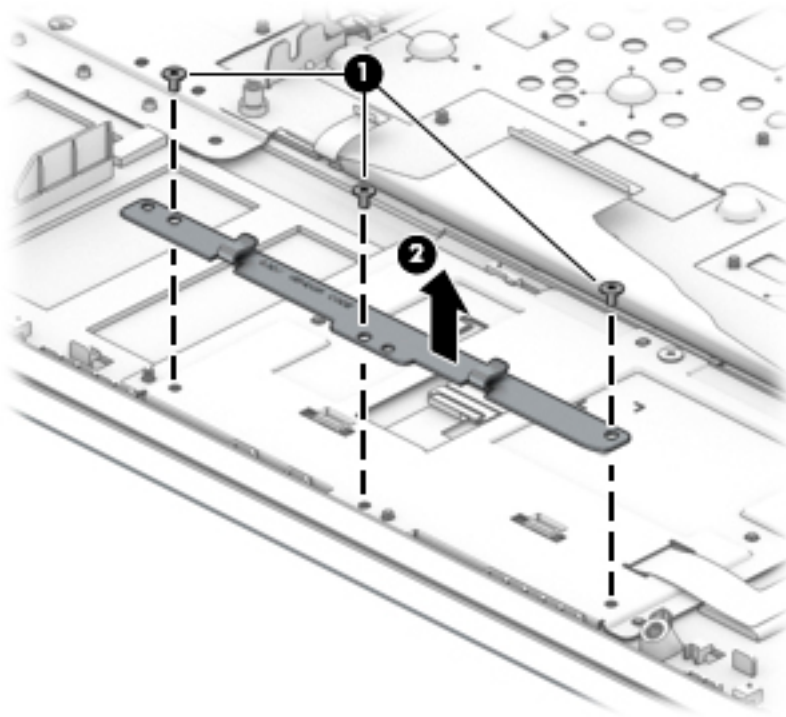

3. Disconnect the TouchPad cable **(1)** from the system board.

4. Remove the Phillips screw **(2)** that secures the TouchPad click board to the computer, and then release the thermal tape connected to the board.
5. Lift the front of the TouchPad board **(3)** to disconnect it from the plastic clips.
6. Release the plastic clips **(4)** securing the board to the computer, and then remove the board.

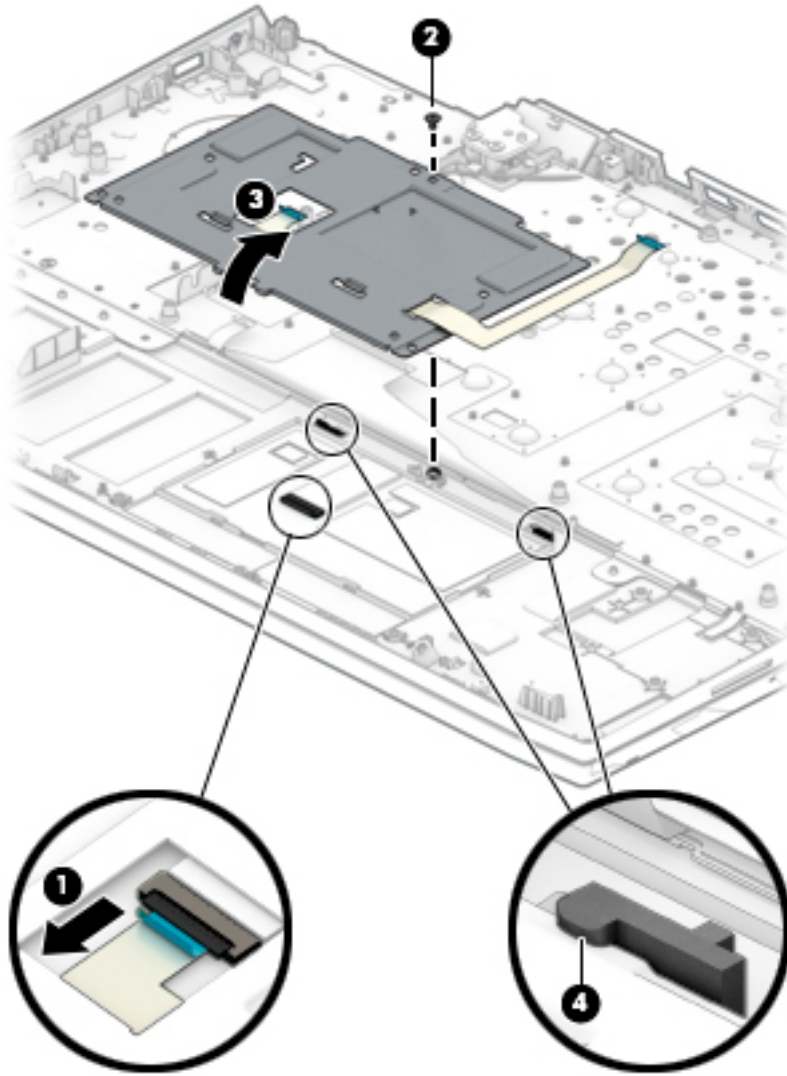

Reverse this procedure to install the TouchPad board.

Power button board

| Description | Spare part number |
|--------------------|-------------------|
| Power button board | L14374-001 |

Before removing the power button board, follow these steps:

1. Turn off the computer. If you are unsure whether the computer is off or in Hibernation, turn the computer on, and then shut it down through the operating system.
2. Disconnect the power from the computer by unplugging the power cord from the computer.
3. Disconnect all external devices from the computer.
4. Remove the any smart cards and memory cards.
5. Remove the base enclosure (see [Base enclosure on page 35](#)).
6. Remove the battery (see [Battery on page 46](#)).
7. Remove the hard drive (see [Hard drive \(HDD\) on page 38](#)).
8. Remove the SSD (see [Solid-state drive \(SSD\) on page 40](#)).
9. Remove the power connector cable (see [Power connector cable on page 52](#)).
10. Remove the fans (see [Fans on page 49](#)).
11. Remove the system board (see [System board on page 55](#)).

Remove the power button board:

1. Remove the two Phillips 3 mm screws **(1)** that secure the power button board.
2. Disconnect the power button board cable **(2)**.

3. Remove the power button board (3) from the computer.

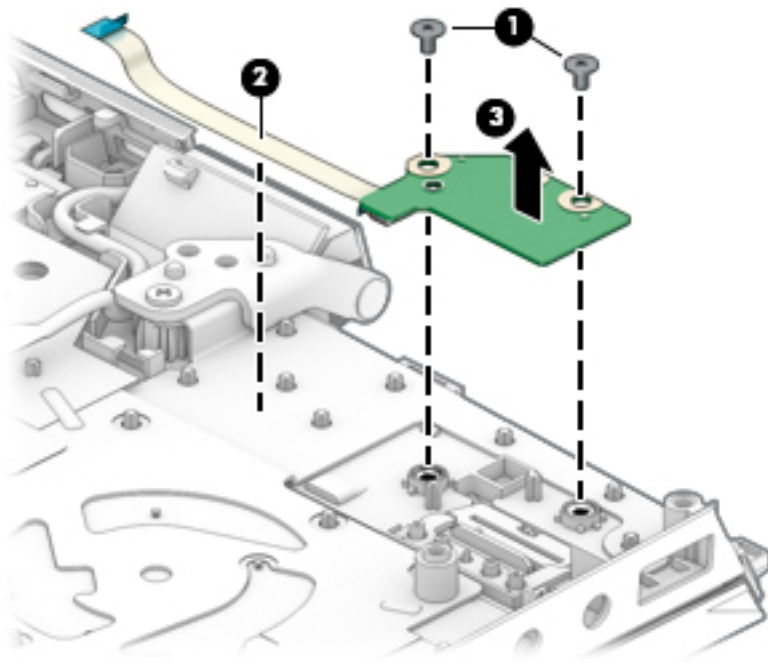

Reverse this procedure to install the power button board.

Display assembly



NOTE: Display assemblies are spared at the subcomponent level only. Additional display assembly spare part information is available at [Display assembly subcomponents on page 27](#).

Before removing the display assembly, follow these steps:

1. Turn off the computer. If you are unsure whether the computer is off or in Hibernation, turn the computer on, and then shut it down through the operating system.
2. Disconnect the power from the computer by unplugging the power cord from the computer.
3. Disconnect all external devices from the computer.
4. Remove the any smart cards and memory cards.
5. Remove the base enclosure (see [Base enclosure on page 35](#)).
6. Remove the battery (see [Battery on page 46](#)).
7. Remove the hard drive (see [Hard drive \(HDD\) on page 38](#)).
8. Remove the SSD (see [Solid-state drive \(SSD\) on page 40](#)).
9. Remove the power connector cable (see [Power connector cable on page 52](#)).
10. Remove the fans (see [Fans on page 49](#)).
11. Remove the system board (see [System board on page 55](#)).

Remove the display assembly:

1. Remove the three Phillips M2.5×5.0 screws **(1)** from the display cable brackets.
2. Position the display hinges **(2)** up.
3. Remove the antenna cables from the clips built into the computer **(3)**.

4. Lift the display assembly **(4)** straight up and remove it.

⚠ CAUTION: When installing the display assembly, be sure that the wireless antenna cables are routed and arranged properly.

Failure to properly route the antennas can result in degradation of the computer's wireless performance.

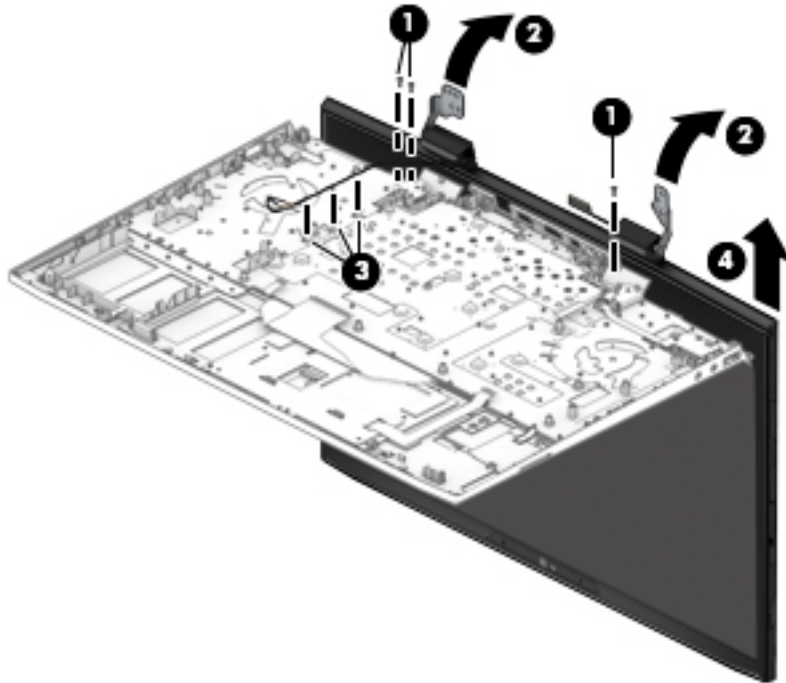

5. To remove the display bezel, flex the top **(1)** of the bezel, the inside edges of the left and right sides **(2)**, and then the bottom **(3)** of the bezel until it disengages from the display enclosure.

6. Remove the display bezel (4).

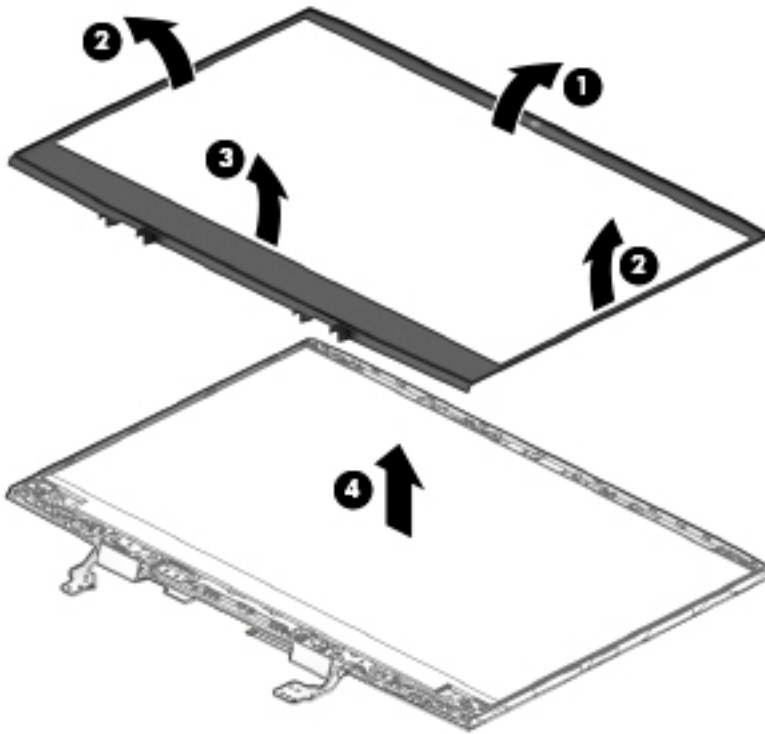

7. To remove the camera module, disconnect the cable (1) from the camera module board, and then remove the module (2) from the display

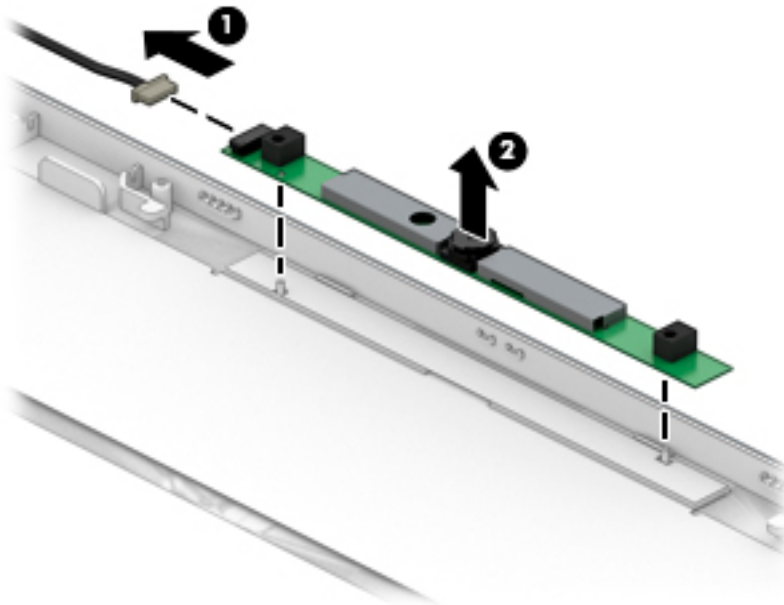

8. If it is necessary to remove the display panel from the enclosure, pull the display adhesive strips **(1)**, and then rotate the panel **(2)** forward.

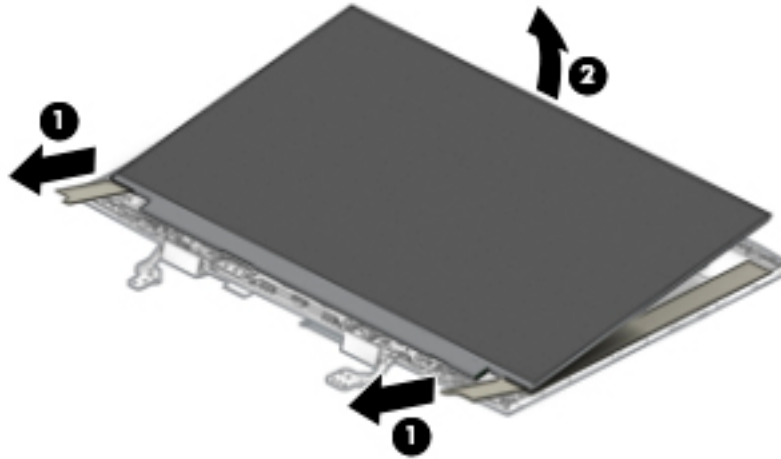

9. On the back of the display panel, lift the tape from atop the connector and then remove the cable **(1)**.
10. Remove the panel **(2)**.

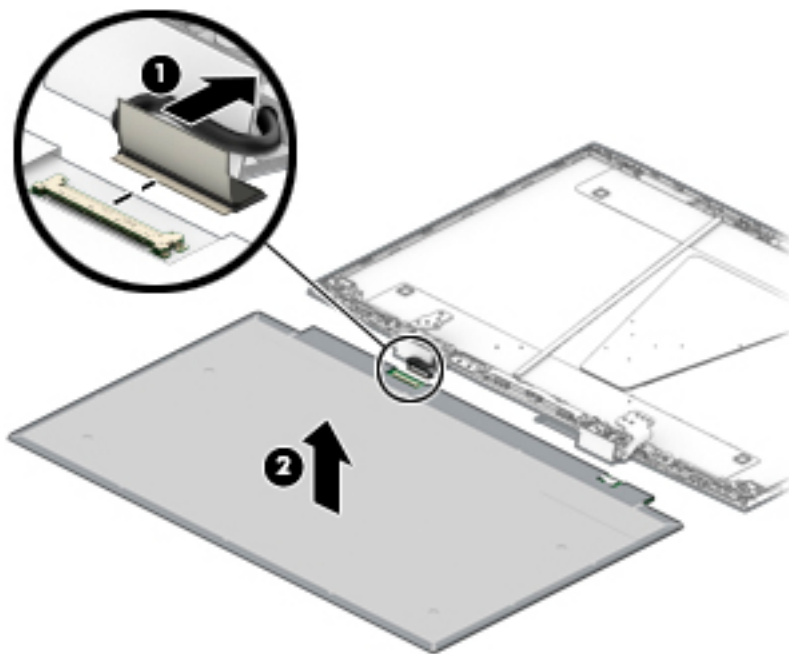

11. If it is necessary to replace the display hinges, remove the four Phillips M2.5x11.0 screws **(1)** that secure each hinge, and then remove the hinges **(2)** from the display enclosure.

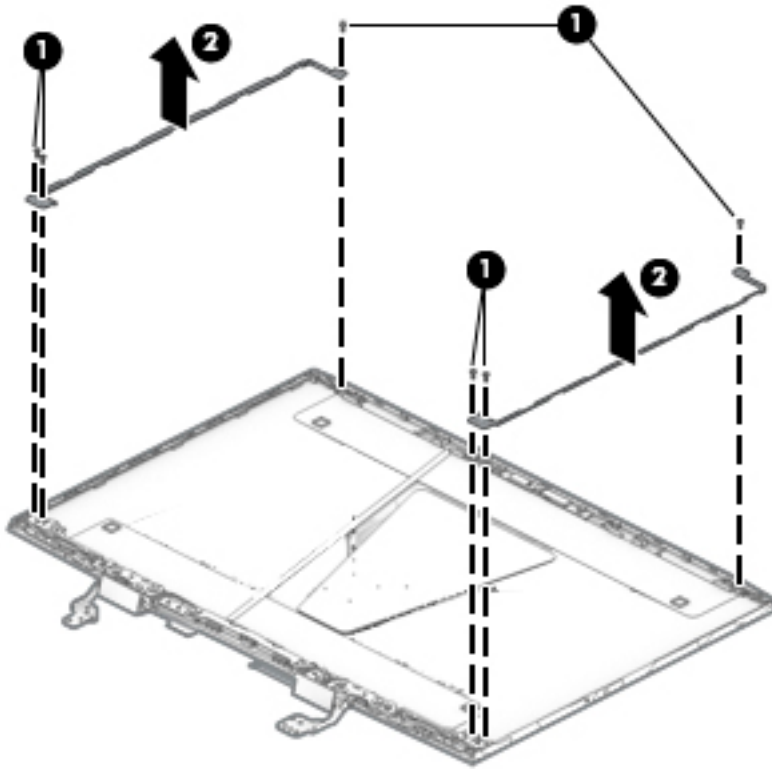

12. If it is necessary to replace the display hinge brackets, remove the six Phillips screws (1) that secure each bracket, and then remove the bracket (2) from the display enclosure.

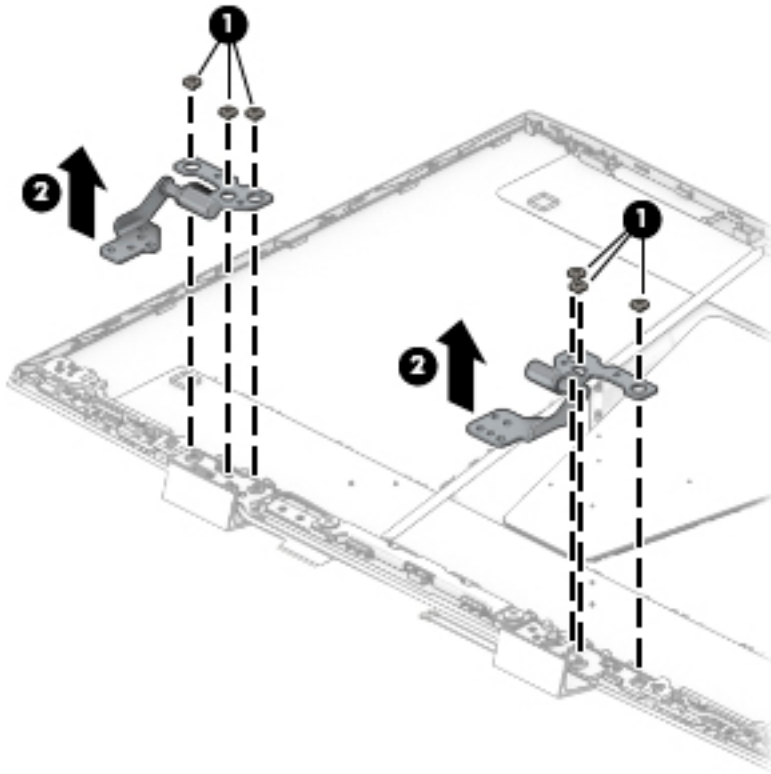

13. If it is necessary to replace the display cable, release the cable from adhesive (1), release the cable from the routing path (2) on the bottom of the display enclosure, and then remove the cable (3).

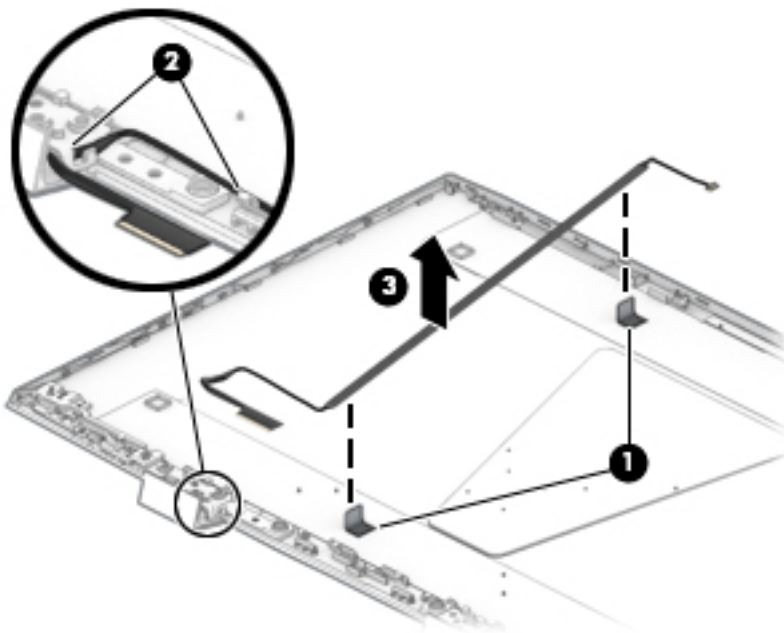

14. If it is necessary to replace the WLAN antenna cables, peel the antennas from the top of the display enclosure (1), remove the antenna cables from the routing path on the bottom of the display enclosure (2), and then remove the antenna cables.

 **NOTE:** The WLAN antennas are spared with the display enclosure.

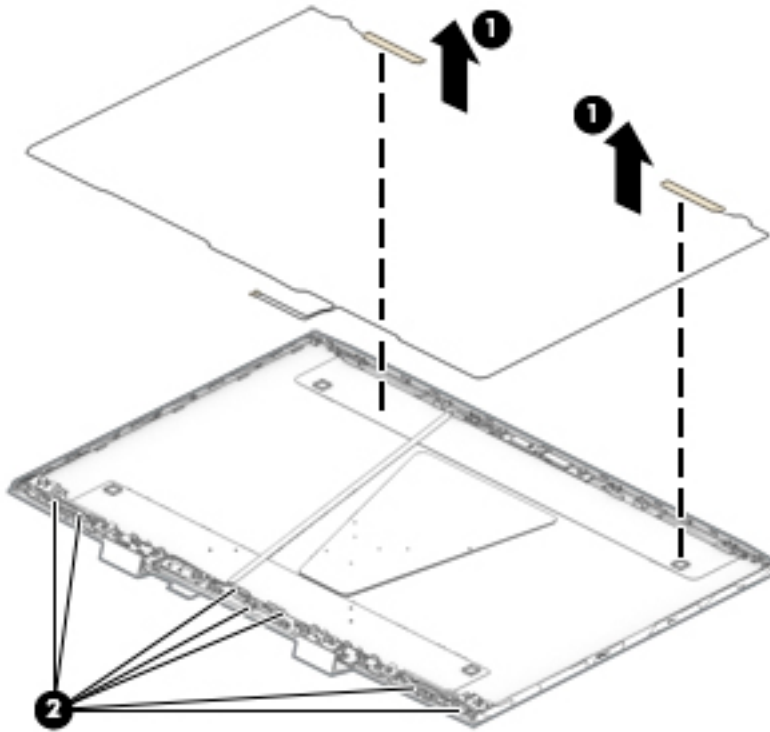

Reverse this procedure to reassemble and install the display assembly.

Keyboard/top cover



NOTE: The table below lists an XXX extension. The country part number extensions are listed in the next table.



NOTE: The keyboard cable is included.

| Description | Spare part number |
|---|-------------------|
| Full-size backlit 3-coat paint island-style keyboard with numeric key pad, 2-zone lighting, Dragon Red with red backlight, N17P | L24369-XXX |
| Full-size backlit 3-coat paint island-style keyboard with numeric key pad, 4-zone lighting, white with RGB backlight, N17P | L32770-XXX |
| Full-size backlit 3-coat paint island-style keyboard with numeric key pad, 2-zone lighting, Dragon Red with red backlight, N17E | L32774-XXX |
| Full-size backlit 3-coat paint island-style keyboard with numeric key pad, 4-zone lighting, white with RGB backlight, N17E | L32775-XXX |

| Description | Spare part number extension | Description | Spare part number |
|--|-----------------------------|-------------------------------|-------------------|
| For use in Belgium | A41 | For use in Portugal | 131 |
| For use in Bulgaria | 261 | For use in Romania | 271 |
| For use in Canada | DB1 | For use in Russia | 251 |
| For use in the Czech Republic and Slovenia | FL1 | For use in Saudi Arabia | 171 |
| For use in Denmark, Finland, and Norway | DH1 | For use in Slovenia | BA1 |
| For use in France | 051 | For use in South Korea | AD1 |
| For use in Germany | 041 | For use in Spain | 071 |
| For use in Greece | 151 | For use in Switzerland | BG1 |
| For use in Hungary | 211 | For use in Taiwan | AB1 |
| For use in Israel | BB1 | For use in Thailand | 281 |
| For use in Italy | 061 | For use in Turkey | 141 |
| For use in Japan | 291 | For use in the United Kingdom | 031 |
| For use in Latin America | 161 | For use in the United States | 001 |
| For use in the Netherlands | B31 | | |

The keyboard/top cover is what remains when all parts are removed.

7 Using Setup Utility (BIOS)

Setup Utility, or Basic Input/Output System (BIOS), controls communication between all the input and output devices on the system (such as disk drives, display, keyboard, mouse, and printer). Setup Utility (BIOS) includes settings for the types of devices installed, the startup sequence of the computer, and the amount of system and extended memory.

 **NOTE:** To start Setup Utility on convertible computers, your computer must be in notebook mode and you must use the keyboard attached to your notebook.

Starting Setup Utility (BIOS)

 **CAUTION:** Use extreme care when making changes in Setup Utility (BIOS). Errors can prevent the computer from operating properly.

- ▲ Turn on or restart the computer, quickly press `esc`, and then press `f10`.

Updating Setup Utility (BIOS)

Updated versions of Setup Utility (BIOS) may be available on the HP website.

Most BIOS updates on the HP website are packaged in compressed files called *SoftPaqs*.

Some download packages contain a file named `Readme.txt`, which contains information regarding installing and troubleshooting the file.

Determining the BIOS version

To decide whether you need to update Setup Utility (BIOS), first determine the BIOS version on your computer.

To reveal the BIOS version information (also known as *ROM date* and *System BIOS*), use one of these options.

- HP Support Assistant
 1. Type `support` in the taskbar search box, and then select the **HP Support Assistant** app.
– or –
Click the question mark icon in the taskbar.
 2. Select **My PC**, and then select **Specifications**.
- Setup Utility (BIOS)
 1. Start Setup Utility (BIOS) (see [Starting Setup Utility \(BIOS\) on page 72](#)).
 2. Select **Main**, select **System Information**, and then make note of the BIOS version.
 3. Select **Exit**, select **No**, and then follow the on-screen instructions.

To check for later BIOS versions, see [Downloading a BIOS update on page 73](#).

Downloading a BIOS update

 **CAUTION:** To reduce the risk of damage to the computer or an unsuccessful installation, download and install a BIOS update only when the computer is connected to reliable external power using the AC adapter. Do not download or install a BIOS update while the computer is running on battery power, docked in an optional docking device, or connected to an optional power source. During the download and installation, follow these instructions:

- Do not disconnect power from the computer by unplugging the power cord from the AC outlet.
- Do not shut down the computer or initiate Sleep.
- Do not insert, remove, connect, or disconnect any device, cable, or cord.

 **NOTE:** If your computer is connected to a network, consult the network administrator before installing any software updates, especially system BIOS updates.

1. Type `support` in the taskbar search box, and then select the **HP Support Assistant** app.
– or –
Click the question mark icon in the taskbar.
2. Click **Updates**, and then click **Check for updates and messages**.
3. Follow the on-screen instructions.
4. At the download area, follow these steps:
 - a. Identify the most recent BIOS update and compare it to the BIOS version currently installed on your computer. If the update is more recent than your BIOS version, make a note of the date, name, or other identifier. You may need this information to locate the update later, after it has been downloaded to your hard drive.
 - b. Follow the on-screen instructions to download your selection to the hard drive.

Make a note of the path to the location on your hard drive where the BIOS update is downloaded. You will need to access this path when you are ready to install the update.

BIOS installation procedures vary. Follow any instructions that appear on the screen after the download is complete. If no instructions appear, follow these steps:

1. Type `file` in the taskbar search box, and then select **File Explorer**.
2. Click your hard drive designation. The hard drive designation is typically Local Disk (C:).
3. Using the hard drive path you recorded earlier, open the folder that contains the update.
4. Double-click the file that has an `.exe` extension (for example, `filename.exe`).
The BIOS installation begins.
5. Complete the installation by following the on-screen instructions.

 **NOTE:** After a message on the screen reports a successful installation, you can delete the downloaded file from your hard drive.

8 Using HP PC Hardware Diagnostics

Using HP PC Hardware Diagnostics Windows (select products only)

HP PC Hardware Diagnostics Windows is a Windows-based utility that allows you to run diagnostic tests to determine whether the computer hardware is functioning properly. The tool runs within the Windows operating system in order to diagnose hardware failures.

If HP PC Hardware Diagnostics Windows is not installed on your computer, first you must download and install it. To download HP PC Hardware Diagnostics Windows, see [Downloading HP PC Hardware Diagnostics Windows on page 74](#).

After HP PC Hardware Diagnostics Windows is installed, follow these steps to access it from HP Help and Support or HP Support Assistant.

1. To access HP PC Hardware Diagnostics Windows from HP Help and Support:
 - a. Select the **Start** button, and then select **HP Help and Support**.
 - b. Right-click **HP PC Hardware Diagnostics Windows**, select **More**, and then select **Run as administrator**.

– or –

To access HP PC Hardware Diagnostics Windows from HP Support Assistant:

- a. Type `support` in the taskbar search box, and then select the **HP Support Assistant** app.
 - or –
 - Select the question mark icon in the taskbar.
 - b. Select **Troubleshooting and fixes**.
 - c. Select **Diagnostics**, and then select **HP PC Hardware Diagnostics Windows**.
2. When the tool opens, select the type of diagnostic test you want to run, and then follow the on-screen instructions.



NOTE: If you need to stop a diagnostic test at any time, select **Cancel**.

3. When HP PC Hardware Diagnostics Windows detects a failure that requires hardware replacement, a 24-digit Failure ID code is generated. For assistance in correcting the problem, contact support, and then provide the Failure ID code.

Downloading HP PC Hardware Diagnostics Windows

- The HP PC Hardware Diagnostics Windows download instructions are provided in English only.
- You must use a Windows computer to download this tool because only .exe files are provided.

Downloading the latest HP PC Hardware Diagnostics Windows version

To download HP PC Hardware Diagnostics Windows, follow these steps:

1. Go to <http://www.hp.com/go/techcenter/pcdiags>. The HP PC Diagnostics home page is displayed.
2. In the **HP PC Hardware Diagnostics** section, select **Download**, and then select a location on your computer or a USB flash drive.

The tool is downloaded to the selected location.

Downloading HP Hardware Diagnostics Windows by product name or number (select products only)

 **NOTE:** For some products, it may be necessary to download the software to a USB flash drive by using the product name or number.

To download HP PC Hardware Diagnostics Windows by product name or number, follow these steps:

1. Go to <http://www.hp.com/support>.
2. Select **Get software and drivers**, select your type of product, and then enter the product name or number in the search box that is displayed.
3. In the **HP PC Hardware Diagnostics** section, select **Download**, and then select a location on your computer or a USB flash drive.

The tool is downloaded to the selected location.

Installing HP PC Hardware Diagnostics Windows

To install HP PC Hardware Diagnostics Windows, follow these steps:

- ▲ Navigate to the folder on your computer or the flash drive where the .exe file was downloaded, double-click the .exe file, and then follow the on-screen instructions.

Using HP PC Hardware Diagnostics UEFI

 **NOTE:** For Windows 10 S computers, you must use a Windows computer and a USB flash drive to download and create the HP UEFI support environment because only .exe files are provided. For more information, see [Downloading HP PC Hardware Diagnostics UEFI to a USB flash drive on page 76](#).

HP PC Hardware Diagnostics UEFI (Unified Extensible Firmware Interface) allows you to run diagnostic tests to determine whether the computer hardware is functioning properly. The tool runs outside the operating system so that it can isolate hardware failures from issues that are caused by the operating system or other software components.

If your PC will not boot into Windows, you can use HP PC Hardware Diagnostics UEFI to diagnose hardware issues.

When HP PC Hardware Diagnostics UEFI detects a failure that requires hardware replacement, a 24-digit Failure ID code is generated. For assistance in correcting the problem, contact support, and provide the Failure ID code.

 **NOTE:** To start diagnostics on a convertible computer, your computer must be in notebook mode, and you must use the attached keyboard.

 **NOTE:** If you need to stop a diagnostic test, press [esc](#).

Starting HP PC Hardware Diagnostics UEFI

To start HP PC Hardware Diagnostics UEFI, follow these steps:

1. Turn on or restart the computer, and quickly press **esc**.
2. Press **f2**.

The BIOS searches three places for the diagnostic tools, in the following order:

- a. Connected USB flash drive



NOTE: To download the HP PC Hardware Diagnostics UEFI tool to a USB flash drive, see [Downloading the latest HP PC Hardware Diagnostics UEFI version on page 76](#).

- b. Hard drive

- c. BIOS

3. When the diagnostic tool opens, select the type of diagnostic test you want to run, and then follow the on-screen instructions.

Downloading HP PC Hardware Diagnostics UEFI to a USB flash drive

Downloading HP PC Hardware Diagnostics UEFI to a USB flash drive can be useful in the following situations:

- HP PC Hardware Diagnostics UEFI is not included in the preinstall image.
- HP PC Hardware Diagnostics UEFI is not included in the HP Tool partition.
- The hard drive is damaged.



NOTE: The HP PC Hardware Diagnostics UEFI download instructions are provided in English only, and you must use a Windows computer to download and create the HP UEFI support environment because only .exe files are provided.

Downloading the latest HP PC Hardware Diagnostics UEFI version

To download the latest HP PC Hardware Diagnostics UEFI version to a USB flash drive:

1. Go to <http://www.hp.com/go/techcenter/pcdiags>. The HP PC Diagnostics home page is displayed.
2. In the **HP PC Hardware Diagnostics UEFI** section, select **Download UEFI Diagnostics**, and then select **Run**.

Downloading HP PC Hardware Diagnostics UEFI by product name or number (select products only)



NOTE: For some products, it may be necessary to download the software to a USB flash drive by using the product name or number.

To download HP PC Hardware Diagnostics UEFI by product name or number (select products only) to a USB flash drive:

1. Go to <http://www.hp.com/support>.
2. Enter the product name or number, select your computer, and then select your operating system.
3. In the **Diagnostics** section, follow the on-screen instructions to select and download the specific UEFI Diagnostics version for your computer.

Using Remote HP PC Hardware Diagnostics UEFI settings (select products only)

Remote HP PC Hardware Diagnostics UEFI is a firmware (BIOS) feature that downloads HP PC Hardware Diagnostics UEFI to your computer. It can then execute the diagnostics on your computer, and it may upload results to a preconfigured server. For more information on Remote HP PC Hardware Diagnostics UEFI, go to <http://www.hp.com/go/techcenter/pcdiags>, and then select **Find out more**.

Downloading Remote HP PC Hardware Diagnostics UEFI

 **NOTE:** HP Remote PC Hardware Diagnostics UEFI is also available as a Softpaq that can be downloaded to a server.

Downloading the latest Remote HP PC Hardware Diagnostics UEFI version

To download the latest Remote HP PC Hardware Diagnostics UEFI version, follow these steps:

1. Go to <http://www.hp.com/go/techcenter/pcdiags>. The HP PC Diagnostics home page is displayed.
2. In the **HP PC Hardware Diagnostics UEFI** section, select **Download Remote Diagnostics**, and then select **Run**.

Downloading Remote HP PC Hardware Diagnostics UEFI by product name or number

 **NOTE:** For some products, it may be necessary to download the software by using the product name or number.

To download HP Remote PC Hardware Diagnostics UEFI by product name or number, follow these steps:

1. Go to <http://www.hp.com/support>.
2. Select **Get software and drivers**, select your type of product, enter the product name or number in the search box that is displayed, select your computer, and then select your operating system.
3. In the **Diagnostics** section, follow the on-screen instructions to select and download the **Remote UEFI** version for the product.

Customizing Remote HP PC Hardware Diagnostics UEFI settings

Using the Remote HP PC Hardware Diagnostics setting in Computer Setup (BIOS), you can perform the following customizations:

- Set a schedule for running diagnostics unattended. You can also start diagnostics immediately in interactive mode by selecting **Execute Remote HP PC Hardware Diagnostics**.
- Set the location for downloading the diagnostic tools. This feature provides access to the tools from the HP website or from a server that has been preconfigured for use. Your computer does not require the traditional local storage (such as a disk drive or USB flash drive) to run remote diagnostics.
- Set a location for storing the test results. You can also set the user name and password settings used for uploads.
- Display status information about the diagnostics run previously.

To customize Remote HP PC Hardware Diagnostics UEFI settings, follow these steps:

1. Turn on or restart the computer, and when the HP logo appears, press **f10** to enter Computer Setup.
2. Select **Advanced**, and then select **Settings**.

3. Make your customization selections.
4. Select **Main**, and then **Save Changes and Exit** to save your settings.

Your changes take effect when the computer restarts.

9 Specifications

| | Metric | U.S. |
|---|----------------------------|---------------------|
| Computer dimensions | | |
| Width | 36.0 cm | 14.17 in |
| Depth | 26.3 cm | 10.35 in |
| Height | .25 cm | 0.098 in |
| Weight | | |
| SSD+52 W battery+N17P | 2.324 kg | 5.12 lbs |
| HD+52W battery+N17P | 2.386 kg | 5.26 lbs |
| HD+70W battery+N17P | 2.45 kg | 5.4 lbs |
| SSD+70W battery+N17E | 2.458 kg | 5.42 lbs |
| HD+70W battery+N17E | 2.520 kg | 5.56 lbs |
| Input power | Rating | |
| Operating voltage and current | 19.5 V dc @ 6.9 A – 135 W | |
| | 19.5 V dc @ 7.70 A – 150 W | |
| | 19.5 V dc @ 10.3 A – 200 W | |
| Temperature | | |
| Operating | 5°C to 35°C | 41°F to 95°F |
| Nonoperating | -20°C to 60°C | -4°F to 140°F |
| Relative humidity (noncondensing) | | |
| Operating | 10% to 90% | |
| Nonoperating | 5% to 95% | |
| Maximum altitude (unpressurized) | | |
| Operating | -15 m to 3,048 m | -50 ft to 10,000 ft |
| Nonoperating | -15 m to 12,192 m | -50 ft to 40,000 ft |
| NOTE: Applicable product safety standards specify thermal limits for plastic surfaces. The device operates well within this range of temperatures. | | |

10 Backing up, restoring, and recovering

This chapter provides information about the following processes, which are standard procedure for most products:

- **Backing up your personal information**—You can use Windows tools to back up your personal information (see [Using Windows tools on page 80](#)).
- **Creating a restore point**—You can use Windows tools to create a restore point (see [Using Windows tools on page 80](#)).
- **Creating recovery media** (select products only)—You can use HP Recovery Manager or HP Cloud Recovery Download Tool (select products only) to create recovery media (see [Creating HP Recovery media \(select products only\) on page 80](#)).
- **Restoring and recovery**—Windows offers several options for restoring from backup, refreshing the computer, and resetting the computer to its original state (see [Using Windows tools on page 80](#)).
- **Removing the Recovery Partition**—To remove the Recovery partition to reclaim hard drive space (select products only), select the **Remove Recovery Partition** option of HP Recovery Manager. For more information, see [Removing the HP Recovery partition \(select products only\) on page 84](#).

Using Windows tools

 **IMPORTANT:** Windows is the only option that allows you to back up your personal information. Schedule regular backups to avoid information loss.

You can use Windows tools to back up personal information and create system restore points and recovery media, allowing you to restore from backup, refresh the computer, and reset the computer to its original state.

 **NOTE:** If computer storage is 32 GB or less, Microsoft System Restore is disabled by default.

For more information and steps, see the Get Help app.

- ▲ Select the **Start** button, and then select the **Get Help** app.

 **NOTE:** You must be connected to the Internet to access the Get Help app.

Creating HP Recovery media (select products only)

After you have successfully set up the computer, use HP Recovery Manager to create a backup of the HP Recovery partition on the computer. This backup is called HP Recovery media. In cases where the hard drive is corrupted or has been replaced, the HP Recovery media can be used to reinstall the original operating system.

To check for the presence of the Recovery partition in addition to the Windows partition, right-click the **Start** button, select **File Explorer**, and then select **This PC**.

 **NOTE:** If your computer does not list the Recovery partition in addition to the Windows partition, contact support to obtain recovery discs. Go to <http://www.hp.com/support>, select your country or region, and then follow the on-screen instructions.

On select products, you can use the HP Cloud Recovery Download Tool to create HP Recovery media on a bootable USB flash drive. For more information, see [Using the HP Cloud Recovery Download Tool to create recovery media on page 82](#).

Using HP Recovery Manager to create recovery media

 **NOTE:** If you cannot create recovery media yourself, contact support to obtain recovery discs. Go to <http://www.hp.com/support>, select your country or region, and then follow the on-screen instructions.

Before you begin

Before you begin, note the following:

- Only one set of recovery media can be created. Handle these recovery tools carefully, and keep them in a safe place.
- HP Recovery Manager examines the computer and determines the required media storage capacity.
- To create recovery media, use one of the following options:

 **NOTE:** If the computer does not have a recovery partition, HP Recovery Manager displays the Windows Create a Recovery Drive feature. Follow the on-screen instructions to create a recovery image on a blank USB flash drive or hard drive.

- If your computer has an optical drive with DVD writer capability, be sure to use only high-quality blank DVD-R, DVD+R, DVD-R DL, or DVD+R DL discs. Do not use rewritable discs such as CD±RW, DVD±RW, double-layer DVD±RW, or BD-RE (rewritable Blu-ray) discs, which are not compatible with HP Recovery Manager software.
 - If your computer does not include an integrated optical drive with DVD writer capability, you can use an external optical drive (purchased separately) to create recovery discs, as described above. If an external optical drive is used, you must connect it directly to a USB port on the computer. It cannot be connected to a USB port on an external device, such as a USB hub.
 - To create a recovery flash drive, use a high-quality blank USB flash drive.
- Be sure that the computer is connected to AC power before you begin creating the recovery media.
 - The creation process can take an hour or more. Do not interrupt this process.
 - If necessary, you can exit the program before you have finished creating all of the recovery media. HP Recovery Manager will finish the current DVD or flash drive. The next time you start HP Recovery Manager, you will be prompted to continue.

Creating the recovery media

To create HP Recovery media using HP Recovery Manager:

 **IMPORTANT:** For a tablet with a detachable keyboard, connect the tablet to the keyboard base before beginning these steps.

1. Type `recovery` in the taskbar search box, and then select **HP Recovery Manager**.
2. Select **Create recovery media**, and then follow the on-screen instructions.

If you need to recover the system, see [Recovering using HP Recovery Manager on page 82](#).

Using the HP Cloud Recovery Download Tool to create recovery media

To create HP Recovery media using the HP Cloud Recovery Download Tool:

1. Go to <http://www.hp.com/support>.
2. Select **Software and Drivers**, and then follow the on-screen instructions.

Restoring and recovery

Restoring and recovery can be performed using one or more of the following options: Windows tools, HP Recovery Manager, or the HP Recovery partition.

 **IMPORTANT:** Not all methods are available on all products.

Restoring, resetting, and refreshing using Windows tools

Windows offers several options for restoring, resetting, and refreshing the computer. For details, see [Using Windows tools on page 80](#).

Restoring using HP Recovery Manager and the HP Recovery partition

You can use HP Recovery Manager and the HP Recovery partition (select products only) to restore the computer to the original factory state:

- **Resolving problems with preinstalled applications or drivers**—To correct a problem with a preinstalled application or driver:
 1. Type `recovery` in the taskbar search box, and then select **HP Recovery Manager**.
 2. Select **Reinstall drivers and/or applications**, and then follow the on-screen instructions.
- **Using System Recovery**—To recover the Windows partition to original factory content, select the **System Recovery** option from the HP Recovery partition (select products only) or use the HP Recovery media. For more information, see [Recovering using HP Recovery Manager on page 82](#). If you have not already created recovery media, see [Creating HP Recovery media \(select products only\) on page 80](#).
- **Using Factory Reset** (select products only)—Restores the computer to its original factory state by deleting all information from the hard drive and recreating the partitions and then reinstalling the operating system and the software that was installed at the factory (select products only). To use the **Factory Reset** option, you must use HP Recovery media. If you have not already created recovery media, see [Creating HP Recovery media \(select products only\) on page 80](#).

 **NOTE:** If you have replaced the hard drive in the computer, you can use the Factory Reset option to install the operating system and the software that was installed at the factory.

Recovering using HP Recovery Manager

You can use HP Recovery Manager software to recover the computer to its original factory state by using the HP Recovery media that you either created or that you obtained from HP, or by using the HP Recovery partition (select products only).

If you have not already created HP Recovery media, see [Creating HP Recovery media \(select products only\) on page 80](#).

 **IMPORTANT:** HP Recovery Manager does not automatically provide backups of your personal data. Before beginning recovery, back up any personal data that you want to retain. See [Using Windows tools on page 80](#).

IMPORTANT: Recovery through HP Recovery Manager should be used as a final attempt to correct computer issues.

 **NOTE:** When you start the recovery process, only the options available for your computer are displayed.

Before you begin, note the following:

- HP Recovery Manager recovers only software that was installed at the factory. For software not provided with this computer, you must either download the software from the manufacturer's website or reinstall the software from the media provided by the manufacturer.
- If the computer hard drive fails, HP Recovery media must be used. This media is created using HP Recovery Manager. See [Creating HP Recovery media \(select products only\) on page 80](#).
- If your computer does not allow the creation of HP Recovery media or if the HP Recovery media does not work, contact support to obtain recovery media. Go to <http://www.hp.com/support>, select your country or region, and then follow the on-screen instructions.

Recovering using the HP Recovery partition (select products only)

The HP Recovery partition allows you to perform a system recovery without recovery discs or a recovery USB flash drive. This type of recovery can be used only if the hard drive is still working.

The HP Recovery partition (select products only) allows System Recovery only.

To start HP Recovery Manager from the HP Recovery partition:

 **IMPORTANT:** For a tablet with a detachable keyboard, connect the tablet to the keyboard base before beginning these steps (select products only).

1. Type `recovery` in the taskbar search box, select **HP Recovery Manager**, and then select **Windows Recovery Environment**.

– or –

For computers or tablets with keyboards attached:

- ▲ Press **f11** while the computer boots, or press and hold **f11** as you press the power button.

For tablets without keyboards:

- ▲ Turn on or restart the tablet, quickly hold down the volume up button, and then select **f11**.

2. Select **Troubleshoot** from the boot options menu.
3. Select **Recovery Manager**, and then follow the on-screen instructions.

 **NOTE:** If your computer does not automatically restart in HP Recovery Manager, change the computer boot order, and then follow the on-screen instructions. See [Changing the computer boot order on page 84](#).

Recovering using HP Recovery media

If your computer does not have an HP Recovery partition or if the hard drive is not working properly, you can use HP Recovery media to recover the original operating system and software programs that were installed at the factory.

- ▲ Insert the HP Recovery media, and then restart the computer.

 **NOTE:** If your computer does not automatically restart in HP Recovery Manager, change the computer boot order, and then follow the on-screen instructions. See [Changing the computer boot order on page 84](#).

Changing the computer boot order

If your computer does not restart in HP Recovery Manager, you can change the computer boot order. This is the order of devices listed in BIOS where the computer looks for startup information. You can change the selection to an optical drive or a USB flash drive, depending on the location of your HP Recovery media.

To change the boot order:

 **IMPORTANT:** For a tablet with a detachable keyboard, connect the tablet to the keyboard base before beginning these steps.

1. Insert the HP Recovery media.
2. Access the system **Startup** menu.

For computers or tablets with keyboards attached:

- ▲ Turn on or restart the computer or tablet, quickly press **esc**, and then press **f9** for boot options.

For tablets without keyboards:

- ▲ Turn on or restart the tablet, quickly hold down the volume up button, and then select **f9**.

– or –

Turn on or restart the tablet, quickly hold down the volume down button, and then select **f9**.

3. Select the optical drive or USB flash drive from which you want to boot, and then follow the on-screen instructions.

Removing the HP Recovery partition (select products only)

HP Recovery Manager software allows you to remove the HP Recovery partition (select products only) to free up hard drive space.

 **IMPORTANT:** After you remove the HP Recovery partition, you will not be able to perform System Recovery or create HP Recovery media. Before removing the Recovery partition, create HP Recovery media. See [Creating HP Recovery media \(select products only\) on page 80](#).

Follow these steps to remove the HP Recovery partition:

1. Type `recovery` in the taskbar search box, and then select **HP Recovery Manager**.
2. Select **Remove Recovery Partition**, and then follow the on-screen instructions.

11 Power cord set requirements

The wide-range input feature of the computer permits it to operate from any line voltage from 100 to 120 V ac, or from 220 to 240 V ac.

The 3-conductor power cord set included with the computer meets the requirements for use in the country or region where the equipment is purchased.

Power cord sets for use in other countries or regions must meet the requirements of the country and region where the computer is used.

Requirements for all countries

The following requirements are applicable to all countries and regions:

- The length of the power cord set must be at least **1.0 m** (3.3 ft) and no more than **2.0 m** (6.5 ft).
- All power cord sets must be approved by an acceptable accredited agency responsible for evaluation in the country or region where the power cord set will be used.
- The power cord sets must have a minimum current capacity of 10 A and a nominal voltage rating of 125 or 250 V ac, as required by the power system of each country or region.
- The appliance coupler must meet the mechanical configuration of an EN 60 320/IEC 320 Standard Sheet C13 connector for mating with the appliance inlet on the back of the computer.

Requirements for specific countries and regions

| Country/region | Accredited agency | Applicable note number |
|--------------------------------|-------------------|------------------------|
| Argentina | IRAM | 1 |
| Australia | SAA | 1 |
| Austria | OVE | 1 |
| Belgium | CEBEC | 1 |
| Brazil | ABNT | 1 |
| Canada | CSA | 2 |
| Chile | IMQ | 1 |
| Denmark | DEMKO | 1 |
| Finland | FIMKO | 1 |
| France | UTE | 1 |
| Germany | VDE | 1 |
| India | ISI | 1 |
| Israel | SII | 1 |
| Italy | IMQ | 1 |
| Japan | JIS | 3 |
| The Netherlands | KEMA | 1 |
| New Zealand | SANZ | 1 |
| Norway | NEMKO | 1 |
| The People's Republic of China | CCC | 4 |
| Saudi Arabia | SASO | 7 |
| Singapore | PSB | 1 |
| South Africa | SABS | 1 |
| South Korea | KTL | 5 |
| Sweden | SEMKO | 1 |
| Switzerland | SEV | 1 |
| Taiwan | BSMI | 6 |
| Thailand | TISI | 1 |
| The United Kingdom | ASTA | 1 |
| The United States | UL | 2 |

1. The flexible cord must be Type H05VV-F, 3-conductor, 0.75 mm² conductor size. Power cord set fittings (appliance coupler and wall plug) must bear the certification mark of the agency responsible for evaluation in the country or region where it will be used.
2. The flexible cord must be Type SVT/SJT or equivalent, No. 18 AWG, 3-conductor. The wall plug must be a two-pole grounding type with a NEMA 5-15P (15 A, 125 V ac) or NEMA 6-15P (15 A, 250 V ac) configuration. CSA or C-UL mark. UL file number must be on each element.

| Country/region | Accredited agency | Applicable note number |
|----------------|-------------------|---|
| | | 3. The appliance coupler, flexible cord, and wall plug must bear a “T” mark and registration number in accordance with the Japanese Dentori Law. The flexible cord must be Type VCR, 3-conductor, 0.75 mm ² or 1.25 mm ² conductor size. The wall plug must be a two-pole grounding type with a Japanese Industrial Standard c/o (7 A, 125 V ac) configuration. |
| | | 4. The flexible cord must be Type REV, 3-conductor, 0.75 mm ² conductor size. Power cord set fittings (appliance coupler and wall plug) must bear the CCC certification mark. |
| | | 5. The flexible cord must be Type H05VV-F 3-conductor, 0.75 mm ² conductor size. KTL logo and individual approval number must be on each element. Corset approval number and logo must be printed on a flag label. |
| | | 6. The flexible cord must be Type HVCTF 3-conductor, 1.25 mm ² conductor size. Power cord set fittings (appliance coupler, cable, and wall plug) must bear the BSMI certification mark. |
| | | 7. For 127 V ac, the flexible cord must be Type SVT or SJT 3-conductor, 18 AWG, with plug NEMA 5-15P (15 A, 125 V ac), with UL and CSA or C-UL marks. For 240 V ac, the flexible cord must be Type H05VV-F 3-conductor, 0.75 mm ² or 1.00 mm ² conductor size, with plug BS 1363/A with BSI or ASTA marks. |

12 Recycling

When a non-rechargeable or rechargeable battery has reached the end of its useful life, do not dispose of the battery in general household waste. Follow the local laws and regulations in your area for battery disposal.

HP encourages customers to recycle used electronic hardware, HP original print cartridges, and rechargeable batteries. For more information about recycling programs, see the HP Web site at <http://www.hp.com/recycle>.

Index

A

- AC adapter and battery light, identifying 11
- AC adapter, spare part numbers 28
- action keys
 - airplane mode 21
 - help 20
 - identifying 19, 20
 - keyboard backlight 20
 - mute 21
 - next track 20
 - pause 20
 - play 20
 - privacy screen 20
 - screen brightness 20
 - speaker volume 20
 - stop 20
 - switch screen image 20
 - using 20
- airplane mode key 19, 21
- antenna
 - spare part numbers 28
- audio
 - adjusting volume 20
- audio board
 - removal 53
 - spare part number 25, 53
- audio cable
 - spare part number 25
- audio, product description 5
- audio-in (microphone) jack, identifying 12
- audio-out (headphone)/audio-in (microphone) combo jack, identifying 12

B

- backup, creating 80
- backups 80
- base enclosure
 - removing 35
 - spare part number 35
- base enclosure, spare part numbers 26

battery

- removal 46
- spare part number 26, 46

BIOS

- determining version 72
- downloading an update 73
- starting the Setup Utility 72
- updating 72

Bluetooth label 22

boot order, changing 84

bottom components 21

buttons

- left TouchPad 16
- power 18
- right TouchPad 16

C

- cables, service considerations 30
- camera
 - identifying 15
- camera light, identifying 15
- camera module
 - removal 66
- caps lock light, identifying 17
- case, spare part number 28
- chipset, product description 1
- components
 - bottom 21
 - display 15
 - keyboard area 16
 - left side 12
 - right side 11
- computer major components 24
- connector board
 - spare part numbers 25
- connector board cable
 - spare part numbers 25
- connector, power 11, 13
- connectors
 - service considerations 30

D

- display
 - removal 67

display assembly

- removal 64
- spare part numbers 64
- subcomponents 27

display bezel

- removal 65
- spare part numbers 27

display components 15

display enclosure, spare part number 28

display hinge bracket

- spare part number 27

Display Hinge Kit, spare part number 27

display panel

- product description 3
- spare part numbers 27

display panel cable

- spare part number 28

display support bracket

- spare part number 28

display tape, spare part number 28

dongle, USB-C to USB-A, spare part number 28

drive light, identifying 11

drives

- precautions 31
- preventing damage 31

Dual-Mode DisplayPort

- identifying 13

E

- electrostatic discharge 32
- END key 19
- equipment guidelines 34
- esc key, identifying 19
- ethernet, product description 5
- external media cards, product description 7

F

fan

- removal 49
- spare part number 49
- fn key, identifying 19

- G**
- Get Help in Windows 10 action key 20
- graphics, product description 1
- grounding guidelines 32
- guidelines
 - equipment 34
 - grounding 32
 - packaging 33
 - transporting 33
 - workstation 33
- H**
- hard drive
 - spare part number 25, 38
- hard drive brackets
 - spare part number 25, 38
- Hard drive cable connector
 - spare part number 25, 38
- hard drive dummy
 - spare part number 25, 38
- hard drives, product description 4
- HDD
 - removal 38
 - spare part numbers 38
- HDMI port
 - identifying 13
- HDMI to VGA adapter, spare part number 28
- heat sink
 - removal 58
 - spare part number 26, 58
- hinge
 - spare part number 27
- HP PC Hardware Diagnostics UEFI
 - downloading 76
 - starting 76
 - using 75
- HP PC Hardware Diagnostics Windows
 - downloading 74
 - installing 75
 - using 74
- HP Recovery Manager
 - correcting boot problems 84
 - starting 83
- HP Recovery media
 - recovery 83
 - using 81
- HP Recovery partition
 - recovery 83
 - removing 84
- I**
- internal card expansion, product description 6
- internal microphones, identifying 15
- J**
- jacks
 - audio-in (microphone) 12
 - audio-out (headphone)/audio-in (microphone) 12
 - network 13
 - RJ-45 (network) 13
- K**
- keyboard backlight action key 20
- keyboard/top cover
 - removal 71
 - spare part numbers 25, 71
- keys
 - action 19
 - airplane mode 19, 21
 - END key 19
 - esc 19
 - fn 19
 - OMEN key 19
 - PRT SC 19
 - Windows 19
- L**
- labels
 - Bluetooth 22
 - regulatory 22
 - serial number 22
 - service 21
 - wireless certification 22
 - WLAN 22
- left side components 12
- lights
 - AC adapter and battery 11
 - camera 15
 - caps lock 17
 - drive 11
 - power 17
 - RJ-45 (network) status 13
 - TouchPad 17
- M**
- memory module
 - removal 41
 - spare part numbers 41
- memory, product description 4
- microphone
 - product description 5
- MicroSD memory card reader, identifying 12
- mini security cable slot, identifying 14
- minimized image recovery 83
- minimized image, creating 82
- model name 1
- mute volume action key 21
- N**
- network jack, identifying 13
- next track action key 20
- O**
- OMEN key 19
- operating system, product description 8
- optical drive, spare part number 29
- original system recovery 82
- P**
- packaging guidelines 33
- pause action key 20
- plastic parts, service considerations 30
- play action key 20
- ports
 - Dual-Mode DisplayPort 13
 - HDMI 13
 - product description 6
 - USB SuperSpeed 11, 12
 - USB SuperSpeed port with HP Sleep and Charge 13
 - USB Type-C power connector and Thunderbolt port with HP Sleep and Charge 13
 - USB Type-C with HP Sleep and Charge 13
- power button board
 - removal 62
 - spare part number 62
- power button, identifying 18
- power connector
 - identifying 11, 13

- power connector board
 - spare part number 25
- power connector cable
 - removal 52
 - spare part number 25, 52
- power cord
 - requirements for all countries 85
 - requirements for specific countries and regions 86
 - set requirements 85
 - spare part numbers 28
- power lights, identifying 17
- power requirements, product description 7
- privacy screen action key 20
- privacy screen action key, identifying 20
- processor, product description 1
- product description
 - audio 5
 - chipset 1
 - display panel 3
 - ethernet 5
 - external media cards 7
 - graphics 1
 - hard drives 4
 - internal card expansion 6
 - memory 4
 - microphone 5
 - operating system 8
 - ports 6
 - power requirements 7
 - processors 1
 - product name 1
 - serviceability 9
 - video 5
 - wireless 5
- product name 1
- product name and number, computer 22
- PRT SC key 19
- R**
- recovery 80
 - discs 81, 83
 - HP Recovery Manager 82
 - HP Recovery partition 82
 - media 83
 - starting 83
- supported discs 81
- system 82
- USB flash drive 83
 - using HP Recovery media 81
- recovery media
 - creating using HP Cloud Recovery Download Tool 82
 - creating using HP Recovery Manager 81
 - creating using Windows tools 80
 - discs 81
 - HP Recovery partition 80
 - USB flash drive 81
 - using 81
- recovery partition, removing 84
- regulatory information
 - regulatory label 22
 - wireless certification labels 22
- Remote HP PC Hardware Diagnostics
 - UEFI settings
 - customizing 77
 - using 77
 - removal/replacement procedures 35, 45
 - restoring 80
 - right side components 11
 - RJ-45 (network) jack, identifying 13
 - RJ-45 (network) status lights, identifying 13
- S**
- screen brightness action keys 20
- Screw Kit, spare part number 29
- serial number, computer 22
- service considerations
 - cables 30
 - connectors 30
 - plastic parts 30
- service labels, locating 21
- serviceability, product description 9
- slots
 - memory card reader 12
 - security cable 14
- smart card board
 - removal 48
 - spare part number 48
- solid-state drive
 - removal 40
 - spare part numbers 40
- speaker
 - removal 47
 - spare part number 47
- speaker volume action keys 20
- speakers
 - identifying 21
 - spare part number 25
- special keys, using 19
- SSD
 - spare part numbers 40
- stop action key 20
- supported discs, recovery 81
- switch screen image action key 20
- system board
 - removal 55
 - spare part numbers 25, 55
- system recovery 82
- system restore point, creating 80
- T**
- Thunderbolt port with HP Sleep and Charge, identifying USB Type-C 13
- tools required 30
- TouchPad
 - removing 60
 - spare part number 60
- TouchPad board
 - spare part numbers 25
- TouchPad buttons
 - identifying 16
- TouchPad click board
 - removing 60
 - spare part number 60
- TouchPad click board bracket
 - spare part number 60
- TouchPad light 17
- TouchPad zone, identifying 16
- transporting guidelines 33
- traveling with the computer 22
- U**
- USB board
 - removal 54
 - spare part number 54
- USB SuperSpeed port with HP Sleep and Charge, identifying 13
- USB SuperSpeed port, identifying 11, 12
- USB Type-C port with HP Sleep and Charge, identifying 13

USB Type-C power connector and
Thunderbolt port with HP Sleep and
Charge, identifying 13

V

vents, identifying 13, 21
video, product description 5
volume
 adjusting 20
 mute 21

W

webcam/microphone module
 spare part number 27
Windows
 backup 80
 recovery media 80
 system restore point 80
Windows key, identifying 19
Windows tools, using 80
wireless antenna
 spare part numbers 28
wireless certification label 22
wireless, product description 5
WLAN antenna
 spare part number 28
WLAN antennas, identifying 15
WLAN device 22
WLAN label 22
WLAN module
 removing 43
 spare part numbers 26
workstation guidelines 33