



# SAR TEST REPORT

No. I16Z42198-SEM01

For

**TCL Communication Ltd.**

**GSM Quad Band Mobile phone**

**Model Name: 2051A**

With

**Hardware Version: PIO**

**Software Version: V1.0**

**FCC ID: 2ACCJB069**

**Issued Date: 2016-12-26**



**Note:**

The test results in this test report relate only to the devices specified in this report. This report shall not be reproduced except in full without the written approval of CTTL.

**Test Laboratory:**

CTTL, Telecommunication Technology Labs, Academy of Telecommunication Research, MIIT  
No. 51 Shouxiang Science Building, Xueyuan Road, Haidian District, Beijing, P. R. China100191  
Tel:+86(0)10-62304633-2512,Fax:+86(0)10-62304633-2504  
Email:[cttl\\_terminals@catr.cn](mailto:cttl_terminals@catr.cn), website:[www.chinattl.com](http://www.chinattl.com)



## **REPORT HISTORY**

<b>Report Number</b>	<b>Revision</b>	<b>Issue Date</b>	<b>Description</b>
I16Z42198-SEM01	Rev.0	2016-11-29	Initial creation of test report
I16Z42198-SEM01	Rev.1	2016-12-15	<ol style="list-style-type: none"><li>1. Add the note2 of no headset testing below the table 13.1-2 on page 23</li><li>2. Update the table I.1-1 and I.1-2 on page 115</li><li>3. Add note in section I.3 on page 116</li></ol>
I16Z42198-SEM01	Rev.2	2016-12-26	Update the description of headset in section 4.1 on page 8



## TABLE OF CONTENT

<b>1 TEST LABORATORY</b> .....	<b>5</b>
1.1 TESTING LOCATION .....	5
1.2 TESTING ENVIRONMENT.....	5
1.3 PROJECT DATA .....	5
1.4 SIGNATURE.....	5
<b>2 STATEMENT OF COMPLIANCE</b> .....	<b>6</b>
<b>3 CLIENT INFORMATION</b> .....	<b>7</b>
3.1 APPLICANT INFORMATION .....	7
3.2 MANUFACTURER INFORMATION .....	7
<b>4 EQUIPMENT UNDER TEST (EUT) AND ANCILLARY EQUIPMENT (AE)</b> .....	<b>8</b>
4.1 ABOUT EUT .....	8
4.2 INTERNAL IDENTIFICATION OF EUT USED DURING THE TEST .....	8
4.3 INTERNAL IDENTIFICATION OF AE USED DURING THE TEST .....	8
<b>5 TEST METHODOLOGY</b> .....	<b>9</b>
5.1 APPLICABLE LIMIT REGULATIONS .....	9
5.2 APPLICABLE MEASUREMENT STANDARDS.....	9
<b>6 SPECIFIC ABSORPTION RATE (SAR)</b> .....	<b>10</b>
6.1 INTRODUCTION.....	10
6.2 SAR DEFINITION.....	10
<b>7 TISSUE SIMULATING LIQUIDS</b> .....	<b>11</b>
7.1 TARGETS FOR TISSUE SIMULATING LIQUID .....	11
7.2 DIELECTRIC PERFORMANCE .....	11
<b>8 SYSTEM VERIFICATION</b> .....	<b>14</b>
8.1 SYSTEM SETUP.....	14
8.2 SYSTEM VERIFICATION.....	15
<b>9 MEASUREMENT PROCEDURES</b> .....	<b>16</b>
9.1 TESTS TO BE PERFORMED .....	16
9.2 GENERAL MEASUREMENT PROCEDURE.....	18
9.3 POWER DRIFT.....	19
<b>10 AREA SCAN BASED 1-G SAR</b> .....	<b>19</b>
10.1 REQUIREMENT OF KDB.....	19
10.2 FAST SAR ALGORITHMS .....	19
<b>11 CONDUCTED OUTPUT POWER</b> .....	<b>20</b>
11.1 MANUFACTURING TOLERANCE .....	20
11.2 GSM MEASUREMENT RESULT .....	21



<b>12 ANTENNA LOCATIONS.....</b>	<b>22</b>
<b>13 SAR TEST RESULT .....</b>	<b>23</b>
13.1 SAR RESULTS FOR FAST SAR.....	23
13.2 SAR RESULTS FOR STANDARD PROCEDURE.....	24
<b>14 SAR MEASUREMENT VARIABILITY.....</b>	<b>26</b>
<b>15 MEASUREMENT UNCERTAINTY .....</b>	<b>27</b>
15.1 MEASUREMENT UNCERTAINTY FOR NORMAL SAR TESTS (300MHZ~3GHZ) .....	27
15.2 MEASUREMENT UNCERTAINTY FOR NORMAL SAR TESTS (3~6GHZ) .....	28
15.3 MEASUREMENT UNCERTAINTY FOR FAST SAR TESTS (300MHZ~3GHZ) .....	29
15.4 MEASUREMENT UNCERTAINTY FOR FAST SAR TESTS (3~6GHZ).....	30
<b>16 MAIN TEST INSTRUMENTS.....</b>	<b>31</b>
<b>ANNEX A GRAPH RESULTS.....</b>	<b>32</b>
<b>ANNEX B SYSTEMVERIFICATION RESULTS .....</b>	<b>40</b>
<b>ANNEX C SAR MEASUREMENT SETUP .....</b>	<b>49</b>
<b>ANNEX D POSITION OF THE WIRELESS DEVICE IN RELATION TO THE PHANTOM .....</b>	<b>55</b>
<b>ANNEX E EQUIVALENT MEDIA RECIPES.....</b>	<b>58</b>
<b>ANNEX F SYSTEM VALIDATION .....</b>	<b>59</b>
<b>ANNEX G PROBE CALIBRATION CERTIFICATE.....</b>	<b>61</b>
<b>ANNEX H DIPOLE CALIBRATION CERTIFICATE .....</b>	<b>83</b>
<b>ANNEX I SPOT CHECK TEST .....</b>	<b>115</b>
<b>ANNEX J ACCREDITATION CERTIFICATE.....</b>	<b>125</b>

## 1 Test Laboratory

### 1.1 Testing Location

Company Name:	CTTL(Shouxiang)
Address:	No. 51 Shouxiang Science Building, Xueyuan Road, Haidian District, Beijing, P. R. China100191

### 1.2 Testing Environment

Temperature:	18°C~25°C,
Relative humidity:	30%~ 70%
Ground system resistance:	< 0.5 $\Omega$
Ambient noise & Reflection:	< 0.012 W/kg

### 1.3 Project Data

Project Leader:	Qi Dianyuan
Test Engineer:	Lin Xiaojun
Testing Start Date:	July 13, 2016
Testing End Date:	November 11, 2016

### 1.4 Signature



---

Lin Xiaojun  
(Prepared this test report)

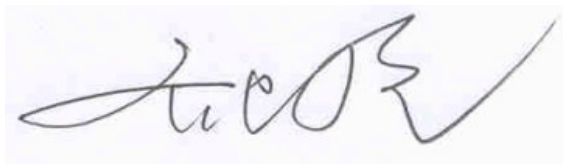

---

Qi Dianyuan  
(Reviewed this test report)

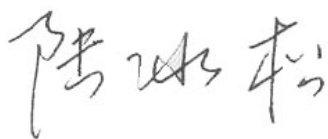

---

Lu Bingsong  
Deputy Director of the laboratory  
(Approved this test report)

## 2 Statement of Compliance

This EUT is a variant product and the report of original sample is No.I16Z41517-SEM01. According to the client request, we quote the test results of original sample, add the results of a new battery and remove the Bluetooth. The results of spot check are presented in the annex I.

The maximum results of Specific Absorption Rate (SAR) found during testing for TCL Communication Ltd. GSM Quad Band Mobile phone 2051A are as follows:

**Table 2.1: Highest Reported SAR (1g)**

Exposure Configuration	Technology Band	Highest Reported SAR 1g(W/Kg)	Equipment Class
Head (Separation Distance 0mm)	GSM 850	1.17	PCE
	PCS 1900	0.48	
Body-worn (Separation Distance 10mm)	GSM 850	1.54	PCE
	PCS 1900	1.11	

The SAR values found for the Mobile Phone are below the maximum recommended levels of 1.6 W/Kg as averaged over any 1g tissue according to the ANSI C95.1-1992.

For body worn operation, this device has been tested and meets FCC RF exposure guidelines when used with any accessory that contains no metal and which provides a minimum separation distance of 10 mm between this device and the body of the user. Use of other accessories may not ensure compliance with FCC RF exposure guidelines.

The EUT battery must be fully charged and checked periodically during the test to ascertain uniform power output.

The measurement together with the test system set-up is described in annex C of this test report. A detailed description of the equipment under test can be found in chapter 4 of this test report.

The highest reported SAR value is obtained at the case of **(Table 2.1)**, and the values are: **1.54 W/kg (1g)**.



### 3 Client Information

#### 3.1 Applicant Information

Company Name:	TCL Communication Ltd.
Address /Post:	5F, C-Tower, No. 232, Liang Jing Road, ZhangJiang High-Tech Park, Pudong Area, Shanghai, 201203, P.R.China
Contact:	Smile. Wu
Email:	xia.wu@tcl.com
Telephone:	(0)21 51798260
Fax:	(0)21 6146 0600

#### 3.2 Manufacturer Information

Company Name:	TCL Communication Ltd.
Address /Post:	5F, C-Tower, No. 232, Liang Jing Road, ZhangJiang High-Tech Park, Pudong Area, Shanghai, 201203, P.R.China
Contact:	Smile. Wu
Email:	xia.wu@tcl.com
Telephone:	(0)21 51798260
Fax:	(0)21 6146 0600

## 4 Equipment Under Test (EUT) and Ancillary Equipment (AE)

### 4.1 About EUT

Description:	GSM Quad Band Mobile phone
Model Name:	2051A
Operating mode(s):	GSM 850/900/1800/1900
Tested Tx Frequency:	825 – 848.8 MHz (GSM 850)
	1850.2 – 1910 MHz (GSM 1900)
GPRS Multislot Class:	12
GPRS capability Class:	B
Device type:	Portable device
Antenna type:	Integrated antenna
Accessories/Body-worn configurations:	Headset (When the phone is folded, it can't works with headset in voice mode)

### 4.2 Internal Identification of EUT used during the test

EUT ID*	SN or IMEI	HW Version	SW Version
EUT1	358326070001653	PIO	V1.0
EUT2	358326070001976	PIO	V1.0

\*EUT ID: is used to identify the test sample in the lab internally.

**Note:** It is performed to spot check with the EUT 1 and conducted power with the EUT 2.

### 4.3 Internal Identification of AE used during the test

AE ID*	Description	Model	SN	Manufacturer
AE1	Battery	CAB22B0000C1	/	BYD
AE2	Battery	CAB0400016C1	/	BYD
AE3	Headset	CCB0050A11C7	/	JIAYIKANG

\*AE ID: is used to identify the test sample in the lab internally.





## 5 TEST METHODOLOGY

### 5.1 Applicable Limit Regulations

**ANSI C95.1–1992:** IEEE Standard for Safety Levels with Respect to Human Exposure to Radio Frequency Electromagnetic Fields, 3 kHz to 300 GHz.

It specifies the maximum exposure limit of **1.6 W/kg** as averaged over any 1 gram of tissue for portable devices being used within 20 cm of the user in the uncontrolled environment.

### 5.2 Applicable Measurement Standards

**IEEE 1528–2013:** Recommended Practice for Determining the Peak Spatial-Average Specific Absorption Rate (SAR) in the Human Head from Wireless Communications Devices: Measurement Techniques.

**KDB447498 D01: General RF Exposure Guidance v06:** Mobile and Portable Devices RF Exposure Procedures and Equipment Authorization Policies.

**KDB648474 D04 Handset SAR v01r03:** SAR Evaluation Considerations for Wireless Handsets.

**KDB865664 D01 SAR measurement 100 MHz to 6 GHz v01r04:** SAR Measurement Requirements for 100 MHz to 6 GHz.

**KDB865664 D02 RF Exposure Reporting v01r02:** RF Exposure Compliance Reporting and Documentation Considerations

## 6 Specific Absorption Rate (SAR)

### 6.1 Introduction

SAR is related to the rate at which energy is absorbed per unit mass in an object exposed to a radio field. The SAR distribution in a biological body is complicated and is usually carried out by experimental techniques or numerical modeling. The standard recommends limits for two tiers of groups, occupational/controlled and general population/uncontrolled, based on a person's awareness and ability to exercise control over his or her exposure. In general, occupational/controlled exposure limits are higher than the limits for general population/uncontrolled.

### 6.2 SAR Definition

The SAR definition is the time derivative (rate) of the incremental energy ( $dW$ ) absorbed by (dissipated in) an incremental mass ( $dm$ ) contained in a volume element ( $dv$ ) of a given density ( $\rho$ ). The equation description is as below:

$$SAR = \frac{d}{dt} \left( \frac{dW}{dm} \right) = \frac{d}{dt} \left( \frac{dW}{\rho dv} \right)$$

SAR is expressed in units of Watts per kilogram (W/kg)

SAR measurement can be either related to the temperature elevation in tissue by

$$SAR = c \left( \frac{\delta T}{\delta t} \right)$$

Where:  $C$  is the specific heat capacity,  $\delta T$  is the temperature rise and  $\delta t$  is the exposure duration, or related to the electrical field in the tissue by

$$SAR = \frac{\sigma |E|^2}{\rho}$$

Where:  $\sigma$  is the conductivity of the tissue,  $\rho$  is the mass density of tissue and  $E$  is the RMS electrical field strength.

However for evaluating SAR of low power transmitter, electrical field measurement is typically applied.

## 7 Tissue Simulating Liquids

### 7.1 Targets for tissue simulating liquid

**Table 7.1: Targets for tissue simulating liquid**

Frequency (MHz)	Liquid Type	Conductivity ( $\sigma$ )	$\pm 5\%$ Range	Permittivity ( $\epsilon$ )	$\pm 5\%$ Range
835	Head	0.90	0.86~0.95	41.5	39.4~43.6
835	Body	0.97	0.92~1.02	55.2	52.4~58.0
1900	Head	1.40	1.33~1.47	40.0	38.0~42.0
1900	Body	1.52	1.44~1.60	53.3	50.6~56.0

### 7.2 Dielectric Performance

**Table 7.2: Dielectric Performance of Tissue Simulating Liquid**

Measurement Date (yyyy-mm-dd)	Type	Frequency	Permittivity $\epsilon$	Drift (%)	Conductivity $\sigma$ (S/m)	Drift (%)
2016-07-13	Head	835 MHz	41.23	-0.65	0.924	2.67
	Body	835 MHz	56.37	2.12	0.947	-2.37
2016-07-22	Head	1900 MHz	40.69	1.72	1.409	0.64
	Body	1900 MHz	52.62	-1.28	1.575	3.62
2016-11-10	Head	835 MHz	42.93	3.45	0.925	2.78
	Body	835 MHz	56.61	2.55	0.953	-1.75
2016-11-11	Head	1900 MHz	40.37	0.92	1.427	1.93
	Body	1900 MHz	54.27	1.82	1.545	1.64

Note: The liquid temperature is 22.0°C

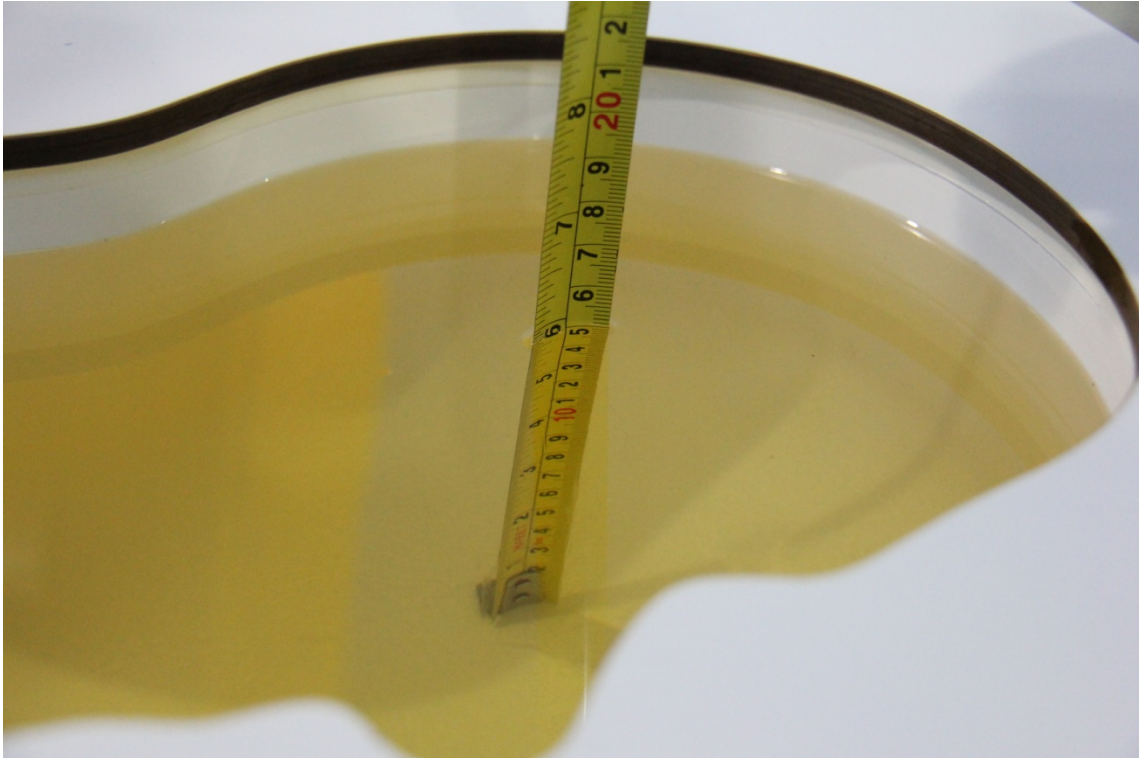

**Picture 7-1: Liquid depth in the Head Phantom (835MHz)**

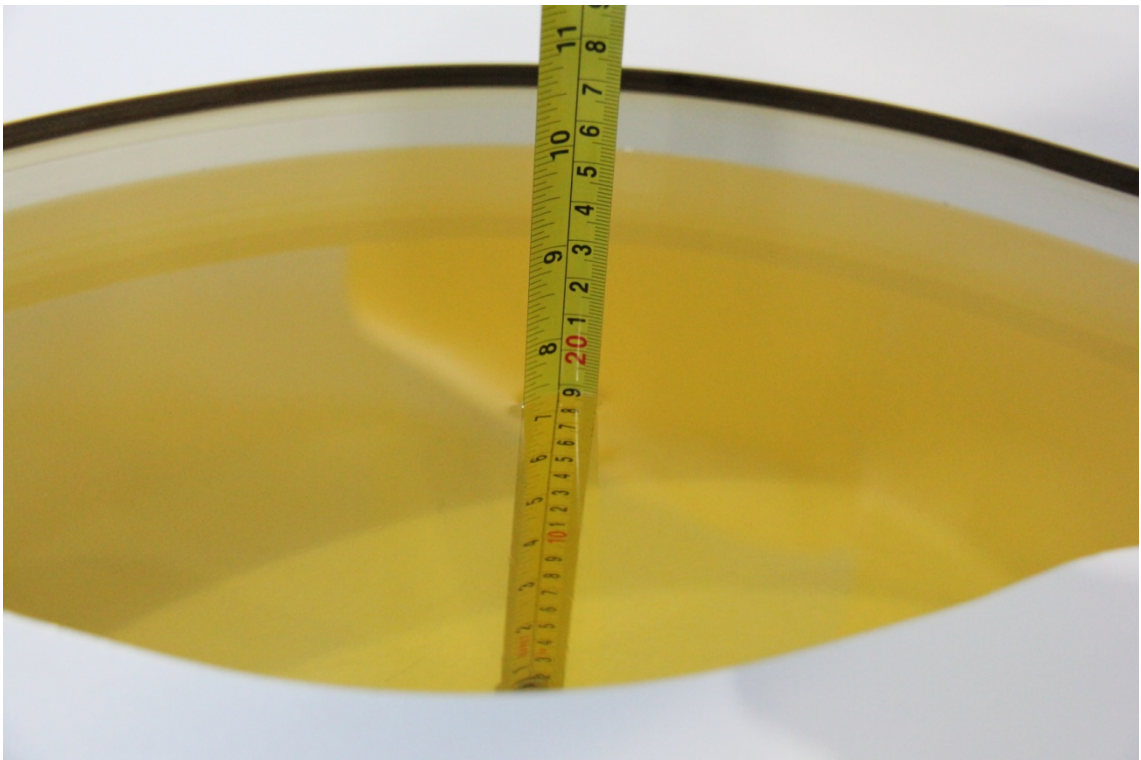

**Picture 7-2: Liquid depth in the Flat Phantom (835MHz)**

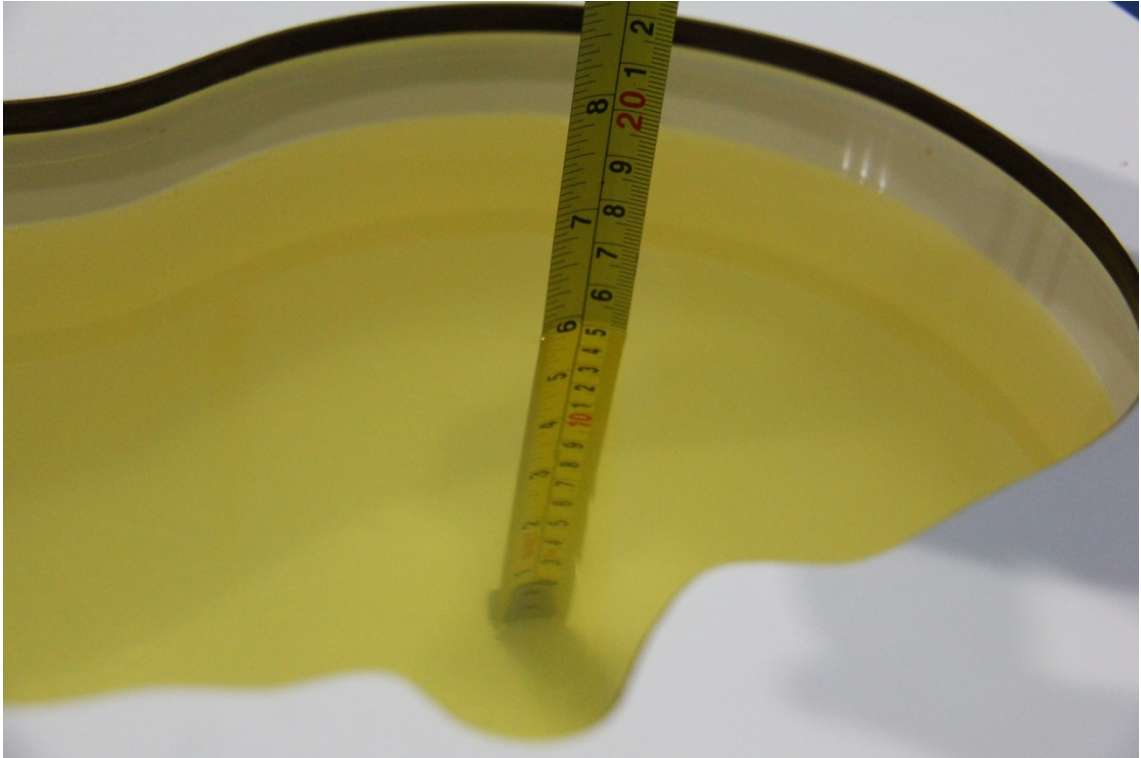

Picture 7-3: Liquid depth in the Head Phantom (1900 MHz)

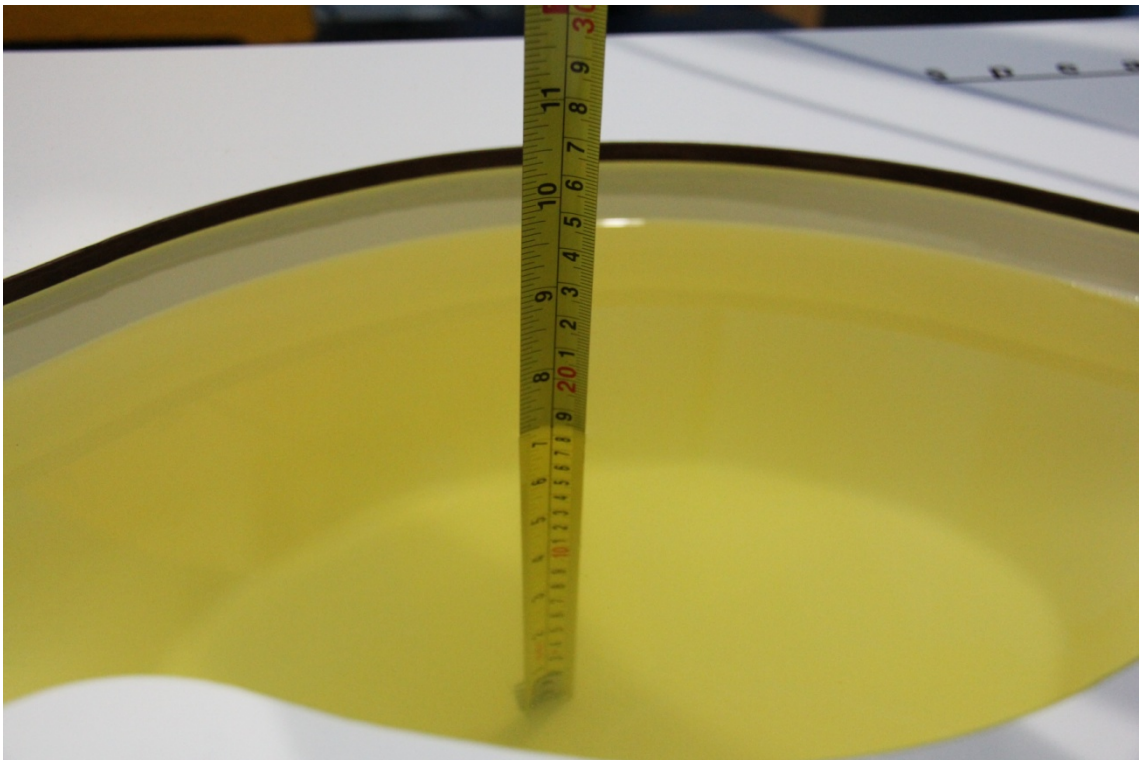

Picture 7-4 Liquid depth in the Flat Phantom (1900MHz)

## 8 System verification

### 8.1 System Setup

In the simplified setup for system evaluation, the DUT is replaced by a calibrated dipole and the power source is replaced by a continuous wave that comes from a signal generator. The calibrated dipole must be placed beneath the flat phantom section of the SAM twin phantom with the correct distance holder. The distance holder should touch the phantom surface with a light pressure at the reference marking and be oriented parallel to the long side of the phantom. The equipment setup is shown below:

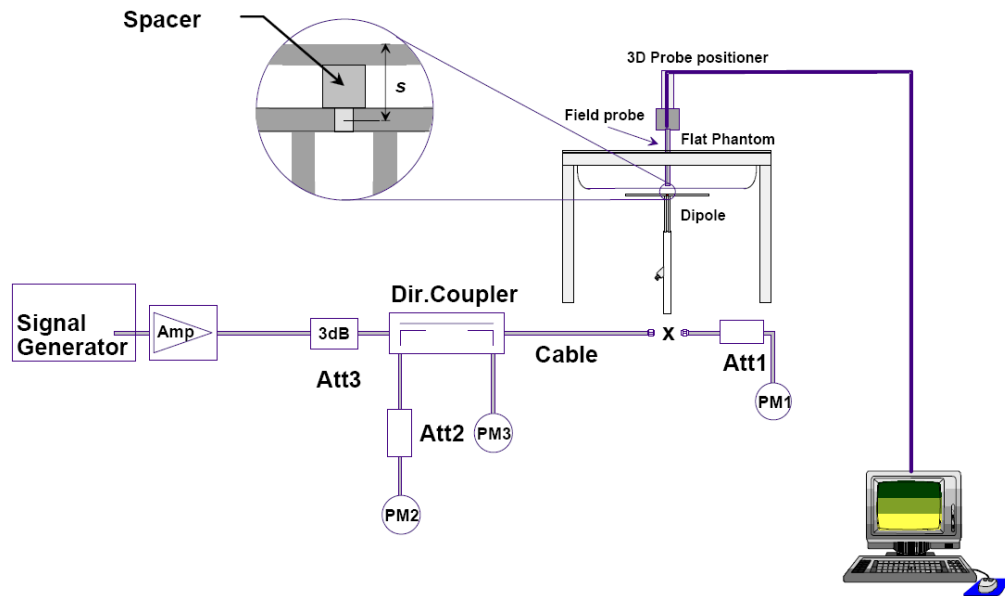

Picture 8.1 System Setup for System Evaluation

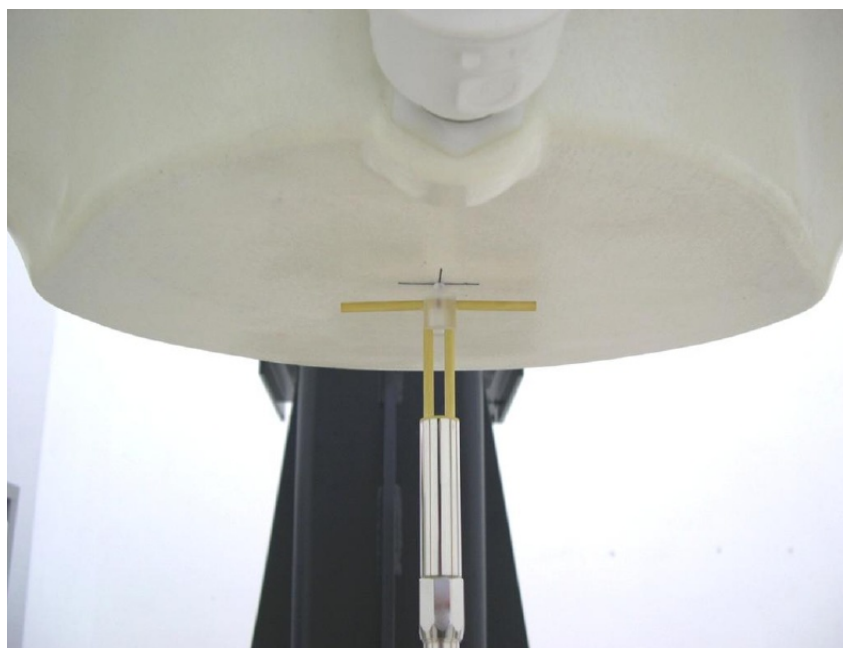

Picture 8.2 Photo of Dipole Setup

## 8.2 System Verification

SAR system verification is required to confirm measurement accuracy, according to the tissue dielectric media, probe calibration points and other system operating parameters required for measuring the SAR of a test device. The system verification must be performed for each frequency band and within the valid range of each probe calibration point required for testing the device.

The system verification results are required that the area scan estimated 1-g SAR is within 3% of the zoom scan 1-g SAR. The details are presented in annex B.

**Table 8.1: System Verification of Head**

Measurement Date (yyyy-mm-dd)	Frequency	Target value (W/kg)		Measured value(W/kg)		Deviation	
		10 g Average	1 g Average	10 g Average	1 g Average	10 g Average	1 g Average
2016-07-13	835 MHz	5.86	9.01	5.96	9.08	1.71%	0.78%
2016-07-22	1900 MHz	21.5	40.7	22.08	42.00	2.70%	3.19%
2016-11-10	835 MHz	6.18	9.44	6.00	9.16	-2.91%	-2.97%
2016-11-11	1900 MHz	21.20	40.70	21.5	41.6	1.51%	2.21%

**Table 8.2: System Verification of Body**

Measurement Date (yyyy-mm-dd)	Frequency	Target value (W/kg)		Measured value (W/kg)		Deviation	
		10 g Average	1 g Average	10 g Average	1 g Average	10 g Average	1 g Average
2016-07-13	835 MHz	6.12	9.29	6.16	9.48	0.65%	2.05%
2016-07-22	1900 MHz	21.7	40.4	21.96	41.20	1.20%	1.98%
2016-11-10	835 MHz	6.36	9.69	6.24	9.52	-1.89%	-1.75%
2016-11-11	1900 MHz	21.30	40.10	21.80	41.20	2.35%	2.74%

## 9 Measurement Procedures

### 9.1 Tests to be performed

In order to determine the highest value of the peak spatial-average SAR of a handset, all device positions, configurations and operational modes shall be tested for each frequency band according to steps 1 to 3 below. A flowchart of the test process is shown in picture 9.1.

**Step 1:** The tests described in 9.2 shall be performed at the channel that is closest to the centre of the transmit frequency band ( $f_c$ ) for:

- a) all device positions (cheek and tilt, for both left and right sides of the SAM phantom, as described in annex D),
- b) all configurations for each device position in a), e.g., antenna extended and retracted, and
- c) all operational modes, e.g., analogue and digital, for each device position in a) and configuration in b) in each frequency band.

If more than three frequencies need to be tested according to 11.1 (i.e.,  $N_c > 3$ ), then all frequencies, configurations and modes shall be tested for all of the above test conditions.

**Step 2:** For the condition providing highest peak spatial-average SAR determined in Step 1, perform all tests described in 9.2 at all other test frequencies, i.e., lowest and highest frequencies. In addition, for all other conditions (device position, configuration and operational mode) where the peak spatial-average SAR value determined in Step 1 is within 3 dB of the applicable SAR limit, it is recommended that all other test frequencies shall be tested as well.

**Step 3:** Examine all data to determine the highest value of the peak spatial-average SAR found in Steps 1 to 2.



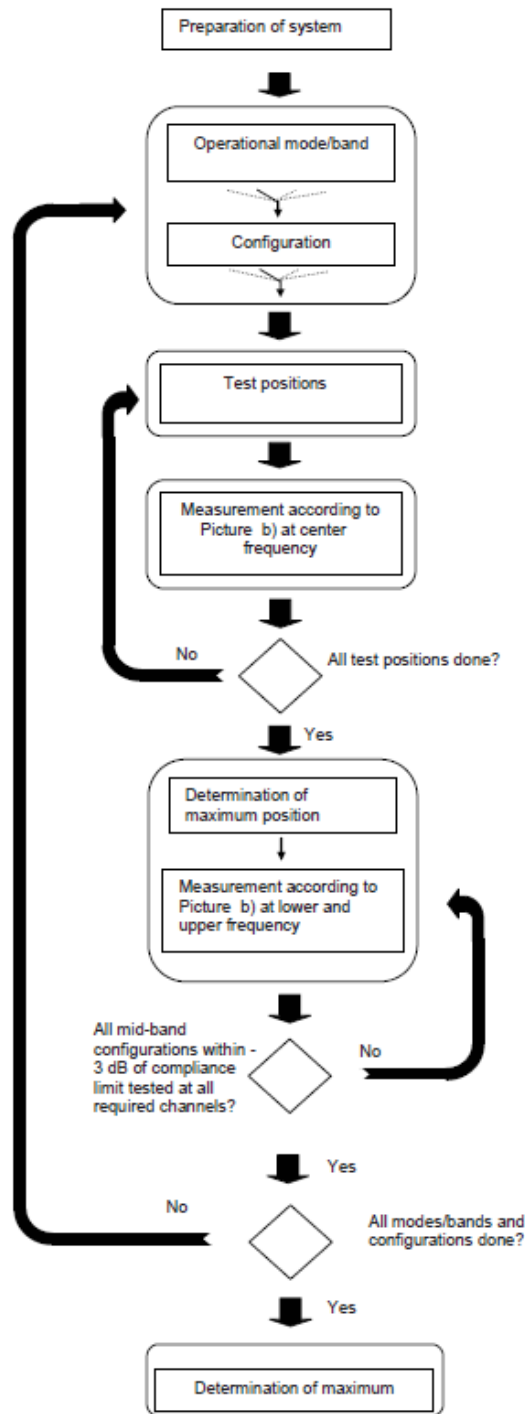

Picture a – Tests to be performed

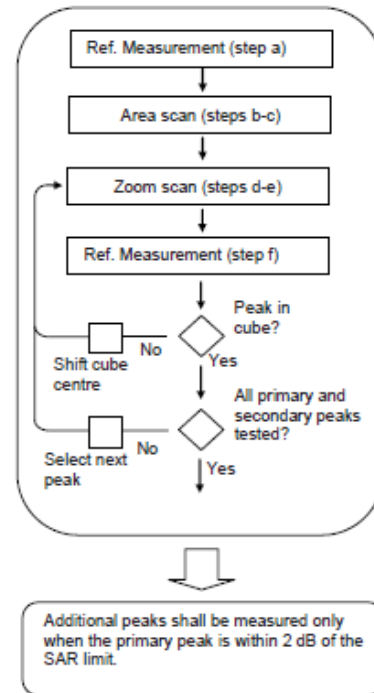

Picture b – General procedure

Picture 9.1 Block diagram of the tests to be performed

## 9.2 General Measurement Procedure

The area and zoom scan resolutions specified in the table below must be applied to the SAR measurements and fully documented in SAR reports to qualify for TCB approval. Probe boundary effect error compensation is required for measurements with the probe tip closer than half a probe tip diameter to the phantom surface. Both the probe tip diameter and sensor offset distance must satisfy measurement protocols; to ensure probe boundary effect errors are minimized and the higher fields closest to the phantom surface can be correctly measured and extrapolated to the phantom surface for computing 1-g SAR. Tolerances of the post-processing algorithms must be verified by the test laboratory for the scan resolutions used in the SAR measurements, according to the reference distribution functions specified in IEEE Std 1528-2003. The results should be documented as part of the system validation records and may be requested to support test results when all the measurement parameters in the following table are not satisfied.

		$\leq 3$ GHz	$> 3$ GHz
Maximum distance from closest measurement point (geometric center of probe sensors) to phantom surface		$5 \pm 1$ mm	$\frac{1}{2} \cdot \delta \cdot \ln(2) \pm 0.5$ mm
Maximum probe angle from probe axis to phantom surface normal at the measurement location		$30^\circ \pm 1^\circ$	$20^\circ \pm 1^\circ$
Maximum area scan spatial resolution: $\Delta x_{Area}$ , $\Delta y_{Area}$		$\leq 2$ GHz: $\leq 15$ mm 2 – 3 GHz: $\leq 12$ mm	3 – 4 GHz: $\leq 12$ mm 4 – 6 GHz: $\leq 10$ mm
		When the x or y dimension of the test device, in the measurement plane orientation, is smaller than the above, the measurement resolution must be $\leq$ the corresponding x or y dimension of the test device with at least one measurement point on the test device.	
Maximum zoom scan spatial resolution: $\Delta x_{Zoom}$ , $\Delta y_{Zoom}$		$\leq 2$ GHz: $\leq 8$ mm 2 – 3 GHz: $\leq 5$ mm*	3 – 4 GHz: $\leq 5$ mm* 4 – 6 GHz: $\leq 4$ mm*
Maximum zoom scan spatial resolution, normal to phantom surface	uniform grid: $\Delta z_{Zoom}(n)$	$\leq 5$ mm	3 – 4 GHz: $\leq 4$ mm 4 – 5 GHz: $\leq 3$ mm 5 – 6 GHz: $\leq 2$ mm
	graded grid	$\Delta z_{Zoom}(1)$ : between 1 <sup>st</sup> two points closest to phantom surface	$\leq 4$ mm
		$\Delta z_{Zoom}(n>1)$ : between subsequent points	$\leq 1.5 \cdot \Delta z_{Zoom}(n-1)$
Minimum zoom scan volume	x, y, z	$\geq 30$ mm	3 – 4 GHz: $\geq 28$ mm 4 – 5 GHz: $\geq 25$ mm 5 – 6 GHz: $\geq 22$ mm
Note: $\delta$ is the penetration depth of a plane-wave at normal incidence to the tissue medium; see draft standard IEEE P1528-2011 for details. * When zoom scan is required and the <i>reported</i> SAR from the area scan based <i>1-g SAR estimation</i> procedures of KDB 447498 is $\leq 1.4$ W/kg, $\leq 8$ mm, $\leq 7$ mm and $\leq 5$ mm zoom scan resolution may be applied, respectively, for 2 GHz to 3 GHz, 3 GHz to 4 GHz and 4 GHz to 6 GHz.			

### 9.3 Power Drift

To control the output power stability during the SAR test, DASY4 system calculates the power drift by measuring the E-field at the same location at the beginning and at the end of the measurement for each test position. These drift values can be found in section 13 labeled as: (Power Drift [dB]). This ensures that the power drift during one measurement is within 5%.

## 10 Area Scan Based 1-g SAR

### 10.1 Requirement of KDB

According to the KDB447498 D01 v05, when the implementation is based the specific polynomial fit algorithm as presented at the 29th Bioelectromagnetics Society meeting (2007) and the estimated 1-gSAR is  $\leq 1.2$  W/kg, a zoom scan measurement is not required provided it is also not needed for any other purpose; for example, if the peak SAR location required for simultaneous transmission SAR test exclusion can be determined accurately by the SAR system or manually to discriminate between distinctive peaks and scattered noisy SAR distributions from area scans.

There must not be any warning or alert messages due to various measurement concerns identified by the SAR system; for example, noise in measurements, peaks too close to scan boundary, peaks are too sharp, spatial resolution and uncertainty issues etc. The SAR system verification must also demonstrate that the area scan estimated 1-g SAR is within 3% of the zoom scan 1-g SAR (See Annex B). When all the SAR results for each exposure condition in a frequency band and wireless mode are based on estimated 1-g SAR, the 1-g SAR for the highest SAR configuration must be determined by a zoom scan.

### 10.2 Fast SAR Algorithms

The approach is based on the area scan measurement applying a frequency dependent attenuation parameter. This attenuation parameter was empirically determined by analyzing a large number of phones. The MOTOROLA FAST SAR was developed and validated by the MOTOROLA Research Group in Ft. Lauderdale.

In the initial study, an approximation algorithm based on Linear fit was developed. The accuracy of the algorithm has been demonstrated across a broad frequency range (136-2450 MHz) and for both 1- and 10-g averaged SAR using a sample of 264 SAR measurements from 55 wireless handsets. For the sample size studied, the root-mean-squared errors of the algorithm are 1.2% and 5.8% for 1- and 10-g averaged SAR, respectively. The paper describing the algorithm in detail is expected to be published in August 2004 within the Special Issue of Transactions on MTT.

In the second step, the same research group optimized the fitting algorithm to an Polynomial fit whereby the frequency validity was extended to cover the range 30-6000MHz. Details of this study can be found in the BEMS 2007 Proceedings.

Both algorithms are implemented in DASY software.

## 11 Conducted Output Power

### 11.1 Manufacturing tolerance

**Table 11.1: GSM Speech**

GSM 850			
Channel	Channel 251	Channel 190	Channel 128
Target (dBm)	32.3	32.3	32.3
Tune-up(dBm)	33.3	33.3	33.3
GSM 1900			
Channel	Channel 810	Channel 661	Channel 512
Target (dBm)	29.3	29.3	29.3
Tune-up(dBm)	30.3	30.3	30.3

**Table 11.2: GPRS**

GSM 850 GPRS (GMSK)				
Channel		<b>251</b>	<b>190</b>	<b>128</b>
1 Txslot	Target (dBm)	32.3	32.3	32.3
	Tune-up(dBm)	33.3	33.3	33.3
2 Txslots	Target (dBm)	29.5	29.5	29.5
	Tune-up(dBm)	30.5	30.5	30.5
3Txslots	Target (dBm)	28	28	28
	Tune-up(dBm)	29	29	29
4 Txslots	Target (dBm)	26.5	26.5	26.5
	Tune-up(dBm)	27.5	27.5	27.5
GSM 1900 GPRS (GMSK)				
Channel		<b>810</b>	<b>661</b>	<b>512</b>
1 Txslot	Target (dBm)	29.3	29.3	29.3
	Tune-up(dBm)	30.3	30.3	30.3
2 Txslots	Target (dBm)	27	27	27
	Tune-up(dBm)	28	28	28
3Txslots	Target (dBm)	25	25	25
	Tune-up(dBm)	26	26	26
4 Txslots	Target (dBm)	23	23	23
	Tune-up(dBm)	24	24	24

## 11.2 GSM Measurement result

During the process of testing, the EUT was controlled via Agilent Digital Radio Communication tester (E5515C) to ensure the maximum power transmission and proper modulation. This result contains conducted output power for the EUT. In all cases, the measured peak output power should be greater and within 5% than EMI measurement.

**Table 11.3: The conducted power measurement results for GSM850/1900**

GSM 850MHz	Conducted Power (dBm)		
	Channel 251(848.8MHz)	Channel 190(836.6MHz)	Channel 128(824.2MHz)
	31.69	31.57	31.74
GSM 1900MHz	Conducted Power(dBm)		
	Channel 810(1909.8MHz)	Channel 661(1880MHz)	Channel 512(1850.2MHz)
	28.98	28.85	28.91

**Table 11.4: The conducted power measurement results for GPRS**

GSM 850 GPRS (GMSK)	Measured Power (dBm)			calculation	Averaged Power (dBm)		
	251	190	128		251	190	128
1 Txslot	31.71	31.64	31.81	-9.03	22.68	22.61	22.78
2 Txslots	30.02	30.06	30.16	-6.02	24.00	24.04	24.14
3Txslots	28.54	28.61	28.72	-4.26	24.28	24.35	24.46
4 Txslots	25.76	25.79	25.91	-3.01	22.75	22.78	22.90
PCS1900 GPRS (GMSK)	Measured Power (dBm)			calculation	Averaged Power (dBm)		
	810	661	512		810	661	512
1 Txslot	28.98	28.84	28.92	-9.03	19.95	19.81	19.89
2 Txslots	26.30	26.50	26.74	-6.02	20.28	20.48	20.72
3Txslots	24.99	25.20	25.45	-4.26	20.73	20.94	21.19
4 Txslots	22.07	22.35	22.58	-3.01	19.06	19.34	19.57

NOTES:

1) Division Factors

To average the power, the division factor is as follows:

1TX-slot = 1 transmit time slot out of 8 time slots=> conducted power divided by (8/1) => -9.03dB

2TX-slots = 2 transmit time slots out of 8 time slots=> conducted power divided by (8/2) => -6.02dB

3TX-slots = 3 transmit time slots out of 8 time slots=> conducted power divided by (8/3) => -4.26dB

4TX-slots = 4 transmit time slots out of 8 time slots=> conducted power divided by (8/4) => -3.01dB

**According to the conducted power as above, the body measurements are performed with 3Txslots for GSM850 and 3Txslots for PCS1900.**

## 12 Antenna Locations

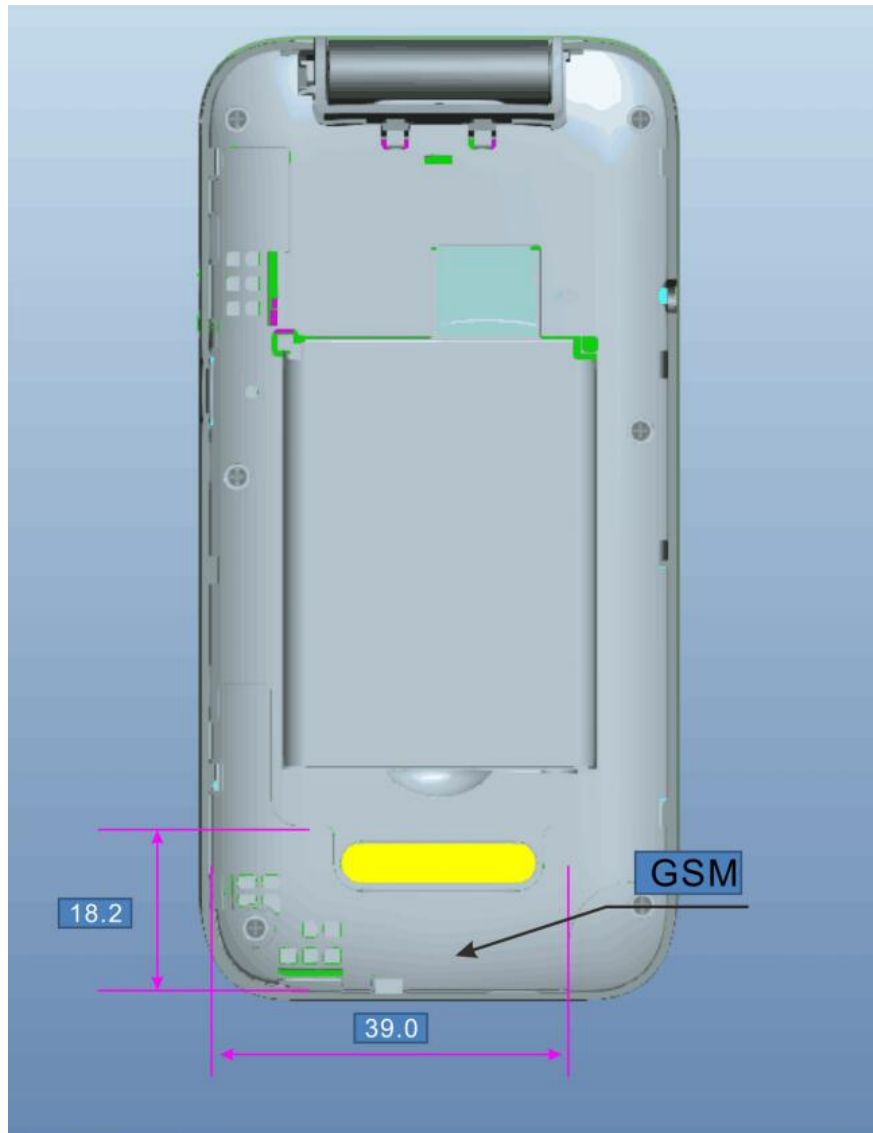

Picture 12.1 Antenna Locations

### 13 SAR Test Result

It is determined by user manual for the distance between the EUT and the phantom bottom.

The distance is 10mm and just applied to the condition of body worn accessory.

It is performed for all SAR measurements with area scan based 1-g SAR estimation (Fast SAR). A zoom scan measurement is added when the estimated 1-gSAR is the highest measured SAR in each exposure configuration, wireless mode and frequency band combination or >1.2W/kg.

The calculated SAR is obtained by the following formula:

$$\text{Reported SAR} = \text{Measured SAR} \times 10^{(P_{\text{Target}} - P_{\text{Measured}})/10}$$

Where  $P_{\text{Target}}$  is the power of manufacturing upper limit;

$P_{\text{Measured}}$  is the measured power in chapter 11.

**Table 14.1: Duty Cycle**

Mode	Duty Cycle
Speech for GSM850/1900	1:8.3
GPRS for GSM850 and PCS1900	1:2.67

### 13.1 SAR results for Fast SAR

**Table 13.1-1: SAR Values (GSM 850 MHz Band - Head)**

Frequency		Side	Test Position	Figure No.	Ambient Temperature: 22.5°C		Liquid Temperature: 22.0°C		Measured SAR(1g) (W/kg)	Reported SAR(1g)(W/kg)	Power Drift (dB)
MHz	Ch.				Conducted Power (dBm)	Max. tune-up Power (dBm)	Measured SAR(10g) (W/kg)	Reported SAR(10g) (W/kg)			
836.6	190	Left	Touch	/	31.57	33.3	0.270	<b>0.40</b>	0.435	<b>0.65</b>	-0.01
836.6	190	Left	Tilt	/	31.57	33.3	0.038	<b>0.06</b>	0.061	<b>0.09</b>	0.02
848.8	251	Right	Touch	Fig.1	31.69	33.3	0.398	<b>0.58</b>	0.640	<b>0.93</b>	-0.02
836.6	190	Right	Touch	/	31.57	33.3	0.293	<b>0.44</b>	0.485	<b>0.72</b>	0.09
824.2	128	Right	Touch	/	31.74	33.3	0.232	<b>0.33</b>	0.376	<b>0.54</b>	0.06
836.6	190	Right	Tilt	/	31.57	33.3	0.030	<b>0.04</b>	0.043	<b>0.06</b>	-0.04

**Table 13.1-2: SAR Values (GSM 850 MHz Band-Body)**

Frequency		Mode (number of timeslots)	Test Position	Figure No.	Ambient Temperature: 22.5°C		Liquid Temperature: 22.0°C		Measured SAR(1g) (W/kg)	Reported SAR(1g) (W/kg)	Power Drift (dB)
MHz	Ch.				Conducted Power (dBm)	Max. tune-up Power (dBm)	Measured SAR(10g) (W/kg)	Reported SAR(10g) (W/kg)			
836.6	190	GPRS (3)	Front closed	/	28.61	29	0.392	<b>0.43</b>	0.571	<b>0.62</b>	-0.08
848.8	251	GPRS (3)	Rear closed	Fig.2	28.64	29	1.02	<b>1.11</b>	1.42	<b>1.54</b>	-0.08
836.6	190	GPRS (3)	Rear closed	/	28.61	29	0.949	<b>1.04</b>	1.40	<b>1.53</b>	0.06
824.2	128	GPRS (3)	Rear closed	/	28.72	29	0.862	<b>0.92</b>	1.26	<b>1.34</b>	-0.01
836.6	190	GPRS (3)	Rear open	/	28.61	29	0.383	<b>0.42</b>	0.561	<b>0.61</b>	0.01

Note1: The distance between the EUT and the phantom bottom is 10mm.

Note2: The reported SAR is higher than 1.2W/k, but the position of rear closed can't support to work with headset. So the headset is not required to be tested.

**Table 13.1-3: SAR Values (GSM1900 MHz Band - Head)**

Frequency		Side	Test Position	Figure No.	Conducted Power (dBm)	Max. tune-up Power (dBm)	Measured SAR(10g) (W/kg)	Reported SAR(10g) (W/kg)	Measured SAR(1g) (W/kg)	Reported SAR(1g) (W/kg)	Power Drift (dB)
MHz	Ch.										
Ambient Temperature: 22.5°C      Liquid Temperature: 22.0°C											
1880	661	Left	Touch	/	28.85	30.3	0.140	<b>0.20</b>	0.238	<b>0.33</b>	-0.12
1880	661	Left	Tilt	/	28.85	30.3	0.027	<b>0.04</b>	0.044	<b>0.06</b>	-0.10
1909.8	810	Right	Touch	/	28.98	30.3	0.132	<b>0.18</b>	0.244	<b>0.33</b>	0.14
1880	661	Right	Touch	Fig.3	28.85	30.3	0.215	<b>0.30</b>	0.343	<b>0.48</b>	-0.05
1850.2	512	Right	Touch	/	28.91	30.3	0.157	<b>0.22</b>	0.288	<b>0.40</b>	0.08
1880	661	Right	Tilt	/	28.85	30.3	0.040	<b>0.06</b>	0.073	<b>0.10</b>	-0.01

**Table 13.1-4: SAR Values (GSM 1900 MHz Band-Body)**

Frequency		Mode (number of timeslots)	Test Position	Figure No.	Conducted Power (dBm)	Max. tune-up Power (dBm)	Measured SAR(10g) (W/kg)	Reported SAR(10g) (W/kg)	Measured SAR(1g) (W/kg)	Reported SAR(1g) (W/kg)	Power Drift (dB)
MHz	Ch.										
Ambient Temperature: 22.5°C      Liquid Temperature: 22.0°C											
1880	661	GPRS (3)	Front closed	/	25.20	26	0.195	<b>0.23</b>	0.341	<b>0.41</b>	-0.16
1909.8	810	GPRS (3)	Rear closed	/	24.99	26	0.308	<b>0.39</b>	0.543	<b>0.68</b>	-0.01
1880	661	GPRS (3)	Rear closed	/	25.20	26	0.389	<b>0.47</b>	0.657	<b>0.79</b>	-0.02
1850.2	512	GPRS (3)	Rear closed	Fig.4	25.45	26	0.581	<b>0.66</b>	0.975	<b>1.11</b>	-0.05
1880	661	GPRS (3)	Rear open	/	25.20	26	0.286	<b>0.34</b>	0.476	<b>0.57</b>	0.08

Note1: The distance between the EUT and the phantom bottom is 10mm.

### 13.2 SAR results for Standard procedure

There is zoom scan measurement to be added for the highest measured SAR in each exposure configuration/band.

**Table 13.2-1: SAR Values (GSM 850 MHz Band - Head)**

Frequency		Side	Test Position	Figure No.	Conducted Power (dBm)	Max. tune-up Power (dBm)	Measured SAR(10g) (W/kg)	Reported SAR(10g) (W/kg)	Measured SAR(1g) (W/kg)	Reported SAR(1g) (W/kg)	Power Drift (dB)
MHz	Ch.										
Ambient Temperature: 22.5°C      Liquid Temperature: 22.0°C											
848.8	251	Right	Touch	Fig.1	31.69	33.3	0.398	<b>0.58</b>	0.640	<b>0.93</b>	-0.02

**Table 13.2-2: SAR Values (GSM 850 MHz Band-Body)**

Frequency		Mode (number of timeslots)	Test Position	Figure No.	Conducted Power (dBm)	Max. tune-up Power (dBm)	Measured SAR(10g) (W/kg)	Reported SAR(10g) (W/kg)	Measured SAR(1g) (W/kg)	Reported SAR(1g) (W/kg)	Power Drift (dB)
MHz	Ch.										
Ambient Temperature: 22.5°C      Liquid Temperature: 22.0°C											
848.8	251	GPRS (3)	Rear closed	Fig.2	28.64	29	1.02	<b>1.11</b>	1.42	<b>1.54</b>	-0.08

Note1: The distance between the EUT and the phantom bottom is 10mm.



**Table 13.2-3: SAR Values (GSM1900 MHz Band - Head)**

Ambient Temperature: 22.5 °C      Liquid Temperature: 22.0 °C											
Frequency		Side	Test Position	Figure No.	Conducted Power (dBm)	Max. tune-up Power (dBm)	Measured SAR(10g) (W/kg)	Reported SAR(10g) (W/kg)	Measured SAR(1g) (W/kg)	Reported SAR(1g) (W/kg)	Power Drift (dB)
MHz	Ch.										
1880	661	Right	Touch	Fig.3	28.85	30.3	0.215	<b>0.30</b>	0.343	<b>0.48</b>	-0.05

**Table 13.2-4: SAR Values (GSM 1900 MHz Band-Body)**

Ambient Temperature: 22.5 °C      Liquid Temperature: 22.0 °C											
Frequency		Mode (number of timeslots)	Test Position	Figure No.	Conducted Power (dBm)	Max. tune-up Power (dBm)	Measured SAR(10g) (W/kg)	Reported SAR(10g) (W/kg)	Measured SAR(1g) (W/kg)	Reported SAR(1g) (W/kg)	Power Drift (dB)
MHz	Ch.										
1850.2	512	GPRS (3)	Rear closed	Fig.4	25.45	26	0.581	<b>0.66</b>	0.975	<b>1.11</b>	-0.05

Note1: The distance between the EUT and the phantom bottom is 10mm.