

TEST REPORT

Report No.: BCTC2308448381-4E

Applicant: SHENZHEN NST INDUSTRY AND TRADE CO.,LTD

Product Name: 10.1 inch tablet PC

Model/Type
reference: T10S

Tested Date: 2023-08-29 to 2023-09-12

Issued Date: 2023-09-14

Shenzhen BCTC Testing Co., Ltd.



FCC ID: 2AAMS-SGINT10S

Product Name: 10.1 inch tablet PC
Trademark: N/A
Model/Type reference: T10S
M107GA
Prepared For: SHENZHEN NST INDUSTRY AND TRADE CO.,LTD
Address: 3-4/F, Bldg 1, Hongbang Intelligent Technology Park, No.30 Cuibao Road, Baolong Street, Longgang District, Shenzhen, China
Manufacturer: SHENZHEN NST INDUSTRY AND TRADE CO.,LTD
Address: 3-4/F, Bldg 1, Hongbang Intelligent Technology Park, No.30 Cuibao Road, Baolong Street, Longgang District, Shenzhen, China
Prepared By: Shenzhen BCTC Testing Co., Ltd.
Address: 1-2/F., Building B, Pengzhou Industrial Park, No.158, Fuyuan 1st Road, Zhancheng, Fuhai Subdistrict, Bao'an District, Shenzhen, Guangdong, China
Sample Received Date: 2023-08-28
Sample tested Date: 2023-08-29 to 2023-09-12
Issue Date: 2023-09-14
Report No.: BCTC2308448381-4E
FCC Part15 15.407
Test Standards: ANSI C63.10-2013
KDB 662911 D01 v02r01
KDB 789033 D02 v02r01
Test Results: PASS

Tested by:

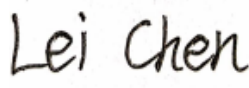

Lei Chen/Project Handler

Approved by:



Zero Zhou/Reviewer

The test report is effective only with both signature and specialized stamp. This result(s) shown in this report refer only to the sample(s) tested. Without written approval of Shenzhen BCTC Testing Co., Ltd, this report can't be reproduced except in full. The tested sample(s) and the sample information are provided by the client.

Table Of Content

	Page
Test Report Declaration	
1. Version	5
2. Test Summary	6
3. Measurement Uncertainty	7
4. Product Information And Test Setup	8
4.1 Product Information.....	8
4.2 Test Setup Configuration	8
4.3 Support Equipment	9
4.4 Channel List	9
4.5 Test Mode	10
4.6 Table Of Parameters Of Text Software Setting.....	10
5. Test Facility And Test Instrument Used.....	11
5.1 Test Facility.....	11
5.2 Test Instrument Used.....	11
6. Conducted Emissions.....	13
6.1 Block Diagram Of Test Setup.....	13
6.2 Limit	13
6.3 Test Procedure	13
6.4 EUT Operating Conditions	13
6.5 Test Result.....	14
7. Radiated Emissions.....	16
7.1 Block Diagram Of Test Setup.....	16
7.2 Limit	17
7.3 Test Procedure	18
7.4 EUT Operating Conditions	19
7.5 Test Result.....	19
8. Power Spectral Density Test	36
8.1 Block Diagram Of Test Setup.....	36
8.2 Limit	36
8.3 Test Procedure	37
8.4 EUT Operating Conditions	37
8.5 Test Result.....	38
9. 26dB & 6dB & 99% Emission Bandwidth	58
9.1 Block Diagram Of Test Setup.....	58
9.2 Limit	58
9.3 Test Procedure	58
9.4 EUT Operating Conditions	59
9.5 Test Result.....	59
10. Maximum Conducted Output Power.....	97
10.1 Block Diagram Of Test Setup.....	97
10.2 Limit	97
10.3 Test Procedure	97
10.4 EUT Operating Conditions	98
10.5 Test Result.....	99

11. Out Of Band Emissions	119
11.1 Block Diagram Of Test Setup.....	119
11.2 Limit	119
11.3 Test Procedure	119
11.4 EUT Operating Conditions	119
11.5 Test Result.....	120
12. Spurious RF Conducted Emissions.....	134
12.1 Block Diagram Of Test Setup.....	134
12.2 Limit	134
12.3 Test Procedure	134
12.4 Test Result.....	134
13. Frequency Stability Measurement	153
13.1 Block Diagram Of Test Setup.....	153
13.2 Limit	153
13.3 Test Procedure	153
13.4 Test Result.....	154
14. Antenna Requirement	160
14.1 Limit	160
14.2 Test Result.....	160
15. EUT Photographs.....	161
16. EUT Test Setup Photographs.....	162

(Note: N/A Means Not Applicable)

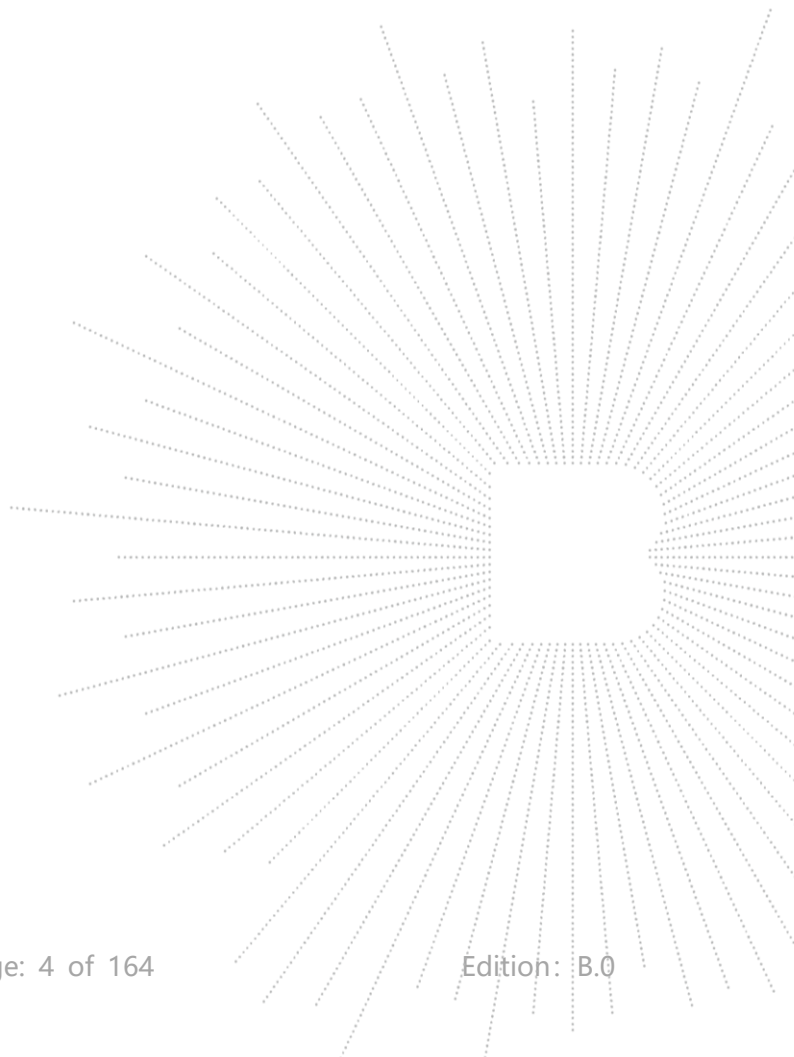

1. Version

Report No.	Issue Date	Description	Approved
BCTC2308448381-4E	2023-09-14	Original	Valid

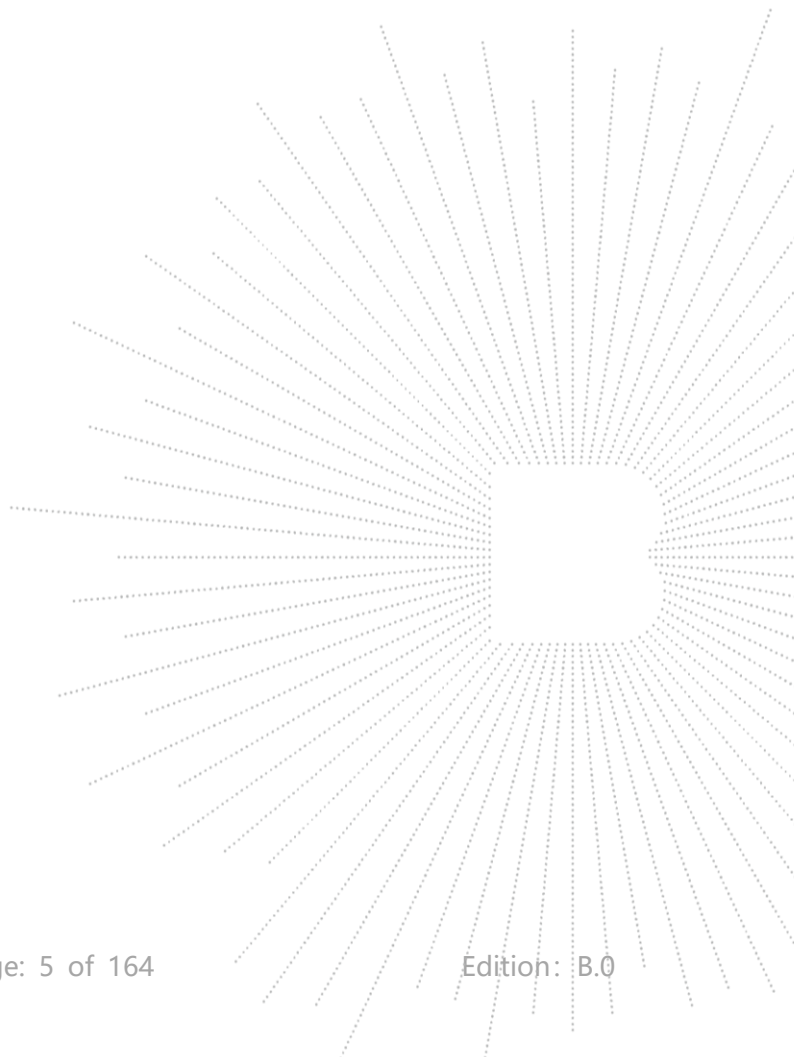

2. Test Summary

The Product has been tested according to the following specifications:

No.	Test Parameter	Clause No	Results
1	Spurious Radiated Emissions	15.209(a), 15.407 (b)(1) 15.407 (b)(4) 15.407 (b)(8)	PASS
2	Conducted Emission	15.207	PASS
3	26 dB and 99% Emission Bandwidth	15.407 (a)(12) 15.1049	PASS
4	Minimum 6 dB bandwidth	15.407(e)	PASS
5	Maximum Conducted Output Power	15.407 (a)(1) 15.407 (a)(3)	PASS
6	Band Edge	2.1051, 15.407(b)(1) 15.407(b)(4)	PASS
7	Power Spectral Density	15.407 (a)(1) 15.407 (a)(3)	PASS
8	Spurious Emissions at Antenna Terminals	2.1051, 15.407(b)	PASS
9	Antenna Requirement	15.203	PASS

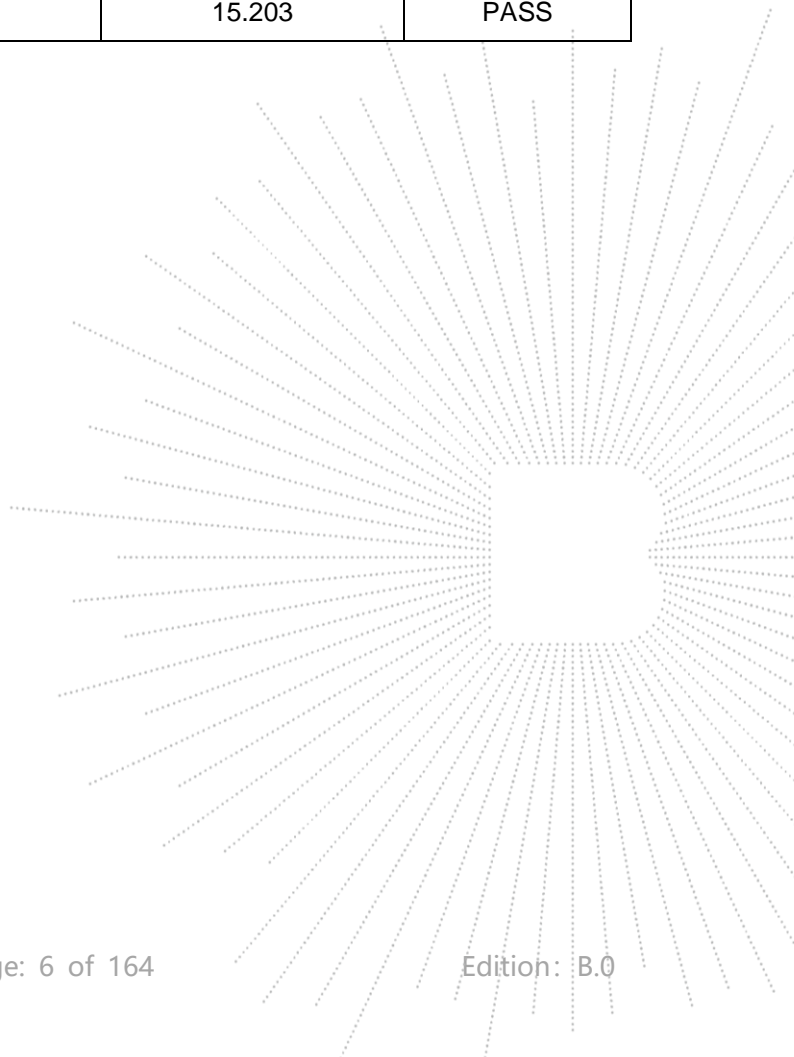

3. Measurement Uncertainty

Where relevant, the following measurement uncertainty levels have been estimated for tests performed on the Product as specified in CISPR 16-4-2. This uncertainty represents an expanded uncertainty expressed at approximately the 95% confidence level using a coverage factor of $k=2$.

No.	Item	Uncertainty
1	3m chamber Radiated spurious emission(9kHz-30MHz)	U=3.7dB
2	3m chamber Radiated spurious emission(30MHz-1GHz)	U=4.3dB
3	3m chamber Radiated spurious emission(1GHz-18GHz)	U=4.5dB
4	3m chamber Radiated spurious emission(18GHz-40GHz)	U=3.34dB
5	Conducted Emission(150kHz-30MHz)	U=3.20dB
6	Conducted Adjacent channel power	U=1.38dB
7	Conducted output power uncertainty Above 1G	U=1.576dB
8	Conducted output power uncertainty below 1G	U=1.28dB
9	humidity uncertainty	U=5.3%
10	Temperature uncertainty	U=0.59°C

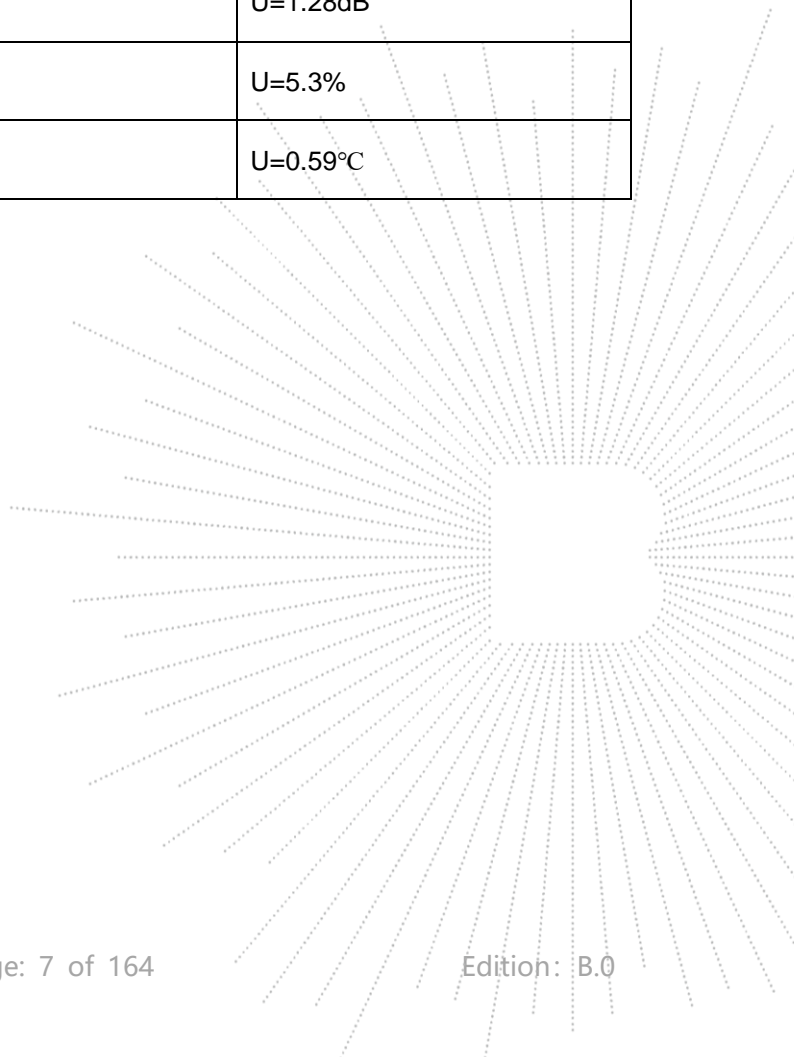

4. Product Information And Test Setup

4.1 Product Information

Model/Type Ref.:	T10S M107GA
Model differences:	All the model are the same circuit and RF module, except model names.
Hardware Version:	CC863_MB_V2.2
Software Version:	T10S20230906
IEEE 802.11 WLAN Mode Supported	802.11a/n/ac/ax(20MHz channel bandwidth) 802.11n/ac/ax(40MHz channel bandwidth)
Operation Frequency:	5180-5240MHz for 802.11a/n(HT20)/ax(HT20); 5190-5230MHz for 802.11n(HT40)/ax(HT40); 5745-5825 MHz for 802.11a/n(HT20)/ax(HT20); 5755-5795 MHz for 802.11n(HT40)/ax(HT40);
Data Rate	802.11a: 6,9,12,18,24,36,48,54Mbps; 802.11n(HT20/HT40): MCS0-MCS15; 802.11ac/ax(VHT20): NSS1, MCS0-MCS8 802.11ac/ax(VHT40):NSS1, MCS0-MCS
Type of Modulation:	OFDM/OFDMA
Number Of Channel	4 channels for 802.11a/n20/ax20 in the 5180-5240MHz band ; 2 channels for 802.11 n40/ax40 in the 5190-5230MHz band ; 5 channels for 802.11a/n20/ax20 in the 5745-5825MHz band ; 2 channels for 802.11 n40/ax40 in the 5755-5795MHz band
Antenna installation:	FPC antenna
Antenna Gain:	5.1G: 2.1 dBi 5.8G: 1.12 dBi
Ratings:	DC 5V from adapter, DC 3.8V from battery
Adapter Information:	Model No.: MK050200-T10USU Input: AC 100-240V 50/60Hz 0.5A Max Output: AC120V/60Hz 2A

4.2 Test Setup Configuration

See test photographs attached in *EUT TEST SETUP PHOTOGRAPHS* for the actual connections between Product and support equipment.

Conducted Emission:

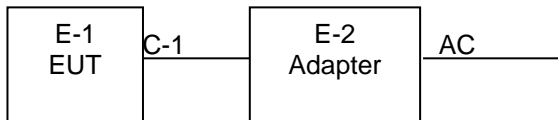

Radiated Spurious Emission

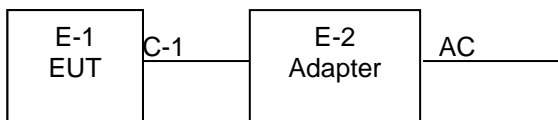

4.3 Support Equipment

No.	Device Type	Brand	Model	Series No.	Note
E-1	10.1 inch tablet PC	N/A	T10S	N/A	EUT
E-2	Adapter	N/A	MK050200-T10 USU	N/A	Auxiliary

Item	Shielded Type	Ferrite Core	Length	Note
C-1	N/A	N/A	0.5M	DC cable unshielded

Notes:

1. All the equipment/cables were placed in the worst-case configuration to maximize the emission during the test.
2. Grounding was established in accordance with the manufacturer's requirements and conditions for the intended use.

4.4 Channel List

5.1G

802.11a/n/ac(20MHz)/ax(20MHz) Carrier Frequency Channel							
Channel	Frequency (MHz)	Channel	Frequency (MHz)	Channel	Frequency (MHz)	Channel	Frequency (MHz)
36	5180	44	5220	-	-	-	-
40	5200	48	5240	-	-	-	-

802.11n /ac(40MHz)/ax(40MHz) Carrier Frequency Channel							
Channel	Frequency (MHz)	Channel	Frequency (MHz)	Channel	Frequency (MHz)	Channel	Frequency (MHz)
38	5190	-	-	-	-	-	-
46	5230	-	-	-	-	-	-

5.8G

802.11a/n/ac(20 MHz)/ax(20 MHz) Carrier Frequency Channel							
Channel	Frequency (MHz)	Channel	Frequency (MHz)	Channel	Frequency (MHz)	Channel	Frequency (MHz)
149	5745	153	5765	157	5785	161	5805
165	5825	-	-	-	-	-	-

802.11n/ ac(40MHz)/ax(40MHz) Carrier Frequency Channel					
Channel	Frequency (MHz)	Channel	Frequency (MHz)	Channel	Frequency (MHz)
151	5755	159	5795	-	-

4.5 Test Mode

To investigate the maximum EMI emission characteristics generated from EUT, the test system was pre-scanning tested based on the consideration of following EUT operation mode or test configuration mode which possibly have effect on EMI emission level. Each of these EUT operation mode(s) or test configuration mode(s) mentioned above was evaluated respectively.

Pretest Mode	Description
Mode 1	802.11a / n/ ac/ax 20 CH36/ CH40/ CH 48 802.11a /n/ ac/ax 20 CH149/ CH157/ CH 165
Mode 2	802.11n/ ac/ax 40 CH38/ CH 46 802.11n/ ac/ax 40 CH 151 / CH 159
Mode 3	Link Mode

Conducted Emission	
Final Test Mode	Description
Mode 3	Link Mode

For Radiated Emission	
Final Test Mode	Description
Mode 1	802.11a / n/ ac/ax 20 CH36/ CH40/ CH 48 802.11a /n/ ac/ax 20 CH149/ CH157/ CH 165
Mode 2	802.11n/ ac/ax 40 CH38/ CH 46 802.11n/ ac/ax 40 CH 151 / CH 159

Note:

1. The measurements are performed at all Bit Rate of Transmitter, the worst data was reported.
2. We're testing antenna A data.

4.6 Table Of Parameters Of Text Software Setting

During testing channel & power controlling software provided by the customer was used to control the operating channel as well as the output power level. The RF output power selection is for the setting of RF output power expected by the customer and is going to be fixed on the firmware of the final end product power parameters

Test software Version	rf_test		
Parameters	DEF	DEF	DEF

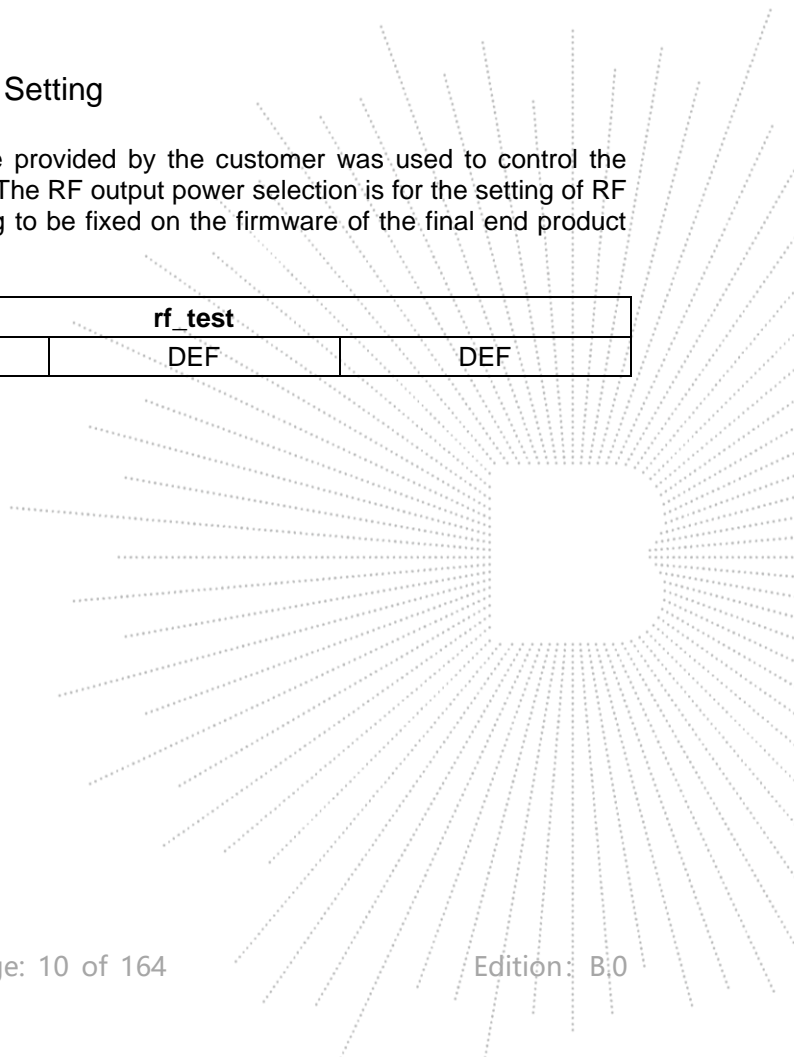

5. Test Facility And Test Instrument Used

5.1 Test Facility

All measurement facilities used to collect the measurement data are located at Shenzhen BCTC Testing Co., Ltd. Address: 1-2/F., Building B, Pengzhou Industrial Park, No.158, Fuyuan 1st Road, Zhancheng, Fuhai Subdistrict, Bao'an District, Shenzhen, Guangdong, China. The site and apparatus are constructed in conformance with the requirements of ANSI C63.4 and CISPR 16-1-1 other equivalent standards.

FCC Test Firm Registration Number: 712850

A2LA certificate registration number is: CN1212

ISED Registered No.: 23583

ISED CAB identifier: CN0017

5.2 Test Instrument Used

Conducted Emissions Test					
Equipment	Manufacturer	Model#	Serial#	Last Cal.	Next Cal.
Receiver	R&S	ESR3	102075	May 15, 2023	May 14, 2024
LISN	R&S	ENV216	101375	May 15, 2023	May 14, 2024
Software	Frad	EZ-EMC	EMC-CON 3A1	\	\
Attenuator	\	10dB DC-6GHz	1650	May 15, 2023	May 14, 2024

RF Conducted Test					
Equipment	Manufacturer	Model#	Serial#	Last Cal.	Next Cal.
Power Meter	Keysight	E4419	\	May 15, 2023	May 14, 2024
Power Sensor (AV)	Keysight	E9300A	\	May 15, 2023	May 14, 2024
Signal Analyzer20kHz-26.5GHz	Keysight	N9020A	MY49100060	May 15, 2023	May 14, 2024
Spectrum Analyzer9kHz-40GHz	R&S	FSP40	100363	May 15, 2023	May 14, 2024
Radio frequency control box	MAIWEI	MW100-RFC B	\	\	\
Software	MAIWEI	MTS 8310	\	\	\

Radiated Emissions Test (966 Chamber01)					
Equipment	Manufacturer	Model#	Serial#	Last Cal.	Next Cal.
966 chamber	ChengYu	966 Room	966	May 15, 2023	May 14, 2026
Receiver	R&S	ESR3	102075	May 15, 2023	May 14, 2024
Receiver	R&S	ESRP	101154	May 15, 2023	May 14, 2024
Amplifier	Schwarzbeck	BBV9744	9744-0037	May 15, 2023	May 14, 2024
TRILOG Broadband Antenna	Schwarzbeck	VULB9163	942	May 29, 2023	May 28, 2024
Loop Antenna(9KHz -30MHz)	Schwarzbeck	FMZB1519B	00014	May 31, 2023	May 30, 2024
Amplifier	SKET	LAPA_01G18 G-45dB	\	May 15, 2023	May 14, 2024
Horn Antenna	Schwarzbeck	BBHA9120D	1541	May 31, 2023	May 30, 2024
Amplifier(18G Hz-40GHz)	MITEQ	TTA1840-35-HG	2034381	May 15, 2023	May 14, 2024
Horn Antenna(18G Hz-40GHz)	Schwarzbeck	BBHA9170	00822	May 31, 2023	May 30, 2024
Spectrum Analyzer9kHz-40GHz	R&S	FSP40	100363	May 15, 2023	May 14, 2024
Software	Frad	EZ-EMC	FA-03A2 RE	\	\

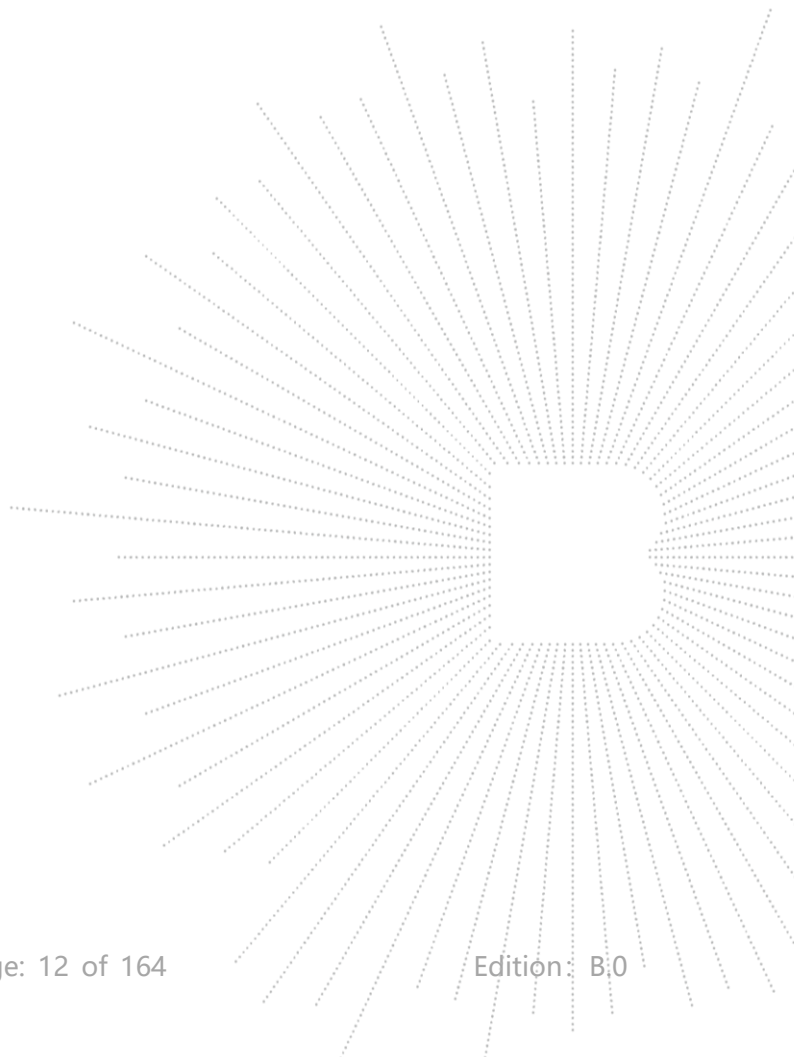

6. Conducted Emissions

6.1 Block Diagram Of Test Setup

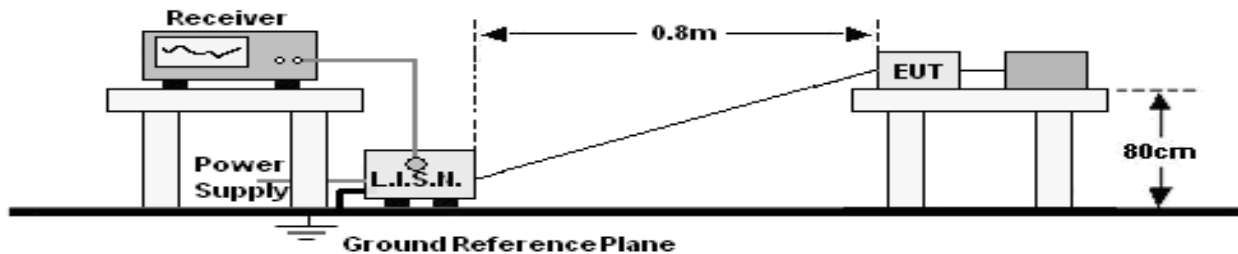

6.2 Limit

Frequency (MHz)	Limit (dBuV)	
	Quas-peak	Average
0.15 -0.5	66 - 56 *	56 - 46 *
0.50 -5.0	56.00	46.00
5.0 -30.0	60.00	50.00

Notes:
 1. *Decreasing linearly with logarithm of frequency.
 2. The lower limit shall apply at the transition frequencies.

6.3 Test Procedure

Receiver Parameters	Setting
Attenuation	10 dB
Start Frequency	0.15 MHz
Stop Frequency	30 MHz
IF Bandwidth	9 kHz

- The Product was placed on a nonconductive table 0.8 m above the horizontal ground reference plane, and 0.4 m from the vertical ground reference plane, and connected to the main through Line Impedance Stability Network (L.I.S.N).
- The RBW of the receiver was set at 9 kHz in 150 kHz ~ 30MHz with Peak and AVG detector in Max Hold mode. Run the receiver's pre-scan to record the maximum disturbance generated from Product in all power lines in the full band.
- For each frequency whose maximum record was higher or close to limit, measure its QP and AVG values and record.

6.4 EUT Operating Conditions

The EUT was configured for testing in a typical fashion (as a customer would normally use it). The EUT has been programmed to continuously transmit during test. This operating condition was tested and used to collect the included data.

6.5 Test Result

Temperature:	26 °C	Relative Humidity:	54%
Pressure:	101KPa	Phase :	L
Test Mode:	Mode 3	Test Voltage :	AC120V/60Hz

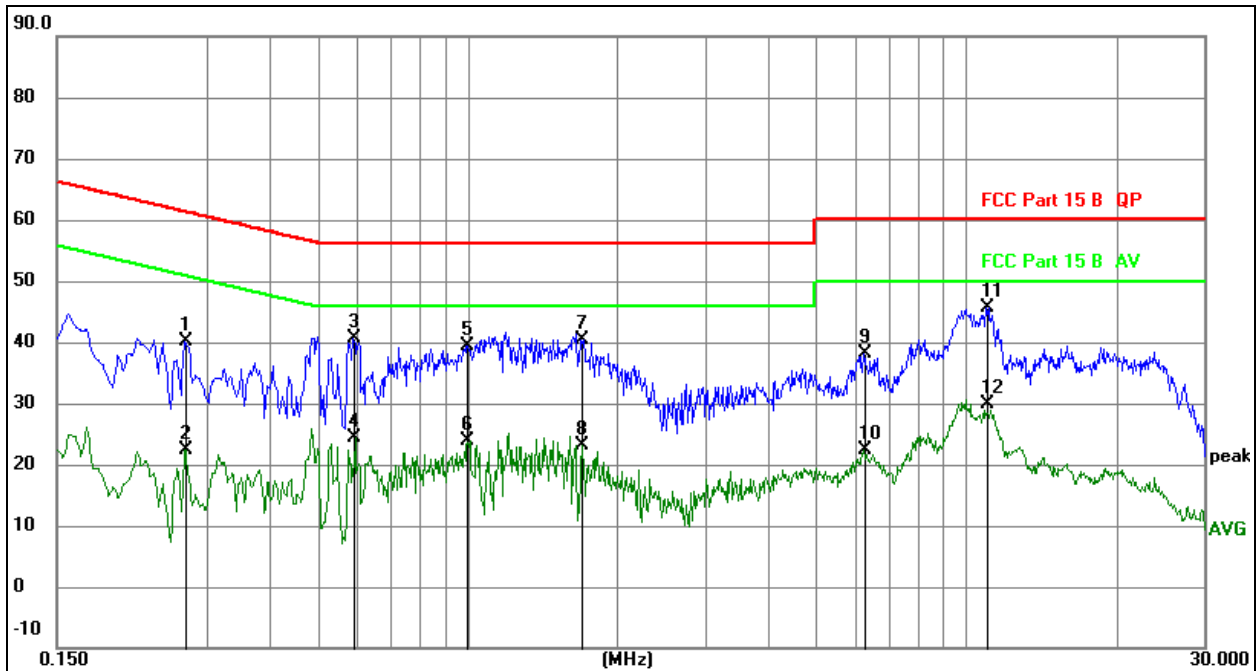

Remark:

1. All readings are Quasi-Peak and Average values.
2. Factor = Insertion Loss + Cable Loss.
3. Measurement=Reading Level+ Correct Factor
4. Over= Measurement-Limit

No.	Mk.	Freq. MHz	Reading Level	Correct Factor dB	Measure- ment dBuV	Limit dBuV	Over dB	Detector
1		0.2714	30.53	9.61	40.14	61.07	-20.93	QP
2		0.2714	12.70	9.61	22.31	51.07	-28.76	AVG
3		0.5910	30.91	9.62	40.53	56.00	-15.47	QP
4		0.5910	14.77	9.62	24.39	46.00	-21.61	AVG
5		0.9960	29.68	9.73	39.41	56.00	-16.59	QP
6		0.9960	14.03	9.73	23.76	46.00	-22.24	AVG
7		1.6935	30.71	9.73	40.44	56.00	-15.56	QP
8		1.6935	13.28	9.73	23.01	46.00	-22.99	AVG
9		6.2430	28.38	9.77	38.15	60.00	-21.85	QP
10		6.2430	12.62	9.77	22.39	50.00	-27.61	AVG
11	*	11.0130	36.00	9.66	45.66	60.00	-14.34	QP
12		11.0130	20.31	9.66	29.97	50.00	-20.03	AVG

Temperature:	26 °C	Relative Humidity:	54%
Pressure:	101KPa	Phase :	N
Test Mode:	Mode 3	Test Voltage :	AC120V/60Hz

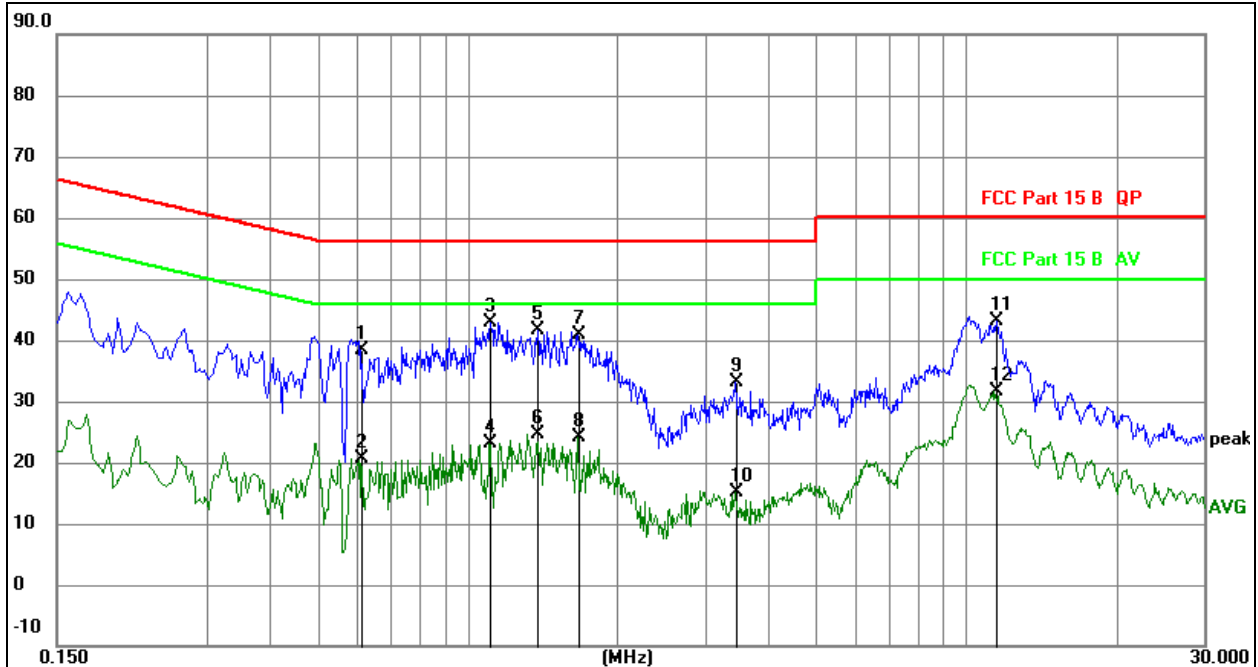
Remark:

1. All readings are Quasi-Peak and Average values.
2. Factor = Insertion Loss + Cable Loss.
3. Measurement=Reading Level+ Correct Factor
4. Over= Measurement-Limit

No.	Mk.	Freq. MHz	Reading Level	Correct Factor dB	Measure- ment dBuV	Limit dBuV	Over dB	Detector
1		0.6108	28.69	9.62	38.31	56.00	-17.69	QP
2		0.6108	10.92	9.62	20.54	46.00	-25.46	AVG
3	*	1.1114	33.05	9.73	42.78	56.00	-13.22	QP
4		1.1114	13.42	9.73	23.15	46.00	-22.85	AVG
5		1.3810	32.02	9.73	41.75	56.00	-14.25	QP
6		1.3810	14.83	9.73	24.56	46.00	-21.44	AVG
7		1.6625	31.17	9.73	40.90	56.00	-15.10	QP
8		1.6625	14.43	9.73	24.16	46.00	-21.84	AVG
9		3.4356	23.30	9.81	33.11	56.00	-22.89	QP
10		3.4356	5.29	9.81	15.10	46.00	-30.90	AVG
11		11.4983	33.37	9.66	43.03	60.00	-16.97	QP
12		11.4983	22.03	9.66	31.69	50.00	-18.31	AVG

7. Radiated Emissions

7.1 Block Diagram Of Test Setup

(A) Radiated Emission Test-Up Frequency Below 30MHz

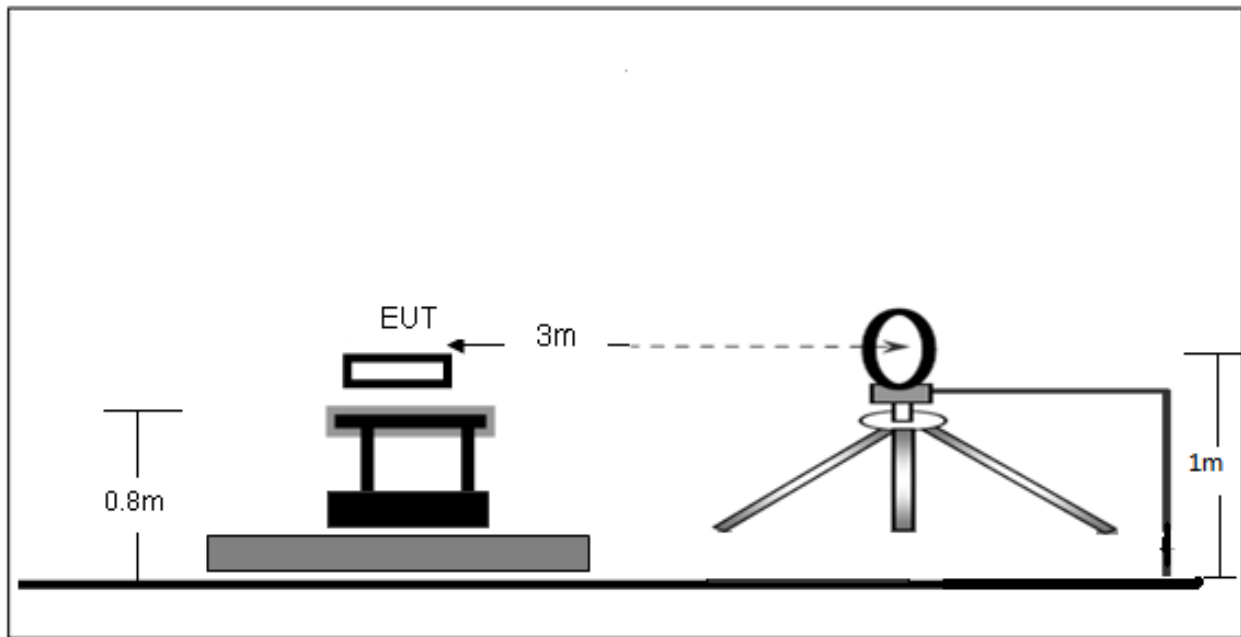

(B) Radiated Emission Test-Up Frequency 30MHz~1GHz

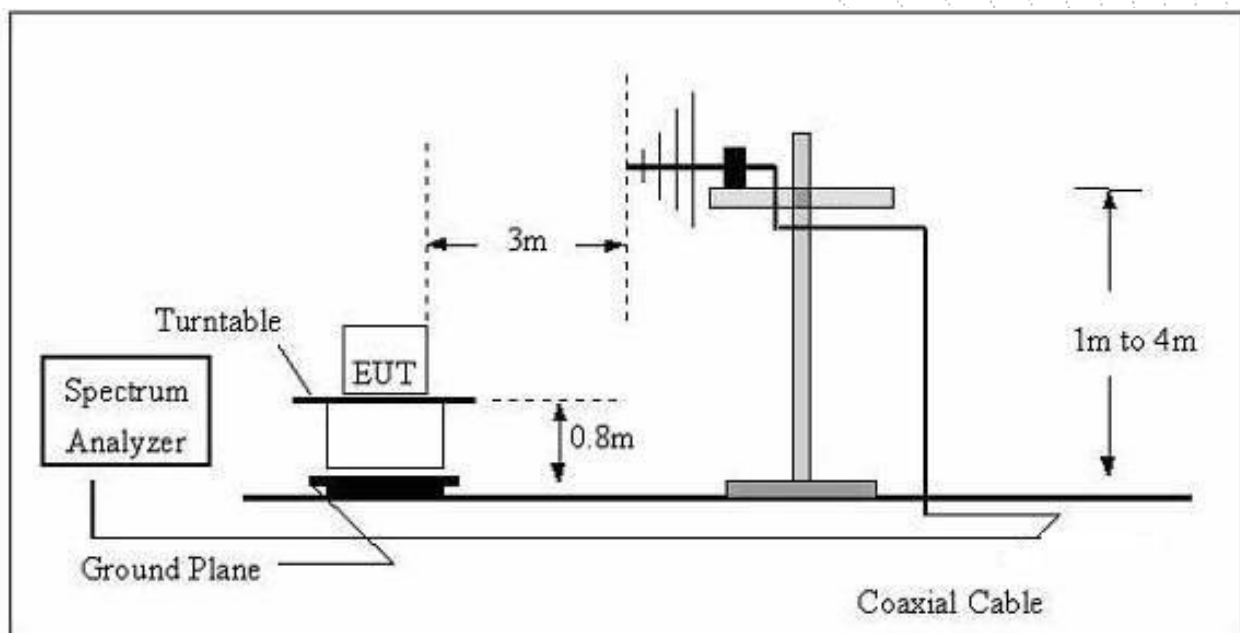

(C) Radiated Emission Test-Up Frequency Above 1GHz

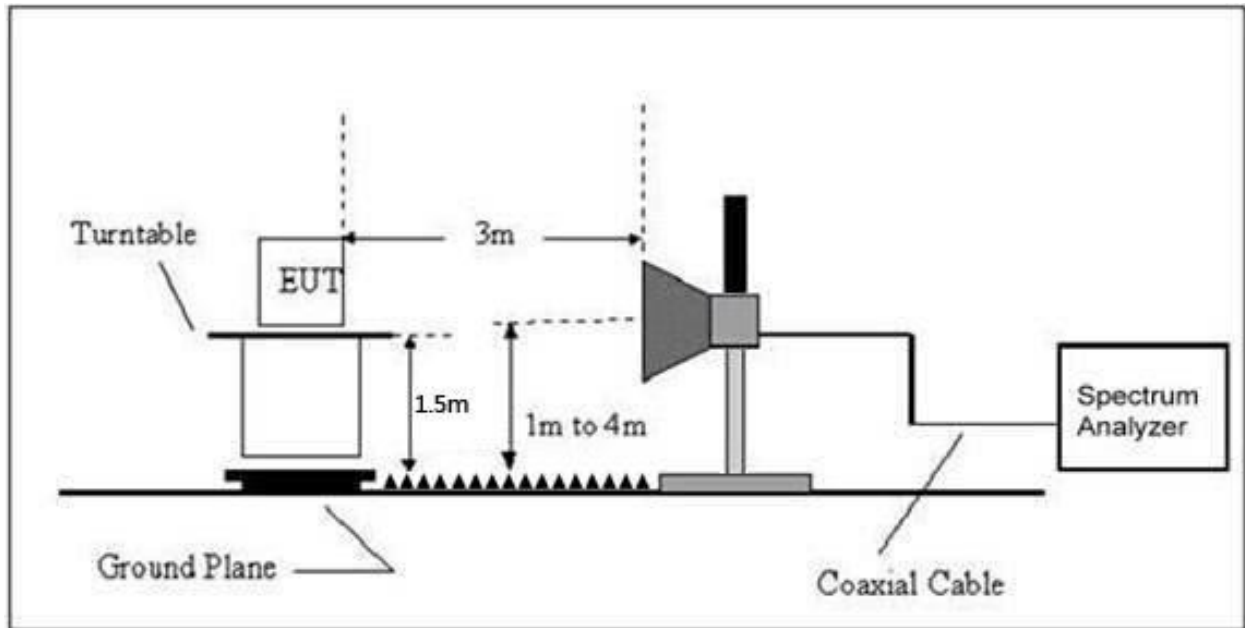

7.2 Limit

20dBc in any 100 kHz bandwidth outside the operating frequency band. In case the emission fall within the restricted band specified on 15.205(a), then the 15.209(a) limit in the table below has to be followed.

Frequency (MHz)	Field Strength uV/m	Distance (m)	Field Strength Limit at 3m Distance	
			uV/m	dBuV/m
0.009 ~ 0.490	2400/F(kHz)	300	10000 * 2400/F(kHz)	20log ^{(2400/F(kHz))} + 80
0.490 ~ 1.705	24000/F(kHz)	30	100 * 24000/F(kHz)	20log ^{(24000/F(kHz))} + 40
1.705 ~ 30	30	30	100 * 30	20log ⁽³⁰⁾ + 40
30 ~ 88	100	3	100	20log ⁽¹⁰⁰⁾
88 ~ 216	150	3	150	20log ⁽¹⁵⁰⁾
216 ~ 960	200	3	200	20log ⁽²⁰⁰⁾
Above 960	500	3	500	20log ⁽⁵⁰⁰⁾

Limits Of Radiated Emission Measurement (Above 1000MHz)

Frequency (MHz)	Limit (dBuV/m) (at 3M)	
	Peak	Average
Above 1000	74	54

Notes:

- (1)The limit for radiated test was performed according to FCC PART 15C.
- (2)The tighter limit applies at the band edges.
- (3) Emission level (dBuV/m)=20log Emission level (uV/m).

7.3 Test Procedure

The test site semi-anechoic chamber has met the requirement of NSA tolerance 4 dB according to the standards: ANSI C63.10-2013. The test distance is 3m. The setup is according to the requirements in Section 13.1.4.1 of ANSI C63.10-2013 and CAN/CSA-CEI/IEC CISPR 22.

This test is required for any spurious emission that falls in a Restricted Band, as defined in Section 15.205.

It must be performed with the highest gain of each type of antenna proposed for use with the EUT.

Use the following spectrum analyzer settings:

Spectrum Parameter	Setting
Attenuation	Auto
Start Frequency	1000 MHz
Stop Frequency	10th carrier harmonic
RB / VB (emission in restricted band)	1 MHz / 1 MHz for Peak, 1 MHz / 10Hz for Average

Receiver Parameter	Setting
Attenuation	Auto
Start ~ Stop Frequency	9kHz~150kHz / RB 200Hz for QP
Start ~ Stop Frequency	150kHz~30MHz / RB 9kHz for QP
Start ~ Stop Frequency	30MHz~1000MHz / RB 120kHz for QP

- The measuring distance of at 3 m shall be used for measurements at frequency up to 1GHz. For frequencies above 1GHz, any suitable measuring distance may be used.
- The EUT was placed on the top of a rotating table 0.8 m for below 1GHz and 1.5m for above 1GHz the ground at a 3 meter. The table was rotated 360 degrees to determine the position of the highest radiation.
- The height of the equipment or of the substitution antenna shall be 0.8 m for below 1GHz and 1.5m for above 1GHz; the height of the test antenna shall vary between 1 m to 4 m. Both horizontal and vertical polarizations of the antenna are set to make the measurement.
- The initial step in collecting conducted emission data is a spectrum analyzer peak detector mode pre-scanning the measurement frequency range. Significant peaks are then marked and then Quasi Peak detector mode re-measured.
- If the Peak Mode measured value compliance with and lower than Quasi Peak Mode Limit, the EUT shall be deemed to meet QP Limits and then no additional QP Mode measurement performed.
- For the actual test configuration, please refer to the related Item –EUT Test Photos.

Note:

Both horizontal and vertical antenna polarities were tested and performed pretest to three orthogonal axis. The worst case emissions were reported

During the radiated emission test, the Spectrum Analyzer was set with the following configurations:

Frequency Band (MHz)	Function	Resolution bandwidth	Video Bandwidth
30 to 1000	QP	120 kHz	300 kHz
Above 1000	Peak	1 MHz	1 MHz
	Average	1 MHz	10 Hz

Note: for the frequency ranges below 30 MHz, a narrower RBW is used for these ranges but the measured value should add a RBW correction factor (RBWCF) where $RBWCF [dB] = 10 \cdot \lg(100 [kHz] / \text{narrower RBW} [kHz])$. , the narrower RBW is 1 kHz and RBWCF is 20 dB for the frequency 9 kHz to 150 kHz, and the narrower RBW is 10 kHz and RBWCF is 10 dB for the frequency 150 kHz to 30 MHz.

7.4 EUT Operating Conditions

The EUT was configured for testing in a typical fashion (as a customer would normally use it). The EUT has been programmed to continuously transmit during test. This operating condition was tested and used to collect the included data.

7.5 Test Result

Below 30MHz

Temperature:	26°C	Relative Humidity:	54%
Pressure:	101 kPa	Test Voltage:	AC120V/60Hz
Test Mode:	Mode 3	Polarization:	--

Freq. (MHz)	Reading (dBuV/m)	Limit (dBuV/m)	Margin (dB)	State P/F
--	--	--	--	PASS
--	--	--	--	PASS

Note:

The amplitude of spurious emissions which are attenuated by more than 20dB below the permissible value has no need to be reported.

Distance extrapolation factor = $40 \log(\text{specific distance/test distance})(\text{dB})$;

Limit line = specific limits(dBuv) + distance extrapolation factor.

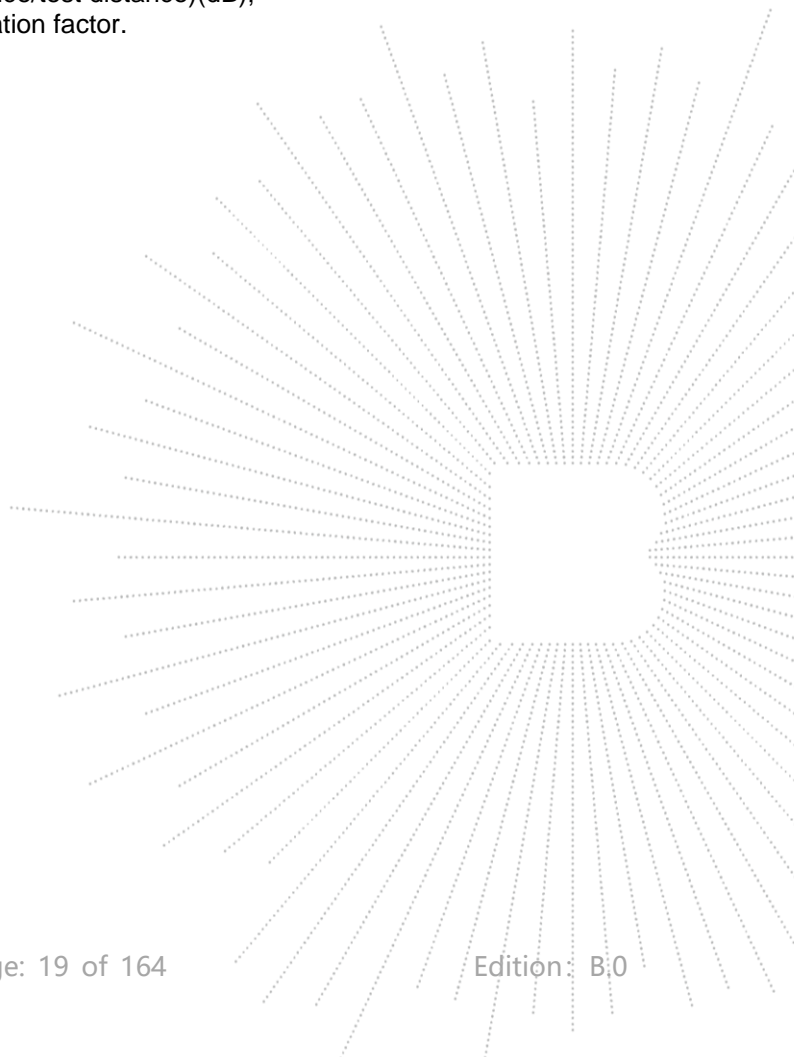

Between 30MHz – 1GHz

Temperature:	26 °C	Relative Humidity:	54%
Pressure:	101KPa	Phase :	Horizontal
Test Mode:	Mode 3	Test Voltage :	AC120V/60Hz

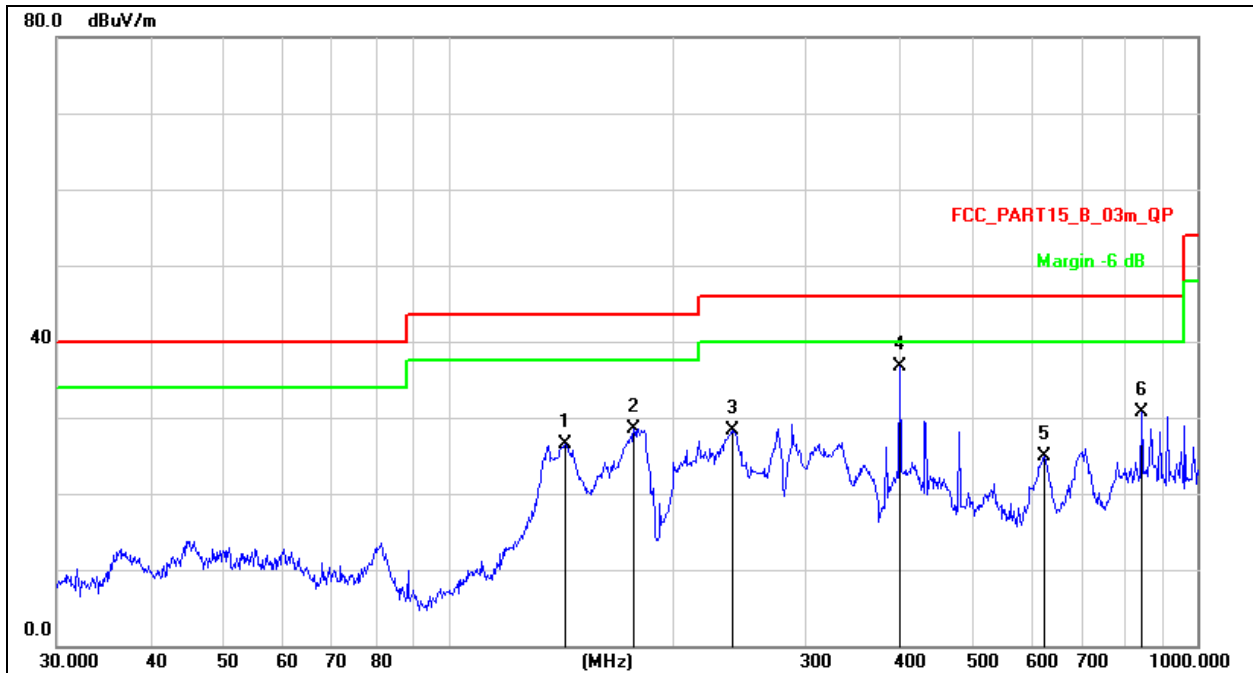
Remark:

1. Factor = Antenna Factor + Cable Loss – Pre-amplifier.
2. Measurement=Reading Level+ Correct Factor
3. Over=Measurement-Limit

No.	Mk.	Freq. MHz	Reading Level dBuV	Correct Factor dB	Measure- ment dBuV/m	Limit dB/m	Over dB	Detector
1		143.3261	47.13	-20.61	26.52	43.50	-16.98	QP
2		176.8878	47.59	-19.07	28.52	43.50	-14.98	QP
3		239.1473	44.41	-16.16	28.25	46.00	-17.75	QP
4	*	400.4319	48.98	-12.20	36.78	46.00	-9.22	QP
5		625.0780	32.92	-8.05	24.87	46.00	-21.13	QP
6		842.1296	35.84	-5.22	30.62	46.00	-15.38	QP

Temperature:	26 °C	Relative Humidity:	54%
Pressure:	101KPa	Phase :	Vertical
Test Mode:	Mode 3	Test Voltage :	AC120V/60Hz

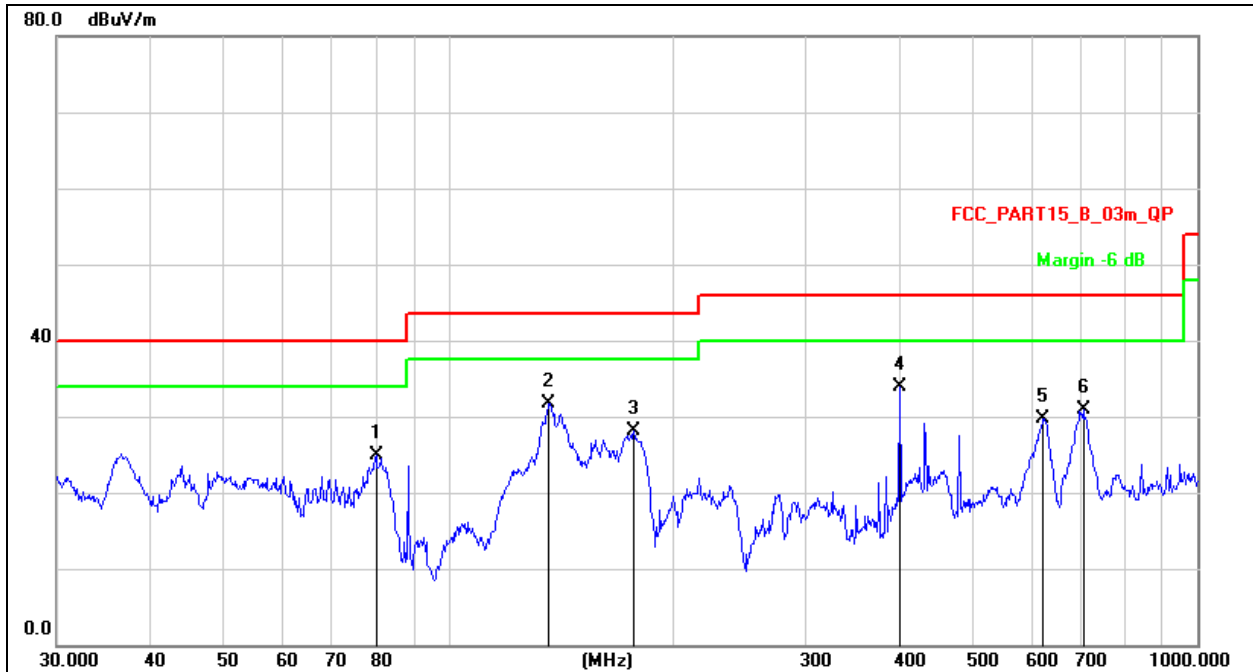
Remark:

1. Factor = Antenna Factor + Cable Loss – Pre-amplifier.
2. Measurement = Reading Level + Correct Factor
3. Over = Measurement - Limit

No.	Mk.	Freq. MHz	Reading Level dBuV	Correct Factor dB	Measure- ment dBuV/m	Limit dB/m	Over dB	Detector
1		80.0806	46.38	-21.54	24.84	40.00	-15.16	QP
2	*	135.9822	51.87	-20.13	31.74	43.50	-11.76	QP
3		176.8878	47.24	-19.07	28.17	43.50	-15.33	QP
4		400.4319	46.13	-12.20	33.93	46.00	-12.07	QP
5		622.8900	37.77	-8.08	29.69	46.00	-16.31	QP
6		704.2261	37.98	-7.12	30.86	46.00	-15.14	QP

Between 1GHz – 40GHz

Test Mode:	TX(5.1G) - 802.11a
------------	--------------------

Polar (H/V)	Frequency	Meter Reading	Cable loss	Antenna Factor	Preamp Factor	Emission Level	Limits	Margin	Detector Type
	(MHz)	(dBuV)	(dB)	dB/m	(dB)	(dBuV/m)	(dBuV/m)	(dB)	
Low Channel (5180 MHz)-Above 1G									
V	4434.095	64.75	5.94	35.40	44.00	62.09	68.2	-6.11	PK
V	4434.095	43.68	5.94	35.40	44.00	41.02	54	-12.98	AV
V	10360.161	62.75	8.46	39.75	44.50	66.46	68.2	-1.74	PK
V	10360.161	43.12	8.46	39.75	44.50	46.83	54	-7.17	AV
V	15540.073	60.15	10.12	38.80	44.10	64.97	74	-9.03	PK
V	15540.073	43.90	10.12	38.80	42.70	50.12	54	-3.88	AV
H	4434.015	62.69	5.94	35.18	44.00	59.81	68.2	-8.39	PK
H	4434.015	43.23	5.94	35.18	44.00	40.35	54	-13.65	AV
H	10360.191	50.05	8.46	38.71	44.50	52.72	68.2	-15.48	PK
H	10360.191	41.46	8.46	38.71	44.50	44.13	54	-9.87	AV
H	15540.163	50.35	10.12	38.38	44.10	54.75	74	-19.25	PK
H	15540.163	43.31	10.12	38.38	44.10	47.71	54	-6.29	AV
middle Channel (5200 MHz)-Above 1G									
V	4592.166	61.15	6.48	36.35	44.05	59.93	74	-14.07	PK
V	4592.166	43.95	6.48	36.35	44.05	42.73	54	-11.27	AV
V	10400.019	61.32	8.47	37.88	44.51	63.16	68.2	-5.04	PK
V	10400.019	43.76	8.47	37.88	44.51	45.60	54	-8.40	AV
V	15600.152	60.12	10.12	38.80	44.10	64.94	74	-9.06	PK
V	15600.152	43.65	10.12	38.80	42.70	49.87	54	-4.13	AV
H	4592.052	62.93	6.48	36.37	44.05	61.73	74	-12.27	PK
H	4592.052	43.21	6.48	36.37	44.05	42.01	54	-11.99	AV
H	10400.036	54.88	8.47	38.64	44.50	57.49	68.2	-10.71	PK
H	10400.036	41.54	8.47	38.64	44.50	44.15	54	-9.85	AV
H	15600.069	50.38	10.12	38.38	44.10	54.78	74	-19.22	PK
H	15600.069	43.91	10.12	38.38	44.10	48.31	54	-5.69	AV
High Channel (5240 MHz)-Above 1G									
V	4739.115	61.95	7.10	37.24	43.50	62.79	74	-11.21	PK
V	4739.115	43.75	7.10	37.24	43.50	44.59	54	-9.41	AV
V	10640.067	64.74	8.46	37.68	44.50	66.38	68.2	-1.82	PK
V	10640.067	43.41	8.46	37.68	44.50	45.05	54	-8.95	AV
V	15960.061	64.32	10.12	38.80	44.10	69.14	74	-4.86	PK
V	15960.061	43.67	10.12	38.80	42.70	49.89	54	-4.11	AV
H	4739.063	61.25	7.10	37.24	43.50	62.09	74	-11.91	PK
H	4739.063	43.47	7.10	37.24	43.50	44.31	54	-9.69	AV
H	10640.139	53.79	8.46	38.57	44.50	56.32	68.2	-11.88	PK
H	10640.139	40.47	8.46	38.57	44.50	43.00	54	-11.00	AV
H	15960.018	51.81	10.12	38.38	44.10	56.21	74	-17.79	PK
H	15960.018	42.48	10.12	38.38	44.10	46.88	54	-7.12	AV

Note: PK value is lower than the Average value limit, So average didn't record.

The 26.5-40G amplitude of spurious emissions that are attenuated by more than 20dB below the permissible value has no need to be reported.

Emission level (dBuV/m) = 20 log Emission level (uV/m).

Corrected Reading: Antenna Factor + Cable Loss + Read Level - Preamp Factor = Level.

Test Mode:	TX(5.1G) - 802.11n-HT20
------------	-------------------------

Polar (H/V)	Frequency (MHz)	Meter Reading (dBuV)	Cable loss (dB)	Antenna Factor dB/m	Preamp Factor (dB)	Emission Level (dBuV/m)	Limits (dBuV/m)	Margin (dB)	Detector Type
Low Channel (5180 MHz)-Above 1G									
V	4434.026	64.64	5.94	35.40	44.00	61.98	68.2	-6.22	PK
V	4434.026	43.91	5.94	35.40	44.00	41.25	54	-12.75	AV
V	10360.108	62.80	8.46	39.75	44.50	66.51	68.2	-1.69	PK
V	10360.108	43.85	8.46	39.75	44.50	47.56	54	-6.44	AV
V	15540.191	60.02	10.12	38.80	44.10	64.84	74	-9.16	PK
V	15540.191	43.75	10.12	38.80	42.70	49.97	54	-4.03	AV
H	4434.179	63.11	5.94	35.18	44.00	60.23	68.2	-7.97	PK
H	4434.179	43.76	5.94	35.18	44.00	40.88	54	-13.12	AV
H	10360.117	52.06	8.46	38.71	44.50	54.73	68.2	-13.47	PK
H	10360.117	41.39	8.46	38.71	44.50	44.06	54	-9.94	AV
H	15540.132	50.45	10.12	38.38	44.10	54.85	74	-19.15	PK
H	15540.132	42.93	10.12	38.38	44.10	47.33	54	-6.67	AV
middle Channel (5200 MHz)-Above 1G									
V	4592.117	64.64	6.48	36.35	44.05	63.42	74	-10.58	PK
V	4592.117	43.24	6.48	36.35	44.05	42.02	54	-11.98	AV
V	10400.060	61.02	8.47	37.88	44.51	62.86	68.2	-5.34	PK
V	10400.060	43.08	8.47	37.88	44.51	44.92	54	-9.08	AV
V	15600.061	61.28	10.12	38.80	44.10	66.10	74	-7.90	PK
V	15600.061	43.13	10.12	38.80	42.70	49.35	54	-4.65	AV
H	4592.194	63.97	6.48	36.37	44.05	62.77	74	-11.23	PK
H	4592.194	43.19	6.48	36.37	44.05	41.99	54	-12.01	AV
H	10400.197	50.62	8.47	38.64	44.50	53.23	68.2	-14.97	PK
H	10400.197	41.59	8.47	38.64	44.50	44.20	54	-9.80	AV
H	15600.112	53.86	10.12	38.38	44.10	58.26	74	-15.74	PK
H	15600.112	41.25	10.12	38.38	44.10	45.65	54	-8.35	AV
High Channel (5240 MHz)-Above 1G									
V	4739.080	60.68	7.10	37.24	43.50	61.52	74	-12.48	PK
V	4739.080	43.18	7.10	37.24	43.50	44.02	54	-9.98	AV
V	10480.161	63.25	8.46	37.68	44.50	64.89	68.2	-3.31	PK
V	10480.161	43.94	8.46	37.68	44.50	45.58	54	-8.42	AV
V	15720.107	61.90	10.12	38.80	44.10	66.72	74	-7.28	PK
V	15720.107	43.64	10.12	38.80	42.70	49.86	54	-4.14	AV
H	4739.148	62.92	7.10	37.24	43.50	63.76	74	-10.24	PK
H	4739.148	43.41	7.10	37.24	43.50	44.25	54	-9.75	AV
H	10480.107	54.01	8.46	38.57	44.50	56.54	68.2	-11.66	PK
H	10480.107	44.52	8.46	38.57	44.50	47.05	54	-6.95	AV
H	15720.032	51.56	10.12	38.38	44.10	55.96	74	-18.04	PK
H	15720.032	43.35	10.12	38.38	44.10	47.75	54	-6.25	AV

Note: PK value is lower than the Average value limit, So average didn't record.
 The 26.5-40G amplitude of spurious emissions that are attenuated by more than 20dB below the permissible value has no need to be reported.
 Emission level (dBuV/m) = 20 log Emission level (uV/m).
 Corrected Reading: Antenna Factor + Cable Loss + Read Level - Preamp Factor = Level.

Test Mode:	TX(5.1G) - 802.11n-HT40
------------	-------------------------

Polar (H/V)	Frequency (MHz)	Meter Reading (dBuV)	Cable loss (dB)	Antenn a Factor dB/m	Preamp Factor (dB)	Emission Level (dBuV/m)	Limits (dBuV /m)	Margi n (dB)	Detecto r Type
Low Channel (5190 MHz)-Above 1G									
V	4434.131	61.59	5.94	35.40	44.00	58.93	68.2	-9.27	PK
V	4434.131	43.13	5.94	35.40	44.00	40.47	54	-13.53	AV
V	10380.034	62.65	8.46	39.75	44.50	66.36	68.2	-1.84	PK
V	10380.034	43.21	8.46	39.75	44.50	46.92	54	-7.08	AV
V	15570.150	60.34	10.12	38.80	44.10	65.16	74	-8.84	PK
V	15570.150	43.83	10.12	38.80	42.70	50.05	54	-3.95	AV
H	4434.118	62.97	5.94	35.18	44.00	60.09	74	-13.91	PK
H	4434.118	43.71	5.94	35.18	44.00	40.83	54	-13.17	AV
H	10380.028	54.59	8.46	38.71	44.50	57.26	68.2	-10.94	PK
H	10380.028	43.12	8.46	38.71	44.50	45.79	54	-8.21	AV
H	15570.113	54.36	10.12	38.38	44.10	58.76	74	-15.24	PK
H	15570.113	40.71	10.12	38.38	44.10	45.11	54	-8.89	AV
middle Channel (5230 MHz)-Above 1G									
V	4739.020	64.02	6.48	36.35	44.05	62.80	68.2	-5.40	PK
V	4739.020	43.37	6.48	36.35	44.05	42.15	54	-11.85	AV
V	10460.006	64.29	8.47	37.88	44.51	66.13	68.2	-2.07	PK
V	10460.006	43.68	8.47	37.88	44.51	45.52	54	-8.48	AV
V	15690.060	63.64	10.12	38.80	44.10	68.46	74	-5.54	PK
V	15690.060	43.76	10.12	38.80	42.70	49.98	54	-4.02	AV
H	4739.098	61.09	6.48	36.37	44.05	59.89	68.2	-8.31	PK
H	4739.098	43.29	6.48	36.37	44.05	42.09	54	-11.91	AV
H	10460.114	54.87	8.47	38.64	44.50	57.48	68.2	-10.72	PK
H	10460.114	44.82	8.47	38.64	44.50	47.43	54	-6.57	AV
H	15690.128	52.34	10.12	38.38	44.10	56.74	74	-17.26	PK
H	15690.128	41.19	10.12	38.38	44.10	45.59	54	-8.41	AV

Note: PK value is lower than the Average value limit, So average didn't record.
 The 26.5-40G amplitude of spurious emissions that are attenuated by more than 20dB below the permissible value has no need to be reported.
 Emission level (dBuV/m) = 20 log Emission level (uV/m).
 Corrected Reading: Antenna Factor + Cable Loss + Read Level - Preamp Factor = Level.

Test Mode:	TX(5.1G) - 802.11ac-HT20
------------	--------------------------

Polar (H/V)	Frequency	Meter Reading	Cable loss	Antenna Factor	Preamp Factor	Emission Level	Limits	Margin	Detector Type
	(MHz)	(dBuV)	(dB)	dB/m	(dB)	(dBuV/m)	(dBuV/m)	(dB)	
Low Channel (5180 MHz)-Above 1G									
V	4434.164	63.85	5.94	35.40	44.00	61.19	68.2	-7.01	PK
V	4434.164	43.86	5.94	35.40	44.00	41.20	54	-12.80	AV
V	10360.161	61.92	8.46	39.75	44.50	65.63	68.2	-2.57	PK
V	10360.161	43.22	8.46	39.75	44.50	46.93	54	-7.07	AV
V	15540.191	62.65	10.12	38.80	44.10	67.47	74	-6.53	PK
V	15540.191	43.55	10.12	38.80	42.70	49.77	54	-4.23	AV
H	4434.070	63.72	5.94	35.18	44.00	60.84	68.2	-7.36	PK
H	4434.070	43.13	5.94	35.18	44.00	40.25	54	-13.75	AV
H	10360.176	52.84	8.46	38.71	44.50	55.51	68.2	-12.69	PK
H	10360.176	40.33	8.46	38.71	44.50	43.00	54	-11.00	AV
H	15540.073	54.81	10.12	38.38	44.10	59.21	74	-14.79	PK
H	15540.073	43.41	10.12	38.38	44.10	47.81	54	-6.19	AV
middle Channel (5200 MHz)-Above 1G									
V	4592.107	63.46	6.48	36.35	44.05	62.24	74	-11.76	PK
V	4592.107	43.15	6.48	36.35	44.05	41.93	54	-12.07	AV
V	10400.105	64.41	8.47	37.88	44.51	66.25	68.2	-1.95	PK
V	10400.105	43.66	8.47	37.88	44.51	45.50	54	-8.50	AV
V	15600.071	64.31	10.12	38.80	44.10	69.13	74	-4.87	PK
V	15600.071	43.75	10.12	38.80	42.70	49.97	54	-4.03	AV
H	4592.107	61.96	6.48	36.37	44.05	60.76	74	-13.24	PK
H	4592.107	43.14	6.48	36.37	44.05	41.94	54	-12.06	AV
H	10400.138	51.91	8.47	38.64	44.50	54.52	68.2	-13.68	PK
H	10400.138	45.00	8.47	38.64	44.50	47.61	54	-6.39	AV
H	15600.051	50.23	10.12	38.38	44.10	54.63	74	-19.37	PK
H	15600.051	44.59	10.12	38.38	44.10	48.99	54	-5.01	AV
High Channel (5240 MHz)-Above 1G									
V	4739.160	62.44	7.10	37.24	43.50	63.28	74	-10.72	PK
V	4739.160	43.16	7.10	37.24	43.50	44.00	54	-10.00	AV
V	10480.007	60.41	8.46	37.68	44.50	62.05	68.2	-6.15	PK
V	10480.007	43.51	8.46	37.68	44.50	45.15	54	-8.85	AV
V	15720.119	61.57	10.12	38.80	44.10	66.39	74	-7.61	PK
V	15720.119	43.45	10.12	38.80	42.70	49.67	54	-4.33	AV
H	4739.106	61.60	7.10	37.24	43.50	62.44	74	-11.56	PK
H	4739.106	43.69	7.10	37.24	43.50	44.53	54	-9.47	AV
H	10480.037	51.70	8.46	38.57	44.50	54.23	68.2	-13.97	PK
H	10480.037	44.11	8.46	38.57	44.50	46.64	54	-7.36	AV
H	15720.070	50.66	10.12	38.38	44.10	55.06	74	-18.94	PK
H	15720.070	40.17	10.12	38.38	44.10	44.57	54	-9.43	AV

Note: PK value is lower than the Average value limit, So average didn't record.
 The 26.5-40G amplitude of spurious emissions that are attenuated by more than 20dB below the permissible value has no need to be reported.
 Emission level (dBuV/m) = 20 log Emission level (uV/m).
 Corrected Reading: Antenna Factor + Cable Loss + Read Level - Preamp Factor = Level.

Test Mode:	TX(5.1G) - 802.11ac-HT40
------------	--------------------------

Polar (H/V)	Frequency (MHz)	Meter Reading (dBuV)	Cable loss (dB)	Antenn a Factor dB/m	Preamp Factor (dB)	Emission Level (dBuV/m)	Limits (dBuV /m)	Margi n (dB)	Detecto r Type
Low Channel (5190 MHz)-Above 1G									
V	4434.019	62.82	5.94	35.40	44.00	60.16	68.2	-8.04	PK
V	4434.019	43.36	5.94	35.40	44.00	40.70	54	-13.30	AV
V	10380.147	63.40	8.46	39.75	44.50	67.11	68.2	-1.09	PK
V	10380.147	43.14	8.46	39.75	44.50	46.85	54	-7.15	AV
V	15570.135	63.78	10.12	38.80	44.10	68.60	74	-5.40	PK
V	15570.135	43.59	10.12	38.80	42.70	49.81	54	-4.19	AV
H	4434.036	63.73	5.94	35.18	44.00	60.85	74	-13.15	PK
H	4434.036	43.82	5.94	35.18	44.00	40.94	54	-13.06	AV
H	10380.056	52.23	8.46	38.71	44.50	54.90	68.2	-13.30	PK
H	10380.056	43.24	8.46	38.71	44.50	45.91	54	-8.09	AV
H	15570.106	53.45	10.12	38.38	44.10	57.85	74	-16.15	PK
H	15570.106	44.21	10.12	38.38	44.10	48.61	54	-5.39	AV
middle Channel (5230 MHz)-Above 1G									
V	4739.088	61.29	6.48	36.35	44.05	60.07	68.2	-8.13	PK
V	4739.088	43.03	6.48	36.35	44.05	41.81	54	-12.19	AV
V	10460.077	60.15	8.47	37.88	44.51	61.99	68.2	-6.21	PK
V	10460.077	43.94	8.47	37.88	44.51	45.78	54	-8.22	AV
V	15690.175	63.19	10.12	38.80	44.10	68.01	74	-5.99	PK
V	15690.175	43.86	10.12	38.80	42.70	50.08	54	-3.92	AV
H	4739.187	63.21	6.48	36.37	44.05	62.01	68.2	-6.19	PK
H	4739.187	43.66	6.48	36.37	44.05	42.46	54	-11.54	AV
H	10460.002	52.00	8.47	38.64	44.50	54.61	68.2	-13.59	PK
H	10460.002	40.88	8.47	38.64	44.50	43.49	54	-10.51	AV
H	15690.110	54.98	10.12	38.38	44.10	59.38	74	-14.62	PK
H	15690.110	40.97	10.12	38.38	44.10	45.37	54	-8.63	AV

Note: PK value is lower than the Average value limit, So average didn't record.
 The 26.5-40G amplitude of spurious emissions that are attenuated by more than 20dB below the permissible value has no need to be reported.
 Emission level (dBuV/m) = 20 log Emission level (uV/m).
 Corrected Reading: Antenna Factor + Cable Loss + Read Level - Preamp Factor = Level.

Test Mode:	TX(5.1G) - 802.11ax-HT20
------------	--------------------------

Polar (H/V)	Frequency (MHz)	Meter Reading (dBuV)	Cable loss (dB)	Antenn a Factor dB/m	Preamp Factor (dB)	Emission Level (dBuV/m)	Limits (dBuV /m)	Margi n (dB)	Detecto r Type
Low Channel (5180 MHz)-Above 1G									
V	4434.070	62.98	5.94	35.40	44.00	60.32	68.2	-7.88	PK
V	4434.070	43.58	5.94	35.40	44.00	40.92	54	-13.08	AV
V	10360.067	62.29	8.46	39.75	44.50	66.00	68.2	-2.20	PK
V	10360.067	43.86	8.46	39.75	44.50	47.57	54	-6.43	AV
V	15540.139	62.09	10.12	38.80	44.10	66.91	74	-7.09	PK
V	15540.139	43.10	10.12	38.80	42.70	49.32	54	-4.68	AV
H	4434.072	62.49	5.94	35.18	44.00	59.61	68.2	-8.59	PK
H	4434.072	43.57	5.94	35.18	44.00	40.69	54	-13.31	AV
H	10360.154	53.94	8.46	38.71	44.50	56.61	68.2	-11.59	PK
H	10360.154	42.16	8.46	38.71	44.50	44.83	54	-9.17	AV
H	15540.003	51.21	10.12	38.38	44.10	55.61	74	-18.39	PK
H	15540.003	44.23	10.12	38.38	44.10	48.63	54	-5.37	AV
middle Channel (5200 MHz)-Above 1G									
V	4592.034	63.65	6.48	36.35	44.05	62.43	74	-11.57	PK
V	4592.034	43.75	6.48	36.35	44.05	42.53	54	-11.47	AV
V	10400.105	64.29	8.47	37.88	44.51	66.13	68.2	-2.07	PK
V	10400.105	43.91	8.47	37.88	44.51	45.75	54	-8.25	AV
V	15600.167	64.51	10.12	38.80	44.10	69.33	74	-4.67	PK
V	15600.167	43.04	10.12	38.80	42.70	49.26	54	-4.74	AV
H	4592.106	63.85	6.48	36.37	44.05	62.65	74	-11.35	PK
H	4592.106	43.36	6.48	36.37	44.05	42.16	54	-11.84	AV
H	10400.161	54.81	8.47	38.64	44.50	57.42	68.2	-10.78	PK
H	10400.161	40.32	8.47	38.64	44.50	42.93	54	-11.07	AV
H	15600.104	51.12	10.12	38.38	44.10	55.52	74	-18.48	PK
H	15600.104	43.89	10.12	38.38	44.10	48.29	54	-5.71	AV
High Channel (5240 MHz)-Above 1G									
V	4739.124	62.18	7.10	37.24	43.50	63.02	74	-10.98	PK
V	4739.124	43.03	7.10	37.24	43.50	43.87	54	-10.13	AV
V	10480.170	60.12	8.46	37.68	44.50	61.76	68.2	-6.44	PK
V	10480.170	43.45	8.46	37.68	44.50	45.09	54	-8.91	AV
V	15720.110	64.47	10.12	38.80	44.10	69.29	74	-4.71	PK
V	15720.110	43.20	10.12	38.80	42.70	49.42	54	-4.58	AV
H	4739.168	61.35	7.10	37.24	43.50	62.19	74	-11.81	PK
H	4739.168	43.43	7.10	37.24	43.50	44.27	54	-9.73	AV
H	10480.149	53.37	8.46	38.57	44.50	55.90	68.2	-12.30	PK
H	10480.149	42.77	8.46	38.57	44.50	45.30	54	-8.70	AV
H	15720.178	54.23	10.12	38.38	44.10	58.63	74	-15.37	PK
H	15720.178	43.13	10.12	38.38	44.10	47.53	54	-6.47	AV

Note: PK value is lower than the Average value limit, So average didn't record.
 The 26.5-40G amplitude of spurious emissions that are attenuated by more than 20dB below the permissible value has no need to be reported.
 Emission level (dBuV/m) = 20 log Emission level (uV/m).
 Corrected Reading: Antenna Factor + Cable Loss + Read Level - Preamp Factor = Level.

Test Mode:	TX(5.1G) - 802.11ax-HT40
------------	--------------------------

Polar (H/V)	Frequency (MHz)	Meter Reading (dBuV)	Cable loss (dB)	Antenn a Factor dB/m	Preamp Factor (dB)	Emission Level (dBuV/m)	Limits (dBuV /m)	Margi n (dB)	Detecto r Type
Low Channel (5190 MHz)-Above 1G									
V	4434.052	63.14	5.94	35.40	44.00	60.48	68.2	-7.72	PK
V	4434.052	43.86	5.94	35.40	44.00	41.20	54	-12.80	AV
V	10380.075	62.44	8.46	39.75	44.50	66.15	68.2	-2.05	PK
V	10380.075	43.34	8.46	39.75	44.50	47.05	54	-6.95	AV
V	15570.001	60.80	10.12	38.80	44.10	65.62	74	-8.38	PK
V	15570.001	43.91	10.12	38.80	42.70	50.13	54	-3.87	AV
H	4434.063	63.03	5.94	35.18	44.00	60.15	74	-13.85	PK
H	4434.063	43.03	5.94	35.18	44.00	40.15	54	-13.85	AV
H	10380.104	52.99	8.46	38.71	44.50	55.66	68.2	-12.54	PK
H	10380.104	41.70	8.46	38.71	44.50	44.37	54	-9.63	AV
H	15570.042	53.31	10.12	38.38	44.10	57.71	74	-16.29	PK
H	15570.042	43.58	10.12	38.38	44.10	47.98	54	-6.02	AV
middle Channel (5230 MHz)-Above 1G									
V	4739.139	64.51	6.48	36.35	44.05	63.29	68.2	-4.91	PK
V	4739.139	43.35	6.48	36.35	44.05	42.13	54	-11.87	AV
V	10460.011	62.79	8.47	37.88	44.51	64.63	68.2	-3.57	PK
V	10460.011	43.92	8.47	37.88	44.51	45.76	54	-8.24	AV
V	15690.174	61.22	10.12	38.80	44.10	66.04	74	-7.96	PK
V	15690.174	43.38	10.12	38.80	42.70	49.60	54	-4.40	AV
H	4739.055	62.02	6.48	36.37	44.05	60.82	68.2	-7.38	PK
H	4739.055	43.56	6.48	36.37	44.05	42.36	54	-11.64	AV
H	10460.017	51.57	8.47	38.64	44.50	54.18	68.2	-14.02	PK
H	10460.017	41.26	8.47	38.64	44.50	43.87	54	-10.13	AV
H	15690.179	53.37	10.12	38.38	44.10	57.77	74	-16.23	PK
H	15690.179	42.45	10.12	38.38	44.10	46.85	54	-7.15	AV

Note: PK value is lower than the Average value limit, So average didn't record.
 The 26.5-40G amplitude of spurious emissions that are attenuated by more than 20dB below the permissible value has no need to be reported.
 Emission level (dBuV/m) = 20 log Emission level (uV/m).
 Corrected Reading: Antenna Factor + Cable Loss + Read Level - Preamp Factor = Level.

Test Mode:	TX (5.8G) -- 802.11a
------------	----------------------

Polar (H/V)	Frequency	Meter Reading	Cable loss	Antenn a Factor	Preamp Factor	Emission Level	Limits	Margi n	Detecto r Type
	(MHz)	(dBuV)	(dB)	dB/m	(dB)	(dBuV/m)	(dBuV /m)	(dB)	
Low Channel (5745 MHz)-Above 1G									
V	4679.163	56.31	5.94	35.40	44.00	53.65	74	-20.35	PK
V	4679.163	43.17	5.94	35.40	44.00	40.51	54	-13.49	AV
V	11490.074	54.97	8.46	39.75	44.50	58.68	68.2	-9.52	PK
V	11490.074	43.33	8.46	39.75	44.50	47.04	54	-6.96	AV
V	17235.079	60.86	10.12	38.80	44.10	65.68	68.2	-2.52	PK
V	17235.079	43.74	10.12	38.80	42.70	49.96	54	-4.04	AV
H	4679.044	58.77	5.94	35.18	44.00	55.89	74	-18.11	PK
H	4679.044	43.76	5.94	35.18	44.00	40.88	54	-13.12	AV
H	11490.017	53.31	8.46	38.71	44.50	55.98	68.2	-12.22	PK
H	11490.017	44.27	8.46	38.71	44.50	46.94	54	-7.06	AV
H	17235.067	54.16	10.12	38.38	44.10	58.56	68.2	-9.64	PK
H	17235.067	43.29	10.12	38.38	44.10	47.69	54	-6.31	AV
middle Channel (5785 MHz)-Above 1G									
V	4592.060	56.14	6.48	36.35	44.05	54.92	74	-19.08	PK
V	4592.060	43.37	6.48	36.35	44.05	42.15	54	-11.85	AV
V	11570.141	55.22	8.47	37.88	44.51	57.06	68.2	-11.14	PK
V	11570.141	43.34	8.47	37.88	44.51	45.18	54	-8.82	AV
V	17355.025	58.82	10.12	38.80	44.10	63.64	68.2	-4.56	PK
V	17355.025	39.16	10.12	38.80	42.70	45.38	54	-8.62	AV
H	4592.074	56.22	6.48	36.37	44.05	55.02	74	-18.98	PK
H	4592.074	43.79	6.48	36.37	44.05	42.59	54	-11.41	AV
H	11570.072	53.24	8.47	38.64	44.50	55.85	68.2	-12.35	PK
H	11570.072	40.18	8.47	38.64	44.50	42.79	54	-11.21	AV
H	17355.164	52.03	10.12	38.38	44.10	56.43	68.2	-11.77	PK
H	17355.164	42.36	10.12	38.38	44.10	46.76	54	-7.24	AV
High Channel (5825 MHz)-Above 1G									
V	6039.110	60.17	7.10	37.24	43.50	61.01	68.2	-7.19	PK
V	6039.110	43.07	7.10	37.24	43.50	43.91	54	-10.09	AV
V	11650.173	60.82	8.46	37.68	44.50	62.46	74	-11.54	PK
V	11650.173	43.33	8.46	37.68	44.50	44.97	54	-9.03	AV
V	17475.094	54.10	10.12	38.80	44.10	58.92	68.2	-9.28	PK
V	17475.094	43.88	10.12	38.80	42.70	50.10	54	-3.90	AV
H	6039.020	56.22	7.10	37.24	43.50	57.06	68.2	-11.14	PK
H	6039.020	43.69	7.10	37.24	43.50	44.53	54	-9.47	AV
H	11650.175	54.33	8.46	38.57	44.50	56.86	74	-17.14	PK
H	11650.175	44.06	8.46	38.57	44.50	46.59	54	-7.41	AV
H	17475.046	52.45	10.12	38.38	44.10	56.85	68.2	-11.35	PK
H	17475.046	41.64	10.12	38.38	44.10	46.04	54	-7.96	AV

Note: PK value is lower than the Average value limit, So average didn't record.
 The 26.5-40G amplitude of spurious emissions that are attenuated by more than 20dB below the permissible value has no need to be reported.
 Emission level (dBuV/m) = 20 log Emission level (uV/m).
 Corrected Reading: Antenna Factor + Cable Loss + Read Level - Preamp Factor = Level.

Test Mode:	TX (5.8G) --802.11n-HT20
------------	--------------------------

Polar (H/V)	Frequency	Meter Reading	Cable loss	Antenn a Factor	Preamp Factor	Emission Level	Limits	Margi n	Detecto r Type
	(MHz)	(dBuV)	(dB)	dB/m	(dB)	(dBuV/m)	(dBuV/m)	(dB)	
Low Channel (5745 MHz)-Above 1G									
V	4679.090	60.38	5.94	35.40	44.00	57.72	74	-16.28	PK
V	4679.090	43.91	5.94	35.40	44.00	41.25	54	-12.75	AV
V	11490.145	55.00	8.46	39.75	44.50	58.71	68.2	-9.49	PK
V	11490.145	43.35	8.46	39.75	44.50	47.06	54	-6.94	AV
V	17235.119	59.44	10.12	38.80	44.10	64.26	68.2	-3.94	PK
V	17235.119	43.11	10.12	38.80	42.70	49.33	54	-4.67	AV
H	4679.066	56.28	5.94	35.18	44.00	53.40	74	-20.60	PK
H	4679.066	43.97	5.94	35.18	44.00	41.09	54	-12.91	AV
H	11490.152	50.41	8.46	38.71	44.50	53.08	68.2	-15.12	PK
H	11490.152	42.31	8.46	38.71	44.50	44.98	54	-9.02	AV
H	17235.062	51.12	10.12	38.38	44.10	55.52	68.2	-12.68	PK
H	17235.062	44.51	10.12	38.38	44.10	48.91	54	-5.09	AV
middle Channel (5785 MHz)-Above 1G									
V	4592.155	59.20	6.48	36.35	44.05	57.98	74	-16.02	PK
V	4592.155	43.98	6.48	36.35	44.05	42.76	54	-11.24	AV
V	11570.114	55.54	8.47	37.88	44.51	57.38	68.2	-10.82	PK
V	11570.114	43.15	8.47	37.88	44.51	44.99	54	-9.01	AV
V	17355.031	60.22	10.12	38.80	44.10	65.04	68.2	-3.16	PK
V	17355.031	43.40	10.12	38.80	42.70	49.62	54	-4.38	AV
H	4592.086	56.36	6.48	36.37	44.05	55.16	74	-18.84	PK
H	4592.086	43.20	6.48	36.37	44.05	42.00	54	-12.00	AV
H	11570.077	54.14	8.47	38.64	44.50	56.75	68.2	-11.45	PK
H	11570.077	43.67	8.47	38.64	44.50	46.28	54	-7.72	AV
H	17355.025	50.92	10.12	38.38	44.10	55.32	68.2	-12.88	PK
H	17355.025	42.28	10.12	38.38	44.10	46.68	54	-7.32	AV
High Channel (5825 MHz)-Above 1G									
V	6039.137	58.72	7.10	37.24	43.50	59.56	68.2	-8.64	PK
V	6039.137	43.85	7.10	37.24	43.50	44.69	54	-9.31	AV
V	11650.176	57.90	8.46	37.68	44.50	59.54	74	-14.46	PK
V	11650.176	43.98	8.46	37.68	44.50	45.62	54	-8.38	AV
V	17475.018	56.40	10.12	38.80	44.10	61.22	68.2	-6.98	PK
V	17475.018	43.12	10.12	38.80	42.70	49.34	54	-4.66	AV
H	6039.195	55.65	7.10	37.24	43.50	56.49	68.2	-11.71	PK
H	6039.195	43.92	7.10	37.24	43.50	44.76	54	-9.24	AV
H	11650.151	54.21	8.46	38.57	44.50	56.74	74	-17.26	PK
H	11650.151	40.98	8.46	38.57	44.50	43.51	54	-10.49	AV
H	17475.068	50.87	10.12	38.38	44.10	55.27	68.2	-12.93	PK
H	17475.068	43.90	10.12	38.38	44.10	48.30	54	-5.70	AV

Note: PK value is lower than the Average value limit, So average didn't record.
 The 26.5-40G amplitude of spurious emissions that are attenuated by more than 20dB below the permissible value has no need to be reported.

Emission level (dBuV/m) = 20 log Emission level (uV/m).

Corrected Reading: Antenna Factor + Cable Loss + Read Level - Preamp Factor = Level.

Test Mode:	TX (5.8G) -- 802.11n-HT40
------------	---------------------------

Polar (H/V)	Frequency	Meter Reading	Cable loss	Antenn a Factor	Preamp Factor	Emission Level	Limits	Margi n	Detecto r Type
	(MHz)	(dBuV)	(dB)	dB/m	(dB)	(dBuV/m)	(dBuV /m)	(dB)	
Low Channel (5755 MHz)-Above 1G									
V	4679.193	60.69	5.94	35.40	44.00	58.03	74	-15.97	PK
V	4679.193	43.27	5.94	35.40	44.00	40.61	54	-13.39	AV
V	11510.000	56.61	8.46	39.75	44.50	60.32	74	-13.68	PK
V	11510.000	43.06	8.46	39.75	44.50	46.77	54	-7.23	AV
V	17265.051	59.99	10.12	38.80	44.10	64.81	68.2	-3.39	PK
V	17265.051	43.22	10.12	38.80	42.70	49.44	54	-4.56	AV
H	4679.072	60.17	5.94	35.18	44.00	57.29	74	-16.71	PK
H	4679.072	43.47	5.94	35.18	44.00	40.59	54	-13.41	AV
H	11510.168	51.58	8.46	38.71	44.50	54.25	74	-19.75	PK
H	11510.168	44.96	8.46	38.71	44.50	47.63	54	-6.37	AV
H	17265.015	53.32	10.12	38.38	44.10	57.72	68.2	-10.48	PK
H	17265.015	44.85	10.12	38.38	44.10	49.25	54	-4.75	AV
middle Channel (5795 MHz)-Above 1G									
V	6039.074	57.31	6.48	36.35	44.05	56.09	68.2	-12.11	PK
V	6039.074	43.81	6.48	36.35	44.05	42.59	54	-11.41	AV
V	11590.161	58.29	8.47	37.88	44.51	60.13	74	-13.87	PK
V	11590.161	43.89	8.47	37.88	44.51	45.73	54	-8.27	AV
V	17385.029	55.43	10.12	38.80	44.10	60.25	68.2	-7.95	PK
V	17385.029	41.90	10.12	38.80	42.70	48.12	54	-5.88	AV
H	6039.127	60.57	6.48	36.37	44.05	59.37	68.2	-8.83	PK
H	6039.127	43.85	6.48	36.37	44.05	42.65	54	-11.35	AV
H	11590.052	54.28	8.47	38.64	44.50	56.89	74	-17.11	PK
H	11590.052	40.12	8.47	38.64	44.50	42.73	54	-11.27	AV
H	17385.189	54.77	10.12	38.38	44.10	59.17	68.2	-9.03	PK
H	17385.189	42.84	10.12	38.38	44.10	47.24	54	-6.76	AV

Note: PK value is lower than the Average value limit, So average didn't record.

The 26.5-40G amplitude of spurious emissions that are attenuated by more than 20dB below the permissible value has no need to be reported.

Emission level (dBuV/m) = 20 log Emission level (uV/m).

Corrected Reading: Antenna Factor + Cable Loss + Read Level - Preamp Factor = Level.

Test Mode:	TX (5.8G) --802.11ac-HT20
------------	---------------------------

Polar (H/V)	Frequency	Meter Reading	Cable loss	Antenn a Factor	Preamp Factor	Emission Level	Limits	Margi n	Detecto r Type
	(MHz)	(dBuV)	(dB)	dB/m	(dB)	(dBuV/m)	(dBuV /m)	(dB)	
Low Channel (5745 MHz)-Above 1G									
V	4679.165	59.15	5.94	35.40	44.00	56.49	74	-17.51	PK
V	4679.165	43.73	5.94	35.40	44.00	41.07	54	-12.93	AV
V	11490.078	53.91	8.46	39.75	44.50	57.62	68.2	-10.58	PK
V	11490.078	43.08	8.46	39.75	44.50	46.79	54	-7.21	AV
V	17235.190	60.97	10.12	38.80	44.10	65.79	68.2	-2.41	PK
V	17235.190	43.55	10.12	38.80	42.70	49.77	54	-4.23	AV
H	4679.114	57.45	5.94	35.18	44.00	54.57	74	-19.43	PK
H	4679.114	43.85	5.94	35.18	44.00	40.97	54	-13.03	AV
H	11490.145	51.07	8.46	38.71	44.50	53.74	68.2	-14.46	PK
H	11490.145	42.51	8.46	38.71	44.50	45.18	54	-8.82	AV
H	17235.185	54.50	10.12	38.38	44.10	58.90	68.2	-9.30	PK
H	17235.185	41.93	10.12	38.38	44.10	46.33	54	-7.67	AV
middle Channel (5785 MHz)-Above 1G									
V	4592.024	60.04	6.48	36.35	44.05	58.82	74	-15.18	PK
V	4592.024	43.29	6.48	36.35	44.05	42.07	54	-11.93	AV
V	11570.164	55.98	8.47	37.88	44.51	57.82	68.2	-10.38	PK
V	11570.164	43.52	8.47	37.88	44.51	45.36	54	-8.64	AV
V	17355.084	57.85	10.12	38.80	44.10	62.67	68.2	-5.53	PK
V	17355.084	43.58	10.12	38.80	42.70	49.80	54	-4.20	AV
H	4592.028	56.88	6.48	36.37	44.05	55.68	74	-18.32	PK
H	4592.028	43.22	6.48	36.37	44.05	42.02	54	-11.98	AV
H	11570.048	51.79	8.47	38.64	44.50	54.40	68.2	-13.80	PK
H	11570.048	40.29	8.47	38.64	44.50	42.90	54	-11.10	AV
H	17355.100	52.70	10.12	38.38	44.10	57.10	68.2	-11.10	PK
H	17355.100	41.35	10.12	38.38	44.10	45.75	54	-8.25	AV
High Channel (5825 MHz)-Above 1G									
V	6039.078	56.94	7.10	37.24	43.50	57.78	68.2	-10.42	PK
V	6039.078	43.47	7.10	37.24	43.50	44.31	54	-9.69	AV
V	11650.120	56.56	8.46	37.68	44.50	58.20	74	-15.80	PK
V	11650.120	43.53	8.46	37.68	44.50	45.17	54	-8.83	AV
V	17475.067	57.40	10.12	38.80	44.10	62.22	68.2	-5.98	PK
V	17475.067	43.39	10.12	38.80	42.70	49.61	54	-4.39	AV
H	6039.131	59.02	7.10	37.24	43.50	59.86	68.2	-8.34	PK
H	6039.131	43.42	7.10	37.24	43.50	44.26	54	-9.74	AV
H	11650.004	50.26	8.46	38.57	44.50	52.79	74	-21.21	PK
H	11650.004	44.04	8.46	38.57	44.50	46.57	54	-7.43	AV
H	17475.055	50.66	10.12	38.38	44.10	55.06	68.2	-13.14	PK
H	17475.055	41.64	10.12	38.38	44.10	46.04	54	-7.96	AV

Note: PK value is lower than the Average value limit, So average didn't record.
 The 26.5-40G amplitude of spurious emissions that are attenuated by more than 20dB below the permissible value has no need to be reported.
 Emission level (dBuV/m) = 20 log Emission level (uV/m).
 Corrected Reading: Antenna Factor + Cable Loss + Read Level - Preamp Factor = Level.

Test Mode :	TX (5.8G) -- 802.11ac-HT40
-------------	----------------------------

Polar (H/V)	Frequency	Meter Reading	Cable loss	Antenn a Factor	Preamp Factor	Emission Level	Limits	Margi n	Detecto r Type
	(MHz)	(dBuV)	(dB)	dB/m	(dB)	(dBuV/m)	(dBuV /m)	(dB)	
Low Channel (5755 MHz)-Above 1G									
V	4679.079	57.27	5.94	35.40	44.00	54.61	74	-19.39	PK
V	4679.079	43.11	5.94	35.40	44.00	40.45	54	-13.55	AV
V	11510.048	55.97	8.46	39.75	44.50	59.68	74	-14.32	PK
V	11510.048	43.64	8.46	39.75	44.50	47.35	54	-6.65	AV
V	17265.177	56.38	10.12	38.80	44.10	61.20	68.2	-7.00	PK
V	17265.177	43.45	10.12	38.80	42.70	49.67	54	-4.33	AV
H	4679.181	58.49	5.94	35.18	44.00	55.61	74	-18.39	PK
H	4679.181	43.50	5.94	35.18	44.00	40.62	54	-13.38	AV
H	11510.035	54.11	8.46	38.71	44.50	56.78	74	-17.22	PK
H	11510.035	44.02	8.46	38.71	44.50	46.69	54	-7.31	AV
H	17265.024	50.27	10.12	38.38	44.10	54.67	68.2	-13.53	PK
H	17265.024	43.73	10.12	38.38	44.10	48.13	54	-5.87	AV
middle Channel (5795 MHz)-Above 1G									
V	6039.069	59.01	6.48	36.35	44.05	57.79	68.2	-10.41	PK
V	6039.069	43.65	6.48	36.35	44.05	42.43	54	-11.57	AV
V	11590.016	58.09	8.47	37.88	44.51	59.93	74	-14.07	PK
V	11590.016	43.93	8.47	37.88	44.51	45.77	54	-8.23	AV
V	17385.199	55.02	10.12	38.80	44.10	59.84	68.2	-8.36	PK
V	17385.199	41.82	10.12	38.80	42.70	48.04	54	-5.96	AV
H	6039.125	59.04	6.48	36.37	44.05	57.84	68.2	-10.36	PK
H	6039.125	43.66	6.48	36.37	44.05	42.46	54	-11.54	AV
H	11590.169	51.20	8.47	38.64	44.50	53.81	74	-20.19	PK
H	11590.169	43.53	8.47	38.64	44.50	46.14	54	-7.86	AV
H	17385.194	54.45	10.12	38.38	44.10	58.85	68.2	-9.35	PK
H	17385.194	41.35	10.12	38.38	44.10	45.75	54	-8.25	AV

Note: PK value is lower than the Average value limit, So average didn't record.

The 26.5-40G amplitude of spurious emissions that are attenuated by more than 20dB below the permissible value has no need to be reported.

Emission level (dBuV/m) = 20 log Emission level (uV/m).

Corrected Reading: Antenna Factor + Cable Loss + Read Level - Preamp Factor = Level.