

S

T

S

L

A

B



# RADIO TEST REPORT

Report No: STS1809078W02

Issued for

Shenzhen Reflying Electronic Co., Limited

6 Bldg, GaoXinJian Industrial zone, HePing village, Fuyong  
Town, Bao' an district, Shenzhen, Guangdong, China

|                       |                                |
|-----------------------|--------------------------------|
| <b>Product Name:</b>  | bluetooth speaker              |
| <b>Brand Name:</b>    | Mangotek , Reflying , Excelvan |
| <b>Model Name:</b>    | RSD12                          |
| <b>Series Model:</b>  | MSD12, EX-BS100                |
| <b>FCC ID:</b>        | A7MRSD12                       |
| <b>Test Standard:</b> | FCC Part 15.247                |

Any reproduction of this document must be done in full. No single part of this document may be reproduced without permission from STS, All Test Data Presented in this report is only applicable to presented Test sample.

Shenzhen STS Test Services Co., Ltd.  
1/F., Building B, Zhuoke Science Park, No.190, Chongqing Road,  
Fuyong Street, Bao'an District, Shenzhen, Guangdong, China  
TEL: +86-755 3688 6288 FAX: +86-755 3688 6277 E-mail:sts@stsapp.com

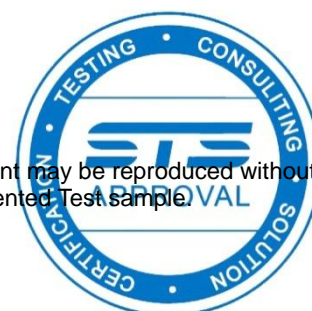



### TEST RESULT CERTIFICATION

**Applicant's name**.....: Shenzhen Reflying Electronic Co., Limited

Address .....: 6 Bldg, GaoXinJian Industrial zone, HePing village, Fuyong Town, Bao' an district, Shenzhen, Guangdong, China

**Manufacture's Name** .....: Shenzhen Reflying Electronic Co., Limited

Address .....: 6 Bldg, GaoXinJian Industrial zone, HePing village, Fuyong Town, Bao' an district, Shenzhen, Guangdong, China

**Product description**

Product Name .....: bluetooth speaker

Brand Name .....: Mangotek , Reflying , Excelvan

Model Name .....: RSD12

Series Model .....: MSD12, EX-BS100

**Test Standards**.....: FCC Part15.247

Test procedure.....: ANSI C63.10-2013

This device described above has been tested by STS, the test results show that the equipment under test (EUT) is in compliance with the FCC requirements. And it is applicable only to the tested sample identified in the report.

This report shall not be reproduced except in full, without the written approval of STS, this document may be altered or revised by STS, personal only, and shall be noted in the revision of the document..

**Date of Test**.....:

Date (s) of performance of tests.: 12 Sept.2018 ~28 Sept.2018

Date of Issue .....: 30 Sept.2018

Test Result .....: Pass

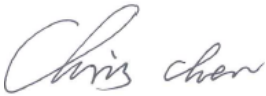
Testing Engineer :   
 \_\_\_\_\_  
 ( Chris chen )

Technical Manager :   
 \_\_\_\_\_  
 ( Sean she )

Authorized Signatory :   
 \_\_\_\_\_  
 (Vita Li)





| Table of Contents   | Page      |
|---|-----------|
| <b>1. SUMMARY OF TEST RESULTS</b>                           | <b>6</b>  |
| 1.1 TEST FACTORY  | 7         |
| 1.2 MEASUREMENT UNCERTAINTY                                 | 7         |
| <b>2. GENERAL INFORMATION</b>                               | <b>8</b>  |
| 2.1 GENERAL DESCRIPTION OF EUT                              | 8         |
| 2.2 DESCRIPTION OF TEST MODES                               | 10        |
| 2.3 TABLE OF PARAMETERS OF TEXT SOFTWARE SETTING            | 10        |
| 2.4 BLOCK DIGRAM SHOWING THE CONFIGURATION OF SYSTEM TESTED | 11        |
| 2.5 DESCRIPTION OF SUPPORT UNITS                            | 12        |
| 2.6 EQUIPMENTS LIST FOR ALL TEST ITEMS                      | 13        |
| <b>3. EMC EMISSION TEST</b>                                 | <b>14</b> |
| 3.1 CONDUCTED EMISSION MEASUREMENT                          | 14        |
| <b>4. CONDUCTED SPURIOUS &amp; BAND EDGE EMISSION</b>       | <b>29</b> |
| 4.1 REQUIREMENT   | 29        |
| 4.2 TEST PROCEDURE  | 29        |
| 4.3 TEST SETUP  | 29        |
| 4.4 EUT OPERATION CONDITIONS                                | 29        |
| 4.5 TEST RESULTS  | 30        |
| <b>5. NUMBER OF HOPPING CHANNEL</b>                         | <b>42</b> |
| 5.1 APPLIED PROCEDURES / LIMIT                              | 42        |
| 5.2 TEST PROCEDURE  | 42        |
| 5.3 TEST SETUP  | 42        |
| 5.4 EUT OPERATION CONDITIONS                                | 42        |
| 5.5 TEST RESULTS  | 43        |
| <b>6. AVERAGE TIME OF OCCUPANCY</b>                         | <b>44</b> |
| 6.1 APPLIED PROCEDURES / LIMIT                              | 44        |
| 6.2 TEST PROCEDURE  | 44        |
| 6.3 TEST SETUP  | 44        |
| 6.4 EUT OPERATION CONDITIONS                                | 44        |
| 6.5 TEST RESULTS  | 45        |
| <b>7. HOPPING CHANNEL SEPARATION MEASUREMENT</b>            | <b>51</b> |
| 7.1 APPLIED PROCEDURES / LIMIT                              | 51        |
| 7.2 TEST PROCEDURE  | 51        |



| Table of Contents              | Page      |
|--------------------------------|-----------|
| 7.3 TEST SETUP                 | 51        |
| 7.4 EUT OPERATION CONDITIONS   | 51        |
| 7.5 TEST RESULTS               | 52        |
| <b>8. BANDWIDTH TEST</b>       | <b>58</b> |
| 8.1 APPLIED PROCEDURES / LIMIT | 58        |
| 8.2 TEST PROCEDURE             | 58        |
| 8.3 TEST SETUP                 | 58        |
| 8.4 EUT OPERATION CONDITIONS   | 58        |
| 8.5 TEST RESULTS               | 59        |
| <b>9. OUTPUT POWER TEST</b>    | <b>65</b> |
| 9.1 APPLIED PROCEDURES / LIMIT | 65        |
| 9.2 TEST PROCEDURE             | 65        |
| 9.3 TEST SETUP                 | 65        |
| 9.4 EUT OPERATION CONDITIONS   | 65        |
| 9.5 TEST RESULTS               | 66        |
| <b>10. ANTENNA REQUIREMENT</b> | <b>67</b> |
| 10.1 STANDARD REQUIREMENT      | 67        |
| 10.2 EUT ANTENNA               | 67        |



**Revision History**

| Rev. | Issue Date   | Report NO.    | Effect Page | Contents      |
|------|--------------|---------------|-------------|---------------|
| 00   | 30 Sept.2018 | STS1809078W02 | ALL         | Initial Issue |
|      |              |               |             |               |





## 1. SUMMARY OF TEST RESULTS

Test procedures according to the technical standards: DA 00-705

| FCC Part 15.247, Subpart C    |   |          |        |
|-------------------------------|---|----------|--------|
| Standard Section              | Test Item                               | Judgment | Remark |
| 15.207                        | Conducted Emission                      | N/A      | --     |
| 15.247(a)(1)                  | Hopping Channel Separation              | PASS     | --     |
| 15.247(a)(1)&(b)(1)           | Output Power                            | PASS     | --     |
| 15.247(c)                     | Radiated Spurious Emission              | PASS     | --     |
| 15.247(d)                     | Conducted Spurious & Band Edge Emission | PASS     | --     |
| 15.247(a)(iii)                | Number of Hopping Frequency             | PASS     | --     |
| 15.247(a)(iii)                | Dwell Time                              | PASS     | --     |
| 15.247(a)(1)                  | Bandwidth                               | PASS     | --     |
| 15.205                        | Restricted Band Edge Emission           | PASS     | --     |
| Part 15.247(d)/part 15.209(a) | Band Edge Emission                      | PASS     | --     |
| 15.203                        | Antenna Requirement                     | PASS     | --     |

### NOTE:

(1) "N/A" denotes test is not applicable in this Test Report

(2) All tests are according to ANSI C63.10-2013



### 1.1 TEST FACTORY

Shenzhen STS Test Services Co., Ltd.

Add. : 1/F., Building B, Zhuoke Science Park, No.190, Chongqing Road,  
Fuyong Street, Bao'an District, Shenzhen, Guangdong, China

CNAS Registration No.: L7649; FCC Registration No.: 625569

IC Registration No.: 12108A; A2LA Certificate No.: 4338.01;

### 1.2 MEASUREMENT UNCERTAINTY

The reported uncertainty of measurement  $y \pm U$ , where expanded uncertainty  $U$  is based on a standard uncertainty multiplied by a coverage factor of  $k=2$ , providing a level of confidence of approximately **95 %**.

| No. | Item                                    | Uncertainty         |
|-----|---|---------------------|
| 1   | Conducted Emission (9KHz-150KHz)        | $\pm 2.88\text{dB}$ |
| 2   | Conducted Emission (150KHz-30MHz)       | $\pm 2.67\text{dB}$ |
| 3   | RF power,conducted                      | $\pm 0.71\text{dB}$ |
| 4   | Spurious emissions,conducted            | $\pm 0.63\text{dB}$ |
| 5   | All emissions,radiated (9KHz-30MHz)     | $\pm 3.02\text{dB}$ |
| 6   | All emissions,radiated (30MHz-200MHz)   | $\pm 3.80\text{dB}$ |
| 7   | All emissions,radiated (200MHz-1000MHz) | $\pm 3.97\text{dB}$ |
| 8   | All emissions,radiated(>1G)             | $\pm 3.03\text{dB}$ |



## 2. GENERAL INFORMATION

### 2.1 GENERAL DESCRIPTION OF EUT

|                         |  |
|-------------------------|--|
| Product Name            | bluetooth speaker  |
| Trade Name              | Mangotek , Reflying , Excelvan   |
| Model Name              | RSD12  |
| Series Model            | MSD12, EX-BS100  |
| Model Difference        | Only different in mode name and Brand Name   |
| Channel List            | Please refer to the Note 2.  |
| Bluetooth               | Frequency:2402 – 2480 MHz<br>Modulation: GFSK(1Mbps), $\pi/4$ -DQPSK(2Mbps),<br>8DPSK(3Mbps) |
| Bluetooth Version       | 4.2 BR+EDR   |
| Battery                 | Battery(rating):<br>Rated Voltage: 3.7V<br>Charge Limit: 5V<br>Capacity: 400mAh              |
| Hardware version number | V1.0   |
| Software version number | V1.0   |
| Connecting I/O Port(s)  | Please refer to the User's Manual  |

Note:

1. For a more detailed features description, please refer to the manufacturer's specifications or the User's Manual.





2.

| Channel List |                 |         |                 |         |                 |
|--------------|-----------------|---------|-----------------|---------|-----------------|
| Channel      | Frequency (MHz) | Channel | Frequency (MHz) | Channel | Frequency (MHz) |
| 00           | 2402            | 27      | 2429            | 54      | 2456            |
| 01           | 2403            | 28      | 2430            | 55      | 2457            |
| 02           | 2404            | 29      | 2431            | 56      | 2458            |
| 03           | 2405            | 30      | 2432            | 57      | 2459            |
| 04           | 2406            | 31      | 2433            | 58      | 2460            |
| 05           | 2407            | 32      | 2434            | 59      | 2461            |
| 06           | 2408            | 33      | 2435            | 60      | 2462            |
| 07           | 2409            | 34      | 2436            | 61      | 2463            |
| 08           | 2410            | 35      | 2437            | 62      | 2464            |
| 09           | 2411            | 36      | 2438            | 63      | 2465            |
| 10           | 2412            | 37      | 2439            | 64      | 2466            |
| 11           | 2413            | 38      | 2440            | 65      | 2467            |
| 12           | 2414            | 39      | 2441            | 66      | 2468            |
| 13           | 2415            | 40      | 2442            | 67      | 2469            |
| 14           | 2416            | 41      | 2443            | 68      | 2470            |
| 15           | 2417            | 42      | 2444            | 69      | 2471            |
| 16           | 2418            | 43      | 2445            | 70      | 2472            |
| 17           | 2419            | 44      | 2446            | 71      | 2473            |
| 18           | 2420            | 45      | 2447            | 72      | 2474            |
| 19           | 2421            | 46      | 2448            | 73      | 2475            |
| 20           | 2422            | 47      | 2449            | 74      | 2476            |
| 21           | 2423            | 48      | 2450            | 75      | 2477            |
| 22           | 2424            | 49      | 2451            | 76      | 2478            |
| 23           | 2425            | 50      | 2452            | 77      | 2479            |
| 24           | 2426            | 51      | 2453            | 78      | 2480            |
| 25           | 2427            | 52      | 2454            |         |                 |
| 26           | 2428            | 53      | 2455            |         |                 |

3. Table for Filed Antenna

| Ant | Brand                                | Model Name | Antenna Type | Connector | Gain (dBi) | NOTE          |
|-----|--------------------------------------|------------|--------------|-----------|------------|---------------|
| 1   | Mangotek ,<br>Reflying ,<br>Excelvan | RSD12      | PCB Antenna  | N/A       | 0          | BT<br>Antenna |



## 2.2 DESCRIPTION OF TEST MODES

To investigate the maximum EMI emission characteristics generates from EUT, the test system was pre-scanning tested base on the consideration of following EUT operation mode or test configuration mode which possible have effect on EMI emission level. Each of these EUT operation mode(s) or test configuration mode(s) mentioned above was evaluated respectively.

| Worst Mode | Description | Data Rate/Modulation   |
|------------|-------------|------------------------|
| Mode 1     | TX CH00     | 1Mbps/GFSK             |
| Mode 2     | TX CH39     | 1Mbps/GFSK             |
| Mode 3     | TX CH78     | 1Mbps/GFSK             |
| Mode 4     | TX CH00     | 2 Mbps/ $\pi/4$ -DQPSK |
| Mode 5     | TX CH39     | 2 Mbps/ $\pi/4$ -DQPSK |
| Mode 6     | TX CH78     | 2 Mbps/ $\pi/4$ -DQPSK |
| Mode7      | TX CH00     | 3 Mbps/8DPSK           |
| Mode 8     | TX CH39     | 3 Mbps/8DPSK           |
| Mode 9     | TX CH78     | 3 Mbps/8DPSK           |

Note:

- (1) The measurements are performed at all Bit Rate of Transmitter, the worst data was reported
- (2) We have be tested for all avaiable U.S. voltage and frequencies(For 120V,50/60Hz and 240V, 50/60Hz) for which the device is capable of operation, and the worst case of 120V/ 60Hz is shown in the report

## 2.3 TABLE OF PARAMETERS OF TEXT SOFTWARE SETTING

During testing channel & power controlling software provided by the customer was used to control the operating channel as well as the output power level. The RF output power selection is for the setting of RF output power expected by the customer and is going to be fixed on the firmware of the final end product power parameters of FHSS.

| Test software Version                             | Test program: Bluetooth   |   |   |
|---|---|---|---|
| Frequency   | 2402 MHz  | 2441 MHz  | 2480 MHz  |
| (Power control software)<br>Parameters(1/2/3Mbps) | Power class:<br>1 M rate:4:27<br>2 M rate:11:183<br>3 M rate:15:339 | Power class:<br>1 M rate:4:27<br>2 M rate:11:183<br>3 M rate:15:339 | Power class:<br>1 M rate:4:27<br>2 M rate:11:183<br>3 M rate:15:339 |



### 2.4 BLOCK DIGRAM SHOWING THE CONFIGURATION OF SYSTEM TESTED

During testing channel & power controlling software provided by the customer was used to control the operating channel as well as the output power level. The RF output power selection is for the setting of RF output power expected by the customer and is going to be fixed on the firmware of the final end product power parameters of FHSS

#### Radiated Spurious EmissionTest





## 2.5 DESCRIPTION OF SUPPORT UNITS

The EUT has been tested as an independent unit together with other necessary accessories or support units. The following support units or accessories were used to form a representative test configuration during the tests.

| Item | Equipment | Mfr/Brand | Model/Type No. | Serial No. | Note |
|------|-----------|-----------|----------------|------------|------|
| N/A  | N/A       | N/A       | N/A            | N/A        | N/A  |
|      |           |           |                |            |      |
|      |           |           |                |            |      |
|      |           |           |                |            |      |

| Item | Shielded Type | Ferrite Core | Length      | Note |
|------|---------------|--------------|-------------|------|
| E-2  | Notebook      | DELL         | VOSTRO.3800 | N/A  |
| C-1  | USB Cable     | N/A          | N/A         | N/A  |
|      |               |              |             |      |

Note:

- (1) The support equipment was authorized by Declaration of Confirmation.
- (2) For detachable type I/O cable should be specified the length in cm in 『Length』 column.
- (3) “YES” is means “shielded” “with core”; “NO” is means “unshielded” “without core”.



## 2.6 EQUIPMENTS LIST FOR ALL TEST ITEMS

## Radiation Test equipment

| Kind of Equipment                | Manufacturer | Type No.     | Serial No. | Last calibration | Calibrated until |
|----------------------------------|--------------|--------------|------------|------------------|------------------|
| EMI Test Receiver                | R&S          | ESCI         | 102086     | 2017.10.15       | 2018.10.14       |
| Bilog Antenna                    | TESEQ        | CBL6111D     | 34678      | 2017.11.02       | 2018.11.01       |
| Horn Antenna                     | Schwarzbeck  | BBHA 9120D   | 9120D-1343 | 2017.10.27       | 2018.10.26       |
| SHF-EHF Horn Antenna (18G-40GHz) | A-INFO       | LB-180400-KF | N/A        | 2018.03.11       | 2019.03.10       |
| Temperature & Humidity           | HH660        | Mieo         | N/A        | 2017.10.15       | 2018.10.14       |
| Temperature & Humidity           | HH660        | Mieo         | N/A        | 2017.10.15       | 2018.10.14       |
| Pre-mpifier (0.1M-3GHz)          | EM           | EM330        | 60538      | 2018.03.11       | 2019.03.10       |
| PreAmplifier (1G-26.5GHz)        | Agilent      | 8449B        | 60538      | 2017.10.15       | 2018.10.14       |
| Passive Loop (9K--30MHz)         | ZHNAN        | ZN3090C      | 16035      | 2018.03.11       | 2019.03.10       |
| Low frequency cable              | EM           | R01          | N/A        | 2018.03.11       | 2019.03.10       |
| Low frequency cable              | EM           | R06          | N/A        | 2018.03.11       | 2019.03.10       |
| High frequency cable             | SCHWARZBECK  | R04          | N/A        | 2018.03.11       | 2019.03.10       |
| High frequency cable             | SCHWARZBECK  | R02          | N/A        | 2018.03.11       | 2019.03.10       |
| Semi-anechoic chamber            | Changling    | 966          | N/A        | 2017.10.15       | 2018.10.14       |
| trun table                       | EM           | SC100_1      | 60531      | N/A              | N/A              |
| Antnna mast                      | EM           | SC100        | N/A        | N/A              | N/A              |
| Max-full Antenna Corp            | MF           | MFA-440H     | N/A        | N/A              | N/A              |

## RF Connected Test

| Kind of Equipment   | Manufacturer | Type No. | Serial No.    | Last calibration | Calibrated until |
|---------------------|--------------|----------|---------------|------------------|------------------|
| USB RF power sensor | DARE         | RPR3006W | 15I00041SNO03 | 2017.10.15       | 2018.10.14       |
| Power Meter         | R&S          | NRP      | 100510        | 2017.10.15       | 2018.10.14       |
| Spectrum Analyzer   | Agilent      | N9020A   | MY51110105    | 2018.03.08       | 2019.03.07       |
| Signal Analyzer     | Agilent      | N9020A   | MY49100060    | 2017.10.15       | 2018.10.14       |



### 3. EMC EMISSION TEST

#### 3.1 CONDUCTED EMISSION MEASUREMENT

##### 3.1.1 POWER LINE CONDUCTED EMISSION LIMITS

Operating frequency band. In case the emission fall within the restricted band specified on Part 207(a) limit in the table below has to be followed.

| FREQUENCY (MHz) | Conducted Emissionlimit (dBuV) |           |
|-----------------|--------------------------------|-----------|
|                 | Quasi-peak                     | Average   |
| 0.15 -0.5       | 66 - 56 *                      | 56 - 46 * |
| 0.50 -5.0       | 56.00                          | 46.00     |
| 5.0 -30.0       | 60.00                          | 50.00     |

Note:

- (1) The tighter limit applies at the band edges.
- (2) The limit of " \* " marked band means the limitation decreases linearly with the logarithm of the frequency in the range.

The following table is the setting of the receiver

| Receiver Parameters | Setting  |
|---------------------|----------|
| Attenuation         | 10 dB    |
| Start Frequency     | 0.15 MHz |
| Stop Frequency      | 30 MHz   |
| IF Bandwidth        | 9 kHz    |

### 3.1.2 TEST PROCEDURE

- a. The EUT was 0.8 meters from the horizontal ground plane and 0.4 meters from the vertical ground plane with EUT being connected to the power mains through a line impedance stabilization network (LISN). All other support equipments powered from additional LISN(s). The LISN provide 50 Ohm/ 50uH of coupling impedance for the measuring instrument.
- b. Interconnecting cables that hang closer than 40 cm to the ground plane shall be folded back and forth in the center forming a bundle 30 to 40 cm long.
- c. I/O cables that are not connected to a peripheral shall be bundled in the center. The end of the cable may be terminated, if required, using the correct terminating impedance. The overall length shall not exceed 1 m.
- d. LISN at least 80 cm from nearest part of EUT chassis.
- e. For the actual test configuration, please refer to the related Item –EUT Test Photos.

### 3.1.3 TEST SETUP

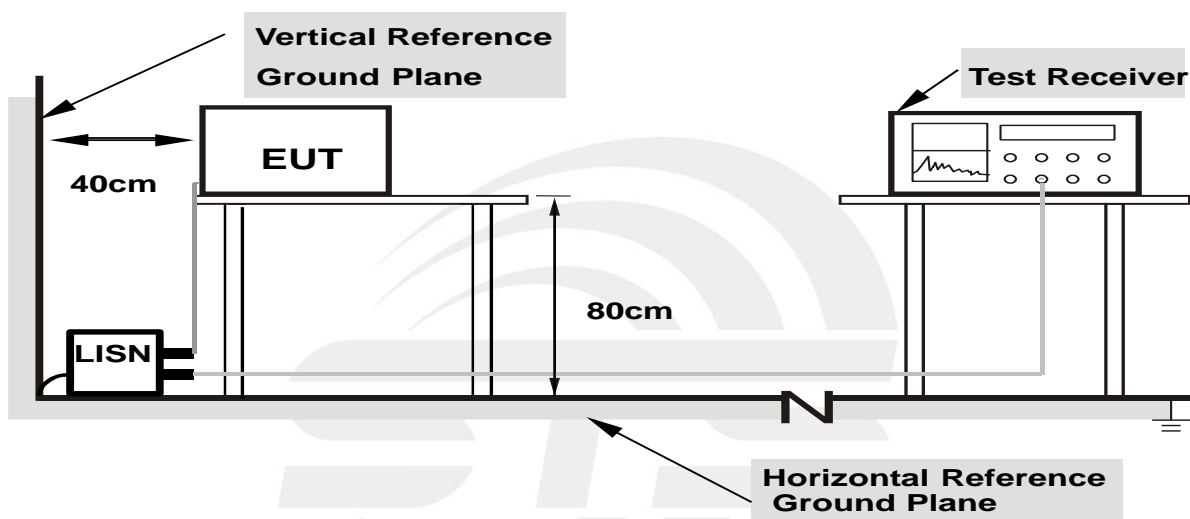

**Note: 1.Support units were connected to second LISN.  
 2.Both of LISNs (AMN) are 80 cm from EUT and at least 80 from other units and other metal planes**

### 3.1.4 EUT OPERATING CONDITIONS

The EUT was configured for testing in a typical fashion (as a customer would normally use it). The EUT has been programmed to continuously transmit during test. This operating condition was tested and used to collect the included data.



## 3.1.5 TEST RESULT

|               |              |                    |     |
|---------------|--------------|--------------------|-----|
| Temperature:  | 26 °C        | Relative Humidity: | 54% |
| Test Voltage: | AC 120V/60Hz | Phase:             | L/N |
| Test Mode:    | N/A          |                    |     |

Note: The BT function will be disabled (not transmitting) when the EUT is charging, the test is not available.







3.2.1 RADIATED EMISSION LIMITS

in any 100 kHz bandwidth outside the operating frequency band. In case the emission fall within the Restricted band specified on Part15.205(a)&209(a) limit in the table and according to ANSI C63.10-2013 below has to be followed

LIMITS OF RADIATED EMISSION MEASUREMENT (0.009MHz - 1000MHz)

| Frequencies (MHz) | Field Strength (microvolts/meter) | Measurement Distance (meters) |
|-------------------|-----------------------------------|-------------------------------|
| 0.009~0.490       | 2400/F(KHz)                       | 300                           |
| 0.490~1.705       | 24000/F(KHz)                      | 30                            |
| 1.705~30.0        | 30                                | 30                            |
| 30~88             | 100                               | 3                             |
| 88~216            | 150                               | 3                             |
| 216~960           | 200                               | 3                             |
| Above 960         | 500                               | 3                             |

LIMITS OF RADIATED EMISSION MEASUREMENT (1GHz-25 GHz)

| FREQUENCY (MHz) | (dBuV/m) (at 3M) |         |
|-----------------|------------------|---------|
|                 | PEAK             | AVERAGE |
| Above 1000      | 74               | 54      |

Notes:

- (1) The limit for radiated test was performed according to FCC PART 15C.
- (2) The tighter limit applies at the band edges.
- (3) Emission level (dBuV/m)=20log Emission level (uV/m).

For Radiated Emission

| Spectrum Parameter                    | Setting                         |
|---------------------------------------|---------------------------------|
| Attenuation                           | Auto                            |
| Detector                              | Peak/AV                         |
| Start Frequency                       | 1000 MHz(Peak/AV)               |
| Stop Frequency                        | 10th carrier hamonic(Peak/AV)   |
| RB / VB (emission in restricted band) | PK=1MHz / 1MHz, AV=1 MHz /10 Hz |

For Band edge

| Spectrum Parameter                    | Setting  |
|---------------------------------------|--|
| Detector                              | Peak/AV  |
| Start/Stop Frequency                  | Lower Band Edge: 2300 to 2403 MHz<br>Upper Band Edge: 2479 to 2500 MHz |
| RB / VB (emission in restricted band) | PK=1MHz / 1MHz, AV=1 MHz / 10 Hz                                       |



| Receiver Parameter     | Setting                              |
|------------------------|--------------------------------------|
| Attenuation            | Auto                                 |
| Start ~ Stop Frequency | 9kHz~90kHz / RB 200Hz for PK & AV    |
| Start ~ Stop Frequency | 90kHz~110kHz / RB 200Hz for QP       |
| Start ~ Stop Frequency | 110kHz~490kHz / RB 200Hz for PK & AV |
| Start ~ Stop Frequency | 490kHz~30MHz / RB 9kHz for QP        |
| Start ~ Stop Frequency | 30MHz~1000MHz / RB 120kHz for QP     |

### 3.2.2 TEST PROCEDURE

- The measuring distance of at 3 m shall be used for measurements at frequency 0.009MHz up to 1GHz, and above 1GHz.
- The EUT was placed on the top of a rotating table 0.8 meters (above 1GHz is 1.5 m) above the ground at a 3 meter anechoic chamber test site. The table was rotated 360 degrees to determine the position of the highest radiation.
- The height of the equipment shall be 0.8 m (above 1GHz is 1.5 m); the height of the test antenna shall vary between 1 m to 4 m. horizontal and vertical polarizations of the antenna are set to make the measurement.
- The initial step in collecting conducted emission data is a spectrum analyzer peak detector mode pre-scanning the measurement frequency range. Significant peaks are then marked and then QuasiPeak detector mode re-measured.
- If the Peak Mode measured value compliance with and lower than Quasi Peak Mode Limit, the EUT shall be deemed to meet QP Limits and then no additional QP Mode measurement performed.
- For the actual test configuration, please refer to the related Item –EUT Test Photos.

Note:

Both horizontal and vertical antenna polarities were tested and performed pretest to three orthogonal axis. The worst case emissions were reported

### 3.2.3 DEVIATION FROM TEST STANDARD

No deviation

### 3.2.4 TESTSETUP

(A) Radiated Emission Test-Up Frequency Below 30MHz

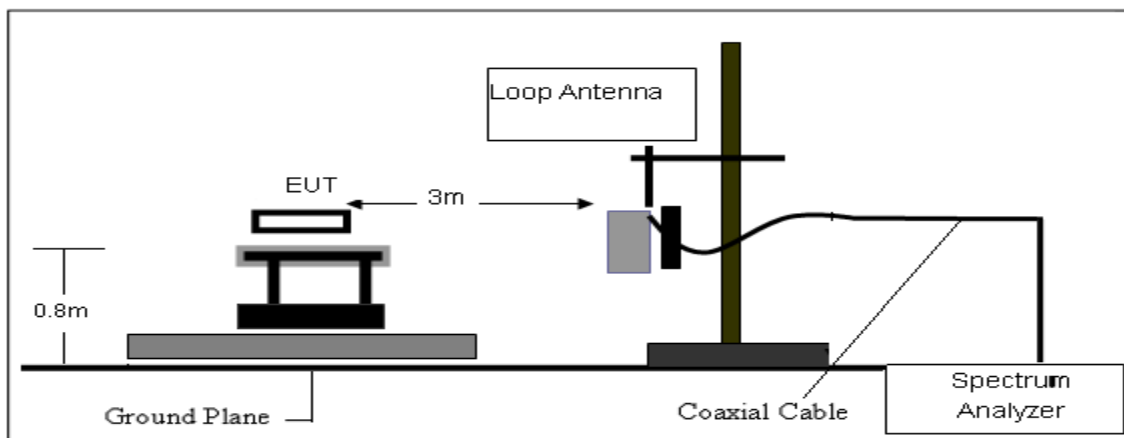

(B) Radiated Emission Test-Up Frequency 30MHz~1GHz

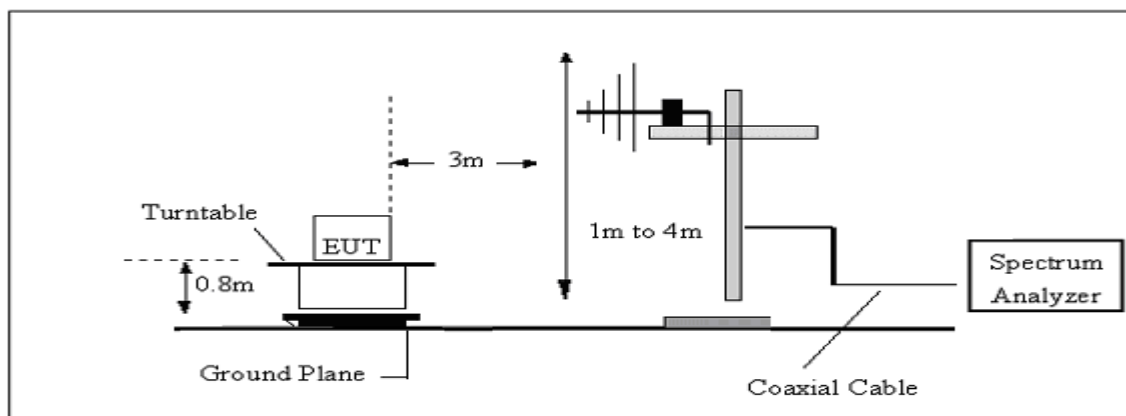

(C) Radiated Emission Test-Up Frequency Above 1GHz

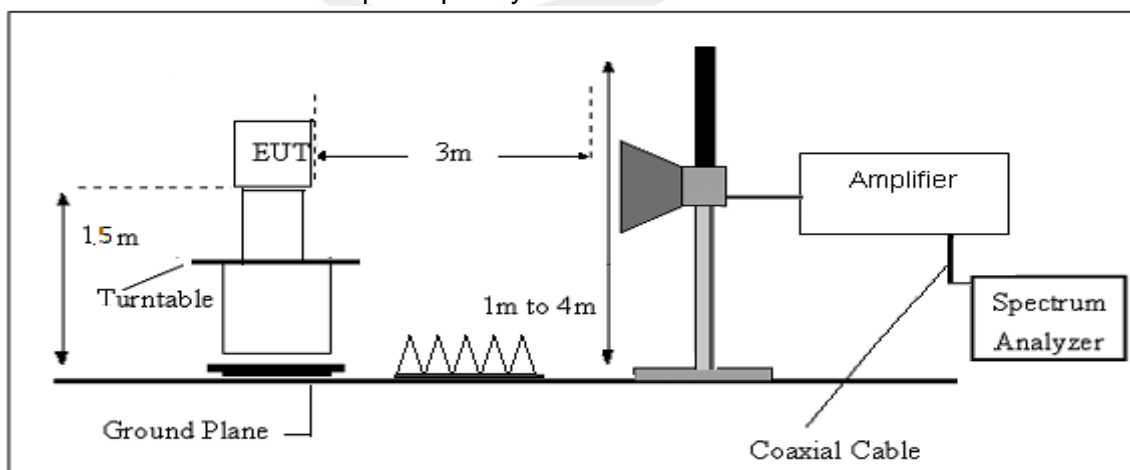

### 3.2.5 EUT OPERATING CONDITIONS

The EUT tested system was configured as the statements of 2.4 Unless otherwise a special operating condition is specified in the follows during the testing.



### 3.2.6 FIELD STRENGTH CALCULATION

The field strength is calculated by adding the Antenna Factor and Cable Factor and subtracting the Amplifier Gain and Duty Cycle Correction Factor (if any) from the measured reading. The basic equation with a sample calculation is as follows:

$$FS = RA + AF + CL - AG$$

Where

FS = Field Strength

CL = Cable Attenuation Factor (Cable Loss)

RA = Reading Amplitude

AG = Amplifier Gain

AF = Antenna Factor

For example

| Frequency<br>(MHz) | FS<br>(dB $\mu$ V/m) | RA<br>(dB $\mu$ V/m) | AF<br>(dB) | CL<br>(dB) | AG<br>(dB) | Factor<br>(dB) |
|--------------------|----------------------|----------------------|------------|------------|------------|----------------|
| 300                | 40                   | 58.1                 | 12.2       | 1.6        | 31.9       | -18.1          |

$$\text{Factor} = \text{AF} + \text{CL} - \text{AG}$$





## 3.2.7 TEST RESULTS

(9KHz-30MHz)

|               |                      |                    |         |
|---------------|----------------------|--------------------|---------|
| Temperature:  | 20.4 °C              | Relative Humidity: | 76%     |
| Test Voltage: | DC 3.7V from battery | Test Mode:         | TX Mode |

| Freq.<br>(MHz) | Reading<br>(dBuV/m) | Limit<br>(dBuV/m) | Margin<br>(dB) | State<br>P/F | Test Result |
|----------------|---------------------|-------------------|----------------|--------------|-------------|
| --             | --                  | --                | --             | --           | PASS        |
| --             | --                  | --                | --             | --           | PASS        |

## Note:

The amplitude of spurious emissions which are attenuated by more than 20dB below the permissible value has no need to be reported.

Distance extrapolation factor =  $40 \log(\text{specific distance}/\text{test distance})$ (dB);

Limit line = specific limits(dBuv) + distance extrapolation factor.

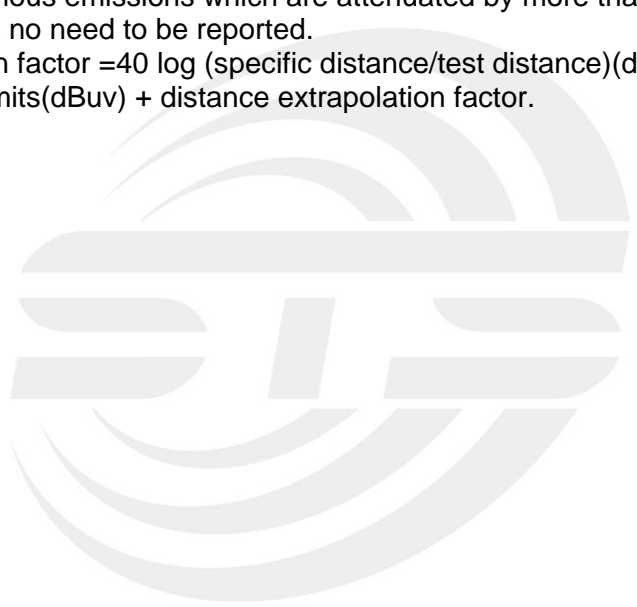



(30MHz-1000MHz)

|               |  |                    |            |
|---------------|--|--------------------|------------|
| Temperature:  | 20.4 °C                                      | Relative Humidity: | 76%        |
| Test Voltage: | DC 3.7V from battery                         | Phase:             | Horizontal |
| Test Mode:    | Mode 1/2/3/4/5/6/7/8/9(Mode 3-1M worst mode) |                    |            |

| Frequency (MHz) | Reading (dBuV) | Correct Factor(dB/m) | Result (dBuV/m) | Limit (dBuV/m) | Margin (dB) | Remark |
|-----------------|----------------|----------------------|-----------------|----------------|-------------|--------|
| 48.8430         | 47.88          | -20.89               | 26.99           | 40.00          | -13.01      | QP     |
| 68.1514         | 49.94          | -24.15               | 25.79           | 40.00          | -14.21      | QP     |
| 100.9340        | 43.00          | -19.12               | 23.88           | 43.50          | -19.62      | QP     |
| 316.5890        | 35.78          | -14.28               | 21.50           | 46.00          | -24.50      | QP     |
| 580.7026        | 34.32          | -6.73                | 27.59           | 46.00          | -18.41      | QP     |
| 979.1804        | 33.39          | -0.16                | 33.23           | 54.00          | -20.77      | QP     |

Remark:

1. Margin = Result (Result =Reading + Factor )–Limit

80.0 dBuV/m

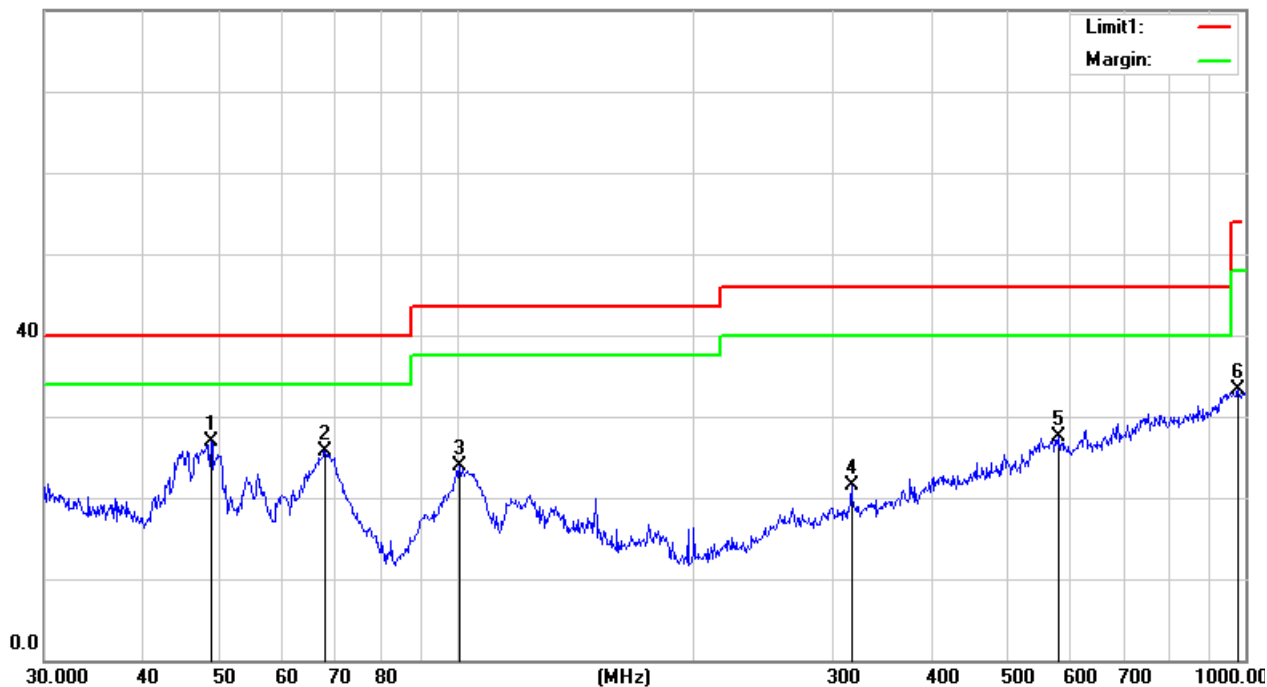



|               |  |                    |          |
|---------------|--|--------------------|----------|
| Temperature:  | 20.4 °C                                      | Relative Humidity: | 76%      |
| Test Voltage: | DC 3.7V from battery                         | Phase:             | Vertical |
| Test Mode:    | Mode 1/2/3/4/5/6/7/8/9(Mode 3-1M worst mode) |                    |          |

| Frequency (MHz) | Reading (dBuV) | Correct Factor(dB/m) | Result (dBuV/m) | Limit (dBuV/m) | Margin (dB) | Remark |
|-----------------|----------------|----------------------|-----------------|----------------|-------------|--------|
| 67.9130         | 47.90          | -24.15               | 23.75           | 40.00          | -16.25      | QP     |
| 104.9033        | 40.84          | -18.78               | 22.06           | 43.50          | -21.44      | QP     |
| 175.0368        | 38.49          | -19.38               | 19.11           | 43.50          | -24.39      | QP     |
| 261.9753        | 35.88          | -15.14               | 20.74           | 46.00          | -25.26      | QP     |
| 501.1790        | 35.99          | -8.90                | 27.09           | 46.00          | -18.91      | QP     |
| 771.4486        | 34.88          | -3.32                | 31.56           | 46.00          | -14.44      | QP     |

Remark:

1. Margin = Result (Result =Reading + Factor )–Limit

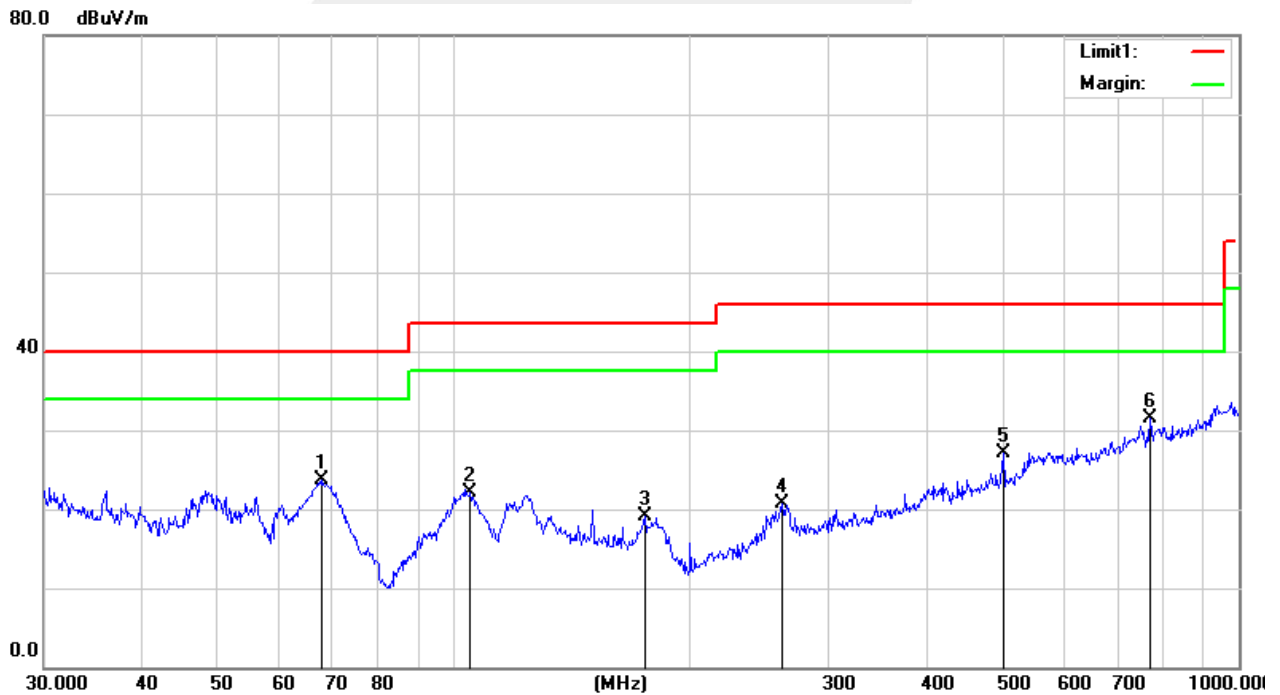



(1GHz~25GHz) Restricted band and Spurious emission Requirements

### GFSK Low Channel

| Frequency<br>(MHz)     | Reading<br>(dBμV) | Amplifier<br>(dB) | Loss<br>(dB) | Antenna<br>Factor<br>(dB/m) | Corrected<br>Factor<br>(dB) | Emission<br>Level<br>(dBμV/m) | Limits<br>(dBμV/m) | Margin<br>(dB) | Detector<br>Type | Comment    |
|------------------------|-------------------|-------------------|--------------|-----------------------------|-----------------------------|-------------------------------|--------------------|----------------|------------------|------------|
| Low Channel (2402 MHz) |                   |                   |              |                             |                             |                               |                    |                |                  |            |
| 3264.82                | 61.23             | 44.70             | 6.70         | 28.20                       | -9.80                       | 51.43                         | 74.00              | -22.57         | PK               | Vertical   |
| 3264.82                | 50.39             | 44.70             | 6.70         | 28.20                       | -9.80                       | 40.59                         | 54.00              | -13.41         | AV               | Vertical   |
| 3264.70                | 61.74             | 44.70             | 6.70         | 28.20                       | -9.80                       | 51.94                         | 74.00              | -22.06         | PK               | Horizontal |
| 3264.70                | 50.04             | 44.70             | 6.70         | 28.20                       | -9.80                       | 40.24                         | 54.00              | -13.76         | AV               | Horizontal |
| 4804.35                | 59.33             | 44.20             | 9.04         | 31.60                       | -3.56                       | 55.77                         | 74.00              | -18.23         | PK               | Vertical   |
| 4804.35                | 50.24             | 44.20             | 9.04         | 31.60                       | -3.56                       | 46.68                         | 54.00              | -7.32          | AV               | Vertical   |
| 4804.51                | 59.26             | 44.20             | 9.04         | 31.60                       | -3.56                       | 55.70                         | 74.00              | -18.30         | PK               | Horizontal |
| 4804.51                | 50.07             | 44.20             | 9.04         | 31.60                       | -3.56                       | 46.51                         | 54.00              | -7.49          | AV               | Horizontal |
| 5359.86                | 49.21             | 44.20             | 9.86         | 32.00                       | -2.34                       | 46.87                         | 74.00              | -27.13         | PK               | Vertical   |
| 5359.86                | 40.25             | 44.20             | 9.86         | 32.00                       | -2.34                       | 37.91                         | 54.00              | -16.09         | AV               | Vertical   |
| 5359.75                | 47.81             | 44.20             | 9.86         | 32.00                       | -2.34                       | 45.47                         | 74.00              | -28.53         | PK               | Horizontal |
| 5359.75                | 38.10             | 44.20             | 9.86         | 32.00                       | -2.34                       | 35.76                         | 54.00              | -18.24         | AV               | Horizontal |
| 7205.82                | 54.51             | 43.50             | 11.40        | 35.50                       | 3.40                        | 57.91                         | 74.00              | -16.09         | PK               | Vertical   |
| 7205.82                | 44.69             | 43.50             | 11.40        | 35.50                       | 3.40                        | 48.09                         | 54.00              | -5.91          | AV               | Vertical   |
| 7205.87                | 53.87             | 43.50             | 11.40        | 35.50                       | 3.40                        | 57.27                         | 74.00              | -16.73         | PK               | Horizontal |
| 7205.87                | 44.93             | 43.50             | 11.40        | 35.50                       | 3.40                        | 48.33                         | 54.00              | -5.67          | AV               | Horizontal |





### GFSK Mid Channel

| Frequency<br>(MHz)     | Reading<br>(dBμV) | Amplifier<br>(dB) | Loss<br>(dB) | Antenna<br>Factor<br>(dB/m) | Corrected<br>Factor<br>(dB) | Emission<br>Level<br>(dBμV/m) | Limits<br>(dBμV/m) | Margin<br>(dB) | Detector<br>Type | Comment    |
|------------------------|-------------------|-------------------|--------------|-----------------------------|-----------------------------|-------------------------------|--------------------|----------------|------------------|------------|
| Mid Channel (2441 MHz) |                   |                   |              |                             |                             |                               |                    |                |                  |            |
| 3264.60                | 60.87             | 44.70             | 6.70         | 28.20                       | -9.80                       | 51.07                         | 74.00              | -22.93         | PK               | Vertical   |
| 3264.60                | 49.94             | 44.70             | 6.70         | 28.20                       | -9.80                       | 40.14                         | 54.00              | -13.86         | AV               | Vertical   |
| 3264.79                | 61.24             | 44.70             | 6.70         | 28.20                       | -9.80                       | 51.44                         | 74.00              | -22.56         | PK               | Horizontal |
| 3264.79                | 50.67             | 44.70             | 6.70         | 28.20                       | -9.80                       | 40.87                         | 54.00              | -13.13         | AV               | Horizontal |
| 4882.38                | 58.95             | 44.20             | 9.04         | 31.60                       | -3.56                       | 55.39                         | 74.00              | -18.61         | PK               | Vertical   |
| 4882.38                | 50.16             | 44.20             | 9.04         | 31.60                       | -3.56                       | 46.60                         | 54.00              | -7.40          | AV               | Vertical   |
| 4882.43                | 59.50             | 44.20             | 9.04         | 31.60                       | -3.56                       | 55.94                         | 74.00              | -18.06         | PK               | Horizontal |
| 4882.43                | 50.00             | 44.20             | 9.04         | 31.60                       | -3.56                       | 46.44                         | 54.00              | -7.56          | AV               | Horizontal |
| 5359.73                | 48.91             | 44.20             | 9.86         | 32.00                       | -2.34                       | 46.57                         | 74.00              | -27.43         | PK               | Vertical   |
| 5359.73                | 39.05             | 44.20             | 9.86         | 32.00                       | -2.34                       | 36.71                         | 54.00              | -17.29         | AV               | Vertical   |
| 5359.75                | 47.16             | 44.20             | 9.86         | 32.00                       | -2.34                       | 44.82                         | 74.00              | -29.18         | PK               | Horizontal |
| 5359.75                | 39.12             | 44.20             | 9.86         | 32.00                       | -2.34                       | 36.78                         | 54.00              | -17.22         | AV               | Horizontal |
| 7313.82                | 53.66             | 43.50             | 11.40        | 35.50                       | 3.40                        | 57.06                         | 74.00              | -16.94         | PK               | Vertical   |
| 7313.82                | 44.06             | 43.50             | 11.40        | 35.50                       | 3.40                        | 47.46                         | 54.00              | -6.54          | AV               | Vertical   |
| 7313.73                | 54.00             | 43.50             | 11.40        | 35.50                       | 3.40                        | 57.40                         | 74.00              | -16.60         | PK               | Horizontal |
| 7313.73                | 44.42             | 43.50             | 11.40        | 35.50                       | 3.40                        | 47.82                         | 54.00              | -6.18          | AV               | Horizontal |



### GFSK High Channel

| Frequency<br>(MHz)      | Reading<br>(dBμV) | Amplifier<br>(dB) | Loss<br>(dB) | Antenna<br>Factor<br>(dB/m) | Corrected<br>Factor<br>(dB) | Emission<br>Level<br>(dBμV/m) | Limits<br>(dBμV/m) | Margin<br>(dB) | Detector<br>Type | Comment    |
|-------------------------|-------------------|-------------------|--------------|-----------------------------|-----------------------------|-------------------------------|--------------------|----------------|------------------|------------|
| High Channel (2480 MHz) |                   |                   |              |                             |                             |                               |                    |                |                  |            |
| 3264.85                 | 61.63             | 44.70             | 6.70         | 28.20                       | -9.80                       | 51.83                         | 74.00              | -22.17         | PK               | Vertical   |
| 3264.85                 | 51.77             | 44.70             | 6.70         | 28.20                       | -9.80                       | 41.97                         | 54.00              | -12.03         | AV               | Vertical   |
| 3264.86                 | 61.50             | 44.70             | 6.70         | 28.20                       | -9.80                       | 51.70                         | 74.00              | -22.30         | PK               | Horizontal |
| 3264.86                 | 49.85             | 44.70             | 6.70         | 28.20                       | -9.80                       | 40.05                         | 54.00              | -13.95         | AV               | Horizontal |
| 4960.30                 | 59.50             | 44.20             | 9.04         | 31.60                       | -3.56                       | 55.94                         | 74.00              | -18.06         | PK               | Vertical   |
| 4960.30                 | 50.50             | 44.20             | 9.04         | 31.60                       | -3.56                       | 46.94                         | 54.00              | -7.06          | AV               | Vertical   |
| 4960.55                 | 58.93             | 44.20             | 9.04         | 31.60                       | -3.56                       | 55.37                         | 74.00              | -18.63         | PK               | Horizontal |
| 4960.55                 | 49.40             | 44.20             | 9.04         | 31.60                       | -3.56                       | 45.84                         | 54.00              | -8.16          | AV               | Horizontal |
| 5359.88                 | 48.69             | 44.20             | 9.86         | 32.00                       | -2.34                       | 46.35                         | 74.00              | -27.65         | PK               | Vertical   |
| 5359.88                 | 39.65             | 44.20             | 9.86         | 32.00                       | -2.34                       | 37.31                         | 54.00              | -16.69         | AV               | Vertical   |
| 5359.67                 | 47.09             | 44.20             | 9.86         | 32.00                       | -2.34                       | 44.75                         | 74.00              | -29.25         | PK               | Horizontal |
| 5359.67                 | 39.50             | 44.20             | 9.86         | 32.00                       | -2.34                       | 37.16                         | 54.00              | -16.84         | AV               | Horizontal |
| 7439.83                 | 53.76             | 43.50             | 11.40        | 35.50                       | 3.40                        | 57.16                         | 74.00              | -16.84         | PK               | Vertical   |
| 7439.83                 | 43.89             | 43.50             | 11.40        | 35.50                       | 3.40                        | 47.29                         | 54.00              | -6.71          | AV               | Vertical   |
| 7439.80                 | 53.70             | 43.50             | 11.40        | 35.50                       | 3.40                        | 57.10                         | 74.00              | -16.90         | PK               | Horizontal |
| 7439.80                 | 44.12             | 43.50             | 11.40        | 35.50                       | 3.40                        | 47.52                         | 54.00              | -6.48          | AV               | Horizontal |

Note:

- 1) Scan with GFSK, π/4-DQPSK, 8DPSK, the worst case is GFSK Mode
- 2) Factor = Antenna Factor + Cable Loss – Pre-amplifier.  
Emission Level = Reading + Factor
- 3) The frequency emission of peak points that did not show above the forms are at least 20dB below the limit, the frequency emission is mainly from the environment noise.



Band edge Requirements

**GFSK-Low**  
Horizontal

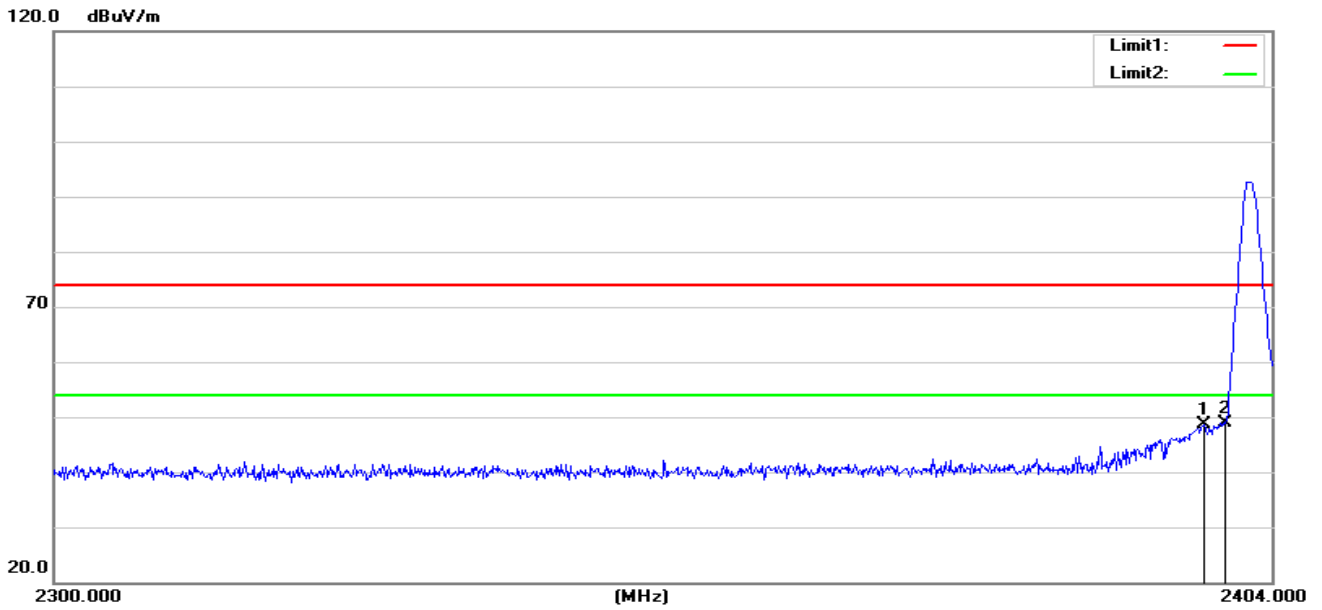

| No. | Frequency (MHz) | Reading (dBuV) | Correct Factor(dB/m) | Result (dBuV/m) | Limit (dBuV/m) | Margin (dB) | Remark |
|-----|-----------------|----------------|----------------------|-----------------|----------------|-------------|--------|
| 1   | 2398.176        | 50.28          | -1.70                | 48.58           | 74.00          | -25.42      | peak   |
| 2   | 2400.000        | 50.45          | -1.69                | 48.76           | 74.00          | -25.24      | peak   |

Vertical

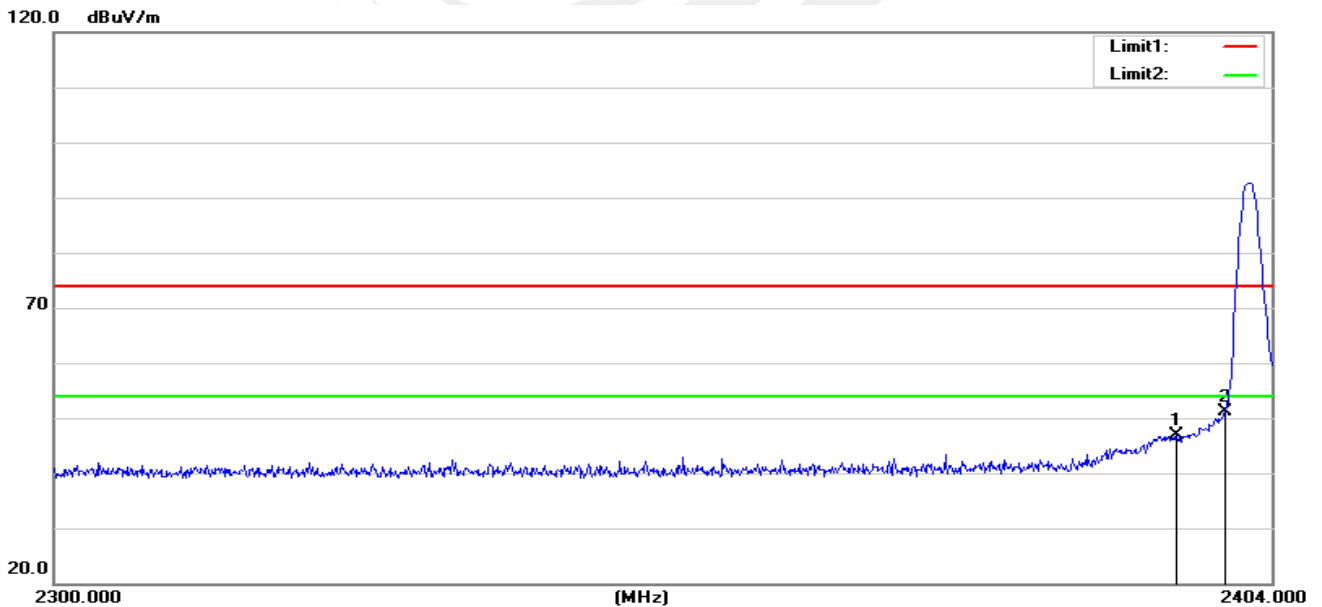

| No. | Frequency (MHz) | Reading (dBuV) | Correct Factor(dB/m) | Result (dBuV/m) | Limit (dBuV/m) | Margin (dB) | Remark |
|-----|-----------------|----------------|----------------------|-----------------|----------------|-------------|--------|
| 1   | 2395.784        | 48.54          | -1.73                | 46.81           | 74.00          | -27.19      | peak   |
| 2   | 2400.000        | 52.83          | -1.69                | 51.14           | 74.00          | -22.86      | peak   |



**GFSK-High**  
Horizontal

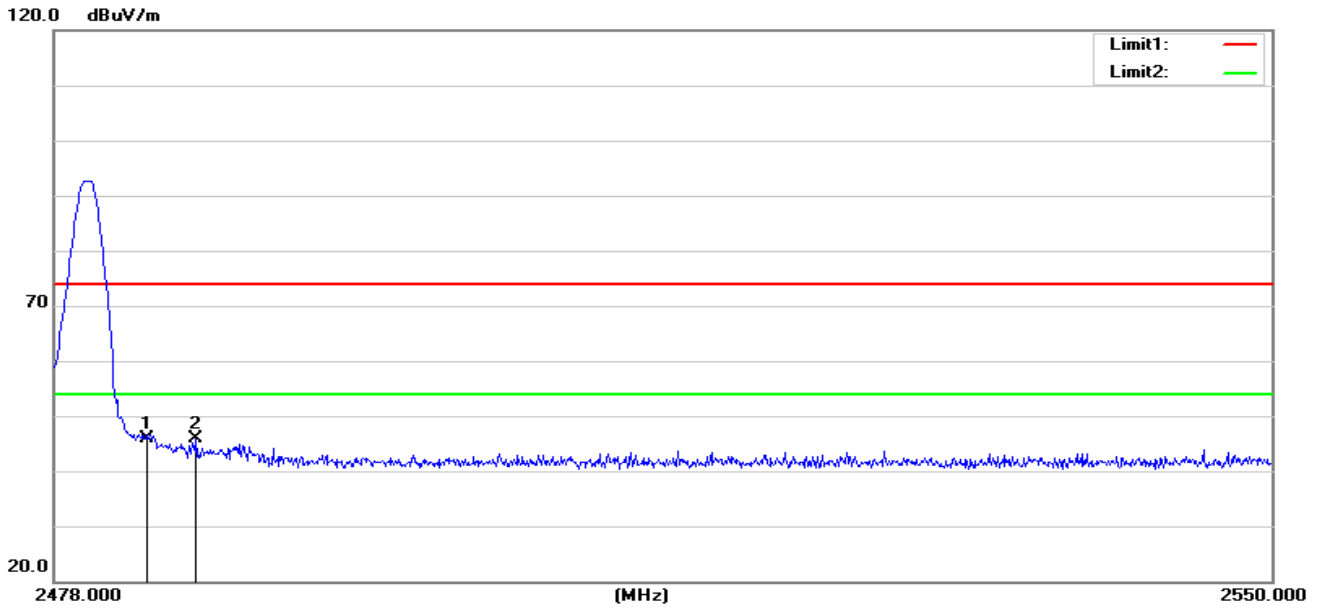

| No. | Frequency (MHz) | Reading (dBuV) | Correct Factor(dB/m) | Result (dBuV/m) | Limit (dBuV/m) | Margin (dB) | Remark |
|-----|-----------------|----------------|----------------------|-----------------|----------------|-------------|--------|
| 1   | 2483.500        | 47.10          | -1.20                | 45.90           | 74.00          | -28.10      | peak   |
| 2   | 2486.352        | 47.19          | -1.19                | 46.00           | 74.00          | -28.00      | peak   |

Vertical

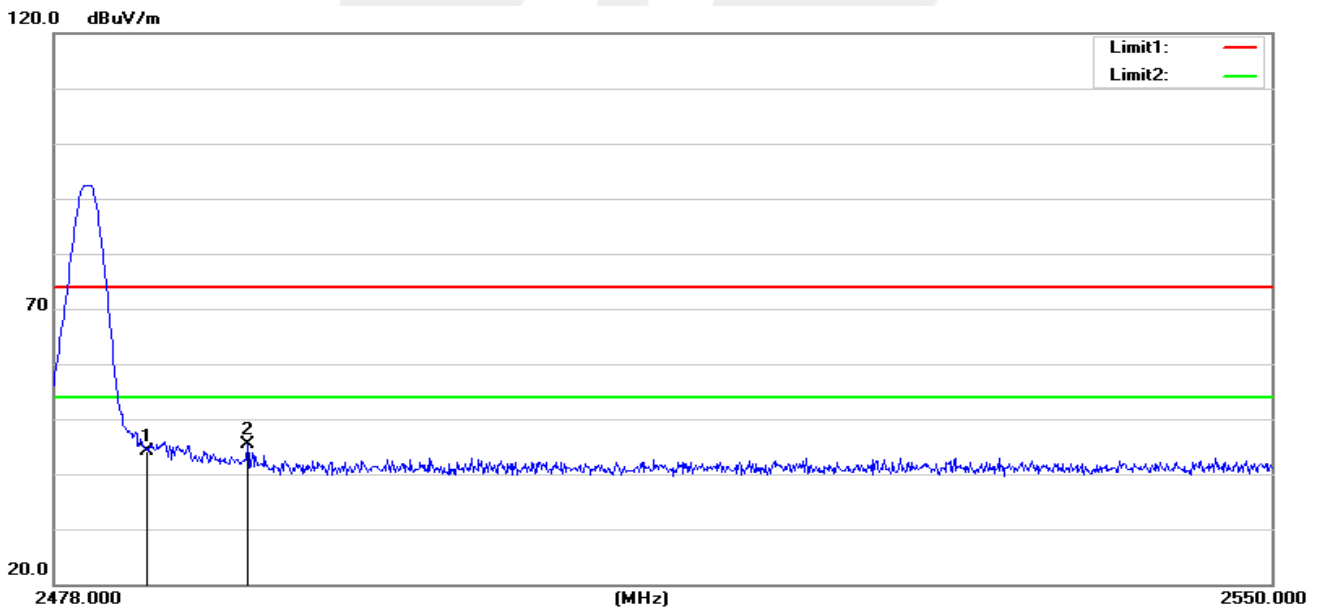

| No. | Frequency (MHz) | Reading (dBuV) | Correct Factor(dB/m) | Result (dBuV/m) | Limit (dBuV/m) | Margin (dB) | Remark |
|-----|-----------------|----------------|----------------------|-----------------|----------------|-------------|--------|
| 1   | 2483.500        | 45.26          | -1.20                | 44.06           | 74.00          | -29.94      | peak   |
| 2   | 2489.376        | 46.66          | -1.18                | 45.48           | 74.00          | -28.52      | peak   |

Note: GFSK,  $\pi/4$ -DQPSK, 8DPSK of the nohopping and hopping mode all have been test, the worst case is GFSK of the nohopping mode, this report only show the worst case.

#### 4. CONDUCTED SPURIOUS & BAND EDGE EMISSION

##### 4.1 REQUIREMENT

According to FCC section 15.247(d), in any 100kHz bandwidth outside the frequency band in which the spread spectrum or digitally modulated intentional radiator is operating, the radio frequency power that is produced by the intentional radiator shall be at least 20dB below that in the 100kHz bandwidth within the band that contains the highest level of the desired power, based on either an RF conducted or a radiated measurement.

##### 4.2 TEST PROCEDURE

| Spectrum Parameter                    | Setting                         |
|---------------------------------------|---------------------------------|
| Detector                              | Peak                            |
| Start/Stop Frequency                  | 30 MHz to 10th carrier harmonic |
| RB / VB (emission in restricted band) | 100 KHz/300 KHz                 |
| Trace-Mode:                           | Max hold                        |

For Band edge

| Spectrum Parameter                    | Setting   |
|---------------------------------------|---|
| Detector                              | Peak  |
| Start/Stop Frequency                  | Lower Band Edge: 2300– 2403 MHz<br>Upper Band Edge: 2479 – 2500 MHz |
| RB / VB (emission in restricted band) | 100 KHz/300 KHz   |
| Trace-Mode:                           | Max hold  |

Remark : Hopping on and Hopping off mode all have been tested,only worst case hopping off is reported.

##### 4.3 TEST SETUP

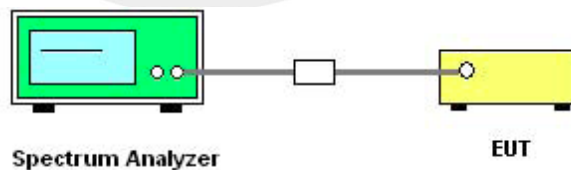

The EUT is coupled to the Spectrum Analyzer; the RF load attached to the EUT antenna terminal is 50Ohm; the path loss as the factor is calibrated to correct the reading. Make the measurement with the spectrum analyzer's resolution bandwidth(RBW) = 100 kHz. In order to make an accurate measurement, set the span greater than RBW.

##### 4.4 EUT OPERATION CONDITIONS

The EUT tested system was configured as the statements of 2.3 Unless otherwise a special operating condition is specified in the follows during the testing.



4.5 TEST RESULTS

|              |                         |                    |         |
|--------------|-------------------------|--------------------|---------|
| Temperature: | 25°C                    | Relative Humidity: | 50%     |
| Test Mode:   | GFSK(1Mbps)-00/39/78 CH | Test Voltage:      | DC 3.7V |

00 CH

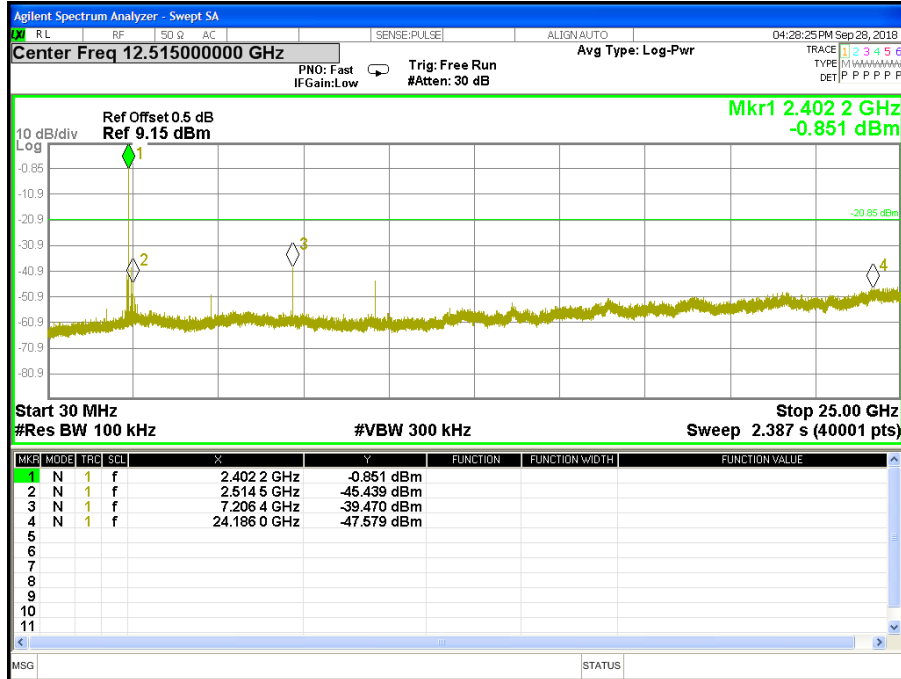

39 CH

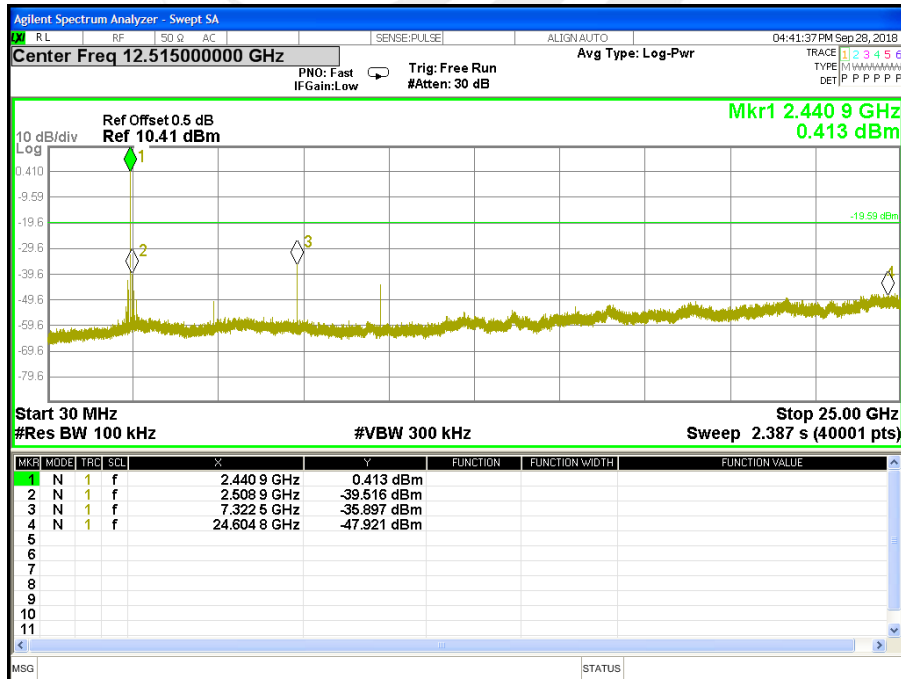



78 CH

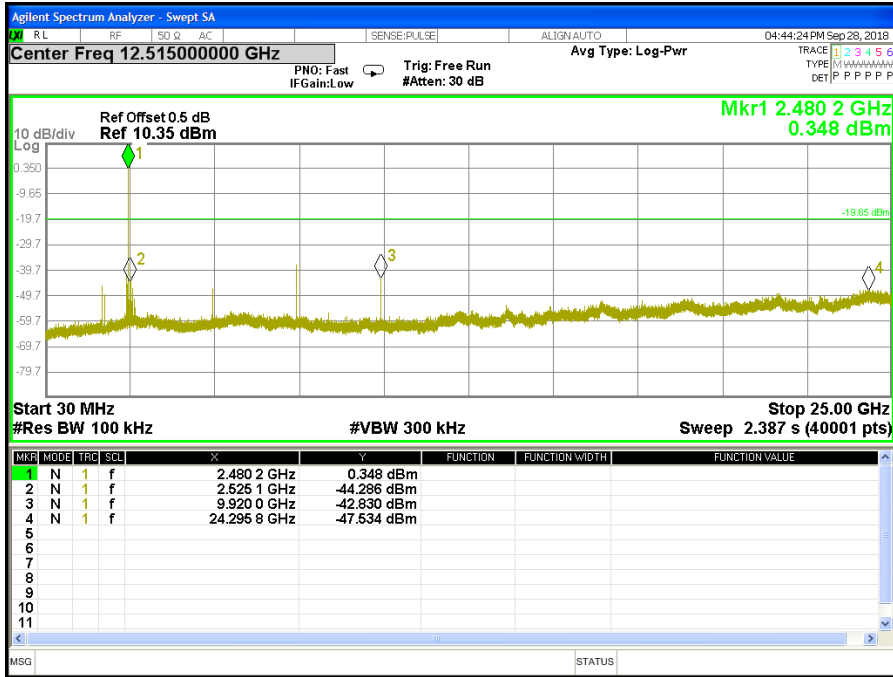



For Band edge

00 CH

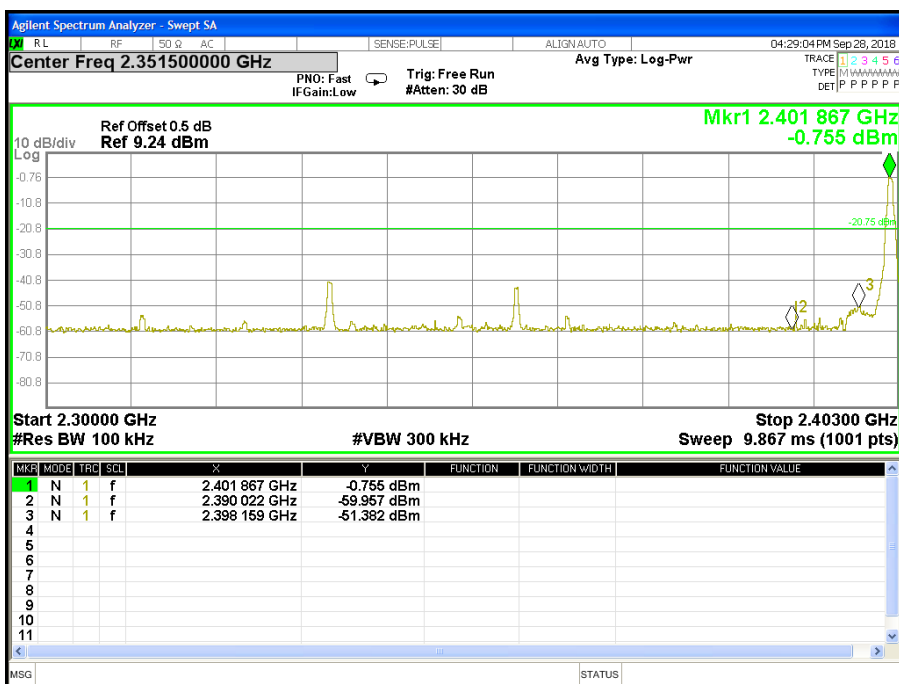

78 CH

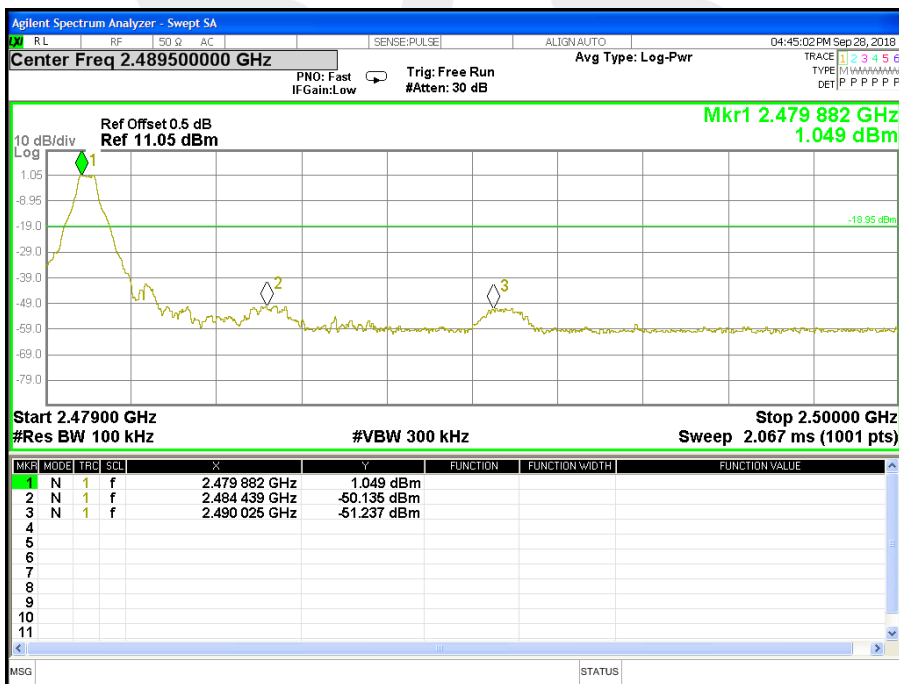





For Hopping Band edge

00 CH

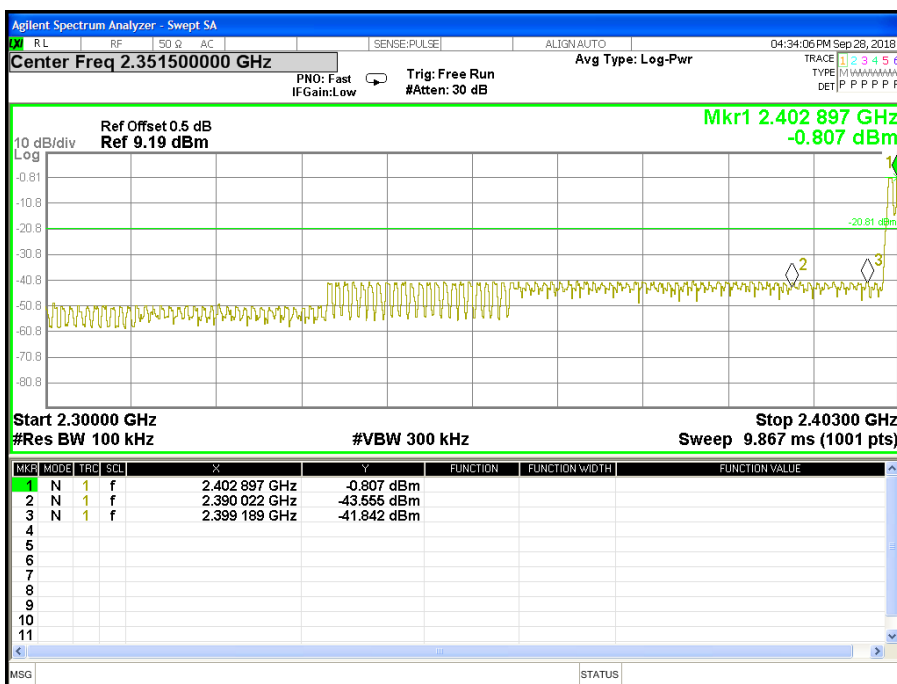

78 CH

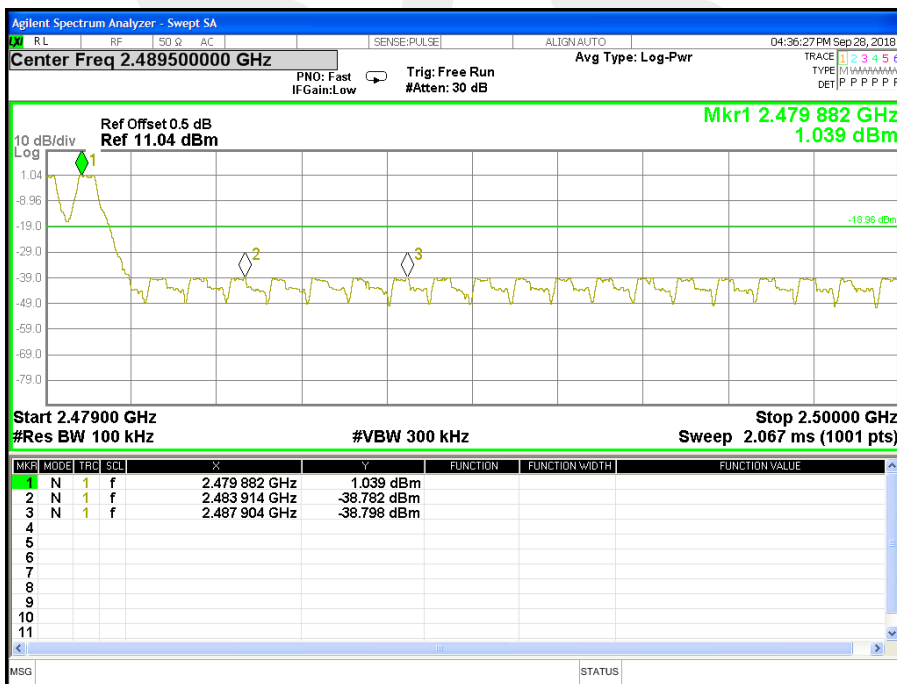



|              |                                       |                    |         |
|--------------|---------------------------------------|--------------------|---------|
| Temperature: | 25°C                                  | Relative Humidity: | 50%     |
| Test Mode:   | $\pi/4$ -DQPSK(2Mbps)-<br>00/39/78 CH | Test Voltage:      | DC 3.7V |

00 CH

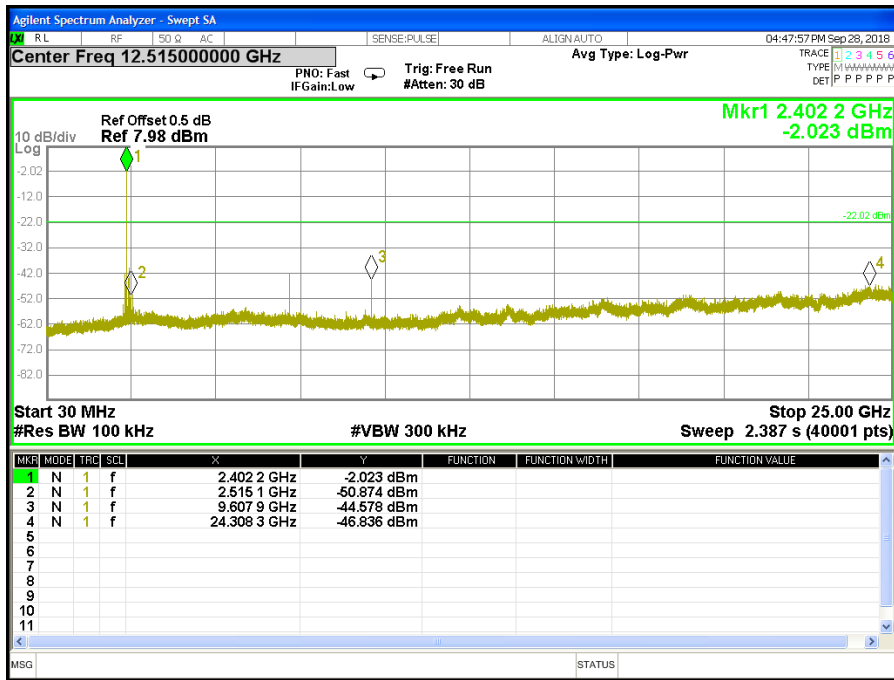

39 CH

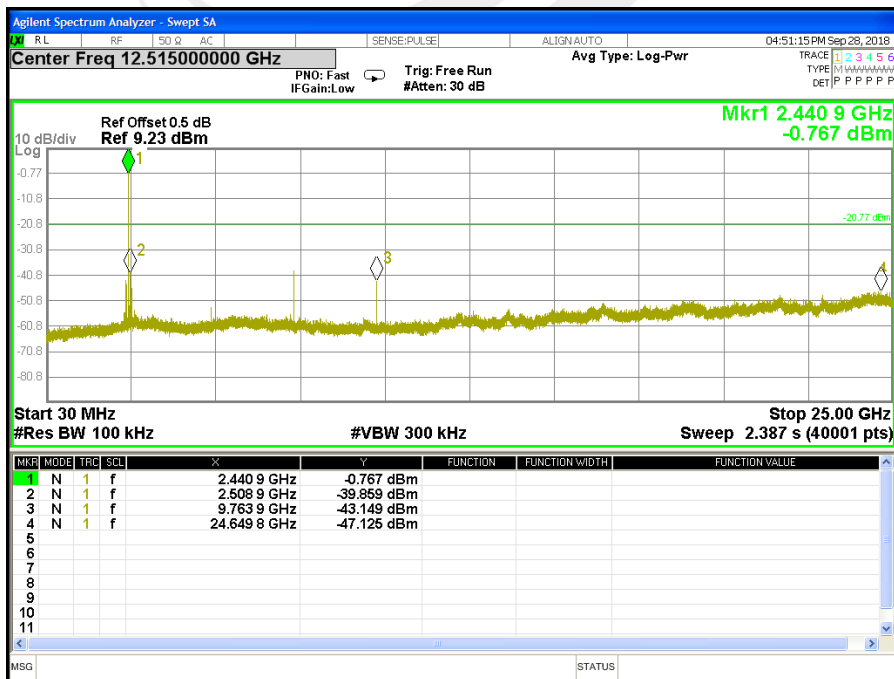



78 CH

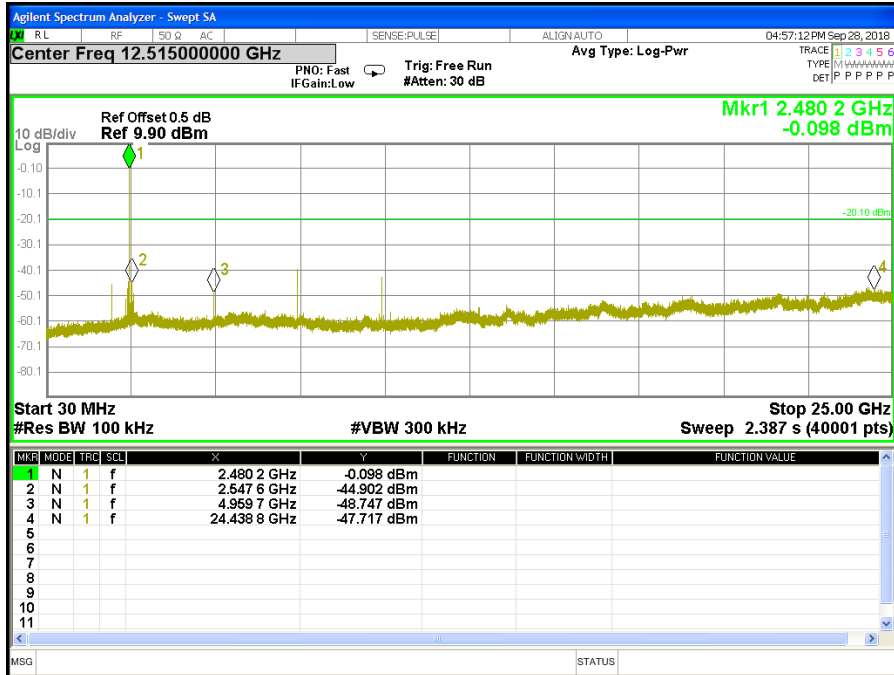



For Band edge

00 CH

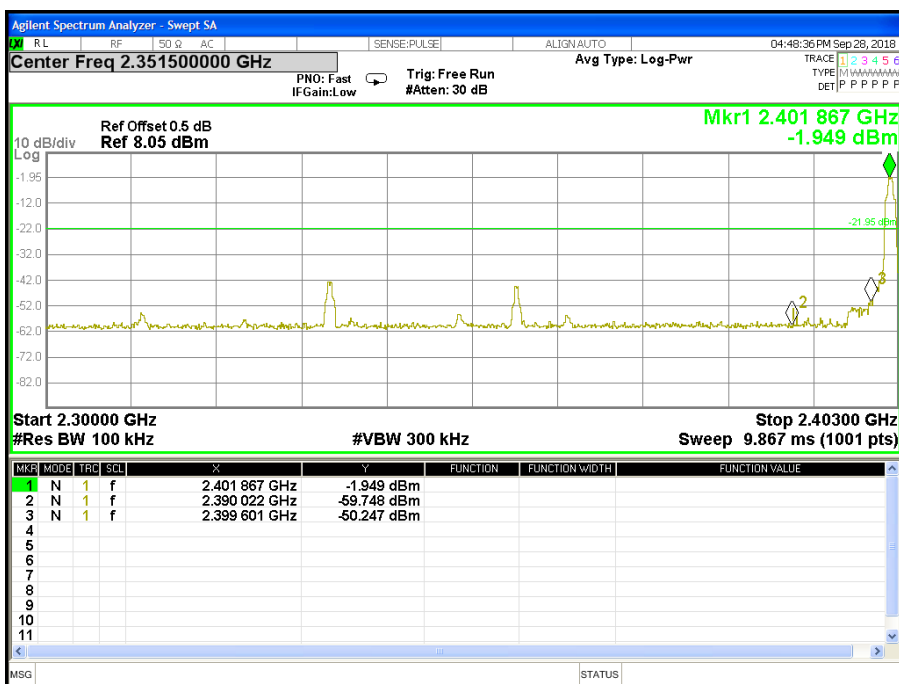

78 CH

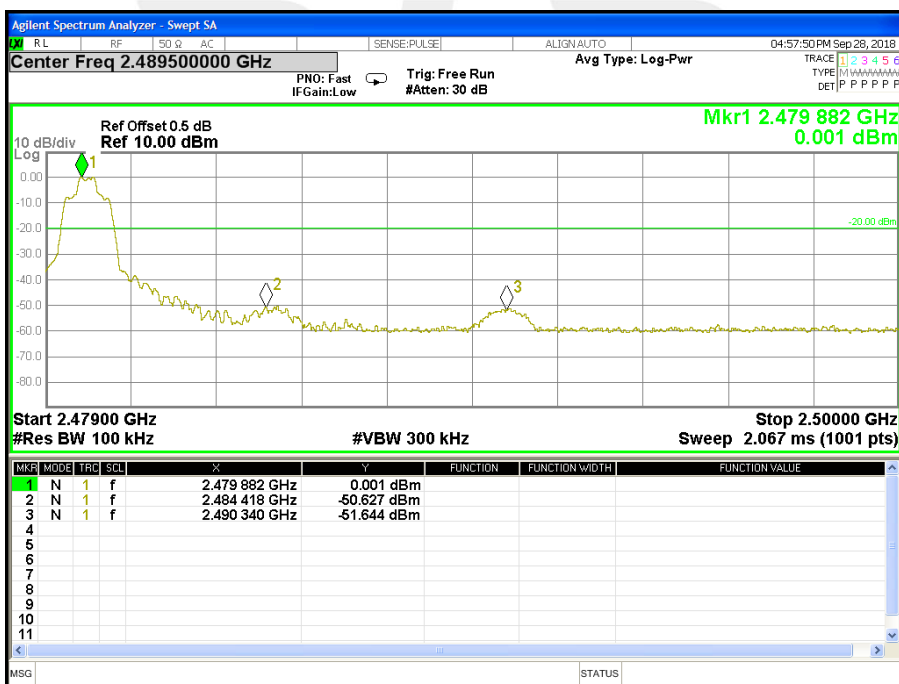



For Hopping Band edge

00 CH

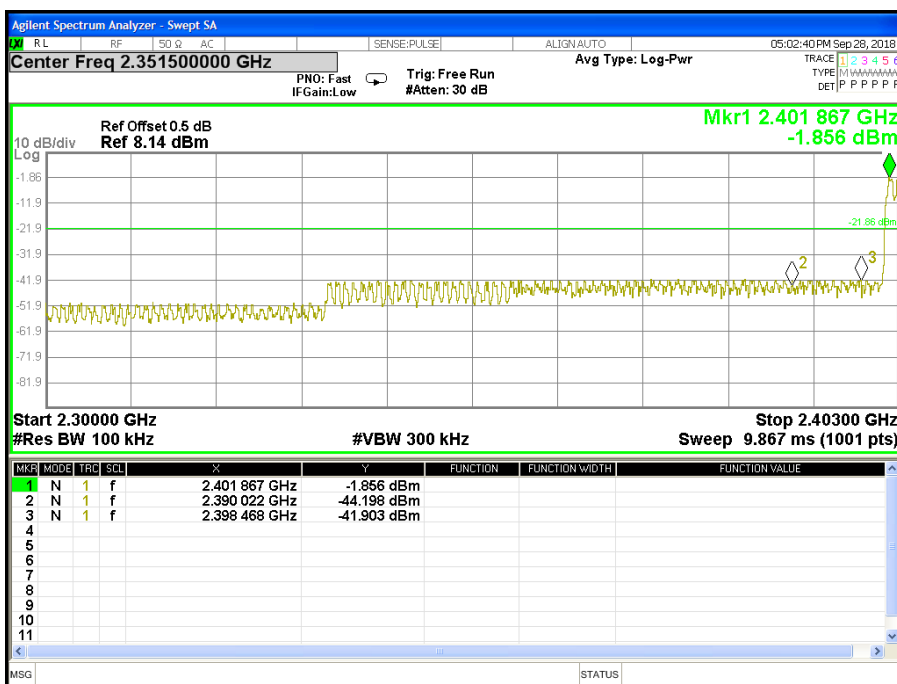

78 CH

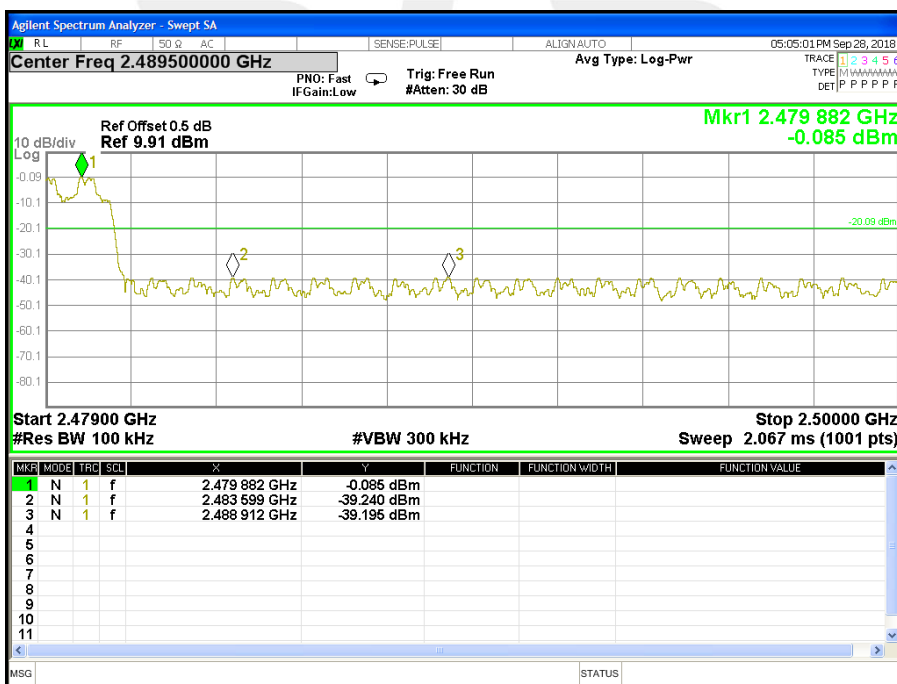



|              |                           |                    |         |
|--------------|---------------------------|--------------------|---------|
| Temperature: | 25°C                      | Relative Humidity: | 50%     |
| Test Mode:   | 8DPSK(3Mbps) -00/39/78 CH | Test Voltage:      | DC 3.7V |

00 CH

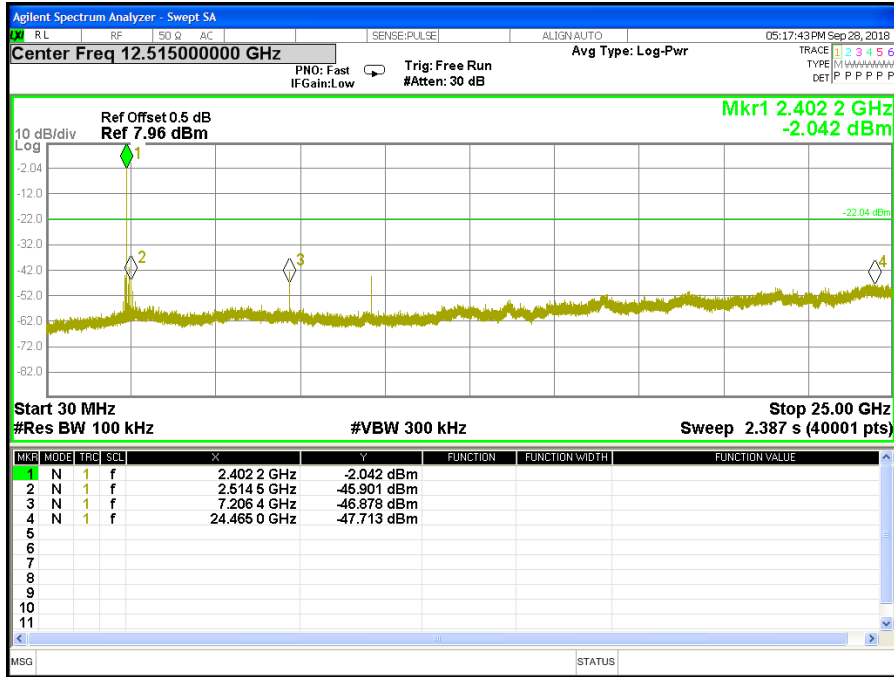

39 CH

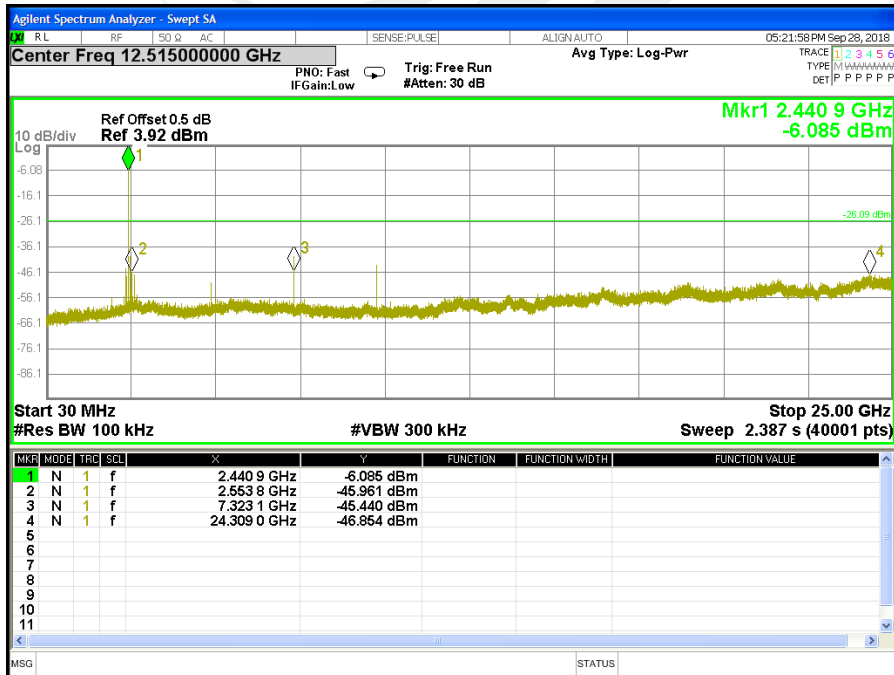



78 CH

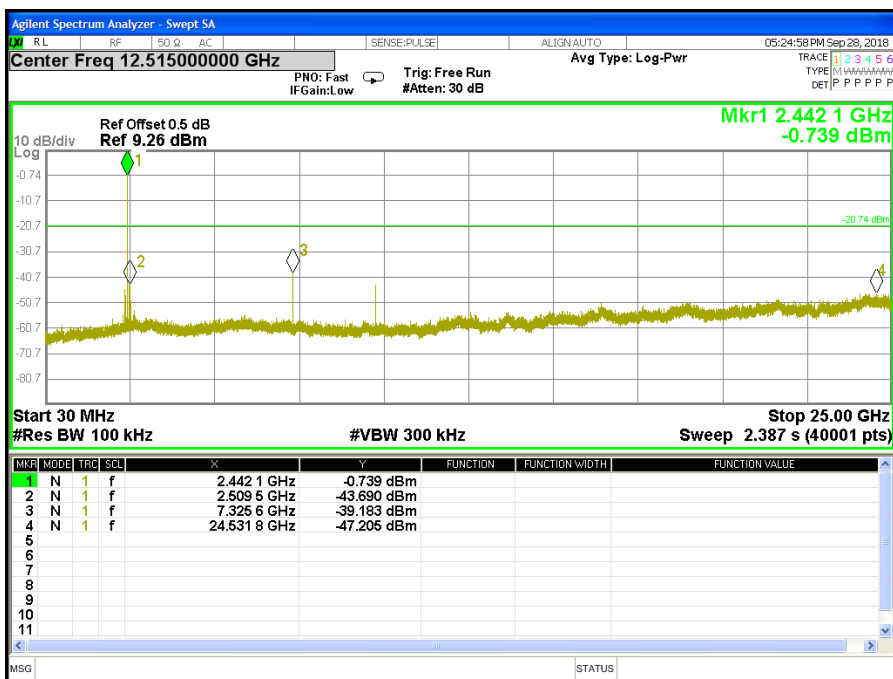



For Band edge

00 CH

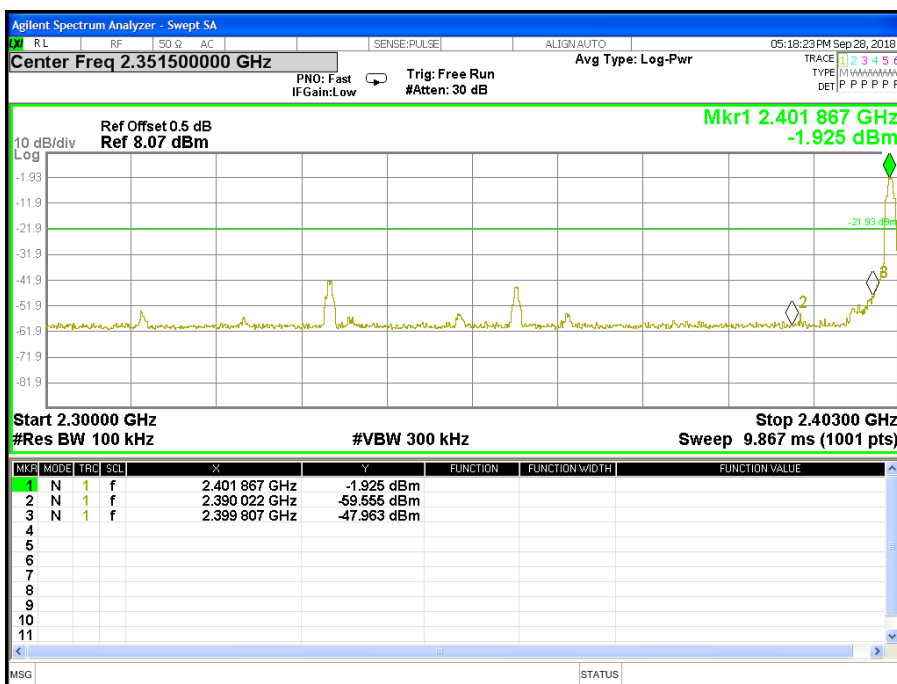

78 CH

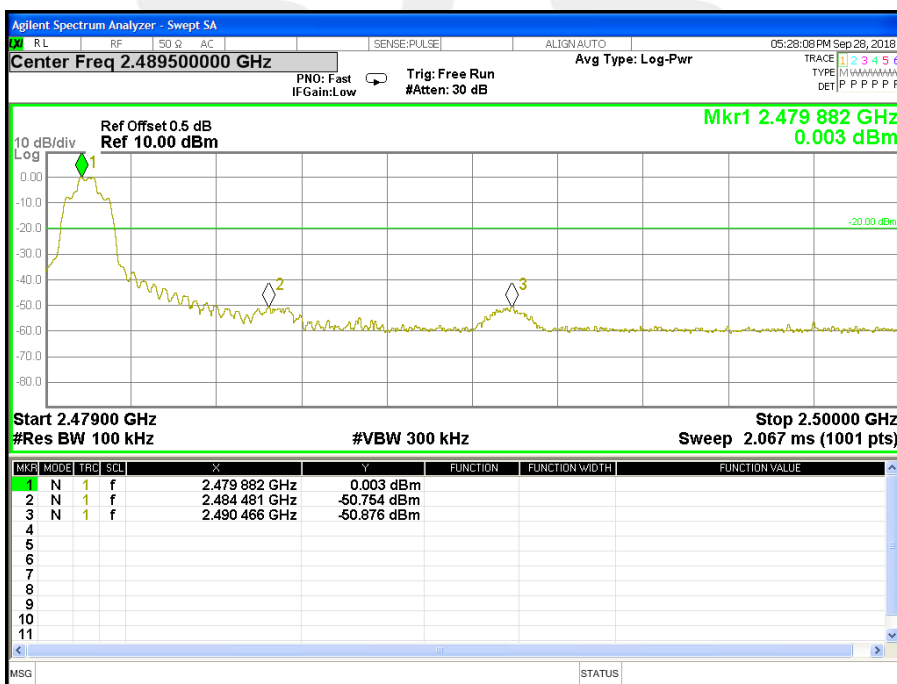





For Hopping Band edge

00 CH

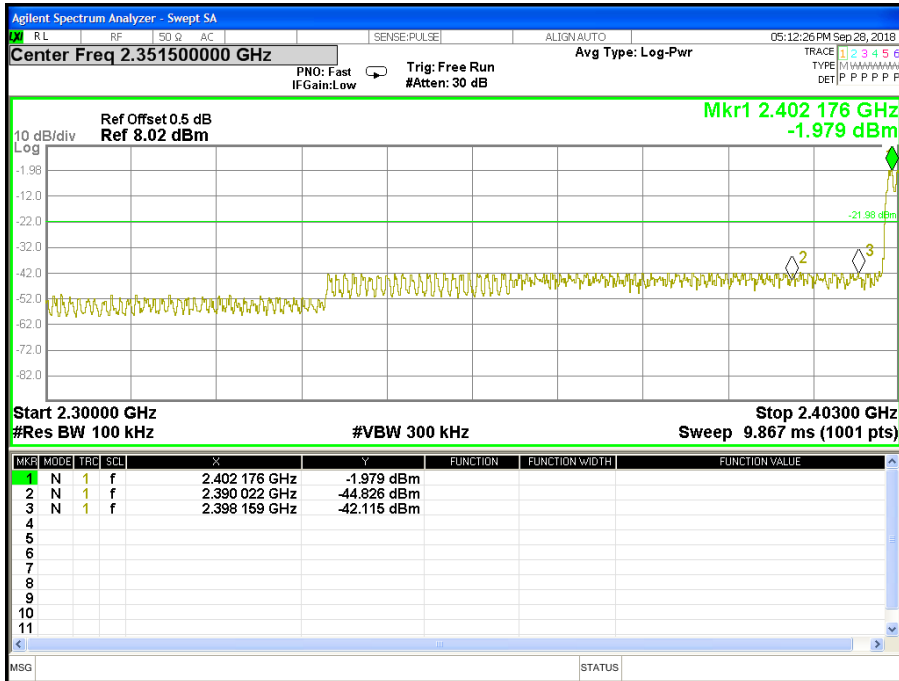

78 CH

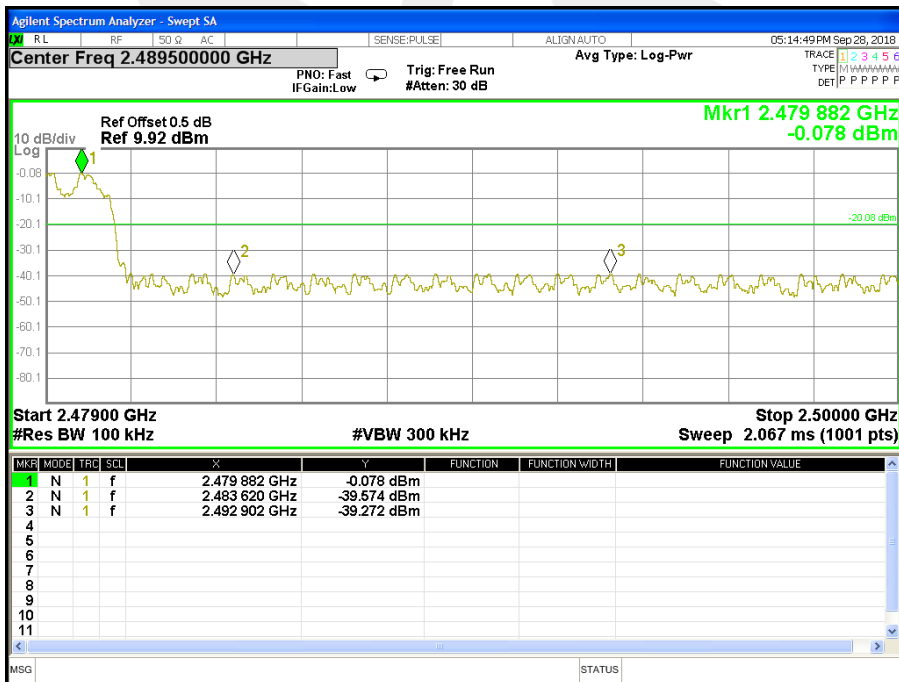



## 5. NUMBER OF HOPPING CHANNEL

### 5.1 APPLIED PROCEDURES / LIMIT

| FCC Part 15.247, Subpart C |                           |       |                      |        |
|----------------------------|---------------------------|-------|----------------------|--------|
| Section                    | Test Item                 | Limit | FrequencyRange (MHz) | Result |
| 15.247 (a)(1)(iii)         | Number of Hopping Channel | ≥15   | 2400-2483.5          | PASS   |

| Spectrum Parameters | Setting                    |
|---------------------|----------------------------|
| Attenuation         | Auto                       |
| Span Frequency      | > Operating FrequencyRange |
| RB                  | 1MHz                       |
| VB                  | 1MHz                       |
| Detector            | Peak                       |
| Trace               | Max Hold                   |
| Sweep Time          | Auto                       |

### 5.2 TEST PROCEDURE

- The EUT was directly connected to the spectrum analyzer and antenna output port as show in the block diagram below,
- Spectrum Setting : RBW= 1MHz, VBW=1MHz, Sweep time = Auto.

### 5.3 TEST SETUP



### 5.4 EUT OPERATION CONDITIONS

The EUT tested system was configured as the statements of 2.4 Unless otherwise a special operating condition is specified in the follows during the testing.



5.5 TEST RESULTS

|              |                        |                    |         |
|--------------|------------------------|--------------------|---------|
| Temperature: | 25°C                   | Relative Humidity: | 60%     |
| Test Mode:   | Hopping Mode-GFSK Mode | Test Voltage:      | DC 3.7V |

Number of Hopping Channel

79

Hopping channel

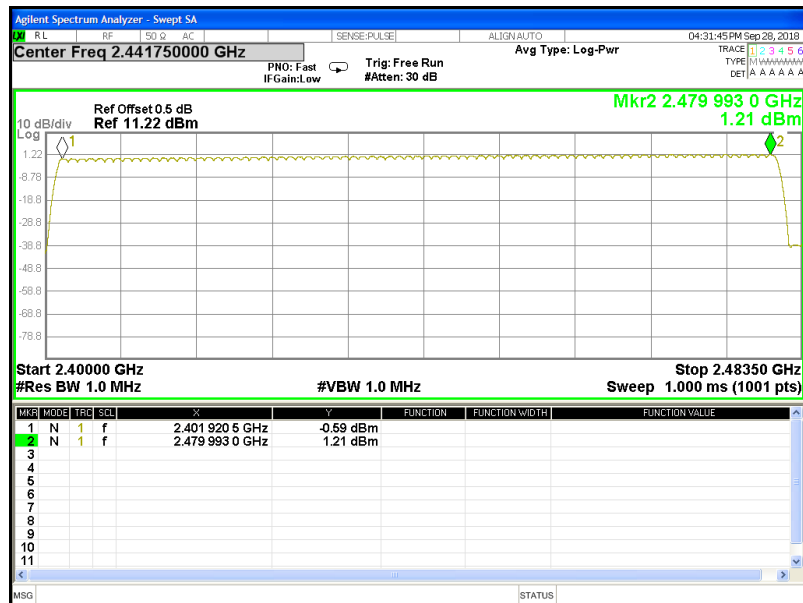

## 6. AVERAGE TIME OF OCCUPANCY

### 6.1 APPLIED PROCEDURES / LIMIT

| FCC Part 15.247, Subpart C |                           |        |                      |        |
|----------------------------|---------------------------|--------|----------------------|--------|
| Section                    | Test Item                 | Limit  | FrequencyRange (MHz) | Result |
| 15.247 (a)(1)(iii)         | Average Time of Occupancy | 0.4sec | 2400-2483.5          | PASS   |

### 6.2 TEST PROCEDURE

- a. The transmitter output (antenna port) was connected to the spectrum analyzer
- b. Set RBW =1MHz/VBW =3MHz.
- c. Use a video trigger with the trigger level set to enable triggering only on full pulses.
- d. Sweep Time is more than once pulse time.  
Set the center frequency on any frequency would be measure and set the frequency span to
- e. zero span.
- f. Measure the maximum time duration of one single pulse.
- g. Set the EUT for DH5, DH3 and DH1 packet transmitting.
- h. Measure the maximum time duration of one single pulse.
- i. DH5 Packet permit maximum  $1600 / 79 / 6 = 3.37$  hops per second in each channel (5 time slots RX, 1 time slot TX). So the dwell time is the time duration of the pulse times  $3.37 \times 31.6 = 106.6$  within 31.6 seconds.
- j. DH3 Packet permit maximum  $1600 / 79 / 4 = 5.06$  hops per second in each channel (3 time slots RX, 1 time slot TX). So the dwell time is the time duration of the pulse times  $5.06 \times 31.6 = 160$  within 31.6 seconds.
- k. DH1 Packet permit maximum  $1600 / 79 / 2 = 10.12$  hops per second in each channel (1 time slot RX, 1 time slot TX). So the dwell time is the time duration of the pulse times  $10.12 \times 31.6 = 320$  within 31.6 seconds.

### 6.3 TEST SETUP

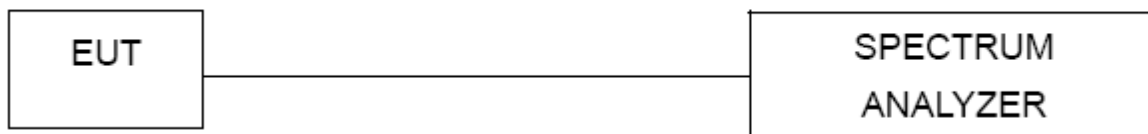

### 6.4 EUT OPERATION CONDITIONS

The EUT tested system was configured as the statements of 2.4 Unless otherwise a special operating condition is specified in the follows during the testing.



## 6.5 TEST RESULTS

|              |                         |                    |         |
|--------------|-------------------------|--------------------|---------|
| Temperature: | 25°C                    | Relative Humidity: | 50%     |
| Test Mode:   | GFSK(1Mbps)-DH1/DH3/DH5 | Test Voltage:      | DC 3.7V |

| Data Packet | Frequency | Pulse Duration(ms) | Dwell Time(s) | Limits(s) |
|-------------|-----------|--------------------|---------------|-----------|
| DH1         | 2441 MHz  | 0.370              | 0.118         | 0.4       |
| DH3         | 2441 MHz  | 1.640              | 0.262         | 0.4       |
| DH5         | 2441 MHz  | 2.880              | 0.307         | 0.4       |





### CH39-DH1

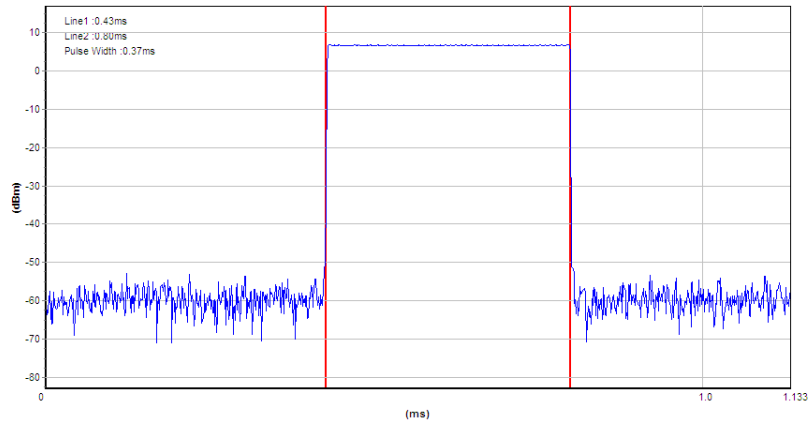

### CH39-DH3

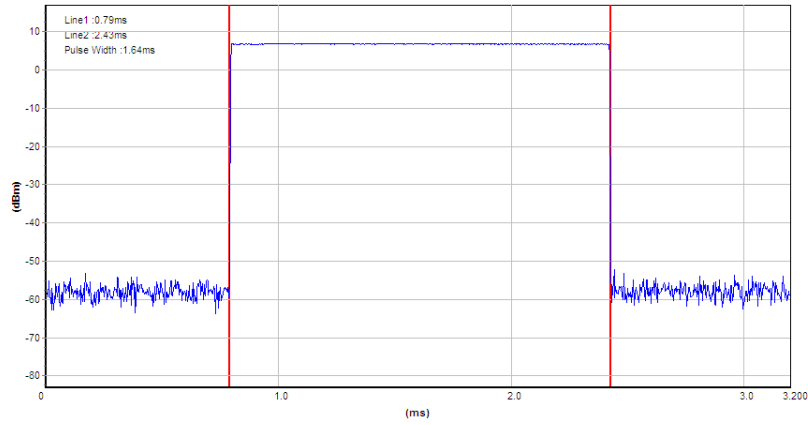

### CH39-DH5

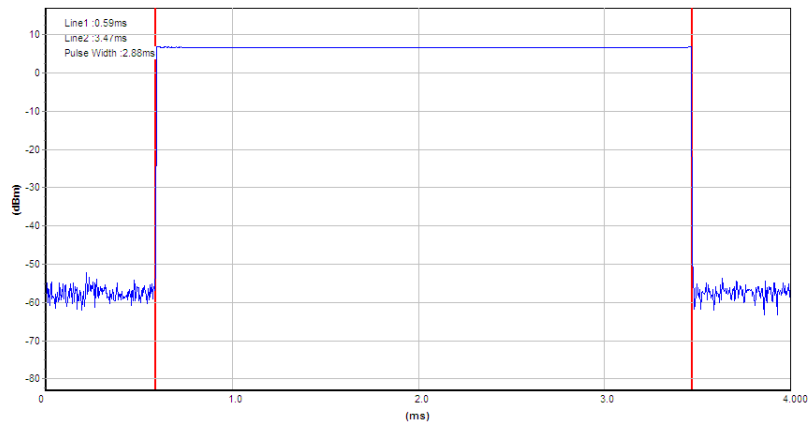



|              |  |                    |         |
|--------------|--|--------------------|---------|
| Temperature: | 25°C                                     | Relative Humidity: | 50%     |
| Test Mode:   | $\pi/4$ -DQPSK(2Mbps)-<br>2DH1/2DH3/2DH5 | Test Voltage:      | DC 3.7V |

| Data Packet | Frequency | Pulse Duration(ms) | Dwell Time(s) | Limits(s) |
|-------------|-----------|--------------------|---------------|-----------|
| 2DH1        | 2441 MHz  | 0.380              | 0.122         | 0.4       |
| 2DH3        | 2441 MHz  | 1.640              | 0.262         | 0.4       |
| 2DH5        | 2441 MHz  | 2.880              | 0.307         | 0.4       |





### CH39-2DH1

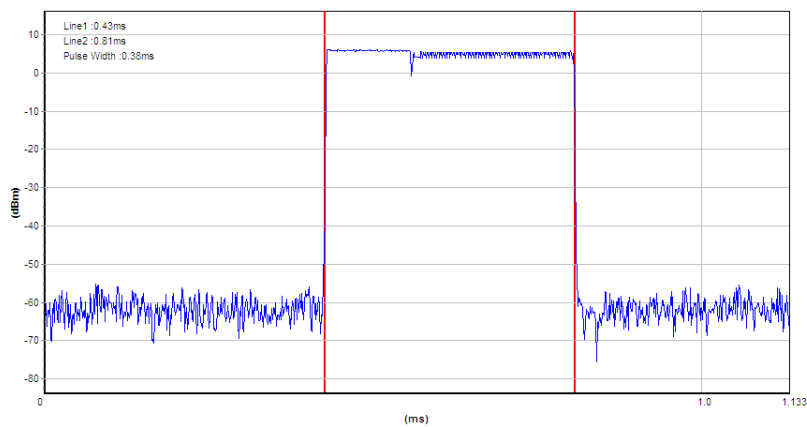

### CH39-2DH3

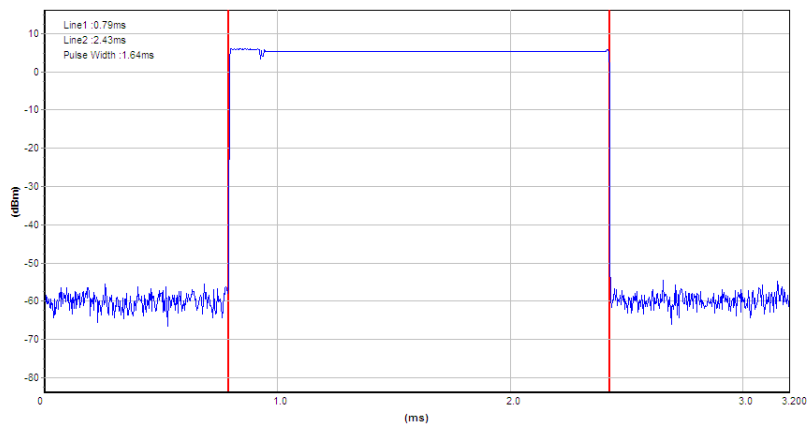

### CH39-2DH5

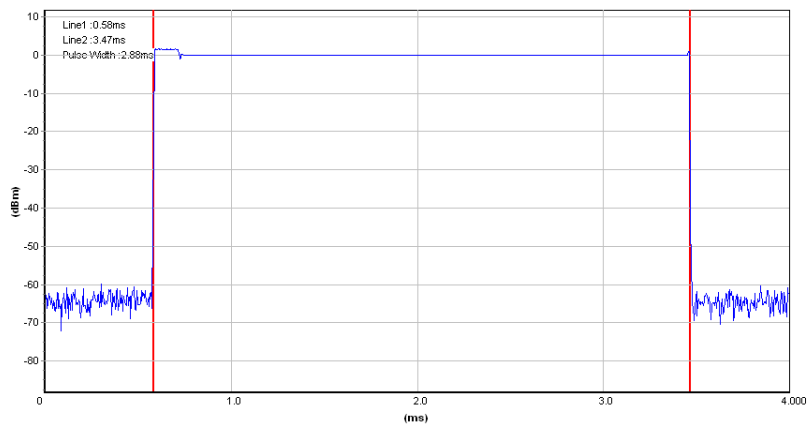





|              |                                 |                    |         |
|--------------|---------------------------------|--------------------|---------|
| Temperature: | 25°C                            | Relative Humidity: | 50%     |
| Test Mode:   | 8DPSK(3Mbps)-<br>3DH1/3DH3/3DH5 | Test Voltage:      | DC 3.7V |

| Data Packet | Frequency | Pulse Duration(ms) | Dwell Time(s) | Limits(s) |
|-------------|-----------|--------------------|---------------|-----------|
| 3DH1        | 2441 MHz  | 0.380              | 0.122         | 0.4       |
| 3DH3        | 2441 MHz  | 1.640              | 0.262         | 0.4       |
| 3DH5        | 2441 MHz  | 2.890              | 0.308         | 0.4       |





### CH39-3DH1

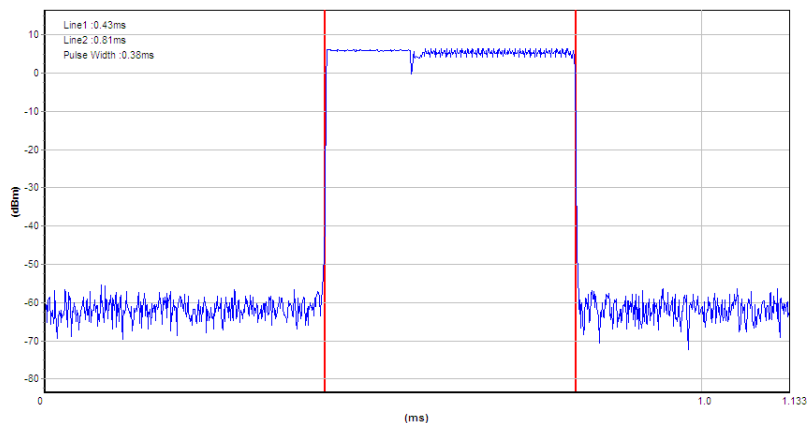

### CH39-3DH3

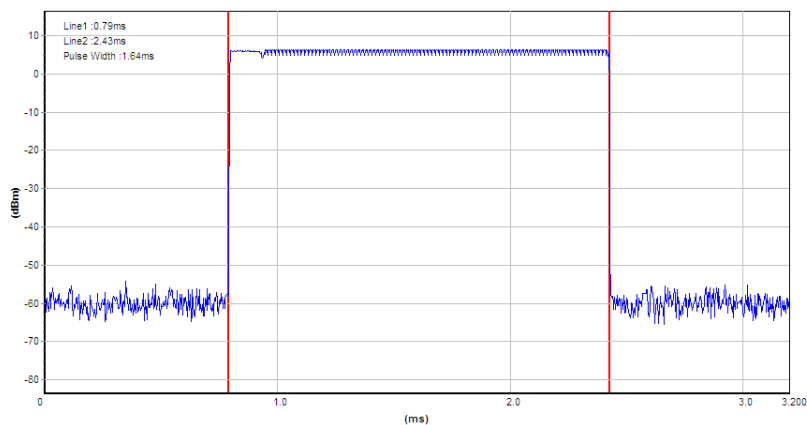

### CH39-3DH5

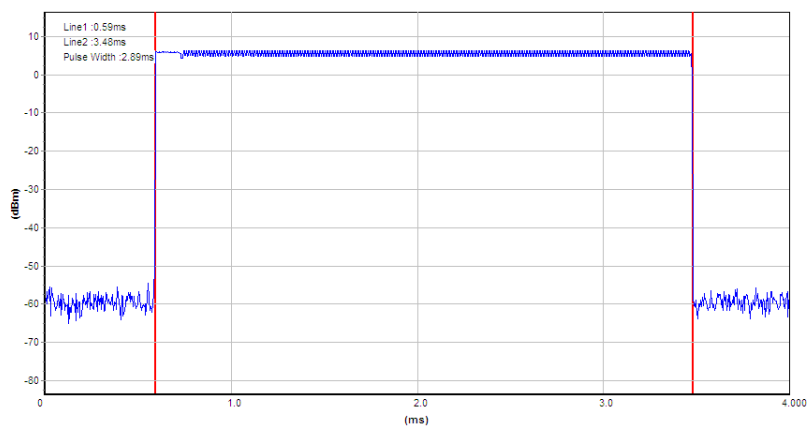

## 7. HOPPING CHANNEL SEPARATION MEASUREMENT

### 7.1 APPLIED PROCEDURES / LIMIT

Frequency hopping systems shall have hopping channel carrier frequencies separated by a minimum of 25 kHz or the 20 dB bandwidth of the hopping channel, whichever is greater. Alternatively, frequency hopping systems operating in the 2400-2483.5 MHz band may have hopping channel carrier frequencies that are separated by 25 kHz or two-thirds of the 20 dB bandwidth of the hopping channel, whichever is greater, provided the systems operate with an output power no greater than 125 mW.

| Spectrum Parameter | Setting   |
|--------------------|---|
| Attenuation        | Auto  |
| Span Frequency     | > 20 dB Bandwidth or Channel Separation                 |
| RB                 | 30 kHz (20dB Bandwidth) / 30 kHz (Channel Separation)   |
| VB                 | 100 kHz (20dB Bandwidth) / 100 kHz (Channel Separation) |
| Detector           | Peak  |
| Trace              | Max Hold  |
| Sweep Time         | Auto  |

### 7.2 TEST PROCEDURE

- The transmitter output (antenna port) was connected to the spectrum analyser in peak hold mode.
- The resolution bandwidth of 30 kHz and the video bandwidth of 100 kHz were utilised for 20 dB bandwidth measurement.
- The resolution bandwidth of 30 kHz and the video bandwidth of 100 kHz were utilised for channel separation measurement.

### 7.3 TEST SETUP

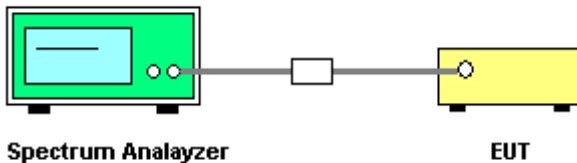

### 7.4 EUT OPERATION CONDITIONS

The EUT was programmed to be in continuously transmitting mode.



7.5 TEST RESULTS

|              |  |                    |         |
|--------------|--|--------------------|---------|
| Temperature: | 25°C                                     | Relative Humidity: | 50%     |
| Test Mode:   | CH00 / CH39 / CH78<br>(GFSK(1Mbps) Mode) | Test Voltage:      | DC 3.7V |

| Frequency | Ch. Separation (MHz) | Limit | Result   |
|-----------|----------------------|-------|----------|
| 2402 MHz  | 0.999                | 0.807 | Complies |
| 2441 MHz  | 0.999                | 0.807 | Complies |
| 2480 MHz  | 1.002                | 0.814 | Complies |

For GFSK: Ch. Separation Limits: > 20dB bandwidth

CH00 -1Mbps

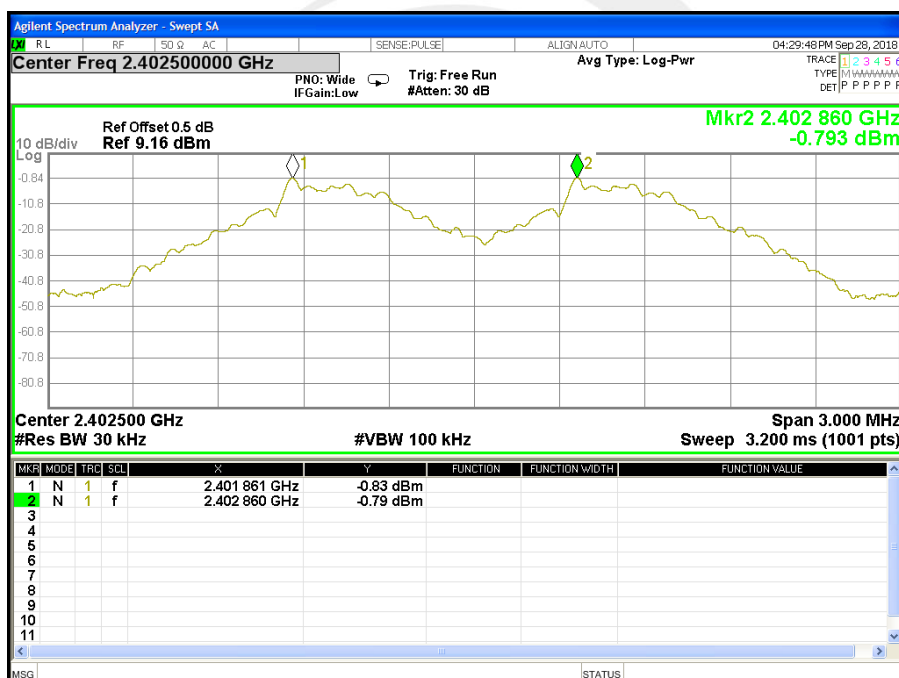



### CH39 -1Mbps

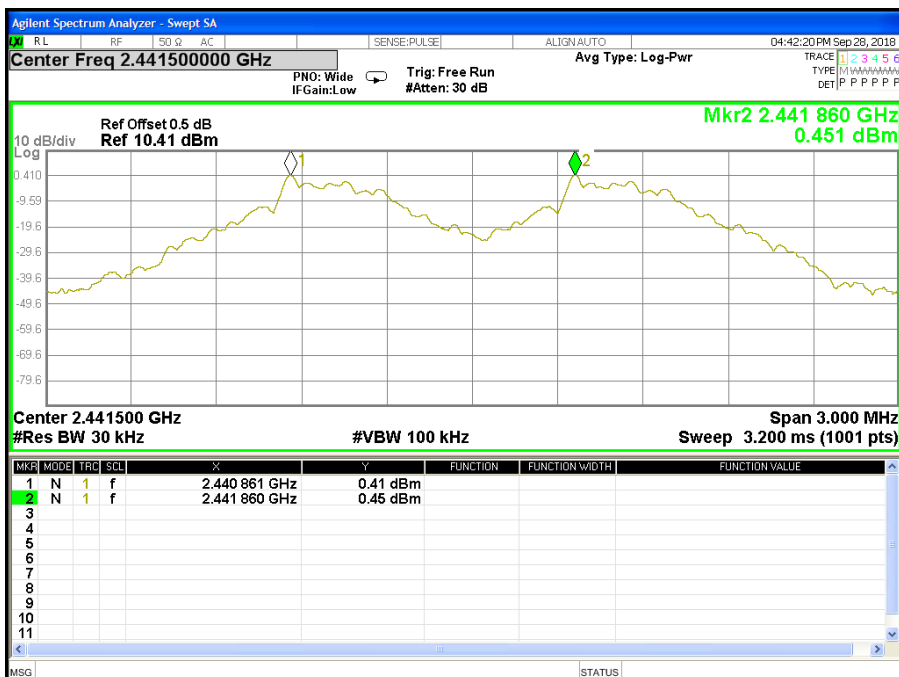

### CH78 -1Mbps

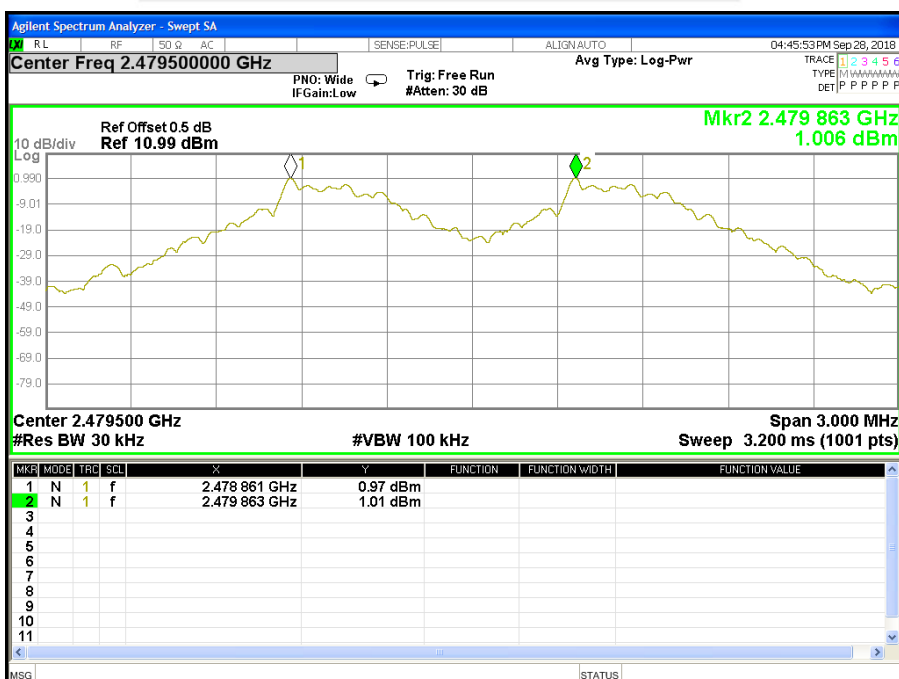



|              |   |                    |         |
|--------------|---|--------------------|---------|
| Temperature: | 25°C  | Relative Humidity: | 50%     |
| Test Mode:   | CH00 / CH39 / CH78<br>( $\pi/4$ -DQPSK(2Mbps) Mode) | Test Voltage:      | DC 3.7V |

| Frequency | Ch. Separation (MHz) | Limit | Result   |
|-----------|----------------------|-------|----------|
| 2402 MHz  | 0.999                | 0.753 | Complies |
| 2441 MHz  | 0.999                | 0.753 | Complies |
| 2480 MHz  | 1.002                | 0.753 | Complies |

For  $\pi/4$ -DQPSK(2Mbps): Ch. Separation Limits: > two-thirds 20dB bandwidth

### CH00 -2Mbps

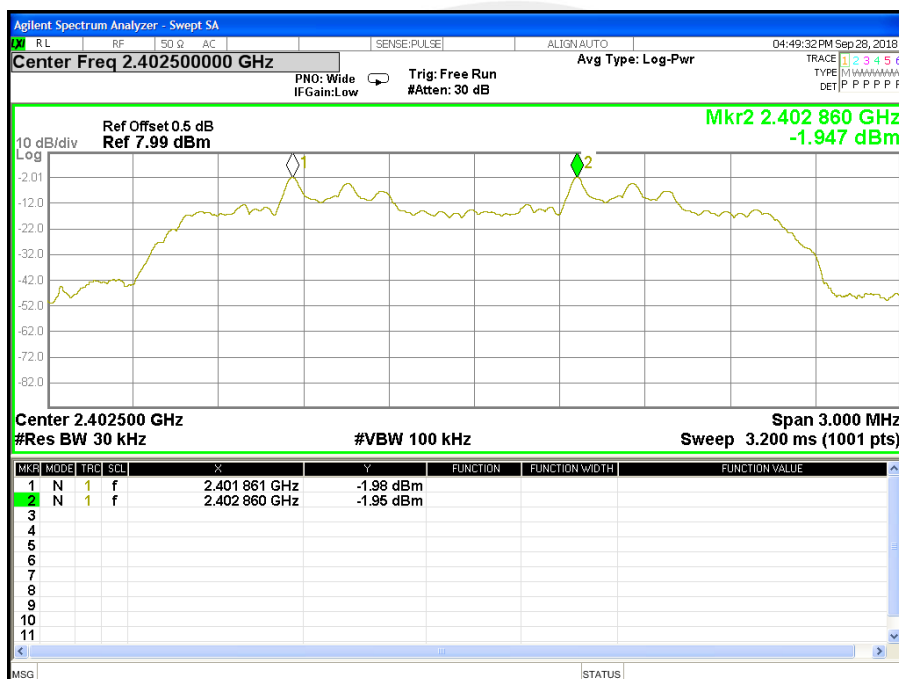



### CH39 -2Mbps

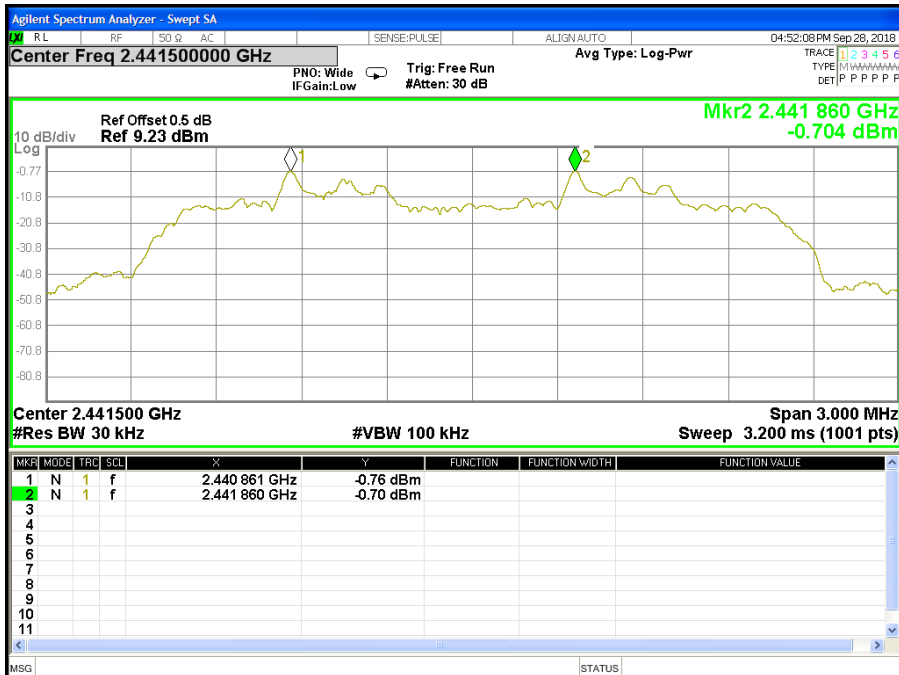

### CH78 -2Mbps

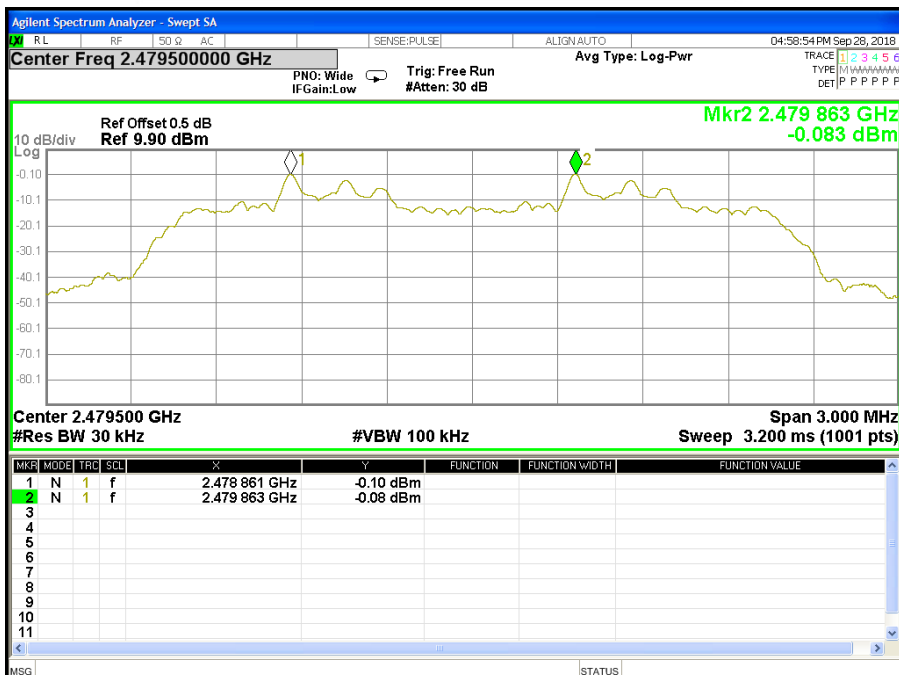



|              |  |                    |         |
|--------------|--|--------------------|---------|
| Temperature: | 25°C                                     | Relative Humidity: | 50%     |
| Test Mode:   | CH00 / CH39 / CH78<br>(8DPSK(3Mbps)Mode) | Test Voltage:      | DC 3.7V |

| Frequency | Ch. Separation (MHz) | Limit | Result   |
|-----------|----------------------|-------|----------|
| 2402 MHz  | 0.999                | 0.755 | Complies |
| 2441 MHz  | 0.999                | 0.755 | Complies |
| 2480 MHz  | 1.002                | 0.824 | Complies |

For 8DPSK(3Mbps):Ch. Separation Limits: > two-thirds 20dB bandwidth

**CH00 -3Mbps**

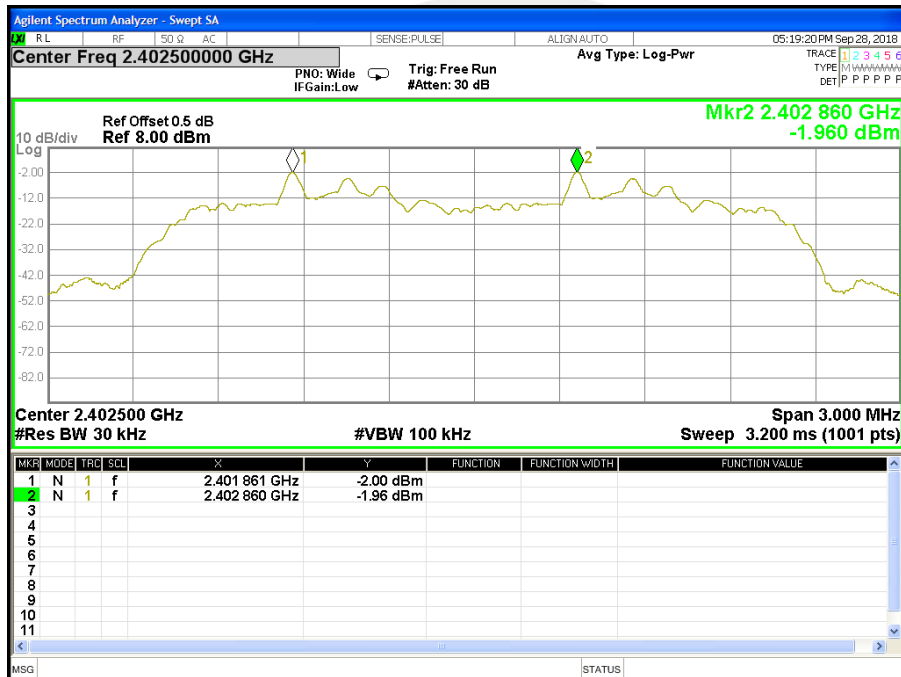





### CH39 -3Mbps

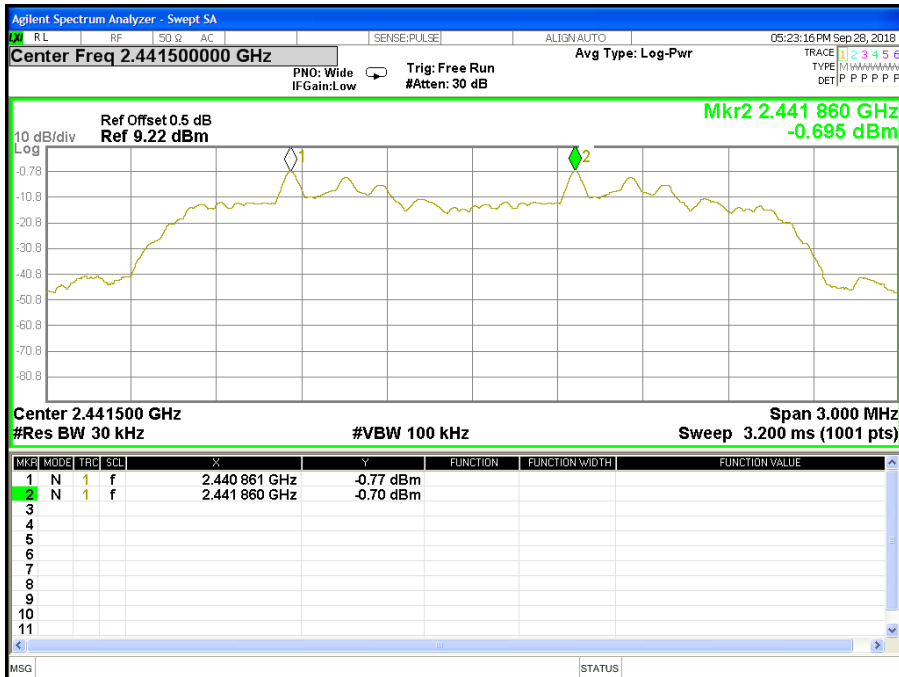

### CH78 -3Mbps

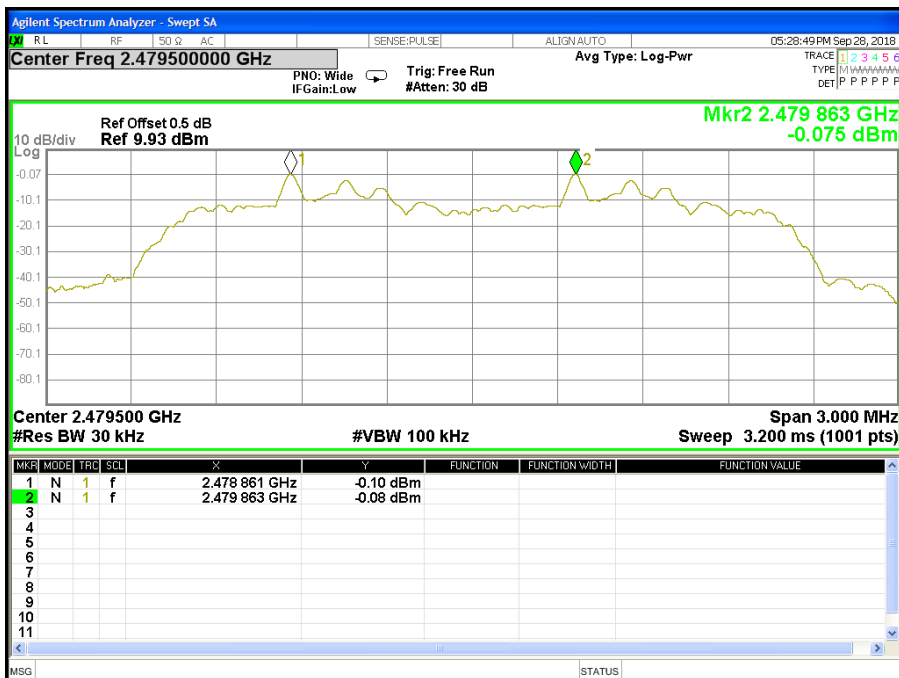



## 8. BANDWIDTH TEST

### 8.1 APPLIED PROCEDURES / LIMIT

| FCC Part15 15.247, Subpart C |           |                  |                      |        |
|------------------------------|-----------|------------------|----------------------|--------|
| Section                      | Test Item | Limit            | FrequencyRange (MHz) | Result |
| 15.247<br>(a)(1)             | Bandwidth | (20dB bandwidth) | 2400-2483.5          | PASS   |

| Spectrum Parameter | Setting   |
|--------------------|---|
| Attenuation        | Auto  |
| Span Frequency     | > Measurement Bandwidth or Channel Separation           |
| RB                 | 30 kHz (20dB Bandwidth) / 30 kHz (Channel Separation)   |
| VB                 | 100 kHz (20dB Bandwidth) / 100 kHz (Channel Separation) |
| Detector           | Peak  |
| Trace              | Max Hold  |
| Sweep Time         | Auto  |

### 8.2 TEST PROCEDURE

- The EUT was directly connected to the spectrum analyzer and antenna output port as show in the block diagram below,
- Spectrum Setting : RBW= 30KHz, VBW=100KHz, Sweep time = Auto.

### 8.3 TEST SETUP



### 8.4 EUT OPERATION CONDITIONS

The EUT tested system was configured as the statements of 2.4 Unless otherwise a special operating condition is specified in the follows during the testing.



8.5 TEST RESULTS

|              |                                  |                    |         |
|--------------|----------------------------------|--------------------|---------|
| Temperature: | 25°C                             | Relative Humidity: | 50%     |
| Test Mode:   | GFSK(1Mbps)<br>CH00 / CH39 / C78 | Test Voltage:      | DC 3.7V |

| Frequency | 20dB Bandwidth (MHz) | Result |
|-----------|----------------------|--------|
| 2402 MHz  | 0.807                | PASS   |
| 2441 MHz  | 0.807                | PASS   |
| 2480 MHz  | 0.814                | PASS   |

CH00 -1Mbps

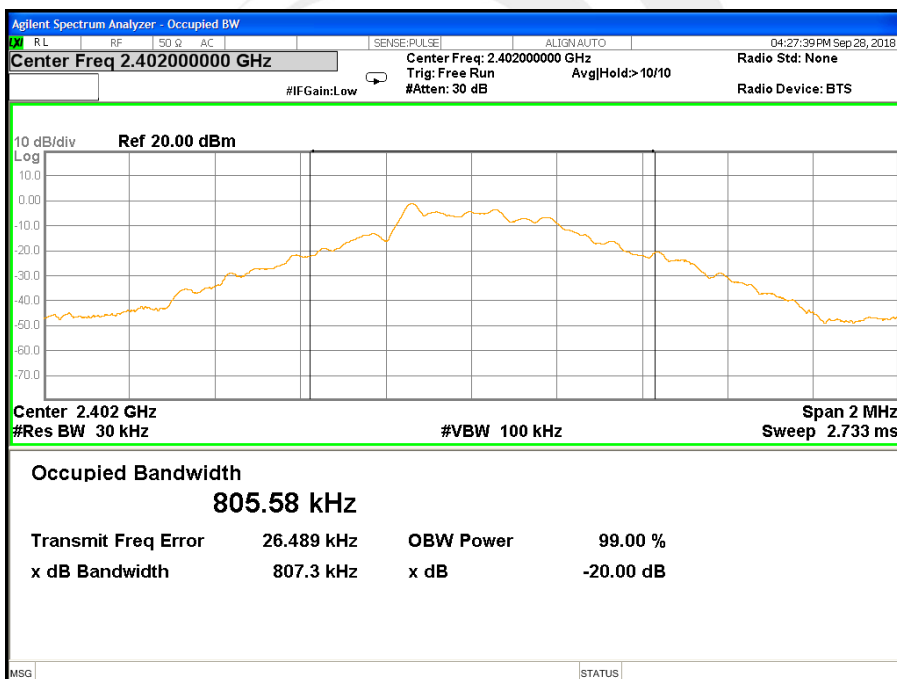



### CH39 -1Mbps

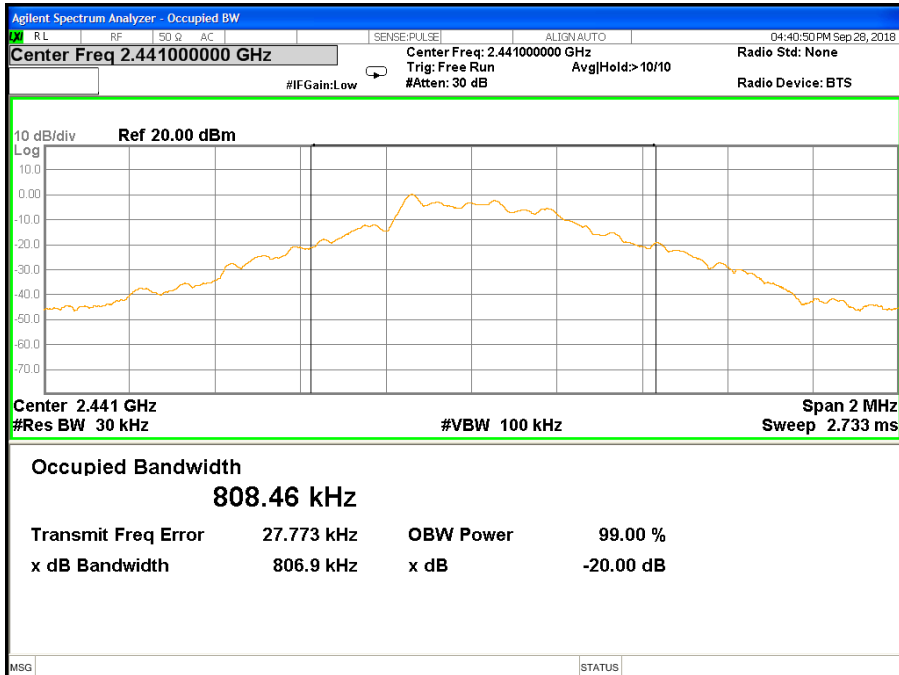

### CH78 -1Mbps

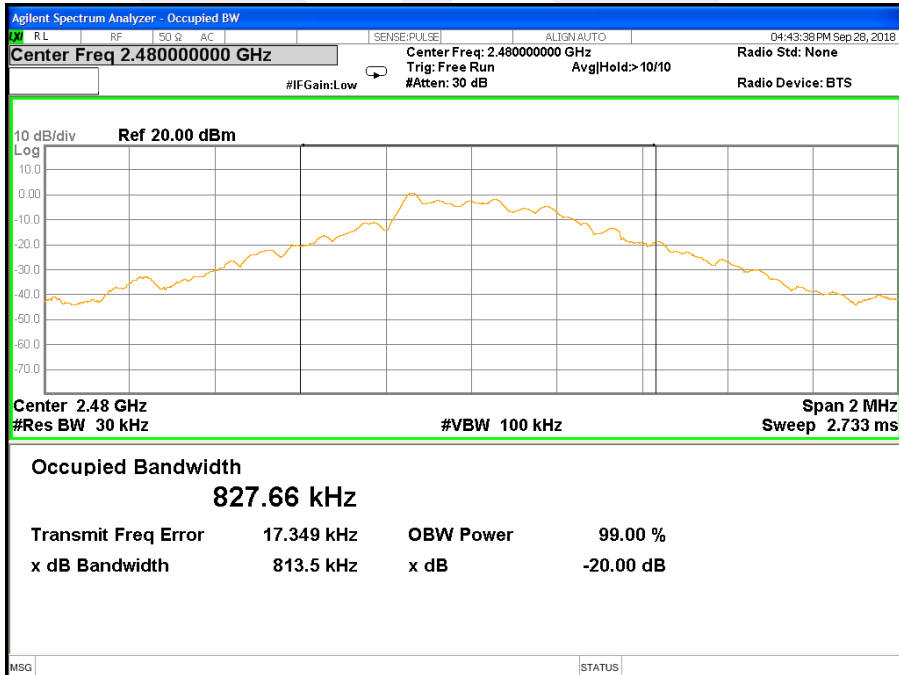



|              |  |                    |         |
|--------------|--|--------------------|---------|
| Temperature: | 25°C                                       | Relative Humidity: | 50%     |
| Test Mode:   | $\pi/4$ -DQPSK(2Mbps)<br>CH00 / CH39 / C78 | Test Voltage:      | DC 3.7V |

| Frequency | 20dB Bandwidth(MHz) | Result |
|-----------|---------------------|--------|
| 2402 MHz  | 1.130               | PASS   |
| 2441 MHz  | 1.129               | PASS   |
| 2480 MHz  | 1.130               | PASS   |

### CH00 -2Mbps

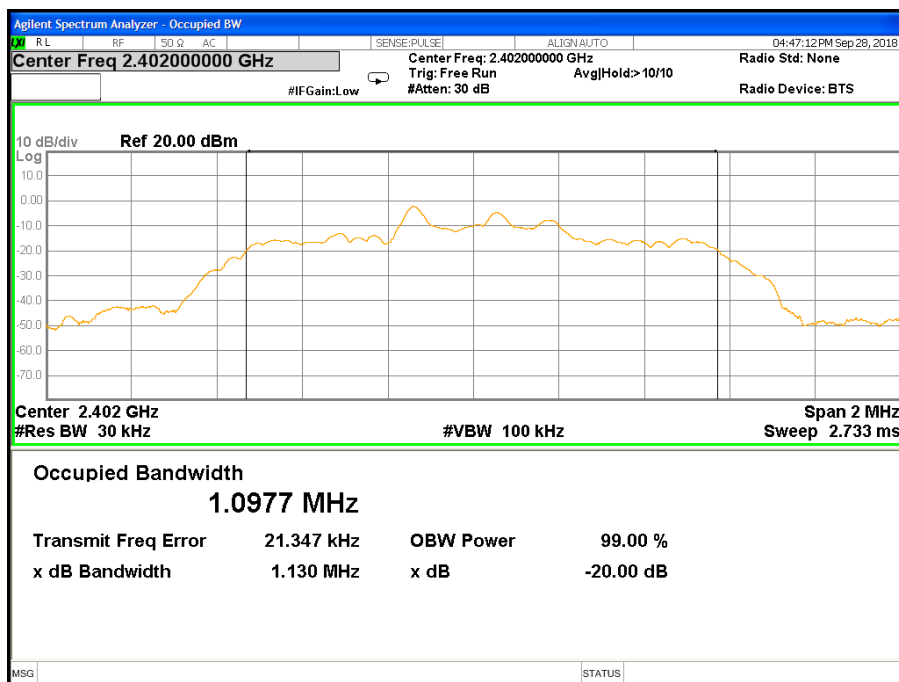



### CH39 -2Mbps

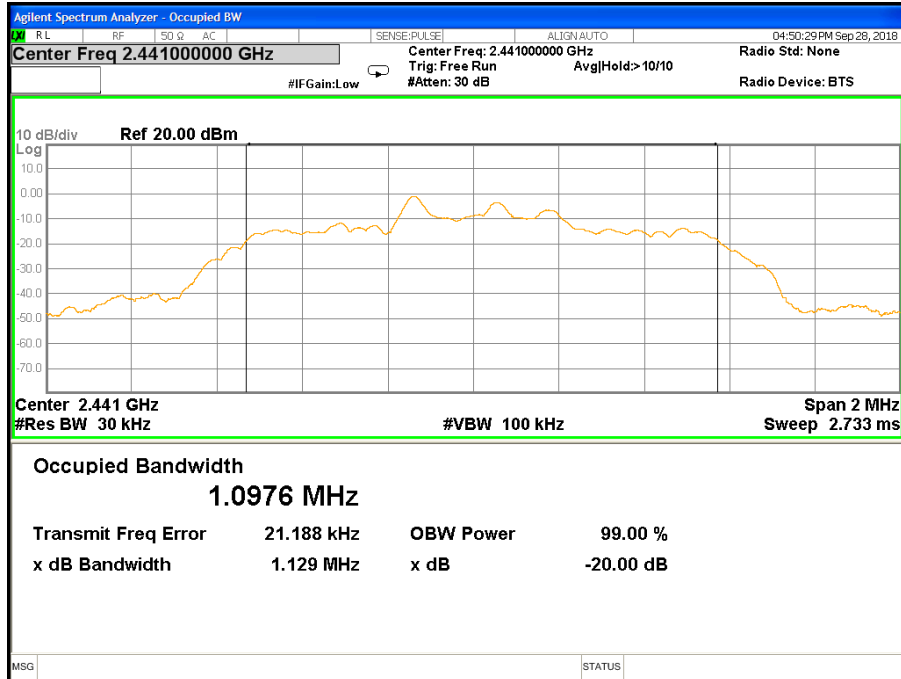

### CH78 -2Mbps

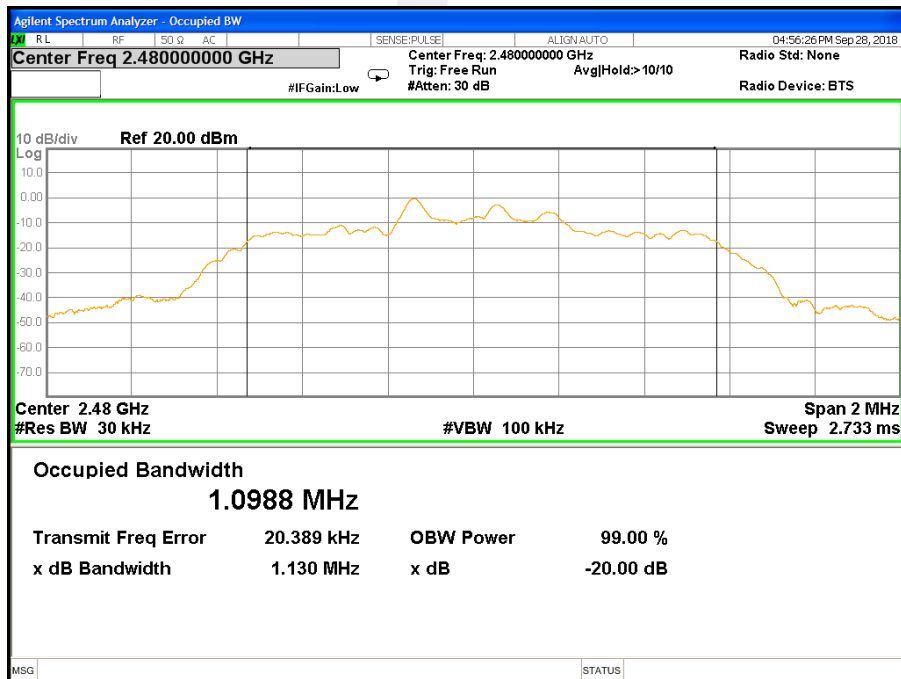



|              |                                    |                    |         |
|--------------|------------------------------------|--------------------|---------|
| Temperature: | 25°C                               | Relative Humidity: | 50%     |
| Test Mode:   | 8DPSK(3Mbps)<br>CH00 / CH39 / CH78 | Test Voltage:      | DC 3.7V |

| Frequency | 20dB Bandwidth (MHz) | Result |
|-----------|----------------------|--------|
| 2402 MHz  | 1.133                | PASS   |
| 2441 MHz  | 1.132                | PASS   |
| 2480 MHz  | 1.236                | PASS   |

### CH00 -3Mbps

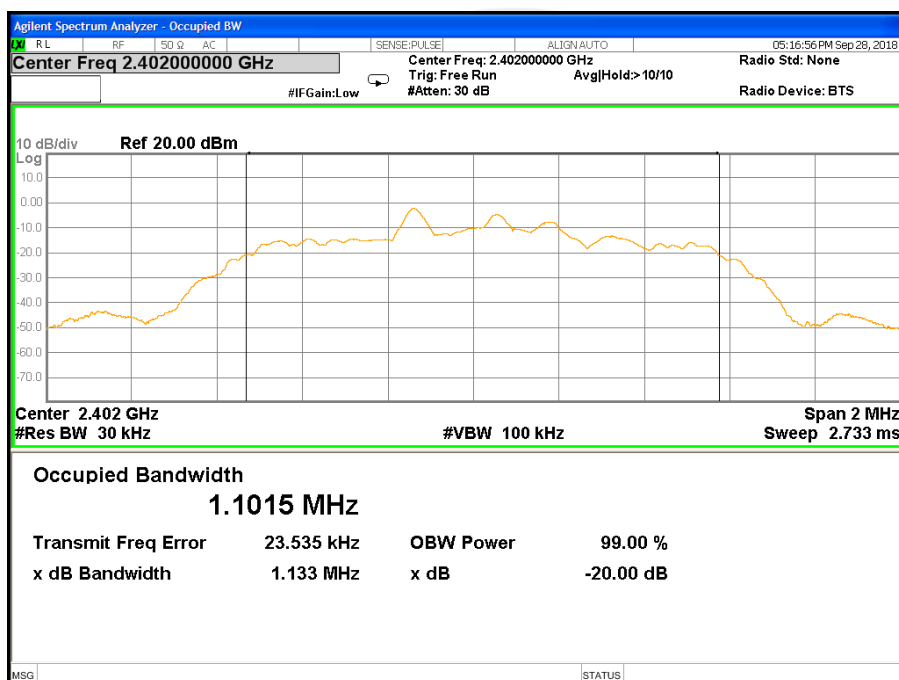



### CH39 -3Mbps

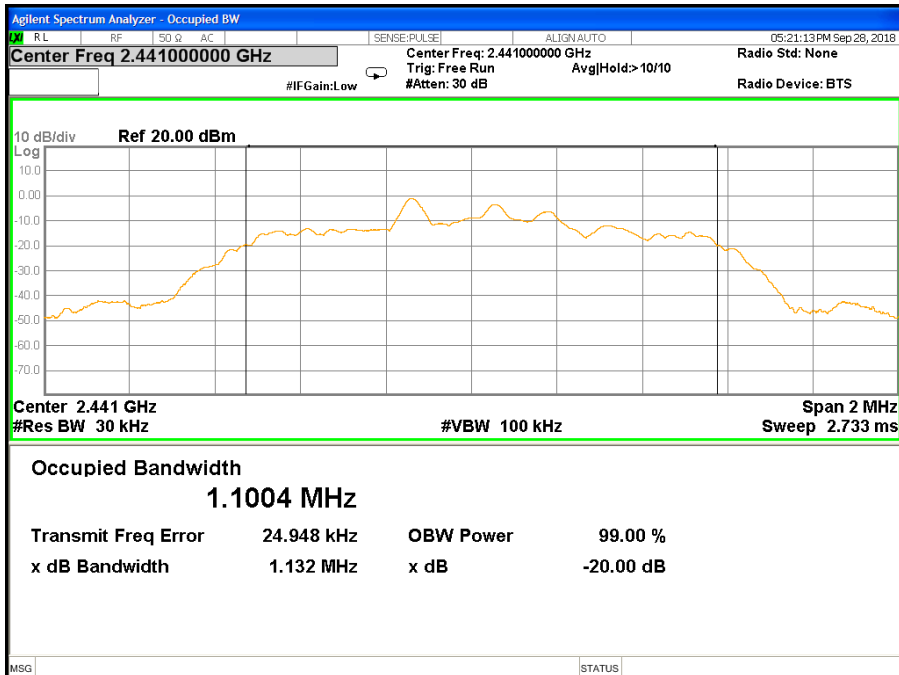

### CH78 -3Mbps

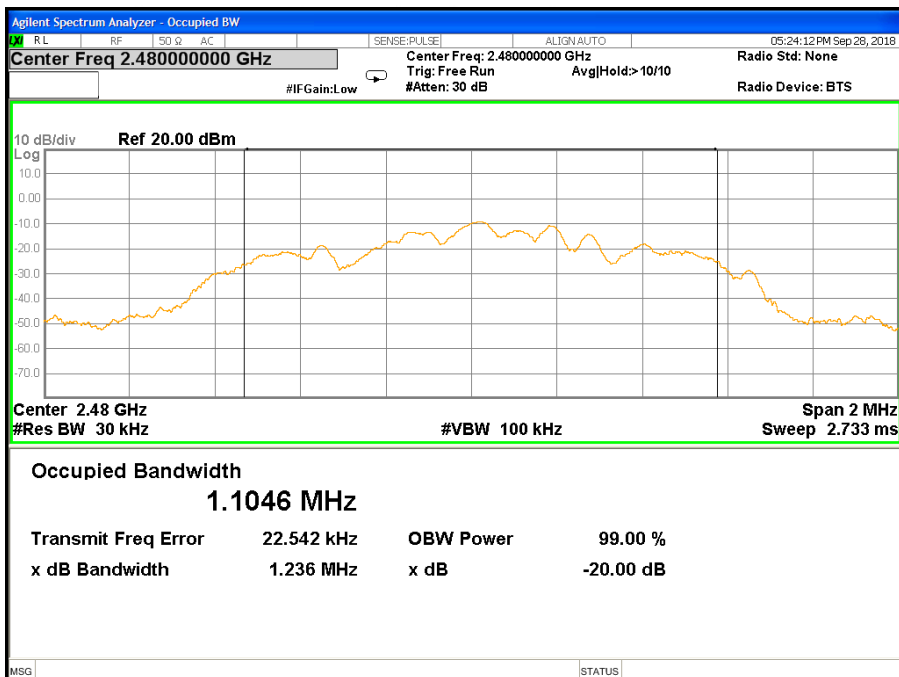





## 9. OUTPUT POWER TEST

### 9.1 APPLIED PROCEDURES / LIMIT

| FCC Part 15.247, Subpart C |              |  |                       |        |
|----------------------------|--------------|--|-----------------------|--------|
| Section                    | Test Item    | Limit  | Frequency Range (MHz) | Result |
| 15.247<br>(a)(1)&(b)(1)    | Output Power | 1 W or 0.125W  | 2400-2483.5           | PASS   |
|                            |              | if channel separation > 2/3 bandwidth provided the systems operate with an output power no greater than 125 mW (20.97 dBm) |                       |        |

### 9.2 TEST PROCEDURE

- a. The EUT was directly connected to the Power Meter

### 9.3 TEST SETUP

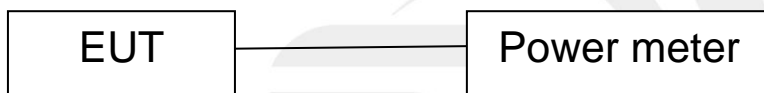

### 9.4 EUT OPERATION CONDITIONS

The EUT tested system was configured as the statements of 2.4 Unless otherwise a special operating condition is specified in the follows during the testing.



## 9.5 TEST RESULTS

|               |         |                    |     |
|---------------|---------|--------------------|-----|
| Temperature:  | 25°C    | Relative Humidity: | 60% |
| Test Voltage: | DC 3.7V |                    |     |

| <b>GFSK(1Mbps)</b> |           |                        |           |       |
|--------------------|-----------|------------------------|-----------|-------|
| Test Channel       | Frequency | Conducted Output Power |           | LIMIT |
|                    | (MHz)     | Peak (dBm)             | AVG (dBm) | dBm   |
| CH00               | 2402      | 3.31                   | 1.67      | 30    |
| CH39               | 2441      | 3.96                   | 2.43      | 30    |
| CH78               | 2480      | 4.07                   | 2.84      | 30    |

Note: the channel separation >20dB bandwidth

| <b><math>\pi/4</math>QPSK(2Mbps)</b> |           |                        |           |       |
|--------------------------------------|-----------|------------------------|-----------|-------|
| Test Channel                         | Frequency | Conducted Output Power |           | LIMIT |
|                                      | (MHz)     | Peak (dBm)             | AVG (dBm) | dBm   |
| CH00                                 | 2402      | 2.18                   | 0.83      | 20.97 |
| CH39                                 | 2441      | 2.73                   | 1.48      | 20.97 |
| CH78                                 | 2480      | 2.81                   | 1.26      | 20.97 |

Note: the channel separation >2/3 20dB bandwidth

| <b>8DPSK(3Mbps)</b> |           |                        |           |       |
|---------------------|-----------|------------------------|-----------|-------|
| Test Channel        | Frequency | Conducted Output Power |           | LIMIT |
|                     | (MHz)     | Peak (dBm)             | AVG (dBm) | dBm   |
| CH00                | 2402      | 2.04                   | 0.57      | 20.97 |
| CH39                | 2441      | 2.68                   | 1.12      | 20.97 |
| CH78                | 2480      | 2.73                   | 1.37      | 20.97 |

Note: the channel separation >2/3 20dB bandwidth



## 10. ANTENNA REQUIREMENT

### 10.1 STANDARD REQUIREMENT

15.203 requirement: For intentional device, according to 15.203: an intentional radiator shall be designed to ensure that no antenna other than that furnished by the responsible party shall be used with the device.

### 10.2 EUT ANTENNA

The EUT antenna is PCB Antenna. It comply with the standard requirement.



## APPENDIX-PHOTOS OF TEST SETUP

### Radiated Measurement Photos

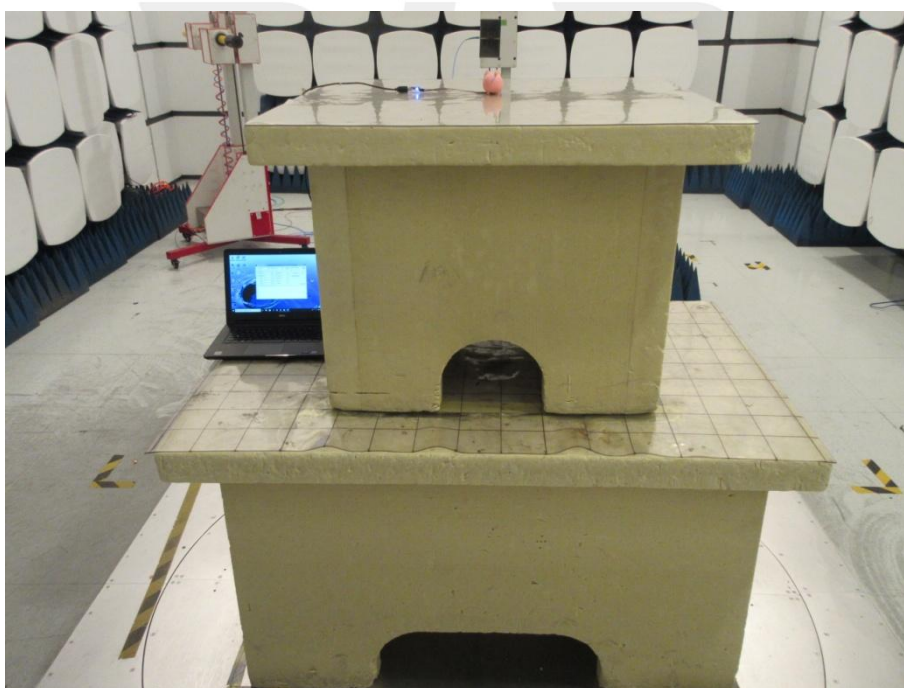
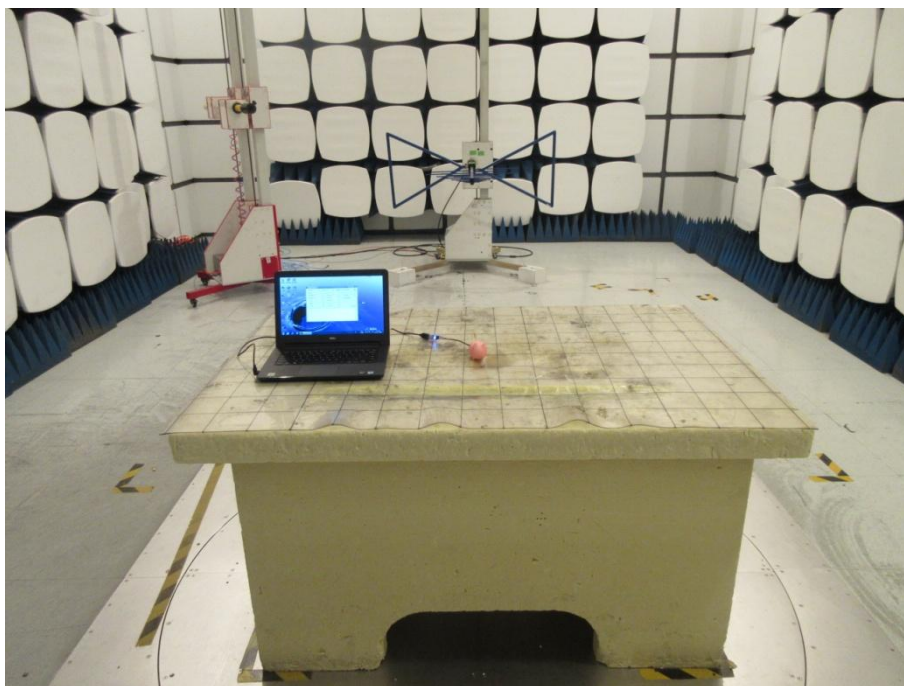

\*\*\*\*\*END OF THE REPORT\*\*\*\*\*